

SIEMENS



System Manual

SIDOOR

Elevator door drive

AT12

06/2020

support.industry.siemens.com

Automatic door controllers

SIDOOR Elevator door drive AT12



Equipment Manual

<u>Introduction</u>	1
<u>Safety notes</u>	2
<u>Definitions</u>	3
<u>Overview of controls</u>	4
<u>Functions and device responses</u>	5
<u>Mechanical installation and setting</u>	6
<u>Electric adjustment and commissioning</u>	7
<u>The relay contacts</u>	8
<u>CAN</u>	9
<u>Travel curve</u>	10
<u>Operating status display</u>	11
<u>Technical data</u>	12
<u>Appendix</u>	A

Legal information

Warning notice system

This manual contains notices you have to observe in order to ensure your personal safety, as well as to prevent damage to property. The notices referring to your personal safety are highlighted in the manual by a safety alert symbol, notices referring only to property damage have no safety alert symbol. These notices shown below are graded according to the degree of danger.

 DANGER
indicates that death or severe personal injury will result if proper precautions are not taken.
 WARNING
indicates that death or severe personal injury may result if proper precautions are not taken.
 CAUTION
indicates that minor personal injury can result if proper precautions are not taken.
NOTICE
indicates that property damage can result if proper precautions are not taken.

If more than one degree of danger is present, the warning notice representing the highest degree of danger will be used. A notice warning of injury to persons with a safety alert symbol may also include a warning relating to property damage.

Qualified Personnel

The product/system described in this documentation may be operated only by **personnel qualified** for the specific task in accordance with the relevant documentation, in particular its warning notices and safety instructions. Qualified personnel are those who, based on their training and experience, are capable of identifying risks and avoiding potential hazards when working with these products/systems.

Proper use of Siemens products

Note the following:

 WARNING
Siemens products may only be used for the applications described in the catalog and in the relevant technical documentation. If products and components from other manufacturers are used, these must be recommended or approved by Siemens. Proper transport, storage, installation, assembly, commissioning, operation and maintenance are required to ensure that the products operate safely and without any problems. The permissible ambient conditions must be complied with. The information in the relevant documentation must be observed.

Trademarks

All names identified by ® are registered trademarks of Siemens AG. The remaining trademarks in this publication may be trademarks whose use by third parties for their own purposes could violate the rights of the owner.

Disclaimer of Liability

We have reviewed the contents of this publication to ensure consistency with the hardware and software described. Since variance cannot be precluded entirely, we cannot guarantee full consistency. However, the information in this publication is reviewed regularly and any necessary corrections are included in subsequent editions.

Table of contents

- 1 Introduction..... 5**
- 2 Safety notes..... 6**
 - 2.1 General safety instructions..... 6
- 3 Definitions 7**
- 4 Overview of controls 8**
- 5 Functions and device responses..... 9**
 - 5.1 Learn and test run..... 9
 - 5.2 DOOR OPEN command..... 9
 - 5.3 DOOR CLOSE command 9
 - 5.4 Learn run button..... 10
 - 5.5 Parameter settings..... 11
 - 5.6 Blockage detection "CLOSE" 11
 - 5.7 Blockage detection "OPEN" 12
 - 5.8 Nudge 12
 - 5.9 Restart after power failure..... 12
 - 5.10 Closing force 13
 - 5.11 Emergency release..... 13
 - 5.12 Overload protection..... 14
- 6 Mechanical installation and setting 15**
- 7 Electric adjustment and commissioning 16**
- 8 The relay contacts..... 20**
- 9 CAN 21**
- 10 Travel curve 23**
- 11 Operating status display..... 24**
 - 11.1 Speed limit curve 25
- 12 Technical data..... 26**
 - 12.1 DC geared motor 26
 - 12.2 Control unit 26
 - 12.3 Regulations and standards 27

A	Appendix	28
A.1	Order nos. of the individual parts	28
A.2	Dimension drawing of AT12 controller	29
A.3	24 V geared motor with rubber-metal anti-vibration mount and mounting bracket	30
A.4	Deflector pulley with tensioning device and mounting bracket	31
A.5	Door clutch holder	32
A.6	Assembly suggestion	33
A.7	Terminal circuit diagram of control inputs	34
A.8	Diagnostics and parameterization	35
A.9	Settings record	36
A.10	Service & support.....	37

Introduction

The comfort elevator door drive AT12 is an "intelligent" door drive with which the cabin and shaft doors can be opened and closed at adjustable speeds and accelerations. This maintenance-free drive unit consists of a speed-controlled DC motor with non-self-locking gearing. The power is transmitted by a toothed belt. The toothed belt passes over a deflector pulley, and can be fitted with two clutch holders. This enables it to drive both single-sided and centrally-opening doors.

The AT12 is currently supplied with the following motor:

– 24 V / 1.8 A motor, suitable for a maximum total door panel weight of 120 kg

The door drive can be ordered with the drive pinion either on the left or right-hand side, please see the drawing in the Appendix.

Operation of the door drive does not require limit switches.

The door width and the "OPEN" and "CLOSED" positions are determined automatically.

An LED display on the controller indicates the current operating states.

The Appendix includes all the important dimension drawings, an assembly suggestion, and the identification numbers for ordering the individual drive components.

Note

For reasons of clarity, these operating instructions do not contain complete, detailed information about all product types. Similarly, they cannot cover every conceivable type of installation, operation or maintenance.

Additional information about this product and its application can be found in the Internet (www.siemens.com/sidoor).

Furthermore, the contents of these Operating Instructions shall not become a part of or modify any prior or existing agreement, commitment, or legal relationship. The sales contract contains the entire obligation of SIEMENS. The warranty contained in the contract between the parties is the sole warranty of SIEMENS. Any statements contained in these operating instructions neither expand nor restrict the scope of these contractual warranty conditions.

Safety notes

Before commissioning

Please read through these instructions carefully. They contain essential information for the installation, use and safety of the equipment.

2.1 General safety instructions

 **WARNING**

Only appropriately qualified personnel should work on or in the vicinity of this equipment. Personnel must be thoroughly familiar with all the warnings, notices, and functions of the AT12 door controller described in the operating instructions.

In the context of the operating instructions and warning notices, a *qualified person* is a person who is familiar with assembling, installing, commissioning, and operating the product, and who has the relevant qualifications, such as:

- Training, instruction or authorization to commission electric circuits and devices/systems in compliance with safety engineering standards.
- Training or instruction in the maintenance and use of appropriate safety equipment in compliance with safety engineering standards.
- Training in first aid measures

The successful and safe operation of this equipment is dependent on proper transportation, storage, installation, and assembly, as well as on careful operation and maintenance.

Before commissioning, all electrical connections must be inspected to ensure that all contacts are secure.

Before starting work on the door drive, it must be disconnected from the power supply by unplugging the power plug.

Definitions

Initial speed

Reduced speed in the opening and closing directions after power on until normal operation is detected.

Creep speed

Reduced speed in the vicinity of the OPEN position of the elevator door (creep distance).

Cutter speed

Reduced speed in the vicinity of the CLOSED position of the elevator door (cutter distance).

Creep distance

Range of door travel in the vicinity of the OPEN position.

Cutter distance

Range of door travel in the vicinity of the CLOSED position.

Overview of controls



Sidoor AT12:	
X204:	Mains connection 230 V (1 A, 50 / 60 Hz)
X102:	Connector for Service Tool and USB adapter (Software Kit)
S501:	Learn run button
X902:	CAN connector (CAN OPEN RJ45)
T901:	Switchable CAN terminating resistor 120 ohms
X202:	Voltage output 24 VDC / 120 mA
X801:	Motor plug
X101:	Connector for output signals <ul style="list-style-type: none"> • Open • Closed Connector for input signals: <ul style="list-style-type: none"> • Nudge • Close • Open

Functions and device responses

5.1 Learn and test run

Pressing the learn run button for more than five seconds (*S501*) executes the automatic determination of the parameters:

1. Detection of the direction of door movement and the "CLOSED" position
2. Determination of the friction values of the door system and the weight of the door.
3. Determination of the door width and the "OPEN" position. Closure of the door until it has traveled through the entire determined door width and reached the "CLOSED" position.

These parameters are then saved, which takes three seconds.

5.2 DOOR OPEN command

The *DOOR OPEN* command opens the door according to the set speed of travel curve as long as the command is present.

The transitions along the speed of travel curve (e.g. from acceleration to constant velocity) are smoothed to prevent noises possibly arising from the play between the cabin and shaft doors. The door reaches the "OPEN" position at creep speed. Then, if the *DOOR OPEN* command is present, the door is held open with a reduced torque.

- The *DOOR OPEN* command must remain present throughout the entire opening movement.
- The *DOOR OPEN* command must remain present continuously in order to maintain continuous torque in the *OPEN* position.

The *DOOR OPEN* command has priority over all other control commands.

5.3 DOOR CLOSE command

The *DOOR CLOSE* command must remain present continuously in order to close the door. After the door has closed, it is held in this position with reduced torque as long as the *DOOR CLOSE* command remains present.

5.4 Learn run button

The learn run button (S501) combines the functions of the automatic learn and test run, and the option of opening and closing the door from the controller.

The learn and test run is activated by pressing the learn run button for more than five seconds.

The door can be moved by pressing the learn run button briefly for between 0.1 and two seconds.

The inputs "Open" and "Close" must not be activated:

- First button press for between 0.1 and 2 seconds in normal or initial operation → door opens until it reaches the "OPEN" end position, and remains stationary with the average value of the PWM signal.
- If the button is pressed for between 0.1 and 2 seconds again before the door has completely opened, the door stops and remains stationary with the average value of the PWM signal.
- When the button is pressed again for between 0.1 and 2 seconds in normal or initial operation → door closes until it reaches the "CLOSED" end position, and remains stationary with the average value of the PWM signal.
- If the button is pressed for between 0.1 and 2 seconds again before the door has completely closed, the door stops and remains stationary with the average value of the PWM signal.
- The next button press opens the door again.
- If no buttons are pressed for a period longer than 10 seconds, the next button press for between 0.1 and 2 seconds always opens the door.

5.5 Parameter settings

The Service Tool and the Sidor User Software offer additional setting and diagnostic options.

The Service Tool is available as an extra, separate option.

It is connected to the *X102* connector on the controller.

The Sidor User Software offers the easiest diagnostic option.

A PC can be connected to *X102* on the controller via the USB adapter (Software Kit accessory).

Note

The current parameters are overwritten by the factory parameters at the end of the learn run if the *learn run button* (S501) is pressed at the same time as the supply voltage is switched on.

If the *learn run button* is pressed during operation in order to start a learn and test run, only the door width and weight are determined. The speed of travel curve parameters, force limits and continuous torques are retained unchanged. The maximum closing speed and the nudge speed are limited as a function of the determined weight.

NOTICE
The determination of the door weight has to be done while the cabin door is coupled with the heaviest shaft door in the entire system so that the kinetic energy on each door in the system is less than 10 J.

5.6 Blockage detection "CLOSE"

If the door is blocked in the "CLOSE" direction with a *DOOR CLOSE* command present, the door stops and reverses direction.

After reaching the open position, the door closes again at normal speed to within about 2 cm of the obstacle. It then travels at reduced speed (initial speed) against the obstruction before reversing again.

This function is repeated continuously, as long as the obstruction remains.

Once the obstruction has been cleared, the door travels at reduced speed to approximately 2 cm past the stored position of the obstruction, and then continues the rest of the way at normal closing speed.

5.7 Blockage detection "OPEN"

The door stops if it is blocked in the "OPEN" direction with a *DOOR OPEN* command present. After approximately 2 seconds, the door automatically tries to reach its open position again.

This action is repeated a maximum of three times.

The door then remains stationary in this position.

If the *DOOR OPEN* command is canceled, the close command given, and the *DOOR OPEN* command is then repeated, the door travels at normal speed to within about 2 cm of the stored position of the obstruction, and then up to the obstruction at reduced speed.

The door drive stops there, and the opening action is repeated another 3 times.

If the obstruction has been removed beforehand, the door travels at reduced speed to approximately 2 cm past the stored position of the obstruction, and then continues to its open position at normal speed.

5.8 Nudge

The door does not automatically reverse in the operating state *NUDGE*. The *DOOR CLOSE* and *NUDGE* commands must be present simultaneously. When an obstruction is detected, the torque is reduced after one second to the motor's holding shut torque limit.

5.9 Restart after power failure

After a supply voltage failure, the door controller has to redetermine the end positions of the door travel. To do this, the door travels on command at reduced speed (initial speed) until the controller has detected both the "OPEN" and "CLOSED" end positions. The door then resumes traveling at normal speed.

5.10 Closing force

The closing force can be set between 70 N and 120 N.

Note

The resulting closing force must be checked by a suitable measuring method, and must not exceed 150 N.

WARNING

When the closing force is set, it is imperative that any effective closing weight is taken into account.

The desired closing force must be reduced by 10 N for each 1 kg of counterweight.

This concerns the:

- Closing force "CLOSE"
- Closing force "Cam distance CLOSE"
- Nudge force "CLOSE"

Example:

Closing weight = 4 kg

Desired static force limit "CLOSE" = 150 N

The counterweight of 4 kg corresponds to a force of 40 N. The force limit then has to be adjusted to $150\text{ N} - 40\text{ N} = 110\text{ N}$.

The factory setting is designed to take into account a counterweight of 4 kg. This means that the resulting static closing force is limited to 110 N.

5.11 Emergency release

WARNING

An emergency release can only be actuated if:

- Neither a DOOR OPEN nor a DOOR CLOSE command is present
- the learn run button is not pressed,
- The Service Tool or Software Kit are not in the menu item Quick adjustment or Total adjustment or one of their sub-menus
- The door has come to a standstill

The door drive is only torque-free if these conditions are fulfilled. According to TRA (German Technical Rules for Elevators) and EN 81, the force required to open the door must be less than 300 N.

5.12 Overload protection

If the drive motor is subjected to severe strain by *DOOR OPEN* and *DOOR CLOSE* commands repeated in quick succession, the hold-open time is automatically increased. The next closing movement is delayed, even if a *DOOR CLOSE* command is present, the LED flashes red 4 times.

This function prevents the motor from overheating.

Mechanical installation and setting

! CAUTION

Safe operation of the elevator door drive requires proper assembly and commissioning by qualified personnel, with due attention given to the warning notices in the operating instructions.

The controller must be disconnected from the power supply before starting any work on the door drive. Only then is immobility of the door guaranteed.

The mechanical assembly and setting of the elevator door drive are performed in the following steps:

1. Mount the motor on the rubber-metal anti-vibration motor mounting.
Then, if necessary, mount the motor on the mounting bracket.
2. Mount the deflector pulley, if necessary with a mounting bracket.
Align the drive pinion and the deflector pulley as precisely as possible with each other (flush).
3. Bolt the toothed belt to the door clutch holder, and put it in position.

Note

Only install the door clutch holders (toothed-belt joint) specified in the Appendix. Unsuitable fastenings can concentrate the stress on the toothed belt, which can lead to its destruction. The door clutch holder (toothed-belt joint) must not run over or touch the drive pinion or deflector pulley.

4. Tension the toothed belt with the aid of the tensioning device. The correct tension has been reached when the midpoint of the toothed belt can be pushed in by approximately 3 cm for every meter of distance between the drive pinion and the deflector pulley.
5. Mount the controller close to the drive motor (take the length of the cable into account). Observe the permissible ambient temperatures, and take action to remain within the limits when necessary.

Electric adjustment and commissioning

WARNING

When electrical devices are used, certain parts of them have to carry dangerous voltages. Failure to observe the operating instructions can therefore lead to serious injuries or material damage.

It is essential to observe the warning notices.

The door movements cannot always be externally controlled while the controller is being commissioned (in particular during the automatic determination of parameters).

Therefore an authorized person must be posted near the door to ensure that no one else can come near the elevator door during commissioning.

After commissioning, the forces and energies in the entire elevator system must be checked by the service personnel to ensure that they are within their permissible limits.

Note

The AT12 controller is powered via a direct plug-in connection to the 230 VAC mains supply. The controller must be protected by a 6 A to 10 A ($I^2t > 30 \text{ A}^2/\text{sec}$) fuse in the building. It is essential to connect the PE to the X204 connector.

Note

The power socket for the controller must be easily accessible and identifiable as a mains disconnecting device.

Note

If the removable power cable is damaged, it must not be replaced by an inadequately dimensioned power cable.

Note

The motor temperature must not be below 0°C during the parameter learn run, as otherwise the weight of the door will be incorrectly determined, and the closing and nudge speeds may lie in impermissible ranges.

Note

The X101 control inputs plug is not plugged in during commissioning in order to prevent uncontrolled movements.

1. Push the door into the "CLOSED" position.
2. Plug in the X801 motor plug.

3. Plug in the X204 power plug (supply voltage is switched off).
4. Press and hold down the learn run button (S501) .
5. Switch on the supply voltage.
6. Keep the learn run button (S501) pressed until the door moves (learn run has started).
During the learn run, the door is opened about 10 cm, and closed once or twice at creep speed.
The friction of the door system is then determined by opening and closing the door once through a range of 25 cm at creep speed.
The door then opens and closes through its complete range of movement at reduced speed.
After the door has opened about 10 cm, it passes through a short acceleration ramp to determine the weight of the door.
In the "CLOSED" position, the door parameters and the determined door width are saved.
During the learn run and while the parameters are being saved, LED H501 flashes green.
When saving has finished, the LED shows a steady green light.
7. The door can now be completely opened by briefly pressing the learn run button. Pressing the button again, when the door is in the end position "Open", closes the door completely.
8. Switch off mains supply
9. Connect the cable for control signals to the X101 connector as shown in the circuit diagram (see Appendix Terminal circuit diagram of control inputs (Page 34)).

 CAUTION

The controller will be operative after the next switch-on. If a control signal is present, the door will move in the set direction.

10. Switch on the controller (plug in the mains plug or connector X101).
LED H501 lights red for about two seconds, and then changes to a steady green after the application software has started and there are no errors in the controller. If the LED continues to show red, repeat the learn run once more, as described above. If the LED lights with a red flash code, one of the errors described below is present:
Flash code:
 - 1: CPU error
 - 2: Brake chopper error
 - 3: Error in the second shutdown route
 - 4: Motor temperature monitoring
 - 5: Unknown motor (X801)
 - 6: Blockage detected in closing direction
 - 7: Incremental encoder error (X801)
 - 8: Parameter learn run ended with error
 - 9: Motor overcurrent
 - 10: Blockage detected in opening direction
 - 11: Overvoltage (motor)
 - 12: Undervoltage (motor)
 - 13: Error at the ammeter
 - 14: Determined door weight too high
 - 15: Output stage faulty
 - 16: Overvoltage 15 V circuit
 - 17: Undervoltage 15 V circuit
 - 18: CAN error

11. If the control signal "CLOSE" is present, the door moves into the "CLOSED" position at initial speed. If the control signal "OPEN" is present, the door moves into the "OPEN" position at initial speed.
12. Once the controller has detected the door "OPEN" and "CLOSED" end positions, the subsequent opening and closing movements proceed at normal speed once again.

Note

Door movements in the "OPEN" and "CLOSE" directions can also be actuated with the learn run button S501.

13. The door travel values can be matched to the individual door for specific applications. This requires the Service Tool to be connected. A PC, on which the Software Kit operating program has been started, can also be connected via the USB adapter, which is available as a special accessory. Its operation is described in the Appendix to these instructions.

The following settings can be made:

Function	Adjustment range	Factory setting
Creep distance Open	0... 100 mm	25 mm
Cutter distance Open	0... 100 mm	30 mm
Creep distance Close	0... 100 mm	20 mm
Cutter distance Close	0... 100 mm	40 mm
Maximum speed Open	100... 500 mm/s	500 mm/s
Creep speed Open	30... 90 mm/s	40 mm/s
Cutter speed Open	30... 90 mm/s	60 mm/s
Initial speed Open	30... 90 mm/s	90 mm/s
Maximum speed Close	100... 500 mm/s	250 mm/s
Creep speed Close	30... 90 mm/s	60 mm/s
Cutter speed Close	30... 90 mm/s	40 mm/s
Initial speed Close	30... 90 mm/s	90 mm/s
Nudge speed Close	50... 250 mm/s	150 mm/s
Acceleration ramp OPEN	300... 850 mm/s ²	850 mm/s ²
Braking ramp OPEN	300... 850 mm/s ²	600 mm/s ²
Reversing ramp OPEN/CLOSE	300... 850 mm/s ²	850 mm/s ²
Acceleration ramp CLOSE	300... 850 mm/s ²	500 mm/s ²
Braking ramp CLOSE	300... 850 mm/s ²	500 mm/s ²
Reversing ramp CLOSE/OPEN	300... 850 mm/s ²	850 mm/s ²
Continuous torque (power) OPEN	0... 1.5 A	1 A
Continuous torque (power) CLOSE	0... 1.5 A	1 A
Cutter press-on torque	0... 5.0 A	2.5 A
Opening force static	70... 120 N	120 N
Closing force static	70... 120 N	110 N
Cutter force static Close	70... 120 N	110 N
Nudge force static Close	70... 120 N	110 N

Parameters should always be adjusted during normal operation with the door in the "CLOSED" position, because the controller then accepts the values immediately.

 **CAUTION**

Taking the counterweights into account, the maximum static closing force must not exceed 150 N!

 **WARNING**

Risk of injury through moving mechanical parts

After the elevator door has been commissioned, the permitted energies and forces on the heaviest door in the entire (elevator) system must be checked by service personnel with landing door and cabin door coupled, and adjusted if they exceed their limit values.

Gearing up or down is not allowed on the toothed belt because this would change the kinetic energies or static forces on the door. The door width would then no longer be valid.

Note

After the optimal parameter settings have been determined, they can be noted in the configuration record (see Appendix Settings record (Page 36)). This record should also be kept at hand when asking questions on the Hotline.

The relay contacts

The relay contacts can be used to report the following door states to the higher-level elevator controller:

- *X101 (PIN3 and PIN4)*
Door has reached the "CLOSED" position.
The relay switches on when the controller has detected the "CLOSED" position and the pulse generator ceases to output pulses, that is the door is stationary. *Pin 3* remains connected to *Pin 4* only until the *DOOR OPEN* command is issued. The relay then drops again immediately.
- *X101 (PIN1 and PIN2)*
Door has reached the "OPEN" position.
The relay switches on when the distance of the door from the "OPEN" position falls below 2 cm. *Pin 1* and *Pin 2* are then connected. If the distance falls below 2 cm again, the relay drops immediately.

In the "Overview of operator controls", the contacts are always shown with the relay de-energized (inactive).



WARNING

The door controller is not a safety mechanism. Therefore the relay contacts must not be used for the elevator safety circuit.

A voltage greater than 42 V must not be connected to the relay contacts.



The movement commands and door states can be sent by means of a CAN Bus protocol.

A 120 ohms terminating resistor can be optionally connected via the slide switch T901. The resistor is switched in as default.

The pin assignment of the RJ45 X902 socket corresponds to the CANopen pin assignment. The cable shield is not connected to the printed circuit board of the AT12. This must be connected appropriately by the user, system manager, in order to ensure secure communication.

Table 9- 1 RJ45 connector X902

Pin assignment	Pin	Signal
	1	CAN_H
	2	CAN_L
	3	GND
	4	–
	5	–
	6	Shield
	7	GND
	8	–

The interface supports the CANopen protocol according to CiA 301, profile 417.

The SIDOOR SERVICE TOOL must be used to set the command input to CAN, so that the controller can be addressed via the CAN bus.

The factory settings of the major parameters are:

Parameter	Factory setting
Command output	Digital IO (digital inputs)
CANopen node ID	7
Baud rate	Automatic
Door number	1

When the baud rate is set to "automatic", the CAN module automatically determines the baud rate on the CAN bus. To do this, the CAN module must have received some valid CAN telegrams.

SIDOOR AT-12 EDS file (<https://support.industry.siemens.com/cs/ww/en/view/88851362>)

SIDOOR CANopen AT12 (<https://support.industry.siemens.com/cs/ww/en/view/59004938>)

Travel curve

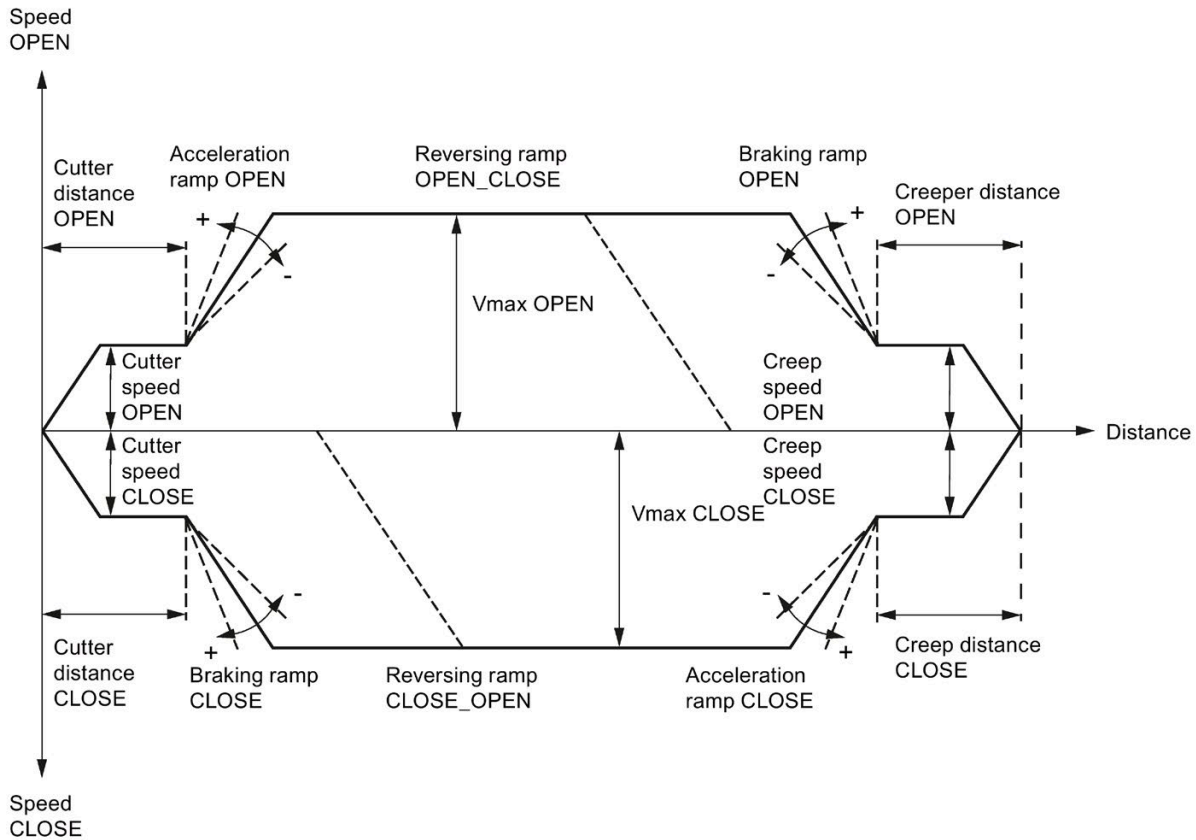

Figure 10-1 Travel curve

Reversing ramp OPEN_CLOSE = direction of travel reverses from OPEN to CLOSE.

Reversing ramp CLOSE_OPEN = direction of travel reverses from CLOSE to OPEN.

When reversing from the open to the close direction, the door is braked with the reversing ramp OPEN_CLOSE, and starts the closing movement with the acceleration ramp CLOSE.

Operating status display

The current operating states of the AT12 are indicated by a suitable error state display (Service Tool).

Display	Meaning
0	Reserve
1	RAM, EEPROM or CPU error (system error)
2	Brake chopper error
3	Error in the second shutdown route
4	Increased hold-open time with longer motor switch-on time
5	Motor undefined
6	Motor blocked in direction of closure
7	Incremental encoder error
8	Reserve
9	Motor overcurrent
A	Reserve
b	15 V overvoltage
c	Blockage while opening
C	Reserve
d	Door remains stationary during initialization run (no OPEN or CLOSE signal, or door has reached end position)
E	Motor overvoltage
F	Motor undervoltage
h	15 V undervoltage
H	Parameter determination (learn run)
n	Output stage defective
L	Ammeter error
o	Function OK
P	Parameter error (error during learn run)
r	CAN error
u	Door is closed
U	Maximum door weight exceeded
—	Controller waiting for learn run, door system has no valid parameter values

Note

The flash code of the H501 device LED is described in the section Electrical setting and commissioning (Page 16).

11.1 Speed limit curve

The speed limit curve is the characteristic curve which defines the maximum permissible door speed V_{\max} as a function of the total door panel weight.

According to EN 81, the maximum kinetic energy of the door in the closing direction must not exceed 10 joules. $W_{\text{KIN}} = 1/2 m \cdot v^2 = 10 \text{ J}$.

Example from the following speed limit curve:

Total door panel weight $m = 120 \text{ kg} \Rightarrow V_{\max} = 0.4 \text{ m/s}$.

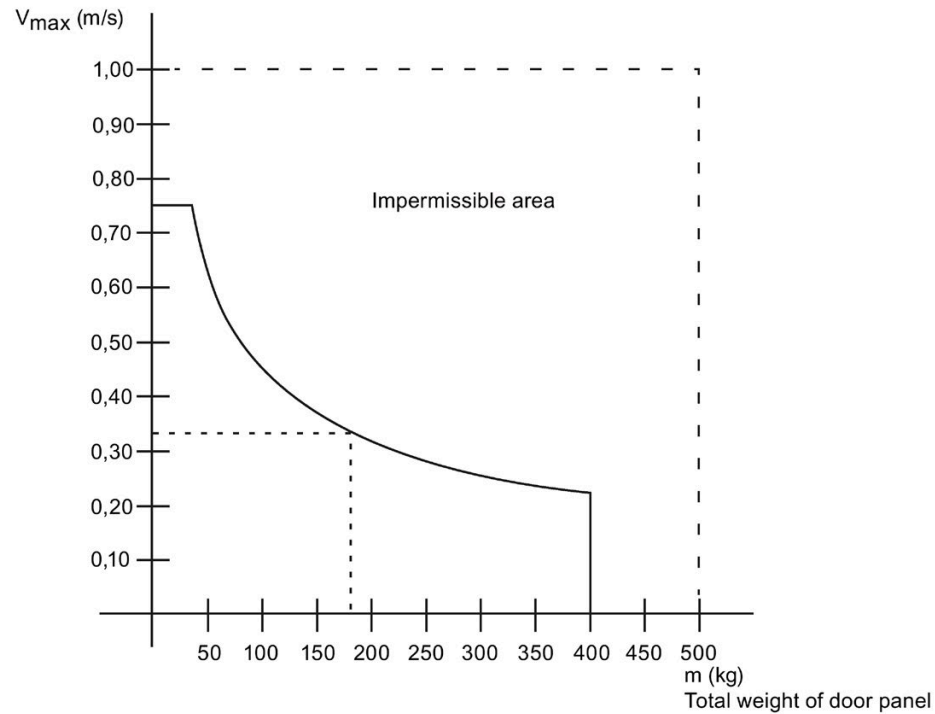

Figure 11-1 Speed limit curve

Note

The speed can be adjusted between 0 (corresponds to 0.10 m/s) and 100% (corresponds to 0.50 m/s).

Technical data

12.1 DC geared motor

Supply voltage	24 VDC
Maximum speed	0.5 m/s
Degree of protection	IP 21
Gear ratio	15:1
Pulse generator	100 pulses/revolution
Rated current	1.8 A

12.2 Control unit

Supply voltage	230 V, 50/60 Hz
Relative symmetrical tolerance of the supply voltage	±15 %
Tolerance	±15 %
On-site protection	6 A to 10 A ($I^2t > 30 \text{ A}^2\text{s}$)
Maximum power consumption	1 A
Degree of protection	IP 20
Control inputs	+10 V DC to +28 V DC, 6 mA to 18 mA per input (floating, p switching)
Door width	0.3 m to 2.40 m
Maximum counterweight	4 kg
Output relay switching capacity	30 VDC, 0.5 A (10 mA min.)
Max. perm. storage temperature	- 20 to + 85°C
Max. perm. operating temperature	- 0 to + 50°C
Pollution degree	2
Moisture requirement	No condensation
Installation altitude above MSL	2 000 m
24 V output	Max. output current 120 mA, short-circuit and overload-proof CAUTION: Do not supply with external voltage!
Use	For indoor use only
Operating altitude	Up to 2 000 m
Overvoltage category	II
Pollution degree	2

12.3 Regulations and standards

EMC tests	EN 12015 and EN 12016
TÜV (German Technical Inspectorate)	Type-tested
CE	Certified
Electrical Safety in accordance with EN61010-1, EN61010-2-201	Conforming
Elevator standard EN 81	Conforming

Recycling and disposal

The products are low in pollutants and are recyclable. To ensure eco-friendly recycling and to dispose of your old device, contact a certified disposal company for electronic waste.

Appendix

A

A.1 Order nos. of the individual parts

Order No.	Plain text	Short designation
Control unit		
6FB1111-1AT20-1AT1	AT12 controller	AT12
Geared motor		
6FB1103-0AT10-5MA0	24 V motor, pinion left, for doors up to 120 kg	
6FB1103-0AT11-5MA0	24 V motor, pinion right, for doors up to 120 kg	
Accessories		
6FB1104-0AT02-0AD0	Vibrating metal fitting small motor	
6FB1104-0AT02-0AS0	Mounting bracket with tensioning device for deflector pulley	
6FB1104-0AT01-0AS0	Mounting bracket for gear motor	
6FB1104-0AT01-0CPO	Door clutch holder	
6FB1104-0AT03-0AS0	Deflector unit	
6FB1104-0AT01-0AB0	Toothed belt 4 m	
6FB1104-0AT02-0AB0	Toothed belt 45 m	
Servicing accessories		
6FB1105-0AT01-6ST0	Service Tool	
6FB1105-0AT01-6SW0	Software Kit with USB adapter	

A.2 Dimension drawing of AT12 controller

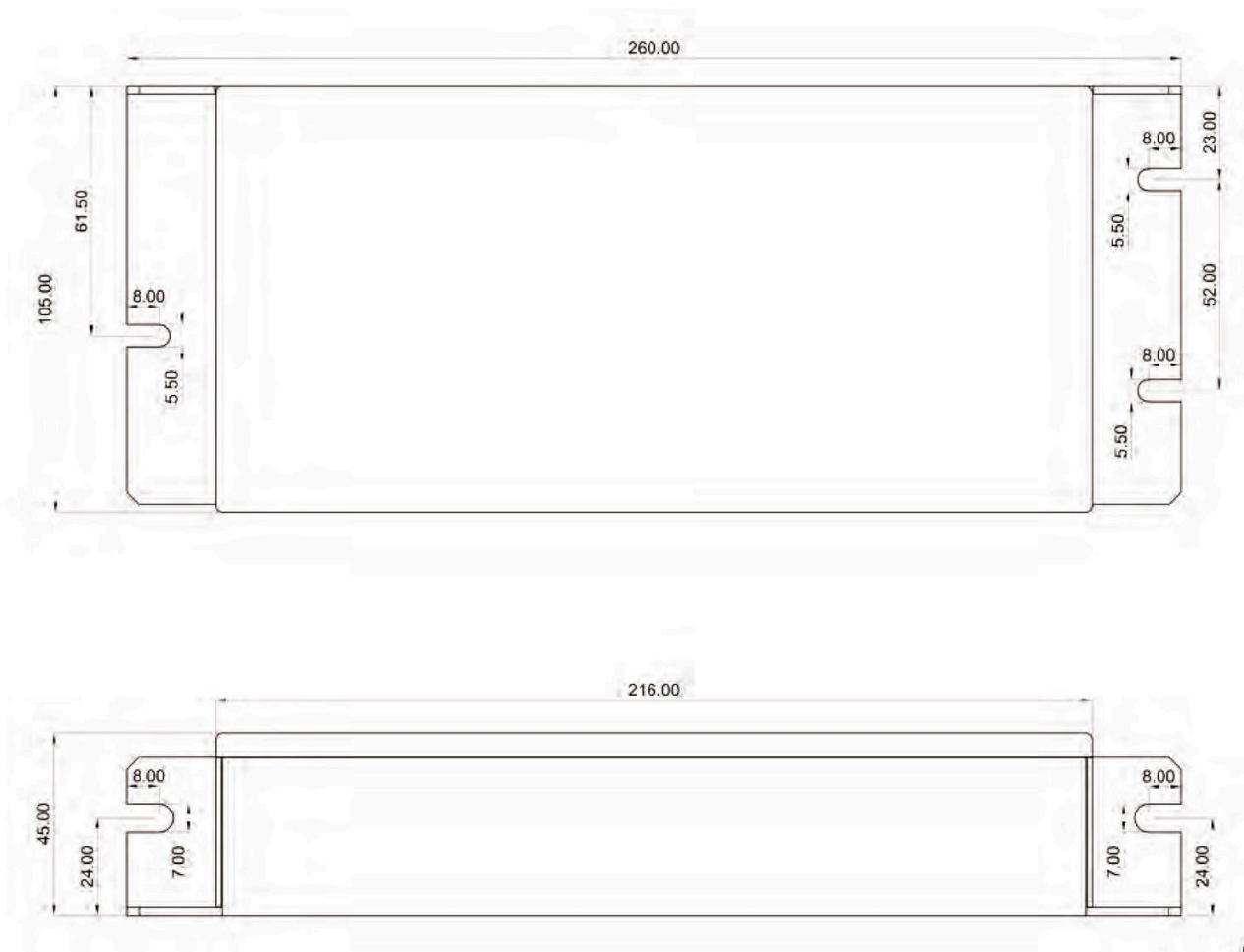

Figure A-1 Dimension drawing of AT12 controllers

Dimensions in mm

A.3 24 V geared motor with rubber-metal anti-vibration mount and mounting bracket

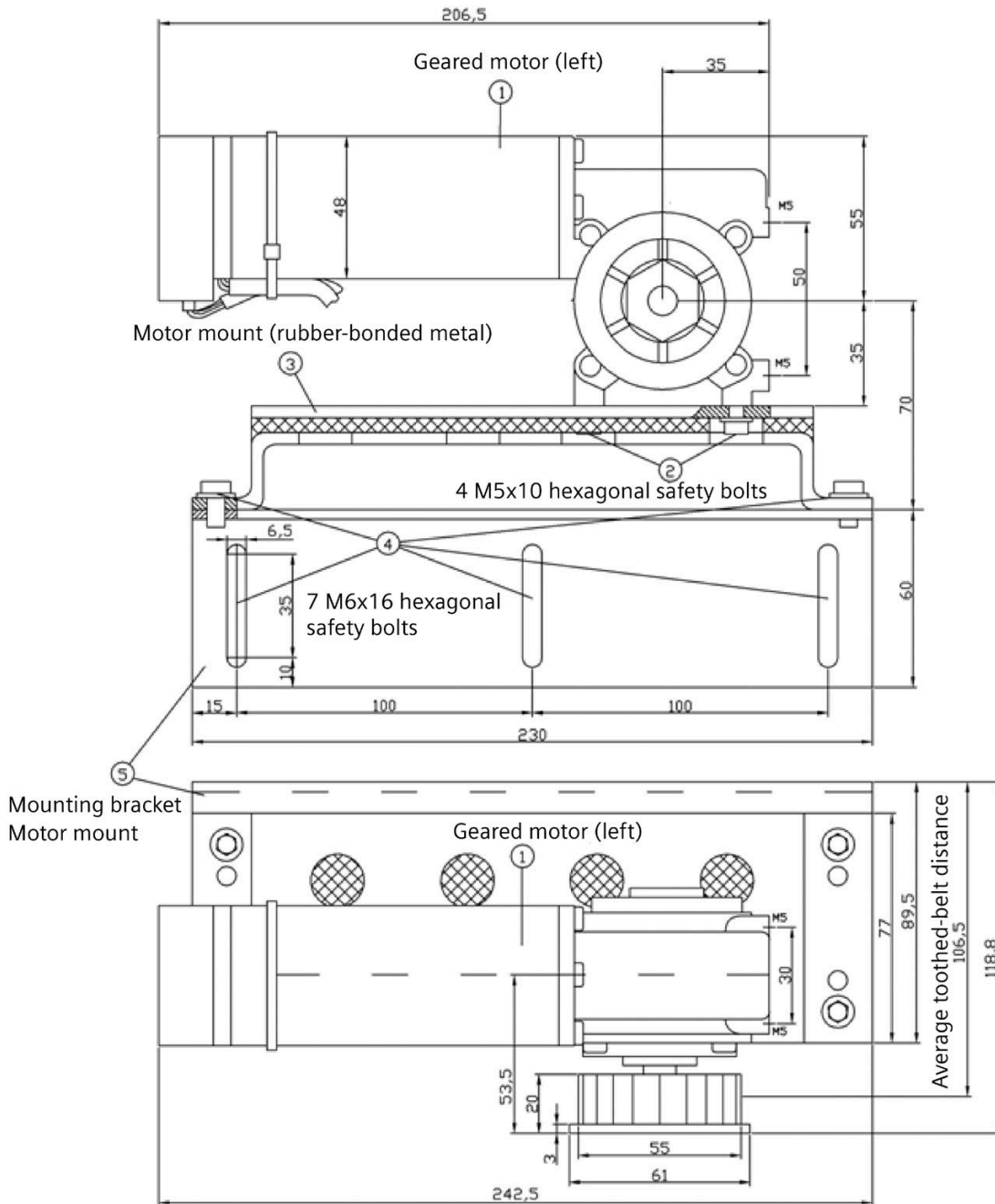

Figure A-2 24 V geared motor with rubber-metal anti-vibration mount and mounting bracket

Diagram of motor with drive pinion left

A.4 Deflector pulley with tensioning device and mounting bracket

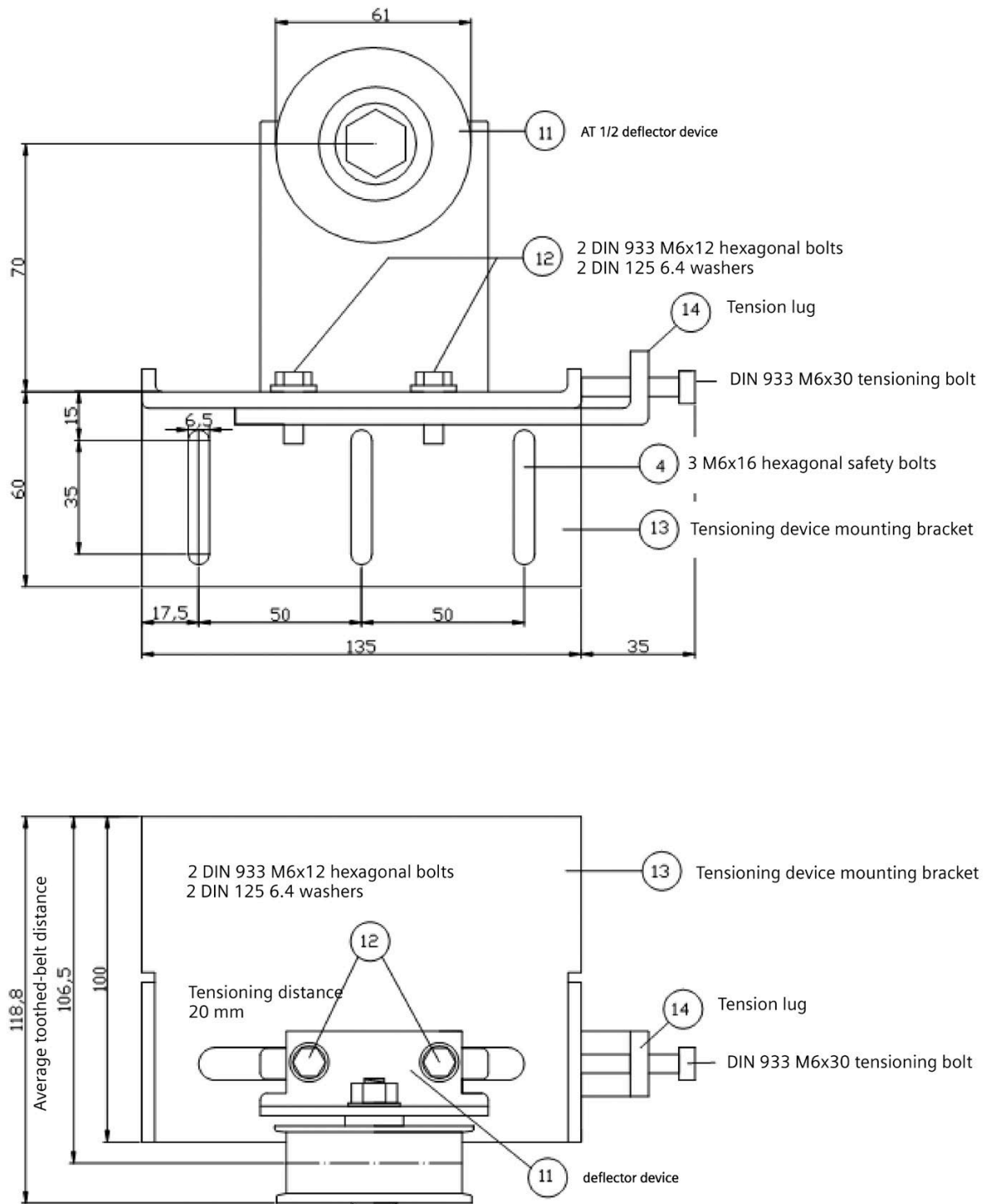

Figure A-3 Deflector pulley with tensioning device and mounting bracket

A.5 Door clutch holder

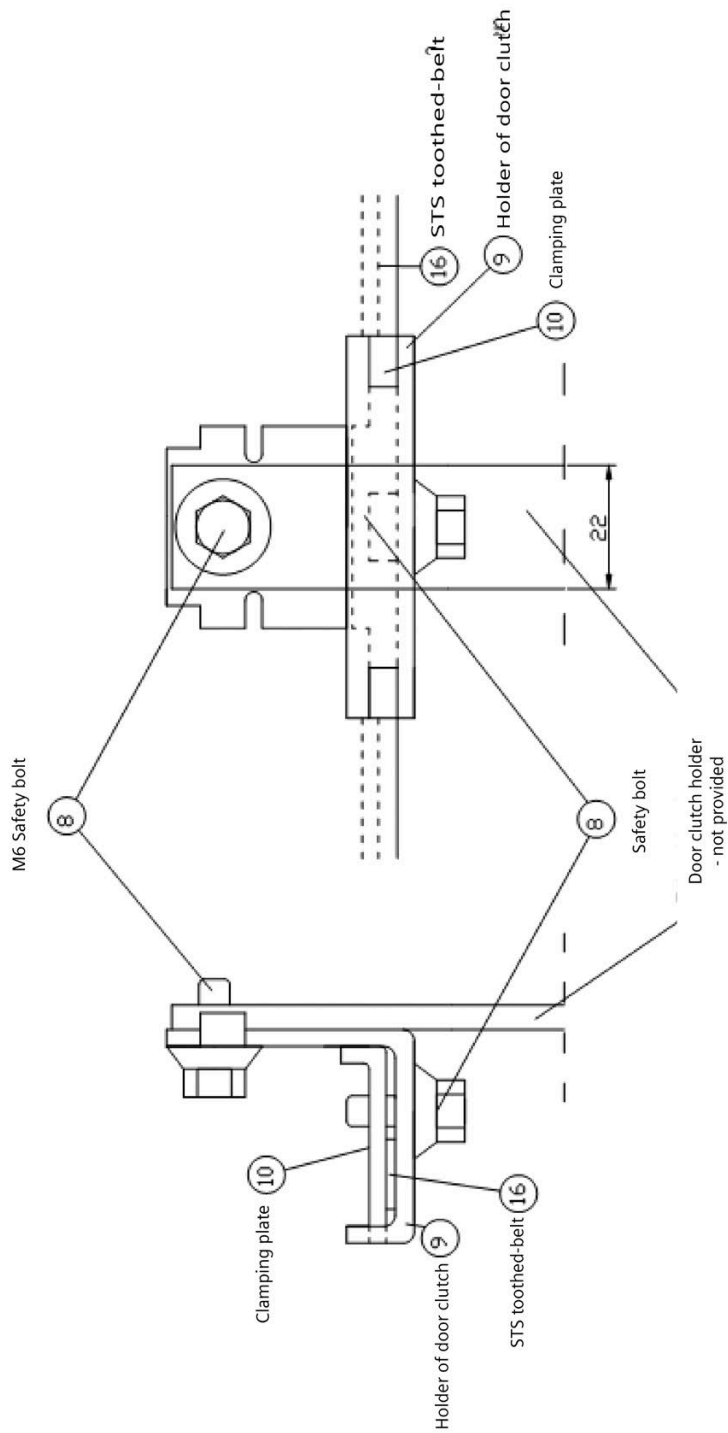

Figure A-4 Door clutch holder

A.7 Terminal circuit diagram of control inputs

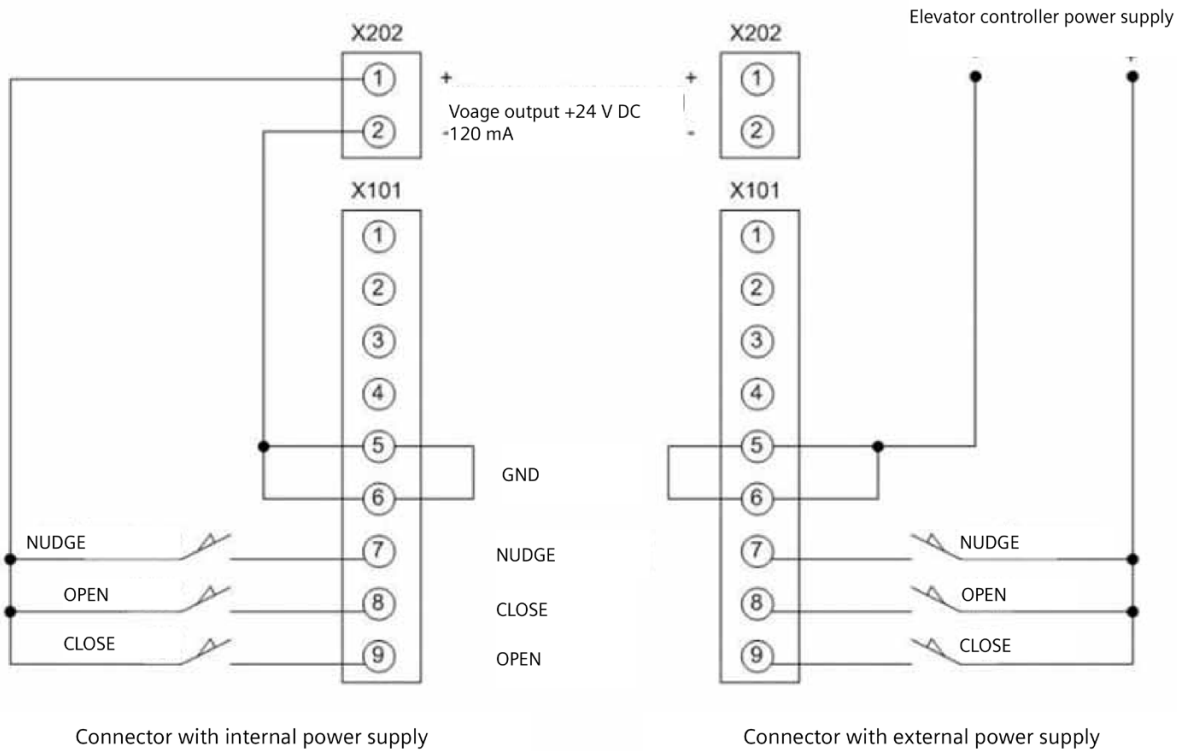

Figure A-6 Terminal circuit diagram of control inputs

Nudge = simultaneous activation of the *CLOSE* and *Nudge* commands (effective only in the closing direction).

Please see chapter Control unit (Page 26) for the permissible voltage values of an external power supply.

Note

The X202 24 V voltage output must not be connected to an external voltage potential, for example a higher-level elevator controller.

The X202 connector 2 (minus 24 V) can be connected to the PE.





A.8 Diagnostics and parameterization

The Service Tool and the Sidoor User Software can be used equally well for diagnostics and setting the parameters



These tools are optionally available (see Appendix Order nos. of the individual parts (Page 28)).

The Service Tool and the USB adapter for the Software Kit (Sidoor User Software) can be connected to X102 on the controller with the associated cable.

The tool keys and buttons have identical inscriptions and functions.

	Enter key, jumps to the next menu below
	Escape key, jumps back to the menu above
	Menu selection key, increases a parameter value
	Menu selection key, decreases a parameter value

Parameters can be changed in the "MAIN MENU QUICK ADJUSTMENT → Parameter Setting" and in the "MAIN MENU TOTAL ADJUSTMENT → Profile Parameter" menus.

The desired parameter is selected with the  or the  key, and activated for the setting with the Return key  (parameter value flashes).

The parameter value can then be increased or decreased by pressing the corresponding key (see above).

The value is accepted by pressing the Return key again.

A.9 Settings record

Note

Please take the adjustment range and the factory settings from chapter Electric adjustment and commissioning (Page 16)

Function	Set value
Creep distance Open	mm
Cam distance Open	mm
Creep distance Close	mm
Cam distance Close	mm
Maximum speed Open	mm/s
Creep speed Open	mm/s
Cam speed Open	mm/s
Initial speed Open	mm/s
Maximum speed Close	mm/s
Creep speed Close	mm/s
Cam speed Close	mm/s
Initial speed Close	mm/s
Nudge speed Close	mm/s
Acceleration ramp OPEN	mm/s ²
Braking ramp OPEN	mm/s ²
Reversing ramp OPEN/CLOSE	mm/s ²
Acceleration ramp CLOSE	mm/s ²
Braking ramp CLOSE	mm/s ²
Reversing ramp CLOSE/OPEN	mm/s ²
Continuous torque (power) OPEN	A
Continuous torque (power) CLOSE	A
Cam press-on torque	A
Opening force static	N
Closing force static	N
Cam force static Close	N
Nudge force static Close	N

A.10 Service & support

Product information

You will find current product information and further links on the Product page SIDOOR Automatic Door Controls (<http://w3.siemens.com/mcms/siplus/de/sidoor/>).

Online catalog and ordering system

The online catalog and the online ordering system can also be found at Industry Mall homepage (<https://mall.industry.siemens.com/>)

Online support

The Online support (<https://support.industry.siemens.com>) gives you direct access to information about products, systems and services, as well as a large number of programming, configuration and application examples.

Furthermore, the Online Support portal gives central access to further Services and contact persons (<http://www.siemens.com/automation/partner>).

Technical Support

Expert advice on technical questions with a wide range of demand-optimized services for all our products and systems.

If you have any technical questions, contact Technical Support at:

- Tel.: +49 (0)911 895 7 222
- Fax: +49 (0)911 895 7 223
- Email Technical Support (<mailto:support.automation@siemens.com>)
- Support Request (<https://support.industry.siemens.com/My/ww/de/requests>)