

# Free function blocks

Function Manual · 01/2011

SINAMICS

**SIEMENS**



# SIEMENS

## SINAMICS

### Free function blocks

#### Function Manual

---

Preface

---

General description

---

Parameter

---

Function diagrams

---

Faults and alarms

---

List of abbreviations

---

Index

---

**1**

**2**

**3**

**4**

**A**

**B**

#### Valid for

##### Drive

**SINAMICS**

**SINAMICS DCM**

##### Firmware version

**4.4**

**1.2 (basierend  
auf 4.3 SP2)**

**A5E00779137A**

**01/2011**

## Safety Notices

This manual contains information that you should observe to ensure your own personal safety and prevent material damage. The notices referring to your personal safety are highlighted in the manual by a warning triangle; notices that relate to material damage only have no warning triangle. The notices shown below are graded according to the level of hazard (from most to least hazardous):



---

### Danger

Indicates that death or serious injury **will** result if proper precautions are not taken.

---



---

### Warning

Indicates that death or serious injury **may** result if proper precautions are not taken.

---



---

### Caution

With a warning triangle, indicates that minor injury **may** result if proper precautions are not taken.

---

---

### Caution

Without a warning triangle, indicates that material damage may result if proper precautions are not taken.

---

---

### Notice

Indicates that an undesirable result or state may occur if the corresponding instructions are not observed.

---

If more than one level of hazard exists, the warning for the highest hazard level is always used. A warning notice with a warning triangle indicating possible personal injury may also include a warning relating to material damage.

## Qualified personnel

The associated device/system may only be installed and operated in conjunction with this documentation. The device/system may only be commissioned and operated by **qualified personnel**. For the purpose of the safety notices in this documentation, "qualified personnel" are those authorized to commission, ground, and label equipment, systems, and circuits in accordance with established safety procedures.

## Proper use of Siemens products

Note the following:



---

### Warning

Siemens products are only permitted to be used for the applications specified in the catalog and in the associated technical documentation. If third-party products and components are used, they must be recommended or approved by Siemens. To ensure proper and safe operation of these products, they must be correctly transported, stored, set up, mounted, installed, commissioned, operated, and maintained. The permissible ambient conditions must be met. Information in the associated documentation must be observed.

---

## Trademarks

All names identified with © are registered trademarks of Siemens AG. Any other names used in this publication may be trademarks whose use by third parties for their own purposes could violate the rights of the owner.

### Copyright Siemens AG 2011 All Rights Reserved

The reproduction, transmission, or use of this document or its contents is not permitted without express written permission. Violation of this rule will cause indemnities. All rights reserved, especially those relating to granting patents or GM registration.

Siemens AG  
Industry Sector  
P.O. Box 4848  
90327 NUREMBERG  
GERMANY

### Liability Disclaimer

We have checked that the contents of this document correspond to the hardware and software described. Nevertheless, we cannot assume responsibility for any deviations that may arise. The data in this document is regularly checked and any necessary corrections included in subsequent editions.

♥ ΣΙΕΜΕΝΣ ΑΓ 2011  
Subject to change without prior notice.

# Preface

## Information about the SINAMICS documentation

The SINAMICS documentation is organized in the following categories:

- General documentation/catalogs
- Manufacturer/service documentation

This documentation is part of the Technical Customer Documentation for SINAMICS.

In the interests of clarity, this documentation does not contain all the detailed information for all product types and cannot take into account every possible aspect of installation, operation, or maintenance.

The contents of this documentation are not part of an earlier or existing agreement, a promise, or a legal agreement, nor do they change this. All obligations on the part of Siemens can be found in the respective sales contract, which also contains the complete and sole warranty provisions. These contractual warranty provisions are neither extended nor restricted as a result of the statements made in this documentation.

## Target group

This documentation addresses commissioning engineers and service personnel who use SINAMICS.

## Purpose

This manual contains information about all parameters, function diagrams, faults, and alarms required to commission and service the system.

This manual should be used in addition to the other manuals and tools provided for the product.

## Release of the free function blocks for firmware version 4.4

SINAMICS free function blocks are released for:

- SINAMICS G130
- SINAMICS G150
- SINAMICS GL150
- SINAMICS GM150
- SINAMICS S120 Cabinet Modules
- SINAMICS S120 Chassis > 250 kW

- SINAMICS S150
- SINAMICS SL150
- SINAMICS SM150
- SINAMICS DCM (from firmware version 1.1 and higher)

### **Search tools**

The following guides are provided to help you locate information in this manual:

1. Table of contents
  - General table of contents for the complete manual (after the preface).
  - List of contents for function diagrams (Chapter 3.1).
2. List of abbreviations
3. Index (Index)

### **Technical Support**

Country-specific telephone numbers for technical support are provided on the Internet at:

<http://www.siemens.com/automation/service&support>

### **SINAMICS**

You can find information on SINAMICS at:

<http://www.siemens.com/sinamics>

# List of contents

<b>1</b>	<b>General description</b>	<b>1-9</b>
1.1	Overview of free function blocks	1-10
1.1.1	Application range, characteristics	1-10
1.1.2	Configuration and operation	1-12
1.1.3	Runtime group, sampling time and run sequence	1-12
1.1.4	Using free function blocks across drive objects	1-20
1.1.5	Computing sequence of runtime groups in different drive objects	1-20
1.1.6	Range of blocks	1-21
1.1.7	Connection to the drive	1-22
1.2	Commissioning	1-27
1.2.1	Activating the "free function blocks" function module	1-27
1.2.2	Activating the individual function blocks	1-29
1.2.3	Computation time load for firmware version 2.6 and higher	1-30
1.2.4	Computation time load for firmware versions 4.3 and higher	1-32
1.2.5	Number of possible different hardware sampling times	1-33
1.3	Description of the function blocks	1-35
1.3.1	AND	1-35
1.3.2	OR	1-35
1.3.3	XOR (exclusive OR)	1-36
1.3.4	NOT (inverter)	1-36
1.3.5	ADD (adder)	1-37
1.3.6	SUB (subtractor)	1-37
1.3.7	MUL (multiplier)	1-38
1.3.8	DIV (divider)	1-38
1.3.9	AVA (absolute value generator with sign evaluation)	1-39
1.3.10	MFP (pulse generator)	1-39
1.3.11	PCL (pulse shortener)	1-39
1.3.12	PDE (ON delay)	1-41
1.3.13	PDF (OFF delay)	1-42
1.3.14	PST (pulse stretcher)	1-43
1.3.15	RSR (RS flip-flop, reset dominant)	1-43
1.3.16	DFR (D flip-flop, reset dominant)	1-44
1.3.17	BSW (binary change-over switch)	1-45
1.3.18	NSW (numeric change-over switch)	1-45
1.3.19	LIM (limiter)	1-46
1.3.20	PT1 (smoothing element)	1-47
1.3.21	INT (integrator)	1-48
1.3.22	DIF (derivative action element)	1-49
1.3.23	LVM (double-sided limit monitor with hysteresis)	1-50

<b>2</b>	<b>Parameter</b> .....	2-51
2.1	Overview of parameters .....	2-52
2.1.1	Explanation of list of parameters .....	2-52
2.2	List of parameters .....	2-61
<b>3</b>	<b>Function diagrams</b> .....	3-133
3.1	Table of contents .....	3-134
3.2	Explanations on the function diagrams .....	3-135
3.3	Logic function blocks .....	3-137
3.4	Arithmetic function blocks .....	3-142
3.5	Time function blocks .....	3-146
3.6	Memory function blocks .....	3-150
3.7	Switch function blocks .....	3-152
3.8	Control function blocks .....	3-154
3.9	Complex function blocks .....	3-158
<b>4</b>	<b>Faults and alarms</b> .....	4-161
4.1	Overview of faults and alarms .....	4-162
4.1.1	General information on faults and alarms .....	4-162
4.1.2	Explanation of the list of faults and alarms .....	4-164
4.2	List of faults and alarms .....	4-167
<b>A</b>	<b>List of abbreviations</b> .....	A-169
<b>B</b>	<b>Index</b> .....	B-179



# General description

# 1

## Contents

1.1	Overview of free function blocks	1-10
1.2	Commissioning	1-27
1.3	Description of the function blocks	1-35

## 1.1 Overview of free function blocks

### 1.1.1 Application range, characteristics

A logic operation, which combines several states (e.g. access control, plant status) to a control signal (e.g. ON command), is required for controlling the drive system in a wide variety of applications.

Along with logic operations, a number of mathematical functions and latching elements are becoming increasingly important in drive systems.

This functionality is available on almost every drive object of the drive system as a "Free function blocks" (FBLOCKS) function module.

The "Free function blocks" function module is activated on each of the individual drive objects. In a Control Unit, this function module can be activated simultaneously on several drive objects.

The "Free function blocks" function module can be activated on the following drive object types:

Table 1-1 Drive object types for "Free function blocks"

Drive object type	Object number (p0107)	Meaning
CU_S	1	Control Unit SINAMICS S (SINAMICS S120/S150)
CU_G	2	Control Unit SINAMICS G (SINAMICS G130/G150)
CU_I	3	Control Unit SINAMICS Integrated (SIMOTION SM150 only)
CU_CX32	4	Controller Extension for increasing the computing power (operation on SINAMICS SM150 only)
CU_GM	5	Control Unit SINAMICS GM150
CU_DC	6	Control Unit SINAMICS DC MASTER
CU_GL	7	Control Unit SINAMICS GL150
CU_S110	9	Control Unit SINAMICS S110
A_INF	10	Active Infeed closed-loop control Closed-loop controlled, self-commutated infeed/regenerative feedback unit for generating a constant DC-link voltage
SERVO	11	Servo drive
VECTOR	12	Vector drive
VECTORMV	13	Vector drive for SINAMICS GM150/SM150
VECTORGL	14	Vector drive for SINAMICS GL150
VECTORSL	16	Vector drive for SINAMICS SL150
DC_CTRL	17	Closed-loop control for DC drives

Table 1-1 Drive object types for "Free function blocks"

Drive object type	Object number (p0107)	Meaning
S_INF	20	Smart Infeed closed-loop control Unregulated line infeed/feedback unit for generating the DC link voltage.
B_INF	30	Basic Infeed closed-loop control Unregulated infeed unit (without feedback) for rectifying the line voltage of the DC link
A_INF MV	40	Active Infeed control for SINAMICS SM150
B_INF MV	41	Basic Infeed control for SINAMICS GM150
TB30	100	Terminal Board 30
CU_SL	101	Control Unit SINAMICS SL150
TM31	200	Terminal Module 31
TM41	201	Terminal Module 41
TM15DI_DO	204	Terminal Module 15 (for SINAMICS)
TM120	207	Terminal Module 120
ENCODER	300	Drive object for encoder

In the free function blocks, analog signals are treated as dimensionless per unit variables (See Chapter 1.1.7)

---

#### Note

This additional functionality increases the CPU time load. This means that the maximum possible configuration with a Control Unit may be restricted (See Chapter 1.2.3).

---

#### Drive Control Chart (DCC)

For more complex applications, the "Drive Control Chart" function (DCC) is available from SINAMICS firmware version 2.5 and higher.

DCC allows you to configure the required functionality graphically and then download it to the drive. A much wider range of block types is available.

From SINAMICS firmware version 2.6 and higher, signal values in the DCC plan can be monitored in the online mode in STARTER/SCOUT.

---

#### Note

Note that using the free function blocks reduces the computation time, hardware sampling time, and storage capacity available to the DCC function.

The required storage capacity depends on the number of drive objects on which the free function blocks are activated.

---

### 1.1.2 Configuration and operation

The free function blocks are configured at the parameter level. The following parameters are required for this:

- Input parameters (e.g. inputs I0 ... I3 for the AND function block).
- Output parameters (e.g. output Y for the numerical change-over switch).
- Adjustable parameters (e.g. pulse duration for pulse generator MFP).
- Runtime group (this includes the sampling time; the free function blocks are not computed in the factory setting).
- Run sequence within the runtime group.

A parameter is assigned to each input, output, and adjustable variable. These can be accessed by means of the Advanced Operator Panel (AOP) or STARTER commissioning tool. The "free function blocks" can all be interconnected at the BICO level.

The "free function blocks" do not support data set dependency.

### 1.1.3 Runtime group, sampling time and run sequence

#### Runtime groups

Runtime groups are groups of free function blocks within the system that are computed in the same sampling time and at a specific time.

A total of 10+1 "runtime groups" (runtime group 0 to 9 and runtime group 9999 (= runtime group is not computed)) are available for which the sampling time can be set in specific intervals.

Each function block is assigned one runtime group via a parameter. In the factory setting, the value 9999 (i.e. the function block is not computed) is assigned to each function block.

Example:

For function block ADD 0 (See Chapter 3.4, function diagram 7220), the runtime group is set in p20096.

The runtime groups are divided into one "fixed runtime group" and several "free runtime groups".

- The "fixed runtime group" is called at a fixed position in the system sequence. The only fixed runtime group (p20000[x] = 9003) is arranged before the setpoint channel and is computed in the sampling time of the setpoint channel (p0115[3]). This set value is only available with the drive object types SERVO, VECTOR, and VECTORMV.
- The "free runtime groups" are only defined via their sampling time.

---

**Note**

If the same sampling time is assigned to two or more runtime groups (the same fixed or free runtime group), the runtime groups are processed in numerical order.

---

Example:

$p20000[0] = p20000[3] = p20000[9] = 9003$

The computing sequence is:

runtime group 0 first, then runtime group 3, then runtime group 9, and then the setpoint channel.

The minimum sampling time is 1 ms. If the sampling time of the setpoint channel is  $p0115[3] < 1$  ms for the fixed runtime group ( $p20000[x] = 9003$ ), the runtime group is still called with a sampling time of 1 ms.

The actual sampling time in ms is displayed for each runtime group in parameter  $r20001[0...9]$ .

In the factory setting, none of the runtime groups is called ( $p20000[x] = 0$ ).

---

**Notice**

The assignment of a runtime group can only be changed if all of the closed-loop controls are disabled. When changing, the runtime group involved is first logged off from the sampling time management and then logged on again with the new assignment. The runtime group is not calculated during this operation.

Logon and logoff are performed in a background process of the drive unit. This is the reason this duration is not defined and depends on the actual calculation time load. This influences the output signal characteristic in the case of time-dependent blocks (e.g. DIF derivative action element). Prior to the first computation cycle after logging back on, internal status variables of the blocks are partially reset.

For both of these reasons, this can result in jumps in the output signal of blocks, which for example, can influence the torque/force setpoint and, for axes in operation, the torque/force actual value as well. Logic signals can also assume an unexpected state at this instant.

---

**Sampling times**

Two types of sampling times are available for runtime groups:

- Sampling times generated in the hardware (See Chapter 1.2.5):

Every integer multiple of the basic sampling time ( $r20002$ ) can be generated as sampling time in  $p20000[0...9]$  in the range from  $1 \times r20002 \dots 256 \times r20002$  with the following limits:

- Min. sampling time = 1 ms
- Max. sampling time =  $r20003$

Sampling times of 1 ms ...  $r20003 - r20002$  are generated in the hardware from these.

---

**Note**

When configuring offline using the STARTER commissioning software, values 0 ... 256 can be entered in p20000[x] even if this violates the above-mentioned limits for the hardware sampling times of 1 ms ... r20003 - r20002 and r20003. This is not detected until a download from the Control Module and results in fault F01042 (parameter error during project download).

---

The basic sampling time for the different drive object types is as follows:

- Drive object SERVO, VECTOR, VECTORMV, VECTORGL, A\_INF, S\_INF:  
r20002 = current controller sampling time
  - Drive object B\_INF:  
r20002 = 2 ms (= current controller sampling time)
  - Drive object A\_INF MV, B\_INF MV:  
r20002 = 0.5 ms (= current controller sampling time)
  - Drive object TM15, TM31, TM41, TB30:  
r20002 = 4 ms
  - Drive object CU\_S, CU\_G, CU\_I, CX32 (with SM150 only), CU\_GM, CU\_GL, CU\_S110:  
r20002 = 4 ms
- Sampling times generated in the software:  
These sampling times are generated as integer multiples of the basic value for software sampling times and must be read in parameter r20003 when the "free function blocks" function module is active.  
For the possible set values for the software sampling times, refer to the parameter description for p20000 (See Chapter 2.2).
- 

**Note**

When p20000[x] = 0, the corresponding runtime group (and, in turn, all the associated function blocks) is not computed.

---

The sampling time of runtime group x is displayed in r20001[x] in ms.

Examples of settable sampling times:

- SINAMICS G or SINAMICS S:  
Vector drive (400 V, 250 kW, chassis format, pulse frequency 2 kHz) or Active Line Module in chassis format, 400 V, frame size FX, GX:

The basic sampling time (r20002) is 250  $\mu$ s, which means that the following sampling times are possible:

- Hardware sampling times:
  - p20000[x] = 0 (runtime group not computed)
  - p20000[x] = 1 x 250  $\mu$ s = 250  $\mu$ s (not permitted because less than 1 ms)
  - p20000[x] = 2 x 250  $\mu$ s = 500  $\mu$ s (not permitted because less than 1 ms)
  - p20000[x] = 3 x 250  $\mu$ s = 750  $\mu$ s (not permitted because less than 1 ms)
  - p20000[x] = 4 x 250  $\mu$ s = 1000  $\mu$ s
  - p20000[x] = 5 x 250  $\mu$ s = 1250  $\mu$ s
  - ...
  - p20000[x] = 31 x 250  $\mu$ s = 7750  $\mu$ s (longest hardware sampling time)
  - p20000[x] = 32 x 250  $\mu$ s = 8000  $\mu$ s (can be selected as a multiple of r20002 - but is a software sampling time)
  - p20000[x] = 33 x 250  $\mu$ s = 8250  $\mu$ s (rejected because greater than r20003!)

The settings below are no longer possible because the sampling times would exceed 8 ms.

The basic value of the software sampling time is: r20003 = 8 ms.

- Software sampling times:
  - p20000[x] = 1001: Sampling time = 1 x 8 ms = 8 ms
  - p20000[x] = 1002: Sampling time = 2 x 8 ms = 16 ms
  - p20000[x] = 1003: Sampling time = 3 x 8 ms = 24 ms
  - p20000[x] = 1004: Sampling time = 4 x 8 ms = 32 ms
  - p20000[x] = 1005: Sampling time = 5 x 8 ms = 40 ms
  - p20000[x] = 1006: Sampling time = 6 x 8 ms = 48 ms
  - p20000[x] = 1008: Sampling time = 8 x 8 ms = 64 ms
  - p20000[x] = 1010: Sampling time = 10 x 8 ms = 80 ms
  - p20000[x] = 1012: Sampling time = 12 x 8 ms = 96 ms
  - p20000[x] = 1016: Sampling time = 16 x 8 ms = 128 ms
  - p20000[x] = 1020: Sampling time = 20 x 8 ms = 160 ms
  - p20000[x] = 1024: Sampling time = 24 x 8 ms = 192 ms
  - p20000[x] = 1032: Sampling time = 32 x 8 ms = 256 ms
  - p20000[x] = 1040: Sampling time = 40 x 8 ms = 320 ms
  - p20000[x] = 1048: Sampling time = 48 x 8 ms = 384 ms
  - p20000[x] = 1064: Sampling time = 64 x 8 ms = 512 ms
  - p20000[x] = 1096: Sampling time = 96 x 8 ms = 768 ms

---

### Note

The missing intermediate values for the software sampling times are not permitted for technical reasons.

---

- SINAMICS G or SINAMICS S:  
Motor Module (690 V, 90 kW, chassis format, pulse frequency 1.25 kHz) or  
Active Line Module chassis format, 400 V, frame sizes HX, JX or Active Line  
Module chassis format, 690 V frame sizes FX, GX, HX, JX:

The basic sampling time (r20002) is 400  $\mu$ s, which means that the following  
sampling times are possible:

- Hardware sampling times:

p20000[x] = 0 (runtime group not computed)

p20000[x] = 1 x 400  $\mu$ s = 400  $\mu$ s (not permitted because less than 1 ms)

p20000[x] = 2 x 400  $\mu$ s = 800  $\mu$ s (not permitted because less than 1 ms)

p20000[x] = 3 x 400  $\mu$ s = 1200  $\mu$ s

p20000[x] = 4 x 400  $\mu$ s = 1600  $\mu$ s

...

p20000[x] = 19 x 400  $\mu$ s = 7600  $\mu$ s (longest hardware sampling time)

p20000[x] = 20 x 400  $\mu$ s = 8000  $\mu$ s (software sampling time)

p20000[x] = 21 x 400  $\mu$ s = 8400  $\mu$ s (rejected because greater than r20003!)

All of the following settings are no longer possible because the sampling  
times would exceed 8 ms.

The basic value of the software sampling time is: r20003 = 8 ms.

- Software sampling times:

p20000[x] = 1001: Sampling time = 1 x 8 ms = 8 ms

p20000[x] = 1002: Sampling time = 2 x 8 ms = 16 ms

p20000[x] = 1003: Sampling time = 3 x 8 ms = 24 ms

p20000[x] = 1004: Sampling time = 4 x 8 ms = 32 ms

p20000[x] = 1005: Sampling time = 5 x 8 ms = 40 ms

p20000[x] = 1006: Sampling time = 6 x 8 ms = 48 ms

p20000[x] = 1008: Sampling time = 8 x 8 ms = 64 ms

p20000[x] = 1010: Sampling time = 10 x 8 ms = 80 ms

p20000[x] = 1012: Sampling time = 12 x 8 ms = 96 ms

p20000[x] = 1016: Sampling time = 16 x 8 ms = 128 ms

p20000[x] = 1020: Sampling time = 20 x 8 ms = 160 ms

p20000[x] = 1024: Sampling time = 24 x 8 ms = 192 ms

p20000[x] = 1032: Sampling time = 32 x 8 ms = 256 ms

p20000[x] = 1040: Sampling time = 40 x 8 ms = 320 ms

p20000[x] = 1048: Sampling time = 48 x 8 ms = 384 ms

p20000[x] = 1064: Sampling time = 64 x 8 ms = 512 ms

p20000[x] = 1096: Sampling time = 96 x 8 ms = 768 ms

---

### Note

The missing intermediate values for the software sampling times are not permit-  
ted for technical reasons.

---



- SINAMICS S:

Basic Line Module chassis format:

The basic sampling time (r20002) is 2 ms, which means that the following sampling times are possible:

- Hardware sampling times:

p20000[x] = 0 (runtime group not computed)

p20000[x] = 1 x 2 ms = 2 ms

p20000[x] = 2 x 2 ms = 4 ms

p20000[x] = 3 x 2 ms = 6 ms (longest hardware sampling time)

p20000[x] = 4 x 2 ms = 8 ms (software sampling time)

p20000[x] = 5 x 2 ms = 10 ms (rejected because greater than r20003!)

All of the following settings are no longer possible because the sampling times would exceed 8 ms.

The basic value of the software sampling time is: r20003 = 8 ms.

- Software sampling times:

p20000[x] = 1001: Sampling time = 1 x 8 ms = 8 ms

p20000[x] = 1002: Sampling time = 2 x 8 ms = 16 ms

p20000[x] = 1003: Sampling time = 3 x 8 ms = 24 ms

p20000[x] = 1004: Sampling time = 4 x 8 ms = 32 ms

p20000[x] = 1005: Sampling time = 5 x 8 ms = 40 ms

p20000[x] = 1006: Sampling time = 6 x 8 ms = 48 ms

p20000[x] = 1008: Sampling time = 8 x 8 ms = 64 ms

p20000[x] = 1010: Sampling time = 10 x 8 ms = 80 ms

p20000[x] = 1012: Sampling time = 12 x 8 ms = 96 ms

p20000[x] = 1016: Sampling time = 16 x 8 ms = 128 ms

p20000[x] = 1020: Sampling time = 20 x 8 ms = 160 ms

p20000[x] = 1024: Sampling time = 24 x 8 ms = 192 ms

p20000[x] = 1032: Sampling time = 32 x 8 ms = 256 ms

p20000[x] = 1040: Sampling time = 40 x 8 ms = 320 ms

p20000[x] = 1048: Sampling time = 48 x 8 ms = 384 ms

p20000[x] = 1064: Sampling time = 64 x 8 ms = 512 ms

p20000[x] = 1096: Sampling time = 96 x 8 ms = 768 ms

---

**Note**

The missing intermediate values for the software sampling times are not permitted for technical reasons.

---

- SINAMICS G or SINAMICS S:  
Control Unit CU320 or TM31 or TB30:

The basic sampling time (r20002) is 4 ms, which means that the following sampling times are possible:

- Hardware sampling times:  
p20000[x] = 0 (runtime group not computed)  
p20000[x] = 1 x 4 ms = 4 ms  
p20000[x] = 2 x 4 ms = 8 ms (software sampling time)  
p20000[x] = 3 x 4 ms = 12 ms (rejected because greater than r20003!)  
All of the following settings are no longer possible because the sampling times would exceed 8 ms.

The basic value of the software sampling time is: r20003 = 8 ms.

- Software sampling times:  
p20000[x] = 1001: Sampling time = 1 x 8 ms = 8 ms  
p20000[x] = 1002: Sampling time = 2 x 8 ms = 16 ms  
p20000[x] = 1003: Sampling time = 3 x 8 ms = 24 ms  
p20000[x] = 1004: Sampling time = 4 x 8 ms = 32 ms  
p20000[x] = 1005: Sampling time = 5 x 8 ms = 40 ms  
p20000[x] = 1006: Sampling time = 6 x 8 ms = 48 ms  
p20000[x] = 1008: Sampling time = 8 x 8 ms = 64 ms  
p20000[x] = 1010: Sampling time = 10 x 8 ms = 80 ms  
p20000[x] = 1012: Sampling time = 12 x 8 ms = 96 ms  
p20000[x] = 1016: Sampling time = 16 x 8 ms = 128 ms  
p20000[x] = 1020: Sampling time = 20 x 8 ms = 160 ms  
p20000[x] = 1024: Sampling time = 24 x 8 ms = 192 ms  
p20000[x] = 1032: Sampling time = 32 x 8 ms = 256 ms  
p20000[x] = 1040: Sampling time = 40 x 8 ms = 320 ms  
p20000[x] = 1048: Sampling time = 48 x 8 ms = 384 ms  
p20000[x] = 1064: Sampling time = 64 x 8 ms = 512 ms  
p20000[x] = 1096: Sampling time = 96 x 8 ms = 768 ms

---

**Note**

The missing intermediate values for the software sampling times are not permitted for technical reasons.

---

## Run sequence

In the factory setting, each free function block is assigned a default setting for the run sequence. The run sequence of consecutive free function blocks within a runtime group can be optimized by changing these values accordingly.

A run sequence value can be used on a drive object once only. If the same run sequence value is assigned twice in the online mode for a drive object, the second value is rejected and the first value retained.

The run sequence can be set to between 0 and 32000. A function block with a lower run sequence value is computed within a runtime group before one with a higher value.

---

**Note:**

If a configuration is carried out OFFLINE, you can initially set each run sequence value at the beginning (e.g. a value can also be assigned to more than one function block simultaneously). The system does not check this until the configuration has been downloaded to the Control Unit.

---

Once downloaded, the parameter values are checked in the order of the parameter numbers. If the system detects that the run sequence value for one function block is already being used by a different function block, the value is not applied and fault F01042 (message in STARTER: Error occurred when downloading) is output. You are informed about this in the "Target system output" window.

---

**Note:**

In the factory setting, value range 10 ... 750 is already assigned the run sequence values of the function blocks.

In user configurations, for example, the only run sequence values outside this range which should be used are those above 1000. This will avoid conflicts during the download process with the run sequence values that have already been assigned.

---

If at all possible, the signals for a drive object should only be processed by the function blocks on this drive object.

### 1.1.4 Using free function blocks across drive objects

When drive object signals are processed, function blocks on other drive objects with the same sampling time can also be used. This can result in dead time, which must be taken into account in time-critical applications.

The dead time that occurs when signals are transferred between the drive objects depends on the computing sequence of the drive objects.

Example: The signal source and sink have the same sampling time.

- If the drive object (Drive Object, DO) of the signal source is computed first followed by the drive object of the signal sink, the dead time is virtually zero.
- If the drive object of the signal sink is computed first, the signal sink reads the output value of the signal source from the previous sampling time. The dead time is approximately one sampling time.

If the signals change slowly compared with the sampling time, the dead time can be disregarded.

### 1.1.5 Computing sequence of runtime groups in different drive objects

The computing sequence only needs to be analyzed for runtime groups with the same sampling times.

On one drive object, the runtime groups with the same sampling time are computed in numerical order (starting with the runtime group with the lowest number, followed by the runtime group with the next highest number, and so on).

If two runtime groups exist with the same sampling time and the same Control Unit is used on two different drive objects, then the following applies:

1. If both drive objects are of type A\_INF, SERVO, VECTOR, VECTORMV, S\_INF, B\_INF, A\_INF MV, or B\_INF MV, the runtime groups are computed in the order of their drive object numbers (see p0101[0...15]).
2. If both drive objects are of type CU\_S, CU\_G, CU\_I, CU\_CX32, TB30, TM31, TM41, or TM15DI/DO, the runtime groups are also computed in the order of their drive object numbers (see p0101[0...15]).
3. If one runtime group is used on a drive object type listed under 1. and the other runtime group on a drive object type listed under 2., then the runtime group of the drive object listed under 1. is computed first.

### 1.1.6 Range of blocks

The table below shows the range of free function blocks available. For information about the special technical properties of the individual function blocks, see the function diagrams in Chapter 3.

Table 1-2 Range of "free function blocks"

Code	Name of function block	Data type	No. per drive object
AND	AND function block	BOOL	4
OR	OR function block	BOOL	4
XOR	XOR function block	BOOL	4
NOT	Inverter	BOOL	4
ADD	Adder	REAL	2
SUB	Subtractor	REAL	2
MUL	Multiplier	REAL	2
DIV	Divider	REAL	2
AVA	Absolute value generator with sign evaluation	REAL	2
MFP	Pulse generator	BOOL	2
PCL	Pulse shortener	BOOL	2
PDE	ON delay	BOOL	2
PDF	OFF delay	BOOL	2
PST	Pulse stretcher	BOOL	2
RSR	RS flip-flop, reset dominant	BOOL	2
DFR	D flip-flop, reset dominant	BOOL	2
BSW	Binary change-over switch	BOOL	2
NSW	Numeric change-over switch	REAL	2
LIM	Limiter	REAL	2
PT1	Smoothing element	REAL	2
INT	Integrator	REAL	1
DIF	Derivative-action element	REAL	1
LVM	Double-sided limit monitor with hysteresis	BOOL	2

### 1.1.7 Connection to the drive

Connector inputs (CI) and connector outputs (CO) on the free function blocks (p20094 ... p20286) have the properties of per unit variables. This means that calculations in the free function blocks are only carried out with per unit signal values (1.0 = 100%). Conversion to the connectors of the drive with units is performed automatically.

---

**Note:**

This manual only contains the function diagrams for "Free function blocks" (see Chapter 3).

The product-specific function diagrams for SINAMICS (e.g. function diagram 3010) can be found in the following documents:

References: SINAMICS S120/S150 List Manual, Chapter "Function diagrams"

References: SINAMICS GM150 List Manual, Chapter "Function diagrams"

References: SINAMICS SM150 List Manual, Chapter "Function diagrams"

References: SINAMICS S110 List Manual, Chapter "Function diagrams"

References: SINAMICS DCM List Manual, Chapter "Function diagrams"

---

**Example 1 (interconnecting the input value)**

The actual fixed speed setpoint (CO: r1024, function diagram 3010) is to be read into the free function block ADD 0 (function diagram 7220) for further processing.

p20094[0] is set to 1024 for this purpose.

Function block ADD 0 is to be called cyclically and is, therefore, assigned to runtime group 9. It is also to be called with the sampling time  $2 \times r20003$ . The runtime group number is chosen here at random.

p20096 is set to 9 and p20000[9] is set to 1002.

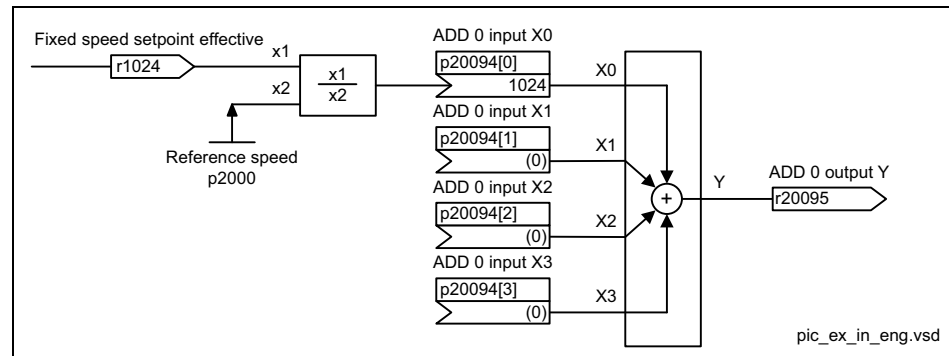

Fig. 1-1 Example 1: Interconnecting the input value

Input signal r1024 with the unit rpm is referred to its reference variable p2000.

Assumption:

- r1024 = 1500 rpm
- p2000 = 3000 rpm reference speed

Result:

- r20095 = 0.5

**Example 2 (interconnecting the output value)**

The per unit output value of the free function block LIM 0 (function diagram 7260) is to be switched in as additional torque  $M_{\text{additional 2}}$  (function diagram 6060) in the VECTOR control mode.

$p1513[0]$  is set to 20231 for this purpose.

Function block LIM 0 is to be called cyclically and is, therefore, assigned to runtime group 8.

$p20234$  is set to 8.

The runtime group number is chosen here at random.

The sampling time for calling LIM 0 is to be 1 ms.

$p20000[8]$  is set to 4 ( $= 4 \times r20002 = 4 \times 250 \mu\text{s}$ )

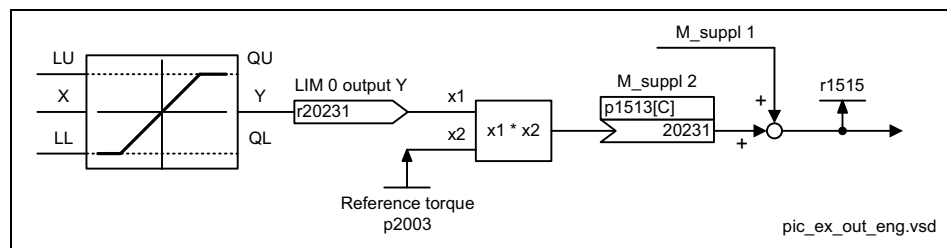

Fig. 1-2 Example 2: Interconnecting the output value

Due to the interconnection of  $p1513$  (additional torque 2) to  $r20231$ , the per unit output signal  $Y$  of the function block is multiplied internally with the reference torque  $p2003$  and interpreted as additional torque with units.

Assumption:

- Basic sampling time:  $r20002 = 0.25 \text{ ms}$
- $r20231 = 0.3333$
- $p2003 = 300 \text{ Nm}$  reference torque
- $p1511[0] = 0$  (additional torque 1 = "0")
- $p1513[0] = 20231$

Result:

- $r1515 = 100.0 \text{ Nm}$  (for CDS0)



**Example 3 (interconnecting the PROFIBUS receive word (WORD))**

The PZD receive word 2 (CO: r2050[1], function diagram 2460) is to be interconnected with the free function block ADD 0 (function diagram 7220).

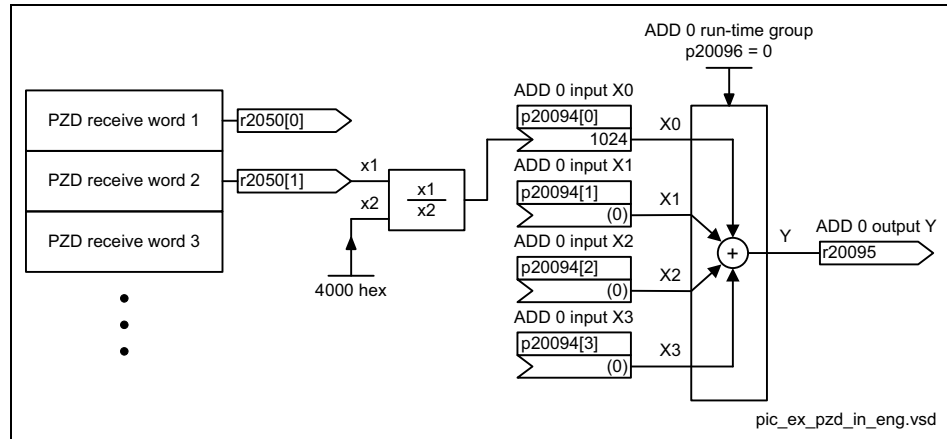

Fig. 1-3 Example 3: Interconnecting the PROFIBUS receive word (WORD)

The PROFIBUS process data of data type WORD (16 bits) has the reference variable 4000 hex. At the inputs of the free function blocks, this reference variable is equivalent to 1.0.

Assumption:

- p20096 = 0  
Assign function block ADD 0 to runtime group 0.
- p20000[0] = 1002  
Call runtime group 0 with the sampling time 2 x r20003. The runtime group number zero was chosen at random.
- PROFIBUS receive word 2: r2050[1] = 6000 hex

Result:

- r20095 = (6000 hex / 4000 hex) x 1.0 = 1.5

**Example 4 (interconnecting the PROFIBUS transmit word (DWORD))**

The output of the free function block LIM 1 (CO: r20234, function diagram 7260) is to be interconnected with a PZD send word (function diagram 2470) of data type DWORD.

The input of the free function block LIM 1 is supplied with a fixed speed setpoint (p1002, function diagram 3010).

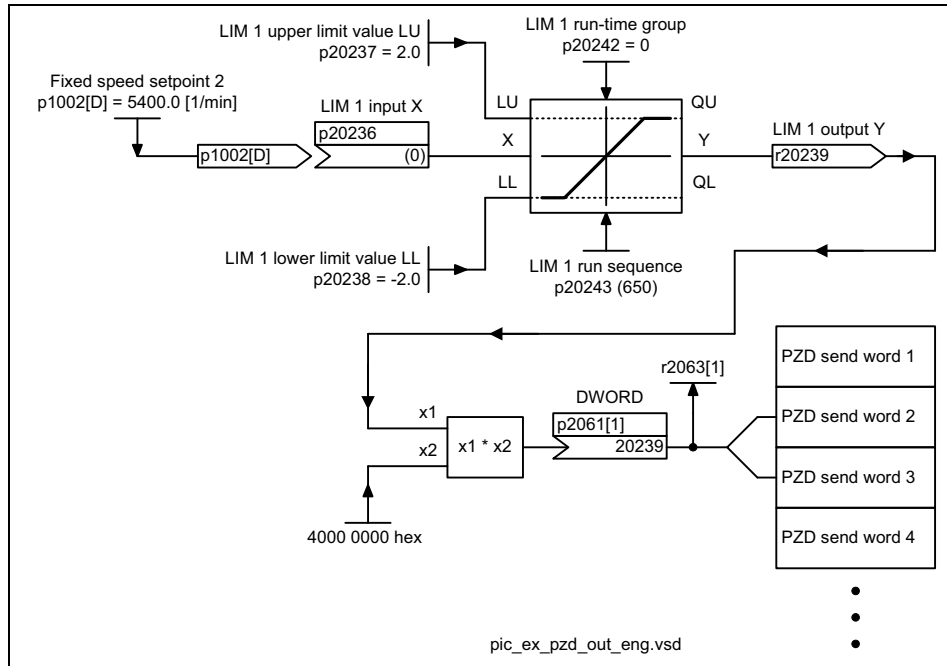

Fig. 1-4 Example 4: Interconnecting the PROFIBUS send word (DWORD)

The PROFIBUS process data of data type DWORD (32 bits) has the reference variable 4000 0000 hex. At the outputs of the free function blocks, this reference variable is equivalent to 1.0. Parameter r2063 is only updated when cyclic data exchange actually takes place on PROFIBUS.

Assumption:

- p20000[0] = 1002  
Call runtime group 0 with the sampling time 2 x r20003. The runtime group number zero was chosen at random.
- p1002 = 5400 rpm
- p2000 = 3000 rpm

Result:

- Output value of LIM 1: r20239 = 5400 rpm / 3000 rpm = 1.8
- r2063[1] = X1 x X2 = 1.8 x 4000 0000 hex = 7333 3333 hex

## 1.2 Commissioning

### 1.2.1 Activating the "free function blocks" function module

#### STARTER commissioning software

Activation with the STARTER commissioning software is **only** possible OFFLINE and is performed via the "Properties" dialog box for the drive objects. The "free function blocks" can be selected under the "Function modules" tab.

To do so, open the relevant project in STARTER and, in the project navigator, open the sub-elements by clicking the plus sign.

To call up a context menu, right-click the selected drive object. In each case, left-click once to select "Properties" and "Function modules". Then scroll to "Free function blocks". Select this function module (set the checkbox) and confirm with "OK". The properties dialog is then closed automatically.

In its factory setting, the "Free function blocks" checkbox is not selected. If you select the checkbox and confirm with "OK", the "free function blocks" function module is activated once the project has been downloaded.

#### AOP30 (Advanced Operator Panel 30)

In AOP30, the "free function blocks" function module in the parameter list is activated directly via p0108[x] in the status "Definition of the drive type (p0009 = 2)". In index "x", select the number of the drive object on which the "free function blocks" are to be activated.

You can find out which drive objects (Drive Object, DO) are available along with their associated numbers as follows:

- In parameter p0107[0...15] (DO type), an index entry with the relevant drive object type exists for each available drive object in the drive line-up.
- In parameter p0101[0...15] (DO number), the number under which the drive object can be addressed appears in the corresponding index entry for each drive object.

You need this information to help you determine the drive object number for BICO interconnections.

Example:

- $p0107[1] = "12: VECTOR"$
- In this example, the "VECTOR" drive object can be addressed under the drive object number  $p0101[1]$ .
- The "free function blocks" function module for the "VECTOR" drive object can be activated via  $p0108[1] = 262144 (= 40000 \text{ hex})$ . This means that bit 18 in  $p0108[\text{index no.}]$  must be set to activate it.

The index in  $p0108$  for the "VECTOR" drive object is the same as that in  $p0107$ .

Procedure to activate the function module via AOP30:

- Starting from the main menu ("Menu" key) of the AOP30, select the "Parameterization" menu and confirm with "OK". There, select "Individual DO" and confirm with "OK".
- In the menu "Parameterize DO selection" select point "1: CU\_G" and confirm with "OK".
- Select parameter  $p0009$  ("Raise"/"Lower" key) and after pressing "Change", set the value 2: ("Raise"/"Lower" key) and confirm with "OK".
- Now press the key-operated pushbutton (bottom left).

If the access level has the value "3: Expert" or higher, then exit this menu with "Back".

Otherwise, in this menu, select access level ("Raise"/"Lower" key) and confirm with "OK". In the submenu "Access level", select point "3: Expert" and confirm with "OK". The menu "All parameters" is reached after pressing the "Back" key.

- In the menu "All parameters", select parameter  $p0108$  and press "Change". Then select the index of  $p0108$ , which is assigned to the required drive object (in this example, index 1), on which the function module should be activated and press "Change".
- In the submenu  $p0108[xx]$ , select bit 18: Free F. blocks, activate by pressing "Change", and confirm with "OK".
- Select the menu "All parameters" for the drive object CU\_G by pressing "Back". In this menu, now reselect  $p0009$  ("Raise"/"Lower" key) and press "Change".
- In the submenu of  $p0009$ , select the value "0: Ready" ("Raise"/"Lower" key) and confirm with "OK".

The control module now performs a warm restart and the AOP30 reloads the parameter description. This process may take several minutes.

## 1.2.2 Activating the individual function blocks

Each individual function block is assigned to a runtime group via two parameters:

- The first parameter defines the runtime group.
- The second parameter defines the run sequence within the runtime group.

Within a runtime group, a function block with a lower value for the run sequence is computed before a function block with a higher value.

---

### Note

In the factory setting, each function block is assigned to runtime group 9999. This means that the function block is not computed.

---

You also have to ensure that runtime group x is called cyclically. This can be done by setting parameter p20000[x] to a value > 0.

### Example:

On a "VECTOR" drive object type and Chassis Motor Module, the basic hardware sampling time r20002 = 0.25 ms (see example on Page 1-15). Runtime group 0 is to be called every 2 ms.

This means:

Set p20000[0] = 8 (sampling time 8 x r20002).

Check via r20001[0] = 2.0 ms (sampling time of runtime group 0).

### 1.2.3 Computation time load for firmware version 2.6 and higher

---

#### Note

The following statements apply when using the "free function blocks" (FBLOCKS) on SINAMICS S120, S150, G130 and G150 units. Information on the other units is provided in the relevant equipment documentation.

---

Processing free function blocks requires considerable computation time. This means that when this function module is activated, the maximum number of drive objects on a CU3xx, CX32 (for operation with SM150 only) and SM150 can no longer be computed.

#### Dependency

The resulting computation time load depends on the following:

- Number of activated runtime groups ( $p20000[x] > 0$ ).
- Number of computed function blocks.
- Sampling time.

#### Computation time online

Parameter r9976 (system utilization) is available as online help in the basic SINAMICS system with firmware version 2.4, 2.5 and 2.6 SP1 (not firmware version 4.x). The average value of the computation time load in r9976[1] should always be lower than 85%. Likewise, the maximum value for the computation time load in r9976[5] should always be lower than 85%. If the limit of 92% for the computation time load is exceeded, alarm A50512 is output. If the computation time load is less than 88%, then the alarm is reset (not firmware version 4.x).

#### Computation time offline

When the system is in offline mode, SIZER provides an approximate statement regarding whether a configuration can be computed on a CU3xx or D4xx. The additional computation time load is **not** taken into account when the "free function blocks" function module is activated.

---

**Notice**

The computation time load reaches its maximum value when the following conditions are met:

- All necessary function modules are activated.
- All the drives and infeeds have been switched on.
- Closed-loop control is enabled on all drives and infeeds.

The values displayed in r9976 have been significantly smoothed internally. This means that a change in the computation time load is not fully displayed in r9976 until after 2 to 3 minutes.

---

If one function block of each type (i.e. 23 different function blocks) is computed on a drive object with a sampling time  $T_{\text{sample}} = 1$  ms, then this increases the computation time load by approx. 21 %.

If you are not sure whether the limit value for the computation time load of 85% (r9976[1] and r9976[5]) is maintained in an OFFLINE configuration, leave  $p20000[0...9] = 0$  as it is for all drive objects.

In the OFFLINE project, the following should be carried out:

- Activate all necessary function modules on the drive objects.
- Assign all the required function blocks to their runtime groups.
- Establish all connections between the function blocks and, where suitable, with the drive objects.

**After the project has been downloaded**

After the project has been downloaded, the free function blocks do not cause any additional computation time load because no runtime group is called cyclically.

r9976[1] and r9976[5] should be read-out in this state.

In the ONLINE mode, the runtime groups can be activated consecutively for each drive object by parameterizing the relevant value in  $p20000[x]$ . The computation time load can then be monitored in r9976 (not firmware version 4.x). The drive and infeed controls can then be switched on and enabled individually in succession.

When the closed-loop controls of all drive objects, all required function modules, and all runtime groups are in operation, the limit value of 85% for the computation time load should be checked in r9976[1] and r9976[5].

---

**Note**

Any computation time load caused by the free function blocks reduces the maximum possible additional computation time load for Drive Control Chart (DCC) on the same device.

---

## 1.2.4 Computation time load for firmware versions 4.3 and higher

---

### Note

The following statements apply when using the "free function blocks" (FBLOCKS) on SINAMICS S120, S150, G130 and G150 units.

Information on the other units is provided in the relevant equipment documentation.

---

From version 4.3 and higher, after a download or a parameter change (e.g. where the sampling time of a runtime group is changed) using the configuration data, the Control Unit (CU) determines the computation time load to be expected (including the computation time load caused by FBLOCKS and DCC diagrams). This value is displayed in r9976 (system utilization) for the system as a whole.

If the calculated average computation time utilization for the complete system r9976[1] or the maximum utilization in a sampling time r9976[5] (including interruptions due to time slices with shorter sampling times) exceeds the value of 100.00 %, then fault F01054 (CU: System limit exceeded) is output with fault reaction OFF2.

The utilization is calculated on the Control Unit, i.e. the utilization values are displayed in STARTER/SCOUT in the online mode only.

The resulting computation time load caused by FBLOCKS depends on the following:

- Number of calculated runtime groups.
- Sampling time of the runtime groups.
- Number of calculated blocks.
- Calculated block types.

The proportion of the computation time load as a result of FBLOCKS is displayed on the drive objects, on which the function module FBLOCKS is activated, in r20005[0...9] for runtime groups 0 to 9 (from firmware version 4.3 and higher). Note that the computation time load for a runtime group k can only be calculated if this has been logged on for cyclic processing (p20000[k-1] not equal to 0).

For firmware version 4.3 and higher, and unlike with version 2.5 and 2.6, if a parameter is changed (in the STARTER online mode) that has an influence on the computation time load (e.g. changes the sampling time of a runtime group in FBLOCKS), the drive unit immediately recalculates r9976 (and r20005). For parameters which can only be changed in the device states C1 (commissioning device) or C2 (commissioning drive object), i.e. only when STARTER/SCOUT is in the offline mode, r9976 is only updated after the project has been downloaded and the Control Unit has powered up.

For firmware version 4.3, the computation time load displayed in r9976 can be up to 100.00% without triggering a fault.



## 1.2.5 Number of possible different hardware sampling times

The sampling times for the runtime groups can be selected in p20000[x] as a multiple of r20002 (basic sampling time of hardware time slices), as a multiple of r20003 (basic sampling time of software time slices), or dependent on the sampling time of a basic SINAMICS system function (e.g. when p20000[x] = 9003 == "before setpoint channel calculation" from the sampling time of the setpoint channel p0115[3]).

As hardware sampling times, only sampling times for which the following applies can be set:

$1 \text{ ms} \leq T_{\text{sample}} \leq r20003 - r20002$  in p20000[x]

Sampling time r20003 is always a software sampling time regardless of whether it is parameterized as p20000[x] = 1001 (== 1 x r20003) or as a multiple of r20002 (p20000[x] <= 256).

### Hardware sampling times, number, and assignment

When configuring, note that the number of different hardware sampling times ( $1 \text{ ms} \leq \text{time period } T_{\text{sampling}} < r20003 - r20002$ ) used by the basic SINAMICS system, "Free function blocks", and Drive Control Chart is restricted as follows:

- CU310, CU320, CU320-2, D4xx --> No. of hardware sampling times = 13
- CU305, CUD --> No. of hardware sampling times = 11

The assignment of the available hardware sampling times is displayed in r20008[0...12] as follows (STARTER/SCOUT in the online mode only):

- Value = 0.0 --> sampling time not assigned
- Value != 0.0 (not equal to 0.0) --> sampling time in ms
- Value = 9999900.00000 --> sampling time not supported

---

### Note

Note that a long-term trace registers a sampling time of 2 ms and the trace registers sampling times in accordance with the selected trace clock cycle. If these sampling times have not already been registered by the basic SINAMICS system, "Free blocks" (FBLOCKS), or Drive Control Chart (DCC), these functions require additional free hardware sampling times.

The registered hardware sampling times can be read (if the FBLOCKS are activated) in r20008[0...12]. The actual number of free hardware sampling times can be read in r7903.

In addition to the basic SINAMICS system, for DCC, the total number of hardware sampling times that have been introduced for FBLOCKS and DCC together is limited to a total of 5.

---

### Hardware sampling times, usage

A sampling time can be used simultaneously by more than one runtime group of "Free function blocks", DCC, and the basic SINAMICS system.

For this reason, the runtime groups should ideally be registered with existing sampling times or – if it makes more sense due to the function – the fixed runtime group "Calculate before setpoint channel" should be used.

For internal reasons, the drive unit always requires at least one (or more, depending on how the basic sampling times p0115[0] of the drive objects are parameterized) free hardware sampling time. This is why the actual number of free hardware sampling times can be read in r7903.

### Project download, error message, and procedure

If too many different hardware sampling times are configured offline, an error message is not output until the project is downloaded.

In this case, proceed as follows:

1. When the project is in the offline mode, set the free runtime groups that have been assigned hardware sampling times to software sampling times.
  - Hardware sampling times  
(FBLOCKS: p20000 < 256; DCC: p21000 < 256)
  - Software sampling times  
(FBLOCKS: p20000 >= 1001; DCC: p21000 >= 1001)

The assignment of fixed runtime groups (FBLOCKS: p20000 = 9003; DCC: p21000 >= 2000) does not need to be changed because the fixed runtime groups use the same sampling time as the assigned basic SINAMICS system function.

2. Download the project again.
3. Once the project has been downloaded and the Control Unit has powered up, check:
  - r7903: Number of hardware sampling times still available.
  - r20008: Number of hardware sampling times already registered by the basic SINAMICS system.
4. Adjust the runtime group parameters accordingly.

---

#### Note

The number of different hardware sampling times possible on a Control Unit is restricted. For this reason, software sampling times (multiple of r20003) should be preferably used or – if necessary – the fixed runtime group "Calculate before setpoint channel" (p20000[0...9] = 9003).

---

## 1.3 Description of the function blocks

### 1.3.1 AND

#### Short description

BOOL-type AND function block with four inputs.

#### Mode of operation

This function block logically ANDs the binary variables at inputs I and outputs the result to its digital output Q.

$$Q = I_0 \wedge I_1 \wedge I_2 \wedge I_3$$

Output Q = 1 when the value 1 is present at all inputs I0 to I3. In all other cases, output Q = 0.

### 1.3.2 OR

#### Short description

BOOL-type OR function block with four inputs

#### Mode of operation

This function block logically ORs the binary variables at inputs I (disjunction) and outputs the result to its digital output Q.

$$Q = I_0 \vee I_1 \vee I_2 \vee I_3$$

Output Q = 0 when the value 0 is present at all inputs I0 to I3. In all other cases, output Q = 1.

### 1.3.3 XOR (exclusive OR)

#### Short description

BOOL-type XOR function block with four inputs.

#### Mode of operation

This function block links the binary variables at the inputs I according to the exclusive OR logic function and outputs the result to its digital output Q.

Output Q = 0 when the value 0 is present at every input from I0 to I3 or when the value 1 is present at an even number of inputs from I0 to I3.

Output Q = 1 when the value 1 is present at an odd number of inputs from I0 to I3.

### 1.3.4 NOT (inverter)

#### Short description

BOOL-type inverter

#### Mode of operation

This function block inverts the binary variables at input I and outputs the result to output Q.

$$Q = \bar{I}$$

Output Q = 1 when the value 0 is present at input I.

Output Q = 0 when the value 1 is present at input I.

### 1.3.5 ADD (adder)

#### Short description

REAL-type adder with four inputs.

#### Mode of operation

This function block adds (taking into account the sign) the values entered at inputs X.

The result is limited to a range of -3.4E38 ... 3.4E38 and output at output Y.

$$Y = X_0 + X_1 + X_2 + X_3$$

### 1.3.6 SUB (subtractor)

#### Short description

REAL-type subtracter with two inputs.

#### Mode of operation

This function block subtracts (taking into account the sign) the value entered at input X1 from the value entered at input X0.

The result is limited to a range of -3.4E38 ... 3.4E38 and output at output Y.

$$Y = X_0 - X_1$$

### 1.3.7 MUL (multiplier)

#### Short description

REAL-type multiplier with four inputs.

#### Mode of operation

This function block multiplies (taking into account the sign) the values entered at inputs X.

The result is limited to a range of -3.4E38 ... +3.4E38 and output at output Y.

$$Y = X_0 \cdot X_1 \cdot X_2 \cdot X_3$$

### 1.3.8 DIV (divider)

#### Short description

REAL-type divider with two inputs.

#### Mode of operation

This function block divides the value entered at input X0 by the value entered at input X1.

The result is output at the outputs as follows:

- Y output: Quotient with places before and after the decimal point
- YIN output: Integer quotient
- MOD output: Division remainder (absolute remainder value, MOD = (Y - YIN) x X0)

The Y output is limited to a range of approx. -3.4E38 ... +3.4E38.

$$Y = \frac{X_0}{X_1}$$

If output value Y exceeds the permissible value range of approx. -3.4E38 ... 3.4E38 (because divisor X1 is very small or zero), the limit value of the output range with the correct sign is output at the Y output. At the same time, digital output QF is set to 1.

With a division of 0/0, block output Y remains unchanged. Digital output QF is set to 1.

### 1.3.9 AVA (absolute value generator with sign evaluation)

#### Short description

REAL-type arithmetic function block for generating absolute values.

#### Mode of operation

This function block generates the absolute value of the value present at input X. The result is output at output Y.

$$Y = |X|$$

If the input variable is negative, digital output SN is set to 1.

### 1.3.10 MFP (pulse generator)

#### Short description

- Timer for generating a pulse with a fixed duration.
- Used as a pulse-contracting or pulse-stretching monoflop.

#### Mode of operation

The rising edge of a pulse at input I sets output Q to 1 for pulse duration T. The pulse generator cannot be retriggered.

#### Time flow chart

Output pulse Q as a function of pulse duration T and input pulse I.

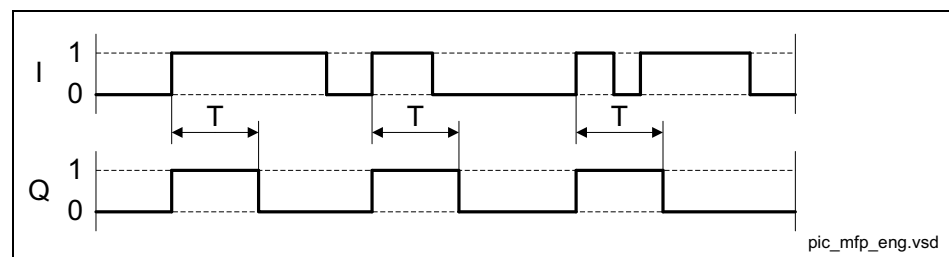

Fig. 1-5 MFP (pulse generator): Time flow chart

### 1.3.11 PCL (pulse shortener)

#### Short description

Timer for limiting the pulse duration.

**Mode of operation**

The rising edge of a pulse at input I sets output Q to 1.

Output Q becomes 0 when input I is 0 or pulse duration T has expired.

**Time flow chart**

Output pulse Q as a function of pulse duration T and input pulse I.

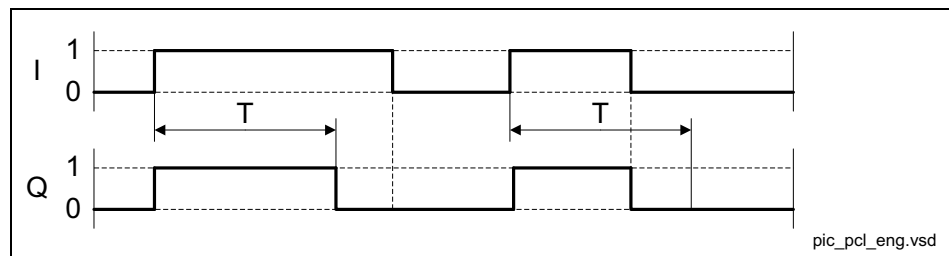

Fig. 1-6 PCL (pulse shortener): Time flow chart



### 1.3.12 PDE (ON delay)

#### Short description

BOOL-type timer with ON delay

#### Mode of operation

The rising edge of a pulse at input I sets output Q to 1 after pulse delay time T.

Output Q becomes 0 when I is 0.

If the duration of input pulse I is less than pulse delay time T, Q remains 0.

If time T is so long that the maximum value that can be displayed internally ( $T/t_a$  as 32 bit value, where  $t_a$  = sampling time) is exceeded, the maximum value is set (e.g. when  $t_a = 1$  ms, approx. 50 days).

#### Time flow chart

Output pulse Q as a function of pulse duration T and input pulse I.

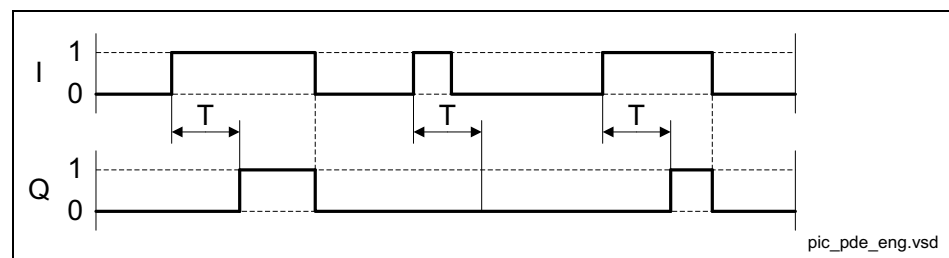

Fig. 1-7 PDE (ON delay): Time flow chart

### 1.3.13 PDF (OFF delay)

#### Short description

Timer with OFF delay.

#### Mode of operation

The falling edge of a pulse at input I resets output Q to 0 after OFF delay time T.

Output Q becomes 1 when I is 1.

Output Q becomes 0 when input pulse I is 0 and OFF delay time T has expired.

If input I is reset to 1 before time T has expired, output Q remains 1.

#### Time flow chart

Output pulse Q as a function of pulse duration T and input pulse I.

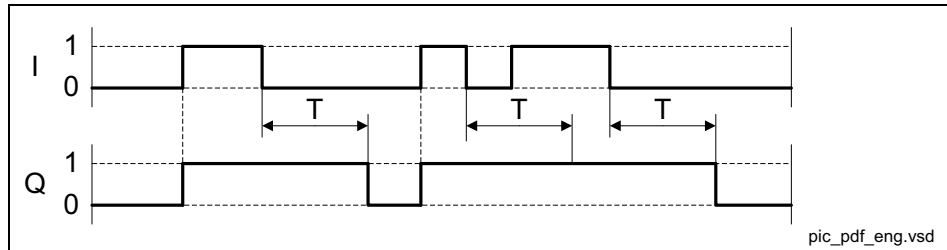

Fig. 1-8 PDF (OFF delay): Time flow chart

### 1.3.14 PST (pulse stretcher)

#### Short description

Timer for generating a pulse with a minimum duration and an additional reset input

#### Mode of operation

The rising edge of a pulse at input I sets output Q to 1.

Output Q does not return to 1 until input pulse I is 0 and pulse duration T has expired.

Output Q can be set to zero at any time via reset input R with  $R = 1$ .

#### Time flow chart

Output pulse Q as a function of pulse duration T and input pulse I (when  $R = 0$ ).

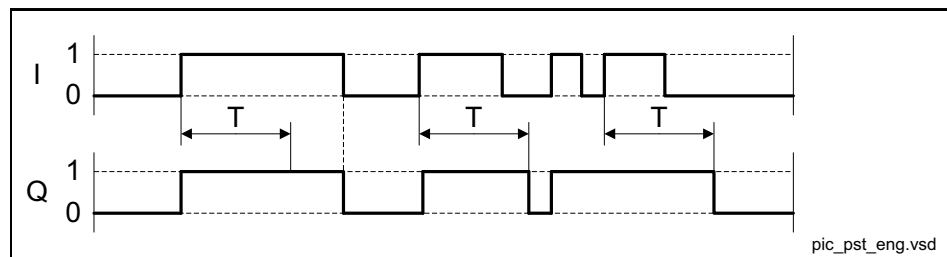

Fig. 1-9 PST (pulse stretcher): Time flow chart

### 1.3.15 RSR (RS flip-flop, reset dominant)

#### Short description

Reset dominant RS flip-flop for use as a static binary value memory

#### Mode of operation

With logical 1 at input S, output Q is set to logical 1.

If input R is set to logical 1, output Q is set to logical 0.

If both inputs are logical 0, Q does not change.

If both inputs are logical 1, however, Q is logical 0 because the reset input dominates.

Output QN always has the opposite value to Q.

### 1.3.16 DFR (D flip-flop, reset dominant)

#### Short description

BOOL-type function block for use as a D flip-flop with reset dominance.

#### Mode of operation

If inputs S and R are logical 0, the D input data is switched through to output Q when a rising edge is present at trigger input I.

Output QN always has the opposite value to Q. With logical 1 at input S, output Q is set to logical 1.

If input R is set to logical 1, output Q is set to logical 0. If both inputs are logical 0, Q does not change.

If inputs S and R are logical 1, however, Q is logical 0 because the reset input dominates.

#### Time flow chart

Output pulse Q as a function of the D input and input pulse I for S = R = 0.

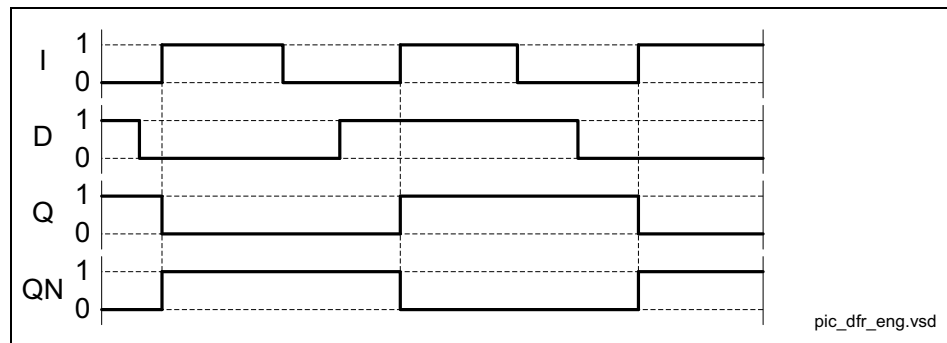

Fig. 1-10 DFR (D flip-flop, reset dominant): Time flow chart

### 1.3.17 BSW (binary change-over switch)

#### Short description

This function block switches one of two binary input variables (BOOL type) to the output.

#### Mode of operation

If input I = 0, I0 is switched to output Q.

If input I = 1, I1 is switched to output Q.

### 1.3.18 NSW (numeric change-over switch)

#### Short description

This function block switches one of two numeric input variables (REAL type) to the output.

#### Mode of operation

If input I = 0, X0 is switched to output Y.

If input I = 1, X1 is switched to output Y.

### 1.3.19 LIM (limiter)

#### Short description

- Function block for limiting.
- Adjustable upper and lower limit.
- Indication when set limits are reached.

#### Mode of operation

This function block transfers input variable  $X$  to its output  $Y$ . The input variable is limited depending on  $LU$  and  $LL$ .

If the input variable reaches the upper limit  $LU$ , output  $QU$  is set to 1.

If the input variable reaches the lower limit  $LL$ , output  $QL$  is set to 1.

If the lower limit is greater than or equal to the upper limit, output  $Y$  is set to the upper limit  $LU$ .

Algorithm:

$$Y = \begin{cases} LU & \text{für } X \geq LU \\ X & \text{für } LL < X < LU \\ LL & \text{für } X \leq LL \end{cases}$$

Constraint:  $LL < LU$

### 1.3.20 PT1 (smoothing element)

#### Short description

- First-order delay element with setting function.
- Used as smoothing element.

#### Mode of operation

##### Setting function not active (S = 0)

Input variable X, dynamically delayed by smoothing time constant T, is switched to output Y.

T determines the steepness of the rise of the output variable. It specifies the time at which the transfer function has risen to 63% of its full-scale value.

When  $t = 3T$ , the transfer function reaches approximately 95% of its full-scale value.

The internally fixed proportional gain is 1 and cannot be changed.

If  $T/TA$  is sufficiently large ( $T/TA > 10$ ), the transfer function has the following characteristic:

$$Y(t) = X \cdot (1 - e^{-t/T})$$

Constraint:  $t = n \cdot TA$

The discrete values are calculated according to the following algorithm:

$$Y_n = Y_{n-1} + \frac{TA}{T} \cdot (X_n - Y_{n-1})$$

$Y_n$  Value of Y in sampling time n

$Y_{n-1}$  Value of Y in sampling time n-1

$X_n$  Value of X in sampling time n

##### Setting function active (S = 1)

When the setting function is active, the actual setting value  $SV_n$  is accepted at the output variable:

$$Y_n = SV_n$$

---

#### Note

The higher that  $T/TA$  is, the smaller the amplitude change at Y from one sampling time to the next.  $TA$  is the configured sampling time of the function block.

T is limited internally:  $T \geq TA$

---

### 1.3.21 INT (integrator)

#### Short description

- Function block with integrating action.
- Integrator functions:
  - Set initial value.
  - Adjustable integral time constant.
  - Adjustable limits.
  - For normal integrator operation, a positive limit value must be specified for LU and a negative limit value for LL.

#### Mode of operation

The change in output variable Y is proportional to input variable X and inversely proportional to the integral time constant TI.

Output Y of the integrator can be limited via inputs LU and LL. If the output reaches one of the two limits, a signal is issued via output QU or QL. If LL >= LU, output Y = LU.

The discrete values (TA is the configured sampling time of the function block) are calculated according to the following algorithm:

$$Y_n = Y_{n-1} + \frac{TA}{TI} \cdot X_n$$

Yn Value of Y in sampling time n

Yn-1 Value of Y in sampling time n-1

Xn Value of X in sampling time n

When S = 1, the output variable Y is set to the setting value SV. Two functions can be performed via S:

- Track integrator (Y = SV)

The digital input is S = 1 and the setting value SV is changed. If applicable, the output makes a jump to the setting value immediately after the setting operation.

- Set integrator to initial value SV.

S is switched to 1. S is then set to 0, and the integrator starts from SV in the direction specified by the polarity of input variable X.

---

#### Note

TI is limited internally: TI >= TA

---



### 1.3.22 DIF (derivative action element)

#### Short description

Function block with derivative action behavior.

#### Mode of operation

Output variable Y is proportional to the rate of change of input variable X multiplied by derivative time constant TD.

The discrete values are calculated according to the following algorithm:

$$Y_n = (X_n - X_{n-1}) \cdot \frac{TD}{TA}$$

Y<sub>n</sub> Value of Y in sampling time n

Y<sub>n-1</sub> Value of Y in sampling time n-1

X<sub>n</sub> Value of X in sampling time n

---

#### Note

The higher that TD/TA is, the higher the amplitude change on Y from one sampling time to the next. TA is the configured sampling time of the function block.

TD is limited internally to TD >= 0.

Caution: Overcontrol possible!

---

### 1.3.23 LVM (double-sided limit monitor with hysteresis)

#### Short description

- This BOOL-type function block monitors an input variable by comparing it with selectable reference variables.
- Application:
  - Monitoring setpoints, actual, and measured values.
  - Suppressing frequent switching (jitter).
- This function block provides a window discriminator function.

#### Mode of operation

This function block uses a transfer characteristic (see transfer characteristic) with hysteresis to calculate an internal intermediate value.

The intermediate value is compared with the interval limits and the result is output at outputs QU, QM, and QL.

The transfer characteristic is configured with the values for the mean value  $M$ , the interval limit  $L$ , and the hysteresis  $HY$ .

#### Transfer characteristic

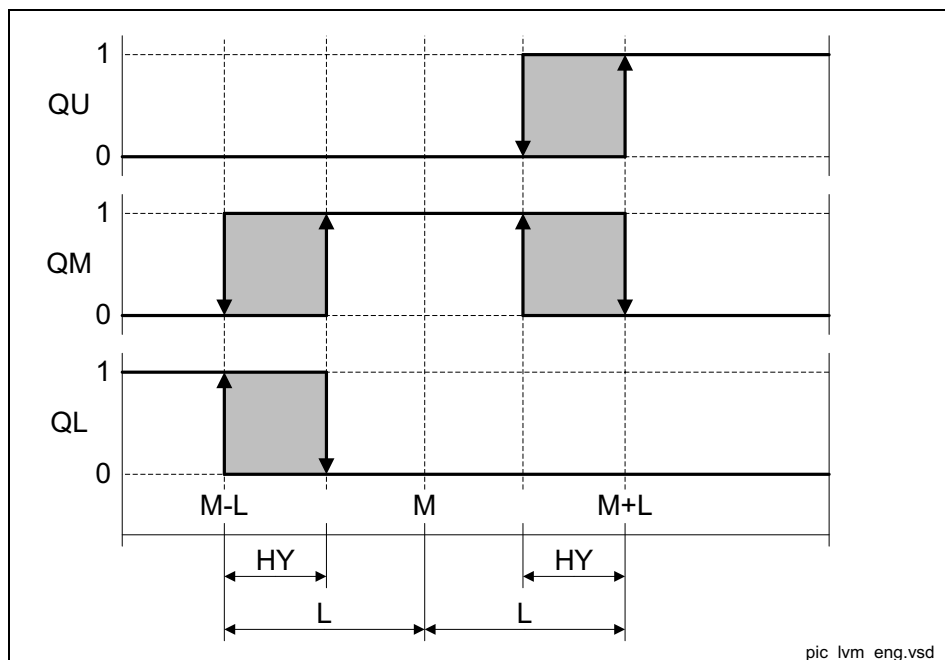

Fig. 1-11 LVM (double-sided limit monitor with hysteresis): Transfer characteristic

# Parameter

# 2

## Contents

2.1	Overview of parameters	2-52
2.2	List of parameters	2-61

## 2.1 Overview of parameters



### 2.1.1 Explanation of list of parameters

#### Basic structure of parameter descriptions

The data in the following example has been chosen at random. The table below contains all the information that can be included in a parameter description. Some of the information is optional.

The parameter list (See Chapter 2.2) is structured as follows:

----- **Start of example** -----

pxxxx[0...n]	<b>BICO: Full parameter name/short parameter name</b>			
Drive object (function module)	<b>Changeable:</b> C1(x), C2(x), U, T	<b>Calculated:</b> CALC_MOD_REG	<b>Access level:</b> 2	
	<b>Data type:</b> Unsigned32 / Integer16	<b>Dynamic index:</b> CDS, p0170	<b>Function diagram:</b> 2080	
	<b>P group:</b> Closed-loop control	<b>Unit group:</b> 7_1	<b>Unit selection:</b> p0505	
	<b>Not for motor type:</b> FEM	<b>Normalizing:</b> p2000	<b>Expert list:</b> 1	
	<b>Min</b> 0.00 [Nm]	<b>Max</b> 10.00 [Nm]	<b>Factory setting</b> 0.00 [Arms]	
<b>Description:</b>	Text			
<b>Values:</b>	0: Name and meaning of value 0 1: Name and meaning of value 1 2: Name and meaning of value 2 etc.			
<b>Recommendation:</b>	Text			
<b>Index:</b>	[0] = Name and meaning of index 0 [1] = Name and meaning of index 1 [2] = Name and meaning of index 2 etc.			
<b>Bit array:</b>	<b>Bit</b>	<b>Signal name</b>	<b>1 signal</b>	<b>0 signal</b>
	00	Name and meaning of bit 0	Yes	No
	01	Name and meaning of bit 1	Yes	No
	02	Name and meaning of bit 2 etc.	Yes	No
				<b>FP</b> 8010 - 8012
<b>Dependency:</b>	Text See also: pxxxx, rxxxx See also: Fxxxx, Axxxx			
<b>Danger:</b>	<b>Warning:</b>	<b>Caution:</b>	Safety notices with a warning triangle	
				
<b>Caution:</b>	<b>Notice:</b>	Safety notices without a warning triangle		
<b>Note:</b>	Information that might be useful.			

----- **End of example** -----

**pxxxx[0...n] Parameter number**

The parameter number is made up of a "p" or "r", followed by the parameter number and the index (optional).

Examples of representation in the parameter list:

- p... Adjustable parameter (read and write parameter)
- r... Display parameter (read-only)
- p0918 Adjustable parameter 918
- p0099[0...3] Adjustable parameter 99, indices 0 to 3
- p1001[0...n] Adjustable parameter 1001, indices 0 to n (n = configurable)
- r0944 Display parameter 944

Other examples of notation in the documentation:

- p1070[1] Adjustable parameter 1070, index 1
- p2098[1].3 Adjustable parameter 2098, index 1 bit 3
- r0945[2](3) Display parameter 945, index 2 of drive object 3
- p0795.4 Adjustable parameter 795, bit 4

The following applies to adjustable parameters:

The parameter value when shipped from the factory is specified under "Factory setting" with the relevant unit in square brackets. The value can be adjusted within the range defined by "Min" and "Max".

The term "linked parameterization" is used in cases where changes to adjustable parameters affect the settings of other parameters.

Linked parameterization can occur, for example, as a result of the following actions or parameters:

- Execute macros  
p0015, p0700, p1000, p1500
- Set PROFIBUS telegram (BICO interconnections)  
p0922
- Set component lists  
p0230, p0300, p0301, p0400
- Calculate and pre-assign automatically  
p0112, p0340, p0578, p3900
- Restore factory settings  
p0970

The following applies to display parameters:

The fields "Min", "Max" and "Factory setting" are specified with a dash "-" and the relevant unit in square brackets.

**Note:**

The parameter list can contain parameters that are not visible in the expert lists of the particular commissioning software (e.g. parameters for trace functions).

**BICO: Full parameter name/short parameter name**

The following abbreviations can appear in front of the parameter name:

- **BI:** Binector Input  
This parameter is used for selecting the source of a digital signal.
- **BO:** Binector Output  
This parameter is available as a digital signal for interconnection with other parameters.
- **CI:** Connector Input  
This parameter is used for selecting the source of an "analog" signal.
- **CO:** Connector Output  
This parameter is available as an "analog" signal for interconnection with other parameters.
- **CO/BO:** Connector/Binector Output  
This parameter is available as an "analog" and digital signal for interconnection with other parameters.

**Drive object (function module)**

A drive object (DO) is an independent, "self-contained" functional unit that has its own parameters and, in some cases, faults and alarms.

When carrying out commissioning using the commissioning software, you can select/deselect additional functions and their parameters by activating/deactivating function modules accordingly.

The parameter list specifies the associated drive object and function module for each individual parameter.

A parameter can belong to one, several, or all drive objects.

The following information relating to "Drive object" and "Function module" can be displayed under the parameter number:

Table 2-1 Data in the "Drive object (function module)" field

Drive object (function module)	Meaning
FBL object (FBL)	Drive object type for which the "Free function blocks" function module (FBL) can be activated (See Chapter 1.1.1).

**Changeable**

The "-" sign indicates that the parameter can be changed in any object state and that the change will be effective immediately.

The letters "C1(x), C2(x), T, U" ((x): optional) mean that the parameter can be changed in the specified drive unit state only and that the change will not take effect until the object switches to another state. This can be one or more states.

The following states may be specified:

- C1(x) Device commissioning                      C1: **Commissioning 1**  
     Device commissioning is in progress (p0009 > 0).  
     Pulses cannot be enabled.  
     The parameter can only be changed in the following device commissioning settings (p0009 > 0):
  - C1: Changeable for all settings p0009 > 0.
  - C1(x): Only changeable for the settings p0009 = x.
     A modified parameter value does not take effect until device commissioning mode is exited with p0009 = 0.
  
- C2(x) Drive object commissioning                      C2: **Commissioning 2**  
     Drive commissioning is in progress (p0009 = 0 and p0010 > 0).  
     Pulses cannot be enabled.  
     The parameter can only be changed in the following drive commissioning settings (p0010 > 0):
  - C2: Changeable for all settings p0010 > 0.
  - C2(x): Only changeable for the settings p0010 = x.
     A modified parameter value does not take effect until drive commissioning mode is exited with p0010 = 0.
  
- U    Operation    U: **Run**  
     Pulses are enabled.
  
- T    Ready    T: **Ready to run**  
     The pulses are not enabled and the state "C1(x)" or "C2(x)" is not active.

---

**Note:**

Parameter p0009 is CU-specific (available on the Control Unit).

Parameter p0010 is drive-specific (belongs to each drive object).

The operating state of individual drive objects is displayed in r0002.

---

**Calculated**

This information is not relevant for the "Free function blocks" function.

### Access level

Specifies the access level required for displaying and changing the relevant parameter. The required access level can be set via p0003.

The system uses the following access levels:

1. Standard
2. Advanced
3. Expert
4. Service  
Parameters with this access level are password protected.

---

#### Note:

Parameter p0003 is CU-specific (available on the Control Unit).

---

### Data type

The information on the data type can consist of the following two items (separated by a slash):

- First item  
Data type of the parameter.
- Second item (for binector or connector input only)  
Data type of the signal source to be interconnected (binector/connector output).

Parameters can have the following data types:

- I8 Integer8 8-bit integer
- I16 Integer16 16-bit integer
- I32 Integer32 32-bit integer
- U8 Unsigned8 8 bits without sign
- U16 Unsigned16 16 bits without sign
- U32 Unsigned32 32 bits without sign
- Float FloatingPoint32 32-bit floating point number



Depending on the data type of the BICO input parameter (signal sink) and BICO output parameter (signal source), the following combinations are possible when BICO interconnections are established:

Table 2-2 Possible combinations of BICO interconnections

	BICO input parameter			
	CI parameter			BI parameter
BICO output parameter	Unsigned32 / Integer16	Unsigned32 / Integer32	Unsigned32 / FloatingPoint32	Unsigned32 / Binary
CO: Unsigned8	x	x	–	–
CO: Unsigned16	x	x	–	–
CO: Integer16	x	x	–	–
CO: Unsigned32	x	x	–	–
CO: Integer32	x	x	–	–
CO: FloatingPoint32	x	x	x <sup>1</sup>	–
BO: Unsigned8	–	–	–	x
BO: Unsigned16	–	–	–	x
BO: Integer16	–	–	–	x
BO: Unsigned32	–	–	–	x
BO: Integer32	–	–	–	x
BO: FloatingPoint32	–	–	–	–
Legend:	x: BICO interconnection permitted –: BICO interconnection not permitted			
1 Exception:	BICO input parameters with data type "Unsigned32 / FloatingPoint32" can also be interconnected with the following BICO output parameters, although these are not of the "FloatingPoint32" data type: CO: r8850, CO: r8860, CO: r2050, CO: r2060			

### Dynamic index

This information is not relevant for the "Free function blocks" function.

The "Free function blocks" function does not support data sets.

### Function diagram

The parameter is included in this function diagram. The structure of the parameter function and its relationship with other parameters is shown in the specified function diagram.

#### Example:

Function diagram: 3060.3      3060:      Function diagram number  
3:      Signal path (optional)

**P group (refers only to access via BOP (Basic Operator Panel))**

Specifies the functional group to which the parameter belongs. The required parameter group can be set via p0004.

---

**Note:**

Parameter p0004 is CU-specific (available on the Control Unit).

---

**Unit, unit group, and unit selection**

This information is not relevant for the "Free function blocks" function.

The "Free function blocks" function does not support "Unit group" or "Unit selection".

**Parameter values**

Min	Minimum value of the parameter [unit]
Max	Maximum value of the parameter [unit]
Factory setting	Value when shipped [unit]

A different value may be displayed for certain parameters (e.g. p1800) at the initial commissioning stage.  
Reason:  
The setting of these parameters is determined by the operating environment of the Control Unit (e.g. depending on converter type, macro, power unit).

---

**Note:**

For SINAMICS G150/G130/S150, the macros and their settings are provided in the following reference:

References: /BAx/    x = 1, 2, 3  
                  SINAMICS G150/G130/S150 operating instructions

---

**Normalizing**

Specification of the reference variable with which a signal value is automatically converted for a BICO interconnection.

The following reference variables are available:

- p2000 ... p2007: Reference speed, reference voltage, etc.
- PERCENT: 1.0 = 100%
- 4000H: 4000 hex = 100%

**Description**

Explanation of the function of a parameter.

**Values**

Lists the possible values of a parameter.

**Recommendation**

Information about recommended settings.

**Index**

The name and meaning of each individual index is specified for indexed parameters.

The following applies to the values (Min, Max, Factory setting) for indexed adjustable parameters:

- Min, Max:

The adjustment range and unit apply to all indices.

- Factory setting:

When all indices have the same factory setting, index 0 is specified with the unit to represent all indices.

When the indices have different factory settings, they are all listed individually with the unit.

**Bit array**

For parameters with bit arrays, the following information is provided about each bit:

- Bit number and signal name
- Meaning with signal states 0 and 1
- Function diagram (optional)

The signal is shown on this function diagram.

**Dependency**

Conditions that must be fulfilled in connection with this parameter. Also includes special effects that can occur between this parameter and others.

See also: List of other parameters to be additionally considered.

## Safety notices

Important information that must be observed to avoid the risk of physical injury or material damage.

Information that must be observed to avoid any problems.

Information that the user may find useful.

### **Danger**



The description of this safety notice can be found at the beginning of this manual (see **Safety Notices**).

### **Warning**



The description of this safety notice can be found at the beginning of this manual (see **Safety Notices**).

### **Caution**



The description of this safety notice can be found at the beginning of this manual (see **Safety Notices**).

### **Caution**

The description of this safety notice can be found at the beginning of this manual (see **Safety Notices**).

### **Notice**

The description of this safety notice can be found at the beginning of this manual (see **Safety Notices**).

### **Note**

Information that the user may find useful.

## 2.2 List of parameters

Product: SINAMICS FBLOCKS, Version: 4402100, Language: eng  
Objects: All objects

<b>p20000[0...9] Run-time group property / RTG property</b>			
All objects (FBLOCKS)	<b>Can be changed:</b> T	<b>Calculated:</b> -	<b>Access level:</b> 1
	<b>Data type:</b> Integer16	<b>Dynamic index:</b> -	<b>Func. diagram:</b> -
	<b>P-Group:</b> -	<b>Units group:</b> -	<b>Unit selection:</b> -
	<b>Not for motor type:</b> -	<b>Scaling:</b> -	<b>Expert list:</b> 1
	<b>Min</b> 0	<b>Max</b> 9003	<b>Factory setting</b> 0
<b>Description:</b>	<p>Allocates properties to run-time groups 0 to 9. This property comprises the sampling time and for p20000[x] = 9003, the instant of the call within the sampling time. Index x of p20000 corresponds to the number of the run-time group. p20000[0] is used to set the property of run-time group 0. ... p20000[9] is used to set the property of run-time group 9. p20000[x] = 0 run-time group is not calculated. p20000[x] = 1 free run-time group <math>T_{\text{sample}} = 1 * r20002</math> p20000[x] = 2 free run-time group <math>T_{\text{sample}} = 2 * r20002</math> p20000[x] = 3 free run-time group <math>T_{\text{sample}} = 3 * r20002</math> p20000[x] = 4 free run-time group <math>T_{\text{sample}} = 4 * r20002</math> ... p20000[x] = 255 free run-time group <math>T_{\text{sample}} = 255 * r20002</math> p20000[x] = 256 free run-time group <math>T_{\text{sample}} = 256 * r20002</math> p20000[x] = 1001 free run-time group <math>T_{\text{sample}} = 1 * r20003</math> p20000[x] = 1002 free run-time group <math>T_{\text{sample}} = 2 * r20003</math> p20000[x] = 1003 free run-time group <math>T_{\text{sample}} = 3 * r20003</math> p20000[x] = 1004 free run-time group <math>T_{\text{sample}} = 4 * r20003</math> p20000[x] = 1005 free run-time group <math>T_{\text{sample}} = 5 * r20003</math> p20000[x] = 1006 free run-time group <math>T_{\text{sample}} = 6 * r20003</math> p20000[x] = 1008 free run-time group <math>T_{\text{sample}} = 8 * r20003</math> p20000[x] = 1010 free run-time group <math>T_{\text{sample}} = 10 * r20003</math> p20000[x] = 1012 free run-time group <math>T_{\text{sample}} = 12 * r20003</math> p20000[x] = 1016 free run-time group <math>T_{\text{sample}} = 16 * r20003</math> p20000[x] = 1020 free run-time group <math>T_{\text{sample}} = 20 * r20003</math> p20000[x] = 1024 free run-time group <math>T_{\text{sample}} = 24 * r20003</math> p20000[x] = 1032 free run-time group <math>T_{\text{sample}} = 32 * r20003</math> p20000[x] = 1040 free run-time group <math>T_{\text{sample}} = 40 * r20003</math> p20000[x] = 1048 free run-time group <math>T_{\text{sample}} = 48 * r20003</math> p20000[x] = 1064 free run-time group <math>T_{\text{sample}} = 64 * r20003</math> p20000[x] = 1096 free run-time group <math>T_{\text{sample}} = 96 * r20003</math> p20000[x] = 9003 fixed run-time group "calculate before setpoint channel" (only VECTOR, SERVO)</p>		
<b>Value:</b>	<p>0: Do not calculate 1: <math>T = 1 * r20002</math> 2: <math>T = 2 * r20002</math> 3: <math>T = 3 * r20002</math> 4: <math>T = 4 * r20002</math> 5: <math>T = 5 * r20002</math> 6: <math>T = 6 * r20002</math> 7: <math>T = 7 * r20002</math> 8: <math>T = 8 * r20002</math> 9: <math>T = 9 * r20002</math> 10: <math>T = 10 * r20002</math></p>		

List of parameters

---

11: T = 11 \* r20002  
12: T = 12 \* r20002  
13: T = 13 \* r20002  
14: T = 14 \* r20002  
15: T = 15 \* r20002  
16: T = 16 \* r20002  
17: T = 17 \* r20002  
18: T = 18 \* r20002  
19: T = 19 \* r20002  
20: T = 20 \* r20002  
21: T = 21 \* r20002  
22: T = 22 \* r20002  
23: T = 23 \* r20002  
24: T = 24 \* r20002  
25: T = 25 \* r20002  
26: T = 26 \* r20002  
27: T = 27 \* r20002  
28: T = 28 \* r20002  
29: T = 29 \* r20002  
30: T = 30 \* r20002  
31: T = 31 \* r20002  
32: T = 32 \* r20002  
33: T = 33 \* r20002  
34: T = 34 \* r20002  
35: T = 35 \* r20002  
36: T = 36 \* r20002  
37: T = 37 \* r20002  
38: T = 38 \* r20002  
39: T = 39 \* r20002  
40: T = 40 \* r20002  
41: T = 41 \* r20002  
42: T = 42 \* r20002  
43: T = 43 \* r20002  
44: T = 44 \* r20002  
45: T = 45 \* r20002  
46: T = 46 \* r20002  
47: T = 47 \* r20002  
48: T = 48 \* r20002  
49: T = 49 \* r20002  
50: T = 50 \* r20002  
51: T = 51 \* r20002  
52: T = 52 \* r20002  
53: T = 53 \* r20002  
54: T = 54 \* r20002  
55: T = 55 \* r20002  
56: T = 56 \* r20002  
57: T = 57 \* r20002  
58: T = 58 \* r20002  
59: T = 59 \* r20002  
60: T = 60 \* r20002  
61: T = 61 \* r20002  
62: T = 62 \* r20002  
63: T = 63 \* r20002  
64: T = 64 \* r20002  
65: T = 65 \* r20002  
66: T = 66 \* r20002  
67: T = 67 \* r20002  
68: T = 68 \* r20002  
69: T = 69 \* r20002  
70: T = 70 \* r20002  
71: T = 71 \* r20002  
72: T = 72 \* r20002  
73: T = 73 \* r20002  
74: T = 74 \* r20002

75: T = 75 \* r20002  
76: T = 76 \* r20002  
77: T = 77 \* r20002  
78: T = 78 \* r20002  
79: T = 79 \* r20002  
80: T = 80 \* r20002  
81: T = 81 \* r20002  
82: T = 82 \* r20002  
83: T = 83 \* r20002  
84: T = 84 \* r20002  
85: T = 85 \* r20002  
86: T = 86 \* r20002  
87: T = 87 \* r20002  
88: T = 88 \* r20002  
89: T = 89 \* r20002  
90: T = 90 \* r20002  
91: T = 91 \* r20002  
92: T = 92 \* r20002  
93: T = 93 \* r20002  
94: T = 94 \* r20002  
95: T = 95 \* r20002  
96: T = 96 \* r20002  
97: T = 97 \* r20002  
98: T = 98 \* r20002  
99: T = 99 \* r20002  
100: T = 100 \* r20002  
101: T = 101 \* r20002  
102: T = 102 \* r20002  
103: T = 103 \* r20002  
104: T = 104 \* r20002  
105: T = 105 \* r20002  
106: T = 106 \* r20002  
107: T = 107 \* r20002  
108: T = 108 \* r20002  
109: T = 109 \* r20002  
110: T = 110 \* r20002  
111: T = 111 \* r20002  
112: T = 112 \* r20002  
113: T = 113 \* r20002  
114: T = 114 \* r20002  
115: T = 115 \* r20002  
116: T = 116 \* r20002  
117: T = 117 \* r20002  
118: T = 118 \* r20002  
119: T = 119 \* r20002  
120: T = 120 \* r20002  
121: T = 121 \* r20002  
122: T = 122 \* r20002  
123: T = 123 \* r20002  
124: T = 124 \* r20002  
125: T = 125 \* r20002  
126: T = 126 \* r20002  
127: T = 127 \* r20002  
128: T = 128 \* r20002  
129: T = 129 \* r20002  
130: T = 130 \* r20002  
131: T = 131 \* r20002  
132: T = 132 \* r20002  
133: T = 133 \* r20002  
134: T = 134 \* r20002  
135: T = 135 \* r20002  
136: T = 136 \* r20002  
137: T = 137 \* r20002  
138: T = 138 \* r20002

List of parameters

---

139: T = 139 \* r20002  
140: T = 140 \* r20002  
141: T = 141 \* r20002  
142: T = 142 \* r20002  
143: T = 143 \* r20002  
144: T = 144 \* r20002  
145: T = 145 \* r20002  
146: T = 146 \* r20002  
147: T = 147 \* r20002  
148: T = 148 \* r20002  
149: T = 149 \* r20002  
150: T = 150 \* r20002  
151: T = 151 \* r20002  
152: T = 152 \* r20002  
153: T = 153 \* r20002  
154: T = 154 \* r20002  
155: T = 155 \* r20002  
156: T = 156 \* r20002  
157: T = 157 \* r20002  
158: T = 158 \* r20002  
159: T = 159 \* r20002  
160: T = 160 \* r20002  
161: T = 161 \* r20002  
162: T = 162 \* r20002  
163: T = 163 \* r20002  
164: T = 164 \* r20002  
165: T = 165 \* r20002  
166: T = 166 \* r20002  
167: T = 167 \* r20002  
168: T = 168 \* r20002  
169: T = 169 \* r20002  
170: T = 170 \* r20002  
171: T = 171 \* r20002  
172: T = 172 \* r20002  
173: T = 173 \* r20002  
174: T = 174 \* r20002  
175: T = 175 \* r20002  
176: T = 176 \* r20002  
177: T = 177 \* r20002  
178: T = 178 \* r20002  
179: T = 179 \* r20002  
180: T = 180 \* r20002  
181: T = 181 \* r20002  
182: T = 182 \* r20002  
183: T = 183 \* r20002  
184: T = 184 \* r20002  
185: T = 185 \* r20002  
186: T = 186 \* r20002  
187: T = 187 \* r20002  
188: T = 188 \* r20002  
189: T = 189 \* r20002  
190: T = 190 \* r20002  
191: T = 191 \* r20002  
192: T = 192 \* r20002  
193: T = 193 \* r20002  
194: T = 194 \* r20002  
195: T = 195 \* r20002  
196: T = 196 \* r20002  
197: T = 197 \* r20002  
198: T = 198 \* r20002  
199: T = 199 \* r20002  
200: T = 200 \* r20002  
201: T = 201 \* r20002  
202: T = 202 \* r20002



203: T = 203 \* r20002  
204: T = 204 \* r20002  
205: T = 205 \* r20002  
206: T = 206 \* r20002  
207: T = 207 \* r20002  
208: T = 208 \* r20002  
209: T = 209 \* r20002  
210: T = 210 \* r20002  
211: T = 211 \* r20002  
212: T = 212 \* r20002  
213: T = 213 \* r20002  
214: T = 214 \* r20002  
215: T = 215 \* r20002  
216: T = 216 \* r20002  
217: T = 217 \* r20002  
218: T = 218 \* r20002  
219: T = 219 \* r20002  
220: T = 220 \* r20002  
221: T = 221 \* r20002  
222: T = 222 \* r20002  
223: T = 223 \* r20002  
224: T = 224 \* r20002  
225: T = 225 \* r20002  
226: T = 226 \* r20002  
227: T = 227 \* r20002  
228: T = 228 \* r20002  
229: T = 229 \* r20002  
230: T = 230 \* r20002  
231: T = 231 \* r20002  
232: T = 232 \* r20002  
233: T = 233 \* r20002  
234: T = 234 \* r20002  
235: T = 235 \* r20002  
236: T = 236 \* r20002  
237: T = 237 \* r20002  
238: T = 238 \* r20002  
239: T = 239 \* r20002  
240: T = 240 \* r20002  
241: T = 241 \* r20002  
242: T = 242 \* r20002  
243: T = 243 \* r20002  
244: T = 244 \* r20002  
245: T = 245 \* r20002  
246: T = 246 \* r20002  
247: T = 247 \* r20002  
248: T = 248 \* r20002  
249: T = 249 \* r20002  
250: T = 250 \* r20002  
251: T = 251 \* r20002  
252: T = 252 \* r20002  
253: T = 253 \* r20002  
254: T = 254 \* r20002  
255: T = 255 \* r20002  
256: T = 256 \* r20002  
1001: T = 1 \* r20003  
1002: T = 2 \* r20003  
1003: T = 3 \* r20003  
1004: T = 4 \* r20003  
1005: T = 5 \* r20003  
1006: T = 6 \* r20003  
1008: T = 8 \* r20003  
1010: T = 10 \* r20003  
1012: T = 12 \* r20003  
1016: T = 16 \* r20003

1020: T = 20 \* r20003  
 1024: T = 24 \* r20003  
 1032: T = 32 \* r20003  
 1040: T = 40 \* r20003  
 1048: T = 48 \* r20003  
 1064: T = 64 \* r20003  
 1080: T = 80 \* r20003  
 1096: T = 96 \* r20003  
 9003: Before setp chann

**Index:** [0] = Run-time group 0  
 [1] = Run-time group 1  
 [2] = Run-time group 2  
 [3] = Run-time group 3  
 [4] = Run-time group 4  
 [5] = Run-time group 5  
 [6] = Run-time group 6  
 [7] = Run-time group 7  
 [8] = Run-time group 8  
 [9] = Run-time group 9

**Dependency:** Refer to: r20008

**Caution:** The assignment of the properties of the run-time groups should not be changed on drives in operation as this could result in discontinuous signal transitions depending on the blocks used. At the 1st arithmetic cycle after the change, the respective internal initialization value is present at the block connections and in each subsequent cycle the calculated value is then present.

**Note:** Re value = 1 ... 256:

This value can only be set if, for sampling time  $T_{\text{sample}}$  of this run-time group, the following applies:  $1 \text{ ms} \leq T_{\text{sample}} \leq r20003$ .

If value = 9003:

The fixed run-time groups  $p20000[x] = 9003$  log on with the sampling time of the setpoint channel, although the sampling time must be at least 1 ms. If, as a result of this limit, the actual sampling time deviates from the sampling time of the setpoint channel  $p0115[3]$ , alarm A20103 is output. Another run-time group with a sampling time  $\geq 1$  ms should be selected. "Calculate before setpoint channel" means before function diagrams 3010, 3020, 3030, 3040, etc. are calculated, if the setpoint channel is activated ( $p0108.8 = 1$ ). If, e.g. for SERVO, a setpoint channel has not been configured ( $p0108.8 = 0$ ), then the calculation is made before function diagram 3095.

---

### r20001[0...9] Run-time group sampling time / RTG sampling time

All objects  
 (FBLOCKS)

**Can be changed:** -

**Calculated:** -

**Access level:** 1

**Data type:** FloatingPoint32

**Dynamic index:** -

**Func. diagram:** -

**P-Group:** -

**Units group:** -

**Unit selection:** -

**Not for motor type:** -

**Scaling:** -

**Expert list:** 1

**Min**

**Max**

**Factory setting**

- [ms]

- [ms]

- [ms]

**Description:** Displays the current sampling time of the run-time group 0 to 9.

**Index:** [0] = Run-time group 0  
 [1] = Run-time group 1  
 [2] = Run-time group 2  
 [3] = Run-time group 3  
 [4] = Run-time group 4  
 [5] = Run-time group 5  
 [6] = Run-time group 6  
 [7] = Run-time group 7  
 [8] = Run-time group 8  
 [9] = Run-time group 9

<b>r20002</b>	<b>Basis sampling time, hardware / Basis samp time HW</b>		
All objects (FBLOCKS)	<b>Can be changed:</b> - <b>Data type:</b> FloatingPoint32 <b>P-Group:</b> - <b>Not for motor type:</b> - <b>Min</b> - [ms]	<b>Calculated:</b> - <b>Dynamic index:</b> - <b>Units group:</b> - <b>Scaling:</b> - <b>Max</b> - [ms]	<b>Access level:</b> 1 <b>Func. diagram:</b> - <b>Unit selection:</b> - <b>Expert list:</b> 1 <b>Factory setting</b> - [ms]
<b>Description:</b>	Displays the lowest sampling time effective at this drive object for values 1 to 256 of p20000. $T\_sample = p20000 * r20002$		
<b>r20003</b>	<b>Basis sampling time, software / Basis samp time SW</b>		
All objects (FBLOCKS)	<b>Can be changed:</b> - <b>Data type:</b> FloatingPoint32 <b>P-Group:</b> - <b>Not for motor type:</b> - <b>Min</b> - [ms]	<b>Calculated:</b> - <b>Dynamic index:</b> - <b>Units group:</b> - <b>Scaling:</b> - <b>Max</b> - [ms]	<b>Access level:</b> 1 <b>Func. diagram:</b> - <b>Unit selection:</b> - <b>Expert list:</b> 1 <b>Factory setting</b> - [ms]
<b>Description:</b>	Displays the sampling time as factor effective on this drive object for values 1001 to 1096 of p20000. $T\_sample = (p20000 - 1000) * r20003$		
<b>r20005[0...9]</b>	<b>Average computing time load of the run-time groups / Comp_load RTG</b>		
All objects (FBLOCKS)	<b>Can be changed:</b> - <b>Data type:</b> FloatingPoint32 <b>P-Group:</b> - <b>Not for motor type:</b> - <b>Min</b> - [%]	<b>Calculated:</b> - <b>Dynamic index:</b> - <b>Units group:</b> - <b>Scaling:</b> - <b>Max</b> - [%]	<b>Access level:</b> 3 <b>Func. diagram:</b> - <b>Unit selection:</b> - <b>Expert list:</b> 1 <b>Factory setting</b> - [%]
<b>Description:</b>	Share of the average computing time load which the FBLOCKS run-time group contributes to the overall computing time load for the drive unit (r9976).		
<b>Index:</b>	[0] = Run-time group 0 [1] = Run-time group 1 [2] = Run-time group 2 [3] = Run-time group 3 [4] = Run-time group 4 [5] = Run-time group 5 [6] = Run-time group 6 [7] = Run-time group 7 [8] = Run-time group 8 [9] = Run-time group 9		
<b>Note:</b>	The run-time group to be measured has to be logged on ( $p20000[x] > 0$ ). The value for the computation time load is calculated in the drive unit using the project loaded. As such, the $r20005[x]$ values are not available in the expert list in SCOUT/STARTER offline mode.		
<b>r20008[0...12]</b>	<b>Hardware sampling times available / HW t_samp</b>		
All objects (FBLOCKS)	<b>Can be changed:</b> - <b>Data type:</b> FloatingPoint32 <b>P-Group:</b> - <b>Not for motor type:</b> - <b>Min</b> - [ms]	<b>Calculated:</b> - <b>Dynamic index:</b> - <b>Units group:</b> - <b>Scaling:</b> - <b>Max</b> - [ms]	<b>Access level:</b> 3 <b>Func. diagram:</b> - <b>Unit selection:</b> - <b>Expert list:</b> 1 <b>Factory setting</b> - [ms]
<b>Description:</b>	Displays the assignment of the available hardware sampling times of the drive unit. The term "hardware sampling times" refers to those r20002 sampling times that are formed as a multiple of the basic sampling time and always $< r20003$ .		

**Dependency:** Refer to: p20000

**Notice:** For internal purposes, the drive unit always requires at least two (or several, depending on the parameterization of p0115 of the drive objects) free hardware sampling times. Therefore the current number of hardware sampling times that are still free can be read out in r7903.

If r7903=0, no additional sampling time that differs from r20008[0...12] can be provided from the Control Unit. If, when selecting in this state, a run-time group with a sampling time < r20003 (p20000 <= 255) is to be set in p20000, only run-time groups whose sampling time is already provided in r20008[0...12] can be selected.

**Note:** The 13 different sampling times available are displayed in r20008[0...12].

If the value of r20008[0...12] is not equal to 0, then it specifies the sampling time in ms.

A sampling time that is provided can be simultaneously used by system functions, several FBLOCKS run-time groups, and several DCC run-time groups.

If the value of r20008[0...12] = 0, then this sampling time can still be freely assigned. It should be noted that the basic system, depending on the selected basic sampling times p0115[0], requires at least two (sometimes several) freely assignable hardware sampling times for internal functions. The number of hardware sampling times that can still be freely assigned can be read out in r7903.

r20008[11] = 99999.00000 --> Hardware sampling time is not supported.  
r20008[12] = 99999.00000 --> Hardware sampling time is not supported.

The sampling time of run-time groups that have been assigned to the PROFIBUS run-time groups (p20000 = 4000 ... 4004) is not displayed in r20008. For this sampling time, one of the internally and permanently assigned hardware sampling times is used.

---

<b>p20020</b>	<b>Computing time measurement run-time group / t_meas RTG</b>		
All objects (FBLOCKS)	<b>Can be changed:</b> U, T	<b>Calculated:</b> -	<b>Access level:</b> 4
	<b>Data type:</b> Unsigned32	<b>Dynamic index:</b> -	<b>Func. diagram:</b> -
	<b>P-Group:</b> -	<b>Units group:</b> -	<b>Unit selection:</b> -
	<b>Not for motor type:</b> -	<b>Scaling:</b> -	<b>Expert list:</b> 1
	<b>Min</b>	<b>Max</b>	<b>Factory setting</b>
	0	10	0
<b>Description:</b>	Only for internal Siemens service purposes.		

---

<b>p20022</b>	<b>Computing time measurement, duration / t_meas duration</b>		
All objects (FBLOCKS)	<b>Can be changed:</b> U, T	<b>Calculated:</b> -	<b>Access level:</b> 4
	<b>Data type:</b> Unsigned32	<b>Dynamic index:</b> -	<b>Func. diagram:</b> -
	<b>P-Group:</b> -	<b>Units group:</b> -	<b>Unit selection:</b> -
	<b>Not for motor type:</b> -	<b>Scaling:</b> -	<b>Expert list:</b> 1
	<b>Min</b>	<b>Max</b>	<b>Factory setting</b>
	60 [s]	10000 [s]	60 [s]
<b>Description:</b>	Only for internal Siemens service purposes.		

---

<b>r20024[0...9]</b>	<b>Computing time, minimum value / t_comp min.</b>		
All objects (FBLOCKS)	<b>Can be changed:</b> -	<b>Calculated:</b> -	<b>Access level:</b> 4
	<b>Data type:</b> FloatingPoint32	<b>Dynamic index:</b> -	<b>Func. diagram:</b> -
	<b>P-Group:</b> -	<b>Units group:</b> -	<b>Unit selection:</b> -
	<b>Not for motor type:</b> -	<b>Scaling:</b> -	<b>Expert list:</b> 1
	<b>Min</b>	<b>Max</b>	<b>Factory setting</b>
	- [µs]	- [µs]	- [µs]
<b>Description:</b>	Only for internal Siemens service purposes.		

**Index:**

- [0] = Run-time group 0
- [1] = Run-time group 1
- [2] = Run-time group 2
- [3] = Run-time group 3
- [4] = Run-time group 4
- [5] = Run-time group 5
- [6] = Run-time group 6
- [7] = Run-time group 7

[8] = Run-time group 8  
 [9] = Run-time group 9

<b>r20025[0...9]</b>	<b>Computing time, mean value / t_comp average</b>		
All objects (FBLOCKS)	<b>Can be changed:</b> - <b>Data type:</b> FloatingPoint32 <b>P-Group:</b> - <b>Not for motor type:</b> - <b>Min</b> - [µs]	<b>Calculated:</b> - <b>Dynamic index:</b> - <b>Units group:</b> - <b>Scaling:</b> - <b>Max</b> - [µs]	<b>Access level:</b> 4 <b>Func. diagram:</b> - <b>Unit selection:</b> - <b>Expert list:</b> 1 <b>Factory setting</b> - [µs]
<b>Description:</b>	Only for internal Siemens service purposes.		
<b>Index:</b>	[0] = Run-time group 0 [1] = Run-time group 1 [2] = Run-time group 2 [3] = Run-time group 3 [4] = Run-time group 4 [5] = Run-time group 5 [6] = Run-time group 6 [7] = Run-time group 7 [8] = Run-time group 8 [9] = Run-time group 9		
<b>r20026[0...9]</b>	<b>Computing time, maximum value / t_comp max.</b>		
All objects (FBLOCKS)	<b>Can be changed:</b> - <b>Data type:</b> FloatingPoint32 <b>P-Group:</b> - <b>Not for motor type:</b> - <b>Min</b> - [µs]	<b>Calculated:</b> - <b>Dynamic index:</b> - <b>Units group:</b> - <b>Scaling:</b> - <b>Max</b> - [µs]	<b>Access level:</b> 4 <b>Func. diagram:</b> - <b>Unit selection:</b> - <b>Expert list:</b> 1 <b>Factory setting</b> - [µs]
<b>Description:</b>	Only for internal Siemens service purposes.		
<b>Index:</b>	[0] = Run-time group 0 [1] = Run-time group 1 [2] = Run-time group 2 [3] = Run-time group 3 [4] = Run-time group 4 [5] = Run-time group 5 [6] = Run-time group 6 [7] = Run-time group 7 [8] = Run-time group 8 [9] = Run-time group 9		
<b>p20030[0...3]</b>	<b>BI: AND 0 inputs / AND 0 inputs</b>		
All objects (FBLOCKS)	<b>Can be changed:</b> T <b>Data type:</b> Unsigned32 / Binary <b>P-Group:</b> - <b>Not for motor type:</b> - <b>Min</b> -	<b>Calculated:</b> - <b>Dynamic index:</b> - <b>Units group:</b> - <b>Scaling:</b> - <b>Max</b> -	<b>Access level:</b> 1 <b>Func. diagram:</b> 7210 <b>Unit selection:</b> - <b>Expert list:</b> 1 <b>Factory setting</b> 0
<b>Description:</b>	Sets the signal source of input quantities I0, I1, I2, I3 of instance AND 0 of the AND function block.		
<b>Index:</b>	[0] = Input I0 [1] = Input I1 [2] = Input I2 [3] = Input I3		

<b>r20031</b>	<b>BO: AND 0 output Q / AND 0 output Q</b>		
All objects (FBLOCKS)	<b>Can be changed:</b> - <b>Data type:</b> Unsigned32 <b>P-Group:</b> - <b>Not for motor type:</b> - <b>Min</b> -	<b>Calculated:</b> - <b>Dynamic index:</b> - <b>Units group:</b> - <b>Scaling:</b> - <b>Max</b> -	<b>Access level:</b> 1 <b>Func. diagram:</b> 7210 <b>Unit selection:</b> - <b>Expert list:</b> 1 <b>Factory setting</b> -
<b>Description:</b>	Display parameter for binary quantity Q = I0 & I1 & I2 & I3 of instance AND 0 of the AND function block.		
<b>p20032</b>	<b>AND 0 run-time group / AND 0 RTG</b>		
All objects (FBLOCKS)	<b>Can be changed:</b> T <b>Data type:</b> Integer16 <b>P-Group:</b> - <b>Not for motor type:</b> - <b>Min</b> 0	<b>Calculated:</b> - <b>Dynamic index:</b> - <b>Units group:</b> - <b>Scaling:</b> - <b>Max</b> 9999	<b>Access level:</b> 1 <b>Func. diagram:</b> 7210 <b>Unit selection:</b> - <b>Expert list:</b> 1 <b>Factory setting</b> 9999
<b>Description:</b>	Setting parameter for the run-time group in which the instance AND 0 of the AND function block is to be called.		
<b>Value:</b>	0: Run-time group 0 1: Run-time group 1 2: Run-time group 2 3: Run-time group 3 4: Run-time group 4 5: Run-time group 5 6: Run-time group 6 7: Run-time group 7 8: Run-time group 8 9: Run-time group 9 9999: Do not calculate		
<b>p20033</b>	<b>AND 0 run sequence / AND 0 RunSeq</b>		
All objects (FBLOCKS)	<b>Can be changed:</b> T <b>Data type:</b> Unsigned16 <b>P-Group:</b> - <b>Not for motor type:</b> - <b>Min</b> 0	<b>Calculated:</b> - <b>Dynamic index:</b> - <b>Units group:</b> - <b>Scaling:</b> - <b>Max</b> 32000	<b>Access level:</b> 1 <b>Func. diagram:</b> 7210 <b>Unit selection:</b> - <b>Expert list:</b> 1 <b>Factory setting</b> 10
<b>Description:</b>	Setting parameter for the run sequence of instance AND 0 within the run-time group set in p20032.		
<b>Note:</b>	The function blocks with a lower run sequence value are calculated before function blocks with a higher run sequence value.		
<b>p20034[0...3]</b>	<b>BI: AND 1 inputs / AND 1 inputs</b>		
All objects (FBLOCKS)	<b>Can be changed:</b> T <b>Data type:</b> Unsigned32 / Binary <b>P-Group:</b> - <b>Not for motor type:</b> - <b>Min</b> -	<b>Calculated:</b> - <b>Dynamic index:</b> - <b>Units group:</b> - <b>Scaling:</b> - <b>Max</b> -	<b>Access level:</b> 1 <b>Func. diagram:</b> 7210 <b>Unit selection:</b> - <b>Expert list:</b> 1 <b>Factory setting</b> 0
<b>Description:</b>	Sets the signal source of input quantities I0, I1, I2, I3 of instance AND 1 of the AND function block.		
<b>Index:</b>	[0] = Input I0 [1] = Input I1 [2] = Input I2 [3] = Input I3		

---

<b>r20035</b>	<b>BO: AND 1 output Q / AND 1 output Q</b>		
All objects (FBLOCKS)	<b>Can be changed:</b> -	<b>Calculated:</b> -	<b>Access level:</b> 1
	<b>Data type:</b> Unsigned32	<b>Dynamic index:</b> -	<b>Func. diagram:</b> 7210
	<b>P-Group:</b> -	<b>Units group:</b> -	<b>Unit selection:</b> -
	<b>Not for motor type:</b> -	<b>Scaling:</b> -	<b>Expert list:</b> 1
	<b>Min</b>	<b>Max</b>	<b>Factory setting</b>
	-	-	-
<b>Description:</b>	Display parameter for binary quantity Q = I0 & I1 & I2 & I3 of instance AND 1 of the AND function block.		

---

<b>p20036</b>	<b>AND 1 run-time group / AND 1 RTG</b>		
All objects (FBLOCKS)	<b>Can be changed:</b> T	<b>Calculated:</b> -	<b>Access level:</b> 1
	<b>Data type:</b> Integer16	<b>Dynamic index:</b> -	<b>Func. diagram:</b> 7210
	<b>P-Group:</b> -	<b>Units group:</b> -	<b>Unit selection:</b> -
	<b>Not for motor type:</b> -	<b>Scaling:</b> -	<b>Expert list:</b> 1
	<b>Min</b>	<b>Max</b>	<b>Factory setting</b>
	0	9999	9999
<b>Description:</b>	Setting parameter for the run-time group in which the instance AND 1 of the AND function block is to be called.		
<b>Value:</b>	0: Run-time group 0 1: Run-time group 1 2: Run-time group 2 3: Run-time group 3 4: Run-time group 4 5: Run-time group 5 6: Run-time group 6 7: Run-time group 7 8: Run-time group 8 9: Run-time group 9 9999: Do not calculate		

---

<b>p20037</b>	<b>AND 1 run sequence / AND 1 RunSeq</b>		
All objects (FBLOCKS)	<b>Can be changed:</b> T	<b>Calculated:</b> -	<b>Access level:</b> 1
	<b>Data type:</b> Unsigned16	<b>Dynamic index:</b> -	<b>Func. diagram:</b> 7210
	<b>P-Group:</b> -	<b>Units group:</b> -	<b>Unit selection:</b> -
	<b>Not for motor type:</b> -	<b>Scaling:</b> -	<b>Expert list:</b> 1
	<b>Min</b>	<b>Max</b>	<b>Factory setting</b>
	0	32000	20
<b>Description:</b>	Setting parameter for the run sequence of instance AND 1 within the run-time group set in p20036.		
<b>Note:</b>	The function blocks with a lower run sequence value are calculated before function blocks with a higher run sequence value.		

---

<b>p20038[0...3]</b>	<b>BI: AND 2 inputs / AND 2 inputs</b>		
All objects (FBLOCKS)	<b>Can be changed:</b> T	<b>Calculated:</b> -	<b>Access level:</b> 1
	<b>Data type:</b> Unsigned32 / Binary	<b>Dynamic index:</b> -	<b>Func. diagram:</b> 7210
	<b>P-Group:</b> -	<b>Units group:</b> -	<b>Unit selection:</b> -
	<b>Not for motor type:</b> -	<b>Scaling:</b> -	<b>Expert list:</b> 1
	<b>Min</b>	<b>Max</b>	<b>Factory setting</b>
	-	-	0
<b>Description:</b>	Sets the signal source of input quantities I0, I1, I2, I3 of instance AND 2 of the AND function block.		
<b>Index:</b>	[0] = Input I0 [1] = Input I1 [2] = Input I2 [3] = Input I3		

<b>r20039</b>	<b>BO: AND 2 output Q / AND 2 output Q</b>		
All objects (FBLOCKS)	<b>Can be changed:</b> - <b>Data type:</b> Unsigned32 <b>P-Group:</b> - <b>Not for motor type:</b> - <b>Min</b> -	<b>Calculated:</b> - <b>Dynamic index:</b> - <b>Units group:</b> - <b>Scaling:</b> - <b>Max</b> -	<b>Access level:</b> 1 <b>Func. diagram:</b> 7210 <b>Unit selection:</b> - <b>Expert list:</b> 1 <b>Factory setting</b> -
<b>Description:</b>	Display parameter for binary quantity Q = I0 & I1 & I2 & I3 of instance AND 2 of the AND function block.		
<b>p20040</b>	<b>AND 2 run-time group / AND 2 RTG</b>		
All objects (FBLOCKS)	<b>Can be changed:</b> T <b>Data type:</b> Integer16 <b>P-Group:</b> - <b>Not for motor type:</b> - <b>Min</b> 0	<b>Calculated:</b> - <b>Dynamic index:</b> - <b>Units group:</b> - <b>Scaling:</b> - <b>Max</b> 9999	<b>Access level:</b> 1 <b>Func. diagram:</b> 7210 <b>Unit selection:</b> - <b>Expert list:</b> 1 <b>Factory setting</b> 9999
<b>Description:</b>	Setting parameter for the run-time group in which the instance AND 2 of the AND function block is to be called.		
<b>Value:</b>	0: Run-time group 0 1: Run-time group 1 2: Run-time group 2 3: Run-time group 3 4: Run-time group 4 5: Run-time group 5 6: Run-time group 6 7: Run-time group 7 8: Run-time group 8 9: Run-time group 9 9999: Do not calculate		
<b>p20041</b>	<b>AND 2 run sequence / AND 2 RunSeq</b>		
All objects (FBLOCKS)	<b>Can be changed:</b> T <b>Data type:</b> Unsigned16 <b>P-Group:</b> - <b>Not for motor type:</b> - <b>Min</b> 0	<b>Calculated:</b> - <b>Dynamic index:</b> - <b>Units group:</b> - <b>Scaling:</b> - <b>Max</b> 32000	<b>Access level:</b> 1 <b>Func. diagram:</b> 7210 <b>Unit selection:</b> - <b>Expert list:</b> 1 <b>Factory setting</b> 30
<b>Description:</b>	Setting parameter for the run sequence of instance AND 2 within the run-time group set in p20040.		
<b>Note:</b>	The function blocks with a lower run sequence value are calculated before function blocks with a higher run sequence value.		
<b>p20042[0...3]</b>	<b>BI: AND 3 inputs / AND 3 inputs</b>		
All objects (FBLOCKS)	<b>Can be changed:</b> T <b>Data type:</b> Unsigned32 / Binary <b>P-Group:</b> - <b>Not for motor type:</b> - <b>Min</b> -	<b>Calculated:</b> - <b>Dynamic index:</b> - <b>Units group:</b> - <b>Scaling:</b> - <b>Max</b> -	<b>Access level:</b> 1 <b>Func. diagram:</b> 7210 <b>Unit selection:</b> - <b>Expert list:</b> 1 <b>Factory setting</b> 0
<b>Description:</b>	Sets the signal source of input quantities I0, I1, I2, I3 of instance AND 3 of the AND function block.		
<b>Index:</b>	[0] = Input I0 [1] = Input I1 [2] = Input I2 [3] = Input I3		



---

<b>r20043</b>	<b>BO: AND 3 output Q / AND 3 output Q</b>		
All objects (FBLOCKS)	<b>Can be changed:</b> -	<b>Calculated:</b> -	<b>Access level:</b> 1
	<b>Data type:</b> Unsigned32	<b>Dynamic index:</b> -	<b>Func. diagram:</b> 7210
	<b>P-Group:</b> -	<b>Units group:</b> -	<b>Unit selection:</b> -
	<b>Not for motor type:</b> -	<b>Scaling:</b> -	<b>Expert list:</b> 1
	<b>Min</b>	<b>Max</b>	<b>Factory setting</b>
	-	-	-
<b>Description:</b>	Display parameter for binary quantity Q = I0 & I1 & I2 & I3 of instance AND 3 of the AND function block.		

---

<b>p20044</b>	<b>AND 3 run-time group / AND 3 RTG</b>		
All objects (FBLOCKS)	<b>Can be changed:</b> T	<b>Calculated:</b> -	<b>Access level:</b> 1
	<b>Data type:</b> Integer16	<b>Dynamic index:</b> -	<b>Func. diagram:</b> 7210
	<b>P-Group:</b> -	<b>Units group:</b> -	<b>Unit selection:</b> -
	<b>Not for motor type:</b> -	<b>Scaling:</b> -	<b>Expert list:</b> 1
	<b>Min</b>	<b>Max</b>	<b>Factory setting</b>
	0	9999	9999
<b>Description:</b>	Setting parameter for the run-time group in which the instance AND 3 of the AND function block is to be called.		
<b>Value:</b>	0: Run-time group 0 1: Run-time group 1 2: Run-time group 2 3: Run-time group 3 4: Run-time group 4 5: Run-time group 5 6: Run-time group 6 7: Run-time group 7 8: Run-time group 8 9: Run-time group 9 9999: Do not calculate		

---

<b>p20045</b>	<b>AND 3 run sequence / AND 3 RunSeq</b>		
All objects (FBLOCKS)	<b>Can be changed:</b> T	<b>Calculated:</b> -	<b>Access level:</b> 1
	<b>Data type:</b> Unsigned16	<b>Dynamic index:</b> -	<b>Func. diagram:</b> 7210
	<b>P-Group:</b> -	<b>Units group:</b> -	<b>Unit selection:</b> -
	<b>Not for motor type:</b> -	<b>Scaling:</b> -	<b>Expert list:</b> 1
	<b>Min</b>	<b>Max</b>	<b>Factory setting</b>
	0	32000	40
<b>Description:</b>	Setting parameter for the run sequence of instance AND 3 within the run-time group set in p20044.		
<b>Note:</b>	The function blocks with a lower run sequence value are calculated before function blocks with a higher run sequence value.		

---

<b>p20046[0...3]</b>	<b>BI: OR 0 inputs / OR 0 inputs</b>		
All objects (FBLOCKS)	<b>Can be changed:</b> T	<b>Calculated:</b> -	<b>Access level:</b> 1
	<b>Data type:</b> Unsigned32 / Binary	<b>Dynamic index:</b> -	<b>Func. diagram:</b> 7212
	<b>P-Group:</b> -	<b>Units group:</b> -	<b>Unit selection:</b> -
	<b>Not for motor type:</b> -	<b>Scaling:</b> -	<b>Expert list:</b> 1
	<b>Min</b>	<b>Max</b>	<b>Factory setting</b>
	-	-	0
<b>Description:</b>	Sets the signal source of input quantities I0, I1, I2, I3 of instance OR 0 of the OR function block.		
<b>Index:</b>	[0] = Input I0 [1] = Input I1 [2] = Input I2 [3] = Input I3		

<b>r20047</b>	<b>BO: OR 0 output Q / OR 0 output Q</b>		
All objects (FBLOCKS)	<b>Can be changed:</b> - <b>Data type:</b> Unsigned32 <b>P-Group:</b> - <b>Not for motor type:</b> - <b>Min</b> -	<b>Calculated:</b> - <b>Dynamic index:</b> - <b>Units group:</b> - <b>Scaling:</b> - <b>Max</b> -	<b>Access level:</b> 1 <b>Func. diagram:</b> 7212 <b>Unit selection:</b> - <b>Expert list:</b> 1 <b>Factory setting</b> -
<b>Description:</b>	Display parameter for binary quantity Q = I0   I1   I2   I3 of instance OR 0 of the OR function block.		
<b>p20048</b>	<b>OR 0 run-time group / OR 0 RTG</b>		
All objects (FBLOCKS)	<b>Can be changed:</b> T <b>Data type:</b> Integer16 <b>P-Group:</b> - <b>Not for motor type:</b> - <b>Min</b> 0	<b>Calculated:</b> - <b>Dynamic index:</b> - <b>Units group:</b> - <b>Scaling:</b> - <b>Max</b> 9999	<b>Access level:</b> 1 <b>Func. diagram:</b> 7212 <b>Unit selection:</b> - <b>Expert list:</b> 1 <b>Factory setting</b> 9999
<b>Description:</b>	Setting parameter for the run-time group in which the instance OR 0 of the OR function block is to be called.		
<b>Value:</b>	0: Run-time group 0 1: Run-time group 1 2: Run-time group 2 3: Run-time group 3 4: Run-time group 4 5: Run-time group 5 6: Run-time group 6 7: Run-time group 7 8: Run-time group 8 9: Run-time group 9 9999: Do not calculate		
<b>p20049</b>	<b>OR 0 run sequence / OR 0 RunSeq</b>		
All objects (FBLOCKS)	<b>Can be changed:</b> T <b>Data type:</b> Unsigned16 <b>P-Group:</b> - <b>Not for motor type:</b> - <b>Min</b> 0	<b>Calculated:</b> - <b>Dynamic index:</b> - <b>Units group:</b> - <b>Scaling:</b> - <b>Max</b> 32000	<b>Access level:</b> 1 <b>Func. diagram:</b> 7212 <b>Unit selection:</b> - <b>Expert list:</b> 1 <b>Factory setting</b> 60
<b>Description:</b>	Setting parameter for the run sequence of instance OR 0 within the run-time group set in p20048.		
<b>Note:</b>	The function blocks with a lower run sequence value are calculated before function blocks with a higher run sequence value.		
<b>p20050[0...3]</b>	<b>BI: OR 1 inputs / OR 1 inputs</b>		
All objects (FBLOCKS)	<b>Can be changed:</b> T <b>Data type:</b> Unsigned32 / Binary <b>P-Group:</b> - <b>Not for motor type:</b> - <b>Min</b> -	<b>Calculated:</b> - <b>Dynamic index:</b> - <b>Units group:</b> - <b>Scaling:</b> - <b>Max</b> -	<b>Access level:</b> 1 <b>Func. diagram:</b> 7212 <b>Unit selection:</b> - <b>Expert list:</b> 1 <b>Factory setting</b> 0
<b>Description:</b>	Sets the signal source of input quantities I0, I1, I2, I3 of instance OR 1 of the OR function block.		
<b>Index:</b>	[0] = Input I0 [1] = Input I1 [2] = Input I2 [3] = Input I3		

<b>r20051</b>	<b>BO: OR 1 output Q / OR 1 output Q</b>		
All objects (FBLOCKS)	<b>Can be changed:</b> - <b>Data type:</b> Unsigned32 <b>P-Group:</b> - <b>Not for motor type:</b> - <b>Min</b> -	<b>Calculated:</b> - <b>Dynamic index:</b> - <b>Units group:</b> - <b>Scaling:</b> - <b>Max</b> -	<b>Access level:</b> 1 <b>Func. diagram:</b> 7212 <b>Unit selection:</b> - <b>Expert list:</b> 1 <b>Factory setting</b> -
<b>Description:</b>	Display parameter for binary quantity Q = I0   I1   I2   I3 of instance OR 1 of the OR function block.		
<b>p20052</b>	<b>OR 1 run-time group / OR 1 RTG</b>		
All objects (FBLOCKS)	<b>Can be changed:</b> T <b>Data type:</b> Integer16 <b>P-Group:</b> - <b>Not for motor type:</b> - <b>Min</b> 0	<b>Calculated:</b> - <b>Dynamic index:</b> - <b>Units group:</b> - <b>Scaling:</b> - <b>Max</b> 9999	<b>Access level:</b> 1 <b>Func. diagram:</b> 7212 <b>Unit selection:</b> - <b>Expert list:</b> 1 <b>Factory setting</b> 9999
<b>Description:</b>	Setting parameter for the run-time group in which the instance OR 1 of the OR function block is to be called.		
<b>Value:</b>	0: Run-time group 0 1: Run-time group 1 2: Run-time group 2 3: Run-time group 3 4: Run-time group 4 5: Run-time group 5 6: Run-time group 6 7: Run-time group 7 8: Run-time group 8 9: Run-time group 9 9999: Do not calculate		
<b>p20053</b>	<b>OR 1 run sequence / OR 1 RunSeq</b>		
All objects (FBLOCKS)	<b>Can be changed:</b> T <b>Data type:</b> Unsigned16 <b>P-Group:</b> - <b>Not for motor type:</b> - <b>Min</b> 0	<b>Calculated:</b> - <b>Dynamic index:</b> - <b>Units group:</b> - <b>Scaling:</b> - <b>Max</b> 32000	<b>Access level:</b> 1 <b>Func. diagram:</b> 7212 <b>Unit selection:</b> - <b>Expert list:</b> 1 <b>Factory setting</b> 70
<b>Description:</b>	Setting parameter for the run sequence of instance OR 1 within the run-time group set in p20052.		
<b>Note:</b>	The function blocks with a lower run sequence value are calculated before function blocks with a higher run sequence value.		
<b>p20054[0...3]</b>	<b>BI: OR 2 inputs / OR 2 inputs</b>		
All objects (FBLOCKS)	<b>Can be changed:</b> T <b>Data type:</b> Unsigned32 / Binary <b>P-Group:</b> - <b>Not for motor type:</b> - <b>Min</b> -	<b>Calculated:</b> - <b>Dynamic index:</b> - <b>Units group:</b> - <b>Scaling:</b> - <b>Max</b> -	<b>Access level:</b> 1 <b>Func. diagram:</b> 7212 <b>Unit selection:</b> - <b>Expert list:</b> 1 <b>Factory setting</b> 0
<b>Description:</b>	Sets the signal source of input quantities I0, I1, I2, I3 of instance OR 2 of the OR function block.		
<b>Index:</b>	[0] = Input I0 [1] = Input I1 [2] = Input I2 [3] = Input I3		

<b>r20055</b>	<b>BO: OR 2 output Q / OR 2 output Q</b>		
All objects (FBLOCKS)	<b>Can be changed:</b> - <b>Data type:</b> Unsigned32 <b>P-Group:</b> - <b>Not for motor type:</b> - <b>Min</b> -	<b>Calculated:</b> - <b>Dynamic index:</b> - <b>Units group:</b> - <b>Scaling:</b> - <b>Max</b> -	<b>Access level:</b> 1 <b>Func. diagram:</b> 7212 <b>Unit selection:</b> - <b>Expert list:</b> 1 <b>Factory setting</b> -
<b>Description:</b>	Display parameter for binary quantity Q = I0   I1   I2   I3 of instance OR 2 of the OR function block.		
<b>p20056</b>	<b>OR 2 run-time group / OR 2 RTG</b>		
All objects (FBLOCKS)	<b>Can be changed:</b> T <b>Data type:</b> Integer16 <b>P-Group:</b> - <b>Not for motor type:</b> - <b>Min</b> 0	<b>Calculated:</b> - <b>Dynamic index:</b> - <b>Units group:</b> - <b>Scaling:</b> - <b>Max</b> 9999	<b>Access level:</b> 1 <b>Func. diagram:</b> 7212 <b>Unit selection:</b> - <b>Expert list:</b> 1 <b>Factory setting</b> 9999
<b>Description:</b>	Setting parameter for the run-time group in which the instance OR 2 of the OR function block is to be called.		
<b>Value:</b>	0: Run-time group 0 1: Run-time group 1 2: Run-time group 2 3: Run-time group 3 4: Run-time group 4 5: Run-time group 5 6: Run-time group 6 7: Run-time group 7 8: Run-time group 8 9: Run-time group 9 9999: Do not calculate		
<b>p20057</b>	<b>OR 2 run sequence / OR 2 RunSeq</b>		
All objects (FBLOCKS)	<b>Can be changed:</b> T <b>Data type:</b> Unsigned16 <b>P-Group:</b> - <b>Not for motor type:</b> - <b>Min</b> 0	<b>Calculated:</b> - <b>Dynamic index:</b> - <b>Units group:</b> - <b>Scaling:</b> - <b>Max</b> 32000	<b>Access level:</b> 1 <b>Func. diagram:</b> 7212 <b>Unit selection:</b> - <b>Expert list:</b> 1 <b>Factory setting</b> 80
<b>Description:</b>	Setting parameter for the run sequence of instance OR 2 within the run-time group set in p20056.		
<b>Note:</b>	The function blocks with a lower run sequence value are calculated before function blocks with a higher run sequence value.		
<b>p20058[0...3]</b>	<b>BI: OR 3 inputs / OR 3 inputs</b>		
All objects (FBLOCKS)	<b>Can be changed:</b> T <b>Data type:</b> Unsigned32 / Binary <b>P-Group:</b> - <b>Not for motor type:</b> - <b>Min</b> -	<b>Calculated:</b> - <b>Dynamic index:</b> - <b>Units group:</b> - <b>Scaling:</b> - <b>Max</b> -	<b>Access level:</b> 1 <b>Func. diagram:</b> 7212 <b>Unit selection:</b> - <b>Expert list:</b> 1 <b>Factory setting</b> 0
<b>Description:</b>	Sets the signal source of input quantities I0, I1, I2, I3 of instance OR 3 of the OR function block.		
<b>Index:</b>	[0] = Input I0 [1] = Input I1 [2] = Input I2 [3] = Input I3		

<b>r20059</b>	<b>BO: OR 3 output Q / OR 3 output Q</b>		
All objects (FBLOCKS)	<b>Can be changed:</b> - <b>Data type:</b> Unsigned32 <b>P-Group:</b> - <b>Not for motor type:</b> - <b>Min</b> -	<b>Calculated:</b> - <b>Dynamic index:</b> - <b>Units group:</b> - <b>Scaling:</b> - <b>Max</b> -	<b>Access level:</b> 1 <b>Func. diagram:</b> 7212 <b>Unit selection:</b> - <b>Expert list:</b> 1 <b>Factory setting</b> -
<b>Description:</b>	Display parameter for binary quantity Q = I0   I1   I2   I3 of instance OR 3 of the OR function block.		
<b>p20060</b>	<b>OR 3 run-time group / OR 3 RTG</b>		
All objects (FBLOCKS)	<b>Can be changed:</b> T <b>Data type:</b> Integer16 <b>P-Group:</b> - <b>Not for motor type:</b> - <b>Min</b> 0	<b>Calculated:</b> - <b>Dynamic index:</b> - <b>Units group:</b> - <b>Scaling:</b> - <b>Max</b> 9999	<b>Access level:</b> 1 <b>Func. diagram:</b> 7212 <b>Unit selection:</b> - <b>Expert list:</b> 1 <b>Factory setting</b> 9999
<b>Description:</b>	Setting parameter for the run-time group in which the instance OR 3 of the OR function block is to be called.		
<b>Value:</b>	0: Run-time group 0 1: Run-time group 1 2: Run-time group 2 3: Run-time group 3 4: Run-time group 4 5: Run-time group 5 6: Run-time group 6 7: Run-time group 7 8: Run-time group 8 9: Run-time group 9 9999: Do not calculate		
<b>p20061</b>	<b>OR 3 run sequence / OR 3 RunSeq</b>		
All objects (FBLOCKS)	<b>Can be changed:</b> T <b>Data type:</b> Unsigned16 <b>P-Group:</b> - <b>Not for motor type:</b> - <b>Min</b> 0	<b>Calculated:</b> - <b>Dynamic index:</b> - <b>Units group:</b> - <b>Scaling:</b> - <b>Max</b> 32000	<b>Access level:</b> 1 <b>Func. diagram:</b> 7212 <b>Unit selection:</b> - <b>Expert list:</b> 1 <b>Factory setting</b> 90
<b>Description:</b>	Setting parameter for the run sequence of instance OR 3 within the run-time group set in p20060.		
<b>Note:</b>	The function blocks with a lower run sequence value are calculated before function blocks with a higher run sequence value.		
<b>p20062[0...3]</b>	<b>BI: XOR 0 inputs / XOR 0 inputs</b>		
All objects (FBLOCKS)	<b>Can be changed:</b> T <b>Data type:</b> Unsigned32 / Binary <b>P-Group:</b> - <b>Not for motor type:</b> - <b>Min</b> -	<b>Calculated:</b> - <b>Dynamic index:</b> - <b>Units group:</b> - <b>Scaling:</b> - <b>Max</b> -	<b>Access level:</b> 1 <b>Func. diagram:</b> 7214 <b>Unit selection:</b> - <b>Expert list:</b> 1 <b>Factory setting</b> 0
<b>Description:</b>	Sets the signal source of input quantities I0, I1, I2, I3 of instance XOR 0 of the XOR function block.		
<b>Index:</b>	[0] = Input I0 [1] = Input I1 [2] = Input I2 [3] = Input I3		

<b>r20063</b>	<b>BO: XOR 0 output Q / XOR 0 output Q</b>		
All objects (FBLOCKS)	<b>Can be changed:</b> -	<b>Calculated:</b> -	<b>Access level:</b> 1
	<b>Data type:</b> Unsigned32	<b>Dynamic index:</b> -	<b>Func. diagram:</b> 7214
	<b>P-Group:</b> -	<b>Units group:</b> -	<b>Unit selection:</b> -
	<b>Not for motor type:</b> -	<b>Scaling:</b> -	<b>Expert list:</b> 1
	<b>Min</b>	<b>Max</b>	<b>Factory setting</b>
	-	-	-
<b>Description:</b>	Display parameter for binary quantity Q of instance XOR 0 of the XOR function block.		
<b>p20064</b>	<b>XOR 0 run-time group / XOR 0 RTG</b>		
All objects (FBLOCKS)	<b>Can be changed:</b> T	<b>Calculated:</b> -	<b>Access level:</b> 1
	<b>Data type:</b> Integer16	<b>Dynamic index:</b> -	<b>Func. diagram:</b> 7214
	<b>P-Group:</b> -	<b>Units group:</b> -	<b>Unit selection:</b> -
	<b>Not for motor type:</b> -	<b>Scaling:</b> -	<b>Expert list:</b> 1
	<b>Min</b>	<b>Max</b>	<b>Factory setting</b>
	0	9999	9999
<b>Description:</b>	Setting parameter for the run-time group in which the instance XOR 0 of the XOR function block is to be called.		
<b>Value:</b>	0: Run-time group 0 1: Run-time group 1 2: Run-time group 2 3: Run-time group 3 4: Run-time group 4 5: Run-time group 5 6: Run-time group 6 7: Run-time group 7 8: Run-time group 8 9: Run-time group 9 9999: Do not calculate		
<b>p20065</b>	<b>XOR 0 run sequence / XOR 0 RunSeq</b>		
All objects (FBLOCKS)	<b>Can be changed:</b> T	<b>Calculated:</b> -	<b>Access level:</b> 1
	<b>Data type:</b> Unsigned16	<b>Dynamic index:</b> -	<b>Func. diagram:</b> 7214
	<b>P-Group:</b> -	<b>Units group:</b> -	<b>Unit selection:</b> -
	<b>Not for motor type:</b> -	<b>Scaling:</b> -	<b>Expert list:</b> 1
	<b>Min</b>	<b>Max</b>	<b>Factory setting</b>
	0	32000	110
<b>Description:</b>	Setting parameter for the run sequence of instance XOR 0 within the run-time group set in p20064.		
<b>Note:</b>	The function blocks with a lower run sequence value are calculated before function blocks with a higher run sequence value.		
<b>p20066[0...3]</b>	<b>BI: XOR 1 inputs / XOR 1 inputs</b>		
All objects (FBLOCKS)	<b>Can be changed:</b> T	<b>Calculated:</b> -	<b>Access level:</b> 1
	<b>Data type:</b> Unsigned32 / Binary	<b>Dynamic index:</b> -	<b>Func. diagram:</b> 7214
	<b>P-Group:</b> -	<b>Units group:</b> -	<b>Unit selection:</b> -
	<b>Not for motor type:</b> -	<b>Scaling:</b> -	<b>Expert list:</b> 1
	<b>Min</b>	<b>Max</b>	<b>Factory setting</b>
	-	-	0
<b>Description:</b>	Sets the signal source of input quantities I0, I1, I2, I3 of instance XOR 1 of the XOR function block.		
<b>Index:</b>	[0] = Input I0 [1] = Input I1 [2] = Input I2 [3] = Input I3		

<b>r20067</b>	<b>BO: XOR 1 output Q / XOR 1 output Q</b>		
All objects (FBLOCKS)	<b>Can be changed:</b> - <b>Data type:</b> Unsigned32 <b>P-Group:</b> - <b>Not for motor type:</b> - <b>Min</b> -	<b>Calculated:</b> - <b>Dynamic index:</b> - <b>Units group:</b> - <b>Scaling:</b> - <b>Max</b> -	<b>Access level:</b> 1 <b>Func. diagram:</b> 7214 <b>Unit selection:</b> - <b>Expert list:</b> 1 <b>Factory setting</b> -
<b>Description:</b>	Display parameter for binary quantity Q of instance XOR 1 of the XOR function block.		
<b>p20068</b>	<b>XOR 1 run-time group / XOR 1 RTG</b>		
All objects (FBLOCKS)	<b>Can be changed:</b> T <b>Data type:</b> Integer16 <b>P-Group:</b> - <b>Not for motor type:</b> - <b>Min</b> 0	<b>Calculated:</b> - <b>Dynamic index:</b> - <b>Units group:</b> - <b>Scaling:</b> - <b>Max</b> 9999	<b>Access level:</b> 1 <b>Func. diagram:</b> 7214 <b>Unit selection:</b> - <b>Expert list:</b> 1 <b>Factory setting</b> 9999
<b>Description:</b>	Setting parameter for the run-time group in which the instance XOR 1 of the XOR function block is to be called.		
<b>Value:</b>	0: Run-time group 0 1: Run-time group 1 2: Run-time group 2 3: Run-time group 3 4: Run-time group 4 5: Run-time group 5 6: Run-time group 6 7: Run-time group 7 8: Run-time group 8 9: Run-time group 9 9999: Do not calculate		
<b>p20069</b>	<b>XOR 1 run sequence / XOR 1 RunSeq</b>		
All objects (FBLOCKS)	<b>Can be changed:</b> T <b>Data type:</b> Unsigned16 <b>P-Group:</b> - <b>Not for motor type:</b> - <b>Min</b> 0	<b>Calculated:</b> - <b>Dynamic index:</b> - <b>Units group:</b> - <b>Scaling:</b> - <b>Max</b> 32000	<b>Access level:</b> 1 <b>Func. diagram:</b> 7214 <b>Unit selection:</b> - <b>Expert list:</b> 1 <b>Factory setting</b> 120
<b>Description:</b>	Setting parameter for the run sequence of instance XOR 1 within the run-time group set in p20068.		
<b>Note:</b>	The function blocks with a lower run sequence value are calculated before function blocks with a higher run sequence value.		
<b>p20070[0...3]</b>	<b>BI: XOR 2 inputs / XOR 2 inputs</b>		
All objects (FBLOCKS)	<b>Can be changed:</b> T <b>Data type:</b> Unsigned32 / Binary <b>P-Group:</b> - <b>Not for motor type:</b> - <b>Min</b> -	<b>Calculated:</b> - <b>Dynamic index:</b> - <b>Units group:</b> - <b>Scaling:</b> - <b>Max</b> -	<b>Access level:</b> 1 <b>Func. diagram:</b> 7214 <b>Unit selection:</b> - <b>Expert list:</b> 1 <b>Factory setting</b> 0
<b>Description:</b>	Sets the signal source of input quantities I0, I1, I2, I3 of instance XOR 2 of the XOR function block.		
<b>Index:</b>	[0] = Input I0 [1] = Input I1 [2] = Input I2 [3] = Input I3		

<b>r20071</b>	<b>BO: XOR 2 output Q / XOR 2 output Q</b>		
All objects (FBLOCKS)	<b>Can be changed:</b> -	<b>Calculated:</b> -	<b>Access level:</b> 1
	<b>Data type:</b> Unsigned32	<b>Dynamic index:</b> -	<b>Func. diagram:</b> 7214
	<b>P-Group:</b> -	<b>Units group:</b> -	<b>Unit selection:</b> -
	<b>Not for motor type:</b> -	<b>Scaling:</b> -	<b>Expert list:</b> 1
	<b>Min</b>	<b>Max</b>	<b>Factory setting</b>
	-	-	-
<b>Description:</b>	Display parameter for binary quantity Q of instance XOR 2 of the XOR function block.		
<b>p20072</b>	<b>XOR 2 run-time group / XOR 2 RTG</b>		
All objects (FBLOCKS)	<b>Can be changed:</b> T	<b>Calculated:</b> -	<b>Access level:</b> 1
	<b>Data type:</b> Integer16	<b>Dynamic index:</b> -	<b>Func. diagram:</b> 7214
	<b>P-Group:</b> -	<b>Units group:</b> -	<b>Unit selection:</b> -
	<b>Not for motor type:</b> -	<b>Scaling:</b> -	<b>Expert list:</b> 1
	<b>Min</b>	<b>Max</b>	<b>Factory setting</b>
	0	9999	9999
<b>Description:</b>	Setting parameter for the run-time group in which the instance XOR 2 of the XOR function block is to be called.		
<b>Value:</b>	0: Run-time group 0 1: Run-time group 1 2: Run-time group 2 3: Run-time group 3 4: Run-time group 4 5: Run-time group 5 6: Run-time group 6 7: Run-time group 7 8: Run-time group 8 9: Run-time group 9 9999: Do not calculate		
<b>p20073</b>	<b>XOR 2 run sequence / XOR 2 RunSeq</b>		
All objects (FBLOCKS)	<b>Can be changed:</b> T	<b>Calculated:</b> -	<b>Access level:</b> 1
	<b>Data type:</b> Unsigned16	<b>Dynamic index:</b> -	<b>Func. diagram:</b> 7214
	<b>P-Group:</b> -	<b>Units group:</b> -	<b>Unit selection:</b> -
	<b>Not for motor type:</b> -	<b>Scaling:</b> -	<b>Expert list:</b> 1
	<b>Min</b>	<b>Max</b>	<b>Factory setting</b>
	0	32000	130
<b>Description:</b>	Setting parameter for the run sequence of instance XOR 2 within the run-time group set in p20072.		
<b>Note:</b>	The function blocks with a lower run sequence value are calculated before function blocks with a higher run sequence value.		
<b>p20074[0...3]</b>	<b>BI: XOR 3 inputs / XOR 3 inputs</b>		
All objects (FBLOCKS)	<b>Can be changed:</b> T	<b>Calculated:</b> -	<b>Access level:</b> 1
	<b>Data type:</b> Unsigned32 / Binary	<b>Dynamic index:</b> -	<b>Func. diagram:</b> 7214
	<b>P-Group:</b> -	<b>Units group:</b> -	<b>Unit selection:</b> -
	<b>Not for motor type:</b> -	<b>Scaling:</b> -	<b>Expert list:</b> 1
	<b>Min</b>	<b>Max</b>	<b>Factory setting</b>
	-	-	0
<b>Description:</b>	Sets the signal source of input quantities I0, I1, I2, I3 of instance XOR 3 of the XOR function block.		
<b>Index:</b>	[0] = Input I0 [1] = Input I1 [2] = Input I2 [3] = Input I3		



<b>r20075</b>	<b>BO: XOR 3 output Q / XOR 3 output Q</b>		
All objects (FBLOCKS)	<b>Can be changed:</b> - <b>Data type:</b> Unsigned32 <b>P-Group:</b> - <b>Not for motor type:</b> - <b>Min</b> -	<b>Calculated:</b> - <b>Dynamic index:</b> - <b>Units group:</b> - <b>Scaling:</b> - <b>Max</b> -	<b>Access level:</b> 1 <b>Func. diagram:</b> 7214 <b>Unit selection:</b> - <b>Expert list:</b> 1 <b>Factory setting</b> -
<b>Description:</b>	Display parameter for binary quantity Q of instance XOR 3 of the XOR function block.		
<b>p20076</b>	<b>XOR 3 run-time group / XOR 3 RTG</b>		
All objects (FBLOCKS)	<b>Can be changed:</b> T <b>Data type:</b> Integer16 <b>P-Group:</b> - <b>Not for motor type:</b> - <b>Min</b> 0	<b>Calculated:</b> - <b>Dynamic index:</b> - <b>Units group:</b> - <b>Scaling:</b> - <b>Max</b> 9999	<b>Access level:</b> 1 <b>Func. diagram:</b> 7214 <b>Unit selection:</b> - <b>Expert list:</b> 1 <b>Factory setting</b> 9999
<b>Description:</b>	Setting parameter for the run-time group in which the instance XOR 3 of the XOR function block is to be called.		
<b>Value:</b>	0: Run-time group 0 1: Run-time group 1 2: Run-time group 2 3: Run-time group 3 4: Run-time group 4 5: Run-time group 5 6: Run-time group 6 7: Run-time group 7 8: Run-time group 8 9: Run-time group 9 9999: Do not calculate		
<b>p20077</b>	<b>XOR 3 run sequence / XOR 3 RunSeq</b>		
All objects (FBLOCKS)	<b>Can be changed:</b> T <b>Data type:</b> Unsigned16 <b>P-Group:</b> - <b>Not for motor type:</b> - <b>Min</b> 0	<b>Calculated:</b> - <b>Dynamic index:</b> - <b>Units group:</b> - <b>Scaling:</b> - <b>Max</b> 32000	<b>Access level:</b> 1 <b>Func. diagram:</b> 7214 <b>Unit selection:</b> - <b>Expert list:</b> 1 <b>Factory setting</b> 140
<b>Description:</b>	Setting parameter for the run sequence of instance XOR 3 within the run-time group set in p20076.		
<b>Note:</b>	The function blocks with a lower run sequence value are calculated before function blocks with a higher run sequence value.		
<b>p20078</b>	<b>BI: NOT 0 input I / NOT 0 input I</b>		
All objects (FBLOCKS)	<b>Can be changed:</b> T <b>Data type:</b> Unsigned32 / Binary <b>P-Group:</b> - <b>Not for motor type:</b> - <b>Min</b> -	<b>Calculated:</b> - <b>Dynamic index:</b> - <b>Units group:</b> - <b>Scaling:</b> - <b>Max</b> -	<b>Access level:</b> 1 <b>Func. diagram:</b> 7216 <b>Unit selection:</b> - <b>Expert list:</b> 1 <b>Factory setting</b> 0
<b>Description:</b>	Sets the signal source of input quantity I of instance NOT 0 of the inverter.		

<b>r20079</b>	<b>BO: NOT 0 inverted output / NOT 0 inv output</b>		
All objects (FBLOCKS)	<b>Can be changed:</b> - <b>Data type:</b> Unsigned32 <b>P-Group:</b> - <b>Not for motor type:</b> - <b>Min</b> -	<b>Calculated:</b> - <b>Dynamic index:</b> - <b>Units group:</b> - <b>Scaling:</b> - <b>Max</b> -	<b>Access level:</b> 1 <b>Func. diagram:</b> 7216 <b>Unit selection:</b> - <b>Expert list:</b> 1 <b>Factory setting</b> -
<b>Description:</b>	Display parameter for the inverted output of instance NOT 0 of the inverter.		
<b>p20080</b>	<b>NOT 0 run-time group / NOT 0 RTG</b>		
All objects (FBLOCKS)	<b>Can be changed:</b> T <b>Data type:</b> Integer16 <b>P-Group:</b> - <b>Not for motor type:</b> - <b>Min</b> 0	<b>Calculated:</b> - <b>Dynamic index:</b> - <b>Units group:</b> - <b>Scaling:</b> - <b>Max</b> 9999	<b>Access level:</b> 1 <b>Func. diagram:</b> 7216 <b>Unit selection:</b> - <b>Expert list:</b> 1 <b>Factory setting</b> 9999
<b>Description:</b>	Setting parameter for the run-time group in which the instance NOT 0 of the inverter is to be called.		
<b>Value:</b>	0: Run-time group 0 1: Run-time group 1 2: Run-time group 2 3: Run-time group 3 4: Run-time group 4 5: Run-time group 5 6: Run-time group 6 7: Run-time group 7 8: Run-time group 8 9: Run-time group 9 9999: Do not calculate		
<b>p20081</b>	<b>NOT 0 run sequence / NOT 0 RunSeq</b>		
All objects (FBLOCKS)	<b>Can be changed:</b> T <b>Data type:</b> Unsigned16 <b>P-Group:</b> - <b>Not for motor type:</b> - <b>Min</b> 0	<b>Calculated:</b> - <b>Dynamic index:</b> - <b>Units group:</b> - <b>Scaling:</b> - <b>Max</b> 32000	<b>Access level:</b> 1 <b>Func. diagram:</b> 7216 <b>Unit selection:</b> - <b>Expert list:</b> 1 <b>Factory setting</b> 160
<b>Description:</b>	Setting parameter for the run sequence of instance NOT 0 within the run-time group set in p20080.		
<b>Note:</b>	The function blocks with a lower run sequence value are calculated before function blocks with a higher run sequence value.		
<b>p20082</b>	<b>BI: NOT 1 input I / NOT 1 input I</b>		
All objects (FBLOCKS)	<b>Can be changed:</b> T <b>Data type:</b> Unsigned32 / Binary <b>P-Group:</b> - <b>Not for motor type:</b> - <b>Min</b> -	<b>Calculated:</b> - <b>Dynamic index:</b> - <b>Units group:</b> - <b>Scaling:</b> - <b>Max</b> -	<b>Access level:</b> 1 <b>Func. diagram:</b> 7216 <b>Unit selection:</b> - <b>Expert list:</b> 1 <b>Factory setting</b> 0
<b>Description:</b>	Sets the signal source of input quantity I of instance NOT 1 of the inverter.		

<b>r20083</b>	<b>BO: NOT 1 inverted output / NOT 1 inv output</b>		
All objects (FBLOCKS)	<b>Can be changed:</b> - <b>Data type:</b> Unsigned32 <b>P-Group:</b> - <b>Not for motor type:</b> - <b>Min</b> -	<b>Calculated:</b> - <b>Dynamic index:</b> - <b>Units group:</b> - <b>Scaling:</b> - <b>Max</b> -	<b>Access level:</b> 1 <b>Func. diagram:</b> 7216 <b>Unit selection:</b> - <b>Expert list:</b> 1 <b>Factory setting</b> -
<b>Description:</b>	Display parameter for the inverted output of instance NOT 1 of the inverter.		
<b>p20084</b>	<b>NOT 1 run-time group / NOT 1 RTG</b>		
All objects (FBLOCKS)	<b>Can be changed:</b> T <b>Data type:</b> Integer16 <b>P-Group:</b> - <b>Not for motor type:</b> - <b>Min</b> 0	<b>Calculated:</b> - <b>Dynamic index:</b> - <b>Units group:</b> - <b>Scaling:</b> - <b>Max</b> 9999	<b>Access level:</b> 1 <b>Func. diagram:</b> 7216 <b>Unit selection:</b> - <b>Expert list:</b> 1 <b>Factory setting</b> 9999
<b>Description:</b>	Setting parameter for the run-time group in which the instance NOT 1 of the inverter is to be called.		
<b>Value:</b>	0: Run-time group 0 1: Run-time group 1 2: Run-time group 2 3: Run-time group 3 4: Run-time group 4 5: Run-time group 5 6: Run-time group 6 7: Run-time group 7 8: Run-time group 8 9: Run-time group 9 9999: Do not calculate		
<b>p20085</b>	<b>NOT 1 run sequence / NOT 1 RunSeq</b>		
All objects (FBLOCKS)	<b>Can be changed:</b> T <b>Data type:</b> Unsigned16 <b>P-Group:</b> - <b>Not for motor type:</b> - <b>Min</b> 0	<b>Calculated:</b> - <b>Dynamic index:</b> - <b>Units group:</b> - <b>Scaling:</b> - <b>Max</b> 32000	<b>Access level:</b> 1 <b>Func. diagram:</b> 7216 <b>Unit selection:</b> - <b>Expert list:</b> 1 <b>Factory setting</b> 170
<b>Description:</b>	Setting parameter for the run sequence of instance NOT 1 within the run-time group set in p20084.		
<b>Note:</b>	The function blocks with a lower run sequence value are calculated before function blocks with a higher run sequence value.		
<b>p20086</b>	<b>BI: NOT 2 input I / NOT 2 input I</b>		
All objects (FBLOCKS)	<b>Can be changed:</b> T <b>Data type:</b> Unsigned32 / Binary <b>P-Group:</b> - <b>Not for motor type:</b> - <b>Min</b> -	<b>Calculated:</b> - <b>Dynamic index:</b> - <b>Units group:</b> - <b>Scaling:</b> - <b>Max</b> -	<b>Access level:</b> 1 <b>Func. diagram:</b> 7216 <b>Unit selection:</b> - <b>Expert list:</b> 1 <b>Factory setting</b> 0
<b>Description:</b>	Sets the signal source of input quantity I of instance NOT 2 of the inverter.		

<b>r20087</b>	<b>BO: NOT 2 inverted output / NOT 2 inv output</b>		
All objects (FBLOCKS)	<b>Can be changed:</b> - <b>Data type:</b> Unsigned32 <b>P-Group:</b> - <b>Not for motor type:</b> - <b>Min</b> -	<b>Calculated:</b> - <b>Dynamic index:</b> - <b>Units group:</b> - <b>Scaling:</b> - <b>Max</b> -	<b>Access level:</b> 1 <b>Func. diagram:</b> 7216 <b>Unit selection:</b> - <b>Expert list:</b> 1 <b>Factory setting</b> -
<b>Description:</b>	Display parameter for the inverted output of instance NOT 2 of the inverter.		
<b>p20088</b>	<b>NOT 2 run-time group / NOT 2 RTG</b>		
All objects (FBLOCKS)	<b>Can be changed:</b> T <b>Data type:</b> Integer16 <b>P-Group:</b> - <b>Not for motor type:</b> - <b>Min</b> 0	<b>Calculated:</b> - <b>Dynamic index:</b> - <b>Units group:</b> - <b>Scaling:</b> - <b>Max</b> 9999	<b>Access level:</b> 1 <b>Func. diagram:</b> 7216 <b>Unit selection:</b> - <b>Expert list:</b> 1 <b>Factory setting</b> 9999
<b>Description:</b>	Setting parameter for the run-time group in which the instance NOT 2 of the inverter is to be called.		
<b>Value:</b>	0: Run-time group 0 1: Run-time group 1 2: Run-time group 2 3: Run-time group 3 4: Run-time group 4 5: Run-time group 5 6: Run-time group 6 7: Run-time group 7 8: Run-time group 8 9: Run-time group 9 9999: Do not calculate		
<b>p20089</b>	<b>NOT 2 run sequence / NOT 2 RunSeq</b>		
All objects (FBLOCKS)	<b>Can be changed:</b> T <b>Data type:</b> Unsigned16 <b>P-Group:</b> - <b>Not for motor type:</b> - <b>Min</b> 0	<b>Calculated:</b> - <b>Dynamic index:</b> - <b>Units group:</b> - <b>Scaling:</b> - <b>Max</b> 32000	<b>Access level:</b> 1 <b>Func. diagram:</b> 7216 <b>Unit selection:</b> - <b>Expert list:</b> 1 <b>Factory setting</b> 180
<b>Description:</b>	Setting parameter for the run sequence of instance NOT 2 within the run-time group set in p20088.		
<b>Note:</b>	The function blocks with a lower run sequence value are calculated before function blocks with a higher run sequence value.		
<b>p20090</b>	<b>BI: NOT 3 input I / NOT 3 input I</b>		
All objects (FBLOCKS)	<b>Can be changed:</b> T <b>Data type:</b> Unsigned32 / Binary <b>P-Group:</b> - <b>Not for motor type:</b> - <b>Min</b> -	<b>Calculated:</b> - <b>Dynamic index:</b> - <b>Units group:</b> - <b>Scaling:</b> - <b>Max</b> -	<b>Access level:</b> 1 <b>Func. diagram:</b> 7216 <b>Unit selection:</b> - <b>Expert list:</b> 1 <b>Factory setting</b> 0
<b>Description:</b>	Sets the signal source of input quantity I of instance NOT 3 of the inverter.		

<b>r20091</b>	<b>BO: NOT 3 inverted output / NOT 3 inv output</b>		
All objects (FBLOCKS)	<b>Can be changed:</b> - <b>Data type:</b> Unsigned32 <b>P-Group:</b> - <b>Not for motor type:</b> - <b>Min</b> -	<b>Calculated:</b> - <b>Dynamic index:</b> - <b>Units group:</b> - <b>Scaling:</b> - <b>Max</b> -	<b>Access level:</b> 1 <b>Func. diagram:</b> 7216 <b>Unit selection:</b> - <b>Expert list:</b> 1 <b>Factory setting</b> -
<b>Description:</b>	Display parameter for the inverted output of instance NOT 3 of the inverter.		
<b>p20092</b>	<b>NOT 3 run-time group / NOT 3 RTG</b>		
All objects (FBLOCKS)	<b>Can be changed:</b> T <b>Data type:</b> Integer16 <b>P-Group:</b> - <b>Not for motor type:</b> - <b>Min</b> 0	<b>Calculated:</b> - <b>Dynamic index:</b> - <b>Units group:</b> - <b>Scaling:</b> - <b>Max</b> 9999	<b>Access level:</b> 1 <b>Func. diagram:</b> 7216 <b>Unit selection:</b> - <b>Expert list:</b> 1 <b>Factory setting</b> 9999
<b>Description:</b>	Setting parameter for the run-time group in which the instance NOT 3 of the inverter is to be called.		
<b>Value:</b>	0: Run-time group 0 1: Run-time group 1 2: Run-time group 2 3: Run-time group 3 4: Run-time group 4 5: Run-time group 5 6: Run-time group 6 7: Run-time group 7 8: Run-time group 8 9: Run-time group 9 9999: Do not calculate		
<b>p20093</b>	<b>NOT 3 run sequence / NOT 3 RunSeq</b>		
All objects (FBLOCKS)	<b>Can be changed:</b> T <b>Data type:</b> Unsigned16 <b>P-Group:</b> - <b>Not for motor type:</b> - <b>Min</b> 0	<b>Calculated:</b> - <b>Dynamic index:</b> - <b>Units group:</b> - <b>Scaling:</b> - <b>Max</b> 32000	<b>Access level:</b> 1 <b>Func. diagram:</b> 7216 <b>Unit selection:</b> - <b>Expert list:</b> 1 <b>Factory setting</b> 190
<b>Description:</b>	Setting parameter for the run sequence of instance NOT 3 within the run-time group set in p20092.		
<b>Note:</b>	The function blocks with a lower run sequence value are calculated before function blocks with a higher run sequence value.		
<b>p20094[0...3]</b>	<b>CI: ADD 0 inputs / ADD 0 inputs</b>		
All objects (FBLOCKS)	<b>Can be changed:</b> T <b>Data type:</b> Unsigned32 / FloatingPoint32 <b>P-Group:</b> - <b>Not for motor type:</b> - <b>Min</b> -	<b>Calculated:</b> - <b>Dynamic index:</b> - <b>Units group:</b> - <b>Scaling:</b> PERCENT <b>Max</b> -	<b>Access level:</b> 1 <b>Func. diagram:</b> 7220 <b>Unit selection:</b> - <b>Expert list:</b> 1 <b>Factory setting</b> 0
<b>Description:</b>	Sets the signal source of input quantities X0, X1, X2, X3 of instance ADD 0 of the adder.		
<b>Index:</b>	[0] = Input X0 [1] = Input X1 [2] = Input X2 [3] = Input X3		

<b>r20095</b>	<b>CO: ADD 0 output Y / ADD 0 output Y</b>		
All objects (FBLOCKS)	<b>Can be changed:</b> -	<b>Calculated:</b> -	<b>Access level:</b> 1
	<b>Data type:</b> FloatingPoint32	<b>Dynamic index:</b> -	<b>Func. diagram:</b> 7220
	<b>P-Group:</b> -	<b>Units group:</b> -	<b>Unit selection:</b> -
	<b>Not for motor type:</b> -	<b>Scaling:</b> PERCENT	<b>Expert list:</b> 1
	<b>Min</b>	<b>Max</b>	<b>Factory setting</b>
	-	-	-
<b>Description:</b>	Display parameter for the output quantity $Y = X0 + X1 + X2 + X3$ of instance ADD 0 of the adder.		
<b>p20096</b>	<b>ADD 0 run-time group / ADD 0 RTG</b>		
All objects (FBLOCKS)	<b>Can be changed:</b> T	<b>Calculated:</b> -	<b>Access level:</b> 1
	<b>Data type:</b> Integer16	<b>Dynamic index:</b> -	<b>Func. diagram:</b> 7220
	<b>P-Group:</b> -	<b>Units group:</b> -	<b>Unit selection:</b> -
	<b>Not for motor type:</b> -	<b>Scaling:</b> -	<b>Expert list:</b> 1
	<b>Min</b>	<b>Max</b>	<b>Factory setting</b>
	0	9999	9999
<b>Description:</b>	Setting parameter for the run-time group in which the instance ADD 0 of the adder is to be called.		
<b>Value:</b>	0: Run-time group 0 1: Run-time group 1 2: Run-time group 2 3: Run-time group 3 4: Run-time group 4 5: Run-time group 5 6: Run-time group 6 7: Run-time group 7 8: Run-time group 8 9: Run-time group 9 9999: Do not calculate		
<b>p20097</b>	<b>ADD 0 run sequence / ADD 0 RunSeq</b>		
All objects (FBLOCKS)	<b>Can be changed:</b> T	<b>Calculated:</b> -	<b>Access level:</b> 1
	<b>Data type:</b> Unsigned16	<b>Dynamic index:</b> -	<b>Func. diagram:</b> 7220
	<b>P-Group:</b> -	<b>Units group:</b> -	<b>Unit selection:</b> -
	<b>Not for motor type:</b> -	<b>Scaling:</b> -	<b>Expert list:</b> 1
	<b>Min</b>	<b>Max</b>	<b>Factory setting</b>
	0	32000	210
<b>Description:</b>	Setting parameter for the run sequence of instance ADD 0 within the run-time group set in p20096.		
<b>Note:</b>	The function blocks with a lower run sequence value are calculated before function blocks with a higher run sequence value.		
<b>p20098[0...3]</b>	<b>CI: ADD 1 inputs / ADD 1 inputs</b>		
All objects (FBLOCKS)	<b>Can be changed:</b> T	<b>Calculated:</b> -	<b>Access level:</b> 1
	<b>Data type:</b> Unsigned32 / FloatingPoint32	<b>Dynamic index:</b> -	<b>Func. diagram:</b> 7220
	<b>P-Group:</b> -	<b>Units group:</b> -	<b>Unit selection:</b> -
	<b>Not for motor type:</b> -	<b>Scaling:</b> PERCENT	<b>Expert list:</b> 1
	<b>Min</b>	<b>Max</b>	<b>Factory setting</b>
	-	-	0
<b>Description:</b>	Sets the signal source of input quantities X0, X1, X2, X3 of instance ADD 1 of the adder.		
<b>Index:</b>	[0] = Input X0 [1] = Input X1 [2] = Input X2 [3] = Input X3		

<b>r20099</b>	<b>CO: ADD 1 output Y / ADD 1 output Y</b>		
All objects (FBLOCKS)	<b>Can be changed:</b> - <b>Data type:</b> FloatingPoint32 <b>P-Group:</b> - <b>Not for motor type:</b> - <b>Min</b> -	<b>Calculated:</b> - <b>Dynamic index:</b> - <b>Units group:</b> - <b>Scaling:</b> PERCENT <b>Max</b> -	<b>Access level:</b> 1 <b>Func. diagram:</b> 7220 <b>Unit selection:</b> - <b>Expert list:</b> 1 <b>Factory setting</b> -
<b>Description:</b>	Display parameter for the output quantity $Y = X0 + X1 + X2 + X3$ of instance ADD 1 of the adder.		
<b>p20100</b>	<b>ADD 1 run-time group / ADD 1 RTG</b>		
All objects (FBLOCKS)	<b>Can be changed:</b> T <b>Data type:</b> Integer16 <b>P-Group:</b> - <b>Not for motor type:</b> - <b>Min</b> 0	<b>Calculated:</b> - <b>Dynamic index:</b> - <b>Units group:</b> - <b>Scaling:</b> - <b>Max</b> 9999	<b>Access level:</b> 1 <b>Func. diagram:</b> 7220 <b>Unit selection:</b> - <b>Expert list:</b> 1 <b>Factory setting</b> 9999
<b>Description:</b>	Setting parameter for the run-time group in which the instance ADD 1 of the adder is to be called.		
<b>Value:</b>	0: Run-time group 0 1: Run-time group 1 2: Run-time group 2 3: Run-time group 3 4: Run-time group 4 5: Run-time group 5 6: Run-time group 6 7: Run-time group 7 8: Run-time group 8 9: Run-time group 9 9999: Do not calculate		
<b>p20101</b>	<b>ADD 1 run sequence / ADD 1 RunSeq</b>		
All objects (FBLOCKS)	<b>Can be changed:</b> T <b>Data type:</b> Unsigned16 <b>P-Group:</b> - <b>Not for motor type:</b> - <b>Min</b> 0	<b>Calculated:</b> - <b>Dynamic index:</b> - <b>Units group:</b> - <b>Scaling:</b> - <b>Max</b> 32000	<b>Access level:</b> 1 <b>Func. diagram:</b> 7220 <b>Unit selection:</b> - <b>Expert list:</b> 1 <b>Factory setting</b> 220
<b>Description:</b>	Setting parameter for the run sequence of instance ADD 1 within the run-time group set in p20100.		
<b>Note:</b>	The function blocks with a lower run sequence value are calculated before function blocks with a higher run sequence value.		
<b>p20102[0...1]</b>	<b>CI: SUB 0 inputs / SUB 0 inputs</b>		
All objects (FBLOCKS)	<b>Can be changed:</b> T <b>Data type:</b> Unsigned32 / FloatingPoint32 <b>P-Group:</b> - <b>Not for motor type:</b> - <b>Min</b> -	<b>Calculated:</b> - <b>Dynamic index:</b> - <b>Units group:</b> - <b>Scaling:</b> PERCENT <b>Max</b> -	<b>Access level:</b> 1 <b>Func. diagram:</b> 7220 <b>Unit selection:</b> - <b>Expert list:</b> 1 <b>Factory setting</b> 0
<b>Description:</b>	Sets the signal source of minuend X1 and subtrahend X2 of instance SUB 0 of the subtractor.		
<b>Index:</b>	[0] = Minuend X1 [1] = Subtrahend X2		

<b>p20103</b>	<b>CO: SUB 0 difference Y / SUB 0 difference Y</b>		
All objects (FBLOCKS)	<b>Can be changed:</b> - <b>Data type:</b> FloatingPoint32 <b>P-Group:</b> - <b>Not for motor type:</b> - <b>Min</b> -	<b>Calculated:</b> - <b>Dynamic index:</b> - <b>Units group:</b> - <b>Scaling:</b> PERCENT <b>Max</b> -	<b>Access level:</b> 1 <b>Func. diagram:</b> 7220 <b>Unit selection:</b> - <b>Expert list:</b> 1 <b>Factory setting</b> -
<b>Description:</b>	Display parameter for the difference $Y = X1 - X2$ of instance SUB 0 of the subtractor.		
<b>p20104</b>	<b>SUB 0 run-time group / SUB 0 RTG</b>		
All objects (FBLOCKS)	<b>Can be changed:</b> T <b>Data type:</b> Integer16 <b>P-Group:</b> - <b>Not for motor type:</b> - <b>Min</b> 0	<b>Calculated:</b> - <b>Dynamic index:</b> - <b>Units group:</b> - <b>Scaling:</b> - <b>Max</b> 9999	<b>Access level:</b> 1 <b>Func. diagram:</b> 7220 <b>Unit selection:</b> - <b>Expert list:</b> 1 <b>Factory setting</b> 9999
<b>Description:</b>	Setting parameter for the run-time group in which instance SUB 0 of the subtractor is to be called.		
<b>Value:</b>	0: Run-time group 0 1: Run-time group 1 2: Run-time group 2 3: Run-time group 3 4: Run-time group 4 5: Run-time group 5 6: Run-time group 6 7: Run-time group 7 8: Run-time group 8 9: Run-time group 9 9999: Do not calculate		
<b>p20105</b>	<b>SUB 0 run sequence / SUB 0 RunSeq</b>		
All objects (FBLOCKS)	<b>Can be changed:</b> T <b>Data type:</b> Unsigned16 <b>P-Group:</b> - <b>Not for motor type:</b> - <b>Min</b> 0	<b>Calculated:</b> - <b>Dynamic index:</b> - <b>Units group:</b> - <b>Scaling:</b> - <b>Max</b> 32000	<b>Access level:</b> 1 <b>Func. diagram:</b> 7220 <b>Unit selection:</b> - <b>Expert list:</b> 1 <b>Factory setting</b> 240
<b>Description:</b>	Setting parameter for the run sequence of instance SUB 0 within the run-time group set in p20104.		
<b>Note:</b>	The function blocks with a lower run sequence value are calculated before function blocks with a higher run sequence value.		
<b>p20106[0...1]</b>	<b>CI: SUB 1 inputs / SUB 1 inputs</b>		
All objects (FBLOCKS)	<b>Can be changed:</b> T <b>Data type:</b> Unsigned32 / FloatingPoint32 <b>P-Group:</b> - <b>Not for motor type:</b> - <b>Min</b> -	<b>Calculated:</b> - <b>Dynamic index:</b> - <b>Units group:</b> - <b>Scaling:</b> PERCENT <b>Max</b> -	<b>Access level:</b> 1 <b>Func. diagram:</b> 7220 <b>Unit selection:</b> - <b>Expert list:</b> 1 <b>Factory setting</b> 0
<b>Description:</b>	Sets the signal source of minuend X1 and subtrahend X2 of instance SUB 1 of the subtractor.		
<b>Index:</b>	[0] = Minuend X1 [1] = Subtrahend X2		



<b>p20107</b>	<b>CO: SUB 1 difference Y / SUB 1 difference Y</b>		
All objects (FBLOCKS)	<b>Can be changed:</b> - <b>Data type:</b> FloatingPoint32 <b>P-Group:</b> - <b>Not for motor type:</b> - <b>Min</b> -	<b>Calculated:</b> - <b>Dynamic index:</b> - <b>Units group:</b> - <b>Scaling:</b> PERCENT <b>Max</b> -	<b>Access level:</b> 1 <b>Func. diagram:</b> 7220 <b>Unit selection:</b> - <b>Expert list:</b> 1 <b>Factory setting</b> -
<b>Description:</b>	Display parameter for the difference $Y = X1 - X2$ of instance SUB 1 of the subtractor.		
<b>p20108</b>	<b>SUB 1 run-time group / SUB 1 RTG</b>		
All objects (FBLOCKS)	<b>Can be changed:</b> T <b>Data type:</b> Integer16 <b>P-Group:</b> - <b>Not for motor type:</b> - <b>Min</b> 0	<b>Calculated:</b> - <b>Dynamic index:</b> - <b>Units group:</b> - <b>Scaling:</b> - <b>Max</b> 9999	<b>Access level:</b> 1 <b>Func. diagram:</b> 7220 <b>Unit selection:</b> - <b>Expert list:</b> 1 <b>Factory setting</b> 9999
<b>Description:</b>	Setting parameter for the run-time group in which instance SUB 1 of the subtractor is to be called.		
<b>Value:</b>	0: Run-time group 0 1: Run-time group 1 2: Run-time group 2 3: Run-time group 3 4: Run-time group 4 5: Run-time group 5 6: Run-time group 6 7: Run-time group 7 8: Run-time group 8 9: Run-time group 9 9999: Do not calculate		
<b>p20109</b>	<b>SUB 1 run sequence / SUB 1 RunSeq</b>		
All objects (FBLOCKS)	<b>Can be changed:</b> T <b>Data type:</b> Unsigned16 <b>P-Group:</b> - <b>Not for motor type:</b> - <b>Min</b> 0	<b>Calculated:</b> - <b>Dynamic index:</b> - <b>Units group:</b> - <b>Scaling:</b> - <b>Max</b> 32000	<b>Access level:</b> 1 <b>Func. diagram:</b> 7220 <b>Unit selection:</b> - <b>Expert list:</b> 1 <b>Factory setting</b> 250
<b>Description:</b>	Setting parameter for the run sequence of instance SUB 1 within the run-time group set in p20108.		
<b>Note:</b>	The function blocks with a lower run sequence value are calculated before function blocks with a higher run sequence value.		
<b>p20110[0...3]</b>	<b>CI: MUL 0 inputs / MUL 0 inputs</b>		
All objects (FBLOCKS)	<b>Can be changed:</b> T <b>Data type:</b> Unsigned32 / FloatingPoint32 <b>P-Group:</b> - <b>Not for motor type:</b> - <b>Min</b> -	<b>Calculated:</b> - <b>Dynamic index:</b> - <b>Units group:</b> - <b>Scaling:</b> PERCENT <b>Max</b> -	<b>Access level:</b> 1 <b>Func. diagram:</b> 7222 <b>Unit selection:</b> - <b>Expert list:</b> 1 <b>Factory setting</b> 0
<b>Description:</b>	Sets the signal source of the factors X0, X1, X2, X3 of instance MUL 0 of the multiplier.		
<b>Index:</b>	[0] = Factor X0 [1] = Factor X1 [2] = Factor X2 [3] = Factor X3		

<b>r20111</b>	<b>CO: MUL 0 product Y / MUL 0 product Y</b>		
All objects (FBLOCKS)	<b>Can be changed:</b> -	<b>Calculated:</b> -	<b>Access level:</b> 1
	<b>Data type:</b> FloatingPoint32	<b>Dynamic index:</b> -	<b>Func. diagram:</b> 7222
	<b>P-Group:</b> -	<b>Units group:</b> -	<b>Unit selection:</b> -
	<b>Not for motor type:</b> -	<b>Scaling:</b> PERCENT	<b>Expert list:</b> 1
	<b>Min</b>	<b>Max</b>	<b>Factory setting</b>
	-	-	-
<b>Description:</b>	Display parameter for the product $Y = X0 * X1 * X2 * X3$ of instance MUL 0 of the multiplier.		
<b>p20112</b>	<b>MUL 0 run-time group / MUL 0 RTG</b>		
All objects (FBLOCKS)	<b>Can be changed:</b> T	<b>Calculated:</b> -	<b>Access level:</b> 1
	<b>Data type:</b> Integer16	<b>Dynamic index:</b> -	<b>Func. diagram:</b> 7222
	<b>P-Group:</b> -	<b>Units group:</b> -	<b>Unit selection:</b> -
	<b>Not for motor type:</b> -	<b>Scaling:</b> -	<b>Expert list:</b> 1
	<b>Min</b>	<b>Max</b>	<b>Factory setting</b>
	0	9999	9999
<b>Description:</b>	Setting parameter for the run-time group in which instance MUL 0 of the multiplier is to be called.		
<b>Value:</b>	0: Run-time group 0 1: Run-time group 1 2: Run-time group 2 3: Run-time group 3 4: Run-time group 4 5: Run-time group 5 6: Run-time group 6 7: Run-time group 7 8: Run-time group 8 9: Run-time group 9 9999: Do not calculate		
<b>p20113</b>	<b>MUL 0 run sequence / MUL 0 RunSeq</b>		
All objects (FBLOCKS)	<b>Can be changed:</b> T	<b>Calculated:</b> -	<b>Access level:</b> 1
	<b>Data type:</b> Unsigned16	<b>Dynamic index:</b> -	<b>Func. diagram:</b> 7222
	<b>P-Group:</b> -	<b>Units group:</b> -	<b>Unit selection:</b> -
	<b>Not for motor type:</b> -	<b>Scaling:</b> -	<b>Expert list:</b> 1
	<b>Min</b>	<b>Max</b>	<b>Factory setting</b>
	0	32000	270
<b>Description:</b>	Setting parameter for the run sequence of instance MUL 0 within the run-time group set in p20112.		
<b>Note:</b>	The function blocks with a lower run sequence value are calculated before function blocks with a higher run sequence value.		
<b>p20114[0...3]</b>	<b>CI: MUL 1 inputs / MUL 1 inputs</b>		
All objects (FBLOCKS)	<b>Can be changed:</b> T	<b>Calculated:</b> -	<b>Access level:</b> 1
	<b>Data type:</b> Unsigned32 / FloatingPoint32	<b>Dynamic index:</b> -	<b>Func. diagram:</b> 7222
	<b>P-Group:</b> -	<b>Units group:</b> -	<b>Unit selection:</b> -
	<b>Not for motor type:</b> -	<b>Scaling:</b> PERCENT	<b>Expert list:</b> 1
	<b>Min</b>	<b>Max</b>	<b>Factory setting</b>
	-	-	0
<b>Description:</b>	Sets the signal source of the factors X0, X1, X2, X3 of instance MUL 1 of the multiplier.		
<b>Index:</b>	[0] = Factor X0 [1] = Factor X1 [2] = Factor X2 [3] = Factor X3		

<b>r20115</b>	<b>CO: MUL 1 product Y / MUL 1 product Y</b>		
All objects (FBLOCKS)	<b>Can be changed:</b> - <b>Data type:</b> FloatingPoint32 <b>P-Group:</b> - <b>Not for motor type:</b> - <b>Min</b> -	<b>Calculated:</b> - <b>Dynamic index:</b> - <b>Units group:</b> - <b>Scaling:</b> PERCENT <b>Max</b> -	<b>Access level:</b> 1 <b>Func. diagram:</b> 7222 <b>Unit selection:</b> - <b>Expert list:</b> 1 <b>Factory setting</b> -
<b>Description:</b>	Display parameter for the product $Y = X0 * X1 * X2 * X3$ of instance MUL 1 of the multiplier.		
<b>p20116</b>	<b>MUL 1 run-time group / MUL 1 RTG</b>		
All objects (FBLOCKS)	<b>Can be changed:</b> T <b>Data type:</b> Integer16 <b>P-Group:</b> - <b>Not for motor type:</b> - <b>Min</b> 0	<b>Calculated:</b> - <b>Dynamic index:</b> - <b>Units group:</b> - <b>Scaling:</b> - <b>Max</b> 9999	<b>Access level:</b> 1 <b>Func. diagram:</b> 7222 <b>Unit selection:</b> - <b>Expert list:</b> 1 <b>Factory setting</b> 9999
<b>Description:</b>	Setting parameter for the run-time group in which instance MUL 1 of the multiplier is to be called.		
<b>Value:</b>	0: Run-time group 0 1: Run-time group 1 2: Run-time group 2 3: Run-time group 3 4: Run-time group 4 5: Run-time group 5 6: Run-time group 6 7: Run-time group 7 8: Run-time group 8 9: Run-time group 9 9999: Do not calculate		
<b>p20117</b>	<b>MUL 1 run sequence / MUL 1 RunSeq</b>		
All objects (FBLOCKS)	<b>Can be changed:</b> T <b>Data type:</b> Unsigned16 <b>P-Group:</b> - <b>Not for motor type:</b> - <b>Min</b> 0	<b>Calculated:</b> - <b>Dynamic index:</b> - <b>Units group:</b> - <b>Scaling:</b> - <b>Max</b> 32000	<b>Access level:</b> 1 <b>Func. diagram:</b> 7222 <b>Unit selection:</b> - <b>Expert list:</b> 1 <b>Factory setting</b> 280
<b>Description:</b>	Setting parameter for the run sequence of instance MUL 1 within the run-time group set in p20116.		
<b>Note:</b>	The function blocks with a lower run sequence value are calculated before function blocks with a higher run sequence value.		
<b>p20118[0...1]</b>	<b>CI: DIV 0 inputs / DIV 0 inputs</b>		
All objects (FBLOCKS)	<b>Can be changed:</b> T <b>Data type:</b> Unsigned32 / FloatingPoint32 <b>P-Group:</b> - <b>Not for motor type:</b> - <b>Min</b> -	<b>Calculated:</b> - <b>Dynamic index:</b> - <b>Units group:</b> - <b>Scaling:</b> PERCENT <b>Max</b> -	<b>Access level:</b> 1 <b>Func. diagram:</b> 7222 <b>Unit selection:</b> - <b>Expert list:</b> 1 <b>Factory setting</b> 0
<b>Description:</b>	Sets the signal source of dividend X1 and divisor X2 of instance DIV 0 of the divider.		
<b>Index:</b>	[0] = Dividend X0 [1] = Divisor X1		

<b>r20119[0...2]</b>	<b>CO: DIV 0 quotient / DIV 0 quotient</b>		
All objects (FBLOCKS)	<b>Can be changed:</b> - <b>Data type:</b> FloatingPoint32 <b>P-Group:</b> - <b>Not for motor type:</b> - <b>Min</b> -	<b>Calculated:</b> - <b>Dynamic index:</b> - <b>Units group:</b> - <b>Scaling:</b> PERCENT <b>Max</b> -	<b>Access level:</b> 1 <b>Func. diagram:</b> 7222 <b>Unit selection:</b> - <b>Expert list:</b> 1 <b>Factory setting</b> -
<b>Description:</b>	Display parameter for quotients $Y = X1/X2$ , integer number quotients $YIN$ , and division remainder $MOD = (Y - YIN) \times X2$ of instance DIV 0 of the divider.		
<b>Index:</b>	[0] = Quotient Y [1] = Integer number quotient YIN [2] = Div remainder MOD		
<b>r20120</b>	<b>BO: DIV 0 divisor is zero QF / DIV 0 divisor=0 QF</b>		
All objects (FBLOCKS)	<b>Can be changed:</b> - <b>Data type:</b> Unsigned32 <b>P-Group:</b> - <b>Not for motor type:</b> - <b>Min</b> -	<b>Calculated:</b> - <b>Dynamic index:</b> - <b>Units group:</b> - <b>Scaling:</b> - <b>Max</b> -	<b>Access level:</b> 1 <b>Func. diagram:</b> 7222 <b>Unit selection:</b> - <b>Expert list:</b> 1 <b>Factory setting</b> -
<b>Description:</b>	Display parameter for the signal QF that the divisor X2 of instance DIV 0 of the divider is zero. $X2 = 0.0 \Rightarrow QF = 1$		
<b>p20121</b>	<b>DIV 0 run-time group / DIV 0 RTG</b>		
All objects (FBLOCKS)	<b>Can be changed:</b> T <b>Data type:</b> Integer16 <b>P-Group:</b> - <b>Not for motor type:</b> - <b>Min</b> 0	<b>Calculated:</b> - <b>Dynamic index:</b> - <b>Units group:</b> - <b>Scaling:</b> - <b>Max</b> 9999	<b>Access level:</b> 1 <b>Func. diagram:</b> 7222 <b>Unit selection:</b> - <b>Expert list:</b> 1 <b>Factory setting</b> 9999
<b>Description:</b>	Setting parameter for the run-time group in which instance DIV 0 of the divider is to be called.		
<b>Value:</b>	0: Run-time group 0 1: Run-time group 1 2: Run-time group 2 3: Run-time group 3 4: Run-time group 4 5: Run-time group 5 6: Run-time group 6 7: Run-time group 7 8: Run-time group 8 9: Run-time group 9 9999: Do not calculate		
<b>p20122</b>	<b>DIV 0 run sequence / DIV 0 RunSeq</b>		
All objects (FBLOCKS)	<b>Can be changed:</b> T <b>Data type:</b> Unsigned16 <b>P-Group:</b> - <b>Not for motor type:</b> - <b>Min</b> 0	<b>Calculated:</b> - <b>Dynamic index:</b> - <b>Units group:</b> - <b>Scaling:</b> - <b>Max</b> 32000	<b>Access level:</b> 1 <b>Func. diagram:</b> 7222 <b>Unit selection:</b> - <b>Expert list:</b> 1 <b>Factory setting</b> 300
<b>Description:</b>	Setting parameter for the run sequence of instance DIV 0 within the run-time group set in p20121.		
<b>Note:</b>	The function blocks with a lower run sequence value are calculated before function blocks with a higher run sequence value.		

<b>p20123[0...1]</b>	<b>CI: DIV 1 inputs / DIV 1 inputs</b>		
All objects (FBLOCKS)	<b>Can be changed:</b> T	<b>Calculated:</b> -	<b>Access level:</b> 1
	<b>Data type:</b> Unsigned32 / FloatingPoint32	<b>Dynamic index:</b> -	<b>Func. diagram:</b> 7222
	<b>P-Group:</b> -	<b>Units group:</b> -	<b>Unit selection:</b> -
	<b>Not for motor type:</b> -	<b>Scaling:</b> PERCENT	<b>Expert list:</b> 1
	<b>Min</b>	<b>Max</b>	<b>Factory setting</b>
	-	-	0
<b>Description:</b>	Sets the signal source of dividend X1 and divisor X2 of instance DIV 1 of the divider.		
<b>Index:</b>	[0] = Dividend X0 [1] = Divisor X1		
<b>r20124[0...2]</b>	<b>CO: DIV 1 quotient / DIV 1 quotient</b>		
All objects (FBLOCKS)	<b>Can be changed:</b> -	<b>Calculated:</b> -	<b>Access level:</b> 1
	<b>Data type:</b> FloatingPoint32	<b>Dynamic index:</b> -	<b>Func. diagram:</b> 7222
	<b>P-Group:</b> -	<b>Units group:</b> -	<b>Unit selection:</b> -
	<b>Not for motor type:</b> -	<b>Scaling:</b> PERCENT	<b>Expert list:</b> 1
	<b>Min</b>	<b>Max</b>	<b>Factory setting</b>
	-	-	-
<b>Description:</b>	Display parameter for quotients $Y = X1/X2$ , integer number quotients YIN, and division remainder $MOD = (Y - YIN) \times X2$ of instance DIV 1 of the divider.		
<b>Index:</b>	[0] = Quotient Y [1] = Integer number quotient YIN [2] = Div remainder MOD		
<b>r20125</b>	<b>BO: DIV 1 divisor is zero QF / DIV 1 divisor=0 QF</b>		
All objects (FBLOCKS)	<b>Can be changed:</b> -	<b>Calculated:</b> -	<b>Access level:</b> 1
	<b>Data type:</b> Unsigned32	<b>Dynamic index:</b> -	<b>Func. diagram:</b> 7222
	<b>P-Group:</b> -	<b>Units group:</b> -	<b>Unit selection:</b> -
	<b>Not for motor type:</b> -	<b>Scaling:</b> -	<b>Expert list:</b> 1
	<b>Min</b>	<b>Max</b>	<b>Factory setting</b>
	-	-	-
<b>Description:</b>	Display parameter for the signal QF that the divisor X2 of instance DIV 1 of the divider is zero. $X2 = 0.0 \Rightarrow QF = 1$		
<b>p20126</b>	<b>DIV 1 run-time group / DIV 1 RTG</b>		
All objects (FBLOCKS)	<b>Can be changed:</b> T	<b>Calculated:</b> -	<b>Access level:</b> 1
	<b>Data type:</b> Integer16	<b>Dynamic index:</b> -	<b>Func. diagram:</b> 7222
	<b>P-Group:</b> -	<b>Units group:</b> -	<b>Unit selection:</b> -
	<b>Not for motor type:</b> -	<b>Scaling:</b> -	<b>Expert list:</b> 1
	<b>Min</b>	<b>Max</b>	<b>Factory setting</b>
	0	9999	9999
<b>Description:</b>	Setting parameter for the run-time group in which instance DIV 1 of the divider is to be called.		
<b>Value:</b>	0: Run-time group 0 1: Run-time group 1 2: Run-time group 2 3: Run-time group 3 4: Run-time group 4 5: Run-time group 5 6: Run-time group 6 7: Run-time group 7 8: Run-time group 8 9: Run-time group 9 9999: Do not calculate		

<b>p20127</b>	<b>DIV 1 run sequence / DIV 1 RunSeq</b>		
All objects (FBLOCKS)	<b>Can be changed:</b> T	<b>Calculated:</b> -	<b>Access level:</b> 1
	<b>Data type:</b> Unsigned16	<b>Dynamic index:</b> -	<b>Func. diagram:</b> 7222
	<b>P-Group:</b> -	<b>Units group:</b> -	<b>Unit selection:</b> -
	<b>Not for motor type:</b> -	<b>Scaling:</b> -	<b>Expert list:</b> 1
	<b>Min</b> 0	<b>Max</b> 32000	<b>Factory setting</b> 310
<b>Description:</b>	Setting parameter for the run sequence of instance DIV 1 within the run-time group set in p20126.		
<b>Note:</b>	The function blocks with a lower run sequence value are calculated before function blocks with a higher run sequence value.		
<b>p20128</b>	<b>CI: AVA 0 input X / AVA 0 input X</b>		
All objects (FBLOCKS)	<b>Can be changed:</b> T	<b>Calculated:</b> -	<b>Access level:</b> 1
	<b>Data type:</b> Unsigned32 / FloatingPoint32	<b>Dynamic index:</b> -	<b>Func. diagram:</b> 7224
	<b>P-Group:</b> -	<b>Units group:</b> -	<b>Unit selection:</b> -
	<b>Not for motor type:</b> -	<b>Scaling:</b> PERCENT	<b>Expert list:</b> 1
	<b>Min</b> -	<b>Max</b> -	<b>Factory setting</b> 0
<b>Description:</b>	Sets the signal source of the input quantity X of instance AVA 0 of the absolute value generator with sign evaluation.		
<b>r20129</b>	<b>CO: AVA 0 output Y / AVA 0 output Y</b>		
All objects (FBLOCKS)	<b>Can be changed:</b> -	<b>Calculated:</b> -	<b>Access level:</b> 1
	<b>Data type:</b> FloatingPoint32	<b>Dynamic index:</b> -	<b>Func. diagram:</b> 7224
	<b>P-Group:</b> -	<b>Units group:</b> -	<b>Unit selection:</b> -
	<b>Not for motor type:</b> -	<b>Scaling:</b> PERCENT	<b>Expert list:</b> 1
	<b>Min</b> -	<b>Max</b> -	<b>Factory setting</b> -
<b>Description:</b>	Display parameter for output quantity Y of instance AVA 0 of the absolute value generator with sign evaluation.		
<b>r20130</b>	<b>BO: AVA 0 input negative SN / AVA 0 input neg SN</b>		
All objects (FBLOCKS)	<b>Can be changed:</b> -	<b>Calculated:</b> -	<b>Access level:</b> 1
	<b>Data type:</b> Unsigned32	<b>Dynamic index:</b> -	<b>Func. diagram:</b> 7224
	<b>P-Group:</b> -	<b>Units group:</b> -	<b>Unit selection:</b> -
	<b>Not for motor type:</b> -	<b>Scaling:</b> -	<b>Expert list:</b> 1
	<b>Min</b> -	<b>Max</b> -	<b>Factory setting</b> -
<b>Description:</b>	Display parameter for signal SN that the input quantity X of instance AVA 0 of the absolute value generator with sign evaluation is negative. $X < 0.0 \Rightarrow SN = 1$		
<b>p20131</b>	<b>AVA 0 run-time group / AVA 0 RTG</b>		
All objects (FBLOCKS)	<b>Can be changed:</b> T	<b>Calculated:</b> -	<b>Access level:</b> 1
	<b>Data type:</b> Integer16	<b>Dynamic index:</b> -	<b>Func. diagram:</b> 7224
	<b>P-Group:</b> -	<b>Units group:</b> -	<b>Unit selection:</b> -
	<b>Not for motor type:</b> -	<b>Scaling:</b> -	<b>Expert list:</b> 1
	<b>Min</b> 0	<b>Max</b> 9999	<b>Factory setting</b> 9999
<b>Description:</b>	Setting parameter for the run-time group in which instance AVA 0 of the absolute value generator with sign evaluation is to be called.		

<b>Value:</b>	0:	Run-time group 0
	1:	Run-time group 1
	2:	Run-time group 2
	3:	Run-time group 3
	4:	Run-time group 4
	5:	Run-time group 5
	6:	Run-time group 6
	7:	Run-time group 7
	8:	Run-time group 8
	9:	Run-time group 9
	9999:	Do not calculate

**p20132 AVA 0 run sequence / AVA 0 RunSeq**

All objects (FBLOCKS)	<b>Can be changed:</b> T	<b>Calculated:</b> -	<b>Access level:</b> 1
	<b>Data type:</b> Unsigned16	<b>Dynamic index:</b> -	<b>Func. diagram:</b> 7224
	<b>P-Group:</b> -	<b>Units group:</b> -	<b>Unit selection:</b> -
	<b>Not for motor type:</b> -	<b>Scaling:</b> -	<b>Expert list:</b> 1
	<b>Min</b>	<b>Max</b>	<b>Factory setting</b>
	0	32000	340

**Description:** Setting parameter for the run sequence of instance AVA 0 within the run-time group set in p20131.

**Note:** The function blocks with a lower run sequence value are calculated before function blocks with a higher run sequence value.

**p20133 CI: AVA 1 input X / AVA 1 input X**

All objects (FBLOCKS)	<b>Can be changed:</b> T	<b>Calculated:</b> -	<b>Access level:</b> 1
	<b>Data type:</b> Unsigned32 / FloatingPoint32	<b>Dynamic index:</b> -	<b>Func. diagram:</b> 7224
	<b>P-Group:</b> -	<b>Units group:</b> -	<b>Unit selection:</b> -
	<b>Not for motor type:</b> -	<b>Scaling:</b> PERCENT	<b>Expert list:</b> 1
	<b>Min</b>	<b>Max</b>	<b>Factory setting</b>
	-	-	0

**Description:** Sets the signal source of the input quantity X of instance AVA 1 of the absolute value generator with sign evaluation.

**r20134 CO: AVA 1 output Y / AVA 1 output Y**

All objects (FBLOCKS)	<b>Can be changed:</b> -	<b>Calculated:</b> -	<b>Access level:</b> 1
	<b>Data type:</b> FloatingPoint32	<b>Dynamic index:</b> -	<b>Func. diagram:</b> 7224
	<b>P-Group:</b> -	<b>Units group:</b> -	<b>Unit selection:</b> -
	<b>Not for motor type:</b> -	<b>Scaling:</b> PERCENT	<b>Expert list:</b> 1
	<b>Min</b>	<b>Max</b>	<b>Factory setting</b>
	-	-	-

**Description:** Display parameter for output quantity Y of instance AVA 1 of the absolute value generator with sign evaluation.

**r20135 BO: AVA 1 input negative SN / AVA 1 input neg SN**

All objects (FBLOCKS)	<b>Can be changed:</b> -	<b>Calculated:</b> -	<b>Access level:</b> 1
	<b>Data type:</b> Unsigned32	<b>Dynamic index:</b> -	<b>Func. diagram:</b> 7224
	<b>P-Group:</b> -	<b>Units group:</b> -	<b>Unit selection:</b> -
	<b>Not for motor type:</b> -	<b>Scaling:</b> -	<b>Expert list:</b> 1
	<b>Min</b>	<b>Max</b>	<b>Factory setting</b>
	-	-	-

**Description:** Display parameter for signal SN that the input quantity X of instance AVA 1 of the absolute value generator with sign evaluation is negative.

X < 0.0 => SN = 1

<b>p20136</b>	<b>AVA 1 run-time group / AVA 1 RTG</b>		
All objects (FBLOCKS)	<b>Can be changed:</b> T	<b>Calculated:</b> -	<b>Access level:</b> 1
	<b>Data type:</b> Integer16	<b>Dynamic index:</b> -	<b>Func. diagram:</b> 7224
	<b>P-Group:</b> -	<b>Units group:</b> -	<b>Unit selection:</b> -
	<b>Not for motor type:</b> -	<b>Scaling:</b> -	<b>Expert list:</b> 1
	<b>Min</b> 0	<b>Max</b> 9999	<b>Factory setting</b> 9999
<b>Description:</b>	Setting parameter for the run-time group in which instance AVA 1 of the absolute value generator with sign evaluation is to be called.		
<b>Value:</b>	0: Run-time group 0 1: Run-time group 1 2: Run-time group 2 3: Run-time group 3 4: Run-time group 4 5: Run-time group 5 6: Run-time group 6 7: Run-time group 7 8: Run-time group 8 9: Run-time group 9 9999: Do not calculate		
<b>p20137</b>	<b>AVA 1 run sequence / AVA 1 RunSeq</b>		
All objects (FBLOCKS)	<b>Can be changed:</b> T	<b>Calculated:</b> -	<b>Access level:</b> 1
	<b>Data type:</b> Unsigned16	<b>Dynamic index:</b> -	<b>Func. diagram:</b> 7224
	<b>P-Group:</b> -	<b>Units group:</b> -	<b>Unit selection:</b> -
	<b>Not for motor type:</b> -	<b>Scaling:</b> -	<b>Expert list:</b> 1
	<b>Min</b> 0	<b>Max</b> 32000	<b>Factory setting</b> 350
<b>Description:</b>	Setting parameter for the run sequence of instance AVA 1 within the run-time group set in p20136.		
<b>Note:</b>	The function blocks with a lower run sequence value are calculated before function blocks with a higher run sequence value.		
<b>p20138</b>	<b>BI: MFP 0 input pulse I / MFP 0 inp_pulse I</b>		
All objects (FBLOCKS)	<b>Can be changed:</b> T	<b>Calculated:</b> -	<b>Access level:</b> 1
	<b>Data type:</b> Unsigned32 / Binary	<b>Dynamic index:</b> -	<b>Func. diagram:</b> 7230
	<b>P-Group:</b> -	<b>Units group:</b> -	<b>Unit selection:</b> -
	<b>Not for motor type:</b> -	<b>Scaling:</b> -	<b>Expert list:</b> 1
	<b>Min</b> -	<b>Max</b> -	<b>Factory setting</b> 0
<b>Description:</b>	Sets the signal source for the input pulse I of instance MFP 0 of the pulse generator.		
<b>p20139</b>	<b>MFP 0 pulse duration in ms / MFP 0 pulse_dur ms</b>		
All objects (FBLOCKS)	<b>Can be changed:</b> T	<b>Calculated:</b> -	<b>Access level:</b> 1
	<b>Data type:</b> FloatingPoint32	<b>Dynamic index:</b> -	<b>Func. diagram:</b> 7230
	<b>P-Group:</b> -	<b>Units group:</b> -	<b>Unit selection:</b> -
	<b>Not for motor type:</b> -	<b>Scaling:</b> -	<b>Expert list:</b> 1
	<b>Min</b> 0.00	<b>Max</b> 60000.00	<b>Factory setting</b> 0.00
<b>Description:</b>	Setting parameter for pulse duration T in milliseconds of instance MFP 0 of the pulse generator.		



<b>r20140</b>	<b>BO: MFP 0 output Q / MFP 0 output Q</b>		
All objects (FBLOCKS)	<b>Can be changed:</b> -	<b>Calculated:</b> -	<b>Access level:</b> 1
	<b>Data type:</b> Unsigned32	<b>Dynamic index:</b> -	<b>Func. diagram:</b> 7230
	<b>P-Group:</b> -	<b>Units group:</b> -	<b>Unit selection:</b> -
	<b>Not for motor type:</b> -	<b>Scaling:</b> -	<b>Expert list:</b> 1
	<b>Min</b>	<b>Max</b>	<b>Factory setting</b>
	-	-	-
<b>Description:</b>	Display parameter for output pulse Q of instance MFP 0 of the pulse generator.		
<b>p20141</b>	<b>MFP 0 run-time group / MFP 0 RTG</b>		
All objects (FBLOCKS)	<b>Can be changed:</b> T	<b>Calculated:</b> -	<b>Access level:</b> 1
	<b>Data type:</b> Integer16	<b>Dynamic index:</b> -	<b>Func. diagram:</b> 7230
	<b>P-Group:</b> -	<b>Units group:</b> -	<b>Unit selection:</b> -
	<b>Not for motor type:</b> -	<b>Scaling:</b> -	<b>Expert list:</b> 1
	<b>Min</b>	<b>Max</b>	<b>Factory setting</b>
	0	9999	9999
<b>Description:</b>	Setting parameter for the run-time group in which the instance MFP 0 of the pulse generator is to be called.		
<b>Value:</b>	0: Run-time group 0 1: Run-time group 1 2: Run-time group 2 3: Run-time group 3 4: Run-time group 4 5: Run-time group 5 6: Run-time group 6 7: Run-time group 7 8: Run-time group 8 9: Run-time group 9 9999: Do not calculate		
<b>p20142</b>	<b>MFP 0 run sequence / MFP 0 RunSeq</b>		
All objects (FBLOCKS)	<b>Can be changed:</b> T	<b>Calculated:</b> -	<b>Access level:</b> 1
	<b>Data type:</b> Unsigned16	<b>Dynamic index:</b> -	<b>Func. diagram:</b> 7230
	<b>P-Group:</b> -	<b>Units group:</b> -	<b>Unit selection:</b> -
	<b>Not for motor type:</b> -	<b>Scaling:</b> -	<b>Expert list:</b> 1
	<b>Min</b>	<b>Max</b>	<b>Factory setting</b>
	0	32000	370
<b>Description:</b>	Setting parameter for the run sequence of instance MFP 0 within the run-time group set in p20141.		
<b>Note:</b>	The function blocks with a lower run sequence value are calculated before function blocks with a higher run sequence value.		
<b>p20143</b>	<b>BI: MFP 1 input pulse I / MFP 1 inp_pulse I</b>		
All objects (FBLOCKS)	<b>Can be changed:</b> T	<b>Calculated:</b> -	<b>Access level:</b> 1
	<b>Data type:</b> Unsigned32 / Binary	<b>Dynamic index:</b> -	<b>Func. diagram:</b> 7230
	<b>P-Group:</b> -	<b>Units group:</b> -	<b>Unit selection:</b> -
	<b>Not for motor type:</b> -	<b>Scaling:</b> -	<b>Expert list:</b> 1
	<b>Min</b>	<b>Max</b>	<b>Factory setting</b>
	-	-	0
<b>Description:</b>	Sets the signal source for the input pulse I of instance MFP 1 of the pulse generator.		

<b>p20144</b>	<b>MFP 1 pulse duration in ms / MFP 1 pulse_dur ms</b>		
All objects (FBLOCKS)	<b>Can be changed:</b> T	<b>Calculated:</b> -	<b>Access level:</b> 1
	<b>Data type:</b> FloatingPoint32	<b>Dynamic index:</b> -	<b>Func. diagram:</b> 7230
	<b>P-Group:</b> -	<b>Units group:</b> -	<b>Unit selection:</b> -
	<b>Not for motor type:</b> -	<b>Scaling:</b> -	<b>Expert list:</b> 1
	<b>Min</b> 0.00	<b>Max</b> 60000.00	<b>Factory setting</b> 0.00
<b>Description:</b>	Setting parameter for pulse duration T in milliseconds of instance MFP 1 of the pulse generator.		
<b>r20145</b>	<b>BO: MFP 1 output Q / MFP 1 output Q</b>		
All objects (FBLOCKS)	<b>Can be changed:</b> -	<b>Calculated:</b> -	<b>Access level:</b> 1
	<b>Data type:</b> Unsigned32	<b>Dynamic index:</b> -	<b>Func. diagram:</b> 7230
	<b>P-Group:</b> -	<b>Units group:</b> -	<b>Unit selection:</b> -
	<b>Not for motor type:</b> -	<b>Scaling:</b> -	<b>Expert list:</b> 1
	<b>Min</b> -	<b>Max</b> -	<b>Factory setting</b> -
<b>Description:</b>	Display parameter for output pulse Q of instance MFP 1 of the pulse generator.		
<b>p20146</b>	<b>MFP 1 run-time group / MFP 1 RTG</b>		
All objects (FBLOCKS)	<b>Can be changed:</b> T	<b>Calculated:</b> -	<b>Access level:</b> 1
	<b>Data type:</b> Integer16	<b>Dynamic index:</b> -	<b>Func. diagram:</b> 7230
	<b>P-Group:</b> -	<b>Units group:</b> -	<b>Unit selection:</b> -
	<b>Not for motor type:</b> -	<b>Scaling:</b> -	<b>Expert list:</b> 1
	<b>Min</b> 0	<b>Max</b> 9999	<b>Factory setting</b> 9999
<b>Description:</b>	Setting parameter for the run-time group in which the instance MFP 1 of the pulse generator is to be called.		
<b>Value:</b>	0: Run-time group 0 1: Run-time group 1 2: Run-time group 2 3: Run-time group 3 4: Run-time group 4 5: Run-time group 5 6: Run-time group 6 7: Run-time group 7 8: Run-time group 8 9: Run-time group 9 9999: Do not calculate		
<b>p20147</b>	<b>MFP 1 run sequence / MFP 1 RunSeq</b>		
All objects (FBLOCKS)	<b>Can be changed:</b> T	<b>Calculated:</b> -	<b>Access level:</b> 1
	<b>Data type:</b> Unsigned16	<b>Dynamic index:</b> -	<b>Func. diagram:</b> 7230
	<b>P-Group:</b> -	<b>Units group:</b> -	<b>Unit selection:</b> -
	<b>Not for motor type:</b> -	<b>Scaling:</b> -	<b>Expert list:</b> 1
	<b>Min</b> 0	<b>Max</b> 32000	<b>Factory setting</b> 380
<b>Description:</b>	Setting parameter for the run sequence of instance MFP 1 within the run-time group set in p20146.		
<b>Note:</b>	The function blocks with a lower run sequence value are calculated before function blocks with a higher run sequence value.		

---

<b>p20148</b>	<b>BI: PCL 0 input pulse I / PCL 0 inp_pulse I</b>		
All objects (FBLOCKS)	<b>Can be changed:</b> T	<b>Calculated:</b> -	<b>Access level:</b> 1
	<b>Data type:</b> Unsigned32 / Binary	<b>Dynamic index:</b> -	<b>Func. diagram:</b> 7230
	<b>P-Group:</b> -	<b>Units group:</b> -	<b>Unit selection:</b> -
	<b>Not for motor type:</b> -	<b>Scaling:</b> -	<b>Expert list:</b> 1
	<b>Min</b>	<b>Max</b>	<b>Factory setting</b>
	-	-	0
<b>Description:</b>	Sets the signal source for the input pulse I of instance PCL 0 of the pulse shortener.		

---

<b>p20149</b>	<b>PCL 0 pulse duration in ms / PCL 0 pulse_dur ms</b>		
All objects (FBLOCKS)	<b>Can be changed:</b> T	<b>Calculated:</b> -	<b>Access level:</b> 1
	<b>Data type:</b> FloatingPoint32	<b>Dynamic index:</b> -	<b>Func. diagram:</b> 7230
	<b>P-Group:</b> -	<b>Units group:</b> -	<b>Unit selection:</b> -
	<b>Not for motor type:</b> -	<b>Scaling:</b> -	<b>Expert list:</b> 1
	<b>Min</b>	<b>Max</b>	<b>Factory setting</b>
	0.00	60000.00	0.00
<b>Description:</b>	Setting parameter for pulse duration T in milliseconds of instance PCL 0 of the pulse shortener.		

---

<b>r20150</b>	<b>BO: PCL 0 output Q / PCL 0 output Q</b>		
All objects (FBLOCKS)	<b>Can be changed:</b> -	<b>Calculated:</b> -	<b>Access level:</b> 1
	<b>Data type:</b> Unsigned32	<b>Dynamic index:</b> -	<b>Func. diagram:</b> 7230
	<b>P-Group:</b> -	<b>Units group:</b> -	<b>Unit selection:</b> -
	<b>Not for motor type:</b> -	<b>Scaling:</b> -	<b>Expert list:</b> 1
	<b>Min</b>	<b>Max</b>	<b>Factory setting</b>
	-	-	-
<b>Description:</b>	Display parameter for output pulse Q of instance PCL 0 of the pulse shortener.		

---

<b>p20151</b>	<b>PCL 0 run-time group / PCL 0 RTG</b>		
All objects (FBLOCKS)	<b>Can be changed:</b> T	<b>Calculated:</b> -	<b>Access level:</b> 1
	<b>Data type:</b> Integer16	<b>Dynamic index:</b> -	<b>Func. diagram:</b> 7230
	<b>P-Group:</b> -	<b>Units group:</b> -	<b>Unit selection:</b> -
	<b>Not for motor type:</b> -	<b>Scaling:</b> -	<b>Expert list:</b> 1
	<b>Min</b>	<b>Max</b>	<b>Factory setting</b>
	0	9999	9999
<b>Description:</b>	Setting parameter for the run-time group in which the instance PCL 0 of the pulse shortener is to be called.		
<b>Value:</b>	0: Run-time group 0 1: Run-time group 1 2: Run-time group 2 3: Run-time group 3 4: Run-time group 4 5: Run-time group 5 6: Run-time group 6 7: Run-time group 7 8: Run-time group 8 9: Run-time group 9 9999: Do not calculate		

<b>p20152</b>	<b>PCL 0 run sequence / PCL 0 RunSeq</b>		
All objects (FBLOCKS)	<b>Can be changed:</b> T	<b>Calculated:</b> -	<b>Access level:</b> 1
	<b>Data type:</b> Unsigned16	<b>Dynamic index:</b> -	<b>Func. diagram:</b> 7230
	<b>P-Group:</b> -	<b>Units group:</b> -	<b>Unit selection:</b> -
	<b>Not for motor type:</b> -	<b>Scaling:</b> -	<b>Expert list:</b> 1
	<b>Min</b> 0	<b>Max</b> 32000	<b>Factory setting</b> 400
<b>Description:</b>	Setting parameter for the run sequence of instance PCL 0 within the run-time group set in p20151.		
<b>Note:</b>	The function blocks with a lower run sequence value are calculated before function blocks with a higher run sequence value.		
<b>p20153</b>	<b>BI: PCL 1 input pulse I / PCL 1 inp_pulse I</b>		
All objects (FBLOCKS)	<b>Can be changed:</b> T	<b>Calculated:</b> -	<b>Access level:</b> 1
	<b>Data type:</b> Unsigned32 / Binary	<b>Dynamic index:</b> -	<b>Func. diagram:</b> 7230
	<b>P-Group:</b> -	<b>Units group:</b> -	<b>Unit selection:</b> -
	<b>Not for motor type:</b> -	<b>Scaling:</b> -	<b>Expert list:</b> 1
	<b>Min</b> -	<b>Max</b> -	<b>Factory setting</b> 0
<b>Description:</b>	Sets the signal source for the input pulse I of instance PCL 1 of the pulse shortener.		
<b>p20154</b>	<b>PCL 1 pulse duration in ms / PCL 1 pulse_dur ms</b>		
All objects (FBLOCKS)	<b>Can be changed:</b> T	<b>Calculated:</b> -	<b>Access level:</b> 1
	<b>Data type:</b> FloatingPoint32	<b>Dynamic index:</b> -	<b>Func. diagram:</b> 7230
	<b>P-Group:</b> -	<b>Units group:</b> -	<b>Unit selection:</b> -
	<b>Not for motor type:</b> -	<b>Scaling:</b> -	<b>Expert list:</b> 1
	<b>Min</b> 0.00	<b>Max</b> 60000.00	<b>Factory setting</b> 0.00
<b>Description:</b>	Setting parameter for pulse duration T in milliseconds of instance PCL 1 of the pulse shortener.		
<b>r20155</b>	<b>BO: PCL 1 output Q / PCL 1 output Q</b>		
All objects (FBLOCKS)	<b>Can be changed:</b> -	<b>Calculated:</b> -	<b>Access level:</b> 1
	<b>Data type:</b> Unsigned32	<b>Dynamic index:</b> -	<b>Func. diagram:</b> 7230
	<b>P-Group:</b> -	<b>Units group:</b> -	<b>Unit selection:</b> -
	<b>Not for motor type:</b> -	<b>Scaling:</b> -	<b>Expert list:</b> 1
	<b>Min</b> -	<b>Max</b> -	<b>Factory setting</b> -
<b>Description:</b>	Display parameter for output pulse Q of instance PCL 1 of the pulse shortener.		
<b>p20156</b>	<b>PCL 1 run-time group / PCL 1 RTG</b>		
All objects (FBLOCKS)	<b>Can be changed:</b> T	<b>Calculated:</b> -	<b>Access level:</b> 1
	<b>Data type:</b> Integer16	<b>Dynamic index:</b> -	<b>Func. diagram:</b> 7230
	<b>P-Group:</b> -	<b>Units group:</b> -	<b>Unit selection:</b> -
	<b>Not for motor type:</b> -	<b>Scaling:</b> -	<b>Expert list:</b> 1
	<b>Min</b> 0	<b>Max</b> 9999	<b>Factory setting</b> 9999
<b>Description:</b>	Setting parameter for the run-time group in which the instance PCL 1 of the pulse shortener is to be called.		
<b>Value:</b>	0: Run-time group 0 1: Run-time group 1 2: Run-time group 2 3: Run-time group 3 4: Run-time group 4 5: Run-time group 5		

6: Run-time group 6  
7: Run-time group 7  
8: Run-time group 8  
9: Run-time group 9  
9999: Do not calculate

---

<b>p20157</b>	<b>PCL 1 run sequence / PCL 1 RunSeq</b>		
All objects (FBLOCKS)	<b>Can be changed:</b> T	<b>Calculated:</b> -	<b>Access level:</b> 1
	<b>Data type:</b> Unsigned16	<b>Dynamic index:</b> -	<b>Func. diagram:</b> 7230
	<b>P-Group:</b> -	<b>Units group:</b> -	<b>Unit selection:</b> -
	<b>Not for motor type:</b> -	<b>Scaling:</b> -	<b>Expert list:</b> 1
	<b>Min</b>	<b>Max</b>	<b>Factory setting</b>
	0	32000	410
<b>Description:</b>	Setting parameter for the run sequence of instance PCL 1 within the run-time group set in p20156.		
<b>Note:</b>	The function blocks with a lower run sequence value are calculated before function blocks with a higher run sequence value.		

---

<b>p20158</b>	<b>BI: PDE 0 input pulse I / PDE 0 inp_pulse I</b>		
All objects (FBLOCKS)	<b>Can be changed:</b> T	<b>Calculated:</b> -	<b>Access level:</b> 1
	<b>Data type:</b> Unsigned32 / Binary	<b>Dynamic index:</b> -	<b>Func. diagram:</b> 7232
	<b>P-Group:</b> -	<b>Units group:</b> -	<b>Unit selection:</b> -
	<b>Not for motor type:</b> -	<b>Scaling:</b> -	<b>Expert list:</b> 1
	<b>Min</b>	<b>Max</b>	<b>Factory setting</b>
	-	-	0
<b>Description:</b>	Sets the signal source for the input pulse I of instance PDE 0 of the closing delay device.		

---

<b>p20159</b>	<b>PDE 0 pulse delay time in ms / PDE 0 t_del ms</b>		
All objects (FBLOCKS)	<b>Can be changed:</b> T	<b>Calculated:</b> -	<b>Access level:</b> 1
	<b>Data type:</b> FloatingPoint32	<b>Dynamic index:</b> -	<b>Func. diagram:</b> 7232
	<b>P-Group:</b> -	<b>Units group:</b> -	<b>Unit selection:</b> -
	<b>Not for motor type:</b> -	<b>Scaling:</b> -	<b>Expert list:</b> 1
	<b>Min</b>	<b>Max</b>	<b>Factory setting</b>
	0.00	60000.00	0.00
<b>Description:</b>	Setting parameter for pulse delay time T in milliseconds of instance PDE 0 of the closing delay device.		

---

<b>r20160</b>	<b>BO: PDE 0 output Q / PDE 0 output Q</b>		
All objects (FBLOCKS)	<b>Can be changed:</b> -	<b>Calculated:</b> -	<b>Access level:</b> 1
	<b>Data type:</b> Unsigned32	<b>Dynamic index:</b> -	<b>Func. diagram:</b> 7232
	<b>P-Group:</b> -	<b>Units group:</b> -	<b>Unit selection:</b> -
	<b>Not for motor type:</b> -	<b>Scaling:</b> -	<b>Expert list:</b> 1
	<b>Min</b>	<b>Max</b>	<b>Factory setting</b>
	-	-	-
<b>Description:</b>	Display parameter for output pulse Q of instance PDE 0 of the closing delay device.		

---

<b>p20161</b>	<b>PDE 0 run-time group / PDE 0 RTG</b>		
All objects (FBLOCKS)	<b>Can be changed:</b> T	<b>Calculated:</b> -	<b>Access level:</b> 1
	<b>Data type:</b> Integer16	<b>Dynamic index:</b> -	<b>Func. diagram:</b> 7232
	<b>P-Group:</b> -	<b>Units group:</b> -	<b>Unit selection:</b> -
	<b>Not for motor type:</b> -	<b>Scaling:</b> -	<b>Expert list:</b> 1
	<b>Min</b>	<b>Max</b>	<b>Factory setting</b>
	0	9999	9999
<b>Description:</b>	Setting parameter for the run-time group in which instance PDE 0 of the closing delay device is to be called.		

<b>Value:</b>	0:	Run-time group 0
	1:	Run-time group 1
	2:	Run-time group 2
	3:	Run-time group 3
	4:	Run-time group 4
	5:	Run-time group 5
	6:	Run-time group 6
	7:	Run-time group 7
	8:	Run-time group 8
	9:	Run-time group 9
	9999:	Do not calculate

---

<b>p20162</b>	<b>PDE 0 run sequence / PDE 0 RunSeq</b>		
All objects (FBLOCKS)	<b>Can be changed:</b> T	<b>Calculated:</b> -	<b>Access level:</b> 1
	<b>Data type:</b> Unsigned16	<b>Dynamic index:</b> -	<b>Func. diagram:</b> 7232
	<b>P-Group:</b> -	<b>Units group:</b> -	<b>Unit selection:</b> -
	<b>Not for motor type:</b> -	<b>Scaling:</b> -	<b>Expert list:</b> 1
	<b>Min</b>	<b>Max</b>	<b>Factory setting</b>
	0	32000	430
<b>Description:</b>	Setting parameter for the run sequence of instance PDE 0 within the run-time group set in p20161.		
<b>Note:</b>	The function blocks with a lower run sequence value are calculated before function blocks with a higher run sequence value.		

---

<b>p20163</b>	<b>BI: PDE 1 input pulse I / PDE 1 inp_pulse I</b>		
All objects (FBLOCKS)	<b>Can be changed:</b> T	<b>Calculated:</b> -	<b>Access level:</b> 1
	<b>Data type:</b> Unsigned32 / Binary	<b>Dynamic index:</b> -	<b>Func. diagram:</b> 7232
	<b>P-Group:</b> -	<b>Units group:</b> -	<b>Unit selection:</b> -
	<b>Not for motor type:</b> -	<b>Scaling:</b> -	<b>Expert list:</b> 1
	<b>Min</b>	<b>Max</b>	<b>Factory setting</b>
	-	-	0
<b>Description:</b>	Sets the signal source for the input pulse I of instance PDE 1 of the closing delay device.		

---

<b>p20164</b>	<b>PDE 1 pulse delay time in ms / PDE 1 t_del ms</b>		
All objects (FBLOCKS)	<b>Can be changed:</b> T	<b>Calculated:</b> -	<b>Access level:</b> 1
	<b>Data type:</b> FloatingPoint32	<b>Dynamic index:</b> -	<b>Func. diagram:</b> 7232
	<b>P-Group:</b> -	<b>Units group:</b> -	<b>Unit selection:</b> -
	<b>Not for motor type:</b> -	<b>Scaling:</b> -	<b>Expert list:</b> 1
	<b>Min</b>	<b>Max</b>	<b>Factory setting</b>
	0.00	60000.00	0.00
<b>Description:</b>	Setting parameter for pulse delay time T in milliseconds of instance PDE 1 of the closing delay device.		

---

<b>r20165</b>	<b>BO: PDE 1 output Q / PDE 1 output Q</b>		
All objects (FBLOCKS)	<b>Can be changed:</b> -	<b>Calculated:</b> -	<b>Access level:</b> 1
	<b>Data type:</b> Unsigned32	<b>Dynamic index:</b> -	<b>Func. diagram:</b> 7232
	<b>P-Group:</b> -	<b>Units group:</b> -	<b>Unit selection:</b> -
	<b>Not for motor type:</b> -	<b>Scaling:</b> -	<b>Expert list:</b> 1
	<b>Min</b>	<b>Max</b>	<b>Factory setting</b>
	-	-	-
<b>Description:</b>	Display parameter for output pulse Q of instance PDE 1 of the closing delay device.		

<b>p20166</b>	<b>PDE 1 run-time group / PDE 1 RTG</b>		
All objects (FBLOCKS)	<b>Can be changed:</b> T	<b>Calculated:</b> -	<b>Access level:</b> 1
	<b>Data type:</b> Integer16	<b>Dynamic index:</b> -	<b>Func. diagram:</b> 7232
	<b>P-Group:</b> -	<b>Units group:</b> -	<b>Unit selection:</b> -
	<b>Not for motor type:</b> -	<b>Scaling:</b> -	<b>Expert list:</b> 1
	<b>Min</b> 0	<b>Max</b> 9999	<b>Factory setting</b> 9999
<b>Description:</b>	Setting parameter for the run-time group in which instance PDE 1 of the closing delay device is to be called.		
<b>Value:</b>	0: Run-time group 0 1: Run-time group 1 2: Run-time group 2 3: Run-time group 3 4: Run-time group 4 5: Run-time group 5 6: Run-time group 6 7: Run-time group 7 8: Run-time group 8 9: Run-time group 9 9999: Do not calculate		
<b>p20167</b>	<b>PDE 1 run sequence / PDE 1 RunSeq</b>		
All objects (FBLOCKS)	<b>Can be changed:</b> T	<b>Calculated:</b> -	<b>Access level:</b> 1
	<b>Data type:</b> Unsigned16	<b>Dynamic index:</b> -	<b>Func. diagram:</b> 7232
	<b>P-Group:</b> -	<b>Units group:</b> -	<b>Unit selection:</b> -
	<b>Not for motor type:</b> -	<b>Scaling:</b> -	<b>Expert list:</b> 1
	<b>Min</b> 0	<b>Max</b> 32000	<b>Factory setting</b> 440
<b>Description:</b>	Setting parameter for the run sequence of instance PDE 1 within the run-time group set in p20166.		
<b>Note:</b>	The function blocks with a lower run sequence value are calculated before function blocks with a higher run sequence value.		
<b>p20168</b>	<b>BI: PDF 0 input pulse I / PDF 0 inp_pulse I</b>		
All objects (FBLOCKS)	<b>Can be changed:</b> T	<b>Calculated:</b> -	<b>Access level:</b> 1
	<b>Data type:</b> Unsigned32 / Binary	<b>Dynamic index:</b> -	<b>Func. diagram:</b> 7232
	<b>P-Group:</b> -	<b>Units group:</b> -	<b>Unit selection:</b> -
	<b>Not for motor type:</b> -	<b>Scaling:</b> -	<b>Expert list:</b> 1
	<b>Min</b> -	<b>Max</b> -	<b>Factory setting</b> 0
<b>Description:</b>	Sets the signal source for the input pulse I of instance PDF 0 of the breaking delay device.		
<b>p20169</b>	<b>PDF 0 pulse extension time in ms / PDF 0 t_ext ms</b>		
All objects (FBLOCKS)	<b>Can be changed:</b> T	<b>Calculated:</b> -	<b>Access level:</b> 1
	<b>Data type:</b> FloatingPoint32	<b>Dynamic index:</b> -	<b>Func. diagram:</b> 7232
	<b>P-Group:</b> -	<b>Units group:</b> -	<b>Unit selection:</b> -
	<b>Not for motor type:</b> -	<b>Scaling:</b> -	<b>Expert list:</b> 1
	<b>Min</b> 0.00	<b>Max</b> 60000.00	<b>Factory setting</b> 0.00
<b>Description:</b>	Setting parameter for pulse extension time T in milliseconds of instance PDF 0 of the breaking delay device.		

<b>r20170</b>	<b>BO: PDF 0 output Q / PDF 0 output Q</b>		
All objects (FBLOCKS)	<b>Can be changed:</b> - <b>Data type:</b> Unsigned32 <b>P-Group:</b> - <b>Not for motor type:</b> - <b>Min</b> -	<b>Calculated:</b> - <b>Dynamic index:</b> - <b>Units group:</b> - <b>Scaling:</b> - <b>Max</b> -	<b>Access level:</b> 1 <b>Func. diagram:</b> 7232 <b>Unit selection:</b> - <b>Expert list:</b> 1 <b>Factory setting</b> -
<b>Description:</b>	Display parameter for output pulse Q of instance PDF 0 of the breaking delay device.		
<b>p20171</b>	<b>PDF 0 run-time group / PDF 0 RTG</b>		
All objects (FBLOCKS)	<b>Can be changed:</b> T <b>Data type:</b> Integer16 <b>P-Group:</b> - <b>Not for motor type:</b> - <b>Min</b> 0	<b>Calculated:</b> - <b>Dynamic index:</b> - <b>Units group:</b> - <b>Scaling:</b> - <b>Max</b> 9999	<b>Access level:</b> 1 <b>Func. diagram:</b> 7232 <b>Unit selection:</b> - <b>Expert list:</b> 1 <b>Factory setting</b> 9999
<b>Description:</b>	Setting parameter for the run-time group in which the instance PDF 0 of the breaking delay device is to be called.		
<b>Value:</b>	0: Run-time group 0 1: Run-time group 1 2: Run-time group 2 3: Run-time group 3 4: Run-time group 4 5: Run-time group 5 6: Run-time group 6 7: Run-time group 7 8: Run-time group 8 9: Run-time group 9 9999: Do not calculate		
<b>p20172</b>	<b>PDF 0 run sequence / PDF 0 RunSeq</b>		
All objects (FBLOCKS)	<b>Can be changed:</b> T <b>Data type:</b> Unsigned16 <b>P-Group:</b> - <b>Not for motor type:</b> - <b>Min</b> 0	<b>Calculated:</b> - <b>Dynamic index:</b> - <b>Units group:</b> - <b>Scaling:</b> - <b>Max</b> 32000	<b>Access level:</b> 1 <b>Func. diagram:</b> 7232 <b>Unit selection:</b> - <b>Expert list:</b> 1 <b>Factory setting</b> 460
<b>Description:</b>	Setting parameter for the run sequence of instance PDF 0 within the run-time group set in p20171.		
<b>Note:</b>	The function blocks with a lower run sequence value are calculated before function blocks with a higher run sequence value.		
<b>p20173</b>	<b>BI: PDF 1 input pulse I / PDF 1 inp_pulse I</b>		
All objects (FBLOCKS)	<b>Can be changed:</b> T <b>Data type:</b> Unsigned32 / Binary <b>P-Group:</b> - <b>Not for motor type:</b> - <b>Min</b> -	<b>Calculated:</b> - <b>Dynamic index:</b> - <b>Units group:</b> - <b>Scaling:</b> - <b>Max</b> -	<b>Access level:</b> 1 <b>Func. diagram:</b> 7232 <b>Unit selection:</b> - <b>Expert list:</b> 1 <b>Factory setting</b> 0
<b>Description:</b>	Sets the signal source for the input pulse I of instance PDF 1 of the breaking delay device.		



<b>p20174</b>	<b>PDF 1 pulse extension time in ms / PDF 1 t_ext ms</b>		
All objects (FBLOCKS)	<b>Can be changed:</b> T	<b>Calculated:</b> -	<b>Access level:</b> 1
	<b>Data type:</b> FloatingPoint32	<b>Dynamic index:</b> -	<b>Func. diagram:</b> 7232
	<b>P-Group:</b> -	<b>Units group:</b> -	<b>Unit selection:</b> -
	<b>Not for motor type:</b> -	<b>Scaling:</b> -	<b>Expert list:</b> 1
	<b>Min</b> 0.00	<b>Max</b> 60000.00	<b>Factory setting</b> 0.00
<b>Description:</b>	Setting parameter for pulse extension time T in milliseconds of instance PDF 1 of the breaking delay device.		
<b>r20175</b>	<b>BO: PDF 1 output Q / PDF 1 output Q</b>		
All objects (FBLOCKS)	<b>Can be changed:</b> -	<b>Calculated:</b> -	<b>Access level:</b> 1
	<b>Data type:</b> Unsigned32	<b>Dynamic index:</b> -	<b>Func. diagram:</b> 7232
	<b>P-Group:</b> -	<b>Units group:</b> -	<b>Unit selection:</b> -
	<b>Not for motor type:</b> -	<b>Scaling:</b> -	<b>Expert list:</b> 1
	<b>Min</b> -	<b>Max</b> -	<b>Factory setting</b> -
<b>Description:</b>	Display parameter for output pulse Q of instance PDF 1 of the breaking delay device.		
<b>p20176</b>	<b>PDF 1 run-time group / PDF 1 RTG</b>		
All objects (FBLOCKS)	<b>Can be changed:</b> T	<b>Calculated:</b> -	<b>Access level:</b> 1
	<b>Data type:</b> Integer16	<b>Dynamic index:</b> -	<b>Func. diagram:</b> 7232
	<b>P-Group:</b> -	<b>Units group:</b> -	<b>Unit selection:</b> -
	<b>Not for motor type:</b> -	<b>Scaling:</b> -	<b>Expert list:</b> 1
	<b>Min</b> 0	<b>Max</b> 9999	<b>Factory setting</b> 9999
<b>Description:</b>	Setting parameter for the run-time group in which the instance PDF 1 of the breaking delay device is to be called.		
<b>Value:</b>	0: Run-time group 0 1: Run-time group 1 2: Run-time group 2 3: Run-time group 3 4: Run-time group 4 5: Run-time group 5 6: Run-time group 6 7: Run-time group 7 8: Run-time group 8 9: Run-time group 9 9999: Do not calculate		
<b>p20177</b>	<b>PDF 1 run sequence / PDF 1 RunSeq</b>		
All objects (FBLOCKS)	<b>Can be changed:</b> T	<b>Calculated:</b> -	<b>Access level:</b> 1
	<b>Data type:</b> Unsigned16	<b>Dynamic index:</b> -	<b>Func. diagram:</b> 7232
	<b>P-Group:</b> -	<b>Units group:</b> -	<b>Unit selection:</b> -
	<b>Not for motor type:</b> -	<b>Scaling:</b> -	<b>Expert list:</b> 1
	<b>Min</b> 0	<b>Max</b> 32000	<b>Factory setting</b> 470
<b>Description:</b>	Setting parameter for the run sequence of instance PDF 1 within the run-time group set in p20176.		
<b>Note:</b>	The function blocks with a lower run sequence value are calculated before function blocks with a higher run sequence value.		

<b>p20178[0...1]</b>	<b>BI: PST 0 inputs / PST 0 inputs</b>		
All objects (FBLOCKS)	<b>Can be changed:</b> T	<b>Calculated:</b> -	<b>Access level:</b> 1
	<b>Data type:</b> Unsigned32 / Binary	<b>Dynamic index:</b> -	<b>Func. diagram:</b> 7234
	<b>P-Group:</b> -	<b>Units group:</b> -	<b>Unit selection:</b> -
	<b>Not for motor type:</b> -	<b>Scaling:</b> -	<b>Expert list:</b> 1
	<b>Min</b> -	<b>Max</b> -	<b>Factory setting</b> 0
<b>Description:</b>	Sets the signal source for input pulse I and the reset input R of instance PST 0 of the pulse extension element.		
<b>Index:</b>	[0] = Input pulse I [1] = Reset input R		
<b>p20179</b>	<b>PST 0 pulse duration in ms / PST 0 pulse_dur ms</b>		
All objects (FBLOCKS)	<b>Can be changed:</b> T	<b>Calculated:</b> -	<b>Access level:</b> 1
	<b>Data type:</b> FloatingPoint32	<b>Dynamic index:</b> -	<b>Func. diagram:</b> 7234
	<b>P-Group:</b> -	<b>Units group:</b> -	<b>Unit selection:</b> -
	<b>Not for motor type:</b> -	<b>Scaling:</b> -	<b>Expert list:</b> 1
	<b>Min</b> 0.00	<b>Max</b> 60000.00	<b>Factory setting</b> 0.00
<b>Description:</b>	Setting parameter for pulse duration T in milliseconds of instance PST 0 of the pulse extension element.		
<b>r20180</b>	<b>BO: PST 0 output Q / PST 0 output Q</b>		
All objects (FBLOCKS)	<b>Can be changed:</b> -	<b>Calculated:</b> -	<b>Access level:</b> 1
	<b>Data type:</b> Unsigned32	<b>Dynamic index:</b> -	<b>Func. diagram:</b> 7234
	<b>P-Group:</b> -	<b>Units group:</b> -	<b>Unit selection:</b> -
	<b>Not for motor type:</b> -	<b>Scaling:</b> -	<b>Expert list:</b> 1
	<b>Min</b> -	<b>Max</b> -	<b>Factory setting</b> -
<b>Description:</b>	Display parameter for output pulse Q of instance PST 0 of the pulse extension element.		
<b>p20181</b>	<b>PST 0 run-time group / PST 0 RTG</b>		
All objects (FBLOCKS)	<b>Can be changed:</b> T	<b>Calculated:</b> -	<b>Access level:</b> 1
	<b>Data type:</b> Integer16	<b>Dynamic index:</b> -	<b>Func. diagram:</b> 7234
	<b>P-Group:</b> -	<b>Units group:</b> -	<b>Unit selection:</b> -
	<b>Not for motor type:</b> -	<b>Scaling:</b> -	<b>Expert list:</b> 1
	<b>Min</b> 0	<b>Max</b> 9999	<b>Factory setting</b> 9999
<b>Description:</b>	Setting parameter for the run-time group in which the instance PST 0 of the pulse extension element is to be called.		
<b>Value:</b>	0: Run-time group 0 1: Run-time group 1 2: Run-time group 2 3: Run-time group 3 4: Run-time group 4 5: Run-time group 5 6: Run-time group 6 7: Run-time group 7 8: Run-time group 8 9: Run-time group 9 9999: Do not calculate		

<b>p20182</b>	<b>PST 0 run sequence / PST 0 RunSeq</b>		
All objects (FBLOCKS)	<b>Can be changed:</b> T	<b>Calculated:</b> -	<b>Access level:</b> 1
	<b>Data type:</b> Unsigned16	<b>Dynamic index:</b> -	<b>Func. diagram:</b> 7234
	<b>P-Group:</b> -	<b>Units group:</b> -	<b>Unit selection:</b> -
	<b>Not for motor type:</b> -	<b>Scaling:</b> -	<b>Expert list:</b> 1
	<b>Min</b> 0	<b>Max</b> 7999	<b>Factory setting</b> 490
<b>Description:</b>	Setting parameter for the run sequence of instance PST 0 within the run-time group set in p20181.		
<b>Note:</b>	The function blocks with a lower run sequence value are calculated before function blocks with a higher run sequence value.		
<b>p20183[0...1]</b>	<b>BI: PST 1 inputs / PST 1 inputs</b>		
All objects (FBLOCKS)	<b>Can be changed:</b> T	<b>Calculated:</b> -	<b>Access level:</b> 1
	<b>Data type:</b> Unsigned32 / Binary	<b>Dynamic index:</b> -	<b>Func. diagram:</b> 7234
	<b>P-Group:</b> -	<b>Units group:</b> -	<b>Unit selection:</b> -
	<b>Not for motor type:</b> -	<b>Scaling:</b> -	<b>Expert list:</b> 1
	<b>Min</b> -	<b>Max</b> -	<b>Factory setting</b> 0
<b>Description:</b>	Sets the signal source for input pulse I and the reset input R of instance PST 1 of the pulse extension element.		
<b>Index:</b>	[0] = Input pulse I [1] = Reset input R		
<b>p20184</b>	<b>PST 1 pulse duration in ms / PST 1 pulse_dur ms</b>		
All objects (FBLOCKS)	<b>Can be changed:</b> T	<b>Calculated:</b> -	<b>Access level:</b> 1
	<b>Data type:</b> FloatingPoint32	<b>Dynamic index:</b> -	<b>Func. diagram:</b> 7234
	<b>P-Group:</b> -	<b>Units group:</b> -	<b>Unit selection:</b> -
	<b>Not for motor type:</b> -	<b>Scaling:</b> -	<b>Expert list:</b> 1
	<b>Min</b> 0.00	<b>Max</b> 60000.00	<b>Factory setting</b> 0.00
<b>Description:</b>	Setting parameter for pulse duration T in milliseconds of instance PST 1 of the pulse extension element.		
<b>r20185</b>	<b>BO: PST 1 output Q / PST 1 output Q</b>		
All objects (FBLOCKS)	<b>Can be changed:</b> -	<b>Calculated:</b> -	<b>Access level:</b> 1
	<b>Data type:</b> Unsigned32	<b>Dynamic index:</b> -	<b>Func. diagram:</b> 7234
	<b>P-Group:</b> -	<b>Units group:</b> -	<b>Unit selection:</b> -
	<b>Not for motor type:</b> -	<b>Scaling:</b> -	<b>Expert list:</b> 1
	<b>Min</b> -	<b>Max</b> -	<b>Factory setting</b> -
<b>Description:</b>	Display parameter for output pulse Q of instance PST 1 of the pulse extension element.		
<b>p20186</b>	<b>PST 1 run-time group / PST 1 RTG</b>		
All objects (FBLOCKS)	<b>Can be changed:</b> T	<b>Calculated:</b> -	<b>Access level:</b> 1
	<b>Data type:</b> Integer16	<b>Dynamic index:</b> -	<b>Func. diagram:</b> 7234
	<b>P-Group:</b> -	<b>Units group:</b> -	<b>Unit selection:</b> -
	<b>Not for motor type:</b> -	<b>Scaling:</b> -	<b>Expert list:</b> 1
	<b>Min</b> 0	<b>Max</b> 9999	<b>Factory setting</b> 9999
<b>Description:</b>	Setting parameter for the run-time group in which the instance PST 1 of the pulse extension element is to be called.		
<b>Value:</b>	0: Run-time group 0 1: Run-time group 1 2: Run-time group 2 3: Run-time group 3		

4: Run-time group 4  
 5: Run-time group 5  
 6: Run-time group 6  
 7: Run-time group 7  
 8: Run-time group 8  
 9: Run-time group 9  
 9999: Do not calculate

<b>p20187</b>	<b>PST 1 run sequence / PST 1 RunSeq</b>		
All objects (FBLOCKS)	<b>Can be changed:</b> T	<b>Calculated:</b> -	<b>Access level:</b> 1
	<b>Data type:</b> Unsigned16	<b>Dynamic index:</b> -	<b>Func. diagram:</b> 7234
	<b>P-Group:</b> -	<b>Units group:</b> -	<b>Unit selection:</b> -
	<b>Not for motor type:</b> -	<b>Scaling:</b> -	<b>Expert list:</b> 1
	<b>Min</b> 0	<b>Max</b> 7999	<b>Factory setting</b> 500
<b>Description:</b>	Setting parameter for the run sequence of instance PST 1 within the run-time group set in p20186.		
<b>Note:</b>	The function blocks with a lower run sequence value are calculated before function blocks with a higher run sequence value.		
<b>p20188[0...1]</b>	<b>BI: RSR 0 inputs / RSR 0 inputs</b>		
All objects (FBLOCKS)	<b>Can be changed:</b> T	<b>Calculated:</b> -	<b>Access level:</b> 1
	<b>Data type:</b> Unsigned32 / Binary	<b>Dynamic index:</b> -	<b>Func. diagram:</b> 7240
	<b>P-Group:</b> -	<b>Units group:</b> -	<b>Unit selection:</b> -
	<b>Not for motor type:</b> -	<b>Scaling:</b> -	<b>Expert list:</b> 1
	<b>Min</b> -	<b>Max</b> -	<b>Factory setting</b> 0
<b>Description:</b>	Sets the signal source for set input S and reset input R of instance RSR 0 of the RS flipflop.		
<b>Index:</b>	[0] = Set S [1] = Reset R		
<b>r20189</b>	<b>BO: RSR 0 output Q / RSR 0 output Q</b>		
All objects (FBLOCKS)	<b>Can be changed:</b> -	<b>Calculated:</b> -	<b>Access level:</b> 1
	<b>Data type:</b> Unsigned32	<b>Dynamic index:</b> -	<b>Func. diagram:</b> 7240
	<b>P-Group:</b> -	<b>Units group:</b> -	<b>Unit selection:</b> -
	<b>Not for motor type:</b> -	<b>Scaling:</b> -	<b>Expert list:</b> 1
	<b>Min</b> -	<b>Max</b> -	<b>Factory setting</b> -
<b>Description:</b>	Display parameter for output Q of instance RSR 0 of the RS flipflop		
<b>r20190</b>	<b>BO: RSR 0 inverted output QN / RSR 0 inv outp QN</b>		
All objects (FBLOCKS)	<b>Can be changed:</b> -	<b>Calculated:</b> -	<b>Access level:</b> 1
	<b>Data type:</b> Unsigned32	<b>Dynamic index:</b> -	<b>Func. diagram:</b> 7240
	<b>P-Group:</b> -	<b>Units group:</b> -	<b>Unit selection:</b> -
	<b>Not for motor type:</b> -	<b>Scaling:</b> -	<b>Expert list:</b> 1
	<b>Min</b> -	<b>Max</b> -	<b>Factory setting</b> -
<b>Description:</b>	Display parameter for inverted output QN of instance RSR 0 of the RS flipflop.		

<b>p20191</b>	<b>RSR 0 run-time group / RSR 0 RTG</b>		
All objects (FBLOCKS)	<b>Can be changed:</b> T	<b>Calculated:</b> -	<b>Access level:</b> 1
	<b>Data type:</b> Integer16	<b>Dynamic index:</b> -	<b>Func. diagram:</b> 7240
	<b>P-Group:</b> -	<b>Units group:</b> -	<b>Unit selection:</b> -
	<b>Not for motor type:</b> -	<b>Scaling:</b> -	<b>Expert list:</b> 1
	<b>Min</b>	<b>Max</b>	<b>Factory setting</b>
	0	9999	9999
<b>Description:</b>	Setting parameter for the run-time group in which instance RSR 0 of the RS flipflop is to be called.		
<b>Value:</b>	0: Run-time group 0 1: Run-time group 1 2: Run-time group 2 3: Run-time group 3 4: Run-time group 4 5: Run-time group 5 6: Run-time group 6 7: Run-time group 7 8: Run-time group 8 9: Run-time group 9 9999: Do not calculate		
<b>p20192</b>	<b>RSR 0 run sequence / RSR 0 RunSeq</b>		
All objects (FBLOCKS)	<b>Can be changed:</b> T	<b>Calculated:</b> -	<b>Access level:</b> 1
	<b>Data type:</b> Unsigned16	<b>Dynamic index:</b> -	<b>Func. diagram:</b> 7240
	<b>P-Group:</b> -	<b>Units group:</b> -	<b>Unit selection:</b> -
	<b>Not for motor type:</b> -	<b>Scaling:</b> -	<b>Expert list:</b> 1
	<b>Min</b>	<b>Max</b>	<b>Factory setting</b>
	0	7999	520
<b>Description:</b>	Setting parameter for the run sequence of instance RSR 0 within the run-time group set in p20191.		
<b>Note:</b>	The function blocks with a lower run sequence value are calculated before function blocks with a higher run sequence value.		
<b>p20193[0...1]</b>	<b>BI: RSR 1 inputs / RSR 1 inputs</b>		
All objects (FBLOCKS)	<b>Can be changed:</b> T	<b>Calculated:</b> -	<b>Access level:</b> 1
	<b>Data type:</b> Unsigned32 / Binary	<b>Dynamic index:</b> -	<b>Func. diagram:</b> 7240
	<b>P-Group:</b> -	<b>Units group:</b> -	<b>Unit selection:</b> -
	<b>Not for motor type:</b> -	<b>Scaling:</b> -	<b>Expert list:</b> 1
	<b>Min</b>	<b>Max</b>	<b>Factory setting</b>
	-	-	0
<b>Description:</b>	Sets the signal source for set input S and reset input R of instance RSR 1 of the RS flipflop.		
<b>Index:</b>	[0] = Set S [1] = Reset R		
<b>r20194</b>	<b>BO: RSR 1 output Q / RSR 1 output Q</b>		
All objects (FBLOCKS)	<b>Can be changed:</b> -	<b>Calculated:</b> -	<b>Access level:</b> 1
	<b>Data type:</b> Unsigned32	<b>Dynamic index:</b> -	<b>Func. diagram:</b> 7240
	<b>P-Group:</b> -	<b>Units group:</b> -	<b>Unit selection:</b> -
	<b>Not for motor type:</b> -	<b>Scaling:</b> -	<b>Expert list:</b> 1
	<b>Min</b>	<b>Max</b>	<b>Factory setting</b>
	-	-	-
<b>Description:</b>	Display parameter for output Q of instance RSR 1 of the RS flipflop		

<b>p20195</b>	<b>BO: RSR 1 inverted output QN / RSR 1 inv outp QN</b>		
All objects (FBLOCKS)	<b>Can be changed:</b> - <b>Data type:</b> Unsigned32 <b>P-Group:</b> - <b>Not for motor type:</b> - <b>Min</b> -	<b>Calculated:</b> - <b>Dynamic index:</b> - <b>Units group:</b> - <b>Scaling:</b> - <b>Max</b> -	<b>Access level:</b> 1 <b>Func. diagram:</b> 7240 <b>Unit selection:</b> - <b>Expert list:</b> 1 <b>Factory setting</b> -
<b>Description:</b>	Display parameter for inverted output QN of instance RSR 1 of the RS flipflop.		
<b>p20196</b>	<b>RSR 1 run-time group / RSR 1 RTG</b>		
All objects (FBLOCKS)	<b>Can be changed:</b> T <b>Data type:</b> Integer16 <b>P-Group:</b> - <b>Not for motor type:</b> - <b>Min</b> 0	<b>Calculated:</b> - <b>Dynamic index:</b> - <b>Units group:</b> - <b>Scaling:</b> - <b>Max</b> 9999	<b>Access level:</b> 1 <b>Func. diagram:</b> 7240 <b>Unit selection:</b> - <b>Expert list:</b> 1 <b>Factory setting</b> 9999
<b>Description:</b>	Setting parameter for the run-time group in which instance RSR 1 of the RS flipflop is to be called.		
<b>Value:</b>	0: Run-time group 0 1: Run-time group 1 2: Run-time group 2 3: Run-time group 3 4: Run-time group 4 5: Run-time group 5 6: Run-time group 6 7: Run-time group 7 8: Run-time group 8 9: Run-time group 9 9999: Do not calculate		
<b>p20197</b>	<b>RSR 1 run sequence / RSR 1 RunSeq</b>		
All objects (FBLOCKS)	<b>Can be changed:</b> T <b>Data type:</b> Unsigned16 <b>P-Group:</b> - <b>Not for motor type:</b> - <b>Min</b> 0	<b>Calculated:</b> - <b>Dynamic index:</b> - <b>Units group:</b> - <b>Scaling:</b> - <b>Max</b> 7999	<b>Access level:</b> 1 <b>Func. diagram:</b> 7240 <b>Unit selection:</b> - <b>Expert list:</b> 1 <b>Factory setting</b> 530
<b>Description:</b>	Setting parameter for the run sequence of instance RSR 1 within the run-time group set in p20196.		
<b>Note:</b>	The function blocks with a lower run sequence value are calculated before function blocks with a higher run sequence value.		
<b>p20198[0...3]</b>	<b>BI: DFR 0 inputs / DFR 0 inputs</b>		
All objects (FBLOCKS)	<b>Can be changed:</b> T <b>Data type:</b> Unsigned32 / Binary <b>P-Group:</b> - <b>Not for motor type:</b> - <b>Min</b> -	<b>Calculated:</b> - <b>Dynamic index:</b> - <b>Units group:</b> - <b>Scaling:</b> - <b>Max</b> -	<b>Access level:</b> 1 <b>Func. diagram:</b> 7240 <b>Unit selection:</b> - <b>Expert list:</b> 1 <b>Factory setting</b> 0
<b>Description:</b>	Sets the signal source for trigger input I, D input D, set input S, and reset input R of instance DFR 0 of the D flipflop.		
<b>Index:</b>	[0] = Trigger input I [1] = D input D [2] = Set S [3] = Reset R		

<b>r20199</b>	<b>BO: DFR 0 output Q / DFR 0 output Q</b>		
All objects (FBLOCKS)	<b>Can be changed:</b> - <b>Data type:</b> Unsigned32 <b>P-Group:</b> - <b>Not for motor type:</b> - <b>Min</b> -	<b>Calculated:</b> - <b>Dynamic index:</b> - <b>Units group:</b> - <b>Scaling:</b> - <b>Max</b> -	<b>Access level:</b> 1 <b>Func. diagram:</b> 7240 <b>Unit selection:</b> - <b>Expert list:</b> 1 <b>Factory setting</b> -
<b>Description:</b>	Display parameter for output Q of instance DFR 0 of the D flipflop.		
<b>r20200</b>	<b>BO: DFR 0 inverted output QN / DFR 0 inv outp QN</b>		
All objects (FBLOCKS)	<b>Can be changed:</b> - <b>Data type:</b> Unsigned32 <b>P-Group:</b> - <b>Not for motor type:</b> - <b>Min</b> -	<b>Calculated:</b> - <b>Dynamic index:</b> - <b>Units group:</b> - <b>Scaling:</b> - <b>Max</b> -	<b>Access level:</b> 1 <b>Func. diagram:</b> 7240 <b>Unit selection:</b> - <b>Expert list:</b> 1 <b>Factory setting</b> -
<b>Description:</b>	Display parameter for the inverted output QN of instance DFR 0 of the D flipflop.		
<b>p20201</b>	<b>DFR 0 run-time group / DFR 0 RTG</b>		
All objects (FBLOCKS)	<b>Can be changed:</b> T <b>Data type:</b> Integer16 <b>P-Group:</b> - <b>Not for motor type:</b> - <b>Min</b> 0	<b>Calculated:</b> - <b>Dynamic index:</b> - <b>Units group:</b> - <b>Scaling:</b> - <b>Max</b> 9999	<b>Access level:</b> 1 <b>Func. diagram:</b> 7240 <b>Unit selection:</b> - <b>Expert list:</b> 1 <b>Factory setting</b> 9999
<b>Description:</b>	Setting parameter for the run-time group in which instance DFR 0 of the D flipflop is to be called.		
<b>Value:</b>	0: Run-time group 0 1: Run-time group 1 2: Run-time group 2 3: Run-time group 3 4: Run-time group 4 5: Run-time group 5 6: Run-time group 6 7: Run-time group 7 8: Run-time group 8 9: Run-time group 9 9999: Do not calculate		
<b>p20202</b>	<b>DFR 0 run sequence / DFR 0 RunSeq</b>		
All objects (FBLOCKS)	<b>Can be changed:</b> T <b>Data type:</b> Unsigned16 <b>P-Group:</b> - <b>Not for motor type:</b> - <b>Min</b> 0	<b>Calculated:</b> - <b>Dynamic index:</b> - <b>Units group:</b> - <b>Scaling:</b> - <b>Max</b> 32000	<b>Access level:</b> 1 <b>Func. diagram:</b> 7240 <b>Unit selection:</b> - <b>Expert list:</b> 1 <b>Factory setting</b> 550
<b>Description:</b>	Setting parameter for the run sequence of instance DFR 0 within the run-time group set in p20201.		
<b>Note:</b>	The function blocks with a lower run sequence value are calculated before function blocks with a higher run sequence value.		

<b>p20203[0...3]</b>	<b>BI: DFR 1 inputs / DFR 1 inputs</b>		
All objects (FBLOCKS)	<b>Can be changed:</b> T	<b>Calculated:</b> -	<b>Access level:</b> 1
	<b>Data type:</b> Unsigned32 / Binary	<b>Dynamic index:</b> -	<b>Func. diagram:</b> 7240
	<b>P-Group:</b> -	<b>Units group:</b> -	<b>Unit selection:</b> -
	<b>Not for motor type:</b> -	<b>Scaling:</b> -	<b>Expert list:</b> 1
	<b>Min</b>	<b>Max</b>	<b>Factory setting</b>
	-	-	0
<b>Description:</b>	Sets the signal source for trigger input I, D input D, set input S, and reset input R of instance DFR 1 of the D flipflop.		
<b>Index:</b>	[0] = Trigger input I [1] = D input D [2] = Set S [3] = Reset R		
<b>r20204</b>	<b>BO: DFR 1 output Q / DFR 1 output Q</b>		
All objects (FBLOCKS)	<b>Can be changed:</b> -	<b>Calculated:</b> -	<b>Access level:</b> 1
	<b>Data type:</b> Unsigned32	<b>Dynamic index:</b> -	<b>Func. diagram:</b> 7240
	<b>P-Group:</b> -	<b>Units group:</b> -	<b>Unit selection:</b> -
	<b>Not for motor type:</b> -	<b>Scaling:</b> -	<b>Expert list:</b> 1
	<b>Min</b>	<b>Max</b>	<b>Factory setting</b>
	-	-	-
<b>Description:</b>	Display parameter for output Q of instance DFR 1 of the D flipflop.		
<b>r20205</b>	<b>BO: DFR 1 inverted output QN / DFR 1 inv outp QN</b>		
All objects (FBLOCKS)	<b>Can be changed:</b> -	<b>Calculated:</b> -	<b>Access level:</b> 1
	<b>Data type:</b> Unsigned32	<b>Dynamic index:</b> -	<b>Func. diagram:</b> 7240
	<b>P-Group:</b> -	<b>Units group:</b> -	<b>Unit selection:</b> -
	<b>Not for motor type:</b> -	<b>Scaling:</b> -	<b>Expert list:</b> 1
	<b>Min</b>	<b>Max</b>	<b>Factory setting</b>
	-	-	-
<b>Description:</b>	Display parameter for the inverted output QN of instance DFR 1 of the D flipflop.		
<b>p20206</b>	<b>DFR 1 run-time group / DFR 1 RTG</b>		
All objects (FBLOCKS)	<b>Can be changed:</b> T	<b>Calculated:</b> -	<b>Access level:</b> 1
	<b>Data type:</b> Integer16	<b>Dynamic index:</b> -	<b>Func. diagram:</b> 7240
	<b>P-Group:</b> -	<b>Units group:</b> -	<b>Unit selection:</b> -
	<b>Not for motor type:</b> -	<b>Scaling:</b> -	<b>Expert list:</b> 1
	<b>Min</b>	<b>Max</b>	<b>Factory setting</b>
	0	9999	9999
<b>Description:</b>	Setting parameter for the run-time group in which instance DFR 1 of the D flipflop is to be called.		
<b>Value:</b>	0: Run-time group 0 1: Run-time group 1 2: Run-time group 2 3: Run-time group 3 4: Run-time group 4 5: Run-time group 5 6: Run-time group 6 7: Run-time group 7 8: Run-time group 8 9: Run-time group 9 9999: Do not calculate		



<b>p20207</b>	<b>DFR 1 run sequence / DFR 1 RunSeq</b>		
All objects (FBLOCKS)	<b>Can be changed:</b> T <b>Data type:</b> Unsigned16 <b>P-Group:</b> - <b>Not for motor type:</b> - <b>Min</b> 0	<b>Calculated:</b> - <b>Dynamic index:</b> - <b>Units group:</b> - <b>Scaling:</b> - <b>Max</b> 32000	<b>Access level:</b> 1 <b>Func. diagram:</b> 7240 <b>Unit selection:</b> - <b>Expert list:</b> 1 <b>Factory setting</b> 560
<b>Description:</b>	Setting parameter for the run-time group of instance DFR 1 within the run-time group set in p20206.		
<b>Note:</b>	The function blocks with a lower run sequence value are calculated before function blocks with a higher run sequence value.		
<b>p20208[0...1]</b>	<b>BI: BSW 0 inputs / BSW 0 inputs</b>		
All objects (FBLOCKS)	<b>Can be changed:</b> T <b>Data type:</b> Unsigned32 / Binary <b>P-Group:</b> - <b>Not for motor type:</b> - <b>Min</b> -	<b>Calculated:</b> - <b>Dynamic index:</b> - <b>Units group:</b> - <b>Scaling:</b> - <b>Max</b> -	<b>Access level:</b> 1 <b>Func. diagram:</b> 7250 <b>Unit selection:</b> - <b>Expert list:</b> 1 <b>Factory setting</b> 0
<b>Description:</b>	Sets the signal source of input quantities I0 and I1 of instance BSW 0 of the binary changeover switch.		
<b>Index:</b>	[0] = Input I0 [1] = Input I1		
<b>p20209</b>	<b>BI: BSW 0 switch setting I / BSW 0 sw_setting</b>		
All objects (FBLOCKS)	<b>Can be changed:</b> T <b>Data type:</b> Unsigned32 / Binary <b>P-Group:</b> - <b>Not for motor type:</b> - <b>Min</b> -	<b>Calculated:</b> - <b>Dynamic index:</b> - <b>Units group:</b> - <b>Scaling:</b> - <b>Max</b> -	<b>Access level:</b> 1 <b>Func. diagram:</b> 7250 <b>Unit selection:</b> - <b>Expert list:</b> 1 <b>Factory setting</b> 0
<b>Description:</b>	Sets the signal source of the switch setting I of instance BSW 0 of the binary changeover switch.		
<b>r20210</b>	<b>BO: BSW 0 output Q / BSW 0 output Q</b>		
All objects (FBLOCKS)	<b>Can be changed:</b> - <b>Data type:</b> Unsigned32 <b>P-Group:</b> - <b>Not for motor type:</b> - <b>Min</b> -	<b>Calculated:</b> - <b>Dynamic index:</b> - <b>Units group:</b> - <b>Scaling:</b> - <b>Max</b> -	<b>Access level:</b> 1 <b>Func. diagram:</b> 7250 <b>Unit selection:</b> - <b>Expert list:</b> 1 <b>Factory setting</b> -
<b>Description:</b>	Display parameter for output quantity Q of instance BSW 0 of the binary changeover switch.		
<b>p20211</b>	<b>BSW 0 run-time group / BSW 0 RTG</b>		
All objects (FBLOCKS)	<b>Can be changed:</b> T <b>Data type:</b> Integer16 <b>P-Group:</b> - <b>Not for motor type:</b> - <b>Min</b> 0	<b>Calculated:</b> - <b>Dynamic index:</b> - <b>Units group:</b> - <b>Scaling:</b> - <b>Max</b> 9999	<b>Access level:</b> 1 <b>Func. diagram:</b> 7250 <b>Unit selection:</b> - <b>Expert list:</b> 1 <b>Factory setting</b> 9999
<b>Description:</b>	Setting parameter for the run-time group in which the instance BSW 0 of the binary changeover switch is to be called.		
<b>Value:</b>	0: Run-time group 0 1: Run-time group 1 2: Run-time group 2		

3: Run-time group 3  
 4: Run-time group 4  
 5: Run-time group 5  
 6: Run-time group 6  
 7: Run-time group 7  
 8: Run-time group 8  
 9: Run-time group 9  
 9999: Do not calculate

**p20212 BSW 0 run sequence / BSW 0 RunSeq**

All objects (FBLOCKS)	<b>Can be changed:</b> T	<b>Calculated:</b> -	<b>Access level:</b> 1
	<b>Data type:</b> Unsigned16	<b>Dynamic index:</b> -	<b>Func. diagram:</b> 7250
	<b>P-Group:</b> -	<b>Units group:</b> -	<b>Unit selection:</b> -
	<b>Not for motor type:</b> -	<b>Scaling:</b> -	<b>Expert list:</b> 1
	<b>Min</b>	<b>Max</b>	<b>Factory setting</b>
	0	7999	580

**Description:** Setting parameter for the run sequence of instance BSW 0 within the run-time group set in p20211.

**Note:** The function blocks with a lower run sequence value are calculated before function blocks with a higher run sequence value.

**p20213[0...1] BI: BSW 1 inputs / BSW 1 inputs**

All objects (FBLOCKS)	<b>Can be changed:</b> T	<b>Calculated:</b> -	<b>Access level:</b> 1
	<b>Data type:</b> Unsigned32 / Binary	<b>Dynamic index:</b> -	<b>Func. diagram:</b> 7250
	<b>P-Group:</b> -	<b>Units group:</b> -	<b>Unit selection:</b> -
	<b>Not for motor type:</b> -	<b>Scaling:</b> -	<b>Expert list:</b> 1
	<b>Min</b>	<b>Max</b>	<b>Factory setting</b>
	-	-	0

**Description:** Sets the signal source of input quantities I0 and I1 of instance BSW 1 of the binary changeover switch.

**Index:**  
 [0] = Input I0  
 [1] = Input I1

**p20214 BI: BSW 1 switch setting I / BSW 1 sw\_setting**

All objects (FBLOCKS)	<b>Can be changed:</b> T	<b>Calculated:</b> -	<b>Access level:</b> 1
	<b>Data type:</b> Unsigned32 / Binary	<b>Dynamic index:</b> -	<b>Func. diagram:</b> 7250
	<b>P-Group:</b> -	<b>Units group:</b> -	<b>Unit selection:</b> -
	<b>Not for motor type:</b> -	<b>Scaling:</b> -	<b>Expert list:</b> 1
	<b>Min</b>	<b>Max</b>	<b>Factory setting</b>
	-	-	0

**Description:** Sets the signal source of the switch setting I of instance BSW 1 of the binary changeover switch.

**r20215 BO: BSW 1 output Q / BSW 1 output Q**

All objects (FBLOCKS)	<b>Can be changed:</b> -	<b>Calculated:</b> -	<b>Access level:</b> 1
	<b>Data type:</b> Unsigned32	<b>Dynamic index:</b> -	<b>Func. diagram:</b> 7250
	<b>P-Group:</b> -	<b>Units group:</b> -	<b>Unit selection:</b> -
	<b>Not for motor type:</b> -	<b>Scaling:</b> -	<b>Expert list:</b> 1
	<b>Min</b>	<b>Max</b>	<b>Factory setting</b>
	-	-	-

**Description:** Display parameter for output quantity Q of instance BSW 1 of the binary changeover switch.

<b>p20216</b>	<b>BSW 1 run-time group / BSW 1 RTG</b>		
All objects (FBLOCKS)	<b>Can be changed:</b> T	<b>Calculated:</b> -	<b>Access level:</b> 1
	<b>Data type:</b> Integer16	<b>Dynamic index:</b> -	<b>Func. diagram:</b> 7250
	<b>P-Group:</b> -	<b>Units group:</b> -	<b>Unit selection:</b> -
	<b>Not for motor type:</b> -	<b>Scaling:</b> -	<b>Expert list:</b> 1
	<b>Min</b> 0	<b>Max</b> 9999	<b>Factory setting</b> 9999
<b>Description:</b>	Setting parameter for the run-time group in which the instance BSW 1 of the binary changeover switch is to be called.		
<b>Value:</b>	0: Run-time group 0 1: Run-time group 1 2: Run-time group 2 3: Run-time group 3 4: Run-time group 4 5: Run-time group 5 6: Run-time group 6 7: Run-time group 7 8: Run-time group 8 9: Run-time group 9 9999: Do not calculate		
<b>p20217</b>	<b>BSW 1 run sequence / BSW 1 RunSeq</b>		
All objects (FBLOCKS)	<b>Can be changed:</b> T	<b>Calculated:</b> -	<b>Access level:</b> 1
	<b>Data type:</b> Unsigned16	<b>Dynamic index:</b> -	<b>Func. diagram:</b> 7250
	<b>P-Group:</b> -	<b>Units group:</b> -	<b>Unit selection:</b> -
	<b>Not for motor type:</b> -	<b>Scaling:</b> -	<b>Expert list:</b> 1
	<b>Min</b> 0	<b>Max</b> 7999	<b>Factory setting</b> 590
<b>Description:</b>	Setting parameter for the run sequence of instance BSW 1 within the run-time group set in p20216.		
<b>Note:</b>	The function blocks with a lower run sequence value are calculated before function blocks with a higher run sequence value.		
<b>p20218[0...1]</b>	<b>CI: NSW 0 inputs / NSW 0 inputs</b>		
All objects (FBLOCKS)	<b>Can be changed:</b> T	<b>Calculated:</b> -	<b>Access level:</b> 1
	<b>Data type:</b> Unsigned32 / FloatingPoint32	<b>Dynamic index:</b> -	<b>Func. diagram:</b> 7250
	<b>P-Group:</b> -	<b>Units group:</b> -	<b>Unit selection:</b> -
	<b>Not for motor type:</b> -	<b>Scaling:</b> PERCENT	<b>Expert list:</b> 1
	<b>Min</b> -	<b>Max</b> -	<b>Factory setting</b> 0
<b>Description:</b>	Sets the signal source of input quantities X0 and X1 of instance NSW 0 of the numeric changeover switch.		
<b>Index:</b>	[0] = Input X0 [1] = Input X1		
<b>p20219</b>	<b>BI: NSW 0 switch setting I / NSW 0 sw_setting</b>		
All objects (FBLOCKS)	<b>Can be changed:</b> T	<b>Calculated:</b> -	<b>Access level:</b> 1
	<b>Data type:</b> Unsigned32 / Binary	<b>Dynamic index:</b> -	<b>Func. diagram:</b> 7250
	<b>P-Group:</b> -	<b>Units group:</b> -	<b>Unit selection:</b> -
	<b>Not for motor type:</b> -	<b>Scaling:</b> -	<b>Expert list:</b> 1
	<b>Min</b> -	<b>Max</b> -	<b>Factory setting</b> 0
<b>Description:</b>	Sets the signal source of the switch setting I of instance NSW 0 of the numeric changeover switch.		

<b>r20220</b>	<b>CO: NSW 0 output Y / NSW 0 output Y</b>		
All objects (FBLOCKS)	<b>Can be changed:</b> - <b>Data type:</b> FloatingPoint32 <b>P-Group:</b> - <b>Not for motor type:</b> - <b>Min</b> -	<b>Calculated:</b> - <b>Dynamic index:</b> - <b>Units group:</b> - <b>Scaling:</b> PERCENT <b>Max</b> -	<b>Access level:</b> 1 <b>Func. diagram:</b> 7250 <b>Unit selection:</b> - <b>Expert list:</b> 1 <b>Factory setting</b> -
<b>Description:</b>	Display parameter for output quantity Y of instance NSW 0 of the numeric changeover switch.		
<b>p20221</b>	<b>NSW 0 run-time group / NSW 0 RTG</b>		
All objects (FBLOCKS)	<b>Can be changed:</b> T <b>Data type:</b> Integer16 <b>P-Group:</b> - <b>Not for motor type:</b> - <b>Min</b> 0	<b>Calculated:</b> - <b>Dynamic index:</b> - <b>Units group:</b> - <b>Scaling:</b> - <b>Max</b> 9999	<b>Access level:</b> 1 <b>Func. diagram:</b> 7250 <b>Unit selection:</b> - <b>Expert list:</b> 1 <b>Factory setting</b> 9999
<b>Description:</b>	Setting parameter for the run-time group in which the instance NSW 0 of the numeric changeover switch is to be called.		
<b>Value:</b>	0: Run-time group 0 1: Run-time group 1 2: Run-time group 2 3: Run-time group 3 4: Run-time group 4 5: Run-time group 5 6: Run-time group 6 7: Run-time group 7 8: Run-time group 8 9: Run-time group 9 9999: Do not calculate		
<b>p20222</b>	<b>NSW 0 run sequence / NSW 0 RunSeq</b>		
All objects (FBLOCKS)	<b>Can be changed:</b> T <b>Data type:</b> Unsigned16 <b>P-Group:</b> - <b>Not for motor type:</b> - <b>Min</b> 0	<b>Calculated:</b> - <b>Dynamic index:</b> - <b>Units group:</b> - <b>Scaling:</b> - <b>Max</b> 32000	<b>Access level:</b> 1 <b>Func. diagram:</b> 7250 <b>Unit selection:</b> - <b>Expert list:</b> 1 <b>Factory setting</b> 610
<b>Description:</b>	Setting parameter for the run sequence of instance NSW 0 within the run-time group set in p20221.		
<b>Note:</b>	The function blocks with a lower run sequence value are calculated before function blocks with a higher run sequence value.		
<b>p20223[0...1]</b>	<b>CI: NSW 1 inputs / NSW 1 inputs</b>		
All objects (FBLOCKS)	<b>Can be changed:</b> T <b>Data type:</b> Unsigned32 / FloatingPoint32 <b>P-Group:</b> - <b>Not for motor type:</b> - <b>Min</b> -	<b>Calculated:</b> - <b>Dynamic index:</b> - <b>Units group:</b> - <b>Scaling:</b> PERCENT <b>Max</b> -	<b>Access level:</b> 1 <b>Func. diagram:</b> 7250 <b>Unit selection:</b> - <b>Expert list:</b> 1 <b>Factory setting</b> 0
<b>Description:</b>	Sets the signal source of input quantities X0 and X1 of instance NSW 1 of the numeric changeover switch.		
<b>Index:</b>	[0] = Input X0 [1] = Input X1		

<b>p20224</b>	<b>BI: NSW 1 switch setting I / NSW 1 sw_setting</b>		
All objects (FBLOCKS)	<b>Can be changed:</b> T	<b>Calculated:</b> -	<b>Access level:</b> 1
	<b>Data type:</b> Unsigned32 / Binary	<b>Dynamic index:</b> -	<b>Func. diagram:</b> 7250
	<b>P-Group:</b> -	<b>Units group:</b> -	<b>Unit selection:</b> -
	<b>Not for motor type:</b> -	<b>Scaling:</b> -	<b>Expert list:</b> 1
	<b>Min</b>	<b>Max</b>	<b>Factory setting</b>
	-	-	0
<b>Description:</b>	Sets the signal source of the switch setting I of instance NSW 1 of the numeric changeover switch.		
<b>r20225</b>	<b>CO: NSW 1 output Y / NSW 1 output Y</b>		
All objects (FBLOCKS)	<b>Can be changed:</b> -	<b>Calculated:</b> -	<b>Access level:</b> 1
	<b>Data type:</b> FloatingPoint32	<b>Dynamic index:</b> -	<b>Func. diagram:</b> 7250
	<b>P-Group:</b> -	<b>Units group:</b> -	<b>Unit selection:</b> -
	<b>Not for motor type:</b> -	<b>Scaling:</b> PERCENT	<b>Expert list:</b> 1
	<b>Min</b>	<b>Max</b>	<b>Factory setting</b>
	-	-	-
<b>Description:</b>	Display parameter for output quantity Y of instance NSW 1 of the numeric changeover switch.		
<b>p20226</b>	<b>NSW 1 run-time group / NSW 1 RTG</b>		
All objects (FBLOCKS)	<b>Can be changed:</b> T	<b>Calculated:</b> -	<b>Access level:</b> 1
	<b>Data type:</b> Integer16	<b>Dynamic index:</b> -	<b>Func. diagram:</b> 7250
	<b>P-Group:</b> -	<b>Units group:</b> -	<b>Unit selection:</b> -
	<b>Not for motor type:</b> -	<b>Scaling:</b> -	<b>Expert list:</b> 1
	<b>Min</b>	<b>Max</b>	<b>Factory setting</b>
	0	9999	9999
<b>Description:</b>	Setting parameter for the run-time group in which the instance NSW 1 of the numeric changeover switch is to be called.		
<b>Value:</b>	0: Run-time group 0 1: Run-time group 1 2: Run-time group 2 3: Run-time group 3 4: Run-time group 4 5: Run-time group 5 6: Run-time group 6 7: Run-time group 7 8: Run-time group 8 9: Run-time group 9 9999: Do not calculate		
<b>p20227</b>	<b>NSW 1 run sequence / NSW 1 RunSeq</b>		
All objects (FBLOCKS)	<b>Can be changed:</b> T	<b>Calculated:</b> -	<b>Access level:</b> 1
	<b>Data type:</b> Unsigned16	<b>Dynamic index:</b> -	<b>Func. diagram:</b> 7250
	<b>P-Group:</b> -	<b>Units group:</b> -	<b>Unit selection:</b> -
	<b>Not for motor type:</b> -	<b>Scaling:</b> -	<b>Expert list:</b> 1
	<b>Min</b>	<b>Max</b>	<b>Factory setting</b>
	0	32000	620
<b>Description:</b>	Setting parameter for the run sequence of instance NSW 1 within the run-time group set in p20226.		
<b>Note:</b>	The function blocks with a lower run sequence value are calculated before function blocks with a higher run sequence value.		

<b>p20228</b>	<b>CI: LIM 0 input X / LIM 0 input X</b>		
All objects (FBLOCKS)	<b>Can be changed:</b> T <b>Data type:</b> Unsigned32 / FloatingPoint32 <b>P-Group:</b> - <b>Not for motor type:</b> - <b>Min</b> -	<b>Calculated:</b> - <b>Dynamic index:</b> - <b>Units group:</b> - <b>Scaling:</b> PERCENT <b>Max</b> -	<b>Access level:</b> 1 <b>Func. diagram:</b> 7260 <b>Unit selection:</b> - <b>Expert list:</b> 1 <b>Factory setting</b> 0
<b>Description:</b>	Sets the signal source of input quantity X of instance LIM 0 of the limiter.		
<b>p20229</b>	<b>LIM 0 upper limit value LU / LIM 0 upper lim LU</b>		
All objects (FBLOCKS)	<b>Can be changed:</b> T <b>Data type:</b> FloatingPoint32 <b>P-Group:</b> - <b>Not for motor type:</b> - <b>Min</b> -340.28235E36	<b>Calculated:</b> - <b>Dynamic index:</b> - <b>Units group:</b> - <b>Scaling:</b> - <b>Max</b> 340.28235E36	<b>Access level:</b> 1 <b>Func. diagram:</b> 7260 <b>Unit selection:</b> - <b>Expert list:</b> 1 <b>Factory setting</b> 0.0000
<b>Description:</b>	Setting parameter for the upper limit value LU of instance LIM 0 of the limiter.		
<b>p20230</b>	<b>LIM 0 lower limit value LL / LIM 0 lower lim LL</b>		
All objects (FBLOCKS)	<b>Can be changed:</b> T <b>Data type:</b> FloatingPoint32 <b>P-Group:</b> - <b>Not for motor type:</b> - <b>Min</b> -340.28235E36	<b>Calculated:</b> - <b>Dynamic index:</b> - <b>Units group:</b> - <b>Scaling:</b> - <b>Max</b> 340.28235E36	<b>Access level:</b> 1 <b>Func. diagram:</b> 7260 <b>Unit selection:</b> - <b>Expert list:</b> 1 <b>Factory setting</b> 0.0000
<b>Description:</b>	Setting parameter for the lower limit value LL of instance LIM 0 of the limiter.		
<b>r20231</b>	<b>CO: LIM 0 output Y / LIM 0 output Y</b>		
All objects (FBLOCKS)	<b>Can be changed:</b> - <b>Data type:</b> FloatingPoint32 <b>P-Group:</b> - <b>Not for motor type:</b> - <b>Min</b> -	<b>Calculated:</b> - <b>Dynamic index:</b> - <b>Units group:</b> - <b>Scaling:</b> PERCENT <b>Max</b> -	<b>Access level:</b> 1 <b>Func. diagram:</b> 7260 <b>Unit selection:</b> - <b>Expert list:</b> 1 <b>Factory setting</b> -
<b>Description:</b>	Display parameter for the limited output quantity Y of instance LIM 0 of the limiter.		
<b>r20232</b>	<b>BO: LIM 0 input quantity at the upper limit QU / LIM 0 QU</b>		
All objects (FBLOCKS)	<b>Can be changed:</b> - <b>Data type:</b> Unsigned32 <b>P-Group:</b> - <b>Not for motor type:</b> - <b>Min</b> -	<b>Calculated:</b> - <b>Dynamic index:</b> - <b>Units group:</b> - <b>Scaling:</b> - <b>Max</b> -	<b>Access level:</b> 1 <b>Func. diagram:</b> 7260 <b>Unit selection:</b> - <b>Expert list:</b> 1 <b>Factory setting</b> -
<b>Description:</b>	Display parameter of instance LIM 0 of limiter QU (upper limit reached), i.e. QU = 1 for X >= LU.		

<b>r20233</b>	<b>BO: LIM 0 input quantity at the lower limit QL / LIM 0 QL</b>		
All objects (FBLOCKS)	<b>Can be changed:</b> - <b>Data type:</b> Unsigned32 <b>P-Group:</b> - <b>Not for motor type:</b> - <b>Min</b> -	<b>Calculated:</b> - <b>Dynamic index:</b> - <b>Units group:</b> - <b>Scaling:</b> - <b>Max</b> -	<b>Access level:</b> 1 <b>Func. diagram:</b> 7260 <b>Unit selection:</b> - <b>Expert list:</b> 1 <b>Factory setting</b> -
<b>Description:</b>	Display parameter of instance LIM 0 of limiter QL (lower limit reached), i.e. QL = 1 for X <= LL.		
<b>p20234</b>	<b>LIM 0 run-time group / LIM 0 RTG</b>		
All objects (FBLOCKS)	<b>Can be changed:</b> T <b>Data type:</b> Integer16 <b>P-Group:</b> - <b>Not for motor type:</b> - <b>Min</b> 0	<b>Calculated:</b> - <b>Dynamic index:</b> - <b>Units group:</b> - <b>Scaling:</b> - <b>Max</b> 9999	<b>Access level:</b> 1 <b>Func. diagram:</b> 7260 <b>Unit selection:</b> - <b>Expert list:</b> 1 <b>Factory setting</b> 9999
<b>Description:</b>	Setting parameter for the run-time group in which instance LIM 0 of the limiter is to be called.		
<b>Value:</b>	0: Run-time group 0 1: Run-time group 1 2: Run-time group 2 3: Run-time group 3 4: Run-time group 4 5: Run-time group 5 6: Run-time group 6 7: Run-time group 7 8: Run-time group 8 9: Run-time group 9 9999: Do not calculate		
<b>p20235</b>	<b>LIM 0 run sequence / LIM 0 RunSeq</b>		
All objects (FBLOCKS)	<b>Can be changed:</b> T <b>Data type:</b> Unsigned16 <b>P-Group:</b> - <b>Not for motor type:</b> - <b>Min</b> 0	<b>Calculated:</b> - <b>Dynamic index:</b> - <b>Units group:</b> - <b>Scaling:</b> - <b>Max</b> 32000	<b>Access level:</b> 1 <b>Func. diagram:</b> 7260 <b>Unit selection:</b> - <b>Expert list:</b> 1 <b>Factory setting</b> 640
<b>Description:</b>	Setting parameter for the run sequence of instance LIM 0 within the run-time group set in p20234.		
<b>Note:</b>	The function blocks with a lower run sequence value are calculated before function blocks with a higher run sequence value.		
<b>p20236</b>	<b>CI: LIM 1 input X / LIM 1 input X</b>		
All objects (FBLOCKS)	<b>Can be changed:</b> T <b>Data type:</b> Unsigned32 / FloatingPoint32 <b>P-Group:</b> - <b>Not for motor type:</b> - <b>Min</b> -	<b>Calculated:</b> - <b>Dynamic index:</b> - <b>Units group:</b> - <b>Scaling:</b> PERCENT <b>Max</b> -	<b>Access level:</b> 1 <b>Func. diagram:</b> 7260 <b>Unit selection:</b> - <b>Expert list:</b> 1 <b>Factory setting</b> 0
<b>Description:</b>	Sets the signal source of input quantity X of instance LIM 1 of the limiter.		

<b>p20237</b>	<b>LIM 1 upper limit value LU / LIM 1 upper lim LU</b>		
All objects (FBLOCKS)	<b>Can be changed:</b> T <b>Data type:</b> FloatingPoint32 <b>P-Group:</b> - <b>Not for motor type:</b> - <b>Min</b> -340.28235E36	<b>Calculated:</b> - <b>Dynamic index:</b> - <b>Units group:</b> - <b>Scaling:</b> - <b>Max</b> 340.28235E36	<b>Access level:</b> 1 <b>Func. diagram:</b> 7260 <b>Unit selection:</b> - <b>Expert list:</b> 1 <b>Factory setting</b> 0.0000
<b>Description:</b>	Setting parameter for the upper limit value LU of instance LIM 1 of the limiter.		
<b>p20238</b>	<b>LIM 1 lower limit value LL / LIM 1 lower lim LL</b>		
All objects (FBLOCKS)	<b>Can be changed:</b> T <b>Data type:</b> FloatingPoint32 <b>P-Group:</b> - <b>Not for motor type:</b> - <b>Min</b> -340.28235E36	<b>Calculated:</b> - <b>Dynamic index:</b> - <b>Units group:</b> - <b>Scaling:</b> - <b>Max</b> 340.28235E36	<b>Access level:</b> 1 <b>Func. diagram:</b> 7260 <b>Unit selection:</b> - <b>Expert list:</b> 1 <b>Factory setting</b> 0.0000
<b>Description:</b>	Setting parameter for the lower limit value LL of instance LIM 1 of the limiter.		
<b>r20239</b>	<b>CO: LIM 1 output Y / LIM 1 output Y</b>		
All objects (FBLOCKS)	<b>Can be changed:</b> - <b>Data type:</b> FloatingPoint32 <b>P-Group:</b> - <b>Not for motor type:</b> - <b>Min</b> -	<b>Calculated:</b> - <b>Dynamic index:</b> - <b>Units group:</b> - <b>Scaling:</b> PERCENT <b>Max</b> -	<b>Access level:</b> 1 <b>Func. diagram:</b> 7260 <b>Unit selection:</b> - <b>Expert list:</b> 1 <b>Factory setting</b> -
<b>Description:</b>	Display parameter for the limited output quantity Y of instance LIM 1 of the limiter.		
<b>r20240</b>	<b>BO: LIM 1 input quantity at the upper limit QU / LIM 1 QU</b>		
All objects (FBLOCKS)	<b>Can be changed:</b> - <b>Data type:</b> Unsigned32 <b>P-Group:</b> - <b>Not for motor type:</b> - <b>Min</b> -	<b>Calculated:</b> - <b>Dynamic index:</b> - <b>Units group:</b> - <b>Scaling:</b> - <b>Max</b> -	<b>Access level:</b> 1 <b>Func. diagram:</b> 7260 <b>Unit selection:</b> - <b>Expert list:</b> 1 <b>Factory setting</b> -
<b>Description:</b>	Display parameter of instance LIM 1 of limiter QU (upper limit reached), i.e. QU = 1 for X >= LU.		
<b>r20241</b>	<b>BO: LIM 1 input quantity at the lower limit QL / LIM 1 QL</b>		
All objects (FBLOCKS)	<b>Can be changed:</b> - <b>Data type:</b> Unsigned32 <b>P-Group:</b> - <b>Not for motor type:</b> - <b>Min</b> -	<b>Calculated:</b> - <b>Dynamic index:</b> - <b>Units group:</b> - <b>Scaling:</b> - <b>Max</b> -	<b>Access level:</b> 1 <b>Func. diagram:</b> 7260 <b>Unit selection:</b> - <b>Expert list:</b> 1 <b>Factory setting</b> -
<b>Description:</b>	Display parameter of instance LIM 1 of limiter QL (lower limit reached), i.e. QL = 1 for X <= LL.		



<b>p20242</b>	<b>LIM 1 run-time group / LIM 1 RTG</b>		
All objects (FBLOCKS)	<b>Can be changed:</b> T	<b>Calculated:</b> -	<b>Access level:</b> 1
	<b>Data type:</b> Integer16	<b>Dynamic index:</b> -	<b>Func. diagram:</b> 7260
	<b>P-Group:</b> -	<b>Units group:</b> -	<b>Unit selection:</b> -
	<b>Not for motor type:</b> -	<b>Scaling:</b> -	<b>Expert list:</b> 1
	<b>Min</b>	<b>Max</b>	<b>Factory setting</b>
	0	9999	9999
<b>Description:</b>	Setting parameter for the run-time group in which instance LIM 1 of the limiter is to be called.		
<b>Value:</b>	0: Run-time group 0 1: Run-time group 1 2: Run-time group 2 3: Run-time group 3 4: Run-time group 4 5: Run-time group 5 6: Run-time group 6 7: Run-time group 7 8: Run-time group 8 9: Run-time group 9 9999: Do not calculate		
<b>p20243</b>	<b>LIM 1 run sequence / LIM 1 RunSeq</b>		
All objects (FBLOCKS)	<b>Can be changed:</b> T	<b>Calculated:</b> -	<b>Access level:</b> 1
	<b>Data type:</b> Unsigned16	<b>Dynamic index:</b> -	<b>Func. diagram:</b> 7260
	<b>P-Group:</b> -	<b>Units group:</b> -	<b>Unit selection:</b> -
	<b>Not for motor type:</b> -	<b>Scaling:</b> -	<b>Expert list:</b> 1
	<b>Min</b>	<b>Max</b>	<b>Factory setting</b>
	0	32000	650
<b>Description:</b>	Setting parameter for the run sequence of instance LIM 1 within the run-time group set in p20242.		
<b>Note:</b>	The function blocks with a lower run sequence value are calculated before function blocks with a higher run sequence value.		
<b>p20244[0...1]</b>	<b>CI: PT1 0 inputs / PT1 0 inputs</b>		
All objects (FBLOCKS)	<b>Can be changed:</b> T	<b>Calculated:</b> -	<b>Access level:</b> 1
	<b>Data type:</b> Unsigned32 / FloatingPoint32	<b>Dynamic index:</b> -	<b>Func. diagram:</b> 7262
	<b>P-Group:</b> -	<b>Units group:</b> -	<b>Unit selection:</b> -
	<b>Not for motor type:</b> -	<b>Scaling:</b> PERCENT	<b>Expert list:</b> 1
	<b>Min</b>	<b>Max</b>	<b>Factory setting</b>
	-	-	0
<b>Description:</b>	Sets the signal source of input quantity X and of setting value SV of instance PT1 0 of the smoothing element.		
<b>Index:</b>	[0] = Input X [1] = Setting value SV		
<b>p20245</b>	<b>BI: PT1 0 accept setting value S / PT1 0 acc set val</b>		
All objects (FBLOCKS)	<b>Can be changed:</b> T	<b>Calculated:</b> -	<b>Access level:</b> 1
	<b>Data type:</b> Unsigned32 / Binary	<b>Dynamic index:</b> -	<b>Func. diagram:</b> 7262
	<b>P-Group:</b> -	<b>Units group:</b> -	<b>Unit selection:</b> -
	<b>Not for motor type:</b> -	<b>Scaling:</b> -	<b>Expert list:</b> 1
	<b>Min</b>	<b>Max</b>	<b>Factory setting</b>
	-	-	0
<b>Description:</b>	Sets the signal source for the "accept setting value" signal of instant PT1 0 of the smoothing element.		

<b>p20246</b>	<b>PT1 0 smoothing time constant in ms / PT1 0 T_smooth ms</b>		
All objects (FBLOCKS)	<b>Can be changed:</b> T	<b>Calculated:</b> -	<b>Access level:</b> 1
	<b>Data type:</b> FloatingPoint32	<b>Dynamic index:</b> -	<b>Func. diagram:</b> 7262
	<b>P-Group:</b> -	<b>Units group:</b> -	<b>Unit selection:</b> -
	<b>Not for motor type:</b> -	<b>Scaling:</b> -	<b>Expert list:</b> 1
	<b>Min</b> 0.00	<b>Max</b> 340.28235E36	<b>Factory setting</b> 0.00
<b>Description:</b>	Sets the smoothing time constant T in milliseconds of instance PT1 0 of the smoothing element.		
<b>r20247</b>	<b>CO: PT1 0 output Y / PT1 0 output Y</b>		
All objects (FBLOCKS)	<b>Can be changed:</b> -	<b>Calculated:</b> -	<b>Access level:</b> 1
	<b>Data type:</b> FloatingPoint32	<b>Dynamic index:</b> -	<b>Func. diagram:</b> 7262
	<b>P-Group:</b> -	<b>Units group:</b> -	<b>Unit selection:</b> -
	<b>Not for motor type:</b> -	<b>Scaling:</b> PERCENT	<b>Expert list:</b> 1
	<b>Min</b> -	<b>Max</b> -	<b>Factory setting</b> -
<b>Description:</b>	Display parameter for the smoothed output quantity Y of instance PT1 0 of the smoothing element.		
<b>p20248</b>	<b>PT1 0 run-time group / PT1 0 RTG</b>		
All objects (FBLOCKS)	<b>Can be changed:</b> T	<b>Calculated:</b> -	<b>Access level:</b> 1
	<b>Data type:</b> Integer16	<b>Dynamic index:</b> -	<b>Func. diagram:</b> 7262
	<b>P-Group:</b> -	<b>Units group:</b> -	<b>Unit selection:</b> -
	<b>Not for motor type:</b> -	<b>Scaling:</b> -	<b>Expert list:</b> 1
	<b>Min</b> 0	<b>Max</b> 9999	<b>Factory setting</b> 9999
<b>Description:</b>	Setting parameter for the run-time group in which instance PT1 0 of the smoothing element is to be called.		
<b>Value:</b>	0: Run-time group 0 1: Run-time group 1 2: Run-time group 2 3: Run-time group 3 4: Run-time group 4 5: Run-time group 5 6: Run-time group 6 7: Run-time group 7 8: Run-time group 8 9: Run-time group 9 9999: Do not calculate		
<b>p20249</b>	<b>PT1 0 run sequence / PT1 0 RunSeq</b>		
All objects (FBLOCKS)	<b>Can be changed:</b> T	<b>Calculated:</b> -	<b>Access level:</b> 1
	<b>Data type:</b> Unsigned16	<b>Dynamic index:</b> -	<b>Func. diagram:</b> 7262
	<b>P-Group:</b> -	<b>Units group:</b> -	<b>Unit selection:</b> -
	<b>Not for motor type:</b> -	<b>Scaling:</b> -	<b>Expert list:</b> 1
	<b>Min</b> 0	<b>Max</b> 32000	<b>Factory setting</b> 670
<b>Description:</b>	Setting parameter for the run sequence of instance PT1 0 within the run-time group set in p20248.		
<b>Note:</b>	The function blocks with a lower run sequence value are calculated before function blocks with a higher run sequence value.		

---

<b>p20250[0...1]</b>	<b>CI: PT1 1 inputs / PT1 1 inputs</b>		
All objects (FBLOCKS)	<b>Can be changed:</b> T	<b>Calculated:</b> -	<b>Access level:</b> 1
	<b>Data type:</b> Unsigned32 / FloatingPoint32	<b>Dynamic index:</b> -	<b>Func. diagram:</b> 7262
	<b>P-Group:</b> -	<b>Units group:</b> -	<b>Unit selection:</b> -
	<b>Not for motor type:</b> -	<b>Scaling:</b> PERCENT	<b>Expert list:</b> 1
	<b>Min</b>	<b>Max</b>	<b>Factory setting</b>
	-	-	0
<b>Description:</b>	Sets the signal source of input quantity X and of setting value SV of instance PT1 1 of the smoothing element.		
<b>Index:</b>	[0] = Input X [1] = Setting value SV		

---

<b>p20251</b>	<b>BI: PT1 1 accept setting value S / PT1 1 acc set val</b>		
All objects (FBLOCKS)	<b>Can be changed:</b> T	<b>Calculated:</b> -	<b>Access level:</b> 1
	<b>Data type:</b> Unsigned32 / Binary	<b>Dynamic index:</b> -	<b>Func. diagram:</b> 7262
	<b>P-Group:</b> -	<b>Units group:</b> -	<b>Unit selection:</b> -
	<b>Not for motor type:</b> -	<b>Scaling:</b> -	<b>Expert list:</b> 1
	<b>Min</b>	<b>Max</b>	<b>Factory setting</b>
	-	-	0
<b>Description:</b>	Sets the signal source for the "accept setting value" signal of instant PT1 1 of the smoothing element.		

---

<b>p20252</b>	<b>PT1 1 smoothing time constant in ms / PT1 1 T_smooth ms</b>		
All objects (FBLOCKS)	<b>Can be changed:</b> T	<b>Calculated:</b> -	<b>Access level:</b> 1
	<b>Data type:</b> FloatingPoint32	<b>Dynamic index:</b> -	<b>Func. diagram:</b> 7262
	<b>P-Group:</b> -	<b>Units group:</b> -	<b>Unit selection:</b> -
	<b>Not for motor type:</b> -	<b>Scaling:</b> -	<b>Expert list:</b> 1
	<b>Min</b>	<b>Max</b>	<b>Factory setting</b>
	0.00	340.28235E36	0.00
<b>Description:</b>	Sets the smoothing time constant T in milliseconds of instance PT1 1 of the smoothing element.		

---

<b>r20253</b>	<b>CO: PT1 1 output Y / PT1 1 output Y</b>		
All objects (FBLOCKS)	<b>Can be changed:</b> -	<b>Calculated:</b> -	<b>Access level:</b> 1
	<b>Data type:</b> FloatingPoint32	<b>Dynamic index:</b> -	<b>Func. diagram:</b> 7262
	<b>P-Group:</b> -	<b>Units group:</b> -	<b>Unit selection:</b> -
	<b>Not for motor type:</b> -	<b>Scaling:</b> PERCENT	<b>Expert list:</b> 1
	<b>Min</b>	<b>Max</b>	<b>Factory setting</b>
	-	-	-
<b>Description:</b>	Display parameter for the smoothed output quantity Y of instance PT1 1 of the smoothing element.		

---

<b>p20254</b>	<b>PT1 1 run-time group / PT1 1 RTG</b>		
All objects (FBLOCKS)	<b>Can be changed:</b> T	<b>Calculated:</b> -	<b>Access level:</b> 1
	<b>Data type:</b> Integer16	<b>Dynamic index:</b> -	<b>Func. diagram:</b> 7262
	<b>P-Group:</b> -	<b>Units group:</b> -	<b>Unit selection:</b> -
	<b>Not for motor type:</b> -	<b>Scaling:</b> -	<b>Expert list:</b> 1
	<b>Min</b>	<b>Max</b>	<b>Factory setting</b>
	0	9999	9999
<b>Description:</b>	Setting parameter for the run-time group in which instance PT1 1 of the smoothing element is to be called.		
<b>Value:</b>	0: Run-time group 0 1: Run-time group 1 2: Run-time group 2 3: Run-time group 3 4: Run-time group 4 5: Run-time group 5 6: Run-time group 6		

7: Run-time group 7  
 8: Run-time group 8  
 9: Run-time group 9  
 9999: Do not calculate

<b>p20255</b>	<b>PT1 1 run sequence / PT1 1 RunSeq</b>		
All objects (FBLOCKS)	<b>Can be changed:</b> T	<b>Calculated:</b> -	<b>Access level:</b> 1
	<b>Data type:</b> Unsigned16	<b>Dynamic index:</b> -	<b>Func. diagram:</b> 7262
	<b>P-Group:</b> -	<b>Units group:</b> -	<b>Unit selection:</b> -
	<b>Not for motor type:</b> -	<b>Scaling:</b> -	<b>Expert list:</b> 1
	<b>Min</b>	<b>Max</b>	<b>Factory setting</b>
	0	32000	680
<b>Description:</b>	Setting parameter for the run sequence of instance PT1 1 within the run-time group set in p20254.		
<b>Note:</b>	The function blocks with a lower run sequence value are calculated before function blocks with a higher run sequence value.		
<b>p20256[0...1]</b>	<b>CI: INT 0 inputs / INT 0 inputs</b>		
All objects (FBLOCKS)	<b>Can be changed:</b> T	<b>Calculated:</b> -	<b>Access level:</b> 1
	<b>Data type:</b> Unsigned32 / FloatingPoint32	<b>Dynamic index:</b> -	<b>Func. diagram:</b> 7264
	<b>P-Group:</b> -	<b>Units group:</b> -	<b>Unit selection:</b> -
	<b>Not for motor type:</b> -	<b>Scaling:</b> PERCENT	<b>Expert list:</b> 1
	<b>Min</b>	<b>Max</b>	<b>Factory setting</b>
	-	-	0
<b>Description:</b>	Sets the signal source of input quantity X and of setting value SV of instance INT 0 of the integrator.		
<b>Index:</b>	[0] = Input X [1] = Setting value SV		
<b>p20257</b>	<b>INT 0 upper limit value LU / INT 0 upper lim LU</b>		
All objects (FBLOCKS)	<b>Can be changed:</b> T	<b>Calculated:</b> -	<b>Access level:</b> 1
	<b>Data type:</b> FloatingPoint32	<b>Dynamic index:</b> -	<b>Func. diagram:</b> 7264
	<b>P-Group:</b> -	<b>Units group:</b> -	<b>Unit selection:</b> -
	<b>Not for motor type:</b> -	<b>Scaling:</b> -	<b>Expert list:</b> 1
	<b>Min</b>	<b>Max</b>	<b>Factory setting</b>
	-340.28235E36	340.28235E36	0.0000
<b>Description:</b>	Sets the upper limit value LU of instance INT 0 of the integrator.		
<b>p20258</b>	<b>INT 0 lower limit value LL / INT 0 lower lim LL</b>		
All objects (FBLOCKS)	<b>Can be changed:</b> T	<b>Calculated:</b> -	<b>Access level:</b> 1
	<b>Data type:</b> FloatingPoint32	<b>Dynamic index:</b> -	<b>Func. diagram:</b> 7264
	<b>P-Group:</b> -	<b>Units group:</b> -	<b>Unit selection:</b> -
	<b>Not for motor type:</b> -	<b>Scaling:</b> -	<b>Expert list:</b> 1
	<b>Min</b>	<b>Max</b>	<b>Factory setting</b>
	-340.28235E36	340.28235E36	0.0000
<b>Description:</b>	Sets the lower limit value LL of instance INT 0 of the integrator.		
<b>p20259</b>	<b>INT 0 integrating time constant in ms / INT 0 T_Integr ms</b>		
All objects (FBLOCKS)	<b>Can be changed:</b> T	<b>Calculated:</b> -	<b>Access level:</b> 1
	<b>Data type:</b> FloatingPoint32	<b>Dynamic index:</b> -	<b>Func. diagram:</b> 7264
	<b>P-Group:</b> -	<b>Units group:</b> -	<b>Unit selection:</b> -
	<b>Not for motor type:</b> -	<b>Scaling:</b> -	<b>Expert list:</b> 1
	<b>Min</b>	<b>Max</b>	<b>Factory setting</b>
	0.00	340.28235E36	0.00
<b>Description:</b>	Sets the integrating time constant Ti in milliseconds of instance INT 0 of the integrator.		

<b>p20260</b>	<b>BI: INT 0 accept setting value S / INT 0 acc set val</b>		
All objects (FBLOCKS)	<b>Can be changed:</b> T <b>Data type:</b> Unsigned32 / Binary <b>P-Group:</b> - <b>Not for motor type:</b> - <b>Min</b> -	<b>Calculated:</b> - <b>Dynamic index:</b> - <b>Units group:</b> - <b>Scaling:</b> - <b>Max</b> -	<b>Access level:</b> 1 <b>Func. diagram:</b> 7264 <b>Unit selection:</b> - <b>Expert list:</b> 1 <b>Factory setting</b> 0
<b>Description:</b>	Sets the signal source for the "accept setting value" signal of instant INT 0 of the integrator.		
<b>r20261</b>	<b>CO: INT 0 output Y / INT 0 output Y</b>		
All objects (FBLOCKS)	<b>Can be changed:</b> - <b>Data type:</b> FloatingPoint32 <b>P-Group:</b> - <b>Not for motor type:</b> - <b>Min</b> -	<b>Calculated:</b> - <b>Dynamic index:</b> - <b>Units group:</b> - <b>Scaling:</b> PERCENT <b>Max</b> -	<b>Access level:</b> 1 <b>Func. diagram:</b> 7264 <b>Unit selection:</b> - <b>Expert list:</b> 1 <b>Factory setting</b> -
<b>Description:</b>	Display parameter for output quantity Y of instance INT 0 of the integrator. If LL >= LU, then the output quantity Y = LU.		
<b>r20262</b>	<b>BO: INT 0 integrator at the upper limit QU / INT 0 QU</b>		
All objects (FBLOCKS)	<b>Can be changed:</b> - <b>Data type:</b> Unsigned32 <b>P-Group:</b> - <b>Not for motor type:</b> - <b>Min</b> -	<b>Calculated:</b> - <b>Dynamic index:</b> - <b>Units group:</b> - <b>Scaling:</b> - <b>Max</b> -	<b>Access level:</b> 1 <b>Func. diagram:</b> 7264 <b>Unit selection:</b> - <b>Expert list:</b> 1 <b>Factory setting</b> -
<b>Description:</b>	Display parameter for the signal QU that output quantity Y of instance INT 0 of the integrator has reached the upper limit value LU.		
<b>r20263</b>	<b>BO: INT 0 integrator at the lower limit QL / INT 0 QL</b>		
All objects (FBLOCKS)	<b>Can be changed:</b> - <b>Data type:</b> Unsigned32 <b>P-Group:</b> - <b>Not for motor type:</b> - <b>Min</b> -	<b>Calculated:</b> - <b>Dynamic index:</b> - <b>Units group:</b> - <b>Scaling:</b> - <b>Max</b> -	<b>Access level:</b> 1 <b>Func. diagram:</b> 7264 <b>Unit selection:</b> - <b>Expert list:</b> 1 <b>Factory setting</b> -
<b>Description:</b>	Display parameter for the signal QL that output quantity Y of instance INT 0 of the integrator has reached the lower limit value LL.		
<b>p20264</b>	<b>INT 0 run-time group / INT 0 RTG</b>		
All objects (FBLOCKS)	<b>Can be changed:</b> T <b>Data type:</b> Integer16 <b>P-Group:</b> - <b>Not for motor type:</b> - <b>Min</b> 0	<b>Calculated:</b> - <b>Dynamic index:</b> - <b>Units group:</b> - <b>Scaling:</b> - <b>Max</b> 9999	<b>Access level:</b> 1 <b>Func. diagram:</b> 7264 <b>Unit selection:</b> - <b>Expert list:</b> 1 <b>Factory setting</b> 9999
<b>Description:</b>	Setting parameter for the run-time group in which instance INT 0 of the integrator is to be called.		
<b>Value:</b>	0: Run-time group 0 1: Run-time group 1 2: Run-time group 2 3: Run-time group 3 4: Run-time group 4		

5: Run-time group 5  
 6: Run-time group 6  
 7: Run-time group 7  
 8: Run-time group 8  
 9: Run-time group 9  
 9999: Do not calculate

<b>p20265</b>	<b>INT 0 run sequence / INT 0 RunSeq</b>		
All objects (FBLOCKS)	<b>Can be changed:</b> T	<b>Calculated:</b> -	<b>Access level:</b> 1
	<b>Data type:</b> Unsigned16	<b>Dynamic index:</b> -	<b>Func. diagram:</b> 7264
	<b>P-Group:</b> -	<b>Units group:</b> -	<b>Unit selection:</b> -
	<b>Not for motor type:</b> -	<b>Scaling:</b> -	<b>Expert list:</b> 1
	<b>Min</b> 0	<b>Max</b> 32000	<b>Factory setting</b> 700
<b>Description:</b>	Setting parameter for the run sequence of instance INT 0 within the run-time group set in p20264.		
<b>Note:</b>	The function blocks with a lower run sequence value are calculated before function blocks with a higher run sequence value.		
<b>p20266</b>	<b>CI: LVM 0 input X / LVM 0 input X</b>		
All objects (FBLOCKS)	<b>Can be changed:</b> T	<b>Calculated:</b> -	<b>Access level:</b> 1
	<b>Data type:</b> Unsigned32 / FloatingPoint32	<b>Dynamic index:</b> -	<b>Func. diagram:</b> 7270
	<b>P-Group:</b> -	<b>Units group:</b> -	<b>Unit selection:</b> -
	<b>Not for motor type:</b> -	<b>Scaling:</b> PERCENT	<b>Expert list:</b> 1
	<b>Min</b> -	<b>Max</b> -	<b>Factory setting</b> 0
<b>Description:</b>	Sets the signal source of input quantity X of instance LVM 0 of the double-sided limiter.		
<b>p20267</b>	<b>LVM 0 interval average value M / LVM 0 avg value M</b>		
All objects (FBLOCKS)	<b>Can be changed:</b> T	<b>Calculated:</b> -	<b>Access level:</b> 1
	<b>Data type:</b> FloatingPoint32	<b>Dynamic index:</b> -	<b>Func. diagram:</b> 7270
	<b>P-Group:</b> -	<b>Units group:</b> -	<b>Unit selection:</b> -
	<b>Not for motor type:</b> -	<b>Scaling:</b> -	<b>Expert list:</b> 1
	<b>Min</b> -340.28235E36	<b>Max</b> 340.28235E36	<b>Factory setting</b> 0.0000
<b>Description:</b>	Setting parameter for the interval average M of instance LVM 0 of the double-sided limiter.		
<b>p20268</b>	<b>LVM 0 interval limit L / LVM 0 limit L</b>		
All objects (FBLOCKS)	<b>Can be changed:</b> T	<b>Calculated:</b> -	<b>Access level:</b> 1
	<b>Data type:</b> FloatingPoint32	<b>Dynamic index:</b> -	<b>Func. diagram:</b> 7270
	<b>P-Group:</b> -	<b>Units group:</b> -	<b>Unit selection:</b> -
	<b>Not for motor type:</b> -	<b>Scaling:</b> -	<b>Expert list:</b> 1
	<b>Min</b> -340.28235E36	<b>Max</b> 340.28235E36	<b>Factory setting</b> 0.0000
<b>Description:</b>	Setting parameter for the interval limit L of instance LVM 0 of the double-sided limiter.		
<b>p20269</b>	<b>LVM 0 hyst HY / LVM 0 hyst HY</b>		
All objects (FBLOCKS)	<b>Can be changed:</b> T	<b>Calculated:</b> -	<b>Access level:</b> 1
	<b>Data type:</b> FloatingPoint32	<b>Dynamic index:</b> -	<b>Func. diagram:</b> 7270
	<b>P-Group:</b> -	<b>Units group:</b> -	<b>Unit selection:</b> -
	<b>Not for motor type:</b> -	<b>Scaling:</b> -	<b>Expert list:</b> 1
	<b>Min</b> -340.28235E36	<b>Max</b> 340.28235E36	<b>Factory setting</b> 0.0000
<b>Description:</b>	Setting parameter for hysteresis HY of instance LVM 0 of the double-sided limiter.		

<b>r20270</b>	<b>BO: LVM 0 input quantity above interval QU / LVM 0 X above QU</b>		
All objects (FBLOCKS)	<b>Can be changed:</b> -	<b>Calculated:</b> -	<b>Access level:</b> 1
	<b>Data type:</b> Unsigned32	<b>Dynamic index:</b> -	<b>Func. diagram:</b> 7270
	<b>P-Group:</b> -	<b>Units group:</b> -	<b>Unit selection:</b> -
	<b>Not for motor type:</b> -	<b>Scaling:</b> -	<b>Expert list:</b> 1
	<b>Min</b>	<b>Max</b>	<b>Factory setting</b>
	-	-	-
<b>Description:</b>	Display parameter of instance LVM 0 of the double-sided limiter that input quantity X was at least once $X > M + L$ and X is $\geq M + L - HY$ .		
<b>r20271</b>	<b>BO: LVM 0 input quantity within interval QM / LVM 0 X within QM</b>		
All objects (FBLOCKS)	<b>Can be changed:</b> -	<b>Calculated:</b> -	<b>Access level:</b> 1
	<b>Data type:</b> Unsigned32	<b>Dynamic index:</b> -	<b>Func. diagram:</b> 7270
	<b>P-Group:</b> -	<b>Units group:</b> -	<b>Unit selection:</b> -
	<b>Not for motor type:</b> -	<b>Scaling:</b> -	<b>Expert list:</b> 1
	<b>Min</b>	<b>Max</b>	<b>Factory setting</b>
	-	-	-
<b>Description:</b>	Display parameter of instance LVM 0 of the double-sided limiter that the input quantity X lies within the interval.		
<b>r20272</b>	<b>BO: LVM 0 input quantity below interval QL / LVM 0 X below QL</b>		
All objects (FBLOCKS)	<b>Can be changed:</b> -	<b>Calculated:</b> -	<b>Access level:</b> 1
	<b>Data type:</b> Unsigned32	<b>Dynamic index:</b> -	<b>Func. diagram:</b> 7270
	<b>P-Group:</b> -	<b>Units group:</b> -	<b>Unit selection:</b> -
	<b>Not for motor type:</b> -	<b>Scaling:</b> -	<b>Expert list:</b> 1
	<b>Min</b>	<b>Max</b>	<b>Factory setting</b>
	-	-	-
<b>Description:</b>	Display parameter of instance LVM 0 of the double-sided limiter that input quantity X was at least once $X < M - L$ and X is $\leq M - L + HY$ .		
<b>p20273</b>	<b>LVM 0 run-time group / LVM 0 RTG</b>		
All objects (FBLOCKS)	<b>Can be changed:</b> T	<b>Calculated:</b> -	<b>Access level:</b> 1
	<b>Data type:</b> Integer16	<b>Dynamic index:</b> -	<b>Func. diagram:</b> 7270
	<b>P-Group:</b> -	<b>Units group:</b> -	<b>Unit selection:</b> -
	<b>Not for motor type:</b> -	<b>Scaling:</b> -	<b>Expert list:</b> 1
	<b>Min</b>	<b>Max</b>	<b>Factory setting</b>
	0	9999	9999
<b>Description:</b>	Setting parameter for the run-time group in which instance LVM 0 of the double-sided limiter is to be called.		
<b>Value:</b>	0: Run-time group 0 1: Run-time group 1 2: Run-time group 2 3: Run-time group 3 4: Run-time group 4 5: Run-time group 5 6: Run-time group 6 7: Run-time group 7 8: Run-time group 8 9: Run-time group 9 9999: Do not calculate		

<b>p20274</b>	<b>LVM 0 run sequence / LVM 0 RunSeq</b>			
All objects (FBLOCKS)	<b>Can be changed:</b> T	<b>Calculated:</b> -	<b>Access level:</b> 1	
	<b>Data type:</b> Unsigned16	<b>Dynamic index:</b> -	<b>Func. diagram:</b> 7270	
	<b>P-Group:</b> -	<b>Units group:</b> -	<b>Unit selection:</b> -	
	<b>Not for motor type:</b> -	<b>Scaling:</b> -	<b>Expert list:</b> 1	
	<b>Min</b> 0	<b>Max</b> 7999	<b>Factory setting</b> 720	
<b>Description:</b>	Setting parameter for the run sequence of instance LVM 0 within the run-time group set in p20273.			
<b>Note:</b>	The function blocks with a lower run sequence value are calculated before function blocks with a higher run sequence value.			
<b>p20275</b>	<b>CI: LVM 1 input X / LVM 1 input X</b>			
All objects (FBLOCKS)	<b>Can be changed:</b> T	<b>Calculated:</b> -	<b>Access level:</b> 1	
	<b>Data type:</b> Unsigned32 / FloatingPoint32	<b>Dynamic index:</b> -	<b>Func. diagram:</b> 7270	
	<b>P-Group:</b> -	<b>Units group:</b> -	<b>Unit selection:</b> -	
	<b>Not for motor type:</b> -	<b>Scaling:</b> PERCENT	<b>Expert list:</b> 1	
	<b>Min</b> -	<b>Max</b> -	<b>Factory setting</b> 0	
<b>Description:</b>	Sets the signal source of input quantity X of instance LVM 1 of the double-sided limiter.			
<b>p20276</b>	<b>LVM 1 interval average value M / LVM 1 avg value M</b>			
All objects (FBLOCKS)	<b>Can be changed:</b> T	<b>Calculated:</b> -	<b>Access level:</b> 1	
	<b>Data type:</b> FloatingPoint32	<b>Dynamic index:</b> -	<b>Func. diagram:</b> 7270	
	<b>P-Group:</b> -	<b>Units group:</b> -	<b>Unit selection:</b> -	
	<b>Not for motor type:</b> -	<b>Scaling:</b> -	<b>Expert list:</b> 1	
	<b>Min</b> -340.28235E36	<b>Max</b> 340.28235E36	<b>Factory setting</b> 0.0000	
<b>Description:</b>	Setting parameter for the interval average M of instance LVM 1 of the double-sided limiter.			
<b>p20277</b>	<b>LVM 1 interval limit L / LVM 1 limit L</b>			
All objects (FBLOCKS)	<b>Can be changed:</b> T	<b>Calculated:</b> -	<b>Access level:</b> 1	
	<b>Data type:</b> FloatingPoint32	<b>Dynamic index:</b> -	<b>Func. diagram:</b> 7270	
	<b>P-Group:</b> -	<b>Units group:</b> -	<b>Unit selection:</b> -	
	<b>Not for motor type:</b> -	<b>Scaling:</b> -	<b>Expert list:</b> 1	
	<b>Min</b> -340.28235E36	<b>Max</b> 340.28235E36	<b>Factory setting</b> 0.0000	
<b>Description:</b>	Setting parameter for the interval limit L of instance LVM 1 of the double-sided limiter.			
<b>p20278</b>	<b>LVM 1 hyst HY / LVM 1 hyst HY</b>			
All objects (FBLOCKS)	<b>Can be changed:</b> T	<b>Calculated:</b> -	<b>Access level:</b> 1	
	<b>Data type:</b> FloatingPoint32	<b>Dynamic index:</b> -	<b>Func. diagram:</b> 7270	
	<b>P-Group:</b> -	<b>Units group:</b> -	<b>Unit selection:</b> -	
	<b>Not for motor type:</b> -	<b>Scaling:</b> -	<b>Expert list:</b> 1	
	<b>Min</b> -340.28235E36	<b>Max</b> 340.28235E36	<b>Factory setting</b> 0.0000	
<b>Description:</b>	Setting parameter for hysteresis HY of instance LVM 1 of the double-sided limiter.			



<b>r20279</b>	<b>BO: LVM 1 input quantity above interval QU / LVM 1 X above QU</b>		
All objects (FBLOCKS)	<b>Can be changed:</b> -	<b>Calculated:</b> -	<b>Access level:</b> 1
	<b>Data type:</b> Unsigned32	<b>Dynamic index:</b> -	<b>Func. diagram:</b> 7270
	<b>P-Group:</b> -	<b>Units group:</b> -	<b>Unit selection:</b> -
	<b>Not for motor type:</b> -	<b>Scaling:</b> -	<b>Expert list:</b> 1
	<b>Min</b>	<b>Max</b>	<b>Factory setting</b>
	-	-	-
<b>Description:</b>	Display parameter of instance LVM 1 of the double-sided limiter that input quantity X was at least once $X > M + L$ and X is $\geq M + L - HY$ .		
<b>r20280</b>	<b>BO: LVM 1 input quantity within interval QM / LVM 1 X within QM</b>		
All objects (FBLOCKS)	<b>Can be changed:</b> -	<b>Calculated:</b> -	<b>Access level:</b> 1
	<b>Data type:</b> Unsigned32	<b>Dynamic index:</b> -	<b>Func. diagram:</b> 7270
	<b>P-Group:</b> -	<b>Units group:</b> -	<b>Unit selection:</b> -
	<b>Not for motor type:</b> -	<b>Scaling:</b> -	<b>Expert list:</b> 1
	<b>Min</b>	<b>Max</b>	<b>Factory setting</b>
	-	-	-
<b>Description:</b>	Display parameter of instance LVM 1 of the double-sided limiter that the input quantity X lies within the interval.		
<b>r20281</b>	<b>BO: LVM 1 input quantity below interval QL / LVM 1 X below QL</b>		
All objects (FBLOCKS)	<b>Can be changed:</b> -	<b>Calculated:</b> -	<b>Access level:</b> 1
	<b>Data type:</b> Unsigned32	<b>Dynamic index:</b> -	<b>Func. diagram:</b> 7270
	<b>P-Group:</b> -	<b>Units group:</b> -	<b>Unit selection:</b> -
	<b>Not for motor type:</b> -	<b>Scaling:</b> -	<b>Expert list:</b> 1
	<b>Min</b>	<b>Max</b>	<b>Factory setting</b>
	-	-	-
<b>Description:</b>	Display parameter of instance LVM 1 of the double-sided limiter that input quantity X was at least once $X < M - L$ and X is $\leq M - L + HY$ .		
<b>p20282</b>	<b>LVM 1 run-time group / LVM 1 RTG</b>		
All objects (FBLOCKS)	<b>Can be changed:</b> T	<b>Calculated:</b> -	<b>Access level:</b> 1
	<b>Data type:</b> Integer16	<b>Dynamic index:</b> -	<b>Func. diagram:</b> 7270
	<b>P-Group:</b> -	<b>Units group:</b> -	<b>Unit selection:</b> -
	<b>Not for motor type:</b> -	<b>Scaling:</b> -	<b>Expert list:</b> 1
	<b>Min</b>	<b>Max</b>	<b>Factory setting</b>
	0	9999	9999
<b>Description:</b>	Setting parameter for the run-time group in which instance LVM 1 of the double-sided limiter is to be called.		
<b>Value:</b>	0: Run-time group 0 1: Run-time group 1 2: Run-time group 2 3: Run-time group 3 4: Run-time group 4 5: Run-time group 5 6: Run-time group 6 7: Run-time group 7 8: Run-time group 8 9: Run-time group 9 9999: Do not calculate		

<b>p20283</b>	<b>LVM 1 run sequence / LVM 1 RunSeq</b>		
All objects (FBLOCKS)	<b>Can be changed:</b> T	<b>Calculated:</b> -	<b>Access level:</b> 1
	<b>Data type:</b> Unsigned16	<b>Dynamic index:</b> -	<b>Func. diagram:</b> 7270
	<b>P-Group:</b> -	<b>Units group:</b> -	<b>Unit selection:</b> -
	<b>Not for motor type:</b> -	<b>Scaling:</b> -	<b>Expert list:</b> 1
	<b>Min</b> 0	<b>Max</b> 7999	<b>Factory setting</b> 730
<b>Description:</b>	Setting parameter for the run sequence of instance LVM within the run-time group set in p20282.		
<b>Note:</b>	The function blocks with a lower run sequence value are calculated before function blocks with a higher run sequence value.		
<b>p20284</b>	<b>CI: DIF 0 input X / DIF 0 input X</b>		
All objects (FBLOCKS)	<b>Can be changed:</b> T	<b>Calculated:</b> -	<b>Access level:</b> 1
	<b>Data type:</b> Unsigned32 / FloatingPoint32	<b>Dynamic index:</b> -	<b>Func. diagram:</b> 7264
	<b>P-Group:</b> -	<b>Units group:</b> -	<b>Unit selection:</b> -
	<b>Not for motor type:</b> -	<b>Scaling:</b> PERCENT	<b>Expert list:</b> 1
	<b>Min</b> -	<b>Max</b> -	<b>Factory setting</b> 0
<b>Description:</b>	Sets the signal source of input quantity X of instance DIF 0 of the differentiating element.		
<b>p20285</b>	<b>DIF 0 differentiating time constant in ms / DIF 0 T_diff ms</b>		
All objects (FBLOCKS)	<b>Can be changed:</b> T	<b>Calculated:</b> -	<b>Access level:</b> 1
	<b>Data type:</b> FloatingPoint32	<b>Dynamic index:</b> -	<b>Func. diagram:</b> 7264
	<b>P-Group:</b> -	<b>Units group:</b> -	<b>Unit selection:</b> -
	<b>Not for motor type:</b> -	<b>Scaling:</b> -	<b>Expert list:</b> 1
	<b>Min</b> 0.00	<b>Max</b> 340.28235E36	<b>Factory setting</b> 0.00
<b>Description:</b>	Sets the differentiating time constant Td in milliseconds of instance DIF 0 of the differentiating element.		
<b>r20286</b>	<b>CO: DIF 0 output Y / DIF 0 output Y</b>		
All objects (FBLOCKS)	<b>Can be changed:</b> -	<b>Calculated:</b> -	<b>Access level:</b> 1
	<b>Data type:</b> FloatingPoint32	<b>Dynamic index:</b> -	<b>Func. diagram:</b> 7264
	<b>P-Group:</b> -	<b>Units group:</b> -	<b>Unit selection:</b> -
	<b>Not for motor type:</b> -	<b>Scaling:</b> PERCENT	<b>Expert list:</b> 1
	<b>Min</b> -	<b>Max</b> -	<b>Factory setting</b> -
<b>Description:</b>	Display parameter for output quantity Y of instance DIF 0 of the differentiating element.		
<b>p20287</b>	<b>DIF 0 run-time group / DIF 0 RTG</b>		
All objects (FBLOCKS)	<b>Can be changed:</b> T	<b>Calculated:</b> -	<b>Access level:</b> 1
	<b>Data type:</b> Integer16	<b>Dynamic index:</b> -	<b>Func. diagram:</b> 7264
	<b>P-Group:</b> -	<b>Units group:</b> -	<b>Unit selection:</b> -
	<b>Not for motor type:</b> -	<b>Scaling:</b> -	<b>Expert list:</b> 1
	<b>Min</b> 0	<b>Max</b> 9999	<b>Factory setting</b> 9999
<b>Description:</b>	Setting parameter for the run-time group in which instance DIF 0 of the differentiating element is to be called.		
<b>Value:</b>	0: Run-time group 0 1: Run-time group 1 2: Run-time group 2 3: Run-time group 3 4: Run-time group 4 5: Run-time group 5		

6: Run-time group 6  
 7: Run-time group 7  
 8: Run-time group 8  
 9: Run-time group 9  
 9999: Do not calculate

**p20288****DIF 0 run sequence / DIF 0 RunSeq**

All objects  
 (FBLOCKS)

**Can be changed:** T

**Calculated:** -

**Access level:** 1

**Data type:** Unsigned16

**Dynamic index:** -

**Func. diagram:** 7264

**P-Group:** -

**Units group:** -

**Unit selection:** -

**Not for motor type:** -

**Scaling:** -

**Expert list:** 1

**Min**

**Max**

**Factory setting**

0

32000

750

**Description:**

Setting parameter for the run sequence of instance DIF 0 within the run-time group set in p20287.

**Note:**

The function blocks with a lower run sequence value are calculated before function blocks with a higher run sequence value.



# Function diagrams

# 3

## Contents

3.1	Table of contents	3-134
3.2	Explanations on the function diagrams	3-135
3.3	Logic function blocks	3-137
3.4	Arithmetic function blocks	3-142
3.5	Time function blocks	3-146
3.6	Memory function blocks	3-150
3.7	Switch function blocks	3-152
3.8	Control function blocks	3-154
3.9	Complex function blocks	3-158

## 3.1 Table of contents

<b>3.2 Explanations on the function diagrams</b> .....	3-135
7200 – General information .....	3-136
<b>3.3 Logic function blocks</b> .....	3-137
7210 – AND (AND function block with 4 inputs) .....	3-138
7212 – OR (OR function block with 4 inputs) .....	3-139
7214 – XOR (XOR function block with 4 inputs) .....	3-140
7216 – NOT (inverter) .....	3-141
<b>3.4 Arithmetic function blocks</b> .....	3-142
7220 – ADD (adder with 4 inputs), SUB (subtractor) .....	3-143
7222 – MUL (multiplier), DIV (divider) .....	3-144
7224 – AVA (absolute value generator) .....	3-145
<b>3.5 Time function blocks</b> .....	3-146
7230 – MFP (pulse generator), PCL (pulse contractor) .....	3-147
7232 – PDE (ON delay), PDF (OFF delay) .....	3-148
7234 – PST (pulse stretcher) .....	3-149
<b>3.6 Memory function blocks</b> .....	3-150
7240 – RSR (RS flip-flop), DFR (D flip-flop) .....	3-151
<b>3.7 Switch function blocks</b> .....	3-152
7250 – BSW (binary change-over switch), NSW (numeric change-over switch) .....	3-153
<b>3.8 Control function blocks</b> .....	3-154
7260 – LIM (limiter) .....	3-155
7262 – PT1 (smoothing element) .....	3-156
7264 – INT (integrator), DIF (derivative action element) .....	3-157
<b>3.9 Complex function blocks</b> .....	3-158
7270 – LVM (double-sided limit monitor with hysteresis) .....	3-159

## 3.2 Explanations on the function diagrams

### Function diagrams

---

7200 – General information

3-136

---

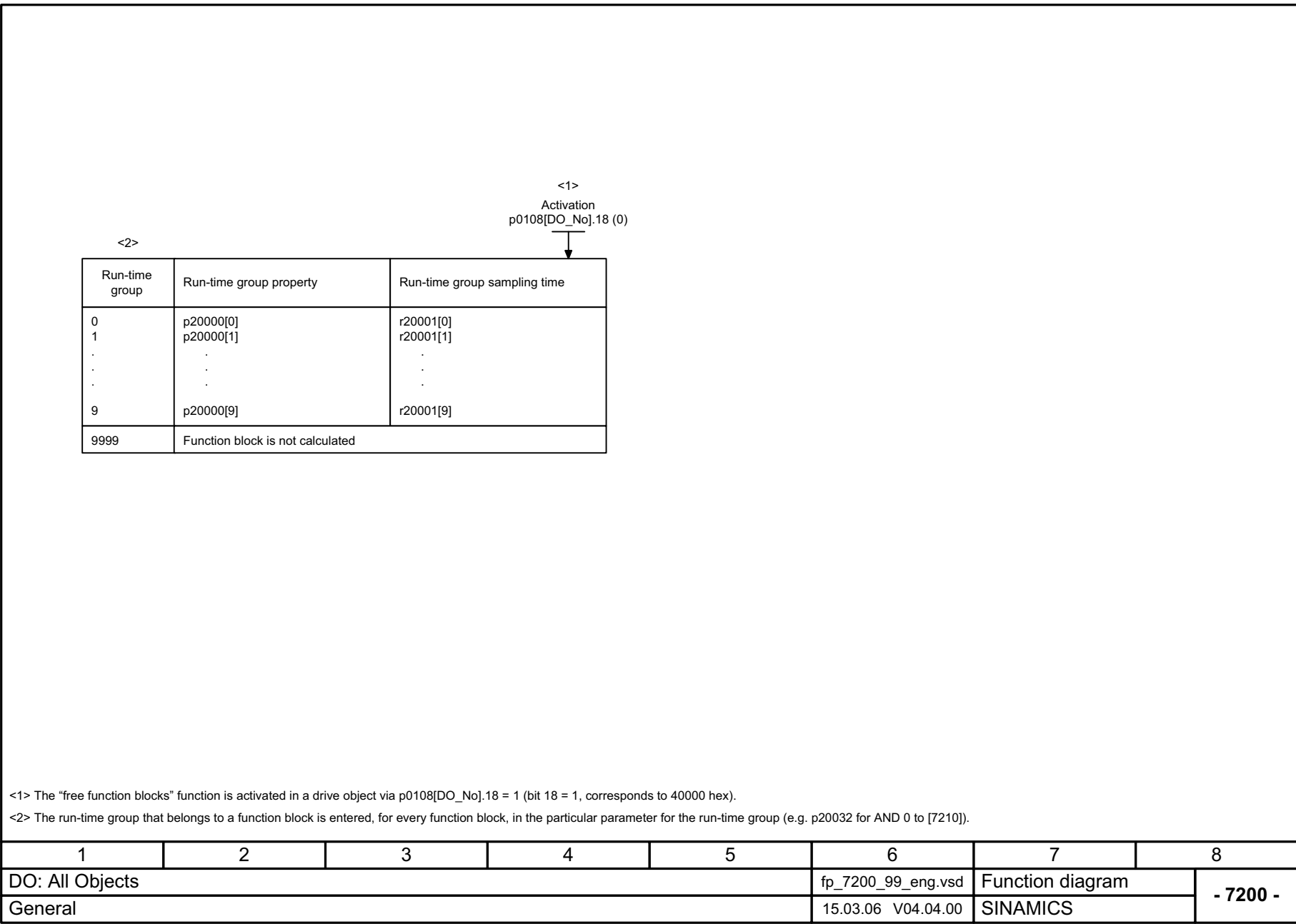

Fig. 3-1 7200 – General information



### 3.3 Logic function blocks

#### Function diagrams

---

7210 – AND (AND function block with 4 inputs)	3-138
7212 – OR (OR function block with 4 inputs)	3-139
7214 – XOR (XOR function block with 4 inputs)	3-140
7216 – NOT (inverter)	3-141

---

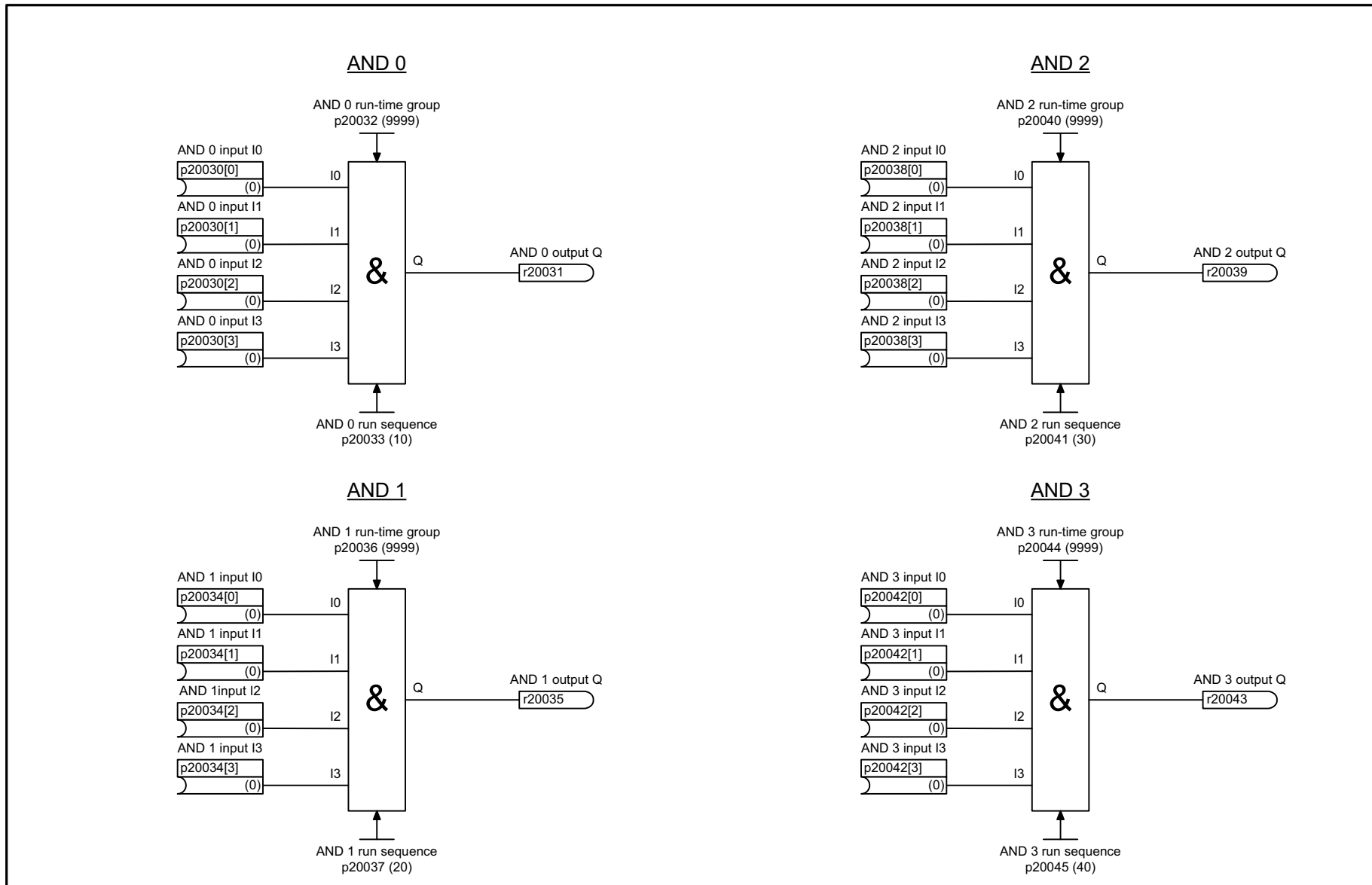

1	2	3	4	5	6	7	8
DO: All Objects					fp_7210_99_eng.vsd	Function diagram	
Logic function blocks - AND (AND function block with 4 inputs)					15.03.06 V04.04.00	SINAMICS	
							<b>- 7210 -</b>

Fig. 3-2 7210 – AND (AND function block with 4 inputs)

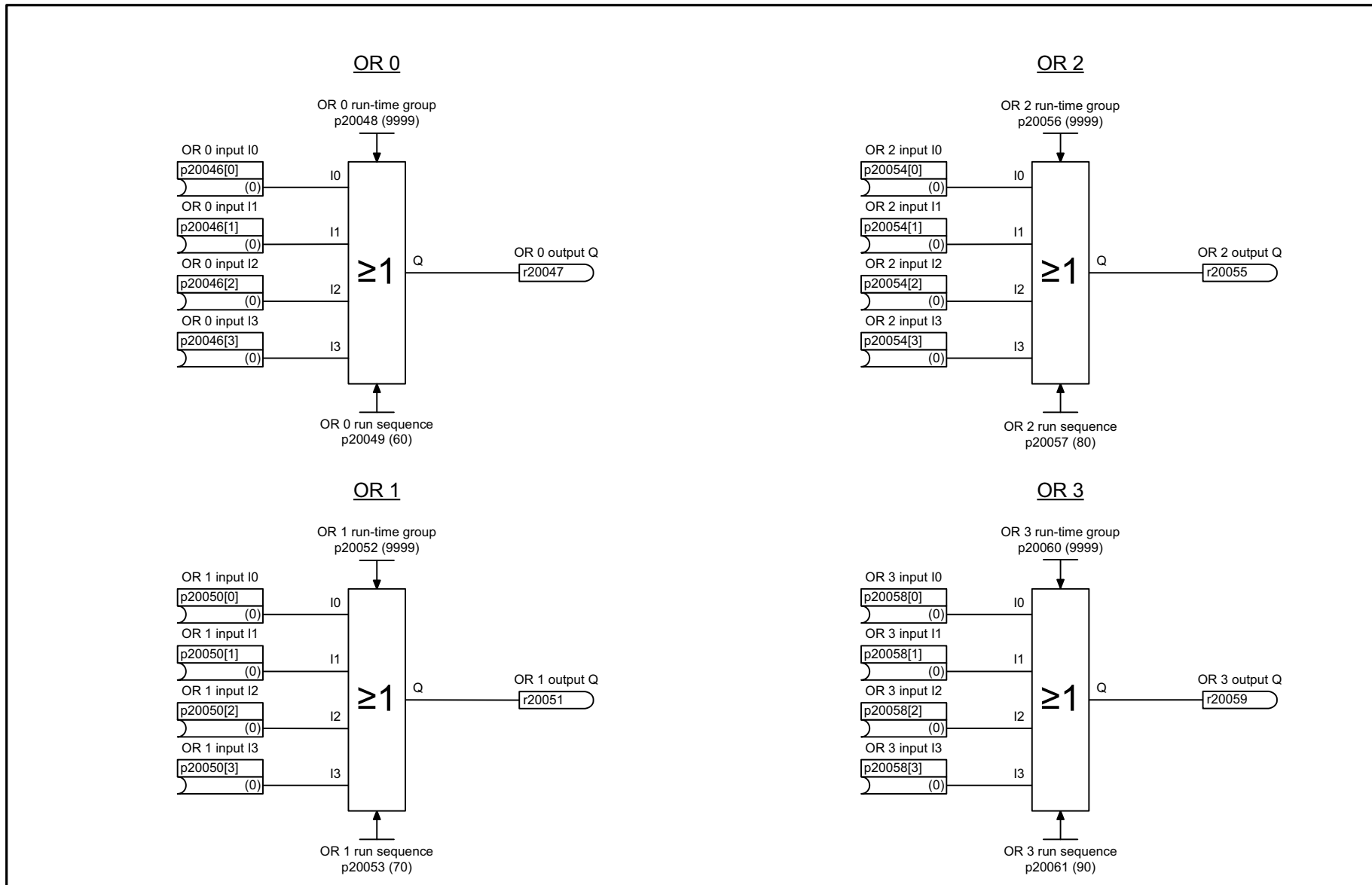
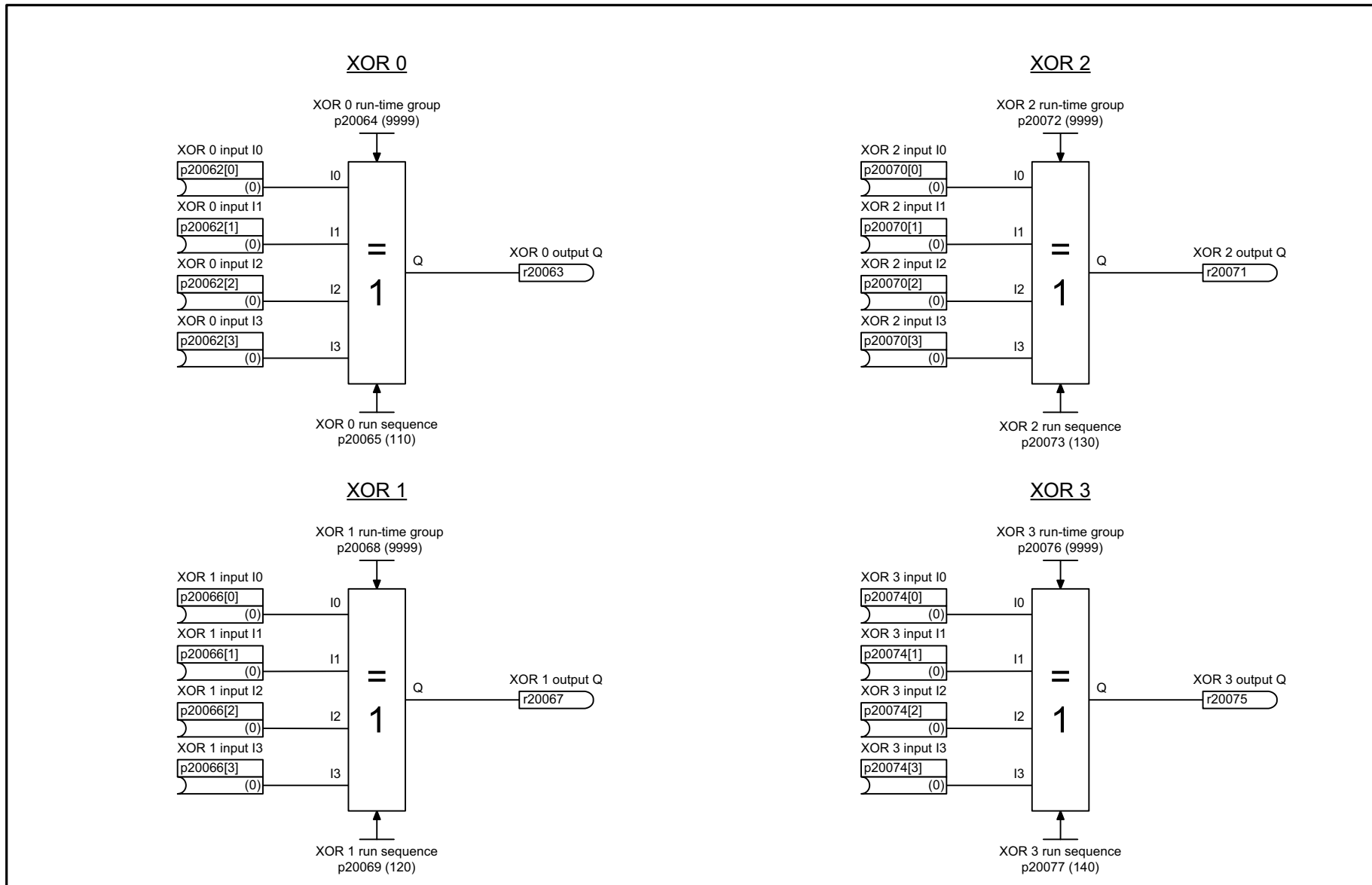

Fig. 3-3 7212 – OR (OR function block with 4 inputs)

1	2	3	4	5	6	7	8
DO: All Objects					fp_7212_99_eng.vsd	Function diagram	
Logic function blocks - OR (OR function block with 4 inputs)					15.03.06 V04.04.00	SINAMICS	
							<b>- 7212 -</b>



1	2	3	4	5	6	7	8
DO: All Objects					fp_7214_99_eng.vsd	Function diagram	
Logic function blocks - XOR (XOR function block with 4 inputs)					15.03.06 V04.04.00	SINAMICS	
							<b>- 7214 -</b>

Fig. 3-4 7214 – XOR (XOR function block with 4 inputs)

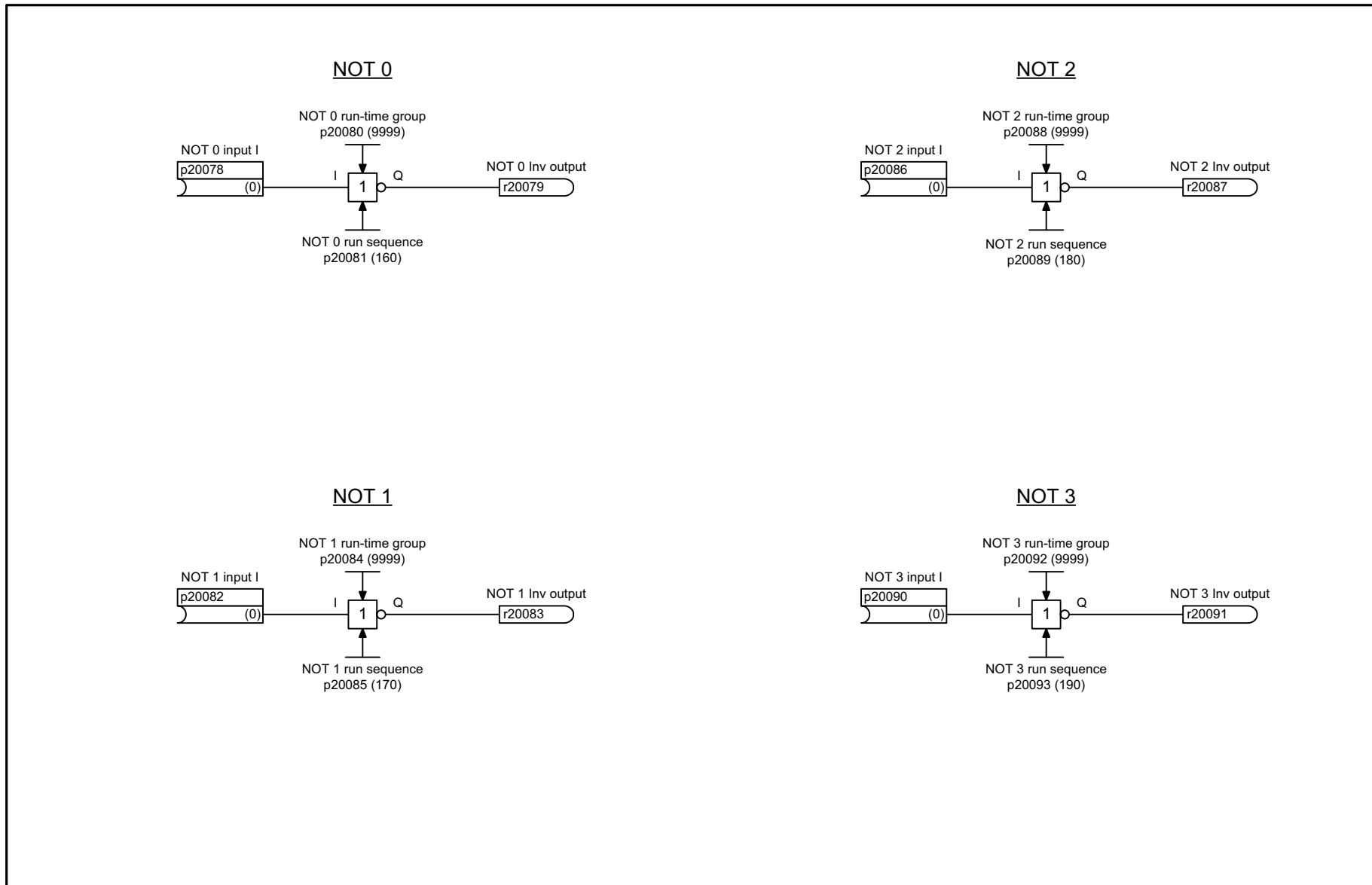

Fig. 3-5 7216 – NOT (inverter)

1	2	3	4	5	6	7	8
DO: All Objects					fp_7216_99_eng.vsd	Function diagram	
Logic function block - NOT (inverter)					18.09.08 V04.04.00	SINAMICS	
							<b>- 7216 -</b>

## 3.4 Arithmetic function blocks

### Function diagrams

---

7220 – ADD (adder with 4 inputs), SUB (subtractor)	3-143
7222 – MUL (multiplier), DIV (divider)	3-144
7224 – AVA (absolute value generator)	3-145

---

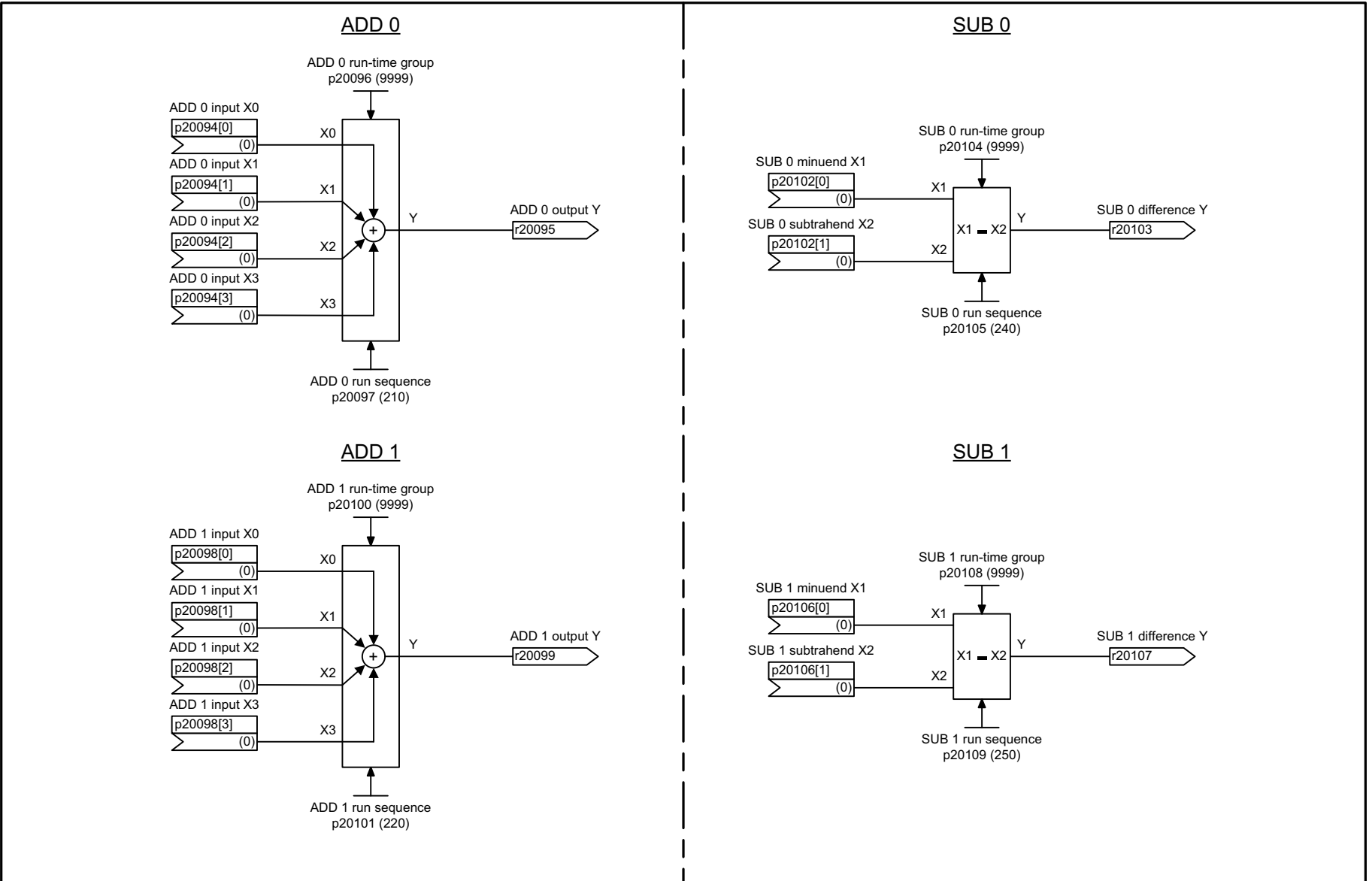
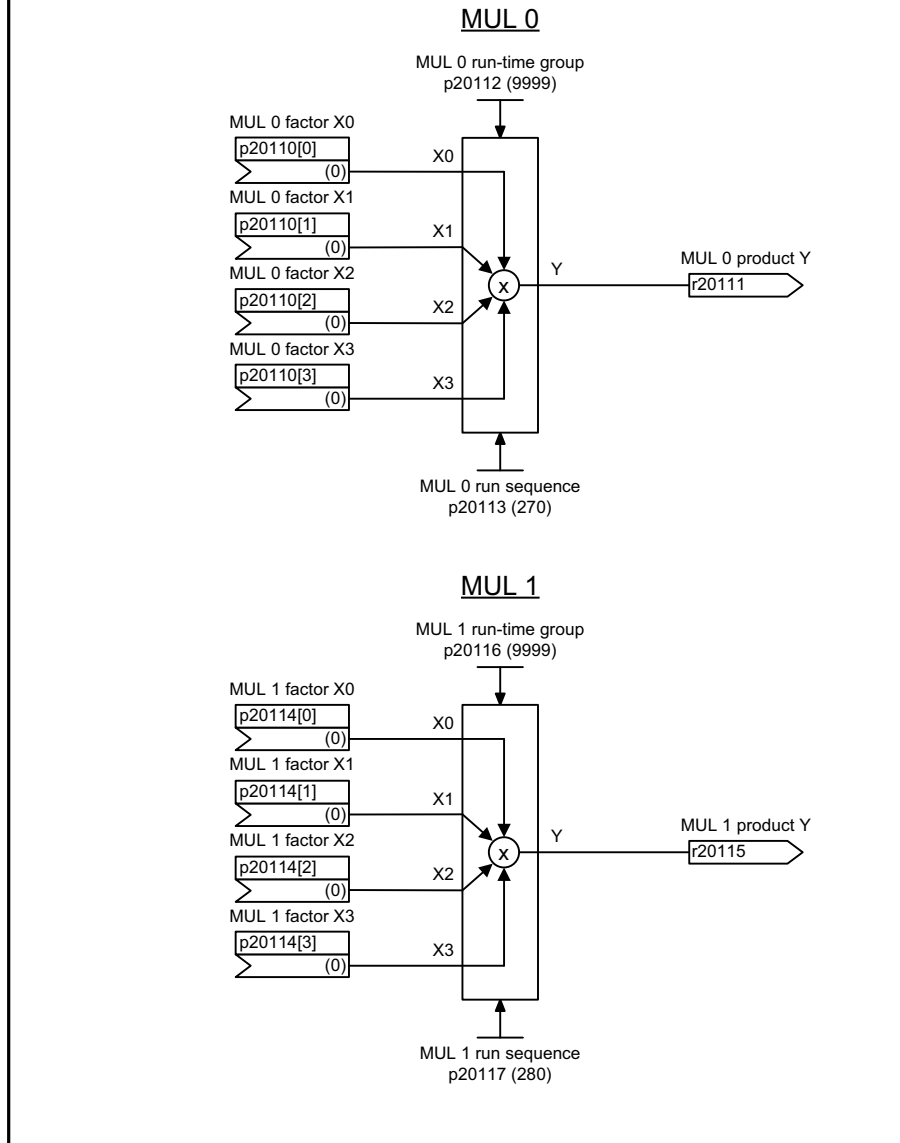
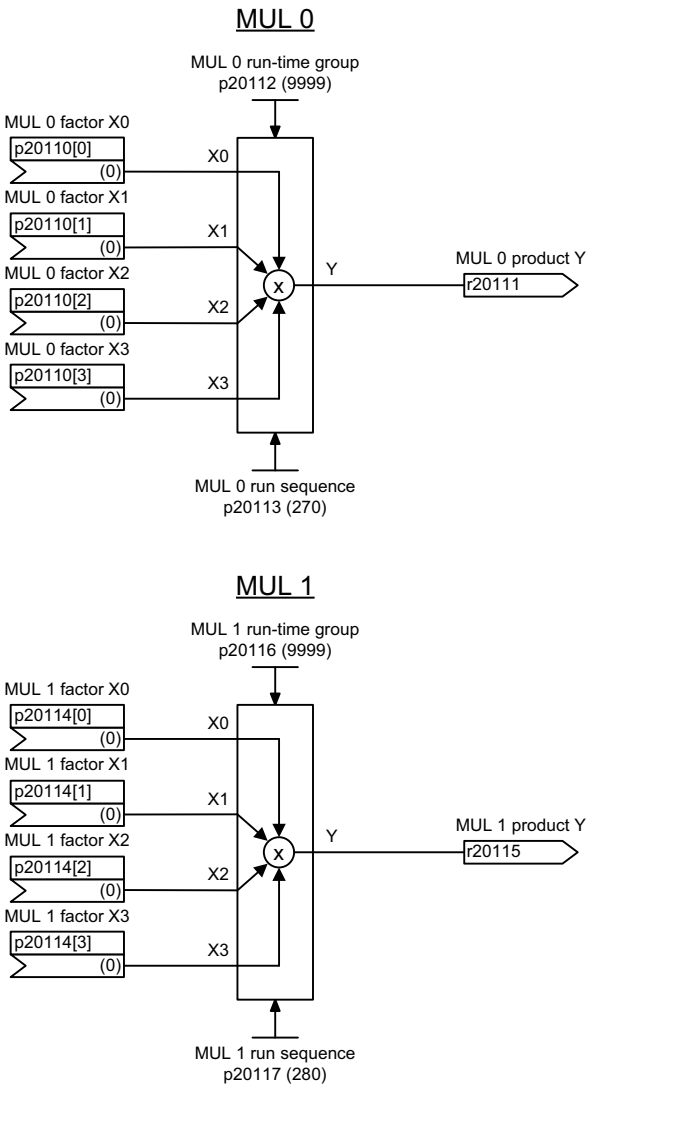
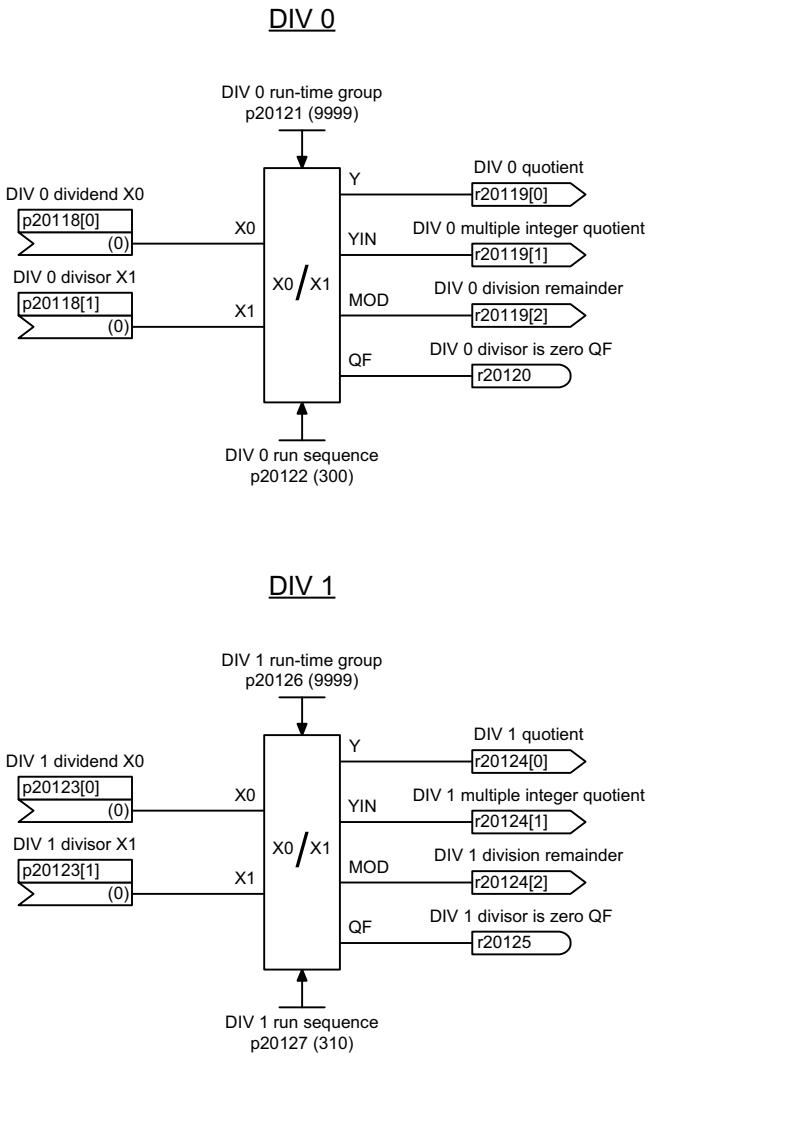

Fig. 3-6 7220 – ADD (adder with 4 inputs), SUB (subtractor)

1	2	3	4	5	6	7	8
DO: All Objects					fp_7220_99_eng.vsd	Function diagram	
Arithmetic function blocks - ADD (adder with 4 inputs), SUB (subtractor)					23.12.08 V04.04.00	SINAMICS	
							<b>- 7220 -</b>



1	2	3	4	5	6	7	8
DO: All Objects					fp_7222_99_eng.vsd	Function diagram	
Arithmetic function blocks - MUL (multiplier), DIV (divider)					15.03.06 V04.04.00	SINAMICS	
<b>- 7222 -</b>							

Fig. 3-7 7222 – MUL (multiplier), DIV (divider)



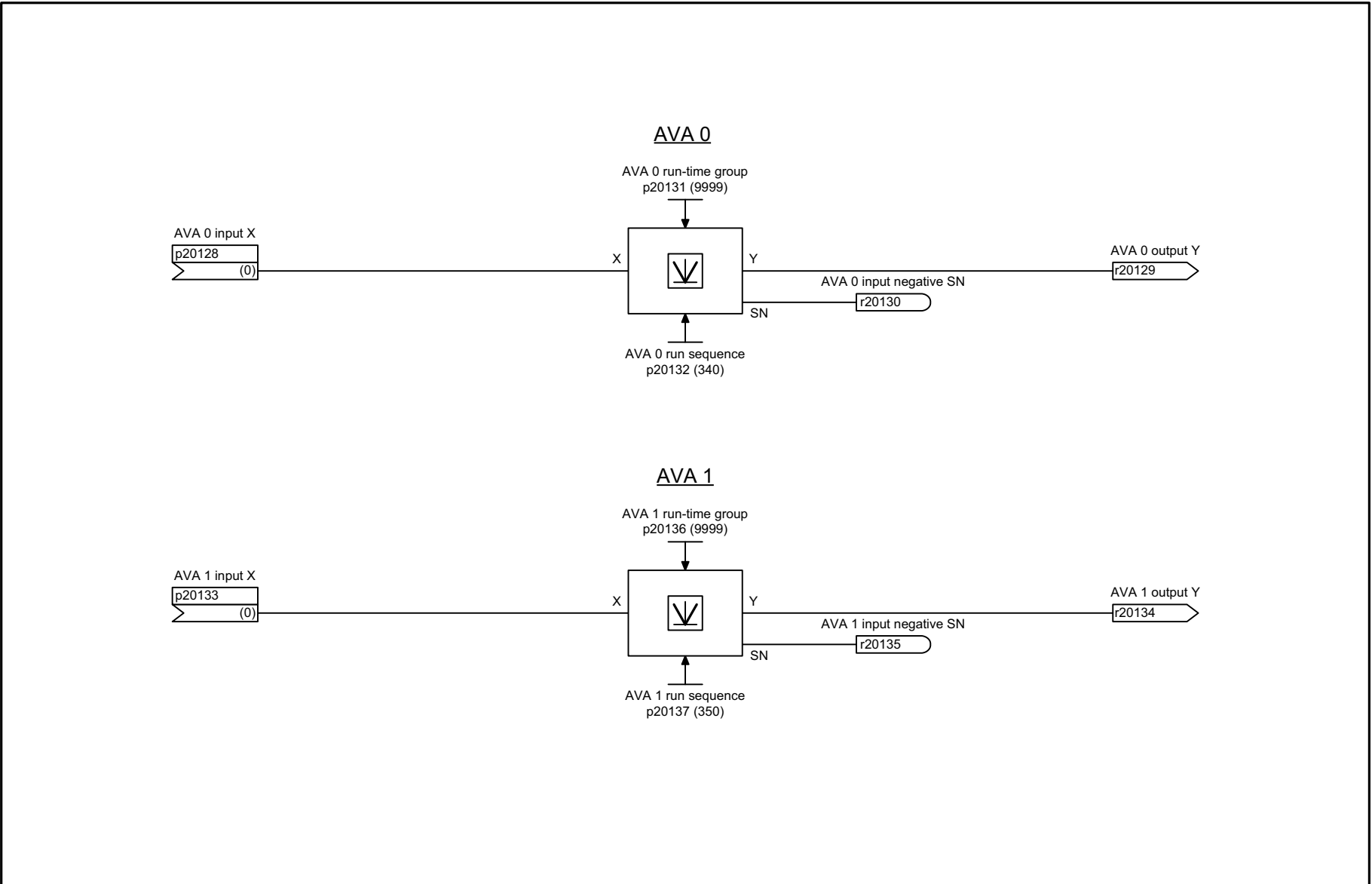

Fig. 3-8 7224 – AVA (absolute value generator)

1	2	3	4	5	6	7	8
DO: All Objects					fp_7224_99_eng.vsd	Function diagram	
Arithmetic function blocks - AVA (absolute value generators)					15.03.06 V04.04.00	SINAMICS	
							<b>- 7224 -</b>

## 3.5 Time function blocks

### Function diagrams

---

7230 – MFP (pulse generator), PCL (pulse contractor)	3-147
7232 – PDE (ON delay), PDF (OFF delay)	3-148
7234 – PST (pulse stretcher)	3-149

---

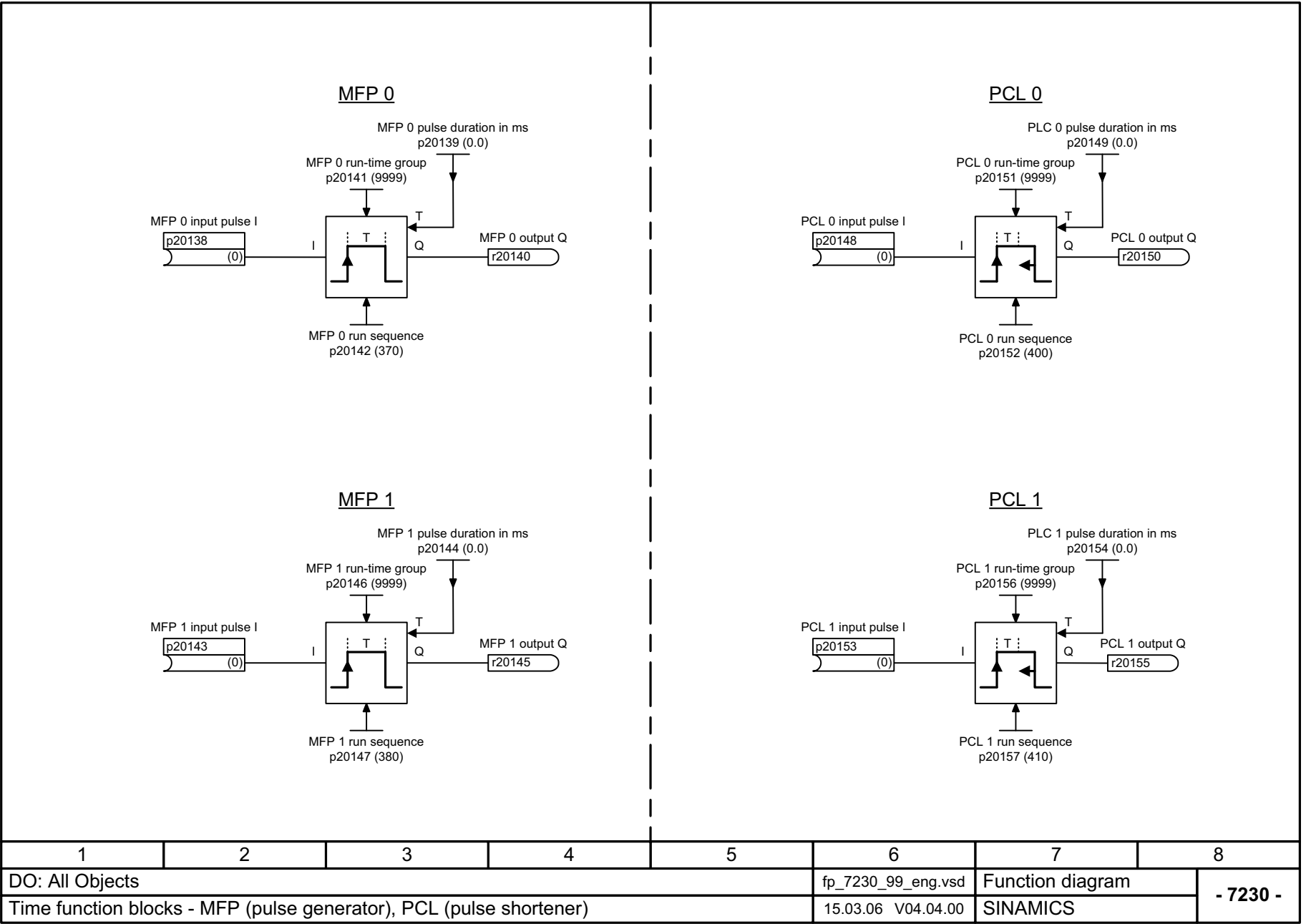

Fig. 3-9 7230 – MFP (pulse generator), PCL (pulse contractor)

1	2	3	4	5	6	7	8
DO: All Objects					fp_7230_99_eng.vsd	Function diagram	
Time function blocks - MFP (pulse generator), PCL (pulse shortener)					15.03.06 V04.04.00	SINAMICS	
							<b>- 7230 -</b>

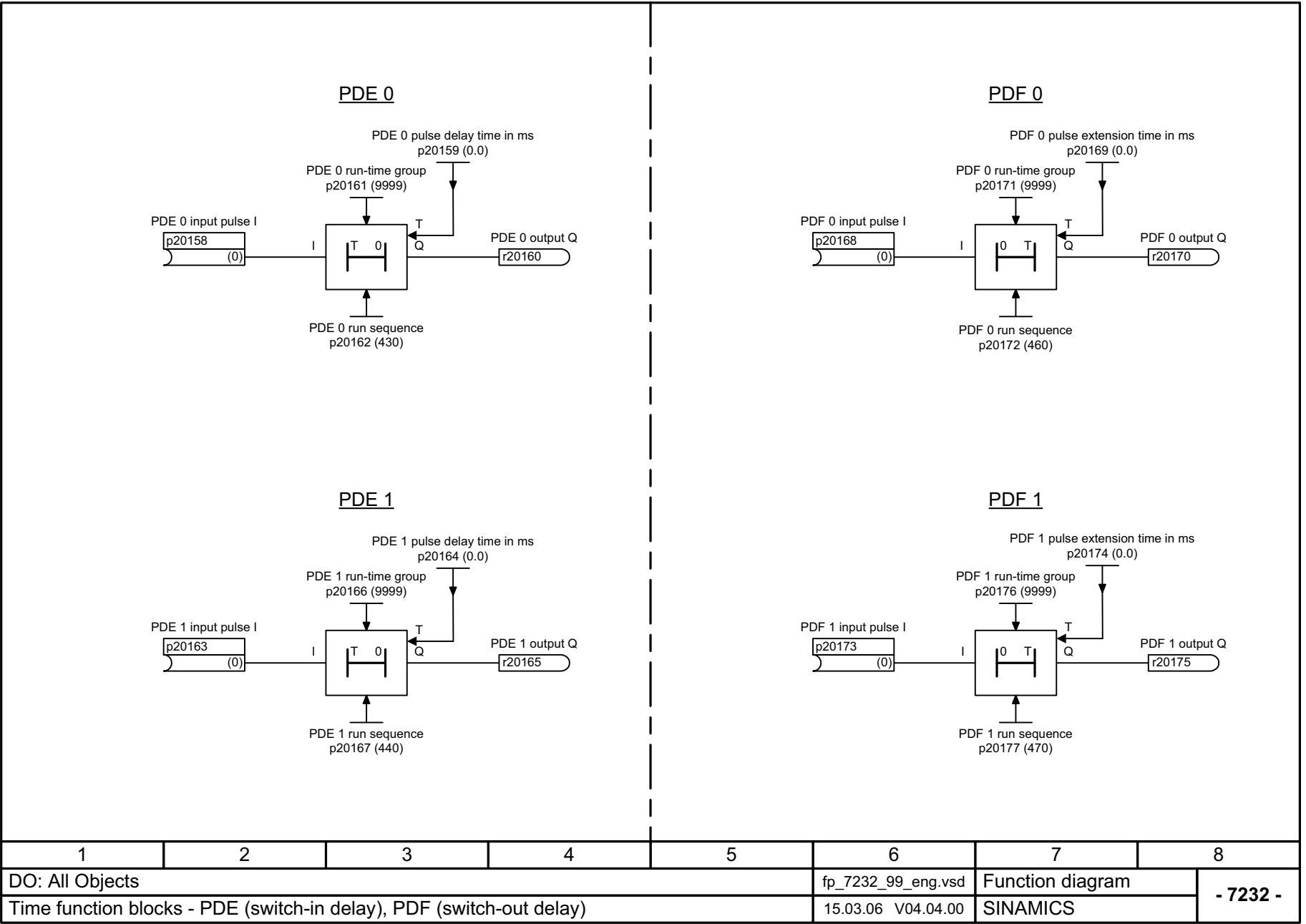

Fig. 3-10 7232 – PDE (ON delay), PDF (OFF delay)

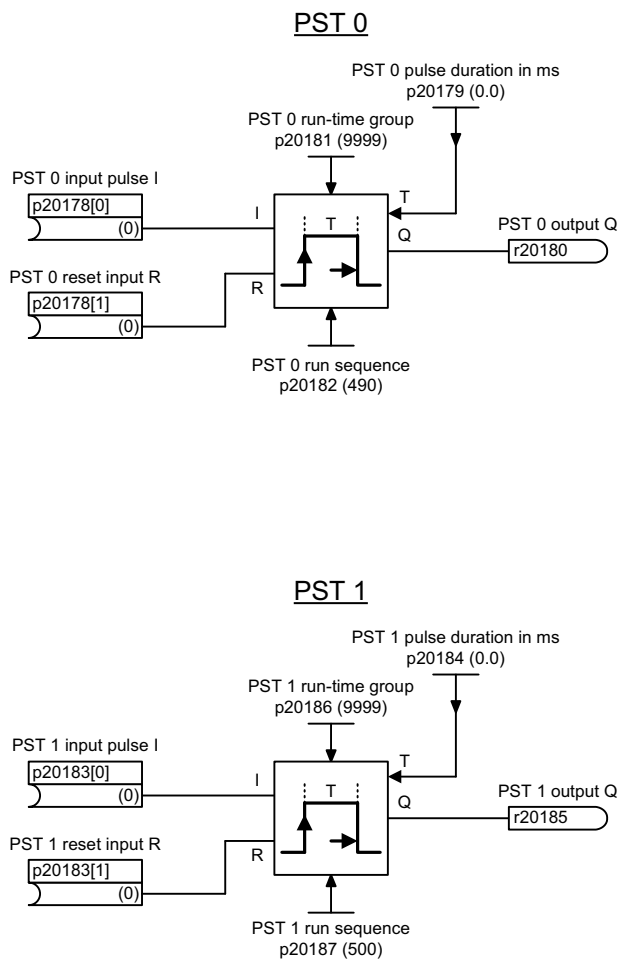

Fig. 3-11 7234 – PST (pulse stretcher)

1	2	3	4	5	6	7	8
DO: All Objects					fp_7234_99_eng.vsd	Function diagram	
Time function blocks - PST (pulse extender)					15.03.06 V04.04.00	SINAMICS	
							<b>- 7234 -</b>

## 3.6 Memory function blocks

### Function diagrams

---

7240 – RSR (RS flip-flop), DFR (D flip-flop)

3-151

---

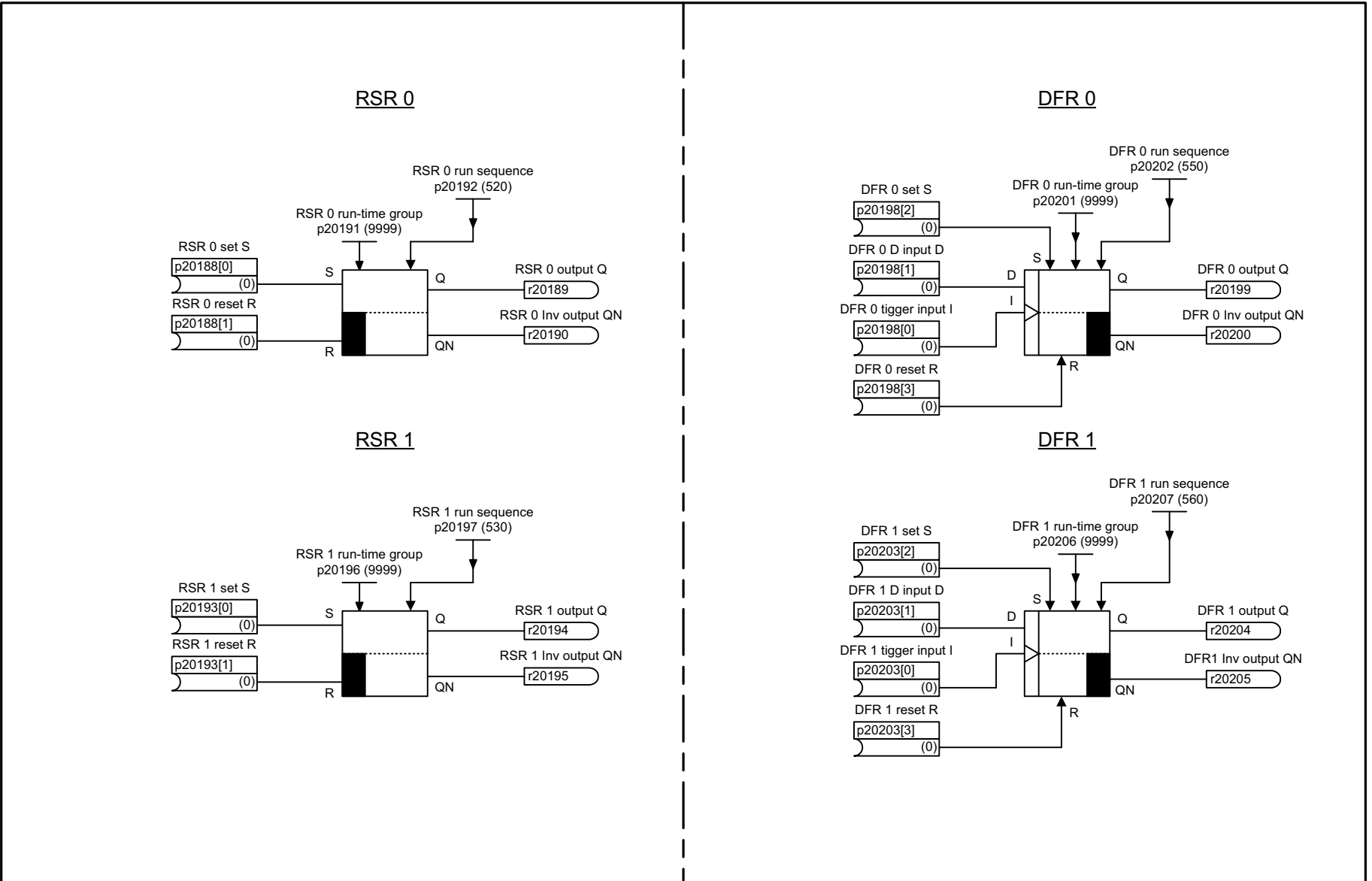

Fig. 3-12 7240 – RSR (RS flip-flop), DFR (D flip-flop)

1	2	3	4	5	6	7	8
DO: All Objects					fp_7240_99_eng.vsd	Function diagram	
Flipflop function blocks - RSR (RS flipflop), DFR (D flipflop)					15.03.06 V04.04.00	SINAMICS	
							<b>- 7240 -</b>

## 3.7 Switch function blocks

### Function diagrams

---

7250 – BSW (binary change-over switch), NSW (numeric change-over switch)

3-153

---



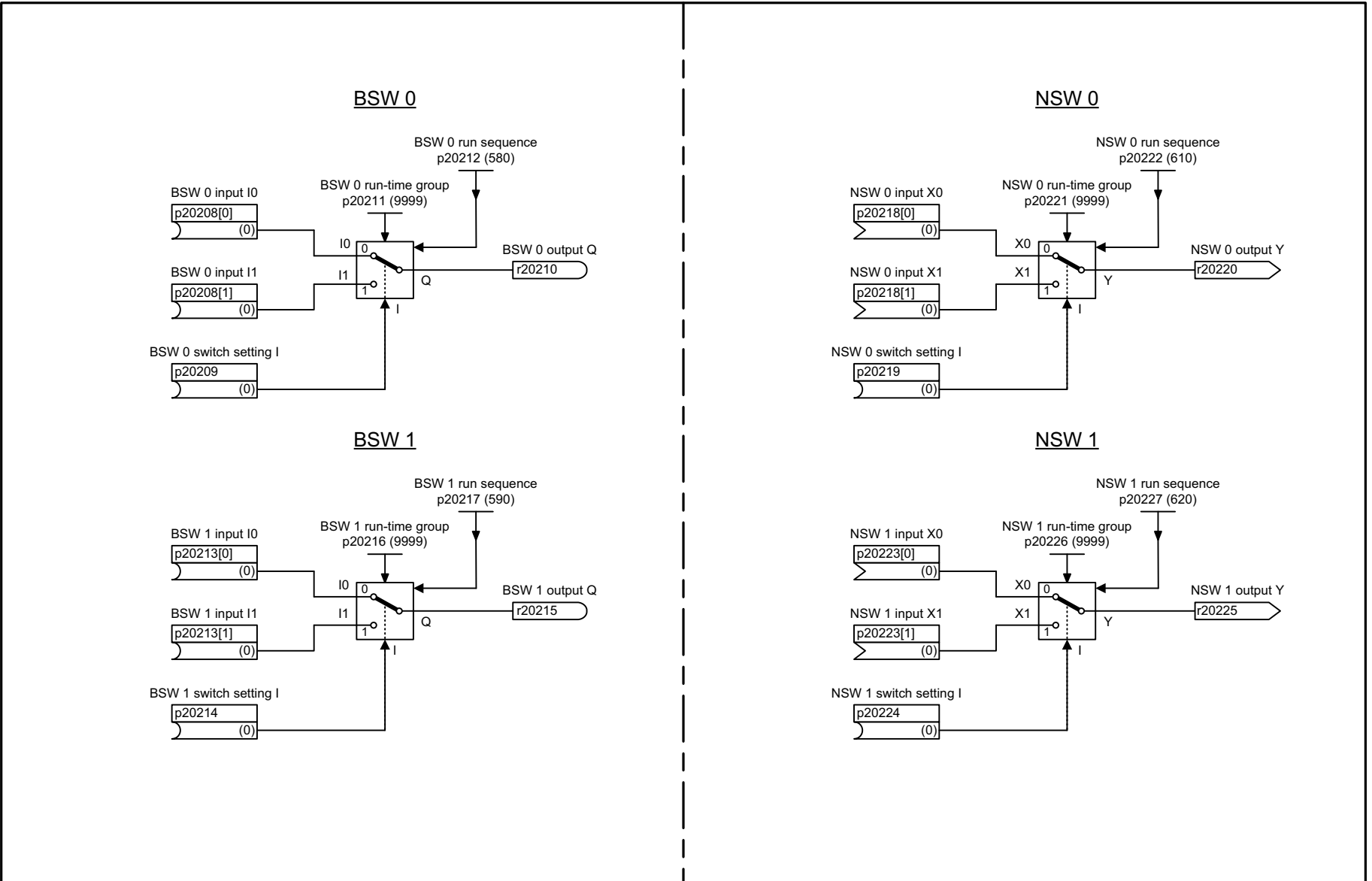

Fig. 3-13 7250 – BSW (binary change-over switch), NSW (numeric change-over switch)

1	2	3	4	5	6	7	8
DO: All Objects					fp_7250_99_eng.vsd	Function diagram	
Switch function blocks - BSW (binary changeover switch), NSW (numerical changeover switch)					02.10.08 V04.04.00	SINAMICS	
							<b>- 7250 -</b>

## 3.8 Control function blocks

### Function diagrams

---

7260 – LIM (limiter)	3-155
7262 – PT1 (smoothing element)	3-156
7264 – INT (integrator), DIF (derivative action element)	3-157

---

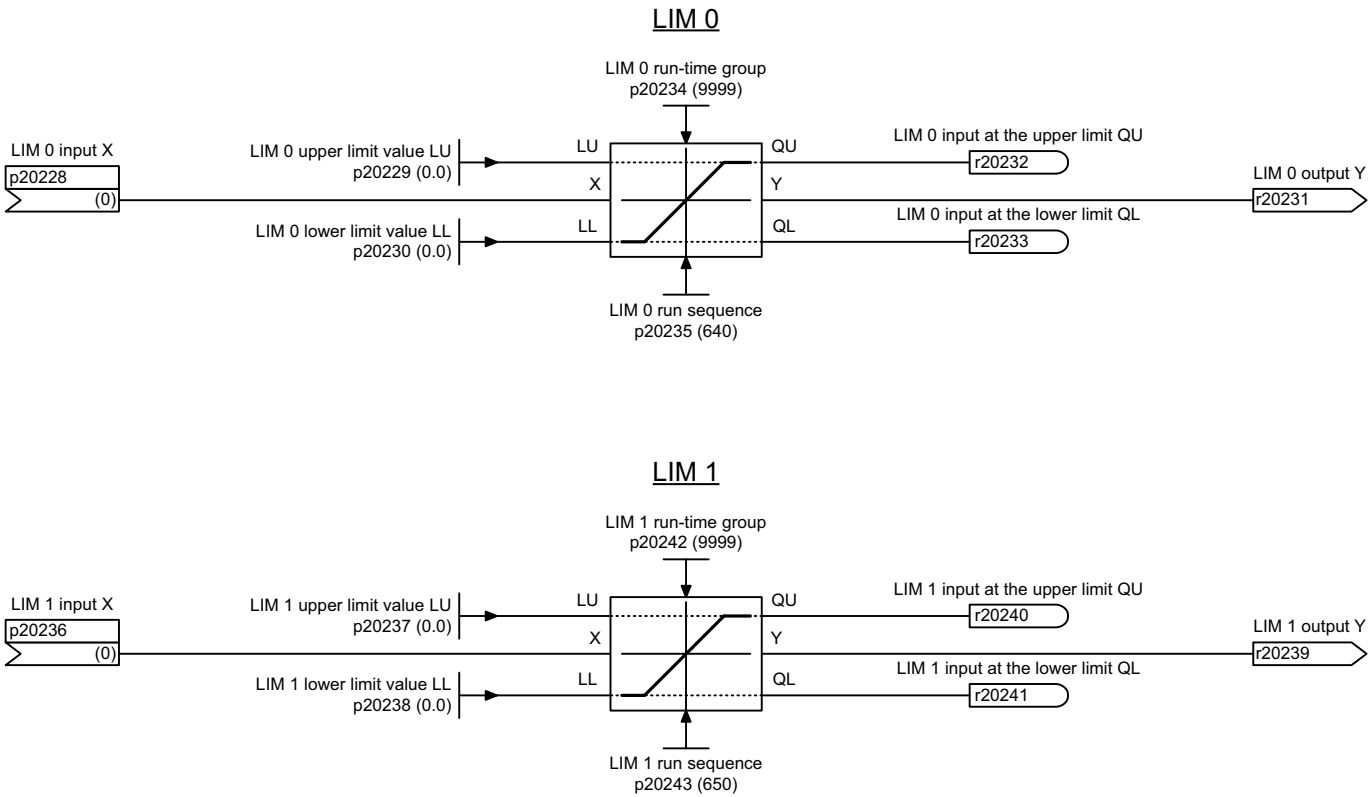

Fig. 3-14 7260 – LIM (limiter)

1	2	3	4	5	6	7	8
DO: All Objects					fp_7260_99_eng.vsd	Function diagram	
Basic function blocks - LIM (limiter)					15.03.06 V04.04.00	SINAMICS	
							<b>- 7260 -</b>

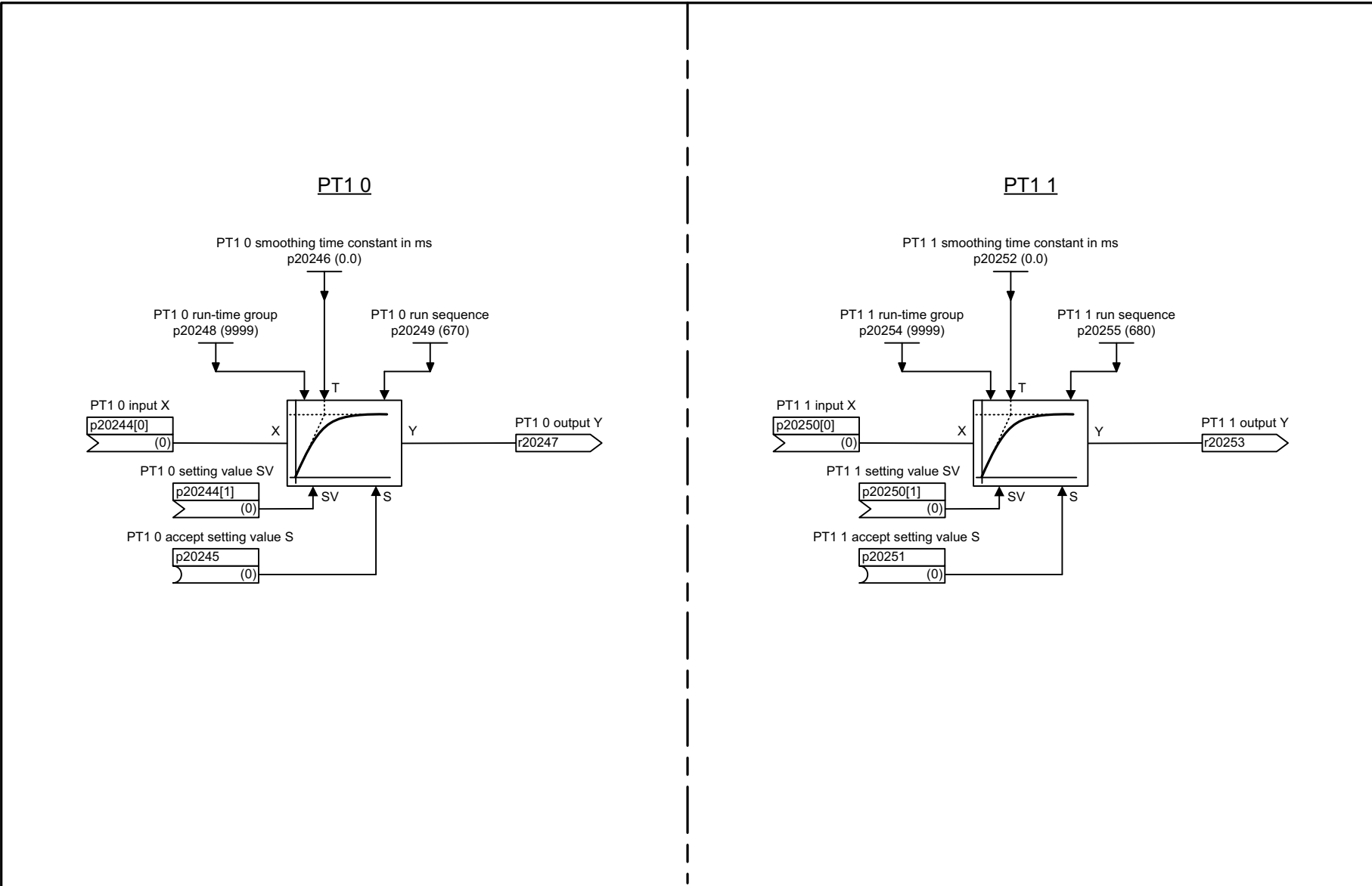

Fig. 3-15 7262 – PT 1 (smoothing element)

1	2	3	4	5	6	7	8
DO: All Objects					fp_7262_99_eng.vsd	Function diagram	
Basic function blocks - PT1 (smoothing element)					15.03.06 V04.04.00	SINAMICS	
							<b>- 7262 -</b>

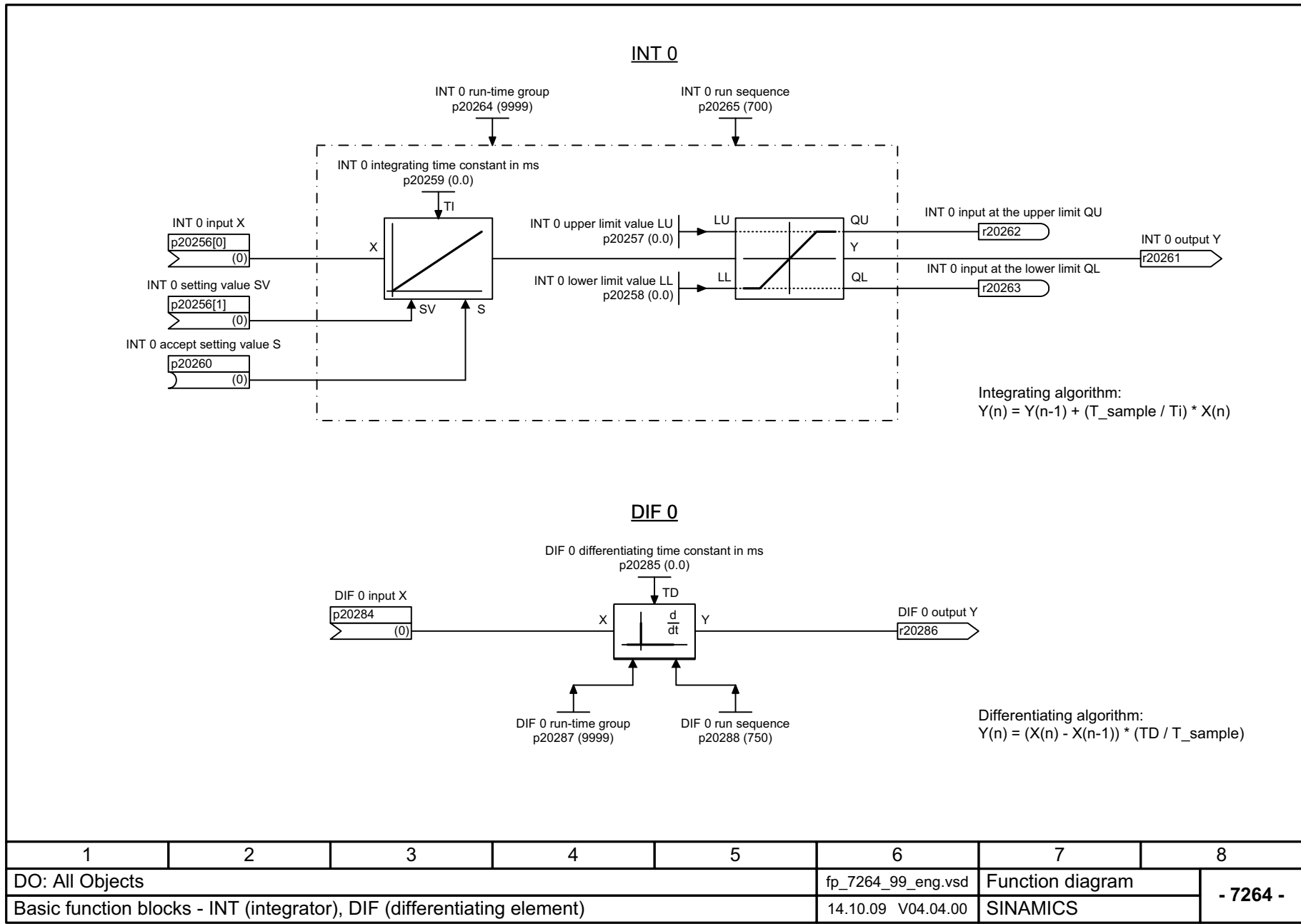

Fig. 3-16 7264 – INT (integrator), DIF (derivative action element)

1	2	3	4	5	6	7	8
DO: All Objects					fp_7264_99_eng.vsd	Function diagram	
Basic function blocks - INT (integrator), DIF (differentiating element)					14.10.09 V04.04.00	SINAMICS	
							<b>- 7264 -</b>

## 3.9 Complex function blocks

### Function diagrams

---

7270 – LVM (double-sided limit monitor with hysteresis)

3-159

---

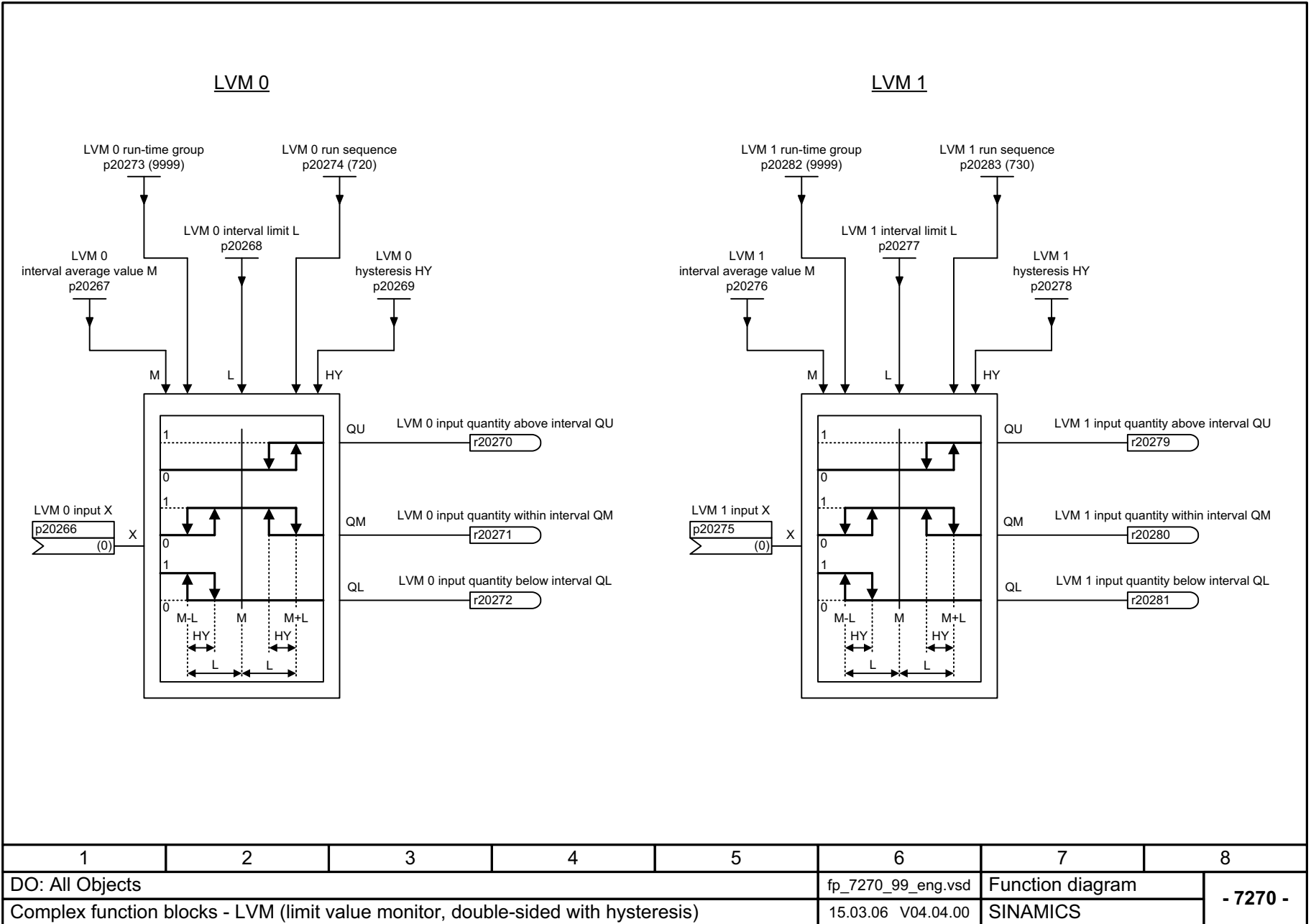

Fig. 3-17 7270 – LVM (double-sided limit monitor with hysteresis)

1	2	3	4	5	6	7	8
DO: All Objects					fp_7270_99_eng.vsd	Function diagram	
Complex function blocks - LVM (limit value monitor, double-sided with hysteresis)					15.03.06 V04.04.00	SINAMICS	
							<b>- 7270 -</b>





# Faults and alarms

# 4

## Contents

4.1	Overview of faults and alarms	4-162
4.2	List of faults and alarms	4-167

## 4.1 Overview of faults and alarms

### 4.1.1 General information on faults and alarms

#### Displaying faults and alarms

If a fault occurs, the drive indicates this by issuing corresponding fault(s) and/or alarm(s).

The following methods for displaying faults and alarms are available:

- Display via the fault and alarm buffer with PROFIBUS.
- Display online via the commissioning software.

#### Differences between faults and alarms

The differences between faults and alarms are as follows:

Table 4-1 Differences between faults and alarms

Type	Description
Faults	<p>What happens when a fault occurs?</p> <ul style="list-style-type: none"> <li>• The appropriate fault reaction is triggered.</li> <li>• Status signal ZSW1.3 is set.</li> <li>• The fault is entered in the fault buffer.</li> </ul> <p>How are faults removed?</p> <ul style="list-style-type: none"> <li>• Remove the original cause of the fault.</li> <li>• Acknowledge the fault.</li> </ul>
Alarms	<p>What happens when an alarm occurs?</p> <ul style="list-style-type: none"> <li>• Status signal ZSW1.7 is set.</li> <li>• The alarm is entered in the alarm buffer.</li> </ul> <p>How are alarms removed?</p> <ul style="list-style-type: none"> <li>• Alarms acknowledge themselves. If the cause of the alarm is no longer present, they automatically reset themselves.</li> </ul>

#### Fault reactions

The list of faults and alarms indicates the type of response initiated by the message for each fault.

---

#### Note:

Information on the fault reactions for this device can be taken from the corresponding List Manual.

---

### Acknowledging faults

The list of faults and alarms specifies how to acknowledge each fault after the cause has been remedied.

---

**Note:**

Information on the acknowledgment options for this device can be taken from the corresponding List Manual.

---

### Saving the fault buffer when switching off

The contents of the fault buffer are saved to the non-volatile memory when the Control Unit is switched off, i.e. the fault buffer history is still available when the unit is switched on again.

The fault buffer of a drive object comprises the following parameters:

- r0945[0...63], r0947[0...63], r0948[0...63], r0949[0...63]
- r2109[0...63], r2130[0...63], r2133[0...63], r2136[0...63]

The fault buffer contents can be deleted manually as follows:

- Delete fault buffer for all drive objects:  
p2147 = 1 --> After execution, p2147 = 0 is automatically set.
- Delete fault buffer for a specific drive object:  
p0952 = 0 --> The parameter belongs to the specified drive object.

The fault buffer contents are automatically deleted when the following occurs:

- Restore factory setting (p0009 = 30 and p0976 = 1).
- Download with modified structure (e.g. number of drive objects changed).
- Power-up after other parameter values have been loaded (e.g. p0976 = 10).
- Upgrade firmware to later version.

### 4.1.2 Explanation of the list of faults and alarms

The data in the following example has been chosen at random. The information listed below is the maximum amount of information that a description can contain. Some of the information is optional.

The list of faults and alarms (See Chapter 4.2) is structured as follows:

----- **Start of example** -----

---

<b>Axxxxx (F, N)</b>	<b>Fault location (optional): Name</b>
<b>Message value:</b>	Component number: %1, fault cause: %2
<b>Drive object:</b>	List of objects.
<b>Reaction:</b>	NONE
<b>Acknowledgment:</b>	NONE
<b>Cause:</b>	Description of possible causes. Fault value (r0949, interpret format): or alarm value (r2124, interpret format): (optional) Information about fault or alarm values (optional).
<b>Remedy:</b>	Description of possible remedies.
Reaction to F:	A_INFEED: OFF2 (OFF1, NONE) SERVO: NONE (OFF1, OFF2, OFF3) VECTOR: NONE (OFF1, OFF2, OFF3)
Acknowledgment for F:	IMMEDIATELY (POWER ON)
Reaction to N:	NONE
Acknowledgment for N:	NONE

----- **End of example** -----

- Axxxxx**            **Alarm xxxxx**
- Axxxxx (F, N)** **Alarm xxxxx (message type can be changed to F or N)**
- Fxxxxx**            **Fault xxxxx**
- Fxxxxx (A, N)** **Fault xxxxx (message type can be changed to F or N)**
- Nxxxxx**            **No message**
- Nxxxxx (A)**      **No message (message type can be changed to A)**
- Cxxxxx**            **Safety message (separate message buffer)**

A message comprises a letter followed by the relevant number.

The letters have the following meanings:

- A means "Alarm".
- F means "Fault".
- N means "No message" or "Internal message" ("No Report")
- C means "Safety message"

The optional brackets indicate whether the type specified for this message can be changed and which message types can be adjusted via parameters (p2118, p2119).

Information on reaction and acknowledgment is specified independently for a message with an adjustable message type (e.g. reaction to F, acknowledgment for F).

**Note:**

You can change the default properties of a fault or alarm by setting parameters. Information can be taken from the corresponding List Manual.

The list of faults and alarms (see Chapter 4.2) provides information in relation to the properties of a message that have been set as standard. If the properties of a specific message are changed, the corresponding information may have to be modified in this list.

---

**Fault location (optional): Name**

The fault location (optional), the name of the fault or alarm, and the message number are all used to identify the message (e.g. with the commissioning software).

**Message value:**

The information provided under the message value tells you about the composition of the fault/alarm value.

**Example:**

Message value: Component number: %1, fault cause: %2

This message value contains information about the component number and cause of the fault. The entries %1 and %2 are placeholders, which are filled appropriately in online operation (e.g. with the commissioning software).

**Reaction: Default fault reaction (adjustable fault reaction)**

Specifies the default reaction in the event of a fault.

The optional brackets indicate whether the default fault reaction can be changed and which fault reactions can be adjusted via parameters (p2100, p2101).

**Note:**

See Chapter 4.1.1

**Acknowledgment: Default acknowledgment (adjustable acknowledgment)**

Specifies the default method of acknowledging the fault after the cause has been removed.

The optional brackets indicate whether the default acknowledgment can be changed and which acknowledgment can be adjusted via parameters (p2126, p2127).

**Note:**

See Chapter 4.1.1

**Cause:**

Describes the possible causes of the fault or alarm. A fault or alarm value can also be specified (optional).

Fault value (r0949, format):

The fault value is entered in the fault buffer in r0949[0...63] and specifies additional, more precise information about a fault.

Alarm value (r2124, format):

The alarm value specifies additional, more precise information about an alarm.

The alarm value is entered in the alarm buffer in r2124[0...7] and specifies additional, more precise information about an alarm.

**Remedy:**

Describes the methods available for eliminating the cause of the active fault or alarm.



**Alarm**

In certain cases, service and maintenance personnel are responsible for choosing a suitable method to eliminate the cause of faults.

---

## 4.2 List of faults and alarms

Product: SINAMICS FBLOCKS, Version: 4402100, Language: eng,  
Objects: All objects

<b>F50510</b>	<b>FBLOCKS: Logon of the run-time group rejected</b>
<b>Message value:</b>	-
<b>Drive object:</b>	All objects
<b>Reaction:</b>	NONE
<b>Acknowledge:</b>	IMMEDIATELY
<b>Cause:</b>	When the run-time groups of the free function blocks attempted to log on with the sampling time management, the logon of at least one run-time group was rejected. Too many different hardware sampling times may have been assigned to the free function blocks. See also: r20008 (Hardware sampling times available)
<b>Remedy:</b>	- check number of different hardware sampling times (r20008, r7903). - if necessary, deactivate again the drive object on which the function module "free function blocks" was last activated (p0108[0...15].18 = 0). Then carry out a POWER ON. Note: The assignment of drive object numbers to the index numbers of p0108[0...15] can be read out in p0101[0...15]; the assignment to the drive object types can be read out in p0107[0...15] on the drive object of the CU or CX (only with SM150).
<b>F50511</b>	<b>FBLOCKS: Memory no longer available for free function blocks</b>
<b>Message value:</b>	-
<b>Drive object:</b>	All objects
<b>Reaction:</b>	NONE
<b>Acknowledge:</b>	IMMEDIATELY
<b>Cause:</b>	When the free function blocks were activated, more memory was requested than was available on the Control Unit.
<b>Remedy:</b>	Deactivate again the drive object on which the function module "free function blocks" was last activated (p0108[0...15].18 = 0). Then carry out a POWER ON. Note: The assignment of drive object numbers to the index numbers of p0108[0...15] can be read out in p0101[0...15]; the assignment to the drive object types can be read out in p0107[0...15] on the drive object of the CU or CX (only with SM150).
<b>A50513 (F)</b>	<b>FBLOCKS: Run sequence value already assigned</b>
<b>Message value:</b>	-
<b>Drive object:</b>	All objects
<b>Reaction:</b>	NONE
<b>Acknowledge:</b>	NONE
<b>Cause:</b>	An attempt was made to assign a run sequence value already assigned to a function block on this drive object to another additional function block on the same drive object. A run sequence value can only be precisely assigned to one function block on one drive object.
<b>Remedy:</b>	Set another value that is still available on this drive object for the run sequence.
Reaction upon F:	NONE
Acknowl. upon F:	IMMEDIATELY
<b>A50514</b>	<b>FBLOCKS: Sampling time of fixed run-time group differs</b>
<b>Message value:</b>	-
<b>Drive object:</b>	All objects
<b>Reaction:</b>	NONE
<b>Acknowledge:</b>	NONE
<b>Cause:</b>	The sampling time of a system function was set to a value (p0112, p0115) lower than the smallest permissible sampling time that is allowed for the fixed run-time group belonging to this system block (1 ms). The fixed run-time group involved is assigned as a minimum to one block.
<b>Remedy:</b>	Using p0112 or p0115, increase the sampling time of the system function to the minimum permissible sampling time for the run-time groups of 1 ms or change the sampling time assignment of this run-time group in p20000[0...9].

---

**A50517      FBLOCKS: Int. meas. active**

**Message value:** -  
**Drive object:** All objects  
**Reaction:** NONE  
**Acknowledge:** NONE  
**Cause:** A Siemens internal measurement has been activated.  
**Remedy:** Carry out a POWER ON (power off/on) for the Control Unit involved.

---

**F50518      FBLOCKS: Sampling time of free run-time group differs at download**

**Message value:** %1  
**Drive object:** All objects  
**Reaction:** NONE  
**Acknowledge:** IMMEDIATELY  
**Cause:** In the STARTER/SCOUT project that was downloaded, the hardware sampling time of a free run-time group (1 <= p20000[i] <= 256) was set to a value that was either too low or too high.  
 The sampling time must be between 1 ms and the value r20003 - r20002.  
 If the sampling time of the selected free run-time group is < 1 ms, the equivalent value of 1 ms is used.  
 If the value >= r20003, then the sampling time is set to the next higher or the same software sampling time >= r21003.  
 Fault value (r0949, decimal interpretation):  
 Number of the p20000 index of the run-time group where the sampling time is incorrectly set.  
 Number of the run-time group = fault value + 1  
**Note:**  
 For SIMOTION D410, r20003 (unlike all the other Control Units) is automatically set the same as the PROFIBUS sampling time.  
 See also: r20008 (Hardware sampling times available)  
**Remedy:** - correctly set the sampling time of the run-time group.  
 - if required, take all of the blocks from the run-time group.  
**Note:**  
 Fault F50518 only detects an incorrectly parameterized run-time group. If, after correcting p20000[i] in the project, this error occurs again at download, then the run-time group involved should be identified using the fault value (r0949) and the sampling time correctly set.



# List of abbreviations

# A

---

**Note:**

The following list of abbreviations includes all abbreviations and their meanings used in the entire SINAMICS family of drives.

---

<b>Abbreviation</b>	<b>Source of abbreviation</b>	<b>Meaning</b>
<b>A</b>		
A...	Alarm	Alarm
AC	Alternating Current	Alternating current
ADC	Analog Digital Converter	Analog-Digital converter
AI	Analog Input	Analog input
AIM	Active Interface Module	Active Interface Module
ALM	Active Line Module	Active Line Module
AO	Analog Output	Analog output
AOP	Advanced Operator Panel	Advanced Operator Panel
APC	Advanced Positioning Control	Advanced Positioning Control
AR	Automatic Restart	Automatic restart
ASC	Armature Short Circuit	Armature short circuit
ASCII	American Standard Code for Information Interchange	American Standard Code for Information Interchange
ASM	Asynchronmotor	Induction motor
<b>B</b>		
BB	Betriebsbedingung	Operating condition
BERO	-	Contact-free proximity switch
BI	Binector Input	Binector input
BIA	Berufsgenossenschaftliches Institut für Arbeitssicherheit	Germany's Institute for Occupational Safety and Health
BICO	Binector Connector Technology	Binector connector technology
BLM	Basic Line Module	Basic Line Module
BO	Binector Output	Binector output
BOP	Basic Operator Panel	Basic Operator Panel
<b>C</b>		
C	Capacitance	Capacitance
C...	-	Safety message
CAN	Controller Area Network	Serial bus system

<b>Abbreviation</b>	<b>Source of abbreviation</b>	<b>Meaning</b>
CBC	Communication Board CAN	Communication Board CAN
CD	Compact Disk	Compact Disk
CDS	Command Data Set	Command data set
CF Card	CompactFlash Card	CompactFlash memory card
CI	Connector Input	Connector input
CLC	Clearance Control	Clearance control
CNC	Computerized Numerical Control	Computerized numerical control
CO	Connector Output	Connector output
CO/BO	Connector Output/Binector Output	Connector output/binector output
COB ID	CAN object identification	CAN object identification
COM	Common contact of a changeover relay	Center contact on a changeover contact
COMM	Commissioning	Commissioning
CP	Communications Processor	Communications processor
CPU	Central Processing Unit	Central processing unit
CRC	Cyclic Redundancy Check	Cyclic redundancy check
CSM	Control Supply Module	Control Supply Module
CU	Control Unit	Control Unit
CUA	Control Unit Adapter	Control Unit Adapter
CUD	Control Unit DC MASTER	Control Unit DC MASTER
<b>D</b>		
DAC	Digital Analog Converter	Digital-Analog converter
DC	Direct Current	Direct current
DCB	Drive Control Block	Drive Control Block
DCBRK	DC Brake	DC brake
DCC	Drive Control Chart	Drive Control Chart
DCN	Direct Current Negative	Direct current negative
DCP	Direct Current Positive	Direct current positive
DDS	Drive Data Set	Drive data set
DI	Digital Input	Digital input
DI/DO	Digital Input/Digital Output	Digital input/digital output, bidirectional
DMC	DRIVE-CLiQ Hub Module Cabinet	DRIVE-CLiQ Hub Module Cabinet
DME	DRIVE-CLiQ Hub Module External	DRIVE-CLiQ Hub Module External
DO	Digital Output	Digital output
DO	Drive Object	Drive object
DP	Decentralized Peripherals	Distributed I/O
DPRAM	Dual Port Random Access Memory	Memory with dual access
DRAM	Dynamic Random Access Memory	Dynamic memory
DRIVE-CLiQ	Drive Component Link with IQ	Drive Component Link with IQ
DSC	Dynamic Servo Control	Dynamic Servo Control
DTC	Digital Time Clock	Digital Time Clock

<b>Abbreviation</b>	<b>Source of abbreviation</b>	<b>Meaning</b>
<b>E</b>		
EASC	External Armature Short Circuit	External armature short circuit
EDS	Encoder Data Set	Encoder data set
EGB	Elektrostatisch gefährdete Baugruppen	Electrostatically Sensitive Devices
ELCB	Earth Leakage Circuit Breaker	Residual current operated circuit breaker
ELP	Earth Leakage Protection	Ground-fault monitoring
EMC	Electromagnetic Compatibility	Electromagnetic compatibility
EMF	Electromagnetic Force	Electromagnetic force
EMK	Elektromagnetische Kraft	Electromagnetic force
EMV	Elektromagnetische Verträglichkeit	Electromagnetic compatibility
EN	Europäische Norm	European standard
EnDat	Encoder Data Interface	Encoder interface
EP	Enable Pulses	Pulse enable
EPOS	Einfachpositionierer	Basic positioner
ES	Engineering System	Engineering System
ESB	Ersatzschaltbild	Equivalent circuit diagram
ESD	Electrostatically Sensitive Devices	Electrostatically Sensitive Devices
ESR	Extended Stop and Retract	Extended stop and retract
<b>F</b>		
F...	Fault	Fault
FAQ	Frequently Asked Questions	Frequently asked questions
FBL	Free Blocks	Free function blocks
FCC	Function Control Chart	Function Control Chart
FCC	Flux Current Control	Flux current control
FD	Function Diagram	Function diagram
F-DI	Failsafe Digital Input	Failsafe digital input
F-DO	Failsafe Digital Output	Failsafe digital output
FEM	Fremderregter Synchronmotor	Separately excited synchronous motor
FEPROM	Flash EPROM	Non-volatile read/write memory
FG	Function Generator	Function generator
FI	-	Fault current
FOC	Fiber-Optic Cable	Fiber-optic cable
FP	Funktionsplan	Function diagram
FPGA	Field Programmable Gate Array	Field Programmable Gate Array
FW	Firmware	Firmware
<b>G</b>		
GB	Gigabyte	Gigabyte
GC	Global Control	Global Control Telegram (Broadcast Telegram)
GND	Ground	Reference potential for all signal and operating voltages, usually defined as 0 V (also referred to as G)

<b>Abbreviation</b>	<b>Source of abbreviation</b>	<b>Meaning</b>
GSD	Generic Station Description	Generic Station Description: Describes the characteristics of a PROFIBUS slave
GSV	Gate Supply Voltage	Gate Supply Voltage
GUID	Globally Unique Identifier	Globally Unique Identifier
<b>H</b>		
HF	High Frequency	High frequency
HFD	Hochfrequenzdrossel	High-frequency reactor
HLG	Hochlaufgeber	Ramp-function generator
HMI	Human Machine Interface	Human Machine Interface
HTL	High-Threshold Logic	Logic with a high fault threshold
HW	Hardware	Hardware
<b>I</b>		
i. V.	In Vorbereitung	Under development: This feature is not currently available
I/O	Input/Output	Input/Output
I2C	Inter-Integrated Circuit	Internal serial data bus
IASC	Internal Armature Short Circuit	Internal armature short circuit
IBN	Inbetriebnahme	Commissioning
ID	Identifier	Identification
IE	Industrial Ethernet	Industrial Ethernet
IEC	International Electrotechnical Commission	International Electrotechnical Commission
IF	Interface	Interface
IGBT	Insulated Gate Bipolar Transistor	Insulated gate bipolar transistor
IGCT	Integrated Gate-Controlled Thyristor	Semiconductor circuit breaker with integrated control electrode
IL	Impulslöschung	Pulse cancelation
IP	Internet Protocol	Internet Protocol
IPO	Interpolator	Interpolator
IT	Isolé Terré	Insulated three-phase supply network
IVP	Internal Voltage Protection	Internal voltage protection
<b>J</b>		
JOG	Jogging	Jog
<b>K</b>		
CDC	Crosswise data comparison	Crosswise data comparison
KIP	Kinetische Pufferung	Kinetic buffering
Kp	-	Proportional gain
KTY	-	Special temperature sensor
<b>L</b>		
L	-	Formula symbol for inductance
LED	Light-Emitting Diode	Light-emitting diode
LIN	Linear motor	Linear motor
LR	Lageregler	Position controller

<b>Abbreviation</b>	<b>Source of abbreviation</b>	<b>Meaning</b>
LSB	Least Significant Bit	Least significant bit
LSC	Line Side Converter	Line side converter
LSS	Line Side Switch	Line side switch
LU	Length Unit	Length unit
LWL	Fiber-optic cable	Fiber-optic cable
<b>M</b>		
M	-	Formula symbol for torque
M	Masse	Reference potential for all signal and operating voltages, usually defined as 0 V (also referred to as GND)
MB	Megabyte	Megabyte
MCC	Motion Control Chart	Motion Control Chart
MDI	Manual Data Input	Manual data input
MDS	Motor Data Set	Motor data set
MLFB	Maschinenlesbare Fabrikatebezeichnung	Machine-Readable Product Code
MMC	Man-Machine Communication	Man-machine communication
MMC	Micro Memory Card	Micro memory card
MSB	Most Significant Bit	Most significant bit
MSC	Motor Side Converter	Motor side converter
MSCY_C1	Master Slave Cycle Class 1	Cyclic communication between master (Class 1) and slave
MSR	Motorstromrichter	Motor side converter
MT	Messtaster	Probe
<b>N</b>		
N. C.	Not Connected	Not connected
N...	No Report	No message or internal message
NAMUR	Normenarbeitsgemeinschaft für Mess- und Regeltechnik in der chemischen Industrie	Standardization association for measurement and control in the chemical industry
NC	Normally Closed (contact)	NC contact
NC	Numerical Control	Numerical control
NEMA	National Electrical Manufacturers Association	Standardization body in the USA (United States of America)
NM	Nullmarke	Zero mark
NO	Normally Open (contact)	NO contact
NSR	Netzstromrichter	Line side converter
NVRAM	Non-Volatile Random Access Memory	Non-volatile read/write memory
<b>O</b>		
OA	Open Architecture	Open Architecture
OC	Operating Condition	Operating condition
OEM	Original equipment manufacturer	Original equipment manufacturer
OLP	Optical Link Plug	Fiber-optic bus connector
OMI	Option Module Interface	Option Module Interface

<b>Abbreviation</b>	<b>Source of abbreviation</b>	<b>Meaning</b>
<b>P</b>		
p...	-	Adjustable parameter
P1	Processor 1	Processor 1
P2	Processor 2	Processor 2
PB	PROFIBUS	PROFIBUS
PcCtrl	PC Control	Control for master
PD	PROFIdrive	PROFIdrive
PDS	Power unit Data Set	Power unit data set
PE	Protective Earth	Protective earth
PELV	Protective Extra Low Voltage	Protective extra low voltage
PEM	Permanenterregter Synchronmotor	Permanent-magnet synchronous motor
PG	Programmiergerät	Programming device
PI	Proportional integral	Proportional integral
PID	Proportional Integral Differential	Proportional Integral Differential
PLC	Programmable Logic Controller	Programmable logic controller
PLL	Phase-locked loop	Phase-locked loop
PN	PROFINET	PROFINET
PNO	PROFIBUS user organization	PROFIBUS user organization
PPI	Point-to-Point Interface	Point-to-point interface
PRBS	Pseudo Random Binary Signal	White noise
PROFIBUS	Process Field Bus	Serial data bus
PS	Power Supply	Power supply
PSA	Power Stack Adapter	Power Stack Adapter
PTC	Positive Temperature Coefficient	Positive temperature coefficient
PTP	Point-To-Point	Point-to-Point
PWM	Pulse Width Modulation	Pulse width modulation
PZD	Prozessdaten	Process data
<b>Q</b>		
<b>R</b>		
r...	-	Display parameters (read-only)
RAM	Random Access Memory	Read/write memory
RCCB	Residual Current Circuit Breaker	Residual current operated circuit breaker
RCD	Residual Current Device	Residual current operated circuit breaker
RCM	Residual Current Monitor	Residual current monitor
RFG	Ramp-Function Generator	Ramp-function generator
RJ45	Registered Jack 45	Term for an 8-pin socket system for data transmission with shielded or non-shielded multi-wire copper cables
RKA	Rückkühlanlage	Cooling unit
RO	Read Only	Read only
RPDO	Receive Process Data Object	Receive Process Data Object

<b>Abbreviation</b>	<b>Source of abbreviation</b>	<b>Meaning</b>
RS232	Recommended Standard 232	Interface standard for cable-connected serial data transmission between a sender and receiver (also known as EIA232)
RS485	Recommended Standard 485	Interface standard for a cable-connected differential, parallel, and/or serial bus system (data transmission between a number of senders and receivers, also known as EIA485)
RTC	Real Time Clock	Real time clock
SVA	Space vector approximation	Space vector approximation
<b>S</b>		
S1	-	Uninterrupted duty
S3	-	Intermittent duty
SAM	Safe Acceleration Monitor	Safe acceleration monitoring
SBC	Safe Brake Control	Safe brake control
SBH	Sicherer Betriebshalt	Safe operating stop
SBR	Safe Brake Ramp	Safe brake ramp monitoring
SCA	Safe Cam	Safe cam
SD Card	Secure Digital Card	Secure digital memory card
SDI	Safe Direction	Safe motion direction
SE	Sicherer Software-Endschalter	Safe software limit switch
SG	Sicher reduzierte Geschwindigkeit	Safely-Limited Speed
SGA	Sicherheitsgerichteter Ausgang	Safety-related output
SGE	Sicherheitsgerichteter Eingang	Safety-related input
SH	Sicherer Halt	Safe standstill
SI	Safety Integrated	Safety Integrated
SIL	Safety Integrity Level	Safety Integrity Level
SLM	Smart Line Module	Smart Line Module
SLP	Safely-Limited Position	Safely-Limited Position
SLS	Safely-Limited Speed	Safely-Limited Speed
SLVC	Sensorless Vector Control	Vector control without encoder (sensorless)
SM	Sensor Module	Sensor Module
SMC	Sensor Module Cabinet	Sensor Module Cabinet
SME	Sensor Module External	Sensor Module External
SMI	SINAMICS Sensor Module Integrated	SINAMICS Sensor Module Integrated
SN	Sicherer Software-Nocken	Safe software cam
SOS	Safe Operating Stop	Safe operating stop
SP	Service Pack	Service Pack
SPC	Setpoint Channel	Setpoint channel
SPI	Serial Peripheral Interface	Serial interface for connecting peripherals
SPS	Speicherprogrammierbare Steuerung	Programmable logic controller

<b>Abbreviation</b>	<b>Source of abbreviation</b>	<b>Meaning</b>
SS1	Safe Stop 1	Safe Stop 1 (monitored for time and ramping up)
SS2	Safe Stop 2	Safe Stop 2
SSI	Synchronous Serial Interface	Synchronous serial interface
SSM	Safe Speed Monitor	Safe feedback from speed monitor
SSP	SINAMICS Support Package	SINAMICS Support Package
STO	Safe Torque Off	Safe torque off
STW	Steuerwort	Control word
<b>T</b>		
TB	Terminal Board	Terminal Board
TIA	Totally Integrated Automation	Totally Integrated Automation
TM	Terminal Module	Terminal Module
TN	Terre Neutre	Grounded three-phase supply network
Tn	-	Integral time
TPDO	Transmit Process Data Object	Transmit Process Data Object
TT	Terre Terre	Grounded three-phase supply network
TTL	Transistor-Transistor Logic	Transistor-transistor logic
Tv	-	Rate time
<b>U</b>		
UL	Underwriters Laboratories Inc.	Underwriters Laboratories Inc.
UPS	Uninterruptible Power Supply	Uninterruptible Power Supply
USV	Unterbrechungsfreie Stromversorgung	Uninterruptible Power Supply
UTC	Universal Time Coordinated	Universal time coordinated
<b>V</b>		
VC	Vector Control	Vector control
Vdc	-	DC link voltage
VdcN	-	Partial DC link voltage, negative
VdcP	-	Partial DC link voltage, positive
VDE	Verband Deutscher Elektrotechniker	Association of German Electrical Engineers
VDI	Verein Deutscher Ingenieure	Association of German Engineers
VPM	Voltage Protection Module	Voltage Protection Module
Vpp	Volt peak to peak	Volt peak to peak
VSM	Voltage Sensing Module	Voltage Sensing Module
<b>W</b>		
WEA	Wiedereinschaltautomatik	Automatic restart
MT	Machine tool	Machine tool
<b>X</b>		
XML	Extensible Markup Language	Standard language for web publishing and document management



<b>Abbreviation</b>	<b>Source of abbreviation</b>	<b>Meaning</b>
<b>Y</b>		
<b>Z</b>		
ZK	Zwischenkreis	DC link
ZM	Zero Mark	Zero mark
ZSW	Zustandswort	Status word



# Index

# B

## Numbers

- 7200
  - General information, 3-136
- 7210
  - AND (AND function block with 4 inputs), 3-138
- 7212
  - OR (OR function block with 4 inputs), 3-139
- 7214
  - XOR (XOR function block with 4 inputs), 3-140
- 7216
  - NOT (inverter), 3-141
- 7220
  - ADD (adder with 4 inputs),  
SUB (subtractor), 3-143
- 7222
  - MUL (multiplier),  
DIV (divider), 3-144
- 7224
  - AVA (absolute value generator), 3-145
- 7230
  - MFP (pulse generator), PCL (pulse contractor), 3-147
- 7232
  - PDE (ON delay), PDF (OFF delay), 3-148
- 7234
  - PST (pulse stretcher), 3-149
- 7240
  - RSR (RS flip-flop),  
DFR (D flip-flop), 3-151
- 7250
  - BSW (binary change-over switch),  
NSW (numeric change-over switch), 3-153
- 7260
  - LIM (limiter), 3-155
- 7262
  - PT1 (smoothing element), 3-156

- 7264
  - INT (integrator),  
DIF (derivative action element), 3-157
- 7270
  - LVM (double-sided limit monitor with hysteresis), 3-159

## A

- Access level (parameter), 2-56
- Acknowledgment
  - Adjustable, 4-165
  - Default, 4-165
- Activation
  - "Free function blocks", 1-27
  - Individual free function blocks, 1-29
- Active (parameter, C1(x), C2(x), U, T), 2-55
- Address
  - Technical Support, Preface-6
- Adjustable parameter, 2-53
- Alarm
  - Cause, 4-166
  - Display, 4-162
  - Explanation of list, 4-164
  - Fault location, 4-165
  - General information, 4-162
  - How to distinguish an alarm from a fault, 4-162
  - List of all alarms, 4-167
  - Message value, 4-165
  - Name, 4-165
  - Number, 4-164
  - Number range, 4-167
  - Remedy, 4-166
- Alarm value, 4-166
- AOP30, 1-27
- Axxxx, 4-164

## B

- BI, Binector Input, 2-54
- Binector
  - Input (BI), 2-54
  - Output (BO), 2-54
- Bit array (parameter), 2-59

**Blocks**

- ADD (adder), 1-37, 3-143
  - AND, 1-35, 3-138
  - AVA (absolute value generator), 1-39, 3-145
  - BSW (binary change-over switch), 1-45, 3-153
  - DFR (D flip-flop), 1-44, 3-151
  - DIF (derivative action element), 1-49, 3-157
  - DIV (divider), 1-38, 3-144
  - INT (integrator), 1-48, 3-157
  - LIM (limiter), 1-46, 3-155
  - LVM (limit monitor), 1-50, 3-159
  - MFP (pulse generator), 1-39, 3-147
  - MUL (multiplier), 1-38, 3-144
  - NOT (inverter), 1-36, 3-141
  - NSW (numeric change-over switch), 1-45, 3-153
  - OR, 1-35, 3-139
  - PCL (pulse shortener), 1-39, 3-147
  - PDE (ON delay), 1-41, 3-148
  - PDF (OFF delay), 1-42, 3-148
  - PST (pulse stretcher), 1-43, 3-149
  - PT1 (smoothing element), 1-47, 3-156
  - RSR (RS flip-flop), 1-43, 3-151
  - SUB (subtractor), 1-37, 3-143
  - XOR (exclusive OR), 1-36, 3-140
- BO, Binector Output, 2-54

**C**

- C1(x) - State commissioning device, 2-55
- C2(x) - State commissioning drive, 2-55
- Calculated (parameter), 2-55
- Changeable (parameter, C1(x), C2(x), U, T), 2-55
- CI, Connector Input, 2-54
- CO, Connector Output, 2-54
- CO/BO, Connector/Binector Output, 2-54
- Commissioning software, 1-27
- Computation time load
  - From 4.3 and higher, 1-32
  - Up to 2.6, 1-30
- Connector
  - Input (CI), 2-54
  - Output (CO), 2-54
- Cxxxxx, 4-164

**D**

- Data type (parameter, signal source), 2-56

- Dependency (parameter), 2-59
- Description (parameter), 2-58
- Description of the function blocks, 1-35
- Directory
  - List of abbreviations, A-169
  - Table of contents, Contents-7
  - Table of contents, function diagrams, 3-134

**Display**

- Alarms, 4-162
- Faults, 4-162
- Display parameter, 2-53
- DO, Drive Object, 2-54
- Drive Control Chart (DCC), 1-11
- Drive object, 2-54

**E****Example**

- Adjustable sampling times, 1-15, 1-16, 1-17, 1-18
- Interconnecting the input value, 1-23
- Interconnecting the output value, 1-24
- Interconnecting the PROFIBUS receive value (WORD), 1-25
- Interconnecting the PROFIBUS send word (DWORD), 1-26

**F**

- Factory setting, 2-58

**Fault**

- Acknowledgment, 4-163, 4-165
  - Cause, 4-166
  - Display, 4-162
  - Explanation of list, 4-164
  - Fault location, 4-165
  - Fault reaction, 4-162, 4-165
  - General information, 4-162
  - How to distinguish a fault from an alarm, 4-162
  - List of all faults, 4-167
  - Message value, 4-165
  - Name, 4-165
  - Number, 4-164
  - Number range, 4-167
  - Remedy, 4-166
  - Saving when switching off, 4-163
- Fault buffer
- Saving when switching off, 4-163
- Fault value, 4-166
- Fixed runtime group, 1-12

- Free function blocks
  - Application range, 1-10
  - Configuration, 1-12
  - Drive object types, 1-10
  - Features, 1-10
  - Operation, 1-12
  - Range of blocks, 1-21
  - Release for products, Preface-5
  - Run sequence, 1-19
  - Runtime groups, 1-12
  - Sampling times, 1-13
- Free runtime group, 1-12
- Function (parameter), 2-58
- Function diagrams
  - ADD (adder with 4 inputs),  
SUB (subtractor), 3-143
  - AND (AND function block with 4 inputs),  
3-138
  - AVA (absolute value generator), 3-145
  - BSW (binary change-over switch),  
NSW (numeric change-over switch),  
3-153
  - General information, 3-136
  - INT (integrator),  
DIF (derivative action element), 3-157
  - LIM (limiter), 3-155
  - LVM (double-sided limit monitor  
with hysteresis), 3-159
  - MFP (pulse generator), PCL (pulse con-  
tractor), 3-147
  - MUL (multiplier),  
DIV (divider), 3-144
  - NOT (inverter), 3-141
  - OR (OR function block with 4 inputs),  
3-139
  - PDE (ON delay), PDF (OFF delay), 3-148
  - PST (pulse stretcher), 3-149
  - PT1 (smoothing element), 3-156
  - RSR (RS flip-flop),  
DFR (D flip-flop), 3-151
  - XOR (XOR function block with 4 inputs),  
3-140
- Function module, 2-54
- Fxxxx, 4-164
- G**
  - General information
    - about parameters, 2-52
    - on faults and alarms, 4-162
- H**
  - Hardware sampling times, 1-13
  - Hotline, Preface-6
- I**
  - Index
    - Factory setting, 2-59
    - Parameter, 2-53, 2-59
- L**
  - Linked parameter, 2-53
  - List
    - Abbreviations, A-169
    - Drive object types for "Free function  
blocks", 1-10
    - Faults and alarms, 4-167
    - Message ranges, 4-167
    - Parameters, all, 2-61
    - Range of blocks, 1-21
  - List of abbreviations, A-169
- M**
  - Message value, 4-165
- N**
  - Name
    - Alarm, 4-165
    - Fault, 4-165
    - Parameter, 2-54
  - Normalizing, 2-58
  - Notes
    - Hotline, Preface-6
    - Product information, Preface-6
    - Technical Support, Preface-6
  - Number
    - Alarm, 4-164
    - Fault, 4-164
    - Parameter, 2-53
  - Number range
    - Alarms, 4-167
    - Faults, 4-167
- O**
  - Object, 2-54
- P**
  - P group (parameter), 2-58

**Parameter**

- Access level, 2-56
  - Calculated, 2-55
  - Changeable, 2-55
  - Data type, 2-56
  - Description, 2-58
  - Dynamic index, 2-57
  - Full name, 2-54
  - Function, 2-58
  - Index, 2-53, 2-59
  - Linked parameter, 2-53
  - List of all parameters, 2-61
  - Name, 2-54
  - Normalizing, 2-58
  - Number, 2-53
  - P group, 2-58
  - Safety notices, 2-60
  - Short name, 2-54
  - Unit, 2-58
  - Unit group, 2-58
  - Unit selection, 2-58
  - Values, 2-59
- Password for access level 4, 2-56
- Product information, Preface-6
- Products with FBLOCKS, Preface-5
- Purpose of this manual, Preface-5
- pxxxx, 2-53

**R**

- Range of blocks, 1-21

- Reaction to faults, 4-162
- Resetting faults, 4-165
- Run sequence, 1-19
- Runtime groups, 1-12
- rxxxx, 2-53

**S**

- Safety notices (parameter), 2-60
- Sampling times, 1-13
- Search tools for manual, Preface-6
- Software sampling times, 1-14
- STARTER, 1-27
- Support, Preface-6
- Support Request, Preface-6

**T**

- T - Ready state, 2-55
- Target group for this manual, Preface-5
- Technical Support, Preface-6

**U**

- U - Operation state, 2-55
- Unit (parameter), 2-58

**V**

- Values (parameter), 2-59
- Version
  - List of all parameters, 2-61
  - List of faults and alarms, 4-167



Siemens AG  
Industry Sector  
Drive Technologies  
Large Drives  
P.O. Box 4743  
90025 NUREMBERG  
GERMANY

[www.siemens.com/automation](http://www.siemens.com/automation)

Subject to change without prior notice  
© Siemens AG 2011