



Edition

05/2024

EQUIPMENT MANUAL

SIMATIC

S7-1500

CPU 1511C-1 PN

6ES7511-1CL03-0AB0

support.industry.siemens.com

SIEMENS

SIMATIC

S7-1500
CPU 1511C-1 PN
(6ES7511-1CL03-0AB0)

Equipment Manual

Introduction

1

Industrial cybersecurity

2

Product overview

3

Technology functions

4

Wiring

5

Parameters/address space

6

Interrupts/diagnostics alarms

7

Technical specifications

8

Dimension drawings

A

Parameter data records

B

Analog value processing

C



05/2024

A5E40898565-AC

Legal information

Warning notice system

This manual contains notices you have to observe in order to ensure your personal safety, as well as to prevent damage to property. The notices referring to your personal safety are highlighted in the manual by a safety alert symbol, notices referring only to property damage have no safety alert symbol. These notices shown below are graded according to the degree of danger.

 DANGER
indicates that death or severe personal injury will result if proper precautions are not taken.
 WARNING
indicates that death or severe personal injury may result if proper precautions are not taken.
 CAUTION
indicates that minor personal injury can result if proper precautions are not taken.
NOTICE
indicates that property damage can result if proper precautions are not taken.

If more than one degree of danger is present, the warning notice representing the highest degree of danger will be used. A notice warning of injury to persons with a safety alert symbol may also include a warning relating to property damage.

Qualified Personnel

The product/system described in this documentation may be operated only by **personnel qualified** for the specific task in accordance with the relevant documentation, in particular its warning notices and safety instructions. Qualified personnel are those who, based on their training and experience, are capable of identifying risks and avoiding potential hazards when working with these products/systems.

Proper use of Siemens products

Note the following:

 WARNING
Siemens products may only be used for the applications described in the catalog and in the relevant technical documentation. If products and components from other manufacturers are used, these must be recommended or approved by Siemens. Proper transport, storage, installation, assembly, commissioning, operation and maintenance are required to ensure that the products operate safely and without any problems. The permissible ambient conditions must be complied with. The information in the relevant documentation must be observed.

Trademarks

All names identified by ® are registered trademarks of Siemens Aktiengesellschaft. The remaining trademarks in this publication may be trademarks whose use by third parties for their own purposes could violate the rights of the owner.

Disclaimer of Liability

We have reviewed the contents of this publication to ensure consistency with the hardware and software described. Since variance cannot be precluded entirely, we cannot guarantee full consistency. However, the information in this publication is reviewed regularly and any necessary corrections are included in subsequent editions.

Table of contents

1	Introduction.....	7
1.1	Guide documentation S7-1500/ET 200MP.....	8
1.1.1	Information classes S7-1500/ET 200MP.....	8
1.1.2	SIMATIC Technical Documentation.....	10
2	Industrial cybersecurity.....	12
2.1	Introduction to industrial cybersecurity.....	12
2.2	Cybersecurity information.....	12
2.3	Cybersecurity-relevant information.....	13
3	Product overview.....	15
3.1	New functions.....	15
3.2	Application.....	17
3.3	Hardware properties and firmware functions.....	24
3.3.1	Hardware properties of the CPU part.....	25
3.3.2	Firmware functions of the CPU part.....	26
3.3.3	Hardware properties of the analog on-board I/O module.....	30
3.3.4	Firmware functions of the analog on-board I/O module.....	32
3.3.5	Hardware properties of the digital on-board I/O module.....	33
3.3.6	Firmware functions of the digital on-board I/O module.....	35
3.4	Operator controls and display elements.....	36
3.4.1	Front view with closed front panel.....	36
3.4.2	Front view of the CPU without front panel and view from below.....	38
3.4.3	Rear view.....	40
3.5	Operating mode buttons.....	40
4	Technology functions.....	42
4.1	High-speed counters.....	42
4.1.1	Functions.....	43
4.1.1.1	Counting.....	43
4.1.1.2	Measuring.....	44
4.1.1.3	Position detection for motion control.....	45
4.1.1.4	Additional functions.....	46
4.1.2	Configuring the high-speed counters.....	47
4.1.2.1	General.....	47
4.1.2.2	Assignment of the control interface of the high-speed counters.....	47
4.1.2.3	Assignment of the feedback interface of the high-speed counters.....	49
4.2	Pulse generators.....	50
4.2.1	Operating modes.....	50

4.2.1.1	Operating mode: Pulse-width modulation (PWM).....	50
4.2.1.2	Operating mode: Frequency output.....	57
4.2.1.3	Operating mode: PTO.....	61
4.2.2	Functions.....	66
4.2.2.1	Function: High-speed output.....	66
4.2.2.2	Function: Direct control of the pulse output (DQA).....	66
4.2.3	Configuring the PWM and frequency output modes.....	67
4.2.3.1	Assignment of the control interface.....	67
4.2.3.2	Handling the SLOT parameter (control interface).....	69
4.2.3.3	Assignment of the feedback interface.....	72
5	Wiring.....	74
5.1	Supply voltage.....	74
5.2	PROFINET interfaces.....	75
5.3	Terminal and block diagrams.....	77
5.3.1	Block diagram of the CPU part.....	77
5.3.2	Terminal and block diagram of the analog on-board I/O.....	78
5.3.3	Wiring and block diagrams of the digital on-board I/O.....	87
5.3.4	Addresses of the high-speed counters.....	100
5.3.5	Addresses of the pulse generators in the Pulse Width Modulation (PWM) and Frequency Output modes	103
5.3.6	Addresses of pulse generators in the PTO mode.....	103
5.3.7	Interconnection overview of the inputs.....	104
5.3.8	Interconnection overview of the outputs.....	105
6	Parameters/address space.....	108
6.1	Address space of the analog on-board I/O.....	108
6.2	Address space of the digital on-board I/O.....	110
6.3	Address space of the high-speed counters.....	111
6.4	Address space of the pulse generators.....	112
6.5	Measurement types and measuring ranges of the analog on-board I/O.....	112
6.6	Output type and output ranges of the analog on-board I/O.....	113
6.7	Parameters of the analog on-board I/O.....	114
6.8	Parameters of the digital on-board I/O.....	116
7	Interrupts/diagnostics alarms.....	118
7.1	Status and error displays.....	118
7.1.1	Status and error displays of the CPU part.....	118
7.1.2	Status and error displays of the analog on-board I/O.....	121
7.1.3	Status and error displays of the digital on-board I/O.....	123
7.2	Interrupts and diagnostics.....	125
7.2.1	Interrupts and diagnostics of the CPU part.....	125
7.2.2	Interrupts and diagnostics of the analog on-board I/O.....	125
7.2.3	Interrupts and diagnostics of the digital on-board I/O.....	128
8	Technical specifications.....	131

A	Dimension drawings.....	155
B	Parameter data records.....	156
B.1	Parameter assignment and structure of the parameter data records of the analog on-board I/O	156
B.2	Structure of a data record for input channels of the analog on-board I/O.....	157
B.3	Structure of a data record for output channels of the analog on-board I/O.....	163
B.4	Parameter assignment and structure of the parameter data records of the digital on-board I/O	166
B.5	Structure of a data record for input channels of the digital on-board I/O.....	167
B.6	Structure of a data record for output channels of the digital on-board I/O.....	168
B.7	Parameter data records of the high-speed counters.....	169
B.8	Parameter data records (PWM).....	176
C	Analog value processing.....	179
C.1	Conversion method.....	179
C.2	Representation of analog values.....	184
C.3	Representation of input ranges.....	185
C.3.1	Representation of analog values in voltage measuring ranges.....	186
C.3.2	Representation of analog values in current measuring ranges.....	187
C.3.3	Representation of the analog values of resistance-type sensors/resistance-type thermometers	188
C.3.4	Measured values for wire break diagnostics.....	189
C.4	Representation of output ranges.....	190
C.4.1	Representation of analog values in the voltage output ranges.....	191
C.4.2	Representation of analog values in the current output ranges.....	192

Introduction

Purpose of the documentation

This manual supplements the system manual of the S7-1500 automation system/ET 200MP distributed I/O system as well as the function manuals. This manual contains a description of the module-specific information. The system-related functions are described in the system manual. All system-spanning functions are described in the function manuals.

The information provided in this equipment manual and the system manual enables you to commission the CPU .

Conventions

STEP 7: In this documentation, "STEP 7" is used as a synonym for all versions of the configuration and programming software "STEP 7 (TIA Portal)".

Please also observe notes marked as follows:

NOTE

A note contains important information on the product described in the documentation, on the handling of the product or on the section of the documentation to which particular attention should be paid.

Recycling and disposal

For environmentally friendly recycling and disposal of your old equipment, contact a certified electronic waste disposal company and dispose of the equipment according to the applicable regulations in your country.

Industry Mall

The Industry Mall is the catalog and order system of Siemens AG for automation and drive solutions on the basis of Totally Integrated Automation (TIA) and Totally Integrated Power (TIP).

You can find catalogs for all automation and drive products on the Internet (<https://mall.industry.siemens.com>).

ID-Link for the digital nameplate



The ID-Link is a globally unique identifier according to IEC 61406-1, which you will find in the future as a QR code on your product.

The figure shows an example of an ID-Link for the CPU 1511C-1 PN.

You can recognize the ID-Link by the frame with a black corner at the bottom right. The ID-Link takes you to the digital nameplate of your product.

Scan the QR code on the product or on the packaging label with a smartphone camera, barcode scanner, or reader app. Call the ID-Link.

In the digital nameplate, you will find product data, manuals, declarations of conformity, certificates, and other helpful information about your product.

1.1 Guide documentation S7-1500/ET 200MP

1.1.1 Information classes S7-1500/ET 200MP



The documentation for the SIMATIC S7-1500 automation system and the ET 200MP distributed I/O system is arranged into three areas.

This arrangement enables you to access the specific content you require. Changes and supplements to the manuals are documented in a Product Information.

You can download the documentation free of charge from the Internet

(<https://support.industry.siemens.com/cs/ww/en/view/109742691>).

Basic information



The System Manual and Getting Started describe in detail the configuration, installation, wiring and commissioning of the SIMATIC S7-1500 and ET 200MP systems.

The STEP 7 online help supports you in the configuration and programming.

Examples:

- Getting Started S7-1500
- S7-1500/ET 200MP System Manual
- Online help TIA Portal

Device information



Equipment manuals contain a compact description of the module-specific information, such as properties, wiring diagrams, characteristics and technical specifications.

Examples:

- Equipment Manuals CPUs
- Equipment Manuals Interface Modules
- Equipment Manuals Digital Modules
- Equipment Manuals Analog Modules
- Equipment Manuals Communications Modules
- Equipment Manuals Technology Modules
- Equipment Manuals Power Supply Modules

General information



The function manuals contain detailed descriptions on general topics relating to the SIMATIC S7-1500 and ET 200MP systems.

Examples:

- Function Manual Diagnostics
- Function Manual Communication
- Function Manual Motion Control
- Function Manual Web Server
- Function Manual Cycle and Response Times
- PROFINET Function Manual
- PROFIBUS Function Manual

Product Information

Changes and supplements to the manuals are documented in a Product Information. The Product Information takes precedence over the device and system manuals.

You can find the latest Product Information on the S7-1500 and ET 200MP systems on the Internet (<https://support.industry.siemens.com/cs/de/en/view/68052815>).

Manual Collection S7-1500/ET 200MP

The Manual Collection contains the complete documentation on the SIMATIC S7-1500 automation system and the ET 200MP distributed I/O system gathered together in one file. You can find the Manual Collection on the Internet.

(<https://support.industry.siemens.com/cs/ww/en/view/86140384>)

Manual Collection fail-safe modules

The Manual Collection contains the complete documentation on the fail-safe SIMATIC modules, gathered together in one file.

You can find the Manual Collection on the Internet.

(<https://support.industry.siemens.com/cs/de/en/view/109806400>)

SIMATIC S7-1500 comparison list for programming languages

The comparison list contains an overview of which instructions and functions you can use for which controller families.

You can find the comparison list on the Internet

(<https://support.industry.siemens.com/cs/ww/en/view/86630375>).

1.1.2 SIMATIC Technical Documentation

Additional SIMATIC documents will complete your information. You can find these documents and their use at the following links and QR codes.

The Industry Online Support gives you the option to get information on all topics. Application examples support you in solving your automation tasks.

Overview of the SIMATIC Technical Documentation

Here you will find an overview of the SIMATIC documentation available in Siemens Industry Online Support:



Industry Online Support International

(<https://support.industry.siemens.com/cs/ww/en/view/109742705>)

Watch this short video to find out where you can find the overview directly in Siemens Industry Online Support and how to use Siemens Industry Online Support on your mobile device:



Quick introduction to the technical documentation of automation products per video (<https://support.industry.siemens.com/cs/us/en/view/109780491>)



YouTube video: Siemens Automation Products - Technical Documentation at a Glance (<https://youtu.be/TwLSxxRQsA>)

Retention of the documentation

Retain the documentation for later use.

For documentation provided in digital form:

1. Download the associated documentation after receiving your product and before initial installation/commissioning. Use the following download options:

- Industry Online Support International: (<https://support.industry.siemens.com>)

The article number is used to assign the documentation to the product. The article number is specified on the product and on the packaging label. Products with new, non-compatible functions are provided with a new article number and documentation.

- ID link:

Your product may have an ID link. The ID link is a QR code with a frame and a black frame corner at the bottom right. The ID link takes you to the digital nameplate of your product. Scan the QR code on the product or on the packaging label with a smartphone camera, barcode scanner, or reader app. Call up the ID link.

2. Retain this version of the documentation.

Updating the documentation

The documentation of the product is updated in digital form. In particular in the case of function extensions, the new performance features are provided in an updated version.

1. Download the current version as described above via the Industry Online Support or the ID link.
2. Also retain this version of the documentation.

mySupport

With "mySupport" you can get the most out of your Industry Online Support.

Registration	You must register once to use the full functionality of "mySupport". After registration, you can create filters, favorites and tabs in your personal workspace.
Support requests	Your data is already filled out in support requests, and you can get an overview of your current requests at any time.
Documentation	In the Documentation area you can build your personal library.
Favorites	You can use the "Add to mySupport favorites" to flag especially interesting or frequently needed content. Under "Favorites", you will find a list of your flagged entries.
Recently viewed articles	The most recently viewed pages in mySupport are available under "Recently viewed articles".
CAX data	The CAX data area gives you access to the latest product data for your CAX or CAE system. You configure your own download package with a few clicks: <ul style="list-style-type: none"> • Product images, 2D dimension drawings, 3D models, internal circuit diagrams, EPLAN macro files • Manuals, characteristics, operating manuals, certificates • Product master data

You can find "mySupport" on the Internet. (<https://support.industry.siemens.com/My/ww/en>)

Application examples

The application examples support you with various tools and examples for solving your automation tasks. Solutions are shown in interplay with multiple components in the system - separated from the focus on individual products.

You can find the application examples on the Internet.
(<https://support.industry.siemens.com/cs/ww/en/ps/ae>)

Industrial cybersecurity

2.1 Introduction to industrial cybersecurity

Due to the digitalization and increasing networking of machines and industrial plants, the risk of cyber attacks is also growing. Appropriate protective measures are therefore mandatory, particularly in the case of critical infrastructure facilities.

Refer to the System Manual (<https://support.industry.siemens.com/cs/us/en/view/59191792>) for general information and measures regarding industrial cybersecurity.

This section provides an overview of security-related information pertaining to your SIMATIC device.

NOTE

Security-relevant changes to software or devices are documented in the section "New functions ([Page 15](#))".

2.2 Cybersecurity information

Siemens provides products and solutions with industrial cybersecurity functions that support the secure operation of plants, systems, machines, and networks.

In order to protect plants, systems, machines, and networks against cyber threats, it is necessary to implement – and continuously maintain – a holistic, state-of-the-art industrial cybersecurity concept. Siemens' products and solutions constitute one element of such a concept.

Customers are responsible for preventing unauthorized access to their plants, systems, machines and networks. Such systems, machines and components should only be connected to an enterprise network or the internet if and to the extent such a connection is necessary and only when appropriate security measures (e.g. firewalls and/or network segmentation) are in place.

For more information on protective industrial cybersecurity measures for implementation, please visit (<https://www.siemens.com/global/en/products/automation/topic-areas/industrial-cybersecurity.html>).

Siemens' products and solutions undergo continuous development to make them more secure. Siemens strongly recommends that product updates are applied as soon as they are available and that the latest product versions are used. Use of product versions that are no longer supported, and failure to apply the latest updates may increase customers' exposure to cyber threats.

To stay informed about product updates at all times, subscribe to the Siemens Industrial Cybersecurity RSS Feed under (<https://new.siemens.com/global/en/products/services/cert.html>).

2.3 Cybersecurity-relevant information

Note all cybersecurity-relevant information.

Topics with cybersecurity-relevant information	Reference
Operational application environment and security assumptions	
Requirements for the operational application environment of the system and security assumptions	This section is found in the System Manual (https://support.industry.siemens.com/cs/us/en/view/59191792).
Area of application	You can find the section Area of application (Page 17) in this Equipment Manual.
Security properties of the product	
Access protection Physical protection: <ul style="list-style-type: none"> You can protect the CPU against unauthorized access by locking the front flap. Password protection You can also protect the CPU with a password. Password categories: <ul style="list-style-type: none"> Password to protect confidential configuration data Password in the context of user management (UMAC) Password for display 	Information on locking and on password protection can be found in this Equipment Manual in the section Operator controls and display elements (Page 36). Also note the information on the topic of access protection in the Protection section of the System Manual (https://support.industry.siemens.com/cs/us/en/view/59191792).
Integrated protection functions <ul style="list-style-type: none"> The CPUs have integrated protection functions. 	For information on the protection functions, refer to the "Overview of protection functions" section of the System Manual (https://support.industry.siemens.com/cs/us/en/view/59191792).
PROFINET Security Class 1 <ul style="list-style-type: none"> The device supports PROFINET Security Class 1. With the introduction of PROFINET Security Class 1, additional security settings have been integrated into the PROFINET communication. 	Detailed information about PROFINET Security Class 1 and the additional security settings can be found in the PROFINET with STEP 7 Function Manual (https://support.industry.siemens.com/cs/us/en/view/49948856).
Reading out and verifying signatures	You can find detailed information on reading and verifying signatures in the STEP 7 online help (TIA Portal).
Supported Ethernet services	Information about supported services can be found in the section Technical specifications (Page 131). You can find detailed information on the supported Ethernet services in the Communication Function Manual (https://support.industry.siemens.com/cs/us/en/view/59192925).
Interfaces, ports, protocols and services	
Information on the following is security related: <ul style="list-style-type: none"> Communications layer and communication role Default states Enabling/disabling ports and services 	You can find detailed information on these topics in the Communication Function Manual (https://support.industry.siemens.com/cs/us/en/view/59192925).
Secure operation	

2.3 Cybersecurity-relevant information

Topics with cybersecurity-relevant information	Reference
Corrective measures for known risks	Corrective measures for known risks are announced on the Siemens ProductCERT (https://siemens.com/productcert) Web page. For more information on SIEMENS ProductCERT, refer to the System Manual (https://support.industry.siemens.com/cs/us/en/view/59191792).
Security checks	Application-specific security measures such as cyclic checks of the configuration via checksums are described in the System Manual (https://support.industry.siemens.com/cs/us/en/view/59191792).
Recording Security events	Information on recording security events can be found in the "Safe operation of CPUs" section of the System Manual (https://support.industry.siemens.com/cs/us/en/view/59191792).
Secure decommissioning Products that contain security-relevant data must be securely decommissioned before disposal or resale.	Information on secure decommissioning can be found in the "Safe operation of the system" section of the System Manual (https://support.industry.siemens.com/cs/us/en/view/59191792).

Product overview

3.1 New functions

This section contains an overview of the most important new firmware functions of the CPU compared with the predecessor version CPU.

New functions of the CPU in firmware version V3.1

New functions	Applications	Customer benefits
Integrated safety		
Syslog messages	The CPU stores syslog messages in a local cache (temporary memory). The messages can be forwarded to a syslog server.	The syslog server saves all syslog messages from its connected devices. The messages can be displayed on the user interface of the server and potential security risks can be identified.
Local user management	As of TIA Portal version V19 and FW version V3.1, the CPUs feature improved management of users, roles and CPU function rights (User Management & Access Control, UMAC). Starting with the above mentioned version, you can manage all project users with their rights (e.g. access rights) for all CPUs in the project. Management is performed in the editor for users and roles in TIA Portal.	Project users can be managed via the TIA Portal with their rights (for example, access rights) for all CPUs in the project in the editor for users and roles.
Communication of the CPU		
Implementation of PROFINET Security Class 1	As of V19, STEP 7 offers extended configuration options for the SNMP and DCP protocols in order to meet the requirements for PROFINET Security Class 1.	Additional protection of communication within your PROFINET network.
Project-internal shared device/shared I-device	As of STEP7 V19, a shared device/shared I-device can be created together with a maximum of 2 IO controllers in a project. Previously it was mandatory for the second IO controller to have its own project.	Simpler configuration
Handling timeouts while exchanging data	In the event of high network loads, timeouts can occur in data record communication with PROFINET IO devices. In the past this resulted in the PROFINET IO communication being terminated by the CPU. As of STEP 7 V19 and FW version V3.1, you can configure the behavior of the respective PROFINET interface.	PROFINET IO communication is maintained even under high grid loads
Web server of the CPU		
New Web API methods	Many new API methods extend your access options to the CPU via the Web API.	Additional Web server applications
Technology functions of the CPU		

3.1 New functions

New functions	Applications	Customer benefits
Axis functions	Measuring gearbox for positioning/synchronous axis	Extended configuration options
	Torque feedforward control for positioning/synchronous axis. The torque feedforward control of the CPU controls the required torque for acceleration of the axis, taking into account the motion profile.	Complex motion sequences can be performed faster and more precisely. This results in a reduction of the tracking error during acceleration phases.
	Three drive stop modes can be configured for the "Remove enable" alarm response.	You choose between a deceleration ramp, coasting down, and rapid stop.
	Dynamic filter with floating mean	The new "Floating mean value filter" mode is available for the dynamic filter.
	Standstill signal on external encoder	The standstill signal is also available for external encoders. The standstill signal is output if the encoder values are in a defined standstill window.
	Virtual axis	The axis is operated in virtual mode with improved runtime behavior. The new mode replaces the existing behavior of the virtual axis.
Measuring input functions	Monitoring measuring input	Using the measuring input type "Measuring via listening", the measuring input can acquire the measured signal of another configured measuring input.
	Cyclic measuring for central measuring input	Cyclic measuring possible without additional technology module
Trace functionality of the CPU		
Live monitoring for the long-term trace	With the live monitoring function for the long-term trace you can: <ul style="list-style-type: none"> • Display and analyze the values directly in the graph during recording • Use superimposed measurements for the long-term trace • Synchronize time bases 	Improved display and analysis of long-term traces
Long-term project trace	With the long-term project trace, you can record signals from different CPUs simultaneously. The CPUs must be configured in a network. The recording is stored on a drive that you have configured.	Extended scope of functions

Reference

You can find an overview of all new functions, improvements, and revisions in the respective firmware versions on the Internet (<https://support.industry.siemens.com/cs/ww/en/view/109478459>).

3.2 Application

SIMATIC S7-1500 is the modular control system for a wide variety of automation applications in discrete automation.

SIMATIC S7-1500 is the cost-effective and convenient solution for a broad range of tasks and offers the following advantages:

- Modular, fanless design
- Simple realization of distributed structures
- User-friendly handling

Areas of application of the SIMATIC S7-1500 automation system include, for example:

- Special-purpose machines
- Textile machinery
- Packaging machines
- General mechanical engineering
- Controller engineering
- Machine tool engineering
- Installation engineering
- Electrical industry and crafts
- Automobile engineering
- Water/waste water
- Food & Beverage

Areas of application of the SIMATIC S7-1500R/H redundant system include, for example:

- Tunnels
- Airports (e.g. baggage conveyors)
- Subways
- Shipbuilding
- Wastewater treatment plants
- High-bay warehouses

Areas of application of the SIMATIC S7-1500T automation system for advanced motion control applications include, for example:

- Packaging machines
- Converting applications
- Assembly automation
- Pick-and-place automation
- Palletizers

Several CPUs with various levels of performance and a comprehensive range of modules with many convenient features are available. Fail-safe CPUs enable use in fail-safe applications.

The modular design allows you to use only those modules that you need for your application. The controller can be retrofitted with additional modules at any time to expand its range of tasks.

High industrial suitability due to the high resistance to EMC, shock and vibration enable universal use of the SIMATIC S7-1500, S7-1500R/H and S7-1500T automation systems.

Performance segments of standard CPUs

The CPUs can be used for smaller and mid-range applications, as well as for the high-end range of machine and plant automation.

Table 3-1 Standard CPUs

CPU	Performance segment	PROFIBUS interfaces	PROFINET IO RT/IRT interfaces	PROFINET IO RT interface	Basic PROFINET functionality	Work memory	Processing time for bit operations
CPU 1511-1 PN	Standard CPU for small to mid-range applications	--	1	--	--	1.8 MB	25 ns
CPU 1513-1 PN	Standard CPU for mid-range applications	--	1	--	--	3.1 MB	25 ns
CPU 1515-2 PN	Standard CPU for mid-range to large applications	--	1	1	--	5.5 MB	6 ns
CPU 1516-3 PN/DP	Standard CPU for demanding applications and communication tasks	1	1	1	--	9.5 MB	6 ns
CPU 1517-3 PN/DP	Standard CPU for demanding applications and communication tasks	1	1	1	--	10 MB	2 ns
CPU 1518-4 PN/DP	Standard CPU for high-performance applications, demanding communication tasks and very short reaction times	1	1	1	1	66 MB	1 ns
CPU 1518-4 PN/DP MFP	Standard CPU for high-performance applications, demanding communication tasks, very short reaction times and C/C++ blocks for the user program	1	1	1	1	116* MB	1 ns

* 50 MB of the integrated work memory is reserved for the function library of CPU runtime

Performance segments of redundant CPUs

The CPUs of the S7-1500R/H redundant system offer a high degree of reliability and system availability. A redundant configuration of the most important automation components reduces the likelihood of production downtimes and the consequences of component errors. The higher the risks and costs of a production downtime, the more worthwhile the use of a redundant system. The avoidance of production downtimes compensates for the generally higher investment costs.

Table 3-2 Redundant CPUs

CPU	Performance segment	PROFIBUS interfaces	PROFINET IO RT/IRT interfaces	PROFINET IO RT interface	Basic PROFINET functionality	Work memory	Processing time for bit operations
CPU 1513R-1 PN	Redundant CPU for smaller to mid-range applications	--	1	--	--	3.1 MB	50 ns
CPU 1515R-2 PN	Redundant CPU for mid-range to large applications	--	1	--	1	5.5 MB	20 ns
CPU 1517H-3 PN	Redundant CPU for demanding applications and communication tasks	--	1	--	1	10 MB	4 ns
CPU 1518HF-4 PN	Fail-safe and redundant CPU for demanding applications and communication tasks	--	1	--	2	69 MB	4 ns

Performance segments of compact CPUs

The compact CPUs can be used for smaller to mid-range applications and have an integrated analog and digital on-board I/O as well as integrated technology functions.

Table 3-3 Compact CPUs

CPU	Performance segment	PROFIBUS interfaces	PROFINET IO RT/IRT interfaces	PROFINET IO RT interface	Basic PROFINET functionality	Work memory	Processing time for bit operations
CPU 1511C-1 PN	Compact CPU for small to mid-range applications	--	1	--	--	1.8 MB	25 ns
CPU 1512C-1 PN	Compact CPU for mid-range applications	--	1	--	--	2.4 MB	25 ns

The following table shows the specific properties of the Compact CPUs.

	CPU 1511C-1 PN	CPU 1512C-1 PN
Integrated analog inputs/outputs	5 inputs/2 outputs	5 inputs/2 outputs
Integrated digital inputs/outputs	16 inputs/16 outputs	32 inputs/32 outputs
High-speed counters	6	6
Frequency meters	6 (max. 100 kHz)	6 (max. 100 kHz)
Period duration measurement	6 channels	6 channels

3.2 Application

	CPU 1511C-1 PN	CPU 1512C-1 PN
Pulse width modulation (PWM output)	Max. 4 (up to 100 kHz)	Max. 4 (up to 100 kHz)
Pulse Train Output (PTO output)	Max. 4 (up to 100 kHz)	Max. 4 (up to 100 kHz)
Frequency output	Up to 100 kHz	Up to 100 kHz

Performance segments of technology CPUs

The technology CPUs can be used for low and mid-range applications, as well as for the high-end range of machine and plant automation. Because of their extended motion control functions, they are primarily used for drive control.

Table 3-4 Technology CPUs

CPU	Performance segment	PROFIBUS interfaces	PROFINET IO RT/IRT interfaces	PROFINET IO RT interface	Basic PROFINET functionality	Work memory	Processing time for bit operations
CPU 1511T-1 PN	Technology CPU for small to mid-range applications	--	1	--	--	1.95 MB	25 ns
CPU 1515T-2 PN	Technology CPU for mid-range to large applications	--	1	1	--	6 MB	6 ns
CPU 1516T-3 PN/DP	Technology CPU for high-end applications and communication tasks	1	1	1	--	10.5 MB	6 ns
CPU 1517T-3 PN/DP	Technology CPU for high-end applications and communication tasks	1	1	1	--	11 MB	2 ns
CPU 1518T-4 PN/DP	Technology CPU for high-performance motion control applications with large quantities, demanding communication tasks and very short reaction times	1	1	1	1	69 MB	1 ns
CPU 1511TF-1 PN CPU 1515TF-2 PN CPU 1516TF-3 PN/DP CPU 1517TF-3 PN/DP CPU 1518TF-4 PN/DP	These CPUs are described in the fail-safe CPUs.						

Performance segments of fail-safe CPUs

The fail-safe CPUs are intended for users who want to implement demanding standard and fail-safe applications both centrally and decentrally.

These fail-safe CPUs allow the processing of standard and safety programs on a single CPU. This allows fail-safe data to be evaluated in the standard user program. The integration also provides the system advantages and the extensive functionality of SIMATIC for fail-safe applications.

The fail-safe CPUs are certified for use in safety mode up to:

- Safety class (Safety Integrity Level) SIL 3 according to IEC 61508:2010
- Performance Level (PL) e and Category 4 according to ISO 13849-1:2015 or EN ISO 13849-1:2015

For IT security, local user management can be used to individually restrict F-Configuration and F-Program access for users.

Table 3-5 Fail-safe CPUs

CPU	Performance segment	PROFIBUS interfaces	PROFINET IO RT/IRT interfaces	PROFINET IO RT interface	Basic PROFINET functionality	Work memory	Processing time for bit operations
CPU 1511F-1 PN	Fail-safe CPU for small to mid-range applications	--	1	--	--	1.95 MB	25 ns
CPU 1511TF-1 PN	Fail-safe technology CPU for small to mid-range applications	--	1	--	--	1.95 MB	25 ns
CPU 1513F-1 PN	Fail-safe CPU for mid-range applications	--	1	--	--	3.4 MB	25 ns
CPU 1515F-2 PN	Fail-safe CPU for mid-range to large applications	--	1	1	--	6 MB	6 ns
CPU 1515TF-2 PN	Fail-safe technology CPU for high-end applications and communication tasks	--	1	1	--	6 MB	6 ns
CPU 1516F-3 PN/DP	Fail-safe CPU for demanding applications and communication tasks	1	1	1	--	10.5 MB	6 ns
CPU 1516TF-3 PN/DP	Fail-safe technology CPU for high-end applications and communication tasks	1	1	1	--	10.5 MB	6 ns
CPU 1517F-3 PN/DP	Fail-safe CPU for demanding applications and communication tasks	1	1	1	--	11 MB	2 ns
CPU 1517TF-3 PN/DP	Fail-safe technology CPU for high-end applications and communication tasks	1	1	1	--	11 MB	2 ns

* 50 MB of the integrated work memory is reserved for the function library of CPU runtime

3.2 Application

CPU	Performance segment	PROFIBUS interfaces	PROFINET IO RT/IRT interfaces	PROFINET IO RT interface	Basic PROFINET functionality	Work memory	Processing time for bit operations
CPU 1518F-4 PN/DP	Fail-safe CPU for high-performance applications, demanding communication tasks and very short reaction times	1	1	1	1	69 MB	1 ns
CPU 1518F-4 PN/DP MFP	Fail-safe CPU for high-performance applications, demanding communication tasks, very short reaction times and C/C++ blocks for the user program	1	1	1	1	119* MB	1 ns
CPU 1518TF-4 P-N/DP	Technology CPU for high-performance motion control applications with large quantities, demanding communication tasks and very short reaction times	1	1	1	1	69 MB	1 ns

* 50 MB of the integrated work memory is reserved for the function library of CPU runtime

In addition to the CPUs, further components such as SINAMICS drives dispose of integrated safety functions. Additional information about integrated safety functions in drives can be found in the manuals for the respective products.

Security Integrated

In conjunction with STEP 7, each CPU offers password-based know-how protection against unauthorized reading out or modification of the program blocks.

Copy protection provides reliable protection against unauthorized reproduction of program blocks. With copy protection, individual blocks on the SIMATIC Memory Card are linked to its serial number so that the block can only be executed if the configured memory card is inserted in the CPU.

In addition, all project users can be managed via the local user management. Rights such as access rights can be set individually for each user.

Improved manipulation protection allows changed or unauthorized transfers of engineering data to be detected by the controller.

The use of an Ethernet CP (CP 1543-1) provides you with additional access protection through a firewall or possibilities to establish secure VPN connections.

Design and handling

All CPUs of the SIMATIC S7-1500 product series feature a display with plain text information. The display provides information on order numbers, firmware versions, and serial numbers of all connected modules. Additionally the IP address of the CPU and other network settings can be set directly on site, without a programming device. Error messages are shown on the display directly in plain text. When performing servicing, you can minimize plant downtimes by quickly accessing the diagnostics alarms. Detailed information about this and a multitude of other display functions is available in the SIMATIC S7-1500 Display Simulator (<https://support.industry.siemens.com/cs/ww/en/view/109761758>).

Uniform front connectors for all modules and integrated potential jumpers for flexible formation of potential groups simplify storage. Additional components such as circuit breakers, relays, etc., can be installed quickly and easily, since a DIN rail is implemented in the rail of the SIMATIC S7-1500. The CPUs of the SIMATIC S7-1500 product series can be expanded centrally and in a modular fashion with signal modules. Space-saving expansion enables flexible adaptation to each application.

The system cabling for digital signal modules enables fast and clear connection to sensors and actuators from the field (fully modular connection consisting of front connector modules, connection cables and I/O modules), as well as easy wiring inside the control cabinet (flexible connection consisting of front connectors with assembled single conductors).

System diagnostics and alarms

Integrated system diagnostics is activated by default for the CPUs. The different types of diagnostics are configured instead of programmed. System diagnostics information and alarms from the drives are displayed consistently and in plain text:

- On the CPU display
- In STEP 7
- On the HMI
- On the Web server

This information is available in RUN mode, but also in STOP mode of the CPU. The diagnostic information is updated automatically when you configure new hardware components.

The CPU is available as a central interrupt server in up to three project languages. The HMI takes over the display in the project languages defined for the CPU. If you require alarm texts in additional languages, you can load them into your HMI via the configured connection. The CPU, STEP 7 and their HMI ensure data consistency without additional engineering steps. The maintenance work is easier.

3.3 Hardware properties and firmware functions

The CPU 1511C-1 PN consists of a CPU part, an analog on-board I/O module (X10) and a digital on-board I/O module (X11). When configured in the TIA Portal, the compact CPU therefore occupies a single shared slot (slot 1).

The properties and functions of the CPU part and the analog and digital on-board I/O modules can be found in the subsections below. The **properties** describe the hardware features of the CPU part and the analog and digital on-board I/O modules. The **functions** describe the functions of the firmware of the CPU part and the analog and digital on-board I/O modules.

Article number

6ES7511-1CL03-0AB0

Accessories

The following accessories are included in the scope of delivery and can also be ordered separately as spare parts:

- 2 x front connector (push-in terminals) including cable ties
- 2 x shield clamp
- 2 x shield terminal
- 2 x infeed element (push-in terminals)
- 2 x labeling strip
- 2 x universal front flap

For more information on accessories, refer to the S7-1500, ET 200MP System Manual (<http://support.automation.siemens.com/WW/view/en/59191792>).

3.3.1 Hardware properties of the CPU part

View of the CPU

The figure below shows the CPU part of the CPU 1511C-1 PN.

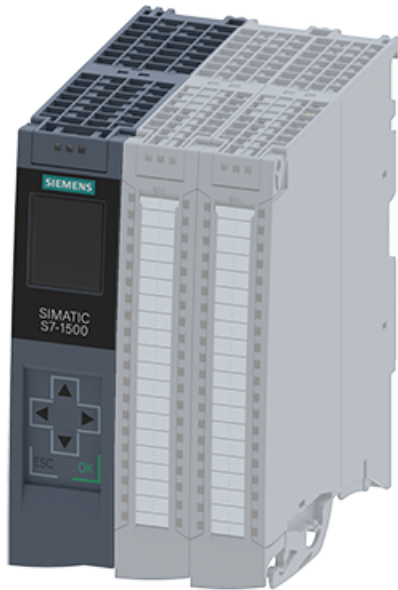

Figure 3-1 CPU 1511C-1 PN

NOTE

Protective film

Note that a protective film is attached to the display of the CPU when shipped from the factory. Remove the protective film if necessary.

Properties

The CPU 1511C-1 PN has the following technical properties:

Property	Description	Additional information
CPU display	All CPUs of the SIMATIC S7-1500 product series feature a display with plain text information. The display of the CPU 1511C-1 PN provides information on the order numbers, firmware version, and serial numbers of all connected modules. In addition, you can set the IP address of the CPU and carry out further network settings. The display shows occurring error messages directly in plain text. In addition to the functions listed here, a multitude of other functions that are described in the SIMATIC S7-1500 Display Simulator are shown on the display.	<ul style="list-style-type: none"> S7-1500, ET 200MP System Manual (http://support.automation.siemens.com/WW/view/en/59191792) SIMATIC S7-1500 Display Simulator or (https://support.industry.siemens.com/cs/ww/en/view/109761758)

3.3 Hardware properties and firmware functions

Property	Description	Additional information
Supply voltage	A 4-pole connection plug that is located at the front of the CPU supplies the 24 V DC supply voltage.	<ul style="list-style-type: none"> Chapter Wiring (Page 74) S7-1500, ET 200MP System Manual (http://support.automation.siemens.com/WW/view/en/59191792)
PROFINET IO		
PROFINET interface (X1 P1R and X1 P2R)	<p>The X1 interface has two ports (P1R and P2R). In addition to basic PROFINET functionality, it also supports PROFINET IO RT (real time) and IRT (isochronous real time), which means you can configure PROFINET IO communication or real-time settings on the interface. Port 1 and Port 2 can also be used as ring ports for the configuration of redundant ring structures in Ethernet (media redundancy).</p> <p>Basic PROFINET functionality comprises:</p> <ul style="list-style-type: none"> HMI communication Communication with the configuration system Communication with a higher-level network (backbone, router, Internet) Communication with another machine or automation cell 	PROFINET Function Manual (http://support.automation.siemens.com/WW/view/en/68039307)
Operation of the CPU as <ul style="list-style-type: none"> IO controller I-device 	<ul style="list-style-type: none"> IO controller: As an IO controller the CPU addresses the connected IO devices I-device: As an I-device (intelligent IO device) the CPU is assigned to a higher-level IO controller and is used in the process as an intelligent pre-processing unit of sub-processes 	

3.3.2 Firmware functions of the CPU part

Functions

The CPU 1511C-1 PN supports the following functions:

Function	Description	Additional information
Integrated system diagnostics	The system automatically generates the messages for the system diagnostics and outputs these messages via a programming device/PC, HMI device, the Web server or the integrated display. System diagnostics information is also available when the CPU is in STOP mode.	Diagnostics Function Manual (http://support.automation.siemens.com/WW/view/en/59192926)
Integrated Web server	The Web server lets you access the CPU data by means of a network. Evaluations, diagnostics, and modifications are thus possible over long distances. Monitoring and evaluation is possible without STEP 7, only a web browser is required. Make sure that you take appropriate measures (e.g. limiting network access, using firewalls) to protect the CPU from being compromised.	<ul style="list-style-type: none"> Web server Function Manual (http://support.automation.siemens.com/WW/view/en/59193560) Security with SIMATIC S7 controllers System Manual (https://support.industry.siemens.com/cs/ww/en/view/90885010)

Function	Description	Additional information
Integrated trace functionality	<p>Trace functionality supports you in troubleshooting and/or optimizing the user program. You record device tags and evaluate the recordings with the trace and logic analyzer function. Tags are, for example, drive parameters or system and user tags of a CPU.</p> <p>The device saves the recordings. You can read out and permanently save the recordings with the configuration system (ES), if required. The trace and logic analyzer function is therefore suitable for monitoring highly dynamic processes.</p> <p>The trace record can also be displayed through the Web server.</p>	<p>Using the trace and logic analyzer function Function Manual http://support.automation.siemens.com/WW/view/en/64897128</p>
OPC UA	<p>With OPC UA, data is exchanged via an open and vendor-neutral communication protocol. The CPU can act as OPC UA server. The CPU can communicate with OPC UA clients as an OPC UA server.</p> <p>Through OPC UA Companion Specification, the methods can be specified uniformly and independently of manufacturers. The specified methods enable you to integrate devices from various manufacturers more easily into your plants and production processes.</p>	<p>Communication Function Manual https://support.industry.siemens.com/cs/ww/en/view/59192925</p>
Configuration control	<p>You can use configuration control to operate different real hardware configurations with a configured maximum configuration of the hardware. This means that, in series machine manufacturing in particular, you have the option of operating/configuring different configuration variants of a machine with a single project.</p>	<p>S7-1500, ET 200MP System Manual http://support.automation.siemens.com/WW/view/en/59191792</p>
PROFINET IO		
RT (real time)	<p>RT prioritizes PROFINET IO telegrams over standard telegrams. This ensures the required determinism in the automation technology. In this process the data is transferred via prioritized Ethernet telegrams.</p>	<p>PROFINET Function Manual http://support.automation.siemens.com/WW/view/en/49948856</p>
IRT (isochronous real time)	<p>A reserved bandwidth within the send clock is available for IRT data. The reserved bandwidth ensures that the IRT data can be transmitted in time-synchronized intervals, unaffected by other high network loading (e.g. TCP/IP communication or additional real time communication). Update times with maximum determinism can be realized through IRT. Isochronous applications are possible with IRT.</p>	
Isochronous mode	<p>The Isochronous mode system property acquires measured values and process data and processes the signals in a fixed system clock. Isochronous mode thus contributes to high control quality and hence to greater manufacturing precision. Isochronous mode reduces possible fluctuations of the process reaction times to a minimum. Time-assured processing makes higher machine cycles possible.</p>	

3.3 Hardware properties and firmware functions

Function	Description	Additional information
MRP (Media Redundancy Protocol)	It is possible to establish redundant networks via the Media Redundancy Protocol. Redundant transmission links (ring topology) ensure that an alternative communication path is made available if a transmission link fails. The PROFINET devices that are part of this redundant network form an MRP domain. RT operation is possible with the use of MRP.	PROFINET Function Manual (http://support.automation.siemens.com/WW/view/en/49948856)
MRPD (Media Redundancy with Planned Duplication)	The advantage of the MRP extension MRPD is that, in the event of a failure of a device or a line in the ring, all other devices continue to be supplied with IO data without interruption and with short update times. MRPD is based on IRT and MRP. To realize media redundancy with short update times, the PROFINET devices participating in the ring send their data in both directions. The devices receive this data at both ring ports so that there is no reconfiguration time.	
Shared device	The "Shared device" function allows you to divide the modules or submodules of an IO device up among different IO controllers. Numerous IO controllers are often used in larger or widely distributed systems. Without the "Shared device" function, each I/O module of an IO device is assigned to the same IO controller. If sensors that are physically close to each other must provide data to different IO controllers, several IO devices are required. The "Shared device" function allows the modules or submodules of an IO device to be divided up among different IO controllers, thus allowing flexible automation concepts. You can, for example, combine I/O modules that are physically close to each other in one IO device.	
PROFIenergy	PROFIenergy is a PROFINET-based data interface for switching off consumers centrally and with full coordination during pause times regardless of the manufacturer or device type. Through this, the process should only be provided with the energy that is absolutely required. The majority of the energy is saved by the process; the PROFINET device itself only contributes a few watts of savings potential.	
Integrated technology		
Motion Control	S7-1500 CPUs support the controlled positioning and traveling of axes via S7-1500 Motion Control functions by means of the following technology objects: Speed axes, positioning axes, synchronous axes, external encoders, output cams, cam tracks, and measuring inputs. <ul style="list-style-type: none"> • Speed-controlled axis for controlling a drive with speed specification • Positioning axis for position-controlled positioning of a drive • Synchronous axis to interconnect with a master value. The axis is synchronized to the master axis position. 	<ul style="list-style-type: none"> • Section Technology functions (Page 42) • S7-1500T Motion Control function manuals (https://support.industry.siemens.com/cs/ww/en/view/109751049)

Function	Description	Additional information
	<ul style="list-style-type: none"> External encoder for detecting the actual position of an encoder and its use as a master value for synchronous operation Cams, cam track for position-dependent generation of switching signals Measuring input for fast, accurate and event-dependent sensing of actual positions 	
Integrated closed-loop control functionality	<ul style="list-style-type: none"> PID Compact (continuous PID controller) PID 3Step (step controller for integrating actuators) PID Temp (temperature controller for heating and cooling with two separate actuators) 	PID control Function Manual https://support.industry.siemens.com/cs/ww/en/view/108210036
Integrated safety		
Know-how protection	The know-how protection protects user blocks against unauthorized access and modifications.	S7-1500, ET 200MP System Manual http://support.automation.siemens.com/WW/view/en/59191792
Copy protection	Copy protection links user blocks to the serial number of the SIMATIC memory card or to the serial number of the CPU. User programs cannot run without the corresponding SIMATIC memory card or CPU.	
Local user management (as of FW version V3.1)	Improved management of users, roles, and CPU function rights (User Management & Access Control, UMAC). You can use the local user management in the editor to manage all project users along with their rights (e.g. access rights) for users and roles of the project in the TIA Portal.	
Access protection (up to FW version V3.0)	You can use authorization levels to assign separate rights to different users.	
Integrity protection	The CPUs feature an integrity protection function by default. This helps to detect any manipulation of the engineering data on the SIMATIC Memory Card or during data transfer between the TIA Portal and the CPU, and to check communication from a SIMATIC HMI system to the CPU for possible manipulation of engineering data. The user receives a corresponding message about the manipulation of engineering data detected by the integrity protection.	
Password provider	As an alternative to manual password entry, you can link a password provider to STEP 7. A password provider offers the following advantages: <ul style="list-style-type: none"> Convenient handling of passwords. STEP 7 automatically imports the password for the blocks. This saves you time. Optimum block protection because the users do not know the password itself. 	

3.3.3 Hardware properties of the analog on-board I/O module

View

The following figure shows the analog on-board I/O (X10) of the CPU 1511C-1 PN.



Figure 3-2 Analog on-board I/O

Properties of the analog inputs

The 5 inputs of the analog on-board I/O module have the following properties:

Property	Description	Additional information
Resolution: 16 bits including sign	A CPU processes information exclusively in digital format. An ADC (analog-to-digital converter) integrated into the analog on-board I/O module therefore converts the analog value into a bit pattern. For the CPU, this conversion always returns a 16-bit word for SIMATIC products. The ADC used digitalizes the analog signal and approximates its value with a stepped curve. The resolution specifies the number of increments of the analog value along this stepped curve here.	<ul style="list-style-type: none"> Chapter Analog value processing Analog value processing function manual http://support.automation.siemens.com/WW/view/en/67989094
Integrated types of measuring	Controllers are only capable of processing analog values in the form of bit patterns. For this purpose, transducers which can be connected to the analog module measure physical variables such as pressure or temperature. This analog value is measured by the analog input module in the form of the measurement types current, voltage or resistance. The analog on-board I/O module supports the following measurement types on the following channels.	

Property	Description	Additional information
	<ul style="list-style-type: none"> Voltage measurement type can be set individually for channel 0 to 3 Current measurement type can be set individually for channel 0 to 3 Resistor measurement type can be set for channel 4 Thermal resistor measurement type can be set for channel 4 	
Configurable diagnostics	The analog on-board I/O module can diagnose errors. The module reports the diagnosed state to the CPU using a diagnostics error interrupt. Different types of diagnostics are available that you can parameterize channel-granularly.	Chapter Parameters of the analog on-board I/O (Page 114)
Hardware interrupt	You can react to process events (such as negative/positive exceeding of specific limits) through the configuration of a hardware interrupt. Hardware interrupts can be parameterized channel-granularly.	<ul style="list-style-type: none"> Chapter Parameters of the analog on-board I/O (Page 114) Chapter Structure of a data record for input channels of the analog on-board I/O (Page 157) STEP 7 online help

Properties of the analog outputs

The 2 outputs of the analog on-board I/O module have the following properties:

Property	Description	Additional information
Resolution: 16 bits including sign	Once the CPU has processed the digital signal, a DAC (digital-to-analog converter) integrated in the analog on-board I/O module converts the output signal to an analog current or voltage value. The resulting value of the output signal corresponds to the output value with which the analog on-board I/O module controls the analog actuators.	<ul style="list-style-type: none"> Chapter Analog value processing Analog value processing function manual (http://support.automation.siemens.com/WW/view/en/67989094)
Integrated output types	With the selection of the type of output you specify whether the digital-to-analog converter is to convert the output signal into the type of output "Current" or "Voltage". The output can be selected by individual channel.	
Configurable diagnostics	The analog on-board I/O module can diagnose errors. The module reports the diagnosed state to the CPU using a diagnostics error interrupt. Different types of diagnostics are available that you can parameterize channel-granularly.	Chapter Parameters of the analog on-board I/O (Page 114)

See also

[Parameter assignment and structure of the parameter data records of the analog on-board I/O \(Page 156\)](#)

3.3.4 Firmware functions of the analog on-board I/O module

Functions of the analog inputs

The 5 inputs of the analog on-board I/O module have the following functions:

Function	Description	Additional information
Reconfiguration in RUN	You have the option of reassigning parameters for the analog on-board I/O module in RUN (for example, measuring ranges of individual channels can be modified in RUN without affecting the other channels).	<ul style="list-style-type: none"> Chapter Parameters of the analog on-board I/O (Page 114) Chapter Parameter assignment and structure of the parameter data records of the analog on-board I/O (Page 156)
Support of the value status (Quality Information, QI)	Value status = 1 ("Good") indicates that the value of the assigned input at the terminal is valid. Value status = 0 ("Bad") indicates that the read value is not valid.	Chapter Address space of the analog on-board I/O (Page 108)

Functions of the analog outputs

The 2 outputs of the analog on-board I/O module have the following functions:

Function	Description	Additional information
Reconfiguration in RUN	You have the option of reassigning parameters for the analog on-board I/O module in RUN (for example, output ranges of individual channels can be modified in RUN without affecting the other channels).	<ul style="list-style-type: none"> Chapter Parameters of the analog on-board I/O (Page 114) Chapter Parameter assignment and structure of the parameter data records of the analog on-board I/O (Page 156)
Support of the value status (Quality Information, QI)	Value status = 1 ("Good") indicates that the process value specified by the user program is correctly output at the terminal. Value status = 0 ("Bad") indicates that the process value output at the hardware output is incorrect.	Chapter Address space of the analog on-board I/O (Page 108)

3.3.5 Hardware properties of the digital on-board I/O module

View

The following figure shows the digital on-board I/O (X11) of the CPU 1511C-1 PN.



Figure 3-3 Digital on-board I/O

Properties of the digital inputs

The digital inputs of the digital on-board I/O module have the following properties:

Property	Description	Additional information
Standard and high-speed inputs	The digital on-board I/O module has 16 high-speed inputs for signals up to a max. of 100 kHz. The inputs can be used as standard inputs and as inputs for technology functions. The inputs have a rated input voltage of 24 V DC. The inputs are suitable for switches and 2-/3-/4-wire proximity switches.	Chapter Wiring (Page 74)
Configurable diagnostics	The digital on-board I/O module is able to diagnose errors. The module reports the diagnosed state to the CPU using a diagnostics error interrupt. You can parameterize the type of diagnostics channel-specifically.	Chapter Parameters of the digital on-board I/O (Page 116)
Hardware interrupt	You can react to process events (such as positive edge, negative edge) through the configuration of a hardware interrupt. Hardware interrupts can be parameterized channel-granularly.	Chapter Parameters of the digital on-board I/O (Page 116) Chapter Structure of a data record for input channels of the digital on-board I/O (Page 167) STEP 7 online help

Properties of the digital outputs

The digital outputs of the digital on-board I/O module have the following properties:

Property	Description	Additional information
Configurable diagnostics	The digital on-board I/O module is able to diagnose errors. The module reports the diagnosed state to the CPU using a diagnostics error interrupt. You can parameterize the type of diagnostics channel-specifically.	Chapter Interconnection overview of the outputs (Page 105)
Standard and high-speed outputs		
Standard outputs	The digital on-board I/O module has 16 standard outputs.	Chapter Wiring (Page 74)
High-speed outputs	Of the 16 standard outputs you can also use 8 outputs as high-speed outputs for technology functions.	
Rated output voltage	The outputs have a rated output voltage of 24 V DC.	
Output frequencies and output currents	Rated output current as output for standard mode: 0.5 A per channel. As an output for technology functions, you can select between an output current of up to 0.5 A at an output frequency up to 10 kHz (load dependent) and a reduced output current of max. 0.1 A at an increased output frequency of up to 100 kHz.	Chapter Interconnection overview of the outputs (Page 105)
Application	The outputs are suitable for, e.g. solenoid valves, DC contactors and indicator lights, or also for signal transmission or proportional valves.	
Driver blocks with push-pull outputs.	The digital outputs feature driver blocks with push-pull outputs. Due to their basic functional design, such driver blocks always contain parasitic diodes that act as free-wheeling diodes when shutting off inductive loads. The shutdown voltage is limited to -0.8 V. Therefore, the demagnetization of inductive loads takes longer and can be approximately calculated using the following formula. $\tau = L / R$ (τ = time constant, L = inductance value, R = ohmic resistance value) After the expiration of a period of $5 * \tau$, the current has decreased in effect to 0 A due to the inductive load. The maximum value is derived from: $\tau = 1.15H / 48 \text{ Ohm} = 24 \text{ ms}$. After $5 * 24 \text{ ms} = 120 \text{ ms}$, the current has decreased in effect to 0 A. For comparison: With standard modules, inductive shutdown voltage is limited, for example, to $V_{cc} - 53 \text{ V}$ (supply voltage – 53 V), which causes the current to decrease to 0 A after about 15 ms.	Figure "Current flow with correct wiring using the digital on-board I/O X11 as an example" in Chapter Wiring and block diagrams of the digital on-board I/O (Page 87) .

Simultaneous use of technology and standard functions

You can use technology and standard functions at the same time, provided the hardware allows this. For example, all the digital inputs not assigned to the counting, measuring or position detection or PTO technology functions can be used as standard DI.

Inputs to which technology functions are assigned can be read. Outputs to which technology functions are assigned cannot be written.

3.3.6 Firmware functions of the digital on-board I/O module

Functions of the digital inputs

The digital inputs of the digital on-board I/O module have the following functions:

Function	Description	Additional information
Technology functions	The high-speed digital inputs of the digital on-board I/O module support technology functions such as fast counting, measuring, position detection and pulse generators (PWM, PTO and frequency output).	Chapter Technology functions (Page 42)
Reconfiguration in RUN	You have the option of reassigning parameters for the digital on-board I/O module in RUN (for example, values for input delay of individual channels can be modified without affecting the other channels).	<ul style="list-style-type: none"> Chapter Parameters of the digital on-board I/O (Page 116) Chapter Parameter assignment and structure of the parameter data records of the digital on-board I/O (Page 166)
Support of the value status (Quality Information, QI)	Value status = 1 ("Good") indicates that the value of the assigned input at the terminal is valid. Value status = 0 ("Bad") indicates that no/too little supply voltage L+ is applied at the terminal and that the read value is therefore not valid.	Chapter Address space of the digital on-board I/O (Page 110)

Functions of the digital outputs

The digital outputs of the digital on-board I/O module have the following functions:

Function	Description	Additional information
Technology functions	The high-speed digital outputs of the digital on-board I/O module support technology functions such as fast counting, measuring, position detection and pulse generators (PWM, PTO and frequency output). Due to the supported technology functions, the compact CPUs are suitable for controlling pumps, fans, mixers, conveyor belts, lifting platforms, gate control systems, building management systems, synchronized axes, etc.	Chapter Technology functions (Page 42)
Reconfiguration in RUN	You have the option of reassigning parameters for the digital on-board I/O module in RUN (for example, behavior during CPU STOP, without affecting the other channels).	<ul style="list-style-type: none"> Chapter Parameters of the digital on-board I/O (Page 116) Chapter Parameter assignment and structure of the parameter data records of the digital on-board I/O (Page 166)
Support of the value status (Quality Information, QI)	Value status = 1 ("Good") indicates that the process value specified by the user program is correctly output at the terminal. Value status = 0 ("Bad") indicates that the process value output at the hardware output is incorrect or the channel is used for technology functions.	Chapter Address space of the digital on-board I/O (Page 110)

3.4 Operator controls and display elements

3.4.1 Front view with closed front panel

The following figure shows the front view of the CPU 1511C-1 PN.

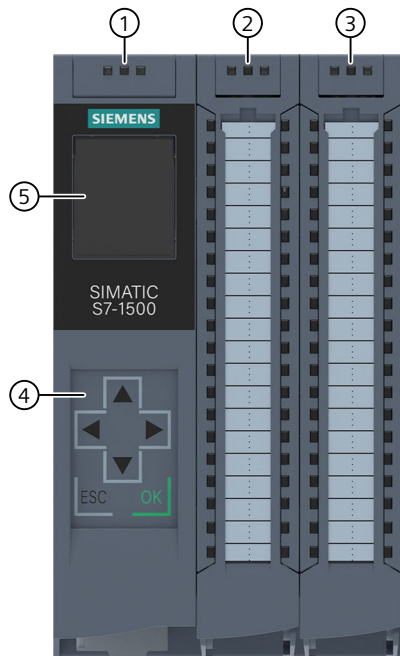

- ① LEDs for the current operating mode and diagnostics status of the CPU
- ② Status and error displays RUN/ERROR of the analog on-board I/O
- ③ Status and error displays RUN/ERROR of the digital on-board I/O
- ④ Control keys
- ⑤ Display

Figure 3-4 View of the CPU 1511C-1 PN with closed front panels (front)

NOTE

Temperature range for display

To increase its service life, the display switches off at a temperature below the permitted operating temperature of the device. When the display cools down again, it automatically switches itself on again. When the display is switched off, the LEDs continue to show the status of the CPU.

You can find additional information on the temperatures at which the display switches itself on and off in the Technical specifications [\(Page 131\)](#).

Removing and fitting the front panel or display

You can remove and fit the front panel or the display during operation.

WARNING

Personal injury and damage to property may occur

In Zone 2 hazardous areas, personal injury or damage to property can occur if you pull or plug the display of an S7-1500 automation system during operation.

Before you pull or plug the display in Zone 2 hazardous areas, first make sure that the S7-1500 automation system is de-energized.

Locking the front panel

You can lock the front panel to protect your CPU against unauthorized access.

You can attach a security seal or a padlock with a hoop diameter of 3 mm to the front panel.

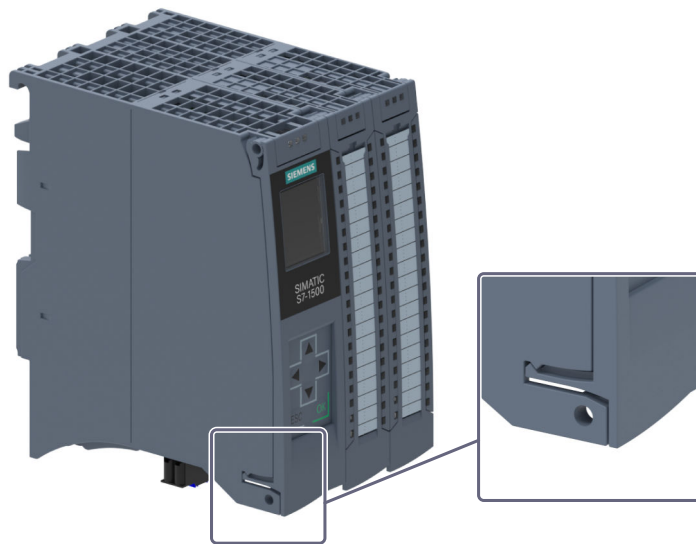

Figure 3-5 Locking latch on the CPU

In addition to the mechanical lock, you can also block access to a password-protected CPU on the display (local lock) and assign a password for the display. For more information on the display, the configurable protection levels and the local lock, refer to the S7-1500, ET 200MP (<http://support.automation.siemens.com/WW/view/en/59191792>) system manual.

Reference

You will find detailed information on the individual display options, a training course and a simulation of the available menu commands in the SIMATIC S7-1500 Display Simulator (<https://support.industry.siemens.com/cs/ww/en/view/109761758>).

3.4.2 Front view of the CPU without front panel and view from below

The following figure shows the operator control and connection elements of the CPU 1511C-1 PN with the front cover of the CPU open.

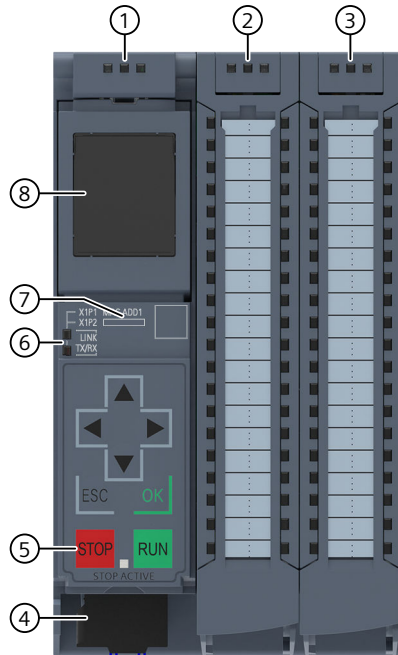

- ① LEDs for the current operating mode and diagnostics status of the CPU
- ② Status and error displays RUN/ERROR of the analog on-board I/O
- ③ Status and error displays RUN/ERROR of the digital on-board I/O
- ④ Connector for power supply
- ⑤ Operating modes with "STOP ACTIVE" LED
- ⑥ LEDs for the 2 ports (X1 P1 and X1 P2) of the PROFINET interface X1
- ⑦ MAC address
- ⑧ Display

Figure 3-6 View of the CPU 1511C-1 PN without front panel on the CPU (front)

NOTE

Removing the display

Only remove the display if it is faulty.

You can find information on removing and replacing displays in the S7-1500, ET 200MP system manual (<http://support.automation.siemens.com/WW/view/en/59191792>).

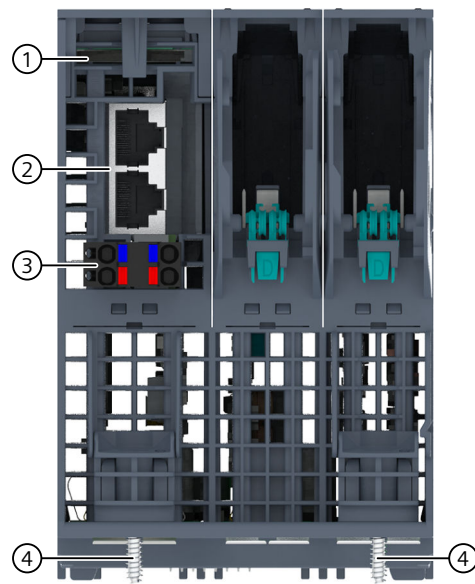

- ① Slot for the SIMATIC memory card
- ② PROFINET IO interface (X1) with 2 ports
- ③ Connection for supply voltage
- ④ Fastening screw

Figure 3-7 View of the CPU 1511C-1 PN – bottom

3.4.3 Rear view

The following figure shows the connection elements on the rear of the CPU 1511C-1 PN.

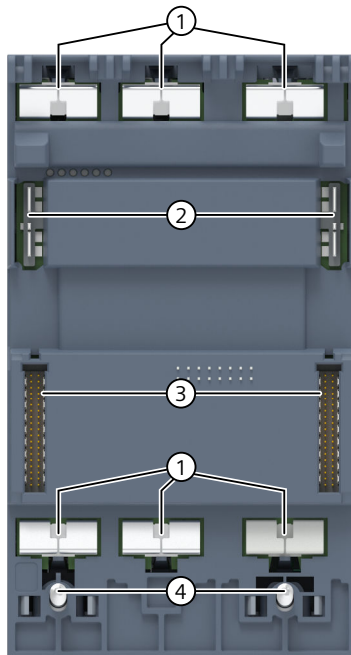

- ① Shield contact surfaces
- ② Plug-in connection for power supply
- ③ Plug-in connection for backplane bus
- ④ Fastening screws

Figure 3-8 View of the CPU 1511C-1 PN - rear

3.5 Operating mode buttons

You use the operating mode buttons to set the operating mode of the CPU.

The following table shows the meaning of the corresponding operation of the operating mode buttons.

Table 3-6 Meaning of the operating mode buttons

Operation of the operating mode buttons	Meaning	Explanation
RUN	RUN mode	The CPU executes the user program.
STOP	STOP mode	The user program is not executed. (STOP ACTIVE LED lights up).
MRES	Manual memory reset (with inserted SIMATIC memory card) or Reset to factory settings (without inserted SIMATIC memory card):	The CPU executes memory reset. or The CPU is reset to its factory settings. You can find additional information in the S7-1500/ET 200MP system manual (https://support.industry.siemens.com/cs/ww/en/view/59191792).

Operation of the operating mode buttons	Meaning	Explanation
<ol style="list-style-type: none">1. Press the operating mode button STOP. Result: The RUN/STOP LED lights up yellow.2. Press the operating mode button STOP until the RUN/STOP LED lights up for the 2nd time and remains continuously lit (this takes three seconds). After this, release the button.3. Press the operating mode button STOP again within the next three seconds.		

Technology functions

4.1 High-speed counters

Properties

The technology functions of the compact CPU have the following technical properties:

- 16 high-speed digital inputs (up to 100 kHz), isolated
 - 6 high-speed counters (High Speed Counter/HSC), 4 of which can be used as A/B/N
- Interfaces
 - 24 V encoder signals of sourcing or push-pull encoders and sensors
 - 24 V encoder supply output, short-circuit-proof
 - Up to 2 additional digital inputs per high-speed counter for possible HSC DI functions (Sync, Capture, Gate)
 - 1 digital output per high-speed counter for fast reaction to the count
- Counting range: 32 bits
- Diagnostics and hardware interrupts can be configured
- Supported encoder/signal types
 - 24 V incremental encoder (with 2 tracks A and B, phase-shifted by 90°, up to 4 incremental encoders also with zero track N)
 - 24 V pulse encoder with direction signal
 - 24 V pulse encoder without direction signal
 - 24 V pulse encoder each for forward pulse & reverse pulse

The high-speed counters support reconfiguration in RUN. You can find additional information in chapter Parameter data records of the high-speed counters ([Page 169](#)).

4.1.1 Functions

4.1.1.1 Counting

Counting refers to the detection and adding up of events. The counters acquire and evaluate encoder signals and pulses. You can specify the count direction using suitable encoder or pulse signals or through the user program. You can control counting processes using the digital inputs. You can switch the digital outputs exactly at defined count values, regardless of the user program. You can configure the response of the counters using the functionalities described below.

Counting limits

The counting limits define the count value range used. The counting limits are selectable and can be modified during runtime by the user program.

The highest counting limit that can be set is 2147483647 ($2^{31}-1$). The lowest counting limit that can be set is -2147483648 (-2^{31}).

You can configure the response of the counter at the counting limits:

- Continue or stop counting (automatic gate stop) on violation of a counting limit
- Set count value to start value or to opposite counting limit on violation of a counting limit

Start value

You can configure a start value within the counting limits. The start value can be modified during runtime by the user program.

Depending on the parameter assignment, the compact CPU can set the current count value to the start value during synchronization, during the Capture function, on violation of a counting limit or when the gate is opened.

Gate control

The opening and closing of the hardware gate (HW gate) and software gate (SW gate) defines the period of time during which the counting signals are acquired.

The digital inputs of the digital on-board I/O control the HW gate. The user program controls the software gate. You can enable the hardware gate using the parameter assignment. The software gate (bit in the control interface of the cyclic I/O data) cannot be disabled.

Capture

You can configure an external reference signal edge that triggers the saving of the current count value as a Capture value. The following external signals can trigger the Capture function:

- Rising or falling edge of a digital input
- Both edges of a digital input
- Rising edge of signal N at the encoder input

You can configure whether counting continues from the current count value or from the start value after the Capture function.

Hysteresis

You can specify hysteresis for the comparison values, within which a digital output is prevented from switching again. An encoder may stop at a certain position, and slight movements may make the count value fluctuate around this position. If a comparison value or a counting limit lies within this fluctuation range, the corresponding digital output will be switched on and off often if hysteresis is not used. The hysteresis prevents these unwanted switching operations.

Reference

For more information on the counter, refer to the S7-1500, ET 200MP, ET 200SP Counting, measurement and position detection function manual (<http://support.automation.siemens.com/WW/view/en/59709820>).

4.1.1.2 Measuring

Measuring functions

The following measuring functions are available:

Table 4-1 Overview of available measuring functions

Measurement type	Description
Frequency measurement	A measuring interval calculates the average frequency based on the time sequence of the count pulses, and returns this frequency as a floating-point number in units of hertz.
Period measurement	A measuring interval calculates the average period duration based on the time sequence of the count pulses, and returns this period duration as a floating-point number in units of seconds.
Velocity measurement	A measuring interval calculates the average velocity based on the time sequence of the count pulses, and returns this velocity in the configured unit.

The measured value and count value are both available in the feedback interface.

Update time

You can configure the interval at which the compact CPU updates the measured values cyclically as the update time. Greater update times smooth uneven measured variables and increase the measuring accuracy.

Gate control

Opening and closing the hardware gate and software gate defines the period of time during which the count signals are acquired. The update time is asynchronous to the opening of the gate, which means that the update time is not started when the gate is opened. After the gate is closed, the last measured value calculated is still returned.

Measuring ranges

The measuring functions have the following measuring range limits:

Table 4-2 Overview of low and high measuring range limits

Measurement type	Low measuring range limit	High measuring range limit
Frequency measurement	0.04 Hz	400 kHz *
Period measurement	2.5 μ s *	25 s
Velocity measurement	Depending on the configured number of "increments per unit" and the "timebase for velocity measurement"	

* Applies to 24 V incremental encoder and "quadruple" signal evaluation

All measured values are returned as signed values. The sign indicates whether the count value increased or decreased during the relevant time period. For example, a value of -80 Hz means that the count value decreases at 80 Hz.

Reference

For more information on measuring, refer to the S7-1500, ET 200MP, ET 200SP Counting, measurement and position detection function manual (<http://support.automation.siemens.com/WW/view/en/59709820>).

4.1.1.3 Position detection for motion control

You can use the digital on-board I/O, e.g. with an incremental encoder, for position detection with S7-1500 Motion Control. The position detection is based on the counting function, which evaluates the acquired encoder signals and provides them for S7-1500 Motion Control. In the hardware configuration of the CPU 1511C-1 PN in STEP 7 (TIA Portal), select the "Position input for Motion Control" mode.

Reference

For a detailed description of the use of motion control and its configuration, refer to the S7-1500/S7-1500T Motion Control function manual (<https://support.industry.siemens.com/cs/ww/en/view/109766459>). In the function manual, the interface between the drives and encoders is referred to as a technology module (TM). In this context, a technology module (TM) also refers to the digital on-board I/O of the compact CPU described here.

4.1.1.4 Additional functions

Synchronization

You can configure an external reference signal edge to load the counter with the specified start value. The following external signals can trigger a synchronization:

- Rising or falling edge of a digital input
- Rising edge of signal N at the encoder input
- Rising edge of signal N at the encoder input depending on the level of the assigned digital input

Comparison values

The integrated counter supports 2 comparison values and digital output HSC DQ1. If the counter or measured value meets the set comparison condition, HSC DQ1 can be set in order to trigger direct control operations in the process.

Both comparison values can be set in the parameters and can be changed during runtime via the user program.

Hardware interrupts

If you have enabled a hardware interrupt in the hardware configuration, the counter can trigger a hardware interrupt in the CPU when a comparison event occurs, if there is overflow or underflow, at a zero crossing of the counter, and/or at a change of count direction (direction reversal). You can specify which events are to trigger a hardware interrupt during operation in the hardware configuration.

Diagnostics interrupts

If you have enabled a diagnostics interrupt in the hardware configuration, the counter can trigger a diagnostics interrupt if the supply voltage is missing, if there is an incorrect A/B count signal or lost hardware interrupt.

4.1.2 Configuring the high-speed counters

4.1.2.1 General

You configure the high-speed counters (HSC) in STEP 7 (TIA Portal). The functions are controlled via the user program.

Reference

A detailed description of configuring the counting and measuring functions can be found in:

- S7-1500, ET 200MP, ET 200SP Counting, measurement and position detection (<http://support.automation.siemens.com/WW/view/en/59709820>) function manual
- in the STEP 7 online help under "Using technology functions > Counting, measuring and position detection > Counting, measuring and position detection (S7-1500)"

A detailed description of configuring Motion Control be found in:

- in the S7-1500/S7-1500T Motion Control (<http://support.automation.siemens.com/WW/view/en/59381279>) function manual
- in the STEP 7 online help under "Using technology functions > Motion Control > Motion Control (S7-1500)"

4.1.2.2 Assignment of the control interface of the high-speed counters

The user program uses the control interface to influence the behavior of the high speed counter.

NOTE

Operation with High_Speed_Counter technology object

The High_Speed_Counter technology object is available for high-speed counting mode. We therefore recommend use of the High_Speed_Counter technology object instead of the control interface/feedback interface for controlling the high speed counter.

For information on configuring the technology object and programming the associated instruction, refer to the S7-1500, ET 200MP, ET 200SP Counting, measurement and position detection (<http://support.automation.siemens.com/WW/view/en/59709820>) function manual.

Control interface per channel

The following table shows the control interface assignment:

Table 4-3 Assignment of the control interface

Offset from start address	Parameter	Meaning			
Bytes 0 to 3	Slot 0	Load value (meaning of the value is specified in LD_SLOT_0)			
Bytes 4 to 7	Slot 1	Load value (meaning of the value is specified in LD_SLOT_1)			
Byte 8	LD_SLOT_0*	Specifies the meaning of the value in Slot 0			
		Bit 3	Bit 2	Bit 1	Bit 0

* If values are loaded simultaneously via LD_SLOT_0 and LD_SLOT_1, the value from Slot 0 is taken first internally and then the value from Slot 1. This may lead to unexpected intermediate states.

Offset from start address	Parameter	Meaning				
Byte 8	LD_SLOT_0*	0	0	0	0	No action, idle state
		0	0	0	1	Load counter
		0	0	1	0	Reserve
		0	0	1	1	Load start value
		0	1	0	0	Load comparison value 0
		0	1	0	1	Load comparison value 1
		0	1	1	0	Load low counting limit
		0	1	1	1	Load high counting limit
		1	0	0	0	Reserve
		to				
	1	1	1	1		
	LD_SLOT_1*	Specifies the meaning of the value in Slot 1				
		Bit 7	Bit 6	Bit 5	Bit 4	
		0	0	0	0	No action, idle state
		0	0	0	1	Load counter
		0	0	1	0	Reserve
		0	0	1	1	Load start value
		0	1	0	0	Load comparison value 0
		0	1	0	1	Load comparison value 1
		0	1	1	0	Load low counting limit
0		1	1	1	Load high counting limit	
1	0	0	0	Reserve		
to						
1	1	1	1			
Byte 9	EN_CAPTURE	Bit 7: Enable capture function				
	EN_SYNC_DN	Bit 6: Enable downward synchronization				
	EN_SYNC_UP	Bit 5: Enable upward synchronization				
	SET_DQ1	Bit 4: Set DQ1				
	SET_DQ0	Bit 3: Set DQ0				
	TM_CTRL_DQ1	Bit 2: Enable technological function DQ1				
	TM_CTRL_DQ0	Bit 1: Enable technological function DQ0				
	SW_GATE	Bit 0: Software gate				
Byte 10	SET_DIR	Bit 7: Count direction (with encoder without direction signal)				
	–	Bits 2 to 6: Reserve; bits must be set to 0				
	RES_EVENT	Bit 1: Reset of saved events				
	RES_ERROR	Bit 0: Reset of saved error states				
Byte 11	–	Bits 0 to 7: Reserve; bits must be set to 0				

* If values are loaded simultaneously via LD_SLOT_0 and LD_SLOT_1, the value from Slot 0 is taken first internally and then the value from Slot 1. This may lead to unexpected intermediate states.

Reference

You can find a graphic representation of the processing of the various SLOT parameters in the section Handling the SLOT parameter (control interface) (Page 69).

4.1.2.3 Assignment of the feedback interface of the high-speed counters

The user program receives current values and status information from the high speed counter via the feedback interface.

NOTE

Operation with High_Speed_Counter technology object

The High_Speed_Counter technology object is available for high-speed counting mode. We therefore recommend use of the High_Speed_Counter technology object instead of the control interface/feedback interface for controlling the high speed counter.

For information on configuring the technology object and programming the associated instruction, refer to the S7-1500, ET 200MP, ET 200SP Counting, measurement and position detection (<http://support.automation.siemens.com/WW/view/en/59709820>) function manual.

Feedback interface per channel

The following table shows the feedback interface assignment:

Table 4-4 Assignment of the feedback interface

Offset from start address	Parameter	Meaning
Bytes 0 to 3	COUNT VALUE	Current count value
Bytes 4 to 7	CAPTURED VALUE	Last Capture value acquired
Bytes 8 to 11	MEASURED VALUE	Current measured value
Byte 12	–	Bits 3 to 7: Reserve; set to 0
	LD_ERROR	Bit 2: Error when loading via control interface
	ENC_ERROR	Bit 1: Incorrect encoder signal
	POWER_ERROR	Bit 0: Incorrect supply voltage L+
Byte 13	–	Bits 6 to 7: Reserve; set to 0
	STS_SW_GATE	Bit 5: Software gate status
	STS_READY	Bit 4: Digital on-board I/O started up and parameters assigned
	LD_STS_SLOT_1	Bit 3: Load request for Slot 1 detected and executed (toggling)
	LD_STS_SLOT_0	Bit 2: Load request for Slot 0 detected and executed (toggling)
	RES_EVENT_ACK	Bit 1: Reset of event bits active
	–	Bit 0: Reserve; set to 0
Byte 14	STS_DI2	Bit 7: Reserve; set to 0
	STS_DI1	Bit 6: Status HSC DI1
	STS_DI0	Bit 5: Status HSC DIO
	STS_DQ1	Bit 4: Status HSC DQ1
	STS_DQ0	Bit 3: Status HSC DQ0

Offset from start address	Parameter	Meaning
Byte 14	STS_GATE	Bit 2: Internal gate status
	STS_CNT	Bit 1: Count pulse detected within last approx. 0.5 s
	STS_DIR	Bit 0: Direction of last count value change
Byte 15	STS_M_INTERVAL	Bit 7: Count pulse detected in previous measuring interval
	EVENT_CAP	Bit 6: Capture event has occurred
	EVENT_SYNC	Bit 5: Synchronization has occurred
	EVENT_CMP1	Bit 4: Comparison event for DQ1 has occurred
	EVENT_CMP0	Bit 3: Comparison event for DQ0 has occurred
	EVENT_OFLW	Bit 2: Overflow has occurred
	EVENT_UFLW	Bit 1: Underflow has occurred
	EVENT_ZERO	Bit 0: Zero crossing has occurred

4.2 Pulse generators

4.2.1 Operating modes

4.2.1.1 Operating mode: Pulse-width modulation (PWM)

Properties

The pulse-width modulation (PWM) mode of the compact CPU has the following technical properties:

	Minimum			Maximum		
	Standard output	High-speed output deactivated	High-speed output activated	Standard output	High-speed output deactivated	High-speed output activated
Pulse duration	400 μ s with load > 0.1 A ¹⁾ 500 μ s with load \geq 2 mA ¹⁾	20 μ s with load > 0.1 A ¹⁾ 40 μ s with load \geq 2 mA ¹⁾	2 μ s ¹⁾	10 000 000 μ s (10 s)		
Period duration	10 ms ²⁾	100 μ s ²⁾	10 μ s			

¹⁾ A lower value is theoretically possible but, depending on the connected load, the output voltage can no longer be output as complete rectangular pulse

²⁾ Load-dependent

Principle of operation

With pulse width modulation, a signal with defined cycle duration and variable on-load factor is output at the digital output. The on-load factor is the relationship of the pulse duration to the cycle duration. In PWM mode, you can control the on-load factor and the cycle duration. With pulse width modulation, you vary the mean value of the output voltage. Depending on the connected load, you can control the load current or the power with this.

You can specify the pulse duration as one-hundredth of the period duration (0 to 100), as one-thousandth (0 to 1 000), as one ten-thousandth (0 to 10 000) or in S7 analog format.



- ① Period duration
- ② Pulse duration

The pulse duration can be between 0 (no pulse, always off) and full scale (no pulse, period duration always on).

The PWM output can, for example, be used to control the speed of a motor from standstill to full speed or you can use it to control the position of a valve from closed to completely open. You configure the pulse width modulation (PWM) mode in STEP 7 (TIA Portal).

The pulse width modulation mode has the following functions:

- When the option "High-speed output (0.1 A)" is activated, you can generate a minimum pulse duration of 2 μs at a current of 100 mA. If the option "High-speed output (0.1 A)" is not activated, you can generate a minimum pulse duration of 20 μs with a load > 0.1 A and a minimum pulse duration of 40 μs with a load of ≥ 2 mA and a current of maximum 0.5 A. If a standard output is used, you can generate a minimum pulse duration of 400 μs with a load of > 0.1 A and a minimum pulse duration of 500 μs with a load of ≥ 2 mA.
- You can control the pulse output (DQA) of the channel manually via the control and feedback interface.
- You can configure the reaction to CPU STOP. Upon change to CPU STOP, the pulse output (DQA) is set to the configured state.

Controller

For the pulse width modulation (PWM) mode, the user program directly accesses the control and feedback interface of the channel.

Reconfiguration via the instructions WRREC/RDREC and parameter assignment data record 128 is supported. You can find additional information in section Parameter data records (PWM) (Page 176).

You control the on-load factor (pulse-cycle ratio) of the pulse width via the OUTPUT_VALUE field of the control interface. Pulse width modulation generates continuous pulses based on this value. The period duration is adjustable.

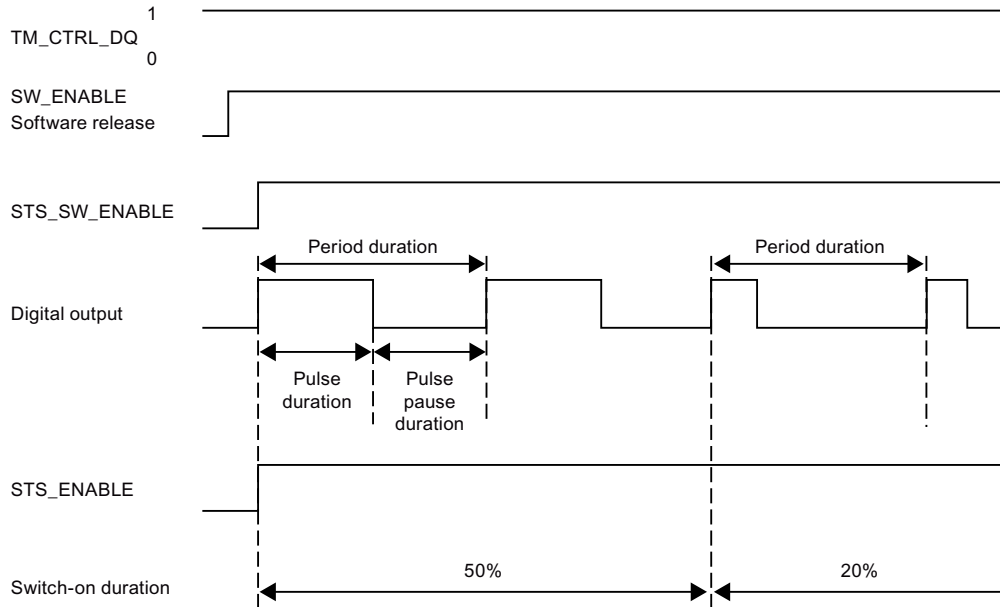

Figure 4-1 Pulse schematic

Starting the output sequence

The control program must output the enable for the output sequence with the help of the software enable (SW_ENABLE 0 → 1). The feedback bit STS_SW_ENABLE indicates that the software enable is pending at the PWM.

If the software enable is activated (rising edge), STS_ENABLE is set. The output sequence runs continuously, as long as SW_ENABLE is set.

NOTE

Output control signal TM_CTRL_DQ

- If TM_CTRL_DQ = 1, the technology function takes over the control and generates pulse sequences at the output PWM DQA.
- If TM_CTRL_DQ = 0, the user program takes over the control and the user can set the output PWM DQA directly via the control bit SET_DQA.

Canceling the output sequence

Deactivating the software enable ($SW_ENABLE = 1 \rightarrow 0$) cancels the current output sequence. The last period duration is not completed. STS_ENABLE and the digital output PWM DQA are immediately reset to 0.

A renewed pulse output is only possible after a restart of the output sequence.

Minimum pulse duration and minimum interpulse period

You assign the minimum pulse duration and the minimum interpulse period with the parameter "Minimum pulse duration".

- A pulse duration determined by the technology function or PWM channel which is shorter than the minimum pulse duration will be suppressed.
- A pulse duration determined by the technology function or PWM channel which is longer than the cycle duration less the minimum interpulse period will be set to the value of the cycle duration (output switched on permanently).

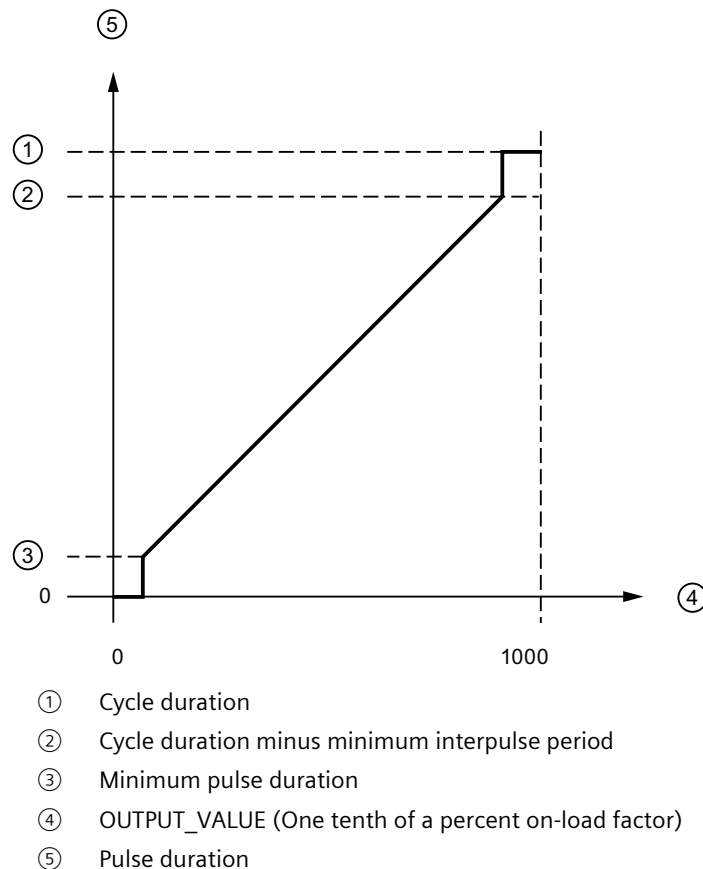

Figure 4-2 Minimum pulse duration and minimum interpulse period

Setting and changing the pulse on-load factor

OUTPUT_VALUE assigns the on-load factor for the current period duration. You select the range of the field OUTPUT_VALUE of the control interface with the "Output format" parameter.

- Output format 1/100: Value range between 0 and 100
Pulse duration = (OUTPUT_VALUE/100) x period duration.
- Output format 1/1000: Value range between 0 and 1 000
Pulse duration = (OUTPUT_VALUE/1 000) x period duration.
- Output format 1/10000: Value range between 0 and 10 000
Pulse duration = (OUTPUT_VALUE/10 000) x period duration.
- Output format "S7 analog output": Value range between 0 and 27 648
Pulse duration = (OUTPUT_VALUE/27 648) x period duration.

You assign OUTPUT_VALUE directly via the control program. A new OUTPUT_VALUE is applied at the output when the next rising edge occurs.

Setting and changing the period duration

- Permanent update
The period duration is permanently controlled via the control interface. The MODE_SLOT bit must be set ("1" means permanent update); LD_SLOT must be set to value 1 ("1" means period duration). Set the period value in the field SLOT. The unit is always a microsecond.
 - High-speed output activated: between 10 µs and 10 000 000 µs (10 s) in the field SLOT
 - High-speed output deactivated: between 100 µs and 10 000 000 µs (10 s) in the field SLOT
 - Standard output (100 Hz output): between 10 000 µs (10 ms) and 10 000 000 µs (10 s) in the field SLOT
- Individual updating
Set the period duration in the configuration parameters. Alternatively, execute an individual update via the control interface. MODE_SLOT must be deleted ("0" means individual update); LD_SLOT must be set to value 1 ("1" means period duration). Set the period duration value in the field SLOT. The unit is always a microsecond.
 - High-speed output activated: between 10 µs and 10 000 000 µs (10 s) in the parameters
 - High-speed output deactivated: between 100 µs and 10 000 000 µs (10 s) in the parameters
 - Standard output (100 Hz output): between 10 000 µs (10 ms) and 10 000 000 µs (10 s) in the parameters

The new period duration is applied at the next rising edge of the output.

Setting the minimum pulse duration and the minimum interpulse period

You assign the minimum pulse duration and the minimum interpulse period as DWORD numerical value between 0 and 10 000 000 µs (10 s) with the help of the channel parameter configuration "Minimum pulse duration".

Parameters of the pulse width modulation (PWM) mode

Category	Parameter	Meaning	Value range	Default
Reaction to CPU STOP	Reaction to CPU STOP	The parameter "Output substitute value" generates a substitute value upon CPU STOP, which you can define with the parameter "Substitute value for pulse output (DQA)".	Output substitute value	Output substitute value
		On CPU STOP, the parameter "Continue" still generates the PWM output signal which was generated before the CPU STOP.	Continue	
	Substitute value for pulse output (DQA)	If you have set the option "Output substitute value" for "Reaction to CPU STOP", the parameter "Substitute value for pulse output (DQA)" defines the substitute value to be used for the pulse output of the channel. If you have set the option "Continue" for "Reaction to CPU STOP", the parameter "Substitute value for pulse output (DQA)" cannot be selected.	0 (use substitute value 0)	0
		1 (use substitute value 1)		
Diagnostics interrupt	No supply voltage L+	The parameter "Missing supply voltage L+" activates the diagnostic interrupt of the channel in the case of no supply voltage L+	Deactivated	Deactivated
			Activated	
Parameter	High-speed output (0.1 A)	The "High-speed output (0.1 A)" parameter is used to specify whether you want to use the selected pulse output as high-speed output. The requirement for this is that the selected pulse output supports operation as high-speed output.	Deactivated The output supports frequencies of up to 10 kHz (load dependent) and currents of up to 0.5 A or frequencies of up to 100 Hz and currents of up to 0.5 A depending on the performance capability of the selected output.	Deactivated
			Activated The output supports frequencies of up to 100 kHz and currents of up to 0.1 A.	
	Output format	Defines the format of the ratio value (on-load factor) in the field "OUTPUT_VALUE" of the control interface of the channel.	S7 analog output Interprets the ratio value in the field "OUTPUT_VALUE" of the control interface as 1/27648 of the current period duration. Supported value range from 0 to 27 648	1/100
		1/100 Interprets the ratio value in the field "OUTPUT_VALUE" of the control interface as percentage value of the current period duration. Supported value range 0 to 100		

Category	Parameter	Meaning	Value range	Default
Parameter	Output format	Defines the format of the ratio value (on-load factor) in the field "OUTPUT_VALUE" of the control interface of the channel.	1/1000 Interprets the ratio value in the field "OUTPUT_VALUE" of the control interface as a one-tenth percentage point of the current period duration. Supported value range from 0 to 1 000	1/100
			1/10000 Interprets the ratio value in the field "OUTPUT_VALUE" of the control interface as a one-hundredth percentage point of the current period duration. Supported value range from 0 to 10 000	
	Minimum pulse duration	Defines the minimum pulse duration and the minimum interpulse period of the output signal of the channel. The channel suppresses all pulses and pauses that are below the specified value.	0 µs to 10 000 000 µs (10 s)	0 µs
	Period duration	Defines the period duration of the output signal of the channel in µs. In RUN, the user program can control the period duration via the control and feedback interface of the channel.	x to 10 000 000 µs (10 s) at 100 kHz hardware output (high-speed output (0.1 A) activated): 10 µs to 10 000 000 µs (10 s) at 10 kHz hardware output (high-speed output (0.1 A) deactivated): 100 µs to 10 000 000 µs (10 s) at 100 kHz hardware output (high-speed output (0.1 A) deactivated): 10 000 µs (10 ms) to 10 000 000 µs (10 s)	2 000 000 µs (2 s)
Hardware inputs/ outputs	Pulse output (DQA)	The parameter "Pulse output (DQA)" defines the hardware output to use as pulse output channel.	For B: X11, terminal 21 (DQ0 / %Q4.0): 10 kHz / 0.5 A or 100 kHz / 0.1 A	Hardware output with the least significant address
			For B: X11, terminal 31 (DQ8 / %Q5.0): 100 Hz / 0.5 A	

Output signals for pulse width modulation (PWM) mode

Output signal	Meaning	Value range
Continuous pulse current at the digital output PWM DQA	A pulse is output at the digital output PWM DQA for the set on-load factor and period duration.	Continuous pulse current

4.2.1.2 Operating mode: Frequency output

In this operating mode, you can assign a frequency value with high frequencies more precisely than by using the period duration in PWM mode.

A rectangular signal with an assigned frequency and a constant on-load factor of 50% is generated at the digital output.

The frequency output mode has the following functions:

- When the option "High-speed output (0.1 A)" is activated, you can generate a minimum pulse duration of 2 μ s at a current of 100 mA. If the option "High-speed output (0.1 A)" is not activated, you can generate a minimum pulse duration of 20 μ s with a load > 0.1 A and a minimum pulse duration of 40 μ s with a load of \geq 2mA and a current of maximum 0.5 A.

If you use a standard output, you can generate a minimum pulse duration of 400 μ s with a load of > 0.1 A and a minimum pulse duration of 500 μ s with a load of \geq 2 mA and a current of max. 0.5 A.

	Minimum			Maximum		
	Standard output	High-speed output deactivated	High-speed output activated	Standard output	High-speed output deactivated	High-speed output activated
Frequency	0.1 Hz			100 Hz ¹⁾	10 kHz ¹⁾	100 kHz

¹⁾ Load-dependent

- You can control the pulse output (DQA) of the channel manually via the control and feedback interface.
- You can configure the reaction to CPU STOP. Upon change to CPU STOP, the pulse output (DQA) is set to the configured state.

Controller

For the frequency output mode, the user program directly accesses the control and feedback interface of the channel.

Reconfiguration via the instructions WRREC/RDREC and parameter assignment data record 128 is supported. You can find additional information in section Parameter data records (PWM) ([Page 176](#)).

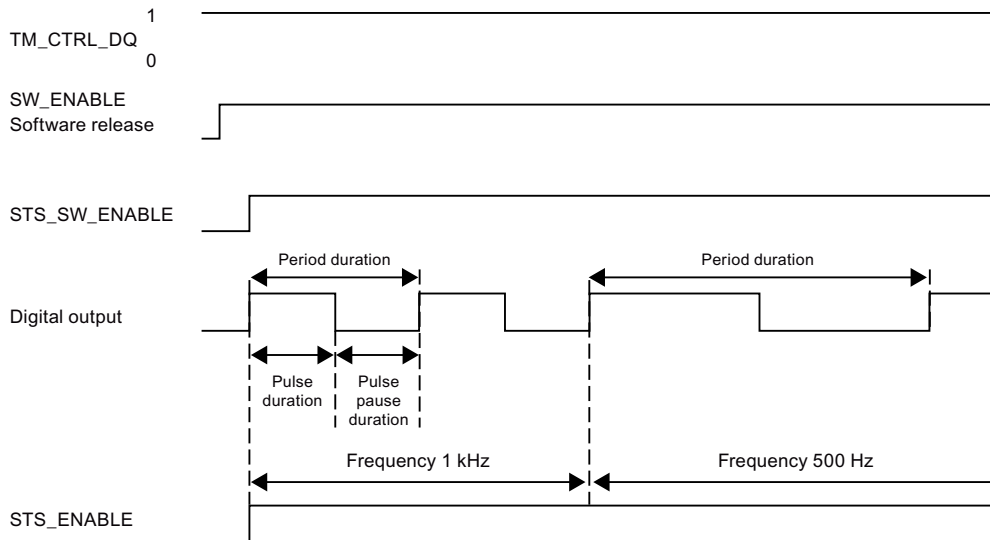

Figure 4-3 Pulse schematic

Starting the output sequence

The control program must initiate the enable for the output sequence with the help of the software enable (SW_ENABLE 0 → 1). The feedback bit STS_SW_ENABLE indicates that the software enable is pending at the pulse generator.

If the software enable is activated (rising edge), STS_ENABLE is set. The output sequence runs continuously, as long as SW_ENABLE is set.

NOTE

Output control signal TM_CTRL_DQ

- If TM_CTRL_DQ = 1, the technology function takes over the control and generates pulse sequences at the output PWM DQA.
- If TM_CTRL_DQ = 0, the user program takes over the control and the user can directly set the output PWM DQA via the control bit SET_DQA.

Canceling the output sequence

Deactivating the software enable (SW_ENABLE = 1 → 0) during the frequency output cancels the current output sequence. The last period duration is not completed. STS_ENABLE and the digital output PWM DQA are immediately reset to 0.

A renewed pulse output is only possible after a restart of the output sequence.

Setting and changing the output value (frequency)

You set the frequency with the OUTPUT_VALUE directly with the control program in the control interface. The value is specified in the real format and the unit is always "Hz". The possible range depends on the parameter "High-speed output (0.1 A)" as follows:

- High-speed pulse output deactivated
 - Frequency (OUTPUT_VALUE) 0.1 Hz to 10 000 Hz
- High-speed pulse output activated
 - Frequency (OUTPUT_VALUE) 0.1 Hz to 100 000 Hz
- Standard output (100 Hz output)
 - Frequency (OUTPUT_VALUE) 0.1 Hz to 100 Hz

The new frequency is applied at the start of the next period. The new frequency has no impact on the falling edge or the pulse-cycle ratio. However, the application can take up to 10 s depending on the previously set frequency.

Accuracy of the output frequency

The configured output frequency is output with a frequency-dependent accuracy at the digital output PWM DQA. You can find an overview of the accuracy as a function of the frequency used in the section Interconnection overview of the outputs ([Page 105](#)).

Parameters of the frequency output mode

Category	Parameter	Meaning	Value range	Default
Reaction to CPU STOP	Reaction to CPU STOP	The parameter "Output substitute value" generates a substitute value upon CPU STOP, which you can define with the parameter "Substitute value for pulse output (DQA)".	Output substitute value	Output substitute value
		The parameter "Continue" still generates the frequency output signal upon CPU STOP, which was generated before the CPU STOP.	Continue	
	Substitute value for pulse output (DQA)	If you have set the option "Output substitute value" for "Reaction to CPU STOP", the parameter "Substitute value for pulse output (DQA)" defines the substitute value to be used for the pulse output of the channel. If you have set the option "Continue" for "Reaction to CPU STOP", the parameter "Substitute value for pulse output (DQA)" cannot be selected.	0 (use substitute value 0)	0
			1 (use substitute value 1)	
Diagnostics interrupt	No supply voltage L+	The parameter "Missing supply voltage L+" activates the diagnostic interrupt of the channel in the case of no supply voltage L+	Deactivated	Deactivated
			Activated	

Category	Parameter	Meaning	Value range	Default
Parameter	High-speed output (0.1 A)	The "High-speed output (0.1 A)" parameter is used to specify whether you want to use the selected pulse output as high-speed output. The requirement for this is that the selected pulse output supports operation as high-speed output.	Deactivated The output supports frequencies of up to 10 kHz (load dependent) and currents of up to 0.5 A or frequencies of up to 100 Hz and currents of up to 0.5 A depending on the performance capability of the selected output.	Deactivated
			Activated The output supports frequencies of up to 100 kHz and currents of up to 0.1 A.	
	Output format	Defines the value for the frequency output in the field "OUTPUT_VALUE" of the control interface of the channel.	1 Hz Interprets the value of the frequency output in the field "OUTPUT_VALUE" as frequency with the unit Hz.	1 Hz
Hardware inputs/ outputs	Pulse output (DQA)	The parameter "Pulse output (DQA)" is used to define the hardware output that you want to use as pulse output channel.	For B: X11, terminal 21 (DQ0 / %Q4.0): 10 kHz / 0.5 A or 100 kHz / 0.1 A	Hardware output with the least significant address
			For B: X11, terminal 31 (DQ8 / %Q5.0): 100 Hz / 0.5 A	

Output signals for frequency output mode

Output signal	Meaning	Value range
Continuous pulse current at the digital output PWM DQA	A pulse for the assigned frequency is output at the digital output PWM DQA.	Continuous pulse current

4.2.1.3 Operating mode: PTO

The PTO (Pulse Train Output) mode can be used to output position information. This allows you to, for example, control stepper motor drives or simulate an incremental encoder. The frequency of the pulses represents the speed, while the number of pulses represents the distance. The direction can also be specified by using two signals per channel. You can use a PTO channel for setpoint output (drive) for an axis technology object.

PTO mode is divided into the following four signal types:

- PTO (pulse (A) and direction (B)): If you select the PTO signal type (pulse (A) and direction (B)), an output (A) controls the pulses and an output (B) controls the direction. B is 'High' (active) when pulses are generated in a negative direction. B is 'Low' (inactive) when pulses are generated in a positive direction.

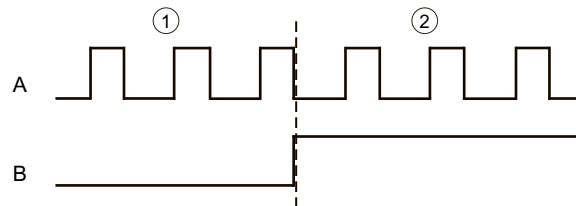

- ① Positive direction of rotation
- ② Negative direction of rotation

- PTO (Count up (A) and Count down (B)): When you select the PTO signal type (count up (A) and count down (B)), an output (A) outputs pulses for positive directions and another output (B) outputs pulses for negative directions.

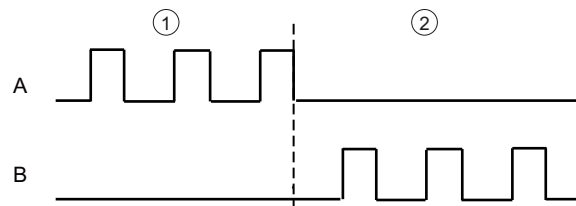

- ① Positive direction of rotation
- ② Negative direction of rotation

- PTO (A, B phase-shifted): When you select the PTO signal type (A, B phase-shifted), the two outputs pulses with the specified velocity, but phase-shifted by 90 degrees. This is a 1x combination in which the pulse shows the duration between two positive transitions of A. In this case, the direction is determined based on the output which first changes from 0 to 1. With positive direction, A precedes B. With negative direction B precedes A.

The number of generated pulses is based on the number of 0-to-1 transitions from phase A. The phase ratio determines the direction of motion:

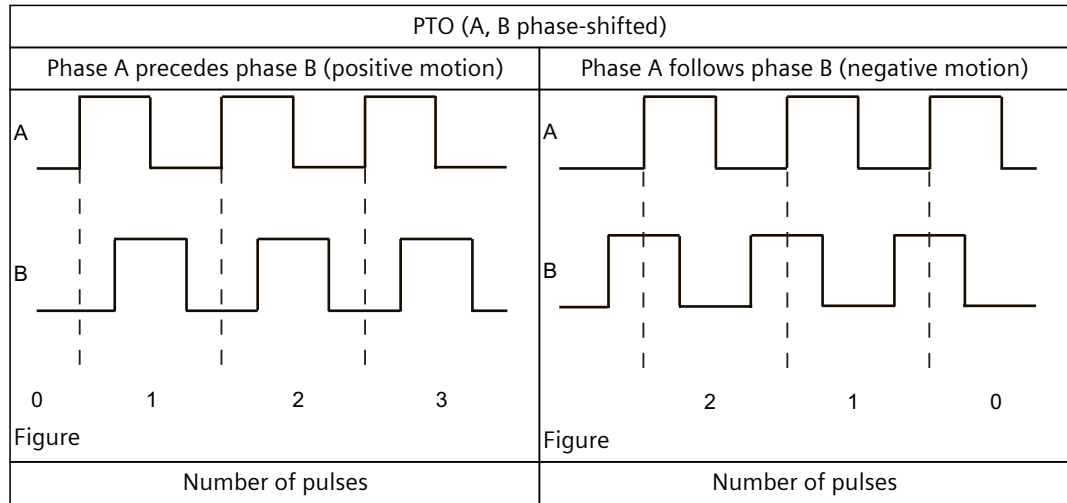

- PTO (A, B phase-shifted - quadruple): When you select the PTO signal type (A, B phase-shifted, quadruple), the two outputs transmit pulses with the specified velocity, but phase-shifted by 90 degrees. The quadruple signal type is a 4x configuration in which each edge transition corresponds to an increment. Therefore, a full period of the signal A contains four increments. In this way, two outputs, each with 100 kHz signal frequency, can be used to output a control signal that supplies 400 000 increments per second. The direction is determined based on the output which first changes from 0 to 1. With positive direction, A precedes B. With negative direction B precedes A.

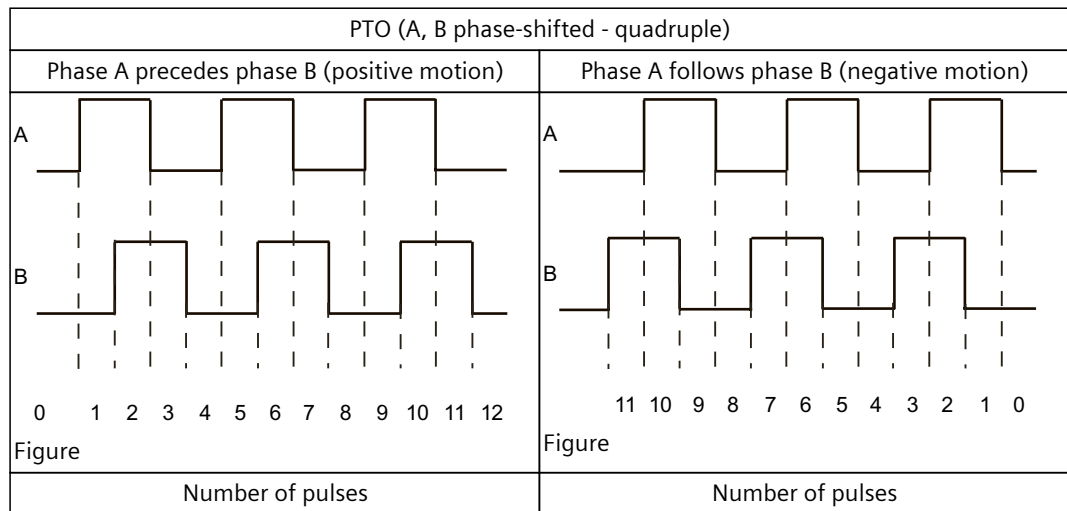

Parameters of PTO mode

Category	Parameter	Meaning	Value range	Default
Diagnostics interrupt	No supply voltage L+	With the parameter "Missing supply voltage L+", you activate the diagnostic interrupt of the channel in the event of no supply voltage L+.	Deactivated	Deactivated
			Activated	
Data exchange with the drive	Reference speed	With the parameter "Reference speed", you define the reference value for the drive velocity. The drive velocity is defined as percentage value of the reference speed in the range from -200% to +200%.	Floating-point number: 1.0 to 20 000.0 (rpm)	3 000.0 (rpm)
	Maximum speed	The parameter "Maximum speed" is used to define the required maximum speed for your application.	The supported value range depends on: <ul style="list-style-type: none"> the signal type selected under "Operating mode" the value defined under "Increments per revolution" the value defined under "Reference speed" The low limit of the value range is: <ul style="list-style-type: none"> for the signal type "PTO (A, B phase-shifted - quadruple)": $0.1 \text{ Hz} * 60 \text{ s/min} * 4 / \text{Increments per revolution}$ for the non-quadruple PTO signal types: $(0.1 \text{ Hz} * 60 \text{ s/min}) / \text{increments per revolution}$ The high limit of the value range is the minimum of the value: <ul style="list-style-type: none"> $2 * \text{reference speed}$ and of the value: <ul style="list-style-type: none"> for the signal type "PTO (A, B phase-shifted - quadruple)": $(100\,000 \text{ Hz} * 60 \text{ s/min} * 4) / \text{increments per revolution}$ for the non-quadruple PTO signal types: $(100\,000 \text{ Hz} * 60 \text{ s/min}) / \text{increments per revolution}$ 	3 000.0 (rpm)
	Increments per revolution	The "Increments per revolution" is used to define the number of increments per revolution (also in microstep mode), which is required by the drive for a revolution.	1 to 1 000 000	200

Category	Parameter	Meaning	Value range	Default
Fine resolution	Bits in incr. actual value (G1_XIST1)	The parameter defines the number of bits for the coding of the fine resolution in the current incremental value of G1_XIST1.	0	0
Stop behavior	Quick stop time	The parameter "Quick stop time" defines the time period within which the drive should go from the maximum speed to a standstill (OFF3).	1 to 65 535 (ms)	1 000 (ms)
Hardware inputs/ outputs	Reference switch input	The parameter "Reference switch input" defines the hardware input of the reference switch.	[Input address of the reference switch DI]	--
	Edge selection reference switch	The parameter "Edge selection reference switch" defines the edge type which is to be detected by the reference switch.	Rising edge	Rising edge
			Falling edge	
	Measuring input	The parameter "Measuring input" defines the hardware input of the measuring input.	[Input address of the measuring input DI]	--
	"Drive ready" input	The parameter ""Drive ready" input" defines the hardware input of the input "Drive ready".	[Input addresses of the inputs "Drive ready" DI _n]	--
	Pulse output A for "PTO (pulse (A) and direction B)"	The parameter "Pulse output A" defines the hardware output for PTO signal A.	[Output address DQ for PTO signal A (output frequency 100 kHz)]	Grayed out Read only access to the parameter
	Direction output B for "PTO (pulse (A) and direction B)"	The parameter "Direction output B" defines the hardware output for PTO signal B.	[Output address 1 of the DQ for PTO signal B (output frequency 100 kHz)]	Qn (output frequency 100 kHz)
			[Output address 2 of the DQ for PTO signal B (output frequency 100 kHz)]	
	Count up for "PTO (Count up (A) and Count down (B))"	The "Clock generator forward (A)" parameter defines the hardware output for PTO signal A.	[Output address DQ for PTO signal A (output frequency 100 kHz)]	Grayed out Read only access to the parameter
Count down for "PTO (Count up (A) and Count down (B))"	The "Clock generator backward (B)" parameter defines the hardware output for PTO signal B.	[Output address 1 of the DQ for PTO signal B (output frequency 100 kHz)]	Grayed out Read only access to the parameter	

Category	Parameter	Meaning	Value range	Default
Hardware inputs/ outputs	Phase A for "PTO (A, B phase-shifted)" and "PTO (A, B phase-shifted, quadruple)"	The "Clock generator output (A)" parameter defines the hardware output for PTO signal A.	[Output address of the DQ for PTO signal A (output frequency 100 kHz)]	Grayed out Read only access to the parameter
	Phase B for "PTO (A, B phase-shifted)" and "PTO (A, B phase-shifted, quadruple)"	The "Clock generator output (B)" parameter defines the hardware output for PTO signal B.	[Output address 1 of the DQ for PTO signal B (output frequency 100 kHz)]	Grayed out Read only access to the parameter
	Drive enable output	The parameter "Drive enable output" defines the hardware output of the output "Drive enable output".	[Output addresses of the enable outputs DQn (output frequency 100 Hz)]	--

 **WARNING**

Digital input as a measuring input

If you configure a digital input as a measuring input, the value which the digital input returns via the input data of the "DI 16/DQ 16" is not reliable. If you configure a hardware interrupt on this input it can trigger sporadically without a rising or falling edge actually existing.

Reaction of the PTO channel to CPU STOP

The PTO channel reacts to a change to CPU STOP by removing the drive enable (if the drive enable output is configured) and outputting the velocity setpoint 0 at the hardware outputs configured for the signal tracks A and B. The CPU STOP reaction of the PTO channels cannot be configured.

NOTE

Reaction to CPU STOP

Upon CPU STOP, the hardware outputs assigned for the PTO outputs A and B can switch to signal state 'High' (1) and/or remain there. It is not guaranteed that the two hardware outputs switch to/remain in signal level 'Low' (0).

Controller

The pulse output channels for the four modes of the pulse generators (PTO) are controlled using Motion Control via the technology objects TO_SpeedAxis, TO_PositioningAxis and TO_SynchronousAxis. With these operating modes, the control and feedback interface of the channels is a partial implementation of the PROFIdrive interface "Telegram 3". For a detailed description of the use of motion control and its configuration, refer to the S7-1500/S7-1500T Motion Control Function Manual

(<https://support.industry.siemens.com/cs/ww/en/view/109766459>) and the STEP 7 online help.

4.2.2 Functions

4.2.2.1 Function: High-speed output

The function "High-speed output (0.1 A)" improves the signal clock of the digital outputs (DQ0 to DQ7). Less delay, fluctuation, jitter, and shorter rise and fall times occur at the switching edges.

The function "High-speed output (0.1 A)" is suitable for generating pulse signals in a more precise clock, but provides a lower maximum load current.

For the PWM and Frequency output modes, select the high-speed output of the channel in STEP 7 (TIA Portal). You can also change the parameter assignment during runtime with the help of the program via the data record.

High-speed pulse output (high-speed output) is available for the following operating modes:

- PWM
- Frequency output
- PTO (the pulse outputs for the PTO mode are always "High-speed output (0.1 A)")

High-speed output

	Minimum		Maximum	
	High-speed output deactivated	High-speed output activated	High-speed output deactivated	High-speed output activated
Pulse duration	20 μs with load > 0.1 A ¹⁾ 40 μs with load \geq 2 mA ¹⁾	2 μs ¹⁾	10 000 000 μs (10 s)	
Period duration	100 μs ²⁾	10 μs		
Frequency	0.1 Hz		10 kHz ²⁾	100 kHz

¹⁾ A lower value is theoretically possible but, depending on the connected load, the output voltage can no longer be output as complete rectangular pulse

²⁾ Load-dependent

4.2.2.2 Function: Direct control of the pulse output (DQA)

Direct control of the pulse output (DQA)

In the modes "Pulse width modulation PWM" and "Frequency output", you can set the pulse output (DQA) of a pulse generator directly via the control program. Select the function for the DQ direct control by deleting the output control bit of the PWM channel (TM_CTRL_DQ = 0) in the control interface.

The direct control of the pulse output (DQA) can be helpful when commissioning a control system for automation.

When you select the direct control of the pulse output (DQA) during a pulse output sequence, the sequence continues to run in the background so that the output sequence is continued as soon as the channel takes control again (by setting TM_CTRL_DQ = 1).

You assign the status of the pulse output (DQA) using the control bits SET_DQA.

When you set TM_CTRL_DQ = 1, you deselect the direct control of the pulse output (DQA) and the channel takes over the processing. If the output sequence is still running (STS_ENABLE

still active), the PWM channel takes over the control of the output again. If TM_CTRL_DQ = 1 and STS_ENABLE is not active, the module's channel also takes over processing, but then outputs "0".

NOTE**Output control signal TM_CTRL_DQ of the PWM channel**

- If TM_CTRL_DQ = 1, the technology function takes over the control and generates pulse sequences at the output PWM DQA.
- If TM_CTRL_DQ = 0, the user program takes over the control and the user can set the PWM DQA directly using the control bits SET_DQA.

4.2.3 Configuring the PWM and frequency output modes

4.2.3.1 Assignment of the control interface

The user program influences the behavior of the PWM channel through the control interface.

Control interface per channel

The following table shows the control interface assignment:

Table 4-5 Assignment of the control interface

	7	6	5	4	3	2	1	0
Byte 0	OUTPUT_VALUE PWM: On-load factor * (Int) In PWM mode, the on-load factor uses only the two least significant bytes (byte 2 and byte 3). Frequency output: Frequency in Hz (Real)							
Byte 1								
Byte 2								
Byte 3								
Byte 4	SLOT							
Byte 5								
Byte 6								
Byte 7								
Byte 8	Reserved = 0			MODE_SLOT	LD_SLOT			
					Specifies the meaning of the value under SLOT			
					0000: No action			
					0001: Period duration (PWM)			
					0010 to 1111: Reserved			
Byte 9	Reserved = 0		Reserved = 0	Reserved = 0	SET_DQA	Reserved = 0	TM_CTRL_DQ	SW_ENABLE
Byte 10	Reserved = 0							RES_ERROR
Byte 11	Reserved = 0							

* The terms "On-load factor", "Pulse duty factor" and "Duty factor" can be used synonymously

Use case

1. Transfer the control for the output to the PWM channel.
2. Set SW_ENABLE so that the output can be started.
3. Set the required on-load factor using OUTPUT_VALUE.
4. If necessary, change the period duration (cyclically or once). If you do not change the value, the period duration from the hardware configuration will be used.
5. With TM_CTRL_DQ and SET_DQ, set the output from the user program permanently to 1 or 0.
6. Acknowledge any errors that occur using RES_ERROR.

Additional parameters for the output sequence are defined before the start of an output sequence.

The data record of the parameter assignment is changed in the device configuration in STEP 7 (TIA Portal) or through WRREC execution.

Control interface parameters

OUTPUT_VALUE

The interpretation of the value OUTPUT_VALUE depends on the set operating mode. OUTPUT_VALUE is always updated. When an invalid value is detected (outside the permissible range), the error memory bit ERR_OUT_VAL is set until a valid value is detected. During the error condition, the invalid value is ignored and the PWM channel continues with the last valid OUTPUT_VALUE. Note that, in the frequency output mode, it is also possible that no last valid value is available. In this case, the pulse output returns the value 0, i.e. there is no pulse output.

Please note that the on-load factor is not checked in PWM mode. If the on-load factor is greater than the format permits, the PWM channel uses a ratio of 100%. For values < 0, 0% is effective.

SLOT, MODE_SLOT and LD_SLOT

Use these control interface fields if you occasionally change the period duration in PWM mode before the start of the output sequence or during operation. You can find a description of the interaction between SLOT, MODE_SLOT and LD_SLOT under Handling the SLOT parameter (control interface) [\(Page 69\)](#).

SW_ENABLE

If 0 → 1, activate the output sequence.

TM_CTRL_DQ

- If 1, the output is controlled by the PWM channel and generates the pulse sequences
- If 0, the output is controlled directly by the program using the SET_DQA assignments

SET_DQA

- If 1, set the output A to 1, if TM_CTRL_DQ is inactive
- If 0, set the output A to 0, if TM_CTRL_DQ is inactive

RES_ERROR

Resetting the error bit memory ERR_LD in the feedback interface

4.2.3.2 Handling the SLOT parameter (control interface)

SLOT and MODE_SLOT

SLOT has the following operating modes.

- **Mode for individual update (MODE_SLOT = 0)**

Use this mode if you occasionally change the specific parameters (such as period duration) before the start of the output sequence or during operation.

 - The value in SLOT is always applied when the value changes in LD_SLOT.
 - The acknowledgment bit STS_LD_SLOT in the feedback interface is switched.
 - The value of LD_SLOT defines the interpretation of SLOT (see the table below "Interpretation of the SLOT parameter value").
 - If the LD_SLOT value is invalid, the setting of the feedback bit ERR_LD indicates a parameter assignment error. The user has to reset the error using the control bit RES_ERROR and enable the SLOT parameter again for the next value.
 - Changes made in this mode can be read back by the channel to the parameter assignment data record.
 - The current changes are entered in the data record 128 during readback of the parameter assignment data from the user program with RDREC. These changes are lost during a warm restart of the CPU.
- **Mode for cyclic updating (MODE_SLOT = 1)**

Use this operating mode if the program is to continuously control another parameter in addition to the main parameter to be controlled.

 - The value in SLOT is transferred with each module cycle.
 - No acknowledgment bit is available.
 - The value of LD_SLOT defines the interpretation of SLOT (see the table below "Interpretation of the SLOT parameter value").
 - If the value in SLOT is not valid, the error ERR_SLOT_VAL occurs. The error is automatically reset as soon as a valid value is loaded.
 - In this mode, the value in the parameter assignment data record is not updated. If LD_SLOT is changed in this mode, the last value applied from LD_SLOT is valid.
 - The mode for permanent updating can be stopped by setting LD_SLOT to 0 and MODE_SLOT to 0. By stopping the mode for permanent updating, the changes made at the parameters during permanent updating are retained until the next changes via SLOT (cyclic or once) or until the next STOP-RUN transition.

Interpretation of the SLOT parameter value

The value written in the SLOT parameter is interpreted depending on the LD_SLOT value and the mode as shown in the table below.

LD_SLOT	Meaning of SLOT value	Valid modes for using the SLOT value	SLOT data type
0	No action / idling	All operating modes	
1	Period duration	PWM	UDInt Permissible value range*: Minimum value: 10 μ s, 100 μ s or 10 000 μ s (10 ms) Maximum value: 10 000 000 μ s (10 s)

* The permissible value range depends on the selected hardware output and sometimes on the high-speed mode (high-speed/standard).

Individual updating of the parameter 'Period duration'

The following representation illustrates the sequence of the individual updating of the parameter 'Period duration'. The described workflow principle can also be used on the channels of the high-speed counters.

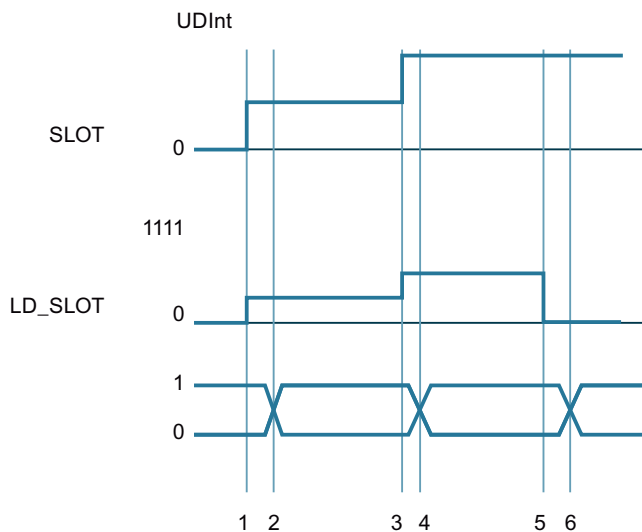

- ① User writes the first parameter in SLOT and specifies the first parameter in LD_SLOT
- ② Technology channel applies the first parameter and indicates the application with a change in the bit STS_LD_SLOT
- ③ User writes the second parameter in SLOT and specifies the second parameter in LD_SLOT
- ④ Technology channel applies the second parameter and indicates the application with a change in the bit STS_LD_SLOT
- ⑤ User writes 0 in LD_SLOT, (SLOT inactive)
- ⑥ Technology channel answers change in LD_SLOT with a change in STS_LD_SLOT

Figure 4-4 Individual updating

Note that the following requirements apply to the representation shown above:

- The value `MODE_SLOT` must be set to 0
- Errors or invalid values are shown in the feedback bit `ERR_SLOT_VAL`
- The error must be acknowledged

If `MODE_SLOT = 1`, the following applies (for PWM mode only):

- The value in `SLOT` is continuously evaluated according to `LD_SLOT`
- `STS_LD_SLOT` does not change
- An error is automatically reset as soon as a valid value is set in `SLOT`

Cyclic updating of the parameter 'Period duration'

The following representation illustrates the sequence of the cyclic updating of the parameter 'Period duration'. The described workflow principle can also be used on the channels of the high-speed counters.

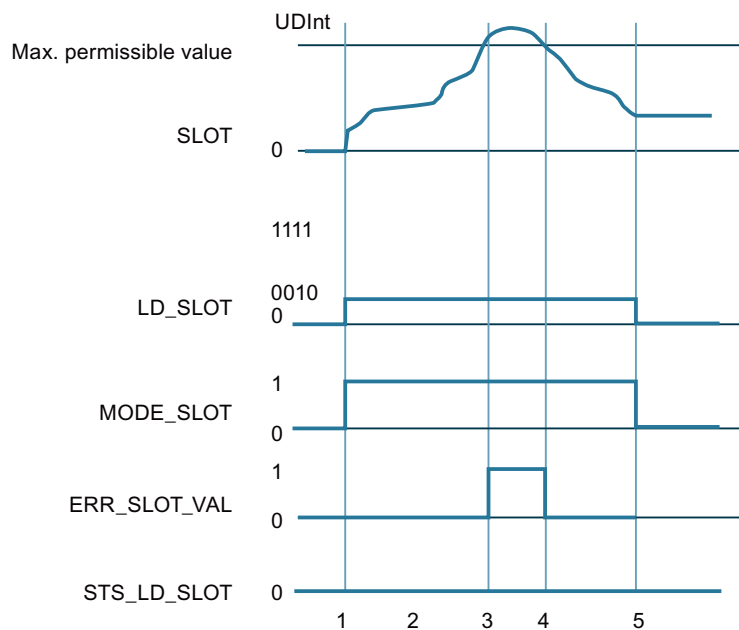

- ①
 - User sets `SLOT` to the required parameter
 - User sets `MODE_SLOT` to 1
 - User sets `LD_SLOT` to the required value (1 for period duration)
- ② User changes value in `SLOT` continuously and technology channel evaluates continuously
- ③ Value in `SLOT` exceeds permitted limit, technology channel shows this `ERR_SLOT_VAL` and continues working with the last valid value
- ④ Value in `SLOT` again in permitted range, technology channel resets `ERR_SLOT_VAL` independently and continues working with the value in `SLOT`
- ⑤ User resets `LD_SLOT` and `MODE_SLOT`, technology channel continues to work with last value

Figure 4-5 Cyclic updating

4.2.3.3 Assignment of the feedback interface

The user program receives current values and status information from the pulse width modulation via the feedback interface.

Feedback interface per channel

The following table shows the feedback interface assignment:

Table 4-6 Assignment of the feedback interface

	7	6	5	4	3	2	1	0
Byte 0	ERR_SLOT_V- AL The valid in SLOT is inval- id	ERR_OUT_V- AL The value in OUTPUT_VA- LUE is invalid	Reserved = 0	Reserved = 0	ERR_PULSE	ERR_LD Error during loading via control inter- face	Reserved = 0	ERR_PWR missing supply voltage L+
Byte 1	Reserved = 0		STS_SW_EN- ABLE SW_ENABLE detected or feedback status SW_ENABLE	STS_READY Channel parameters assigned and ready	Reserved = 0	STS_LD_SLOT Load prompt detected and executed for slot (tog- gling)	Reserved = 0	
Byte 2	Reserved = 0			Reserved = 0	Reserved = 0	Reserved = 0	STS_DQA	STS_ENABL- E
Byte 3	Reserved = 0				Reserved = 0			

Feedback parameters

Table 4-7 Status feedback

Feedback parameters	Meaning	Value range
STS_READY	The channel is correctly configured, is operating and supplying valid data.	0: Not ready to run 1: Ready to run
STS_SW_ENABLE	Current status of the software enable	0: SW_ENABLE is not active 1: SW_ENABLE detected
STS_LD_SLOT	Acknowledgment bit for each action of the SLOT in the SLOT mode for individual updating (for a description of the acknowledgment bit, refer to the section Handling the SLOT parameter (control interface) (Page 69)).	Each switching of this bit represents a successful LD_SLOT action.
STS_ENABLE	The output sequence is active. (STS_ENABLE always depends on the status of the software enable STS_SW_ENABLE)	0: No output sequence running 1: Output sequence running
STS_DQA	State of the pulse output (DQA)	0: Pulse output is not active 1: Pulse output is active

Feedback parameters	Meaning	Value range
ERR_PWR	No supply voltage L+	0: No error 1: Error
ERR_LD	Error during loading of a parameter value in the operating mode for individual updating	0: No error 1: Error
ERR_OUT_VAL	The value in OUTPUT_VALUE is invalid	0: No error 1: Error
ERR_SLOT_VAL	The value in SLOT is invalid, where MODE_SLOT = 1 (permanent updating)	0: No error 1: Error

Wiring

5.1 Supply voltage

24 V DC supply voltage (X80)

The connecting plug for the supply voltage is plugged in when the CPU ships from the factory.

The following table shows the signal names and the descriptions of the pin assignment of the 24 V DC supply voltage.

Table 5-1 Pin assignment 24 V DC supply voltage

View	Signal name ¹⁾		Description
Connector			
	1	1L+	+ 24 V DC of the supply voltage
	2	1M	Ground of the supply voltage
	3	2M	Ground of the supply voltage for loop-through ²⁾
	4	2L+	+ 24 V DC of the supply voltage for loop-through ²⁾

¹⁾ 1L+ and 2L+ as well as 1M and 2M are bridged internally

²⁾ Maximum 10 A permitted

If the CPU is supplied by a system power supply, it is not necessary to connect the 24 V supply.

5.2 PROFINET interfaces

PROFINET interface X1 with 2-port switch (X1 P1R and X1 P2R)

The assignment corresponds to the Ethernet standard for an RJ45 plug.

- When autonegotiation is deactivated, the RJ45 socket is allocated as a switch (MDI-X).
- When autonegotiation is activated, autocrossing is in effect and the RJ45 socket is allocated either as data terminal equipment (MDI) or a switch (MDI-X).

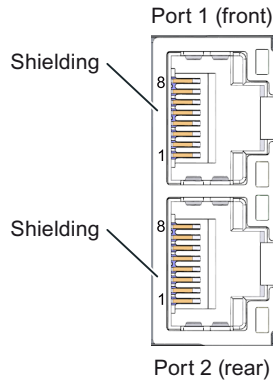

Figure 5-1 PROFINET ports

NOTE

You need a screwdriver (max. blade width 2.5 mm) to remove the PROFINET plug.

Remove display

You can find a description of how to remove and replace the display in the S7-1500, ET 200MP (<http://support.automation.siemens.com/WW/view/en/59191792>) System Manual.

Reference

For more information on "Wiring the CPU" and "Accessories/spare parts", refer to the S7-1500, ET 200MP System Manual (<http://support.automation.siemens.com/WW/view/en/59191792>).

Assignment of the MAC addresses

The CPU 1511C-1 PN has a PROFINET interface with two ports. The PROFINET interface itself has a MAC address, and each of the two PROFINET ports has its own MAC address. The CPU 1511C-1 PN therefore has three MAC addresses in total.

The MAC addresses of the PROFINET ports are needed for the LLDP protocol, for example for the neighborhood discovery function.

The number range of the MAC addresses is continuous. The first and last MAC address are lasered on the rating plate on the right side of each CPU 1511C-1 PN.

The table below shows how the MAC addresses are assigned.

Table 5-2 Assignment of the MAC addresses

	Assignment	Labeling
MAC address 1	PROFINET interface X1 (visible in STEP 7 for accessible devices)	<ul style="list-style-type: none"> • Front, lasered • Right side, lasered (start of number range)
MAC address 2	Port X1 P1R (required for LLDP, for example)	<ul style="list-style-type: none"> • Front and right side, not lasered
MAC address 3	Port X1 P2R (required for LLDP, for example)	<ul style="list-style-type: none"> • Front, not lasered • Right side, lasered (end of number range)

5.3 Terminal and block diagrams

5.3.1 Block diagram of the CPU part

Block diagram

The following figure shows the block diagram of the CPU part.

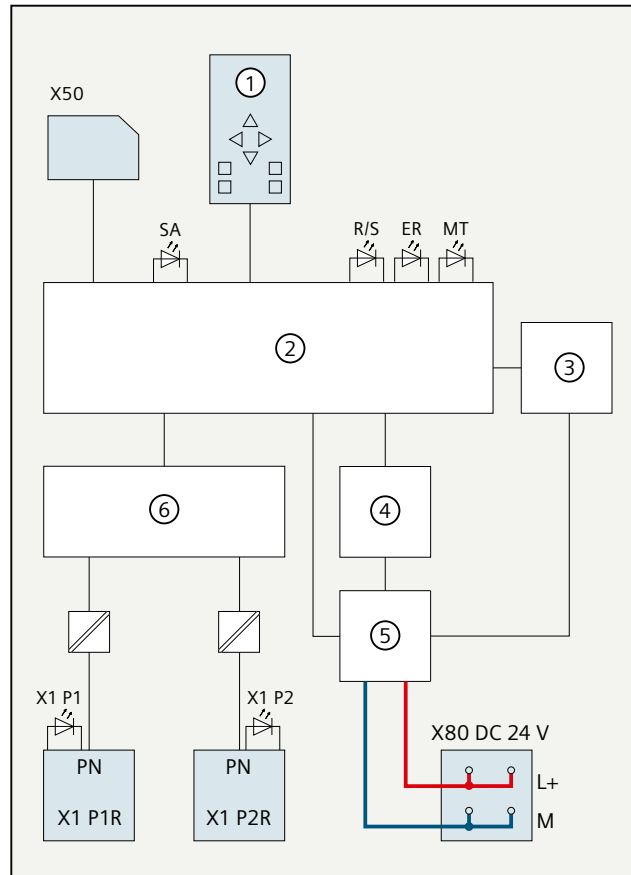

①	CPU with control and operating mode buttons	PN X1 P2R	PROFINET interface X1 port 2
②	Electronics	L+	24 V DC supply voltage
③	Interface to on-board I/O	M	Ground
④	Backplane bus interface	SF	STOP ACTIVE LED (yellow)
⑤	Internal supply voltage	R/S	RUN/STOP LED (yellow/green)
⑥	2-port switch	ER	ERROR LED (red)
X50	SIMATIC Memory Card	MT	MAINT LED (yellow)
X80 24 V DC	Infeed of supply voltage	X1 P1, X1 P2	Link TX/RX LED
PN X1 P1R	PROFINET interface X1 port 1		

Figure 5-2 Block diagram of the CPU part

5.3.2 Terminal and block diagram of the analog on-board I/O

This section contains the block diagram of the analog on-board I/O (X10) and various wiring options.

For information on wiring the front connector, establishing the cable shield, etc., refer to the S7-1500, ET 200MP (<http://support.automation.siemens.com/WW/view/en/59191792>) system manual.

NOTE

You can use and combine the different wiring options for all channels. Note, however, that unneeded terminals of an analog input channel must not be connected.

Definition

U_n+/U_n-	Voltage input channel n (voltage only)
M_n+/M_n-	Measuring input channel n (only resistance-type transmitters or thermal resistors (RTD))
I_n+/I_n-	Current input channel n (current only)
$I_{c,n}+/I_{c,n}-$	Current output for RTD, channel n
QV_n	Voltage output channel
QI_n	Current output channel
M_{ANA}	Reference potential of the analog circuit
CHX	Channel or display of the channel status

Infeed element

The infeed element is inserted on the front connector and serves to shield the analog on-board I/O.

NOTE

The analog on-board I/O does not require power to be supplied by the infeed element. The infeed element is, however, necessary for shielding.

Wiring: Voltage measurement

The following figure shows the terminal assignment for voltage measurement at the channels available for this measurement type (channels 0 to 3).

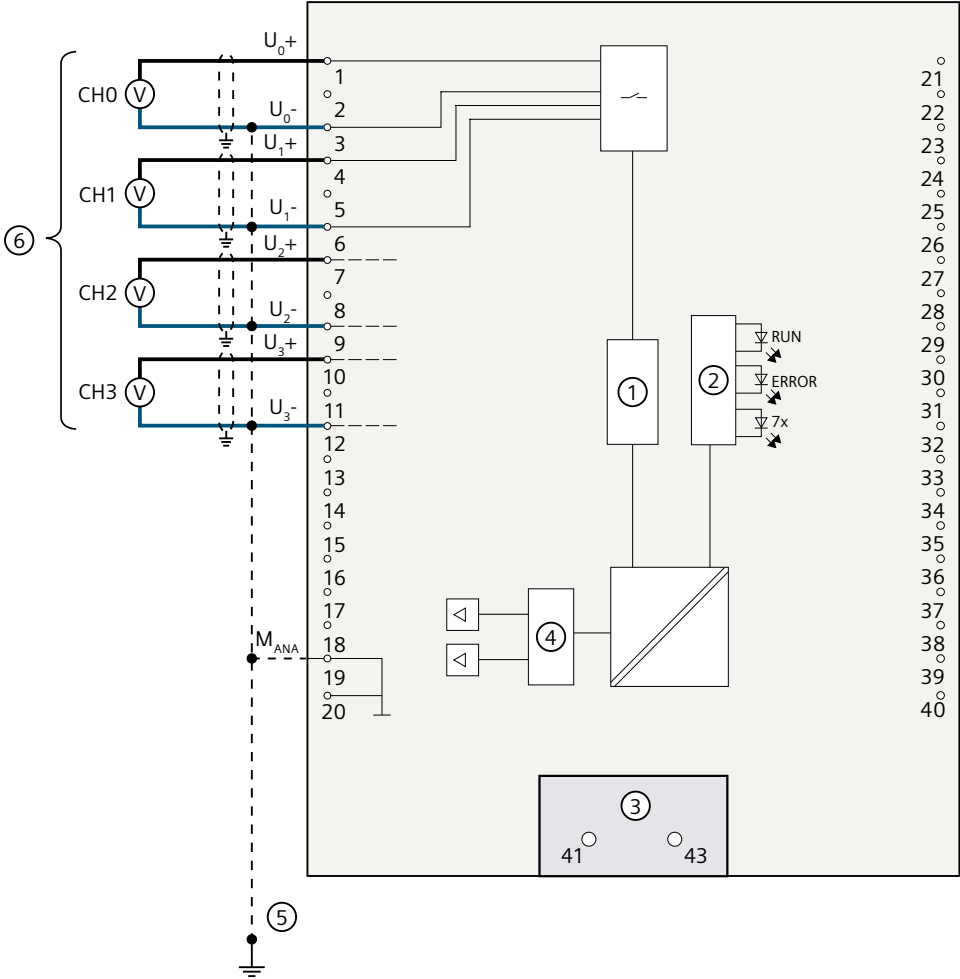

- ① Analog-to-digital converter (ADC)
- ② LED interface
- ③ Infeed element (for shielding only)
- ④ Digital-to-analog converter (DAC)
- ⑤ Equipotential bonding cable (optional)
- ⑥ Voltage measurement

Figure 5-3 Block diagram and terminal assignment for voltage measurement

Wiring: 4-wire measuring transducer for current measurement

The following figure shows the terminal assignment for current measurement with 4-wire measuring transducer at the channels available for this measurement type (channels 0 to 3).

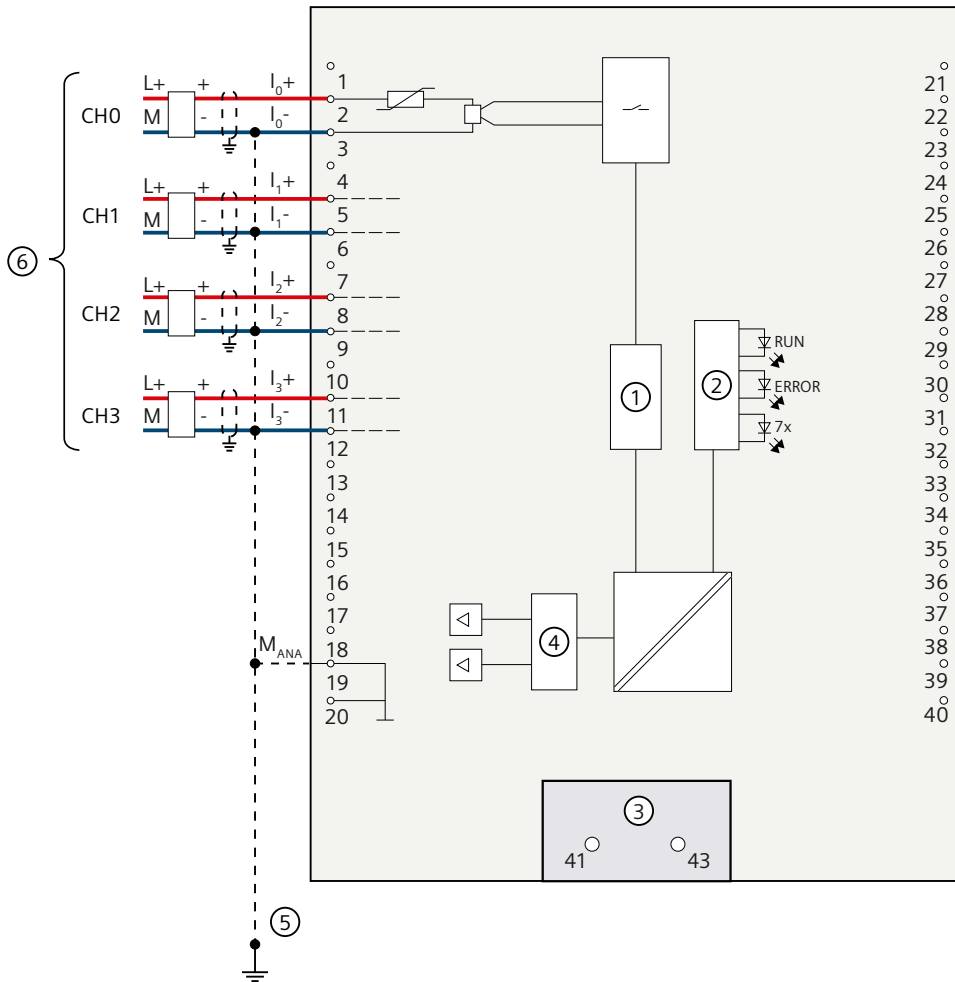

- ① Analog-to-digital converter (ADC)
- ② LED interface
- ③ Infeed element (for shielding only)
- ④ Digital-to-analog converter (DAC)
- ⑤ Equipotential bonding cable (optional)
- ⑥ Connector 4-wire measuring transducer

Figure 5-4 Block diagram and terminal assignment for current measurement with 4-wire measuring transducer

Wiring: 2-wire measuring transducer for current measurement

As an alternative to connecting a 4-wire measuring transducer, you can also connect 2-wire measuring transducers to channels 0 to 3. An external 24 V power supply is required to connect a 2-wire measuring transducer to the analog on-board I/O of the compact CPU. Feed this voltage short-circuit proof to the 2-wire transducer. Use a fuse to protect the power supply unit.

NOTICE

Defective measuring transducer

Note that the analog input of the measuring transducer is not protected against destruction in the event of a defect (short circuit). Take the necessary precautions against such cases.

The figure below shows an example of the connection of a 2-wire measuring transducer to channel 0 (CH0) of the analog on-board I/O.

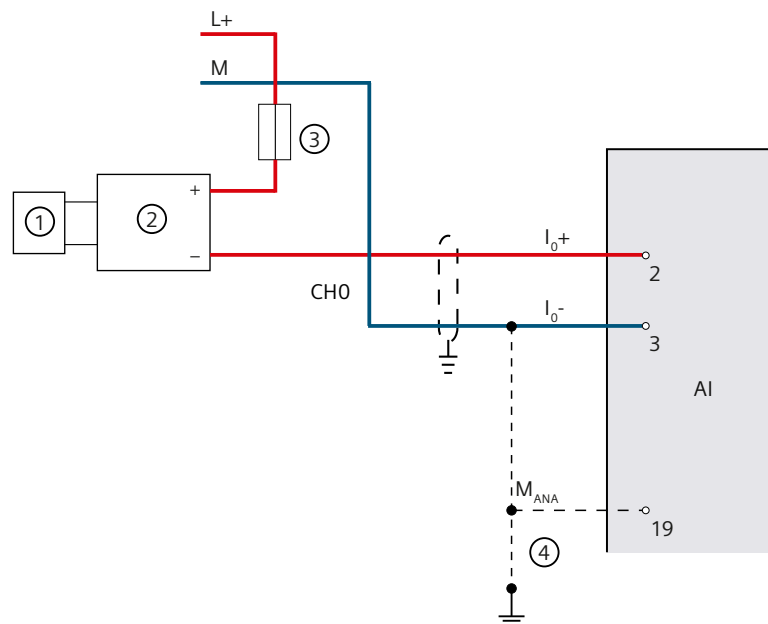

- ① Sensor (e.g. pressure gauge)
- ② 2-wire measuring transducer
- ③ Fuse
- ④ Equipotential bonding cable (optional)

Figure 5-5 2-wire measuring transducer at channel 0

Use the measurement type "Current (4-wire transducer)" and the measuring range 4 to 20 mA for the parameter assignment of the 2-wire measuring transducer in STEP 7 (TIA Portal).

Wiring: 4-wire connection of resistance-type sensors or thermal resistors (RTD)

The following figure shows the terminal assignment for 4-wire connection of resistance-type sensors or thermal resistors at the channel available for this (channel 4).

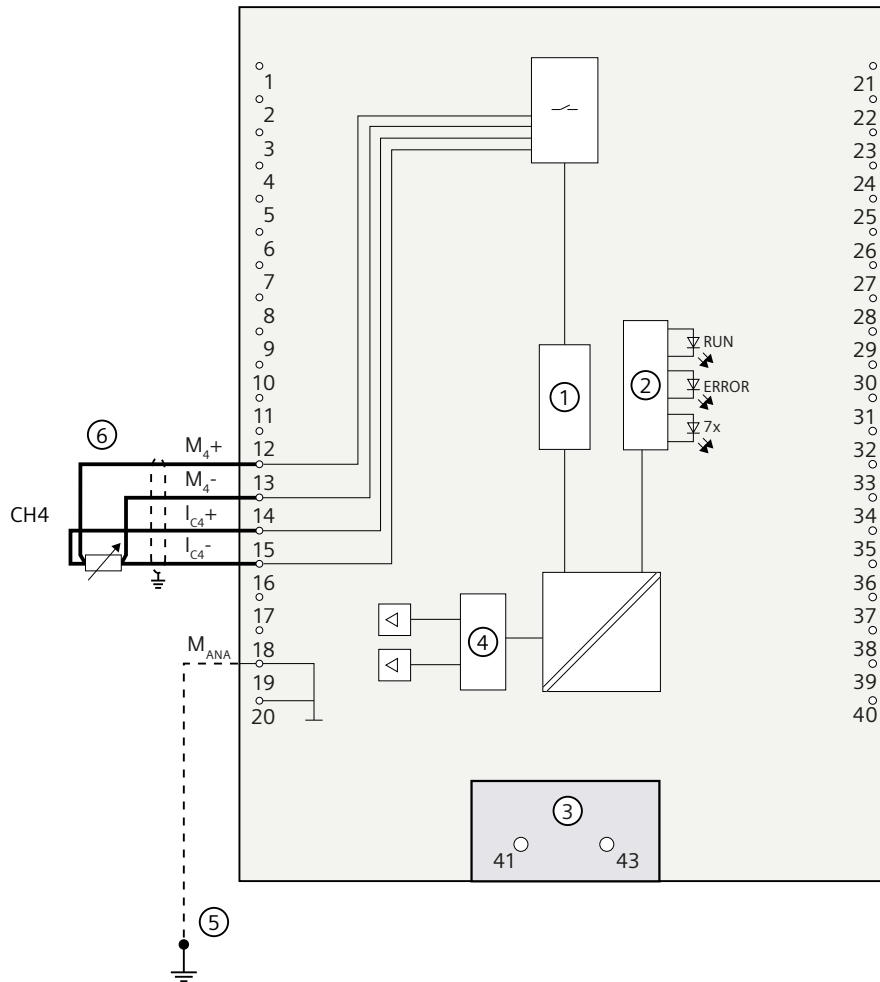

- ① Analog-to-digital converter (ADC)
- ② LED interface
- ③ Infeed element (for shielding only)
- ④ Digital-to-analog converter (DAC)
- ⑤ Equipotential bonding cable (optional)
- ⑥ 4-wire connection

Figure 5-6 Block diagram and terminal assignment for 4-wire connection

Wiring: 3-wire connection of resistance-type sensors or thermal resistors (RTD)

The following figure shows the terminal assignment for 3-wire connection of resistance-type sensors or thermal resistors at the channel available for this (channel 4).

NOTE

3-wire connection

Note that line resistances are not compensated with a 3-wire connection.

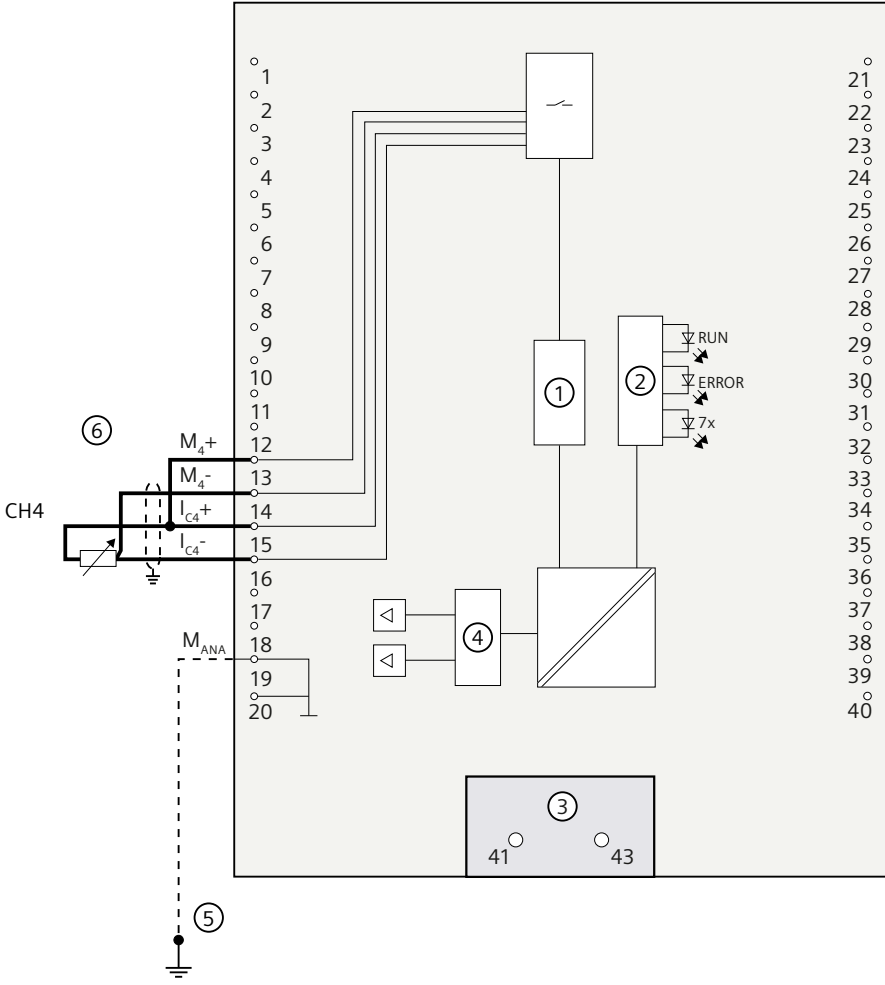

- ① Analog-to-digital converter (ADC)
- ② LED interface
- ③ Infeed element (for shielding only)
- ④ Digital-to-analog converter (DAC)
- ⑤ Equipotential bonding cable (optional)
- ⑥ 3-wire connection

Figure 5-7 Block diagram and terminal assignment for 3-wire connection

Wiring: 2-wire connection of resistance-type sensors or thermal resistors (RTD)

The following figure shows the terminal assignment for 2-wire connection of resistance-type sensors or thermal resistors at the channel available for this (channel 4).

NOTE

2-wire connection

Note that line resistances are not compensated with a 2-wire connection.

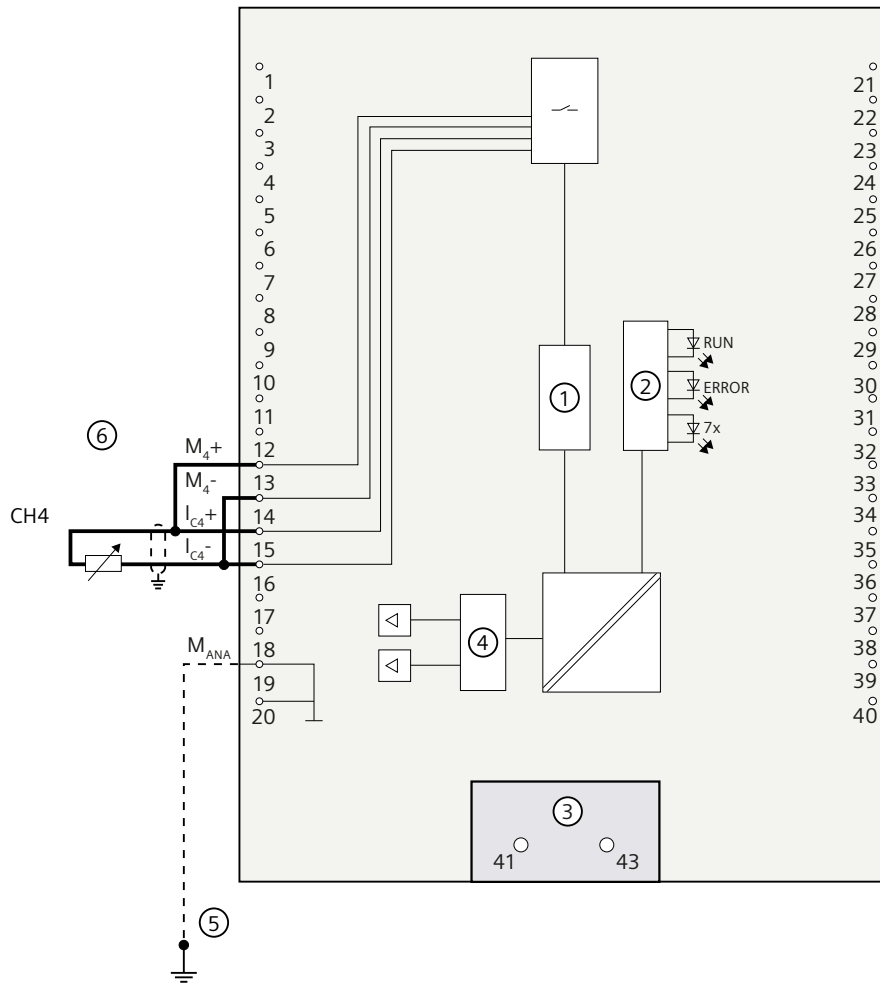

- ① Analog-to-digital converter (ADC)
- ② LED interface
- ③ Infeed element (for shielding only)
- ④ Digital-to-analog converter (DAC)
- ⑤ Equipotential bonding cable (optional)
- ⑥ 2-wire connection

Figure 5-8 Block diagram and terminal assignment for 2-wire connection

Wiring: Voltage output

The figure below shows the terminal assignment for the wiring of the voltage outputs with:

- 2-wire connection without compensation for line resistances.

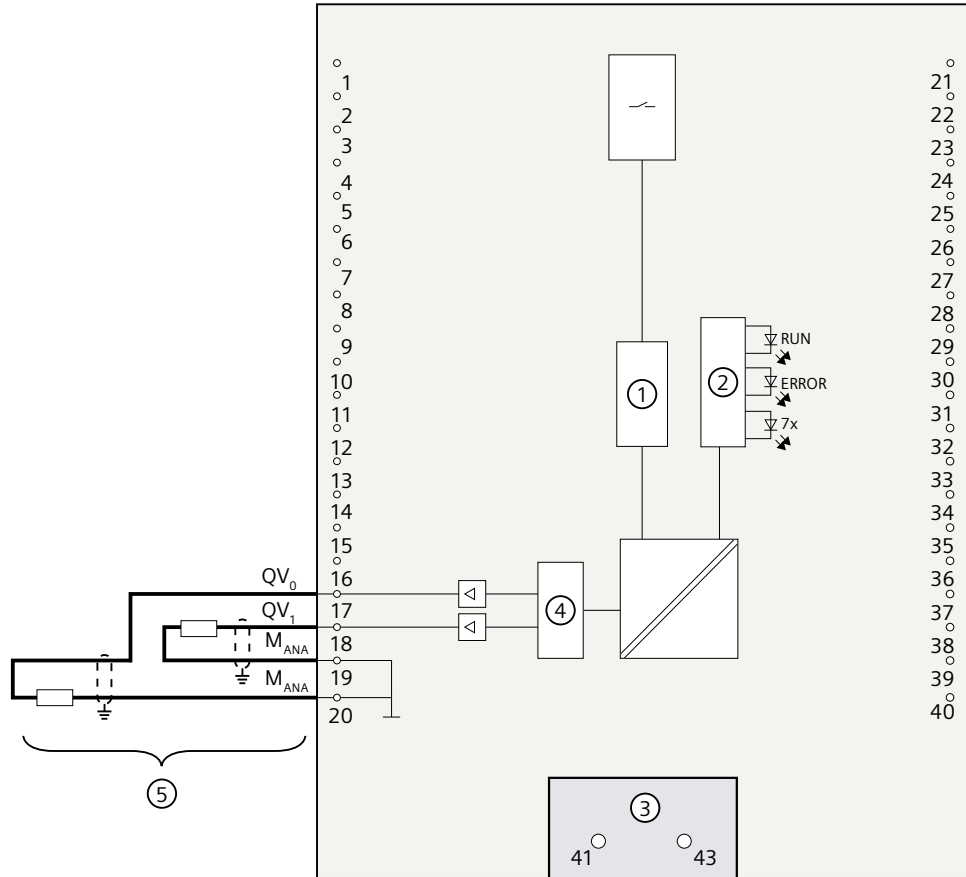

- ① Analog-to-digital converter (ADC)
- ② LED interface
- ③ Infeed element (for shielding only)
- ④ Digital-to-analog converter (DAC)
- ⑤ 2-wire connection CH0 and CH1

Figure 5-9 Block diagram and terminal assignment for voltage output

NOTE

M_{ANA} on terminals 19 and 20 is equivalent.

Wiring: Current output

The following figure shows an example of the terminal assignment for wiring current outputs.

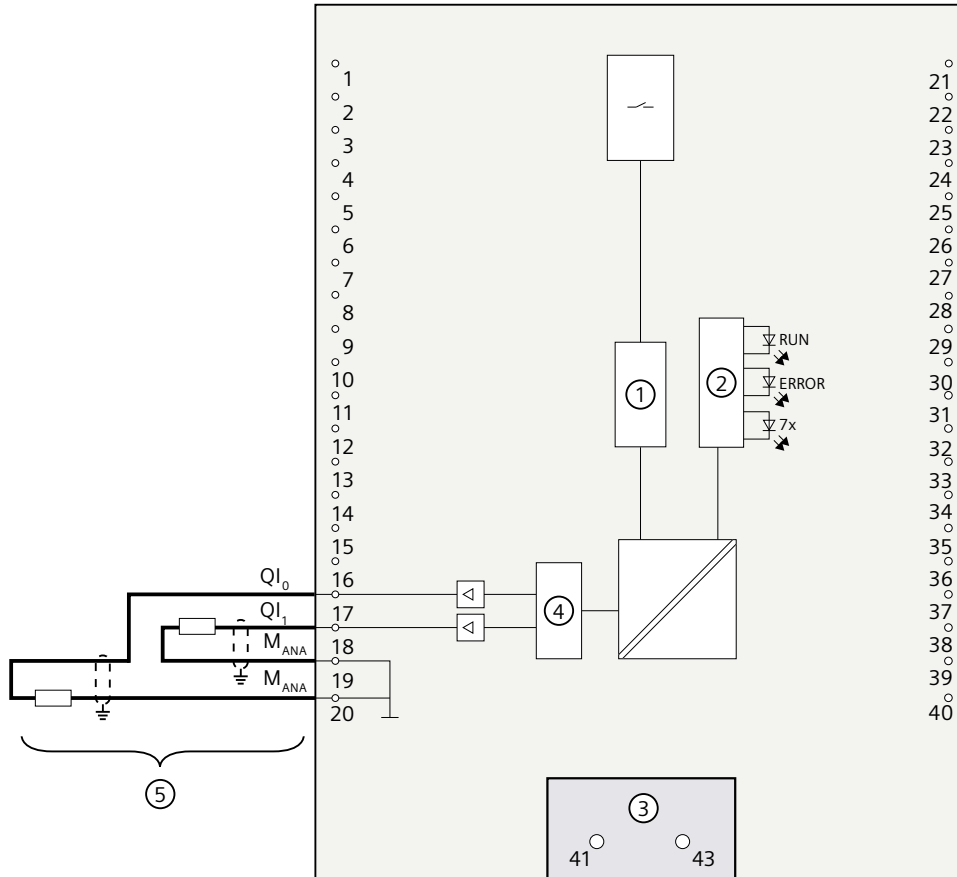

- ① Analog-to-digital converter (ADC)
- ② LED interface
- ③ Infeed element (for shielding only)
- ④ Digital-to-analog converter (DAC)
- ⑤ Current output CH0 and CH1

Figure 5-10 Block diagram and terminal assignment for current output

NOTE

M_{ANA} on terminals 19 and 20 is equivalent.

5.3.3 Wiring and block diagrams of the digital on-board I/O

This section contains the block diagram of the digital on-board I/O (X11) with standard inputs and outputs and the encoder supply, as well as the rules for the correct wiring of the ground connections.

For information on wiring the front connector, establishing the cable shield, etc., refer to the S7-1500, ET 200MP (<http://support.automation.siemens.com/WW/view/en/59191792>) System Manual.

NOTICE

Electromagnetic compatibility

The high-frequency switching (> 30 kHz) of the 24 V outputs generates electromagnetic feedback on the supply network. In order to comply with the limit values that correspond to the current state of the art, plan for a corresponding filter for the 24 V supply. The interference radiation measurements were carried out with filters of the type "EPCOS-C B84113C". Use this type of filter, or a filter with the same characteristic curve or with a characteristic curve with greater attenuation.

Possible filters, depending on the load:

- 3 A: B84113C0000B030
- 6 A: B84113C0000B060
- 10 A: B84113C0000B110

The figure below shows how to integrate the filter in the 24 V supply.

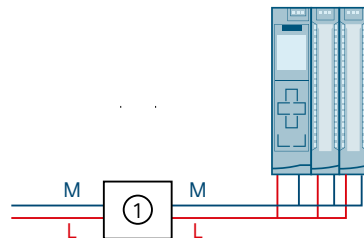

① Filters, depending on the load:

Figure 5-11 Connection of a filter for the 24 V supply.

NOTICE

Signal influences through reflections

When using fast outputs with the technology functions, the input signals may be influenced through reflection depending on the connected load and the cable length. To determine whether your application may be affected, note the following characteristic curve for a typical digital input.

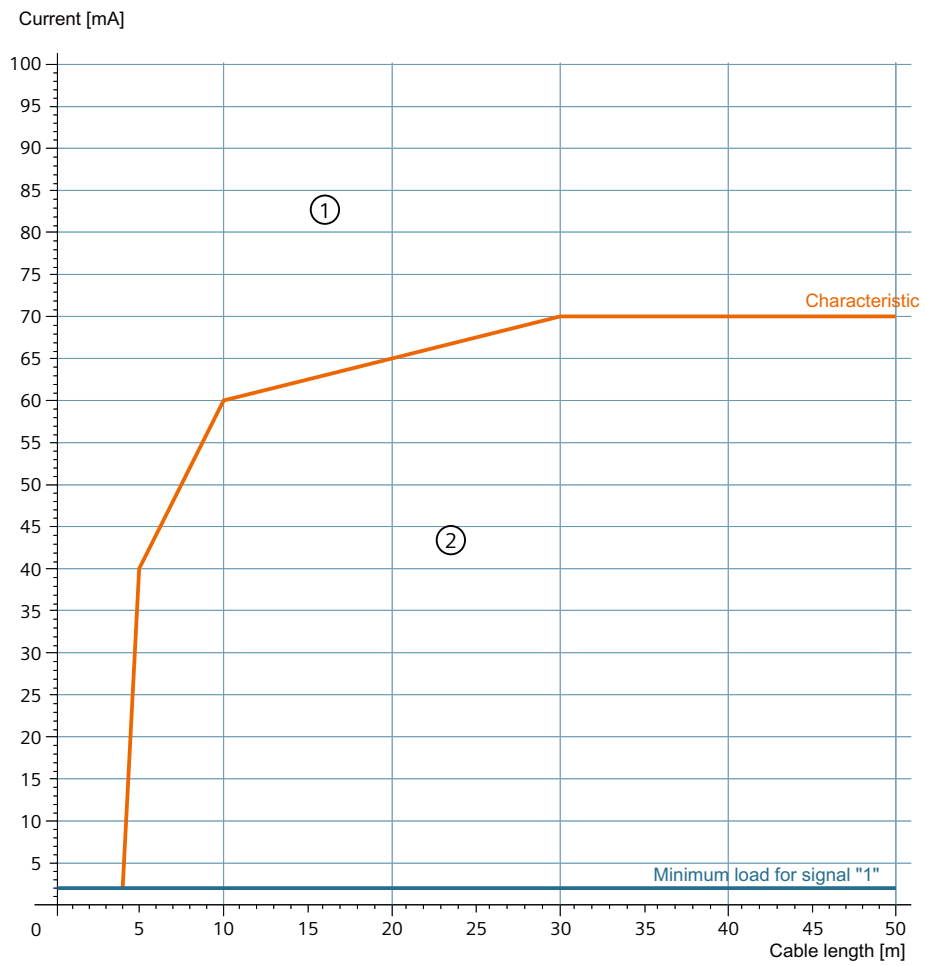

① No diode required

② Diode required

Figure 5-12 Characteristic curve of a typical digital input

If your application lies below the characteristic curve and faulty pulses are detected by the receiver, the installation of a Siemens diode (8WH2003-5CF00) is recommended. The figure below shows how to connect the diode.

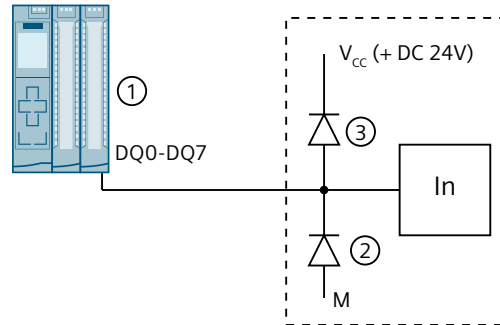

- ① CPU 1511C with used technology function
- ② Diode
- ③ Diode (may be omitted when using a Siemens diode (8WH2003-5CF00) for ②)

Figure 5-13 Installation of a diode before the input

Alternatively you can also suppress the interfering signals (reflections) through the selection of a suitable input filter. For example, with an input filter of approx. 5 μ s or 200 kHz.

Infeed element

The infeed element is inserted on the front connector and serves to shield the digital on-board I/O.

NOTE

The digital on-board I/O is supplied via the front connector terminals and therefore does not require power to be supplied by the infeed element. The infeed element is, however, necessary for shielding.

Output driver

The digital onboard I/O uses the following output drivers:

- X11, DQ0 to DQ7: Push-pull stage and freewheeling diode
- X11, DQ8 to DQ15: High-side switch and freewheeling diode

Block diagram and terminal assignment

The figure below shows you how to connect the digital on-board I/O and the assignment of the channels to the addresses (input byte a and b, output byte c and d).

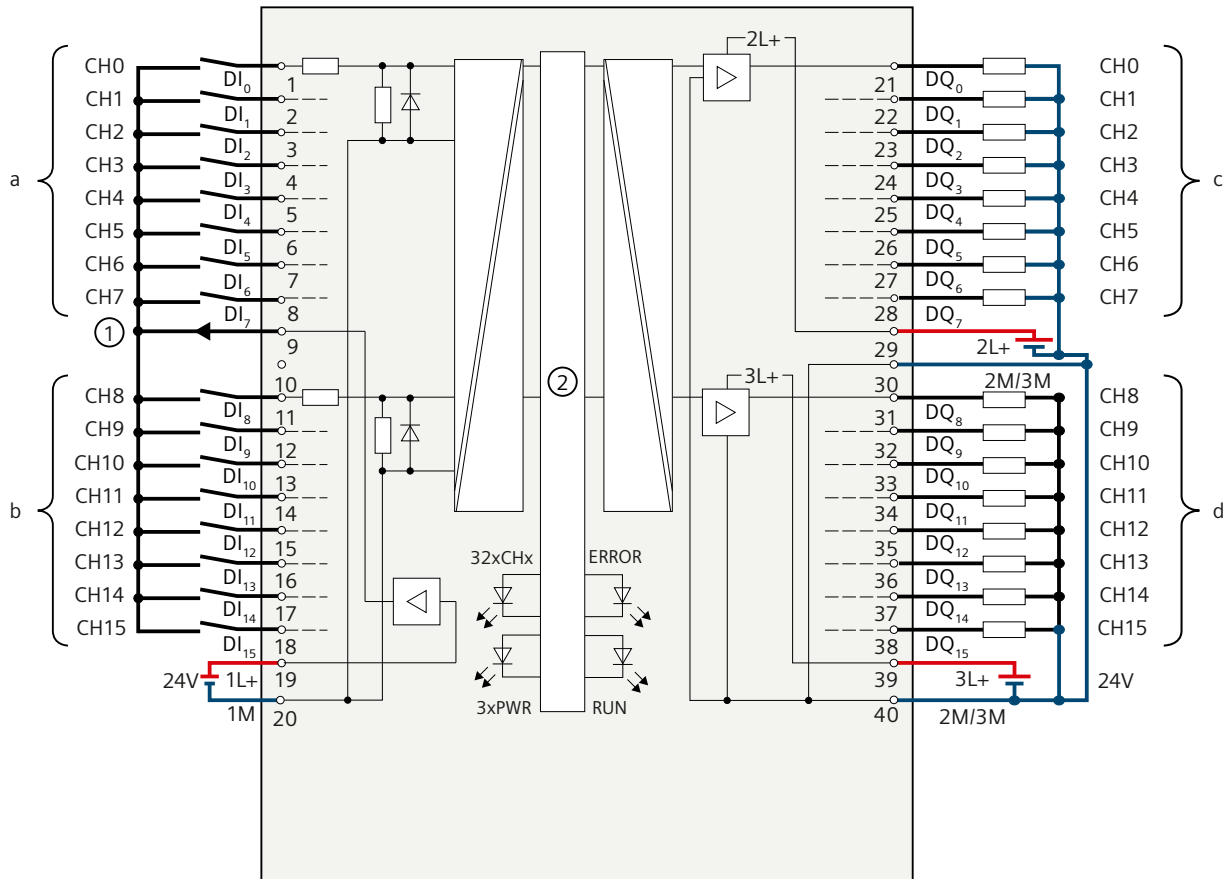

- ① Encoder supply for the digital inputs
- ② CPU interface
- xL+ Connection for 24 V DC supply voltage
- xM Connection for ground
- CHx Channel or channel status LED (green)
- RUN Status display LED (green)
- ERROR Error display LED (red)
- PWR POWER supply voltage LED (green)

Figure 5-14 Block diagram and terminal assignment

NOTICE

Polarity reversal of the supply voltage

An internal protective circuit protects the digital on-board I/O against destruction if the polarity of the supply voltage is reversed. In the case of polarity reversal of the supply voltage, however, unexpected states can occur at the digital outputs.

Supply voltage

The inputs and outputs of the digital on-board I/O are divided into two load groups which are supplied with 24 V DC.

The digital inputs DI0 to DI15 form a load group and are supplied via the connections 1L+ (terminal 19) and 1M (terminal 20).

The digital outputs DQ0 to DQ7 are supplied via the connection 2L+ (terminal 29). The digital outputs DQ8 to DQ15 are supplied via the connection 3L+ (terminal 39). Please note that the digital outputs DQ0 to DQ15 only have a common ground. In each case, they are led through to the two terminals 30 and 40 (2M/3M) and bridged in the module. The digital outputs form a common load group.

Response of the digital outputs to a wire break at ground connection of the outputs

Due to the characteristics of the output driver used in the module, approx. 25 mA supply current flows out through the outputs via a parasitic diode in the event of a ground wire break. This behavior can lead to non-set outputs also carrying high levels and emitting up to 25 mA output current. Depending on the type of load, 25 mA can be sufficient to control the load with high level. To prevent unintended switching of the digital outputs in the event of a ground wire break, follow these steps:

Wire to ground twice

Connect ground to terminal 30 and to terminal 40.

1. Route the first ground connection from terminal 30 to the central ground connection of the plant.
2. Route the second ground connection from terminal 40 to the central ground connection of the plant.

If terminal 30 or 40 are interrupted by a ground wire break, the outputs will continue to be supplied via the second, intact ground connection.

WARNING

Wire break at ground connection

Never bridge from terminal 30 to terminal 40 in the front connector and **never** lead only one wire to the central ground connection.

Connect terminal 30 and terminal 40 to a common ground point.

As a supplement to the block diagram and terminal assignment, the following figure shows the correct wiring of the outputs in order to prevent switching of the outputs in the event of a ground wire break.

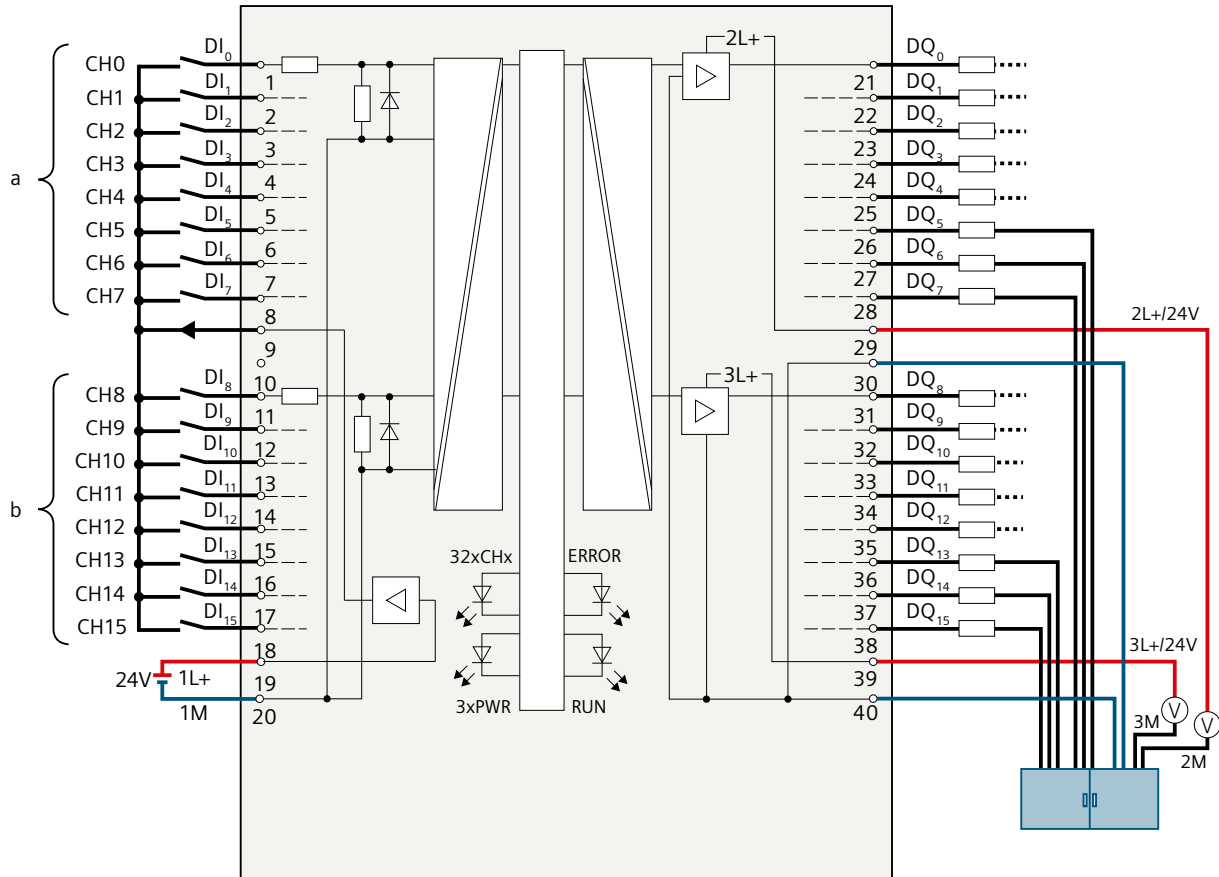

Figure 5-15 Correct wiring

The ground is supplied with a first cable from the central terminal block to terminal 30 of the module and additionally with a second cable also from the central terminal block to terminal 40 of the module.

At the digital outputs, each of the ground connections of the loads is connected with a separate cable for each load to the central terminal block.

The figure below shows the current flow with correct wiring.

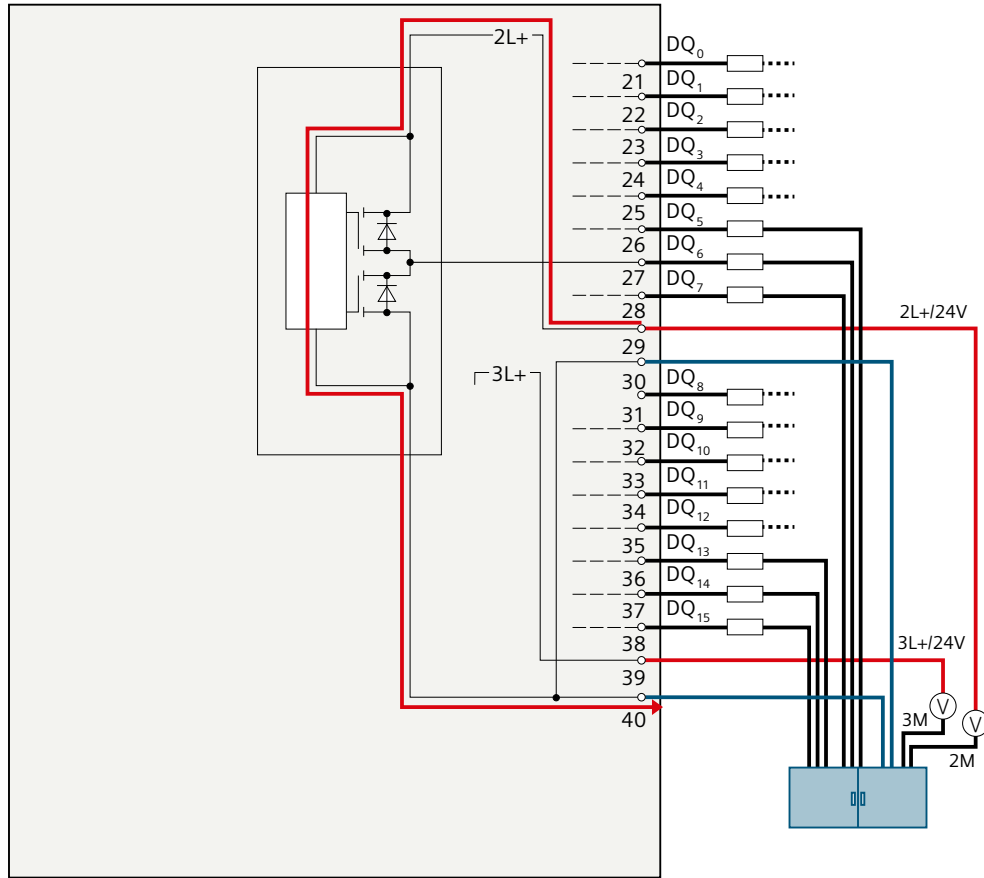

Figure 5-16 Current flow with correct wiring

With correct wiring, the supply current flows from the power supply 2L+ via terminal 29 to the module. In the module, the current flows via the output driver and exits the module via terminal 40.

The figure below shows the reaction to interruption of the first ground cable.

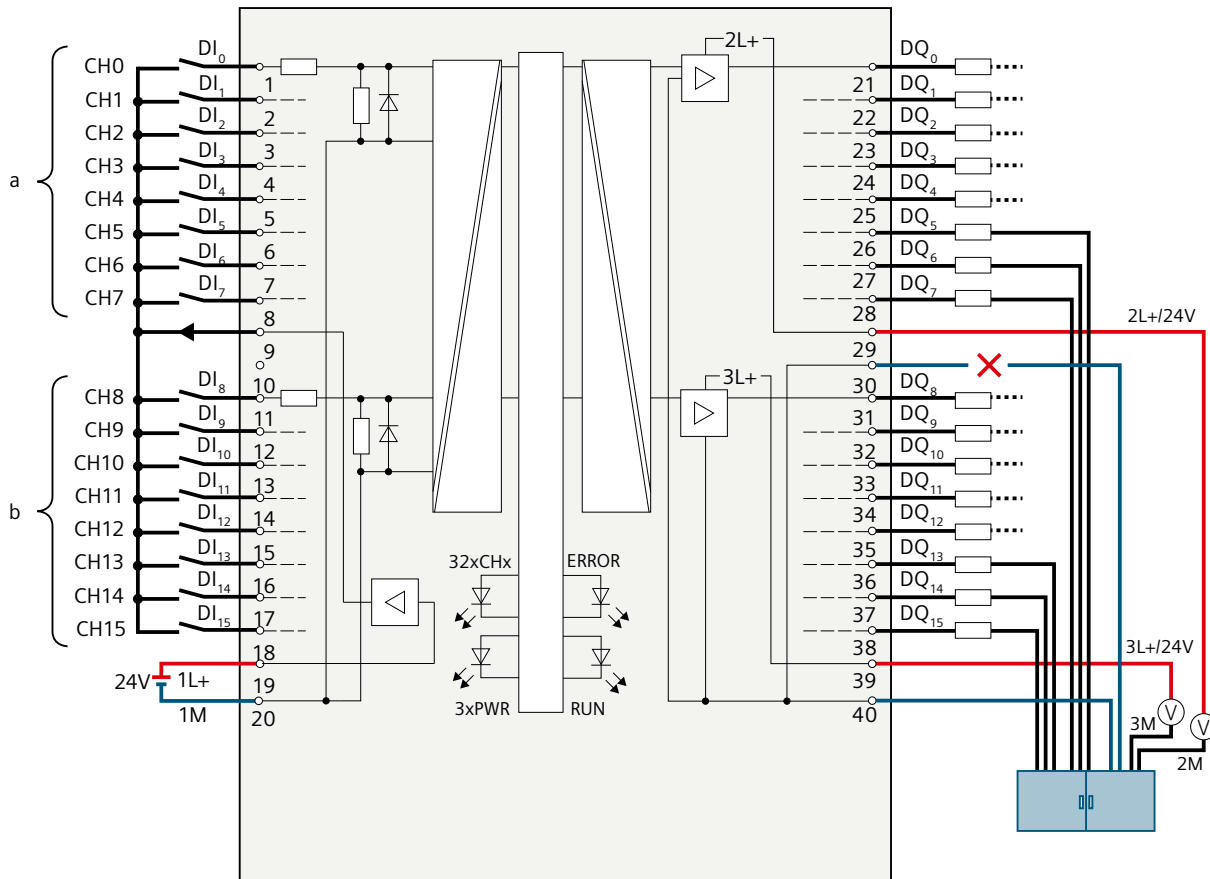

Figure 5-17 Interruption of the first ground cable

If a wire break occurs on the first ground cable from the central terminal block to terminal 30, the module can continue to operate without restrictions, as it is still connected to the ground via the second cable from the central terminal block to terminal 40.

The figure below shows the reaction to interruption of the second ground cable.

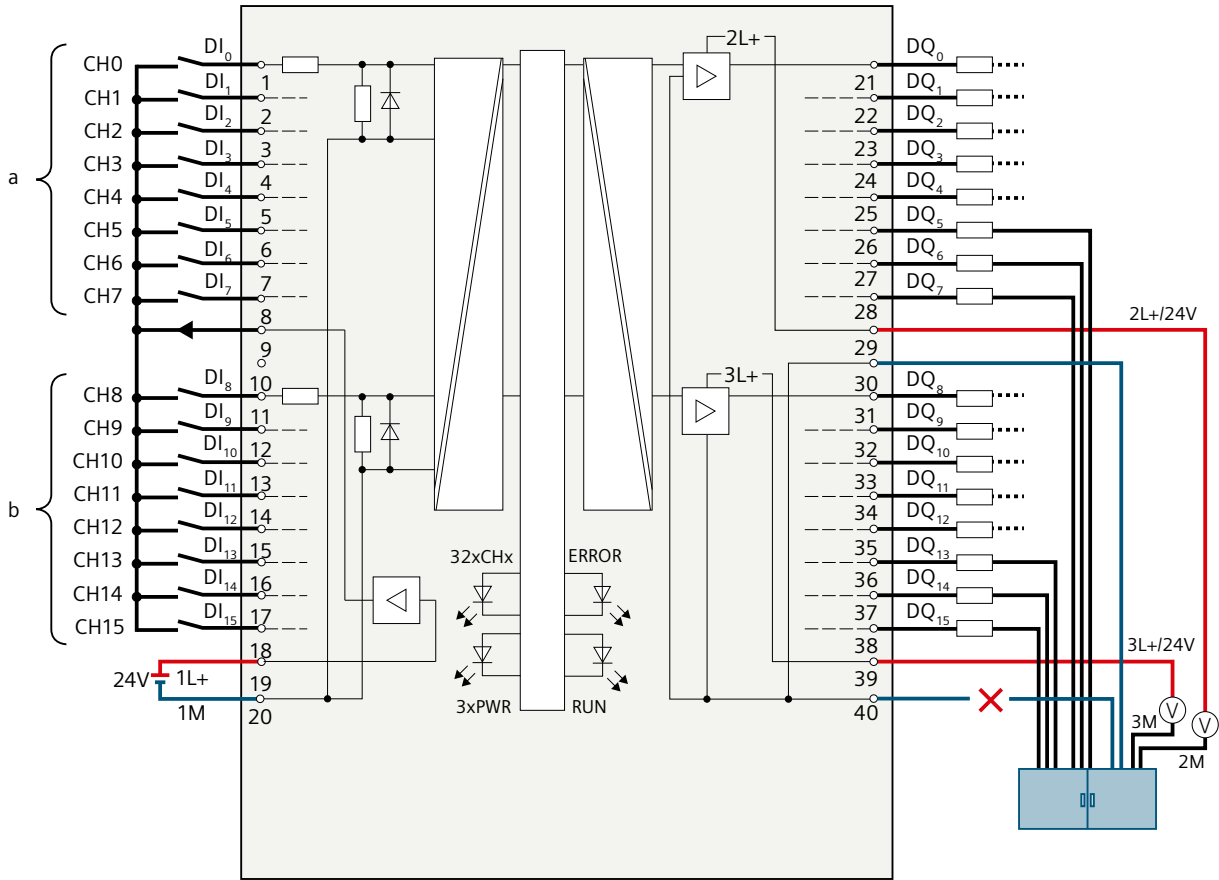

Figure 5-18 Interruption of the second ground cable

If a wire break occurs on the second ground cable from the central block terminal to terminal 30, the module can continue to operate without restrictions, as it is still connected to the ground via the first cable from the central terminal block to terminal 40.

The figure below shows the current flow upon interruption of both ground cables.

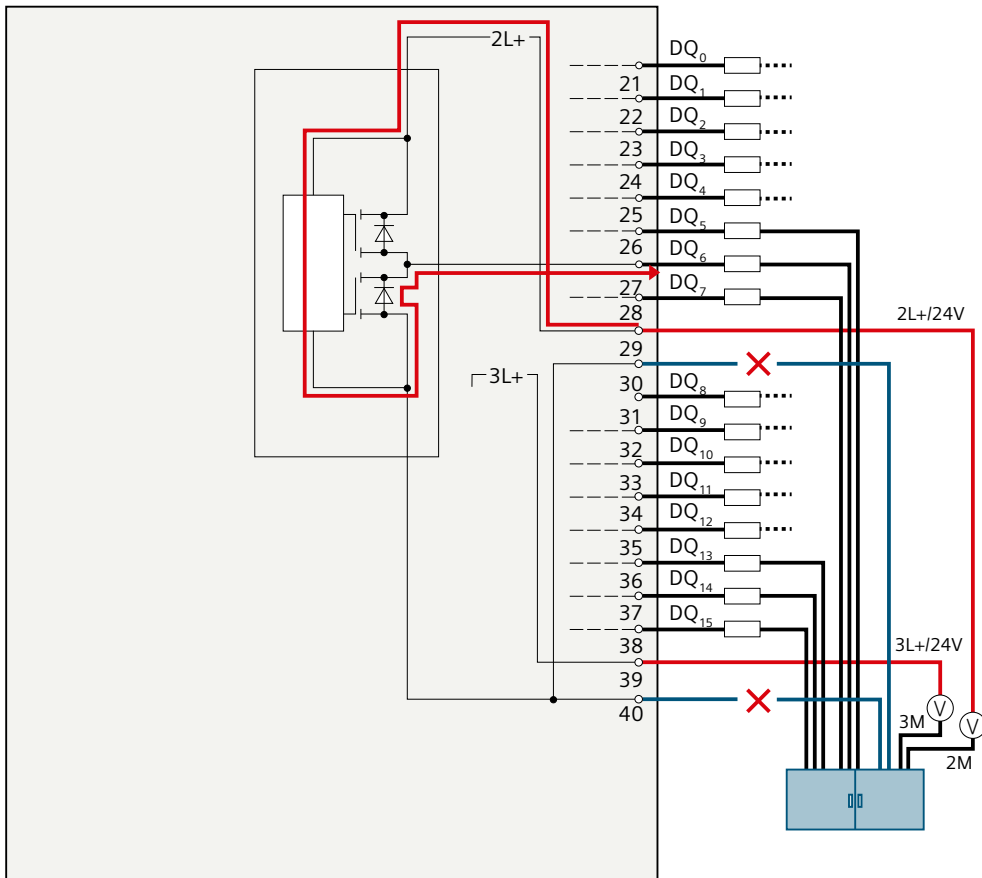

Figure 5-19 Current flow upon interruption of both ground cables

If a wire break occurs on the first and on the second ground cable from the central terminal block to the terminals 30 and 40 of the module, a malfunction occurs on the module. Both ground connections of the module are interrupted.

The supply current flows from the power supply 2L+ via terminal 29 to the module. In the module, the current flows via the output driver into the parasitic diode and exits the module via the output terminal, e.g. as shown in the figure via terminal 27. The supply current therefore flows via the connected load. The internal supply current is typically 25 mA.

! WARNING

Interruption of both ground cables

If the ground terminals 30 and 40 are interrupted, the following incorrect response can occur:

The activated outputs, which are switched to high, start to switch back and forth between high and low. If the load connected at the output is sufficiently small, the output is continuously activated.

Faulty wiring

The following figure shows faulty wiring which has a bridge on the front connector.

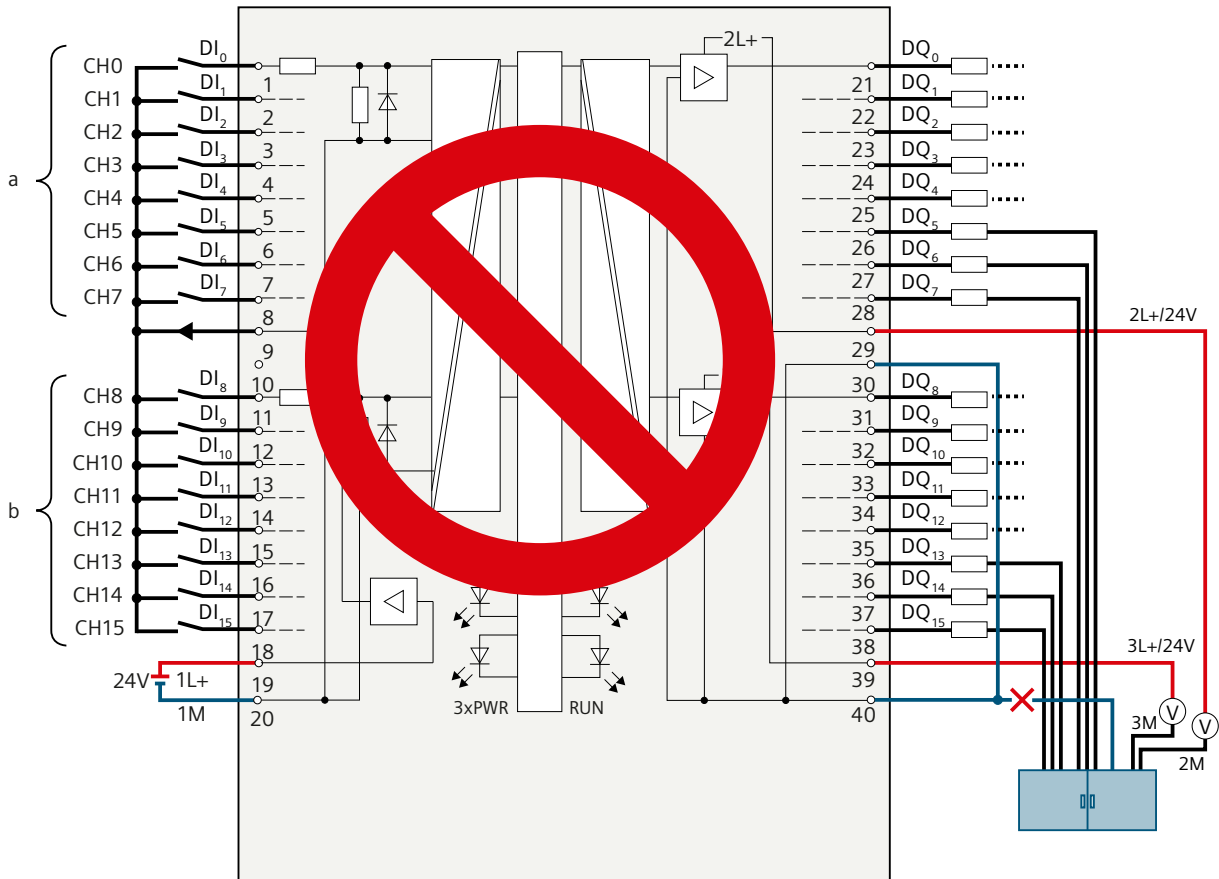
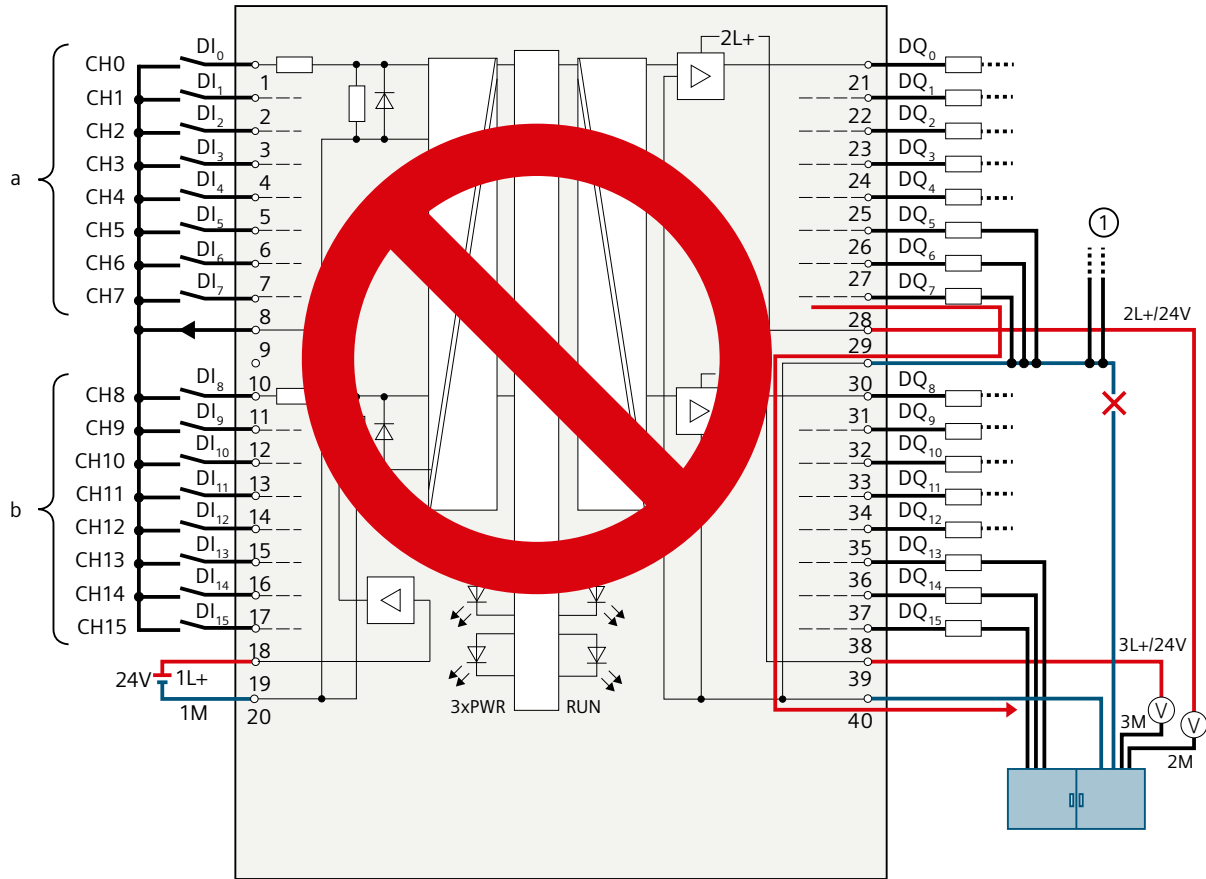

Figure 5-20 Faulty wiring: Bridge

Terminals 30 and 40 are connected in the front connector and only routed with one cable to the central terminal block. If this cable breaks, terminals 30 and 40 are no longer connected to the ground. The module's supply current flows out via the output terminal.

The figure below shows the current flow when the ground connections of the loads and the ground connection of terminal 30 are routed with a common cable to the central terminal block.



① Ground connections of other plant parts that can also carry large currents.

Figure 5-21 Faulty wiring: Common cable

If a break occurs in the common cable, the current of the outputs flows via terminal 30 to the module and via terminal 40 to the central terminal block. The current flows via the module.

	WARNING
Current flow with faulty wiring	
If a break occurs in the common cable, the current can be very high, depending on the plant, and lead to the destruction of the module.	

The figure below shows the current flow with correct wiring when a potential difference exists between the grounding points.

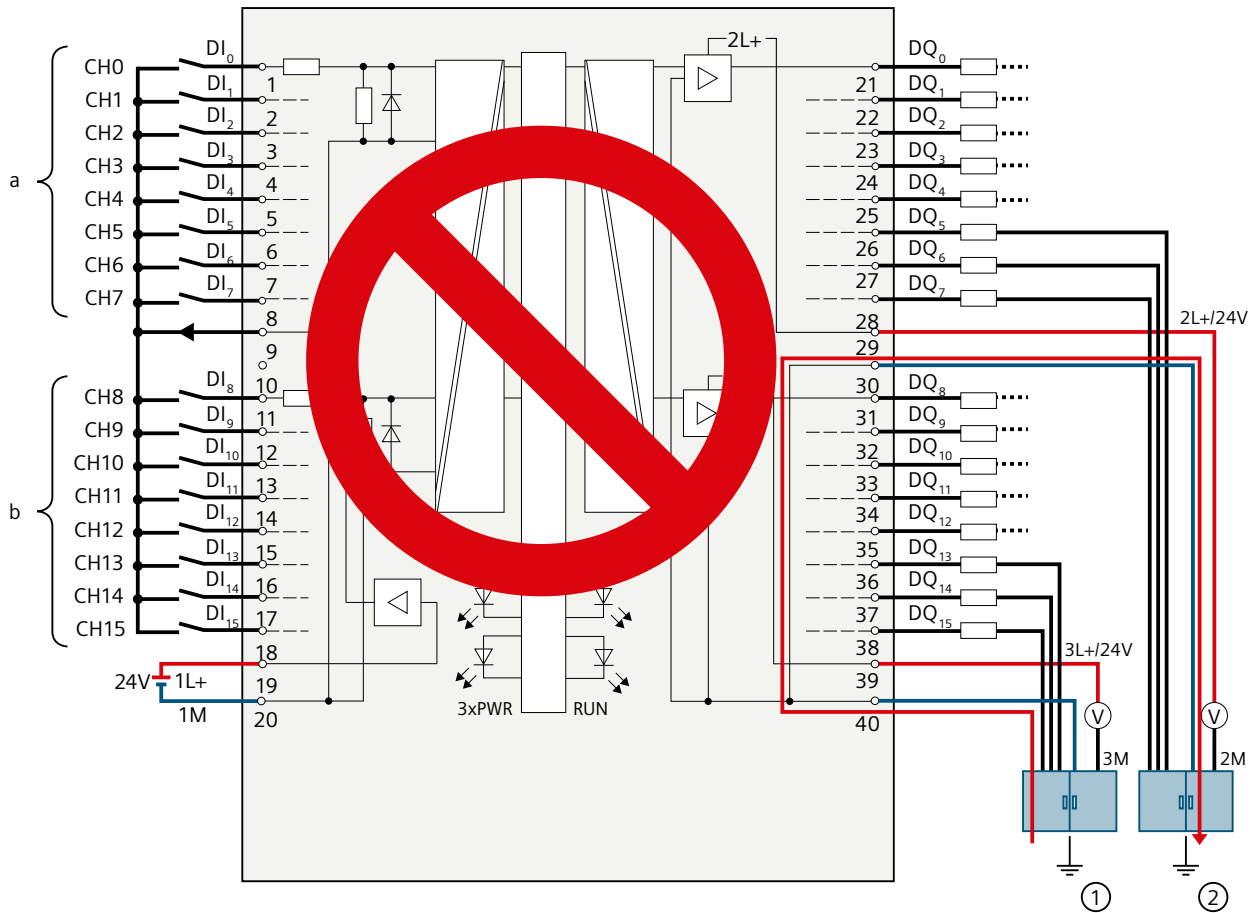

- ① Grounding point functional earth 1 (FE 1)
- ② Grounding point functional earth 2 (FE 2)

Figure 5-22 Potential difference

Equipotential bonding occurs via terminals 30 and 40. When a potential difference exists between the grounding points FE1 and FE2, the compensating current flows via terminals 30 and 40.

⚠ WARNING

Current flow with faulty wiring

In the event of a potential difference, the current can be very high, depending on the potential conditions, and lead to the destruction of the module.

Input filter for digital inputs

To suppress disruptions, you can configure an input delay for the digital inputs. You can specify the following values for the input delay:

- None
- 0.05 ms
- 0.1 ms
- 0.4 ms
- 1.6 ms
- 3.2 ms (default setting)
- 12.8 ms
- 20 ms

NOTE

Shielding

If you use standard digital inputs with "None" set as the input delay, you must use shielded cables. Shielding and the infeed element are recommended for use of standard digital inputs starting from an input delay of 0.05 ms but are not absolutely necessary.

 **WARNING**

Digital input as a measuring input

If you configure a digital input as a measuring input, the value which the digital input returns via the input data of the "DI 16/DQ 16" is not reliable. If you configure a hardware interrupt on this input it can trigger sporadically without a rising or falling edge actually existing.

5.3.4 Addresses of the high-speed counters

You connect the encoder signals, the digital input and output signals and the encoder supplies to the 40-pin front connector of the digital on-board I/O. For information on wiring the front connector, creating the cable shield, etc., refer to the S7-1500, ET 200MP (<http://support.automation.siemens.com/WW/view/en/59191792>) system manual.

Encoder signals

The 24 V encoder signals are designated with letters A, B and N. You can connect the following encoder types:

- Incremental encoder with signal N:
Signals A, B and N are connected using the correspondingly marked connections. Signals A and B are the two incremental signals, phase-shifted by 90°. N is the zero mark signal that supplies a pulse per revolution.
- Incremental encoder without signal N:
Signals A and B are connected using the correspondingly marked connections. Signals A and B are the two incremental signals, phase-shifted by 90°.
- Pulse encoder without direction signal:
The count signal is connected to the A connection.

- Pulse encoder with direction signal:
The count signal is connected to the A connection. The direction signal is connected to the B connection.
- Pulse encoder with up/down count signal:
The up count signal is connected to the A connection. The down count signal is connected to the B connection.

You can connect the following encoders or sensors to the A, B and N inputs:

- Sourcing output:
The encoder or sensor switches the A, B and N inputs to 24 V DC.

NOTE**External load resistance**

Note that, depending on the characteristics of the signal source, effective load and height of the signal frequency, you may require an external load resistance to limit the fall time of the signal from high level to low level.

The specifications/technical data of the signal source (e.g. sensor) are decisive for the configuration of such a load resistance.

- Push-pull:
The encoder or sensor switches the A, B and N inputs alternately to 24 V DC and to ground M.

Digital inputs HSC DI0 and HSC DI1

The digital inputs are logically assigned to the high-speed counters (HSC). For information on the possible assignment of the on-board I/O inputs to the high-speed counters, refer to the table Interconnection overview of the inputs (Page 104). Up to two digital inputs are available for each high-speed counter (HSC DI0 and HSC DI1). You can use the digital inputs for the gate control (Gate), synchronization (Sync) and Capture functions. Alternatively, you can use one or more digital inputs as standard digital inputs without the functions mentioned and read the signal state of the respective digital input using the feedback interface.

Digital inputs that you do not use for high-speed counting are available for use as standard DIs.

Input addresses of the high-speed counters

You set the digital input addresses used by the high-speed counters (HSC) and the assignment of A/B/N, DI0, DI1 and DQ1 signals in STEP 7 (TIA Portal). You can enable and configure each HSC when you configure the compact CPU.

The compact CPU assigns the input addresses for the A/B/N signals automatically according to the configuration.

You specify the input addresses for DI0 and DI1 according to the table Interconnection overview of the inputs (Page 104). The interconnection produces a direct connection of the HSC to an input of the on-board I/O. The high-speed counter then uses this input as HSC DI0 or HSC DI1 ([DI] symbol). The [DI] symbols in the table identify the input addresses for HSC DI0 and HSC DI1 that are offered for selection in the hardware configuration.

Assignment of HSC addresses of inputs

You can find an overview of the options for interconnecting the inputs of the front connectors X11 and X12 in the section Interconnection overview of the inputs ([Page 104](#)).

Digital outputs HSC-DQ0 and HSC-DQ1

Two digital outputs are available for each high-speed counter. Digital output HSC-DQ0 is a logical output that cannot be interconnected with a digital output of the on-board I/O. Digital output HSC-DQ0 can only be used via the user program. HSC-DQ1 is a physical output that can be interconnected with a digital output of the on-board I/O.

The digital outputs are 24 V sourcing output switches relative to M and can be loaded with a rated load current of 0.1 A. The outputs used as standard outputs have a rated load current of 0.5 A. The digital outputs are protected against overload and short-circuit.

NOTE

It is possible to directly connect relays and contactors without external wiring. For information on the maximum possible operating frequencies and the inductance values of the inductive loads at the digital outputs, refer to the Technical specifications section.

The section Interconnection overview of the outputs ([Page 105](#)) provides an overview of which digital outputs you can interconnect to which high-speed counters. Digital outputs to which no high-speed counter is interconnected can be used as standard outputs. The maximum output delay of each digital output used as standard output is 500 µs.

Shielding

NOTE

When you use digital inputs/outputs with technology functions, i.e. interconnect high-speed counters with the inputs/outputs, you must use shielded cables and the infeed element for shielding.

Reference

For more information on configuring the inputs of the high-speed counters, refer to the S7-1500, ET 200MP, ET 200SP Counting, measurement and position detection (<http://support.automation.siemens.com/WW/view/en/59709820>) function manual and the STEP 7 online help.

5.3.5 Addresses of the pulse generators in the Pulse Width Modulation (PWM) and Frequency Output modes

Configuring the outputs as pulse generators

If you configure the memory of the outputs of the CPU as pulse generators (for PWM or PTO), the corresponding addresses of the outputs are removed from the memory of the outputs. You cannot use the addresses of the outputs for other purposes in your user program. When your user program writes a value to an output that you are using as a pulse generator, the CPU does not write this value to the physical output.

Assignment of the PWM addresses of the outputs

The section Interconnection overview of the outputs (Page 105) provides an overview of which digital outputs you can interconnect to which PWM channels.

NOTE

The digital inputs and outputs assigned to PWM and PTO cannot be forced.

You assign the digital inputs and outputs to the pulse duration modulation (PWM) and the pulse train output (PTO) during the device configuration. If you assign digital inputs and outputs to these functions, the values of the addresses of the assigned digital inputs and outputs cannot be changed by the function for forcing in the watch table. Instead, you can force the output bit TM_CTRL_DQ to 0 and switch the output on or off with the bit SET_DQA (relevant for the PWM and Frequency Output modes).

For more information on forcing inputs and outputs, refer to the S7-1500, ET 200MP system manual (<http://support.automation.siemens.com/WW/view/en/59191792>).

5.3.6 Addresses of pulse generators in the PTO mode

You connect the encoder signals, the digital input and output signals and the encoder supply to the 40-pin front connector of the digital on-board I/O. For information on wiring the front connectors, establishing the cable shields, etc., refer to the S7-1500, ET 200MP system manual. (<http://support.automation.siemens.com/WW/view/en/59191792>)

Encoder signals

In addition to supporting its outputs, each PTO channel also supports the three following optional inputs:

- Reference Switch (RS)
- Measuring Input (MI)
- Drive Ready (DR)

Input addresses of the pulse generators (PTO)

You make the settings of the digital input addresses used by the pulse generators (PTO) in the hardware configuration of STEP 7 (TIA Portal). When you configure the compact CPU, you can individually activate and configure the four PTO channels.

Assignment of PTO addresses of inputs

A direct connection from the PTO to an input of the on-board I/O is established through the interconnection. You can find an overview of the options for interconnecting the inputs (DI0 to DI15) to the available PTO channels (PTO1 to PTO4) in the section Interconnection overview of the inputs (Page 104).

Assignment of the PTO addresses of the outputs

The section Interconnection overview of the outputs (Page 105) provides an overview of which digital outputs you can interconnect to which PTO channels.

5.3.7 Interconnection overview of the inputs

Combined interconnection of the technology channels

The following table provides you with an overview of the possible interconnections of the inputs of front connector X11 to allow you to correctly distribute the available inputs over the possible technology channels HSC and PTO. This overview is a combination of interconnection options of technology channels for HSC and PTO.

Front connector	Terminal	Channel	PTO				High-speed counters (HSC)															
			PTO1	PTO2	PTO3	PTO4	HSC1	HSC2	HSC3	HSC4	HSC5	HSC6										
X1-1	1	DI0	[DR]		[DR]		[DR]		[DR]		A			[DI]		[DI]						
	2	DI1	[DR]	[MI]	[DR]		[DR]		[DR]		[B]	[DI]		[DI]		[DI]						
	3	DI2	[DR]	[RS]	[DR]		[DR]		[DR]		[N]	[DI]		[DI]		[DI]						
	4	DI3	[DR]		[DR]		[DR]		[DR]			[DI]	A		[DI]							
	5	DI4	[DR]		[DR]	[MI]	[DR]		[DR]			[DI]	[B]	[DI]		[DI]						
	6	DI5	[DR]		[DR]	[RS]	[DR]		[DR]			[DI]	[N]	[DI]		[DI]						
	7	DI6	[DR]		[DR]		[DR]	[MI]	[DR]			[DI]		[DI]	A							
	8	DI7	[DR]		[DR]		[DR]	[RS]	[DR]			[DI]		[DI]	[B]	[DI]						
	11	DI8	[DR]		[DR]		[DR]		[DR]								A			[DI]		[DI]
	12	DI9	[DR]		[DR]		[DR]		[DR]							[B]	[DI]			[DI]		[DI]
	13	DI10	[DR]		[DR]		[DR]		[DR]							[N]	[DI]			[DI]		[DI]
	14	DI11	[DR]		[DR]		[DR]		[DR]								[DI]	A				[DI]
	15	DI12	[DR]		[DR]		[DR]		[DR]								[DI]	[B]	[DI]			[DI]

X1-1	16	DI13	[DR]		[DR]		[DR]		[DR]							[DI]	[N]	[DI]		[DI]
	17	DI14	[DR]		[DR]		[DR]	[MI]								[DI]		[DI]	A	
	18	DI15	[DR]		[DR]		[DR]	[RS]								[DI]		[DI]	[B]	[DI]

[...] = Use is optional

[DR] = Drive ready; [MI] = Measuring input; [RS] = Reference switch

[DI] stands for [HSC DI0/HSC DI1] = DI: Is used for the HSC functions: Gate, Sync and Capture

The assignment to [B] or [N] takes precedence over the assignment to HSC DI0 or HSC DI1. This means that input addresses that are assigned to count signal [B] or [N] based on the selected signal type cannot be used for other signals such as HSC DI0 or HSC DI1.

5.3.8 Interconnection overview of the outputs

Combined interconnection of the technology channels

The following table provides you with an overview of the possible interconnections of the outputs of front connector X11 to allow you to correctly distribute the available outputs over the possible technology channels HSC, PWM and PTO. This overview is a combination of interconnection options of technology channels for HSC, PWM and PTO.

Front connector	Hardware output			Standard DQ	PWM	PTO			HSC
	Terminal	Channel	Output module	Configurable as standard DQ for channel	Configurable as PWM output for channel	Configurable as PTO output A for channel 1)	Configurable as PTO output B for channel 2)	Configurable as "Drive enable output" for channel	Can be used as HSC-DQ1 for channel
X11	1	DQ0	High-speed		PWM 1	PTO1			
			Standard	DQ0	PWM 1			[PTO 2/3/4]	
	2	DQ1	High-speed				PTO1 ¹⁾		[HSC1]
			Standard	DQ1					[PTO 1/2/3/4]
	3	DQ2	High-speed		PWM 2	PTO2			
			Standard	DQ2	PWM 2				[PTO 1/3/4]
	4	DQ3	High-speed				PTO2		[HSC2]
			Standard	DQ3					[PTO 1/2/3/4]
	5	DQ4	High-speed		PWM 3	PTO3			[HSC3]
			Standard	DQ4	PWM 3				[PTO 1/2/4]
	6	DQ5	High-speed				PTO3		[HSC4]
			Standard	DQ5					[PTO 1/2/3/4]
	7	DQ6	High-speed		PWM 4	PTO4			[HSC6]

* Only supports for PTO direction signal (signal type "pulse A and direction B")

1) "PTOx - Output A" stands for the signal types Pulse output A or Pulse

2) "PTOx - Output B" stands for the signal types Pulse output B or Direction

5.3 Terminal and block diagrams

X11	7	DQ6	Standard	DQ6	PWM 4			[PTO 1/2/3]	
	8	DQ7	High-speed				PTO4		[HSC5]
			Standard	DQ7				[PTO 1/2/3/4]	
	11	DQ8	Standard	DQ8	PWM 1			[PTO 1/2/3/4]	
	12	DQ9		DQ9			PTO1*	[PTO 1/2/3/4]	[HSC1]
	13	DQ1-0		DQ10	PWM 2			[PTO 1/2/3/4]	
	14	DQ1-1		DQ11			PTO2*	[PTO 1/2/3/4]	[HSC2]
	15	DQ1-2		DQ12	PWM 3			[PTO 1/2/3/4]	[HSC3]
	16	DQ1-3		DQ13			PTO3*	[PTO 1/2/3/4]	[HSC4]
	17	DQ1-4		DQ14	PWM 4			[PTO 1/2/3/4]	[HSC6]
18	DQ1-5	DQ15				PTO4*	[PTO 1/2/3/4]	[HSC5]	

* Only supports for PTO direction signal (signal type "pulse A and direction B")

- 1) "PTOx - Output A" stands for the signal types Pulse output A or Pulse
- 2) "PTOx - Output B" stands for the signal types Pulse output B or Direction

Technical characteristics of the outputs

The following table shows an overview of the technical characteristics of the individual outputs.

	(period duration)Frequency range	DQ0 to DQ7		DQ8 to DQ15
		(0.1 A) activated High-speed output	(0.1 A) deactivated High-Speed output	Standard output
		max. 100 kHz	max. 10 kHz	max. 100 Hz
		max. 0.1 A	max. 0.5 A	max. 0.5 A
		Sourcing/sinking output	Switching to P potential ¹⁾	Switching to P potential ¹⁾
Accuracy of the pulse duration	10 to <= 100 kHz (100 to > = 10 μs)	±100 ppm ±2 μs	---	---
	100 Hz to <10 kHz (10 ms to > 100 μs)		±100 ppm ±10 μs with load > 0.1 A	

- 1) With sourcing outputs, it must be taken into consideration that falling edges can be delayed as compared to rising edges depending on the load. The on-load factor can therefore be falsified. Consider using a high-speed output if the load at the output is greater than 240 Ω.
- 2) The frequency has a basic accuracy of ±100 ppm with a resolution of 0.3638 mHz.
- 3) Standard outputs are affected by jitter during generation of frequencies. The set period duration is not adhered to in every period, but it is adhered to on average over several periods.

Accuracy of the pulse duration	10 to < 100 Hz (0.1 s to > 10 ms)	$\pm 100 \text{ ppm} \pm 2 \text{ } \mu\text{s}$	$\pm 100 \text{ ppm} \pm 20 \text{ } \mu\text{s}$ with load $\geq 2 \text{ mA}$	$\pm 100 \text{ ppm} \pm 100 \text{ } \mu\text{s}$ with load > 0.1 A $\pm 100 \text{ ppm} \pm 200 \text{ } \mu\text{s}$ with load $\geq 2 \text{ mA}$
	1 to < 10 Hz (1 to > 0.1 s)	$\pm 150 \text{ ppm} \pm 2 \text{ } \mu\text{s}$	$\pm 150 \text{ ppm} \pm 10 \text{ } \mu\text{s}$ with load > 0.1 A $\pm 150 \text{ ppm} \pm 20 \text{ } \mu\text{s}$ with load $\geq 2 \text{ mA}$	$\pm 150 \text{ ppm} \pm 100 \text{ } \mu\text{s}$ with load > 0.1 A $\pm 150 \text{ ppm} \pm 200 \text{ } \mu\text{s}$ with load $\geq 2 \text{ mA}$
	0.1 to < 1 Hz (10 to > 1 s)	$\pm 600 \text{ ppm} \pm 2 \text{ } \mu\text{s}$	$\pm 600 \text{ ppm} \pm 10 \text{ } \mu\text{s}$ with load > 0.1 A $\pm 600 \text{ ppm} \pm 20 \text{ } \mu\text{s}$ with load $\geq 2 \text{ mA}$	$\pm 600 \text{ ppm} \pm 100 \text{ } \mu\text{s}$ with load > 0.1 A $\pm 600 \text{ ppm} \pm 200 \text{ } \mu\text{s}$ with load $\geq 2 \text{ mA}$
Accuracy of the frequency	---	$\pm 100 \text{ ppm}^{2)}$	$\pm 100 \text{ ppm}^{2)}$	$\pm 100 \text{ ppm}^{2)3)}$
Minimum pulse duration		2 μs	20 μs with load > 0.1 A 40 μs with load $\geq 2 \text{ mA}$ 20 μs with load < 240 $\Omega^{1)}$	400 μs with load > 0.1 A 500 μs with load $\geq 2 \text{ mA}$ 400 μs with load < 240 $\Omega^{1)}$

- 1) With sourcing outputs, it must be taken into consideration that falling edges can be delayed as compared to rising edges depending on the load. The on-load factor can therefore be falsified. Consider using a high-speed output if the load at the output is greater than 240 Ω .
- 2) The frequency has a basic accuracy of $\pm 100 \text{ ppm}$ with a resolution of 0.3638 mHz.
- 3) Standard outputs are affected by jitter during generation of frequencies. The set period duration is not adhered to in every period, but it is adhered to on average over several periods.

Parameters/address space

6.1 Address space of the analog on-board I/O

Address space of the analog input and analog output channels

The addresses are divided into five analog input channels and two analog output channels. STEP 7 (TIA Portal) assigns the addresses automatically. You can change the addresses in the hardware configuration of STEP 7 (TIA Portal), i.e. freely assign the start address. The addresses of the channels are based on the start address.

"IB x", for example, stands for the start address input byte x. "QB x" stands, for example, for the start address output byte x.

Assignment of five analog input channels in the process image input (PII)

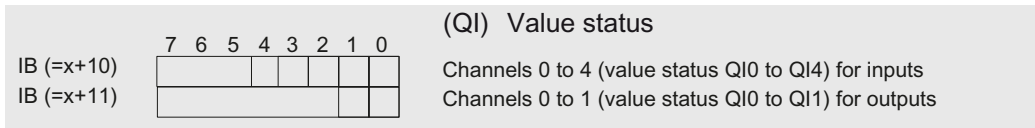
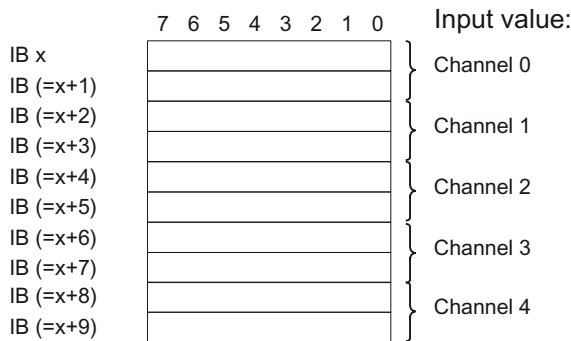

0 = Value read in at the channel is faulty

Assignment of two analog output channels in the process image output (PIQ)

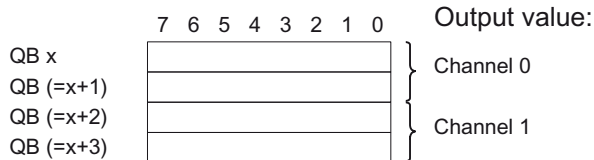

Figure 6-1 Address space 7-channel analog on-board I/O with value status

Value status (quality information, QI)

As of firmware version 2.0, the analog and digital on-board I/O support the value status as diagnostics option. You activate the use of the value status in the hardware configuration of STEP 7 (TIA Portal). Value status is deactivated by default.

When you activate the value status, the input area of the analog on-board I/O contains two additional bytes, which provide the QI bits to the five analog input channels and two analog output channels. You access the QI bits through the user program.

Value status of input channels

Value status = 1 ("Good") indicates that the value of the assigned input at the terminal is valid.

Value status = 0 ("Bad") indicates that the read value is not valid.

Possible cause for value status = 0:

- A channel has been deactivated
- A measured value was not updated after a parameter change
- A measured value is outside the low/high measuring range (overflow/underflow)
- Wire break has occurred (only for the "Voltage" measurement type in the measuring range "1 to 5 V" and for the "Current" measurement type in the measuring range "4 to 20 mA")

Value status of output channels

The value status = 1 ("Good") indicates that the process value specified by the user program is correctly output at the terminal.

The value status = 0 ("Bad") indicates that the process value output at the hardware output is incorrect.

Possible cause for value status = 0:

- A channel has been deactivated
- Outputs are inactive (for example, CPU in STOP)
- An output value is outside the high/low measuring range (overflow/underflow)
- Wire break has occurred (only for the "Current" output type)
- Short-circuit has occurred (only for the "Voltage" output type)

Value status (quality information, QI)

As of firmware version 2.0, the analog and digital on-board I/O support the value status as diagnostics option. You activate the use of the value status in the hardware configuration of STEP 7 (TIA Portal). Value status is deactivated by default. You can activate/deactivate the value status of the digital on-board I/O for X11 and X12 independently of each other. When you activate the value status, the input area of the digital on-board I/O (X11/X12) contains four additional bytes, which provide the QI bits to the 16 digital input channels and 16 digital output channels. You access the QI bits through the user program.

Value status of input channels

Value status = 1 ("Good") indicates that the value of the assigned input at the terminal is valid.

Value status = 0 ("Bad") indicates that no or too little supply voltage L+ is applied at the terminal and that the read value is therefore not valid.

Value status of output channels

The value status = 1 ("Good") indicates that the process value specified by the user program is correctly output at the terminal.

The value status = 0 ("Bad") indicates that the process value output at the hardware output is incorrect or the channel is used for technology functions.

Possible cause for value status = 0:

- The supply voltage L+ is missing at the terminals or is not sufficient
- Outputs are inactive (for example, CPU in STOP)
- Technology functions (HSC, PWM or PTO) use the channel

NOTE

Behavior of the value status at the output channels for technology functions

The output channels return the value status 0 ("Bad") when a technology channel (HSC, PWM or PTO) is used. It does not matter in this context whether the output value is incorrect or not.

6.3 Address space of the high-speed counters

Address space of the high-speed counters

Table 6-1 Size of the input and output addresses of the high-speed counters

	Inputs	Outputs
Size per high-speed counter (6x)	16 bytes	12 bytes

You can find a description of the control interface in the section Assignment of the control interface of the high-speed counters ([Page 47](#)). You can find a description of the feedback interface in the section Assignment of the feedback interface of the high-speed counters ([Page 49](#)).

Table 6-2 Size of the input and output addresses in operating mode "Position detection for Motion Control"

	Inputs	Outputs
Size per high-speed counter (6x)	16 bytes	4 bytes

6.4 Address space of the pulse generators

Address space of the pulse generators in the PWM, frequency output and PTO modes

Operating mode	Feedback interface (inputs)	Control interface (outputs)
PWM (4x)	4 bytes	12 bytes
Frequency output	4 bytes	12 bytes
PTO	18 bytes	10 bytes
Deactivated	4 bytes *	12 bytes *

* In "Deactivated" mode, the control interface is not evaluated and the feedback interface is set to 0 values

6.5 Measurement types and measuring ranges of the analog on-board I/O

Introduction

The analog on-board I/O is set to voltage measurement type and measuring range ± 10 V by default for the inputs on channels 0 to 3. By default, channel 4 is set to resistance measuring type and measuring range 600 Ω . If you want to use another measurement type or measuring range, change the parameter settings of the analog on-board I/O with STEP 7 (TIA Portal).

Disable unused inputs to prevent disturbances that cause incorrect behavior (e.g. triggering of a hardware interrupt).

Measurement types and measuring ranges

The following table shows the measurement types, the measuring range and the possible channels.

Table 6-3 Measurement types and measuring range

Measurement type	Measuring range	Channel
Voltage	0 to 10 V 1 to 5 V ± 5 V ± 10 V	0 to 3
Current 4WMT (4-wire measuring transducer)	0 to 20 mA 4 to 20 mA ± 20 mA	0 to 3
Resistance	150 Ω 300 Ω 600 Ω	4
Thermal resistor RTD	Pt 100 Standard/Climate Ni 100 Standard/Climate	4
Deactivated	-	-

The tables of the input ranges, overflow, underrange, etc. can be found in the appendix .

6.6 Output type and output ranges of the analog on-board I/O

Introduction

The analog on-board I/O is set to voltage output type and output range ± 10 V as default for the outputs. If you want to use another output range or output type, you need to change the parameter settings of the analog on-board I/O with STEP 7 (TIA Portal).

Output types and output ranges

The following table shows the output type and the corresponding output ranges.

Table 6-4 Output type and output ranges

Output type	Output range
Voltage	1 to 5 V 0 to 10 V ± 10 V
Current	0 to 20 mA 4 to 20 mA ± 20 mA
Deactivated	-

6.7 Parameters of the analog on-board I/O

Parameters of the analog on-board I/O

You specify the properties of the analog on-board I/O during parameter assignment with STEP 7 (TIA Portal). The tables below list the parameters that can be set for inputs and outputs, respectively.

When parameters are assigned in the user program, they are transferred to the analog on-board I/O via data records with the WRREC instruction, see section Parameter assignment and structure of the parameter data records of the analog on-board I/O ([Page 156](#)).

Configurable parameters and default settings for inputs

Table 6-5 Configurable "Diagnostics" parameters

Parameters ¹⁾	Value range	Default	Reconfiguration in RUN
Diagnostics			
• Overflow	Yes/No	No	Yes
• Underflow	Yes/No	No	Yes
• Wire break ²⁾	Yes/No	No	Yes
• Current limit for wire break diagnostics	1.185 mA or 3.6 mA	1.185 mA	Yes

¹⁾ All parameters can be set for on a channel-specific basis

²⁾ Only for the "Voltage" measurement type in the measuring range 1 to 5 V and for the "Current" measurement type in the measuring range 4 to 20 mA

Table 6-6 Configurable "Measuring" parameters

Parameters ¹⁾	Value range	Default	Reconfiguration in RUN
Measuring			
• Measurement type	See section Measurement types and measuring ranges of the analog on-board I/O (Page 112)	Voltage (channels 0 to 3) Resistance (channel 4)	Yes
• Measuring range		±10 V (channels 0 to 3) 600 Ω (channel 4)	Yes
• Temperature coefficient	Pt: 0.003851 Pt: 0.003916 Pt: 0.003902 Pt: 0.003920 Ni: 0.006180 Ni: 0.006720	0.003851	Yes

¹⁾ All parameters can be set for on a channel-specific basis

²⁾ Kelvin (K) is only possible for the "Standard range" measuring range and not for the "Climatic range" measuring range

³⁾ The interference frequency suppression must have the same value for all active input channels. This value can only be changed by reassigning parameters in RUN with single channel parameter assignment (data records 0 to 4) if all other input channels are disabled.

Parameters ¹⁾	Value range	Default	Reconfiguration in RUN
• Temperature unit	<ul style="list-style-type: none"> • Kelvin (K) ²⁾ • Fahrenheit (°F) • Celsius (°C) 	°C	Yes
• Interference frequency suppression	400 Hz 60 Hz 50 Hz 10 Hz	50 Hz	Yes ³⁾
• Smoothing	None/weak/medium/strong	None	Yes

1) All parameters can be set for on a channel-specific basis

2) Kelvin (K) is only possible for the "Standard range" measuring range and not for the "Climatic range" measuring range

3) The interference frequency suppression must have the same value for all active input channels. This value can only be changed by reassigning parameters in RUN with single channel parameter assignment (data records 0 to 4) if all other input channels are disabled.

Table 6-7 Configurable "Hardware interrupt" parameters

Parameters ¹⁾	Value range	Default	Reconfiguration in RUN
Hardware interrupts			
• Hardware interrupt low limit 1	Yes/No	No	Yes
• Hardware interrupt high limit 1	Yes/No	No	Yes
• Hardware interrupt low limit 2	Yes/No	No	Yes
• Hardware interrupt high limit 2	Yes/No	No	Yes

1) All parameters can be set for on a channel-specific basis

You can find an overview of the limits for the hardware interrupts in the section Structure of a data record for input channels of the analog on-board I/O [\(Page 157\)](#).

Configurable parameters and default settings for outputs

Table 6-8 Configurable "Diagnostics" parameters

Parameters ¹⁾	Value range	Default	Reconfiguration in RUN
Diagnostics			
• Wire break ²⁾	Yes/No	No	Yes
• Short-circuit to ground ³⁾	Yes/No	No	Yes
• Overflow	Yes/No	No	Yes
• Underflow	Yes/No	No	Yes

1) All parameters can be set for on a channel-specific basis

2) Only for the "Current" output type

3) Only for the "Voltage" output type

6.8 Parameters of the digital on-board I/O

Table 6-9 Configurable output parameters

Parameters ¹⁾	Value range	Default	Reconfiguration in RUN
Output parameters			
• Output type	See section Output type and output ranges of the analog on-board I/O (Page 113)	Voltage	Yes
• Output range		±10 V	Yes
• Reaction to CPU STOP	<ul style="list-style-type: none"> • Turn off • Keep last value • Output substitute value 	Turn off	Yes
• Substitute value	Must be within the permitted voltage/current output range. See "Valid substitute value for the output range" table in the section Structure of a data record for output channels of the analog on-board I/O (Page 163)	0	Yes

¹⁾ All parameters can be set for on a channel-specific basis

Short-circuit detection

The diagnostics for short circuit to ground can be configured for the voltage output type. Short-circuit detection is not possible for low output values. The output voltages must therefore be under -0.1 V or over +0.1 V.

Wire break detection

The diagnostics for wire break can be configured for the current output type. Wire break detection is not possible for low output values; the output currents must therefore be below -0.2 mA or above +0.2 mA.

6.8 Parameters of the digital on-board I/O

Parameters of the digital on-board I/O in standard mode

You specify the properties of the digital on-board I/O during parameter assignment with STEP 7 (TIA Portal). The tables below list the parameters that can be set for inputs and outputs, respectively.

When parameters are assigned in the user program, they are transferred to the digital on-board I/O via data records with the WRREC instruction, see section Parameter assignment and structure of the parameter data records of the digital on-board I/O (Page 166).

The use of a digital input by a technology channel

When a digital input is in use by a technology channel (HSC, PTO or PWM) the corresponding digital input channel remains fully usable without any restriction.

Use of a digital output by a technology channel

When a digital output is in use by a technology channel (HSC, PTO or PWM), the following restrictions apply to the use of the corresponding digital output channel:

- Output values for the digital output channel are not effective. The output values are specified by the technology channel.
- The CPU STOP behavior configured for the digital output channel is not effective. The reaction of the output to CPU Stop is specified by the technology channel.
- With activated value status (Quality Information) for the DI16/DQ16 submodule, the QI bit for the digital output channel shows the value 0 (= Status "Bad").
- The current state of the digital output is not returned to the process image output. In the PTO operating mode, you can only observe the switching operations of the assigned digital outputs directly at the output. In the PWM operating mode and with high-speed counters (HSC), you can observe the current state additionally via the feedback interface. Note, however, that high frequencies may no longer be observed under certain circumstances due to an excessively low sampling rate.

Configurable parameters and default settings for inputs

Table 6-10 Configurable parameters of inputs

Parameters ¹⁾	Value range	Default	Reconfiguration in RUN
Diagnostics			
• Missing supply voltage L+	Yes/No	No	Yes
Input delay	None, 0.05 ms, 0.1 ms, 0.4 ms, 1.6 ms, 3.2 ms, 12.8 ms, 20 ms	3.2 ms	Yes
Hardware interrupt			
• Rising edge	Yes/No	No	Yes
• Falling edge	Yes/No	No	Yes

¹⁾ All parameters can be set for on a channel-specific basis

Configurable parameters and default settings for outputs

Table 6-11 Configurable parameters of outputs

Parameters ¹⁾	Value range	Default	Reconfiguration in RUN
Diagnostics			
• Missing supply voltage L+	Yes/No	No	Yes
Reaction to CPU STOP When the digital output is controlled by a technology channel (HSC, PTO or PWM), this parameter is not effective. In this case, the technology channel specifies the reaction of the digital output to CPU STOP.	<ul style="list-style-type: none"> • Turn off • Keep last value • Output substitute value 1 	Turn off	Yes

¹⁾ All parameters can be set for on a channel-specific basis

Interrupts/diagnostics alarms

7.1 Status and error displays

7.1.1 Status and error displays of the CPU part

LED display

The figure below shows the LED displays of the CPU part.

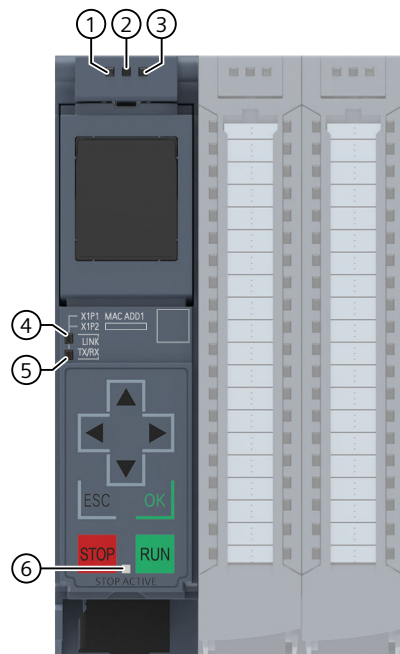





































- ① RUN/STOP LED (yellow/green LED)
- ② ERROR LED (red LED)
- ③ MAINT LED (yellow LED)
- ④ LINK RX/TX LED for port X1 P1 (yellow/green LED)
- ⑤ LINK RX/TX LED for port X1 P2 (yellow/green LED)
- ⑥ STOP ACTIVE-LED (yellow LED)



Figure 7-1 LED display of the CPU 1511C-1 PN (without front flap)

Meaning of the RUN/STOP, ERROR and MAINT LEDs

The CPU has three LEDs for displaying the current operating mode and diagnostics status. The following table shows the meaning of the various combinations of colors for the RUN/STOP, ERROR and MAINT LEDs.

Table 7-1 Meaning of the LEDs





RUN/STOP LED	ERROR LED	MAINT LED	Meaning
 LED off	 LED off	 LED off	Missing or insufficient supply voltage on the CPU.
 LED off	 LED flashes red	 LED off	An error has occurred.
 LED lit green	 LED off	 LED off	CPU is in RUN mode.
 LED lit green	 LED flashes red	 LED off	A diagnostics event is pending.
 LED lit green	 LED off	 LED lit yellow	Maintenance demanded for the plant. You need to promptly check/replace the affected hardware within a short period of time.
			Active Force job
			OPC UA server of the CPU expects initial trust lists and CRLs via the GDS push function.
 LED lit green	 LED off	 LED flashes yellow	Bad configuration
 LED lit yellow	 LED flashes red	 LED off	A diagnostics event is pending.
 LED lit yellow	 LED off	 LED flashes yellow	Firmware update via SIMATIC Memory Card completed successfully.
 LED lit yellow	 LED off	 LED off	CPU is in STOP mode.
			CPU runs a program with active breakpoints. The program is at a breakpoint.
 LED lit yellow	 LED flashes red	 LED flashes yellow	The program on the SIMATIC memory card is causing an error.
			Firmware update via SIMATIC Memory Card failed.
			The CPU has detected an error state. Additional information is available via the CPU diagnostic buffer.
 LED flashes yellow	 LED off	 LED off	CPU is performing internal activities during STOP, e.g. ramp-up after STOP.
			Download of the user program from the SIMATIC memory card
			CPU carries out a program with active breakpoint. The program is presently moving from one breakpoint to another.
			Firmware update is being performed.
 LED flashes yellow/green	 LED off	 LED off	Startup (transition from STOP → RUN)

RUN/STOP LED	ERROR LED	MAINT LED	Meaning
 LED flashes yellow/green	 LED flashes red	 LED flashes yellow	Startup (CPU booting)
			Test of LEDs during startup, inserting a module.
			LED flashing test

Meaning of LINK RX/TX LED

Each port has a LINK RX/TX LED. The table below shows the various "LED scenarios" of the CPU ports.

Table 7-2 Meaning of the LED

LINK TX/RX LED	Meaning
 LED off	There is no Ethernet connection between the PROFINET interface of the PROFINET device and the communication partner. No data is currently being sent/received via the PROFINET interface. There is no LINK connection.
 LED flashes green	The CPU is performing an "LED flash test".
 LED lit green	There is an Ethernet connection between the PROFINET interface of your PROFINET device and a communication partner.
 LED flashes yellow/green	Data is currently being received from or sent to a communications partner on Ethernet via the PROFINET interface of the PROFINET device.

NOTE

"LED" instruction

You can read the status (e.g. "On" or "Off") of LEDs of a CPU or a module using the "LED" instruction. Note, however, that it is not possible to read the LED status of the LINK RX/TX LEDs on all S7-1500 CPUs.

You can find additional information on the "LED" instruction in the STEP 7 online help.

Meaning of the STOP ACTIVE LED

The following table shows the meaning of the STOP ACTIVE LED for the CPU 1511C-1 PN.

Table 7-3 Meaning of the LED

STOP ACTIVE LED	Meaning
 LED lit yellow	The CPU has been switched to STOP mode using the STOP button. <ul style="list-style-type: none"> As long as the STOP ACTIVE LED is lit up, switching the CPU to RUN mode is only possible using the RUN button. The CPU can then no longer be set to RUN mode via the display operation or via online functions. The state of the buttons is retained at power-off. If the CPU does not start up automatically after a power-on, you have to keep the STOP button pressed during start-up until the STOP ACTIVE LED is activated. If an automatic start-up is to be reliably prevented after a power-up, the STOP button has to be kept pressed during the start-up of the CPU until the STOP ACTIVE LED is activated.

STOP ACTIVE LED	Meaning
<div style="text-align: center;"> LED off </div>	<ul style="list-style-type: none"> The CPU is set to "STOP" mode using the display or programming device and not with the STOP button on the device. The CPU is in RUN mode.

7.1.2 Status and error displays of the analog on-board I/O

LED displays

The figure below shows the LED displays (status and error displays) of the analog on-board I/O.

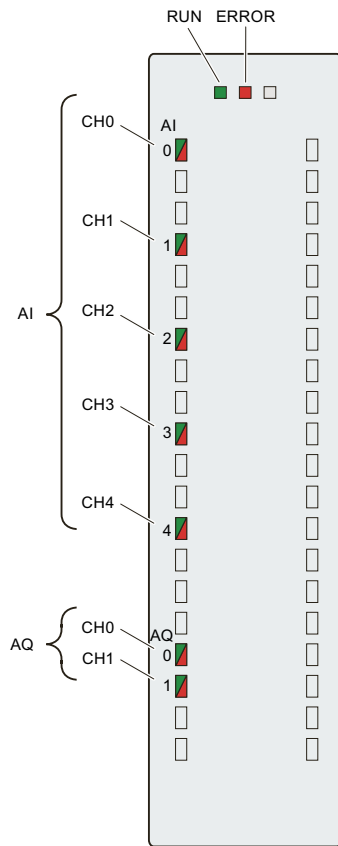









Figure 7-2 LED displays

Meaning of the LED displays



The following tables explain the meaning of the status and error displays. Remedial measures for diagnostics alarms can be found in the Interrupts and diagnostics of the analog on-board I/O (Page 125) section.

Table 7-4 RUN/ERROR status and error displays

LEDs		Meaning	Remedy
RUN	ERROR		
 Off	 Off	No voltage or voltage too low.	<ul style="list-style-type: none"> Turn on the CPU and/or the system power supply modules.
 Flashes	 Off	Analog on-board I/O starts up and flashes until valid parameter assignment.	---
 On	 Off	Parameters have been set for the analog on-board I/O.	---
 On	 Flashes	Indicates module errors (at least one error is present on one channel, e.g. wire break).	Evaluate the diagnostics and eliminate the error (e.g. wire break).

CHx LED

Table 7-5 CHx status display

CHx LED	Meaning	Remedy
 Off	Channel disabled.	---
 On	Channel parameters set and OK.	---
 On	Channel parameters set, channel error present. Diagnostics alarm: e.g. wire break	Check the wiring. Disable diagnostics.

NOTE

Maintenance LED

During ramp-up, the firmware of the CPU checks the consistency of the calibration data of the analog on-board I/O stored by the SIEMENS production. The yellow MAINT LED lights up if the firmware detects an inconsistency (e.g. an invalid value) or missing calibration data. The MAINT LED is located next to the red ERROR LED on the analog on-board I/O.

Note that the MAINT LED on the analog on-board I/O is only intended for troubleshooting by SIEMENS. In normal conditions, the MAINT LED should not light up. However, if this is the case, please contact SIEMENS "mySupport" on the Internet (<https://support.industry.siemens.com/My/ww/en/>).

7.1.3 Status and error displays of the digital on-board I/O

LED displays

The figure below shows the LED displays (status and error displays) of the digital on-board I/O. Remedial measures for diagnostics alarms can be found in the Interrupts and diagnostics (Page 125) section.

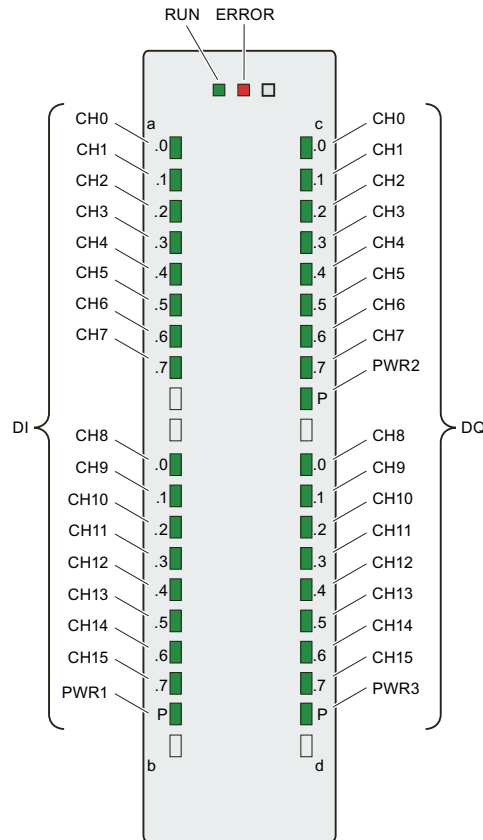









Figure 7-3 LED displays

Meaning of the LED displays

The following tables explain the meaning of the status and error displays.



RUN/ERROR LED

Table 7-6 RUN/ERROR status and error displays

LED		Meaning	Remedy
RUN	ERROR		
 Off	 Off	No voltage or voltage too low.	<ul style="list-style-type: none"> Turn on the CPU. Check whether too many modules are inserted.
 Flashes	 Off	Digital on-board I/O starts up.	---
 On	 Off	Digital on-board I/O is ready for operation.	
 On	 Flashes	A diagnostics interrupt is pending. Supply voltage missing.	Check supply voltage L+.



PWRx LED

Table 7-7 PWRx status display

PWRx LED	Meaning	Remedy
 Off	Supply voltage L+ to module too low or missing.	Check supply voltage L+.
 On	Supply voltage L+ is present and OK.	---

CHx LED

Table 7-8 CHx status display

CHx LED	Meaning	Remedy
 Off	0 = Status of the input/output signal.	---
 On	1 = Status of the input/output signal.	---

NOTE

For the status display, the digital inputs only take into account the filter time of the corresponding DI and not the filter time of the A/B/N signals of the fast counters (HSC). For example, a static signal may be displayed when the DI has a configured input delay of 3.2 ms, even though a 100 kHz counter on these inputs still detects edge transitions.

7.2 Interrupts and diagnostics

7.2.1 Interrupts and diagnostics of the CPU part

For information on the topic of "Interrupts", refer to the STEP 7 (TIA Portal) online help. For information on "Diagnostics" and "System alarms", refer to the Diagnostics (<http://support.automation.siemens.com/WW/view/en/59192926>) function manual.

7.2.2 Interrupts and diagnostics of the analog on-board I/O

Diagnostics interrupt

The analog on-board I/O generates a diagnostics interrupt at the following events:

Table 7-9 Diagnostics interrupt for inputs and outputs

Event	Diagnostics interrupt	
	Inputs	Outputs
Overflow	x	x
Underflow	x	x
Wire break	x ¹⁾	x ²⁾
Short-circuit to ground	---	x ³⁾

1) Possible for the voltage measuring range (1 to 5 V), current measuring range (4 to 20 mA)

2) Possible for current output type

3) Possible for voltage output type

Hardware interrupt for inputs

The compact CPU can generate a hardware interrupt for the following events:

- Below low limit 1
- Above high limit 1
- Below low limit 2
- Above high limit 2

You can find detailed information on the event in the hardware interrupt organization block with the "RALARM" (read additional interrupt information) instruction and in the STEP 7 (TIA Portal) online help.

The start information of the organization block includes information on which channel of the analog on-board I/O triggered the hardware interrupt. The figure below shows the assignment to the bits of double word 8 in local data.

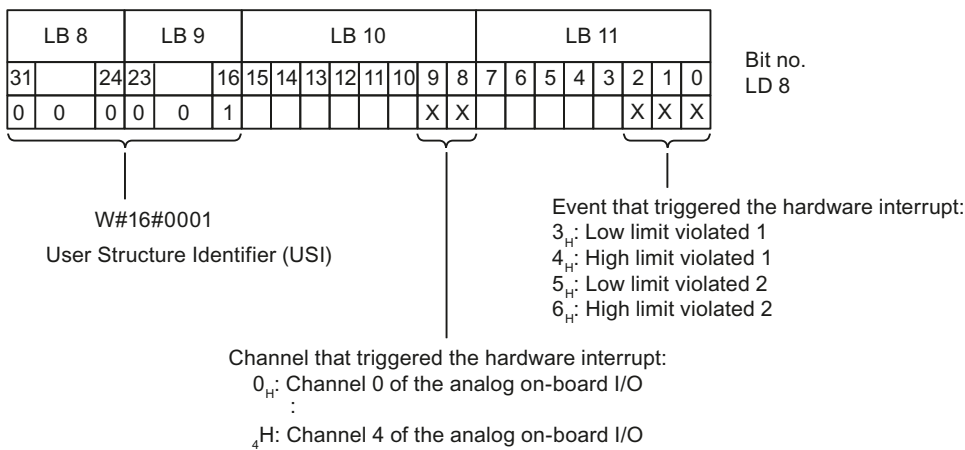

Figure 7-4 Start information of the organization block

Behavior when limits 1 and 2 are reached at the same time

If the two high limits 1 and 2 are reached at the same time, the analog on-board I/O always signals the hardware interrupt for high limit 1 first. The configured value for high limit 2 is irrelevant. After processing the hardware interrupt for high limit 1, the compact CPU triggers the hardware interrupt for high limit 2.

The analog on-board I/O behaves accordingly when the low limits are reached simultaneously. If the two low limits 1 and 2 are reached at the same time, the analog on-board I/O always signals the hardware interrupt for low limit 1 first. After processing the hardware interrupt for low limit 1, the analog on-board I/O triggers the hardware interrupt for low limit 2.

Structure of the additional interrupt information

Table 7-10 Structure of USI = W#16#0001

Data block name	Contents	Comment	Bytes
USI (User Structure Identifier)	W#16#0001	Additional interrupt information of the analog on-board I/O	2
The channel that triggered the hardware interrupt follows.			
Channel	B#16#00 to B#16#n	Number of the event-triggering channel (n = number of analog on-board I/O channels -1)	1
It is followed by the event that triggered the hardware interrupt.			
Event	B#16#03	Below low limit 1	1
	B#16#04	Above high limit 1	
	B#16#05	Below low limit 2	
	B#16#06	Above high limit 2	

Diagnostics alarms

A diagnostics alarm is output for each diagnostics event and the ERROR LED flashes on the analog on-board I/O. The diagnostics alarms can, for example, be read out in the diagnostics buffer of the CPU. You can evaluate the error codes with the user program.

Table 7-11 Diagnostics alarms, their meaning and corrective measures

Diagnostics alarm	Error code	Meaning	Remedy
Wire break	6 _H	Resistance of encoder circuit too high	Use a different encoder type or modify the wiring, for example, using cables with larger cross-section
		Interruption of the cable between the analog on-board I/O and sensor	Connect the cable
		Channel not connected (open)	<ul style="list-style-type: none"> Disable diagnostics Connect the channel
Overflow	7 _H	Measuring range exceeded	Check the measuring range
		The output value set by the user program exceeds the valid rated range/overrange	Correct the output value
Underflow	8 _H	Value below measuring range	Check the measuring range
		The output value set by the user program is below the valid rated range/underrange	Correct the output value
Short-circuit to ground	1 _H	Overload at output	Eliminate overload
		Short-circuit of output Q _V to M _{ANA}	Eliminate the short-circuit

7.2.3 Interrupts and diagnostics of the digital on-board I/O

Diagnostics interrupt

A diagnostics alarm is output for each diagnostics event and the ERROR LED flashes on the digital on-board I/O. You can read out the diagnostics alarms, for example, in the diagnostics buffer of the CPU. You can evaluate the error codes with the user program.

Table 7-12 Diagnostics alarms, their meaning and corrective measures

Diagnostics alarm	Error code	Meaning	Corrective measures
Load voltage missing	11 _H	No supply voltage L+	Feed supply voltage L+
Hardware interrupt lost	16 _H	The digital on-board I/O cannot trigger an interrupt because the previous interrupt was not acknowledged; possibly a configuration error	<ul style="list-style-type: none"> Change the interrupt processing in the CPU and reconfigure the digital on-board I/O.

Diagnostics interrupt when using high-speed counters

Table 7-13 Diagnostics alarms, their meaning and corrective measures

Diagnostics alarm	Error code	Meaning	Corrective measures
Illegal A/B signal ratio	500 _H	<ul style="list-style-type: none"> Time sequence of the A and B signals of the incremental encoder do not meet certain requirements Possible causes: <ul style="list-style-type: none"> Signal frequency too high Encoder is defective Process wiring is incorrect 	<ul style="list-style-type: none"> Correct the process wiring Check the encoder/sensor Check the parameter assignment

Hardware interrupt

The compact CPU can generate a hardware interrupt for the following events:

- Rising edge
- Falling edge

You will find detailed information on the event in the hardware interrupt organization block with the "RALRM" (read additional interrupt information) instruction and in the STEP 7 online help.

The start information of the organization block includes information on which channel triggered the hardware interrupt. The figure below shows the assignment to the bits of double word 8 in local data.

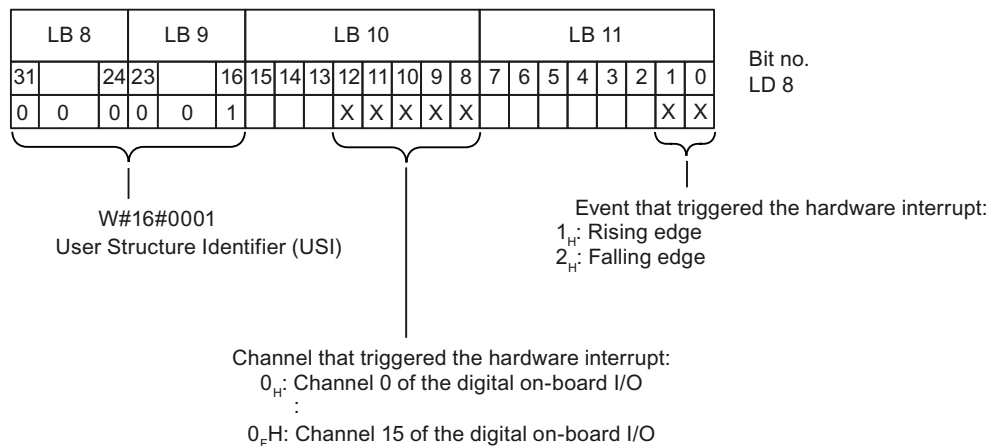

Figure 7-5 Start information of the organization block

Structure of the additional interrupt information

Table 7-14 Structure of USI = W#16#0001

Data block name	Contents	Comment	Bytes
USI (User Structure Identifier)	W#16#0001	Additional interrupt information of the hardware interrupts of the digital on-board I/O	2
The channel that triggered the hardware interrupt follows.			
Channel	B#16#00 to B#16#0F	Number of the event-triggering channel (channel 0 to channel 15)	1
The error event that triggered the hardware interrupt follows.			
Event	B#16#01	Rising edge	1
	B#16#02	Falling edge	

Hardware interrupts when using the high-speed counters

Table 7-15 Hardware interrupts and their meaning

Hardware interrupt	Event type number	Meaning
Opening of the internal gate (gate start)	1	When the internal gate is opened, the technology function triggers a hardware interrupt in the CPU.
Closing of the internal gate (gate stop)	2	When the internal gate is closed, the technology function triggers a hardware interrupt in the CPU.
Overflow (high counting limit violated)	3	When the count value exceeds the high counting limit, the technology function triggers a hardware interrupt in the CPU.
Underflow (low counting limit violated)	4	When the count value falls below the low counting limit, the technology function triggers a hardware interrupt in the CPU.
Comparison event for DQ0 occurred	5	When a comparison event for DQ0 occurs due to the selected comparison condition, the technology function triggers a hardware interrupt in the CPU. When the change of the count value for an incremental or pulse encoder was not caused by a count pulse, the technology function does not trigger a hardware interrupt.
Comparison event for DQ1 occurred	6	When a comparison event for DQ1 occurs due to the selected comparison condition, the technology function triggers a hardware interrupt in the CPU. When the change of the count value for an incremental or pulse encoder was not caused by a count pulse, the technology function does not trigger a hardware interrupt.
Zero crossing	7	At a zero crossing of the counter or position value, the technology function triggers a hardware interrupt in the CPU.
New Capture value present ¹⁾	8	When the current counter or position value is saved as a Capture value, the technology function triggers a hardware interrupt in the CPU.
Synchronization of the counter by an external signal	9	At the synchronization of the counter by an N signal or edge at DI, the technology function triggers a hardware interrupt in the CPU.
Direction reversal ²⁾	10	When the count value or position value changes direction, the technology function triggers a hardware interrupt in the CPU.

1) Can only be set in counting mode

2) Feedback bit STS_DIR is preset to "0". When the first count value or position value change occurs in the reverse direction directly after switching on the digital on-board I/O, a hardware interrupt is not triggered.

Technical specifications

Technical specifications of the CPU 1511C-1 PN

The following table shows the technical specifications as of 05/2024. You will find a data sheet including daily updated technical specifications on the Internet

(<https://support.industry.siemens.com/cs/ww/en/pv/6ES7511-1CL03-0AB0/td?dl=en>).

Article number	6ES7511-1CL03-0AB0
General information	
Product type designation	CPU 1511C-1 PN
HW functional status	FS01
Firmware version	V3.1
<ul style="list-style-type: none"> FW update possible 	Yes
Product function	
<ul style="list-style-type: none"> I&M data 	Yes; I&M0 to I&M3
<ul style="list-style-type: none"> Isochronous mode 	Yes; with minimal OB 6x cycle of 500 µs (distributed)
<ul style="list-style-type: none"> SysLog 	Yes
Engineering with	
<ul style="list-style-type: none"> STEP 7 TIA Portal configurable/integrated from version 	V19 (FW V3.1); with older TIA Portal versions configurable as 6ES7511-1CK00-0AB0
Configuration control	
via dataset	Yes
Display	
Screen diagonal [cm]	3.45 cm
Control elements	
Number of keys	8
Mode buttons	2
Supply voltage	
Rated value (DC)	24 V
permissible range, lower limit (DC)	19.2 V; 20.4 V DC, for supplying the digital inputs/outputs
permissible range, upper limit (DC)	28.8 V
Reverse polarity protection	Yes
Mains buffering	
<ul style="list-style-type: none"> Mains/voltage failure stored energy time 	5 ms; Refers to the power supply on the CPU section
<ul style="list-style-type: none"> Repeat rate, min. 	1/s

Article number	6ES7511-1CL03-0AB0
Input current	
Current consumption (rated value)	0.62 A; without DI/DO load
Current consumption, max.	0.9 A; without DI/DO load
Inrush current, max.	1.22 A; Rated value
I^2t	0.6 A ² ·s
Digital inputs	
• from load voltage L+ (without load), max.	20 mA; per group
Digital outputs	
• from load voltage L+, max.	30 mA; Per group, without load
output voltage / header	
Rated value (DC)	24 V
Encoder supply	
Number of outputs	1; One common 24 V encoder supply
24 V encoder supply	
• 24 V	Yes; L+ (-0.8 V)
• Short-circuit protection	Yes
• Output current, max.	1 A
Power	
Infeed power to the backplane bus	10 W
Power consumption from the backplane bus (balanced)	8.5 W
Power loss	
Power loss, typ.	5 W
Memory	
Number of slots for SIMATIC memory card	1
SIMATIC memory card required	Yes
Work memory	
• integrated (for program)	300 kbyte
• integrated (for data)	1.5 Mbyte
Load memory	
• Plug-in (SIMATIC Memory Card), max.	32 Gbyte
Backup	
• maintenance-free	Yes
CPU processing times	
for bit operations, typ.	25 ns
for word operations, typ.	32 ns
for fixed point arithmetic, typ.	42 ns
for floating point arithmetic, typ.	170 ns
CPU-blocks	
Number of elements (total)	4 000; Blocks (OB, FB, FC, DB) and UDTs

Article number	6ES7511-1CL03-0AB0
DB	
<ul style="list-style-type: none"> Number range 	1 ... 60 999; subdivided into: number range that can be used by the user: 1 ... 59 999, and number range of DBs created via SFC 86: 60 000 ... 60 999
<ul style="list-style-type: none"> Size, max. 	1.5 Mbyte; For DBs with absolute addressing, the max. size is 64 KB
FB	
<ul style="list-style-type: none"> Number range 	0 ... 65 535
<ul style="list-style-type: none"> Size, max. 	300 kbyte
FC	
<ul style="list-style-type: none"> Number range 	0 ... 65 535
<ul style="list-style-type: none"> Size, max. 	300 kbyte
OB	
<ul style="list-style-type: none"> Size, max. 	300 kbyte
<ul style="list-style-type: none"> Number of free cycle OBs 	100
<ul style="list-style-type: none"> Number of time alarm OBs 	20
<ul style="list-style-type: none"> Number of delay alarm OBs 	20
<ul style="list-style-type: none"> Number of cyclic interrupt OBs 	20; With minimum OB 3x cycle of 250 μs
<ul style="list-style-type: none"> Number of process alarm OBs 	50
<ul style="list-style-type: none"> Number of DPV1 alarm OBs 	3
<ul style="list-style-type: none"> Number of isochronous mode OBs 	1
<ul style="list-style-type: none"> Number of technology synchronous alarm OBs 	2
<ul style="list-style-type: none"> Number of startup OBs 	100
<ul style="list-style-type: none"> Number of asynchronous error OBs 	4
<ul style="list-style-type: none"> Number of synchronous error OBs 	2
<ul style="list-style-type: none"> Number of diagnostic alarm OBs 	1
Nesting depth	
<ul style="list-style-type: none"> per priority class 	24
Counters, timers and their retentivity	
S7 counter	
<ul style="list-style-type: none"> Number 	2 048
Retentivity	
– adjustable	Yes
IEC counter	
<ul style="list-style-type: none"> Number 	Any (only limited by the main memory)
Retentivity	
– adjustable	Yes
S7 times	
<ul style="list-style-type: none"> Number 	2 048

Article number	6ES7511-1CL03-0AB0
Retentivity – adjustable	Yes
IEC timer • Number	Any (only limited by the main memory)
Retentivity – adjustable	Yes
Data areas and their retentivity	
Retentive data area (incl. timers, counters, flags), max.	256 kbyte; in total; available retentive memory for bit memories, timers, counters, DBs, and technology data (axes): 216 KB
Extended retentive data area (incl. timers, counters, flags), max.	1.5 Mbyte; When using PS 6 0W 24/48/60 V DC HF
Flag • Size, max. • Number of clock memories	16 kbyte 8; 8 clock memory bit, grouped into one clock memory byte
Data blocks • Retentivity adjustable • Retentivity preset	Yes No
Local data • per priority class, max.	64 kbyte; max. 16 KB per block
Address area	
Number of IO modules	2 048; max. number of modules / submodules
I/O address area • Inputs • Outputs	32 kbyte; All inputs are in the process image 32 kbyte; All outputs are in the process image
per integrated IO subsystem – Inputs (volume) – Outputs (volume)	8 kbyte 8 kbyte
per CM/CP – Inputs (volume) – Outputs (volume)	8 kbyte 8 kbyte
Subprocess images • Number of subprocess images, max.	32
Hardware configuration	
Number of distributed IO systems	32; A distributed I/O system is characterized not only by the integration of distributed I/O via PROFINET or PROFIBUS communication modules, but also by the connection of I/O via AS-i master modules or links (e.g. IE/PB-Link)
Number of DP masters • Via CM	4; A maximum of 4 CMs/CPs (PROFIBUS, PROFINET, Ethernet) can be inserted in total

Article number	6ES7511-1CL03-0AB0
Number of IO Controllers <ul style="list-style-type: none"> integrated Via CM 	1 4; A maximum of 4 CMs/CPs (PROFIBUS, PROFINET, Ethernet) can be inserted in total
Rack <ul style="list-style-type: none"> Modules per rack, max. Number of lines, max. 	32; CPU + 31 modules 1
PtP CM <ul style="list-style-type: none"> Number of PtP CMs 	the number of connectable PtP CMs is only limited by the number of available slots
Time of day	
Clock <ul style="list-style-type: none"> Type Backup time Deviation per day, max. 	Hardware clock 6 wk; At 40 °C ambient temperature, typically 10 s; Typ.: 2 s
Operating hours counter <ul style="list-style-type: none"> Number 	16
Clock synchronization <ul style="list-style-type: none"> supported in AS, master in AS, slave on Ethernet via NTP 	Yes Yes Yes Yes
Digital inputs <ul style="list-style-type: none"> integrated channels (DI) Digital inputs, parameterizable Source/sink input Input characteristic curve in accordance with IEC 61131, type 3 	16 Yes P-reading Yes
Digital input functions, parameterizable <ul style="list-style-type: none"> Gate start/stop Capture Synchronization 	Yes Yes Yes
Input voltage <ul style="list-style-type: none"> Type of input voltage Rated value (DC) for signal "0" for signal "1" 	DC 24 V -3 to +5V +11 to +30V
Input current <ul style="list-style-type: none"> for signal "1", typ. 	2.5 mA

Article number	6ES7511-1CL03-0AB0
Input delay (for rated value of input voltage) for standard inputs <ul style="list-style-type: none"> – parameterizable – at "0" to "1", min. – at "0" to "1", max. – at "1" to "0", min. – at "1" to "0", max. for interrupt inputs <ul style="list-style-type: none"> – parameterizable for technological functions <ul style="list-style-type: none"> – parameterizable 	Yes; none / 0.05 / 0.1 / 0.4 / 1.6 / 3.2 / 12.8 / 20 ms 4 µs; for parameterization "none" 20 ms 4 µs; for parameterization "none" 20 ms Yes; Same as for standard inputs Yes; Same as for standard inputs
Cable length <ul style="list-style-type: none"> • shielded, max. • unshielded, max. 	1 000 m; 600 m for technological functions; depending on input frequency, encoder and cable quality; max. 50 m at 100 kHz 600 m; for technological functions: No
Digital outputs Type of digital output integrated channels (DO) Current-sourcing Short-circuit protection <ul style="list-style-type: none"> • Response threshold, typ. Controlling a digital input Accuracy of pulse duration minimum pulse duration	Transistor 16 Yes; Push-pull output Yes; electronic/thermal 1.6 A with standard output, 0.5 A with high-speed output; see manual for details Yes Up to ±100 ppm ±2 µs at high-speed output; see manual for details 2 µs; With High Speed output
Digital output functions, parameterizable <ul style="list-style-type: none"> • Switching tripped by comparison values • PWM output <ul style="list-style-type: none"> – Number, max. – Cycle duration, parameterizable – ON period, min. – ON period, max. – Resolution of the duty cycle • Frequency output 	Yes; As output signal of a high-speed counter Yes 4 Yes 0 % 100 % 0.0036 %; For S7 analog format, min. 40 ns Yes

Article number	6ES7511-1CL03-0AB0
Switching capacity of the outputs <ul style="list-style-type: none"> with resistive load, max. on lamp load, max. 	0.5 A; 0.1 A with high-speed output, i.e. when using a high-speed output; see manual for details 5 W; 1 W with high-speed output, i.e. when using a high-speed output; see manual for details
Load resistance range <ul style="list-style-type: none"> lower limit upper limit 	48 Ω; 240 ohms with high-speed output, i.e. when using a high-speed output; see manual for details 12 kΩ
Output voltage <ul style="list-style-type: none"> Type of output voltage for signal "0", max. for signal "1", min. 	DC 1 V; With high-speed output, i.e. when using a high-speed output; see manual for details 23.2 V; L+ (-0.8 V)
Output current <ul style="list-style-type: none"> for signal "1" rated value for signal "1" permissible range, min. for signal "1" permissible range, max. for signal "0" residual current, max. 	0.5 A; 0.1 A with high-speed output, i.e. when using a high-speed output, observe derating; see manual for details 2 mA 0.6 A; 0.12 A with high-speed output, i.e. when using a high-speed output, observe derating; see manual for details 0.5 mA
Output delay with resistive load <ul style="list-style-type: none"> "0" to "1", max. "1" to "0", max. 	200 μs 500 μs; Load-dependent
for technological functions <ul style="list-style-type: none"> "0" to "1", max. "1" to "0", max. 	5 μs; Depending on the output used, see additional description in manual 5 μs; Depending on the output used, see additional description in manual
Parallel switching of two outputs <ul style="list-style-type: none"> for logic links for uprating for redundant control of a load 	Yes; for technological functions: No No Yes; for technological functions: No
Switching frequency <ul style="list-style-type: none"> with resistive load, max. with inductive load, max. on lamp load, max. 	100 kHz; For high-speed output, 100 Hz for standard output 0.5 Hz; Acc. to IEC 60947-5-1, DC-13; observe derating curve 10 Hz

Article number	6ES7511-1CL03-0AB0
Total current of the outputs	
<ul style="list-style-type: none"> • Current per channel, max. • Current per group, max. • Current per power supply, max. 	<p>0.5 A; see additional description in the manual</p> <p>8 A; see additional description in the manual</p> <p>4 A; 2 power supplies for each group, current per power supply max. 4 A, see additional description in manual</p>
for technological functions	
<ul style="list-style-type: none"> – Current per channel, max. 	0.5 A; see additional description in the manual
Relay outputs	
<ul style="list-style-type: none"> • Number of relay outputs 	0
Cable length	
<ul style="list-style-type: none"> • shielded, max. • unshielded, max. 	<p>1 000 m; 600 m for technological functions; depending on output frequency, load, and cable quality; max. 50 m at 100 kHz</p> <p>600 m; for technological functions: No</p>
Analog inputs	
Number of analog inputs	5; 4x for U/I, 1x for R/RTD
<ul style="list-style-type: none"> • For current measurement • For voltage measurement • For resistance/resistance thermometer measurement 	<p>4; max.</p> <p>4; max.</p> <p>1</p>
permissible input voltage for voltage input (destruction limit), max.	28.8 V
permissible input current for current input (destruction limit), max.	40 mA
Cycle time (all channels), min.	1 ms; Dependent on the parameterized interference frequency suppression; for details, see conversion procedure in manual
Technical unit for temperature measurement adjustable	Yes; °C/°F/K
Input ranges (rated values), voltages	
<ul style="list-style-type: none"> • 0 to +10 V <ul style="list-style-type: none"> – Input resistance (0 to 10 V) • 1 V to 5 V <ul style="list-style-type: none"> – Input resistance (1 V to 5 V) • -10 V to +10 V <ul style="list-style-type: none"> – Input resistance (-10 V to +10 V) • -5 V to +5 V <ul style="list-style-type: none"> – Input resistance (-5 V to +5 V) 	<p>Yes; Physical measuring range: ± 10 V</p> <p>100 kΩ</p> <p>Yes; Physical measuring range: ± 10 V</p> <p>100 kΩ</p> <p>Yes</p> <p>100 kΩ</p> <p>Yes; Physical measuring range: ± 10 V</p> <p>100 kΩ</p>
Input ranges (rated values), currents	
<ul style="list-style-type: none"> • 0 to 20 mA <ul style="list-style-type: none"> – Input resistance (0 to 20 mA) 	<p>Yes; Physical measuring range: ± 20 mA</p> <p>50 Ω; Plus approx. 55 ohm for overvoltage protection by PTC</p>

Article number	6ES7511-1CL03-0AB0
<ul style="list-style-type: none"> • -20 mA to +20 mA <ul style="list-style-type: none"> – Input resistance (-20 mA to +20 mA) • 4 mA to 20 mA <ul style="list-style-type: none"> – Input resistance (4 mA to 20 mA) 	Yes 50 Ω; Plus approx. 55 ohm for overvoltage protection by PTC Yes; Physical measuring range: ± 20 mA 50 Ω; Plus approx. 55 ohm for overvoltage protection by PTC
Input ranges (rated values), resistance thermometer <ul style="list-style-type: none"> • Ni 100 <ul style="list-style-type: none"> – Input resistance (Ni 100) • Pt 100 <ul style="list-style-type: none"> – Input resistance (Pt 100) 	Yes; Standard/climate 10 MΩ Yes; Standard/climate 10 MΩ
Input ranges (rated values), resistors <ul style="list-style-type: none"> • 0 to 150 ohms <ul style="list-style-type: none"> – Input resistance (0 to 150 ohms) • 0 to 300 ohms <ul style="list-style-type: none"> – Input resistance (0 to 300 ohms) • 0 to 600 ohms <ul style="list-style-type: none"> – Input resistance (0 to 600 ohms) 	Yes; Physical measuring range: 0 ... 600 ohms 10 MΩ Yes; Physical measuring range: 0 ... 600 ohms 10 MΩ Yes 10 MΩ
Cable length <ul style="list-style-type: none"> • shielded, max. 	800 m; for U/I, 200 m for R/RTD
Analog outputs <ul style="list-style-type: none"> integrated channels (AO) Voltage output, short-circuit protection Cycle time (all channels), min. 	2 Yes 1 ms; Dependent on the parameterized interference frequency suppression; for details, see conversion procedure in manual
Output ranges, voltage <ul style="list-style-type: none"> • 0 to 10 V • 1 V to 5 V • -10 V to +10 V 	Yes Yes Yes
Output ranges, current <ul style="list-style-type: none"> • 0 to 20 mA • -20 mA to +20 mA • 4 mA to 20 mA 	Yes Yes Yes
Load impedance (in rated range of output) <ul style="list-style-type: none"> • with voltage outputs, min. • with voltage outputs, capacitive load, max. • with current outputs, max. • with current outputs, inductive load, max. 	1 kΩ 100 nF 500 Ω 1 mH

Article number	6ES7511-1CL03-0AB0
Cable length	
<ul style="list-style-type: none"> shielded, max. 	200 m
Analog value generation for the inputs	
Integration and conversion time/resolution per channel	
<ul style="list-style-type: none"> Resolution with overrange (bit including sign), max. 	16 bit
<ul style="list-style-type: none"> Integration time, parameterizable 	Yes; 2.5 / 16.67 / 20 / 100 ms, acts on all channels
<ul style="list-style-type: none"> Interference voltage suppression for interference frequency f1 in Hz 	400 / 60 / 50 / 10
Smoothing of measured values	
<ul style="list-style-type: none"> parameterizable 	Yes
<ul style="list-style-type: none"> Step: None 	Yes
<ul style="list-style-type: none"> Step: low 	Yes
<ul style="list-style-type: none"> Step: Medium 	Yes
<ul style="list-style-type: none"> Step: High 	Yes
Analog value generation for the outputs	
Integration and conversion time/resolution per channel	
<ul style="list-style-type: none"> Resolution with overrange (bit including sign), max. 	16 bit
Settling time	
<ul style="list-style-type: none"> for resistive load 	1.5 ms
<ul style="list-style-type: none"> for capacitive load 	2.5 ms
<ul style="list-style-type: none"> for inductive load 	2.5 ms
Encoder	
Connection of signal encoders	
<ul style="list-style-type: none"> for voltage measurement 	Yes
<ul style="list-style-type: none"> for current measurement as 4-wire transducer 	Yes
<ul style="list-style-type: none"> for resistance measurement with two-wire connection 	Yes
<ul style="list-style-type: none"> for resistance measurement with three-wire connection 	Yes
<ul style="list-style-type: none"> for resistance measurement with four-wire connection 	Yes
Connectable encoders	
<ul style="list-style-type: none"> 2-wire sensor 	Yes
<ul style="list-style-type: none"> – permissible quiescent current (2-wire sensor), max. 	1.5 mA

Article number	6ES7511-1CL03-0AB0
Encoder signals, incremental encoder (asymmetrical)	
<ul style="list-style-type: none"> • Input voltage • Input frequency, max. • Counting frequency, max. • Signal filter, parameterizable • Incremental encoder with A/B tracks, 90° phase offset • Incremental encoder with A/B tracks, 90° phase offset and zero track • pulse encoder • pulse encoder with direction • pulse encoder with one impulse signal per count direction 	24 V 100 kHz 400 kHz; with quadruple evaluation Yes Yes Yes Yes Yes Yes
Errors/accuracies	
Linearity error (relative to input range), (+/-)	0.1 %
Temperature error (relative to input range), (+/-)	0.005 %/K
Crosstalk between the inputs, max.	-60 dB
Repeat accuracy in steady state at 25 °C (relative to input range), (+/-)	0.05 %
Output ripple (relative to output range, bandwidth 0 to 50 kHz), (+/-)	0.02 %
Linearity error (relative to output range), (+/-)	0.15 %
Temperature error (relative to output range), (+/-)	0.005 %/K
Crosstalk between the outputs, max.	-80 dB
Repeat accuracy in steady state at 25 °C (relative to output range), (+/-)	0.05 %
Operational error limit in overall temperature range	
<ul style="list-style-type: none"> • Voltage, relative to input range, (+/-) • Current, relative to input range, (+/-) • Resistance, relative to input range, (+/-) • Resistance thermometer, relative to input range, (+/-) • Voltage, relative to output range, (+/-) • Current, relative to output range, (+/-) 	0.3 % 0.3 % 0.3 % Pt100 Standard: ±2 K, Pt100 Climate: ±1 K, Ni100 Standard: ±1.2 K, Ni100 Climate: ±1 K 0.3 % 0.3 %

Article number	6ES7511-1CL03-0AB0
Basic error limit (operational limit at 25 °C)	
<ul style="list-style-type: none"> Voltage, relative to input range, (+/-) Current, relative to input range, (+/-) Resistance, relative to input range, (+/-) Resistance thermometer, relative to input range, (+/-) Voltage, relative to output range, (+/-) Current, relative to output range, (+/-) 	0.2 % 0.2 % 0.2 % Pt100 Standard: ±1 K, Pt100 Climate: ±0.5 K, Ni100 Standard: ±0.6 K, Ni100 Climate: ±0.5 K 0.2 % 0.2 %
Interference voltage suppression for $f = n \times (f1 \pm 1 \%)$, $f1 =$ interference frequency	
<ul style="list-style-type: none"> Series mode interference (peak value of interference < rated value of input range), min. Common mode voltage, max. Common mode interference, min. 	30 dB 10 V 60 dB; at 400 Hz: 50 dB
Interfaces	
Number of PROFINET interfaces	1
1. Interface	
Interface types	
<ul style="list-style-type: none"> RJ 45 (Ethernet) Number of ports integrated switch 	Yes; X1 2 Yes
Protocols	
<ul style="list-style-type: none"> IP protocol PROFINET IO Controller PROFINET IO Device SIMATIC communication Open IE communication Web server Media redundancy 	Yes; IPv4 Yes Yes Yes Yes; Optionally also encrypted Yes Yes

Article number	6ES7511-1CL03-0AB0
PROFINET IO Controller	
Services	
– Isochronous mode	Yes
– Direct data exchange	Yes; Requirement: IRT and isochronous mode (MRPD optional)
– IRT	Yes
– PROFlenergy	Yes; per user program
– Prioritized startup	Yes; Max. 32 PROFINET devices
– Number of connectable IO Devices, max.	128; In total, up to 512 distributed I/O devices can be connected via AS-i, PROFIBUS or PROFINET
– Of which IO devices with IRT, max.	64
– Number of connectable IO Devices for RT, max.	128
– of which in line, max.	128
– Number of IO Devices that can be simultaneously activated/deactivated, max.	8; in total across all interfaces
– Number of IO Devices per tool, max.	8
– Updating times	The minimum value of the update time also depends on communication share set for PROFINET IO, on the number of IO devices, and on the quantity of configured user data
– PROFINET Security Class	1
Update time for IRT	
– for send cycle of 250 µs	250 µs to 4 ms; Note: In the case of IRT with isochronous mode, the minimum update time of 500 µs of the isochronous OB is decisive
– for send cycle of 500 µs	500 µs to 8 ms
– for send cycle of 1 ms	1 ms to 16 ms
– for send cycle of 2 ms	2 ms to 32 ms
– for send cycle of 4 ms	4 ms to 64 ms
– With IRT and parameterization of "odd" send cycles	Update time = set "odd" send clock (any multiple of 125 µs: 375 µs, 625 µs ... 3 875 µs)
Update time for RT	
– for send cycle of 250 µs	250 µs to 128 ms
– for send cycle of 500 µs	500 µs to 256 ms
– for send cycle of 1 ms	1 ms to 512 ms
– for send cycle of 2 ms	2 ms to 512 ms
– for send cycle of 4 ms	4 ms to 512 ms

Article number	6ES7511-1CL03-0AB0
PROFINET IO Device	
Services	
– Isochronous mode	No
– IRT	Yes
– PROFINergy	Yes; per user program
– Shared device	Yes
– Number of IO Controllers with shared device, max.	4
– activation/deactivation of I-devices	Yes; per user program
– Asset management record	Yes; per user program
– PROFINET Security Class	SNMP Configuration and DCP Read Only
Interface types	
RJ 45 (Ethernet)	
• 100 Mbps	Yes
• Autonegotiation	Yes
• Autocrossing	Yes
• Industrial Ethernet status LED	Yes
Protocols	
Number of connections	
• Number of connections, max.	128; via integrated interfaces of the CPU and connected CPs / CMs
• Number of connections reserved for ES/HMI/web	10
• Number of connections via integrated interfaces	88
• Number of S7 routing paths	16
Redundancy mode	
• H-Sync forwarding	Yes
Media redundancy	
– Media redundancy	only via 1st interface (X1)
– MRP	Yes; MRP Automanager according to IEC 62439-2 Edition 2.0, MRP Manager; MRP Client
– MRP interconnection, supported	Yes; as MRP ring node according to IEC 62439-2 Edition 3.0
– MRPD	Yes; Requirement: IRT
– Switchover time on line break, typ.	200 ms; For MRP, bumpless for MRPD
– Number of stations in the ring, max.	50

Article number	6ES7511-1CL03-0AB0
SIMATIC communication	
<ul style="list-style-type: none"> • PG/OP communication • S7 routing • Data record routing • S7 communication, as server • S7 communication, as client • User data per job, max. 	<p>Yes; encryption with TLS V1.3 pre-selected</p> <p>Yes</p> <p>Yes</p> <p>Yes</p> <p>Yes</p> <p>See online help (S7 communication, user data size)</p>
Open IE communication	
<ul style="list-style-type: none"> • TCP/IP <ul style="list-style-type: none"> – Data length, max. – several passive connections per port, supported • ISO-on-TCP (RFC1006) <ul style="list-style-type: none"> – Data length, max. • UDP <ul style="list-style-type: none"> – Data length, max. – UDP multicast • DHCP • DNS • SNMP • DCP • LLDP • Encryption 	<p>Yes</p> <p>64 kbyte</p> <p>Yes</p> <p>Yes</p> <p>64 kbyte</p> <p>Yes</p> <p>2 kbyte; 1 472 bytes for UDP broadcast</p> <p>Yes; max. 78 multicast circuits</p> <p>Yes</p> <p>Yes</p> <p>Yes</p> <p>Yes</p> <p>Yes</p> <p>Yes; Optional</p>
Web server	
<ul style="list-style-type: none"> • HTTP • HTTPS • web API <ul style="list-style-type: none"> – Number of sessions, max. – number of simultaneous HTTP calls, max. – HTTP request body, max. 	<p>Yes; Standard and user pages</p> <p>Yes; Standard and user pages</p> <p>50</p> <p>4</p> <p>131 072 byte</p>

Article number	6ES7511-1CL03-0AB0
OPC UA	
<ul style="list-style-type: none"> • Runtime license required 	Yes; "Small" license required
<ul style="list-style-type: none"> • OPC UA Client 	Yes; Data Access (registered Read/Write), Method Call
<ul style="list-style-type: none"> – Application authentication 	Yes
<ul style="list-style-type: none"> – Security policies 	Available security policies: None, Basic128Rsa15, Basic256Rsa15, Basic256Sha256
<ul style="list-style-type: none"> – User authentication 	"anonymous" or by user name & password
<ul style="list-style-type: none"> – Number of connections, max. 	4
<ul style="list-style-type: none"> – Number of nodes of the client interfaces, recommended max. 	1 000
<ul style="list-style-type: none"> – Number of elements for one call of OPC-UA_NodeGetHandleList/OPC-UA_ReadList/OPC-UA_WriteList, max. 	300
<ul style="list-style-type: none"> – Number of elements for one call of OPC-UA_NameSpaceGetIndexList, max. 	20
<ul style="list-style-type: none"> – Number of elements for one call of OPC-UA_MethodGetHandleList, max. 	100
<ul style="list-style-type: none"> – Number of simultaneous calls of the client instructions for session management, per connection, max. 	1
<ul style="list-style-type: none"> – Number of simultaneous calls of the client instructions for data access, per connection, max. 	5
<ul style="list-style-type: none"> – Number of registerable nodes, max. 	5 000
<ul style="list-style-type: none"> – Number of registerable method calls of OPC-UA_MethodCall, max. 	100
<ul style="list-style-type: none"> – Number of inputs/outputs when calling OPC-UA_MethodCall, max. 	20

Article number	6ES7511-1CL03-0AB0
<ul style="list-style-type: none"> • OPC UA Server <ul style="list-style-type: none"> – Application authentication – Security policies – User authentication – GDS support (certificate management) – Number of sessions, max. – Number of accessible variables, max. – Number of registerable nodes, max. – Number of subscriptions per session, max. – Sampling interval, min. – Publishing interval, min. – Number of server methods, max. – Number of inputs/outputs per server method, max. – Number of monitored items, recommended max. – Number of server interfaces, max. – Number of nodes for user-defined server interfaces, max. • Alarms and Conditions <ul style="list-style-type: none"> – Number of program alarms – Number of alarms for system diagnostics 	<p>Yes; Data Access (Read, Write, Subscribe), Method Call, Alarms & Condition (A&C), Custom Address Space</p> <p>Yes</p> <p>available security policies: None, Basic128Rsa15, Basic256Rsa15, Basic256Sha256, Aes128Sha256RsaOaep, Aes256Sha256RsaPss "anonymous" or by user name & password</p> <p>Yes</p> <p>32</p> <p>50 000</p> <p>10 000</p> <p>50</p> <p>100 ms</p> <p>200 ms</p> <p>20</p> <p>20</p> <p>4 000; for 1 s sampling interval and 1 s send interval</p> <p>10 of each "Server interfaces" / "Companion specification" type and 20 of the type "Reference namespace"</p> <p>15 000</p> <p>Yes</p> <p>100</p> <p>50</p>
<p>Further protocols</p> <ul style="list-style-type: none"> • MODBUS 	<p>Yes; MODBUS TCP</p>
S7 message functions	
<p>Number of login stations for message functions, max.</p> <p>number of subscriptions, max.</p> <p>number of tags/attributes for subscriptions, max.</p> <p>Program alarms</p> <p>Number of configurable program messages, max.</p> <p>Number of loadable program messages in RUN, max.</p>	<p>32</p> <p>250</p> <p>2 000</p> <p>Yes</p> <p>5 000; Program messages are generated by the "Program_Alarm" block, ProDiag or GRAPH</p> <p>5 000</p>

Article number	6ES7511-1CL03-0AB0
Number of simultaneously active program alarms	
<ul style="list-style-type: none"> • Number of program alarms • Number of alarms for system diagnostics • Number of alarms for motion technology objects 	<p>600</p> <p>100</p> <p>160</p>
Test commissioning functions	
Joint commission (Team Engineering)	Yes; Parallel online access possible for up to 5 engineering systems
Status block	Yes; Up to 8 simultaneously (in total across all ES clients)
Single step	No
Number of breakpoints	8
Profiling	Yes
Status/control	
<ul style="list-style-type: none"> • Status/control variable • Variables • Number of variables, max. <ul style="list-style-type: none"> – of which status variables, max. – of which control variables, max. 	<p>Yes</p> <p>Inputs/outputs, memory bits, DBs, distributed I/Os, timers, counters</p> <p>200; per job</p> <p>200; per job</p>
Forcing	
<ul style="list-style-type: none"> • Forcing • Forcing, variables • Number of variables, max. 	<p>Yes</p> <p>Peripheral inputs/outputs</p> <p>200</p>
Diagnostic buffer	
<ul style="list-style-type: none"> • present • Number of entries, max. <ul style="list-style-type: none"> – of which powerfail-proof 	<p>Yes</p> <p>1 000</p> <p>500</p>
Traces	
<ul style="list-style-type: none"> • Number of configurable Traces 	4; Up to 512 KB of data per trace are possible
Interrupts/diagnostics/status information	
Alarms	
<ul style="list-style-type: none"> • Diagnostic alarm • Hardware interrupt 	<p>Yes</p> <p>Yes</p>
Diagnoses	
<ul style="list-style-type: none"> • Monitoring the supply voltage • Wire-break • Short-circuit • A/B transition error at incremental encoder 	<p>Yes</p> <p>Yes; for analog inputs/outputs, see description in manual</p> <p>Yes; for analog outputs, see description in manual</p> <p>Yes</p>

Article number	6ES7511-1CL03-0AB0
Diagnostics indication LED	
<ul style="list-style-type: none"> • RUN/STOP LED • ERROR LED • MAINT LED • STOP ACTIVE LED • Monitoring of the supply voltage (PWR-LED) • Channel status display • for channel diagnostics • Connection display LINK TX/RX 	<p>Yes</p> <p>Yes</p> <p>Yes</p> <p>Yes</p> <p>Yes</p> <p>Yes</p> <p>Yes; For analog inputs/outputs</p> <p>Yes</p>
Supported technology objects	
Motion Control	Yes; Note: The number of technology objects affects the cycle time of the PLC program; selection guide via the TIA Selection Tool
<ul style="list-style-type: none"> • Number of available Motion Control resources for technology objects • Required Motion Control resources <ul style="list-style-type: none"> – per speed-controlled axis – per positioning axis – per synchronous axis – per external encoder – per output cam – per cam track – per probe • Positioning axis <ul style="list-style-type: none"> – Number of positioning axes at motion control cycle of 4 ms (typical value) – Number of positioning axes at motion control cycle of 8 ms (typical value) 	<p>1 120</p> <p>40</p> <p>80</p> <p>160</p> <p>80</p> <p>20</p> <p>160</p> <p>40</p> <p>11</p> <p>14</p>
Controller	
<ul style="list-style-type: none"> • PID_Compact • PID_3Step • PID-Temp 	<p>Yes; Universal PID controller with integrated optimization</p> <p>Yes; PID controller with integrated optimization for valves</p> <p>Yes; PID controller with integrated optimization for temperature</p>
Counting and measuring	
<ul style="list-style-type: none"> • High-speed counter 	Yes
Integrated Functions	
Counter	
<ul style="list-style-type: none"> • Number of counters • Counting frequency, max. 	<p>6; Of which max. 4x A/B/N</p> <p>400 kHz; with quadruple evaluation</p>

Article number	6ES7511-1CL03-0AB0
Counting functions	
<ul style="list-style-type: none"> • Continuous counting • Counter response parameterizable • Hardware gate via digital input • Software gate • Event-controlled stop • Synchronization via digital input • Counting range, parameterizable 	<ul style="list-style-type: none"> Yes Yes Yes Yes Yes Yes Yes
Comparator	
<ul style="list-style-type: none"> – Number of comparators – Direction dependency – Can be changed from user program 	<ul style="list-style-type: none"> 2; per count channel; see manual for details Yes Yes
Position detection	
<ul style="list-style-type: none"> • Incremental acquisition • Suitable for S7-1500 Motion Control 	<ul style="list-style-type: none"> Yes Yes
Measuring functions	
<ul style="list-style-type: none"> • Measuring time, parameterizable • Dynamic measurement period adjustment • Number of thresholds, parameterizable 	<ul style="list-style-type: none"> Yes Yes 2
Measuring range	
<ul style="list-style-type: none"> – Frequency measurement, min. – Frequency measurement, max. – Cycle duration measurement, min. – Cycle duration measurement, max. 	<ul style="list-style-type: none"> 0.04 Hz 400 kHz; with quadruple evaluation 2.5 μs 25 s
Accuracy	
<ul style="list-style-type: none"> – Frequency measurement – Cycle duration measurement – Velocity measurement 	<ul style="list-style-type: none"> 100 ppm; depending on measuring interval and signal evaluation 100 ppm; depending on measuring interval and signal evaluation 100 ppm; depending on measuring interval and signal evaluation
Potential separation	
Potential separation digital inputs	
<ul style="list-style-type: none"> • between the channels • between the channels, in groups of 	<ul style="list-style-type: none"> No 16
Potential separation digital outputs	
<ul style="list-style-type: none"> • between the channels • between the channels, in groups of 	<ul style="list-style-type: none"> No 16

Article number	6ES7511-1CL03-0AB0
Potential separation channels	
<ul style="list-style-type: none"> • between the channels and backplane bus 	Yes
<ul style="list-style-type: none"> • Between the channels and load voltage L+ 	No
Ambient conditions	
Ambient temperature during operation	
<ul style="list-style-type: none"> • horizontal installation, min. 	-30 °C; No condensation
<ul style="list-style-type: none"> • horizontal installation, max. 	60 °C; note derating data for onboard I/O in the manual. Display: 50 °C, at an operating temperature of typically 50 °C, the display is switched off
<ul style="list-style-type: none"> • vertical installation, min. 	-30 °C; No condensation
<ul style="list-style-type: none"> • vertical installation, max. 	40 °C; note derating data for onboard I/O in the manual. Display: 40 °C, at an operating temperature of typically 40 °C, the display is switched off
Ambient temperature during storage/transportation	
<ul style="list-style-type: none"> • min. 	-40 °C
<ul style="list-style-type: none"> • max. 	70 °C
Altitude during operation relating to sea level	
<ul style="list-style-type: none"> • Installation altitude above sea level, max. 	5 000 m; Restrictions for installation altitudes > 2 000 m, see manual
configuration / header	
configuration / programming / header	
Programming language	
<ul style="list-style-type: none"> – LAD 	Yes
<ul style="list-style-type: none"> – FBD 	Yes
<ul style="list-style-type: none"> – STL 	Yes
<ul style="list-style-type: none"> – SCL 	Yes
<ul style="list-style-type: none"> – GRAPH 	Yes
Know-how protection	
<ul style="list-style-type: none"> • User program protection/password protection 	Yes
<ul style="list-style-type: none"> • Copy protection 	Yes
<ul style="list-style-type: none"> • Block protection 	Yes

Article number	6ES7511-1CL03-0AB0
Access protection	
<ul style="list-style-type: none"> • protection of confidential configuration data • Password for display • Protection level: Write protection • Protection level: Read/write protection • Protection level: Write protection for Failsafe • Protection level: Complete protection • User administration 	<ul style="list-style-type: none"> Yes Yes Yes Yes No Yes Yes; device-wide
programming / cycle time monitoring / header	
<ul style="list-style-type: none"> • lower limit • upper limit 	<ul style="list-style-type: none"> adjustable minimum cycle time adjustable maximum cycle time
Dimensions	
Width	85 mm
Height	147 mm
Depth	129 mm
Weights	
Weight, approx.	935 g; with front connector

Power reduction (derating) to total current of digital outputs (per power supply)

The following figure shows the load rating of the digital outputs in relation to the mounting position and the ambient temperature.

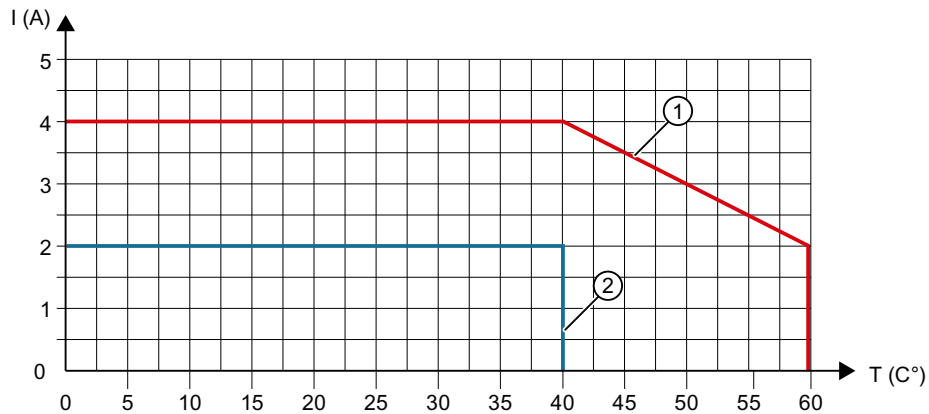

- ① Horizontal mounting position
- ② Vertical mounting position

Figure 8-1 Loading capacity of the digital outputs per mounting position

The following trends shows the load rating of the digital outputs when technology functions are used in dependence on the ambient temperature.

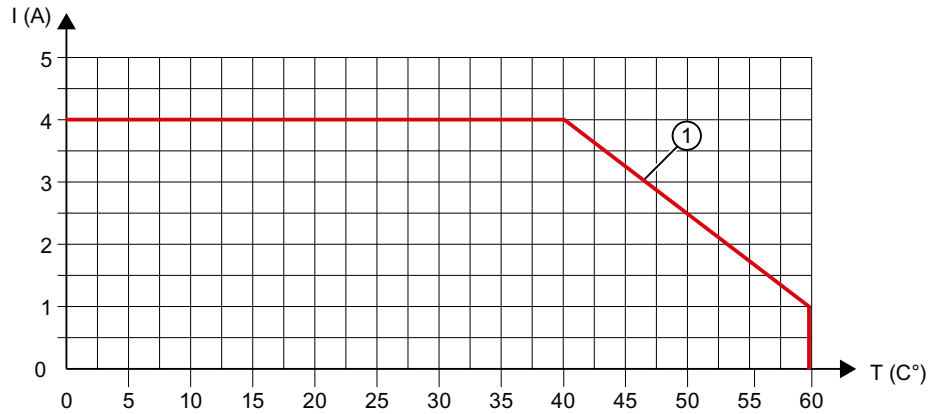

① Horizontal mounting position

Figure 8-2 Load rating of the digital outputs when technology functions are used

Power reduction (derating) to total current of digital inputs (per power supply)

The following figure shows the load rating of the current for encoder supplies of digital inputs.

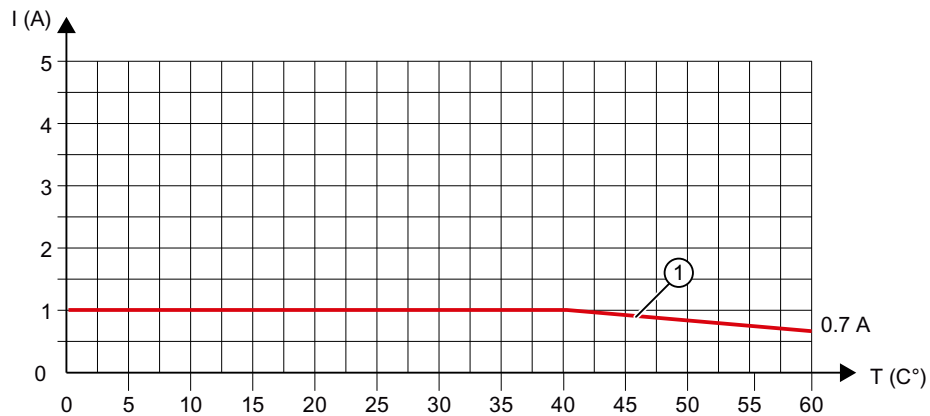

① Horizontal mounting position

Figure 8-3 Load rating of the current for encoder supplies of digital inputs

Simultaneous operation of digital inputs per group

If the maximum voltage at the inputs is 24 V, all the digital inputs may be simultaneously at high level (corresponds to 100% of the digital inputs).

If the maximum voltage at the inputs is 30 V, only 12 digital inputs of 16 digital inputs of one group may be simultaneously at high level (corresponds to 75% of the digital inputs).

General technical specifications

For information on the general technical specifications, such as standards and approvals, electromagnetic compatibility, protection class, etc., refer to the S7-1500, ET 200MP System Manual (<http://support.automation.siemens.com/WW/view/en/59191792>).

Dimension drawings

This appendix contains the dimension drawings of the compact CPU installed on a mounting rail. You must take the dimensions into consideration for installation in cabinets, control rooms, etc.

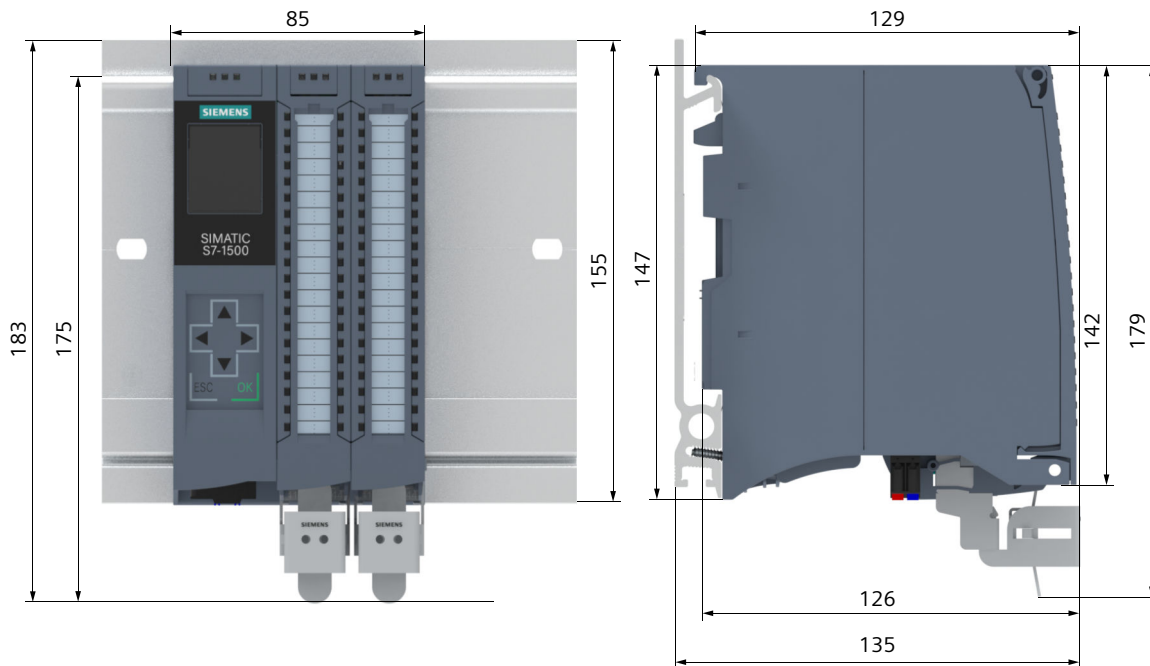

Figure A-1 Dimension drawing of CPU 1511C-1 PN – front and side views

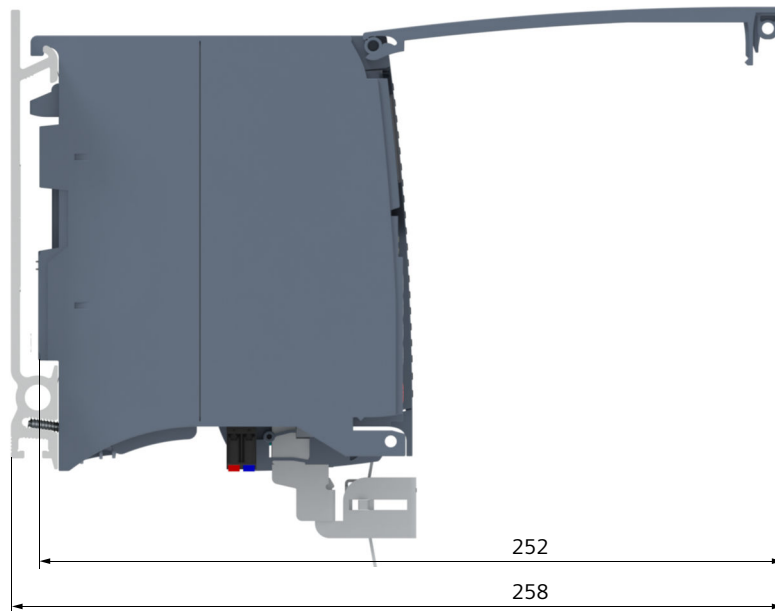

Figure A-2 Dimension drawing of CPU 1511C-1 PN – side view with front panel open

Parameter data records

B.1 Parameter assignment and structure of the parameter data records of the analog on-board I/O

Parameter assignment in the user program

You have the option of reassigning parameters for the analog on-board I/O in RUN (for example, measuring ranges of individual channels can be modified in RUN without affecting the other channels).

Changing parameters in RUN

The parameters are transferred to the analog on-board I/O via data records with the WRREC instruction. The parameters set with STEP 7 (TIA Portal) are not changed in the CPU, which means that the parameters set in STEP 7 (TIA Portal) will be valid again after a restart. The parameters are checked for plausibility by the analog on-board I/O only after the transfer.

Output parameter STATUS

If errors occur when transferring parameters with the "WRREC" instruction, the analog on-board I/O continues operation with the previous parameter assignment. However, a corresponding error code is written to the STATUS output parameter. You will find a description of the "WRREC" instruction and the error codes in the STEP 7 (TIA Portal) online help.

B.2 Structure of a data record for input channels of the analog on-board I/O

Assignment of data record and channel

The parameters for the 5 analog input channels are located in data records 0 to 4 and are assigned as follows:

- Data record 0 for channel 0
- Data record 1 for channel 1
- Data record 2 for channel 2
- Data record 3 for channel 3
- Data record 4 for channel 4

Data record structure

The figure below shows the structure of data record 0 for channel 0 as an example. The structure is identical for channels 1 to 4. The values in byte 0 and byte 1 are fixed and must not be changed.

You enable a parameter by setting the corresponding bit to "1".

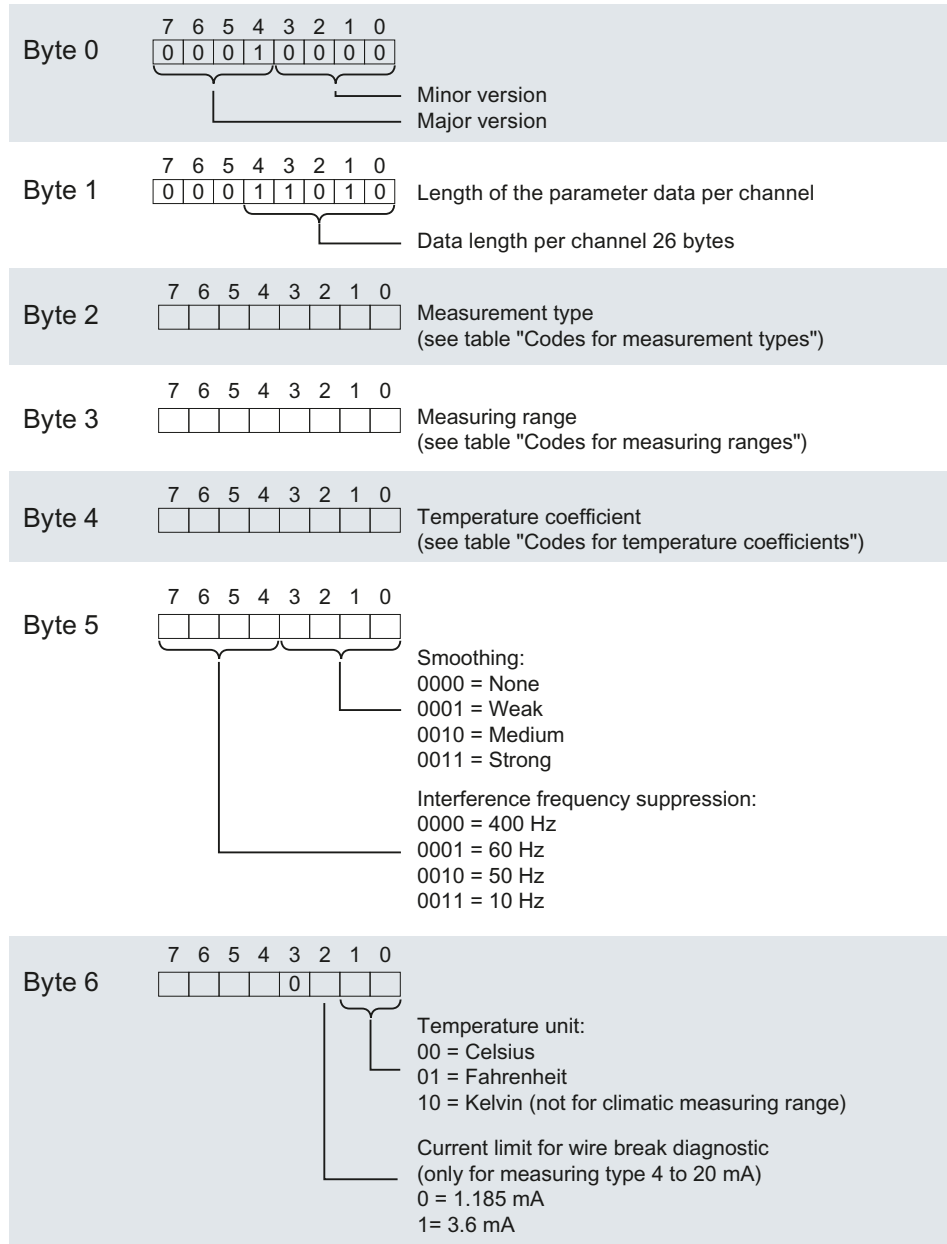
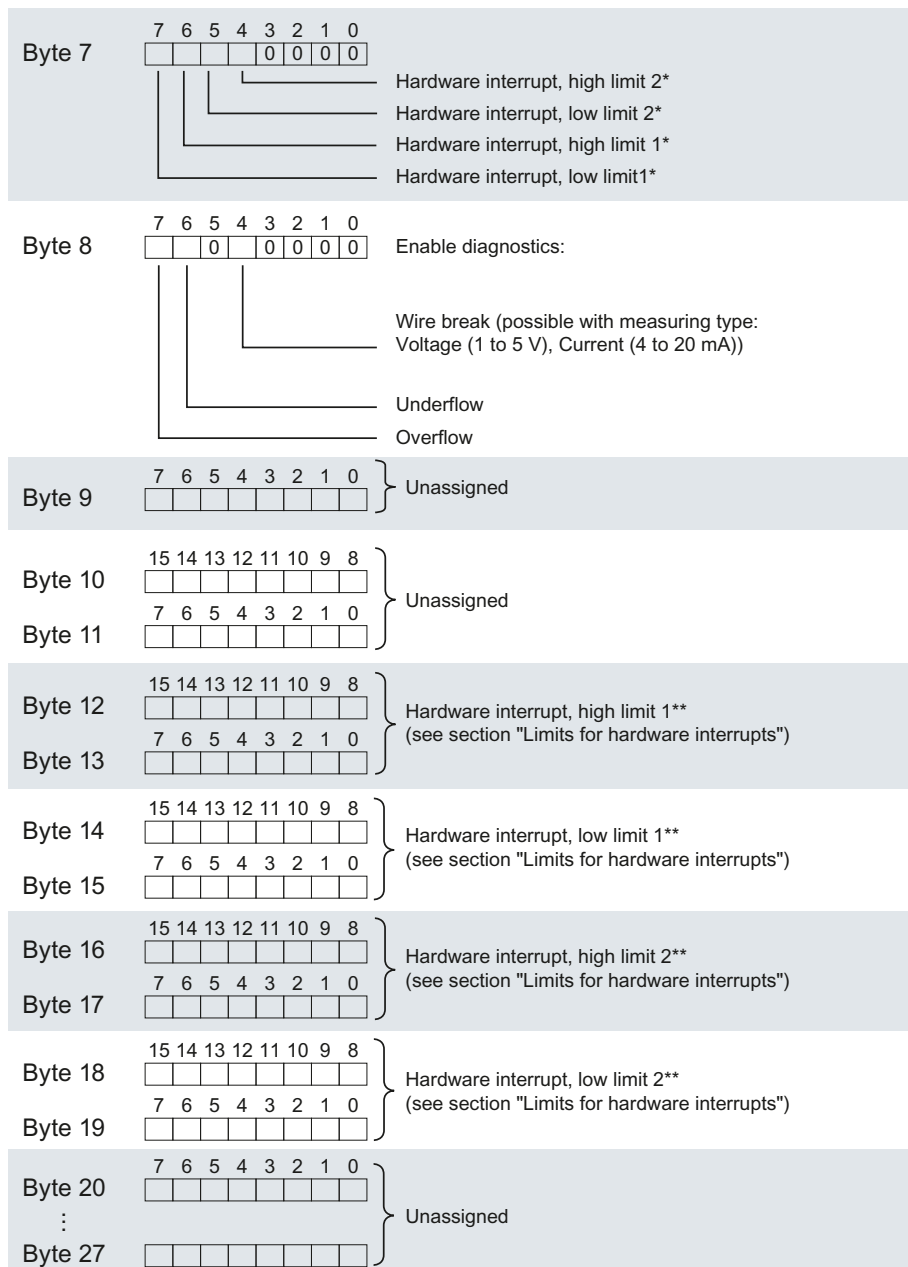

Figure B-1 Structure of data record 0: Bytes 0 to 6

B.2 Structure of a data record for input channels of the analog on-board I/O



* Activation of hardware limits via data records is only possible when a hardware interrupt OB is assigned to the channel in STEP 7

** High limit must be greater than low limit

Figure B-2 Structure of data record 0: Bytes 7 to 27

B.2 Structure of a data record for input channels of the analog on-board I/O

Codes for measurement types

The following table contains all measurement types of the inputs of the analog on-board I/O with the corresponding codes. You must enter these codes in byte 2 of the data record for the corresponding channel (refer to the figure Structure of data record 0: Bytes 0 to 6).

Table B-1 Codes for measurement type

Measurement type	Code
Deactivated	0000 0000
Voltage (valid for channels 0 to 3)	0000 0001
Current, 4-wire measuring transducer (valid for channels 0 to 3)	0000 0010
Resistance (valid for channel 4)	0000 0100
Thermal resistor linear (valid for channel 4)	0000 0111

Codes for measuring ranges

The following table contains all measuring ranges of the inputs of the analog on-board I/O with the corresponding codes. You must enter these codes in each case in byte 3 of the data record for the corresponding channel (refer to the figure Structure of data record 0: Bytes 0 to 6).

Table B-2 Codes for measuring range

Measuring range	Code
Voltage	
±5 V	0000 1000
±10 V	0000 1001
1 to 5 V	0000 1010
0 to 10 V	0000 1011
Current, 4-wire measuring transducer	
0 to 20 mA	0000 0010
4 to 20 mA	0000 0011
±20 mA	0000 0100
Resistance	
150 Ω	0000 0001
300 Ω	0000 0010
600 Ω	0000 0011
Thermal resistor	
Pt 100 Climate	0000 0000
Ni 100 Climate	0000 0001
Pt 100 Standard	0000 0010
Ni 100 Standard	0000 0011

Codes for temperature coefficient

The following table lists all temperature coefficients for temperature measurement of the thermal resistors along with their codes. You must enter these codes in each case in byte 4 of the data record for the corresponding channel (refer to the figure Structure of data record 0: Bytes 0 to 6)

Table B-3 Codes for temperature coefficient

Temperature coefficient	Code
Pt xxx	
0.003851	0000 0000
0.003916	0000 0001
0.003902	0000 0010
0.003920	0000 0011
Ni xxx	
0.006180	0000 1000
0.006720	0000 1001

Hardware interrupt limits

The values that can be set for hardware interrupts (high/low limit) must be within the nominal range and overrange/underrange of the relevant measuring range.

The following tables list the permitted hardware interrupt limits. The limits depend on the selected measurement type and measuring range.

Table B-4 Voltage limits

Voltage		
±5 V, ±10 V	1 to 5 V, 0 to 10 V	
32510	32510	High limit
-32511	-4863	Low limit

Table B-5 Current and resistance limits

Current		Resistance	
±20 mA	4 to 20 mA / 0 to 20 mA	(all configurable measuring ranges)	
32510	32510	32510	High limit
-32511	-4863	1	Low limit

Table B-6 Limits for thermal resistor Pt 100 Standard and Pt 100 Climate

Thermal resistor						
Pt 100 Standard			Pt 100 Climate			
°C	°F	K	°C	°F	K	
9999	18319	12731	15499	31099	---	High limit
-2429	-4053	303	-14499	-22899	---	Low limit

B.2 Structure of a data record for input channels of the analog on-board I/O

Table B-7 Limits for thermal resistor Ni 100 Standard and Ni 100 Climate

Thermal resistor						
Ni 100 Standard			Ni 100 Climate			
°C	°F	K	°C	°F	K	
2949	5629	5681	15499	31099	---	High limit
-1049	-1569	1683	-10499	-15699	---	Low limit

B.3 Structure of a data record for output channels of the analog on-board I/O

Assignment of data record and channel

The parameters for the 2 analog output channels are located in data records 64 and 65 and are assigned as follows:

- Data record 64 for channel 0
- Data record 65 for channel 1

Data record structure

The figure below shows the structure of data record 64 for channel 0 as an example. The structure is identical for channel 1. The values in byte 0 and byte 1 are fixed and must not be changed.

You enable a parameter by setting the corresponding bit to "1".

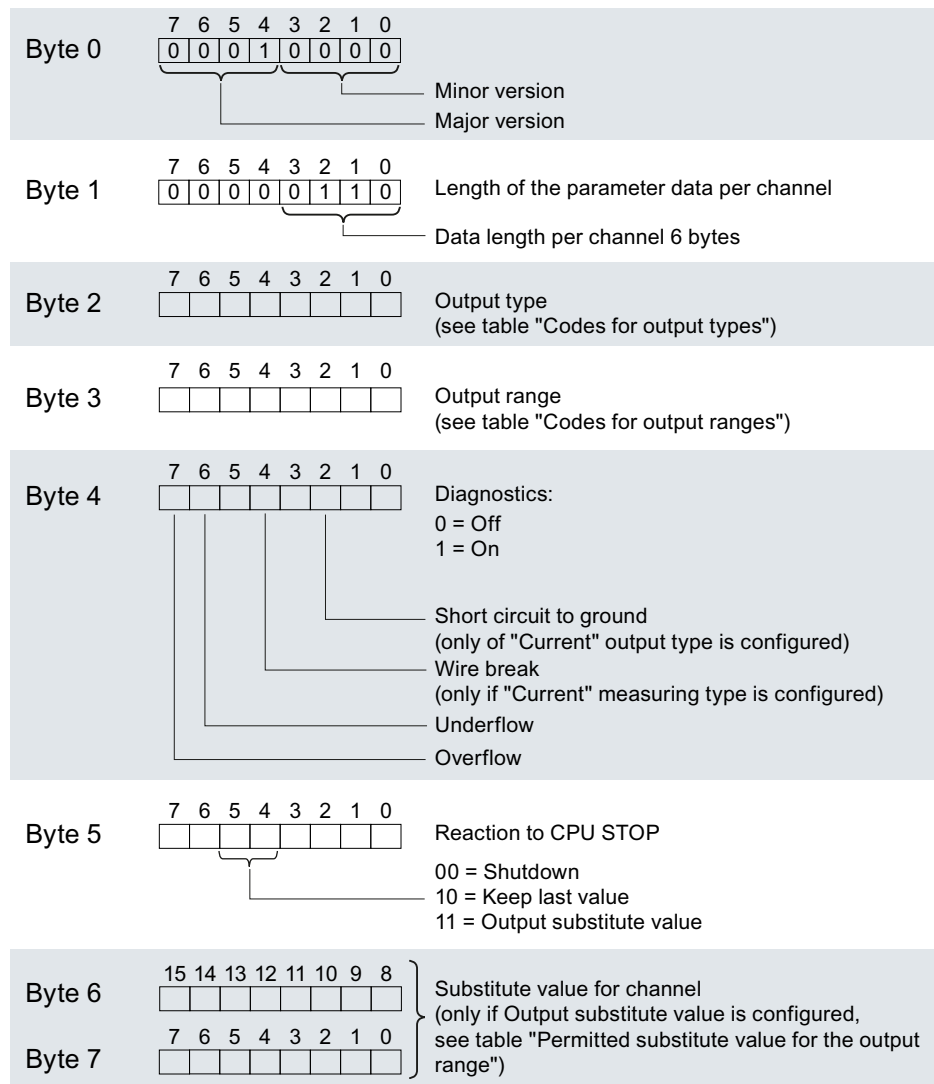

Figure B-3 Structure of data record 64: Bytes 0 to 7

B.3 Structure of a data record for output channels of the analog on-board I/O

Codes for the output type

The following table contains all output types of the outputs of the analog on-board I/O with the corresponding codes. You must enter these codes in each case in byte 2 of the data record for the corresponding channel (see the previous figure).

Table B-8 Codes for the output type

Output type	Code
Disabled	0000 0000
Voltage	0000 0001
Current	0000 0010

Codes for output ranges

The following table contains all output ranges for voltage and current of the outputs of the analog on-board I/O with the corresponding codes. You must enter these codes in each case in byte 3 of the corresponding data record (see previous figure).

Table B-9 Code for the output range

Output range for voltage	Code
1 to 5 V	0000 0011
0 to 10 V	0000 0010
±10 V	0000 0000
Output range for current	Code
0 to 20 mA	0000 0001
4 to 20 mA	0000 0010
±20 mA	0000 0000

Permitted substitute values

The following table lists all output ranges for the permitted substitute values. You must enter these substitute values in each case in bytes 6 and 7 of the data record for the corresponding channel (see the previous figure). You can find the binary representation of the output ranges in the section Representation of output ranges ([Page 190](#)).

Table B-10 Permitted substitute value for the output range

Output range	Permitted substitute value
±10 V	-32512 ... +32511
1 to 5 V	-6912 ... +32511
0 to 10 V	0 ... +32511
±20 mA	-32512 ... +32511
4 to 20 mA	-6912 ... +32511
0 to 20 mA	0 ... +32511

B.4 Parameter assignment and structure of the parameter data records of the digital on-board I/O

Parameter assignment in the user program

You have the option of reassigning parameters for the digital on-board I/O in RUN (for example, values for input delay of individual channels can be modified in RUN without affecting the other channels).

Changing parameters in RUN

The parameters are transferred to the digital on-board I/O via data records 0 to 15 with the WRREC instruction. The parameters set with STEP 7 (TIA Portal) are not changed in the CPU, which means the parameters set in STEP 7 (TIA Portal) will be valid again after a restart. The parameters are only checked for plausibility after the transfer.

Output parameter STATUS

If errors occur when transferring parameters with the "WRREC" instruction, the digital on-board I/O continues operation with the previous parameter assignment. However, a corresponding error code is written to the STATUS output parameter.

You will find a description of the "WRREC" instruction and the error codes in the STEP 7 (TIA Portal) online help.

B.5 Structure of a data record for input channels of the digital on-board I/O

Assignment of data record and channel

The parameters for the 16 digital input channels are located in data records 0 to 15 and are assigned as follows:

- Data record 0 for channel 0
- Data record 1 for channel 1
- ...
- Data record 14 for channel 14
- Data record 15 for channel 15

Data record structure

The figure below shows the structure of data record 0 for channel 0 as an example. The structure is identical for channels 1 to 15. The values in byte 0 and byte 1 are fixed and must not be changed.

You enable a parameter by setting the corresponding bit to "1".

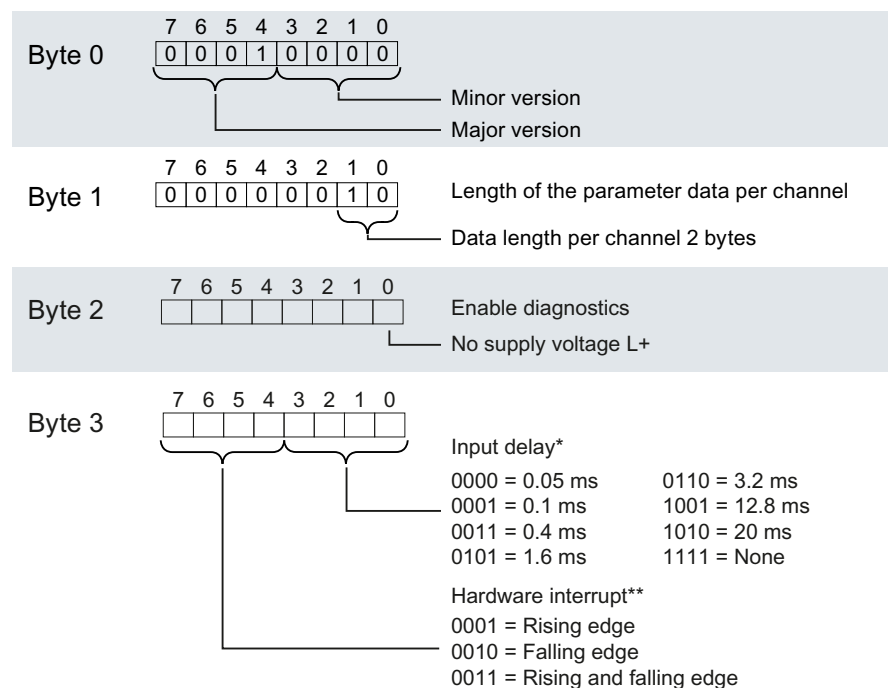

* In isochronous mode 0.05 ms (cannot be changed)

** Activation of hardware limits via data records is only possible when a hardware interrupt OB is assigned to the channel in STEP 7

Figure B-4 Structure of data record 0: Bytes 0 to 3

B.6 Structure of a data record for output channels of the digital on-board I/O

Assignment of data record and channel

The parameters for the 16 digital output channels are located in data records 64 to 79 and are assigned as follows:

- Data record 64 for channel 0
- Data record 65 for channel 1
- ...
- Data record 78 for channel 14
- Data record 79 for channel 15

Data record structure

The figure below shows the structure of data record 64 for channel 0 as an example. The structure is identical for channels 1 to 15. The values in byte 0 and byte 1 are fixed and must not be changed.

You enable a parameter by setting the corresponding bit to "1".

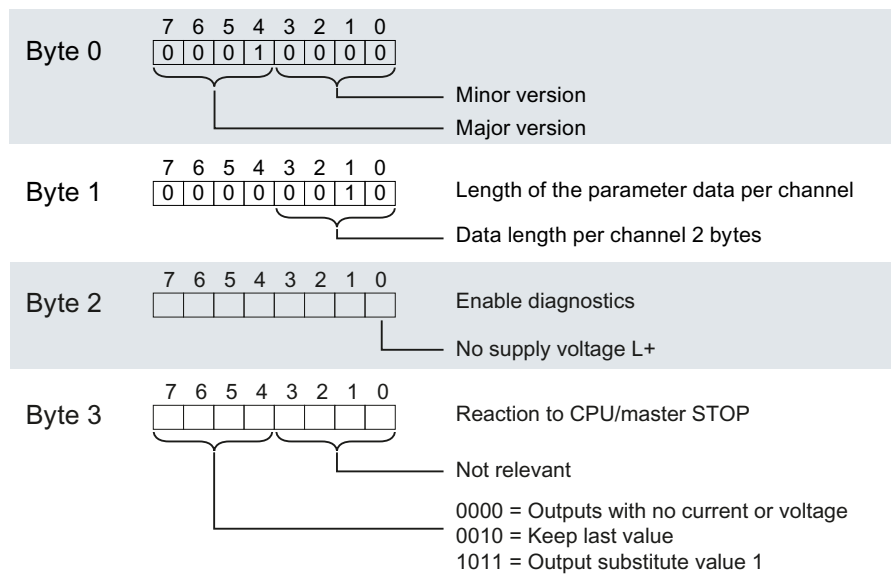

Figure B-5 Structure of data record 64: Bytes 0 to 3

B.7 Parameter data records of the high-speed counters

You can change the parameters of the High Speed Counter in RUN. The WRREC instruction is used to transfer the parameters to the High Speed Counter using data record 128.

If errors occur when transferring or validating parameters with the WRREC instruction, the High Speed Counter continues operation with the previous parameter assignment. The STATUS output parameter then contains a corresponding error code. If no error has occurred, the length of the data actually transferred is entered in the STATUS output parameter.

You will find a description of the "WRREC" instruction and the error codes in the STEP 7 (TIA Portal) online help.

Data record structure

The following table shows you the structure of data record 128 with the counter channel. The values in byte 0 to byte 3 are fixed and must not be changed. The value in byte 4 may only be changed by parameter reassignment and not in RUN mode.

Table B-11 Parameter data record 128 - HSC parameter header

Bit →	7	6	5	4	3	2	1	0
Byte								
0	Major Version = 1				Minor Version = 0			
1	Length of parameter data of the channel = 48							
2	Reserved = 0 ¹⁾							
3								

1) Reserved bits must be set to 0

Table B-12 Parameter data record 128 - Operating mode

Bit →	7	6	5	4	3	2	1	0
Byte								
	Operating mode							
4	Reserved = 0 ¹⁾				Operating mode:			
					0000 _B : Deactivated			
					0001 _B : Counting			
					0010 _B : Measuring			
					0011 to 1111 _B : Reserved			

1) Reserved bits must be set to 0

Table B-13 Parameter data record 128 - Basic parameters

Bit →	7	6	5	4	3	2	1	0
Byte								
	Basic parameters							
5	Reserved = 0 ¹⁾				Enable addi-	Reaction to CPU STOP:		

1) Reserved bits must be set to 0

2) Must be set to 1 for the activation of the diagnostic interrupts "Missing supply voltage L+", "Illegal A/B signal ratio" and "Hardware interrupt lost"

B.7 Parameter data records of the high-speed counters

Bit →	7	6	5	4	3	2	1	0	
Byte									
5	Reserved = 0 ¹⁾					tional diagnostic interrupts ²⁾	00 _B : Output substitute value		
							01 _B : Keep last value		
							10 _B : Continue		
							11 _B : Reserved		

1) Reserved bits must be set to 0

2) Must be set to 1 for the activation of the diagnostic interrupts "Missing supply voltage L+", "Illegal A/B signal ratio" and "Hardware interrupt lost"

Table B-14 Parameter data record 128 - Counter inputs

Bit →	7	6	5	4	3	2	1	0
Byte	Counter inputs							
6	Reserved = 0 ¹⁾		Signal evaluation:		Signal type:			
			00 _B : Single		0000 _B : Pulse (A)			
			01 _B : Double		0001 _B : Pulse (A) and direction (B)			
			10 _B : Quadruple		0010 _B : Count up (A), count down (B)			
			11 _B : Reserved		0011 _B : Incremental encoder (A, B phase-shifted)			
					0100 _B : Incremental encoder (A, B, N)			
		0101 to 1111 _B : Reserved						
7	Response to signal N:		Invert direction	Reserved = 0 ¹⁾		Filter frequency.		
	00 _B : No reaction to signal N					0000 _B : 100 Hz		
	01 _B : Synchronization at signal N					0001 _B : 200 Hz		
	10 _B : Capture at signal N					0010 _B : 500 Hz		
	11 _B : Reserved					0011 _B : 1 kHz		
			0100 _B : 2 kHz					
			0101 _B : 5 kHz					
			0110 _B : 10 kHz					
			0111 _B : 20 kHz					
			1000 _B : 50 kHz					
			1001 _B : 100 kHz					
		1010 _B : Reserved						
		1011 to 1111 _B : Reserved						

¹⁾ Reserved bits must be set to 0

Table B-15 Parameter data record 128 - Hardware interrupts

Bit →	7	6	5	4	3	2	1	0
Byte	Hardware interrupts ¹⁾							
8	Reserved = 0 ¹⁾	Reserved = 0 ¹⁾	Reserved = 0 ¹⁾	Direction reversal	Underflow (low counting limit violated)	Overflow (high counting limit violated)	Gate stop	Gate start
9	Synchronization of the counter by an external signal	New capture value available	Reserved = 0 ¹⁾	Zero crossing	Reserved = 0 ¹⁾	Comparison event for DQ1 occurred	Reserved = 0 ¹⁾	Comparison event for DQ0 occurred

¹⁾ Reserved bits must be set to 0

Table B-16 Parameter data record 128 - Behavior DQ0/1

Bit →	7	6	5	4	3	2	1	0
Byte	Behavior of DQ0/1							
10	Set output (DQ1):				Set output (DQ0):			
	0000 _B : Use by user program				0000 _B : Use by user program			
	0001 _B : Counting: Between comparison value 1 and high counting limit; Measuring: Measured value >= Comparison value 1				0001 _B : Counting: Between comparison value 0 and high counting limit; Measuring: Measured value >= Comparison value 0			
	0010 _B : Counting: Between comparison value 1 and low counting limit; Measuring: Measured value <= Comparison value 1				0010 _B : Counting: Between comparison value 0 and low counting limit; Measuring: Measured value <= Comparison value 0			
	0011 _B : Counting: At comparison value 1 for one pulse duration; Measuring: Reserved				0011 _B : Counting: At comparison value 0 for one pulse duration; Measuring: Reserved			
	0100 _B : Between comparison value 0 and 1				0100 _B : Reserved			
	0101 _B : Counting: After set command from CPU until comparison value 1; Measuring: Reserved				0101 _B : Counting: After set command from CPU until comparison value 0; Measuring: Reserved			
	0110 _B : Counting: Reserved Measuring: Not between comparison value 0 and 1				0110 to 1111 _B : Reserved			
	0111 to 1111 _B : Reserved							
	11	Count direction (DQ1):		Count direction (DQ0):		Reserved = 0 ¹⁾		Substitute value for DQ1
00 _B : Reserved		00 _B : Reserved						
01 _B : Up		01 _B : Up						

¹⁾ Reserved bits must be set to 0

B.7 Parameter data records of the high-speed counters

Bit →	7	6	5	4	3	2	1	0
Byte	6		5		4		3	
11	10 _B : Down		10 _B : Down		Reserved = 0 ¹⁾		Substitute value for DQ1	Substitute value for DQ0
	11 _B : In both directions		11 _B : In both directions					
12	Pulse duration (DQ0): WORD: Value range in ms/10: 0 to 65535 _D							
13								
14								
15	Pulse duration (DQ1): WORD: Value range in ms/10: 0 to 65535 _D							

1) Reserved bits must be set to 0

Table B-17 Parameter data record 128 - Behavior DI0

Bit →	7	6	5	4	3	2	1	0
Byte	6		5		4		3	
Behavior of DI0								
16	Behavior of count value after Capture (DI0):	Edge selection (DI0):		Level selection (DI0):	Reserved = 0 ¹⁾	Set function of the DI (DI0):		
		00 _B : Reserved				0 _B : Active at high level	000 _B : Gate start/stop (level-controlled)	
		01 _B : On a rising edge		1 _B : Active at low level			001 _B : Gate start (edge-controlled)	
		10 _B : On a falling edge				010 _B : Gate stop (edge-controlled)		
	0 _B : Continue counting		11 _B : On rising and falling edge			011 _B : Synchronization		
	1 _B : Set to start value and continue counting					100 _B : Enable synchronization at signal N		
						101 _B : Capture		
						110 _B : Digital input without function		
				111 _B : Reserved				

1) Reserved bits must be set to 0

Table B-18 Parameter data record 128 - Behavior DI1

Bit →	7	6	5	4	3	2	1	0
Byte	6		5		4		3	
17	Behavior of DI1: See byte 16							
18	Reserved = 0 ¹⁾							
19	Sync option	Reserved = 0 ¹⁾			Reserved = 0 ¹⁾			
	0 _B : Once							
	1 _B : Periodically							

1) Reserved bits must be set to 0

Table B-19 Parameter data record 128 - Behavior DI1

Bit →	7	6	5	4	3	2	1	0
Byte								
	Values							
20-23	High counting limit: DWORD: Value range: -2147483648 to 2147483647 _D or 80000000 to 7FFFFFFF _H							
24-27	Comparison value 0: Counting mode: DWORD Value range: -2147483648 to 2147483647 _D or 80000000 to 7FFFFFFF _H ; Measuring mode: REAL Floating-point number in the set unit of the measured variable							
28-31	Comparison value 1: Counting mode: DWORD Value range: -2147483648 to 2147483647 _D or 80000000 to 7FFFFFFF _H ; Measuring mode: REAL Floating-point number in the set unit of the measured variable							
32-35	Start value: DWORD: Value range: -2147483648 to 2147483647 _D or 80000000 to 7FFFFFFF _H							
36-39	Low counting limit: DWORD: Value range: -2147483648 to 2147483647 _D or 80000000 to 7FFFFFFF _H							
40-43	Update time: DWORD: Value range in μ s: 0 to 25000000 _D							

Table B-20 Parameter data record 128 - Counter behavior at limits and at gate start

Bit →	7	6	5	4	3	2	1	0
Byte								
	Counter behavior at limits and at gate start							
44	Response to gate start:		Response to counting limit violation:			Reset at counting limit violation:		
	00 _B : Set to start value		000 _B : Stop counting			000 _B : To other counting limit		
	01 _B : Continue with current value		001 _B : Continue counting			001 _B : On start value		
	10 to 11 _B : Reserved		010 to 111 _B : Reserved			010 to 111 _B : Reserved		

Table B-21 Parameter data record 128 - Specify measured value

Bit →	7	6	5	4	3	2	1	0	
Byte									
	Specify measured value								
45	Reserved = 0 ¹⁾			Time base for velocity measurement:			Measured variable:		
				000 _B : 1 ms			00 _B : Frequency		
				001 _B : 10 ms			01 _B : Period duration		
				010 _B : 100 ms			10 _B : Velocity		
				011 _B : 1 s			11 _B : Reserved		
				100 _B : 60 s/1 min					
101 to 111 _B : Reserved									
46	Increments per unit:								

1) Reserved bits must be set to 0

Parameter data records

B.7 Parameter data records of the high-speed counters

Bit →	7	6	5	4	3	2	1	0
Byte								
47	WORD: Value range: 1 to 65535 _D							
48	Set hysteresis range: Value range: 0 to 255 _D							
49	Use of HSC DIO 0 _B : Not used	Reserved = 0 ¹⁾		Selection HSC DIO Value range: HSC1:				

1) Reserved bits must be set to 0

B.7 Parameter data records of the high-speed counters

Bit →	7	6	5	4	3	2	1	0	
Byte									
49	1 _B : Used	Reserved = 0 ¹⁾			00001 _B : Front connector X11, terminal 2 (DI1) 00010 _B : Front connector X11, terminal 3 (DI2) 00011 _B : Front connector X11, terminal 4 (DI3) 00100 _B : Front connector X11, terminal 5 (DI4) 00101 _B : Front connector X11, terminal 6 (DI5) 00110 _B : Front connector X11, terminal 7 (DI6) 00111 _B : Front connector X11, terminal 8 (DI7) HSC2: 00000 _B : Front connector X11, terminal 1 (DI0) 00001 _B : Front connector X11, terminal 2 (DI1) 00010 _B : Front connector X11, terminal 3 (DI2) 00100 _B : Front connector X11, terminal 5 (DI4) 00101 _B : Front connector X11, terminal 6 (DI5) 00110 _B : Front connector X11, terminal 7 (DI6) 00111 _B : Front connector X11, terminal 8 (DI7) HSC3: 00000 _B : Front connector X11, terminal 1 (DI0) 00001 _B : Front connector X11, terminal 2 (DI1) 00010 _B : Front connector X11, terminal 3 (DI2) 00011 _B : Front connector X11, terminal 4 (DI3) 00100 _B : Front connector X11, terminal 5 (DI4) 00101 _B : Front connector X11, terminal 6 (DI5) 00111 _B : Front connector X11, terminal 8 (DI7) HSC4: 01001 _B : Front connector X11, terminal 12 (DI9) 01010 _B : Front connector X11, terminal 13 (DI10) 01011 _B : Front connector X11, terminal 14 (DI11) 01100 _B : Front connector X11, terminal 15 (DI12) 01101 _B : Front connector X11, terminal 16 (DI13) 01110 _B : Front connector X11, terminal 17 (DI14) 01111 _B : Front connector X11, terminal 18 (DI15) HSC5: 01000 _B : Front connector X11, terminal 11 (DI8) 01001 _B : Front connector X11, terminal 12 (DI9) 01010 _B : Front connector X11, terminal 13 (DI10) 01100 _B : Front connector X11, terminal 15 (DI12) 01101 _B : Front connector X11, terminal 16 (DI13) 01110 _B : Front connector X11, terminal 17 (DI14) 01111 _B : Front connector X11, terminal 18 (DI15) HSC6: 01000 _B : Front connector X11, terminal 11 (DI8) 01001 _B : Front connector X11, terminal 12 (DI9) 01010 _B : Front connector X11, terminal 13 (DI10) 01011 _B : Front connector X11, terminal 14 (DI11) 01100 _B : Front connector X11, terminal 15 (DI12) 01101 _B : Front connector X11, terminal 16 (DI13) 01111 _B : Front connector X11, terminal 18 (DI15) All other values: Reserved The value range also applies for the 'Selection HSC DI1' parameter in the same way.				
50	Use of HSC DI1	Reserved = 0 ¹⁾			Selection HSC DI1				
	0 _B : Not used				Value range:				

¹⁾ Reserved bits must be set to 0

B.8 Parameter data records (PWM)

Bit →	7	6	5	4	3	2	1	0
Byte	7	6	5	4	3	2	1	0
50	1 _B : Used	Reserved = 0 ¹⁾		The value range also applies for the 'Selection HSC DIO' parameter in the same way.				
51	Use of HSC DQ1	Reserved = 0 ¹⁾		Selection HSC DQ1 Value range: HSC1: 00001 _B : Front connector X11, terminal 22 (DQ1) 01001 _B : Front connector X11, terminal 32 (DQ9) HSC2: 00011 _B : Front connector X11, terminal 24 (DQ3) 01011 _B : Front connector X11, terminal 34 (DQ11) HSC3: 00100 _B : Front connector X11, terminal 25 (DQ4) 01100 _B : Front connector X11, terminal 35 (DQ12) HSC4: 00101 _B : Front connector X11, terminal 26 (DQ5) 01101 _B : Front connector X11, terminal 36 (DQ13) HSC5: 00111 _B : Front connector X11, terminal 28 (DQ7) 01111 _B : Front connector X11, terminal 38 (DQ15) HSC6: 00110 _B : Front connector X11, terminal 27 (DQ6) 01110 _B : Front connector X11, terminal 37 (DQ14) All other values: Reserved				
	0 _B : Not used							
	1 _B : Used							

1) Reserved bits must be set to 0

B.8 Parameter data records (PWM)

You have the option of reassigning the pulse width modulation parameters in RUN. The parameters are transferred with the instruction WRREC via the data record 128 to the PWM submodule.

If errors occur when transferring or validating parameters with the WRREC instruction, the module continues operation with the previous parameter assignment. The output parameter STATUS then contains a corresponding error code. If no error has occurred, the length of the data actually transferred is entered in the output parameter STATUS.

You can find a description of the "WRREC" instruction and the error codes in the STEP 7 (TIA Portal) online help.

Data record structure

The following table shows the structure of the data record 128 for the pulse width modulation. The values in byte 0 to byte 3 are fixed and must not be changed.

Table B-22 Parameter data record 128

Bit →	7	6	5	4	3	2	1	0
Byte	7	6	5	4	3	2	1	0
0	Major Version = 1				Minor Version = 0			
1	Length of the parameter data of the channel in bytes = 12							
2	Reserved = 0 ¹⁾							

1) Reserved bits must be set to 0

Bit →	7	6	5	4	3	2	1	0
Byte								
3	Reserved = 0 ¹⁾							
4	Current control	Dithering	High-speed output		Operating mode			
	0 _B : Deactivated	0 _B : Deactivated	0 _B : Deactivated		0000 _B : Reserved			
	1 _B : Reserved	1 _B : Reserved	01 _B : Activated		0001 _B : PWM (pulse-width modulation)			
			10 _B -11 _B : Reserved		0010 _B : Reserved			
			0011 _B : Reserved					
			0100 _B : Frequency output					
			0110 _B to 1110 _B : Reserved					
1111 _B : Deactivated								
5	Reserved = 0 ¹⁾			Reserved = 0 ¹⁾		Diagnostics interrupt	Reaction to CPU STOP	
						0 _B : Deactivated	00 _B : DQ substitute value	
						1 _B : Activated	01 _B : Reserved	
							10 _B : Operating mode for continuation of operation	
					11 _B : Reserved			
6	Reserved = 0 ¹⁾			Pulse output (DQA) selection Range of values for PWM1: 00000 _B : Front connector X11, terminal 21 (DQ0) 01000 _B : Front connector X11, terminal 31 (DQ8) Range of values for PWM2: 00010 _B : Front connector X11, terminal 23 (DQ2) 01010 _B : Front connector X11, terminal 33 (DQ10) Range of values for PWM3: 00100 _B : Front connector X11, terminal 25 (DQ4) 01100 _B : Front connector X11, terminal 35 (DQ12) Range of values for PWM4: 00110 _B : Front connector X11, terminal 27 (DQ6) 01110 _B : Front connector X11, terminal 37 (DQ14) All other values: Reserved				
7	Reserved = 0 ¹⁾		Output format		Reserved = 0 ¹⁾	Reserved = 0 ¹⁾	Reserved = 0 ¹⁾	Substitute value DQA
			PWM	Frequency output				0 _B : 0 V
			00 _B : S7 analog format	00 _B : Reserved				1 _B : 24 V
			01 _B : per 100 (%)	01 _B : 1 Hz				
			10 _B : per 1000	10 _B : Reserved				
			11 _B : per 10 000	11 _B : Reserved				

¹⁾ Reserved bits must be set to 0

B.8 Parameter data records (PWM)

Bit →	7	6	5	4	3	2	1	0
Byte								
8-11	DWORD minimum pulse duration							
	PWM: Minimum pulse duration (default = 0 µs)							
	Frequency output: Reserved							
12-15	DWORD period duration							
	PWM: Period duration							
	Supported value range depending on configured values for "Pulse output (DQA)" and "High-speed output (0.1 A)"							
	<ul style="list-style-type: none"> • for 100 kHz DQ (high-speed output activated): 10 µs to 10 000 000 µs (10 s) • for 10 kHz DQ (high-speed output deactivated): 100 µs to 10 000 000 µs (10 s) • for 100 Hz DQ (high-speed output deactivated): 10 000 µs (10 ms) to 10 000 000 µs (10 s) Default = 2 000 000 µs (2 s)							
Frequency output: Reserved								

1) Reserved bits must be set to 0

Analog value processing

C.1 Conversion method

Conversion

An integrated analog-to-digital converter converts the analog signal into a digital signal so that the compact CPU can process the analog signal read in by an analog channel. Once the CPU has processed the digital signal, an integrated digital-to-analog converter converts the output signal into an analog current or voltage value.

Interference frequency suppression

The interference frequency suppression of the analog inputs suppresses the interference caused by the frequency of the AC voltage network used. The frequency of the AC voltage network may interfere with measured values, particularly for measurements within narrow voltage ranges.

You set the line frequency with which the plant operates (400, 60, 50 or 10 Hz) using the "Interference frequency suppression" parameter in STEP 7 (TIA Portal). The "Interference frequency suppression" parameter can only be set module-wide (for all input channels). The interference frequency suppression filters out the set interference frequency (400/60/50/10 Hz) as well as multiples of it. The selected interference frequency suppression also defines the integration time. The conversion time changes depending on the set interference frequency suppression.

For example, an interference frequency suppression of 50 Hz corresponds to an integration time of 20 ms. The analog on-board I/O supplies one measured value to the CPU every millisecond over a period of 20 ms. This measured value corresponds to the floating mean value of the last 20 measurements.

The following figure shows how this works using a 400 Hz interference frequency suppression as an example. A 400 Hz interference frequency suppression corresponds to an integration time of 2.5 ms. The analog on-board I/O supplies a measured value to the CPU every 1.25 milliseconds within the integration time.

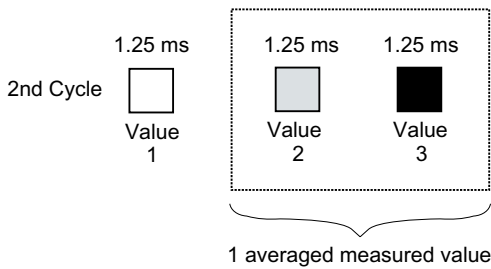
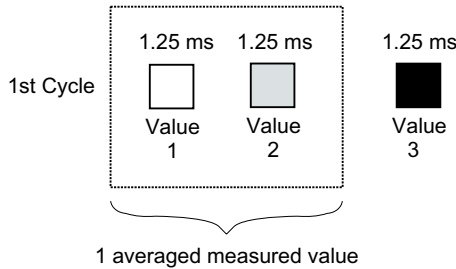

Figure C-1 Interference frequency suppression 400 Hz

The following figure shows how this works using a 60 Hz interference frequency suppression as an example. A 60 Hz interference frequency suppression corresponds to an integration time of 16.6 ms. The analog on-board I/O supplies a measured value to the CPU every 1.04 milliseconds within the integration time.

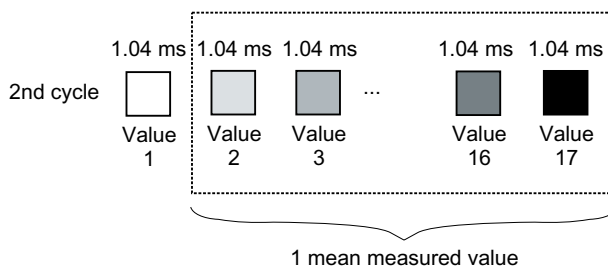
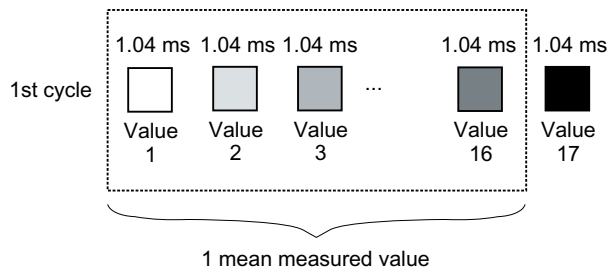

Figure C-2 Interference frequency suppression 60 Hz

The following figure shows how this works using a 50 Hz interference frequency suppression as an example. A 50 Hz interference frequency suppression corresponds to an integration time of 20 ms. The analog on-board I/O supplies a measured value to the CPU every millisecond within the integration time.

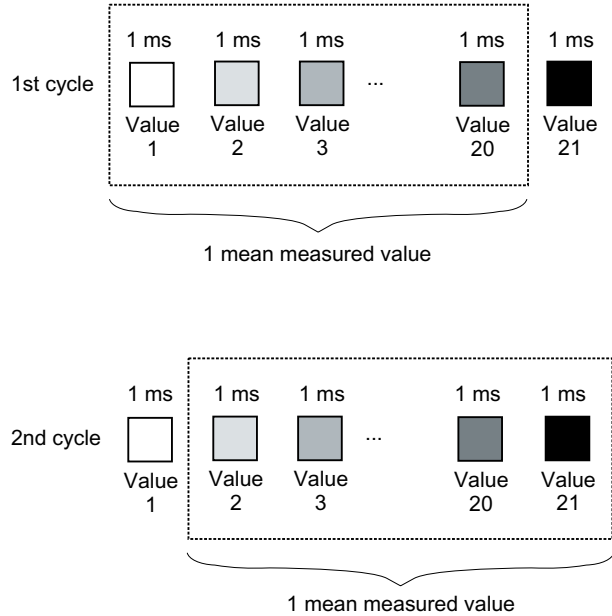

Figure C-3 Interference frequency suppression 50 Hz

The following figure shows how this works using a 10 Hz interference frequency suppression as an example. A 10 Hz interference frequency suppression corresponds to an integration time of 100 ms. The analog on-board I/O supplies a measured value to the CPU every millisecond within the integration time.

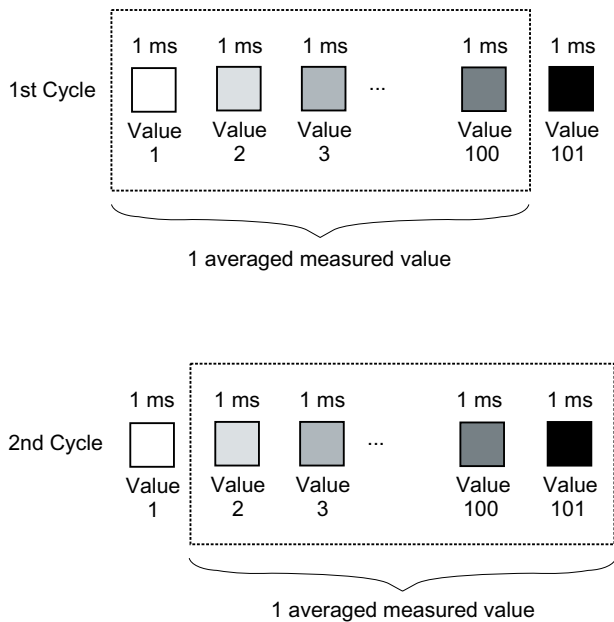

Figure C-4 Interference frequency suppression 10 Hz

The following table provides an overview of the configurable line frequencies, the integration time and the intervals within which measured values are supplied to the CPU.

Table C-1 Overview of the configurable line frequencies

Interference frequency suppression	Integration time	Interval
400 Hz	2.5 ms	2 x 1.25 ms
60 Hz	16.6 ms	16 x 1.04 ms
50 Hz	20 ms	20 x 1 ms
10 Hz	100 ms	100 x 1 ms

NOTE

Basic error with an integration time of 2.5 ms.

With an integration time of 2.5 ms, the measured value is changed by the following values based on the additionally obtained basic error and noise:

- with "voltage", "current" and "resistance" by $\pm 0.1\%$
- with "Thermal resistor Pt 100 Standard" by $\pm 0.4\text{ K}$
- with "Thermal resistor Pt 100 Climatic" by $\pm 0.3\text{ K}$
- with "Thermal resistor Ni 100 Standard" by $\pm 0.2\text{ K}$
- with "Thermal resistor Ni 100 Climatic" by $\pm 0.1\text{ K}$

A detailed description of the basic and operating error is available in the function manual Analog value processing (<http://support.automation.siemens.com/WW/view/en/67989094>).

Smoothing

The individual measured values are smoothed by filtering. The smoothing can be set in 4 levels for individual channels in STEP 7 (TIA Portal).

Smoothing time = Smoothing (k) x configured integration time

The following figure shows the time it takes for the smoothed analog value to reach approximately 100% depending on the set smoothing. This is valid for all signal changes at the analog input.

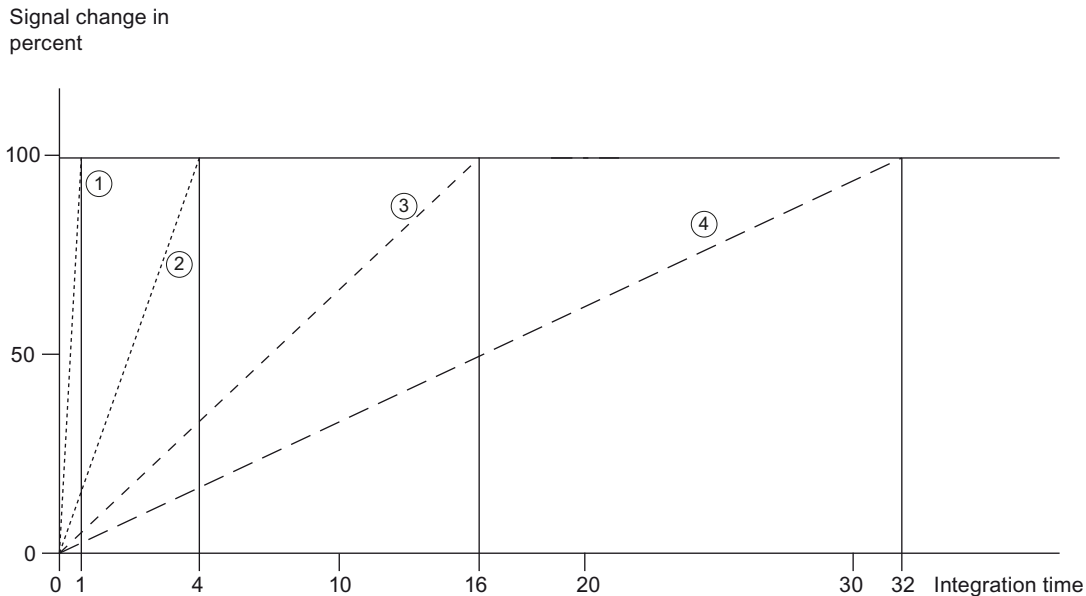

- ① None (smoothing = 1 x integration time)
- ② Weak (smoothing = 4 x integration time) *
- ③ Medium (smoothing = 16 x integration time) *
- ④ Strong (smoothing = 32 x integration time) *

* The smoothing time can increase by 1 x integration time.

Figure C-5 Smoothing time depending on the set smoothing level

The following table shows the time it takes for the smoothed analog value to reach approximately 100% depending on the set smoothing and the set interference frequency suppression.

Table C-2 Smoothing time depending on the set smoothing level and interference frequency suppression

(mean value generation from scan values) Selection of the smoothing	Interference frequency suppression/smoothing time			
	400 Hz	60 Hz	50 Hz	10 Hz
None	2.5 ms	16.6 ms	20 ms	100 ms
Weak	10 ms	66.4 ms	80 ms	400 ms
Medium	40 ms	265.6 ms	320 ms	1600 ms
Strong	80 ms	531.2 ms	640 ms	3200 ms

Cycle time

The cycle times (1 ms, 1.04 ms and 1.25 ms) result from the configured interference frequency suppression. The cycle time is independent of the number of configured analog channels. The values for the analog input channels are detected sequentially in each cycle.

Reference

For more information on conversion time, cycle time and conversion method, refer to the Analog value processing (<http://support.automation.siemens.com/WW/view/en/67989094>) function manual.

C.2 Representation of analog values

Introduction

The analog values for all measuring ranges that you can use with the analog on-board I/O are represented in this appendix.

For cross-product information on "analog value processing", refer to the Analog value processing (<http://support.automation.siemens.com/WW/view/en/67989094>) function manual.

Measured value resolution

Each analog value is entered left aligned into the tags. The bits marked with "x" are set to "0".

NOTE

This resolution does not apply to temperature values. The digitalized temperature values are the result of a conversion in the analog on-board I/O.

Table C-3 Resolution of the analog values

Resolution in bits including sign	Values		Analog value	
	Decimal	Hexadecimal	High byte	Low byte
16	1	1 _H	Sign 0 0 0 0 0 0	0 0 0 0 0 0 1

C.3 Representation of input ranges

The tables below set out the digitized representation of the input ranges separately for bipolar and unipolar input ranges. The resolution is 16 bits.

Table C-4 Bipolar input ranges

Dec. value	Measured value in %	Data word															Range	
		2 ¹⁵	2 ¹⁴	2 ¹³	2 ¹²	2 ¹¹	2 ¹⁰	2 ⁹	2 ⁸	2 ⁷	2 ⁶	2 ⁵	2 ⁴	2 ³	2 ²	2 ¹		2 ⁰
32767	>117.589	0	1	1	1	1	1	1	1	1	1	1	1	1	1	1	1	Overflow
32511	117.589	0	1	1	1	1	1	1	0	1	1	1	1	1	1	1	1	Overrange
27649	100.004	0	1	1	0	1	1	0	0	0	0	0	0	0	0	0	1	
27648	100.000	0	1	1	0	1	1	0	0	0	0	0	0	0	0	0	0	Nominal range
1	0.003617	0	0	0	0	0	0	0	0	0	0	0	0	0	0	0	1	
0	0.000	0	0	0	0	0	0	0	0	0	0	0	0	0	0	0	0	
-1	-0.003617	1	1	1	1	1	1	1	1	1	1	1	1	1	1	1	1	
-27648	-100.000	1	0	0	1	0	1	0	0	0	0	0	0	0	0	0	0	Underrange
-27649	-100.004	1	0	0	1	0	0	1	1	1	1	1	1	1	1	1	1	
-32512	-117.593	1	0	0	0	0	0	0	1	0	0	0	0	0	0	0	0	
-32768	<-117.593	1	0	0	0	0	0	0	0	0	0	0	0	0	0	0	0	Underflow

Table C-5 Unipolar input ranges

Dec. value	Measured value in %	Data word															Range	
		2 ¹⁵	2 ¹⁴	2 ¹³	2 ¹²	2 ¹¹	2 ¹⁰	2 ⁹	2 ⁸	2 ⁷	2 ⁶	2 ⁵	2 ⁴	2 ³	2 ²	2 ¹		2 ⁰
32767	>117.589	0	1	1	1	1	1	1	1	1	1	1	1	1	1	1	1	Overflow
32511	117.589	0	1	1	1	1	1	1	0	1	1	1	1	1	1	1	1	Overrange
27649	100.004	0	1	1	0	1	1	0	0	0	0	0	0	0	0	0	1	
27648	100.000	0	1	1	0	1	1	0	0	0	0	0	0	0	0	0	0	Nominal range
1	0.003617	0	0	0	0	0	0	0	0	0	0	0	0	0	0	0	1	
0	0.000	0	0	0	0	0	0	0	0	0	0	0	0	0	0	0	0	
-1	-0.003617	1	1	1	1	1	1	1	1	1	1	1	1	1	1	1	1	Underrange
-4864	-17.593	1	1	1	0	1	1	0	1	0	0	0	0	0	0	0	0	
-32768	<-17.593	1	0	0	0	0	0	0	0	0	0	0	0	0	0	0	0	Underflow

C.3.1 Representation of analog values in voltage measuring ranges

The following tables list the decimal and hexadecimal values (codes) of the possible voltage measuring ranges.

Table C-6 Voltage measuring ranges ± 10 V, ± 5 V

Values		Voltage measuring range		Range
dec.	hex.	± 10 V	± 5 V	
32767	7FFF	>11.759 V	>5.879 V	Overflow
32511	7EFF	11.759 V	5.879 V	Overrange
27649	6C01			
27648	6C00	10 V	5 V	Nominal range
20736	5100	7.5 V	3.75 V	
1	1	361.7 μ V	180.8 μ V	
0	0	0 V	0 V	
-1	FFFF			
-20736	AF00	-7.5 V	-3.75 V	
-27648	9400	-10 V	-5 V	
-27649	93FF			Underrange
-32512	8100	-11.759 V	-5.879 V	
-32768	8000	<-11.759 V	<-5.879 V	Underflow

Table C-7 Voltage measuring range 1 to 5 V, 0 to 10 V

Values		Voltage measuring range		Range
dec.	hex.	1 to 5 V	0 to 10 V	
32767	7FFF	>5.704 V	>11.759 V	Overflow
32511	7EFF	5.704 V	11.759 V	Overrange
27649	6C01			
27648	6C00	5 V	10.0 V	Nominal range
20736	5100	4 V	7.5 V	
1	1	1 V + 144.7 μ V	361.7 μ V	
0	0	1 V	0 V	
-1	FFFF			
-4864	ED00	0.296 V	-1.759 V	Underrange
-32768	8000	< 0.296 V	< -1.759 V	
				Underflow

C.3.2 Representation of analog values in current measuring ranges

The following tables list the decimal and hexadecimal values (codes) of the possible current measuring ranges.

Table C-8 Current measuring range ± 20 mA

Values		Current measuring range		
dec.	hex.	± 20 mA		
32767	7FFF	>23.52 mA		Overflow
32511	7EFF	23.52 mA		Overrange
27649	6C01			
27648	6C00	20 mA		Nominal range
20736	5100	15 mA		
1	1	723.4 nA		
0	0	0 mA		
-1	FFFF			
-20736	AF00	-15 mA		
-27648	9400	-20 mA		
-27649	93FF			Underrange
-32512	8100	-23.52 mA		
-32768	8000	<-23.52 mA		Underflow

Table C-9 Current measuring ranges 0 to 20 mA and 4 to 20 mA

Values		Current measuring range		
dec.	hex.	0 to 20 mA	4 to 20 mA	
32767	7FFF	>23.52 mA	>22.81 mA	Overflow
32511	7EFF	23.52 mA	22.81 mA	Overrange
27649	6C01			
27648	6C00	20 mA	20 mA	Nominal range
20736	5100	15 mA	16 mA	
1	1	723.4 nA	4 mA + 578.7 nA	
0	0	0 mA	4 mA	
-1	FFFF			
-4864	ED00	-3.52 mA	1.185 mA	Underrange
-32768	8000	<-3.52 mA	<1.185 mA	
				Underflow

C.3.3 Representation of the analog values of resistance-type sensors/resistance-type thermometers

The following tables list the decimal and hexadecimal values (codes) of the possible resistance-type sensor ranges.

Table C-10 Resistance-type sensors of 150 Ω, 300 Ω and 600 Ω

Values		Resistance-type sensor range			
dec.	hex.	150 Ω	300 Ω	600 Ω	
32767	7FFF	>176.38 Ω	>352.77 Ω	>705.53 Ω	Overflow
32511	7EFF	176.38 Ω	352.77 Ω	705.53 Ω	Overrange
27649	6C01				
27648	6C00	150 Ω	300 Ω	600 Ω	Nominal range
20736	5100	112.5 Ω	225 Ω	450 Ω	
1	1	5.43 mΩ	10.85 mΩ	21.70 mΩ	
0	0	0 Ω	0 Ω	0 Ω	

Table C-11 Resistance-type thermometer Pt 100 Standard

Pt 100 Standard in °C (1 digit = 0.1°C)	Values		Pt 100 Standard in °F (1 digit = 0.1 °F)	Values		Pt 100 Standard in K (1 digit = 0.1 K)	Values		Range
	dec.	hex.		dec.	hex.		dec.	hex.	
> 1000.0	32767	7FFF	> 1832.0	32767	7FFF	> 1273.2	32767	7FFF	Overflow
1000.0	10000	2710	1832.0	18320	4790	1273.2	12732	31BC	Overrange
:	:	:	:	:	:	:	:	:	
850.1	8501	2135	1562.1	15621	3D05	1123.3	11233	2BE1	
850.0	8500	2134	1562.0	15620	3D04	1123.2	11232	2BE0	Nominal range
:	:	:	:	:	:	:	:	:	
-200.0	-2000	F830	-328.0	-3280	F330	73.2	732	2DC	
-200.1	-2001	F82F	-328.1	-3281	F32F	73.1	731	2DB	Underrange
:	:	:	:	:	:	:	:	:	
-243.0	-2430	F682	-405.4	-4054	F02A	30.2	302	12E	
< -243.0	-32768	8000	< -405.4	-32768	8000	< 30.2	32768	8000	Underflow

Table C-12 Resistance-type thermometer Pt 100 Climate

Pt 100 Climate/ in °C (1 digit = 0.01 °C)	Values		Pt 100 Climate/ in °F (1 digit = 0.01 °F)	Values		Range
	dec.	hex.		dec.	hex.	
> 155.00	32767	7FFF	> 311.00	32767	7FFF	Overflow
155.00	15500	3C8C	311.00	31100	797C	Overrange
:	:	:	:	:	:	
130.01	13001	32C9	266.01	26601	67E9	
130.00	13000	32C8	266.00	26600	67E8	Nominal range
:	:	:	:	:	:	
-120.00	-12000	D120	-184.00	-18400	B820	
-120.01	-12001	D11F	-184.01	-18401	B81F	Underrange
:	:	:	:	:	:	
-145.00	-14500	C75C	-229.00	-22900	A68C	
< -145.00	-32768	8000	< -229.00	-32768	8000	Underflow

Table C-13 Resistance-type thermometer Ni 100 standard

Ni 100 Standard in °C (1 digit = 0.1 °C)	Values		Ni 100 Standard in °F (1 digit = 0.1 °F)	Values		Ni 100 Standard in K (1 digit = 0.1 K)	Values		Range
	dec.	hex.		dec.	hex.		dec.	hex.	
> 295.0	32767	7FFF	> 563.0	32767	7FFF	> 568.2	32767	7FFF	Overflow
295.0	2950	B86	563.0	5630	15FE	568.2	5682	1632	Overrange
:	:	:	:	:	:	:	:	:	
250.1	2501	9C5	482.1	4821	12D5	523.3	5233	1471	
250.0	2500	9C4	482.0	4820	12D4	523.2	5232	1470	Nominal range
:	:	:	:	:	:	:	:	:	
-60.0	-600	FDA8	-76.0	-760	FD08	213.2	2132	854	
-60.1	-601	FDA7	-76.1	-761	FD07	213.1	2131	853	Underrange
:	:	:	:	:	:	:	:	:	
-105.0	-1050	FBE6	-157.0	-1570	F9DE	168.2	1682	692	
< -105.0	-32768	8000	< -157.0	-32768	8000	< 168.2	32768	8000	Underflow

Table C-14 Resistance-type thermometer Ni 100 Climate

Ni 100 Climate in °C (1 digit = 0.01 °C)	Values		Ni 100 Climate in °F (1 digit = 0.01 °F)	Values		Range
	dec.	hex.		dec.	hex.	
> 155.00	32767	7FFF	> 311.00	32767	7FFF	Overflow
155.00	15500	3C8C	311.00	31100	797C	Overrange
:	:	:	:	:	:	
130.01	13001	32C9	266.01	26601	67E9	
130.00	13000	32C8	266.00	26600	67E8	Nominal range
:	:	:	:	:	:	
-60.00	-6000	E890	-76.00	-7600	E250	
-60.01	-6001	E88F	-76.01	-7601	E24F	Underrange
:	:	:	:	:	:	
-105.00	-10500	D6FC	-157.00	-15700	C2AC	
< - 105.00	-32768	8000	< - 157.00	-32768	8000	Underflow

C.3.4 Measured values for wire break diagnostics

Measured values for "Wire break" diagnostics as a function of diagnostics enables

With suitable parameter assignment, events that occur trigger a diagnostics entry and a diagnostics interrupt.

Table C-15 Measured values for wire break diagnostics

Format	Parameter assignment	Measured values		Explanation
S7	<ul style="list-style-type: none"> "Wire break" diagnostics enabled "Overflow/Underflow" diagnostics enabled or disabled ("Wire break" diagnostics has a higher priority than "Overflow/Underflow" diagnostics)	32767	7FFF _H	"Wire break" or "Cable break" diagnostics alarm

Format	Parameter assignment	Measured values		Explanation
	<ul style="list-style-type: none"> "Wire break" diagnostics disabled "Overflow/Underflow" diagnostics enabled 	-32767	8000 _H	<ul style="list-style-type: none"> Measured value after leaving the under-range Diagnostics alarm "Low limit" violated
	<ul style="list-style-type: none"> "Wire break" diagnostics disabled "Overflow/Underflow" diagnostics disabled 	-32767	8000 _H	Measured value after leaving the underrange

C.4 Representation of output ranges

The tables below set out the digitalized representation of the output ranges separately for bipolar and unipolar ranges. The resolution is 16 bits.

Table C-16 Bipolar output ranges

Dec. value	Output value in %	Data word																Range
		2 ¹⁵	2 ¹⁴	2 ¹³	2 ¹²	2 ¹¹	2 ¹⁰	2 ⁹	2 ⁸	2 ⁷	2 ⁶	2 ⁵	2 ⁴	2 ³	2 ²	2 ¹	2 ⁰	
32511	117.589	0	1	1	1	1	1	1	0	1	1	1	1	1	1	1	1	Maximum output value*
32511	117.589	0	1	1	1	1	1	1	0	1	1	1	1	1	1	1	1	Overrange
27649	100.004	0	1	1	0	1	1	0	0	0	0	0	0	0	0	0	1	
27648	100.000	0	1	1	0	1	1	0	0	0	0	0	0	0	0	0	0	Nominal range
1	0.003617	0	0	0	0	0	0	0	0	0	0	0	0	0	0	0	1	
0	0.000	0	0	0	0	0	0	0	0	0	0	0	0	0	0	0	0	
-1	-0.003617	1	1	1	1	1	1	1	1	1	1	1	1	1	1	1	1	
-27648	-100.000	1	0	0	1	0	1	0	0	0	0	0	0	0	0	0	0	
-27649	-100.004	1	0	0	1	0	0	1	1	1	1	1	1	1	1	1	1	Underrange
-32512	-117.593	1	0	0	0	0	0	0	1	0	0	0	0	0	0	0	0	
-32512	-117.593	1	0	0	0	0	0	0	1	0	0	0	0	0	0	0	0	Minimum output value**

* When values > 32511 are specified, the output value is limited to 117.589%.

** When values < -32512 are specified, the output value is limited to -117.593%.

Table C-17 Unipolar output ranges

Dec. value	Output value in %	Data word																Range
		2 ¹⁵	2 ¹⁴	2 ¹³	2 ¹²	2 ¹¹	2 ¹⁰	2 ⁹	2 ⁸	2 ⁷	2 ⁶	2 ⁵	2 ⁴	2 ³	2 ²	2 ¹	2 ⁰	
32511	117.589	0	1	1	1	1	1	1	1	x	x	x	x	x	x	x	x	Maximum output value*
32511	117.589	0	1	1	1	1	1	1	0	1	1	1	1	1	1	1	1	Overrange
27649	100.004	0	1	1	0	1	1	0	0	0	0	0	0	0	0	0	1	
27648	100.000	0	1	1	0	1	1	0	0	0	0	0	0	0	0	0	0	Nominal range

* When values > 32511 are specified, the output value is limited to 117.589%.

** When values < 0 are specified, the output value is limited to 0%.

1	0.003617	0	0	0	0	0	0	0	0	0	0	0	0	0	0	0	1	Nominal range
0	0.000	0	0	0	0	0	0	0	0	0	0	0	0	0	0	0	0	
0	0	0	0	0	0	0	0	0	0	0	0	0	0	0	0	0	0	Minimum output value**

* When values > 32511 are specified, the output value is limited to 117.589%.

** When values < 0 are specified, the output value is limited to 0%.

C.4.1 Representation of analog values in the voltage output ranges

The tables below list the decimal and hexadecimal values (codes) of the possible voltage output ranges.

Table C-18 Voltage output range ± 10 V

Values			Voltage output range	Range
	dec.	hex.	± 10 V	
>117.589%	>32511	>7EFF	11.76 V	Maximum output value
117.589%	32511	7EFF	11.76 V	Overrange
	27649	6C01		
100%	27648	6C00	10 V	Nominal range
75%	20736	5100	7.5 V	
0.003617%	1	1	361.7 μ V	
0%	0	0	0 V	
	-1	FFFF	-361.7 μ V	
-75%	-20736	AF00	-7.5 V	
-100%	-27648	9400	-10 V	
	-27649	93FF		Underrange
-117.593%	-32512	8100	-11.76 V	Minimum output value
<-117.593%	<-32512	< 8100	-11.76 V	

Table C-19 Voltage output range 0 V to 10 V

Values			Voltage output range	Range
	dec.	hex.	0 to 10 V	
>117.589%	>32511	>7EFF	11.76 V	Maximum output value
117.589%	32511	7EFF	11.76 V	Overrange
	27649	6C01		
100%	27648	6C00	10 V	Nominal range
75%	20736	5100	7.5 V	
0.003617%	1	1	361.7 μ V	
0%	0	0	0 V	
<0%	<0	<0	0 V	

C.4 Representation of output ranges

Table C-20 Voltage output range 1 V to 5 V

Values			Voltage output range	Range
	dec.	hex.	1 to 5 V	
>117.589%	>32511	>7EFF	5.70 V	Maximum output value
117.589%	32511	7EFF	5.70 V	Overrange
	27649	6C01		
100%	27648	6C00	5 V	Nominal range
75%	20736	5100	4 V	
0.003617%	1	1	1 V +144.7 μ V	
0%	0	0	1 V	
	-1	FFFF	1 V -144.7 μ V	
-25%	-6912	E500	0 V	Underrange
<-25%	<-6912	<E500	0 V	Minimum output value

C.4.2 Representation of analog values in the current output ranges

The tables below list the decimal and hexadecimal values (codes) of the possible current output ranges.

Table C-21 Current output range \pm 20 mA

Values			Current output range	Range
	dec.	hex.	\pm 20 mA	
>117.589%	>32511	>7EFF	23.52 mA	Maximum output value
117.589%	32511	7EFF	23.52 mA	Overrange
	27649	6C01		
100%	27648	6C00	20 mA	Nominal range
75%	20736	5100	15 mA	
0.003617%	1	1	723.4 mA	
0%	0	0	0 mA	
	-1	FFFF	-723.4 mA	
-75%	-20736	AF00	-15 mA	
-100%	-27648	9400	-20 mA	
	-27649	93FF		Underrange
-117.593%	-32512	8100	-23.52 mA	Minimum output value
<-117.593%	<-32512	<8100	-23.52 mA	

Table C-22 Current output range 0 to 20 mA

Values			Current output range	Range
	dec.	hex.	0 to 20 mA	
>117.589%	>32511	>7EFF	23.52 mA	Maximum output value
117.589%	32511	7EFF	23.52 mA	Overrange
	27649	6C01		
100%	27648	6C00	20 mA	

Values			Current output range	Range
75%	20736	5100	15 mA	Nominal range
0.003617%	1	1	723.4 mA	
0%	0	0	0 mA	
<0%	<0	<0	0 mA	Minimum output value

Table C-23 Current output range 4 to 20 mA

Values			Current output range	Range
	dec.	hex.	4 to 20 mA	
>117.589%	>32511	>7EFF	22.81 mA	Maximum output value
117.589%	32511	7EFF	22.81 mA	Overrange
	27649	6C01		
100%	27648	6C00	20 mA	Nominal range
75%	20736	5100	16 mA	
0.003617%	1	1	4 mA	
0%	0	0	4 mA	
	-1	FFFF		Underrange
-25%	-6912	E500	0 mA	Minimum output value
<-25%	<-6912	<E500	0 mA	