

SINAMICS S120

1FW3 complete torque motors

Configuration Manual · 07/2011

SINAMICS

SIEMENS

SIEMENS

SINAMICS S120

1FW3 complete torque motors

Configuration Manual

Preface

Motor description

1

Configuration

2

Mechanical properties of the motors

3

Technical specifications and characteristic curves

4

Motor components

5

Connection system

6

Assembly

7



Appendix

A

Legal information

Warning notice system

This manual contains notices you have to observe in order to ensure your personal safety, as well as to prevent damage to property. The notices referring to your personal safety are highlighted in the manual by a safety alert symbol, notices referring only to property damage have no safety alert symbol. These notices shown below are graded according to the degree of danger.

 DANGER
indicates that death or severe personal injury will result if proper precautions are not taken.
 WARNING
indicates that death or severe personal injury may result if proper precautions are not taken.
 CAUTION
with a safety alert symbol, indicates that minor personal injury can result if proper precautions are not taken.
CAUTION
without a safety alert symbol, indicates that property damage can result if proper precautions are not taken.
NOTICE
indicates that an unintended result or situation can occur if the relevant information is not taken into account.

If more than one degree of danger is present, the warning notice representing the highest degree of danger will be used. A notice warning of injury to persons with a safety alert symbol may also include a warning relating to property damage.

Qualified Personnel

The product/system described in this documentation may be operated only by **personnel qualified** for the specific task in accordance with the relevant documentation, in particular its warning notices and safety instructions. Qualified personnel are those who, based on their training and experience, are capable of identifying risks and avoiding potential hazards when working with these products/systems.

Proper use of Siemens products

Note the following:

 WARNING
Siemens products may only be used for the applications described in the catalog and in the relevant technical documentation. If products and components from other manufacturers are used, these must be recommended or approved by Siemens. Proper transport, storage, installation, assembly, commissioning, operation and maintenance are required to ensure that the products operate safely and without any problems. The permissible ambient conditions must be complied with. The information in the relevant documentation must be observed.

Trademarks

All names identified by ® are registered trademarks of Siemens AG. The remaining trademarks in this publication may be trademarks whose use by third parties for their own purposes could violate the rights of the owner.

Disclaimer of Liability

We have reviewed the contents of this publication to ensure consistency with the hardware and software described. Since variance cannot be precluded entirely, we cannot guarantee full consistency. However, the information in this publication is reviewed regularly and any necessary corrections are included in subsequent editions.

Preface

Motor documentation

The motor documentation is organized in the following categories:

- General documentation e.g. catalogs
- Manufacturer/service documentation e.g. Operating Instructions and Configuration Manuals

More information

Information on the following topics is available under the link:

- Ordering documentation/overview of documentation
- Additional links to download documents
- Using documentation online (find and search in manuals/information)

<http://www.siemens.com/motioncontrol/docu>

Please send any questions about the technical documentation (e.g. suggestions for improvement, corrections) to the following e-mail address:

docu.motioncontrol@siemens.com

My Documentation Manager

The following link provides information on how to create your own individual documentation based on Siemens content, and adapt it for your own machine documentation:

<http://www.siemens.com/mdm>

Training

The following link provides information on SITRAIN - training from Siemens for products, systems and automation engineering solutions:

<http://siemens.com/sitrain>

FAQs

You can find Frequently Asked Questions in the Service&Support pages under **Product Support**:

<http://support.automation.siemens.com>

Technical Support

For technical support telephone numbers for different countries, go to:
<http://www.siemens.com/automation/service&support>

Internet addresses for drive technology

Internet address for motors: <http://www.siemens.com/motors>

Internet address for products: <http://www.siemens.com/motioncontrol>

Internet address for SINAMICS: <http://www.siemens.com/sinamics>

Target group

This documentation addresses project planners and project engineers as well as machine manufacturers and commissioning engineers.

Benefits

The Configuration Manual supports you when selecting motors, calculating the drive components, selecting the required accessories as well as when selecting line and motor-side power options.

Standard scope

The scope of the functionality described in this document can differ from the scope of the functionality of the drive that is actually supplied.

- Other functions not described in this documentation might be able to be executed in the drive. However, no claim can be made regarding the availability of these functions when the equipment is first supplied or in the event of servicing.
- The documentation can also contain descriptions of functions that are not available in a particular product version of the drive. The functionalities of the supplied drive should only be taken from the ordering documentation.
- Extensions or changes made by the machine manufacturer are documented by the machine manufacturer.

For reasons of clarity, this documentation does not contain all of the detailed information on all of the product types. This documentation cannot take into consideration every conceivable type of installation, operation and service/maintenance.

EC Declarations of Conformity

The EC Declaration of Conformity for the EMC Directive can be found on the Internet at
<http://support.automation.siemens.com>

There – as a search term – enter the number **15257461** or contact your local Siemens office.

Danger and warning information

 DANGER
<p>Commissioning is absolutely prohibited until it has been completely ensured that the machine, in which the components described here are to be installed, is in full compliance with the provisions of the EC Machinery Directive.</p> <p>Only appropriately qualified personnel may commission the SINAMICS units and the motors.</p> <p>This personnel must carefully observe the technical customer documentation associated with this product and be knowledgeable about and carefully observe the danger and warnings.</p> <p>Operation of electrical equipment and motors inevitably involves electrical circuits with dangerous voltages. All of the work carried out on the electrical machine or system must be carried out while it is in a no-voltage condition.</p> <p>When the machine or system is operated, hazardous axis movements can occur.</p> <p>SINAMICS drive units with synchronous motors can only be connected to the line supply via residual-current operated circuit breakers if it has been verified (in accordance with EN 61800-5-1) that the units are compatible with the particular residual-current operated circuit breaker.</p> <p>In combination with the drive system, the motors are generally approved for operation on TN and TT line supply systems with grounded neutral and on IT line supply systems.</p> <p>When connected to IT line supply systems, when a first fault occurs between an active part and ground, this must be signaled using appropriate monitoring equipment. In accordance with IEC 60364-4-41, it is recommended that the first fault is removed as quickly as is practically possible.</p> <p>In systems with a grounded external conductor, an isolating transformer with grounded neutral (secondary side) must be connected between the line supply and the drive system to protect the motor insulation from excessive stress. The majority of TT line supply systems have a grounded phase conductor, so in this case an isolating transformer must be used.</p>

 WARNING
<p>For 1FW3 motors, voltages are present at the motor terminals when the rotor is rotating (as a result of the permanent magnets). The voltage can be as high as 1000 V depending on the type of motor.</p> <p>The equipment and motors must be transported, stored, installed, mounted, operated, serviced, and maintained properly in order to ensure that they function correctly and safely.</p> <p>In the case of special versions of the drive units and motors, the information and data provided in the catalogs and quotations also apply.</p> <p>In addition to the danger and warning information/instructions in the technical customer documentation supplied, the applicable domestic, local and plant-specific regulations and requirements must be carefully taken into account.</p>

 **CAUTION**

The motors can have surface temperatures of over +100°C.

For this reason, temperature-sensitive components (e.g. cables or electronic components) must not come into contact with or be attached to the motor.

When connecting the cables, ensure that they

- are not damaged
- are not subject to tensile stress
- cannot be touched by rotating components.

CAUTION

Motors should be connected in accordance with the operating instructions. They must not be connected directly to the three-phase supply because this will damage them.

SINAMICS units and synchronous motors are subject to a voltage test during routine testing. While the electrical equipment of industrial machines is being subjected to a voltage test in accordance with EN60204-1, Section 19.4, all SINAMICS drive unit connections must be disconnected/withdrawn in order to avoid damaging the SINAMICS drive units.

CAUTION

Motors with DRIVE-CLiQ interface have an electronic rating plate which contains motor and encoder-specific data. This is the reason that encoder modules with DRIVE-CLiQ interface or mounted Sensor Module may only be operated on the original motor - and may not be mounted onto other motors or replaced by a Sensor Module from other motors.

The DRIVE-CLiQ interface has direct contact to components that can be damaged/destroyed by electrostatic discharge (ESDS). Neither hands nor tools that could be electrostatically charged should come into contact with the connections.

Note

When operational and in dry operating rooms, SINAMICS units with synchronous motors fulfill the Low-Voltage Directive.

In the configurations specified in the associated EC Declaration of Conformity, SINAMICS units with synchronous motors fulfill the EMC Directive.

ESDS instructions and electromagnetic fields

CAUTION

An **electrostatic-sensitive device** (ESDS) is an individual component, integrated circuit, or module that can be damaged by electrostatic fields or discharges.

ESDS regulations for handling boards and equipment:

When handling components that can be destroyed by electrostatic discharge, it must be ensured that personnel, the workstation and packaging are well grounded!

Personnel in ESD zones with conductive floors may only touch electronic components if they are

- grounded through an ESDS bracelet and
- wearing ESDS shoes or ESDS shoe grounding strips.

Electronic boards may only be touched when absolutely necessary.

Electronic boards may not be brought into contact with plastics and articles of clothing manufactured from man-made fibers.

Electronic boards may only be placed on conductive surfaces (table with ESDS surface, conductive ESDS foam rubber, ESDS packing bag, ESDS transport containers).

Electronic boards may not be brought close to data terminals, monitors or television sets. Minimum clearance to screens > 10 cm).

Measurements may only be carried-out on electronic boards and modules if

- the measuring instrument is grounded (e.g. via a protective conductor) or
- before making measurements with a potential-free measuring device, the measuring head is briefly discharged

(e.g. by touching an unpainted blank piece of metal on the control cabinet).

DANGER

It may be dangerous for people to remain in the immediate proximity of the product – especially for those with pacemakers, implants or similar – due to electric, magnetic and electromagnetic fields (EMF) occurring as a consequence of operation.

The machine/system operator and the people present near the product must observe the relevant guidelines and standards! These are, for example, in the European Economic Area (EEA) the Electromagnetic Fields Directive 2004/40/EC and the standards EN 12198-1 to 12198-3 and in the Federal Republic of Germany the Employer's Liability Insurance Association Regulations for the Prevention of Industrial Accidents BGV 11, with the relevant rule BGR 11 "Electromagnetic Fields".

Then a risk assessment must be carried out for every workplace, activities for reducing dangers and exposure for people decided upon and implemented, as well as determining and observing exposure and danger areas.

Information regarding third-party products

NOTICE
<p>This document contains recommendations relating to third-party products. This involves third-party products whose fundamental suitability is familiar to us. It goes without saying that equivalent products from other manufacturers may be used. Our recommendations are to be seen as helpful information, not as requirements or regulations. We cannot accept any liability for the quality and properties/features of third-party products.</p>

Environmental compatibility

- Environmental aspects during development

When selecting supplier parts, environmental compatibility was an essential criteria.

Special emphasis was placed on reducing the envelope dimensions, mass and type variety of metal and plastic parts.

Effects of paint-wetting impairment substances can be excluded (PWIS test)

- Environmental aspects during production

Supplier parts and the products are predominantly transported in re-usable packing. Transport for hazardous materials is not required.

The packing materials themselves essentially comprises paperboard containers that are in compliance with the Packaging Directive 94/62/EC.

Energy consumption during production was optimized.

Production has low emission levels.

- Environmental aspects for disposal

Motors must be disposed of carefully taking into account domestic and local regulations in the normal recycling process or by returning to the manufacturer.

The following must be taken into account when disposing of the motor:

Oil according to the regulations for disposing of old oil (e.g. gear oil when a gearbox is mounted)

Not mixed with solvents, cold cleaning agents or remains of paint

Components that are to be recycled should be separated according to:

- Electronics scrap (e.g. encoder electronics, sensor modules)
- Iron to be recycled
- Aluminum
- Non-ferrous metal (gearwheels, motor windings)

Residual risks of power drive systems

When carrying out a risk assessment of the machine in accordance with the EU Machinery Directive, the machine manufacturer must consider the following residual risks associated with the control and drive components of a power drive system (PDS).

1. Unintentional movements of driven machine components during commissioning, operation, maintenance, and repairs caused by, for example:
 - Hardware defects and/or software errors in the sensors, controllers, actuators, and connection technology
 - Response times of the controller and drive
 - Operating and/or ambient conditions not within the scope of the specification
 - Parameterization, programming, cabling, and installation errors
 - Use of radio devices / cellular phones in the immediate vicinity of the controller
 - External influences / damage
2. Exceptional temperatures as well as emissions of light, noise, particles, or gas caused by, for example:
 - Component malfunctions
 - Software errors
 - Operating and/or ambient conditions not within the scope of the specification
 - External influences / damage
3. Hazardous shock voltages caused by, for example:
 - Component malfunctions
 - Influence of electrostatic charging
 - Induction of voltages in moving motors
 - Operating and/or ambient conditions not within the scope of the specification
 - Condensation / conductive contamination
 - External influences / damage
4. Electrical, magnetic and electromagnetic fields generated in operation that can pose a risk to people with a pacemaker, implants or metal replacement joints, etc. if they are too close.
5. Release of environmental pollutants or emissions as a result of improper operation of the system and/or failure to dispose of components safely and correctly.

More extensive information concerning the residual risks associated with the PDS is provided in the relevant chapters of the technical user documentation.

Table of contents

	Preface	3
1	Motor description	15
1.1	Properties.....	15
1.2	Torque overview	18
1.3	Technical features.....	19
1.4	Technical specifications	21
1.5	Rating plate data	25
1.6	Order no.	26
2	Configuration	29
2.1	Configuration software	29
2.1.1	Configuration tool SIZER for SIEMENS Drives	29
2.1.2	STARTER drive/commissioning software	31
2.2	Procedure when engineering	32
2.3	Dimensioning	33
2.3.1	1. Clarification of the type of drive	33
2.3.2	2. Definition of supplementary conditions and integration into an automation system.....	34
2.3.3	3. Definition of load cycle, calculation of max. load torque, definition of motor	35
3	Mechanical properties of the motors	45
3.1	Cooling	45
3.1.1	Cooling circuit.....	45
3.1.2	Engineering the cooling circuit.....	48
3.1.3	Cooling water	52
3.1.4	Cooling water connection.....	54
3.2	Degree of protection	55
3.3	Bearing version	56
3.4	Radial and axial forces.....	58
3.4.1	Hollow shaft.....	59
3.4.2	Plug-on shaft.....	62
3.4.3	Solid shaft	66
3.5	Shaft versions	70
3.6	Vibration severity grade	71
3.7	Noise emission.....	71
3.8	Gear ratio	72
3.9	Paint finish.....	72

4	Technical specifications and characteristic curves	73
4.1	Torque-speed characteristic	79
4.1.1	Shaft height 150	80
4.1.2	Shaft height 200	110
4.1.3	Shaft height 280, High Torque	146
4.1.4	Shaft height 280, High Speed	162
4.2	Dimension drawings	178
4.2.1	Hollow shaft	180
4.2.2	Encoderless	183
4.2.3	Plug-on shaft	186
4.2.4	Solid shaft	189
5	Motor components	191
5.1	Thermal motor protection	191
5.2	Encoder (option)	195
5.2.1	Encoder connection for motors with DRIVE-CLiQ interface	197
5.2.2	Encoder connection for motors without DRIVE-CLiQ interface	197
5.2.3	Incremental encoder sin/cos 1Vpp	198
5.2.4	Absolute encoders	201
5.2.5	Multi-pole resolver	203
5.2.6	Encoder with belt drive	205
5.2.7	Coaxial encoder mounting	206
5.2.8	Motor version without encoder	206
5.3	Braking resistors (armature short-circuit braking)	207
5.3.1	Function description	207
5.3.2	Dimensioning of braking resistors	210
6	Connection system	215
6.1	SINAMICS drive I/O	215
6.2	Line connection	216
6.3	Signal connection	219
6.4	Rotating the connector at the motor	221
6.5	Connecting-up information	222
6.6	Routing cables in a damp environment	225
7	Assembly	227
7.1	Warning and danger information when mounting	227
7.2	Overview of the mounting options	228
7.3	Mounting the motor frame	230
7.4	Plug-on installation	232
7.4.1	Plug-on shaft	235
7.4.2	Hollow shaft, inner clamping element	238
7.4.3	Hollow shaft, outer clamping system for clamping machine shafts	241
7.5	Coupling mounting	242
7.6	No bearings at the DE	243

7.7	Natural frequency when mounted	245
7.8	Vibration resistance	246
7.9	Heavy Duty.....	248
A	Appendix.....	251
A.1	Description of terms	251
A.2	Conformity certificates	255
A.3	References.....	256
	Index.....	257

Motor description

1.1 Properties

Overview

The 1FW3 series was developed as direct drive. This direct drive is a compact drive unit where the mechanical motor power is transferred directly to the driven machine without any mechanical transmission elements. 1FW3 complete torque motors are water-cooled, high-pole (slow running) permanent-magnet-excited synchronous motors. The operating characteristics are comparable to those of regular synchronous motors.



The range includes 3 outer diameters with various shaft lengths. For shaft heights 150 and 200, the stator and rotor have a flange with centering edges and tapped holes at the DE that allow them to be integrated into a machine.

The complete torque motor 1FW3 can be ordered with various shaft versions:

- Hollow shaft
- Plug-on shaft with integrated shaft centering
- Solid shaft

These allow highly flexible design and maintenance concepts to be implemented. 1FW3 torque motors can be combined with the SINAMICS S120 drive system to create a powerful, high-performance system. The integrated encoder systems for speed and position control can be selected according to the application.

Table 1- 1 Shaft versions

Versions	Hollow shaft	Plug-on shaft	Solid shaft
<p>Photograph</p>			
<p>Advantages</p>	<ul style="list-style-type: none"> • continuously hollow shafts can be used for feeding coolant/heating media, measuring cables, etc. • motors with various lengths can be connected to the machine shaft 	<ul style="list-style-type: none"> • simple and quick installation as a result of the integrated shaft adapter with centering • simpler clamping element • simple encoder replacement 	<ul style="list-style-type: none"> • "classic" motor installation • Simplest overall solution • simple replacement of a geared motor without having to change the connection to the machine • simple encoder replacement

Use and highlights

- High torque for a compact design and low envelope dimensions
- Optimized mechatronic solution
 - High degree of stiffness
 - High speeds possible
 - Innovative machine concepts are possible
 - Increased productivity and quality
- The optimum version for any application
 - Wide power range from 3 to 380 kW
 - Rated torques from 100 to 7000 Nm
 - Rated speeds from 150 to 1200 rpm
 - Hollow shaft, plug-on shaft or solid shaft
 - Different encoder types for speed control and precision positioning
- Outstanding performance characteristics
 - Maximum speeds of up to 1800 rpm
 - Excellent rotational accuracy
 - High dynamic response (short acceleration times)
- The ideal motor for energy-saving solutions
- Simple encoder replacement without requiring any readjustment for plug-on and solid shafts

Field of applications

- Main extruder drives
- Worm drives for injection molding machines
- Roll drive
- Winder
- Cross lapper
- Pull-roll drives for foil drawing machines
- Stretch, calender, casting and cooling rolls
- Dynamic positioning tasks, e.g. rotary tables, clocked conveyor belts
- Replacing hydraulic motors
- Roll drives in paper machines
- Cross-cutter drives for continuous material webs, e.g. paper, textiles, metal sheet
- Wire-drawing machines
- Chippers

1.2 Torque overview

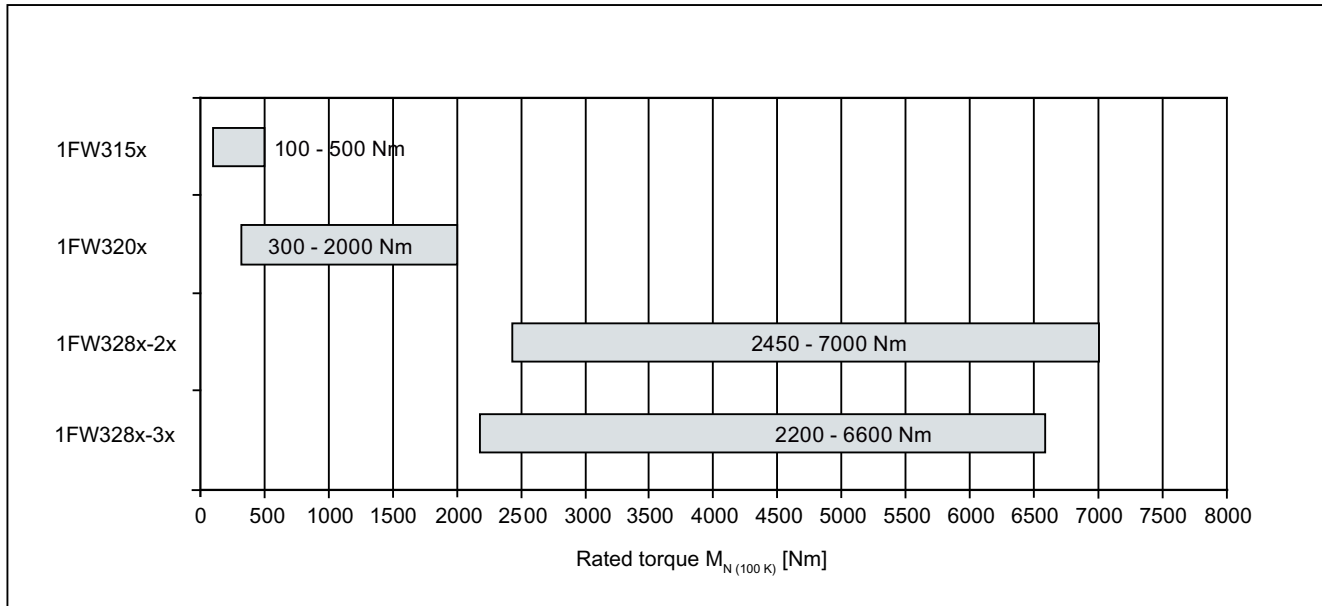

Figure 1-1 Torque overview, 1FW3

1.3 Technical features

Table 1- 2 Technical features

Motor type	Permanent-magnet synchronous motor
Magnet material	Rare-earth magnetic material
Stator winding insulation (acc. to EN 60034-1; IEC 60034-1)	Temperature class 155 (F) for a winding temperature rise of $\Delta T = 100$ K for a cooling water intake temperature of +30 °C.
Installation altitude (to IEC 60034-1)	For an installation altitude > 1000 m above sea level, the relevant data in the drive converter documentation must be carefully observed (secondary conditions/limitations).
Type of construction (acc. to EN 60034-7; IEC 60034-7)	Shaft height 150: IM B14, IM V18, IM V19 shaft height 200: IM B14, IM V18, IM V19 shaft height 280: IM B35
Degree of protection (acc. to EN 60034-5; IEC 60034-5)	Hollow shaft: IP54 plug-on shaft: IP55, SH 280 IP54 solid shaft: IP55
Cooling (acc. to EN 60034-6; IEC 60034-6)	Water cooling
Thermal motor protection (acc. to EN 60034-11; IEC 60034-11)	KTY 84 temperature sensor in stator winding
Paint finish	Anthracite (RAL 7016)
2. Rating plate	Enclosed separately
Shaft version (acc. to DIN 748-3; IEC 60072-1)	Hollow shaft, plug-on shaft, solid shaft Details see Chapter "Shaft version" and Chapter "Dimension drawings"
Shaft and flange accuracy (acc. to DIN 42955; IEC 60072-1)	Tolerance class N (at normal running temperature)
Vibration severity (acc. to EN 60034-14; IEC 60034-14)	Grade A is observed up to rated speed.
Sound pressure level (acc. to DIN EN ISO 1680)	Max. 73 dB(A) at 4 kHz rated pulse frequency at the nominal operating point
Bearing version	Roller bearings with permanent grease lubrication (bearing change interval = 20000h)
Built-in encoder systems for motors without DRIVE-CLiQ interface	<ul style="list-style-type: none"> • Incremental encoder, sin/cos 1 V_{pp}, 2048 S/R¹⁾ with C and D tracks, encoder IC2048S/R¹⁾, belt-mounted • Absolute encoder 2048 S/R¹⁾ singleturn, 4096 revolutions multiturn, with EnDat interface, encoder AM2048S/R¹⁾, belt-mounted or coaxially mounted at NDE • Multi-pole resolver, belt mounted
Built-in encoder systems for motors with DRIVE-CLiQ interface Belt-mounted	<ul style="list-style-type: none"> • Incremental encoder, 22-bit (resolution 4194304, internal encoder 2048 S/R¹⁾) + commutation position, 11-bit, encoder IC22DQ • absolute encoder 22 bit singleturn (resolution 4194304, in the encoder 2048 S/R¹⁾) + 12 bit multiturn (traversing range 4096 revolutions), encoder AM22DQ • Resolver 15 bit (resolution 32768, internal, multi-pole), encoder R15DQ

Motor description

1.3 Technical features

Built-in encoder systems for motors with DRIVE-CLiQ interface	<ul style="list-style-type: none">• Absolute encoder 24 bit singleturn (resolution 16777216), encoder AS24DQI
Coaxially mounted at NDE	<ul style="list-style-type: none">• Absolute encoder 24 bit singleturn (resolution 16777216), + 12 bit multiturn (traversing range 4096 revolutions), encoder AM24DQI
Connection	Terminal box for power cable Connector for encoder signals and KTY 84
Options	<ul style="list-style-type: none">• PTC thermistor motor protection using 3 integrated temperature sensors for shutdown• Version with/without encoder• Shaft cover at NDE for the hollow shaft version• Regreasing system• Special paint finish• Non-standard rated speeds (an inquiry is required)• Natural cooling on request• Special grease lubrication for low speeds

1) S/R = Signals/Revolution

1.4 Technical specifications

Table 1- 3 Technical data

Motor type	n _N		M _N	I _N	P _N		η ³⁾	M _{max}	I _{max}	n _{max mech.}
	[rpm]		[Nm]	[A]	[kW]		[%]	[Nm]	[A]	[rpm]
	ALM ¹⁾ 425 V	SLM/ BLM ²⁾ 380 V			ALM ¹⁾ 425 V	SLM/ BLM ²⁾ 380 V				
1FW3150-1□H	300	270	100	8.0	3.1	2.8	89	200	17	1700
1FW3150-1□L	500	450	100	12	5.2	4.7	90	200	26	1700
1FW3150-1□P	750	670	100	18	7.9	7.0	90	200	41	1700
1FW3152-1□H	300	270	200	14	6.3	5.7	92	400	35	1700
1FW3152-1□L	500	450	200	22	10.5	9.4	92	400	53	1700
1FW3152-1□P	750	670	200	32.5	15.7	14.0	93	400	79	1700
1FW3154-1□H	300	270	300	20.5	9.4	8.5	93	600	49	1700
1FW3154-1□L	500	450	300	32	15.7	14.1	93	600	75	1700
1FW3154-1□P	750	670	300	47.5	23.6	21.0	93	600	113	1700
1FW3155-1□H	300	270	400	28	12.6	11.3	94	800	67	1700
1FW3155-1□L	500	450	400	43	20.9	18.8	94	800	103	1700
1FW3155-1□P	750	670	400	64	31.4	28.1	94	800	153	1700
1FW3156-1□H	300	270	500	34	15.7	14.1	94	1000	81	1700
1FW3156-1□L	500	450	500	53	26.2	23.6	94	1000	126	1700
1FW3156-1□P	750	670	500	76	39.3	35.1	94	1000	183	1700
1FW3201-1□E	150	140	300	13	4.7	4.4	91	555	28	1000
1FW3201-1□H	300	270	300	23	9.4	8.5	92	555	50	1000
1FW3201-1□L	500	450	300	37	15.7	14.1	92	555	82	1000
1FW3202-1□E	150	140	500	21	7.9	7.3	93	925	47	1000
1FW3202-1□H	300	270	500	37	15.7	14.1	94	925	81	1000
1FW3202-1□L	500	450	500	59	26.2	23.6	94	925	131	1000
1FW3203-1□E	150	140	750	30	11.8	11.0	94	1390	69	1000
1FW3203-1□H	300	270	750	59	23.6	21.2	95	1390	132	1000
1FW3203-1□L	500	450	750	92	39.3	35.3	95	1390	204	1000
1FW3204-1□E	150	140	1000	40	15.7	14.7	94	1850	90	1000
1FW3204-1□H	300	270	1000	74	31.4	28.3	95	1850	163	1000
1FW3204-1□L	500	450	1000	118	52.3	47.1	95	1850	260	1000
1FW3206-1□E	150	140	1500	65	23.6	22.0	94	2775	145	1000
1FW3206-1□H	300	270	1500	118	47.1	42.4	95	2775	256	1000
1FW3206-1□L	500	450	1400	169	73.3	66.0	95	2775	399	1000
1FW3208-1□E	150	140	2000	84	31.4	29.3	94	3700	187	1000
1FW3208-1□H	300	270	2000	153	62.8	56.5	94	3700	340	1000
1FW3208-1□L	500	450	1850	226	96.8	87.2	94	3700	533	1000
1FW3281-2□E	150	140	2500	82	39.0	37.0	94	4050	145	1000
1FW3281-2□G	250	220	2450	126	64.0	56.0	95	4050	226	1000
1FW3283-2□E	150	140	3500	115	55.0	51.0	95	5700	203	1000
1FW3283-2□G	250	220	3450	176	90.0	79.0	96	5700	316	1000
1FW3285-2□E	150	140	5000	160	79.0	73.0	95	8150	284	1000

Motor description

1.4 Technical specifications

Motor type	n_N		M_N	I_N	P_N		η ³⁾	M_{max}	I_{max}	$n_{max\ mech.}$
	[rpm]				[Nm]	[A]				
	ALM ¹⁾ 425 V	SLM/ BLM ²⁾ 380 V			ALM ¹⁾ 425 V	SLM/ BLM ²⁾ 380 V				
1FW3285-2□G	250	220	4950	244	130.0	114.0	96	8150	436	1000
1FW3287-2□E	150	140	7000	230	110.0	103.0	96	11400	406	1000
1FW3287-2□G	250	220	6900	352	181.0	160.0	96	11400	632	1000
1FW3281-3□J	400	350	2350	188	98.0	88.0	96	4050	352	1000
1FW3281-3□M	600	520	2200	256	138.0	123.0	96	4050	512	1000
1FW3283-3□J	400	350	3300	275	138.0	123.0	96	5700	516	1000
1FW3283-3□M	600	520	3100	357	195.0	172.0	96	5700	712	1000
1FW3285-3□J	400	350	4700	376	197.0	174.0	96	8150	709	1000
1FW3285-3□M	600	520	4400	469	276.0	248.0	97	8150	942	1000
1FW3287-3□J	400	350	6600	504	276.0	244.0	97	11400	946	1000
1FW3287-3□M	600	520	6050	696	380.0	338.0	97	11400	1424	1000

1) ALM = Active Line Module

2) SLM = Smart Line Module / BLM = Basic Line Module

3) Efficiency

Motor Module

The rated motor current (I_N) is used as a basis to dimension the appropriate Motor Modules for the 1FW3 motors. If the full motor stall torque is required, the Motor Modules must be dimensioned according to the motor stall current (I_0).

If the motor is temporarily operated at operating points above the S1 characteristic, the current requirement of the motors at these points must be taken into account and the appropriate Motor Module configured. The Sizer Plus engineering tool can be used here (see "Engineering").

Format of the MLFB for Motor Modules

6SL3□20-1TE□□-□□□□ └─── 1 = Booksize 3 = Chassis
--

Table 1- 4 Assignment, 1FW3 torque motors - Motor Module

Motor type	Rated current / stall current I_N [A] / I_0 [A]	Order designation (MLFB) SINAMICS S120 Motor Modules	Rated current Motor Module I_N [A]
Supply voltage of 400 V 3 AC, Active Line Module ($V_{mot} = 425$ V)			
1FW3150-1□H	7.2 / 7.3	6SL312□-□TE21-0AA3	9
1FW3150-1□L	11 / 11.5	6SL312□-□TE21-8AA3	18
1FW3150-1□P	17 / 17.5	6SL312□-1TE21-8AA3	18
1FW3152-1□H	14 / 15	6SL312□-□TE21-8AA3	18
1FW3152-1□L	22 / 22.5	6SL332□-1TE23-0AA3	30
1FW3152-1□P	32.5 / 33.5	6SL312□-1TE24-5AA3	45
1FW3154-1□H	20.5 / 21.5	6SL312□-1TE23-0AA3	30
1FW3154-1□L	32 / 33	6SL332□-1TE24-5AA3	45
1FW3154-1□P	47.5 / 49	6SL312□-1TE26-0AA3	60
1FW3155-1□H	28 / 29	6SL312□-1TE23-0AA3	30
1FW3155-1□L	43 / 45	6SL332□-1TE26-0AA3	60
1FW3155-1□P	64 / 67	6SL312□-1TE28-5AA3	85
1FW3156-1□H	34 / 35	6SL312□-1TE24-5AA3	45
1FW3156-1□L	53 / 55	6SL312□-1TE26-0AA3	60
1FW3156-1□P	76 / 80	6SL312□-1TE28-5AA3	85
1FW3201-1□E	13 / 13	6SL312□-□TE21-8AA3	18
1FW3201-1□H	23 / 24	6SL312□-1TE23-0AA3	30
1FW3201-1□L	37 / 38	6SL312□-1TE24-5AA3	45
1FW3202-1□E	21 / 22	6SL312□-1TE23-0AA3	30
1FW3202-1□H	37 / 39	6SL312□-1TE24-5AA3	45
1FW3202-1□L	59 / 62	6SL312□-1TE26-0AA3	60
1FW3203-1□E	30 / 32	6SL312□-1TE23-0AA3	30
1FW3203-1□H	59 / 62	6SL312□-1TE26-0AA3	60
1FW3203-1□L	92 / 100	6SL312□-1TE31-3AA3	132
1FW3204-1□E	40 / 42	6SL312□-1TE24-5AA3	45
1FW3204-1□H	74 / 77	6SL312□-1TE28-5AA3	85
1FW3204-1□L	118 / 129	6SL312□-1TE31-3AA3	132
1FW3206-1□E	65 / 68	6SL312□-1TE28-5AA3	85
1FW3206-1□H	118 / 121	6SL312□-1TE31-3AA3	132
1FW3206-1□L	169 / 189	6SL312□-1TE32-0AA3	200
1FW3208-1□E	84 / 88	6SL312□-1TE28-5AA3	85
1FW3208-1□H	153 / 160	6SL312□-1TE32-0AA3	200
1FW3208-1□L	226 / 256	6SL3320-1TE32-6AA3	260
1FW3281-2□E	82 / 84	6SL312□-1TE28-5AA3	85
1FW3281-2□G	126 / 131	6SL312□-1TE31-3AA3	132
1FW3283-2□E	115 / 116	6SL312□-1TE31-3AA3	132
1FW3283-2□G	176 / 181	6SL312□-1TE32-0AA3	200
1FW3285-2□E	160 / 163	6SL312□-1TE32-0AA3	200

Motor description

1.4 Technical specifications

Motor type	Rated current / stall current I_N [A] / I_0 [A]	Order designation (MLFB) SINAMICS S120 Motor Modules	Rated current Motor Module I_N [A]
Supply voltage of 400 V 3 AC, Active Line Module ($V_{mot} = 425$ V)			
1FW3285-2□G	244 / 251	6SL3320-1TE32-6AA0	260
1FW3287-2□E	230 / 234	6SL3320-1TE32-6AA0	260
1FW3287-2□G	352 / 365	6SL3320-1TE33-8AA0	380
1FW3281-3□J	188 / 200	6SL312□-1TE32-0AA3	200
1FW3281-3□M	256 / 291	6SL3320-1TE33-1AA0	310
1FW3283-3□J	275 / 292	6SL3320-1TE33-1AA0	310
1FW3283-3□M	357 / 402	6SL3320-1TE33-8AA0	380
1FW3285-3□J	376 / 400	6SL3320-1TE33-8AA0	380
1FW3285-3□M	469 / 532	6SL3320-1TE35-0AA0	490
1FW3287-3□J	504 / 534	6SL3320-1TE36-1AA0	605
1FW3287-3□M	696 / 787	6SL3320-1TE37-5AA0	745

Note

Sound pressure level when reducing the pulse frequency

When the pulse frequency is reduced, a significantly higher sound pressure level can occur.

1.5 Rating plate data

The rating plate refers to the technical data of the motor.

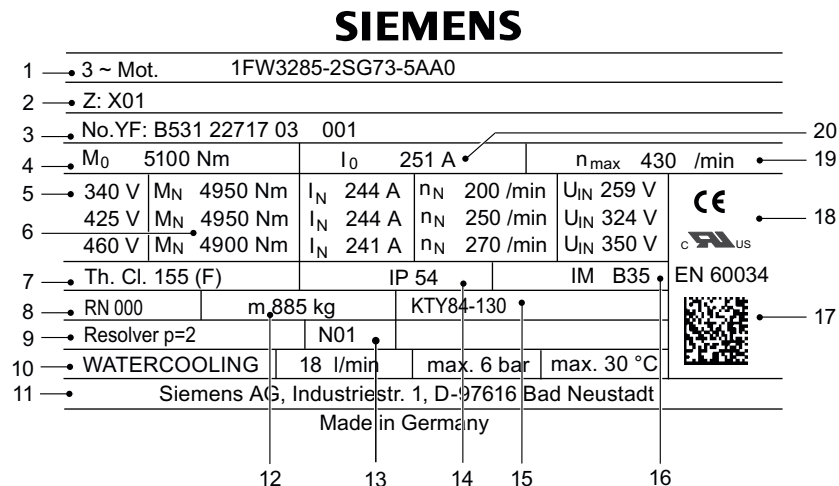
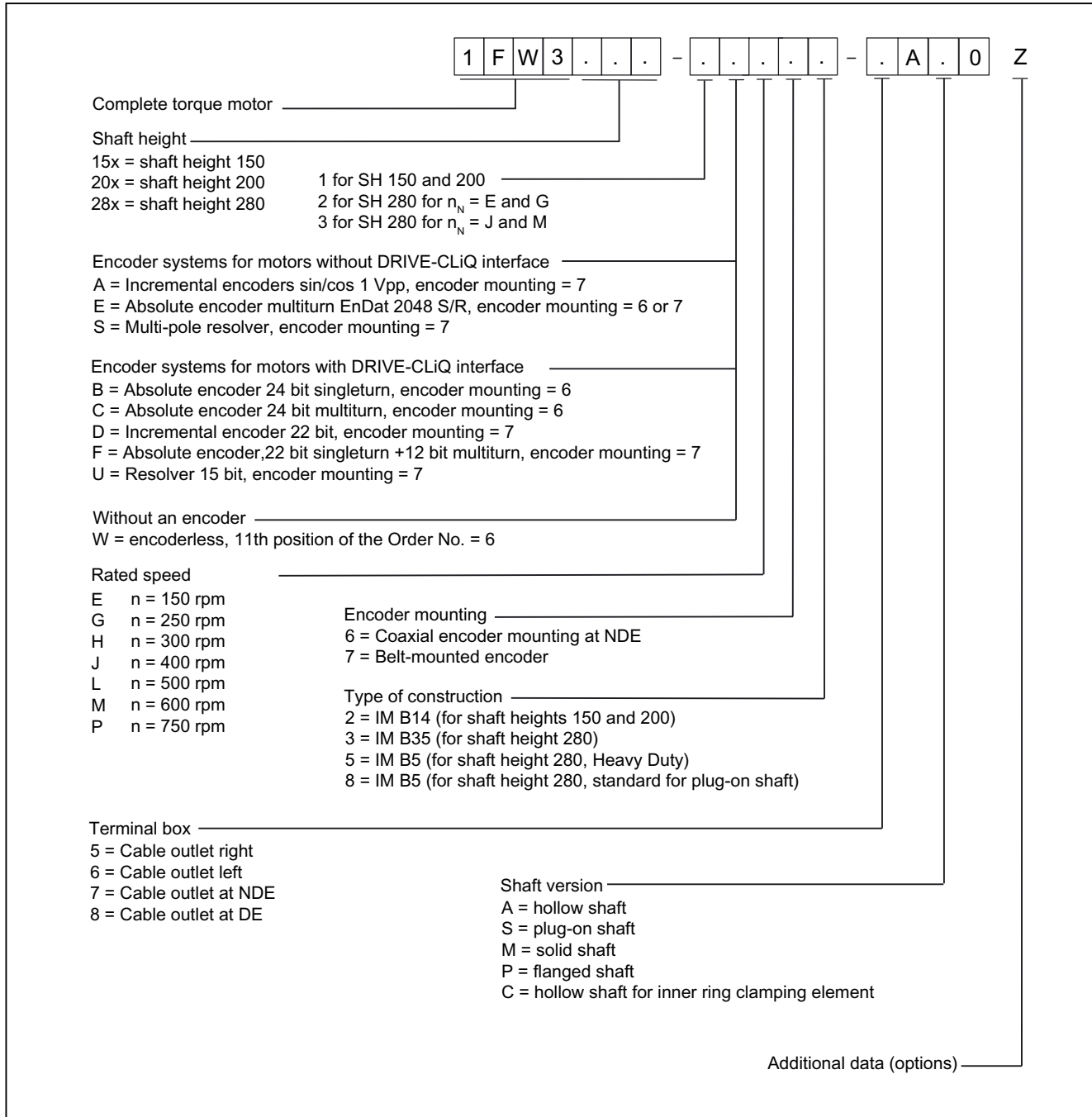

Figure 1-2 Schematic layout of the rating plate

Table 1-5 Description of the rating plate data

Position	Description / Technical specifications
1	Motor type: Synchronous motor, complete torque motor, order number
2	Additional information
3	Ident. No., production number
4	Static torque [Nm]
5	Output voltages [V]
6	Motor technical data
7	Temperature class
8	Motor version
9	Code, encoder type
10	Technical data of the cooling
11	Production address
12	Motor weight [kg]
13	Supplement to item 9 (encoder type)
14	Degree of protection
15	ID, temperature sensor
16	Type of construction
17	2D code
18	Standards and regulations, approximations
19	Max. permissible speed (inverter) [rpm]
20	Stall current [A]

1.6 Order no.



Order codes

When ordering a complete torque motor with options, **-Z** should be added to the order number. The order code should also be specified for each additional required option.

Order codes must not be repeated in plain text in the order.

Table 1- 6 List of order codes

Order code	Designation
A11	Motor protection using PTC thermistors
K40	Regreasing system
L03	Heavy-duty version
T20	Shaft cover at NDE
V07	Special grease for low speeds
X01	Paint finish, matt black RAL9005 paint finish
X02	Paint finish, cream white RAL9001
X03	Paint finish, reseda green RAL 6011
X04	Paint finish, pebble gray RAL 7032
X05	Paint finish, sky blue RAL 5015
X06	Paint finish, light ivory RAL 1015
X08	Paint finish, white aluminum, RAL 9006
X13	Paint finish, pastel blue RAL 5024
X18	Paint finish, papyrus white RAL 9018
X22	Paint finish, gray white RAL 9002
X28	Paint finish, azure blue RAL 9009
X29	Paint finish, mouse gray RAL 7005
X30	Paint finish, ivory RAL 1014
X31	Paint finish, brilliant blue RAL 5007
X32	Paint finish, pale green RAL 6021
X36	Paint finish, traffic white RAL 9016
X53	Paint finish, light gray RAL 7035

Configuration

2.1 Configuration software

2.1.1 Configuration tool SIZER for SIEMENS Drives

Overview

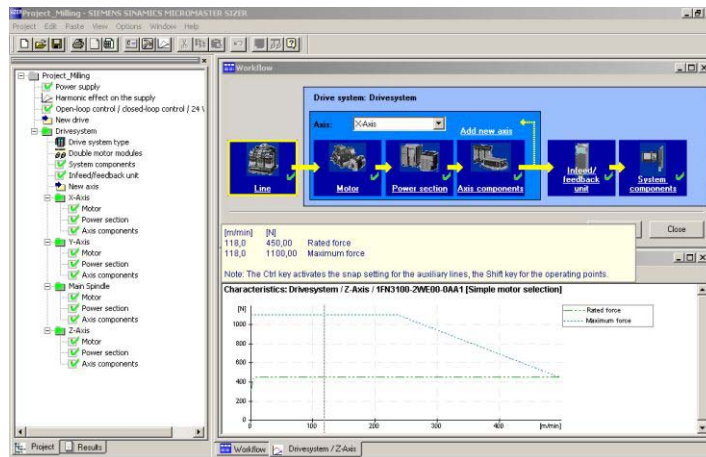

Figure 2-1 SIZER for SIEMENS Drives

The user-friendly configuration of the SINAMICS drive family is carried out using the configuration tool SIZER for SIEMENS Drives. It provides support for the technical planning of the hardware and firmware components required for a drive task. SIZER for SIEMENS Drives covers the full range of operations required to configure a complete drive system, from simple single drives to complex multi-axis applications.

SIZER for SIEMENS Drives supports all the configuration steps in a single workflow:

- Configuring the power supply
- Designing the motor and gearbox, including calculation of mechanical transmission elements
- Configuring the drive components
- Compiling the required accessories
- Selection of the line-side and motor-side power options

When SIZER for SIEMENS Drives was being designed, particular importance was placed on a high degree of usability and a holistic, function-based approach to the drive application. The extensive user navigation makes it easy to use the tool. Status information keeps you continually informed about how engineering is progressing.

The SIZER for SIEMENS Drives user interface is available in German and English. The drive configuration is saved in a project. In the project, the components and functions used are displayed in a hierarchical tree structure. The project view permits the configuration of drive systems and the copying/inserting/modifying of drives already configured.

The configuration process produces the following results:

- Parts list of components required (Export to Excel)
- Technical specifications of the system
- Characteristics
- Comments on system reactions
- Location diagram of drive and control components and dimension drawings

These results are displayed in a results tree and can be reused for documentation purposes. User support is provided by technological online help, which provides the following information:

- Detailed technical data
- Information about the drive systems and their components
- Decision-making criteria for the selection of components.

Table 2- 1 Order number for SIZER for SIEMENS Drives

Configuration tool	Order number (MLFB) of the DVD
SIZER for SIEMENS Drives German/English	6SL3070-0AA00-0AG0

Minimum system requirements

- PC or PG with Pentium™ III 800 MHz (recommended > 1 GHz)
- 512 MB RAM (1 GB recommended)
- At least 4.1 GB free hard disk space
- In addition, 100 MB free hard disk space on the Windows system drive
- Screen resolution 1024 × 768 pixels (1280 x 1024 pixels recommended)
- Windows™ XP Prof SP2, XP Home SP2, XP 64 Bit SP2, Vista Business
- Microsoft Internet Explorer 5.5 SP2

2.1.2 STARTER drive/commissioning software

The STARTER commissioning tool provides

- Commissioning
- Optimization
- Diagnostics

Table 2- 2 Order number for STARTER

Commissioning tool	Order number (MLFB) of the DVD
STARTER German, English, French, Italian, Spanish	6SL3072-0AA00-0AG0

Minimum system requirements

- Hardware
 - PG or PC with Pentium III min. 800 MHz (recommended > 1 GHz)
 - 512 MB RAM (1 GB recommended)
 - Screen resolution 1024 × 768 pixels, 16-bit color depth
 - Free hard disk memory: min. 2 GB;
- Software
 - Microsoft Windows 2000 SP4
 - Microsoft Windows Server 2003 SP1 and SP2 (PCS7)
 - Microsoft Windows XP Professional SP2 and SP3
 - Microsoft Windows VISTA Business SP1 *)
 - Microsoft Windows VISTA Ultimate SP1 *)
 - Microsoft Internet Explorer V6.0 or higher

*) DCC cannot be used.

STARTER can be used on these operating systems only if it does not include the DCC option.

2.2 Procedure when engineering

Motion Control

Servo drives are optimized for motion control applications. They execute linear or rotary movements within a defined movement cycle. All movements should be optimized in terms of time.

As a result of these considerations, servo drives must meet the following requirements:

- High dynamic response, i.e., short rise times
- Capable of overload, i.e. a high reserve for accelerating
- Wide control range, i.e. high resolution for precise positioning

General procedure when engineering

The function description of the machine provides the basis when engineering the drive application. The definition of the components is based on physical interdependencies and is usually carried-out as follows:

	Step	Description of the engineering activity
See following sections	1.	The type of drive/infeed type is clarified
	2.	Definition of supplementary conditions and integration into an automation system
	3.	The load is defined, the max. load torque is calculated, the motor selected
See Catalog	4.	The SINAMICS Motor Module is selected
	5.	Steps 3 and 4 are repeated for additional axes
	6.	The required DC link power is calculated and the SINAMICS Line Module is selected
	7.	The line-side options (main switch, fuses, line filters, etc.) are selected
	8.	Specification of the required control performance and selection of the Control Unit, definition of component cabling
	9.	Additional system components are defined and selected
	10.	The current demand of the 24 V DC supply for the components is calculated and the power supplies (SITOP devices, control supply modules) specified
	11.	The components for the connection system are selected
	12.	Design of the components of the drive line-up

2.3 Dimensioning

2.3.1 1. Clarification of the type of drive

The motor is selected on the basis of the required torque, which is defined by the application, e.g. traveling drives, hoisting drives, test stands, centrifuges, paper and rolling mill drives, feed drives or main spindle drives. Gear units to convert motion or to adapt the motor speed and motor torque to the load conditions must also be considered.

As well as the load torque, which is determined by the application, the following mechanical data are among those required to calculate the torque to be provided by the motor:

- Masses moved
- Diameter of the drive wheel/diameter
- Leadscrew pitch, gear ratios
- Frictional resistance
- Mechanical efficiency
- Traversing paths
- Maximum velocity
- Maximum acceleration and maximum deceleration
- Cycle time

You must decide whether synchronous or induction motors are to be used.

Synchronous motors are the best choice if it is important to have low envelope dimensions, low rotor moment of inertia and therefore maximum dynamic response. These motors are operated in control type "servo".

The following factors are especially important when engineering a drive application:

- The line system configuration, when using specific types of motor and/or line filters on IT systems (non-grounded systems)
- The ambient temperatures and the installation altitude of the motors and drive components.

The motor-specific limiting characteristics provide the basis for defining the motors.

These define the torque or power characteristic versus the speed and take into account the motor limits based on the DC-link voltage of the power or motor module. The DC-link voltage, in turn, is dependent on the supply voltage and, with multi-motor drives, on the type of the line module.

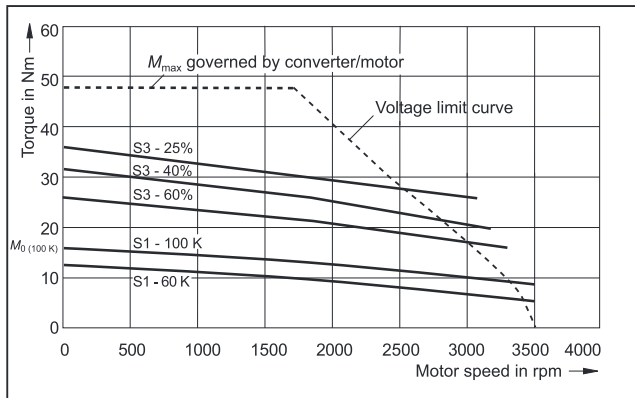

Figure 2-2 Limit curves for synchronous motors

2.3.2 2. Definition of supplementary conditions and integration into an automation system

You must decide whether synchronous or induction motors are to be used.

Synchronous motors are the best choice if it is important to have low envelope dimensions, low rotor moment of inertia and therefore maximum dynamic response.

Induction motors can be used to increase maximum speeds in the field weakening range. Induction motors for higher power ratings are also available.

You should also specify whether the drives are to be operated as single-axis drives or in a group as multi-axis drives.

The following factors are especially important when engineering a drive application:

- The type of line supply, when using specific types of motor and/or line filters on IT line supply systems (non-grounded systems)
- The utilization of the motor in accordance with rated values for winding temperatures of 60 K or 100 K
- The ambient temperatures and the installation altitude of the motors and drive components.

Other supplementary conditions apply when integrating the drives into an automation environment such as SIMATIC or SIMOTION.

For motion control and technology functions (e.g. positioning), as well as for synchronous functions, the corresponding automation system, e.g. SIMOTION D, is used.

The drives are interfaced to the higher-level automation system via PROFIBUS.

2.3.3 3. Definition of load cycle, calculation of max. load torque, definition of motor

The motor-specific limiting curves are used as basis when selecting a motor.

These define the torque characteristic with respect to speed and take into account the motor limits based on the line supply voltage and the function of the infeed.

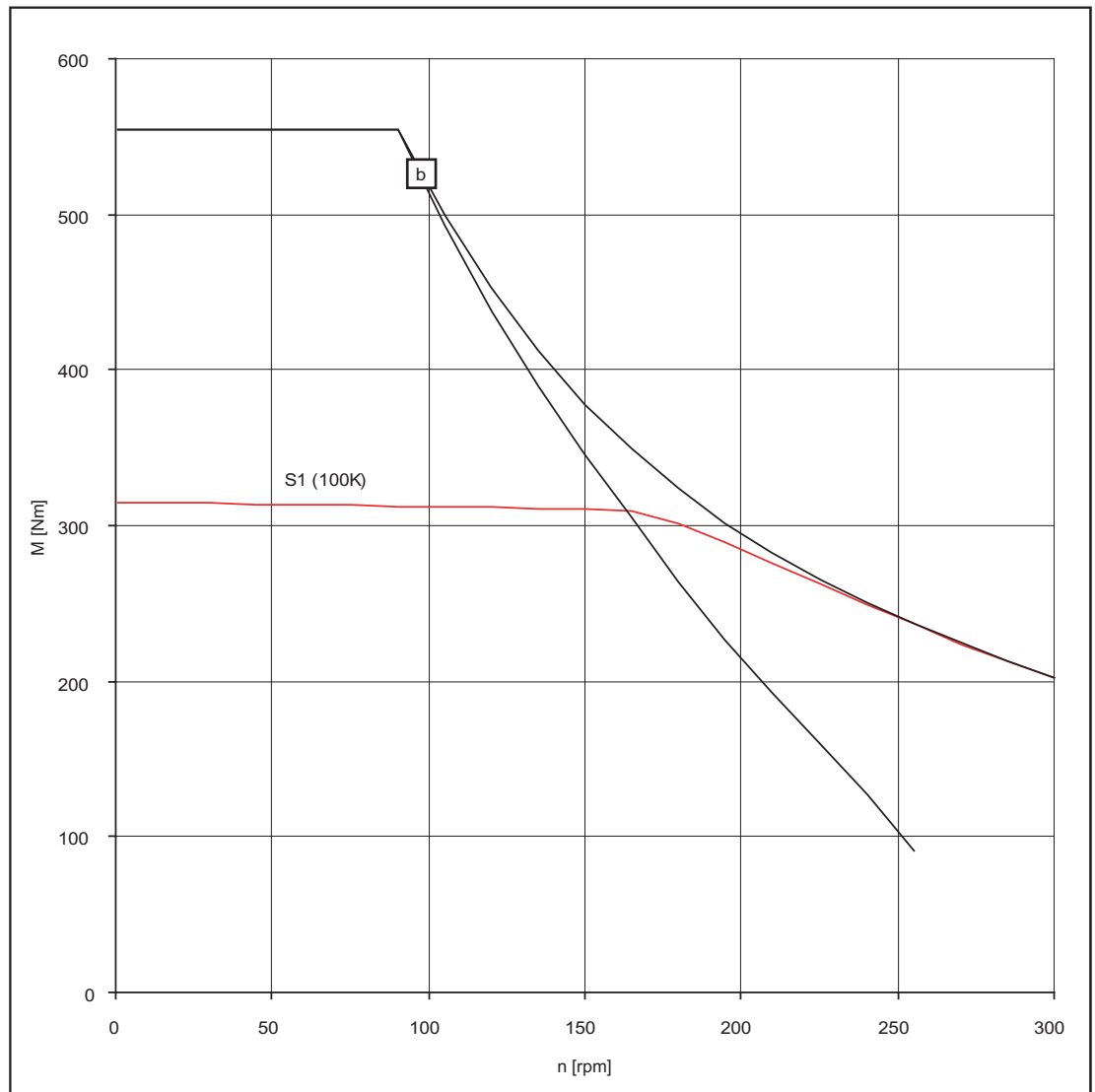

[b] SINAMICS S 120 Active Line Module, $V_{line\ rms} = 400\ V$

Figure 2-3 Limiting characteristics for synchronous motors 1FW3201-1□E□

$$M_{Mot,\ eff} = \sqrt{\frac{\sum M_{Mot,\ i}^2 \cdot \Delta t_i}{T}} = M_{S1\ (100K)}$$

The motor is selected on the basis of the load specified by the application. Different characteristics must be used for different loads.

The following operating scenarios have been defined:

- Load duty cycles with constant on period
- Load duty cycles with varying on period
- Duty cycle, variable

The objective is to identify characteristic torque and speed operating points, which can be used as a basis for selecting the motor depending on the load.

Once the operating scenario has been defined and specified, the maximum motor torque is calculated. Generally, the maximum motor torque is required when accelerating. The load torque and the torque required to accelerate the motor are added.

The maximum motor torque is then verified using the motor limiting curves.

The following criteria must be taken into account when the motor is selected:

- The dynamic limits must be observed, that is, all speed-torque points of the load must lie below the relevant limiting curve.
- The thermal limits must be observed, that is, in the case of synchronous motors, the RMS motor torque at the average motor speed resulting from the load duty cycle must lie below the S1 curve (continuous duty).
- In the case of synchronous motors, note that the maximum permissible motor torque is reduced at higher speeds as a result of the voltage limiting curve. A clearance of 10% from the voltage limiting characteristic should also be observed to safeguard against voltage fluctuations.

Load duty cycles with constant on period

For load duty cycles with constant on time, specific requirements are placed on the torque characteristic as a function of the speed

e.g. $M = \text{constant}$, $M \sim n^2$, $M \sim n$ or $P = \text{constant}$.

These drives typically operate at a specific operating point. and are dimensioned for a base load. The base load torque must lie on or below the S1 curve.

In the event of transient overloads (e.g. during acceleration), an overload must be taken into account. For synchronous motors, the peak torque must lie below the voltage limiting characteristic.

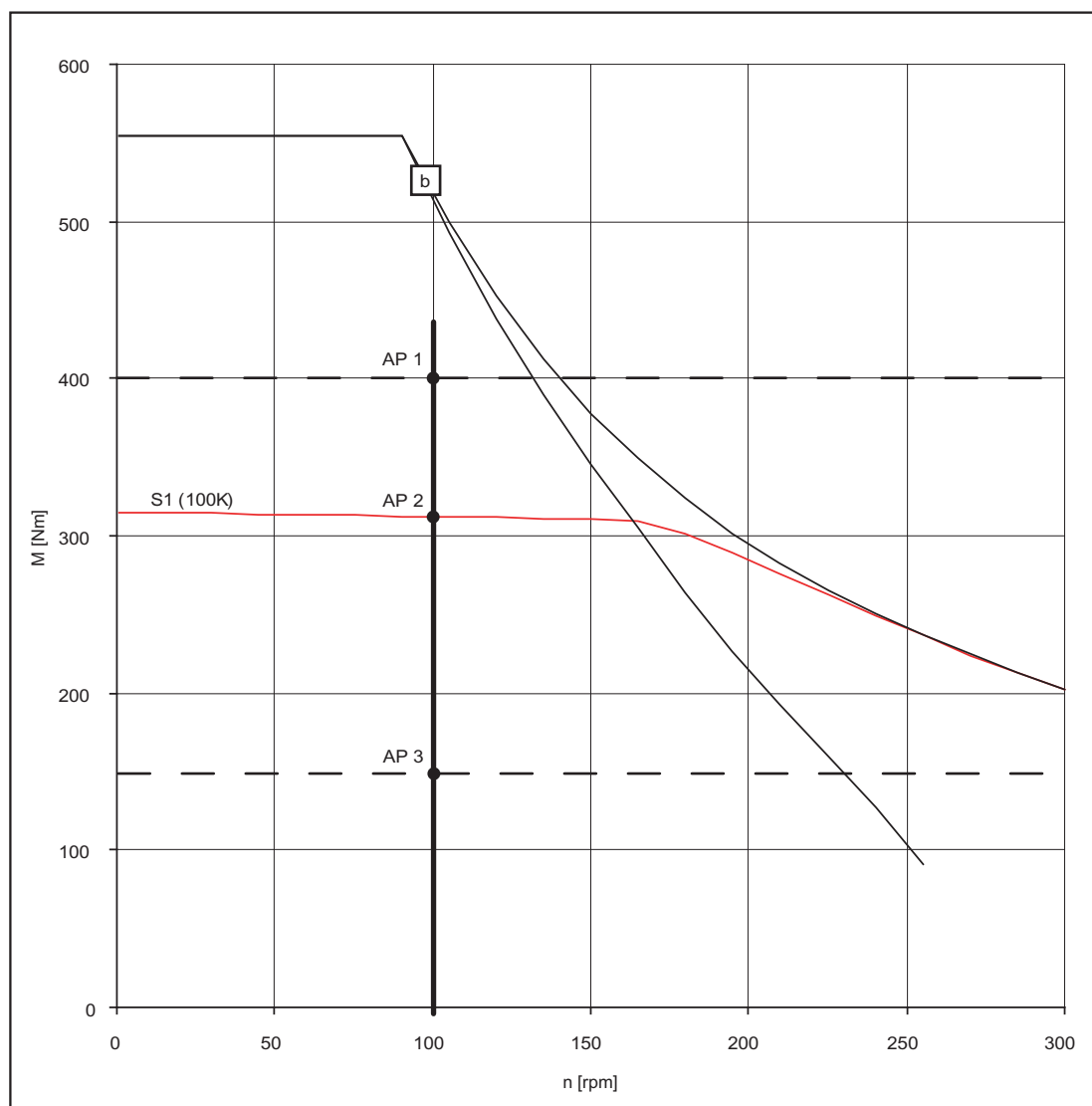

[b] SINAMICS S120 Active Line Module, $V_{line\ rms} = 400\ V$

AP 1 Operate for e.g. 1 min

AP 2 Continuous operation (S1) for x h (with water cooling)

AP 3 Continuous operation (S1) for x h (without water cooling)

Figure 2-4 Selecting motors for load examples with constant on time 1FW3201-□E□

Note

Free convection must be possible for operation without water cooling.

Load duty cycles with varying on period

As well as continuous duty (S1), standard intermittent duty types (S3) are also defined for load duty cycles with varying on periods. This involves operation that comprises a sequence of similar load cycles, each of which comprises a time with constant load and an off period.

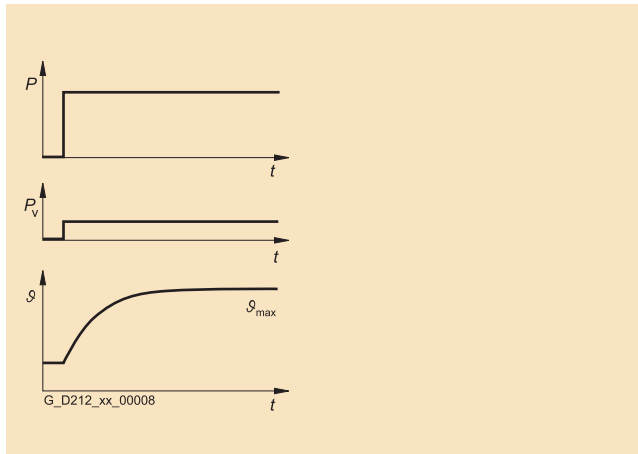

Figure 2-5 S1 duty (continuous operation)

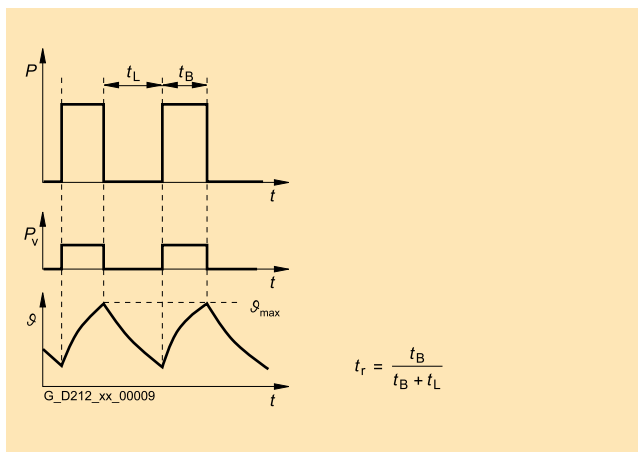

Figure 2-6 S3 duty (intermittent operation without influencing starting)

The load torque must lie below the corresponding thermal limiting characteristic of the motor. An overload must be taken into consideration for load duty cycles with varying on times.

Note

For duty cycles in the field weakening range, the SIZER for SIEMENS Drives engineering tool must be used. The following formulas can be used for duty cycles outside the field weakening range.

$$M_{\text{Mot, eff}} = \sqrt{\frac{\sum M_{\text{Mot, } i}^2 \cdot \Delta t_i}{T}}$$

$$n_{\text{Mot, medium}} = \frac{\sum \frac{n_{\text{Mot, k, A}} + n_{\text{Mot, k, E}}}{2} \cdot \Delta t_i}{T}$$

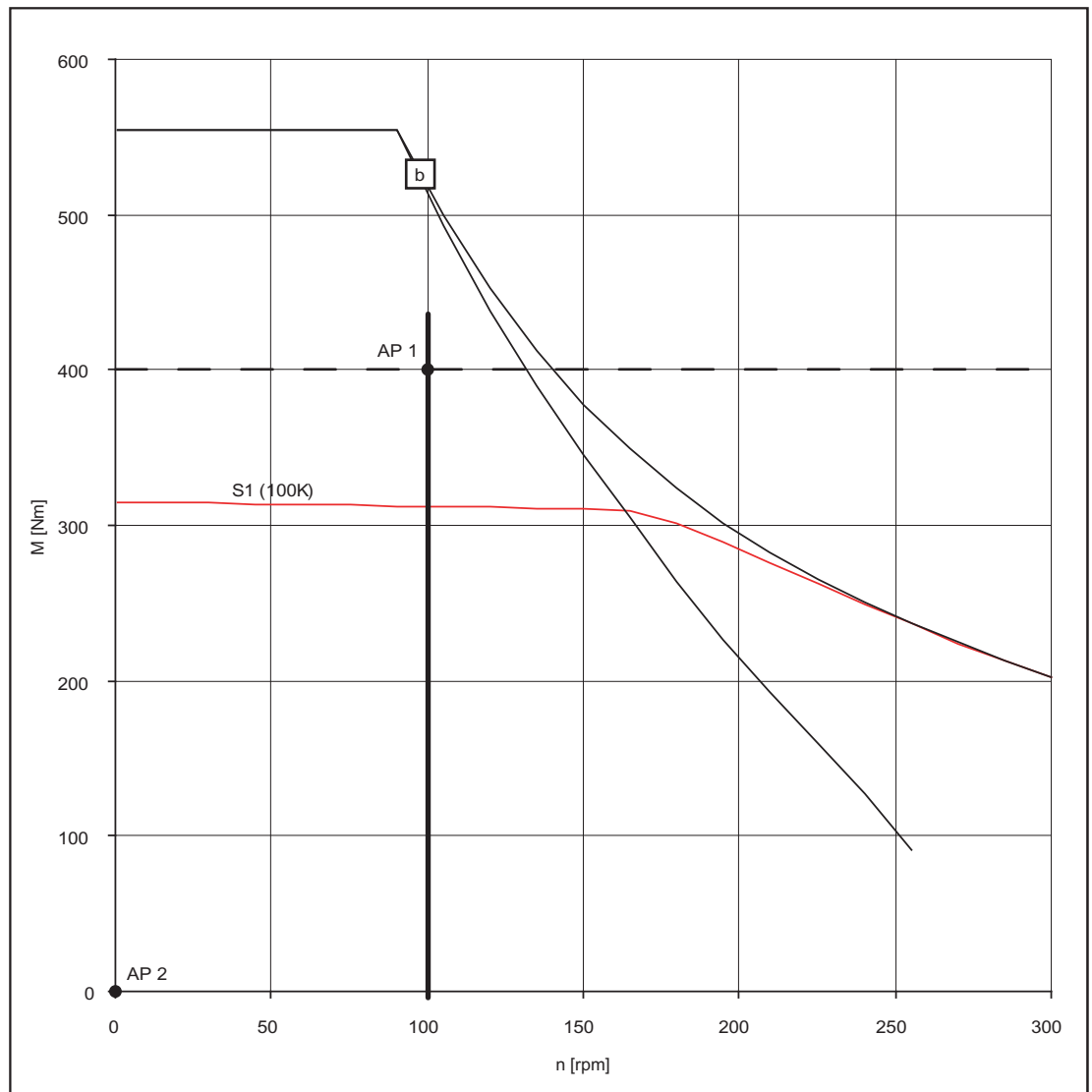

[b] SINAMICS S120 Active Line Module, $V_{\text{line rms}} = 400 \text{ V}$

AP 1 = 400 Nm at 150 rpm

AP 2 = 0 Nm at 0 rpm

Figure 2-7 Selecting motors for load duty cycles with different on time 1FW3201-□E□

Note

A holding torque may be required when the motor is stationary. This holding torque must be taken into consideration for M_{rms} . The reason could be that self-locking gearboxes are not used.

Duty cycle, variable

A load duty cycle defines the characteristics of the motor speed and the torque with respect to time.

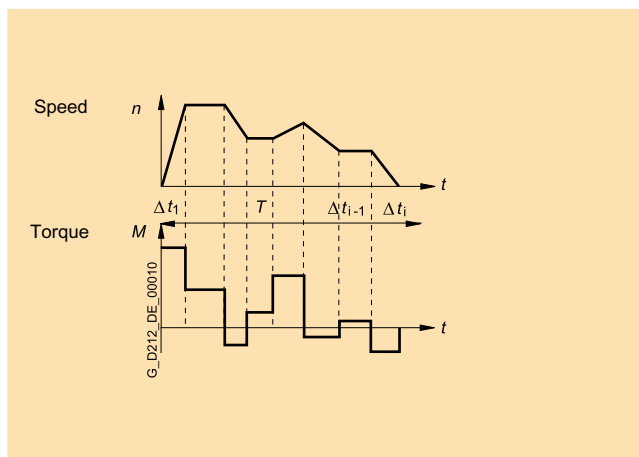

Figure 2-8 Example of a load duty cycle

A load torque is specified for each time period. In addition to the load torque, the average load moment of inertia and motor moment of inertia must be taken into account for acceleration. It may be necessary to take into account a frictional torque that opposes the direction of motion.

The gear ratio and gear efficiency must be taken into account when calculating the load and/or accelerating torque to be provided by the motor.

Note

For duty cycles in the field weakening range, the SIZER for SIEMENS Drives engineering tool must be used. The following formulas can be used for duty cycles outside the field weakening range.

For the motor torque in a time slice Δt_i the following applies:

$$M_{\text{Mot, rms}} = (J_M + J_G) \cdot \frac{2 \pi}{60} \cdot \frac{\Delta n_{\text{load, i}}}{\Delta t_i} \cdot i + (J_{\text{load}} \cdot \frac{2 \pi}{60} \cdot \frac{\Delta n_{\text{Last, i}}}{\Delta t_i} + (M_{\text{load, i}} + M_R) \cdot \frac{1}{i \cdot \eta_G}$$

Calculation of the motor speed

$$n_{\text{mot, i}} = n_{\text{load, i}} \cdot i$$

Calculating the rms torque

$$M_{\text{mot, rms}} = \sqrt{\frac{\sum M_{\text{mot, i}}^2 \cdot \Delta t_i}{T}}$$

Calculating the average motor speed

$$n_{\text{Mot, medium}} = \frac{\sum \frac{n_{\text{Mot, k, A}} + n_{\text{Mot, k, E}}}{2} \cdot \Delta t_i}{T}$$

J_M	Motor moment of inertia
J_G	Gearbox moment of inertia
J_{load}	Load moment of inertia
n_{Load}	Load speed
i	Gear ratio
η_G	Gearbox efficiency
M_{load}	Load torque
M_R	Frictional torque
T	Cycle time, clock cycle time
$A;E$	Initial value, final value in time slice Δt_i
t_e	On period
Δt_i	Time interval

The rms torque $M_{\text{mot, rms}}$ must, for $n_{\text{mot, average}}$, lie below the S1 curve.

The maximum torque M_{max} is required when the drive is accelerating and for synchronous motors must lie below the voltage limiting curve/ M_{max} characteristic.

In summary, the motor is selected as follows:

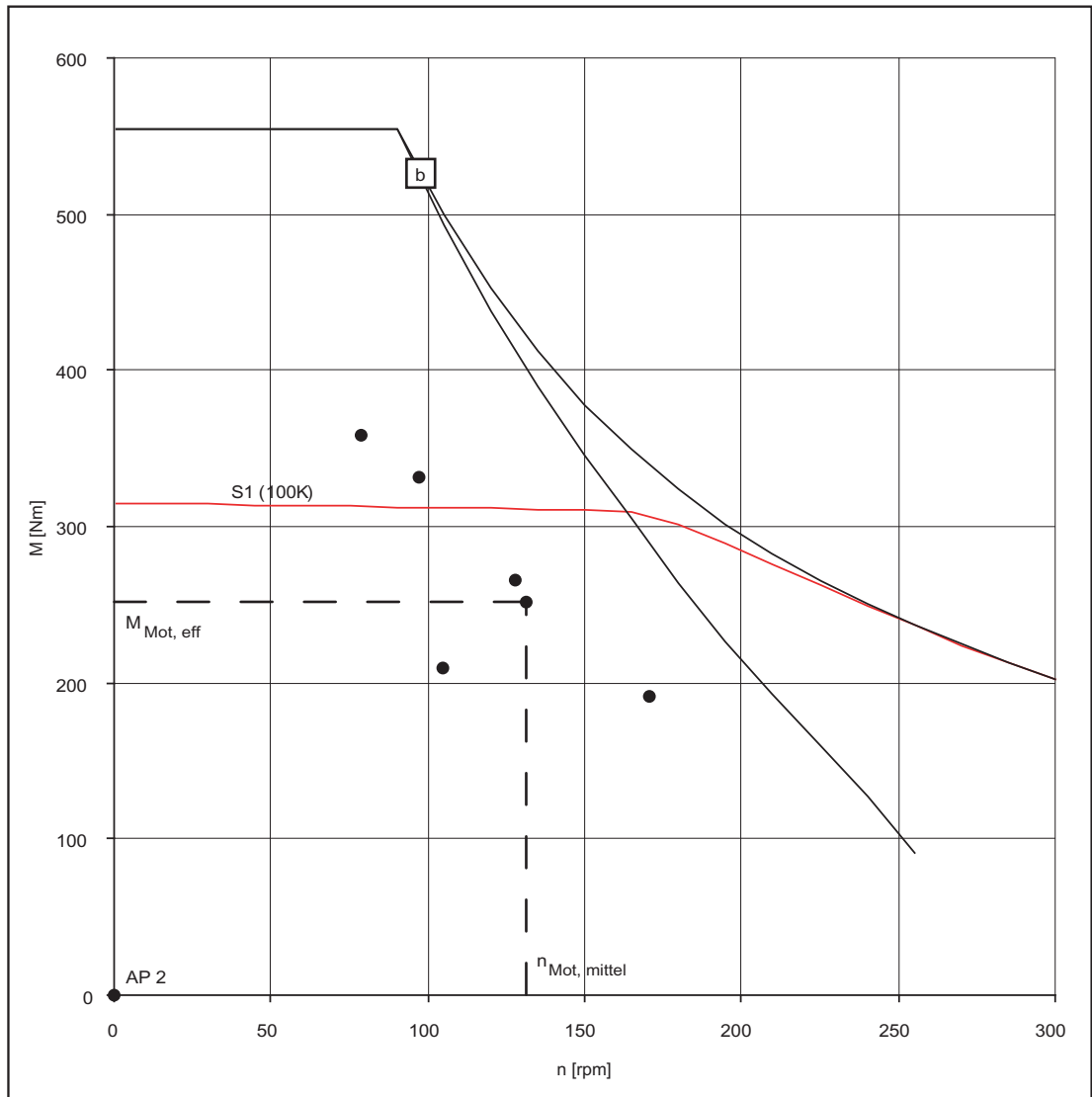

[b] SINAMICS S120 Active Line Module, $V_{line\ rms} = 400\ V$

Figure 2-9 Selecting motors according to the load duty cycle for motor 1FW3201-□E□

Motor selection

By making the appropriate iterations, a motor can now be selected that precisely fulfills the operating conditions and application

In a second step, a check is made as to whether the thermal limits are maintained. To do this, the motor current at the base load must be calculated. When engineering a drive according to the load duty cycle with a constant on period with overload, the overload current based on the required overload torque must be calculated. The calculation rules for this purpose depend on the type of motor used (synchronous motor, induction motor) and the operating scenario (duty cycles with constant or with different switch-on duration).

Finally, the other motor features must be defined. This is realized by appropriately configuring the motor options.

Mechanical properties of the motors

3.1 Cooling

 **WARNING**

The equipment must be safely disconnected from the supply before any installation or service work is carried out on cooling water circuit components.

Only qualified personnel may design, install and commission the cooling circuit.

3.1.1 Cooling circuit

The electrochemical processes that take place in a cooling system must be minimized by choosing the right materials. For this reason, mixed installations, i.e. a combination of different materials, such as copper, brass, iron, or halogenated plastic (PVC hoses and seals), should not be used or limited to the absolutely essential minimum.

A differentiation is made between 3 different cooling circuits:

- Closed cooling circuit
- Semi-open cooling circuit
- Open cooling circuit

Table 3- 1 Description of the various cooling circuits

Definition	Description
Closed cooling circuit	The pressure equalizing tank is closed (oxygen cannot enter the system) and has a pressure relief valve. The cooling water is only routed in the motors and converters as well as the components that have to be cooled.
Semi-open cooling circuit	Oxygen can only enter the cooling system through the pressure equalization tank, otherwise the same as "closed cooling circuit".
Open cooling circuit (tower system)	The cooling water is cooled in a tower. In this case, there is intensive oxygen contact.

Note

Cooling circuits

Only closed and semi-open cooling circuits are permissible for motors. Converter systems must be connected before the motors in the cooling circuit.

3.1 Cooling

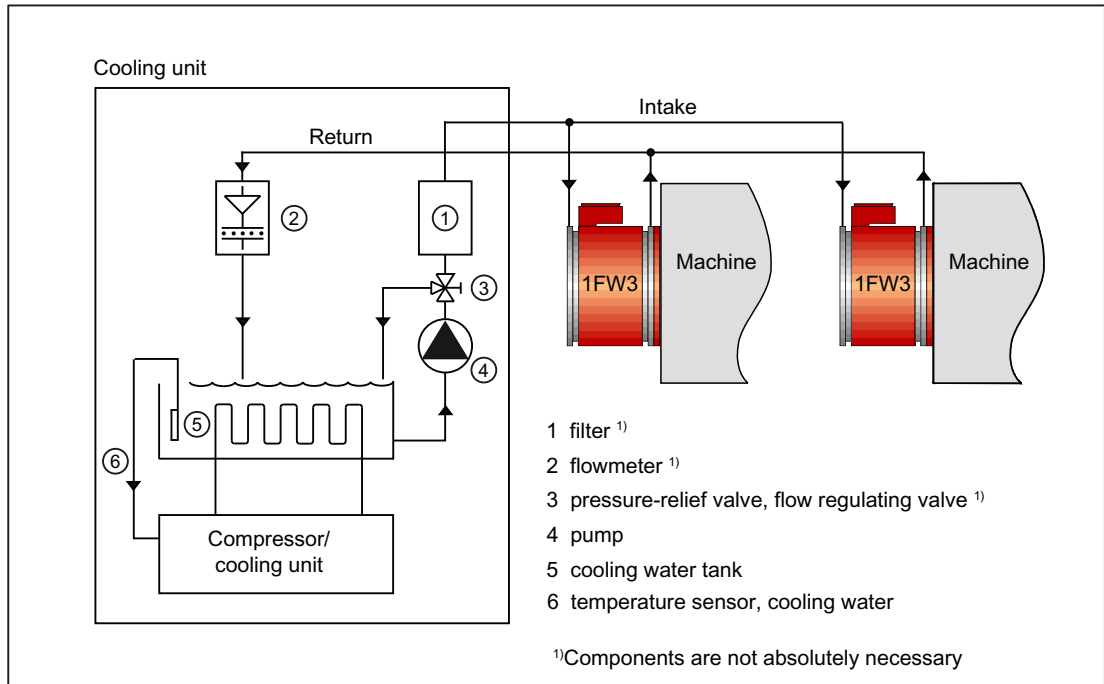

Figure 3-1 Example of a semi-open cooling circuit

Equipotential bonding

All components in the cooling system (motor, heat exchanger, piping system, pump, pressure equalization tank, etc.) must be connected to an equipotential bonding system. This is implemented using a copper bar or finely stranded copper cable with the appropriate cable cross-sections.

NOTICE
Under no circumstances may the cooling water pipes come into contact with live components. There must always be an isolating clearance of > 13 mm! The pipes must be securely mounted and checked for leaks.

Materials used in the motor cooling circuit

The materials used in the cooling circuit must be coordinated with the materials in the motor. Materials used in the motor (cooling jacket material): S355J2+N

Materials and components in the cooling circuit

The following table lists a wide variety of materials and components which may or may not be used in a cooling circuit.

Table 3- 2 Materials and components of a cooling circuit

Material	Used as	Description
Zinc	Pipes, valves and fittings	Use is not permitted.
Brass	Pipes, valves and fittings	Can be used in closed circuits with inhibitor.
Copper	Pipes, valves and fittings	Can be used only in closed circuits with inhibitors in which the heat sink and copper component are separated (e.g. connection hose on units).
Common steel (e.g. St37)	Pipes	Permissible in closed circuits and semi-open circuits with inhibitors or Antifrogen N, check for oxide formation, inspection window recommended.
Cast steel, cast iron	Pipes, motors	Closed circuit and use of strainers and flushback filters. Fe separator for stainless heat sink.
High-alloy steel, Group 1 (V2A)	Pipes, valves and fittings	Can be used for drinking or municipal water with a chloride content up to < 250 ppm, suitable according to definition in Section "Cooling water definition".
High-alloy steel, Group 2 (V4A)	Pipes, valves and fittings	Can be used for drinking or municipal water with a chloride content up to < 500 ppm, suitable according to definition in Section "Cooling water definition".
ABS (AcrylnitrileButadieneStyrene)	Pipes, valves and fittings	Suitable according to the definition in Section "Cooling water definition". Suitable for mixing with inhibitor and/or biocide as well as Antifrogen N.
Installation comprising different materials (mixed installation)	Pipes, valves and fittings	Use is not permitted.
PVC	Pipes, valves, fittings and hoses	Use is not permitted.
Hoses		Reduce the use of hoses to a minimum (device connection). Must not be used as the main pipe for the whole system. Recommendation: EPDM hoses with an electrical resistance > 10 ⁹ Ω (e.g. Semperflex FKD supplied from Semperit or DEMITTEL; from PE/EPD, supplied from Telle).
Gaskets	Pipes, valves and fittings	Use of FPM (Viton), AFM34, EPDM is recommended.
Hose connections	Transition Hose - pipe	Secure with clips conforming to DIN 2817, available e.g. from Telle.

The following recommendation applies in order to achieve an optimum motor heatsink (enclosure) lifetime:

- Engineer a closed cooling circuit with cooling unit manufactured out of stainless steel that dissipates the heat through a water-water heat exchanger.
- All other components such as cooling circuit cables and fittings manufactured out of ABS, stainless steel or general construction steel.

3.1 Cooling

Cooling system manufacturers

BKW Kälte-Wärme-Versorgungstechnik GmbH	http://www.bkw-kuema.de
DELTATHERM Hirmer GmbH	http://www.deltatherm.de
Glen Dimplex Deutschland GmbH	http://www.riedel-cooling.com
Helmut Schimpke und Team Industriekühlanlagen GmbH + Co. KG	http://www.schimpke.org
Hydac System GmbH	http://www.hydac.com
Hyfra Industriekühlanlagen GmbH	http://www.hyfra.de
KKT Kraus Kälte- und Klimatechnik GmbH	http://www.kkt-kraus.de
Pfannenberg GmbH	http://www.pfannenberg.com
Rittal GmbH & Co. KG	http://www.rittal.de

Note

It goes without saying that equivalent products from other manufacturers may be used. Our recommendations are to be seen as helpful information, not as requirements or regulations. We cannot accept any liability for the quality and properties/features of third-party products.

3.1.2 Engineering the cooling circuit

Pressure

The operating pressure must be set according to the flow conditions in the supply and return lines of the cooling circuit. The required cooling water flow rate per time unit must be set according to the technical data of the equipment and motors.

The maximum permissible pressure with respect to atmosphere in the heat sink and thus in the cooling circuit must not exceed 0.6 MPa (6 bar) If a pump that can achieve a higher pressure is used, suitable measures must be provided on the system side (e.g. safety valve $p \leq 0.6$ MPa, pressure control etc.) to ensure that the maximum pressure is not exceeded.

The lowest possible differential pressure between the cooling water in the supply and return lines should be selected to allow pumps with a flat characteristic to be used.

An additional flushback filter should be used in the circuit in order to help prevent blockages and corrosion. This allows any material deposits to be flushed out in operation.

Pressure equalization

If various components are connected up in the cooling circuit, it may be necessary to provide pressure equalization.

Note

Reactor elements must be fitted at the cooling water outlet of the motor or the relevant component!

Avoiding cavitation

During uninterrupted duty, the pressure drop by a converter or motor must not exceed 0.2 MPa (2 bar). Otherwise, the high flow rate results in damage due to cavitation and/or abrasion.

Connecting motors in series

For the following reasons, connecting motors in series can only be conditionally recommended:

- The required flow rates of the motors must be approximately the same (< a factor of 2)
- An increase in the cooling water temperature can result in having to derate the second or third motor if the maximum cooling water inlet temperature is exceeded.

Cooling water inlet temperature

Note

The cooling water inlet temperature must be selected so that condensation does not form on the surface of the motor: $T_{\text{cooling}} > T_{\text{ambient}} - 5 \text{ K}$.

Cooling water temperatures which are lower than the ambient temperature tend to result in increased water condensation. The difference between the cooling water inlet temperature and the ambient temperature should therefore not exceed a maximum of 5 K (Kelvin). Furthermore, the inflow of cooling water must be interrupted when the motor is idle for prolonged periods.

The motors are designed for operation up to a cooling water inlet temperature of +30 °C, as long as all of the specified motor data is maintained. If the cooling water inlet temperature deviates from this, the continuous torque will change (see the table titled "Derating factors").

Table 3- 3 Derating factors

Cooling water inlet temperature	≤ 30 °C	35 °C	40 °C	45 °C
Derating factor	1.00	0.97	0.95	0.92

3.1 Cooling

Cooling powers to be dissipated and the cooling flow rate

The values specified in the table "Cooling power to be dissipated" refer to a cooling-water temperature of +30 °C and S1 duty.

The cooling power to be dissipated [kW] specified in the table refers to the highest power loss to be dissipated for the particular shaft height for a maximum temperature difference between cooling water intake/cooling water discharge of 10 K.

Table 3- 4 Cooling power to be dissipated

Motor type	Cooling power to be dissipated at n_N [kW]	Pressure loss [bar]	Cooling flow rate [l/min]
1FW3150-	1.4	0.1	2.0
1FW3152-	1.6	0.1	3.0
1FW3154-	2.3	0.2	4.5
1FW3155-	2.7	0.1	5.5
1FW3156-	3.4	0.2	7.0
1FW3201-	1.7	0.1	3.0
1FW3202-	2.3	0.2	4.0
1FW3203-	3.4	0.1	5.0
1FW3204-	3.9	0.1	6.0
1FW3206-	5.5	0.3	8.0
1FW3208-	8.4	0.6	10.0
1FW3281-2	7.9	0.5	11.0
1FW3283-2	9.0	0.7	13.0
1FW3285-2	12.8	0.7	16.0
1FW3287-2	15.7	0.8	20.0
1FW3281-3	7.4	0.5	11.0
1FW3283-3	10.3	0.7	13.0
1FW3285-3	12.6	0.7	16.0
1FW3287-3	15.8	0.8	20.0

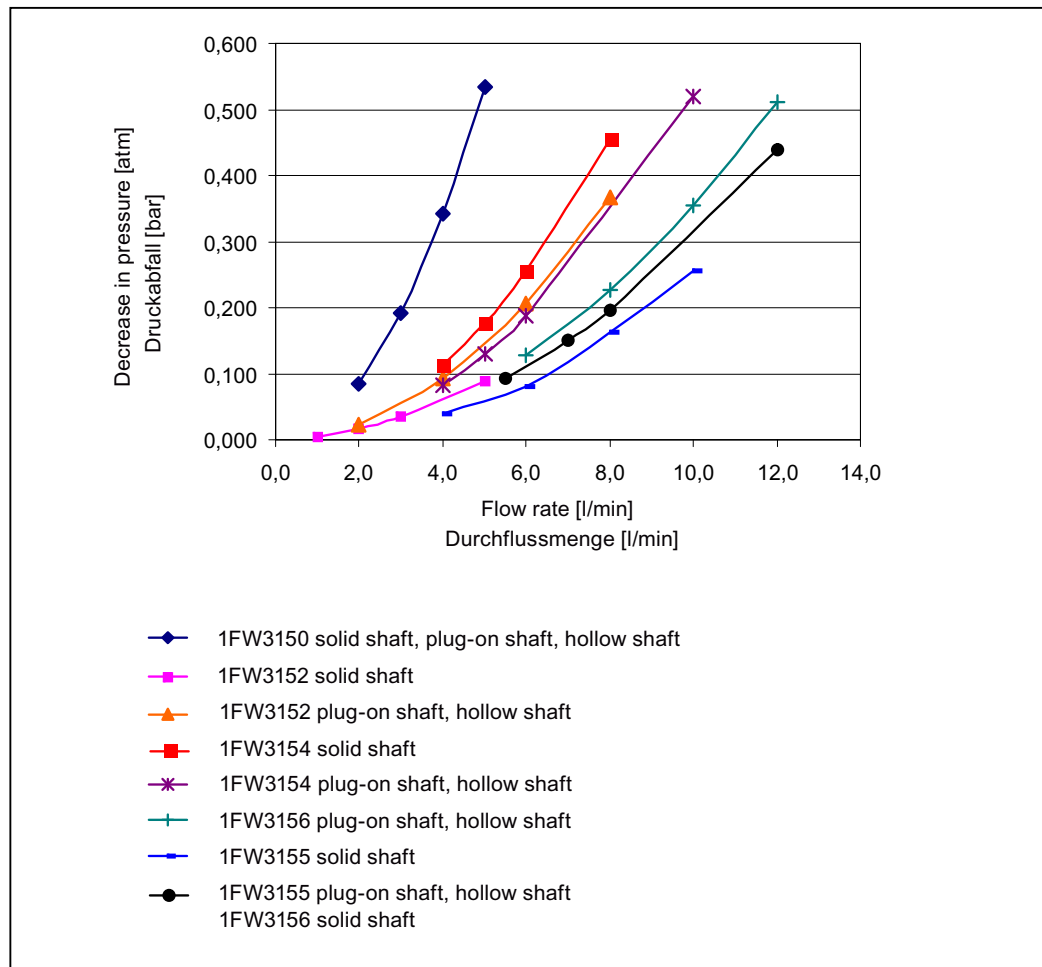

Figure 3-2 Flow rate for SH 150

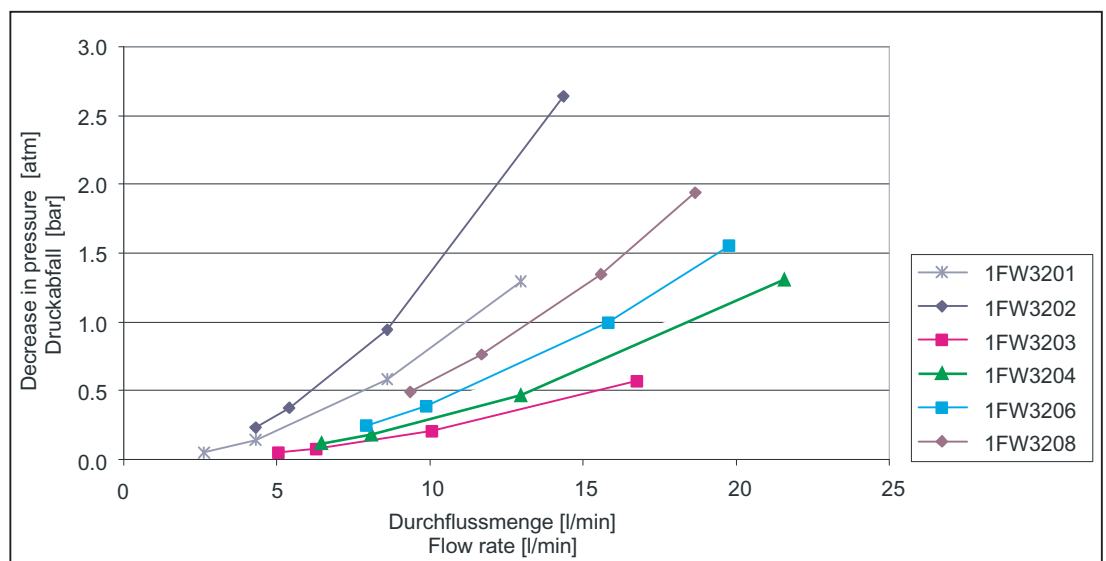

Figure 3-3 Flow rate for SH 200

3.1 Cooling

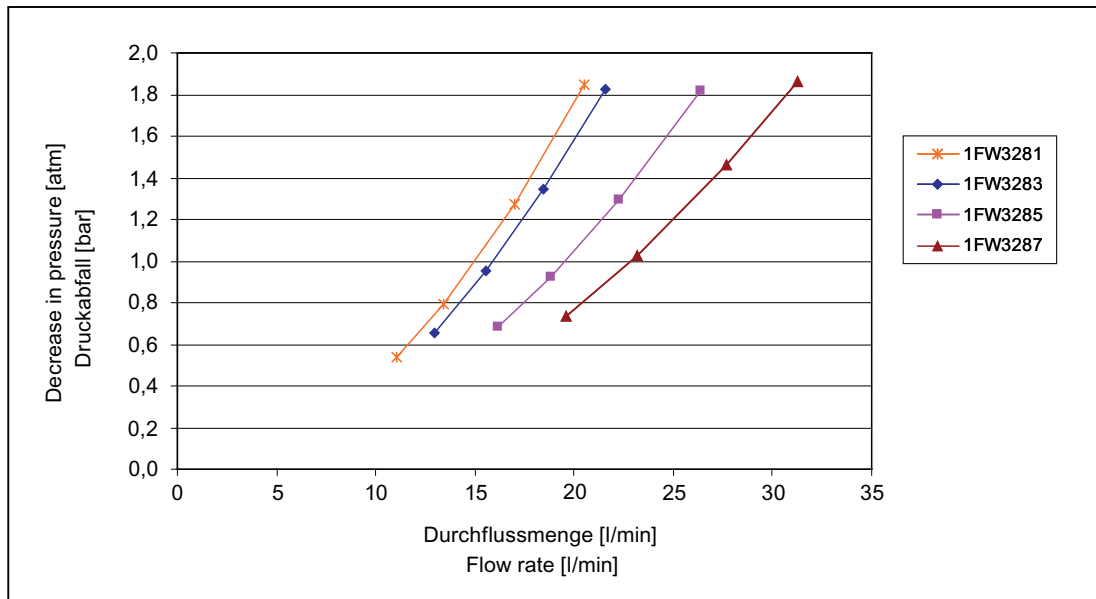

Figure 3-4 Flow rate for SH 280

3.1.3 Cooling water

Table 3- 5 Cooling water specification

	Quality of the water used as coolant for motors with aluminum, stainless steel tubes + cast iron or steel jacket
Chloride ions	< 40 ppm, can be achieved by adding deionized water.
Sulfate ions	< 50 ppm
Nitrate ions	< 50 ppm
pH value	6 ... 9 (for aluminum 6 ... 8)
Electrical conductivity	< 500 μ S/cm
Total hardness	< 170 ppm

Note

It is recommended to use deionized water with reduced conductivity (5 ... 10 μ S/cm) (if required, ask the water utility for the values). According to 98/83/EC, drinking water may contain up to 2500 ppm of chloride!

Manufacturers of chemical additives can provide support when analyzing the water that is available on the plant side.

Table 3- 6 Cooling water quality

	Coolant quality
Cooling water	According to the table "Specifications for cooling water"
Corrosion protection	0.2 to 0.25 % inhibitor, Nalco TRAC100 (previously 0GE056) ¹⁾
Anti-freeze protection	When required, 20 - 30 % Antifrogen N (from the Clariant Company) ²⁾
Dissolved solids	< 340 ppm
Size of particles in the coolant	< 100 µm

1) The inhibitor is not required if it ensured that the concentration of Antifrogen N is > 20%.

2) Derating is not required for an anti-freeze protection concentration < 30%.

Biocide

Closed cooling circuits with soft water are susceptible to microbes. The risk of corrosion caused by microbes is virtually non-existent in chlorinated drinking water systems.

Antifrogen N has a biocidal effect even at the minimum required concentration of > 20 %. No strain of bacteria can survive if >20 % Antifrogen N is added.

The suitability of a biocide depends on the type of microbe. The following types of microbes are encountered in practice:

- Slime-forming bacteria
- Corrosive bacteria
- Iron-depositing bacteria

At least one water analysis per annum is recommended to determine the number of bacterial colonies. Suitable biocides are available from the manufacturer Nalco for example. The manufacturer's recommendations must be followed regarding the concentration and compatibility with any inhibitor used.

NOTICE
Biocides and Antifrogen N must not be mixed.

There are other manufacturers of chemical additives in the market. Equivalent products from other manufacturers may be used. The suitability must be checked by testing.

3.1 Cooling

Manufacturers of chemical additives

Tyforop Chemie GmbH	http://www.tyfo.de
Clariant Produkte Deutschland GmbH	http://www.antifrogen.de
Cimcool Industrial Products	http://www.cimcool.net
FUCHS PETROLUB AG	http://www.fuchs-oil.com
Hebro chemie GmbH	http://www.hebro-chemie.de
HOUGHTON Deutschland GmbH	http://www.houghton.com
Nalco Deutschland GmbH	http://www.nalco.com
Schweitzer-Chemie GmbH	http://www.schweitzer-chemie.de

NOTICE
It goes without saying that equivalent products from other manufacturers may be used. Our recommendations are to be seen as helpful information, not as requirements or regulations. We cannot accept any liability for the quality and properties/features of third-party products.

3.1.4 Cooling water connection

The motor is connected to the cooling circuit using two female threads. These are located on the side of the motor. The intake and discharge connections can be selected as required. Recommendation: Inlet at NDE

The units should be connected with hoses to provide mechanical decoupling (refer to the table "Materials and components of a cooling circuit").

Cooling water connection	
for 1FW315x and 1FW320x	G 1/2"
for 1FW328x	G 1"

3.2 Degree of protection

The degree of protection designation in accordance with EN 60034-5 (IEC 60034-5) is described using the letters IP and two digits.

IP = International Protection

1st digit = protection against ingress of foreign bodies

2nd digit = protection against harmful ingress of water

Since coolants used for machine tools and transfer machines usually contain oil, are able to creep, and may also be corrosive, protection against water alone is insufficient. The motors must be protected by suitable covers.

Attention must be paid to providing suitable sealing of the motor shaft for the selected degree of protection for the motor.

Table 3- 7 Degree of protection of the 1FW3 complete torque motors

Motor	Shaft version		
	Hollow shaft	Plug-on shaft	Solid shaft
1FW315x	IP54	IP55	IP55
1FW320x	IP54	IP55	IP55
1FW328x	IP54	IP54	-

3.3 Bearing version

3.3 Bearing version

The bearings for the complete torque motors are greased for life and designed for a minimum ambient temperature range in operation of -15°C.

Table 3- 8 Normal design with standard bearings

	SH 150	SH 200	SH 280
Hollow shaft DE (fixed bearing)	61838	61838	61864
Hollow shaft NDE (floating bearing)	61832	61832	61856
Plug-on shaft DE (fixed bearing)	61838	61838	61864
Plug-on shaft NDE (floating bearing)	6213	6020	6230
Solid shaft DE (fixed bearing)	6215	6220	---
Solid shaft NDE (floating bearing)	6213	6020	---
Possible mounting positions	Horizontal and vertical	Horizontal and vertical	Horizontal and vertical
Bearing change interval with permanent grease lubrication, horizontal mounting position	20000 h at max. 40 °C ambient temperature	20000 h at max. 40 °C ambient temperature	---
Regreasing	Option +K40 See table "Bearings with regreasing system"	Option +K40 See table "Bearings with regreasing system"	Regreasing in the standard See table "Bearings with regreasing system"

Special versions

Special versions for increased radial and axial forces on request.

Typical applications: General machine construction.

Note

Bearings without regreasing system

For bearings without regreasing system (SH 150 and SH 200), we recommend that the bearings are replaced after approx. 20000 operating hours for an ambient temperatures up to a maximum of 40°C, or after 5 years (after delivery) at the latest.

The bearing lifetime is reduced by 50 % when motors are mounted vertically. This is the reason that we recommend that a regreasing system is used when motors are mounted vertically.

Regreasing system (option for 1FW315x and 1FW320x, standard for 1FW328x)

If required, 1FW3 complete torque motors can be equipped with a re-lubricating device with a lubricating nipple M8 x 1 to DIN 71412-A for the DE and NDE bearings. This increases the bearing change interval in accordance with the table "Bearings with regreasing system" if the regreasing intervals are maintained and the ambient temperature 40 °C is not exceeded.

Ordering options: Order code K40

The re-lubricating device cannot be retrofitted!

Table 3- 9 Bearings with regreasing system (for 1FW315x, 1FW320x and 1FW328x-1, optional)

Motor	Bearing change interval with regreasing [h]	Regreasing intervals [h]	Quantity of grease for each regreasing [g]	
			DE	NDE
1FW315x hollow shaft	40000	10000	26 - 30	16 - 20
1FW315x plug-on shaft	60000	10000	26 - 30	14 - 18
1FW315x solid shaft	60000	10000	17 - 21	14 - 18
1FW320x hollow shaft	40000	10000	26 - 30	16 - 20
1FW320x plug-on shaft	60000	10000	26 - 30	19 - 23
1FW320x solid shaft	60000	10000	35 - 39	19 - 23
1FW328x-1 and 1FW328x-2 $n_N = 150/200$ hollow shaft	40000	10000	76 - 80	56 - 60
1FW328x-1 and 1FW328x-3 $n_N = 400$ hollow shaft	40000	6500	76 - 80	56 - 60
1FW328x-3 $n_N = 600$ hollow shaft	24000	4000	76 - 80	56 - 60
1FW328x-2/3 plug-on shaft	40000	8000	76 - 80	116 - 120

NOTICE**Vertical mounting position**

The regreasing interval is reduced to 50% when motors are mounted vertically.

Re-lubricating should be carried out manually using a grease gun (not a hydraulic gun). The grease quantities must be observed. Bearings should be re-lubricated at a low speed if it is not dangerous for persons. The recommended re-lubricating intervals relate to normal loads:

- Operation at speeds in accordance with the rating plate data
- Precision-balanced operation
- Use of the specified roller bearing greases

Option, special grease for low speeds +V07 (for 1FW315x and 1FW320x)**Solid shaft and plug-on shaft**

For motors with solid shaft and plug-shaft, in order to achieve the bearing change interval, we recommend for effective speeds up to 500 rpm that the special LGHB2 grease is ordered with option +V07.

Hollow shaft

For motors with hollow shaft, we recommend for effective speeds up to 25 rpm that the special LGHB2 grease is ordered with option +V07.

Special versions

Unfavorable factors (e.g. effects of mounting/installation, speeds, special modes of operation or high mechanical loads) may require special measures. Contact your local Siemens office, specifying the prevailing general conditions.

3.4 Radial and axial forces

Point of application of radial forces F_R at the torque motor

- for average operating speeds
- for a nominal bearing change interval of 20000 h

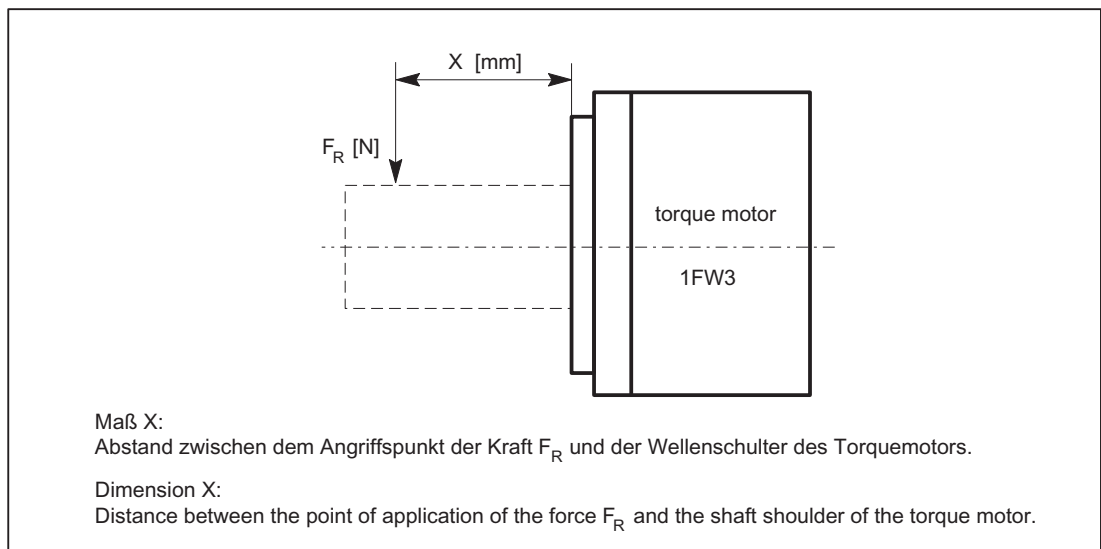

Figure 3-5 Point of application F_R

CAUTION

If you use mechanical transmission elements that subject the shaft end to a radial force, you must ensure that the maximum limit values specified in the radial force diagrams are not exceeded.

NOTICE

When the axial force diagram is used, the maximum permissible radial force must be noted. The axial force diagram is valid for $x < 100$ mm.

When the bearing is designed, the motor operating speed must be rounded-off according to the next-higher speed curve.

3.4.1 Hollow shaft

Radial force diagram for 1FW315□ hollow shaft

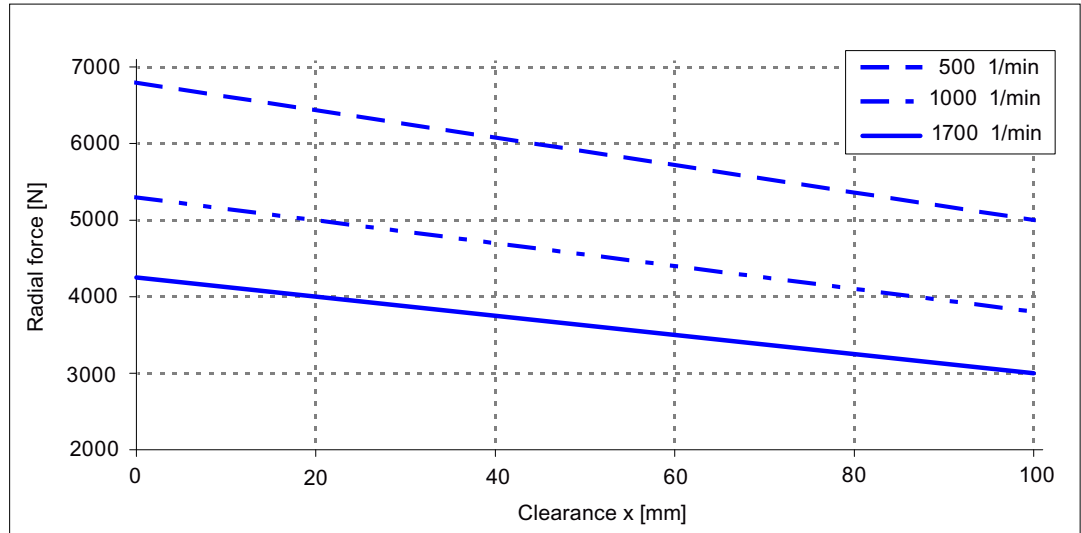

Figure 3-6 Radial force diagram for 1FW315□, with nominal bearing change interval of 20000 h

Axial force diagram for 1FW315□ hollow shaft

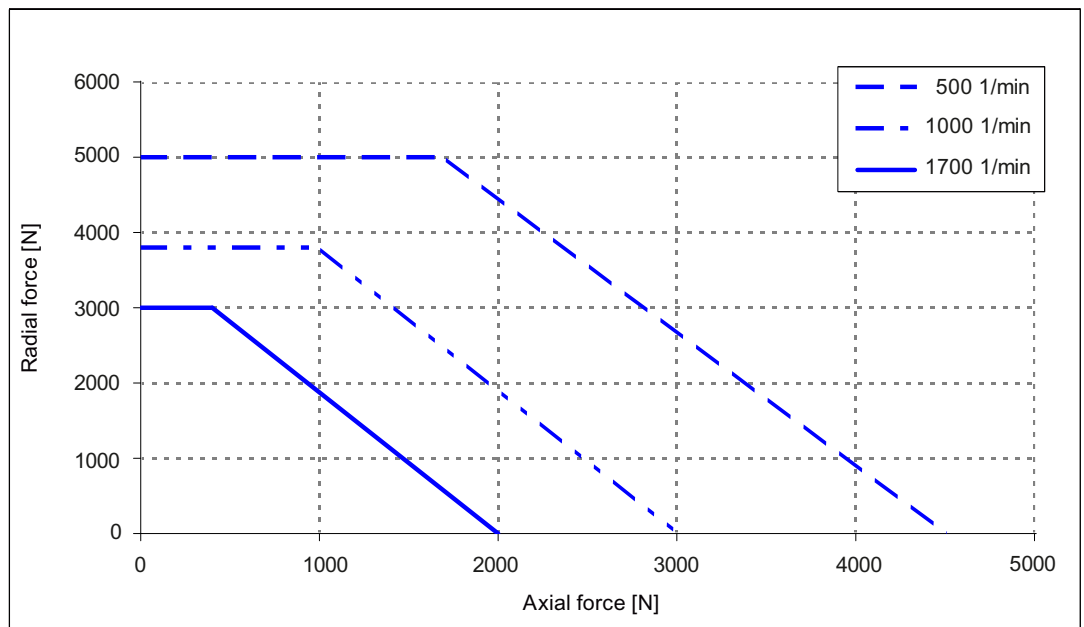

Figure 3-7 Permissible axial force as a function of radial force for 1FW315□

Radial force diagram for 1FW320□ hollow shaft

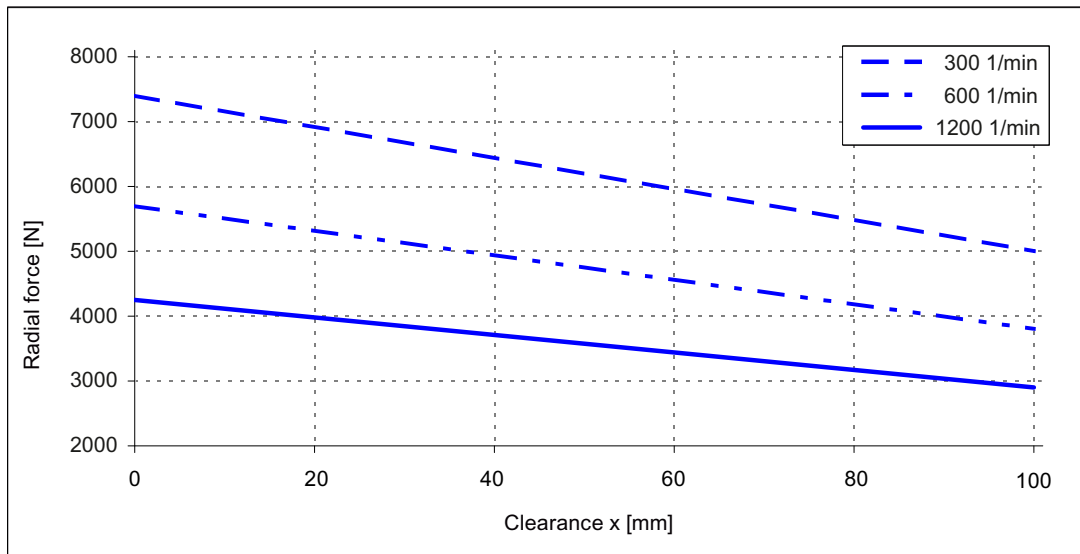

Figure 3-8 Radial force diagram for 1FW320□, with nominal bearing change interval of 20000 h

Axial force diagram for 1FW320□ hollow shaft

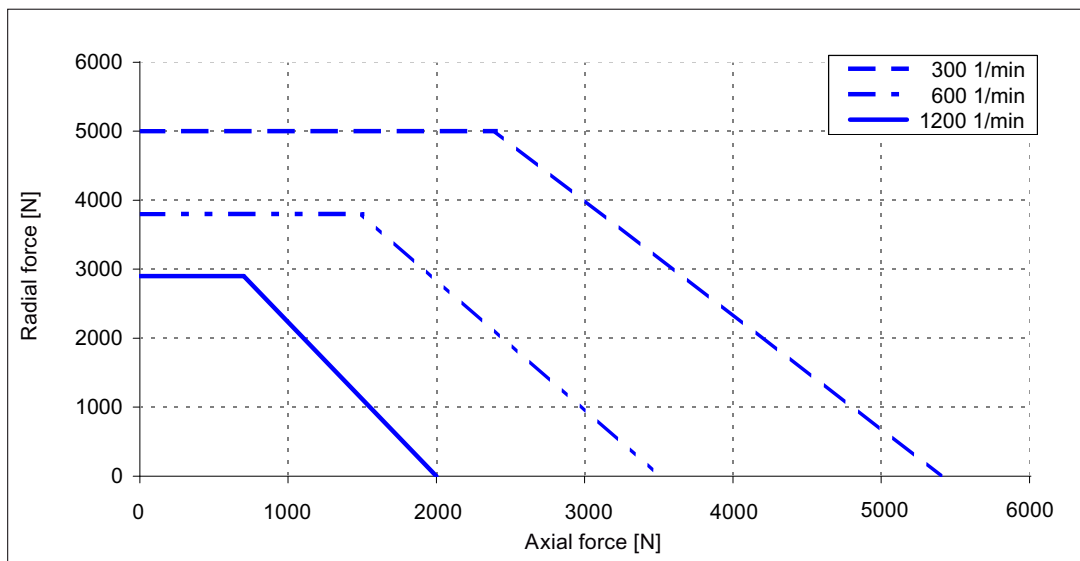

Figure 3-9 Permissible axial force as a function of radial force for 1FW320□

Radial force diagram for 1FW328□ hollow shaft

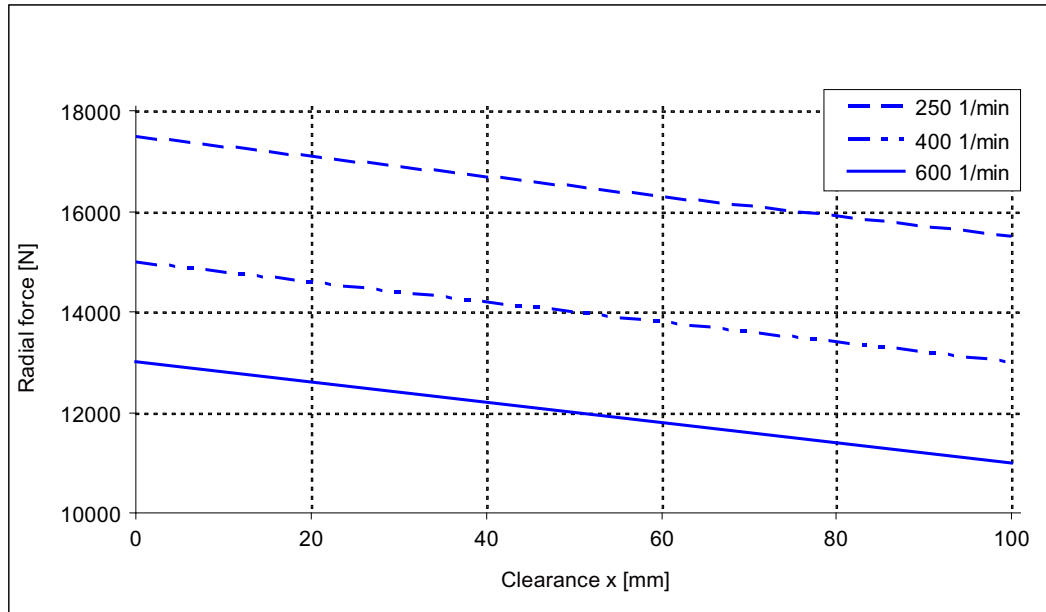

Figure 3-10 Radial force diagram for 1FW328□, with nominal bearing change interval of 20000 h

Axial force diagram for 1FW328□ hollow shaft

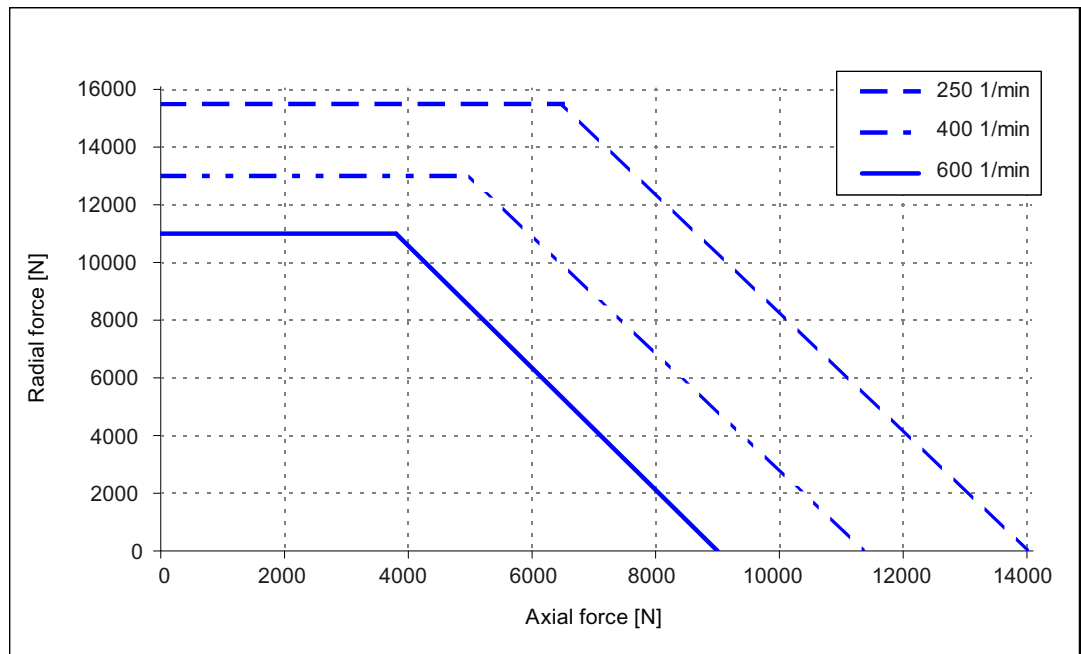

Figure 3-11 Permissible axial force as a function of radial force for 1FW328□

3.4.2 Plug-on shaft

Radial force diagram, 1FW315□ plug-on shaft

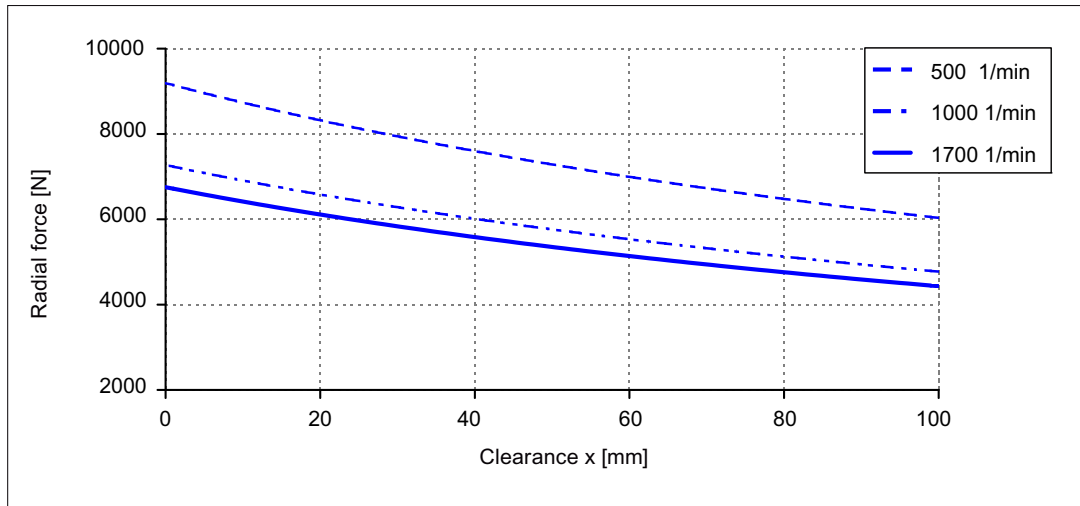

Figure 3-12 Radial force diagram for 1FW315□, with nominal bearing change interval of 20000 h

Axial force diagram 1FW315□ plug-on shaft

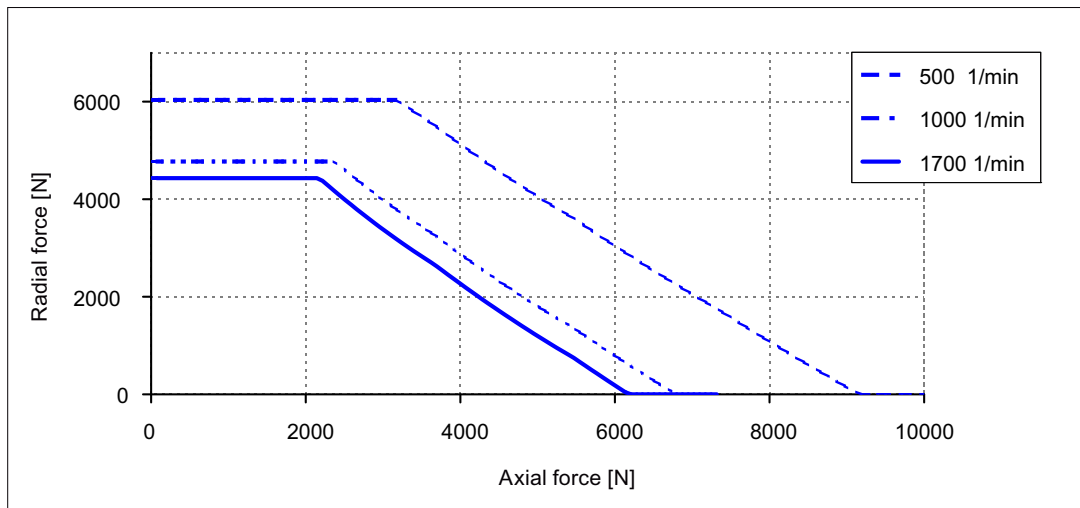

Figure 3-13 Permissible axial force as a function of radial force for 1FW315□ (20000 h)

Radial force diagram, 1FW315□ plug-on shaft

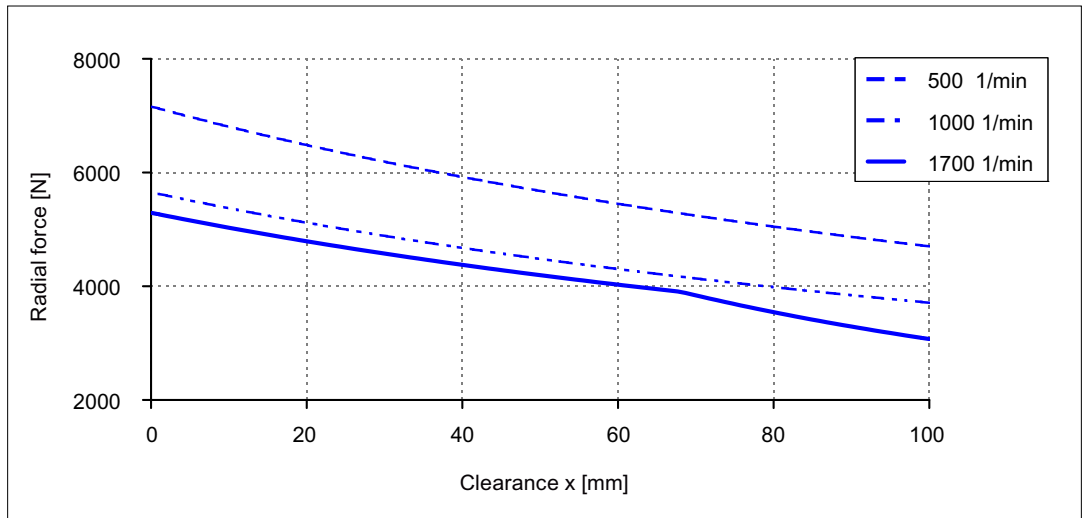

Figure 3-14 Radial force diagram for 1FW315□, with nominal bearing change interval of 60000 h

Axial force diagram 1FW315□ plug-on shaft

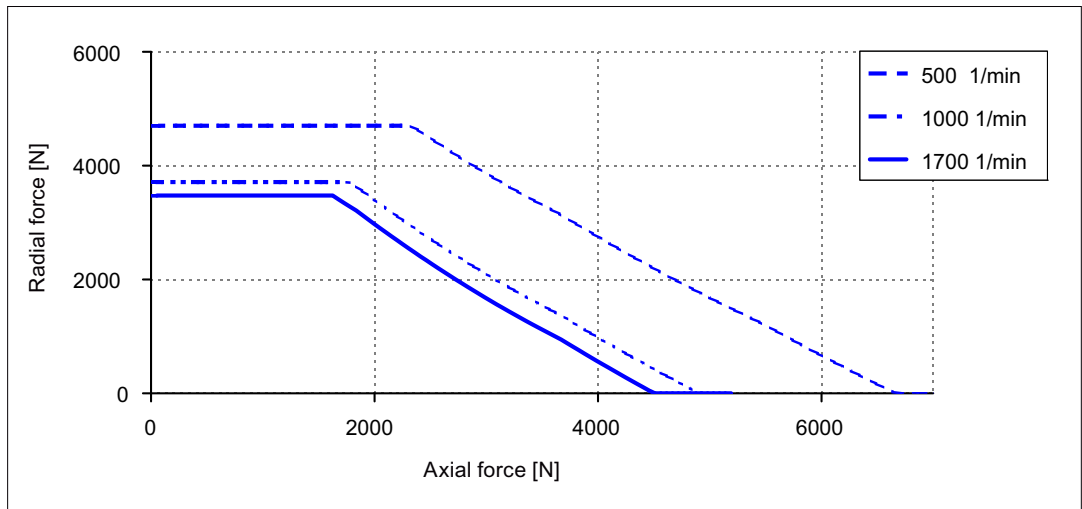

Figure 3-15 Permissible axial force as a function of radial force for 1FW315□ (60000 h)

Radial force diagram 1FW320□ plug-on shaft

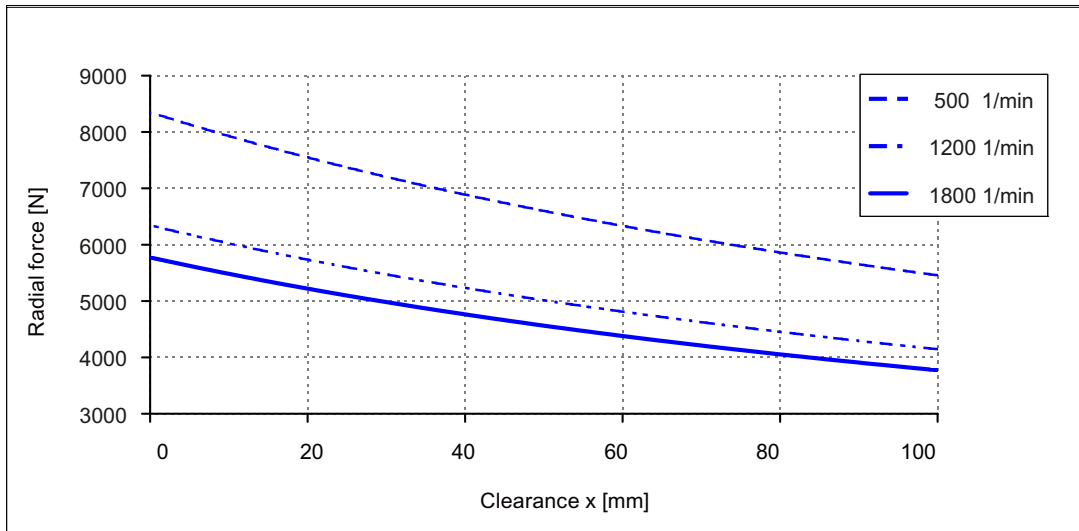

Figure 3-16 Radial force diagram for 1FW320□, with nominal bearing change interval of 20000 h

Axial force diagram 1FW320□ plug-on shaft

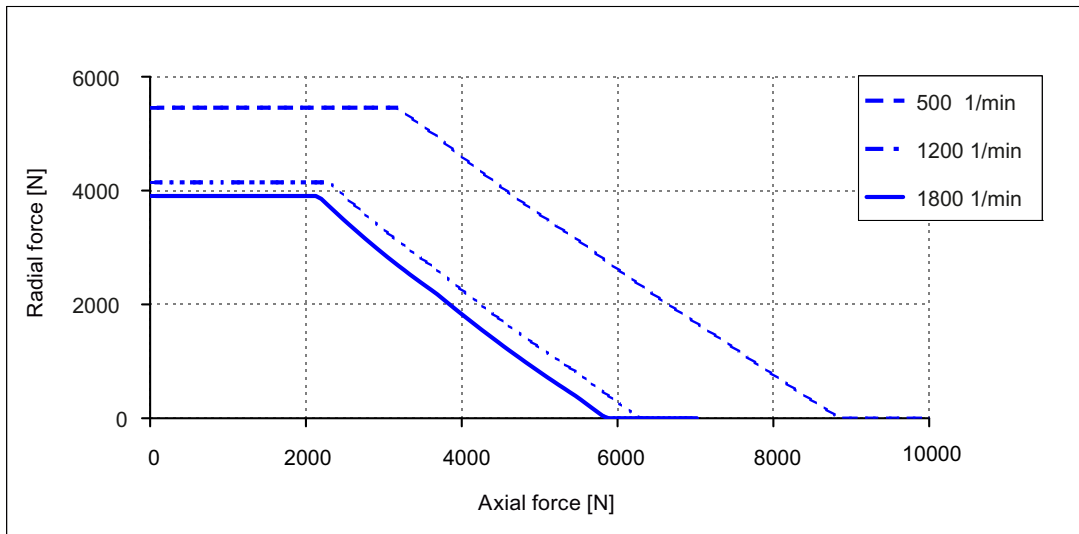

Figure 3-17 Permissible axial force as a function of radial force for 1FW320□ (20000 h)

Radial force diagram 1FW320□ plug-on shaft

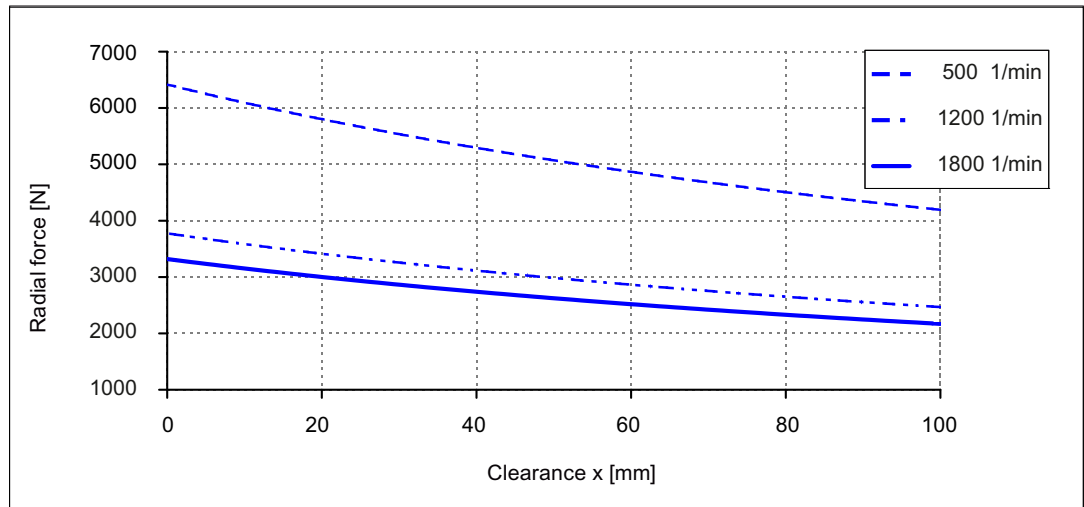

Figure 3-18 Radial force diagram for 1FW320□, with nominal bearing change interval of 60000 h

Axial force diagram 1FW320□ plug-on shaft

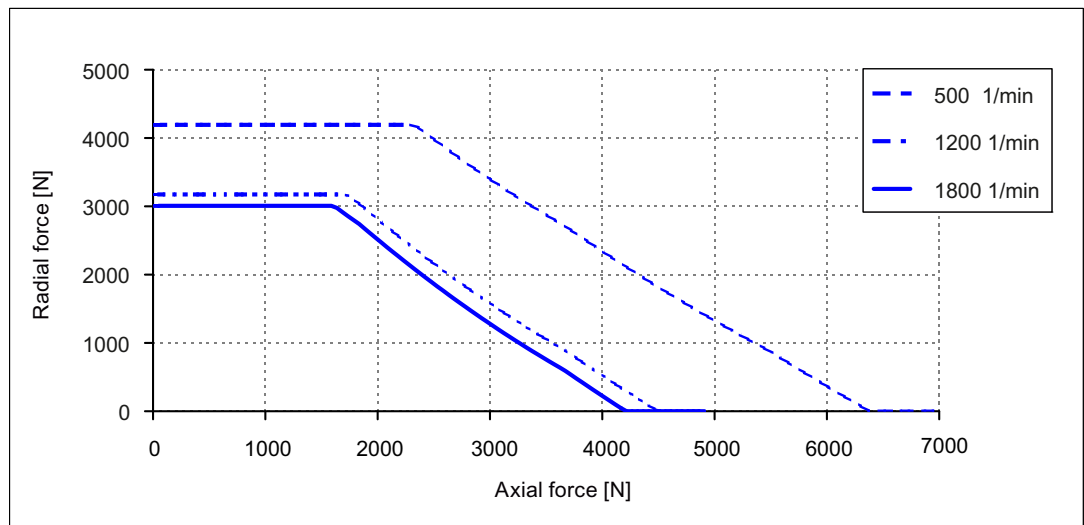

Figure 3-19 Permissible axial force as a function of radial force for 1FW320□ (60000 h)

3.4.3 Solid shaft

Radial force diagram for 1FW315□, solid shaft

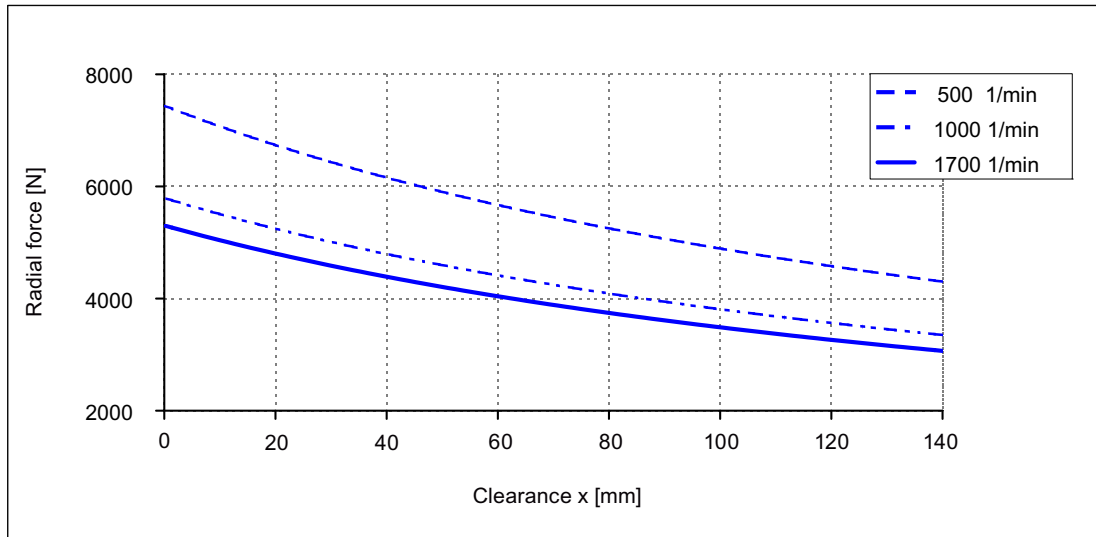

Figure 3-20 Radial force diagram for 1FW315□, with nominal bearing change interval of 20000 h

Axial force diagram for 1FW315□, solid shaft

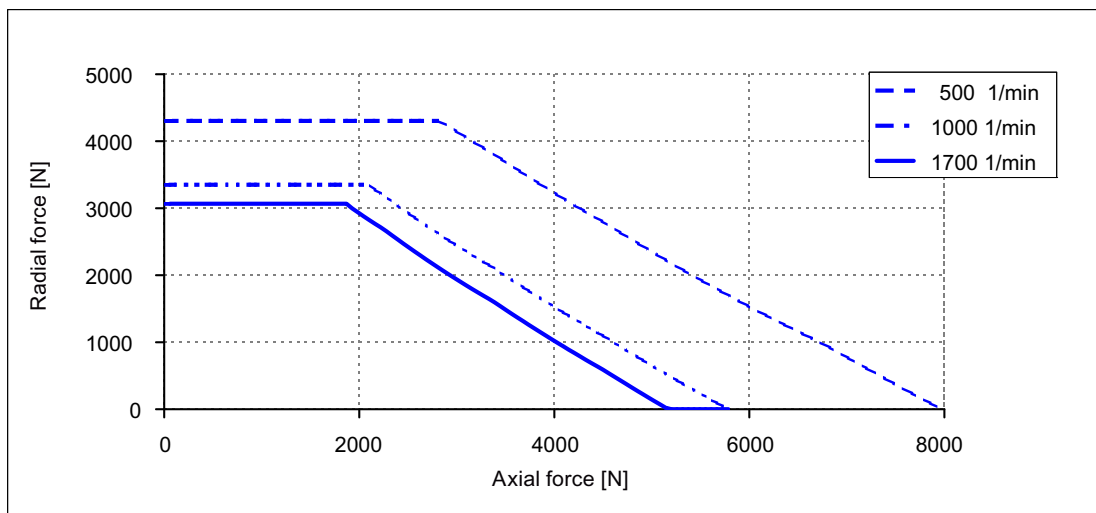

Figure 3-21 Permissible axial force as a function of radial force for 1FW315□ (20000 h)

Radial force diagram for 1FW315□, solid shaft

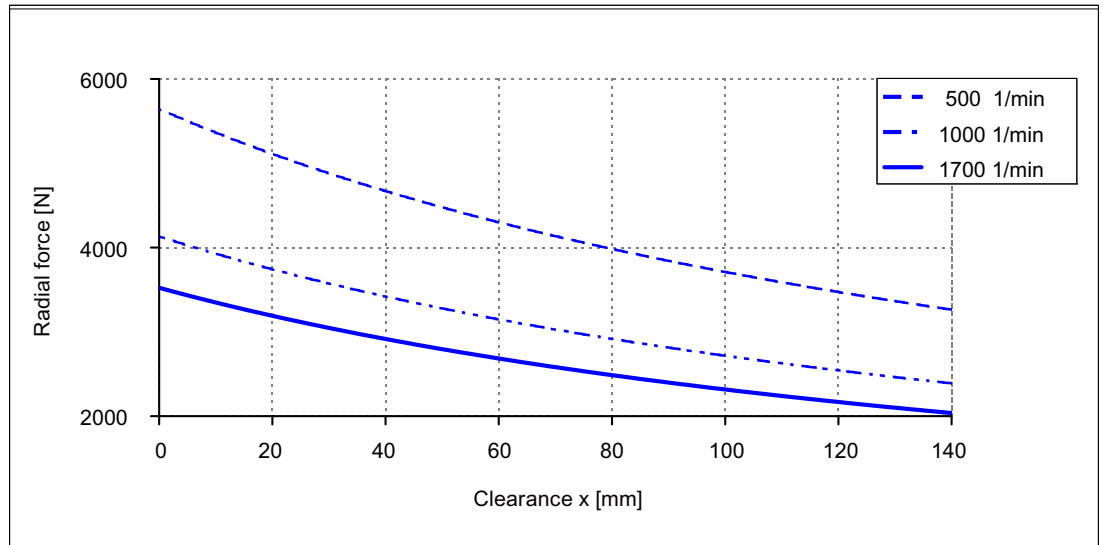

Figure 3-22 Radial force diagram for 1FW315□, with nominal bearing change interval of 60000 h

Axial force diagram for 1FW315□, solid shaft

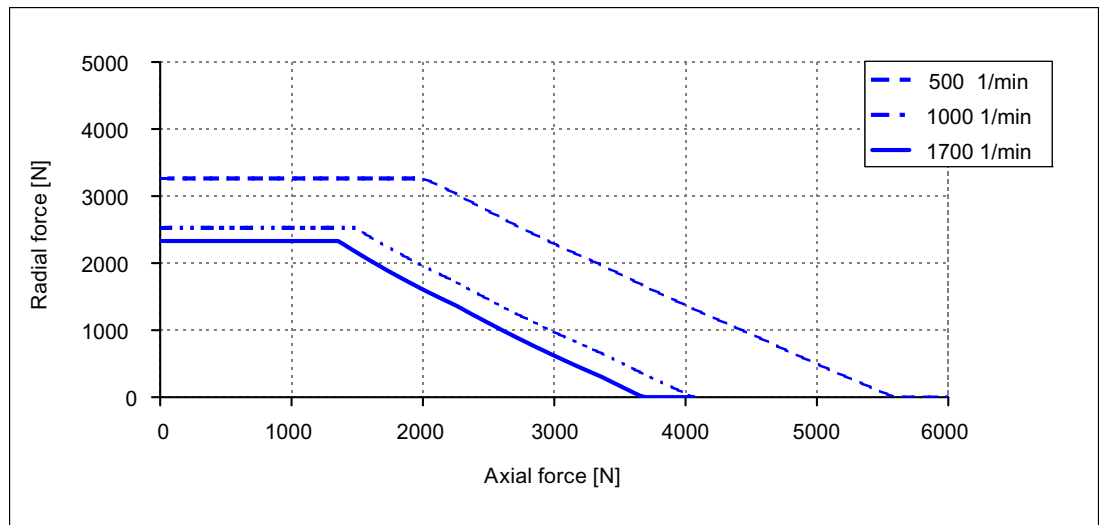

Figure 3-23 Permissible axial force as a function of radial force for 1FW315□ (60000 h)

Radial force diagram for 1FW320□, solid shaft

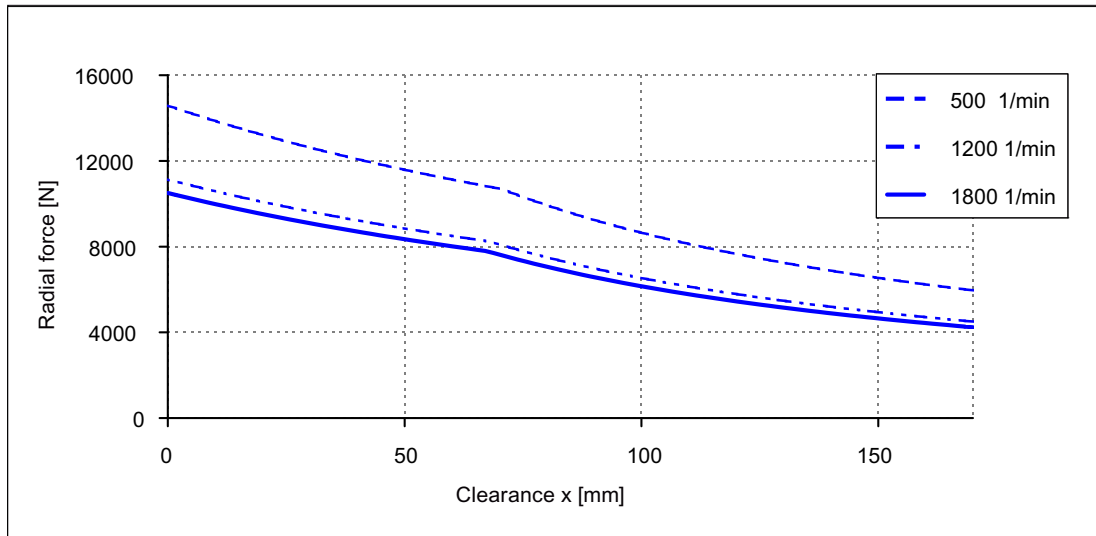

Figure 3-24 Radial force diagram for 1FW320□, with nominal bearing change interval of 20000 h

Axial force diagram for 1FW320□, solid shaft

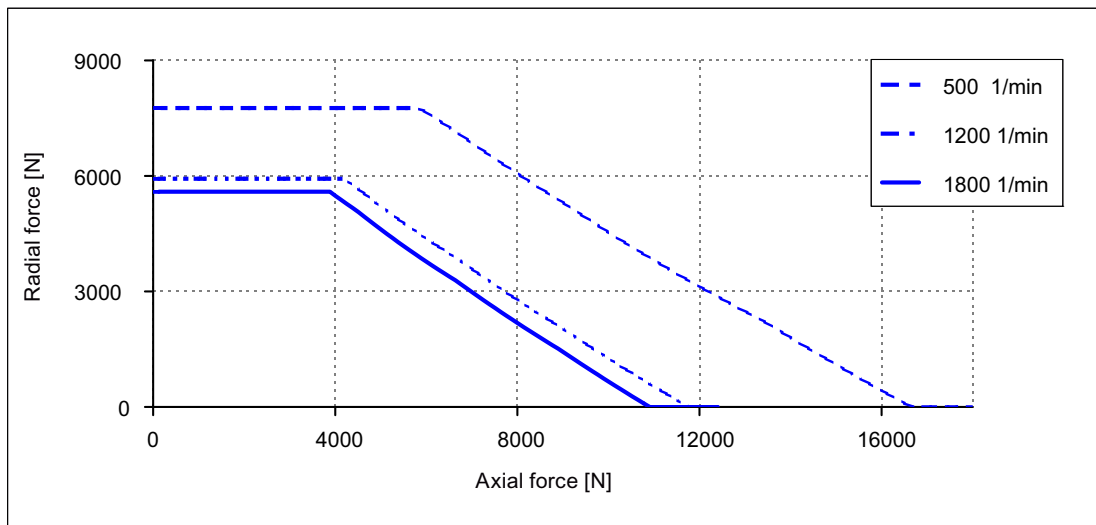

Figure 3-25 Permissible axial force as a function of radial force for 1FW320□ (20000 h)

Radial force diagram for 1FW320□, solid shaft

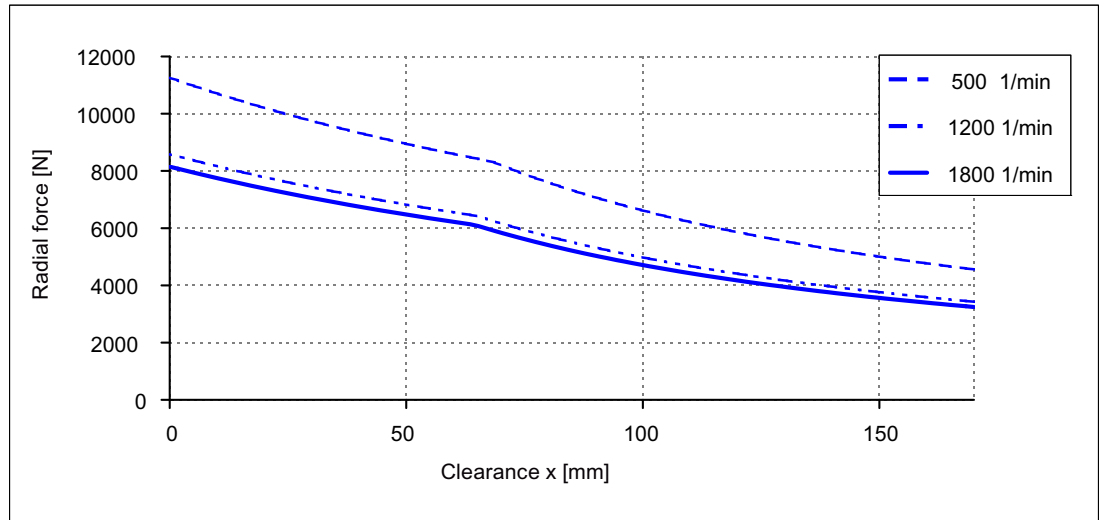

Figure 3-26 Radial force diagram for 1FW320□, with nominal bearing change interval of 60000 h

Axial force diagram for 1FW320□, solid shaft

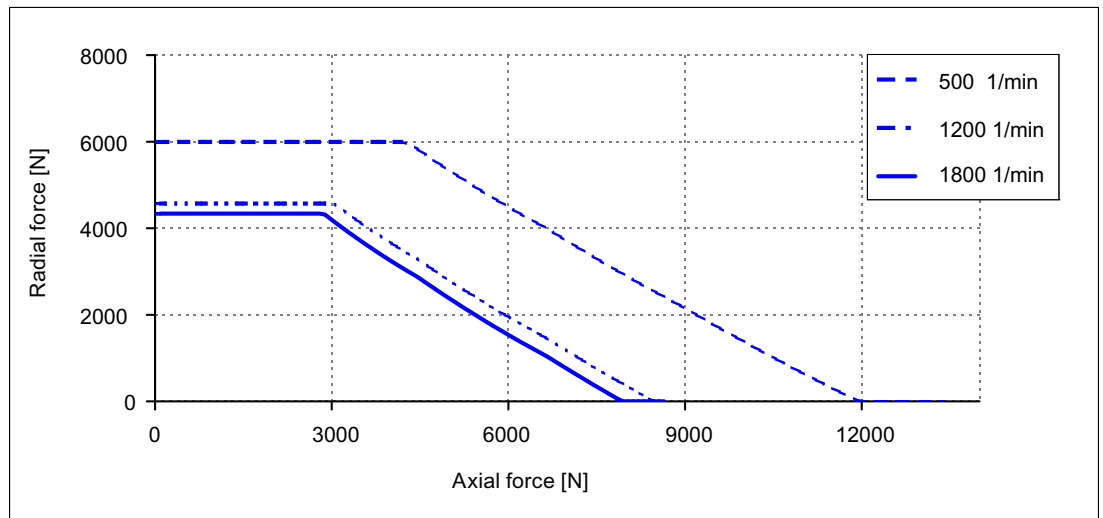

Figure 3-27 Permissible axial force as a function of radial force for 1FW320□ (60000 h)

3.5 Shaft versions

The complete torque motor 1FW3 can be ordered with 3 different shaft versions:

- Hollow shaft
- Plug-on shaft
- Solid shaft

Table 3- 10 Hollow shaft

Frame size	Flange centering edge d _i [mm]
1FW315x	153 H7
1FW320x	153 H7
1FW328x	250 H7

Table 3- 11 Plug-on shaft

Frame size	Flange centering edge d _i [mm]	Support d _i [mm]
1FW315x	153 H7	70 H6
1FW320x	153 H7	85 H6
1FW328x	250 H7	110 H7 and 180 H7

Table 3- 12 Solid shaft

Frame size	Shaft length l [mm]	Shaft diameter d [mm]
1FW315x	140	65 m6
1FW320x	170	90 m6

The shaft version "solid shaft" has a plain shaft end as standard. Version with fitted key or gearing on request.

Note

Shaft cover at NDE for the "hollow shaft" version

If the hollow through-shaft is not used by the customer and must be sealed at the NDE for touch protection reasons, the motor can be supplied with a shaft cover at the NDE. Ordering options: Order code T20.

See the dimension drawings for further details.

Direction of rotation

The positive direction of rotation is clockwise when viewing the drive end (flange side).

3.6 Vibration severity grade

The motors conform to vibration severity grade A in accordance with EN 60034-14 (IEC 60034-14).

The specified values refer to the motor only. The vibration behavior as a result of the mounting can result in increased values at the motor.

The vibration severity grade is maintained up to the rated speed (n_N).

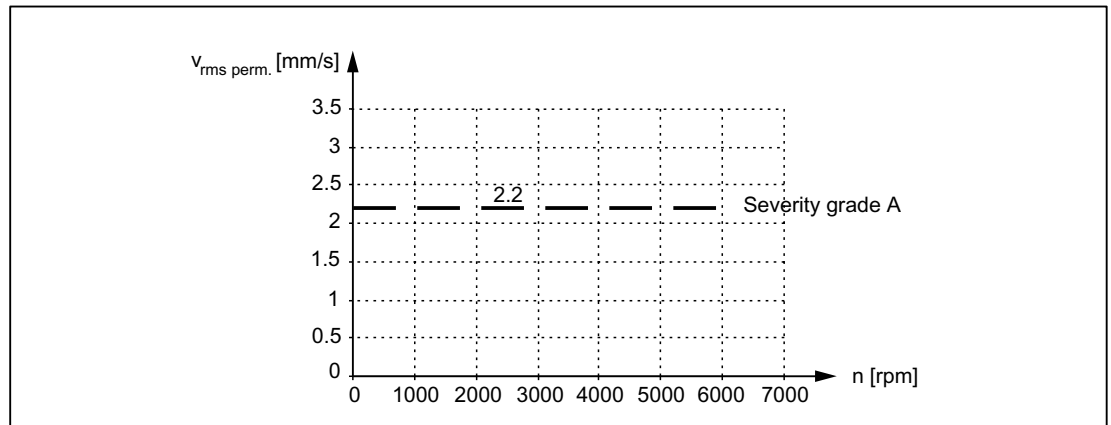

Figure 3-28 Vibration severity grade

3.7 Noise emission

When operated in the approved speed range, 1FW3 motors can reach the following measuring-surface sound-pressure level $L_p(A)$:

Max. 73 dB(A) at 4 kHz rated pulse frequency at the nominal operating point

Note

Sound pressure level when reducing the pulse frequency

When the pulse frequency is reduced, a significantly higher sound pressure level can occur.

The motors are certified for a wide range of installation and operating conditions. These conditions, such as rigid or vibration-isolated foundation design, influence noise emission, sometimes significantly.

3.8 Gear ratio

3.8 Gear ratio

For the "hollow shaft" version, the encoder can be driven by a toothed belt. Order designation (MLFB) 11th position = 5 or 7. The gear ratio is in accordance with the table "Gear ratio".

Table 3- 13 Ratio

Shaft height	<i>i</i>	Remarks
1FW315□	-3.5	The encoders are connected to the motor shaft through a belt drive (toothed belts). The sign for the gear ratio is negative due to the reverse direction of rotation of the encoder with respect to the motor.
1FW320□	-3.5	
1FW328□	-5	
Toothed belt lifetime: max. 20000 h.		

3.9 Paint finish

The 1FW3 complete torque motors are shipped with an anthracite paint finish (similar to RAL 7016).

Option: Special paint finish.

Technical specifications and characteristic curves

Permissible operating range

The permissible operating range is limited by thermal, mechanical, and electromagnetic boundaries.

Permissible winding temperature range

The temperature rise of the motor is caused by the losses generated in the motor (current-dependent losses, no-load losses, friction losses). Utilizing the insulation system according to temperature class 155 (F) has a limiting effect.

Torque characteristics of motor

The maximum permissible torque depends on the permissible winding overtemperature (100 K) and, in turn, on the mode. To adhere to the temperature limits, the torque must be reduced as the speed increases, starting from static torque M_0 .

The characteristics refer to continuous duty S1 (100 K).

 WARNING
Continuous duty in the area above the S1 characteristic curve is not thermally permitted for the motor.

The speed range is affected by:

- The maximum permissible speed (mechanical) $n_{\max \text{ mech}}$ (centrifugal forces on the rotor, bearing lifetime), or
- The maximum permissible speed on the converter $n_{\max \text{ Inv}}$ (output frequency, voltage strength of the converter and/or motor)

Winding versions

A number of winding versions (armature circuit versions) for different rated speeds n_N are possible within one motor frame size.

Table 4- 1 Code letter for the winding version

Rated speed n_N [rpm]	Winding version (10. position of the Order No.)
150	E
250	G
300	H
400	J
500	L
600	M
750	P ¹⁾

1) only for 1FW315x

Converter output voltage

The converter output voltages differ according to the converter type and supply voltage.

Table 4- 2 Converter output voltages

Converter type	Infeed module	Supply voltage	DC link voltage	Output voltage
		V_{line}	$V_{DC\ link}$	V_{mot}
SINAMICS S120 3-ph. 380 - 480 V AC	ALM	400 V	600 V	425 V
	ALM	480 V	720 V	510 V
	SLM	400 V	528 V	380 V
	SLM	480 V	634 V	460 V

Torque limit when operating on a SINAMICS S120 with field weakening

The SINAMICS S120 converter injects a field weakening current, which means that the motor can operate above the voltage limiting characteristic. The method used by the converter to inject the field weakening current has a significant influence on the curve characteristic.

The characteristics shown apply to operation on a SINAMICS S120 converter.

Field weakening operation is always active for a SINAMICS S120 converter.

The shape of the characteristics in field weakening mode depends on the position of the voltage limiting characteristic. A torque/speed chart is, therefore, assigned to each voltage limiting characteristic.

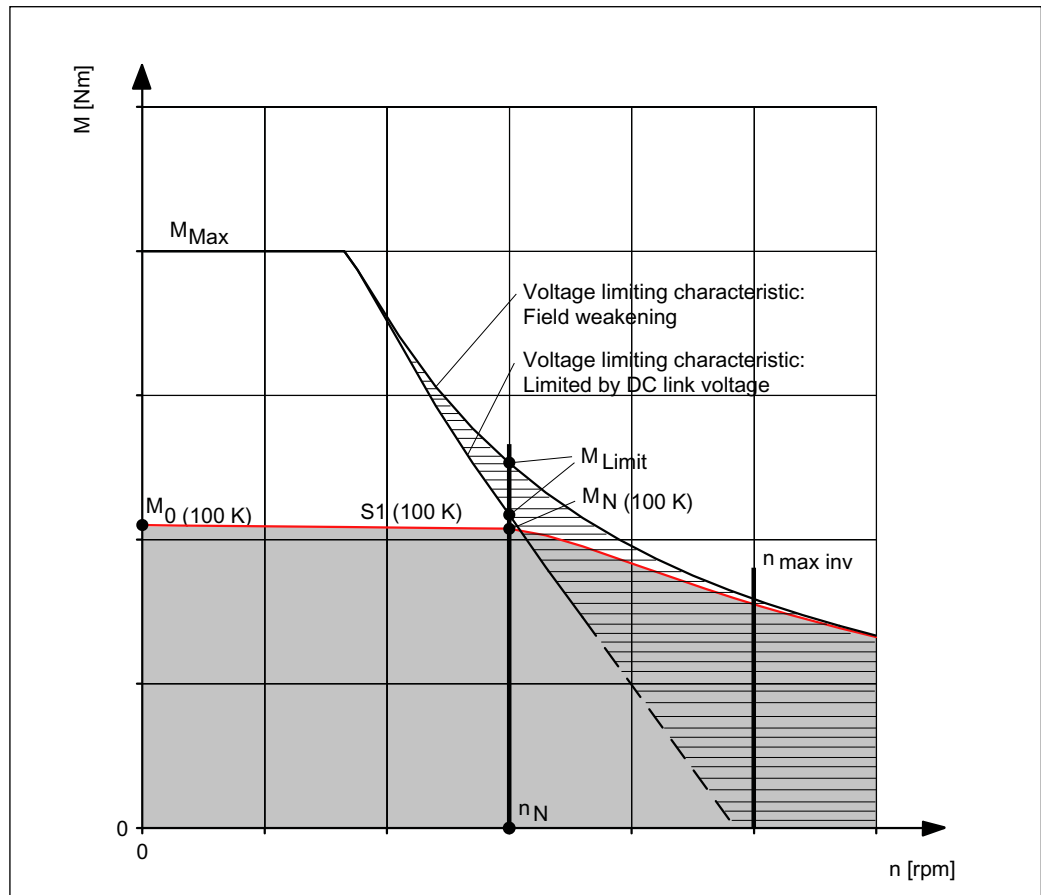

Figure 4-1 Torque characteristic of a synchronous motor operating on a SINAMICS drive system with field weakening (example characteristic)

The permissible speed range has been limited to $n_{\max \text{ Inv.}}$.

Torque limit when operating on a SINAMICS S120 without field weakening

It is possible to deactivate the field weakening function with the SINAMICS S120 drive system. This therefore reduces the operating range that is available.

The shape of the voltage limiting characteristic is determined by the winding version and the magnitude of the converter output voltage.

The voltage induced in the motor winding increases as the speed increases. The difference between the DC link voltage of the converter and the induced motor voltage can be used to apply the current.

For converters **without field weakening option**, this limits the magnitude of the current that can be impressed. This causes the torque to drop off quickly at high speeds. All operating points that can be achieved with the motor lie to the left of the voltage limiting characteristic that is shown in the diagram.

The characteristic curve is plotted for each winding version in a separate data sheet (see Chapter "Speed-torque characteristics"). The speed-torque characteristics for different converter output voltages are then assigned to each data sheet.

Note

The voltage limit characteristic of a motor with 600 rpm rated speed lies far above that of the same motor type with 200 rpm. However, for the same torque, this motor requires a significantly higher current.

For this reason, you should select the rated speed such that it does not lie too far above the maximum speed required for the application.

The size (rating) of the converter module (output current) can be minimized in this fashion

Offset of the voltage limit characteristic

NOTICE
<p>The offset of the voltage limiting characteristic applies only in the case of approximately linear limiting characteristic curves, e.g. for 1FW3 motors. The voltage limiting characteristic can be offset only if the condition $V_{\text{mot, new}} > V_{\text{IN}}$ is fulfilled.</p> <p>The induced voltage U_{IN} can be taken from the motor rating plate or calculated according to the following formula: $U_{\text{IN}} = k_E \cdot n_N / 1000$</p>

In order to identify the limits of the motor for a converter output voltage (U_{mot}) other than 380 V, 425 V, 460 V or 510 V, the relevant voltage limiting characteristic curve must be shifted (offset) for the particular new output voltage ($U_{\text{mot, new}}$).

The degree of offset is obtained as follows:

For an output voltage of $V_{\text{mot, new}}$, an offset is obtained along the X axis (speed) by a factor of:

$V_{\text{mot, new}}$ = new converter output voltage

V_{mot} = drive converter output voltage from the characteristic curve for 380 V, 425 V, 460 V or 510 V

$$n_{\text{new}} = \frac{U_{\text{Mot, new}}}{U_{\text{Mot}}} \cdot n$$

Calculating the new limit torque with the new limiting characteristic

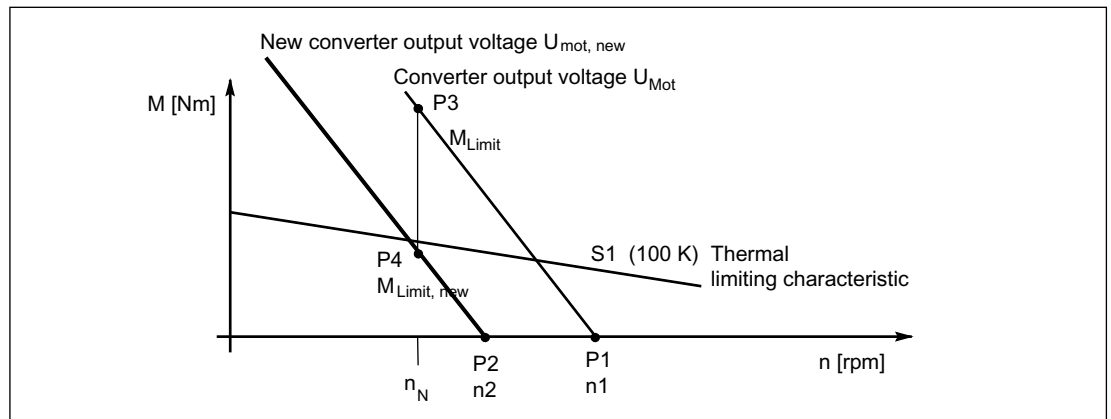

- P1 Intersection between voltage limiting characteristic and x axis: Read off or calculate the speed

$$n_1 \text{ [rpm]} = \frac{U_{Mot}}{k_E}$$

- P2 Offset from point where the voltage limiting characteristic curve intersects with the x axis from n_1 to n_2 .

$$n_2 \text{ [rpm]} = n_1 \cdot \frac{U_{mot, new}}{U_{Mot}}$$

- P3 Read-off M_{limit} on the voltage limiting characteristic curve specified for V_{mot} .

- P4 Calculate $M_{limit, new}$:

$$M_{limit, new} = \frac{U_{Mot, new} - U_{iN}}{U_{Mot} - U_{iN}} \cdot M_{limit}$$

The offset voltage limiting characteristic curve is obtained with points P2 and P4.

Offset of voltage limiting characteristic from V_{mot} to $V_{mot, new}$

Example of offset of voltage limiting characteristic curve without field weakening

Motor 1FW3201-1□L; $n_N = 500$ rpm; $k_E = 519$ V/1000 rpm

$V_{mot, new} = 290$ V; calculated with $V_{mot} = 425$ V

$V_{iN} = k_E \cdot n_N/1000$; $V_{iN} = 519 \cdot 500/1000 = 259.5$ V

Condition $V_{mot, new} > V_{iN}$ is fulfilled.

Calculation P1: $n_1 = \frac{425}{519} \cdot 1000 = 819 \text{ rpm}$

Calculation P2: $n_2 = \frac{290}{425} \cdot 819 = 559 \text{ rpm}$

Calculation P3: Calculate M_{limit} for 425 V and $n = 500 \text{ rpm} = 313 \text{ Nm}$

Calculation P4: $M_{\text{limit, new}} = \frac{290 - 259,5}{425 - 259,5} \cdot 313 = 58 \text{ Nm}$

Enter and connect points P2 and P4. This line is the new voltage limiting characteristic for $V_{\text{mot, new}} = 290 \text{ V}$.

Tolerance data

The characteristic data listed in the data sheets are nominal values that are subject to natural scatter.

Table 4- 3 Tolerance data in the motor list data

Motor list data		Typ. value	Guaranteed value
Stall current	I_0	$\pm 3 \%$	$\pm 7,5 \%$
Electrical time constant	T_{el}	$\pm 5 \%$	$\pm 10 \%$
Torque constant	k_T	$\pm 3 \%$	$\pm 7,5 \%$
Voltage constant	k_E	$\pm 3 \%$	$\pm 7,5 \%$
Winding resistance	R_{ph}	$\pm 5 \%$	$\pm 10 \%$
Moment of inertia	J_{mot}	$\pm 2 \%$	$\pm 10 \%$

Effects of temperature and parameter scatter on the characteristic

The torque-speed characteristics specified in the following chapter relate to the nominal values at operating temperature.

NOTICE

The motor temperature results in a clear shift of the voltage limiting characteristic in the upper speed range. This must be taken into consideration during engineering (especially for applications in which the cold motor has to operate at maximum speeds) with converter systems without field weakening.

Speed limits $n_{\max \text{ Inv}}$

The speed is limited by the mechanical limit speed $n_{\max \text{ mech}}$ (centrifugal forces at the rotor, bearing service life) or the electrical limit speed $n_{\max \text{ Inv}}$.

⚠ CAUTION

When the machine is running (with shaft operated by motor or separately driven) at speeds higher than $n_{\max \text{ Inv}}$, a voltage in excess of the maximum permissible converter voltage might be induced in the winding. This can cause irreparable damage to the converter. Operation is not permissible above the speed $n_{\max \text{ Inv}}$ without protective measures or other additional measures. Siemens AG accepts no liability for any damage occurring as a result of failing to observe the danger warning.

Converter type	Max. permissible voltage at the converter $U_{\text{perm. inv}}$
SINAMICS S120, 380-480 V 3AC	820 V

The following formula can be used to determine the maximum permissible speed $n_{\max \text{ Inv}}$ up to which the system can be operated without restrictions.

$$n_{\max \text{ Inv}} [\text{rpm}] = \frac{U_{\text{Perm Inv}} [\text{V}] \cdot 1000}{k_E [\text{V} / 1000 \text{ rpm}] \cdot \sqrt{2}}$$

k_E = voltage constant (see Chapter "Speed-torque characteristics").

The SINAMICS S120 drive system calculates this value automatically.

When the converter is functioning properly, the voltage that occurs at the motor terminals in field-weakening mode can be limited by generating a voltage in phase opposition to the induced voltage.

4.1 Torque-speed characteristic

The voltages and currents specified in the data sheets are rms values. Other rated speeds on request.

The specified rated data refer to $V_{\text{line rms}} = 400 \text{ V}$, Active Line Module, characteristic [b].

Note

Operation without water cooling

Complete torque motors 1FW3 can be operated without water cooling if the torque is appropriately reduced and the thermal losses can be adequately dissipated. The reduction factor depends on the shaft height, length and speed and can be provided when requested.

4.1 Torque-speed characteristic

4.1.1 Shaft height 150

Table 4- 4 1FW3150, rated speed 300 rpm

Configuration data	Code	Unit	1FW3150-1□H
Rated speed	n_N	rpm	300
Rated torque (100 K)	$M_N (100 K)$	Nm	100
Rated power (100 K)	$P_N (100 K)$	kW	3.1
Rated current (100 K)	$I_N (100 K)$	A	8.0
Static torque (100 K)	$M_0 (100 K)$	Nm	105
Stall current (100 K)	$I_0 (100 K)$	A	7.3
Limiting data			
Max. permissible speed (mech.)	$n_{max mech.}$	rpm	1700
Max. permissible speed (converter)	$n_{max Inv}$	rpm	630
Maximum torque	M_{max}	Nm	200
Maximum current	I_{max}	A	17.0
Motor data			
Number of poles	$2p$	--	14
Ratio of speed measurement (belt-mounted encoder)	i_{enc}	--	-3.5
Torque constant (100 K)	k_T	Nm/A	14.4
Voltage constant (at 20 °C)	k_E	V/1000 rpm	915
Winding resistance (at 20 °C)	R_{ph}	Ω	3.95
Rotating field inductance	L_D	mH	110
Electrical time constant	T_{el}	ms	27.5
Thermal time constant	T_{th}	min	4.0
Mechanical data: Hollow-shaft version			
Mechanical time constant	T_{mech}	ms	6.8
Moment of inertia	J_{mot}	kgm ²	0.12
Shaft torsional stiffness	C_t	Nm/rad	3.13E+07
Weight	m	kg	87
Mechanical data: Solid shaft version			
Mechanical time constant	T_{mech}	ms	3.4
Moment of inertia	J_{mot}	kgm ²	0.06
Shaft torsional stiffness	C_t	Nm/rad	1.13e+06
Weight	m	kg	102
Mechanical data: Plug-on shaft version			
Mechanical time constant	T_{mech}	ms	8.0
Moment of inertia	J_{mot}	kgm ²	0.14
Shaft torsional stiffness	C_t	Nm/rad	4.17E+07
Weight	m	kg	102

The specified rated data are valid for a 600 V DC link voltage

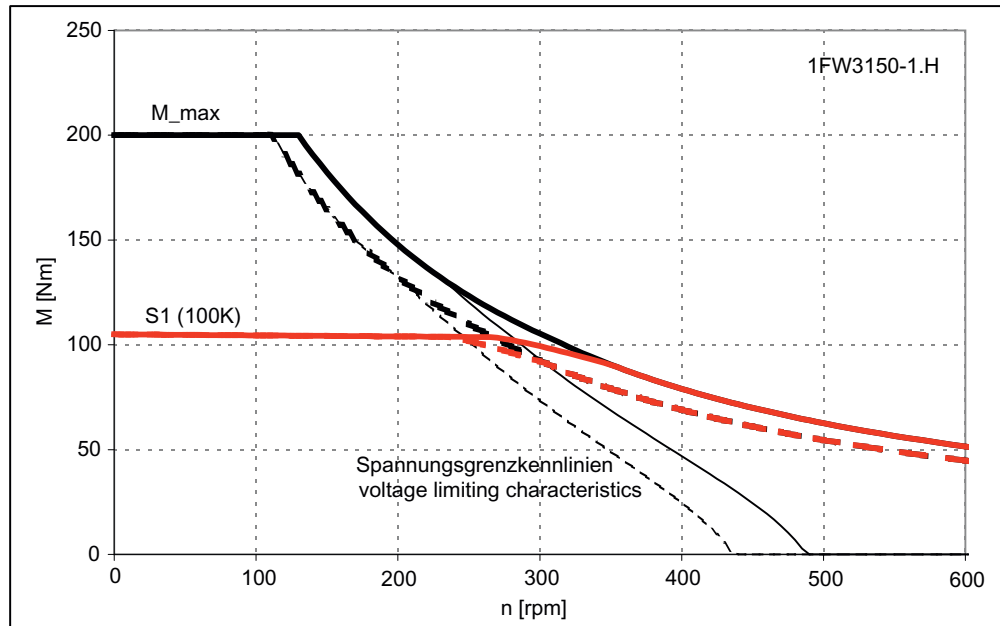

- SINAMICS ALM 400 V-Netz (Zwischenkreisspannung 600 V DC)
SINAMICS ALM 400 V line (DC-link voltage 600 V)
- - - SINAMICS BLM/SLM 400 V-Netz (Zwischenkreisspannung 540 V DC)
SINAMICS BLM/SLM 400 V line (DC-link voltage 540 V)

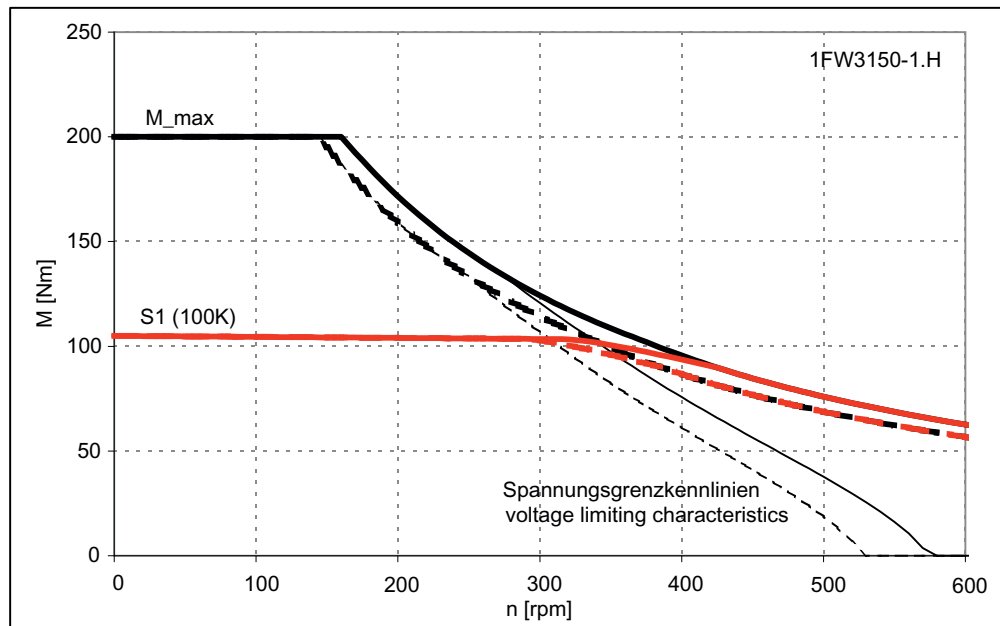

- SINAMICS ALM 480 V-Netz (Zwischenkreisspannung 720 V DC)
SINAMICS ALM 480 V line (DC-link voltage 720 V)
- - - SINAMICS BLM/SLM 480 V-Netz (Zwischenkreisspannung 650 V DC)
SINAMICS BLM/SLM 480 V line (DC-link voltage 650 V)

4.1 Torque-speed characteristic

Table 4- 5 1FW3150, rated speed 500 rpm

Configuration data	Code	Unit	1FW3150-1□L
Rated speed	n_N	rpm	500
Rated torque (100 K)	$M_N (100 K)$	Nm	100
Rated power (100 K)	$P_N (100 K)$	kW	5.2
Rated current (100 K)	$I_N (100 K)$	A	12.0
Static torque (100 K)	$M_0 (100 K)$	Nm	105
Stall current (100 K)	$I_0 (100 K)$	A	11.5
Limiting data			
Max. permissible speed (mech.)	$n_{max mech.}$	rpm	1700
Max. permissible speed (converter)	$n_{max 830 V}$	rpm	960
Maximum torque	M_{max}	Nm	200
Maximum current	I_{max}	A	26.0
Motor data			
Number of poles	2p		14
Ratio of speed measurement (belt-mounted encoder)	i_{enc}	--	-3.5
Torque constant (100 K)	k_T	Nm/A	9.4
Voltage constant (at 20 °C)	k_E	V/1000 rpm	600
Winding resistance (at 20 °C)	R_{ph}	Ω	1.68
Rotating field inductance	L_D	mH	47
Electrical time constant	T_{el}	ms	28.0
Thermal time constant	T_{th}	min	4.0
Mechanical data: Hollow-shaft version			
Mechanical time constant	T_{mech}	ms	6.8
Moment of inertia	J_{mot}	kgm ²	0.12
Shaft torsional stiffness	C_t	Nm/rad	3.13E+07
Weight	m	kg	87
Mechanical data: Solid shaft version			
Mechanical time constant	T_{mech}	ms	3.4
Moment of inertia	J_{mot}	kgm ²	0.06
Shaft torsional stiffness	C_t	Nm/rad	1.13E+06
Weight	m	kg	102
Mechanical data: Plug-on shaft version			
Mechanical time constant	T_{mech}	ms	8.0
Moment of inertia	J_{mot}	kgm ²	0.14
Shaft torsional stiffness	C_t	Nm/rad	4.17E+07
Weight	m	kg	102

The specified rated data are valid for a 600 V DC link voltage

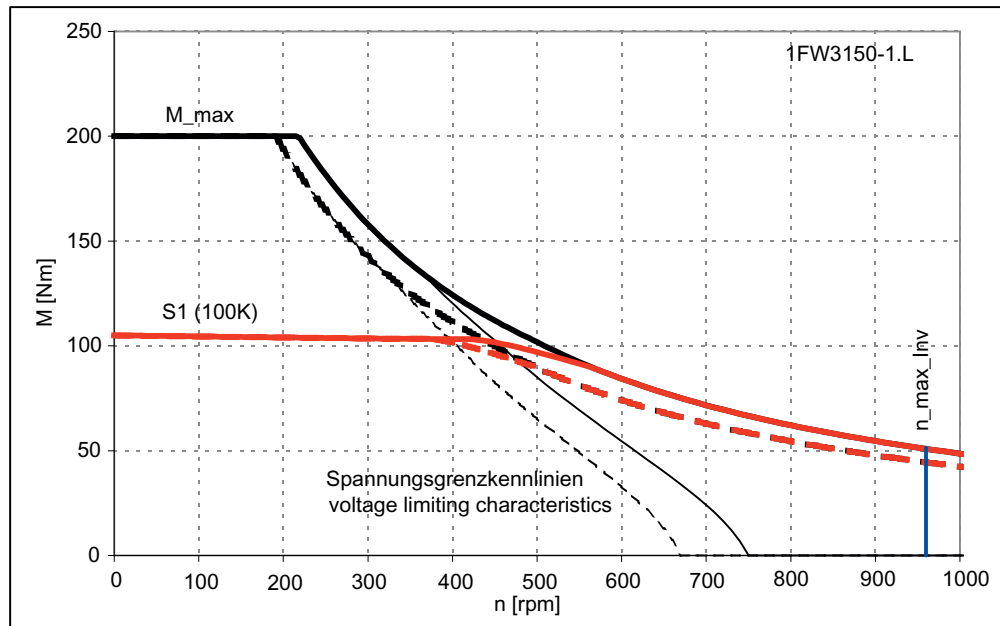

- SINAMICS ALM 400 V-Netz (Zwischenkreisspannung 600 V DC)
SINAMICS ALM 400 V line (DC-link voltage 600 V)
- - - SINAMICS BLM/SLM 400 V-Netz (Zwischenkreisspannung 540 V DC)
SINAMICS BLM/SLM 400 V line (DC-link voltage 540 V)

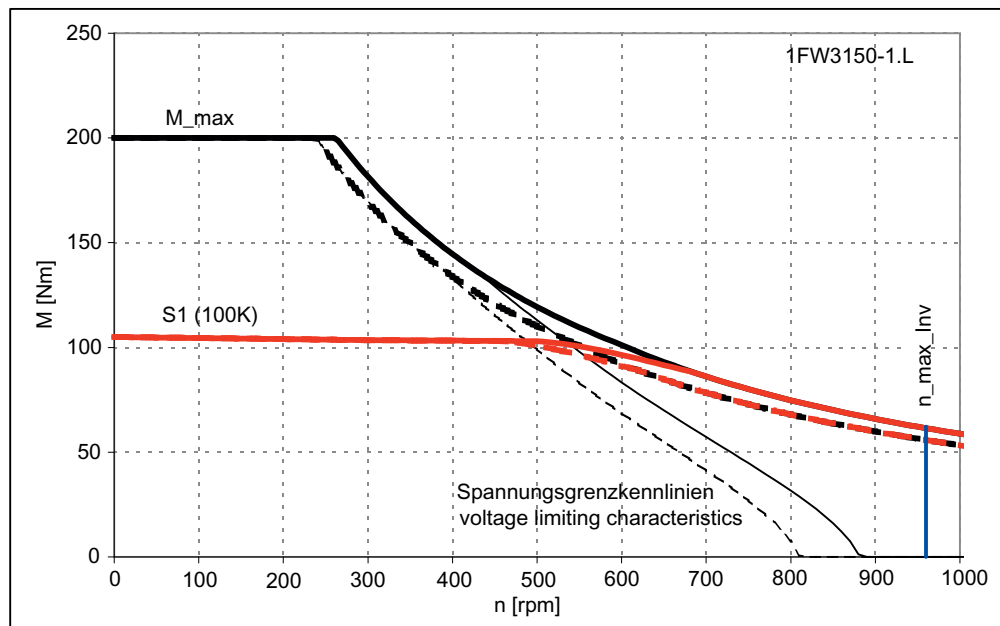

- SINAMICS ALM 480 V-Netz (Zwischenkreisspannung 720 V DC)
SINAMICS ALM 480 V line (DC-link voltage 720 V)
- - - SINAMICS BLM/SLM 480 V-Netz (Zwischenkreisspannung 650 V DC)
SINAMICS BLM/SLM 480 V line (DC-link voltage 650 V)

4.1 Torque-speed characteristic

Table 4- 6 1FW3150, rated speed 750 rpm

Configuration data	Code	Unit	1FW3150-1□P
Rated speed	n_N	rpm	750
Rated torque (100 K)	$M_N (100 K)$	Nm	100
Rated power (100 K)	$P_N (100 K)$	kW	7.9
Rated current (100 K)	$I_N (100 K)$	A	18.0
Static torque (100 K)	$M_0 (100 K)$	Nm	105
Stall current (100 K)	$I_0 (100 K)$	A	17.5
Limiting data			
Max. permissible speed (mech.)	$n_{max \text{ mech.}}$	rpm	1700
Max. permissible speed (converter)	$n_{max \text{ 830 V}}$	rpm	1470
Maximum torque	M_{max}	Nm	200
Maximum current	I_{max}	A	41.0
Motor data			
Number of poles	2p		14
Ratio of speed measurement (belt-mounted encoder)	i_{enc}	--	-3.5
Torque constant	k_T	Nm/A	6.1
Voltage constant (at 20 °C)	k_E	V/1000 rpm	393
Winding resistance (at 20 °C)	R_{ph}	Ω	0.75
Rotating field inductance	L_D	mH	21
Electrical time constant	T_{el}	ms	28.0
Thermal time constant	T_{th}	min	4.0
Mechanical data: Hollow-shaft version			
Mechanical time constant	T_{mech}	ms	7.3
Moment of inertia	J_{mot}	kgm ²	0.12
Shaft torsional stiffness	C_t	Nm/rad	3.13E+07
Weight	m	kg	87
Mechanical data: Hollow-shaft version			
Mechanical time constant	T_{mech}	ms	3.6
Moment of inertia	J_{mot}	kgm ²	0.06
Shaft torsional stiffness	C_t	Nm/rad	1.13E+06
Weight	m	kg	102
Mechanical data: Hollow-shaft version			
Mechanical time constant	T_{mech}	ms	8.5
Moment of inertia	J_{mot}	kgm ²	0.14
Shaft torsional stiffness	C_t	Nm/rad	3.14E+07
Weight	m	kg	102

The specified rated data are valid for a 600 V DC link voltage

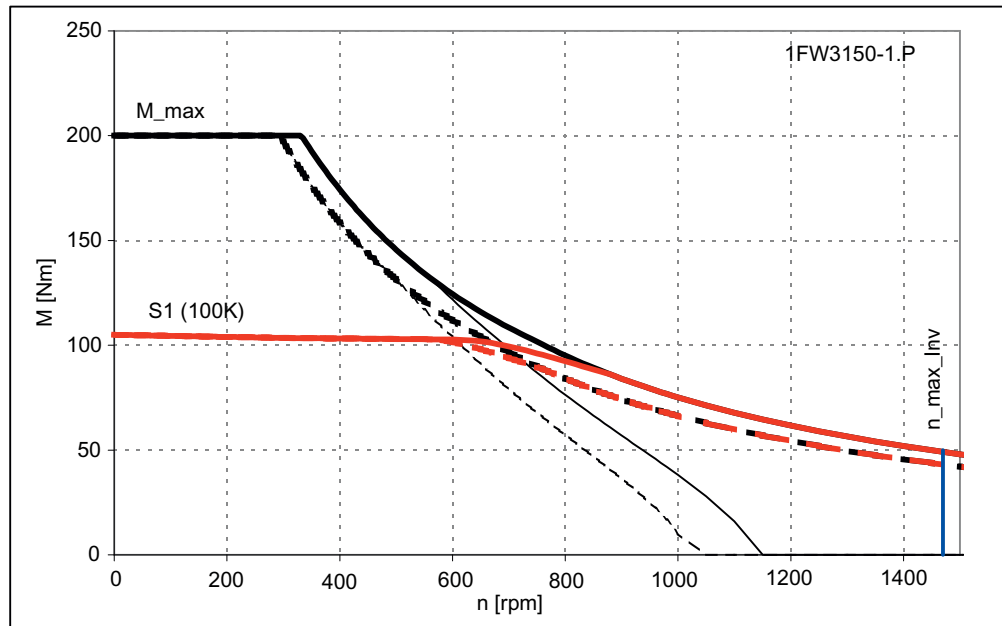

- SINAMICS ALM 400 V-Netz (Zwischenkreisspannung 600 V DC)
SINAMICS ALM 400 V line (DC-link voltage 600 V)
- - - SINAMICS BLM/SLM 400 V-Netz (Zwischenkreisspannung 540 V DC)
SINAMICS BLM/SLM 400 V line (DC-link voltage 540 V)

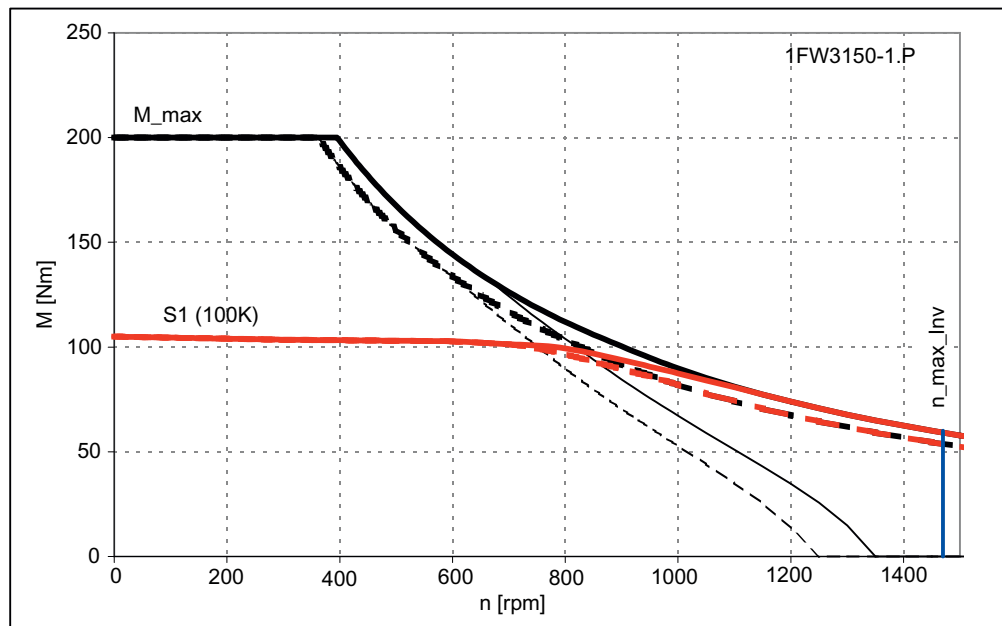

- SINAMICS ALM 480 V-Netz (Zwischenkreisspannung 720 V DC)
SINAMICS ALM 480 V line (DC-link voltage 720 V)
- - - SINAMICS BLM/SLM 480 V-Netz (Zwischenkreisspannung 650 V DC)
SINAMICS BLM/SLM 480 V line (DC-link voltage 650 V)

4.1 Torque-speed characteristic

Table 4-7 1FW3152, rated speed 300 rpm

Configuration data	Code	Unit	1FW3152-1□H
Rated speed	n_N	rpm	300
Rated torque (100 K)	$M_N (100\text{ K})$	Nm	200
Rated power (100 K)	$P_N (100\text{ K})$	kW	6.3
Rated current (100 K)	$I_N (100\text{ K})$	A	14
Static torque (100 K)	$M_0 (100\text{ K})$	Nm	210
Stall current (100 K)	$I_0 (100\text{ K})$	A	15.0
Limiting data			
Max. permissible speed (mech.)	$n_{\text{max mech.}}$	rpm	1700
Max. permissible speed (converter)	$n_{\text{max 830 V}}$	rpm	630
Maximum torque	M_{max}	Nm	400
Maximum current	I_{max}	A	35.0
Motor data			
Number of poles	2p		14
Ratio of speed measurement (belt-mounted encoder)	i_{enc}	--	-3.5
Torque constant (100 K)	$k_T (100\text{ K})$	Nm/A	14.4
Voltage constant (at 20 °C)	k_E	V/1000 rpm	915
Winding resistance (at 20 °C)	R_{ph}	Ω	1.47
Rotating field inductance	L_D	mH	49
Electrical time constant	T_{el}	ms	33.5
Thermal time constant	T_{th}	min	4.0
Mechanical data: Hollow-shaft version			
Mechanical time constant	T_{mech}	ms	3.4
Moment of inertia	J_{mot}	kgm ²	0.16
Shaft torsional stiffness	C_t	Nm/rad	2.17E+07
Weight	m	kg	108
Mechanical data: Solid shaft version			
Mechanical time constant	T_{mech}	ms	1.9
Moment of inertia	J_{mot}	kgm ²	0.09
Shaft torsional stiffness	C_t	Nm/rad	1.1E+06
Weight	m	kg	121
Mechanical data: Plug-on shaft version			
Mechanical time constant	T_{mech}	ms	4.3
Moment of inertia	J_{mot}	kgm ²	0.2
Shaft torsional stiffness	C_t	Nm/rad	2.92E+07
Weight	m	kg	124

The specified rated data are valid for a 600 V DC link voltage

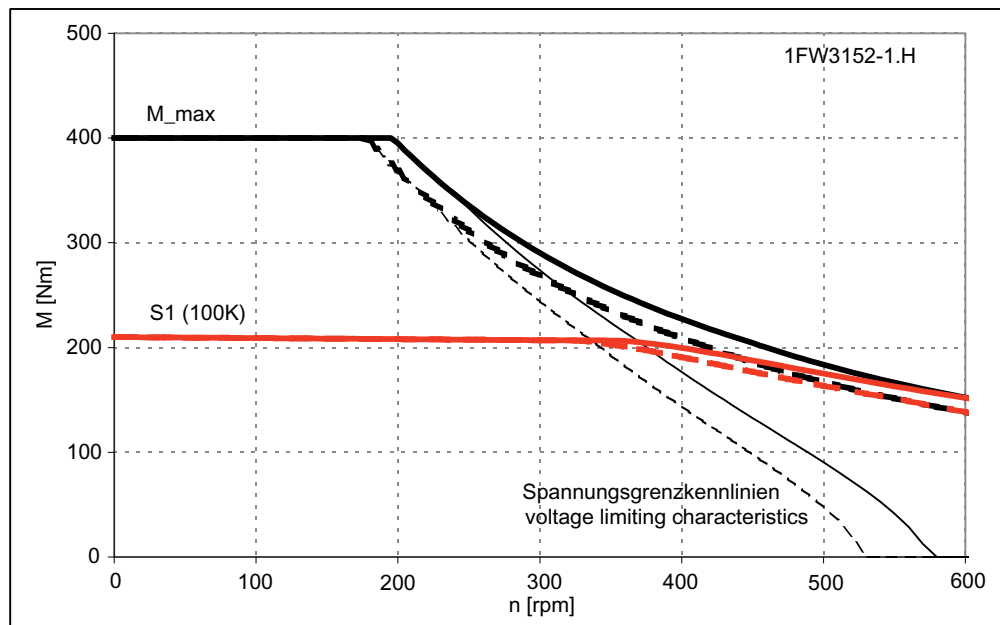
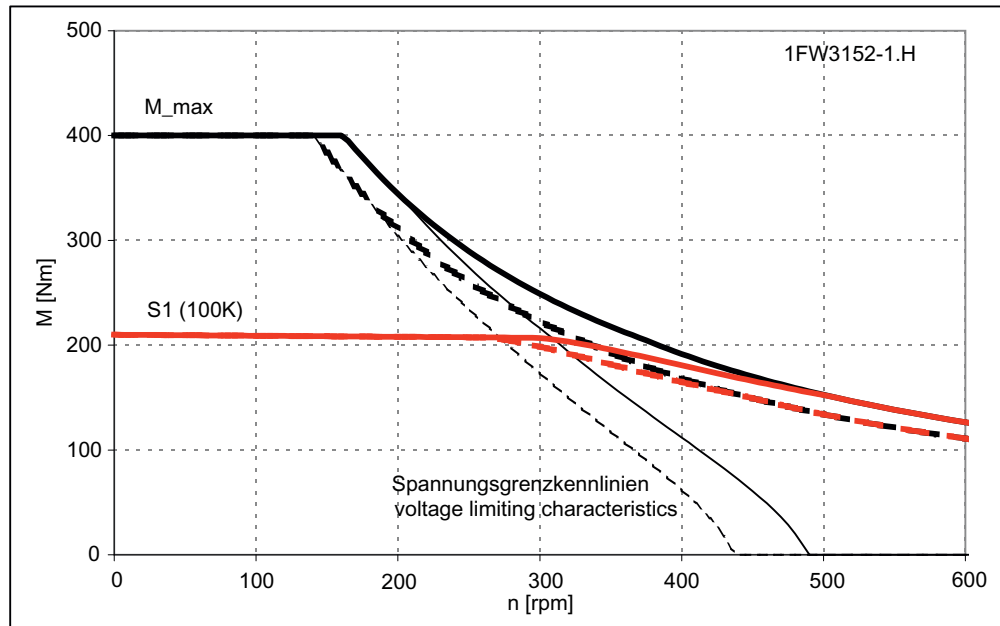

4.1 Torque-speed characteristic

Table 4- 8 1FW3152, rated speed 500 rpm

Configuration data	Code	Unit	1FW3152-1□L	
Rated speed	n_N	rpm	500	
Rated torque (100 K)	$M_N (100 K)$	Nm	200	
Rated power (100 K)	$P_N (100 K)$	kW	10.5	
Rated current (100 K)	$I_N (100 K)$	A	22.0	
Static torque (100 K)	$M_0 (100 K)$	Nm	210	
Stall current (100 K)	$I_0 (100 K)$	A	22.5	
Limiting data				
Max. permissible speed (mech.)	$n_{max mech.}$	rpm	1700	
Max. permissible speed (converter)	$n_{max 830 V}$	rpm	960	
Maximum torque	M_{max}	Nm	400	
Maximum current	I_{max}	A	53	
Motor data				
Number of poles	2p		14	
Ratio of speed measurement (belt-mounted encoder)	i_{enc}	--	-3.5	
Torque constant (100 K)	$k_T (100 K)$	Nm/A	9.4	
Voltage constant (at 20 °C)	k_E	V/1000 rpm	600	
Winding resistance (at 20 °C)	R_{ph}	Ω	0.62	
Rotating field inductance	L_D	mH	21	
Electrical time constant	T_{el}	ms	34.0	
Thermal time constant	T_{th}	min	4.0	
Mechanical data: Hollow-shaft version				
Mechanical time constant	T_{mech}	ms	3.4	
Moment of inertia	J_{mot}	kgm ²	0.16	
Shaft torsional stiffness	C_t	Nm/rad	2.17E+07	
Weight	m	kg	108	
Mechanical data: Solid shaft version				
Mechanical time constant	T_{mech}	ms	1.9	
Moment of inertia	J_{mot}	kgm ²	0.09	
Shaft torsional stiffness	C_t	Nm/rad	1.1E+06	
Weight	m	kg	121	
Mechanical data: Plug-on shaft version				
Mechanical time constant	T_{mech}	ms	4.2	
Moment of inertia	J_{mot}	kgm ²	0.2	
Shaft torsional stiffness	C_t	Nm/rad	2.92E+07	
Weight	m	kg	124	

The specified rated data are valid for a 600 V DC link voltage

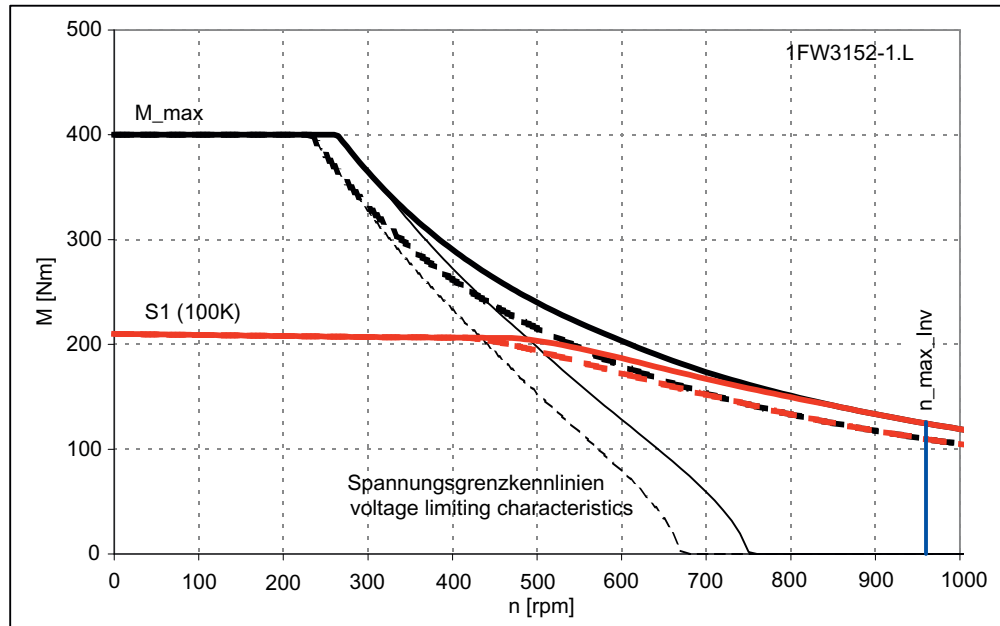

- SINAMICS ALM 400 V-Netz (Zwischenkreisspannung 600 V DC)
SINAMICS ALM 400 V line (DC-link voltage 600 V)
- - - SINAMICS BLM/SLM 400 V-Netz (Zwischenkreisspannung 540 V DC)
SINAMICS BLM/SLM 400 V line (DC-link voltage 540 V)

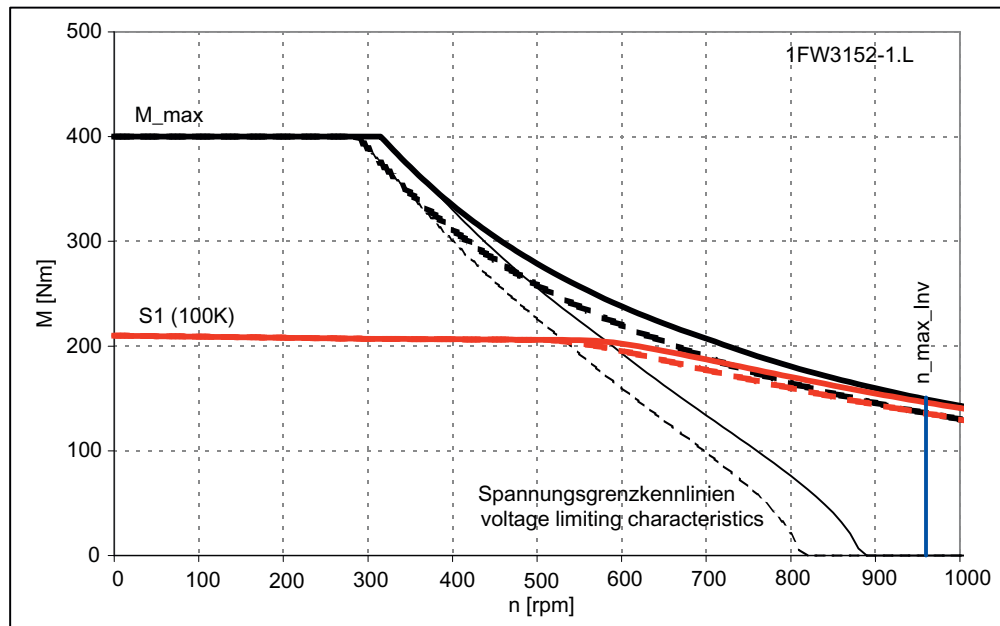

- SINAMICS ALM 480 V-Netz (Zwischenkreisspannung 720 V DC)
SINAMICS ALM 480 V line (DC-link voltage 720 V)
- - - SINAMICS BLM/SLM 480 V-Netz (Zwischenkreisspannung 650 V DC)
SINAMICS BLM/SLM 480 V line (DC-link voltage 650 V)

4.1 Torque-speed characteristic

Table 4-9 1FW3152, rated speed 750 rpm

Configuration data	Code	Unit	1FW3152-1□P
Rated speed	n_N	rpm	750
Rated torque (100 K)	$M_N (100 K)$	Nm	200
Rated power (100 K)	$P_N (100 K)$	kW	15.7
Rated current (100 K)	$I_N (100 K)$	A	32.5
Static torque (100 K)	$M_0 (100 K)$	Nm	210
Stall current (100 K)	$I_0 (100 K)$	A	33.5
Limiting data			
Max. permissible speed (mech.)	$n_{max mech.}$	rpm	1700
Max. permissible speed (converter)	$n_{max 830 V}$	rpm	1450
Maximum torque	M_{max}	Nm	400
Maximum current	I_{max}	A	79
Motor data			
Number of poles	2p		14
Ratio of speed measurement (belt-mounted encoder)	i_{enc}	--	-3.5
Torque constant (100 K)	$k_T (100 K)$	Nm/A	6.3
Voltage constant (at 20 °C)	k_E	V/1000 rpm	399
Winding resistance (at 20 °C)	R_{ph}	Ω	0.28
Rotating field inductance	L_D	mH	9.5
Electrical time constant	T_{el}	ms	33.5
Thermal time constant	T_{th}	min	4.0
Mechanical data: Hollow-shaft version			
Mechanical time constant	T_{mech}	ms	3.4
Moment of inertia	J_{mot}	kgm ²	0.16
Shaft torsional stiffness	C_t	Nm/rad	2.17E+07
Weight	m	kg	108
Mechanical data: Solid shaft version			
Mechanical time constant	T_{mech}	ms	1.9
Moment of inertia	J_{mot}	kgm ²	0.09
Shaft torsional stiffness	C_t	Nm/rad	1.1E+06
Weight	m	kg	121
Mechanical data: Plug-on shaft version			
Mechanical time constant	T_{mech}	ms	4.2
Moment of inertia	J_{mot}	kgm ²	0.2
Shaft torsional stiffness	C_t	Nm/rad	2.92E+07
Weight	m	kg	124

The specified rated data are valid for a 600 V DC link voltage

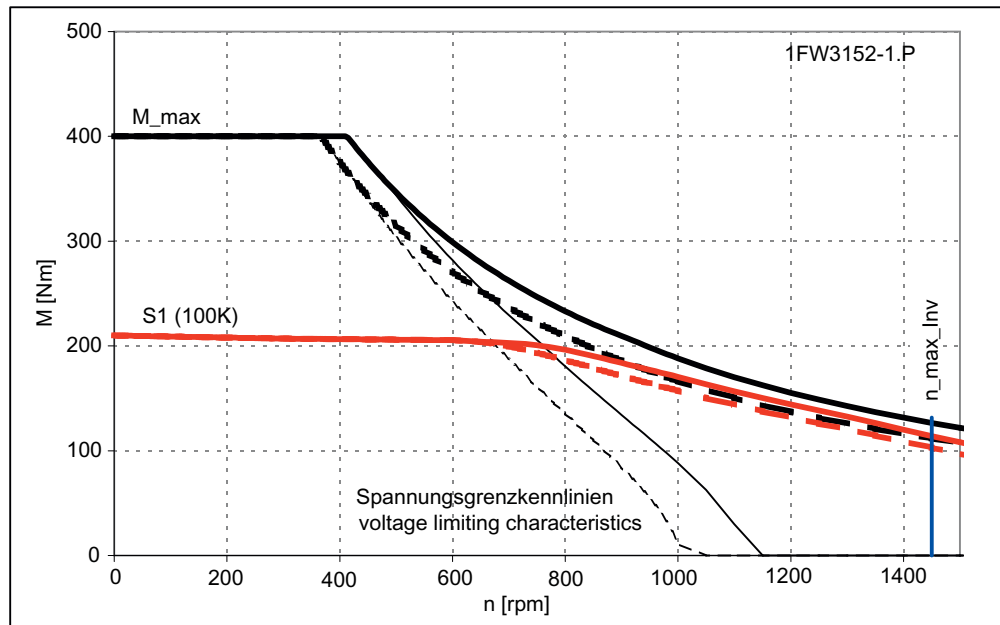

- SINAMICS ALM 400 V-Netz (Zwischenkreisspannung 600 V DC)
SINAMICS ALM 400 V line (DC-link voltage 600 V)
- - - SINAMICS BLM/SLM 400 V-Netz (Zwischenkreisspannung 540 V DC)
SINAMICS BLM/SLM 400 V line (DC-link voltage 540 V)

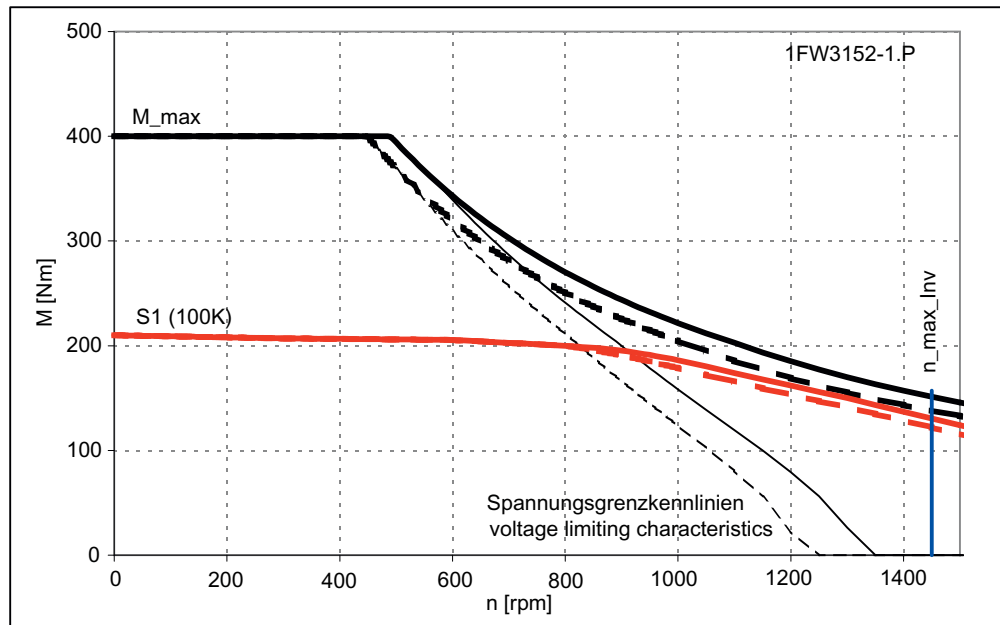

- SINAMICS ALM 480 V-Netz (Zwischenkreisspannung 720 V DC)
SINAMICS ALM 480 V line (DC-link voltage 720 V)
- - - SINAMICS BLM/SLM 480 V-Netz (Zwischenkreisspannung 650 V DC)
SINAMICS BLM/SLM 480 V line (DC-link voltage 650 V)

4.1 Torque-speed characteristic

Table 4- 10 1FW3154, rated speed 300 rpm

Configuration data	Code	Unit	1FW3154-1□H	
Rated speed	n_N	rpm	300	
Rated torque (100 K)	$M_N (100\text{ K})$	Nm	300	
Rated power (100 K)	$P_N (100\text{ K})$	kW	9.4	
Rated current (100 K)	$I_N (100\text{ K})$	A	20.5	
Static torque (100 K)	$M_0 (100\text{ K})$	Nm	315	
Stall current (100 K)	$I_0 (100\text{ K})$	A	21.5	
Limiting data				
Max. permissible speed (mech.)	$n_{\text{max mech.}}$	rpm	1700	
Max. permissible speed (converter)	$n_{\text{max 830 V}}$	rpm	610	
Maximum torque	M_{max}	Nm	600	
Maximum current	I_{max}	A	49.0	
Motor data				
Number of poles	2p		14	
Ratio of speed measurement (belt-mounted encoder)	i_{enc}	--	-3.5	
Torque constant (100 K)	$k_T (100\text{ K})$	Nm/A	14.8	
Voltage constant (at 20 °C)	k_E	V/1000 rpm	945	
Winding resistance (at 20 °C)	R_{ph}	Ω	0.92	
Rotating field inductance	L_D	mH	33	
Electrical time constant	T_{el}	ms	36.0	
Thermal time constant	T_{th}	min	4.0	
Mechanical data: Hollow-shaft version				
Mechanical time constant	T_{mech}	ms	2.5	
Moment of inertia	J_{mot}	kgm ²	0.2	
Shaft torsional stiffness	C_t	Nm/rad	1.66E+07	
Weight	m	kg	129	
Mechanical data: Solid shaft version				
Mechanical time constant	T_{mech}	ms	1.6	
Moment of inertia	J_{mot}	kgm ²	0.13	
Shaft torsional stiffness	C_t	Nm/rad	9.10E+05	
Weight	m	kg	143	
Mechanical data: Plug-on shaft version				
Mechanical time constant	T_{mech}	ms	3.2	
Moment of inertia	J_{mot}	kgm ²	0.25	
Shaft torsional stiffness	C_t	Nm/rad	2.24E+07	
Weight	m	kg	143	

The specified rated data are valid for a 600 V DC link voltage

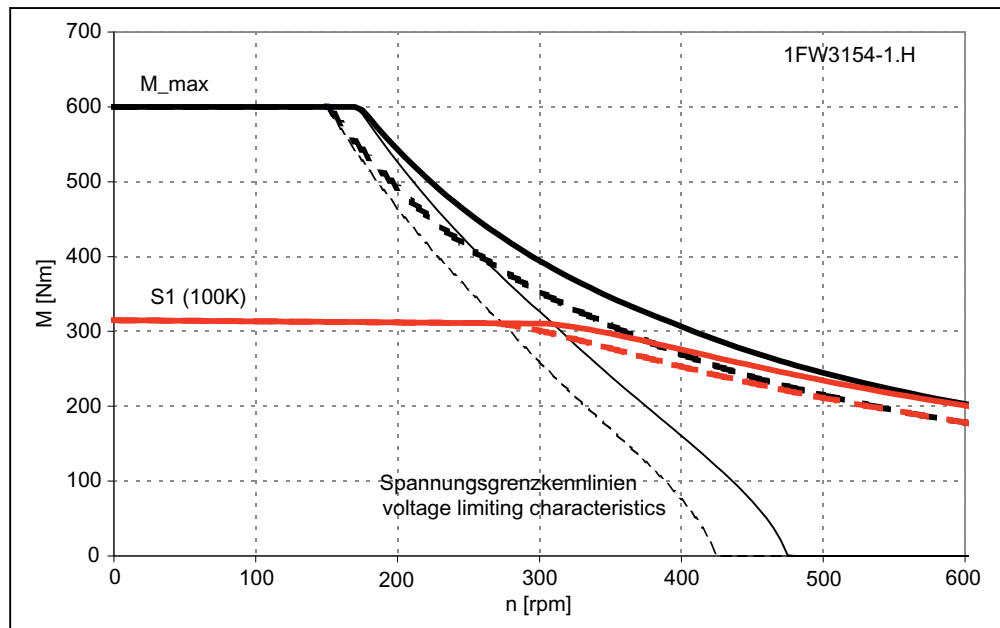

- SINAMICS ALM 400 V-Netz (Zwischenkreisspannung 600 V DC)
SINAMICS ALM 400 V line (DC-link voltage 600 V)
- - - SINAMICS BLM/SLM 400 V-Netz (Zwischenkreisspannung 540 V DC)
SINAMICS BLM/SLM 400 V line (DC-link voltage 540 V)

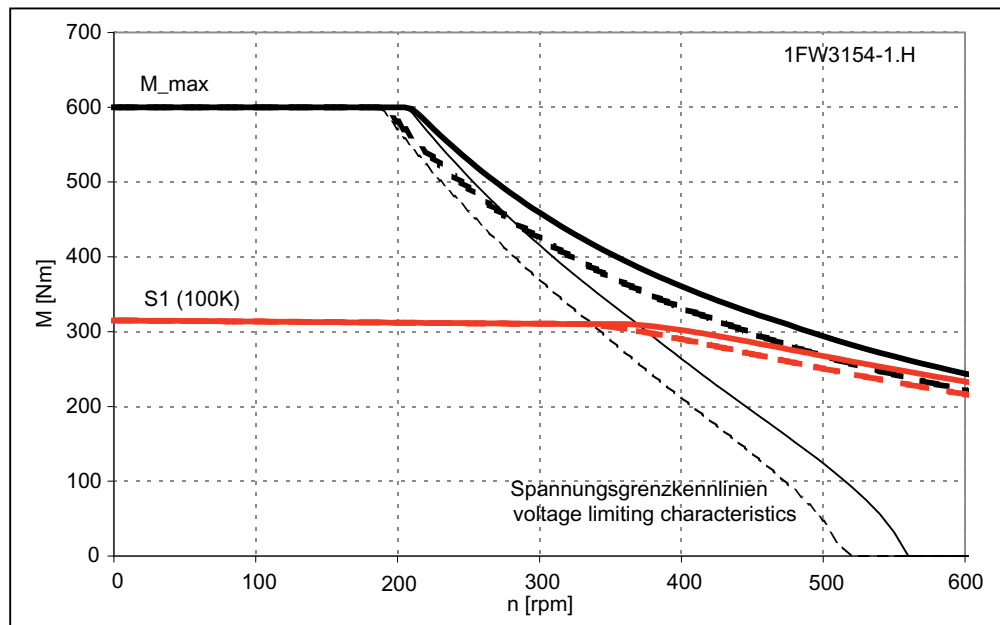

- SINAMICS ALM 480 V-Netz (Zwischenkreisspannung 720 V DC)
SINAMICS ALM 480 V line (DC-link voltage 720 V)
- - - SINAMICS BLM/SLM 480 V-Netz (Zwischenkreisspannung 650 V DC)
SINAMICS BLM/SLM 480 V line (DC-link voltage 650 V)

4.1 Torque-speed characteristic

Table 4- 11 1FW3154, rated speed 500 rpm

Configuration data	Code	Unit	1FW3154-1□L
Rated speed	n_N	rpm	500
Rated torque (100 K)	$M_N (100\text{ K})$	Nm	300
Rated power (100 K)	$P_N (100\text{ K})$	kW	15.7
Rated current (100 K)	$I_N (100\text{ K})$	A	32.0
Static torque (100 K)	$M_0 (100\text{ K})$	Nm	315
Stall current (100 K)	$I_0 (100\text{ K})$	A	33.0
Limiting data			
Max. permissible speed (mech.)	$n_{\text{max mech.}}$	rpm	1700
Max. permissible speed (converter)	$n_{\text{max 830 V}}$	rpm	950
Maximum torque	M_{max}	Nm	600
Maximum current	I_{max}	A	75
Motor data			
Number of poles	2p		14
Ratio of speed measurement (belt-mounted encoder)	i_{enc}	--	-3.5
Torque constant (100 K)	$k_T (100\text{ K})$	Nm/A	9.6
Voltage constant (at 20 °C)	k_E	V/1000 rpm	610
Winding resistance (at 20 °C)	R_{ph}	Ω	0.39
Rotating field inductance	L_D	mH	14.0
Electrical time constant	T_{el}	ms	36.0
Thermal time constant	T_{th}	min	4.0
Mechanical data: Hollow-shaft version			
Mechanical time constant	T_{mech}	ms	2.5
Moment of inertia	J_{mot}	kgm ²	0.2
Shaft torsional stiffness	C_t	Nm/rad	1.66E+07
Weight	m	kg	129
Mechanical data: Solid shaft version			
Mechanical time constant	T_{mech}	ms	1.6
Moment of inertia	J_{mot}	kgm ²	0.13
Shaft torsional stiffness	C_t	Nm/rad	9.10E+05
Weight	m	kg	143
Mechanical data: Plug-on shaft version			
Mechanical time constant	T_{mech}	ms	3.2
Moment of inertia	J_{mot}	kgm ²	0.25
Shaft torsional stiffness	C_t	Nm/rad	2.24E+07
Weight	m	kg	143

The specified rated data are valid for a 600 V DC link voltage

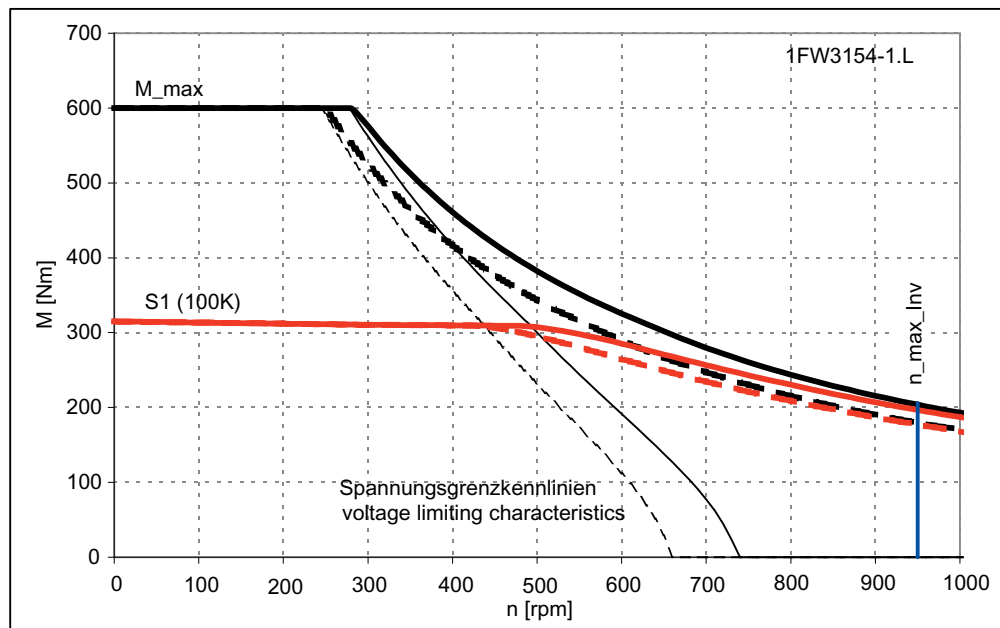

- SINAMICS ALM 400 V-Netz (Zwischenkreisspannung 600 V DC)
SINAMICS ALM 400 V line (DC-link voltage 600 V)
- - - SINAMICS BLM/SLM 400 V-Netz (Zwischenkreisspannung 540 V DC)
SINAMICS BLM/SLM 400 V line (DC-link voltage 540 V)

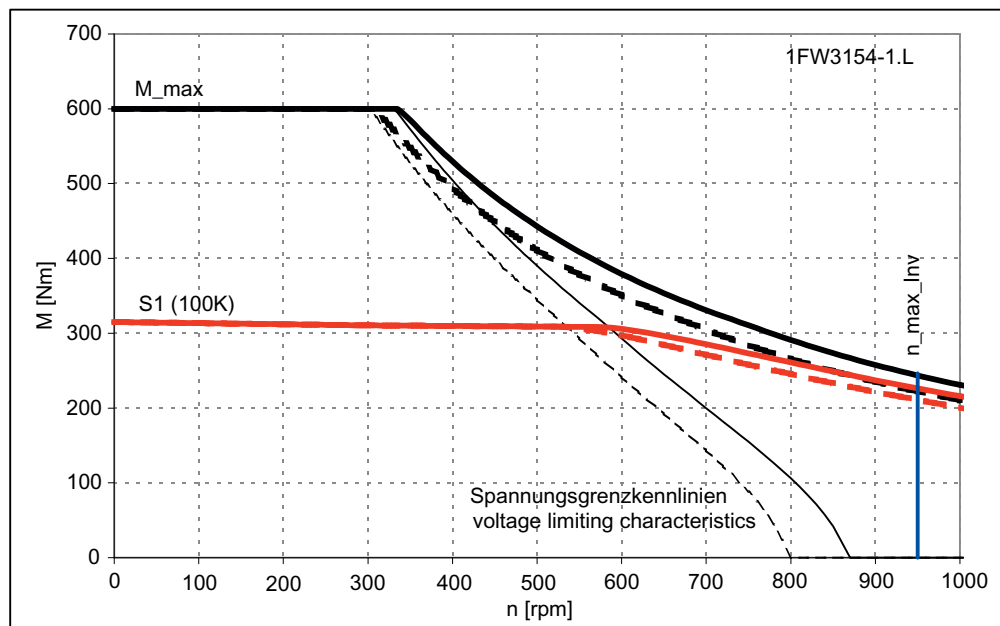

- SINAMICS ALM 480 V-Netz (Zwischenkreisspannung 720 V DC)
SINAMICS ALM 480 V line (DC-link voltage 720 V)
- - - SINAMICS BLM/SLM 480 V-Netz (Zwischenkreisspannung 650 V DC)
SINAMICS BLM/SLM 480 V line (DC-link voltage 650 V)

4.1 Torque-speed characteristic

Table 4- 12 1FW3154, rated speed 750 rpm

Configuration data	Code	Unit	1FW3154-1□P	
Rated speed	n_N	rpm	750	
Rated torque (100 K)	$M_N (100\text{ K})$	Nm	300	
Rated power (100 K)	$P_N (100\text{ K})$	kW	23.5	
Rated current (100 K)	$I_N (100\text{ K})$	A	47.5	
Static torque (100 K)	$M_0 (100\text{ K})$	Nm	315	
Stall current (100 K)	$I_0 (100\text{ K})$	A	49.0	
Limiting data				
Max. permissible speed (mech.)	$n_{\text{max mech.}}$	rpm	1700	
Max. permissible speed (converter)	$n_{\text{max 830 V}}$	rpm	1420	
Maximum torque	M_{max}	Nm	600	
Maximum current	I_{max}	A	113	
Motor data				
Number of poles	2p		14	
Ratio of speed measurement (belt-mounted encoder)	i_{enc}	--	-3.5	
Torque constant (100 K)	$k_T (100\text{ K})$	Nm/A	6.4	
Voltage constant (at 20 °C)	k_E	V/1000 rpm	407	
Winding resistance (at 20 °C)	R_{ph}	Ω	0.171	
Rotating field inductance	L_D	mH	6.0	
Electrical time constant	T_{el}	ms	35.5	
Thermal time constant	T_{th}	min	4.0	
Mechanical data: Hollow-shaft version				
Mechanical time constant	T_{mech}	ms	2.5	
Moment of inertia	J_{mot}	kgm ²	0.2	
Shaft torsional stiffness	C_t	Nm/rad	1.66E+07	
Weight	m	kg	129	
Mechanical data: Solid shaft version				
Mechanical time constant	T_{mech}	ms	1.6	
Moment of inertia	J_{mot}	kgm ²	0.13	
Shaft torsional stiffness	C_t	Nm/rad	9.10E+05	
Weight	m	kg	143	
Mechanical data: Plug-on shaft version				
Mechanical time constant	T_{mech}	ms	3.2	
Moment of inertia	J_{mot}	kgm ²	0.25	
Shaft torsional stiffness	C_t	Nm/rad	2.24E+07	
Weight	m	kg	143	

The specified rated data are valid for a 600 V DC link voltage

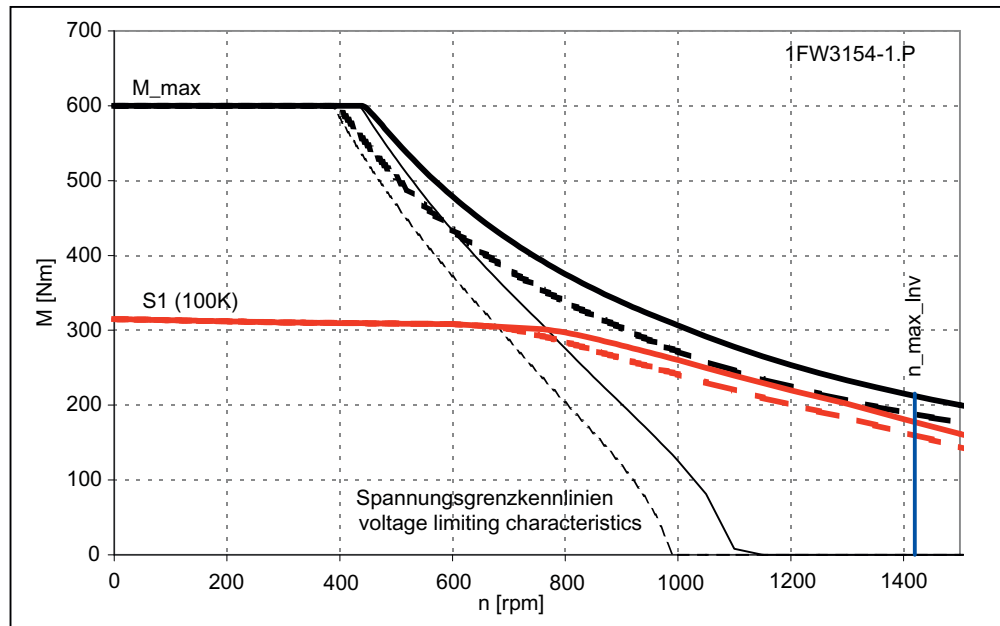

- SINAMICS ALM 400 V-Netz (Zwischenkreisspannung 600 V DC)
SINAMICS ALM 400 V line (DC-link voltage 600 V)
- - - SINAMICS BLM/SLM 400 V-Netz (Zwischenkreisspannung 540 V DC)
SINAMICS BLM/SLM 400 V line (DC-link voltage 540 V)

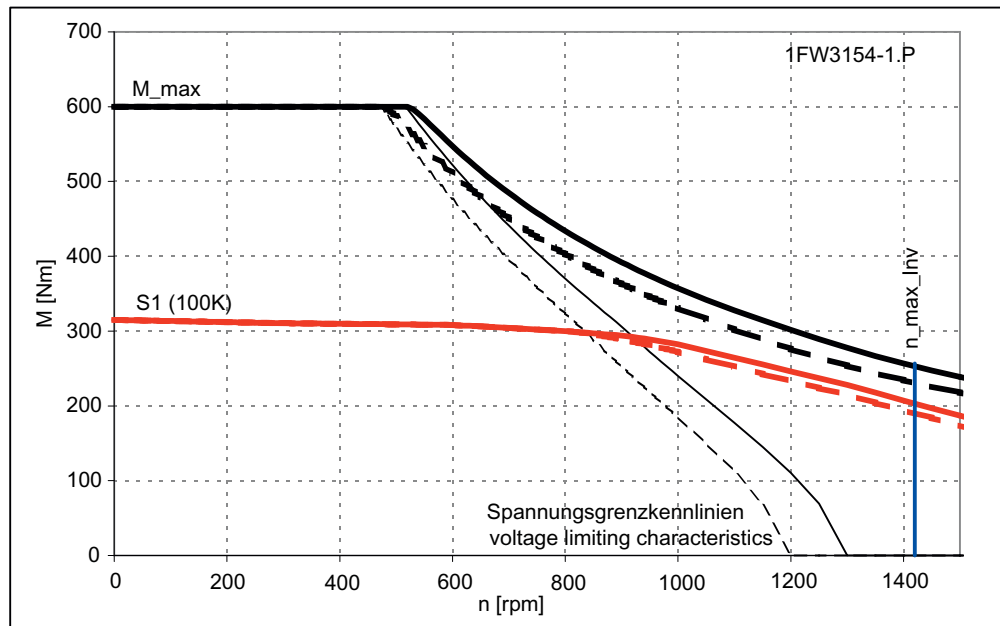

- SINAMICS ALM 480 V-Netz (Zwischenkreisspannung 720 V DC)
SINAMICS ALM 480 V line (DC-link voltage 720 V)
- - - SINAMICS BLM/SLM 480 V-Netz (Zwischenkreisspannung 650 V DC)
SINAMICS BLM/SLM 480 V line (DC-link voltage 650 V)

4.1 Torque-speed characteristic

Table 4- 13 1FW3155, rated speed 300 rpm

Configuration data	Code	Unit	1FW3155-1□H
Rated speed	n_N	rpm	300
Rated torque (100 K)	$M_N (100 K)$	Nm	400
Rated power (100 K)	$P_N (100 K)$	kW	12.6
Rated current (100 K)	$I_N (100 K)$	A	28.0
Static torque (100 K)	$M_0 (100 K)$	Nm	420
Stall current (100 K)	$I_0 (100 K)$	A	29.0
Limiting data			
Max. permissible speed (mech.)	$n_{max mech.}$	rpm	1700
Max. permissible speed (converter)	$n_{max 830 V}$	rpm	630
Maximum torque	M_{max}	Nm	800
Maximum current	I_{max}	A	67
Motor data			
Number of poles	2p		14
Ratio of speed measurement (belt-mounted encoder)	i_{enc}	--	-3.5
Torque constant (100 K)	k_T	Nm/A	14.4
Voltage constant (at 20 °C)	k_E	V/1000 rpm	915
Winding resistance (at 20 °C)	R_{ph}	Ω	0.61
Rotating field inductance	L_D	mH	24
Electrical time constant	T_{el}	ms	39.0
Thermal time constant	T_{th}	min	4.0
Mechanical data: Hollow-shaft version			
Mechanical time constant	T_{mech}	ms	2.1
Moment of inertia	J_{mot}	kgm ²	0.24
Shaft torsional stiffness	C_t	Nm/rad	1.40E+07
Weight	m	kg	150
Mechanical data: Solid shaft version			
Mechanical time constant	T_{mech}	ms	1.5
Moment of inertia	J_{mot}	kgm ²	0.17
Shaft torsional stiffness	C_t	Nm/rad	8.30E+05
Weight	m	kg	164
Mechanical data: Plug-on shaft version			
Mechanical time constant	T_{mech}	ms	2.6
Moment of inertia	J_{mot}	kgm ²	0.29
Shaft torsional stiffness	C_t	Nm/rad	1.84E+07
Weight	m	kg	163

The specified rated data are valid for a 600 V DC link voltage

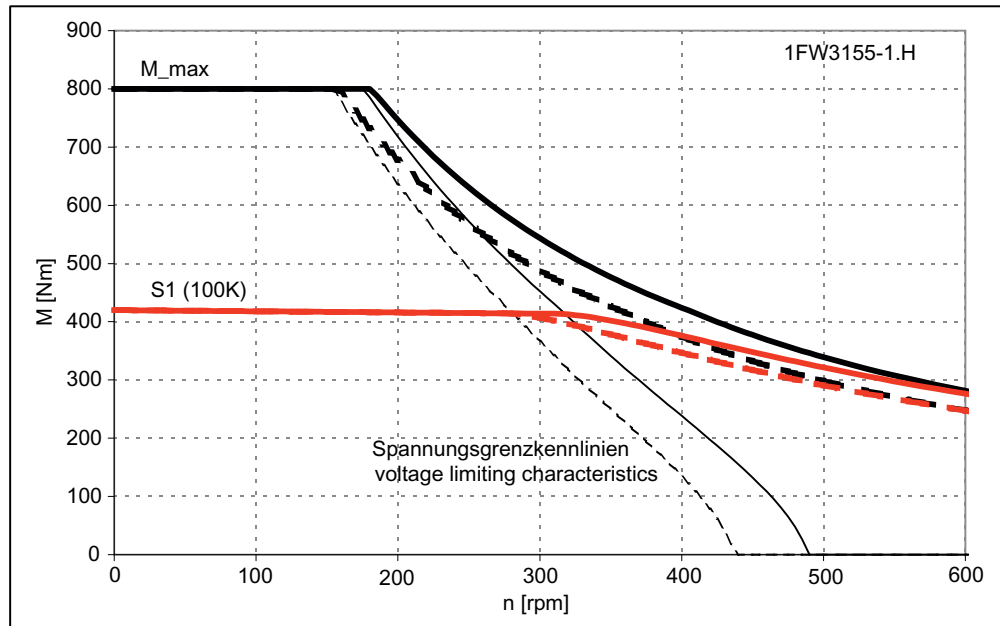

- SINAMICS ALM 400 V-Netz (Zwischenkreisspannung 600 V DC)
SINAMICS ALM 400 V line (DC-link voltage 600 V)
- - - SINAMICS BLM/SLM 400 V-Netz (Zwischenkreisspannung 540 V DC)
SINAMICS BLM/SLM 400 V line (DC-link voltage 540 V)

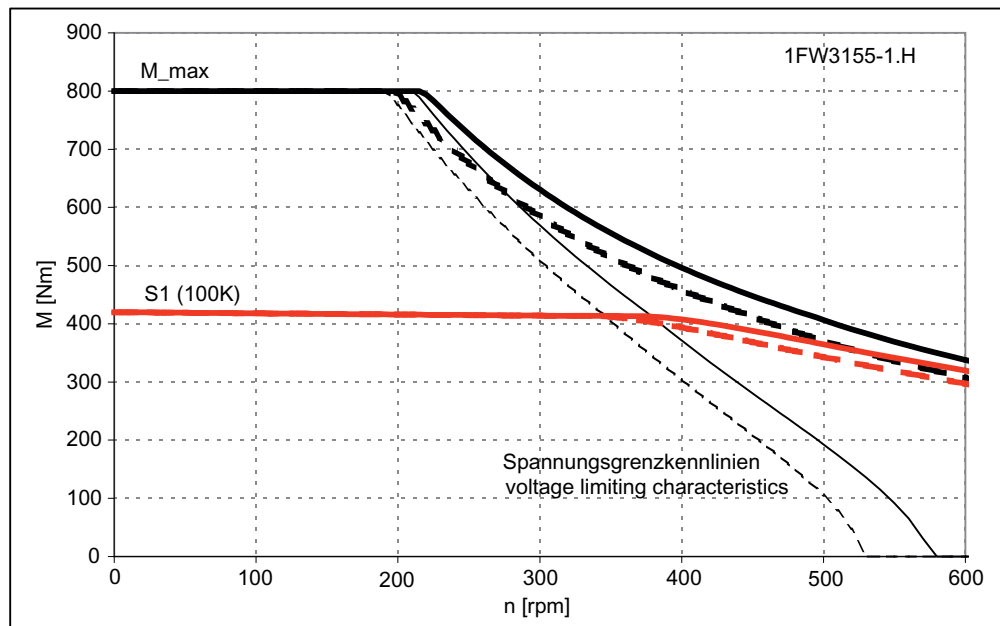

- SINAMICS ALM 480 V-Netz (Zwischenkreisspannung 720 V DC)
SINAMICS ALM 480 V line (DC-link voltage 720 V)
- - - SINAMICS BLM/SLM 480 V-Netz (Zwischenkreisspannung 650 V DC)
SINAMICS BLM/SLM 480 V line (DC-link voltage 650 V)

4.1 Torque-speed characteristic

Table 4- 14 1FW3155, rated speed 500 rpm

Configuration data	Code	Unit	1FW3155-1□L	
Rated speed	n_N	rpm	500	
Rated torque (100 K)	$M_N (100\text{ K})$	Nm	400	
Rated power (100 K)	$P_N (100\text{ K})$	kW	21.0	
Rated current (100 K)	$I_N (100\text{ K})$	A	43.0	
Static torque (100 K)	$M_0 (100\text{ K})$	Nm	420	
Stall current (100 K)	$I_0 (100\text{ K})$	A	45.0	
Limiting data				
Max. permissible speed (mech.)	$n_{\text{max mech.}}$	rpm	1700	
Max. permissible speed (converter)	$n_{\text{max 830 V}}$	rpm	960	
Maximum torque	M_{max}	Nm	800	
Maximum current	I_{max}	A	103	
Motor data				
Number of poles	2p		14	
Ratio of speed measurement (belt-mounted encoder)	i_{enc}	--	-3.5	
Torque constant (100 K)	k_T	Nm/A	9.4	
Voltage constant (at 20 °C)	k_E	V/1000 rpm	600	
Winding resistance (at 20 °C)	R_{ph}	Ω	0.265	
Rotating field inductance	L_D	mH	10.0	
Electrical time constant	T_{el}	ms	38.0	
Thermal time constant	T_{th}	min	4.0	
Mechanical data: Hollow-shaft version				
Mechanical time constant	T_{mech}	ms	2.2	
Moment of inertia	J_{mot}	kgm ²	0.24	
Shaft torsional stiffness	C_t	Nm/rad	1.40E+07	
Weight	m	kg	150	
Mechanical data: Solid shaft version				
Mechanical time constant	T_{mech}	ms	1.5	
Moment of inertia	J_{mot}	kgm ²	0.17	
Shaft torsional stiffness	C_t	Nm/rad	8.30E+05	
Weight	m	kg	164	
Mechanical data: Plug-on shaft version				
Mechanical time constant	T_{mech}	ms	2.6	
Moment of inertia	J_{mot}	kgm ²	0.29	
Shaft torsional stiffness	C_t	Nm/rad	1.84E+07	
Weight	m	kg	163	

The specified rated data are valid for a 600 V DC link voltage

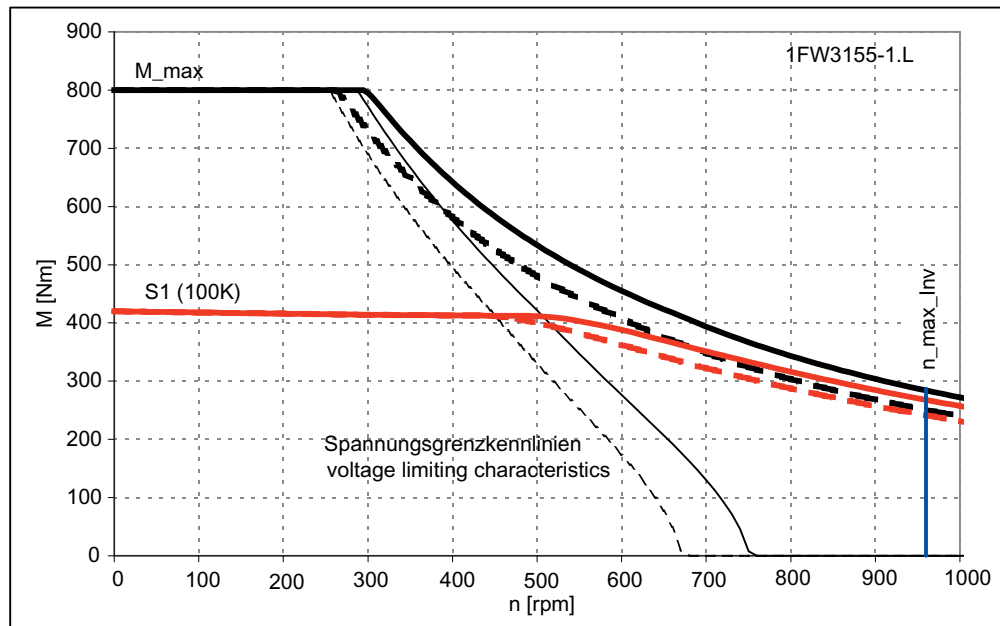

- SINAMICS ALM 400 V-Netz (Zwischenkreisspannung 600 V DC)
SINAMICS ALM 400 V line (DC-link voltage 600 V)
- - - SINAMICS BLM/SLM 400 V-Netz (Zwischenkreisspannung 540 V DC)
SINAMICS BLM/SLM 400 V line (DC-link voltage 540 V)

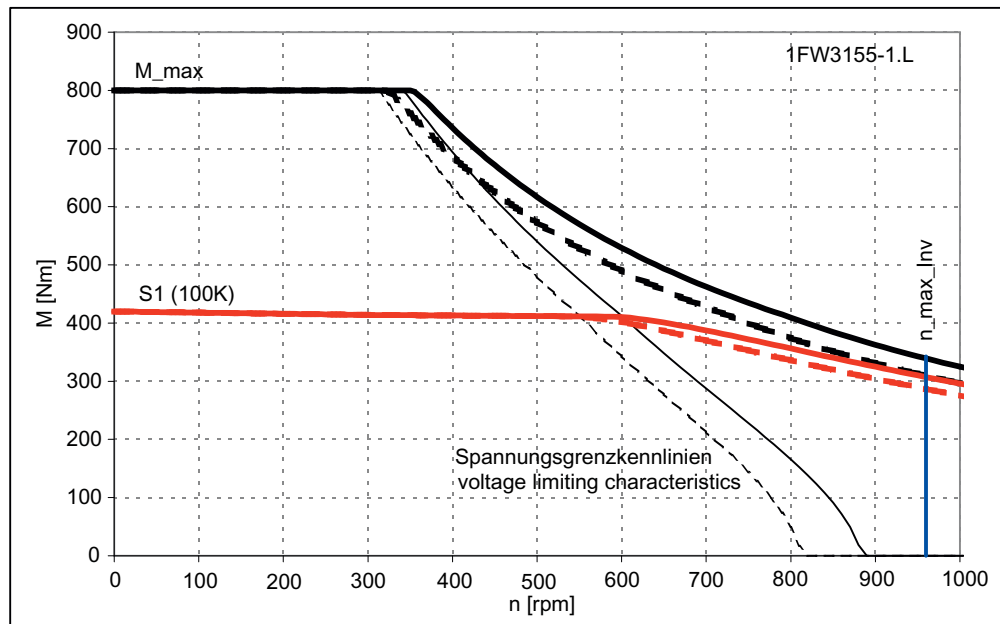

- SINAMICS ALM 480 V-Netz (Zwischenkreisspannung 720 V DC)
SINAMICS ALM 480 V line (DC-link voltage 720 V)
- - - SINAMICS BLM/SLM 480 V-Netz (Zwischenkreisspannung 650 V DC)
SINAMICS BLM/SLM 480 V line (DC-link voltage 650 V)

4.1 Torque-speed characteristic

Table 4- 15 1FW3155, rated speed 750 rpm

Configuration data	Code	Unit	1FW3155-1□P
Rated speed	n_N	rpm	750
Rated torque (100 K)	$M_N (100\text{ K})$	Nm	400
Rated power (100 K)	$P_N (100\text{ K})$	kW	31.5
Rated current (100 K)	$I_N (100\text{ K})$	A	64
Static torque (100 K)	$M_0 (100\text{ K})$	Nm	420
Stall current (100 K)	$I_0 (100\text{ K})$	A	67
Limiting data			
Max. permissible speed (mech.)	$n_{\text{max mech.}}$	rpm	1700
Max. permissible speed (converter)	$n_{\text{max 830 V}}$	rpm	1450
Maximum torque	M_{max}	Nm	800
Maximum current	I_{max}	A	153
Motor data			
Number of poles	2p		14
Ratio of speed measurement (belt-mounted encoder)	i_{enc}	--	-3.5
Torque constant (100 K)	k_T	Nm/A	6.3
Voltage constant (at 20 °C)	k_E	V/1000 rpm	399
Winding resistance (at 20 °C)	R_{ph}	Ω	0.112
Rotating field inductance	L_D	mH	4.4
Electrical time constant	T_{el}	ms	39.5
Thermal time constant	T_{th}	min	4.0
Mechanical data: Hollow-shaft version			
Mechanical time constant	T_{mech}	ms	2.0
Moment of inertia	J_{mot}	kgm ²	0.24
Shaft torsional stiffness	C_t	Nm/rad	1.40E+07
Weight	m	kg	150
Mechanical data: Solid shaft version			
Mechanical time constant	T_{mech}	ms	1.4
Moment of inertia	J_{mot}	kgm ²	0.17
Shaft torsional stiffness	C_t	Nm/rad	8.30E+05
Weight	m	kg	164
Mechanical data: Plug-on shaft version			
Mechanical time constant	T_{mech}	ms	2.5
Moment of inertia	J_{mot}	kgm ²	0.29
Shaft torsional stiffness	C_t	Nm/rad	1.84E+07
Weight	m	kg	163

The specified rated data are valid for a 600 V DC link voltage

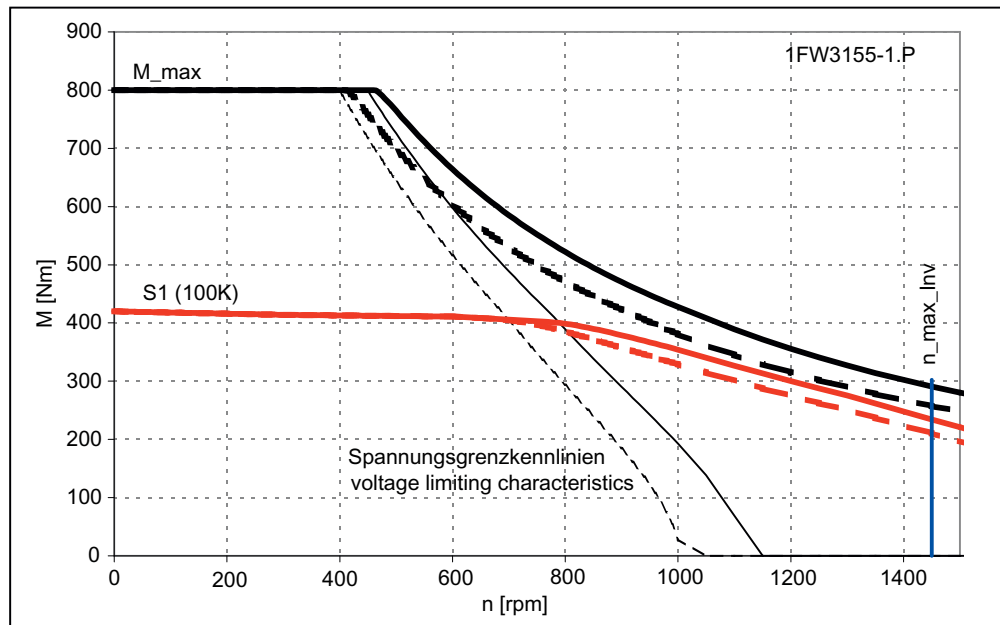

- SINAMICS ALM 400 V-Netz (Zwischenkreisspannung 600 V DC)
SINAMICS ALM 400 V line (DC-link voltage 600 V)
- - - SINAMICS BLM/SLM 400 V-Netz (Zwischenkreisspannung 540 V DC)
SINAMICS BLM/SLM 400 V line (DC-link voltage 540 V)

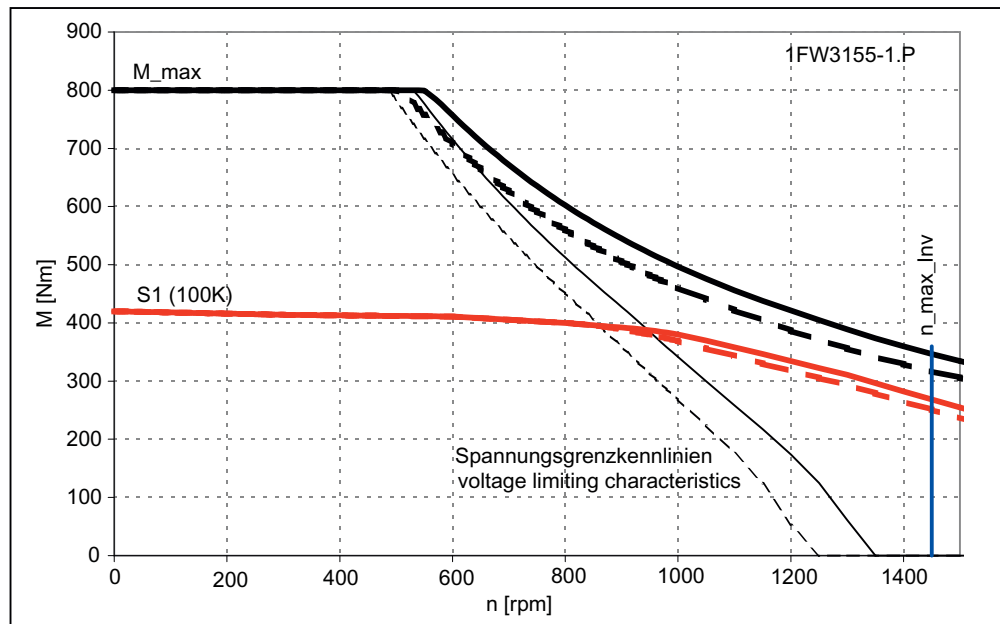

- SINAMICS ALM 480 V-Netz (Zwischenkreisspannung 720 V DC)
SINAMICS ALM 480 V line (DC-link voltage 720 V)
- - - SINAMICS BLM/SLM 480 V-Netz (Zwischenkreisspannung 650 V DC)
SINAMICS BLM/SLM 480 V line (DC-link voltage 650 V)

4.1 Torque-speed characteristic

Table 4- 16 1FW3156, rated speed 300 rpm

Configuration data	Code	Unit	1FW3156-1□H	
Rated speed	n_N	rpm	300	
Rated torque (100 K)	$M_N (100\text{ K})$	Nm	500	
Rated power (100 K)	$P_N (100\text{ K})$	kW	15.7	
Rated current (100 K)	$I_N (100\text{ K})$	A	34.0	
Static torque (100 K)	$M_0 (100\text{ K})$	Nm	525	
Stall current (100 K)	$I_0 (100\text{ K})$	A	35.0	
Limiting data				
Max. permissible speed (mech.)	$n_{\text{max mech.}}$	rpm	1700	
Max. permissible speed (converter)	$n_{\text{max 830 V}}$	rpm	610	
Maximum torque	M_{max}	Nm	1000	
Maximum current	I_{max}	A	81	
Motor data				
Number of poles	2p		14	
Ratio of speed measurement (belt-mounted encoder)	i_{enc}	--	-3.5	
Torque constant (100 K)	$k_T (100\text{ K})$	Nm/A	14.9	
Voltage constant (at 20 °C)	k_E	V/1000 rpm	945	
Winding resistance (at 20 °C)	R_{ph}	Ω	0.5	
Rotating field inductance	L_D	mH	20	
Electrical time constant	T_{el}	ms	39.5	
Thermal time constant	T_{th}	min	5.0	
Mechanical data: Hollow-shaft version				
Mechanical time constant	T_{mech}	ms	1.9	
Moment of inertia	J_{mot}	kgm ²	0.28	
Shaft torsional stiffness	C_t	Nm/rad	1.13E+07	
Weight	m	kg	171	
Mechanical data: Solid shaft version				
Mechanical time constant	T_{mech}	ms	1.4	
Moment of inertia	J_{mot}	kgm ²	0.2	
Shaft torsional stiffness	C_t	Nm/rad	7.60E+05	
Weight	m	kg	187	
Mechanical data: Plug-on shaft version				
Mechanical time constant	T_{mech}	ms	2.3	
Moment of inertia	J_{mot}	kgm ²	0.34	
Shaft torsional stiffness	C_t	Nm/rad	1.55E+07	
Weight	m	kg	184	

The specified rated data are valid for a 600 V DC link voltage

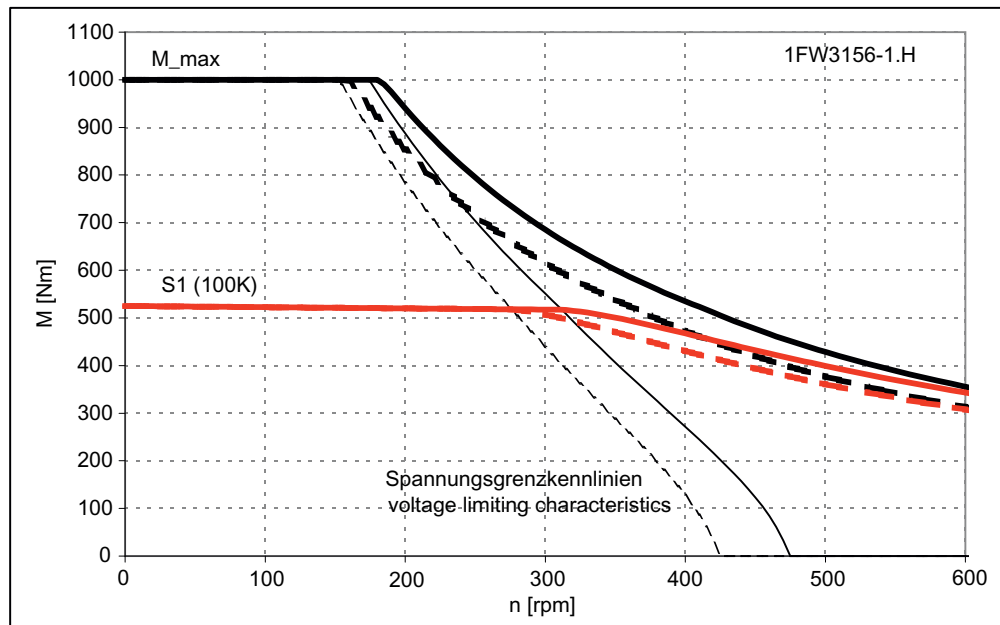

- SINAMICS ALM 400 V-Netz (Zwischenkreisspannung 600 V DC)
SINAMICS ALM 400 V line (DC-link voltage 600 V)
- - - SINAMICS BLM/SLM 400 V-Netz (Zwischenkreisspannung 540 V DC)
SINAMICS BLM/SLM 400 V line (DC-link voltage 540 V)

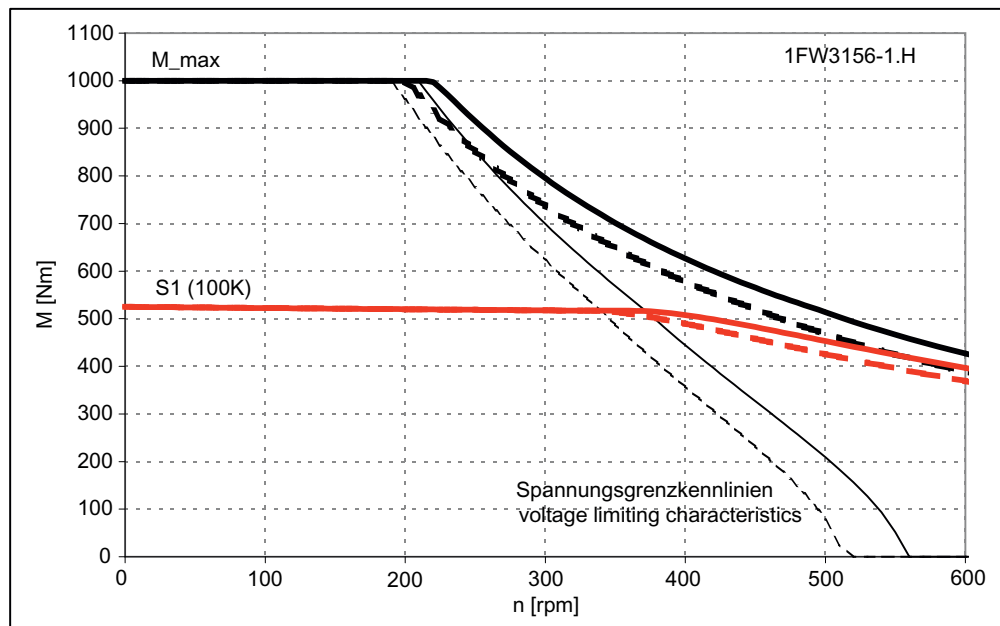

- SINAMICS ALM 480 V-Netz (Zwischenkreisspannung 720 V DC)
SINAMICS ALM 480 V line (DC-link voltage 720 V)
- - - SINAMICS BLM/SLM 480 V-Netz (Zwischenkreisspannung 650 V DC)
SINAMICS BLM/SLM 480 V line (DC-link voltage 650 V)

4.1 Torque-speed characteristic

Table 4- 17 1FW3156, rated speed 500 rpm

Configuration data	Code	Unit	1FW3156-1□L	
Rated speed	n_N	rpm	500	
Rated torque (100 K)	$M_N (100\text{ K})$	Nm	500	
Rated power (100 K)	$P_N (100\text{ K})$	kW	26.0	
Rated current (100 K)	$I_N (100\text{ K})$	A	53	
Static torque (100 K)	$M_0 (100\text{ K})$	Nm	525	
Stall current (100 K)	$I_0 (100\text{ K})$	A	55	
Limiting data				
Max. permissible speed (mech.)	$n_{\text{max mech.}}$	rpm	1700	
Max. permissible speed (converter)	$n_{\text{max 830 V}}$	rpm	950	
Maximum torque	M_{max}	Nm	1000	
Maximum current	I_{max}	A	126	
Motor data				
Number of poles	2p		14	
Ratio of speed measurement (belt-mounted encoder)	i_{enc}	--	-3.5	
Torque constant (100 K)	$k_T (100\text{ K})$	Nm/A	9.6	
Voltage constant (at 20 °C)	k_E	V/1000 rpm	610	
Winding resistance (at 20 °C)	R_{ph}	Ω	0.215	
Rotating field inductance	L_D	mH	8.5	
Electrical time constant	T_{el}	ms	40.0	
Thermal time constant	T_{th}	min	5.0	
Mechanical data: Hollow-shaft version				
Mechanical time constant	T_{mech}	ms	1.9	
Moment of inertia	J_{mot}	kgm ²	0.28	
Shaft torsional stiffness	C_t	Nm/rad	1.13E+07	
Weight	m	kg	171	
Mechanical data: Solid shaft version				
Mechanical time constant	T_{mech}	ms	1.4	
Moment of inertia	J_{mot}	kgm ²	0.2	
Shaft torsional stiffness	C_t	Nm/rad	7.60E+05	
Weight	m	kg	187	
Mechanical data: Plug-on shaft version				
Mechanical time constant	T_{mech}	ms	2.4	
Moment of inertia	J_{mot}	kgm ²	0.34	
Shaft torsional stiffness	C_t	Nm/rad	1.55E+07	
Weight	m	kg	184	

The specified rated data are valid for a 600 V DC link voltage

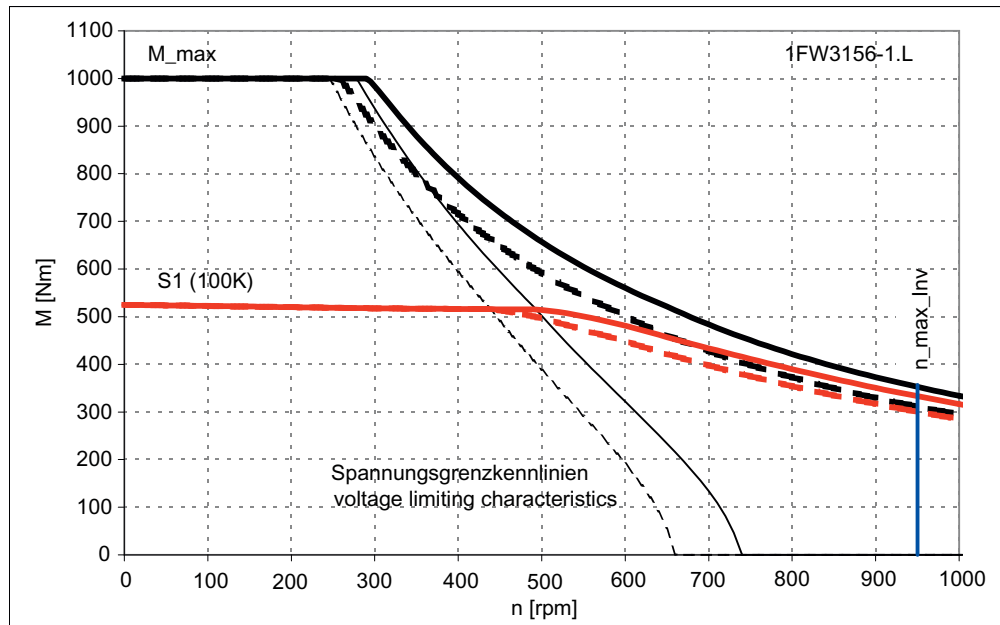

- SINAMICS ALM 400 V-Netz (Zwischenkreisspannung 600 V DC)
SINAMICS ALM 400 V line (DC-link voltage 600 V)
- - - SINAMICS BLM/SLM 400 V-Netz (Zwischenkreisspannung 540 V DC)
SINAMICS BLM/SLM 400 V line (DC-link voltage 540 V)

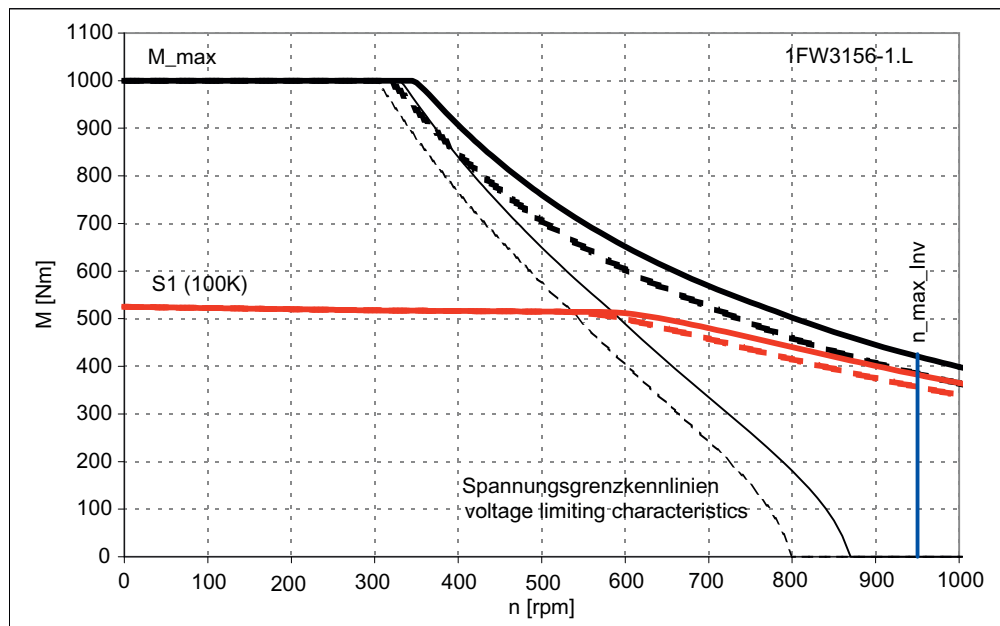

- SINAMICS ALM 480 V-Netz (Zwischenkreisspannung 720 V DC)
SINAMICS ALM 480 V line (DC-link voltage 720 V)
- - - SINAMICS BLM/SLM 480 V-Netz (Zwischenkreisspannung 650 V DC)
SINAMICS BLM/SLM 480 V line (DC-link voltage 650 V)

4.1 Torque-speed characteristic

Table 4- 18 1FW3156, rated speed 750 rpm

Configuration data	Code	Unit	1FW3156-1□P	
Rated speed	n_N	rpm	750	
Rated torque (100 K)	$M_N (100\text{ K})$	Nm	500	
Rated power (100 K)	$P_N (100\text{ K})$	kW	39.5	
Rated current (100 K)	$I_N (100\text{ K})$	A	76	
Static torque (100 K)	$M_0 (100\text{ K})$	Nm	525	
Stall current (100 K)	$I_0 (100\text{ K})$	A	80	
Limiting data				
Max. permissible speed (mech.)	$n_{\text{max mech.}}$	rpm	1700	
Max. permissible speed (converter)	$n_{\text{max 830 V}}$	rpm	1380	
Maximum torque	M_{max}	Nm	1000	
Maximum current	I_{max}	A	183	
Motor data				
Number of poles	2p		14	
Ratio of speed measurement (belt-mounted encoder)	i_{enc}	--	-3.5	
Torque constant (100 K)	$k_T (100\text{ K})$	Nm/A	6.6	
Voltage constant (at 20 °C)	k_E	V/1000 rpm	419	
Winding resistance (at 20 °C)	R_{ph}	Ω	0.098	
Rotating field inductance	L_D	mH	3.9	
Electrical time constant	T_{el}	ms	40.0	
Thermal time constant	T_{th}	min	5.0	
Mechanical data: Hollow-shaft version				
Mechanical time constant	T_{mech}	ms	1.9	
Moment of inertia	J_{mot}	kgm ²	0.28	
Shaft torsional stiffness	C_t	Nm/rad	1.13E+07	
Weight	m	kg	171	
Mechanical data: Solid shaft version				
Mechanical time constant	T_{mech}	ms	1.3	
Moment of inertia	J_{mot}	kgm ²	0.2	
Shaft torsional stiffness	C_t	Nm/rad	7.60E+05	
Weight	m	kg	187	
Mechanical data: Plug-on shaft version				
Mechanical time constant	T_{mech}	ms	2.3	
Moment of inertia	J_{mot}	kgm ²	0.34	
Shaft torsional stiffness	C_t	Nm/rad	1.55E+07	
Weight	m	kg	184	

The specified rated data are valid for a 600 V DC link voltage

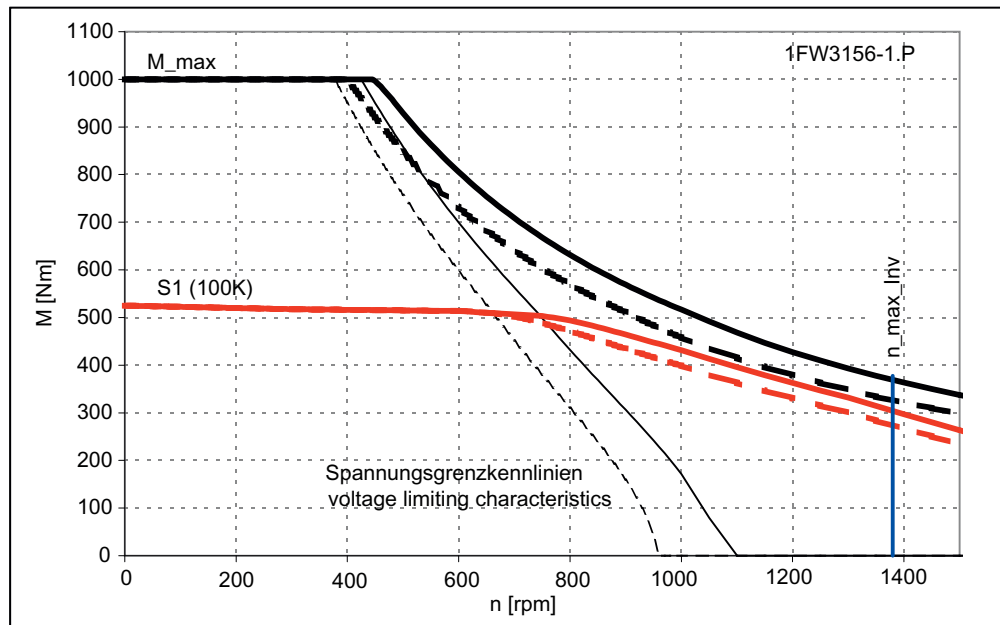

- SINAMICS ALM 400 V-Netz (Zwischenkreisspannung 600 V DC)
SINAMICS ALM 400 V line (DC-link voltage 600 V)
- - - SINAMICS BLM/SLM 400 V-Netz (Zwischenkreisspannung 540 V DC)
SINAMICS BLM/SLM 400 V line (DC-link voltage 540 V)

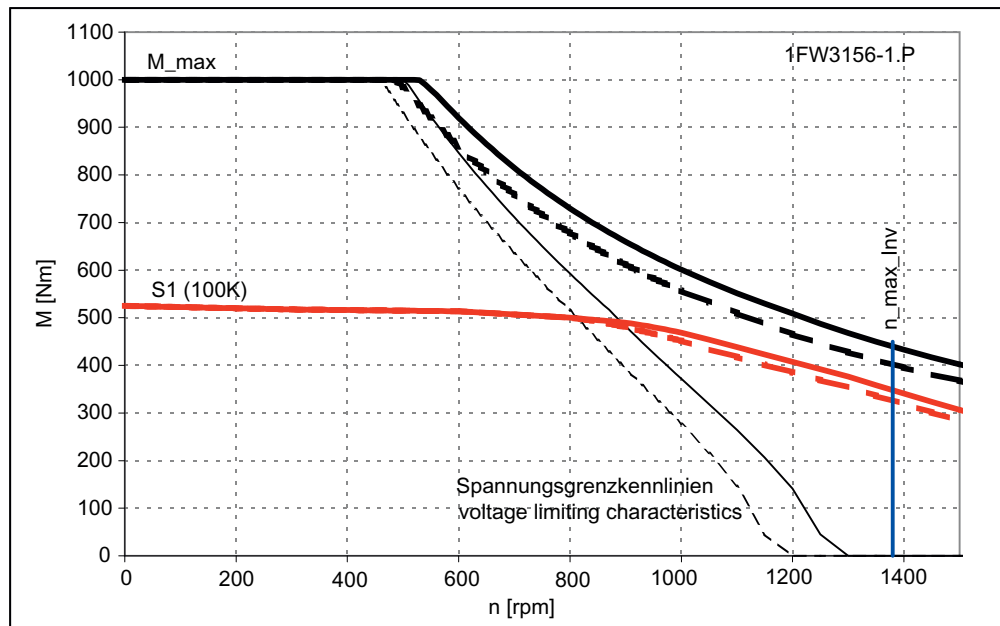

- SINAMICS ALM 480 V-Netz (Zwischenkreisspannung 720 V DC)
SINAMICS ALM 480 V line (DC-link voltage 720 V)
- - - SINAMICS BLM/SLM 480 V-Netz (Zwischenkreisspannung 650 V DC)
SINAMICS BLM/SLM 480 V line (DC-link voltage 650 V)

4.1 Torque-speed characteristic

4.1.2 Shaft height 200

Table 4- 19 1FW3201, rated speed 150 rpm

Configuration data	Code	Unit	1FW3201-1□E
Rated speed	n_N	rpm	150
Rated torque (100 K)	$M_N (100\text{ K})$	Nm	300
Rated power (100 K)	$P_N (100\text{ K})$	kW	4.7
Rated current (100 K)	$I_N (100\text{ K})$	A	13.0
Static torque (100 K)	$M_0 (100\text{ K})$	Nm	315
Stall current (100 K)	$I_0 (100\text{ K})$	A	13.0
Limiting data			
Max. permissible speed (mech.)	$n_{\text{max mech.}}$	rpm	1000
Max. permissible speed (converter)	$n_{\text{max 630 V}}$	rpm	380
Maximum torque	M_{max}	Nm	555
Maximum current	I_{max}	A	28.0
Motor data			
Number of poles	2p		28
Ratio of speed measurement (belt-mounted encoder)	i_{enc}	--	-3.5
Torque constant (100 K)	$k_T (100\text{ K})$	Nm/A	24.0
Voltage constant (at 20 °C)	k_E	V/1000 rpm	1520
Winding resistance (at 20 °C)	R_{ph}	Ω	1.89
Rotating field inductance	L_D	mH	50
Electrical time constant	T_{el}	ms	27.0
Thermal time constant	T_{th}	min	10.0
Mechanical data: Hollow-shaft version			
Mechanical time constant	T_{mech}	ms	2.2
Moment of inertia	J_{mot}	kgm ²	0.22
Shaft torsional stiffness	c_t	Nm/rad	3.73E+07
Weight	m	kg	127
Mechanical data: Solid shaft version			
Mechanical time constant	T_{mech}	ms	2.3
Moment of inertia	J_{mot}	kgm ²	0.23
Shaft torsional stiffness	c_t	Nm/rad	3.48E+06
Weight	m	kg	179
Mechanical data: Plug-on shaft version			
Mechanical time constant	T_{mech}	ms	2.7
Moment of inertia	J_{mot}	kgm ²	0.27
Shaft torsional stiffness	c_t	Nm/rad	4.90E+07
Weight	m	kg	171

The specified rated data are valid for a 600 V DC link voltage

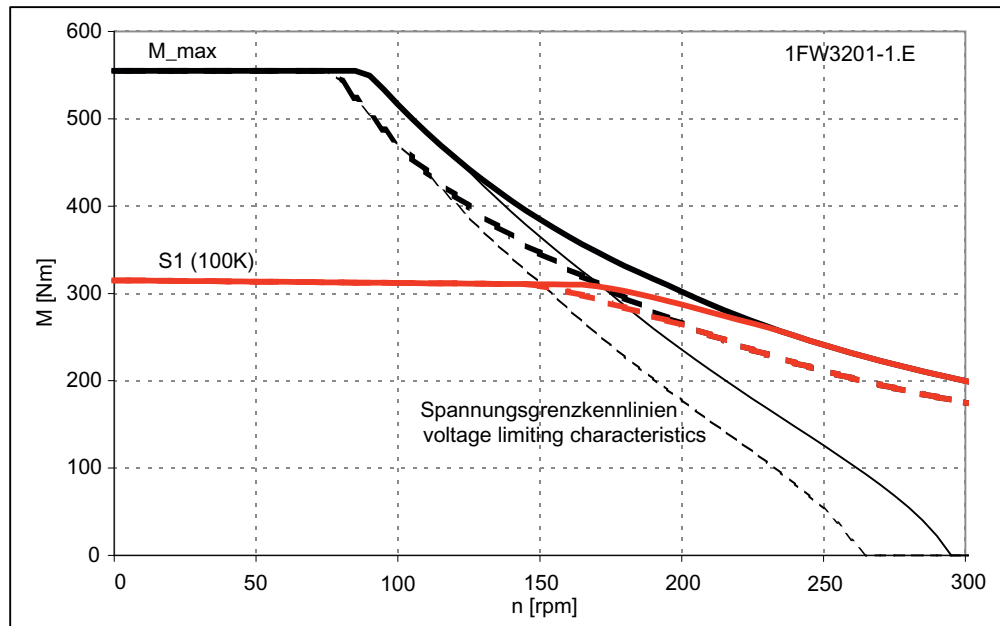

- SINAMICS ALM 400 V-Netz (Zwischenkreisspannung 600 V DC)
SINAMICS ALM 400 V line (DC-link voltage 600 V)
- - - SINAMICS BLM/SLM 400 V-Netz (Zwischenkreisspannung 540 V DC)
SINAMICS BLM/SLM 400 V line (DC-link voltage 540 V)

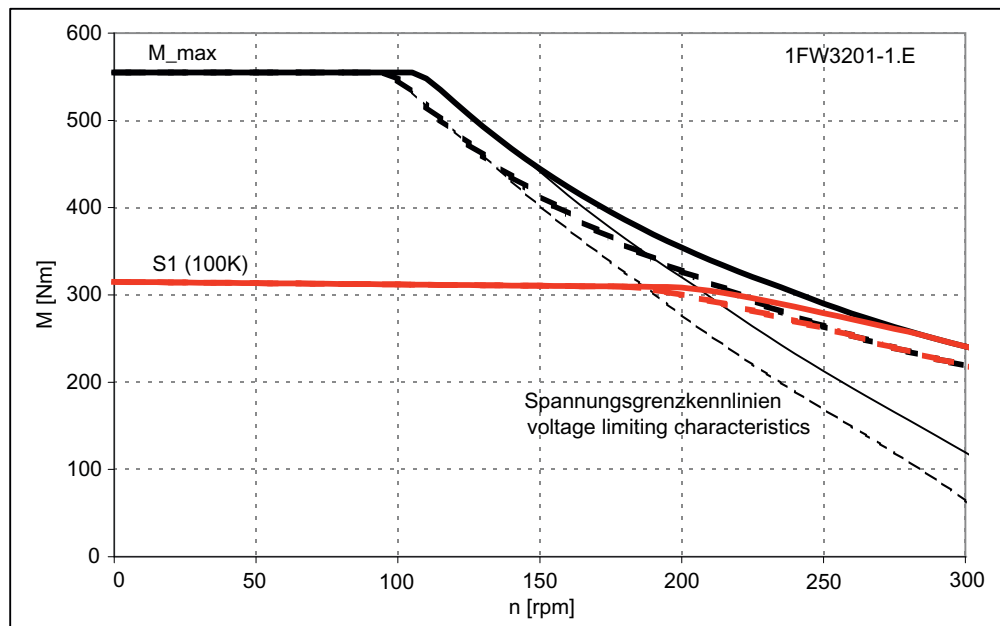

- SINAMICS ALM 480 V-Netz (Zwischenkreisspannung 720 V DC)
SINAMICS ALM 480 V line (DC-link voltage 720 V)
- - - SINAMICS BLM/SLM 480 V-Netz (Zwischenkreisspannung 650 V DC)
SINAMICS BLM/SLM 480 V line (DC-link voltage 650 V)

4.1 Torque-speed characteristic

Table 4- 20 1FW3201, rated speed 300 rpm

Configuration data	Code	Unit	1FW3201-1□H	
Rated speed	n_N	rpm	300	
Rated torque (100 K)	$M_N (100 K)$	Nm	300	
Rated power (100 K)	$P_N (100 K)$	kW	9.4	
Rated current (100 K)	$I_N (100 K)$	A	23.0	
Static torque (100 K)	$M_0 (100 K)$	Nm	315	
Stall current (100 K)	$I_0 (100 K)$	A	24.0	
Limiting data				
Max. permissible speed (mech.)	$n_{max mech.}$	rpm	1000	
Max. permissible speed (converter)	$n_{max 830 V}$	rpm	680	
Maximum torque	M_{max}	Nm	555	
Maximum current	I_{max}	A	50	
Motor data				
Number of poles	2p		28	
Ratio of speed measurement (belt-mounted encoder)	i_{enc}	--	-3.5	
Torque constant (100 K)	$k_T (100 K)$	Nm/A	13.3	
Voltage constant (at 20 °C)	k_E	V/1000 rpm	845	
Winding resistance (at 20 °C)	R_{ph}	Ω	0.57	
Rotating field inductance	L_D	mH	15.0	
Electrical time constant	T_{el}	ms	26.0	
Thermal time constant	T_{th}	min	10.0	
Mechanical data: Hollow-shaft version				
Mechanical time constant	T_{mech}	ms	2.1	
Moment of inertia	J_{mot}	kgm ²	0.22	
Shaft torsional stiffness	C_t	Nm/rad	3.73E+07	
Weight	m	kg	127	
Mechanical data: Solid shaft version				
Mechanical time constant	T_{mech}	ms	2.2	
Moment of inertia	J_{mot}	kgm ²	0.23	
Shaft torsional stiffness	C_t	Nm/rad	3.48E+06	
Weight	m	kg	179	
Mechanical data: Plug-on shaft version				
Mechanical time constant	T_{mech}	ms	2.6	
Moment of inertia	J_{mot}	kgm ²	0.27	
Shaft torsional stiffness	C_t	Nm/rad	4.90E+07	
Weight	m	kg	171	

The specified rated data are valid for a 600 V DC link voltage

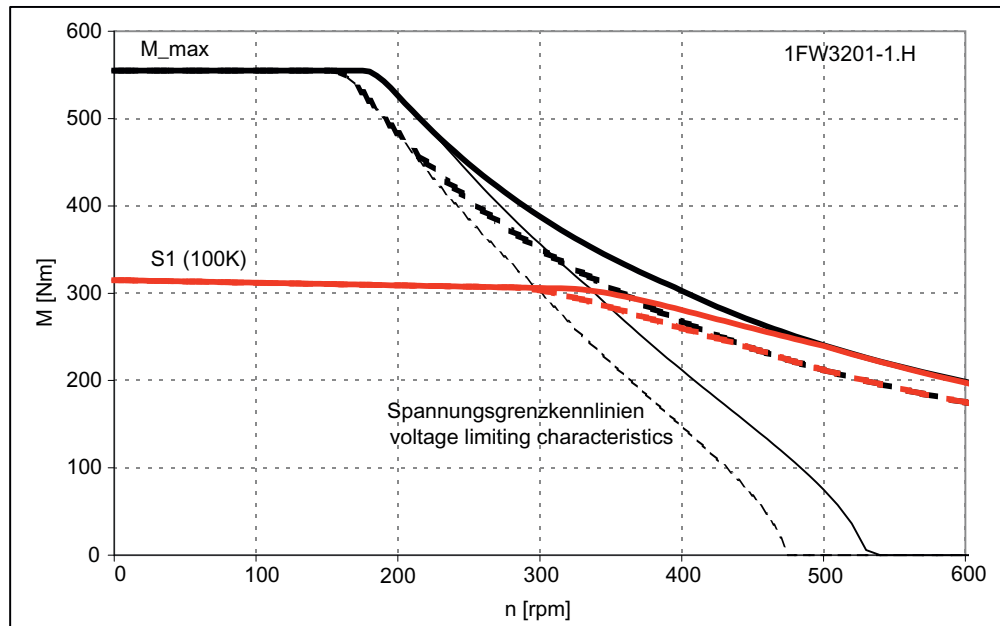

- SINAMICS ALM 400 V-Netz (Zwischenkreisspannung 600 V DC)
SINAMICS ALM 400 V line (DC-link voltage 600 V)
- - - SINAMICS BLM/SLM 400 V-Netz (Zwischenkreisspannung 540 V DC)
SINAMICS BLM/SLM 400 V line (DC-link voltage 540 V)

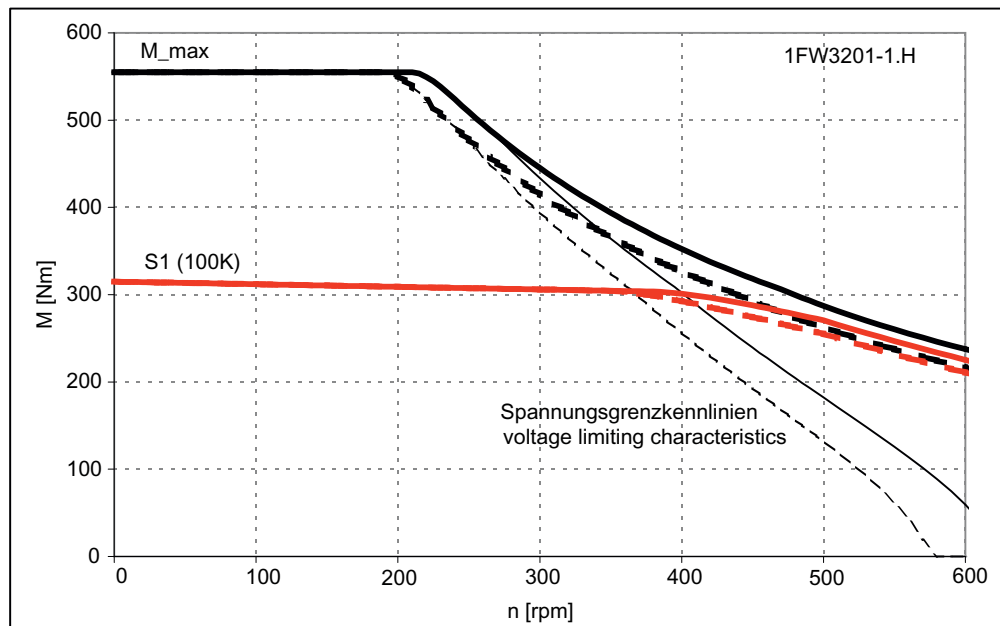

- SINAMICS ALM 480 V-Netz (Zwischenkreisspannung 720 V DC)
SINAMICS ALM 480 V line (DC-link voltage 720 V)
- - - SINAMICS BLM/SLM 480 V-Netz (Zwischenkreisspannung 650 V DC)
SINAMICS BLM/SLM 480 V line (DC-link voltage 650 V)

4.1 Torque-speed characteristic

Table 4- 21 1FW3201, rated speed 500 rpm

Configuration data	Code	Unit	1FW3201-1□L	
Rated speed	n_N	rpm	500	
Rated torque (100 K)	$M_N (100\text{ K})$	Nm	500	
Rated power (100 K)	$P_N (100\text{ K})$	kW	15.7	
Rated current (100 K)	$I_N (100\text{ K})$	A	37.0	
Static torque (100 K)	$M_0 (100\text{ K})$	Nm	315	
Stall current (100 K)	$I_0 (100\text{ K})$	A	38.0	
Limiting data				
Max. permissible speed (mech.)	$n_{\text{max mech.}}$	rpm	1000	
Max. permissible speed (converter)	$n_{\text{max 830 V}}$	rpm	1110	
Maximum torque	M_{max}	Nm	555	
Maximum current	I_{max}	A	82	
Motor data				
Number of poles	2p		28	
Ratio of speed measurement (belt-mounted encoder)	i_{enc}	--	-3.5	
Torque constant (100 K)	$k_T (100\text{ K})$	Nm/A	8.2	
Voltage constant (at 20 °C)	k_E	V/1000 rpm	520	
Winding resistance (at 20 °C)	R_{ph}	Ω	0.225	
Rotating field inductance	L_D	mH	6.0	
Electrical time constant	T_{el}	ms	26.5	
Thermal time constant	T_{th}	min	10.0	
Mechanical data: Hollow-shaft version				
Mechanical time constant	T_{mech}	ms	2.2	
Moment of inertia	J_{mot}	kgm ²	0.22	
Shaft torsional stiffness	C_t	Nm/rad	3.73E+07	
Weight	m	kg	127	
Mechanical data: Solid shaft version				
Mechanical time constant	T_{mech}	ms	2.3	
Moment of inertia	J_{mot}	kgm ²	0.23	
Shaft torsional stiffness	C_t	Nm/rad	3.48E+06	
Weight	m	kg	179	
Mechanical data: Plug-on shaft version				
Mechanical time constant	T_{mech}	ms	2.7	
Moment of inertia	J_{mot}	kgm ²	0.27	
Shaft torsional stiffness	C_t	Nm/rad	4.90E+07	
Weight	m	kg	171	

The specified rated data are valid for a 600 V DC link voltage

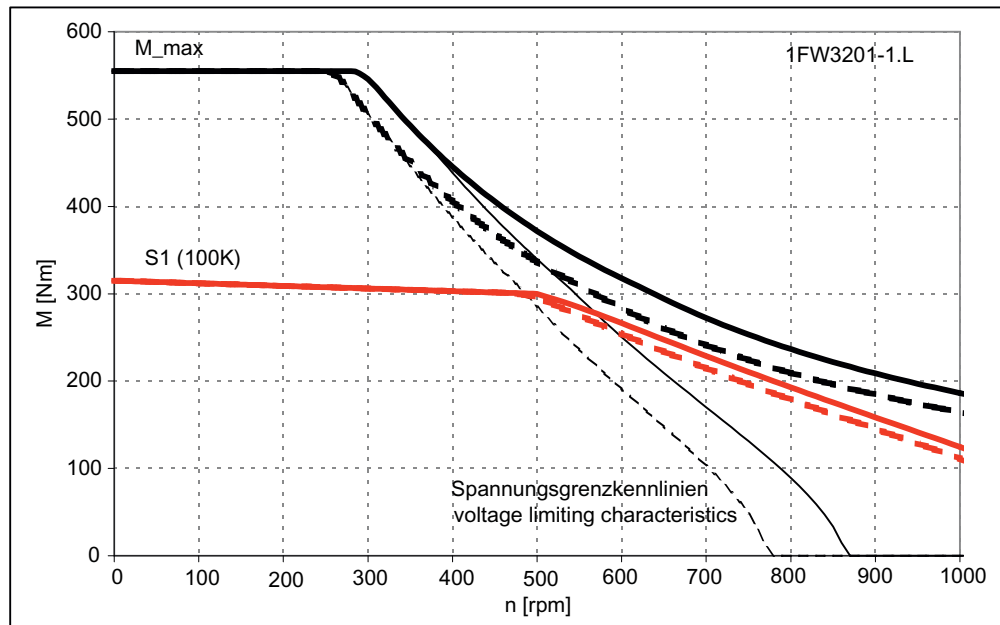

- SINAMICS ALM 400 V-Netz (Zwischenkreisspannung 600 V DC)
SINAMICS ALM 400 V line (DC-link voltage 600 V)
- - - SINAMICS BLM/SLM 400 V-Netz (Zwischenkreisspannung 540 V DC)
SINAMICS BLM/SLM 400 V line (DC-link voltage 540 V)

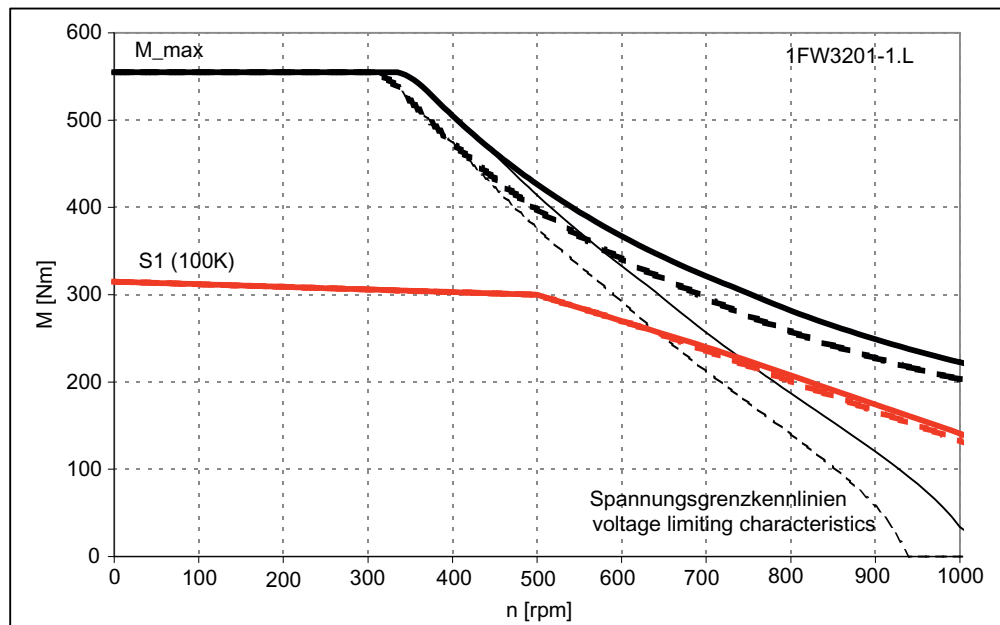

- SINAMICS ALM 480 V-Netz (Zwischenkreisspannung 720 V DC)
SINAMICS ALM 480 V line (DC-link voltage 720 V)
- - - SINAMICS BLM/SLM 480 V-Netz (Zwischenkreisspannung 650 V DC)
SINAMICS BLM/SLM 480 V line (DC-link voltage 650 V)

4.1 Torque-speed characteristic

Table 4- 22 1FW3202, rated speed 150 rpm

Configuration data	Code	Unit	1FW3202-1□E	
Rated speed	n_N	rpm	150	
Rated torque (100 K)	$M_N (100 K)$	Nm	500	
Rated power (100 K)	$P_N (100 K)$	kW	7.9	
Rated current (100 K)	$I_N (100 K)$	A	21.0	
Static torque (100 K)	$M_0 (100 K)$	Nm	525	
Stall current (100 K)	$I_0 (100 K)$	A	22.0	
Limiting data				
Max. permissible speed (mech.)	$n_{max mech.}$	rpm	1000	
Max. permissible speed (converter)	$n_{max 830 V}$	rpm	380	
Maximum torque	M_{max}	Nm	925	
Maximum current	I_{max}	A	47.0	
Motor data				
Number of poles	2p		28	
Ratio of speed measurement (belt-mounted encoder)	i_{enc}	--	-3.5	
Torque constant (100 K)	$k_T (100 K)$	Nm/A	24.0	
Voltage constant (at 20 °C)	k_E	V/1000 rpm	1520	
Winding resistance (at 20 °C)	R_{ph}	Ω	0.94	
Rotating field inductance	L_D	mH	29	
Electrical time constant	T_{el}	ms	31.0	
Thermal time constant	T_{th}	min	10.0	
Mechanical data: Hollow-shaft version				
Mechanical time constant	T_{mech}	ms	1.8	
Moment of inertia	J_{mot}	kgm ²	0.36	
Shaft torsional stiffness	C_t	Nm/rad	2.74E+07	
Weight	m	kg	156	
Mechanical data: Solid shaft version				
Mechanical time constant	T_{mech}	ms	1.7	
Moment of inertia	J_{mot}	kgm ²	0.35	
Shaft torsional stiffness	C_t	Nm/rad	3.28E+06	
Weight	m	kg	215	
Mechanical data: Plug-on shaft version				
Mechanical time constant	T_{mech}	ms	1.9	
Moment of inertia	J_{mot}	kgm ²	0.39	
Shaft torsional stiffness	C_t	Nm/rad	4.05E+07	
Weight	m	kg	200	

The specified rated data are valid for a 600 V DC link voltage

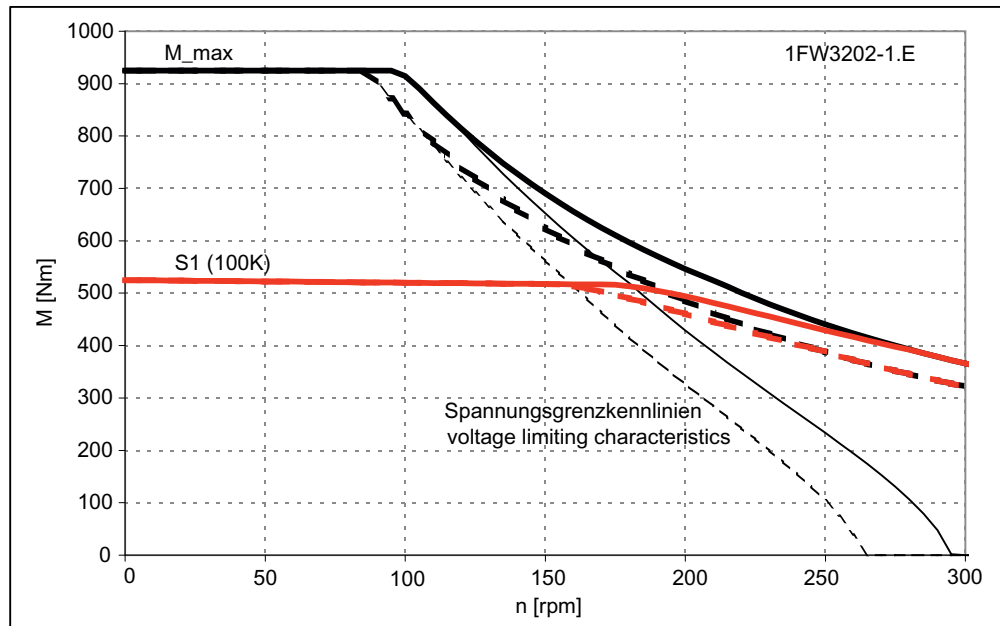

- SINAMICS ALM 400 V-Netz (Zwischenkreisspannung 600 V DC)
SINAMICS ALM 400 V line (DC-link voltage 600 V)
- - - SINAMICS BLM/SLM 400 V-Netz (Zwischenkreisspannung 540 V DC)
SINAMICS BLM/SLM 400 V line (DC-link voltage 540 V)

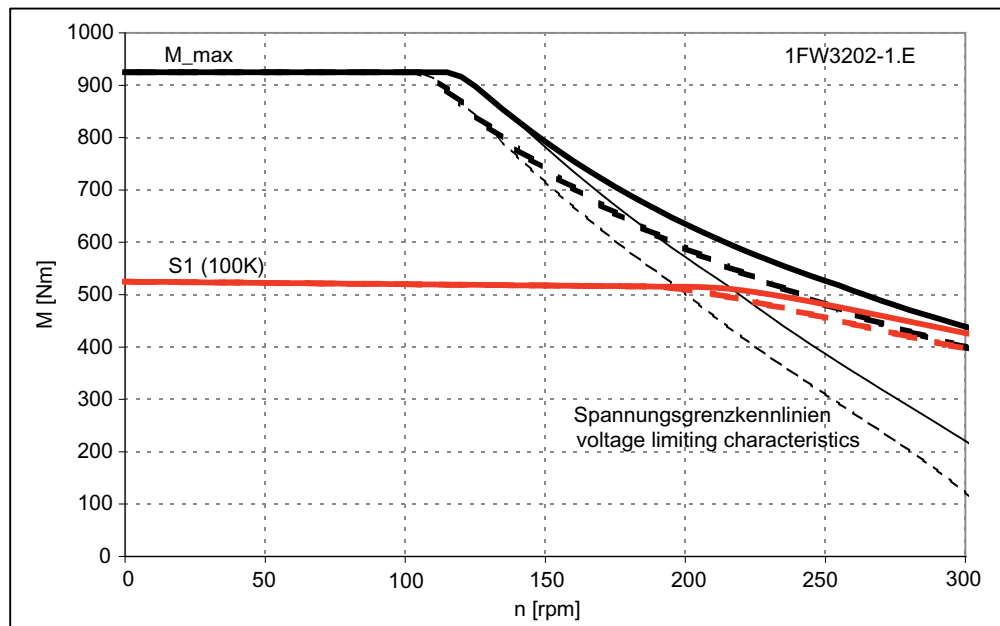

- SINAMICS ALM 480 V-Netz (Zwischenkreisspannung 720 V DC)
SINAMICS ALM 480 V line (DC-link voltage 720 V)
- - - SINAMICS BLM/SLM 480 V-Netz (Zwischenkreisspannung 650 V DC)
SINAMICS BLM/SLM 480 V line (DC-link voltage 650 V)

4.1 Torque-speed characteristic

Table 4- 23 1FW3202, rated speed 300 rpm

Configuration data	Code	Unit	1FW3202-1□H	
Rated speed	n_N	rpm	300	
Rated torque (100 K)	$M_N (100\text{ K})$	Nm	500	
Rated power (100 K)	$P_N (100\text{ K})$	kW	15.7	
Rated current (100 K)	$I_N (100\text{ K})$	A	37.0	
Static torque (100 K)	$M_0 (100\text{ K})$	Nm	525	
Stall current (100 K)	$I_0 (100\text{ K})$	A	39.0	
Limiting data				
Max. permissible speed (mech.)	$n_{\text{max mech.}}$	rpm	1000	
Max. permissible speed (converter)	$n_{\text{max 830 V}}$	rpm	670	
Maximum torque	M_{max}	Nm	925	
Maximum current	I_{max}	A	81	
Motor data				
Number of poles	2p		28	
Ratio of speed measurement (belt-mounted encoder)	i_{enc}	--	-3.5	
Torque constant (100 K)	$k_T (100\text{ K})$	Nm/A	13.5	
Voltage constant (at 20 °C)	k_E	V/1000 rpm	855	
Winding resistance (at 20 °C)	R_{ph}	Ω	0.285	
Rotating field inductance	L_D	mH	9.0	
Electrical time constant	T_{el}	ms	31.0	
Thermal time constant	T_{th}	min	10.0	
Mechanical data: Hollow-shaft version				
Mechanical time constant	T_{mech}	ms	1.7	
Moment of inertia	J_{mot}	kgm ²	0.36	
Shaft torsional stiffness	C_t	Nm/rad	2.74E+07	
Weight	m	kg	156	
Mechanical data: Solid shaft version				
Mechanical time constant	T_{mech}	ms	1.6	
Moment of inertia	J_{mot}	kgm ²	0.35	
Shaft torsional stiffness	C_t	Nm/rad	3.28E+06	
Weight	m	kg	215	
Mechanical data: Plug-on shaft version				
Mechanical time constant	T_{mech}	ms	1.8	
Moment of inertia	J_{mot}	kgm ²	0.39	
Shaft torsional stiffness	C_t	Nm/rad	4.05E+07	
Weight	m	kg	200	

The specified rated data are valid for a 600 V DC link voltage

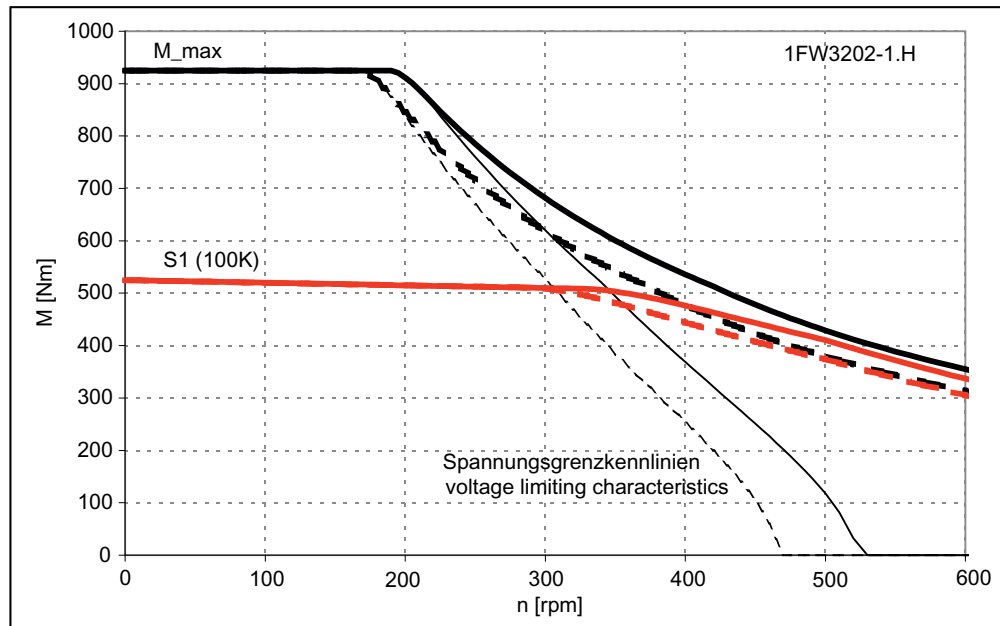

- SINAMICS ALM 400 V-Netz (Zwischenkreisspannung 600 V DC)
SINAMICS ALM 400 V line (DC-link voltage 600 V)
- - - SINAMICS BLM/SLM 400 V-Netz (Zwischenkreisspannung 540 V DC)
SINAMICS BLM/SLM 400 V line (DC-link voltage 540 V)

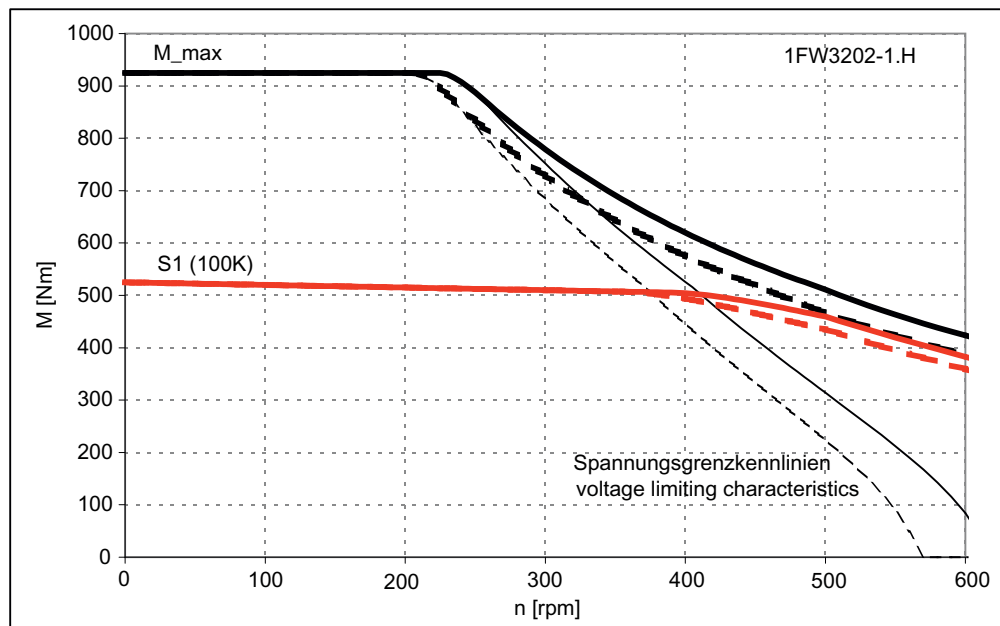

- SINAMICS ALM 480 V-Netz (Zwischenkreisspannung 720 V DC)
SINAMICS ALM 480 V line (DC-link voltage 720 V)
- - - SINAMICS BLM/SLM 480 V-Netz (Zwischenkreisspannung 650 V DC)
SINAMICS BLM/SLM 480 V line (DC-link voltage 650 V)

4.1 Torque-speed characteristic

Table 4- 24 1FW3202, rated speed 500 rpm

Configuration data	Code	Unit	1FW3202-1□L
Rated speed	n_N	rpm	500
Rated torque (100 K)	$M_N (100\text{ K})$	Nm	500
Rated power (100 K)	$P_N (100\text{ K})$	kW	26.0
Rated current (100 K)	$I_N (100\text{ K})$	A	59
Static torque (100 K)	$M_0 (100\text{ K})$	Nm	525
Stall current (100 K)	$I_0 (100\text{ K})$	A	62
Limiting data			
Max. permissible speed (mech.)	$n_{\text{max mech.}}$	rpm	1000
Max. permissible speed (converter)	$n_{\text{max 830 V}}$	rpm	1070
Maximum torque	M_{max}	Nm	925
Maximum current	I_{max}	A	131
Motor data			
Number of poles	2p		28
Ratio of speed measurement (belt-mounted encoder)	i_{enc}	--	-3.5
Torque constant (100 K)	$k_T (100\text{ K})$	Nm/A	8.5
Voltage constant (at 20 °C)	k_E	V/1000 rpm	540
Winding resistance (at 20 °C)	R_{ph}	Ω	0.117
Rotating field inductance	L_D	mH	3.5
Electrical time constant	T_{el}	ms	30.0
Thermal time constant	T_{th}	min	10.0
Mechanical data: Hollow-shaft version			
Mechanical time constant	T_{mech}	ms	1.7
Moment of inertia	J_{mot}	kgm ²	0.36
Shaft torsional stiffness	C_t	Nm/rad	2.74E+07
Weight	m	kg	156
Mechanical data: Solid shaft version			
Mechanical time constant	T_{mech}	ms	1.7
Moment of inertia	J_{mot}	kgm ²	0.35
Shaft torsional stiffness	C_t	Nm/rad	3.28E+06
Weight	m	kg	215
Mechanical data: Plug-on shaft version			
Mechanical time constant	T_{mech}	ms	1.9
Moment of inertia	J_{mot}	kgm ²	0.39
Shaft torsional stiffness	C_t	Nm/rad	4.05E+07
Weight	m	kg	200

The specified rated data are valid for a 600 V DC link voltage

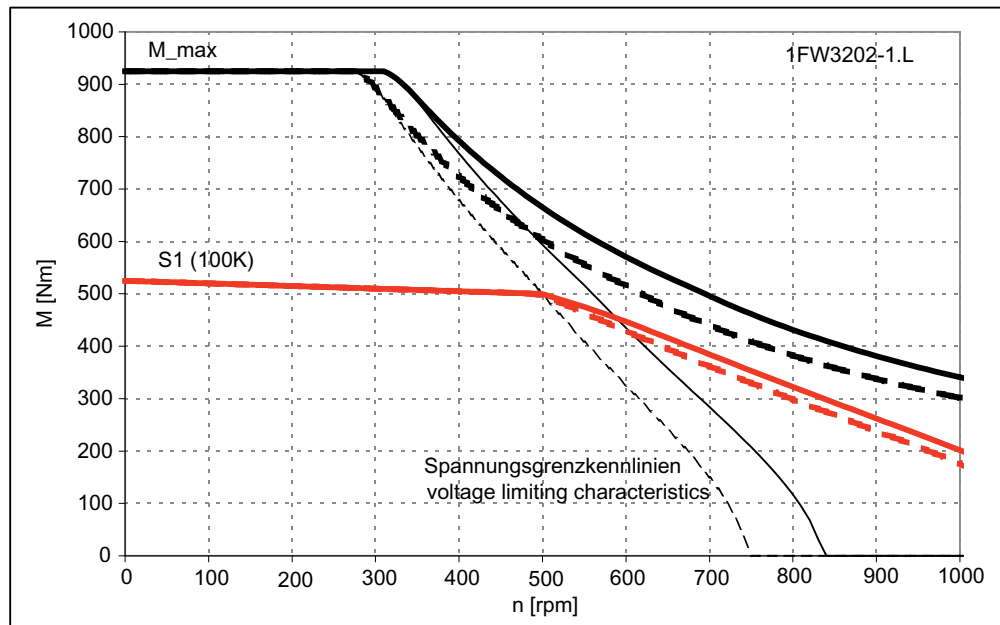

- SINAMICS ALM 400 V-Netz (Zwischenkreisspannung 600 V DC)
SINAMICS ALM 400 V line (DC-link voltage 600 V)
- - - SINAMICS BLM/SLM 400 V-Netz (Zwischenkreisspannung 540 V DC)
SINAMICS BLM/SLM 400 V line (DC-link voltage 540 V)

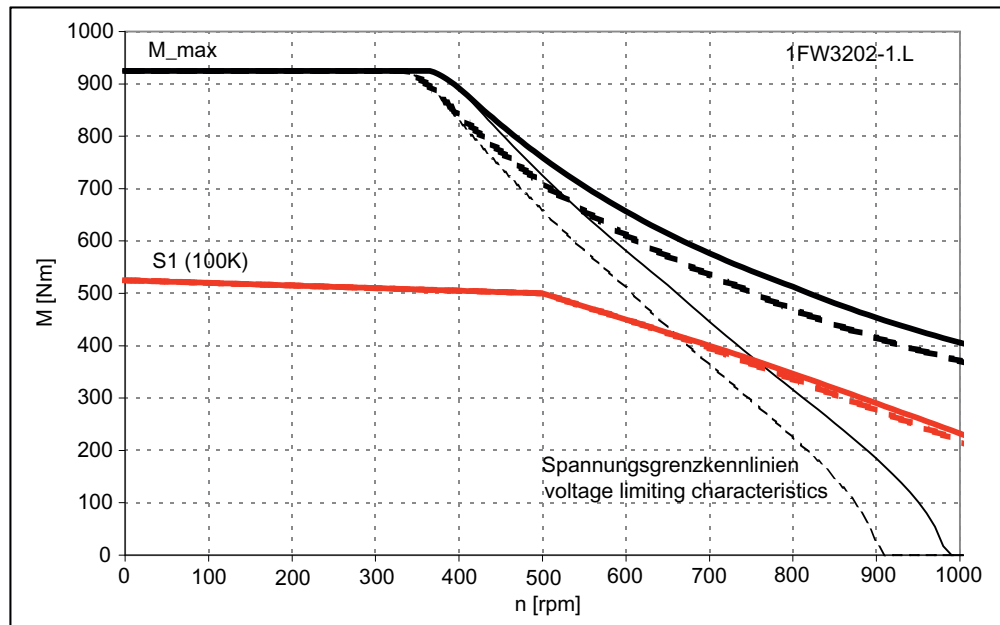

- SINAMICS ALM 480 V-Netz (Zwischenkreisspannung 720 V DC)
SINAMICS ALM 480 V line (DC-link voltage 720 V)
- - - SINAMICS BLM/SLM 480 V-Netz (Zwischenkreisspannung 650 V DC)
SINAMICS BLM/SLM 480 V line (DC-link voltage 650 V)

4.1 Torque-speed characteristic

Table 4- 25 1FW3203, rated speed 150 rpm

Configuration data	Code	Unit	1FW3203-1□E	
Rated speed	n_N	rpm	150	
Rated torque (100 K)	$M_N (100 K)$	Nm	750	
Rated power (100 K)	$P_N (100 K)$	kW	11.8	
Rated current (100 K)	$I_N (100 K)$	A	31.0	
Static torque (100 K)	$M_0 (100 K)$	Nm	790	
Stall current (100 K)	$I_0 (100 K)$	A	32.0	
Limiting data				
Max. permissible speed (mech.)	$n_{max mech.}$	rpm	1000	
Max. permissible speed (converter)	$n_{max 830 V}$	rpm	370	
Maximum torque	M_{max}	Nm	1390	
Maximum current	I_{max}	A	69	
Motor data				
Number of poles	2p		28	
Ratio of speed measurement (belt-mounted encoder)	i_{enc}	--	-3.5	
Torque constant (100 K)	$k_T (100 K)$	Nm/A	24.5	
Voltage constant (at 20 °C)	k_E	V/1000 rpm	1555	
Winding resistance (at 20 °C)	R_{ph}	Ω	0.64	
Rotating field inductance	L_D	mH	20	
Electrical time constant	T_{el}	ms	31.5	
Thermal time constant	T_{th}	min	12.0	
Mechanical data: Hollow-shaft version				
Mechanical time constant	T_{mech}	ms	1.6	
Moment of inertia	J_{mot}	kgm ²	0.49	
Shaft torsional stiffness	C_t	Nm/rad	2.16E+07	
Weight	m	kg	182	
Mechanical data: Solid shaft version				
Mechanical time constant	T_{mech}	ms	1.5	
Moment of inertia	J_{mot}	kgm ²	0.46	
Shaft torsional stiffness	C_t	Nm/rad	3.11E+06	
Weight	m	kg	240	
Mechanical data: Plug-on shaft version				
Mechanical time constant	T_{mech}	ms	1.7	
Moment of inertia	J_{mot}	kgm ²	0.52	
Shaft torsional stiffness	C_t	Nm/rad	3.44E+07	
Weight	m	kg	225	

The specified rated data are valid for a 600 V DC link voltage

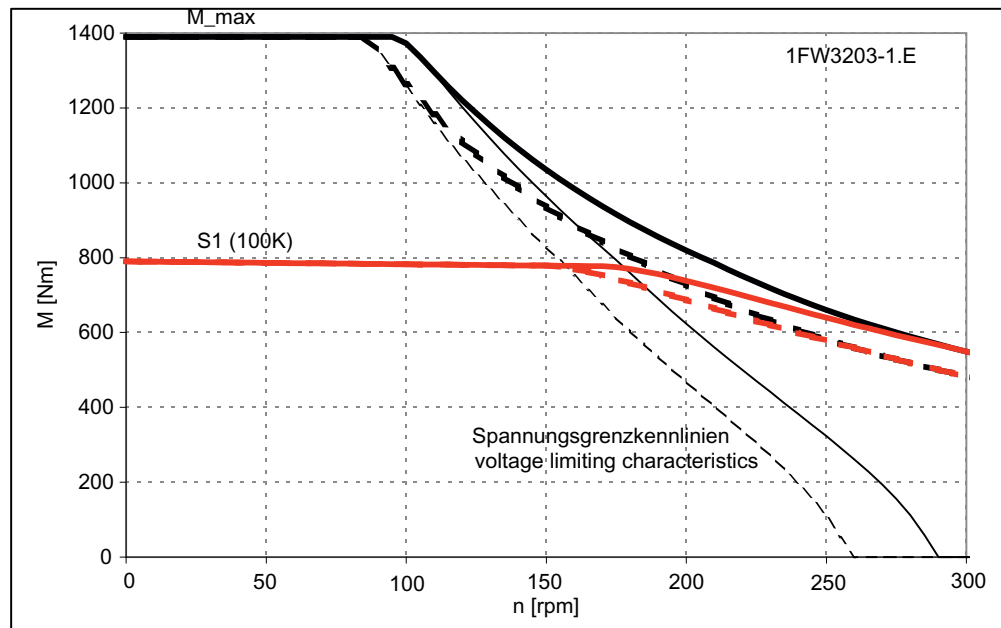

- SINAMICS ALM 400 V-Netz (Zwischenkreisspannung 600 V DC)
SINAMICS ALM 400 V line (DC-link voltage 600 V)
- - - SINAMICS BLM/SLM 400 V-Netz (Zwischenkreisspannung 540 V DC)
SINAMICS BLM/SLM 400 V line (DC-link voltage 540 V)

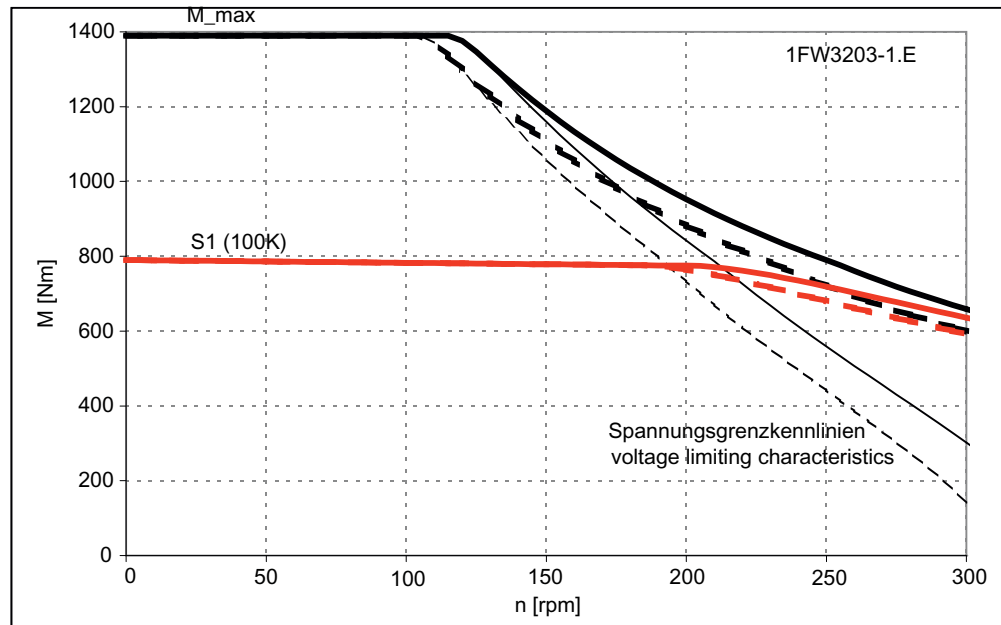

- SINAMICS ALM 480 V-Netz (Zwischenkreisspannung 720 V DC)
SINAMICS ALM 480 V line (DC-link voltage 720 V)
- - - SINAMICS BLM/SLM 480 V-Netz (Zwischenkreisspannung 650 V DC)
SINAMICS BLM/SLM 480 V line (DC-link voltage 650 V)

4.1 Torque-speed characteristic

Table 4- 26 1FW3203, rated speed 300 rpm

Configuration data	Code	Unit	1FW3203-1□H	
Rated speed	n_N	rpm	300	
Rated torque (100 K)	$M_N (100\text{ K})$	Nm	750	
Rated power (100 K)	$P_N (100\text{ K})$	kW	23.5	
Rated current (100 K)	$I_N (100\text{ K})$	A	59	
Static torque (100 K)	$M_0 (100\text{ K})$	Nm	790	
Stall current (100 K)	$I_0 (100\text{ K})$	A	62	
Limiting data				
Max. permissible speed (mech.)	$n_{\text{max mech.}}$	rpm	1000	
Max. permissible speed (converter)	$n_{\text{max 830 V}}$	rpm	710	
Maximum torque	M_{max}	Nm	1390	
Maximum current	I_{max}	A	132	
Motor data				
Number of poles	2p		28	
Ratio of speed measurement (belt-mounted encoder)	i_{enc}	--	-3.5	
Torque constant (100 K)	$k_T (100\text{ K})$	Nm/A	12.7	
Voltage constant (at 20 °C)	k_E	V/1000 rpm	810	
Winding resistance (at 20 °C)	R_{ph}	Ω	0.162	
Rotating field inductance	L_D	mH	5.0	
Electrical time constant	T_{el}	ms	32.0	
Thermal time constant	T_{th}	min	12.0	
Mechanical data: Hollow-shaft version				
Mechanical time constant	T_{mech}	ms	1.5	
Moment of inertia	J_{mot}	kgm ²	0.49	
Shaft torsional stiffness	C_t	Nm/rad	2.16E+07	
Weight	m	kg	182	
Mechanical data: Solid shaft version				
Mechanical time constant	T_{mech}	ms	1.4	
Moment of inertia	J_{mot}	kgm ²	0.46	
Shaft torsional stiffness	C_t	Nm/rad	3.11E+06	
Weight	m	kg	240	
Mechanical data: Plug-on shaft version				
Mechanical time constant	T_{mech}	ms	1.6	
Moment of inertia	J_{mot}	kgm ²	0.52	
Shaft torsional stiffness	C_t	Nm/rad	3.44E+07	
Weight	m	kg	225	

The specified rated data are valid for a 600 V DC link voltage

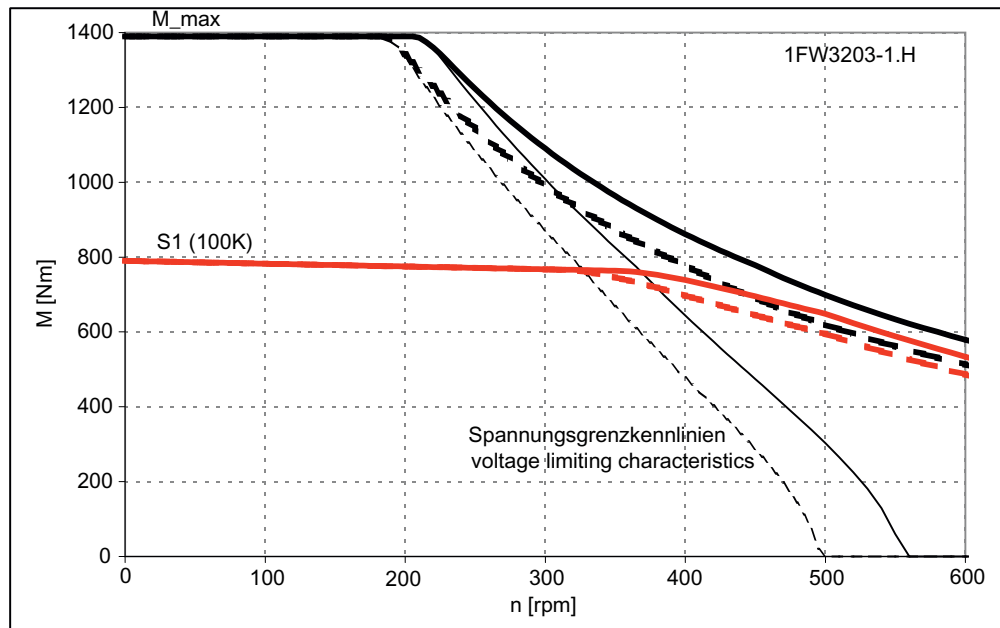

- SINAMICS ALM 400 V-Netz (Zwischenkreisspannung 600 V DC)
SINAMICS ALM 400 V line (DC-link voltage 600 V)
- - - SINAMICS BLM/SLM 400 V-Netz (Zwischenkreisspannung 540 V DC)
SINAMICS BLM/SLM 400 V line (DC-link voltage 540 V)

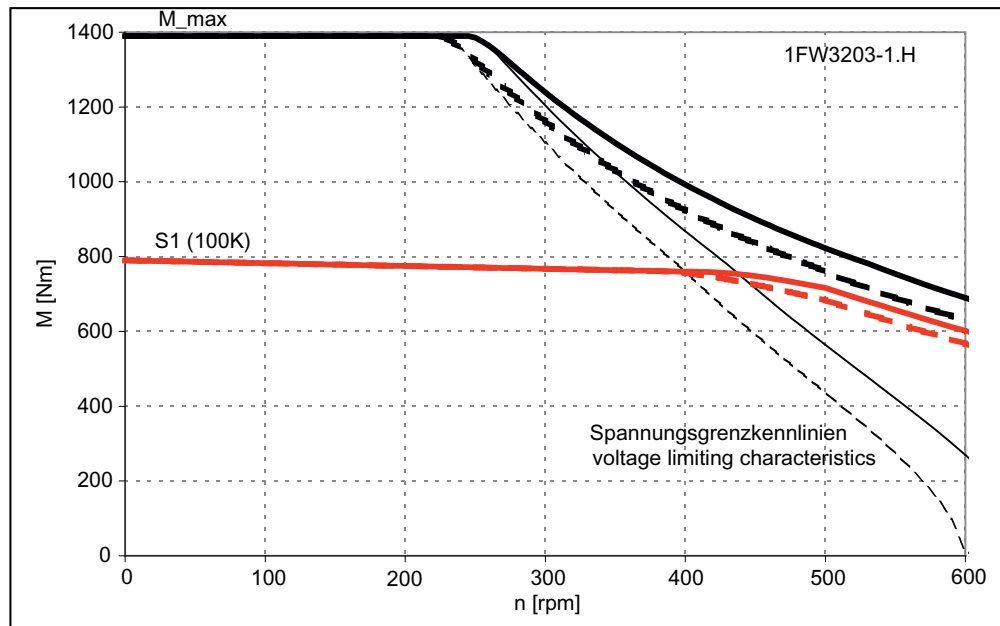

- SINAMICS ALM 480 V-Netz (Zwischenkreisspannung 720 V DC)
SINAMICS ALM 480 V line (DC-link voltage 720 V)
- - - SINAMICS BLM/SLM 480 V-Netz (Zwischenkreisspannung 650 V DC)
SINAMICS BLM/SLM 480 V line (DC-link voltage 650 V)

4.1 Torque-speed characteristic

Table 4- 27 1FW3203, rated speed 500 rpm

Configuration data	Code	Unit	1FW3203-1□L
Rated speed	n_N	rpm	500
Rated torque (100 K)	$M_N (100\text{ K})$	Nm	750
Rated power (100 K)	$P_N (100\text{ K})$	kW	39.5
Rated current (100 K)	$I_N (100\text{ K})$	A	92
Static torque (100 K)	$M_0 (100\text{ K})$	Nm	790
Stall current (100 K)	$I_0 (100\text{ K})$	A	100
Limiting data			
Max. permissible speed (mech.)	$n_{\text{max mech.}}$	rpm	1000
Max. permissible speed (converter)	$n_{\text{max 830 V}}$	rpm	1110
Maximum torque	M_{max}	Nm	1390
Maximum current	I_{max}	A	205
Motor data			
Number of poles	2p		28
Ratio of speed measurement (belt-mounted encoder)	i_{enc}	--	-3.5
Torque constant (100 K)	$k_T (100\text{ K})$	Nm/A	8.2
Voltage constant (at 20 °C)	k_E	V/1000 rpm	520
Winding resistance (at 20 °C)	R_{ph}	Ω	0.07
Rotating field inductance	L_D	mH	2.2
Electrical time constant	T_{el}	ms	31.5
Thermal time constant	T_{th}	min	12.0
Mechanical data: Hollow-shaft version			
Mechanical time constant	T_{mech}	ms	1.5
Moment of inertia	J_{mot}	kgm ²	0.49
Shaft torsional stiffness	C_t	Nm/rad	2.16E+07
Weight	m	kg	182
Mechanical data: Solid shaft version			
Mechanical time constant	T_{mech}	ms	1.4
Moment of inertia	J_{mot}	kgm ²	0.46
Shaft torsional stiffness	C_t	Nm/rad	3.11E+06
Weight	m	kg	240
Mechanical data: Plug-on shaft version			
Mechanical time constant	T_{mech}	ms	1.6
Moment of inertia	J_{mot}	kgm ²	0.52
Shaft torsional stiffness	C_t	Nm/rad	3.44E+07
Weight	m	kg	225

The specified rated data are valid for a 600 V DC link voltage

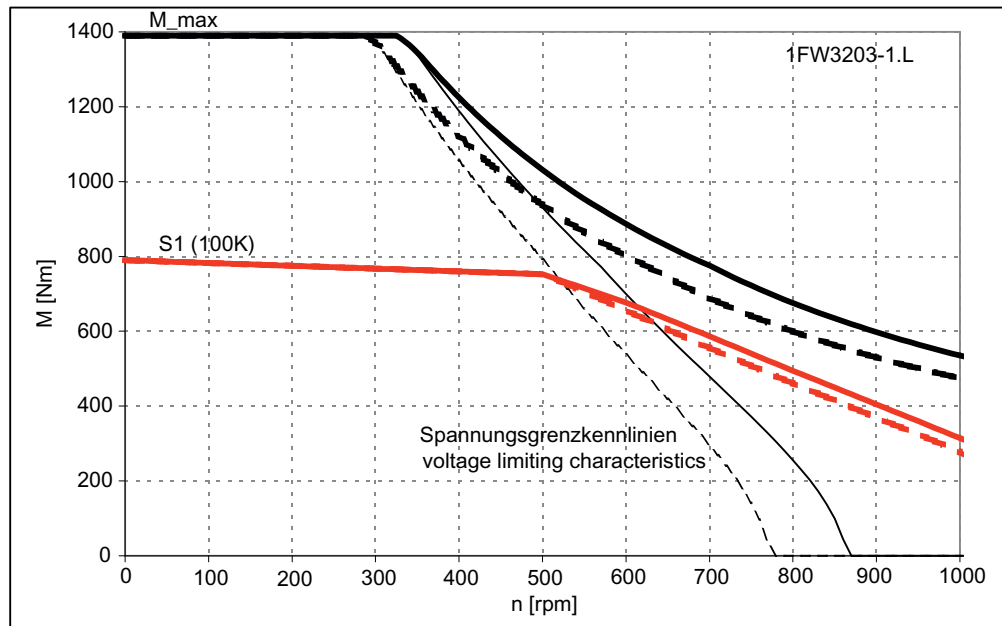

- SINAMICS ALM 400 V-Netz (Zwischenkreisspannung 600 V DC)
SINAMICS ALM 400 V line (DC-link voltage 600 V)
- - - SINAMICS BLM/SLM 400 V-Netz (Zwischenkreisspannung 540 V DC)
SINAMICS BLM/SLM 400 V line (DC-link voltage 540 V)

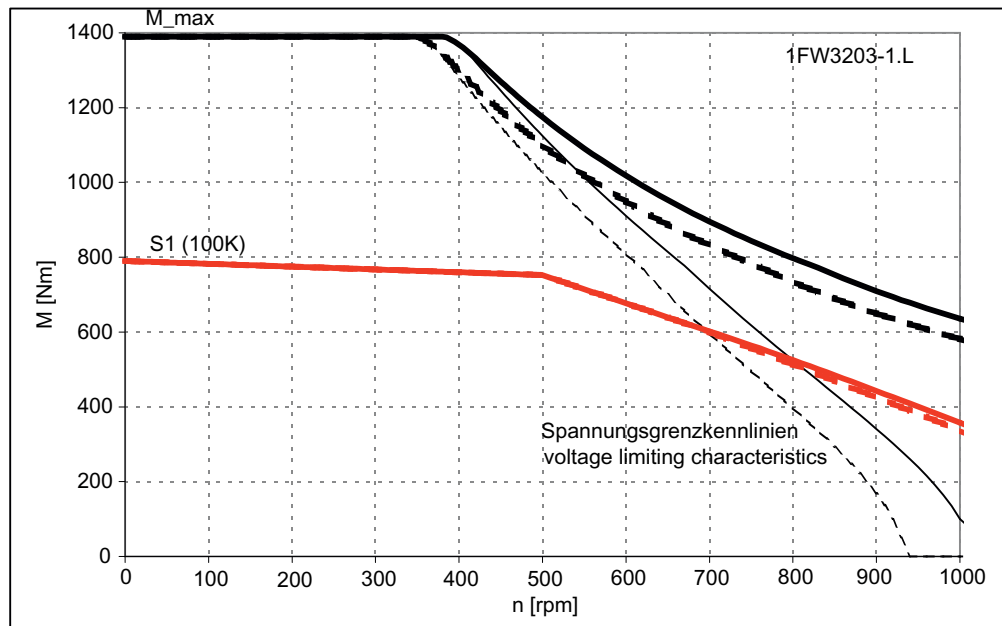

- SINAMICS ALM 480 V-Netz (Zwischenkreisspannung 720 V DC)
SINAMICS ALM 480 V line (DC-link voltage 720 V)
- - - SINAMICS BLM/SLM 480 V-Netz (Zwischenkreisspannung 650 V DC)
SINAMICS BLM/SLM 480 V line (DC-link voltage 650 V)

4.1 Torque-speed characteristic

Table 4- 28 1FW3204, rated speed 150 rpm

Configuration data	Code	Unit	1FW3204-1□E	
Rated speed	n_N	rpm	150	
Rated torque (100 K)	$M_N (100 K)$	Nm	1000	
Rated power (100 K)	$P_N (100 K)$	kW	15.7	
Rated current (100 K)	$I_N (100 K)$	A	40.0	
Static torque (100 K)	$M_0 (100 K)$	Nm	1050	
Stall current (100 K)	$I_0 (100 K)$	A	42.0	
Limiting data				
Max. permissible speed (mech.)	$n_{max mech.}$	rpm	1000	
Max. permissible speed (converter)	$n_{max 830 V}$	rpm	360	
Maximum torque	M_{max}	Nm	1850	
Maximum current	I_{max}	A	90	
Motor data				
Number of poles	2p		28	
Ratio of speed measurement (belt-mounted encoder)	i_{enc}	--	-3.5	
Torque constant (100 K)	$k_T (100 K)$	Nm/A	25	
Voltage constant (at 20 °C)	k_E	V/1000 rpm	1585	
Winding resistance (at 20 °C)	R_{ph}	Ω	0.44	
Rotating field inductance	L_D	mH	15.0	
Electrical time constant	T_{el}	ms	34.0	
Thermal time constant	T_{th}	min	14.0	
Mechanical data: Hollow-shaft version				
Mechanical time constant	T_{mech}	ms	1.5	
Moment of inertia	J_{mot}	kgm ²	0.7	
Shaft torsional stiffness	C_t	Nm/rad	1.64E+07	
Weight	m	kg	225	
Mechanical data: Solid shaft version				
Mechanical time constant	T_{mech}	ms	1.3	
Moment of inertia	J_{mot}	kgm ²	0.61	
Shaft torsional stiffness	C_t	Nm/rad	2.88E+06	
Weight	m	kg	285	
Mechanical data: Plug-on shaft version				
Mechanical time constant	T_{mech}	ms	1.5	
Moment of inertia	J_{mot}	kgm ²	0.7	
Shaft torsional stiffness	C_t	Nm/rad	3.00E+07	
Weight	m	kg	275	

The specified rated data are valid for a 600 V DC link voltage

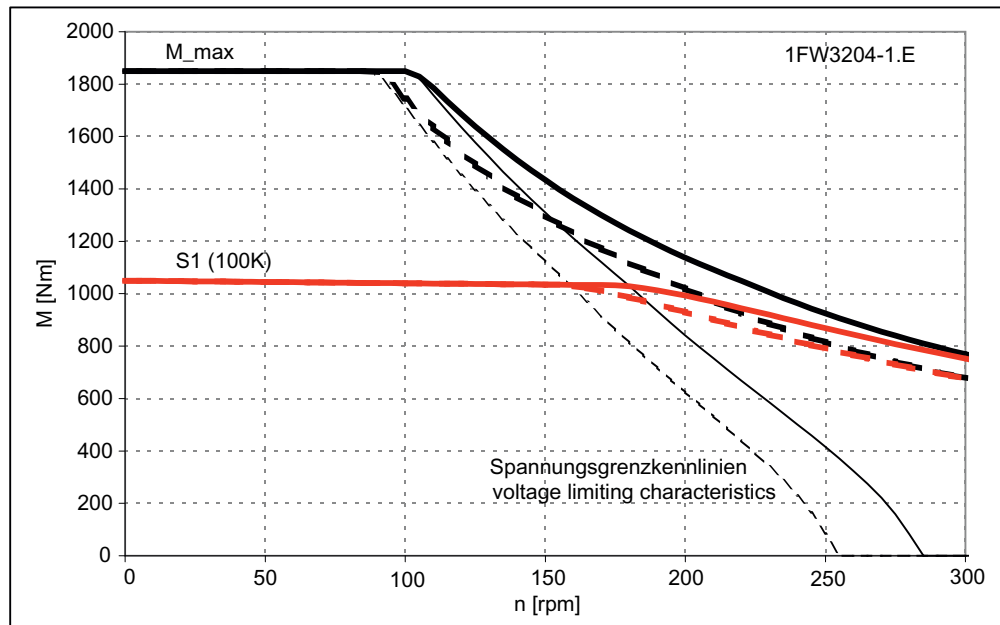

- SINAMICS ALM 400 V-Netz (Zwischenkreisspannung 600 V DC)
SINAMICS ALM 400 V line (DC-link voltage 600 V)
- - - SINAMICS BLM/SLM 400 V-Netz (Zwischenkreisspannung 540 V DC)
SINAMICS BLM/SLM 400 V line (DC-link voltage 540 V)

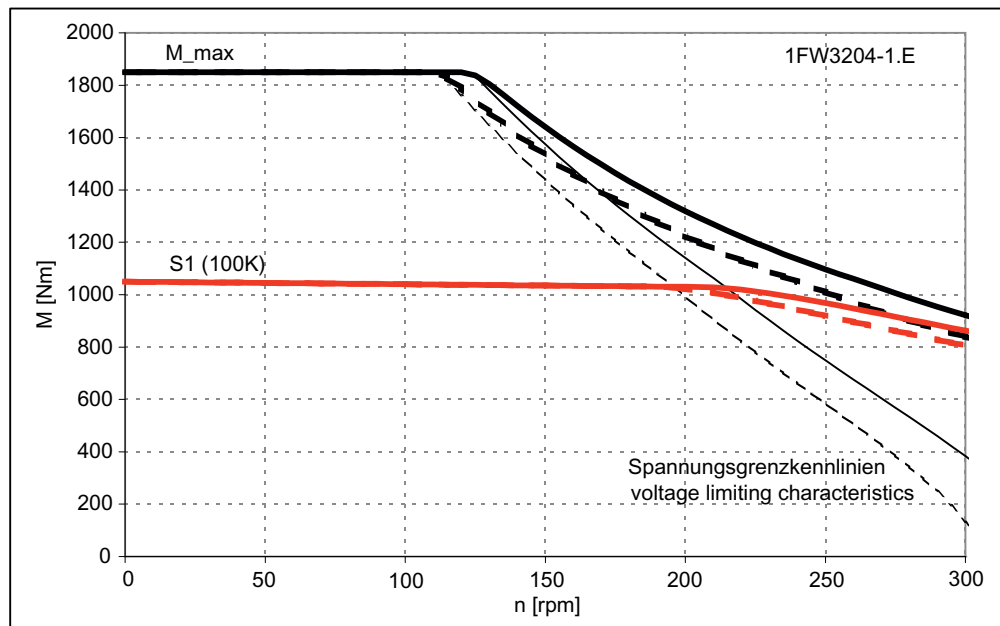

- SINAMICS ALM 480 V-Netz (Zwischenkreisspannung 720 V DC)
SINAMICS ALM 480 V line (DC-link voltage 720 V)
- - - SINAMICS BLM/SLM 480 V-Netz (Zwischenkreisspannung 650 V DC)
SINAMICS BLM/SLM 480 V line (DC-link voltage 650 V)

4.1 Torque-speed characteristic

Table 4- 29 1FW3204, rated speed 300 rpm

Configuration data	Code	Unit	1FW3204-1□H
Rated speed	n_N	rpm	300
Rated torque (100 K)	$M_N (100 K)$	Nm	1000
Rated power (100 K)	$P_N (100 K)$	kW	31.5
Rated current (100 K)	$I_N (100 K)$	A	74
Static torque (100 K)	$M_0 (100 K)$	Nm	1050
Stall current (100 K)	$I_0 (100 K)$	A	77
Limiting data			
Max. permissible speed (mech.)	$n_{max mech.}$	rpm	1000
Max. permissible speed (converter)	$n_{max 830 V}$	rpm	670
Maximum torque	M_{max}	Nm	1850
Maximum current	I_{max}	A	163
Motor data			
Number of poles	2p		28
Ratio of speed measurement (belt-mounted encoder)	i_{enc}	--	-3.5
Torque constant (100 K)	$k_T (100 K)$	Nm/A	13.5
Voltage constant (at 20 °C)	k_E	V/1000 rpm	855
Winding resistance (at 20 °C)	R_{ph}	Ω	0.125
Rotating field inductance	L_D	mH	4.2
Electrical time constant	T_{el}	ms	33.5
Thermal time constant	T_{th}	min	14.0
Mechanical data: Hollow-shaft version			
Mechanical time constant	T_{mech}	ms	1.4
Moment of inertia	J_{mot}	kgm ²	0.7
Shaft torsional stiffness	C_t	Nm/rad	1.64E+07
Weight	m	kg	225
Mechanical data: Solid shaft version			
Mechanical time constant	T_{mech}	ms	1.3
Moment of inertia	J_{mot}	kgm ²	0.61
Shaft torsional stiffness	C_t	Nm/rad	2.88E+06
Weight	m	kg	285
Mechanical data: Plug-on shaft version			
Mechanical time constant	T_{mech}	ms	1.4
Moment of inertia	J_{mot}	kgm ²	0.7
Shaft torsional stiffness	C_t	Nm/rad	3.00E+07
Weight	m	kg	275

The specified rated data are valid for a 600 V DC link voltage

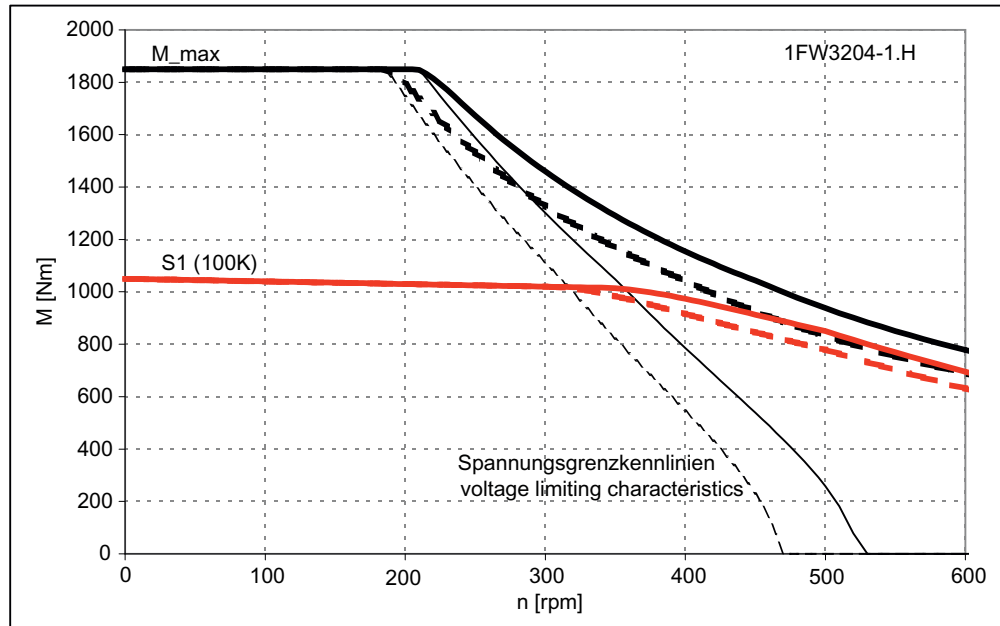

- SINAMICS ALM 400 V-Netz (Zwischenkreisspannung 600 V DC)
SINAMICS ALM 400 V line (DC-link voltage 600 V)
- - - SINAMICS BLM/SLM 400 V-Netz (Zwischenkreisspannung 540 V DC)
SINAMICS BLM/SLM 400 V line (DC-link voltage 540 V)

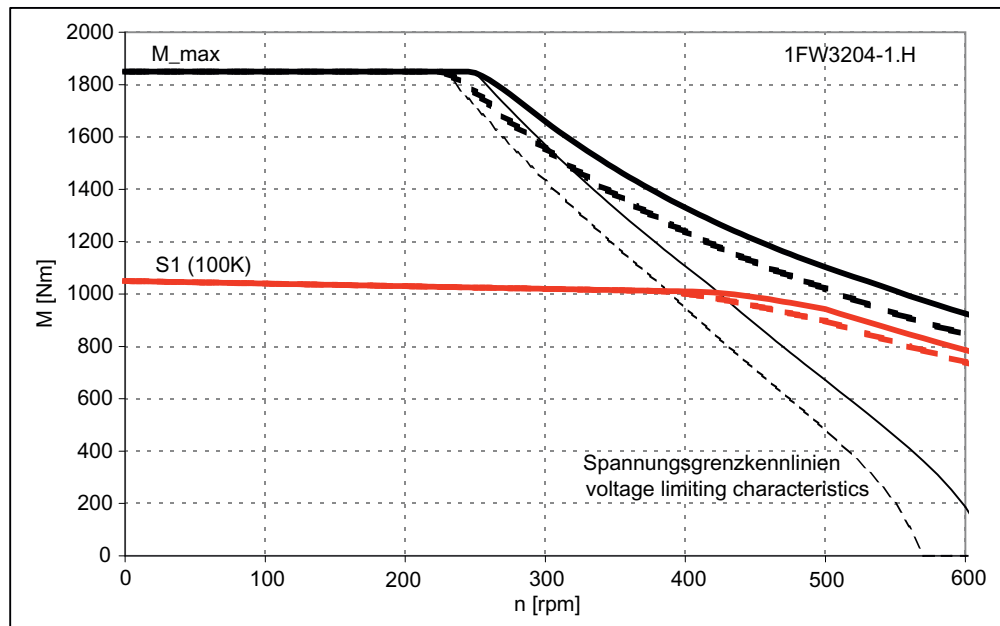

- SINAMICS ALM 480 V-Netz (Zwischenkreisspannung 720 V DC)
SINAMICS ALM 480 V line (DC-link voltage 720 V)
- - - SINAMICS BLM/SLM 480 V-Netz (Zwischenkreisspannung 650 V DC)
SINAMICS BLM/SLM 480 V line (DC-link voltage 650 V)

4.1 Torque-speed characteristic

Table 4- 30 1FW3204, rated speed 500 rpm

Configuration data	Code	Unit	1FW3204-1□L	
Rated speed	n_N	rpm	500	
Rated torque (100 K)	$M_N (100\text{ K})$	Nm	1000	
Rated power (100 K)	$P_N (100\text{ K})$	kW	52	
Rated current (100 K)	$I_N (100\text{ K})$	A	118	
Static torque (100 K)	$M_0 (100\text{ K})$	Nm	1050	
Stall current (100 K)	$I_0 (100\text{ K})$	A	129	
Limiting data				
Max. permissible speed (mech.)	$n_{\text{max mech.}}$	rpm	1000	
Max. permissible speed (converter)	$n_{\text{max 830 V}}$	rpm	1060	
Maximum torque	M_{max}	Nm	1850	
Maximum current	I_{max}	A	260	
Motor data				
Number of poles	2p		28	
Ratio of speed measurement (belt-mounted encoder)	i_{enc}	--	-3.5	
Torque constant (100 K)	$k_T (100\text{ K})$	Nm/A	8.5	
Voltage constant (at 20 °C)	k_E	V/1000 rpm	545	
Winding resistance (at 20 °C)	R_{ph}	Ω	0.049	
Rotating field inductance	L_D	mH	1.7	
Electrical time constant	T_{el}	ms	34.5	
Thermal time constant	T_{th}	min	14.0	
Mechanical data: Hollow-shaft version				
Mechanical time constant	T_{mech}	ms	1.4	
Moment of inertia	J_{mot}	kgm ²	0.7	
Shaft torsional stiffness	C_t	Nm/rad	1.64E+07	
Weight	m	kg	225	
Mechanical data: Solid shaft version				
Mechanical time constant	T_{mech}	ms	1.2	
Moment of inertia	J_{mot}	kgm ²	0.61	
Shaft torsional stiffness	C_t	Nm/rad	2.88E+06	
Weight	m	kg	285	
Mechanical data: Plug-on shaft version				
Mechanical time constant	T_{mech}	ms	1.4	
Moment of inertia	J_{mot}	kgm ²	0.7	
Shaft torsional stiffness	C_t	Nm/rad	3.00E+07	
Weight	m	kg	275	

The specified rated data are valid for a 600 V DC link voltage

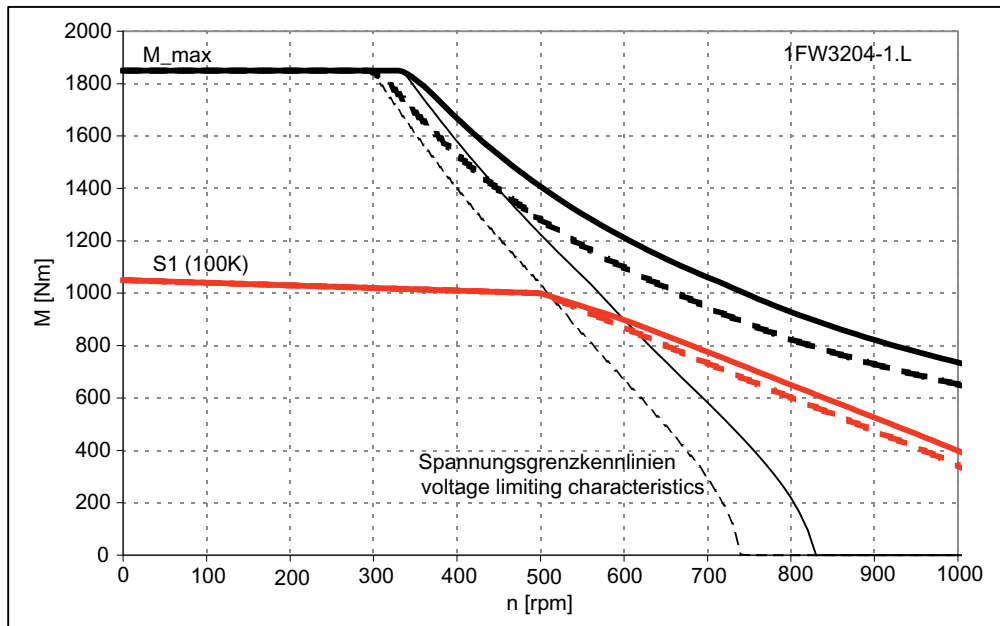

- SINAMICS ALM 400 V-Netz (Zwischenkreisspannung 600 V DC)
SINAMICS ALM 400 V line (DC-link voltage 600 V)
- - - SINAMICS BLM/SLM 400 V-Netz (Zwischenkreisspannung 540 V DC)
SINAMICS BLM/SLM 400 V line (DC-link voltage 540 V)

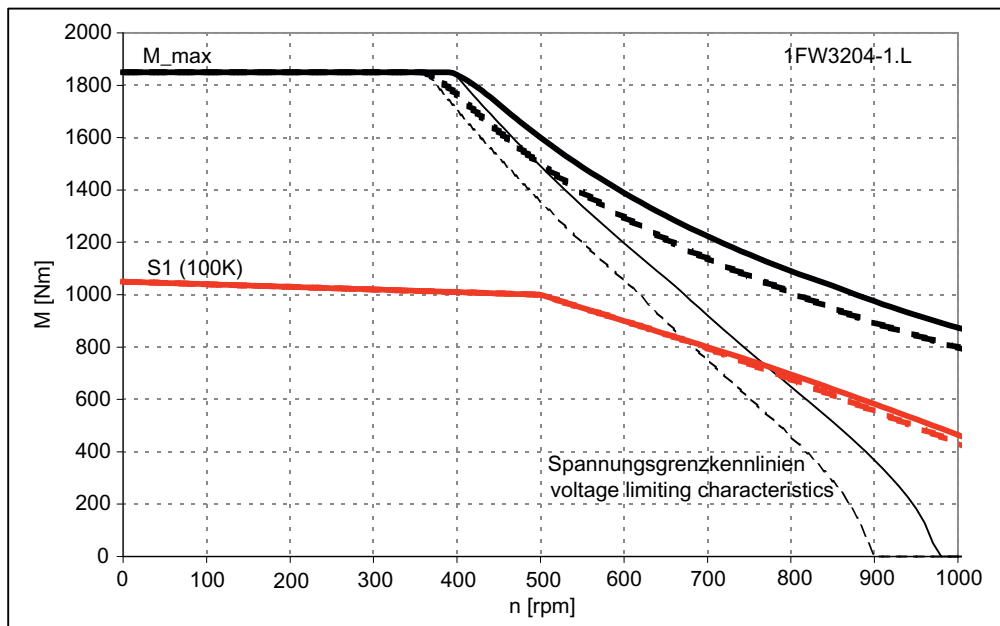

- SINAMICS ALM 480 V-Netz (Zwischenkreisspannung 720 V DC)
SINAMICS ALM 480 V line (DC-link voltage 720 V)
- - - SINAMICS BLM/SLM 480 V-Netz (Zwischenkreisspannung 650 V DC)
SINAMICS BLM/SLM 480 V line (DC-link voltage 650 V)

4.1 Torque-speed characteristic

Table 4- 31 1FW3206, rated speed 150 rpm

Configuration data	Code	Unit	1FW3206-1□E	
Rated speed	n_N	rpm	150	
Rated torque (100 K)	$M_N (100\text{ K})$	Nm	1500	
Rated power (100 K)	$P_N (100\text{ K})$	kW	23.5	
Rated current (100 K)	$I_N (100\text{ K})$	A	65	
Static torque (100 K)	$M_0 (100\text{ K})$	Nm	1575	
Stall current (100 K)	$I_0 (100\text{ K})$	A	68	
Limiting data				
Max. permissible speed (mech.)	$n_{\text{max mech.}}$	rpm	1000	
Max. permissible speed (converter)	$n_{\text{max 830 V}}$	rpm	390	
Maximum torque	M_{max}	Nm	2775	
Maximum current	I_{max}	A	145	
Motor data				
Number of poles	2p		28	
Ratio of speed measurement (belt-mounted encoder)	i_{enc}	--	-3.5	
Torque constant (100 K)	$k_T (100\text{ K})$	Nm/A	23.0	
Voltage constant (at 20 °C)	k_E	V/1000 rpm	1465	
Winding resistance (at 20 °C)	R_{ph}	Ω	0.255	
Rotating field inductance	L_D	mH	9.0	
Electrical time constant	T_{el}	ms	35.0	
Thermal time constant	T_{th}	min	16.0	
Mechanical data: Hollow-shaft version				
Mechanical time constant	T_{mech}	ms	1.4	
Moment of inertia	J_{mot}	kgm ²	0.97	
Shaft torsional stiffness	C_t	Nm/rad	1.24E+07	
Weight	m	kg	280	
Mechanical data: Solid shaft version				
Mechanical time constant	T_{mech}	ms	1.2	
Moment of inertia	J_{mot}	kgm ²	0.97	
Shaft torsional stiffness	C_t	Nm/rad	1.24E+07	
Weight	m	kg	345	
Mechanical data: Plug-on shaft version				
Mechanical time constant	T_{mech}	ms	1.4	
Moment of inertia	J_{mot}	kgm ²	0.94	
Shaft torsional stiffness	C_t	Nm/rad	2.65E+07	
Weight	m	kg	330	

The specified rated data are valid for a 600 V DC link voltage

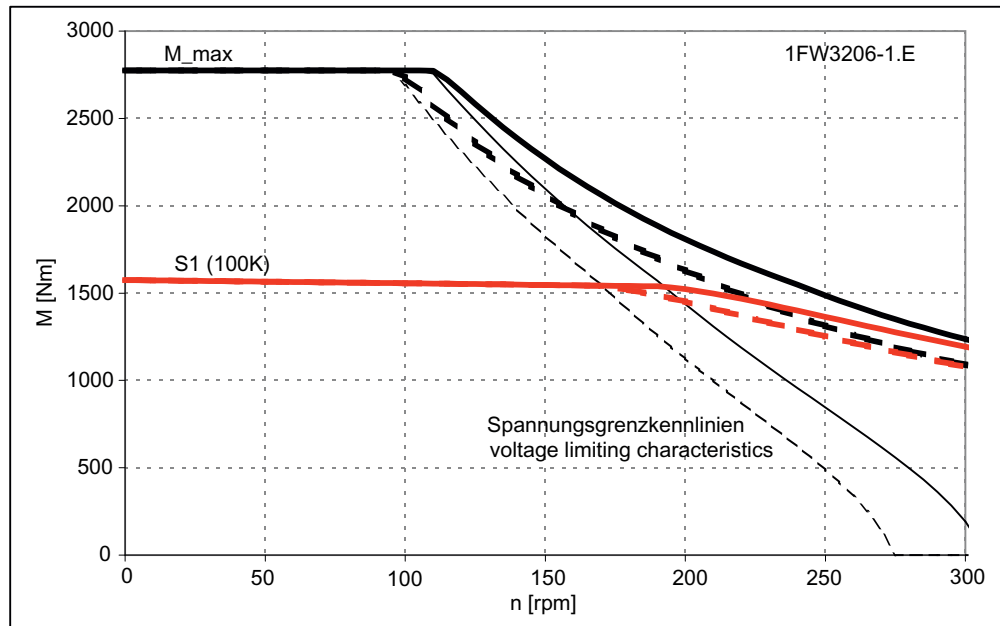

- SINAMICS ALM 400 V-Netz (Zwischenkreisspannung 600 V DC)
SINAMICS ALM 400 V line (DC-link voltage 600 V)
- - - SINAMICS BLM/SLM 400 V-Netz (Zwischenkreisspannung 540 V DC)
SINAMICS BLM/SLM 400 V line (DC-link voltage 540 V)

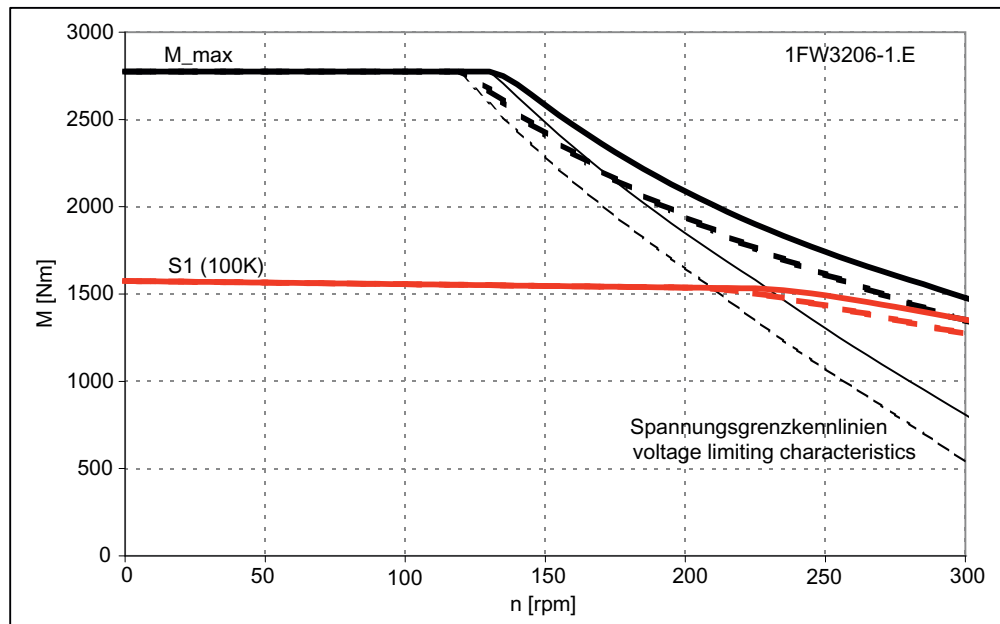

- SINAMICS ALM 480 V-Netz (Zwischenkreisspannung 720 V DC)
SINAMICS ALM 480 V line (DC-link voltage 720 V)
- - - SINAMICS BLM/SLM 480 V-Netz (Zwischenkreisspannung 650 V DC)
SINAMICS BLM/SLM 480 V line (DC-link voltage 650 V)

4.1 Torque-speed characteristic

Table 4- 32 1FW3206, rated speed 300 rpm

Configuration data	Code	Unit	1FW3206-1□H
Rated speed	n_N	rpm	300
Rated torque (100 K)	$M_N (100\text{ K})$	Nm	1500
Rated power (100 K)	$P_N (100\text{ K})$	kW	47.0
Rated current (100 K)	$I_N (100\text{ K})$	A	118
Static torque (100 K)	$M_0 (100\text{ K})$	Nm	1575
Stall current (100 K)	$I_0 (100\text{ K})$	A	121
Limiting data			
Max. permissible speed (mech.)	$n_{\text{max mech.}}$	rpm	1000
Max. permissible speed (converter)	$n_{\text{max 830 V}}$	rpm	700
Maximum torque	M_{max}	Nm	2775
Maximum current	I_{max}	A	255
Motor data			
Number of poles	2p		28
Ratio of speed measurement (belt-mounted encoder)	i_{enc}	--	-3.5
Torque constant (100 K)	$k_T (100\text{ K})$	Nm/A	12.8
Voltage constant (at 20 °C)	k_E	V/1000 rpm	820
Winding resistance (at 20 °C)	R_{ph}	Ω	0.076
Rotating field inductance	L_D	mH	2.7
Electrical time constant	T_{el}	ms	35.5
Thermal time constant	T_{th}	min	16.0
Mechanical data: Hollow-shaft version			
Mechanical time constant	T_{mech}	ms	1.3
Moment of inertia	J_{mot}	kgm ²	0.97
Shaft torsional stiffness	C_t	Nm/rad	1.24E+07
Weight	m	kg	280
Mechanical data: Solid shaft version			
Mechanical time constant	T_{mech}	ms	1.2
Moment of inertia	J_{mot}	kgm ²	0.84
Shaft torsional stiffness	C_t	Nm/rad	1.24E+07
Weight	m	kg	345
Mechanical data: Plug-on shaft version			
Mechanical time constant	T_{mech}	ms	1.3
Moment of inertia	J_{mot}	kgm ²	0.94
Shaft torsional stiffness	C_t	Nm/rad	2.65E+07
Weight	m	kg	330

The specified rated data are valid for a 600 V DC link voltage

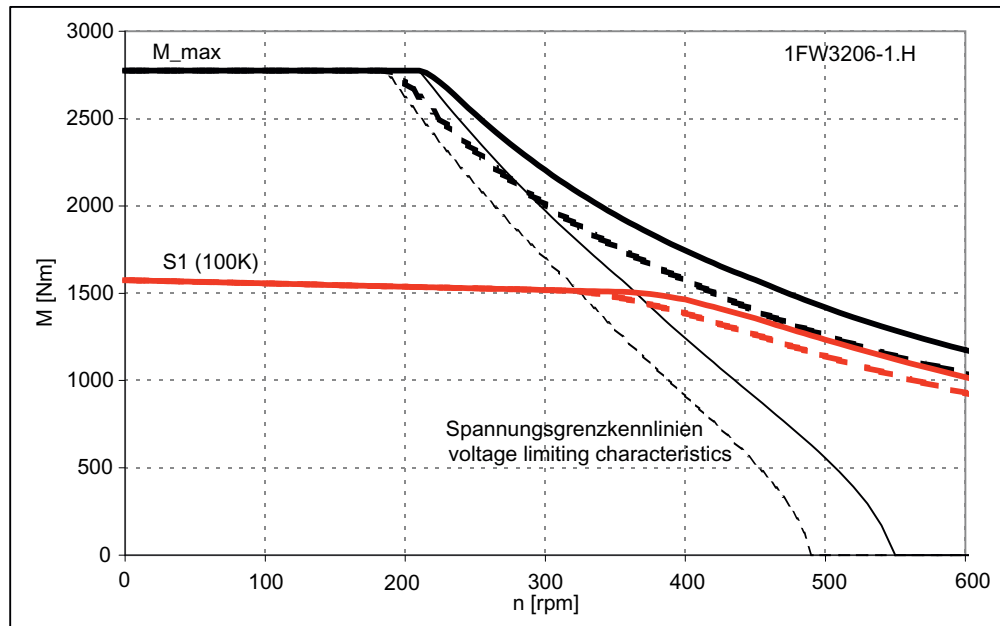

- SINAMICS ALM 400 V-Netz (Zwischenkreisspannung 600 V DC)
SINAMICS ALM 400 V line (DC-link voltage 600 V)
- - - SINAMICS BLM/SLM 400 V-Netz (Zwischenkreisspannung 540 V DC)
SINAMICS BLM/SLM 400 V line (DC-link voltage 540 V)

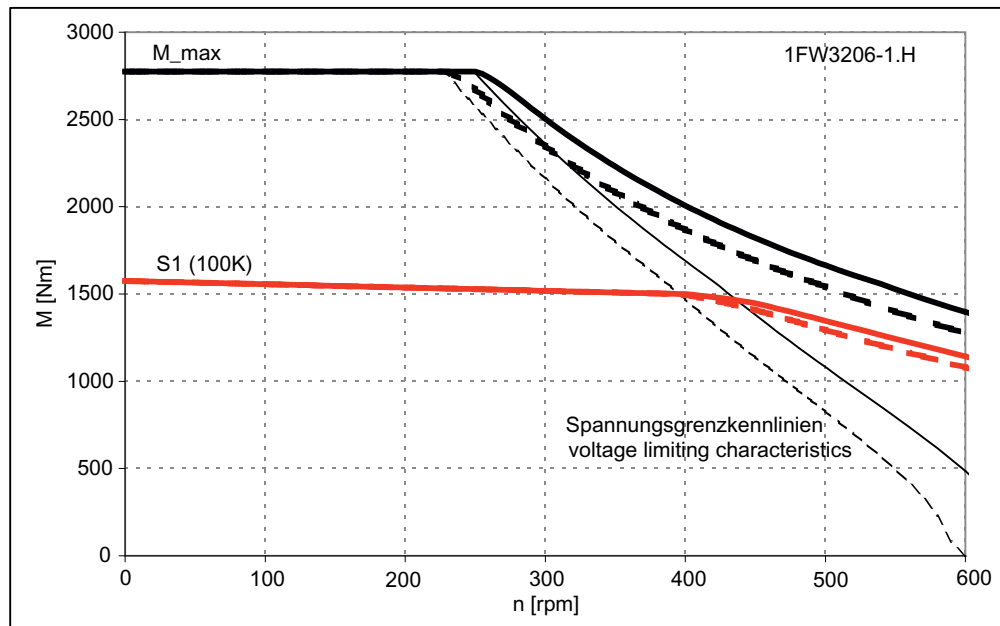

- SINAMICS ALM 480 V-Netz (Zwischenkreisspannung 720 V DC)
SINAMICS ALM 480 V line (DC-link voltage 720 V)
- - - SINAMICS BLM/SLM 480 V-Netz (Zwischenkreisspannung 650 V DC)
SINAMICS BLM/SLM 480 V line (DC-link voltage 650 V)

4.1 Torque-speed characteristic

Table 4- 33 1FW3206, rated speed 500 rpm

Configuration data	Code	Unit	1FW3206-1□L
Rated speed	n_N	rpm	500
Rated torque (100 K)	$M_N (100\text{ K})$	Nm	1400
Rated power (100 K)	$P_N (100\text{ K})$	kW	73
Rated current (100 K)	$I_N (100\text{ K})$	A	169
Static torque (100 K)	$M_0 (100\text{ K})$	Nm	1575
Stall current (100 K)	$I_0 (100\text{ K})$	A	189
Limiting data			
Max. permissible speed (mech.)	$n_{\text{max mech.}}$	rpm	1000
Max. permissible speed (converter)	$n_{\text{max 830 V}}$	rpm	1090
Maximum torque	M_{max}	Nm	2775
Maximum current	I_{max}	A	400
Motor data			
Number of poles	2p		28
Ratio of speed measurement (belt-mounted encoder)	i_{enc}	--	-3.5
Torque constant (100 K)	$k_T (100\text{ K})$	Nm/A	8.3
Voltage constant (at 20 °C)	k_E	V/1000 rpm	530
Winding resistance (at 20 °C)	R_{ph}	Ω	0.032
Rotating field inductance	L_D	mH	1.1
Electrical time constant	T_{el}	ms	34.5
Thermal time constant	T_{th}	min	16.0
Mechanical data: Hollow-shaft version			
Mechanical time constant	T_{mech}	ms	1.4
Moment of inertia	J_{mot}	kgm ²	0.97
Shaft torsional stiffness	C_t	Nm/rad	1.24E+07
Weight	m	kg	280
Mechanical data: Solid shaft version			
Mechanical time constant	T_{mech}	ms	1.2
Moment of inertia	J_{mot}	kgm ²	0.84
Shaft torsional stiffness	C_t	Nm/rad	2.62E+06
Weight	m	kg	345
Mechanical data: Plug-on shaft version			
Mechanical time constant	T_{mech}	ms	1.3
Moment of inertia	J_{mot}	kgm ²	0.94
Shaft torsional stiffness	C_t	Nm/rad	2.65E+07
Weight	m	kg	330

The specified rated data are valid for a 600 V DC link voltage

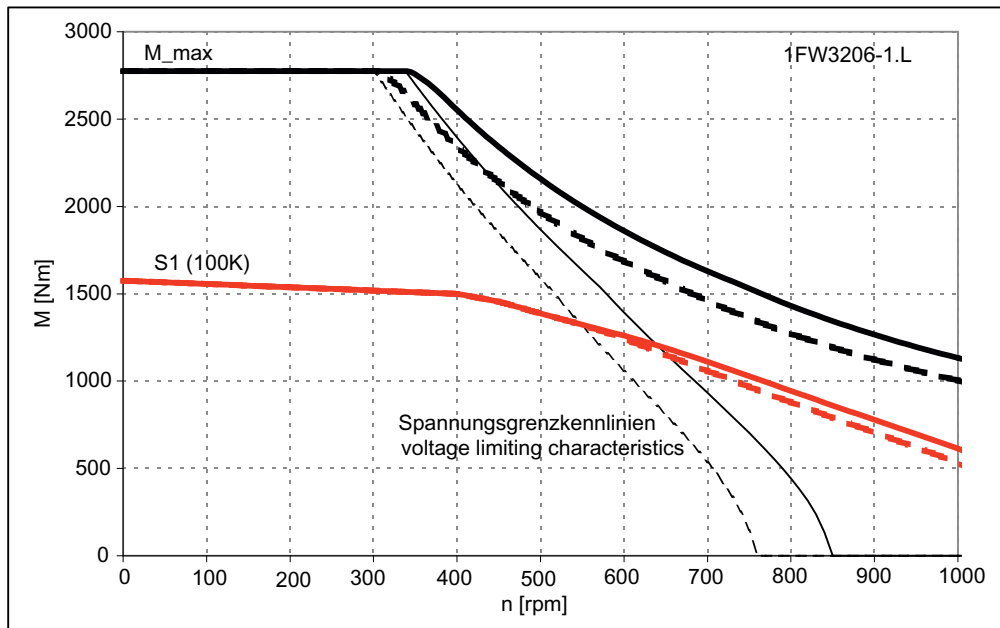

- SINAMICS ALM 400 V-Netz (Zwischenkreisspannung 600 V DC)
SINAMICS ALM 400 V line (DC-link voltage 600 V)
- - - SINAMICS BLM/SLM 400 V-Netz (Zwischenkreisspannung 540 V DC)
SINAMICS BLM/SLM 400 V line (DC-link voltage 540 V)

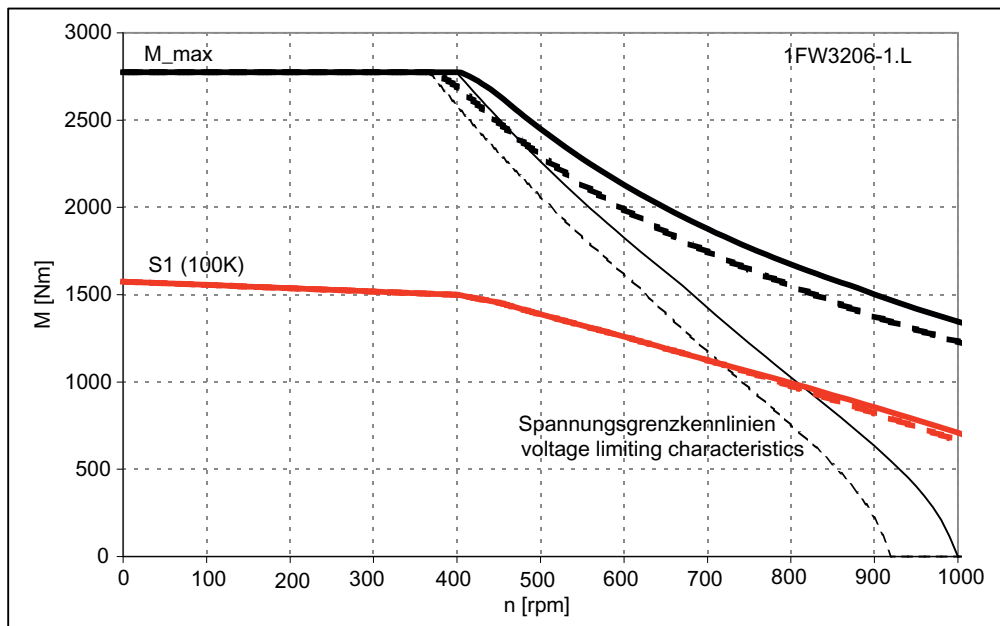

- SINAMICS ALM 480 V-Netz (Zwischenkreisspannung 720 V DC)
SINAMICS ALM 480 V line (DC-link voltage 720 V)
- - - SINAMICS BLM/SLM 480 V-Netz (Zwischenkreisspannung 650 V DC)
SINAMICS BLM/SLM 480 V line (DC-link voltage 650 V)

4.1 Torque-speed characteristic

Table 4- 34 1FW3208, rated speed 150 rpm

Configuration data	Code	Unit	1FW3208-1□E	
Rated speed	n_N	rpm	150	
Rated torque (100 K)	$M_N (100\text{ K})$	Nm	2000	
Rated power (100 K)	$P_N (100\text{ K})$	kW	31.5	
Rated current (100 K)	$I_N (100\text{ K})$	A	84	
Static torque (100 K)	$M_0 (100\text{ K})$	Nm	2100	
Stall current (100 K)	$I_0 (100\text{ K})$	A	88	
Limiting data				
Max. permissible speed (mech.)	$n_{\text{max mech.}}$	rpm	1000	
Max. permissible speed (converter)	$n_{\text{max 830 V}}$	rpm	380	
Maximum torque	M_{max}	Nm	3700	
Maximum current	I_{max}	A	187	
Motor data				
Number of poles	2p		28	
Ratio of speed measurement (belt-mounted encoder)	i_{enc}	--	-3.5	
Torque constant (100 K)	$k_T (100\text{ K})$	Nm/A	24.0	
Voltage constant (at 20 °C)	k_E	V/1000 rpm	1515	
Winding resistance (at 20 °C)	R_{ph}	Ω	0.197	
Rotating field inductance	L_D	mH	7.0	
Electrical time constant	T_{el}	ms	35.0	
Thermal time constant	T_{th}	min	20	
Mechanical data: Hollow-shaft version				
Mechanical time constant	T_{mech}	ms	1.4	
Moment of inertia	J_{mot}	kgm ²	1.31	
Shaft torsional stiffness	C_t	Nm/rad	9.55E+06	
Weight	m	kg	350	
Mechanical data: Solid shaft version				
Mechanical time constant	T_{mech}	ms	1.2	
Moment of inertia	J_{mot}	kgm ²	1.11	
Shaft torsional stiffness	C_t	Nm/rad	2.35E+06	
Weight	m	kg	415	
Mechanical data: Plug-on shaft version				
Mechanical time constant	T_{mech}	ms	1.3	
Moment of inertia	J_{mot}	kgm ²	1.24	
Shaft torsional stiffness	C_t	Nm/rad	2.17E+07	
Weight	m	kg	400	

The specified rated data are valid for a 600 V DC link voltage

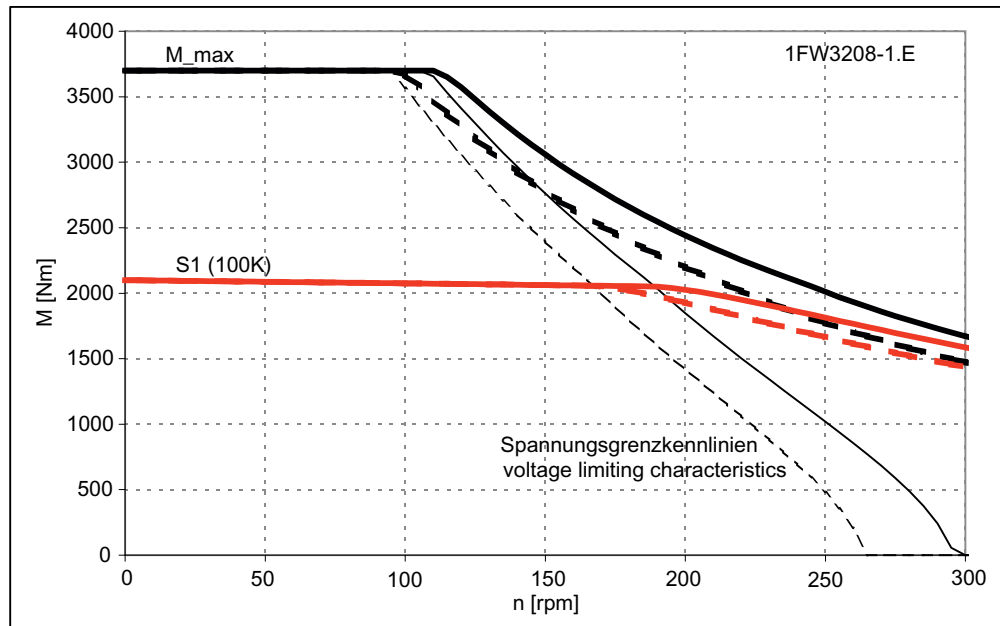

- SINAMICS ALM 400 V-Netz (Zwischenkreisspannung 600 V DC)
SINAMICS ALM 400 V line (DC-link voltage 600 V)
- - - SINAMICS BLM/SLM 400 V-Netz (Zwischenkreisspannung 540 V DC)
SINAMICS BLM/SLM 400 V line (DC-link voltage 540 V)

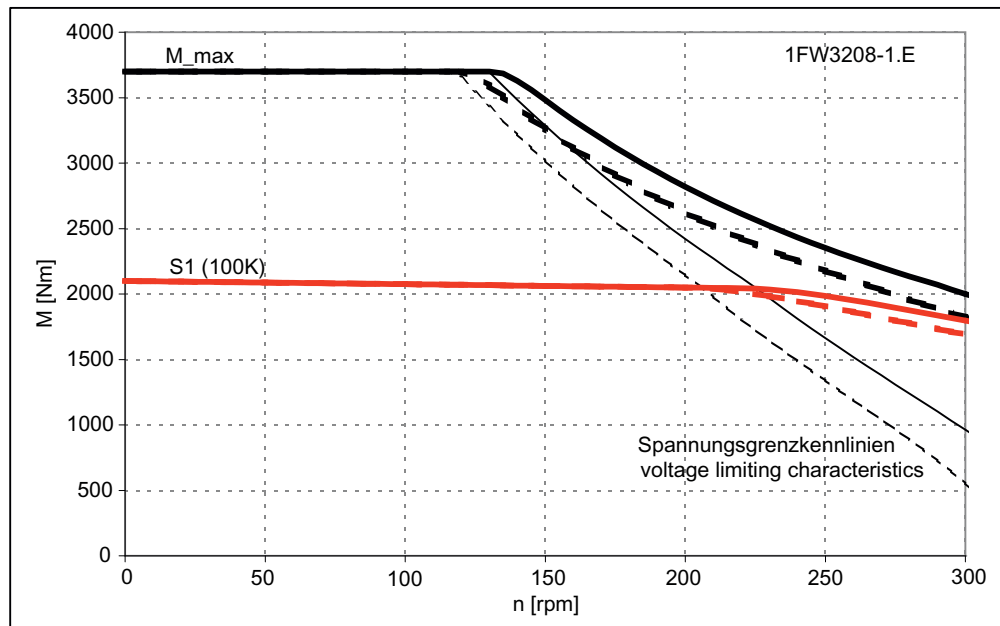

- SINAMICS ALM 480 V-Netz (Zwischenkreisspannung 720 V DC)
SINAMICS ALM 480 V line (DC-link voltage 720 V)
- - - SINAMICS BLM/SLM 480 V-Netz (Zwischenkreisspannung 650 V DC)
SINAMICS BLM/SLM 480 V line (DC-link voltage 650 V)

4.1 Torque-speed characteristic

Table 4- 35 1FW3208, rated speed 300 rpm

Configuration data	Code	Unit	1FW3208-1□H	
Rated speed	n_N	rpm	300	
Rated torque (100 K)	$M_N (100\text{ K})$	Nm	2000	
Rated power (100 K)	$P_N (100\text{ K})$	kW	63	
Rated current (100 K)	$I_N (100\text{ K})$	A	153	
Static torque (100 K)	$M_0 (100\text{ K})$	Nm	2100	
Stall current (100 K)	$I_0 (100\text{ K})$	A	160	
Limiting data				
Max. permissible speed (mech.)	$n_{\text{max mech.}}$	rpm	1000	
Max. permissible speed (converter)	$n_{\text{max 830 V}}$	rpm	690	
Maximum torque	M_{max}	Nm	3700	
Maximum current	I_{max}	A	340	
Motor data				
Number of poles	2p		28	
Ratio of speed measurement (belt-mounted encoder)	i_{enc}	--	-3.5	
Torque constant (100 K)	$k_T (100\text{ K})$	Nm/A	13.1	
Voltage constant (at 20 °C)	k_E	V/1000 rpm	835	
Winding resistance (at 20 °C)	R_{ph}	Ω	0.056	
Rotating field inductance	L_D	mH	2.0	
Electrical time constant	T_{el}	ms	35.5	
Thermal time constant	T_{th}	min	20	
Mechanical data: Hollow-shaft version				
Mechanical time constant	T_{mech}	ms	1.3	
Moment of inertia	J_{mot}	kgm ²	1.31	
Shaft torsional stiffness	C_t	Nm/rad	9.55E+06	
Weight	m	kg	350	
Mechanical data: Solid shaft version				
Mechanical time constant	T_{mech}	ms	1.1	
Moment of inertia	J_{mot}	kgm ²	1.11	
Shaft torsional stiffness	C_t	Nm/rad	2.35E+06	
Weight	m	kg	415	
Mechanical data: Plug-on shaft version				
Mechanical time constant	T_{mech}	ms	1.2	
Moment of inertia	J_{mot}	kgm ²	1.24	
Shaft torsional stiffness	C_t	Nm/rad	2.17E+07	
Weight	m	kg	400	

The specified rated data are valid for a 600 V DC link voltage

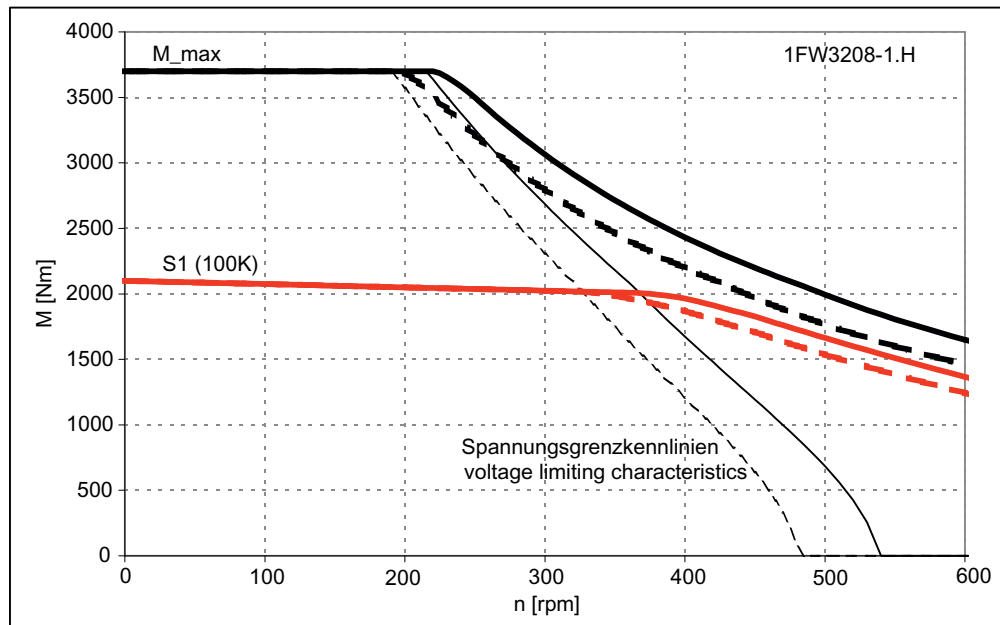

- SINAMICS ALM 400 V-Netz (Zwischenkreisspannung 600 V DC)
SINAMICS ALM 400 V line (DC-link voltage 600 V)
- - - SINAMICS BLM/SLM 400 V-Netz (Zwischenkreisspannung 540 V DC)
SINAMICS BLM/SLM 400 V line (DC-link voltage 540 V)

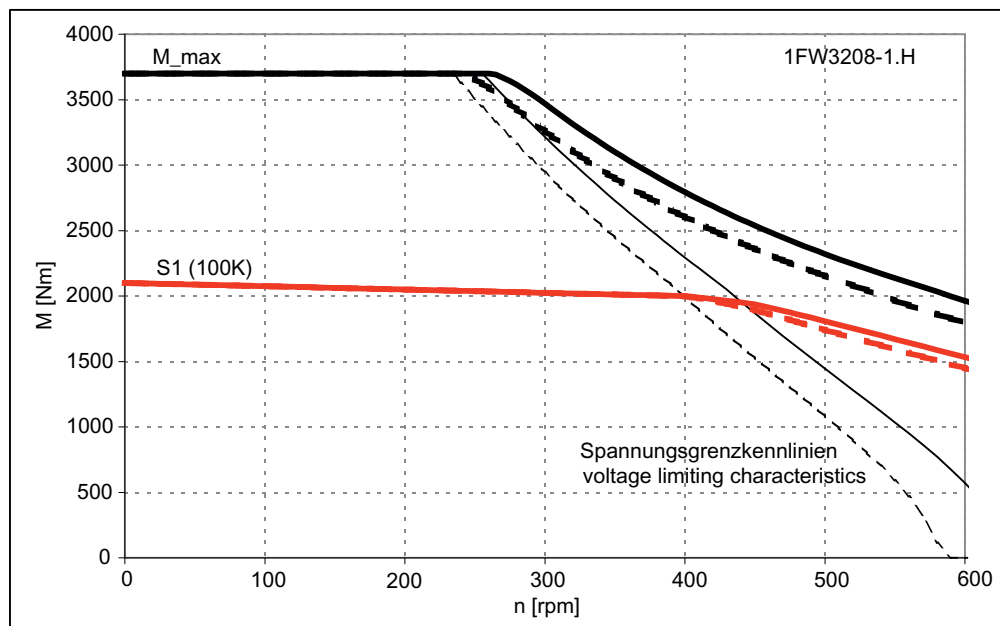

- SINAMICS ALM 480 V-Netz (Zwischenkreisspannung 720 V DC)
SINAMICS ALM 480 V line (DC-link voltage 720 V)
- - - SINAMICS BLM/SLM 480 V-Netz (Zwischenkreisspannung 650 V DC)
SINAMICS BLM/SLM 480 V line (DC-link voltage 650 V)

4.1 Torque-speed characteristic

Table 4- 36 1FW3208, rated speed 500 rpm

Configuration data	Code	Unit	1FW3208-1□L	
Rated speed	n_N	rpm	500	
Rated torque (100 K)	$M_N (100 K)$	Nm	1850	
Rated power (100 K)	$P_N (100 K)$	kW	97	
Rated current (100 K)	$I_N (100 K)$	A	225	
Static torque (100 K)	$M_0 (100 K)$	Nm	2100	
Stall current (100 K)	$I_0 (100 K)$	A	255	
Limiting data				
Max. permissible speed (mech.)	$n_{max mech.}$	rpm	1000	
Max. permissible speed (converter)	$n_{max 830 V}$	rpm	1100	
Maximum torque	M_{max}	Nm	3700	
Maximum current	I_{max}	A	530	
Motor data				
Number of poles	2p		28	
Ratio of speed measurement (belt-mounted encoder)	i_{enc}	--	-3.5	
Torque constant (100 K)	$k_T (100 K)$	Nm/A	8.2	
Voltage constant (at 20 °C)	k_E	V/1000 rpm	525	
Winding resistance (at 20 °C)	R_{ph}	Ω	0.027	
Rotating field inductance	L_D	mH	0.9	
Electrical time constant	T_{el}	ms	33.5	
Thermal time constant	T_{th}	min	20	
Mechanical data: Hollow-shaft version				
Mechanical time constant	T_{mech}	ms	1.6	
Moment of inertia	J_{mot}	kgm ²	1.31	
Shaft torsional stiffness	C_t	Nm/rad	9.55E+06	
Weight	m	kg	350	
Mechanical data: Solid shaft version				
Mechanical time constant	T_{mech}	ms	1.3	
Moment of inertia	J_{mot}	kgm ²	1.11	
Shaft torsional stiffness	C_t	Nm/rad	2.35E+06	
Weight	m	kg	415	
Mechanical data: Plug-on shaft version				
Mechanical time constant	T_{mech}	ms	1.5	
Moment of inertia	J_{mot}	kgm ²	1.24	
Shaft torsional stiffness	C_t	Nm/rad	2.17E+07	
Weight	m	kg	400	

The specified rated data are valid for a 600 V DC link voltage

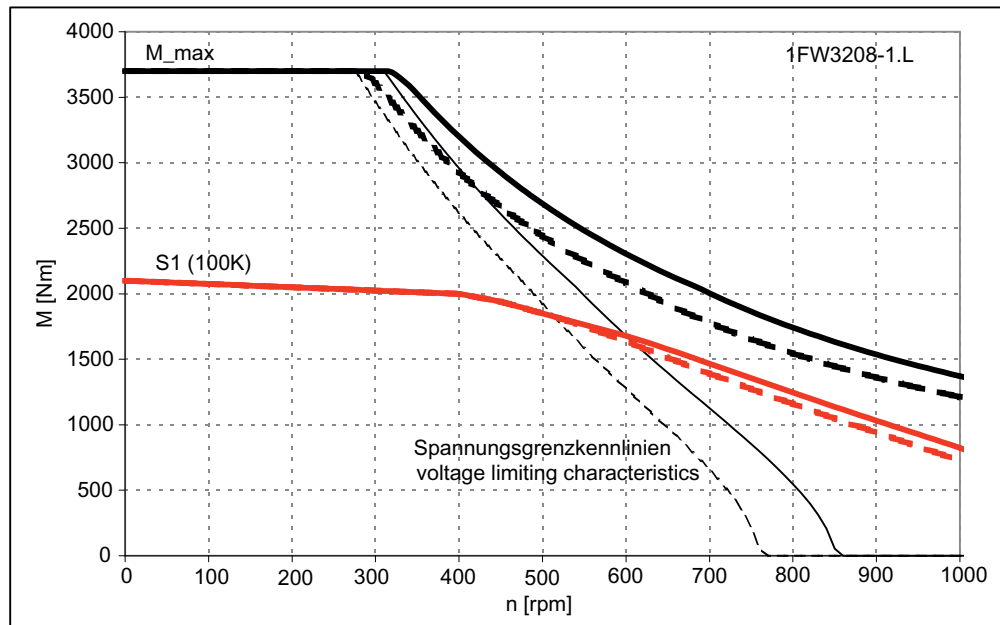

- SINAMICS ALM 400 V-Netz (Zwischenkreisspannung 600 V DC)
SINAMICS ALM 400 V line (DC-link voltage 600 V)
- - - SINAMICS BLM/SLM 400 V-Netz (Zwischenkreisspannung 540 V DC)
SINAMICS BLM/SLM 400 V line (DC-link voltage 540 V)

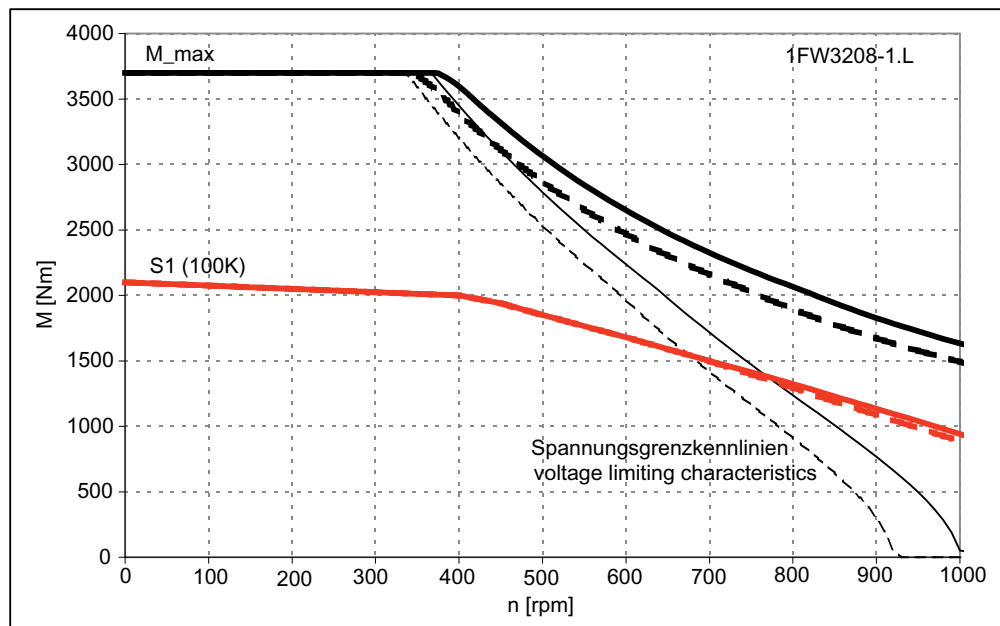

- SINAMICS ALM 480 V-Netz (Zwischenkreisspannung 720 V DC)
SINAMICS ALM 480 V line (DC-link voltage 720 V)
- - - SINAMICS BLM/SLM 480 V-Netz (Zwischenkreisspannung 650 V DC)
SINAMICS BLM/SLM 480 V line (DC-link voltage 650 V)

4.1 Torque-speed characteristic

4.1.3 Shaft height 280, High Torque

Table 4- 37 1FW3281, rated speed 150 rpm

Configuration data	Code	Unit	1FW3281-1□E
Rated speed	n_N	rpm	150
Rated torque (100 K)	$M_N (100\text{ K})$	Nm	2500
Rated power (100 K)	$P_N (100\text{ K})$	kW	39.5
Rated current (100 K)	$I_N (100\text{ K})$	A	82
Static torque (100 K)	$M_0 (100\text{ K})$	Nm	2550
Stall current (100 K)	$I_0 (100\text{ K})$	A	84
Limiting data			
Max. permissible speed (mech.)	$n_{\max\text{ mech.}}$	rpm	1000
Max. permissible speed (converter)	$n_{\max\ 630\text{ V}}$	rpm	290
Maximum torque	M_{\max}	Nm	4050
Maximum current	I_{\max}	A	145
Motor data			
Number of poles	2p		20
Ratio of speed measurement (belt-mounted encoder)	i_{enc}	--	-5
Torque constant (100 K)	$k_T (100\text{ K})$	Nm/A	30.5
Voltage constant (at 20 °C)	k_E	V/1000 rpm	1945
Winding resistance (at 20 °C)	R_{ph}	Ω	0.255
Rotating field inductance	L_D	mH	9.5
Electrical time constant	T_{el}	ms	38.0
Thermal time constant	T_{th}	min	10.0
Mechanical data: Hollow-shaft version			
Mechanical time constant	T_{mech}	ms	3.1
Moment of inertia	J_{mot}	kgm ²	3.8
Shaft torsional stiffness	c_t	Nm/rad	1.32E+08
Weight	m	kg	600

The specified rated data are valid for a 600 V DC link voltage

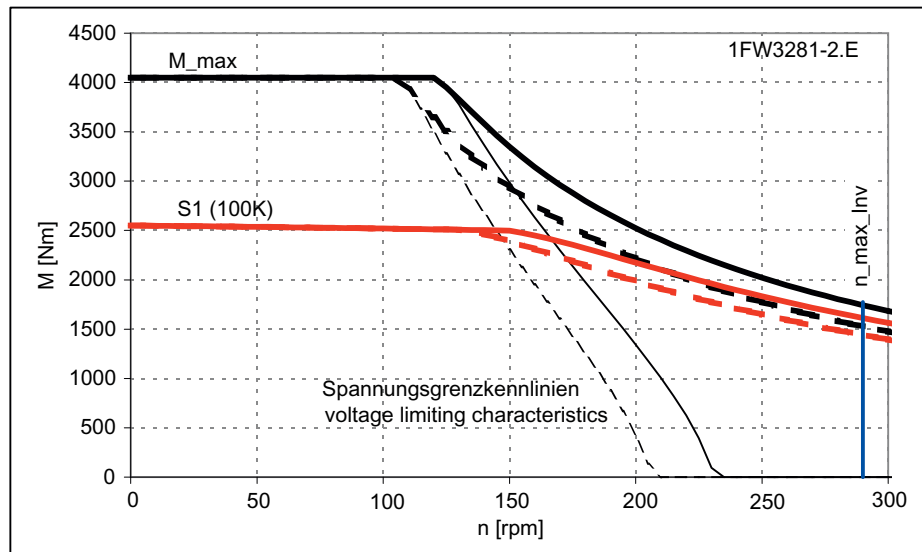

- SINAMICS ALM 400 V-Netz (Zwischenkreisspannung 600 V DC)
SINAMICS ALM 400 V line (DC-link voltage 600 V)
- - - SINAMICS BLM/SLM 400 V-Netz (Zwischenkreisspannung 540 V DC)
SINAMICS BLM/SLM 400 V line (DC-link voltage 540 V)

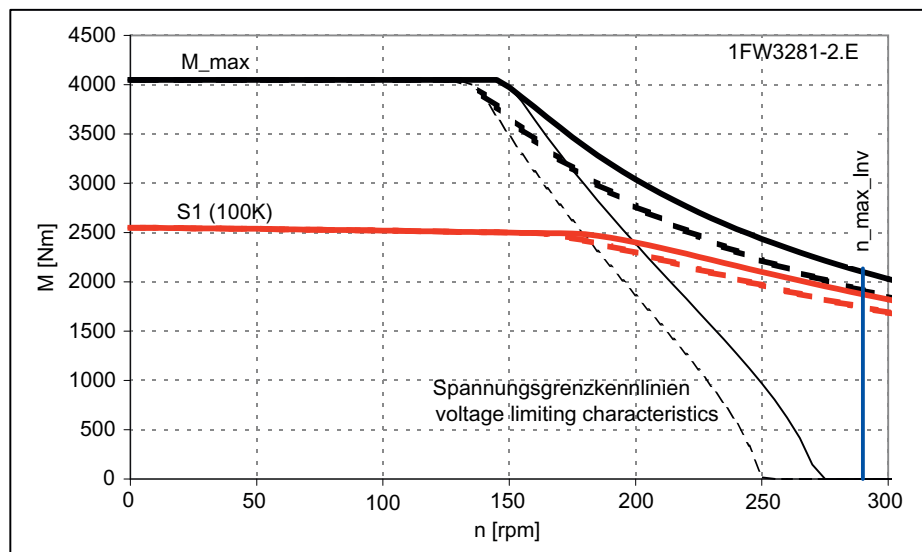

- SINAMICS ALM 480 V-Netz (Zwischenkreisspannung 720 V DC)
SINAMICS ALM 480 V line (DC-link voltage 720 V)
- - - SINAMICS BLM/SLM 480 V-Netz (Zwischenkreisspannung 650 V DC)
SINAMICS BLM/SLM 480 V line (DC-link voltage 650 V)

4.1 Torque-speed characteristic

Table 4- 38 1FW3281, rated speed 250 rpm

Configuration data	Code	Unit	1FW3281-2□G
Rated speed	n_N	rpm	250
Rated torque (100 K)	$M_N (100\text{ K})$	Nm	2450
Rated power (100 K)	$P_N (100\text{ K})$	kW	64
Rated current (100 K)	$I_N (100\text{ K})$	A	126
Static torque (100 K)	$M_0 (100\text{ K})$	Nm	2550
Stall current (100 K)	$I_0 (100\text{ K})$	A	131
Limiting data			
Max. permissible speed (mech.)	$n_{\text{max mech.}}$	rpm	1000
Max. permissible speed (converter)	$n_{\text{max 830 V}}$	rpm	460
Maximum torque	M_{max}	Nm	4050
Maximum current	I_{max}	A	225
Motor data			
Number of poles	2p		20
Ratio of speed measurement (belt-mounted encoder)	i_{enc}	--	-5
Torque constant (100 K)	$k_T (100\text{ K})$	Nm/A	19.5
Voltage constant (at 20 °C)	k_E	V/1000 rpm	1245
Winding resistance (at 20 °C)	R_{ph}	Ω	0.104
Rotating field inductance	L_D	mH	4.0
Electrical time constant	T_{el}	ms	38.0
Thermal time constant	T_{th}	min	10.0
Mechanical data: Hollow-shaft version			
Mechanical time constant	T_{mech}	ms	3.1
Moment of inertia	J_{mot}	kgm ²	3.8
Shaft torsional stiffness	C_t	Nm/rad	1.32E+08
Weight	m	kg	600

The specified rated data are valid for a 600 V DC link voltage

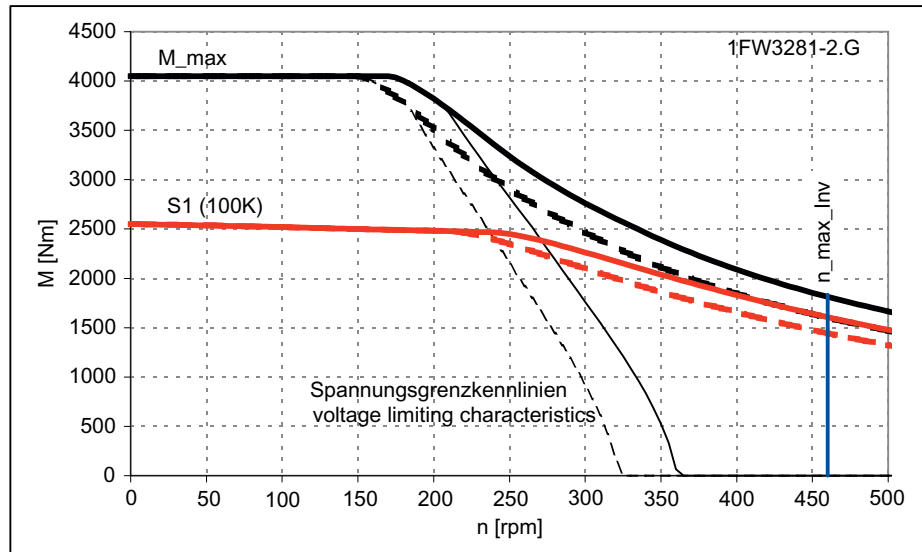

- SINAMICS ALM 400 V-Netz (Zwischenkreisspannung 600 V DC)
SINAMICS ALM 400 V line (DC-link voltage 600 V)
- - - SINAMICS BLM/SLM 400 V-Netz (Zwischenkreisspannung 540 V DC)
SINAMICS BLM/SLM 400 V line (DC-link voltage 540 V)

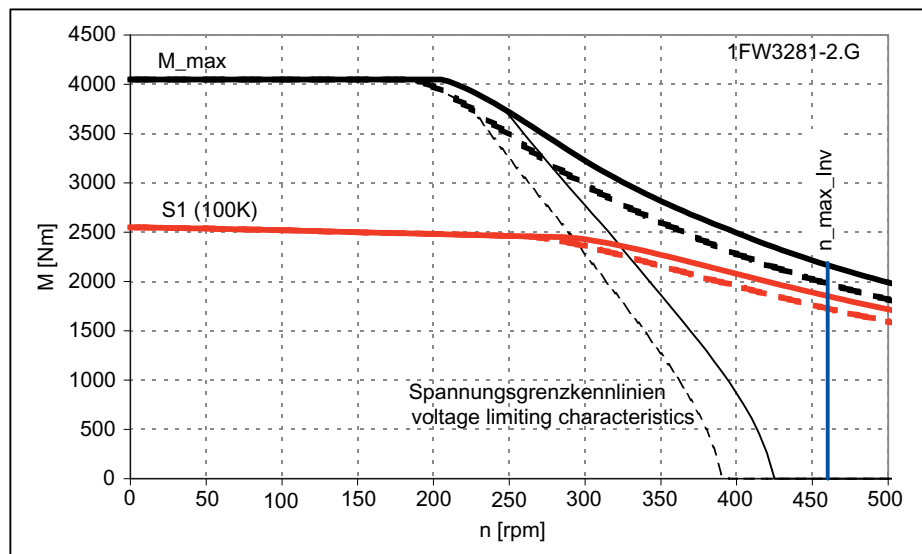

- SINAMICS ALM 480 V-Netz (Zwischenkreisspannung 720 V DC)
SINAMICS ALM 480 V line (DC-link voltage 720 V)
- - - SINAMICS BLM/SLM 480 V-Netz (Zwischenkreisspannung 650 V DC)
SINAMICS BLM/SLM 480 V line (DC-link voltage 650 V)

4.1 Torque-speed characteristic

Table 4- 39 1FW3283, rated speed 150 rpm

Configuration data	Code	Unit	1FW3283-2□E	
Rated speed	n_N	rpm	150	
Rated torque (100 K)	$M_N (100\text{ K})$	Nm	3500	
Rated power (100 K)	$P_N (100\text{ K})$	kW	55	
Rated current (100 K)	$I_N (100\text{ K})$	A	115	
Static torque (100 K)	$M_0 (100\text{ K})$	Nm	3550	
Stall current (100 K)	$I_0 (100\text{ K})$	A	116	
Limiting data				
Max. permissible speed (mech.)	$n_{\text{max mech.}}$	rpm	1000	
Max. permissible speed (converter)	$n_{\text{max 830 V}}$	rpm	290	
Maximum torque	M_{max}	Nm	5700	
Maximum current	I_{max}	A	205	
Motor data				
Number of poles	2p		20	
Ratio of speed measurement (belt-mounted encoder)	i_{enc}	--	-5	
Torque constant (100 K)	$k_T (100\text{ K})$	Nm/A	30.5	
Voltage constant (at 20 °C)	k_E	V/1000 rpm	1955	
Winding resistance (at 20 °C)	R_{ph}	Ω	0.162	
Rotating field inductance	L_D	mH	7.0	
Electrical time constant	T_{el}	ms	43.0	
Thermal time constant	T_{th}	min	12.0	
Mechanical data: Hollow-shaft version				
Mechanical time constant	T_{mech}	ms	2.4	
Moment of inertia	J_{mot}	kgm ²	4.65	
Shaft torsional stiffness	C_t	Nm/rad	1.08E+08	
Weight	m	kg	690	

The specified rated data are valid for a 600 V DC link voltage

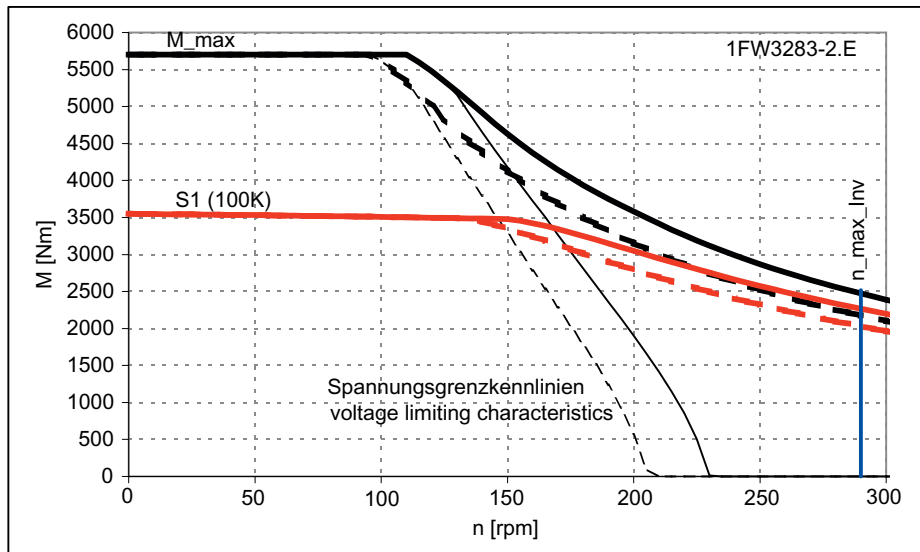

- SINAMICS ALM 400 V-Netz (Zwischenkreisspannung 600 V DC)
SINAMICS ALM 400 V line (DC-link voltage 600 V)
- - - SINAMICS BLM/SLM 400 V-Netz (Zwischenkreisspannung 540 V DC)
SINAMICS BLM/SLM 400 V line (DC-link voltage 540 V)

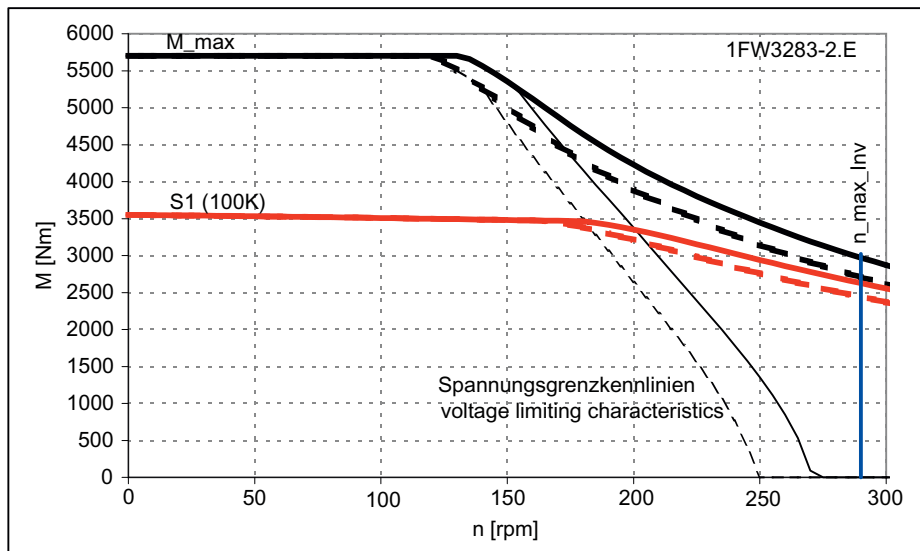

- SINAMICS ALM 480 V-Netz (Zwischenkreisspannung 720 V DC)
SINAMICS ALM 480 V line (DC-link voltage 720 V)
- - - SINAMICS BLM/SLM 480 V-Netz (Zwischenkreisspannung 650 V DC)
SINAMICS BLM/SLM 480 V line (DC-link voltage 650 V)

4.1 Torque-speed characteristic

Table 4- 40 1FW3283, rated speed 250 rpm

Configuration data	Code	Unit	1FW3283-2□G
Rated speed	n_N	rpm	250
Rated torque (100 K)	$M_N (100\text{ K})$	Nm	3450
Rated power (100 K)	$P_N (100\text{ K})$	kW	90
Rated current (100 K)	$I_N (100\text{ K})$	A	176
Static torque (100 K)	$M_0 (100\text{ K})$	Nm	3550
Stall current (100 K)	$I_0 (100\text{ K})$	A	181
Limiting data			
Max. permissible speed (mech.)	$n_{\text{max mech.}}$	rpm	1000
Max. permissible speed (converter)	$n_{\text{max 830 V}}$	rpm	460
Maximum torque	M_{max}	Nm	5700
Maximum current	I_{max}	A	315
Motor data			
Number of poles	2p		20
Ratio of speed measurement (belt-mounted encoder)	i_{enc}	--	-5
Torque constant (100 K)	$k_T (100\text{ K})$	Nm/A	19.6
Voltage constant (at 20 °C)	k_E	V/1000 rpm	1255
Winding resistance (at 20 °C)	R_{ph}	Ω	0.067
Rotating field inductance	L_D	mH	2.9
Electrical time constant	T_{el}	ms	43.0
Thermal time constant	T_{th}	min	12.0
Mechanical data: Hollow-shaft version			
Mechanical time constant	T_{mech}	ms	2.4
Moment of inertia	J_{mot}	kgm ²	4.65
Shaft torsional stiffness	C_t	Nm/rad	1.08E+08
Weight	m	kg	690

The specified rated data are valid for a 600 V DC link voltage

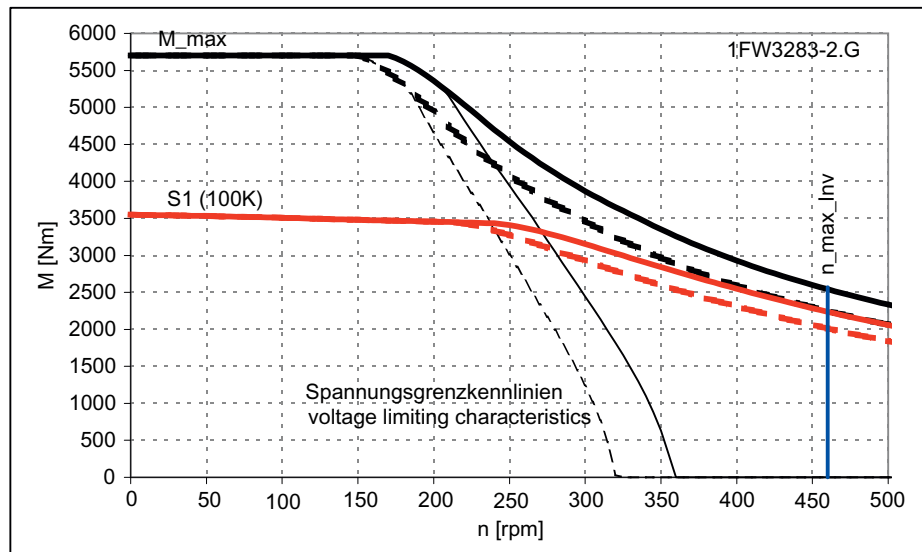

- SINAMICS ALM 400 V-Netz (Zwischenkreisspannung 600 V DC)
SINAMICS ALM 400 V line (DC-link voltage 600 V)
- - - SINAMICS BLM/SLM 400 V-Netz (Zwischenkreisspannung 540 V DC)
SINAMICS BLM/SLM 400 V line (DC-link voltage 540 V)

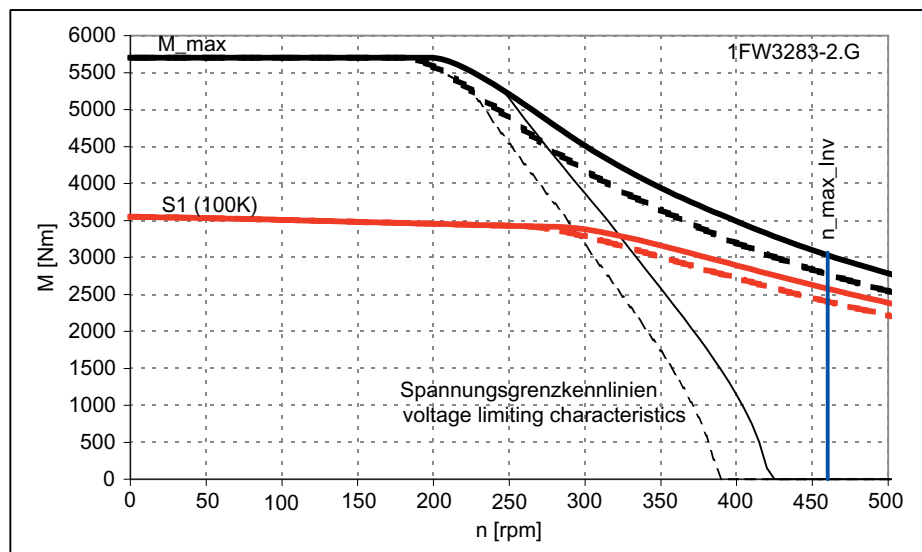

- SINAMICS ALM 480 V-Netz (Zwischenkreisspannung 720 V DC)
SINAMICS ALM 480 V line (DC-link voltage 720 V)
- - - SINAMICS BLM/SLM 480 V-Netz (Zwischenkreisspannung 650 V DC)
SINAMICS BLM/SLM 480 V line (DC-link voltage 650 V)

4.1 Torque-speed characteristic

Table 4- 41 1FW3285, rated speed 150 rpm

Configuration data	Code	Unit	1FW3285-2□E	
Rated speed	n_N	rpm	150	
Rated torque (100 K)	$M_N (100\text{ K})$	Nm	5000	
Rated power (100 K)	$P_N (100\text{ K})$	kW	79	
Rated current (100 K)	$I_N (100\text{ K})$	A	160	
Static torque (100 K)	$M_0 (100\text{ K})$	Nm	5100	
Stall current (100 K)	$I_0 (100\text{ K})$	A	163	
Limiting data				
Max. permissible speed (mech.)	$n_{\text{max mech.}}$	rpm	1000	
Max. permissible speed (converter)	$n_{\text{max 830 V}}$	rpm	290	
Maximum torque	M_{max}	Nm	8150	
Maximum current	I_{max}	A	285	
Motor data				
Number of poles	2p		20	
Ratio of speed measurement (belt-mounted encoder)	i_{enc}	--	-5	
Torque constant (100 K)	$k_T (100\text{ K})$	Nm/A	31.0	
Voltage constant (at 20 °C)	k_E	V/1000 rpm	1995	
Winding resistance (at 20 °C)	R_{ph}	Ω	0.107	
Rotating field inductance	L_D	mH	5.0	
Electrical time constant	T_{el}	ms	47.5	
Thermal time constant	T_{th}	min	14.0	
Mechanical data: Hollow-shaft version				
Mechanical time constant	T_{mech}	ms	2.0	
Moment of inertia	J_{mot}	kgm ²	6.0	
Shaft torsional stiffness	C_t	Nm/rad	8.47E+07	
Weight	m	kg	860	

The specified rated data are valid for a 600 V DC link voltage

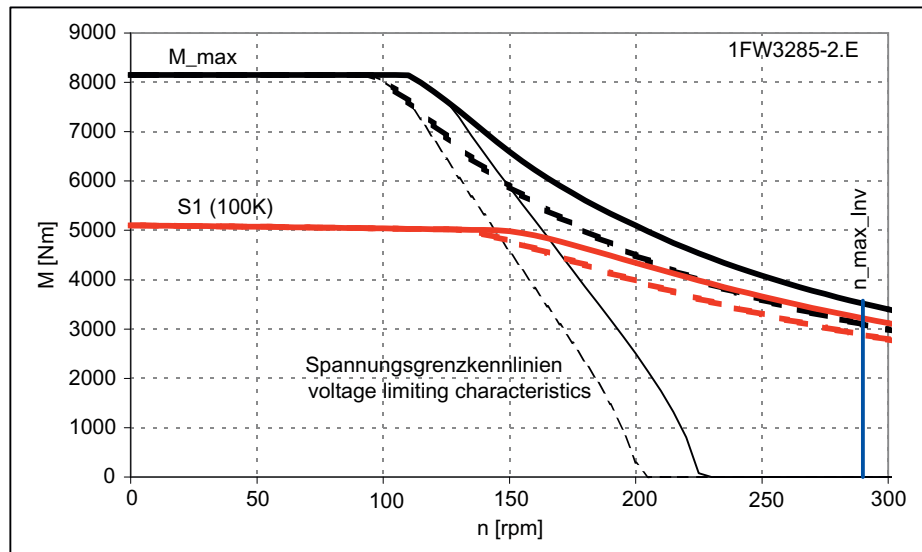

- SINAMICS ALM 400 V-Netz (Zwischenkreisspannung 600 V DC)
SINAMICS ALM 400 V line (DC-link voltage 600 V)
- - - SINAMICS BLM/SLM 400 V-Netz (Zwischenkreisspannung 540 V DC)
SINAMICS BLM/SLM 400 V line (DC-link voltage 540 V)

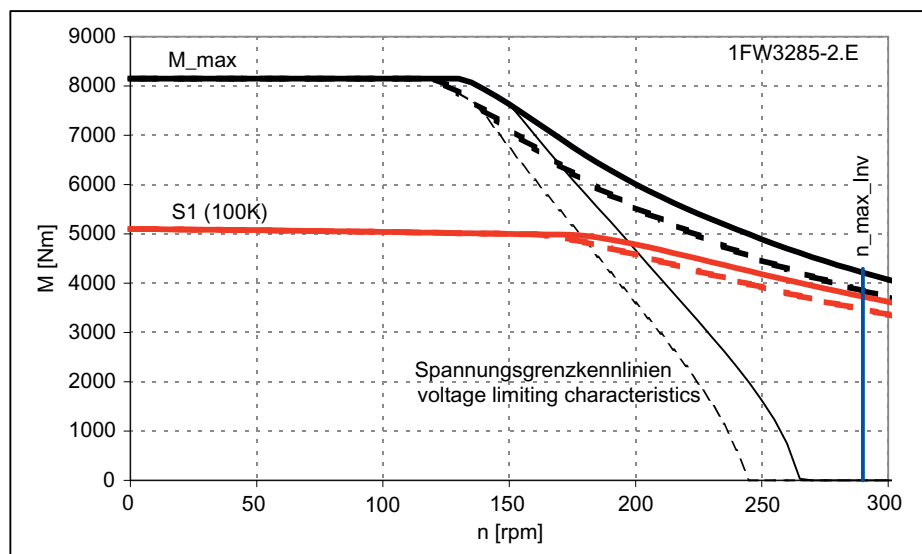

- SINAMICS ALM 480 V-Netz (Zwischenkreisspannung 720 V DC)
SINAMICS ALM 480 V line (DC-link voltage 720 V)
- - - SINAMICS BLM/SLM 480 V-Netz (Zwischenkreisspannung 650 V DC)
SINAMICS BLM/SLM 480 V line (DC-link voltage 650 V)

4.1 Torque-speed characteristic

Table 4- 42 1FW3285, rated speed 250 rpm

Configuration data	Code	Unit	1FW3285-2□G
Rated speed	n_N	rpm	250
Rated torque (100 K)	$M_N (100 K)$	Nm	4950
Rated power (100 K)	$P_N (100 K)$	kW	130
Rated current (100 K)	$I_N (100 K)$	A	245
Static torque (100 K)	$M_0 (100 K)$	Nm	5100
Stall current (100 K)	$I_0 (100 K)$	A	250
Limiting data			
Max. permissible speed (mech.)	$n_{max mech.}$	rpm	1000
Max. permissible speed (converter)	$n_{max 830 V}$	rpm	440
Maximum torque	M_{max}	Nm	8150
Maximum current	I_{max}	A	435
Motor data			
Number of poles	2p		20
Ratio of speed measurement (belt-mounted encoder)	i_{enc}	--	-5
Torque constant (100 K)	$k_T (100 K)$	Nm/A	20.5
Voltage constant (at 20 °C)	k_E	V/1000 rpm	1295
Winding resistance (at 20 °C)	R_{ph}	Ω	0.045
Rotating field inductance	L_D	mH	2.2
Electrical time constant	T_{el}	ms	47.5
Thermal time constant	T_{th}	min	14.0
Mechanical data: Hollow-shaft version			
Mechanical time constant	T_{mech}	ms	2.0
Moment of inertia	J_{mot}	kgm ²	6.0
Shaft torsional stiffness	C_t	Nm/rad	8.47E+07
Weight	m	kg	860

The specified rated data are valid for a 600 V DC link voltage

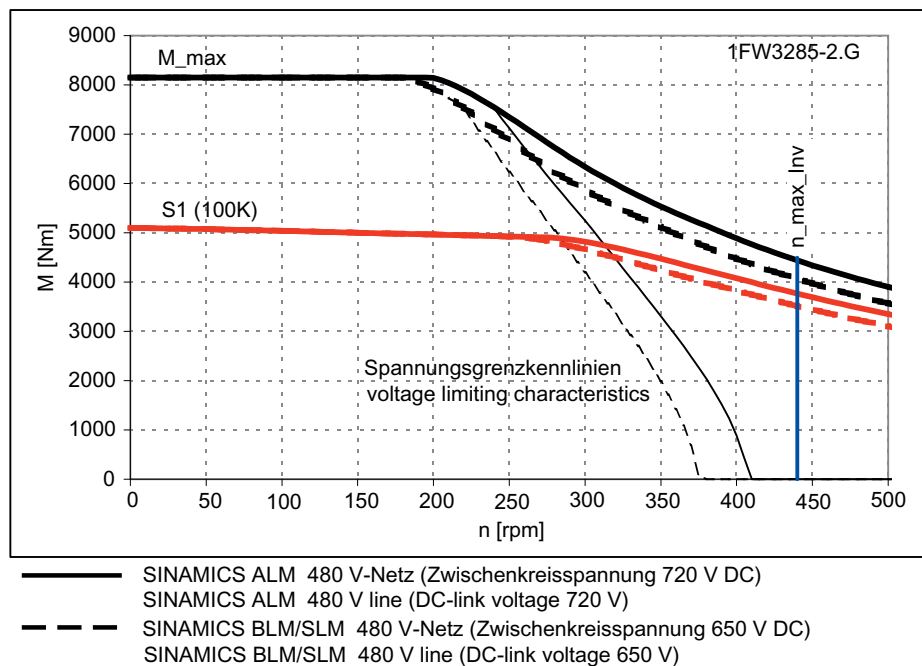
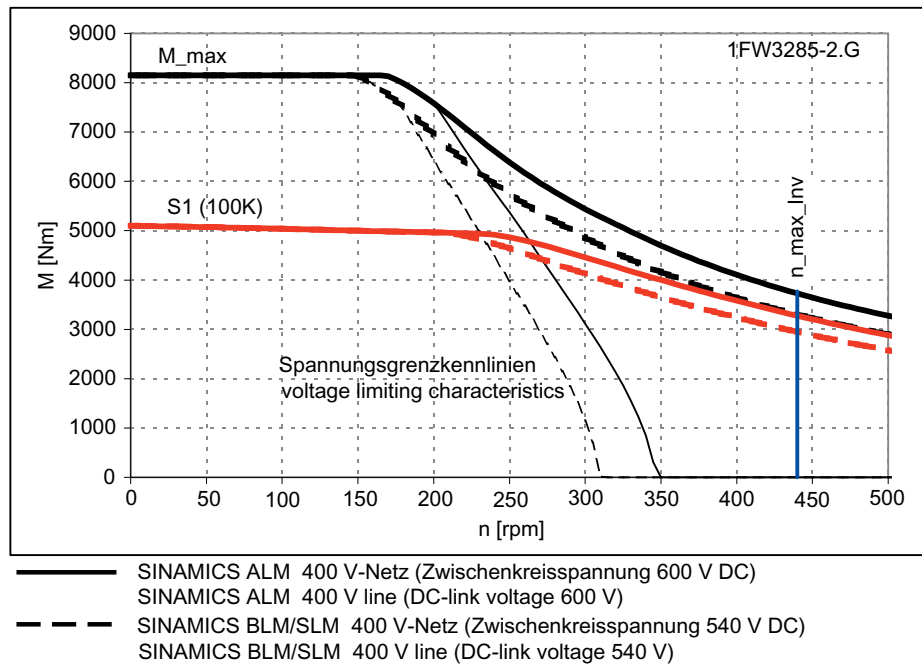

4.1 Torque-speed characteristic

Table 4- 43 1FW3287, rated speed 150 rpm

Configuration data	Code	Unit	1FW3287-2□E
Rated speed	n_N	rpm	150
Rated torque (100 K)	$M_N (100\text{ K})$	Nm	7000
Rated power (100 K)	$P_N (100\text{ K})$	kW	110
Rated current (100 K)	$I_N (100\text{ K})$	A	230
Static torque (100 K)	$M_0 (100\text{ K})$	Nm	7150
Stall current (100 K)	$I_0 (100\text{ K})$	A	235
Limiting data			
Max. permissible speed (mech.)	$n_{\text{max mech.}}$	rpm	1000
Max. permissible speed (converter)	$n_{\text{max 830 V}}$	rpm	290
Maximum torque	M_{max}	Nm	11400
Maximum current	I_{max}	A	405
Motor data			
Number of poles	2p		20
Ratio of speed measurement (belt-mounted encoder)	i_{enc}	--	-5
Torque constant (100 K)	$k_T (100\text{ K})$	Nm/A	30.5
Voltage constant (at 20 °C)	k_E	V/1000 rpm	1955
Winding resistance (at 20 °C)	R_{ph}	Ω	0.068
Rotating field inductance	L_D	mH	3.5
Electrical time constant	T_{el}	ms	51
Thermal time constant	T_{th}	min	16.0
Mechanical data: Hollow-shaft version			
Mechanical time constant	T_{mech}	ms	1.7
Moment of inertia	J_{mot}	kgm ²	7.8
Shaft torsional stiffness	C_t	Nm/rad	6.58E+07
Weight	m	kg	1030

The specified rated data are valid for a 600 V DC link voltage

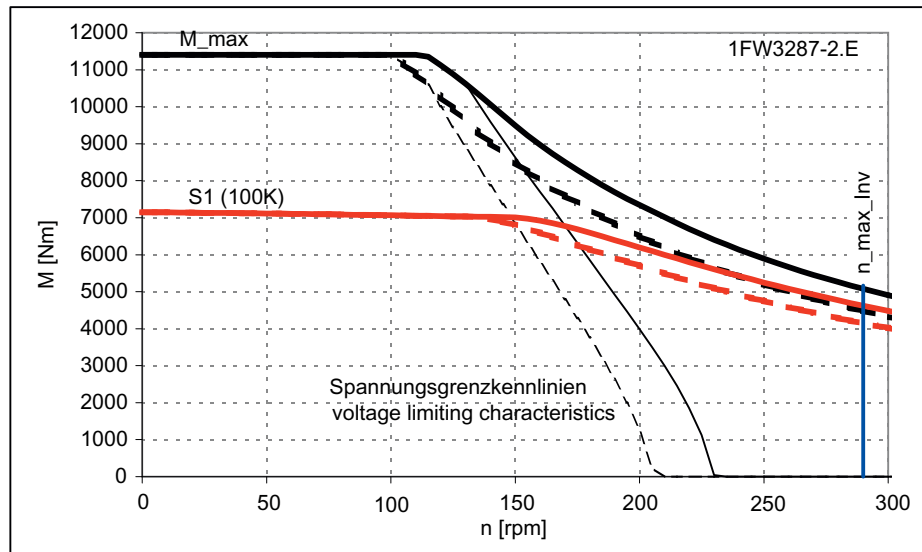

- SINAMICS ALM 400 V-Netz (Zwischenkreisspannung 600 V DC)
SINAMICS ALM 400 V line (DC-link voltage 600 V)
- - - SINAMICS BLM/SLM 400 V-Netz (Zwischenkreisspannung 540 V DC)
SINAMICS BLM/SLM 400 V line (DC-link voltage 540 V)

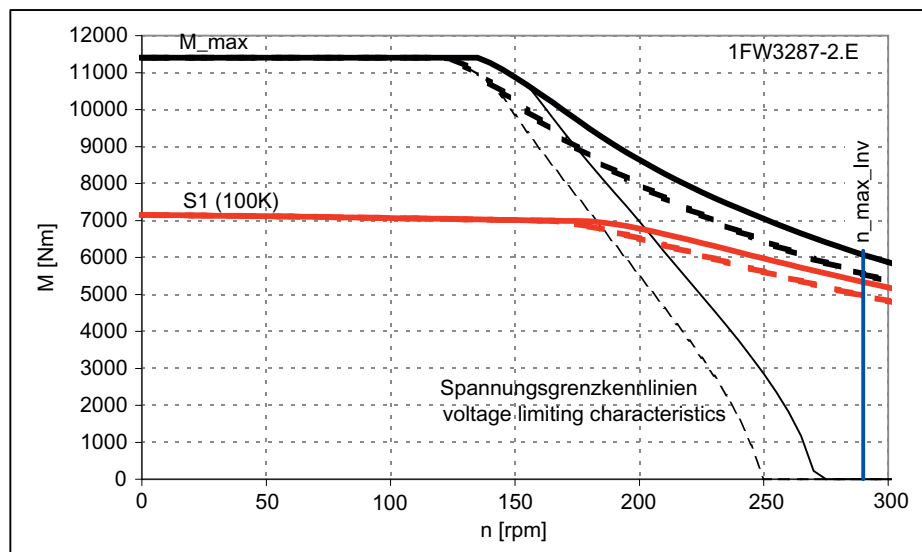

- SINAMICS ALM 480 V-Netz (Zwischenkreisspannung 720 V DC)
SINAMICS ALM 480 V line (DC-link voltage 720 V)
- - - SINAMICS BLM/SLM 480 V-Netz (Zwischenkreisspannung 650 V DC)
SINAMICS BLM/SLM 480 V line (DC-link voltage 650 V)

4.1 Torque-speed characteristic

Table 4- 44 1FW3287, rated speed 250 rpm

Configuration data	Code	Unit	1FW3287-2□G
Rated speed	n_N	rpm	250
Rated torque (100 K)	$M_N (100\text{ K})$	Nm	6900
Rated power (100 K)	$P_N (100\text{ K})$	kW	181
Rated current (100 K)	$I_N (100\text{ K})$	A	350
Static torque (100 K)	$M_0 (100\text{ K})$	Nm	7150
Stall current (100 K)	$I_0 (100\text{ K})$	A	365
Limiting data			
Max. permissible speed (mech.)	$n_{\text{max mech.}}$	rpm	1000
Max. permissible speed (converter)	$n_{\text{max 830 V}}$	rpm	460
Maximum torque	M_{max}	Nm	11400
Maximum current	I_{max}	A	630
Motor data			
Number of poles	2p		20
Ratio of speed measurement (belt-mounted encoder)	i_{enc}	--	-5
Torque constant (100 K)	$k_T (100\text{ K})$	Nm/A	19.6
Voltage constant (at 20 °C)	k_E	V/1000 rpm	1255
Winding resistance (at 20 °C)	R_{ph}	Ω	0.028
Rotating field inductance	L_D	mH	1.45
Electrical time constant	T_{el}	ms	51
Thermal time constant	T_{th}	min	16.0
Mechanical data: Hollow-shaft version			
Mechanical time constant	T_{mech}	ms	1.7
Moment of inertia	J_{mot}	kgm ²	7.8
Shaft torsional stiffness	C_t	Nm/rad	6.58E+07
Weight	m	kg	1030

The specified rated data are valid for a 600 V DC link voltage

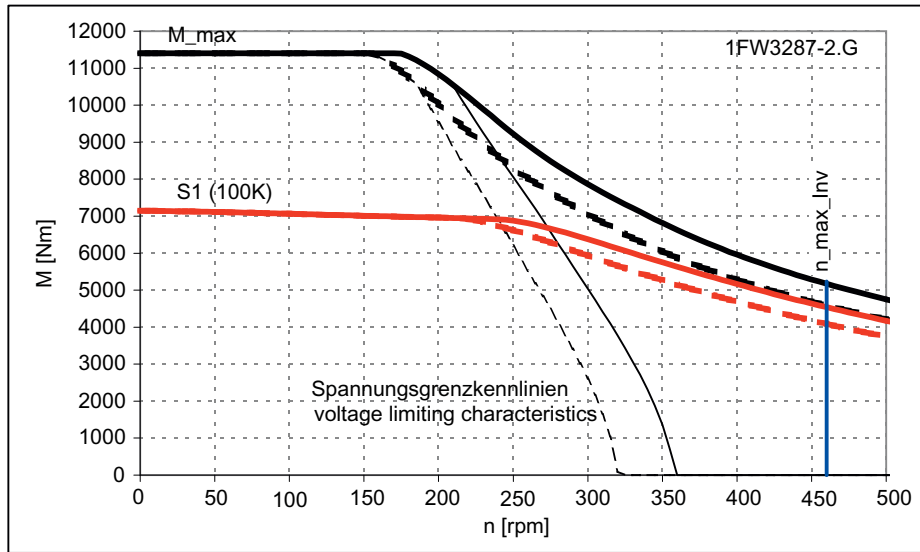

- SINAMICS ALM 400 V-Netz (Zwischenkreisspannung 600 V DC)
SINAMICS ALM 400 V line (DC-link voltage 600 V)
- - - SINAMICS BLM/SLM 400 V-Netz (Zwischenkreisspannung 540 V DC)
SINAMICS BLM/SLM 400 V line (DC-link voltage 540 V)

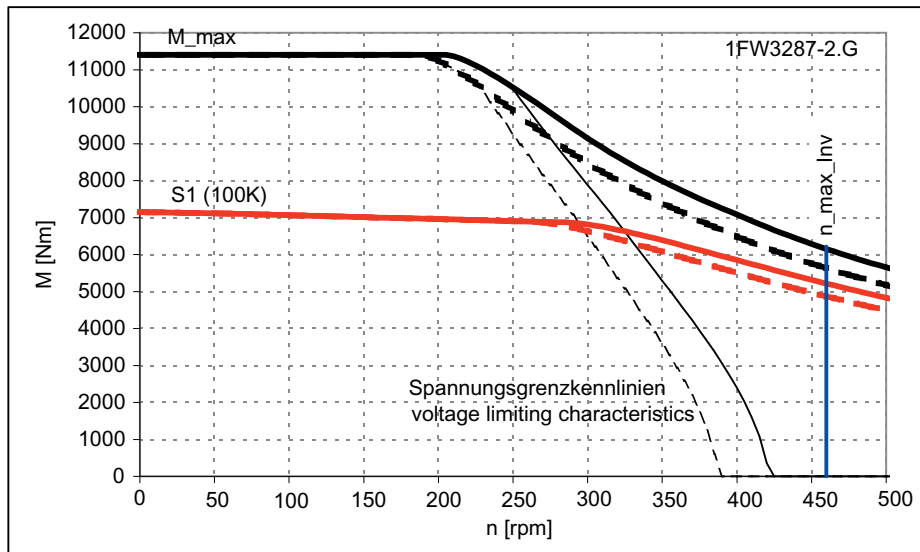

- SINAMICS ALM 480 V-Netz (Zwischenkreisspannung 720 V DC)
SINAMICS ALM 480 V line (DC-link voltage 720 V)
- - - SINAMICS BLM/SLM 480 V-Netz (Zwischenkreisspannung 650 V DC)
SINAMICS BLM/SLM 480 V line (DC-link voltage 650 V)

4.1 Torque-speed characteristic

4.1.4 Shaft height 280, High Speed

Table 4- 45 1FW3281, rated speed 400 rpm

Configuration data	Code	Unit	1FW3281-3□J
Rated speed	n_N	rpm	400
Rated torque (100 K)	$M_N (100\text{ K})$	Nm	2350
Rated power (100 K)	$P_N (100\text{ K})$	kW	98
Rated current (100 K)	$I_N (100\text{ K})$	A	188
Static torque (100 K)	$M_0 (100\text{ K})$	Nm	2500
Stall current (100 K)	$I_0 (100\text{ K})$	A	200
Limiting data			
Max. permissible speed (mech.)	$n_{\max\text{ mech.}}$	rpm	1000
Max. permissible speed (converter)	$n_{\max\ 630\text{ V}}$	rpm	720
Maximum torque	M_{\max}	Nm	4050
Maximum current	I_{\max}	A	350
Motor data			
Number of poles	2p		20
Ratio of speed measurement (belt-mounted encoder)	i_{enc}	--	-5
Torque constant (100 K)	$k_T (100\text{ K})$	Nm/A	12.5
Voltage constant (at 20 °C)	k_E	V/1000 rpm	800
Winding resistance (at 20 °C)	R_{ph}	Ω	0.0425
Rotating field inductance	L_D	mH	1.65
Electrical time constant	T_{el}	ms	38.0
Thermal time constant	T_{th}	min	10.0
Mechanical data: Hollow-shaft version			
Mechanical time constant	T_{mech}	ms	3.1
Moment of inertia	J_{mot}	kgm ²	3.8
Shaft torsional stiffness	c_t	Nm/rad	1.32E+08
Weight	m	kg	600

The specified rated data are valid for a 600 V DC link voltage

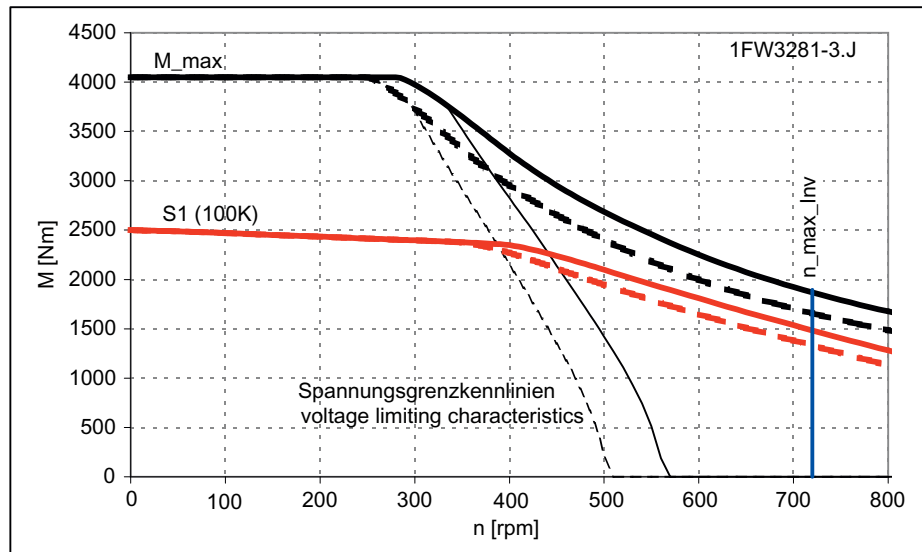

- SINAMICS ALM 400 V-Netz (Zwischenkreisspannung 600 V DC)
SINAMICS ALM 400 V line (DC-link voltage 600 V)
- - - SINAMICS BLM/SLM 400 V-Netz (Zwischenkreisspannung 540 V DC)
SINAMICS BLM/SLM 400 V line (DC-link voltage 540 V)

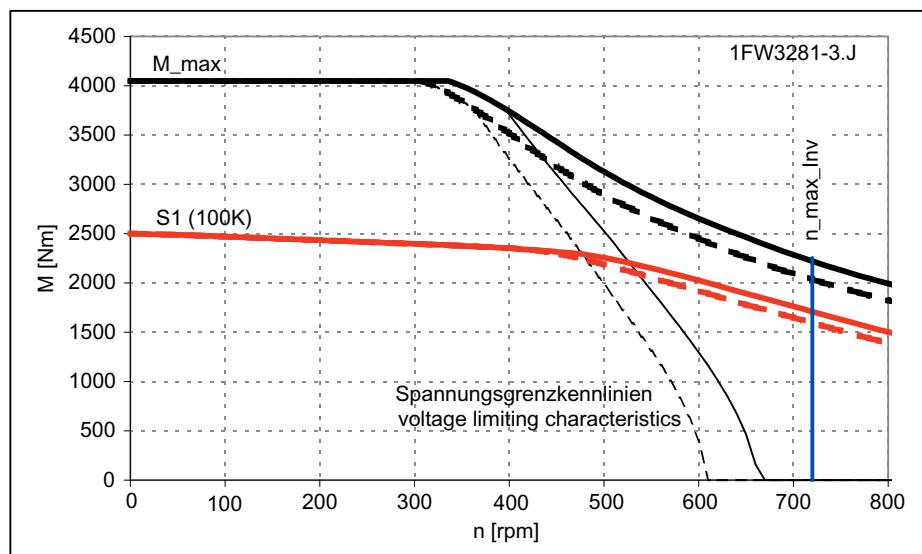

- SINAMICS ALM 480 V-Netz (Zwischenkreisspannung 720 V DC)
SINAMICS ALM 480 V line (DC-link voltage 720 V)
- - - SINAMICS BLM/SLM 480 V-Netz (Zwischenkreisspannung 650 V DC)
SINAMICS BLM/SLM 480 V line (DC-link voltage 650 V)

4.1 Torque-speed characteristic

Table 4- 46 1FW3281, rated speed 600 rpm

Configuration data	Code	Unit	1FW3281-3□M	
Rated speed	n_N	rpm	600	
Rated torque (100 K)	$M_N (100\text{ K})$	Nm	2200	
Rated power (100 K)	$P_N (100\text{ K})$	kW	138	
Rated current (100 K)	$I_N (100\text{ K})$	A	255	
Static torque (100 K)	$M_0 (100\text{ K})$	Nm	2500	
Stall current (100 K)	$I_0 (100\text{ K})$	A	290	
Limiting data				
Max. permissible speed (mech.)	$n_{\text{max mech.}}$	rpm	1000	
Max. permissible speed (converter)	$n_{\text{max 830 V}}$	rpm	1050	
Maximum torque	M_{max}	Nm	4050	
Maximum current	I_{max}	A	510	
Motor data				
Number of poles	2p		20	
Ratio of speed measurement (belt-mounted encoder)	i_{enc}	--	-5	
Torque constant (100 K)	$k_T (100\text{ K})$	Nm/A	8.6	
Voltage constant (at 20 °C)	k_E	V/1000 rpm	550	
Winding resistance (at 20 °C)	R_{ph}	Ω	0.02	
Rotating field inductance	L_D	mH	0.75	
Electrical time constant	T_{el}	ms	38.0	
Thermal time constant	T_{th}	min	10.0	
Mechanical data: Hollow-shaft version				
Mechanical time constant	T_{mech}	ms	3.1	
Moment of inertia	J_{mot}	kgm ²	3.8	
Shaft torsional stiffness	C_t	Nm/rad	1.32E+08	
Weight	m	kg	600	

The specified rated data are valid for a 600 V DC link voltage

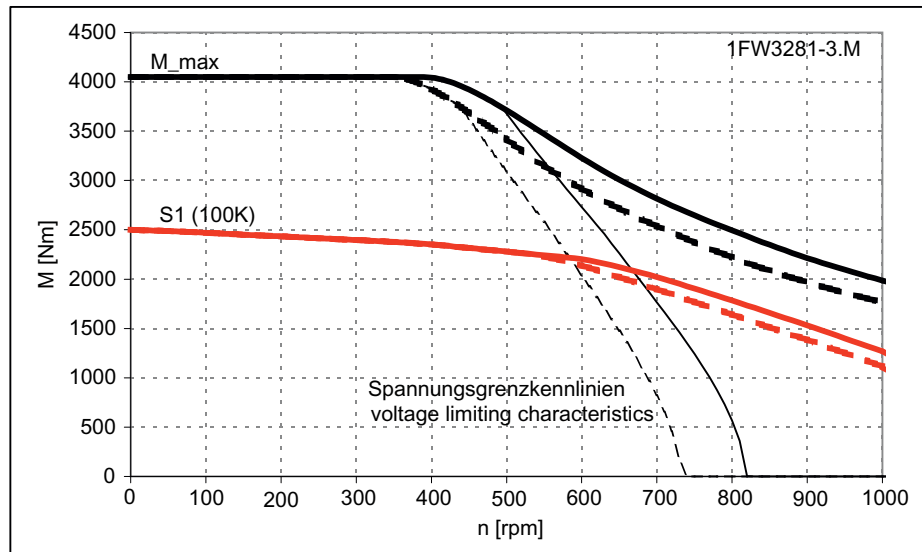

- SINAMICS ALM 400 V-Netz (Zwischenkreisspannung 600 V DC)
SINAMICS ALM 400 V line (DC-link voltage 600 V)
- - - SINAMICS BLM/SLM 400 V-Netz (Zwischenkreisspannung 540 V DC)
SINAMICS BLM/SLM 400 V line (DC-link voltage 540 V)

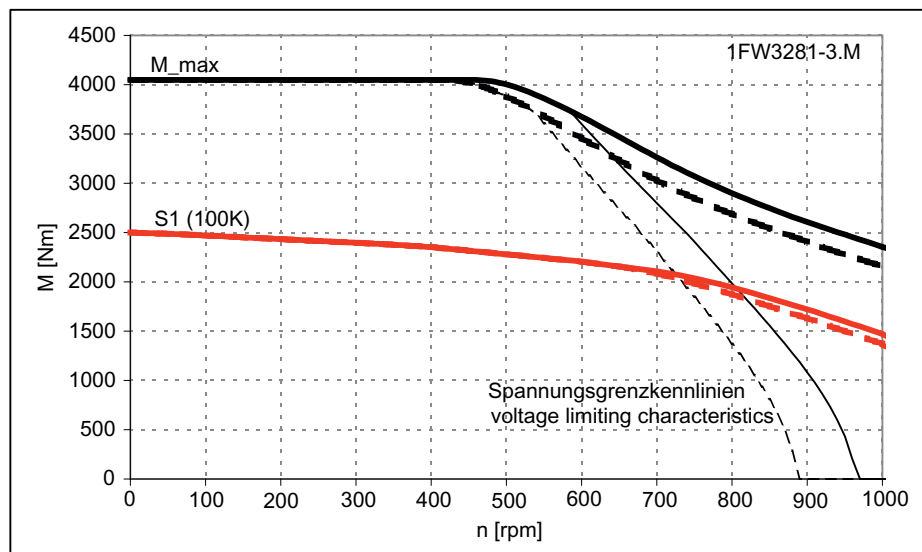

- SINAMICS ALM 480 V-Netz (Zwischenkreisspannung 720 V DC)
SINAMICS ALM 480 V line (DC-link voltage 720 V)
- - - SINAMICS BLM/SLM 480 V-Netz (Zwischenkreisspannung 650 V DC)
SINAMICS BLM/SLM 480 V line (DC-link voltage 650 V)

4.1 Torque-speed characteristic

Table 4- 47 1FW3283, rated speed 400 rpm

Configuration data	Code	Unit	1FW3283-3□J
Rated speed	n_N	rpm	400
Rated torque (100 K)	$M_N (100\text{ K})$	Nm	3300
Rated power (100 K)	$P_N (100\text{ K})$	kW	138
Rated current (100 K)	$I_N (100\text{ K})$	A	275
Static torque (100 K)	$M_0 (100\text{ K})$	Nm	3500
Stall current (100 K)	$I_0 (100\text{ K})$	A	290
Limiting data			
Max. permissible speed (mech.)	$n_{\text{max mech.}}$	rpm	1000
Max. permissible speed (converter)	$n_{\text{max 830 V}}$	rpm	750
Maximum torque	M_{max}	Nm	5700
Maximum current	I_{max}	A	520
Motor data			
Number of poles	2p		20
Ratio of speed measurement (belt-mounted encoder)	i_{enc}	--	-5
Torque constant (100 K)	$k_T (100\text{ K})$	Nm/A	12.0
Voltage constant (at 20 °C)	k_E	V/1000 rpm	765
Winding resistance (at 20 °C)	R_{ph}	Ω	0.025
Rotating field inductance	L_D	mH	1.1
Electrical time constant	T_{el}	ms	43.0
Thermal time constant	T_{th}	min	12.0
Mechanical data: Hollow-shaft version			
Mechanical time constant	T_{mech}	ms	2.4
Moment of inertia	J_{mot}	kgm ²	4.65
Shaft torsional stiffness	C_t	Nm/rad	1.08E+08
Weight	m	kg	690

The specified rated data are valid for a 600 V DC link voltage

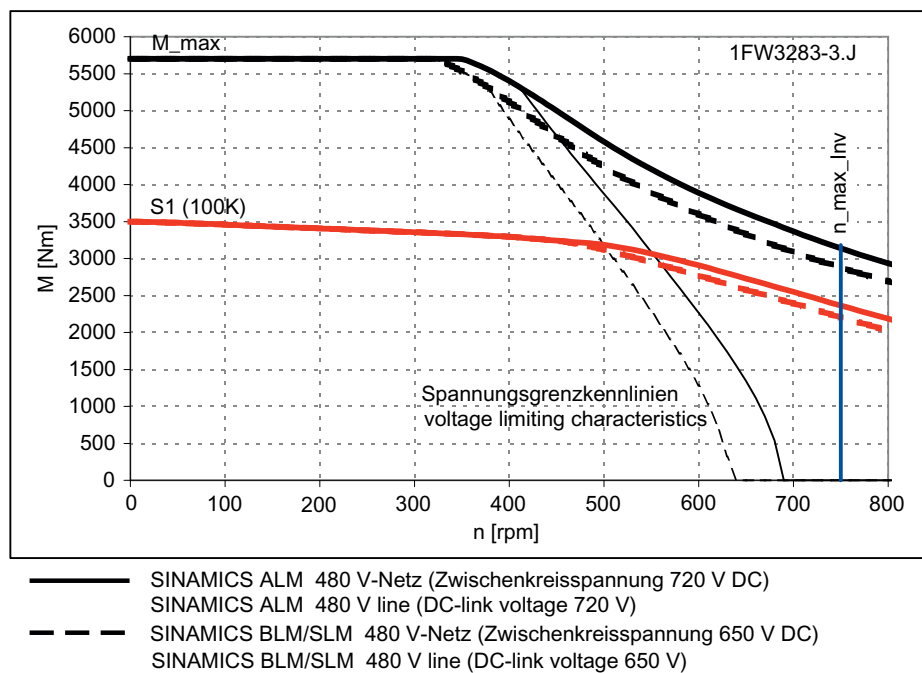
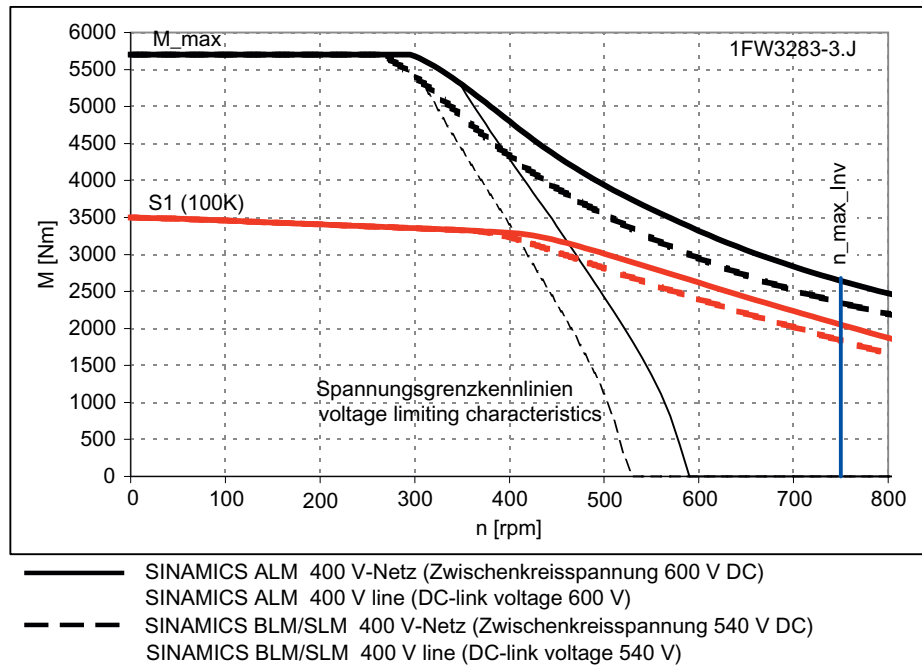

4.1 Torque-speed characteristic

Table 4- 48 1FW3283, rated speed 600 rpm

Configuration data	Code	Unit	1FW3283-3□M
Rated speed	n_N	rpm	600
Rated torque (100 K)	$M_N (100\text{ K})$	Nm	3100
Rated power (100 K)	$P_N (100\text{ K})$	kW	195
Rated current (100 K)	$I_N (100\text{ K})$	A	355
Static torque (100 K)	$M_0 (100\text{ K})$	Nm	3500
Stall current (100 K)	$I_0 (100\text{ K})$	A	400
Limiting data			
Max. permissible speed (mech.)	$n_{\text{max mech.}}$	rpm	1000
Max. permissible speed (converter)	$n_{\text{max 830 V}}$	rpm	1030
Maximum torque	M_{max}	Nm	5700
Maximum current	I_{max}	A	710
Motor data			
Number of poles	2p		20
Ratio of speed measurement (belt-mounted encoder)	i_{enc}	--	-5
Torque constant (100 K)	$k_T (100\text{ K})$	Nm/A	8.7
Voltage constant (at 20 °C)	k_E	V/1000 rpm	560
Winding resistance (at 20 °C)	R_{ph}	Ω	0.0132
Rotating field inductance	L_D	mH	0.55
Electrical time constant	T_{el}	ms	43.0
Thermal time constant	T_{th}	min	12.0
Mechanical data: Hollow-shaft version			
Mechanical time constant	T_{mech}	ms	2.4
Moment of inertia	J_{mot}	kgm ²	4.65
Shaft torsional stiffness	C_t	Nm/rad	1.08E+08
Weight	m	kg	690

The specified rated data are valid for a 600 V DC link voltage

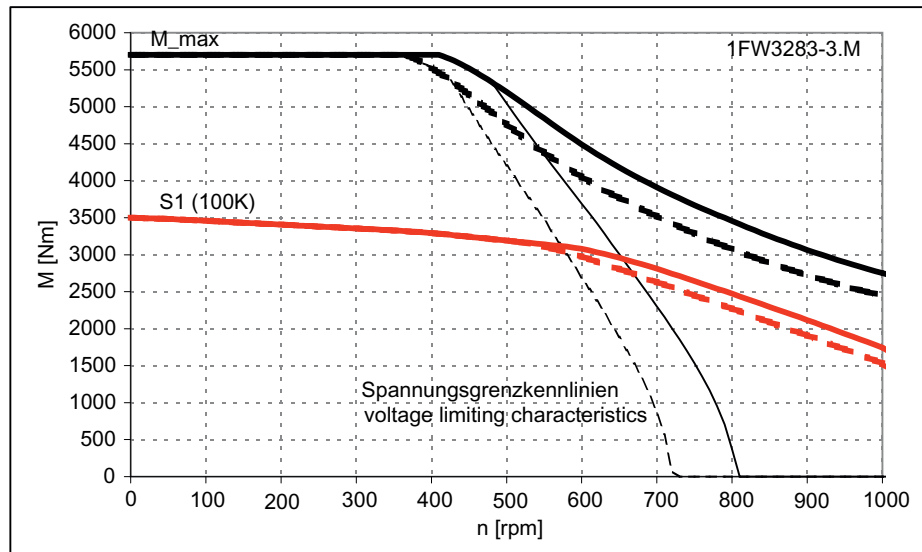

- SINAMICS ALM 400 V-Netz (Zwischenkreisspannung 600 V DC)
- SINAMICS ALM 400 V line (DC-link voltage 600 V)
- - - SINAMICS BLM/SLM 400 V-Netz (Zwischenkreisspannung 540 V DC)
- - - SINAMICS BLM/SLM 400 V line (DC-link voltage 540 V)

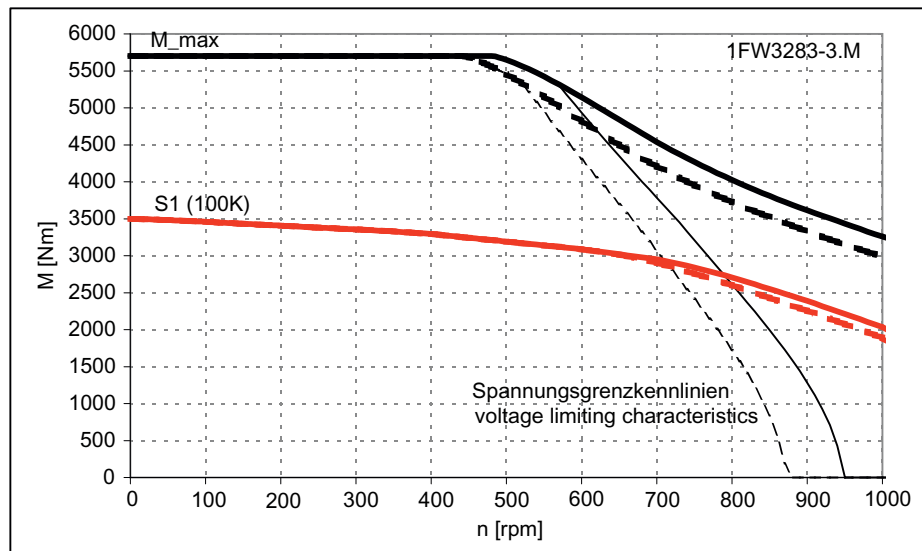

- SINAMICS ALM 480 V-Netz (Zwischenkreisspannung 720 V DC)
- SINAMICS ALM 480 V line (DC-link voltage 720 V)
- - - SINAMICS BLM/SLM 480 V-Netz (Zwischenkreisspannung 650 V DC)
- - - SINAMICS BLM/SLM 480 V line (DC-link voltage 650 V)

4.1 Torque-speed characteristic

Table 4- 49 1FW3285, rated speed 400 rpm

Configuration data	Code	Unit	1FW3285-3□J
Rated speed	n_N	rpm	400
Rated torque (100 K)	$M_N (100\text{ K})$	Nm	4700
Rated power (100 K)	$P_N (100\text{ K})$	kW	197
Rated current (100 K)	$I_N (100\text{ K})$	A	375
Static torque (100 K)	$M_0 (100\text{ K})$	Nm	5000
Stall current (100 K)	$I_0 (100\text{ K})$	A	400
Limiting data			
Max. permissible speed (mech.)	$n_{\text{max mech.}}$	rpm	1000
Max. permissible speed (converter)	$n_{\text{max 830 V}}$	rpm	720
Maximum torque	M_{max}	Nm	8150
Maximum current	I_{max}	A	710
Motor data			
Number of poles	2p		20
Ratio of speed measurement (belt-mounted encoder)	i_{enc}	--	-5
Torque constant (100 K)	$k_T (100\text{ K})$	Nm/A	12.5
Voltage constant (at 20 °C)	k_E	V/1000 rpm	800
Winding resistance (at 20 °C)	R_{ph}	Ω	0.0171
Rotating field inductance	L_D	mH	0.8
Electrical time constant	T_{el}	ms	47.5
Thermal time constant	T_{th}	min	14.0
Mechanical data: Hollow-shaft version			
Mechanical time constant	T_{mech}	ms	2.0
Moment of inertia	J_{mot}	kgm ²	6.0
Shaft torsional stiffness	C_t	Nm/rad	8.47E+07
Weight	m	kg	860

The specified rated data are valid for a 600 V DC link voltage

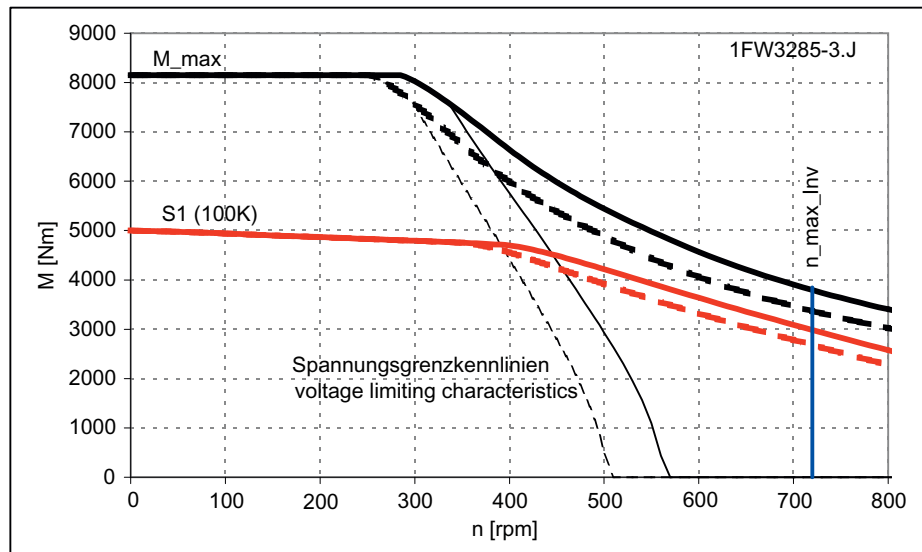

- SINAMICS ALM 400 V-Netz (Zwischenkreisspannung 600 V DC)
SINAMICS ALM 400 V line (DC-link voltage 600 V)
- - - SINAMICS BLM/SLM 400 V-Netz (Zwischenkreisspannung 540 V DC)
SINAMICS BLM/SLM 400 V line (DC-link voltage 540 V)

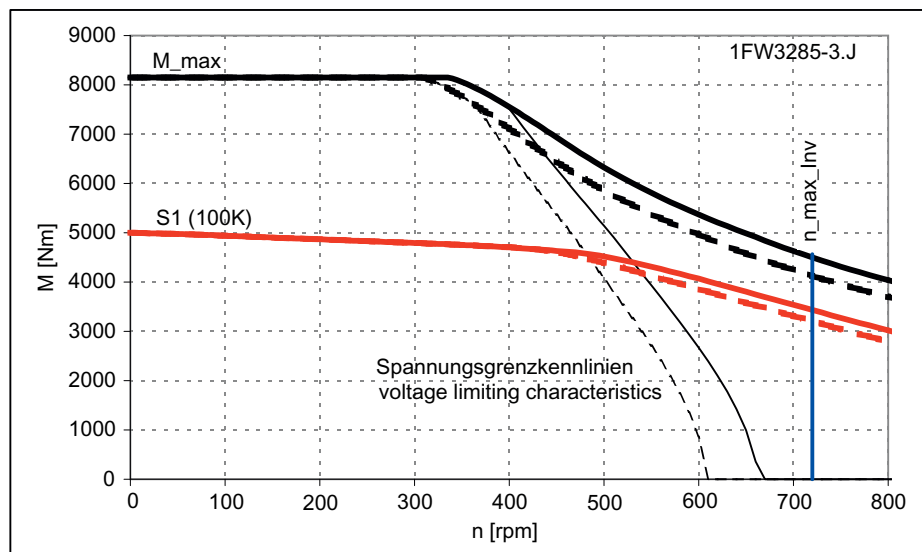

- SINAMICS ALM 480 V-Netz (Zwischenkreisspannung 720 V DC)
SINAMICS ALM 480 V line (DC-link voltage 720 V)
- - - SINAMICS BLM/SLM 480 V-Netz (Zwischenkreisspannung 650 V DC)
SINAMICS BLM/SLM 480 V line (DC-link voltage 650 V)

4.1 Torque-speed characteristic

Table 4- 50 1FW3285, rated speed 600 rpm

Configuration data	Code	Unit	1FW3285-3□M
Rated speed	n_N	rpm	600
Rated torque (100 K)	$M_N (100\text{ K})$	Nm	4400
Rated power (100 K)	$P_N (100\text{ K})$	kW	275
Rated current (100 K)	$I_N (100\text{ K})$	A	470
Static torque (100 K)	$M_0 (100\text{ K})$	Nm	5000
Stall current (100 K)	$I_0 (100\text{ K})$	A	530
Limiting data			
Max. permissible speed (mech.)	$n_{\text{max mech.}}$	rpm	1000
Max. permissible speed (converter)	$n_{\text{max 830 V}}$	rpm	960
Maximum torque	M_{max}	Nm	8150
Maximum current	I_{max}	A	940
Motor data			
Number of poles	2p		20
Ratio of speed measurement (belt-mounted encoder)	i_{enc}	--	-5
Torque constant (100 K)	$k_T (100\text{ K})$	Nm/A	9.4
Voltage constant (at 20 °C)	k_E	V/1000 rpm	600
Winding resistance (at 20 °C)	R_{ph}	Ω	0.0096
Rotating field inductance	L_D	mH	0.46
Electrical time constant	T_{el}	ms	47.5
Thermal time constant	T_{th}	min	14.0
Mechanical data: Hollow-shaft version			
Mechanical time constant	T_{mech}	ms	1.9
Moment of inertia	J_{mot}	kgm ²	6.0
Shaft torsional stiffness	C_t	Nm/rad	8.47E+07
Weight	m	kg	860

The specified rated data are valid for a 600 V DC link voltage

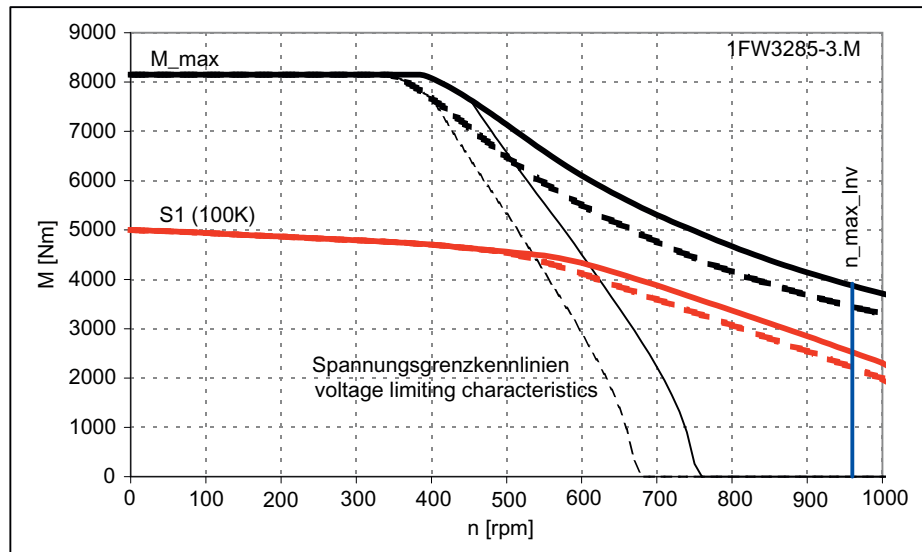

- SINAMICS ALM 400 V-Netz (Zwischenkreisspannung 600 V DC)
SINAMICS ALM 400 V line (DC-link voltage 600 V)
- - - SINAMICS BLM/SLM 400 V-Netz (Zwischenkreisspannung 540 V DC)
SINAMICS BLM/SLM 400 V line (DC-link voltage 540 V)

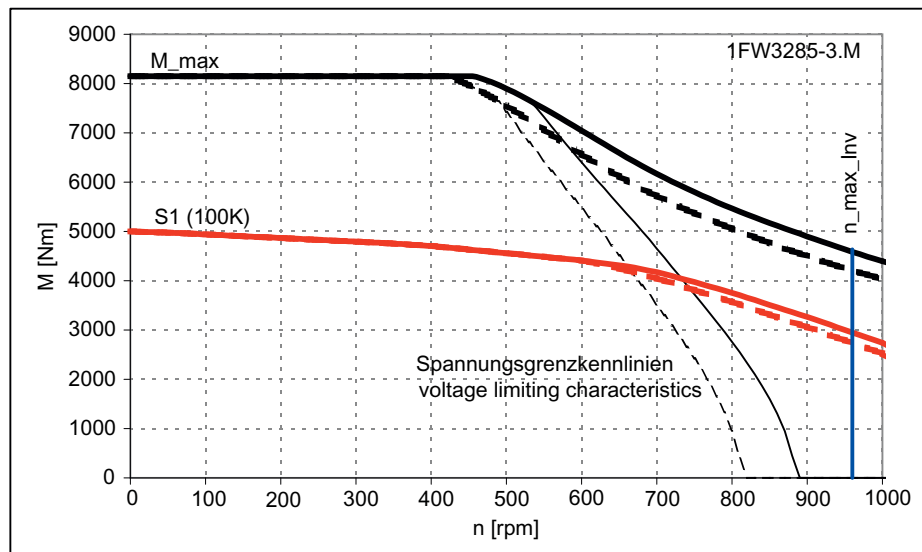

- SINAMICS ALM 480 V-Netz (Zwischenkreisspannung 720 V DC)
SINAMICS ALM 480 V line (DC-link voltage 720 V)
- - - SINAMICS BLM/SLM 480 V-Netz (Zwischenkreisspannung 650 V DC)
SINAMICS BLM/SLM 480 V line (DC-link voltage 650 V)

4.1 Torque-speed characteristic

Table 4- 51 1FW3287, rated speed 400 rpm

Configuration data	Code	Unit	1FW3287-3□J
Rated speed	n_N	rpm	400
Rated torque (100 K)	$M_N (100\text{ K})$	Nm	6600
Rated power (100 K)	$P_N (100\text{ K})$	kW	275
Rated current (100 K)	$I_N (100\text{ K})$	A	500
Static torque (100 K)	$M_0 (100\text{ K})$	Nm	7000
Stall current (100 K)	$I_0 (100\text{ K})$	A	530
Limiting data			
Max. permissible speed (mech.)	$n_{\text{max mech.}}$	rpm	1000
Max. permissible speed (converter)	$n_{\text{max 830 V}}$	rpm	690
Maximum torque	M_{max}	Nm	11400
Maximum current	I_{max}	A	950
Motor data			
Number of poles	2p		20
Ratio of speed measurement (belt-mounted encoder)	i_{enc}	--	-5
Torque constant (100 K)	$k_T (100\text{ K})$	Nm/A	13.1
Voltage constant (at 20 °C)	k_E	V/1000 rpm	835
Winding resistance (at 20 °C)	R_{ph}	Ω	0.0125
Rotating field inductance	L_D	mH	0.65
Electrical time constant	T_{el}	ms	51
Thermal time constant	T_{th}	min	16.0
Mechanical data: Hollow-shaft version			
Mechanical time constant	T_{mech}	ms	1.7
Moment of inertia	J_{mot}	kgm ²	7.8
Shaft torsional stiffness	C_t	Nm/rad	6.58E+07
Weight	m	kg	1030

The specified rated data are valid for a 600 V DC link voltage

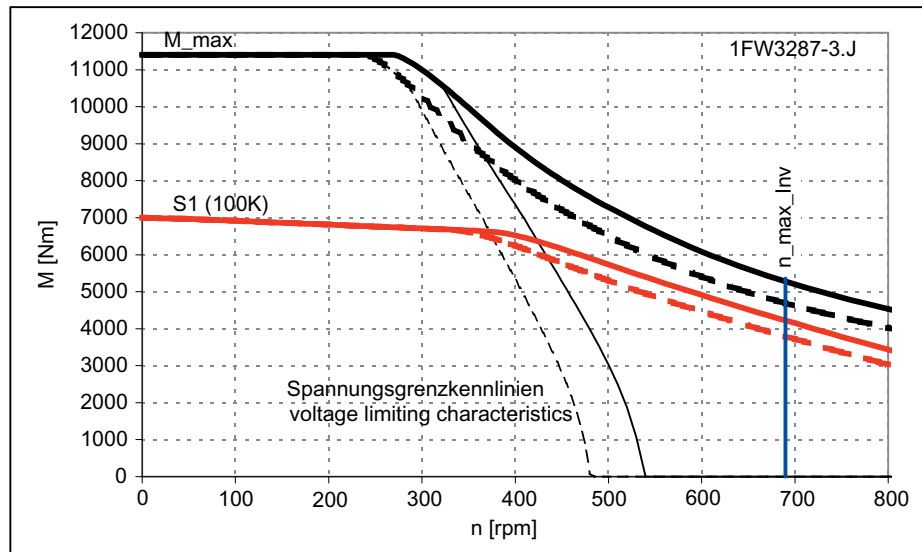

- SINAMICS ALM 400 V-Netz (Zwischenkreisspannung 600 V DC)
SINAMICS ALM 400 V line (DC-link voltage 600 V)
- - - SINAMICS BLM/SLM 400 V-Netz (Zwischenkreisspannung 540 V DC)
SINAMICS BLM/SLM 400 V line (DC-link voltage 540 V)

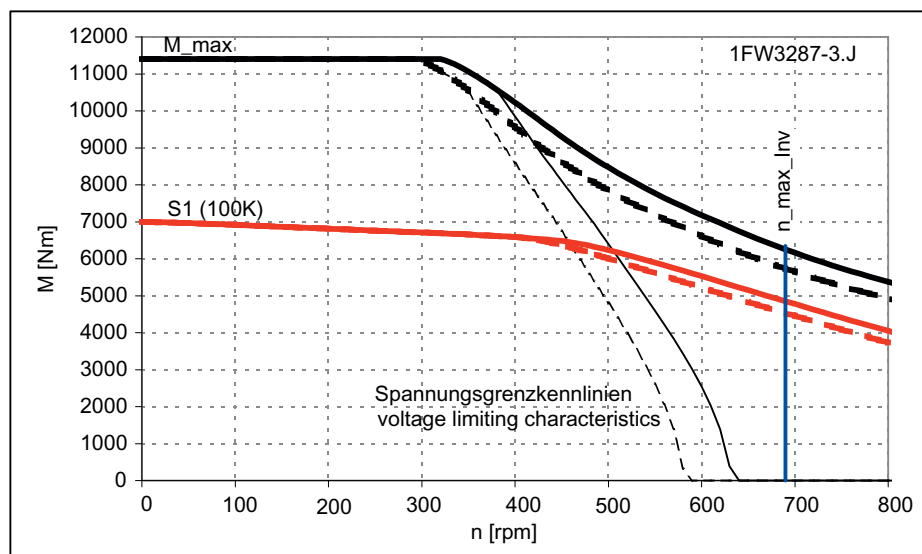

- SINAMICS ALM 480 V-Netz (Zwischenkreisspannung 720 V DC)
SINAMICS ALM 480 V line (DC-link voltage 720 V)
- - - SINAMICS BLM/SLM 480 V-Netz (Zwischenkreisspannung 650 V DC)
SINAMICS BLM/SLM 480 V line (DC-link voltage 650 V)

4.1 Torque-speed characteristic

Table 4- 52 1FW3287, rated speed 600 rpm

Configuration data	Code	Unit	1FW3287-3□M
Rated speed	n_N	rpm	600
Rated torque (100 K)	$M_N (100\text{ K})$	Nm	6050
Rated power (100 K)	$P_N (100\text{ K})$	kW	380
Rated current (100 K)	$I_N (100\text{ K})$	A	700
Static torque (100 K)	$M_0 (100\text{ K})$	Nm	6850
Stall current (100 K)	$I_0 (100\text{ K})$	A	790
Limiting data			
Max. permissible speed (mech.)	$n_{\text{max mech.}}$	rpm	1000
Max. permissible speed (converter)	$n_{\text{max 830 V}}$	rpm	1030
Maximum torque	M_{max}	Nm	11400
Maximum current	I_{max}	A	1420
Motor data			
Number of poles	2p		20
Ratio of speed measurement (belt-mounted encoder)	i_{enc}	--	-5
Torque constant (100 K)	$k_T (100\text{ K})$	Nm/A	8.7
Voltage constant (at 20 °C)	k_E	V/1000 rpm	560
Winding resistance (at 20 °C)	R_{ph}	Ω	0.0055
Rotating field inductance	L_D	mH	0.29
Electrical time constant	T_{el}	ms	51
Thermal time constant	T_{th}	min	16.0
Mechanical data: Hollow-shaft version			
Mechanical time constant	T_{mech}	ms	1.7
Moment of inertia	J_{mot}	kgm ²	7.8
Shaft torsional stiffness	C_t	Nm/rad	6.58E+07
Weight	m	kg	1030

The specified rated data are valid for a 600 V DC link voltage

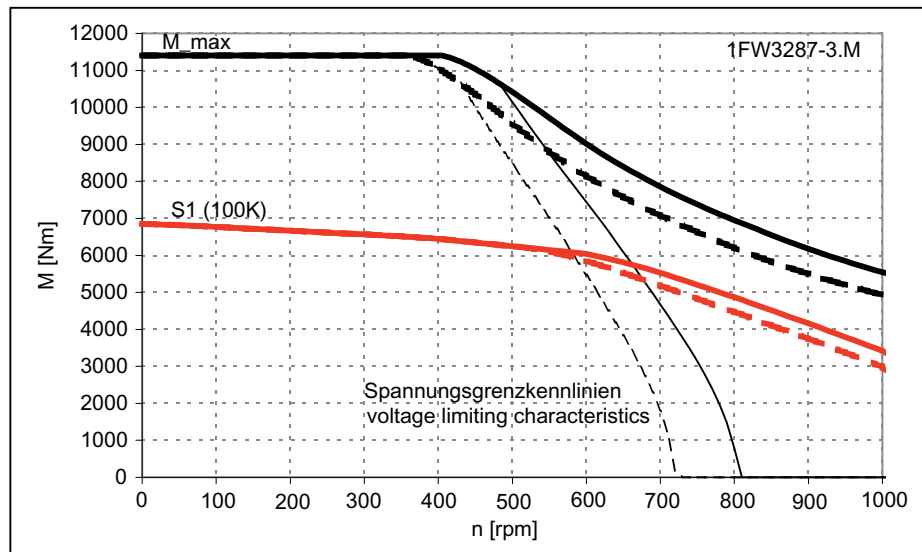

- SINAMICS ALM 400 V-Netz (Zwischenkreisspannung 600 V DC)
SINAMICS ALM 400 V line (DC-link voltage 600 V)
- - - SINAMICS BLM/SLM 400 V-Netz (Zwischenkreisspannung 540 V DC)
SINAMICS BLM/SLM 400 V line (DC-link voltage 540 V)

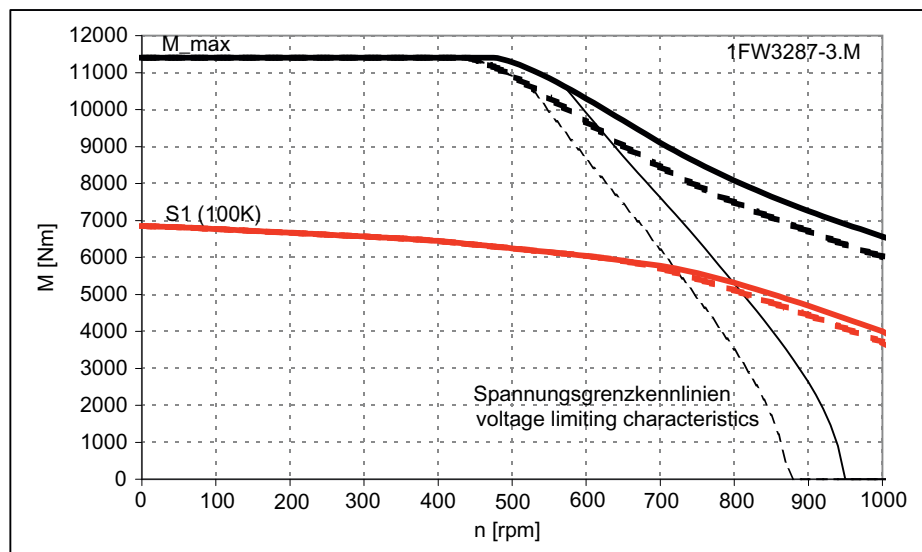

- SINAMICS ALM 480 V-Netz (Zwischenkreisspannung 720 V DC)
SINAMICS ALM 480 V line (DC-link voltage 720 V)
- - - SINAMICS BLM/SLM 480 V-Netz (Zwischenkreisspannung 650 V DC)
SINAMICS BLM/SLM 480 V line (DC-link voltage 650 V)

4.2 Dimension drawings

CAD CREATOR

Thanks to its easy to understand interface, the CAD CREATOR allows you to find the following quickly

- dimension drawings
- 2D/3D CAD data

and supports you when generating plant/system documentation regarding project-specific information. The data for motors, drives and CNC controls is currently available in the online version.

You can find further information on the Internet at: <http://www.siemens.com/cadcreator>

Motors

- 1FK7, 1FT7, 1FT6 synchronous motors
- 1FE1 built-in synchronous motors
- 1FW3 complete torque motors
- 1FW6 built-in torque motors
- 1FK7, 1FT7, 1FT6 geared motors
- 1PH8 synchronous/induction motors
- 1PH7, 1PH4, 1PL6, 1PM4, 1PM6 induction motors
- 2SP1 motor spindles
- 1FN3 linear motors

SINAMICS S120

- Control Units
- Power Modules (blocksize, chassis)
- Line Modules (booksize, chassis)
- Line-side components
- Motor Modules (booksize, chassis)
- DC link components
- Additional system components
- Load-side power components
- Encoder system connection
- MOTION-CONNECT connection system

SIMOTION

- SIMOTION D
- SIMOTION C

SINUMERIK solution line

- Control systems
- Operator components for CNC controls

How up-to-date are the dimension drawings

Note

Siemens AG reserves the right to change the dimensions of the motors as part of mechanical design improvements without prior notice. This means that dimensions drawings can go out-of-date. Up-to-date dimension drawings can be requested at no charge from your local SIEMENS representative.

4.2 Dimension drawings

4.2.1 Hollow shaft

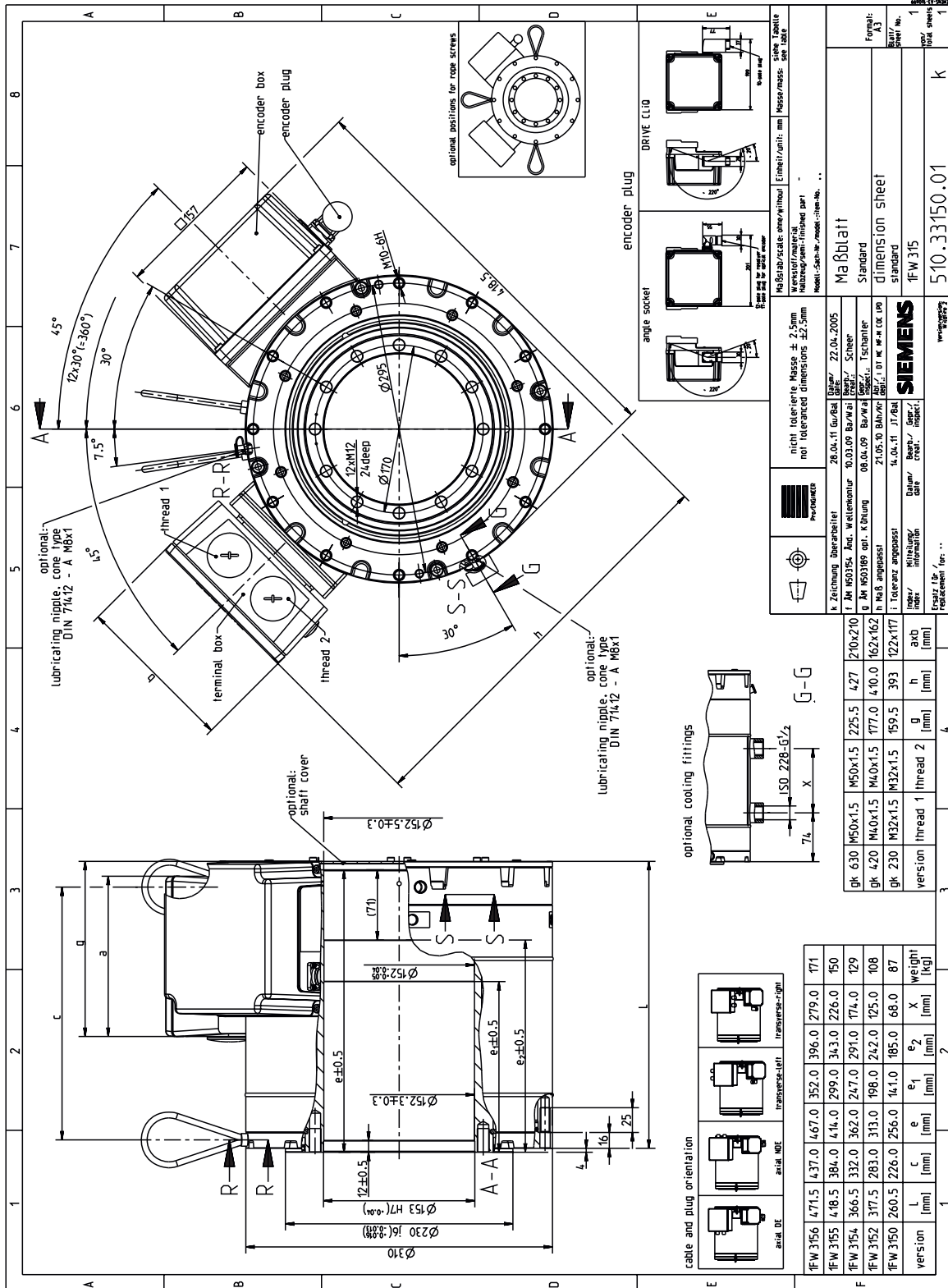

Figure 4-2 1FW315x hollow shaft

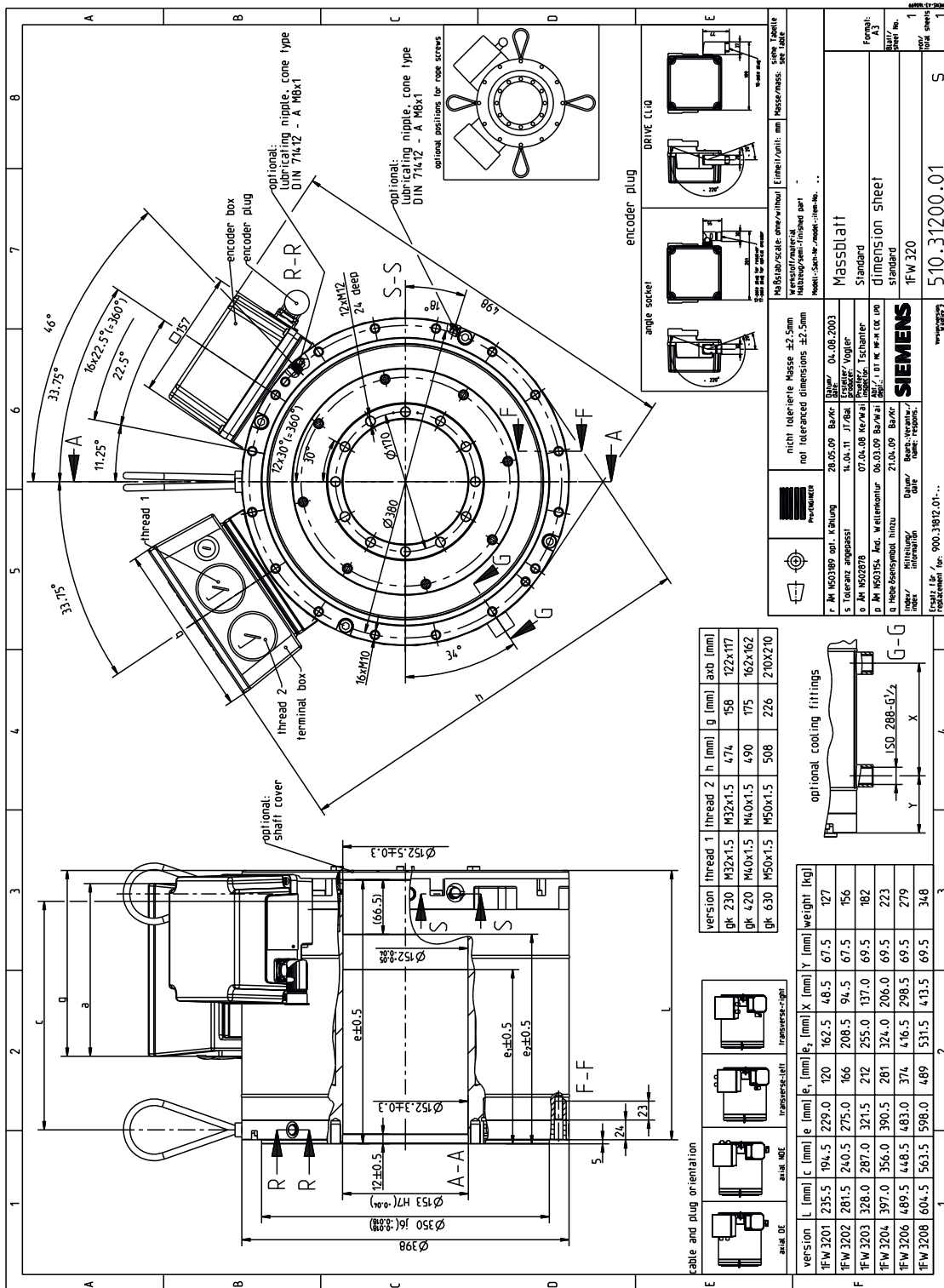

Figure 4-3 1FW320x, hollow shaft

4.2.2 Encoderless

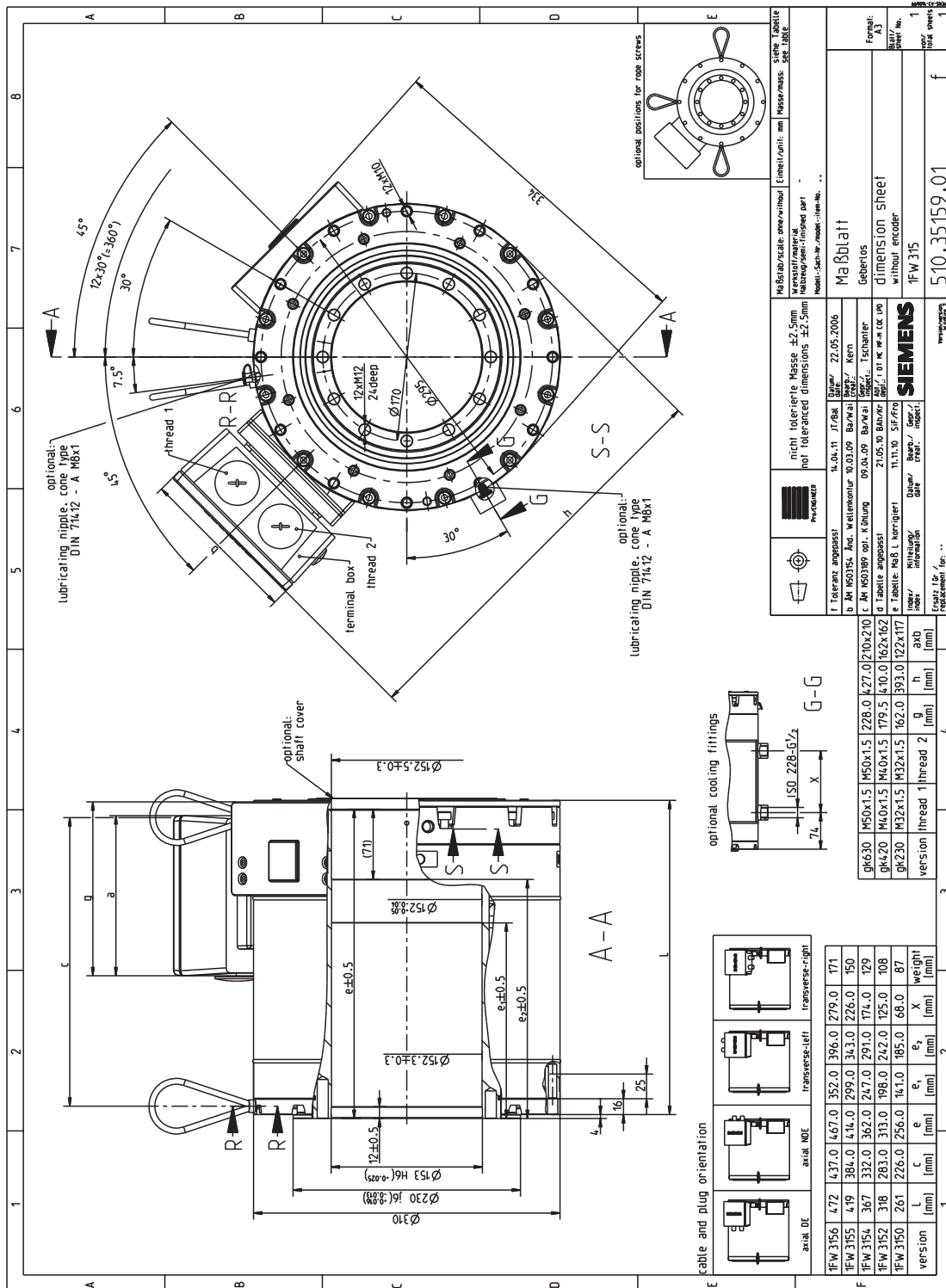

Figure 4-5 1FW315x, without encoder

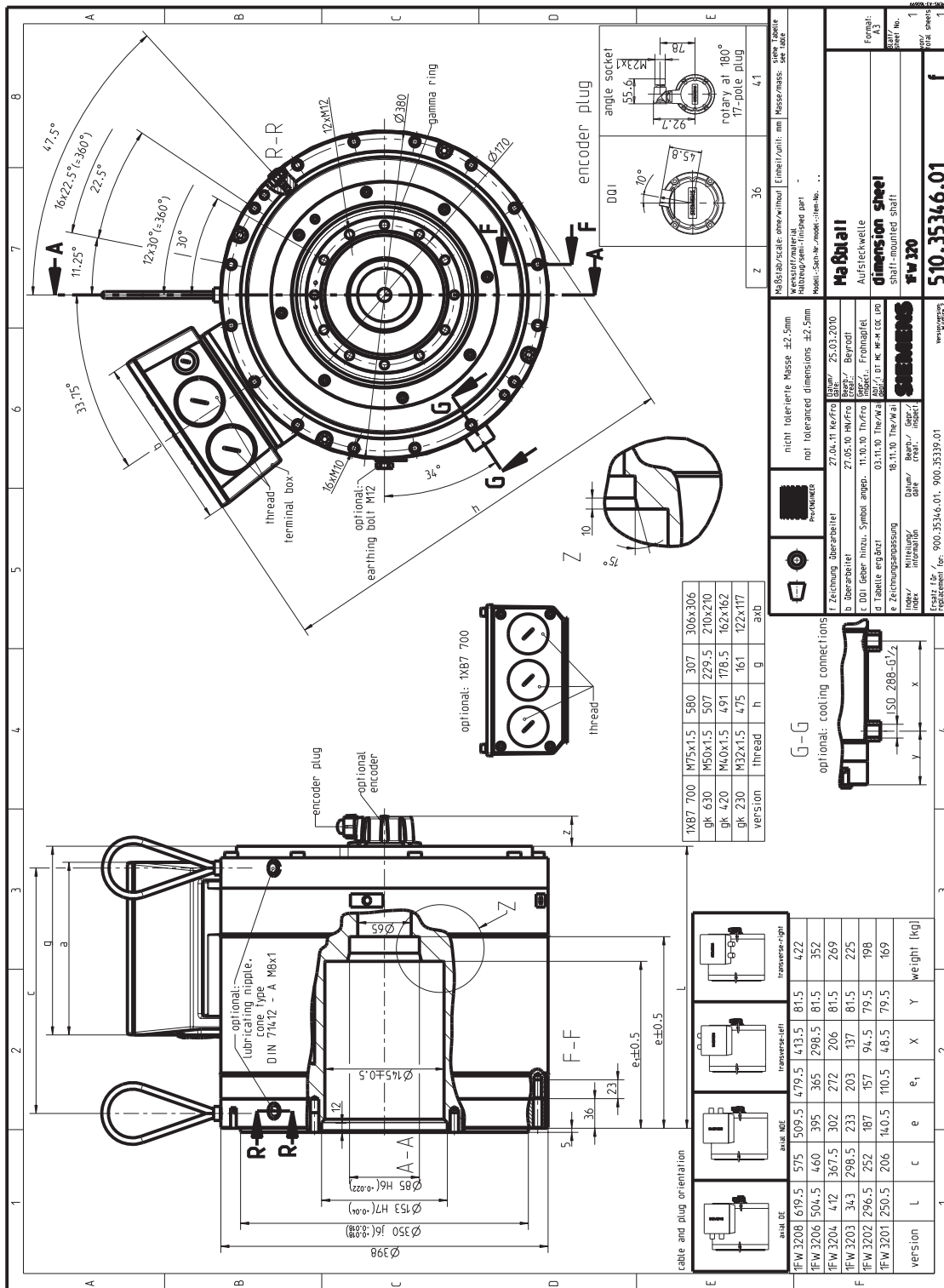

Figure 4-9 1FW320x, plug-on shaft

1FW3 complete torque motors

Configuration Manual, (PKTS), 07/2011, 6SN1197-0AD70-0BP5

4.2 Dimension drawings

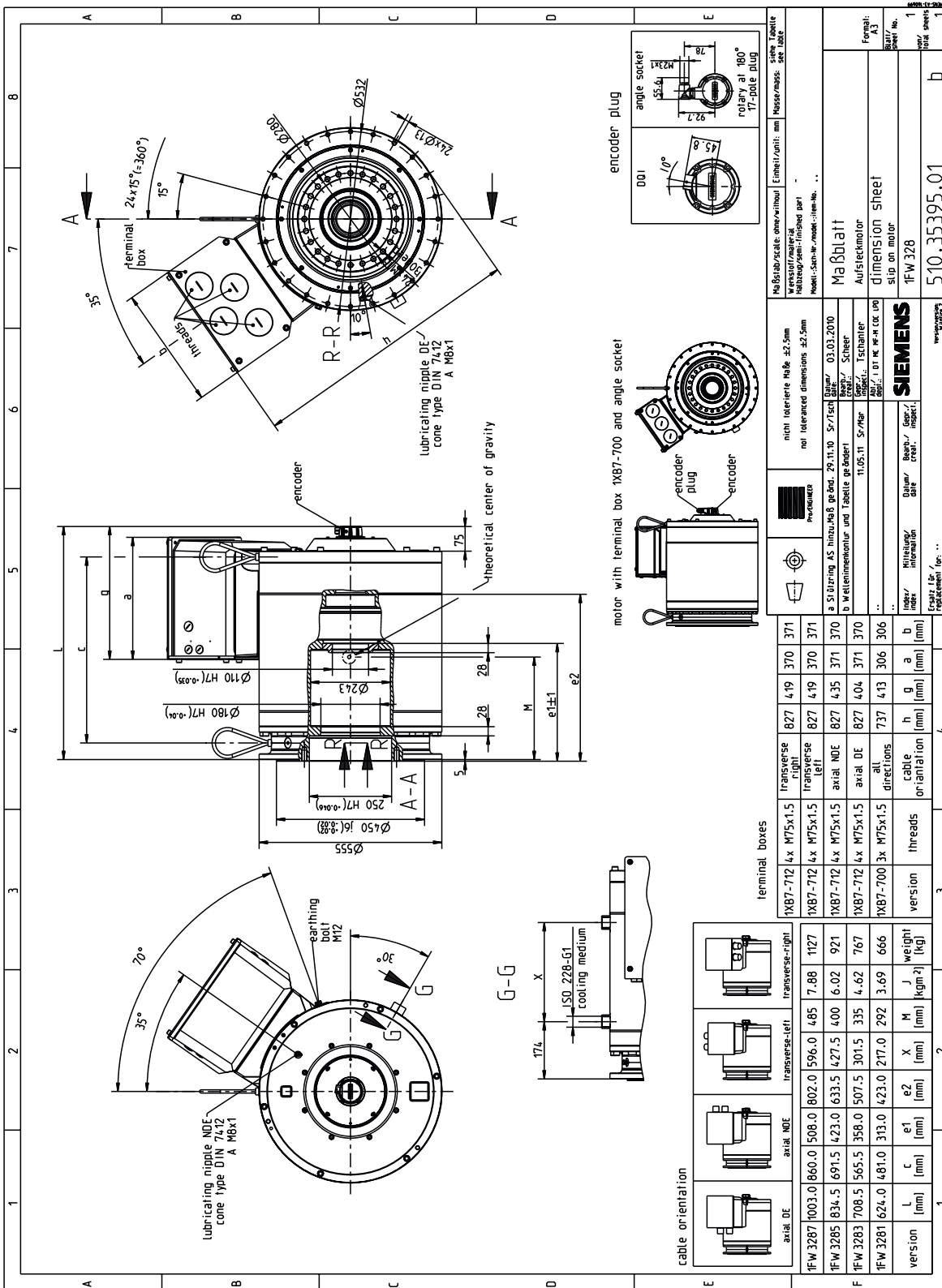

Figure 4-10 1FW328x, plug-on shaft

4.2.4 Solid shaft

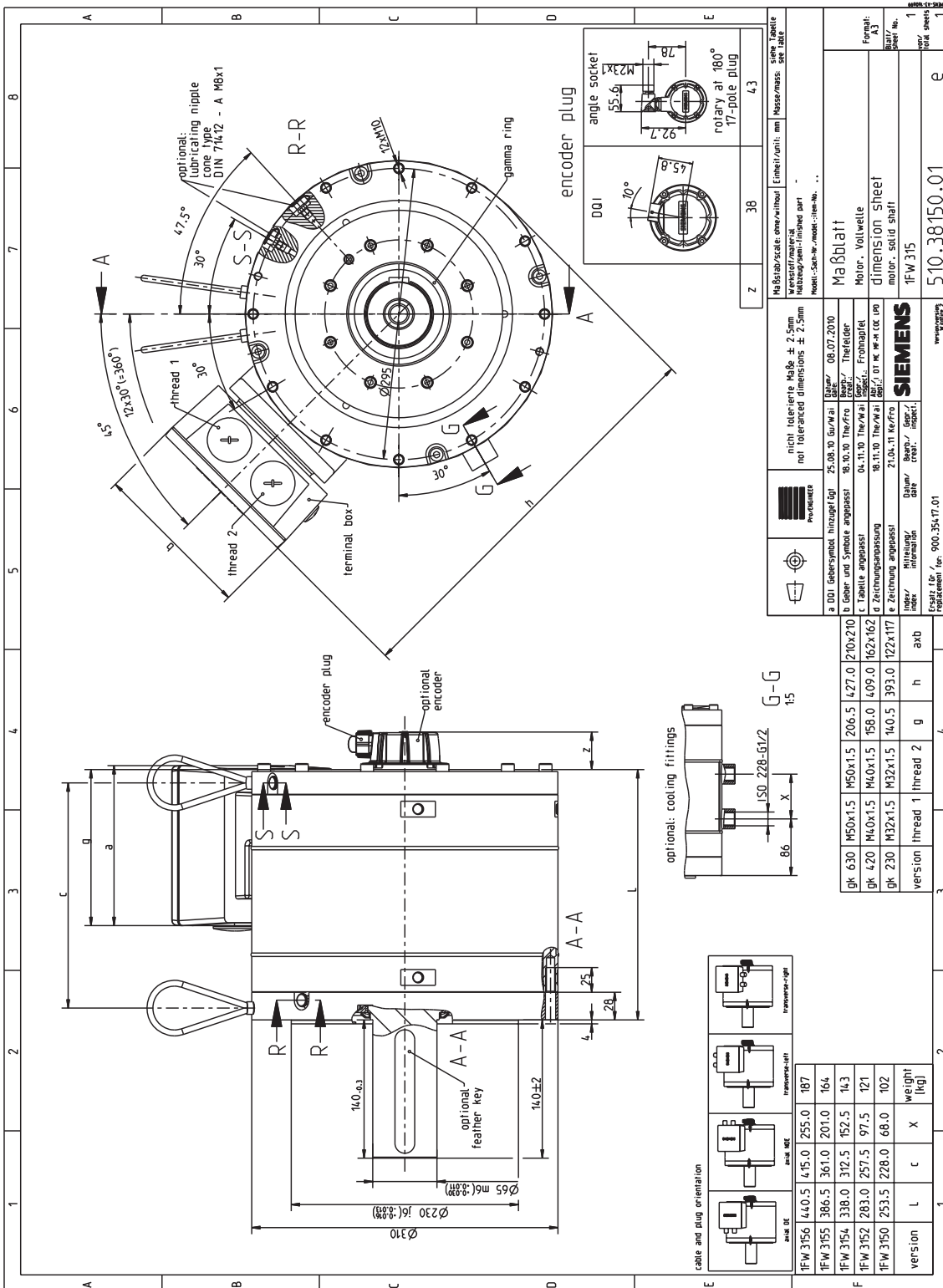

Figure 4-11 1FW315X, solid shaft

1FW3 complete torque motors

Configuration Manual, (PKTS), 07/2011, 6SN1197-0AD70-0BP5

4.2 Dimension drawings

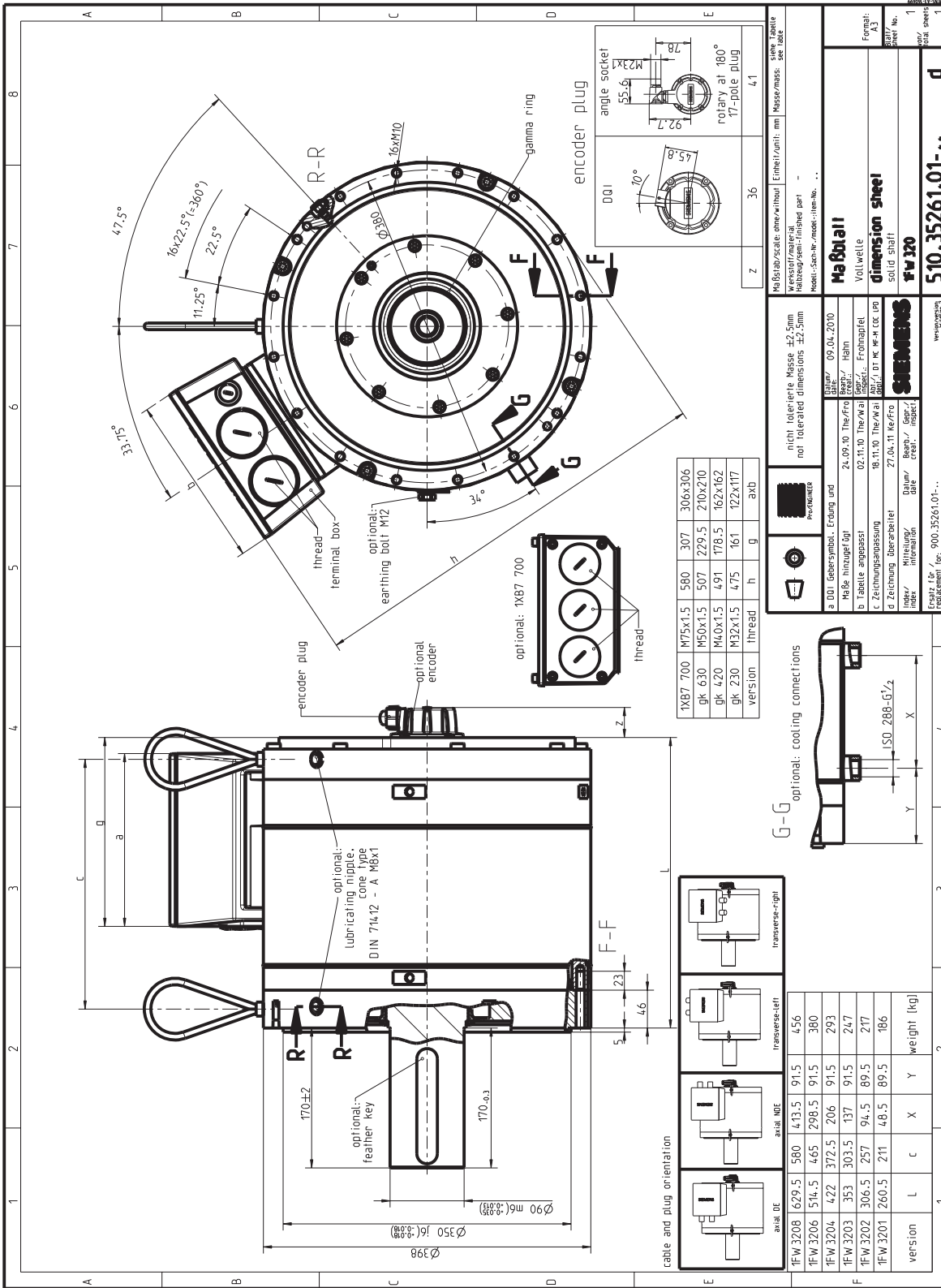

Figure 4-12 1FW320x, solid shaft

Motor components

5.1 Thermal motor protection

KTY 84 (PTC thermistor)

A temperature-dependent resistor is integrated as temperature sensor to monitor the motor temperature.

Table 5- 1 Properties and technical data

Designation	Description
Type	KTY 84 (PTC thermistor)
Resistance when cold (20 °C)	Approx. 580 Ω
Resistance when hot (100 °C)	Approx. 1000 Ω
Response temperature	Prewarning: 120 °C \pm 5° C Shutdown: 155 °C \pm 5° C
Connection	via signal cable

WARNING

The polarity must be carefully observed.

The resistance of the KTY 84 thermistor changes proportionally to the winding temperature change (refer to the following Fig.).

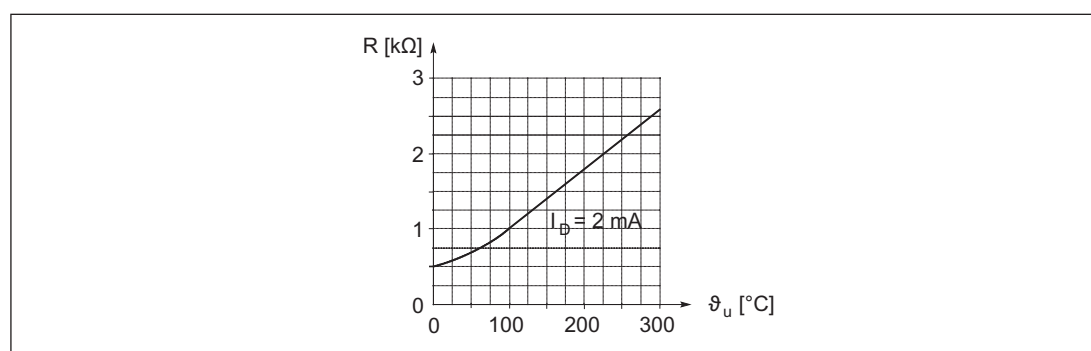

Figure 5-1 Resistance characteristic of the KTY 84 as a function of the temperature

The KTY 84 is evaluated in the converter whose closed-loop control takes into account the temperature characteristic of the motor winding. When a fault occurs, an appropriate message is output on the converter. When the motor temperature increases, a message "Alarm motor overtemperature" is output; this must be externally evaluated. If this signal is ignored, the drive converter shuts down with the appropriate fault message after a preset time period or when the motor limiting temperature or the shutdown temperature is exceeded.

 **CAUTION**

The integrated temperature sensor KTY protects the complete torque motors against overload conditions:

up to $2 \cdot I_0$ and speed $\neq 0$

There is no adequate protection for thermally critical load situations, e.g. a high overload at motor standstill. This is the reason that, for example, a thermal overcurrent relay or a PTC thermistor (optional) must be provided as additional protection.

If the maximum overload condition lasts longer than 4 s, then additional motor protection must be provided.

The temperature sensor is designed so that the DIN/EN requirement for "protective separation" is fulfilled.

 **WARNING**

If the user carries-out an additional high-voltage test, then the ends of the temperature sensor cables must be short-circuited before the test is carried-out! If the test voltage is connected to a temperature sensor terminal, then it will be destroyed.

PTC thermistors (optional)

For special applications (e.g. when a load is applied with the motor stationary or for extremely low speeds), the temperature of all of the three motor phases should be additionally monitored using a PTC thermistor triplet.

Ordering options: order code A11.

Table 5- 2 Connection and evaluation of the PTC thermistor triplet

Motors with DRIVE-CLiQ interfaces	Motors without DRIVE-CLiQ interfaces
<p>The PTC thermistor is connected to the drive system via the DRIVE-CLiQ cable. Evaluation of the PTC thermistor must be activated in the SINAMICS (see references: /GH1/ SINAMICS S120, Control Units and Additional System Components).</p>	<p>The PTC thermistor must be evaluated using an external tripping/evaluation unit (this is not included in the scope of supply). This means that the sensor cable is monitored for wire breakage and short-circuit by this unit. The motor must be de-energized within 1 s when the response temperature is exceeded.</p> <p>The thermistor connections are located in the power terminal box on the terminal block. A cable entry hole M16 x 1.5 is provided in the terminal box to connect this PTC thermistor.</p>

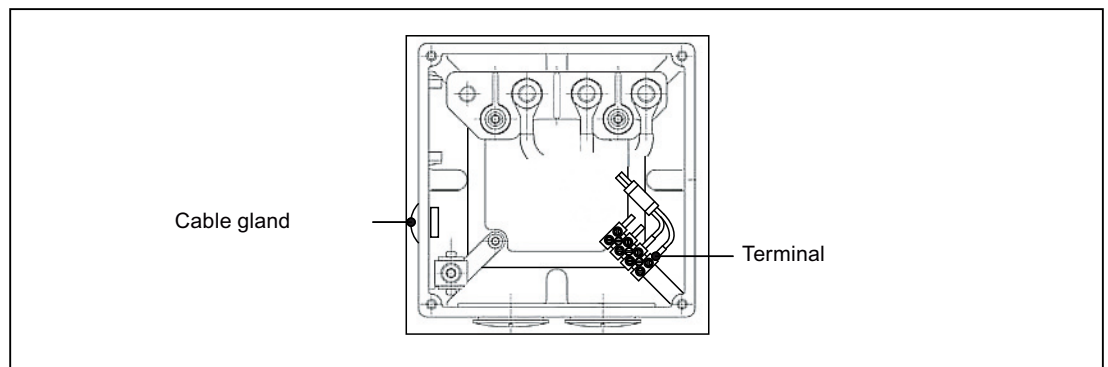

Figure 5-2 Connection for 3x PTC

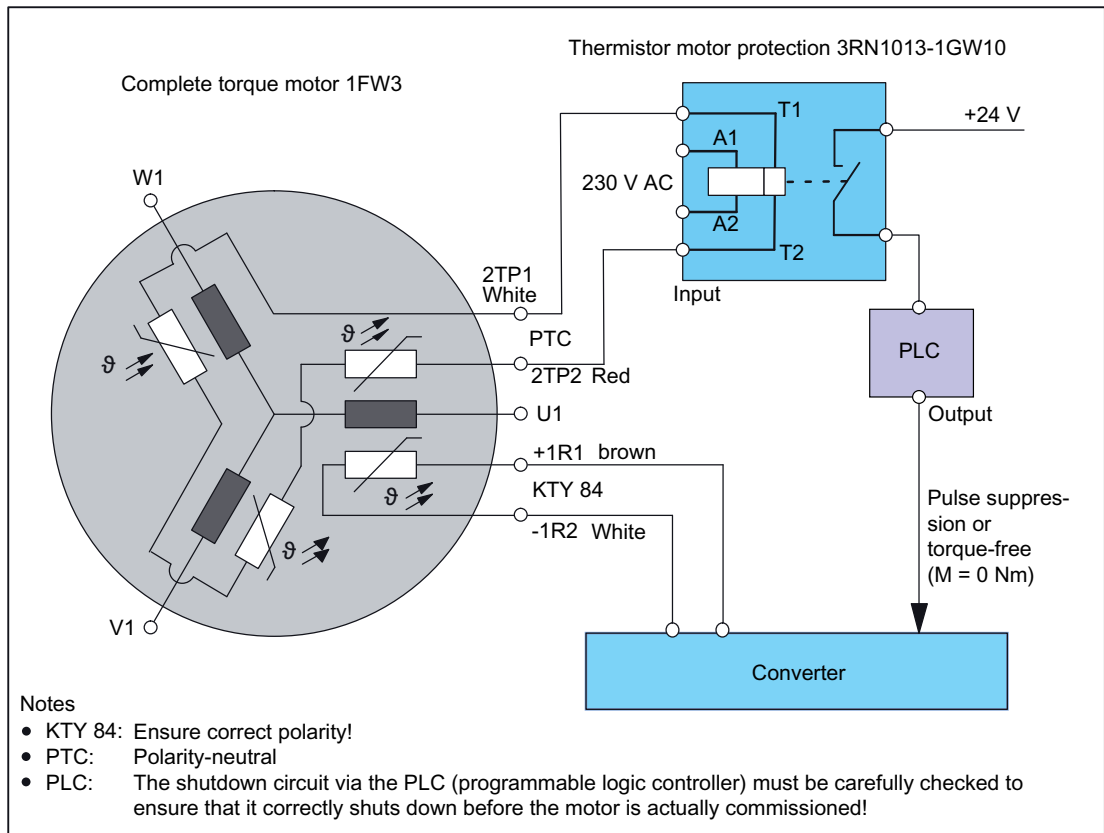

Figure 5-3 Temperature monitoring connection

Table 5-3 Technical specifications for the PTC thermistor triplet

Designation	Description
Type	PTC thermistor triplet
Thermistor resistance (20°C)	≤ 750 Ω
Resistance when hot (180°C)	≥ 1710 Ω
Response temperature	180°C
Connection	Via external evaluation unit
Note: The PTC thermistors do not have a linear characteristic and are, therefore, not suitable to determine the instantaneous temperature. Characteristic to DIN VDE 0660 Teil 303, DIN 44081, DIN 44082.	

5.2 Encoder (option)

Closed-loop position controlled operation is only possible with some restrictions. Please contact your local Siemens office.

 **CAUTION**

Encoder replacement and adjustment

The encoders are adjusted in the factory for SIEMENS drive converters. Another encoder adjustment may be required when operating the motor with a third-party converter.

If the encoder is incorrectly adjusted to the motor EMF, this can result in uncontrolled motion.

When a belt-mounted encoder is replaced, the position of the encoder system with respect to the motor EMF must be adjusted. Only qualified personnel may replace an encoder.

When replacing an absolute encoder it must be re-referenced.

When replacing a coaxially mounted encoder, the encoder system does not have to be adjusted. The position with respect to the motor EMF is ensured using mechanical components.

Encoder selection and identification in the order number (MLFB)

with/without DRIVE-CLiQ interface 9. Position of the Order No. (MLFB) = see table below

Table 5- 4 Letter code of the 9th position of the Order No. (MLFB)

Encoder type	9. Position in the MLFB
Motors without DRIVE-CLiQ interfaces	
Incremental encoder, sin/cos 1 Vpp, 2048 S/R with C and D tracks, encoder IC2048S/R, belt mounted	A
Absolute encoder 2048 S/R singleturn, 4096 revolutions multiturn, with EnDat interface, encoder AM2048S/R, belt mounted or coaxially mounted at NDE	E
Multi-pole resolver (p = x), belt mounted	S
Motors with DRIVE-CLiQ interfaces	
Absolute encoder 24 bit singleturn (resolution 16777216), encoder AS24DQI	B
Absolute encoder 24 bit singleturn (resolution 16777216) + 12 bit multiturn (traversing range 4096 revolutions), encoder AM24DQI	C
Incremental encoder, 22-bit (resolution 4194304, internal 2048 S/R) + commutation position, 11 bit, encoder IC22DQ, belt-mounted	D
Absolute encoder 22 bit singleturn (resolution 4194304, internal 2048 S/R) + 12 bit multiturn (traversing range 4096 revolutions), encoder AM22DQ, belt-mounted	F
Resolver 15-bit (resolution 32.768, internal, multi-pole), R15DQ encoder, belt mounted	U

Belt-mounted encoder 11. Position of the Order No. (MLFB) = 6
 15th position of the Order No. (MLFB) = M or S

Coaxial encoder mounting 11. Position of the Order No. (MLFB) = 7
 15th position of the Order No. (MLFB) = A or C

5.2.1 Encoder connection for motors with DRIVE-CLiQ interface

For motors with a DRIVE-CLiQ interface, the analog encoder signal is internally converted to a digital signal. There is no further conversion of the encoder signal in the drive system required. Motors with DRIVE-CLiQ interface simplify commissioning and diagnostics, as the motor and encoder system are identified automatically.

⚠ CAUTION

The DRIVE-CLiQ contains motor and encoder-specific data as well as an electronic type plate. This is the reason that this may only be operated on the original motor - and may not be mounted onto other motors or replaced by the DRIVE-CLiQ from other motors.

The DRIVE-CLiQ interface has direct contact to components that can be damaged/destroyed by electrostatic discharge (ESD). The precautionary ESD measures listed in the preface should be carefully observed.

Cables

For all encoder types (incremental encoder, absolute value encoder and Resolver) the same DRIVE-CLiQ cables can be used between the motor and converter:

Table 5- 5 Pre-assembled cable

6FX	□	002	-	□DC□□	-	□□□	0
	↓					↓↓↓	
	↓					Length	
		5 MOTION-CONNECT®500				Max. cable length 100 m	
		8 MOTION-CONNECT®800				Max. cable length 50 m	

Only prefabricated cables from Siemens (MOTION-CONNECT) may be used.

For other technical data and length code, refer to Catalog, Chapter "MOTION-CONNECT connection system".

5.2.2 Encoder connection for motors without DRIVE-CLiQ interface

For motors without an integrated DRIVE-CLiQ interface, the analog encoder signal in the drive system is converted into a digital signal. For these motors as well as external encoders, the encoder signals must be connected to SINAMICS S120 via Sensor Modules.

5.2.3 Incremental encoder sin/cos 1Vpp

Description

This encoder senses relative movements and does not supply absolute position information. In combination with an evaluation logic, a zero point can be determined using the integrated reference mark, which can be used to calculate the absolute position.

The encoder outputs sine and cosine signals. These can be interpolated using evaluation logic (usually 2048x) and the direction of rotation can be determined. In the version with DRIVE-CLiQ interface, this evaluation logic is already integrated in the encoder.

Function and technical data

- Angular measuring system for the commutation
- Speed actual value sensing
- Indirect incremental measuring system for the position control loop
- One zero pulse (reference mark) per revolution

Table 5- 6 Technical data for incremental encoders

Encoder type	9. Position in the order number	Operating voltage	Max. current drain	A-B track: Resolution incremental (sin/cos periods per revolution)	C-D track: Rotor/commutation position (sin/cos periods per revolution)	Angular error
without DRIVE-CLiQ interface						
Incremental encoder sin/cos 1 Vpp, 2048 S/R with C and D tracks	A	5 V ± 5 %	140 mA	2048 S/R (1 Vpp)	1 S/R (1 Vpp)	± 40 "
with DRIVE-CLiQ interface						
Incremental encoder 22 bit resolution 4.194.304, internal 2048 S/R) + commutation position 11 bit	D	24 V	180 mA	4.194.304 (=22 bit)	2048 (=11 bit)	± 40 "

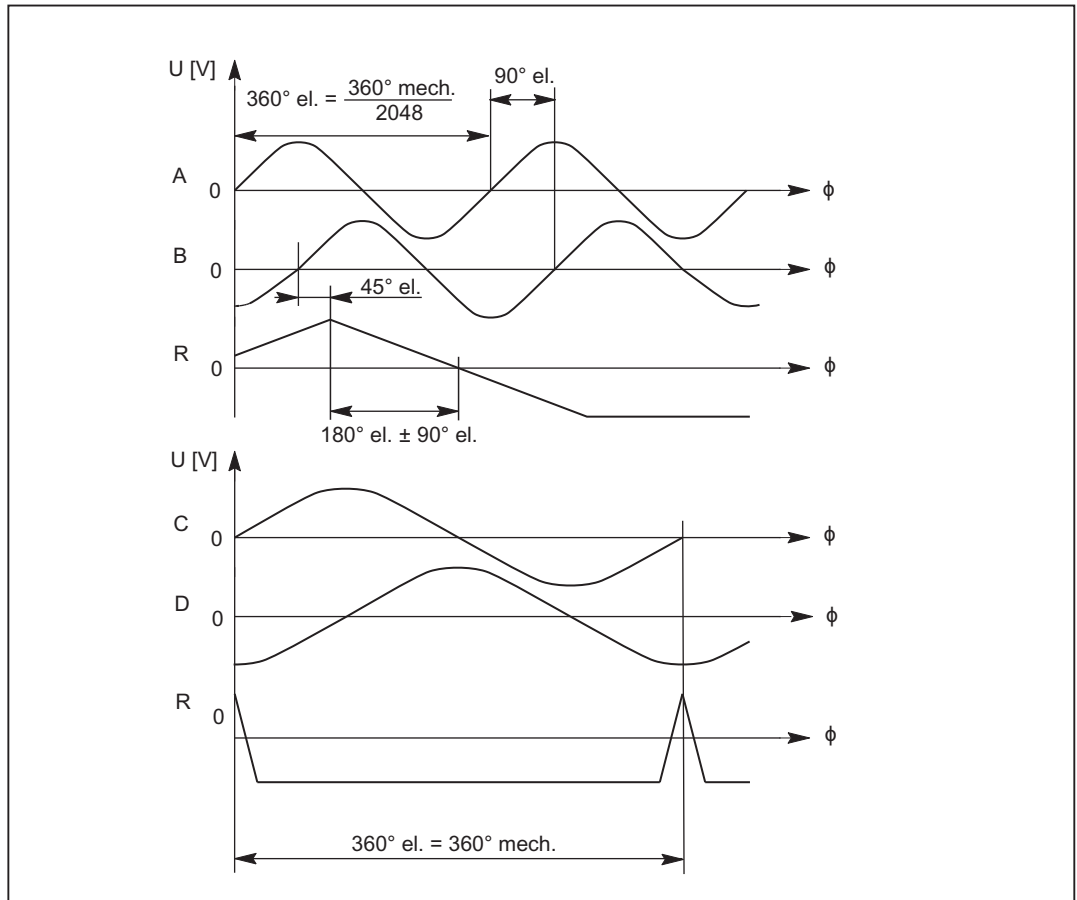
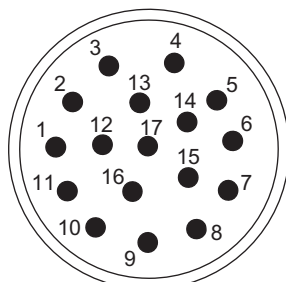

Figure 5-4 Signal sequence and assignment for encoder IC2048S/R without DRIVE-CLiQ interface for a positive direction of rotation

Connection pin assignment for 17-pin flange socket with pin contacts

Table 5- 7 Connection pin assignment, 17-pin flange socket

PIN No.	Signal	
1	A	 <p>When viewing the plug-in side (pins)</p>
2	A*	
3	R	
4	D*	
5	C	
6	C*	
7	M encoder	
8	+1R1	
9	-1R2	
10	P encoder	
11	B	
12	B*	
13	R*	
14	D	
15	M sense	
16	P sense	
17	Not connected	

Cables

Table 5- 8 Pre-assembled cable

6FX	□	002	-	2CA31	-	□□□	0
	↓					↓↓↓	
	↓					Length	
		5 MOTION-CONNECT®500				Max. cable length 100 m	
		8 MOTION-CONNECT®800					

Mating connector: 6FX2003-0SU17 (socket)

For other technical data and length code, refer to catalog, Chapter "MOTION-CONNECT connection system"

5.2.4 Absolute encoders

Description, multiturn absolute encoder

This encoder outputs an absolute angular position between 0° and 360° in the specified resolution. An internal measuring gearbox enables it to differentiate between 4096 rotations.

Description, absolute value singleturn

This encoder outputs an absolute angular position between 0° and 360° in the specified resolution. In contrast to the multi-turn absolute encoder, it has no measuring gearbox and can therefore only supply the position value within one revolution. It does not have a traversing range.

Function and technical data

- Angular measuring system for the commutation
- Speed actual value sensing
- For single-turn encoders: Indirect measuring system for absolute position determination within a traversing range of 1 revolution
- For multi-turn encoders: Indirect measuring system for determining the absolute position within a traversing range of 4096 revolutions

Table 5- 9 Technical specifications, absolute encoder

Encoder type	9. Position in the order number	Operating voltage	Max. current drain	Absolute resolution (singleturn)	Traversing -range (multiturn)	A-B track: Resolution incremental (sin/cos periods per revolution)	Angular error
without DRIVE-CLiQ interface							
Absolute encoder 2048 S/R, (4096 revolutions, multi-turn, with EnDat interface 2.1	E	5 V ±5 %	200 mA	---	4096 (=12 bit)	2048 S/R (1 Vpp)	±40"
with DRIVE-CLiQ interface							
Absolute encoder, single-turn, 24 bit	B	24 V	110 mA	16.777.216 (=24 bit)	---	---	±40"
Absolute encoder 24 bit + 12 bit multiturn	C	24 V	110 mA	16.777.216 (=24 bit)	4096 (=12 bit)	---	±40"
Absolute encoder singleturn 22 bit + 12 bit multiturn	F	5 V ±5 %	200 mA	4.194.304 (=22 bit)	4096 (=12 bit)	---	±40"

Connection pin assignment for 17-pin flange socket with pin contacts

Table 5- 10 Connection pin assignment, 17-pin flange socket

PIN No.	Signal
1	A
2	A*
3	Data
4	Not connected
5	Clock
6	not connected
7	M encoder
8	+1R1
9	-1R2
10	P encoder
11	B
12	B*
13	Data*
14	Clock*
15	M sense
16	P sense
17	not connected

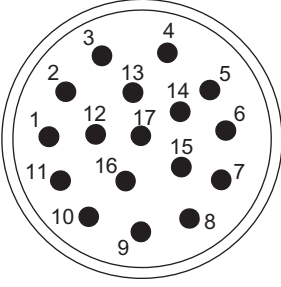

When viewing the plug-in side (pins)

Cables

Table 5- 11 Pre-assembled cable

6FX	<input type="checkbox"/>	002	-	2EQ10	-	<input type="checkbox"/> <input type="checkbox"/> <input type="checkbox"/>	0
↓				↓↓↓			
↓				Length			
5 MOTION-CONNECT®500				Max. cable length 100 m			
8 MOTION-CONNECT®800							

Mating connector: 6FX2003-0SU17 (socket)

For other technical data and length code, refer to catalog, Chapter "MOTION-CONNECT connection system"

5.2.5 Multi-pole resolver

Description

The number of sine and cosine periods per revolution corresponds to the number of pole pairs of the resolver. Resolvers can detect relative motion. The absolute position within one resolver output signal period can be determined.

Function and technical data

- Angular measuring system for the commutation
- Speed actual value sensing
- Indirect incremental measuring system for the position control loop

Table 5- 12 Technical specifications, resolvers

Properties	8-pole (for SH 200)	4-pole (for SH 150 and SH 280)
Excitation voltage	+ 5 V _{rms} to + 13 V _{rms}	
Excitation frequency	4 kHz to 10 kHz	
Current consumption	< 80 mA _{rms}	
Angular error, peak-to-peak (mech.)	< 4 '	< 10 '
Electrical transformation ratio	0.5	

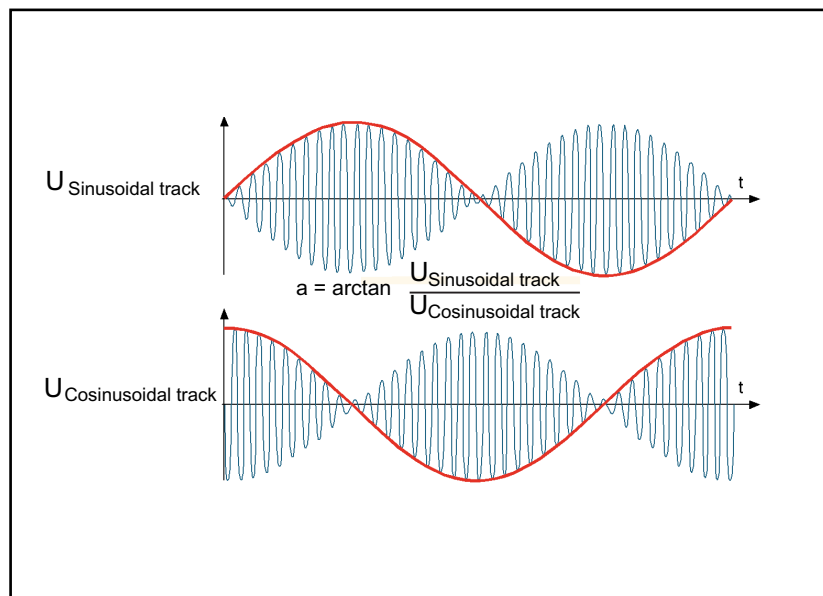
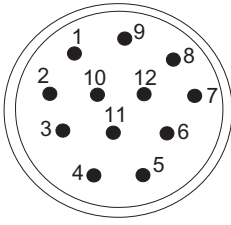

Figure 5-5 Output signals, resolver

Connection pin assignment for 12-pin flange socket with pin contacts

Table 5- 13 Connection pin assignment, 12-pin flange socket

PIN No.	Signal	
1	S2	 <p>When viewing the plug-in side (pins)</p>
2	S4	
3	not connected	
4	not connected	
5	not connected	
6	not connected	
7	R2	
8	+1R1	
9	-1R2	
10	R1	
11	S1	
12	S3	

Cables

Table 5- 14 Pre-assembled cable

6FX	□	002	-	2CF02	-	□□□	0
	↓					↓↓↓	
	↓					Length	
		5 MOTION-CONNECT®500				Max. cable length 150 m	
		8 MOTION-CONNECT®800					

Mating connector: 6FX2003-0SU12 (socket)

For other technical data and length code, refer to catalog, Chapter "MOTION-CONNECT connection system"

5.2.6 Encoder with belt drive

The encoder in the encoder box (on the stator side) is coupled via a belt. This means, for example, the hollow shaft can be used to route media. Gear ratio, refer to Chapter "Mechanical properties of the motors".

NOTICE

Only qualified personnel may replace a belt. To do this, a device is required to measure the belt tension.

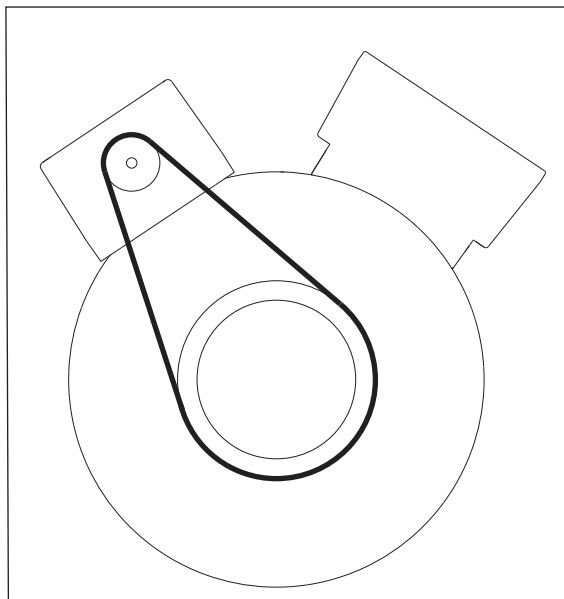

Figure 5-6 Encoder with belt drive

5.2.7 Coaxial encoder mounting

Coaxial encoder mounting is available for high dynamic requirements and the highest precision. The encoder module can be easily replaced without requiring readjustment.

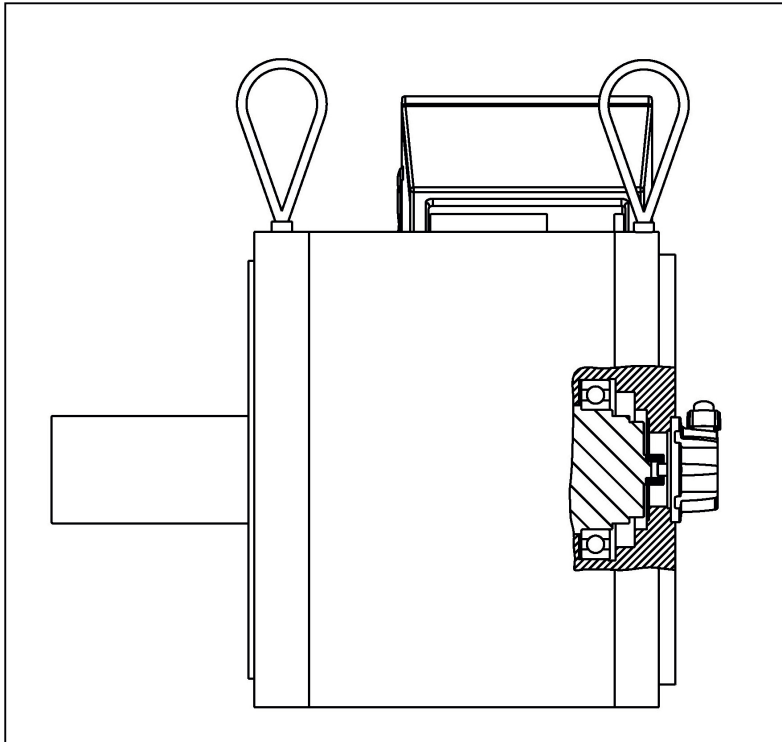

Figure 5-7 Coaxial encoder mounting

5.2.8 Motor version without encoder

The cable gland and the terminal in the terminal box are used to connect the KTY temperature sensor as well as the replacement KTY.

5.3 Braking resistors (armature short-circuit braking)

5.3.1 Function description

For transistor PWM converters, when the DC link voltage values are exceeded or if the electronics fails, then electrical braking is no longer possible. If the drive which is coasting down, can represent a potential hazard, then the motor can be braked by short-circuiting the armature. Armature short-circuit braking should be initiated at the latest by the limit switch in the traversing range of the feed axis.

The friction of the mechanical system and the switching times of the contactors must be taken into account when determining the distance that the feed axis takes to come to a complete stop. In order to avoid mechanical damage, mechanical stops should be located at the end of the absolute traversing range.

For servomotors with integrated holding brake, the holding brake can be simultaneously applied to create an additional braking torque – however, with some delay.

CAUTION
The converter pulses must first be canceled and this actually implemented before an armature short-circuit contactor is closed or opened. This prevents the contactor contacts from burning and eroding and destroying the converter.

 WARNING
The drive must always be operationally braked using the setpoint input. For additional information, refer to the Converter Configuration Manual.

The optimum braking torque of the servomotor in regenerative operation can be obtained using armature short-circuit with a matching external resistor circuit.

Possible ordering address: <http://www.frizlen.com>

Note

It goes without saying that equivalent products from other manufacturers may be used. Our recommendations should be considered as such. We cannot accept any liability for the quality and properties/features of third-party products.

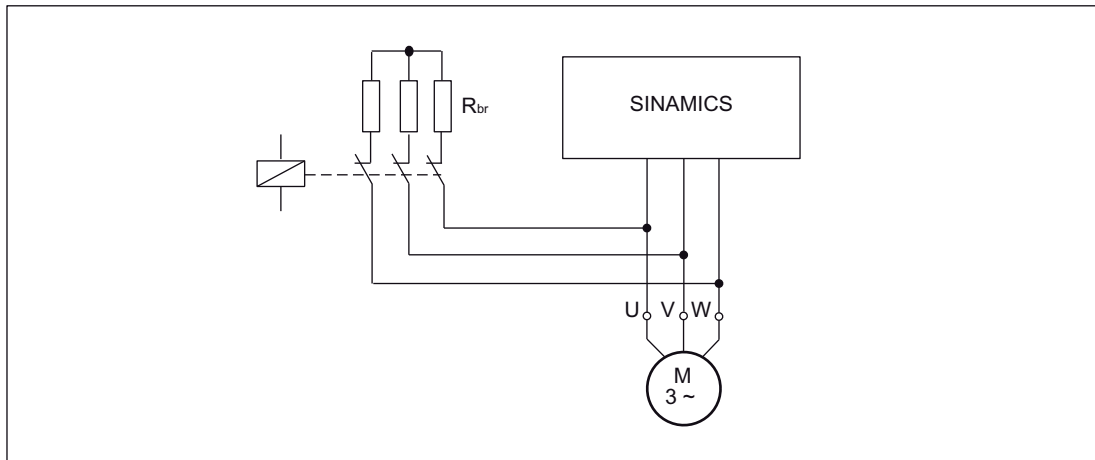

Figure 5-8 Circuit (schematic) with brake resistors

Ordering address

Frizlen GmbH & Co. KG
Gottlieb-Daimler-Str. 61, 71711 Murr
Germany

Phone: +49 (0) 7144 / 8100 - 0
Fax: +40 (0) 7144 / 2076 - 30
E-mail: info@frizlen.com
Internet at: www.frizlen.com

Note

We cannot accept any liability for the quality and properties/features of third-party products.

Rating

The ratings of the resistors must match the particular I²t load capability. The resistors can be dimensioned so that a surface temperature of 300° C can occur briefly (max. 500 ms). In order to prevent the resistors from being destroyed, braking from the rated speed can occur max. every 2 minutes. Other braking cycles must be specified when ordering the resistors. The external moment of inertia and the intrinsic motor moment of inertia are decisive when dimensioning these resistors.

The kinetic energy must be specified when ordering in order to determine the resistor rating.

$$W = \frac{1}{2} \cdot J \cdot \omega^2$$

$$\omega = \frac{2 \cdot \pi}{60} \cdot n$$

W = kinetic energy [Ws]

J = Moment of inertia [kgm²]

ω = Angular speed [s⁻¹]

n = Speed [rpm]

Calculating the braking time

Braking time:
$$t_B = \frac{J_{\text{tot}} \cdot n}{9.55 \cdot M_B}$$

Moment of inertia:
$$J_{\text{tot}} = J_{\text{mot}} + J_{\text{external}}$$

t_B = Braking time [s]

n = operating speed [rpm]

M_B = average braking torque [Nm]

J_{tot} = moment of inertia [kgm²]

J_{mot} = motor moment of inertia [kgm²]

J_{external} = external moment of inertia [kgm²]

NOTICE

When determining the run-on distance, the friction (taken into account as allowance in M_B) of the mechanical transmission elements and the switching delay times of the contactors must be taken into consideration. In order to prevent mechanical damage, mechanical end stops should be provided at the end of the absolute traversing range of the machine axes.

5.3 Braking resistors (armature short-circuit braking)

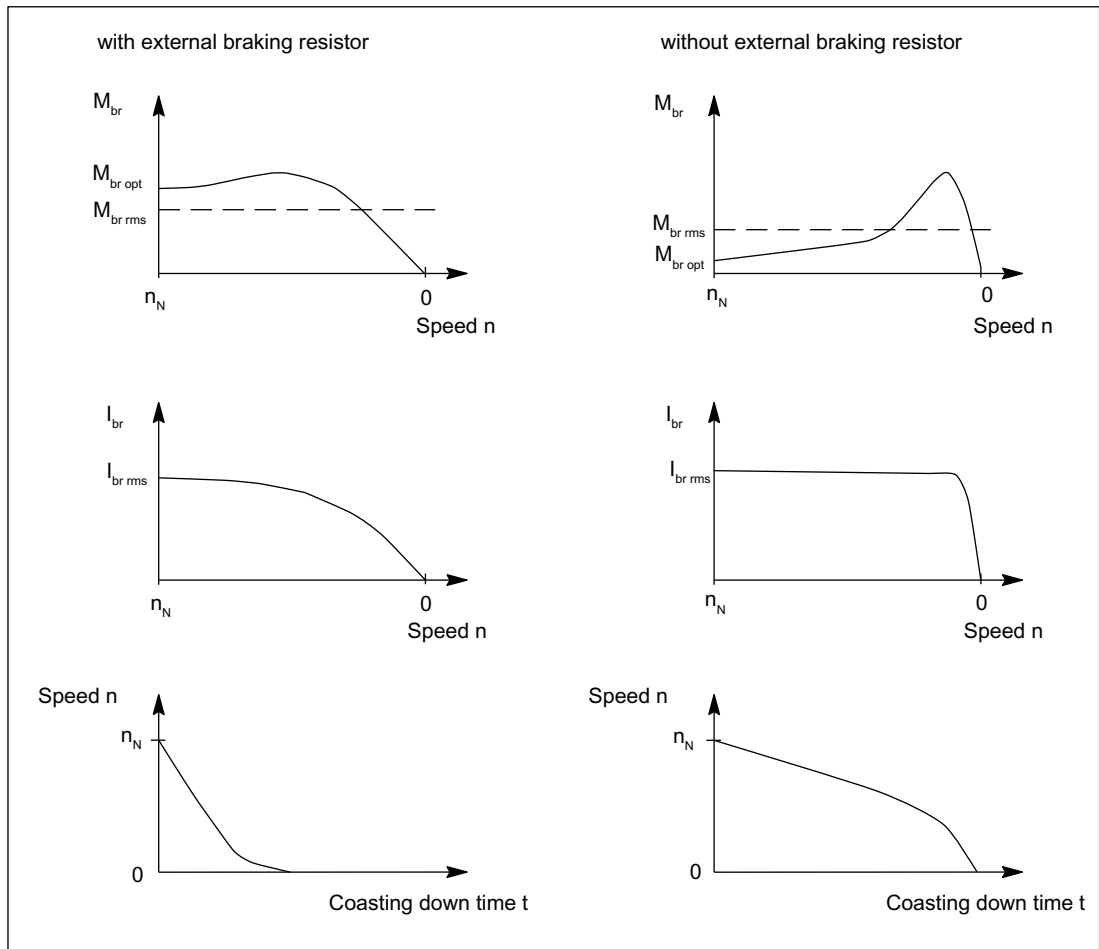

Figure 5-9 Armature short-circuit braking

5.3.2 Dimensioning of braking resistors

The correct dimensioning ensures an optimum braking time. The braking torques which are obtained are also listed in the tables. The data apply for braking from the rated speed. If the motor brakes from another speed, then the braking time **cannot** be linearly reduced. However, longer braking times cannot occur if the speed at the start of braking is less than the rated speed.

The data in the following table is calculated for rated values according to the data sheet. The variance during production as well as iron saturation have not been taken into account here. Higher currents and torques can occur than those calculated as a result of the saturation.

The ratings of the resistors must match the particular I^2t load capability.

Dynamic braking

Table 5- 15 Dynamic braking 1FW3, SH 150

Motor type	External braking resistor R_{opt} [Ω]	Average braking torque $M_{br\ rms}$ [Nm]		Max. braking torque $M_{br\ max}$ [Nm]	rms braking current $I_{br\ rms}$ [A]	
		without external braking resistor	with external braking resistor		without external braking resistor	with external braking resistor
1FW3150-1□H	11	21.5	32.5	40.5	5.3	4.75
1FW3150-1□L	8.3	17.8	34.5	42.5	8.6	7.7
1FW3150-1□P	5.5	14.8	35.5	44.0	13.5	12.1
1FW3152-1□H	5.0	46.5	75	93	12.2	11.0
1FW3152-1□L	3.7	37.5	80	99	20.0	17.9
1FW3152-1□P	2.4	32.0	85	105	32.0	28.5
1FW3154-1□H	3.3	73	122	151	19.3	17.3
1FW3154-1□L	2.4	60	130	161	32.0	28.5
1FW3154-1□P	1.6	50	137	170	51.0	45.0
1FW3155-1□H	2.3	97	164	205	27.0	24.0
1FW3155-1□L	1.7	77	173	215	43.5	39.0
1FW3155-1□P	1.1	66	188	235	71	64.0
1FW3156-1□H	2.0	119	205	255	32.5	29.5
1FW3156-1□L	1.4	96	215	270	54	48.0
1FW3156-1□P	0.97	84	240	295	85	76.0

5.3 Braking resistors (armature short-circuit braking)

Table 5- 16 Dynamic braking 1FW3, SH 200

Motor type	External braking resistor R_{opt} [Ω]	Average braking torque $M_{br\ rms}$ [Nm]		Max. braking torque $M_{br\ max}$ [Nm]	rms braking current $I_{br\ rms}$ [A]	
		without external braking resistor	with external braking resistor		without external braking resistor	with external braking resistor
1FW3201-1□E	4.4	76	106	132	10.4	9.4
1FW3201-1□H	3.2	54	110	136	19.5	17.5
1FW3201-1□L	2.2	39	109	135	31.5	28.0
1FW3202-1□E	2.5	133	196	245	19.1	17.3
1FW3202-1□H	1.8	94	205	255	36.0	32.0
1FW3202-1□L	1.2	69	205	255	57.0	52.0
1FW3203-1□E	1.8	192	290	355	27.5	25.0
1FW3203-1□H	1.0	141	310	390	58.0	52.0
1FW3203-1□L	0.77	101	310	385	89.0	80
1FW3204-1□E	1.3	265	410	510	38.5	35.0
1FW3204-1□H	0.82	200	450	560	78.0	70.0
1FW3204-1□L	0.57	144	455	560	126	113
1FW3206-1□E	0.76	400	610	760	62.0	56.0
1FW3206-1□H	0.54	270	630	780	115	103
1FW3206-1□L	0.37	215	670	830	190	170
1FW3208-1□E	0.58	550	850	1060	83	75
1FW3208-1□H	0.38	395	910	1130	164	147
1FW3208-1□L	0.31	255	790	980	225	200

5.3 Braking resistors (armature short-circuit braking)

Table 5- 17 Dynamic braking 1FW3, SH 280

Motor type	Braking resistor external R_{opt} [Ω]	Average braking torque $M_{br\ rms}$ [Nm]		Max. braking torque $M_{br\ rms}$ [Nm]	rms braking current $I_{br\ rms}$ [A]	
		without external braking resistor	with external braking resistor		without external braking resistor	with external braking resistor
1FW3281-2□E	0.63	850	1230	1520	94	85
1FW3281-2□G	0.5	640	1230	1530	148	133
1FW3283-2□E	0.48	1120	1720	2150	131	118
1FW3283-2□G	0.37	840	1720	2150	205	184
1FW3285-2□E	0.36	1520	2450	3050	184	166
1FW3285-2□G	0.28	1120	2450	3050	285	255
1FW3287-2□E	0.25	2050	3450	4250	265	235
1FW3287-2□G	0.19	1500	3450	4300	410	370
1FW3281-3□J	0.36	480	1230	1530	230	205
1FW3281-3□M	0.26	360	1220	1520	335	300
1FW3283-3□J	0.24	620	1710	2150	335	300
1FW3283-3□M	0.2	460	1710	2100	460	410
1FW3285-3□J	0.18	830	2450	3050	465	415
1FW3285-3□M	0.16	630	2500	3100	620	550
1FW3287-3□J	0.14	1090	3450	4250	610	550
1FW3287-3□M	0.098	830	3450	4300	930	830

Connection system

6.1 SINAMICS drive I/O

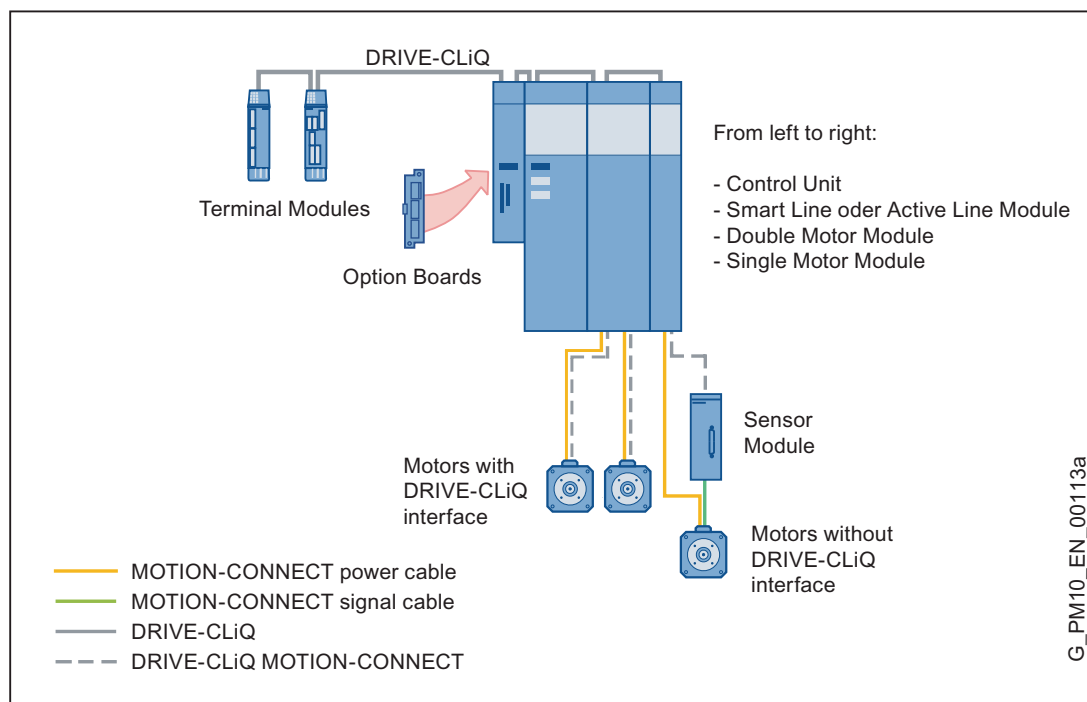

Figure 6-1 SINAMICS S120 system overview

WARNING

Before carrying out any work on the motor, please ensure that it is powered-down and the system is locked-out so that the motor cannot re-start!

The motors may not be connected to the line supply.

The complete torque motors can be operated in a 4-quadrant drive system. They can be connected to either a regulated or non-regulated infeed unit.

Note

The encoders are adjusted in the factory for SIEMENS drive converters. Another encoder adjustment may be required when operating the motor with a third-party converter.

6.2 Line connection

⚠ CAUTION

Carefully observe the current which the motor draws for your particular application! Adequately dimension the connecting cables according to IEC 60204-1 (see table "Cable cross section and current-carrying capacity").

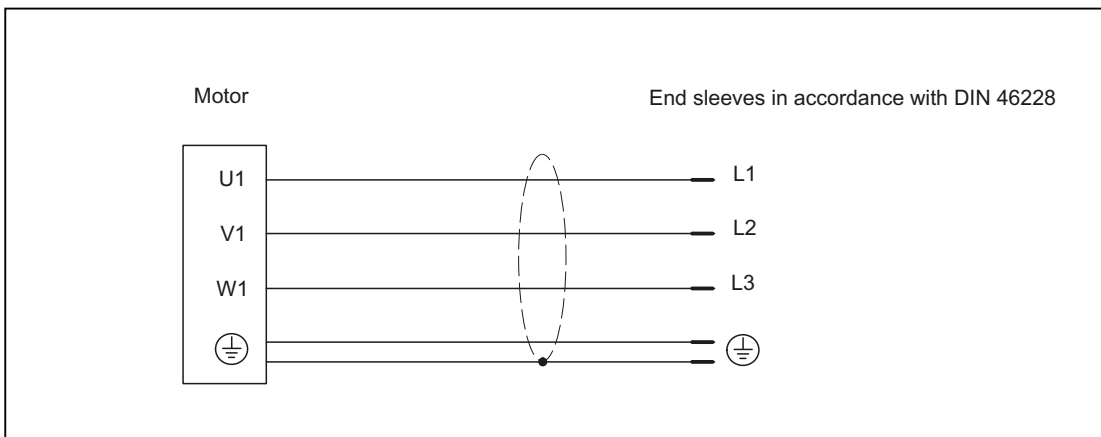

Figure 6-2 Power cable

Terminal box connection

The type designation of the mounted terminal box as well as details for connecting-up the line feeder cables can be taken from Table "Cable cross-sections (Cu) and outer diameter of the connecting cables in the standard version". A circuit diagram to connected-up the motor winding is provided in the terminal box when the motors are shipped.

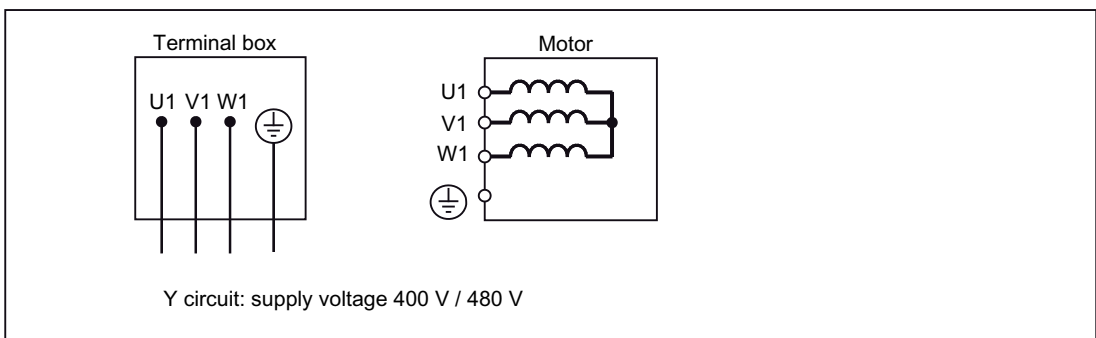

Figure 6-3 Circuit diagram

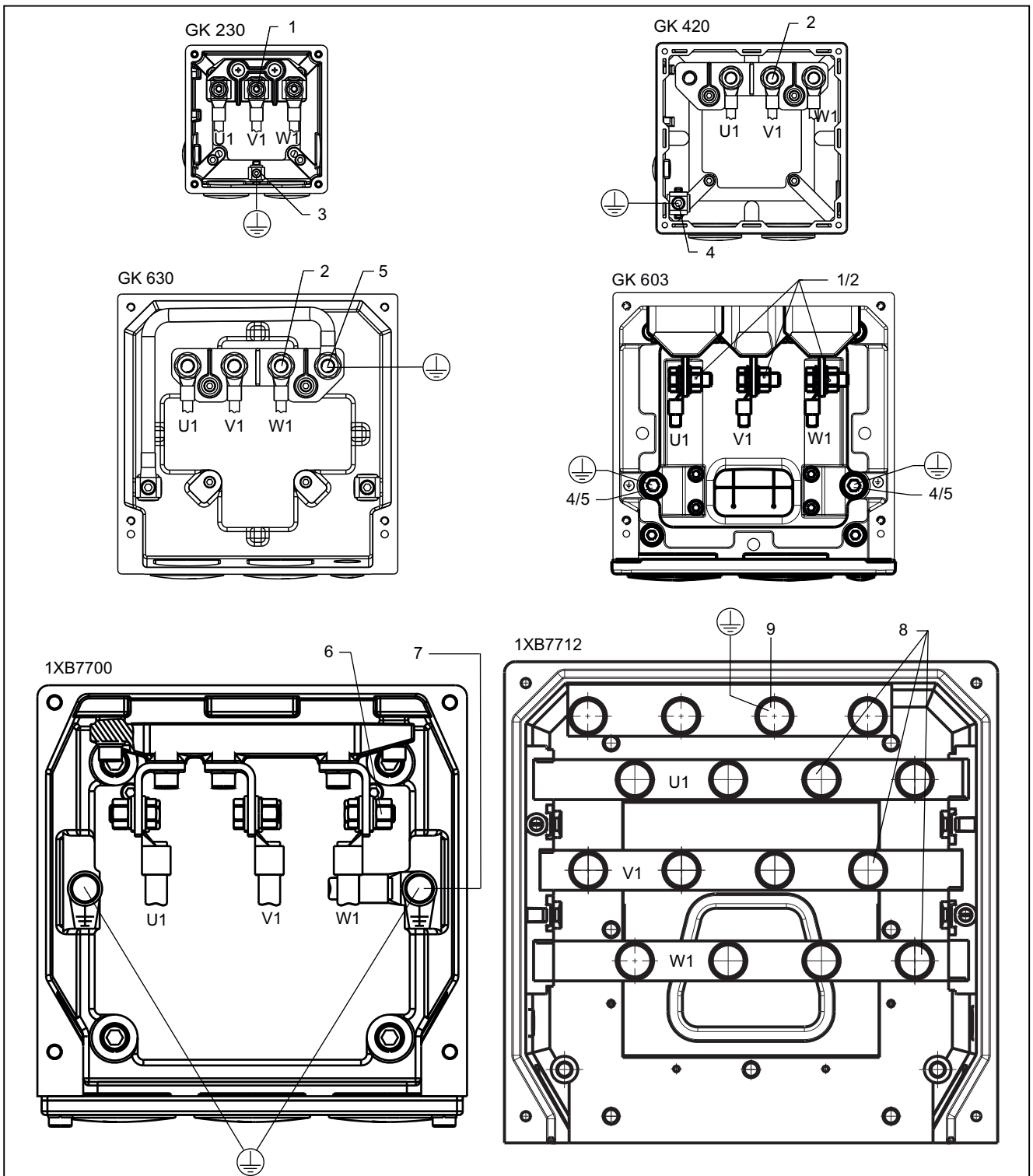

Figure 6-4 Terminal assignment in the terminal boxes

Table 6- 1 Description of the diagram "Terminal assignment in the terminal box"

No.	Description	No.	Description
1	M5 connecting studs	6	Connecting bar 3 x M12
2	M10 connecting studs	7	Grounding screw M12 max. 120 mm ²
3	M4 grounding screw	8	M16 connecting studs
4	M6 grounding screw	9	M16 grounding studs
5	M10 grounding studs		

Table 6- 2 Cable cross-sections (Cu) and outer diameter of the connecting cables in the standard version

Shaft height	Rated current I_N	Terminal box type	Terminal stud	Thread for cable gland	Max. connectable cross-section	Cable diameter
150 - 200	$I_N \leq 50$ A	GK 230	∅ 5 mm	2 x M32 x 1.5	2 x 16 mm ²	11 ... 24 mm
	50 A < $I_N \leq 105$ A	GK 420	∅ 10 mm	2 x M40 x 1.5	2 x 35 mm ²	19 ... 31 mm
	105 A < $I_N \leq 260$ A	GK 630	∅ 10 mm	2 x M50 x 1.5	2 x 50 mm ²	27 ... 38 mm
	$I_N \leq 260$ A	GK 603 ¹⁾	∅ 5 mm ∅ 10 mm	2 x M63 x 1.5	2 x 50 mm ²	11 ... 38 mm
280	$I_N \leq 450$ A	1XB7700	∅ 12 mm	3 x M75 x 1.5	3 x 120 mm ²	41 ... 56 mm
	450 A < $I_N \leq 800$ A	1XB7712	∅ 16 mm	4 x M75 x 1.5	4 x 120 mm ²	41 ... 56 mm

¹⁾ Terminal box with removable front plate (option)

Note

The MOTION-CONNECT 500 and MOTION-CONNECT 800 cables are available in a UL version up to a cross-section of 4 x 185 mm².

6.3 Signal connection

DRIVE-CLiQ is the preferred method for connecting the encoder systems to SINAMICS.

Motors with a DRIVE-CLiQ interface can be ordered for this purpose. Motors with a DRIVE-CLiQ interface can be directly connected to the associated motor module via the available MOTION-CONNECT DRIVE-CLiQ cables. The MOTION-CONNECT DRIVE-CLiQ cable is connected to the motor in degree of protection IP67. The DRIVE-CLiQ interface supplies power to the motor encoder via the integrated 24 VDC supply and transfers the motor encoder and temperature signals and the electronic type plate data, e.g. a unique identification number, rating data (voltage, current, torque) to the control unit. The MOTION-CONNECT DRIVE-CLiQ cable is used universally for connecting the various encoder types. These motors simplify commissioning and diagnostics, as the motor and encoder type are identified automatically.

Motors with DRIVE-CLiQ

Motors with DRIVE-CLiQ interfaces can be directly connected to the corresponding motor module via the available MOTION-CONNECT DRIVE-CLiQ cables. This means that data are transferred directly to the control unit.

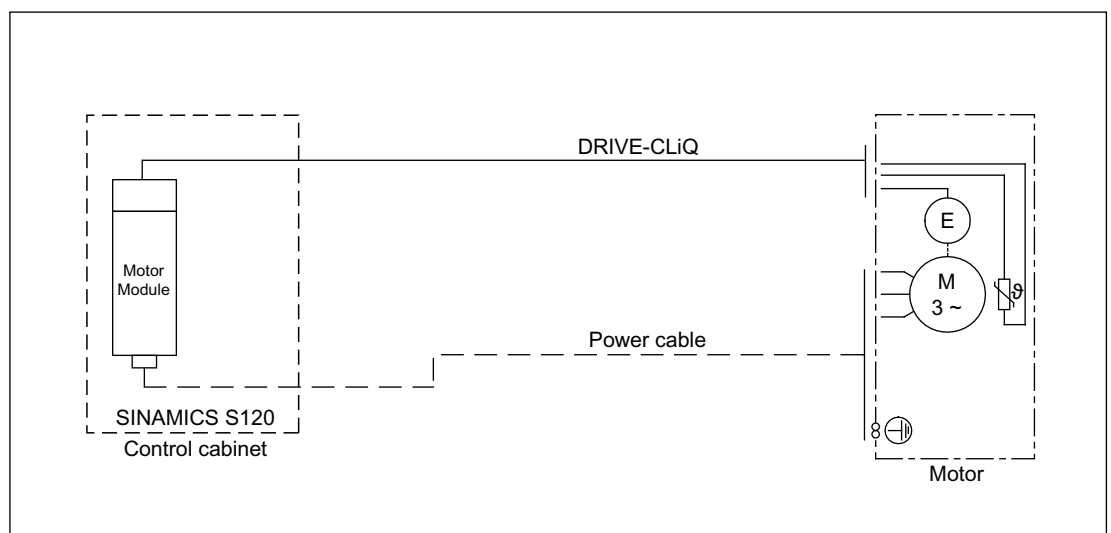

Figure 6-5 Encoder interface with DRIVE-CLiQ

Motors without DRIVE-CLiQ

If a motor is not equipped with a DRIVE-CLiQ interface, the speed encoder and temperature sensor are connected via a signal connector.

Motors that are not equipped with DRIVE-CLiQ require a Cabinet-Mounted Sensor Module (SMC) when operated with SINAMICS S120. The motor is connected to the SMC via a signal line. The SMC is connected to the Motor Module via a MOTION-CONNECT DRIVE-CLiQ cable.

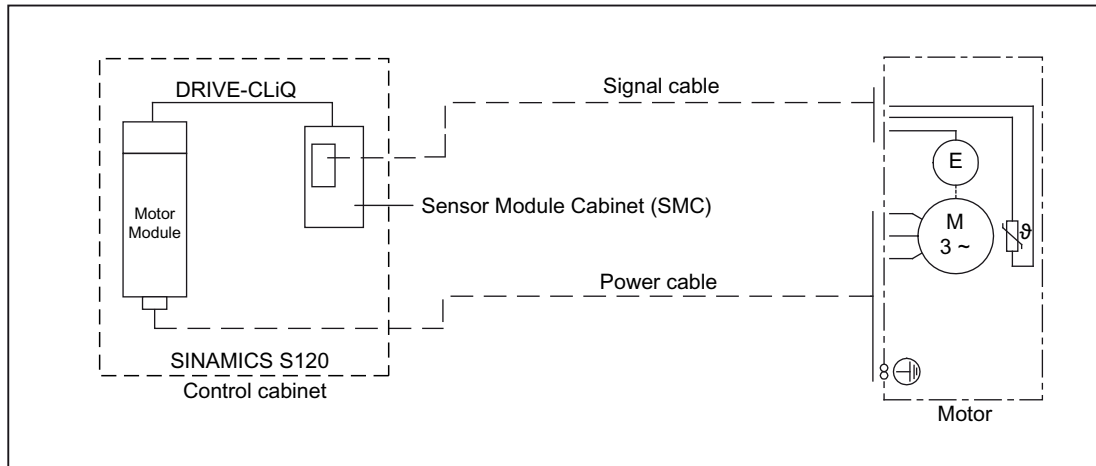

Figure 6-6 Encoder interface without DRIVE-CLiQ

6.4 Rotating the connector at the motor

Signal connector and integrated Sensor Module can be rotated to a limited extent.

NOTICE
<p>When rotating the connector, the following must be observed</p> <ul style="list-style-type: none"> • It is not permissible that the specified rotation range is exceeded. • In order to guarantee the degree of protection, max. 10 revolutions are permissible. • Do not exceed the max. torque when rotating, refer to the table "Rotating torques". • Connectors should be rotated using the matching mating connector located on the connector thread. • Connecting cables must be secured against tension and bending. • The motor connectors must then be secured so that they cannot rotate. • It is not permissible to subject the connector to continuous force.

Table 6- 3 Maximum rotating torques that occur

Connector	Max. rotating torques that occur [Nm]
Signal connector	8
Integrated Sensor Module	8

Signal cable

The manufacturer mounts the plug-in connection for the signal cable (at the encoder terminal box). When inserting the connector, the coding groove must be inserted aligned in the socket connector and the union nut must be tightened by hand to the end stop.

6.5 Connecting-up information

Pre-assembled cables offer many advantages over cables assembled by customers themselves. In addition to being sure that they will work perfectly and the high quality, there are also cost benefits.

Use the power and signal cables from the MOTION CONNECT family. The maximum cable lengths should be carefully observed. Technical data of the cables, refer to Catalog, Chapter "MOTION-CONNECT connection system".

Cable installation

- Shielded power and signal cables must be used.
- In exceptional cases, it is possible to use twisted motor cables or three-core cables with additional ground conductor. Only remove insulation from the cable ends so that the insulation completely extends up to the cable lug, to the terminal, or end sleeve.
- Protruding wire ends must be avoided.
- The connecting cables should be freely arranged in the terminal box so that the protective conductor has an overlength and the cable conductor insulation cannot be damaged. Connecting cables should be appropriately strain relieved.
- The cable lug size must be adapted to the dimensions of the terminal board connections and the cross section of the line supply cable.
- Take measures to ensure that connecting cables cannot rotate, are not subject to strain and pushing force and also provide anti-kink protection. It is not permissible to subject cables to continuous force.
- Take special care that the required minimum air clearances are actually maintained:

Table 6- 4 Minimum air clearance

Max. terminal voltage	< 600 V	< 1000 V
Minimum air clearance	5.5 mm	8 mm

- The screwed electrical connections must be tightened with the specified tightening torques:

Table 6- 5 Tightening torques

Thread Ø	M4	M5	M6	M8	M10	M12	M16
Tightening torque (Nm)	0.8 ... 1.2	1.8 ... 2.5	2.7 ... 4	5.5 ... 8	9 ... 13	14 ... 20	27 ... 40

Note

In order to avoid disturbing effects (e.g. as a result of EMC), the signal cables must be routed separately away from power cables.

Internal potential bonding (for 1FW315□ and 1FW320□)

The potential bonding between the grounding terminal in the box enclosure and the motor housing is established through the terminal box retaining bolts. The contact locations below the heads of the bolts are bare and are protected against corrosion.

The standard screws that are used to connect the terminal box cover to the terminal box are sufficient as potential bonding between the terminal box cover and the terminal box enclosure.

Outer protective conductor or potential bonding conductor (1FW328□)

Note

Connecting an outer protective conductor

For shaft height 1FW328□, there is an additional connection point on the frame to connect an outer protective conductor or potential bonding conductor.

For shaft height 1FW315□ and 1FW320□ this is not required.

Connect-up the ground conductor

The grounding conductor cross-section must be compliance with the appropriate installation/erection regulations, e.g. acc. to IEC/EN 60204-1.

For shaft height 280, the ground conductor must be additionally connected to the motor frame. A threaded hole is provided for the ground conductor at the designated connection point. This is suitable for connecting stranded conductors with cable lugs or straps with an appropriately terminated conductor end.

Please note the following when connecting-up:

- The connecting surface must be bare and must be protected against corrosion using a suitable substance, e.g. using acid-free Vaseline
- Spring washer and normal washer must be located under the head of the screw
- The minimum screw-in depth and tightening torque of the clamping screw must be maintained (refer to the Table)

Table 6- 6 Screw-in depth and tightening torque

Screw	Minimum screw-in depth	Tightening torque
M10 x 30	15 mm	28 - 42 Nm

After connecting-up, the following should be checked/tested

- The inside of the terminal box must be clean and free of any cable pieces
- All of the terminal screws must be tight
- The minimum air clearances must be maintained
- The cable glands must be reliably sealed
- Unused cable glands must be closed and the plugs must be tightly screwed in place
- All of the sealing surfaces must be in a perfect condition

Current-carrying capacity for power and signal cables

The current-carrying capacity of PVC/PUR-insulated copper cables is specified for routing types B1, B2 and C under continuous operating conditions in the table with reference to an ambient air temperature of 40 °C. For other ambient temperatures, the values must be corrected by the factors from the "Derating factors" table.

Table 6- 7 Cable cross section and current-carrying capacity

Cross section [mm ²]	Current-carrying capacity rms; AC 50/60 Hz or DC for routing type		
	B1 [A]	B2 [A]	C [A]
Electronics (according to EN 60204-1)			
0,20	-	4,3	4,4
0,50	-	7,5	7,5
0,75	-	9	9,5
Power (according to EN 60204-1)			
0,75	8,6	8,5	9,8
1,00	10,3	10,1	11,7
1,50	13,5	13,1	15,2
2,50	18,3	17,4	21
4	24	23	28
6	31	30	36
10	44	40	50
16	59	54	66
25	77	70	84
35	96	86	104
50	117	103	125
70	149	130	160
95	180	165	194
120	208	179	225
Power (according to IEC 60364-5-52)			
150	-	-	259 ¹⁾
185	-	-	296 ¹⁾
> 185	Values must be taken from the standard		

1) Extrapolated values

Table 6- 8 Derating factors for power and signal cables

Ambient air temperature [°C]	Derating factor according to EN 60204-1 Table D1
30	1,15
35	1,08
40	1,00
45	0,91
50	0,82
55	0,71
60	0,58

6.6 Routing cables in a damp environment

NOTICE

If the motor is mounted in a humid environment, the power and signal cables must be routed as shown in the following figure.

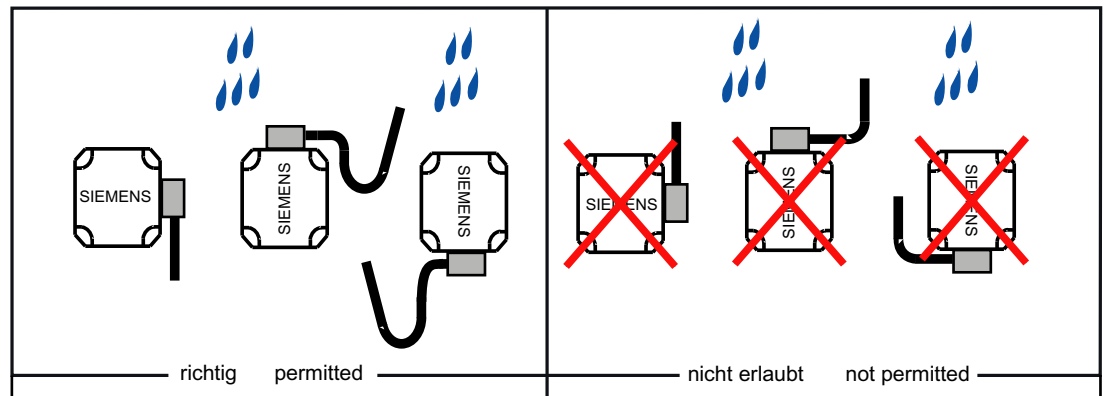



Figure 6-7 Principle of cable routing in a wet/moist environment

Assembly

7.1 Warning and danger information when mounting

 DANGER
<p>Torque motors are equipped with strong magnets. This is the reason that when the motors are open there are strong magnetic fields and high magnetic forces of attraction.</p> <p>It is not permissible that personnel with heart pacemakers or metal implants work on an opened motor.</p> <p>Keep clocks/watches and magnetic data mediums (e.g. floppy disks, credit cards, etc.), away from these motors.</p>

 WARNING
<p>These motors are electrically operated. When electrical equipment is operated, certain parts of these motors are at hazardous voltage levels. If this motor is not correctly handled/operated, this can result in death or severe bodily injury as well as significant material damage.</p> <p>Please carefully observe the warning information in this chapter and on the product itself.</p>

- Only **qualified personnel** are permitted to carry-out installation/mounting and repair work on this motor.
- When transporting, use the cable slings provided
- All work on the motor should be undertaken with the system in a no-voltage condition
- The motor should be connected-up according to the circuit diagram provided
- In the motor terminal box, it must be ensured that the connecting cables are connected so that there is electrical isolation between the cables and the terminal box cover
- It must be ensured that the terminal box is sealed
- It is not permissible to use cables with insulation that is either defective or damaged
- Only spare parts, certified by the manufacturer, may be used
- Check that they match the conditions at the installation location (e.g. temperatures, installation altitude)
- It is prohibited that the motors are used in hazardous zones and areas
- Thoroughly remove all anti-corrosion agents from the connecting flange (use commercially available solvents)
- The drive-out elements should be rotated by hand. If there is a grinding noise, the cause must be rectified or the manufacturer contacted.

7.2 Overview of the mounting options

Torque motors are generally used as direct drives, i.e. without any intermediate gearbox or belts. The principle difference between mounting motors for conventional drives and for direct drives can be seen from the following diagram.

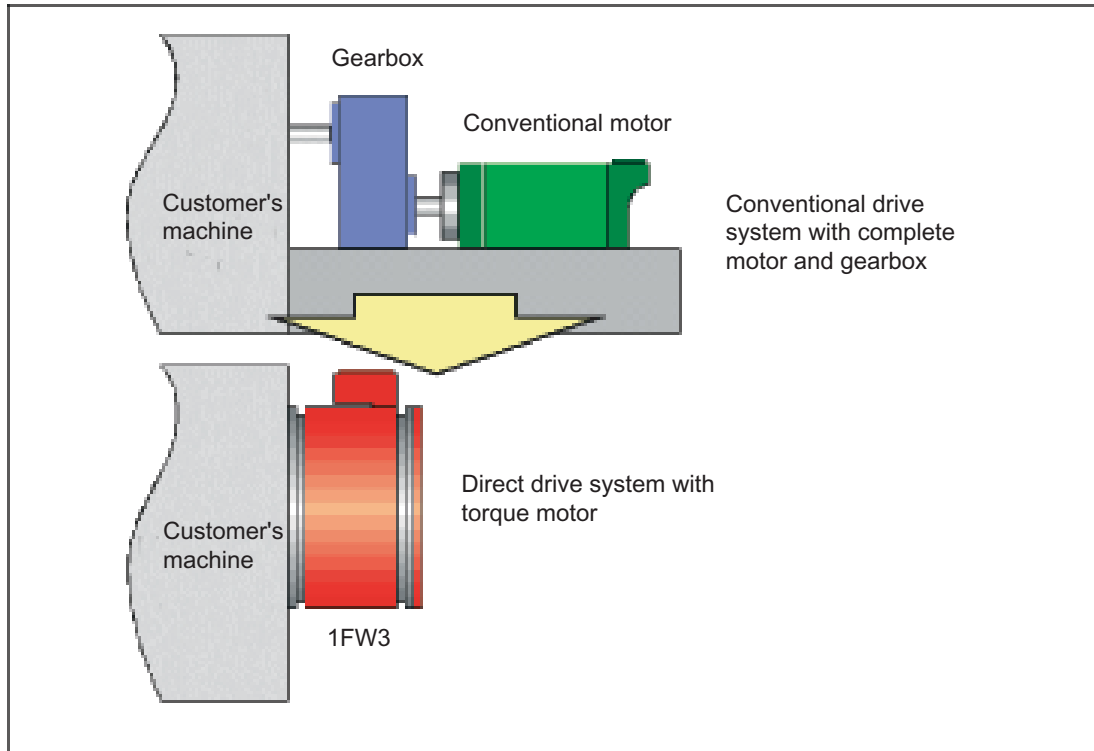

Figure 7-1 Comparison between conventional and direct drive systems

The following must be observed when mounting

The torque motors are complete motors equipped with deep-groove ball bearings.

NOTICE

Under no circumstances may the max. permissible axial and radial forces be exceeded.

Under no circumstances may the bearings of the customer's machine over-determine the motor bearings. If the bearings are over-determined, this can result in immediate bearing damage or the bearing change interval will be significantly reduced.

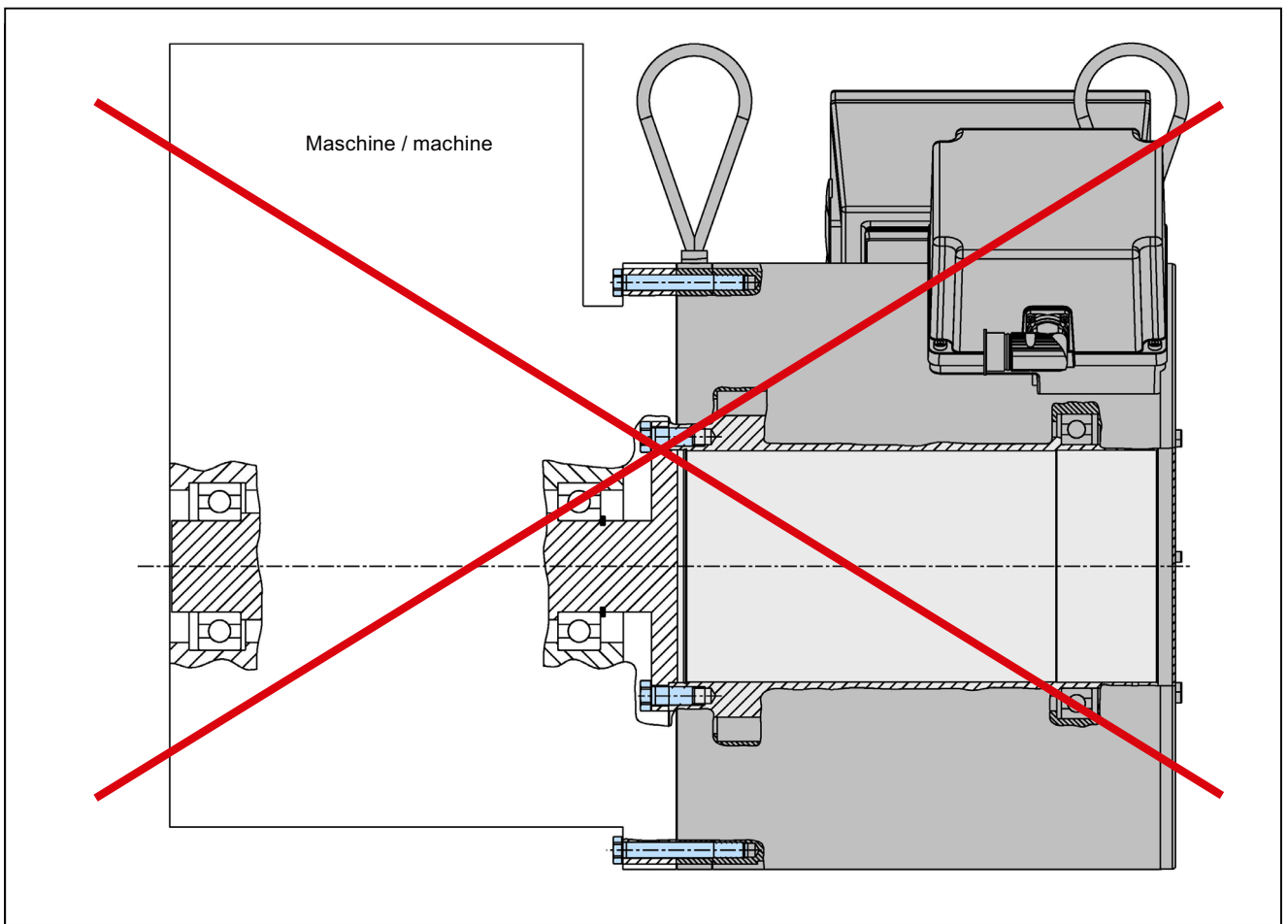

Figure 7-2 Over-determined bearings of a shaft (to be avoided)

7.3 Mounting the motor frame

Mounting the motor frame to the machine on the customer's side

The following possibilities are available for mounting the motor frame of the complete torque motor 1FW3 to the machine on the customer's side:

1. Flange-mounting for 1FW3 motors (SH 150, SH 200)
2. Foot and flange-mounting for 1FW3 motors (SH 280)

Table 7- 1 Mounting the motor frame

Shaft height	Type of construction	Holes at the DE housing flange	Pitch circle diameter
150	IM B14, IM V18/19	12 x M10	295 mm
200	IM B14, IM V18/19	16 x M10	380 mm
280	IM B35	24 x \varnothing 13 mm	532 mm

Rotor connected to the drive shaft

The rotor of the 1FW3 motor can be connected as follows to the drive shaft on the customer's side:

Table 7- 2 Rotor connected to the drive shaft

Shaft height	Threaded hole at the rotor DE (face side)	Tensioning elements in the inner diameter of the rotor
150	12 x M12, 24 mm deep, pitch circle diameter 170 mm	Inside diameter, 153 mm H7
200	12 x M12, 24 mm deep, pitch circle diameter 170 mm	Inside diameter, 153 mm H7
280	24 x M16, 34 mm deep, pitch circle diameter 280 mm	Inside diameter, 250 mm H7

NOTICE

The permissible clamping range must be carefully observed! The permissible surface pressure must not be exceeded!

A stable foundation design and precise motor alignment are prerequisites for smooth, vibration-free operation.

The following mounting notes must be carefully observed:

- Especially for high-speed motors with flange mounting, it is important that the mounting is stiff in order to locate any resonant frequency as high as possible so that it remains above the maximum rotational frequency.
- Thin sheets (shims) can be placed under the motor mounting feet to align the motor and to avoid mechanically stressing the motor. The number of shims used should be kept to a minimum.
- In order to securely mount the motors and reliably and safely transfer the drive torque, bolts with property class 8.8 acc. to ISO 898-1 should be used.

7.4 Plug-on installation

NOTICE
Installation using the plug-on principle
When installing the motor using the plug-on principle (motor on the shaft, enclosure supported with a torque arm), the weight of the motor results in an additional load. This must be taken into account when designing the bearings and shaft. Information on the motor weight is provided in the data sheets or dimension drawings.

Torque arm on the stator side

Advantage: Torque arms ensure a torsionally-rigid motor connection in a radial direction and balance axial tolerances and misalignments.

This is a highly effective solution for applications with a continuous speed/direction of rotation.

Disadvantage: Depending on the version, a torque arm may demonstrate a certain degree of play in a radial direction, which can limit the dynamic response and cause positional errors.

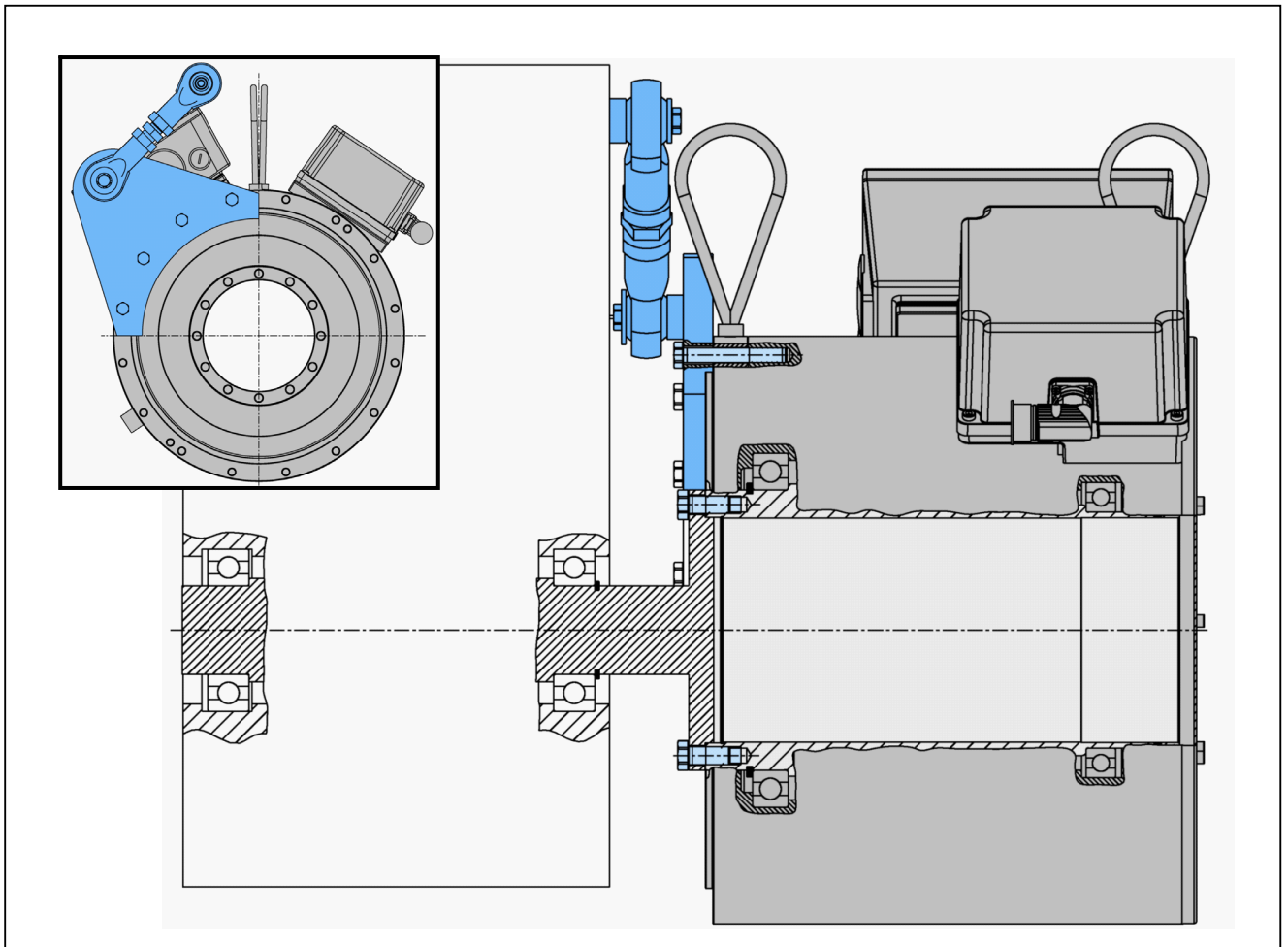

Figure 7-3 De-coupling the stator from the machine base using a torque arm

Shaft-side clamping element connection

Various mounting options using clamping elements are shown in this Chapter. We recommend that clamping systems from RINGSPANN GmbH are used.

Siemens AG in cooperation with RINGSPANN GmbH has developed various clamping system solutions to ensure secure, friction-locked connection of torque motors to cylindrical machine shafts - with the following objectives.

- Safely and reliably transmitting the torque
- Precisely centering the torque motor on the machine shaft
- Avoid inadmissible deformation to the torque motor components
- No stress caused by different temperature changes in the torque motor and in the machine shaft
- Simple mounting
- Simple disassembly, even after longer periods of operation

Mounting using suitable clamping elements is explained in the following.

Technical Support RINGSPANN GmbH

RINGSPANN GmbH is more than welcome to support you when selecting a suitable clamping system for your application.

RINGSPANN GmbH
Schaberberg 30-34
D-61348 Bad Homburg

Telephone: +49 (0) 6172 275 0
Internet: <http://www.ringspann.de>

7.4.1 Plug-on shaft

Available for the motors 1FW315x, 1FW320x and 1FW328x with plug-on shaft (15th position of the order number = S)

Standard clamping element proven from the hollow shaft: RINGSPANN RLK607

Support at the DE with the seat integrated in the motor shaft to prevent inadmissible tumbling motion. Assembly paste should be used to avoid fretting rust at the NDE. When the shaft journal is designed according to dimension drawings 510.31315.01 /510.33320.01, then it is also possible to disassemble using forcing-off screws.

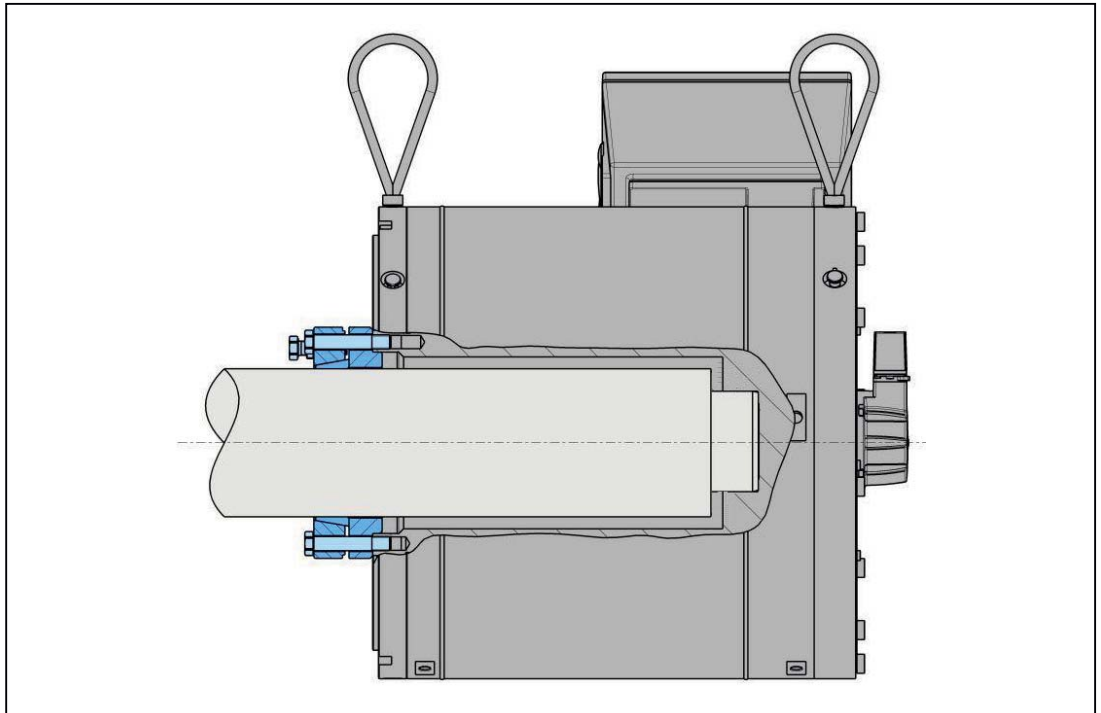

Figure 7-4 Plug-on shaft with RLK607

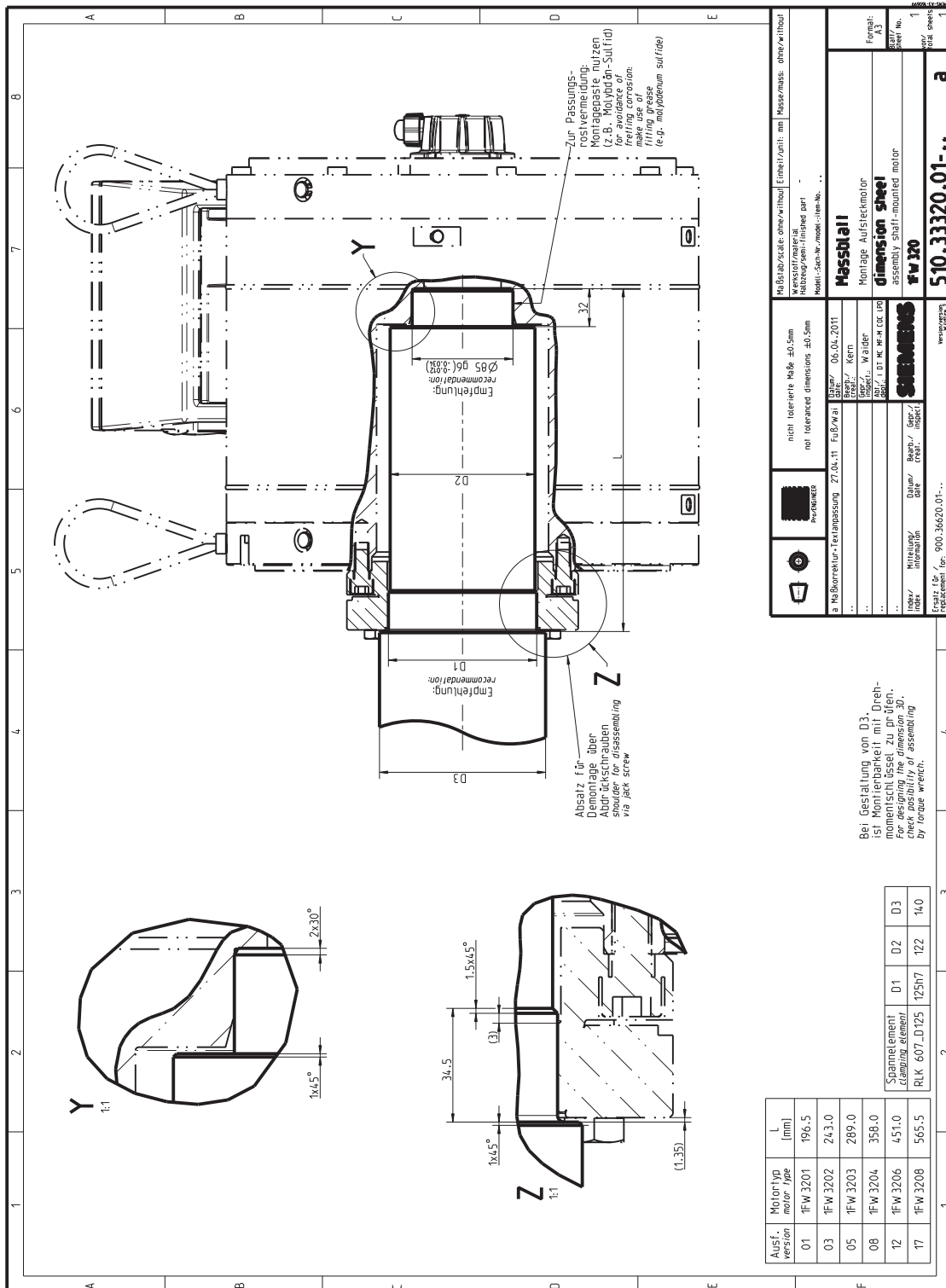

Figure 7-6 Dimension drawing, installation plug-on motor

7.4.2 Hollow shaft, inner clamping element

1FW315x-xxxxx-xxCx

1FW320x-xxxxx-xxCx

- Available for 1FW315x and 1FW320x with special shaft (15th position of the MLFB = C)
- RINGSPANN RTM 134.1
- Torque transmission to the customer shaft (h8 fit) via the clamping element located in the hollow shaft NDE
- Supported at the DE using an aluminum ring to guarantee centered mounting and to prevent any inadmissible wobbling motion
- Compact mounting at the machine is possible as no axial mounting space is required at the DE and the device is completely mounted from the NDE.
- Cannot be combined with a coaxially mounted encoder

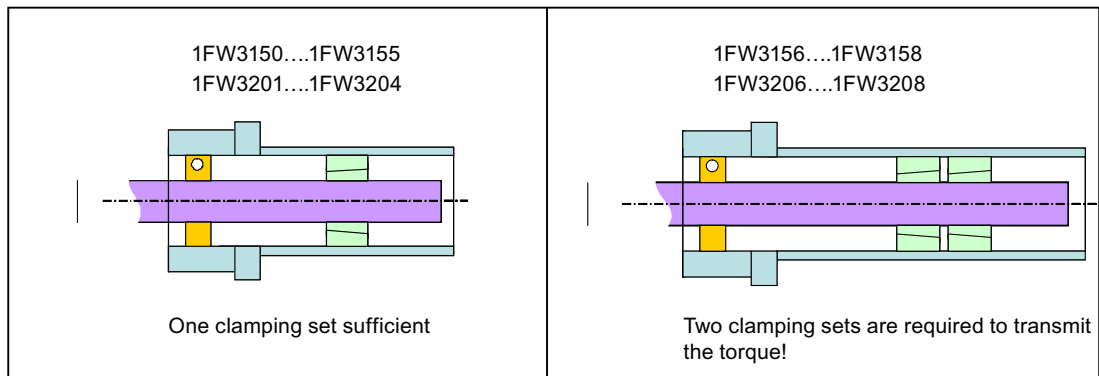

Figure 7-7 Clamping sets required to transmit the torque

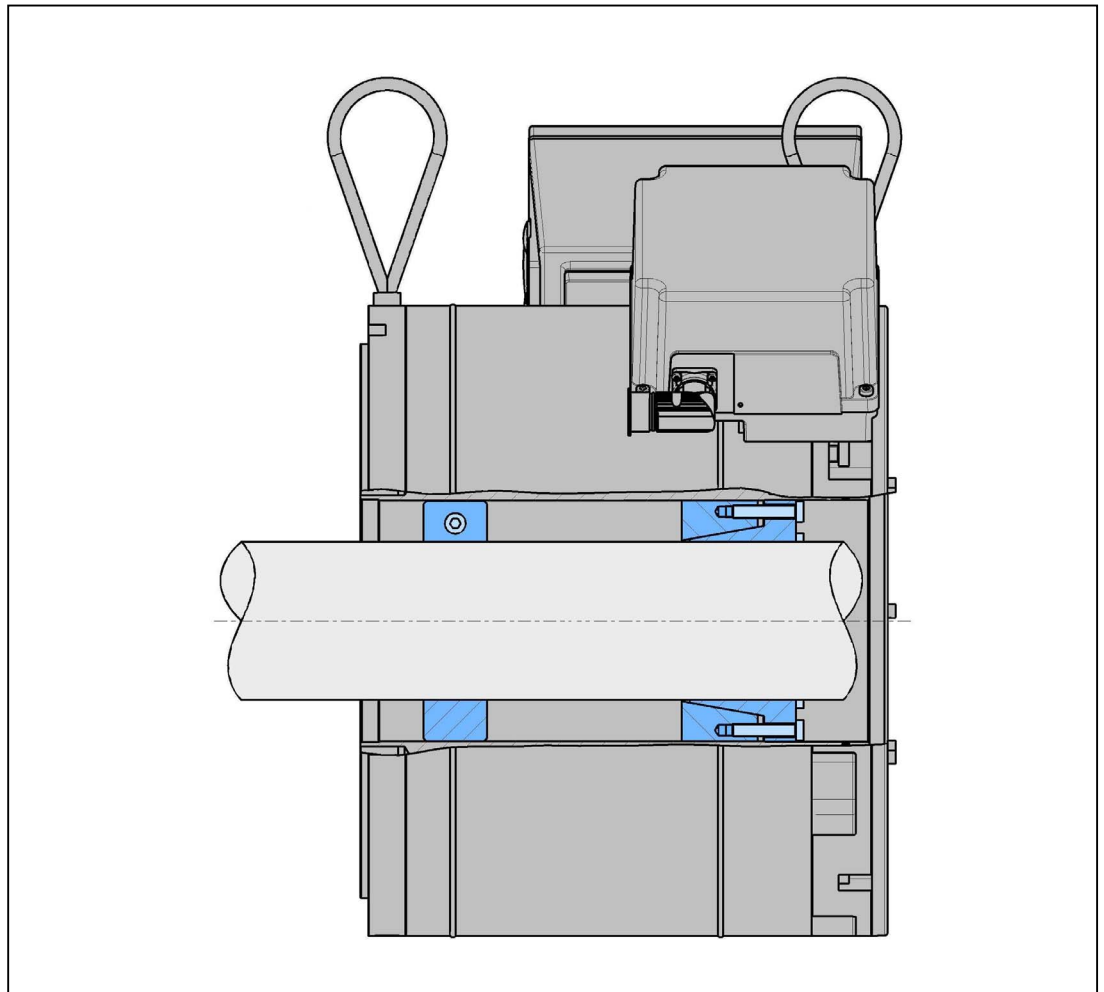

Figure 7-8 Inner clamping system

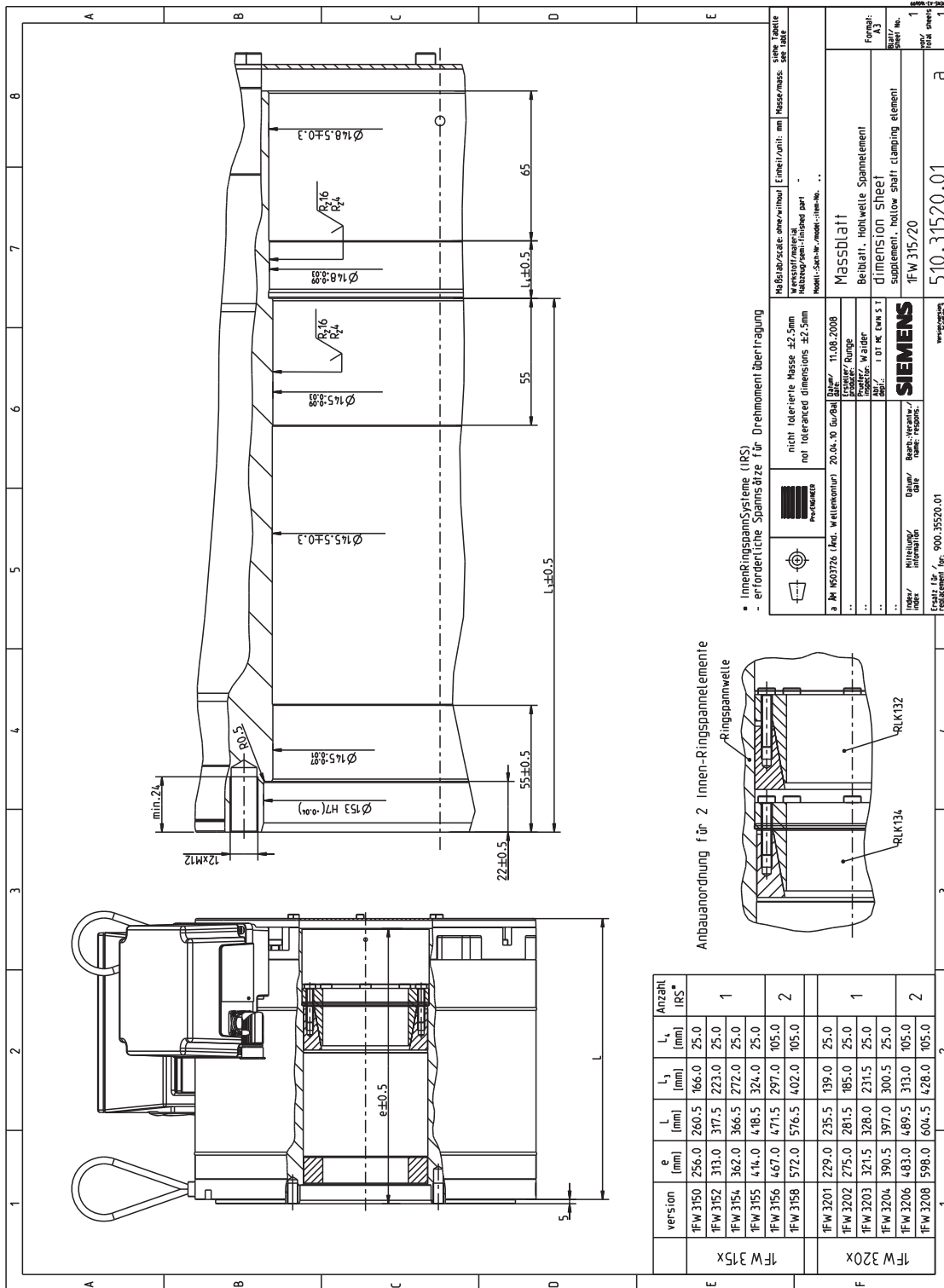

Figure 7-9 Dimension drawing hollow shaft clamping element

7.4.3 Hollow shaft, outer clamping system for clamping machine shafts

1FW315x-xxxxx-xxAx

1FW320x-xxxxx-xxAx

- Harmonized RINGSPANN RTM 607 clamping system
- For hollow shafts through which hot or cold media are routed
- Can be combined with a coaxially mounted encoder
- Axial mounting space is required at the DE
- Mounted only from the DE or alternatively, in two parts from DE/NDE
- Torque transmission to the customer shaft (h8 fit) via a flanged clamping element at the DE
- Supported at the NDE using an aluminum ring to guarantee centered mounting and to prevent any inadmissible wobbling motion.

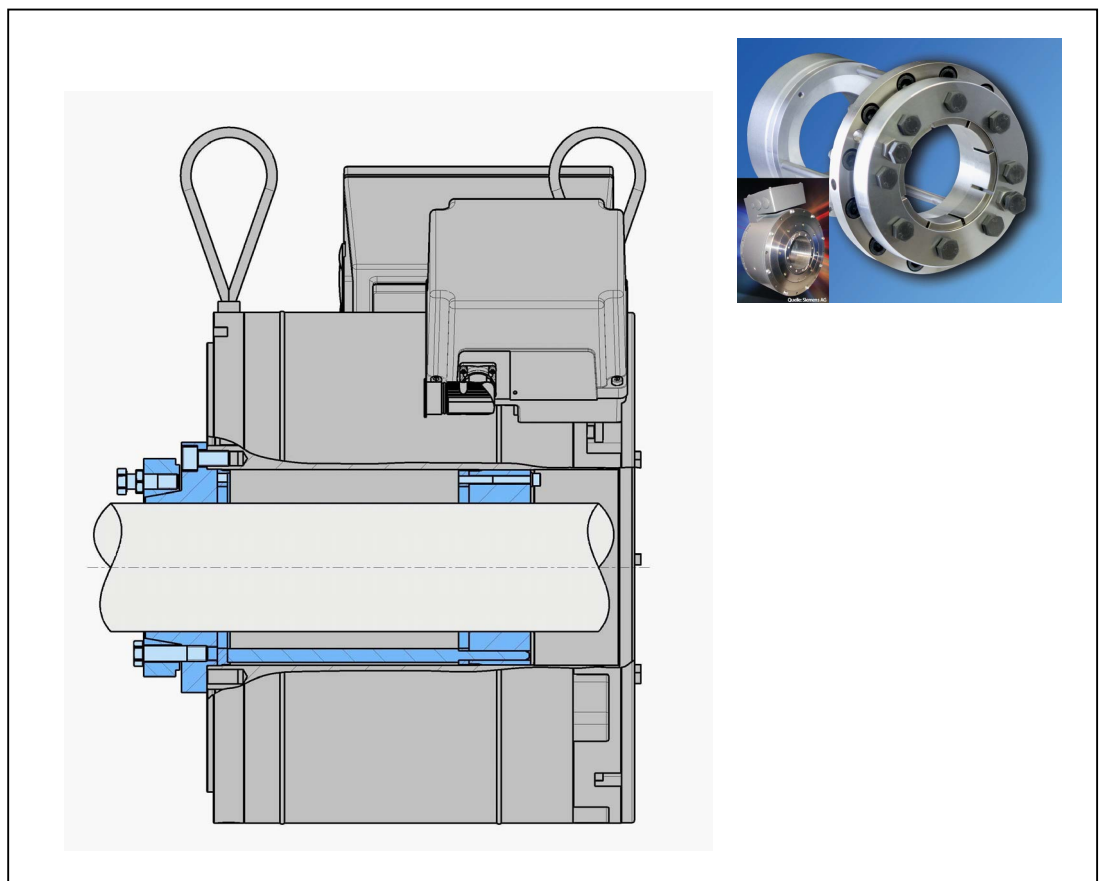

Figure 7-10 Outer clamping system

7.5 Coupling mounting

Advantage: Simple design, a standard motor can be used

Disadvantage: As a result of its function, a coupling must be elastic and therefore has a negative impact on the positive characteristics and features of a directly driven load. The stiffness in the mechanical drive train is reduced.

⚠ CAUTION

If you use mechanical transmission elements which subject the shaft end to a radial force, the maximum limit values specified in the radial force diagrams must not be exceeded.

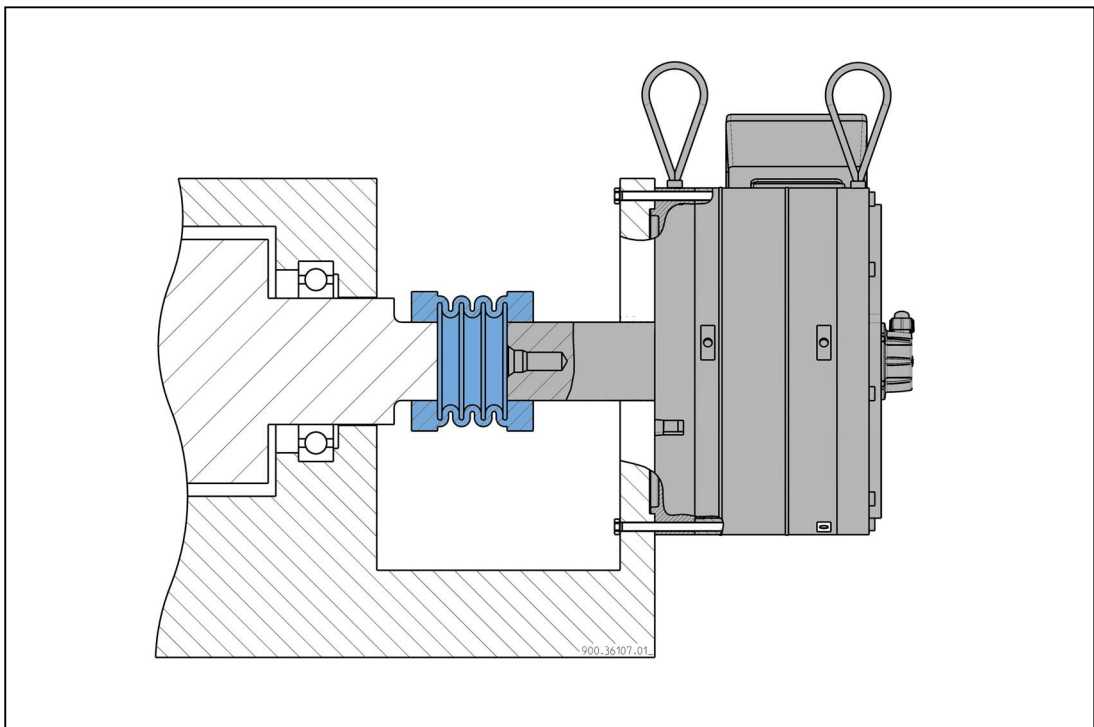

Figure 7-11 De-coupling the machine shaft from the motor shaft using a coupling

7.6 No bearings at the DE

1FW3xxx-xxxxx-xxx3

Properties

- Stiff rotor and stator mounting
- Only a few mounting components are required
- Provides a possibility of mounting bearing modules to absorb increased process forces

NOTICE

- Radial overdetermination of the remaining bearing at the NDE must be avoided; this must be verified by making the appropriate calculation
- Axial temperature expansion of the machine shaft must be limited as specified in dimension drawing 609.30284.01
- Installation conditions must be maintained, refer to the dimension drawing No. 609.30284.01, no bearings at the DE

If you have any questions regarding the limitations and constraints, please contact the Siemens Service Center.

Mounting examples

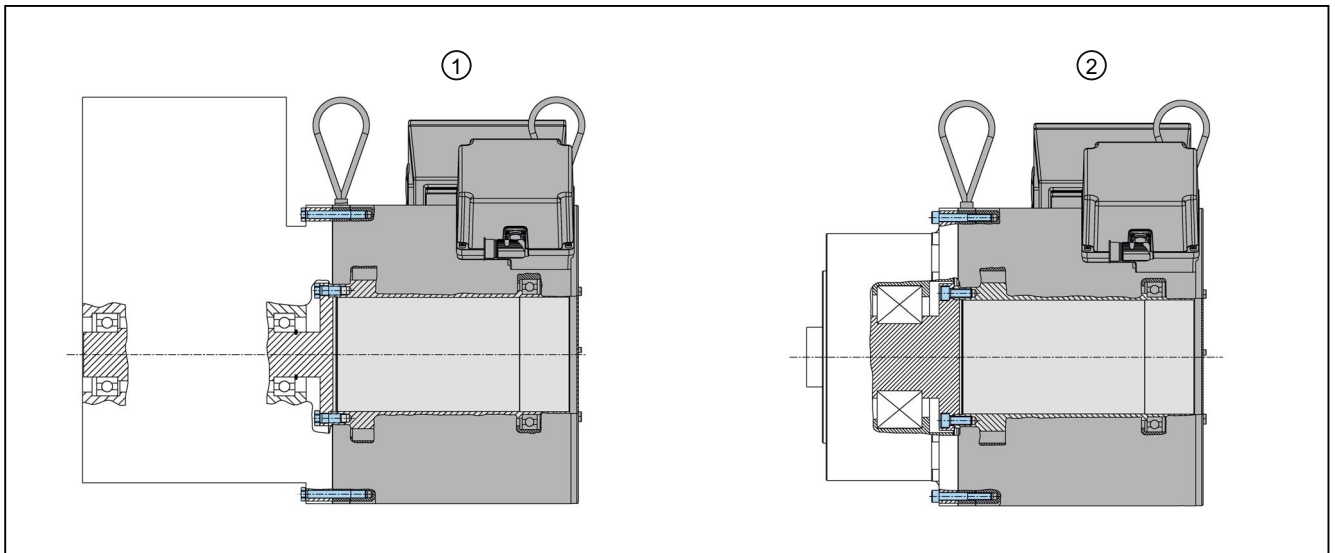

1 The manufacturer must be contacted (if necessary, over-determination)

2 For bearing module with increased radial/axial force load

Figure 7-12 Mounting examples for motors with no bearings at the DE

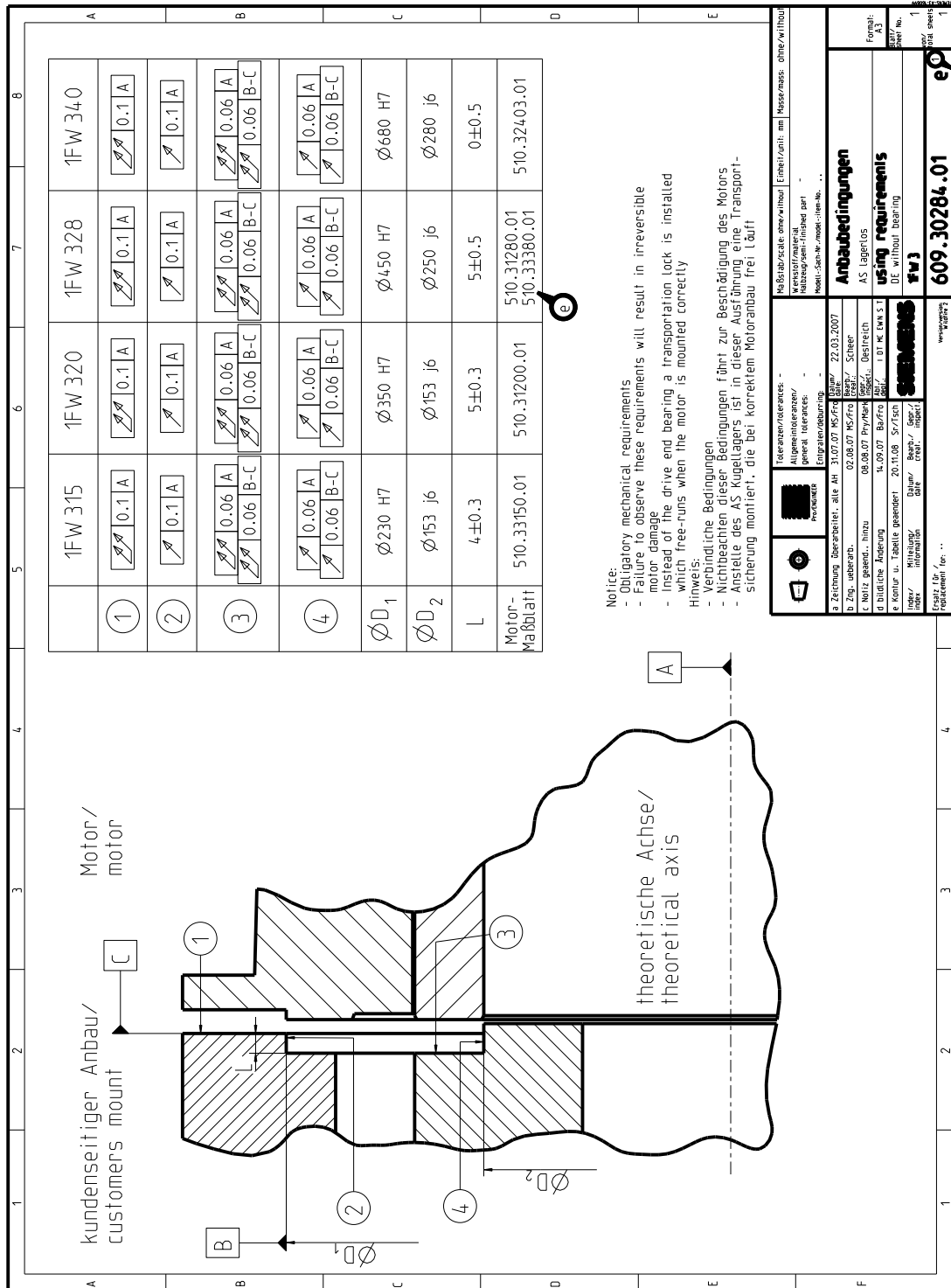

Figure 7-13 Dimension drawing, no bearings at the DE

7.7 Natural frequency when mounted

The motor is an oscillating system with a design-dependent natural frequency, which is higher than the specified maximum speed.

When the motor is mounted onto a machine, a new system, which is capable of vibration, is created with modified natural frequencies. These can lie within the motor speed range.

This can result in undesirable vibrations in the mechanical drive transmission.

NOTICE

Motors must be carefully mounted on adequately stiff foundations or bedplates. Additional elasticities of the foundation/bedplates can cause resonance effects of the natural frequency at the operating speed and, therefore, result in inadmissibly high vibration values.

The magnitude of the natural frequency when the motor is mounted depends on various factors and can be influenced by the following points:

- Mechanical transmission elements (gearboxes, belts, couplings, pinions, etc.)
- Stiffness of the machine design to which the motor is mounted
- Stiffness of the motor in the area around the foot or customer flange
- Motor weight
- Machine weight and the weight of the mechanical system in the vicinity of the motor
- Damping properties of the motor and the driven machine
- Installation type/position (IM B14, IM V18/19, IM B35)
- Motor weight distribution, i.e. length, shaft height

7.8 Vibration resistance

The on-site system vibration behavior depends on factors such as the output elements, mounting situation, alignment, installation, and external vibration and can increase the level of vibration at the motor.

Under certain circumstances, the rotor may have to be completely balanced with the output element.

To ensure problem-free operation and a long service life, the vibration values specified to ISO 10816 must not be exceeded at the defined measuring points on the motor.

Table 7-3 Max. permissible radial vibration values ¹⁾

Vibration frequency	Vibration values
< 6.3 Hz	Vibration amplitude $s \leq 0.16 \text{ mm}$
6.3 - 250 Hz	Vibration velocity $v_{\text{rms}} \leq 4.5 \text{ mm/s}$
> 250 Hz	Vibration acceleration $a \leq 10 \text{ m/s}^2$

Table 7-4 Max. permissible axial vibration values¹⁾

Vibration velocity	Vibration acceleration
$v_{\text{rms}} = 4.5 \text{ mm/s}$	$a_{\text{peak}} = 2.25 \text{ m/s}^2$

1) Both values must be maintained simultaneously

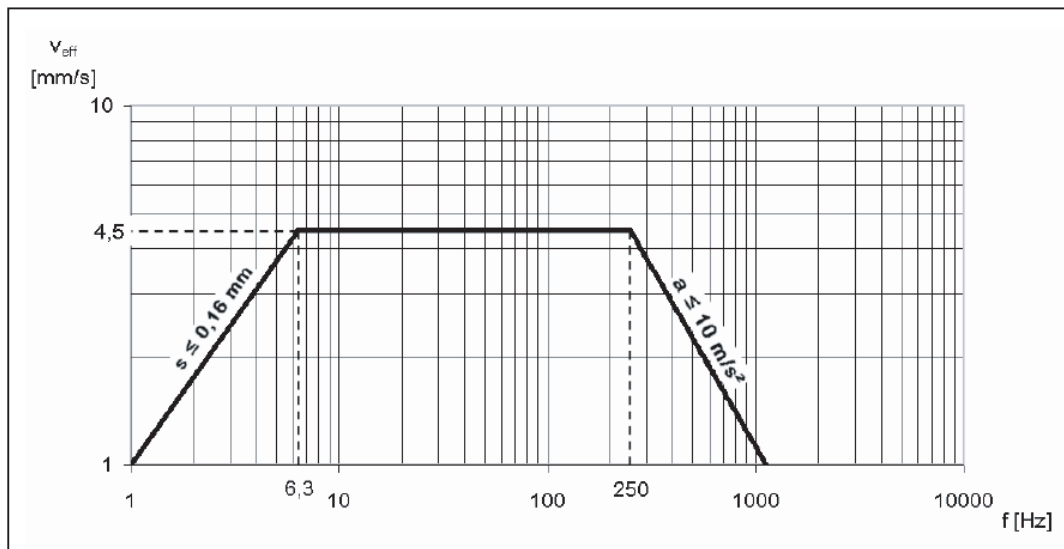

Figure 7-14 Max. permissible vibration velocity, taking into account the vibration displacement and vibration acceleration

To measure the vibration velocity, the measuring equipment must fulfill the requirements of ISO 2954. The vibration acceleration must be measured as a peak value in the time range in a frequency band of 10 to 2000 Hz.

If appreciable vibration excitation in excess of 2000 Hz (e.g. gear teeth meshing frequencies) can be expected, the measurement range must be adapted accordingly. This does not alter the maximum permissible values.

7.9 Heavy Duty

Valid for the following complete torque motors

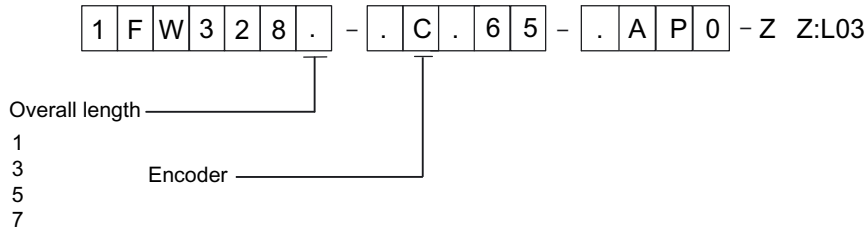

Type of construction: IM B5

Shock load

Table 7- 5 Shock load

	Vibration acceleration a_{peak}
Max. permissible radial shock load	100 m/s ²
Max. permissible axial shock load	50 m/s ²

The vibration acceleration must be measured as a peak value in the time range in a frequency band of 0 to 2000 Hz. The measurement must be made at the DE flange (based on DIN ISO 10816). If vibration excitation exceeding 2000 Hz (e.g. gear meshing frequencies) can be expected, the measurement range must be adapted accordingly. This does not alter the maximum permissible values.

Mounting

A flange is used for mounting.

Table 7- 6 Flange mounting

	Description
Bolt ISO 898-1 ¹⁾	M16
Washer ISO 7092	ISO 7092-16-300 HV (d2 = 30)
Tightening torque	300 Nm

1) Bolts of property class 10.9 or higher must be used

NOTICE
Bolt locking
Bolts must be locked as a result of vibration and shock loads.

Shaft adaptation

The motor must be precisely aligned in order to avoid distortion or over-determining the bearings. For the shaft adaptation, it must be ensured that in operation the motor shaft is not subject to any additional axial shock load. A rigid connection between the motor and customer shaft is not permitted. The shaft adaptation must be designed so that there are no axial forces (straight gearing with splined shaft) and the appropriate play.

Connecting-up notes

There must be a good metallic connection between the motor and the customer's machine (enclosure and shaft) in order to avoid rotor-ground currents. You should contact the manufacturer if this cannot be guaranteed.

Shielded power and signal cables must be used.

Bearing lifetime and regreasing interval

The bearings are equipped with a regreasing device. The values specified in the following table are valid for ambient conditions, according to Chapter "Bearing versions".

Fixed bearings at DE: 61864

Floating bearings at NDE: 6230

Table 7- 7 Regreasing intervals

Motor type	n_N [rpm]	Bearing lifetime with lubrication [h]	Regreasing interval [h]	Grease quantity ¹⁾ DE [g]	Grease quantity ¹⁾ NDE [g]
1FW328x-2/3	150 / 250 / 400 / 600	20000	4000	80	120

1) Bearing grease name: Klüberquiet BQH 72-102, Klüber Lubrication Munich KG, Internet: www.klueber.com

Appendix

A.1 Description of terms

Braking resistance R_{opt}

R_{opt} corresponds to the optimum resistance value per phase that is switched in series external to the motor winding for the armature short-circuit braking function.

Braking torque $M_{br\ rms}$

$M_{br\ rms}$ corresponds to the average braking torque for armature short-circuit braking that is achieved through the upstream braking resistor R_{opt} .

Cyclic inductance L_D

The cyclic inductance is the sum of the air gap inductance and leakage inductance relative to the single-strand equivalent circuit diagram. It consists of the self-inductance of a phase and the coupled inductance to other phases.

DE

Drive end

Efficiency η_{opt}

Maximum achievable efficiency along the S1 characteristic or below the S1 characteristic without field weakening current.

Electrical time constant T_{el}

Quotient obtained from the rotating field inductance and winding resistance. $T_{el} = L_D/R_{ph}$

Max. current $I_{max, RMS}$

This current limit is only determined by the magnetic circuit. Even if this is briefly exceeded, it can result in an irreversible de-magnetization of the magnetic material. Specification of the RMS value of a sinusoidal current.

Maximum permissible speed (mechanical) n_{max} .

The maximum mechanically permissible speed is $n_{max\ mech}$. It is defined by the centrifugal forces and frictional forces in the bearing.

Maximum permissible speed at converter $n_{\max \text{ Inv}}$

The maximum permissible speed during operation on a converter is $n_{\max \text{ Inv}}$. This is calculated by means of the voltage induced in the motor and the voltage strength of the converter.

Maximum speed n_{\max}

The maximum permissible operating speed n_{\max} is the lesser of the maximum mechanically permissible speed and the maximum permissible speed at the converter.

Maximum torque M_{\max}

Torque that is generated at the maximum permissible current.

Mechanical time constant T_{mech}

The mechanical time constant is obtained from the tangent at a theoretical ramp-up function through the origin.

$$T_{\text{mech}} = 3 \cdot R_{\text{ph}} \cdot J_{\text{mot}} / k_{\text{T}}^2 \text{ [s]}$$

J_{mot} = Servomotor moment of inertia [kgm²]

R_{ph} = Phase resistance of the stator winding [Ohm]

k_{T} = Torque constant [Nm/A]

Moment of inertia J_{mot}

Moment of inertia of rotating motor parts.

NDE

Non-drive end

Number of poles $2p$

Number of magnetic north and south poles on the rotor. p is the number of pole pairs.

Rated current I_{N}

RMS motor phase current for generating the particular rated torque. Specification of the RMS value of a sinusoidal current.

Rated speed n_{N}

The characteristic speed range for the motor is defined in the speed-torque diagram by the rated speed.

Rated torque M_N

Thermally permissible continuous torque in S1 duty at the rated motor speed.

Shaft torsional stiffness c_T

This specifies the shaft torsional stiffness from the center of the rotor laminated core to the center of the shaft end.

Static current I_0

Motor phase current for generating the particular static torque. Specification of the RMS value of a sinusoidal current.

Static torque M_0

Thermal limit torque at motor standstill corresponding to a utilization according to 100 K. At $n = 0$, this can be output for an unlimited length of time. M_0 is always greater than the rated torque M_N .

Thermal time constant T_{th}

Defines the increase in the motor frame temperature when the motor load is suddenly increased (step function) to the permissible S1 torque. The motor has reached 63% of its final temperature after T_{th} .

Torque constant k_T (value for a 100 K average winding temperature rise)

Quotient obtained from the static torque and static current.

Calculation: $k_T = M_{0, 100K} / I_{0, 100K}$

Note

This constant is not applicable when configuring the necessary rated and acceleration currents (motor losses!).

The steady-state load and the frictional torques must also be included in the calculation.

The maximum torque is briefly available for high-speed operations (dynamic response to quickly changing loads).

The maximum torque is limited by the closed-loop control parameters. If the current is increased, then the rotor will be de-magnetized.

Voltage constant k_E (value at 20° C rotor temperature)

Value of the induced motor voltage at a speed of 1000 rpm and a rotor temperature of 20°C.
The phase-to-phase RMS motor terminal voltage is specified.

Winding resistance R_{ph} at 20°C winding temperature

The resistance of a phase at a winding temperature of 20° C is specified. The winding has a star circuit configuration.

A.2 Conformity certificates

SIEMENS

EG-Konformitätserklärung EC Declaration of Conformity

No. 664.20032.02

Hersteller: **Siemens Aktiengesellschaft**
 Manufacturer: Industrie Sector
 I DT MC MF-M

Anschrift: Industriestraße 1
 Address: 97615 Bad Neustadt a. d. Saale
 Germany

Produktbezeichnung: **Drehstrom – Synchronmotor, Typ 1FW3...**
 Description of the product: *Three-phase synchronous motor, type 1FW3...*

Die bezeichneten Produkte stimmen in der von uns in Verkehr gebrachten Ausführung mit den Vorschriften folgender Europäischer Richtlinie überein:
The products described above in the form as placed on the market are in conformity with the provisions of the following European Directive:

2006/95/EG Richtlinie des Europäischen Parlaments und de Rates vom 12.Dezember 2006 zur Angleichung der Rechtsvorschriften der Mitgliedstaaten betreffend elektrische Betriebsmittel zur Verwendung innerhalb bestimmter Spannungsgrenzen.
Directive of the European Parliament and the Council of 12. December 2006 on the approximation of the laws of the Member States related to electrical equipment designed for use within certain voltage limits.

Die Konformität mit der Richtlinie wird nachgewiesen durch die Einhaltung folgender Normen:
Conformity to the Directive is assured through the application of the following standards:

EN 60034-1*): 2004 EN 60204-1 : 2006
 *) mit allen relevanten Teilen / *with all relevant parts*

Die Sicherheitshinweise und Betriebsanleitungen sind zu beachten.
The safety and manual documentation shall be considered in detail.

Erste CE - Kennzeichnung: 2003 / *first CE - marking: 2003*

Die bezeichneten Produkte sind zum Einbau in andere Maschinen bestimmt. Die Inbetriebnahme ist solange untersagt, bis die Konformität des Endproduktes mit der Richtlinie 2006/42/EG festgestellt ist. Alle Sicherheitshinweise der zugehörigen Produktdokumentation sind zu beachten sowie dem Endanwender zur Kenntnis zu geben.

The products supplied are intended exclusively for installation in a machine. Commissioning is prohibited until it has been established that the end product conforms with the Directive 2006/42/EU. All safety instructions in the associated product documentation must be observed and given to the end user for his/her information.

Bad Neustadt, den 28.6.2010

Siemens Aktiengesellschaft

i. v. Frank

Michael Frank,
 Head of the electric motor factory Bad Neustadt

i. v. Dainat

Dr. Jan Dainat,
 Head of product development department

Diese Erklärung bescheinigt die Übereinstimmung mit der genannten Richtlinie, ist jedoch keine Beschaffenheits- oder Haltbarkeitsgarantie nach §443 BGB.
This declaration certifies the conformity to the specified directive but does not imply any warranty for properties.

Ersatz für / *Substitute for* 664.20031.02 Stand / *Status:* 12/2003

Ausgabestand / Status: 06/2010
Erstausgabe / first document: 12/2003

Siemens Aktiengesellschaft: Chairman of the Supervisory Board: Gerhard Cromme; Managing Board: Peter Loescher, Chairman, President and Chief Executive Officer; Wolfgang Dehen, Heinrich Hiesinger, Joe Kaeser, Barbara Kux, Hermann Reuquardt, Siegfried Russwurm, Peter Y. Solmsen; Registered offices: Berlin and Munich, Germany; Commercial registries: Berlin Charlottenburg, HRB 12300, Munich, HRB 6684; WEEE-Reg.-No. DE 23691322

A.3 References

Overview of publications of planning manuals

An updated overview of publications is available in a number of languages on the Internet at:
www.siemens.com/motioncontrol
Select "Support" → "Technical Documentation" → "Ordering Documentation" → "Printed Documentation".

Catalogs

Order code	Catalog name
NC 61	SINUMERIK & SINAMICS
NC 60	SINUMERIK & SIMODRIVE
PM 21	SIMOTION & SINAMICS

Electronic Documentation

Order code	DOC ON CD
CD1	The SINUMERIK System (includes all SINUMERIK 840D/810D and SIMODRIVE 611D)
CD2	The SINAMICS System

Index

A

Additional information, 27
Armature short-circuit braking, 207, 211
Axial force diagrams, 58

B

Brake resistors, 207

C

CAD CREATOR, 178
Configuring, 29
Conformity certificates, 256

D

Danger and warning information, 5
Degree of protection, 55
Dimension drawings
 Solid shaft, 189
Disposal, 8
Dynamic braking, 211

E

Electrical connections, 215
Environmental compatibility, 8
ESDS instructions, 7

H

Heavy Duty, 248
Hotline, 4

I

Installation, 227

K

KTY 84, 191

M

Motor Module, 23

N

Natural frequency when mounted, 245

O

Options, 27
Order codes, 27
Order number, 26

P

Paint finish, 72
Procedure when engineering, 32
PTC thermistors, 193

R

Radial force diagrams, 58
Rating plate, 25
Resolver, 203

S

Shaft versions, 70
SIZER for SIEMENS Drives, 29
Speed-torque diagrams
 1FW3150-1xH, 80
 1FW3150-1xL, 82
 1FW3150-1xP, 84
 1FW3152-1xH, 86
 1FW3152-1xL, 88
 1FW3152-1xP, 90
 1FW3154-1xH, 92
 1FW3154-1xL, 94
 1FW3154-1xP, 96

1FW3155-1xH, 98
1FW3155-1xL, 100
1FW3155-1xP, 102
1FW3156-1xH, 104
1FW3156-1xL, 106
1FW3156-1xP, 108
1FW3201-1xE, 110
1FW3201-1xH, 112
1FW3201-1xL, 114
1FW3202-1xE, 116
1FW3202-1xH, 118
1FW3202-1xL, 120
1FW3203-1xE, 122
1FW3203-1xH, 124
1FW3203-1xL, 126
1FW3204-1xE, 128
1FW3204-1xH, 130
1FW3204-1xL, 132
1FW3206-1xE, 134
1FW3206-1xH, 136
1FW3206-1xL, 138
1FW3208-1xE, 140
1FW3208-1xH, 142
1FW3208-1xL, 144
1FW3281-2xE, 146
1FW3281-2xG, 148
1FW3281-3xJ, 162
1FW3281-3xM, 164
1FW3283-2xE, 150
1FW3283-2xG, 152
1FW3283-3xJ, 166
1FW3283-3xM, 168
1FW3285-2xE, 154
1FW3285-2xG, 156
1FW3285-3xJ, 170
1FW3285-3xM, 172
1FW3287-2xE, 158
1FW3287-2xG, 160
1FW3287-3xJ, 174
1FW3287-3xM, 176

STARTER, 31

T

Technical data, 21
Technical features, 19
Technical Support, 4
terminal box, 216
Thermal motor protection, 191
 PTC thermistors, 193
Third-party products, 8
Torque characteristics, 73

Training, 3

W

Water cooling, 45

Siemens AG
Industry Sector
Drive Technologies
Motion Control Systems
P.O. Box 3180
91050 ERLANGEN
GERMANY

www.siemens.com/motioncontrol

Subject to change without prior notice
© Siemens AG 2011