



Edition

08/2022

MANUAL

SIMATIC

S7-1500 / ET 200MP

Communication module IO-Link Master CM 8xIO-Link
6ES7547-1JF00-0AB0

support.industry.siemens.com

SIEMENS

SIMATIC

S7-1500/ET 200MP
Communication module IO-Link
Master CM 8xIO-Link
(6ES7547-1JF00-0AB0)



Equipment Manual

S7-1500/ET 200MP Documentation Guide	1
Product overview	2
Connecting	3
Parameters / address space	4
Diagnostic alarms	5
Technical specifications	6
Dimensional drawing	7
Parameter data record	A

Legal information

Warning notice system

This manual contains notices you have to observe in order to ensure your personal safety, as well as to prevent damage to property. The notices referring to your personal safety are highlighted in the manual by a safety alert symbol, notices referring only to property damage have no safety alert symbol. These notices shown below are graded according to the degree of danger.

 DANGER
indicates that death or severe personal injury will result if proper precautions are not taken.
 WARNING
indicates that death or severe personal injury may result if proper precautions are not taken.
 CAUTION
indicates that minor personal injury can result if proper precautions are not taken.
NOTICE
indicates that property damage can result if proper precautions are not taken.

If more than one degree of danger is present, the warning notice representing the highest degree of danger will be used. A notice warning of injury to persons with a safety alert symbol may also include a warning relating to property damage.

Qualified Personnel

The product/system described in this documentation may be operated only by **personnel qualified** for the specific task in accordance with the relevant documentation, in particular its warning notices and safety instructions. Qualified personnel are those who, based on their training and experience, are capable of identifying risks and avoiding potential hazards when working with these products/systems.

Proper use of Siemens products

Note the following:

 WARNING
Siemens products may only be used for the applications described in the catalog and in the relevant technical documentation. If products and components from other manufacturers are used, these must be recommended or approved by Siemens. Proper transport, storage, installation, assembly, commissioning, operation and maintenance are required to ensure that the products operate safely and without any problems. The permissible ambient conditions must be complied with. The information in the relevant documentation must be observed.

Trademarks

All names identified by ® are registered trademarks of Siemens AG. The remaining trademarks in this publication may be trademarks whose use by third parties for their own purposes could violate the rights of the owner.

Disclaimer of Liability

We have reviewed the contents of this publication to ensure consistency with the hardware and software described. Since variance cannot be precluded entirely, we cannot guarantee full consistency. However, the information in this publication is reviewed regularly and any necessary corrections are included in subsequent editions.

Preface

Purpose of the documentation

This manual supplements the ET 200MP Distributed I/O System (<https://support.industry.siemens.com/cs/ww/en/view/59191792>) system manual. It describes functions that generally affect the ET 200MP distributed I/O system.

The information provided in the present manual, the system manual and the function manuals enables you to commission the ET 200MP distributed I/O system.

Conventions

Please also observe notes marked as follows:

NOTE

A note contains important information on the product described in the documentation, on the handling of the product or on the section of the documentation to which particular attention should be paid.

Recycling and disposal

For environmentally friendly recycling and disposal of your old equipment, contact a certified electronic waste disposal company and dispose of the equipment according to the applicable regulations in your country.

Siemens provides products and solutions with industrial security functions that support the secure operation of plants, systems, machines and networks.

In order to protect plants, systems, machines and networks against cyber threats, it is necessary to implement – and continuously maintain – a holistic, state-of-the-art industrial security concept. Siemens' products and solutions constitute one element of such a concept. Customers are responsible for preventing unauthorized access to their plants, systems, machines and networks. Such systems, machines and components should only be connected to an enterprise network or the internet if and to the extent such a connection is necessary and only when appropriate security measures (e.g. firewalls and/or network segmentation) are in place.

For additional information on industrial security measures that may be implemented, please visit (<https://www.siemens.com/industrialsecurity>).

Siemens' products and solutions undergo continuous development to make them more secure. Siemens strongly recommends that product updates are applied as soon as they are available and that the latest product versions are used. Use of product versions that are no longer supported, and failure to apply the latest updates may increase customers' exposure to cyber threats.

To stay informed about product updates, subscribe to the Siemens Industrial Security RSS Feed visit (<https://www.siemens.com/industrialsecurity>).

Open Source Software

Open-source software is used in the firmware of the I/O modules. Open Source Software is provided free of charge. We are liable for the product described, including the open-source software contained in it, pursuant to the conditions applicable to the product. Siemens accepts no liability for the use of the open source software over and above the intended program sequence, or for any faults caused by modifications to the software.

For legal reasons, we are obliged to publish the original text of the license conditions and copyright notices. Please read the information relating to this on the Internet (<https://support.industry.siemens.com/cs/ww/en/view/109757558>).

Table of contents

1	S7-1500/ET 200MP Documentation Guide.....	7
1.1	S7-1500 / ET 200MP Documentation Guide.....	7
1.2	SIMATIC Technical Documentation.....	8
1.3	Tool support.....	10
2	Product overview.....	12
2.1	Properties.....	12
2.2	Functions.....	13
2.3	Replacing the IO-Link Master CM 8xIO-Link communication module.....	14
2.4	Reset communication module to factory settings.....	14
3	Connecting.....	16
3.1	Wiring and block diagram.....	16
4	Parameters / address space.....	19
4.1	Parameters.....	19
4.2	Declaration of parameters.....	20
4.3	Address space.....	22
5	Diagnostic alarms.....	26
5.1	Status and error displays.....	26
5.2	Diagnostic alarms.....	28
6	Technical specifications.....	30
7	Dimensional drawing.....	33
7.1	Dimensional drawing.....	33
A	Parameter data record.....	35
A.1	Parameter assignment and structure of parameter data set.....	35

S7-1500/ET 200MP Documentation Guide

1.1 S7-1500 / ET 200MP Documentation Guide



The documentation for the SIMATIC S7-1500 automation system and the ET 200MP distributed I/O system is arranged into three areas.

This arrangement enables you to access the specific content you require. Changes and supplements to the manuals are documented in a Product Information. You can download the documentation free of charge from the Internet (<https://support.industry.siemens.com/cs/ww/en/view/109742691>).

Basic information



The System Manual and Getting Started describe in detail the configuration, installation, wiring and commissioning of the SIMATIC S7-1500 and ET 200MP systems. The STEP 7 online help supports you in the configuration and programming.

Examples:

- Getting Started S7-1500
- S7-1500/ET 200MP System Manual
- Online help TIA Portal

Device information



Equipment manuals contain a compact description of the module-specific information, such as properties, wiring diagrams, characteristics and technical specifications.

Examples:

- Equipment Manuals CPUs
- Equipment Manuals Interface Modules
- Equipment Manuals Digital Modules
- Equipment Manuals Analog Modules
- Equipment Manuals Communications Modules
- Equipment Manuals Technology Modules
- Equipment Manuals Power Supply Modules

General information



The function manuals contain detailed descriptions on general topics relating to the SIMATIC S7-1500 and ET 200MP systems.

Examples:

- Function Manual Diagnostics
- Function Manual Communication
- Function Manual Motion Control
- Function Manual Web Server
- Function Manual Cycle and Response Times
- PROFINET Function Manual
- PROFIBUS Function Manual

Product Information

Changes and supplements to the manuals are documented in a Product Information. The Product Information takes precedence over the device and system manuals.

You can find the latest Product Information on the S7-1500 and ET 200MP systems on the Internet (<https://support.industry.siemens.com/cs/de/en/view/68052815>).

Manual Collection S7-1500/ET 200MP

The Manual Collection contains the complete documentation on the SIMATIC S7-1500 automation system and the ET 200MP distributed I/O system gathered together in one file. You can find the Manual Collection on the Internet.

(<https://support.industry.siemens.com/cs/ww/en/view/86140384>)

SIMATIC S7-1500 comparison list for programming languages

The comparison list contains an overview of which instructions and functions you can use for which controller families.

You can find the comparison list on the Internet

(<https://support.industry.siemens.com/cs/ww/en/view/86630375>).

1.2 SIMATIC Technical Documentation

Additional SIMATIC documents will complete your information. You can find these documents and their use at the following links and QR codes.

The Industry Online Support gives you the option to get information on all topics. Application examples support you in solving your automation tasks.

Overview of the SIMATIC Technical Documentation

Here you will find an overview of the SIMATIC documentation available in SIOS:



Industry Online Support International
<https://support.industry.siemens.com/cs/ww/en/view/109742705>

Watch this short video to find out where you can find the overview directly in SIOS and how to use SIOS on your mobile device:



Quick introduction to the technical documentation of automation products per video <https://support.industry.siemens.com/cs/us/en/view/109780491>



YouTube video: Siemens Automation Products - Technical Documentation at a Glance <https://youtu.be/TwLSxxRQQsA>

mySupport

With "mySupport" you can get the most out of your Industry Online Support.

Registration	You must register once to use the full functionality of "mySupport". After registration, you can create filters, favorites and tabs in your personal workspace.
Support requests	Your data is already filled out in support requests, and you can get an overview of your current requests at any time.
Documentation	In the Documentation area you can build your personal library.
Favorites	You can use the "Add to mySupport favorites" to flag especially interesting or frequently needed content. Under "Favorites", you will find a list of your flagged entries.
Recently viewed articles	The most recently viewed pages in mySupport are available under "Recently viewed articles".
CAX data	The CAX data area gives you access to the latest product data for your CAX or CAE system. You configure your own download package with a few clicks: <ul style="list-style-type: none"> • Product images, 2D dimension drawings, 3D models, internal circuit diagrams, EPLAN macro files • Manuals, characteristics, operating manuals, certificates • Product master data

You can find "mySupport" on the Internet. <https://support.industry.siemens.com/My/ww/en>

Application examples

The application examples support you with various tools and examples for solving your automation tasks. Solutions are shown in interplay with multiple components in the system - separated from the focus on individual products.

You can find the application examples on the Internet.
<https://support.industry.siemens.com/cs/ww/en/ps/ae>

1.3 Tool support

The tools described below support you in all steps: from planning, over commissioning, all the way to analysis of your system.

TIA Selection Tool

The TIA Selection Tool tool supports you in the selection, configuration, and ordering of devices for Totally Integrated Automation (TIA).

As successor of the SIMATIC Selection Tools , it assembles the configuration editors for automation technology already familiar into a single tool.

With the TIA Selection Tool , you can generate a complete order list from your product selection or product configuration.

You can find the TIA Selection Tool on the Internet.

(<https://support.industry.siemens.com/cs/ww/en/view/109767888>)

SIMATIC Automation Tool

You can use the SIMATIC Automation Tool to perform commissioning and maintenance activities on various SIMATIC S7 stations as bulk operations independent of TIA Portal.

The SIMATIC Automation Tool offers a wide range of functions:

- Scanning of a PROFINET/Ethernet system network and identification of all connected CPUs
- Assignment of addresses (IP, subnet, Gateway) and device name (PROFINET device) to a CPU
- Transfer of the date and the programming device/PC time converted to UTC time to the module
- Program download to CPU
- RUN/STOP mode switchover
- CPU localization through LED flashing
- Reading out of CPU error information
- Reading the CPU diagnostic buffer
- Reset to factory settings
- Firmware update of the CPU and connected modules

You can find the SIMATIC Automation Tool on the Internet.

(<https://support.industry.siemens.com/cs/ww/en/view/98161300>)

PRONETA

SIEMENS PRONETA (PROFINET network analysis) is a commissioning and diagnostic tool for PROFINET networks. PRONETA Basic has two core functions:

- The "Network analysis" offers a quick overview of the PROFINET topology. It is possible to make simple parameter changes (for example, to the names and IP addresses of the devices). In addition, a quick and convenient comparison of the real configuration with a reference system is also possible.
- The "IO test" is a simple and rapid test of the wiring and the module configuration of a plant, including documentation of the test results.

You can find SIEMENS PRONETA Basic on the Internet:

(<https://support.industry.siemens.com/cs/ww/en/view/67460624>)

SIEMENS PRONETA Professional is a licensed product that offers you additional functions. It offers you simple asset management in PROFINET networks and supports operators of automation systems in automatic data collection/acquisition of the components used through various functions:

- The user interface (API) offers an access point to the automation cell to automate the scan functions using MQTT or a command line.
- With PROFIenergy diagnostics, you can quickly detect the current pause mode or the readiness for operation of devices that support PROFIenergy and change these as needed.
- The data record wizard supports PROFINET developers in reading and writing acyclic PROFINET data records quickly and easily without PLC and engineering.

You can find SIEMENS PRONETA Professional on the Internet:

(<https://www.siemens.com/proneta-professional>)

SINETPLAN

SINETPLAN, the Siemens Network Planner, supports you in planning automation systems and networks based on PROFINET. The tool facilitates professional and predictive dimensioning of your PROFINET installation as early as in the planning stage. In addition, SINETPLAN supports you during network optimization and helps you to exploit network resources optimally and to plan reserves. This helps to prevent problems in commissioning or failures during productive operation even in advance of a planned operation. This increases the availability of the production plant and helps improve operational safety.

The advantages at a glance

- Network optimization thanks to port-specific calculation of the network load
- Increased production availability thanks to online scan and verification of existing systems
- Transparency before commissioning through importing and simulation of existing STEP 7 projects
- Efficiency through securing existing investments in the long term and the optimal use of resources

You can find SINETPLAN on the Internet

(<https://new.siemens.com/global/en/products/automation/industrial-communication/profinet/sinetplan.html>).

Product overview

2.1 Properties

Article number

6ES7547-1JF00-0AB0

View of the module

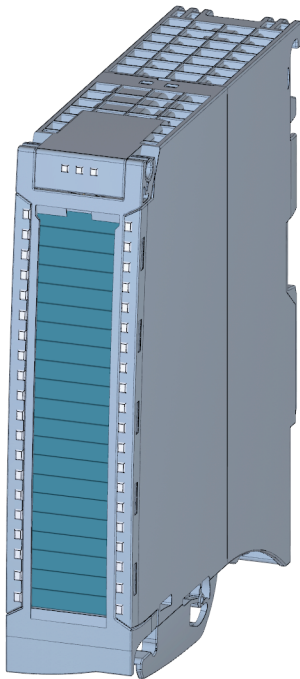

Figure 2-1 View of the IO-Link Master CM 8xIO-Link communication module

Properties

The module has the following technical properties:

- IO-Link master according to IO-Link specification V1.1
- Communication module with 8 ports (channels)
- Data transfer rates COM1 (4.8 kB), COM2 (38.4 kB), COM3 (230.4 kB)
- Standard DI mode
- Suitable for connecting up to eight IO-Link devices (3-wire connection) or eight standard encoders

- Configurable diagnostics can be set for each channel
- Automatic backup of the device parameters during replacement of the IO-Link device (only for V1.1 devices)
- Configuration limits:
 - Max. 32 bytes input and output data per port
 - Max. 240 bytes input and output data per module

The module supports the following functions:

- Firmware update
- Identification and maintenance data (I&M)
- IO-Link port configuration with S7-PCT
- IO-Link port configuration with STEP7 or GSD (without S7-PCT)
- Variable address range of I/O data with up to 240 byte inputs and 240 byte outputs
- Master backup with function block "LIOLink_Master"
- Port Qualifier Information (PQI)
- I&M 0 to 3

The module can be used with the following engineering tools:

Table 2-1 Engineering tools

Firmware version of the module	S7-PCT	STEP 7 (TIA Portal)	GSD file
V1.0 (in CPU/PROFINET/PROFIBUS station)	As of V3.5 SP1	As of V15.1	X

Accessories/spare parts

The following accessories/spare parts are available for the module and can also be ordered separately:

- Labeling strips
- U connector
- Universal front cover

The following component must be ordered separately:

- Front connectors, including potential jumpers and cable ties

Additional information

You can find more information on accessories in the S7-1500/ET 200MP Distributed I/O System (<https://support.industry.siemens.com/cs/ww/en/view/59191792>) system manual in the Accessories/Spare parts section.

2.2 Functions

IO-Link is a point-to-point connection between a master and a device. Both conventional and intelligent sensors/actuators can be used as devices at the IO-Link via unshielded standard

2.4 Reset communication module to factory settings

cables using proven 3-wire technology. IO-Link is backward compatible to conventional sensors. The switching state and data channels are designed with trusted 24 V DC technology.

Reference

Additional information can be found in the IO-Link System (<https://support.automation.siemens.com/WW/view/en/65949252>) function manual.

2.3 Replacing the IO-Link Master CM 8xIO-Link communication module

Master Backup

You can back up the parameters of your module with the function block "LIOLink_Master". The "LIOLink_Master" function block is used to read all relevant IO-Link device and IO-Link Master parameters. The parameters can be stored retentively at a central location, such as in a data block in the IO controller.

The status of the IO-Link devices or IO-Link ports stored in the IO-Link Master can be restored with the "LIOLink_Master" function block.

As a result, the IO-Link ports and the IO-Link Master are configured with the values stored in the master backup.

A typical application is the restoration of parameters after replacement of the IO-Link Master.

Firmware version	
Module	Function block LIOLink_Master
as of V 1.0	as of V 1.0.0

Compatibility table of the firmware versions

NOTE

Availability

Note that the Master Backup function is available only for IO-Link devices that are specified for the IO-Link Standard as of V1.1.

You can find additional information on the master backup functions in the section 'Integration into the automation system' in the IO-Link System (<https://support.industry.siemens.com/cs/ww/en/view/65949252>) function manual.

2.4 Reset communication module to factory settings

Effects of resetting to the factory settings

Use the "Reset to factory settings" function to restore the parameter assignments of your IO-Link Master CM 8xIO-Link communication module made with S7-PCT to the factory state.

After a "Reset to factory settings", the parameters of the IO-Link Master CM 8xIO-Link communication module are assigned as follows:

- The ports are in DI mode
- The ports are mapped to the relative addresses 0.0 ... 0.7
- The PortQualifier is disabled
- I&M data 1 to 3 is deleted

NOTE

The master backup of the IO-Link Master is deleted and the delivery condition is restored. You should reset a removed IO-Link Master CM 8xIO-Link communication module to the factory settings before you place it in storage.

Procedure

To perform a "Reset to factory settings", proceed as described in the S7-PCT online help.

Connecting

3.1 Wiring and block diagram

This section includes the block diagram of the communication module IO-Link Master CM 8xIO-Link with the terminal assignments for 3-wire and 5-wire connection of IO-Link devices or 2-wire and 3-wire connection in DI operating mode.

You can use and combine the different wiring options for all channels.

Ensure that all devices are connected to the SELV/PELV power supply (or equivalent).

NOTICE
Internal transducer supply
Use only the supply voltage ($U_{S_n/M}$) made available by the IO-Link Master CM 8xIO-Link communication module to supply the IO-Link device (L+/L-).

Wiring: 3-wire and 5-wire connection of IO-Link devices

The example in the following figure shows the terminal assignment of the communication module IO-Link Master CM 8xIO-Link (3- and 5-conductor connection of IO-Link devices).

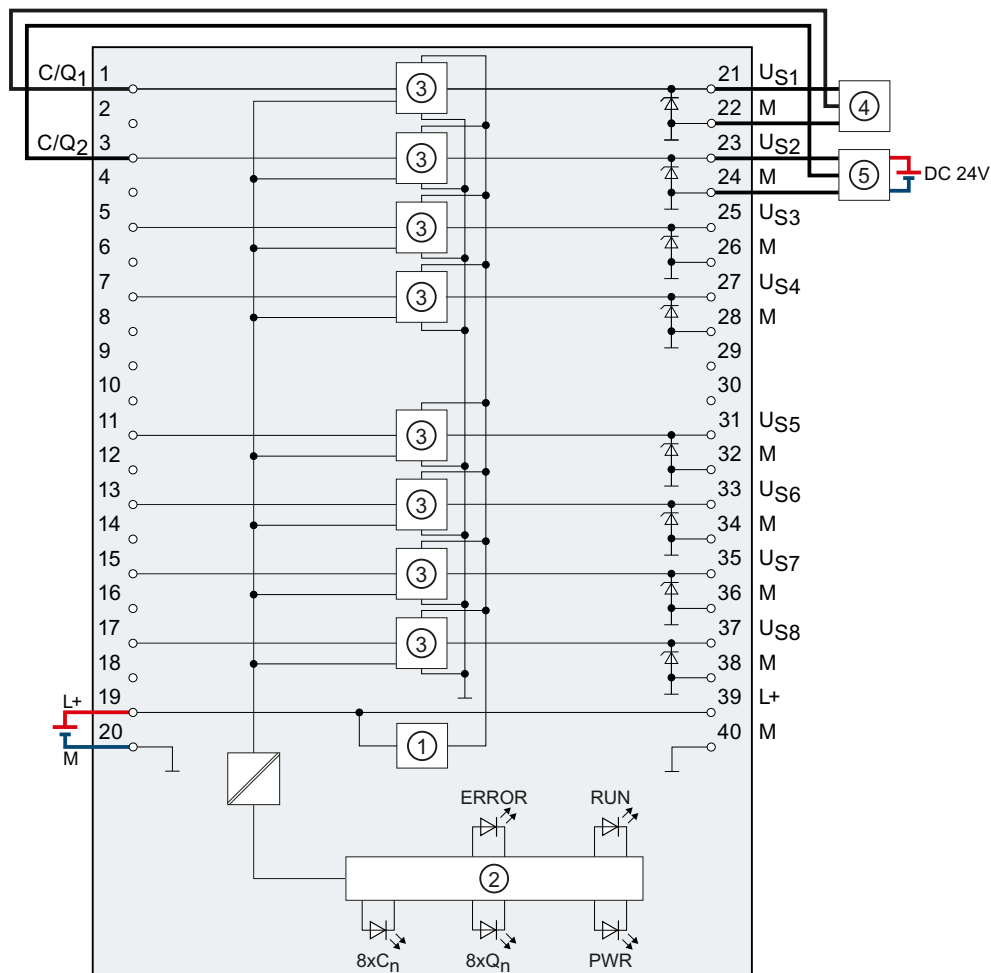

- | | | | |
|----|-----------------------------|----------|--|
| ① | Reverse polarity protection | U_{Sn} | Supply voltage (positive) |
| ② | Backplane bus interface | RUN | Status display LED (green) |
| ③ | IO-Link circuitry | ERROR | Error display LED (red) |
| ④ | Device, 3-wire connection | PWR | Power LED (green) |
| ⑤ | Device, 5-wire connection | C/Q_n | Port n |
| M | Ground | C_n | Port status/channel error LED (green/red) |
| L+ | Supply voltage 24 V DC | Q_n | LED channel status in standard DI mode (green) |

Figure 3-1 Block diagram and terminal assignment for 3-wire and 5-wire connection of IO-Link devices

Wiring: 2-wire and 3-wire connection in DI operating mode

The example in the following figure shows the terminal assignment of the IO-Link Master CM 8xIO-Link communication module in DI operating mode.

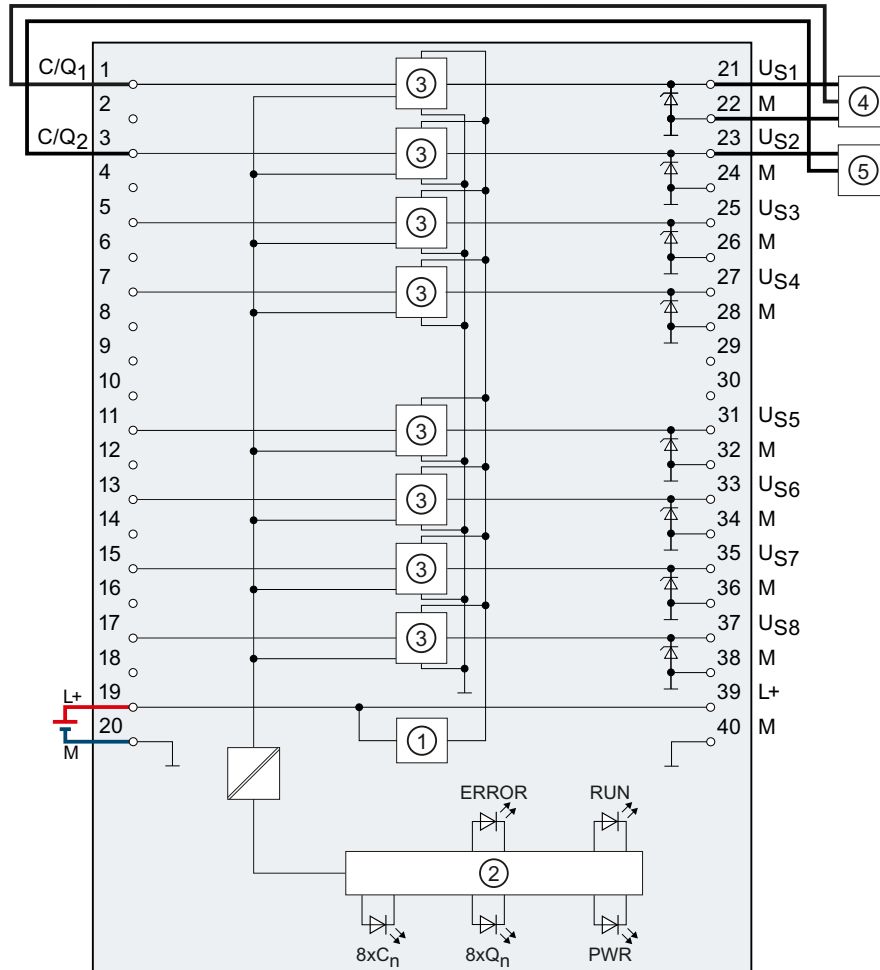

- | | | | |
|----|-----------------------------|-----------------|--|
| ① | Reverse polarity protection | U _{Sn} | Supply voltage (positive) |
| ② | Backplane bus interface | RUN | Status display LED (green) |
| ③ | IO-Link circuitry | ERROR | Error display LED (red) |
| ④ | Sensor, 3-wire connection | PWR | Power LED (green) |
| ⑤ | Sensor, 2-wire connection | C/Qn | Port n |
| M | Ground | C _n | Port status/channel error LED (green/red) |
| L+ | Supply voltage 24 V DC | Q _n | LED channel status in standard DI mode (green) |

Figure 3-2 Terminal assignment for 2-wire and 3-wire connection in DI operating mode

Parameters / address space

4.1 Parameters

Parameters (GSD file)

The following table shows the general parameters for the IO-Link Master CM 8xIO-Link communication module.

The default settings of the parameters are marked in bold in the "Value ranges" column.

Table 4-1 General parameters (GSD file)

Parameters	Value range	Effective range
Diagnostics		
Diagnostics: No supply voltage L+	<ul style="list-style-type: none"> • Disable • Enable 	Module
Diagnostics: Port	<ul style="list-style-type: none"> • Disable • Enable 	Port (channel)
Master parameter		
Port Qualifier Information (PQI)	<ul style="list-style-type: none"> • Disable • Enable 	Module
Port configuration without S7-PCT	<ul style="list-style-type: none"> • Disable • Enable 	Module

The following table shows the port parameters for the IO-Link Master CM 8xIO-Link communication module.

Parameters	Value range	Default
Port configuration		
Operating mode	<ul style="list-style-type: none"> • IO-Link Autostart • IO-Link Manual • DI • Deactivated 	IO-Link Autostart
Length of the input data*	depending on the selected input/output type**	depending on the selected input/output type**
Length of output data	depending on the selected input/output type**	depending on the selected input/output type**

* If PQI is activated, 1 byte less space remains for input data of the device. For example: GSD setting 16 bytes = 15 bytes + PQI

** Make sure not to exceed the maximum possible length of the input or output data for all ports.

*** Only effective if you use the "IO-Link Manual" port mode.

4.2 Declaration of parameters

Parameters	Value range	Default
Vendor ID***	Manufacturer ID of the connected IO-Link device	0
Device ID***	Device ID of the connected IO-Link device	0
Inspection Level/Data Storage***	<ul style="list-style-type: none"> • Identical type (V1.0) without Backup&Restore • Type-compatible (V1.1) without Backup&Restore • Type-compatible (V1.1) with Backup&Restore • Type-compatible (V1.1) with Restore 	Type-compatible (V1.1) with Backup&Restore

* If PQI is activated, 1 byte less space remains for input data of the device. For example: GSD setting 16 bytes = 15 bytes + PQI

** Make sure not to exceed the maximum possible length of the input or output data for all ports.

*** Only effective if you use the "IO-Link Manual" port mode.

Maximum possible length of the input or output data

Example:

You have selected the configuration 64 I / 64 Q.

You have assigned 4 bytes of input data to the first port.

For the remaining ports, you can assign a total of 60 bytes of input data.

Reference

You can find additional information on the Vendor ID and Device ID on the Internet (<https://support.industry.siemens.com/cs/ww/en/view/109748852>).

4.2 Declaration of parameters

Diagnostics: No supply voltage L+

Enabling the diagnostic alarm for missing or insufficient supply voltage L+.

Diagnostics: Port

This parameter allows the enabling of the diagnostics for the selected port.

The possible diagnostics are dependent on the IO-Link device used. Additional information about the diagnostic interrupts can be found in the description of the utilized IO-Link device.

Port Qualifier Information

This parameter releases the Port Qualifier Information (PQI).
The PQI provides information on the port status and the IO-Link device status.

Port configuration without S7-PCT

This parameter enables the port configuration without S7-PCT for the module.

Operating mode

This parameter determines the mode in which you operate the selected port.
You can select from the following options:

- IO-Link Autostart
- IO-Link Manual
- DI
- Deactivated

The setting of the port is granular and you can combine the operating modes as you like.

IO-Link Autostart

The connected IO-Link device starts automatically (Plug&Play functionality). The IO-Link device is immediately available to you and operational.

IO-Link Manual

If the Vendor ID and Device ID match the connected device, the connected IO-Link device is automatically started. In other words, in contrast to "IO-Link Autostart", the system checks here whether the correct device is connected. You need to configure the Device ID / Vendor ID to enable this.

You need to store the Vendor ID and Device ID of the connected IO-Link device in STEP 7.

In addition, you can select the inspection level for data storage:

- Identical type (V1.0) without Backup&Restore
- Type-compatible (V1.1) without Backup&Restore
- Type-compatible (V1.1) with Backup&Restore
- Type-compatible (V1.1) with Restore

You can find instructions for determining the Vendor ID and Device ID on the Internet (<https://support.industry.siemens.com/cs/ww/en/view/109748852>).

DI

The port operates as standard digital input.

Deactivated

The port is deactivated.

4.3 Address space

Configuration options of the communication module IO-Link Master CM 8xIO-Link

The size of the input and output addresses of the IO-Link Master CM 8xIO-Link communication module with firmware version V1.0 are 32 bytes per port in each case. The following table provides an overview of the configuration options of the supported address areas for I/O data:

Module configuration	IM 155-5 PN BA	IM 155-5 PN ST	IM 155-5 PN HF	IM 155-5 DP ST	S7-1500 CPU
8 byte inputs 8 byte outputs	X	X	X	X	X
16 byte inputs 0 byte outputs	X	X	X	X	X
16 byte inputs 16 byte outputs	X	X	X	X	X
24 byte inputs 16 byte outputs	X	X	X	X	X
32 byte inputs 32 byte outputs	X	X	X	X	X
40 byte inputs 32 byte outputs	X	X	X	-	X
64 byte inputs 64 byte outputs	X	X	X	-	X
72 byte inputs 64 byte outputs	-	X	X	-	X
128 byte inputs 128 byte outputs	-	X	X	-	X
136 byte inputs 128 byte outputs	-	X	X	-	X
240 byte inputs 240 byte outputs	-	X	X	-	X

The IO area defined for an ET 200MP limits the number of IO modules per station. The interface module supports a maximum of 512 bytes for input and output data for all I/O modules in the station. Exceptions are 2 interface modules: IM 155-5 PN BA, which only supports 64 bytes, and IM 155-5 DP ST with a limit of 244 bytes per station.

The following table provides an overview of the maximum address spaces for the respective interface modules.

IM	Firmware version	Max. address space per station	Max. address space per module
IM 155-5 PN BA	V4.0.2	64 bytes	64 bytes
IM 155-5 PN ST	V4.1.0	512 bytes	256 bytes
IM 155-5 PN HF	V3.0.1	512 bytes	256 bytes
IM 155-5 DP ST	V3.0.0	244 bytes	32 bytes

NOTE

IO-Link Master behind an IM 155-5 DP ST

In connection with an IM 155-5 DP ST, you configure the IO-Link master exclusively using a GSD file. Install the corresponding GSD file. You can find this for download on the Internet (<https://support.industry.siemens.com/cs/ww/en/view/80206700>).

Port configuration CPU

With an IO-Link Master CM 8xIO-Link, you can commission the IO-Link ports of the IO-Link Master or the connected IO-Link devices in two different ways:

- Port configuration with STEP7 or GSD (without S7-PCT)
- Port configuration with S7-PCT

Port configuration with STEP7 or GSD (without S7-PCT)

Requirements

You have selected the "Port configuration without S7-PCT" check box in the configuration of the IO-Link master in STEP 7.

Procedure

You configure the IO-Link master directly in STEP 7:

- Activate the diagnostics
- Configuration of the I/O data lengths for each port
- Activating the Port Qualifier Information (PQI)
- Port mode:
 - Operation in "IO-Link Autostart" mode (default)
 - Operation in "IO-Link Manual" mode
 - Operated as DI
 - Deactivated

Port configuration with S7-PCT

Requirements

4.3 Address space

You deselected the "Port configuration without S7-PCT" check box in the configuration of the IO-Link master in STEP 7.

Procedure

You configure the IO-Link Master ports with the Port Configuration Tool S7-PCT, V3.5 SP1 or higher. In doing so, select the IO-Link device from the device catalog of S7-PCT and assign the device to an IO-Link port.

Port Qualifier Information (PQI)

You can activate the Port Qualifier Information (PQI) for your IO-Link Master.

NOTE

Port Qualifier Information (PQI)

If you have activated the Port Qualifier Information (PQI), it is always transferred with the size 1 byte together with the input data of the IO-Link device.

PQI is not available for 8 bytes input / 8 bytes output.

The figure below shows the structure of the PQI byte.

Port Qualifier Information (PQI)

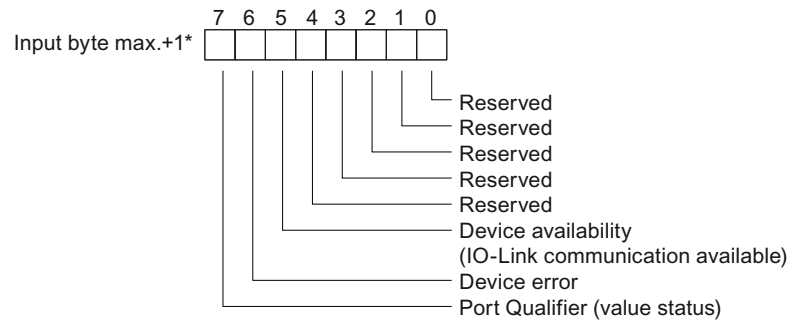

* The PQI byte is always after the last input byte of the port.

Figure 4-1 Structure of the PQI byte

Description of the PQI byte:

Name	Value	Meaning
Device availability	0	IO-Link device is not available
	1	IO-Link device is in the "Preoperate" or "Operate" state
Device error	0	No error
	1	An error or warning has occurred.
Port Qualifier	0	IO data is not valid
	1	IO data is valid

Position of the PQI byte in the process image (example):

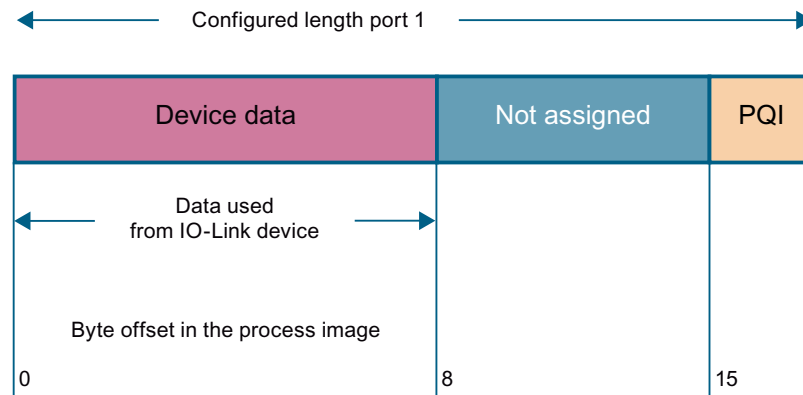

Figure 4-2 Address space IO-Link Master

In the example above, 16 bytes are set for port 1, the IO-Link device transfers the data in bytes 0 to 7 and the PQI byte is set to byte 15.

NOTE

Restriction

The graphic only applies to the input range.

Standard DI mode

The following figure shows the assignment of the address space of a port for the IO-Link Master CM 8xIO-Link, if you have configured the port as a digital input.

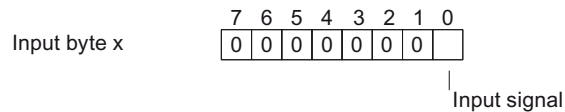

Figure 4-3 Address space of the inputs of the IO-Link Master CM 8xIO-Link in standard DI mode

Reference

You can find additional information in the IO-Link System

(<https://support.automation.siemens.com/WW/view/en/65949252>) function manual.

Diagnostic alarms

5.1 Status and error displays

LED display

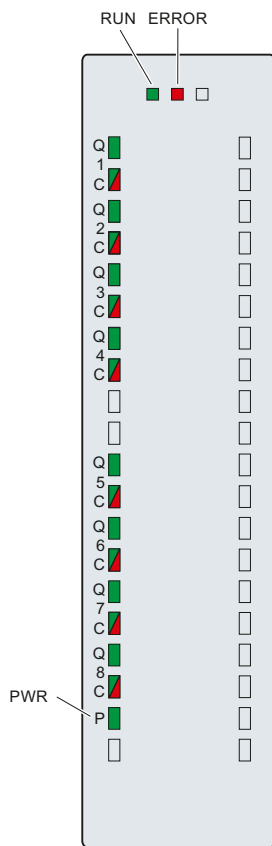

Cn	Port status/channel error
Qn	Channel status in standard DI mode
PWR	Supply voltage L+
n	Channel number

Figure 5-1 LED display

Meaning of the LED displays

The following tables show the meaning of the status and error displays. Remedial measures for diagnostic alarms can be found in the Diagnostic alarms [\(Page 28\)](#) chapter.

RUN and ERROR LED

Table 5-1 Status and error displays RUN and ERROR

LED		Meaning	Solution
RUN	ERROR		
□ Off	□ Off	Voltage missing or too low at backplane bus.	<ul style="list-style-type: none"> Switch on the CPU and/or the system power supply modules. Verify that the U connectors are inserted. Check whether too many modules are inserted.
☀ Flashes	□ Off	The module starts up and flashes until the valid parameter assignment is set.	-
■ On	□ Off	Module parameters are assigned.	
■ On	☀ Flashes	Indicates module errors (at least one error is present on one channel, e.g. wire break).	Evaluate the diagnostics and eliminate the error (e.g. wire break).
☀ Flashes	☀ Flashes	The hardware is defective.	Replace the module.

LED PWR

Table 5-2 POWER status display

LED P	Meaning	Solution
□ Off	Supply voltage L+ too low or missing.	Check the supply voltage L+.
■ On (green)	Supply voltage L+ is present and OK.	-

Cn LEDs

Valid for IO-Link port in port status.

Table 5-3 Status displays of LEDs C1 to C8

C1 to C8	Meaning
□ Off	The port is disabled or in standard DI mode.
☀ Flashes (green)	The port is in IO-Link mode, the device is not connected or the port is not connected with the configured device.
■ On (green)	Port in IO-Link mode, device not connected
■ On (red)	<ul style="list-style-type: none"> Wire break or short-circuit to ground Supply voltage L+ missing or too low IO-Link device error

Qn LEDs

Valid for the IO-Link port that is in standard DI mode.

Table 5-4 Status displays of LEDs Q1 to Q8

Q1 to Q8	Meaning
□ Off	Process signal = 0 in standard DI mode, deactivated or in IO-Link mode
■ On (green)	Process signal = 1 in standard DI mode

5.2 Diagnostic alarms

For each diagnostics event, a diagnostic alarm is issued and the ERROR LED flashes red on the communication module. You can read out the diagnostics alarms, for example, in the diagnostics buffer of the CPU. You can evaluate the error codes with the user program.

Table 5-5 Error types

Diagnostic alarm	Error code	Meaning (IO-Link error code)	IO-Link Master	IO-Link device
Short-circuit	1 _H	• Short-circuit in the process cables on the IO-Link device (1804 _H)	X	
		• Short-circuit on IO device (7710 _H)		X
Undervoltage	2 _H	• Supply voltage too low (5111 _H , 5112 _H)		X
Oversvoltage	3 _H	• Supply voltage too high (5110 _H)		X
Overheating	5 _H	• Temperature exceeded on master (1805 _H)	X	
		• Temperature exceeded on device (4000 _H , 4210 _H)		X
Wire break	6 _H	• No IO-Link device connected • There is a break in the signal line to the IO-Link device • IO-Link device cannot communicate due to another error (1800 _H)	X	
Overflow	7 _H	• Process tag range exceeded (8C10 _H) • Measuring range exceeded (8C20 _H)		X
Underflow	8 _H	• Process tag range too low (8C30 _H)		X
Error	9 _H	• All IO-Link error codes which are not listed here are mapped to this error		X
Configuration error	10 _H	• Incorrect device (1802 _H) • Vendor ID and Device ID not defined (1817 _H) • Process data length of the IO-Link device exceeded (1818 _H) • No cycle time configured (1819 _H) • Could not configure IO-Link Master (1882 _H , 1883 _H) • Storage error (1886 _H) • Process data length exceeded (1887 _H) • PQI not supported (1889 _H)	X	
		• Device was not configured correctly (6320 _H , 6321 _H , 6350 _H)		X
Supply voltage missing	11 _H	• L+ supply voltage too low (<20 V) (1890 _H) • L+ supply voltage for device missing (1806 _H) • L+ supply voltage for device too low (<20 V) (1807 _H)	X	

Diagnostic alarm	Error code	Meaning (IO-Link error code)	IO-Link Master	IO-Link device
Defective fuse	12 _H	<ul style="list-style-type: none"> Fuse on device is defective (5101_H) 		X
Safety shutdown	19 _H	<ul style="list-style-type: none"> Serious error (master has to be replaced) (1880_H) 	X	
External fault	1 A _H	<ul style="list-style-type: none"> Error in data storage (1809_H, 180A_H, 180B_H, 180C_H, 180D_H) More than 6 errors are pending simultaneously on the IO-Link device (1808_H) Consistency error in electronic coding element (1885_H) Process data length exceeded (1887_H) 	X	

Technical specifications

Technical specifications of the IO-Link Master CM 8xIO-Link communication module

The following table shows the technical specifications as of the issue date. You can find a data sheet including daily updated technical specifications on the Internet (<https://support.industry.siemens.com/cs/de/en/pv/6ES7547-1JF00-0AB0/td?dl=en>).

Article number	6ES7547-1JF00-0AB0
General information	
Product type designation	CM 8xIO-Link
HW functional status	FS04
Firmware version	V1.0.2
<ul style="list-style-type: none"> FW update possible 	Yes
Product function	
<ul style="list-style-type: none"> I&M data 	Yes; I&M0 to I&M3
Engineering with	
<ul style="list-style-type: none"> STEP 7 TIA Portal configurable/integrated from version 	V15.1 with HSP 274
<ul style="list-style-type: none"> STEP 7 configurable/integrated from version 	Configurable via GSD file
<ul style="list-style-type: none"> PROFIBUS from GSD version/GSD revision 	GSD as of Revision 5
<ul style="list-style-type: none"> PROFINET from GSD version/GSD revision 	GSDML V2.34
Supply voltage	
Rated value (DC)	24 V
permissible range, lower limit (DC)	20.4 V
permissible range, upper limit (DC)	28.8 V
Reverse polarity protection	Yes
Input current	
Current consumption, max.	50 mA; without load
Encoder supply	
Number of outputs	8
Output current	
<ul style="list-style-type: none"> Rated value 	1 A; 4 A total current per module
24 V encoder supply	
<ul style="list-style-type: none"> Short-circuit protection 	Yes; per channel, electronic
IO-Link	
Number of ports	8
<ul style="list-style-type: none"> of which simultaneously controllable 	8
IO-Link protocol 1.0	Yes

Article number	6ES7547-1JF00-0AB0
IO-Link protocol 1.1	Yes
Cycle time, min.	2 ms
Size of process data, input per port	33 byte; max.
Size of process data, input per module	240 byte; max.
Size of process data, output per port	32 byte; max.
Size of process data, output per module	240 byte; max.
Memory size for device parameter	2 kbyte; for each port
Master backup	Yes
Configuration without S7-PCT	Yes
Cable length unshielded, max.	20 m
Operating modes	
<ul style="list-style-type: none"> • IO-Link 	Yes
<ul style="list-style-type: none"> • DI 	Yes
<ul style="list-style-type: none"> • DQ 	No
Time Based IO	
– TIO IO-Link IN	No
– TIO IO-Link OUT	No
– TIO IO-Link IN/OUT	No
Connection of IO-Link devices	
<ul style="list-style-type: none"> • Port type A 	Yes
<ul style="list-style-type: none"> • Port type B 	Yes; 24 V DC via external terminal
Interrupts/diagnostics/status information	
Alarms	
<ul style="list-style-type: none"> • Diagnostic alarm 	Yes; The port diagnosis is available in the IO-Link mode only.
Diagnoses	
<ul style="list-style-type: none"> • Monitoring the supply voltage 	Yes
<ul style="list-style-type: none"> • Wire-break 	Yes
<ul style="list-style-type: none"> • Short-circuit 	Yes
<ul style="list-style-type: none"> • Group error 	Yes
Diagnostics indication LED	
<ul style="list-style-type: none"> • Monitoring of the supply voltage (PWR-LED) 	Yes; green LED
<ul style="list-style-type: none"> • Channel status display 	Yes; green LED
<ul style="list-style-type: none"> • for channel diagnostics 	Yes; red LED
<ul style="list-style-type: none"> • for module diagnostics 	Yes; red LED
Potential separation	
Potential separation channels	
<ul style="list-style-type: none"> • between the channels 	No
<ul style="list-style-type: none"> • between the channels and backplane bus 	Yes

Article number	6ES7547-1JF00-0AB0
Isolation	
Isolation tested with	707 V DC (type test)
Ambient conditions	
Ambient temperature during operation	
<ul style="list-style-type: none"> horizontal installation, min. horizontal installation, max. vertical installation, min. vertical installation, max. 	-30 °C 60 °C; Observe derating -30 °C 40 °C; Observe derating
Altitude during operation relating to sea level	
<ul style="list-style-type: none"> Installation altitude above sea level, max. 	5 000 m; Restrictions for installation altitudes > 2 000 m, see manual
Dimensions	
Width	35 mm
Height	147 mm
Depth	129 mm

Power reduction (derating) to total current of outputs, per module

The following derating curves show the load capacity of the transducer supply outputs in relation to the mounting position and the ambient temperature.

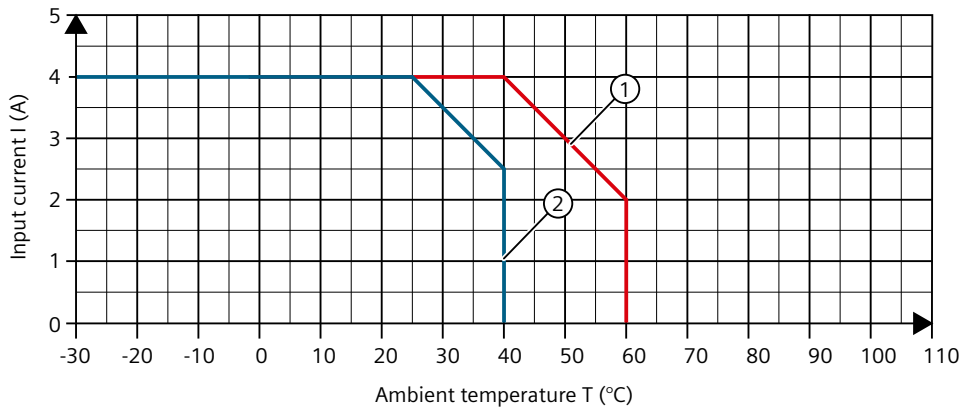

- ① Horizontal mounting of the system
- ② Vertical mounting of the system

Figure 6-1 Derating curve, IO-Link master

Dimensional drawing

7.1 Dimensional drawing

The dimensional drawing of the module on the mounting rail, as well as a dimensional drawing with open front panel, are provided in the appendix. Always observe the specified dimensions for installation in cabinets, control rooms, etc.

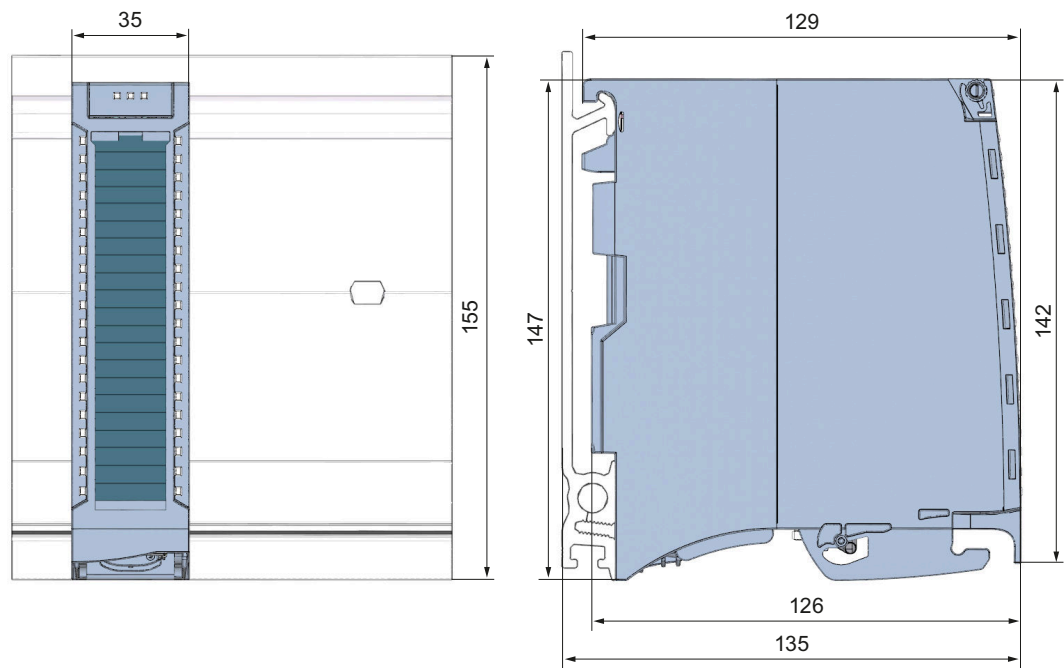

Figure 7-1 Dimensional drawing of the IO-Link Master CM 8xIO-Link module

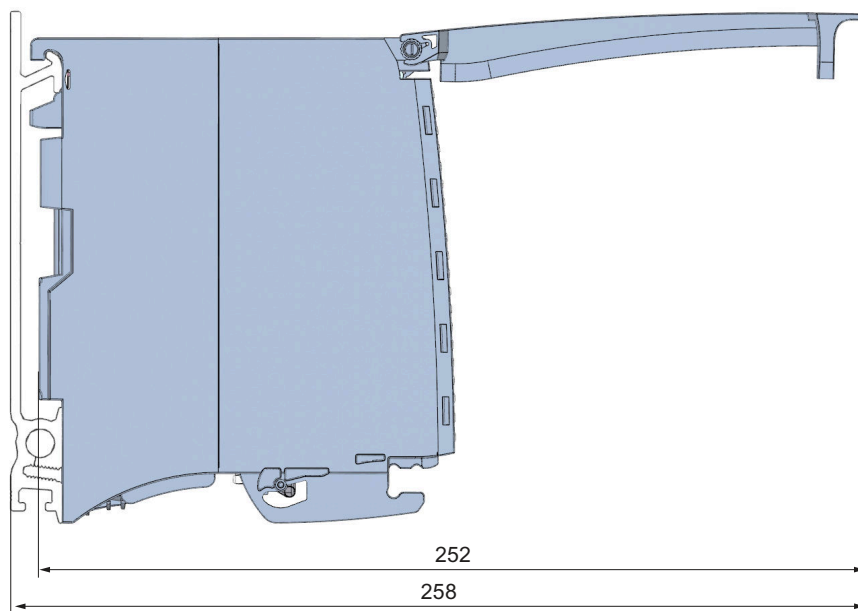

Figure 7-2 Dimensional drawing of the IO-Link Master CM 8xIO-Link module, side view with open front cover

Parameter data record

A.1 Parameter assignment and structure of parameter data set

The data record of the module has an identical structure, regardless of whether you configure the module with PROFIBUS DP or PROFINET IO. With data record 128, you can reconfigure the module in your user program regardless of your programming.

The following figures describe the structure of data record 128 as of firmware version V1.0.

Configuration in the user program

You can configure the modules in runtime.

Changing parameters in RUN

The "WRREC" instruction is used to transfer the parameters to the module using data record 128. The parameters set with STEP 7 are not changed in the CPU by this action. This means the parameters set in STEP 7 are still valid after a restart.

Output parameter STATUS

If errors occur when transmitting parameters with the "WRREC" instruction, the module continues operation with the previous parameter assignment. The STATUS output parameter contains a corresponding error code.

You will find a description of the "WRREC" instruction and the error codes in the STEP 7 online help.

Error message

The module always checks all the values of the transferred data record. Only if all the values were transferred without errors does the module apply the values from the data record.

The instruction WRREC for writing data records returns corresponding error codes when errors occur in the parameter STATUS.

The following table shows the module-specific error codes and their meaning for the parameter data record 128:

Table A-1 Error message

Error code	Meaning
80B1 _H	Error in data length
80E0 _H	Error in header information
80E1 _H	Parameter error

Structure of data record 128

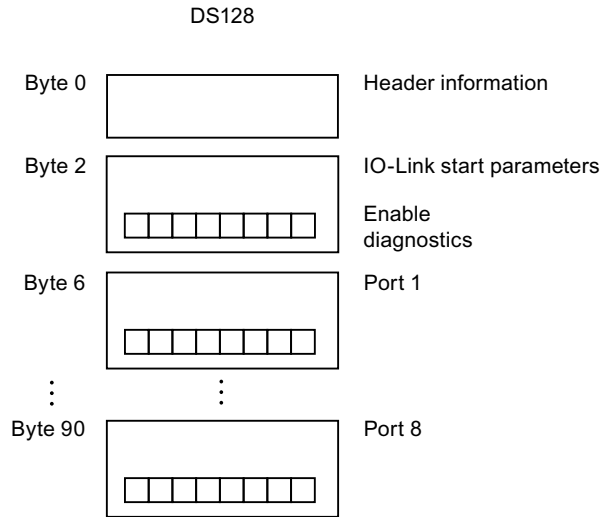

Figure A-1 Structure of data record 128

Header information

The figure below shows the structure of the header information.

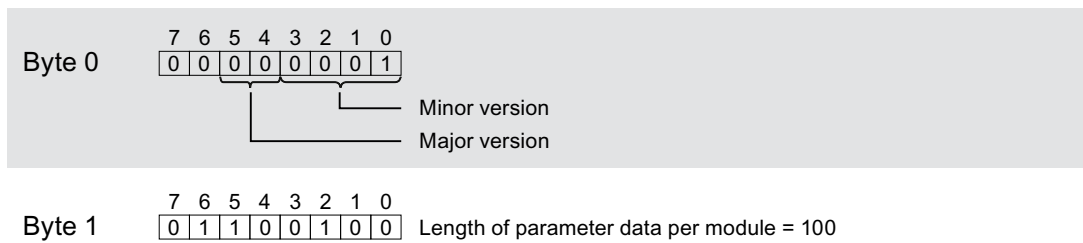

Figure A-2 Header information

IO-Link start parameters

The following figure shows the structure of the IO-Link start parameter.
Activate a parameter by setting the corresponding bit to "1".

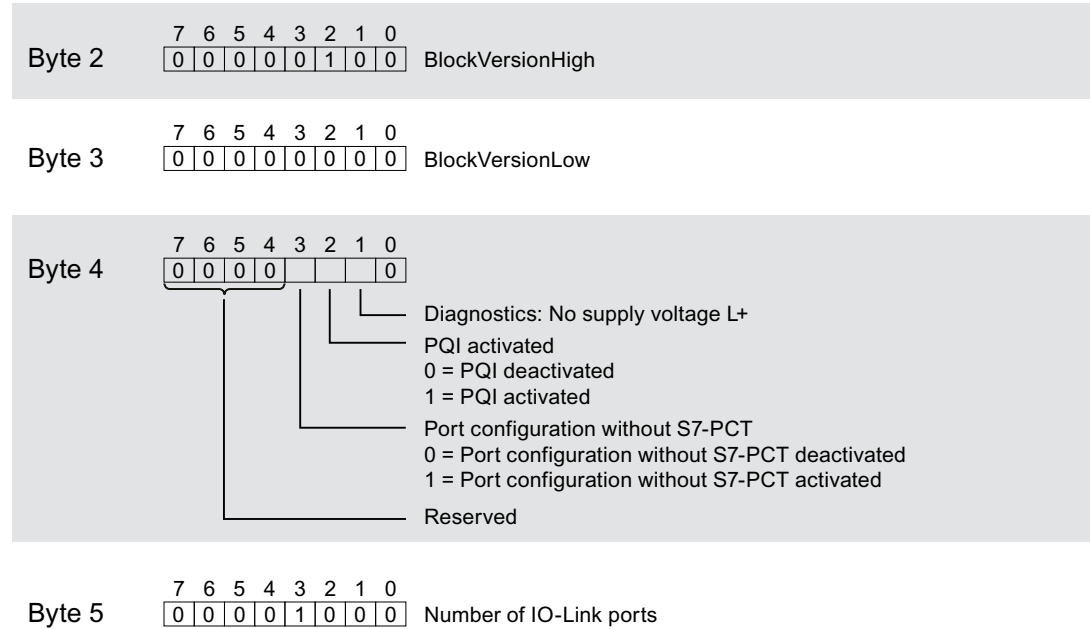

Figure A-3 IO-Link start parameters

Port parameter

The following figure shows an extract from the structure of the port parameter.
Activate a parameter by setting the corresponding bit to "1".

A.1 Parameter assignment and structure of parameter data set

If you have selected IO-Link Manual operating mode, you must enter the Vendor ID (byte x+5 and x+6) and Device ID (byte x+7 to x+10) yourself. You can find the Vendor ID and Device ID in the IO-DD of the IO-Link device being used.

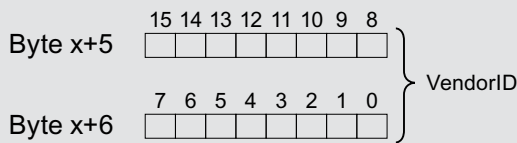
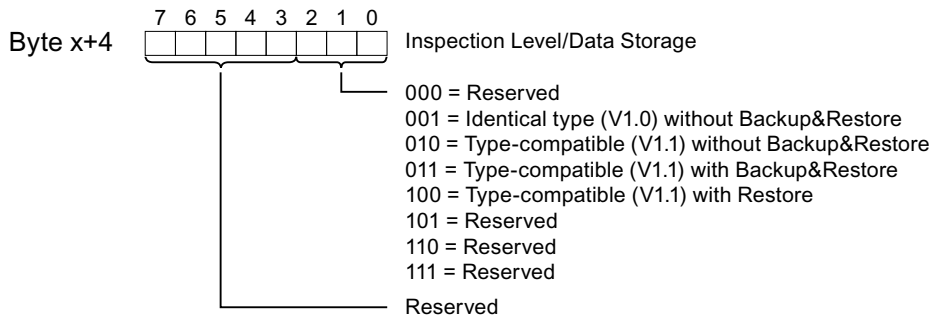
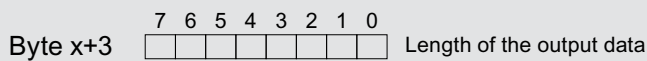
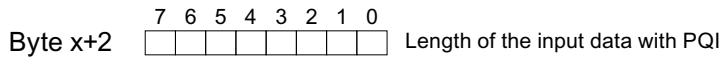
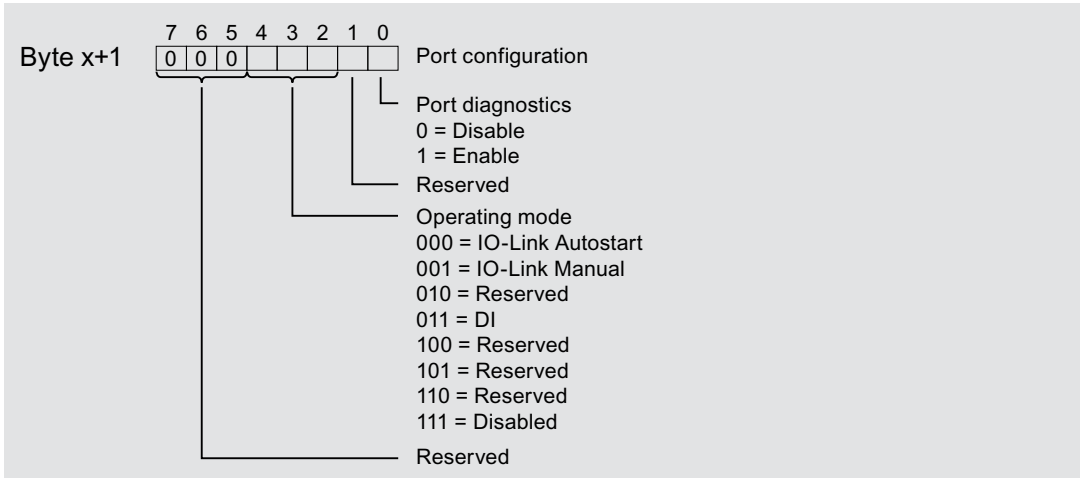
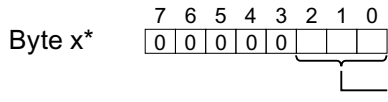

* x = 6 + ((port number-1) x 12); port numbers = 1 to 8.

A.1 Parameter assignment and structure of parameter data set

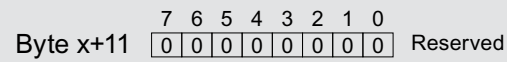
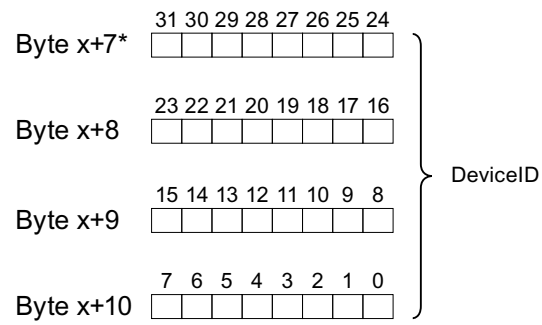

* $x = 6 + ((\text{port number} - 1) \times 12)$; port numbers = 1 to 8.

Figure A-4 Port parameter