

Catalog
Edition 6.0

SICAM Substation Automation

siemens.com/sicam

SIEMENS

SICAM Substation Automation

Catalog - Edition 6.0

Invalid:
Edition 5.0

General	1
Introduction	1.1
Distribution-System Automation	1.2
Station Automation	1.3
Cybersecurity	1.4
Station and Telecontrol Engineering	2
SICAM PAS	2.1
SICAM 8 - Description	2.2
SICAM 8 - A8000 Series	2.3
SICAM 8 - A8000 Rack	2.4
SICAM 8 Software Solution	2.5
SICAM HMI	2.6
SICAM EGS	2.7
SICAM DLM	2.8
Control, Monitoring, and Diagnosis	3
SICAM SCC	3.1
SICAM PQ Analyzer	3.2
SICAM DISTO	3.3
Software for Station Automation	4
SICAM PAS UI	4.1
SICAM TOOLBOX II	4.2
SICAM WEB	4.3
SICAM Device Manager	4.4
SICAM Protocol Test System	4.5
SICAM Power Management System for Load Shedding	4.6
DIGSI 5	4.7
IEC 61850 System Configurator	4.8
SIGRA	4.9

Content

5	Bay Controllers
5.1	Introduction
5.2	SIPROTEC 6MD84
5.3	SIPROTEC 6MD85
5.4	SIPROTEC 6MD86
5.5	SIPROTEC 6MD89
6	Distribution-System Automation
6.1	SICAM A8000 Series
6.2	SIPROTEC 7SC80
7	Short-Circuit Indicator
7.1	SICAM FCM
7.2	SICAM FCM plus
7.3	SICAM FPI
7.4	SICAM EFI
7.5	SICAM FSI
7.6	SICAM FSI B-Sensor
7.7	SICAM FCG
8	Accessories
8.1	SICAM I/O-Unit
8.2	SICAM AI-Unit
9	Appendix

Preface

Siemens won the 2006 Frost & Sullivan Technology Leadership Award in acknowledgment of Siemens' pioneering work in the development of innovative technology – the IEC 61850. Users are in safe hands with the energy automation solutions from Siemens. The combination of extensive experience and the latest innovation provides security for many years. Our solutions are also compatible with older devices.

Overview and Solutions

In recent years, influences on the business of power utilities have changed considerably. Running the power grid has changed from a static, virtually stable layout to a dynamic operation. The requirements regarding a longer service life for all grid system components continue to gain importance.

As a result, the importance of substation automation technology has grown considerably and the requirements with respect to control, protection, and remote control have experienced a great paradigm shift:

- Flexible and customized solutions for diverse applications
- Safe and reliable operations management

- Cost-effective investments and economic operation
- Efficient project management
- Long-term concepts, upgradeable and open for new requirements

The energy-automation solutions from Siemens offer a multitude of standardized configurations and functions for many typical tasks. These default settings allow the use of flexible products but, at the same time, are open for more challenging and customized applications. The acquisition of all kinds of data, computing and automation functions as well as versatile communication can be very flexibly combined to create special solutions and facilitate integration into the existing system environment.

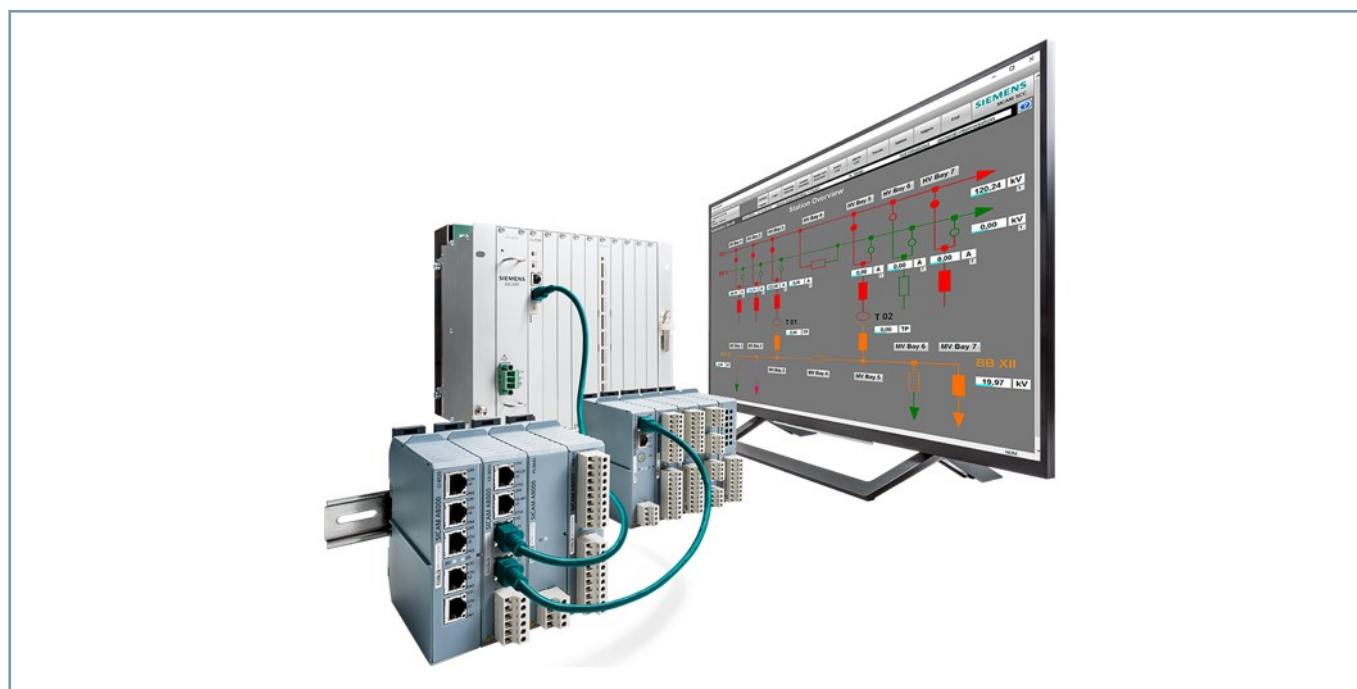

[ph_siemens_st_auto_products, 1, --]

Figure 1.1/1 Siemens - Station Automation Products

General

Distribution-System Automation

1.2

Distribution-system automation from Siemens considerably optimizes the reliability and availability of your energy distribution systems. Here, the functionality extends from the acquisition of network data, telemonitoring and remote control up to fully automated applications such as high-speed FISR (Fault Isolation and Service Restoration), Volt-Var Control and similar.

The technology supports the network operation and, for example, takes over monitoring of the currents and voltage in the distribution system and also the command output to remote-controllable units such as switches and transformers.

Furthermore, the distribution-system automation uses well-proven technologies and characteristics of sensors, control and remote terminal units (RTUs) right up to communication devices such as routers and modems.

The hardware is supplemented by specially developed software and algorithms for special distribution-system functionality.

Advantages

- Continuous power-system monitoring ensures early detection of problems
- Fast Fault Isolation and Service Restoration increases the efficiency level

- Automatic operation and the use of standards provide time and cost savings
- Network automation and control guarantee adherence to the specified voltage range

With the Siemens solutions for distribution-system automation, you will benefit in all respects from a wide spectrum of know-how. As a supplement to distribution-system automation, Siemens offers a complete portfolio for power-system monitoring, power-quality recording, fault recording, phasor measurement, and system-software applications.

The Siemens products of the SICAM product family for power quality and measurement support power utilities and consumers with solutions for precise measurement, recording, and indication of the required information for continuous determination, adaptation, and improvement of power quality. Always the right fit, for your application as well.



[ph_distribution_automation, 1, _-_-]

Figure 1.2/1 Siemens Short-Circuit Indicators and Distribution-System Automation Products

For station automation, Siemens offers proven concepts in all task areas of switchgear automation – on all voltage levels and for all types of switchgear. Distributed solutions on the basis of distributed bay units can also be implemented with our offer in the same way as central telecontrol systems with integrated automation and node functions or multifunctional protection systems for coordination and the interaction of different protection devices.

Advantages

- Excellent overall system performance due to flexibility in the architecture and implementation of redundancies (optional)
- Support of intelligent power systems and applications on the basis of the standard IEC 61850
- Upgradeable due to evolutionary system development and sophisticated migration concepts
- Limited outlay for logistics, training, etc. due to a scalable system family for all power-system levels and the widest variety of energy systems – whether electricity, gas, water, or district heating
- Cost-efficiency through custom solutions – from standard to customer-specific

Siemens products and solutions for switchgear automation correspond to the standard IEC 61850. This standard marks a major step towards power-system intelligence as it fulfills high communication demands with regard to data volume, speed, etc. Additional advantages: easy integration of devices from the competition and highest levels of upgradability due to reusable engineering data. Intelligent applications can also be implemented with IEC 61850.

Siemens offers you preconfigured and hence particularly economic system solutions for switchgear automation for many typical applications. Siemens develops individual solutions for specific customer requirements. Siemens supplies complete secondary equipment in power transmission and distribution systems – for new systems, extensions, and modernization projects. Siemens products and solutions are distinguished by scalable quantity structures. They offer diverse interfaces, efficient operation at all levels and ensure seamless system integration. The information and control of substations is based on distributed devices. This offers a multitude of functions and applications for data acquisition, control and monitoring, for protection and for communication.

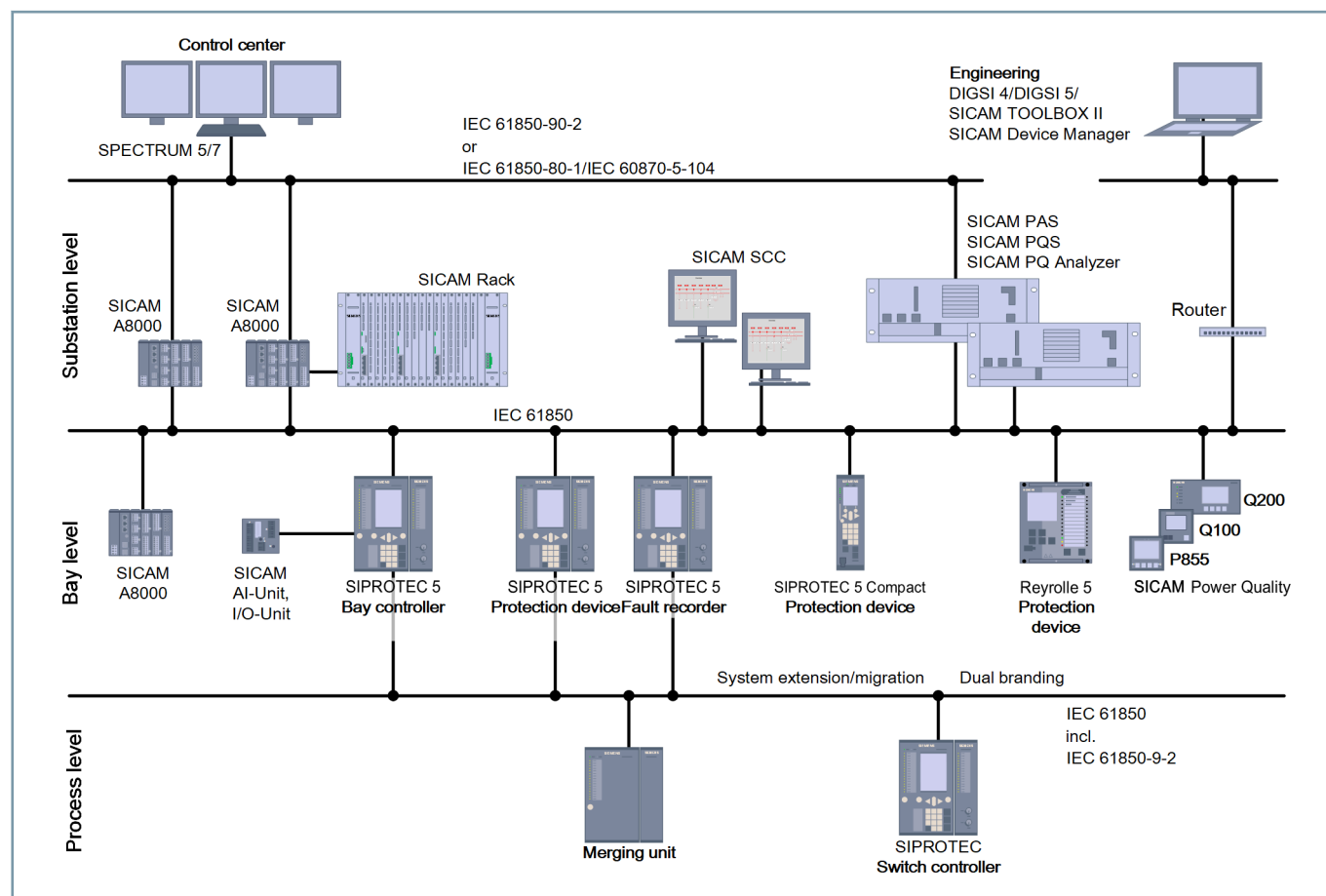

[dw_application_station-config_4_en_US]

Figure 1.3/1 Application Example: Station Automation

Product Security

Siemens provides secure solutions by aligning the product development process and security features with international security standards such as IEC 62351, IEC 62443, or ISO 27001. These standards help ensure interoperable and secure products that meet industry best practices for cybersecurity.

Siemens aims to provide:

- Stringent access control measures
- Data integrity
- Secure communication
- Seamless monitoring capabilities

Additionally, Siemens products ensure 24/7 protection together with flexible and secure deployment.

Secure Product Development Process

Product security begins with an initial idea for a new product and shapes the choices to setup technologies, functionalities, processes, and architectures. Siemens follows a **Security by Design** approach to the product development.

The security principles cover a wide range of activities, including:

- Security threat and risk analysis
- Supplier and component selection
- Coding
- Configuration and hardening
- Testing

The development process for Siemens protection, automation, and Internet of Things (IoT) products include all the steps and are certified to comply with the cybersecurity requirements of the international standard IEC 62443-4-1 with Maturity Level 4. Additionally, Research and Development, Engineering, Production, Sales and Service operates a certified management system in accordance with ISO/IEC 27001.

Security Features and Functions

The products in the Siemens portfolio offer organized comprehensive security features that adhere to the standard IEC 62351. Some of the key security features include:

- A central user and account management along with role-based access control
- Certificate-based authentication and authorization
- Integrity measures for software and firmware
- Secure communication on application and transport level TLS (Transport Layer Security)
- Centralized security event logging and installed base monitoring

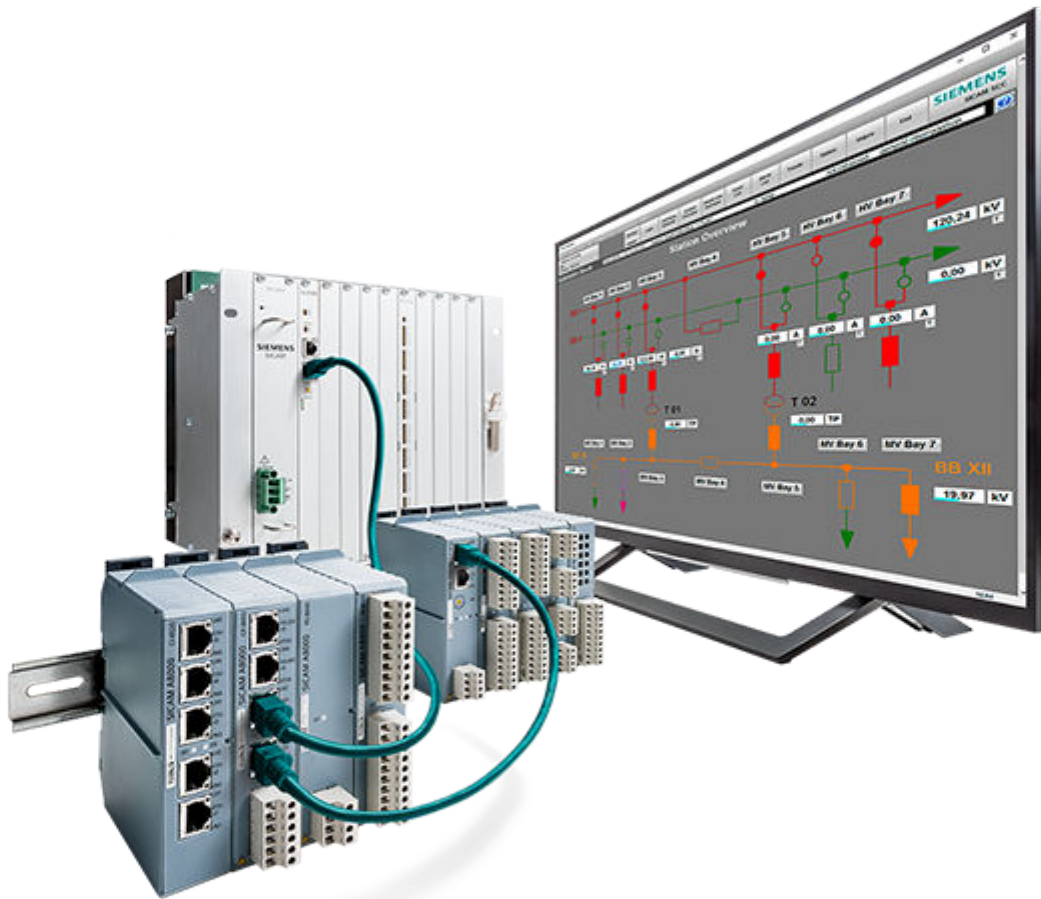

Station and Telecontrol Engineering



2

Device	SICAM A8000			
	CP-8000	CP-8021	CP-8022	CP-8031
Fields of Application	Electrical distribution stations, pipelines, gas distribution stations, railway power supplies, tunnels, site protection, data concentrator, telecontrol substations, automation units			
Max. Number of Data Points	20000			
Max. Number of I/O	20 integrated 116 (modular)	128 (modular)	128 (modular)	128 (modular)
Max. Number of Interfaces	2 x RJ45: Ethernet 1 x RS232 (serial) 1 x RS485 (serial)	3 x RJ45: 2 x Ethernet/ 1 x RS232 1 x RS485	3 x RJ45: 2 x Ethernet/ 1 x RS232 1 x RS232/RS485 selectable 1 x RS485 1 x LTE CAT1/GPRS	4 x RJ45: 2 x Ethernet 1 x RS485 (serial) 1 x RS232 (serial)
Human-Machine Interface (HMI)				
SICAM SCC	■	■	■	■
Engineering				
SICAM PAS software	-	-	-	-
SICAM TOOLBOX II and SICAM Device Manager	■	■	■	■
Integrated tools	-	-	-	-
Web server (for device configuration)	■	■	■	-
Integrated, customer-specific dashboard	-	-	-	■
Remote maintenance	■	■	■	■
Automation Functions				
Automation function (CFC/PLC, IEC 61131-3)	128 k	128 k	128 k	1 x 3 MB
CFC/PLC online test	■	■	■	■
Time Synchronization				
Remote NTP	■	■	■	■
GPS/DCF	-	-	-	-
Resolution/sampling rate	1 ms	1 ms	1 ms	1 ms
PTP (PTP protocol) (IEEE 1588)	-	-	-	■ ¹

¹ Not used for transparent clock

Station and Telecontrol Engineering



SICAM A8000		SICAM PAS
CP-8050	Rack solution	
Electrical distribution stations, pipelines, gas distribution stations, railway power supplies, tunnels, site protection, data concentrator, telecontrol substations, automation units, hydropower plants, central control units, substation controllers, data nodes with high packing density and direct process connection, front end, or gateway		Power automation to operate switchgear with a single station computer (full server) or with up to 2 additional computers (DIPs)
400000	400000 per expansion firmware (max.4)	80 000 master information objects
0 to 2048 (modular)	0 to 4096 (modular)	Distributed via IEDs
4 x RJ45: 2 x Ethernet 1 x RS485 (serial) 1 x RS232 (serial) 30 x modular, of which max. 10 Ethernet	2 x RJ45 (serial) in conjunction with CI-2530	200 x serial Ethernet depending on PC
■	■	■
-	-	■
■	■	-
-	-	■
-	-	-
■	■	-
■	■	Remote desktop
5 x 3 MB	5 x 3 MB	>1.5 M
■	■	■
-	-	-
■	■	■
-	-	■
1 ms	1 ms	1 ms
■ ¹	■ ¹	■ ¹

Station and Telecontrol Engineering



2

Device		SICAM A8000			
		CP-8000	CP-8021	CP-8022	CP-8031
Communication					
To the server protocol control center	Serial		IEC 60870-5-101 DNP3 Modbus RTU		IEC 60870-5-101 IEC 60870-5-103 DNP3 Modbus RTU
	TCP/IP		IEC 60870-5-104 IEC 61850 Ed2 DNP3i Modbus		IEC 60870-5-104 IEC 61850 Ed2 DNP3i Modbus
To IEDs client protocols	Serial		IEC 60870-5-101 IEC 60870-5-103 Modbus RTU		IEC 60870-5-101 IEC 60870-5-103 Modbus RTU PROFIBUS DP
	TCP/IP		IEC 60870-5-104 IEC 61850 Ed2 Modbus		IEC 60870-5-104 IEC 61850 Ed2 Modbus PROFINET IO
Service forwarding/pass through for TCP and UDP protocols			–		■
Notifications via SMS or e-mail			–		–
Further IED protocols		■	■	■	■
Secure Communication					
IEC 60870-5-104 Master/Slave (Transport Layer Security (TLS))		■	■	■	■
IEC 61850 Client/Server (Transport Layer Security (TLS))		■	■	■	■
DNP3i master/slave (Transport Layer Security (TLS))		–	–	–	■
Redundancy		–	–	–	–
Power Quality Applications					
PQ data (PQDIF) are transmitted by the PQ devices P855, Q100, Q200, and 7KE85 with IEC 61850. Grid-code evaluation, scheduled reports, automatic COMTRADE/PQDIF import and export, notification, fault location		–	–	–	–

Station and Telecontrol Engineering



SICAM A8000		SICAM PAS
CP-8050	Rack solution	
IEC 60870-5-101 IEC 60870-5-103 DNP3 Modbus RTU	IEC 60870-5-101 IEC 60870-5-103 DNP3 Modbus RTU	IEC 60870-5-101 DNP3 Modbus RTU
IEC 60870-5-104 IEC 61850 Ed2 DNP3i Modbus	IEC 60870-5-104 IEC 61850 Ed2 DNP3i Modbus	IEC 60870-5-104 IEC 61850 Ed2 DNP3i Modbus OPC DA, OPC XML DA
IEC 60870-5-101 IEC 60870-5-103 Modbus RTU PROFIBUS DP	IEC 60870-5-101 IEC 60870-5-103 Modbus RTU PROFIBUS DP	IEC 60870-5-101 IEC 60870-5-103 DNP3 Modbus RTU PROFIBUS DP (DPV0)
IEC 60870-5-104 IEC 61850 Ed2 Modbus PROFINET IO	IEC 60870-5-104 IEC 61850 Ed2 Modbus PROFINET IO	IEC 60870-5-104 IEC 61850 Ed1, Ed2 DNP3i Modbus PROFINET IO OPC DA; SNMP V2/V3
■	■	-
-	-	■
■	■	■
■	■	■
■	■	■
■	■	■
■	■	■
-	-	■

2

Station and Telecontrol Engineering



2

Device	SICAM A8000			
	CP-8000	CP-8021	CP-8022	CP-8031
Archiving				
Fault records, events, and mean value or PQ data in the device	–	–	–	–
Process-data archive	■	■	■	■
Security Functions				
Security Eventlog (syslog)	■	■	■	■
SNMP agent	■	■	■	■
Asset information, security events	–	–	–	–
SNMP Client, IEC 61850 Client	–	–	–	–
Asset information	–	–	–	–
Role Based Access Control (RBAC)	■	■	■	■
Additional Information				
Supply voltage	DC 18 V to 72 V (PS integrated in the CPU module)	DC 18 V to 78 V DC 82.5 V to 286 V (PS as a separate module)	DC 18 V to 78 V DC 82.5 V to 286 V AC 230 V (PS as a separate module)	
Memory card for parameters and firmware	SD			
Temperature range	-40 °C to +70 °C			-25 °C to +70 °C ²
Assembly	DIN rail			
Degree of protection	Max. IP40			

² -40 °C on request



SICAM A8000		SICAM PAS
CP-8050	Rack solution	
–	–	■ ³
■	–	■
■	■	■
■	■	■
–	–	■ ⁴
■	■	■
DC 18 V to 78 V DC 82.5 V to 186 V AC 230 V (PS as a separate module)	DC 24 V to 60 V DC 110 V to 220 V AC 230 V (PS as a separate module)	No spec., depends on PC
SD		
–25 °C to +70 °C ²	–5 °C to +55 °C	
DIN rail	Rack, 19-inch assembly ⁵	
Max. IP40	Max. IP30	

2

³ Fault records can be transmitted to superordinate control centers via an IEC 61850 server.

⁴ Asset information of connected devices can be passed onto superordinate control centers via an IEC 61850 server.

⁵ Applicable to A8000 rack I/Os

Station and Telecontrol Engineering

SICAM PAS – Description

Description

With SICAM PAS, the Power Automation System for energy automation, you have an instrument for innovative solutions for the most varied conceptual formulations that can occur when using spatially distributed information systems.

The system is equally suitable for use with the switchgear of power utilities and in industrial plants.

SICAM PAS has been designed as a modular, open system which complies with all widely used communication standards and furthermore supports you in the implementation of project-specific automation tasks in the fields of substation automation technology and power automation.

2.1 Diverse functions for the determination and evaluation of Power Quality measured data (PQ measured data) to determine power quality supplement the possible fields of application of the SICAM PAS system.

The user-management tool ensures that configuration, operation, and system-management tasks can only be performed by authorized persons. The assignment of individual switching authorization up to the information level further enhances the security of system management. Notification functions inform you via e-mail and/or SMS about pending system incidents, fault records, and reports, such as fault-location reports.

The system can be structured redundantly at the system, interface, and device levels. This approach significantly improves fail-safe operation. When communication connections are interrupted, the redundant component takes over the process connection. Depending on the transmission protocol, the process image of the redundant system is updated either continually or by means of a general interrogation upon process take-over. The DNP3i, IEC 60870-5-104, and IEC 61850 protocols permit TSL-based secure data transmission via certificates. User authentication is also supported for DNP3i. In Ethernet TCP/IP networks, switches are used for communication with terminal devices. SICAM PAS supports the SNMPv2/v3 protocols (Simple Network Management Protocol) for monitoring the operating state of the plant and for fast error detection in order to ensure operational reliability.

Benefits

- Modular and scalable hardware and software
- User-friendly
- Fulfills strict IT security requirements for use in the area of critical infrastructures
- Flexible, graphic project engineering for automation
- Openness from the use of standards

Functions

- Automation – store switching sequences such as busbar changes in SICAM PAS, make functional processes more flexible and also simultaneously increase the cost-effectiveness of your energy plants
- Remote and on-site operation – there is an option at each occasion to carry out manual operating steps – via a control center or directly on site.

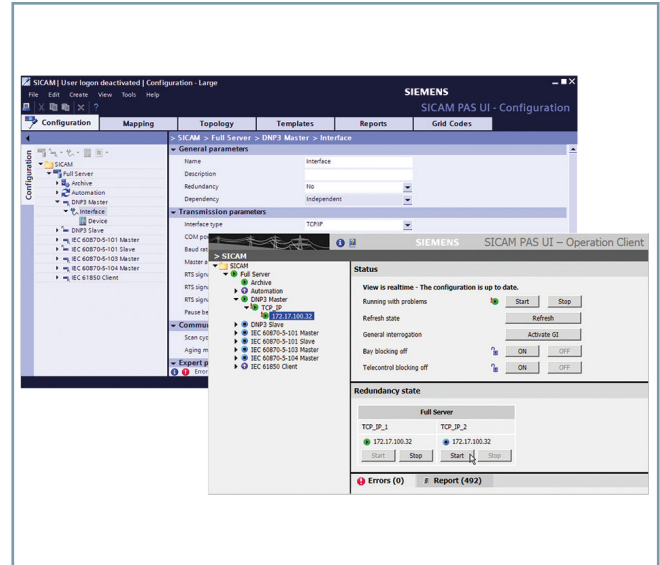

[ph_SICAM PAS, 2, ...]

Figure 2.1/1 SICAM PAS User Interface

- Acquisition and processing of
 - Indications
 - Measured and metered values
 - Fault records
 - Power-quality data
 - IEC 61850 Common Format for Event Data Exchange (COMFEDE files) can be logged to SIPROTEC 5 devices
- Compression and selective distribution – SICAM PAS does not just constantly collect all power-system data, SICAM PAS also handles corresponding assignment and distribution of data points to, for example control centers, HMIs, and archives
- Logging and archiving – SICAM PAS supports the storage of fault records and events in one archive. Evaluation and visualization of the archive is done via the SICAM PQ Analyzer.

Applications

SICAM PAS can be used for all applications where the following are required:

- Different communications standards and interfaces to connect bay units and substations, or to connect network control centers (Ethernet TCP/IP, serial interfaces, or OPC DA client/server, OPC XML DA server)
- Data acquisition and transmission under real-time conditions
- Secured data transmission
- Ethernet network monitoring, for example, based on SNMPv2/v3
- Dual-channel connection for enhanced availability of communication to control centers
- Data exchange via OPC DA as the connection to office desktop computers
- Realization of automation tasks

- Process visualization – Human-Machine Interface (HMI)
 - Flexible solutions for local visualization, control, archiving, and logging
 - Remove visualization, control, archiving, and logging with SICAM SCC and the SIMATIC Web Navigator
 - Visualization of process data via individually designed user interfaces such as overview diagrams, system diagrams, event lists, etc.
 - Archiving of indications and measured values
- Archiving of fault records and PDR records, as well as evaluation with the SICAM PQ Analyzer
- Archiving of events and evaluation with the SICAM PQ Analyzer
- Notification upon receipt of fault records, status changes of selected information or when creating fault-location reports
- Automatic or manual export of fault records
- Assignment of individual switching authorizations up to information level
- Secure data access via the user-management tool
- Switchgear interlocking in the case of control/remote control
- Redundant configuration of the substation level
- Test and diagnostic functions
- (Remote) visualization and control of SICAM PAS applications, interfaces, and connection to devices and control centers via SICAM PAS UI – Operation Client

SICAM PAS can be used for all applications where the following is required:

- Different communication standards and interfaces for the connection of bay devices and substations or for the connection to telecontrol centers (Ethernet TCP/IP, serial interfaces, or OPC DA Client/Server, OPC XML DA Server)
- Data acquisition and transmission under real time conditions
- Secured data transmission
- Ethernet network monitoring, for example, based on SNMPv2/v3
- Double-channel connection for enhanced availability of communication to the control centers
- Data exchange via OPC DA for connection with office computers
- Realization of automation tasks
- Process visualization - Human-Machine Interface (HMI)
 - Flexible solutions for local visualization, control, archiving, and logging
 - Remote visualization, control, archiving, and logging, using SICAM SCC and the SIMATIC Web Navigator
 - Visualization of process data via individually designed user interfaces such as overview diagrams, station diagrams, and event lists
 - Archiving of measured and metered values
- Archiving fault records and PDR records and evaluation with the SICAM PQ Analyzer

- Archiving events and evaluation with the SICAM PQ Analyzer
- Notification on the arrival of fault records, state changes of selected items of information or the completion of fault location reports
- Automatic or manual export of fault records
- Transmission of fault records from IEC 61850 devices to a control center via IEC 61850 Server
- Transmission of asset Information from IEC 61850 devices and SNMP devices to a control center via IEC 61850 Server
- Assignment of individual switching authorities down to the information level
- Secured data access via the User Administration tool
- Switchgear interlocks for telecontrolling/controlling
- Redundant structure of the substation level
- Test and diagnostic functions
- (Remote) visualization and control of SICAM PAS applications, interfaces, and connection to devices and control centers with SICAM PAS UI – Operation Client

Configuration Examples

Due to its modular system structure, SICAM PAS can be used for multiple purposes on the substation control level of interconnected control centers.

SICAM PAS can be set up in the following different variants:

- With a Full Server and SICAM SCC
- As a distributed system consisting of
 - 1 or several Full Servers
 - 1 or several DIPs (Device Interface Processor)
 - SICAM SCC

SICAM PAS systems communicate with higher-level control centers through:

- Ethernet TCP/IP (LAN/WAN)
- Serial interfaces

SICAM PAS communicates with bay devices, protection devices, and substations through:

- Ethernet TCP/IP (LAN/WAN)
- Serial interfaces
- PROFIBUS interfaces

Station and Telecontrol Engineering

SICAM PAS – Configuration Examples

The example below illustrates the connection of 2 SICAM PAS systems to a higher-level control center

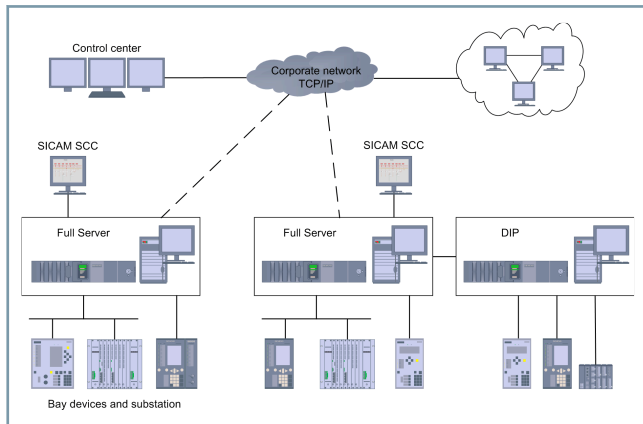

[dw_PAS_2_systems, 2, en_US]

Figure 2.1/2 Sample Configuration with 2 SICAM PAS Systems

Distributed System with Full Server and DIP

The example shows a distributed SICAM PAS system. It consists of a Full Server and DIP and communicates with a control center through TCP/IP. Bay devices and substations are connected to a distributed system through Ethernet and serial interfaces.

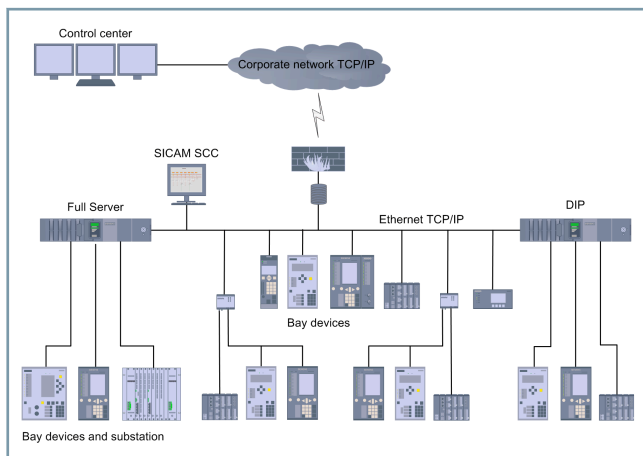

[dw_PAS_distributed_FS_DIP, 2, en_US]

Figure 2.1/3 Example of a Distributed SICAM PAS System with Full Server and DIP

Redundant Connection of Bay Devices and Substations

SICAM PAS supports the redundant connection of bay devices and substations.

The following example illustrates the configuration:

- Redundant Full Servers
- Redundant SICAM SCC implemented in server/client architecture
- Connection of bay devices to 2 SICAM PAS stations

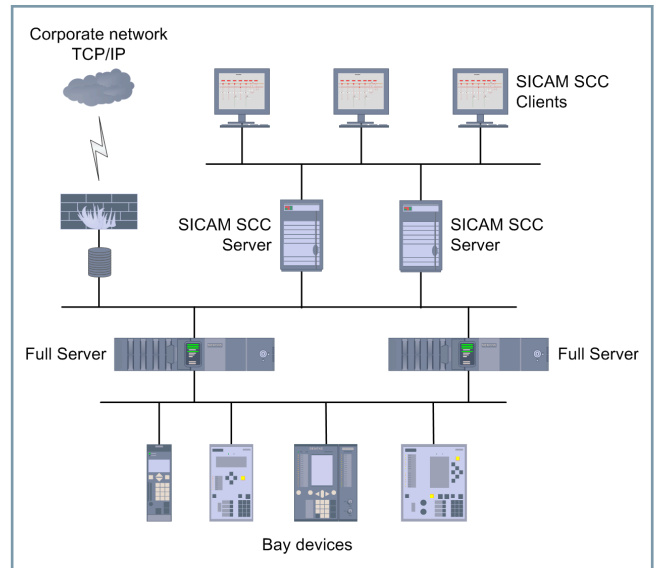

[dw_PAS_station_bus_config, 2, en_US]

Figure 2.1/4 SICAM PAS Station Bus Configuration with Redundant Connection of the Bay Devices through a Switch and Redundant SICAM SCC in Server/Client Architecture

Bay devices with 2 interfaces are required for the redundant connection of bay devices with serial communication. Alternatively, bay devices equipped with 1 interface can be connected redundantly through a modem splitter.

Configuration for Small Applications

With systems comprising up to 80 bay devices and depending on the amount of data and the complexity of the automation and HMI functionality, you can operate SICAM PAS and SICAM SCC on the same computer.

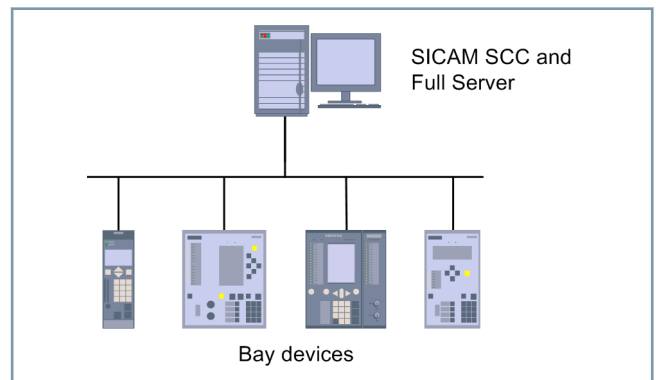

[dw_PAS_station, 1, en_US]

Figure 2.1/5 Connection of Bay Devices to SICAM PAS

Configuration for Medium Applications

If your station comprises more than approximately 80 bay devices, SICAM PAS and SICAM SCC must run on separate computers. The example below illustrates the connection of the bay devices to 1 SICAM PAS computer.

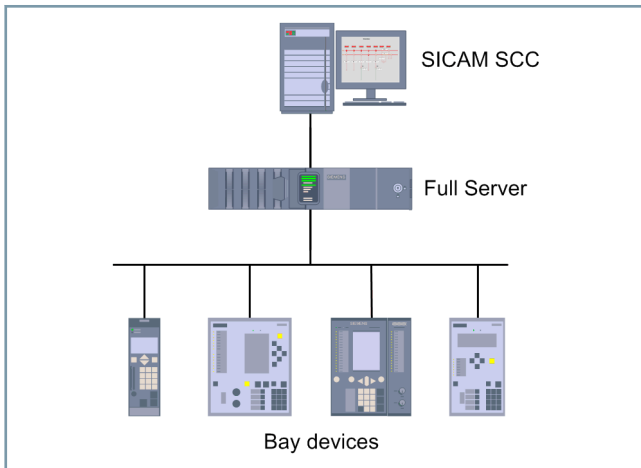

[dw_PAS_station_SCC_2_en_US]

Figure 2.1/6 Connection of Bay Devices to a SICAM PAS Computer

Configuration for Large Applications

Up to 400 bay devices can be connected to 1 SICAM PAS Full Server.

In large applications with up to 800 bay devices, SICAM PAS is implemented as a distributed system equipped with a Full Server and up to 2 DIPs.

SICAM SCC is installed on a separate computer.

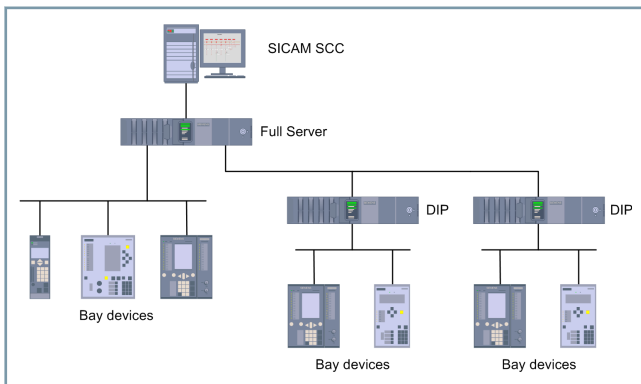

[dw_PAS_station_DIP_SCC_2_en_US]

Figure 2.1/7 Connection of Bay Devices in a Distributed System

Several SICAM PAS Full Servers Connected to a Human-Machine Interface (HMI)

The following example illustrates a SICAM SCC Human-Machine Interface (HMI) with 2 SICAM PAS computers to which bay devices are connected.

This configuration makes sense in cases where no spatially distributed Human-Machine Interface and no fail-safe SICAM SCC are required.

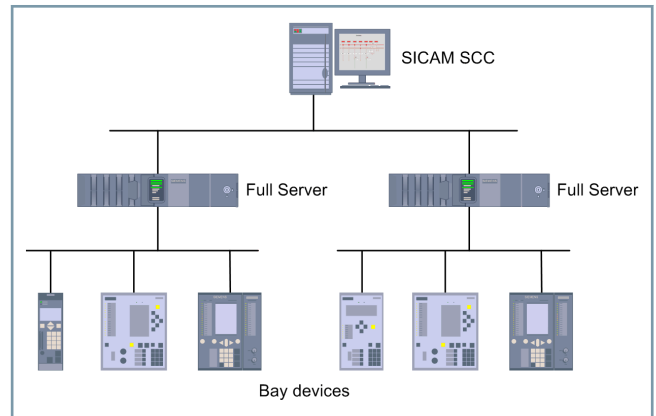

[dw_several_FS_same_SCC_2_en_US]

Figure 2.1/8 Several Full Server Connected to the same SICAM SCC

Redundant Human-Machine Interface (HMI)

The connection of several Full Servers to a redundant SICAM SCC Human-Machine Interface represents another configuration option. This configuration enhances the system's operational reliability.

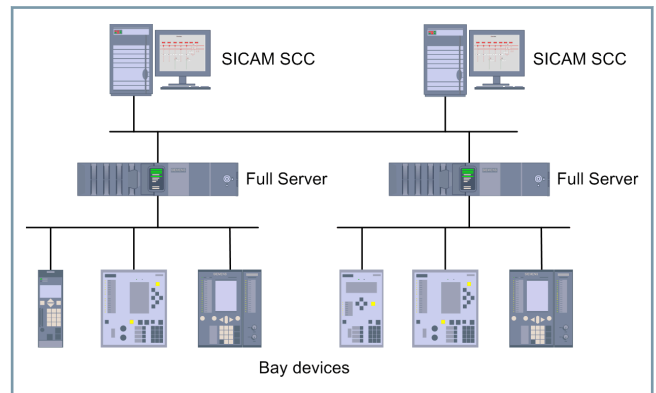

[dw_several_FS_redundant_SCC_2_en_US]

Figure 2.1/9 Several Full Servers with Redundant SICAM SCC

Redundant Human-Machine Interface (HMI) in Server/Client Architecture

In large stations, it may be necessary to distribute station management tasks between several components. In such cases, you set up a SICAM SCC Human-Machine Interface in server/client configuration. The following example illustrates a redundant SICAM SCC comprising 2 Full Servers.

Station and Telecontrol Engineering

SICAM PAS – Configuration Examples

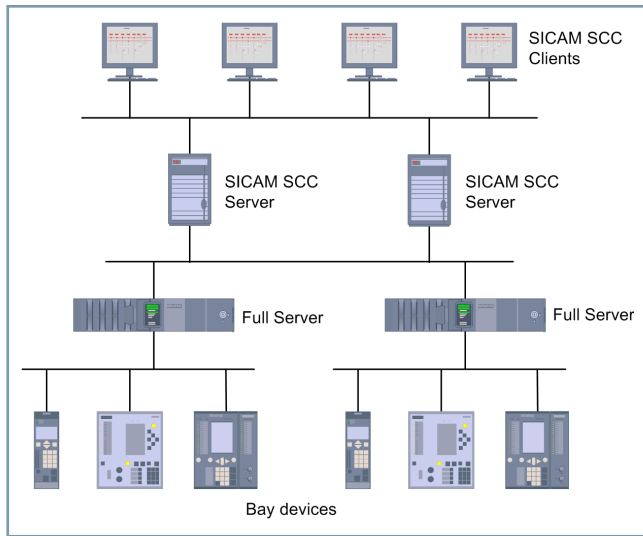

[dw_Redundant_FS_redundant_SCC, 2, en_US]

Figure 2.1/10 Redundant SICAM SCC with Redundant Full Server

Communication Interfaces

SICAM PAS is a modularly structured system. It is open for the connection of the most versatile components, which exchange their process data based on state-of-the-art communication standards.

The following data exchange options are available:

- SICAM PAS with the SICAM SCC Human-Machine Interface (HMI) via Ethernet (TCP/IP)
- SICAM PAS with bay devices and substations
- SICAM PAS with higher-level control centers
- SICAM PAS with OPC DA servers such as the SIMATIC automation system
- SICAM PAS with OPC DA clients, for example, process visualization systems of other manufacturers
- SICAM PAS with systems with OPC XML DA clients

SICAM PAS allows the user to save events, fault records, PDR records, PQ measuring data and fault location information to an archive. The archive contents can be visualized and evaluated in the various views provided by the **SICAM PQ Analyzer** installed on the same or a different computer. With the SICAM PQ Analyzer **Collector** function, the archive can be transferred to a dedicated archive computer, and the (source) archives of several SICAM PAS systems can be combined to a (Collector) archive. In addition to the **Incident Explorer** view, where the fault records are displayed in chronological order, the **Event Viewer** shows the events and the **Fault Event Viewer** shows the fault events detected by SICAM PAS (that is several fault records from different protection devices captured in a predefined, tight time slot). In the **Incident Explorer**, the fault records are sorted into the (device) configuration tree or the (process) topology tree depending on the respective selection.

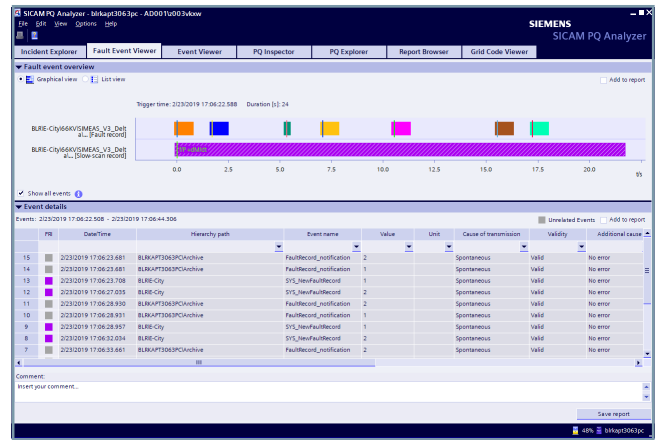

[sc_faulteventviewer, 2, en_US]

Figure 2.1/11 SICAM PQ Analyzer – Fault Event Viewer

SICAM PAS can also integrate additional PQS functions for the evaluation of PQ measuring data. These include a connection option for third-party devices, which provide fault records or PQ measuring data and the automatic export of fault records (with file naming convention IEEE Std. C37.232-2011), messages during a fault (<=> fault log), reports, or PQ data.

The SNMP protocol allows you to monitor the communication links of the switches connected through Ethernet network.

In order to perform **asset monitoring** tasks, SICAM PAS provides an SNMPv3 agent which makes available asset information, for example, the product name, product version, as well as project-specific product applications, to an SNMP client.

In order to perform **security notification** tasks, SICAM PAS provides an SNMPv3 agent to store security related logs, for example, start/stop of system components, modification in the archive (import records, import PQDIF, delete records, delete reports, add or edit traffic lights) available as information and traps for the SNMPv3 client. In addition, the spontaneous transmission of safety-relevant events is supported.

Following protocols are included in the basic license:

- SNMP client and agent
- OPC DA servers
- Communication with SICAM MIC RTU (CP-8000, CP-8021/22) based on IEC 60870-5-104
- SIPROTEC 4 service interface master
- SIMEAS R master and SICAM Q80 master
- IEC 61850 GOOSE monitoring and publisher
- Event list/fault events

Via the system's communication interfaces, you can connect SICAM PAS to:

- Higher-level control centers
- Bay devices and substations
- Components for data exchange with industrial automation systems, such as SIMATIC

Communication with Higher-Level Control Centers

Communication takes place via the following protocols:

- IEC 61850 Server ⁶
- IEC 60870-5-104 Slave
- IEC 60870-5-101 Slave
- DNP3 Slave (serial, TCP/IP)
- Modbus Slave (serial, TCP/IP)
- Telegyr 8979 Slave
- CDT Slave

Connection of Bay Devices and Substations

Communication takes place via the following protocols:

- IEC 61850 Client, GOOSE status monitoring
- IEC 61850 Server, GOOSE Publisher
- IEC 60870-5-103 Master
- IEC 60870-5-104 Master
- IEC 60870-5-101 Master
- SICAM MIC Master
- DNP3 Master (serial, TCP/IP)
- Modbus Master (serial, TCP/IP)
- PROFIBUS DP Master
- PROFINET IO Master
- SINAUT LSA ILSA Master
- SIPROTEC 4 Service IF Master (fault records)

OPC Connection

- OPC XML DA Server
Exchange of structured information via Internet in XML format
- OPC Server (DA V3.0)
Data exchange with OPC clients of other applications, for example, process visualization systems
- OPC Client (DA V3.0)
Data exchange with any OPC server of other applications, for example, automation systems or other manufacturers' protocol drivers

IEC 61850

The communication standard for the IEC 61850 station bus is based on Ethernet TCP/IP.

The optional use of TLS (Transport Layer Security) provides additional security during data transmission.

IEC 61850 defines the communication and the exchange of configuration data between bay devices and substations from different manufacturers. Based on the IEC 61850 GOOSE mechanism, bay devices can directly exchange data - independently of the operating state of the substation controller. This cross

communication enables for example, the implementation of bay-independent interlocks on the device level.

The state of the IED GOOSE server can be monitored via SICAM PAS and visualized via the SICAM PAS UI – Operation Client Web user interface without the need for additional engineering.

The IEC 61850 Server – GOOSE Publisher enables the transmission of data from other station components (for example, devices connected via IEC 60870-5-103, -101, ...) or from the SoftPLC (Automation) to the IED GOOSE server.

Depending on the project requirements, the IEC 61850 station bus based on Ethernet TCP/IP can be realized in different configurations:

- Star configuration, electrical variant
- Ring structures, optical variant
- Combination of star and ring structures
- Redundant LAN with seamless operation (Parallel Redundancy Protocol – PRP)

Through their integrated communication modules, SIPROTEC 4 and SIPROTEC 5 devices can be incorporated directly into an Ethernet ring. External switches are not required.

In a ring structure, a redundancy mechanism (Rapid Spanning Tree Protocol – RSTP, High-availability Seamless Redundancy – HSR) ensures that the communication to the devices is maintained even in case of a communication interruption in a ring segment or in case of failure of a device in the ring.

For the connection of other devices to this ring, for example, an industrial PC or third-party devices, Siemens recommends the use of switches manufactured by Siemens, Scalance/Ruggedcom or Hirschmann. The switches used in ring structures must originate from the same manufacturer.

The following paragraphs explain the principal communication configurations for the IEC 61850 connection.

The following connection type is used for stations in which SICAM PAS and the devices connected through a switch are located close to each other.

⁶ Fault records from IEC 61850 protection devices as well as asset information from devices connected with IEC 61850 or SNMP can be transmitted to higher-level control centers with IEC 61850 Server.

Station and Telecontrol Engineering

SICAM PAS – Communication Interfaces

The connection of the bay devices to a switch can be realized either electrically or through FO. For an electrical connection, shielded copper Twisted Pair (TP) cables are required. The cable between the switch and the device must not exceed 20 m in length.

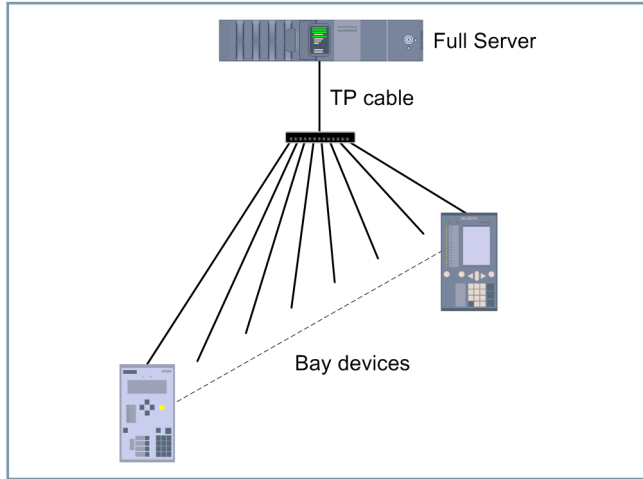

[dw_IEC_61850_2_en_US]

Figure 2.1/12 IEC 61850 Connection Example

If larger distances have to be overcome or if a larger number of devices have to be connected, the configuration shown below should be considered.

The example below illustrates the connection of bay devices to an Ethernet ring through switches.

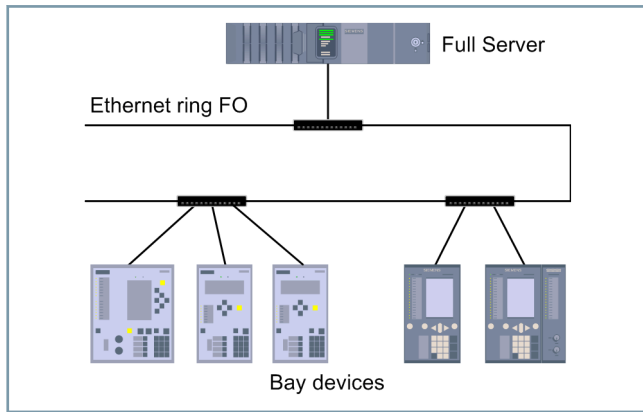

[dw_IEC_61850_Ethernet_ring_2_en_US]

Figure 2.1/13 IEC 61850 Connection Example to an Ethernet Ring through Switches

The example below illustrates the direct connection (without additional switches) of SIPROTEC 4 and SIPROTEC 5 devices which are equipped with Ethernet communication modules.

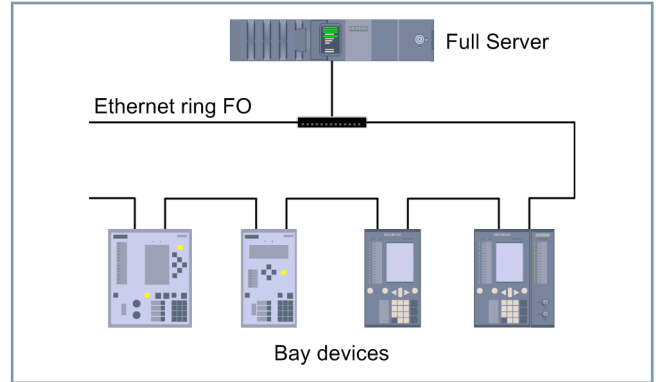

[dw_SIPROTEC_devices_2_en_US]

Figure 2.1/14 Connection Example – SIPROTEC 4 and SIPROTEC 5 Devices

IEC 60870-5-103

The IEC 60870-5-103 protocol is supported by the protection and bay devices of numerous manufacturers. For example, SIPROTEC devices, SICAM T, SICAM P850/855, or transformer controllers manufactured by Eberle or Reinhausen can be connected to SICAM PAS.

IEC 60870-5-104

The IEC 60870-5-104 protocol is used for the connection of bay devices and SICAM PAS at the station level using Ethernet TCP/IP.

The optional use of TLS (Transport Layer Security) provides additional security during data transmission.

IEC 60870-5-101

The IEC 60870-5-101 protocol is used for the connection of substations to SICAM PAS through a serial COM port or a modem connection.

The connection through a **COM port** allows the operating modes **balanced** for point-to-point configuration and **unbalanced** for line operation with up to 16 substations.

Modems (IAWD, analog, ISDN, GSM dial-up mode) with the capability of being staggered enable line operation.

If a modem is busy communicating with another substation or if a modem has failed, a configured spare modem automatically takes over the communication.

Siemens recommends the use of INSYS modems.

DNP3

The DNP3 protocol is used for the connection of bay devices and substations to SICAM PAS through Ethernet TCP/IP or serial interfaces.

The optional use of TLS (Transport Layer Security) and authentication provides additional security during data transmission. TLS can only be used if DNP3 protocol is communicating through Ethernet TCP/IP.

Modbus

The Modbus standard is used in the field of automation engineering and supported by distributed I/Os.

The communication can be performed through Ethernet TCP/IP or serial interfaces.

PROFIBUS DP

The PROFIBUS DP bay bus standard is frequently used in the field of automation engineering and supported by distributed I/Os.

The devices equipped with a PROFIBUS DP interface (DPV0), such as SIMEAS P, ET200, or SIPROTEC 4 devices, can be connected to SICAM PAS.

For the connection of PROFIBUS DP devices, Siemens recommends the use of PROFIBUS components manufactured by Siemens (for example, OLM for fiber-optic connections).

PROFINET IO

The PROFINET IO bay bus standard is used in the field of automation engineering and supported by distributed I/Os.

The devices equipped with a PROFINET IO interface, such as ET200, can be connected to SICAM PAS.

The following applies for the connection to SICAM PAS:

- A separate Ethernet module must be used for PROFINET IO.
- The PROFINET configuration is configured using the TIA Portal (\geq SIMATIC Step7 V13 SP1).
- The XML file exported via the TIA Portal is imported using SICAM PAS UI – Configuration.

Additional Station Control Functions

During, for example, maintenance work or for other system-management reasons, information exchange with the control centers or the station itself can be blocked with the **telecontrol blocking** and **bay blocking** functions. You can also configure the telecontrol blocking in a channel-specific manner so that information transmission to a control center can be blocked during operation whilst transmission to other control centers remains unaffected. Bay and telecontrol blocking have an effect in signaling and command direction.

Channel-specific **switching authority** permits distinction between local control (SICAM SCC) and remote control as well as between network control center connections to be made for the control direction.

In addition, you can declare information-specific exceptions for these 3 functions. This permits, for example, certain messages to be transferred despite an activated blocking, or special commands to be processed and output despite a defined switching authority.

There is also an option for an object-specific blocking (individual indication or measured values). Blocked data points (bay blocking, object-specific blocking) or those with an invalid status can also be updated with a substitute value by the operator so that all other recipients (control centers, automation) receive the correct state.

While a 1-of-N check is effective in the individual bay units (this means that only one command is accepted and output at the same time), m-out-of-n control is supported with SICAM PAS on the substation-automation technology side. This permits the number of commands that may be processed simultaneously across the bay units to be defined. Synchronized/unsynchronized control of circuit breaker is possible.

Triggered by an event, the SICAM PAS option **Post Disturbance Review (PDR)** records the status changes of messages and measured values over a period of up to 6 min. The trigger event, the length of the time frame (including 1 min pre-trigger time) and the information objects to be recorded can be parameterized. The resulting disturbance data file is archived. Graphical and tabular evaluation is possible in the Incident Explorer of the SICAM PQ Analyzer.

Automation tasks can be configured in SICAM PAS with the IEC 61131-compliant CFC (Continuous Function Chart). In this editor, the task is resolved graphically by circuiting function blocks. The SICAM PAS scope of delivery includes a large library of CFC function blocks that have been developed and system-tested specifically for power automation. The field of application stretches from group-indication generation via switchgear interlocking up to complex switching sequences. The SFC (Sequential Function Chart) editor supports the creation of switching sequences. In this context, additional preconfigured and system-tested applications, such as frequency-based load shedding, transformer monitoring, and SF6 gas monitor can optionally be licensed. In addition to special function blocks and CFC diagrams, the scope of delivery also includes operation images for SICAM SCC.

If the SICAM PAS station is to take over the **time synchronization** of bay units, substations and SICAM SCC, this can be done via a DCF77 or GPS time-signal receiver with the Network Time Protocol (NTP) or with the IEEE 1588 Precision Time Protocol (PTP) in the computer. Time synchronization of the SICAM PAS system components is also possible from a network control center.

SICAM PAS Applications

SICAM PAS Applications reduces the effort and the technical risk during the implementation of selected automation task in accordance with the automation standard IEC 61131-3, and provides finished applications from automation practice as an enhancement of SICAM PAS.

Redundancy

SICAM PAS contains large redundancy functions to increase the availability of station automation:

- The substation controller can be used twice.
- Communication to bay units and RTUs can be redundant (interface redundancy).
- The network (LAN) can be redundant (PRP).

Station and Telecontrol Engineering

SICAM PAS – Additional Functions

2.1

- Subordinate devices can be duplicated (redundancy at bay-control level).
- Subdevices can be supported that have been designed for communication with only one master (only one serial interface, for example).

The individual applications (communication protocols) work independently of each other in a hot standby relationship. This means that a fault-related switchover (such as switching the IEC 61850 Client from one substation controller to another one) does not have any loading effect on the communication connection to the control center. This connection remains without interruption on the first substation controller. In addition to increased stability in unaffected communication connections, redundancy switchover of affected components is performed within a very short time (depending on application and configuration, between 250 ms and max. 3 s). Adjustments during operation, such as bay and telecontrol blocking, switching authorities, marker commands to the SoftPLC for an operation-related control of the automation functions are kept synchronous in redundancy operation in both substation controllers. The current settings remain valid after redundancy switchover. SICAM SCC communicates simultaneously with both redundant substation controllers. Redundant operation of process visualization with SICAM SCC and of fault recording archiving with SICAM PQ Analyzer (independent of SICAM PAS) is also possible.

SICAM PAS Compact

The SICAM PAS Compact package contains the functionality of the Runtime & Configuration base package supporting up to 2000 master-information objects, up to 4 optional communication protocols, as well as automation with SoftPLC. SICAM PAS Compact can be enhanced with options and add-ons.

Multilanguage Manager Tool

The Multilanguage Manager Tool can be used to translate the SICAM PAS/PQS user interface and the language of the runtime system. The repository with the translated text is integrated into the installed product.

The Multilanguage Manager Tool is installed together with SICAM PAS/PQS and/or SICAM PQ Analyzer. It does not require a licensed version of SICAM PAS/PQS. A project can only be created to check the translation when SICAM PAS/PQS is installed as a demo version or as a licensed version.

Security

SICAM PAS Secure Communication enables tap-proof data traffic via a TCP/IP connection between SICAM PAS and a control center or device. The asymmetrical TLS-based encryption method is used for this purpose.

In addition, an authentication procedure can be set up for DNP3i protocol in order to clearly determine the user's identity before executing critical tasks.

Secure communication is possible with the following communication protocols:

- **DNP3i Master/Slave**
Both TLS conform to the IEC 62351-5 standard and authentication can be set up.
DNP3 Slave Secure Authentication conforms to Secure Authentication SAv5 based on IEEE Std 1815-2012.
- **IEC 60870-5-104 Master/Slave**
TLS conform to the IEC 62351-5 standard can be set up.
- **IEC 61850 Client/Server**
TLS conform to the IEC 62351-4 standard can be set up.

Via the **SICAM PAS User Administration**, you can assign passwords in order to define which persons can access individual programs conform to the IEC 62351-8 standard. To this end, you assign different user roles, such as administrator, data engineer or operating personnel. For access authorization, you can either use Windows access rights or define your own SICAM PAS access rights.

Security related logs, for example, user login/logout, start/stop of system components, modifications in the archive (import records, import PQDIF, delete records, delete reports, add or edit traffic lights), are displayed in the **Windows Event Viewer** in the **PASSecurity** and **PQ Analyzer Security** folders.

Use **Syslog** conform to the IEC 62351-14 (Draft) standard to collect the security related logs of the applications within a system on a syslog server.

Use **Enable security notification** to generate these security related logs of the applications within a system as traps to SNMP manager.

Safety-relevant events can also be transmitted to an SNMP client using the SNMP agent.

When installing SICAM PAS for the first time, Windows user groups are added to provide a role-based access control for the archive (**RBAC** conform to the IEC 62351-8 standard) to perform various operations for the archive data.

Software and Hardware Requirements

One of the following operating systems is required:

- Windows 11 Professional/Enterprise/IoT Enterprise LTSC (64-bit)
- Windows Server 2022 Standard with Desktop Experience (64-bit)

Computer equipped with:

- Processor:
 - Minimum: Intel Core 2 Duo 1.6 GHz
 - Recommended: Quad Core CPU 3 GHz
- Primary storage capacity:
 - Minimum: 2 GB
 - Recommended for engineering of large stations: ≥ 8 GB
- Hard disk capacity:
 - Minimum: 4 GB plus configured archive size

- Graphics card:
 - Minimum: 1024 x 768 pixel
 - Recommended: 1920 x 1080 pixel
- Monitor suitable for graphics card
- DVD drive
- Keyboard
- Mouse
- Network interface
- USB port

SICAM PAS/PQS is released for computers with multi-core processors. Computers with multi-processor main boards are supported when working in single-processor mode.

Station and Telecontrol Engineering

SICAM PAS – Ordering and Selection Data

Selection and Ordering Data

Description	Variants	Order No.																	
		1	2	3	4	5	6	7	8	9	10	11	12	13	14	15	16		
SICAM PAS/PQS licensed with ALM is only delivered electronically (OSD = Online Software Delivery). The MLFB position 8 with value 3 defines the ALM license type.									▲										
ALM license									3										
SICAM PAS/PQS UI Configuration																			
	UI Configuration	6	M	D	9	0	0	0	-	3	A	A	2	0	-	8	A	A	0
Features/log, licensed with SICAM PAS Compact and SICAM PAS/PQS RT (basic package and bundles)																			
	SIPROTEC 4 service interface master, SNMP protocol client, SNMP protocol agent, SIMEAS R master, SICAM Q80 master, OPC DA server, IEC 61850 GOOSE monitoring, IEC 61850 GOOSE publisher (SICAM PAS only (incl. control direction)), event list/fault events																		
SICAM PAS Compact		6	M	D	9	0	2	0	-	3	M	A	1	0	-	8	A	A	0
	Runtime (RT) supports the following: <ul style="list-style-type: none"> • Up to 4 communication protocols • Max. 2000 master information objects (cannot be upgraded) • Control and monitoring direction • Automation • UI configuration It can be expanded with the options: <ul style="list-style-type: none"> • "n" protocols (protocol-independent) • "n" (PQ) applications (application-independent) • Secure communication 																		
SICAM PAS Basic Package																			
Runtime (control and monitoring direction), IEC 61850 client																			
	Small (up to 4 devices)	6	M	D	9	0	0	0	-	3	R	A	1	0	-	8	D	A	0
	Medium (up to 2000 master information objects)	6	M	D	9	0	0	0	-	3	M	A	1	0	-	8	D	A	0
	Large (up to 180 devices)	6	M	D	9	0	0	0	-	3	A	A	1	0	-	8	D	A	0
	XLarge (more than 180 devices)	6	M	D	9	0	0	0	-	3	B	A	1	0	-	8	D	A	0
SICAM PAS Bundles – Large																			
Runtime (control and monitoring direction), supports up to 180 devices, automation, IEC 61850 client, and additional n protocols																			
	Large with automation, IEC 61850 client, and additional n=2 protocols	6	M	D	9	0	0	0	-	3	A	L	0	2	-	8	A	A	0
	Large with automation, IEC 61850 client, and additional n=3 protocols	6	M	D	9	0	0	0	-	3	A	L	0	3	-	8	A	A	0
	Large with automation, IEC 61850 client, and additional n=5 protocols	6	M	D	9	0	0	0	-	3	A	L	0	5	-	8	A	A	0

Table 2.1/1 SICAM PAS Selection and Ordering Data ≥ Version 8.17

Station and Telecontrol Engineering

SICAM PAS – Ordering and Selection Data

Description	Variants	Order No.																	
		1	2	3	4	5	6	7	8	9	10	11	12	13	14	15	16		
Upgrades																			
Functional upgrades with respect to the supported number of devices																			
	RT upgrade to medium (from small)	6	M	D	9	0	0	4	-	3	M	A	1	0	-	8	A	A	0
	<i>Prerequisite</i>	6	M	D	9	0	0	0	-	3	R	A	1	0	-	8	D	A	0
		7	K	E	9	0	0	0	-	3	R	A	1	0	-	8	D	A	0
	RT upgrade to large (from medium)	6	M	D	9	0	0	4	-	3	A	A	1	0	-	8	A	A	0
	<i>Prerequisite</i>	6	M	D	9	0	0	0	-	3	M	A	1	0	-	8	D	A	0
		7	K	E	9	0	0	0	-	3	M	A	1	0	-	8	D	A	0
	RT upgrade to XLarge (from large)	6	M	D	9	0	0	4	-	3	B	A	1	0	-	8	A	A	0
	<i>Prerequisite</i>	6	M	D	9	0	0	0	-	3	A	A	1	0	-	8	D	A	0
		7	K	E	9	0	0	0	-	3	A	A	1	0	-	8	D	A	0
		6	M	D	9	0	0	0	-	3	A	L	0	0	-	8	A	A	0
		7	K	E	9	0	0	0	-	3	A	L	0	0	-	8	A	A	0
Version upgrade – the initial order must be referenced in the order)																			
	SICAM PAS/PQS upgrade to V8.xx	6	M	D	9	0	0	3	-	3	A	A	0	0	-	8	A	A	0
Protocols that must be licensed with an "n" protocols license (For options and add-ons, refer to Table 2.1/3)																			
<i>Master/client protocols</i>																			
	IEC 60870-5-101, IEC 60870-5-104, IEC 60870-5-103, Modbus, DNP3, SINAUT LSA – ILSA, Driver Module for PROFIBUS DP, PROFINET IO, OPC DA																		
<i>Slave/server protocols</i>																			
	IEC 61850 Server, IEC 60870-5-101, IEC 60870-5-104, Modbus, DNP3, CDT, TG8979, OPC XML-DA Server																		
(PQ) applications that must be licensed with an "n" (PQ) applications license (For options and add-ons, refer to Table 2.1/3)																			
	Automatic COMTRADE import, automatic COMTRADE export, automatic PQDif import, automatic PQ data export, automatic report export, automatic fault-location determination, automatic GridCode evaluation, notifications (email, SMS), scheduled PQ reports, PDR (Post Disturbance Review)																		

2.1

Table 2.1/2 SICAM PAS Selection and Ordering Data ≥ Version 8.17

Station and Telecontrol Engineering

SICAM PAS – Ordering and Selection Data

Description	Variants	Order No.																	
		1	2	3	4	5	6	7	8	9	10	11	12	13	14	15	16		
Options & Add-ons																			
<i>Applications (Power Automation)</i>																			
	1 protocol (protocol-independent, countable)	6	M	D	9	0	0	0	-	3	S	A	0	1	-	8	A	A	0
	2 protocols (protocol-independent, countable)	6	M	D	9	0	0	0	-	3	S	A	0	2	-	8	A	A	0
	3 protocols (protocol-independent, countable)	6	M	D	9	0	0	0	-	3	S	A	0	3	-	8	A	A	0
	4 protocols (protocol-independent, countable)	6	M	D	9	0	0	0	-	3	S	A	0	4	-	8	A	A	0
	5 protocols (protocol-independent, countable)	6	M	D	9	0	0	0	-	3	S	A	0	5	-	8	A	A	0
	SoftPLC automation	6	M	D	9	0	0	0	-	3	B	A	5	0	-	8	A	A	0
	Secure communication (TLS)	6	M	D	9	0	0	0	-	3	S	C	0	0	-	8	A	A	0
<i>(PQ) applications (Power Quality)</i>																			
	1 (PQ) application (application-independent, countable)	7	K	E	9	0	0	0	-	3	P	A	0	1	-	8	A	A	0
	2 (PQ) applications (application-independent, countable)	7	K	E	9	0	0	0	-	3	P	A	0	2	-	8	A	A	0
	3 (PQ) applications (application-independent, countable)	7	K	E	9	0	0	0	-	3	P	A	0	3	-	8	A	A	0
	4 (PQ) applications (application-independent, countable)	7	K	E	9	0	0	0	-	3	P	A	0	4	-	8	A	A	0
	5 (PQ) applications (application-independent, countable)	7	K	E	9	0	0	0	-	3	P	A	0	5	-	8	A	A	0

Table 2.1/3 SICAM PAS Selection and Ordering Data ≥ Version 8.17

Hint:

- Additional computers with DIP installation:
DIP installations must be licensed with at least 1 application license (for example 1 protocol (6MD9000-3SA01-8AA0)). This also applies to DIPs that are only used with license-free protocols.

Order Examples

Example 1:

SICAM PAS is required for up to 2000 master information objects incl. automation and in addition to the IEC 61850 client 3 proto-

cols must be supported (for example IEC 6070-5-103 master, Modbus master and IEC 60870-5-104 slave). In future, the system must be expandable for more than 2000 master information objects. The following MLFB numbers must be ordered:

Description	Order No.
Medium (up to 2000 master information objects)	6 M D 9 0 0 0 - 3 M A 1 0 - 8 D A 0
SoftPLC automation	6 M D 9 0 0 0 - 3 B A 5 0 - 8 A A 0
3 protocols (protocol-independent, countable)	6 M D 9 0 0 0 - 3 S A 0 3 - 8 A A 0

Example 2:

SICAM PAS is required for up to 180 devices including automation and in addition to the IEC 61850 client, 4 protocols

must be supported (e.g. IEC6070-5-103 master, Modbus master and IEC 60870-5-104 slave, DNP3 slave). The following MLFB numbers must be ordered:

Description	Order No.
Large with automation, IEC 61850 client and additional n=3 protocols	6 M D 9 0 0 0 - 3 A L 0 3 - 8 A A 0
1 protocol (protocol-independent, countable)	6 M D 9 0 0 0 - 3 S A 0 1 - 8 A A 0

Example 3:

SICAM PAS is required for more than 180 devices incl. automation and in addition to the IEC61850 client, 2 protocols

must be supported (for example IEC 6070-5-103 master and IEC 60870-5-101 slave). The following MLFB numbers must be ordered:

Description	Order No.
XLarge (more than 180 devices)	6 M D 9 0 0 0 - 3 B A 1 0 - 8 A A 0
SoftPLC automation	6 M D 9 0 0 0 - 3 B A 5 0 - 8 A A 0
2 protocols (protocol-independent, countable)	6 M D 9 0 0 0 - 3 S A 0 2 - 8 A A 0

It becomes apparent during the project that IEC 60870-5-104 is required, instead of IEC 60870-5-101 that has been adopted. This does not affect the order as the licenses are protocol-independent => it is not needed to be replaced.

Example 4:

For example, the following bundle was ordered first

Description	Order No.
Large with automation, IEC 61850 client and additional n=2 protocols	6 M D 9 0 0 0 - 3 A L 0 2 - 8 A A 0

Then it becomes apparent that 2 additional protocols need to be supported. In this case, you can order the following at a later date:

Description	Order No.
2 protocols (protocol-independent, countable)	6 M D 9 0 0 0 - 3 S A 0 2 - 8 A A 0

4 (2+2) protocols can be supported as the protocol licenses are countable.

Station and Telecontrol Engineering

SICAM 8 - Description

Description

SICAM 8 is an universal, hardware, and software based all-in-one platform. This platform enables you to meet all the practical requirements in the field of energy supply.

Power Automation Platform – Structure

- The SICAM 8 Core is responsible for:
 - Security functions
 - Time synchronization
 - Certificate and application management
- The SICAM 8 Software is divided into the following SICAM 8 applications and SICAM 8 Controller applications:
 - SICAM S8000 (RTU, communication protocols, SoftPLC)
 - SICAM HMI (control and monitor)
 - SICAM EVA (event and alarm list)
 - SICAM Web (diagnosis, monitoring, and simulation)
 - SICAM Applications (SIAPPs)
 - SICAM DLM (Dynamic Load Management)
 - SICAM MGC (Microgrid Control)
 - SICAM PPC (Photovoltaic Plant Control)
 - SICAM LS (Load Shedding)
 - SICAM SOG (Self optimizing Grid)⁷
- The SICAM 8 Hardware is based on Linux, consists of modules and devices of the SICAM A8000 series and new industrial PCs of different manufacturers:
 - SICAM A8000 CP-8050/8031, PS-, CI- and I/O modules
 - SICAM Rack modules (for high data volume)
 - SICAM EGS (Enhanced Grid Sensor) combination of measuring device and RTU-Gateway for MS- and NS⁷
 - Third-party industrial PCs with Linux operating system

Benefits

SICAM 8 supports with:

- Measures to achieve climate goals
 - Expansion of renewable energies
 - Integration of renewable energies
 - Faster expansion of existing infrastructure
- Meeting the increasing demands of cybersecurity
 - Holistic cybersecurity solutions
 - Competence around energy automation
- Mitigating the shortage of skilled personnel
 - Reduced know-how requirement
 - Performance with minimized personnel

Applications

- Hydro-power plants
 - Turbine controls, sequence controls or switch interlocks with the aid of the integrated logic functions

- Processing and bundling of information for control centers and neighboring substations
- Solar and onshore windparks: as a bidirectional link between the grid control center and wind or solar farms
 - Information about, for example, the current power flow to the grid control center
 - Operation of feed-in controller from the grid control center
- Power transmission
 - For this application, substation automation is an essential requirement
 - SICAM A8000 CP-8050 is designed for this task, processes and bundles information for control centers and neighboring substations
- Power distribution: monitoring and control of overhead line or cable distribution grids
 - Distribution grid transformers with low-voltage feeders
 - Control of transformer tap changers
- Industry: The SICAM 8 supports the on-demand supply, distribution, and monitoring of electrical power
 - Energy automation system from the power suppliers feed-in to the low-voltage distribution level
- Offshore windparks: more universally applicable with the new SICAM S8000 software variant
 - Hardware independent through IPC applications
 - Marine certified solutions for offshore operations
- IoT: Increasing grid availability and service quality for power grids
- Data node/Gateway
 - Communication gateway for RTU networks based on various networks and communication protocols
- Railway power supply
 - Automation of railway power supply starting with the control system, through protection to communication

⁷ Development in progress for SICAM 8 platform

Description

The SICAM A8000 device series has been designed for lots of different tasks, both simple and complex. The area of application spans the entire energy-supply chain. Customer requirements such as IT security, scalability, flexible communication, space-saving design, and the ability to be used in harsh conditions were taken into account when the SICAM A8000 was being designed. The modular SICAM A8000 series offers optimized solutions for all kinds of performance requirements.

SICAM A8000 – Module Types

- Processor modules (up to a max. of 34 interfaces)
- Power-supply modules (DC 24 V to 60 V; DC 110 V to 220 V; AC 230 V)
- Ethernet or serial communication expansion modules
- Interface modules for a max. of 16 expansion lines
- Binary inputs (DC 24 V; DC 48/60 V; DC 110 V; DC 220 V)
- Binary outputs (DC 24/48/60/110/220 V; AC 110/230 V)
- Analog inputs (-20 mA/+20 mA; -10 V/+10 V; Pt 100)
- Analog outputs (-20 mA/+20 mA; -10 mA/+10 mA; -10 V/+10 V)
- Current/voltage inputs (1 A/5 A; LoPo; 230 V)

The universally applicable binary or analog input/output modules can be plugged in any order and are suitable for even the tightest spaces as they have a module width of 30 mm.

Benefits

- They can also be used in harsh ambient temperatures due to the extended temperature range of -40 °C to +70 °C
- The increased EMC stability of up to 5 kV (IEC 60255) qualifies the devices for direct use in switchgears
- Simple engineering with the integrated Web parameterization tool and the SICAM Device Manager
- It meets the most stringent cybersecurity requirements due to an integrated crypto chip and IPsec encryption
- It is a safe investment as international standards such as IEC 61850 IEC 60870-5-101/-103/-104 etc. are followed.
- The modular platform offers a variety of application options and reduces warehousing.
- Adaptation to existing communication infrastructures with a multitude of interfaces and the integrated GPRS module
- The integrated short-circuit indicator functionality enables use in power-system monitoring.
- You can save time and money as installation and maintenance are really simple – plug & play

Device Characteristics

Communication Interfaces and Protocols

- CP-8000: 3 x RJ45 (2 x Ethernet, 1 x RS232), 1 x RS485
- CP-8021: 3 x RJ45 (2 x Ethernet, 1 x RS232), 1 x RS485



[ph_SICAM A8000_5 devices, 1, ...]

Figure 2.3/1 SICAM A8000 Devices

- CP-8022: 3 x RJ45 (2 x Ethernet, 1 x RS232); 1 x RS485, 1 x RS232/RS485 (selectable), 1 x LTE CAT1/GPRS
- CP-8031: 4 x RJ45 (2 x Ethernet, 1 x RS485, 1 x RS232)
- CP-8050: 4 x RJ45 (2 x Ethernet, 1 x RS232, 1 x RS485), up to 12 x Ethernet or 30 x serial with CI modules
- IEC 60870-5-101/-103/-104, Modbus RTU/TCP
- IEC 61850 Ed1/Ed2 client & server incl. GOOSE
- DNP3 serial master/slave, TCP/IP
- Other protocols on request

Auxiliary Voltages

- DC 24 V to 60 V (12 W or 45 W)
- DC 110 V to 220 V (12 W or 45 W)
- AC 230 V (45 W)
- Can be redundant

Inputs and outputs

- CP-8000: max. 116 I/O with up to 6 I/O modules
- CP-8021, CP-8022, CP-8031: max. 128 I/O with up to 8 I/O modules
- CP-8050: max. 2048 I/O with up to 16 expansion lines for every 8 I/O modules

Real-Time Clock

- +/- 2 ppm, time synchronization using NTP protocol, SNTP protocol

Electromagnetic Compatibility

- IEC 60870-2-1, IEC 61010, IEC 60255-5, IEC 61000-4, EN 55022, CE marking

Station and Telecontrol Engineering

SICAM 8 - A8000 Series – Description

Temperature Range

- CP-8021, CP-8022: From -40 °C to +70 °C
- CP-8031, CP-8050: From -25 °C to +70 °C⁸

Housing Specifications

- Plastic housing for DIN rail mounting
- Dimensions of the CP-8000: 128 mm x 124 mm x 123 mm (W/H/D)
- Dimensions of the CP-8021/22/31/50, CI, power-supply module and I/O modules: 30 mm x 132 mm x 124 mm (W/H/D)

Special Features

- Integrated display and function keys for CP-8000
- Integrated Web server for configuration and diagnostics with CP-8000/21/22, engineering using the SICAM Device Manager and SICAM TOOLBOX II for the A8000 series
- Data storage using an SD memory card (parameters and device firmware)
- Freely programmable user programs according to IEC 61131-3
- Device redundancy with CP-8050
- The security requirements of the future:
 - Compliance with the BDEW white paper
 - Integrated crypto chip
 - TLS encryption
 - IPsec encryption
 - HTTPS protocol
 - Security Logbook

Additionally for CP-8031 and CP-8050:

- Integrated software firewall
- Firmware signature
- Role-based access control
- Configurable system functions
- Hardware-based application layer firewall for IEC 60870-5-104
- Automated certificate handling via the EST protocol with SICAM Grid Pass

Fields of Application

The SICAM A8000 has virtually limitless scalability and can be expanded at any time due to the various power levels in the processor modules, interface modules, and the I/O modules. The area of application for the SICAM A8000 series extends from distribution-system automation, via the connection of renewable energies (wind, solar, hydro), right up to railway power supply and industrial applications.

The I/O modules are pluggable in any order. With a module width of 30 mm, they are suitable for even the most minimal spatial conditions and are scalable and extendable at any time in an almost infinitely variable manner.

Example 1: High power and interfaces for complex tasks

- Automation tasks in power distribution and transmission, microgrids
- Control and turbine regulation in hydropower plants
- Transformer control and regulation
- Control and communication in railway power supply
- Redundant communication gateway for different networks and protocols

Example 2: Everything at a glance with on-site compact solution

- Use in distribution-system automation
- Optimized for use in MS switchgear
- Power-flow control available

Example 3: Without display, dimensioned to be space-saving with slim PCB assembly

- Network connection of solar and wind farms
- Control and monitoring of power and gas distribution stations
- Simple gateway function

⁸ -40 °C on request

SICAM A8000 with HSR, PRP – Ethernet Redundancy Protocols for Optimal Availability

In order to satisfy the requirements of important time-sensitive applications, the latest High Availability Seamless Redundancy (HSR) and Parallel Redundancy Protocol (PRP) Ethernet redundancy systems have been developed in line with the latest IEC 62439-3 standard.

The seamless PRP and HSR redundancy solutions are available for the entire Siemens SICAM A8000, SIPROTEC 4, SIPROTEC Compact, SIPROTEC 5, and Reyrolle 7SR2x series.

High Availability Seamless Redundancy (HSR)

HSR is a redundancy protocol for lossless, redundant transmission of data via Ethernet networks in ring topologies and offers redundancy without changeover times.

Every device in the network is connected via 2 Ethernet interfaces. The notifications are sent to both interfaces and therefore transmitted in both directions in the ring simultaneously. 2 identical notifications arrive at the target (in a healthy state) within a time frame. The 1st one is forwarded to the application whilst the 2nd is discarded. The ring is monitored by cyclical HSR management telegrams (cycle time of 2 seconds). An open ring is signaled by a warning.

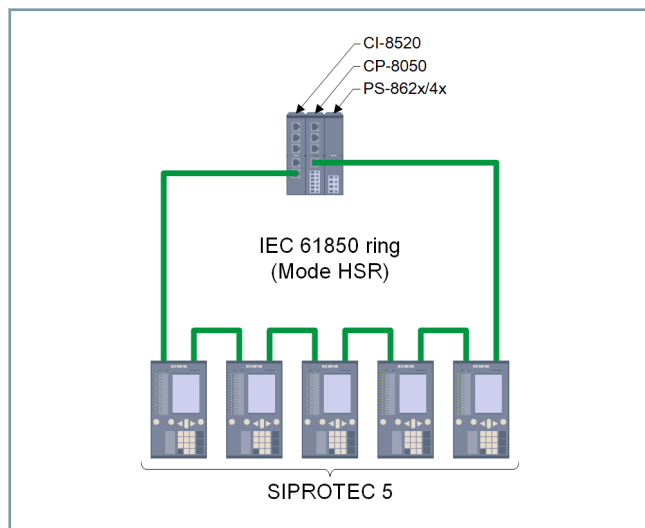

[dw_SICAM-A8000_with_HSR_IEC61850-ring_2_en_US]

Figure 2.3/2 SICAM A8000 with HSR

Configuration notes

- HSR can only be used with the CI-8520 Ethernet interface module.
- Only one HSR ring is permitted per CI-8520 module.
- The selection of the 2 interfaces for the HRS ring per CI-8520 module is arbitrary.
- HSR mode must be activated on the CI-8520 Ethernet interface in use.
- A maximum of 512 MAC addresses are permitted per HSR ring.

Parallel Redundancy Protocol (PRP)

PRP is a redundancy protocol to support seamless redundancy (= no reconfiguration times in case of a failure in one of the networks). The layer-2 redundancy process was developed for automation networks which require a high degree of availability for continuous operational function.

All data is transmitted simultaneously via 2 independent networks (LAN A and LAN B) with the PRP structure.

Topology, performance, and latency can differ in the case of both networks, however, the latencies must only differ up to a certain upper limit. As shown in the figure, the 2 networks may not be connected to one another.

The advantage of PRP compared to other protocols is that if a communication is interrupted in a network, a seamless switch-over takes place. Data losses are therefore avoided.

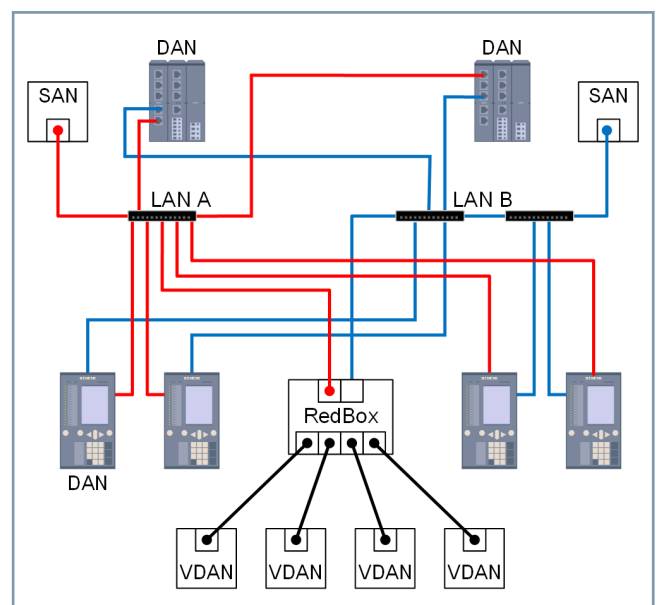

[dw_SICAM-A8000_config_2_en_US]

Figure 2.3/3 PRP Structure

Configuration notes

- Dual Attached Nodes (DAN)
Devices which are connected to both networks. An interface is available for every network connection.
- Single Attached Nodes (SAN)
Devices which are connected to a single network via an interface.
- Virtual Double Attached Nodes (VDAN)
VDANS are devices which only have one interface, but are connected to both networks via a redundancy box (RedBox).
- PRP can only be used with the CI-8520 Ethernet interface module

Advantages

- Maximum network reliability, seamless reconfiguration
- Process can be easily configured

Station and Telecontrol Engineering

SICAM 8 - A8000 Series – Fields of Application

- Minimal wiring effort due to the use of efficient ring structures
- Cost-efficient structures
- Easily expandable by integrating additional HSR rings
- Guaranteed interoperability, standardized in IEC 62439
- Full compatibility between IEC 61850 Editions 1 and 2 as well as all other Ethernet protocols

RetroFit with SICAM A8000 - Ready for IP Technology and Cybersecurity by Replacing Parts

Fast and secure communication of telecontrol systems is the key to secure, reliable electrical energy systems in today's highly complex electrical power systems.

SICAM A8000 offers the option of fully and “securely” enjoying the advantages of new IP technology.

Also, the whole system has components from the SICAM MIC or TM1703MIC series.

After replacing the master control and power-supply modules, the available telecontrol systems for the latest SICAM A8000 CP and PS modules, your plant is now ready for integration into the IT network and is optimally secured against cyber attacks.

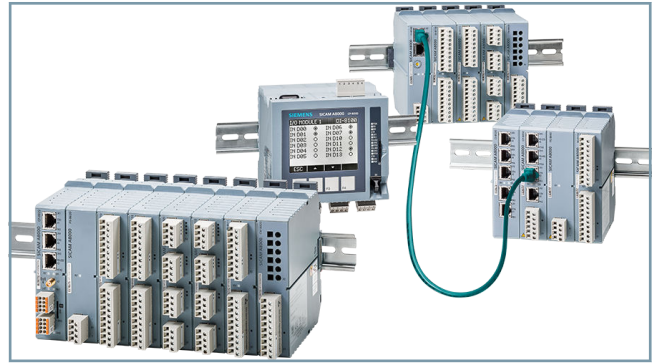

[ph_SICAM A8000 devices, 1, -...]

Figure 2.3/5 SICAM A8000 Devices

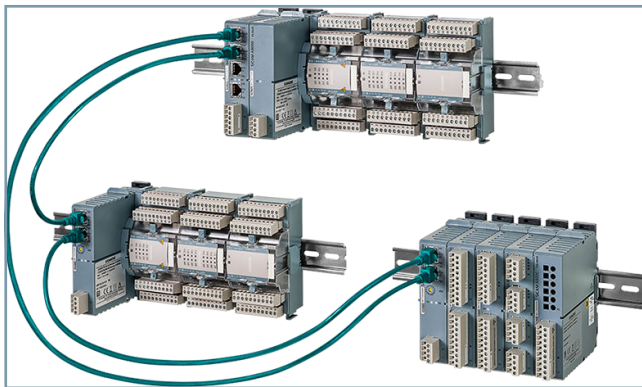

[ph_A8000_CP8050_Retrofit, 1, -...]

Figure 2.3/4 SICAM A8000-CP8050 Retrofit

The free firmware updates means that, in terms of cybersecurity, it demonstrates the high standard expected from Siemens. These downloads are available in our SIOS portal.

Replacement of the SICAM EMIC (CP-6010) with the associated power-supply module (PS-66xx) results in free space of 129 mm on the DIN rail. This can be used to expand with a max. of 2 TM-IO modules.

Advantages

- Cybersecurity requirements in line with BDEW Whitepaper, NERC CIP, and IEC 62351 with support for RADIUS, Syslog, IPsec, and TLS
- Cost-effective upgrading of your telecontrol stations and adapting to the latest technology
- Continued use of available TM-IO modules, resulting in less need for spare parts
- Quick retrofitting due to minimal intervention in the existing wiring
- Use of existing communication lines
- Power-supply modules for almost every auxiliary voltage
- Parameterization via SICAM TOOLBOX II, SICAM WEB, or SICAM Device Manager

Station and Telecontrol Engineering

SICAM 8 - A8000 Series – Modules

Module Combinations

The SICAM A8000 series is a module combination of a power supply, processor, and extensions, and is used for various tasks such as control, telecontrol, automation, and communication. The SICAM A8000 CP-8000 compact device combines power supply, display with function key, as well as binary inputs and outputs.

Module dimensions (L x W x H): 124 mm x 30 mm x 132 mm (dimensions without DIN rail)

You can get an overview of the different module types in the following tables.

System Components and Technical Data

For additional system components and technical data, refer to the current manual: [Industry Online Support](#)



2.3

Compact Device	CP-8000
Dimensions (W x H x D)	132 mm x 30 mm x 142 mm
Temperature range	-40 °C to +70 °C
Input voltage	DC 18 V to 78 V incl. tolerance
Interfaces	2 x Ethernet LAN 1 x RS232 1 x RS485 (galvanically separated)
Storage	SD card up to 2 GB
Max. number of data points	20000
Special features	Integrated power supply 12 DI and 8 DO integrated Max. 116 I/O (max. 6 expansion modules) 4 function keys and display

Table 2.3/1 Compact Device



Processor Module	CP-8021	CP-8022	CP-8031	CP-8050
Temperature range	-40 °C to +70 °C		-25 °C to +70 °C ⁹	-25 °C to +70 °C ⁹
Max. number of interfaces	3 x RJ45: 2 x Ethernet/1 x RS232 1 x RS485	3 x RJ45: 2 x Ethernet/1 x RS232 1 x RS232/RS485 selectable 1 x RS485 1 x LTE CAT1/GPRS	4 x RJ45: 2 x Ethernet 1 x RS485 (serial) 1 x RS232 (serial)	4 x RJ45: 2 x Ethernet 1 x RS485 (serial) 1 x RS232 (serial) 30 x serial (modular) 12 x Ethernet (modular)
Storage	SD up to 2 GB		SD up to 4 GB	SD up to 4 GB
Data points	20000			400000
Distributed archive	Available			
Device redundancy	–	–	Yes	Yes
Automation function (CFC/PLC, IEC 61131-3)	1 x 128 kB	1 x 128 kB	1 x 3 MB	5 x 3 MB

Table 2.3/2 Processor Modules



Power-supply modules	PS-8620	PS-8622	PS-8640	PS-8642
Input voltages	DC 24 V to 60 V, 12 W	DC 110 V to 220 V, 12 W	DC 24 to 60 V, 45 W	DC110 to 220 V, 45 W AC 100 to 240 V, 45 W
Output voltage 1	DC 5.15 V ± 2 % static, ± 3 % dynamic		DC 5.15 V ± 2 % static, ± 3 % dynamic	
Output current 1	0 A to 1.8 A		0 A to 2 A	
Output voltage 2	DC 28.0 V ± 10 % static, ± 3 % dynamic		DC 28.0 V ± 0 % static, ± 3 % dynamic ¹⁰	
Output current 2	0 A to 0.43 A		0 A to 1.79 A	
Output voltage 3	–		–	DC 24 V + 0 % / -15 %
Output current 3	–		–	0.42 A

Table 2.3/3 Power-Supply Modules

⁹ -40 °C on request

¹⁰ for the generation of auxiliary voltage for specific transmission devices

Station and Telecontrol Engineering

SICAM 8 - A8000 Series – Modules



Communication Modules	CI-8520	CI-8522	CI-8551
Communication redundancy function	HSR, PRP, RSTP, line mode	HSR, PRP, RSTP, line mode	Tri-state mode to serial interfaces
Interface	5 Ethernet/LAN interfaces	5 Ethernet with 2 x SFP modules (optical/electrical) and 3 x sockets for electr. TP cables	2 x serial RS232 1 x serial RS485/422 2 x serial RS232/485/422
	The engineering tools (SICAM TOOLBOX II and SICAM WEB) can also be connected for programming the CP-8050.		
Max. number of expansion modules	2	2	6
Operating voltage	DC 28 V input DC 25.2 V to 30.8 V; 2.5 W	DC 28 V input DC 25.2 V to 30.8 V; 4.5 W	DC 28 V input DC 25.2 V to 30.8 V

2.3

Table 2.3/4 Communication Modules – Only Used in Conjunction with CP-8050



Digital Input Module	DI-8110	DI-8111	DI-8112	DI-8113
Inputs	16 binary inputs 2 groups each with 8 inputs			
Rated voltage	DC 24 V	DC 48 V/60 V	DC 110 V	DC 220 V
Input circuits	DC 18 V to 31.2 V	DC 36 V to 78 V	DC 82.5 V to 143 V	DC 165 V to 253 V
Operating voltage	DC 4.75 to 5.5 V			
Current consumption	0.9 mA to 4.8 mA at 18 V to 31.2 V	0.5 mA to 2.5 mA at 36 V to 78 V	0.4 mA to 1.4 mA at 82.5 V to 143 V	0.3 mA to 0.7 mA at 165 V to 253 V

Table 2.3/5 Digital Input Modules



Digital Output Module	DO-8212	DO-8221	DO-8230
Outputs	8 relay outputs (4 groups of 2)	12 relay outputs (1 group)	16 digital outputs (2 groups of 8)
	Galvanic separation		
Rated voltage	DC 24 V to 220 V; AC 110/230 V	DC 24/48/60/110/220 V ¹¹ , AC 230 V	DC 24 V to 60 V

¹¹ DC 110/220 V as of CC production status



Digital Output Module		DO-8212	DO-8221	DO-8230
Max. continuous current		Standard wiring <ul style="list-style-type: none"> • 8 outputs, each max. 3 A (5 A/1 min) Wiring with derating at 5 A <ul style="list-style-type: none"> • 2 outputs, each with a max. of 5 A • 6 outputs, each with a max. of 2 A or • 4 outputs, each with a max. of 5 A • 4 outputs, each with a max. of 0 A (relay must not be activated) 46 power increase <ul style="list-style-type: none"> • 4 outputs, 6 A each (max. DC 24 V +20 %; max. AC 230 V +10 %¹²) 	1 A	Standard wiring <ul style="list-style-type: none"> • 16 outputs, each max. 0.5 A
Switching power	Direct voltage	DC min. 50 mW at 5 V	1000 VA; 4 A at DC 250 V, L/R ≤ 40 ms ¹³ 800 VA; 3.25 A at AC 250 V, cos φ ≤ 0.4	<ul style="list-style-type: none"> • 78 W at DC 78 V (with power increase) • 30 W at DC 60 V • 24 W at DC 48 V • 12 W at DC 24 V
	Alternating voltage	Max. 1250 VA; 5 A/AC 250 V, resistive load Max. 500 VA; 2 A/AC 250 V, cos φ = 0.4		
Power supply	Operating voltage	DC 4.75 to 5.5 V	DC 4.75 V to 5.5 V	DC 4.75 V to 5.5 V
	Power consumption	800 mW	<ul style="list-style-type: none"> • 2 W during command output • 1.3 W in idle state 	500 mW

Table 2.3/6 Digital Output Modules

¹² With a parallel connection

¹³ DO-8221 supports the IEC 60947-4-1 usage category for DC. DC-supported category: DC-1,3,5,6 from IEC 60747-4-1 Table 10.

Station and Telecontrol Engineering

SICAM 8 - A8000 Series – Modules



Analog Output Module		AO-8380
4 outputs (4 groups of 1)		All outputs galvanically separated
Current output		Max. ± 20 mA to max. 500 Ω load Max. ± 10 mA to max. 1 k Ω load
Voltage output		Max. ± 10 V to min. 1 k Ω load
Resolution		0.025 % at ± 20 mA, mA to 10 mA, V to 10 V
Accuracy		0.3 % at +25 °C 0.4 % at 0 °C to +50 °C 0.7 % at -20 °C to +70 °C 0.8 % at -40 °C to +70 °C
Power supply	Operating voltage	DC 4.75 V to 5.5 V The voltage is taken from the system bus.
	Power consumption	Max. 2200 mW

2.3

Table 2.3/7 Analog Output Module



Analog Input Modules	AI-8310	AI-8320	AI-8330	AI-8340
4 analog inputs	2 groups, 2 inputs each Galvanically separated Voltage between 2 inputs of a group max. DC 600 mV	4 groups, each with 1 input Galvanically separated	3 current measuring inputs The current inputs are galvanically separated by transformers, from each other, and from the logic voltage	4 current inputs (250 V) are galvanically separated by transformers, from each other, and from the logic voltage
Measuring range	40 Ω to 400 Ω (Pt100, Ni100) 400 Ω to 4000 Ω (Pt1000)	Current measurement -20 mA to 0 mA to +20 mA Voltage measurement -10 V to 0 V to +10 V Overrange current ~20 %, voltage ~30 %	300 V rated voltage	300 V rated voltage
Resolution	10 m Ω (Pt100, Ni100) 100 m Ω (Pt1000)	0.004 % at ± 20 mA 0.004 % at ± 10 V	16 bits	16 bits
Noise rejection	16 $\frac{2}{3}$ Hz, 50 Hz, 60 Hz	50 dB (50 Hz, 60 Hz, 16 $\frac{2}{3}$ Hz)		
Accuracy	0.19 % 0 °C to +50 °C 0.4 % 40 °C to +70 °C	0.15 % at 25 °C		
Power supply	DC 4.75 V to DC 5.5 V; max. 500 mW	DC 4.75 V to 5.5 V; max. 180 mW	DC 4.75 V to 5.50 V; 300 mW	DC 4.75 V to 5.50 V; 1400 mW

Table 2.3/8 Analog Input Modules



Analog Input Modules		AI-8510	AI-8511
Properties		<ul style="list-style-type: none"> • 3 low-power (LoPo) current measuring inputs (225 mV) • 3 low-power (LoPo) voltage measuring inputs (3.25 V/√3) 	<ul style="list-style-type: none"> • 3 low-power (LoPo) current measuring inputs in conjunction with adaptor module CM-8820 • 3 voltage measuring inputs (can be set as 100 V/√3, 240 V, or 415 V/√3)
Inputs for measuring currents	Input voltage at I_N	AC 225 mV based on IEC 60044-8	
	Max. input voltage	AC 2.25 V	
	Rated frequency	50 Hz, 60 Hz (range between 45 Hz and 65 Hz)	
	Resolution	16 bits	
	Sampling	1 value/ms	
Inputs for measuring voltages	Input voltage U_N	AC 100 V/√3, AC 240 V, AC 415 V/√3 in accordance with IEC 60044-7 (parameterizable)	AC 3.25 V/√3 in accordance with IEC 60044-7
	Max. measuring voltage	150 % U_N (error condition)	
	Rated frequency	50 Hz, 60 Hz (range between 45 Hz and 65 Hz)	
	Resolution	16 bits	
	Sampling	1 value/ms	
	Internal consumption	< 0.3 VA at $V_N = AC 240 V$ < 0.02 VA at $V_N = AC 100 V/√3$	Internal resistance: 200 kΩ
Power supply	Operating voltage	DC 4.75 V to 5.5 V	
	Power consumption	Max. 800 mW (typ. 625 mW)	

2.3

Table 2.3/9 Analog Input Modules



LED module		CM-8830
Power supply	Operating voltage	DC 4.75 V to 5.5 V The voltage is picked off from the bus.
	Power consumption	500 mW

Table 2.3/10 LED Module

Station and Telecontrol Engineering

SICAM 8 - A8000 Series – Modules



Current -transformer adaptor module		CM-8820
Inputs for measuring currents	Rated current I_N	1 A/5 A (parameterizable)
	Max. measuring current	200 % I_N
	Rated frequency	50 Hz, 60 Hz (Range between 45 Hz and 65 Hz)
	Internal consumption	< 0.1 W at $I_N = 1$ A < 0.3 at $I_N = 5$ A
	Thermal rating	10 A continuously 100 A 1 s
Outputs for measuring currents	Rated voltage	225 mV at $I_N = 1$ A based on IEC 60044-8 1.125 V at $I_N = 5$ A
	Max. voltage	2.25 V at $I_N = 10$ A
	Rated frequency	50 Hz, 60 Hz (Range between 45 Hz and 65 Hz)

2.3

Table 2.3/11 Current-Transformer Adaptor Module



Expansion Modules	CI-8530	CI-8531	CI-8532	CI-8533
Power supply	DC 24 V to 60 V		DC 110 V to 220 V	
Operating voltage	DC 18 V to 78 V		DC 82.5 V to 286 V	
Input current	0.6/0.3/0.25 A (DC 24/48/60 V)		0.13/0.07 A (DC 110/220 V)	
Output rated voltage	5.15 DCV \pm 2 % static, \pm 3 % dynamic			
Output rated current	0 A to 1.4 A			
Output power	7 W			
Interfaces	2 x Ethernet	2 x SFP plug-ins for optical Ethernet 2 x LC Multimode plug-ins are provided.	2 x Ethernet	2 x SFP plug-ins for optical Ethernet 2 x LC Multimode plug-ins are provided.
Special features	Up to 8 I/O modules Ethernet-based I/O bus support Ring, star and daisy chain			

Table 2.3/12 Expansion Modules

System Components and Technical Data

For additional system components and technical data, refer to the current manual: [Industry Online Support](#)

Selection and Ordering Data

Description	Order No.	
<u>Compact Device</u>		
CP-8000 Compact device with display/incl. SD card Communication interfaces 2 x Ethernet 1 x RS232, 1 x RS485 Power supply DC 24 V to 60 V Temperature range -40 °C to +70 °C 12 DI (DC 24 V to 60 V)/8 DO relays (AC/DC max. 250 V)	6MF2101-1AB10-0AA0	
<u>Coupling</u>		
CM-6811	Coupling TM I/O module for CP-8000	6MF1113-0GJ11-0AA0
CM-6812	Coupling TM I/O adaptor	6MF1113-0GJ12-0AA0
CM-8811	Coupling SICAM I/O module for CP-8000	6MF2881-1AA00
<u>Processor Modules</u>		
CP-8021	Processor module 3 x RJ45, 1 x RS485	6MF2802-1AA00
CP-8022	Processor module 3 x RJ45, 1 x RS485, 1 x RS232/RS485 selectable, 1 x LTE CAT1/GPRS	6MF2802-2AA10
CP-8031	Processor module 4 x RJ45	6MF2803-1AA00
CP-8050	Processor module 4 x RJ45, it can be expanded with CI-85xx	6MF2805-0AA00
<u>Power-Supply Modules</u>		
PS-8620	DC 24 V to 60 V (12 W)	6MF2862-0AA00
PS-8622	DC 110 V to 220 V (12 W)	6MF2862-2AA00
PS-8640	DC 24 V to 60 V (45 W)	6MF2864-0AA00
PS-8642	DC 110 V to 220 V, AC 230 V (45 W)	6MF2864-2AA00
<u>Communication Modules</u>		
CI-8520	Ethernet communication interface module	6MF2852-0AA00
CI-8551	Serial communication module	6MF2855-1AA00
CI-8522	CI-8522 Ethernet communication interface module with 2 x F/O; 3 x RJ45	6MF2852 - 2AA00
<u>Binary Inputs</u>		
DI-8110	2 x 8, DC 24 V, 1 ms	6MF2811-0AA00
DI-8111	2 x 8, DC 48 V to 60 V, 1 ms	6MF2811-1AA00
DI-8112	2 x 8, DC 110 V, 1 ms	6MF2811-2AA00
DI-8113	2 x 8, DC 220 V, 1 ms	6MF2811-3AA00
<u>Binary Outputs</u>		
DO-8212	Binary output relay 4x2, DC 24 V to 220 V/AC 230 V	6MF2821-2AA00
DO-8221	Secure command output	6MF2822-1AA00
DO-8230	DO transistor	6MF2823-0AA00
<u>Analog Output</u>		
AO-8380	4 x, ±20 mA, ±10 mA, ±10 V	6MF2838-0AA00
<u>Analog Inputs</u>		
AI-8310	Pt100/Ni100 (2 groups, each with 2 AI)	6MF2831-0AA00
AI-8320	4 x +/-20mA, +/-10 V	6MF2832-0AA00
AI-8330	3 x I (6 A) with AI-8340	6MF2833-0AA00
AI-8340	4 x V (250 V), 2 x DO	6MF2834-0AA00
AI-8510	3 x V (AC 100/√3 V, AC 230 V, AC 400/√3 V), 3 x I (LoPo)	6MF2851-0AA00
AI-8511	3 x V (LoPo), 3 x I (LoPo)	6MF2851-1AA00
<u>Current-Transformer Adaptor Module</u>		
CM-8820	CT adaptor for AI-8510 3 x I 1 A/5 A, 225 mV	6MF2882-0AA00
<u>LED Module</u>		
CM-8830	SICAM I/O module LED display	6MF2883-0AA00

Table 2.3/13 SICAM A8000 Series Selection and Ordering Data

Station and Telecontrol Engineering

SICAM 8 - A8000 Series – Selection and Ordering Data

Description		Order No.
Continued from previous page		
<i>SICAM I/O Remote Modules</i>		
CI-8530	Ethernet expansion module for interfacing remote I/Os DC 24 V to 60 V	6MF2853-0AA00
CI-8531	SICAM I/O remote interface module F/O DC 24 V to 60 V	6MF2853-1AA00
CI-8532	Ethernet expansion module for interfacing remote I/Os DC 110 V to 220 V	6MF2853-2AA00
CI-8533	SICAM I/O remote interface module F/O DC 110 V to 220 V	6MF2853-3AA00
	CM-8813 bus connector CP-8031/CP-8050 (this bus connector plug is included for CP-8031/CP-8050)	C53207-A5813-D481-1
<i>Licenses (OSD)</i>		
	SICAM A8000 CP-803x Extended CI module DL	6MF2750-2EX00
	SICAM A8000 Licensed protocol DL	6MF2750-2PR00
	SICAM A8000 CI-852x Redbox DL	6MF2750-2RB00
	SICAM A8000 Extended processing	6MF2750-2EP00
	SICAM A8000 IEC 104 firewall	6MF2750-2FW40
	SICAM A8000 LXC container	6MF2750-2LX00
	SICAM A8000 Redundancy DL	6MF2750-2RE00
	SICAM A8000 Extended SICAM WEB license DL	6MF2750-2WE00
SICAM Rack Solution, see Table 2.4/9		
<i>Spare Parts</i>		
	CM-8812-bus connector plug SICAM I/O (this bus connector plug is included in all SICAM I/O modules) ¹⁴	C53207-A5812-D481-3
	CM-8813 bus connector CP-8031/CP-8050 (this bus connector plug is included for CP-8031/CP-8050)	C53207-A5813-D481-1
	Locking hook SICAM A8000 3 cm module ¹⁴	C53207-A5014-D481-1
	CM-0822 fieldbus interface star (4 x optical fiber)	6MF1111-0AJ22-0AA0
	PS-6630 power supply DC 24 V to 60 V EMC+	6MF1113-0GG30-0AA0
	PS-6632 power supply DC 110 V to 220 V EMC+	6MF1113-0GG32-0AA0
	SD card 2 GB	6MF1213-AGA05-0AA0
	SD card 512 MB (optional)	6MF1213-2GA05-0AA0
	Temperature range -40 °C to 70 °C	

Table 2.3/14 SICAM A8000 Series Selection and Ordering Data

Function Point Manager

The SICAM & SIPROTEC Function Point Manager is a cloud-based service for SICAM & SIPROTEC customers for the central administration of Function Points and to generate license files. With the Function Point Manager SICAM, SIPROTEC 5 and SIPROTEC 5 Compact device functionality can be easily extended within seconds.

Advantages

- One service for all your SICAM, SIPROTEC 5, SIPROTEC 5 Compact devices
- Switch between different SICAM and SIPROTEC budget accounts via one user account
- Order now, pay later: The Function Points are only invoiced when the license file is generated
- Activate device functionality quickly and easily through ad hoc generated license files
- Specify features late in the engineering process after device purchase

- Use the Function Point Manager to organize and share all generated SICAM and SIPROTEC license files in your organization
- Share your budget account with colleagues
- Create multiple project-related budget accounts

Description		Order No.
Function point budget	1 Function point	6MF2752-1AA

Table 2.3/15 Function Point Budget

¹⁴ Minimum order quantity: 10 units

Procedure

- Create SICAM license files (SICLIC) and manage function point budgets with the Function Point Manager. Registration is required in the Function Point Manager and the creation of a budget account.
Website: <https://sicam-function-point-manager.siemens.com/>.
- To order function points use the account specific article number that is displayed in your SICAM Function Point Manager account.

Order function points from your regional sales partner or from the <https://sieportal.siemens.com/en-ww/home>.

- When placing an order, you accept the terms and conditions: <https://siprotec-function-point-manager.siemens.com/terms>

Station and Telecontrol Engineering

SICAM 8 - A8000 Series – Selection and Ordering Data

License Type	Function Points	Can be used with		
		SICAM A8000		SICAM 8
		CP-8050	CP-8031	Software Solution
SICAM 8 HMI (for 200 to 2.000 data points)	200	X	X	X
SICAM 8 EVA (Event and Alarm list for > 4.000 entries)	30	X	X	X
SICAM 8 Dynamic Load Management¹⁵				
Dynamic load management for ≤ 25 charging units	100	X	X	X
Dynamic load management for ≤ 50 charging units	145	X	X	X
Dynamic load management for ≤ 75 charging units	190	X		X
Dynamic load management for ≤ 100 charging units	225	X		X
Dynamic load management for ≤ 125 charging units	260	X		X
Dynamic load management for ≤ 150 charging units	295	X		X
Dynamic load management for ≤ 175 charging units	330	X		X
Dynamic load management for ≤ 200 charging units	365	X		X
Dynamic load management for ≤ 225 charging units	400	X		X
Dynamic load management for ≤ 250 charging units	435	X		X
SICAM 8 Fast Power based Load Shedding Compact (96 loads, 10 contingencies)				
Fast power based load shedding	200	X	X	
SICAM 8 OPC UA Server	45	X	X	X
SICAM 8 SICORE	100			X
SICAM 8 SICAM S8000 RTU¹⁵				
S8000 base for ≤ 15 IEDs/connections	60			X
S8000 base for ≤ 50 IEDs/connections	200			X
S8000 base for ≤180 IEDs/connections	840			X
S8000 base for ≤ 400 EDs/connections	1600			X
S8000 base for ≤ 800 IEDs/connections	2230			X
S8000 base for ≤ 1200 IEDs/connections	2410			X
SICAM 8 Redundancy¹⁶	55	X		X
SICAM 8 LXC Container (SIAPP Runtime)	70	X	X	
SICAM 8 IEC104 Firewall	35	X	X	
SICAM 8 Extended Processing	90	X		X
SICAM 8 Extended SICAM Web	35	X	X	X
SICAM 8 Licensed Protocol (Legacy Protocol)	40	X	X	
SICAM 8 CP-803x Extended CI-Module	85		X	
SICAM 8 CI-852X, RedBox¹⁷	40	X	X	

Table 2.3/16 Function Points

¹⁵ Only 1 instance of listed licences below can be loaded (upgrade to higher number is possible)

¹⁶ Per RTU one license needed

¹⁷ For CP-8031, the CI-85XX Extension license is required

Description

The SICAM A8000 rack solution offers the benefits of the proven and powerful SICAM AK 3 in conjunction with the latest SICAM A8000 platform.

Beside all the benefits offered by the SICAM A8000 CP-8050, the rack solution goes the extra mile by allowing for a high level of signal density to further widen its scope of applications. I/O units in 19-inch format and the resulting small footprint enable a wide variety of signals to be channeled into the process.

Retrofit

By using the following components, existing legacy SICAM AK I/O modules can easily be migrated into a SICAM A8000 rack solution and connected to a SICAM A8000 CP-8050 unit:

- SICAM CM-2846 I/O rack
- CI 2530 interfacing module
- PS-2630 or PS-2632 power-supply module
- CM-8846 adaptor for fitting the CP-8050 to a swing frame as necessary

The following SICAM AK modules can continue to be used as SICAM A8000 rack I/O units in conjunction with the CP-8050, and are aligned with the product lifecycle of the SICAM A8000 CP-8050:

- SICAM DI-2112/13/14/15
- SICAM DO-2201
- SICAM DO-2210/11 incl. SM-2506
- SICAM AI-2300 incl. SM-057x

Legacy SICAM AK I/O units are also supported by the CP-8050 and can remain in operation:

- AI-2302/03
- DI-2100/10/11
- MX-2400

To continue using the process wiring of SICAM AK Ax racks, the handle molds of the connector plugs are adapted and locked into position in the new rack.

When the existing I/O rack does not comply with the specifications, it can easily be replaced – with all the wiring of the I/O modules remaining in place! The same goes for the power supply (refer to the [manual](#) for details).

Automation devices used in critical infrastructural areas are subject to stringent requirements, also in terms of ever-evolving cybersecurity. Thanks to the combination of the SICAM A8000 rack and the SICAM A8000 CP-8050, all safety features are state-of-the-art and continuously improved.



[ph_SICAM A8000 Rack, 1, --, --]

Figure 2.4/1 SICAM A8000 Rack

Station and Telecontrol Engineering

SICAM 8 - A8000 Rack – Description

Technical Information and Combination Examples

- CM-8846 adaptor for swing-frame installation in a 19" frame (Figure 2.4/2)
- SICAM A8000 CI-2530: Connection interface to connect SICAM I/O racks to a CP-8050 unit
- 1 x CI-2530 required per I/O rack
- One I/O rack can hold a total of 16 rack I/O modules
- Up to 4 I/O racks can be used
- Operating temperature -5 °C to +55 °C
- Singular or redundant power supply can be used for I/O racks supporting PS-2630 and PS-2632

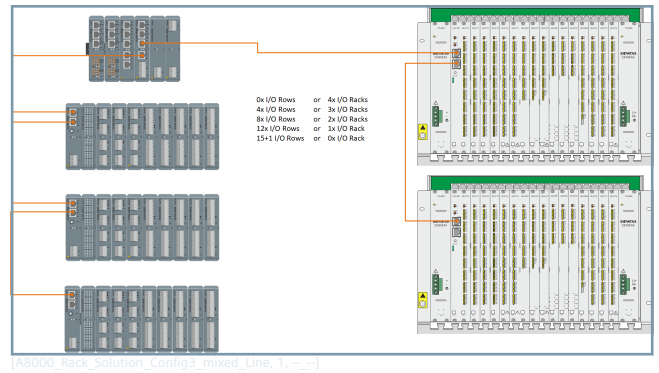

Figure 2.4/4 SICAM A8000 Rack – Combination Example 2

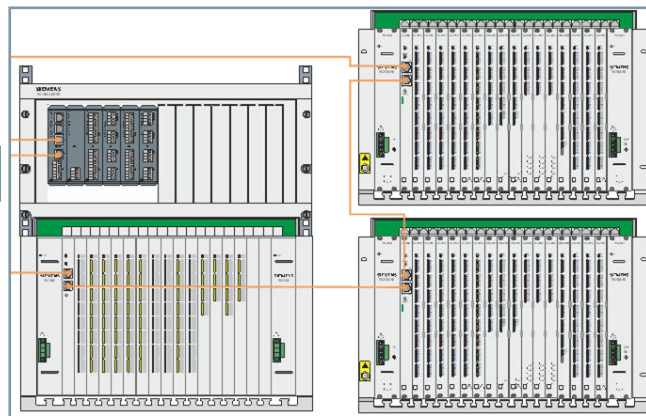

Figure 2.4/2 SICAM A8000 Rack – Swing-Frame Mounting

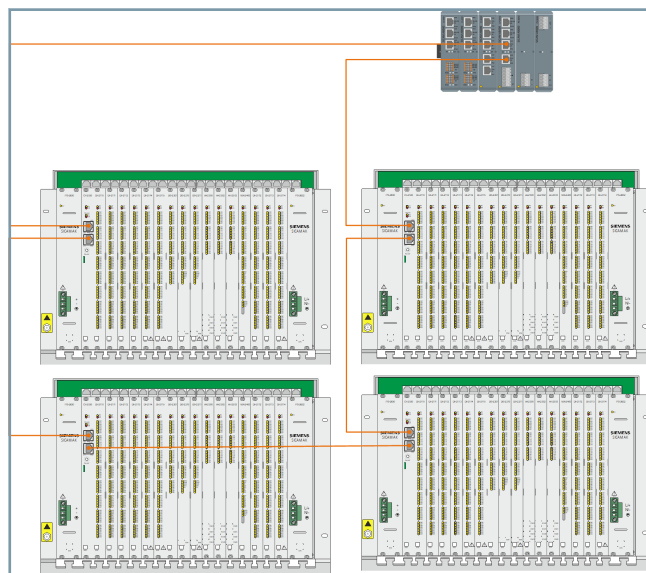

Figure 2.4/3 SICAM A8000 Rack – Combination Example 1



Power-Supply Modules	PS-2630	PS-2632
Operating voltage	DC 18 V to 78 V	DC 82.5 V to 286 V AC 90 V to 264 V
	The 5 V output is galvanically separated and protected against continuous short-circuit	
Output voltage	DC 5.05 V (-1/+2 %)	
Max. output voltage in case of a fault	DC 6 V	
Output rated current	0.5 A to 24 A	
Output rated power (Pout)	<ul style="list-style-type: none"> • 120 W at -5 °C to + 55 °C • 120 W at +55 °C to + 70 °C • Reduction of power from + 55 °C: -10 %/3 °C • 60 W at +70 °C 	

Table 2.4/1 SICAM A8000 Rack – Power-Supply Modules

2.4



I/O Remote Module	CI-2530	
Properties	<p>CI-2530 is an Ethernet expansion module for connecting remote rack I/Os. Up to 4 racks, each with up to 16 rack I/Os can be connected via the EbIO bus. Ring and line topologies can be used.</p> <ul style="list-style-type: none"> • Communication with the master module CP-8050 via EbIO • It can be installed in the CM-2846 rack • Ethernet-connection status display via LED (LKx, PKx) • Power supply via the bus-connector plug • Module status display via LED (RY, ER) • Master-module status display via LED (RY, ER) • Rack assembly 	
Power supply	Operating voltage	DC 4.75 to DC 5.25 V The voltage is picked off from the rack bus.
	Power consumption	Typ. 1.3 W

Table 2.4/2 SICAM A8000 Rack I/O Remote Module – Can only be Used in Conjunction with CP-8050

Station and Telecontrol Engineering

SICAM 8 - A8000 Rack – Modules



Rack I/O Modules	DI-2112	DI-2113	DI-2114	DI-2115
Recording binary input signals				
64 binary inputs, 8 additional inputs	<ul style="list-style-type: none"> • 8 groups, 8 inputs and 1 additional input each • Galvanic separation • Each group has a reference potential and configurable polarity • Sensor voltage monitoring via the auxiliary input of each group (optional) 			
Rated voltage	DC 24 V	DC 48 V to 60 V	DC 110 V	DC 220 V
Switching thresholds	≤ 12 V (logic "0"); ≥ 18 V (logic "1")	≤ 24 V (logic "0"); ≥ 36 V (logic "1")	≤ 55 V (logic "0"); ≥ 82.5 V (logic "1")	≤ 110 V (logic "0"); ≥ 165 V (logic "1")
Input circuits (operated with external voltage)	DC 18 V to 31.2 V	<ul style="list-style-type: none"> • DC 36 V to 70 V as per EN 61010-1:2010 • DC 36 V to 60 V as per IEC 61010-1:2010/AMD1:2016 	DC 82.5 V to 143 V	DC 165 V to 250 V
Current consumption	1.4 mA to 5.2 mA (at 18 V to 31.2 V)	0.6 mA to 2.2 mA (at 36 V to 78 V)	0.4 mA to 1.1 mA (at 82.5 V to 143 V)	0.2 mA to 0.4 mA (at 165 V to 250 V)
Operating voltage	DC 4.75 V to 5.25 V The voltage is picked off from the rack bus.			

Table 2.4/3 SICAM A8000 Rack I/O Modules – Can only be Used in Conjunction with CP-8050



I/O Module	DO-2201	
Properties	<ul style="list-style-type: none"> • Processing and output according to IEC 60870-5-101/104 <ul style="list-style-type: none"> – Up to 40 single-point indications • 40 digital outputs • In terms of galvanic separation, the outputs are divided into 8 groups with 2 outputs and 8 groups with 3 outputs • The groups are galvanically separated from each other and within a group. • The potential that should be switched (plus or minus) can be determined for each output by external wiring. • Any 2 outputs can be connected in parallel to increase switching capacity • If an output short-circuits, it does not affect other outputs. • Input function and status display via LEDs 	
Rated current (for resistive load)	<ul style="list-style-type: none"> • 0.7 A at DC 24, 48, 60 V • 1.0 can be achieved when connecting 2 outputs in parallel 	
Power supply	Operating voltage	DC 4.75 to DC 5.25 V The voltage is picked off from the rack bus.
	Power consumption	type 0.6 W + 0.03 W for each active output

Table 2.4/4 SICAM A8000 Rack I/O Module – Can only be Used in Conjunction with CP-8050



I/O Remote Module	DO-2210	DO-2211
Properties	<ul style="list-style-type: none"> ● Processing and output according to IEC 60870-5-101/104 <ul style="list-style-type: none"> – Up to 32 pulse commands (2-pole) or – Up to 64 pulse commands (1-pole 1 1/2 pole) or – a combination thereof – Secure command output <ul style="list-style-type: none"> – Internal checks (IC1) – Optional resistance check (RC1) via a SM-2506 measuring-circuit module that can be installed ● 64 relay outputs (2 groups) plus <ul style="list-style-type: none"> – 2 group outputs – 4 pulse outputs ● Each group has a common potential. ● An intrinsic fuse circuit is produced for each group. ● The pulse outputs are current-limited via an electronic fuse. ● Input function and status display via LEDs 	
Max. contact voltage	DC 24 V to 60 V + 30 %	DC 24 V to 125 V + 20 %
Output circuits (operated with external voltage)	<ul style="list-style-type: none"> ● DC 18 V to 70 V as per EN 61010-1:2010 ● DC 18 V to 60 V as per IEC 61010-1:2010/AMD1:2016 	<ul style="list-style-type: none"> ● DC 18 V to 150 V
Rated switching capacity	<ul style="list-style-type: none"> ● 48 W/DC 24 V ● 96 W/DC 48 V ● 120 W/DC 60 V 	<ul style="list-style-type: none"> ● 48 W/DC 24 V ● 96 W/DC 48 V ● 120 W/DC 60 V ● 250 W/DC 125 V
Operating voltage	DC 5 V ± 5 %, typ. 1.0 W without SM-2506 typ. 1.6 W with SM-2506 + 0.6 W during the command output The voltage is picked off from the rack bus.	

Table 2.4/5 SICAM A8000 Rack I/O Remote Module – Can only be Used in Conjunction with CP-8050

Station and Telecontrol Engineering

SICAM 8 - A8000 Rack – Modules



Rack I/O Modules	AI-2300
For detection of analog values and counter pulses, as well as for the output of analog values	
16 current inputs	Max. ± 20 mA to 122.5 Ω burden <ul style="list-style-type: none"> • Load voltage 2.45 V • Overrange typ. 2 % • Voltage between the inputs of a group max. DC 4 V • Every 2 inputs form a group (8 groups) • All inputs are galvanically separated from logic circuits and ground. • The inputs of a group are not galvanically separated from each other. • The inputs of a group are galvanically separated from those of the other groups and from the inputs/outputs of the input/output modules.
Operating voltage	DC 4.75 V to 5.25 V The voltage is picked off from the rack bus.

2.4

Table 2.4/6 SICAM A8000 Rack I/O Modules – Can only be Used in Conjunction with CP-8050



Submodules	SM-0570	SM-0571	SM-0572	SM-0574
Overview	<p>2 current inputs</p> <ul style="list-style-type: none"> • Max. ± 20 mA to 122.5 Ω burden • Load voltage 2.45 V • Overrange type 2 % • Voltage between 2 inputs max. DC 4 V • All inputs are galvanically separated from logic circuits and ground. • The inputs are not galvanically separated from each other. 	<p>2 resistance thermometer inputs</p> <ul style="list-style-type: none"> • Pt100, Ni100 • Either 2-, 3- or 4-phase technology • The inputs are galvanically separated from logic circuits and ground. • The inputs are not galvanically separated from each other. 	<p>2 analog outputs</p> <ul style="list-style-type: none"> • The current or voltage output can be selected for each submodule. • The measuring range can be adjusted as follows with an output current: <ul style="list-style-type: none"> – -20 mA to +20 mA – -10 mA to +10 mA – -5 mA to +5 mA • The measuring range can be adjusted as follows with and output voltage: <ul style="list-style-type: none"> – -1 V to +1 V – -10 V to +10 V 	<p>2 pulse inputs</p> <ul style="list-style-type: none"> • Rated voltage DC 24 V to 60 V • The pulse inputs can be used as follows: <ul style="list-style-type: none"> – 2 counter inputs – 1 counter input + 1 control input • 1 counter input operates 1 counter (pulse counting) <ul style="list-style-type: none"> – The counter has a max. counter status of 24-bits width • The submodule functions, which can be operated autonomously, are operated by way of a buffer • This ensures that counter functionality and counter status remain correct, even in the event of a voltage failure lasting up to 72 hours (counter pulse frequency ≤ 50 Hz) • The counter status is either still correct or marked as “lost” in the event of a voltage failure lasting longer than 72 hours
Operating voltage	DC 5 V ± 5 %, typ. 0.6 W	DC 5 V ± 5 %, typ. 0.9 W	DC 5 V ± 5 %, typ. 1.5 W	DC 5 V ± 5 %

Table 2.4/7 SM-057x Submodules

Station and Telecontrol Engineering

SICAM 8 - A8000 Rack – Modules



Rack	CM-2846	
Power supply	With power supply	With redundant power supply
Overview	<p>The CM-2846 rack provides 17 slots for double Europe format assemblies. It has primarily been designed for 19" (swing) frame installation, but it is also suitable for rear plate mounting using the rear plate assembly set.</p> <p>The rack (84 TE, 9 HE) can be equipped as follows (these components are not included in the scope of delivery):</p> <ul style="list-style-type: none"> ● 1 SICAM rack I/O remote module (CI-2530) ● Up to 16 SICAM rack I/O modules <ul style="list-style-type: none"> – DI-2112, DI-2113, DI-2114, DI-2115 – DO-2201, DO-2210, DO-2211 – AI-2300, AI-2302, AI-2303 ● 1 to 2 power-supply modules (PS-263x) 	
Properties	<ul style="list-style-type: none"> ● The installed rack I/O modules are connected to the EbIO, which is operated by exactly 1 master module (CP-8050/CPCi85), that may be redundant. ● Wiring peripherals using prefabricated peripheral cables CM-2890 ● 2 slots for PS-263x power-supply modules ● ESD Earth Facility for connecting a ground strap when replacing a module ● Release tool included for assemblies 	
Slot for CI-2530	0	
Slots for SICAM A8000 rack I/O modules	1 to 17	
Slots for PS-263x	<ul style="list-style-type: none"> ● 1st power-supply module, left ● 2nd power-supply module, right 	
Operating voltage	5.1 V; supplied by the installed power-supply module PS-263x	
Dimensions	Height: 320 mm Width: 483 mm Depth: 258 mm (power-supply module is not installed) Depth: 280 mm (power-supply module is installed)	

Table 2.4/8 SICAM A8000 Rack – Can only be Used in Conjunction with CP-8050

SICAM A8000 Module Rack CM-8846

The SICAM A8000 module rack CM-8846 allows you to install up to 13 SICAM A8000 modules in one 19" rack.

5 height units (222.25 mm) must be taken into account for the module rack.

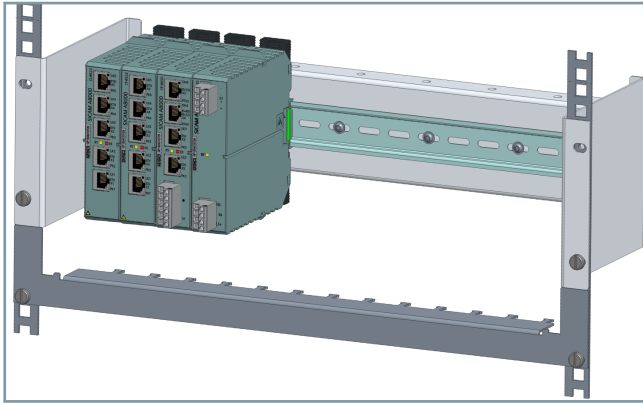

[dw_sicam_a8000_module-rack5, 1, -_-]

Figure 2.4/5 SICAM A8000 Module Rack CM-8846

System Components and Technical Data

For additional system components and technical data, refer to the current manual: [Industry Online Support](#)

Station and Telecontrol Engineering

SICAM 8 - A8000 Rack – Selection and Ordering Data

Selection and Ordering Data

Description	Order No.	
Base Units		
CP-8050 Master Module	6MF2805-0AA00	
SICAM rack solution¹⁸		
CM-2846	17-slot rack	6MF1113-0CJ46-0AA0
CM-2846	Wall-mounting kit	6MF1313-0CH02-0AA0
CI-2530	SICAM rack I/O remote	6MF2253-0AA00
	CI-2530 complete front cover	6MF2253-0FA00
CM-8846	SICAM A8000 module rack	C53207-A5846-D481-1
CM-8813	CP-8031/CP-8050 bus connector (this bus-connector plug is included for CP-8031/CP-8050)	C53207-A5813-D481-1
SICAM A8000 Rack – Power-Supply Modules		
PS-2630	DC 24 V to 60 V	6MF1113-0CG30-0AA0
PS-2632	DC 110 V to 220 V, AC 230 V	6MF1113-0CG3-20AA0
SICAM A8000 Rack I/O Modules		
DI-2112	Binary input 8x8, DC 24 VC, 1 ms	6MF1013-0CB1-20AA0
	Front cover DI-2112	6MF1313-0CA7-20AA0
DI-2113	Binary input 8x8, DC 48/60 V, 1 ms	6MF1013-0CB13-0AA0
	Front cover DI-2113	6MF1313-0CA73-0AA0
DI-2114	Binary input 8x8, DC 110 V, 1 ms	6MF1013-0CB14-0AA0
	Front cover DI-2114	6MF1313-0CA74-0AA0
DI-2115	Binary input 8x8, DC 220 V, 1 ms	6MF1013-0CB15-0AA0
	Front cover DI-2115	6MF1313-0CA75-0AA0
DO-2201	Binary output Trans 40x1, DC 24 V to 60 V	6MF1011-0CC01-0AA0
	Front cover DO-2201	6MF1313-0CA76-0AA0
DO-2210	Command output DC 24 V to 60 V	6MF1011-0CC10-0AA0
	Front cover DO-2210	6MF1313-0CA77-0AA0
DO-2211	Command output DC 125 V	6MF1011-0CC11-0AA0
	Front cover DO-2211	6MF1313-0CA78-0AA0
AI-2300	Analog input 16x ±20 mA + 4x opt.IOM	6MF1011-0CD00-0AA0
	AI-2300 front cover	6MF1313-0CA79-0AA0
Submodules		
SM-0570	Analog input extension (2 x ±20 mA)	6MF1011-0AF70-0AA0
SM-0571	Analog value extension (2 x Pt100)	6MF1011-0AF71-0AA0
SM-0572	Analog output extension (2 x ±20 mA, ±1/10 V)	6MF1011-0AF72-0AA0
SM-0574	Counter input (2 x DC 24 V to 60 V)	6MF1011-0AF74-0AA0
SM-2506 M	Measuring-circuit module command output DC 24 V to 60 V	6MF1011-0CF06-0AA0
Licenses (OSD)		
	SICAM A8000 CP-803x Extended CI module DL	6MF2750-2EX00
	SICAM A8000 Licensed protocol DL	6MF2750-2PR00
	SICAM A8000 CI-852x Redbox DL	6MF2750-2RB00
	SICAM A8000 Extended processing	6MF2750-2EP00
	SICAM A8000 IEC 104 firewall	6MF2750-2FW40
	SICAM A8000 LXC container	6MF2750-2LX00
	SICAM A8000 Redundancy DL	6MF2750-2RE00
	SICAM A8000 Extended SICAM WEB license DL	6MF2750-2WE00
Accessories		
CM-2890	Periphery cable crimp 5 m, 100-pole	6MF1313-1CJ00-0AA0

¹⁸ 1x firmware license, order number 6MF2750-0EP00 is required for each SICAM I/O rack to allow you to use SICAM A8000 rack I/Os in conjunction with SICAM A8000 CP-8050. A front cover is also required for each CI-2530.

Description		Order No.
	Handle mold for CM-2890 plug	6MF1313-OCA00-0AA1
	Empty front cover	6MF1313-OCA86-0AA0

Table 2.4/9 SICAM A8000 Rack – Selection and Ordering Data

Function Point Manager

The SICAM & SIPROTEC Function Point Manager is a cloud-based service for SICAM & SIPROTEC customers for the central administration of Function Points and to generate license files. With the Function Point Manager SICAM, SIPROTEC 5 and SIPROTEC 5 Compact device functionality can be easily extended within seconds.

Advantages

- One service for all your SICAM, SIPROTEC 5, SIPROTEC 5 Compact devices
- Switch between different SICAM and SIPROTEC budget accounts via one user account
- Order now, pay later: The Function Points are only invoiced when the license file is generated
- Activate device functionality quickly and easily through ad hoc generated license files
- Specify features late in the engineering process after device purchase
- Use the Function Point Manager to organize and share all generated SICAM and SIPROTEC license files in your organization

- Share your budget account with colleagues
- Create multiple project-related budget accounts

Description		Order No.
Function point budget	1 Function point	6MF2752-1AA

Table 2.4/10 Function Point Budget

Procedure

- Create SICAM license files (SICLIC) and manage function point budgets with the Function Point Manager. Registration is required in the Function Point Manager and the creation of a budget account.
Website: <https://sicam-function-point-manager.siemens.com/>.
- To order function points use the account specific article number that is displayed in your SICAM Function Point Manager account.
Order function points from your regional sales partner or from the <https://sieportal.siemens.com/en-ww/home>.
- When placing an order, you accept the terms and conditions: <https://siprotec-function-point-manager.siemens.com/terms>

Station and Telecontrol Engineering

SICAM 8 - A8000 Rack – Selection and Ordering Data

License Type	Function Points	Can be used with		
		SICAM A8000		SICAM 8
		CP-8050	CP-8031	Software Solution
SICAM 8 HMI (for 200 to 2.000 data points)	200	X	X	X
SICAM 8 EVA (Event and Alarm list for > 4.000 entries)	30	X	X	X
SICAM 8 Dynamic Load Management¹⁹				
Dynamic load management for ≤ 25 charging units	100	X	X	X
Dynamic load management for ≤ 50 charging units	145	X	X	X
Dynamic load management for ≤ 75 charging units	190	X		X
Dynamic load management for ≤ 100 charging units	225	X		X
Dynamic load management for ≤ 125 charging units	260	X		X
Dynamic load management for ≤ 150 charging units	295	X		X
Dynamic load management for ≤ 175 charging units	330	X		X
Dynamic load management for ≤ 200 charging units	365	X		X
Dynamic load management for ≤ 225 charging units	400	X		X
Dynamic load management for ≤ 250 charging units	435	X		X
SICAM 8 Fast Power based Load Shedding Compact (96 loads, 10 contingencies)				
Fast power based load shedding	200	X	X	
SICAM 8 OPC UA Server	45	X	X	X
SICAM 8 SICORE	100			X
SICAM 8 SICAM S8000 RTU¹⁹				
S8000 base for ≤ 15 IEDs/connections	60			X
S8000 base for ≤ 50 IEDs/connections	200			X
S8000 base for ≤180 IEDs/connections	840			X
S8000 base for ≤ 400 EDs/connections	1600			X
S8000 base for ≤ 800 IEDs/connections	2230			X
S8000 base for ≤ 1200 IEDs/connections	2410			X
SICAM 8 Redundancy²⁰	55	X		X
SICAM 8 LXC Container (SIAPP Runtime)	70	X	X	
SICAM 8 IEC104 Firewall	35	X	X	
SICAM 8 Extended Processing	90	X		X
SICAM 8 Extended SICAM Web	35	X	X	X
SICAM 8 Licensed Protocol (Legacy Protocol)	40	X	X	
SICAM 8 CP-803x Extended CI-Module	85		X	
SICAM 8 CI-852X, RedBox²¹	40	X	X	

Table 2.4/11 Function Points

¹⁹ Only 1 instance of listed licences below can be loaded (upgrade to higher number is possible)

²⁰ Per RTU one license needed

²¹ For CP-8031, the CI-85XX Extension license is required

Description

The SICAM 8 software solution (SICAM 8 SWS) supports to run power automation applications on a third-party industrial PC with Debian Linux OS. The first power automation application is S8000 which includes RTU, PLC, and communication protocols. The solution runs on SICAM A8000 CP-8050/31 modules, but the performance (number of IEDs connected or data points processed) is limited to the SICAM A8000 CP module type. The size of the application can be scaled by licensing the SICAM Function Points.

The SICAM 8 SWS Supports

- Integration of up to 1200 IEDs
- TCP/IP based communication protocols
 - IEC61850
 - IEC104
 - DNP
 - Modbus TCP
- CFC Logic (up to 8 additional CFC instances via extended processing license)
- CIS benchmark level 2 with appropriate installation
- Secure boot with appropriate installation and hardware
- Redundancy

Security Features

- TLS and IPSec encryption
- RBAC
- Secure Storage Manager
- 802.1x Supplicant
- LDAP
- Radius

System Features

- HTTPS
- NTP client and server
- SNMP server
- Syslog
- VLAN for local Ethernet ports

SICAM Web Features

- Diagnostic
- Simulation
- Monitoring
- Tracing (without SVG graphics – single lines only via SICAM HMI)

Besides the SICAM S8000 application, additional functionalities can be used in the first step:

- SICAM HMI, Event and Alarm list (EVA)
- OPC UA Server
- SICAM Application Dynamic Load Management (DLM)



[sc_sicam8_logo, 1, ---]

The SICAM 8 SWS is tested on the following hardware:

- SIMATIC IPC 227g
- WELOTEC RSAPC
- Ruggedcom APE1808 Module

SICAM 8 SWS Redundancy

The example shows a SICAM 8 SWS supports redundancy for S8000 application.

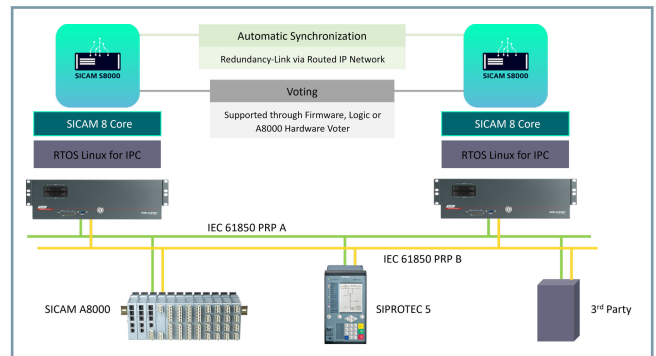

[dw_software_sws_logic, 1, en_US]

Station and Telecontrol Engineering

SICAM HMI – Selection and Ordering Data

Description

SICAM HMI is a high performing technology with modularized architecture and is a part of the universal power automation platform SICAM 8. SICAM HMI provides you the advantage of configuring the entire range of the SICAM 8 platform with one engineering tool, that is the SICAM Device Manager.

The visualization and operation tool controls and monitors smaller plants around the entire energy chain from the:

- Power generator to the consumer
- Low voltage to high voltage
- Infrastructure to industry

Features

- SICAM HMI can be used along with SICAM S8000 on a Linux based SICAM A8000 CP-8031/CP-8050
- SICAM HMI can be used along with SICAM S8000 as a SICAM 8 Software Solution on third-party Linux based industrial PCs
- Parameterization with SICAM Device Manager (engineering tool for RTU and HMI)
- Graphics editor integrated in SICAM Device Manager

- Event and alarm list
- Web-browser based application for tablets and HTML5 browser compatibility
- Applications with up to 200 data points are license free
- With SICAM HMI, you have a product with security features such as HTTPS, RBAC (role-based access control), and patch management

Benefits

- One engineering tool for HMI and RTU – minimization of maintenance effort and costs
- Unified platform for hardware, software, controller, and engineering – reduced training effort for operating personnel
- Hardware from SICAM A8000 portfolio
- Use of manufacturer independent hardware (industrial PCs with Linux operating system) in combination with the SICAM 8 Software Solution

2.6

The SICAM HMI configuration is an add-on and works only in conjunction with the SICAM Device Manager.

Description	Versions	Order no.												
		1	2	3	4	5	6	7	8	9	10	11	12	
SICAM Device Manager Basic		6	M	F	7	8	0	0	-	2	F	B	0	0
SICAM Device Manager Standard		6	M	F	7	8	0	0	-	2	F	S	0	0
SICAM HMI Configuration		6	M	F	7	8	0	0	-	2	F	H	0	0

Table 2.6/1 SICAM HMI Selection and Ordering Data

SICAM HMI	SICAM HMI Graphic Editor	License with MLFB orderable
	SICAM Event/Alarm List (Configuration)	Included in HMI configuration license
	SICAM HMI Runtime	<ul style="list-style-type: none"> • Up to 200 data points license free • Up to 2000 data points license can be ordered with SICAM FPM (Function Point Manager)
	SICAM Event/Alarm List (Runtime)	<ul style="list-style-type: none"> • Up to 4000 data points license free • Up to 30 000 data points license can be ordered with SICAM FPM (Function Point Manager)

Table 2.6/2 SICAM HMI Software Package

The licensing of the SICAM HMI configuration is done as an add-on to the SICAM Device Manager.

- Activation via ALM license (MLFB)
- Delivery via OSD (Online Software Delivery)

The SICAM HMI Runtime and SICAM Event/Alarm List Runtime is licensable with function points.

- License file can be generated with SICAM FPM

Description

The SICAM Enhanced Grid Sensor (EGS) enables the combination of measurement and a secure RTU gateway in one compact device while complying with the highest safety standards. The SICAM EGS is an all-in-one device solution for local substations, low-voltage cabinets, cable distribution cabinets, and household junction boxes. The SICAM EGS is a part of the universal power automation platform SICAM 8.

Benefits

The SICAM (EGS) is an effective retrofit solution for the recording and reporting of messages and measured values from the medium-voltage switchgear and low-voltage fuse distribution in existing local substations.

- Flexible and easily expandable: prepared for upcoming changes in the power distribution
- Permanent power monitoring: working at the power limit with the existing infrastructure
- Use existing space: operate local network and distribution stations without conversion
- Designed for harsh operating conditions: direct integration in cable distribution panelboards without cubicles
- Inexpensive and easy to install: Easy installation and commissioning, short changeover times
- Proven, advanced technology: investment into the future, based on the proven SICAM 8 platform availability
- Cybersecurity: according to the highest standard, secure updates
- Maintenance-free: long service life based on RTU standards

Applications

- Power distribution monitoring: distribution network automation optimized for use in LV/MV switchgears
- Asset monitoring: for transformers and switchgears
- Grid connection monitoring: for solar and wind parks and charging stations for electric vehicles
- Communication gateway: for different networks, protocols, and easy SCADA integration
- IoT gateway: for an easy connection of products and solutions for measurement technology, sensor technology, protection and automation, power quality and measurement technology to cloud-based platforms for asset management and data analytics
- Technology beyond the local network station: system connections and cloud-based monitoring/control

Technical Data

The following is an excerpt from the technical data. For more information, refer to the user manual.

- Integrated 3-phase measurement functionality for current and voltage monitoring in low-voltage grids
- Calculation of electrical values (P, Q, S, $\cos \phi$, frequency)
- Automation functions (IEC 6113-3), for example, for control of a regulated distribution transformer



Figure 2.7/1 SICAM EGS Sensor (Rogowski Coil), SENTRON 3NA COM

- Support of SIAPP - application based on Docker using the SIAPP Software Development Kit (SDK)
- Recording of outgoing currents from the low-voltage fuse distribution via direct radio communication (ZigBee) to the SENTRON 3NA COM fuses with integrated current sensors
- Telecontrol communication via standards IEC 61850, IEC 60870-5-104, and DNP 3.0
- Connection of multimeters and short-circuit indicators (for example: SICAM FCM plus) via serial Modbus RTU interface
- Ethernet interface and integrated LTE module for easy adaptation to existing communication infrastructures
- IoT connectivity: provision of data via a secure Internet connection for cloud-based applications and services (OPC UA Pub/Sub, MQTT, and MindConnect)
- Auxiliary power supply from the measuring voltage, bridging time in case of power failure (1 minute)
- Dimensions: 200 mm x 100 mm x 60 mm (WxHxD)
- Weight: 1.2 kg
- Protection class: IP54

Station and Telecontrol Engineering

SICAM DLM

Description

The expansion of the electric vehicles infrastructure brings various challenges to the grid. The challenges include grid upgrades, utility capacity limitations, and high demand charges. The SICAM Dynamic Load Management (DLM) is based on SICAM 8 which supports the integration of charging units into electrical grids by dynamically limiting the charging power.

Benefits

- Significant reduction of grid expansions up to complete avoidance
- Prevention of transformers overload
- Minimization of peak loads and the resulting high charges
- Compliance with grid connection conditions, for example, load reduction at the request of the grid operator
- Best possible use of the charging infrastructure with varying simultaneous factors

Functions

The installation of SICAM DLM takes place on a SICAM A8000 CP-8031/CP-8050 in conjunction with the SICAM Device Manager. A user interface is achieved through the integrated SICAM WEB Dashboard functionality. The DLM sends power set point values to the connected chargers of a configured charger group. The SICAM DLM supports a maximum of 250 charging units in 10 groups, where each group is assigned a grid measurement. Phase balancing can also be included.

The SICAM DLM allows 5 algorithms for power sharing:

- Split charging without priorities
 - Distributes the power equally among the vehicles based on the maximum power of the charging units, without status information of the charging stations
 - Distributes power evenly among vehicles based on the maximum charging power and pre-set priorities
 - By round-robin: for fleets and long-term parking lots with highly fluctuating charging requirements, ensures that vehicles with low charging requirements are fully charged more quickly
- First-in/First-out
 - For fleets with higher overcrowding rates, ensures fastest possible vehicle charging - based on charge start, ensures fleets always have fully charged vehicles when needed
 - Reverse order as stated in point above - for fleets with higher over-crowding rate, ensures fastest possible vehicle charging - based on charging start, ensures that fleets always have fully charged vehicles when needed

Applications

The SICAM DLM is applied to following areas:

- Depots
- Parking garages
- Real estate
- Industrial sites
- Gas stations

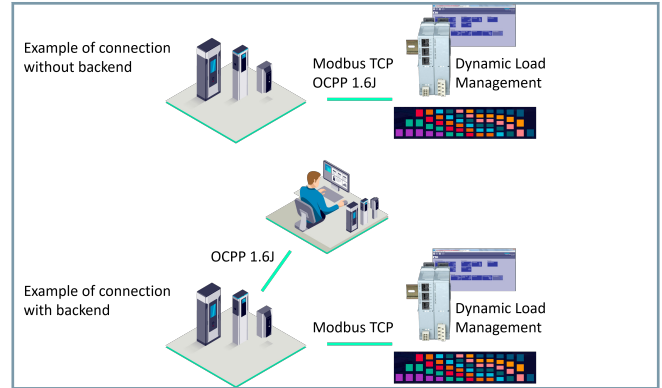

Figure 2.8/1 SICAM DLM Architecture

- Truck stations
- Business Parks

Connections

Connection of charging stations and backend systems

- Modbus TCP (electrical data)
- OCPP (electrical and process data)

Connection options between SICAM DLM and charging units

- OCPP 1.6J
- Modbus TCP

Connection options between SICAM DLM and grid operator

- Modbus TCP
- IEC 60870-5-101
- IEC 60870-5-104
- IEC 61850
- DNP3
- Digital and analog I/O

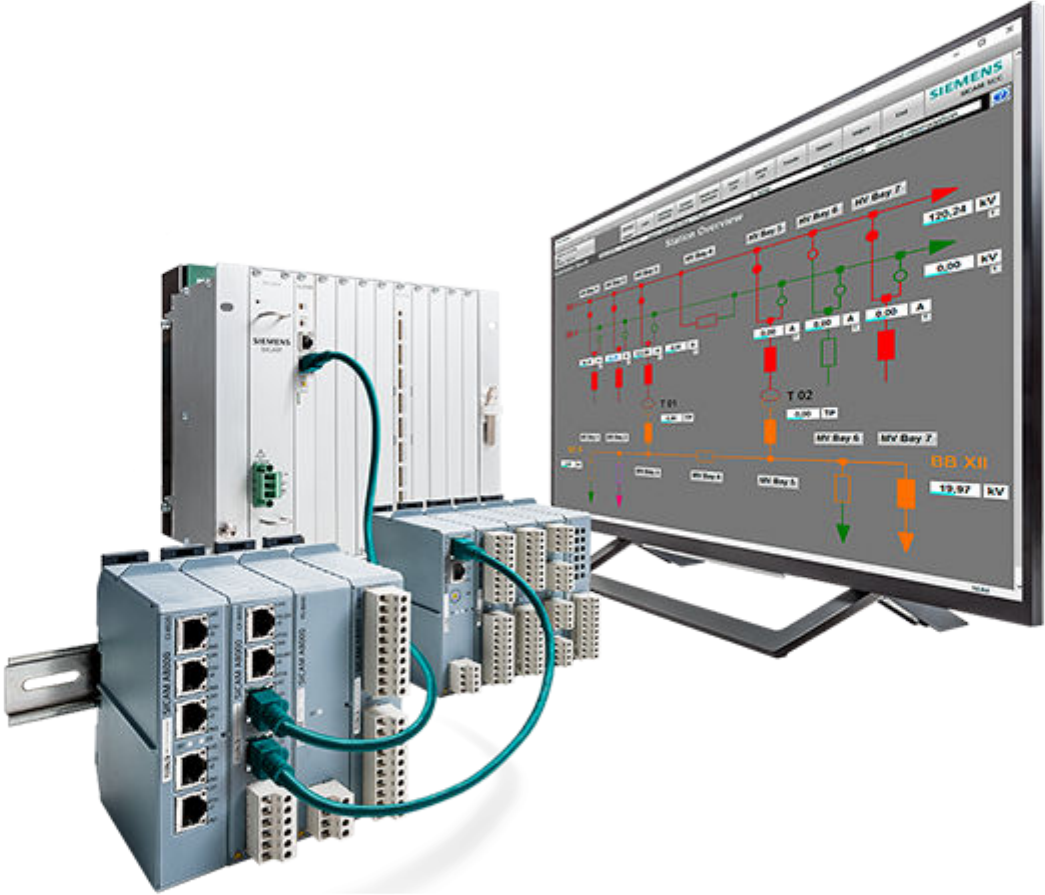

Control, Monitoring, and Diagnosis

The operation of electricity-supply systems is becoming more and more dynamic. In order to prepare themselves for future requirements, increasing the service lives of plant components is central to power utilities. They also make the highest demands of control, protection, and remote control.

Siemens is a pioneer in flexible and customized process visualization in power automation. Thanks to an extensive product portfolio and many years' experience, Siemens offers you innovative solutions for all voltage levels and every substation. You benefit from cost-effective investments and economic operation – without needing to compromise on safety and reliability. Be persuaded by our upgradeable concepts.

On the following pages, you will find information about:

- SICAM SCC
- SICAM PQ Analyzer (Incident Explorer)
- SICAM DISTO



[BBD, 1, ...]

Figure 3/1 Operation, Observation, and Diagnosis

Description

The process and visualization system SICAM SCC (SICAM Substation Control Center) is an important component of the power-automation solutions. Independent of the utilized substation, SICAM SCC can be used with both the power-automation system SICAM PAS, as well as with the products of the SICAM RTU range. SICAM SCC can communicate directly with bay and protection devices that support the communication standard IEC 61850, and can be used for this as a cross-device HMI system. SICAM SCC, based on SIMATIC WinCC, is scalable for individual applications, and supports efficient engineering for the power-automation solutions of power utilities and industry.

Configuration Options

Easily configurable HMI system for system control in power automation:

- SICAM PAS
- SICAM A8000
- Devices with communication standard IEC 61850
- Scalable functionality from a stand-alone system up to redundant client/server systems, Internet access via Web Navigator
- Process visualization with topological coloring
- Power-system management via SNMP

System Overview

An important component of power distribution and transmission plants is process visualization and control. In the SICAM product range, this task is undertaken by SICAM SCC, an HMI system that optimally fulfills the requirements of plant control and monitoring – regardless of the Siemens substation technology used. SICAM SCC can be used with the power-automation system SICAM PAS, as well as the A8000 series products.

Common HMI for SICAM and SIMATIC

As a base system SICAM SCC uses SIMATIC WinCC, one of the world's leading process visualization systems and supplements this with the necessary functions for utilization as station operation of the electrical process in high and medium-voltage systems. SIMATIC WinCC compatibility allows the use of SICAM SCC as an add-on together with SIMATIC WinCC on one computer. This enables an integrated system solution for the visualization and control of the industrial production process with SIMATIC automation devices (for example, S7) and the electrical energy process (for example, with SICAM PAS).

Functions for Use with SICAM and IEC 61850

SICAM SCC is customized for use in the energy sector and supports the operational crew in optimizing system management. SICAM SCC allows rapid entry and clear, uncluttered representation of the operating statuses of the plant. The specific properties of the high-voltage and medium-voltage switching devices in the control and monitoring direction (double commands and -indications) are optimally implemented in the message lists and the graphical representation of the process.



[SICAM SCC, 1, ...]

Figure 3.1/1 Process and Visualization System SICAM SCC

Added Value Logging

In the message lists, the original time stamps are logged with ms resolution as they occur in the devices. Each indication is represented with a series of auxiliary information. On the one hand, these provide information about the update status of the information against the background of a device or communication failure (up to date/not up to date) or an activated bay or telecontrol blocking. On the other hand, they provide information about the cause of the status change (spontaneous, command) and, in the case of a command process, about the process source (local, site, remote). In addition to process indication, command indications are also logged. Thus, each command process is documented completely and in detail, from issue of the command by the operational crew and the command output right up to feedback from the process after the change in status of the controlled switching device.

Process Visualization Right up to Topological Coloring

IndustrialX controls are used for control and monitoring of the switching devices in the fully graphic process diagrams (single-line diagrams). These switching device objects support 4 different representation forms (IEC, DIN, SINAUT LSA, SICAM) for circuit breakers and disconnectors. Furthermore, the possibility exists to project-specifically create defined bitmaps to represent the switching devices and to link them with the objects. In addition to target and spontaneous flashing, representation of diverse device and communication states (for example, up to date/not up to date, bay and telecontrol blocking) is also supported for meaningful visualization. Measured values and switching device states that can no longer be updated due to a device or communication failure or applied bay blocking can be updated from the operator console via SICAM SCC. The switching devices can be controlled directly or with **Select before operate**. The option of topological coloration exists for representation of the process with single-line diagrams.

Control, Monitoring, and Diagnosis

SICAM SCC – Description

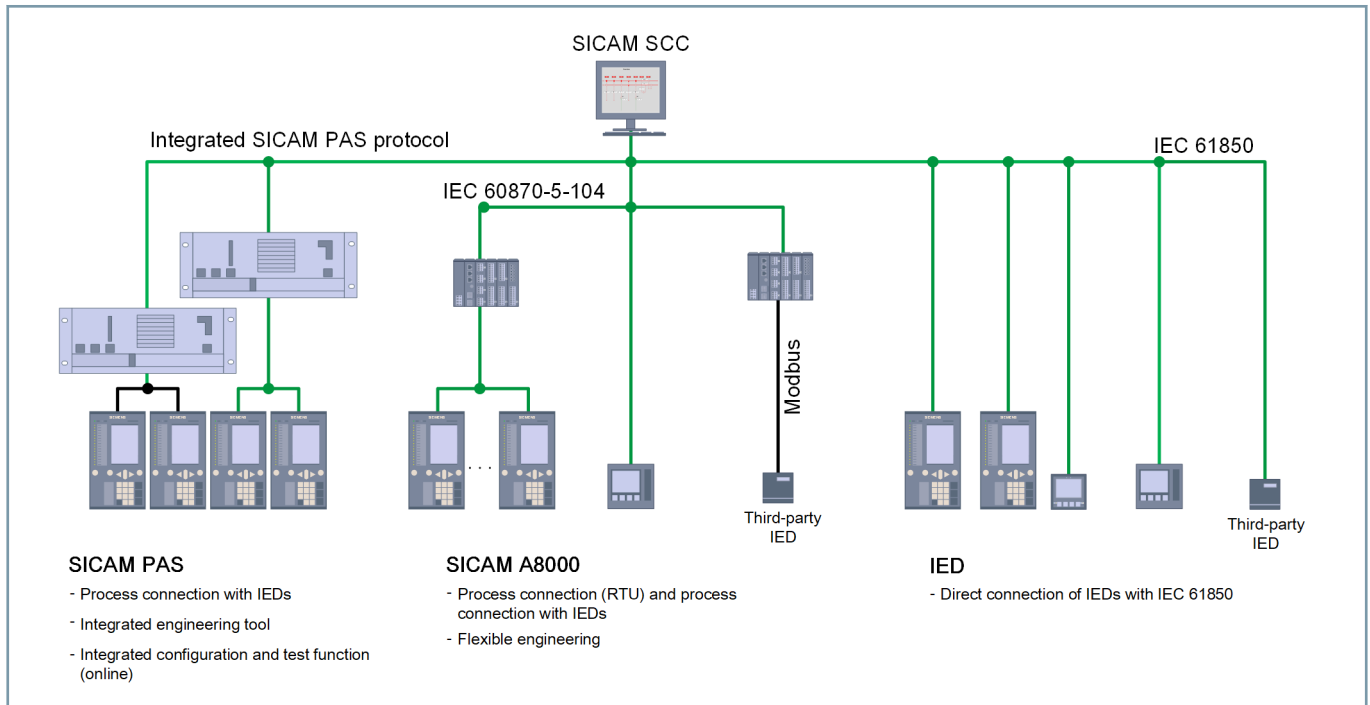

[pic_flexible station unit_4_en_US]

Figure 3.1/2 Process Visualization with SICAM SCC

Substation Automation Technology Functions in Common with SICAM PAS

Additional functions are supported when using with SICAM PAS: If, for example, maintenance work or tests must be carried out for the process area of a bay unit, and if any status changes are not to be taken into consideration in the substation automation technology processing of the SICAM PAS and not logged in HMI, this can easily be activated via the **bay blocking** function. If the status changes are to continue being processed within the substation but the information transmission to superordinated control centers is to be suppressed, this can be achieved by means of the **telecontrol blocking** function.

Normally, substations are controlled by the superordinated control centers, while switching commands are to be rejected by the station's internal HMI; the switching authority is assigned to the superordinated control center. Switching authority can be obtained if control must be effected from the HMI for operational reasons. If the substation is connected to several control centers, the switching authority can also be assigned channel-specifically. Furthermore, different switching authorities can be used for different voltage levels.

Reduced Engineering Expenditure

The data exchange with the connected substation often comprises several thousand indications, measured values and commands. The project engineering of this information is considerably simplified in SICAM SCC via wizards. The required description of process data is made available electronically by the configuration tools (SICAM PAS UI – configuration, SICAM TOOLBOX II) of the substation automation technology and is easily imported by SCC wizards. Redundant data input

is avoided. SCD files can be imported for directly connected IEC 61850 devices.

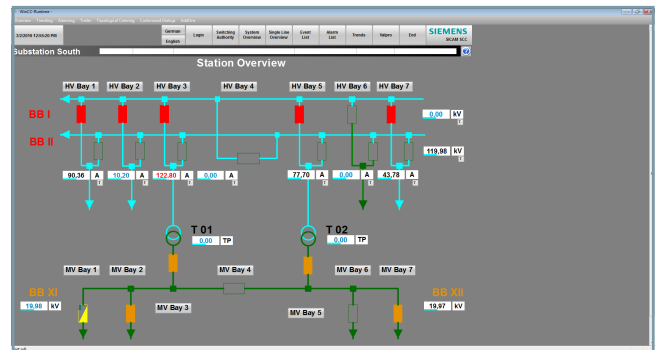

[pic_process_visualization SCC_1_en_US]

Figure 3.1/3 Process Visualization with SICAM SCC

SIMATIC WinCC

SICAM SCC works on the SIMATIC WinCC platform

The WinCC basic software is the core component of a modular system via which you can compile a flexible, customized SCADA solution via options and add-ons. The WinCC basic software alone already represents a powerful, universally applicable process visualization system that has all the features of sophisticated HMI software.

Runtime software

All HMI functions on board - this is how the runtime components of the basic software are available. Starting with user management that satisfies all requirements of Good Manufac-

turing Practice (GMP), via a user interface with a multitude of configurable controls and functions right up to the powerful signaling and archiving system based on the integrated MS SQL Server. Reporting and logging system as well as integrated systems control functions as well as integrated systems control function round off the list.

Configuring software

The engineering component WinCC CS has a range of editors that leave nothing to be desired with respect to their efficiency and user-friendliness. Libraries and wizards simplify and accelerate the creation of projects and considerably reduce the occurrence of defects. As software for the most complex HMI tasks, WinCC is also suitable for handling larger projects and bulk data.

Scalability

The basic system is scalable in all respects via WinCC options. Even the basic system is scalable with respect to the quantity structure via a graduated licensing model, in doing so the selected quantity of process tags can be subsequently increased at any time. WinCC/server offers the option of establishing WinCC as a client-server application. WinCC- redundancy makes this solution a highly-available system. With WinCC CAS, the process value archiving system is extended into an independent, high-performance archive server. WinCC/Web Navigator allows operation and observation via the Web with almost identical functionality to a WinCC client, but with unbeatable flexibility.

Virtualization

In addition to WinCC Clients, WinCC Server can be used under VMware ESXi and engineering stations under VMware workstation or VMware Player. In this way, complex client-server structures and also stand-alone systems can be configured with virtual environments.

Openness

SIMATIC WinCC has always stood for the greatest possible level of openness and integration capability because it consistently uses standard technologies and software tools. From the operating systems and the utilized basic technologies right up to communication mechanisms and the possibility of integrating scripts, WinCC focuses on standards in all fields and dispenses with proprietary solutions.

SIMATIC WinCC - basic functionality

Runtime components of WinCC basic software

- Integrated user management
- User Interface
- Message management system
- Archiving system
- Reporting and logging system
- Systems control functions (Basic Process Control)

Integrated user management

With WinCC User Administrator, the access rights of the users for project engineering and runtime are assigned and controlled. At any time, even during runtime, the administrator can create up to 128 user groups each with up to 128 individual user settings and assign them access rights to WinCC functions. In total, up

to 999 different authorizations are possible. From WinCC version 7.0 onwards, SIMATIC Logon is a component of the WinCC basic software. User management with SIMATIC Logon integrates into the security system and user management of Windows and hence also covers extended safety requirements in accordance with FDA. SIMATIC Logon supports system-wide user management and protects from unauthorized manipulation of data.

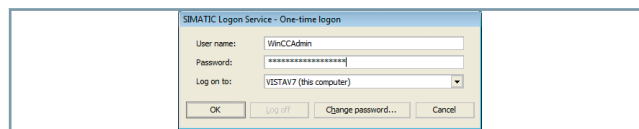

[Pic_SIMATIC Logon, 1, ...]

Figure 3.1/4 SIMATIC Logon Service in WinCC Basic System from Version 7.0 Onwards

User Interface

With the WinCC standards, individually configured user interfaces can be created for any application purpose. They make use of a comprehensive selection of configurable standard objects. With online language change, projects that are created in multiple languages can be switched over online during runtime at any time. Windows elements such as menus and toolbars can be integrated into the user interface of the runtime application. With a maximum resolution of 10,000 x 10,000 pixels for the individual process diagrams, the convenient zoom factor proves to be of particular importance. The zoom factor can be smoothly increased or decreased using a scrolling mouse. The panning function allows the overlay of a navigation cross in a zoomed image. The representation of tiers and objects can be made dependent on the current zoom factor by means of decluttering. Thus, it is, for example, possible to only overlay details above a specific zoom factor.

Message management system

SIMATIC WinCC not only records process indications and local events, it also stores them in circular archives and then makes them available either filtered or sorted as required. Indications can result by derivation from individual bits, as a result of an indication telegram directly from the automation system or as a result of analog alarms in the case of limit violations. Individual acknowledgment processes and views, a freely definable indication structure and also parameterizable archiving and logging of indications are other features. In WinCC alarm control, the display can be individually adapted to the indications. Comprehensive selection options, for example, via a user-specific filter matrix, guarantees the best overview. It is also possible to display indications that have already been stored. The represented indications can be exported or printed out as reports at the press of a button. System-specific functions can be realized via freely configurable toolbar functions.

A search function is offered in the alarm editor of WinCC SP 1. The filter options in the alarm system have been supplemented with process value blocks with **equals** and **contains** in the case of text values.

Control, Monitoring, and Diagnosis

SICAM SCC – Description

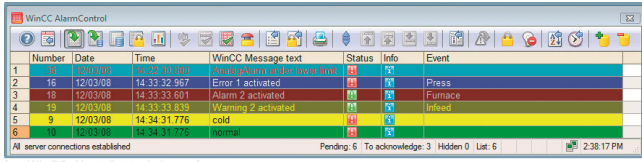

Figure 3.1/5 Report Display via WinCC Alarm Control

Integrated statistic functions allow the harmonic test of hit lists (average and summarized report and acknowledgment times).

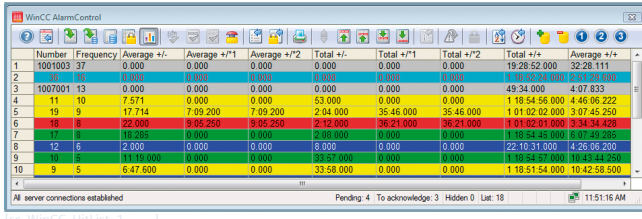

Figure 3.1/6 Report Display with Report Hit List

Indications can also be automatically hidden (alarm hiding). Depending on the current station status (for example, operation, cleaning, maintenance), less relevant indications can be hidden from display.

Archiving system

Historic values or value progressions are stored in process value archives. In addition to process values, WinCC also archives indications and user data. The archiving takes place in circular archives in the integrated MS SQL server database with high performance, that is, up to 10,000 measured values and 100 indications per second. The memory requirement is very low due to effective, lossless compression. In the WinCC base system, 512 archive variables can already be configured. In the final extension, power packs allow extension to up to 120,000 variables. Central, optionally redundant long-term archiving can be realized with a central archive server with the WinCC Central Archive Server option.

In TrendControl (Figure 3.1/7) current values (online trends), historic process values and set point values can be represented in the same curve display. It is also possible to display measured values that have already been stored. Here, individual scaling of the time line and the range of values is possible (for example, percentile standardization). The time and value lines of the individual curves can be moved online by movement of the mouse. This function can be used for, for example, batch comparisons.



Figure 3.1/7 Online TrendControl

Integrated statistic functions allow the harmonic testing of minimum, maximum, average value, standard deviation and integral calculation at the press of a button. Logarithmic representation of curve progressions is also possible. The process values displayed by selection can be printed out as a report at the press of a button or exported in a CSV file. In addition, system-specific functions can be realized via the freely-definable toolbar functions.

Reporting and logging system

WinCC has an integrated log system, via which data from WinCC or other applications can be brought to paper. In configurable layouts, WinCC prints data recorded in runtime relating to different types of log, from reporting sequence and system report and operation logs right up to user reports. The reports can also be stored as a file and displayed via a preview on the screen. WinCC logs can also contain data from the database and third party data in CSV format as a table or curve.

You can find further information in the current manual: [Industry Online Support](#)

Selection and Ordering Data

Description	Variants	Order No.																	
Take the following into account:																			
For SICAM SCC version V9.xx, order numbers from 6MD5501-.....-0AA0 to 6MD5515-.....-0AA0 are delivered with SIMATIC WinCC V8.0. If you require another SIMATIC WinCC version select an order number which is not included in the scope of delivery for SIMATIC WinCC, and order SIMATIC WinCC (suitable, compatible version) separately!																			
		1	2	3	4	5	6	7	8	9	10	11	12	13	14	15	16		
Version and Delivery Form	Version 9														0		▲		
	Physical delivery (DVD/USB)																A		
	Online software delivery (OSD)																H		
Operation and monitoring, runtime (RT)		6	M	D	5	5	0	□	-	0	A	P	0	0	-	0	A	□	0
	Version 9.0x							▲											▲
	128 data points							1											H
	512 data points							2											H
	2048 data points							3											H
	8196 data points							4											H
	65 536 data points							5											H
Operation and monitoring, complete package runtime and configuration (RC)		6	M	D	5	5	1	□	-	0	B	P	0	0	-	0	A	□	0
								▲											▲
	128 data points							1											H
	512 data points							2											H
	2048 data points							3											H
	8196 data points							4											H
	65 536 data points							5											H
Operation and monitoring, runtime (RT) compact with limited functionality		6	M	D	5	5	0	□	-	0	C	P	0	0	-	0	A	□	0
								▲											▲
	2048 data points (the power pack cannot be upgraded)							3											B/H
Functional upgrade of SIMATIC WinCC to SICAM SCC		6	M	D	5	5	□	0	-	0	□	P	0	0	-	0	B	□	0
								▲			▲								▲
	Runtime (format DLL)							0			A								H
	Complete package (format DLL, configuration kit)							1			A								H
SICAM SCC options																			
	SCD import for direct communication with IEC 61850										E								H
	Import for communication with IEC 60870-5-104										F								H
	Network Manager										N								H
	Topological coloring										T								H
	Secure communication										S								H
SICAM SCC version upgrade from V5.x, V6.x, V7.x and V8.0x to V9.0x		6	M	D	5	5	0	0	-	3	B	P	0	□	-	0	B	□	0
														▲					
Upgrade for SIMATIC WinCC is not included	Version upgrade from V6.x,V7.x,V8.x to V9.x, DVD, topological coloring , no licenses													0					H
	Version upgrade from V6.x,V7.x,V8.x to V9.x, DVD, with topological coloring , no licenses													2					H
	Version upgrade from V5.x to V9.x, DVD, with upgrade licenses													1					A ² ₂

Table 3.1/1 SICAM SCC Selection and Ordering Data

22 Only physical delivery available (DVD/USB)

Control, Monitoring, and Diagnosis

SICAM SCC – Selection and Ordering Data

Description	Variants	Order No.																	
		1	2	3	4	5	6	7	8	9	10	11	12	13	14	15	16		
(Continued from previous page)																			
Version and Delivery Form	Version 9													0		▲			
	Physical delivery (DVD/USB)																A		
	Online software delivery (OSD)																H		
Other options																			
SICAM SCC Archive extension for SIMATIC WinCC V8.0 (7.5, 7.4)		6	M	D	5	5	7	1	-	0	A	V	0	8	-	0	□	H	0
	1500 archive variables (countable)																	A	
	5000 archive variables (countable)																	B	
	10 000 archive variables (countable)																	C	
	30 000 archive variables (countable)																	E	
SICAM SCC Web Navigator for WinCC ≥ V7.4		6	M	D	5	5	6	2	-	0	A	V	0	0	-	0	□	□	0
	1 client license (countable)																	B	H
	3 client licenses (countable)																	D	H
	10 client licenses (countable)																	F	H
SICAM SCC redundancy for WinCC V8.0 (7.5, 7.4)		6	M	D	5	5	7	1	-	0	A	V	0	8	-	0	R	H	0
SICAM SCC server for WinCC V8.0 (7.5, 7.4)		6	M	D	5	5	7	1	-	0	A	V	0	8	-	0	S	H	0
SICAM SCC version upgrade for WinCC		6	M	D	5	5	8	1	-	3	□	□	□	□	-	□	□	□	0
	Upgrade for SIMATIC WinCC RT version, V7.x → V7.4											R	V	0	7		4	A	H
	Upgrade for SIMATIC WinCC RT version, V7.2/7.3 → V7.5											R	V	3	7		5	A	H
	Upgrade for SIMATIC WinCC RT version, V7.4 → V7.5											R	V	4	7		5	A	H
	Upgrade for SIMATIC WinCC RC version, V7.x → V7.4											C	V	0	7		4	A	H
	Upgrade for SIMATIC WinCC RC version, V7.2/7.3 → V7.5											C	V	3	7		5	A	H
	Upgrade for SIMATIC WinCC RC version, V7.4 → V7.5											C	V	4	7		5	A	H
	Upgrade for SIMATIC WinCC RT version, V7.3/ V7.4 → V8.0											R	V	4	8		0	H ²³	0
	Upgrade for SIMATIC WinCC RT version, V7.5 → V8.0											R	V	5	8		0	H ²³	0
	Upgrade for SIMATIC WinCC RC version, V7.3/ V7.4 → V8.0											C	V	4	8		0	H ²³	0
	Upgrade for SIMATIC WinCC RC version, V7.5 → V8.0											C	V	5	8		0	H ²³	0

Table 3.1/2 SICAM SCC – Selection and Ordering Data

²³ Only online software delivery (OSD)

The protection of power distribution substations is a crucial task in ensuring a reliable electricity supply. Customers expect maximum availability of electrical energy and current at a constantly high quality level. As a result, it becomes more and more difficult in power system protection, for instance, to distinguish between critical load currents and short circuits with very low fault currents. The requirements for the optimum use of protection devices and for their parameterization are steadily increasing. An intensive evaluation of the existing secondary equipment information with regard to fault recorders is therefore indispensable to ensure that the high reliability and availability of electric transmission and distribution systems, which is standard today will be maintained in the future.

Another point is that the increasing use of power electronics has often a noticeable impact on voltage quality. The consequence is an insufficient voltage quality leading to interruptions, production downtimes, and high consequential costs. Compliance with the generally applicable power system quality criteria specified in the European standard EN 50160 is therefore a must. The basis for this is the reliable detection and evaluation of all quality parameters, so that weaknesses and potential sources of errors can be detected and eliminated.

What is Power Quality?

The purpose of power quality is to ensure a constant quality of electrical energy as a product. It requires, as an integral component of technical risk management, measuring devices and applications are able to reliably measure, record and evaluate the required data. Power quality is normally used in medium voltage substations.

Only an optimum availability and quality of energy can safeguard industrial production and its control. Moreover, power generation and distribution companies are as a rule contractually obliged to meet certain limits for values which are relevant for power quality. The task of power quality is the monitoring of these limits, the evaluation of limit violations, the initiation of suitable countermeasures, as well as the creation of long-term analyses and trends.

The European standards describing the voltage characteristics of electricity supplied by public electrical power systems (EN 50160) and the testing and measurement techniques (IEC 61000-4-30) provide the regulatory framework for this.

The variables to be monitored include:

- Voltage dips and swell
- Harmonic currents
- Transients
- Voltage variations (flicker)
- Frequency changes

Basic Principles for the Evaluation of Power Quality

The power quality of an electric power grid is characterized by 2 main properties:

- Grid stability
Grid stability problems are recorded in the fault records of the PQ devices.
- Voltage quality
The SICAM PQS system evaluates the voltage and current quality by comparing the measured data with the Grid Codes.

Grid Codes define the limiting values of power quality criteria, that is, which limits may never be exceeded, or which limiting values may be exceeded how often/how long. Grid Codes can be based on power quality standards such as the EN 50160 (characteristics of voltage in public electrical power systems).

The PQ Index gives you a quick overview of the power quality of your grid. Grid problems can be recognized at a glance.

The SICAM PQ Analyzer is a tool for display of the data measured by a PQ device and for their evaluation against the power quality criteria by SICAM PQS system.

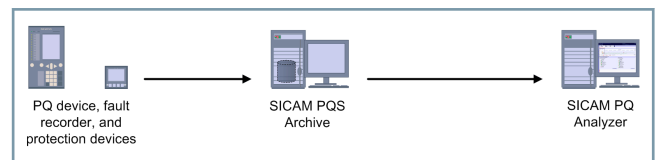

[dw_sicam_pq_analyzer_1_en_US]

Figure 3.2/1 SICAM PQ Analyzer

Functions of SICAM PQS System

SICAM PQS system collects PQ data (such as measurements, fault records) from the connected PQ devices, creates a comprehensive power quality analysis based on these data, and saves the PQ data and the evaluations in a dedicated archive.

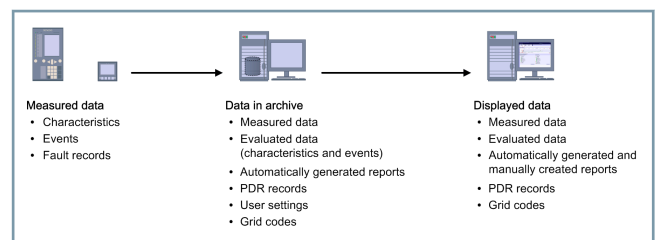

[dw_sicam_pq_analyzer_available-data_1_en_US]

Figure 3.2/2 Available Data

Functions of the SICAM PQ Analyzer

The SICAM PQ Analyzer connects to the archive of the SICAM PAS/PQS system and displays the data in the archive. Depending on the license, the SICAM PQ Analyzer provides a wide range of tools for analyzing these data.

The SICAM PQ Analyzer can be installed on the same computer as the SICAM PAS/PQS system, or on a separate computer in the network.

Control, Monitoring, and Diagnosis

SICAM PQ Analyzer – Functions

The archived PQ measured data and grid faults are evaluated in the different views of the SICAM PQ Analyzer.

• Incident Explorer

The Incident Explorer allows a time-related analysis and provides a topological or configuration view of:

- Fault events
- Fault records
- Slow-scan records
- Fault location reports
- Transient records
- PQ Violation reports (is generated as soon as a PQ violation against Grid Code happens)
- PDR records (Post Disturbance Review)
- SIPROTEC fault records (high-resolution fault record generated from a 7KE85 device)
- SIPROTEC slow-scan records (slow-scan records generated from a 7KE85 device)

Furthermore, you can export individual fault records. You can reduce the amount of data and select a COMTRADE export format.

• Fault Event Viewer

The Fault Event Viewer is used to visualize a fault event, all the associated fault records, and all the related events for the fault event. A graphical representation of the timeline and trigger information of all the associated fault records enables a better fault event analysis.

• Event Viewer

The Event Viewer visualizes the information points that are mapped in SICAM PAS/PQS UI – Configuration. The events are mostly process events that provides an overview of the status of the energy transmission or distribution system. The Event Viewer, therefore, ensures a better system fault analysis.

• PQ Explorer

- The PQ Explorer gives access to all PQ data stored in the archive.
- The PQ Explorer provides a topological view of the measuring points of your station.
- The measured and calculated PQ data are evaluated using PQ diagrams.
- The PQ Explorer allows you to create and save a favorite and favorite folder.

Furthermore, you can create reports of the analysis and preview the reports.

• PQ Inspector

The PQ Inspector shows the grid condition over a selectable time range based on the calculated PQ Index. It selectively provides a status overview of measured value groups which can be arbitrarily combined, as well as user guidance for the creation of PQ reports.

• Report Browser

The Report Browser gives an overview of the scheduled reports, which are generated automatically at defined intervals (daily, weekly, monthly, and yearly).

• Grid Code Viewer

The Grid Code Viewer displays the Grid Codes defined in SICAM PQS. The Grid Codes contain standardized or customer-specific limiting values for evaluating the grid quality. The PQ Index is determined on the basis of a comparison between the measured values and the limiting values of a Grid Code.

Fields of Application

Incident Explorer

The topological structure of the archive data corresponds to the structure that was defined when the SICAM PAS/PQS station was configured.

The Incident Explorer serves for the following tasks:

- Reading the events (confirm)
- Calling up the analysis programs
- Deleting the events from the archive summary
- Manual fault location

Various filter functions are available for selection of events in the power network

- Selecting the time range in the archive
- Filtering for events
- Commenting events

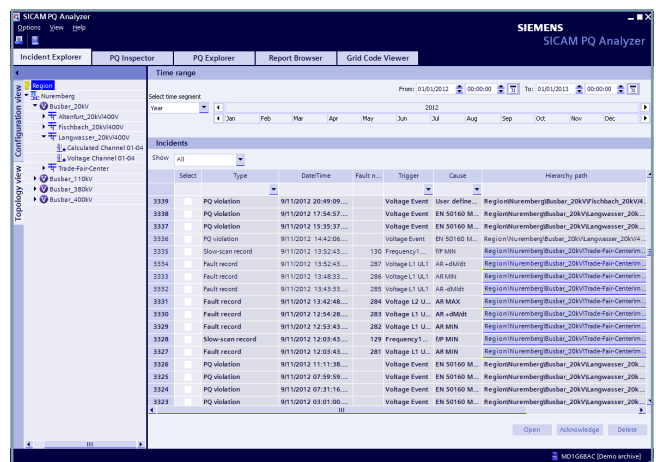

Figure 3.2/3 Incident Explorer

PQ Inspector

The PQ Inspector provides the operator with a quick overview of the plant's power quality based on the PQ index. The archived data is analyzed via any selectable time ranges. Causes of deviations in the measured values for the Grid Codes can thus be detected immediately.

PQ Inspector is divided into 3 steps:

- In **Select time range**, define the observation period and identify possible influencing factors for deviations of the power quality.
- In **Select diagrams**, select the properties of a specific measuring point, and define the diagrams in which you want to show these data items.
- In **Finalize report**, complete your report.

Use the **Select time range** step to view the state of the power quality of the system at a glance. You can set up individual measuring point groups and feature groups so that you can observe critical areas in a targeted manner.

The step **Select diagram** allows the compilation of evaluation diagrams with specific features for a report. The diagrams are represented in a synchronized manner. Hence you can rapidly identify connections in the event of fluctuations in power quality.

The step **Finalize report** allows reports to be prepared and commented upon.

PQ Explorer

PQ Explorer allows access to all PQ data stored in the archive. It offers a topological view of the measuring points in your plant. Measured and calculated PQ data is evaluated via PQ diagrams. Furthermore, you can generate analysis reports and display these in a preview.

Report Browser

The Report Browser provides an overview of the scheduled reports that are created automatically at specified time intervals (daily, weekly, monthly and yearly). You can view the reports with a viewer, print them and store them for future use.

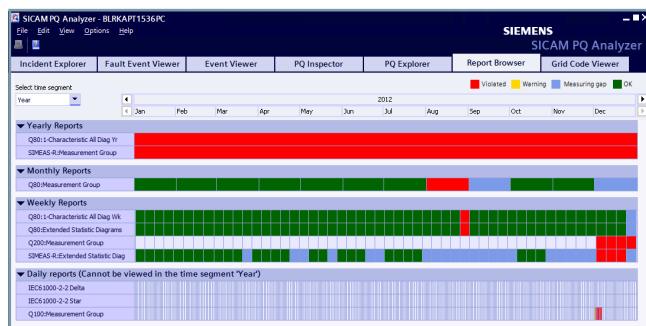

Figure 3.2/4 Report Browser

In Report Browser, the reports are shown for the selected time range – separated into yearly reports, monthly reports, weekly reports and daily reports. If you select the year time grid you cannot open daily reports. However, you can view the status and the time lapses for which infringement reports are available. Scheduled reports are automatically generated by the SICAM PQS system using the set up report templates. If you set up report templates, among other things define the intervals in which the reports are created, and the PQ devices for which the reports are created. The colors of the reports show their status.

Grid Code Viewer

The Grid Code Viewer displays the Grid Codes defined in SICAM PQS. The Grid Codes include normalized or customer-specifically defined limiting values for evaluating the power quality. The PQ Index is determined from a comparison of the measured values with the limiting values of a Grid Code.

The Grid Code Viewer provides the overview required for a supporting analysis:

- Which Grid Codes are available?
- To which elements in the topology have the Grid Codes been assigned?
- What features do the Grid Codes contain?
- What limits have been defined?

SICAM PQ Collector

The SICAM PQ Collector collects the archive data of the individual (source) archives in a central (collector) archive. Depending on the system configuration, the SICAM PQ Analyzer accesses the data of the (source) archives or (collector) archives for its archive evaluation.

In redundant archive systems, 2 SICAM PQ Collectors are connected. In the event of an interruption of the connection to (source) archives or after the failure of a SICAM PQ Collectors, this permits the archives to be matched, thus reaching an identical and complete contents of both (Collector) archives.

Architecture

- SICAM PAS/PQS with (source) archive and SICAM PQ Analyzer
- System with
 - SICAM PAS/PQS with (source) archive
 - SICAM PQ Analyzer clients
- System with
 - SICAM PAS/PQS
 - Archive servers with (collector) archive
 - SICAM PQ Analyzer clients

The number of components which can be used in a system depends on the individual license.

(Source) archive

SICAM PAS/PQS collects the PQ measured data and fault records from the connected devices and stores them in its local (source) archive. This archive data can be directly evaluated by one or more SICAM PQ Analyzer.

(Collector) archive

In distributed systems with one or several SICAM PAS/PQS, the data of the (source) archives is collected by the SICAM PQ Collector and stored in a central (Collector) archive on an archive computer. This archive data is evaluated by one or more SICAM PQ Analyzer.

Control, Monitoring, and Diagnosis

SICAM PQ Analyzer – Software and Hardware Requirements

Software and Hardware Requirements

One of the following operating systems is required:

- Windows 11 Professional/Enterprise/loT Enterprise LTSC (64-bit)
- Windows Server 2022 Standard with Desktop Experience (64-bit)

Computer equipped with:

- Processor:
 - Minimum: Intel Core 2 Duo 1.6 GHz
 - Recommended: Quad Core CPU 3 GHz
- Primary storage capacity:
 - Minimum: 2 GB
 - Recommended: 4 GB
- Hard disk capacity:
 - Minimum: 4 GB
 - (Collector) archive: > 100 GB
- Graphics card:
 - Minimum: 1600 x 1200 pixel
 - Recommended: 1920 x 1200 pixel
- Monitor suitable for graphics card
- DVD drive
- Keyboard
- Mouse
- Network interface
- USB port

SICAM PQ Analyzer is released for computers with multi-core processors. Computers with multi-processor main boards are supported when working in single-processor mode.

Control, Monitoring, and Diagnosis

SICAM PQ Analyzer – Selection and Ordering Data

Selection and Ordering Data

Description	Variants	Order No.																	
		1	2	3	4	5	6	7	8	9	10	11	12	13	14	15	16		
Delivery form	Physical delivery (DVD / USB stick)						0												
	Electronic delivery – OSD (Download)						2												
Incident Explorer for Fault-Record Analysis		6	M	D	5	5	3	□	-	0	A	A	1	0	-	3	□	□	0
																▲	▲	▲	
	Version 3.1x															3			
	Use on the SICAM PAS/PQS full server																A	A	
	Up to 5 clients, archive transfer of 1 server/full server																B	A	
	Up to 5 clients, archive transfer of up to 5 servers/full servers																B	B	
	Up to 5 clients, archive transfer of more than 5 servers/full servers																B	C	
	More than 5 clients, archive transfer of 1 server/full server																C	A	
	More than 5 clients, archive transfer of up to 5 servers/full servers																C	B	
	More than 5 clients, archive transfer of more than 5 servers/full servers																C	C	
Notes:																			
<ul style="list-style-type: none"> • 2 redundant PAS/PQS full servers are counted as 1 server. • 7KE85 and SIPROTEC 5 (if configured accordingly as of V9.20) provide not only fault records but also PQ data (example: continuous records) which are managed with the PQ Explorer. ⇒ for processing 7KE85- and SIROTEC 5- fault records and PQ data, atleast the usage of at least PQ Basic is recommended.																			
PQ Basic		7	K	E	9	2	0	□	-	0	B	A	1	0	-	3	□	□	0
Delivery form	Physical delivery (DVD / USB Stick)							0											
	Electronic delivery – OSD (Download)							2											
Including Incident Explorer for fault-record analysis and PQ Explorer																		▲	▲
Recommended SICAM PAS/PQS option: Automatic grid-code evaluation <-> 7KE9000-0BA67-8AA0																			
	Use on the SICAM PAS/PQS full server																	A	A
	Up to 5 clients, archive transfer of 1 server/full server																	B	A
	Up to 5 clients, archive transfer of up to 5 servers/full servers																	B	B
	Up to 5 clients, archive transfer of more than 5 servers/full servers																	B	C
	More than 5 clients, archive transfer of 1 server/full server																	C	A
	More than 5 clients, archive transfer of up to 5 servers/full servers																	C	B
	More than 5 clients, archive transfer of more than 5 servers/full servers																	C	C

Table 3.2/1 SICAM PQ Analyzer – Selection and Ordering Data

Control, Monitoring, and Diagnosis

SICAM PQ Analyzer – Selection and Ordering Data

Description	Variants	Order No.																		
		1	2	3	4	5	6	7	8	9	10	11	12	13	14	15	16			
Continued from previous page																				
Delivery form	Physical delivery (DVD / USB Stick)						0													
	Electronic delivery – OSD (Download)						2													
PQ Standard		7	K	E	9	2	0	□	-	0	C	A	1	0	-	3	□	□	0	
Including PQ Basic, extended PQ Explorer and Report Browser																		▲	▲	
Recommended SICAM PAS/PQS options: Automatic grid-code evaluation <-> 7KE9000-0BA67-8AA / scheduled PQ reports <-> 7KE9000-0BA68-8AA0																				
	Use on the SICAM PAS/PQS full server																	A	A	
	Up to 5 clients, archive transfer of 1 server/full server																	B	A	
	Up to 5 clients, archive transfer of up to 5 servers/full servers																	B	B	
	Up to 5 clients, archive transfer of more than 5 servers/full servers																	B	C	
	More than 5 clients, archive transfer of 1 server/full server																	C	A	
	More than 5 clients, archive transfer of up to 5 servers/full servers																	C	B	
	More than 5 clients, archive transfer of more than 5 servers/full servers																	C	C	
PQ Professional		7	K	E	9	2	0	□	-	0	D	A	1	0	-	3	□	□	0	
Including PQ Standard and PQ Inspector																			▲	▲
Recommended SICAM PAS/PQS options: Automatic grid-code evaluation <-> 7KE9000-0BA67-8AA0/scheduled PQ reports <-> 7KE9000-0BA68-8AA0																				
	Use on the SICAM PAS/PQS full server																		A	A
	Up to 5 clients, archive transfer of 1 server/full server																		B	A
	Up to 5 clients, archive transfer of up to 5 servers/full servers																		B	B
	Up to 5 clients, archive transfer of more than 5 servers/full servers																		B	C
	More than 5 clients, archive transfer of 1 server/full server																		C	A
	More than 5 clients, archive transfer of up to 5 servers/full servers																		C	B
	More than 5 clients, archive transfer of more than 5 servers/full servers																		C	C

Table 3.2/2 SICAM PQ Analyzer Selection and Ordering Data

Control, Monitoring, and Diagnosis

SICAM PQ Analyzer – Selection and Ordering Data

Description	Variants	Order No.																	
		1	2	3	4	5	6	7	8	9	10	11	12	13	14	15	16		
Continued from previous page																			
Delivery form	Physical delivery (DVD / USB Stick)							0											
	Electronic delivery – OSD (Download)							2											
Functional Upgrades																			
<i>Power Quality functions</i>		7	K	E	9	2	0	□	-	4	□	□	0	0	-	3	A	A	0
	From Incident Explorer to PQ Basic												B	A					
	From PQ Basic to PQ Standard												C	B					
	From PQ Basic to PQ Professional												D	B					
	From PQ Standard to PQ Professional												D	C					
Number of clients ²⁴		6	M	D	5	5	3	□	-	4	A	A	0	0	-	3	□	A	0
	Up to 5 clients																	B	
	From up to 5 clients to more than 5 clients																	C	
Number of full servers ²⁵		6	M	D	5	5	3	□	-	4	A	A	0	0	-	3	A	□	0
	Up to 5 full servers																		B
	From up to 5 full servers to more than 5 full servers																		C
Version Upgrade																			
	Upgrade from SICAM Recpro V5.x to SICAM PQ Analyzer (Incident Explorer)	6	M	D	5	5	3	□	-	3	A	A	0	0	-	3	A	A	0
	Version upgrade SICAM PQ Analyzer	6	M	D	5	5	3	□	-	3	A	A	0	1	-	3	A	A	0
Demo Version		7	K	E	9	2	0	□	-	7	A	A	0	0	-	3	A	A	0

Table 3.2/3 SICAM PQ Analyzer Selection and Ordering Data

SICAM PQ Analyzer can be extended with SIGRA for extended fault-record analysis (ordered separately).

²⁴ Hint: Both MLFB numbers (...3BA0 and ...3CA0) must be ordered when upgrading from **1 client to more than 5 clients**.

²⁵ Hint: Both MLFB numbers (...3AB0 and ...3AC0) must be ordered when upgrading from "1 full server" to "more than 5 full servers".

Control, Monitoring, and Diagnosis

SICAM DISTO – Description

Description

The generation of fault records is an important function of digital protection devices. Fault records support the precise analysis of critical events in the power system. For this task, it has proven its worth for fault records to be retrieved via the station communication of the protection devices and for these to be stored on a hard disk at the station level. Serial communication to digital protection devices was originally standardized in IEC 60870-5-103. Currently, the new standard for communication in power generation and power distribution plants (IEC 61850) has considerably extended and modernized the options for data exchange with instrumentation and control devices.

SICAM DISTO (disturbance data storage) is a software package that detects new fault records in the connected devices, lists these and stores them in preconfigured directories on the hard disk of a PC. In order to support easy evaluation with different software tools, DISTO uses the standardized COMTRADE-format 91 and 99 in accordance with IEC 60255-24 for the files of the fault records. Files that need to be transmitted via IEC 60870-5-103 have to be converted by DISTO into COMTRADE. With IEC 61850, the files arrive in the right format. Some protection devices transmit the COMTRADE files compressed in zip files via IEC 61850. SICAM DISTO detects such files and unpacks them into the correct directories. Basically, with IEC 61850, SICAM DISTO expects the fault record transmissions via MMS. The function variant File Transfer Protocol (FTP) is not supported.

When using IEC 60870-5-103, DISTO additionally creates an event list with all protection-relevant information such as fault record number and fault location, both with absolute and relative real time (within one fault). The stored files contain the temporal behavior of currents and voltages before, during and after a system incident, supplemented with digital events (for example, protection tripping). This data can be represented graphically on the screen and analyzed with the help of SIGRA or other software packages.

For access to station communication, DISTO requires an installed SICAM SCC and its integrated communication drivers. Remote access to the stored files can take place with the standard tools of the operating system.

SICAM DISTO is available for the following system platforms:

SICAM DISTO/OS	Windows 10 Professional	Windows 10 Enterprise	Windows 8.1	Windows Server 2012 R2	Windows Server 2016	Windows Server 2019
V3.10	-	-	■	■	-	-
V3.20	■	■	-	■	■	■

Table 3.3/1 Overview of Basic System - Windows

Platform-dependent differences only exist with the system requirements. In part, there are also visual differences between the different platforms; there are no functional differences. The host system is used as an interface to the automation system, that is, all those interfaces that the respective host system offers to the automation system can also be used to transfer fault record data.

Dependent on the utilized platform, there are various requirements that have to be fulfilled in order to commence the installation of SICAM DISTO.

With version V3.20 and higher, SICAM DISTO also provides the option of storing the data in an archive that is supported by the PQ collector to ensure that the fault records can be displayed and evaluated in the SICAM PQ Analyzer – Incident Explorer.

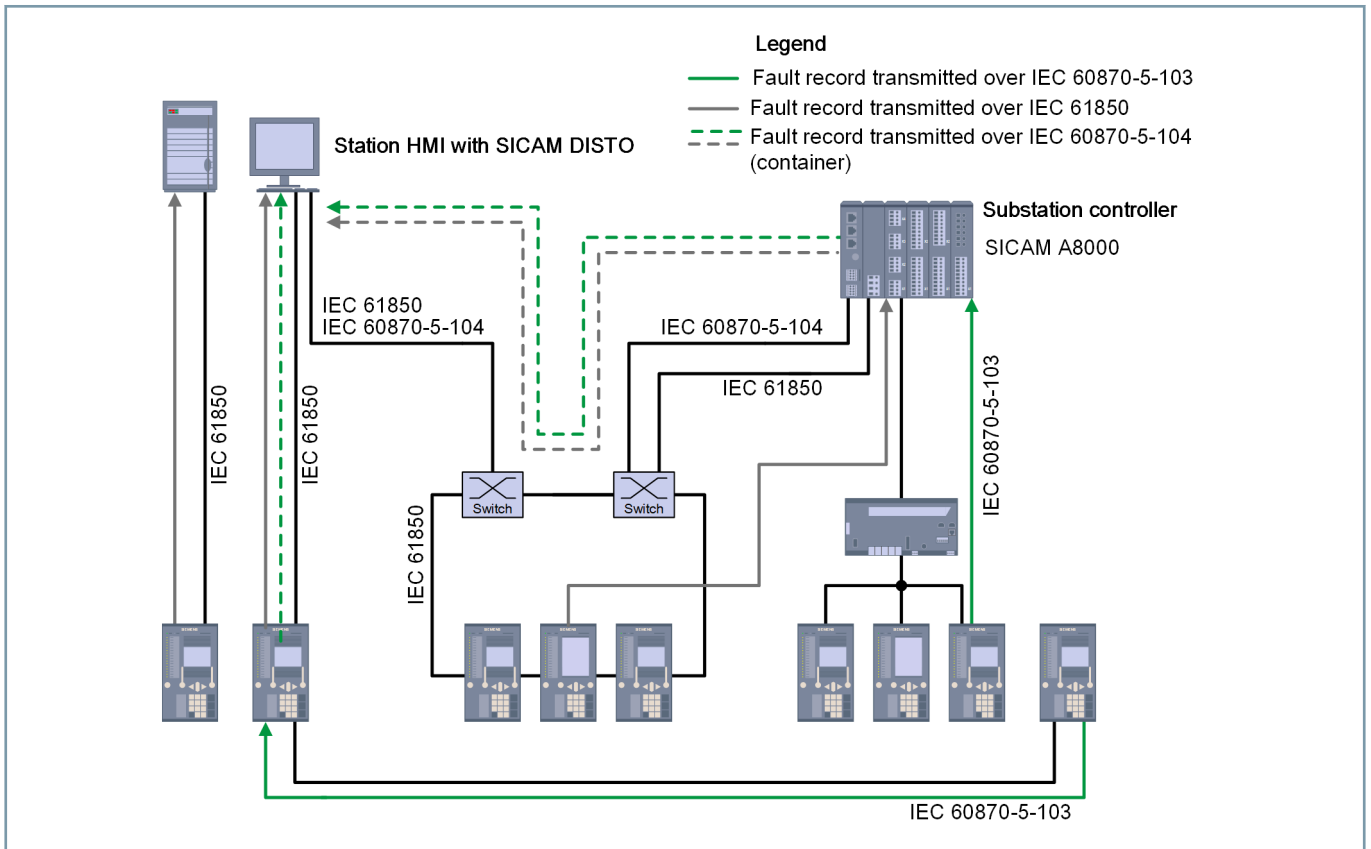

[dw_sicam-disto-application_4_en_US]

Figure 3.3/1 SICAM DISTO, Example Configuration

Selection and Ordering Data

Description	Versions	Order no.
SICAM DISTO	VZ2-014--	6 M F 1 8 2 7 - 0 C A 1 4 - 0 A A 1
SICAM DISTO UPDATE	VZ2-026--	6 M F 1 8 2 7 - 0 C A 2 6 - 0 A A 1

Table 3.3/2 SICAM DISTO Selection and Ordering Data

Control, Monitoring, and Diagnosis

SICAM DISTO – Selection and Ordering Data

3.3

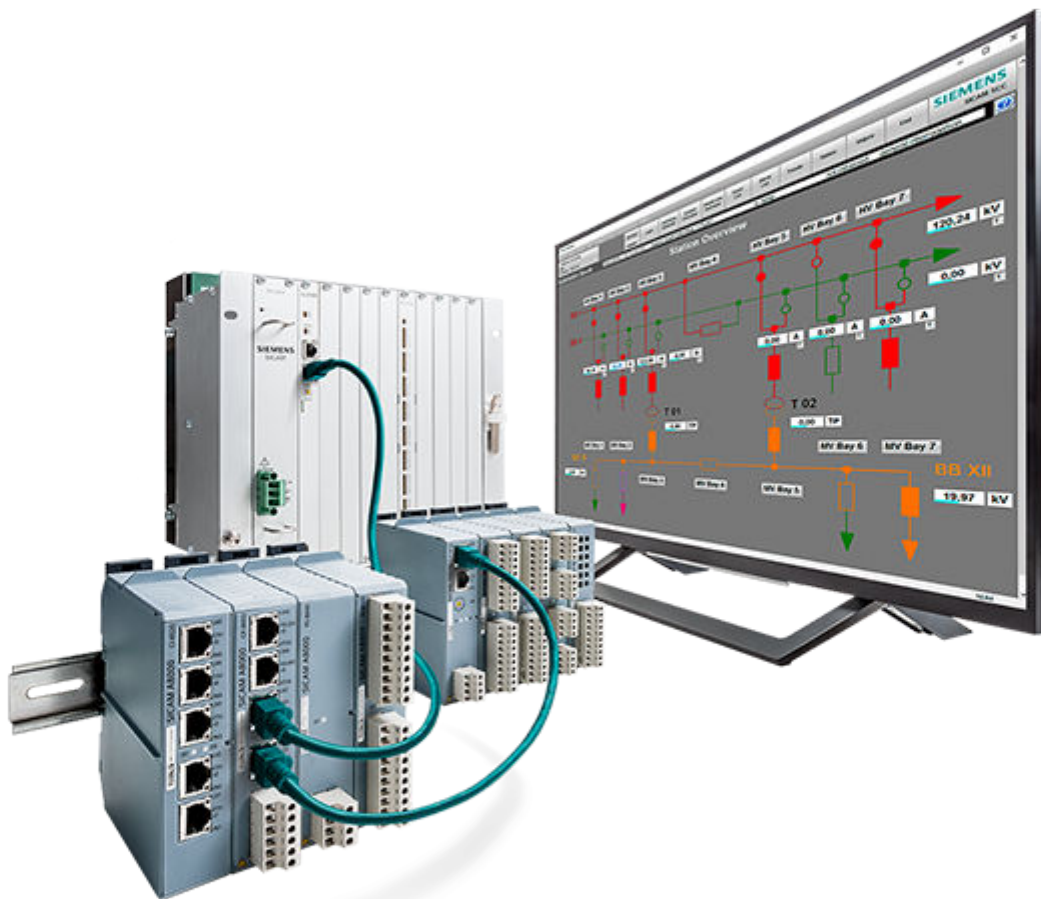

Software for Station Automation

SICAM PAS UI – Description

Description

SICAM PAS/PQS has been designed as a modular system with open communication interfaces. It thus meets the requirements of state-of-the-art substation control and protection systems and of the power management systems required for industrial manufacturing plants. Functions for power quality evaluation complement its versatile fields of application.

The system component **SICAM PAS UI – Configuration** is responsible for:

- Configuration and parameterization of your plant
- Exchange of configuration data

The clearly structured configuration interface provides you with a comprehensive overview of your plant's parameters.

Individual user interface elements can be displayed in a user-specific manner or hidden. For example, table columns which are permanently required can be fixed in position in the individual view; table columns which are not needed can simply be hidden. The settings are also maintained after a restart of the program.

Import and export functions enable data exchange. In this way, expenditure and the tendency to commit errors during system configuration and parameterization can be reduced.

Due to the use of conversion routines, the project data of a SINAUT LSA plant or with older versions of SICAM PAS UI – Configuration generated data can continue to be used.

Predefined device templates, sorting and filter options, copy functions and the processing of parameters in Microsoft Excel increase transparency and flexibility and thus make parameterization more user-friendly.

Plant-specific automation functions are configured via a graphical interface. You can use both standard logic functions and automation blocks specifically developed for the implementation of your power automation tasks.

Your parameter entries are immediately checked for plausibility.

Tooltips provide information on the permissible values or the range of values of a parameter. Explanations on the selected parameter are provided in an information field.

The cause of a setting error is displayed in the error field.

In addition, you are supported by a context-sensitive online help.

The configured and parameterized data does not have to be explicitly generated for the runtime environment.

You can create documentation for your project via the station documentation function. To do this, you can choose between different selection criteria, for example, selection according to individual views (configuration, mapping, topology, etc.) or routed values only. Specific areas of a selected view can be printed out, for example, the routing of individual devices or of a control-center connection.

The project statistics give you an overview of the scope and use of the parameterized information.

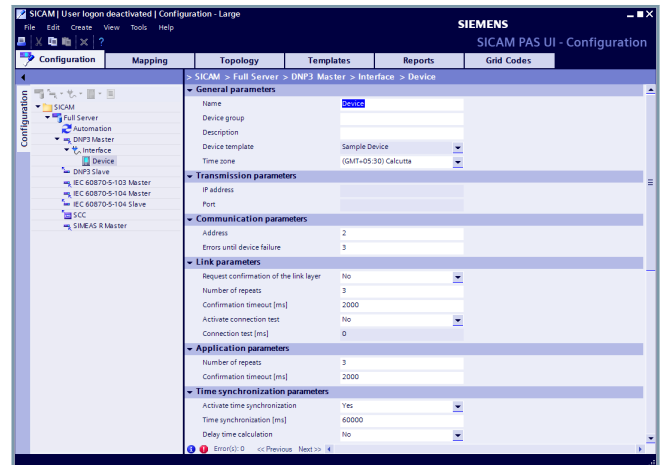

Figure 4.1/1 Configuration of SICAM PAS

SICAM PAS UI – Configuration structures the parameters in the following views:

- Configuration
- Mapping
- Topology
- Templates

In the views **Reports** and **Grid codes**, you can set the parameters of specific power quality functions. You can find further information in the [manuals SICAM PQS, SICAM PQS Overview and SICAM PQ Analyzer](#).

SICAM PAS/PQS UI – Operation

SICAM PAS/PQS UI – Operation can be used to activate and deactivate the individual components, set a bay blocking or tele-control blocking and update device information. In redundant systems, you can see which component is active. The components can be switched over with SICAM PAS/PQS UI – Operation, such as the interface for the communication to devices or network control centers.

SICAM PAS/PQS UI – Operation Client

With SICAM PAS/PQS UI – Operation Client you can start and stop all redundant connections independently of each other. SICAM PAS/PQS UI – Operation Client provides the functions of SICAM PAS/PQS UI – Operation from a local or remote computer with improved performance via an Internet browser.

There are hints for possible causes for defect for the diagnosis of pending failures.

Value Viewer

With intact communication connections, the Value Viewer shows the information of the selected device or the selected substation. This information view can be used, for example, during commissioning to test data connections and to check whether an interface or a device transfers correct values. A detailed time stamp shows the reliability of the values. For test purposes, you can initiate password-protected command outputs or update information.

You can find further information in the [SICAM PAS/PQS – Configuration and Operation manual](#).

Selection and Ordering Data

You can find the selection and ordering data for SICAM PAS UI in the chapter SICAM PAS – [Selection and Ordering Data, Page 26](#).

Software for Station Automation

SICAM TOOLBOX II – Description

Description

The SICAM TOOLBOX II supports all phases of plant engineering, such as configuration, project engineering, diagnostics, testing, documentation and maintenance during the entire plant life cycle. Nowadays, keywords such as integration, networkability, consistent data maintenance and non-redundant data input are an absolute must-have requirement for engineering systems. SICAM TOOLBOX II fulfills all of these requirements and makes use of the latest technological methods to simplify plant engineering. This allows highly-effective working throughout the whole engineering process.

SICAM TOOLBOX II offers all functions for integrated and consistent engineering of the entire plant, such as:

- data collection, data modeling, configuration and parameterization
- engineering of process information for automation and maintenance control
- administration of systems from third party manufacturers and their individual parameters

SICAM TOOLBOX II is an ideal tool for plants of any size.

Benefits

Integrated System

- 1 tool for all systems
- Simple, consistent engineering
- Scalable

Object Orientation

- Easy and transparent engineering
- High efficiency and engineering quality
- Reduced engineering costs

Consistent Data Maintenance

- Central database
- Reduction in the input cost
- No duplicate inputs reduce input errors

Engineering of Process Technology

- Reduction of initial creation effort
- Rational, efficient engineering

Functions for SICAM Automation Systems

- Easy system test – online and offline
- Plaintext diagnostics
- Remote servicing
- Logging and simulation of telegrams
- Functions local and remote

Functions for Maintenance Control Systems

- Engineering of process tags
- Redundancy-free data input, for example, reading out SICAM RTU telegram addresses based on IEC 60870-5-101/104 addressing
- Automatic creation of attributes with equations

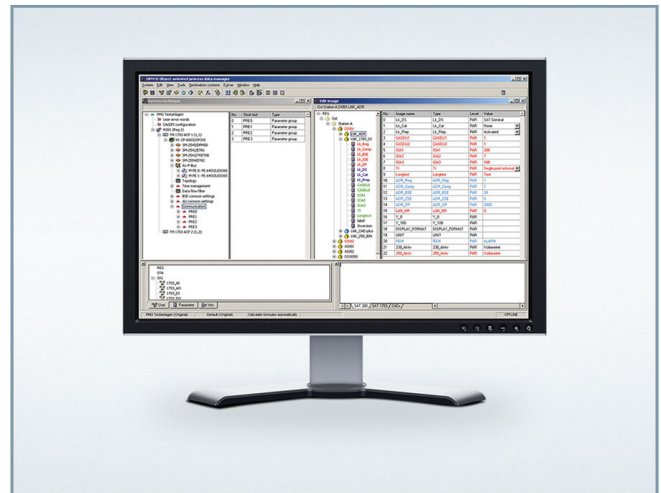

[URL_SICAM TOOLBOX II, 1, ...]

Figure 4.2/1 SICAM TOOLBOX II

- Automatic creation of text addresses
- Generation of the database
- Context-sensitive connection of the OPM II from the system image of the maintenance control system

Functions for PLC Applications

- Fully-graphic user interface
- Object oriented
- Compliance with standards in accordance with IEC 61131-3
- Simple offline/online test

Functions for Third-Party Systems

- Open interface
- Storage and removal of engineering data
- Simple reading out of existing data
- Any attributes definable in the customer project itself

System Overview

Nowadays, engineering has become an important cost factor, not only in the creation of new plants but also in the maintenance of existing plants and the administration of relevant data resources. With the integrated engineering system SICAM TOOLBOX II, Siemens offers a comprehensive and cost-saving solution for these tasks.

Object Orientation: Work more Rapidly and Safely

With the introduction of object orientation, the designer can describe actual units and equipment in the project planning process and can employ them in the engineering process as defined objects. These can be, for example, individual components such as pumps or circuit breakers, but also larger units, such as feeders. Above all, if a plant is composed of a multitude of identical primary assemblies and equipment (such as voltage transformation substations or hydropower plants, and pipelines), object-orientation offers considerable cost-reduction potential.

In parallel to this, the error quota drops because the structure of the equipment is moved into the background due to the creation of process-technology objects with SICAM TOOLBOX II. Thus, the developer no longer has to deal with a large number of individual signals. Instead, they can concentrate on their actual task: engineering of the plant. In order to make optimum use of this advantage, the objects can be completely freely defined without constraint with respect to sector-specific applications.

With respect to networkability and a collaborative working method, SICAM TOOLBOX II offers all possibilities from the individual workstation right up to complex network solutions, in which several project engineers work in parallel on multiple projects. The function of distributed working even allows several project engineers to work simultaneously on a project, even if the individual SICAM TOOLBOX II PCs are not connected via a network. The distributed data resources are easily and conveniently merged at a later point.

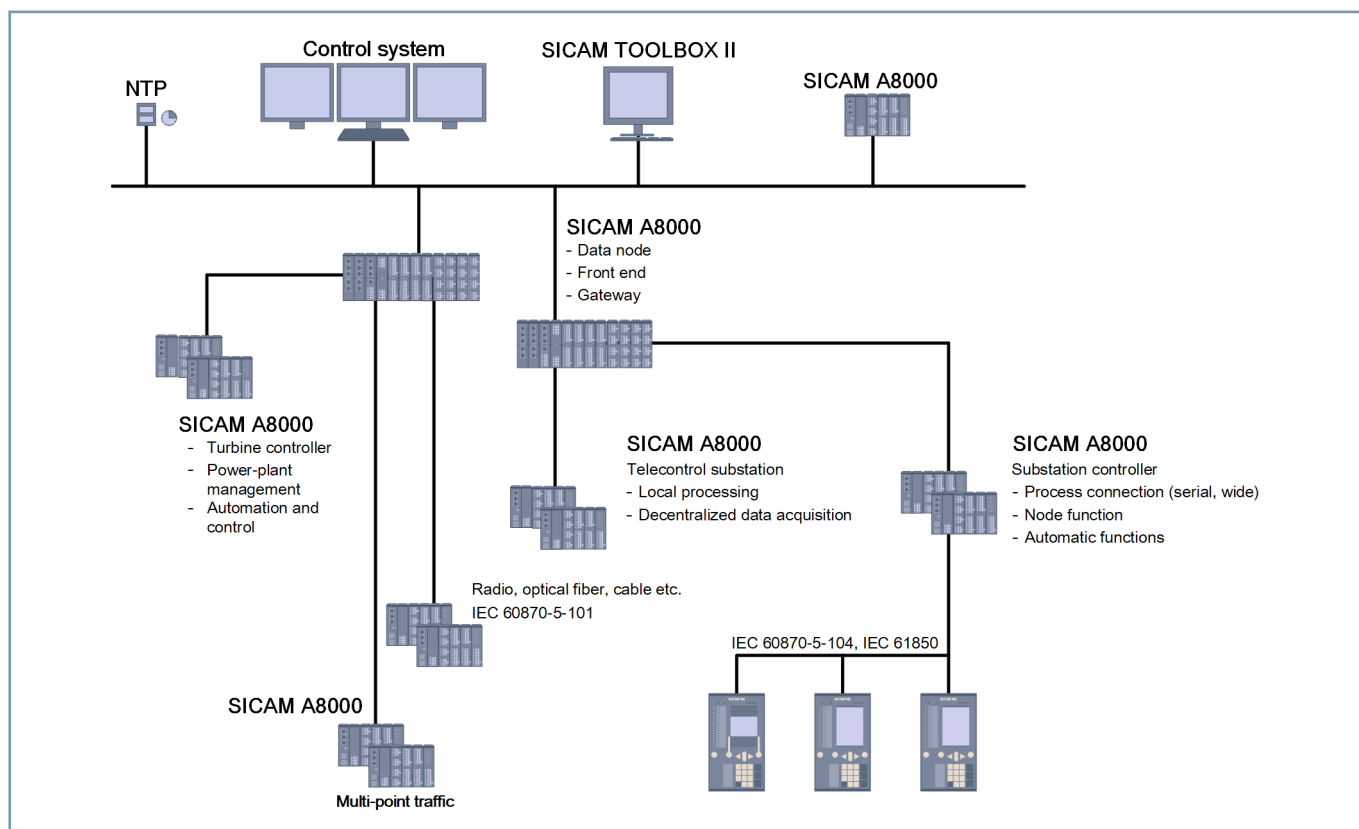

[dw_sicam-toolbox-2-konfig_4_en_US]

Figure 4.2/2 SICAM TOOLBOX II – Example Configuration (also Continues to be Available for SICAM AK3 and SICAM TM)

Engineering on the Web

The diverse functions of SICAM TOOLBOX II can also offer unlimited benefits on the Internet and Intranet – with the same convenient user interface as in the local installation. The Web functions integrated into SICAM TOOLBOX II allow operation in Internet Explorer without further training. To do this, SICAM TOOLBOX II does not even have to be installed locally on the operator's PC – all functions run on the corresponding Windows terminal server.

The core element of data management in SICAM TOOLBOX II is a central database that is accessed by all tools of SICAM TOOLBOX II and in which all information is stored. Information that has been entered is available to all employees on a project and all tools immediately, and at the latest revision status. This reduces the error quota, avoids double entries and thus reduces engineering effort.

Software for Station Automation

SICAM TOOLBOX II – Description

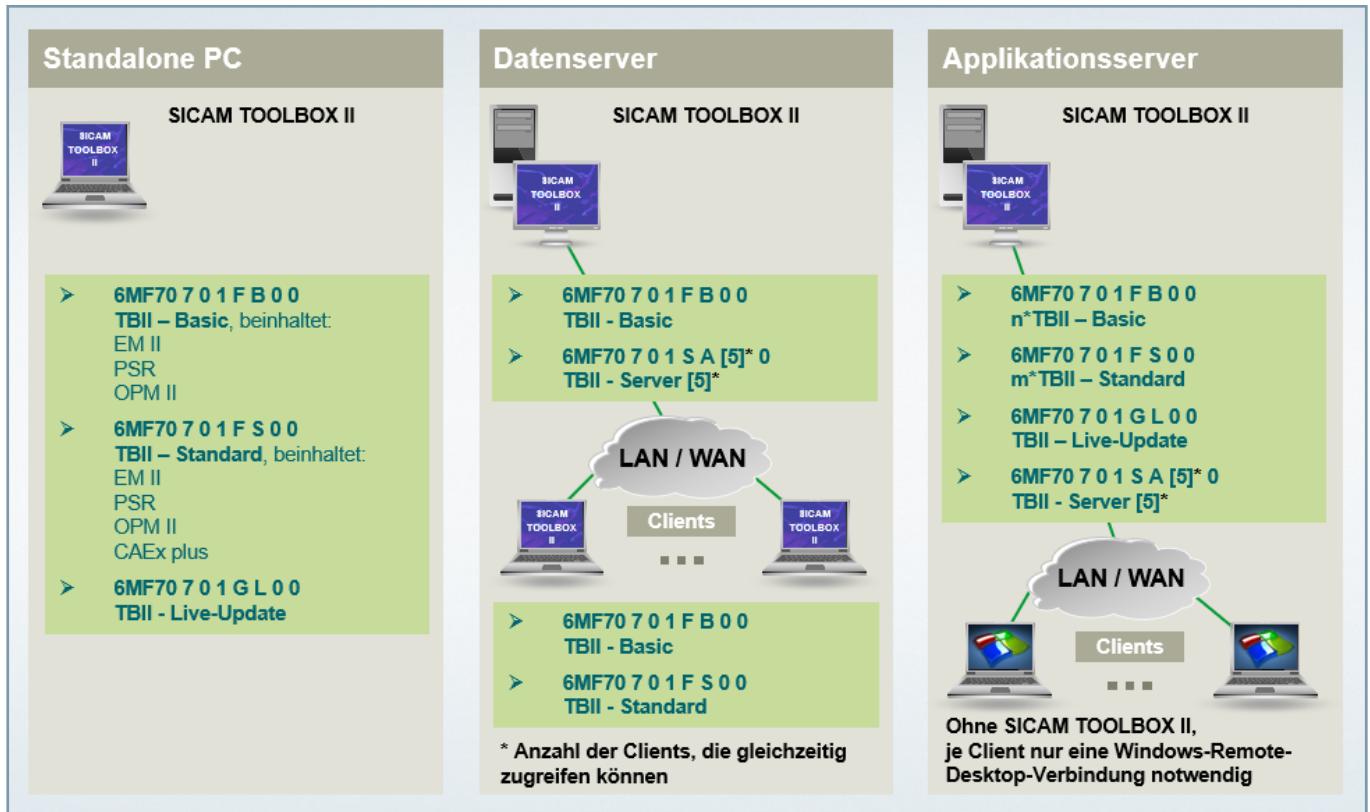

[sc_SICAM TOOLBOXII_System configuration, 3_en_US]

Figure 4.2/3 SICAM TOOLBOX II – Summary of V7.0 ALM Licensing

PLC applications

The linkage, control and regulation applications are created in SICAM TOOLBOX II with CAEx plus. This powerful tool boasts a fully graphic user interface and intuitive operation. This permits short familiarization times and minimized training outlay. CAEx plus is completely integrated in SICAM TOOLBOX II. It allows user programs to be efficiently and easily generated in accordance with the standard IEC 61131-3.

With standardized user programs, the use of typical function block diagrams allows rapid and error-free programming. The concise and clearly-arranged operating structure supports rapid and efficient working, which is further reinforced by a multitude of easily operated functions. Examples include the project explorer, intuitive function block diagram editor, navigator and documentation management. The comprehensive online help provides support at all times in the event of uncertainties. CAEx plus also includes comprehensive and easily operated testing options. The **offline test** can be used – independently from the automation system – for testing the user program under Windows, in almost real time. In the **online test**, the program can then be checked with the automation system.

Functions

For SICAM automation systems

In a SICAM RTU automation network, SICAM TOOLBOX II allows project engineering, loading, system diagnostics, system testing and documentation of the automation and telecontrol functions

for local and remote automation units: All functions can be implemented via the communication routes of the automation system (that is, without their own power line). In this way, the plant can be very easily tested and put into operation. The integrated diagnostic options of SICAM TOOLBOX II allow any errors to be quickly and reliably located and rectified. As a result, it considerably increases the availability of the overall system. In the event of an error, the detailed diagnosis displays comprehensive fault information in plaintext and provides information about possible causes and their rectification. Remote maintenance allows access to automation systems from any location via, for example, telephone, modem, ISDN, TCP/IP, and is thus the basis for the corresponding service activities. For data simulation, any number of telegrams can be defined with menu guidance and hence simulated in the automation system. Logging points can be selected with graphic support in order to follow the data flow. With associated telegram filters, only those telegrams are displayed that are relevant for the respective test.

For maintenance control systems

The process data points in the maintenance control systems and local HMIs (such as SICAM SCC) and their attributes can be defined and their parameters set with SICAM TOOLBOX II. Attributes are transferred from the SICAM RTU automation system in a non-redundant manner via the use of SICAM TOOLBOX II references. This means that the project engineer does not have to, for example, enter the telegram address for the maintenance control system. The use of SICAM TOOLBOX II equations provides the option of automatically calculating attributes of the

maintenance control system, hence accelerating engineering and minimizing errors. Furthermore, the text address is automatically created.

For third-party systems

The open interface to any third-party system is an important feature of SICAM TOOLBOX II. Using this interface, data can be removed or third-party data transferred. Removed data can be converted with any program for automatic post-parameterization. The storing of third-party data can also be batch controlled, that is, without actual operation of SICAM TOOLBOX II. In addition to the storing of individual attributes, signals or any higher-value objects can be created (for example, a feeder, a pump, a circuit breaker). In this way, even old data can very easily be inherited by the SICAM TOOLBOX II. Furthermore, the option exists to define and administer parameters of third-party systems or even general parameters. The attributes can be defined by the project engineer in the customer project itself. Examples of this are parameters from third-party manufacturers. With these self-defined parameters, collaborative engineering is also possible in addition to all SICAM TOOLBOX II standard processing activities, such as mass processing, references and equations.

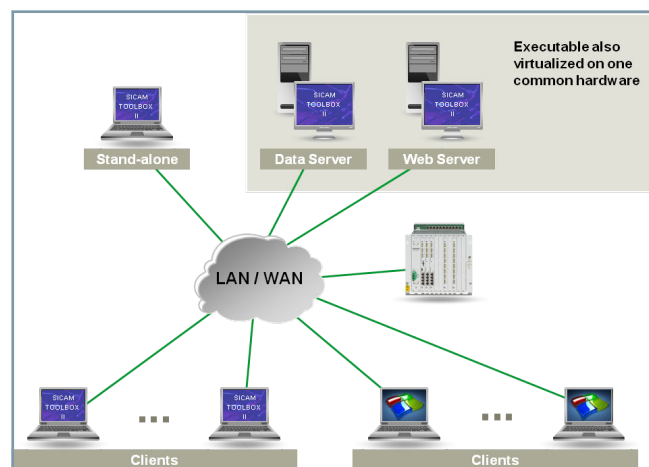

Figure 4.2/4 SICAM TOOLBOX II Server/Client Configuration

Version 7.10 News

The security ORACLE patch update supports Microsoft Windows 11 and Server 2022 (as well as Microsoft Windows 10 and Server 2019).

Version 7.00

The new version of SICAM TOOLBOX II version 7.00 includes the following extensions and improvements:

New Features

- Support of current operating systems
 - SICAM TOOLBOX II version 7.0 supports Windows 10, Windows Server 2016 R2 and Windows Server 2019.
- ALM (Automation License Manager)

- All toolsets in SICAM TOOLBOX II version 7.0 are exclusively licensed by the ALM. This means that you do not need to input license keys when you install or query a dongle when starting up CAEx plus. All licenses and the associated permissions are managed in the ALM (see also product information/installation)

- Migration support for SICAM I/O rack modules
 - SICAM I/O rack modules can be reused by transmitting/migrating to CP-8050 in the system technology
- Signal2csv Command Tool
 - Signals (attributes for the general address link – LNK_ADR) can be exported from TOOLBOX II in a *.csv file in SICAM Device Manager import format.
- CP-8031 support
 - Support for device type CP-8031
- ORACLE DB security
 - SICAM TOOLBOX II Version 7.0 has been converted to ORACLE 19c, including a security patch. Display of the version and the patch levels in the dialog versions of the installed toolsets (default TOOLBOX settings, system menu, TOOLBOX info, toolsets, etc.): Oracle version: XX.X.X.X.X PATCH SET FOR ORACLE DATABASE SERVER.

Improved/Changed Features

- Online help
 - SICAM TOOLBOX II version 7.0 includes improved online help, especially for the new features. Its updated form is provided as a *.chm file.
- CP-8050 diagnostics information
 - Updated/additional diagnostics information for existing/new protocol elements
- Firmware updates
 - Master data for SCALA version 7.20
 - Master data 90014.wls
 - Master data for SICAM SCC MPCC00 Revision@13
 - Incorporating SICAM WEB V5.40

Compatibility

- Existing engineering data from SICAM TOOLBOX II versions 6.xx can be imported into the new SICAM TOOLBOX II version 7.0 and can thus continue to be used. Data that has been created with SICAM TOOLBOX II version 7.0 can NOT be imported into earlier versions (for example, V6.xx).

Software for Station Automation

SICAM TOOLBOX II – Selection and Ordering Data

Selection and Ordering Data

Description	Variants	Order No.											
		1	2	3	4	5	6	7	8	9	10	11	12
Delivery form	Physical delivery (DVD/USB stick)								1				
	Electronic delivery (Download (OSD)) ²⁶								2				
SICAM TOOLBOX II		6	M	F	7	0	□	□	-	□	□	□	□
							▲				▲	▲	▲
Version 7.0						7							
License	Basic									F	B	0	0
	Standard									F	S	0	0
	SERVER 2									S	A	2	0
	SERVER 3									S	A	3	0
	SERVER 5									S	A	5	0
	SERVER 10									S	A	6	0
	SERVER 25									S	A	7	0
	SERVER 100									S	A	8	0
Toolset upgrade	SICAM TOOLBOX II – EM II									G	E	0	0
	SICAM TOOLBOX II – PSR II									G	S	0	0
	SICAM TOOLBOX II – OPM II									G	P	0	0
	SICAM TOOLBOX II – CAExplus									G	C	0	0
	SICAM TOOLBOX II – CAEsafety									G	F	0	0
	SICAM TOOLBOX II – Live update									G	L	0	0
Update	SICAM TOOLBOX II – Basic update						0		2	U	B	0	0
	SICAM TOOLBOX II – Standard update						0		2	U	S	0	0
	SICAM TOOLBOX II – SERVER 2 update						0		2	U	S	2	0
	SICAM TOOLBOX II – SERVER 3 update						0		2	U	S	3	0
	SICAM TOOLBOX II – SERVER 5 update						0		2	U	S	5	0
	SICAM TOOLBOX II – SERVER 10 update						0		2	U	S	6	0
	SICAM TOOLBOX II – SERVER 25 update						0		2	U	S	7	0
	SICAM TOOLBOX II – SERVER 100 update						0		2	U	S	8	0
	<i>Version 7.10</i>												
	SICAM TOOLBOX II - Update 7.0 to 7.10						1		2	U	T	0	0
	SICAM TOOLBOX II - SERVER 2 update 7.10						1		2	U	S	2	0
	SICAM TOOLBOX II - SERVER 3 update 7.10						1		2	U	S	3	0
	SICAM TOOLBOX II - SERVER 5 update 7.10						1		2	U	S	5	0
SICAM TOOLBOX II - SERVER 10 update 7.10						1		2	U	S	6	0	
SICAM TOOLBOX II - SERVER 25 update 7.10						1		2	U	S	7	0	
SICAM TOOLBOX II - SERVER 100 update 7.10						1		2	U	S	8	0	

Table 4.2/1 SICAM TOOLBOX II Selection and Ordering Data

²⁶ From September 2021

Description

Configuration with SICAM WEB can be implemented for modules CP-8000/8021/8022. Configuration for modules CP-8031 and CP-8050 requires the use of SICAM TOOLBOX II or the SICAM Device Manager.

Using a tablet or PC and a browser, SICAM WEB is the easiest way to configure and test devices of the SICAM A8000 series.²⁷

Enter the IP address of the SICAM A8000 device in the browser address bar, and then edit the access data in the SICAM WEB log-on dialog.

This is followed by bidirectional communication with the SICAM A8000 device via an Ethernet connection.

No time-consuming software download and installation.

The SICAM A8000 series supports role-based access control (RBAC).

RBAC is configured online on the device using SICAM WEB. In accordance with IEEE 1686, the BDEW Whitepaper, and IEC 62351-8, 8 roles are predefined in SICAM A8000 series devices. A role contains specific rights to carry out specific functions. Every user can be assigned one or more roles and the associated rights. The ADMINISTRATOR role has all rights, such as the ability to change configuration data and start test runs.

Convenient functions for CP-8000/8021/8022

- Easy online parameter entry for CP-8000/21/22 via HTTPS, with maximum ease of use
- Structured user interface and logical operating steps optimized for every working situation
- Free utilization with any current Web browser; no limitation
- No time-consuming installation necessary
- Utilization via tablet or PC
- Connection via direct Ethernet connection or via WLAN with a router

Additional functions for CP-8031 and CP-8050

- System and firmware overviews
- Wiring test of the I/O modules
- I/O data-point simulation
- Monitoring, simulation, and tracking of signals
- Integrated Wireshark functionality
- Protocol-specific Internet pages
- Customer-specific dashboards

Advantage with SICAM WEB for CP-8031 and CP-8050²⁸

- Direct access to the device via HTTPS using role-based access (RBAC)
- Simulation functions with corresponding authorization only
- A diagnostic entry is made as soon as signals are decoupled from the process

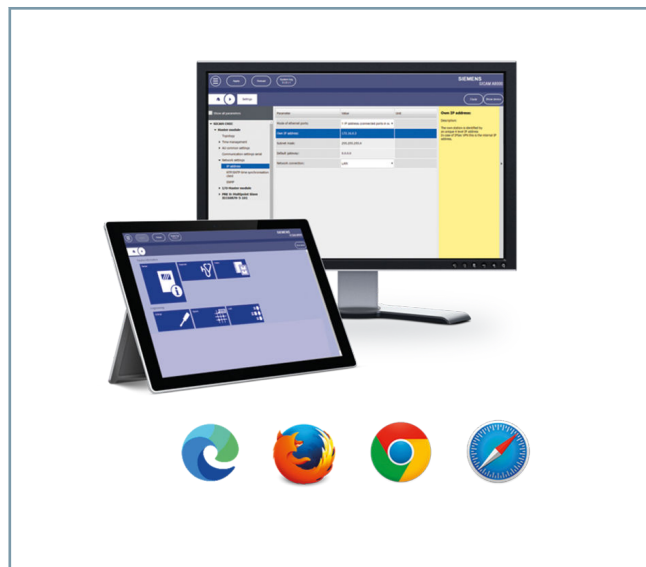

[ph_SICAM WEB, 2, ...]

Figure 4.3/1 SICAM WEB

Customer-specific dashboards

- Inclusion of individual scalable vector graphics (SVG)
- Design of SVG graphics using Inkscape Open Source software
- Tile-based graphics structuring
- LED icons for alarm visualization
- Integrated system functions (command output, menu bar, key switch)
- Role-based operator access via HTTPS
- Without additional engineering tool

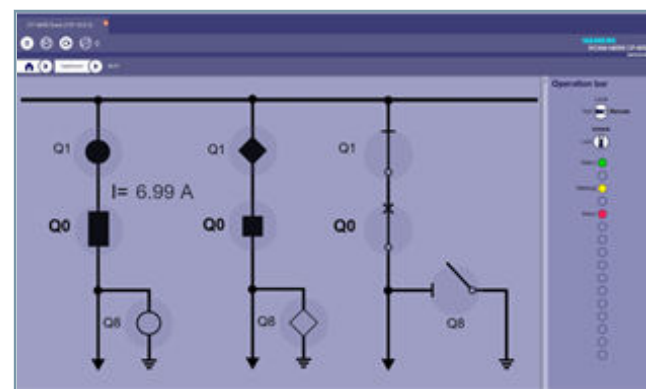

[pc_SVG Graphic, 1, ...]

Figure 4.3/2 SVG Graphic

²⁷ Configuration for modules CP-8031 and CP-8050 requires the use of SICAM TOOLBOX II or the SICAM Device Manager.

²⁸ Firmware version 4.5x and higher

Software for Station Automation

SICAM WEB – Description

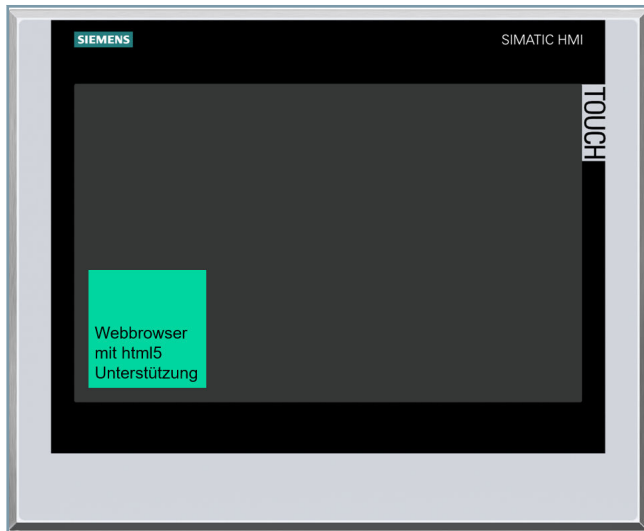

[sc_simATIC Touchpanel, 1, ...]

Figure 4.3/3 SIMATIC Touch Panel

Description

Engineering is a major cost factor in producing new plants for power generation, distribution, and transfer. Servicing existing plants and maintenance of relevant data resources require heavy expenditure.

- Configuring
- Setting parameters
- Testing
- Putting in operation

These tasks or requirements can be resolved with SICAM Device Manager intuitively whilst saving time and money.

The current engineering software for the SICAM A8000 series supports project and device management for:

- CP-8000
- CP-8021
- CP-8022
- CP-8031
- CP-8050
- SICAM 8 Software Solution

SICAM Device Manager is available in both German and English.

Benefits

- Simple parameterization and test tool for SICAM A8000 series devices with maximum user friendliness
- Clearly structured user interface and logical steps optimized for each working situation
- Clear administration of projects and devices in directory structures
- Duplication of devices and automatic adaptation of specific parameters
- Compatibility between SICAM WEB and SICAM Device Manager
- Look and feel corresponds to SICAM WEB
- Download engineering data from the device

Functions

- IEC 61850 Client and Server Engineering Edition2 + GOOSE SCL data export for server function incl. creating a server data model
- Logic Editor – Offline Simulation
- Logic Editor – Online Test
- Logic Editor – Function blocks according to IEC 61131
- Logic Editor – User-defined function blocks and structures
- Logic Editor – ST code support
- Logic Editor – Library function



Figure 4.4/1 SICAM Device Manager

New Functions from V3.5x for CP-8031/8050

- Device Manager functions
 - Graphic management (SVG) for the SICAM A8000 dashboard
 - SICAM A8000 support for 19" rack solution
 - SICAM SCC support
 - SICAM A8000 dashboard
 - Import/export signals incl. attributes
 - Signal engineering across devices
- Logic Editor functions
 - Support for automatic chart generation
 - Support for nested structures in structured text (ST) in the building-block interface
 - Support for standard CFC functions and the function block, call up in structured text (ST)

Cybersecurity

The SICAM Device Manager also handles the appropriate cybersecurity requirements for the SICAM A8000 series.

Alongside recognized features such as BDEW Whitepaper conformity, SICAM Device Manager only supports digitally signed firmware.

There are 3 licenses available to select:²⁹

- 6MF7800-xFB00: SICAM Device Manager Basic, intuitive engineering tool for the SICAM A8000 series
- 6MF7800-xFS00: SICAM Device Manager Standard, intuitive engineering tool for the SICAM A8000 series incl. CFC
- 6MF7800-xGS00: SICAM Device Manager Upgrade Basic to Standard

²⁹ MLFB number 8th position (x): 1 = Physical delivery (DVD/ USB stick)/2 = Electronic delivery (OSD)

Software for Station Automation

SICAM Device Manager – Description

Supported Operating Systems

- Microsoft Windows 10
- Microsoft Windows 11
- Microsoft Windows 2016 Server
- Microsoft Windows 2019 Server
- Microsoft Windows 2019 Server
- Microsoft Windows 2022 Server

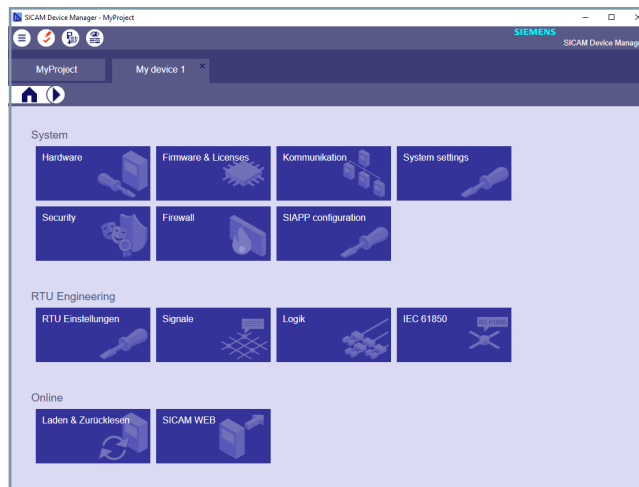

[sc_sicdm_dashboard, 2, en_US]

Figure 4.4/2 Simple and Intuitive User Interface

Selection and Ordering Data

Description	Variants	Order No.												
		1	2	3	4	5	6	7	8	9	10	11	12	
Delivery form	Physical delivery (DVD/USB stick)								1					
	Electronic delivery (Download (OSD))								2					
SICAM Device Manager		6	M	F	7	8	0	0	-	<input type="checkbox"/>	<input type="checkbox"/>	<input type="checkbox"/>	0	0
	Basic										F	B		
	Standard incl. CFC										F	S		
	Basic to standard upgrade										G	S		
	SICAM Device Manager HMI Config. (DL only)									2	F	H		

Table 4.4/1 SICAM Device Manager – Selection and Ordering Data

Description

The IEC standard protocols used in modern substation control and protection systems enable homogeneous, manufacturer-independent solutions and provide optimal protection for the investment made.

Despite the use of standardized protocols, it is still necessary in everyday practice when operating and setting up systems controls to analyze more precisely or even simulate the behavior of the devices used.

The SICAM protocol test system (PTS) offers these functions. A simulation of one or more devices simplifies the processes above all during project engineering of plants. For instance, by importing the IEC 61850 standard files, the behavior of devices can be simulated and the running of tests and commissioning thus simplified. Irrespective of the manufacturer, extensive analysis functions make it easier to eliminate erroneous behavior or failures of individual devices.

SICAM PTS helps make everyday work simpler for the plant project engineer and operator and becomes an indispensable tool.

Benefits

• Analysis and Monitoring

SICAM PTS is the ideal tool for conformance testing, SAT (site acceptance tests), fault analyses and long-term recordings.

• Simulation

In addition to the extensive analysis functions, it is also possible to simulate partners.

In this way, the SICAM PTS not only allows individual telegrams but also entire IEC 61850 devices and plants made up of up to 255 devices to be simulated dynamically. This also includes simulation of the command executions including feedback, measured values and fault records, along with the simulation of IEC 61850 client-server connections and GOOSE messages. The individual server-client connections in the network are then shown in the network overview.

The SICAM Protocol Test System supports the following protocols:

- IEC 61850 Ed1 and Ed2 Client
- IEC 61850 Ed1 and Ed2 Server
- IEC 60870-5-101 (balanced and unbalanced)
- IEC 60870-5-103
- IEC 60870-5-104
- SAT PCBE End-End protocol
- SAT PCBU SSI End-End protocol
- NTP Client
- TLS

Features and Technical Highlights

- Product- and manufacturer-independent test system
- Simulation of up to 255 IEC 61850 servers



[sc_SICAM PTS, 2, ...]

Figure 4.5/1 SICAM PTS

- Interactive simulation (command and feedback) of entire systems including devices from the competition – SCD, ICD import (ICD files of SIPROTEC 4/5 devices are already integrated in the software package)
- Simulating malfunctions
- Dynamic measured values using auto-simulation
- Simulating fault records
- GOOSE publish
- Network overview analysis – which server is connected to which client?
- Test the NTP time server in the network
- Simple operation – without training
- Plaintext display for IEC 60870-5-101, -104 and -103 as well, using stored data models by importing long texts as .csv files
- Long-term recording

Windows Operating Systems

- Microsoft Windows 10
- Microsoft Windows 2016 Server R2
- Microsoft Windows 2019 Server

SICAM PTS runs on a PC under MS Windows and is used to record and simulate process interfaces. A COM port (V.24/V.28) or an Ethernet interface is used as an interface. For unsupported protocols, the recorded data is displayed in Hex mode.

Monitoring

IEC 60870-5-101, -103, PCBU, PCBE (Figure 4.5/2)

- Statistics display (for example number of bytes, number of telegrams, transmission errors)
- Possible to display the telegrams in Hex mode
- Time stamping of all received telegrams

Software for Station Automation

SICAM Protocol Test System – Description

- Freely definable process-technology address down to bit level, including saving and loading the definition
- Plaintext address import of CSV files (display of the data points with their actual name)
- Possibility of online and offline filtering of IEC 60870-5-2 telegrams, type identifications, transmission causes, link addresses, object addresses (function type, information number)
- Individual adaptation of the display format (for example type identification, time, structure)
- Saving the recorded data in binary and ASCII format
- Loading the saved recording for further offline analyses, including offline filter

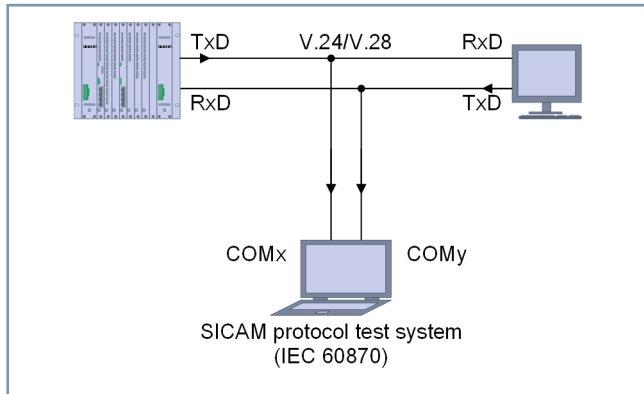

Figure 4.5/2 Monitoring IEC 60870-5-101, -103, PCBE and PCBU

The following function is available when using SICAM PTS (IEC 60870):

- Time stamping with an accuracy of 1 ms

Simulation for IEC 60870-5-101, -103 (Figure 4.5/3)

- Telegram definition using dialog, from existing recordings and plaintext imports (for example, data-point tests, in order to automatically generate and transmit telegrams from a data-point list)
- Predefined monitoring telegrams (for example end of initialization, general interrogation, counter interrogation)
- Saving and loading telegram definitions
- Saving and loading different parameter sets
- Option to import recording of the Frontline **serial test** program (including time stamp)
- IEC 60870-5-101: Send/receive file transfers and generate COMTRADE files from DKE fault records

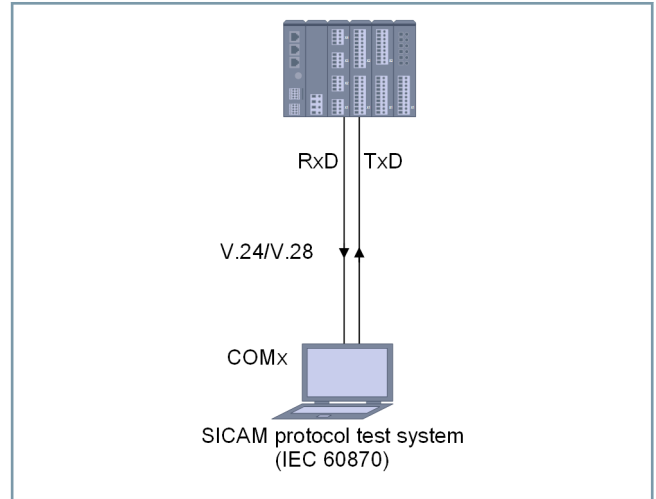

[dw_sicam-protocol_simulation_iec60870_4_en_US]

Figure 4.5/3 Simulation for IEC 60870-5-101, -103

Monitoring and Simulation IEC 60870-5-104 (Figure 4.5/4)

All data transmitted via the TCP/IP log can be recorded using the SICAM PTS if the system can access it on Ethernet, for example, via a switch with port mirroring. This means that SICAM PTS may not be decoupled from the systems to be tested by a switch or router.

This means that the following possibilities are available:

- Filtering in addition to the filtering possibilities for monitoring on serial interfaces according to log, IP address, host name and port number
- Statistics display
- Simulation of a station on the Ethernet

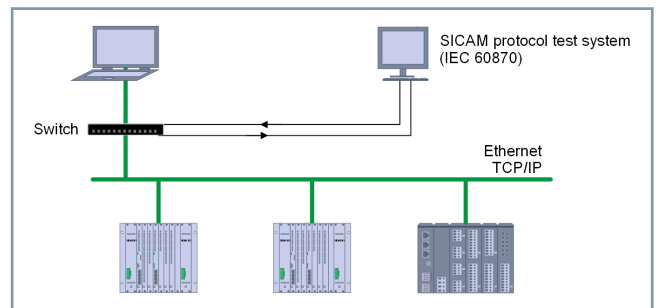

[dw_sicam-protocol_monitoring_and_simulation_4_en_US]

Figure 4.5/4 Monitoring and Simulation IEC 60870-5-104

Software for Station Automation

SICAM Protocol Test System – Selection and Ordering Data

Selection and Ordering Data

Description	Variants	Order No.												
		1	2	3	4	5	6	7	8	9	10	11	12	
Delivery form	Physical delivery (DVD/USB stick)								1					
	Electronic delivery (Download (OSD))								2					
SICAM Protocol Test System V8.0		6	M	F	6	0	8	0	-	<input type="checkbox"/>	F	<input type="checkbox"/>	0	0
	IEC 60870											B		
	IEC 60870 and IEC 61850											S		
	TLS											T		
	IEC 61850											A	8	

Table 4.5/1 SICAM PTS – Selection and Ordering Data

Software for Station Automation

SICAM Power Management System for Load Shedding – Description

Description

SICAM PMS LoadShedding enables selected loads to be switched off automatically to ensure that a defined network is operated safely if the energy supply is critical. The load shedding function ensures a proper balance between power that has been produced and consumed by switching off low-priority consumers. Automatic load shedding is the only way to prevent a strong dip in frequency and the protection tripping, or a collapse in frequency following a severe fault.

Load shedding uses a distributed system architecture and is based on the IEC standard 61850. At factory level, the central load-shedding controller is based on individual or redundant SICAM remote terminal unit. At bay level, the Intelligent Electronic Devices (IEDs) are installed on SIPROTEC devices for protection and control. Operation is insured at factory level via a human-machine interface (HMI).

Main Functions

Fast Power-Based Load Shedding (FPLS)

Low-priority consumers must be shedded quickly if there are any critical events to restore the balance between the energy that has been produced and consumed. The active power result is calculated on a regular basis for each critical event to determine how much energy needs to be shedded. The calculation determines which bays are shedded if there is a critical event, for example using the available power, the rotating reserve and the actual topology. Load shedding occurs within 30 ms to 70 ms if a critical event occurs³⁰. FPLS automatically detects several islands in the power system and operates each island separately.

Dynamic Power-Based Load Shedding (DPLS)

The power result is monitored on a regular basis in island network operation. If the spinning reserve drops under a user-defined threshold, consumers are shedded, starting with the lowest priority until a sufficient spinning reserve has been restored. DPLS is carried out separately for each island network detected. DPLS is an optional function just like a closing lockout, large consumers such as medium motors are monitored that are currently not in operation. If the input power exceeds the rotating reserve for these loads, they are prohibited from starting.

Frequency-Based Load Shedding (FBLS)

FBLS is provided as an additional reserve function for fast shedding. It works independently of power-based load shedding, and

is based on a distributed system architecture. A frequency relay monitors the frequency for up to 4 limiting values for each bus section. The predefined loads are automatically shedded if the limit is violated. Each frequency-relay tripping stage is provided with a time delay to prevent unwanted load shedding. The frequency gradient (DF/DT) can also be monitored to ensure a faster response.

Working Area

Load shedding is carried out by distributed IEDs that communicate via the IEC 61850 protocol. Exceptionally fast GOOSE indications ensure a fast response time. Up to 300 loads can be shedded with a max. of 50 priority levels. Loads of the same priority are treated as a group and shedded together. Up to 60 critical events that trip load shedding can be defined. The FPLS response time is typically a max. of 30 ms to 70 ms³⁰. This duration is defined from once a critical event has been detected until a trip signal is activated for the affected loads.

System Requirements

- Load-shedding calculations based on SICAM A8000 (CP-8050 with constraints) with an Ethernet connection to all IEDs via IEC 61850
- IEDs with an IEC 61850 interface which supports GOOSE and a fast function plan
- Operating station based on SICAM SCC or Spectrum Power 5 for adjusting and monitoring load shedding

Advantages

- Full integration into the automation system; only the additional central component is required for calculation
- The power-based load shedding only sheds as many bays as required for the respective situation
- Very fast response time for power-based load shedding
- The network topology is calculated automatically, for example for several islands
- Based on the IEC 61850 standard for communication between all included components. This significantly reduces parallel wirings, improves system availability, and ensures a solution that is fit for the future
- Very high availability: Redundant shedding-matrix calculation and an independent FBLS as a reserve function ensure system availability.

³⁰ In defined conditions

Software for Station Automation

SICAM Power Management System for Load Shedding – Description

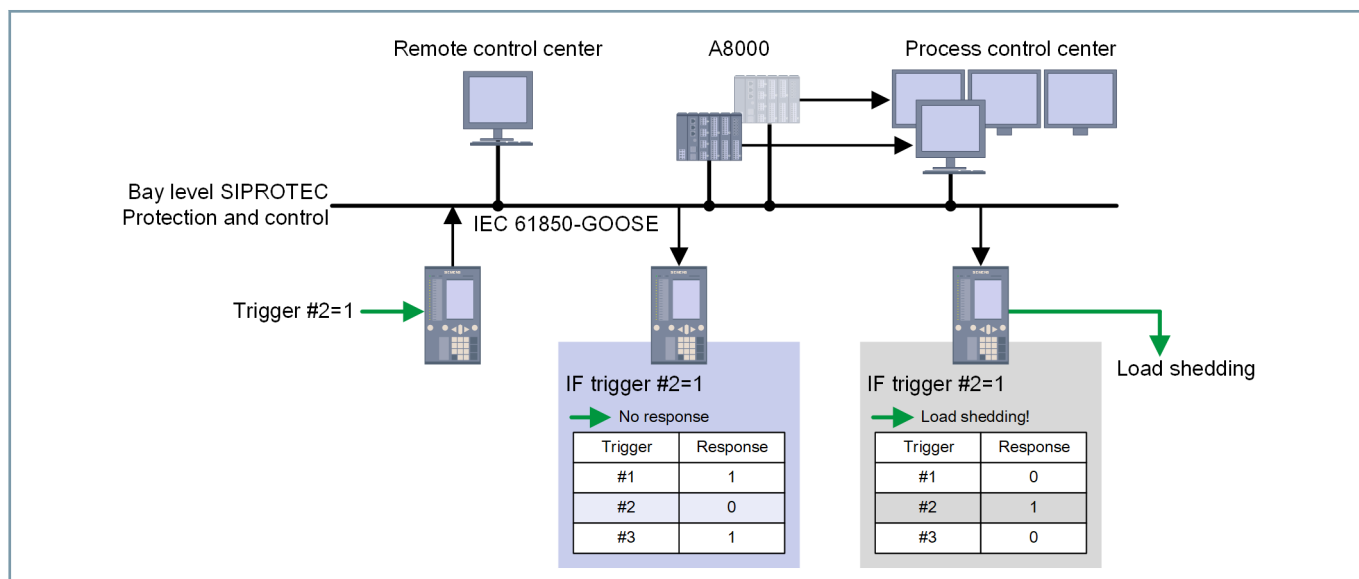

[dw_SICAM-PMS-LS, 2, en_US]

Selection and Ordering Data

Description	Variants	Order No.												
		1	2	3	4	5	6	7	8	9	10	11	12	
SICAM PMS LS		6	M	F	4	2	7	1	-	2	<input type="checkbox"/>	<input type="checkbox"/>	<input type="checkbox"/>	<input type="checkbox"/>
Power Management System	Basic for 8 contingencies										▲	▲	▲	▲
Load Shedding	Small for 8 contingencies										C	R	1	3
	Medium for 15 contingencies										C	R	2	3
	Large for 30 contingencies										C	R	3	3
	Max for 60 contingencies										C	R	4	3

Table 4.6/1 SICAM PMS LS – Selection and Ordering Data

Software for Station Automation

DIGSI 5 – Description

Description

DIGSI 5 is the versatile engineering tool for parameterization, commissioning, and operating all SIPROTEC 5 devices. Its innovative user interface includes context-sensitive user instructions. Simple connection to the device via USB enables you to work with a device easily and efficiently. The full capabilities of DIGSI 5 are revealed when you connect it to a network of protection devices: Then you can work with all of the devices in a substation in one project. DIGSI 5 offers superior usability and is optimized for your work processes. Only the information you actually need to carry out your tasks is shown. This can be reduced further via expanded filter mechanisms. Consistent use of sophisticated and standardized mechanisms in the user interfaces requires less training.

Functions

Using a PC or laptop computer, you can set parameters for the devices using the interfaces and export the fault data.

DIGSI 5 is available in different variants (Compact, Standard, and Premium) with various functionalities:

- Using the Single-Line Editor, you can visually define a substation and the primary equipment. Connect these elements with the protection function of your protection devices.
- The visual display of the SIPROTEC devices can be configured and edited with the Display Editor or with a graphics program. Take your single-line diagram and convert it into a display image. You can also define your own icons.
- You can configure additional functions like interlocking of the devices graphically with the function block diagrams editor (CFC).
- Using the Siemens IEC 61850 System Configurator, you can configure and set parameters for IEC 61850 stations. Using this tool, you can administer subnetworks, network users and their IP addresses and link the information of various participants.
- The DIGSI 5 test suite provides extensive test tools, which accelerate commissioning and support you with operation. One of the test functions enables you to compile and execute test sequences, to test devices without external test equipment.
- SIGRA for simple, fast, and convenient analysis of fault records, such as those recorded during faults in power plants by fault recorders.

Languages: English, German, French, Italian, Portuguese, Spanish, Turkish, Czech, Polish, and Russian (selectable)

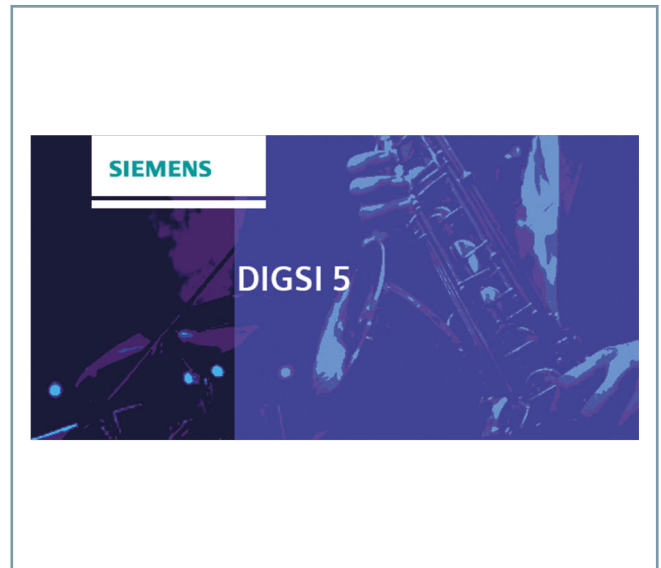

DIGSI 5 is available in 3 different functional scopes:

• DIGSI 5 Compact

Software for configuring and operating smaller projects with up to 8 SIPROTEC 5 Compact (7x800) or non-modular SIPROTEC 5 devices (7x82). Contains graphical editors for Continuous Function Charts (CFC) and device display pages. Integrated test and commissioning functions, including the possibility of creating test sequences and their execution in the protection device without external test equipment. Projects may only contain a single SIPROTEC 5 protection device.

• DIGSI 5 Standard

Like DIGSI 5 Compact, but without constraint with regard to the number of supported SIPROTEC 5 devices per project, incl. IEC 61850 System Configurator. Contains additional graphical editors for single-line diagrams and the network topology. SIGRA for professional fault-record analysis is available as an option.

• DIGSI 5 Premium with SIGRA

Same as DIGSI 5 Standard, but with enhanced functionality for IEC 61850, for example, flexible engineering and functional naming. Contains SIGRA for a professional analysis of fault records.

Hardware Requirements

- Intel® Core™ i3-6100U, 2.30 GHz S-ATA with at least 8 GB of available storage capacity
- 4 GB RAM (recommendation: 8 GB)
- HD Ready graphic display, 1280 x 1024 or 1376 x 768 pixels
- DVD ROM drive
- Keyboard and mouse
- USB port

Software Requirements

- Microsoft Windows 10

- Microsoft Windows Server 2019

- VMWare support for virtual machines

Overview of Functions

	Compact	Standard	Premium
Project processing			
Maximum number of devices per project	8 or 1 ³¹	Unlimited	Unlimited
Copy and paste	■	■	■
Multilingualism is supported	■	■	■
Single-line diagrams and device displays			
Single-Line Editor with ANSI and IEC standard icons available	–	■	■
Device Display Editor permits creation of user-defined displays and icons	32	■	■
Setting parameters and routing			
Information routing including filtering and sorting	■	■	■
Graphical visualization of protection parameters	–	■	■
Comparison of devices (offline/offline – offline/online)	■	■	■
Continuous function charts (CFC)			
Graphic continuous function chart editor (CFC) available	■	■	■
Communication			
Assignment of communications to system interface	■	■	■
Assignment of communications to various logs	■	■	■
Graphical network view of devices	–	■	■
Inter-device communication (via IEC 61850 System Configurator)	–	■	■
IEC 61850			
IEC 61850 Edition 2 fully supported	–	■	■
IEC 61850 structure editor for flexible engineering and functional naming	–	–	■
Access and communication			
Via USB and Ethernet	■	■	■
Access to communication partners via system interface	■	■	■
Online			
Measured values (current values, minimum, maximum, average values) and storage in the project as snapshots	■	■	■
Messages (and storage in the project as snapshots)	■	■	■
Logs and records	■	■	■
Display fault records	■ COMTRADE Viewer	■ COMTRADE Viewer ³³	■ SIGRA
Loading settings for the selected device	■	■	■
Commissioning and testing			
Creating and running multistage test sequences, no external equipment necessary	■	■	■
Test views for testing the device configuration	■	■	■
Analysis/debugging of continuous function charts (CFCs) in offline and online mode	■	■	■
Export and import			
SCL formats (IEC 61850– ICD/IID/MICS)	–	■	■
Device configurations (full and partial)	■	■	■
Single-line diagrams/topology	■	■ ³⁴	■
Display pages	■	■	■
Test object definition (RIO)	■	■	■
Documentation			

³¹ 8 SIPROTEC 5 Compact (7SX800) or non-modular SIPROTEC 5 devices (7xx82); alternatively 1 modular SIPROTEC 5 device

³² For SIPROTEC 5 Compact (7SX800) or non-modular SIPROTEC 5 devices (7xx82)

³³ SIGRA available as optional package

³⁴ WMF export only

Software for Station Automation

DIGSI 5 – Overview of Functions

	Compact	Standard	Premium
Printing and exporting project documentation	■	■	■
Creation of user-defined print formats	■	■	■

	Compact	Standard	Premium
Safeguarding and security			
Authorization of access to devices with NERC CIP-compatible password	■	■	■
Secure connection to the device	■	■	■
Configuration data protected from alteration	■	■	■
Confirmation IDs for safeguarding critical activities (for example switching)	■	■	■

DIGSI 5 Order Variants

	DIGSI 5 Compact	DIGSI 5 Standard	DIGSI 5 Premium with SIGRA
Description	<ul style="list-style-type: none"> • Software for the configuration and operation of smaller projects including transmission of process data from the device • Includes graphical editors for Continuous Function Charts (CFC) and device display pages. • Integrated test and commissioning functions, including the possibility of creating test sequences and executing them in the protection device without external test equipment • Projects can contain up to 8 SIPROTEC 5 Compact (7x800) or non-modular SIPROTEC 5 devices (7x82). Alternatively, it is also possible to create 1 individual modular SIPROTEC 5 device. 	<ul style="list-style-type: none"> • Like DIGSI 5 Compact, but without constraint with regard to the number of supported SIPROTEC 5 devices per project, incl. IEC 61850 System Configurator • Contains additional graphical editors for single-line diagrams, device display pages, and the network topology • SIGRA for professional fault-record analysis is available as an option 	<ul style="list-style-type: none"> • Same as DIGSI 5 Standard, but with enhanced functionality for IEC 61850, for example, flexible engineering and functional naming • Contains SIGRA for a professional analysis of fault records
Product features	All features are listed in the Overview of Functions, Page 99 table.		
Authorization	No license key necessary	Authorization required using the license key; can be used on one computer per license.	
Available interface languages	German, English, Portuguese, Spanish, Italian, French, Russian, Polish, Czech, and Turkish (selectable)		
Contained in the scope of delivery of the DVD version	<ul style="list-style-type: none"> • Program, device drivers, and online documentation on DVD-ROM • USB stick including a 30-day test license for a free test of DIGSI 5 Premium • Product information • USB cable for connecting a PC/laptop computer and all SIPROTEC 5 device types 	<ul style="list-style-type: none"> • Program, device drivers, and online documentation on DVD-ROM • USB stick with the number of licenses ordered. The program can be used on one computer per license. • Includes a 30-day test license for a free test of DIGSI 5 Premium • Product information • USB cable for connecting a PC/laptop computer and all SIPROTEC 5 device types 	<ul style="list-style-type: none"> • Program, device drivers, and online documentation on DVD-ROM • USB stick with the number of licenses ordered. The program can be used on one computer per license. • Product information • USB cable for connecting a PC/laptop computer and all SIPROTEC 5 device types
DIGSI 5 can also be ordered and delivered via online software delivery (OSD). The delivery of the DVD and USB cable is unnecessary. The program is offered for downloading. The license can be loaded online on the Automation License Manager.			

Software for Station Automation

DIGSI 5 – Selection and Ordering Data

Selection and Ordering Data

Versions	Number of licenses	Delivery form	Order no.
DIGSI 5 Compact	Unlimited	DVD/USB ³⁵	7XX8002-0CA00
DIGSI 5 Standard without SIGRA (with COMTRADE viewer)	1 single license	Download	7XX8002-0SA01
	5 single licenses	Download	7XX8002-0SA05
	10 single licenses	Download	7XX8002-0SA10
DIGSI 5 standard with SIGRA	1 single license	Download	7XX8002-1SA01
	5 single licenses	Download	7XX8002-1SA05
	10 single licenses	Download	7XX8002-1SA10
DIGSI 5 Premium with SIGRA	1 single license	Download	7XX8002-1PA01
	5 single licenses	Download	7XX8002-1PA05
	10 single licenses	Download	7XX8002-1PA10
DIGSI 5 Premium Trial (Premium full version for 30 days)	Unlimited	DVD/USB ³⁵	7XX8002-1PT00
DIGSI 5 Premium Scientific (only for technical colleges)	10 single licenses	Download	7XX8002-1PC10
DIGSI 5 Premium Sales (only for Siemens sales and distribution Dept.)	10 single licenses	Download	7XX8002-1PS10
Upgrade from DIGSI 5 Standard to Premium	1 single license	Download	7XX8002-1UP01
	5 single licenses	Download	7XX8002-1UP05
	10 single licenses	Download	7XX8002-1UP10
Upgrade from DIGSI 4 professional to DIGSI 5 standard	10 single licenses	Download	7XX8002-0US10
Upgrade from DIGSI 4 professional to DIGSI 5 premium	10 single licenses	Download	7XX8002-1US10
Upgrade from DIGSI 4 Professional + IEC 61850 to DIGSI 5 Standard	10 single licenses	Download	7XX8002-0UC10
Upgrade from DIGSI 4 Professional + IEC 61850 to DIGSI 5 Premium	10 single licenses	Download	7XX8002-1UC10
SIGRA option package for DIGSI 5 Standard	1 single license	DVD/USB ³⁵	7XS5412-2AA00
	5 single licenses	DVD/USB ³⁵	7XS5413-2AA00
	10 single licenses	DVD/USB ³⁵	7XS5414-2AA00

Table 4.7/1 DIGSI 5 Selection and Ordering Data

³⁵ Exclusively physical delivery (DVD/USB)

Description

The IEC 61850 System Configurator is the manufacturer-independent solution for the interoperable engineering of IEC 61850 products and systems. It supports all devices with IEC 61850, not just Siemens products – like SIPROTEC 5, SIPROTEC 4, SIPROTEC Compact, Reyrolle, SICAM RTUs, SICAM IO/AI/P85x/Q200 – but also devices from other Siemens divisions (such as SITRAS PRO) or from third parties.

The IEC 61850 System Configurator supports the SCL configuration files (substation configuration language) from the IEC 61850-6 through import or export of all formats (ICD/IID/CID/SCD/SSD/SED). Thus, IEC 61850 devices can be added and a complete IEC 61850 station is available for substation automation technology.

IEDs from the IEC 61850 standard of Edition 1, 2.0, or 2.1 are supported. The possible engineering therefore includes not only GOOSE communication and client-server configuration via MMS reporting, but also system topology, process bus communication with SMV (sampled measured values) and IEC 60870-5-104 addresses for the gateway to the network control center via IEC 61850-8-1.

Simple engineering thanks to customer-friendly workflows and the universal display of IEC 61850 addresses as well as customer description texts. Users with basic or expert IEC 61850 knowledge find the desired level of detail. For documentation purposes, the engineering can be displayed in the Web browser in a customer-friendly form. Harmonized interfaces of the tool, such with DIGSI 4 and DIGSI 5, reduce the engineering effort for Siemens plants even more.

Benefits

- Comprehensive – one tool for configuring all digital IEC 61850 devices
- Simple extension and adaptation of plants by using IEC 61850 Edition 1 and 2 in a project
- Customer-specific IEC 61850 structures (flexible engineering) permit the implementation of customer standards
- Easy to understand by using application-oriented signal names instead of the specific IEC 61850 language (logical nodes, etc.)
- Proven by experience from worldwide standardization activities and engineering of more than 500 000 devices
- Facilitated engineering by means of integrated interfaces to DIGSI, SICAM SCC, SICAM PAS, SICAM protocol test system and IEC 6150 browser

Applications

- Interoperable engineering of IEC 61850 (MMS; GOOSE; SMV)
- Import and export of all SCL formats, such as ICD, IID, CID, SCD, SSD or SED



[sc_IEC 61850 SysConf, 2, ...]

Figure 4.8/1 Splash Screen for the IEC 61850 System Configurator

- Supporting of Editions 1, 2.0, and 2.1 of IEC 61850
- Engineering with IEC 61850-80-1
- Engineering independent from manufacturers

Description

The IEC 61850 System Configurator is the manufacturer-independent solution for the interoperable engineering of IEC 61850 products and systems. It supports all devices with IEC 61850, not just Siemens products – like SIPROTEC 5, SIPROTEC 4, SIPROTEC Compact, Reyrolle, SICAM RTUs, SICAM IO/AI/P85x/Q100 – but also devices from other Siemens divisions (such as SITRAS PRO) or from third parties.

The tool supports SCL configuration files (substation configuration language) from the IEC 61850-6 through the import or export of all formats (ICD/IID/CID/SCD/SSD/SED). Thus, IEC 61850 devices can be added and a complete IEC 61850 station is available for substation automation technology.

IEDs from the IEC 61850 standard of Edition 1 or Edition 2 are supported. The possible engineering therefore includes not only GOOSE communication and client-server configuration via MMS reporting, but also system topology, process bus communication with SMV (sampled measured values) and IEC 60870-5-104 addresses for the gateway to the network control center via IEC 61850-80-1.

Simple engineering thanks to customer-friendly workflows and universal display of IEC 61850 addresses, as well as customer description texts. Users with basic or expert IEC 61850 knowledge find the desired level of detail.

Software for Station Automation

IEC 61850 System Configurator – Description

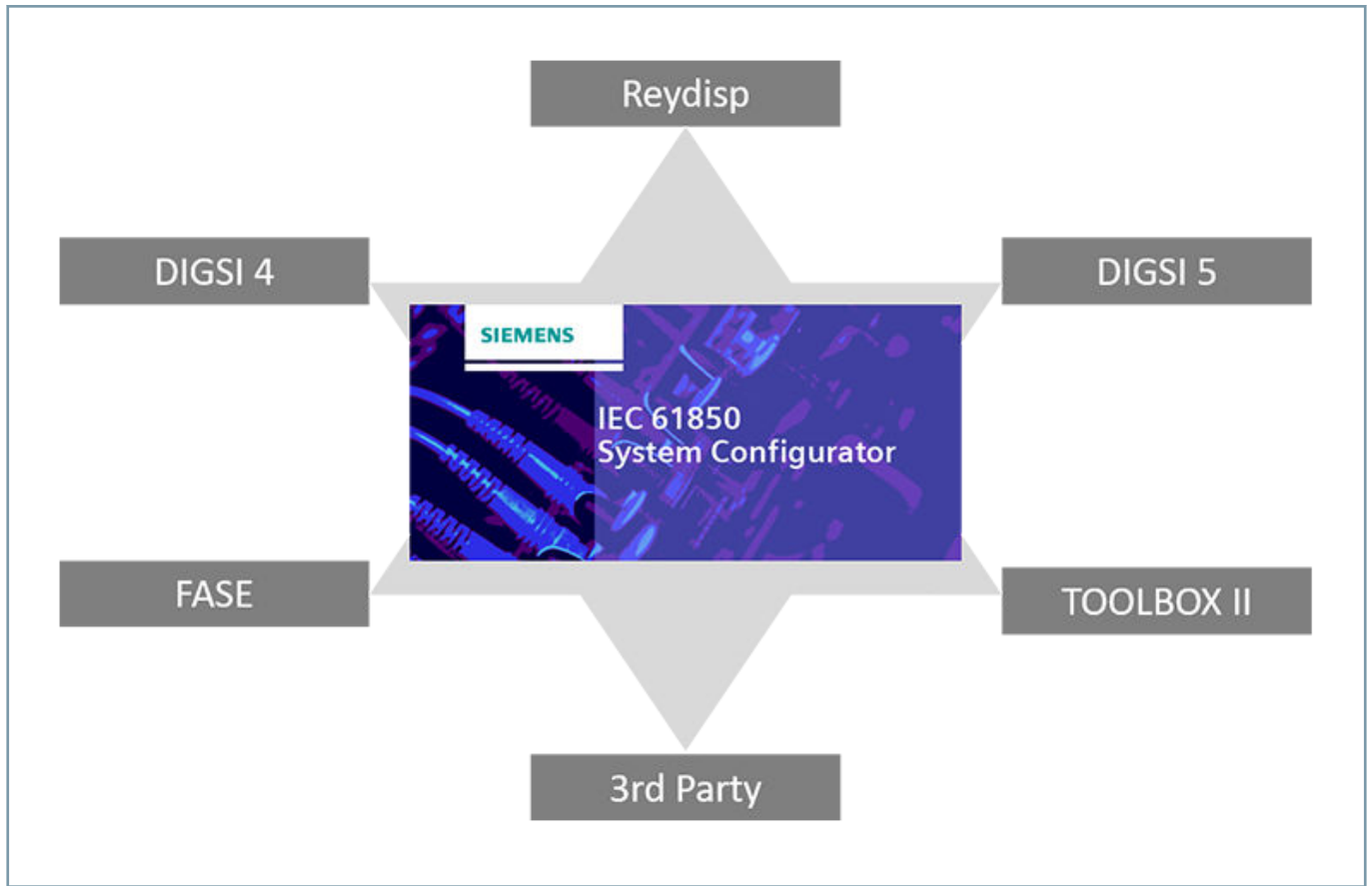

[One IEC 61850, 3, --]

Figure 4.8/2 An IEC 61850 System Configurator for All Devices in the Station

Selection and Ordering Data

Description	Versions	Order no.
<p>IEC 61850 System Configurator</p> <p>Software for configuring stations with IEC 61850 communication</p> <p>Executable under 32-bit and 64-bit MS Windows 7 Ultimate, Enterprise and Professional/MS Windows 8.1/MS Windows Server 2012 R2 64-bit/MS Windows 10 Professional and Enterprise (64-bit)</p> <p>See product information for supported service packs of the operating systems including electronic help and service (update, hotline)</p> <p>Interface languages: German, English, French, Spanish, Italian, Portuguese, Chinese, Russian and Turkish selectable</p> <p>Supplied on DVD-ROM.</p>	<p>Stand-alone</p> <p>For configuration independent from manufacturers of a plant with IEC 61850 devices (SIPROTEC, Reyrolle and devices from the competition), installation independent from DIGSI, with license for 10 computers (authorization using serial number)</p>	<p>7 X S 5 4 6 1 - 0 A A 0 0</p>

Table 4.8/1 IEC 61850 System Configurator – Selection and Ordering Data

Software for Station Automation

SIGRA – Description

Description

The SIGRA user program supports you in analyzing failures in your electrical power system. The program graphically analyzes data recorded during the failure and calculates additional supplemental quantities such as impedances, powers, or RMS values, from the supplied measured values, making evaluation of the fault record easier.

The quantities can be shown as desired in the diagrams of the following views: **time signals**, **vector diagrams**, **locus diagrams**, **harmonic components**, and **fault locators** and represented in the **table** view.

After a system incident, it is especially important to quickly and completely analyze the error, so that the respective measures can be derived immediately from the cause analysis. This will enable the original network status to be restored and the down time to be reduced to an absolute minimum.

As well as the usual time signal display of the recorded measured quantity, the current version is also set up to display vector, pie and bar charts to show the harmonics and data tables. From the measured values recorded in the fault records, SIGRA calculates further values, for instance missing quantities in the 3-phase electrical power system, impedances, outputs, symmetrical components, etc. Using 2 cursors, the fault current can be evaluated easily and conveniently. Using SIGRA however, further fault records can also be added. The signals from another fault record (for example, from the opposite end of the line) are added to the current signal pattern using drag and drop.

SIGRA facilitates the display of signals from various fault records in one diagram as well as a fully automated synchronization of these signals on a common time base. As well as the precise determination of the individual factors of the line fault, the fault location is also of particular interest.

A precise determination of the fault location saves time which the user can use for an on-site inspection of the error. This function is also supported by SIGRA using the **Offline fault location** function. SIGRA can be used for all fault records in COMTRADE file format.

The functions and advantages of SIGRA can often only be best displayed on the product itself. Consequently, SIGRA is available as a 30-day test version.

Functions

- 6 diagram types:
 - Time-signal representation (standard)
 - Pie chart (for example for R/X)
 - Vector diagram (reading angles)
 - Bar chart (for example for displaying the harmonics)
 - Table (list values for different signals at the same time)
 - Fault location (to display the location of faults)
- Additional-value calculation, for example positive-sequence impedances, RMS values, symmetrical components, vectors

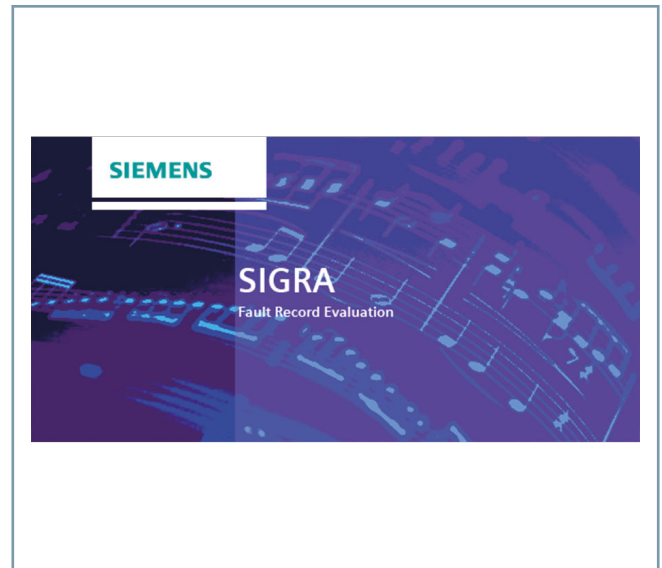

[sc_SIGRA_Splash, 1, ...]

Figure 4.9/1 Fault-Record Analysis with SIGRA

- 2 cursors for for measured values are synchronized in all views
- Powerful zoom function
- User-friendly configuration via drag and drop
- Innovative signal configuration in a clear matrix
- User profiles that save time and can be assigned to individual device types or series
- Additional fault records can be added to the existing fault record
- Synchronization of different fault records to a common time base
- Simple documentation by copying diagrams into documents from other MS Office programs
- Offline fault-location determination

Hardware Requirements

To work with SIGRA, you need a PC or laptop computer with the following minimum specifications, irrespective of the operating-system version you are using:

- Intel® Celeron® Dual Core 2.2 GHz (Ivy/Sandy Bridge) or equivalent
- 2 GB RAM (8 GB recommended)
- Graphic display with resolution of 1024 × 768 pixels (1280 × 1024 recommended)
- 5 GB of available hard-disk space

Operating System	Version/Type	Updates	PC ³⁶	VM ³⁷	32-bit ³⁸	64-bit ³⁹
Windows 10	Professional	1803;1809;1903	+	+	+	+
Windows 10	Enterprise	1803;1809;1903	+	+	+	+
Windows 7	Professional	SP1 ⁴⁰	+	+	+	+
Windows 7	Enterprise	SP1 ⁴⁰	+	+	+	+
Windows 7	Ultimate	SP1 ⁴⁰	+	+	+	+
Windows Server 2019	Standard	–	+	–	–	+

Table 4.9/1 Supported und Tested Operating Systems

Virtual Machines

SIGRA supports VMware virtual machines with the following versions and higher:

- VMware Workstation V6.5.0
- VMware Player V3.1.2
- VMware Tools for Windows V8.4.4

You can find more information on the Internet page: <https://www.vmware.com>

You use other Windows and older VMware versions at your own risk.

Interface Languages:

German, English, French, Spanish, Italian, Chinese, Russian, Turkish (selectable)

³⁶ PC: Windows computer

³⁷ VM: Virtual machines (for example VMWare)

³⁸ 32 bit: Operating system with 32-bit support (DIGSI 5 cannot be installed or used on a 32-bit operating system)

³⁹ 64-bit: Operating system with 64-bit support

⁴⁰ Including security update KB3033929 or other security patch incorporating this security update

Software for Station Automation

SIGRA – Selection and Ordering Data

Selection and Ordering Data

Description	Variants	Order No.												
		1	2	3	4	5	6	7	8	9	10	11	12	
SIGRA		7	S	X	5	4	1	□	-	0	A	H	0	0
Software for graphical visualization, analysis, and evaluation of fault records								▲						
For further information about supported service packs of the operating systems including sample fault record, electronic help, and service (update, hotline), refer to the Product information.	Installation with and without DIGSI, with an individual license							2						
Interface languages: German, English, French, Spanish Delivery form: Online Software Download (OSD)	Installation with and without DIGSI, with 10 individual licenses							4						

Table 4.9/2 SIGRA – Selection and Ordering Data

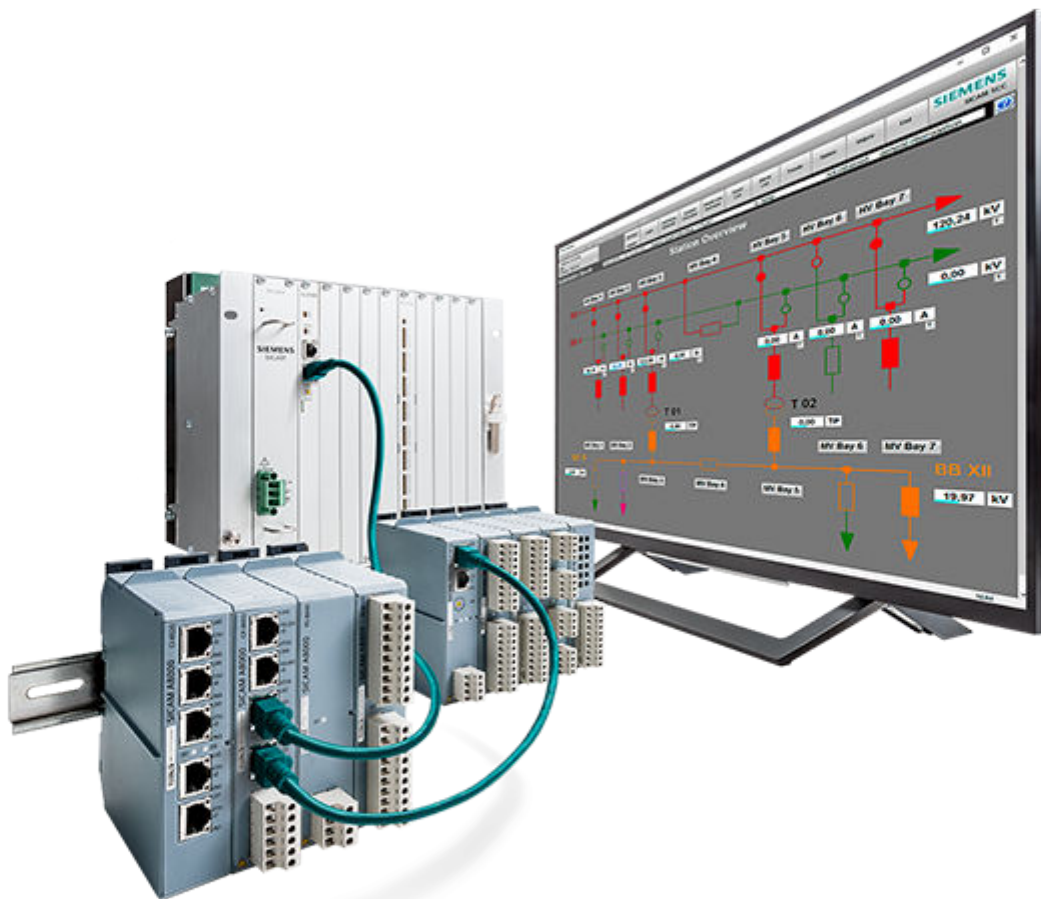

Bay Controllers

Introduction

5.1

The SIPROTEC 5 bay controllers control and monitor plants of all voltage levels. The device automatic functions are used in energy-supply fields and important auxiliary functions for safe network operation. These functions include protection, control, measurement, and monitoring. The communication interfaces and protocols satisfy the requirements of communication-based selective protection and automated operation. Commissioning and maintenance is completely safe, quick, and cost-effective with high-performance test functions. The SIPROTEC 5 bay controllers surface mounting is modular and adaptable and flexibly to the mounting requirements. The new device in the 6MD8 family is the IO-Box 6MD84.

Overview SIPROTEC 6MD84 Device

The SIPROTEC 5 IO-Box 6MD84 is a full member of the SIPROTEC 5 family. The SIPROTEC 5 IO-Box 6MD84 is a modular device which provides connection to the binary inputs and outputs. At process level, the device is designed as a circuit-breaker controller for bus systems, similar to the merging unit 6MU85.

Overview SIPROTEC 6MD85 and 6MD86 Devices

The SIPROTEC 5 bay controllers are based on the flexible and powerful SIPROTEC 5 modular system. The expandability of expansion modules allows individual adaptation to specific applications.

The bay controllers are categorized into product groups SIPROTEC 6MD85 and SIPROTEC 6MD86. The SIPROTEC 6MD85 is tailored for applications in distribution systems and also used in high-voltage and overvoltage applications.

The SIPROTEC 6MD86 devices are designed for applications in the power-transmission system and can be used with a maximum auxiliary functions.

Both 6MD85 and 6MD86 device types can be configured flexibly as per the hardware variant.

Overview of the SIPROTEC 6MD89 Device

Additionally, Siemens offers the 6MD89 railway bay controller. SIPROTEC 5 railway bay controllers control and monitor plants in railway power supply. They are suitable for the trunk lines and the distribution systems for contact wire power supply. They

are equipped with 1-phase or 2-phase measurement and have a rated frequency of 16.7 Hz.

Bay Controller	Description
SIPROTEC 6MD85	Bay controller for control and automation with optional protection functions Expandable hardware
SIPROTEC 6MD86	Bay controller for control, automation, and optional protection functions AREC (79) and SVS (50BF) Expandable hardware
SIPROTEC 6MD89	Bay controllers for railway power supply

Essential Characteristics	6MD84	6MD85	6MD86	6MD89
Circuit-breaker failure protection	-	-	Optional	Optional
Automatic reclosing	-	-	Optional	Optional
Point-on-Wave switching (PoW)	-	-	Optional	-
Phasor measurement unit (PMU)	-	Optional	Optional	-
Synchrocheck	-	Optional	✓	✓
Switching sequences	Optional	Optional	✓	✓
CFC arithmetic	Optional	Optional	✓	✓
CFC measured values: minimum, maximum, and average	Optional	Optional	✓	✓
Number of switching devices greater than 4	Optional	Optional	✓	✓

Common Features

- Modular expansion of the quantity structure
- High-performance automation with CFC
- Configuration of a large number of protection functions (6MD85, 6MD86)
- Optionally usable as Phasor Measurement Unit (PMU) (6MD85, 6MD86)



[ph_bay controller SIPROTEC, 2, --]

Figure 5.1/1 Siemens Bay Controllers

Bay Controllers

SIPROTEC 6MD84 – Description

Description

The SIPROTEC 5 IO-Box 6MD84 is a full member of the SIPROTEC 5 family. A modular device which provides connection to the binary inputs and outputs. At process level, the device is designed as a circuit-breaker controller for bus systems, similar to the merging unit 6MU85.

5.2

Main function	Circuit-breaker controller for process bus applications, IO-Box Modular extendable Powerful automation, simple configuration with DIGSI
Inputs and outputs	AW1: 19 binary inputs, 11 binary outputs (1 life contact, 10 standard) AW2: 45 binary inputs, 35 binary outputs (1 life contact, 34 standard)
Hardware flexibility	Flexibly adjustable and expandable I/O quantity structure within the scope of the SIPROTEC 5 modular system. If high requirements are placed on the quantity structure, then device can be extended in the second row. For example, 240 (and more) binary inputs are possible with the IO230.
Housing width	1/3 x 19 inch, 1/2 x 19 inch

Benefits

- The number of binary inputs and outputs can be scaled
- It can be expanded by a second row
- Additional data acquisition (temperature, pressure, and tapchanger setting)
- Cybersecurity in accordance with NERC CIP and BDEW white-paper requirements
- Highest availability even under extreme environmental conditions by standard coating of the modules

Functions

- Circuit-breaker controller on process level of process bus
- IO-Box for simple control and feedback applications
- Part of decentralized busbar protection system 7SS85 for bays without CTs to send switch positions
- Reliable and redundant data transmission via PRP
- Redundant power supply (optional)
- Expanded temperature ranges (-40 °C to 70 °C)
- Circuit-breaker and disconnecter switch functions:
 - Control system with switchgear interlocking
 - Switching statistics

The SIPROTEC 5 6MD84 can be used either as switch control unit on process level in process-bus systems or as modular IO-Box on bay level.



[SIP5_OD_o.LED_W3, 2, -,-]

Figure 5.2/1 SIPROTEC 5 IO-Box 6MD84

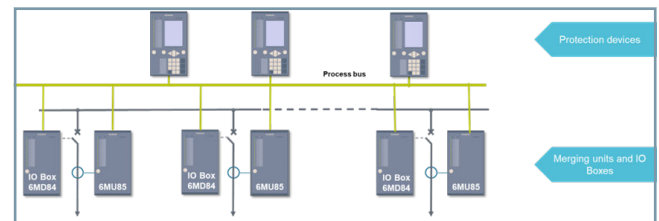

[dw_sip5-6md84_switch-control-unit, 1, -,-]

Figure 5.2/2 IO-Box in Process Bus Systems as Switch Control Unit

The device can also be used in distributed busbar protection systems to provide information about switching-device positions in bays without measurements (Figure 5.2/3). For this purpose, the device supports the communication protocol IEC61850-9-2 MU 7SS85CU.

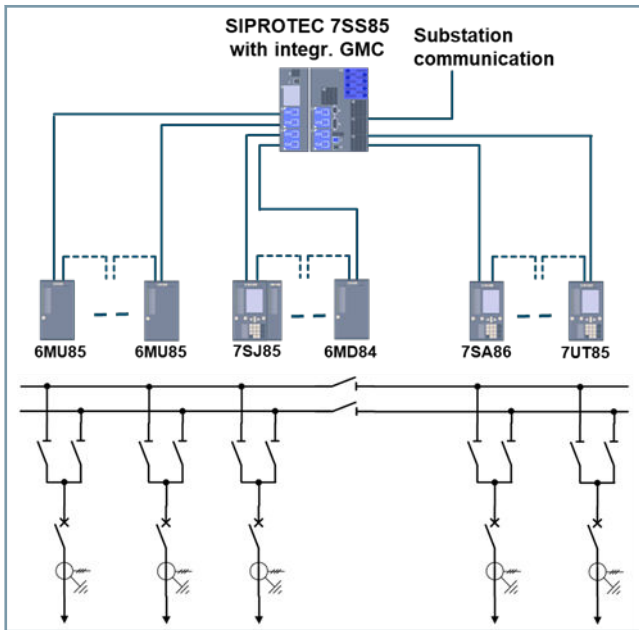

[dw_sip3-6md84_dec-bus-prot, 1, ...]

Figure 5.2/3 IO-Box in the Distributed Busbar Protection System

- Pluggable communication modules, usable for different and redundant protocols (IEC 61850-8-1, IEC 60870-5-103, IEC 60870-5-104, Modbus TCP, DNP3 serial and DNP3 TCP, PROFINET IO, PROFINET IO S2 redundancy).
- Serial protection communication via optical fibers, two-wire connections, and communication networks (IEEE C37.94 and others), including automatic switchover between ring and chain topology.
- Extensive cybersecurity functionality, such as:
 - Role-based access control (RBAC)
 - Logging of security-related events
 - Signed firmware or authenticated IEEE 802.1X network access
- Simple, fast, and secure access to the device via a standard Web browser to display all information and diagnostic data, single-line and device display pages.
- Virtual network partitioning (IEEE 802.1Q - VLAN)

The SIPROTEC 6MD84 is delivered with an unconfigured application template.

Type	Description
AW1	1/3 x 19", 19 BI, 11 BO
	Housing width 1/3 x 19"
	No display
	19 binary inputs
	11 binary outputs (1 life contact, 10 standard)
	Contains the modules: base module with PS201 and IO207

Type	Description
AW2	1/2 x 19", 45 BI, 35 BO
	Housing width 1/2 x 19"
	No display
	45 binary inputs
	35 binary outputs (1 life contact, 34 standard)
	Contains the modules: base module with PS201 and IO207 and extension module IO231

Bay Controllers

SIPROTEC 6MD85 – Description

5.3

Description

The SIPROTEC 6MD85 bay controller is a general-purpose control and automation device with protection function. It is designed for use in all voltage levels from distribution to transmission. As part of the SIPROTEC 5 family, it enables a wealth of protection functions from the SIPROTEC library. The modular hardware permits integration of the IOs depending on the application. Adapt the hardware exactly to your requirements and rely on future-oriented solutions for protection, control, automation, monitoring, and Power Quality – Basic.

Main function	Bay controller for medium and high to extra-high voltage switchgear with integrated operation and comprehensive protection functions. Powerful automation, simple configuration with DIGSI 5
Inputs and outputs	5 predefined standard variants with 4 current transformers, 4 voltage transformers, 11 to 75 binary inputs, 9 to 41 binary outputs
Hardware flexibility	Flexibly adjustable and expandable I/O quantity structure within the scope of the SIPROTEC 5 modular system. If high requirements are placed on the quantity structure, the device can be extended in the 2nd row. For example, 240 (and more) binary inputs are possible with the IO230.
Housing width	1/3 × 19 inch to 2/1 × 19 inch

Benefits

- Safe and reliable automation and control of your plants
- Purposeful and simple operation of the devices and software thanks to user-friendly design
- Cybersecurity as per NERC CIP and BDEW Whitepaper requirements
- Maximum availability even under extreme environmental conditions by standard coating of the populated printed circuit boards

Functions

DIGSI 5 permits all functions to be configured and combined as required and as per the functional scope that has been ordered.

- Integrated bay controller with versatile protection function from medium to extra-high voltage
- Control of switching devices
- Synchrocheck and switchgear interlocking protection
- Fixed integrated electrical Ethernet RJ45 interface for DIGSI 5 and IEC 61850 (reporting and GOOSE)
- Up to 4 pluggable communication modules, usable for different and redundant protocols (IEC 61850-8-1, IEC 61850-9-2 Client, IEC 60870-5-103, IEC 60870-5-104, Modbus TCP, DNP3 serial and TCP, PROFINET IO, PROFINET IO S2 redundancy)
- Virtual network partitioning (IEEE 802.1Q – VLAN)
- Reliable data transmission via PRP and HSR redundancy protocols
- Arc protection



[SIP5_GD_SS_W3_2_...]

Figure 5.3/1 Bay Controller SIPROTEC 6MD85 (1/3 Device with 1/6 Expansion Module with Key-Switch Operation Panel)

- Extensive cybersecurity functionality, such as role-based access control (RBAC), logging of security-related events, signed firmware, or authenticated IEEE 802.1X network access
- Simple, fast, and secure access to the device using a standard Web browser to display all information and diagnostic data, single-line and device display pages
- Graphical logic editor to create powerful automation functions in the device
- Optional overcurrent protection for all voltage levels with 3-pole tripping
- Also used in switchgear with breaker-and-a-half layout
- Selective protection of overhead lines and cables with single-ended and multi-ended feeders using protection communication
- Overcurrent protection also configurable as emergency function
- Secure serial protection communication, also over great distances and all available physical media (optical fiber, two-wire connections and communication networks)
- PQ – Basic: Voltage unbalance; voltage changes: overvoltage, dip, interruptions; TDD, THD, and harmonics
- Detecting operational measured variables and protection function measured values to evaluate the plant state, to support commissioning, and to analyze faults
- Synchrophasor measured values with the IEEE C37.118 protocol integrated (PMU)
- Powerful fault recording (buffer for a max. record time of 80 s at 8 kHz and 320 s at 2 kHz)
- Auxiliary functions for simple tests and commissioning
- Flexibly adjustable I/O quantity structure within the scope of the SIPROTEC 5 modular system.

Applications

The SIPROTEC 6MD85 bay controller is a general-purpose control and automation device with a protection function based on the SIPROTEC 5 system. The standard variants of the SIPROTEC 6MD85 device are delivered with instrument transformers. Furthermore, protection-class current transformers are also possible in SIPROTEC 6MD85 devices, thus allowing protection functions to be used. Due to its high flexibility, the device is suitable as selective protection equipment for overhead lines and cables with single-ended and multi-ended infeeds when protection communication is used. The device supports all SIPROTEC 5 system characteristics as well as detection and recording of power-quality data in the medium-voltage and subordinate low-voltage power system.

Application Templates

Application templates are available in DIGSI for standard applications. They comprise basic configurations and default settings.

The following application templates are available:

- *SIPROTEC 6MD85 Standard*
 - Double busbar feeder with switchgear interlocking protection
- *SIPROTEC 6MD85 Extended control*
 - In addition to SIPROTEC 6MD85 Standard, also includes the CFC blocks for switching sequences and arithmetic

- Switching sequence for automatic busbar switchover preconfigured (triggered by function key)

Double Busbar with Switching Sequence

[Figure 5.3/2](#) shows a simple typical application with a SIPROTEC 6MD85 device on a double busbar. The **circuit breaker** function group includes the synchrocheck. The disconnectors are also controlled by one function group each. Operational measured values and energy metered values are calculated in the VI_3-phase function group. They are available for output on the display, transfer to the substation automation technology, and processing in the CFC. A switching sequence stored in the CFC that is activated via a function key starts an automatic flow final node busbar switchover process.

Bay Controllers

SIPROTEC 6MD85 – Application Templates

5.3

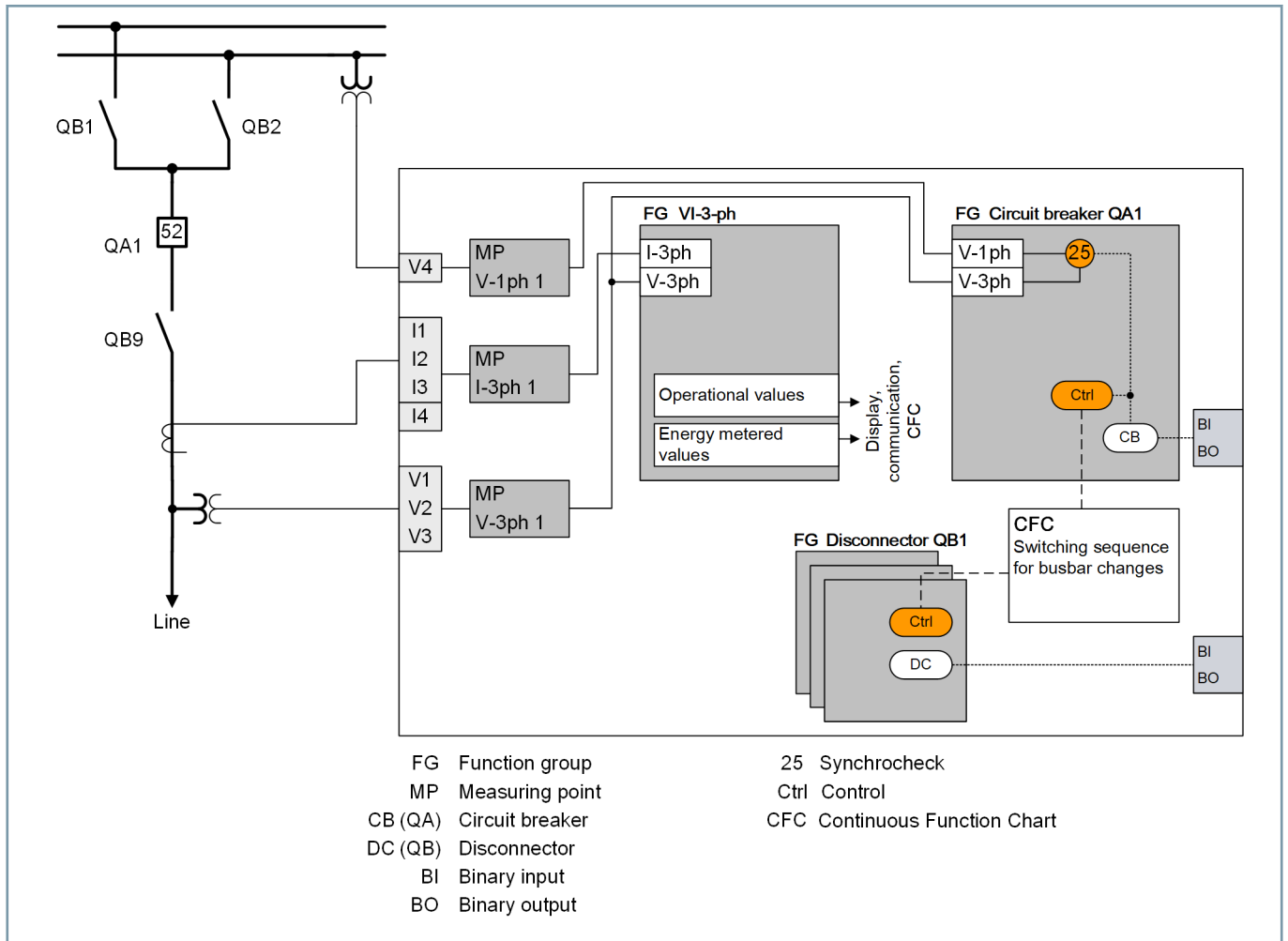

[dw_6MD8-Application-example-1_3_en_US]

Figure 5.3/2 Application Example: SIPROTEC 6MD85 Bay Controller for Double Busbars with Switching Sequence for Busbar Switchover

	Width of the Mounting Opening
1/3 device (base module)	146 ⁺² mm (5.75 ^{+0.08})
1/2 device (base module with one expansion module)	221 ⁺² mm (8.7 ^{+0.08})
2/3 device (base module with 2 expansion modules)	296 ⁺² mm (11.65 ^{+0.08})
5/6 device (base module with 3 expansion modules)	371 ⁺² mm (14.61 ^{+0.08})
1/1 device (base module with 4 expansion modules)	447 ⁺² mm (17.6 ^{+0.08})

Table 5.3/1 Cut-Out Widths

	Dimension a Housing Widths in mm (in Inches) (Total Width = Housing Width + 5 mm (0.2 in))
1/3 device	145 (5.71)
1/2 device	220 (8.66)
2/3 device	295 (11.61)
5/6 device	370 (14.57)
1/1 device	445 (17.52)

Table 5.3/2 Variable Housing Widths

Bay Controllers

SIPROTEC 6MD85 – Selection and Ordering Data

Selection and Ordering Data

Bay Controllers – 6MD85	
Housing: Extendable, 1/3 x 19" to 2/1 x 19" with painted modules (conformal coating)	
Basic function with hardware standard variant ⁴¹	
	J1: 1/3, 11 BI, 9 BO (1 Life, 2 S, 6 F), 4 current transformers, 4 voltage transformers ⁴²
	J2: 1/2, 27 BI, 17 BO (1 Life, 10 S, 6 F), 4 current transformers, 4 voltage transformers ⁴³
	J4: 2/3, 43 BI, 25 BO (1 Life, 18 S, 6 F), 4 current transformers, 4 voltage transformers ⁴³
	J6: 5/6, 59 BI, 33 BO (1 Life, 26 S, 6 F), 4 current transformers, 4 voltage transformers ⁴³
	J7: 1/1, 75 BI, 41 BO (1 Life, 34 S, 6 F), 4 current transformers, 4 voltage transformers ⁴³
Application templates/function points ⁴⁴	
	Double busbar, standard
	Extended control (75 function points)
Process-bus functionality/function points ^{44 45 46}	
	Merging-unit functionality for ETH-BD-2FO plug-in module (200 function points)
	Process-bus client functionality (100 function points)
	Connection to the 7SS85 central unit (95 function points)
Warranty extension	
	Warranty extension, annually
Communication	
	Integrated Ethernet interface (RJ45) for DIGSI
	Integrated Ethernet interface (RJ45) for DIGSI and IEC 61850
	Integrated Ethernet interface (RJ45) for DIGSI, IEC 61850 incl. GOOSE ⁴⁵
	SIPROTEC 5 plug-in modules
For the product configuration and order no., see SIPROTEC 5 Configurator	

Table 5.3/3 SIPROTEC 6MD85 – Selection and Ordering Data

⁴¹ Abbreviations: Housing width of 19 inches/BI: Binary inputs/BO: Binary outputs/S: Standard relay/F: Fast relay

⁴² Small display with 16 LEDs

⁴³ Small display, no key switch, 16 LEDs

⁴⁴ Available functional scope as specified in the catalog or function-point calculator in the order configurator

⁴⁵ For CP300 devices only

⁴⁶ ETH-BD-2FO is required; you cannot simultaneously operate the merging unit and process-bus client on the same plug-in module.

Description

The SIPROTEC 6MD86 bay controller is a general-purpose control and automation device with protection function. It is designed for use in all voltage levels from distribution to transmission. As part of the SIPROTEC 5 family, it enables a wealth of protection functions from the SIPROTEC library. The modular hardware permits integration of the I/Os depending on the application. Adapt the hardware precisely to your requirements and rely on the future-oriented solutions for protection, control, automation, monitoring, and Power Quality – Basic.

Main function	Bay controller for medium and high to extra-high voltage switchgear with integrated operation and comprehensive protection functions; performance automation, simple configuration with DIGSI 5
Inputs and outputs	7 predefined standard variants with 8 current transformers, 8 voltage transformers, 11 to 75 binary inputs, 9 to 41 binary outputs
Hardware flexibility	Flexibly adjustable and expandable I/O quantity structure within the scope of the SIPROTEC 5 modular system. If high requirements are placed on the quantity structure, the device can be extended in the 2nd row. For example, 240 (and more) binary inputs are possible with the IO230 (see Hardware section).
Housing width	1/3 × 19 inches to 2/1 × 19 inches

Benefits

- Safe and reliable automation and control of your plants
- Purposeful and simple operation of the devices and software thanks to user-friendly design
- Cybersecurity in accordance with NERC CIP and BDEW White-paper requirements
- Highest availability even under extreme environmental conditions by standard coating of the populated printed circuit boards

Functions

DIGSI 5 permits all functions to be configured and combined as required and as per the functional scope that has been ordered.

- Integrated bay controller with versatile protection function from medium to extra-high voltage
- Control of switching devices
- Point-on-wave switching
- Synchrocheck, switchgear interlocking protection and switch-related protection functions, such as circuit-breaker failure protection and automatic reclosing
- Fixed integrated electrical Ethernet RJ45 interface for DIGSI 5 and IEC 61850 (reporting and GOOSE)
- Up to 4 pluggable communication modules, usable for different and redundant protocols (IEC 61850-8-1, IEC 61850-9-2 Client, IEC 60870-5-103, IEC 60870-5-104, Modbus TCP, DNP3 serial and TCP, PROFINET IO, PROFINET IO S2 redundancy)
- Virtual network partitioning (IEEE 802.1Q - VLAN)



[SIP5_GD_SS_W3_2_...]

Figure 5.4/1 SIPROTEC 6MD86 (1/3 Device with 1/6 Expansion Module with Key Switch Operation Panel)

- Reliable data transmission via PRP and HSR redundancy protocols
- Extensive cybersecurity functionality, such as role-based access control (RBAC), logging of security-related events, signed firmware, or authenticated IEEE 802.1X network access
- Simple, fast, and secure access to the device via a standard Web browser to display all information and diagnostic data, vector diagrams, single-line and device display pages
- Arc protection
- Graphical logic editor to create powerful automation functions in the device
- Optional overcurrent protection with 3-pole tripping
- Also used in switchgear with breaker-and-a-half layout
- Overcurrent protection also configurable as emergency function
- Secure serial protection communication, also over great distances and all available physical media (optical fiber, two-wire connections and communication networks)
- PQ – Basic: Voltage unbalance; voltage changes: overvoltage, dip, interruption; TDD, THD, and harmonics
- Capturing operational measured variables and protection function measured values to evaluate the plant state, to support commissioning, and to analyze faults
- Synchrophasor measured values with the IEEE C37.118 protocol integrated (PMU)
- Powerful fault recording (buffer for a max. record time of 80 sec. at 8 kHz and 320 sec. at 2 kHz)
- Point-on-wave switching (PoW)
- Auxiliary functions for simple tests and commissioning
- Flexibly adjustable I/O quantity structure within the scope of the SIPROTEC 5 modular system

Bay Controllers

SIPROTEC 6MD86 – Description

5.4

Applications

The SIPROTEC 6MD86 bay controller is a general-purpose control and automation device with a protection function on the basis of the SIPROTEC 5 system. The standard variants of the SIPROTEC 6MD86 device are delivered with instrument transformers. Furthermore, protection-class current transformers are also possible in SIPROTEC 6MD86 devices, allowing protection functions to be used. Due to its high flexibility, the device is suitable as selective protection equipment for overhead lines and cables with single-ended and multi-ended infeeds when protection communication is used. The device supports all SIPROTEC 5 system characteristics as well as detection and recording of power-quality data in the medium-voltage and subordinate low-voltage power system.

Application Templates

Application templates are available in DIGSI for standard applications. They comprise basic configurations and default settings.

The following application templates are available:

- SIPROTEC 6MD86 standard double busbar
 - Double busbar feeder with switchgear interlocking protection
 - Synchrocheck for circuit breaker
 - Switching sequence for automatic busbar switchover preconfigured (triggered by function key)
- SIPROTEC 6MD86 breaker-and-a-half type 1
 - Control of a breaker-and-a-half bay (3 circuit breakers, 14 disconnectors)

- Synchrocheck for the 3 circuit breakers with dynamic measuring-point switchover

- SIPROTEC 6MD86 breaker-and-a-half type 2

- Control of part of a breaker-and-a-half bay
- Supports concepts with multiple bay controllers per bay
- Circuit-breaker failure protection and automatic reclosing

- SIPROTEC 6MD86 point-on-wave switching

- Preconfiguration for point-on-wave switching (PoW)
- Optimized for the following hardware: Base module with IO202, 2 x IO209 with a high-speed relay, 1 x IO212 (fast 20 mA inputs)

Double Busbar with Protection Functions

In [Figure 5.4/2](#) the double busbar feeder is controlled and also protected by a 6MD86. For this purpose, **circuit-breaker failure protection** and **automatic reclosing** are activated in the *circuit breaker* function group. The *UI_3phase* function group contains the protection functions **overvoltage protection**, **frequency protection** and **power protection**. In contrast to [Figure 5.3/2](#), it is therefore connected to the circuit breaker so that the resulting trip signals have a destination. Such linkages can quickly and flexibly be created in the DIGSI 5 editor function group connections ([Figure 5.4/3](#)).

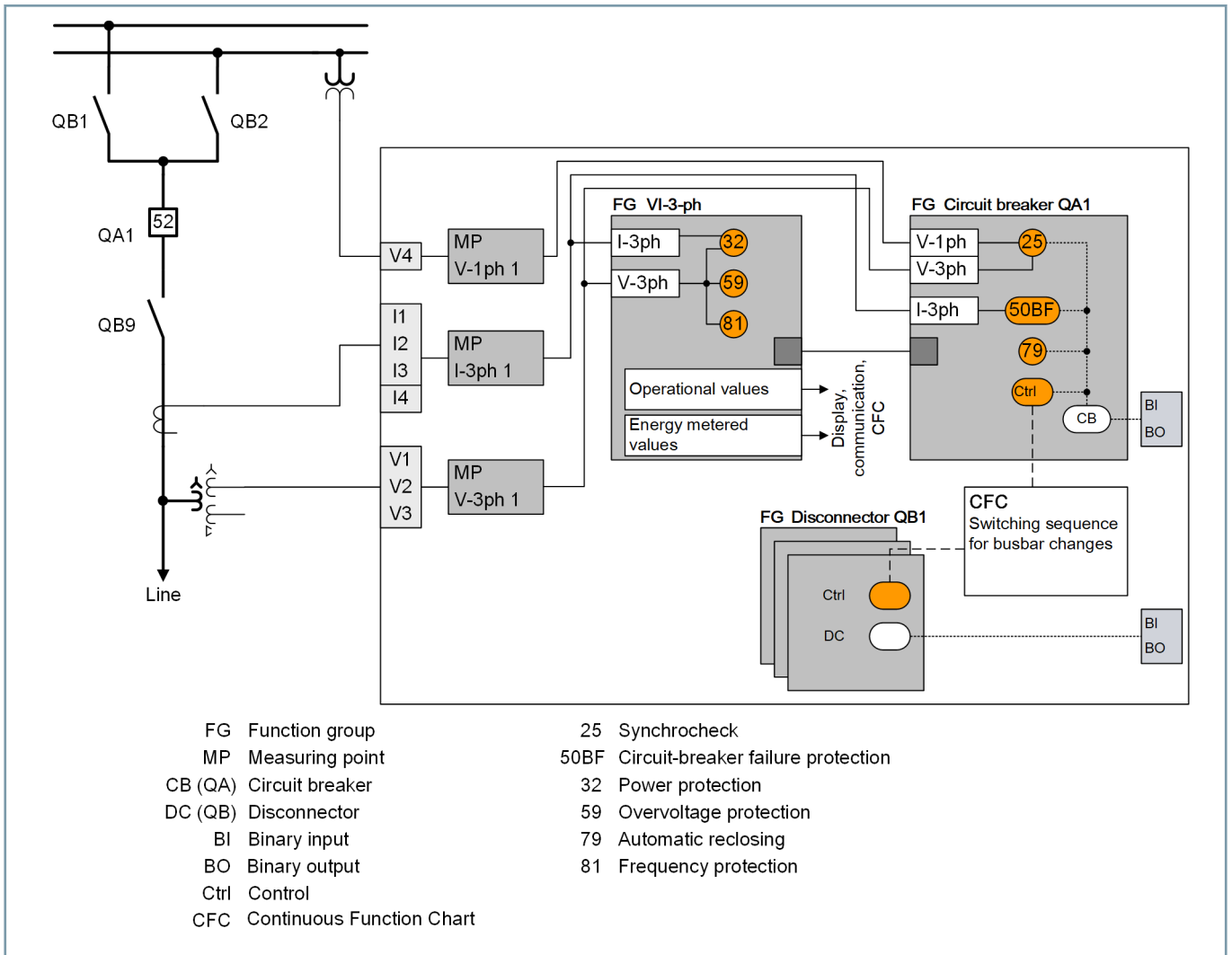

[dw_6MD8-Application-example-2_4_en_US]

Figure 5.4/2 Application Example: Bay Controller 6MD86 For Double Busbar with Protection Functions

▼ Connect function group to circuit-breaker groups	
Protection group	QA1
(All...)	(All...)
I 3ph 1	
V 3ph 1	
VI 3ph 1	X
VI 1ph 1	

[rc_protection object_2_en_US]

Figure 5.4/3 Assignment of the Function Group with Protection Functions to the Switch (Protected Object)

Breaker-and-a-half Bay with Protection and Systems Control

Figure 5.4/4 shows a breaker-and-a-half bay with protection and systems control. It is protected by 2 SIPROTEC 7SL87 line protection devices, which also assume **circuit-breaker failure protection** and **automatic reclosing** of the 3 circuit breakers. Control of all switches and the synchrocheck of the circuit breakers is assumed by the SIPROTEC 6MD86 bay controller. Figure 5.4/5 provides insight into the functions of the SIPROTEC 6MD86 bay controller.

Bay Controllers

SIPROTEC 6MD86 – Application Examples

5.4

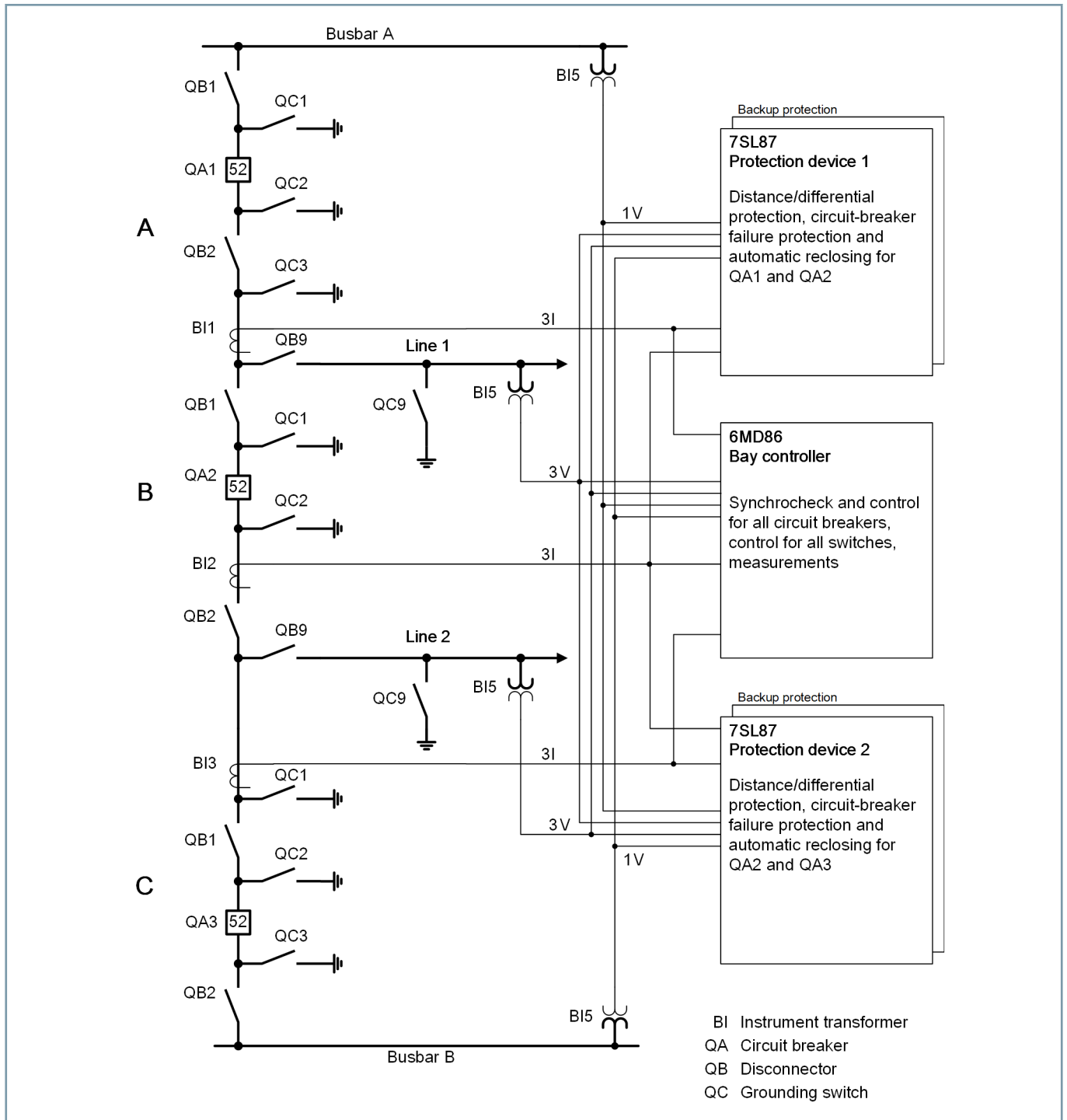

10k_1-9_c8 Bay controller 3_en_US

Figure 5.4/4 Application Example: Breaker-and-A-Half Layout with a Bay Controller and 2 Line Protection Devices (Overview)

Figure 5.4/5 shows the principle of the dynamic switchover of the voltage measurements for the synchrocheck functions of the 3 circuit breakers in the SIPROTEC 6MD86 bay controller. Each synchrocheck function (ANSI number 25) requires both voltages V_{sync1} (feeder voltage) and V_{sync2} (reference voltage). With the middle QA2 circuit breaker, there are 2 possi-

bilities for each of the 2 voltages depending on the position of the disconnector and circuit breaker. For the two outer QA1 and QA3 circuit breakers, there is only one possibility (that is, the neighboring busbar), while the other voltage is connected by means of one of the 3 possibilities (likewise depending on the switch position).

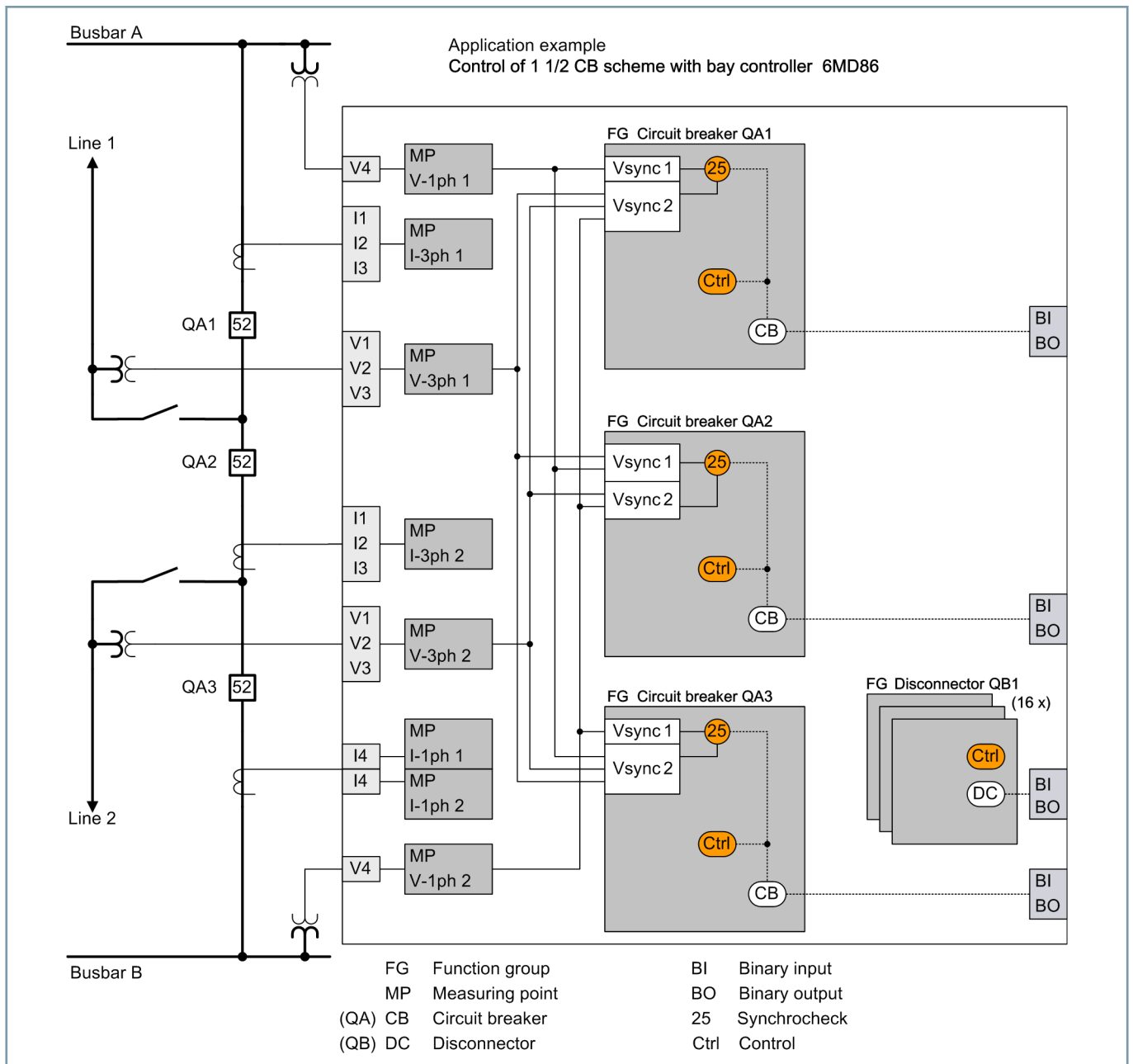

[dw_6MD8-Bsp-Application-3_1_en_US]

Figure 5.4/5 Application Example: Breaker-and-A-Half Layout with a Bay Controller and 2 Line Protection Devices (Detail for Bay Controller)

Bay Controllers

SIPROTEC 6MD86 – Application Examples

5.4

▼ Connect measuring points to function group

Measuring point	QA1		QA2		QA3	
	V sync1	V sync2	V sync1	V sync2	V sync1	V sync2
(All...)	(All...)	(All...)	(All...)	(All...)	(All...)	(All...)
Meas.point I-3ph 1[ID 1]						
Meas.point I-3ph 2[ID 2]						
Meas.point I-1ph 1[ID 3]						
Meas.point I-1ph 2[ID 4]						
Meas.point V-3ph 1[ID 5]		X	X			X
Meas.point V-3ph 2[ID 6]		X		X		X
Meas.point V-1ph 1[ID 7]	X		X			X
Meas.point V-1ph 2[ID 8]		X		X	X	

▼ Connect function group to circuit-breaker groups

Protection group: (All...)

▼ Connect protection-function group to protection-function group

Windings: (All...)

Properties

General | Compile | Cross-reference | Inconsistencies | Search results

I	Result object	Indication	Opens Editor	Date	Time
!	6MD86_20mA			11/28/2011	9:01:13 AM
!	6MD85			11/28/2011	9:01:14 AM
!	6MD86_1,5CB			11/28/2011	9:01:15 AM
?	Power system/Meas.point I-3ph 1	The measuring point is not connected.	Function-gro..	11/28/2011	9:01:15 AM
?	Power system/Meas.point I-3ph 2	The measuring point is not connected.	Function-gro..	11/28/2011	9:01:15 AM
?	Power system/Meas.point I-1ph 1	The measuring point is not connected.	Function-gro..	11/28/2011	9:01:15 AM
?	Power system/Meas.point I-1ph 2	The measuring point is not connected.	Function-gro..	11/28/2011	9:01:15 AM

sc_voltage channels, 2, en_US

Figure 5.4/6 Routing of the Possible Voltage Terminals to the 3 Circuit-Breaker Function Groups

Figure 5.4/6 shows the routing in the **Function Group Connections** editor. All voltages which are considered as a feeder or reference voltage for the synchrocheck are allocated to the Vsync1 or Vsync2 inputs.

The ID number of the measured values are used to select the voltages which are currently operationally attached in a CFC chart (Figure 5.4/7).

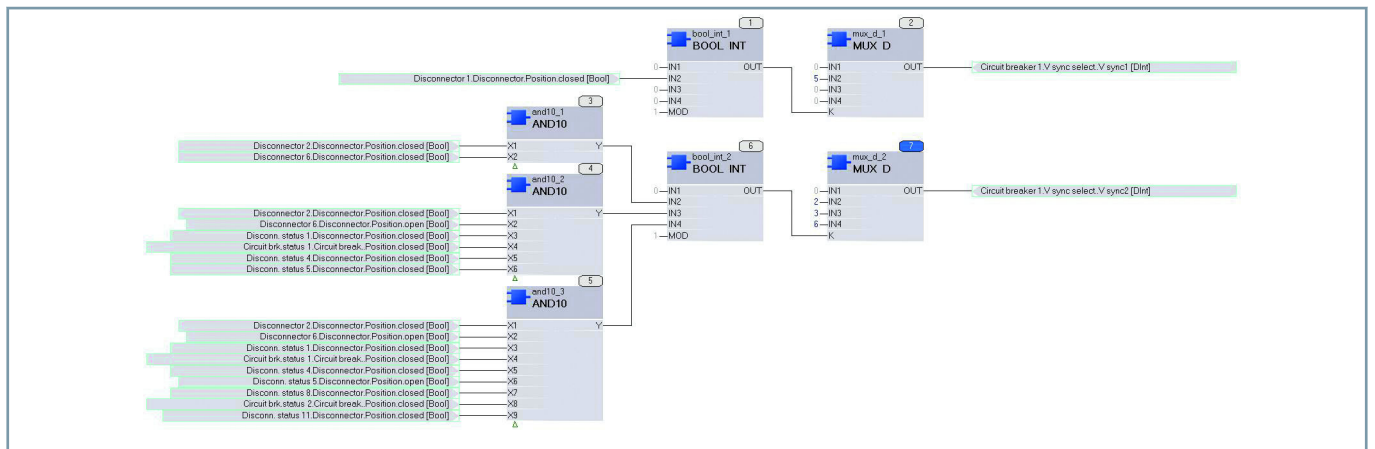

Figure 5.4/7 CFC Chart to Select the Synchrocheck Reference Voltages

Use as a Phasor Measurement Unit

At selected stations of the transmission system, a measurement of current and voltage for absolute value and phase is carried out using PMUs. Due to the high-precision time synchronization (via GPS), the measured values from different substations that are far removed from each other are compared, and conclusions about the system state and dynamic events, such as power fluctuations, are drawn from the phase angles and dynamic curves.

If the *Phasor Measurement Unit* option is selected, the devices determine current and voltage phasors, add high-precision time stamps and send these together with other measured values (frequency, rate of change of frequency) via the communication protocol IEEE C37.118 to an evaluation station, see [Figure 5.4/9](#). With the aid of the synchrophasor and a suitable analysis program (for example, SIGUARD PDP), it is possible to automatically detect power swings and trip alarms which, for instance, are sent to the network control center.

5.4

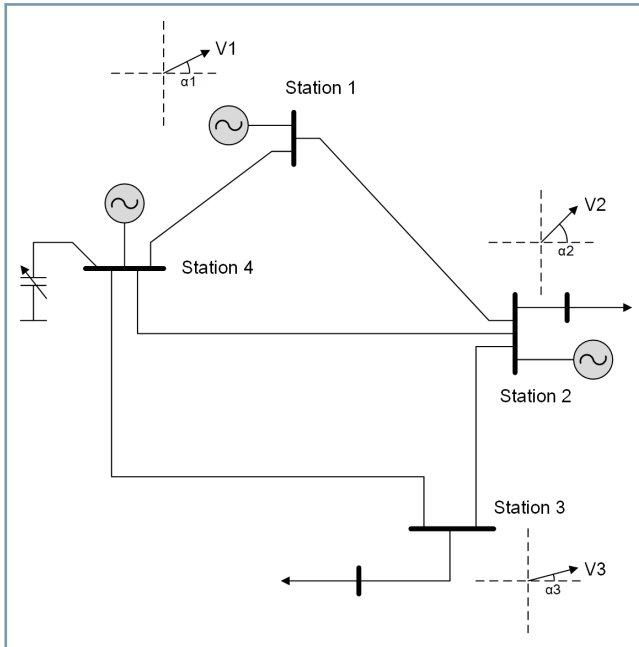

[dw_phasor measurement_pmu, 2, en_US]

Figure 5.4/8 Principle of the Distributed Phasor Measurement

Bay Controllers

SIPROTEC 6MD86 – Application Examples

5.4

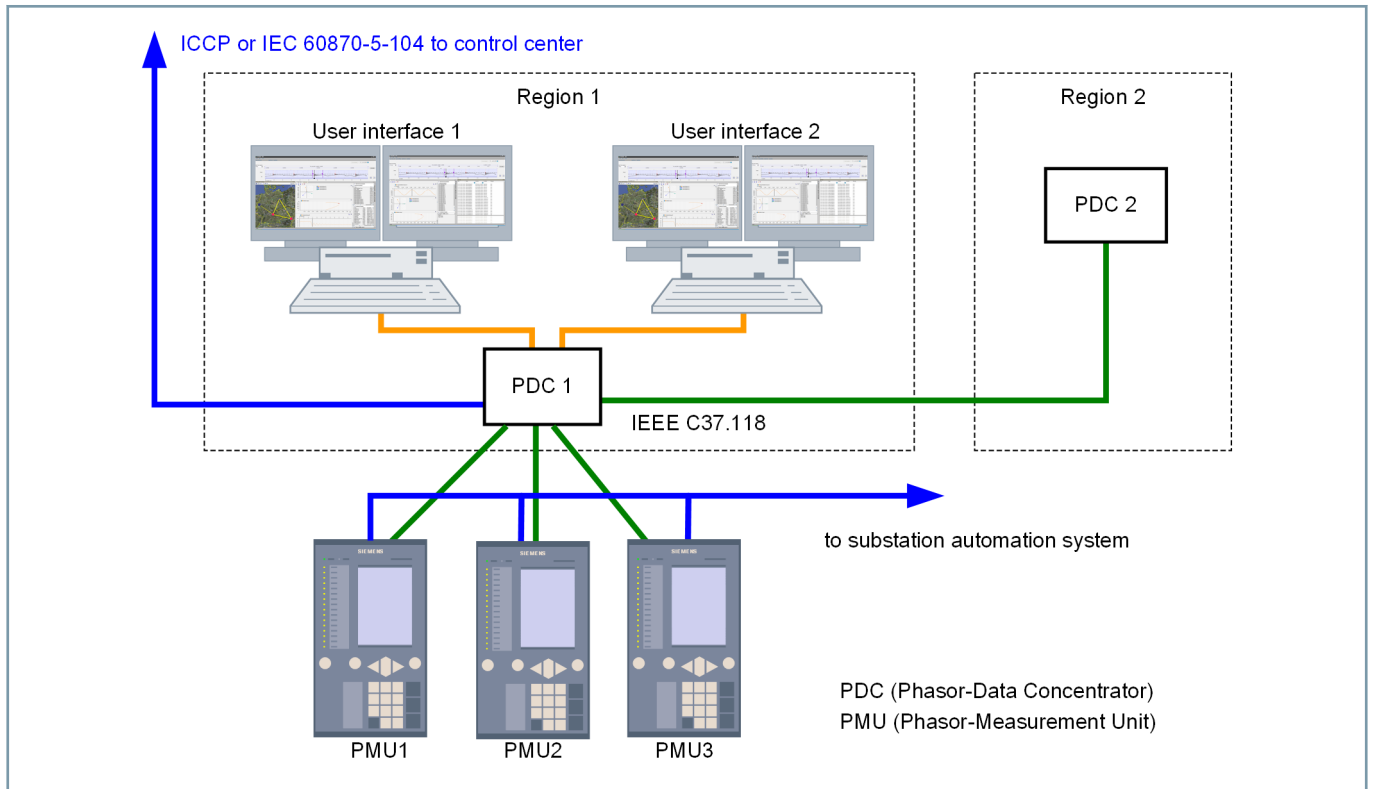

[dw_struct_WAM, 2, en_US]

Figure 5.4/9 Connecting 3 Phasor Measurement Units with 2 Phasor Data Concentrators (PDCs) SIGUARD PDP

When the PMU function is used, a **FG PMU** function group is created in the device. This function group calculates the phasor and analog values, performs time stamping and transmits the data with the protocol IEEE C37.118 to the selected Ethernet

interface. There, they can be received from one or more clients, saved and processed. Up to 3 IP addresses from clients can be assigned in the device. The multicast method can be used for a larger number of clients.

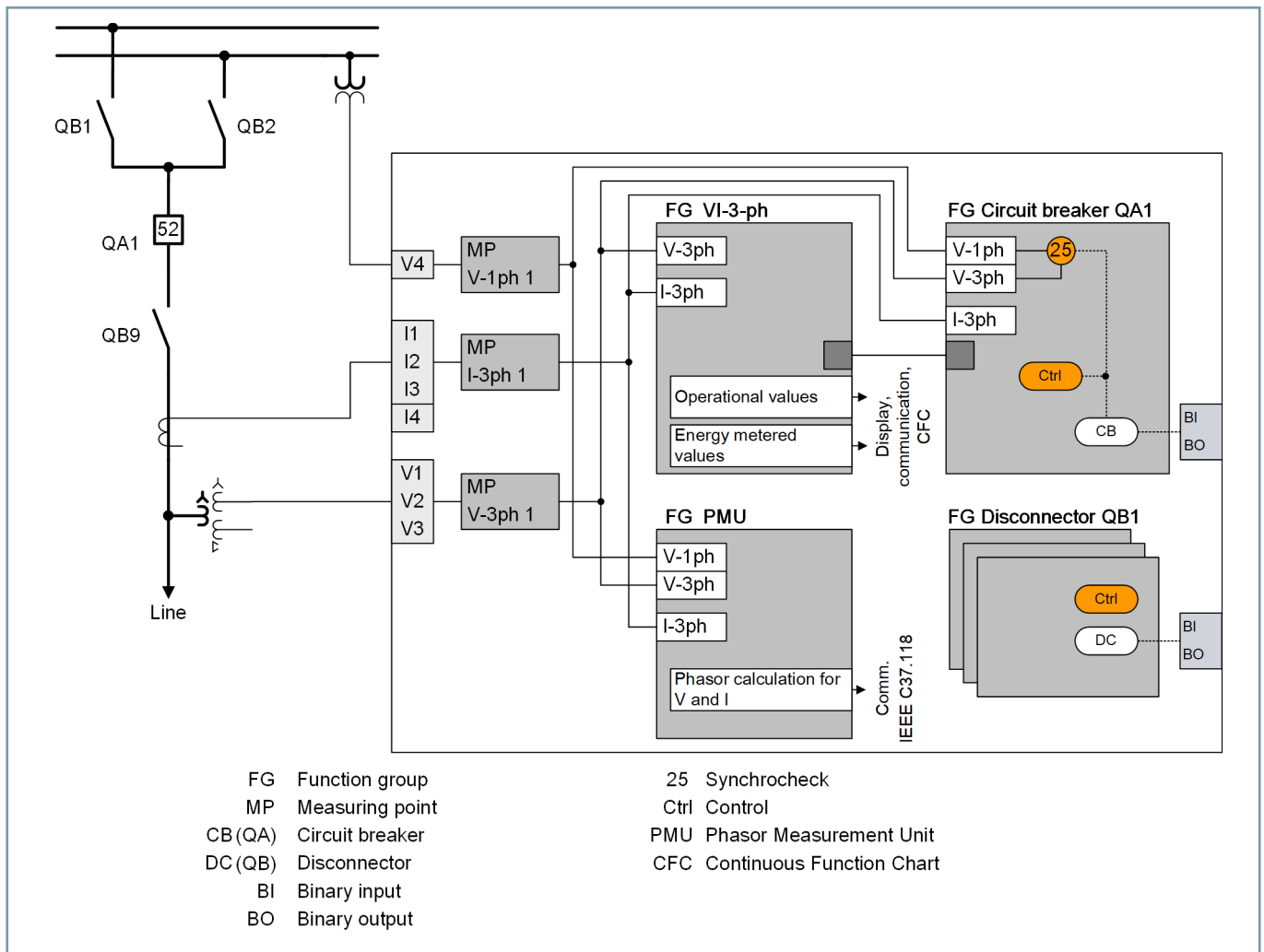

[dw_6MD8-Application-example-4_4_en_US]

Figure 5.4/10 Application Example: Double Busbar with SIPROTEC 6MD86 Used as a Bay Controller and Phasor Measurement Unit (PMU)

Bay Controllers

SIPROTEC 6MD86 – Cut-out and Housing Widths

5.4

	Width of the Mounting Opening
1/3 device (base module)	146 ⁺² mm (5.75 ^{+0.08})
1/2 device (base module with one expansion module)	221 ⁺² mm (8.7 ^{+0.08})
2/3 device (base module with 2 expansion modules)	296 ⁺² mm (11.65 ^{+0.08})
5/6 device (base module with 3 expansion modules)	371 ⁺² mm (14.61 ^{+0.08})
1/1 device (base module with 4 expansion modules)	447 ⁺² mm (17.6 ^{+0.08})

Table 5.4/1 Cut-Out Widths

	Dimension a Housing Widths in mm (in Inches) (Total Width = Housing Width + 5 mm (0.2 in))
1/3 device	145 (5.71)
1/2 device	220 (8.66)
2/3 device	295 (11.61)
5/6 device	370 (14.57)
1/1 device	445 (17.52)

Table 5.4/2 Variable Housing Widths

Selection and Ordering Data

Bay Controllers – 6MD86	
Housing: Extendable, 1/3 x 19" to 2/1 x 19" with painted modules (conformal coating)	
Basic function with hardware standard variant ⁴⁷	
	K1: 1/3, 11 BI, 9 BO (1 Life, 2 S, 6 F), 4 current transformers, 4 voltage transformers ⁴⁸
	K2: 1/2, 27 BI, 17 BO (1 Life, 10 S, 6 F), 4 current transformers, 4 voltage transformers ⁴⁹
	K4: 2/3, 43 BI, 25 BO (1 Life, 18 S, 6 F), 4 current transformers, 4 voltage transformers ⁴⁹
	K6: 5/6, 59 BI, 33 BO (1 Life, 26 S, 6 F), 4 current transformers, 4 voltage transformers ⁴⁹
	K7: 1/1, 75 BI, 41 BO (1 Life, 34 S, 6 F), 4 current transformers, 4 voltage transformers ⁴⁹
	K8: 1/1, 67 BI, 39 BO (1 Life, 26 S, 12 F), 8 current transformers, 8 voltage transformers ⁴⁹
Application templates/function points ⁵⁰	
	Double busbar, standard
	Breaker-and-a-half, Type 1
	Breaker-and-a-half, Type 2 (75 function points)
	Point-on-wave switching
Process-bus functionality/function points ^{50 51 52}	
	Merging-unit functionality for ETH-BD-2FO plug-in module (200 function points)
	Process-bus client functionality (100 function points)
	Connection to the 7SS85 central unit (95 function points)
Warranty extension	
	Warranty extension, annually
Communication	
	Integrated Ethernet interface (RJ45) for DIGSI
	Integrated Ethernet interface (RJ45) for DIGSI and IEC 61850 without GOOSE
	Integrated Ethernet interface (RJ45) for DIGSI, IEC 61850 incl. GOOSE ⁵¹
	SIPROTEC 5 plug-in modules
For the product configuration and order no., see SIPROTEC 5 Configurator	

5.4

Table 5.4/3 SIPROTEC 6MD86 – Selection and Ordering Data

⁴⁷ Abbreviations: Housing width of 19 inches/BI: Binary inputs/BO: Binary outputs/S: Standard relay/F: Fast relay

⁴⁸ Large display with 16 LEDs and Ethernet module ETH-BA-2EL (electric)

⁴⁹ Large display with key switch, with 32 LEDs and Ethernet module ETH-BA-2EL (electric)

⁵⁰ Available functional scope as specified in the function-point calculator in the [SIPROTEC 5 Configurator](#)

⁵¹ For CP300 devices only

⁵² ETH-BD-2FO is required; you cannot simultaneously operate the merging unit and process-bus client on the same plug-in module.

Bay Controllers

SIPROTEC 6MD89 – Description

5.5

Description

The SIPROTEC 6MD89 bay controller is a universal control and automation device with a protection function for railway applications (1-phase and 2-phase systems with a rated frequency of 16.7 Hz). It is designed for use in all voltage levels from contact wire power supply to power transmission. As part of the SIPROTEC 5 family, it enables a wealth of protection functions from the SIPROTEC library. The modular hardware permits integration of the I/Os depending on the application. Adapt the hardware precisely to your requirements and rely on the future-oriented system solutions with a high level of investment protection and low operating costs.

Main function	Bay controller for railway applications, optimized for 1- and 2-phase systems with a rated frequency of 16.7 Hz. Integrated operation and extensive protection functions are possible. Powerful automation, simple configuration with DIGSI 5
Inputs and outputs	2 predefined standard variants, flexible extension possible
Hardware flexibility	Flexibly adjustable and expandable I/O quantity structure within the scope of the SIPROTEC 5 modular system. If high requirements are placed on the quantity structure, the device can be extended in the 2nd row. For example, 240 (and more) binary inputs are possible with the IO230 (see SIPROTEC 5 Hardware section)
Housing width	1/3 × 19 inch to 2/1 × 19 inch

Benefits

- Safe and reliable automation and control of your plants
- Purposeful and simple operation of the devices and software thanks to user-friendly design
- Cyber security to NERC CIP and BDEW Whitepaper requirements
- Highest availability even under extreme environmental conditions by standard coating of the assemblies
- Powerful communication components ensure safe and effective solutions
- High investment security and low operating costs due to future-oriented system solution

Functions

DIGSI 5 permits all functions to be configured and combined as required.

- Integrated bay controller, optimized for 1-phase and 2-phase systems with a rated frequency of 16.7 Hz.
- Control of switching devices
- Synchrocheck and switchgear interlocking protection
- Fixed integrated electrical Ethernet RJ45 interface for DIGSI 5 and IEC 61850 (reporting and GOOSE)
- Up to 4 pluggable communication modules, usable for different and redundant protocols (IEC 61850, IEC 60870-5-103, IEC 60870-5-104, Modbus TCP, DNP3 serial and TCP, PROFINET IO)



[SIP5_OD_0_LED_W3_2_...]

Figure 5.5/1 Railway Bay Controller SIPROTEC 6MD89 (1/3 Device with 1/6 Expansion Module)

- Reliable data transmission via PRP and HSR protocols
- Extensive cyber security functionality, such as role-based access control (RBAC), protocolling security-related events or signed firmware
- Simple, quick and secure access to device data via a standard Web browser – without additional software
- Graphical logic editor to create powerful automation functions in the device
- Optional overcurrent protection for all voltage levels with 2-pole tripping
- Overcurrent protection
- Capturing operational measured variables and protection function measured values to evaluate the plant state, to support commissioning, and to analyze faults
- Powerful fault recording (buffer for a max. record time of 20 sec. at 8 kHz and 80 sec. at 2 kHz)
- Auxiliary functions for simple tests and commissioning
- Flexibly adjustable I/O quantity structure within the scope of the SIPROTEC 5 modular system

Applications

The SIPROTEC 6MD89 bay controller is a general-purpose control and automation device with a protection function for railway applications based on the SIPROTEC 5 system. The device is designed for 1-phase and 2-phase systems with a rated frequency of 16.7 Hz. and supports all SIPROTEC 5 characteristics. The device enables upgradeable system solutions with high investment security and low operating costs.

Application Templates

Application templates are available in DIGSI for standard applications. They comprise basic configurations and default settings.

The following application templates are available:

- *SIPROTEC 6MD89 Standard*
 - Double busbar feeder with switchgear interlocking protection
- *SIPROTEC 6MD89 blank application template*
 - Blank application template for customer-specific engineering

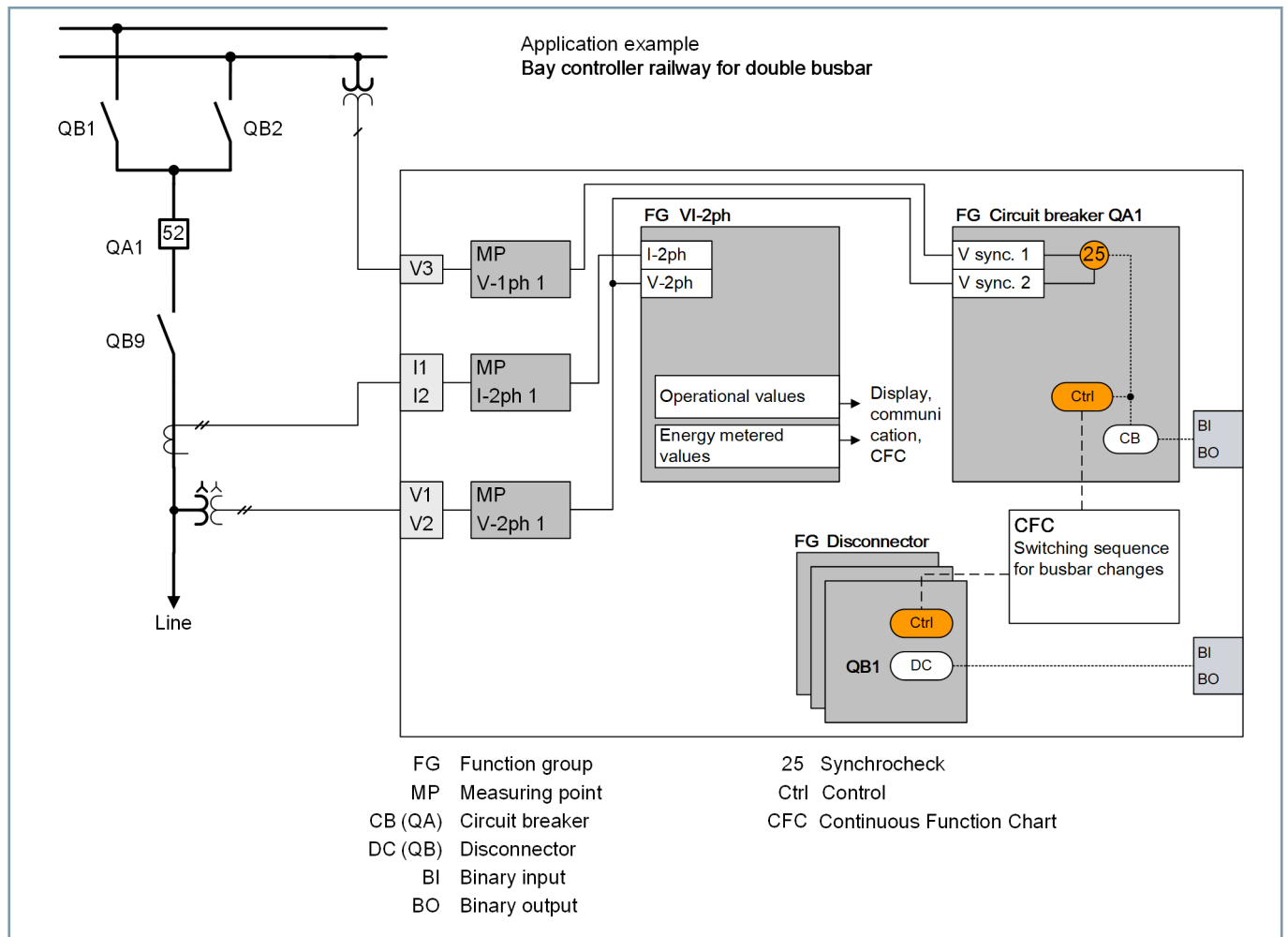

[dw_6MD89-Application-double-busbar, 2, en_US]

Figure 5.5/2 Application Example: Bay Controller Railway 6MD89 for Double Busbar

Bay Controllers

SIPROTEC 6MD89 – Cut-out and Housing Widths

	Width of the Mounting Opening
1/3 device (base module)	146 ⁺² mm (5.75 ^{+0.08})
1/2 device (base module with one expansion module)	221 ⁺² mm (8.7 ^{+0.08})
2/3 device (base module with 2 expansion modules)	296 ⁺² mm (11.65 ^{+0.08})
5/6 device (base module with 3 expansion modules)	371 ⁺² mm (14.61 ^{+0.08})
1/1 device (base module with 4 expansion modules)	447 ⁺² mm (17.6 ^{+0.08})

5.5

Table 5.5/1 Cut-Out Widths

	Dimension a Housing Widths in mm (in Inches) (Total Width = Housing Width + 5 mm (0.2 in))
1/3 device	145 (5.71)
1/2 device	220 (8.66)
2/3 device	295 (11.61)
5/6 device	370 (14.57)
1/1 device	445 (17.52)

Table 5.5/2 Variable Housing Widths

Selection and Ordering Data

Bay Controller – 6MD89	
Housing: Extendable, 1/3 x 19" to 2/1 x 19" with painted modules (conformal coating)	
Basic function with hardware standard variant ⁵³	
	AB1: 1/3, 11 BI, 9 BO (1 Life, 2 S, 6 F), 4 current transformers, 4 voltage transformers ⁵⁴
	AB2: 1/2, 35 BI, 33 BO (1 Life, 26 S, 6 F), 4 current transformers, 4 voltage transformers ⁵⁵
Application templates/function points ⁵⁶	
	Double busbar, standard
Warranty extension	
	Warranty extension, annually
Communication	
	Integrated Ethernet interface (RJ45) for DIGSI
	Integrated Ethernet interface (RJ45) for DIGSI and IEC 61850 without GOOSE
	Integrated Ethernet interface (RJ45) for DIGSI, IEC 61850 incl. GOOSE
	SIPROTEC 5 plug-in modules
For the product configuration and order no., see SIPROTEC 5 Configurator	

5.5

Table 5.5/3 SIPROTEC 6MD89 – Selection and Ordering Data

⁵³ Abbreviations: Housing width of 19 inches/BI: Binary inputs/BO: Binary outputs/S: Standard relay/F: Fast relay

⁵⁴ Without display, with 16 LEDs and Ethernet module ETH-BA-2EL (electric)

⁵⁵ Without display, with 32 LEDs and Ethernet module ETH-BA-2EL (electric)

⁵⁶ Available functional scope as specified in the catalog or function-point calculator in the order configurator

Bay Controllers

SIPROTEC 6MD89 – Selection and Ordering Data

5.5

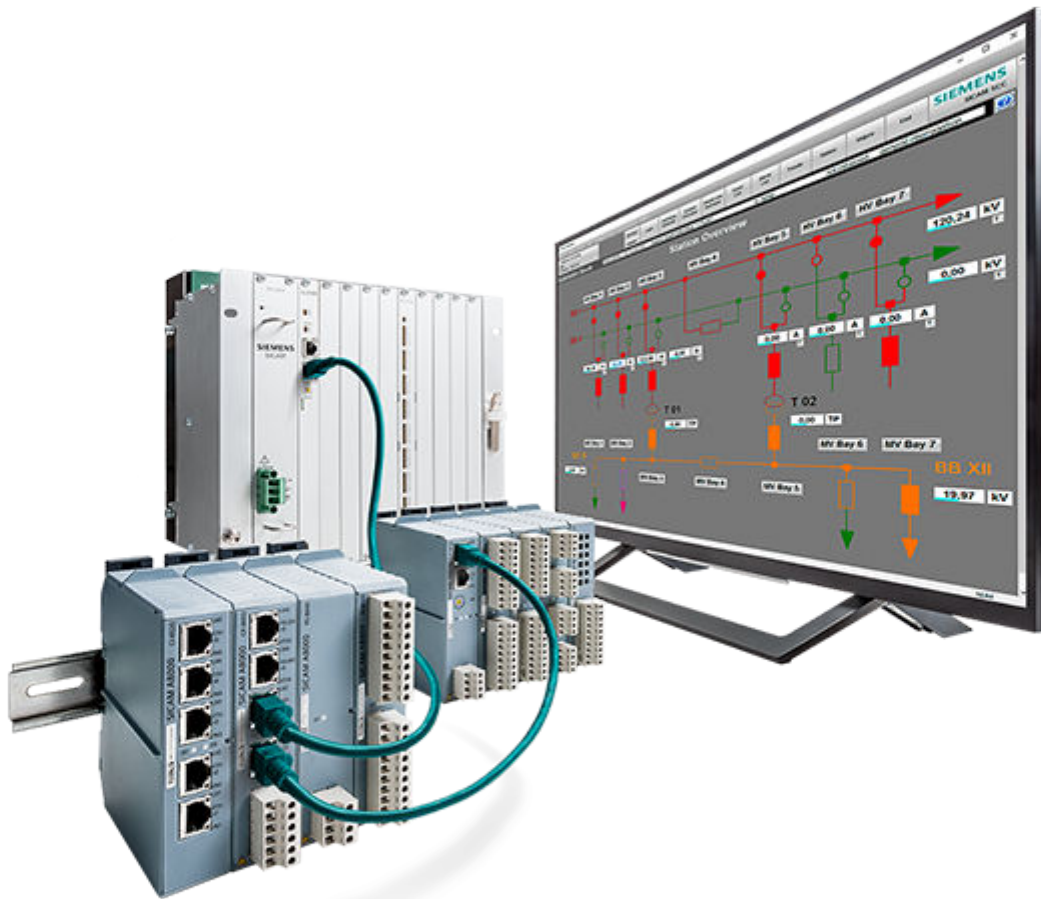

Distribution-System Automation

SICAM A8000 Series – Description

Description

The SICAM A8000 device series has been designed for lots of different tasks, both simple and complex. The area of application spans the entire energy-supply chain. Customer requirements such as IT security, scalability, flexible communication, space-saving design, and the ability to be used in harsh conditions were taken into account when the SICAM A8000 was being designed. The modular SICAM A8000 series offers optimized solutions for all kinds of performance requirements.

SICAM A8000 – Module Types

- Processor modules (up to a max. of 34 interfaces)
- Power-supply modules (DC 24 V to 60 V; DC 110 V to 220 V; AC 230 V)
- Ethernet or serial communication expansion modules
- Interface modules for a max. of 16 expansion lines
- Binary inputs (DC 24 V; DC 48/60 V; DC 110 V; DC 220 V)
- Binary outputs (DC 24/48/60/110/220 V; AC 110/230 V)
- Analog inputs (-20 mA/+20 mA; -10 V/+10 V; Pt 100)
- Analog outputs (-20 mA/+20 mA; -10 mA/+10 mA; -10 V/+10 V)
- Current/voltage inputs (1 A/5 A; LoPo; 230 V)

The universally applicable binary or analog input/output modules can be plugged in any order and are suitable for even the tightest spaces as they have a module width of 30 mm.

Benefits

- They can also be used in harsh ambient temperatures due to the extended temperature range of -40 °C to +70 °C
- The increased EMC stability of up to 5 kV (IEC 60255) qualifies the devices for direct use in switchgears
- Simple engineering with the integrated Web parameterization tool and the SICAM Device Manager
- It meets the most stringent cybersecurity requirements due to an integrated crypto chip and IPsec encryption
- It is a safe investment as international standards such as IEC 61850 IEC 60870-5-101/-103/-104 etc. are followed.
- The modular platform offers a variety of application options and reduces warehousing.
- Adaptation to existing communication infrastructures with a multitude of interfaces and the integrated GPRS module
- The integrated short-circuit indicator functionality enables use in power-system monitoring.
- You can save time and money as installation and maintenance are really simple – plug & play

Device Characteristics

Communication Interfaces and Protocols

- CP-8000: 3 x RJ45 (2 x Ethernet, 1 x RS232), 1 x RS485
- CP-8021: 3 x RJ45 (2 x Ethernet, 1 x RS232), 1 x RS485



[ph_SICAM A8000_5 devices, 1, ...]

Figure 6.1/1 SICAM A8000 Devices

- CP-8022: 3 x RJ45 (2 x Ethernet, 1 x RS232); 1 x RS485, 1 x RS232/RS485 (selectable), 1 x LTE CAT1/GPRS
- CP-8031: 4 x RJ45 (2 x Ethernet, 1 x RS485, 1 x RS232)
- CP-8050: 4 x RJ45 (2 x Ethernet, 1 x RS232, 1 x RS485), up to 12 x Ethernet or 30 x serial with CI modules
- IEC 60870-5-101/-103/-104, Modbus RTU/TCP
- IEC 61850 Ed1/Ed2 client & server incl. GOOSE
- DNP3 serial master/slave, TCP/IP
- Other protocols on request

Auxiliary Voltages

- DC 24 V to 60 V (12 W or 45 W)
- DC 110 V to 220 V (12 W or 45 W)
- AC 230 V (45 W)
- Can be redundant

Inputs and outputs

- CP-8000: max. 116 I/O with up to 6 I/O modules
- CP-8021, CP-8022, CP-8031: max. 128 I/O with up to 8 I/O modules
- CP-8050: max. 2048 I/O with up to 16 expansion lines for every 8 I/O modules

Real-Time Clock

- +/- 2 ppm, time synchronization using NTP protocol, SNTP protocol

Electromagnetic Compatibility

- IEC 60870-2-1, IEC 61010, IEC 60255-5, IEC 61000-4, EN 55022, CE marking

Temperature Range

- CP-8021, CP-8022: From -40 °C to +70 °C
- CP-8031, CP-8050: From -25 °C to +70 °C ⁵⁷

Housing Specifications

- Plastic housing for DIN rail mounting
- Dimensions of the CP-8000: 128 mm x 124 mm x 123 mm (W/H/D)
- Dimensions of the CP-8021/22/31/50, CI, power-supply module and I/O modules: 30 mm x 132 mm x 124 mm (W/H/D)

Special Features

- Integrated display and function keys for CP-8000
- Integrated Web server for configuration and diagnostics with CP-8000/21/22, engineering using the SICAM Device Manager and SICAM TOOLBOX II for the A8000 series
- Data storage using an SD memory card (parameters and device firmware)
- Freely programmable user programs according to IEC 61131-3
- Device redundancy with CP-8050
- The security requirements of the future:
 - Compliance with the BDEW white paper
 - Integrated crypto chip
 - TLS encryption
 - IPSec encryption
 - HTTPS protocol
 - Security Logbook

Additionally for CP-8031 and CP-8050:

- Integrated software firewall
- Firmware signature
- Role-based access control
- Configurable system functions
- Hardware-based application layer firewall for IEC 60870-5-104
- Automated certificate handling via the EST protocol with SICAM Grid Pass

For further information see [Fields of Application, Page 32](#) .

⁵⁷ -40 °C on request

Distribution-System Automation

SIPROTEC 7SC80 – Description

Description

The SIPROTEC 7SC80 distribution system protection is used for protection and automatic functions in feeders with a grounded, low-impedance grounded, isolated or compensated neutral point design.

Protection functions can be configured flexibly; the user can create up to 20 additional protection functions specifically for his requirements. Primary switching devices such as grounding conductors, disconnecter switches and load switches/circuit breakers can be monitored.

With the integrated programmable logic (CFC), the user can implement his own functions, such as automation of a bay (interlocking, load shedding programs). The option of generating user-specific messages demonstrates the versatility of the device.

The device has attachable or Web-based HMI 32 LEDs and 9 freely programmable function keys for direct shortcuts or various applications.

Special features

- Support of applications for distribution-system automation
- Designed for harsh environmental conditions
- Extended temperature range from -50 °C to 85 °C
- Flexible communication possibilities, for example for radio transmission specifically for feeder automation
- Built-in GPS module or IRIG B for time synchronization
- Remote access for firmware and parameter updates
- Meets security requirements of the BDEW
- The Web-based HMI allows complete remote control and tele-monitoring of the device.
- 9 freely programmable function keys
- 6-line display
- Integrated switch for cost-effective and redundant optical ring feeders; for electrical modules, this can be used for directly cascading (concatenating) devices
- Communication protocols running in parallel
- Redundancy protocols RSTP, PRP and HSR for maximum availability
- Jump detection for currents and voltages
- Expanded programming functions
- Single-mode interface for 24 km
- RTU version without protection function
- Plug-in connections
- Secondary current transformer values (1 A/5 A) can be adjusted with DIGSI
- Back-up battery can be replaced without opening the device
- USB front interface
- Inter-device communication via Ethernet with IEC 61850 GOOSE
- Stainless steel housing for flush mounting or surface mounting



[SIPROTEC_7SC80_W3, 1, ...]

Figure 6.2/1 SIPROTEC 7SC80 Front View with HMI

- Millisecond-accurate time synchronization via Ethernet with SNTP
- Inputs for small-signal current and voltage transformers according to IEC 61869-10 and 11

Benefits

- Rapid fault location detection
Disconnection of the faulty feeder
Resupply with healthy feeder
- Support and expanded programming functions for feeder automation applications
- Pluggable terminals with integrated 2-pole cross connectors
- Data transmission up to 24 km with single-mode cable, up to 4 km with multi-mode cable
- Flexible communication possibilities, for example for radio transmission specifically for feeder automation
- Built-in GPS module for time synchronization and location detection
- Complete remote control and telemonitoring as well as firmware upgrades
- Battery supervision and management

Applications

The SIPROTEC 7SC80 distribution system protection is a digital protection device that also carries out control and monitoring tasks. This supports economical management by the user and ensures reliable supplying of customers with electrical energy

The device operation was designed according to economic aspects. A great deal of value was placed on a very legible display and large function keys. Numerous conditions and alarms can be displayed with the 32 LEDs.

Control

The integrated control function makes it possible to control disconnectors and circuit breakers via the integrated operation panel, binary inputs, DIGSI 4 or systems control (for example SICAM).

Programmable Logic

The integrated logic functionality allows the user, with a graphical user interface, to implement functions of his own for automating his switching cell (interlocking), switchgear or a distribution network theater and to generate user-defined indications.

Operational measured values

Extensive operational measured values, limiting values and metered values allow an improved operation management and simplified commissioning.

Operational indications

The operation is documented with traceability due to the storage of fault indications, error messages, fault datasets and statistics.

Line protection

The SIPROTEC 7SC80 devices are used as line protection for high-voltage and medium-voltage power systems with grounded, low-impedance grounded, isolated or compensated neutral point design

Transformer protection

As a supplement to a transformer differential protection, the devices also perform all the tasks for backup protection. Inrush-current detection effectively prevents pickup due to inrush currents. The high impedance ground fault differential protection detects short circuits and insulation faults on the transformer.

Backup protection

The SIPROTEC 7SC80 - devices can be universally used as backup protection.

High-voltage and medium-voltage switchgear

All devices optimally fit the requirements of high-voltage and medium-voltage applications. Separate measuring devices (for example, for current, voltage, frequency, measuring transducers) or additional control components are usually not necessary in the switchgear cabinets.

Distribution-System Automation

SIPROTEC 7SC80 – Overview of Functions

Overview of Functions

Protection functions	IEC standard	ANSI standard
Overcurrent protection (independent; dependent)	$I>, I>>, I>>>, I_p$	50/51
Ground-fault protection	$I_E>, I_E>>, I_E>>>, I_{Ep}$	50N/51N
Sensitive ground-fault protection	$I_{EE}>, I_{EE}>>, I_{EEp}$	50N(s)/51N(s)
Circuit-breaker failure protection	CBFP	50BF
Overload protection	$\vartheta>$	46
High-impedance ground fault differential protection		87N
Trip-circuit supervision	AKU	74TC
Undercurrent monitoring	$I<, P<$	37
Current transformer monitoring		60CTS
Locked OFF/lockout		86
Unbalanced-load protection	$I_2>$	49
Dynamic pickup value switching		51C
Directional overcurrent protection	$I_{ger.>}, I_{ger.>>}, I_p \text{ ger.}$	67
Sensitive ground-fault protection	$I_E \text{ ger.>}, I_E \text{ ger.>>}, I_{Ep} \text{ ger.}$	67N
Directional/non-directional sensitive ground-fault detection	$I_{EE}>, I_{EE}>>, I_{EEp}$	67Ns, 50Ns
Overvoltage, zero-sequence system	$V_r, V_o>$	59N
Overfrequency/Underfrequency protection	$f<, f>$	81O/V
Synchrocheck		25
Inrush-current detection		81HBL2
Overcurrent protection, 1-phase		64H
Overvoltage/undervoltage protection	$V<, V>$	27/59
Residual voltage		64/59N
Voltage transformer monitoring		60VTS
Voltage-controlled overcurrent protection		51V
Negative-sequence system overvoltage protection		47NPS
Flexible protection functions (characteristic key values from current and voltage): Voltage, power, power factor, frequency-change protection	$P<>, Q<>/\cos \phi/df/dt$	32/55/81R
Automatic reclosing	AREC	79
Fault locator	FO	21FL

Table 6.2/1 Overview of Functions

Control functions/programmable logic

- Control commands for circuit breakers and disconnect switches
- Control via keypad, binary inputs, DIGSI 4 or SCADA system
- User-specific PLC logic with CFC (for example, interlocking)

Monitoring functions

- Measured and metered values V, I, f, W_p, W_q
- Minimum and Maximum Values
- Circuit breaker wear monitoring
- Fuse and trip-circuit supervision
- max. 40 fault records
- Load profile for up to 20 various operational measured values

Communication interfaces and protocols

- Ethernet electrical and optical (multi-mode or single-mode)
- IEC 61850 Edition 1 and 2

- DNP3 TCP, IEC 60870-5-104, PROFINET
- Ethernet redundancy protocols RSTP, PRP and HSR
- USB front interface for DIGSI 4
- Serial DNP3 RS485 module

Hardware

- 4 current transformers
- 1/4/6 voltage transformers
- 12/20 binary inputs
- 8/15 binary outputs
- 1 life contact
- Pluggable current and voltage terminal blocks
- Connection option for small-signal current and voltage transformers

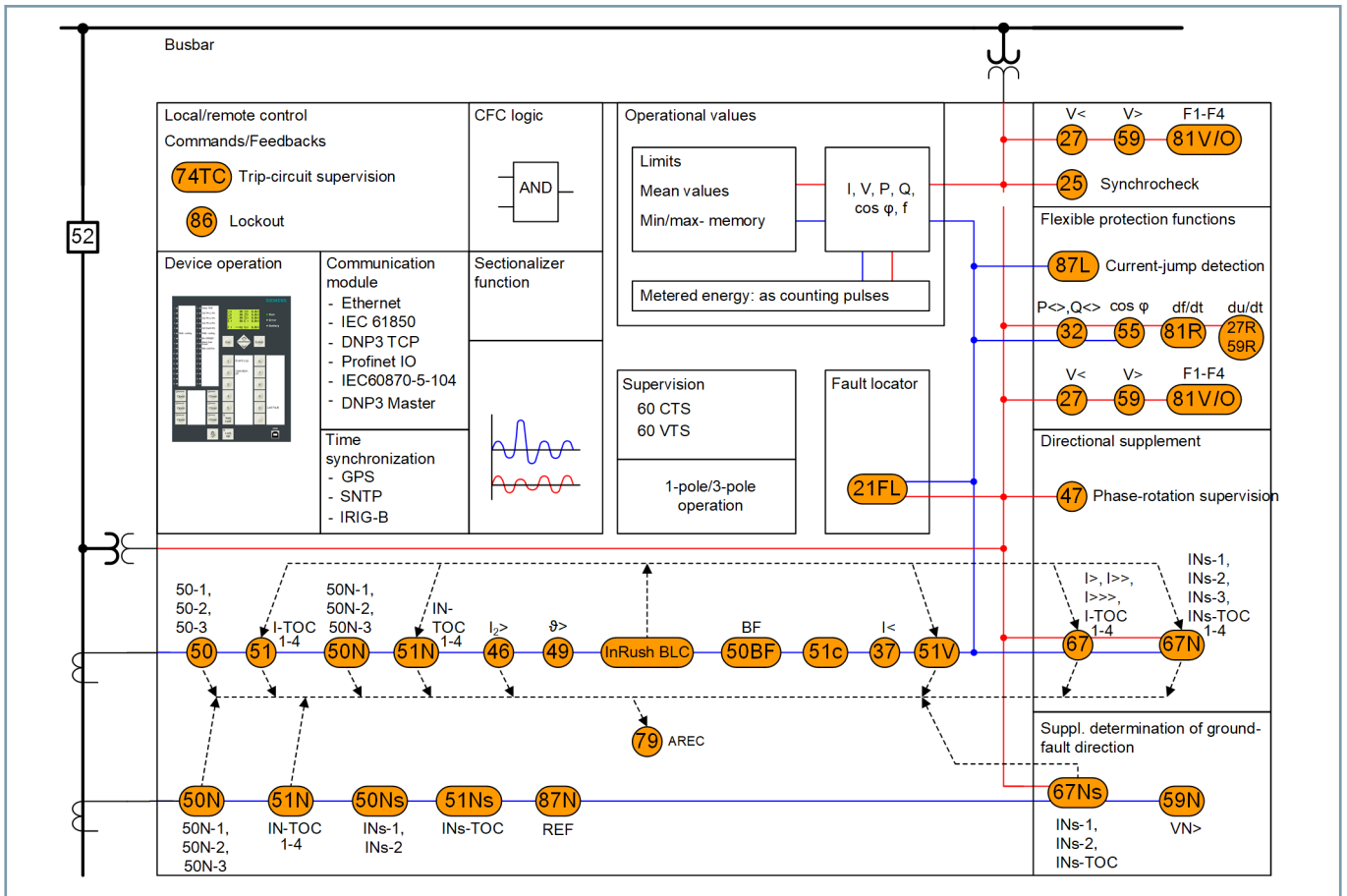

6.2

[dw_app1_dia_funct-7SC80_3_en_US]

Figure 6.2/2 Functional Scope SIPROTEC 7SC80

Distribution-System Automation

SIPROTEC 7SC80 – Dimensioned Drawings

Dimensioned Drawings

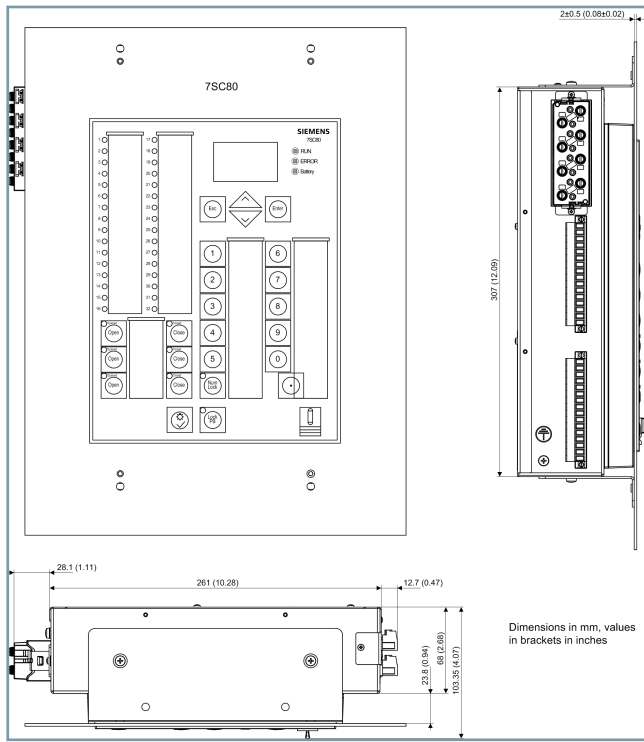

Figure 6.2/3 Variant with Attached Operation Panel

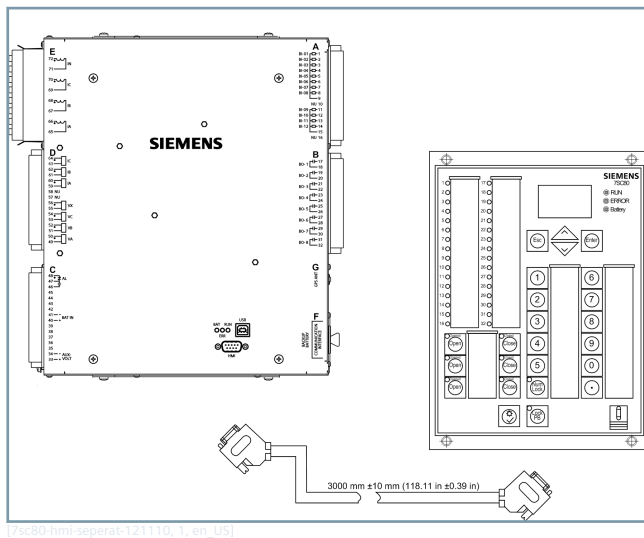

Figure 6.2/4 Variant with Detached Operation Panel

Selection and Ordering Data

Description	Versions	Order no.																				
		1	2	3	4	5	6	7	8	9	10	11	12	13	14	15	16	17	18	19		
SIPROTEC 7SC80		7	S	C	8	0	<input type="checkbox"/>	<input type="checkbox"/>	-	<input type="checkbox"/>	<input type="checkbox"/>	<input type="checkbox"/>	<input type="checkbox"/>	<input type="checkbox"/>	-	<input type="checkbox"/>	<input type="checkbox"/>	<input type="checkbox"/>	<input type="checkbox"/>	<input type="checkbox"/>		
							▲	▲		▲	▲	▲	▲		▲	▲	▲	▲		▲	▲	▲
Base device																						
	Housing, 12 BI, 8 BO, 1 life contact						2															
	Housing, 20 BI, 15 BO, 1 life contact 2 x V ⁵⁸						3															
Measuring inputs																						
	3 x I LPS/LoPo, 1 x V ⁵⁹						1															
	4 x I _{ph} 1 A/5 A, 1 x V						2															
	3 x I LPS/LoPo, 4 x V ⁵⁹						3															
	4 x I _{ph} 1 A/5 A, 4 x V						4															
	3 x I _{ph} 1 A/5 A, 1 x I _{EE} (sensitive) = 0.001 A to 1.6 A/0.005 A to 8 A, 1 x V						5															
	3 x I _{ph} 1 A/5 A, 1 x I _{EE} (sensitive) = 0.001 A to 1.6 A/ 0.005 A to 8 A, 4 x V						6															
Auxiliary voltage (power supply)																						
	DC 60 V to 250 V, AC 115 V, AC 230 V						1															
	DC 24 V/48 V						2															
	DC 24 V/48 V, battery supervision						3															
Design structure																						
	Surface-mounting housing, screw-type terminals, without operation panel						A															
	Surface mounting case, flush-mounting housing with operation panel						B															
	Surface-mounting housing, screw-type terminals, with detached operation panel						C															
Region-specific configuration and default language settings																						
	Region GE, IEC, German language (language can be changed)						A															
	Region World, IEC/ANSI, English language (language can be changed)						B															
	Region US, ANSI, American English language (language can be changed)						C															
	Region World, IEC/ANSI, French language (language can be changed)						D															
	Region World, IEC/ANSI, Spanish language (language can be changed)						E															
	Region World, IEC/ANSI, Russian language (language can be changed)						G															

6.2

Table 6.2/2 SIPROTEC 7SC80 Selection and Ordering Data

⁵⁸ Only with position 7 = 3, 4 or 6

⁵⁹ The sensors mentioned in the chapter "SICAM FCM" can be used; if used for protection purposes, usability must be appropriately checked.

Distribution-System Automation

SIPROTEC 7SC80 – Selection and Ordering Data

Description	Versions	Order no.																				
		1	2	3	4	5	6	7	8	9	10	11	12	13	14	15	16	17	18	19		
Continued from preceding page																						
SIPROTEC 7SC80		7	S	C	8	0	□	□	-	□	□	□	□	-	□	□	□	□	-	□	□	□
												▲	▲	▲	▲	▲	▲	▲	▲	▲	▲	▲
System interface																						
	No assembly											0										
	100 Mbit Ethernet, electric, 2 x RJ45 plugs											9							L		R	
	100 Mbit Ethernet, with integrated switch, optical, double, 2 x LC connector, multi-mode											9							L		S	
	100 Mbit Ethernet, with integrated switch, optical, double, 2 x LC connector, single-mode, 24 km											9							L		T	
Protocol for the system interface																						
	IEC 61850																					0
	IEC 61850/DNP3 TCP																					2
	IEC 61850/PROFINET IO ⁶⁰																					3
	IEC 61850/IEC 60870-5-104																					4
	DNP3, electrical RS485											9							L	6	G	
Additional interfaces																						
	No assembly											0										
	IRIG B-module, optical											6										
	GPS module											7										
Functionality packages - see next page																						

Table 6.2/3 SIPROTEC 7SC80 Selection and Ordering Data

⁶⁰ Only in connection with 100 Mbit Ethernet module, electrical or multi-mode

Description	Versions	Order no.																
		1	2	3	4	5	6	7	8	9	10	11	12	13	14	15	16	
Continued from preceding page		7	S	C	8	0	□	□	-	□	□	□	□	-	3	F	□	□
SIPROTEC 7SC80																		
																		▲ ▲
Functionality packages																		
ANSI no.	Base package A																	A
50/51	Overcurrent protection phase I>, I>>, I>>>, Ip																	
50N/51N	Normal ground-fault protection, protection to ground IGnd>, IGnd>>, IGnd >>>, IGndp																	
50N(s)/51N(s)	Sensitive ground-fault protection IEE>, IEE>>, IEEp ⁶¹																	
50BF	Circuit-breaker failure protection																	
46	Unbalanced-load protection																	
49	Overload protection																	
87N	High-impedance ground fault differential protection ⁶²																	
74TC	Trip-circuit supervision																	
37	Undercurrent monitoring																	
51C	Dynamic pickup value switching																	
81HBL2	Inrush-current detection																	
86	Lockout																	
60CTS	Current transformer monitoring																	
	Jump detection monitoring with the delta measuring method																	
	Parameter set switching																	
	Monitoring functions																	
	Circuit-breaker control																	
	Flexible protection functions (characteristic key values from current)																	
	Underfrequency/overfrequency, f<, f>																	
	with fault recording, with average calculation, with min/max values																	
ANSI no.	Base package B (includes A) ⁵⁸																	B
67	Directional addition for overcurrent protection phase, I>, I>>, I>>>, IGndp																	
67N	Directional addition for overcurrent protection ground, IGnd>, IGnd>>, I>>>, IGndp																	
67N(s)	Directional sensitive ground-fault protection/normal ground-fault protection IEE>, IEE>>, IEEp ⁶¹																	
27/59	Undervoltage/overvoltage																	
81 U/O	Underfrequency/overfrequency (f<, f>)																	
25	Synchrocheck																	
47	Rotating field direction																	
64/59N	Residual voltage																	
60VTS	Voltage transformer monitoring																	
32/55/81R	Flexible protection functions (characteristic key values from current and voltage): Voltage, power, power factor, frequency-change protection																	
	Base package N - see next page																	

6.2

Table 6.2/4 SIPROTEC 7SC80 Selection and Ordering Data

⁶¹ Depending on the ground-current input, the function operates either as sensitive ground-fault protection (sensitive input) or as normal ground-fault protection (normal input).
⁶² 87N (REF) only available with sensitive ground-current input (position 7 = 5 or 6)

Distribution-System Automation

SIPROTEC 7SC80 – Selection and Ordering Data

Description	Versions	Order no.																
		1	2	3	4	5	6	7	8	9	10	11	12	13	14	15	16	
Continued from preceding page		1	2	3	4	5	6	7	8	9	10	11	12	13	14	15	16	
SIPROTEC 7SC80		7	S	C	8	0	□	□	-	□	□	□	□	-	3	F	□	□
																	▲	▲
	Base package N (contains R) ⁶³⁶⁴																	
	SNTP server function (master), no protection functions																N	
	Base package R ⁶³																	
	Telecontrol functions, no protection functions																R	
ANSI no.	Additional functions																	
	Without																	0
79	With AREC																	1
21FL	With fault locator ⁶⁵																	2
79/21FL	With AREC, with fault locator ⁶⁵																	3
79/TS	With AREC, with 1-/3-pol. operation																	4
79/TS/21FL	With AREC, with 1-/3-pol. operation, with fault locator ⁶⁵																	5

Table 6.2/5 SIPROTEC 7SC80 Selection and Ordering Data

⁶³ Only with position 16 = 0,

⁶⁴ Only with position 12 = 7

⁶⁵ Only with position 7 = 3, 4 or 6

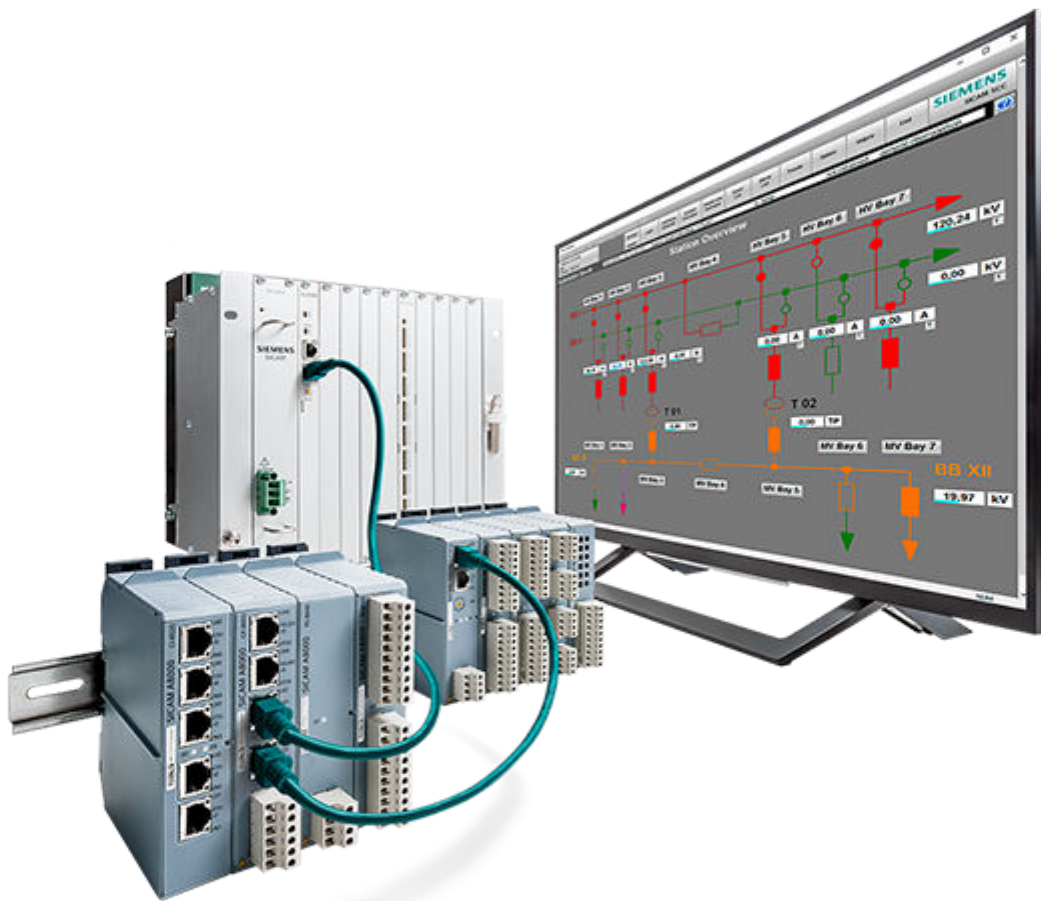

Short-Circuit Indicator

SICAM FCM – Description

Description

The SICAM FCM (Feeder Condition Monitor) is a short-circuit indicator and ground-fault indicator with and without directional indication that operates with detection algorithms and low-power sensor technology in conformity with IEC 60044-8, IEC 61869-10/IEC 60044-7, and IEC 61869-11. Alternatively, the SICAM FCM can also be connected to a capacitive voltage tap. This allows economical directional fault detection in the cable network. SICAM FCM additionally offers the possibility of providing up-to-date measured values via the integrated Modbus RTU interface and thus ensuring a precise assessment of the distribution system.

Benefits

- For grounded, isolated and arc-suppression-coil-ground systems
- Integrated power flow direction indicator
- Directional short-circuit and sensitive ground-fault detection
- Cost savings due to precise and fast fault localization
- Selective fault information with directional indication as a basis for self-healing applications
- Resupply times in the minute or second range (depending on primary equipment) allow minimum power system outages and minimum ultimate consumer payment losses
- Up-to-date measured values for operation and planning support the focused use of investment funds in power system planning and expansion
- Direct voltage measurement in low-voltage power systems
- Support for different ground-fault detection algorithms: $\cos/\sin \varphi$, pulse detection, transient ground-fault detection
- Use of low-power sensors and high quality measurement technology with a high measuring accuracy
- Alternatively: Designed to be connected to the capacitive voltage tap
- Flexible sensitive ground-fault detection from 0.4 A onwards
- Telecontrol parameterization via SICAM A8000 and Modbus

Functions

The SICAM FCM is the first short-circuit indicator that supports standard-compliant sensors according to IEC 60044-8, IEC 61869-10/IEC 60044-7, and IEC 61869-11. This ensures high-precision measurement without calibration and adjustments to the primary values.

- Fault search
 - Overcurrent detection (I), ($I >>$)
 - Ground-fault detection ($I_{n>}$) using the following methods:
 - $\cos \varphi$, $\sin \varphi$
 - Vector method
 - Pulse method
 - Intermittent/interrupting faults
 - Direction-dependent transients
- Expanded fault validation and fault reset function
- Open-phase detection



[ph_SICAM_FCM, 2, ...]

Figure 7.1/1 SICAM FCM

- Inrush-current detection/blocking
- Phase-sequence monitoring
- Power-flow sign and direction
- Undervoltage alarm and undervoltage warning
- Overvoltage alarm and overvoltage warning
- Overcurrent alarm and overcurrent warning
- Alert counters
- Correction factors for LoPo voltage and current transformers in accordance with IEC 60044-8, IEC 61869-10/IEC 60044-7, and IEC 61869-11

Device Characteristics

Communication

- RS485 interface including Modbus RTU communication for all information and for remote parameterization/FW update, alternatively for PC programming
- SICAM FCM can also be configured by the user for the system parameters using the SICAM device configurator via the Modbus RTU.

Indications

- Display for presenting up-to-date measured values or fault information in the power distribution system, 4 function keys
- 3 LEDs signal the operating state
- 1 binary input for fault reset or field-data acquisition
- 2 binary outputs for fault indication. Outputs can be assigned to predefined function operations.

Measured and Derived Quantities

- RMS measured values
- Phase-to-ground voltages and currents, ground current, power frequency and $\cos \phi$, phase angle, phase-sequence display and sequence components, active power, reactive power and apparent power

Energy Measurement

- Import/export of active and reactive energy
- 15-minute to 1-year minimum and maximum values for all line currents as slave-pointer functions

Auxiliary Voltage

- AC 230 V
- DC 24 V to 250 V
- Battery with lifetime > 15 years

Time Synchronization

- Time synchronization via Modbus RTU

Inputs

- 3 inputs for alternating voltage selectively adjustable for $100 \text{ V}/\sqrt{3}$, low-power sensors with $3.25 \text{ V}/\sqrt{3}$ (according to IEC 61869-11) or 3 direct inputs for AC 230 V
- Alternatively: 3 inputs for connection to low resistance-modified (LRM) voltage detection systems (in accordance with IEC 62271-213)
- 3 inputs for AC low-power sensors with 225 mV at rated current (according to IEC 60044-8/IEC 61869-10); the rated primary current is adjustable in SICAM FCM from 10 A to 3000 A; L2 current input selectively, configured for sensitive ground-fault detection with low-power sensor with 225 mV at rated current (according to IEC 60044-8/IEC 61869-10); the rated primary current is adjustable from 0.4 A to 2000 A in SICAM FCM.
- Alternatively: Inputs for conventional instrument transformers 1 A/5 A via adaptors

Temperature range

- From $-40 \text{ }^\circ\text{C}$ to $+70 \text{ }^\circ\text{C}$

Housing

- Polycarbonate housing for panel flush mounting
- Dimensions: 96 mm x 48 mm x 109.5 mm (W/H/D)
- Protection class: Front panel IP40, rear panel IP20

Applications

The SICAM FCM is used:

- For directional/non-directional short-circuit and sensitive ground-fault detection for networks with direct/fixed grounding, networks with an isolated neutral point, and arc-suppression-coil-ground systems in medium- and low-voltage distribution networks in accordance with IEC 62271-213
- For simple measurement of system values, derived quantities, power-flow direction and energy measurement in medium- and low-voltage distribution systems

Short-Circuit Indicator

SICAM FCM – Sensors

Sensors

The SICAM FCM is the first short-circuit indicator that supports standards-compliant sensors for current and voltage measurement according to IEC 60044-8, IEC 61869-10/IEC 60044-7, and IEC 61869-11. This allows high-precision measurement without calibration and adjustments to the primary values.

Low-power summation current sensor for sensitive ground-fault detection



[ph_Core balance current sensor, 1, _--]

Figure 7.1/2 Summation Current Sensor

Low-power phase current sensor for recording phase current



[ph_Phase current sensor, 1, _--]

Figure 7.1/3 Phase Current Sensor

Voltage sensors/resistor divider enable precise and linear measurements

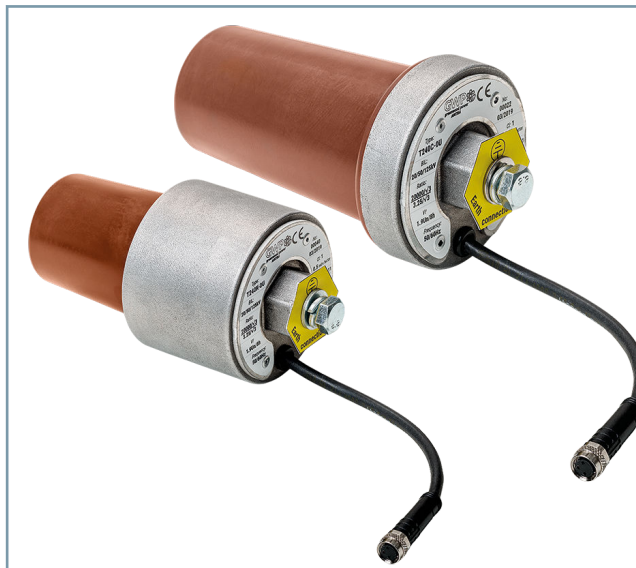

[ph_Voltage Sensor, 1, _--]

Figure 7.1/4 Voltage Sensors - Short and Long Design

SICAM FCM current transformers for connecting to conventional instrument transformers (1 A/5 A) on existing plants.



[ph_FCM CT Adaptor, 1, _--]

Figure 7.1/5 SICAM FCM Current Transformer Adaptor

SICAM FCM with adaptor cable for connecting a LRM voltage testing system according to IEC 62271-213.



[ph_FCM_Kap_Adapter, 1, --]

Figure 7.1/6 SICAM FCM - Adaptor for Capacitive Voltage-Detection Systems

7.1

Application Example

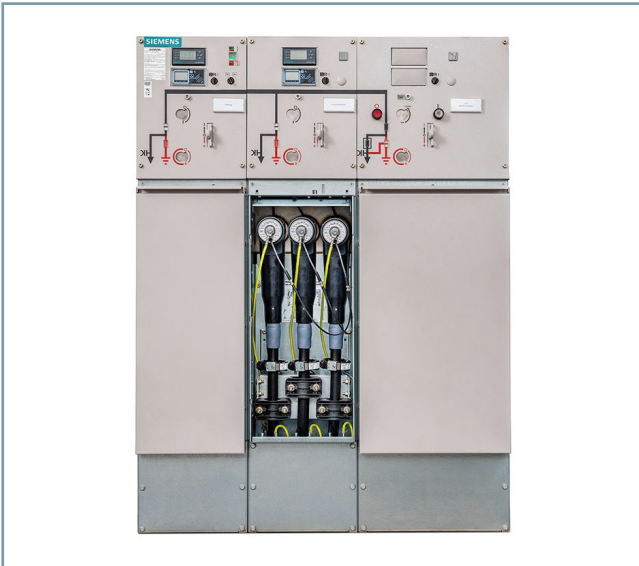

[ph_Schaltfeld, 1, --]

Figure 7.1/7 Phase Current Sensors in a 8DJH Bay

Short-Circuit Indicator

SICAM FCM – Dimensioned Drawings

Front View

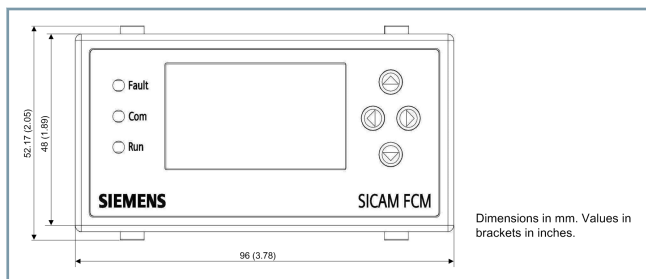

[dw_fcm_front, 1, en_US]

Figure 7.1/8 Front View

Rear View

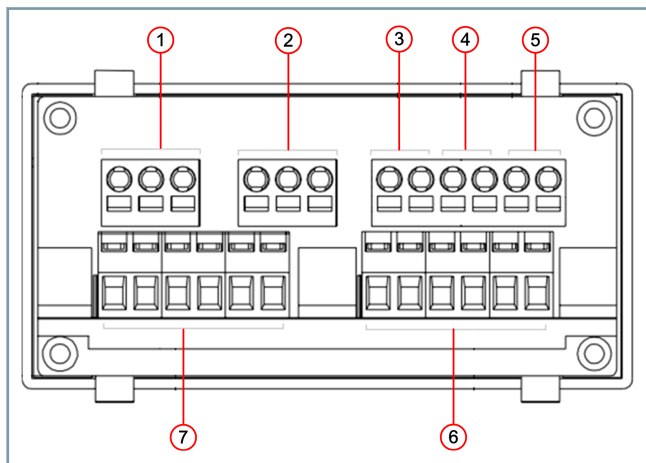

[ie_sicmrearview, 1, --]

Figure 7.1/9 Rear View with Terminals

- (1) Power supply
- (2) Modbus
- (3) Digital input
- (4) Digital output 2
- (5) Digital output 1
- (6) Voltage input
- (7) Current input

Isometric View

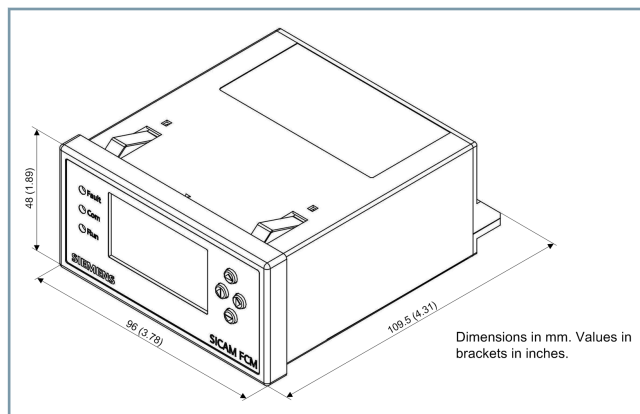

[dw_fcm_iso_view, 1, en_US]

Figure 7.1/10 Isometric View

1 A/5 A Adaptor Drawing

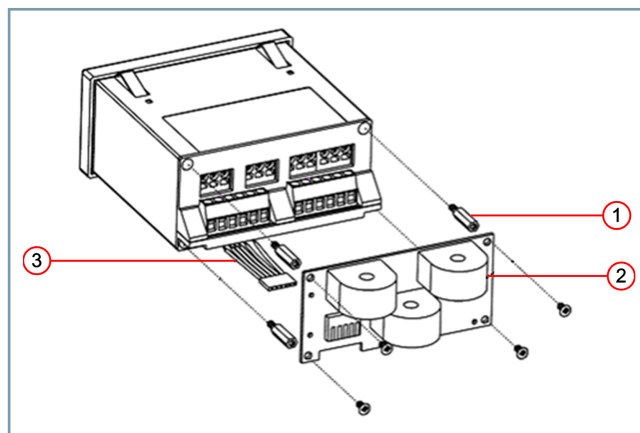

[ie_sicm1aadap-231015, 1, --]

Figure 7.1/11 1 A/5 A Adaptor

- (1) Threaded stud
- (2) CT adaptor PCB
- (3) Cable assembly

SICAM FCM with Connecting Cable (only for 6MD2322-1AA00-1AA0)

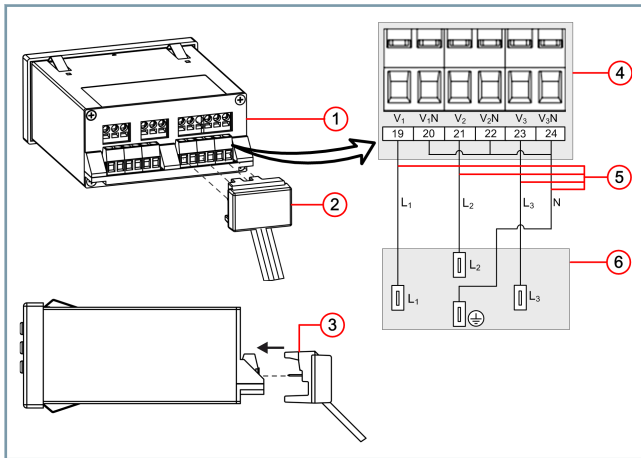

[6_sicm-capconnbl, 2, _1]

Figure 7.1/12 Connecting Cable of SICAM FCM

- (1) SICAM FCM
- (2) Connecting cable (6MD2322-0AA80-0AB3); necessary for 6MD2322-1AA00-1AA0
- (3) Orientation of connecting cable to SICAM FCM voltage-input terminals
- (4) SICAM FCM voltage-input terminals
- (5) Connecting cable (L₁, L₂, L₃, ground)
- (6) Voltage-detection system

Short-Circuit Indicator

SICAM FCM – Selection and Ordering Data

Selection and Ordering Data

Description	Versions	Order No.																	
		1	2	3	4	5	6	7	8	9	10	11	12	13	14	15	16		
SICAM FCM		6	M	D	2	3	2	□	-	□	□	□	□	□	-	□	□	□	□
								▲	▲	▲	▲	▲	▲	▲	▲	▲	▲	▲	▲
LoPo current transformer according to IEC 60044-8, IEC 61869-10	<u>Voltage measurement</u>																		
Fault indicator with directional indication and measurement of V, I, f, P, Q, S, cos φ and power-flow direction	Resistive																		
Energy metered values for panel flush mounting with display	LoPo voltage transformers according to IEC 60044-7, IEC 61869-11, traditional voltage transformers and 230 V							1	1	A	A	0	0	1	A	A	0	0	0
Housing: 96 mm x 48 mm x 109.5 mm	Capacitive																		
Power supply: DC 24 V to 250 VIAC 230 V	For voltage measurement in LRM voltage testing systems according to IEC/EN 62271-213							2	1	A	A	0	0	1	A	A	0	0	0
1 digital input	The mandatory interface cable (6MD2322-0AA80-0AB3) for linkage to the Voltage-Detection and Indicating Systems (VDIS) must be ordered separately.																		
2 digital outputs	Resistive variant – without battery																		
Modbus RTU	Voltage measurements: LoPo VTs according to IEC 60044-7, IEC 61869-11, conventional VT and 230 V							1	1	A	A	0	0	0	B	A	0	0	0
	Battery-less variant																		
	Split core																		
	Ratio: 225 mV@300 A IEC 61869-10																		
	Accuracy class 0.5 (FCM V3.30 and higher), otherwise 1 & 5P10; extension 200 %; connecting cable: 2 m, open end; inside diameter: 92 mm							0	0	G	A	0	0	1	A	A	0	0	0
Phase current sensor	Closed ring core																		
	Ratio: 225 mV@700 A IEC 60044-8																		
	Accuracy class 0.2 (FCM V3.30 and higher), otherwise 0.5 & 5P10, connecting cable: 2 m, open end; inside diameter 85 mm							0	0	J	A	0	0	0	B	A	1	0	0
	Ratio: 225 mV@60 A, IEC 61869-10																		
	Accuracy class 1 (FCM V3.30 and higher), otherwise 3;																		
	Connecting cable: 2 m							0	0	A	F	0	0	1	A	A	0	0	0
	Window diameter: 160 mm																		
Core balance current sensor	Ratio: 225 mV@60 A, IEC 60044-8																		
	Accuracy class: 1																		
	Connecting cable: 3.5 m							0	0	A	F	0	0	1	A	A	1	0	0
	Window diameter: 120 mm; GOST certificate																		

Table 7.1/1 SICAM FCM Selection and Ordering Data

Description	Versions	Order No.																	
		1	2	3	4	5	6	7	8	9	10	11	12	13	14	15	16		
SICAM FCM		6	M	D	2	3	2	□	-	□	□	□	□	□	-	□	□	□	□
								▲	▲	▲	▲	▲	▲	▲	▲	▲	▲	▲	▲
Low Power Phase Current Sensor	3 x current sensor 225 mV@100 A to 400 A, split core type According to IEC 61869-10 Wide-range sensor Inside diameter: 28 mm Accuracy class: 0.5 (FCM V3.30 and higher), otherwise 1; ref. to rated current 100 A With connecting cable: 7 m; open end							0	0	C	L	0	0	1	A	A	0	0	
	3 x current sensor 225 mV@300 A to 1000 A, split core type According to IEC 61869-10 Wide-range sensor Inside diameter: 44 mm Accuracy class: 0.5 (FCM V3.30 and higher), otherwise 1; ref. to rated current 300 A With connecting cable: 7 m; open end							0	0	H	L	0	0	A	A	0	0	0	0
Adaptor 1 A In LoPo IEC 60044-8	3 inputs; transformer ratio 225 mV@1 A Accuracy class: 1 Thermal overload: 100 A for 1 s Coil diameter: 5.8 mm							0	0	A	A	1	0	1	A	A	0	0	
Adapter 5 A In LoPo IEC 60044-8	3 inputs; transformer ratio 225 mV@5 A Accuracy class: 3 Thermal overload: 100 A for 1 s Coil diameter: 5.8 mm							0	0	A	A	2	0	1	A	A	0	0	
Voltage Sensor 10 kV	10 kV/√3: 3.25/√3 Accuracy class: 1 IEC 60044-7 for symmetrical T-connectors with C-cones for cables: Nexans (K) 440TB/Cellpack CTS-S/Süd kabel SEHDT13 and SEHDT23							0	0	A	A	0	4	1	A	A	0	0	
	10 kV/√3: 3.25/√3 Accuracy class: 0.5 IEC 60044-7 for asymmetrical T-connectors with C-cones for cable nkt CB-24, CC-24 and Raychem RSTI-58xx							0	0	A	A	0	4	1	A	B	0	0	
Voltage Sensor 20 kV	20kV/√3: 3.25/√3 Accuracy class 0.5 (FCM V3.30 and higher), otherwise 1 IEC 61869-11 for asymmetrical T-connectors with C-cones for cables: Nexans (K) 440TB/Cellpack CTS-S/Süd kabel SEHDT13 and SEHDT23							0	0	A	A	0	7	1	A	A	0	0	
	20kV/√3: 3.25/√3 Accuracy class 0.5 (FCM V3.30 and higher), otherwise 1 IEC 61869-11 for asymmetrical T connectors of nkt cables type CB-24, CC-24 and Raychem RSTI-58xx/RSTI-CC-58xx							0	0	A	A	0	7	1	A	B	0	0	

7.1

Table 7.1/2 SICAM FCM Selection and Ordering Data

Short-Circuit Indicator

SICAM FCM – Selection and Ordering Data

Description	Versions	Order no.																	
		1	2	3	4	5	6	7	8	9	10	11	12	13	14	15	16		
SICAM FCM		6	M	D	2	3	2	□	-	□	□	□	□	□	-	□	□	□	□
								▲	▲	▲	▲	▲	▲	▲	▲	▲	▲	▲	▲
DIN rail adapter for housing 48 mm x 96 mm								0	0	A	A	4	0	0	M	A		1	
	2 pieces; to snap on TS35 DIN rails; each adapter has 2 cut outs with 45 mm x 92 mm for flush-mounting housings with max. dep. of 135 mm, incl. cable bending, for example for SICAM FCM W/H/D: 105 mm/122 mm/140 mm; alternative wall mounting possible																		
Voltage-detection and indicating systems (VDIS) interface cable								2	-	0	A	A	8	0	-	0	A	B	3
	4-wire connection lead with integrated protection circuit to connect SICAM FCM 6MD2322-1AA00-1AA0/CC and higher with the LRM voltage detection and indication system 1 ground input; length: 0.3 m																		

Table 7.1/3 SICAM FCM Selection and Ordering Data

Description

SICAM FCM plus (Feeder Condition Monitor plus) is an Intelligent Electronic Device (IED) used for detecting and indicating short circuits or ground faults with and without directional information. SICAM FCM plus accurately monitors, measures, and displays operational measured values and performs the condition monitoring task in a medium-voltage distribution system. SICAM FCM plus is typically used in the medium-voltage substation that ranges from 6.6 kV to 36 kV. SICAM FCM plus measures the RMS value for alternating voltage, alternating current, and power frequency.

Benefits

- Suitable for solidly, low-resistive, isolated, and resonant-grounded systems
- Integrated power-flow direction indicator
- Selective fault information with direction indication used as a basis for self-healing applications
- Service restoration times in the range of minutes or seconds
- Up-to-date measured values for operational management
- Remote configuration via SICAM A80xx RTU and Modbus
- Self-test mode function for remote communication connection
- Easy installation and plug-in interface on RJ45 connectors
- Reduced cost of installation, faster to troubleshoot, and easy maintenance
- Minimum 8 hours of fault-status indication in absence of auxiliary power supply
- Up to 50 events can be stored
- Improved measurement accuracy based on auto adaption of correction factor

Functions

SICAM FCM plus provides 2 setting groups – Group 1 and 2 which can both be viewed/edited via the device HMI or configurator Web software.

- Directional phase-fault detection and ground-fault detection (ANSI 50/51/67 and ANSI 50N/51N/67N)
- Non-directional phase-fault detection and ground-fault detection (ANSI 50/51 and 50N/51N)
- Vector, $\cos \phi$ and $\sin \phi$, pulse location, intermittent, and transient methods for ground-fault detection
- Inrush-current detection and blocking (ANSI 81HBL2)
- Open-phase detection (ANSI 46BC)
- Undervoltage detection and overvoltage detection (ANSI 27, 59)

Device Communication and Protocol

- Serial interface on RS485 – Modbus RTU for data communication and remote configuration
- Supports the device configurator tool for configuration/parameterization and firmware upload via the front USB and the rear RS485 port.



[ph_SICAM_FCM_plus_1_...]

Figure 7.2/1 SICAM FCM plus

Device Characteristics

Salient Features

- Device powered via front USB to configure and firmware update
- Current acquisition based on Rogowski sensor inputs
- Auto adaption of correction factors (CF) using a JSON file
- Wide measurement range with accuracy of 0.5 % class
- Minimum 8 hours of fault-status indication by super capacitor during auxiliary supply failure

Archiving and Logging

- Fault information – 50 faults are stored as event logs
- Trailing pointers function for measured values of current, voltage, and power – I_{\min}/I_{\max} , V_{\min}/V_{\max} , and P_{\min}/P_{\max} for 15/30/45/60 minutes, 1 day, 30 days, and 1 year.
- Self-monitoring and supervision – watchdog functionality to indicate device health status

Auxiliary Power Supply Range

- AC 230 V \pm 20 %
- DC 24 V to 250 V \pm 10 %

Analog Inputs

- 3 x RJ45 interfaces for current and voltage inputs directly from the Siemens SIBushing sensors in accordance with IEC 61869-10 and IEC 61869-11
- Measured variables – RMS measured values of phase voltages and currents, power system frequency, and $\cos(\phi)$ phase angle
- Power meters – active, reactive, and apparent power
- Energy meters – active and reactive energy, import and export

Short-Circuit Indicator

SICAM FCM plus – Description

User Interface and Display

- Display for visualization of measured values, derived values, event fault log, and fault screen.
- 4 function keys for HMI navigation, information, and configuration.
- 3 LEDs to indicate the operating mode – Fault, Com, and Run

Binary Inputs/Outputs (User-Configurable)

- 6 binary inputs
- 4 binary outputs

Time Synchronization

- Supported via Modbus RTU

Operating Environment

- Temperature range: -40 °C to +70 °C
- Altitude: maximum 2000 m above sea level

Housing

- Polycarbonate housing for panel flush mounting
- Dimensions: 96 mm x 48 mm x 112.6 mm (W/H/D)
- Protection class: front panel IP40, rear IP20



[ph_sicam_fcm_plus_Bushing, 1, _1]

Figure 7.2/2 SICAM FCM plus with SIBushing

7.2

Applications

The SICAM FCM plus is:

- Used in the medium-voltage system up to 33 kV
- Applicable for radial/ring and compact distribution networks
- Compatible with SIBushing sensor
- Having a wide measuring range of accuracy with class 0.5 as per IEC 61869
- Remote device management - firmware upload and configuration using Siemens A80xx RTU
- A simple load-flow, power and energy measurement device for ring main units (RMU)

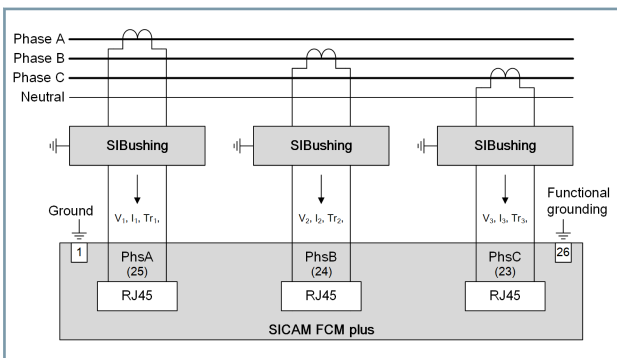

[dw_sicam-sib_sel-curr-temp, 2_en_US]

SIBushing Sensor

SICAM FCM plus is only compatible with SIBushing sensor according to IEC 61869-10, IEC 61869-11.

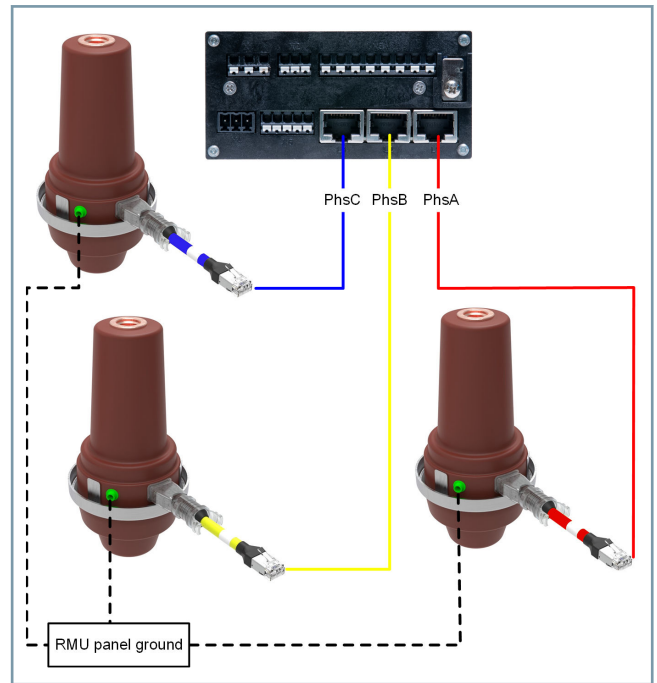

[dw_sicam-sib_sensor-conn, 2_en_US]

Figure 7.2/3 SIBushing Sensor Connection to SICAM FCM plus

Short-Circuit Indicator

SICAM FCM plus – Dimensional Drawings

Front View

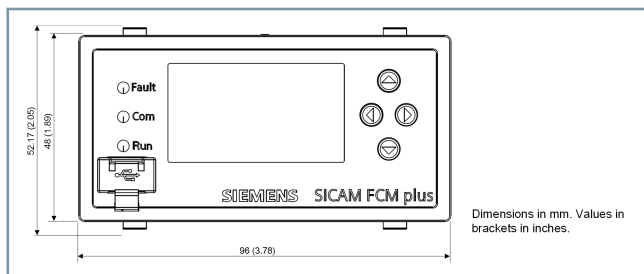

Figure 7.2/4 Front View

Isometric View

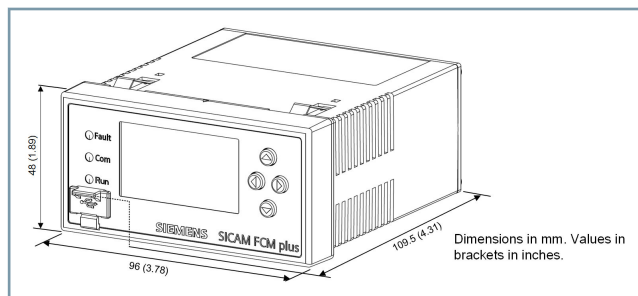

Figure 7.2/6 Isometric View

Rear View

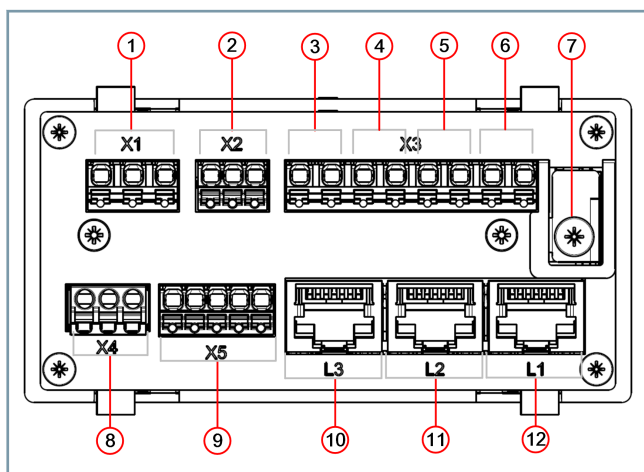

Figure 7.2/5 Rear View with Terminals

- (1) Power supply
- (2) Digital inputs 1 and 2
- (3) Digital output 4
- (4) Digital output 3
- (5) Digital output 2
- (6) Digital output 1
- (7) Functional grounding
- (8) RS485 Modbus RTU
- (9) Digital inputs 3, 4, 5, and 6
- (10) RJ45 interface 3 (L3)
- (11) RJ45 interface 2 (L2)
- (12) RJ45 interface 1 (L1)

Short-Circuit Indicator

SICAM FCM plus – Selection and Ordering Data

Ordering Information

Use the following ordering number to order SICAM FCM plus:

Description	Order No.																		
	1	2	3	4	5	6	7	8	9	10	11	12	13	14	15	16			
SICAM FCM plus	6	M	D	2	3	2	3	-	1	A	A	0	0	-	1	A	A	0	
Directional fault detection and condition monitoring.																			
Compatible with SIBusing sensor according to IEC 61869-10, IEC 61869-11.																			
<ul style="list-style-type: none"> • Voltage, current, and temperature measurement • Housing: 96 mm x 48 mm x 113 mm • Power supply: DC 24 V to 250 V/AC 230 V • 6 digital inputs • 4 digital outputs • RS485 Modbus RTU and USB • 3 RJ45 analog interfaces 																			

You can download the current version of the SICAM FCM plus user manual from the SIOS internet page.

Description

To operate modern distribution systems efficiently, it is necessary to quickly detect faults and provide local indications across each phase for further diagnosis. A device designed for this purpose is the SICAM Fault-Passage Indicator(FPI). This is used for detection, indication, and reporting of phase faults as well as ground faults in radial or open ring cable networks in the medium-voltage range.

4 external current sensors ensure phase faults (A, B, C) and ground faults (Gnd) are detected. The current sensor detects phase faults and ground faults based on the set current threshold and transmits these faults to the SICAM FPI via an optical signal. With the rotary switch for each sensor, you can adjust the fault-current threshold for phase sensors from 200 A to 1200 A (type 1), 200 A to 800 A (type 2), and for ground sensors from 10 A to 100 A (type 1), 40 A to 300 A (type 2). If the current exceeds the set threshold, then current sensor transmits a signal via plastic fibre-optic cables to the SICAM FPI. In this case, the corresponding LEDs flash and the binary contacts are activated. The LEDs are inactive under normal operating conditions.

Medium-voltage distribution	10 kV to 36 kV
Frequency range	50 Hz/60 Hz
Temperature range	From -30 °C to +70 °C
Housing	<ul style="list-style-type: none"> Polycarbonate housing for panel flush mounting Dimensions: 96 mm x 48 mm x 45 mm (W x H x D) Protection class: Front IP 50, rear panel IP 20, sensors IP 67
Internal battery	<p>Lithium battery (Li-SOCl₂), type AA/3.6 V/2400 mAh</p> <p>SICAM FPI with an integrated battery is expected to have a storage life of approximately 10 years.</p> <p>> 2000 hours flashing time when switched on ("fault indication" operating mode)</p>

Benefits

- Self sustained, continues to function using internal lithium battery even after the main incomer feeder has tripped.
- Complies with the IEC 61010-1 safety standards
- Simple setting via DIP switches
- Configurable binary outputs, for remote indication to SCADA for faults/diagnostics via RTU
- Extended diagnostic functions, support for self-diagnostics and sensor cable diagnostics
- 4 LED displays, 3 red LEDs for phase fault, 1 red LED for ground faults, 1 yellow LED for battery status
- Multiple reset functions, auto-reset (via manual reset using push buttons on front fascia), remote reset via binary input or via external front keys
- User configurable momentary fault override function



Figure 7.3/1 SICAM FPI

- Longer battery life- more than 2000 hours of operation under fault conditions (blinking)
- Sensors, IP 67 complaint self sustained accurate sensors with a noise immune plastic fibre-optic cable interface to the SICAM FPI Indicator unit.
- Interference-free connection electrically separated via plastic optical fiber between sensors and SICAM FPI

Applications

SICAM FPI is a device for fault detection and display and is used in distribution-system automation for radial or opened ring cable networks. The device is also used in secondary medium distribution networks from 10 kV to 36 kV/50 Hz/60 Hz networks.

Short-Circuit Indicator

SICAM FPI – Dimensioned Drawings

Dimensioned Drawings

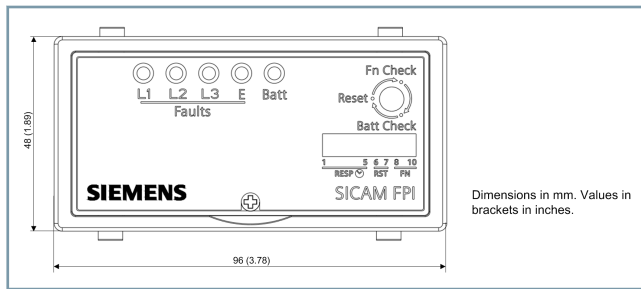

[dw_sicam-fpi_frftv, 1, en_US]

Figure 7.3/2 Front View

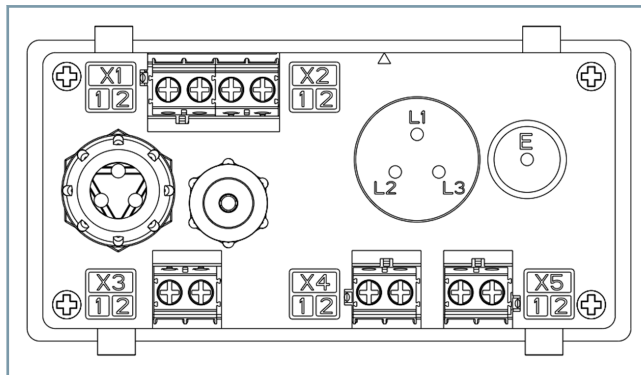

[dw_fpirearv-210114-01, 2, --]

Figure 7.3/3 Rear View

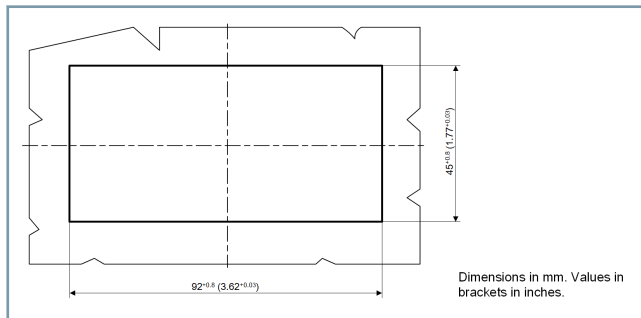

[dw_sicam-fpi_pnlcut, 2, en_US]

Figure 7.3/4 RMU Panel Cut-Out

Technical data

The following is an excerpt from the technical data. Please find additional information in the current manual.

Inputs and Outputs

Current sensor inputs	Phase current inputs: L1, L2, L3 (via a plastic fibre-optic cable) Ground inputs: E (via a plastic fibre-optic cable)
Binary inputs (for reset functions)	AC 230 V reset input (range AC 35 V to AC 275 V), 50 Hz/60 Hz Remote reset input from dry contact
Binary outputs	Number: 2 Type: Potential-free contacts ⁶⁶ Maximum switching voltage: AC 250 V/DC 220 V Maximum rated current: 2 A Maximum switching current: 0.25 A, AC 250 V/0.13 A, DC 220 V

Phase-Fault Current Range (Type 1 Series)

Phase-fault current range	AC 200 A/400 A/500 A/600 A/800 A/1000 A/1200 A
Accuracy	≤10 % of the selected range (cable Ø 25 mm to Ø 45 mm)

Phase-Fault Current Range (Type 2 Series)

Phase-fault current range	AC 200 A/300 A/400 A/500 A/600 A/700 A/800 A
Accuracy	≤15 % of the selected range (cable Ø 30 mm to Ø 45 mm)

Ground-Fault Current Range (Type 1 Series)

Ground-fault current range	AC 10 A/20 A/30 A/40 A/60 A/80 A/100 A
Accuracy	≤10 % of the selected range (cable Ø 80 mm to Ø 105 mm)

Ground-Fault Current Range (Type 2 Series)

Ground-fault current range	AC 40 A/80 A/120 A/160 A/200 A/260 A/300 A
Accuracy	≤15 % of the selected range (cable Ø 80 mm to Ø 105 mm)

Dimensions

Type of fixing	Flush mounting, plug-in (screw less), IEC 61554
Cut-out (W x H)	92+0.8 mm x 45+0.8 mm
Overall depth (D)	46 mm
Mounting position	Horizontal
Weight	≤ 300 g

⁶⁶ In the variant 6MD2310-0EX00-0AA0, 1 NO and 1 NC contact is available. The maximum switchover delay between the two binary output contacts is < 15 ms.

Short-Circuit Indicator

SICAM FPI – Selection and Ordering Data

Description	Versions	Order no.																	
		1	2	3	4	5	6	7	8	9	10	11	12	13	14	15	16		
SICAM FPI, non-directional		6	M	D	2	3	1	0	-	0	□	□	□	0	-	0	A	A	0
											▲	▲	▲						
Type 1 Series																			
Phase-fault sensor: AC 200 A to AC 1200 A, 10 % accuracy; Ground-fault sensor: AC 10 A to AC 100 A, 10 % accuracy																			
Phase-fault and ground-fault indicator with 2 binary outputs (NO), With 3 phase-fault and 1 ground-fault sensors (for L1/L2/L3/E), Plastic fibre-optic cable (3 m in length)											A	A	0						
Phase-fault and ground-fault indicator with 2 binary outputs (NO), without sensor											A	D	0						
Phase-fault and ground-fault indicator with 2 binary outputs (NO), With 3 phase-fault and 1 ground-fault sensors (for L1/L2/L3/E), Plastic fibre-optic cable (10 m in length)											A	A	1						
Phase-fault and ground-fault indicator with 1 binary output (NO), With 3 phase-fault and 1 ground-fault sensors (for L1/L2/L3/E), Plastic fibre-optic cable (3 m in length)											D	A	0						
Phase-fault indicator with 1 binary output (NO), With 3 phase-fault sensors (for L1/L2/L3), Plastic fibre-optic cable (3 m in length)											B	B	0						
Ground-fault indicator with 1 binary output (NO), With 1 ground-fault current sensor (for E), Plastic fibre-optic cable (3 m in length)											C	C	0						
Ground-fault indicator with 2 binary outputs (1 NO + 1 NC), With 1 ground-fault current sensor (for E), Plastic fibre-optic cable (3 m in length)											E	C	0						
Type 2 Series																			
Phase-fault sensor: AC 200 A to AC 800 A, 15 % accuracy; Ground-fault sensor: AC 40 A to AC 300 A, 15 % accuracy																			
Phase-fault and ground-fault indicator with 2 binary outputs (NO), With 3 phase-fault and 1 ground-fault sensors (for L1/L2/L3/E), Plastic fibre-optic cable (3 m in length)											A	E	0						
Phase-fault and ground-fault indicator with 1 binary output (NO), With 3 phase-fault and 1 ground-fault sensors (for L1/L2/L3/E), Plastic fibre-optic cable (3 m in length)											D	E	0						
Phase-fault indicator with 1 binary output (NO), With 3 phase-fault sensors (for L1/L2/L3), Plastic fibre-optic cable (3 m in length)											B	F	0						
Ground-fault indicator with 1 binary output (NO), With 1 ground-fault sensor (for E), Plastic fibre-optic cable (3 m in length)											C	G	0						
Ground-fault indicator with 2 binary outputs (1NO + 1NC), With 1 ground-fault sensor (for E), Plastic fibre-optic cable (3 m in length)											E	G	0						

Table 7.3/1 SICAM FPI Selection and Ordering Data

Description

The SICAM Earth Fault Indicator (EFI) is a device that is used for the detection and signaling of ground faults on medium-voltage underground distribution cable networks. It uses an external current sensor to detect ground faults (E). The device together with the current sensor detects the current unbalance in the underground cables and indicates it as ground fault. The fault indications are based on the ground-fault current threshold set in the device.

SICAM EFI provides a quick detection and localization of faults. This decreases fault outage times and helps in maintaining the medium voltage feeder availability. This device is used in the distribution automation systems having voltage ratings up to 36 kV (+10%) with a highest withstandable voltage for equipment of up to 40.5 kV.

Medium-voltage distribution	Up to 36 kV (+10%)
Highest withstandable voltage	Up to 40.5 kV
System frequency	50 Hz/60 Hz networks, $\pm 10\%$ tolerance
Internal battery	Field replaceable Lithium thionyl chloride battery (Li-SOCl ₂) type AA cell size/3.6 V/ 2700 mAh <ul style="list-style-type: none"> • Either up to 15 years expected operational life • Or up to 2000 h of fault indication flashing (single blink/second) under standard operating temperature of 25 °C
Auxiliary power supply	AC 110 V to 230 V, $\pm 20\%$ tolerance
	Power rating: 6 VA
	DC 12 V to 24 V, $\pm 20\%$ tolerance
	Power rating: 0.5 W
Sensor input interface	Operating range: 9 V to 38 V (Safety extra low voltage - SELV)
	Ground sensor input: S1 and S2 (via an electrical cable)

Benefits

- Easy to operate and install ground fault indicator for medium voltage cable networks
- Current sensors are IP68W compliant and apt for outdoor use
- SICAM EFI suitable for surface mounting

Applications

The SICAM EFI detects and indicates (locally and remotely) ground faults in radial or open ring cable networks - solidly grounded or low-resistive grounded. This is made possible using an external current sensor.

You can choose between 4 types of sensors with different diameters and a sensor cable length of 3.5 m, 5 m, and 16 m.



[PI_SICAM_EFI_1_...]

Figure 7.4/1 SICAM EFI

The split core sensors allow installation even with an already installed medium voltage cable. So, you can optimally adapt the SICAM EFI to your needs and use it, for example, for retrofit measures.

- The SICAM EFI is used in 50 Hz/60 Hz networks.
- The device is primarily intended for radial or open ring medium-voltage cable networks.
- Supports application on solidly grounded or low-resistive grounded networks.
- The SICAM EFI and the signal lamp material are UV stabilized, of flame retardant grade, and of weatherproof polymeric material.
- Split core encapsulated low-power sensor with insulation are for outdoor applications – UV stabilized, flame retardant grade, corrosion-resistant, and weatherproof polymeric material.
- The SICAM EFI fault LED visibility is up to 20 m during the day time and 200 m during the night time.
- The Siemens signal lamp visibility is up to 70 m during the day time and 300 m during the night time.

Short-Circuit Indicator

SICAM EFI – Dimensional Drawings

Dimensions

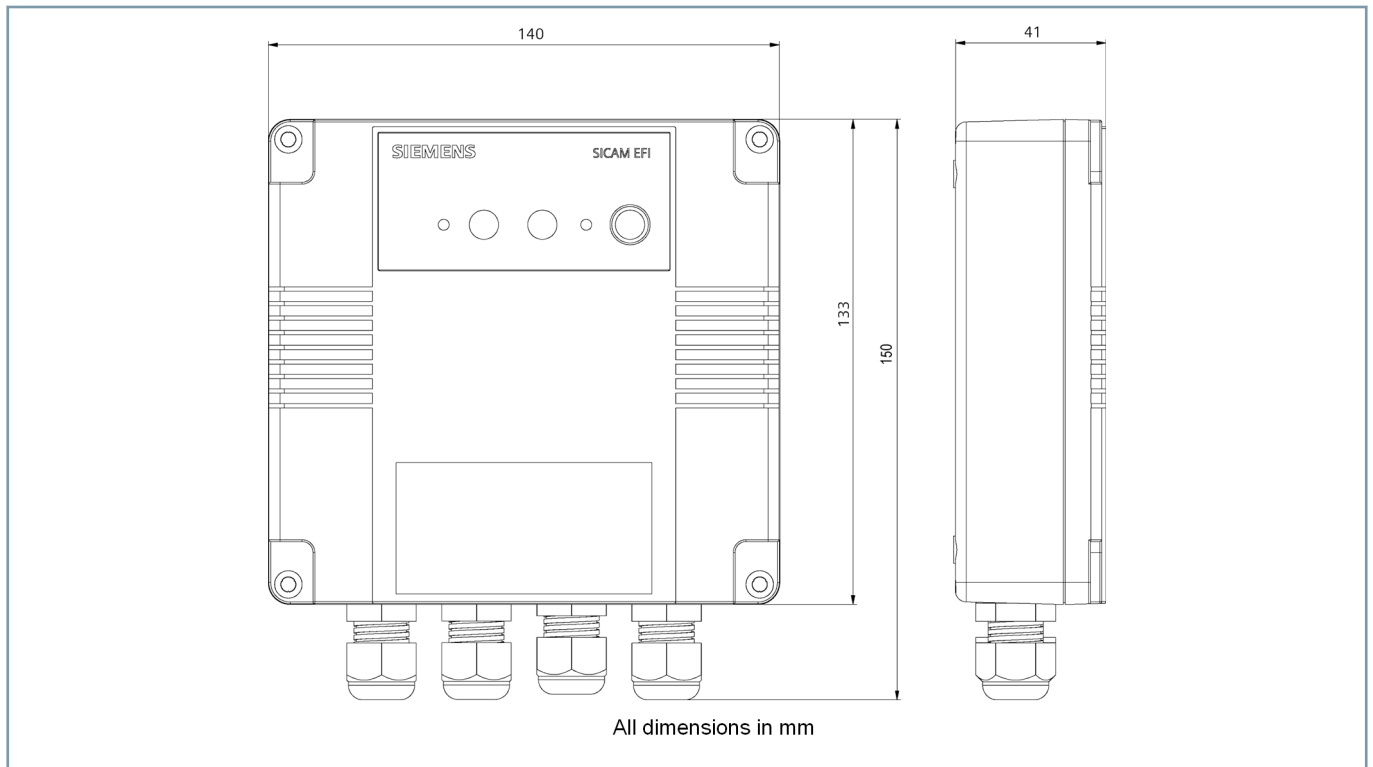

[dw_efi_casedimensions_frontview, 1, en_US]

7.4

Figure 7.4/2 SICAM EFI Front View and Side View

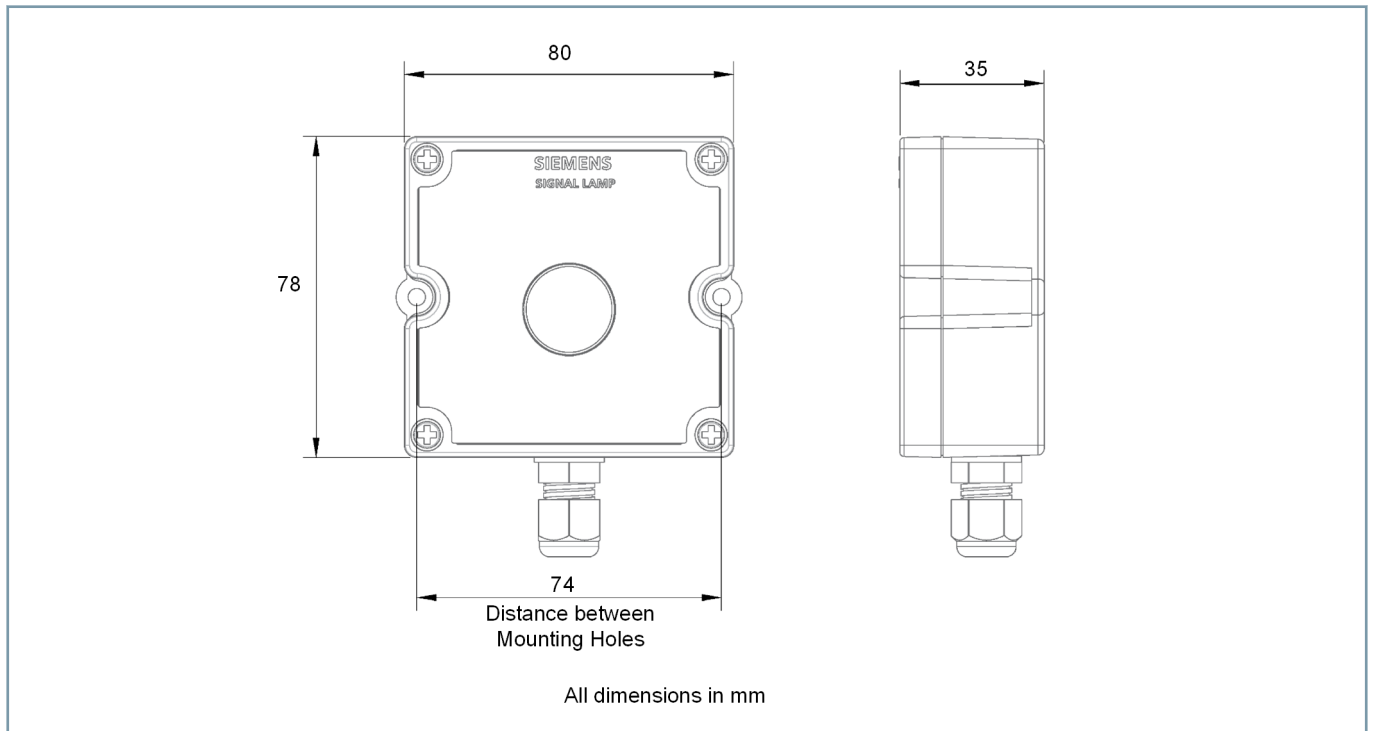

[dw_efi_signalmap_casedimensions_frontview, 1, en_US]

Figure 7.4/3 Siemens Signal Lamp Front and Side View

Technical data

The following is an excerpt from the technical data. Please find additional information in the current manual.

Binary Output

Maximum switching voltage	AC 250 V/DC 220 V
Maximum switching power	62.5 VA/30 W
Maximum carry current	2 A
Maximum switching current	0.25 A, AC 250 V/0.13 A, DC 220 V

Operating Temperature

Operating temperature and ambient storage temperature	Device
	<ul style="list-style-type: none"> • -20 °C to +75° C <ul style="list-style-type: none"> – 6MD2311-1BB00-0AA3 – 6MD2311-1BE00-0AB6 – 6MD2311-1DC00-0AB6 – 6MD2311-1DD00-0AB6 – 6MD2311-1DE00-0AB6 • -30 °C to +75° C <ul style="list-style-type: none"> – 6MD2311-2BB10-0AA5 – 6MD2311-1DC10-0AB6
	Signal Lamp
	<ul style="list-style-type: none"> • -30 °C to +75° C

Mechanical Data

Dimensions (W x H x D)	140 mm x 150 mm x 41 mm (with glands)
Weight	447 g
Mounting position	Surface mounting position (on RMU panel or wall)

Ground-Fault Current Range (for all sensors)

Ground-fault current range	25 A to 100 A (for type 1 sensor) 25 A to 240 A (for type 2, type 3 and type 4 sensor)
Typical accuracy	±10 % of the selected setting

Type 1 Sensor (for 3-core cable)

Sensor Ø	150 mm
Sensor wire length	3.5 m or 5 m
Current cable Ø supported	60 mm to 150 mm
Material	Flexible insulated and UV stabilized material

Type 2 Sensor (for 3-core cable)

Sensor Ø	140 mm
Sensor wire length	16 m
Current cable Ø supported	90 mm to 140 mm
Material	Flexible insulated and UV stabilized material

Type 3 Sensor (for single-core cable)

Sensor Ø	280 mm
Sensor wire length	16 m
Current cable Ø + pitch Ø supported	220 mm - 340 mm
Material	Flexible insulated and UV stabilized material

Type 4 Sensor (for 3-core cable)

Sensor Ø	120 mm
Sensor wire length	16 m
Current cable Ø supported	60 mm to 120 mm
Material	Flexible insulated and UV stabilized material

Signal Lamp Output Rating

Signal lamp BO rating in the following MLFBs:
6MD2311-1BB00-0AA3 and 6MD2311-1BE00-0AB6

Contact rating (resistive load)	1 A, DC 30 V 0.3 A, AC 125 V
Maximum switching voltage	AC 250 V/DC 220 V
Maximum switching power	62.5 VA/30 W
Maximum carry current	2 A

Signal lamp BO rating in the following MLFBs: 6MD2311-2BB10-0AA5, 6MD2311-1DC00-0AB6, 6MD2311-1DD00-0AB6, 6MD2311-1DE00-0AB6 and 6MD2311-1DC10-0AB6.

Contact rating (resistive load)	2 A, DC 30 V 3 A, DC 30 V 0.5 A, AC 125 V
Maximum switching voltage	AC 277 V/DC 220 V
Maximum switching power	62.5 VA/90 W
Maximum switching current	4 A



Short-Circuit Indicator

SICAM EFI – Selection and Ordering Data

Description		Order No.																			
		1	2	3	4	5	6	7	8	9	10	11	12	13	14	15	16				
SICAM Earth Fault Indicator		6	M	D	2	3	1	1	-	□	□	□	□	0	-	0	A	□	□		
										▲	▲	▲	▲					▲	▲		
Device Hardware																					
Battery-Powered	Ground-fault indicator (Li-SOCl ₂ battery) with: <ul style="list-style-type: none"> 1 BO (CO type for ground fault) 1 signal lamp BO (NO type) 2 BI (Potential-free, AC 110 V/230 V, ± 20 % tolerance) LED indications 									1	B	B	0					A	3		
	Ground-fault indicator (Li-SOCl ₂ battery) with: <ul style="list-style-type: none"> 3 BO (1 CO type and 1 NO type spare for ground fault, 1 NO type for battery health) 1 signal lamp BO (NO type) 2 BI (Potential-free, AC 110 V/230 V, ± 20 % tolerance) LED and flag indications 									1	B	E	0					B	6		
Dual-Powered	Ground-fault indicator (Li-SOCl ₂ battery) with: <ul style="list-style-type: none"> 3 BO (1 CO type and 1 NO type spare for ground fault, 1 NO type for battery health) 1 signal lamp BO (NO type) 2 BI (Potential-free, AC 110 V/230 V, ± 20 % tolerance) LED and flag indications 									2	B	B	1					A	5		
	Ground-fault indicator (Li-SOCl ₂ battery + auxiliary power supply: DC 12 V to 24 V, ± 20 % tolerance (operating range: 9 V to 38 V), AC 110 V/230 V, ± 20 % tolerance) with: <ul style="list-style-type: none"> 2 BO (1 CO type for ground fault, 1 NO type for battery health) 1 signal lamp BO (NO type) 3 BI (Potential-free, DC 9 V to 38 V, AC 110 V/230 V, ± 20 % tolerance) LED indications 									1	D	C	0					B	6		
	Ground-fault indicator (Li-SOCl ₂ battery + auxiliary power supply: DC 12 V to 24 V, ± 20 % tolerance (operating range: 9 V to 38 V), AC 110 V/230 V, ± 20 % tolerance) with: <ul style="list-style-type: none"> 2 BO (1 CO type for ground fault, 1 NO type for battery health) 1 signal lamp BO (NO type) 3 BI (Potential-free, DC 9 V to 38 V, AC 110 V/230 V, ± 20 % tolerance) LED indications 									1	D	D	0					B	6		
	Ground-fault indicator (Li-SOCl ₂ battery + auxiliary power supply: DC 12 V to 24 V, ± 20 % tolerance (operating range: 9 V to 38 V), AC 110 V/230 V, ± 20 % tolerance) with: <ul style="list-style-type: none"> 2 BO (1 CO type for ground fault, 1 NO type for battery health) 1 signal lamp BO (NO type) 3 BI (Potential-free, DC 9 V to 38 V, AC 110 V/230 V, ± 20 % tolerance) LED indications 									1	D	E	0					B	6		
Sensor Details	Ground-fault indicator (Li-SOCl ₂ battery + auxiliary power supply: DC 12 V to 24 V, ± 20 % tolerance (operating range: 9 V to 38 V), AC 110 V/230 V, ± 20 % tolerance) with: <ul style="list-style-type: none"> 2 BO (1 CO type for ground fault, 1 NO type for battery health) 1 signal lamp BO (NO type) 3 BI (Potential-free, DC 9 V to 38 V, AC 110 V/230 V, ± 20 % tolerance) LED and flag indications 									1	D	C	1					B	6		
	Ground-fault indicator (Li-SOCl ₂ battery + auxiliary power supply: DC 12 V to 24 V, ± 20 % tolerance (operating range: 9 V to 38 V), AC 110 V/230 V, ± 20 % tolerance) with: <ul style="list-style-type: none"> 2 BO (1 CO type for ground fault, 1 NO type for battery health) 1 signal lamp BO (NO type) 3 BI (Potential-free, DC 9 V to 38 V, AC 110 V/230 V, ± 20 % tolerance) LED and flag indications 									1	D	C	1					B	6		
	Ground-fault trip current range: 25 A to 100 A Sensor Ø: 150 mm Sensor secondary wire length: 3.5 m or 5 m Used for three-core cable Supports cable Ø range: 60 mm to 150 mm (10 % Accuracy)																				
	Ground-fault trip current range: 25 A to 240 A Sensor Ø: 140 mm Sensor secondary wire length: 16 m Used for three-core cable Supports cable Ø range: 90 mm to 140 mm (10 % Accuracy)																		B	A 3/5	
	Ground-fault trip current range: 25 A to 240 A Sensor Ø: 140 mm Sensor secondary wire length: 16 m Used for three-core cable Supports cable Ø range: 90 mm to 140 mm (10 % Accuracy)																		C	B 6	
Ground-fault trip current range: 25 A to 240 A Sensor Ø: 280 mm Sensor secondary wire length: 16 m Used for 3 single-core cable Supports cable pitch range: 220 mm to 340 mm (10 % Accuracy) Type 3 sensor diameter can be adjusted using the line marker and stopper position provided to achieve the desired diameter. This allows for flexibility and customization as per your requirements.																		D	B 6		
Ground-fault trip current range: 25 A to 240 A Sensor Ø: 120 mm Sensor secondary wire length: 16 m To be used for three-core cable Supports cable Ø range: 60 mm to 120 mm (10 % Accuracy)																		E	B 6		
Sensor Connecting Wire Length (Refer description before ordering sensor wire length)																					
3.5 m	3.5 m wire length is only available for 6MD2311-1BB00-OAA3 MLFB variant																		A	3	
5 m	5 m wire length is only available for 6MD2311-2BB10-OAA5 MLFB variant																			A	5
16 m	16 m wire length is available for the remaining MLFB variants.																			B	6

Table 7.4/1 SICAM EFI Selection and Ordering Data

SICAM EFI - Spares and Accessories

MLFB	Description	
6MD2301-1BA00-0AA3 Type 1 Sensor	<ul style="list-style-type: none"> ● Ground-fault trip current range: 25 A to 100 A ● Sensor Ø: 150 mm ● Sensor secondary wire length: 3.5 m ● Used for three-core cable ● Supports cable Ø range: 60 mm to 150 mm (10 % Accuracy) 	
6MD2301-1BA00-0AA5 Type 1 Sensor	<ul style="list-style-type: none"> ● Ground-fault trip current range: 25 A to 100 A ● Sensor Ø: 150 mm ● Sensor secondary wire length: 5 m ● Used for three-core cable ● Supports cable Ø range: 60 mm to 150 mm (10 % Accuracy) 	
6MD2301-1CA00-0AB6 Type 2 Sensor	<ul style="list-style-type: none"> ● Ground-fault trip current range: 25 A to 240 A ● Sensor Ø: 140 mm ● Sensor secondary wire length: 16 m ● To be used for three-core cable ● Supports cable Ø range: 90 mm to 140 mm (10 % Accuracy) 	
6MD2301-1DA00-0AB6 Type 3 Sensor	<ul style="list-style-type: none"> ● Ground-fault trip current range: 25 A to 240 A ● Sensor Ø: 280 mm ● Sensor secondary wire length: 16 m ● Used for 3 single-core cable ● Supports cable pitch range: 220 mm to 340 mm (10 % Accuracy) <p>Type 3 sensor diameter can be adjusted using the line marker and stopper position provided to achieve the desired diameter. This allows for flexibility and customization as per your requirements.</p>	
6MD2301-1EA00-0AB6 Type 4 Sensor	<ul style="list-style-type: none"> ● Ground-fault trip current range: 25 A to 240 A ● Sensor Ø: 120 mm ● Sensor secondary wire length: 16 m ● To be used for three-core cable ● Supports cable Ø range: 60 mm to 120 mm (10 % Accuracy) 	
6MD2301-0AB00-0AA0	Flush mounting bracket (L-clamp)	
6MD2301-0AA00-1LA5	Signal lamp with 5 m wire length	
6MD2301-0AA00-1LB5	Signal lamp with 15 m wire length	

Short-Circuit Indicator

SICAM FSI – Description

Description

The SICAM FSI (Fault Sensor Indicator) measures the phase current continuously and detects the phase fault and ground fault when it is mounted on the medium-voltage overhead line network. The device indicates both the temporary fault and permanent fault via an optical indication. The SICAM FSI is used to improve the distribution grid reliability and reduce the power outages on the medium-voltage overhead line network.

The SICAM FSI can be mounted (in groups of 3 or 6 or 9) on each phase after the branching points and sectionalizer.

SICAM FSI is available in the following variants:

- 6MD2314-1Ax10: The faults are displayed locally via LEDs on the device. Depending on the fault type, a specific flashing sequence is generated.
- 6MD2314-1Ax11 – with integrated communication: In addition to the local LED display, the phase fault and ground fault events are communicated via a secure wireless connection to a gateway (SICAM FCG, 6MD2340-3JM71-8AA2). The SICAM FCG (Fault Collector Gateway) establishes the connection via GSM/GPRS to a higher-level network control center and transmits the messages using the standardized telecontrol protocols IEC 60870-5-104 or DNP3.

Benefits

- Supports installation on non-insulated and insulated cables
- Higher availability for overhead line systems – reduction of down time
- Fast fault detection – accurate fault-location determination and information to the maintenance team
- High sensitivity – measurement starts at 50 A – reliable fault detection for high-impedance faults
- Self supplying sensors reduce the energy consumption of the device – increase the lifetime of the supply batteries in the device (Battery life: 10 years)
- Unique security key and IPsec encryption for data exchange with SICAM FSI – maximum security against unauthorized access (intruders)
- Easy and fast device configuration with the aid of a QR code at the SICAM FSI and a Web browser instead of DIP switches – high level of convenient configurability.
- Maintenance-free design of the device – the SICAM FSI is maintenance-free other than battery replacement after 10 years. The large-format display of the years since the date of commissioning of the device allows the operational crew to determine the proper time for battery replacement from the ground.
- Different frequency of the flashing light depending on the fault type – fast and precise fault diagnosis for the maintenance team



[ph_sicamfs_isoview20_1_--]

Figure 7.5/1 SICAM FSI

Functions

Fault Detection

- Trip threshold range 75 A to 1500 A: I_{rated} adjustable between 50 A and 500 A; enables better coordination with the upstream protection system for the network. The tripping time can be adjusted in steps of $0.5 I_{rated}$ between $1.5 * I_{rated}$ and $3 * I_{rated}$.
- ΔI tripping adjustment 5 A to 160 A: The amperage change ΔI can be set in steps of 5 A to 80 A, 120 A, 160 A.
- Inrush-current detection: Adjustable time delay for inrush current or abrupt changes under load
- Checking of zero potential state for fault confirmation

Configuration

- The SICAM FSI – 6MD2314-1Ax10 – is configured with the **SICAM FSI Configurator** software.
- The SICAM FSI – 6MD2314-1Ax11 – can be configured using the SICAM FCG Web GUI.

Reset Mechanism

- By magnet
- Automatically upon recovery of the system voltage
- Automatically over a predetermined time lapse (adjustable timer)
- Via an acknowledgment signal from the network control center

Applications

Suitable for all overhead lines in the medium voltage range from 3.3 kV to 66 kV, 50/60 Hz

Technical data

The following is an excerpt from the technical data. Please find additional information in the current manual.

Mechanical Data

Weight	0.78 kg	
Dimensions	Diameter	Height
	116 mm	210 mm

Application Data

Rated voltage (V_{rated})	3.3 kV, 6.6 kV, 11 kV, 22 kV, 33 kV, 44 kV ⁶⁷ , 66 kV (non-insulated cable) 6.6 kV, 11 kV, 22 kV, 33 kV, 44 kV ⁶⁷ , 66 kV (insulated cable) NOTE: For ANSI voltage nominal ranges, you can select the nearest rated voltage. For example, for 69 kV ANSI voltage, please select 66 kV rated voltage.
System frequency	50 Hz/60 Hz
Cable overall diameter	5 mm to 40 mm (non-insulated) 15 mm to 40 mm (insulated) ⁶⁸
Measurement cycle period	20 ms for 50 Hz 16.6 ms for 60 Hz
Voltage presence	> 70 % of V_{rated}
Voltage absence	< 45 % of V_{rated}
Rated current (I_{rated})	50 A to 500 A (increments of 50 A)
Current measurement accuracy	± 10 % from 50 A to 800 A (50 Hz and 60 Hz) ⁶⁹
Power source	Lithium-thionyl chloride battery + energy harvesting ⁷⁰
Total fault-indication time	400 h of LED flashing
Temperature with-stand of clamping material	120 °C

Fault Indication – LEDs

Indication	6 red LEDs
Luminous flux	40 lm
Visibility angle	360° (from ground level)
Visibility range	50 m at day time, 300 m at night time

Fault-Detection Parameters

di current	5 A to 80 A (steps of 5 A), 120 A, 160 A
Current threshold value	$1.5 \cdot I_{rated}$ to $3 \cdot I_{rated}$ (steps of 0.5)
Protection measurement range of device	75 A to 1500 A
Fault-indication time	2 h to 16 h (steps of 0.5 h)
Inrush restraint time	3 s, 30 s, and 60 s
Permanent-fault verification time	3 s, 35 s, and 70 s
Automatic reclosing time	0.1 s to 99.9 s

⁶⁷ The 44 kV setting option is only available for combination of SICAM FSI with firmware version V03.03 or higher and SICAM FCG with firmware version V04.12 or higher.

⁶⁸ SICAM FSI with cable overall diameter 5 mm to 15 mm (insulated cables) can be ordered on a special request. Contact the local Siemens office for more information.

⁶⁹ Current measurement accuracy is applicable for temperature range of -25 °C to 70 °C.

⁷⁰ Energy harvesting starts if the phase current is above 60 A.

Short-Circuit Indicator

SICAM FSI – Selection and Ordering Data

Selection and Ordering Data

Description	Versions	Order no.												
		1	2	3	4	5	6	7	8	9	10	11	12	
		6	M	D	2	3	1	4	-	1	A	□	1	□
												▲		▲
SICAM FSI														
	<ul style="list-style-type: none"> Phase-fault detection Ground-fault (di/dt) detection UV stabilised polycarbonate IP68 rated housing Operating temperature range: -25°C to +70°C 											B		
	<ul style="list-style-type: none"> Phase-fault detection Ground-fault (di/dt) detection UV stabilised polycarbonate IP68 rated housing Operating temperature range: -40°C to +70°C 											C		
	Visual fault indication of 40 lumens by 6 high luminous red LEDs													0
	Visual fault indication of 40 lumens by 6 high luminous red LEDs													1
	SICAM FSI with integrated communication, short-range radio communication for fault status and measured values ⁷¹													1
Spare parts and accessories		6	M	D	2	3	1	8	-	4	□	□	0	□
												▲	▲	▲
Spare part														
	SICAM FSI Li-TH Battery Set (Pack of 6)											B	B	0
Accessories														
	UART cable for device configuration (recommended type: FTDI chip, part number TTL-232R-RPi) For more detailed information visit: http://www.ftdichip.com											A	A	0
	Magnetic adaptor for device reset, accessory for hot stick with shotgun or hot stick (telescopic)											M	A	4
	Device adaptor for SICAM FSI mounting via hot stick (telescopic)											M	A	5
Accessory Description														
Hot stick with shotgun for SICAM FSI mounting, 4 m	Recommended brand: Terex hot stick with shotgun, Ritz, catalog number: RC403-0295 For more detailed information visit: http://www.terexutilities.com.br													
	Recommended brand: Hubbell hot stick with shotgun, catalog number: C4030295 For more detailed information visit: https://www.hubbell.com/hubbellpowersystems/en/													
Hot stick (telescopic) for SICAM FSI mounting, 12 m	Recommended brand: Terex Ritz, catalog no.: VTT-1/9 For more detailed information visit: http://www.terexutilities.com.br													

Table 7.5/1 SICAM FSI Selection and Ordering Data



NOTE

For markets requiring FCC certification and ISED certification, SICAM FSI with integrated communication should be ordered as: 6MD2314-1AC11 along with SICAM FCG (6MD2340-3JM71-8AA2 -Z /DD).

⁷¹ SICAM FSI with integrated communication along with SICAM FCG (6MD2340-3JM71-8AA2) must be ordered when the communication with control center is required.

Description

SICAM Fault Sensor Indicator (FSI) V2.0 B-Sensor is developed using the latest hardware technology and is a member of the Siemens SICAM short-circuit indicator product family.

The device is used to improve the reliability and to reduce the down time on the medium-voltage (MV) overhead distribution grid.

The device measures the phase current continuously and detects the phase fault and ground fault when it is mounted on the medium-voltage overhead line system.

The device indicates both the temporary fault and the permanent fault via optical indication (LED flashing).

The device can be mounted in junction points/branching points and areas of frequent fault.

Benefits

Higher availability of overhead line networks

- Quick fault detection and localization, reduced downtime

Ease of use

- The device is effortlessly powered ON/OFF for installation, storage and transportation using a single switch activation.
- Providing user-friendliness, the default auto-threshold function automatically decides threshold values based on rated current and helps to use the device to detect the fault with minimal configuration of parameters.

Installation

- Supports installation on both insulated and non-insulated overhead lines

Simple configuration

- Easy configuration of device parameters using the SICAM FSI Configurator (version 3.03 and above)

Safe mounting

- Safely mountable on the MV overhead line by using a hot stick with shotgun or hot stick (telescopic) with device adaptor.

Long range fault indication visibility

- Fault localization becomes easier with the 6 high luminous fault LEDs of the device, which offer a visibility for up to 400 m during the day and 800 m during night time⁷²

Long battery life

- 10 years of battery life, under standard operating conditions
- Configurable blinking interval of LEDs for optimal battery life

Maintenance free

- The device housing is weatherproof, UV stabilized, and flame retardant with an IP68 rating for durability.



[0w_sicamfsi-b-sensor_isoview, 1, ...]

Figure 7.6/1 SICAM FSI V2.0 B-Sensor

Conformal coating

- The conformal coating on the device electronic modules increases the protection against harmful environmental influences such as extreme moisture, corrosive gases, and aggressive dust.

Functions

Multiple settings available for fault detection

- Threshold settings, auto threshold, and di/dt settings.

Auto-threshold algorithm

- Self-adjustment of the trip threshold based on the phase current.

Inrush restraint

- Avoids false fault detection due to transformer magnetization during the voltage restoration on the MV overhead line.

Auto-reclosure restraint

- Blocks the redundant fault detection during the auto-reclosure retries which are made to restore the MV overhead line.

Multiple fault-indication reset functionalities

- Voltage restoration in MV overhead line, auto-timer reset, and magnetic reset

Self-Test

- Self-test by magnetic reset to verify the battery health of the device. The success/failure of the self-test is indicated by a specific LED flashing pattern.

Low temperature cut-off

- Built-in with an automatic cut-off feature when the temperature falls below -40 °C.⁷²

⁷² Only applicable for B-Sensor Type 2. For information on B-Sensor Type 1 and Type 2, refer to [Ordering Information – SICAM FSI V2.0 B-Sensor](#), Page 176.

Short-Circuit Indicator

SICAM FSI B-Sensor – Description

Applications

- This device is suitable for outdoor applications on the MV overhead line.
- The device supports applications on solidly grounded or resistive star-point grounded systems.
- The device must be configured in close coordination with the protection systems in the MV network. This results in improved fault detection and localization.
- The device can be mounted in groups of 3, one device on each phase.
- The device uses LED patterns to identify faults quickly, distinguishing between temporary and permanent faults.

Indication of Conformity



This product complies with the directive of the Council of the European Communities on the harmonization of the laws of the Member States relating to electromagnetic compatibility (EMC Directive 2014/30/EU) and concerning electrical equipment for use within specified voltage limits (Low Voltage Directive 2014/35/EU) as well as restriction on usage of hazardous substances in electrical and electronic equipment (RoHS Directive 2011/65/EU).

This conformity has been proved by tests conducted by Siemens AG in accordance of the Council Directive in accordance with the product standard IEC/EN 61326-1 for the EMC directives, and with the standard IEC/EN 61010-1 for the low-voltage directive. RoHS directive 2011/65/EU is met using the standard IEC/EN 63000. The device has been designed and produced for industrial use.

7.6

Application Data

Rated voltage (V_{rated})	6.6 kV, 11 kV, 12.5 kV, 13.8 kV, 22 kV, , 33 kV, 34.5 kV, 44 kV, 45 kV, 66 kV, and 69 kV
Maximum operating voltage	83 kV
Maximum operating current	1500 A
Maximum continuous operating current	800 A
Operating current range	0 A to 1500 A
Power frequency	50 Hz or 60 Hz network as per IEC 62689-1
Grounding type	Solidly grounded system or resistive star-point grounded systems
Detection of voltage presence/absence	Supported
Fault detection time	2 cycles \pm 1 cycle
Current measuring accuracy	\pm 10 % or \pm 5 A whichever is greater from 0 A to 800 A
Power source	Lithium thionyl chloride batteries (Each battery: 3.6 V, 19000 mAh). B-Sensor Type 1: 2 batteries, B-Sensor Type 2: 3 batteries 10 years of expected operational life under standard operating temperature of 25 °C

Total fault-indication time	B-Sensor Type 1: 1500 h of LED flashing B-Sensor Type 2: 400 h of LED flashing
Cable overall diameter	5 mm to 40 mm (non-insulated) 15 mm to 40 mm (insulated)
Non-insulated conductor type	Aluminum Conductor Steel Reinforced (ACSR), All Aluminum Alloy Conductor (AAAC)
Insulated conductor type	Single core, aluminum conductor steel reinforced with/without waterblocking, XLPE insulated
Temperature withstand of clamping material	230 °C continuous

Fault-Detection Parameters

Fault current threshold (I_{set})	10 A to 1500 A <ul style="list-style-type: none"> • 10 A to 100 A (steps of 10 A) • 100 A to 300 A (steps of 25 A) • 300 A to 800 A (steps of 50 A) • 800 A to 1500 A (steps of 100 A)
Auto threshold fault factor	2x to 4x (steps of 1x)
Range-change monitoring time (T1)	20 s to 120 s (steps of 10 s)
Range-change memorizing time (T2)	0 s to 120 s (steps of 30 s)
DI current	5 A to 80 A (steps of 5 A), 120 A, 160 A Starting from 10 A phase current
Fault-indication time	B-Sensor Type 1: 2 h to 16 h (steps of 1 h) B-Sensor Type 2: 2 h to 4 h (steps of 1 h)
Permanent-fault verification time	3 s, 35 s, and 70 s
Inrush-restraint time	3 s, 30 s, and 60 s
Auto reclosure time	0.1 s to 99.9 s

Reset Device

Voltage restoration reset	Based on voltage-presence detection
Magnet reset	Using magnetic adaptor
Auto timer reset	B-Sensor Type 1: 2 h to 16 h (steps of 1 h) B-Sensor Type 2: 2 h to 4 h (steps of 1 h)

Fault Indication – LEDs

Indication	6 red LEDs
Luminous flux	40 lm
Visibility angle	360° (from ground level)
Visibility range (for fault indication only) ⁷³	B-Sensor Type 1: 100 m at day time, 500 m at night time B-Sensor Type 2: 400 m at day time, 800 m at night time ⁷⁴
MTBF of LEDs	45000 h

⁷³ The specified visibility range for the LED indications is based on clear weather conditions.

⁷⁴ To have a fault-indication visibility range of 400 m at day time and 800 m at night time on B-Sensor 2, set a 2 s blinking interval.

Mechanical Data

Weight	B-Sensor Type 1: approximately 1.04 kg B-Sensor Type 2: approximately 1.15 kg	
Dimensions	Diameter	Height
	116.8 mm	241.4 mm

Environmental Conditions

Outdoor applications as per IEC 61010-1	
Degree of pollution	Category 2
Maximum altitude above sea level	5000 m

Short-Circuit Indicator

SICAM FSI B-Sensor – Selection and Ordering Data

Ordering Information – SICAM FSI V2.0 B-Sensor

Description	Versions	Order no.												
		1	2	3	4	5	6	7	8	9	10	11	12	
		6	M	D	2	3	1	4	-	2	B	□	□	0
												▲	▲	
SICAM FSI V2.0 B-Sensor														
B-Sensor Type 1	<ul style="list-style-type: none"> Phase-fault detection Ground-fault (di/dt) detection UV stabilized polycarbonate IP68 rated housing Operating temperature range: -25°C to +75°C Fault indication visibility: 100 m during daytime, 500 m during night time 												B	2
B-Sensor Type 2	<ul style="list-style-type: none"> Phase-fault detection Ground-fault (di/dt) detection UV stabilized polycarbonate IP68 rated housing Operating temperature range: -40°C to +75°C Fault indication visibility: 400 m during daytime, 800 m during night time 												C	3
Spare parts and accessories		6	M	D	2	3	1	8	-	4	□	□	0	□
Spare part												▲	▲	▲
	SICAM FSI V2.0 B-Sensor Lithium-thionyl chloride battery set (pack of 6)											B	B	1
Accessories														
	Magnet adaptor for device reset, accessory for hot stick with shotgun											M	A	4
	Device adaptor for SICAM FSI V2.0 mounting via hot stick (telescopic)											M	A	6
Accessory Description														
7.6 Hot stick with shotgun for SICAM FSI V2.0 B-Sensor mounting, 4 m	Recommended brand: Terex hot stick with shotgun, Ritz, catalog number: RC403-0295 For more detailed information visit: http://www.terexutilities.com.br													
	Recommended brand: Hubbell hot stick with shotgun, catalog number: C4030295 For more detailed information visit: https://www.hubbell.com/hubbellpowersystems/en/													
Hot stick (telescopic) for SICAM FSI V2.0 B-Sensor mounting, 12 m	Recommended brand: Terex Ritz, catalog no.: VTT-1/9 For more detailed information visit: http://www.terexutilities.com.br													
	Standard USB Type-A to Type-C communication cable for device configuration using FSI configurator.													
USB Type C cable for SICAM FSI V2.0 B-Sensor configuration														

Table 7.6/1 SICAM FSI V2.0 B-Sensor Selection and Ordering Data

Description

The SICAM Fault Collector Gateway (FCG) device receives both distribution line faults and the load current values from the SICAM Fault Sensor Indicator (FSI) via short-range radio (SRR) communication.

The received current measured values and status information are transmitted to:

- the control center based on the selected communication protocol.
- the MindSphere cloud via General Packet Radio Service (GPRS).

The fault detected by SICAM FSI is communicated to SICAM FCG via SRR communication.

SICAM FCG provides 6 binary inputs and 3 binary outputs. SICAM FCG can be configured and diagnosed locally using the Web GUI by connecting to a PC or laptop computer or remotely via General Packet Radio Service (GPRS).

SICAM FCG must be mounted inside a housing which can comply with standard IP54 or IP65. The Global System for Mobile Communications (GSM) and short-range radio antennas must be mounted outside the housing. Installation distance between short-range and GSM antennas must be at least 30 cm (centre to centre distance) to avoid interference.

SICAM FCG Web GUI allows you to configure the parameters, displays error and operational log, upgrade of firmware, and download the configuration.

Functions

Binary inputs and outputs

- On the terminal block L, all the 3 binary inputs are independent and have a fixed threshold of 8 V. On the terminal block P, 2 binary inputs have a common input (P8, P9, and P10) and 1 binary input (P11, P12) which is independent. These binary inputs have selectable thresholds of DC 19 V, DC 88 V, and DC 176 V. Therefore an optimal adjustment of pickup voltage can be made in case of increased interference level. The binary outputs are designed as relay contacts. The terminal block P has 2 relay outputs - Normally Open (NO) and 1 relay output Change Over (CO). The relays can switch voltages up to AC/DC 250 V and currents up to AC/DC 5 A.



Figure 7.7/1 SICAM FCG

Communication

- SICAM FCG is the gateway device in the communication network between the SICAM FSIs and the control center/cloud service. It provides interfaces and supports communication protocols to the SICAM FSI devices (via short-range radio) and to the network control center/cloud service (via cellular networks). The gateway contains a common function for communication exchange between the SICAM FSI devices and the control center/cloud service. The various communication interfaces and protocols are available for communication between the SICAM FCG and the control center. The SICAM FCG device has an Ethernet interface for device parameterization and monitoring. The communication interface supports device parameterization and transmission of messages and measured values. The information is transmitted securely via telegrams.

GSM/GPRS Module

- The GPRS/GSM module⁷⁵ supports 4 frequency bands: 850 MHz, 900 MHz, 1800 MHz, and 1900 MHz. The communication can be established over the GSM/GPRS network based on:
 - Telecontrol protocols IEC 60870-5-104 or DNP3 to the control center
 - MindConnectLib to the SICAM Localizer
 You can execute the configuration, firmware update and perform diagnosis using SICAM FCG Web GUI via GPRS.

Short-range radio module

- The short-range radio module communicates directly with SICAM FSI via a radio link in the license-free 2400-MHz band and up to 100 meters. Any overhead distribution line fault or other status change detected by SICAM FSI is communicated to the SICAM FCG through the short-range radio module.

⁷⁵ The distance between SICAM FCG (along with GSM and SRR antennas) and SICAM FSI must be less than or equal to 100 m (line of sight). The GSM antenna (MLFB: 6MD2318-OCA10) and Short-range radio antenna (MLFB: 6MD2318-OCA20) are tested along with SICAM FCG.

Short-Circuit Indicator

SICAM FCG – Technical Data

DC 12 V or DC 24 V Power Supply

Rated input voltages	DC 12 V or DC 24 V (Safety Extra Low Voltage - SELV)
Operating voltage range	DC 10.5 V to 28.8 V
Power input typical (12 V)	3 W
Maximum power input	12 W (peak)
Maximum input current	1 A (peak)
Safety	CAT III Fixed installation according to IEC 61010-1 ed. 3
Degree of pollution	2 (according to IEC 61010-1 ed.3)

Binary Inputs (Terminal Block P)

Number according to device	3
Rated input voltage range	DC 24 V to 250 V; AC not allowed
Threshold voltages (adjustable)	
Threshold voltage 19 V (at rated voltage 24 V)	V high \geq 19 V V low \leq 14 V
Threshold voltage 88 V (at rated voltage 110 V)	V high \geq 88 V V low \leq 66 V
Threshold voltage 176 V (at rated voltage 220 V)	V high \geq 176 V V low \leq 132 V
Maximum input voltage	DC 300 V

Binary Inputs (Terminal Block L)

Number according to device	3
Input voltage range	up to DC 20 V; AC not allowed
Rated voltage	12 V
Threshold voltage 8 V (at rated voltage 12 V SELV)	V high \geq 10 V V low \leq 4 V

Binary Outputs (Relay Outputs)

Type of relay	NO relay	CO relay
Number	2	1
Output values		
Switching capacity	On: 1000 W/VA Off: 30 VA; 40 W ohmic 25 W/VA at L/R \leq 40 ms	
Contact voltage AC and DC	250 V	
Permissible current per contact	Continuous: 5 A Switching on and holding: 30 A for 1 s (make contact)	
Short-time current across closed contact	250 A at 30 ms	
Total permissible current for contacts connected to common potential	5 A	
Switching time (OOT)	\leq 10 ms; (OOT = output operating time) more delay of the output medium used	
Rated data of the output contacts		
AC 120 V	5.0 A, GP	

AC 277 V	5.0 A, GP
AC 277 V	0.7 HP
NEMA B300, R300	
Anti-interference capacitor across the contacts	4.7 nF, \pm 20 %, AC 250 V
Contact life	
Expected contact life (resistive load)	$>$ 10 ⁵ , electric (AC), at 20 switching cycles/min

Ethernet Interface

Ethernet, electrical	Connection	Device top side RJ45 connector socket 100BaseT acc. to IEEE802.3 LED green: Link/Activity LED amber: Unused/Reserved
	Voltage strength	DC 700 V
	Transmission rate	10/100 Mbit/s
	Cable for 100Base-T	100 Ω to 150 Ω STP, CAT5
	Maximum cable length 100Base-T	100 m, if installed

GSM Antenna and Antenna Interface

Requirements for Antenna Type	
Fixed antenna	For use in industrial environment acc. to EN/IEC 61010-1 Ed. 3 CAT III
Detached antenna	For remote installation in residential, commercial, and light industrial environments (EN/IEC 61010-1 Ed. 3 CAT III).
Antenna Data	
Antenna Gain	
GSM 850 MHz	\leq 6 dBi
GSM 900 MHz	No maximum value
GSM 1800 MHz	No maximum value
GSM 1900 MHz	\leq 2.25 dBi
Connection Values	
Impedance	50 Ω
VSWR	\leq 2:1
Antenna Interface at the Device	
Type of antenna socket	SMA
Physical Dimensions	
Diameter X Height	76 mm X 23 mm
Mounting Hole Diameter	16.2 mm

Short-Range Radio Antenna and Antenna Interface

Recommended Antenna Specifications	
Frequency band	2440 MHz \pm 100 MHz
Antenna Data	
Antenna Gain	\leq 4 dBi (typical)
Connection Values	

Impedance	50 Ω
VSWR	≤ 1.5:1
Antenna Interface at the Device	
Type of antenna socket	RP-SMA (RP = Reverse Polarity)
Physical Dimensions	
Diameter X Height	76 mm X 23 mm
Mounting Hole Diameter	16.2 mm

Mobile Communication

GSM frequency bands	GSM 850 GSM 900 GSM 1800 GSM 1900
Maximum transmitted RF power	2 W (33 dBm) for GSM 850 and GSM 900 1 W (30 dBm) for GSM 1800 and GSM 1900
Maximum transmission rate	Up to 80-kbit/s uplink Up to 40-kbit/s downlink
General data	GPRS multislots class 10, Coding schemes CS 1-4

Short-Range Radio Communication

Operating frequency band	2.4 GHz
Maximum transmission rate	250 kbit/s
RF output power range used by SICAM FCG per country/region	10 mW to 250 mW (10 dBm to 24 dBm)

Environmental Data

Temperature	Open type; surrounding air temperature	Maximum 63 °C (131 °F), normal operation
	Operating temperature	-20 °C to +70 °C or -4 °F to +158 °F
	Temperature during transport	-25 °C to +70 °C or -13 °F to +158 °F
	Temperature during storage recommendation	-25 °C to +70 °C or -13 °F to +158 °F +10 °C to +35 °C or +50 °F to +95 °F
	Maximum temperature gradient	20 K/h
Air humidity	Mean relative air humidity per year	≤ 75 %
	Maximum relative air humidity	95 %, 30 days a year
	Condensation during operation	Not permitted
	Condensation during transport and storage	Permitted

General Data

Battery	Type	PANASONIC CR2032 or VARTA 6032 101 501
	Voltage	3 V
	Capacity	230 mAh
	Typical life	10 years In operation with continuous supply voltage 2 months within 10 years in operation where supply voltage is not applied continuously
Protection class	DIN rail side	IP20
	Terminal side (terminals)	IP20
	Top side	IP20

Short-Circuit Indicator

SICAM FCG – Selection and Ordering Data

Selection and Ordering Data

Description	Versions	Order no.																	
		1	2	3	4	5	6	7	8	9	10	11	12	13	14	15	16		
SICAM Fault Collector Gateway		6	M	D	2	3	4	0	-	□	□	□	□	□	-	□	A	A	□
										▲	▲	▲	▲	▲	▲				▲
Power supply																			
DC 12 V compatible (suitable or interface with solar panel + battery)										3									
Input/output interface 1																			
Binary input/output (3 BI/3 BO)											J								
Input/output interface 2																			
Short-range radio I/O (3 BI + short-range radio coordinator)												M							
Communication interface																			
General packet radio services (GPRS)													7						
Device with/without antenna																			
	Device without antenna ⁷⁶													0					
	Device with antenna																		
	GPRS antenna – MLFB number 6MD2318-OCA10														1				
	Short-range radio frequency – MLFB number 6MD2318-OCA20																		
Protocol																			
	IEC 60870-5-104 (server) / MindConnect Library/ DNP3slave (TCP/IP) with SMS functionality																8		2
	with IPsec																		2

Table 7.7/1 SICAM FCG Selection and Ordering Data



NOTE

For markets requiring FCC certification and ISED certification, SICAM FCG should be ordered as: 6MD2340-3JM71-8AA2-Z/DD.

7.7

Weight	Approx. 0.550 kg
Dimensions (W x H x D)	96 mm x 96 mm x 100 mm 3.78 in x 3.78 in x 3.94 in

Table 7.7/2 Dimensions

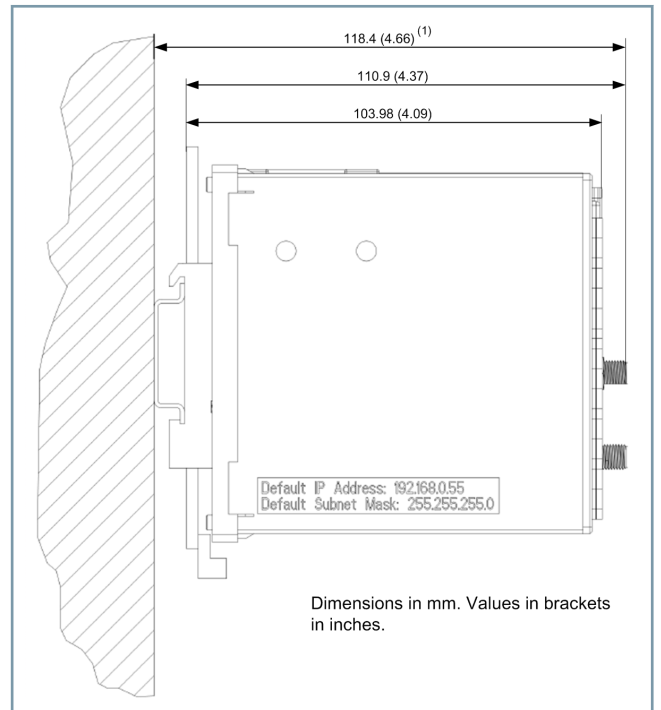

Figure 7.7/2 Dimensional Drawing

(1) Valid for DIN rail DIN EN 60715-35x7.5

⁷⁶ Applicable only for spares/external router based applications. For external router based applications, it is mandatory to order short-range radio frequency antenna (MLFB: 6MD2318-OCA20).

Description

The SICAM I/O-Unit 7XV5673 is a binary input/output device that has been developed for substations and industrial sectors with increased environmental demands. The SICAM I/O-Unit permits transmission from binary inputs to binary outputs locally or over large distances. It can be used for protection applications, such as overcurrent protection, permissive overreach transfer trip scheme, distance protection with signal connection, or as I/O extension in substation automation systems.

Binary inputs	<ul style="list-style-type: none"> • 6 robust EMC-hardened binary inputs • The pickup threshold can be set to DC 19 V, DC 88 V, or DC 176 V for different rated voltages of the station battery
Binary outputs	<ul style="list-style-type: none"> • 6 command relay outputs • Secure contact status after loss of connection, set by the user
Signal/alarm outputs	4 LEDs
Wide-range power supply unit	DC 24 to 250 V ± 20 % and AC 100 V to 230 V, 45 Hz to 65 Hz
Electrical RJ45 Ethernet interface	Cascading many devices without additional cost by using the integrated switch
Serial fiber-optic interface (optional)	ST connector, 820 nm for multimode optical fiber 62.5/125 μm, typical range: 2000 m with optical fiber 62.5 μm/125 μm, baud rate: 1.2 Kbps to 187.5 Kbps, set by software
Communication protocols	<ul style="list-style-type: none"> • IEC 61850 (GOOSE, MMS, Reporting) for the connection to protective and substation controllers • Modbus TCP or Modbus RTU for connection to a substation controller • Modbus UDP for point-to-point connection between 2 SICAM I/O-Units • SNTP for time synchronization
Time synchronization	<ul style="list-style-type: none"> • External time synchronization via Ethernet NTP • External time synchronization via Fieldbus with communication protocol Modbus RTU, Modbus TCP, or Modbus UDP
Housing	IP20, DIN rail

Functions

All types of binary signals from switching devices/protective procedures (such as trip commands, switch position signals, fault and status messages) are reliably recognized via binary inputs. This information can be transferred via contacts directly on this SICAM I/O-Unit or via communication connections to other SICAM I/O-Units or substation automation systems. Secured telegrams are used for communication via Ethernet or serial connections. The parameters of the SICAM I/O-Units can be set easily via a standard Web browser on the PC that is connected via the Ethernet interface.

The SICAM I/O-Unit can for example, be used as:

- Binary signal transmitter (BST): Point-to-point transmission of binary signals between 2 SICAM I/O-Units via Ethernet or a serial connection. Signal inputs and outputs can be assigned by the user.
- I/O extension:
 - Extension of protection devices via binary inputs and outputs with GOOSE



[pic_SICAM_I/O_Unit_1-2-3]

Figure 8.1/1 SICAM I/O-Unit 7XV5673

- Detection and output of binary states via substation controllers with the standard protocols Modbus RTU, Modbus TCP, or IEC 61850
- Extension for protection devices of the compact classes SIPROTEC 7SJ80 and SIPROTEC 7SK80 by connection to their low-cost Ethernet interface (port A)
- Contact duplicator: Transmission of signals via one or more binary inputs by means of relay contacts of the same SICAM I/O-Units, for example for separation between different voltage levels

Applications

Binary signal transmitter

If the SICAM I/O-Unit is used as a binary signal transmitter to [Figure 8.1/2](#), there is a bidirectional transfer of binary signals of exactly 2 units at any one time. The transmission takes place between server and client device via serial connections (option) or via Ethernet networks. Via the relay output contacts, voltages of up to AC/DC 250 V and currents of up to AC/DC 5 A can be switched. The pickup threshold of the binary inputs can be set by the user on different levels. The user can assign signal inputs and outputs as required.

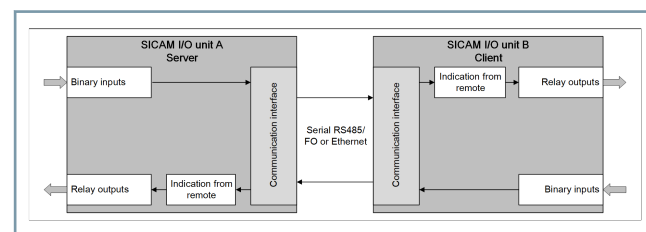

[diw_Io-Mirror_bidirect-trans-2-device_2_en_US]

Figure 8.1/2 Binary Signal Transmitter, Bidirectional Transmission between 2 Units

Accessories

SICAM I/O-Unit – Applications

Extension of the communication route

An extension of the communication route is possible.

The following devices can be used:

- With serial optical repeater 7XV5461, scalable up to 170 km
- Optical fiber connection also with mini star coupler 7XV5450 or RS485/optical fiber converter 7XV5650
- With different communication converters 7XV5662 (pilot wires, X.21/G.703.1 and G.703.6)
- Media converter for Ethernet RMC (Ruggedcom)
- Wireless transmission RS 900WNC (Ruggedcom)

Unidirectional binary signal transmission

When you use SICAM I/O-Units for unidirectional binary signal transmission to [Figure 8.1/3](#) then the units transfer binary signals in one direction from a client unit to several server units. In this application, the transmission takes place exclusively in one direction. Input signals (max. 6) are transmitted from the left device to the output contacts of one or more devices on the right side. The serial ports of the I/O-Unit can be electrical or serial. Alternatively, you may use RS485/optical fiber converters 7XV5650 and mini star couplers 7XV5450 for cascading.

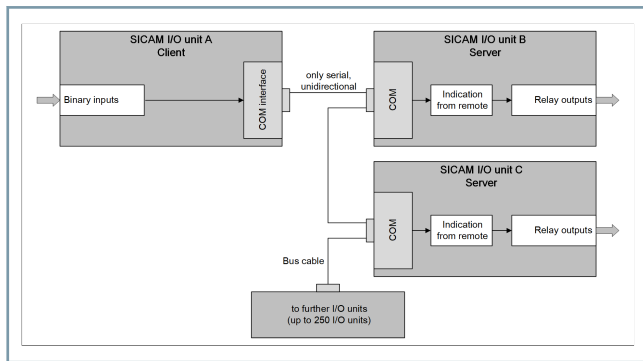

[hw_30-Mirror_unidirect-trans-sicam-io-unit_2_en_US]

Figure 8.1/3 Binary Signal Transmitters, Unidirectional Transmission from One SICAM I/O-Unit to Several SICAM I/O Units

Binary signal transmitters with gateway function

The application shows 2 separate bidirectional binary signal transmissions. The main application is the following constellation:

- Due to EMC environments, one SICAM I/O-Unit is to be installed, for example, in the switch bay and connected via a serial optical fiber.
- The optical fiber arrives in a central communication room and is to be converted to electrical Ethernet. This is implemented via SICAM I/O-Units as a serial gateway server. The logic structure is described in [Figure 8.1/4](#).

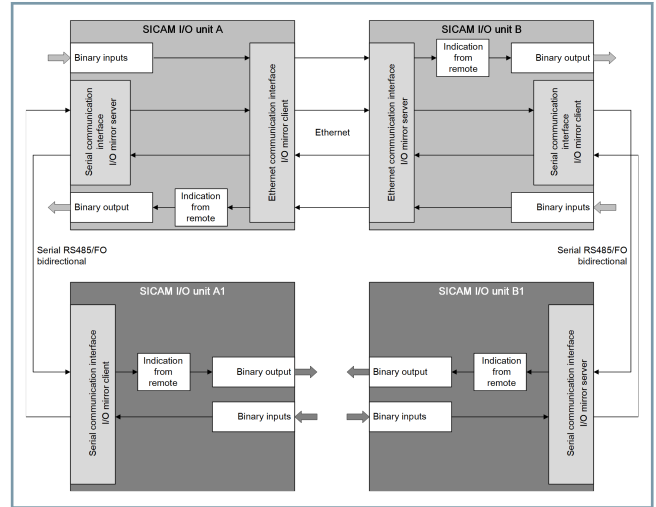

[hw_log-config_of_io-to-bo_2_en_US]

Figure 8.1/4 Logical Structure of Two Separate Binary Signal Transfers from Binary Input (BI) to Binary Output (BO) between Corresponding SICAM I/O Units A1 and B1, Using the Gateway Function of the Units A and B

In this structure, only the pair A-B and the pair A1-B1 exchange the states of their binary inputs to the binary outputs. Here, the SICAM I/O-Units A1 and B1 use the gateway function of devices A and B.

I/O extension of protection devices or direct connection to a station control or power systems control via Ethernet. Protocols: IEC 61850 GOOSE/Reporting/MMS, Modbus TCP/UDP

The SICAM I/O-Unit is used as I/O extension in accordance with [Figure 8.1/5](#). Binary signals are exchanged between a substation controller of the automation substation as Modbus or IEC 61850 client, such as SICAM PAS/SCC, SICAM RTUs or Spectrum Power - CC or a protection device, such as SIPROTEC with GOOSE, SIPROTEC Compact (also directly, proprietary) and the SICAM I/O-Units via an Ethernet network. If the integrated switch in the SICAM I/O-Unit is used, the devices can be operated in a line without an additional external switch.

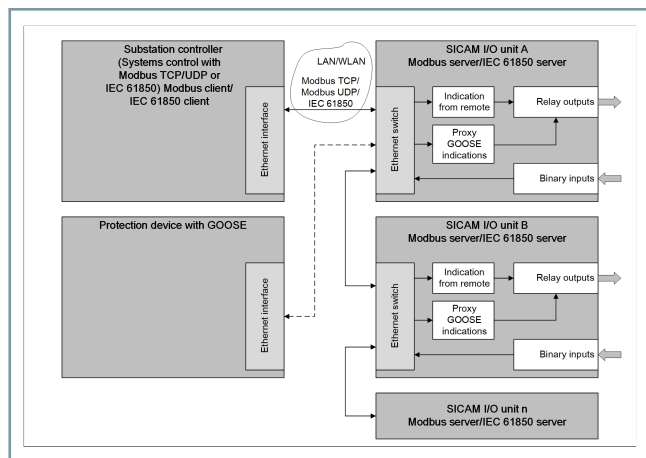

[dw_io-extension_switchgear_BI-and-BO_3_en_US]

Figure 8.1/5 I/O Extension of Switchgear with Binary Inputs and -Outputs

Instead of an Ethernet network, a serial connection with the protocol Modbus RTU can also be used. The connection can be made by an RS485 bus line or an optical star topology.

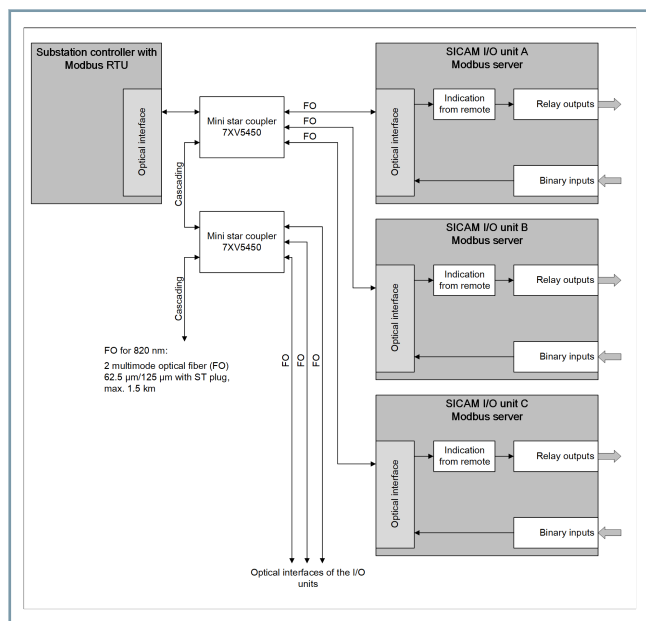

[dw_io-extension_station-unit_star-topology_3_en_US]

Figure 8.1/6 I/O Extension for the Connection to the Substation Controller with Serial, Optical Star Topology

Contact duplicator

Input signals at one or more binary inputs can be allocated to binary outputs of the local unit ([Figure 8.1/7](#)).

- 1 binary signal at up to 6 relay outputs
- Several binary signals to several relay outputs that can be assigned
- Different voltage levels for inputs and outputs in a wide voltage range to isolate different voltage levels

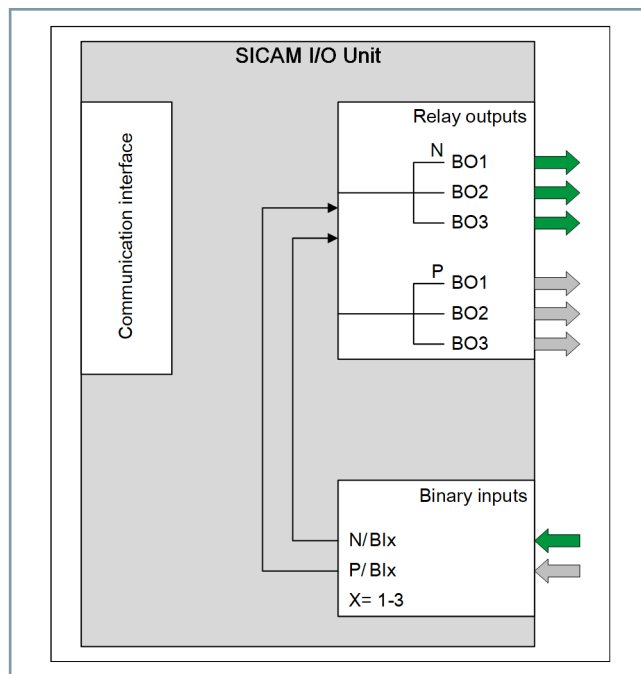

[dw_contact-multiplier_2_en_US]

Figure 8.1/7 Contact Duplicator

Accessories

SICAM I/O-Unit – Applications for Teletransmission

Applications for the Teletransmission of Binary Signals

Binary Signal Transmission via Two-Wire Copper Line with Locking

Figure 8.1/8 shows the optical fiber connection of a SICAM I/O-Unit to a communication converter 7XV5662-0AC01, that establishes a connection via pilot wires. Only 1 pair is required for bidirectional signal exchange.

An additional isolating transformer allows 20 kV isolation of the pilot wire connection.

A maximum of 6 individual binary signals can be transmitted bidirectionally via the pilot wires. The additional time delay that is caused by the transmission via the communication converter and the pilot wires is less than 1 ms.

A typical application is the permissive overreach transfer trip scheme of a directional overcurrent protection via pilot wires. In this case, the independent overcurrent protection is connected to the SICAM I/O-Unit via contacts and binary inputs and directional signals are transmitted.

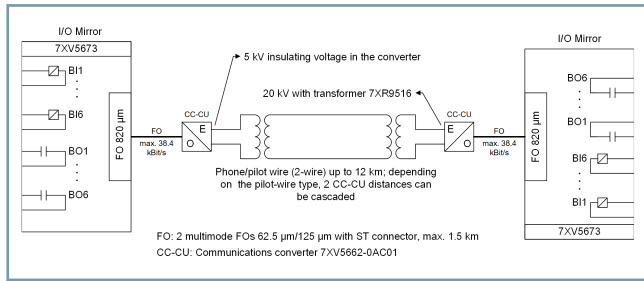
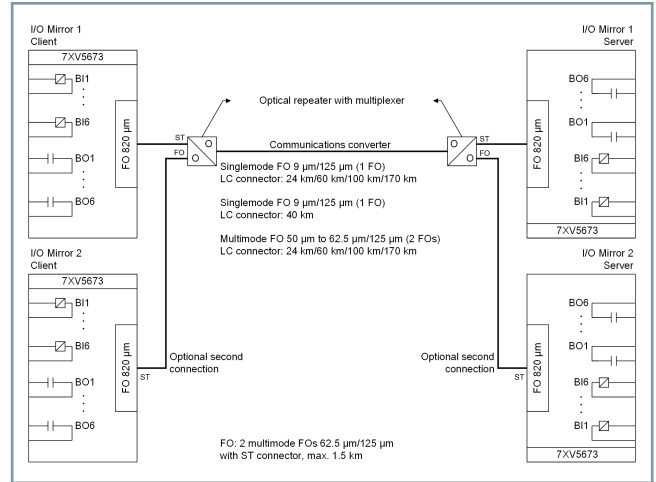

Figure 8.1/8 Binary Signal Exchange of 6 Signals via a Pilot Wire Connection

Binary Signal Exchange via Long Optical Fiber Connections

Figure 8.1/9 shows the optical fiber connection of a SICAM I/O-Unit to a serial optical repeater 7XV5461-0B_00, which establishes a connection to multi-mode or single-mode fiber-optic cables. With this application, a radius of up to 170 km can be attained without additional amplifiers.

A maximum of 12 binary signals can be exchanged via long optical fiber connections because the repeater allows the connection of 2 SICAM I/O-Units.



[0w_bi-com-converter_12sign, 2, en_US]

Figure 8.1/9 Binary Signal Exchange of Up to 12 Signals via Long Optical Fiber Connections

Transmission of Binary Signals via Communication Networks with a G.703.1-/X.21 Interface

Figure 8.1/10 shows the optical connection of a SICAM I/O-Unit to a communication converter (KU-XG) 7XV5662-0AA00, which establishes a connection with a multiplexer with G.703.1 or X.21 interface. In this way, this communication converter can be used to transmit the signals via a communication network. The average time delay in the network and the signal quality are monitored by the SICAM I/O-Unit. Furthermore, a connection loss is displayed. In this case, the state of the binary outputs can be set by the user to a secure state depending on the application. A maximum of 6 individual binary signals can be transmitted bidirectionally via the communication network.

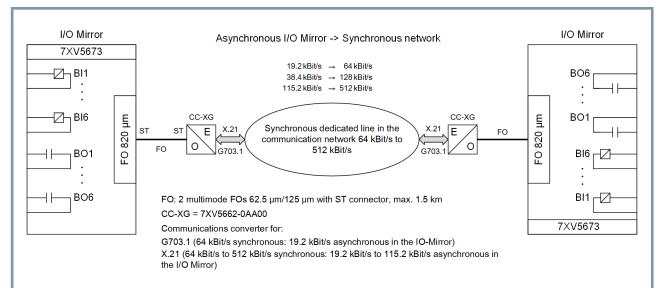

[0w_bi-com-converter_3, en_US]

Figure 8.1/10 Binary Signal Exchange via a Communication Converter with a G.703.1-/X.21 Interface via a Communication Network

Transmission of Binary Signals via Communication Networks with a G.703.6 Interface

The application (Figure 8.1/11) shows the optical fiber connection of 1 to 3 SICAM I/O-Units to a communication converter KU-2M 7XV5662-0AD00, which establishes a connection to a multiplexer with a G.703.6 interface (1.44 Kbps/2 megabits/s, E1/T1).

A maximum of 18 individual binary signals can be transmitted bidirectionally via the communication network. The communica-

tion converter KU-2M has 2 optical interfaces and one electrical RS232 interface. 2 SICAM I/O-Units can be connected directly with the KU-2M via a fiber-optic cable. At the RS232 interface you can connect another SICAM I/O-Unit via an optoelectronic converter 7XV5652. With the use of all input interfaces (2 optical fibers, 1 RS232) of the KU-2M, a maximum of 18 signals can be bidirectionally exchanged.

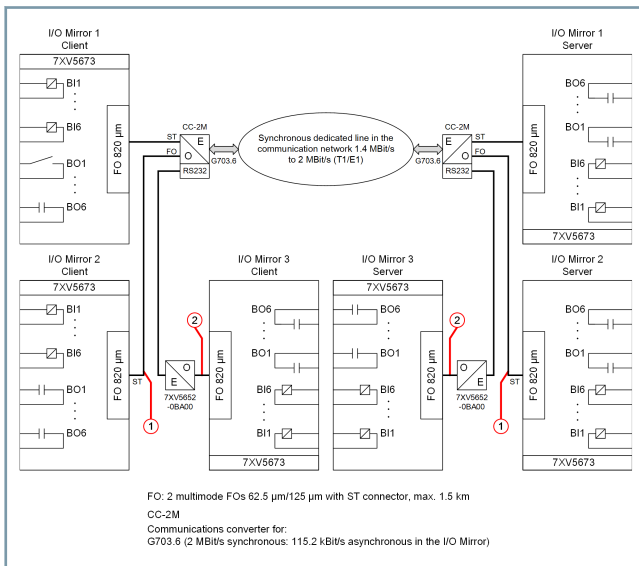

Figure 8.1/11 Binary Signal Exchange with G.703.6 Interface via a Communication Network

- (1) Optional 2nd connection
- (2) Optional 3rd connection

For dial-up network connections via Ethernet, media converters or Ethernet networks are used. The SICAM I/O-Unit supports IP address settings and settings for a standard gateway. The electrical Ethernet interface of the SICAM I/O-Unit is connected with one media converter or switch that transmits the signals of the devices via dial-up network connections with Ethernet. The average time delay in the network is measured by the SICAM I/O-Unit.

Binary Signal Transfer via Optical Fibers or Wireless Connection

The application (Figure 8.1/12) shows the electrical connection of a binary signal transmitter (BST) SICAM I/O-Unit 7XV5673 to Ethernet-based transmission units via patch cables that establish a connection via optical fibers or a wireless connection at the trunk line end. The connection could also be made via switches with long-distance modules or via IP networks.

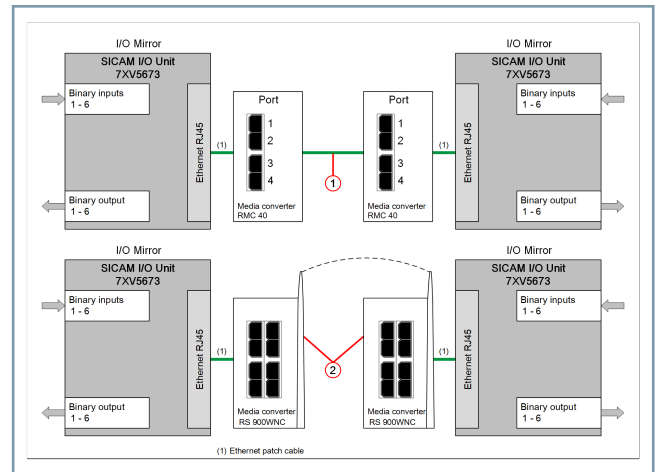

[dw_io-Mirror_fiber-optic_4_en_US]

Figure 8.1/12 Binary Signal Transmission via Optical Fiber or Wireless Connection; Connection via the Integrated Ethernet Interface to External Transmission Devices

- (1) Optical-fiber transmission with media converter for Ethernet, for example RMC40 from Ruggedcom
- (2) Wireless power transmission with media converter for Ethernet, for example RS900WNC from Ruggedcom

Typical application examples can be found in the Internet www.siemens.com/sicam-io -> Downloads.

Device Configuration

The SICAM I/O-Unit is equipped with an integrated Web server that simplifies the settings with the help of a standard Internet Web browser (Microsoft Internet Explorer). Figure 8.1/13 shows the user interface. In the same way, operational logs and commissioning aids are supported by the browser such as display of the actual state of the inputs and outputs.

The SICAM I/O mapping tool is used to configure the IEC 61850 GOOSE.

As soon as the IEC 61850 GOOSE configuration is completed, the SICAM I/O mapping tool reads the corresponding SCD file and generates the binary IEC 61850 parameter set, which can be uploaded via HTML.

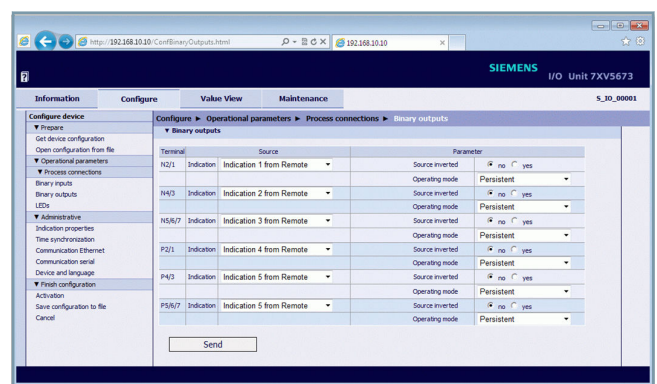

[sc_Lonfig_screen_2_en_US]

Figure 8.1/13 Configuration Screen of the SICAM I/O-Unit in the Web Browser

Accessories

SICAM I/O-Unit – Selection and Ordering Data/Dimensioned Drawing

Selection and Ordering Data

Description	Variants	Order No.																	
		1	2	3	4	5	6	7	8	9	10	11	12	13	14	15	16		
SICAM I/O-Unit		7	X	V	5	6	7	3	-	0	J	J	□	0	-	□	A	A	1
													▲			▲			
<u>Device Type</u>	<u>Serial Interface and Communication Protocol</u>																		
DIN rail device IP20;	Without serial communication												0						
Dimensions 96 mm x 96 mm x 100 mm (W x H x D);	RS485 – Modbus RTU, binary signal transmission												1						
Power supply: DC 24 to 240 V, AC 100 V to 230 V;	Optical, 820 nm – Modbus RTU, binary signal transmission												2						
Integrated Web server for parameterization; Ethernet interface RJ45 connector; integrated switch function; CE and UL approved	<u>Ethernet Interface and Communication Protocol</u>																		
	Ethernet interface with Modbus TCP/UDP, binary signal transmission																	1	
<u>Inputs/Outputs</u>																			
6 binary inputs with selectable threshold voltage;	Ethernet interface with Modbus TCP/UDP, binary signal transmission, and IEC 61850 server (GOOSE and reporting/MMS)																	2	
6 relay outputs (4 make contacts, 2 change-over contacts)																			
Accessories																			
The following components can be obtained as an option:																			
	Y-bus cable (required for using the internal switch/cascading)	7	K	E	6	0	0	0	-	8	G	D	0	0	-	0	B	A	2
	Ethernet patch cable (CAT6) RS485 cable for SIPROTEC devices	6	X	V	1	8	3	0	-	0	E	□	□	0					
RS485 bus plug	RS485 bus connector plug for SIPROTEC devices	6	E	S	7	9	7	2	-	0	B	A	4	2	-	0	X	A	0
	SIMATIC DP, connector plug with oblique cable outlet, 15.8 mm x 54 mm x 39.5 mm (WXHxD), load resistor with separating function, with PG socket	6	E	S	7	9	7	2	-	0	B	B	4	2	-	0	X	A	0
Order information about prefabricated fiber-optic cables can be found on the Internet in the SIPROTEC download section at www.siemens.com/siprotec ->Downloads/SIPROTEC accessories, 6XV81xx																			

Table 8.1/1 SICAM I/O-Unit Selection and Ordering Data

Dimensional Drawing

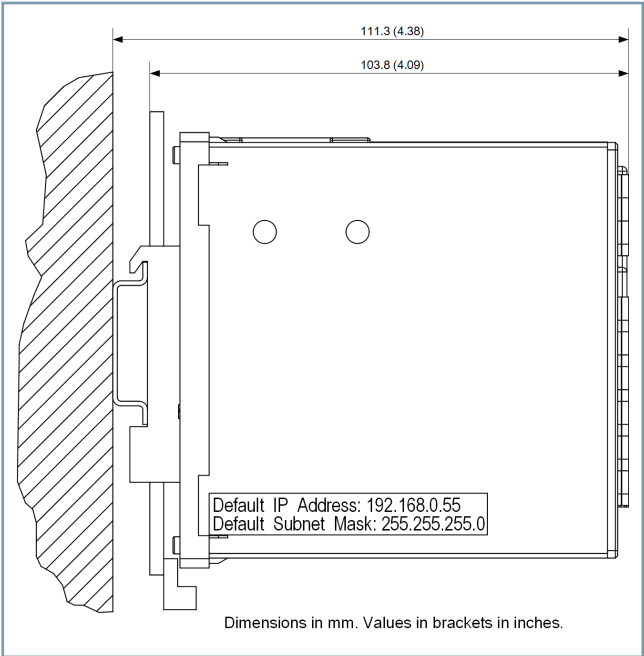

[dw_SICAM IO dimension_01_2_en_US]

Figure 8.1/14 Dimensions SICAM I/O-Unit 7XV5673

Accessories

SICAM AI-Unit – Description

Description

The SICAM AI-Unit 7XV5674 is an analog input device (20 mA) that is used by power utilities in the field of substations and in the industrial sector where there are increased environmental demands. Besides analog signal input, the SICAM AI-Unit can compress the measured data by demand calculation, and can monitor and signal parameterized limiting values. Measured values and messages can be transferred to a protection device, to a SICAM I/O-Unit, or to a substation or power-system control for process automation. Interoperable standard protocols IEC 61850 GOOSE, Reporting/MMS, and Modbus RTU/TCP/UDP are used here. The SICAM AI-Unit is thus a practical external 20mA extension and a local or remote automation unit.

Inputs	12 x 20 mA for direct current measurements (in accordance with IEC 60688)
Insulated housing	96 mm x 96 mm x 100 mm (W x H x D) Assembly on a DIN rail
Degree of protection	IP20
Approval	CE and UL

Benefits

- Wide field of application (SCADA, protection and automation processes) from swift and protected real-time applications to continuous long-term acquisition (24-h value):
 - Current measured value every 642 ms
 - 10 sec, 1 min, 1 hr, 24 hr demand calculation in the device. This on-site compression reduces the data volume that is to be transferred and processed (making handling mass data possible)
 - Independent on-site automation and monitoring unit with signaling of the parameterized limit violation conditions in the unit
- Connection to serial interfaces or Ethernet interfaces of SIPROTEC 4 or SIPROTEC 5 devices
- Connection to all protection and bay devices via IEC 61850-GOOSE messages and IEC 61850 reporting
- Compact and robust design (-25°C to 70°C operating temperature)
- Flexible communication options (Ethernet, optical fiber or RS485 electrical)
- Modbus RTU/TCP, SIPROTEC 20-mA, serial or Ethernet connection to SIPROTEC 5 devices via SUP protocol
- Precise process measurement (0.2% with reference conditions)
- Time synchronization via NTP (support of 2 time servers, fieldbus (Modbus RTU/TCP), IEC 61850, PC, internal RTC)
- Cost saving with integrated Ethernet switch permits a chain structure to be built up (cascading with Y adaptor 7KE6000-8GD00-0BA2)
- Web server for parameterization with an IWeb browser. No special parameterization software necessary
- 4 LEDs for different parameterizable messages/alarms
- 4 freely parameterizable group indications



Figure 8.2/1 SICAM AI-Unit 7XV5674

- Battery-backed real-time clock (RTC) and message logs (can be exported as .csv)
- Binary message and alarm stamp exact to 1 ms
- Simulation of input signals for easier system commissioning (IBS)
- Comparison of redundant measured data from different SICAM AI - units is possible due to the simultaneous start of the average value window generation
- Integrated communication and device supervision

Applications

The SICAM AI-Unit supports various applications. It can be used in the following sections for the acquisition of DC field signals:

- Power system protection
- SCADA (station and power systems control)
- DMS (Distribution Management System)
- EMS (Energy Management System)
- GIS (Gas-insulated switchgear) – gas pressure monitoring
- Other industrial processes
- Modernization of old plants: Automation/interface to old 20 mA technology (for example, 7SA511/513 issuing the fault location)

The currents from the connected transducers (such as temperature, pressure or position sensors) can be transferred via the supporting communication protocols automation processes for further processing (such as visualization). See also [Figure 8.2/2](#).

The DC inputs of the SICAM AI-Unit can be parameterized for the following ranges:

- 0 mA to 20 mADC
- 4 mA to 20 mADC

The measuring accuracy is 0.2% of the rated current (20 mA) at reference conditions. Under environmental influence (including EMC), the measuring accuracy is 1.0% of the rated current (20 mA).

With the integrated Web server, parameterization is carried out by means of HTML pages with the use of a Web browser.

Typical applications can be found on the Internet www.siemens.com/sicam-ai -> Downloads

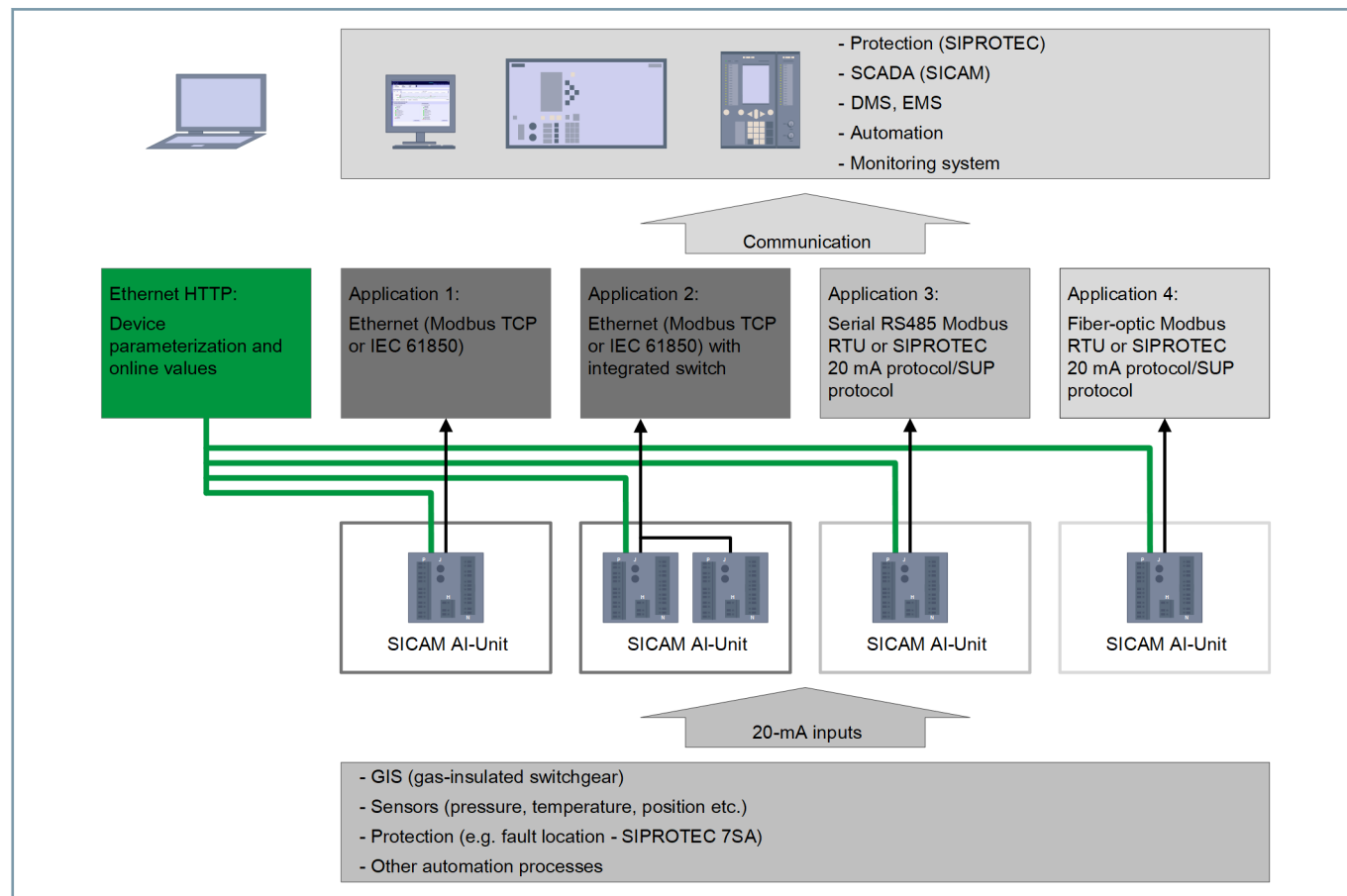

[dw_ai-unit_application_3_en_US]

Figure 8.2/2 Application Example

Measured quantities

The SICAM AI-Unit permits only direct current to be measured. The measurement cycles on both PCB assemblies are carried out at the same time. A complete measuring cycle via 6 channels takes 642 ms. The measurement of a channel takes 107 ms and is repeated after 642 ms. Using the Internet browser, the measured current, 10 second, minute, hour, and day average values of all channels can directly be viewed and measured by the device, and transferred via communication protocols, together with messages (such as limit violation conditions).

Limit settings

Up to 16 limit violations of current measured values in both directions can be set via the **automation functions** menu. Limit violation conditions of the upper and lower range of values can be indicated as an individual or group indication on 3 LEDs. The parameters of 4 group indications can be set, wherein each indication can be assigned up to 16 logically linked single-point indications.

Communication

To communicate with the substation controller / protection device and the other peripheral devices, the SICAM input measuring device has an Ethernet interface and optionally a serial interface (RS485 or optical).

The ordering options for communication via Ethernet are:

- With integrated Ethernet switch: Modbus TCP protocol
- With integrated Ethernet switch: Modbus TCP protocol **and** IEC 61850 protocol

The following functions are supported via Ethernet:

- Connection to SIPROTEC 5 devices via SUP (Slave Unit Protocol)
- Device parameterization
- Transmission of measured data
- Transmission of messages
- Time synchronization via NTP

Accessories

SICAM AI-Unit – Description

- Communication protocols Modbus TCP and IEC 61850 (reporting and GOOSE)
- Integrated Ethernet switch

With the Ethernet switch integrated in the device, further network components can be cascaded via a Y-cable and hence also included in an available network with IEC 61850 or a further Ethernet protocol.

- Serial interface
 - With RS485 interface
 - With optical interface
- Communication with existing RS485 or optical 820 nm interface
 - With the Modbus RTU protocol and SIPROTEC RTU protocol 20 mA/SUP (Slave Unit Protocol)

The serial interface supports the following functions:

- Transmission of measured data
- Transmission of messages
- Time synchronization via Modbus RTU

When selecting the serial interface, either Modbus RTU or the SIPROTEC RTU 20 mA/SUP (Slave Unit Protocol) communication protocol can be used.

Time synchronization

During operation, the SICAM AI-Unit needs the date and time for all time-relevant processes. In communication with peripheral devices, this ensures a uniform time base and allows correct time stamping of the process data.

The following types of time synchronization can be carried out:

- External time synchronization via Ethernet NTP (preferred)
- External time synchronization via Fieldbus with communication protocol Modbus RTU
- Internal time synchronization via RTC (Real-Time Clock) – if external time synchronization is unavailable

LED indications

The SICAM AI-Unit automatically monitors communication connections and the functions of its hardware/software/firmware components. The LEDs on the top of the housing signal the current state of the device. They can be parameterized for individual or group indication.

Parameterization

No special software is required for parameterization. Parameter setting is carried out by the computer via HTML pages and a Web browser. Internet Explorer 6 (or higher) is necessary for this purpose.

Dimensional Drawing

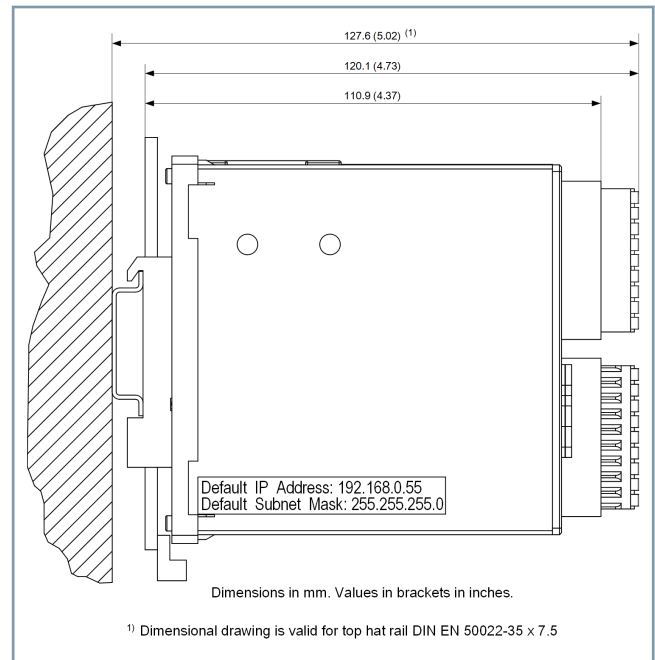

[hw_SICAM AI dimension_2_en_16]

Figure 8.2/3 Dimensions of the SICAM AI-Unit 7XV5674

Selection and Ordering Data

Description	Variants	Order no.																	
		1	2	3	4	5	6	7	8	9	10	11	12	13	14	15	16		
SICAM AI-Unit		7	X	V	5	6	7	4	-	0	K	K	□	0	-	□	A	A	1
													▲			▲			
<u>Device Type</u>	<u>Serial Interface and Communication Protocol</u>																		
DIN rail device, IP20; 12 x 20-mA inputs for example SIPROTEC-/SICAM units; Dimensions: 96 mm x 96 mm x 100 mm (WxHxD); Power supply: DC 24 to 240 V, AC 100 V to 230 V; Ethernet interface, RJ45 connector; integrated switch function; integrated Web server for parameterization; CE and UL approved	Without serial communication												0						
	RS485 – Serial Modbus RTU and SIPROTEC 20 mA protocol/point-to-point connection												3						
	FO 820 nm, ST connector – serial Modbus RTU and SIPROTEC 20 mA protocol/point-to-point connection													4					
	<u>Ethernet Interface and Communication Protocol</u>																		
	Ethernet interface with Modbus TCP																1		
	Ethernet interface with Modbus TCP and IEC 61850 server (GOOSE and reporting/MMS)																2		
Accessories																			
The following components can be obtained as an option:																			
	Y-bus cable (required for using the internal switch/cascading)	7	K	E	6	0	0	0	-	8	G	D	0	0	-	0	B	A	2
	Ethernet patch cable (CAT6) RS485 cable for SIPROTEC devices	6	X	V	1	8	3	0	-	0	E	□	□	0					
RS485 bus plug	RS485 bus connector plug for SIPROTEC devices	6	E	S	7	9	7	2	-	0	B	A	4	2	-	0	X	A	0
	SIMATIC DP, connector plug with oblique cable outlet, 15.8 mm x 54 mm x 39.5 mm (WxHxD), load resistor with separating function, with PG socket	6	E	S	7	9	7	2	-	0	B	B	4	2	-	0	X	A	0
Order information about prefabricated fiber-optic cables can be found on the Internet in the SIPROTEC download section at www.siemens.com/siprotec ->Downloads/SIPROTEC accessories, 6XV81xx																			

Table 8.2/1 SICAM AI-Unit Selection and Ordering Data

Indication of Conformity



This product complies with the directive of the Council of the European Communities on harmonization of the laws of the Member States concerning electromagnetic compatibility (EMC Directive 2014/30/EU), restriction on usage of hazardous substances in electrical and electronic equipment (RoHS Directive 2011/65/EU), and electrical equipment for use within specified voltage limits (Low Voltage Directive 2014/35/EU).

This conformity has been proved by tests performed according to the Council Directive in accordance with the product standard EN 60255-26 (for EMC directive), the standard EN IEC 63000 (for RoHS directive), and with the product standard EN 60255-27 (for Low Voltage Directive) by Siemens.

The device is designed and manufactured for application in an industrial environment.

The product conforms with the international standards of IEC 60255 and the German standard VDE 0435.

Disclaimer of Liability

Subject to changes and errors. The information given in this document only contains general descriptions and/or performance features which may not always specifically reflect those described, or which may undergo modification in the course of further development of the products. The requested performance features are binding only when they are expressly agreed upon in the concluded contract.

Copyright

Copyright © Siemens AG 2022.

The disclosure, duplication, distribution and editing of this document, or utilization and communication of the content are not permitted, unless authorized in writing. All rights, including rights created by patent grant or registration of a utility model or a design, are reserved.

Trademarks

SIPROTEC, DIGSI, SIGRA, SIGUARD, SIMEAS SAFIR, SICAM, and MindSphere are trademarks of Siemens. Any unauthorized use is prohibited.

9

OpenSSL

This product includes software developed by the OpenSSL Project for use in OpenSSL Toolkit (<http://www.openssl.org/>).

This product includes software written by Tim Hudson (tjh@cryptsoft.com).

This product includes cryptographic software written by Eric Young (ey@cryptsoft.com).

Published by

Siemens AG 2023

Smart Infrastructure
Electrification & Automation
Mozartstrasse 31C
91052 Erlangen
Germany

[siemens.com/sicam](https://www.siemens.com/sicam)

For the U.S. published by
Siemens Industry Inc.
3617 Parkway Lane
Peachtree Corners, GA 30092
United States

Siemens Electrification & Automation Global Support
Single entry point – available 24/7
support.ea.sj@siemens.com
Phone: +49 9131 1743072

Article No. SIEA-C10132-00-7600
Produced in Germany
pdf document
CG 01.24 EN

© 2023 by Siemens AG

Subject to changes and errors. The information given in this document only contains general descriptions and/or performance features which may not always specifically reflect those described, or which may undergo modification in the course of further development of the products. The requested performance features are binding only when they are expressly agreed upon in the concluded contract.

All product designations may be trademarks or product names of Siemens AG or other companies whose use by third parties for their own purposes could violate the rights of the owners.