

SIEMENS

SIMATIC

Windows Automation Center WinAC Slot 412/WinAC Slot 416 Version 3.3

Overview

Preface, Contents

Product Overview

Getting Started

Appendix

Distributed Component Object
Model (DCOM)

OLE for Process Control (OPC)

Index

1

2

A

B

This manual is part of the product
packages with the order number:

6ES7 673-6CC21-0YA0

6ES7 673-6CC01-0YA0

Edition 01/2003

A5E00065531-05

Safety Guidelines

This manual contains notices intended to ensure personal safety, as well as to protect the products and connected equipment against damage. These notices are highlighted by the symbols shown below and graded according to severity by the following texts:



Danger

indicates that death, severe personal injury or substantial property damage will result if proper precautions are not taken.



Warning

indicates that death, severe personal injury or substantial property damage can result if proper precautions are not taken.



Caution

indicates that minor personal injury can result if proper precautions are not taken.

Caution

indicates that property damage can result if proper precautions are not taken.

Notice

draws your attention to particularly important information on the product, handling the product, or to a particular part of the documentation.

Qualified Personnel

Only **qualified personnel** should be allowed to install and work on this equipment. Qualified persons are defined as persons who are authorized to commission, to ground and to tag circuits, equipment, and systems in accordance with established safety practices and standards.

Correct Usage

Note the following:



Warning

This device and its components may only be used for the applications described in the catalog or the technical description, and only in connection with devices or components from other manufacturers which have been approved or recommended by Siemens.

This product can only function correctly and safely if it is transported, stored, set up, and installed correctly, and operated and maintained as recommended.

Trademarks

SIMATIC®, SIMATIC HMI® and SIMATIC NET® are registered trademarks of SIEMENS AG.

Third parties using for their own purposes any other names in this document which refer to trademarks might infringe upon the rights of the trademark owners.

Copyright © Siemens AG 2001 - 2003 All rights reserved Disclaim of Liability

The reproduction, transmission or use of this document or its contents is not permitted without express written authority. Offenders will be liable for damages. All rights, including rights created by patent grant or registration of a utility model or design, are reserved.

Siemens AG
Bereich Automation and Drives
Geschäftsgebiet Industrial Automation Systems
Postfach 4848, D- 90327 Nuernberg

Siemens Aktiengesellschaft

We have checked the contents of this manual for agreement with the hardware and software described. Since deviations cannot be precluded entirely, we cannot guarantee full agreement. However, the data in this manual are reviewed regularly and any necessary corrections included in subsequent editions. Suggestions for improvement are welcomed.

© Siemens AG 2001 - 2003
Technical data subject to change.

A5E00065531



Preface

Purpose of the manual

The software and hardware components of the **Windows Automation Center** (WinAC) allow you the combined solution consisting of data processing, control, visualization and communications on your PC (PC-based control). The following versions of the WinAC product are available:

- **WinAC Slot 412**
- **WinAC Slot 416**

This manual will familiarize you with the individual components of the **WinAC Slot 412 and WinAC Slot 416** product versions by way of an overview. In addition, you will find instructions for installing the software required for WinAC Slot 41x.

Essential basic skills

To understand the manual, general knowledge of automation engineering is required.

In addition, knowledge of the following is required:

- Extensive knowledge of the S7-400
- Extensive knowledge of STEP 7

Applicability of the manual

The present manual applies to the following modules:

CPU	Order No.	As of Version	
		Firmware	Hardware
CPU 412-2 PCI	6ES7 612-2QH00-0AB4*	3.1	1
CPU 416-2 PCI	6ES7 616-2QL00-0AB4*	3.1	1
PS extension board	6ES7 678-1RA00-0XB0	-	1

* As spare part

Changes from the previous version

The following changes have been made compared to the previous version of WinAC Slot 41x, version 3.2:

- You can also operate WinAC Slot under Windows XP Professional.
- Windows NT 4.0 is no longer support.
- You can update process image partitions synchronous to the DP clock using SFC 126 "SYNC_PI" und der SFC 127 "SYNC_PO"
- You can determine the bus topology of a DP master system by triggering the diagnostics repeater with SFC 103 "DP_TOPOLOG".

Certification

The CPUs 41x-2 PCI and the PS extension board have the following certification:

- Underwriters Laboratories, Inc.: UL 508 registered (Industrial Control Equipment)
- Canadian Standards Association: CSA C22.2 number 142, (Process Control Equipment)
- Factory Mutual Research: Approval Standard Class Number 3611.

CE Labeling

The CPUs 41x-2 PCI and the PS extension board fulfil the requirements and protection guidelines of the following EU directives:

- EC Directive 73/23/EEC "Low-voltage directive"
- EC Directive 89/336/EEG "EMC directive"

CTick Mark

The CPUs 41x-2 PCI and the PS extension board are compliant with requirements of the AS/NZS 2064 (Australian) standard.





Standards

The CPUs 41x-2 PCI and the PS extension board fulfil the requirements and criteria of IEC 61131-2.

Refer to appendix xx to find out the norms the CPUs are compliant with.

Package as supplied

This package has the order number 6ES7 673-6CC01-8BA0 and consists of three manuals and an operation list containing the following:

	<p>Overview of the Windows Automation Center WinAC Slot 412/WinAC Slot 416</p> <ul style="list-style-type: none"> • Overview of the components of WinAC • Getting started
	<p>Manual "WinAC Controlling with CPU 412-2 PCI/CPU 416-2 PCI; Set-Up, CPU Data"</p> <ul style="list-style-type: none"> • Installing and wiring CPUs 41x-2 PCI and the PS extension board • Instructions for installing the software • Commissioning CPUs 41x-2 PCI and the PS extension board • Description of control panel, time synchronization • Technical specifications • Compatibility with version 3.2 of WinAC Slot 41x
	<p>Manual "SIMATIC Computing"</p> <ul style="list-style-type: none"> • Function and running of the SIMATIC Computing software • Description of the controls
	<p>S7-400 instruction list</p> <ul style="list-style-type: none"> • Instruction set for all CPUs • Brief description of instructions and execution times • List of OBs, system events, SSL IDs, SFCs/SFBs

Recycling and Disposal

The CPUs 41x-2 PCI and the PS extension board are recycleable due to their non-toxic materials. Please contact a company certified in the disposal of electronic scrap for environmentally safe recycling and disposal of your old device.

Further Support

If you have any technical questions, please get in touch with your Siemens representative or agent responsible.

<http://www.siemens.com/automation/partner>

Training Centers

Siemens offers a number of training courses to familiarize you with the SIMATIC S7 automation system. Please contact your regional training center or our central training center in D 90327 Nuremberg, Germany for details:

Telephone: +49 (911) 895-3200.

Internet: <http://www.sitrain.com>

A&D Technical Support

Worldwide, available 24 hours a day:



<p>Worldwide (Nuernberg) Technical Support</p> <p>24 hours a day, 365 days a year Phone: +49 (0) 180 5050-222 Fax: +49 (0) 180 5050-223 E-Mail: adsupport@siemens.com GMT: +1:00</p>		
<p>Europe / Africa (Nuernberg) Authorization</p> <p>Local time: Mon.-Fri. 7:00 to 17:00 Phone: +49 (0) 180 5050-222 Fax: +49 (0) 180 5050-223 E-Mail: adautorisierung@siemens.com GMT: +1:00</p>	<p>United States (Johnson City) Technical Support and Authorization</p> <p>Local time: Mon.-Fri. 8:00 to 17:00 Phone: +1 (0) 423 262 2522 Fax: +1 (0) 423 262 2289 E-Mail: simatic.hotline@sea.siemens.com GMT: -5:00</p>	<p>Asia / Australia (Beijing) Technical Support and Authorization</p> <p>Local time: Mon.-Fri. 8:30 to 17:30 Phone: +86 10 64 75 75 75 Fax: +86 10 64 74 74 74 E-Mail: adsupport.asia@siemens.com GMT: +8:00</p>
<p>The languages of the SIMATIC Hotlines and the authorization hotline are generally German and English.</p>		

Service & Support on the Internet

In addition to our documentation, we offer our Know-how online on the internet at:

<http://www.siemens.com/automation/service&support>

where you will find the following:

- The newsletter, which constantly provides you with up-to-date information on your products.
- The right documents via our Search function in Service & Support.
- A forum, where users and experts from all over the world exchange their experiences.
- Your local representative for Automation & Drives via our representatives database.
- Information on field service, repairs, spare parts and more under “Services”.

Automation and Drives, service and support

Available throughout the world at any time of the day:

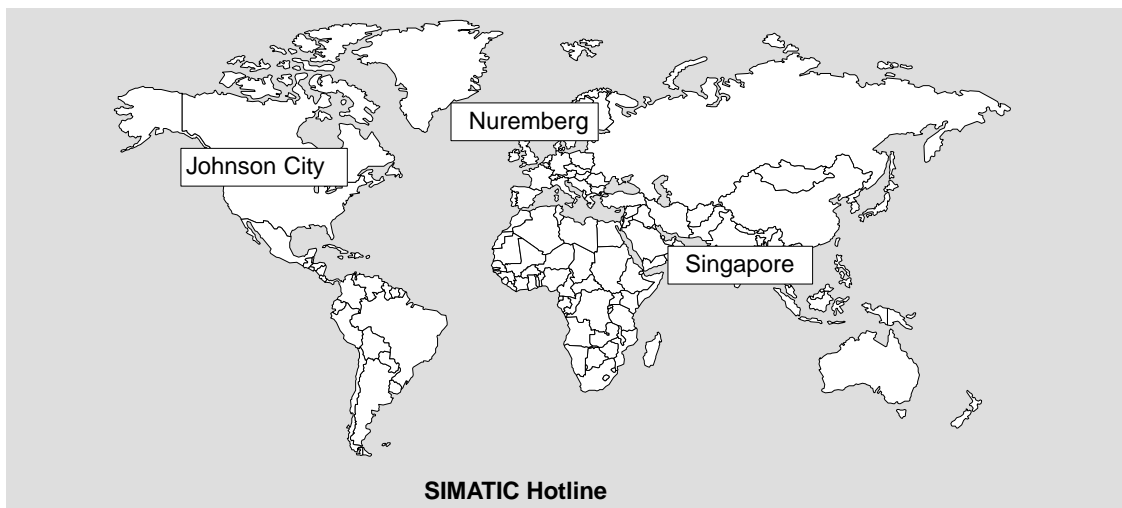

<p>Worldwide (Nuremberg) Technical Support (FreeContact) Local time: Mon. through Fri. 7 a.m. to 5 p.m. Phone: +49 (180) 5050-222 Fax: +49 (180) 5050-223 E-mail: techsupport@ad.siemens.de GMT: +1:00</p>	<p>Worldwide (Nuremberg) Technical Support (subject to charge, with SIMATIC Card only) Local time: Mon. through Fri. 0 a.m. 12 p.m. Phone: +49 (911) 895-7777 Fax: +49 (911) 895-7001 GMT: +01:00</p>	
<p>Europe / Africa (Nuremberg) Authorization Local time: Mon. through Fri. 7 a.m. to 5 p.m. Phone: +49 (911) 895-7200 Fax: +49 (911) 895-7201 E-mail: authorization@nbgm.siemens.de GMT: +1:00</p>	<p>America (Johnson City) Technical Support and Authorization Local time: Mon. through Fri. 8 a.m. to 7 p.m. Phone: +1 423 461-2522 Fax: +1 423 461-2289 E-mail: simatic.hotline@sea.siemens.com GMT: -5:00</p>	<p>Asia / Australia (Singapore) Technical Support and Authorization Local time: Mon. through Fri. 8:30 a.m. to 5.30 p.m. Phone: +65 740-7000 Fax: +65 740-7001 E-mail: simatic.hotline@sae.siemens.com.sg GMT: +8:00</p>
<p>Generally speaking, the languages spoken on the SIMATIC Hotlines are English and German, while French, Italian and Spanish are also spoken on the Authorization Hotline.</p>		

Contents

1	Product Overview	1-1
1.1	What is PC-based Automation with SIMATIC WinAC?	1-3
1.2	CPU 41x-2 PCI Is for Controlling Your Process	1-4
1.3	The PS Extension Board Enhances Safety in Operation	1-6
1.4	Communication Options with CPU 41x-2 PCI	1-7
1.5	Time Synchronization (PLCTimeSync)	1-9
1.6	SIMATIC Computing Creates Access to Process Data	1-10
1.7	Tag Files Allow You To Use Symbols for Process Data...	1-11
1.8	Tag Files Allow You to Access Multiple Control Engines...	1-12
1.9	Use SIMATIC Computing across a DCOM Network	1-13
1.10	Using OPC to Connect Third-Party Applications to SIMATIC Computing	1-14
1.11	Tool Manager Provides Shortcuts to Your Programs	1-15
2	Getting Started	2-1
2.1	Problem Definition: Communication from the CPU 416-2 PCI over the CP 1613 to a S7-400	2-2
2.1.1	Installing the Components of WinAC Slot 41x	2-4
2.1.2	Component Configurator: Assigning Station Names	2-5
2.1.3	Commissioning wizard: assigning CP 1613	2-6
2.1.4	Creating a Project in SIMATIC Manager	2-8
2.1.5	Configuring the Hardware of the Box PC620	2-9
2.1.6	Hardware configuration of the S7-400 Station	2-12
2.1.7	Configuring a Network	2-13
2.1.8	Configuring a Connection	2-14
2.1.9	Communications	2-16
2.2	Starting the Control Panel of WinAC Slot 41x	2-16
2.3	Going Online with STEP 7 to the CPU 41x-2 PCI	2-17
2.4	Creating a Process Form with SIMATIC Computing SoftContainer	2-20
2.5	Establishing Connections for the Process Form	2-22
A	Distributed Component Object Model (DCOM)	A-1
A.1	Using DCOM to Expand the Capabilities of WinAC	A-2
A.2	Connecting to a Specific Control Engine over DCOM	A-4
B	OLE for Process Control (OPC)	B-1
B.1	Using OPC with SIMATIC Computing	B-2

Index

Figures

1-1	Using the CPU 41x-2 PCI in WinAC Slot 41x	1-4
1-2	Control Panel	1-5
1-3	PS Extension Board	1-6
1-4	Communication Options with the CPU 41x-2 PCI	1-7
1-5	Clock synchronization	1-9
1-6	Accessing the Process Data with SIMATIC Computing	1-10
1-7	Using STEP 7 Symbols to Access Data in the Control Engine	1-11
1-8	Using a Tag File to Access Data from Several Control Engines	1-12
1-9	Connecting WinAC on Several Computers across a DCOM Network ...	1-13
1-10	Using OPC to Connect Third-Party Applications to SIMATIC Computing	1-14
1-11	WinAC Tool Manager and Shortcut Icon	1-15
2-1	Communication over CP 1613 to a S7-400	2-3
2-2	Installing the Components of WinAC Slot 41x	2-4
2-3	Component Configurator: Assigning Station Names	2-6
2-4	Commissioning wizard: settings for CP 1613	2-7
2-5	Creating a Project	2-8
2-6	Selecting a Mounting Rack	2-9
2-7	Assigning a CP	2-10
2-8	CP 1613: Properties of the Ethernet Interface	2-11
2-9	Configuring the Hardware of the S7-400 Station	2-12
2-10	Configuring the Network	2-13
2-11	Creating a Connection	2-14
2-12	Connection Properties	2-15
2-13	Calling the WinAC Slot Controller	2-16
2-14	Setting the PG/PC Interface for PC Internal (Local)	2-17
2-15	Connecting STEP 7 to WinAC Slot over a Network	2-18
2-16	Setting the PG/PC Interface	2-19
2-17	Setting the PG/PC Interface for SIMATIC Computing	2-20
2-18	SoftContainer with Blank Process Form;	2-21
2-19	Inserting a SIMATIC Data Control from the Toolbar	2-22
2-20	Opening the "Properties" Dialog Box for the Data Control	2-23
2-21	Connecting the Data Control to WinAC	2-24
A-1	Using WinAC Components with DCOM on a Standalone Computer ...	A-2
A-2	Using WinAC on Several Computers with DCOM	A-3
A-3	Connecting to a Specific Control Engine over DCOM	A-4
B-1	Applications Working with Many OPC Servers	B-2
B-2	Using the WinAC OPC Server to Access Your Process Data	B-2

Tables

1-1	Communication key data	1-8
-----	------------------------------	-----

Product Overview

1

Overview

The WinAC Slot 41x package consists of the following components:

- the Slot PLC "**CPU 412-2 PCI**" or "**CPU 416-2 PCI**", two CPUs from the range of products for the S7-400 for PC-based applications.
- the optional PS extension board (PS: power supply; power supply module) for PC-independent power supply.
- the **control panel** that displays the controls of the CPU 41x-2 PCI on a screen.
- the **time synchronization** for synchronization of the CPU 41x-2 PCI via a SIMATIC NET CP (Industrial Ethernet or PROFIBUS).
- the **SIMATIC Computing** software. The SIMATIC Computing software provides ActiveX controls, which you can use specifically to visualize your process. In SIMATIC Computing, you can use third-party ActiveX controls in addition to S7 Controls to monitor and modify process data.

Furthermore, SIMATIC Computing has an OPC server (OPC = OLE for Process Control) which other OPC applications use to access the data in the controlled device.

In this chapter

Section	Contents	Page
1.1	What Is PC-Based Automation with SIMATIC WinAC?	1-3
1.2	CPU 41x-2 PCI Is for Controlling Your Process	1-4
1.3	The PS Extension Board Enhances Safety in Operation	1-6
1.4	Communication Options with CPU 41x-2 PCI	1-7
1.5	Time Synchronization (PLCTimeSync)	1-9
1.6	SIMATIC Computing Creates Access to Process Data	1-10
1.7	Tag Files Allow You To Use Symbols for Process Data...	1-11
1.8	Tag Files Allow You to Access Multiple Control Engines...	1-12
1.9	Use SIMATIC Computing across a DCOM Network	1-13
1.10	Using OPC to Connect Third-Party Applications to SIMATIC Computing	1-14
1.11	Tool Manager Provides Shortcuts to Your Programs	1-15

1.1 What is PC-based Automation with SIMATIC WinAC?

PC-based automation with SIMATIC WinAC

In the top range of the PLC applications, the number of PC tasks such as data processing and visualization is increasing. The use of PC-based automation with SIMATIC WinAC then frequently represents a better solution. PC-based automation with SIMATIC WinAC is the combination of a PLC and data processing on a PC with WinAC Slot 412/WinAC Slot 416.

SIMATIC WinAC combines the automation tasks of open-loop and closed-loop control, data processing, communications and visualization on a PC. SIMATIC WinAC is based on the Windows 2000 Professional and Windows XP Professional and uses standard interfaces for integration into the Office world. SIMATIC WinAC can be used on SIMATIC PCs and all commercial PCs with Windows 2000 Professional or Windows XP Professional. WinAC stands for **Windows Automation Center**.

Access to process data

SIMATIC WinAC features an ActiveX interface for simple symbolic access to process data from standard Windows applications such as Excel and Access. Furthermore, there are WinAC ActiveX Controls for the display of diagnostic buffer contents and simple display and operator controls.

The integrated OPC server of SIMATIC WinAC features open-system access to the process data by any OPC client applications.

Connection to visualization

An OPC server with a data access interface is available for integrating all kinds of visualization system based on Windows 2000/XP. SIMATIC WinCC and ProTool/Pro can be connected through an optimized interface.

Communication

Communication runs over S7 communication services or TCP/IP by means of DCOM mechanisms.

Technology on the PC

For a rapid exchange of data between the CPU 41x-2 PCI and PC, you can create a technological application using the WinAC Slot T-Kit.

1.2 CPU 41x-2 PCI Is for Controlling Your Process

CPU 41x-2 PCI features an effective hardware solution for your automation projects (refer to Figure 1-1). The I/O is connected via PROFIBUS-DP.

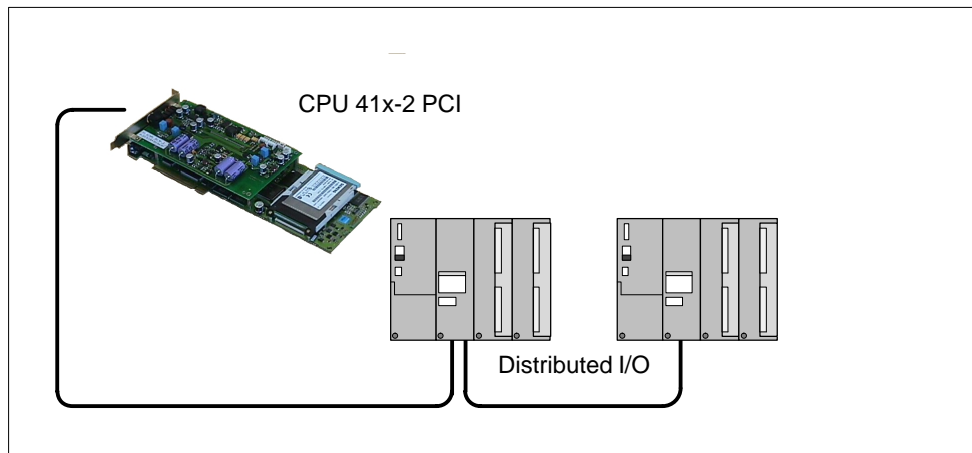

Figure 1-1 Using the CPU 41x-2 PCI in WinAC Slot 41x

WinAC Controlling with CPU 41x-2 PCI

WinAC Controlling is the control component with WinAC Slot 412/ WinAC Slot 416. WinAC Controlling performs the tasks of a conventional programmed logic controller and is completely integrated in the PC.

WinAC Controlling consists optionally of the CPU 412-2 PCI or CPU 416-2 PCI. These CPUs exhibit typical PLC features:

- warm restart (restart) or precise complete restart as commanded (with PS extension board)
- deterministic behavior with real-time response times
- real-time clock
- data retentivity using battery backup (with PS extension board)
- external load memory for saving the PLC program independently of the PC hard disk
- integrated MPI for connecting a programmer for servicing purposes, for programming or for networking with other stations
- integrated PROFIBUS-DP interface for connecting the I/O

Furthermore, there are interfaces to PC applications.

Operation

The CPU 41x-2 PCI is operated from control panel that is displayed on the PC screen. The panel is modeled on the front panel of an S7 CPU and makes available the functions that it features.

Access to the PLC from the control panel can be protected by a password so that only authorized persons can modify the settings.

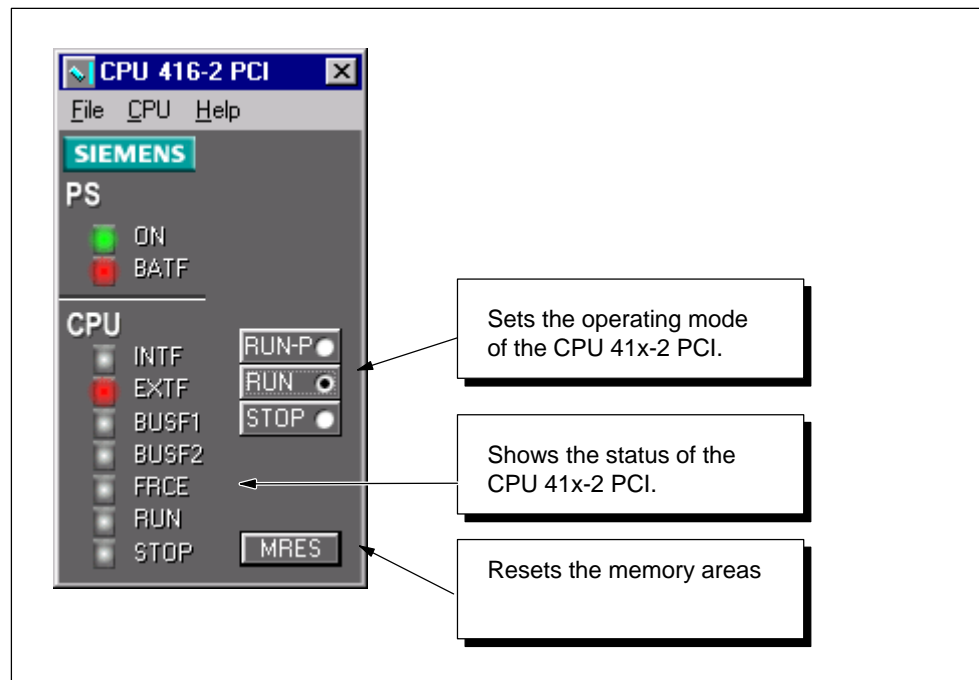

Figure 1-2 Control Panel

Programming

Configuration and programming of the CPU 41x-2 PCI is accomplished in a manner similar to that for the SIMATIC S7 with STEP 7. For these tasks, you can use the programming languages LAD, CSF, STL, S7-SCL and all graphics programming languages such as S7-GRAPH, S7-HiGRAPH and CFC.

1.3 The PS Extension Board Enhances Safety in Operation

The PS extension board (PS: power supply) is used to supply voltage to the CPU 41x-2 PCI independently of the PC power supply unit. In this way it is possible to operate the CPU 41x-2 PCI even when the PC has been powered down.

By connecting the backup battery, warm restart (restart) and complete restart are possible for the CPU 41x-2 PCI.

In addition, you can operate the fan on the PC with the PS extension board.

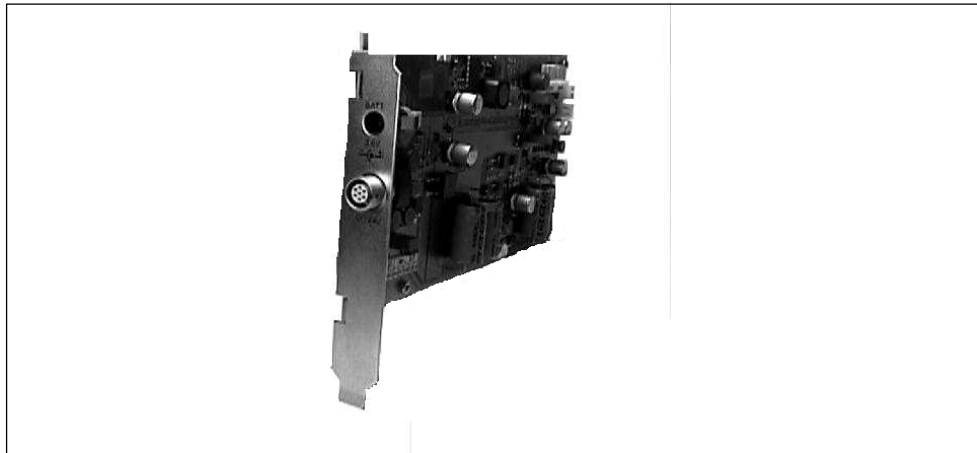

Figure 1-3 PS Extension Board

1.4 Communication Options with CPU 41x-2 PCI

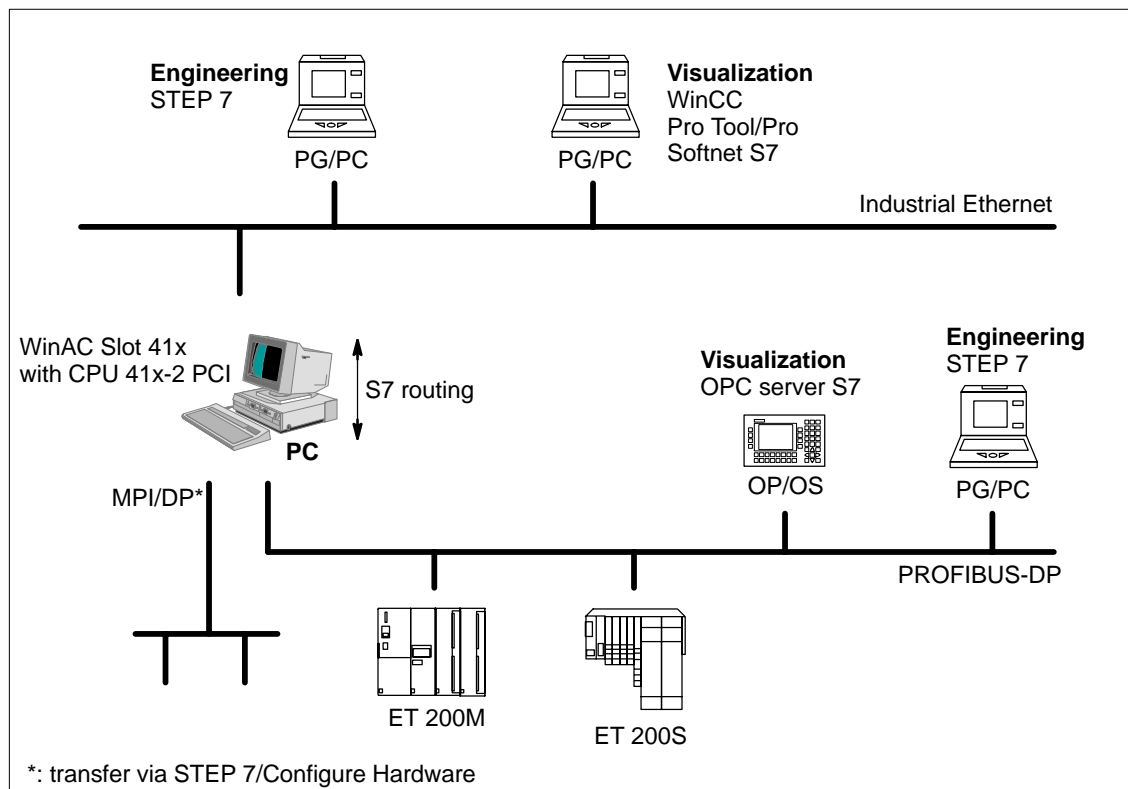

Figure 1-4 Communication Options with the CPU 41x-2 PCI

Figure 1-4 shows the communication options open to you with the CPU 41x-2 PCI. The CPU 41x-2 PCI has one PROFIBUS-DP interface and one MPI/PROFIBUS-DP interface.

If you wish to perform communications via Industrial Ethernet or PROFIBUS subnet, you must install an additional communication processor (CP) on your PC.

The **communication options** with other nodes are:

1. Connection to PROFIBUS-DP through the integrated interface.
2. Connection to MPI or PROFIBUS-DP through the second integrated interface.
3. Connection to PC through the PCI interface.
4. Connection to another network such as Industrial Ethernet/PROFIBUS via a communication processor (CP).

Communication key data

Communication is possible with a PG or an OS, and configured AS/AS communication (with other CPUs) is possible over Industrial Ethernet, MPI or distributed I/O. The following interfaces can be used: CP 1613, 3Com Softnet, CP 5613, CP 5611 and the integrated interfaces.

Constraints: the FMS und FDL protocols and AG-Send/AG-Receive are not supported.

Table 1-1 Communication key data

CP/Interface	Protocol	Time Synchronization Possible	Number of Connections over WinAC Slot 41x ^{1, 2}	Communication over WinAC Slot 41x	
				Communication with PG, OS, etc.	Configured AS/AS Communication
CP1613	Industrial Ethernet	Yes	120	Yes	Yes
3Com Softnet	Industrial Ethernet	Yes	64	Yes	Yes
CP 5613	PROFIBUS	Yes	50	Yes	Yes
	MPI	No	–	No	No
CP 5611 ^{3, 4}	PROFIBUS	No	8	Yes	Yes
	MPI	No	–	No	No
Integrated interfaces	PROFIBUS	Yes	CPU 412-2 PCI: 16 CPU 416-2 PCI: 32	Yes	Yes
	MPI	Yes	CPU 412-2 PCI: 16 CPU 416-2 PCI: 44	Yes	Yes

¹ The number of connections apply to Credit = 1 and PDU size = 480 bytes. For other settings please refer to the product information for SIMATIC NET for additional information.

² With the CPU 412-2 PCI a maximum of 16 connections is allowed, and with the CPU 416-2 PCI a maximum of 64 connections are allowed.

³ If you are routing via the CP 5611 or the integrated interface of the SIMATIC PC, you must make sure, when setting the access point with "Set PG/PC Interface", that you have selected the property "PG/PC is the sole master on bus" at "Station-specific properties" in the properties dialog box of the CP 5611.

⁴ When using the CP 5611 in a dual Pentium PC, Windows NT can sporadically become inoperable. The only remedy is to power down and power up.

1.5 Time Synchronization (PLCTimeSync)

The CPU 41x-2 PCI can be synchronized, together with other nodes (for example, S7 components) with a central time-of-day transmitter.

The time synchronization service in the PC supplies the CPU at intervals with the current date and time. The time-of-day transmitter furnishes the time of day at periodic intervals on the Industrial Ethernet or PROFIBUS (IE/PB). Only the ISO protocol is supported by Industrial Ethernet.

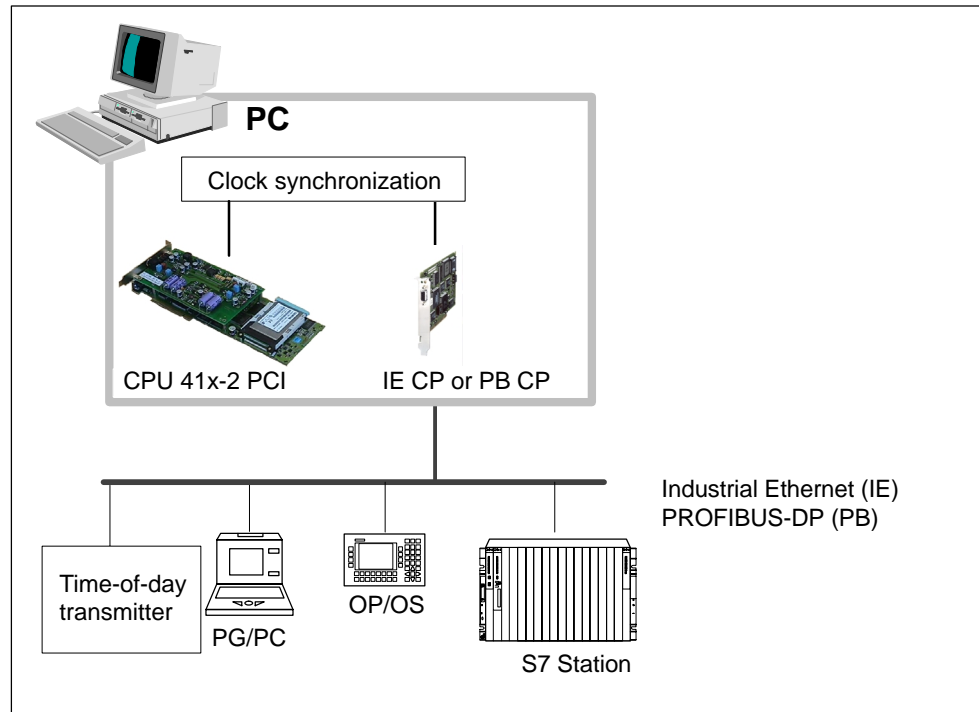

Figure 1-5 Clock synchronization

1.6 SIMATIC Computing Creates Access to Process Data

In Figure 1-6, you can see how you can use the SIMATIC Computing software to access the CPU 41x-2 PCI for monitoring and modifying process data.

SIMATIC Computing provides several methods for accessing the process data:

- You can use standard ActiveX controls (OCX) to access the process data.
- You can use DCOM (Microsoft's Distributed Component Object Model) to integrate distributed applications across a network. A distributed application consists of several processes or different computers that cooperate to jointly solve a task (refer to section 1.9).
- You can use an OPC (OLE for Process Control) server which other OPC clients use to access the data in the controlled device (refer to section 1.10).

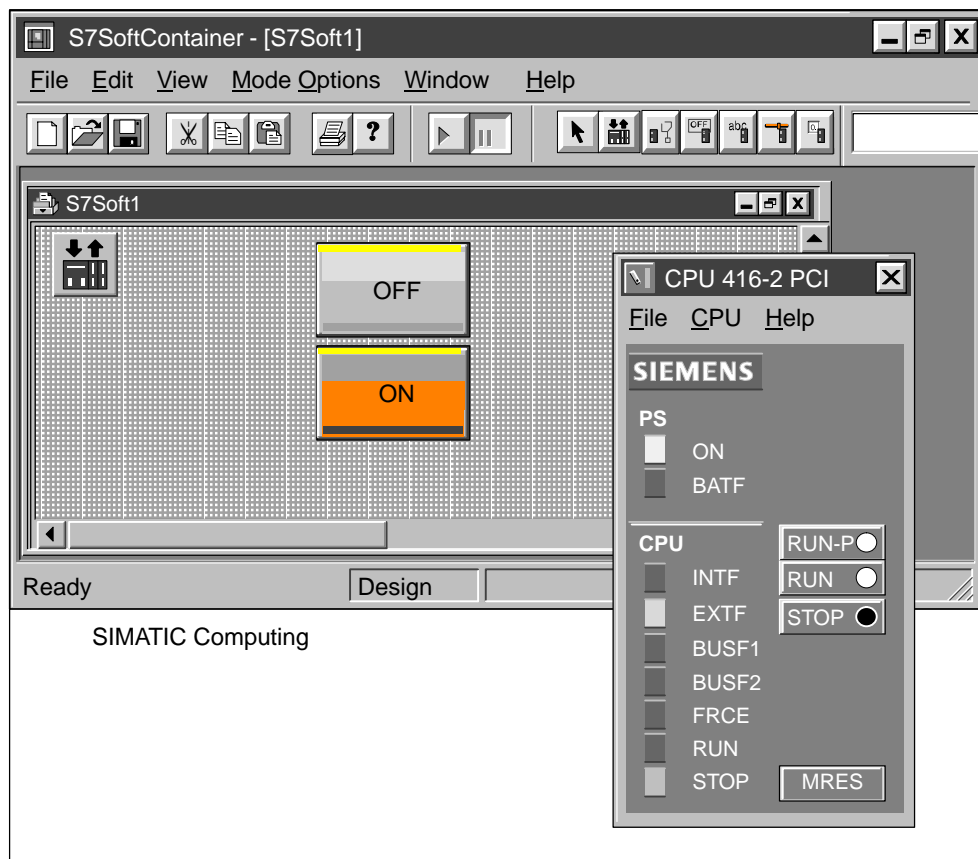

Figure 1-6 Accessing the Process Data with SIMATIC Computing

1.7 Tag Files Allow You To Use Symbols for Process Data...

A tag file provides a source of symbolic information for memory locations and control engines. Linking to a tag file allows you to use symbolic names instead of absolute addresses when assigning tags in SIMATIC Computing (refer to Figure 1-7).

The TagFile Configurator creates a tag file that provides a source of symbolic information for the memory locations and control engines. The tag file can then be used on a computer on which STEP 7 is not installed.

Refer to the *SIMATIC Computing User Manual* for detailed information about using the TagFile Configurator.

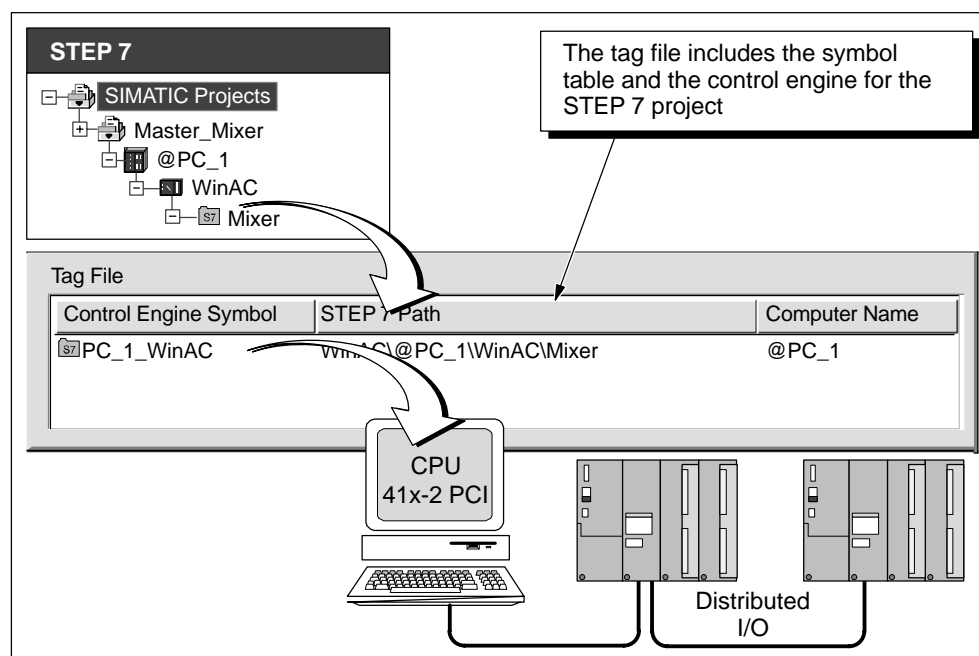

Figure 1-7 Using STEP 7 Symbols to Access Data in the Control Engine

1.8 Tag Files Allow You to Access Multiple Control Engines...

Every STEP 7 program can be assigned to a tag table, with each program providing access to a different computer and a different control engine. This allows SIMATIC Computing to access data from different computers and control engines simultaneously.

As shown in Figure 1-8, you can connect your program to control engines residing on several different computers. You use the TagFile Configurator to insert more than one control engine into a tag file. Refer to the *SIMATIC Computing User Manual* for detailed information about using the TagFile Configurator.

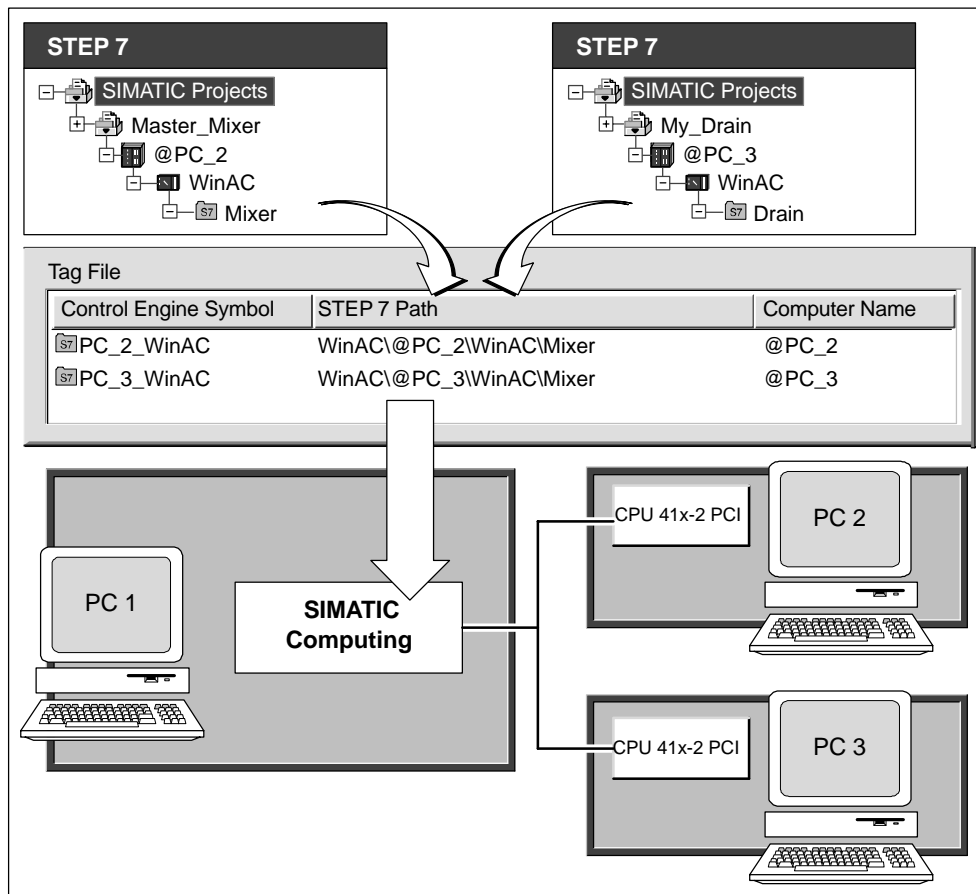

Figure 1-8 Using a Tag File to Access Data from Several Control Engines

1.9 Use SIMATIC Computing across a DCOM Network

Microsoft's Distributed Component Object Model (DCOM) is a set of program interfaces in which client program objects can request services from server program objects on other computers in a network.

In WinAC, you can connect distributed applications across a network using DCOM (refer to Figure 1-9). A distributed application consists of multiple processes or different computers that cooperate to accomplish a single task jointly.

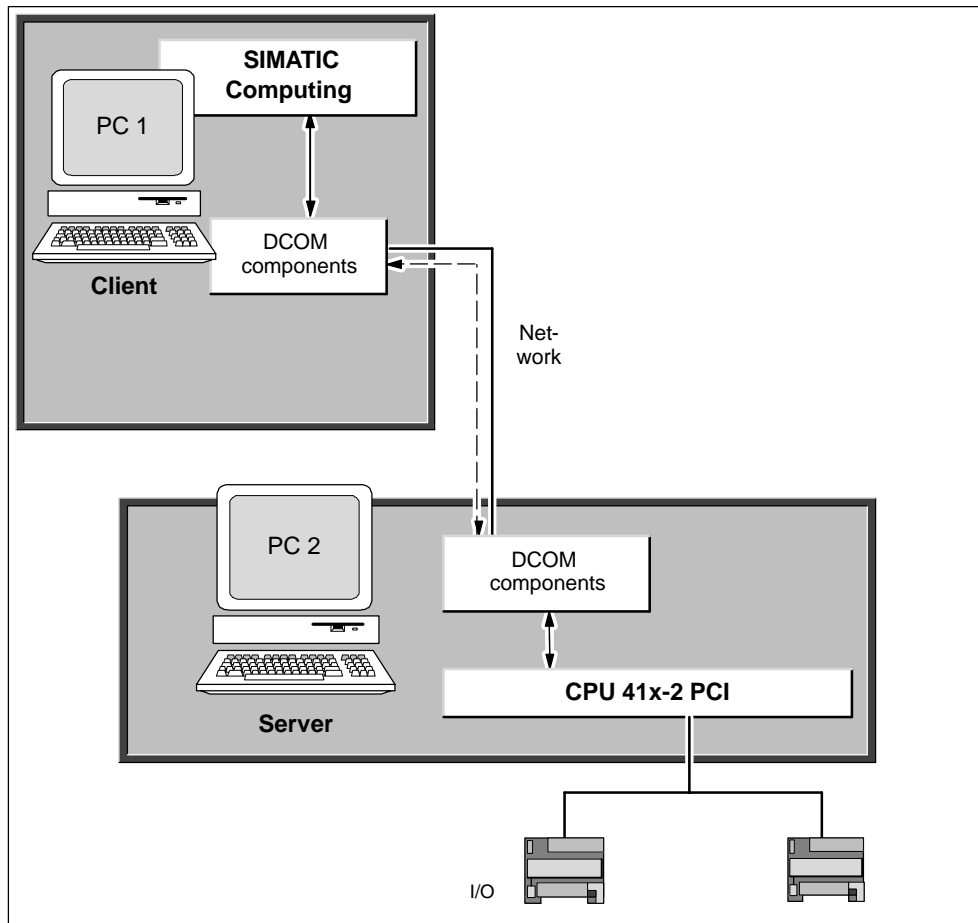

Figure 1-9 Connecting WinAC on Several Computers across a DCOM Network

1.10 Using OPC to Connect Third-Party Applications to SIMATIC Computing

OLE for Process Control (OPC) provides a standard mechanism for communicating with numerous data sources. It is immaterial in this case whether these sources are machines in your factory or a database in your control room. OPC is based on the OLE/COM technology from Microsoft. For more information about OPC, refer to the OPC specification *OLE for Process Control Data Access Standard, version 2.0* from the OPC Foundation.

The OPC Foundation address can be reached on the **Internet** at <http://www.opcfoundation.org>

As shown in Figure 1-10, you can use the OPC server provided with the SIMATIC Computing software to communicate with the control engine and provide access to the process data. SIMATIC Computing provides an OPC server that allows any OPC client application to access data in the control engine. SIMATIC Computing does not provide any OPC client application.

The OPC server is called: OPCServer.WinAC

SIMATIC Computing allows you to use OPC for connecting either to a single control engine or to several control engines. You can also connect to the control engine across a network, such as a local area network (LAN).

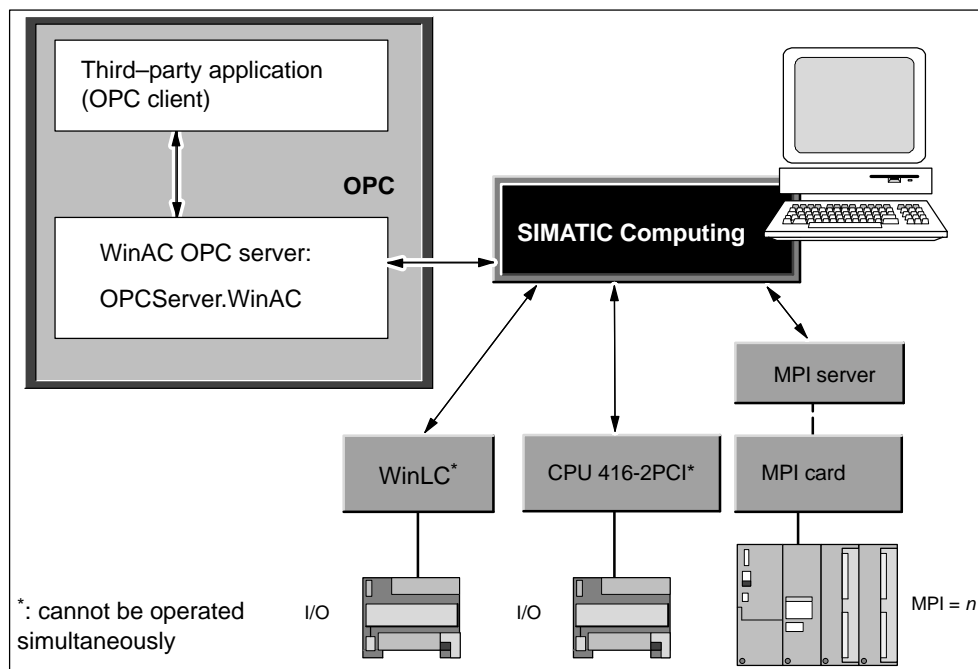

Figure 1-10 Using OPC to Connect Third-Party Applications to SIMATIC Computing

1.11 Tool Manager Provides Shortcuts to Your Programs

The WinAC Tool Manager is a toolbar that lets you consolidate all of the applications that you want to use while working with your process data. For instance, if you plan to use Visual Basic with WinAC Slot 41x or want to put process data into a Microsoft Excel spreadsheet, you can insert shortcuts to those items on the WinAC Tool Manager. The WinAC Tool Manager is especially convenient for users who do not have a mouse on their computer, since all of the functions of the WinAC Tool Manager can be accessed by keystrokes from one central location.

Figure 1-11 shows the WinAC Tool Manager and its shortcut icon. You can insert shortcut icons for any of your programs into the WinAC Tool Manager tray. You then use the WinAC Tool Manager to start these programs.

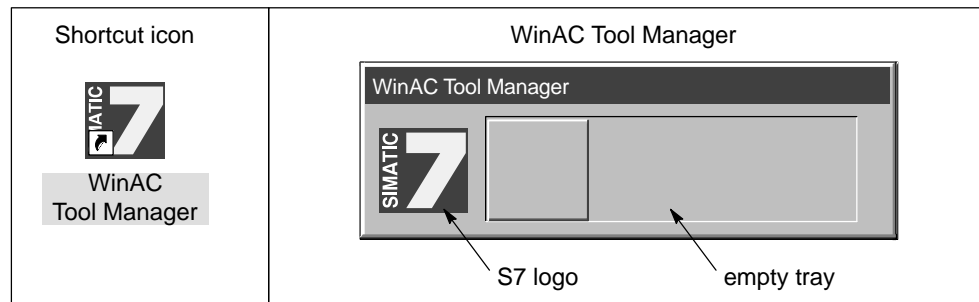

Figure 1-11 WinAC Tool Manager and Shortcut Icon

Getting Started

2

In this chapter

Section	Contents	Page
2.1	Problem Definition: Communication from the CPU 416-2 PCI over the CP 1613 to a S7-400	2-2
2.2	Starting the Control Panel of WinAC Slot 41x	2-16
2.3	Going Online with STEP 7 to the CPU 41x-2 PCI	2-17
2.4	Creating a Process Form with SIMATIC Computing SoftContainer	2-20
2.5	Establishing Connections for the Process Form	2-22

Information on this Getting Started

In this chapter you will learn how to work with WinAC Slot 41x as demonstrated by an example of establishing a connection. We will perform practical exercises to show you the most important screen-based dialog boxes and approaches.

It will be helpful if you are already in a position to work with a mouse, windows, pull-down menus, etc. and have a basic knowledge of PLCs.

There are training courses in which you can add to the knowledge you have acquired with Getting Started and learn how to create complete automation solutions with STEP 7.

Examples in the documentation for SIMATIC Computing

You will find further examples for working with SIMATIC Computing in the SIMATIC Computing documentation.

Requirements for working with Getting Started

To be able to perform the practical exercise in this Getting Started, you will need:

- a Siemens programming device or a PC
- the STEP 7 software package and the authorization disk
- a SIMATIC S7-400 automation system

We wish you lots of pleasure and success.

Your SIEMENS AG

2.1 Problem Definition: Communication from the CPU 416-2 PCI over the CP 1613 to a S7-400

In this chapter

Section	Contents	Page
2.1.1	Installing the components of WinAC Slot 41x	2-4
2.1.2	Component Configurator: Assigning Station Names	2-5
2.1.3	Commissioning wizard: assigning CP 1613	2-6
2.1.4	Creating a Project in SIMATIC Manager	2-8
2.1.5	Configuring the Hardware of the Box PC 620	2-9
2.1.6	Configuring the Hardware of the S7-400 Station	2-12
2.1.7	Configuring a Network	2-13
2.1.8	Configuring a Connection	2-14
2.1.9	Communications	2-16

Example:

In our example, we want to connect a PC station to a CPU 416-2 PCI and a SIMATIC S7-400 station via Industrial Ethernet (IE).

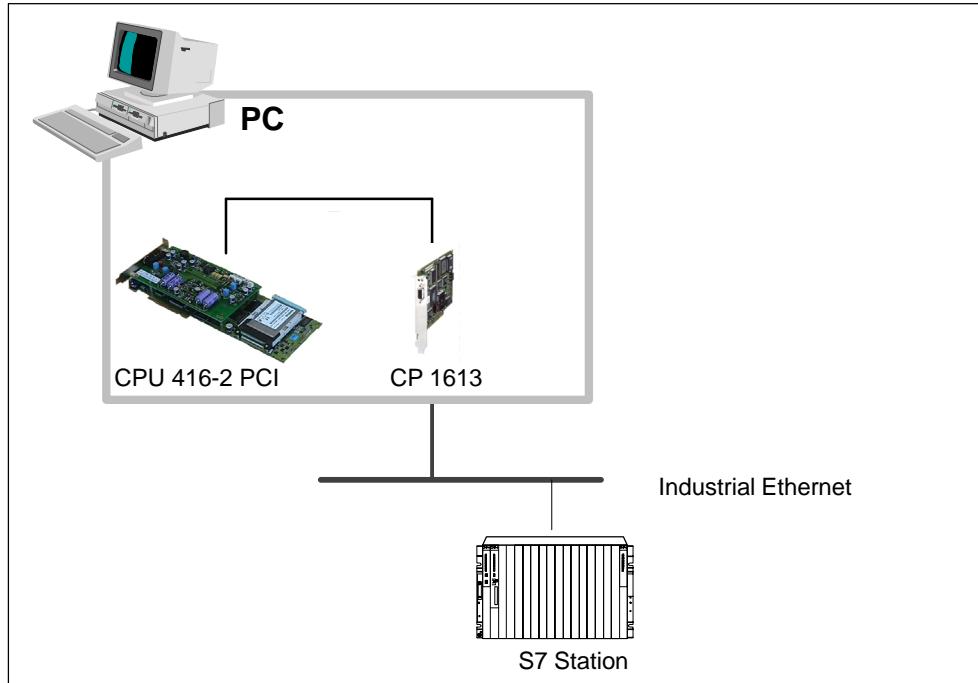

Figure 2-1 Communication over CP 1613 to a S7-400

2.1.1 Installing the Components of WinAC Slot 41x

The WinAC Slot 41x software includes a setup feature for each CPU type that performs automatic installation.

The Setup program guides you step by step through the installation process. You can switch to the next step or to the previous step from any position. To start the installation program, proceed as follows:

1. Insert the CD in your CD-ROM drive.
2. Double-click the “setup.exe” file to select it.

Result: Figure 2-2 shows the dialog box that allows you to choose which components to install.

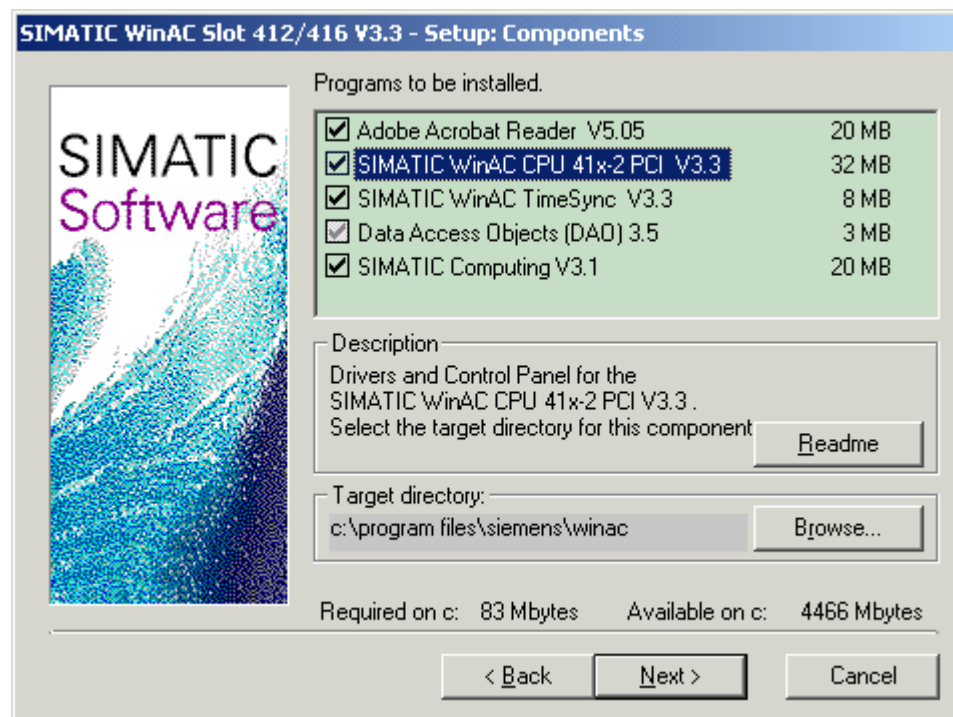

Figure 2-2 Installing the Components of WinAC Slot 41x

3. Select the components that you want to install. Setup automatically highlights the components that it could not find on your PC.

Once the installation has been completed successfully, a message to that effect is displayed on the screen.

Note

You will find detailed information about installing WinAC Slot 41x in the manual *WinAC Controlling with CPU 412-2 PCI/CPU 416-2 PCI; Set-Up, CPU-Data Version 3.2*.

2.1.2 Component Configurator: Assigning Station Names

Function of the component configurator

You notify the following settings to the PC with the help of the component configurator:

- Station name,
- Type of CPU 41x-2 PCI and
- Name of CPU 41x-2 PCI.

Note

The settings in the component configurator must match the subsequent configuration in "STEP 7/Configure Hardware":

- Station name
 - Type
 - Index (corresponds to the slot in "Configure Hardware") and
 - Name.
-

Index

The CPU 41x-2 PCI is automatically operated on index 3. The index corresponds to a virtual slot on the PC.

Name

Note

The name that you assign to the CPU 41x-2 PCI with STEP 7 then corresponds to the name by which you call the control panel of the CPU from the taskbar. If, for example, you assign the name Slot_CPU to the CPU 41x-2 PCI, call the control panel at **Start > Simatic > PC Based Control > Slot_CPU**.

Information about the component configurator

You will find more information about diagnostics in the component configurator, for example, in the appropriate online Help.

Procedure

To assign the name to the PC

1. Open the component configurator by clicking on the



button on the taskbar.

Result: The component configurator opens.

2. Click on “Station name”.
3. Call the station “Box PC 620” and terminate by clicking “OK”.

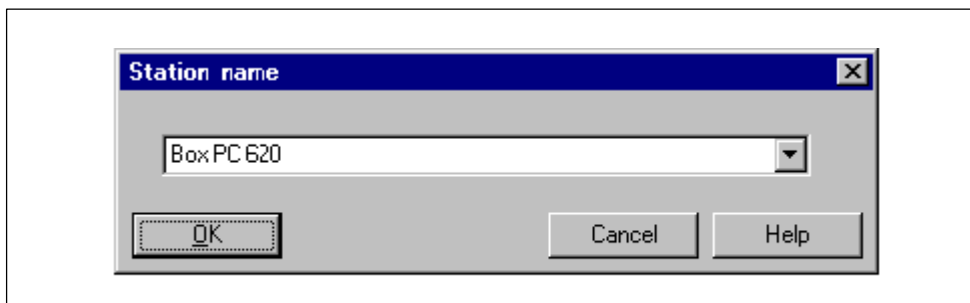

Figure 2-3 Component Configurator: Assigning Station Names

4. Exit the component configurator by clicking on “OK”.

2.1.3 Commissioning wizard: assigning CP 1613

Function of the commissioning wizard

You require the commissioning wizard to notify the CPs that have been plugged in to the PC.

Note

The settings in the commissioning wizard must be identical to those in the subsequent configuration in “STEP 7/Configure Hardware”.

Information about the commissioning wizard

You will find more information about the commissioning wizard in the associated documentation and in the online Help.

Procedure

To configure the CP 1613 for operation within the PC, perform the following steps:

1. Open the commissioning wizard by choosing **Start > SIMATIC > SIMATIC NET > Settings > Commissioning Wizard** from the menu.

Result: The “SIMATIC NET Commissioning Wizard” window opens.

2. Click on “Next”.

Result: The “PC Station Configuration” window opens.

3. Fill out the settings for the CP 1613 as shown in the figure below and confirm by clicking “Next”.

Note

The settings (index, MAC address, IP address, subnet mask) must be identical to those in “STEP 7/Configure Hardware”. The index in “STEP 7/Configure Hardware” corresponds to the slot.

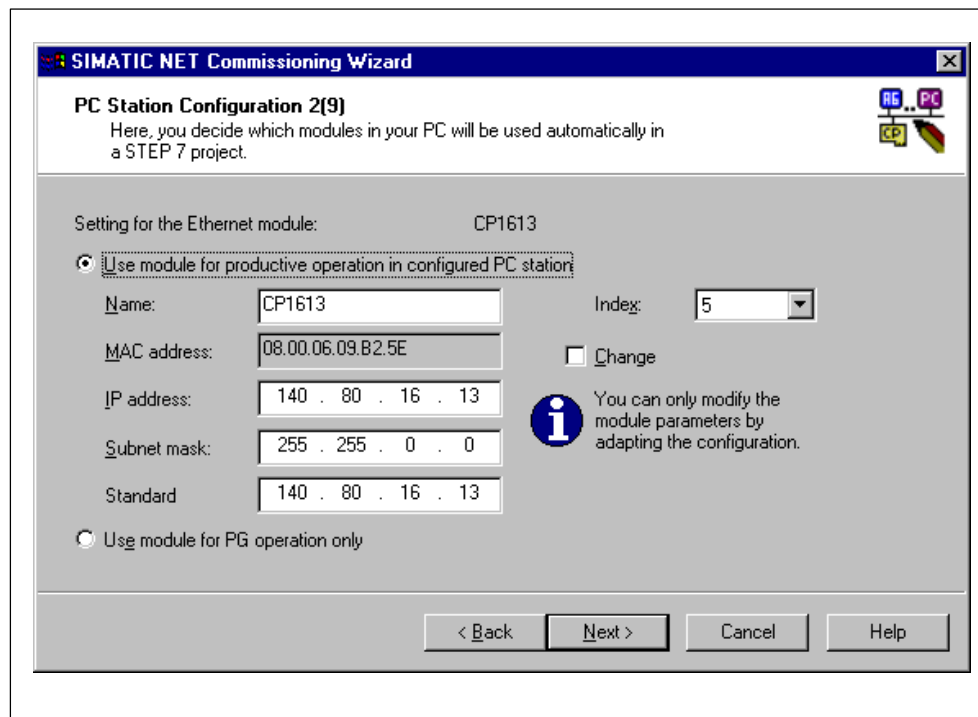

Figure 2-4 Commissioning wizard: settings for CP 1613

Result: You have then entered all the important settings for this Getting Started.

4. Click “Next” or “Finish” as often as is necessary to quit the commissioning wizard.

2.1.4 Creating a Project in SIMATIC Manager

Perform the following steps:

1. Create a project called "START_SLOT".
2. Insert Box PC 620 by entering **Insert > Station > SIMATIC PC Station** and call the PC station **Box PC 620**.
3. Insert the S7-400 station by entering **Insert > Station > SIMATIC 400 Station** and call the SIMATIC S7-400 station **S7-400**.

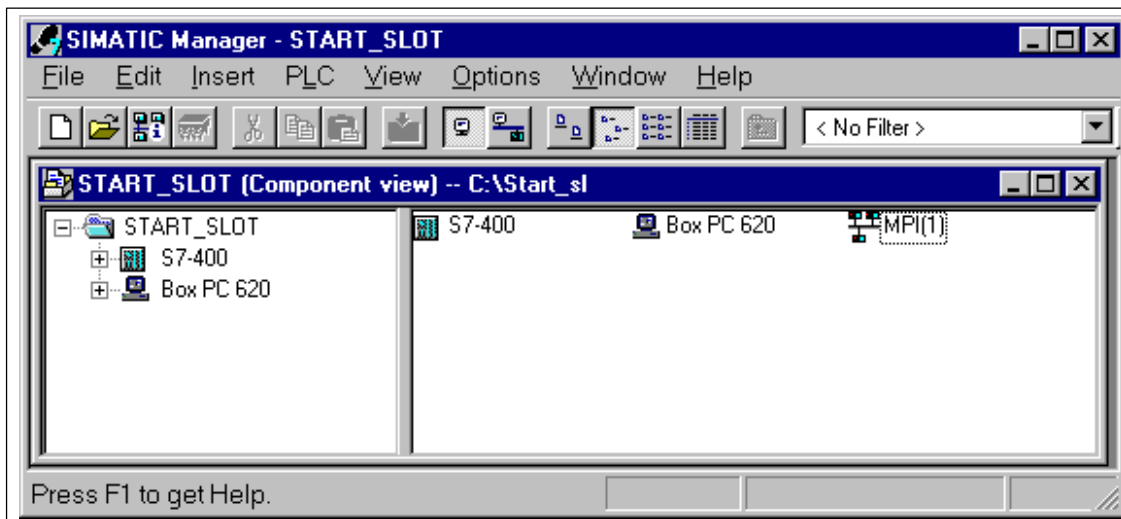

Figure 2-5 Creating a Project

Note

The following settings in the component configurator must match the subsequent configuration in "STEP 7/Configure Hardware":

- Station name
- Type
- Index (corresponds to the slot "Configure Hardware")
- Name.

2.1.5 Configuring the Hardware of the Box PC620

Selecting a subrack

1. Select Box PC 620.
2. Open “HW Config” by double-clicking “Configuration”.
3. Open the catalog and branch to **SIMATIC PC Station > Controller > CPU 416-2 PCI > 6ES7 616-2QL00-0AB4 > V3.1.**
4. Drag and drop the CPU 416-2 PCI onto slot 3.

Slot 3 corresponds to index 3 in the component configurator. The slot and index must always be the same.

Result: the “Properties – PROFIBUS Interfaces DP Master” opens.

5. Do **not** connect the subnet for the DP master.
6. Click “OK” to apply the settings.

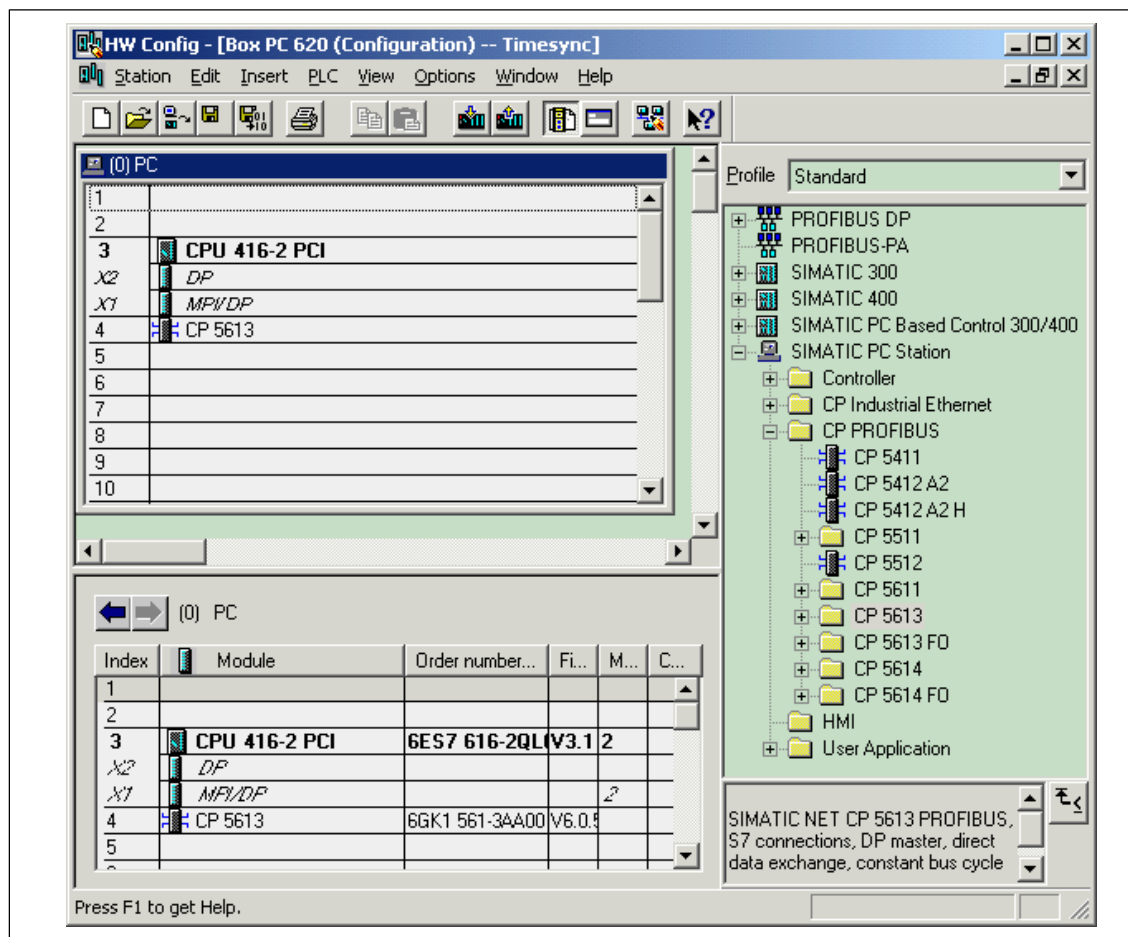

Figure 2-6 Selecting a Mounting Rack

Assigning a CP

1. Branch to **SIMATIC PC Station > CP Industrial Ethernet**.
2. Drag and drop CP 1613 into slot 4.

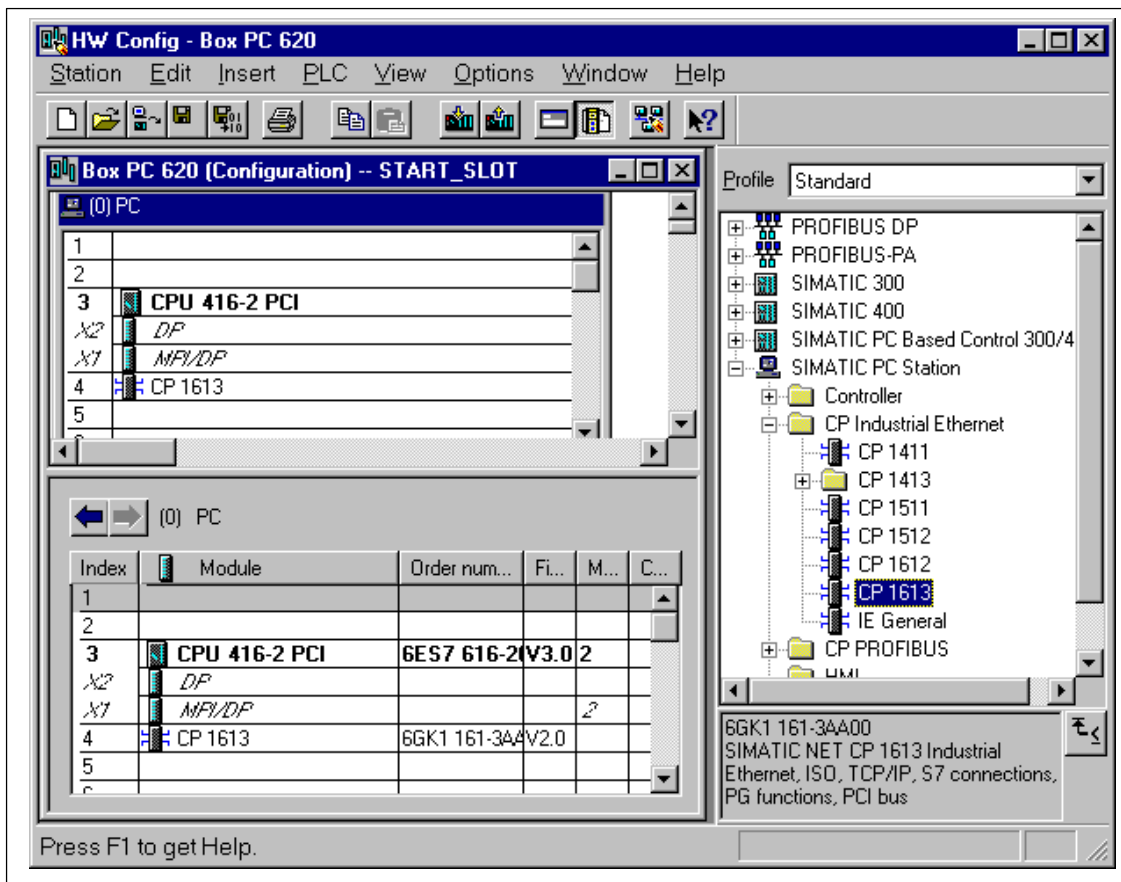

Figure 2-7 Assigning a CP

Slot 4 corresponds to index 4 in the component configurator. The slot and index must always be the same.

Result: the “Properties – Ethernet Interface CP 1613” dialog box opens.

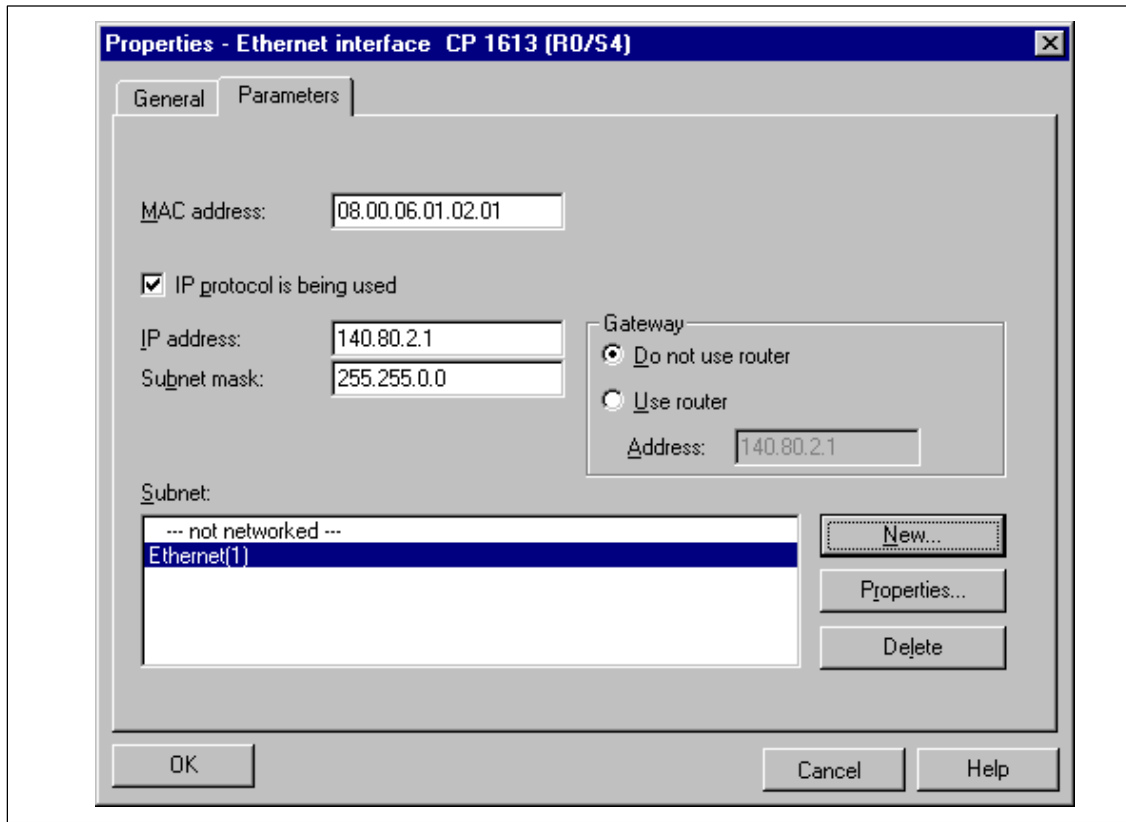

Figure 2-8 CP 1613: Properties of the Ethernet Interface

3. Fill out the properties of the Ethernet interface as shown in Figure 2-8 (create the MAC address and a new subnet) and confirm by clicking on "OK".
4. Close with "Save and Compile".

2.1.6 Hardware configuration of the S7-400 Station

1. Select the components listed below and configure them as shown in Figure 2-9.
 - Rack
 - Power supply
 - CPU 416-1
 - CP 443-1
2. Fill out the properties of the Ethernet interface (create the MAC address and a new subnet) and confirm by clicking on "OK".
3. Close with "Save and Compile".

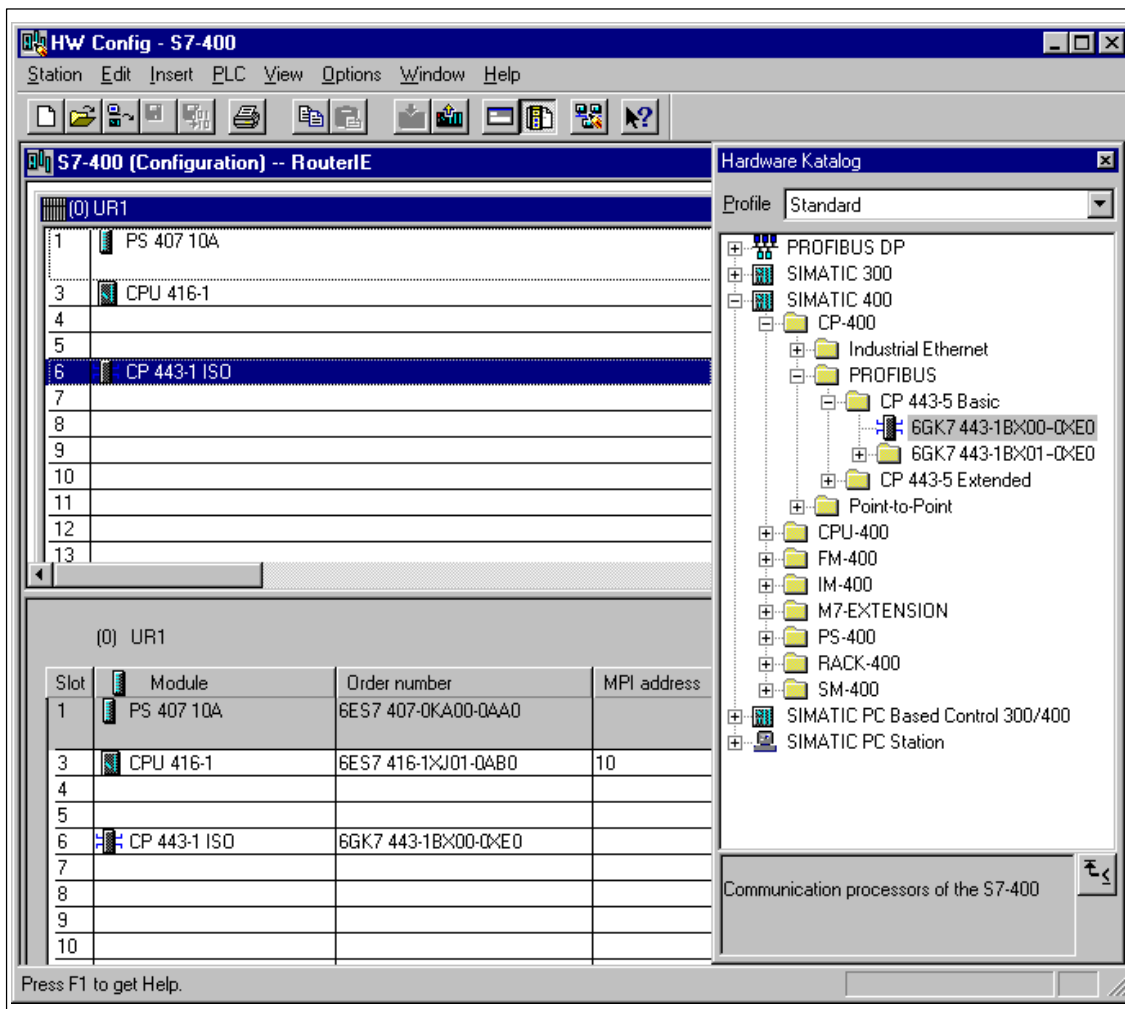

Figure 2-9 Configuring the Hardware of the S7-400 Station

2.1.7 Configuring a Network

1. Open NetPro by clicking on the “Configure Network” button.

Result: The NetPro – [START_SLOT] window opens.

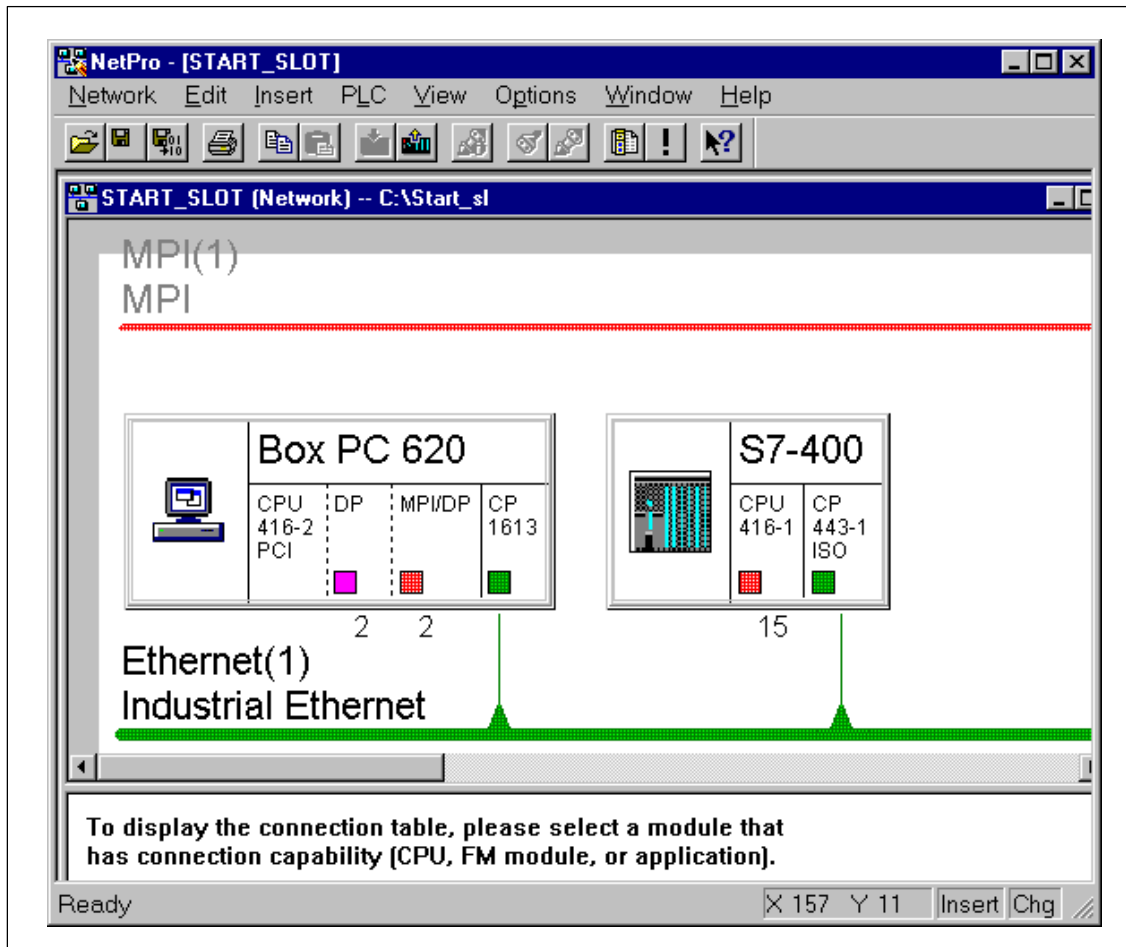

Figure 2-10 Configuring the Network

2.1.8 Configuring a Connection

A connection defines the communication relationship between two nodes. The following parameters are specified in it:

- The two communication nodes
- The type of the connection (in this case an S7 connection)
- Specific properties that depend on the type of the connection (whether a connection remains open continuously, for example, or whether it is established and cleared dynamically in the user program).

To enter a connection, proceed as follows:

1. Select the "CPU 416-1 PCI" module (the connection table is visible).
2. Double-click a blank line in the connection table, or choose **Insert > New Connection...** from the menu. As a result, the "New Connection" dialog box opens.

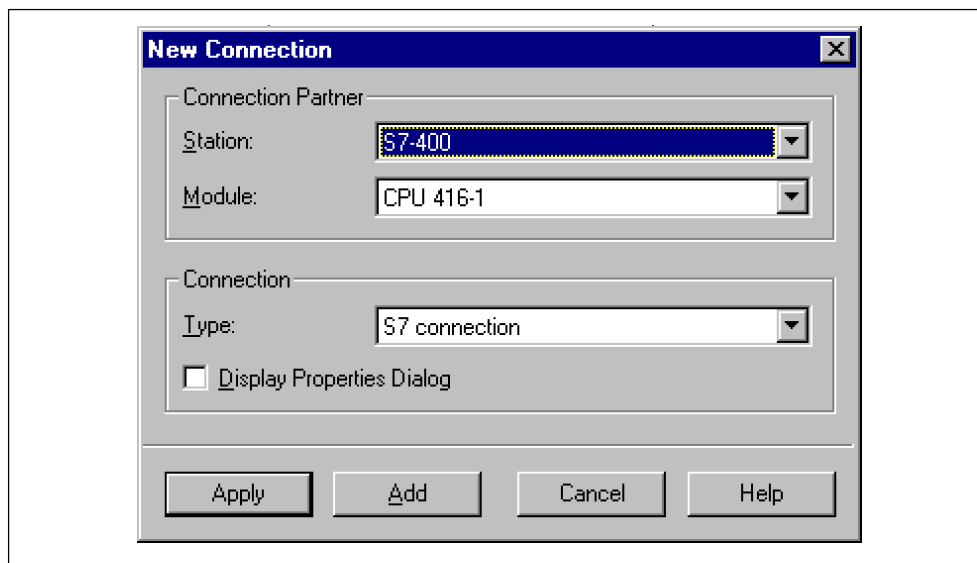

Figure 2-11 Creating a Connection

3. In the "Station" and "Module" boxes, select the programmable module to which the connection is to lead (also referred to as a connection partner or remote node).
4. Select the connection type (S7 connection only) in the "Type" box.
5. Select the "Open Properties Dialog Box" check box.

6. Confirm with "Apply". The "Properties - S7 Connection" dialog box opens (refer to Figure 2-12).

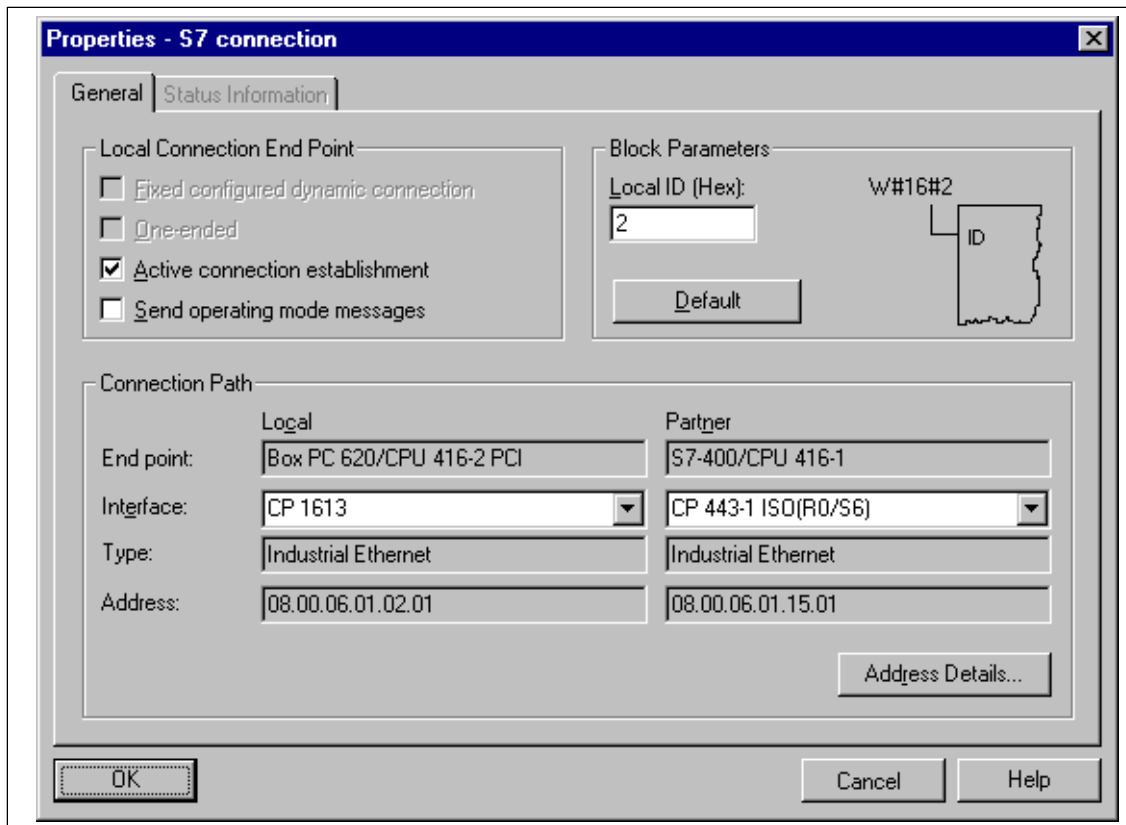

Figure 2-12 Connection Properties

7. Check the settings (interface and type) as in Figure 2-12
8. Accept your entries by clicking "OK".

The first connection has thus been created.

STEP 7 enters the connection in the connection table of the local node and assigns to this connection the local ID and, if applicable, the partner ID that you require when programming the communication function blocks (value for the "ID" block parameter).

These settings conclude the configuration of the "START_SLOT" project.

9. Compile with the "Save and Compile" button.
10. Load the data in the relevant station.

2.1.9 Communications

Embed the appropriate communication blocks (for example, Put/Get) in your user program.

2.2 Starting the Control Panel of WinAC Slot 41x

To call WinAC Slot, choose the following command from the Windows Start menu: **Start > SIMATIC > PC Based Control > CPU 41x-2 PCI** or the symbolic name of the CPU that you assigned to the CPU 41x-2 PCI in the component configurator.

The control panel of the CPU 41x-2 PCI then opens (Figure 2-13). You control the operations of the CPU 41x-2 PCI with this control panel.

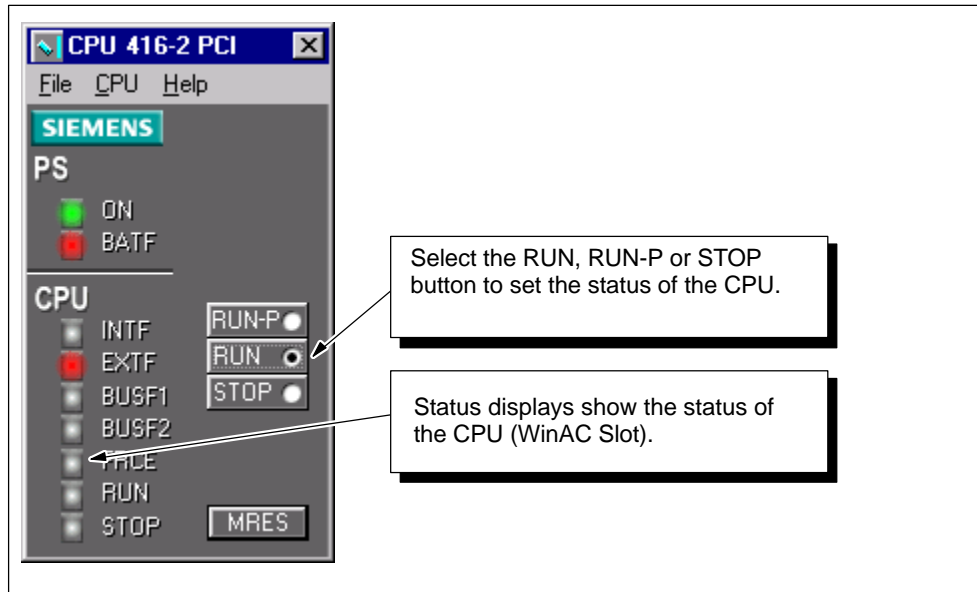

Figure 2-13 Calling the WinAC Slot Controller

2.3 Going Online with STEP 7 to the CPU 41x-2 PCI

Connecting STEP 7 to CPU 41x-2 PCI on the same computer

Perform the following steps if you would like to configure STEP 7 for communication with the CPU 41x-2 PCI on the same computer.

1. Open the interface application in WinAC Slot using the following command: (**CPU > Set PG/PC Interface**).
2. Perform the following work steps to set up STEP 7 as a local access point:
 - At “Access point of application”, select **S7ONLINE (STEP 7)** (Figure 2-14).
 - At “Used parameter set”, select **PC Internal (Local)** as the interface parameter.

STEP 7 is now configured for communication with the CPU 41x-2 PCI on the same computer.

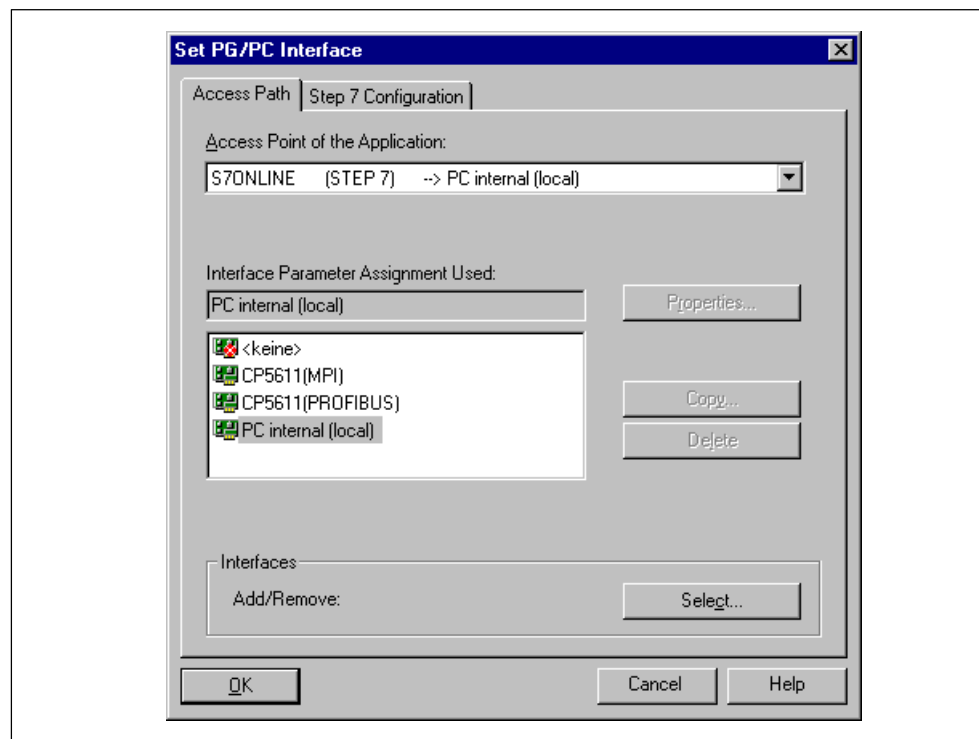

Figure 2-14 Setting the PG/PC Interface for PC Internal (Local)

Connecting STEP 7 with CPU 41x-2 PCI on a different computer

As you can see in Figure 2-15, you can connect STEP 7 to the CPU 41x-2 PCI residing on a different computer. You have to define the network connection over which STEP 7 and the CPU 41x-2 PCI communicate by setting the PG/PC interface on the remote computer.

STEP 7 must be installed on the remote computer, and the CPU 41x-2 PCI has to be installed on the computer with which you wish to establish a connection.

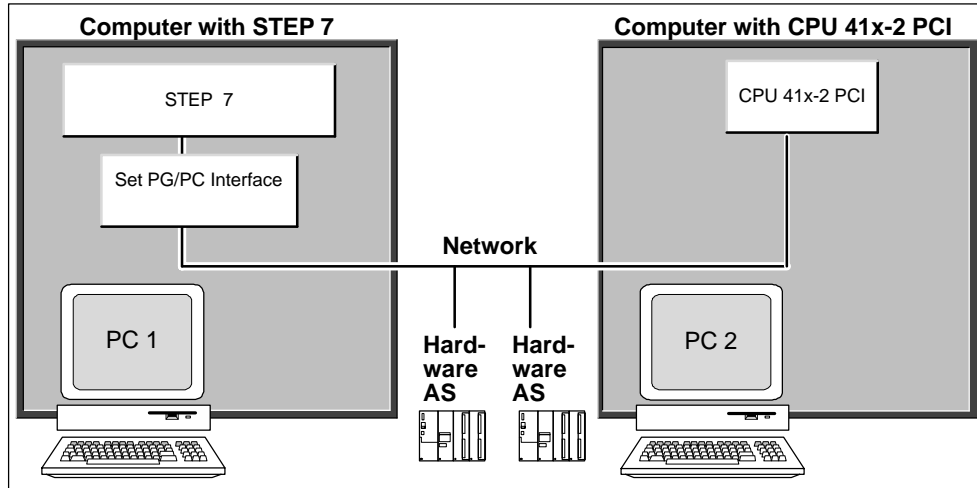

Figure 2-15 Connecting STEP 7 to WinAC Slot over a Network

Perform the following steps if you would like to configure STEP 7 for communication with WinAC Slot on a remote computer.

1. Call the application for interface configuration from the control panel of the CPU 41x-2 PCI. To do this, choose the command (**CPU > Set PG/PC Interface**) (Figure 2-16).

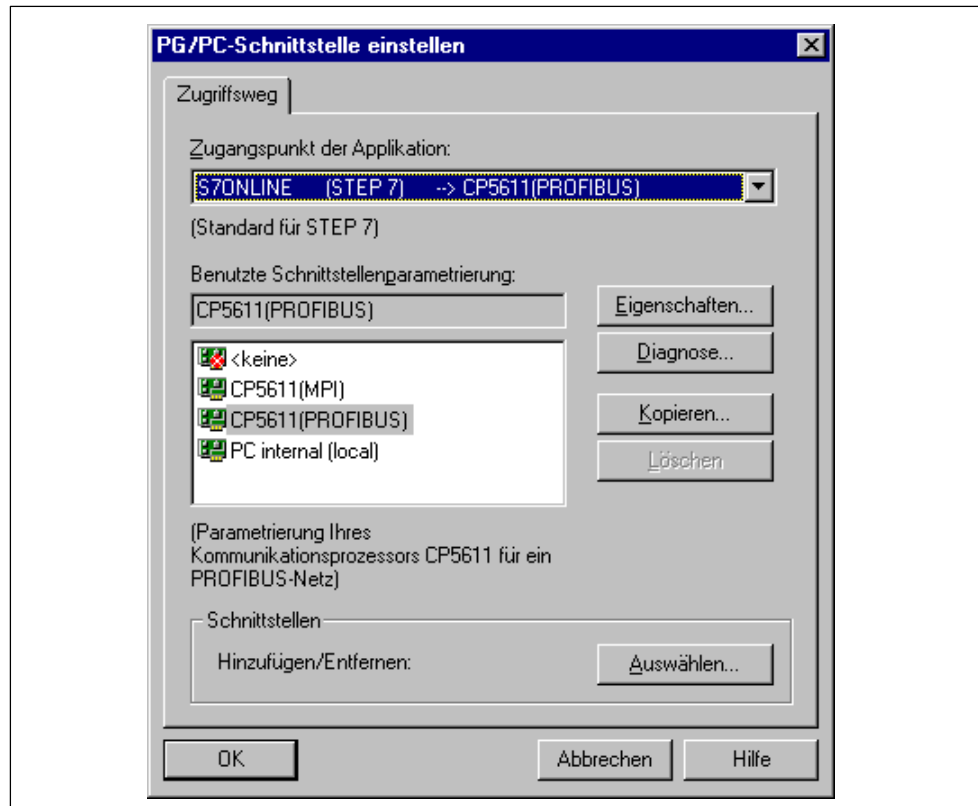

Figure 2-16 Setting the PG/PC Interface

2. At "Access point of application", select **S7ONLINE (STEP7)**.
 - At MPI Communication, select an MPI type interface, such as **CP5611(MPI)**.
 - At PROFIBUS-DP Communication, select a PROFIBUS-DP interface, such as **CP5611(PROFIBUS)**.

The PROFIBUS connection of the CPU 41x-2 PCI must be fully installed using the application **Set PG/PC Interface** before the CPU 41x-2 PCI is visible on other PGs in the PROFIBUS-DP network (**S7ONLINE (STEP7)**

--><name of card> **Profibus....** Select the "Properties" button. On the "PROFIBUS" tab, select the check box "PG/PC is sole master on bus".

2.4 Creating a Process Form with SIMATIC Computing SoftContainer

Setting the access point for SIMATIC Computing

Before working with SIMATIC Computing, you must set the access point of the application.

1. On the control panel of the CPU 41x-2 PCI, go to **CPU > Set PC/PG Interface**.
2. Set the access point of the application to "COMPUTING -> PC internal".

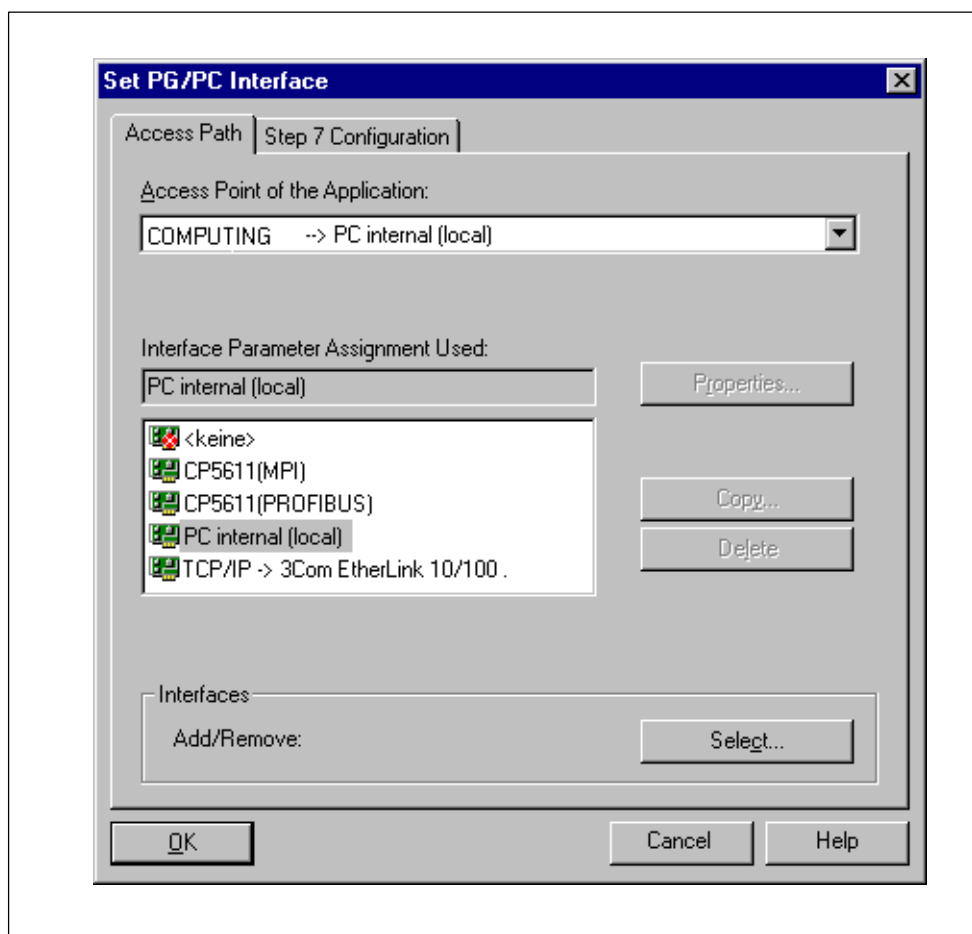

Figure 2-17 Setting the PG/PC Interface for SIMATIC Computing

3. Click "OK" to apply the settings.

SIMATIC Computing

SIMATIC Computing has a SoftContainer, which is an OLE container for ActiveX controls. You can use SoftContainer to create process forms with which you can access the control engine (such as CPU 41x-2 PCI).

The SoftContainer toolbar contains buttons for the SIMATIC controls, which are provided by the SIMATIC Computing software. You can use these buttons as a simple option for inserting the controls in a process form. You can also include other ActiveX controls in a process form (and also in the toolbar of SoftContainer).

Creating a process form

To call SoftContainer and a blank process form, choose the following command from the Windows Start menu: **Start > Simatic > PC Based Control > SIMATIC Computing SoftContainer**. (You can also double-click with the mouse on the SIMATIC Computing button.)

Figure 2-18 shows SoftContainer with a blank process form (S7Soft1).

Choose the command **File > Save As...** from the menu to open the "Save As" dialog box. Give the process form the name `START_SLOT` and save the process form.

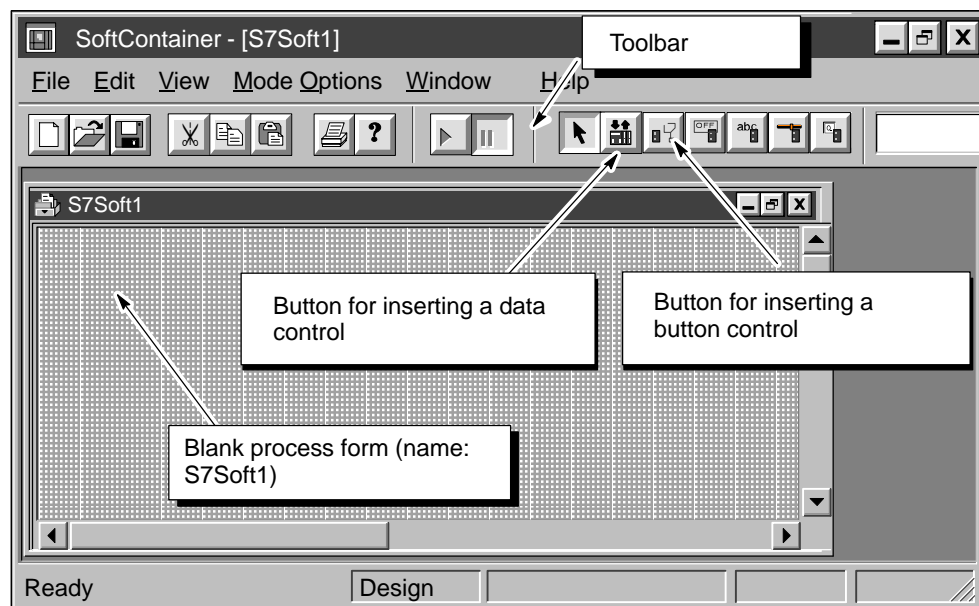

Figure 2-18 SoftContainer with Blank Process Form; Inserting a SIMATIC Control in a Process Form

1. Insert a data control (refer to Figure 2-19):
 - Click on the button for the data control.
 - Move the cursor to the process form.
 - Left click to insert the data control in the process form.

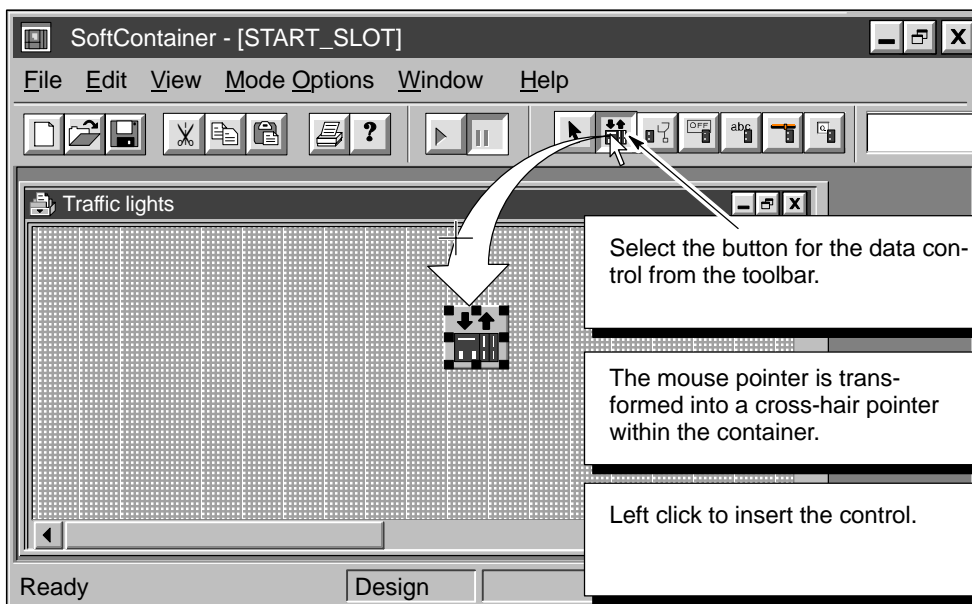

Figure 2-19 Inserting a SIMATIC Data Control from the Toolbar

2.5 Establishing Connections for the Process Form

The SIMATIC controls have dialog boxes, in which you can set up the properties of the controls. In this example, you perform the following task in the “Properties” dialog box of the data control:

- Set the control engine (in this example, CPU 41x-2 PCI)

Opening the "Properties" dialog box for the data control

Perform the following steps to open the "Properties" dialog box for the data control:

1. If the data control has not been selected yet, select the data control (S7Data1).
2. As Figure 2-20 shows, double-click on the data control (or right click and choose from the popup menu the command **S7Data1 Properties**) in order to display the "Properties" dialog box of the data control.

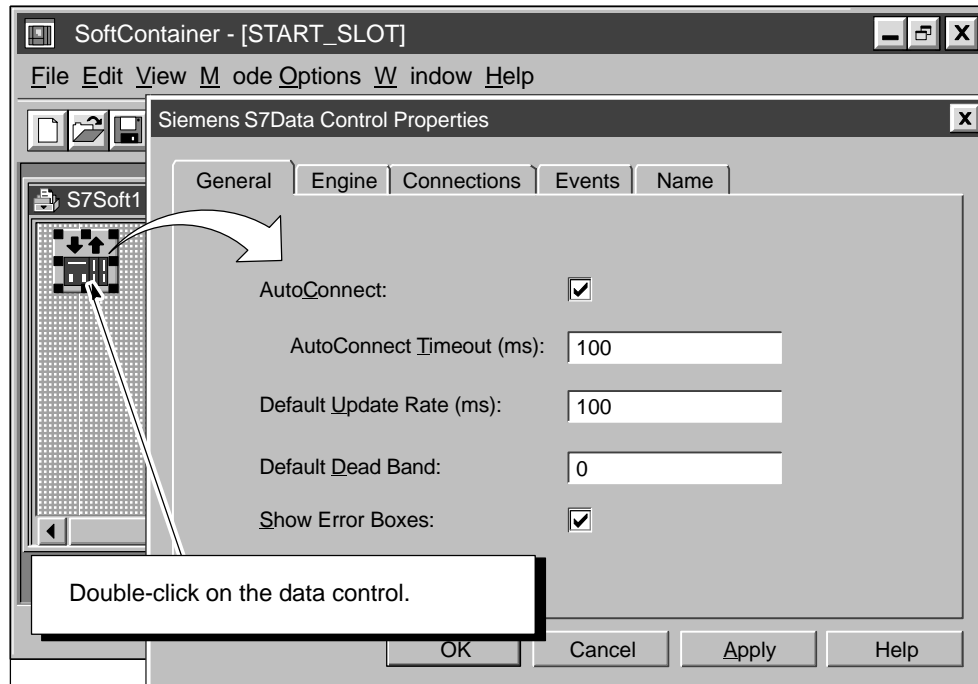

Figure 2-20 Opening the "Properties" Dialog Box for the Data Control

Connecting the data control to the CPU 41x-2 PCI

Perform the following steps in order to set the CPU 41x-2 PCI as the control engine:

1. In the "Properties" dialog box of the data control, open the "Engine" tab to display the options for the control engine (refer to Figure 2-21).
2. Select the "Direct Connect" option.
3. In the "Control Engine" box, enter: **wcS7=3** or the symbolic name that you assigned in the component configurator (refer to Section 2.1.2)
4. Select the "Apply" button to connect the data control to the CPU 41x-2 PCI.

Note

If you click on the “Apply” button, your changes in the dialog box are confirmed, but the dialog box remains open. If you click on the “OK” button, your changes in the dialog box are confirmed and the dialog box is closed.

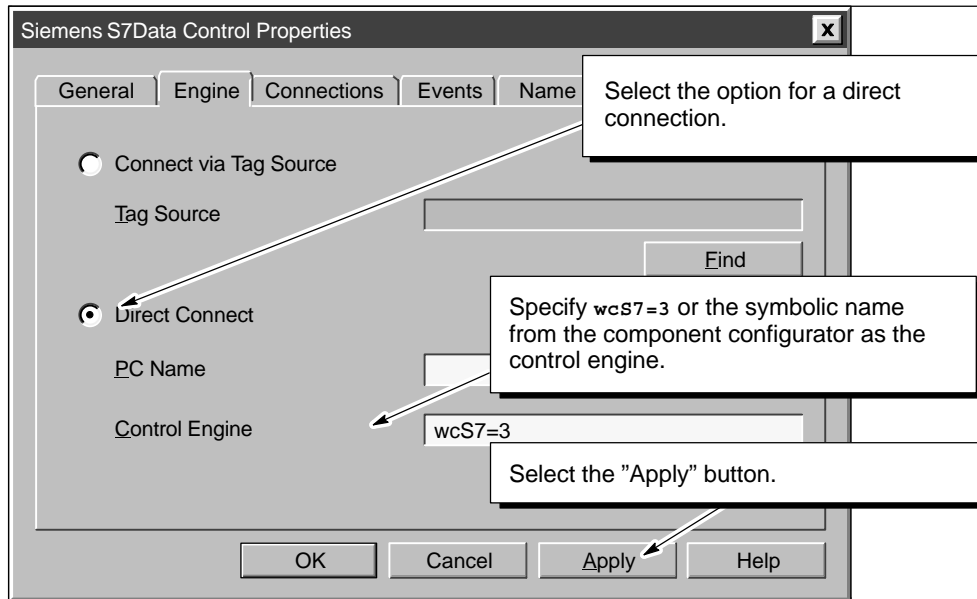

Figure 2-21 Connecting the Data Control to WinAC

Distributed Component Object Model (DCOM)

A

In this appendix

WinAC allows you to communicate across networks using Microsoft's Distributed Component Object Model (DCOM). You can use DCOM to integrate distributed applications by way of a network. A distributed application consists of multiple processes or different computers that cooperate to accomplish a single task jointly.

DCOM is a set of Microsoft concepts and program interfaces in which client programs can request services from server programs on other computers in a network. The Component Object Model (COM) provides a set of interfaces that allow clients and servers to communicate within the same computer.

Section	Description	Page
A.1	Using DCOM to Expand the Capabilities of WinAC	A-2
A.2	Connecting to a Specific Control Engine over DCOM	A-4

A.1 Using DCOM to Expand the Capabilities of WinAC

You can run the components of WinAC on a standalone computer, as shown in Figure A-1. In this model, this computer provides the complete control system.

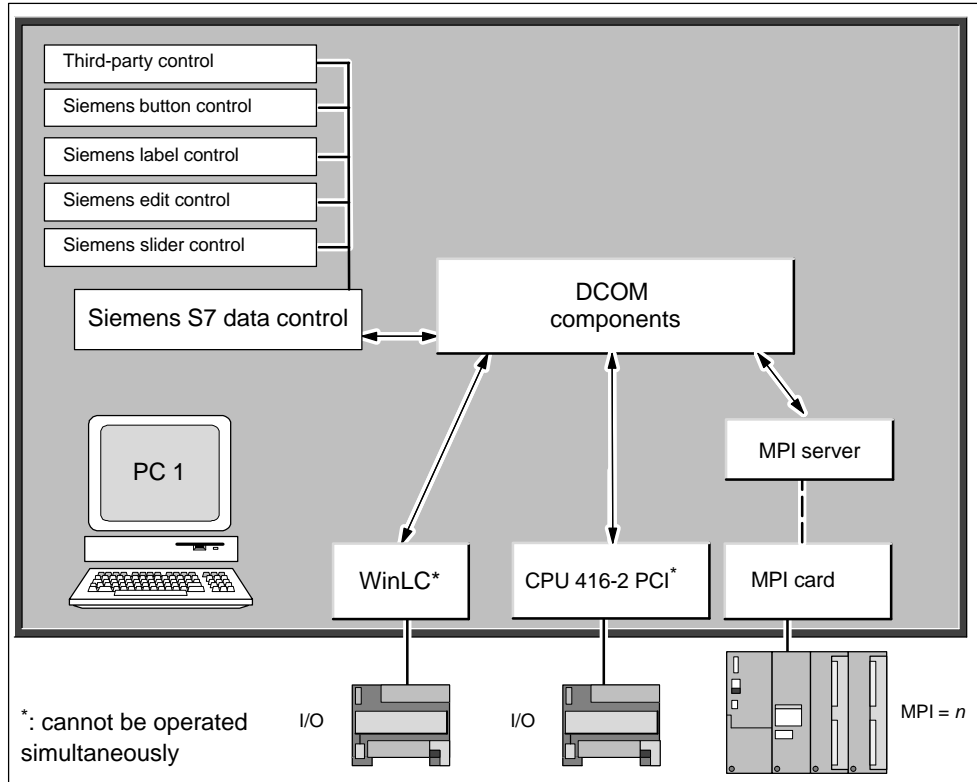

Figure A-1 Using WinAC Components with DCOM on a Standalone Computer

You can also utilize Microsoft's DCOM technology to create a network of computers that cooperate to provide the control system for a machine or process. Figure A-2 shows how one computer running an application that uses ActiveX controls (from SIMATIC Computing) can use DCOM to communicate with a different computer that uses WinLC (or other PLCs) to control a process.

The Windows operating system features a configuration tool (dcomcnfg) for setting up your DCOM security. Use this tool (Start -> Run -> <dcomcnfg>) to configure the server and client computers.

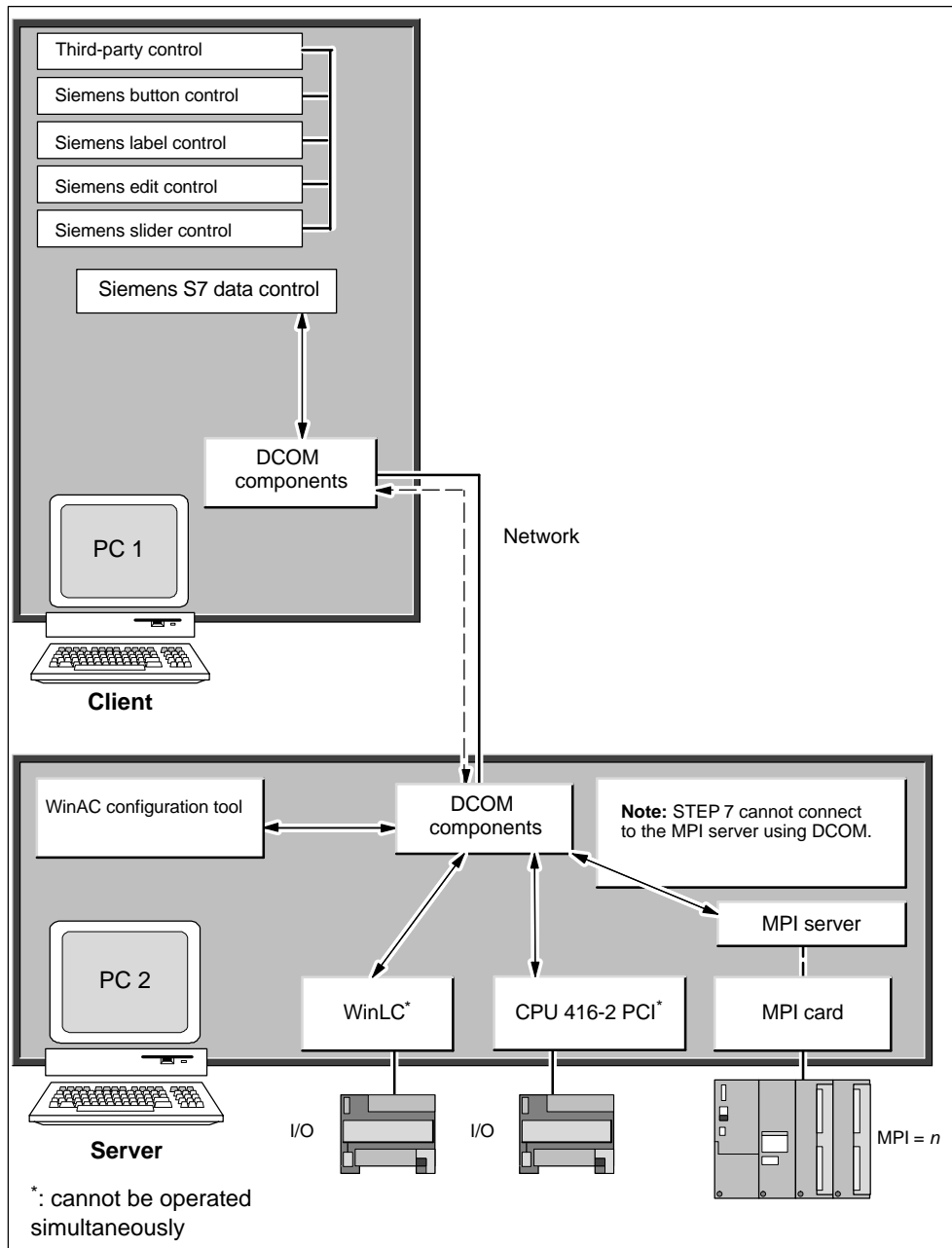

Figure A-2 Using WinAC on Several Computers with DCOM

A.2 Connecting to a Specific Control Engine over DCOM

As shown in Figure A-3, you can use the SIMATIC data control to connect your program to a control engine residing on a different computer.

Note

If you set up SIMATIC Data Control for a direct connection to a control engine, you cannot assign a tag file. In other words, you cannot use symbol names for the tags in the control engine.

To use symbol names, select the option for connecting via a tag source and browse to a tag file that contains symbols for only one control engine. Use the TagFile Configurator to create tag files and connect to control engines using DCOM. See the *SIMATIC Computing User Manual* for information about using STEP 7 and the TagFile Configurator.

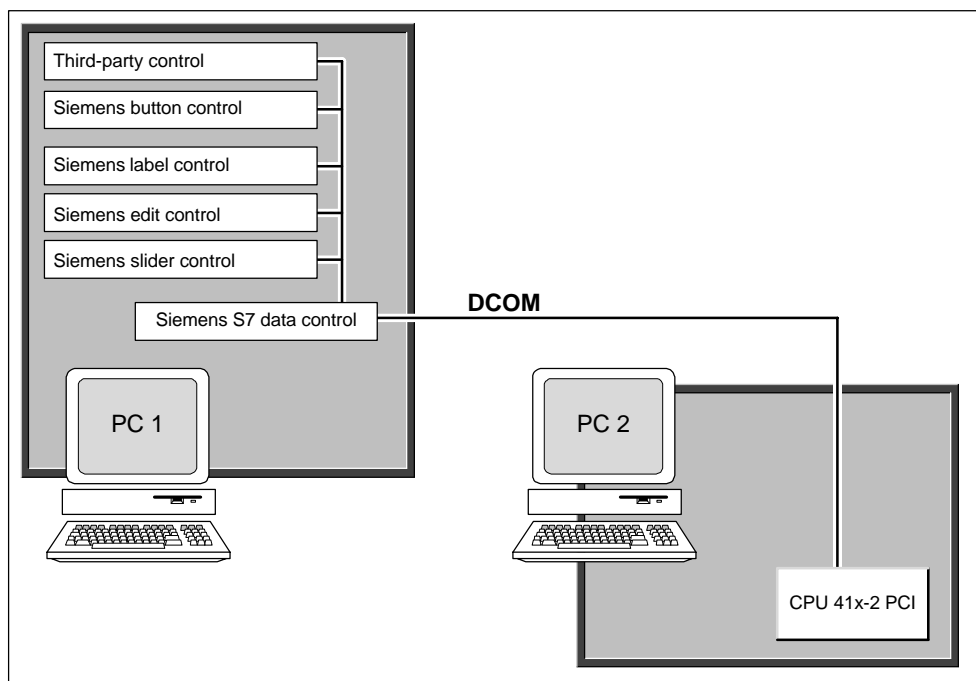

Figure A-3 Connecting to a Specific Control Engine over DCOM

OLE for Process Control (OPC)

B

In this appendix

OLE for Process Control (OPC) provides a standard mechanism for communicating with numerous data sources. It is immaterial in this case whether these sources are machines in your factory or a database in your control room. You can use the OPC server provided with the SIMATIC Computing software to communicate with the control engine and thus provide access to the process data. SIMATIC Computing provides an OPC server that allows any OPC client application to access data in the control engine. SIMATIC Computing does not provide any OPC client application.

SIMATIC Computing implements the mandatory interfaces, as defined in the OPC documentation, version 2.0, from the OPC Foundation. SIMATIC Computing also implements the IOPC BrowseServerAddressSpace interface.

OPC is based on the OLE/COM technology from Microsoft. For more information about OPC, refer to the OPC specification *OLE for Process Control Data Access Standard, version 2.0* from the OPC Foundation.

Section	Description	Page
B.1	Using OPC with SIMATIC Computing	B-2

B.1 Using OPC with SIMATIC Computing

OPC allows you to access data from the plant floor and integrate the data into your existing business systems. You can use off-the-shelf tools (such as SCADA packages, databases, spreadsheets) to assemble a system that meets your needs. As shown in Figure B-1, OPC provides an open and effective communication architecture which concentrates on data access and not the types of data.

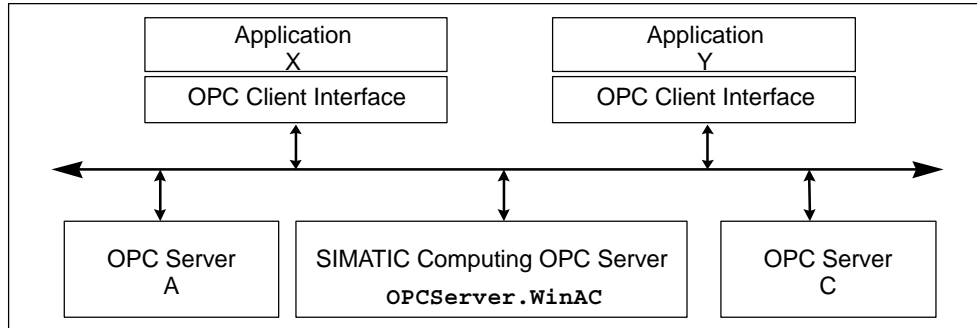

Figure B-1 Applications Working with Many OPC Servers

Your OPC client connects to the OPC server object provided by SIMATIC Computing. Due to this connection, you can create and edit OPC groups. OPC groups structure the data that are accessed. You can activate or deactivate a group as a unit, or you can “subscribe” to the list in a group of items so that you can be notified when the data change. (A group is a collection of items.) Figure B-2 shows the connection from the OPC client application through WinAC to the process data.

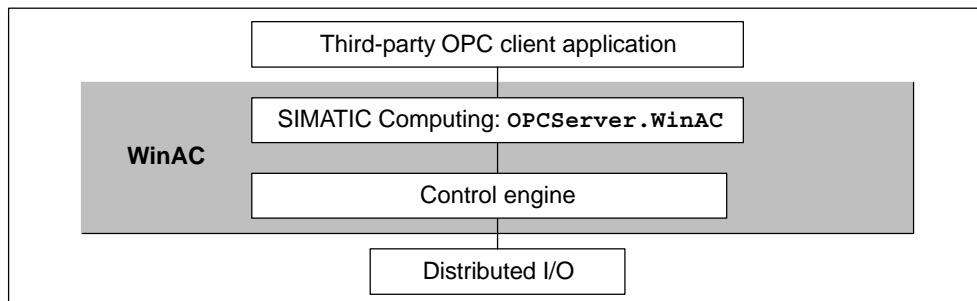

Figure B-2 Using the WinAC OPC Server to Access Your Process Data

To access the OPC server provided by the SIMATIC Computing software, select `OPCServer.WinAC` with you OPC client.

Index

Numbers

3COM card, 1-8

A

Access to process data, OPC controls,
Glossary-2

Accessing memory areas (S7), OPC controls,
Glossary-2

Accessing process data, OPC controls,
Glossary-2

ActiveX Controls, 1-1

ActiveX interface, 1-3

C

Client application (OPC), Glossary-2
connecting to WinAC Computing,
Glossary-2

commissioning wizard, 2-6

Communicating, using DCOM, 1-13–1-15

Communication, 1-3

Communication options with CPU 41x-2 PCI,
1-7

Communications

getting started, 2-16

using DCOM, Glossary-1

via router, getting started, 2-3

component configurator, 2-6

Component Object Model. *Siehe* DCOM

Component Object Model (COM), 1-13–1-15,
Glossary-1

Computing. *Siehe* SIMATIC Computing

Connecting distributed applications (DCOM),
Glossary-1

Connecting to data via OPC, Glossary-2

Connection configuration, getting started, 2-14

Connection table, getting started, 2-14

Control engine

OPC access, Glossary-2

OPC controls, Glossary-2

Control objects, OPC server, Glossary-2

Control panel, 1-1

Control panel startup, getting started, 2-16

Controls, 1-1

CP 1613, 1-8

CP 5611, 1-8

CP 5613, 1-8

CP assignment, getting started, 2-10

CPU 412-2 PCI, 1-1

CPU 416-2 PCI, 1-1

CPU 41x-2 PCI, **1-4**, 1-7

Creating a project, getting started, 2-8

D

Data, OPC controls, Glossary-2

Data access interface, 1-3

Databases, sharing data via OPC, Glossary-2

DCOM, 1-13–1-15, Glossary-1, Glossary-2

DCOM mechanisms, 1-3

Distributed applications (DCOM), 1-13–1-15,
Glossary-1

Distributed Component Object Model. *Siehe*
DCOM

Distributed Component Object Model (DCOM),
1-13–1-15, Glossary-1

E

entering station names, 2-6
 Example, 2-1

G

Getting started, 2-1
 communications, 2-16
 configuring a connection, 2-14
 connection table, 2-14
 CP assignment, 2-10
 hardware configuration of S7-400 station,
 2-12
 hardware configuration of the PC station,
 2-9
 information, 2-1
 project creation, 2-8
 requirements, 2-2
 starting the control panel, 2-16
 task, 2-3

H

Hardware configuration of S7-400 station,
 getting started, 2-12
 Hardware configuration of the PC station,
 getting started, 2-9

I

Index, 2-5
 -component configurator , 2-5
 Industrial Ethernet, 1-7
 Installation, 2-4
 Integrated interfaces, 1-8
 Integrating distributed applications (DCOM),
 1-13–1-15

M

Memory areas of S7 controllers, OPC controls,
 Glossary-2
 Monitoring and modifying data, OPC controls,
 Glossary-2
 MPI, 1-7

N

Name, 2-5

name, -component configurator, 2-5
 Network communications, using DCOM,
 1-13–1-15, Glossary-1

O

Off-the-shelf applications, OPC controls,
 Glossary-2
 OLE, 1-14
 OPC controls, Glossary-2
 OPC documentation, Glossary-1
 OPC, 1-3, 1-14
 OPC controls, Glossary-2
 OPC documentation, Glossary-1
 shared use of data in several applications,
 Glossary-2
 use with WinAC Computing, Glossary-2
 OPC server name, Glossary-2
 OPC-foundation, 1-14
 Overview, OPC controls, Glossary-2

P

parameter assignment, component
 configurator, 2-5
 PC-based automation, 1-3
 PG/PC interface
 connecting STEP 7 to CPU 41-2 PCI on
 same computer, 2-17
 setting up for remote computer, 2-18
 PLC TimeSync. *Siehe* time synchronization
 Power supply module, 1-1
 Process data, 1-3
 OPC controls, Glossary-2
 Process form creation, 2-20
 Product overview, OPC (OLE for Process
 Control), Glossary-2
 PROFIBUS, 1-7
 PROFIBUS-DP, 1-7
 ProTool/Pro, 1-3
 PS extension board, 1-1, 1-6

R

Requirements, getting started, 2-2
 Routing, 1-7

S

S7 controllers, OPC controls, Glossary-2

- S7-400, 1-1
- S7-Controls, 1-1
- Server object (OPC), Glossary-2
- Setup, 2-4
- Sharing data among applications, OPC controls, Glossary-2
- SIMATIC Computing, 1-1, 1-10
- SIMATIC Manager, 1-7
- SIMATIC WinAC, 1-3
- Soft-Container, 2-20
- Spreadsheets, sharing data via OPC, Glossary-2
- station name, -component configurator, 2-5
- STEP 7
 - connecting to CPU41x-2 PCI on a different computer, 2-18
 - Tool Manager, 1-15

T

- T-Kit, 1-3
- Tag file, 1-11
- Tag file configurator, 1-11
- Technical specifications, OLE for Process Control, Glossary-1

- Third-party OCX, OPC controls, Glossary-2
- Time synchronization, 1-1, **1-9**
- Time-of-day synchronization service, 1-9
- Tool Manager, 1-15
- type, component configurator, 2-5

W

- WinAC, 1-3
 - DCOM, 1-13–1-15, Glossary-2
- WinAC Computing, OPC controls, Glossary-2
- WinAC Controlling, 1-4
 - control panel, 1-5
 - programming, 1-5
- WinAC Slot 412, 1-1, 1-3
- WinAC Slot 416, 1-1, 1-3
- WinAC Slot 41x, 1-1
 - access from OPC controls, Glossary-2
 - connecting STEP 7 to CPU 41x-2 PCI on a different computer, 2-18
 - example, 2-1
 - getting started, 2-1
- WinCC, 1-3, 1-7
- Windows Automation Center, 1-3

