

# **SIMODRIVE**

## **AC Main Spindle Drives**

**with 1PH6 AC Motors and**

**SIMODRIVE 650 Transistor PWM Converters**

**Description**

... of the Siemens 5200 Office System.

... TO USE

... of this document or  
... without express written authority.  
... rights, including rights  
... a utility model or design.

Preliminary Information

0

AC Main Spindle Drives

1

AC Motors

2

Transistor PWM Converters

3

Installation Instructions

4

Change Gearbox for AC Motors

5

Appendix

6

Index

7

## Contents

		Page
0	<b>Preliminary information</b> .....	0-1
1	<b>AC main spindle drives</b> .....	1-1
1.1	Application .....	1-1
1.2	Mode of operation .....	1-5
1.3	Complete standard drives .....	1-6
2	<b>AC motors</b> .....	2-1
2.1	Application .....	2-1
2.2	<b>Design</b> .....	2-1
2.2.1	NTC thermistors .....	2-2
2.2.2	ROD 323 shaft encoder .....	2-2
2.3	Mode of operation .....	2-4
2.4	Technical data .....	2-5
2.5	Options .....	2-8
2.6	Type designation .....	2-9
3	<b>Transistor PWM converter</b> .....	3-1
3.1	Application .....	3-1
3.2	Design .....	3-1
3.3	<b>Mode of operation</b> .....	3-3
3.3.1	Power section .....	3-3
3.3.2	Closed-loop control .....	3-4
3.4	<b>Options</b> .....	3-4
3.4.1	"Spindle positioning" board .....	3-5
3.4.2	"C axis" board .....	3-8
3.4.3	"PG coupling" board .....	3-9
3.4.4	External heat dissipation board .....	3-9
3.5	Operation .....	3-8
3.6	<b>PWM converter - Interfaces</b> .....	3-12
3.6.1	Inputs .....	3-12
3.6.2	Outputs .....	3-13
3.7	<b>Startup</b> .....	3-14
3.7.1	Display and operator control elements .....	3-14
3.7.2	Operating display .....	3-15



3.7.3	Measured value displays .....	3-18
3.7.4	Assignment and normalization of the D/A converter (measuring sockets) .....	3-19
3.8	Technical data .....	3-21
3.9	Type designation .....	3-24
<b>4</b>	<b>Installation instructions .....</b>	<b>4-1</b>
4.1	Installation .....	4-1
4.1.1	AC motors .....	4-1
4.1.2	PWM converter .....	4-1
4.2	Connecting up .....	4-2
4.2.1	AC motors .....	4-2
4.2.2	PWM converter .....	4-3
4.3	Interfaces .....	4-13
4.3.1	Relay signals .....	4-13
4.3.2	Digital signals .....	4-14
4.4	Cable connections .....	4-16
<b>5</b>	<b>Change gearboxes for AC motors .....</b>	<b>5-1</b>
5.1	Application .....	5-1
5.2	Design .....	5-2
5.3	Gear changing .....	5-4
5.4	Lubrication .....	5-7
5.5	Technical data .....	5-8
5.6	Circuit diagram .....	5-8
5.7	Dimension sheet .....	5-10
<b>6</b>	<b>Appendix .....</b>	<b>6-1</b>
6.1	Power-speed characteristics .....	6-1
6.2	Cantilever force charts .....	6-41
6.3	Vibrational severity charts .....	6-57
6.4	AC motor dimension sheets .....	6-59
6.5	PWM converter dimension sheets .....	6-66
<b>7</b>	<b>Index .....</b>	<b>7-1</b>



## Catalogs

SIEMENS

SIMODRIVE  
DA 42.1 . 1990

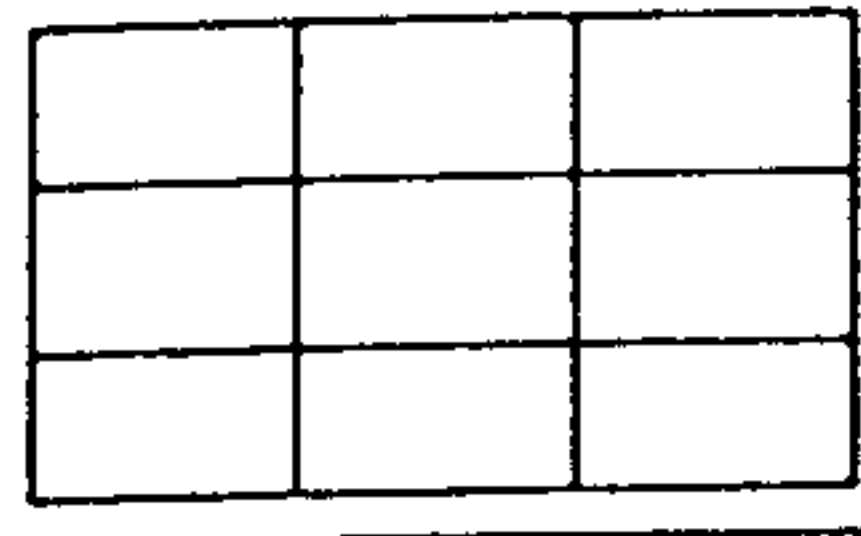

Servomotors

SIEMENS

SIMODRIVE  
DA 42.2 . 1990

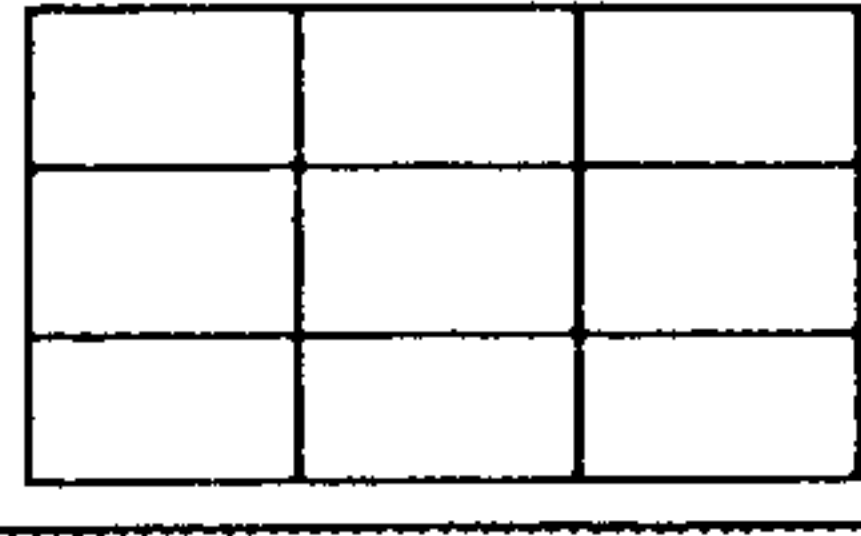

Compact 610  
converter

SIEMENS

SIMODRIVE  
DA 42.3 . 1990

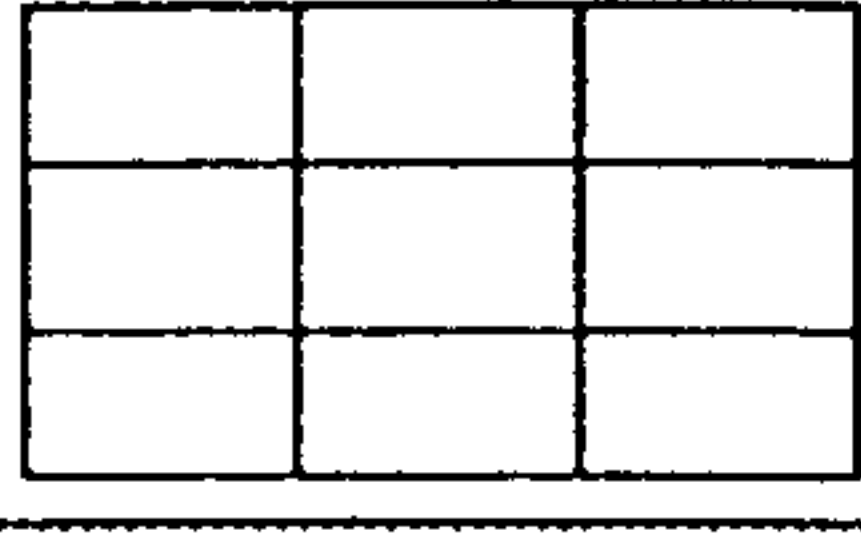

Modular 611  
converter

SIEMENS

SIMODRIVE  
DA 41.1 . 1990

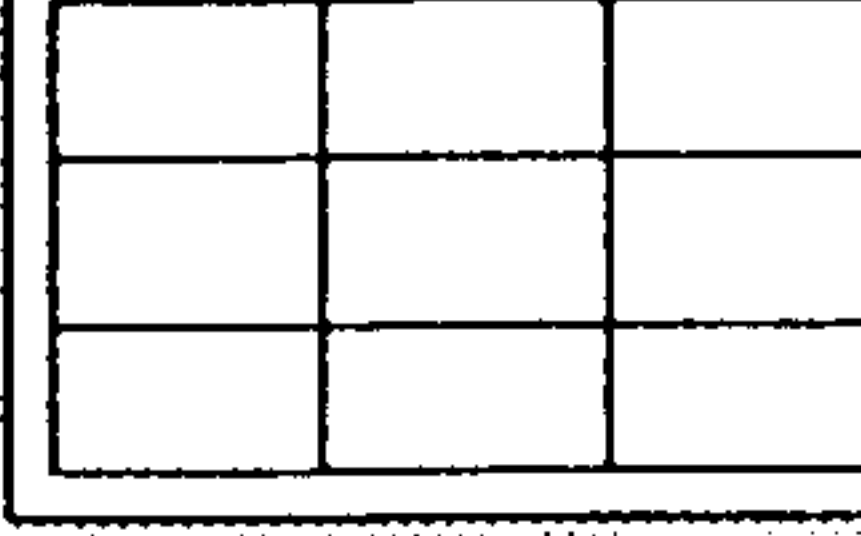

Main spindle  
drive

## Technical Descriptions

SIEMENS

SIMODRIVE  
Accessories

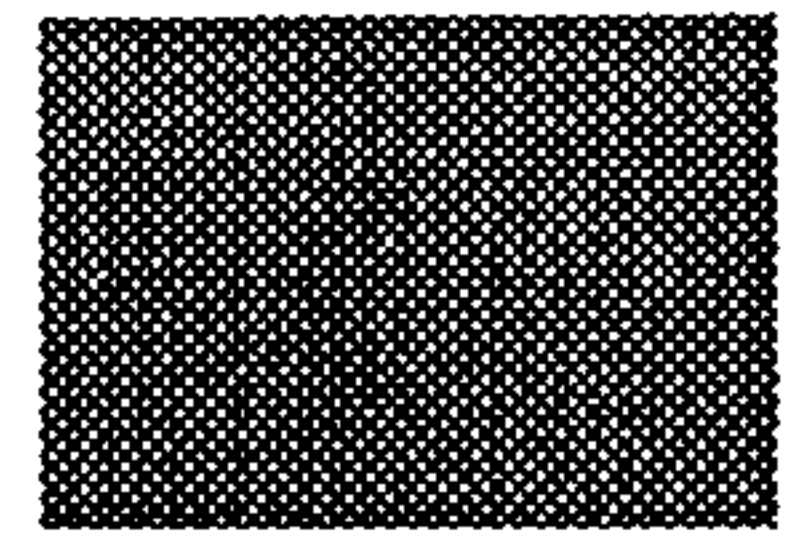

Accessories

SIEMENS

SIMODRIVE  
SIMODRIVE 610

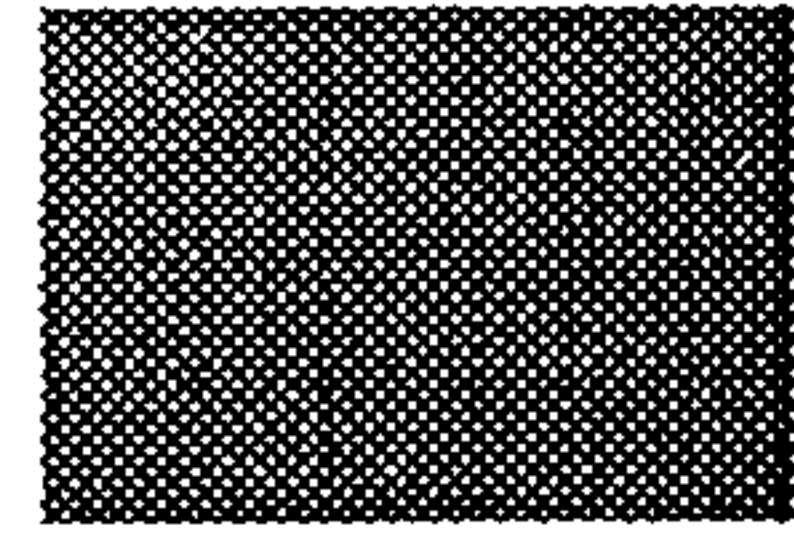

SIMODRIVE 610

SIEMENS

SIMODRIVE  
SIMODRIVE 611

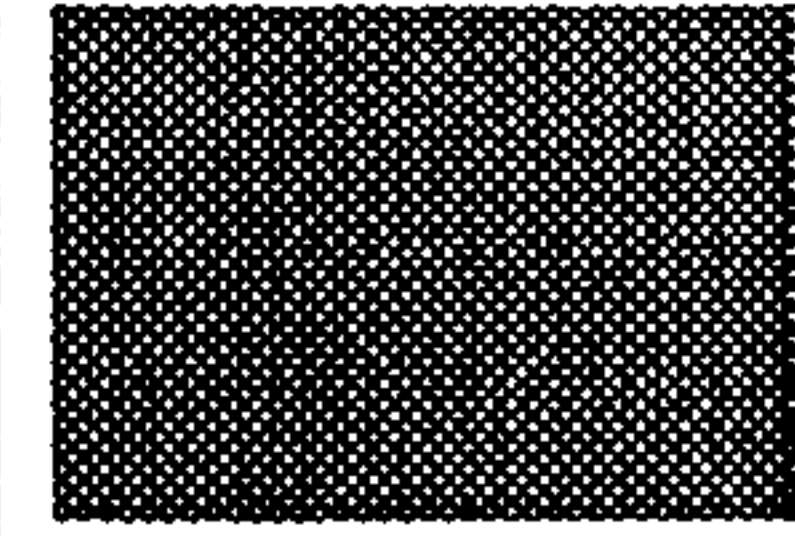

SIMODRIVE 611

SIEMENS

SIMODRIVE  
SIMODRIVE 650

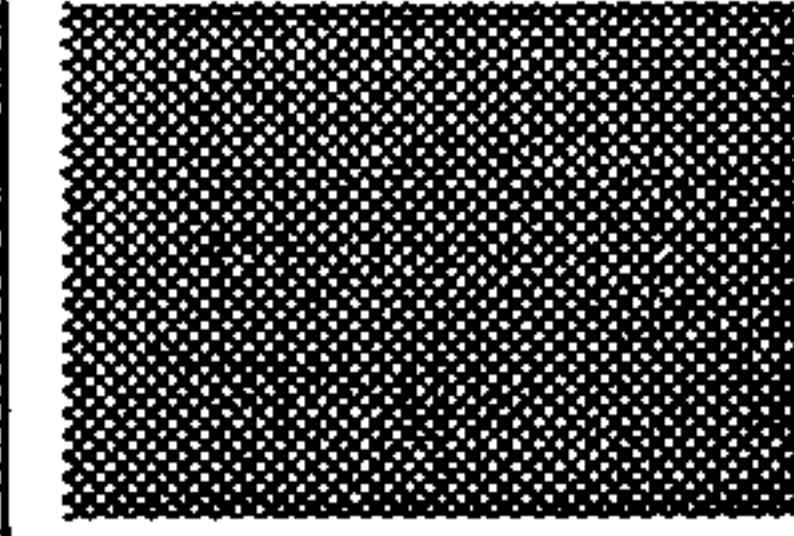

SIMODRIVE 650

SIEMENS

SIMODRIVE  
SIMODRIVE 690

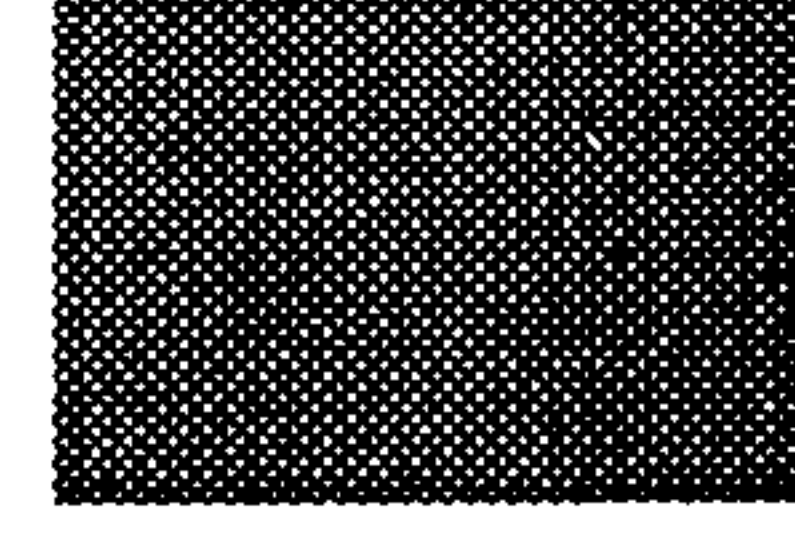

SIMODRIVE 690

## Option Descriptions

SIEMENS

SIMODRIVE  
Ramp function

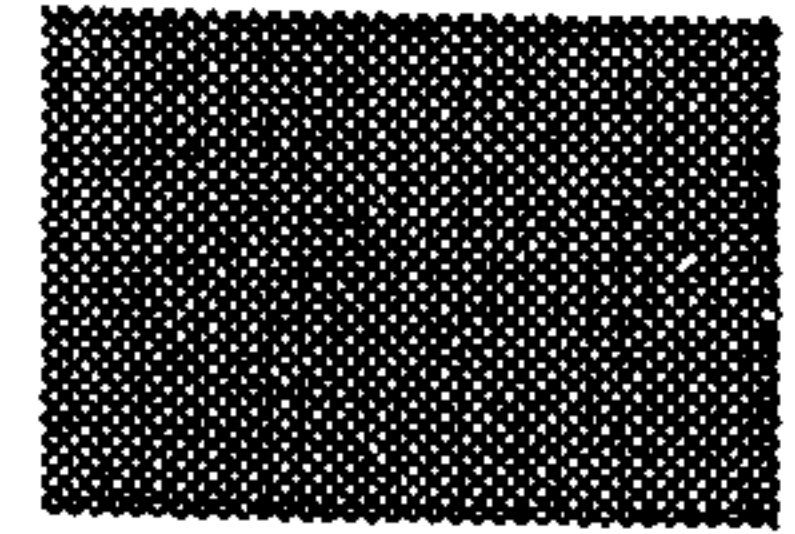

Ramp function  
generator

SIEMENS

SIMODRIVE  
Meas. system

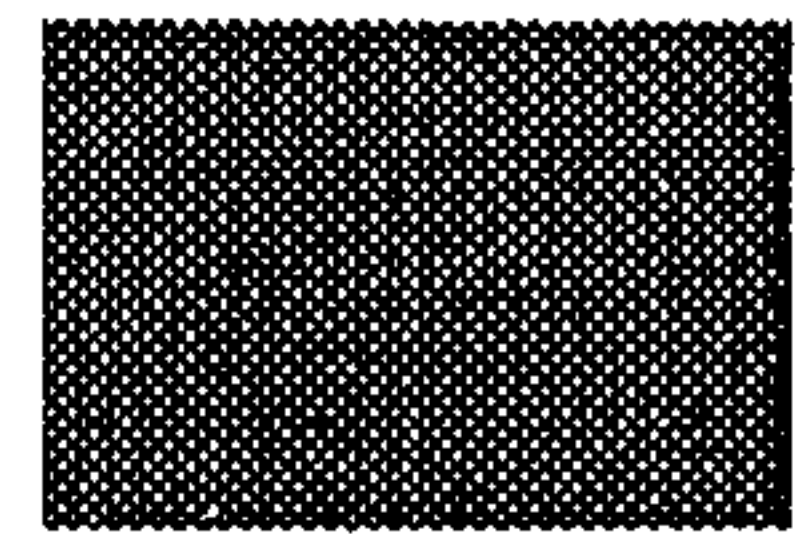

Abs. value meas.  
system.

SIEMENS

SIMODRIVE  
6RA29

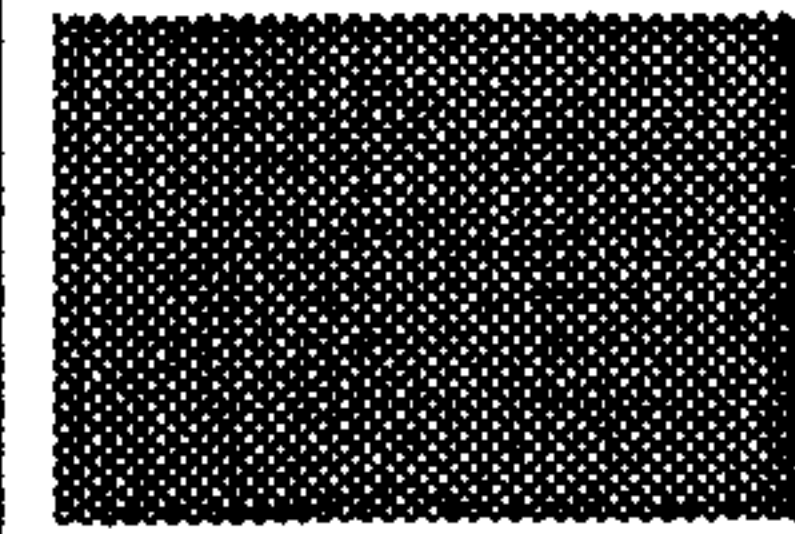

6RA29 infeed/  
regen. feedback  
unit

## Operating instructions



## 0 Preliminary information

The following is a part of the SIMODRIVE documentation. The documents are available individually. The complete list of documentation for all brochures, catalogs, overviews, short descriptions, operating instructions and technical descriptions can be obtained from your local Siemens office with Order No., source and price.



*Please note that the color coding of the connecting cables can change. Always check the signal leads before inserting plug connectors.*



*Important information throughout the text is highlighted in this form.*

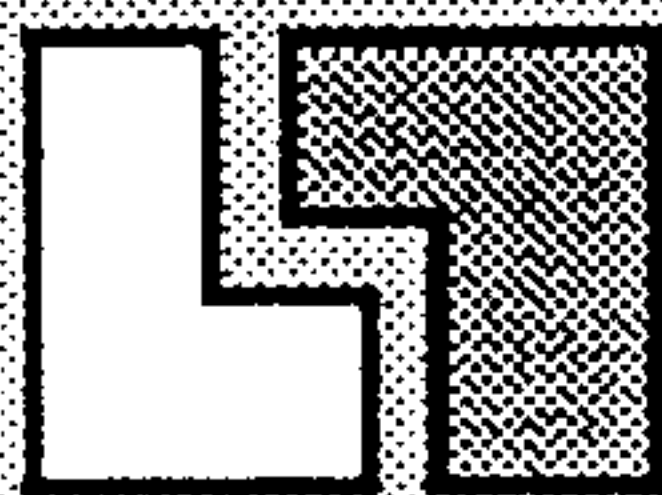
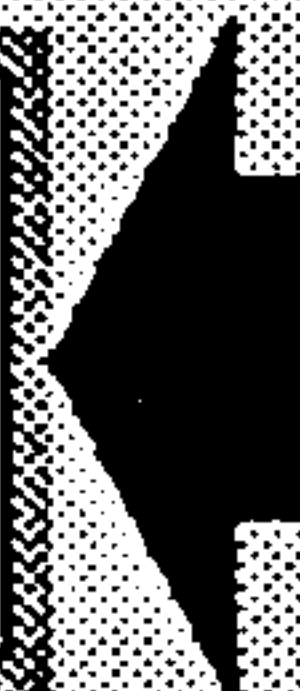

*Reference to an ordering data supplement*

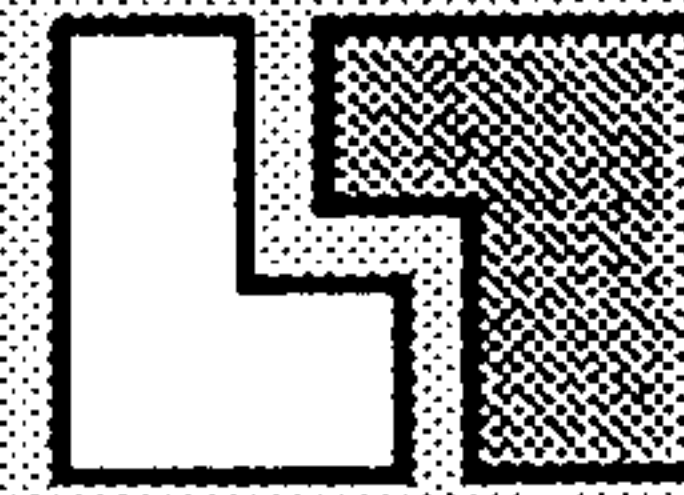

# 1 AC main spindle drives

## 1.1 Application

The SIMODRIVE® AC main spindle drives for machine tools, described here, consist of a matched combination of 1PH6 AC squirrel-cage induction motors and SIMODRIVE 650 transistor PWM converters.

SIMODRIVE main spindle drives combine the advantages of induction motors - rugged and low-maintenance - with state-of-the-art microprocessor technology. Using the TRANSVEKTOR closed-loop control developed by Siemens, it has become possible to control asynchronous induction motors with a control quality comparable to that of DC drives. Digital technology allows extremely short startup times by presetting the main spindle drive, as well as a comprehensive measuring and diagnostics system. With these characteristics, SIMODRIVE AC main spindle drives fulfill all requirements demanded of a drive concept for machine tools in modern production facilities:

- *Fast startup*
- *High degree of operator friendliness and simple diagnostics*
- *High operational reliability*
- *Very low maintenance*
- *Simple reproducibility of set values, e.g. during servicing*
- *Large speed range at constant power*
- *Reduces number of mechanical gear stages*

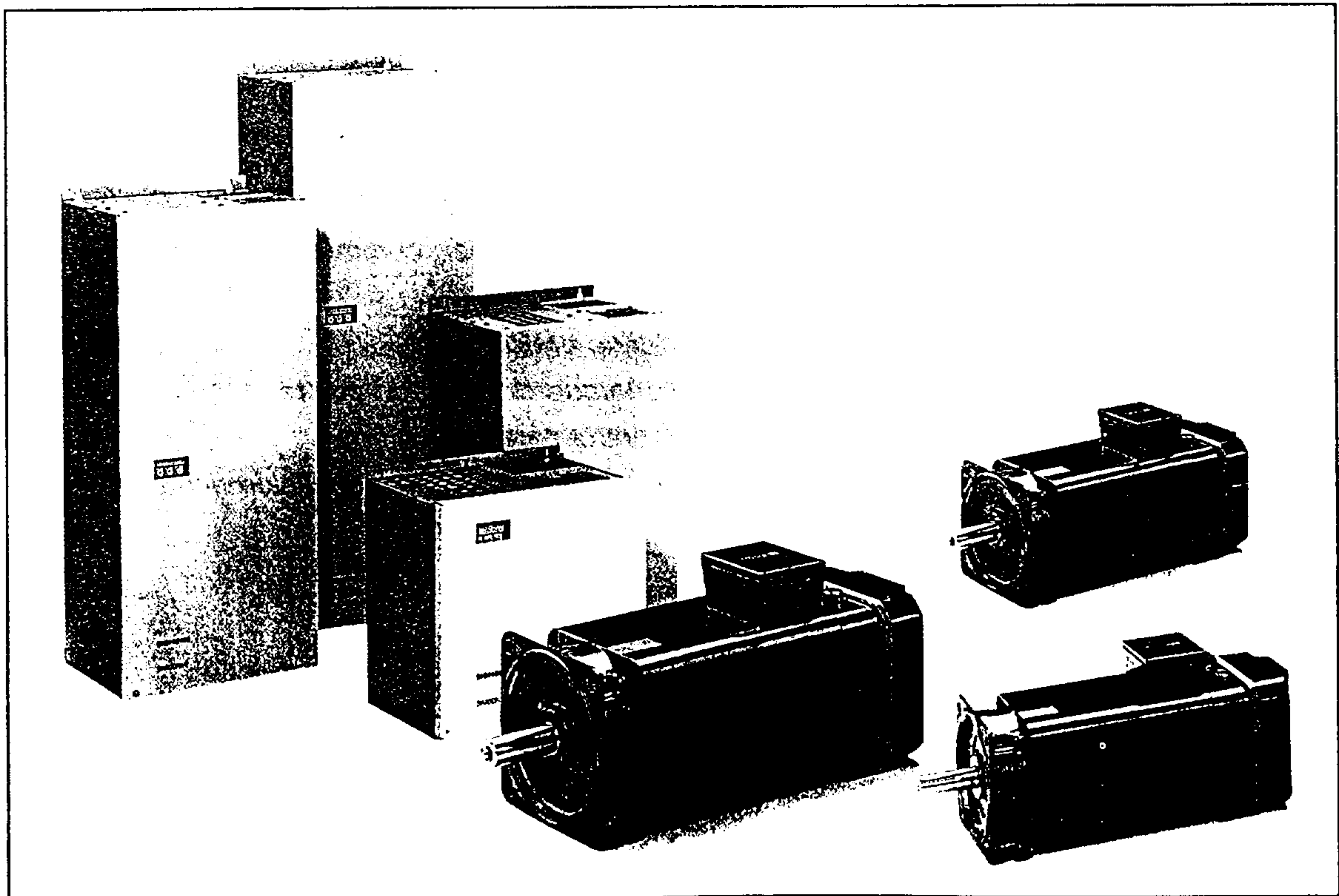

Fig. 1.1 1PH6 AC motors and SIMODRIVE 650 transistor PWM converter



**Important AC motor characteristics:**

- *Rugged and low maintenance four-pole squirrel-cage induction motors*
- *Short torque rise time*
- *Short speed rise time*
- *Low moment of inertia*
- *Full motor torque, even continuously available at standstill*
- *Good smooth running characteristics even at the lowest speeds*
- *Shaft bearings suitable for machine tool applications*
- *No speed-dependent power limiting as a result of commutation*
- *Constant power range 1:4 to 1:16*
- *Speed control range > 1:1000, with "C axis" option > 1:500 000*
- *Speeds down to 0 for C axis operation and positioning*
- *Short design length*
- *Short distance between bearings providing high vibrational stability*
- *High degree of protection : IP 54*
- *Externally cooled from the drive end to non-drive end*
- *Position and speed are brushlessly sensed*
- *Motor temperature monitoring*
- *Wide spectrum providing harmonized power steps*
- *Options:*
  - *Holding brake*
  - *Gearboxes*
  - *Space heaters*
- *IP 55 degree of protection*

**Important characteristics of transistor PWM converters:**

- *Can be directly connected to the supply without transformer, commutating reactors, and in-rush current limiting*
- *Regenerative feedback into the line supply during braking*
- *Digital multiprocessor concept for speed and torque closed-loop control*
- *High long-time accuracy of the closed-loop control parameters*
- *Load and control characteristics similar to a DC motor as a result of field-orientated closed-loop control*
- *Simple and fast digital parameter input*
- *Operating and fault message display*
- *High degree of safety using monitoring circuits*
- *Microprocessor based diagnostics*
- *Options:*
  - *Spindle positioning*
  - *Main drive as C axis*

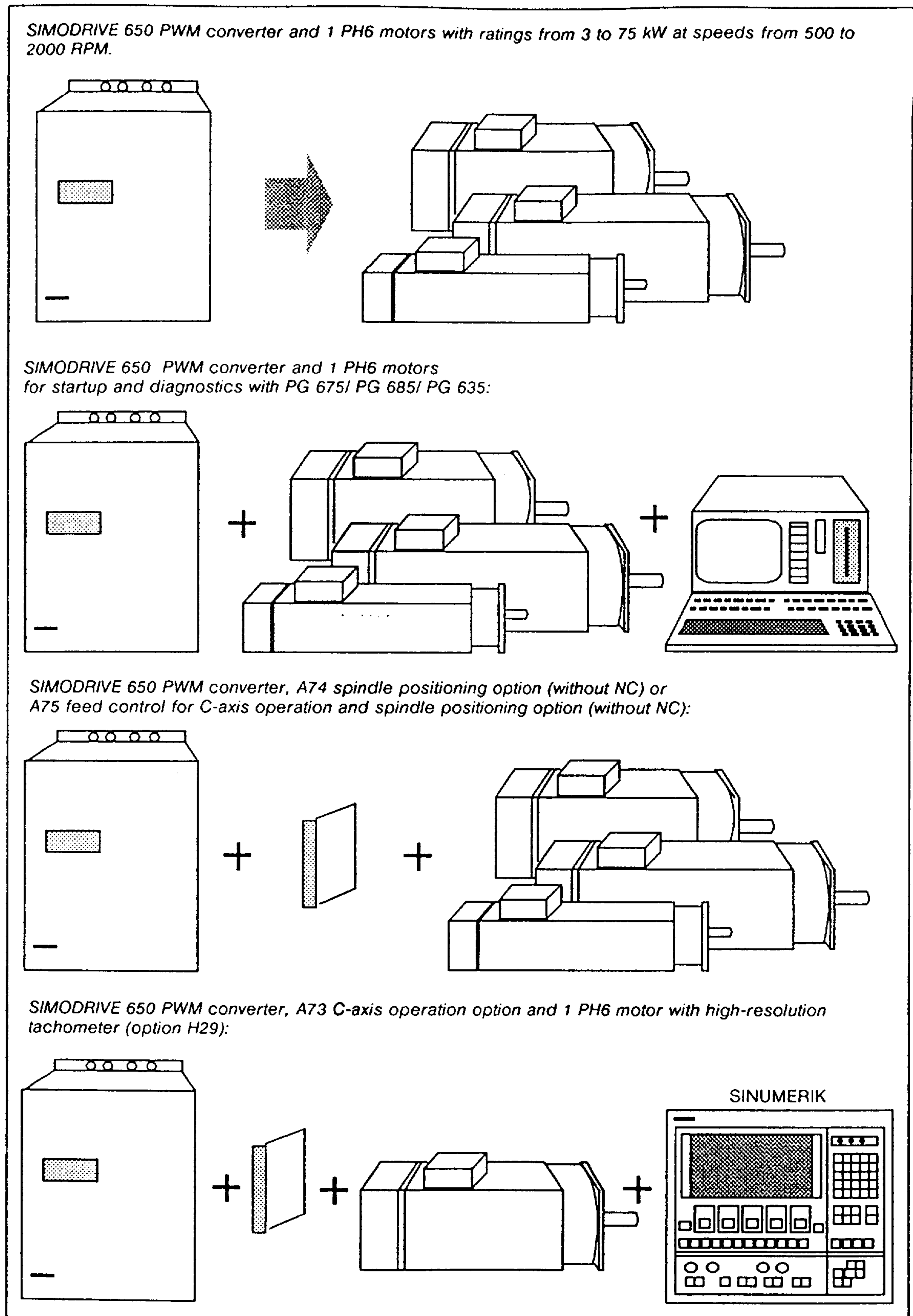

Fig 1.2 Applications of the SIMODRIVE 650 transistor PWM converter

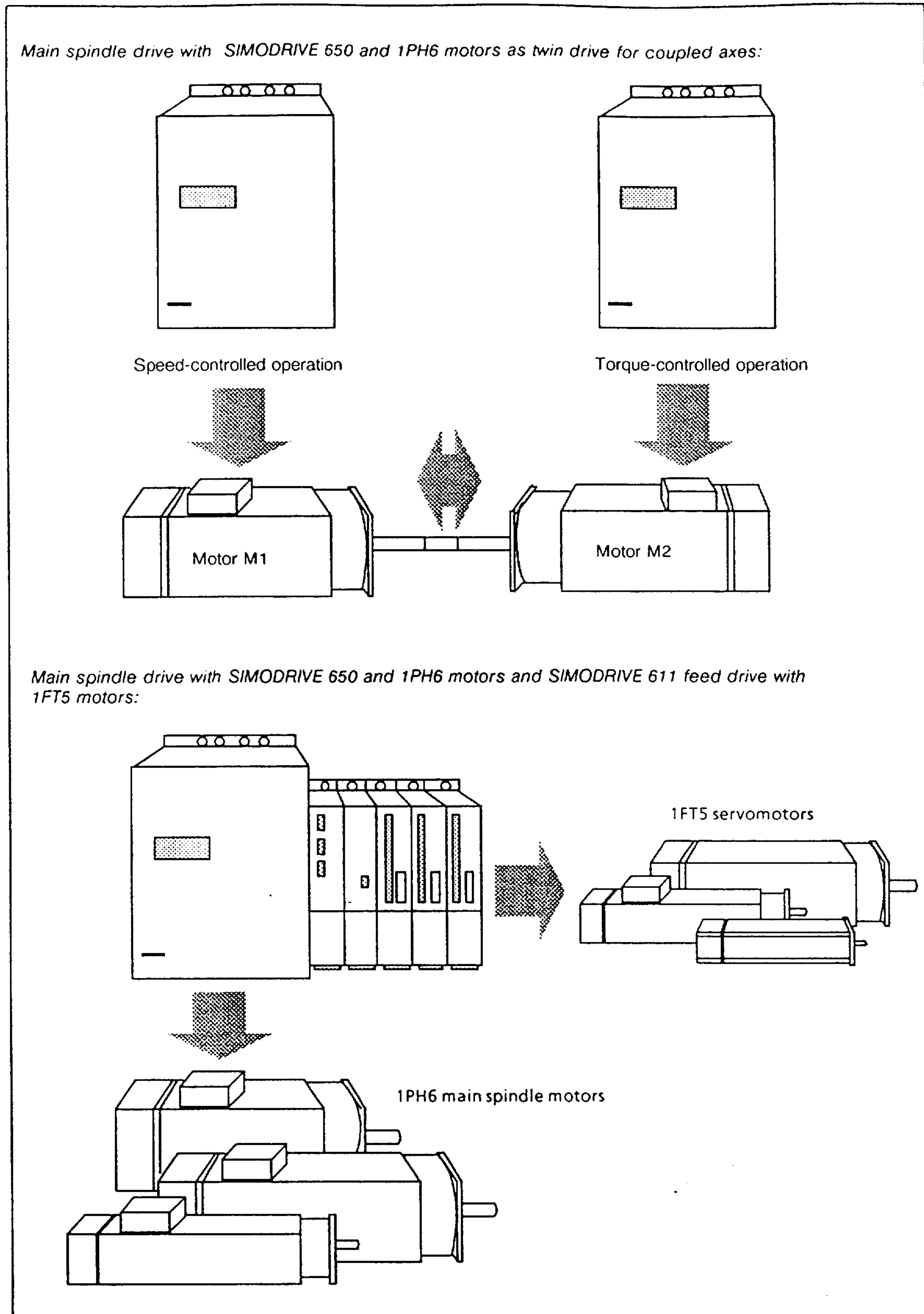

Fig. 1.2a Applications of the SIMODRIVE 650 transistor PWM converter



## 1.2 Mode of operation

With the SIMODRIVE AC main spindle drives, a new closed-loop control concept has been introduced into the machine tool sector, which is based on the principle of the field-orientated closed-loop control. Two microprocessors digitally represent the current and speed closed-loop circuits, and calculate the field. The open-loop and closed-loop control of the AC main spindle drive consists of a closed-loop speed controller with ramp-function generator and stored field weakening characteristic, as well as a secondary closed-loop torque control circuit and control system for the inverter and sequence control.

While AC drives used up until now always represented a non-linear controlled system, here, for the first time, there is a linear relationship, where the induction motor behaves similar to a DC motor and where the armature current (with constant excitation) is proportional to the torque.

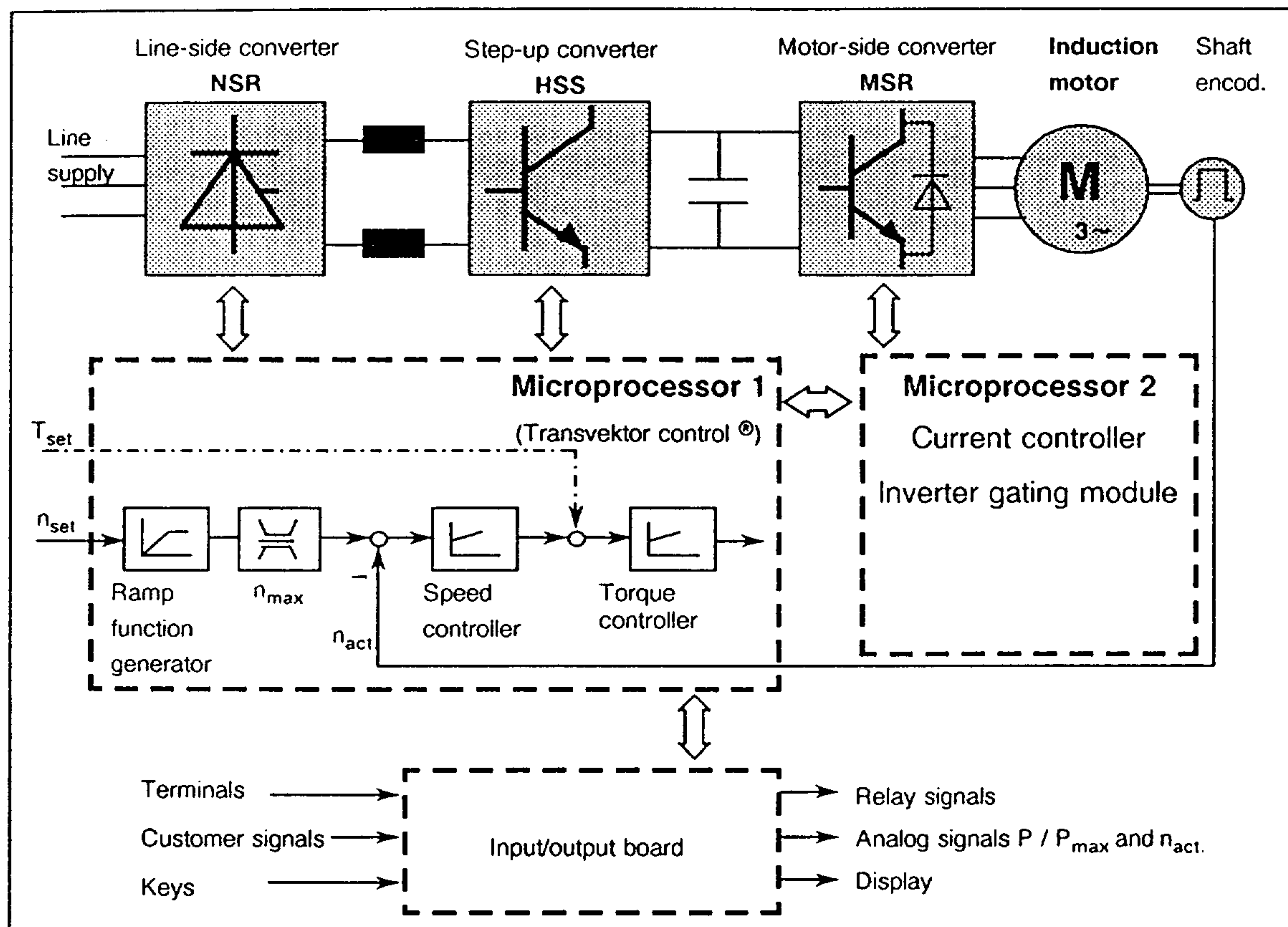

Fig. 1.3 Block diagram of the SIMODRIVE AC main spindle drive

It is possible to rapidly change the stator voltage and frequency of the AC motor using the transistor converter. Further, the magnetic flux and torque are decoupled.

The decoupling of these two motor variables is simulated in a microprocessor computer model. The reference variables for the motor supply, frequency, phase position and amplitude are generated using this computer model in order to provide each required torque and magnetic field, taking into account the torque and field limits. The resulting stator current vector is divided into a rotor flux and torque generating current components to the rotor flux. Field-orientated operation is provided if the current components generating the motor flux remain constant and the current components generating the torque are built up vertically to the rotor flux corresponding to the required torque.



This method of generating the current vector orientated to the flux vector position (field orientation) allows the torque and flux to be separately controlled and provides a closed-loop control quality similar to that for DC drives.

Two microprocessors are used in order to be able to execute arithmetic operations sufficiently fast for this closed-loop control concept. The current and speed controller circuits and the open-loop control are digital.

Digital technology provides a high degree of user friendliness and a high level of reproducibility of the setting variables. The parameters required for the closed-loop control are stored in a non-volatile EEPROM, which can also be used in other PWM converters.

### 1.3 Complete standard drives

The standard drives available are listed in Table 1.1. A suitable PWM converter is allocated to each AC motor depending on the required overload capacity. The available overload capacity refers to S6 or S3 operation with a duration of 10 minutes.

Contrary to DC technology, there is no linear relationship between current and torque of AC motors as a result of the magnetization current. Thus, the currents necessary for the required overload capacity of a specific AC motor are already taken into account for the required PWM converter in Table 1.1.

The PWM converter thermal time constant is significantly lower than that of AC motors. The converters are thermally dimensioned for continuous operation. Further, the 6SC6512 and 6SC6520 units have an overload capability. These characteristics are taken into account in the table below. The on-period in S6 or S3 operation should be taken from the motor data sheets.

AC motor	Motor rating [kW]	Rated speed [RPM]	Max. speed [RPM]	PWM converter for n x overload capacity			
				1.0	1.2	1.4	1.6
1PH6101-4CF4	3.7	1500	9000	6SC6502	6SC6502	6SC6502	6SC6502
1PH6101-4CG4	4.7	2000		6SC6502	6SC6502	6SC6502	6SC6503
1PH6103-4CF4	5.5	1500		6SC6502	6SC6502	6SC6503	6SC6503
1PH6103-4CG4	7.0	2000		6SC6502	6SC6503	6SC6503	6SC6503
1PH6105-4CF4	7.5	1500		6SC6503	6SC6503	6SC6503	6SC6504
1PH6105-4CG4	9.5	2000		6SC6503	6SC6503	6SC6504	6SC6504
1PH6107-4CC4	5.0	750		6SC6503	6SC6503	6SC6504	6SC6504
1PH6107-4CF4	9.0	1500		6SC6503	6SC6503	6SC6504	6SC6504
1PH6107-4CG4	11.5	2000		6SC6503	6SC6504	6SC6504	6SC6506
1PH6131-4CF4	9	1500	8000	6SC6503	6SC6504	6SC6504	6SC6504
1PH6131-4CG4	12	2000		6SC6504	6SC6504	6SC6504	6SC6506
1PH6133-4CB4	4.25	500		6SC6503	6SC6503	6SC6504	6SC6504
1PH6133-4CF0	11	1500		6SC6503	6SC6504	6SC6504	6SC6504
1PH6133-4CF4	11	1500		6SC6504	6SC6504	6SC6506	6SC6506
1PH6133-4CG4	14.5	2000		6SC6504	6SC6506	6SC6506	6SC6506
1PH6135-4CF0	15	1500		6SC6504	6SC6506	6SC6506	6SC6506
1PH6135-4CF4	15	1500		6SC6506	6SC6506	6SC6506	6SC6506
1PH6135-4CG4	20	2000		6SC6506	6SC6506	6SC6508	6SC6508
1PH6137-4CB4	7.5	500		6SC6506	6SC6506	6SC6506	6SC6508
1PH6137-4CF4	18.5	1500		6SC6506	6SC6506	6SC6508	6SC6508
1PH6137-4CG4	24	2000		6SC6506	6SC6508	6SC6508	6SC6508
1PH6138-4CF0	22	1500		6SC6506	6SC6506	6SC6508	6SC6508
1PH6138-4CF4	22	1500		6SC6508	6SC6508	6SC6508	6SC6512
1PH6138-4CG4	28	2000		6SC6508	6SC6508	6SC6512	6SC6512
1PH6161-4CF0	22	1500	6500 (8000)	6SC6506	6SC6508	6SC6508	6SC6508
1PH6161-4CF4	22	1500		6SC6508	6SC6508	6SC6508	6SC6512
1PH6161-4CG4	28	2000		6SC6508	6SC6508	6SC6512	6SC6512
1PH6163-4CB4	11.5	500		6SC6508	6SC6508	6SC6512	6SC6512
1PH6163-4CF0	30	1500		6SC6508	6SC6512	6SC6512	6SC6512
1PH6163-4CF4	30	1500		6SC6512	6SC6512	6SC6512	6SC6512
1PH6163-4CG4	38	2000		6SC6512	6SC6512	6SC6512	6SC6512
1PH6167-4CB4	14.5	500		6SC6508	6SC6512	6SC6512	6SC6512
1PH6167-4CF0	37	1500		6SC6508	6SC6512	6SC6512	6SC6512
1PH6167-4CF4	37	1500		6SC6512	6SC6512	6SC6512	6SC6512
1PH6167-4CG4	45	2000		6SC6512	6SC6512	6SC6512	6SC6512
1PH6186-4CE4	42	1250	5000 (7000)	6SC6508	6SC6512	6SC6512	6SC6512
1PH6186-4CF4	50	1500		6SC6512	6SC6512	6SC6512	6SC6512
1PH6206-4CE4	63	1250		6SC6512	6SC6512	6SC6520	6SC6520
1PH6206-4CF4	76	1500		6SC6520	6SC6520	6SC6520	6SC6520

Table 1.1 Standard drives available



## 2 AC motors

### 2.1 Applications

1PH6 AC motors are squirrel-cage induction motors, which have been especially developed for operation with SIMODRIVE 650 transistor PWM converters. Motor losses and noise have been significantly reduced, and the smooth running characteristics enhanced as a result of this matched system. Maximum speeds of up to 9000 RPM can be attained as a result of the compact mechanical design.

1PH6 AC motors are available with ratings from 3 kW to 75 kW at rated speeds between 500 and 2000 RPM.

The motor is available in two standard ranges with a constant power range between 1:5 and 1:6 at rated speeds of 1500 or 2000 RPM as well as a "wide range" series. This series covers a constant power range from 1:12 or 1:16 at rated speeds from 750 or 500 RPM and above. Thus, gear stages or complete gearboxes can be dispensed with and the drive train stiffness significantly increased.

### 2.2 Design

1PH6 AC motors have flanges and shafts which are compatible to 1G□5 DC motors having the same shaft height. The basic motor design consists of:

- *Active motor component*
- *NTC thermistor for motor temperature sensing*
- *Encoder system for sensing motor speed and rotor position*

#### Standard scope of supply of the 1PH6 range

AC squirrel-cage induction motor

- IM B3 type of construction (foot mounting)
- IP 54 degree of protection
- Insulating class F
- Vibrational severity R
- Terminal box with outlet to the right (without PG gland)
- 2 NTC thermistors in the stator winding
- Incorporated ROD 323 shaft encoder with 1024 pulses/revolution
- Anthracite grey paint finish with turquoise ring

The AC motors are forced-ventilated. The fans are mounted axially on the non-drive end. In order to discharge the dissipated motor heat away from the machine tool the air flows from the drive end to the non-drive end. For 1PH6 motors (shaft heights 100-160), the air is discharged radially towards the bottom, and the fan can be rotated through 4 x 90°. For motors with shaft heights 180 and 200, the radial air discharge can be either to the right or left.

Torque can be increased by using speed changing with a mounted gearbox.

1PH6 AC motors are equipped as standard with double bearings on the drive end to accept higher cantilever forces. The permissible cantilever loading can be taken from the diagrams in the Appendix.

If vibrational severity SR is required for 1PH6 motors (shaft heights 100-160), deep-groove ball bearings must be used on the drive end, which have a lower cantilever force loading capability. With vibration severity S, the motors are equipped with single bearings; double-bearing design is possible.

We recommend only single-bearing design for operation without cantilever loading (coupling, direct drive with gearbox).

1PH6 AC motors (shaft heights 180 + 200) are also available in IM B3 design with strengthened bearings for accepting increased cantilever forces. The maximum speed is reduced with this design.

A two-stage gearbox for extending the constant power range as well as a holding brake are available as option for mounting to the drive-side bearing end shield of the motors.

### 2.2.1 NTC thermistor

Two NTC thermistors are incorporated in the motor stator winding to sense motor temperature. The signals are evaluated in the PWM converter whose closed-loop controller takes into account the temperature characteristic of the motor resistors.

An external tripping unit is not required. The NTC thermistor function is monitored. A corresponding message is output on the PWM converter if a fault condition occurs.

With increasing motor temperature, a "motor overtemperature prewarning" relay signal is output. If this prewarning is not observed, the PWM converter shuts down when the motor limit temperature is exceeded, and issues a corresponding fault message.

The second NTC thermistor is a reserve sensor and can be selected by changing over the connections in the motor terminal box.

### 2.2.2 ROD 323 shaft encoder

A shaft encoder is mounted at the non-drive bearing end shield of the motor in order to sense speed and rotor position. The shaft encoder resolution is 1024 pulses per motor revolution as standard. The shaft encoder signals can be taken from the PWM converter for external applications. (e.g. transfer to a higher-level position control system).

When using the C-axis option (also refer to Section 3.4, Pages. 3-2), this shaft encoder is replaced by a double encoder system with an additional high-resolution track.



## 2.3 Mode of operation

The constant power range of 1PH6 AC motors is essentially from the rated speed  $n_N$  up to maximum speed  $n_{max}$  (5000 RPM, 6500 RPM, 7000 RPM, 8000 RPM or 9000 RPM) <sup>1)</sup>. Constant torque  $T_n$  is available from standstill up to rated speed.

At higher speeds, i.e. in the constant power range, the maximum available torque  $T_{max}$  at a specific speed  $n$  is given, in a first approximation, by the formula:

$$T_{max} \text{ [Nm]} = 9,6 \frac{P_{max} \text{ [W]}}{n \text{ [RPM]}}$$

AC motors have a large overload capacity in the constant torque and constant power ranges. With some AC motors, the overload capacity is reduced in the vicinity of the maximum speed. Specific information should be taken from the motor characteristics in Section 6.

The motor field remains constant in the basic speed range up to the motor rated speed. This is followed by a further constant power range, which is characterized by various gradients as a result of the field weakening.

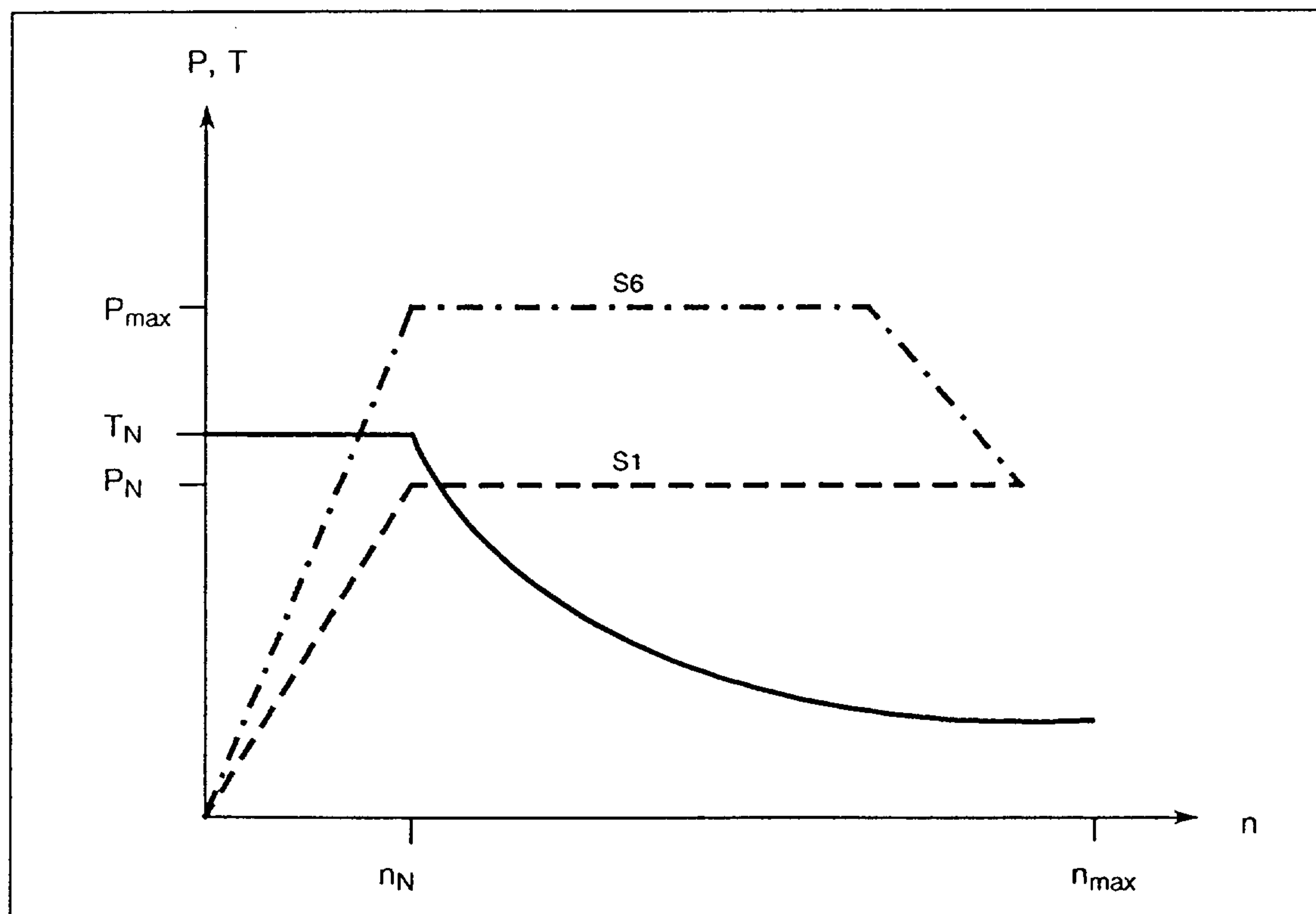

Fig. 2.1 Power  $P$  and torque  $T$  as a function of speed  $n$

1) Refer to the motor characteristics in the Appendix, Section 6, for deviations

## 2.4 Technical data

Motor voltage	Maximum: 3-ph, 430 V AC
Motor frequency	Maximum: 300 Hz
Motor noise (acc. to DIN 45635, 3dB tolerance)	up to/incl. shaft height 132: max. 70 dB(A) shaft height 160: max. 72 dB(A) shaft heights 180 and above: max. 75 dB(A)
Speed control range	> 1 : 1000; with option A73 > 1 : 500 000
Constant power range	≥ 1: 4 to 1:16
Insulation	Insulation class F acc. to DIN VDE 0530 for a winding temperature rise of $\Delta T = 105$ K with a cooling medium temperature of + 40° C
Design	IM B3; IM B35; IM V15 or IM V36
Degree of protection	DIN 40050-IP54; Option: IP55
Ambient temperature	Maximum: + 40°C (otherwise derating necessary)
External fan	1PH610□: 3ph, 380VAC, 50/60 Hz 0.17 A; $I_{max} = 0.39$ A 1PH613□: 3ph, 380VAC, 50/60 Hz 0.26 A; $I_{max} = 0.34$ A 1PH616□: 3ph, 380VAC, 50/60 Hz 0.7 A; $I_{max} = 0.8$ A 1PH618□: 3ph, 380VAC, 50/60 Hz 0.7 A; $I_{max} = 0.8$ A 1PH620□: 3ph, 380VAC, 50/60 Hz 0.7 A; $I_{max} = 0.8$ A
Air flow direction	From the drive end to the non-drive end (standard) Available from the non-drive end to drive end as option. For 1PH6 (shaft heights 100-160) by using a 2CW6 fan unit from the 1GL5 series (motor is longer, dimension sheet on request). For 1PH6 (shaft heights 180 + 200) on request
Space heaters	Option
Terminal boxes	For 1PH6 (shaft heights 100-160), can be rotated through 4 x 90°, top mounting (either left or right). For 1PH6 (shaft heights 180-200) can be rotated (refer to the dimension sheets in the Appendix)
Flange design	Acc. to DIN 42955, tolerance M (option: tolerance R) (motors, frame size 100, can also be supplied with flange dimension $b_1 = 230$ mm and 38 mm shaft diameter).
Vibrational severity	R (option: S, SR) refer to the diagrams in the Appendix
Permissible cantilever forces	At the shaft, refer to the diagrams in the Appendix
Mounting possibility	2LG4 ZF gearbox Fail-safe holding brake on the drive-end bearing end shield

Table 2.1 Technical data of 1PH6 AC motors

Rating $P_N$ [kW]	Rated speed $n_N$ [RPM]	AC motor Order No.	Rated torque $T_N$ [Nm]	Rated current $I_N$ [A]	Time constant (therm.) $T_{th}$ [min]	Max. speed $n_{max}$ [RPM]	Moment of inertia $J$ [kgm <sup>2</sup> ]	Weight $m$ [kg]
<b>100 mm shaft height</b>								
3.7 4.7	1500 2000	1PH6 101-4CF4 -4CG4	24 22	13 13.9	20	9000	0.011	42
5.5 7.0	1500 2000	1PH6 103-4CF4 -4CG4	35 33	18 20	20	9000	0.017	52
7.5 9.5	1500 2000	1PH6 105-4CF4 -4CG4	48 45	23 26	20	9000	0.024	67
5.0 9.0 11.5	750 1500 2000	1PH6 107-4CC4 -4CF4 -4CG4	64 57 55	22.8 27.4 30	20	9000	0.031	80
<b>132 mm shaft height</b>								
9.0 12.0	1500 2000	1PH6 131-4CF4 -4CG4	57 57	28 33	30	8000	0.038	78
4.25 11.0 11.0 14.5	500 1500 1500 2000	1PH6 133-4CB4 -4CF0 -4CF4 -4CG4	81 70 70 69	26 28 32 39	30	8000	0.046	90
15.0 15.0 20.0	1500 1500 2000	1PH6 135-4CF0 -4CF4 -4CG4	95 95 95	36 43 52	30	8000	0.071	112
7.5 18.5 24.0	500 1500 2000	1PH6 137-4CB4 -4CF4 -4CG4	143 118 115	44 52 59	30	8000	0.085	130
22.0 22.0 28.0	1500 1500 2000	1PH6 138-4CF0 -4CF4 -4CG4	140 140 134	52 63 68	30	8000	0.104	150

Table 2.1 Technical data of 1PH6 AC motors



Shaft height	Rated speed $n_N$ [RPM]	AC motor Order No.	Rated torque $T_N$ [Nm]	Rated current $I_N$ [A]	Time constant (therm.) $T_{th}$ [min]	Max. speed $n_{max}$ [RPM]	Moment of inertia J [kgm <sup>2</sup> ]	Weight m [kg]
<b>110 mm shaft height</b>								
110	1500	1PH6 161-4CF0	140	55	35	6500	0.131	140
110	1500	-4CF4	140	63		(8000)*		
110	2000	-4CG4	134	70				
<b>135 mm shaft height</b>								
135	500	1PH6 163-4CB4	220	67	35	6500	0.17	175
135	1500	-4CF0	191	75		(8000)*		
135	1500	-4CF4	191	88				
135	2000	-4CG4	181	90				
<b>160 mm shaft height</b>								
160	500	1PH6 167-4CB4	277	80	35	6500	0.206	210
160	1500	-4CF0	236	82		(8000)*		
160	1500	-4CF4	236	98				
160	2000	-4CG4	215	93				
<b>180 mm shaft height</b>								
180	1250	1PH6 186-4CE4	320	84	40	5000	0.310	350
180	1500	-4CF4	318	100		(7000)*		
<b>200 mm shaft height</b>								
200	1250	1PH6206-4CE4	481	122	40	5000	0.610	470
200	1500	-4CF4	484	154		(7000)*		

Technical data of 1PH6 AC motors, continued



## 2.5 Type designation

The type designation (which is also the Order No.) consists of a combination of digits and letters. It is subdivided into 3 blocks which are connected by two hyphens.

The first block comprises 7 positions and identifies the motor type. The second block contains codes for additional design features. The third block is provided for additional information.

Configuration of the AC motor Order No. :

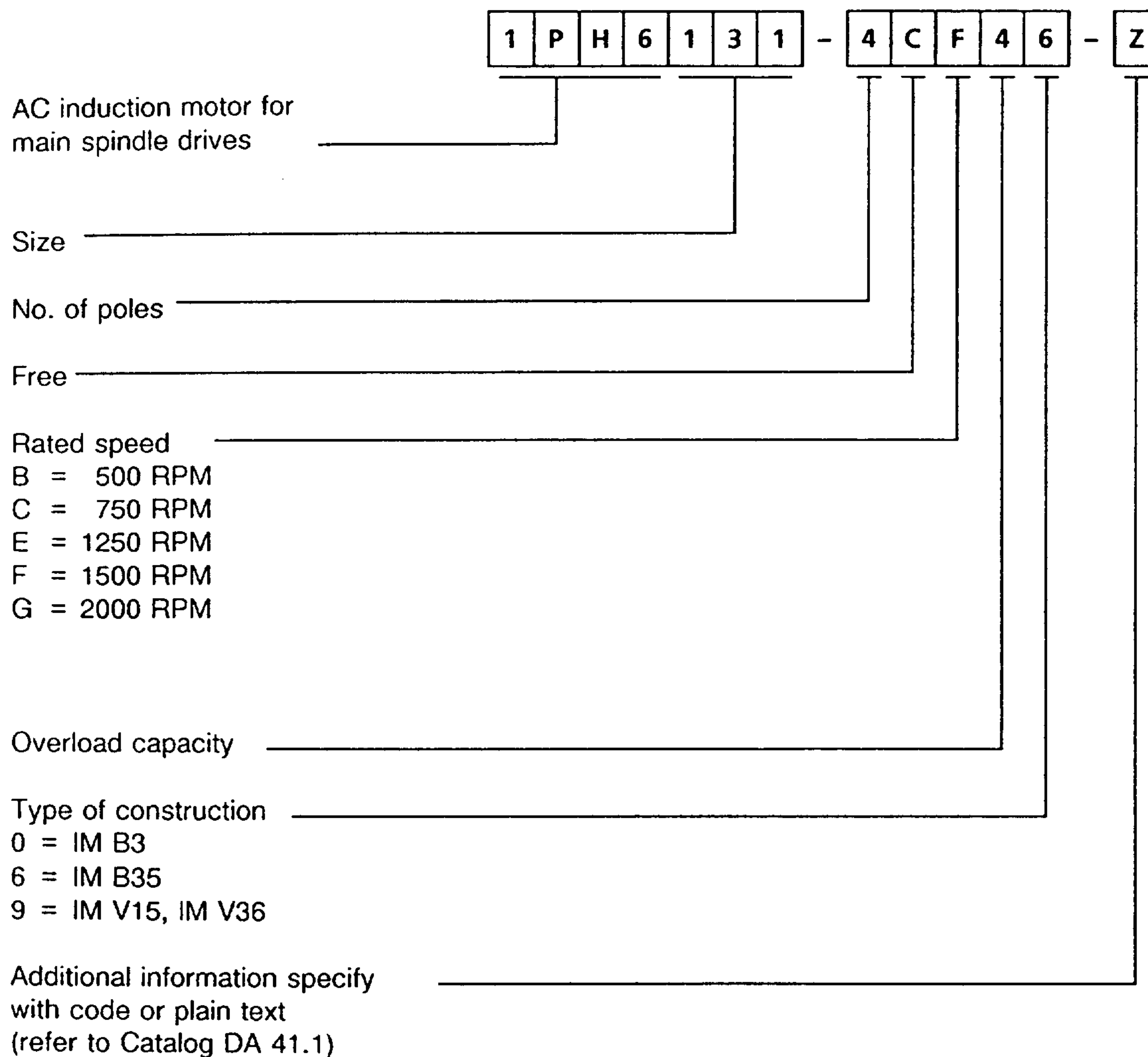

### Additional information for standard design and options

Plain text information	Code
IP 54 degree of protection and additional protection against penetration of electrically conductive dust	L35
IP 55 degree of protection (cannot be combined with K64) <sup>1)</sup>	K49
Terminal box location (when viewing drive end)	
on the righthand side	K09
on the lefthand side	K10
top, shifted to the right <sup>2)</sup>	K29
Bearing design at the drive end	
for gearbox mounting (locating bearing and radial shaft seal) <sup>1)</sup>	K18
for increased radial forces (strengthened roller bearing) <sup>2)</sup>	K20
for increased maximum speeds	
for reduced cantilever forces (spindle bearing) <sup>3)</sup>	L37
Shaft drive end, special cylindrical shaft end	Y55 <sup>4)</sup>
Diameter greater than standard	Y56 <sup>4)</sup>
Vibrational severity	
Grade S (for double-bearing design) <sup>1) 12)</sup>	K05
Grade S (for single-bearing design) <sup>5) 12)</sup>	K02
Grade SR (for single-bearing design with option K18) <sup>1) 12)</sup>	K03
Concentricity, tolerance R (reduced acc. to DIN 42-955R) <sup>6)</sup>	K04
Cooling (airflow from the non-drive end to drive end)	K64
Installation altitude > 1000 m / cooling medium temperature > + 40°C	Y50 <sup>7)</sup>
Paint finish	
None, however with primer	K24
Special paint finish for the tropics, RAL 7030	K26
Standard paint finish in colors other than RAL 7030	Y53 <sup>8)</sup>
Special paint finish for tropics in colors other than RAL 7030	Y54 <sup>9)</sup>
Rating plate in a foreign language	Y80 <sup>11)</sup>
High-resolution shaft encoder for C-axis operation	H29
ZF gearbox mounting (i = 1:4) on motors, IM B35 type of construction	
Gearbox with small output housing <sup>1)</sup>	H34
Gearbox with large output housing <sup>10)</sup>	H31
ZF gearbox mounting (i = 1:4) on motors, IM V15 type of construction	
Gearbox with small output housing <sup>1)</sup>	H38
Gearbox with large output housing <sup>10)</sup>	H36
Motor prepared for mounting a ZF gearbox (also includes the radial shaft seal)	G97



Plain text information	Code
Motor prepared for mounting a holding brake	G95
Holding brake mounted <sup>1)</sup>	G46
Space heater, 220 V AC supply	K45
Space heater, 110 V AC supply	K46
Design "B" drive shaft end (without key)	K42
Special paint finish (for the tropics)	L53

- 1) only for 1PH6 main spindle motors (shaft heights 100, 130 and 160), for single-bearing design
- 2) only for 1PH6 main spindle motors (shaft heights 180 and 200)
- 3) only for 1PH6 main spindle motors (shaft heights 160, 180 and 200)
- 4) additionally specify in plain text: non-standard cylindrical shaft end with diameter (mm) and length (mm)
- 5) only for 1PH6 main spindle motors (shaft heights 100, 130 and 160) with option K18
- 6) only shaft reworking
- 7) specify in plain text: Installation altitude (m above sea level) and/or cooling medium temperature (°C)
- 8) specify in plain text: Standard paint finish in RAL ...
- 9) specify in plain text: Special paint finish in RAL ...
- 10) only for 1PH6 main spindle motors (shaft heights 130 and 160)
- 11) specify in plain text: Language required
- 12) options K02, K03, K05 automatically include option K04

## 3 Transistor PWM converter

### 3.1 Application

SIMODRIVE 650 transistor PWM converters have been developed to supply 1PH6 AC main spindle motors with a controlled 600 V DC link voltage and fully regenerative braking. They control the drive power and speed in 4-quadrant operation. Seven converters are available with ratings between 15 and 150 kVA.

The transistor PWM converters are mounted in an enclosure, together with the incoming fuses, and can be connected directly to a 3-phase 380 V AC 50/60 Hz supply. Transformers, commutating reactors, and inrush limiters are not required. Monitoring electronics ensure short-circuit-, overload-, and ground fault protection for the converter. The TRANSVEKTOR closed-loop control concept guarantees high control performance such as is required for C-axis operation.

All 1PH6 motor data, required for the field calculation, is deposited in a memory in the converter. During startup, the microprocessor automatically provides the complete motor data. Customer-specific closed-loop control parameters can be entered or changed on a display and operator control unit. During operation, operational statuses and faults are indicated on the 6-digit display of the display and operator control unit.

All parameters and fault messages can be displayed in plain text on the programming unit screen with the "interface for connecting PG 685 / 675 programming units" option. A data set can be stored on floppy disk, and can be used for other standard machines.

### 3.2 Design

The power section consists of:

- *a line-side converter with regenerative feedback into the supply*
- *a DC voltage link, and*
- *a transistor PWM converter which generates a variable-voltage and variable-frequency AC system*

The electronics is supplied from the DC link, thus providing ride-through capability during brief supply voltage failures.

The necessary line-side fuses are incorporated in the pulse converter. Fuses are not blown on supply voltage failure when the unit is in the regenerative mode.



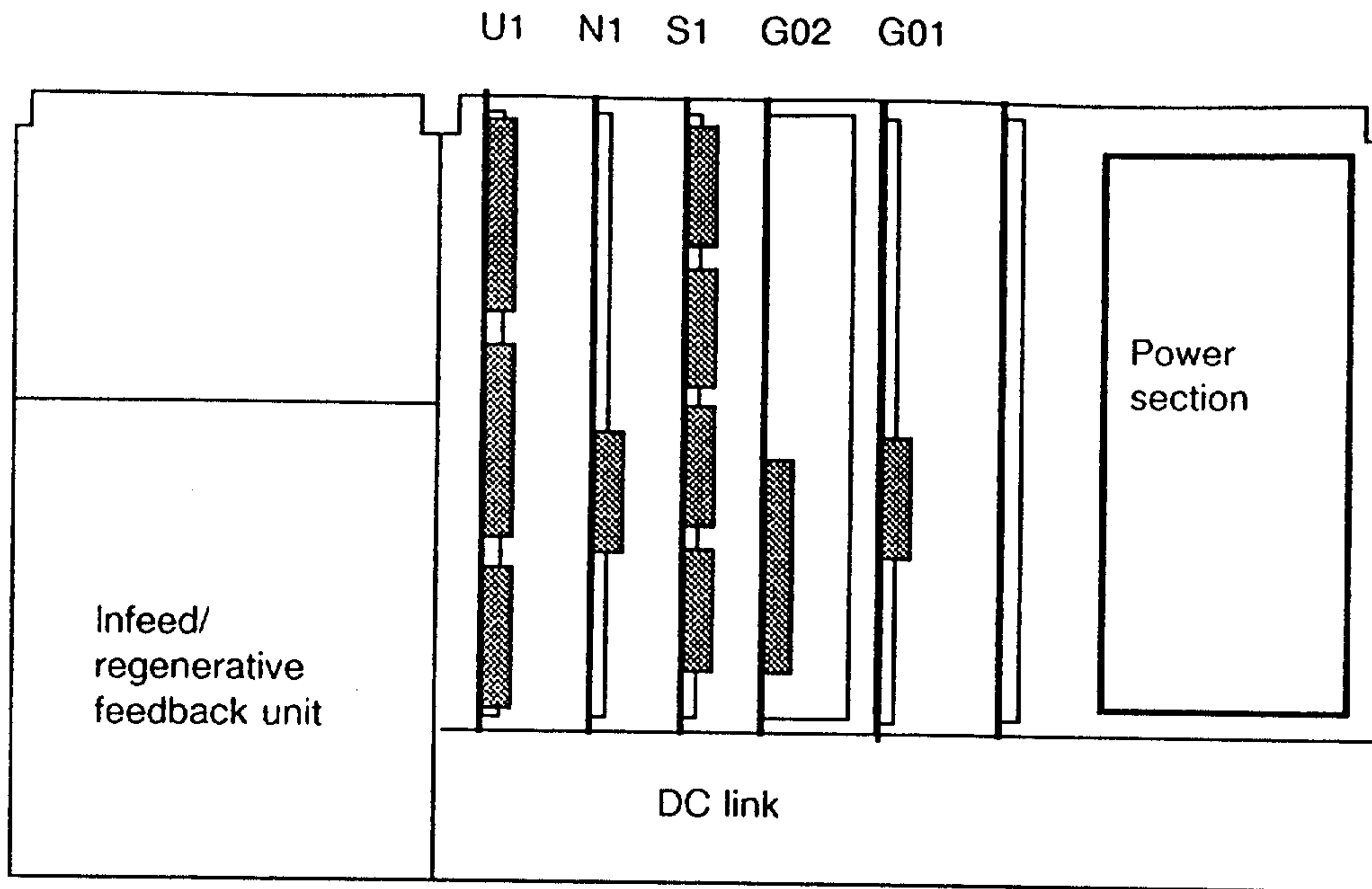

U1 = Input/output board  
 N1 = Closed-loop control board  
 S1 = "Spindle positioning" and "C-axis" option  
 G02 = Central board  
 G01 = Power supply

Fig. 3.1 Design of the 6SC6502 and 6SC6503 transistor PWM converters

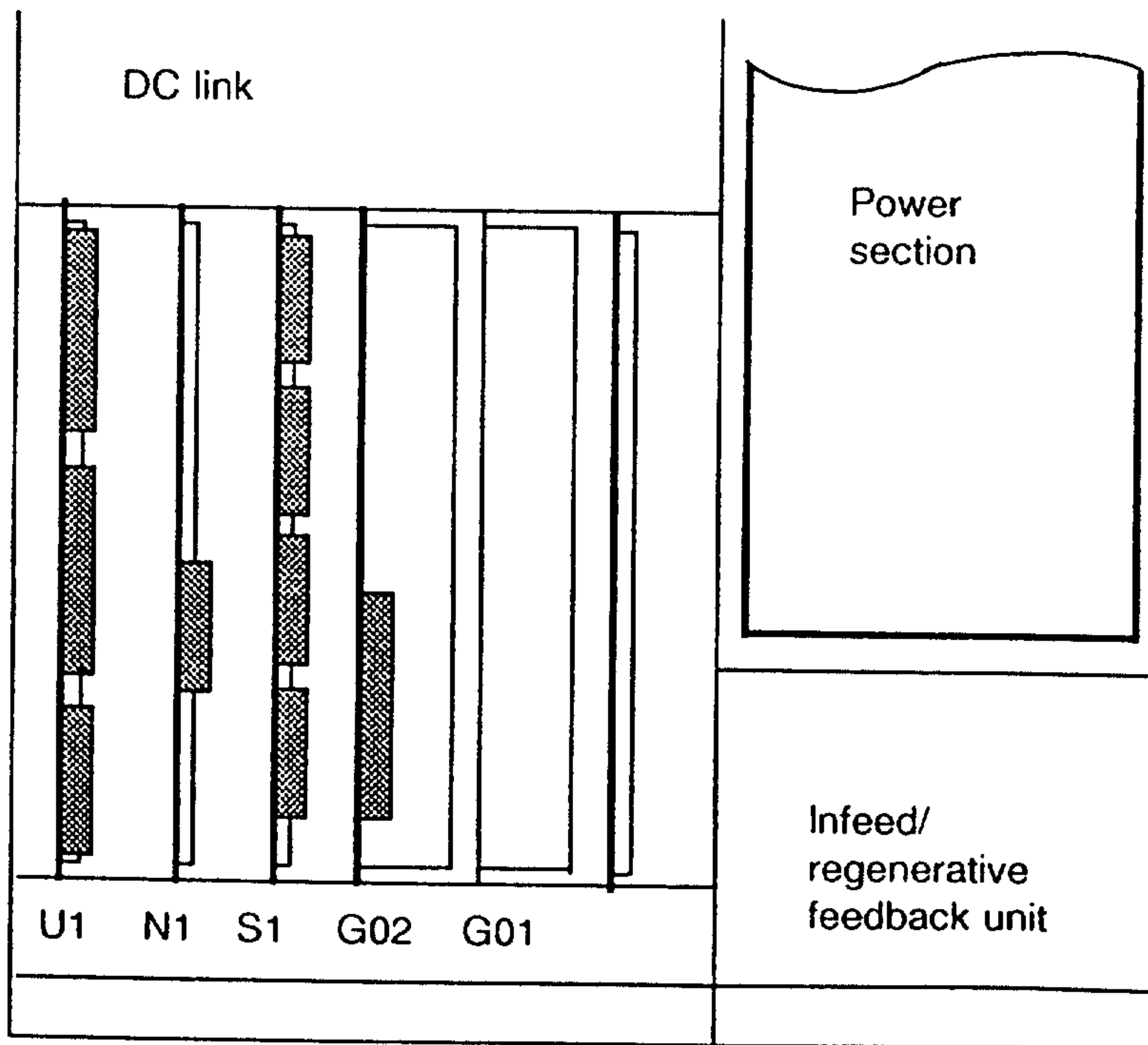

U1 = Input/output board  
 N1 = Closed-loop control board  
 S1 = "Spindle positioning" and "C-axis" option  
 G02 = Central board  
 G01 = Power supply

Fig. 3.2 Design of the 6SC6504, 6SC6506 and 6SC6508 transistor PWM converters

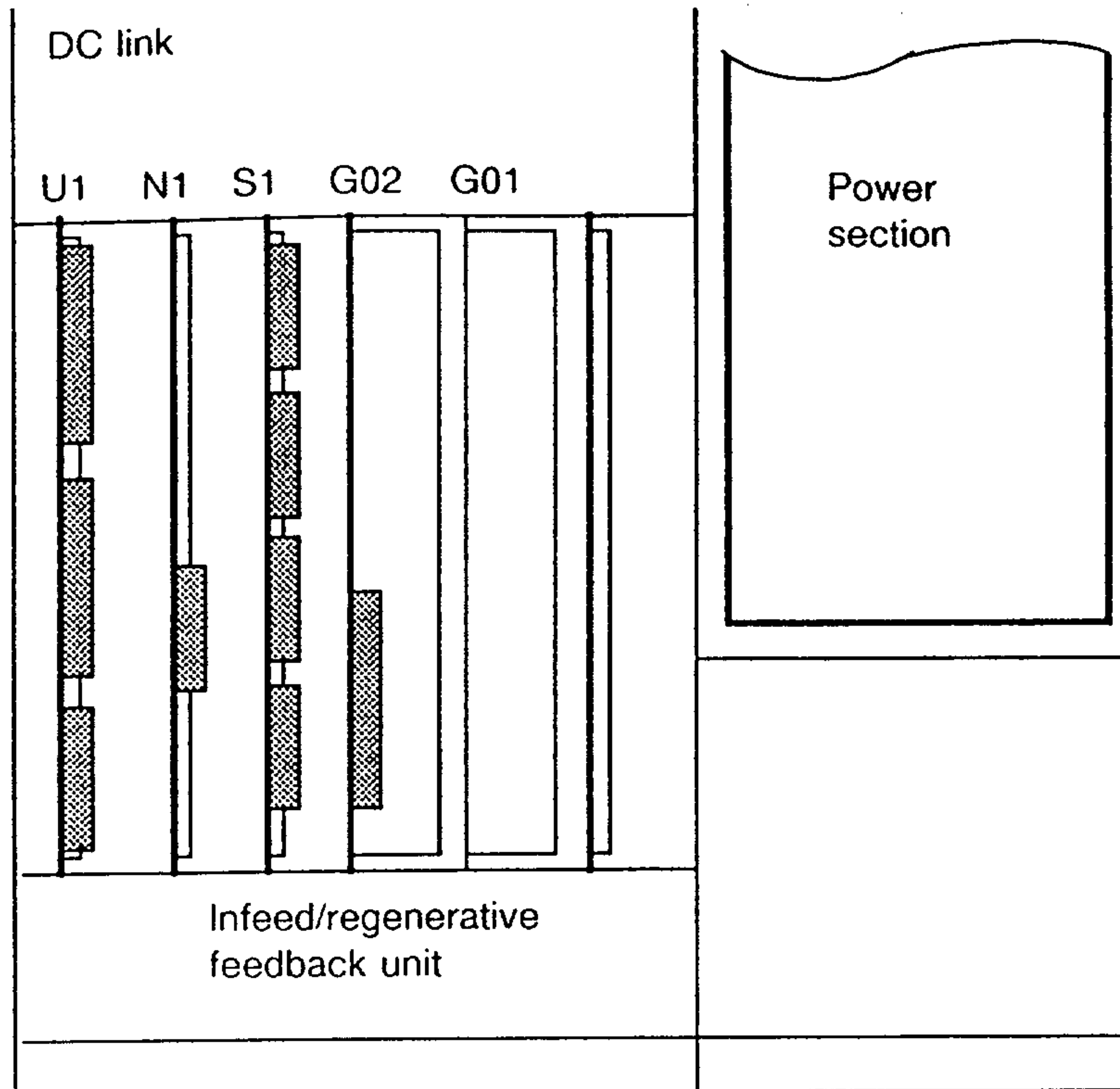

U1 = Input/output board  
N1 = Closed-loop control board  
S1 = "Spindle positioning" and "C-axis" option

G02 = Central board  
G01 = Power supply

Fig. 3.3 Design of the 6SC6512 and 6SC6520 transistor PWM converters

### 3.3 Mode of operation

#### 3.3.1 Power section

The DC link is supplied from a 6-pulse thyristor bridge circuit which operates in both the rectifier and inverter modes. In the rectifier mode, the thyristors behave like diodes. The gating control uses gating transformers. The closed-loop controller realizes the actual pulse generation and the input/output board and gating board, further processing and amplification.

In order to permit regenerative operation with 6 thyristors, the DC link is reversed through the step-up converter, and the thyristors are controlled through the closed-loop control board per software, so that they operate in the inverter mode.

The motor-side converter consists of 6 transistors with integrated anti-parallel free-wheeling diodes. A pulse width modulated voltage of 0 to 430 volts is generated by controlling the transistors.

### 3.3.2 Closed-loop control

The N1 central closed-loop control board is used for the complete converter open-loop control, i.e. it generates the gating pulses for the line-side converter, calculates the control variables for the TRANSVEKTOR closed-loop control and provides the inverter modulation. All input signals are conditioned as frequencies, and all output signals as logic signals. The necessary software is stored in five EPROMs. The settings can be transferred unchanged if a PC board has to be replaced.

The gating and closed-loop control electronics has two microprocessors, which represent the digital current and speed control loops, and calculate the field. The closed-loop control structure is a speed control loop with ramp-function generator and secondary torque control loop. It is possible to directly input the torque setpoint, bypassing the speed controller.

The "orientated spindle stop" with higher-level closed-loop position control in a numerical control (NC function M19) can attain an accuracy of  $\pm 0.5^\circ$  as a result of the extremely accurate closed-loop control concept. Shaft encoders, mounted as standard in the motors, can be used. The position can be maintained, controlled, i.e. load torques are possible but still maintaining the required position.

Operational and fault messages are indicated on the 6-digit display.

### 3.4 Options

The "C-axis" and "spindle positioning" functions are either individually or collectively located on a board. Slots S1 in the converter is prepared for all boards.

- C-axis board with sinusoidal-cosinusoidal encoder **Option A73**
  - 6SC6500-0BB01
  - 6SC6500-0BB81 (with connecting accessories)
  
- Spindle positioning board **Option A74**
  - 6SC6500-0BC01
  - 6SC6500-0BC81 (with connecting accessories)
  
- C axis and spindle positioning board **Option A75**
  - 6SC6500-0BA01
  - 6SC6500-0BA81 (with connecting accessories)
  
- Interface for connecting a PG635/675/685 programming unit **(Retrofit set)**
  - 6SC6500-0SB81

The boards can be used to upgrade all SIMODRIVE 650 PWM converters delivered after 1.87. The boards require software version 03.88 and higher.



### 3.4.1 "Spindle positioning" board

"Spindle positioning" is the fastest possible spindle approach to a specific position (e.g. for tool changing) without higher-level closed-loop position control in a numerical control.

The spindle can be run into a specified position, without overshoot, using an external command, using the "spindle positioning" board.

The position actual value can be sensed

- with the shaft encoder mounted in the motor ( $\pm 0.1^\circ$  accuracy referred to the motor shaft). The encoder zero mark, or with transmission systems between the motor and spindle, an external zero mark (e.g. BERO® proximity switch), can be used on the spindle for absolute position sensing.
- with an additional shaft encoder which is mounted on the spindle, whereby the zero mark is provided either from the shaft encoder or from an external BERO proximity switch.

Orientated spindle stop in conjunction with a numerical control (NC function M19) is included in the basic version and requires no additional board.

Possibilities of spindle position sensing:

- Spindle positioning using the mounted ROD 323 motor shaft encoder without gearbox (direct coupling)

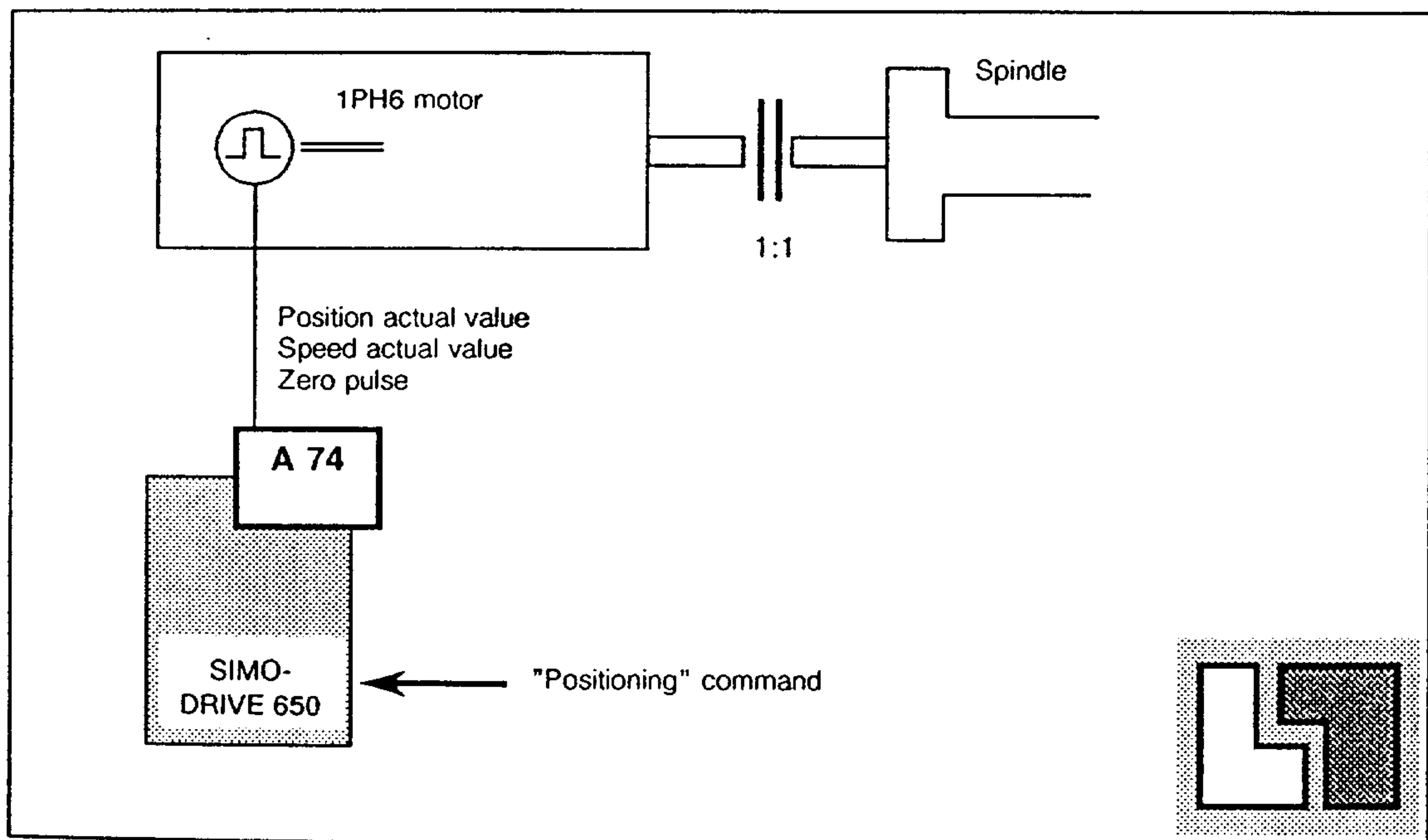



- Positioning the spindle with external spindle encoder (maximum 32767 pulses per revolution). The zero mark can either be supplied from an external spindle encoder or from a BERO proximity switch. (slip compensation with second encoder)

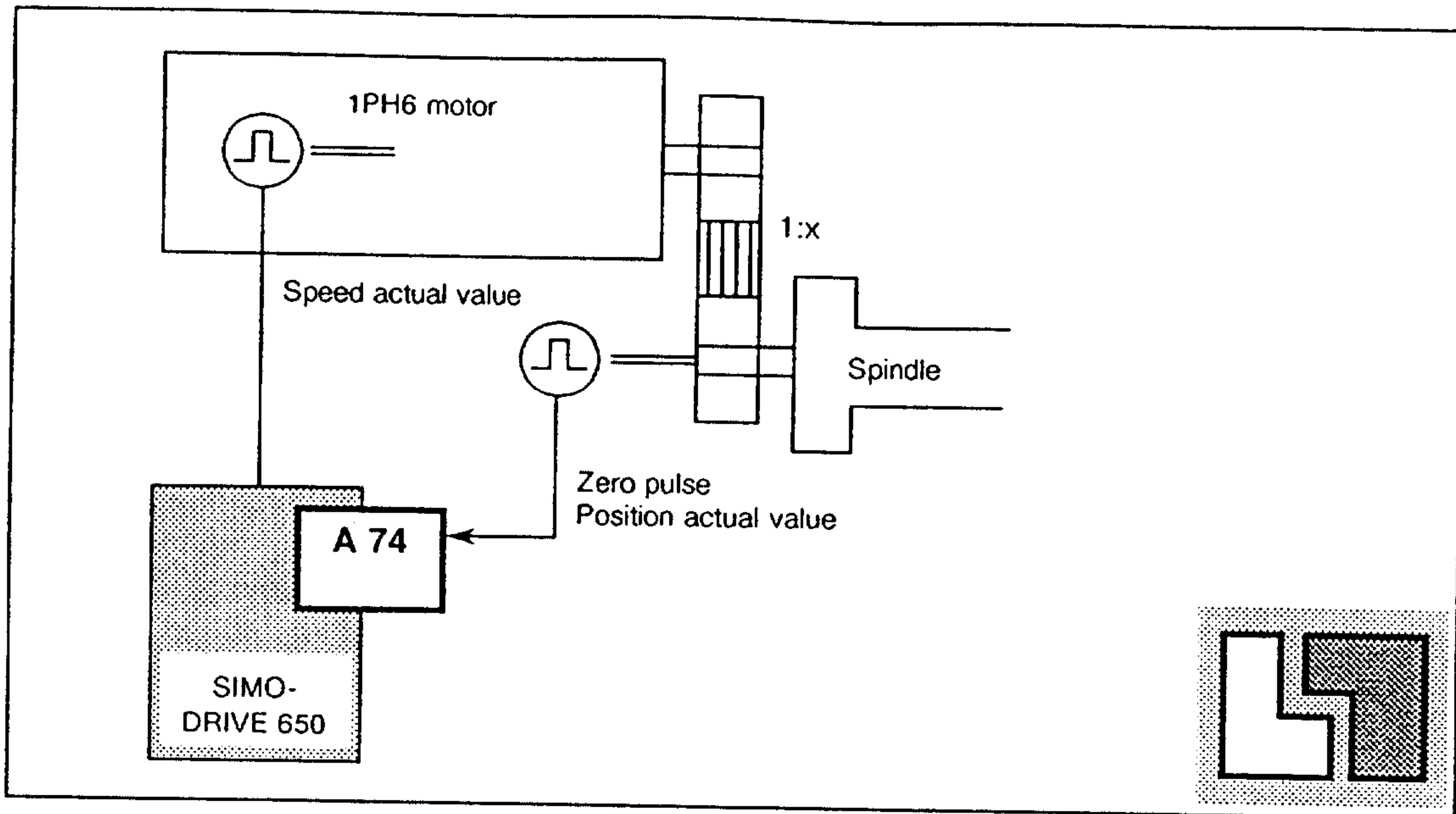

- Positioning the spindle with the mounted ROD 323 motor shaft encoder with gearbox (belt drives can only be used with additional encoder) and external zero mark on the spindle, e.g. BERO

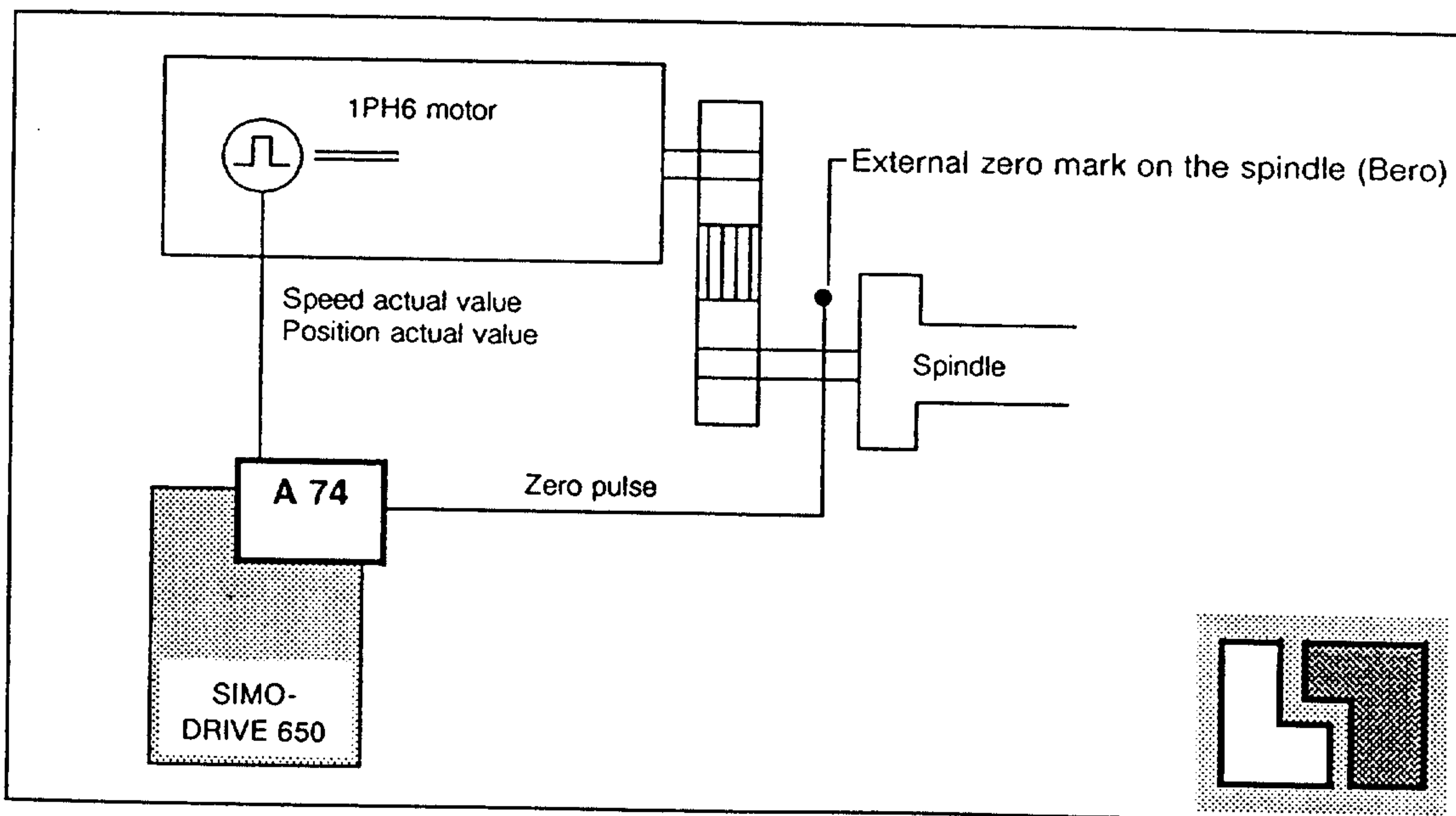

Fixed angular positions can be input as well as repeatable angular steps. The entry is realized either

- externally through a 16-bit parallel interface (24 V) in hexadecimal code (e.g. by a 4-decade thumbwheel switch) or
- internally, using standard parameter input (five various positions are possible: One position for each of the four gear stages and a position independent of this.)

The positioning sequence is executed in several phases:

- *Braking the drive*  
Starting from any speed, the drive brakes down to the search speed according to the characteristic provided by the ramp-function generator. The speed setpoint required is input from the positioning control, and any speed setpoint at terminal 56 is suppressed. The search speed is the highest speed with which the drive can be braked at the target position in one revolution without overshoot.
- *Position sensing*  
The closed-loop position controller is switched-in after the search speed has been reached. The speed setpoint in this case comes directly from the closed-loop position controller. A search speed is input until the target position has been identified.
- *Travel to final position*  
The actual positioning sequence starts during the final revolution. This ensures that the approach sequence is always the same. The last revolution is subdivided into three phases:
  - Braking characteristic
  - Gradient 1
  - Gradient 2

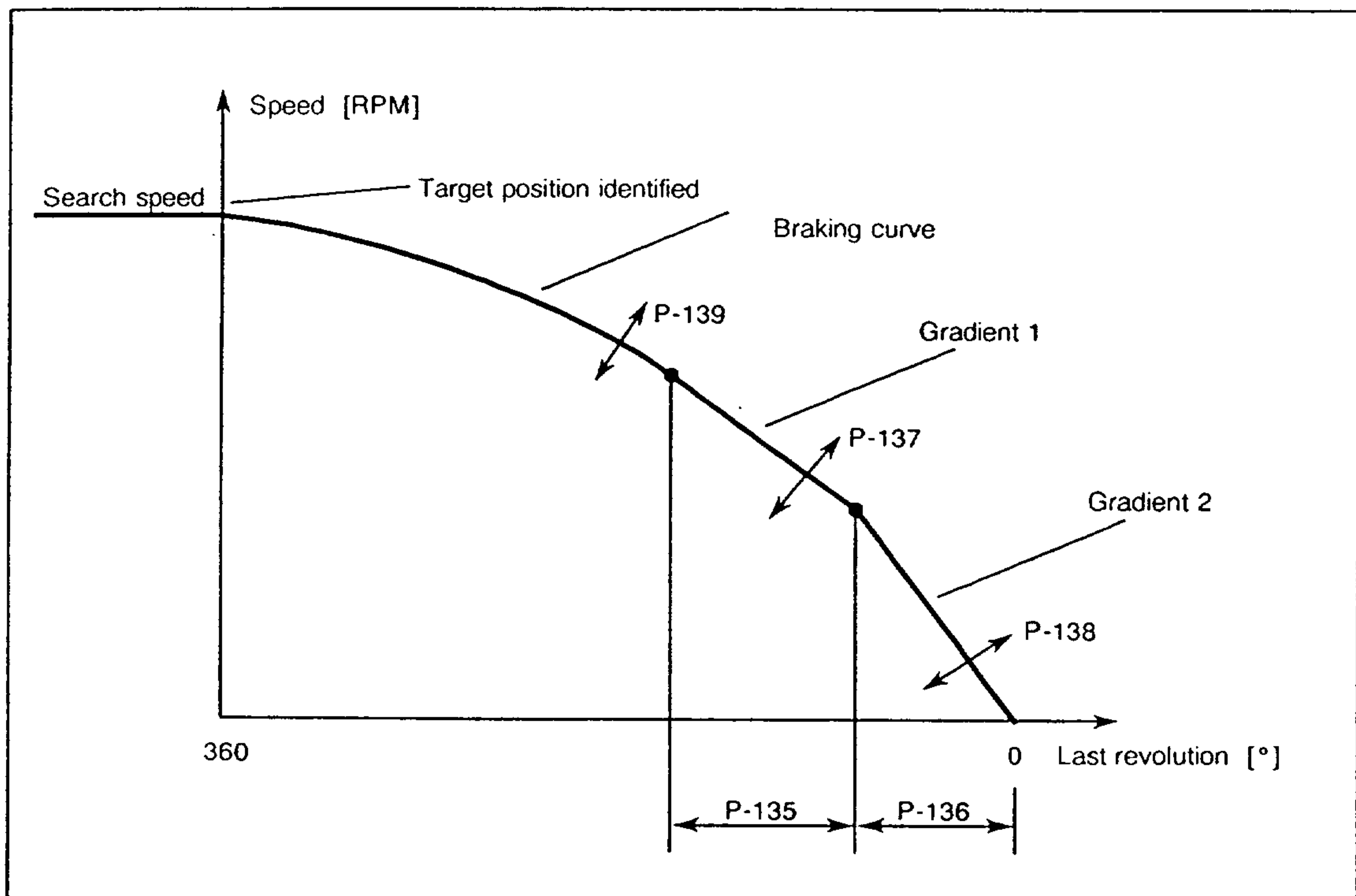

Fig. 3.4 Positioning sequence

The application points and the gradients of the three phases can be set, the approach characteristic can thus be adapted to the various requirements with parameters P-135 to P-139.

The target position is monitored, and after having been reached, two relay signals are output, with different adjustable tolerance thresholds.



### 3.4.2 "C-axis" board

In the "C-axis" mode, the main spindle drive attains feed drive quality. This function is, for instance, necessary for machining with one chucking.

The speed range in the "C-axis" mode is 0.01 RPM up to 25% of the rated speed. High resolution speed actual value sensing must be provided on the motor shaft (motor option H29) in order to fulfill these high requirements.

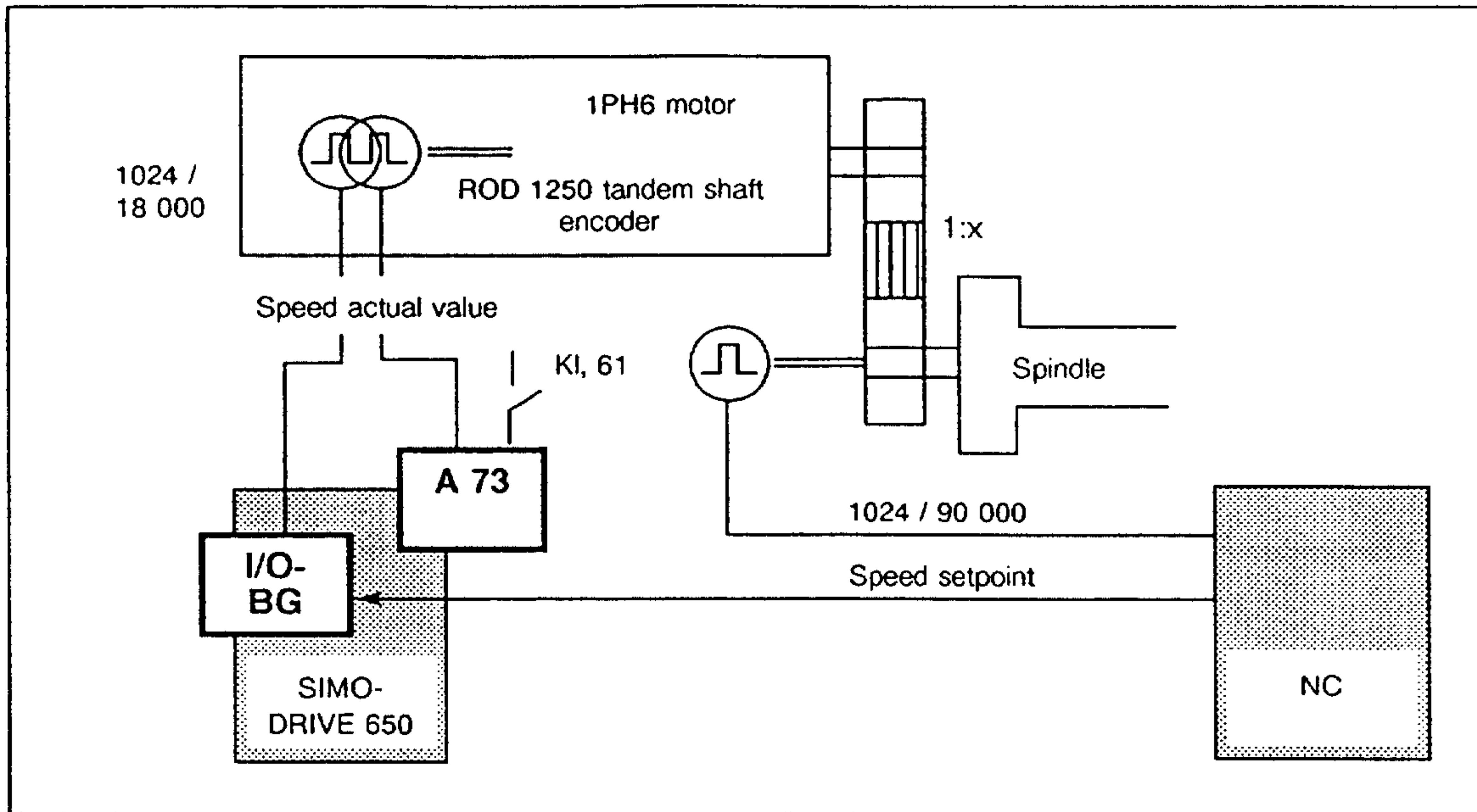

The ROD323 shaft encoder, mounted as standard, with a resolution of 1024 pulses per revolution is in this case no longer sufficient. A special double-track encoder, type ROD1250, is used. This encoder has a square-wave track with 1024 pulses per revolution and a track with 18000 sinusoidal-cosinusoidal impulses per revolution, which are subdivided into a further 256 individual steps. This provides a resolution of 4.600.000 steps per revolution and one step corresponds to a mechanical angle of approx. 0.0001°.

The square-wave track is evaluated, in the normal mode, on the input/output board. The high-resolution encoder track is evaluated on the option board. The square-wave track signals are available on the I/O board for customer use.

The high-resolution encoder track is only evaluated below a changeover speed, which can be set with parameter P-108. The P-gain and integral action time are also changed over when changing from one to the other encoder track. This changeover occurs automatically without restricting operation.

### 3.4.3 "PG coupling" board

A SIMODRIVE 650 converter can be started up in a user-friendly fashion using a PG635/675/685 programming unit, using this board.

This option includes the interface board for connecting a SIMODRIVE 650 unit, and a program floppy disk for the programming unit.

For startup, the interface board is inserted at the plug connector X131 available as standard on the closed-loop control board N1. After startup, the interface board is withdrawn and can be used for other startups. The connection between the programming unit ("print" socket) and the interface board is established using a cable, type 6FC9344-1A (refer to Section 4), which is used as standard for establishing the connection between SINUMERIK and a programming unit or SIMATIC and a programming unit. A 9600 baud transmission rate is recommended to speed up the transmission.

The SIMODRIVE 650 converter startup program is subdivided into "process parameter" and "transfer data" blocks.

The converter parameter set is represented, menu prompted, in the "process parameter" block. The enable signals can either be realized in a file, or directly transferred on-line to the converter, so that their effect at the converter can be checked. In this operating mode, converter fault messages are also displayed in plain text on the programming unit screen. Further, it is possible to simultaneously display all operating messages and data of the converter (P-00-P11) on a program screen mask. In addition, the user can generate his own masks for startup purposes.

It is possible to store an optimized data set on a floppy disk or on a hard disk, or this data set can be directly transferred to the EEPROM of the converter for transcribing, in the "transfer data" block. This capability is especially useful and saves time when starting up standard machines.

### 3.4.4 External heat dissipation option

With this design (option E45), for units 6SC6504, 6SC6506, 6SC6508, 6SC6512 and 6SC6520, the cooling air circuit for the power section is separated from the interior of the machine tool cubicle. In this case, the power section heat dissipation must not be taken into account when dimensioning the cubicle cooling. The incorporated standard filter mat extracts particles having a diameter exceeding 5  $\mu\text{m}$ .

The E45 option includes the complete set and cubicle fan, hose connections, outlet filter, and connecting flange.

Only 6SC6508 to 6SC6520 converters can be retrofitted with the "external heat dissipation" option.

The total duct length cannot be greater than 1.5 m in order to ensure the necessary air-flow rate.

The connecting flanges themselves should be ordered with option E55.



### 3.5 Operation

The SIMODRIVE 650 digital transistor PWM converter can be easily started up and adjusted using the incorporated six-digit display and a simple keyboard. In normal operation, the display indicates the operating conditions. When a fault condition occurs, the fault is indicated which caused the shutdown.

The parameters are preset in the factory but can however be changed as required.

The drive parameters are set using two keys, which increase or decrease the value indicated in the display. The longer a key is pressed, the faster the displayed value is changed. The display mode is changed with the P key (operational display/number of the operational display or display of the parameter value/parameter number).

The parameters can be changed in steps of at least one part per thousand. The parameter is entered in a physical dimension, percentage or in hexadecimal format.

Customer-specific parameters for standard series-production machines can be completely entered in a programmed EEPROM. The motor data, necessary for the field calculation is retrieved from a stored file (EPROM) by entering a motor identification code.

Startup can be executed, menu prompted, with a programming unit. Once the settings have been optimized, the data set can be stored in the programming unit, and when starting up identical machine tools, can be completely transferred to the converter.

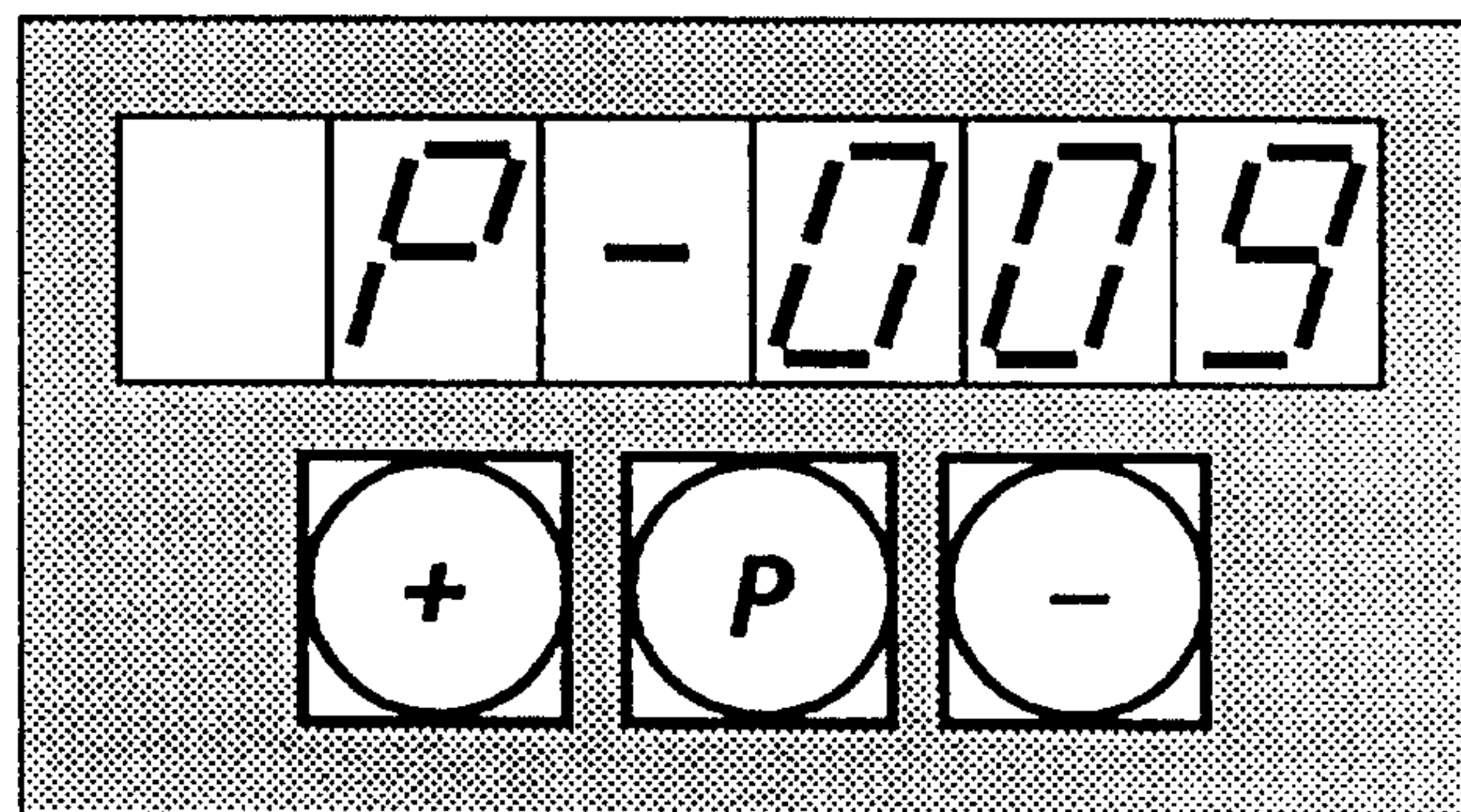

Fig. 3.5 Display and operator control elements

The most important operational and parameter displays are:

**Operating displays:**

P - 00	Enable status and torque direction with gear stage
P - 01	Speed setpoint
P - 02	Speed actual value
P - 03	Torque setpoint
P - 05	PWM converter output frequency
P - 06	DC link voltage
P - 07	DC link current
P - 08	DC link rating (not identical to $P / P_{max}$ )
P - 09	Line supply frequency
P - 10	Motor stator temperature
P - 11	Status of the binary inputs

**Parameter displays:**

P - 12	Normalization, speed actual value output
P - 13	Normalization, output $P / P_{max}$
P - 14, P-15	Setting value, speed setpoint
P - 16, P-18	Setting value, ramp-function generator
P - 21 to P29	Setting value, speed monitoring
P - 21	Response value, message $n_{min}$
P - 22	Reponse value $n_{min}$ internal
P - 23	Response value, message $n_x$
P - 27	Response threshold, message $n_{set} = n_{act}$
P - 29	Maximum speed
P - 31 to 38	P- and I-components of the speed controller for 4 gear stages
P - 39 to 46	Torque limit value (absolute value and selectable for 4 gear stages)
P - 47	Response value, signal $T_x$
P - 51	Overwrite RAM enable
P - 52	Store RAM contents in the EEPROM
P - 65	Line resistance
P - 66 to 69	Measuring socket assignment
P - 95	Pulse converter adaption
P - 96	AC motor adaption
P - 98	Number of pulse tachometer pulses per revolution
P - 99	Software version



## 3.6 PWM converter - Interfaces

### 3.6.1 Inputs

- **Analog signals:**
  - Speed setpoint  $n_{set 1}$  (0 V to  $\pm 10$  V)
  - Speed setpoint  $n_{set 2}$  (0 V to  $\pm 10$  V)
  - Torque setpoint
  
- **Binary signals:**  
(can be driven, floating, with internal or external voltage)
  - Direct pulse suppression (terminal 63)  
(If this terminal is de-energized with the drive running, the motor idles down to standstill. This terminal directly influences the line- and motor-side converters.)
  
  - Closed-loop control enable (terminal 64)  
(If this terminal is de-energized, the drive brakes down to standstill with the selected ramp-down time. The motor is switched-off (no-voltage condition) when the speed is zero. At switch-on, the time constant for the re-magnetization must be taken into account.)
  
  - Ramp-function generator - Fast stop (terminal 81)  
(If this terminal is de-energized, the drive is braked down to standstill with the maximum torque. The motor remains magnetized at standstill.)
  
  - Limiting torque - Reduction (terminal 111)  
(When the terminal is energized, the maximum motor torque is reduced to a set value, dependent on reaching a selectable speed limit.)
  
  - Oscillating setpoint for gear change (terminal 60)  
(When this terminal is energized, an internal drive oscillation is generated, which has a variable frequency and amplitude, in order to facilitate gear change. Setpoints, if available, are suppressed.)
  
  - Set ramp-function generator to zero (terminal 62)  
(Ramp-function generator disabled)
  
  - Selection of four speed controller settings and limiting torques for various gear stages
  
  - Closed-loop torque control (terminal 158)  
(The torque setpoint of the "master" drive can be fed to the "slave" drive, for example for a twin drive. In this case, the "master" drive is speed controlled, and the "slave" drive is torque controlled in an open-loop fashion.)
  
  - Reset  
Remote acknowledgement of fault messages

**Note : Use of the controller enable (terminal 64) and ramp-function generator - fast stop (terminal 81) signals:**

When terminal 64 (closed-loop controller enable) is used to stop the drive, the motor is switched to a no-voltage condition when standstill is reached. This also means that the motor magnetic field decays. If at restart, a speed setpoint is input together with closed-loop controller enable, then the motor can only provide its full torque after approx. 400 ms, because the motor magnetic field must first be built up in this time.

For time-critical applications, such as e.g. automatic tool change, it is recommended that terminal 81 is used to brake the drive to a standstill (ramp-function generator - fast stop). After the motor has come to a stop, the digital speed setpoint zero is input. Terminal 111 should be simultaneously energized if the motor shaft should yield to an external torque. The drive starts instantaneously, and can accelerate with the maximum torque if terminal 81 is energized when the motor is started.

### 3.6.2 Outputs

- **Analog signals:**

- $n_{act}$
- $P / P_{max}$  (e.g. for displaying the output power)
- $T_{set}$

- **Relay signals (floating):**

When configuring external adaptive controls it should be ensured that when faults occur the relays drop out.

- Signal Ready with group fault signal
- Signal  $n < n_{min}$
- Signal  $n < n_x$
- Signal  $n_{set} = n_{act}$
- Signal  $T < T_x$
- Signal Motor overtemperature prewarning

- **Shaft encoder signals:**

The shaft encoder signals are available on the input/output board for external use. This output is fed to the PWM converter through a driver stage and is thus decoupled from the actual function.

An adaptor cable is available for this connection.

- **Display messages (alternative):**

- |   |  |
|---|--|
| <ul style="list-style-type: none"> <li>- Operating displays:           <ul style="list-style-type: none"> <li>• PWM converter ready</li> <li>• Closed-loop control enable</li> <li>• Torque direction</li> <li>• Gear stage</li> <li>• Status of the digital inputs</li> <li>• Status of the digital outputs</li> </ul> </li> </ul> | <ul style="list-style-type: none"> <li>- Measured values:           <ul style="list-style-type: none"> <li>• <math>T_{set}</math></li> <li>• <math>n_{set}</math></li> <li>• <math>n_{act}</math></li> <li>• DC link voltage</li> <li>• DC link current</li> <li>• DC link power</li> <li>• <math>P / P_{max}</math> in %</li> <li>• <math>T / T_{max}</math> in %</li> <li>• Output frequency</li> <li>• Motor temperature</li> <li>• Line frequency</li> </ul> </li> </ul> |
|---|--|



• Display messages:

– Fault messages:

(several simultaneous faults can be called up one after another)

- \* Supply monitoring:
  - Frequency
  - Phase failure
  - Incorrect phase sequence
- \* Supply undervoltage
- \* DC link overcurrent
- \* Inverter overcurrent
- \* Overload
- \* Closed-loop control deviation too great (rotor locking protection)
- \* DC link overvoltage
- \* DC link undervoltage
- \* DC link is not charged (switch-on sequence)
- \* Actual value missing:
  - Encoder
  - Voltage
  - Current
  - NTC thermistor
- \* Defective transistor in the inverter or step-up converter
- \* Converter overtemperature
- \* Motor overtemperature

### 3.7 Startup

#### 3.7.1 Display and operator control elements

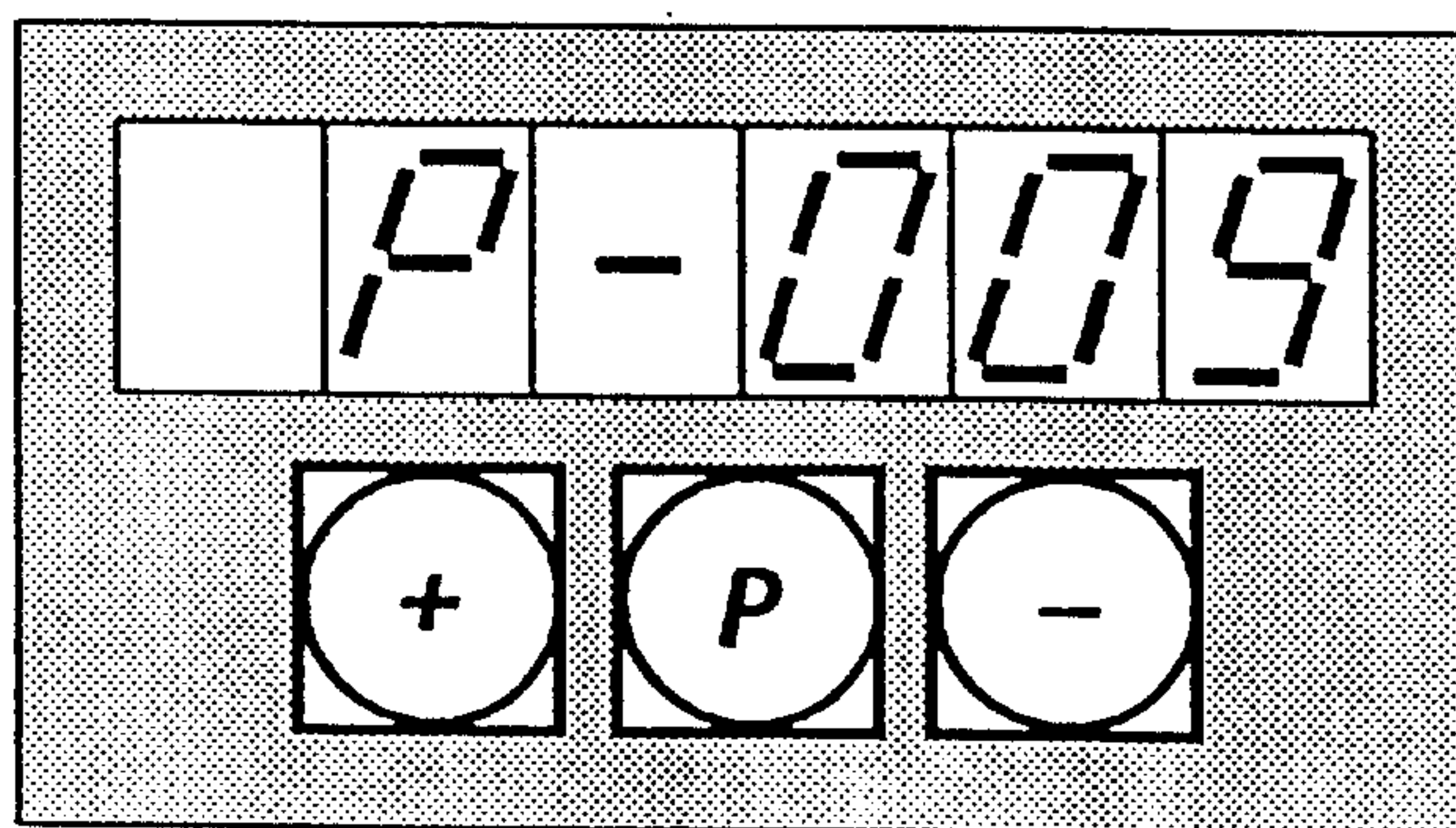

Fig. 3.4 Display and operator control elements

The parameter numbers and the setting values are indicated on the six-digit 7-segment display. The values are either indicated in decimal or hexadecimal format.

If the setting values are to be displayed in decimal, the preliminary zeros are suppressed.

When the setting values are displayed in hexadecimal, the letter "H" is inserted at the last display position, and the leading zeros are not suppressed. A point is inserted at the last position when the parameter number is displayed in hexadecimal.

The operator control elements are the "+" key, "P" key (parameter key) and the "-" key.

The values are changed by +1 or -1 at the last position by briefly depressing the "+" or "-" key. The longer the key is depressed, the quicker the value changes. If the "P" key is simultaneously depressed, then the value changes with 16x speed.

The keys have a different function in the operator control mode as in the fault mode.

Key	Operator control mode function	Fault mode function
"+" key	Increase parameter number or parameter value	Switch to the next fault message
"-" key	Decrease parameter number or parameter value	Brief changeover (for approx. 1 min.) into the operator control mode
"P" key	Changeover parameter number to parameter value or changeover parameter value to parameter number	Fault acknowledgement with controller inhibit available
"+"-key and "P"-key	Fast change of the parameter value to more positive values	none
"-"-key and "P"-key	Fast change of the parameter value to more negative values	none

### 3.7.2 Operating display

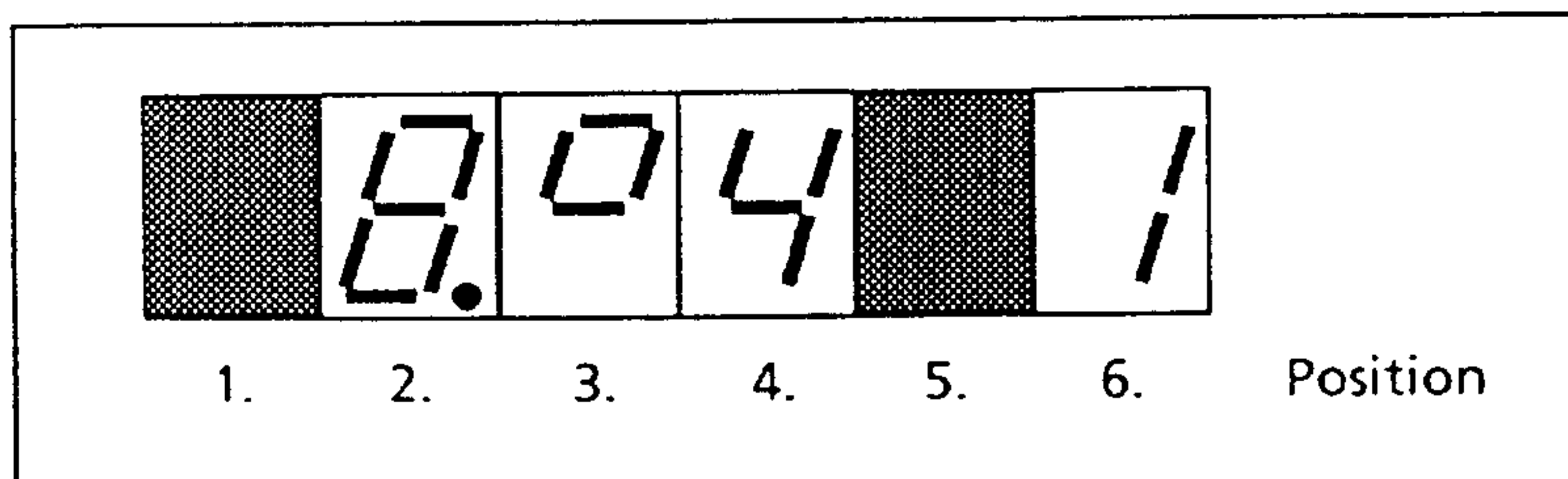

Fig. 3.5 Example of an operating display

The first and fifth position in the operating display are not controlled, and remain dark.

- **Significance of the second position**

The relay statuses are displayed at the second display position after the DC link has been charged. The individual display segments are controlled if the applicable relay signal is active, i.e. the relay has pulled in. The relays drop out when fault conditions occur (fault signals).



The individual display segments are assigned to the relay functions as follows:

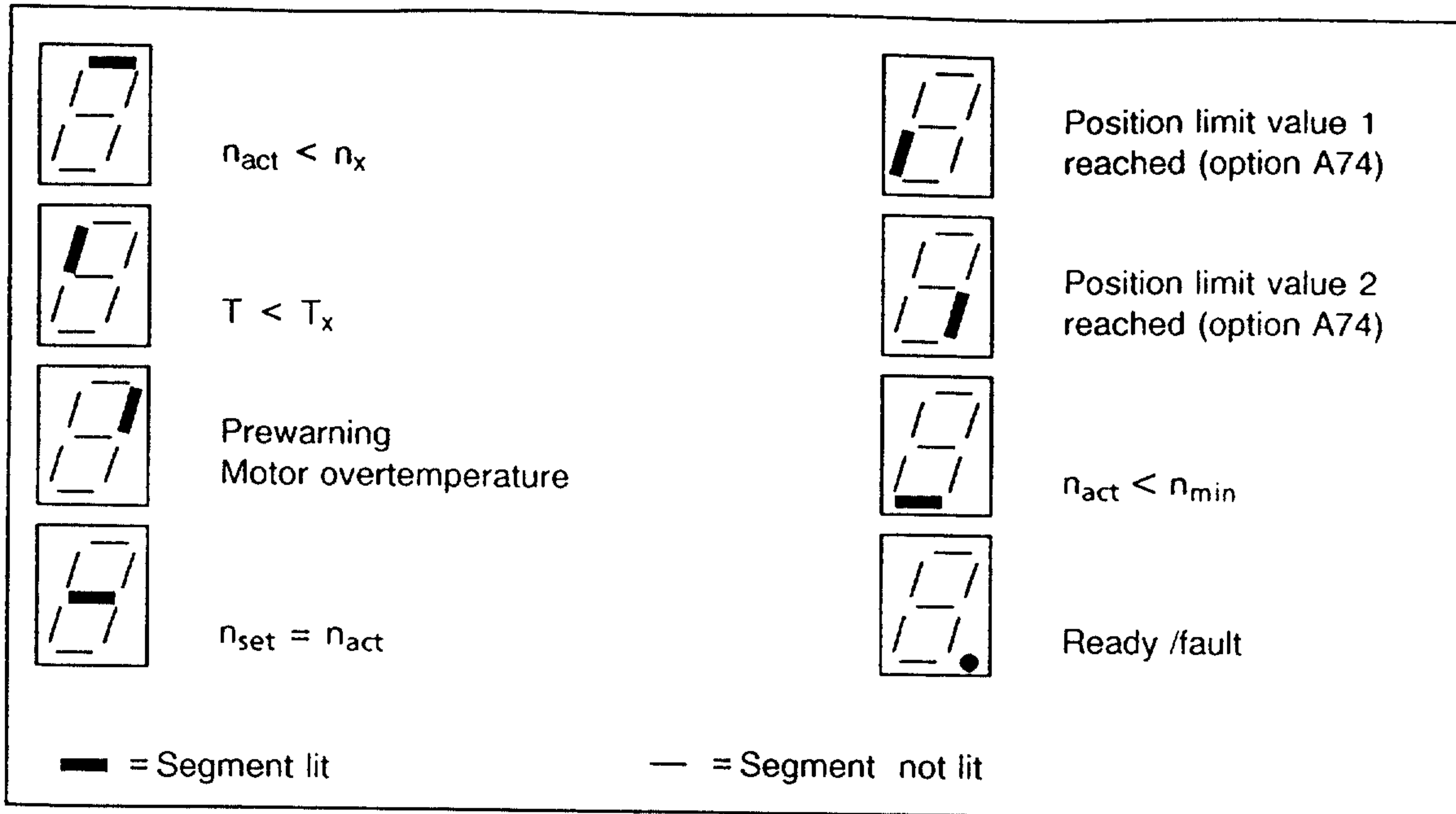
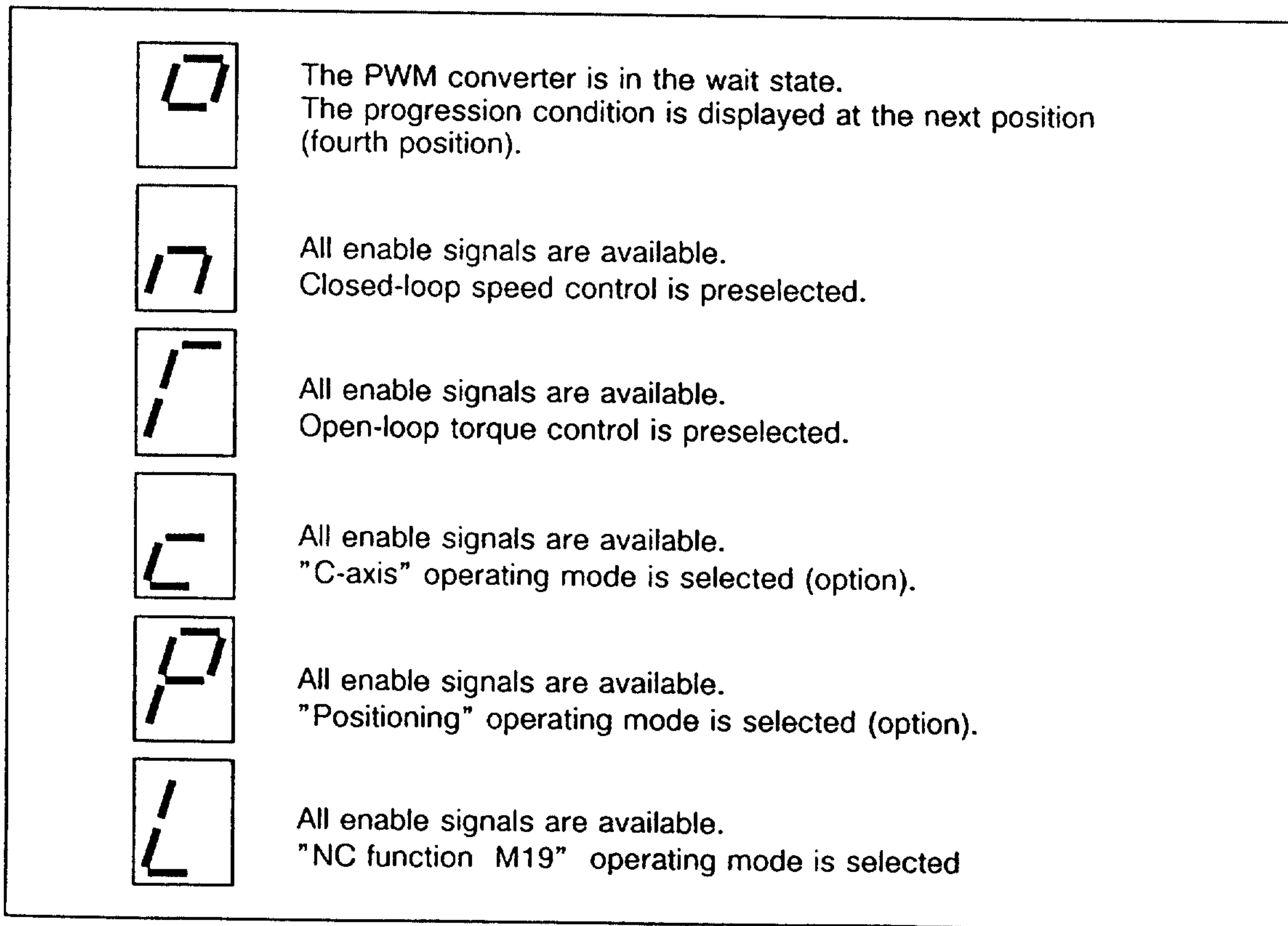

Fig. 3.6 Displays at the second display position





• Significance of the third position





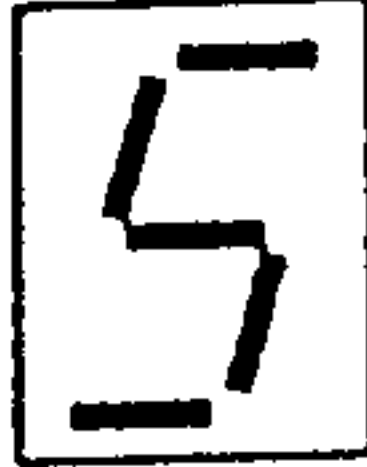
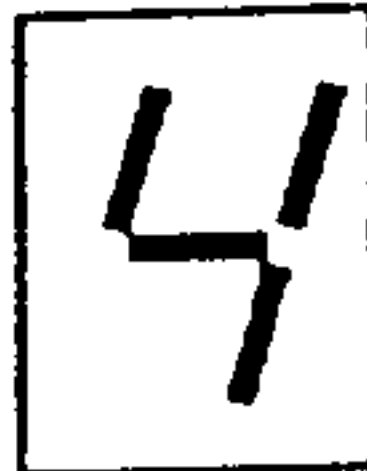

- Significance of the fourth position

The progression conditions are displayed at the fourth position of the display before the motor starts.



	Line-side gating unit enable
	Charge DC link
	Pulse enable (inverter)
	Closed-loop control enable (inverter)
	Ramp-function generator enable

As soon as the progression conditions are fulfilled, the fourth position indicates the torque direction demanded by the closed-loop control.

	Motor operation
	Generator operation

• **Significance of the sixth position**

The sixth position of the display indicates the preselected gear stage.

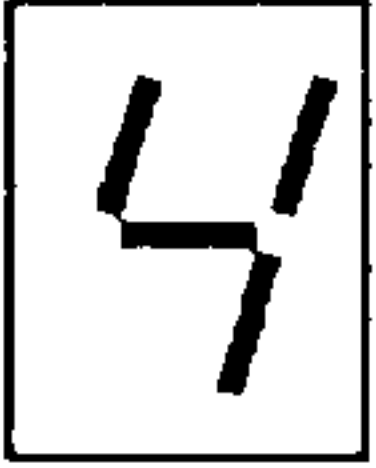
	No gear stage available or selected
	Gear stage 2 selected
	Gear stage 3 selected
	Gear stage 4 selected

**3.7.3 Measured value displays**

The following measured value displays are assigned to parameters (P-01) to (P-10) :

Parameter	Significance	Unit	Format
(P-01)	Speed setpoint	%	0 to 100.0
(P-02)	Speed actual value	RPM	0 to 16000
(P-03)	Torque setpoint (converter related)	%	0 to 100.0
(P-04)	$P/P_{max}$ PWM converter 1)	%	0 to 100.0
(P-05)	Motor frequency	Hz	0 to 300.0
(P-06)	DC link voltage	V	0 to 999
(P-07)	DC link current	A	0 to 300
(P-08)	DC link power	kW	0 to 160.0
(P-09)	Supply voltage frequency	Hz	0 to 100.0
(P-10)	Stator temperature	°C	-10 to + 150

1)  $T/T_{max}$  is valid up to rated speed  $n_N$ ;  $P/P_{max}$  is valid above  $n_N$

### 3.7.4 Assignment and normalization of the D/A converter (measuring sockets)

Measuring sockets are available on the closed-loop control board for diagnostics. The measuring sockets are driven by D/A converters. The assignment of the D/A converters can be freely selected per parameter. Please take the address assignment from the list of variables.

The assignment of the measuring socket  $I_{Dset}$  to the analog converted current setpoint of the DC link is fixed, and cannot be changed.

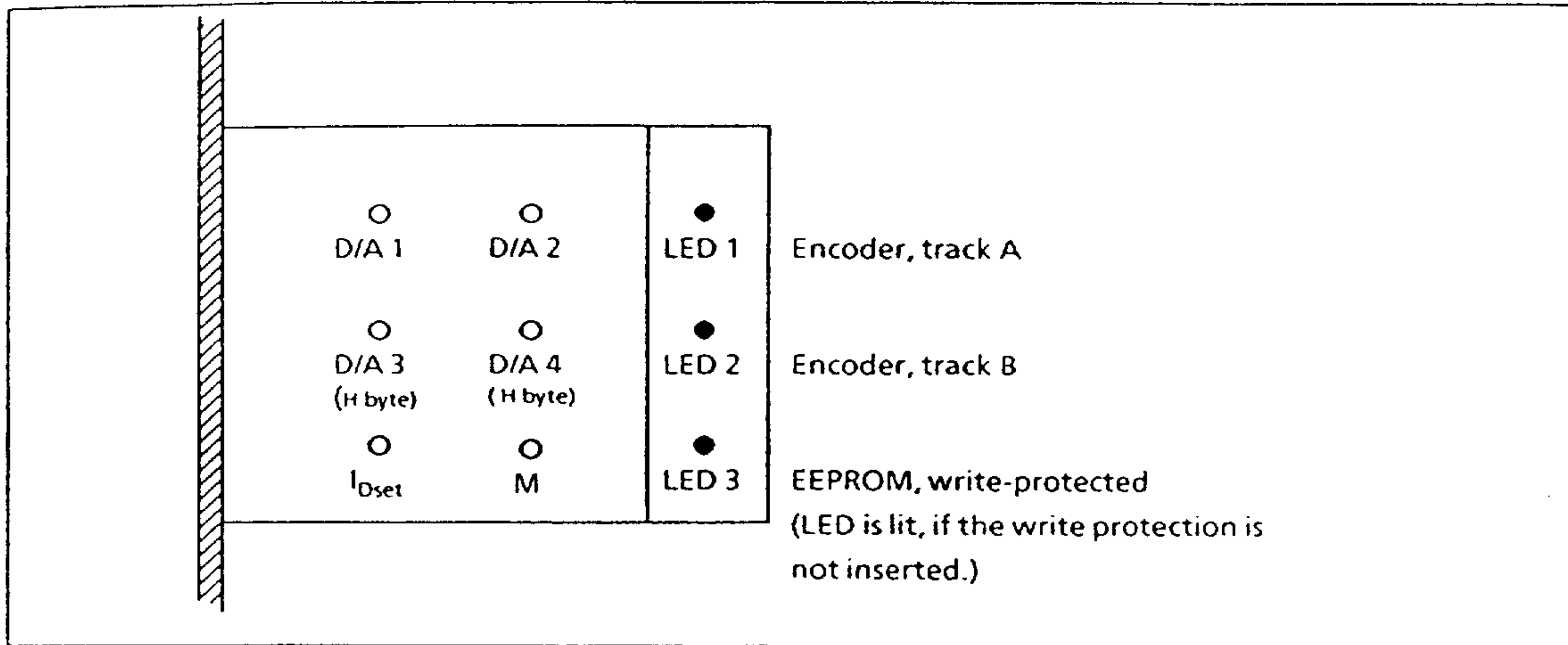

Fig. 3.11 Assignment of the measuring sockets and LEDs on the N1 closed-loop control board N1

Parameter	Significance	Unit	Format
P-66	D/A converter 1 assignment (RAM address: $0272_{Hex} = n_{act}$ )	Hex	0000H.
P-67	D/A converter 1 normalization (shift to the left)	Hex	0000H.
P-68	D/A converter 2 assignment (RAM address: $0274_{Hex} = P/P_{max}$ )	Hex	0000H.
P-69	D/A converter 2 normalization (shift to the left)	Hex	0000H.
P-76	D/A converter 3 assignment (14 bit select output)	Hex	0000H.
P-77	D/A converter 3 normalization (shift to the left)	Hex	0000H.
P-78	D/A converter 1 offset	Hex	0000H.
P-79	D/A converter 2 offset	Hex	0000H.
P-80	D/A converter 3 offset	Hex	0000H.



3 Transistor PWM converter  
3.7 Startup

The normalization is realized by shifting the selected data values to the left. Data values can be shifted a maximum of 15 x to the left (setting the parameter in hexadecimal format 000F<sub>Hex</sub>).

The D/A converters have an 8-bit resolution. The most significant byte of a word is evaluated. If 0007F<sub>Hex</sub> is available at the D/A converter +10 V analog is output, and for 0080<sub>Hex</sub>, -10 V.

A 14-bit resolution is attained at terminals 18 and 78 by connecting D/A converter 3 and D/A converter 4 in parallel.

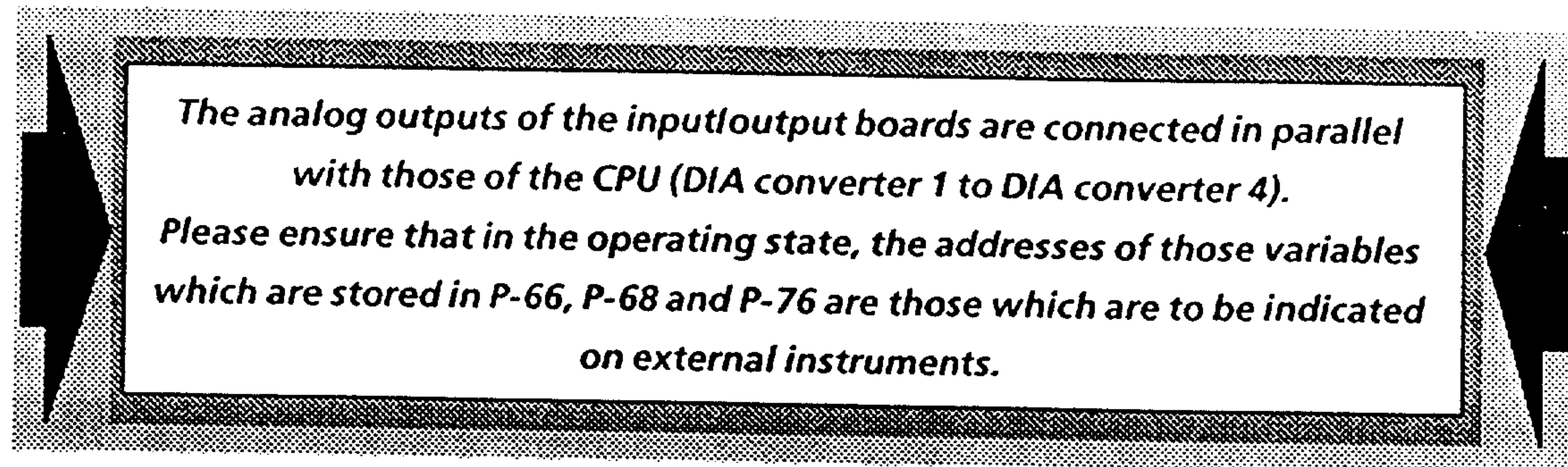

1) preset in the factory

### 3.8 Technical data

Supply voltage	3 phase 400V AC (-15% / + 10%)
Supply frequency	45-63 Hz
Output voltage	3 phase 0 to 430 V AC
Output frequency	0 to 300 Hz
Efficiency	approx. 97%
DC link voltage	575 V DC
Clock frequency	variable, up to 1.8 kHz
Permissible ambient temperature in operation	0°C to 40°C (up to 55°C if derated)
during transport and storage	-30°C to 70°C

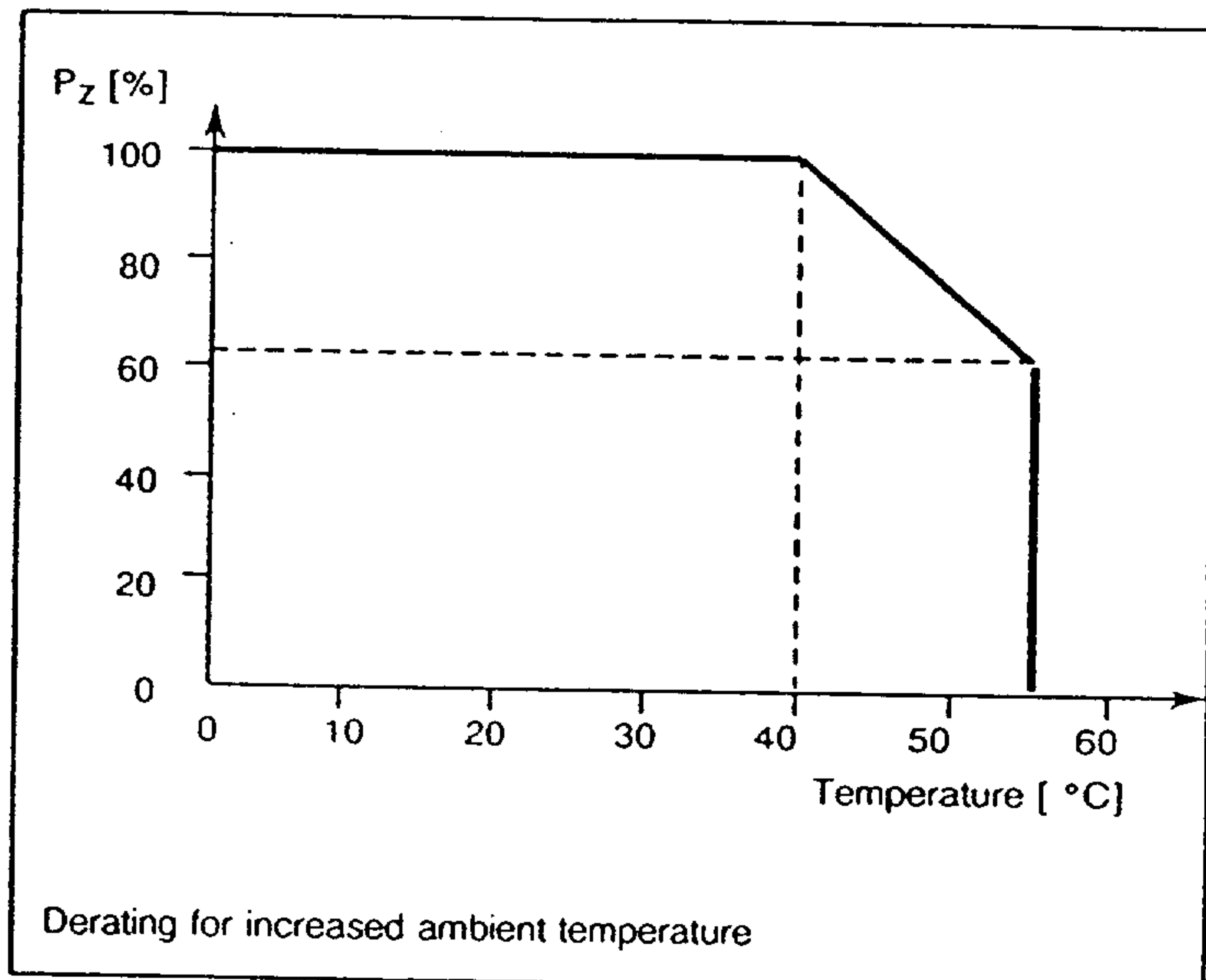

Insulation	Group C according to DIN VDE 0110/11.72 380 V
High voltage test	Units are tested according to VDE 0160/5.88
Degree of protection	IP 00 according to DIN 40050 and IEC 144
Permissible humidity rating	Class F according to DIN 40040 Average annual relative humidity ≤ 75 % 30 days annually, continuous 95 % occasionally on the other days 85 %
Cooling type	External

Installation altitude

The specified values for the rated and limiting DC current refer to installation altitudes up to 1000 m above sea level. The rated DC currents should be reduced according to the diagram below for site altitudes exceeding 1000 m.

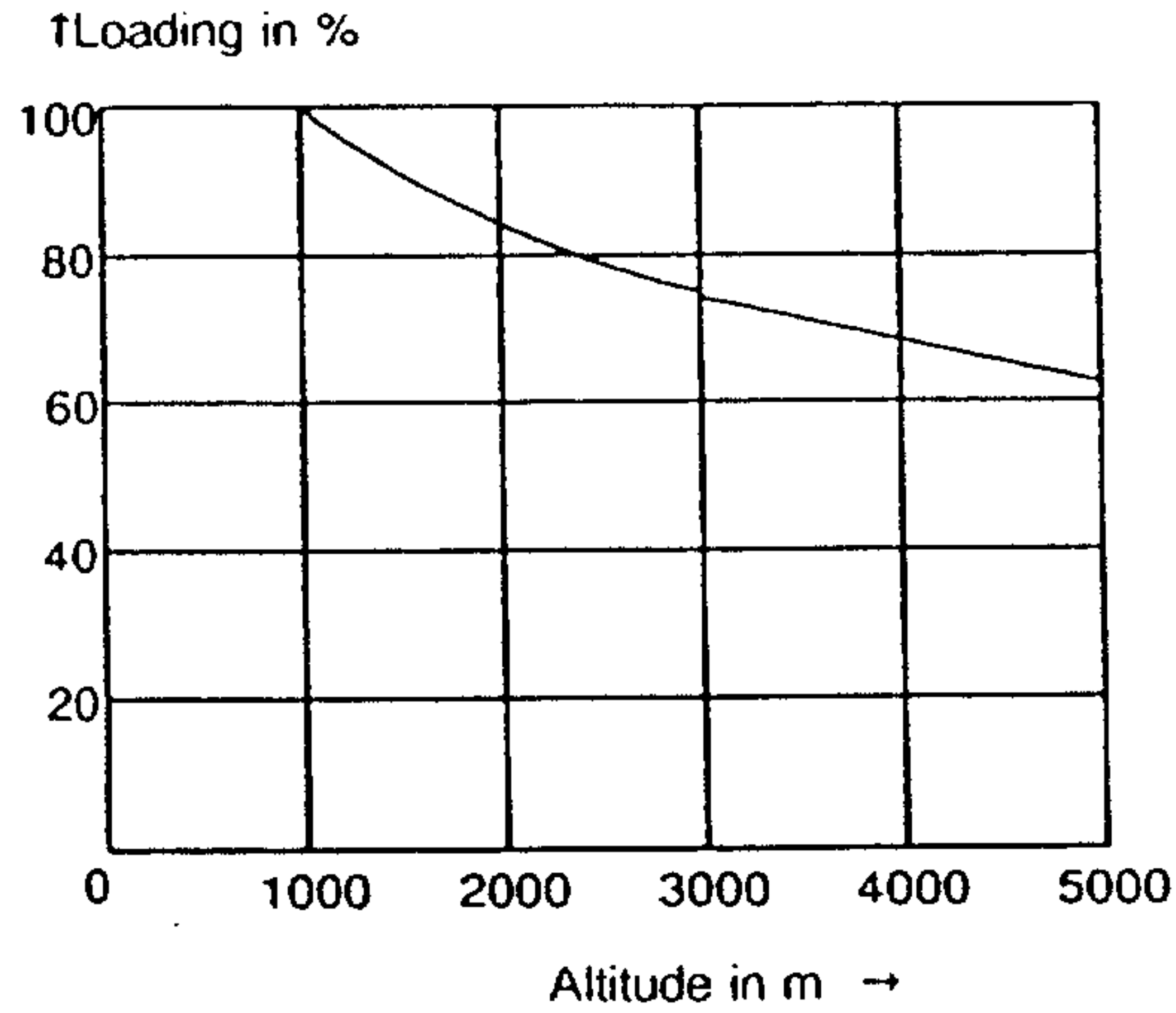

PWM converter Order No.	Line-side current		Rated o/p current [A]	Rated app. power [kVA]	Cont. infeed power [kW]	Cont. regenerative power [kW]	Max. power loss [W]	Incoming fuse (incorporated) [A]	Weight approx. [kg]
	at rated voltage [A]	at under-voltage condition [A]							
6SC65	[A]	[A]	[A]	[kVA]	[kW]	[kW]	[W]	[A]	[kg]
02-4AA□□	18	22.5	20	15	18.5	14	400	45	40
03-4AA□□	30	33.5	30	22.5	18.5	14	450	45	40
04-4AA□□	36	41	40	30	28	22	750	45	55
06-4AA□□	54	62	60	45	33	27	1100	80	55
08-4AA□□	72	82	85	60	56	45	1500	2 x 45	70
12-4AA□□	108	124	120 <sup>1)</sup>	90	87	70	2300	160	120
20-4AA□□	180	205	200 <sup>2)</sup>	150	120	100	3300	250	220

Table 3.2 Technical data of the PWM converter

1) S6-60% (10min cycle) 140A, S6-40% 150A

2) S6-60% 220A



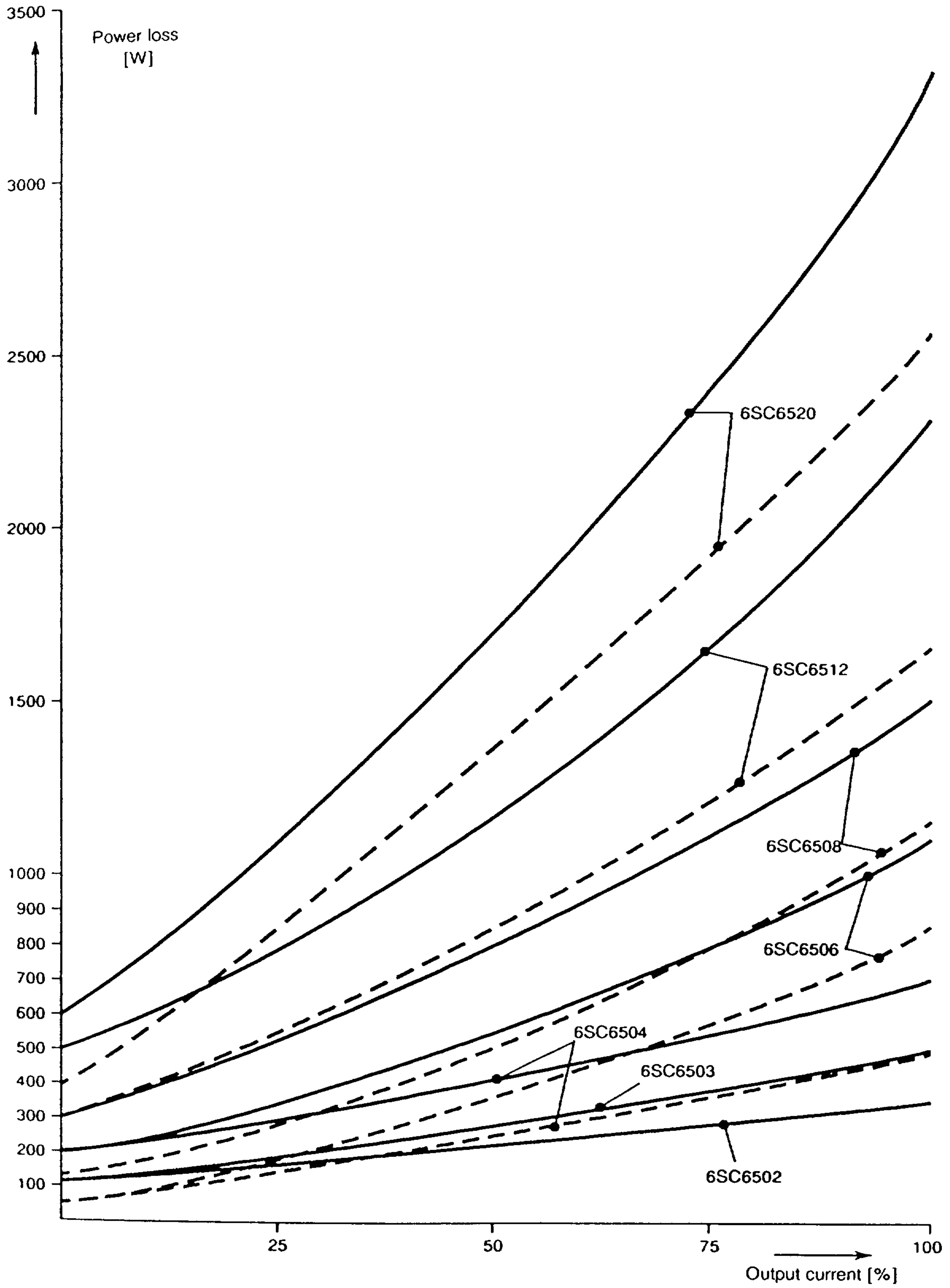

Fig 3.14 ——— Maximum power loss at rated voltage as a function of the output current  
 - - - Power loss dissipated with option E 45 external heat dissipation (the difference between the dotted and continuous lines corresponds to the heat which is not dissipated)

### 3.9 Type designation

The type designation (which is also the Order No.) consists of a combination of digits and letters. It is subdivided into 3 blocks, which are connected by two hyphens.

The first block comprises 7 positions, and identifies the PWM converter type. The second block contains codes for additional design features. The third block is provided for additional information.

Configuration of the PWM converter Order No.:

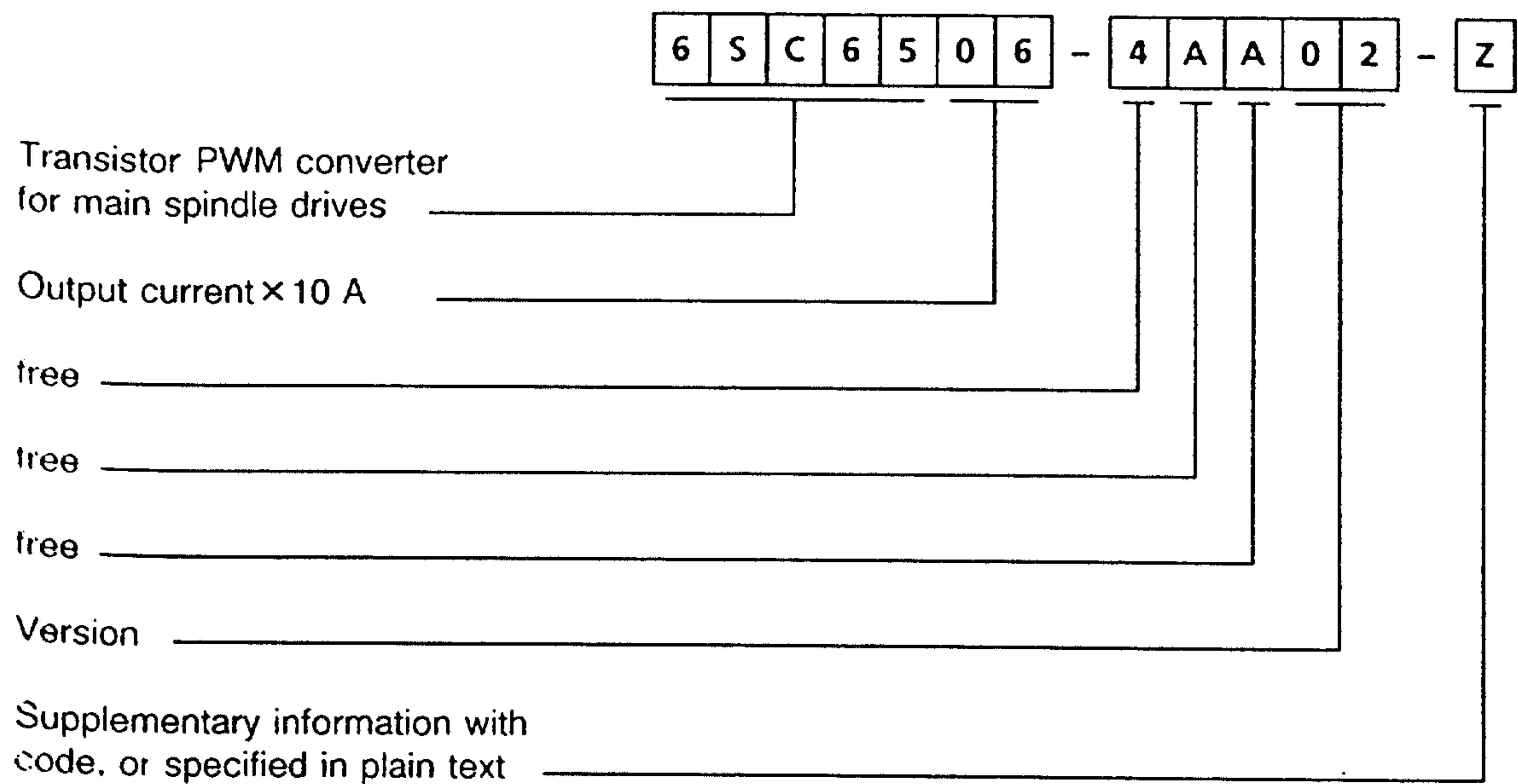

Codes:

- A73 = "C axis" option
- A74 = "Spindle positioning" option without numerical control
- A75 = "Spindle positioning and C axis" option
- E45 = "External heat dissipation" option
- E55 = Option for connecting flange for external heat dissipation

Ordering example:

Transistor PWM converter	6SC6506-4AA02
Special design	-Z
"C axis" code	A73
E45	

Complete Order No.: **6SC6506-4AA02-Z**  
**A73**



## 4 Installation instructions

### 4.1 Installation



#### WARNING



Hazardous voltages are used in the operation of this equipment, and will cause severe personal injury or loss of life and property damage if the equipment is not handled in the correct fashion. Please observe the warnings in the following text and on the equipment itself.

- Only qualified personnel familiar with this equipment should service, repair or troubleshoot the equipment.
- Before carrying out any work the equipment should be isolated from the supply and grounded.
- Only spare parts authorized by the manufacturer should be used.
- The specified maintenance intervals and work as well as the repair and replacement procedures must be strictly adhered to.

#### 4.1.1 AC motors



*Use all of the lifting eyelets during transport.*



- The 1PH6 motor are dynamically balanced. High-speed motors (option L37) are always balanced with half key. Other motors are, at the present, time balanced with full key. It can be assumed that this will change to half key balancing as a result of a change in the balancing specifications for electrical machines (DIN ISO 8821). Motors, balanced with half key, are designated with an "H" on the shaft end face.
- When mounting drive elements the suitable equipment should always be used together with the thread on the shaft.
- It is not permissible to use a hammer, as this will damage the shaft encoder.
- Precise alignment and good balancing of the mounted drive elements are prerequisites for good smooth running, free of vibration. Especially for high-speed motors, it should be ensured that the flange mounting is stiff in order to position the resonant frequency of the mounted unit as high as possible and thus above the maximum rotational frequency.

4.1 Installation

- The AC motors must be located so that the cooling air intake and discharge are not restricted. The discharged air must not be drawn in again.
- The covers for the foot mounting screw holes should be relocated after the motor has been mounted.

#### 4.1.2 PWM converter

- The PWM converters are suitable for installation in enclosed electrical rooms (DIN VDE 0558 Part 1a, Sections 5.4.3.2.1 and 5.4.3.2.2). In the operating condition, protection is thus provided against direct contact.
- The mounting dimensions and positions of the mounting points should be taken from the dimension drawings.
- The PWM converters are designed for vertical mounting in cubicles or machine frames. The incoming connections and motor feeder connections should be mounted below.
- It should be ensured that the air intake and discharge are unrestricted. A space of 100 mm must be maintained above and below the PWM converter. The PWM converters must be mounted so that they are protected from deposits of conductive dust.

#### 4.2 Connecting up

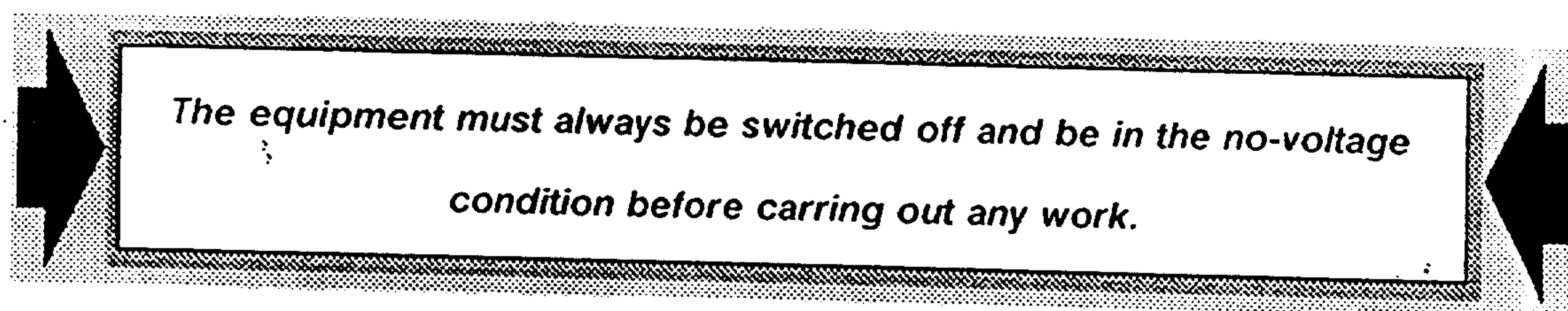

#### 4.2.1 AC motors

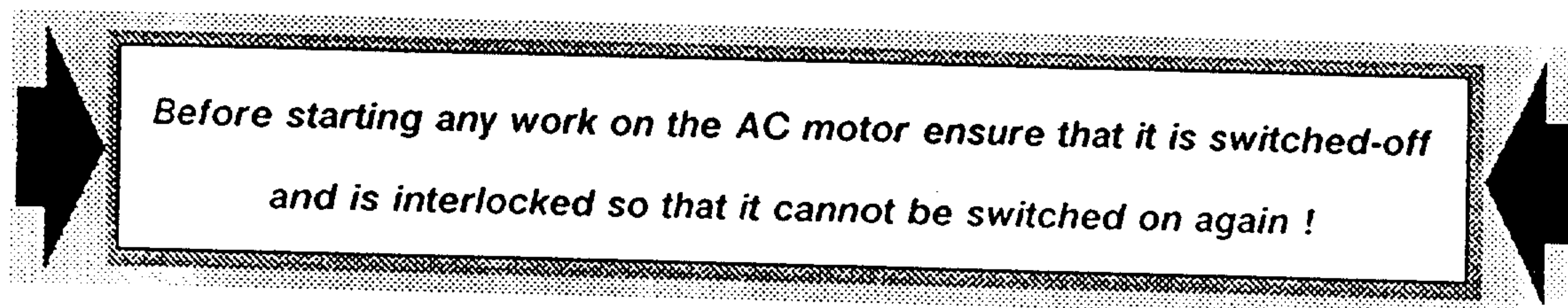

- AC motors can only be operated with the assigned PWM converter.
- Observe the rating plate data and the circuit diagram in the terminal box.
- The terminal box upper section with connecting board can be rotated through 90°. When connecting to the terminal board, the feeder cables should be dimensioned according to the rated current and the correct cable lug size selected for the terminal bolt dimensions.



- Twisted, or a three-core cable with additional ground conductor should be used for the motor feeder. Only enough insulation should be removed from the conductor ends so that the remaining insulation reaches up to the cable lug or terminal.
- The connecting cables should be arranged in the terminal box so that the equipment grounding conductor is somewhat longer, and that the core insulation is not damaged. It should be ensured that the connecting cables are strain relieved.
- Please ensure that the minimum air clearances are maintained:  
Connecting voltages up to 500 V: Minimum air gap 4.5 mm.
- After connecting up it should be checked that
  - the inside of the terminal box is clean and has no conductor remnants in it,
  - all terminal screws are tight,
  - the minimum air gaps are available,
  - the cable glands are reliably sealed,
  - all unused entries are closed and the plug elements are tightly screwed in and
  - all sealing surfaces are secure.
- The cooling air ducts through which the ambient air flows should be cleaned regularly, at intervals depending on the degree of local pollution, e.g. using dry, oil-free compressed air. The inside of surface-cooled motors should be cleaned at the normal routine maintenance intervals.

#### 4.2.2 PWM converter

- Connect-up the PWM converter as recommended (Fig. 4.5).

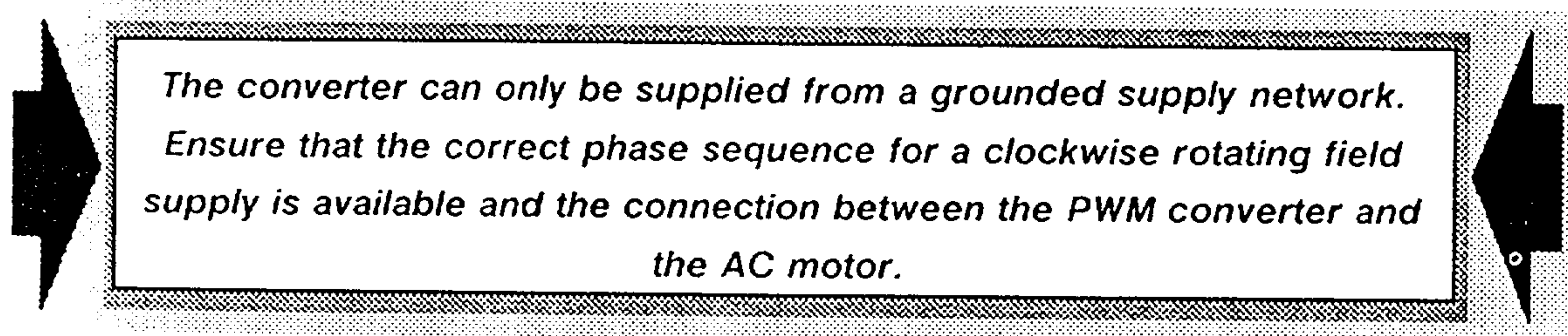

- The ground conductors of the supply and motor feeder must be attached to the grounding rail (grounding bolts) of the PWM converter. If the motor housing is not well grounded, capacitive equalization currents can flow and thus cause faults in the electronic components.
- The PWM converter cover must be screwed into place for operation in order to ensure a good ground connection.
- If SIMODRIVE 611 feed drives are to be fed from the DC link of a SIMODRIVE 650 converter, then during the design phase, the maximum infeed/regenerative feedback power of the SIMODRIVE 650 should be taken into account. The data can be taken from Table 3.2, Section 3.8, Technical data. The calculation of the necessary infeed/regenerative feedback power from feed drives can be taken from the Technical description for SIMODRIVE 611, (Order No. 6ZB5 420-0AG01-0BA1), Section 3.4.4 DC link design. See also Information AUT 221-11-014--drive combination consisting of main spindle and feed drives SIMODRIVE 611 and SIMODRIVE 650.



- The PWM converters are completely protected with the incorporated fuses. The fuses indicated in the recommended connection diagram (Fig. 4.3) are cable fuses according to DIN VDE 0100.
- The setpoint and actual value cables are screened, and routed separately from the power cables. The control lines for the closed-loop controller enable signals and power supply should be separated from the contactor control cables.
- The shaft encoder cable screen and the common AC motor and PWM converter potential should be correctly connected to the screen rail of the PWM converter (for 6SC6504-20) or at connecting bolt X131 of the G01 power supply board (for 6SC6502-03).
- A contactor can be connected between the AC motor and the PWM converter to electrically isolate the motor from the supply voltage for safety reasons. This contactor must be located between the motor and converter as energy is still in the DC link, even after "power off".

***Under no circumstances must the contactor be switched under load as the arc could destroy the power transistors.***

- The control should be interlocked to ensure that this contactor can only be switched at pulse inhibit (terminal 63 not energized). Further, terminal 63 should be interlocked with an auxiliary contact of the contactor.
- A contactor should be used with a delayed dropout time so that even at power failure, the PWM converter buffer time can be overridden. The contactor must override the maximum reaction time of terminal 63 (pulse enable) of 40 ms. This can be easily realized using a contactor with a DC coil (3TB4.17-0B) by connecting a free-wheeling diode (3TX6406-0H) across the contactor coil.
- If a contactor is switched in directly in front of the line-side converter, then it should be ensured that this contactor can only be switched at converter pulse inhibit (terminal 63). A minimum delay time of 40 ms must be maintained between pulse inhibit and contactor switching. If this is not ensured, fuses could blow or thyristors could be damaged.
- Fuses are not blown when power failures occur during operation as a result of line reactance.
- Also refer to the terminal diagram

***Observe the discharge time (approx. 4 minutes) for the DC link capacitors!***

The PWM converter is maintenance free, when the information specified in the installation section is observed.



- If dust and dirt start to collect in the PWM converter we recommend that it be cleaned using dry, oil-free compressed air in order to prevent voltage arcs and reduced cooling.

## Board handling

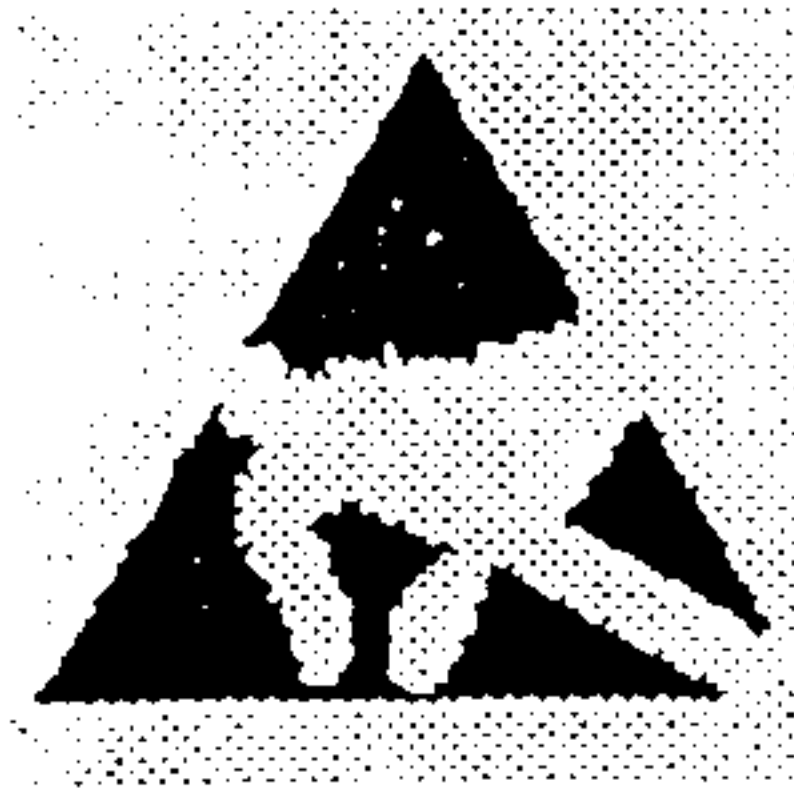

Board/components, which have this warning symbol (yellow hand with a diagonal line through it on a black triangle) can be damaged if they are electrostatically charged.

Thus, the following instructions should be adhered to:

- Basically, electronic boards must only be touched if absolutely necessary as a result of the work to be undertaken.

- Your body should be discharged before coming into contact with electronic boards. This is most easily realized by touching a conductive grounded object directly beforehand (e.g. unpainted cubicle components, protective ground contact in electrical sockets).

- Boards must not come into contact with highly insulating materials (e.g. plastic foils, insulated desktops, clothing articles from man-made fibers).

- Boards must only be deposited on conductive surfaces.

- Boards must only be inserted or withdrawn in the no-voltage condition

- Signal voltages must only be applied with the supply voltage on.

- Boards and components should always be stored or transported in conductive packing materials (e.g. metalized plastic boxes, metal boxes).

- If packages are not conductive, the boards must be covered in a conductive material beforehand. Conductive foam rubber or household aluminum foil.



### Connecting terminals for PWM converters 6SC6502 and 6SC6503

Terminals		Function	Type	Typical voltage	Maximum connected cross-section
Number	Location				

#### Power section

U1,V1,W1	Support a	Supply connection	I	3ph 380V AC 50/60 Hz	M6 connection
PE1		Equip. ground. conductor	I	0 V	
U2,V2,W2	A1	Motor connection	O	3ph 430V AC, 300 Hz	6 mm <sup>2</sup>
PE2		Motor ground conductor	O	0 V	
PE	G01-X131 m	Encoder. cable screen		0 V	M6 connection

#### Analog electronic signals

56	U1-X111.1	c	Speed setpoint 1 (+)	I	+10 V DC	1.5 mm <sup>2</sup>
14	U1-X111.2	c	Speed setpoint 1 (-)	I	-10 V DC	1.5 mm <sup>2</sup>
24	U1-X111.4	c	Speed setpoint 2 (+)	I	+10 V DC	1.5 mm <sup>2</sup>
8	U1-X111.5	c	Speed setpoint 2 (-)	I	-10 V DC	1.5 mm <sup>2</sup>
75	U1-X111.7	c	Speed actual value	O	0 V to ±10 V DC; 5 mA	1.5 mm <sup>2</sup>
76	U1-X111.8	c	Speed actual value	RV	0 V to ±10 V DC; 5 mA	1.5 mm <sup>2</sup>
16	U1-X111.9	c	P / P <sub>max</sub>	O	0 V	1.5 mm <sup>2</sup>
77	U1-X111.10	c	P / P <sub>max</sub>	RV	0 V to ±10 V DC; 5 mA	1.5 mm <sup>2</sup>
18	U1-X111.11	c	Select output (14 bit)	O	0 V	1.5 mm <sup>2</sup>
78	U1-X111.12	c	Select output (14 bit)	RV	+10 V DC; 10 mA	1.5 mm <sup>2</sup>
47	U1-X111.13	c	Reference voltage for speed setpoint input	O	0 V	1.5 mm <sup>2</sup>
69	U1-X111.14	c		O	-10 V DC; 10 mA	1.5 mm <sup>2</sup>
46	U1-X111.15	c		O		1.5 mm <sup>2</sup>

#### Digital electronic signals

9	U1-X121	d	P24 - external (aux. voltage)	O	+24 V DC 150 mA	1.5 mm <sup>2</sup>
19	U1-X121	d	RV for 24 V DC + enable signals	O/I	0 V	1.5 mm <sup>2</sup>
63	U1-X121	d	Pulse enable	I	DC+12 V to +30 V	1.5 mm <sup>2</sup>
64	U1-X121	d	Closed-loop controller enable	I	DC+12 V to +30 V	1.5 mm <sup>2</sup>
81	U1-X121	d	Ramp-function gen. - fast stop	I	DC+12 V to +30 V	1.5 mm <sup>2</sup>
62	U1-X121	d	Set ramp-function gen. to zero	I	DC+12 V to +30 V	1.5 mm <sup>2</sup>
111	U1-X121	d	Torque limiting	I	DC+12 V to +30 V	1.5 mm <sup>2</sup>
60	U1-X121	d	Oscillation	I	DC+12 V to +30 V	1.5 mm <sup>2</sup>
117	U1-X121	d	Gear stage 2	I	DC+12 V to +30 V	1.5 mm <sup>2</sup>
118	U1-X121	d	Gear stage 3	I	DC+12 V to +30 V	1.5 mm <sup>2</sup>
119	U1-X121	d	Gear stage 4	I	DC+12 V to +30 V	1.5 mm <sup>2</sup>
158	U1-X121	d	Torque control (open-loop)	I	DC+12 V to +30 V	1.5 mm <sup>2</sup>
R	U1-X121	d	Remote acknowledgement	I	DC+12 V to +30 V	1.5 mm <sup>2</sup>

#### Encoders

Plug con.	U1-X131	g	Encoder input, motor temp.	I	+5 V 1.8 kΩ - 100 kΩ	screened cable
Plug con.	U1-X231	g	Encoder signals (buffered)	O	+5 V > 150-Ω load	ribbon cable

#### Relay contacts

72	G0.2-X131	e	Ready Fault	NO	160 V AC 5 A	1.5 mm <sup>2</sup>
73.2	G0.2-X131	e		I	160 V AC 5 A	1.5 mm <sup>2</sup>
73.1	G0.2-X131	e		I	160 V AC 5 A	1.5 mm <sup>2</sup>
74	G0.2-X131	e		NC	160 V AC 5 A	1.5 mm <sup>2</sup>
115	G0.2-X131	e	$n < n_{min}$	NO	160 V AC 5 A	1.5 mm <sup>2</sup>
114	G0.2-X131	e		I	160 V AC 5 A	1.5 mm <sup>2</sup>
116	G0.2-X131	e		NC	160 V AC 5 A	1.5 mm <sup>2</sup>
127	G0.2-X131	e	$n_{set} = n_{act}$	NO	160 V AC 5 A	1.5 mm <sup>2</sup>
126	G0.2-X131	e		I	160 V AC 5 A	1.5 mm <sup>2</sup>
128	G0.2-X131	e		NC	160 V AC 5 A	1.5 mm <sup>2</sup>
109	G0.2-X141	e	$T < T_x$	NO	160 V AC 5 A	1.5 mm <sup>2</sup>
108	G0.2-X141	e		I	160 V AC 5 A	1.5 mm <sup>2</sup>
110	G0.2-X141	e		NC	160 V AC 5 A	1.5 mm <sup>2</sup>
215	G0.2-X141	e	$n < n_x$	NO	160 V AC 5 A	1.5 mm <sup>2</sup>
214	G0.2-X141	e		I	160 V AC 5 A	1.5 mm <sup>2</sup>
216	G0.2-X141	e		NC	160 V AC 5 A	1.5 mm <sup>2</sup>
209	G0.2-X141	e	Motor overtemperature prewarning	NO	160 V AC 5 A	1.5 mm <sup>2</sup>
208	G0.2-X141	e		I	160 V AC 5 A	1.5 mm <sup>2</sup>
210	G0.2-X141	e		NC	160 V AC 5 A	1.5 mm <sup>2</sup>



Connecting terminals for PWM converters 6SC6502 and 6SC6503 (continued)

Terminals		Function	Type	Typical voltage	Maximum connected cross-section	
Number	Location					
<b>Option board</b>						
501 503 502	S1-X111 h	Position reached 1	NO I NC	160 V AC 5 A 160 V AC 5 A 160 V AC 5 A	1.5 mm <sup>2</sup> 1.5 mm <sup>2</sup> 1.5 mm <sup>2</sup>	
541 543 542	S1-X111 h		Position reached 2	NO I NC	160 V AC 5 A 160 V AC 5 A 160 V AC 5 A	1.5 mm <sup>2</sup> 1.5 mm <sup>2</sup> 1.5 mm <sup>2</sup>
512 516 513 517 61 518 518	S1-X112 i			M24 external Positioning ON 1st / 2nd position Incremental positioning External/internal pos. setpoint C-axis operation ON Accept external pos. setpoint External zero mark	O/I I I I I I I	0 V +12 V to +30 V DC +12 V to +30 V DC +12 V to +30 V DC +12 V to +30 V DC +12 V to +30 V DC +12 V to +30 V DC +12 V to +30 V DC
Plug con. Plug con.	S1-X113 j	External pos. setpoint Transmitter output for NC		I O	High: +12 to +30 V DC +5 V >150 Ω load	screened cable screened cable
Plug con. Plug con. Plug con.	S1-X114 k S1-X114 k N1-X131 l	Encoder input (rectangular) Encoder input (sinusoidal) Digital interface to PG	I I I/O	+5 V 1.8 kΩ - 100 kΩ μA	screened cable screened cable interface block	

I = Input                      NC = Normally closed    RV = Reference voltage for analog outputs (D/A converter)  
O = Output                    NO = Normally open contact

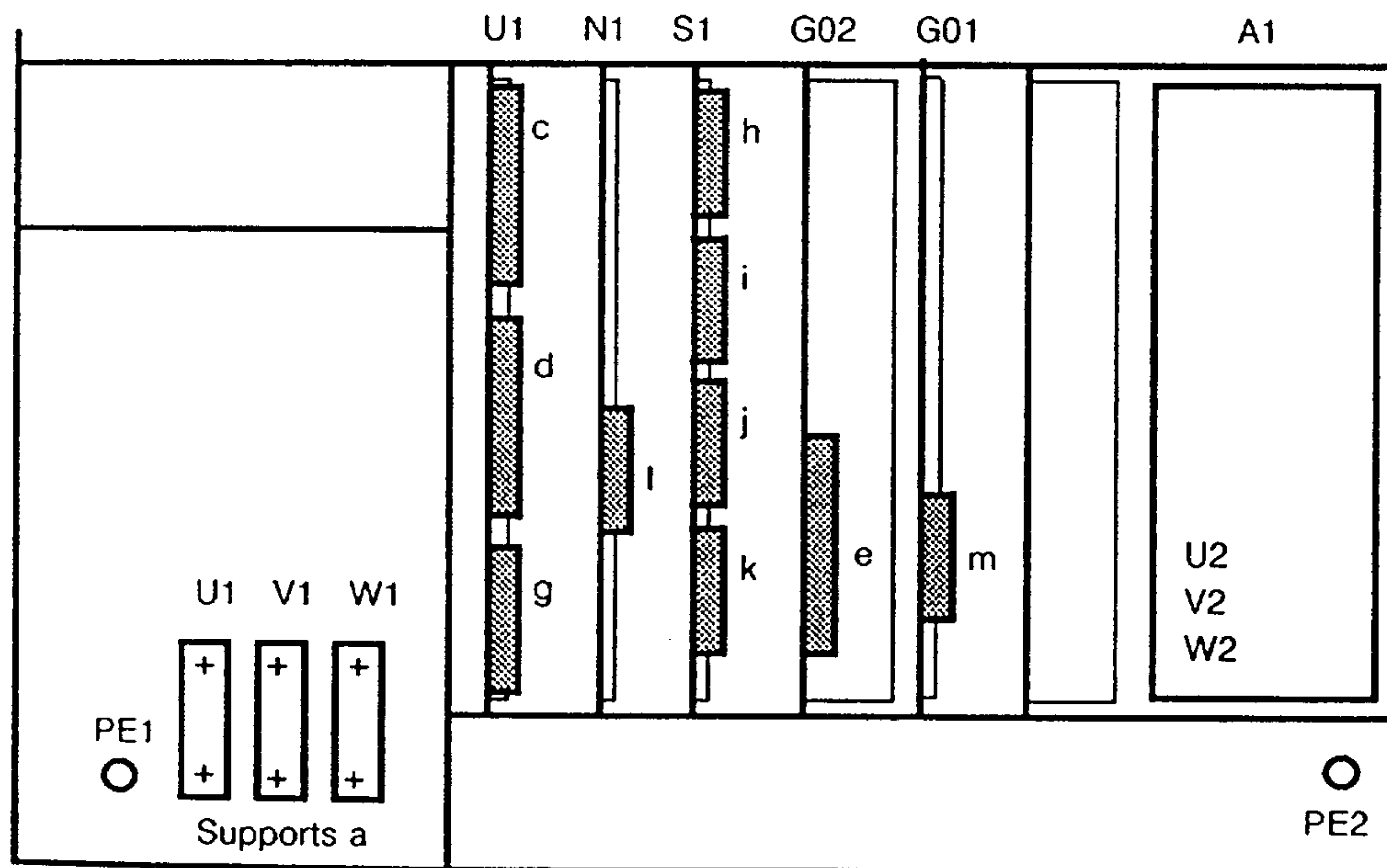

Fig. 4.1 Terminal locations for PWM converters 6SC6502 and 6SC6503

U1 = Input/output board  
N1 = Closed-loop control board                      G02 = Central board  
S1 = "Spindle positioning" and "C-axis" option    G01 = Power supply 1  
c = X111;                      d = X121;                      e = X131 and X141;  
g = X231 and X131;                      h = X111;                      i = X112;  
j = X113;                      k = 114;                      l = X131  
m = X131



## Terminals for PWM converters 6SC6504, 6SC6506, 6SC6508, 6SC6512, 6SC6520

Terminals		Function	Type	Typical voltage	Maximum connected cross-section
Number	Location				

## Power section

U1,V1,W1 PE	Support a	Supply connection Equip. ground. conductor	I I	3 P. 380 V AC 50 /60 Hz 0 V	M6 connection
U2,V2,W2 PE	Support b	Motor connection Motor equip. ground. cond.	O O	3 Ph. 430 V AC 300 Hz 0 V	M6 connection *)
X600	Terminals n	DC link tap	O	600V DC	

## Analog electronic signals

56	U1-X111.1	c	Speed setpoint 1 (+)	I	+10 V DC	1.5 mm <sup>2</sup>
14	U1-X111.2	c	Speed setpoint 1 (-)	I	-10 V DC	1.5 mm <sup>2</sup>
24	U1-X111.4	c	Speed setpoint 2 (+)	I	+10 V DC	1.5 mm <sup>2</sup>
8	U1-X111.5	c	Speed setpoint 2 (-)	I	-10 V DC	1.5 mm <sup>2</sup>
75	U1-X111.7	c	Speed actual value	O	0 V to ± 10 V DC; 5 mA	1.5 mm <sup>2</sup>
76	U1-X111.8	c	Speed actual value	RV	0 V	1.5 mm <sup>2</sup>
16	U1-X111.9	c	P / P <sub>max</sub>	O	0 V to ± 10 V DC; 5 mA	1.5 mm <sup>2</sup>
77	U1-X111.10	c	P / P <sub>max</sub>	RV	0 V	1.5 mm <sup>2</sup>
18	U1-X111.11	c	Select output (14 bit)	O	0 V to ± 10 V DC; 5 mA	1.5 mm <sup>2</sup>
78	U1-X111.12	c	Select output (14 bit)	RV	0 V	1.5 mm <sup>2</sup>
47	U1-X111.13	c	P 10 } Reference voltage for	O	+10 V DC; 10 mA	1.5 mm <sup>2</sup>
69	U1-X111.14	c	M } speed setpoint input	O	0 V	1.5 mm <sup>2</sup>
46	U1-X111.15	c	N10 }	O	-10 V DC; 10 mA	1.5 mm <sup>2</sup>

## Digital electronic signals

9	U1-X121	d	P24 - external (Aux. voltage)	O	+24 V DC 150 mA	1.5 mm <sup>2</sup>
19	U1-X121	d	RV for 24 V DC + enable signals	O/I	0 V	1.5 mm <sup>2</sup>
63	U1-X121	d	Pulse enable	I	+12 V to +30 V DC	1.5 mm <sup>2</sup>
64	U1-X121	d	Closed-loop controller enable	I	+12 V to +30 V DC	1.5 mm <sup>2</sup>
81	U1-X121	d	Ramp-function gen. fast stop	I	+12 V to +30 V DC	1.5 mm <sup>2</sup>
62	U1-X121	d	Set ramp-function gen. to zero	I	+12 V to +30 V DC	1.5 mm <sup>2</sup>
111	U1-X121	d	Torque limiting	I	+12 V to +30 V DC	1.5 mm <sup>2</sup>
60	U1-X121	d	Oscillation	I	+12 V to +30 V DC	1.5 mm <sup>2</sup>
117	U1-X121	d	Gear stage 2	I	+12 V to +30 V DC	1.5 mm <sup>2</sup>
118	U1-X121	d	Gear stage 3	I	+12 V to +30 V DC	1.5 mm <sup>2</sup>
119	U1-X121	d	Gear stage 4	I	+12 V to +30 V DC	1.5 mm <sup>2</sup>
158	U1-X121	d	Torque control	I	+12 V to +30 V DC	1.5 mm <sup>2</sup>
R	U1-X121	d	Remote acknowledgement	I	+12 V to +30 V DC	1.5 mm <sup>2</sup>

## Encoder

Plug con.	U1-X131	g	Encoder input, motor temp.	I	+5 V 1.8 kΩ - 100 kΩ	screened cable
Plug con.	U1-X231	g	Encoder signals (buffered)	O	+5 V > 150 Ω load	ripple cable

## Relay contacts

72	G02-X131	e	Ready	NO	1 ph. 60 V AC 5 A	1.5 mm <sup>2</sup>
73.2	G02-X131	e	Fault	I	1 ph. 60 V AC 5 A	1.5 mm <sup>2</sup>
73.1	G02-X131	e		I	1 ph. 60 V AC 5 A	1.5 mm <sup>2</sup>
74	G02-X131	e		NC	1 ph. 60 V AC 5 A	1.5 mm <sup>2</sup>
115	G02-X131	e	$n < n_{min}$	NO	1 ph. 60 V AC 5 A	1.5 mm <sup>2</sup>
114	G02-X131	e		I	1 ph. 60 V AC 5 A	1.5 mm <sup>2</sup>
116	G02-X131	e		NC	1 ph. 60 V AC 5 A	1.5 mm <sup>2</sup>
127	G02-X131	e	$n_{set} = n_{act}$	NO	1 ph. 60 V AC 5 A	1.5 mm <sup>2</sup>
126	G02-X131	e		I	1 ph. 60 V AC 5 A	1.5 mm <sup>2</sup>
128	G02-X131	e		NC	1 ph. 60 V AC 5 A	1.5 mm <sup>2</sup>
109	G02-X141	e		NO	1 ph. 60 V AC 5 A	1.5 mm <sup>2</sup>
108	G02-X141	e	$T < T_x$	I	1 ph. 60 V AC 5 A	1.5 mm <sup>2</sup>
110	G02-X141	e		NC	1 ph. 60 V AC 5 A	1.5 mm <sup>2</sup>
215	G02-X141	e		NO	1 ph. 60 V AC 5 A	1.5 mm <sup>2</sup>
214	G02-X141	e	$n < n_x$	I	1 ph. 60 V AC 5 A	1.5 mm <sup>2</sup>
216	G02-X141	e		NC	1 ph. 60 V AC 5 A	1.5 mm <sup>2</sup>
209	G02-X141	e		NO	1 ph. 60 V AC 5 A	1.5 mm <sup>2</sup>
208	G02-X141	e	Motor overtemp. prewarning	I	1 ph. 60 V AC 5 A	1.5 mm <sup>2</sup>
210	G02-X141	e		NC	1 ph. 60 V AC 5 A	1.5 mm <sup>2</sup>



Connecting terminals for PWM converters 6SC6504, 6SC6506, 6SC6508, 6SC6512, 6SC6520 (continued)

Terminals		Function	Type	Typical voltage	Maximum connected cross-section
Number	Location				
<b>Option board</b>					
501	S1-X111 h	Position 1 reached	O	1 ph. 60 V AC 5 A	1.5 mm <sup>2</sup>
503	S1-X111 h		I	1 ph. 60 V AC 5 A	1.5 mm <sup>2</sup>
502	S1-X111 h		NC	1 ph. 60 V AC 5 A	1.5 mm <sup>2</sup>
541	S1-X111 h	Position 2 reached	O	1 ph. 60 V AC 5 A	1.5 mm <sup>2</sup>
543	S1-X111 h		I	1 ph. 60 V AC 5 A	1.5 mm <sup>2</sup>
542	S1-X111 h		NC	1 ph. 60 V AC 5 A	1.5 mm <sup>2</sup>
512	S1-X112 i	M24 external Positioning ON	O/I	0 V	1.5 mm <sup>2</sup>
516	S1-X112 i	1st / 2nd position	I	DC + 12 V to + 30 V	1.5 mm <sup>2</sup>
513	S1-X112 i	Incremental positioning	I	DC + 12 V to + 30 V	1.5 mm <sup>2</sup>
517	S1-X112 i	External/internal pos. setpoints	I	DC + 12 V to + 30 V	1.5 mm <sup>2</sup>
61	S1-X112 i	C-axis operation ON	I	DC + 12 V to + 30 V	1.5 mm <sup>2</sup>
518	S1-X112 i	Accept external pos. setpoints	I	DC + 12 V to + 30 V	1.5 mm <sup>2</sup>
518	S1-X112 i	External zero mark	I	DC + 12 V to + 30 V	1.5 mm <sup>2</sup>
Plug con.	S1-X113 j	External pos. setpoint	I	High: DC + 12 to + 30 V	Screened cable
Plug con.	S1-X113 j	Encoder output for NC	O	+ 5 V > 150 Ω load	Screened cable
Plug con.	S1-X114 k	Encoder input (rectangular)	I	+ 5 V 1.8 kΩ - 100 kΩ	Screened cable
Plug con.	S1-X114 k	Encoder input (sinusoidal)	I	μA	Screened cable
Plug con.	N1-X131 l	Digital interface to PG	I/O		Interface block

I = Input                      NC = Normally closed      RV = Reference voltage for analog output (D/A converter)  
O = Output                    NO = NO contact            \*) For 6SC6508 and 6SC6512, M8 connection

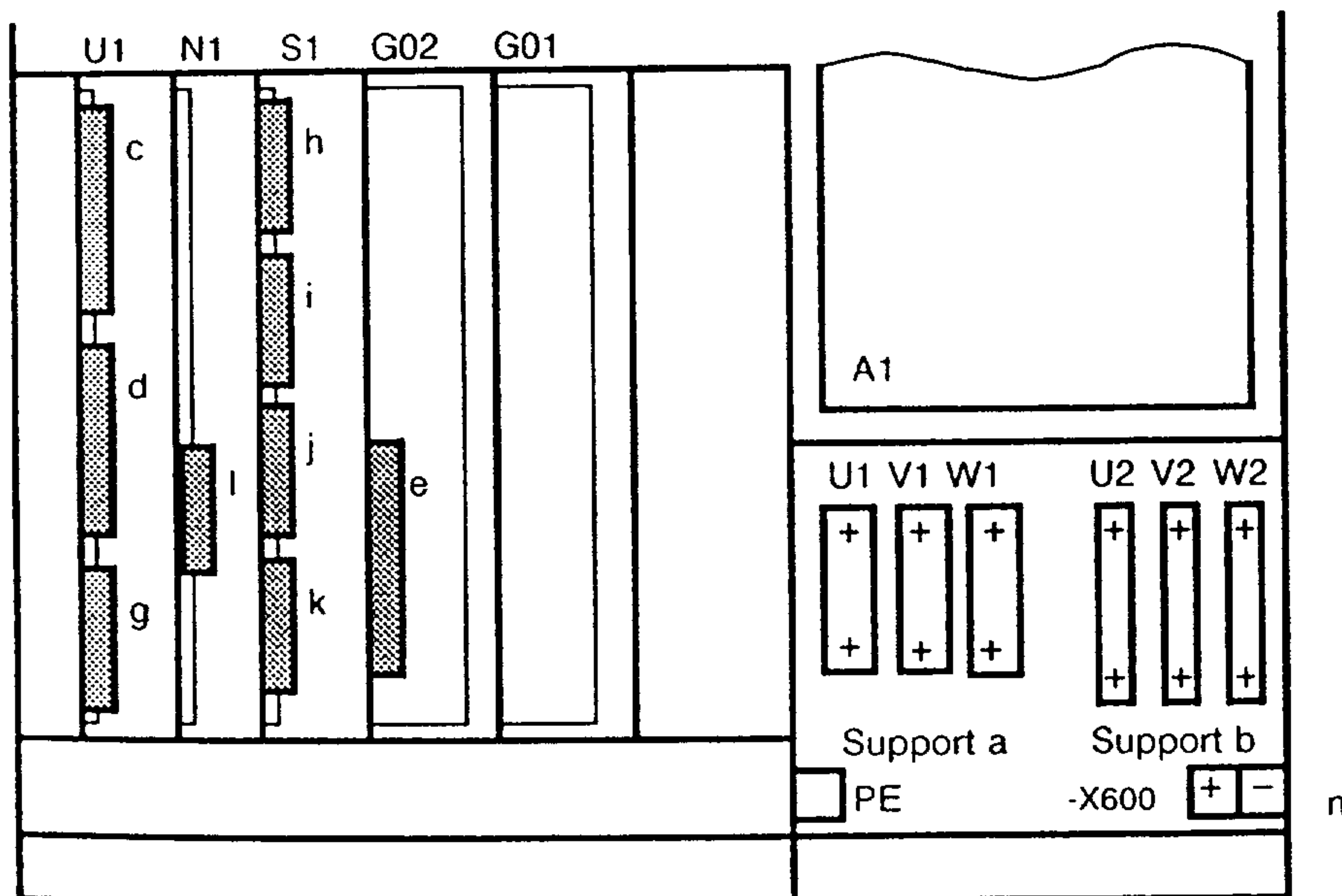

Fig. 4.3 Location of plug connectors, for 6SC6504, 6SC6506 and 6SC6508 transistor PWM converters

U1 = Input/output board                      G02 = Central board  
N1 = Closed-loop control board            G01 = Power supply 1  
S1 = "Spindle positioning" and "C axis" option  
c = X111;                      d = X121;                      e = X131 and X141;  
g = X231 and X131;                      h = X111;                      i = X112;                      j = X113;  
k = 114                      l = X131                      n = X600

4 Installation instructions

4.2 Connecting up

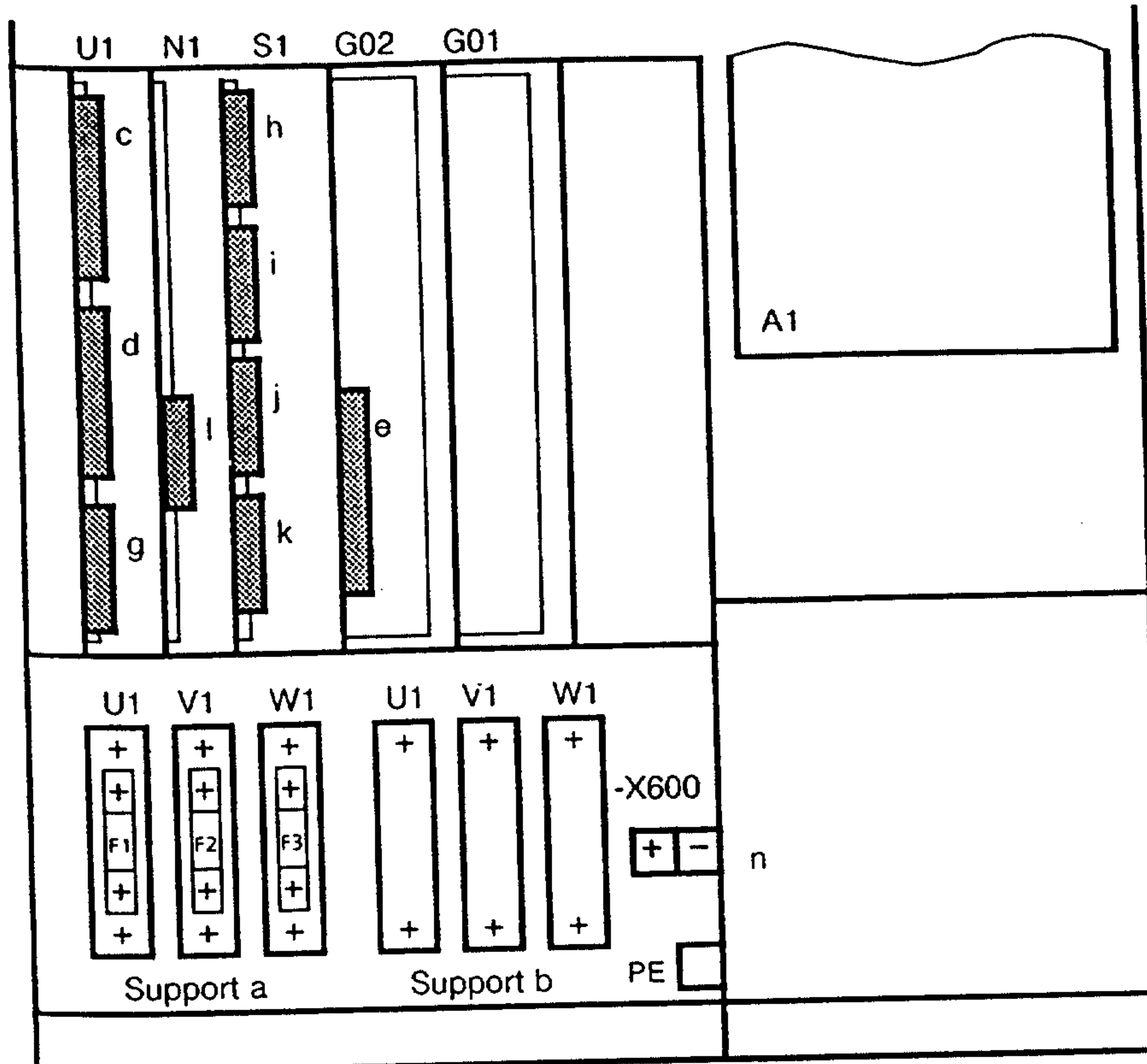
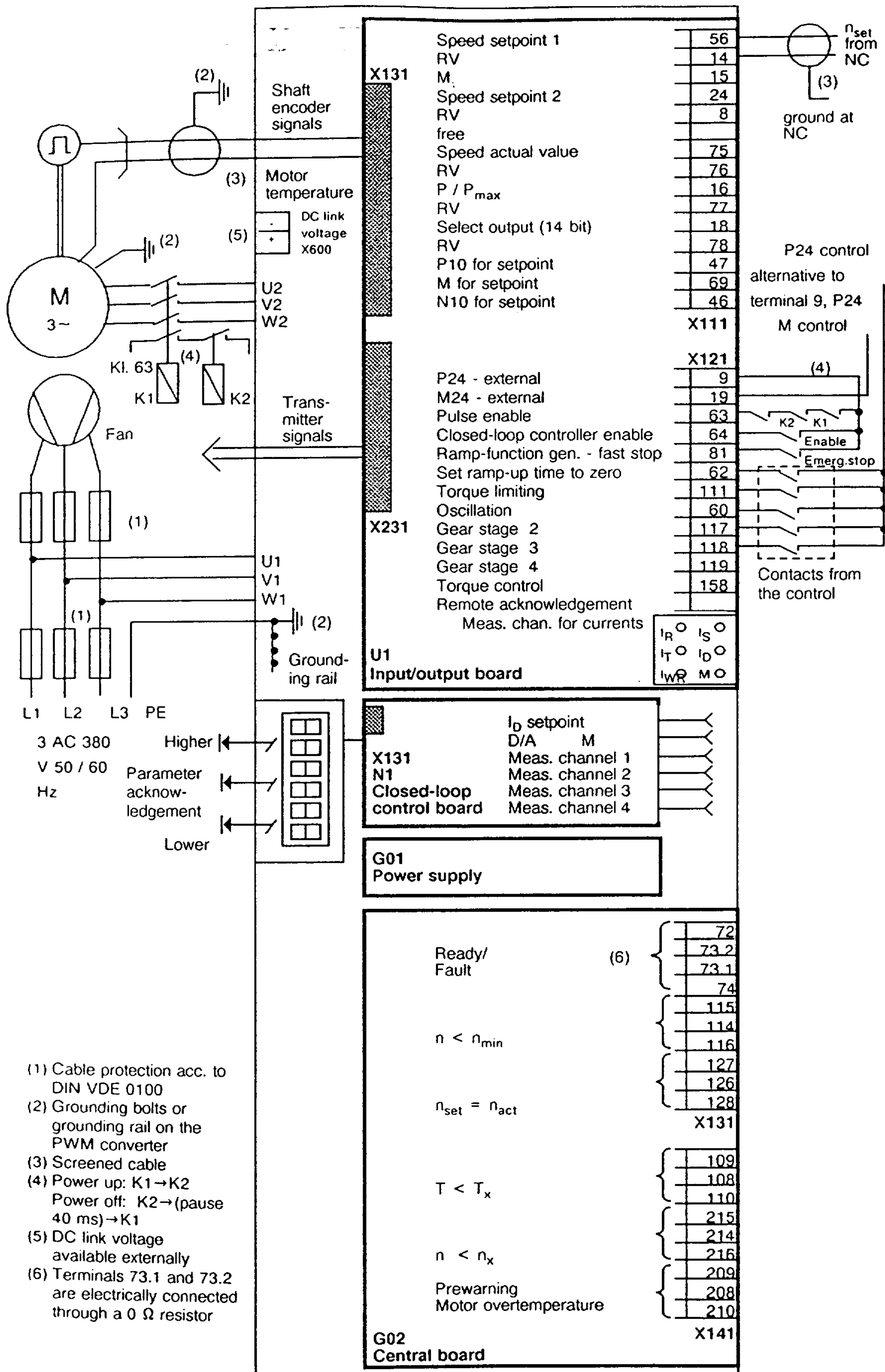

Fig. 4.4 Location of plug connectors, for 6SC6512 and 6SC6520 transistor PWM converters

- |  |           |                    |                      |
|--|-----------|--------------------|----------------------|
| U1 = Input/output board                        |           |                    |                      |
| N1 = Closed-loop control board                 |           |                    | G02 = Central board  |
| S1 = "Spindle positioning" and "C axis" option |           |                    | G01 = Power supply 1 |
| c = X111;                                      | d = X121; | e = X131 and X141; |                      |
| g = X231 and X131;                             | h = X111; | i = X112;          | j = X113;            |
| k = 114  | l = X131  | n = X600           |                      |





- (1) Cable protection acc. to DIN VDE 0100
- (2) Grounding bolts or grounding rail on the PWM converter
- (3) Screened cable
- (4) Power up: K1→K2  
Power off: K2→(pause 40 ms)→K1
- (5) DC link voltage available externally
- (6) Terminals 73.1 and 73.2 are electrically connected through a 0 Ω resistor

Fig. 4.5 Connecting up the SIMODRIVE 650 transistor PWM converter

4 Installation instructions  
 4.2 Connecting up

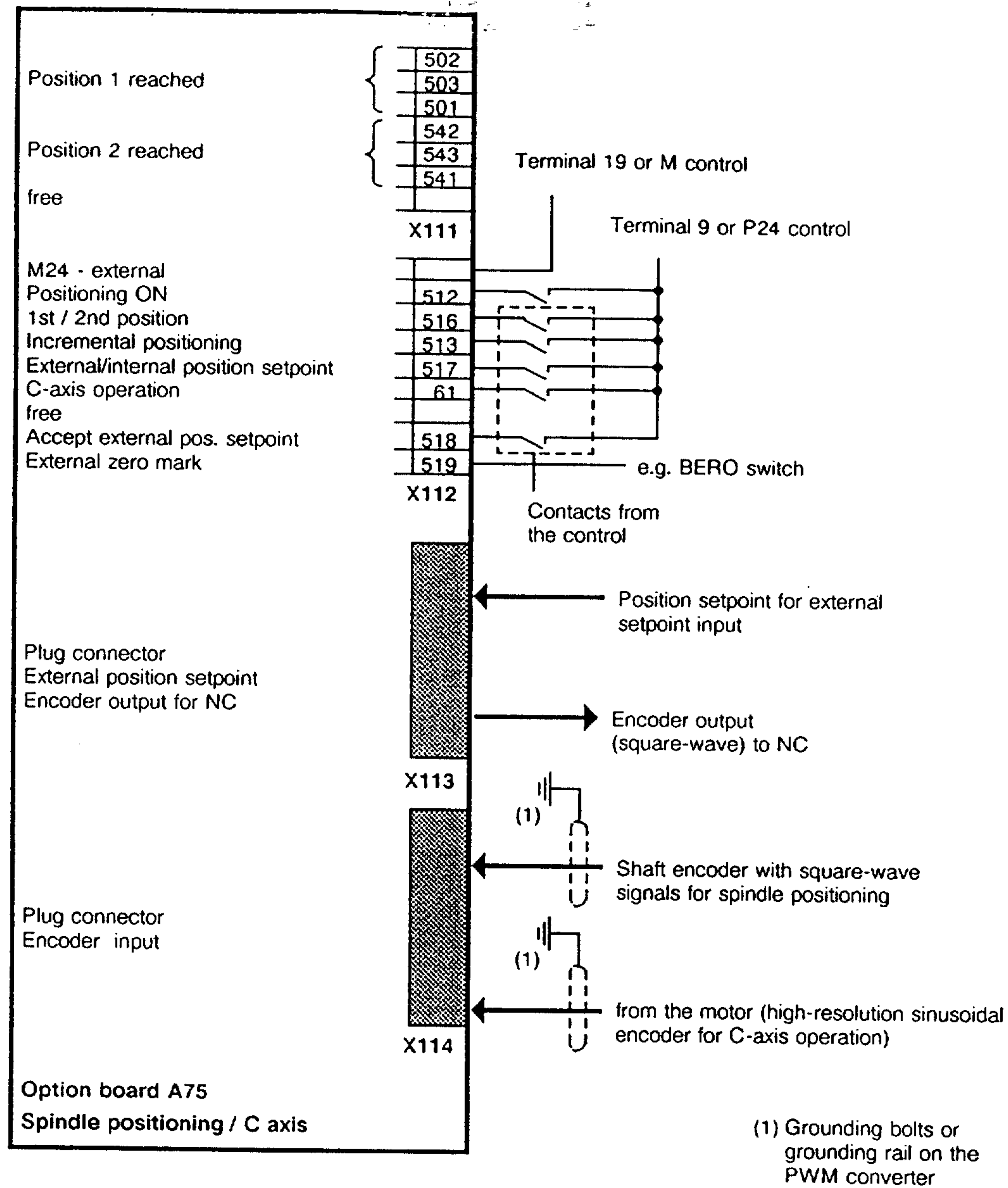

Fig. 4.6 Connecting option board S1



## 4.3 Interfaces

### 4.3.1 Relay signals

When designing external matching controls please note that the relays drop out when faults occur.

Board plug con. pin	Terminal No.	Contact	Explanations
<b>Relay <math>n_{act} &lt; n_x</math></b>			
G1 X141.6	216	NC	Relay drops out if $n_{act} > n_x$ . Can be set with parameters P23 to P26 (dependent on the gear stage).
X141.5	214	I	
X141.4	215	NO	
<b>Relay prewarning motor overtemperature (motor)</b>			
G1 X141.9	210	NC	The relay drops out when the motor overtemperature is reached. If this prewarning is not observed, and the temperature continues to increase, the converter is shutdown after approx. 4 min. with a fault signal.
X141.8	208	I	
X141.7	209	NO	
<b>Relay <math>T &lt; T_x</math></b>			
G1 X141.1	109	NO	The relay drops out for $T > T_x$ . The setting via P-47 refers to the actual torque limiting, and is masked out for $n_{set}$ change
X141.2	108	I	
X141.3	110	NC	
<b>Relay <math>n_{set} = n_{act}</math></b>			
G1 X131.8	127	NO	The relay pulls in for $n_{set} = n_{act}$ taking into account the tolerance band set with parameter P-27. Speed fluctuations as a result of load changes do not cause the relay to switch.
X131.9	126	I	
X131.10	128	NC	
<b>Ready / fault relay</b>			
G1 X131.4	74	NC	Preselectable with parameter P-53.
X131.3	73.1	I	
X131.2	73.2	I	
X131.1	72	NO	
<b>Relay <math>n &lt; n_{min}</math></b>			
G1 X131.7	116	NC	The relay pulls in for $n < n_{min}$ . Can be set with parameter P-21
X131.6	114	I	
X131.5	115	NO	

### 4.3.2 Digital signals

Board plug con. Pin	Terminal No.	Function	Explanations
<b>Input / output boards</b>			
U1 X121.1 X121.2	9 19	P24 external M24 external	The auxiliary voltage is generated from the DC link voltage, and is thus only available after the DC link has charged up.
X121.3	63	Pulse enabling	If terminal 63 is disconnected from P24, the pulses are inhibited and the drive idles down to standstill.
X121.4	64	Closed-loop controller enable	If P24 is fed to terminal 64, the pulses for the power transistors and the closed-loop speed control are enabled. In the first starting phase (approx. 400 ms), the magnetic field must be built-up in the motor. The motor cannot provide its full torque until rated flux has been built up in this first phase. Thus, we recommend for time-critical applications (e.g. automatic tool changing), that the motor is stopped using terminal 81. If P24 is removed, the drive brakes corresponding to the ramp-down characteristics; when $n_{min}$ is reached, the speed controller and pulses are internally inhibited.
X121.5	81	Ramp-function generator - fast stop	$n_{set}$ is instantaneously set to zero if P24 is removed from terminal 81. The motor brakes along the torque limiting characteristic. The speed setpoint is held digitally at zero. The motor remains magnetized and can thus instantaneously run-up with its full torque after terminal 81 has been energized.
X121.6	62	Set ramp-up time to zero	The ramp-function generator is bypassed if P24 is connected to terminal 62.
X121.7	111	Torque limiting	Additional torque limiting is activated by connecting terminal 111.
X121.8	60	Oscillating	Oscillating setpoint is injected for gear change
X121.9 X121.10 X121.11	117 118 119 <sup>1)</sup>	Gear stage 2 Gear stage 3 Gear stage 4	For example, the control parameters are changed over through terminals 117, 118 and 119 When terminal 158 is connected, torque control (open-loop) is selected instead of speed closed-loop control.
X121.12	158 <sup>1)</sup>	Torque control	
X121.13	R <sup>1)</sup>	Remote acknowledgement	Fault signal acknowledgement

<sup>1)</sup> Parameter function can be selected.



Board plug con. pin	Terminal No.	Function	Explanations
<b>Option board</b> (only for 6SC6500-0BA01 and 6SC6500-0BC01!)			
S1 X111.1	502	NO Position 1 reached	The relay pulls in if the position setpoint is reached. The bandwidth can be selected with parameter P-144.
X111.2	503	I reached	
X111.3	501	NC	
X111.4	542	NO Position 2 reached	The relay pulls in if the position setpoint is reached. The bandwidth can be selected with parameter P-145.
X111.5	543	I reached	
X111.6	541	NC	
<b>Option board</b> (X112.1 to 9 only for 6SC6500-0BA01!) (X112.1 and .6 only for 6SC6500 0BB01!) (X112.1 to 5, .8 and .9 only for 6SC6500-0BC01!)			
S1 X112.1		M24 external	Must be connected to terminal 19 or M control, depending on the P24 source
X112.2	512	Positioning ON	The drive travels to the set position. H $\hat{=}$ positioning on.
X112.3	516	1st/2nd position	Select first and second position. H $\hat{=}$ 2nd position
X112.4	513	Incremental positioning	When 24 V is connected, the setpoint input in P-127 is added to the current position and the drive approaches this new position. Condition: Relay 2 signals that the position has been reached
X112.5	517	External/internal positioning setpoint	L = External position setpoint (X112) H $\hat{=}$ Internal position setpoint (P-121 to P-127)
X112.6	61	C-axis operation	H $\hat{=}$ C-axis operation ON
X112.7		free	
X112.8	518	Accept external position setpoint	H $\hat{=}$ Accept position setpoint. The position setpoint is accepted at the change from L to H, and is executed at the next position command.
X112.9	519	External zero mark	Zero is recognized at the change from L to H.

Board plug con. pin	Terminal No.	Function	Explanations
<b>Option board</b>			(S1 X113.1 up to 16 not for 6SC6500-0BB01!)
S1 X113.1		Bit 0	External position setpoint
X113.2		Bit 1	
X113.3		Bit 2	
X113.4		Bit 3	
X113.5		Bit 4	
X113.6		Bit 5	
X113.7		Bit 6	
X113.8		Bit 7	
X113.9		Bit 8	
X113.10		Bit 9	
X113.11		Bit 10	
X113.12		Bit 11	
X113.13		Bit 12	
X113.14		Bit 13	
X113.15		Bit 14	
X113.16		Bit 15	
X113.17		free	Encoder output for NC
X113.18		A	
X113.19		A, inverted	
X113.20		0	
X113.21		B	
X113.22		B, inverted	
X113.23		0, inverted	
X113.24		P6	
X113.25		M6	
<b>Option board</b>			(S1 X114.1 up to .6 not for 6SC6500-0BB01!) (S1 X114.9 up to . 15 not for 6SC6500-0BC01!)
S1 X114.1		M6	Encoder power supply
X114.2		P6	
X114.3		Zero, inverted	Square-wave generator input
X114.4		B, inverted	
X114.5		B	
X114.6		Zero	
X114.7		A, inverted	
X114.8		A	
X114.9		Inner screen	High-resolution sinusoidal-cosinusoidal generator input
X114.10		Zero	
X114.11		cosin., inverted	
X114.12		Cosinusoidal	
X114.13		Zero, inverted	
X114.14		Sinus., inverted	
X114.15		Sinusoidal	



## 4.4 Cable connections

The only cables required between the AC motor and the PWM converter are the shaft encoder cable and the power cables (individual conductors or cables, including ground conductor).

A 16-core screened cable with twisted pairs must be used for connecting the shaft encoder to the PWM converter. The NTC thermistor signals are also transmitted through this cable (Fig. 4.6). The shaft encoder cable can have a maximum length of 50 m.

The shaft encoder cable screening must be correctly connected to the PWM converter (refer to Section 4.2.2 and Pages 4-18). In order to prevent ground loops, the shaft encoder cable screen must be connected to pin H of the motor-side connector and the screen must not be connected to the housing of the motor connector.

The PWM converter connectors are part of the scope of the supply of the PWM converter.

With the "C-axis" option, cable 6FC9348-0B must be used to transmit the signals from the high-resolution encoder. Fault-free signal transmission, and thus drive reliability, can only be guaranteed when this 6FC9348-0B cable is used.

The signals from the motor shaft encoder can also be transmitted directly from the converter through the 6FC9 348-5XB adaptor cable for a higher-level closed-loop position control, with the corresponding option.

Accessories	Order No.	Length
Shaft encoder cable 8 x 2 x 0.18 mm <sup>2</sup> screened, with twisted pairs, <u>without</u> plug connector	6FC9343-0AA	(Available by the meter)
Shaft encoder cable 8 x 2 x 0.18 mm <sup>2</sup> screened, with drill pairs, <u>with</u> plug connector	6FC9348-0A B to G 1)	5 to 50 m
Adaptor cable for connecting to the SINUMERIK measuring circuit cable	6FC9348-5XB	0.65 m
Shaft encoder cable for high-resolution encoder	6FC9348-0B B to F 1)	5 to 25 m
15-pin subminiature socket connector for connecting to the PWM converter,	6FC9348-7AA	–
17-pin socket connector for connecting to the AC motor,	6FC9341-1AC	–
Round plug connector for connecting to the SINUMERIK measuring circuit cable	6FC9341-1FC	–
Connecting cable between the programming unit and the interface block	6FC9344-1A	10 to 30 m

Table 4.3 Accessories

1) Cable lengths B = 5 m C = 10 m D = 15 m E = 18 m  
H = 20 m F = 25 m J = 30 m G = 50 m

Cable name: Shaft encoder cable  
 Order No.: 6FC9 348-0A□

**SIMODRIVE: 650** **AC motor**  
**Board location: U1, Input/output board** **6FC9 341-1AC**  
**Board connector: X131**

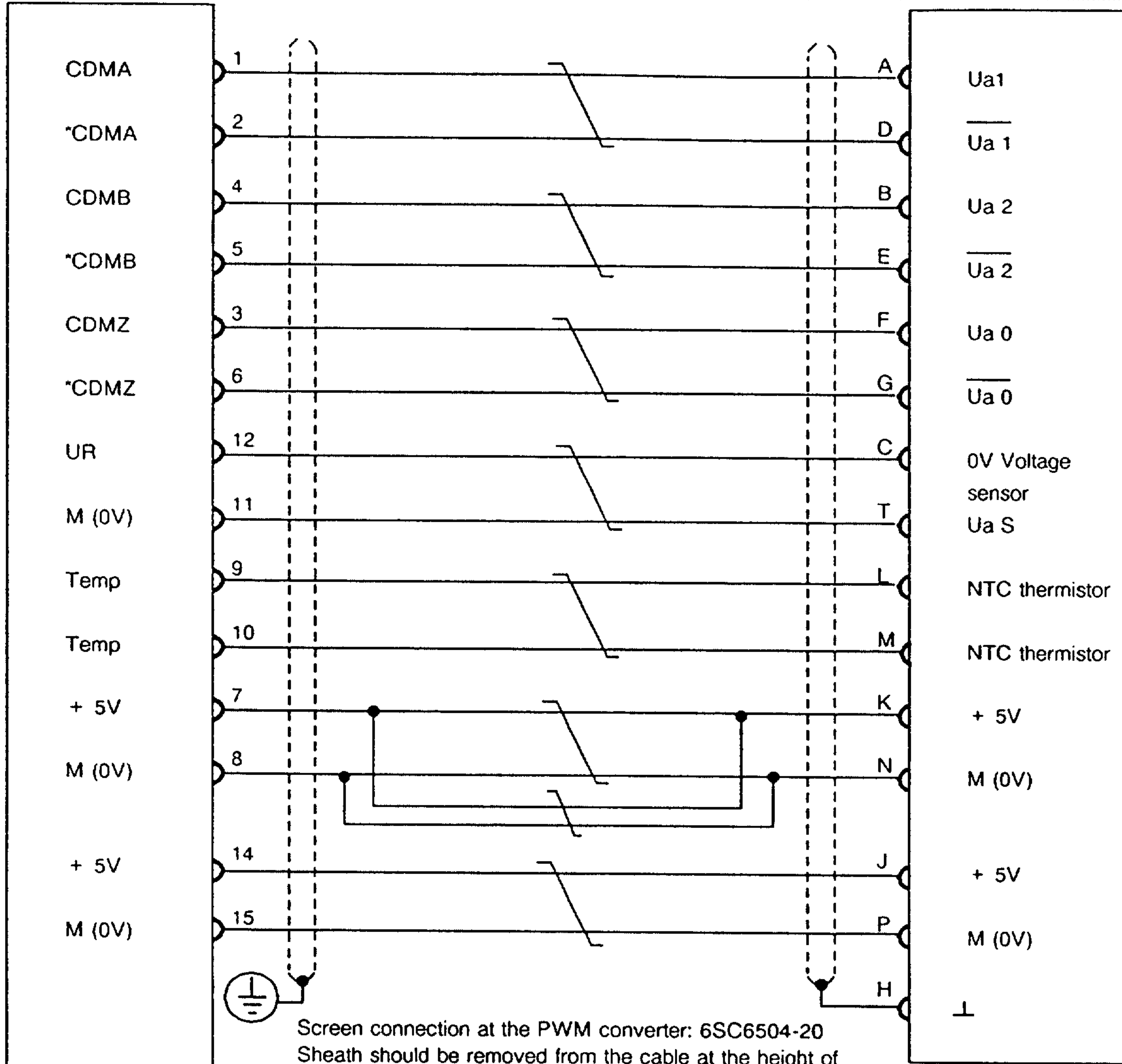

Screen connection at the PWM converter: 6SC6504-20  
 Sheath should be removed from the cable at the height of the screen rail, and the screen should be electrically connected to the screen rail (simultaneous strain relief).  
 6SC6502/30: Route screen to X131 of the G01 board

**PWM converter**  
 Connector X131

**Connector**  
 17-pin, socket  
 ITT Cannon  
 CA 08-20-295  
 Connecting side

6 FC9 341 - 1AC

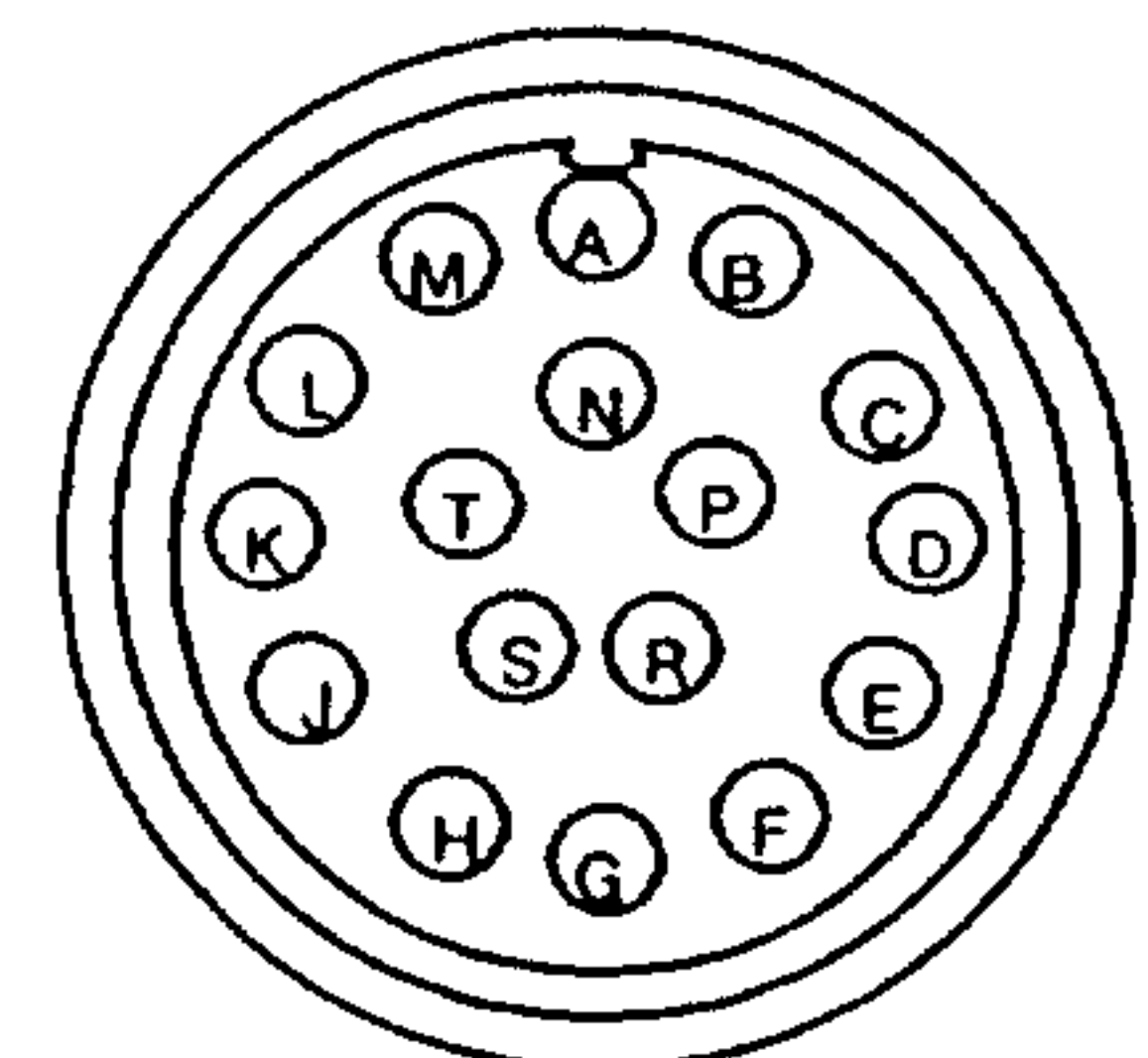



Cable No.: Shaft encoder cable for high-resolution encoder  
Order No.: 6FC9 348-0B□

**SIMODRIVE: 650**  
**Board location: U1, input/output board**  
**Board connector: X114**

**AC motor**  
**6FC9 341-7AU**

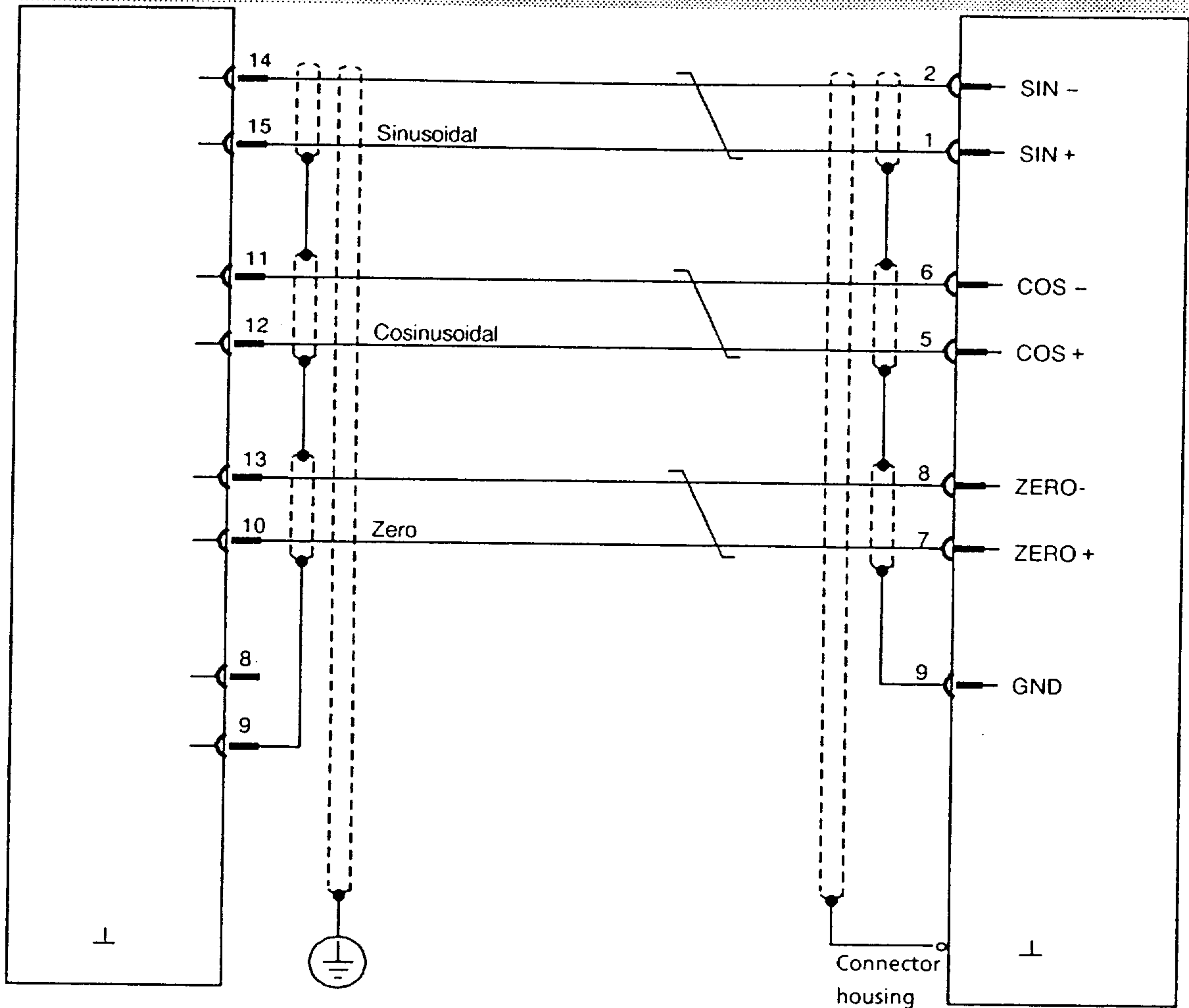

**PWM converter**  
Connector X114  
6FC9348-7AK

**Connector**  
9-pin socket  
SIEMENS  
8 mm cable diameter  
Connecting side  
6 FC9 341 - 1AU

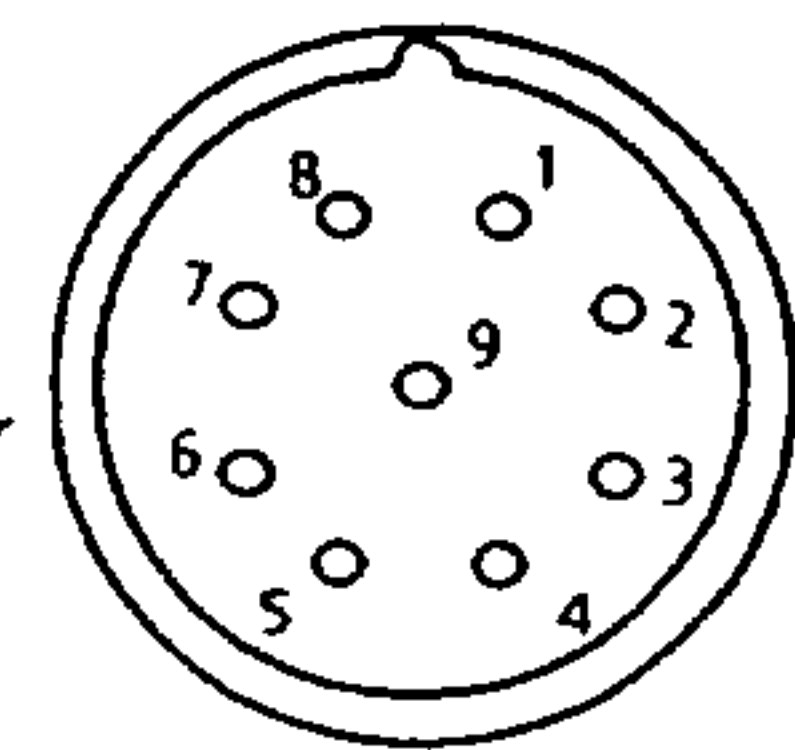

4 Installation instructions  
 4.4 Cable connections

Cable name: Adaptor cable for connecting to the SINUMERIK measuring circuit cable  
 Order No. : 6FC9 348-5XB

**SIMODRIVE : 650** **SINUMERIK**  
**Board location : U1**  
**Board plug connector : X321**

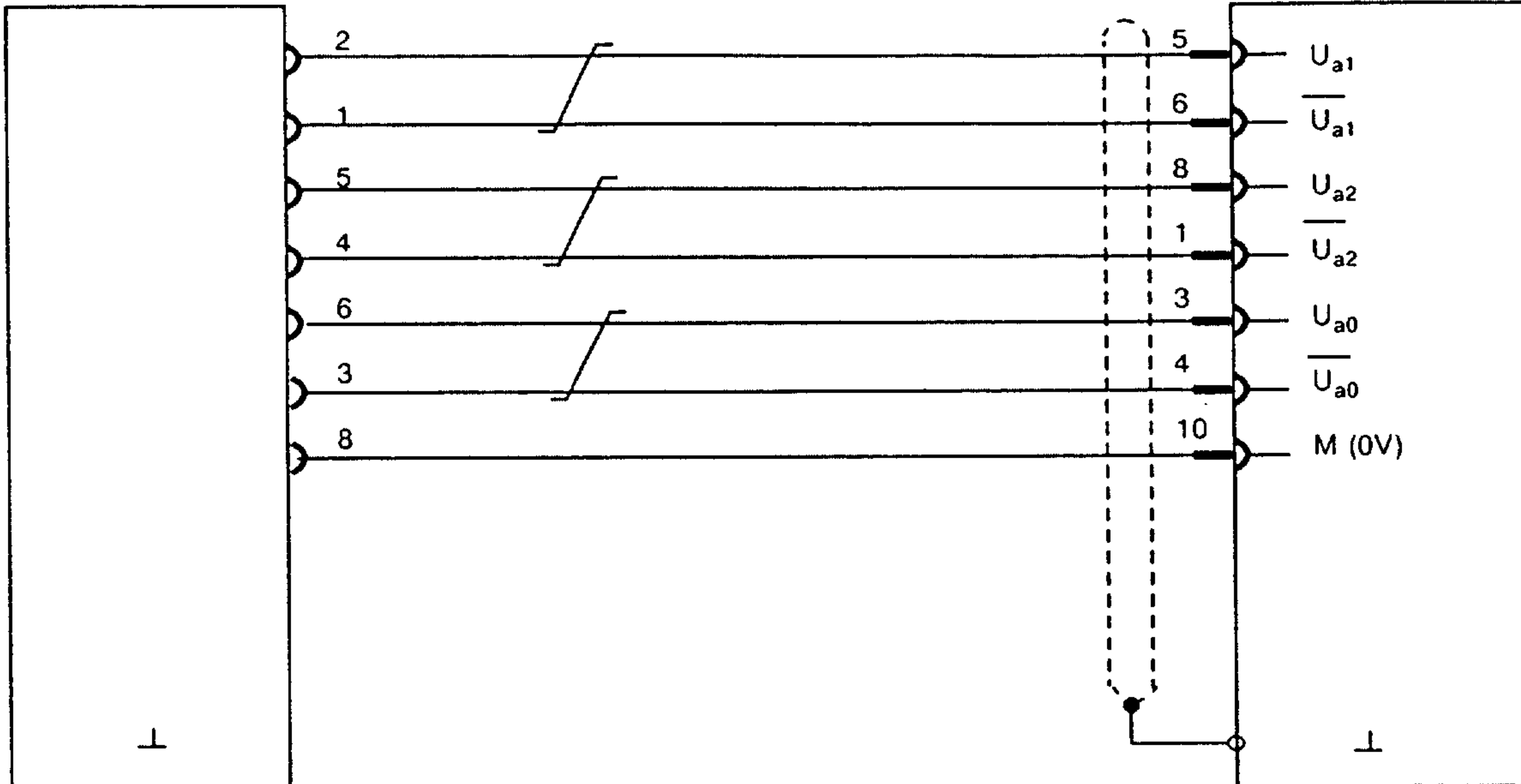

10-pin ribbon cable flat connector,  
 according to DIN 41651  
 Plug connector X231 (6FC9 348-7AH)

**Connector**

12-pin, plug connector  
 SIEMENS  
 6 mm. cable diameter  
 Connecting side  
 6 FC9 341 - 1FQ

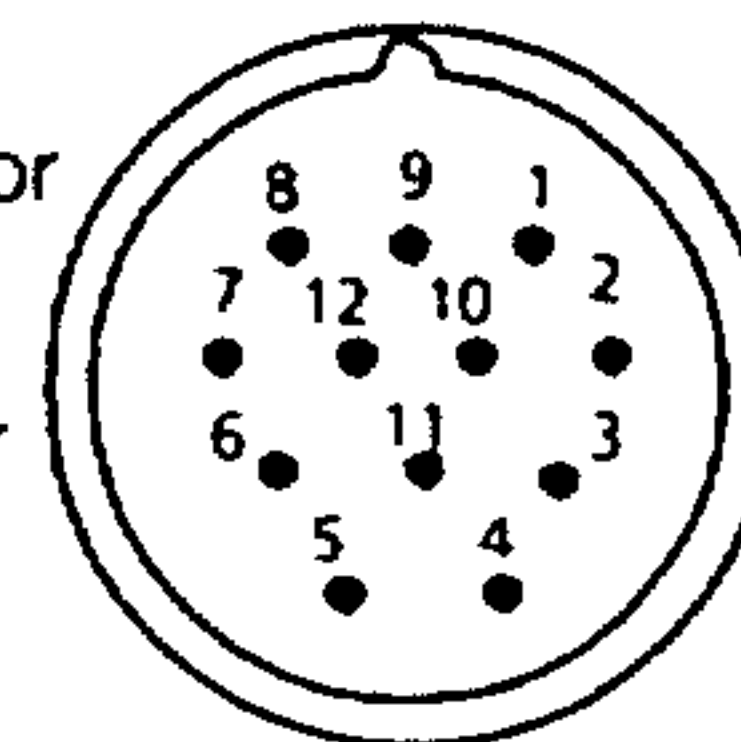

An adaptor cable can be used for connecting to the SINUMERIK measuring circuit cable if the shaft encoder output (connector X231 on input/output board U1) is used.



Cable name: Data line PG 675/PG 685/PG 635 (SINUMERIK-PG IN)  
Order No. : 6FC9 344-1A.

**SIMODRIVE 650**

Board location : Interface block

Board connector :

**PG 675/685**

Plug connector

Printer (V.24)

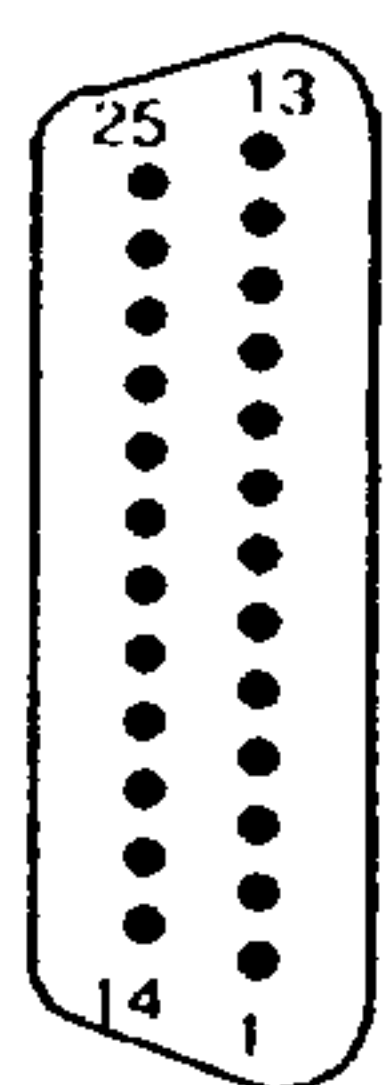
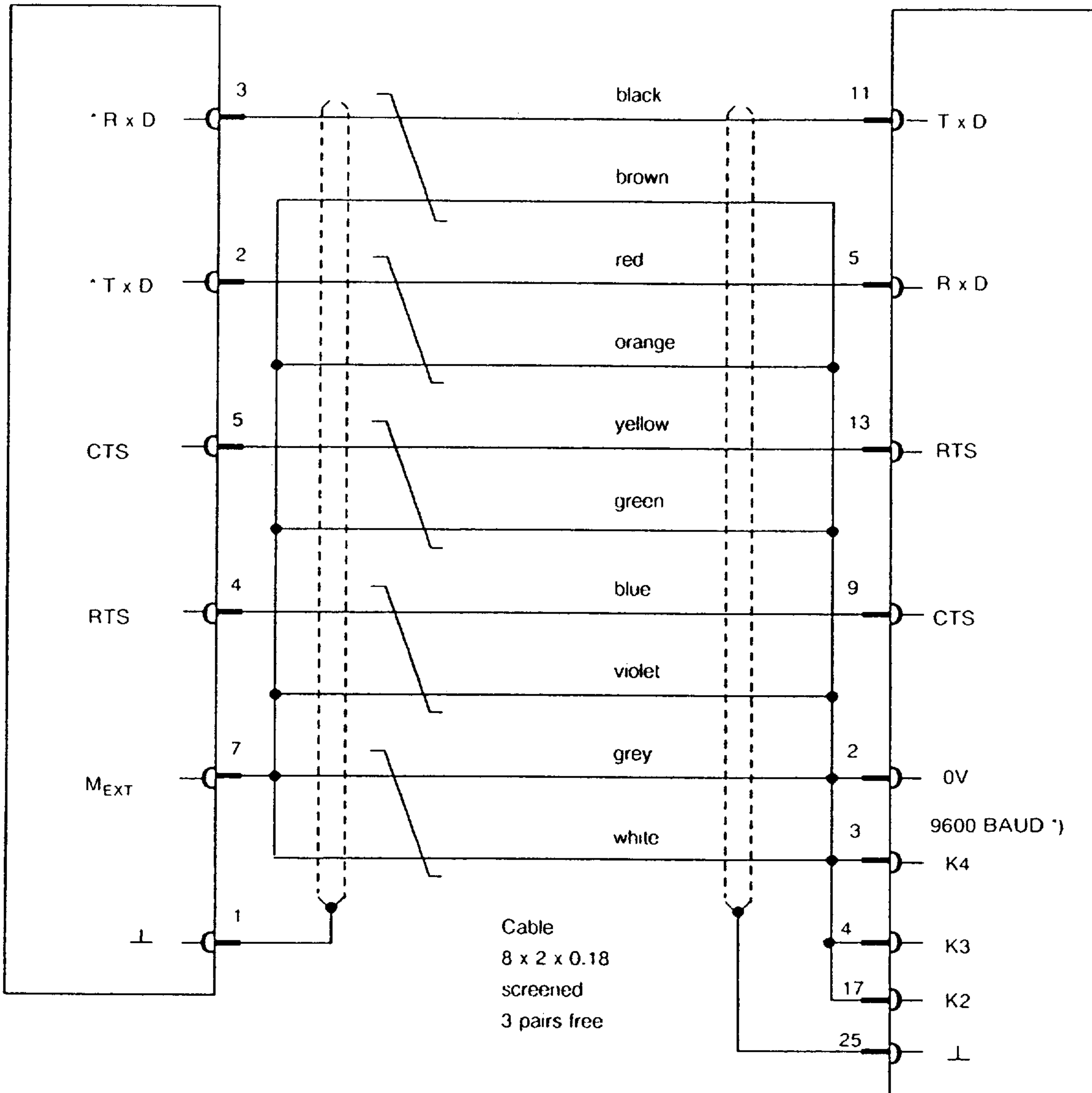

**Connector**

Position 1 below  
D - Sub  
25-pin plug connector  
Connecting side  
Housing with shift lock  
6FC 9 341 - 2AA  
Designation: NC

\*) 9600 baud transmission rate is selected by connecting K1, K2, K3 and ground (0V) at the PG connector.

**Connector**

Position 1 below  
D - sub  
25-pin plug connector  
Connecting side  
Connector housing  
6FC 9 341 - 1ES  
Designation: PG D

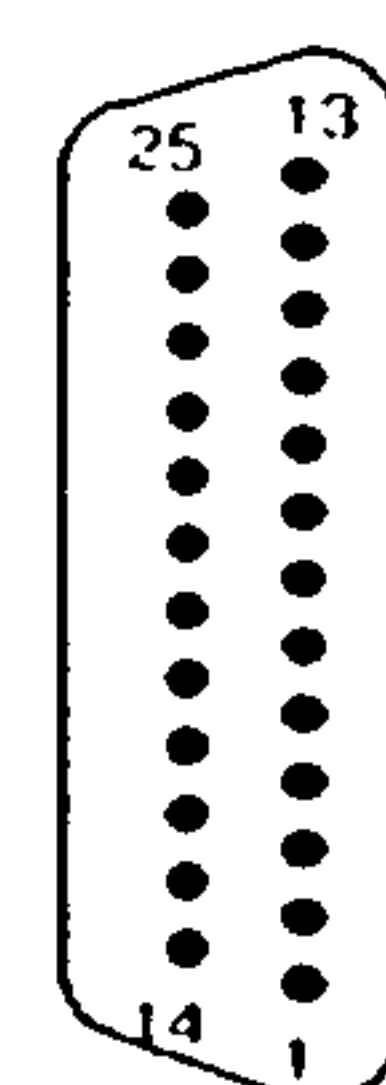

... of the Siemens 5200 Office System.

... TO USE

... of this document or  
... without express written authority.  
... rights, including rights  
... a utility model or design.



## 5 Change gearboxes for AC motors

### 5.1 Application

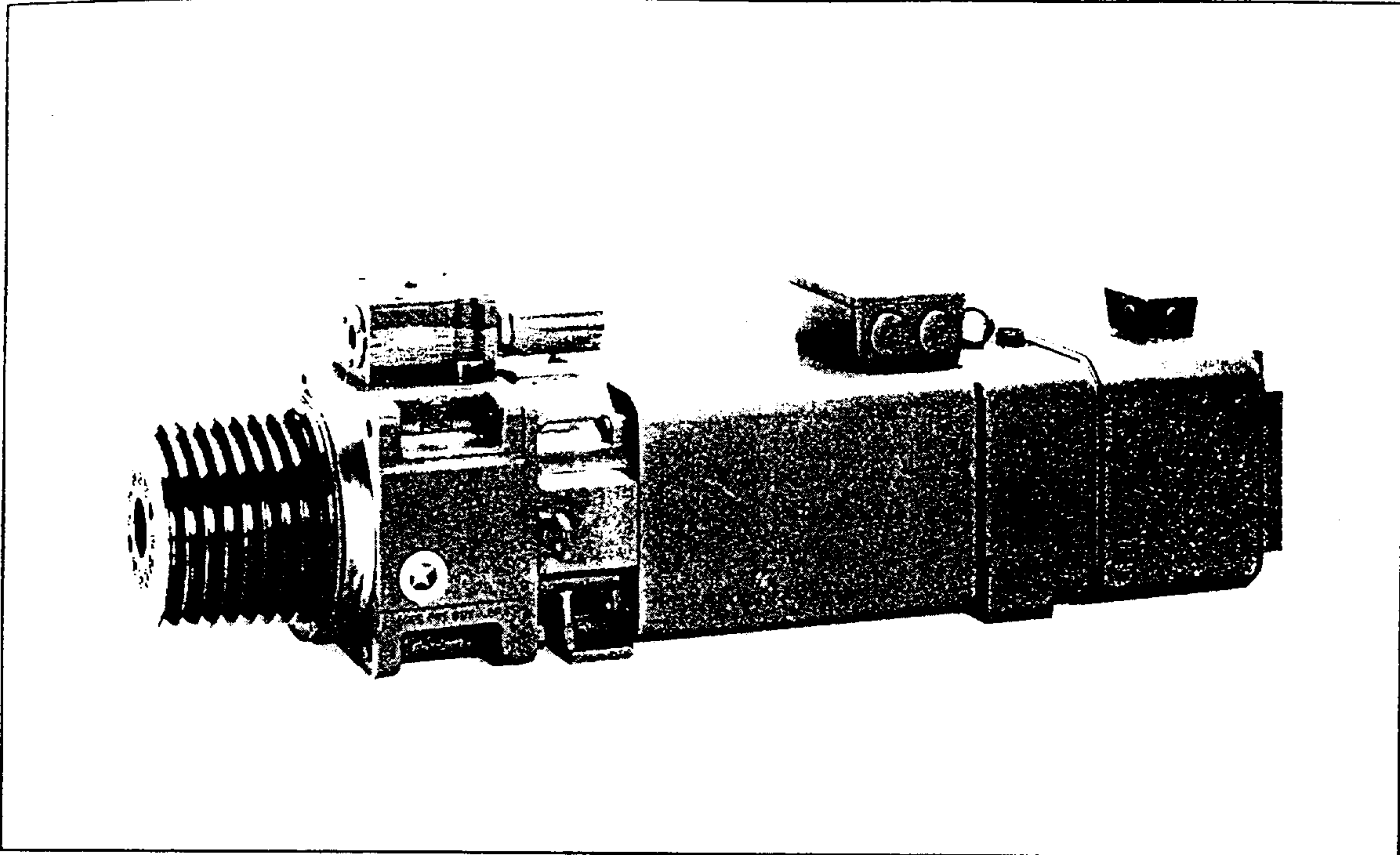

Fig. 5.1 AC motor (15 kW) with ZF gearbox as compact drive unit

A wide speed range at constant drive power is obtained with the gearbox mounted on the AC motor.

The following advantages are provided by locating the gearbox outside the machine tool spindle box, :

- *gearbox oscillations are not transmitted to the main spindle, and thus the machining quality is not diminished*
- *Good adaption to the machine tool*
- *No noise and no temperature drift as a result of the gearbox in the spindle box*
- *Separate lubrication system for the main spindle and the gearbox*
- *High gearbox efficiency (over 95 %)*
- *Only one belt drive necessary*
- *The drive unit (motor and gearbox ) has IMB35 type of construction, and can thus be mounted in B3/B5 and IMV1*
- *The drive power can be transmitted through a gear wheel or a flexible coupling from the gearbox output, instead of through belts.*

## 5.2 Design

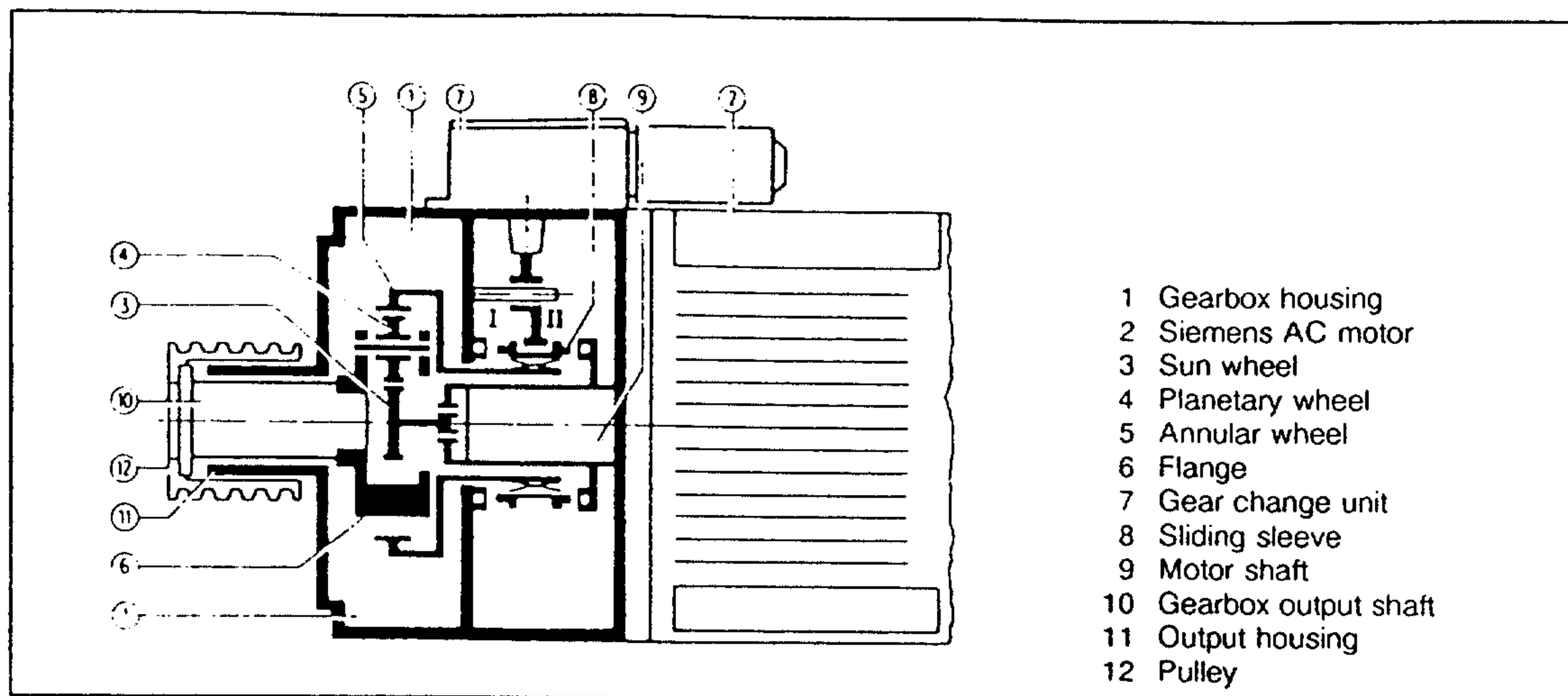

Fig 5.2 Gearbox design

The change gears are planetary gears. The unit is relatively compact as, with this gear system, the power from the central sun wheel is distributed over several planetary wheels. The gear shifting unit, an axially shifted, toothed sliding sleeve, is form-locking.

The following is valid for the change gear:

$$\text{Gear position I: } i_1 = 4$$

$$\text{Gear position II: } i_2 = 1$$

Both gear positions are electrically monitored by limit switches S1 and S2. The gearboxes are suitable for both directions of rotation.

The gearboxes are directly flanged to the drive end of AC motors, IM B35 type of construction, which are prepared for gearbox mounting. IM V1 type of construction is also available.

The compact drive unit can be centered using diameter  $a_{12}$ . The gearbox output is coaxial with the motor shaft.

The gearboxes have, as standard, a play of 30 to 40 minutes at the output, whereby the gear position has almost no effect on the play. Special-design change gears have a maximum play of 25 minutes.

- **Belt pulley**

The belt pulley is designed as cup wheel. The gearbox output shaft has a flange for external centering and threaded holes for mounting the belt pulley. This ensures easy mounting and removal of the pulley.

The complete drive should be designed as stiff as possible using large belt cross-sections. Depending on the particular application and power, then for instance, the SPB belt profile, according to DIN 2211, Sheet .1, has a positive effect on the smoothness of the complete drive.



- **Gearbox output housing**

Change gears for mounting on AC motors, size 100, have an output housing with diameter  $a_{10} = 82$  mm.

For change gears for AC motors, sizes 132 and 160, there are two different output housings with diameters  $a_{10} = 116$  mm or  $a_{10} = 140$  mm.

- **Bearing assignment for permissible cantilever forces  $F_Q$**

The following roller bearings are installed in the gear output shafts of the change gear:

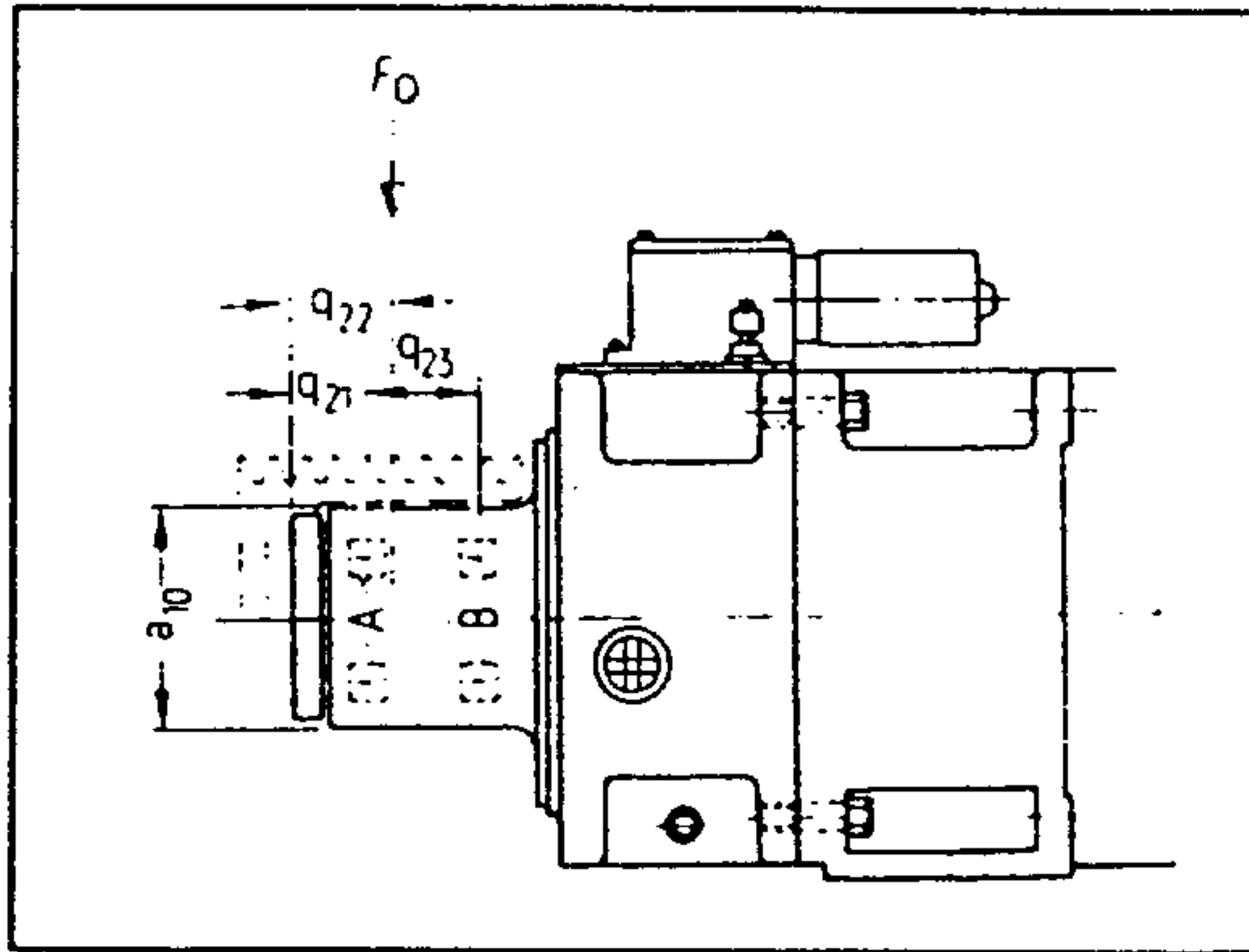

Output housing size (Dimension $a_{10}$ ) [mm]	Bearing for change gear with $i_1 = 4$ in	
	Position A	Position B
82	RNU 2206 EC	NUP 206 EC
116	RNU 308 E	NUP 209 E
140	RNU 309 E	NUP 211 E

Fig. 5.3 Bearing positions A and B

With this information, the service life of the gearbox output shaft bearing can be determined by the user himself by selecting location, diameter and speed of the belt pulley.

The line of action of cantilever force  $F_Q$  (belt tension) under operating conditions, must lie in the vicinity of  $q_{23}$ . This assumption is also made when designing the bearings.

- **Holding brake**

The change gearboxes can also be equipped with a holding brake (single-disk brake) for holding the gearbox output shaft, and thus the main spindle stationary. This electromagnetic single-disk brake is a magnetically operated brake. The solenoid core is incorporated into the gear output drive housing. The holding brake cannot be retrofitted.

Drive with motors of size	Holding torques of the brakes under dry conditions
100	40 Nm
132	90 Nm
160	90 Nm

The holding brake armature disk must be mounted on the front of the belt pulley. The air gap (dimension  $q_{44}$ ) should be set between 0.4 to 1.0 mm depending on the size.

The holding brake is connected to 24 V DC; the polarity of the plug-in contacts is irrelevant.

The holding brake must be released (no current) during gear changing and when the motor is running, and can only be operated when the motor is stationary.

### 5.3 Gear changing

During gear changing the motor must change direction approximately 5 times per second. However, the gears mesh mostly at the first rotation change, so that the shift time is approximately 300 to 400 ms. Terminal 60 ("oscillation") is provided on the transistorized PWM converter in order to attain the necessary oscillation.

The mechanical gear change is realized using a gear change unit on the gearbox. The gear change unit is operated from a DC motor, which requires a separate power supply (24 V DC).

Gear changing must be monitored using a time relay, which reverses the change after 2 s, if the change command was not able to be executed. A 10 s time limit should be provided for approximately 4 to 5 further attempts.

Gear change without oscillation at low speed (creep speed) or at standstill should be prevented as it does not permit perfect gear changing.

The motor can only be started 200 ms after the gear change operation has been completed.



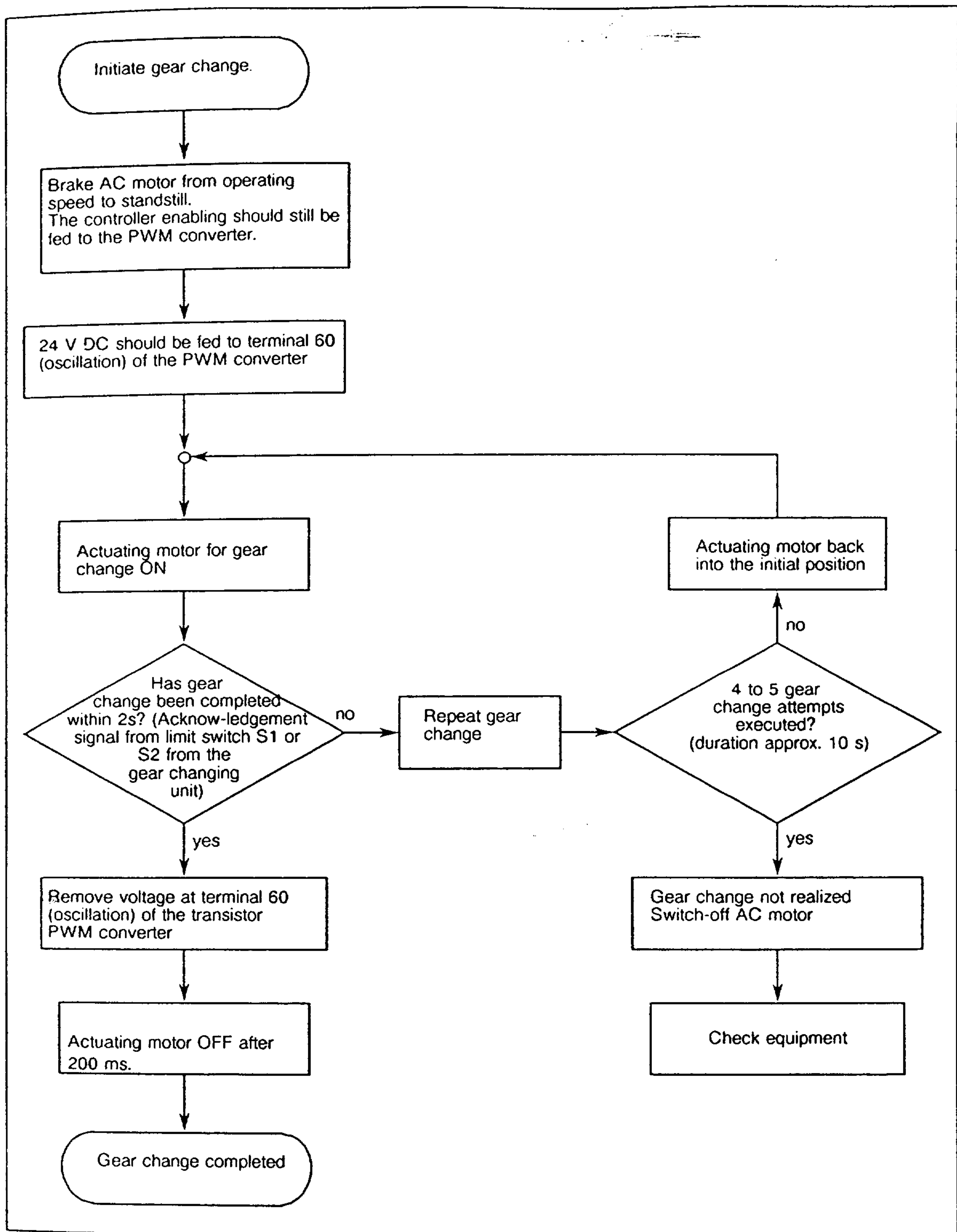

Fig. 5.4 Gear change sequence

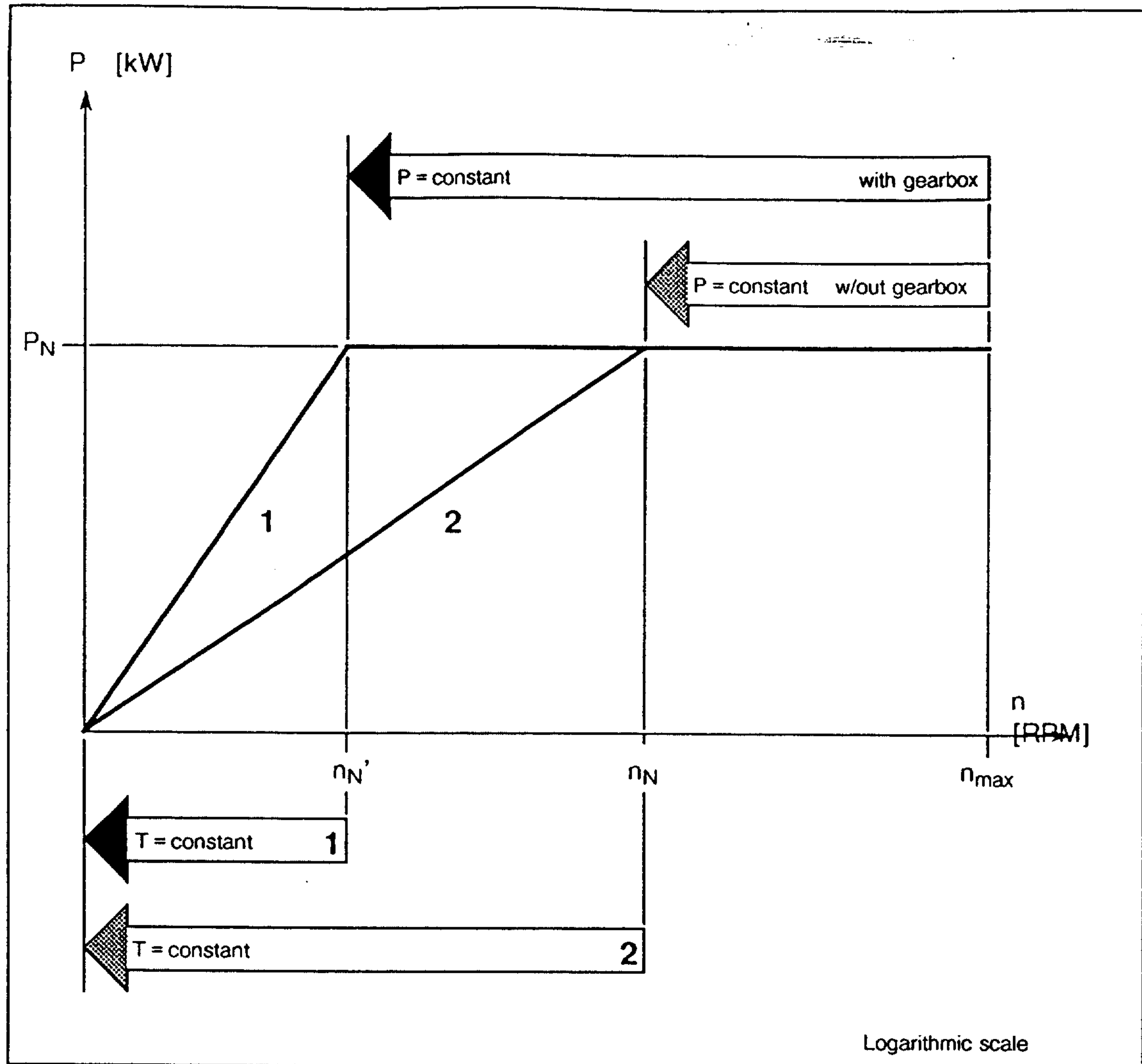

Fig. 5.5 Speed-power characteristic when using a two-stage gearbox for extending the constant power speed range for main spindle drive AC motors

- $n_N$  Rated speed
- $n_{N'}$  Rated speed with two-stage gearbox
- $n_{max}$  Maximum permissible speed
- $P_N$  Rated power and also constant power of the AC motors in the speed range from  $n_N$  to  $n_{max}$  bzw.  $n_{N'}$  to  $n_N$
- $T$  Torque

Example:

AC motor  
 without gearbox:

A constant power control range exceeding 1:4 is possible with  $P = \text{constant}$  from  $n_N = 1500$  RPM to  $n_{max} = 6300$  RPM.

Same AC motor with  
 gearbox:

A constant power control range greater than 1:16 is possible for gear stage  $i_1 = 4$ .  
 ( $n_{N'} = 375$  RPM to  $n_{max} = 6300$  RPM)



## 5.4 Lubrication

The gearboxes have splash lubrication. The oil level can be checked using sight glasses on both sides of the gearbox. Lubricating oil must be filled to the center of the sight glass when the drive is in the horizontal and vertical position.

An angular oil level indicator must be mounted if the gearbox is mounted at an angle. The required oil level should be marked on this. Oil drain screws should be located on both sides.

HLP oils, with viscosity classification ISO-VG 68 (lower viscosity limit), with good aging characteristics and additives to increase the corrosion and wear protection should be used for lubrication

When the gearbox is flange mounted to the motor, some of the heat generated in the gearbox, is transferred to the motor housing. Depending on the machine mechanical design, a machine housing temperature rise can affect the machining accuracy. In these cases, we recommend forced oil lubrication system whose effectivity can be improved by oil cooling.

With the forced oil lubrication, a flow of approx. 1 l/min. should be injected through the oil drain hole. A pressure of 0.5 bar to 2 bar is obtained, depending on the oil viscosity. The oil can be fed through the holes for the oil sight glasses with a sufficiently high drain cross-section.

A forced oil lubrication system should be provided for vertical mounting, so that heat can be dissipated from the gearbox.

Special oil circulating conduits, in some cases dependent on the mounting, can be provided on request.

The measures necessary to dissipate the heat can be most accurately determined with a test run on the machine, as the heat generated in the gearbox is dependent on the speed and the operating time.

Gearbox for motor sizes	Necessary oil quantity in the gearbox	
	horizontal	vertical
Shaft height 100	0.8 Liter	0.5 Liter
Shaft height 132	2.0 Liter	1.0 Liter
Shaft height 160	3.5 Liter	1.5 Liter

### 5.5 Technical data

Gearbox with $i_1 = 4$	Weight of two-stage gearbox with output housing		
	$a_{10} = 82 \text{ mm}$ approx. [kg]	$a_{10} = 116 \text{ mm}$ approx. [kg]	$a_{10} = 140 \text{ mm}$ approx. [kg]
w/out holding brake	28	52	55
with holding brake	29	54	57

### 5.6 Circuit diagram

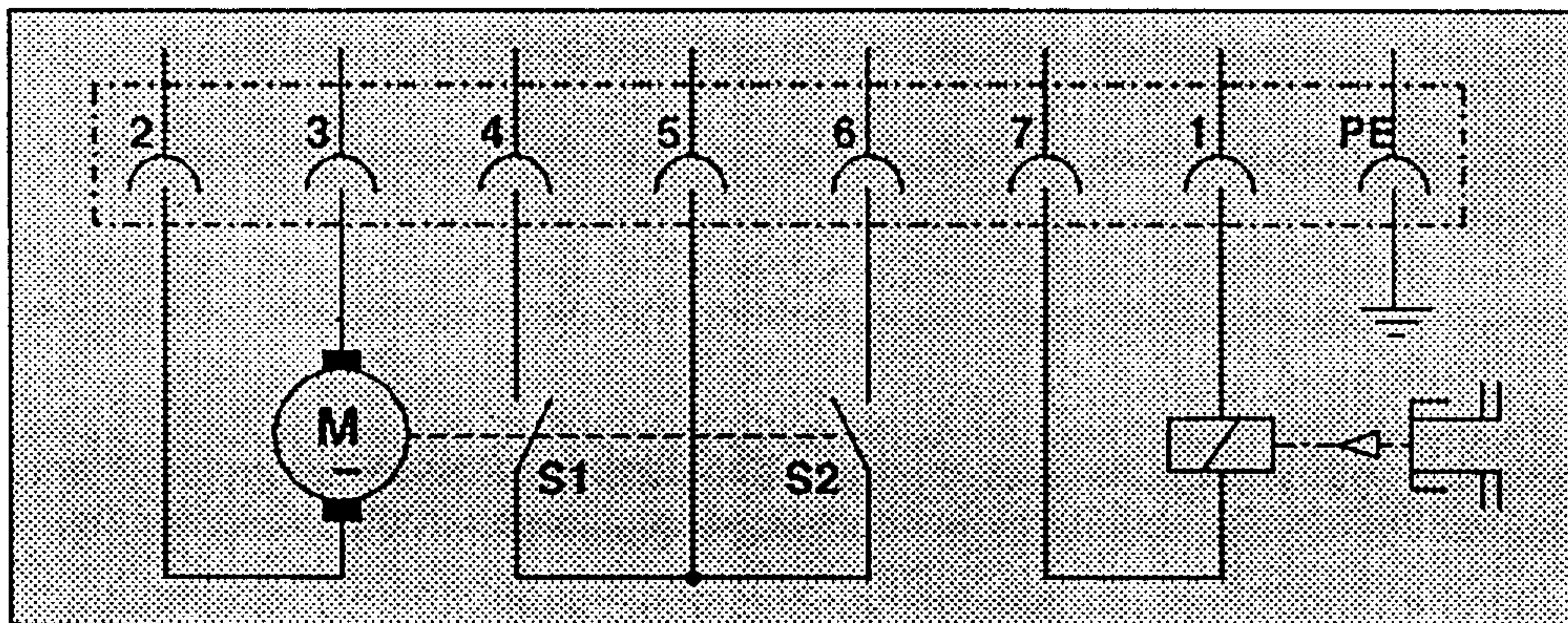

Fig. 5.6 Circuit diagram for gear change circuit

Connected through Harting 7-pin + PE plug connector, Type HAN 7D (connector is part of the scope of supply).

Plug connector contact No.	No. and designation	In-put	Out-put	Voltage	Current
2 and 3	1 actuating motor	o	-	24 V DC	$I_{\max} = 5 \text{ A}$ (in-rush current)
4 to 6	2 limit switches	o	o	24 V DC $U_{\max} = 42 \text{ V DC}$	$I_{\max} = 5 \text{ A}$
1 and 7 (optional)	1 holding brake (open-circuit actuated)	o	-	24 V DC	$I \approx 2 \text{ A}$



Control sequence for gear change	Connector contact No.			
	2	3	4/5 (S1)	5/6 (S2)

for change from stage  $i_2$  to  $i_1$

a Initial position (f)			0	L
b Actuating motor runs	+ 24 V DC	0 V	0	0
c Mechanical change runs to end stop*)			L	0

for change from stage  $i_1$  to  $i_2$

d Initial position (c)			L	0
e Actuating motor runs	0 V	+ 24 V DC	0	0
f Mechanical change runs to end stop (a)*)			0	L

- \*) A limit switch (S1 or S2) issues a signal to the control to switch-off the actuating motor after the change operation  
L Contact closed  
0 Contact open

### 5.7 Dimension sheet

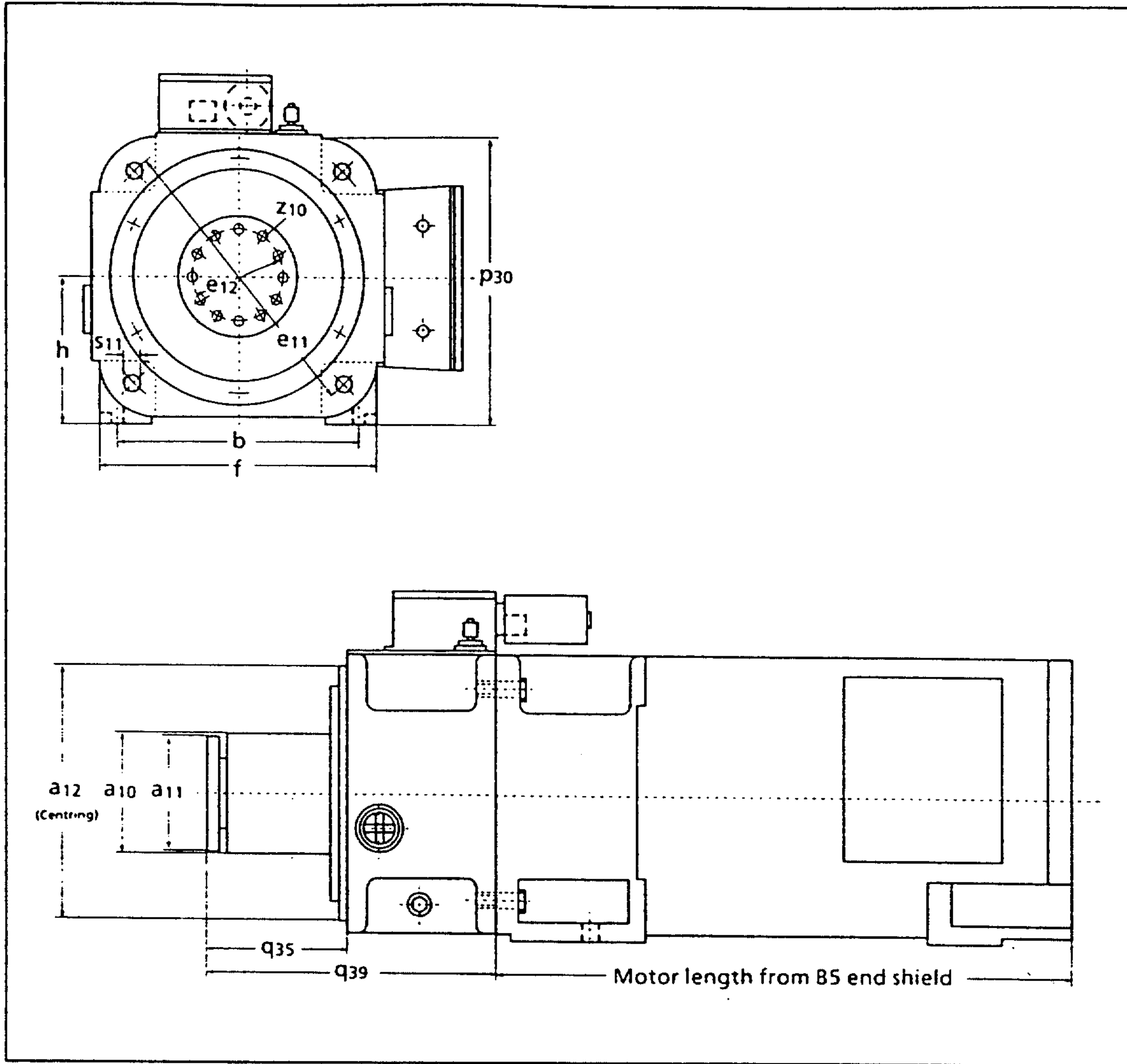

Fig. 5.7 AC motor with gearbox

AC motor, size	Output housing, Size	Dimensions in mm													Threaded holes, Number
		$a_{10}$	$a_{11}$ k6	$a_{12}$ g6	$b$	$e_{11}$ $\pm 0.2$	$e_{12}$ $\pm 0.2$	$f$	$h$	$p_{30}$	$q_{35}$	$q_{39}$	$s_{11}$	$z_{10}$	
100	82	82	85	190	160	215	65	197	100	202	126	257	14	M8	8×45°
132	116	116	118	250	216	300	100	258	132	264	171	321	18	M12	12×30°
	140	140	130												
160	116	116	118	250	254	350	100	314	160	321	171	321	18	M12	12×30°
	140	140	130												



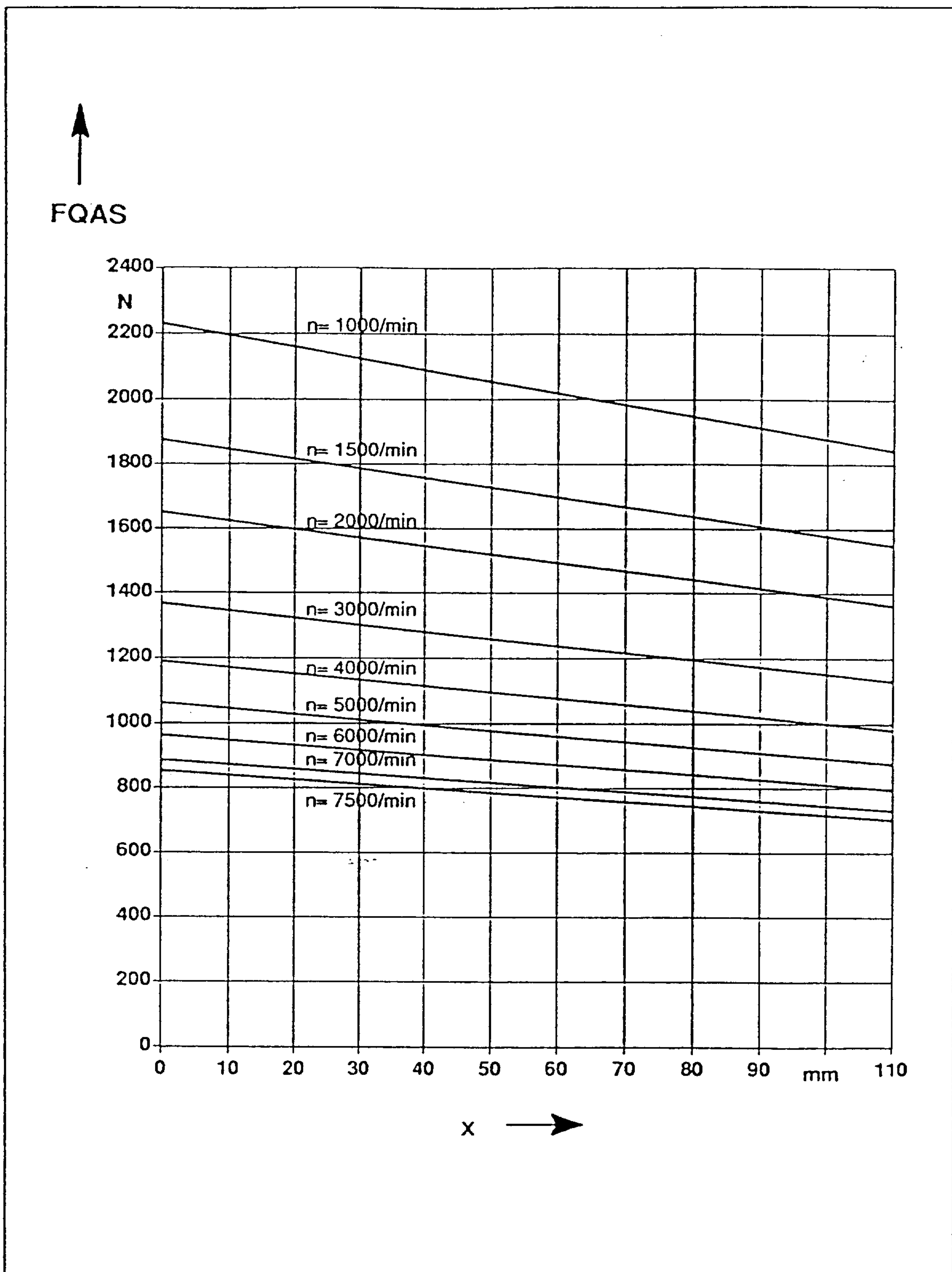

Fig. 6.44 Cantilever force chart for 1PH6 13□-4 AC motors, with single-bearing design

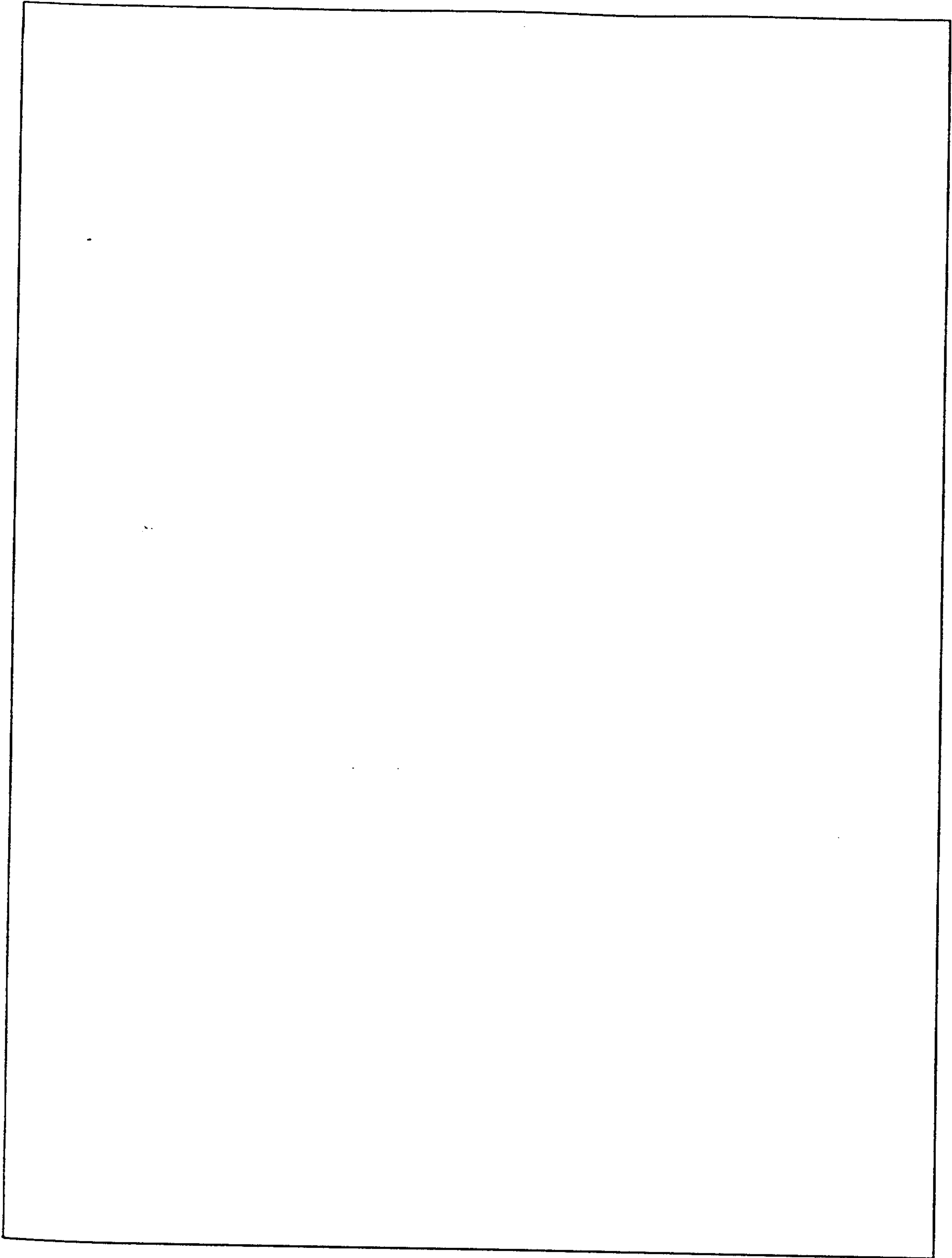

Fig. 6.45 Cantilever force chart 1PH6 13□-4 AC motors, with spindle bearing



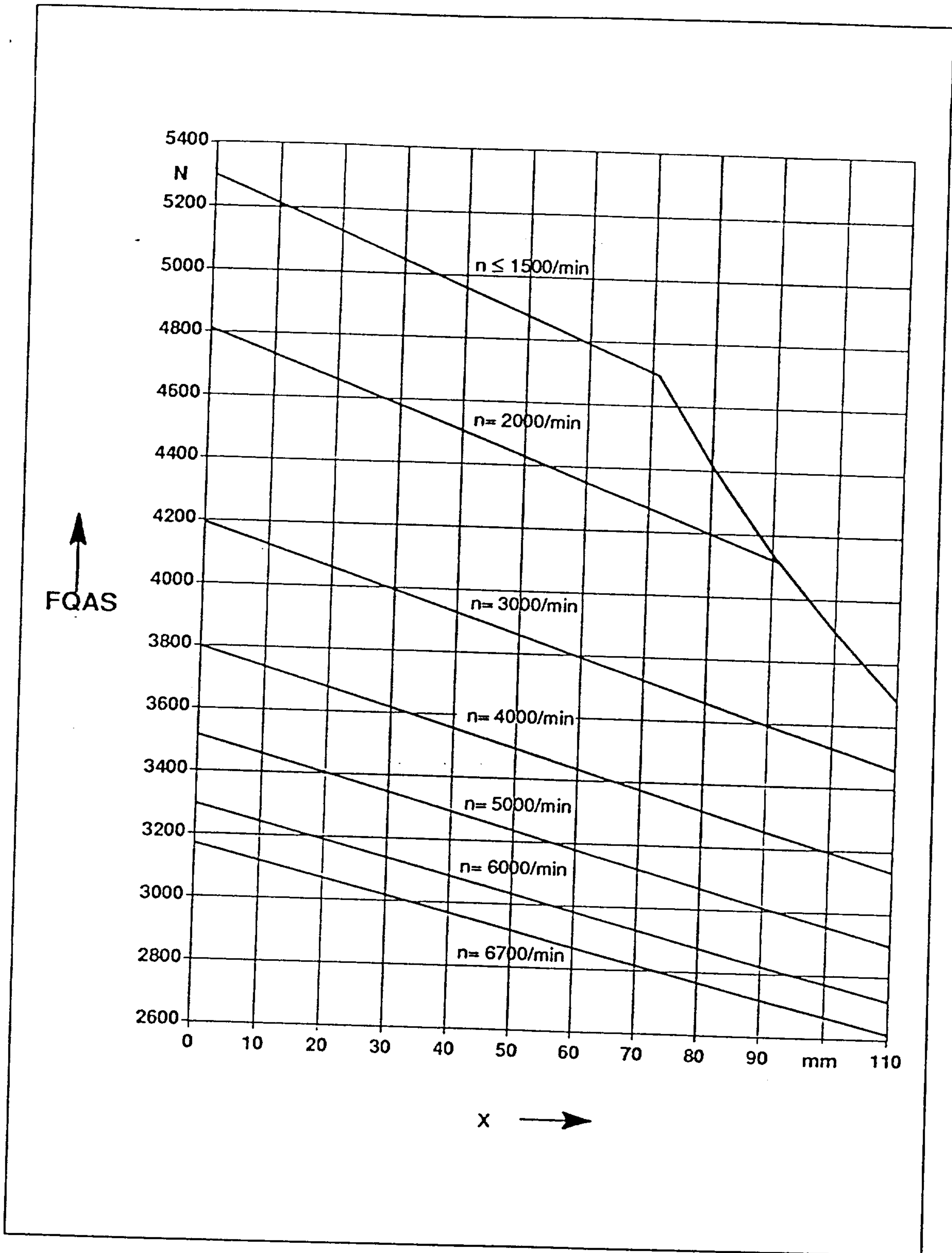

Fig. 6.46 Cantilever force chart for 1PH613-4 AC motors, with double-bearing design

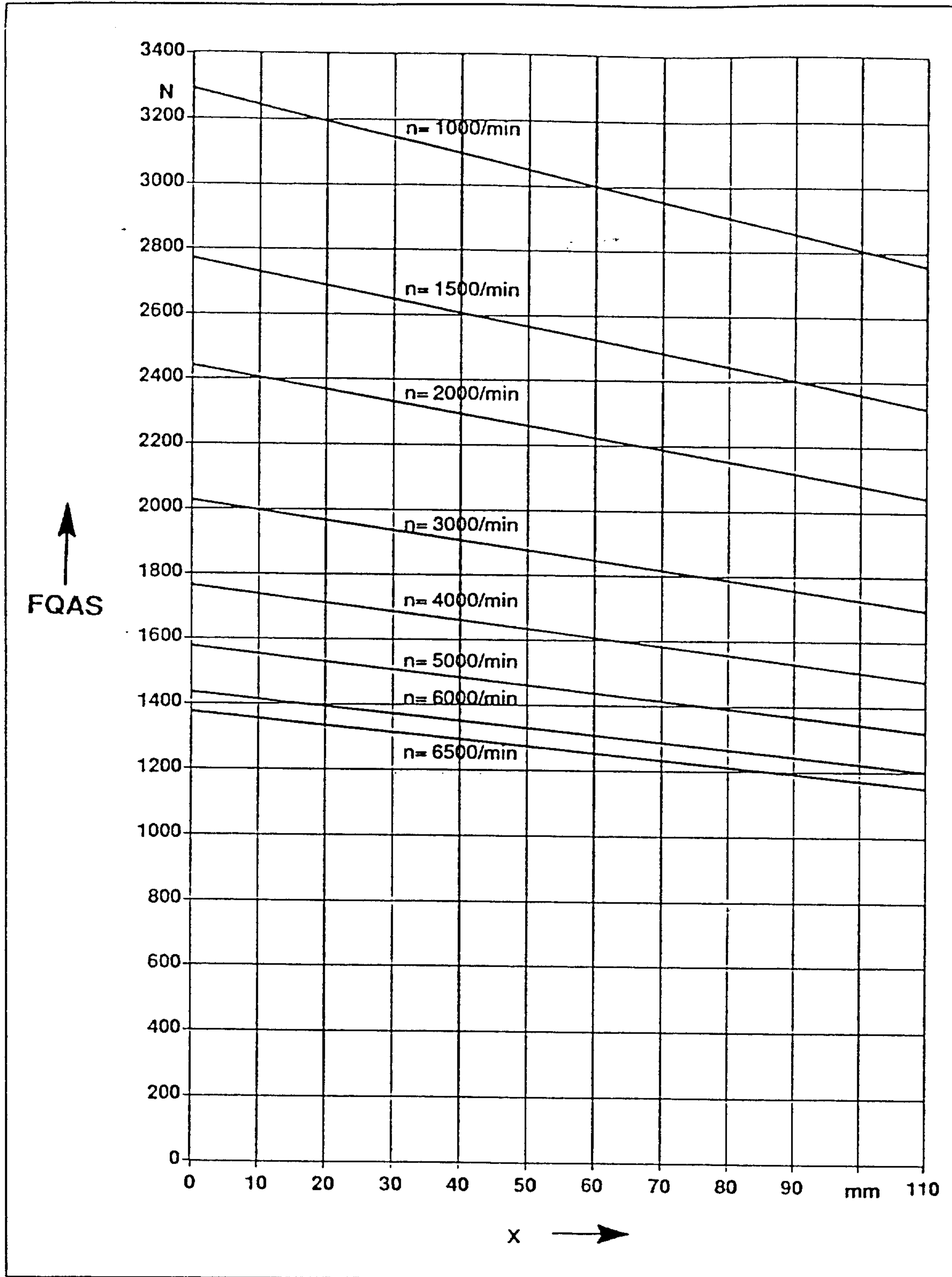

Fig. 6.47 Cantilever force chart for 1PH616-4 AC motors, with single-bearing design



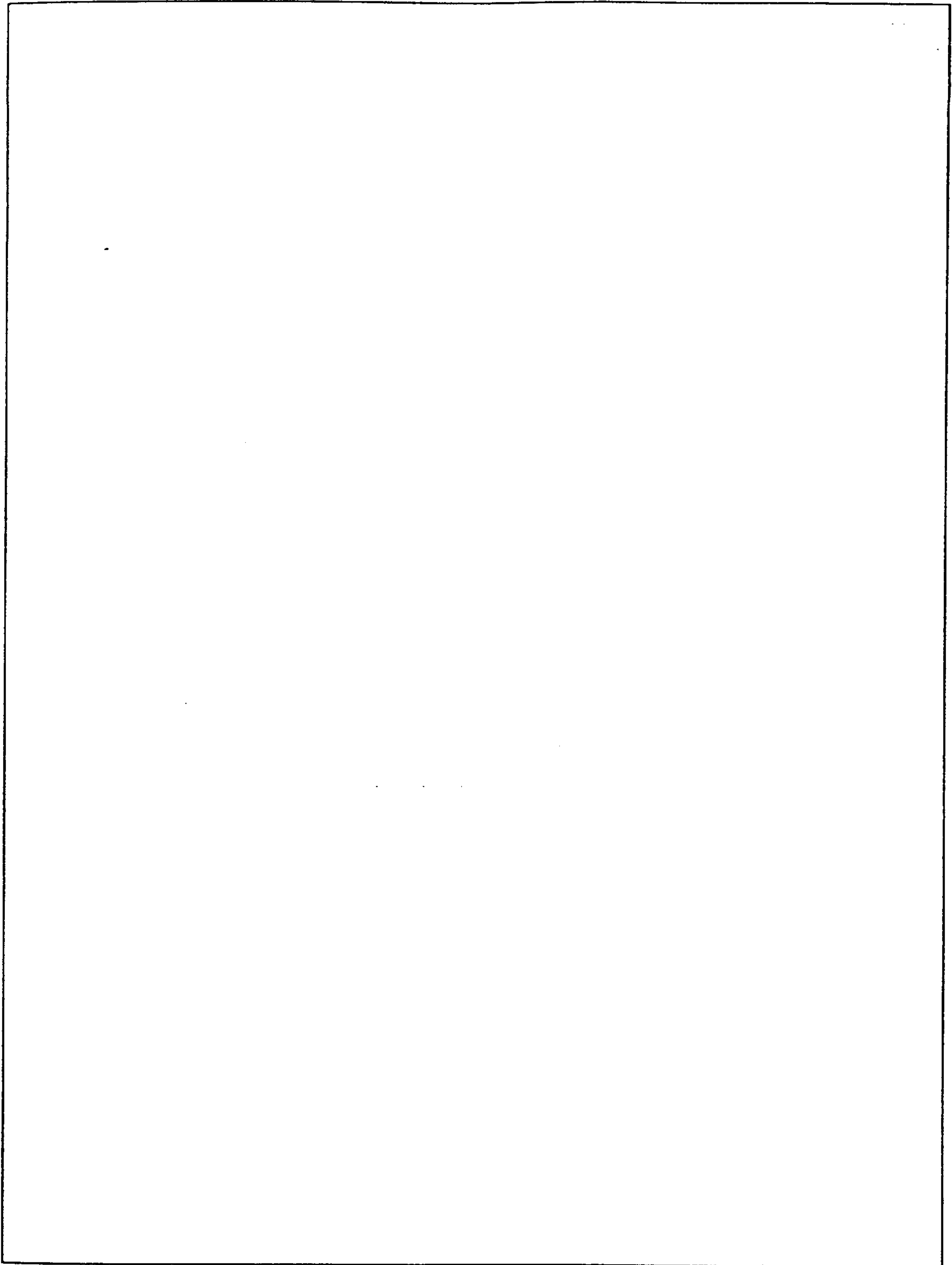

Fig. 6.48 Cantilever force chart for 1PH6 16□-4 AC motors, with spindle bearing

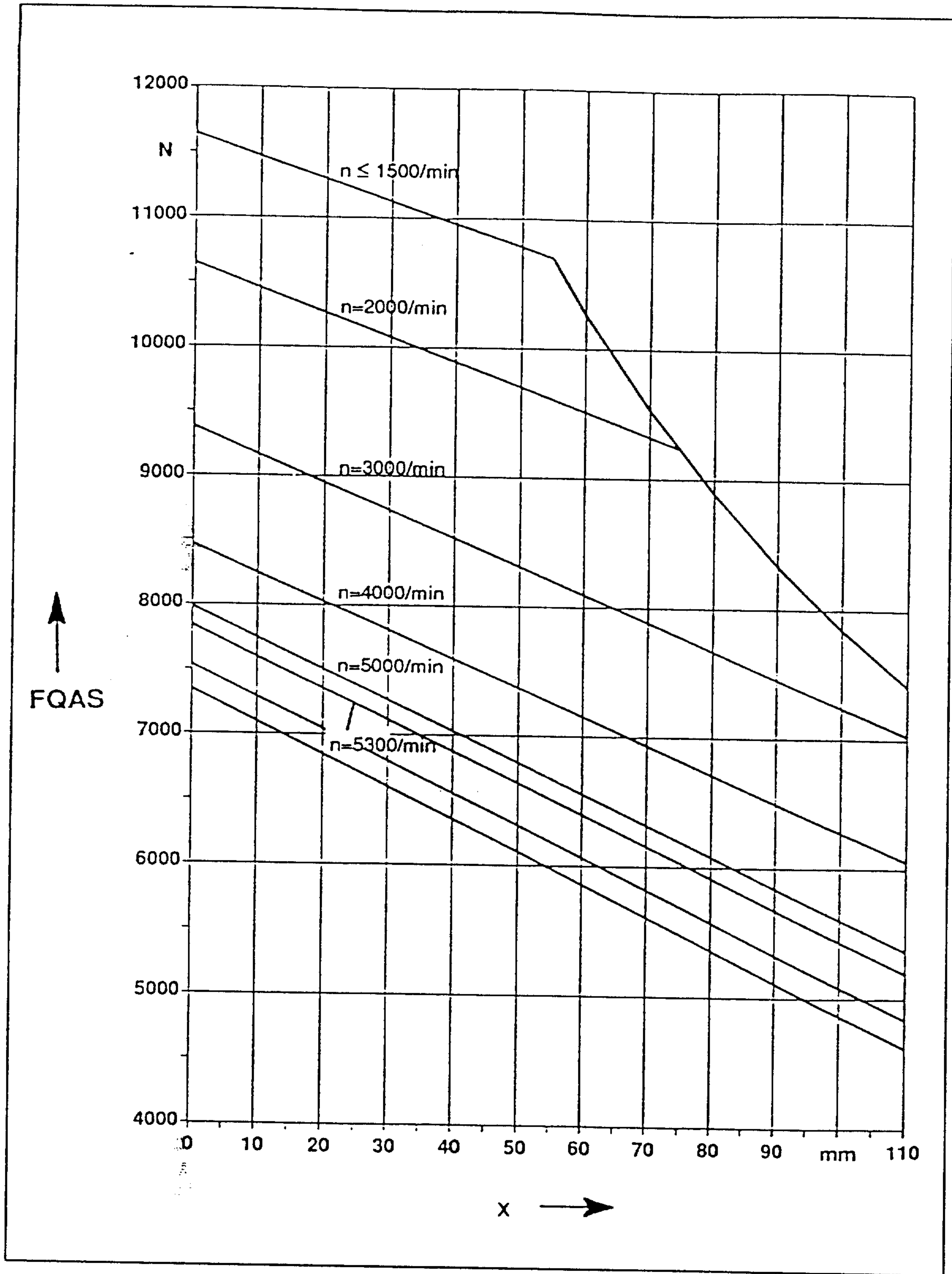

Fig. 6.49 Cantilever force chart for 1PH6 16□-4 AC motors, with double-bearing design



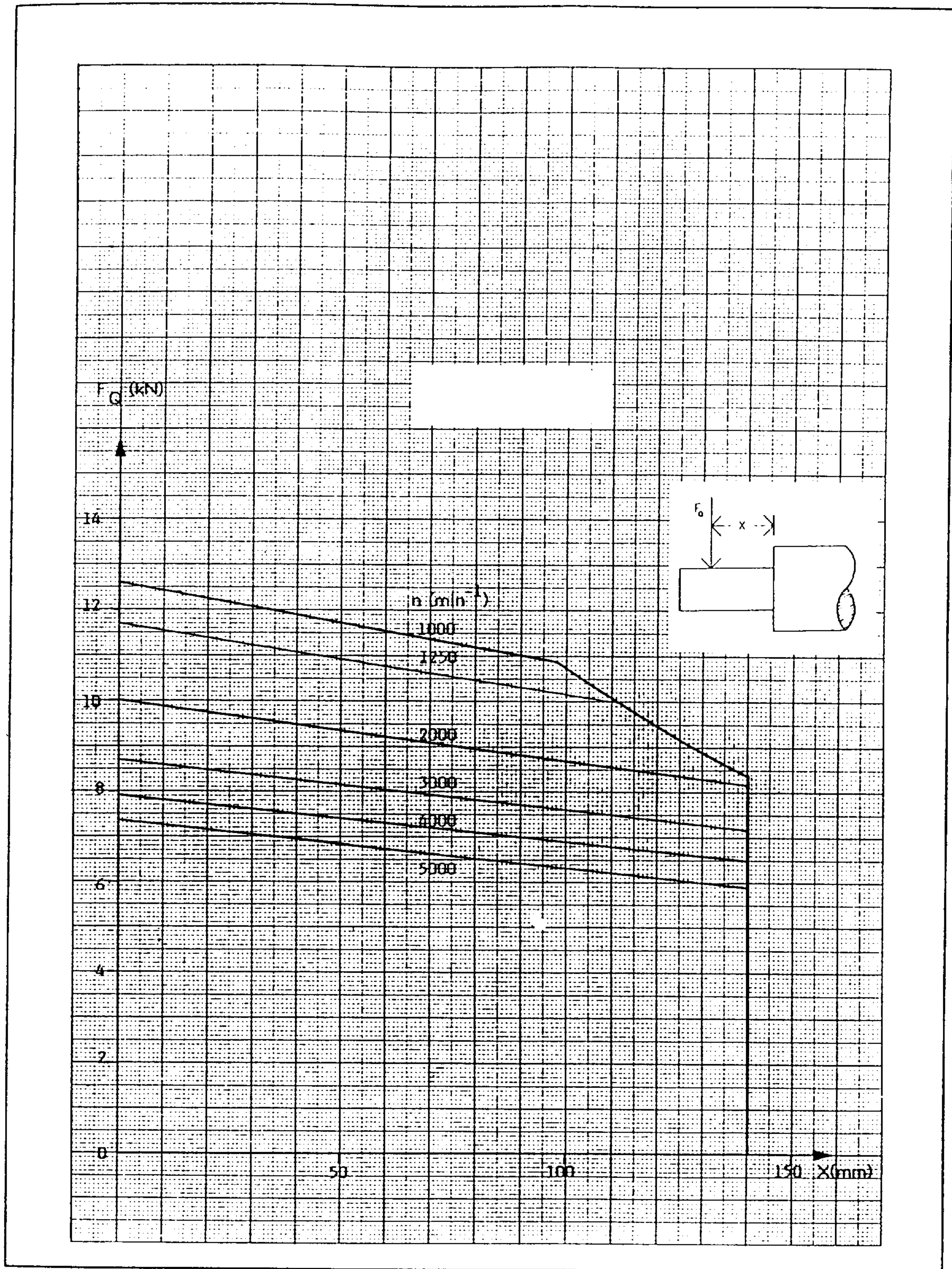

Fig. 6.50 Cantilever force chart for 1PH6 186-4 AC motors, with single-bearing design



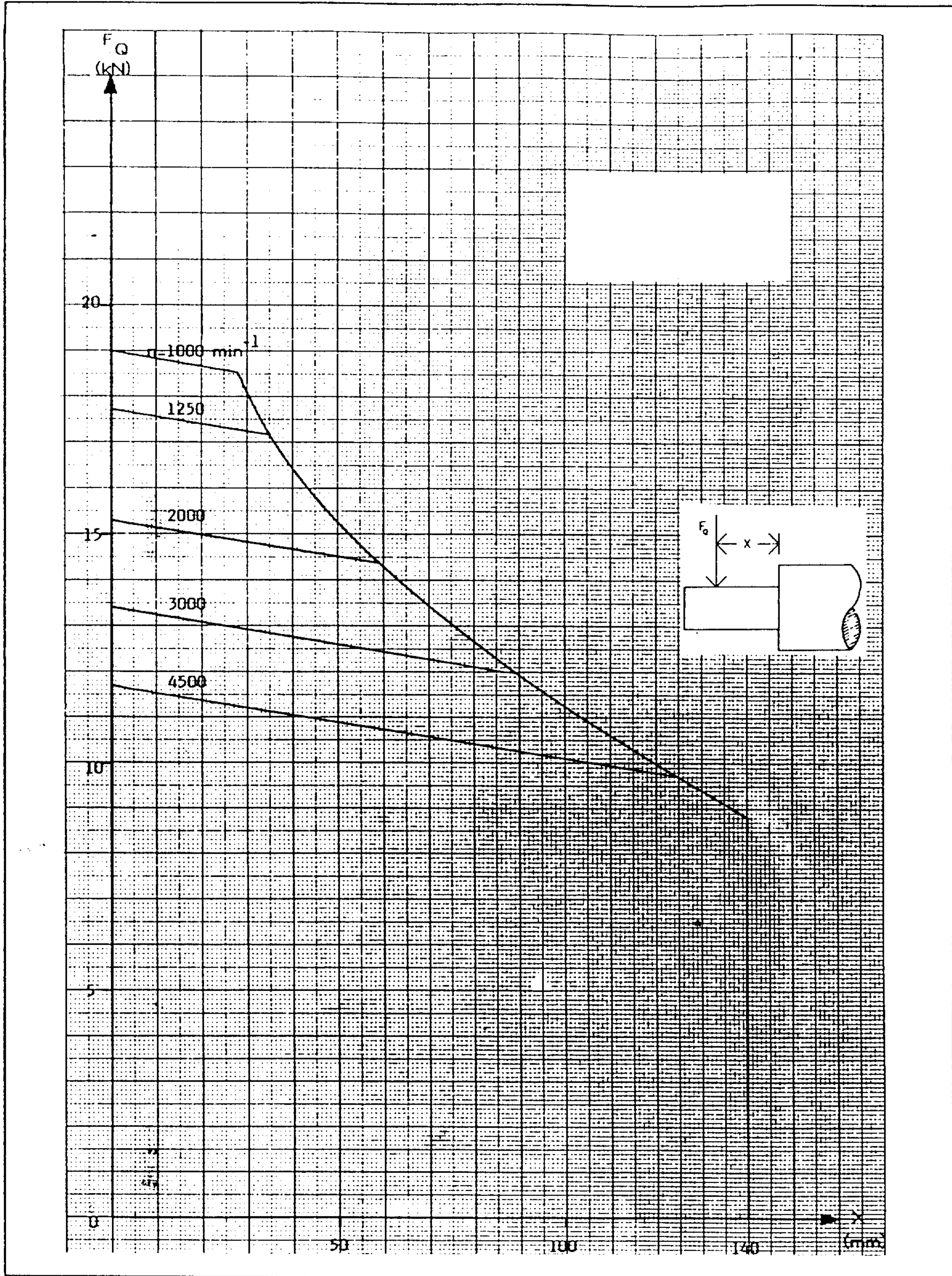

Fig. 6.51 Cantilever force chart for 1PH6 186-4 AC motors, with reinforced bearing



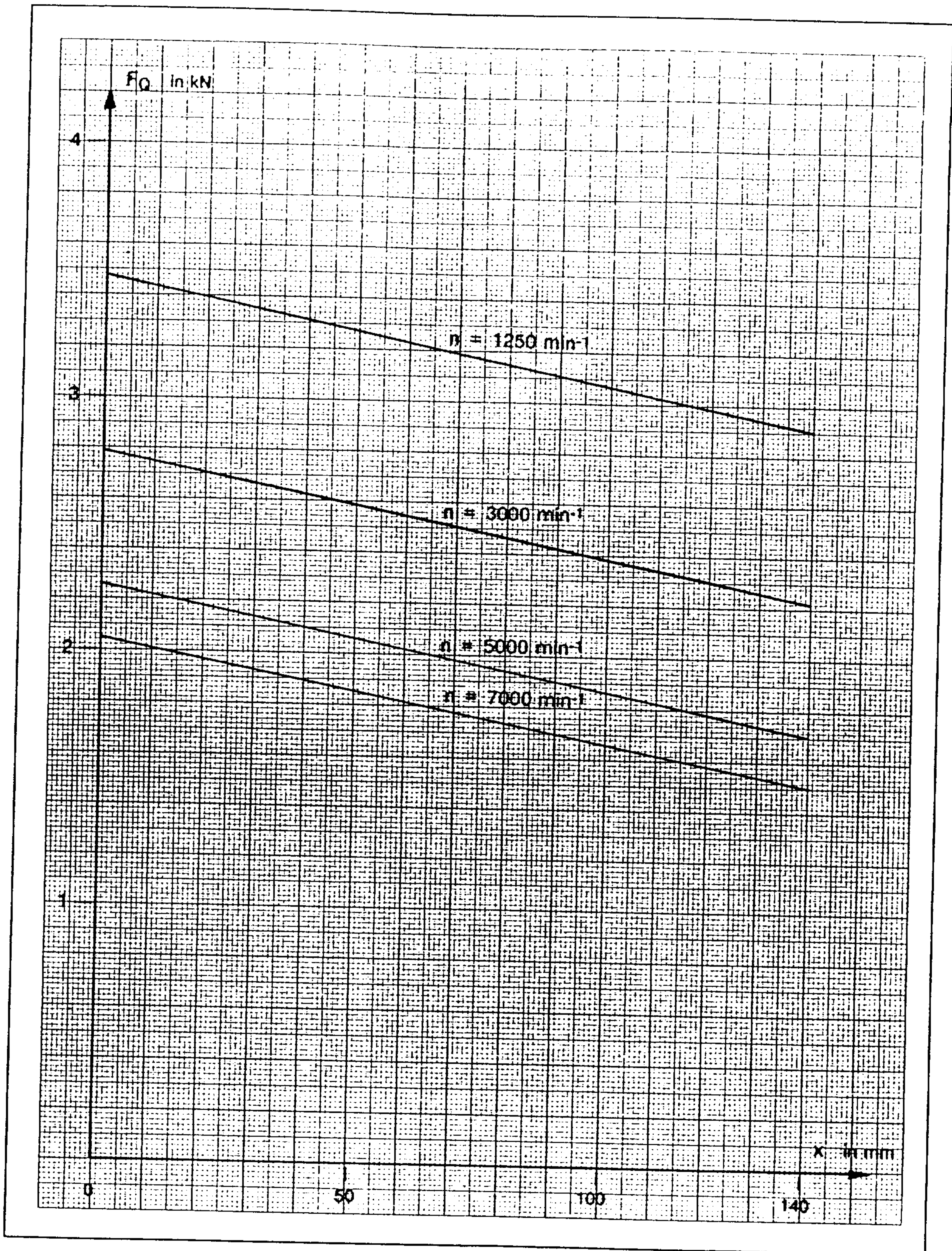

Fig. 6.52 Cantilever force chart for 1PH6 186-4 AC motors, for high speed motors with option L 37



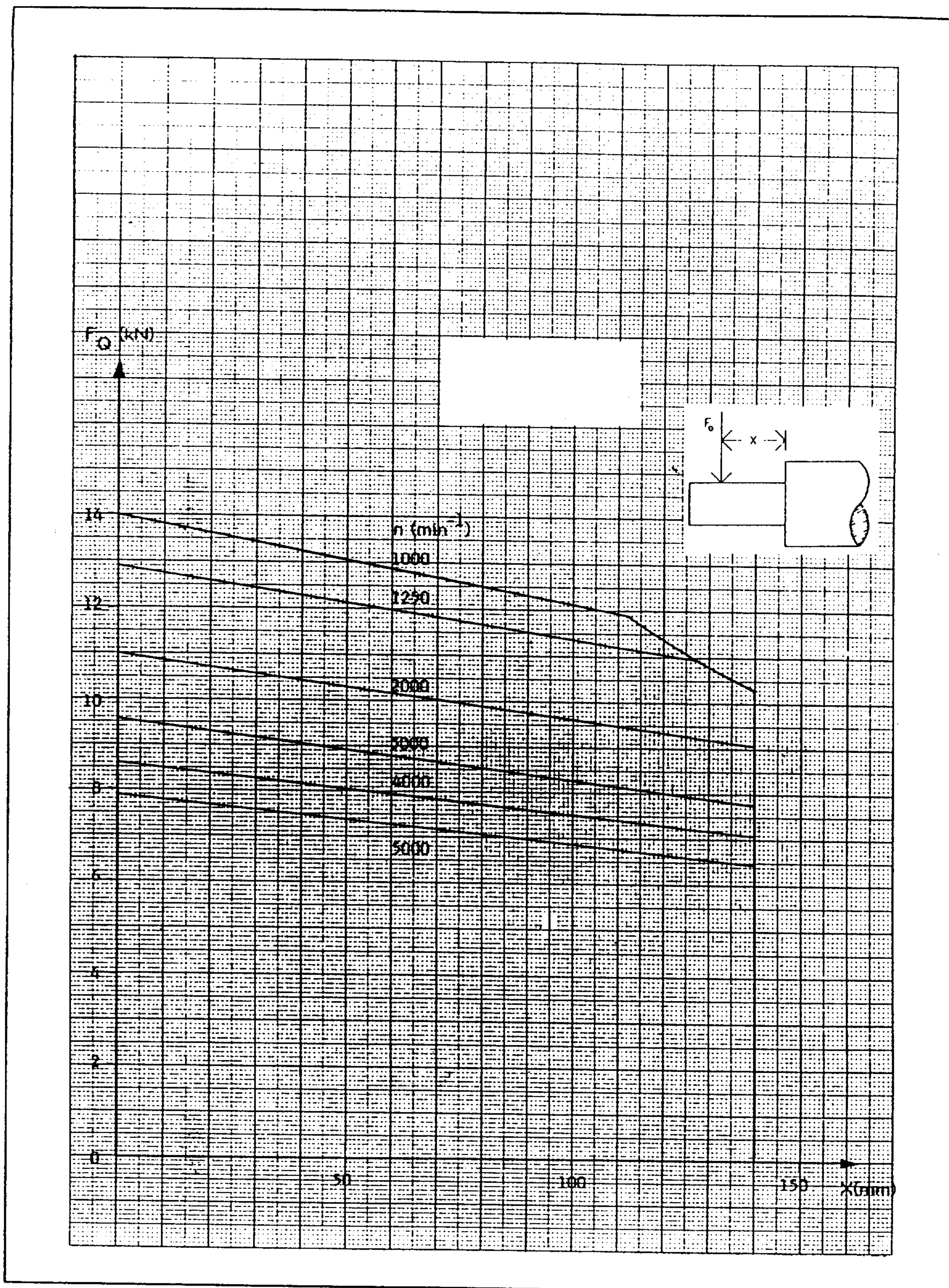

Fig. 6.53 Cantilever force chart for 1PH6 206-4 AC motors, with single-bearing design



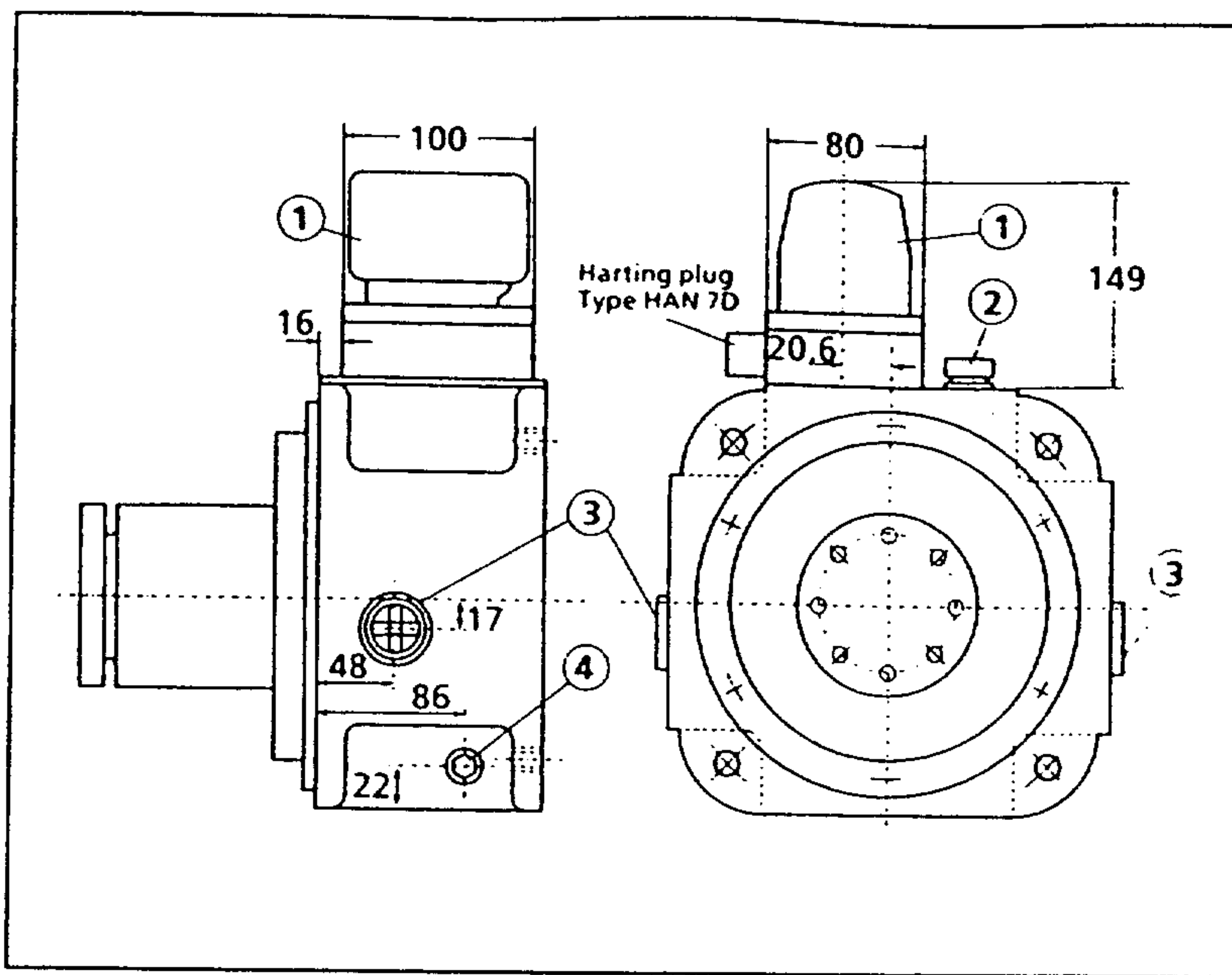

Fig. 5.8 Gearbox with gear change unit for size 100

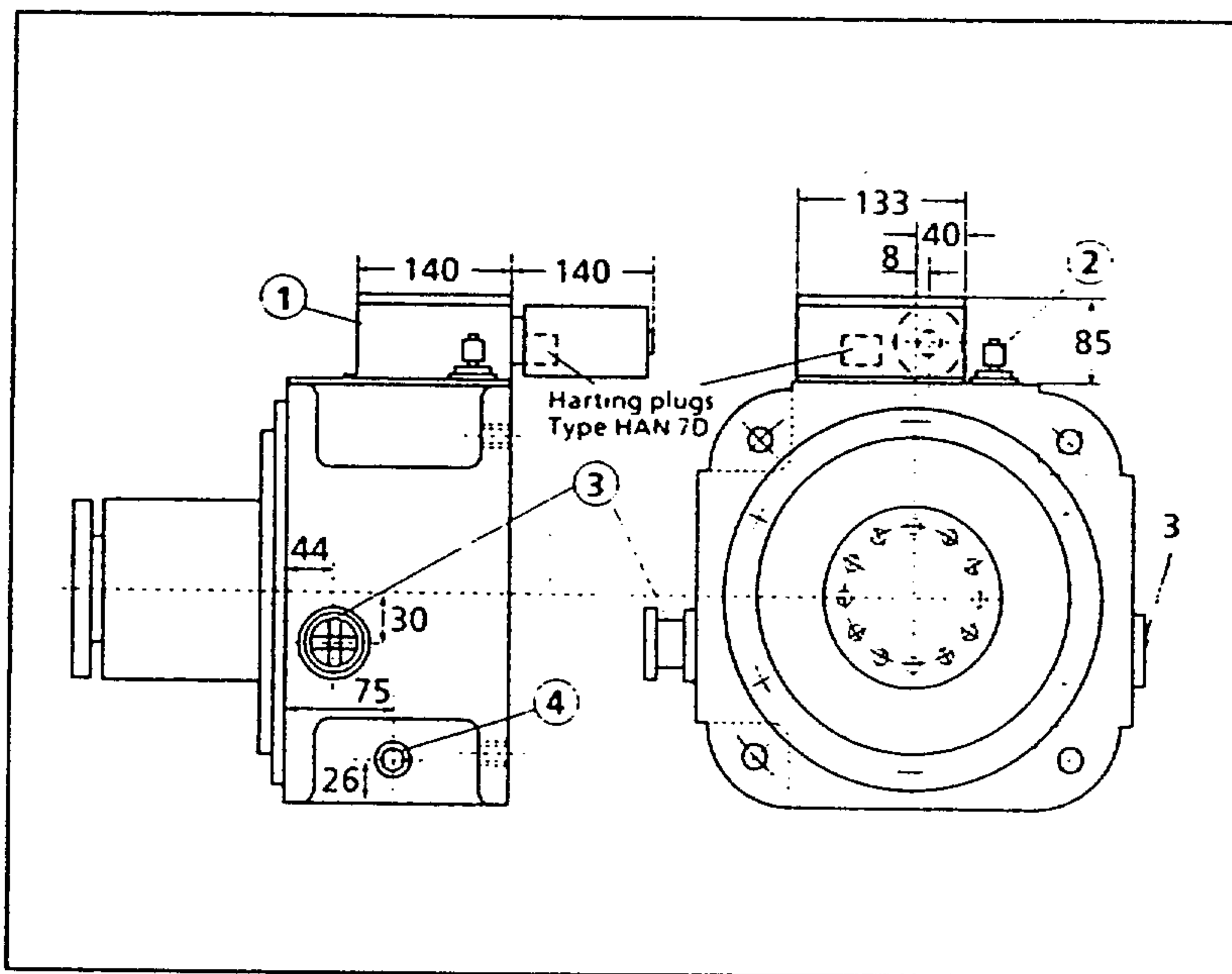

Fig. 5.9 Gearbox with gear change unit for sizes 132 and 160

- ① Gear change unit
- ② Oil filling screw with bleed valve, M22 x 1.5
- ③ Two oil level sight glasses (left and right) in M42 x 1.5 threaded hole, or for closed-loop oil lubrication, an oil level sight glass (left or right) and a M42x1.5 hole for oil return (right or left)
- ④ Two oil drain screws in M22x1.5 threaded hole (left and right) for horizontal mounting, or a threaded hole (right or left) as oil feed for closed-loop oil lubrication

## 6 Appendix

### 6.1 Power - speed characteristics

**Note:** Dotted lines - - - - - are indicated in the power - speed characteristics. These lines indicate the power limit of the PWM converter for the specified AC motor. The converter type is specified.

The speeds designated with \* are optional.

#### Power ratings for duty types S1 and S6:

All power specifications for AC main spindle drive motors are for continuous operation, corresponding to duty type S1 according to VDE 0530, Part 1, Section 4.1. However, duty type S1 (continuous operation) is not valid for many applications, e.g. for high, unspecified loading requirements as a function of time. In this case, an equivalent loading sequence can be specified, which represents at least the same loading as the actual motor loading .

The following duty types can be considered to be valid for most applications met in practice:

- S6 duty types- Continuous duty with intermittent loading

Both duty types are defined in VDE 0530, Part 1, Section 4. VDE 0530, Part 1, Section 6.1 specifies a max. cycle duration of 10 min., if no other conditions are specified. 25%, 40% and 60% are recommended as relative switch-on duration.

AC main spindle drive motors must be continually ventilated in operation independent of the duty type.



6 Appendix  
 6.1 Power - speed characteristics

Rated power	Rated speed	Rated torque	Rated current	Time constant (therm.)	Max. speed	Moment of inertia	Weight
$P_N$	$n_N$	$M_N$	$I_N$	$T_{th}$	$n_{max}$	$J$	$m$
[kW]	[RPM]	[Nm]	[A]	[min]	[RPM]	[kgm <sup>2</sup> ]	[kg]
3.7	1500	24	13	20	9000	0.011	42
<b>1PH6 101-4CF4</b>							

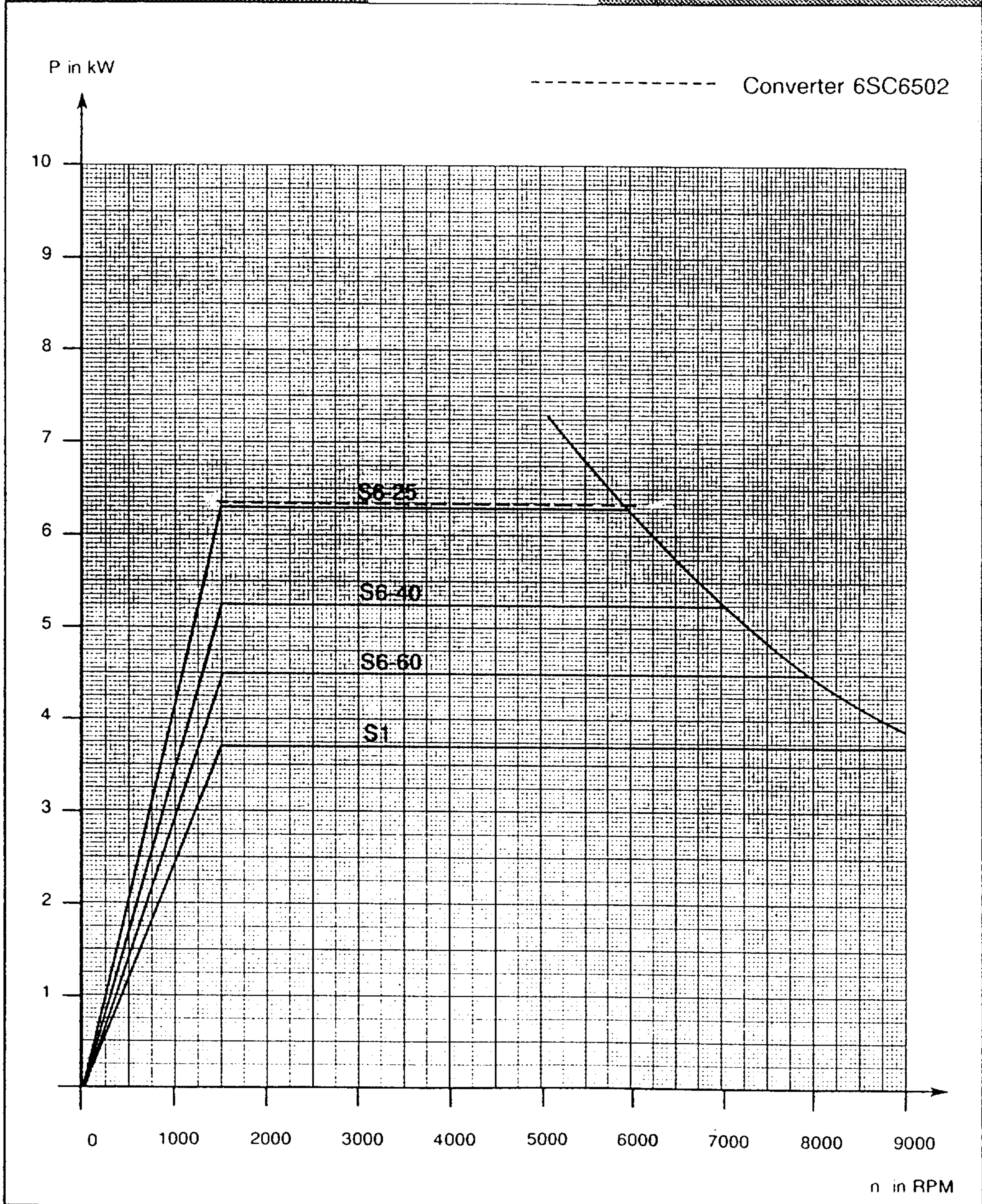

Fig. 6.1 Power - speed characteristic for the 1PH6 101-4CF4 AC motor



Rated power $P_N$ [kW]	Rated speed $n_N$ [RPM]	Rated torque $M_N$ [Nm]	Rated current $I_N$ [A]	Time constant (therm.) $T_{th}$ [min]	Max. speed $n_{max}$ [RPM]	Moment of inertia $J$ [kgm <sup>2</sup> ]	Weight $m$ [kg]
4.7	2000	22	13.9	20	9000	0.011	42
<b>1PH6 101-4CG4</b>							

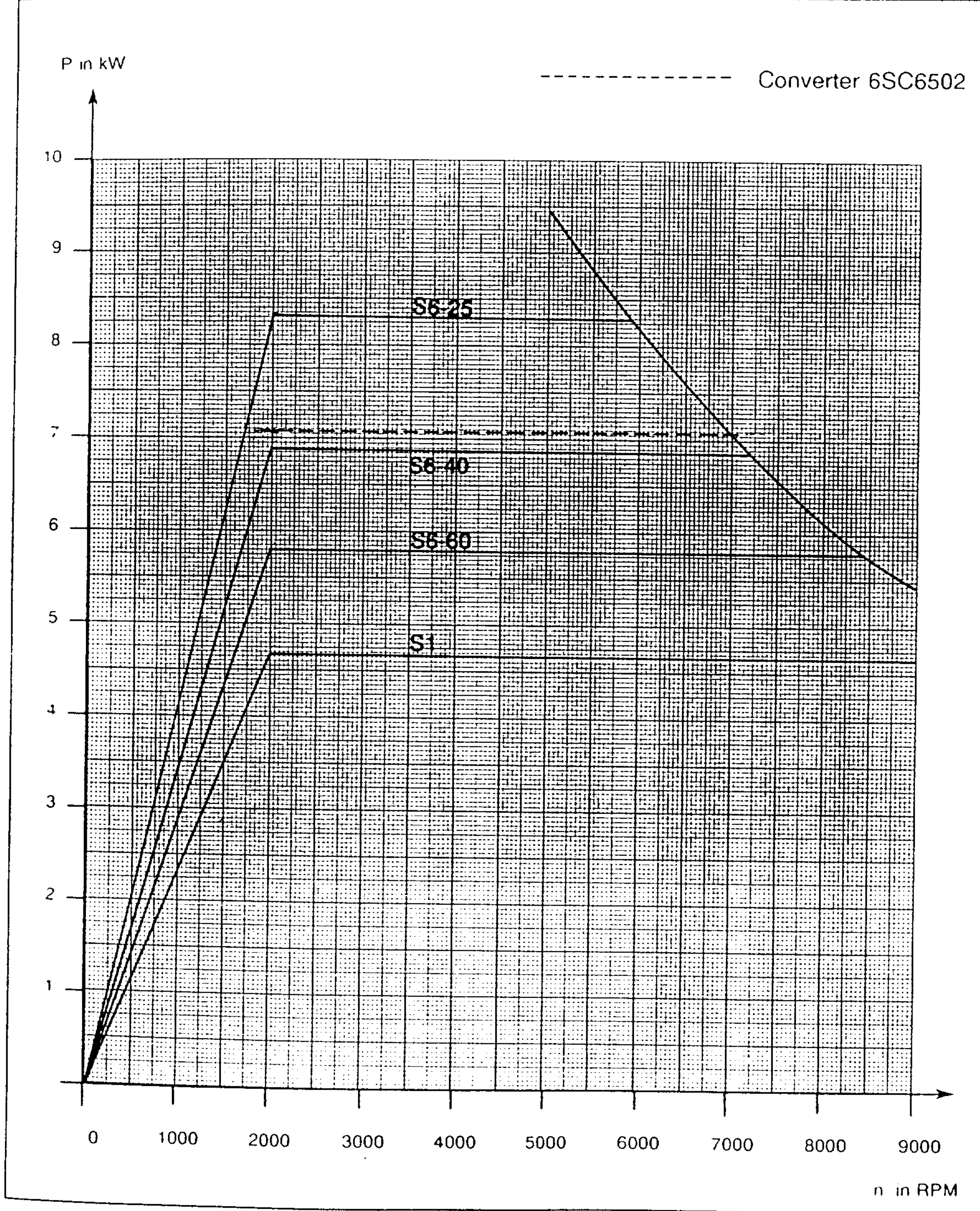

Fig. 6.2 Power - speed characteristic for the 1PH6 101-4CG4 AC motor



6 Appendix  
 6.1 Power - speed characteristics

Rated power	Rated speed	Rated torque	Rated current	Time constant (therm.)	Max. speed	Moment of inertia	Weight
$P_N$	$n_N$	$M_N$	$I_N$	$T_{th}$	$n_{max}$	$J$	$m$
[kW]	[RPM]	[Nm]	[A]	[min]	[RPM]	[kgm <sup>2</sup> ]	[kg]
5.5	1500	35	18	20	9000	0.017	52
<b>1PH6 103-4CF4</b>							

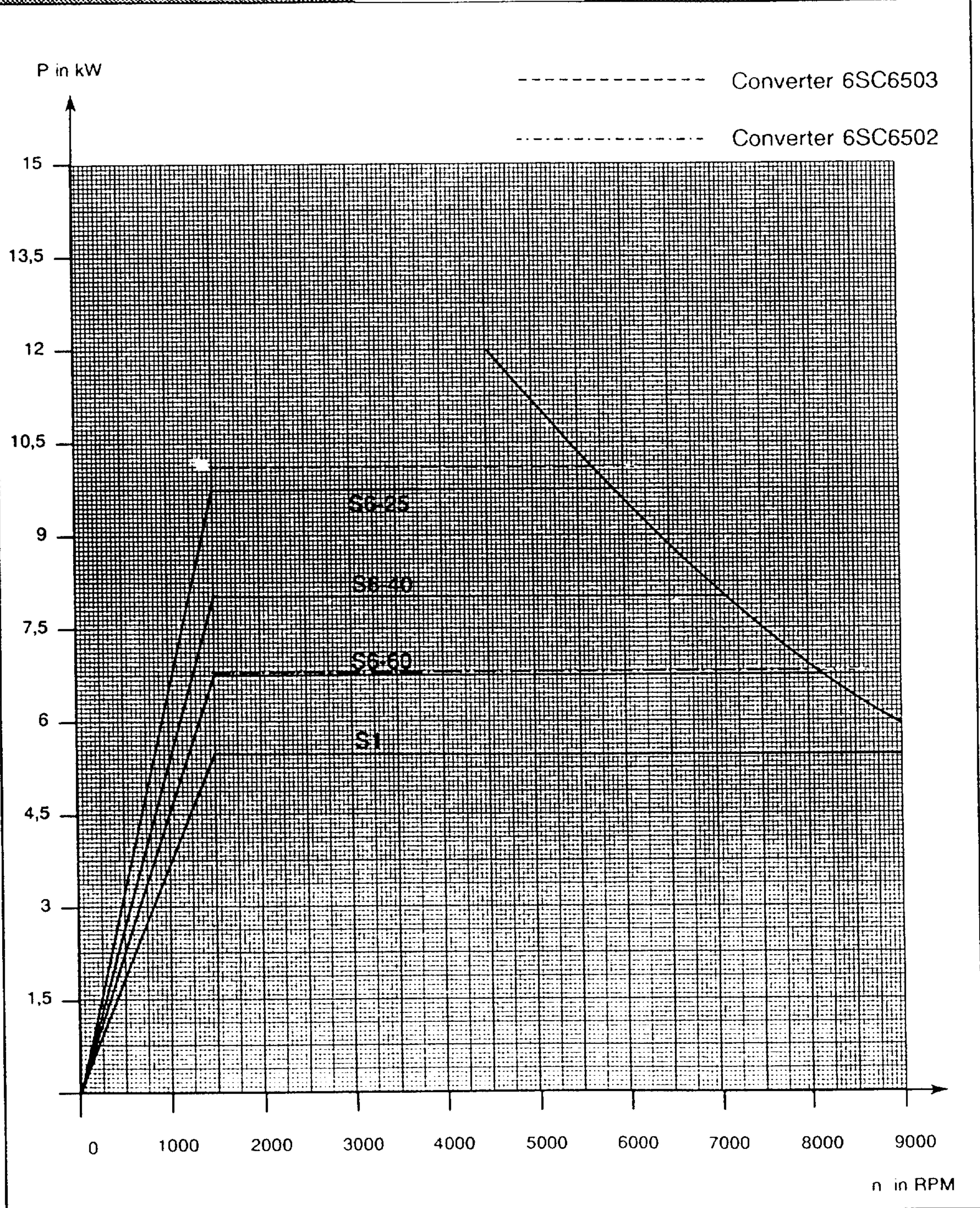

Fig 6.3 Power - speed characteristic for the 1PH6 103-4CF4 AC motor



Rated current	Rated speed	Rated torque	Rated current	Time constant (therm.)	Max. speed	Moment of inertia	Weight
$P_N$ [kW]	$n_N$ [RPM]	$M_N$ [Nm]	$I_N$ [A]	$T_{th}$ [min]	$n_{max}$ [RPM]	$J$ [kgm <sup>2</sup> ]	$m$ [kg]
7.0	2000	33	20	20	9000	0.017	52
<b>1PH6 103-4CG4</b>							

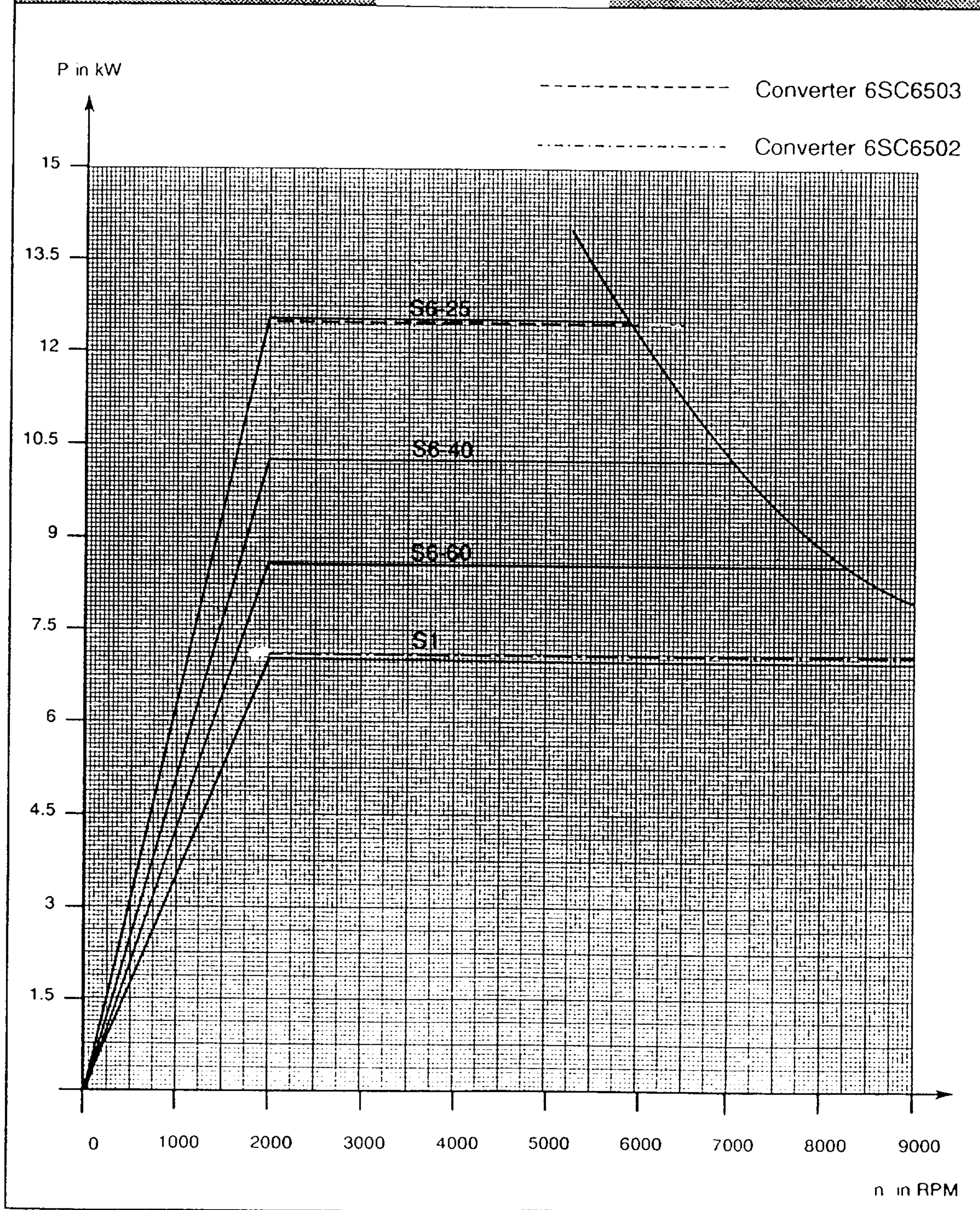

Fig. 6.3 Power - speed characteristic for the 1PH6 103-4CG4 AC motor



6 Appendix  
6.1 Power - speed characteristics

Rated power	Rated speed	Rated torque	Rated current	Time constant (therm.)	Max. speed	Moment of inertia	Weight
$P_N$	$n_N$	$M_N$	$I_N$	$T_{th}$	$n_{max}$	$J$	$m$
[kW]	[RPM]	[Nm]	[A]	[min]	[RPM]	[kgm <sup>2</sup> ]	[kg]
7.5	1500	48	23	20	9000	0.024	67
<b>1PH6 105-4CF4</b>							

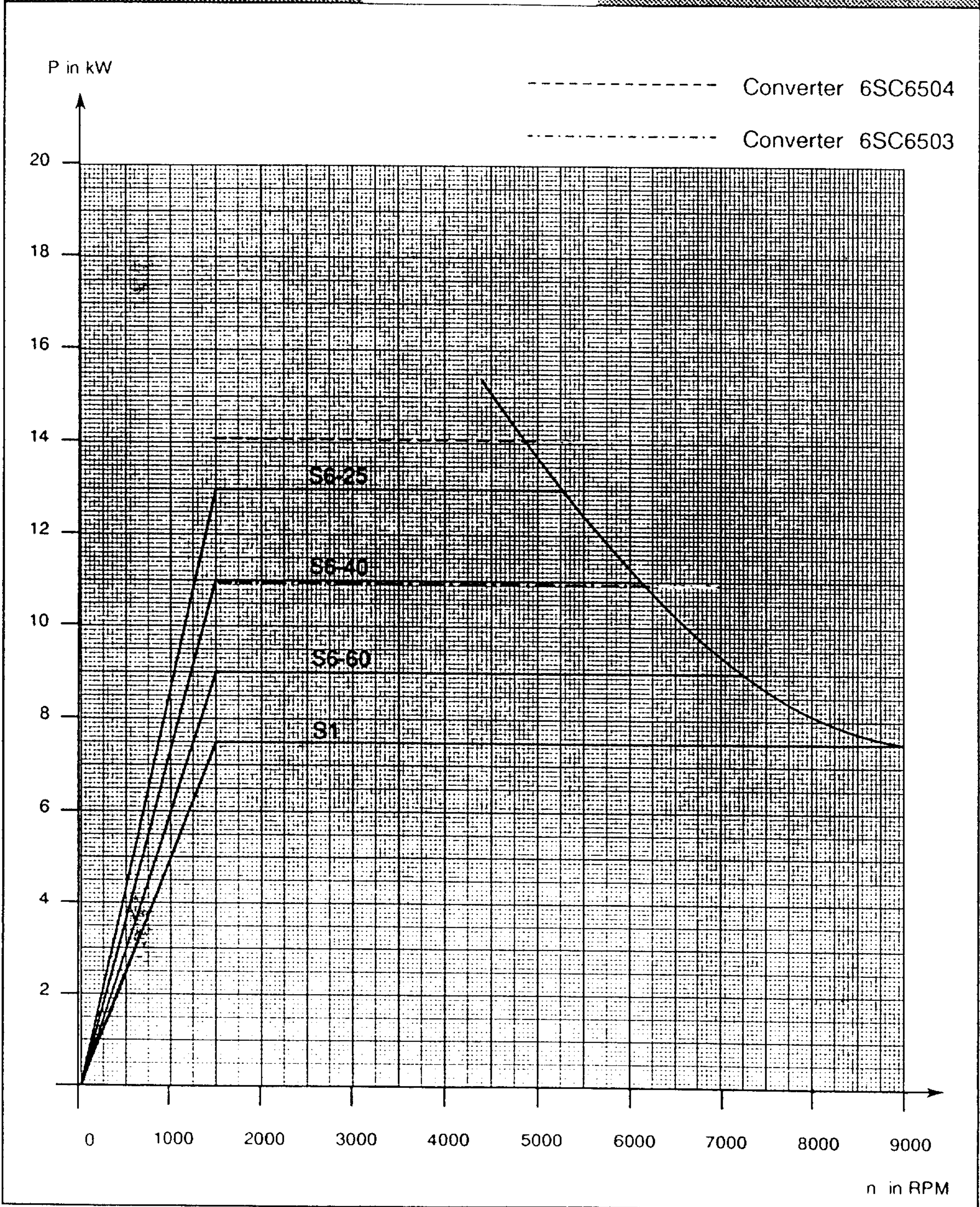

Fig. 6.5 Power - speed characteristic for the 1PH6 105-4CF4 AC motor



Rated power	Rated speed	Rated torque	Rated current	Time constant (therm.)	Max. speed	Moment of inertia	Weight
$P_N$ [kW]	$n_N$ [RPM]	$M_N$ [Nm]	$I_N$ [A]	$T_{th}$ [min]	$n_{max}$ [RPM]	$J$ [kgm <sup>2</sup> ]	$m$ [kg]
9.5	2000	45	26	20	9000	0.024	67

**1PH6 105-4CG4**

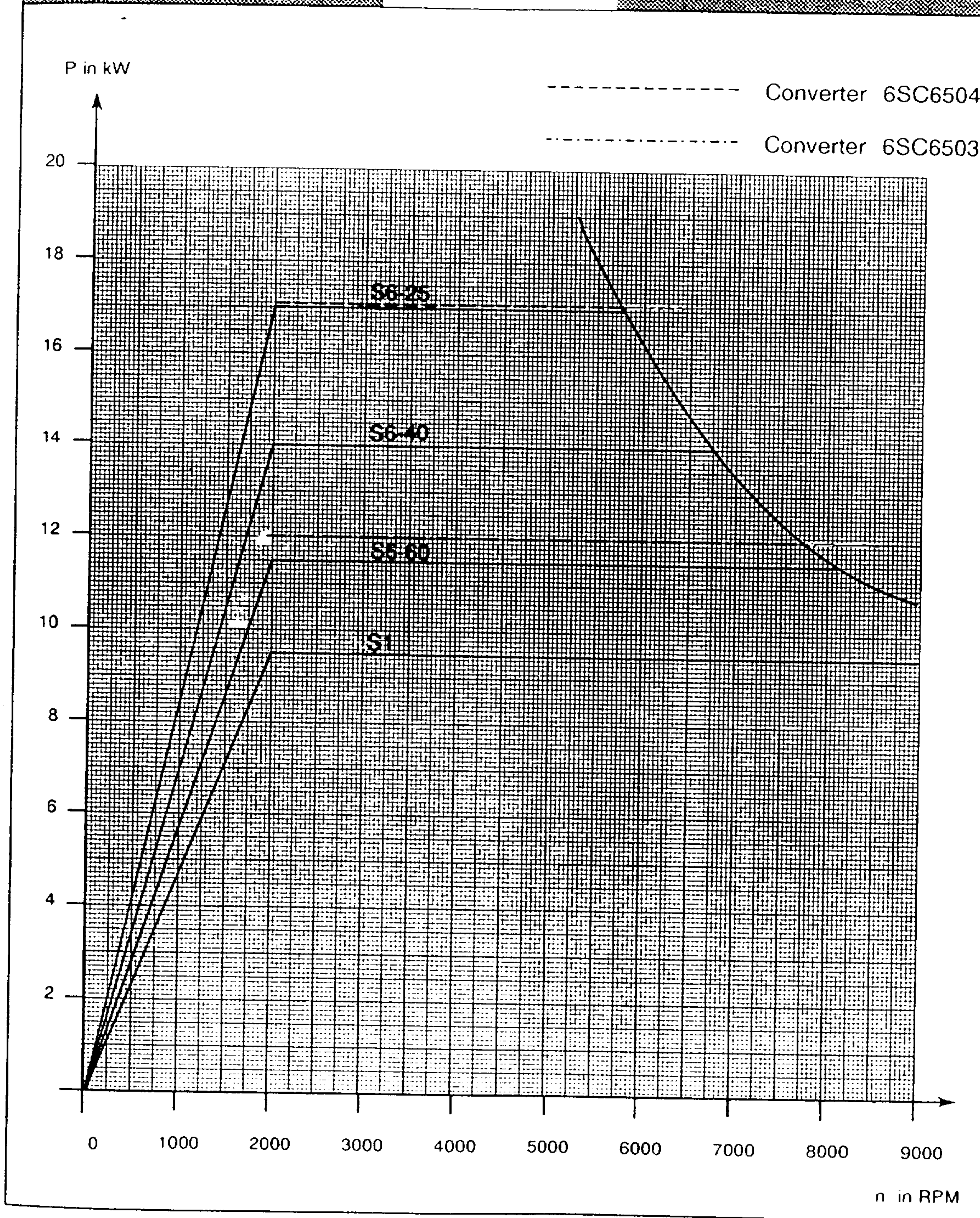

Fig. 6.6 Power - speed characteristic for the 1PH6 105-4CG4 AC motor



6 Appendix  
6.1 Power - speed characteristics

Rated power	Rated speed	Rated torque	Rated current	Time constant (therm.)	Max. speed	Moment of inertia	Weight
$P_N$ [kW]	$n_N$ [RPM]	$M_N$ [Nm]	$I_N$ [A]	$T_{th}$ [min]	$n_{max}$ [RPM]	$J$ [kgm <sup>2</sup> ]	$m$ [kg]
5.0	750	64	22.8	20	9000	0.031	80
<b>1PH6 107-4CC4</b>							

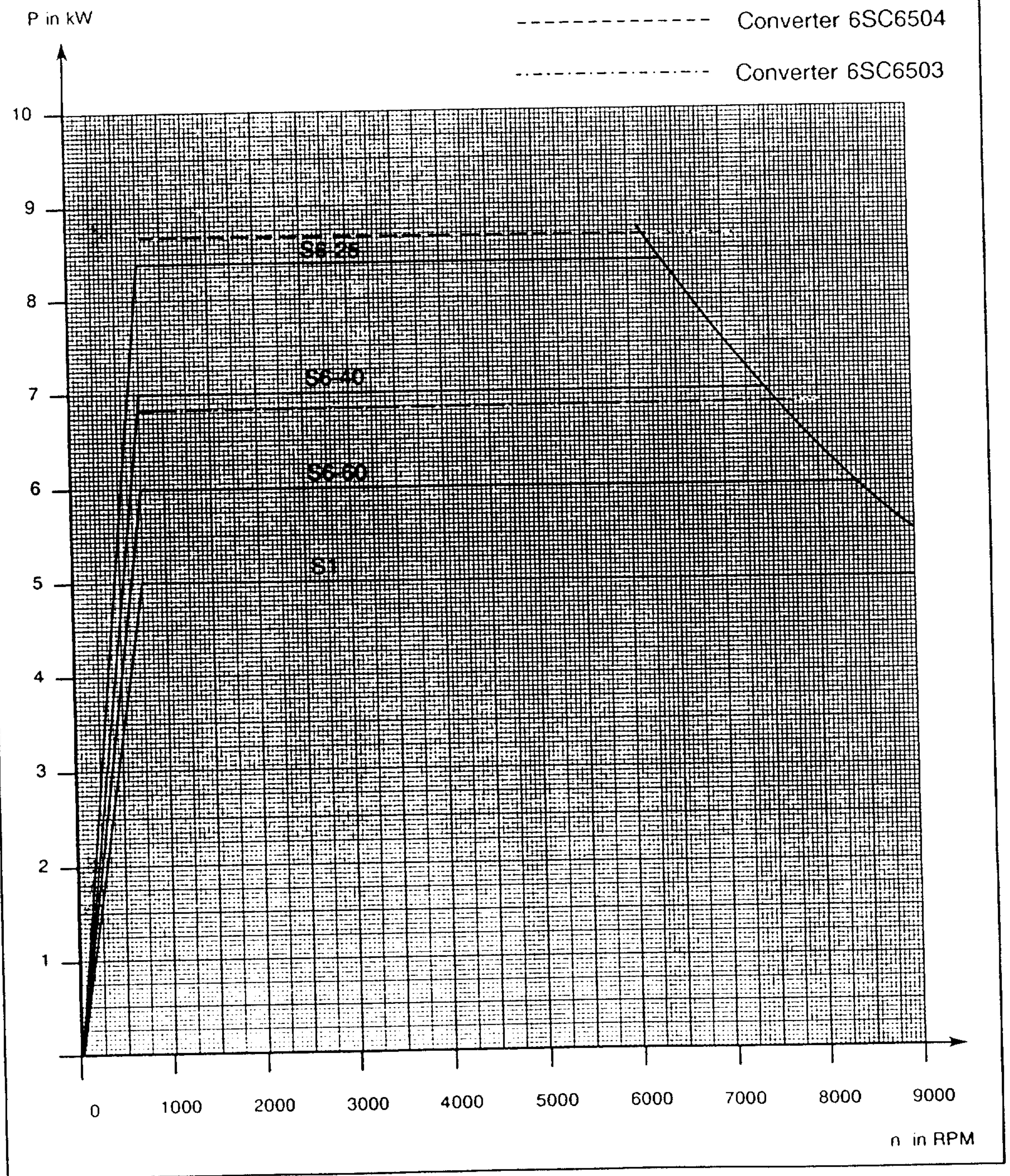

Fig. 6.7 Power - speed characteristic for the 1PH6 107-4CC4 AC motor



Rated power	Rated speed	Rated torque	Rated current	Time constant (therm.)	Max. speed	Moment of inertia	Weight
$P_N$	$n_N$	$M_N$	$I_N$	$T_{th}$	$n_{max}$	$J$	$m$
[kW]	[RPM]	[Nm]	[A]	[min]	[RPM]	[kgm <sup>2</sup> ]	[kg]
9.0	1500	57	27.4	20	9000	0.031	80
<b>1PH6 107-4CF4</b>							

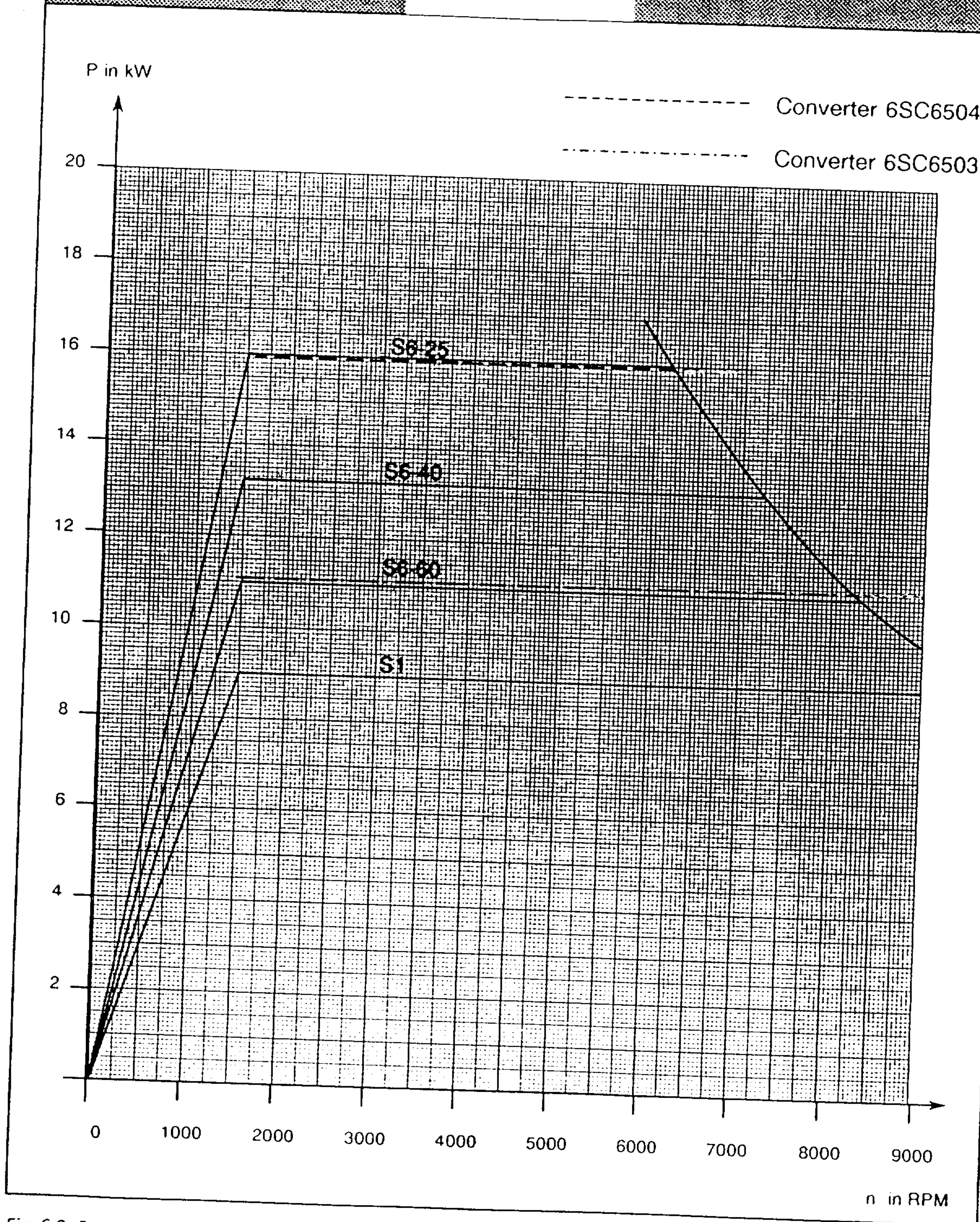

Fig. 6.8 Power - speed characteristic for the 1PH6 107-4CF4 AC motor



Rated power	Rated speed	Rated torque	Rated current	Time constant (therm.)	Max. speed	Moment of inertia	Weight
$P_N$	$n_N$	$M_N$	$I_N$	$T_{th}$	$n_{max}$	$J$	$m$
[kW]	[RPM]	[Nm]	[A]	[min]	[RPM]	[kgm <sup>2</sup> ]	[kg]
11.5	2000	55	30	20	9000	0.031	80
<b>1PH6 107-4CG4</b>							

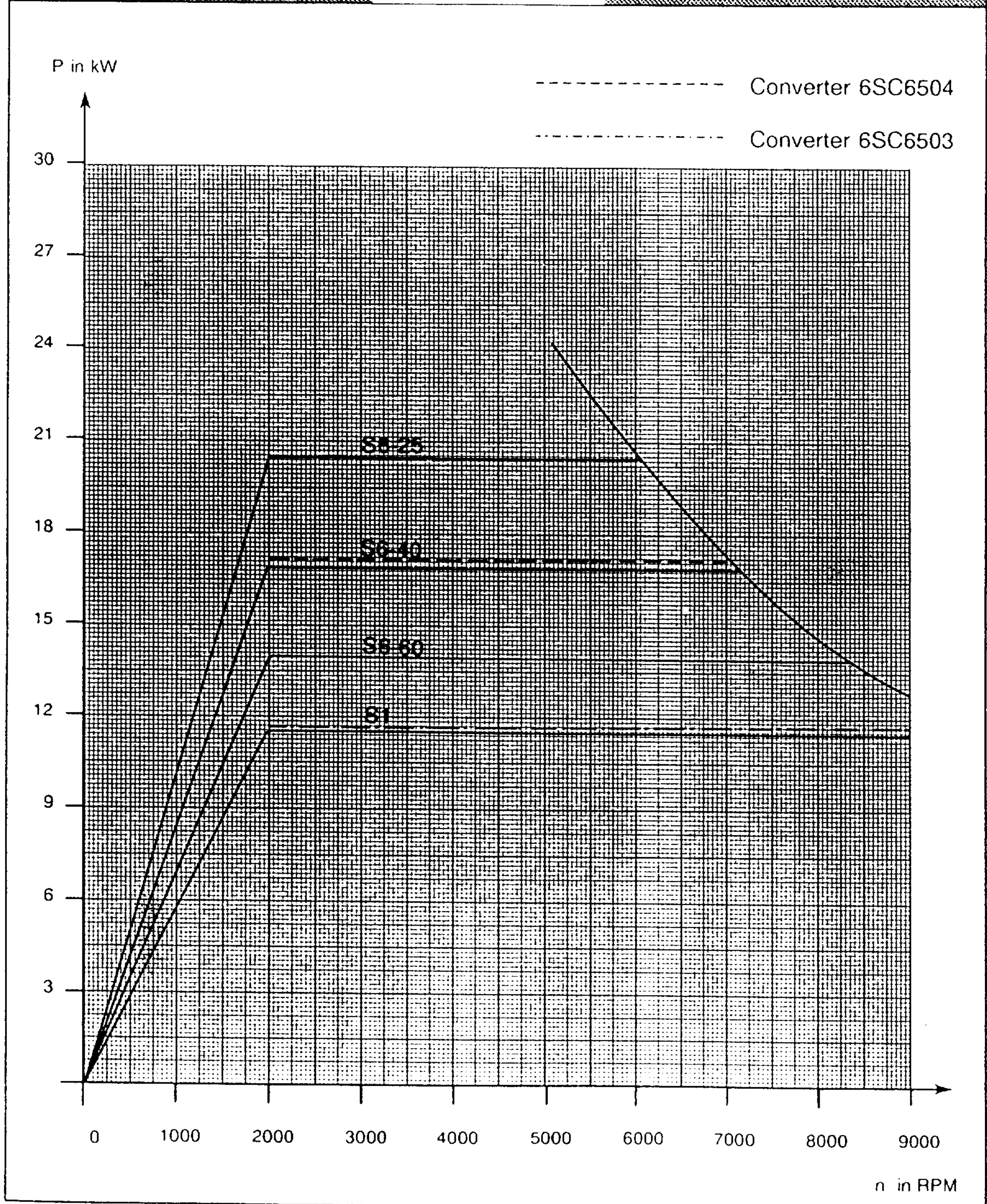

Fig. 6.9 Power - speed characteristic for the 1PH6 107-4CG4 AC motor



Rated power	Rated speed	Rated torque	Rated current	Time constant (therm.)	Max. speed	Moment of inertia	Weight
$P_N$	$n_N$	$M_N$	$I_N$	$T_{th}$	$n_{max}$	$J$	$m$
[kW]	[RPM]	[Nm]	[A]	[min]	[RPM]	[kgm <sup>2</sup> ]	[kg]
9.0	1500	57	28	30	8000	0.038	78

**1PH6 131-4CF4**

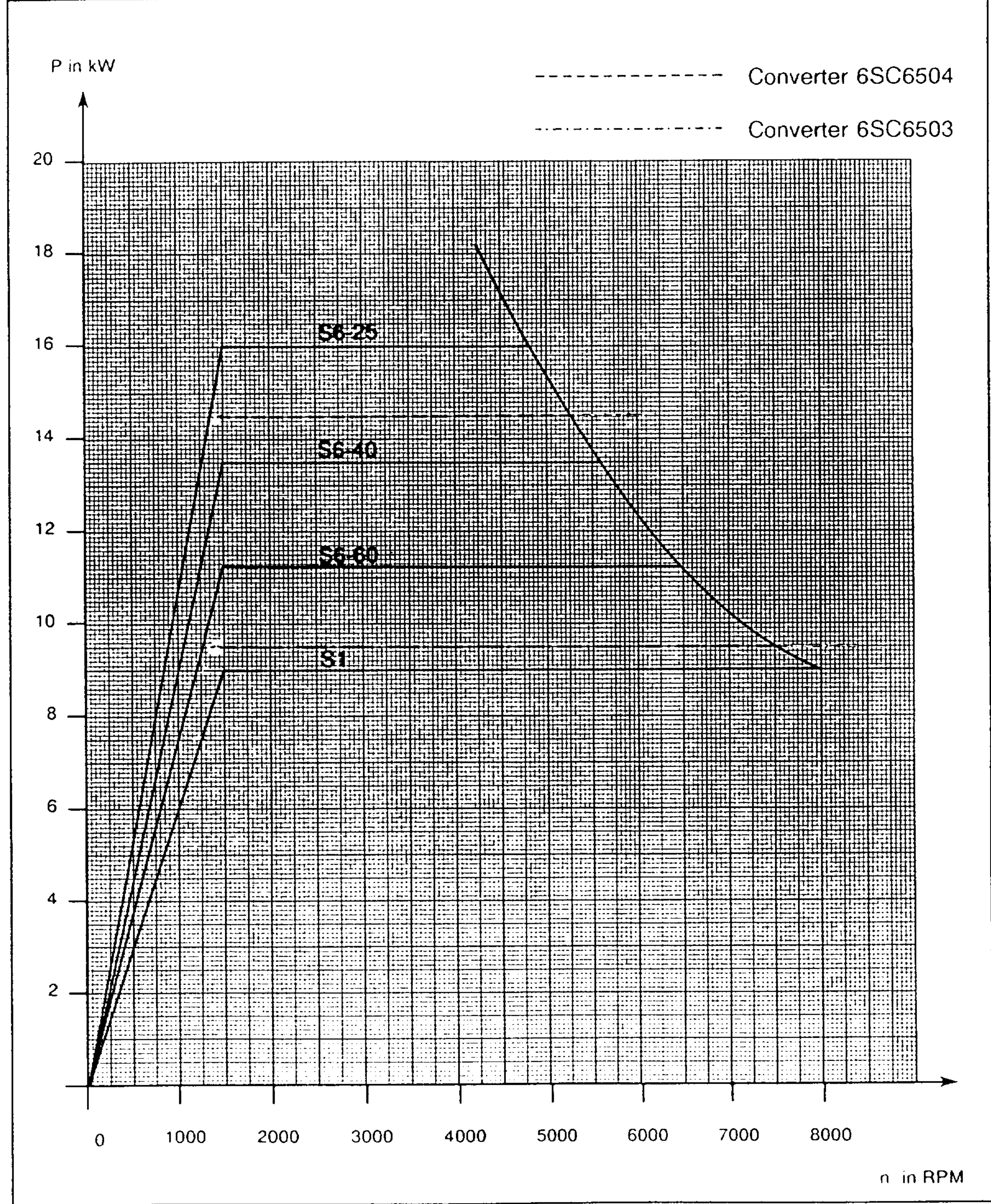

Fig. 6.10 Power - speed characteristic for the 1PH6 131-4CF4 AC motor



Rated power	Rated speed	Rated torque	Rated current	Time constant (therm.)	Max. speed	Moment of inertia	Weight
$P_N$	$n_N$	$M_N$	$I_N$	$T_{th}$	$n_{max}$	$J$	$m$
[kW]	[RPM]	[Nm]	[A]	[min]	[RPM]	[kgm <sup>2</sup> ]	[kg]
12.0	2000	57	33	30	8000	0.038	78
<b>1PH6 131-4CG4</b>							

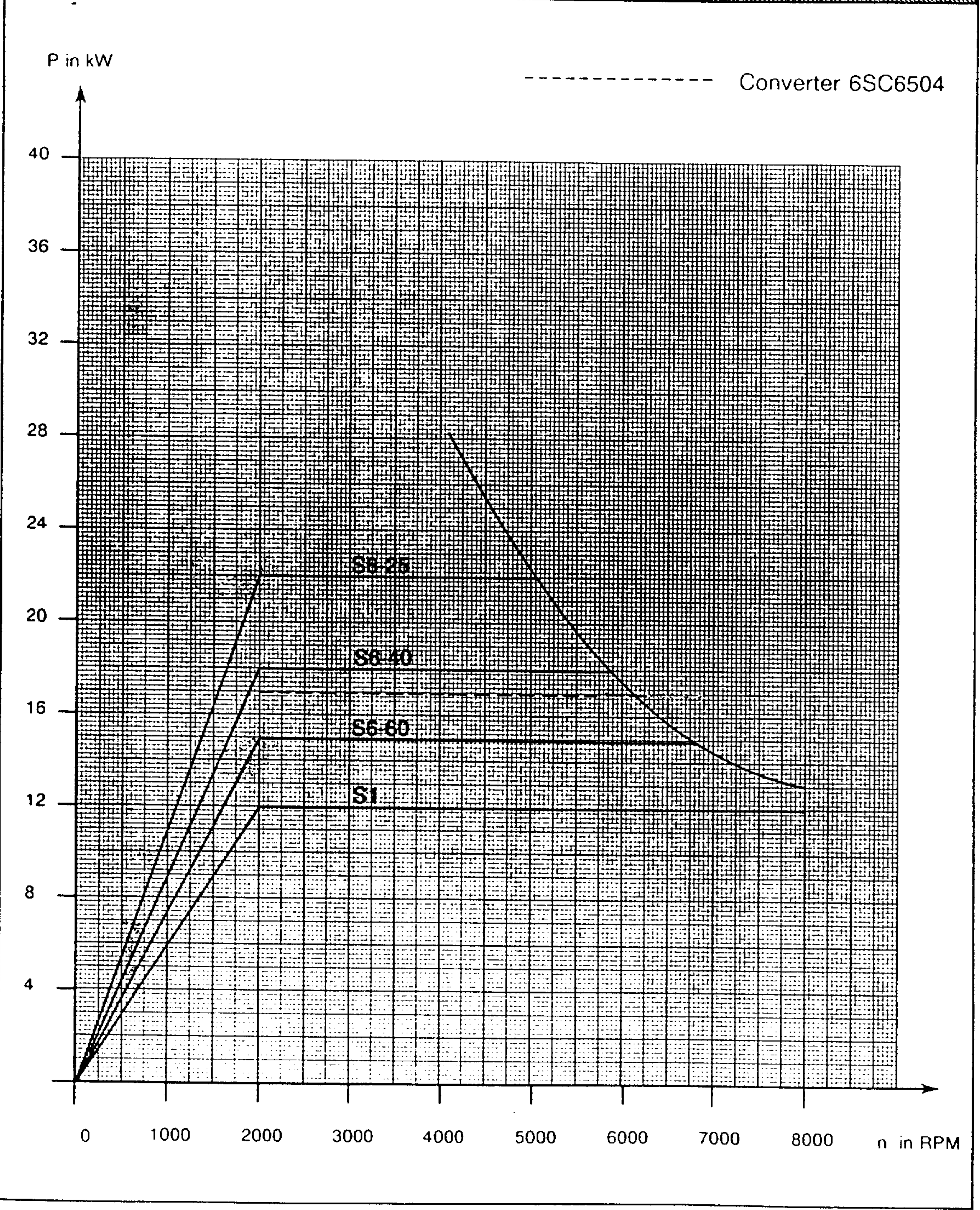

Fig. 6.11 Power - speed characteristic for the 1PH6 131-4CG4 AC motor



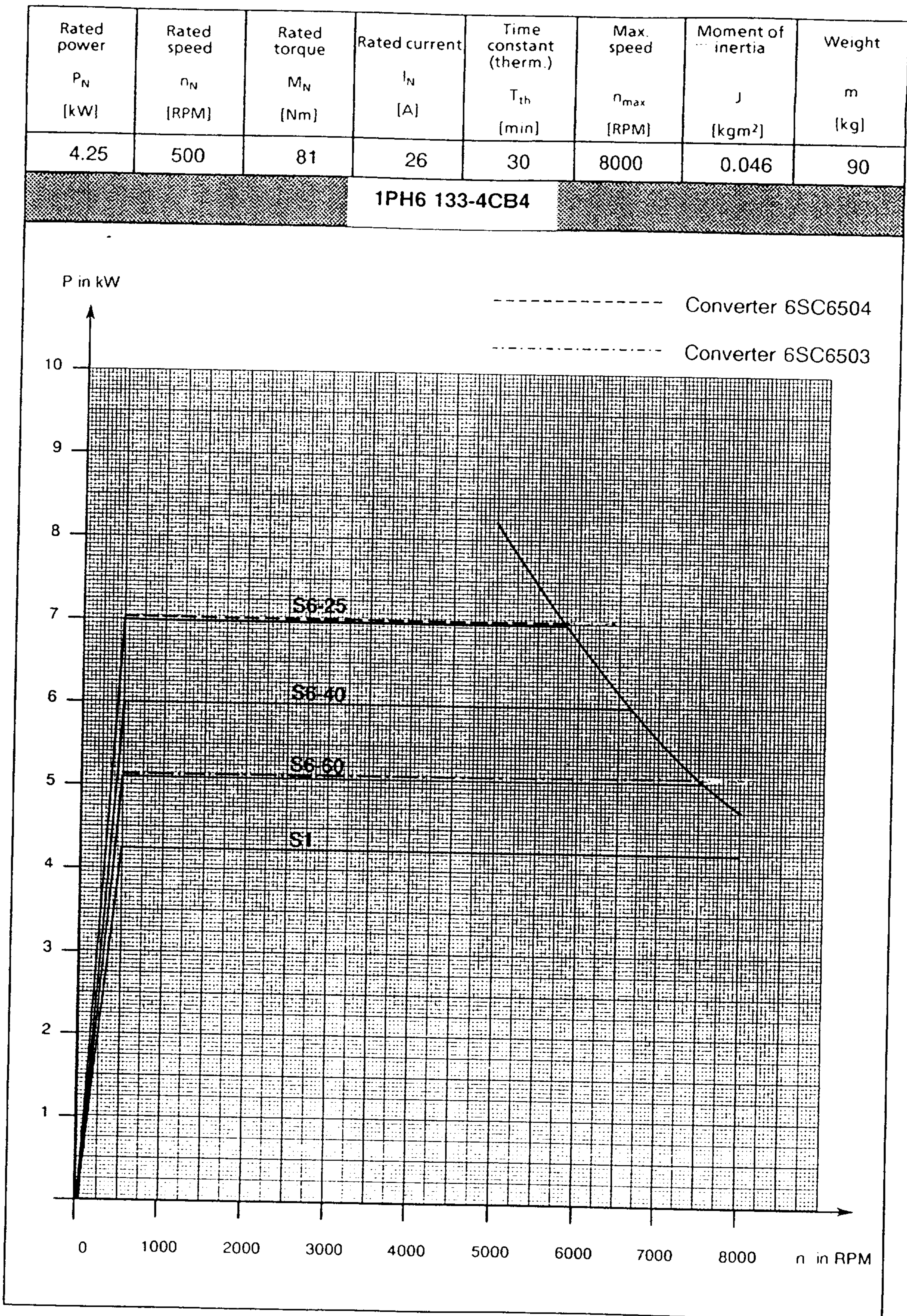

Fig. 6.12 Power - speed characteristic for the 1PH6 133-4CB4 AC motor



Rated power	Rated speed	Rated torque	Rated current	Time constant (therm.)	Max. speed	Moment of inertia	Weight
$P_N$ [kW]	$n_N$ [RPM]	$M_N$ [Nm]	$I_N$ [A]	$T_{th}$ [min]	$n_{max}$ [RPM]	$J$ [kgm <sup>2</sup> ]	$m$ [kg]
11.0	1500	70	28	30	8000	0.046	90
<b>1PH6 133-4CF0</b>							

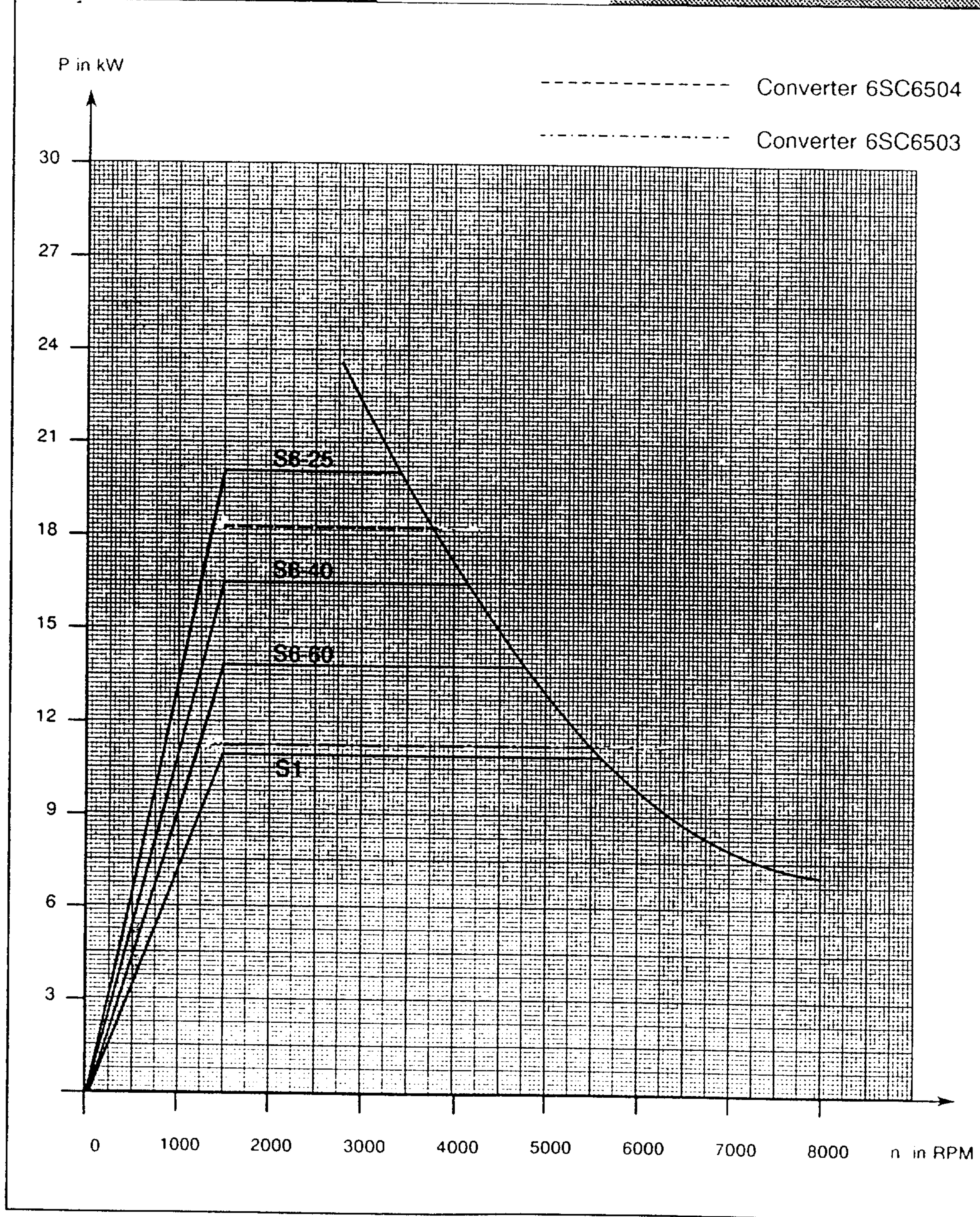

Fig. 6.13 Power - speed characteristic for the 1PH6 133-4CF0 AC motor



Rated power	Rated speed	Rated torque	Rated current	Time constant (therm.)	Max. speed	Moment of inertia	Weight
$P_N$ [kW]	$n_N$ [RPM]	$M_N$ [Nm]	$I_N$ [A]	$T_{th}$ [min]	$n_{max}$ [RPM]	$J$ [kgm <sup>2</sup> ]	$m$ [kg]
11.0	1500	70	32	30	8000	0.046	90
<b>1PH6 133-4CF4</b>							

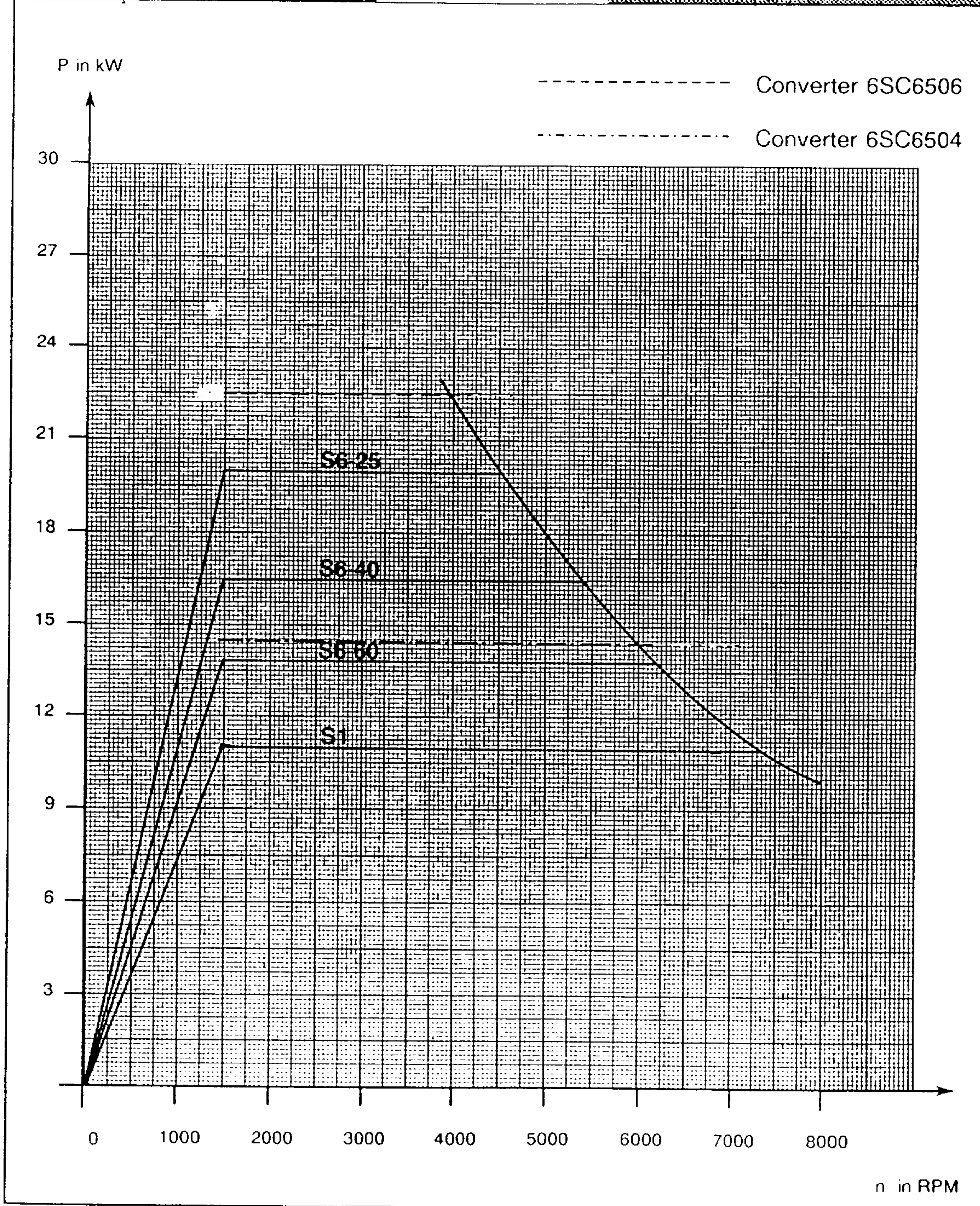

Fig. 6.14 Power - speed characteristic for the 1PH6 133-4CF4 AC motor



Rated power $P_N$ [kW]	Rated speed $n_N$ [RPM]	Rated torque $M_N$ [Nm]	Rated current $I_N$ [A]	Time constant (therm) $T_{th}$ [min]	Max. speed $n_{max}$ [RPM]	Moment of inertia $J$ [kgm <sup>2</sup> ]	Weight $m$ [kg]
14.5	2000	69	39	30	8000	0.046	90
<b>1PH6 133-4CG4</b>							

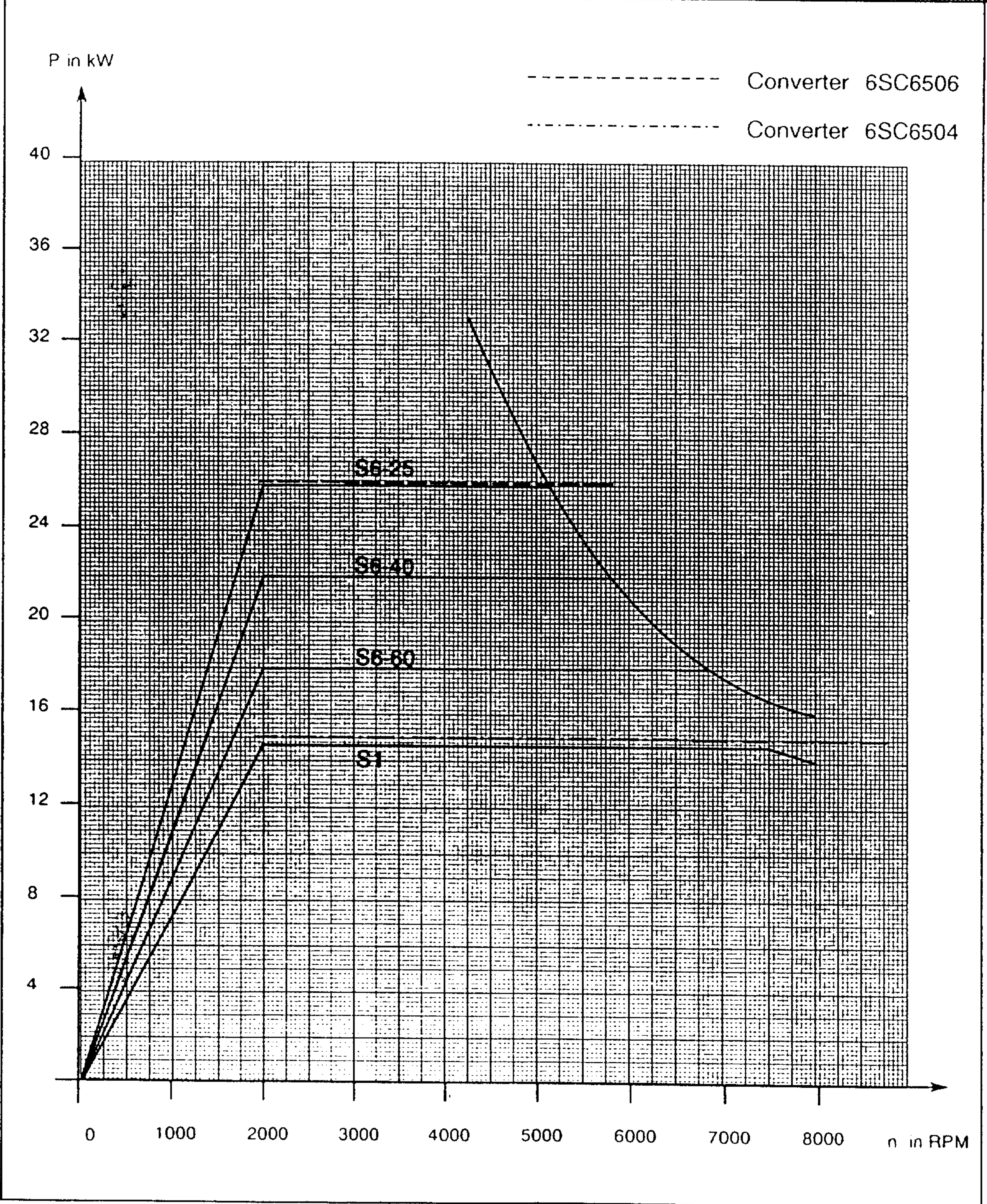

Fig. 6.15 Power - speed characteristic for the 1PH6 133-4CG4 AC motor



Rated power $P_N$ [kW]	Rated speed $n_N$ [RPM]	Rated torque $M_N$ [Nm]	Rated current $I_N$ [A]	Time constant (therm.) $T_{th}$ [min]	Max. speed $n_{max}$ [RPM]	Moment of inertia $J$ [kgm <sup>2</sup> ]	Weight $m$ [kg]
15.0	1500	95	36	30	8000	0.071	112
<b>1PH6 135-4CF0</b>							

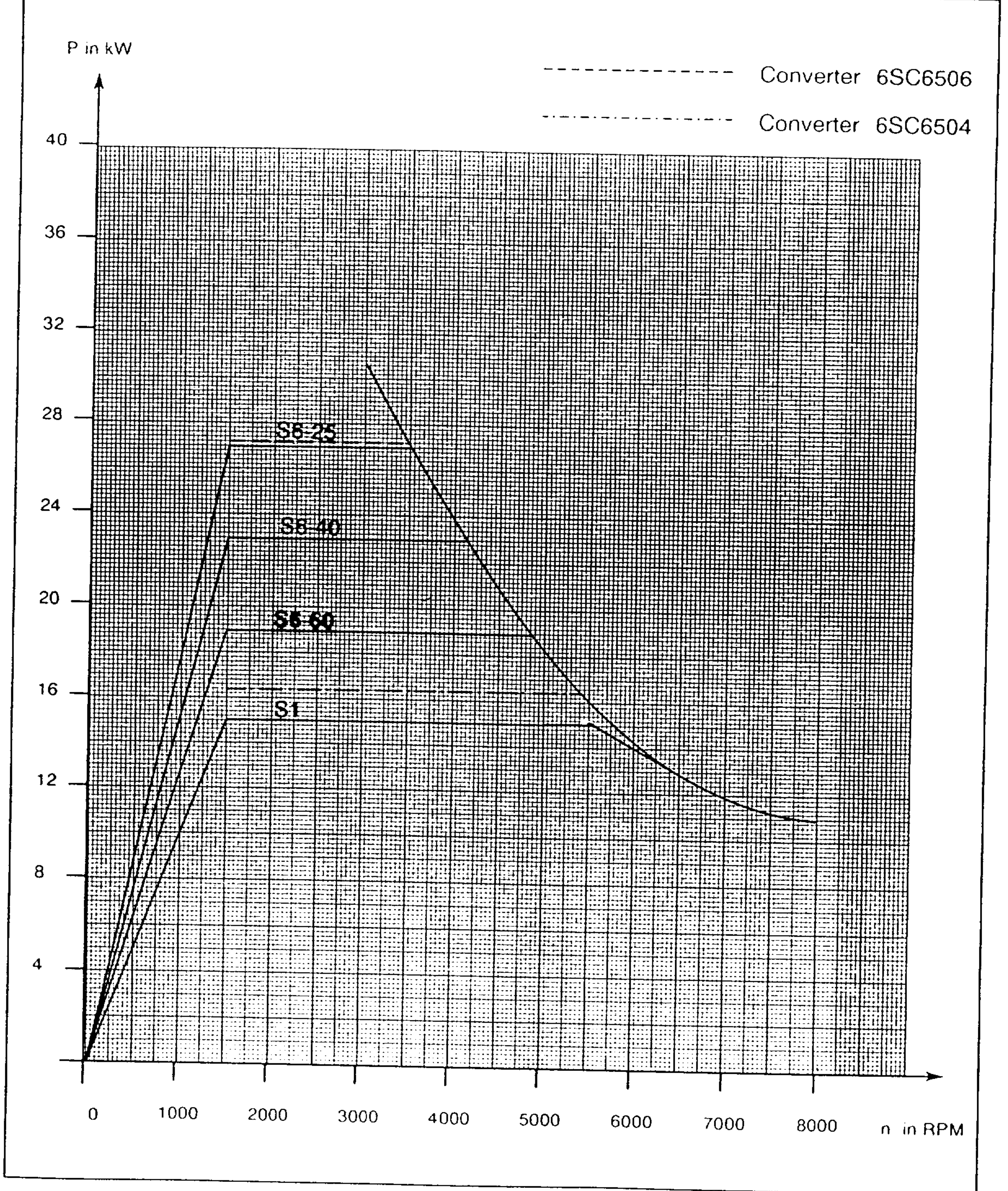

Fig. 6.16 Power - speed characteristic for the 1PH6 135-4CF0 AC motor



Rated power $P_N$ [kW]	Rated speed $n_N$ [RPM]	Rated torque $M_N$ [Nm]	Rated current $I_N$ [A]	Time constant (therm) $T_{th}$ [min]	Max. speed $n_{max}$ [RPM]	Moment of inertia $J$ [kgm <sup>2</sup> ]	Weight $m$ [kg]
15.0	1500	95	43	30	8000	0.071	112
<b>1PH6 135-4CF4</b>							

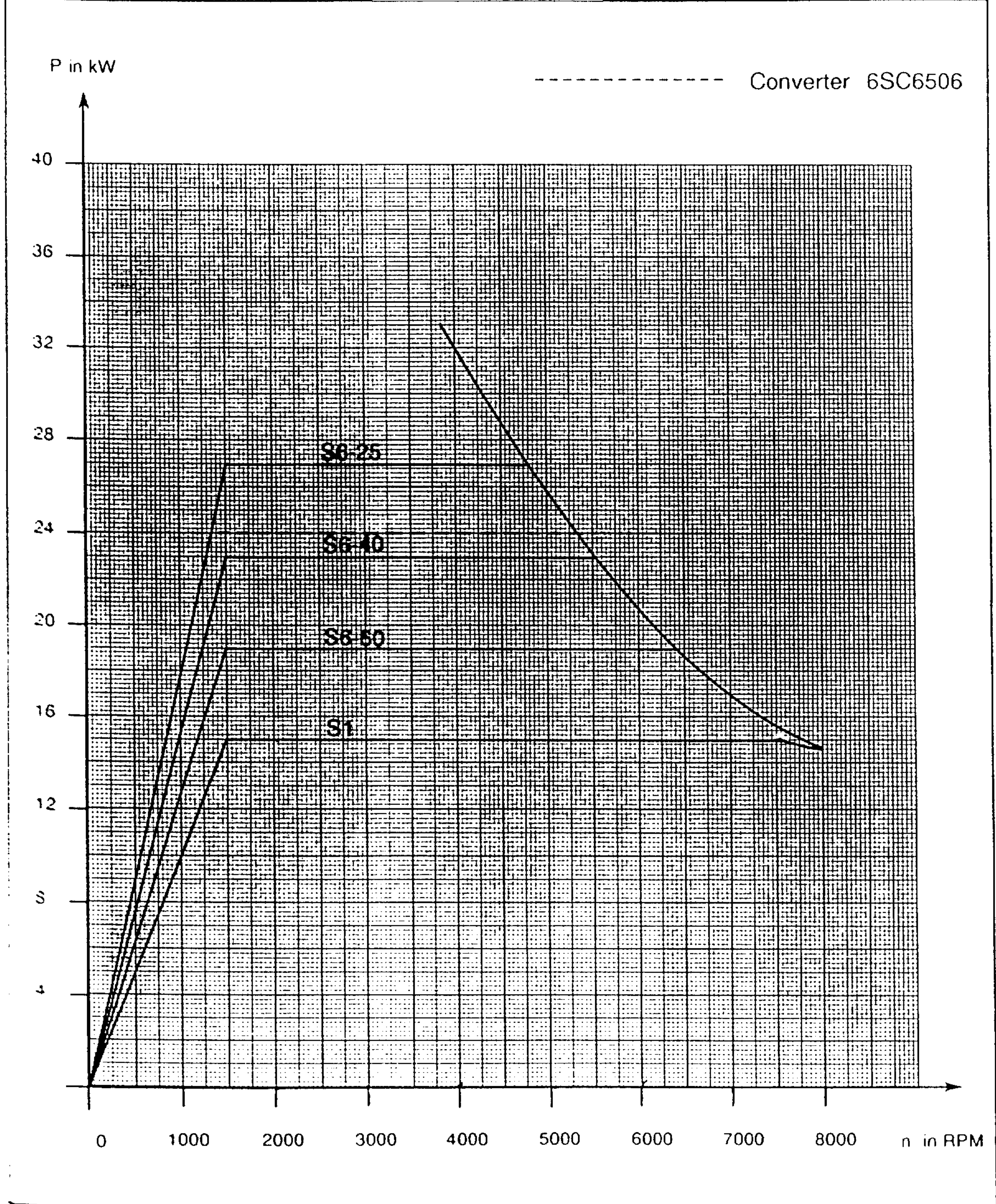

Fig. 5.17 Power - speed characteristic for the 1PH6 135-4CF4 AC motor



Rated power $P_N$ [kW]	Rated speed $n_N$ [RPM]	Rated torque $M_N$ [Nm]	Rated current $I_N$ [A]	Time constant (therm.) $T_{Th}$ [min]	Max. speed $n_{max}$ [RPM]	Moment of inertia $J$ [kgm <sup>2</sup> ]	Weight $m$ [kg]
20.0	2000	95	52	30	8000	0.071	112
<b>1PH6 135-4CG4</b>							

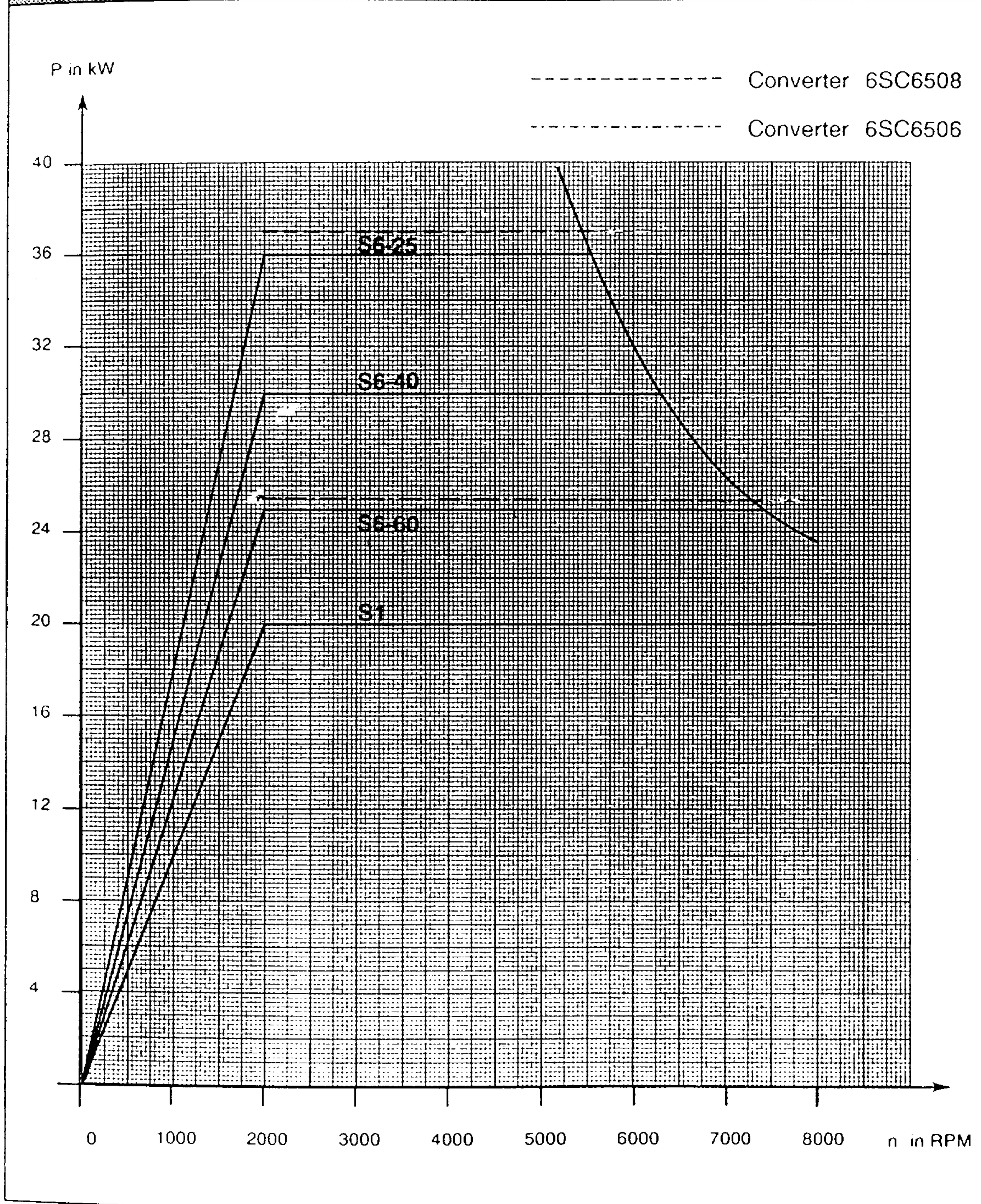

Fig. 6.18 Power - speed characteristic for the 1PH6 135-4CG4 AC motor



Rated power	Rated speed	Rated torque	Rated current	Time constant (therm.)	Max. speed	Moment of inertia	Weight
$P_N$	$n_N$	$M_N$	$I_N$	$T_{th}$	$n_{max}$	$J$	$m$
[kW]	[RPM]	[Nm]	[A]	[min]	[RPM]	[kgm <sup>2</sup> ]	[kg]
7.5	500	143	44	30	8000	0.085	130
<b>1PH6 137-4CB4</b>							

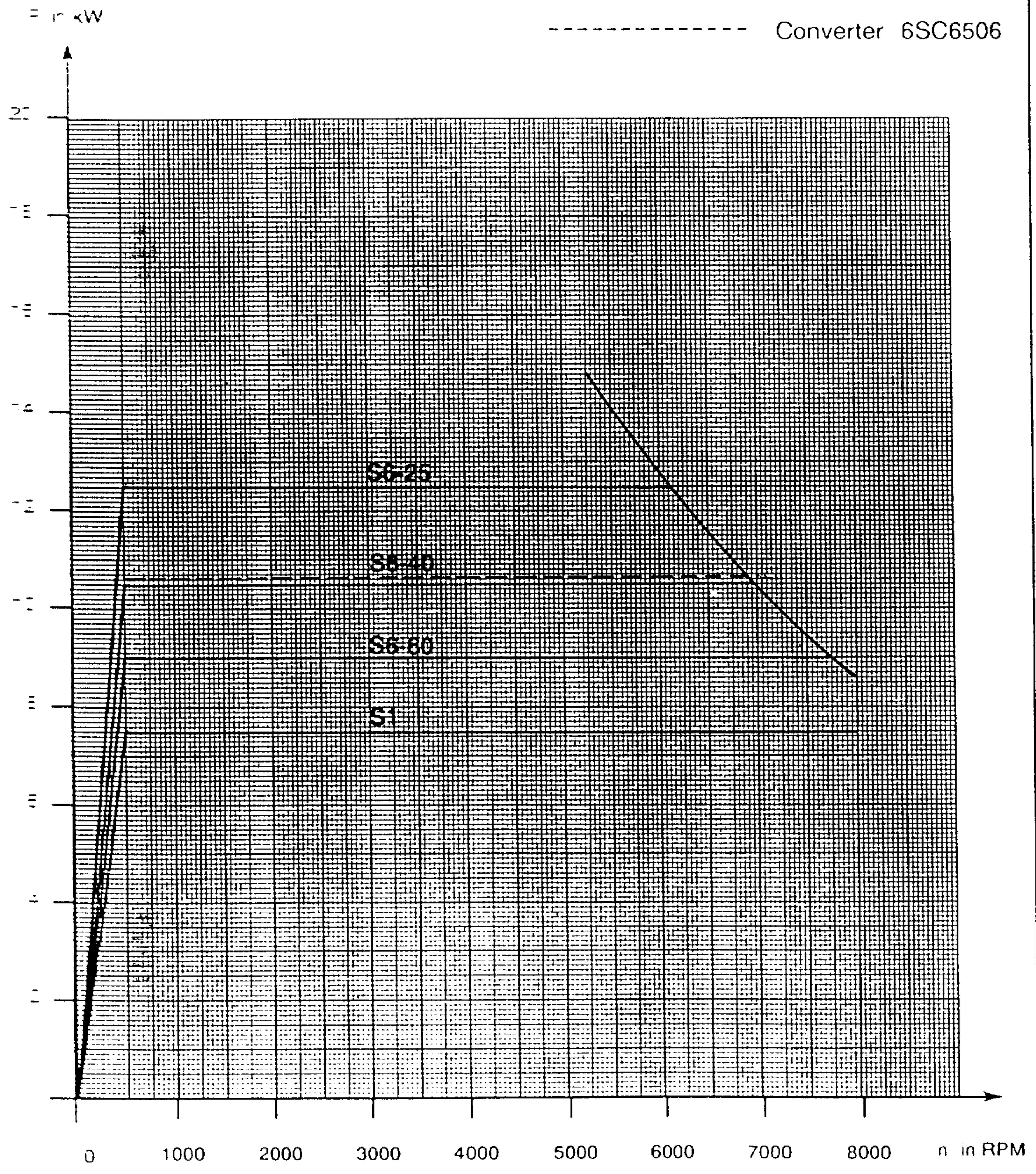

Fig. 5.19 Power - speed characteristic for the 1PH6 137-4CB4 AC motor



Rated power $P_N$ [kW]	Rated speed $n_N$ [RPM]	Rated torque $M_N$ [Nm]	Rated current $I_N$ [A]	Time constant (therm.) $T_{th}$ [min]	Max. speed $n_{max}$ [RPM]	Moment of inertia $J$ [kgm <sup>2</sup> ]	Weight $m$ [kg]
18.5	1500	118	52	30	8000	0.085	130

1PH6 137-4CF4

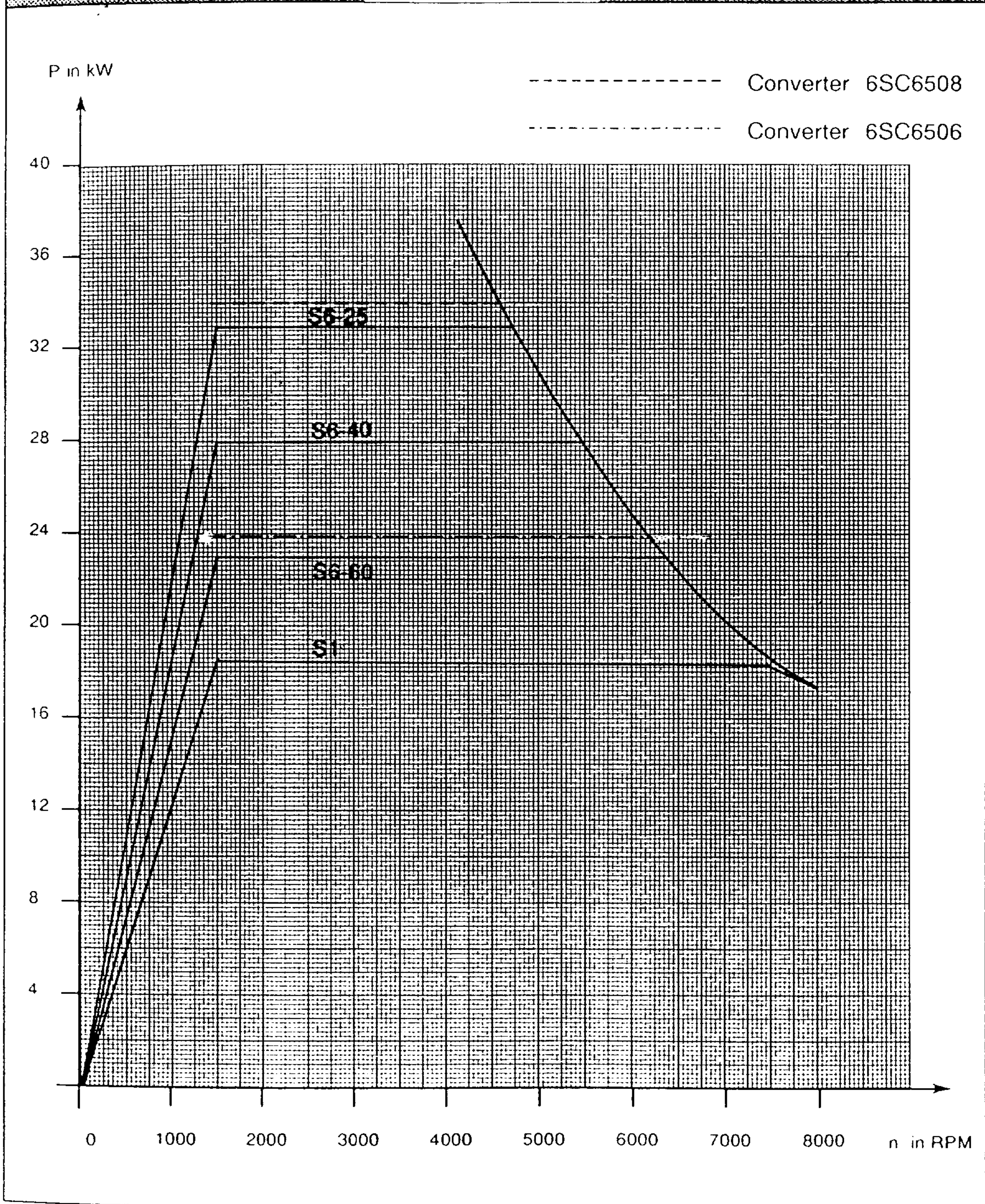

Fig. 6.20 Power - speed characteristic for the 1PH6 137-4CF4 AC motor



Rated power	Rated speed	Rated torque	Rated current	Time constant (therm.)	Max. speed	Moment of inertia	Weight
$P_N$	$n_N$	$M_N$	$I_N$	$T_{th}$	$n_{max}$	$J$	$m$
[kW]	[RPM]	[Nm]	[A]	[min]	[RPM]	[kgm <sup>2</sup> ]	[kg]
24.0	2000	115	59	30	8000	0.085	130

1PH6 137-4CG4

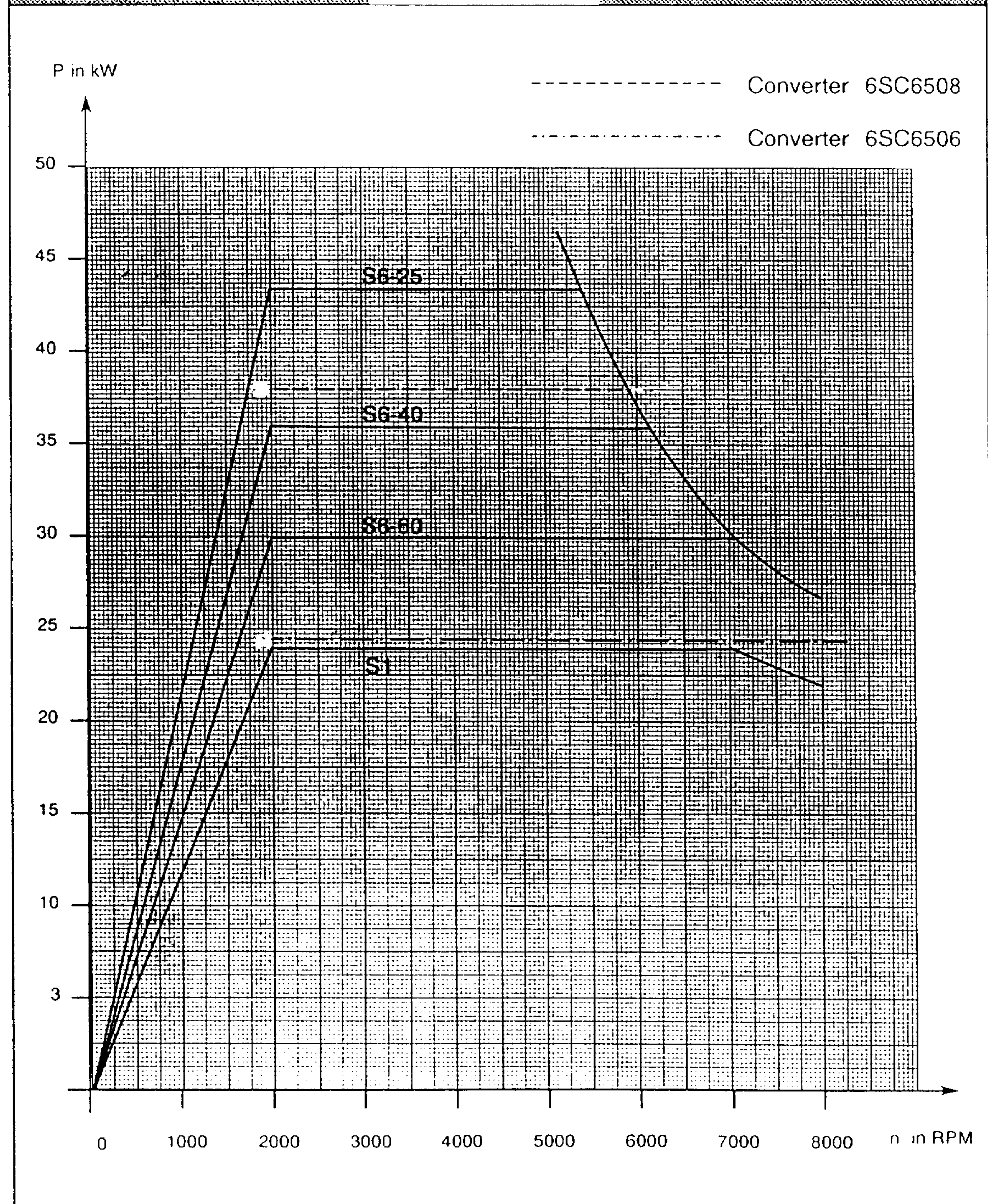

Fig. 6.21 Power - speed characteristic for the 1PH6 137-4CG4 AC motor



Rated power	Rated speed	Rated torque	Rated current	Time constant (therm.)	Max. speed	Moment of inertia	Weight
$P_N$	$n_N$	$M_N$	$I_N$	$T_{th}$	$n_{max}$	$J$	$m$
[kW]	[RPM]	[Nm]	[A]	[min]	[RPM]	[kgm <sup>2</sup> ]	[kg]
22.0	1500	140	52	30	8000	0.104	150
<b>1PH6 138-4CF0</b>							

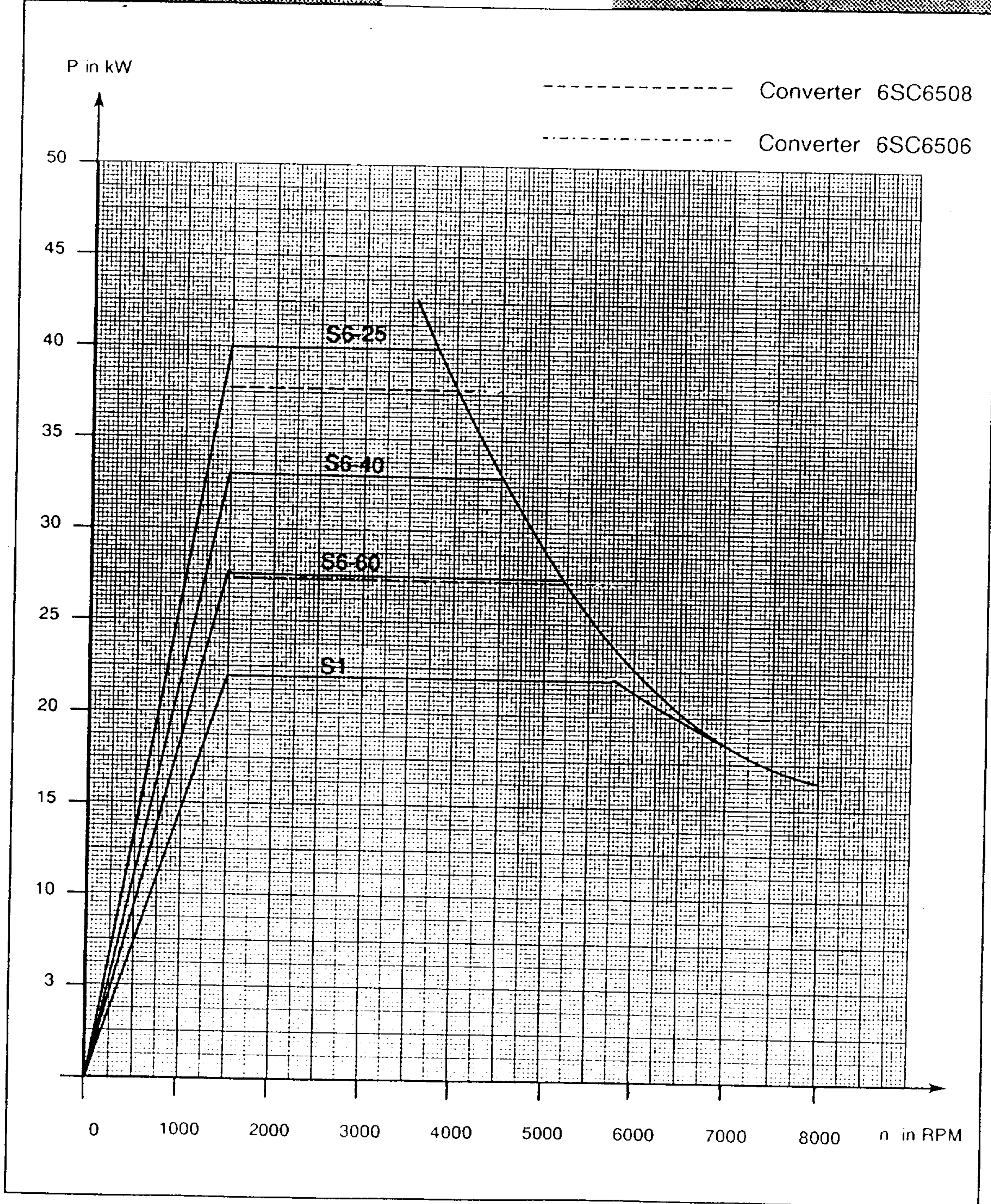

Fig. 6.22 Power - speed characteristic for the 1PH6 138-4CF0 AC motor



Rated power	Rated speed	Rated torque	Rated current	Time constant (therm.)	Max. speed	Moment of inertia	Weight
$P_N$	$n_N$	$M_N$	$I_N$	$T_{th}$	$n_{max}$	$J$	$m$
[kW]	[RPM]	[Nm]	[A]	[min]	[RPM]	[kgm <sup>2</sup> ]	[kg]
22.0	1500	140	63	30	8000	0.104	150
<b>1PH6 138-4CF4</b>							

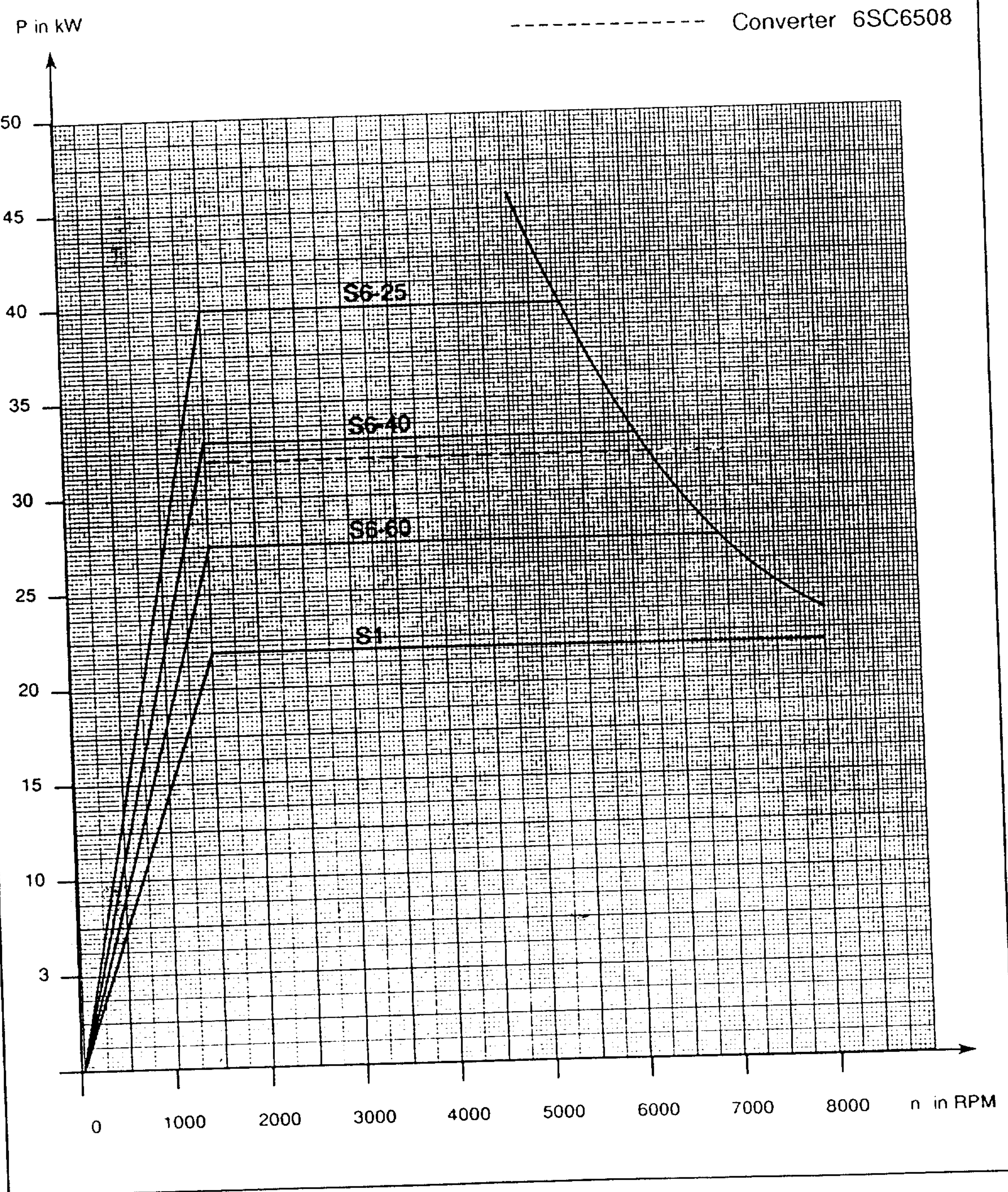

Fig. 6.23 Power - speed characteristic for the 1PH6 138-4CF4 AC motor



Rated power $P_N$ [kW]	Rated speed $n_N$ [RPM]	Rated torque $M_N$ [Nm]	Rated current $I_N$ [A]	Time constant (therm.) $T_{th}$ [min]	Max. speed $n_{max}$ [RPM]	Moment of inertia $J$ [kgm <sup>2</sup> ]	Weight $m$ [kg]
28.0	2000	134	68	30	8000	0.104	150
<b>1PH6 138-4CG4</b>							

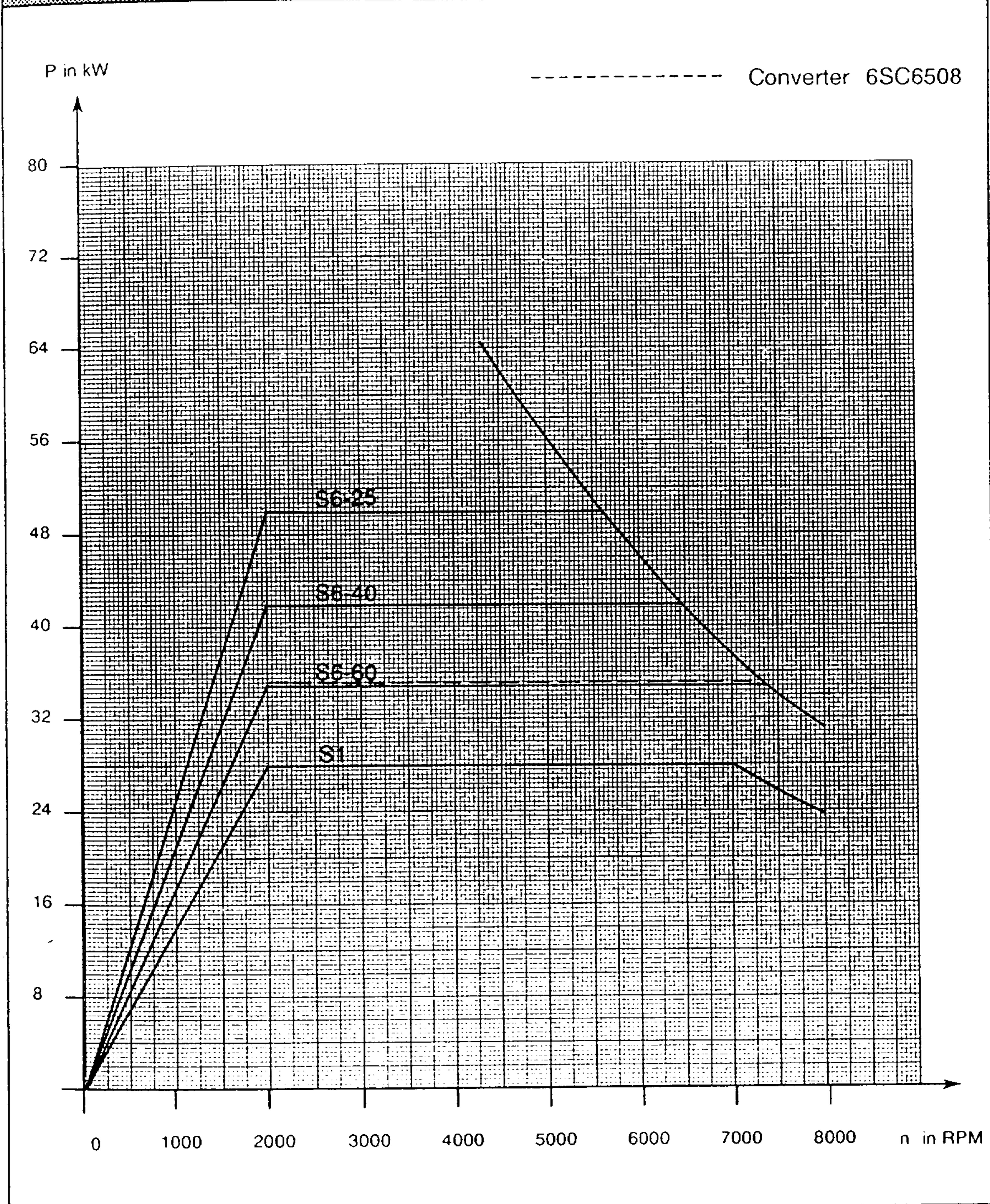

Fig. 6.24 Power - speed characteristic for the 1PH6 138-4CG4 AC motor



6 Appendix  
 6.1 Power - speed characteristics

Rated power	Rated speed	Rated torque	Rated current	Time constant (therm.)	Max. speed	Moment of inertia	Weight
$P_N$ [kW]	$n_N$ [RPM]	$M_N$ [Nm]	$I_N$ [A]	$T_{th}$ [min]	$n_{max}$ [RPM]	$J$ [kgm <sup>2</sup> ]	$m$ [kg]
22.0	1500	140	55	35	6500 (8000)*	0.131	140
<b>1PH6 161-4CF0</b>							

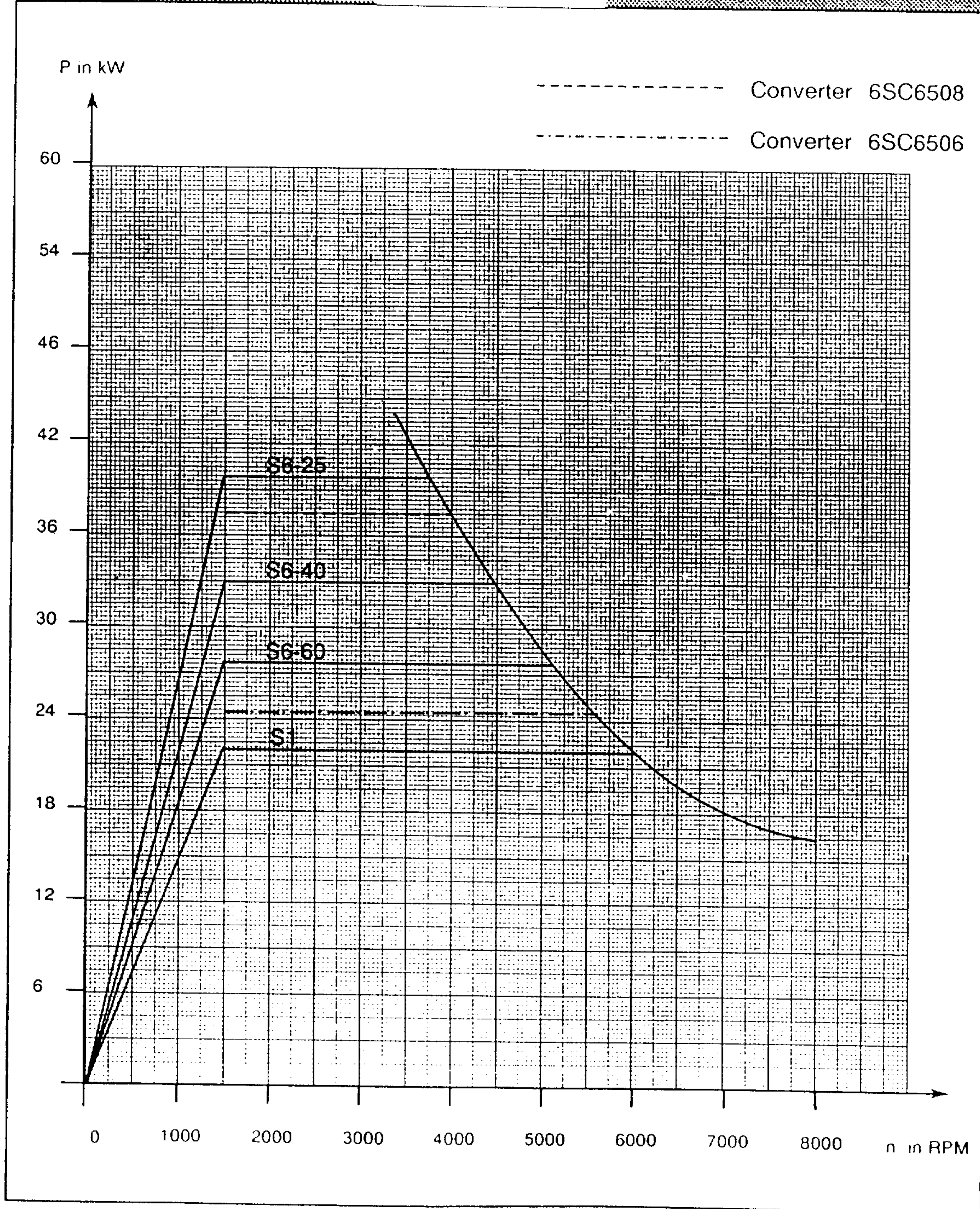

Fig. 6.25 Power - speed characteristic for the 1PH6 161-4CF0 AC motor



Rated power	Rated speed	Rated torque	Rated current	Time constant (therm.)	Max. speed	Moment of inertia	Weight
$P_N$	$n_N$	$M_N$	$I_N$	$T_{th}$	$n_{max}$	$J$	$m$
[kW]	[RPM]	[Nm]	[A]	[min]	[RPM]	[kgm <sup>2</sup> ]	[kg]
22.0	1500	140	63	35	6500 (8000)*	0.131	140
<b>1PH6 161-4CF4</b>							

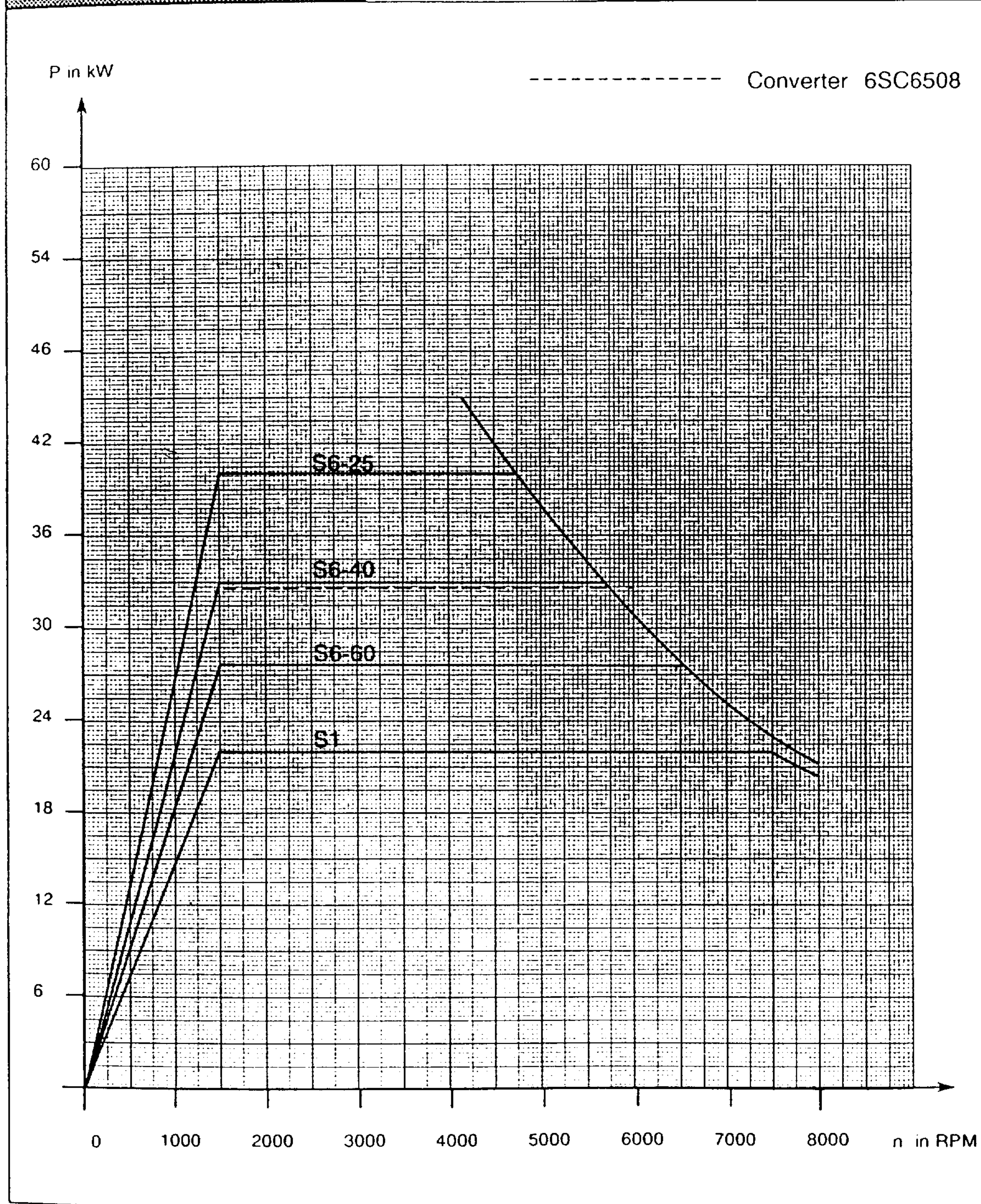

Fig. 6.26 Power - speed characteristic for the 1PH6 161-4CF4 AC motor



6 Appendix  
 6.1 Power - speed characteristics

Rated power $P_N$ [kW]	Rated speed $n_N$ [RPM]	Rated torque $M_N$ [Nm]	Rated current $I_N$ [A]	Time constant (therm.) $T_{th}$ [min]	Max. speed $n_{max}$ [RPM]	Moment of inertia $J$ [kgm <sup>2</sup> ]	Weight $m$ [kg]
28.0	2000	134	70	35	6500 (8000)*	0.131	140
<b>1PH6 161-4CG4</b>							

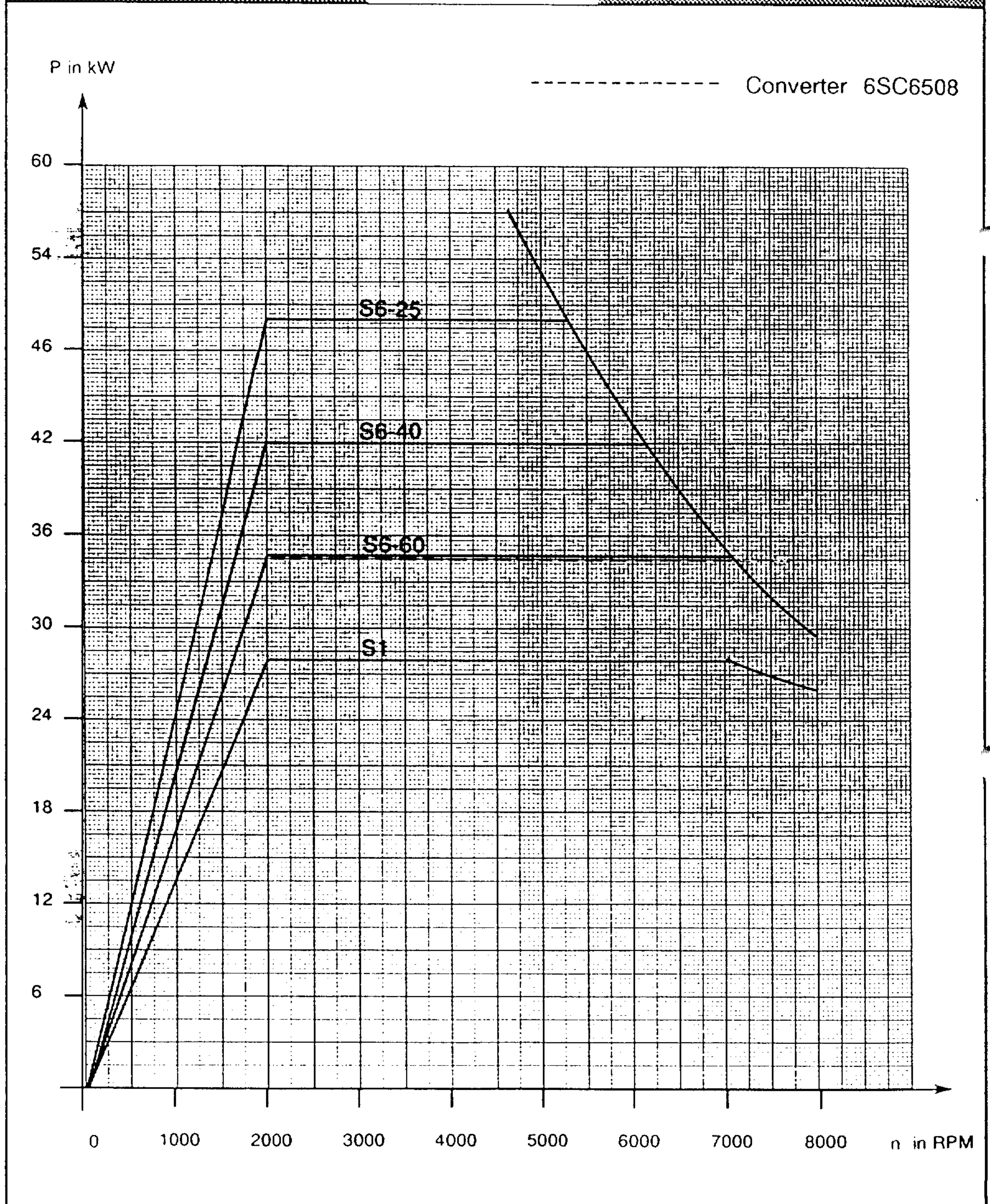

Fig. 6.27 Power - speed characteristic for the 1PH6 161-4CG4 AC motor



Rated power	Rated speed	Rated torque	Rated current	Time constant (therm.)	Max. speed	Moment of inertia	Weight
$P_N$ [kW]	$n_N$ [RPM]	$M_N$ [Nm]	$I_N$ [A]	$T_{th}$ [min]	$n_{max}$ [RPM]	$J$ [kgm <sup>2</sup> ]	$m$ [kg]
11.5	500	220	67	35	6500 (8000)*	0.17	175
<b>1PH6 163-4CB4</b>							

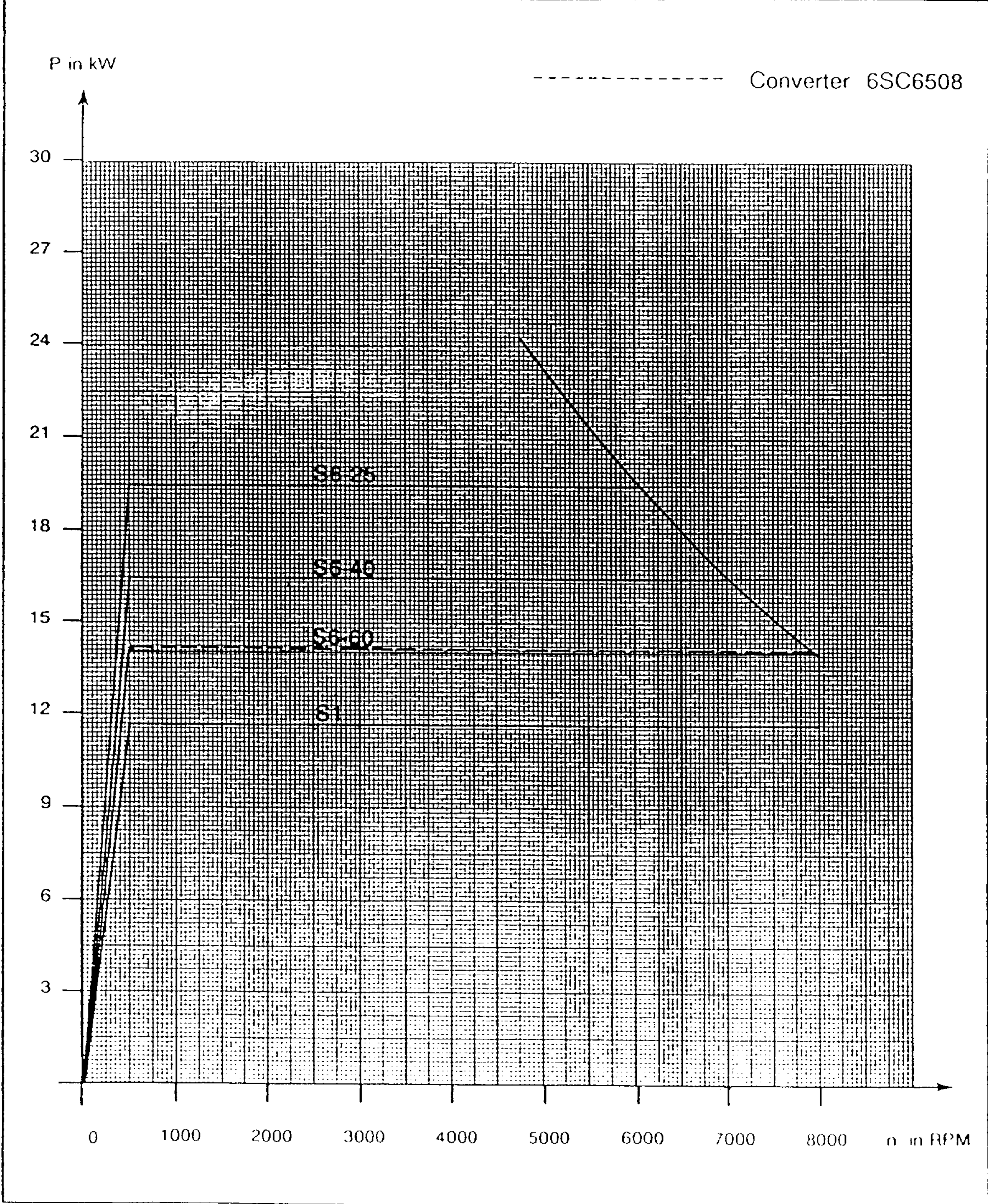

Fig. 6.28 Power - speed characteristic for the 1PH6 163-4CB4 AC motor







Rated power	Rated speed	Rated torque	Rated current	Time constant (therm.)	Max. speed	Moment of inertia	Weight
$P_N$	$n_N$	$M_N$	$I_N$	$T_{th}$	$n_{max}$	$J$	$m$
[kW]	[RPM]	[Nm]	[A]	[min]	[RPM]	[kgm <sup>2</sup> ]	[kg]
30.0	1500	191	88	35	6500 (8000)*	0.17	175
<b>1PH6 163-4CF4</b>							

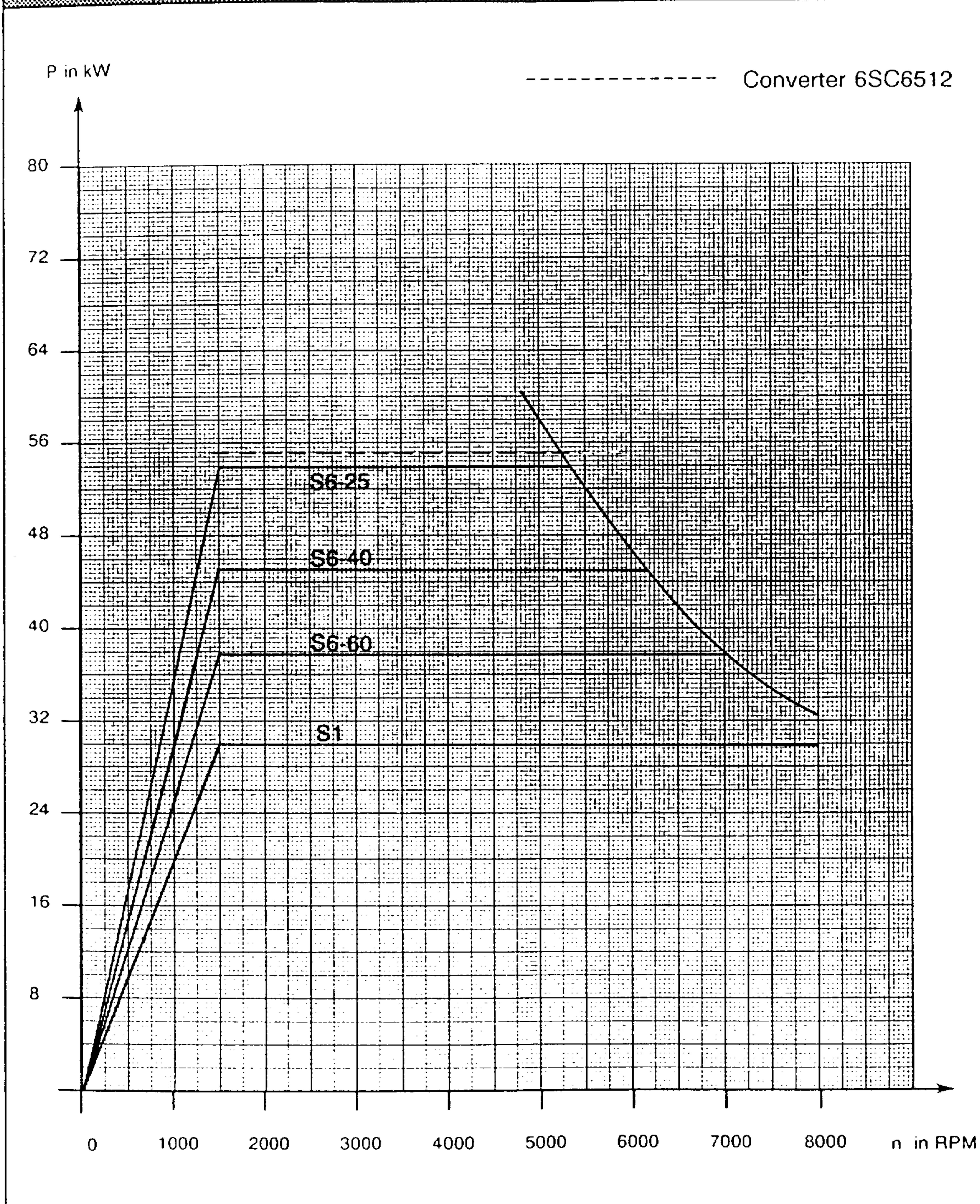

Fig. 6.30 Power - speed characteristic for the 1PH6 163-4CF4 AC motor



Rated power	Rated speed	Rated torque	Rated current	Time constant (therm.)	Max. speed	Moment of inertia	Weight
$P_N$	$n_N$	$M_N$	$I_N$	$T_{th}$	$n_{max}$	$J$	$m$
[kW]	[RPM]	[Nm]	[A]	[min]	[RPM]	[kgm <sup>2</sup> ]	[kg]
38.0	2000	181	90	35	6500 (8000)*	0.17	175
<b>1PH6 163-4CG4</b>							

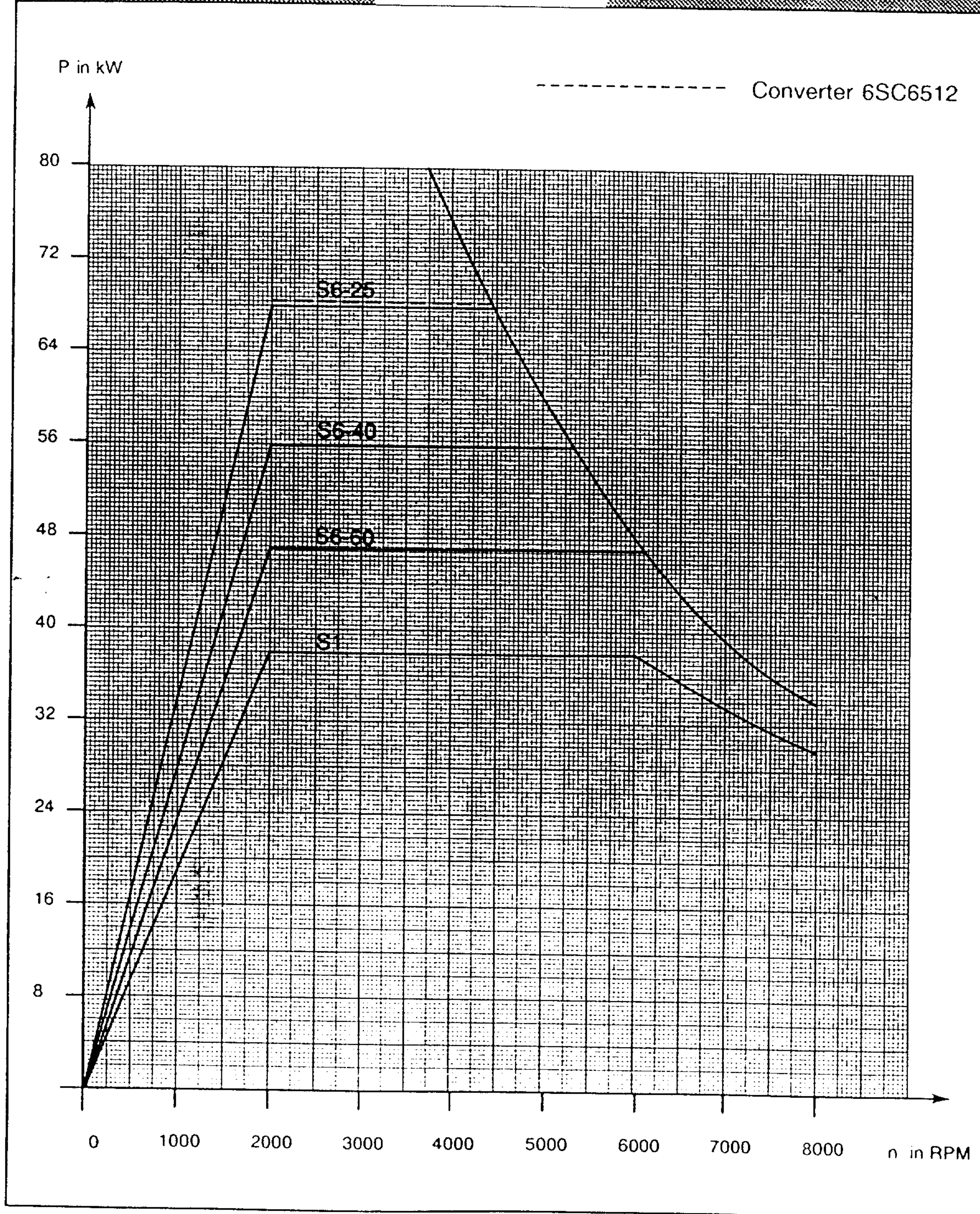

Fig. 6.31 Power - speed characteristic for the 1PH6 163-4CG4 AC motor



Rated power $P_N$ [kW]	Rated speed $n_N$ [RPM]	Rated torque $M_N$ [Nm]	Rated current $I_N$ [A]	Time constant (therm.) $T_{th}$ [min]	Max. speed $n_{max}$ [RPM]	Moment of inertia $J$ [kgm <sup>2</sup> ]	Weight $m$ [kg]
14.5	500	277	80	35	6500 (8000)*	0.206	210
<b>1PH6 167-4CB4</b>							

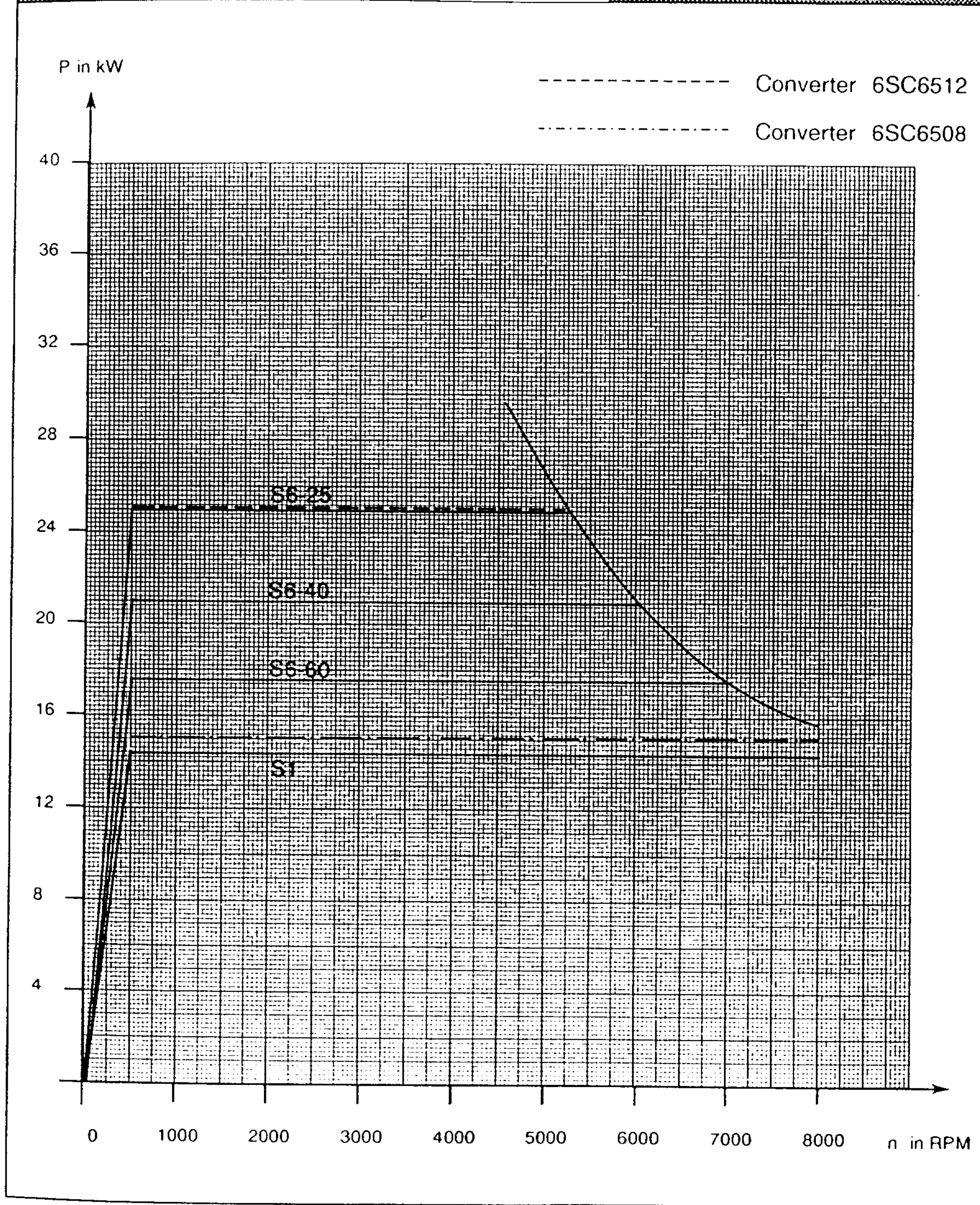

Fig. 6.32 Power - speed characteristic for the 1PH6 167-4CB4 AC motor



Rated power $P_N$ [kW]	Rated speed $n_N$ [RPM]	Rated torque $M_N$ [Nm]	Rated current $I_N$ [A]	Time constant (therm.) $T_{th}$ [min]	Max. speed $n_{max}$ [RPM]	Moment of inertia $J$ [kgm <sup>2</sup> ]	Weight $m$ [kg]
37.0	1500	236	82	35	6500 (8000)*	0.206	210

1PH6 167-4CF0

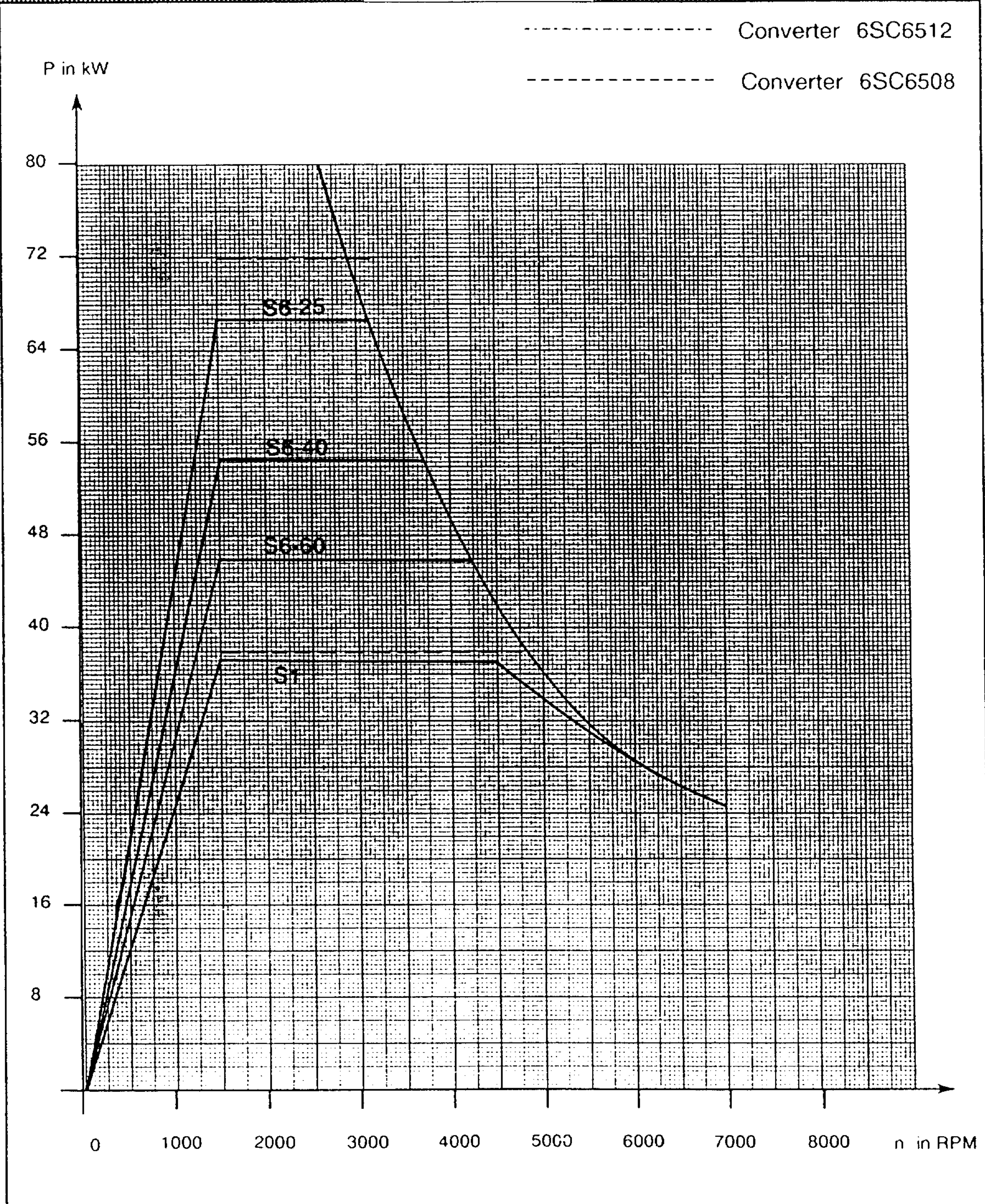

Fig. 6.33 Power - speed characteristic for the 1PH6 167-4CF0 AC motor



Rated power $P_N$ [kW]	Rated speed $n_N$ [RPM]	Rated torque $M_N$ [Nm]	Rated current $I_N$ [A]	Time constant (therm.) $T_{th}$ [min]	Max. speed $n_{max}$ [RPM]	Moment of inertia $J$ [kgm <sup>2</sup> ]	Weight $m$ [kg]
37.0	1500	236	98	35	6500 (8000)*	0.206	210
<b>1PH6 167-4CF4</b>							

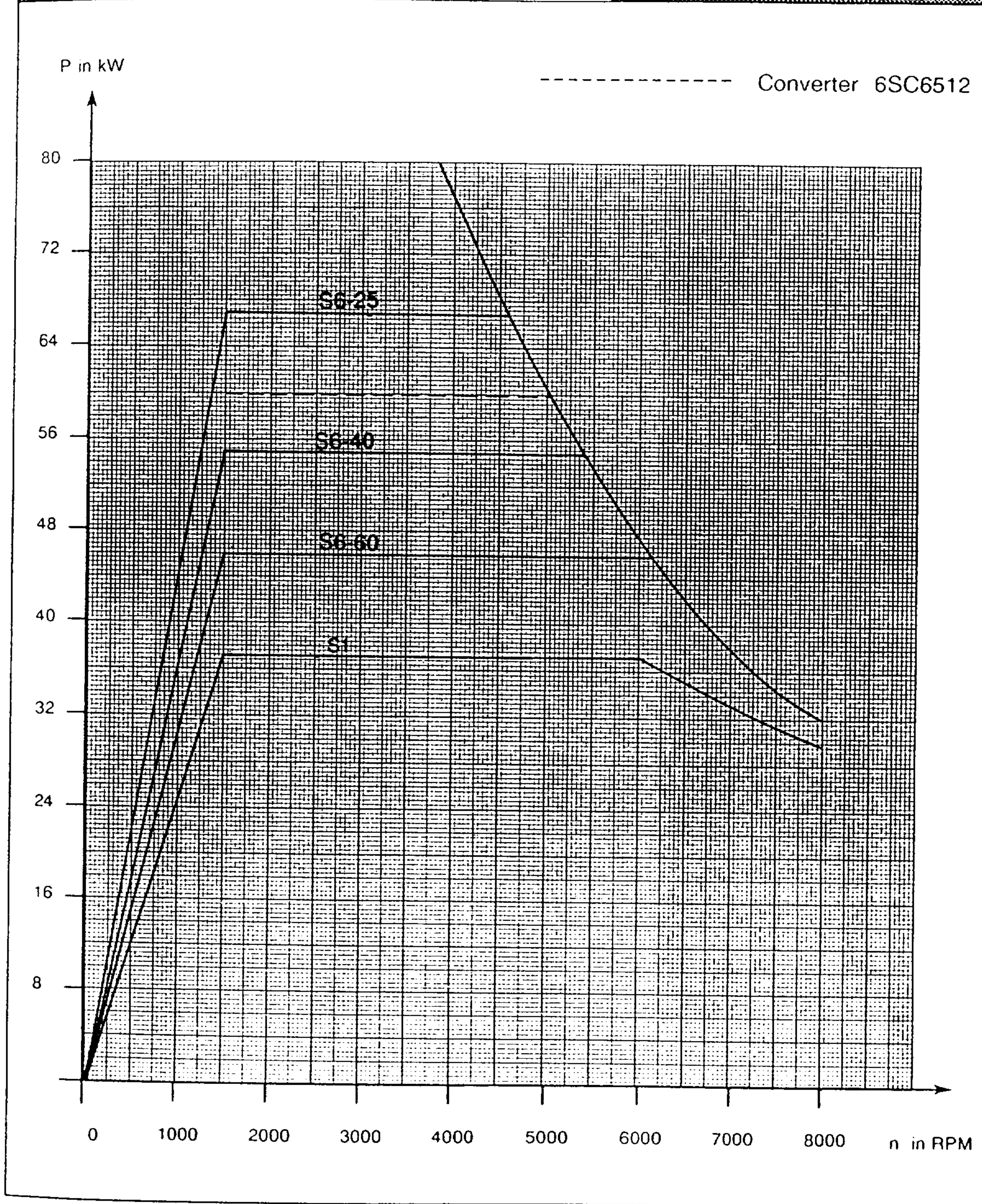

Fig. 6.34 Power - speed characteristic for the 1PH6 167-4CF4 AC motor



Rated power	Rated speed	Rated torque	Rated current	Time constant (therm.)	Max. speed	Moment of inertia	Weight
$P_N$	$n_N$	$M_N$	$I_N$	$T_{th}$	$n_{max}$	$J$	$m$
[kW]	[RPM]	[Nm]	[A]	[min]	[RPM]	[kgm <sup>2</sup> ]	[kg]
45	2000	215	93	35	6500 (8000)*	0.206	210
<b>1PH6 167-4CG4</b>							

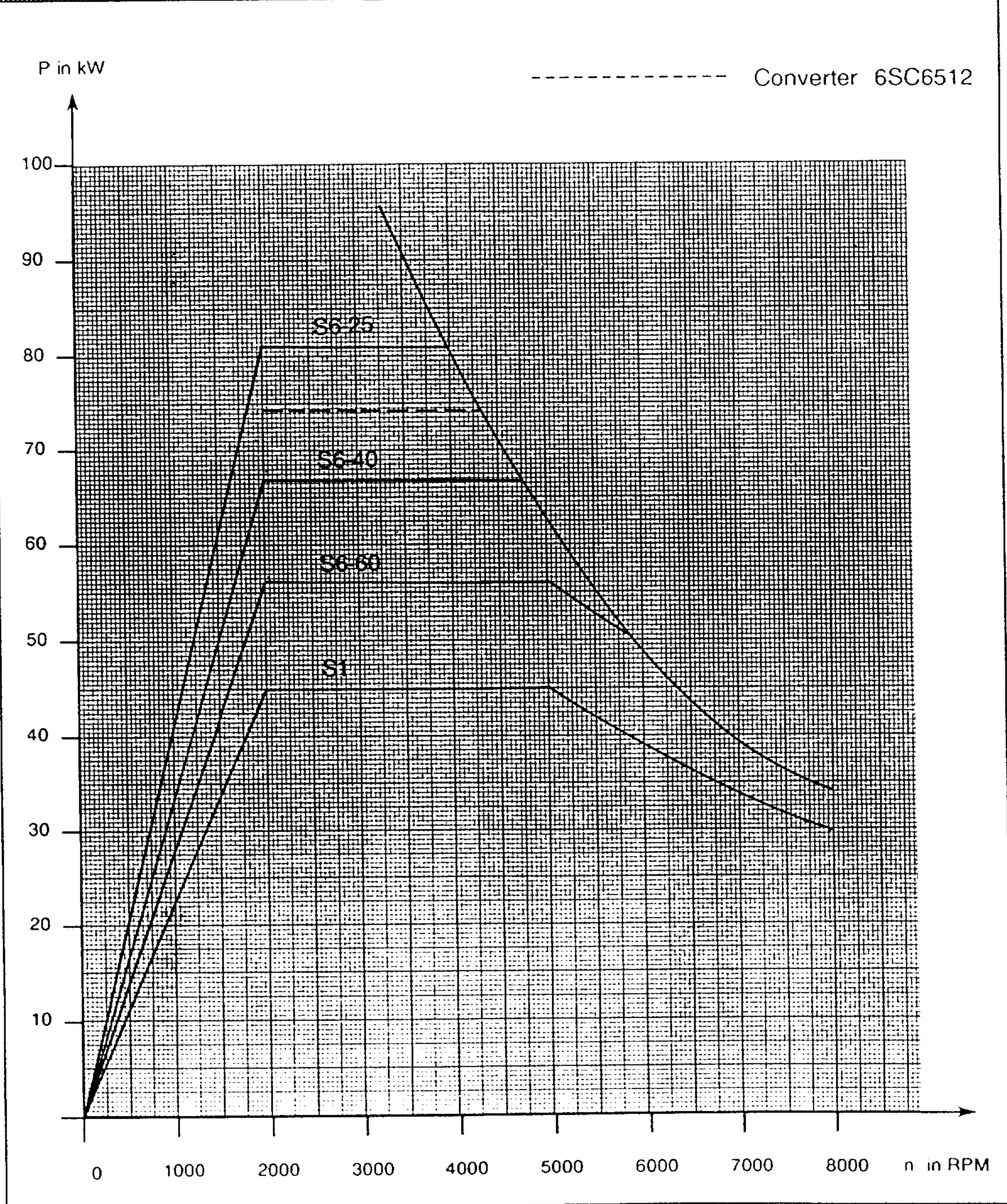

Fig. 6.35 Power - speed characteristic for the 1PH6 167-4CG4 AC motor



Rated power $P_N$ [kW]	Rated speed $n_N$ [RPM]	Rated torque $M_N$ [Nm]	Rated current $I_N$ [A]	Time constant (therm.) $T_{th}$ [min]	Max. speed $n_{max}$ [RPM]	Moment of inertia $J$ [kgm <sup>2</sup> ]	Weight $m$ [kg]
42.0	1250	320	84	40	5000 (7000)*	0.310	350
<b>1PH6 186-4CE4</b>							

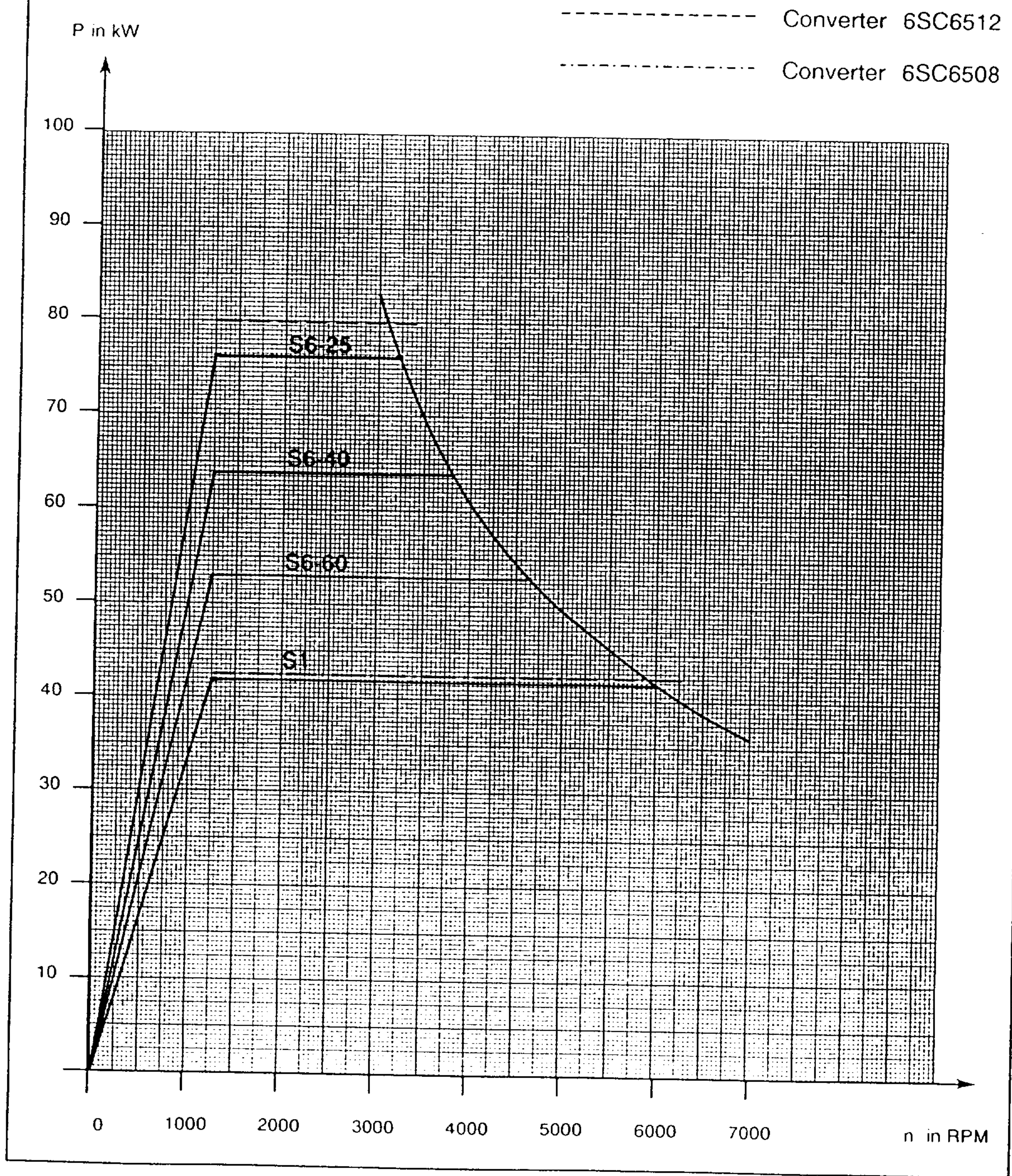

Fig. 6.36 Power - speed characteristic for the 1PH6 186-4CE4 AC motor



Rated power	Rated speed	Rated torque	Rated current	Time constant (therm.)	Max. speed	Moment of inertia	Weight
$P_N$ [kW]	$n_N$ [RPM]	$M_N$ [Nm]	$I_N$ [A]	$T_{th}$ [min]	$n_{max}$ [RPM]	$J$ [kgm <sup>2</sup> ]	$m$ [kg]
50.0	1500	318	100	40	5000 (7000)*	0.310	350
<b>1PH6 186-4CF4</b>							

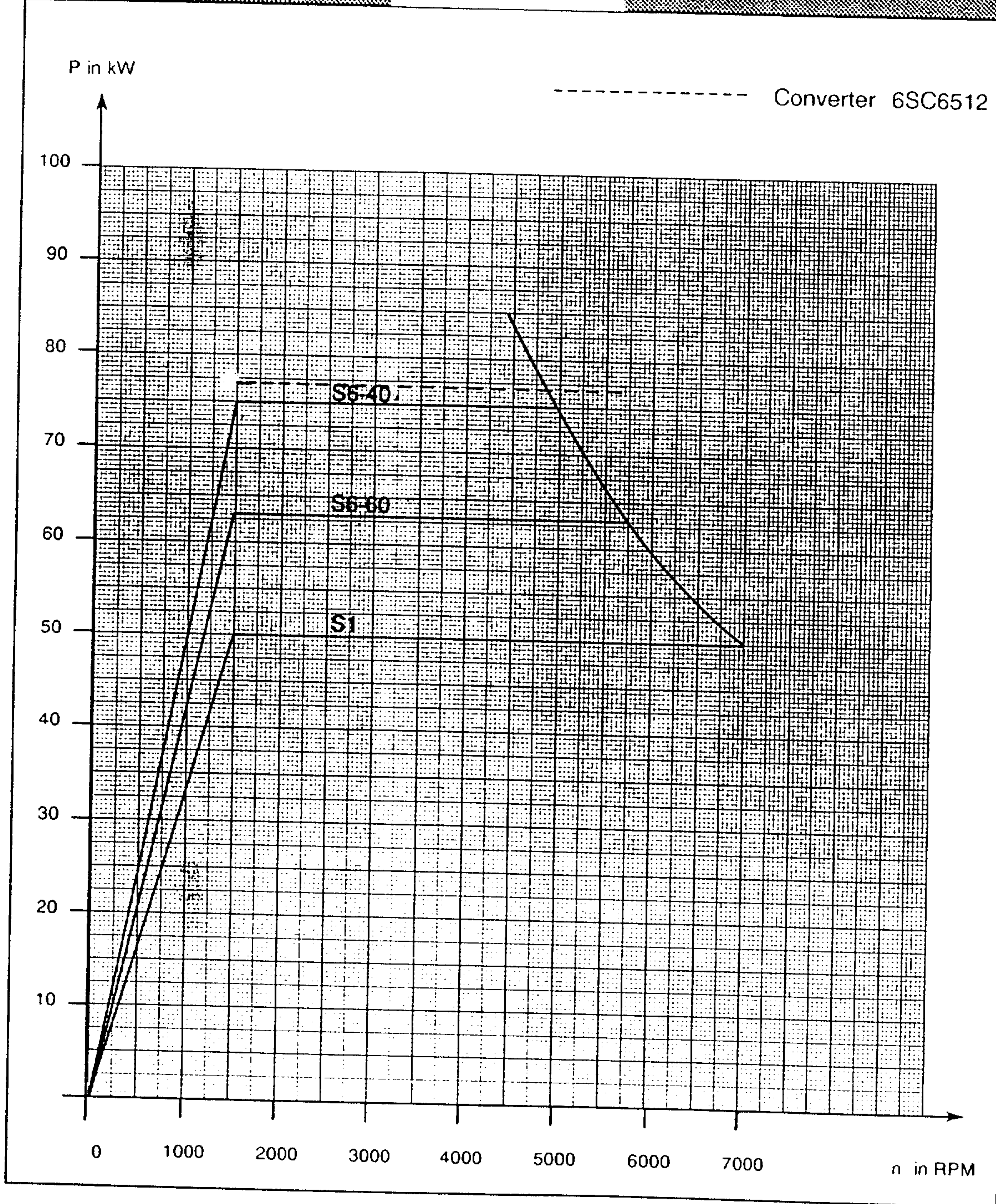

Fig. 6.37 Power-speed characteristic for the 1PH6 186-4CF4 AC motor



Rated power $P_N$ [kW]	Rated speed $n_N$ [RPM]	Rated torque $M_N$ [Nm]	Rated current $I_N$ [A]	Time constant (therm.) $T_{th}$ [min]	Max. speed $n_{max}$ [RPM]	Moment of inertia $J$ [kgm <sup>2</sup> ]	Weight $m$ [kg]
63.0	1250	481	122	40	5000 (7000)*	0.610	470

1PH6 206-4CE4

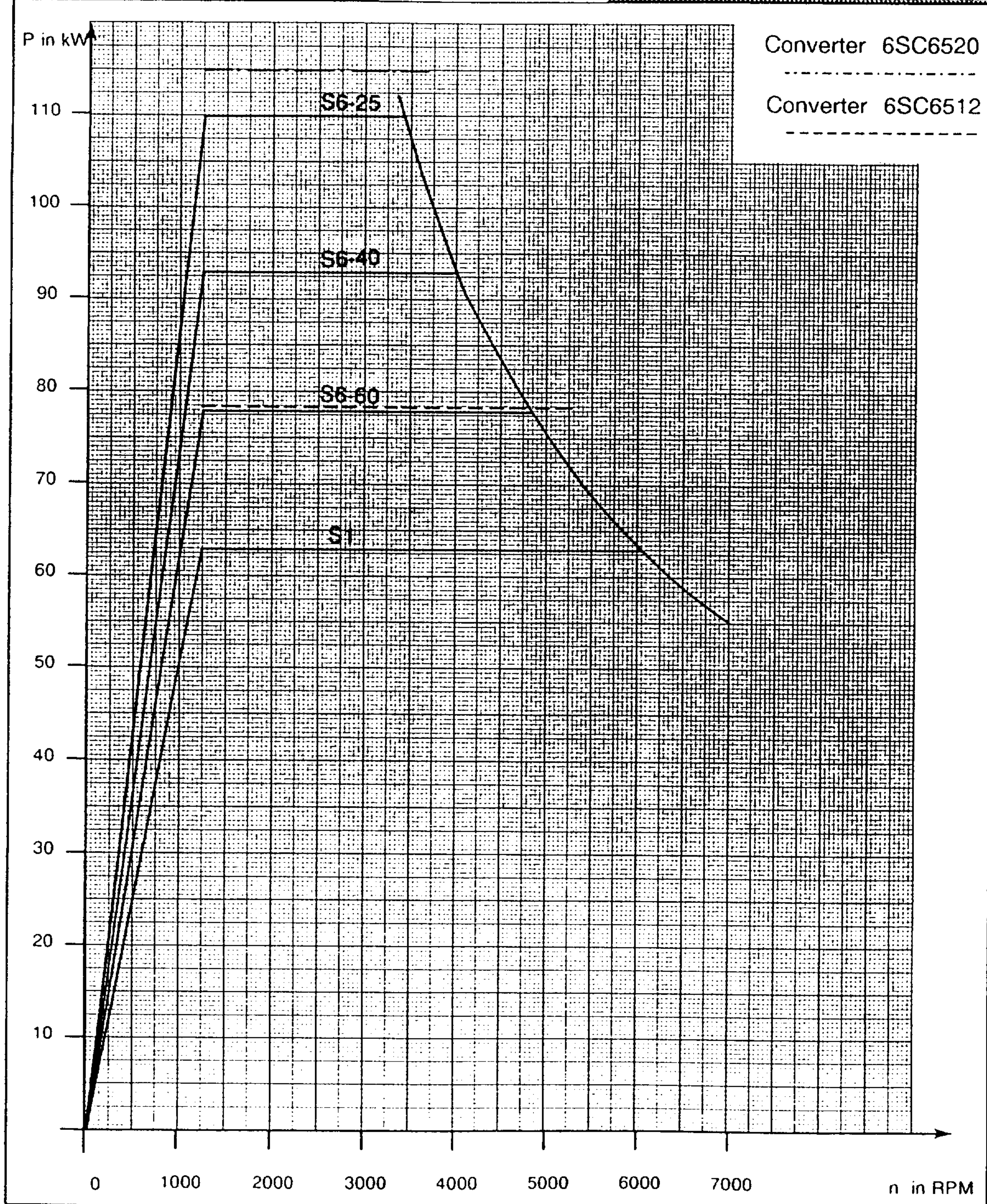

Fig. 6.38 Power - speed characteristic for the 1PH6 206-4CE4 AC motor



6 Appendix  
6.1 Power - speed characteristics

Rated power $P_N$ [kW]	Rated speed $n_N$ [RPM]	Rated torque $M_N$ [Nm]	Rated current $I_N$ [A]	Time constant (therm.) $T_{th}$ [min]	Max. speed $n_{max}$ [RPM]	Moment of inertia $J$ [kgm <sup>2</sup> ]	Weight $m$ [kg]
76.0	1500	484	154	40	5000 (7000)*	0.610	470

1PH6 206-4CF4

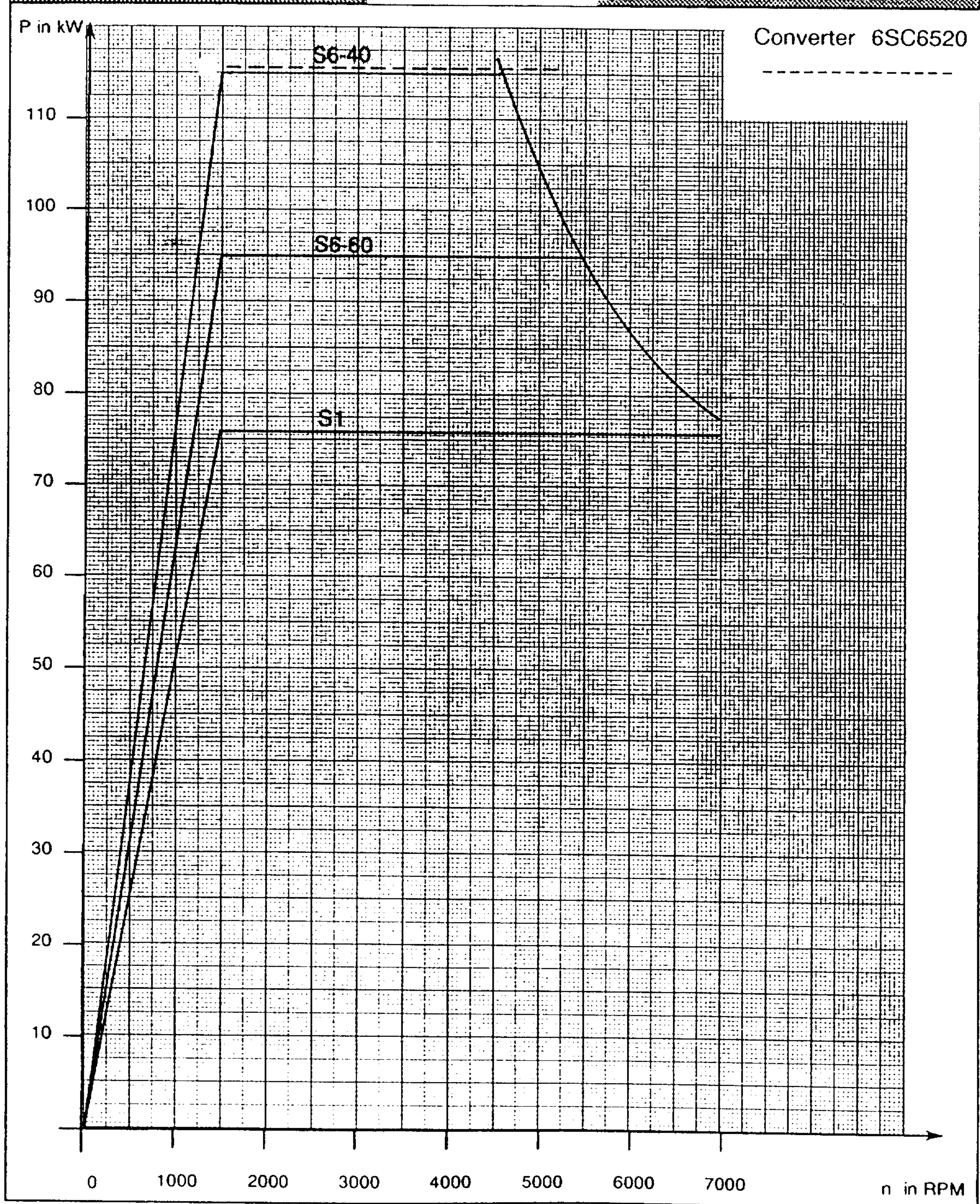

Fig. 6.39 Power - speed characteristic for the 1PH6 206-4CF4 AC motor



## 6.2 Cantilever force charts

**Note:** The cantilever force charts indicate the cantilever force  $F_Q$  at a distance  $x$  from the shaft shoulder for a nominal bearing service life of 20 000 h.

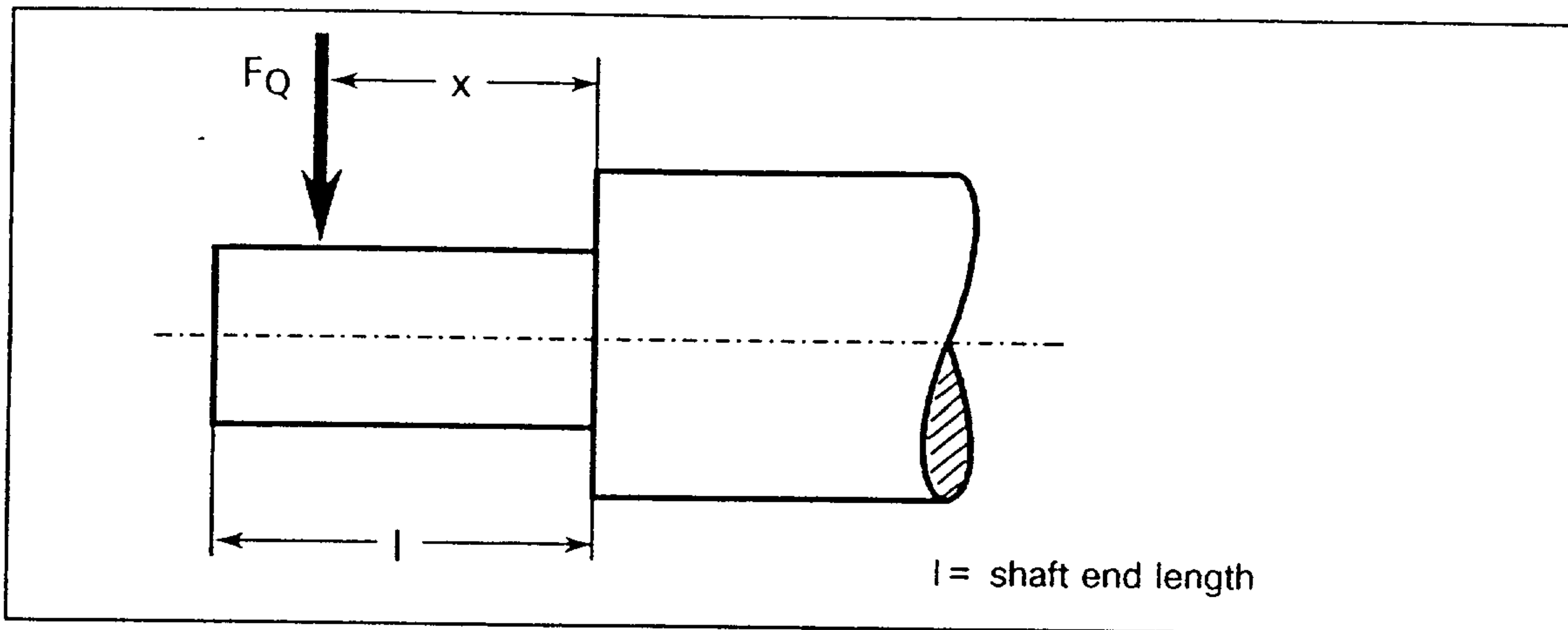

Fig. 6.40 Application point of cantilever forces at the motor shaft end

Total cantilever force

$$F_Q = c \cdot x \cdot F_U$$

In this case, the initial tensioning force  $c$  is a value based on the experience of the belt manufacturer. It can be approximately obtained as follows:

- for standard flat belts with tensioning roll  $c = 2,$
- for V belts  $c = 1.5$  to  $2.5$
- for special plastic belts depending on the loading type and belt type  $c = 2.0$  to  $2.5.$

The peripheral speed  $F_U$  is calculated using the following equation:

$$F_U = 2 \times 10^7 \times P / (n \times D) \quad \text{in N}$$

- $F_U$  Peripheral force in N  
 $P$  Motor power (transmitted power in kW)  
 $D$  Pulley wheel diameter in mm

When using power transmission elements which exert a cantilever force on the shaft end, it should be ensured that the limiting values specified in the cantilever force charts are not exceeded. The cantilever force charts are only valid for standard drive shaft ends; for non-standard drive shaft ends, each particular case is dimensioned according to the permissible cantilever forces.

Cantilever forces exceeding those given in the charts should be separately inquired.



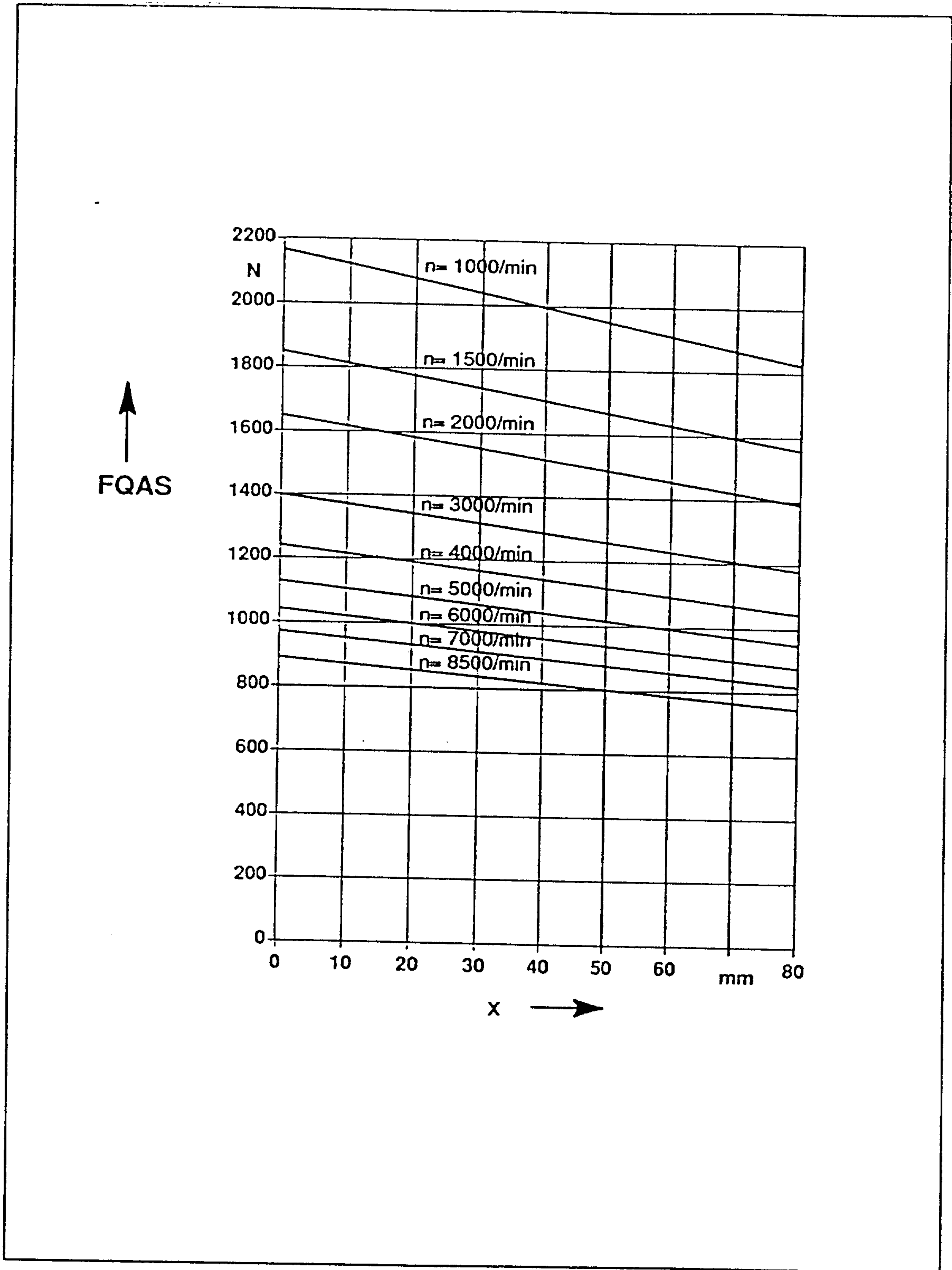

Fig. 6.41 Cantilever force chart for 1PH6 10□-4 AC motors, single-bearing design



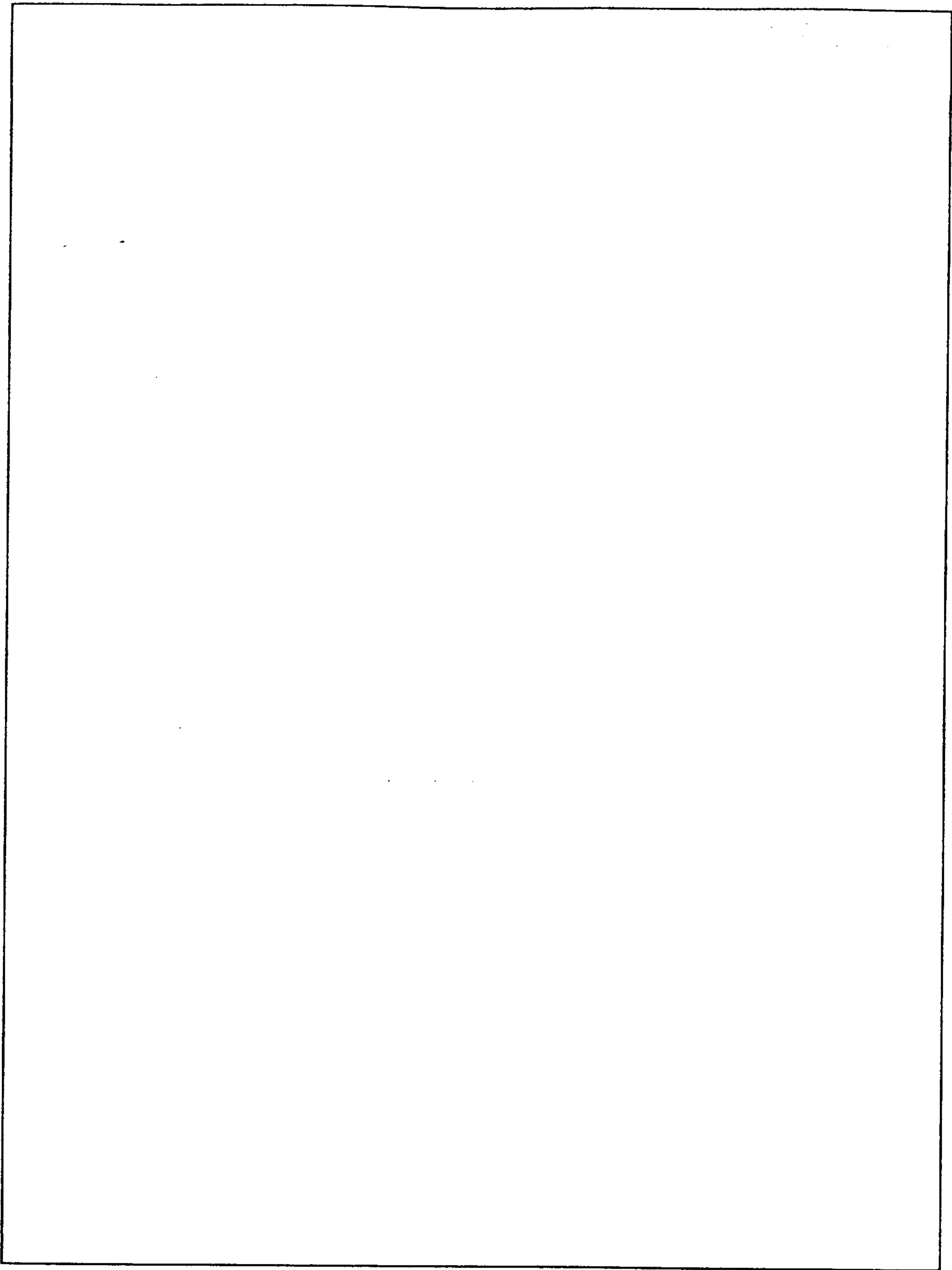

Fig. 6.42 Cantilever force chart for 1PH6 10□-4 AC motors, with spindle bearing



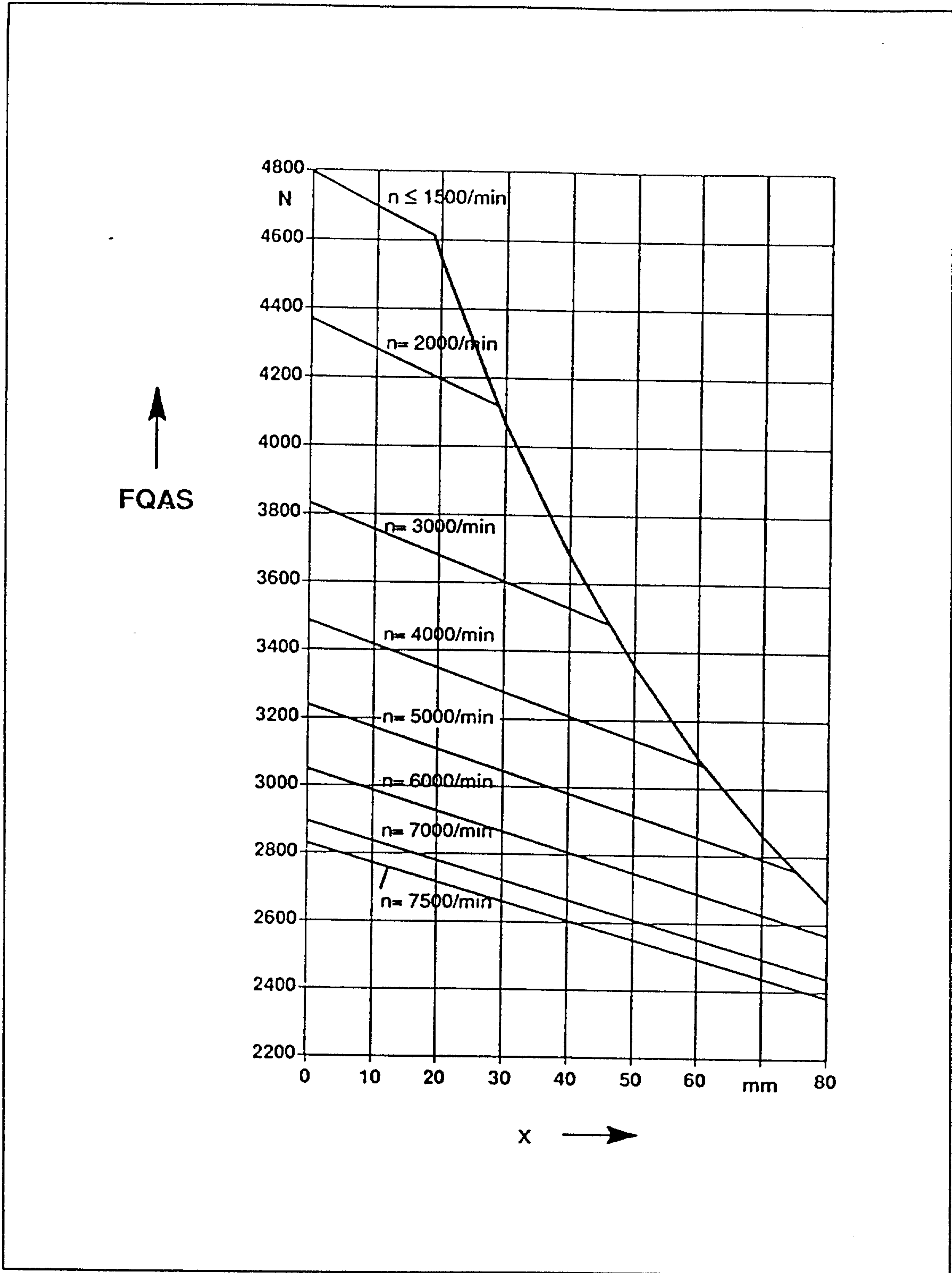

Fig. 6.43 Cantilever force chart for 1PH6 10□-4 AC motors, with double-bearing design



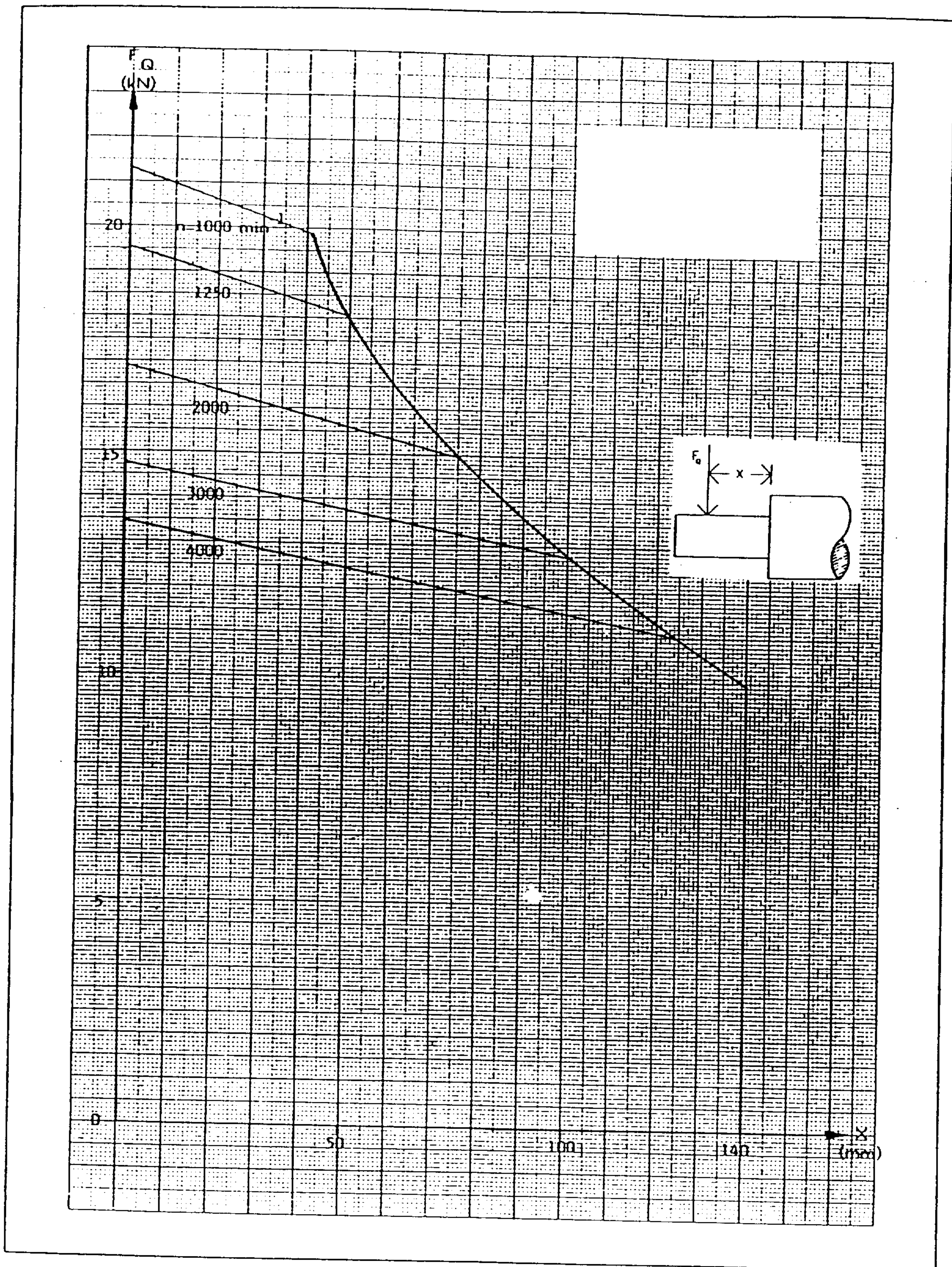

Fig. 6.54 Cantilever force chart for 1PH6 206-4 AC motors, with reinforced bearing



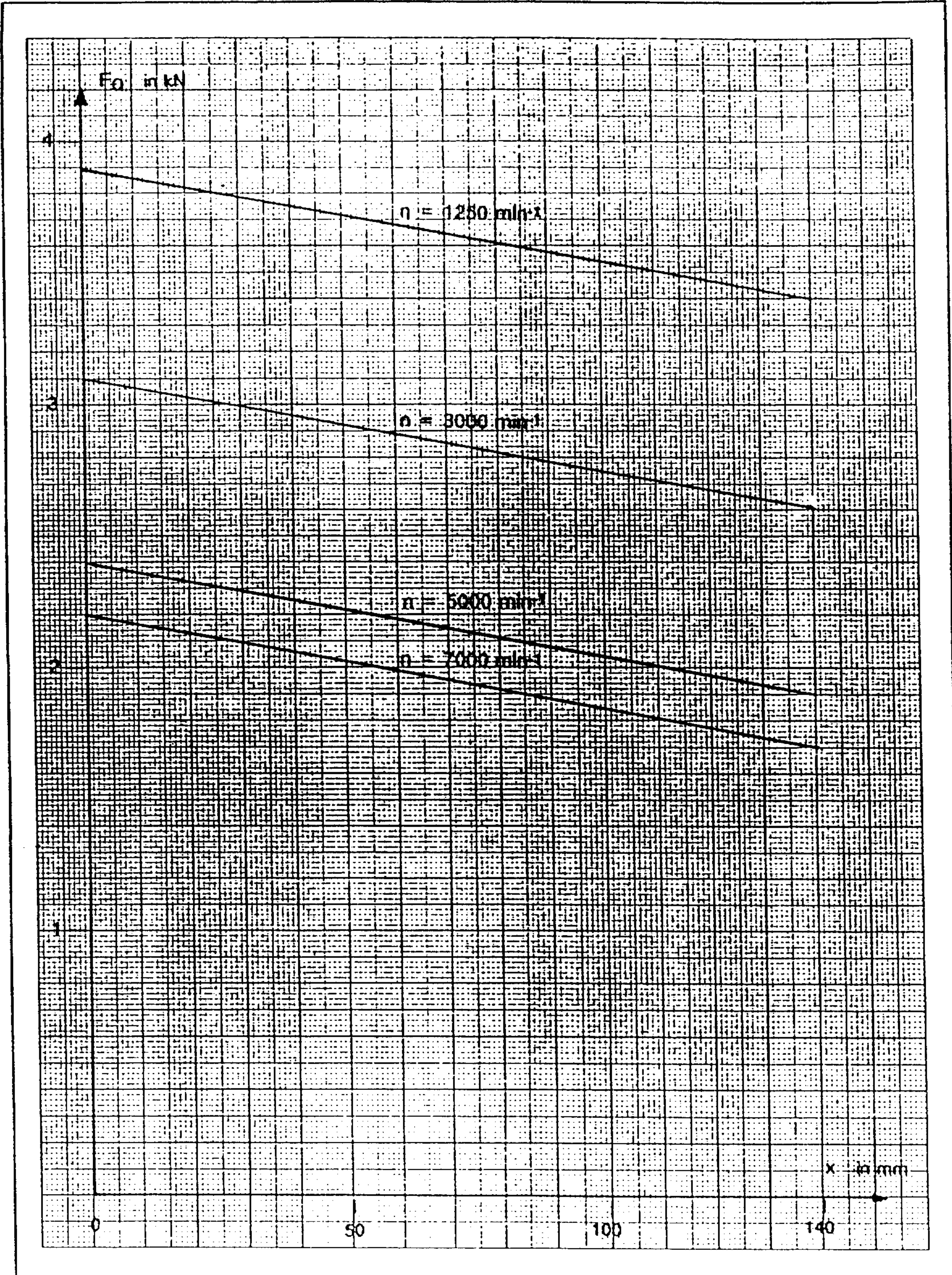

Fig. 6.55 Cantilever force chart for 1PH6 206-4 AC motors, for high-speed motors with option L37



6.3 Vibrational severity charts

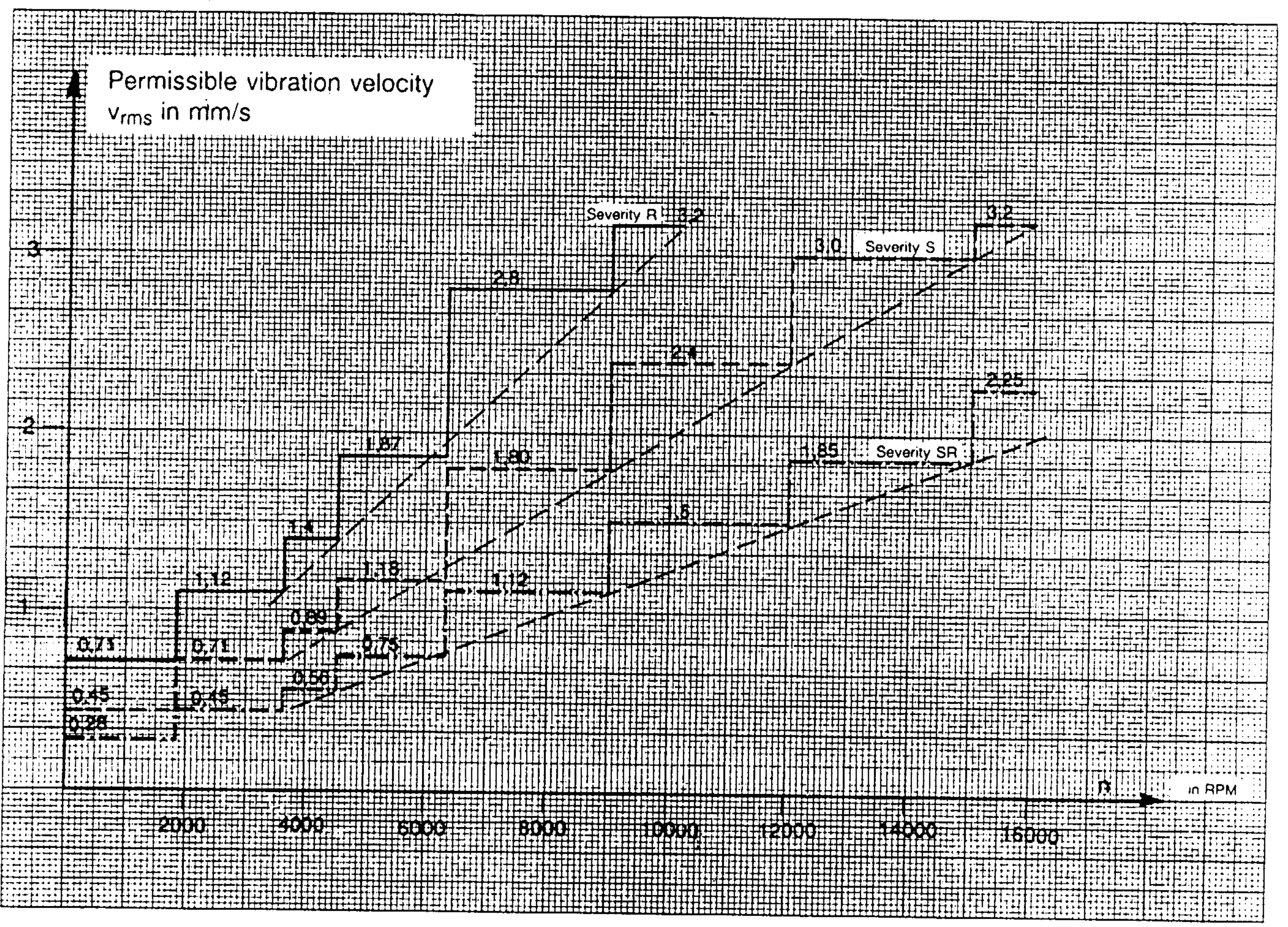

Fig. 6.56 Vibration severity limiting values. AC motors shaft height 100 mm to 132 mm



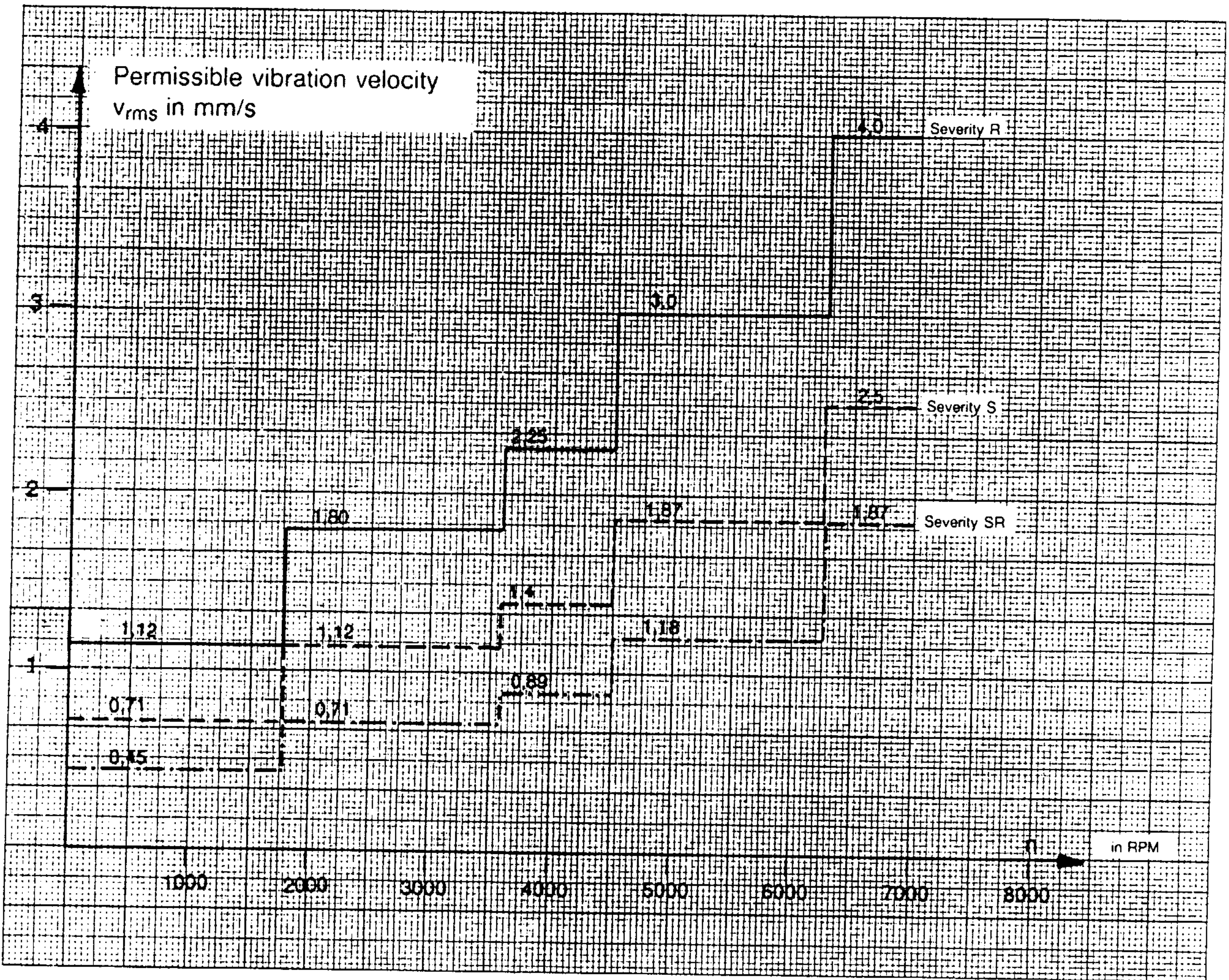

Fig. 6.57 Vibration severity limiting values, AC motors shaft height AH 160 mm to 200 mm



## 6.4 AC motor dimension sheets

Dim.	Permissible deviations		
a, b	up to 250 mm above 250 mm to 500 mm above 500 mm to 750 mm		$\pm 0.75$ mm $\pm 1.0$ mm $\pm 1.5$ mm
b <sub>1</sub>	up to 230 mm above 230 mm	DIN 7160	j6 h6
d, d <sub>1</sub>	up to 11 mm above 11 mm to 50 mm above 50 mm	DIN 7160	j6 k6 m6
e <sub>1</sub>	up to 200 mm above 200 mm to 500 mm		$\pm 0.25$ mm $\pm 0.5$ mm
h	above 50 mm to 250 mm above 250 mm to 500 mm	DIN 747	- 0.5 mm - 1.0 mm
i, i <sub>1</sub> , i <sub>2</sub>	up to 85 mm above 85 mm to 130 mm above 130 mm to 240 mm		$\pm 0.75$ mm $\pm 1.0$ mm $\pm 1.5$ mm
u, t, u <sub>1</sub> , t <sub>1</sub>	according to DIN 6885 Bl.1		

Table 6.1 Permissible deviations



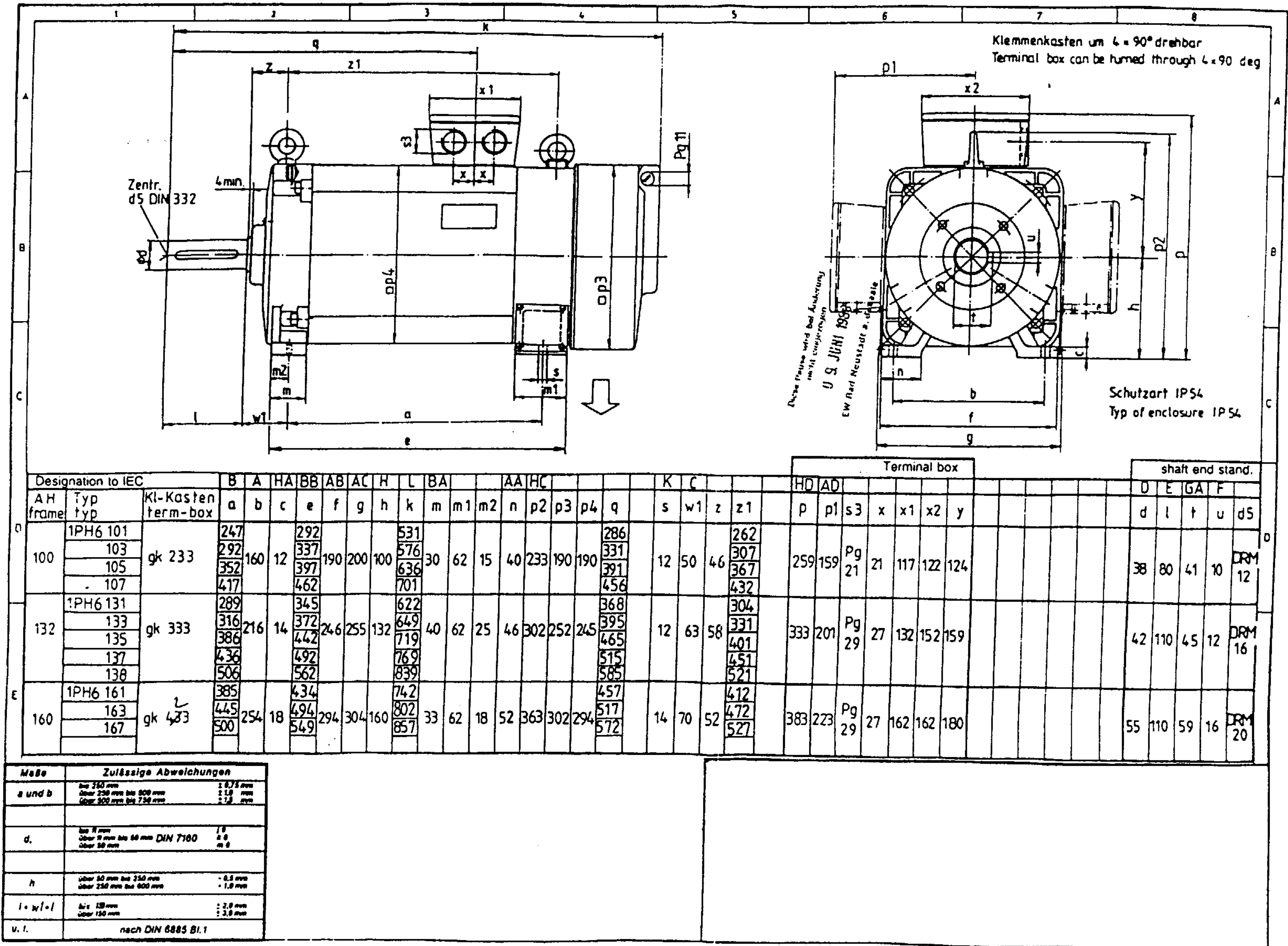
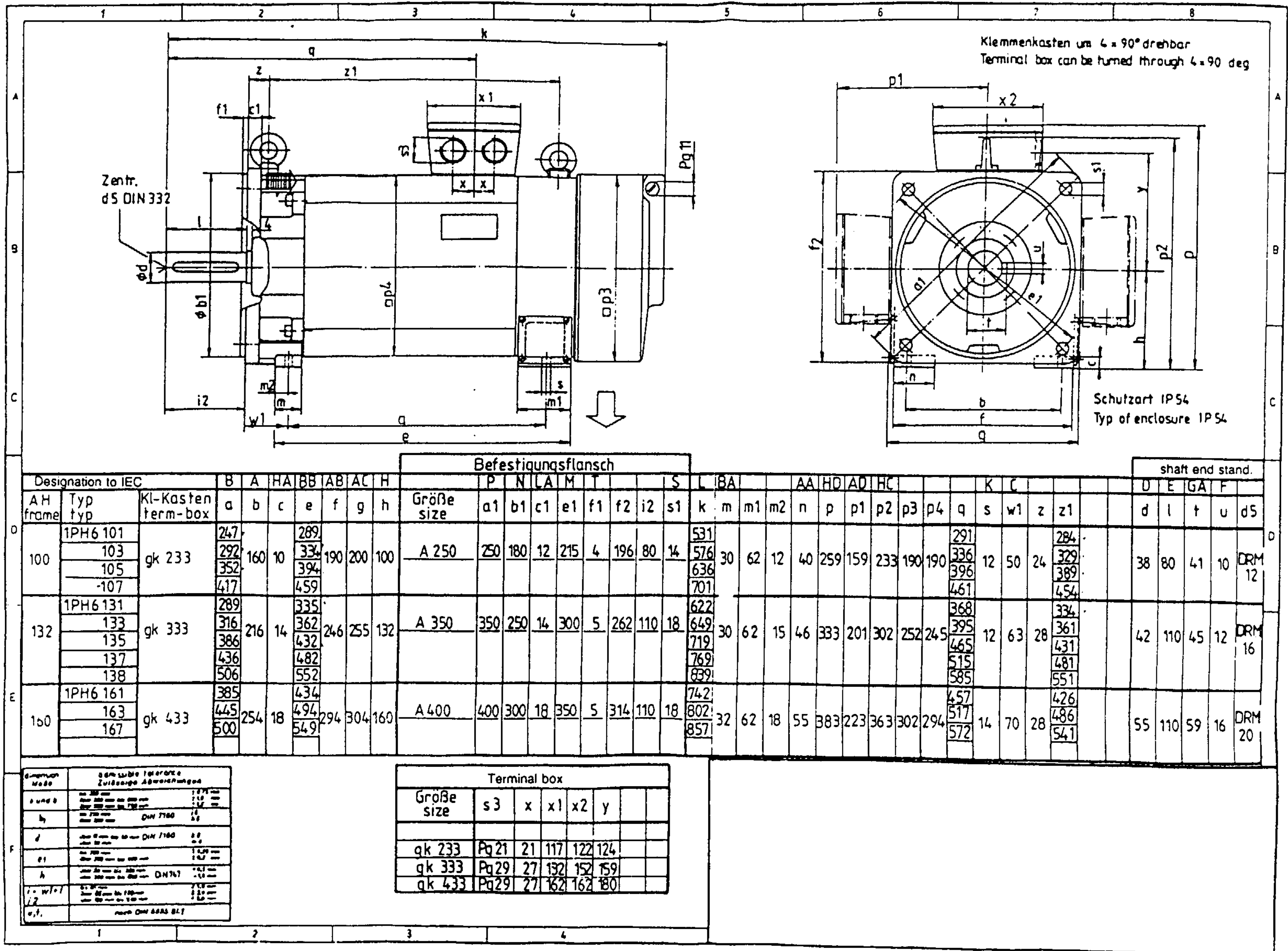

Fig. 6.58 Dimension sheet for 1PH6 101 to 167, AC motors, type of construction IM B3  
(Dimensions in mm, not to scale)



Fig. 6.59 Dimension sheet for 1PH6 101 to 167 AC motors, type of construction IM B35  
 (dimensions in mm, not to scale)





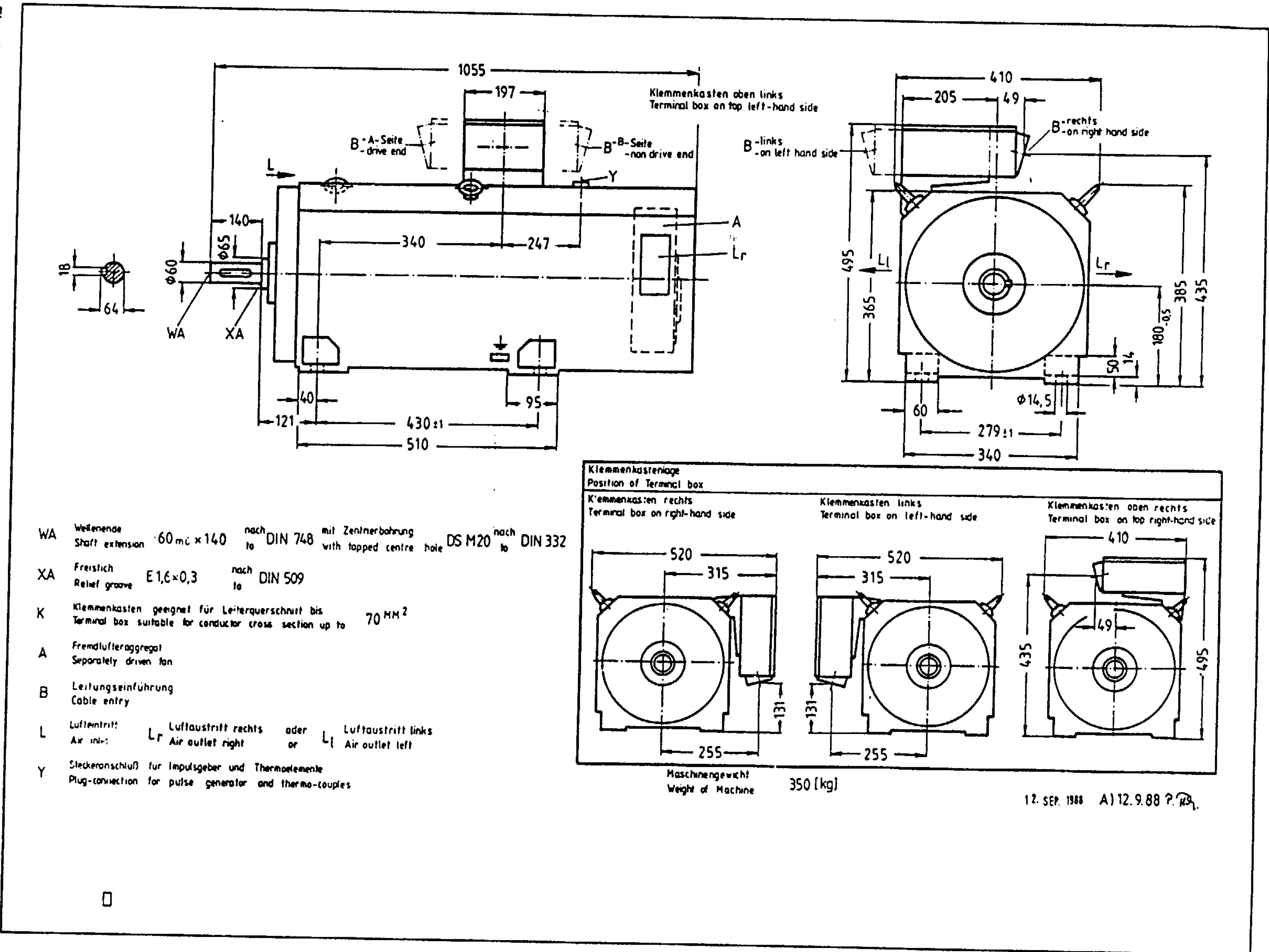
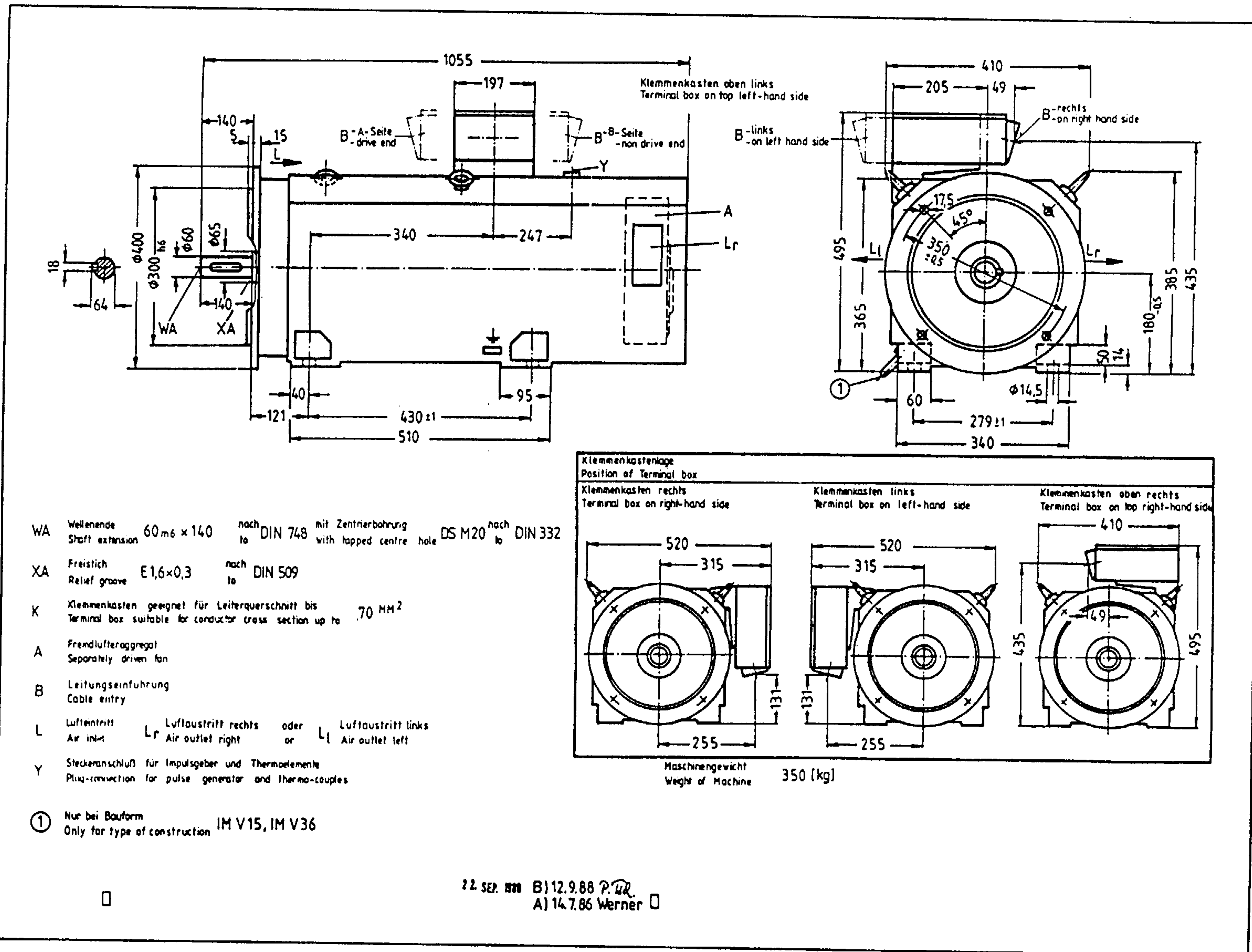

Fig. 6.60 Dimension sheet for 1PH6 186-4C AC motors, type of construction IM B3 (dimensions in mm, not to scale)

- WA Wellenende  
Shaft extension 60 mm x 140 nach DIN 748 mit Zentrierbohrung  
with tapped centre hole DS M20 nach DIN 332
- XA Freistich  
Relief groove E 1,6 x 0,3 nach DIN 509
- K Klemmenkasten geeignet für Leiterquerschnitt bis 70 mm<sup>2</sup>  
Terminal box suitable for conductor cross section up to 70 mm<sup>2</sup>
- A Fremdlüfteraggregat  
Separately driven fan
- B Leitungseinführung  
Cable entry
- L Luftemtritt  
Air inlet: L<sub>r</sub> Luftaustritt rechts oder L<sub>l</sub> Luftaustritt links  
Air outlet right or Air outlet left
- Y Steckeranschluß für Impulsgeber und Thermoelemente  
Plug-connection for pulse generator and thermo-couples



Fig. 6.61 Dimension sheet for 1PH6 186-4C AC motors, type of construction IM B35, IM V15 and IM V36  
 (dimensions in mm, not to scale)





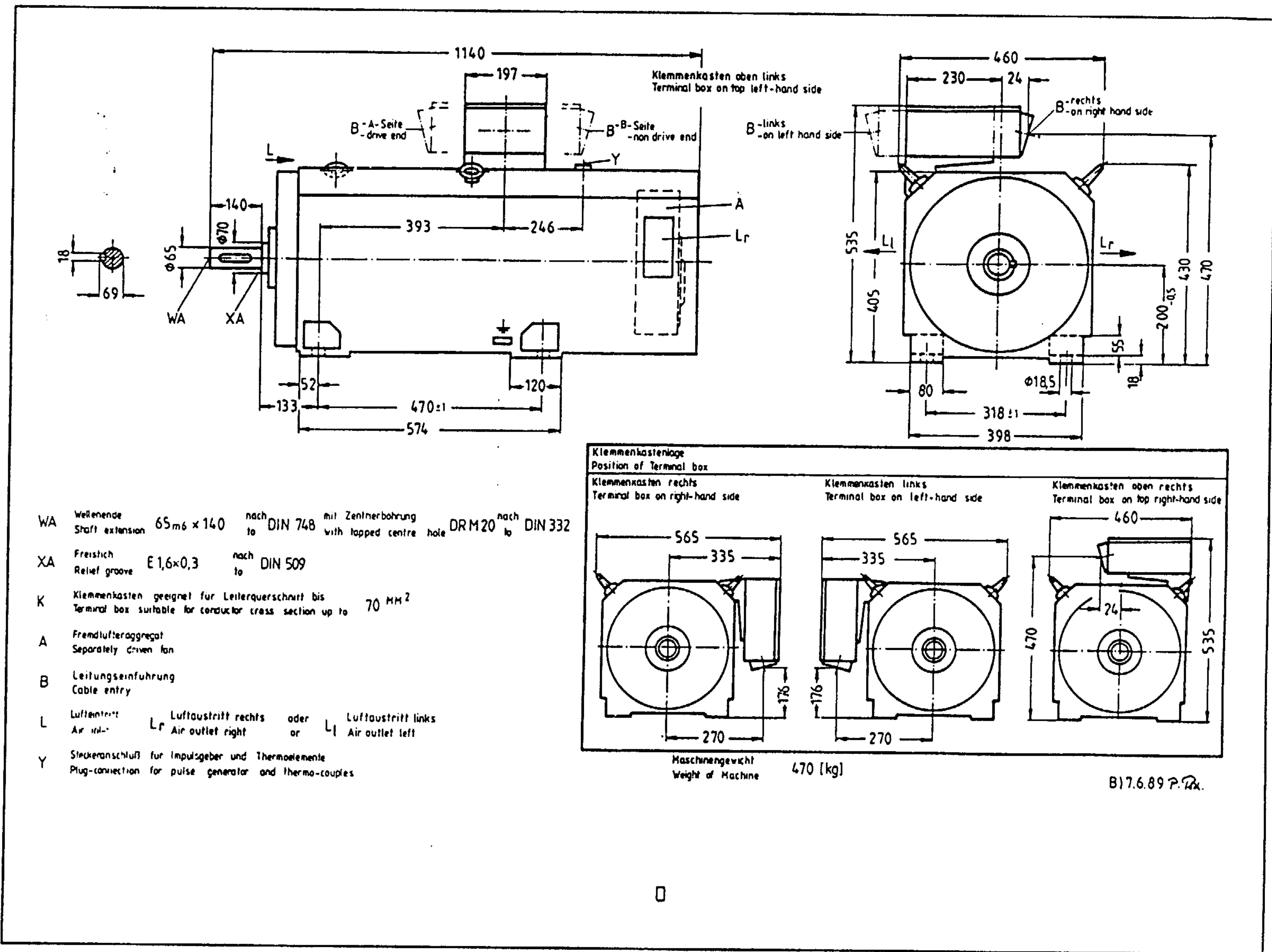

- WA Wellenende 65<sub>m6</sub> x 140 nach DIN 748 mit Zentrierbohrung mit Zentrierbohrung nach DIN 332  
Shaft extension to with tapped centre hole to
- XA Freistich E 1,6 x 0,3 nach DIN 509  
Relief groove to
- K Klemmenkasten geeignet für Leiterquerschnitt bis 70 mm<sup>2</sup>  
Terminal box suitable for conductor cross section up to
- A Fremdlüfteraggregat  
Separately driven fan
- B Leitungseinführung  
Cable entry
- L Luftaustritt Luftaustritt rechts oder Luftaustritt links  
Air inlet Air outlet right or Air outlet left
- Y Steckeranschluss für Impulsgeber und Thermoelemente  
Plug-connection for pulse generator and thermo-couples

Fig. 6.62 Dimension sheets for 1PH6 206-4C AC motors, type of construction IM B3 (dimensions in mm, not to scale)



Fig. 6.63 Dimension sheet for 1PH6 206-4C AC motors, type of construction IM B35, IM V15 and IM V36  
 (dimensions in mm, not to scale)

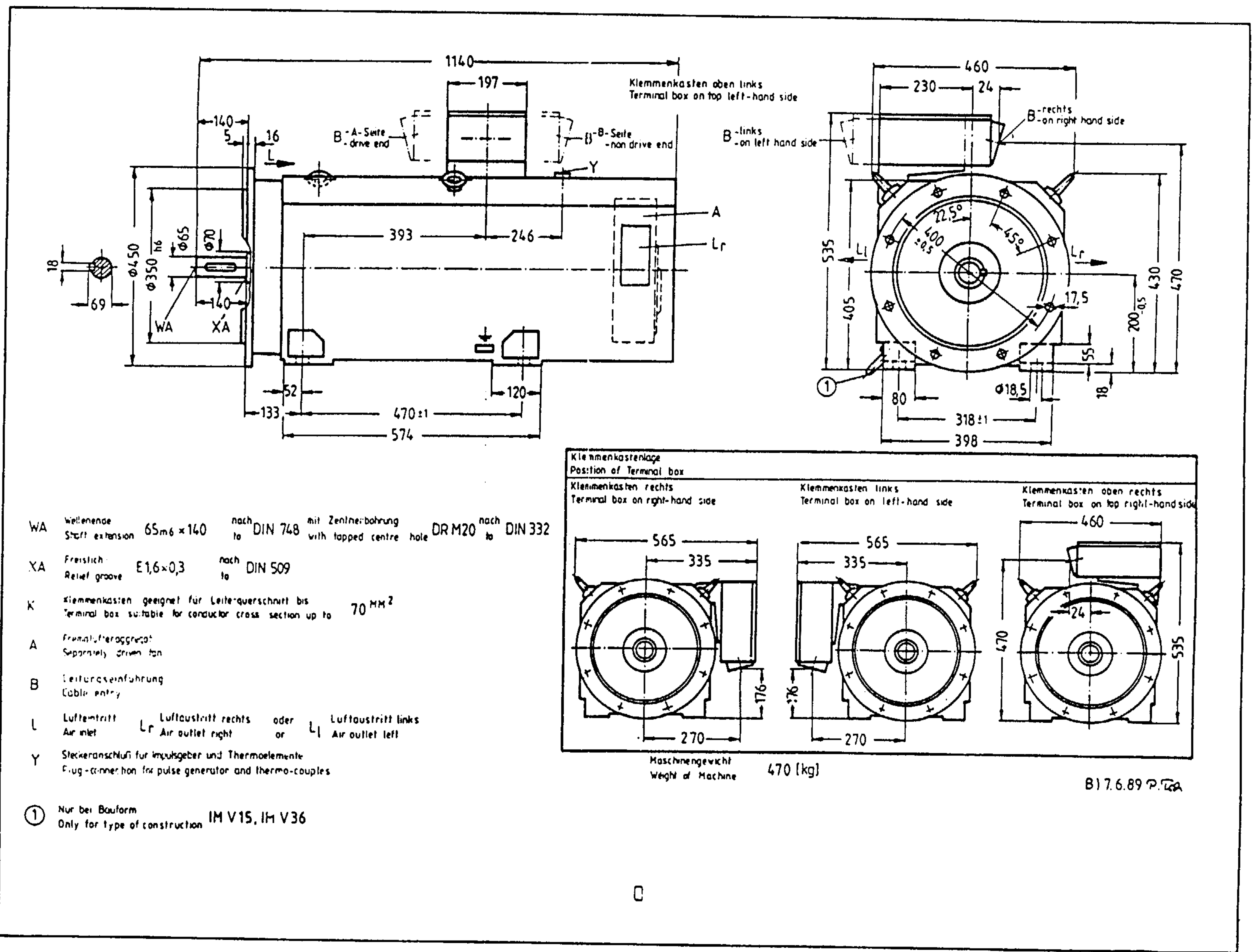

- WA Wellenende nach DIN 748 mit Zentrierbohrung nach DIN 332  
 Shaft extension to with tapped centre hole DR M20 to
  - XA Freistich nach DIN 509  
 Relief groove E 1,6 x 0,3 to
  - K Klemmkasten geeignet für Leiterquerschnitt bis 70 mm<sup>2</sup>  
 Terminal box suitable for conductor cross section up to
  - A Fremdantriebsventilator  
 Separately driven fan
  - B Leitungseinführung  
 Cable entry
  - L Lufttritt Luftaustritt rechts oder Luftaustritt links  
 Air inlet Air outlet right or Air outlet left
  - Y Steckeranschluss für Impulsgeber und Thermoelemente  
 Plug-connection for pulse generator and thermo-couples
- ① Nur bei Bauform IM V15, IM V36  
 Only for type of construction



6.5 PWM converter dimension sheets

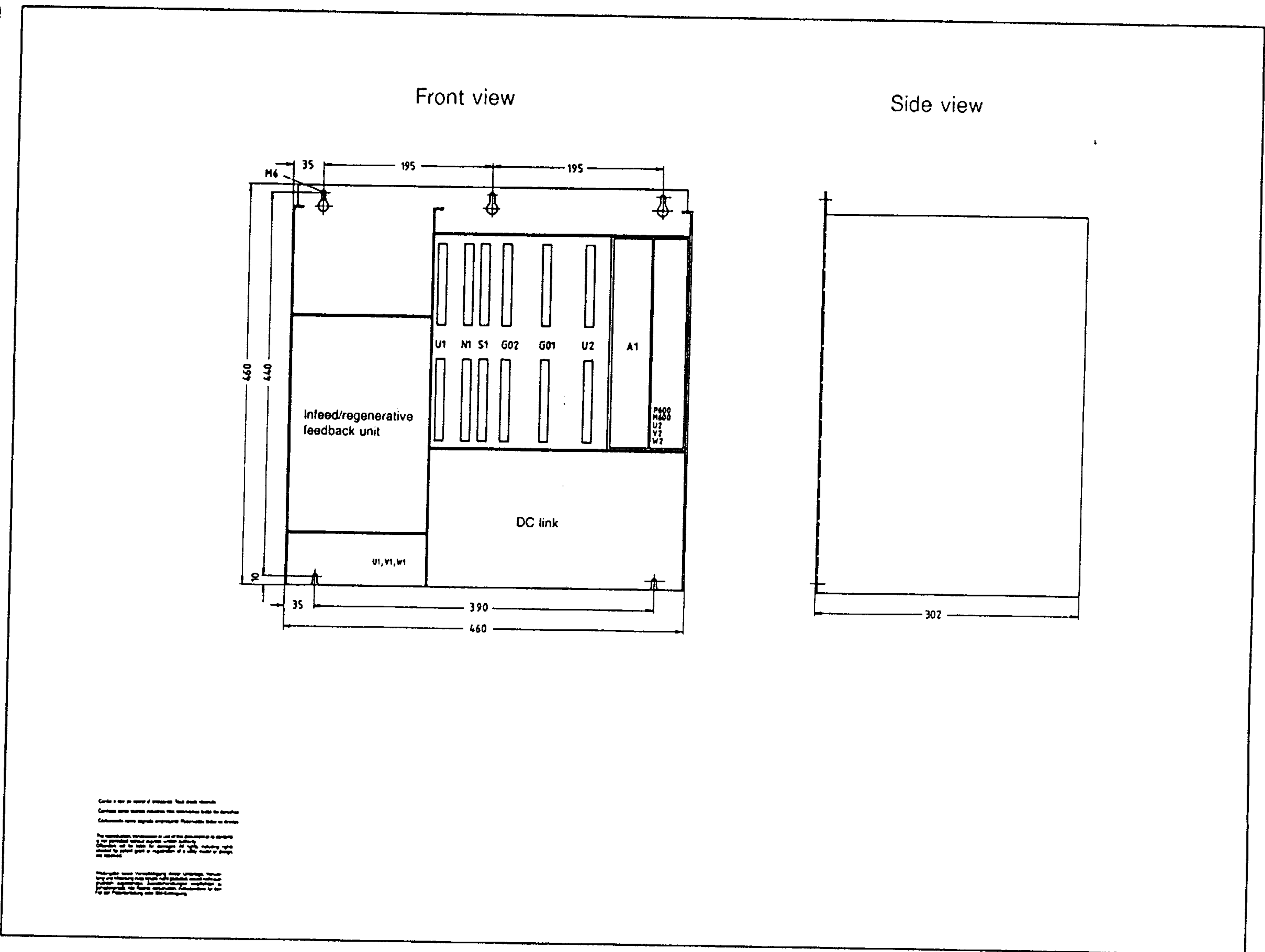

Fig. 6.64 Dimension sheet for PWM converters 6SC6502 and 6SC6503 (dimensions in mm, not to scale)

1. 6SC6502-1  
 2. 6SC6502-2  
 3. 6SC6502-3  
 4. 6SC6502-4  
 5. 6SC6502-5  
 6. 6SC6502-6  
 7. 6SC6502-7  
 8. 6SC6502-8  
 9. 6SC6502-9  
 10. 6SC6502-10  
 11. 6SC6502-11  
 12. 6SC6502-12  
 13. 6SC6502-13  
 14. 6SC6502-14  
 15. 6SC6502-15  
 16. 6SC6502-16  
 17. 6SC6502-17  
 18. 6SC6502-18  
 19. 6SC6502-19  
 20. 6SC6502-20  
 21. 6SC6502-21  
 22. 6SC6502-22  
 23. 6SC6502-23  
 24. 6SC6502-24  
 25. 6SC6502-25  
 26. 6SC6502-26  
 27. 6SC6502-27  
 28. 6SC6502-28  
 29. 6SC6502-29  
 30. 6SC6502-30  
 31. 6SC6502-31  
 32. 6SC6502-32  
 33. 6SC6502-33  
 34. 6SC6502-34  
 35. 6SC6502-35  
 36. 6SC6502-36  
 37. 6SC6502-37  
 38. 6SC6502-38  
 39. 6SC6502-39  
 40. 6SC6502-40  
 41. 6SC6502-41  
 42. 6SC6502-42  
 43. 6SC6502-43  
 44. 6SC6502-44  
 45. 6SC6502-45  
 46. 6SC6502-46  
 47. 6SC6502-47  
 48. 6SC6502-48  
 49. 6SC6502-49  
 50. 6SC6502-50  
 51. 6SC6502-51  
 52. 6SC6502-52  
 53. 6SC6502-53  
 54. 6SC6502-54  
 55. 6SC6502-55  
 56. 6SC6502-56  
 57. 6SC6502-57  
 58. 6SC6502-58  
 59. 6SC6502-59  
 60. 6SC6502-60  
 61. 6SC6502-61  
 62. 6SC6502-62  
 63. 6SC6502-63  
 64. 6SC6502-64  
 65. 6SC6502-65  
 66. 6SC6502-66  
 67. 6SC6502-67  
 68. 6SC6502-68  
 69. 6SC6502-69  
 70. 6SC6502-70  
 71. 6SC6502-71  
 72. 6SC6502-72  
 73. 6SC6502-73  
 74. 6SC6502-74  
 75. 6SC6502-75  
 76. 6SC6502-76  
 77. 6SC6502-77  
 78. 6SC6502-78  
 79. 6SC6502-79  
 80. 6SC6502-80  
 81. 6SC6502-81  
 82. 6SC6502-82  
 83. 6SC6502-83  
 84. 6SC6502-84  
 85. 6SC6502-85  
 86. 6SC6502-86  
 87. 6SC6502-87  
 88. 6SC6502-88  
 89. 6SC6502-89  
 90. 6SC6502-90  
 91. 6SC6502-91  
 92. 6SC6502-92  
 93. 6SC6502-93  
 94. 6SC6502-94  
 95. 6SC6502-95  
 96. 6SC6502-96  
 97. 6SC6502-97  
 98. 6SC6502-98  
 99. 6SC6502-99  
 100. 6SC6502-100



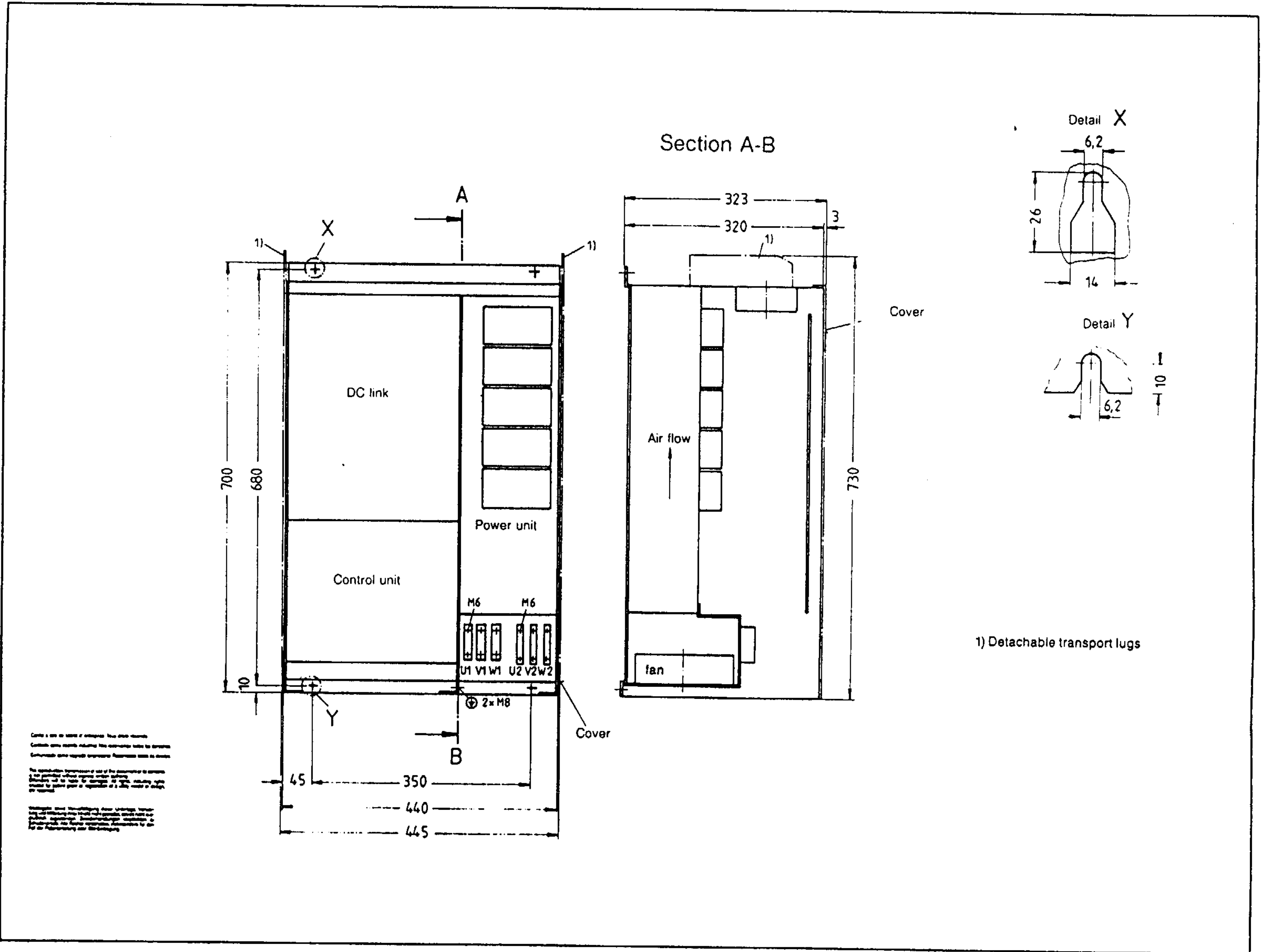
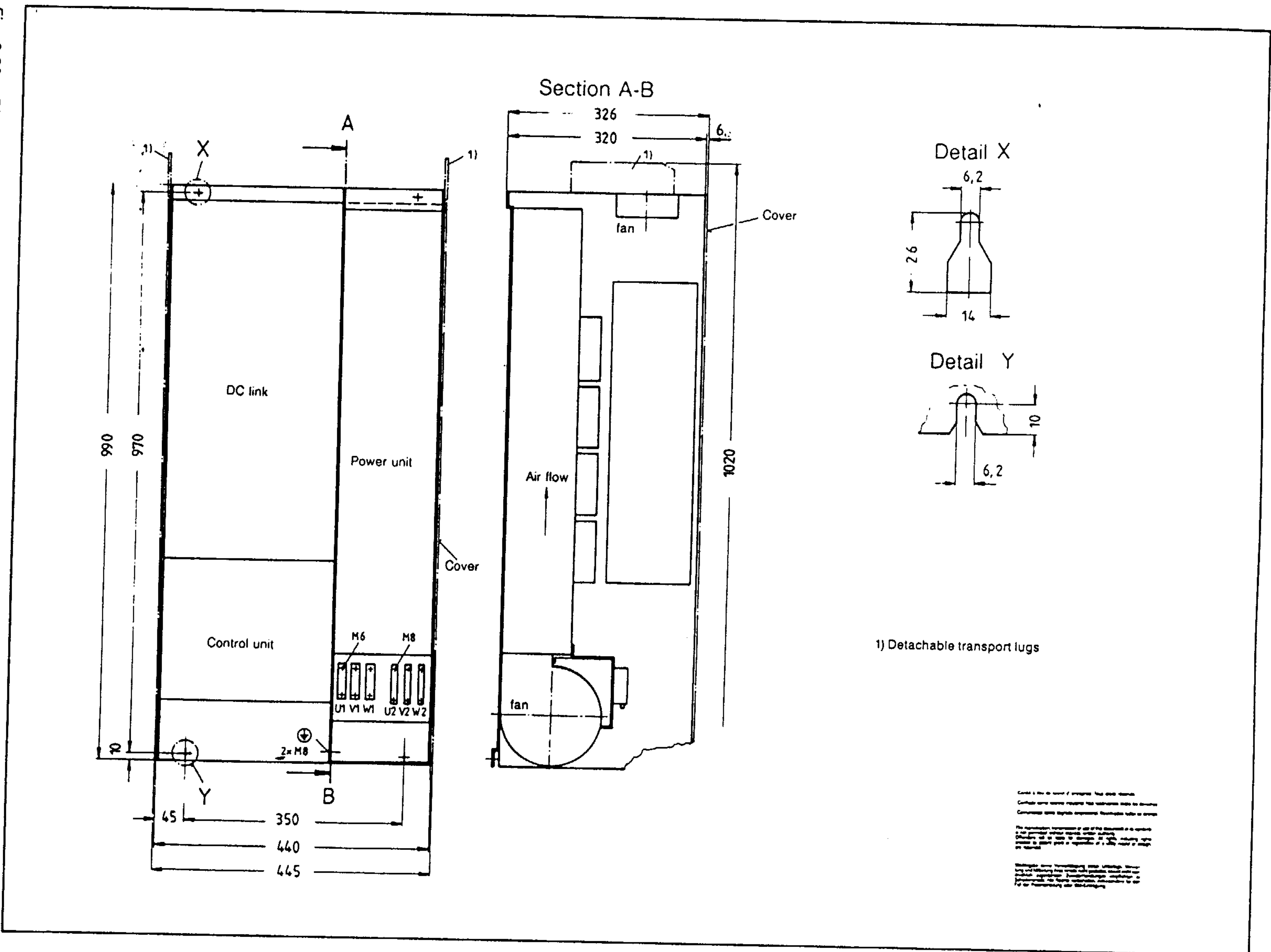

Fig. 6.65 Dimension sheet for PWM converters 6SC6504 and 6SC6506 (dimensions in mm, not to scale)







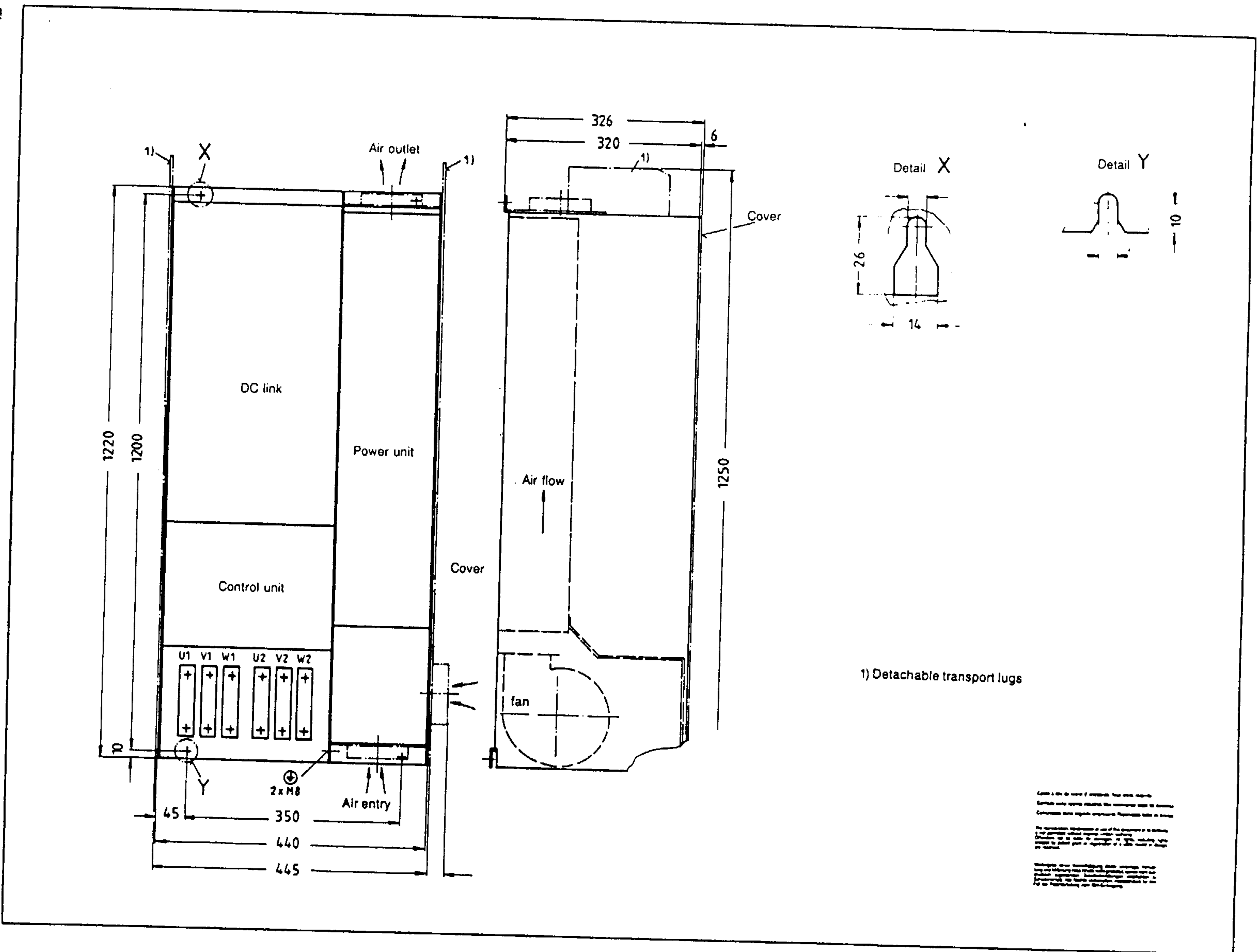

Fig. 6.67 Dimension sheet for PWM converter 6SC6512 (dimensions in mm, not to scale)



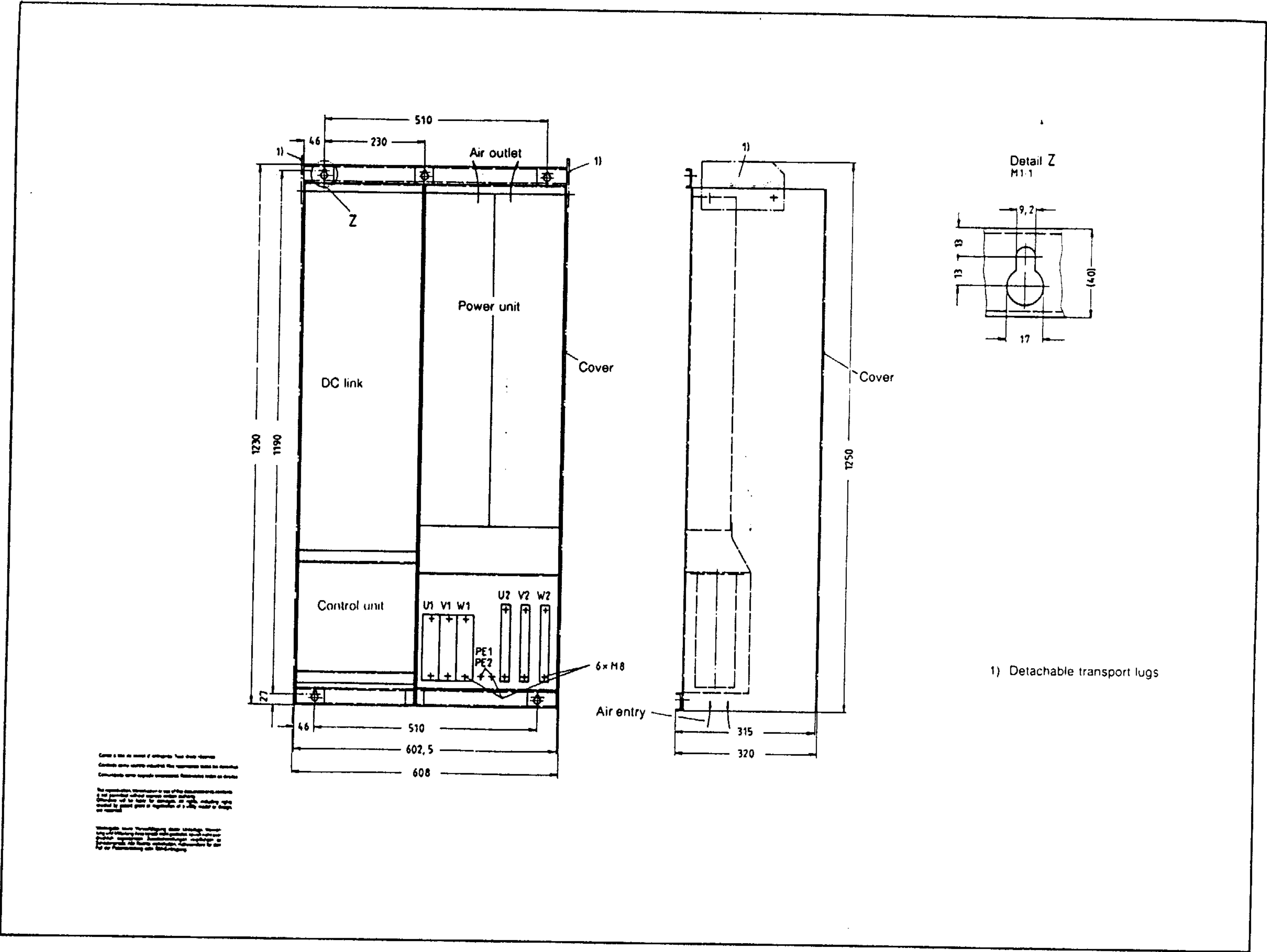

Fig. 6.68 Dimension sheet for PWM converter 6SC6520 (dimensions in mm, not to scale)

1) Detachable transport lugs  
 2) Detachable transport lugs  
 3) Detachable transport lugs  
 4) Detachable transport lugs  
 5) Detachable transport lugs  
 6) Detachable transport lugs  
 7) Detachable transport lugs  
 8) Detachable transport lugs  
 9) Detachable transport lugs  
 10) Detachable transport lugs  
 11) Detachable transport lugs  
 12) Detachable transport lugs  
 13) Detachable transport lugs  
 14) Detachable transport lugs  
 15) Detachable transport lugs  
 16) Detachable transport lugs  
 17) Detachable transport lugs  
 18) Detachable transport lugs  
 19) Detachable transport lugs  
 20) Detachable transport lugs  
 21) Detachable transport lugs  
 22) Detachable transport lugs  
 23) Detachable transport lugs  
 24) Detachable transport lugs  
 25) Detachable transport lugs  
 26) Detachable transport lugs  
 27) Detachable transport lugs  
 28) Detachable transport lugs  
 29) Detachable transport lugs  
 30) Detachable transport lugs  
 31) Detachable transport lugs  
 32) Detachable transport lugs  
 33) Detachable transport lugs  
 34) Detachable transport lugs  
 35) Detachable transport lugs  
 36) Detachable transport lugs  
 37) Detachable transport lugs  
 38) Detachable transport lugs  
 39) Detachable transport lugs  
 40) Detachable transport lugs  
 41) Detachable transport lugs  
 42) Detachable transport lugs  
 43) Detachable transport lugs  
 44) Detachable transport lugs  
 45) Detachable transport lugs  
 46) Detachable transport lugs  
 47) Detachable transport lugs  
 48) Detachable transport lugs  
 49) Detachable transport lugs  
 50) Detachable transport lugs  
 51) Detachable transport lugs  
 52) Detachable transport lugs  
 53) Detachable transport lugs  
 54) Detachable transport lugs  
 55) Detachable transport lugs  
 56) Detachable transport lugs  
 57) Detachable transport lugs  
 58) Detachable transport lugs  
 59) Detachable transport lugs  
 60) Detachable transport lugs  
 61) Detachable transport lugs  
 62) Detachable transport lugs  
 63) Detachable transport lugs  
 64) Detachable transport lugs  
 65) Detachable transport lugs  
 66) Detachable transport lugs  
 67) Detachable transport lugs  
 68) Detachable transport lugs  
 69) Detachable transport lugs  
 70) Detachable transport lugs  
 71) Detachable transport lugs  
 72) Detachable transport lugs  
 73) Detachable transport lugs  
 74) Detachable transport lugs  
 75) Detachable transport lugs  
 76) Detachable transport lugs  
 77) Detachable transport lugs  
 78) Detachable transport lugs  
 79) Detachable transport lugs  
 80) Detachable transport lugs  
 81) Detachable transport lugs  
 82) Detachable transport lugs  
 83) Detachable transport lugs  
 84) Detachable transport lugs  
 85) Detachable transport lugs  
 86) Detachable transport lugs  
 87) Detachable transport lugs  
 88) Detachable transport lugs  
 89) Detachable transport lugs  
 90) Detachable transport lugs  
 91) Detachable transport lugs  
 92) Detachable transport lugs  
 93) Detachable transport lugs  
 94) Detachable transport lugs  
 95) Detachable transport lugs  
 96) Detachable transport lugs  
 97) Detachable transport lugs  
 98) Detachable transport lugs  
 99) Detachable transport lugs  
 100) Detachable transport lugs



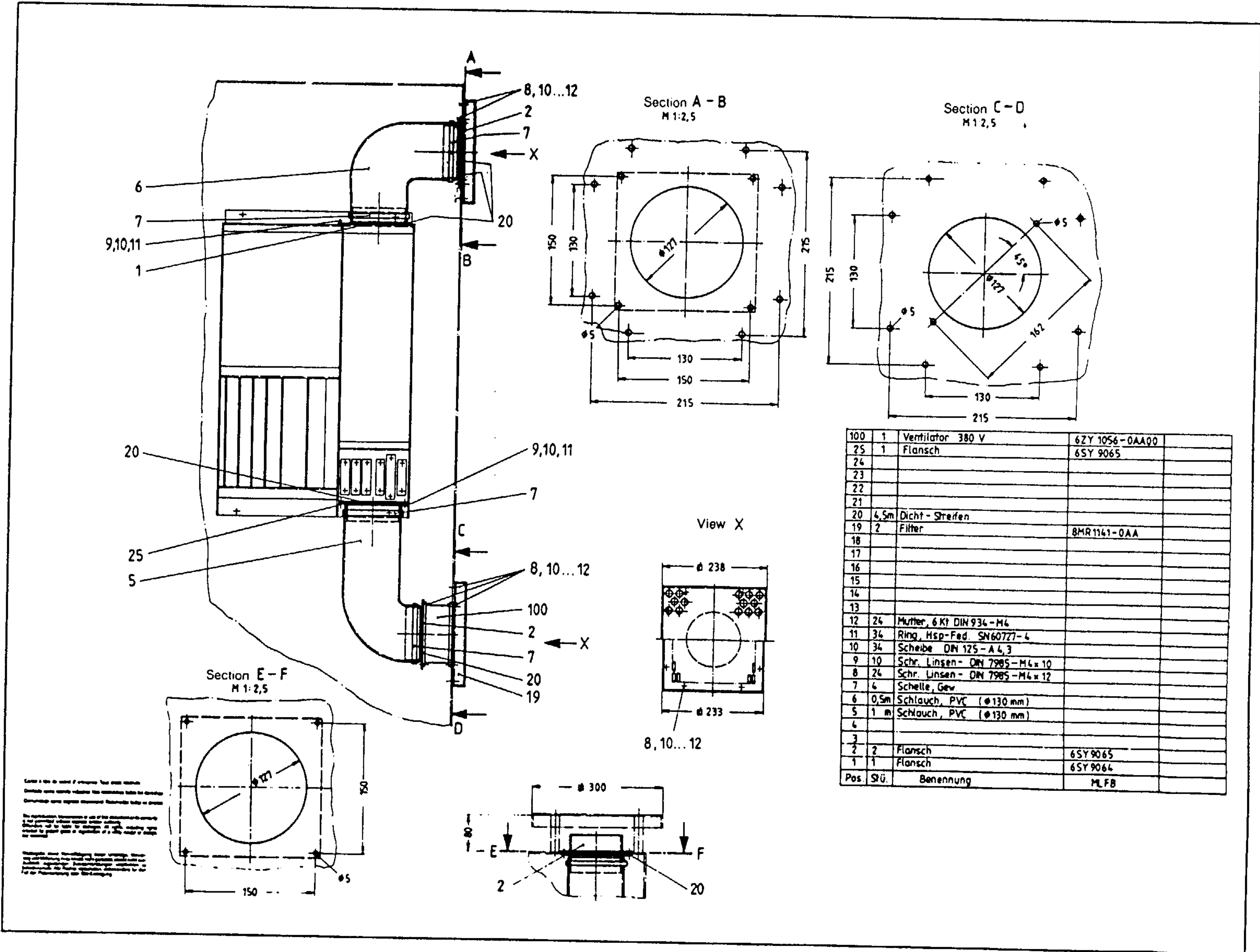

Fig. 6.69 Dimension sheet for external heat dissipation, option E45 (6SC6504, 6SC6506)



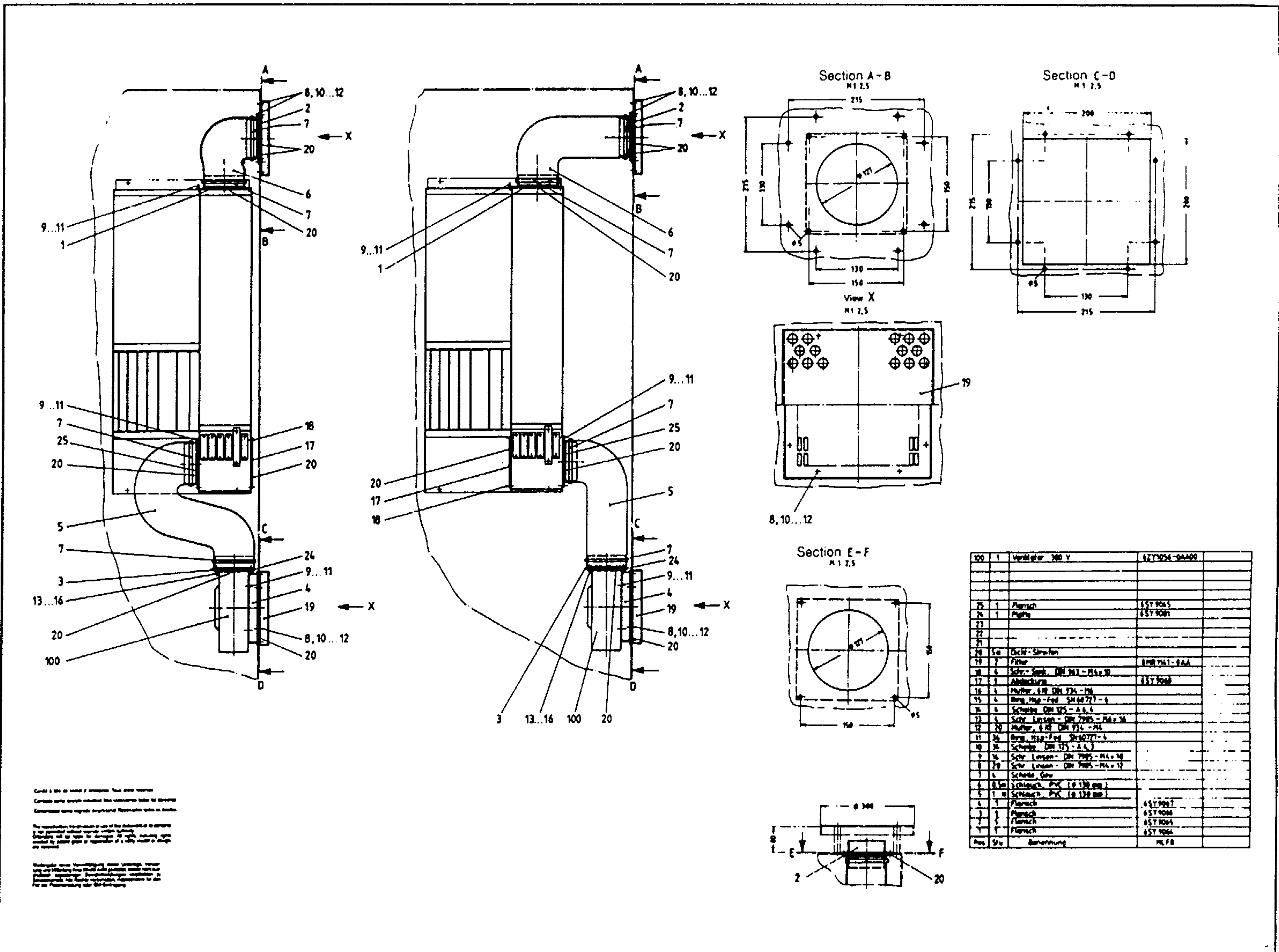

Fig. 6.70 Dimension sheet for external heat dissipation, option E45 (6SC6508)

Control & info on demand of dimensions from other sources  
 Complete with correct technical drawing information for the drawing  
 Construction rules apply unless otherwise specified. Reference shall be made to the drawing  
 The drawing is the basis for the manufacturing of the product.  
 The drawing is the basis for the manufacturing of the product.  
 The drawing is the basis for the manufacturing of the product.  
 The drawing is the basis for the manufacturing of the product.



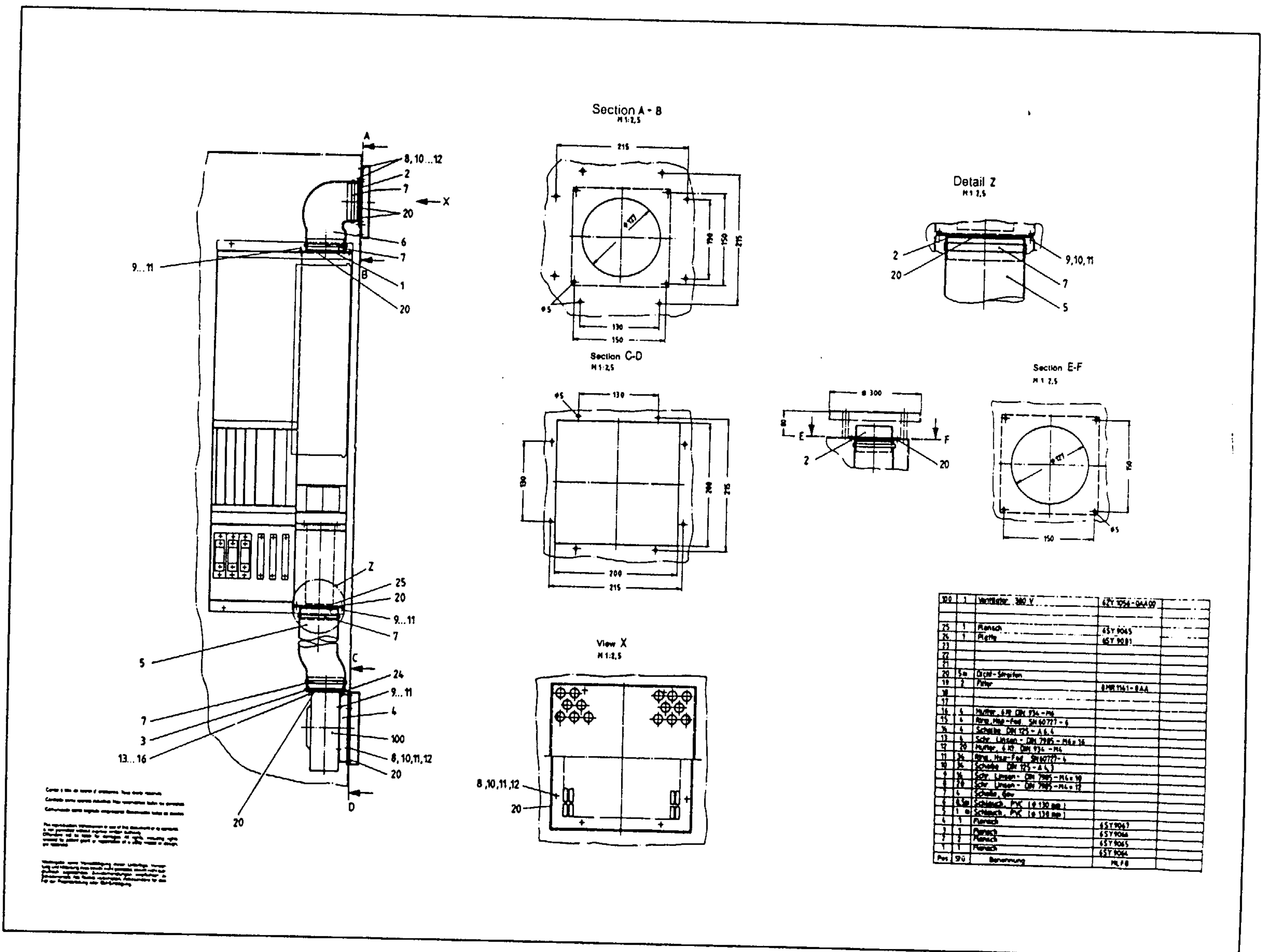

Fig. 6.71 Dimension sheet for external heat dissipation, option E45 (6SC6512)







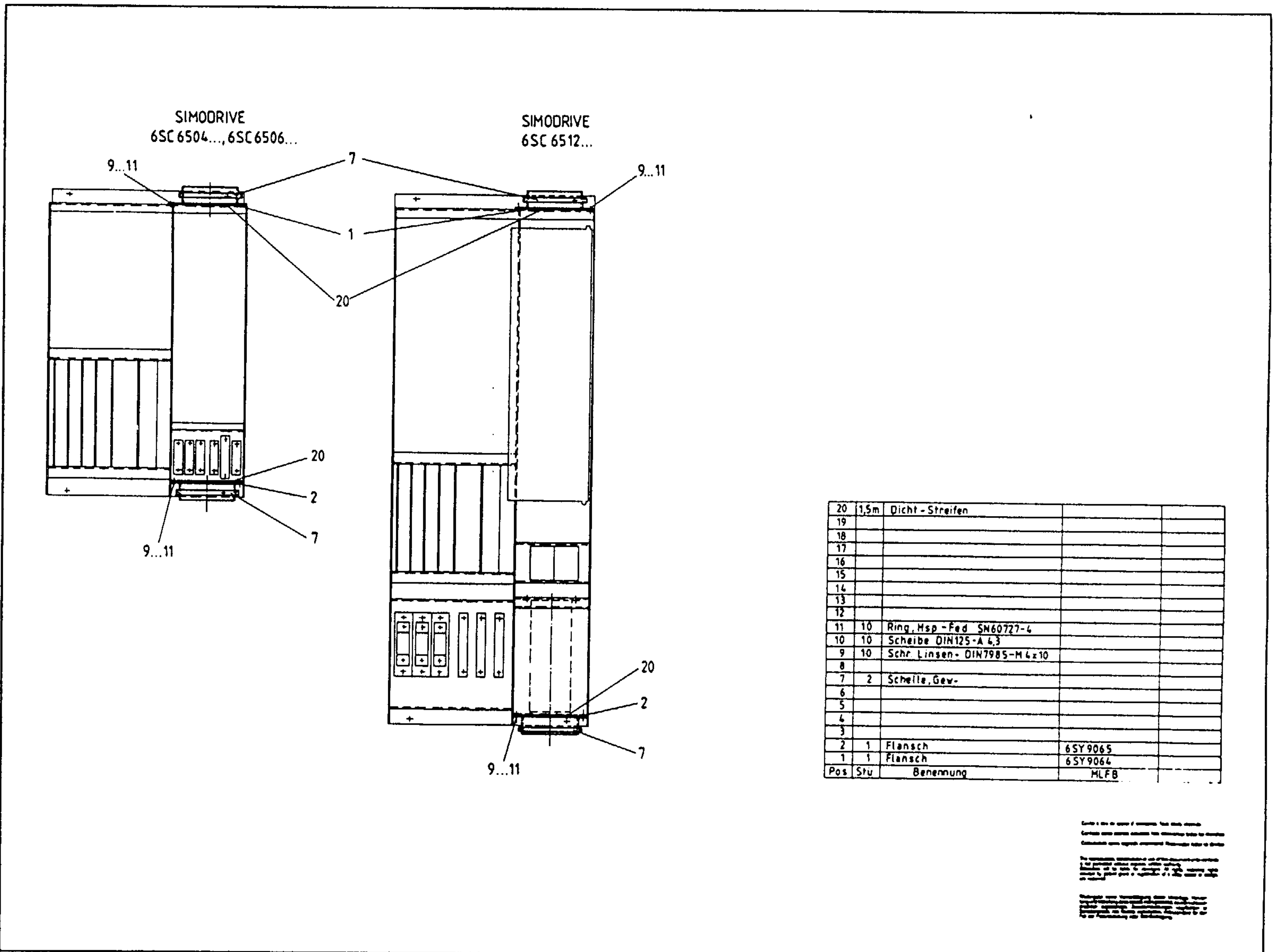

Fig. 6.73 Dimension sheet for external heat dissipation connecting flange, option E55 (6SC6508)



# 7 Index

## A

AC main spindle drives .....	1-1
AC motor .....	2-1-2-3, 4-2, 4-4, 4-17, 5-3-5-4, 5-6, 6-1
AC motor characteristics .....	1-2
AC motor with change gearbox .....	5-10
Accessories .....	4-17
Adaptor cable .....	4-20
Air discharge .....	2-2
Air flowdirection .....	2-2
Analog signals .....	3-13

## B

Balance .....	4-1
Bearing design .....	2-8
Bearings .....	2-2
Belt pulley .....	5-2
BERO proximity switch .....	3-5, 3-6
Board handling .....	4-5
Braking characteristic .....	3-7

## C

C-axis operation .....	3-4, 3-8, 4-12, 4-15
Cable connections .....	4-17 7-3
Cantilever force .....	2-2, 5-3, 6-41
Cantilever force charts .....	6-41
Central board .....	4-7, 4-9-4-11
Change gearbox .....	2-2, 5-1-5-4, 5-7, 5-11
Circuit diagram for gearbox change circuit .....	5-8
Closed-loop torque control .....	3-12
Computer model .....	1-5
Connecting a programming unit .....	3-4
Connecting an option board .....	4-12
Connecting terminals .....	4-6-4-9
Control board .....	3-4, 3-19, 4-7, 4-9-4-11
Control concept .....	1-5
Controller enable .....	3-12-3-13, 4-14
Creep speed .....	5-4
Cubicle fan .....	3-9

## D

D/A converter .....	3-19
Data line .....	4-21
DC link .....	3-3, 3-15, 4-3
DC link voltage .....	3-1, 3-11
Degree of protection .....	2-8
Degree of vibration severity .....	2-2
Diagnostics .....	3-19
Dimension drawings, AC motors .....	6-59
Dimension drawings, PWM converters .....	6-66
Direct pulse suppression .....	3-12



	Display .....	3-10, 3-14
	Display .....	3-10, 3-16
	Double track encoder .....	3-8
	Drive combination .....	4-3
	Duty type S1 .....	6-1
	Duty types S6 .....	6-1
E		
	Electronic signals, analog .....	4-6, 4-8
	Electronic signals, digital .....	4-6, 4-8
	External heat dissipation .....	3-9
F		
	Fault message .....	3-14
	Fault mode .....	3-15
	Feed drive .....	4-3
	Feed drive quality .....	3-8
	Flange mounting .....	5-7
	Forced oil lubrication .....	5-7
G		
	Gear change .....	5-4-5-5, 5-9
	Gearbox mounting .....	5-2
	Gearbox output housing .....	5-3
H		
	Holding brake .....	2-9, 5-4
I		
	I/O board .....	4-7, 4-9-4-11, 4-14
	Installation .....	4-1-4-2
	Interface .....	4-13
	Interface board .....	3-9
	Interfaces .....	3-12
K		
	Keys .....	3-10
L		
	LED .....	3-19
	Limiting torque/reduction .....	3-12
	Lubrication .....	5-7
M		
	Machine tool .....	3-13
	Measured value 3-13 Measured value display .....	3-18
	Measuring socket .....	3-19
	Message .....	3-13
	Motor characteristic .....	2-3
	Motor connecting cable .....	4-3
	Motor option H29 .....	3-8
	Motor type .....	2-7
N		
	N Normalization .....	3-20
	NTC thermistor .....	2-2, 4-18
	NTC thermistor signal .....	4-17



## O

Open-loop torque control	4-14
Operating mode	3-15
Operational display	3-10-3-11, 3-13, 3-15
Operator control	3-10
Operator control element	3-14
Operator control elements	3-10
Option	2-8, 3-1, 3-4, 3-9, 3-24, 4-7, 4-9-4-10, 4-12, 4-15-4-16
Option C axis	2-2, 4-17
Option E45	3-9
Option E45, external heat dissipation	3-9, 3-23, 6-71-6-74
Option E55, external heat dissipation connecting flange	3-9, 6-75-6-76
Option board	3-8, 4-7, 4-9, 4-15-4-16
Order No.	2-7
Ordering example	3-24
Orientated spindle stop	3-5
Oscillation	4-14, 5-4-5-5
Oscillation setpoint	3-12
Overload capacity	1-6, 2-3

## P

Paint finish	2-8
Parameter	3-10, 3-18
Parameter display	3-11
Parameter number	3-14
Peripheral force FU	6-41
Plug connector locations	4-9-4-10
Position actual value	3-5
Position controller	3-7
Positioning sequence	3-7
Positioning setpoint	4-15
Positioning setpoint, external	4-16
Positioning the spindle with the external spindle encoder	3-6
Positioning the spindle with the incorporated motor shaft encoder	3-5-3-6
Power cable	4-17
Power loss	3-23
Power ratings	6-1
Power supply	1 4-7, 4-9-4-11
Power-speed characteristics	6-1
Power-speed characteristics	6-2-6-3
Programming unit	3-9-3-10
Progression condition	3-17
Pulse enabling	4-4, 4-14
PWM converter	1-5, 2-1, 3-1, 3-3, 3-10, 3-24, 4-2-4-4, 4-17, 5-4
PWM converter type	3-24

## R

Ramp function generator, fast stop	3-12-3-13, 4-14
Ramp function generator, zero	3-12
Recommended connection	4-3, 4-11
Regenerative feedback	3-1
Regenerative feedback	3-3
Relay contacts	4-6, 4-8
Relay function	3-16
Relay signal	3-7, 3-13, 4-13
Remote acknowledgement	4-14



## S

Screen rail	4-4
Search speed	3-7
Setting value	3-14
Shaft encoder	2-2, 2-8, 3-4-3-5, 3-8, 4-17
Shaft encoder cable	4-17-4-19
Signal	4-14
Signals	3-12
SIMODRIVE 611	4-3
Speed	2-3
Speed actual value sensing	3-8
Speed-power characteristic	5-6
Speed actual value	3-11
Speed control circuit	3-4
Speed setpoint	3-7, 3-11, 3-13
Spindle positioning	3-4-3-5, 4-12
Standard range	2-1
Standard scope of supply of the 1PH6 range	2-1
Startup	3-9-3-10, 3-14
Step-up converter	3-3

## T

Technical data	3-21, 5-8
Technical data of 1PH6 AC motors	2-4-2-6
Technical data of the PWM converter	3-22
Tensioning factor c	6-41
Terminal 19	4-15
Terminal 56	3-7
Terminal 60	3-12, 5-4
Terminal 62	3-12, 4-14
Terminal 63	3-12, 4-4, 4-14
Terminal 64	3-12-3-13, 4-14
Terminal 81	3-12-3-13, 4-14
Terminal 117	4-14
Terminal 111	3-12, 4-14
Terminal 158	3-5, 3-12, 4-14
Terminal box	4-2-4-3
Terminal box location	2-8
Terminal locations	4-7
Torque	2-3
Torque limiting	4-14
Total cantilever force	6-41
Transistor PWM converter	1-2
Transistor PWM converter design	3-2-3-3
Transmitter	4-6, 4-8, 4-16
Transmitter signal	3-13
TRANSVEKTOR closed-loop control	1-1, 1-5, 3-1, 3-4
Twin drive	3-12
Type designation	2-7, 3-24

## V

Vibration severity-limiting values	6-57
Vibrational severity	2-8



Z

Zero ramp-up time .....	4-14
ZF change gearbox .....	5-1