

SIEMENS

**COMBIMASTER and
MICROMASTER Integrated**

Reference Manual 1999

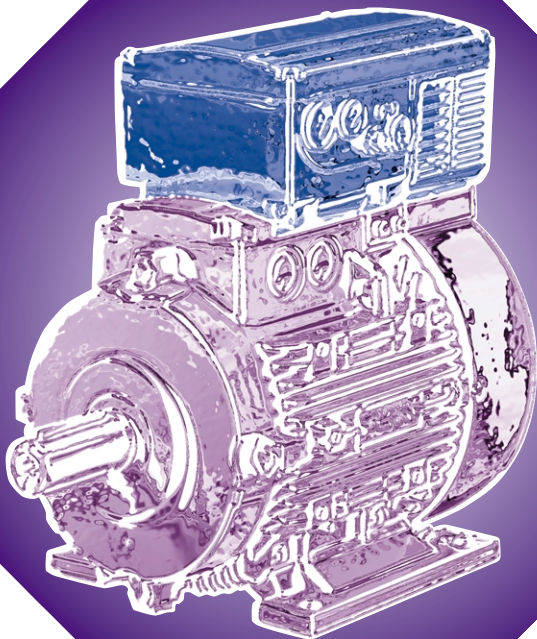

COMBIMASTER Integrated
MICROMASTER Integrated

CONTENTS

1. Safety and CE Compliance	3
2. Overview	7
3. Mechanical Installation	9
3.1 Mechanical Installation I COMBIMASTER	9
3.2 Mechanical Installation I MICROMASTER Integrated	10
4. Electrical Installation	11
4.1 General Wiring Guidelines	11
4.2 Electrical Installation I MICROMASTER Integrated	11
4.3 Electrical Installation I COMBIMASTER and MICROMASTER Integrated	12
4.4 Mains Cable Connections	12
4.5 Control Cable Connections	15
5. Operating Information	17
5.1 General	17
5.2 Basic Operation	17
5.3 Operation – External Analogue Control	18
5.4 Operation – Digital Control	18
5.5 Stopping the Motor	19
5.6 If the Motor Does Not Start Up	19
5.7 Local and Remote Control	19
5.8 Closed Loop Control	20
6. System Parameters	21
6.1 System Parameters Table	21
6.2 Fault Codes	39
7. Options and Accessories	41
7.1 Clear Text Display Module (OPm2)	41
7.2 Profibus CB155	43
7.3 Control and Commissioning with SIMOVIS	47
7.4 Brake Options	50
7.5 Fan Assembly Options	51
7.6 Motor Interface Plate Options	52
8. Specifications	53
8.1 Mechanical Data – Dimensional Drawings	53
8.2 Electrical Data	59
8.3 De-rating Information	60
8.4 Technical Data - COMBIMASTER	61
8.5 Technical Data - MICROMASTER Integrated	63
8.6 Output Current Ratings - MICROMASTER Integrated	65

9. Supplementary Information	67
9.1 Application Example	67
9.2 Motor Interface Plates.....	68
9.3 Electro-Magnetic Compatibility (EMC).....	73
9.4 Environmental Aspects	74
9.5 Users Parameter Settings.....	75

Technical data, selection and ordering data (order numbers), accessories and availability are subject to change.

1. SAFETY AND CE COMPLIANCE

Before installing and operating this equipment read these safety instructions **and** warnings carefully. Also read and obey all the warning signs attached to the equipment. Make sure that the warning labels are kept in a legible condition and replace any missing or damaged labels.



WARNING

This equipment must be installed, operated and maintained by suitably qualified personnel only.

Use only permanently-wired input power connections. The equipment must be grounded (IEC 536 Class 1, NEC and other applicable standards).

Wait at least five minutes after the power has been turned off, before opening the equipment. The dc-link capacitor remains charged to dangerous voltages even when the power is removed. When working on open equipment, note that live parts are exposed and do not touch these parts.

Some parameter settings can start the motor automatically when power is restored after a mains failure.

Do not connect machines with a three-phase power supply, fitted with EMC filters, to a supply via an ELCB (Earth Leakage Circuit Breaker - see EN50178, section 6.5).

Obey all general and regional installation and safety regulations relating to work on high voltage installations, as well as regulations covering correct use of tools and personal protective equipment.

Note that the following terminals can carry dangerous voltages even when the inverter is stopped:

Power supply terminals L1, L2 and L3

Motor terminals U, V and W.

When using the analogue input, the jumpers must be correctly set and the analogue input type selected (P023) before enabling the analogue input with P006. If this is not done the motor may start inadvertently.

This equipment is capable of providing internal motor overload protection in accordance with UL508C section 42.

This equipment is suitable for use in a circuit capable of delivering not more than 10,000 symmetrical amperes (rms), for a maximum voltage of 240V/480V/500V when protected by a time delay fuse (see Electrical Data for details).

Do not operate the equipment in direct sunlight.

This equipment must not be used as an 'emergency stop' mechanism (see EN 60204, 9.2.5.4).



WARNING

Take note of the general and regional installation and safety regulations regarding work on high voltage installations (e.g. VDE). Adhere to relevant regulations regarding correct use of tools and protective gear.

Use the lifting eyes provided if a motor is to be lifted. Do not lift machine sets by suspending the individual machines! Always check the capacity of the hoist before lifting any equipment.

Do not paint over the black case finish of the inverter as this will affect the units thermal performance.



CAUTION

Do not allow children or the general public to access or approach this equipment.

Do not install the inverter where ambient conditions exceed the specified protection rating. IP ratings: COMBIMASTER – IP55; MICROMASTER Integrated – IP65.

Keep operating instructions within easy reach and give them to all users.

Use this equipment only for the purpose specified by the manufacturer. Do not carry out any modifications, or fit any spare parts which are not sold or recommended by the manufacturer; this could cause fires, electric shock or other injuries.



EUROPEAN LOW VOLTAGE & EMC DIRECTIVES

The COMBIMASTER product complies with the requirements of the Low Voltage Directive 73/23/EEC and the EMC Directive 89/336/EEC.

The units are certified for compliance with the following standards:

EN 60204-1 Safety of machinery - Electrical equipment of machines

EN 60146-1-1 Semiconductor converters - General requirements and line commutated converters

BS EN50081-2 1995 General Emission Standard - Industrial Environment

BS EN50082-2 1995 General Immunity Standard - Industrial Environment.

The MICROMASTER Integrated product complies with the requirements of the Low Voltage Directive 73/23/EEC.

The units are certified for compliance with the following standards:

EN 60204-1 Safety of machinery - Electrical equipment of machines

EN 60146-1-1 Semiconductor converters - General requirements and line commutated converters.

EUROPEAN MACHINERY DIRECTIVE

The MICROMASTER Integrated / COMBIMASTER products are suitable for incorporation into machinery.

The MICROMASTER Integrated / COMBIMASTER must not be put into service until the machinery into which it is incorporated has been certified to be in compliance with the provisions of the European Directive 89/392/EEC.



Only valid for machinery to be operated in the European Community.

COMBIMASTER – UL CERTIFICATION



UL cUL listed power conversion equipment
type 5B33 in accordance with UL508C.

For use in pollution degree 2 environment.

(Applies to the Inverter only)

MICROMASTER Integrated – UR CERTIFICATION



UR cUR recognised power conversion
equipment in accordance with UL508C.

For use in pollution degree 2 environment.

This equipment must be externally cooled by
a fan, the rating of which depends on the unit
Case Size. For Case Sizes A and B, the fan
must provide 0.42m³/min and 1.25m³/min
respectively.



ISO 9001

Siemens plc operates a quality management system which complies with the
requirements of ISO 9001.

Intentionally Left Blank



2. OVERVIEW

The COMBIMASTER and MICROMASTER Integrated (MMI) are integrated motor/inverters for variable speed applications.

The inverter is microprocessor controlled and uses state of the art IGBT(Insulated Gate Bipolar Transistor) technology for reliability and flexibility. A special pulse-width modulation method with ultrasonic pulse frequency permits extremely quiet motor operation. Inverter and motor protection is provided by comprehensive protective functions.

Key design features include:

- Easy to install and commission.
- Closed loop control using a proportional, Integral (PI) control loop function.
- High starting torque with programmable starting boost.
- Remote control capability via RS485 serial link using the USS protocol.
- Ability to control up to 31 COMBIMASTERS via the USS protocol.
- Optional remote control capability via RS485 serial link using PROFIBUS-DP.
- Factory default parameter settings pre-programmed for European and North American requirements.
- Output frequency (and hence motor speed) can be controlled by one of four methods:
 - 1 Built in potentiometer.
 - 2 High resolution analogue setpoint (voltage or current input).
 - 3 Fixed frequencies via binary inputs.
 - 4 Serial interface.
- Built-in dc injection braking.
- Acceleration/deceleration times with programmable smoothing.
- Single signal relay output incorporated.
- External connection for optional Clear Text Display (OPm2) or for use as external RS485 interface.
- Fast Current Limit (FCL) for reliable trip-free operation.
- Optional factory-fitted resistive braking unit –Case Size B only (also available as a separate post-sale option).
- Optional motor brake and interface.
- Integral class A or class B filter options.

Reference Literature:

- Variable frequency inverters for AC motors up to 90kW.
 - Catalogue DA64 98/99.
 - E20002-K4064-A101-A2-7600.
- LV three phase motors.
 - Squirrel Cage Motors catalogue M11-1999.
 - E20002-K1711-A101-A3-7600.
- MMI Motor Adaptation Guidelines (English)
 - (Available August 99).
 - G85139-H1731-U500-A.
- COMBIMASTER & MICROMASTER Integrated Operating Instructions (English).
 - 6SE9996-0XA36
- COMBIMASTER & MICROMASTER Integrated Brake Options Operating Instructions (English).
 - G85139-H1731-U450-D1

(Available August 99)

Intentionally Left Blank



3. MECHANICAL INSTALLATION



WARNING

Take note of the general and regional installation and safety regulations regarding work on high voltage installations (e.g. VDE). Adhere to relevant regulations regarding correct use of tools and protective gear.

Use the lifting eyes provided if a motor is to be lifted. Do not lift machine sets by suspending the individual machines! Always check the capacity of the hoist before lifting any equipment.

Do not paint over the black case finish of the inverter as this will affect the units thermal performance.

Take suitable precautions to prevent transmission elements from being touched. If the COMBIMASTER is started up without a transmission element attached, the featherkey must be secured in position to prevent it from flying off while the shaft is rotating.

3.1 Mechanical Installation I COMBIMASTER

Tighten down screw-in lifting eyes prior to using the COMBIMASTER.

Stable foundations or mounting conditions and a well balanced transmission element are essential for quiet, vibration-free running. It may be necessary to balance the whole rotor and transmission element.

The rotors are dynamically balanced with a full featherkey inserted as standard. Since 1991 the type of balance has been marked on the drive end of the shaft (shaft end face). **F** denotes balanced with **full** featherkey; **H** denotes balanced with **half** featherkey. Bear in mind the type of balance when fitting the transmission element.

Poor running characteristics can arise in cases where the transmission elements have a length ratio of hub length to shaft end length < 0.8 and they run at speeds greater than 1500 rpm. In such cases rebalancing may be necessary, e.g. by reducing the distance by which the featherkey protrudes from the transmission element and the shaft surface.

Please check the following prior to commissioning :

- The rotor turns freely without rubbing.
- The motor is assembled and aligned properly.

- The transmission elements are adjusted correctly (e.g. belt tension) and the transmission element is suitable for the given operating conditions.
- All electrical connections, mounting screws and connecting elements are tightened and fitted correctly.
- All protective conductors are installed properly.
- Any auxiliary equipment that might be fitted (e.g. mechanical brake) is in working order.
- Protection guards are installed around all moving and live parts.
- The maximum speed is not exceeded. The maximum speed is the highest operating speed permitted. Remember that motor noise and vibration are worse at this speed and bearing life is reduced.
- The above list is not meant to be exhaustive - additional checks may also be required.

3.2 Mechanical Installation I MICROMASTER Integrated

The motor / MICROMASTER Integrated combination should be installed according to guidelines similar to those given for the COMBIMASTER.



Refer to MMI Motor Adaptation
Guidelines
(Ref. G85139-H1731-U500)

Available August 1999

First fit the Motor Interface Plate (MIP) to the motor. In most cases the MIP makes use of the existing motor gasket.



WARNING

Cooling of the inverter must be provided, either via a cut-out in the motor Fan Cowl or by using the inverter fan option M41

CS A: 6SE9996-0XA01

CS B: 6SE9996-0XA02



4. ELECTRICAL INSTALLATION



WARNING

Take note of the general and regional installation and safety regulations regarding work on high voltage installations (e.g. VDE). Adhere to relevant regulations regarding correct use of tools and protective gear.

4.1 General Wiring Guidelines

The Case size A (CS A) and Case Size B (CS B) COMBIMASTER is designed to operate in an industrial environment where a high level of Electro-Magnetic Interference (EMI) can be expected. Usually, good installation practices will ensure safe and trouble-free operation. However, if problems are encountered, the following guidelines may prove useful. In particular, grounding of the system 0V at the inverter, as described below, may prove effective.

- 1 All equipment must be well earthed using short, thick earthing cable connected to a common star point or busbar. It is particularly important that any control equipment connected to the inverter (such as a PLC) is connected to the same earth or star point as the inverter via a short, thick link. Flat conductors (e.g. metal brackets) are preferred as they have lower impedance at high frequencies.

- 2 Use screened leads for connections to the control circuitry. Terminate the ends of the cable neatly, ensuring that long strands of unscreened wire are not left visible.
- 3 Separate the control cables from the power connections as much as possible, using separate trunking, etc. If control and power cables cross, arrange the cables so that they cross at 90°.
- 4 Ensure that contactors are suppressed, either with R-C suppressers for AC contactors or 'flywheel' diodes for DC contactors, fitted to the coils. Varistor suppressers are also effective.

Safety regulations must not be compromised when installing the COMBIMASTER or MICROMASTER Integrated !

4.2 Electrical Installation I MICROMASTER Integrated

The motor wires should be connected in either star or delta configuration on the MIP (check motor rating plate).

Star Connection

Wire	Terminal
U2/V2/W2	N
U1	U
V1	V
W1	W

Delta Connection

Wire	Terminal
U1/W2	U
U2/V1	V
V2/W1	W

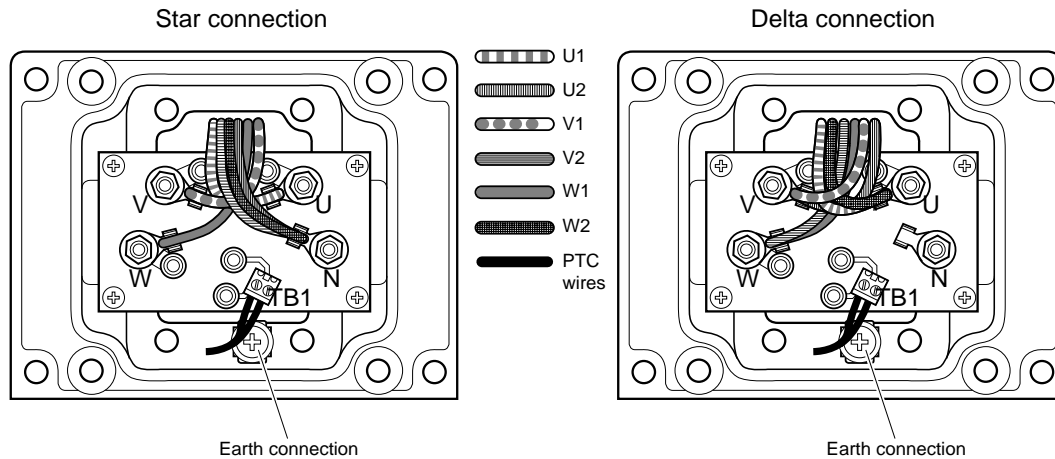

Figure 1 Motor Wire Connection.



WARNING

It is essential that the MIP is correctly earthed to the motor. This is usually achieved using a short earth cable connected between the MIP and a suitable connection point on the motor. Death or severe injury can result if the motor is not correctly earthed. Incorrect earthing can also prevent any MICROMASTER Integrated built-in EMC filter from operating correctly.

4.3 Electrical Installation I COMBIMASTER and MICROMASTER Integrated

Procedure

Remove the four cross-head screws on the inverter's cover to access the electrical terminals.



A 'drip loop' is recommended when connecting the mains and control cables (see Fig. 6).



For details of cable sizes, refer to the Electrical Data (section 8.4) of this document.



CAUTION

The printed circuit boards contain CMOS components that are particularly sensitive to static electricity. For this reason avoid touching the boards or components with your bare hands or metal objects.

4.4 Mains Cable Connections

Ensure that the power source supplies the correct voltage and is designed for the rated current. Use the appropriate circuit-breakers with the specified current rating between the power supply and inverter.

Use Class 1 60/75°C copper wire only. Use a 4-core screened cable. If crimp terminals are used they must be insulated. If crimps are not used, the strip length must not exceed 5mm.

Feed the power cable into the inverter via the gland hole nearest to the motor shaft. Connect the power leads to terminals L1, L2, L3 (L1, L2 for single phase units) and the separate earth.

Use a 4 - 5 mm cross-tip screwdriver to tighten the terminal screws

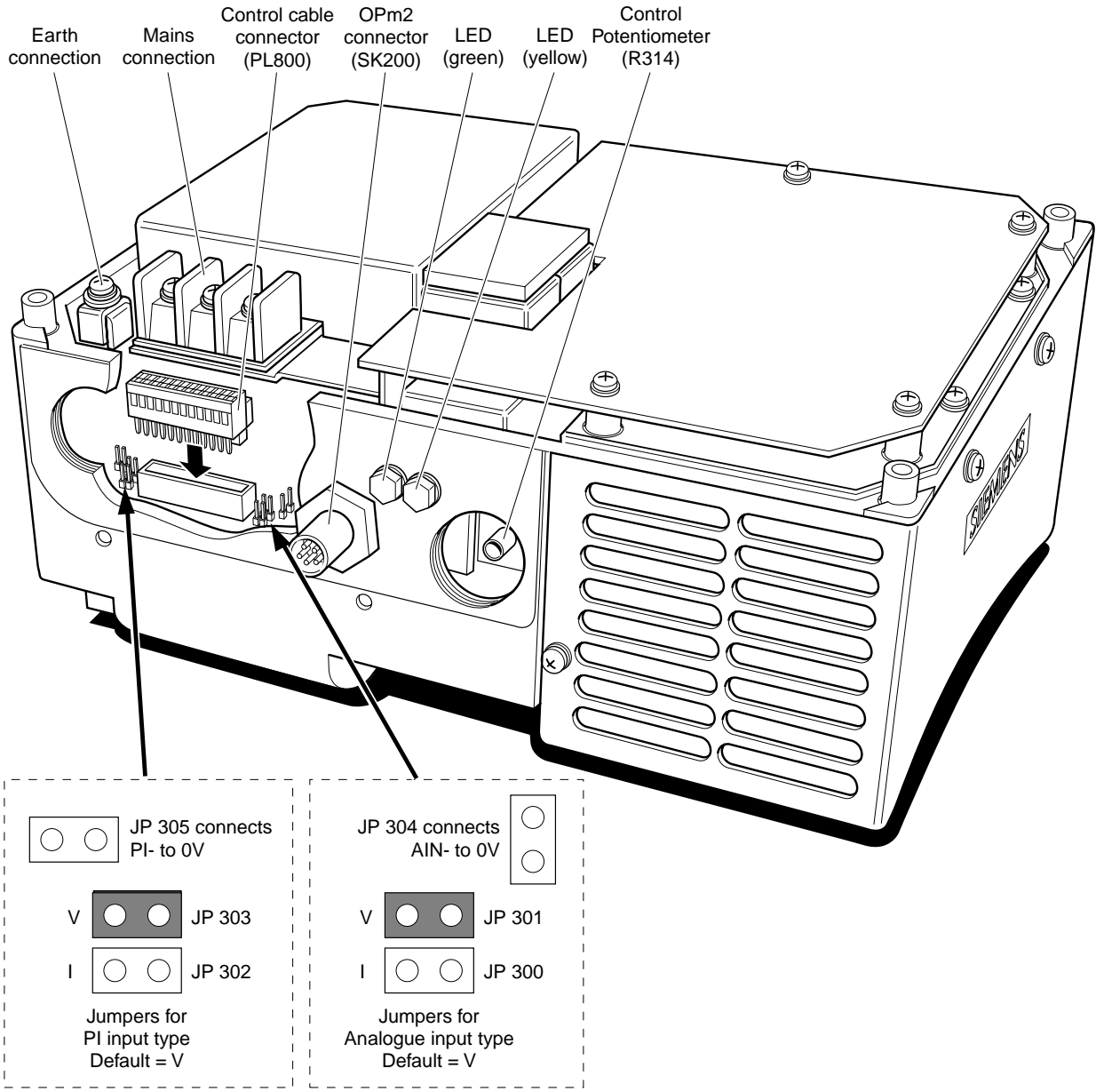

Note: Jumper in 'V' position = voltage input (default)
 Jumper in 'I' position = current input

Check that the supply voltage is correct for the inverter used by referring to the rating label.

Cable Glands: (Case Size B)
 PG21 – Mains
 PG16 - Signal

IMPORTANT
Ensure that the following tightening torques are used:
Access cover retaining screws 4.0 Nm
Gland hole covers 1.0 NM
Main connector screws 1.0 Nm
Earth connection 1.5 Nm.

Figure 2 Electrical Connection (CS B)

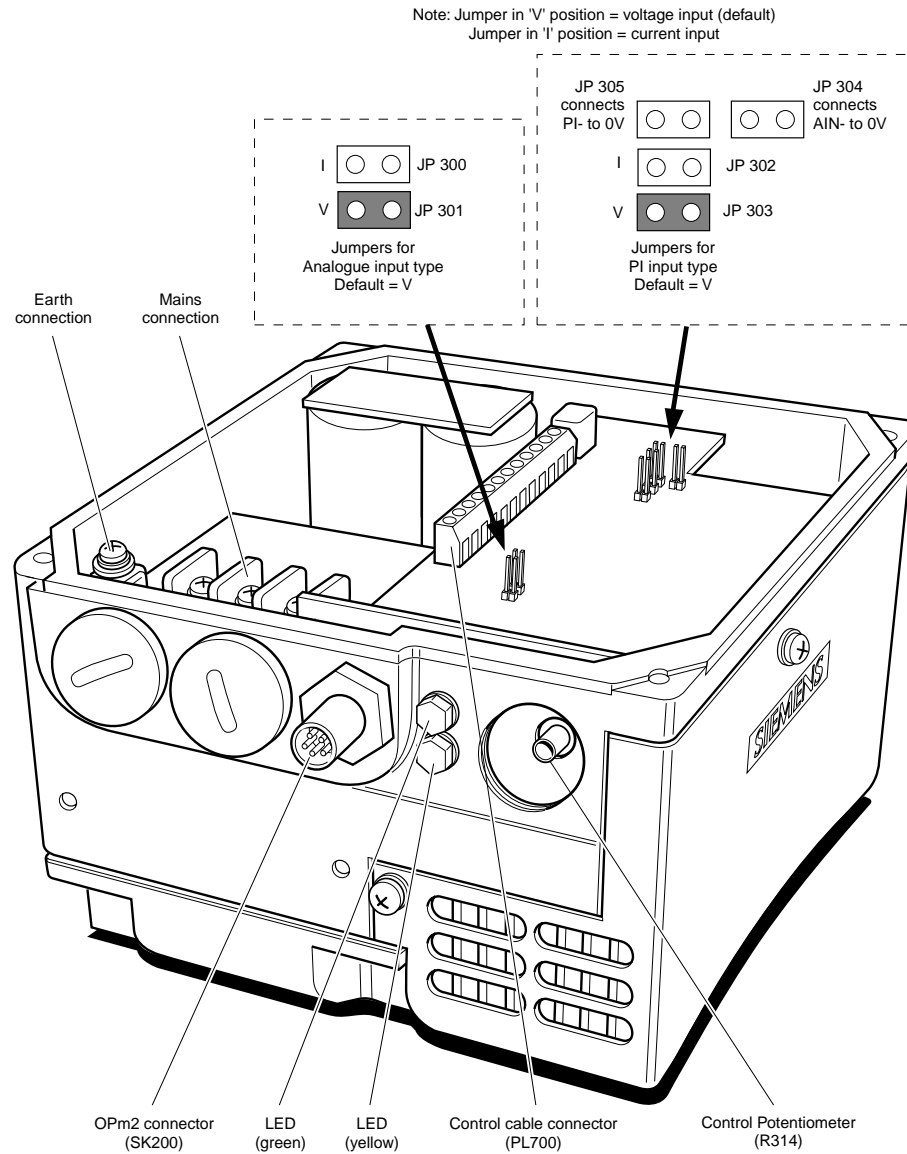

Check that the supply voltage is correct for the inverter used by referring to the rating label.

Cable Glands : (Case Size A)

PG16 – Mains & Signal

⚠ IMPORTANT

Ensure that the following tightening torques are used:

Access cover retaining screws	4.0 Nm
Gland hole covers	1.0 NM
Main connector screws	1.0 Nm
PL700 screws	0.5 Nm
Earth connection	1.5 Nm.

Figure 3 Electrical Connection (CS A)

4.5 Control Cable Connections

CAUTION

The control and power supply cables must be laid separately. They must not be fed through the same cable conduit / trunking.

Use screened cable for the control lead.

Feed the control cable into the inverter via the appropriate gland hole. Connect the control wires in accordance with the information in Figures 4, 5 and 6, having first unplugged connector block PL800 from the PCB (CS B only).

IMPORTANT: A wire link **must** be fitted between control terminals 5 (DIN1) and 1 (P10+) if it is required to start the inverter from the control potentiometer R314, or the analogue input.. The wire link must be removed when operation via a run/stop switch is required.

COMBIMASTER Control Terminal Cabling Information		
	CS A (PL700):	CS B (PL800)
Cable AWG	22 – 18	28 – 20
= approx. mm ²	0.35 – 0.82	0.08 – 0.50
Strip Length (mm)	5 – 6	5 – 6
Strip Length (inch)	0.22	0.22



Note that the optional potentiometer fitted as an analogue set point shown in Figure 4 & 5 assumes that jumper JP304 is connecting 0V (pin 2) to AIN- (pin 4).



+15V can be used as an alternative to P10+ for the digital inputs.

Plug the connector block back into the PCB (CS B only), refit the cover and tighten the four securing screws.

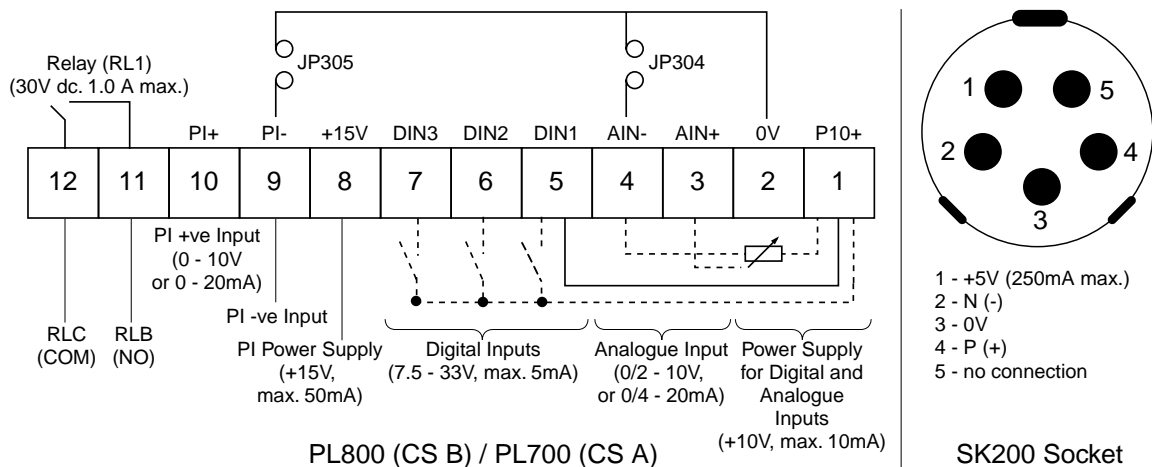

Figure 4 Control Terminal Connections

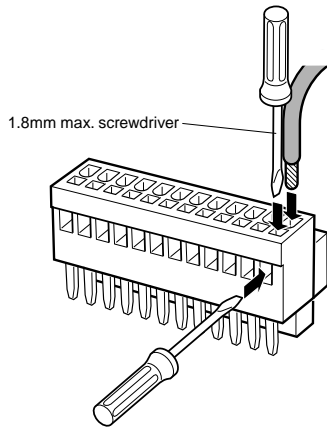

Figure 5 Connecting Control Wires to PL800

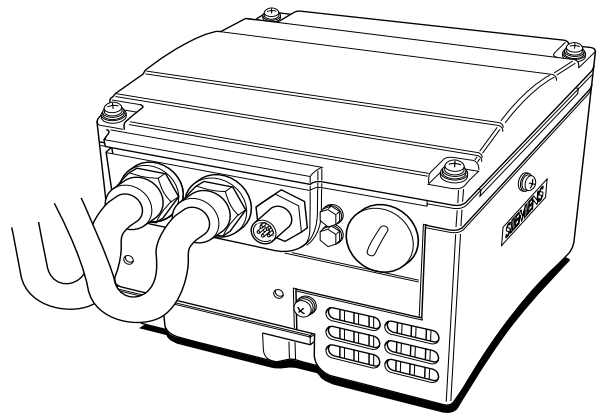

Figure 6 Cable Connections with Drip Loop

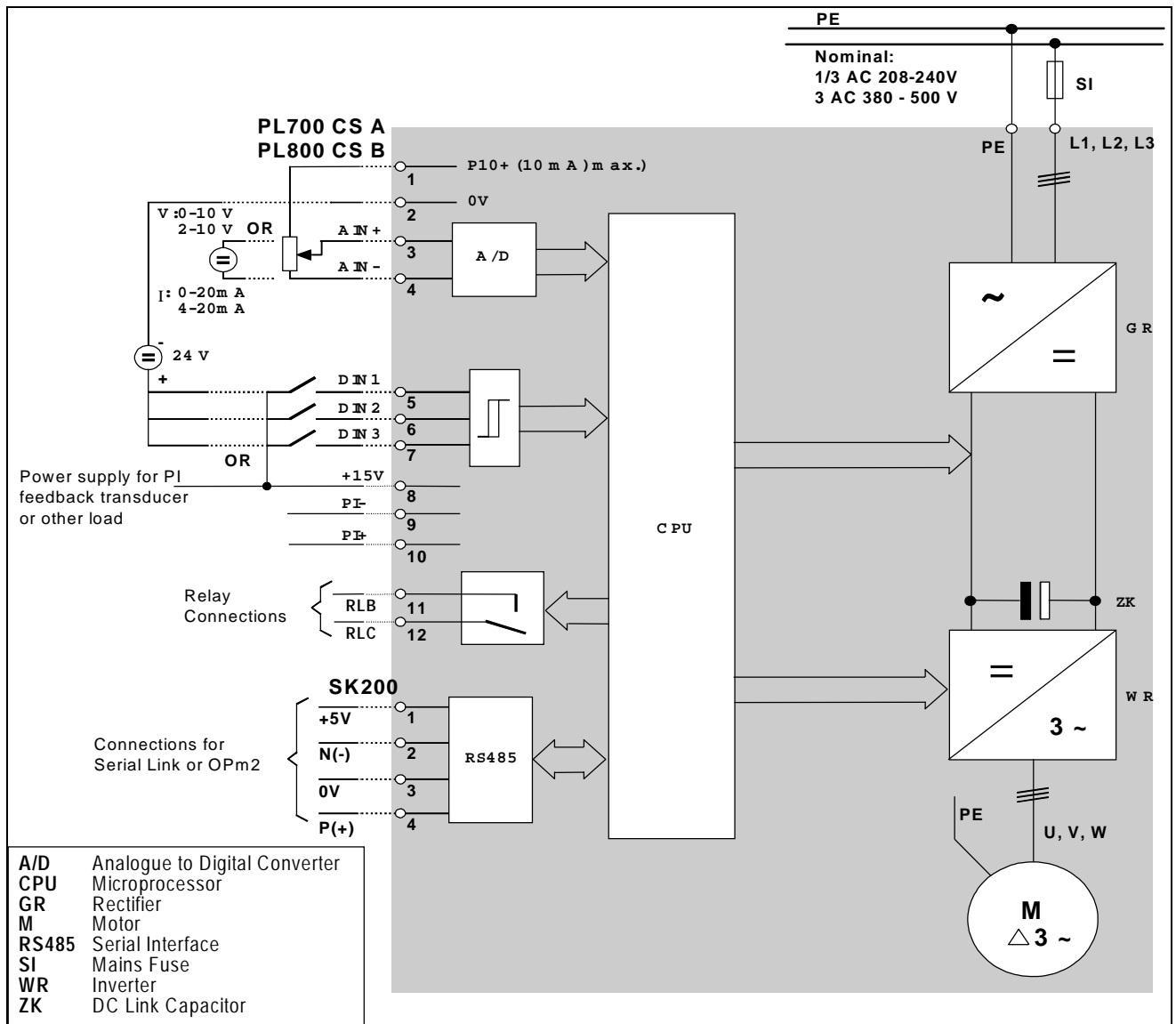

Figure 7 Block Diagram

5. OPERATING INFORMATION



WARNING

The equipment must not be switched on until after its cover has been fitted and the cover screws have been tightened to the correct torque.

After the power has been turned off, you must always wait five minutes so that the dc link capacitors can discharge. Do not remove the cover until this time has elapsed.

All settings must only be entered by qualified personnel, paying particular attention to the safety precautions and warnings.

5.1 General

For basic operation of COMBIMASTER & MICROMASTER Integrated, no additional equipment is required. However, for more complex operation, Opm2 – Clear Text Display is required (Opm2 is available as an option, but must be ordered separately).

The inverter does not have a mains power switch and is therefore live when the mains supply is connected.

When delivered, the inverter has a frequency setpoint range of between 0 Hz and 50 Hz. Regardless of its initial position, internal potentiometer R314 must be turned fully counter-clockwise before it can be used to start the COMBIMASTER.

R314 can be accessed by removing the right-hand gland hole cover (see Fig. 2 & 3).

Connecting a serial link or the OPm2 to the serial interface is made using the circular connector SK200 (see fig. 2 & 3)

Parameter settings can only be changed by using either the serial interface (SK200) or an optional Clear Text Display (OPm2). Refer to the parameter list section in this document for a full description of each available parameter.

Analogue input type is selected by jumpers JP300 and JP301. JP300 closed selects current input, JP301 closed (default) selects voltage input. These jumpers can only be accessed when the cover is removed (see Fig. 2 & 3).



If the motor is run unloaded (e.g. for test purposes) and vibration or trip conditions occur, change P077 from 0 to 3 (requires OPm2).

5.2 Basic Operation

There are two basic modes of operation for the inverter.

- 1 Using the internal potentiometer only:
 - a For forward rotation, ensure that a link is fitted between DIN1 (pin 5) and P10+ (pin 1) on PL800/PL700 (see Fig. 4). For reverse rotation, connect the link to DIN2 (pin 6) instead of DIN1.
 - b Apply mains power. The green and yellow LEDs will illuminate to show that power is applied. Turn potentiometer R314 fully counter-

clockwise. Turn the potentiometer clockwise until the yellow LED extinguishes. This indicates that power is now applied to the motor. Continue turning clockwise to increase the speed of the motor.

- c Turn the potentiometer counter-clockwise to reduce the speed of the motor. Turning the potentiometer fully counter-clockwise causes the motor to slow to a complete stop. Check that both LEDs are illuminated (STANDBY mode).

- 2 Using a combination of the internal potentiometer and a run/stop switch:
 - a Connect a run/stop switch between DIN1 (pin 5) and P10+ (pin 1) on PL700 (see Fig. 4) if forward rotation is required. If reverse rotation is required instead, connect the switch to DIN2 (pin 6) instead of DIN1 (pin 5).

IMPORTANT: Remove the link, if fitted, between pins 5 and 1 before the run/stop switch is fitted.

- b Apply mains power. The green and yellow LEDs will illuminate to show that power is applied.
- c Set the external run/stop switch to ON.
- d Turn potentiometer R314 clockwise to set the required motor speed.
- e Stop the motor by setting the external on/off switch to OFF. When the switch is set to ON again, it will run at the speed previously set using the potentiometer.

5.3 Operation – External Analogue Control

- 1 Connect a 4.7 kΩ potentiometer to the control terminals as shown in Fig.4 or apply a 0 - 10 V signal between pin 2 (0V) and pin 3 (AIN+). In both cases, position jumper JP304 to connect 0V to AIN-.
- 2 Ensure that a link is fitted between pin 5 (DIN1) and pin 1 (P10+).
- 3 Check that voltage input is selected by ensuring that the jumper is fitted to JP301.
- 4 Refit the cover, tighten the cover screws to the correct torque and then apply mains power to the inverter.
- 5 Turn the external potentiometer (or adjust the analogue control voltage) until the desired frequency is achieved. The unit will not switch on until a minimum of 2 V has been applied.



The frequency set by the external voltage is added to the frequency set by the internal potentiometer. Refer to Parameter P331 , Section 6.

As with Basic Operation, a run/stop switch can be used to start and stop the motor, or the direction of rotation can be changed by connecting the link to DIN2 instead of DIN1.

5.4 Operation – Digital Control

This method of operation requires either a Clear Text Display (OPm2) or a serial link connection. The use of the Clear Text Display module is described in the Options section of this document. For a basic start-up configuration using digital control, proceed as follows:

- 1 Remove the link that connects control terminal 5 to terminal 1 (if one has been fitted).
- 2 Connect control terminal 5 to terminal 1 via a simple on/off switch. This sets up the inverter for clockwise rotation (default). If counter-clockwise operation is required, connect a switch between control terminals 6 and 1.
- 3 Connect the OPm2 or serial link to SK200. Refit the cover, tighten the cover screws to the correct torque and then apply mains power to the inverter.
- 4 Set parameter P006 to 0 to specify digital setpoint(see Section 6).
- 5 Set parameter P005 to the desired frequency setpoint.
- 6 Set the external on/off switch to ON or press the ON button on the OPm2 (set P007 = 001 to use the OPm2). The inverter will now run at the frequency set by P005.

5.5 Stopping the Motor

Via the external on/off switch:

Setting the switch to OFF overrides the setting on the potentiometer and causes the motor to come to a controlled stop.

Via the potentiometer:

Turning the potentiometer counter-clockwise until the input voltage drops below 2 V causes the motor to slow to a stop. If an external potentiometer is applied, the input voltage must also be below 2V to stop.

5.6 If the Motor Does Not Start Up

Check the LEDs on the side of the inverter:

LED State	COMBIMASTER / MICROMASTER Integrated Status	
Green	Yellow	
ON	ON	Mains power on, inverter not running (STANDBY)
ON	OFF	Inverter running, as per control commands (ON)
Flashing	Flashing	Current limit warning
Flashing	ON	Inverter overtemperature
ON	Flashing	Motor overtemperature
OFF	ON	Other fault (e.g. tripped)
OFF	Flashing	Mains undervoltage
OFF	OFF	Mains supply fault (e.g. faulty external switch)

If a fault occurs:

Switch off, disconnect and then reconnect the power, and then switch on again.
Switch off if the fault condition persists.
Trips can be reset by using DIN3.

If a warning occurs:

Switch off, disconnect and reconnect the power and then switch on again.

If the fault/warning persists, further investigation requires an OPm2 or a serial link connection.

5.7 Local and Remote Control

The inverter can be controlled either locally (default), or remotely via a USS data line connected to the RS485 connector (SK200).

When local control is used (P910 = 0), the motor can only be controlled via the internal potentiometer or the control terminals. Control commands, setpoints or parameter changes received via the RS485 interface have no effect.

For remote control, the serial interface is designed as a 2-wire connection for bi-directional data transmission. Refer to parameter P910 in System Parameters for the available remote control options.

When operating via remote control the inverter will not accept control commands from the terminals. *Exception: OFF2 or OFF3 can be activated via parameter P051 to P053 (refer to parameters P051 to P053 in System Parameters).*

31 COMBIMASTERS can be connected to an external control unit at the same time and can be addressed individually.

5.8 Closed Loop Control

Closed loop control is only possible when an OPm2 or a serial link is connected to the COMBIMASTER.

Note: The closed loop function is not designed for speed control, but can be used for this provided that fast response times are not required.

5.8.1 General Description

The COMBIMASTER provides a Proportional/Integral (PI) control function for closed loop control (see Figure 8). PI control is ideal for temperature or pressure control, or other applications where the controlled variable changes slowly or where transient errors are not critical. This control loop is **not** suitable for use in systems where fast response times are required.

When closed loop PI control is enabled (P201 = 002), all setpoints are calibrated between zero and 100%, i.e. a setpoint of 50.0 = 50%. This allows general purpose control of any process variable that is actuated by motor speed and for which a suitable transducer is available.

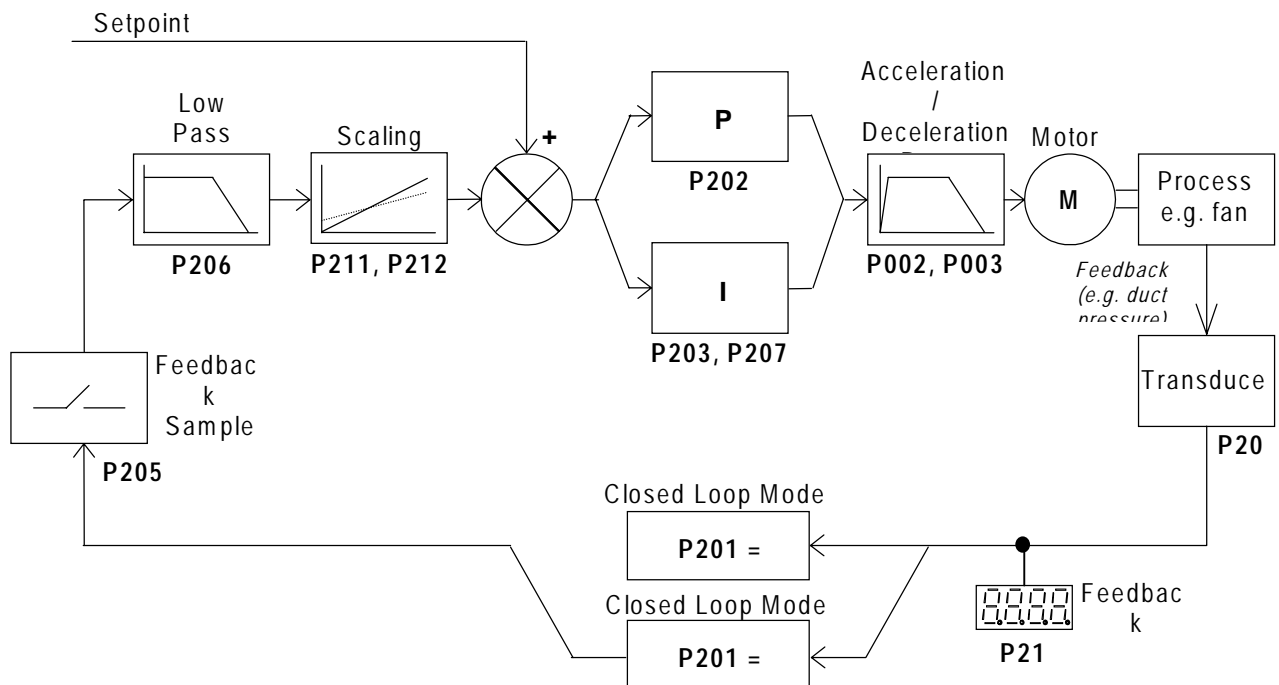

Figure 8: Closed Loop Control

5.8.2 Hardware Setup

Connect the signal wire from the external feedback transducer to control terminal 10. Set jumper JP303 if voltage input type is required (default) or set JP302 if current input type is required.

5.8.2 Parameter Settings

Closed loop control cannot be used unless P201 is first set to 002. Most of the parameters associated with closed loop control are shown in Figure 8. Other parameters which are also associated with closed loop control are as follows:

15 V dc power for the feedback transducer can be supplied from control terminal 8.

- P001 (value = 007)
- P061 (value = 012 or 013)
- P210
- P220.



6. SYSTEM PARAMETERS

6.1 Systems Parameters Table

The parameters listed here can only be accessed via the OPm2 or a serial link to the COMBIMASTER. (see Section 7.1 for details)

If the COMBIMASTER is to be operated only using analogue control within the 0 - 50 Hz frequency range then access to these parameters is not required.



The control buttons on the OPm2 (RUN, REVERSE and JOG) are disabled by default and cannot be used until P007 has been set to '1'.

Access to parameters is determined by the value set in P009. Check that the key parameters necessary for your application have been programmed.

P009 options are:

- **0** = Only the parameters from P001 to P009 can be read and set.
- **1** = Parameters P001 to P009 can be set and all other parameters can only be read.
- **2** = All parameters can be set, but P009 resets to 0 the next time power is removed from the inverter.
- **3** = All programmed parameters can always be set.



In the following parameter table:

Software Versions : Where indicated, some parameter descriptions are dependent on the software version installed, which can be checked using Parameter P922.

- V 3.00 is planned for release 2nd Quarter 1999.

- Includes references to CANbus– not available at time of writing (05.99)

'•' Indicates parameters that can be changed during operation.

'***' fmax This value is software version dependent.



V2.37: COMBIMASTER – fmax = 120Hz; MMI – fmax = 120Hz

V 3.00: COMBIMASTER – Motor dependent; MMI – fmax = 400Hz

[☆☆☆] Indicates that the value of this factory setting depends on the rating of the motor.

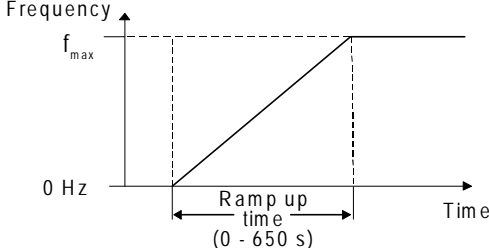
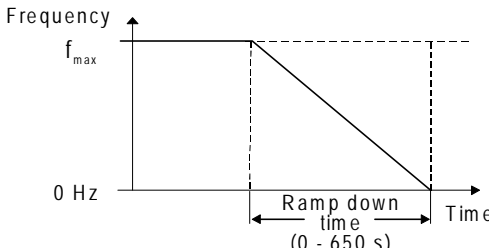
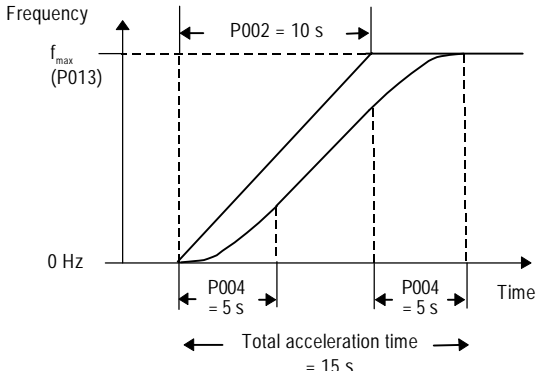
Parameter	Function	Range [Default]	Description / Notes
P000	Operating display	-	This displays the output selected in P001 on the second line of the LCD screen. If output frequency has been selected (P001 = 0) and the inverter is OFF, the display alternates between the current frequency (F) and the frequency that the inverter will run at when the RUN button is pressed (S). If P001 is set to any other value then only the actual value is displayed on this line of the display. In the event of a fault, the relevant fault code (Fxxx) is displayed (see section 6.3). In the event of a warning the display flashes.
P001 •	Display mode	0 - 8 [0]	Display selection: 0 = Output frequency (Hz) 1 = Frequency setpoint (i.e. speed at which inverter is set to run) (Hz) 2 = Motor current (A) 3 = DC-link voltage (V) 4 = Motor torque (% nominal) 5 = Motor speed (RPM) 6 = Not used 7 = Closed loop control setpoint (% of full scale) 8 = Output voltage

Parameter	Function	Range [Default]	Description / Notes
P002 •	Ramp up time (seconds)	0.50-650.00 [10.00] ----- (SW Version : 3.00 onwards) 0.10 - 650.00 [10.00]	<p>This is the time taken for the motor to accelerate from standstill to the maximum frequency as set in P013.</p> <p>Setting the ramp down time too short can cause the inverter to trip (fault code F001 – overvoltage, or F002 - overcurrent).</p> 
P003 •	Ramp down time (seconds)	0.00–650.00 [25.00]	<p>This is the time taken for the motor to decelerate from maximum frequency (P013) to standstill.</p> <p>Setting the ramp down time too short can cause the inverter to trip (fault code F001 – overvoltage, or F002 - overcurrent).</p> <p>This is also the period for which DC injection braking is applied (see P073).</p> 
P004 •	Smoothing (seconds)	0 - 40.0 [0.0]	<p>Used to smooth the acceleration/deceleration of the motor (useful in applications where it is important to avoid 'jerking', e.g. conveyor systems, textiles, etc.). Smoothing is only effective if the ramp up/down time exceeds 0.3 s.</p>  <p>The smoothing curve for deceleration is based on the ramp up gradient (P002) and is added to the ramp down time set by P003. Therefore, the ramp down time is affected by changes to P002.</p>

Parameter	Function	Range [Default]	Description / Notes
P005 •	Digital frequency setpoint (Hz)	0 – fmax** [50.00]	Sets the frequency that the inverter will run at when operated in digital mode. Only effective if P006 set to '0'. Actual limit: CM: 120 Hz. MMI: 120Hz ----- SW Version : 3.00 onwards: OPM display will be 650.00. Actual limit: CM: 90 – 140 Hz (power rating dependent). MMI: 400Hz.
P006	Frequency setpoint source selection	0 - 2 [1]	Sets the control mode of the inverter. 0 = Digital. The inverter runs at the frequency set in P005. If P007 is set to zero, the frequency may be adjusted by setting any two of digital inputs P051 - P053 to values of 11 and 12. 1 = Analogue. The frequency is set via an analogue input signal or the internal potentiometer. 2 = Fixed frequency or motor potentiometer. one binary input (P051 - P053) = 6, 17 or 18.  If P006 = 1 and the inverter is set up for remote control operation, the analogue inputs remain active (added to the serial setpoint).  Motor potentiometer setpoints via digital inputs are stored when P011 = 1.
P007	Keypad control	0 – 1 [0]	0 = The RUN, REVERSE and JOG buttons are disabled. Control is via digital inputs (see parameters P051 - P053). Δ and ∇ may still be used to control frequency provided that P124 = 1 and a digital input has not been selected to perform this function. 1 = OPm2 buttons are enabled (can be individually disabled depending on the setting of parameters P121 - P124). The digital inputs for RUN, JOG and Δ / ∇ are disabled. If P121 – P123 are disabled, digital inputs for RUN, JOG and REVERSE are enabled.
P009 •	Parameter protection setting	0 - 3 [0]	Determines which parameters can be adjusted: 0 = Only parameters from P001 to P009 can be read/set. 1 = Parameters from P001 to P009 can be set and all other parameters can only be read. 2 = All parameters can be read/set but P009 automatically resets to 0 when power is removed. 3 = All parameters can be read/set.
P011	Frequency setpoint memory	0 - 1 [0]	0 = Disabled. 1 = Enabled. The setpoint alterations made with the Δ / ∇ buttons or digital inputs are stored even when power has been removed from the inverter.
P012 •	Minimum motor frequency (Hz)	0 - 400.00 [0.00]	Sets the minimum motor frequency (must be less than the value of P013).
P013 •	Maximum motor frequency (Hz)	0 – fmax** [50.00]	Sets the maximum motor frequency.

Parameter	Function	Range [Default]	Description / Notes
P014 •	Skip frequency 1 (Hz)	0 – fmax** [0.00]	A skip frequency can be set with this parameter to avoid the effects of mechanical resonance. Frequencies within +/- (value of P019) of this setting are suppressed. Stationary operation is not possible within the suppressed frequency range - the range is just passed through.
P015 •	Automatic restart after mains failure	0 - 1 [0]	Setting this parameter to '1' enables the inverter to restart automatically after a mains break or 'brownout', provided the run/stop switch is still closed or the link is fitted, P007 = 0 and P910 = 0, 2 or 4. 0 = Disabled. 1 = Automatic restart.
P016 •	Start on the fly	0 - 2 [0]	Allows the inverter to start onto a spinning motor. Under normal circumstances the inverter runs the motor up from 0 Hz. However, if the motor is still spinning or is being driven by the load, it will undergo braking before running back up to the setpoint - this can cause an overvoltage trip. By using a flying restart, the inverter ramps up the output voltage at the setpoint for the period defined by P020. 0 = Normal restart. 1 = Flying restart after power up, fault or OFF2 (if P018 = 1). 2 = Flying restart every time (useful in circumstances where the motor can be driven by the load). ----- (SW Version : 3.00 onwards) -Current Limit is defined by P845
P017 •	Smoothing type	1 - 2 [1] 	1 = Continuous smoothing (as defined by P004). 2 = Discontinuous smoothing. This provides a fast unsmoothed response to STOP commands and requests to reduce frequency. P004 must be set to a value > 0.0 for this parameter to have any effect.
P018 •	Automatic restart after fault	0 - 1 [0]	Automatic restart after fault: 0 = Disabled. 1 = The inverter will attempt to restart up to 5 times after a fault. If the fault is not cleared after the 5th attempt, the inverter will remain in the fault state until reset. There is an increasing time delay between each restart attempt.
P019 •	Skip frequency bandwidth (Hz)	0 - 10.00 [2.00]	+/- the value of P019 centred on frequencies set by P014, P027, P028 or P029 are suppressed.
P020	Flying start ramp time (seconds)	0.50- 650.00 [25.00] ----- (SW Version : 3.00 onwards) 0.1-650.00 [25.00]	Used in conjunction with P016 (set longer times if persistent F002 trips occur).

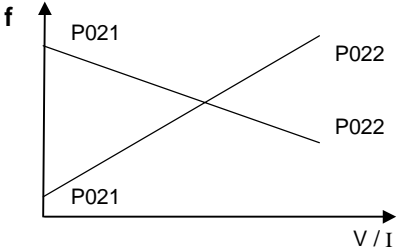
Parameter	Function	Range [Default]	Description / Notes												
P021 •	Minimum analogue frequency (Hz)	0-fmax** [0.00]	Frequency corresponding to the lowest analogue input value, i.e. 0 V / 0 mA or 2 V / 4 mA. This can be set to a higher value than P022 to give an inverse relationship between analogue input and frequency output (see diagram in P022).												
P022 •	Maximum analogue frequency (Hz)	0-fmax** [50.00]	<p>Frequency corresponding to the highest analogue input value, i.e. 10 V / 20 mA, determined by P023. This can be set to a lower value than P021 to give an inverse relationship between analogue input and frequency output.</p> <p>i.e.</p>  <p>The output frequency is limited by values entered for P012/P013.</p>												
P023 •	Analogue input type	0 - 2 [2]	<p>Selects analogue input type according to the setting of jumpers JP300/JP301:</p> <table border="0"> <tr> <td>JP301 closed</td> <td>OR</td> <td>JP300 closed</td> </tr> <tr> <td>0 = 0 V to 10 V</td> <td></td> <td>0 mA to 20 mA</td> </tr> <tr> <td>1 = 2 V to 10 V</td> <td></td> <td>4 mA to 20 mA</td> </tr> <tr> <td>2 = [2 V* to 10 V]</td> <td></td> <td>4 mA* to 20 mA</td> </tr> </table> <p>* The inverter will come to a controlled stop if $V < 1\text{ V}$ or $I < 2\text{ mA}$.</p> <p>The motor can automatically run without a potentiometer or voltage source connected between pins 3 and 4.</p> <p>With P023=2, the motor will automatically start when V exceeds 2 V. This equally applies to analogue and digital control (i.e. P006 = 0 or 1).</p>	JP301 closed	OR	JP300 closed	0 = 0 V to 10 V		0 mA to 20 mA	1 = 2 V to 10 V		4 mA to 20 mA	2 = [2 V* to 10 V]		4 mA* to 20 mA
JP301 closed	OR	JP300 closed													
0 = 0 V to 10 V		0 mA to 20 mA													
1 = 2 V to 10 V		4 mA to 20 mA													
2 = [2 V* to 10 V]		4 mA* to 20 mA													
P024 •	Analogue setpoint addition	0 - 2 [0]	<p>If the inverter is not in analogue mode (P006 = 0 or 2), setting this parameter to '1' causes the analogue input value to be added.</p> <p>0 = No addition.</p> <p>1 = Addition of the analogue setpoint (defined by P023) to the fixed frequency or the motor potentiometer frequency.</p> <p>2 = Scaling of digital/fixed setpoint by analogue input (P023) in the range 0 - 100%.</p> <p>By selecting a combination of reversed negative fixed frequency settings and analogue setpoint addition, it is possible to configure the inverter for 'centre zero' operation with a 0 - 10 V potentiometer so that the output frequency can be 0 Hz at any position, including the centre position.</p>												
P027 •	Skip frequency 2 (Hz)	0 - fmax** [0.00]	See P014.												
P028 •	Skip frequency 3 (Hz)	0 - fmax** [0.00]	See P014.												
P029 •	Skip frequency 4 (Hz)	0- fmax** [0.00]	See P014.												





Parameter	Function	Range [Default]	Description / Notes																																													
P031 •	Jog frequency right (Hz)	0 - fmax** [5.00]	Jogging is used to advance the motor by small amounts. It is controlled via the JOG button or with a non-latching switch on one of the digital inputs (P051 to P053). If jog right is enabled (DINn=7), this parameter controls the frequency at which the inverter will run when the switch is closed. Unlike other setpoints, it can be set lower than the minimum frequency.																																													
P032 •	Jog frequency left (Hz)	0 - fmax** [5.00]	If jog left is enabled (DINn=8), this parameter controls the frequency at which the inverter will run when the switch is closed. Unlike other setpoints, it can be set lower than the minimum frequency.																																													
P033	Jog ramp up time (seconds) <i>(SW Version : 3.00 onwards)</i>	0.00 – 650.00 [10]	This is the time taken to accelerate from 0Hz to maximum frequency (P013) for jog functions. It is not the time taken to accelerate from 0Hz to the jog frequency. If DINn =16 (see P051 to P053) then this parameter can be used to override the normal Ramp-up time set by P002.																																													
P034	Jog ramp down time (seconds) <i>(SW Version : 3.00 onwards)</i>	0.00 – 650.00 [10]	This is the time taken to decelerate from maximum frequency 0Hz to (P013) for jog functions. It is not the time taken to decelerate from the jog frequency to 0Hz. If DINn =16 (see P051 to P053) then this parameter can be used to override the normal Ramp-down time set by P003.																																													
P035	Reverse motor direction	0 – 1 [0]	0 = Normal direction control. 1 = Direction control is reversed.																																													
P041 •	Fixed frequency 1 (Hz)	0 - fmax** [5.00]	Valid if P006 = 2 and P053 = 6 or 18 or P051 = P052 = P053 = 17.																																													
P042 •	Fixed frequency 2 (Hz)	0 - fmax** [10.00]	Valid if P006 = 2 and P052 = 6 or 18 or P051 = P052 = P053 = 17.																																													
P043 •	Fixed frequency 3 (Hz)	0 - fmax** [15.00]	Valid if P006 = 2 and P051 = 6 or 18 or P051 = P052 = P053 = 17.																																													
P044 •	Fixed frequency 4 (Hz)	0 - fmax** [20.00]	Valid if P006 = 2 and P051 = P052 = P053 = 17.																																													
P045	Inversion fixed setpoints for fixed frequencies 1 - 4	0 - 7 [0]	Sets the direction of rotation for the fixed frequency.																																													
			<table border="1"> <thead> <tr> <th></th> <th>FF1</th> <th>FF2</th> <th>FF3</th> <th>FF4</th> </tr> </thead> <tbody> <tr> <td>P045 = 0</td> <td>⇒</td> <td>⇒</td> <td>⇒</td> <td>⇒</td> </tr> <tr> <td>P045 = 1</td> <td>⇐</td> <td>⇒</td> <td>⇒</td> <td>⇒</td> </tr> <tr> <td>P045 = 2</td> <td>⇒</td> <td>⇐</td> <td>⇒</td> <td>⇒</td> </tr> <tr> <td>P045 = 3</td> <td>⇒</td> <td>⇒</td> <td>⇐</td> <td>⇒</td> </tr> <tr> <td>P045 = 4</td> <td>⇒</td> <td>⇒</td> <td>⇒</td> <td>⇐</td> </tr> <tr> <td>P045 = 5</td> <td>⇐</td> <td>⇐</td> <td>⇒</td> <td>⇒</td> </tr> <tr> <td>P045 = 6</td> <td>⇐</td> <td>⇐</td> <td>⇐</td> <td>⇒</td> </tr> <tr> <td>P045 = 7</td> <td>⇐</td> <td>⇐</td> <td>⇐</td> <td>⇐</td> </tr> </tbody> </table>		FF1	FF2	FF3	FF4	P045 = 0	⇒	⇒	⇒	⇒	P045 = 1	⇐	⇒	⇒	⇒	P045 = 2	⇒	⇐	⇒	⇒	P045 = 3	⇒	⇒	⇐	⇒	P045 = 4	⇒	⇒	⇒	⇐	P045 = 5	⇐	⇐	⇒	⇒	P045 = 6	⇐	⇐	⇐	⇒	P045 = 7	⇐	⇐	⇐	⇐
	FF1	FF2	FF3	FF4																																												
P045 = 0	⇒	⇒	⇒	⇒																																												
P045 = 1	⇐	⇒	⇒	⇒																																												
P045 = 2	⇒	⇐	⇒	⇒																																												
P045 = 3	⇒	⇒	⇐	⇒																																												
P045 = 4	⇒	⇒	⇒	⇐																																												
P045 = 5	⇐	⇐	⇒	⇒																																												
P045 = 6	⇐	⇐	⇐	⇒																																												
P045 = 7	⇐	⇐	⇐	⇐																																												
			⇒ Fixed setpoints not inverted. ⇐ Fixed setpoints inverted.																																													
P046 •	Fixed frequency 5 (Hz)	0 - fmax** [25.00]	Valid if P006 = 2 and P051 = P052 = P053 = 17.																																													
P047 •	Fixed frequency 6 (Hz)	0 - fmax** [30.00]	Valid if P006 = 2 and P051 = P052 = P053 = 17.																																													

Parameter	Function	Range [Default]	Description / Notes			
P048 •	Fixed frequency 7 (Hz)	0 - fmax** [35.00]	Valid if P006 = 2 and P051 = P052 = P053 = 17.			
P050	Inversion fixed setpoints for fixed frequencies 5 – 7	0 - 7 [0]	Sets the direction of rotation for the fixed frequency:			
				FF5	FF6	FF7
			P050 = 0	⇒	⇒	⇒
			P050 = 1	⇐	⇒	⇒
			P050 = 2	⇒	⇐	⇒
			P050 = 3	⇒	⇒	⇐
			P050 = 4	⇒	⇒	⇒
			P050 = 5	⇐	⇐	⇒
			P050 = 6 or 7	⇐	⇐	⇐
			⇒ Fixed setpoints not inverted. ⇐ Fixed setpoints inverted.			

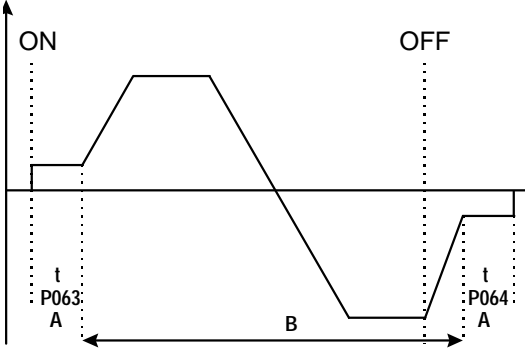

Parameter	Function	Range [Default]	Description / Notes			
P051	Selection control function, DIN 1 (terminal 5), fixed frequency 3 or binary fixed frequency bit 0	0-19 [1]	Value	Function of P051 to P053	Function low state	Function high state
			0	Input disabled	-	-
			1	ON right	Off	On Right
			2	On Left	Off	On Left
P052	Selection control function, DIN 2 (terminal 6), fixed frequency 2 or binary fixed frequency bit 1	0-19 [2]	3	Reverse	Normal	Reverse
			4	OFF 2	OFF 2	On
			5	OFF 3	Off 3	On
			6	Fixed Frequencies 1 – 3	Off	On
			7	Jog Right	Off	Jog right
			8	Jog left	Off	Jog left
			9	Remote operation	Local	Remote
P053	Selection control function, DIN 3 (terminal 7), fixed frequency 1 or binary fixed frequency bit 2	0-19 [10]	10	Fault code reset	Off	Reset on rising edge
			11	Increase frequency *	Off	Increase
			12	Decrease frequency*	Off	Decrease
			13	Disable analogue input (setpoint is 0.0 Hz)	Analogue on	Analogue disabled
			14	Disable the ability to change parameters	'P' Enabled	'P' disabled
			15	Enable dc brake	Off	Brake on
			16	Use jog ramp times instead of normal ramp times(<i>SW Version : 3.00 onwards</i>)	Normal	Jog Ramp Times
			17	Binary fixed frequency control (fixed frequencies1-7)	Off	On
			18	As 6, but input high will also request RUN	Off	On
			19	External trip / PTC	Trip (F012)	No Trip
* Only effective when P007 = 0.						
Binary Coded Fixed Frequency Mapping (P051, P052, P053 = 17)						
			DIN3 (P053)	DIN2 (P052)	DIN1 (P051)	
	STOP		0	0	0	
	Run to FF1 (P041)		0	0	1	
	Run to FF2 (P042)		0	1	0	
	Run to FF3 (P043)		0	1	1	
	Run to FF4 (P044)		1	0	0	
	Run to FF5 (P046)		1	0	1	
	Run to FF6 (P047)		1	1	0	
	Run to FF7 (P048)		1	1	1	

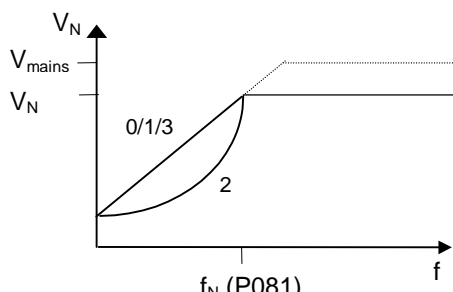
Parameter	Function	Range [Default]	Description / Notes		
P056	Digital input debounce time	0 – 2 [0]	Use a fast response time only when a 'clean' input signal is used, e.g. from a PLC. Use a slow response time to allow filtering of the signal if a noisy input (e.g. a switch) is used. 0 = 12.5 ms 1 = 7.5 ms 2 = 2.5 ms		
P058 •	RUN command delay (seconds)	0.0 - 650.0 [0.0]	Sets a time delay before the RUN command takes effect. This parameter affects run commands from all sources <u>except</u> the RUN button on the OPm2 (this starts the drive immediately).		
P061	Selection relay output RL1	0 - 13 [6]	Value	Relay Function	Active⁴
			0	No function assigned (relay not active)	Low
			1	Inverter is running	High
			2	Inverter Frequency 0.0 Hz	Low
			3	Motor run right has been selected	High
			4	External brake on (see parameters P063/064) ¹	Low
			5	Inverter Frequency less than or equal to minimum frequency	Low
			6	Fault indication ²	Low
			7	Inverter frequency greater than or equal to setpoint	High
			8	Warning active ³	Low
			9	Output current greater than or equal to P065	High
			10	Motor current limit (warning) ³	Low
			11	Motor over temperature (warning) ³	Low
			12	Closed loop, motor LOW speed limit	High
13	Closed loop, motor HIGH speed limit	High			
			¹ External brake requires 24 V (max.) dc slave relay. ² Inverter switches off (see parameter P930) ³ Inverter does not switch off (see parameter P931). ⁴ 'Active low' = relay OPEN. 'Active high' = relay CLOSED.		
P062	Electro-mechanical brake option control	0 - 4 [0]	This enables or disables the electro-mechanical brake option. Operation is the same as for P061 = 4, except that the brake control voltage is supplied directly. 0 = Disabled 1 - 3 = Do not use 4 = Enabled		
P063	External brake release delay (seconds)	0 - 20.0 [1.0]	Only effective if the relay output is set to control an external brake (P061 = 4) or the electro-mechanical brake option is used (P062 = 4). In this case when the inverter is switched on, it will run at the minimum frequency for the time set by this parameter before releasing the brake control relay and ramping up (see illustration in P064).		

Parameter	Function	Range [Default]	Description / Notes
P064	External brake stopping time (seconds)	0 - 20.0 [1.0]	<p>As P063, only effective if the relay output is set to control an external brake (P061 = 4) or the electro-mechanical brake option is used (P062 = 4). This defines the period for which the inverter continues to run at the minimum frequency after ramping down and while the external brake is applied.</p>  <p>A = Brake applied B = Brake removed</p> <p>Settings for P063 and P064 should be slightly longer than the actual time taken for the external brake to apply and release respectively.</p> <p>Setting P063 or P064 to too high a value, especially with P012 set to a high value, can cause an overcurrent warning or trip as the inverter attempts to move a locked motor shaft.</p>
P065	Current threshold for relay (A)	0 - 99.9 [1.0]	This parameter is used when P061 = 9. The relay switches on when the motor current is greater than the value of P065 and switches off when the current falls to 90% of the value of P065 (hysteresis).
P066			Do not use!
P071 •	Slip compensation (%)	0 - 200 [0]	The inverter can estimate the amount of slip in an asynchronous motor at varying loads and increase its output frequency to compensate. This parameter 'fine tunes' the compensation for different motors in the range 0 - 200% of the inverter's nominal estimate.
P072 •	Slip limit (%)	0 - 500 [500]	This limits the slip of the motor to prevent 'pull-out' (stalling), which can occur if slip is allowed to increase indefinitely. When the slip limit is reached, the inverter reduces the frequency until the level of slip is acceptable.
P073 •	DC injection braking (%)	0 - 150 [0]	<p>This stops the motor by applying a DC current. This causes heat to be generated in the motor rather than the inverter and holds the shaft stationary until the end of the braking period. Braking is effective for the period of time set by P003.</p> <p>CAUTION: If a start signal is given during this time, the motor will restart at the end of the braking period.</p> <p>The DC brake can be activated using DIN1 - DIN3 (<i>braking is active for as long as the DIN is high - see P051 - P053</i>).</p> <p>Frequent use of long periods of dc injection braking can cause the motor to overheat.</p> <p>If DC injection braking is enabled via a digital input then DC current is applied for as long as the digital input is high. This causes heat in the motor.</p>

Parameter	Function	Range [Default]	Description / Notes
P074 •	I ² t motor de-rating	0 - 1 [0]	<p>0 = Disabled 1 = Enabled. Causes an F074 trip if the motor I²t calculation reaches its limit. The time taken to trip is dependent on the difference between the overload current and the nominal motor current rating stored in P083 - typically a 150% overload will result in a switch-off in 1-2 minutes.</p> <p> For safety-critical applications, it is recommended that a motor PTC is used to protect the motor from overheating.</p>
P076 •	Pulse frequency	0 - 3 [0 or 2] [2]	<p>Sets the pulse frequency (from 8 to 16kHz). If silent operation is not absolutely necessary, the losses in the inverter can be reduced by selecting lower pulse frequencies.</p> <p>0 & 1 = 16 kHz (- Default for 230 V inverters) 2 & 3 = 8 kHz (- Default for 400V inverters).</p> <p> Derating required and EMC performance is affected on selection of non-default frequency</p>
P077	Control mode	0- 3 [0]	<p>Controls the relationship between the speed of the motor and the voltage supplied by the inverter.</p> <p>0 = Linear voltage/frequency. 1 = Flux current control(FCC) 2 = Quadratic voltage/frequency relationship. This is suitable for centrifugal pumps and fans.</p> <div style="text-align: center;">  </div> <p>3 = Linear voltage/frequency with energy saving. Output voltage is reduced at low load (not recommended for dynamic loads).</p>
P078 •	Continuous boost (%)	0 - 250 [50]	<p>Operates continuously over the whole frequency range.</p> <p>For many applications it is necessary to increase low frequency torque. This parameter sets the start-up voltage at 0 Hz to adjust the available torque for low frequency operation. 100% setting will produce rated motor current at low frequencies.</p> <p> If P078 is set too high, overheating of the motor and/or an overcurrent trip (F002) can occur.</p>
P079 •	Starting boost (%)	0 - 250 [0]	<p>For drives which require a high initial starting torque, it is possible to set an additional current (added to the setting in P078) during ramping. This is only effective during initial start up and until the frequency setpoint is reached.</p> <p> This increase is in addition to P078, but the total is limited to 250%.</p>

Parameter	Function	Range [Default]	Description / Notes																		
P081	Nominal frequency for motor (Hz)	0 - fmax** [☆☆☆]	COMBIMASTER: These parameters are set in the factory and should not be changed under normal circumstances. MMI : Motor data should be entered here																		
P082	Nominal speed for motor (RPM)	0 - 9999 [☆☆☆]																			
P083	Nominal current for motor (A)	0.1 - 99.9 [☆☆☆]																			
P084	Nominal voltage for motor (V)	0 – 1000 [☆☆☆]																			
P085	Nominal power for motor (kW/hp)	0-100.0 [☆☆☆]																			
P086 •	Motor current limit (%)	0 - 250 [150]	<p>The motor current can be limited with this parameter. If the set value is exceeded, the output frequency is reduced until the current falls to this limit. During this process, both LEDs will flash (see <i>Operating Information, Section 5</i>).</p> <table border="1"> <caption>Motor Current Limit - Overload Time to trip</caption> <thead> <tr> <th>Overload%</th> <th>Time/Seconds</th> </tr> </thead> <tbody> <tr> <td>160</td> <td>60</td> </tr> <tr> <td>150</td> <td>60</td> </tr> <tr> <td>140</td> <td>120</td> </tr> <tr> <td>130</td> <td>180</td> </tr> <tr> <td>120</td> <td>240</td> </tr> <tr> <td>115</td> <td>280</td> </tr> <tr> <td>111</td> <td>1680</td> </tr> <tr> <td>110</td> <td>> 1680</td> </tr> </tbody> </table>	Overload%	Time/Seconds	160	60	150	60	140	120	130	180	120	240	115	280	111	1680	110	> 1680
Overload%	Time/Seconds																				
160	60																				
150	60																				
140	120																				
130	180																				
120	240																				
115	280																				
111	1680																				
110	> 1680																				
P087	Motor PTC enable	0 - 1 [0]	<p>Change this parameter only when the PTC option is fitted.</p> <p>0 = Disabled 1 = Motor PTC enabled</p> <p>If P087 = 1 and the Motor PTC input goes high then the inverter will trip (fault code F004). Note that if the internal PTC gets too hot, the inverter will trip (fault code F005).</p> <p>PTC Thresholds : Not tripped : <1k5Ω Typical Trip : >9kΩ Guaranteed trip : >25kΩ</p>																		
P089 •	Stator resistance (Ω)	0.01-100.00 [☆☆☆]	COMBIMASTER :Set in the factory. <i>Do not adjust!</i> MMI : Set for value for Siemens motor. Adjust if required for other motors																		
P091 •	Serial link slave address	0 - 30 [0]	Up to 31 COMBIMASTERS can be connected via the serial link and controlled by a computer or PLC using the USS protocol. This parameter sets a unique address for the inverter.																		

Parameter	Function	Range [Default]	Description / Notes															
P092 •	Serial link baud rate	3 – 7 [6] 	Sets the baud rate of the RS485 serial interface (USS protocol): 3 = 1200 baud 4 = 2400 baud 5 = 4800 baud 6 = 9600 baud 7 = 19200 baud Some RS232 to RS485 converters are not capable of baud rates higher than 4800.															
P093 •	Serial link timeout (seconds)	0 - 240 [0]	This is the maximum permissible period between two incoming data telegrams. This feature is used to turn off the inverter in the event of a communications failure. Timing starts after a valid data telegram has been received and if a further data telegram is not received within the specified time period, the inverter will trip and display fault code F008. Setting the value to zero switches off the control.															
P094 •	Serial link nominal system setpoint (Hz)	0 - fmax** [50.00]	Setpoints are transmitted to the inverter via the serial link as percentages. The value entered in this parameter represents 100% (HSW = 4000H). – refer to USS reference document (see Section 5.7)															
P095 •	USS compatibility	0 - 2 [0]	0 = Compatible with 0.1 Hz resolution 1 = Enable 0.01 Hz resolution 2 = HSW is not scaled but represents the actual frequency value to a resolution of 0.01 Hz (e.g. 5000 = 50 Hz). Note : Unit will only output 0.05Hz resolution															
P099 •	Communication adapter type	0 - 2 [0]	0 = Option module not present 1 = PROFIBUS module (enables parameters relating to PROFIBUS) 2 = CANBUS (SW Version : 3.00 onwards)															
P101 •	Operation for Europe or USA	0 - 1 [0]	This changes the power display between kW and HP: 0 = Europe (kW) 1 = USA (HP)															
P111	Inverter power rating (kW/hp)	0.0-10.00 [☆☆☆] 	Read-only parameter that indicates the power rating of the inverter in kW. e.g. 0.55 = 550 W If P101 = 1 then the rating is displayed in hp.															
P112	Inverter type	1 - 8 [8]	Read-only parameter. 1 = MICROMASTER series 2 (MM2) 2 = COMBIMASTER 3 = MIDIMASTER 4 = MICROMASTER Junior (MMJ) 5 = MICROMASTER series 3 (MM3) 6 = MICROMASTER Vector (MMV) 7 = MIDIMASTER Vector (MDV) 8 = COMBIMASTER/MMI series 2															
P113	COMBIMASTER / MMI model	10-29 [-]	Read only parameter <table border="0"> <tr> <td>10 = CM12(/2)</td> <td>20 = CM37/3</td> <td>25 = CM220/3</td> </tr> <tr> <td>11 = CM25(/2)</td> <td>21 = CM55/3</td> <td>26 = CM300/3</td> </tr> <tr> <td>12 = CM37(/2)</td> <td>22 = CM75/3</td> <td>27 = CM400/3</td> </tr> <tr> <td>13 = CM55(/2)</td> <td>23 = CM110/3</td> <td>28 = CM550/3</td> </tr> <tr> <td>14 = CM75(/2)</td> <td>24 = CM150/3</td> <td>29 = CM750/3</td> </tr> </table>	10 = CM12(/2)	20 = CM37/3	25 = CM220/3	11 = CM25(/2)	21 = CM55/3	26 = CM300/3	12 = CM37(/2)	22 = CM75/3	27 = CM400/3	13 = CM55(/2)	23 = CM110/3	28 = CM550/3	14 = CM75(/2)	24 = CM150/3	29 = CM750/3
10 = CM12(/2)	20 = CM37/3	25 = CM220/3																
11 = CM25(/2)	21 = CM55/3	26 = CM300/3																
12 = CM37(/2)	22 = CM75/3	27 = CM400/3																
13 = CM55(/2)	23 = CM110/3	28 = CM550/3																
14 = CM75(/2)	24 = CM150/3	29 = CM750/3																
P121	Enable/disable RUN button	0 - 1 [1]	0 = RUN button disabled. 1 = RUN button enabled (only possible if P007=1).															

Parameter	Function	Range [Default]	Description / Notes
P122	Enable/disable FORWARD/REVERSE button	0 - 1 [1]	0 = FORWARD/REVERSE button disabled. 1 = FORWARD/REVERSE button enabled (only possible if P007 = 1).
P123	Enable/disable JOG button	0 - 1 [1]	0 = JOG button disabled. 1 = JOG button enabled (only possible if P007=1).
P124	Enable/disable Δ and ∇ buttons	0 - 1 [1] 	0 = Δ and ∇ buttons disabled. 1 = Δ and ∇ buttons enabled (only possible if P007 = 1). This applies for frequency adjustment only. The buttons can still be used to change parameter values.
P125	Reverse direction inhibit	0 - 1 [1]	0 = Reverse direction disabled. Inhibits reverse commands from ALL sources (reverse RUN commands result in forward rotation) 1 = Normal operation (FORWARD/REVERSE operation allowed)
P131	Frequency setpoint (Hz)	0.0-fmax [-]	
P132	Motor current (A)	0.0 - 99.9 [-]	Read-only parameters. These are copies of the values selected by P001 but can be accessed directly via the serial link.
P133	Motor torque(% nominal torque)	0-250 [-]	
P134	DC link voltage (V)	0 - 1000 [-]	
P135	Motor RPM	0 - 40000 [-]	
P137	Output voltage (V)	0 - 1000 [-]	
P140	Most recent fault code	0 - 9999 [-]	The last recorded fault code (<i>see section 5</i>) is stored in this parameter. It is cleared when the inverter is reset (P944 =1). This is a copy of the code stored in P930.
P141	Most recent fault code -1	0 - 9999 [-]	This parameter stores the last recorded fault code prior to that stored in P140/P930.
P142	Most recent fault code -2	0 - 9999 [-]	This parameter stores the last recorded fault code prior to that stored in P141.
P143	Most recent fault code -3	0 - 9999 [-]	This parameter stores the last recorded fault code prior to that stored in P142.
P151 •	Green LED function	0 - 5 [4]	0 = Off 1 = On 2 = Fault mode: On = Tripped Flashing = Warning 3 = Running mode: On = Motor running Flashing = Inverter on but motor stationary 4 = Default mode (see table in Operating Information, Section 5). 5 = <i>Not used</i>

Parameter	Function	Range [Default]	Description / Notes
P152 •	Yellow LED function	0 - 5 [5]	0 = Off 1 = On 2 = Fault mode: On = Tripped Flashing = Warning 3 = Running mode: On = Motor running Flashing = Inverter on but motor stationary 4 = <i>Not used</i> 5 = Default mode (see table in Operating Information Section 5).
P201	PI closed loop mode	0 - 2 [0]	0 = Normal operation (closed loop control disabled). 1 = Not used 2 = Closed loop control using PI input for transducer feedback.
P202 •	P gain	0.0-999.9 [1.0]	Proportional gain.
P203 •	I gain	0.00 - 99.99 [0.00]	Integral gain. 0.01 corresponds to the longest integral response time.
P205 •	Sample interval (x 25 ms)	1 - 2400 [1]	Sampling interval of feedback sensor.
P206 •	Transducer filtering	0 - 255 [0]	0 = Filter off. 1-255 = Low pass filtering applied to transducer.
P207 •	Integral capture range (%)	0 - 100 [100]	Percentage error above which integral term is reset to zero.
P208	Transducer type	0 - 1 [0]	0 = An increase in motor speed causes an increase in sensor voltage/current output. 1 = An increase in motor speed causes a decrease in sensor voltage/current output.
P210	Transducer reading (%)	0.0 - 100.0 [-]	Read only. Value is a percentage of full scale of the PI input. (eg.: 100 = 10V / 20mA)
P211 •	0% setpoint	0.00-100.00 [0.00]	Value of P210 to be maintained for 0% setpoint.
P212 •	100% setpoint	0.00-100.00 [100.00]	Value of P210 to be maintained for 100% setpoint.
P220 •	PI frequency cut-off	0 - 1 [0]	0 = Normal operation 1 = Switch off inverter at or below minimum frequency.
P331	Analogue mode	0 - 4 [2]	0 = Internal potentiometer only 1 = External analogue input only 2 = Internal potentiometer + external analogue input 3 = Internal potentiometer fine, external input coarse 4 = Internal potentiometer coarse, external input fine
P332	Fine adjustment (%)	0 - 100 [10]	Percentage of fine tuning adjustment for P331 = 3 or 4.
P700			Specific to PROFIBUS-DP. See PROFIBUS Handbook for further details. (Access only possible with P099 = 1.)
P701 •			
P702			

Parameter	Function	Range [Default]	Description / Notes																																				
P723	State of digital inputs	0 - 7 [-]	<table border="0"> <tr> <td></td> <td>DIN3</td> <td>DIN2</td> <td>DIN1</td> </tr> <tr> <td>0 =</td> <td>0</td> <td>0</td> <td>0</td> </tr> <tr> <td>1 =</td> <td>0</td> <td>0</td> <td>1</td> </tr> <tr> <td>2 =</td> <td>0</td> <td>1</td> <td>0</td> </tr> <tr> <td>3 =</td> <td>0</td> <td>1</td> <td>1</td> </tr> <tr> <td>4 =</td> <td>1</td> <td>0</td> <td>0</td> </tr> <tr> <td>5 =</td> <td>1</td> <td>0</td> <td>1</td> </tr> <tr> <td>6 =</td> <td>1</td> <td>1</td> <td>0</td> </tr> <tr> <td>7 =</td> <td>1</td> <td>1</td> <td>1</td> </tr> </table>		DIN3	DIN2	DIN1	0 =	0	0	0	1 =	0	0	1	2 =	0	1	0	3 =	0	1	1	4 =	1	0	0	5 =	1	0	1	6 =	1	1	0	7 =	1	1	1
	DIN3	DIN2	DIN1																																				
0 =	0	0	0																																				
1 =	0	0	1																																				
2 =	0	1	0																																				
3 =	0	1	1																																				
4 =	1	0	0																																				
5 =	1	0	1																																				
6 =	1	1	0																																				
7 =	1	1	1																																				
P845	Motor current limit for Flying Start (%)	0 - 250 [50] (SW Version : 3.00 onwards)	The motor current can be limited with this parameter. If the set value is exceeded during flying start, the output frequency is reduced until the current falls below this limit. During this process, both LEDs will flash (<i>see Operating Information section</i>). If trip occurs during flying start, this value should be reduced.																																				
P880			Specific to PROFIBUS-DP. See PROFIBUS Handbook for further details. (Access only possible with P099 = 1.)																																				
P910 •	Local/Remote mode	0 - 4 [0] 	<p>Sets the inverter for local control or remote control over the serial link:</p> <ul style="list-style-type: none"> 0 = Local control 1 = Remote control (and setting of parameter values) 2 = Local control (but remote control of frequency) 3 = Remote control (but local control of frequency) 4 = Local control (but remote read and write access to parameters and facility to reset trips) <p>When operating the inverter via remote control (P910 = 1 or 3), the analogue input remains active when P006 = 1 and is added to the setpoint.</p>																																				
P918 •	Drive Address	0 - 255 [0]	<p>Specific to PROFIBUS-DP/CAN. See PROFIBUS / CAN Handbooks for further details. (Access only possible with P099 = 1 or 2).</p> <p>Each communications object is defined as a combination of base address and offset whereby the offset is referred to the value in P918.</p>																																				
P922	Software version	0.00 – 99.99 [-]	Contains the software version number and cannot be changed.																																				
P923 •	Equipment system number	0 – 255 [0]	You can use this parameter to allocate a unique reference number to the inverter. It has no operational effect.																																				
P927 •	Local or Remote Access for Parameters	0 – 1 [0]	<p>Specific to PROFIBUS-DP/CAN. See PROFIBUS / CAN Handbooks for further details. (Access only possible with P099 = 1 or 2).</p> <p>Determines which parameter access interface can write to parameters. Note that read access is always allowed.</p> <ul style="list-style-type: none"> 0 = Parameter write access via keypad. 1 = Parameter write access via Comms module. 																																				

Parameter	Function	Range [Default]	Description / Notes
P928 •	Local or Remote control of drive	0 – 3 [0]	<p>Specific to PROFIBUS-DP/CAN. See PROFIBUS / CAN Handbooks for further details. (Access only possible with P099 = 1 or 2).</p> <p>Determines which interface has control of the drive. Note that the drive status can always be monitored.</p> <ul style="list-style-type: none"> 0 = Drive control and setpoint source is local. 1 = Drive control and setpoint source is via Comms Module. 2 = Drive control is local and setpoint source is via Comms Module. 3 Drive control is via Comms Module and setpoint source is local.
P930	Most recent fault code	0 – 9999 [-]	The last recorded fault code (see Section 6.3) is stored in this parameter. It is cleared when the inverter is reset(P944=1).
P931	Most recent warning type	0 – 9999 [-]	<p>The last recorded warning is stored in this parameter until power is removed from the inverter:</p> <ul style="list-style-type: none"> 002 = Current limit active 004 = Slip limit exceeded 005 = Inverter over temperature (internal PTC) 006 = Motor overtemperature(I²T) 007 = Undervoltage 010...P10+/P15V/SK200 +5V Power Supply Fault 018 = Auto restart after fault(P018) is pending. The inverter may start at any time.
P944	Reset to factory default settings	0 – 1 [0]	Set to '1' and then press P to reset all parameters except P101 to the factory default settings.
P947			Specific to PROFIBUS-DP. See PROFIBUS Handbook for further details. (Access only possible with P099 = 1).
P958			Specific to PROFIBUS-DP. See PROFIBUS Handbook for further details. (Access only possible with P099 = 1).
P960	Protocol Type	0 – 3 [0] <i>(SW Version : 3.00 onwards)</i>	<p>Specific to PROFIBUS-DP/CAN. See PROFIBUS / CAN Handbooks for further details. (Access only possible with P099 = 1 or 2).</p> <p>Selects the CANbus protocol.</p> <ul style="list-style-type: none"> 0 = CAN communication disabled. 1 = CANopen communication enabled. 2 =CAN masterdrive communication enabled (future). 3 = DeviceNet communication enabled (future).
P962		<i>(SW Version : 3.00 onwards)</i>	Specific to CAN. (Access only possible with P099 = 2).
P963		<i>(SW Version : 3.00 onwards)</i>	Specific to CAN (Access only possible with P099 = 2).
P964		<i>(SW Version : 3.00 onwards)</i>	Specific to CAN (Access only possible with P099 = 2).

Parameter	Function	Range [Default]	Description / Notes
P965	Special Baud Rate 2	0 – 255 (SW Version : 3.00 onwards)	Specific to CAN (Access only possible with P099 = 2).
P966	PZD Send Interval Time	0 – 65535 [0] (SW Version : 3.00 onwards)	Specific to CAN (Access only possible with P099 = 2). The rate in ms at which PZD is sent is set. 0 = Values sent only after a remote request 1...65534 = Values sent after a preset time (in ms) or after a remote request. 65535 = Values sent whenever the PZD changes or after a remote request.
P967	Last Received Control Word	0 – FFFF Hex	Specific to PROFIBUS-DP/CAN. See PROFIBUS / CAN Handbooks for further details. (Access only possible with P099 = 1 or 2). This is the control word which was most recently received and is currently active within the drive.
P968	Last Sent Status Word	0 – FFFF Hex	Specific to PROFIBUS-DP/CAN. See PROFIBUS / CAN Handbooks for further details. (Access only possible with P099 = 1 or 2). This is the status word which currently represents the operating state of the drive and which is returned on demand to the requestor.
P969		(SW Version : 3.00 onwards)	Specific to CAN (Access only possible with P099 = 2).
P971 •	EEPROM storage control	0 – 1 [1]	0 = Changes to parameter settings (including P971 are lost when power is removed. 1 = Changes to parameter settings are retained during periods when power is removed. IMPORTANT Take care not to exceed the EEPROM write cycle limit of 50,000/parameter (approx.) when using the serial link to update parameters, otherwise data loss or corruption may occur. Read cycles are unlimited.
P986	Relay Output	0 – 3 [0] (SW Version : 3.00 onwards)	Relay 1 = Fault Relay (RL1) Relay 2 = Brake Relay 0 = Relay 1 & 2 - open. 1 = Relay 1 – closed 2 = Relay 2 – closed 3 = Relay 1 & 2 - closed

6.2 Fault Codes

Fault codes are only available when an OPm2 is connected to the COMBIMASTER.

In the event of a failure, the COMBIMASTER switches off and a fault code appears on the LCD screen. The last fault that occurred is stored in parameter P930. e.g. '0003' indicates that the last error was F003.

Fault Code	Cause	Corrective Action
F001	Overvoltage	Check whether supply voltage is within the limits indicated on the rating plate. Increase the ramp down time (P003). Check whether the required braking power is within the specified limits.
F002	Overcurrent	Check motor lead and motor for short-circuits and earth faults. Increase the ramp-up time (P002). Increase the ramp down time (P003) Reduce the boost set in P078 and P079. Check whether the motor is obstructed or overloaded.
F003	Overload	Check whether the motor is overloaded.
F004	Overheating of motor (monitoring with PTC)	Check if motor is overloaded. Check the connections to the PTC. Has P087 been set to 1 without a PTC being connected?
F005	Inverter overtemperature (Heatsink PTC)	Check that the ambient temperature is not too high. The motor speed may be too low for a given load.
F008	USS protocol timeout	Check the serial interface. Check the settings of the bus master and P091 - P093. Check whether the timeout interval is too short (P093).
F009	Undervoltage	Check that the power supply is supplying enough voltage to the inverter.
F010	Initialisation fault / Parameter loss *	Check the entire parameter set. Set P009 to `0000` before power down.
F011	Internal interface fault *	Switch off power and switch on again.
F012	External trip	Source of trip is digital input (configured as an external trip input) going low - check the external source.
F013	Programme fault *	Switch off power and switch on again.
F030	PROFIBUS link failure	Check the integrity of the link.
F031	Option module link failure	Check the integrity of the link.
F033	PROFIBUS configuration error	Check the PROFIBUS configuration.
F036	PROFIBUS module watchdog trip	Replace PROFIBUS module
F074	Motor overtemperature by I ² t calculation	Check that the motor current does not exceed the value set in P083.
F105	COMBIMASTER internal overtemperature (electronics PTC)	Check that the ambient temperature is not too high. The motor speed may be too low for a given load.
F106	Parameter fault P006	Programme one or more Digital Inputs to be fixed frequencies. Change P006 to 0 or 1.
F112	Parameter fault P012/P013	Set parameter P012 < P013.
F212	Parameter fault P211/P212	Set parameter P211 < P212.

* Ensure that the wiring guidelines described in *Electrical Installation* have been complied with.

When the fault has been corrected, restart the inverter and the motor will run if the fault has been cleared.

Intentionally Left Blank



7. OPTIONS AND ACCESSORIES

7.1 Clear Text Display Module (OPm2)

This section only applies to users who intend using the optional Clear Text Display module (OPm2) to control the operation of the inverter.

The OPm2 module provides a multi-language user-friendly interface to the inverter.

The display is menu-driven and provides information in simple text form. It also includes built-in context-sensitive Help screens. As well as enabling direct control of the motor, the OPm2 extends the functionality of the COMBIMASTER by providing access to a comprehensive range of adjustable parameters. Setting these parameters will allow you to customise the operation of the COMBIMASTER to meet almost any application requirement.

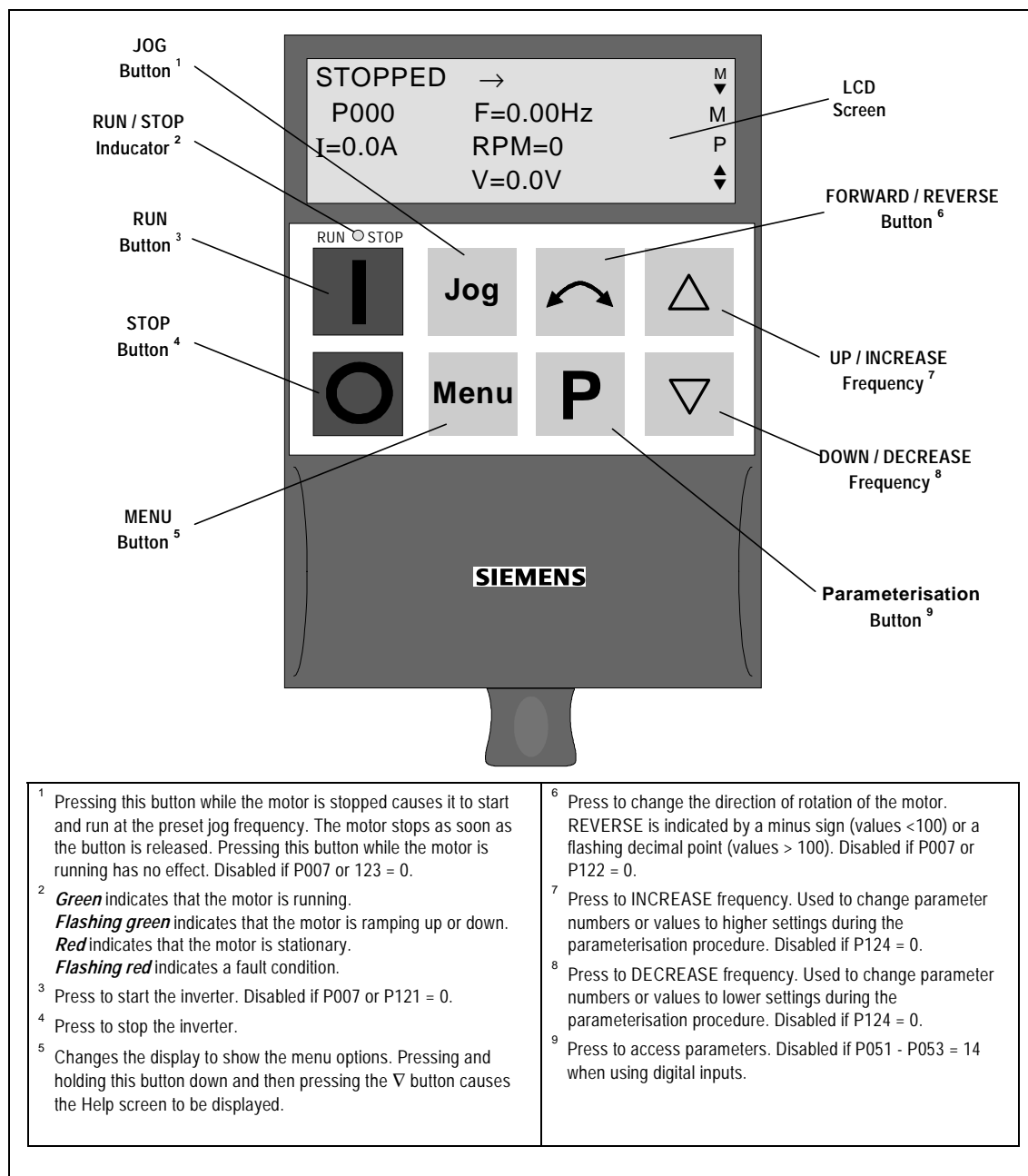

Figure 9 Clear Text Display Module (OPm2)

The user is offered a text-driven format for commissioning, parameterising, configuring and operating the inverter. The following features are included:

- Illuminated high resolution LCD screen with adjustable contrast.
- 7 languages.
- Central device for up to 31 inverters which are networked together via USS.
- Up to 10 parameter sets can be stored in non-volatile memory for uploading and downloading between the clear text operator panel and the drive.
- Help texts for diagnosing faults.
- Isolated RS232 interface for connecting to a PC.

Dimensions H x W x D	130 mm x 73 mm x 40 mm
Current drain at 5 V	250 mA
Degree of protection	IP 54
Maximum cable length	5m

Table 1: Technical Data

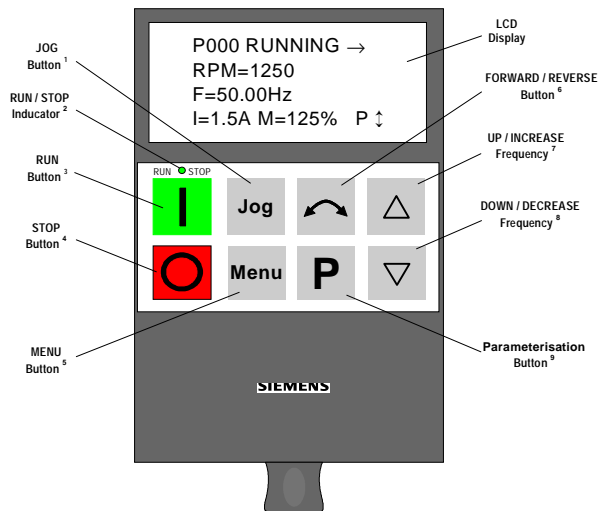

Indications as to which keys to use are shown in the right hand column of the screen.

All the main functions are accessible from the main menu screen:

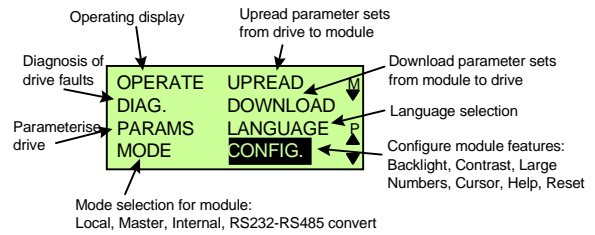

Main Menu Screen

Pressing the Menu and ∇ keys simultaneously causes a help screen, displaying the key features of the Clear Text display module, to appear.

On power-up, unless configured otherwise, the panel will show the Operating Display.

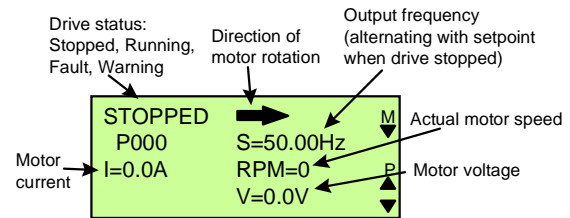

Operating Display when in Local mode.

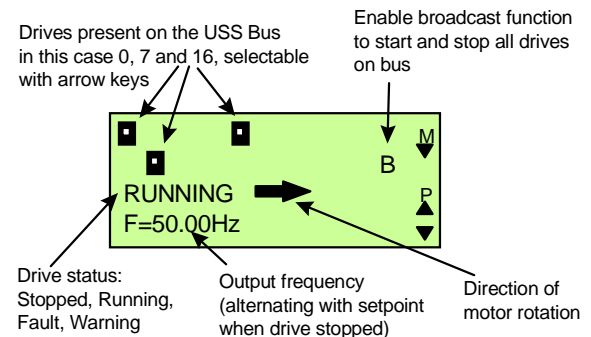

Operating Display when in Master mode.

The status LED indicates whether the drive is running. When the LED is green, the drive is running and when it is red the drive is stopped. When accessing drive parameters, help texts are associated with the parameter and the parameter values.

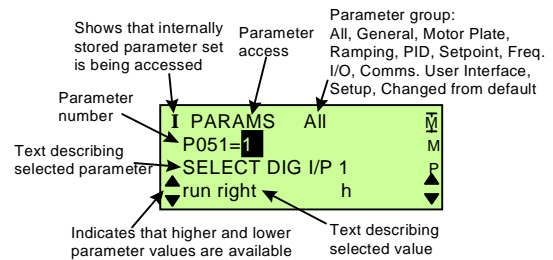

RS232 Interface

The Clear text Display is fitted with an RS232 interface to allow the drive to be connected to a PC.

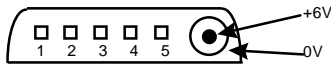

Figure 10: Pin Layout of the RS232 Edge Connector

Terminal	Function, information
1	NC (not connected)
2	External TxD
3	External RxD
4	External RTS
5	Isolated 0V

Table 2: Terminal functions of the RS232 connector

Table 3 gives the ordering information for the OPM2 Clear Text Display Module.

The RS232 interface requires an external power supply to operate. The specification of the power supply interface is as follows:

- Voltage tolerance $6V \pm 0.5V$
- Max Supply Current when connected to drive 50mA, when not connected to drive 250mA
- Connecting Plug
 - - Outside diameter 3.5mm
 - - Inside diameter 1.35mm

Designation	Order No.
OPM2 Clear Text Display Module	6SE 3290-0XX87-8BF0
Connecting cable OPM 3m	6SE 9996-0XA31

Table 3: Ordering Information

7.2 PROFIBUS CB155



This option allows the COMBIMASTER to be controlled via a PROFIBUS-DP serial bus (SINEC L2-DP).

PROFIBUS-DP is a cost-effective high speed serial communication system optimised for the actuator/sensor area where very short system reaction times are critical. It operates as a decentralised I/O system whereby the traditional wiring to the sensors and actuators is replaced by an RS485 serial bus system linking the stations together.

The suitability of the system for such applications has been recently enhanced by the extension of the bus speed up to 12MBd. The protocol is defined as DIN19245 and also as EN50170 guaranteeing open, multi-vendor communications between PROFIBUS-DP stations.

Up to 125 stations can be networked together using this single bus system and a very flexible data structure allows the system to be optimised to exactly match the requirements of each device.

PROFIBUS-DP lies at the heart of the new generation of SIMATIC S7 automation systems offered by Siemens. Using this single bus system, all engineering, visualisation and PLC control operations can be integrated. To configure a SIMATIC based automation system, all that is required is the associated STEP7 configuration tool running on a PC. Bus configuration is performed by using a drag and drop technique in a graphically displayed PROFIBUS-DP network.

Below are listed some of the advantages of automating a system with PROFIBUS-DP:

- Only one single network for operator panels, drives, sensors, actuators, PLCs.
- Cost savings in installation time and cabling.
- Ease of commissioning with the SIMATIC S7 PLC system and STEP7 software.

Flexibility to expand or modify the automation system at a later date.

Simple integration into higher level process visualisation systems such as PCS7.

Remote diagnostics reduce the down-time in the event of a problem.

Features of CB 155 PROFIBUS Option:

- Permits fast cyclic communications via a PROFIBUS connection.
- Supports all PROFIBUS baud rates up to 12MBd.
- Control of up to 125 inverters using PROFIBUS-DP protocol (with repeaters).
- Conforms with the relevant parts of DIN 19245 and EN50170 guaranteeing open communications on a serial bus system. It can be used with other PROFIBUS-DP/SINEC L2-DP peripheral devices on the serial bus. Data format conforms to the VDI/VDE directive 3689 "PROFIBUS Profile for Variable Speed Drives".
- Can be easily configured using Siemens COM ET 200, COM ET Windows or S7 Manager software.
- Simple integration into a SIMATIC S5 or S7 PLC system using specially designed functional blocks (S5) and software modules (S7).
- Simply fits to the side of the COMBIMASTER inverter using two screws.
- No separate power supply necessary.
- Digital and analogue inputs can be read and the digital output controlled via the serial bus.
- Approx. 5 ms response time to process data.

- Output frequency (and therefore motor speed) can be controlled locally on the drive or over the serial bus.
- Multi-mode operation possible, whereby control data can be input via the terminal block (digital inputs) and set point over the serial bus. Alternatively, the set point can be from a local source (analogue input) with the drive control over the serial bus.
- All drive parameters are accessible over the serial link.

The PROFIBUS module fits to the side of the COMBIMASTER using two screws.

COMBIMASTER PROFIBUS Accessories

- The following PROFIBUS accessories are available for COMBIMASTER. All are rated IP65 minimum.
- CM PROFIBUS T Connector - This fits to the PROFIBUS module, and allows in/out PROFIBUS cables to be connected. It also contains the necessary terminating network for 12 Mbaud operation. It is fitted with two female circular connectors, and the cable to the CB155
- CM PROFIBUS Terminator - This houses the resistive terminating devices required at each end of a PROFIBUS link. It can be fitted to the last COMBIMASTER T piece in the link.
- CM PROFIBUS Cable 1m - 1 metre PROFIBUS cable fitted with two male circular connectors.
- CM PROFIBUS Cable 5m - 5 metre PROFIBUS cable fitted with two male circular connectors.
- CM PROFIBUS Cable 10m - 10 metre PROFIBUS cable fitted with two male circular connectors.
- CM PROFIBUS cable link (10cm) - 10cm of PROFIBUS cable fitted with 2 female circular connectors, for connecting two lengths of cable.

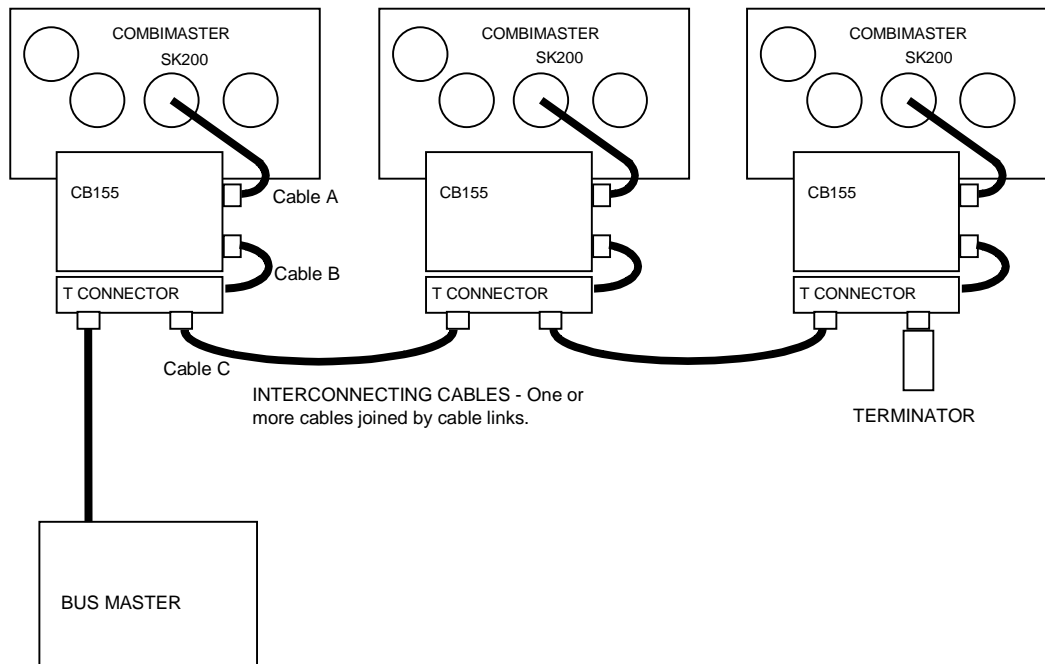

Figure 11 Typical PROFIBUS Installation, Showing Use Of Accessories

PROFIBUS Component	Order Number	Drawing Reference
CM PROFIBUS module CB155 <i>Note: For CS B Issue A units :-</i>	6SE9996-0XA18 6SE9996-0XA20	Includes Cable A
CM PROFIBUS T connector	6SE9996-0XA21	Includes Cable B
CM PROFIBUS terminator	6SE9996-0XA22	
CM PROFIBUS cable 1m	6SE9996-0XA23	Cable C
CM PROFIBUS cable 5m	6SE9996-0XA24	Cable C
CM PROFIBUS cable 10m	6SE9996-0XA25	Cable C
CM PROFIBUS cable link	6SE9996-0XA26	Used for joining lengths of cable C



1. A clear text operator panel (OPM2) is required to set the COMBIMASTER parameters prior to connecting the PROFIBUS module.
2. The PROFIBUS Module may only be connected or disconnected from the drive when the drive is powered off.
3. The PROFIBUS module must only be connected to the drive with the cable supplied for the purpose.
4. The PROFIBUS module cannot be used simultaneously with the Clear Text Display module.

Parameter data exchange may, however, be blocked if bus or PLC memory space is at a premium. The data structure and thus the PPO type is normally specified by the bus master. If no PPO type is specified (e.g. if a combined DP/FMS bus master is used), then the default PPO type is type 1 (parameter data enabled). Parameter write access over the serial link can be enabled or blocked as required.



For more detailed Information , refer to Profibus Manual

The data structure for communication over PROFIBUS-DP can be either PPO type 1 or PPO type 3 as specified in VDI/VDE 3689. This means in practice that process data (control words, set-point in the transmitted telegram and status words, actual values in the received telegram) is always sent.

Parameter read access is permanently enabled, allowing continuous read out of drive data, diagnostics, fault messages etc. A visualisation system can thus be realised with minimal effort.

The PROFIBUS cable is connected to the 5-way miniature circular socket on the side of the PROFIBUS Module, via a special 'T' connector which fits to the edge of the module. This T connector allows the PROFIBUS module to be disconnected from the bus in the event of a fault, without breaking the PROFIBUS link. The pin designation of the circular connectors is given below.

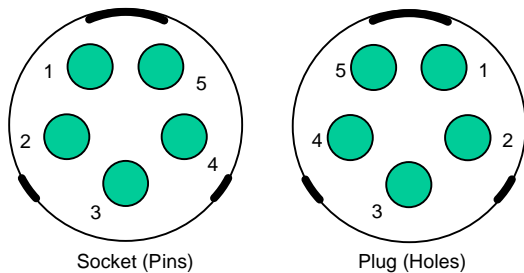

Figure 12 Pin Arrangement For The 5-Way Circular PROFIBUS Connector

Note that the socket is used on the PROFIBUS module, and the cable links. The plug is used on the interconnecting cables.

Terminal	Function, information
1	+5V
2	N (-)
3	0V
4	P (+)
5	No connection

Table 4: Pin Assignment for the 5-way Circular PROFIBUS Connector

Data transfer rate (Kbit/s)	Max. cable length of a segment (m)
9.6	1200
19.2	1200
93.75	1200
187.5	1000
500	400
1500	200
12000	100

Table 5: Cable Lengths

A segment can be extended by using RS 485 repeaters.

Recommendation: RS 485 repeater (Order No.: 6ES7 972-0AA00-0XA0).

For reliable operation of the serial bus system, the cable must be terminated at both ends using terminating resistors. For operation at 12MBd, cables must be terminated in connectors with a built-in damping network (built into T Connector). Additionally, for 12MBd operation, no stub length from the main bus cable is allowed.

Suitable SINEC-L2 DP connectors and cable for reliable operation up to 12MBd are detailed above.

A floppy disk is supplied with the PROFIBUS module containing the handbook and two data files for configuring the relevant PLC system.

Quick Guide to Setting Up PROFIBUS Communications

- The bus cable between the master device and the drive must be connected correctly. This includes the necessary termination resistors and (for 12MBd) the terminating network.
- The bus cable must be screened and the screen must be connected to the housing of the cable connector.
- The PROFIBUS master must be configured correctly so that communications can be realized with a DP slave using PPO type 1 or PPO type 3 (only PPO type 1, if the PPO type cannot be configured via remote operator control).
- When using COM ET software with a SIMATIC S5, the correct type description file must be used, so that an IM 308B/C can be configured as bus master. When using the Simatic Manager for an S7, the Object Manager must be loaded.
- The bus must be operational (for a SIMATIC module, the operator control panel switch must be set to RUN).
- The bus baud rate must not exceed 12 MBd.
- The PROFIBUS Module must be correctly fitted to the inverter and the inverter must be powered up.
- The slave address for the drive (parameter P918) must be set so that it corresponds to the slave address configured at the PROFIBUS master, and must be uniquely defined on the bus.

Installation should be in conformance with EMC directives and regulations (*this is described in section 4 and in the operating manuals for the PLC*).

Dimensions H x W x D	115 mm x 90 mm x 30 mm
Degree of protection	IP 65
Maximum bus speed	12MBd

Table 6: Technical Data

7.3 Control and Commissioning with SIMOVIS

The SIMOVIS drive commissioning software operates under Windows 95 or NT and can be used to configure the COMBIMASTER, MICROMASTER, MICROMASTER Vector and MIDIMASTER Vector drives.

SIMOVIS offers the following benefits:

- Access from the same PC to one or several drives connected to the same serial bus.
- Storage of parameter sets on the PC.
- Control and monitoring of the drives.
- Simplified, text driven, access to all parameters within the drive.
- Upread and download of entire parameter sets.
- Off-line configuration for altering parameter sets stored on the PC hard disk drive without a connection to the drive.

- Interface to the S7 Manager to allow configuring of drives on a PROFIBUS DP* link within an automation system.

* Requires a communication board to operate via PROFIBUS –Ref No. 6GK1541-1AA00 PROFIBUS CP5411.



The minimum recommended PC specification for operation of SIMOVIS is a 90MHz Pentium with 32MB of RAM, 200MB hard drive and WINDOWS95 or NT4.0

Designation	Order No.
SIMOVIS Standalone Version	6SE3290-0XX87-8SA2
Block package for SIMATIC S7 including DVA_S7 and Object Manager	6SX7005-0CB00

Table 7: SIMOVIS Ordering Information

Standalone Operation of SIMOVIS

For direct configuration of one or more drives, SIMOVIS communicates over the PC serial port, COM1 or COM2. An RS232/485 converter must be connected between the PC and the drive. The Clear Text Display module is suitable for this purpose – refer to section 7.1.

Following installation, the Buskon program must be called to define whether one or more drives is connected to the PC. For each connected drive, the drive type must be selected from the hardware directory and the bus address must match the value programmed into P091 in the drive.

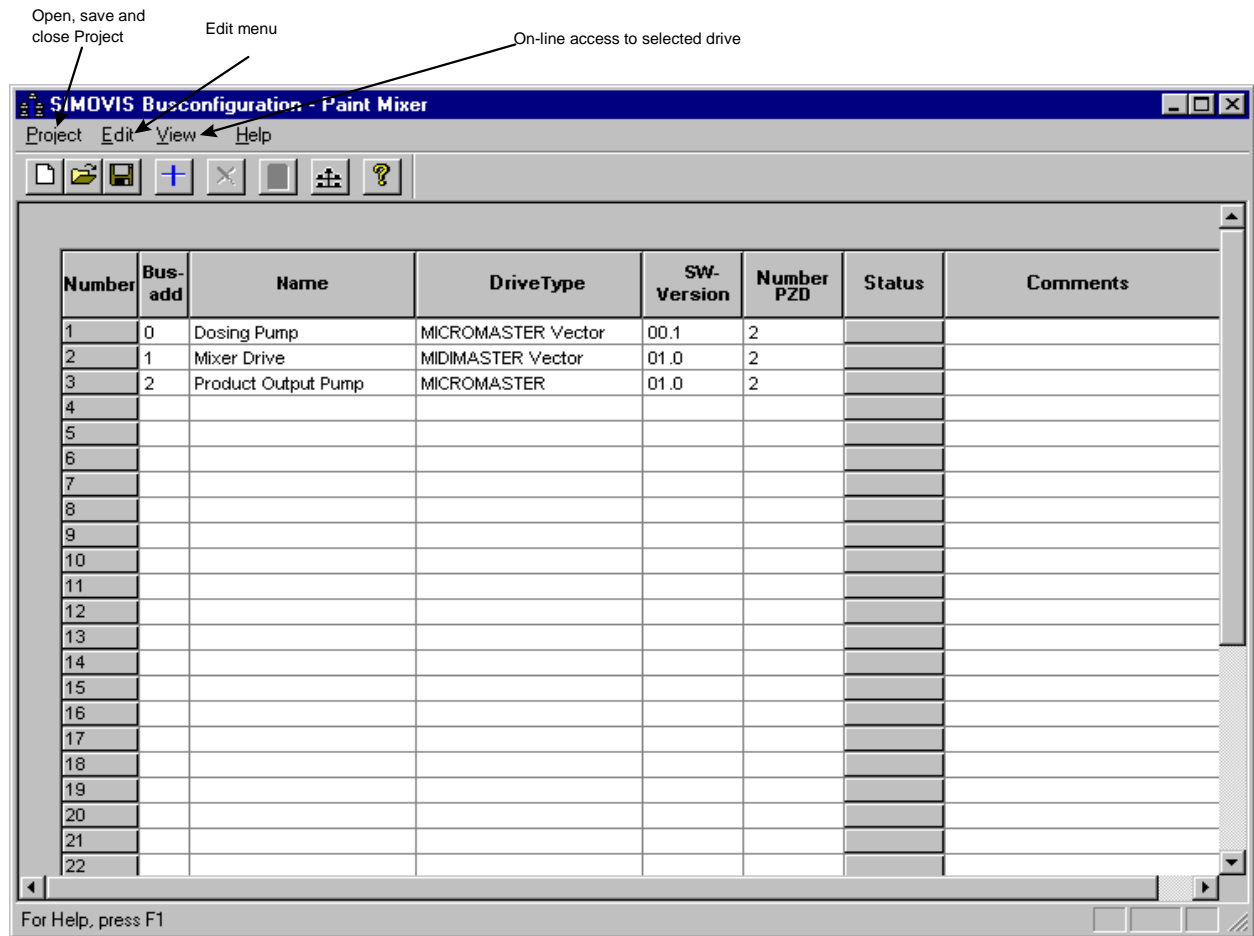

Figure 13 Example Screen From Buskon Program Showing a Project Where 3 Drives are Connected to the PC

SIMOVIS is then started by selecting the drive from the list and selecting drive parameterisation from the edit menu. The drive parameter list (or part thereof) can be accessed from the Parameter menu.

Drive data (parameter sets) save, open, upload, download
 Parameter set in RAM, EEPROM or PC drive
 Parameter screen view, full list or specific parameter groups
 Direct Access to drive process data

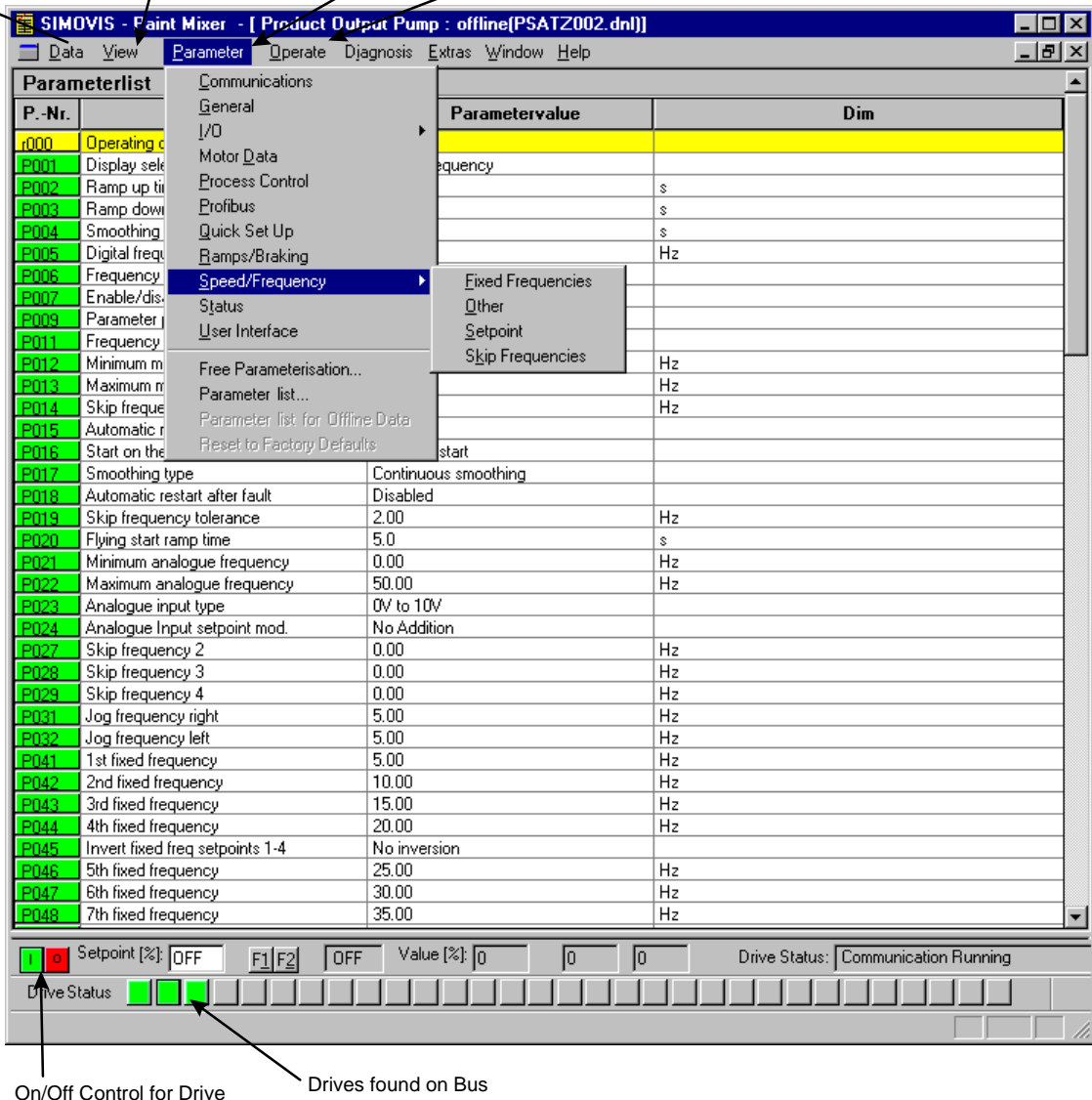

Figure 14 Example Screen From SIMOVIS Where Access to the Whole Parameter List Has Been Selected

Operation of SIMOVIS within an Automation System

SIMOVIS can access the drives on a PROFIBUS DP system when run on a PC or PG with Step 7 V3.2 or higher. In this case the Buskon program is not used and SIMOVIS can be called directly by selecting the required drive from the Step7 HWConfig program once the PROFIBUS network has been configured.

Access to the drive parameters is identical to the standalone case. Details on how to configure the automation system are to be found in the relevant Step7 documentation. The hardware requirement for SIMOVIS is identical to that for Step 7.

7.4 Brake Options

Pulse Resistor Braking Unit (Only available for CS B Inverters)



The pulse resistor braking unit gives the COMBIMASTER increased immunity to over voltage trips, and can also be used to provide up to 7kW (peak) of braking power for stopping the system more quickly than would otherwise be possible.

The braking unit fits in place of the standard cover for the inverter unit. It houses the braking control electronics, and a 7kW (peak) braking resistor with heat sink. Full IP65 environmental protection is maintained.

Technical Overview

The electronics operates completely independently of the inverter electronics, monitoring the DC link voltage. During braking, the motor will regenerate, causing the DC link voltage to rise. When a set threshold is reached, the unit switches the resistor onto the DC link, causing the regenerated energy to be dissipated as heat in the resistor, and preventing an over voltage trip.

While the resistor is switched on, its temperature will rise. When a threshold temperature (T_{max}) is reached, the unit will limit the power in the resistor to approximately 5% of the peak power. (350W). If the temperature continues to rise, the resistor will be disabled completely, until the temperature has reduced. The following diagrams show the relationship between braking power, and resistor temperature with time.

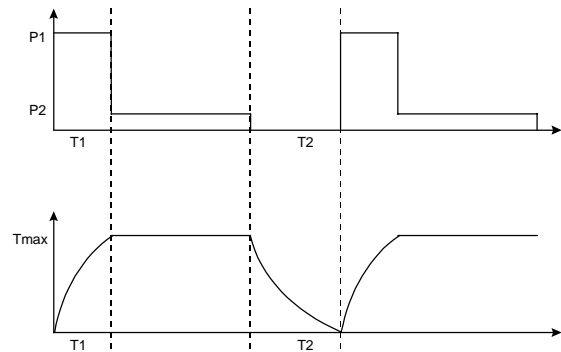

Figures given below are for a 7kW (peak) braking unit. T1 and T2 are variable, depending on ambient temperature. However typical figures are given.

- P1 - 7kW
- P2 - 350W
- T1 - 5 Seconds typical
- T2 - 100 Seconds typical

Protection

In the event of a braking unit fault, it is possible for the resistor to become permanently connected, and to overheat. The resistor temperature is monitored by an internal circuit, and if it becomes too hot, this is indicated by a fault relay. This relay should be used to control an external contactor, to remove power from the COMBIMASTER. See the braking unit installation instructions for more information.

Electromechanical Brake Control



The electromechanical brake control, allows the COMBIMASTER to directly control an electromechanical brake.

The brake control fits in place of the standard cover for the inverter unit. Full IP65 environmental protection is maintained.

The unit provides an output to drive the coil of a DC electromechanical brake. It can be configured for both fast, and slow operation of the coil. The unit is set up using the parameters P062, P063 and P064, which allows full control of the brake release time, and brake stopping time.

Brake coil voltage output will be 180VDC for 400V mains input, and 205VDC for 230V mains input.

Note that the coil voltage for 400V units of 180VDC is not suitable for the standard Siemens electromechanical brake option G26. (refer to Siemens Catalogue M11)

For other mains voltages, the coil voltage will be:

0.9*Vmains for Vmains = 208V to 240V
0.45*Vmains for Vmains = 380V to 500V.

Designation	Order No.
Pulse Resistor Braking Unit (including E-M brake control) -CS B only	6SE9996 -0XA11
Electromechanical Brake Control Unit -CS B	6SE9996 -0XA10
Electromechanical Brake Control Unit -CS A*	6SE9996 -0XA07

Table 8: Brake Options Ordering Information

* Product release date expected August 1999, please contact your local Siemens sales office for further information.

7.5 Fan Assembly Options

Fan Assemblies are only required for the MICROMASTER Integrated Inverters.

A fan assembly unit is only required when the motor associated with the MMI unit does not include a special cutout in the Motor Fan Cowl (with the inverter heatsink positioned just above this cutout).

The following fan options can be ordered using either the Order Reference Number or added to the MICROMASTER Integrated Order Number using the option short code.

The fan assemblies can be customer fitted if required.

Designation	Order No.
Fan assembly -for CS B	6SE9996 -0XA02 (Short Code - for ordering: M41)
Fan assembly -for CS A	6SE9996 -0XA01 (Short Code - for ordering: M41)

7.6 Motor Interface Plate Options

The Motor Interface Plate (MIP) arrangements differ between motor types and inverter case sizes. For a full description of the MIP options, please refer to section 9.2 of this document.

Ordering Information - Motor Interface Plates

Inverter Case Size	Motor type	MIP Type	Motor Frame Size	Order Number
CS A	1LA7(Siemens)	Specific	56 to 71	6SE9996-0XA51
CS A	1LA7	Specific	80 to 90	6SE9996-0XA52
CS B	1LA5	Specific	90 to 132	6SE9996-0XA40
CS B	1LA7	Specific	90	*
CS B	1LA7	Specific	100 to 112	6SE9996-0XA41
CS B	1LA7	Specific	132	6SE9996-0XA42
CS A	Any	'Universal' **		6SE9996-0XA44
CS B	Any	'Universal' **		*

* Not available at time of writing.

**The above Universal MIPs will usually need additional simple 'base plates' to customise for a specific motor - refer to the Section 9.2 for description.

8. SPECIFICATIONS

8.1 Mechanical Data – Dimensional Drawings

COMBIMASTER - Case Size A

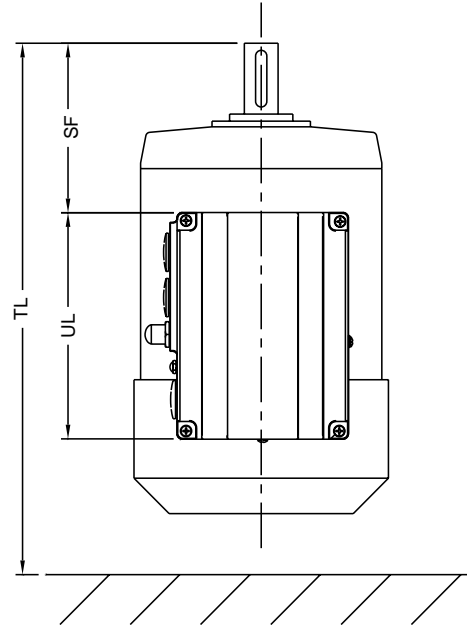
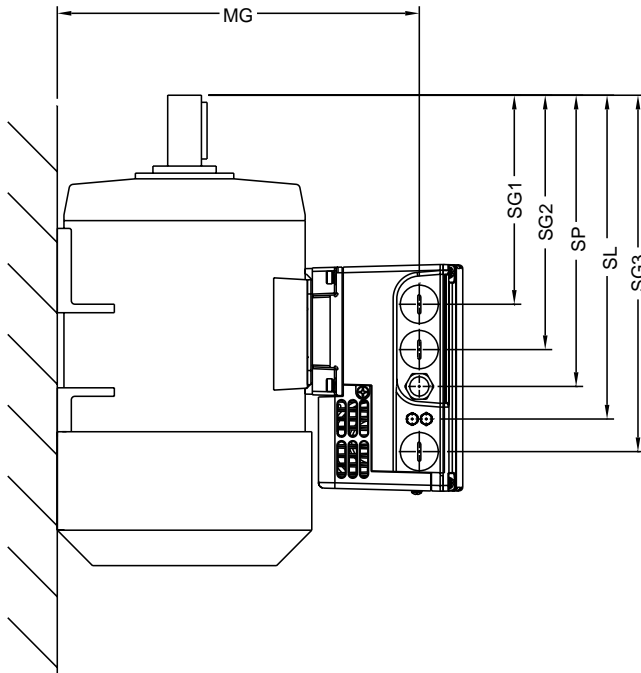

		MOTOR FRAME SIZE				
		56	63	71	80	90
DIMENSION	TH	230	237	255	278	296
	CG	66	66	66	66	66
	UW	122	122	122	122	122
	TL _{min}	205	244	269	303	361
	SF	48	55	46	107	136
	UL	160	160	160	160	160
	MG	199	206	224	247	265
	SG1	76	83	74	135	164
	SG2	108	115	106	167	196
	SP	134	141	132	193	222
	SL	157	164	155	216	245
SG3	180	187	178	239	268	
LC	10	10	10	10	10	

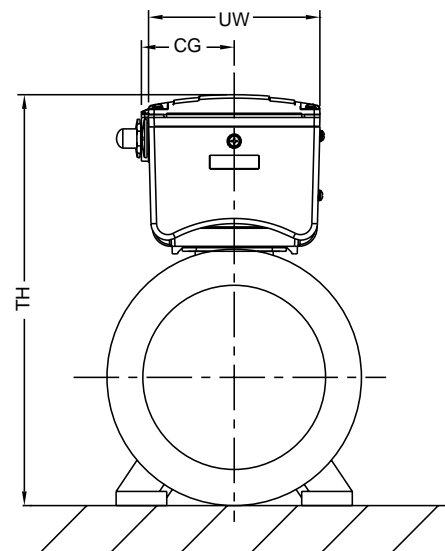

Dimensions in mm

For detailed Motor Dimension drawings, please refer to Siemens Catalogue M11 (ref.: E20002-K1711-A101-A3-7600), Section 8 Dimension Drawings.

COMBIMASTER - Case Size B

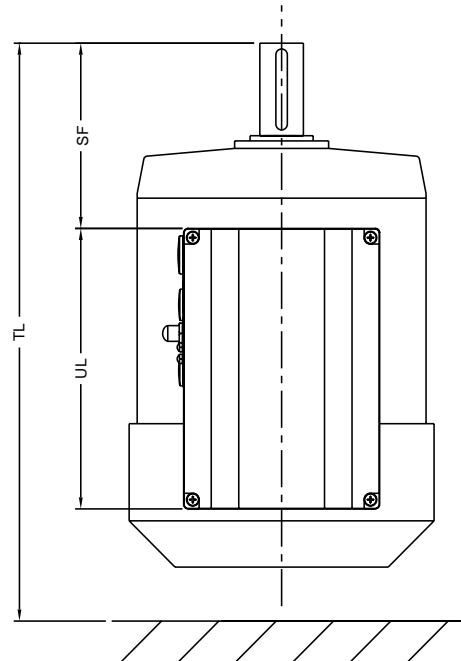
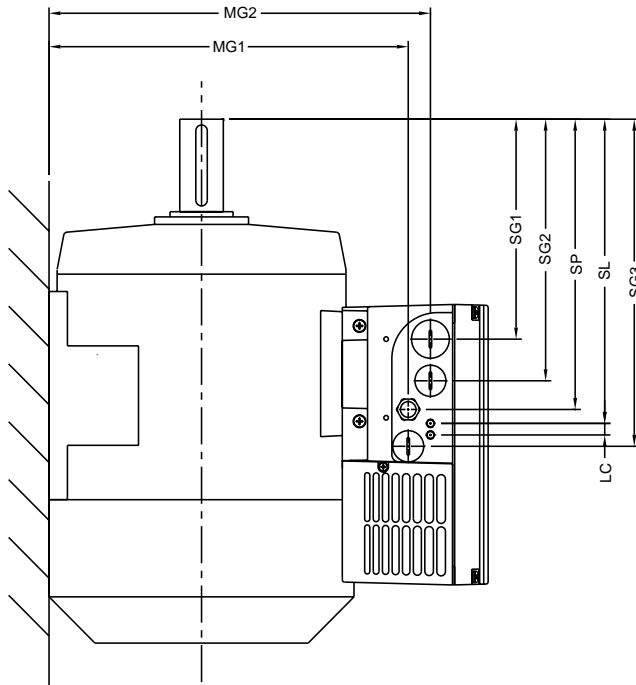

		MOTOR FRAME SIZE			
		90	100	112	132
DIMENSION	TH	317	333	357	396
	CG	86	86	86	86
	UW	171	171	171	171
	TL _{max}	361	424	445	506
	SF	90	139	139	175
	UL	243	243	243	243
	MG1	249	265	289	323
	MG2	269	285	309	348
	SG1	120	169	169	205
	SG2	156	205	205	241
	SP	181	230	230	266
SL	193	242	242	278	
SG3	213	262	262	298	
LC	10	10	10	10	

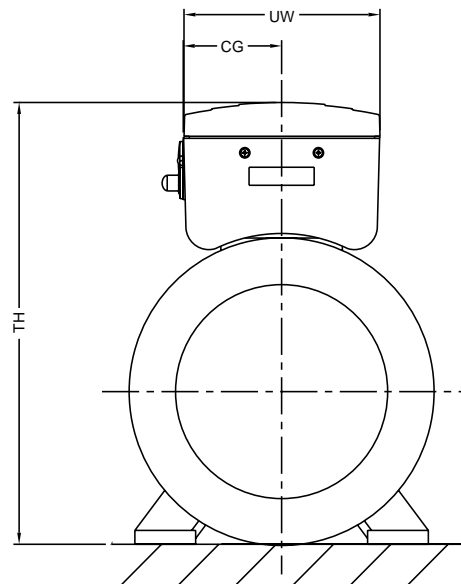

Dimensions in mm.

For detailed Motor Dimension drawings, please refer to Siemens Catalogue M11 (ref.: E20002-K1711-A101-A3-7600), Section 8 Dimension Drawings.

COMBIMASTER - Case Size A - Deep Cover

Deep Cover – used for Electromechanical Brake Control Unit & Class B Filter (400V only)

(for Dimension TH for Case Size A , please refer to table on Page 53)

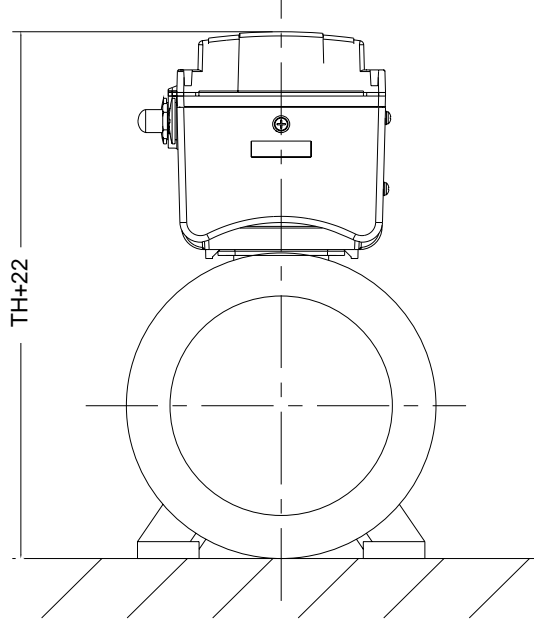

COMBIMASTER - Case Size B – Deep Covers

Deeper Covers:

- i) Resistor Brake (incl. Heatsink)
- ii) Mechanical Brake

(for Dimension TH for Case Size B , please refer to table on Page 54)

For detailed Motor Dimension drawings, please refer to Siemens Catalogue M11 (ref.: E20002-K1711-A101-A3-7600), Section 8 Dimension Drawings.

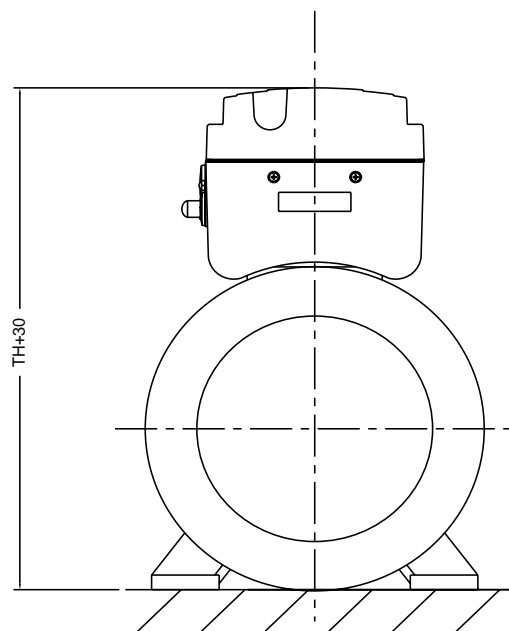
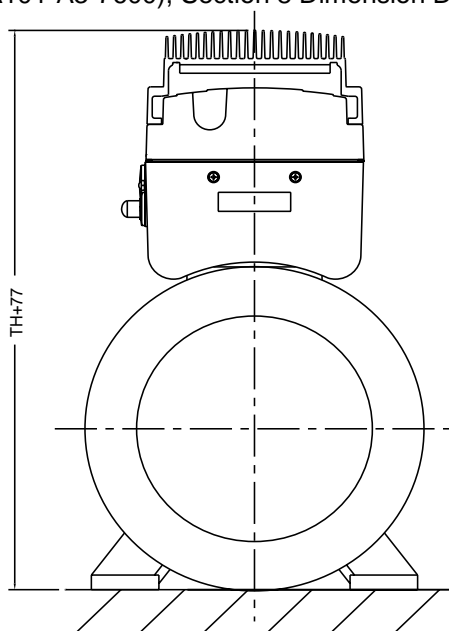

Dimensions in mm.

For detailed Motor Dimension drawings, please refer to Siemens Catalogue M11 (ref.: E20002-K1711-A101-A3-7600), Section 8 Dimension Drawings.

MICROMASTER Integrated - Case Size A

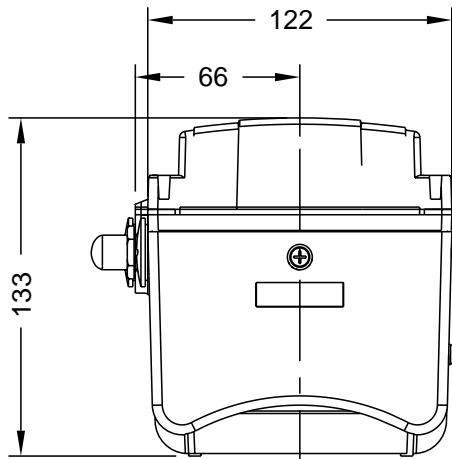
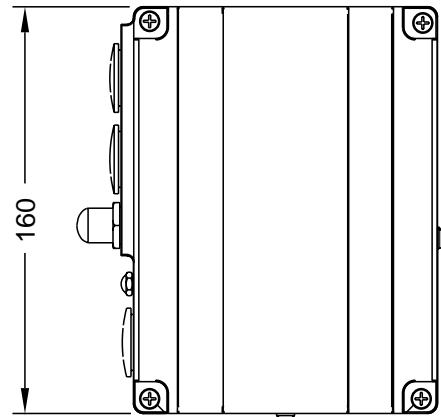
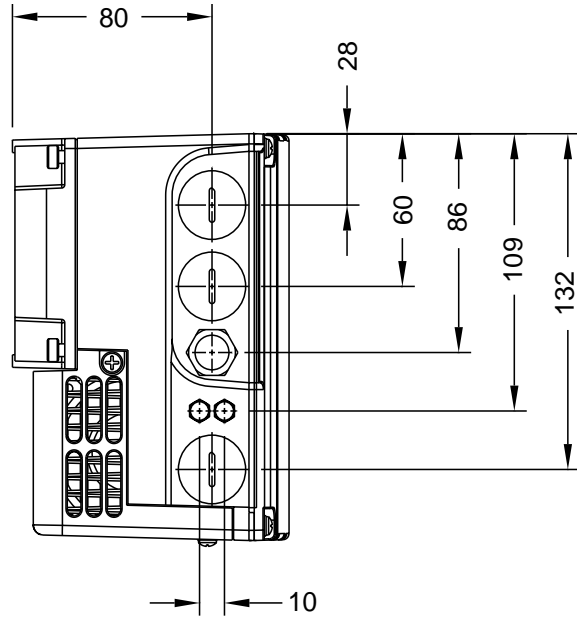

Note : Deep Cover (used for Electromechanical
Brake Control unit
& Class B Filter – 400V only)

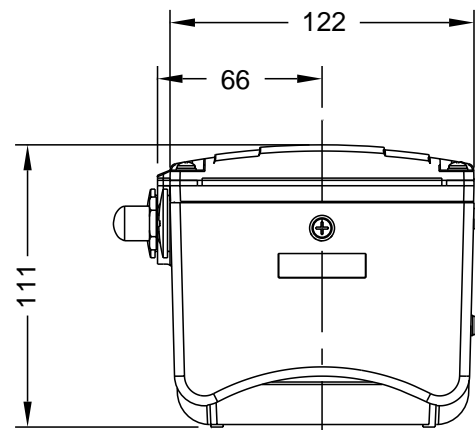

With Normal Cover

Dimensions in mm.

MICROMASTER Integrated - Case Size B

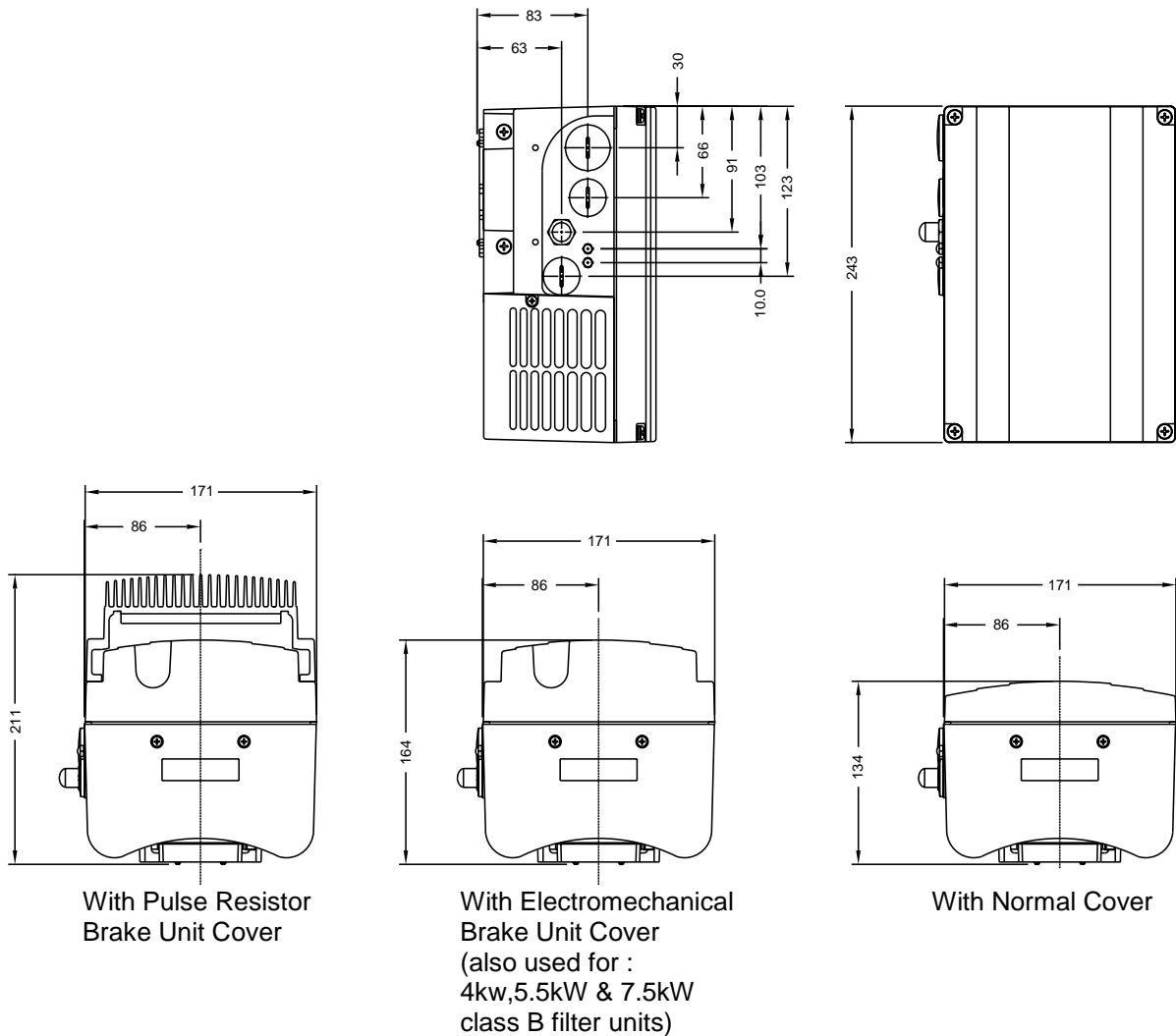

Dimensions in mm.

COMBIMASTER Option – Profibus Module CB155

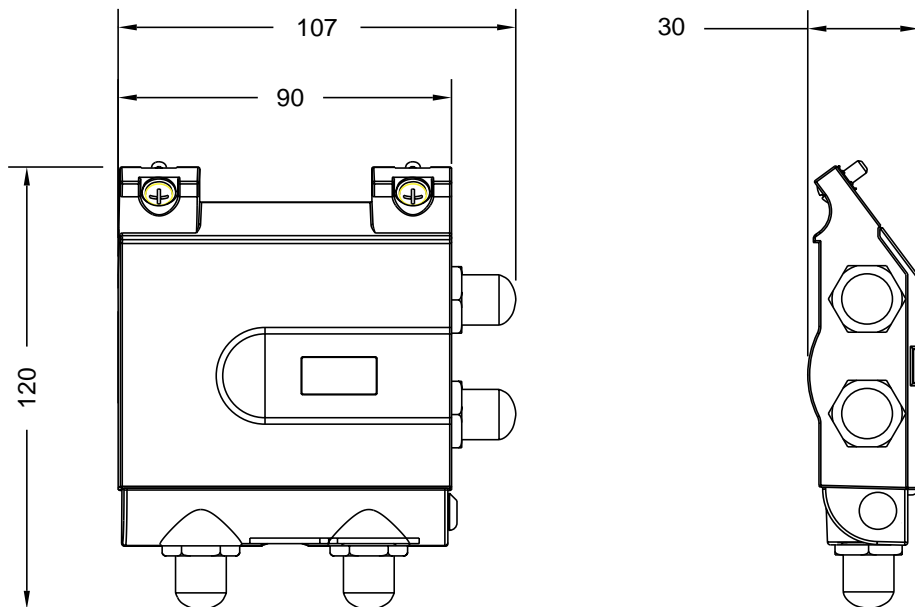
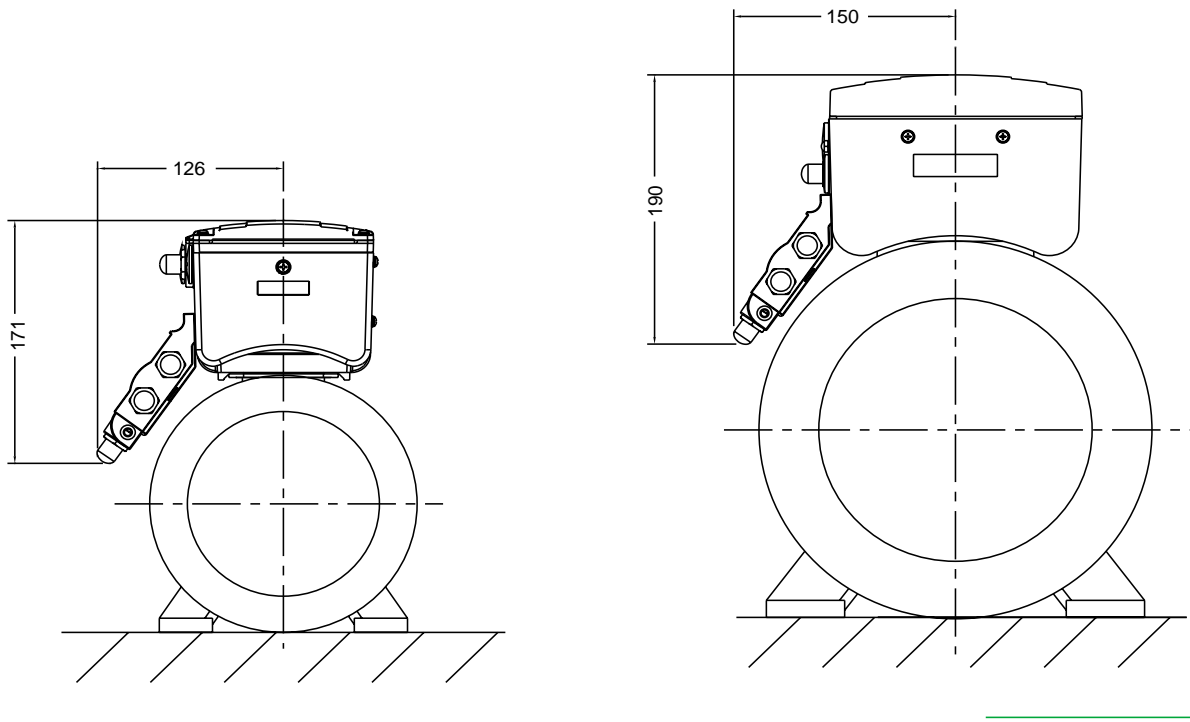

Dimensions in mm

8.2 Electrical Data

General

Feature	Specification	
	COMBIMASTER	MICROMASTER Integrated
Mains voltage	208-240V ± 10% 1/3 Phase	208-240V±10% 1/3 Ph.
Torque derating required for < 380Vrms	380-500V ± 10% 3 Phase *	380-500V±10% 3 Ph. *
	* In case of unearthed mains please contact Siemens	
Power Ranges	1AC 208-240V 3AC 208-240V 3AC 380-500V	0.12kW – 0.75kW 0.12kW – 0.75kW 0.37kW – 7.5kW
Control Method	V/f	
Input frequency:	47 Hz to 63 Hz	
Output frequency :	CM : 0 Hz to 140 Hz (motor dependent)	MMI: 0 Hz to 400 Hz
Setpoint resolution:	0.05 Hz	
Overload capability:	150% for 60 s, related to nominal current	
Protection against:	Inverter overtemperature, Motor overtemperature Overvoltage , Undervoltage Locked Rotor, Motor pull-out	
Standard Functions	DC Injection braking, also when motor stationary 4 quadrant operation Programmable auto-restart following mains break or fault Flying start for already spinning motor 2 programmable ramp generators (0-650s) each with S-curve capability	
Local Setpoint	Built – in potentiometer	
Digital Inputs	3	
Analogue Input:	0/2 - 10 V 0 - 20 mA/4 - 20 mA	
PI Input:	0 - 10 V 0 - 20 mA	
Analogue setpoint resolution:	10-bit	
Setpoint stability:	Analogue < 1% Digital < 0.02%	
Motor temperature monitoring:	I ² t control PTC input	
Ramp times:	0 - 650 s	
Control outputs:	1 relay 30 V DC / 1 A	
	 WARNING External inductive loads must be suppressed in an appropriate manner (see Section 4.1 Electrical Installation – General Wiring Guidelines – Paragraph. 4).	
Serial Interface:	RS485	
Inverter efficiency:	97% typical	
Operating temperature:	-10°C to +40°C	-10°C to +50°C
Storage/transport temperature:	-40°C to +70°C	
Humidity:	99% non-condensing	
Installation height above sea level:	< 1000 m	
Degree of protection:	IP55	IP65
Protective separation of circuits:	Double insulation or protective screening	
Electro-magnetic compatibility (EMC):	Optional EMC Filters to EN55011 Class A or B See section 9.3 - EMC	
Weights	CS A: ca 3.5 Kg (depending on options selected) CS B: ca 5.6 Kg (depending on options selected)	

8.3 De-rating Information

De-rating with altitude

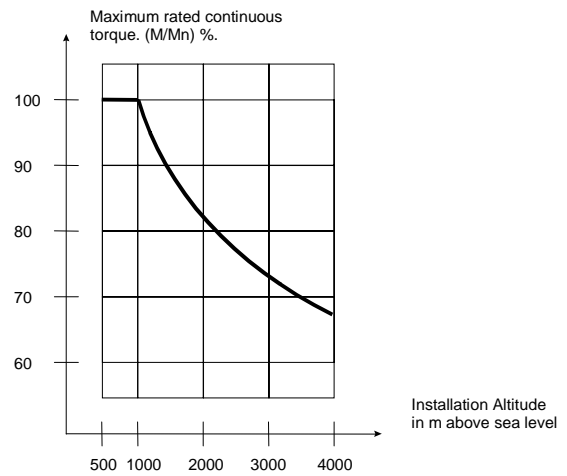
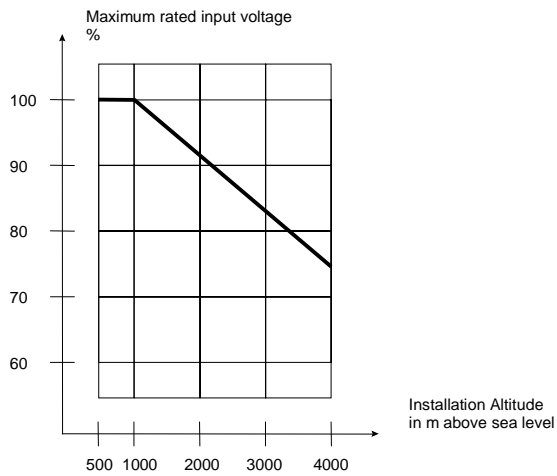

De-rating with switching frequency

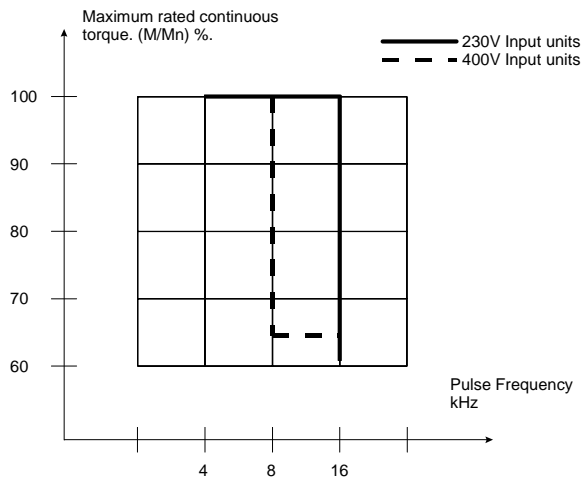

De-rating with mains input voltage

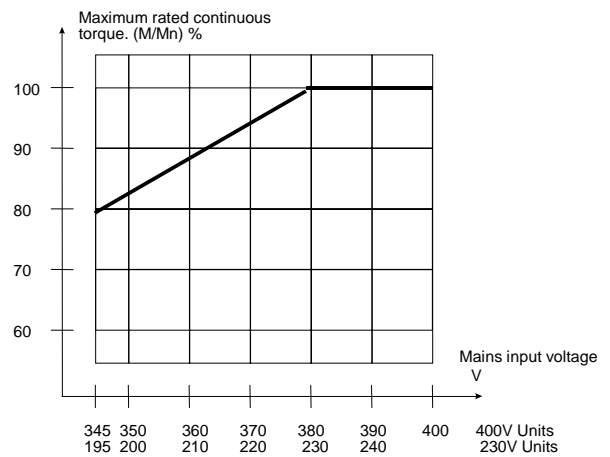

De-rating with temperature

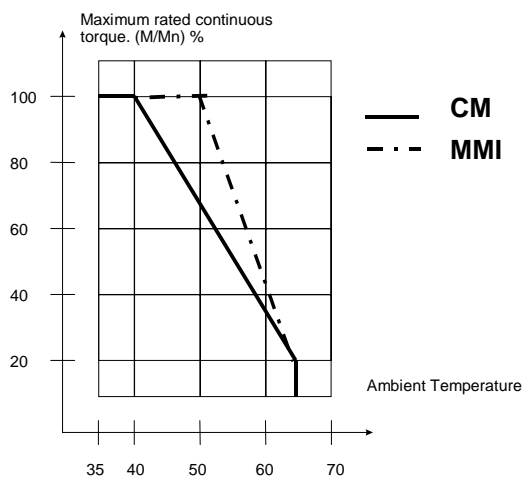

De-rating with inverter frequency

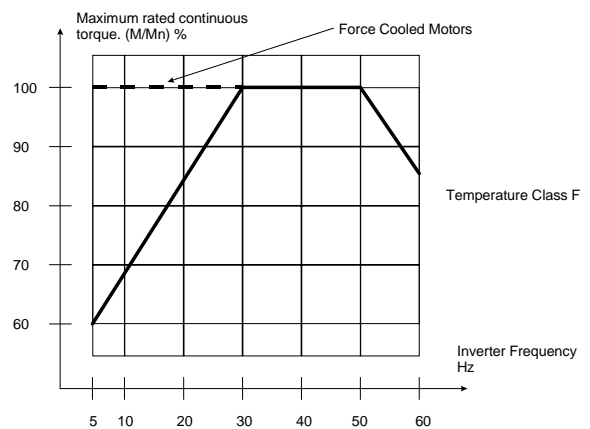

8.4 Technical Data - COMBIMASTER

CS A Low Voltage Single Phase Units

Model:	CM12	CM25	CM37	CM55	CM75
Order Number: *					
2 pole	1UA7053-2B[z]0.	1UA7063-2B[z]0.	1UA7070-2B[z]0.	1UA7073-2B[z]0.	1UA7080-2B[z]0.
4 pole	1UA7060-4B[z]0.	1UA7070-4B[z]0.	1UA7073-4B[z]0.	1UA7080-4B[z]0.	1UA7083-4B[z]0.
Frame size:					
2 pole	56	63	71	71	80
4 pole	63	71	71	80	80
Motor Output Rating:	0.12kW 0.16hp	0.25kW 0.33hp	0.37kW 0.49hp	0.55kW 0.73hp	0.75kW 1.0hp
Operating Input Voltage:	1∅ AC 208 – 240 V _{rms} ± 10%				
Operating Input Frequency:	47 – 63 Hz				
Output Frequency:	0 – 50Hz				
Output Frequency with Opm2 or serial link:					
2 pole	0 – 100Hz	0 – 100Hz	0 – 100Hz	0 – 100Hz	0 – 100Hz
4 pole	0 – 140Hz	0 – 140Hz	0 – 140Hz	0 – 140Hz	0 – 140Hz
Input Current:	1.8 A _{rms}	3.2 A _{rms}	4.6 A _{rms}	6.2 A _{rms}	8.2 A _{rms}
Mains fuse:	10 A			16 A	
Mains Lead cross-section	1mm ²			1.5mm ²	

* [z] = filter option: U = Unfiltered, A = Class A filter, B = Class B filter.

Position 12 (shown as ".") is for the construction type from the Siemens catalogue, M11 (Ref. No.E2002-K1711-A201-A2-7600).

CS A Low Voltage Three Phase Units

Model:	CM12/2	CM25/2	CM37/2	CM55/2	CM75/2
Order Number: *					
2 pole	1UA7053-2BU1.	1UA7063-2BU1.	1UA7070-2BU1.	1UA7073-2BU1.	1UA7080-2BU1.
4 pole	1UA7060-4BU1.	1UA7070-4BU1.	1UA7073-4BU1.	1UA7080-4BU1.	1UA7083-4BU1.
Frame size:					
2 pole	56	63	71	71	80
4 pole	63	71	71	80	80
Motor Output Rating:	0.12kW 0.16hp	0.25kW 0.33hp	0.37kW 0.49hp	0.55kW 0.73hp	0.75kW 1.0hp
Operating Input Voltage:	3∅ AC 208 – 240 V _{rms} ± 10%				
Operating Input Frequency:	47 – 63 Hz				
Output Frequency:	0 – 50Hz				
Output Frequency with Opm2 or serial link:					
2 pole	0 – 100Hz	0 – 100Hz	0 – 100Hz	0 – 100Hz	0 – 100Hz
4 pole	0 – 140Hz	0 – 140Hz	0 – 140Hz	0 – 140Hz	0 – 140Hz
Input Current:	1.1 A _{rms}	1.9 A _{rms}	2.7 A _{rms}	3.6 A _{rms}	4.7 A _{rms}
Mains fuse:	10 A				
Mains Lead cross-section	1mm ²				

* Note that these units are available Unfiltered only.

Position 12 (shown as ".") is for the construction type from the Siemens catalogue, M11 (Ref. No.E2002-K1711-A201-A2-7600).

CS A High Voltage Three Phase Units

Model:	CM37/3	CM55/3	CM75/3	CM110/3	CM150/3
Order Number: *					
2 pole	1UA7070-2B[zz].	1UA7073-2B[zz].	1UA7080-2B[zz].	1UA7083-2B[zz].	1UA7090-2C[zz].
4 pole	1UA7073-4B[zz].	1UA7080-4B[zz].	1UA7083-4B[zz].	1UA7090-4B[zz].	1UA7096-4C[zz].
Frame size:					
2 pole	71	73	80	80	90S
4 pole	71	80	80	90S	90L
Motor Output Rating:	0.37kW 0.49hp	0.55kW 0.73hp	0.75kW 1.0hp	1.1kW 1.5hp	1.5kW 2.0hp
Operating Input Voltage:	3∅ AC 380 – 500 V _{rms} ± 10%		3∅ AC 380 – 480 V _{rms} ± 10% (filtered units only)		
	Torque derating required for < 380V _{rms}				
Operating Input Frequency:	47 – 63 Hz				
Output Frequency:	0 – 50Hz				
Output Frequency with Opm2 or serial link:					
2 pole	100 Hz	100Hz	100Hz	100Hz	100Hz
4 pole	140Hz	140Hz	140Hz	140Hz	140Hz
Input Current:	2.2 A _{rms}	2.8 A _{rms}	3.7 A _{rms}	4.9 A _{rms}	5.9 A _{rms}
Mains fuse:	10 A				
Mains Lead cross-section	1mm ²				

* [zz] = filter option: U = Unfiltered, A = Class A filter, B = Class B filter and mains voltage code: 2 = 380 – 500V, 3 = 460 – 500V/60Hz .

Allowed combinations: A2, B2, U2 and U3. Position 12 (shown as ".") is for the construction type from the Siemens catalogue, M11 (Ref. No. E2002-K1711-A201-A2-7600).

CS B High Voltage Three Phase Units

Model:	CM150/3	CM220/3	CM300/3	CM400/3	CM550/3	CM750/3
Order Number: *						
2 pole	1UA7090-2B[zz].	1UA7096-2B[zz].	1UA7106-2B[zz].	1UA7113-2B[zz].	1UA7130-2B[zz].	1UA7131-2B[zz].
4 pole	1UA7096-4B[zz].	1UA7106-4B[zz].	1UA7107-4B[zz].	1UA7113-4B[zz].	1UA7130-4B[zz].	1UA7133-2B[zz].
Frame size:						
2 pole	90S	90L	100L	112M	132S	132S
4 pole	90L	100L	100L	112M	132S	132M
Motor Output Rating:	1.5kW 2.0hp	2.2kW 2.9hp	3.0kW 4.0hp	4.0kW 5.3hp	5.5kW 7.3hp	7.5kW 10.0hp
Operating Input Voltage:	3∅ AC 380 – 500 V _{rms} ± 10% (all units)			3∅ AC 380 – 480 V _{rms} ± 10% (filtered units only)		
	Torque derating required for < 380V _{rms}					
Operating Input Frequency:	47 – 63 Hz					
Output Frequency:	0 – 50Hz					
Output Frequency with Opm2 or serial link:						
2 pole	100Hz	100Hz	100Hz	100Hz	90Hz	90Hz
4 pole	140Hz	140Hz	140Hz	140Hz	140Hz	140Hz
Input Current:	3.5 A _{rms}	4.7 A _{rms}	6.4 A _{rms}	10.0 A _{rms}	12.2 A _{rms}	16.0 A _{rms}
Mains fuse:	10 A		16 A		20 A	
Mains Lead cross-section	1mm ²		1.5mm ²		2.5mm ²	

* [zz] = filter option: U = Unfiltered, A = Class A filter, B = Class B filter and mains voltage code: 2 = 380 – 500V, 3 = 460 – 500V/60Hz .

Allowed combinations: A2, B2, U2 and U3. Position 12 (shown as ".") is for the construction type from the Siemens catalogue, M11 (Ref. No. E2002-K1711-A201-A2-7600).

8.5 Technical Data - MICROMASTER Integrated

CS A Low Voltage Single Phase Units

Model:	MI12	MI25	MI37	MI55	MI75
Order Number: *	6SE9610-7BF[y]0-Z=C87	6SE9611-5BF[y]0-Z=C87	6SE9612-0BF[y]0-Z=C87	6SE9612-6BF[y]0-Z=C87	6SE9613-4BF[y]0-Z=C87
Motor Output Rating:	0.12kW 0.16hp	0.25kW 0.33hp	0.37kW 0.49hp	0.55kW 0.73hp	0.75kW 1.0hp
Operating Input Voltage:	1∅ AC 208 – 240 V _{rms} ± 10%				
Operating Input Frequency:	47 – 63 Hz				
Output Frequency:	0 – 50Hz				
Output Frequency with Opm2 or serial link: 2 pole & 4 pole	0 – 400Hz				
Input Current:	1.8 A _{rms}	3.2 A _{rms}	4.6 A _{rms}	6.2 A _{rms}	8.2 A _{rms}
Mains Fuse:	10 A				16 A
Mains Lead cross-section	1mm ²				1.5mm ²

* [y] = filter option: 1 = Unfiltered, 5 = Class A filter, 6 = Class B filter.

CS A Low Voltage Three Phase Units

Model:	MI12/2	MI25/2	MI37/2	MI55/2	MI75/2
Order Number: *	6SE9610-7CF10-Z=C87	6SE9611-5CF10-Z=C87	6SE9612-0CF10-Z=C87	6SE9612-6CF10-Z=C87	6SE9613-4CF10-Z=C87
Motor Output Rating:	0.12kW 0.16hp	0.25kW 0.33hp	0.37kW 0.49hp	0.55kW 0.73hp	0.75kW 1.0hp
Operating Input Voltage:	3∅ AC 208 – 240 V _{rms} ± 10%				
Operating Input Frequency:	47 – 63 Hz				
Output Frequency:	0 – 50Hz				
Output Frequency with Opm2 or serial link: 2 pole & 4 pole	0 – 400Hz				
Input Current:	1.1 A _{rms}	1.9 A _{rms}	2.7 A _{rms}	3.6 A _{rms}	4.7 A _{rms}
Mains Fuse:	10 A				
Mains Lead cross-section	1mm ²				

* Note that these units are available Unfiltered only.

CS A High Voltage Three Phase Units

Model:	MI37/3	MI55/3	MI75/3	MI110/3	MI150/3
Order Number: *	6SE9611-1DF[y]0-Z=C87	6SE9611-4DF[y]0-Z=C87	6SE9611-8DF[y]0-Z=C87	6SE9612-7DF[y]0-Z=C87	6SE9613-7DF[y]0-Z=C87
Motor Output Rating:	0.37kW 0.49hp	0.55kW 0.73hp	0.75kW 1.0hp	1.1kW 1.5hp	1.5kW 2.0hp
Operating Input Voltage:	3∅ AC 380 – 500 V _{rms} ± 10% (all units) 3∅ AC 380 – 480 V _{rms} ± 10% (filtered units only)				
Operating Input Frequency:	47 – 63 Hz				
Output Frequency:	0 – 50Hz				
Output Frequency with Opm2 or serial link: 2 pole & 4 pole	0-400Hz				
Input Current:	2.2 A _{rms}	2.8 A _{rms}	3.7 A _{rms}	4.9 A _{rms}	5.9 A _{rms}
Mains Fuse:	10 A				
Mains Lead cross-section	1mm ²				

* [y] = filter option: 1 = Unfiltered, 5 = Class A filter, 6 = Class B filter

CS B High Voltage Three Phase Units

Model:	MI150/3	MI220/3	MI300/3	MI400/3	MI550/3	MI750/3
Order Number: *	6SE9613-7DD[y]0-Z=C87	6SE9615-8DD[y]0-Z=C87	6SE9617-3DD[y]0-Z=C87	6SE9621-1DD[y]0-Z=C87	6SE9621-3DD[y]0-Z=C87	6SE9621-7DD[y]0-Z=C87
Motor Output Rating:	1.5kW 2.0hp	2.2kW 2.9hp	3.0kW 4.0hp	4.0kW 5.3hp	5.5kW 7.3hp	7.5kW 10.0hp
Operating Input Voltage:	3∅ AC 380 – 500 V _{rms} ± 10% (all units)			3∅ AC 380 – 480 V _{rms} ± 10% (filtered units only)		
Operating Input Frequency:	47 – 63 Hz					
Output Frequency:	0 – 50Hz					
Output Frequency with Opm2 or serial link: 2 pole & 4 pole	0-400Hz					
Input Current:	3.5 A _{rms}	4.7 A _{rms}	6.4 A _{rms}	10.0 A _{rms}	12.2 A _{rms}	16.0 A _{rms}
Mains Fuse:	10 A		16 A		20 A	
Mains Lead cross-section	1mm ²		1.5mm ²		2.5mm ²	

*[y] = filter option: 1 = Unfiltered, 5 = Class A filter, 6 = Class B filter.

8.6 Output Current Ratings - MICROMASTER Integrated



The MICROMASTER Integrated is designed to be fitted to a motor, and in most cases, to use air from the motor fan for cooling of the inverter. For this reason it is not possible to specify continuous current ratings which will be achieved under all circumstances. This section provides information about the designed current ratings, and explains the factors which effect the continuous ratings achievable when the inverter is installed on a motor.

Introduction

There are two factors in the design of an inverter which define what current can be delivered the motor :

The first factor is the selection of electronic components. For example, the current rating of the transistors in the output stage of the inverter. This factor normally limits the peak (short time) current that the inverter can provide.

The second factor is the method of cooling of the inverter. Whenever current flows through a conductor, or an electronic component, heat is generated. The cooling method chosen for the inverter must be able to remove enough heat so that when the inverter is run at its maximum current rating **continuously** then

none of the components in the inverter exceed their rated operating temperatures.

With a standard inverter, the cooling method is part of the design of the inverter, therefore it is possible to specify the continuous current ratings of the inverter when it is correctly installed.

The cooling efficiency for MICROMASTER Integrated is dependant upon the motor to which it is fitted, and therefore the continuous current rating must be determined by thermal tests, when the inverter is fitted to the target motor.

Designed Current Ratings.

The following table gives the **designed** current ratings for the MICROMASTER Integrated. All the inverters are capable of short-term overload up to 150% of the values shown.

Voltage Class	Power Ratings							
	208 - 240V				380 - 500V			
Type	P(kW)	P(Hp)	I (A)	KVA	P(kW)	P(Hp)	I (A)	KVA
MI12	0.12	0.16	0.8	0.32				
MI25	0.25	0.33	1.7	0.67				
MI37	0.37	0.50	2.3	0.91	0.37	0.50	1.1	0.76
MI55	0.55	0.75	3.0	1.2	0.55	0.75	1.4	0.97
MI75	0.75	1.00	3.9	1.5	0.75	1.00	1.9	1.3
MI110					1.10	1.50	2.7	1.9
MI150 CS A Inverter					1.50	2.00	3.75	2.6
MI150 CS B Inverter					1.50	2.00	4.0	2.8
MI220					2.20	3.00	5.9	4.0
MI300					3.00	4.00	7.7	5.2
MI400					4.00	5.30	10.2	7.0
MI550					5.50	7.30	13.2	9.0
MI750					7.50	10.0	17.0	12.0

Continuous Current Ratings.

As explained above, the continuous rating depends on the amount of cooling available for the inverter from the motor fan. This can be affected by one or more of the following:

Size of Motor Fan Cover Cutout

There must be a hole cut in the motor fan cover to allow air from the motor fan to be directed onto the inverter heatsink. The size and shape of this hole affects the airflow to the inverter.

Position of the Inverter

Ideally, the inverter should be positioned so that the hole in the motor fan cover is centered directly beneath the inverter heatsink. In addition, the vertical distance from the fan cover to the inverter heatsink should be as small as possible.

Motor Speed

When the motor fan is driven by the motor shaft, then a slower motor will have less air flow to the inverter.

Mains Voltage

When the 380 to 500V inverters are operated on a high mains voltage, there is normally more heat generated in the inverter. This will result in a lower continuous current rating. This is not normally a problem, because a motor operated at the higher voltage will require less current to deliver the same shaft power.



9. SUPPLEMENTARY INFORMATION

9.1 Application Example

Set-up Procedure for a Simple Application

Application requirements: Normal operating frequency set within range 15 - 50 Hz via an external potentiometer. Counter-clockwise rotation required.

COMBIMASTER used: Any model.

- Procedure:
1. Remove the link (if fitted) between control terminals 5 and 8.
 2. Connect a simple on/off switch to control terminals 6 and 8 for reverse rotation.
 3. Connect a 4.7 k Ω potentiometer to the control terminals (see *Figure 4*).
 4. Set jumper JP301 ('V' - voltage) - see *Fig.3(CS A)*, *Fig.2 (CS B)*.
 5. Set the internal and external potentiometers fully counter-clockwise and then apply mains power and switch on.
 6. Turn the internal potentiometer clockwise until the motor rotates at a speed that approximates to 15 Hz.
 7. The external potentiometer now has a range of between 15 Hz at its lowest setting and 50 Hz at its highest setting.

9.2 Motor Interface Plates

Since approximately 01/99 all 1LA5 motors used with COMBIMASTER & MICROMASTER Integrated have been replaced with the 1LA7 equivalents. This has resulted in changes to the motor interface plates (MIP) used with Siemens Motors.

For each inverter case size there are now 3 basic types of motor interface plate:

1LA5
1LA7
'Universal'

The 1LA5 and 1LA7 interface plates are for use with the Siemens motors.

The 'Universal' plate has been designed to simplify adapting the COMBIMASTER for other motors. In most cases, the 'Universal' motor interface plate can be used with a simple flat metal 'Base Plate' and no tooling is required.

The following pages describe the MIPs.

Siemens 1LA5 Motor Case Size A Inverter

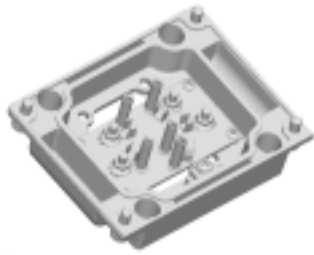

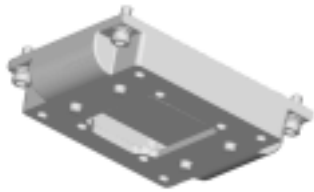

Topside



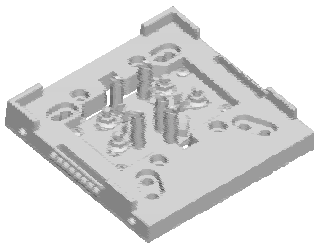

Underside

Description	Standard MIP for 1LA5 Motors and CS A inverters.
Availability	Discontinued
Variants	1 for all motor frame sizes – 6SE9996-0XA43

Siemens 1LA5 Motor Case Size B Inverter



Topside

Description	Standard MIP for 1LA5 motors and CS B Inverters
Variants	1 For all motor frame sizes – 6SE9996-0XA40

Siemens 1LA7 Motor Case Size A Inverter

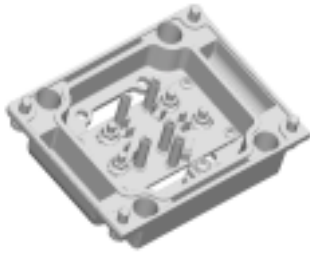

Topside



Underside

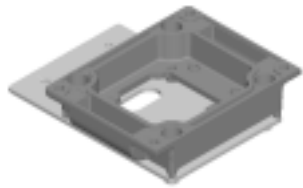

Variant with base plate (Motor
Frame Size 80,90)

Description Standard MIP for 1LA7 Motors and CS A inverters.

The variant for Motor frames 80 and 90 uses a base plate (shown)

Variants Motor Frame 56 to 71 – 6SE9996-0XA51
Motor Frame 80 to 90 – 6SE9996-0XA52

Siemens 1LA7 Motor Case Size B Inverter

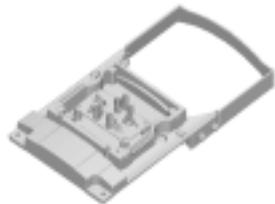

Topside

Description Standard MIP for 1LA7 Motors and CS B inverters.

Variants Motor frame 90 -not available at time of writing
Motor Frame 100 & 112 – 6SE9996-0XA41
Motor Frame 132 – 6SE9996-0XA42

'Universal' MIP Case Size A Inverter

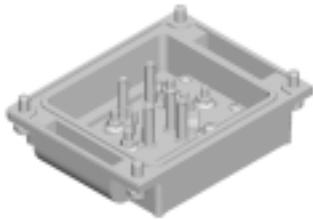

Topside

Description 'Universal' MIP for non-Siemens motors, and CS A Inverters. It will normally be used with a simple flat metal base plate to adapt the MIP to the specific motor.

Variants MIP Assembly – 6SE9996-0XA44

'Universal' MIP Case Size B Inverter

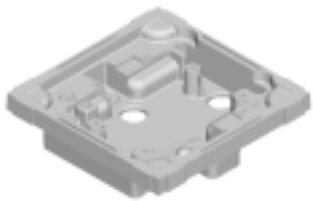

Topside

Description 'Universal' MIP for non-Siemens motors, and CS B Inverters. It will normally be used with a simple flat metal base plate to adapt the MIP to the specific motor.

Availability From August 1999

Variants MIP Assembly : 6SE9996-0XA53.

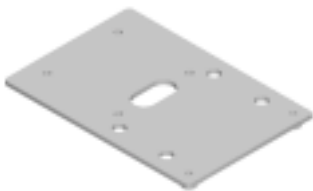

Example base plate

Additional description available – please look at page 7

MIP PCB Assembly

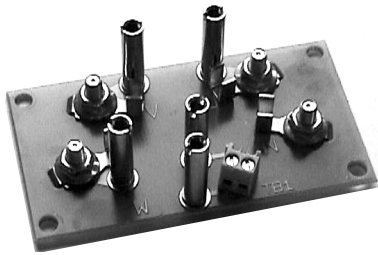

Description The motor interface plate PCB's have been made available for customers who have designed their own MIP. They are supplied in order quantities of 50.

Variants PCB for CS A inverters – 6SE9996-0XA47
PCB for CS B inverters – 6SE9996-0XA48

Order numbers are for 50 pieces.

9.3 Electro-Magnetic Compatibility (EMC)

All manufacturers / assemblers of electrical apparatus which performs a complete intrinsic function which is placed on the market as a single unit intended for the end user must comply with the EMC directive EEC/89/336 after January 1996. There are three routes by which the manufacturer/assembler can demonstrate compliance:

1. *Self-Certification*

This is a manufacturer's declaration that the European standards applicable to the electrical environment for which the apparatus is intended have been met. Only

standards which have been officially published in the Official Journal of the European Community can be cited in the manufacturer's declaration.

2. *Technical Construction File*

A technical construction file can be prepared for the apparatus describing its EMC characteristics. This file must be approved by a 'Competent Body' appointed by the appropriate European government organisation. This approach allows the use of standards which are still in preparation.

3. *EC Type-Examination Certificate*

This approach is only applicable to radio communication transmitting apparatus.

The MICROMASTER Integrated units do not have an intrinsic function until connected with other components (e.g. a motor). Therefore, the basic units are not allowed to be CE marked for compliance with the EMC directive. However, full details are provided below of the EMC performance characteristics of the products when they are installed in accordance with the wiring recommendations in section 4.1 of this document.

Class 2: Filtered Industrial (Class A)

This level of performance will allow the manufacturer/assembler to self-certify their apparatus for compliance with the EMC directive for the industrial environment as regards the EMC performance characteristics of the power drive system. Performance limits are as specified in the Generic Industrial Emissions and Immunity standards EN 50081-2 and EN 50082-2.

EMC Phenomenon	Standard	Level
<i>Emissions: (CM)</i>		
Radiated Emissions	EN 55011	Level A1
Conducted Emissions	EN 55011	Level A1
<i>Immunity: (CM & MMI)</i>		
Supply Voltage Distortion	IEC 1000-2-4 (1993)	
Voltage Fluctuations, Dips, Unbalance, Frequency Variations	IEC 1000-2-1	
Magnetic Fields	EN 61000-4-8	50 Hz, 30 A/m
Electrostatic Discharge	EN 61000-4-2	8 kV air discharge
Burst Interference	EN 61000-4-4	2 kV power cables, 2 kV control
Radio Frequency Electromagnetic Field, amplitude modulated	ENV 50 140	27-1000 MHz, 10 V/m, 80% AM, power and signal lines

Class 3: Filtered - for residential, commercial and light industry (Class B)

This level of performance will allow the manufacturer / assembler to self-certify compliance of their apparatus with the EMC directive for the residential, commercial and light industrial environment as regards the EMC performance characteristics of the power drive system. Performance limits are as specified in the generic emission and immunity standards EN 50081-1 and EN 50082-1.

EMC Phenomenon	Standard	Level
Emissions: (CM)		
Radiated Emissions	EN 55022	Level B1
Conducted Emissions	EN 55022	Level B1
Immunity: (CM & MMI)		
Electrostatic Discharge	EN 61000-4-2	8 kV air discharge
Burst Interference	EN 61000-4-4	1 kV power cables, 0.5 kV control



The COMBIMASTER is intended **exclusively for professional applications**. Therefore, it does not fall within the scope of the harmonics emissions specification EN 61000-3-2.

9.4 Environmental Aspects

Transport and Storage

Protect the COMBIMASTER/MMI against physical shocks and vibration during transport and storage. The unit must also be protected against water (rainfall) and excessive temperatures (*see section 6*).

The packaging is re-usable. Retain the packaging or return it to the manufacturer for future use.

Dismantling and Disposal

The component parts can be recycled, disposed of in accordance with local requirements or returned to the manufacturer.

Documentation

This handbook is printed on chlorine-free paper which has been produced from managed sustainable forests. No solvents have been used in the printing or binding process.

9.5 Users Parameter Settings

Parameter	Default	Your setting
P000	-	
P001	0	
P002	10.00	
P003	25.00	
P004	0.0	
P005	50.00	
P006	1	
P007	0	
P009	0	
P011	0	
P012	0.00	
P013	50.00	
P014	0.00	
P015	0	
P016	0	
P017	1	
P018	0	
P019	2.00	
P020	25.00	
P021	0.00	
P022	50.00	
P023	2	
P024	0	
P027	0.00	
P028	0.00	
P029	0.00	
P031	5.00	
P032	5.00	
P033	10.00	
P034	10.00	
P035	0	
P041	5.00	
P042	10.00	
P043	15.00	
P044	20.00	
P045	0	
P046	25.00	
P047	30.00	
P048	35.00	
P050	0	
P051	1	
P052	2	
P053	10	
P056	0	
P058	0.0	
P061	6	
P062	0	
P063	1.0	
P064	1.0	
P065	1.0	
P071	0	
P072	500	
P073	0	
P074	0	
P076	0 or 2	

Parameter	Default	Your setting
P077	0	
P078	50	
P079	0	
P081	***	
P082	***	
P083	***	
P084	***	
P085	***	
P086	150	
P087	0	
P089	***	
P091	0	
P092	6	
P093	0	
P094	50.00	
P095	0	
P099	0	
P101	0	
P111	***	
P112	8	
P113	-	
P121	1	
P122	1	
P123	1	
P124	1	
P125	1	
P131	-	
P132	-	
P133	-	
P134	-	
P135	-	
P137	-	
P140	-	
P141	-	
P142	-	
P143	-	
P151	4	
P152	5	
P201	0	
P202	1.0	
P203	0.00	
P205	1	
P206	0	
P207	100	
P208	0	
P210	-	
P211	0.00	
P212	100.00	
P220	0	
P331	2	
P332	10	
P700	See PROFIBUS handbook	
P701	See PROFIBUS handbook	

Parameter	Default	Your setting
P702	See PROFIBUS handbook	
P723	-	
P845	50	
P880	See PROFIBUS handbook	
P910	0	
P918	See PROFIBUS /CAN handbook [0]	
P922	-	
P923	0	
P927	See PROFIBUS /CAN handbook [0]	
P928	See PROFIBUS /CAN handbook [0]	
P930	-	
P931	-	
P944	0	
P947	See PROFIBUS handbook	
P958	See PROFIBUS handbook	

Parameter	Default	Your setting
P960	See PROFIBUS /CAN handbook [0]	
P962	See CAN handbook	
P963	See CAN handbook	
P964	See CAN handbook	
P965	See CAN handbook	
P966	See CAN handbook [0]	
P967	See PROFIBUS handbook	
P968	See PROFIBUS handbook	
P969	See CAN handbook	
P971	1	
P986	0	

*** - Value depends on rating of the inverter

For Technical Support Information,
and to submit your suggestions
for improvements,

see our Web Site:

<http://www.con.siemens.co.uk>

Herausgegeben vom
Bereich Automatisierungs-
und Antriebstechnik (A&D)
Geschäftsgebiet Standard Drives
Postfach 3269, D-91050 Erlangen

Issued by
Siemens plc
Drives and Standard Products Group
Siemens House
Varey Road
Congleton
Cheshire CW12 1PH
England

G85139-H1731-U300-D2
August 1999
English

