

SIEMENS

SINUMERIK

SINUMERIK 840D sl Universal

Operating Manual

Valid for:
SINUMERIK 840D sl / 840DE sl
Software version
CNC system software for 840D sl/ 840DE sl V4.95
SINUMERIK Operate for PCU/PC V4.95

07/2021
6FC5398-6AP40-6BA4

Introduction	1
Fundamental safety instructions	2
Fundamentals	3
Multitouch operation with SINUMERIK Operate	4
Setting up the machine	5
Working in manual mode	6
Machining the workpiece	7
Simulating machining	8
Creating a G code program	9
Multi-channel view	10
Collision avoidance	11
Tool management	12
Managing programs	13
Teaching in a program	14
Handheld terminal for multi-touch-operation	15
Ctrl-Energy	16
Alarm, error, and system messages	17

Legal information

Warning notice system

This manual contains notices you have to observe in order to ensure your personal safety, as well as to prevent damage to property. The notices referring to your personal safety are highlighted in the manual by a safety alert symbol, notices referring only to property damage have no safety alert symbol. These notices shown below are graded according to the degree of danger.

 DANGER
indicates that death or severe personal injury will result if proper precautions are not taken.

 WARNING
indicates that death or severe personal injury may result if proper precautions are not taken.

 CAUTION
indicates that minor personal injury can result if proper precautions are not taken.

NOTICE
indicates that property damage can result if proper precautions are not taken.

If more than one degree of danger is present, the warning notice representing the highest degree of danger will be used. A notice warning of injury to persons with a safety alert symbol may also include a warning relating to property damage.

Qualified Personnel

The product/system described in this documentation may be operated only by **personnel qualified** for the specific task in accordance with the relevant documentation, in particular its warning notices and safety instructions. Qualified personnel are those who, based on their training and experience, are capable of identifying risks and avoiding potential hazards when working with these products/systems.

Proper use of Siemens products

Note the following:

 WARNING
Siemens products may only be used for the applications described in the catalog and in the relevant technical documentation. If products and components from other manufacturers are used, these must be recommended or approved by Siemens. Proper transport, storage, installation, assembly, commissioning, operation and maintenance are required to ensure that the products operate safely and without any problems. The permissible ambient conditions must be complied with. The information in the relevant documentation must be observed.

Trademarks

All names identified by ® are registered trademarks of Siemens AG. The remaining trademarks in this publication may be trademarks whose use by third parties for their own purposes could violate the rights of the owner.

Disclaimer of Liability

We have reviewed the contents of this publication to ensure consistency with the hardware and software described. Since variance cannot be precluded entirely, we cannot guarantee full consistency. However, the information in this publication is reviewed regularly and any necessary corrections are included in subsequent editions.

Table of contents

1	Introduction	13
1.1	About SINUMERIK	13
1.2	About this documentation	14
1.3	Documentation on the internet	15
1.3.1	Documentation overview SINUMERIK 840D sl.....	15
1.3.2	Documentation overview SINUMERIK operator components	15
1.4	Feedback on the technical documentation	17
1.5	mySupport documentation	18
1.6	Service and Support.....	19
1.7	Important product information	21
2	Fundamental safety instructions	23
2.1	General safety instructions.....	23
2.2	Warranty and liability for application examples	24
2.3	Security information	25
3	Fundamentals	27
3.1	Product overview	27
3.2	Operator panel fronts.....	28
3.2.1	Overview	28
3.2.2	Keys of the operator panel	30
3.3	Machine control panels	38
3.3.1	Overview	38
3.3.2	Controls on the machine control panel	38
3.4	Operator interface	42
3.4.1	Screen layout	42
3.4.2	Status display.....	43
3.4.3	Actual value window.....	45
3.4.4	T,F,S window	47
3.4.5	Current block display.....	49
3.4.6	Operation via softkeys and buttons	50
3.4.7	Entering or selecting parameters	52
3.4.8	Pocket calculator	53
3.4.9	Pocket calculator functions.....	54
3.4.10	Context menu	56
3.4.11	Changing the user interface language	57
3.4.12	Entering Chinese characters	58
3.4.12.1	Function - input editor	58
3.4.12.2	Entering Asian characters.....	59
3.4.12.3	Editing the dictionary.....	61

3.4.13	Entering Korean characters	62
3.4.14	Work station safety	65
3.4.15	Cleaning mode	65
3.4.16	Display live image from a camera	66
3.4.17	Online help in SINUMERIK Operate	67
4	Multitouch operation with SINUMERIK Operate.....	71
4.1	Multitouch panels	71
4.2	Touch-sensitive user interface	72
4.3	Finger gestures	73
4.4	Multitouch user interface	76
4.4.1	Screen layout.....	76
4.4.2	Function key block	77
4.4.3	Further operator touch controls.....	78
4.4.4	Virtual keyboard	78
4.4.5	Special "tilde" character.....	79
4.5	Expansion with side screen	80
4.5.1	Overview	80
4.5.2	Sidescreen with standard windows.....	80
4.5.3	Standard widgets	82
4.5.4	"Actual value" widget	82
4.5.5	"Zero point" widget	83
4.5.6	"Alarms" widget	83
4.5.7	"NC/PLC variables" widget.....	83
4.5.8	"Axle load" widget.....	84
4.5.9	"Tool" widget	84
4.5.10	"Service life" widget	85
4.5.11	"Program runtime" widget.....	85
4.5.12	Widget "Camera 1" and "Camera 2".....	85
4.5.13	Sidescreen with pages for the ABC keyboard and/or machine control panel	86
4.5.14	Example 1: ABC keyboard in the sidescreen	87
4.5.15	Example 2: Machine control panel in the sidescreen	88
4.6	SINUMERIK Operate Display Manager	89
4.6.1	Overview	89
4.6.2	Screen layout.....	90
4.6.3	Operator controls.....	90
5	Setting up the machine	95
5.1	Switching on and switching off	95
5.2	Approaching a reference point	96
5.2.1	Referencing axes.....	96
5.2.2	User agreement	97
5.3	Modes of operation.....	99
5.3.1	General information.....	99
5.3.2	Modes groups and channels.....	101
5.3.3	Channel switchover	101
5.4	Settings for the machine	103
5.4.1	Switching over the coordinate system (MCS/WCS)	103

5.4.2	Switching the unit of measurement	103
5.4.3	Setting the zero offset	105
5.5	Zero offsets	107
5.5.1	Display active zero offset	108
5.5.2	Displaying the zero offset "overview"	109
5.5.3	Displaying and editing base zero offset	110
5.5.4	Displaying and editing settable zero offset	111
5.5.5	Displaying and editing details of the zero offsets	111
5.5.6	Deleting a zero offset	113
5.6	Monitoring axis and spindle data	115
5.6.1	Specify working area limitations	115
5.6.2	Editing spindle data	115
5.7	Displaying setting data lists	117
5.8	Handwheel assignment	118
5.9	MDA	120
5.9.1	Loading an MDA program from the Program Manager	120
5.9.2	Saving an MDA program	121
5.9.3	Editing/executing a MDI program	122
5.9.4	Deleting an MDA program	123
6	Working in manual mode	125
6.1	General	125
6.2	Selecting a tool and spindle	126
6.2.1	T, S, M windows	126
6.2.2	Selecting a tool	127
6.2.3	Starting and stopping a spindle manually	128
6.2.4	Position spindle	129
6.3	Traversing axes	130
6.3.1	Traverse axes by a defined increment	130
6.3.2	Traversing axes by a variable increment	131
6.4	Positioning axes	132
6.5	Manual retraction	133
6.6	Default settings for manual mode	135
7	Machining the workpiece	137
7.1	Starting and stopping machining	137
7.2	Selecting a program	139
7.3	Program running-in	140
7.4	Displaying the current program block	142
7.4.1	Current block display	142
7.4.2	Displaying a basic block	143
7.4.3	Display program level	144
7.5	Correcting a program	146
7.6	Repositioning axes	147

7.7	Starting execution at a specific point	148
7.7.1	Use block search	148
7.7.2	Continuing program from search target.....	150
7.7.3	Simple search target definition	150
7.7.4	Defining an interruption point as search target	151
7.7.5	Entering the search target via search pointer	151
7.7.6	Parameters for block search in the search pointer	152
7.7.7	Block search mode	153
7.8	Controlling the program run.....	155
7.8.1	Program control.....	155
7.8.2	Skip blocks.....	156
7.9	Overstore.....	158
7.10	Editing a program	160
7.10.1	Searching in programs	160
7.10.2	Replacing program text	162
7.10.3	Copying/pasting/deleting program blocks	163
7.10.4	Renumbering a program	165
7.10.5	Creating a program block.....	166
7.10.6	Opening additional programs.....	167
7.10.7	Editor settings.....	168
7.11	Display and edit user variables	172
7.11.1	Global R parameters.....	173
7.11.2	R parameters	174
7.11.3	Displaying global user data (GUD)	175
7.11.4	Displaying channel GUDs	177
7.11.5	Displaying local user data (LUD)	178
7.11.6	Displaying program user data (PUD)	179
7.11.7	Searching for user variables	179
7.12	Display G and auxiliary functions.....	181
7.12.1	Selected G functions	181
7.12.2	All G functions	183
7.12.3	G functions for mold making.....	183
7.12.4	Auxiliary functions	184
7.13	Displaying superimpositions.....	186
7.14	Displaying status of synchronized actions	187
7.15	Displaying the program runtime and counting workpieces.....	189
7.16	Settings for the automatic mode	191
7.17	Working with DXF files	194
7.17.1	Overview	194
7.17.2	Displaying CAD drawings	195
7.17.2.1	Open a DXF file	195
7.17.2.2	Cleaning a DXF file	195
7.17.2.3	Enlarging or reducing the CAD drawing	196
7.17.2.4	Changing the section	197
7.17.2.5	Rotating the view.....	197
7.17.2.6	Displaying/editing information for the geometric data	198
7.17.3	Importing and editing a DXF file	199

7.17.3.1	General procedure	199
7.17.3.2	Setting the tolerance.....	199
7.17.3.3	Assigning the machining plane	199
7.17.3.4	Selecting the machining range / deleting the range and element	200
7.17.3.5	Saving the DXF file	201
7.17.3.6	Specifying a reference point.....	202
7.17.3.7	Accepting contours	202
7.18	Mold making view	205
7.18.1	Starting the mold making view.....	207
7.18.2	Adapting the mold making view	207
7.18.3	Specifically jump to the program block	208
7.18.4	Searching for program blocks.....	209
7.18.5	Changing the view	209
7.18.5.1	Enlarging or reducing the graphical representation.....	209
7.18.5.2	Moving and rotating the graphic	210
7.18.5.3	Modifying the viewport.....	211
8	Simulating machining.....	213
8.1	Overview	213
8.2	Simulation prior to machining of the workpiece.....	220
8.3	Simultaneous recording prior to machining of the workpiece.....	222
8.4	Simultaneous recording during machining of the workpiece.....	223
8.5	Different views of the workpiece	224
8.5.1	Overview	224
8.5.2	Plan view	224
8.5.3	3D view	225
8.5.4	Side view	225
8.6	Editing the simulation display	227
8.6.1	Blank display.....	227
8.6.2	Showing and hiding the tool path	227
8.7	Program control during simulation	228
8.7.1	Changing the feedrate	228
8.7.2	Simulating the program block by block.....	229
8.8	Modifying and adapting the simulation graphics	230
8.8.1	Enlarging or reducing the graphical representation.....	230
8.8.2	Panning a graphical representation	231
8.8.3	Rotating the graphical representation.....	231
8.8.4	Modifying the viewport.....	232
8.8.5	Defining cutting planes	232
8.9	Displaying simulation alarms.....	234
9	Creating a G code program.....	235
9.1	Graphical programming	235
9.2	Program views	236
9.3	Program structure	240
9.4	Fundamentals.....	241

9.4.1	Machining planes.....	241
9.4.2	Current planes in cycles and input screens.....	241
9.4.3	Programming a tool (T).....	242
9.5	Generating a G code program.....	243
9.6	Blank input.....	244
9.6.1	Overview.....	244
9.6.2	Calling the input screen.....	245
9.6.3	Blank input.....	245
9.7	Selection of the cycles via softkey.....	247
10	Multi-channel view.....	249
10.1	Multi-channel view.....	249
10.2	Multi-channel view in the "Machine" operating area.....	250
10.3	Multi-channel view for large operator panels.....	253
10.4	Setting the multi-channel view.....	255
11	Collision avoidance.....	257
11.1	Activate collision avoidance.....	259
11.2	Set collision avoidance.....	260
12	Tool management.....	263
12.1	Lists for the tool management.....	263
12.2	Magazine management.....	265
12.3	Tool types.....	266
12.4	Tool dimensioning.....	268
12.5	Tool list.....	275
12.5.1	Creating a new tool.....	277
12.5.2	Additional data.....	278
12.5.3	Managing several cutting edges.....	280
12.5.4	Deleting a tool.....	281
12.5.5	Loading and unloading tools.....	281
12.5.6	Selecting a magazine.....	283
12.5.7	Code carrier connection.....	284
12.5.8	Managing a tool in a file.....	286
12.6	Tool wear.....	288
12.6.1	Reactivating a tool.....	290
12.7	Tool data OEM.....	292
12.8	Magazine.....	293
12.8.1	Position magazine.....	295
12.8.2	Relocating a tool.....	295
12.8.3	Deleting / unloading / loading / relocating all tools.....	296
12.9	Tool details.....	298
12.9.1	Displaying tool details.....	298
12.9.2	Cutting edge data.....	298
12.9.3	Tool data.....	300

12.9.4	Monitoring data	301
12.10	Changing a tool type.....	302
12.11	Sorting tool management lists	303
12.12	Filtering the tool management lists	304
12.13	Specific search in the tool management lists	306
12.14	Multiple selection in the tool management lists.....	308
12.15	Working with multitool	309
12.15.1	Tool list for multitool.....	309
12.15.2	Create multitool.....	310
12.15.3	Equipping multitool with tools	312
12.15.4	Removing a tool from multitool.....	313
12.15.5	Deleting multitool.....	314
12.15.6	Loading and unloading multitool.....	314
12.15.7	Reactivating the multitool	315
12.15.8	Relocating a multitool	316
12.15.9	Positioning a multitool	317
12.16	Settings for tool lists	318
13	Managing programs	319
13.1	Overview	319
13.1.1	NC memory	321
13.1.2	Local drive	322
13.1.3	USB drives	323
13.1.4	FTP drive.....	324
13.2	Opening and closing a program	325
13.3	Executing a program.....	327
13.4	Creating a directory/program/job list/program list	329
13.4.1	File and directory names	329
13.4.2	Creating a new directory	329
13.4.3	Creating a new workpiece.....	330
13.4.4	Creating a new G code program	331
13.4.5	Storing any new file	332
13.4.6	Creating a job list.....	333
13.4.7	Creating a program list.....	334
13.5	Creating templates.....	336
13.6	Searching directories and files	337
13.7	Displaying the program in the Preview.....	339
13.8	Selecting several directories/programs.....	340
13.9	Copying and pasting a directory/program	342
13.10	Deleting a directory/program.....	344
13.11	Changing file and directory properties	345
13.12	Set up drives	346
13.12.1	Overview	346

13.12.2	Setting up drives	346
13.13	Viewing PDF documents	352
13.14	EXTCALL	354
13.15	Execution from external memory (EES)	356
13.16	Backing up data	357
13.16.1	Generating an archive in the Program Manager	357
13.16.2	Generating an archive via the system data	358
13.16.3	Reading in an archive in the Program Manager	360
13.16.4	Read in archive from system data	361
13.17	Setup data	362
13.17.1	Reading-in set-up data	363
13.18	Recording tools and determining the demand	366
13.18.1	Overview	366
13.18.2	Opening tool data	367
13.18.3	Checking the loading	367
13.19	Backing up parameters	369
13.20	RS-232-C	372
13.20.1	Reading-in and reading-out archives via a serial interface	372
14	Teaching in a program	377
14.1	Overview	377
14.2	Select teach in mode	379
14.3	Processing a program	380
14.3.1	Inserting a block	380
14.3.2	Editing a block	380
14.3.3	Selecting a block	381
14.3.4	Deleting a block	381
14.4	Teach sets	383
14.4.1	Input parameters for teach-in blocks	384
14.5	Settings for teach-in	386
15	Handheld terminal for multi-touch-operation	387
15.1	HT 8	387
15.1.1	HT 8 overview	387
15.1.2	Traversing keys	389
15.1.3	Machine control panel menu	390
15.1.4	Virtual keyboard	392
15.2	HT 10	394
15.2.1	HT 10: Overview	394
15.2.2	Machine control panel menu	396
15.2.3	Virtual keyboard	398
15.3	Calibrating the touch panel	399
16	Ctrl-Energy	401
16.1	Functions	401

16.2	Ctrl-E analysis	402
16.2.1	Displaying energy consumption	402
16.2.2	Displaying the energy analyses.....	403
16.2.3	Measuring and saving the energy consumption	404
16.2.4	Tracking measurements	405
16.2.5	Tracking usage values	405
16.2.6	Comparing usage values	406
16.2.7	Long-term measurement of the energy consumption	407
16.3	Ctrl-E profiles	408
16.3.1	Using the energy-saving profile	408
17	Alarm, error, and system messages.....	411
17.1	Displaying alarms.....	411
17.2	Displaying an alarm log.....	414
17.3	Displaying messages	415
17.4	Sorting, alarms, faults and messages.....	416
17.5	Creating screenshots.....	417
17.6	PLC and NC variables.....	418
17.6.1	Displaying and editing PLC and NC variables	418
17.6.2	Saving and loading screen forms	422
17.7	Version	423
17.7.1	Displaying version data	423
17.7.2	Save information	424
17.8	Logbook	425
17.8.1	Displaying and editing the logbook	425
17.8.2	Making a logbook entry	426
17.9	Remote diagnostics.....	428
17.9.1	Setting remote access	428
17.9.2	Permit modem.....	429
17.9.3	Request remote diagnostics	430
17.9.4	Exit remote diagnostics.....	431
	Index.....	433

Introduction

1.1 About SINUMERIK

From simple, standardized CNC machines to premium modular machine designs – the SINUMERIK CNCs offer the right solution for all machine concepts. Whether for individual parts or mass production, simple or complex workpieces – SINUMERIK is the highly dynamic automation solution, integrated for all areas of production. From prototype construction and tool design to mold making, all the way to large-scale series production.

Visit our website for more information SINUMERIK (<https://www.siemens.com/sinumerik>).

1.2 About this documentation

Target group

This documentation is intended for users of universal machines running the SINUMERIK Operate software.

Benefits

The Operating Manual helps users familiarize themselves with the control elements and commands. Guided by the manual, users are capable of responding to problems and taking corrective action.

Standard scope

This documentation only describes the functionality of the standard version. This may differ from the scope of the functionality of the system that is actually supplied. Please refer to the ordering documentation only for the functionality of the supplied drive system.

It may be possible to execute other functions in the system which are not described in this documentation. This does not, however, represent an obligation to supply such functions with a new control or when servicing.

For reasons of clarity, this documentation cannot include all of the detailed information on all product types. Further, this documentation cannot take into consideration every conceivable type of installation, operation and service/maintenance.

The machine manufacturer must document any additions or modifications they make to the product themselves.

Websites of third-party companies

This document may contain hyperlinks to third-party websites. Siemens is not responsible for and shall not be liable for these websites and their content. Siemens has no control over the information which appears on these websites and is not responsible for the content and information provided there. The user bears the risk for their use.

1.3 Documentation on the internet

1.3.1 Documentation overview SINUMERIK 840D sl

You will find extensive documentation on the functions of SINUMERIK 840D sl from version 4.8 SP4 at 840D sl documentation overview (<https://support.industry.siemens.com/cs/ww/en/view/109766213>).



You can display documents or download them in PDF and HTML5 format.

The documentation is divided into the following categories:

- User: Operating
- User: Programming
- Manufacturer/Service: Functions
- Manufacturer/Service: Hardware
- Manufacturer/Service: Configuration/Setup
- Manufacturer/Service: Safety Integrated
- Manufacturer/Service: SINUMERIK Integrate/MindApp
- Information and training
- Manufacturer/Service: SINAMICS

1.3.2 Documentation overview SINUMERIK operator components

Comprehensive documentation about the SINUMERIK operator components is provided in the Documentation overview SINUMERIK operator components (<https://support.industry.siemens.com/cs/document/109783841/technische-dokumentation-zu-sinumerik-bedienkomponenten?dti=0&lc=en-WW>).

You can display documents or download them in PDF and HTML5 format.

1.3 Documentation on the internet

The documentation is divided into the following categories:

- Operator Panels
- Machine control panels
- Machine Pushbutton Panel
- Handheld Unit/Mini handheld devices
- Further operator components

An overview of the most important documents, entries and links to SINUMERIK is provided at SINUMERIK Overview - Topic Page (<https://support.industry.siemens.com/cs/document/109766201/sinumerik-an-overview-of-the-most-important-documents-and-links?dti=0&lc=en-WW>).

1.4 Feedback on the technical documentation

If you have any questions, suggestions or corrections regarding the technical documentation which is published in the Siemens Industry Online Support, use the link "Send feedback" link which appears at the end of the entry.

1.5 mySupport documentation

With the "mySupport documentation" web-based system you can compile your own individual documentation based on Siemens content, and adapt it for your own machine documentation.

To start the application, click on the "My Documentation" tile on the mySupport homepage (<https://support.industry.siemens.com/cs/ww/en/my>):

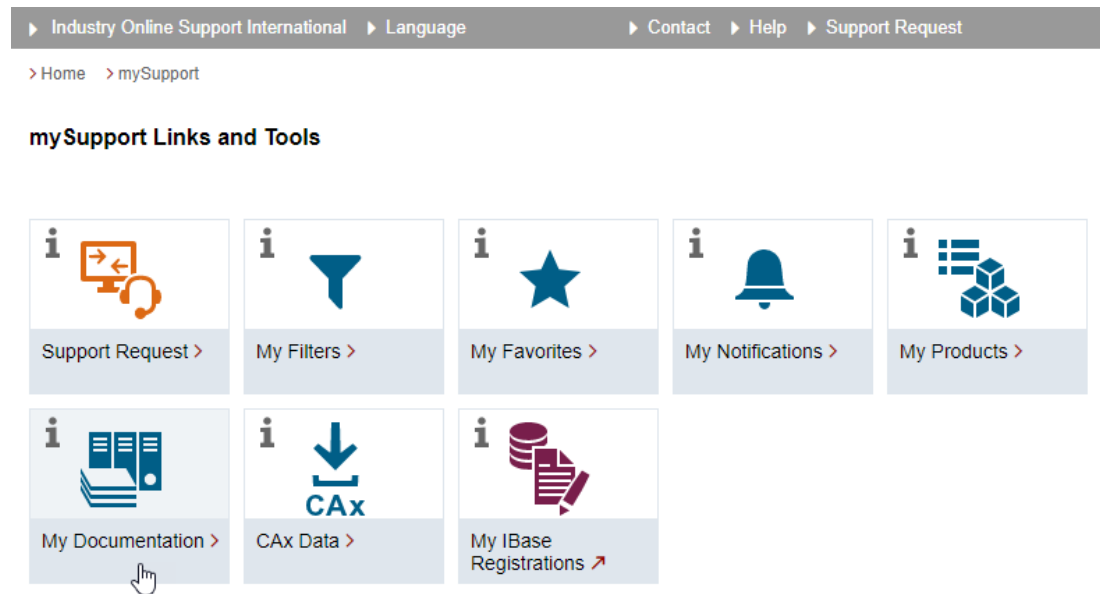

The configured manual can be exported in RTF, PDF or XML format.

Note

Siemens content that supports the mySupport documentation application can be identified by the presence of the "Configure" link.

1.6 Service and Support

Product support

You can find more information about products on the internet:

Product support (<https://support.industry.siemens.com/cs/ww/en/>)

The following is provided at this address:

- Up-to-date product information (product announcements)
- FAQs (frequently asked questions)
- Manuals
- Downloads
- Newsletters with the latest information about your products
- Global forum for information and best practice sharing between users and specialists
- Local contact persons via our Contacts at Siemens database (→ "Contact")
- Information about field services, repairs, spare parts, and much more (→ "Field Service")

Technical support

Country-specific telephone numbers for technical support are provided on the internet at address (<https://support.industry.siemens.com/cs/ww/en/sc/4868>) in the "Contact" area.

If you have any technical questions, please use the online form in the "Support Request" area.

Training

You can find information on SITRAIN at the following address (<https://www.siemens.com/sitrain>).

SITRAIN offers training courses for automation and drives products, systems and solutions from Siemens.

Siemens support on the go





With the award-winning "Siemens Industry Online Support" app, you can access more than 300,000 documents for Siemens Industry products – any time and from anywhere. The app can support you in areas including:

- Resolving problems when implementing a project
- Troubleshooting when faults develop
- Expanding a system or planning a new system

Furthermore, you have access to the Technical Forum and other articles from our experts:

- FAQs
- Application examples
- Manuals
- Certificates
- Product announcements and much more

The "Siemens Industry Online Support" app is available for Apple iOS and Android.

Data matrix code on the nameplate

The data matrix code on the nameplate contains the specific device data. This code can be read with a smartphone and technical information about the device displayed via the "Industry Online Support" mobile app.

1.7 Important product information

Using OpenSSL

This product can contain the following software:

- Software developed by the OpenSSL project for use in the OpenSSL toolkit
- Cryptographic software created by Eric Young.
- Software developed by Eric Young

You can find more information on the internet:

- OpenSSL (<https://www.openssl.org>)
- Cryptsoft (<https://www.cryptsoft.com>)

Compliance with the General Data Protection Regulation

Siemens observes standard data protection principles, in particular the data minimization rules (privacy by design).

For this product, this means:

The product does not process or store any personal data, only technical function data (e.g. time stamps). If the user links this data with other data (e.g. shift plans) or if he/she stores person-related data on the same data medium (e.g. hard disk), thus personalizing this data, he/she must ensure compliance with the applicable data protection stipulations.

Fundamental safety instructions

2.1 General safety instructions

 WARNING
Danger to life if the safety instructions and residual risks are not observed
If the safety instructions and residual risks in the associated hardware documentation are not observed, accidents involving severe injuries or death can occur.
<ul style="list-style-type: none">• Observe the safety instructions given in the hardware documentation.• Consider the residual risks for the risk evaluation.

 WARNING
Malfunctions of the machine as a result of incorrect or changed parameter settings
As a result of incorrect or changed parameterization, machines can malfunction, which in turn can lead to injuries or death.
<ul style="list-style-type: none">• Protect the parameterization against unauthorized access.• Handle possible malfunctions by taking suitable measures, e.g. emergency stop or emergency off.

2.2 Warranty and liability for application examples

Application examples are not binding and do not claim to be complete regarding configuration, equipment or any eventuality which may arise. Application examples do not represent specific customer solutions, but are only intended to provide support for typical tasks.

As the user you yourself are responsible for ensuring that the products described are operated correctly. Application examples do not relieve you of your responsibility for safe handling when using, installing, operating and maintaining the equipment.

2.3 Security information

Siemens provides products and solutions with industrial security functions that support the secure operation of plants, systems, machines and networks.

In order to protect plants, systems, machines and networks against cyber threats, it is necessary to implement – and continuously maintain – a holistic, state-of-the-art industrial security concept. Siemens' products and solutions constitute one element of such a concept.

Customers are responsible for preventing unauthorized access to their plants, systems, machines and networks. Such systems, machines and components should only be connected to an enterprise network or the internet if and to the extent such a connection is necessary and only when appropriate security measures (e.g. firewalls and/or network segmentation) are in place.

For additional information on industrial security measures that may be implemented, please visit

<https://www.siemens.com/industrialsecurity> (<https://www.siemens.com/industrialsecurity>).

Siemens' products and solutions undergo continuous development to make them more secure. Siemens strongly recommends that product updates are applied as soon as they are available and that the latest product versions are used. Use of product versions that are no longer supported, and failure to apply the latest updates may increase customer's exposure to cyber threats.

To stay informed about product updates, subscribe to the Siemens Industrial Security RSS Feed under

<https://www.siemens.com/industrialsecurity> (<https://new.siemens.com/global/en/products/services/cert.html#Subscriptions>).

Further information is provided on the Internet:

Industrial Security Configuration Manual (<https://support.industry.siemens.com/cs/ww/en/view/108862708>)



WARNING

Unsafe operating states resulting from software manipulation

Software manipulations, e.g. viruses, Trojans, or worms, can cause unsafe operating states in your system that may lead to death, serious injury, and property damage.

- Keep the software up to date.
- Incorporate the automation and drive components into a holistic, state-of-the-art industrial security concept for the installation or machine.
- Make sure that you include all installed products into the holistic industrial security concept.
- Protect files stored on exchangeable storage media from malicious software by with suitable protection measures, e.g. virus scanners.
- On completion of commissioning, check all security-related settings.

Fundamentals

3.1 Product overview

The SINUMERIK control system is a CNC (Computerized Numerical Control) for machine tools. You can use the CNC to implement the following basic functions in conjunction with a machine tool:

- Create can adapt part programs
- Execute part programs
- Manual control
- Access internal and external data media
- Edit data for programs
- Manage tools, zero points and further user data required in programs
- Diagnose control system and machine

Operating areas

The basic functions are grouped in the following operating areas in the control:

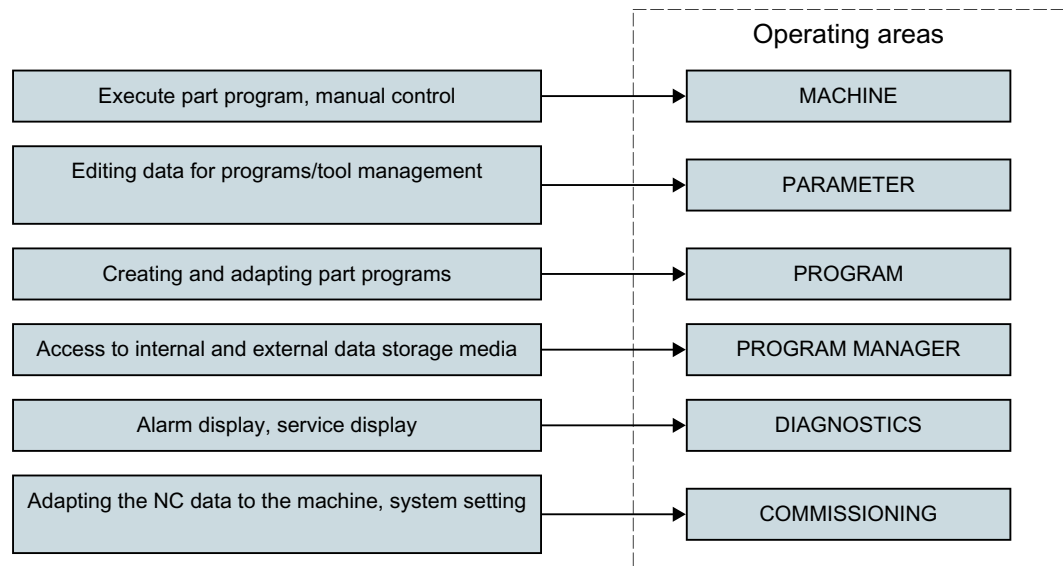

3.2 Operator panel fronts

3.2.1 Overview

The display (screen) and operation (e.g. hardkeys and softkeys) of the SINUMERIK Operate user interface are via the operator panel front.

Operator controls and indicators

In this example, the OP 010 operator panel front is used to illustrate the components that are available for operating the controller and machine tool.

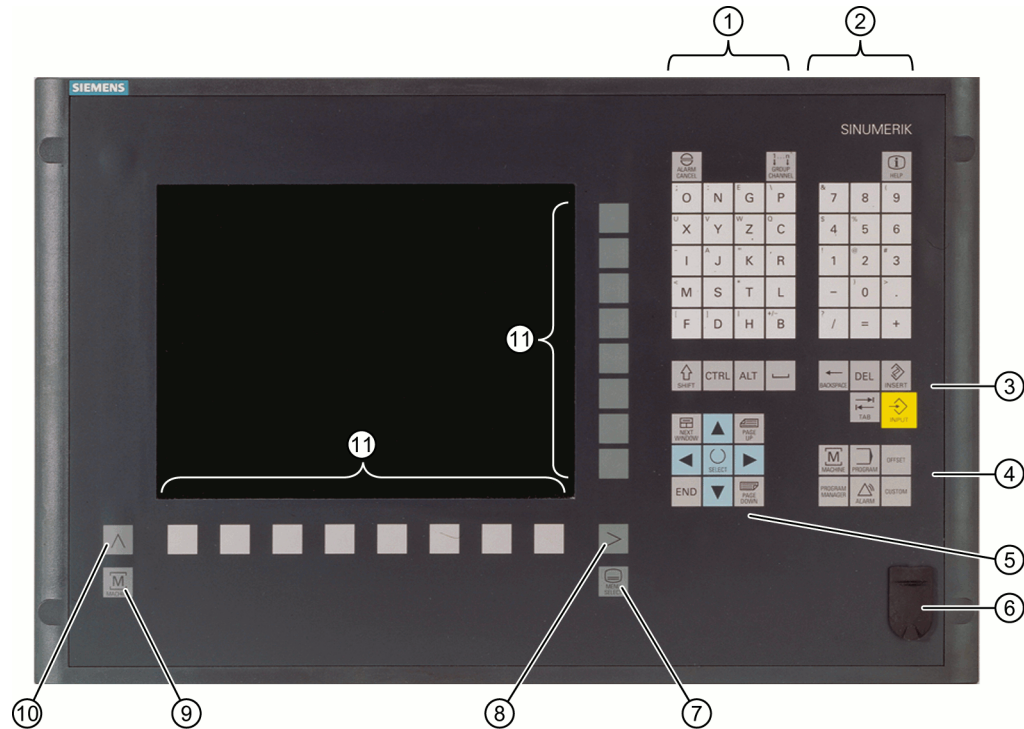

- ① Alphabetic key group
With the <Shift> key pressed, you activate the special characters on keys with double assignments, and write in the uppercase.
Note: Depending on the particular configuration of your control system, uppercase letters are always written
- ② Numerical key group
With the <Shift> key pressed, you activate the special characters on keys with double assignments.
- ③ Control key group
- ④ Hotkey group
- ⑤ Cursor key group
- ⑥ USB interface
- ⑦ Menu select key
- ⑧ Menu forward button
- ⑨ Machine area button
- ⑩ Menu back key
- ⑪ Softkeys

Further information





Further information about the OP 010 and other usable operator panel fronts can be found at:

- Operating Components Equipment Manual - Handheld Units (<https://support.industry.siemens.com/cs/ww/en/view/109736210>)
- Equipment Manual OP 010 (<https://support.industry.siemens.com/cs/ww/en/view/109759204>)
- Equipment Manual OP 012 (<https://support.industry.siemens.com/cs/ww/en/view/109741627>)
- Equipment Manual OP 015A (<https://support.industry.siemens.com/cs/ww/en/view/109748600>)
- Operating Components Equipment Manual - TCU 30.3 (<https://support.industry.siemens.com/cs/ww/en/view/109749929>)
- HT 8 (<https://support.industry.siemens.com/cs/ww/en/view/109763514>)

3.2.2 Keys of the operator panel

The following keys and key combinations are available for operation of the control and the machine tool.

Keys and key combinations

Key	Function
	<p><ALARM CANCEL> Cancels alarms and messages that are marked with this symbol.</p>
	<p><CHANNEL> Advances for several channels.</p>
	<p><HELP> Calls the context-sensitive online help for the selected window.</p>
	<p><NEXT WINDOW> *</p> <ul style="list-style-type: none"> • Toggles between the windows. • For a multi-channel view or for a multi-channel functionality, switches within a channel gap between the upper and lower window. • Selects the first entry in selection lists and in selection fields. • Moves the cursor to the beginning of a text. <p>* on USB keyboards use the <Home> or <Pos 1> key</p>

**<NEXT WINDOW> + <SHIFT>**

- Selects the first entry in selection lists and in selection fields.
- Moves the cursor to the beginning of a text.
- Selects a contiguous selection from the current cursor position up to the target position.
- Selects a contiguous selection from the current cursor position up to the beginning of a program block.

**<NEXT WINDOW> + <ALT>**

- Moves the cursor to the first object.
- Moves the cursor to the first column of a table row.
- Moves the cursor to the beginning of a program block.

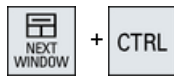
**<NEXT WINDOW> + <CTRL>**

- Moves the cursor to the beginning of a program.
- Moves the cursor to the first row of the current column.

**<NEXT WINDOW> + <CTRL> + <SHIFT>**

- Moves the cursor to the beginning of a program.
- Moves the cursor to the first row of the current column.
- Selects a contiguous selection from the current cursor position up to the target position.
- Selects a contiguous selection from the current cursor position up to the beginning of the program.

**<PAGE UP>**

Scrolls upwards by one page in a window.

**<PAGE UP> + <SHIFT>**

In the program manager and in the program editor from the cursor position, selects directories or program blocks up to the beginning of the window.

**<PAGE UP> + <CTRL>**

Positions the cursor to the topmost line of a window.

**<PAGE DOWN>**

Scrolls downwards by one page in a window.

**<PAGE DOWN> + <SHIFT>**

In the program manager and in the program editor, from the cursor position, selects directories or program blocks up to the end of the window.

**<PAGE DOWN> + <CTRL>**

Positions the cursor to the lowest line of a window.

**<Cursor right>**

- Editing box
 - Opens a directory or program (e.g. cycle) in the editor.
- Navigation
 - Moves the cursor further to the right by one character.

**<Cursor right> + <CTRL>**

- Editing box
Moves the cursor further to the right by one word.
- Navigation
Moves the cursor in a table to the next cell to the right.

**<Cursor left>**

- Editing box
Closes a directory or program (e.g. cycle) in the program editor. If you have made changes, then these are accepted.
- Navigation
Moves the cursor further to the left by one character.

**<Cursor left> + <CTRL>**

- Editing box
Moves the cursor further to the left by one word.
- Navigation
Moves the cursor in a table to the next cell to the left.

**<Cursor up>**

- Editing box
Moves the cursor into the next upper field.
- Navigation
 - Moves the cursor in a table to the next cell upwards.
 - Moves the cursor upwards in a menu screen.

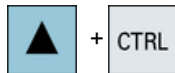
**<Cursor up> + <Ctrl>**

- Moves the cursor in a table to the beginning of the table.
- Moves the cursor to the beginning of a window.

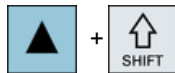
**<Cursor up> + <SHIFT>**

In the program manager and in the program editor, selects a contiguous selection of directories and program blocks.

**<Cursor down>**

- Editing box
Moves the cursor downwards.
- Navigation
 - Moves the cursor in a table to the next cell downwards.
 - Moves the cursor in a window downwards.

**<Cursor down> + <CTRL>**

- Navigation
 - Moves the cursor in a table to the end of the table.
 - Moves the cursor to the end of a window.
- Simulation
Reduces the override.

**<Cursor down> + <SHIFT>**

In the program manager and in the program editor, selects a contiguous selection of directories and program blocks.

**<SELECT>**

Switches between several specified options in selection lists and in selection boxes.

Activates checkboxes.

In the program editor and in the program manager, selects a program block or a program.

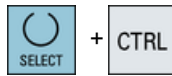
**<SELECT> + <CTRL>**

When selecting table rows, switches between selected and not selected.

**<SELECT> + <SHIFT>**

Selects in selection lists and in selection boxes the previous entry or the last entry.

**<END>**

Moves the cursor to the last entry field in a window, to the end of a table or a program block.

Selects the last entry in selection lists and in selection boxes.

**<END> + <SHIFT>**

Moves the cursor to the last entry.

Selects a contiguous selection from the cursor position up to the end of a program block.

**<END> + <CTRL>**

Moves the cursor to the last entry in the last line of the actual column or to the end of a program.

**<END> + <CTRL> + <SHIFT>**

Moves the cursor to the last entry in the last line of the actual column or to the end of a program.

Selects a contiguous selection from the cursor position up to the end of a program block.

**<BACKSPACE>**

- Editing box
Deletes a character selected to the left of the cursor.
- Navigation
Deletes all of the selected characters to the left of the cursor.

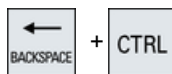
**<BACKSPACE> + <CTRL>**

- Editing box
Deletes a word selected to the left of the cursor.
- Navigation
Deletes all of the selected characters to the left of the cursor.

**<TAB>**

- In the program editor, indents the cursor by one character.
- In the program manager, moves the cursor to the next entry to the right.

**<TAB> + <SHIFT>**

- In the program editor, indents the cursor by one character.
- In the program manager, moves the cursor to the next entry to the left.

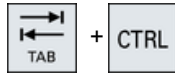
**<TAB> + <CTRL>**

- In the program editor, indents the cursor by one character.
- In the program manager, moves the cursor to the next entry to the right.

**<Tab> + <Ctrl> + <Shift>**

- In the program editor, indents the cursor by one character.
- In the program manager, moves the cursor to the next entry to the left.

**<CTRL> + <A>**

In the actual window, selects all entries (only in the program editor and program manager).

**<CTRL> + <C>**

Copies the selected content.

**<CTRL> + <E>**

Calls the "Ctrl Energy" function.

**<CTRL> + <F>**

Opens the search dialog in the machine data and setting data lists, when loading and saving in the MDI editor as well as in the program manager and in the system data.

**<CTRL> + <G>**

- Switches in the program editor for ShopMill or ShopTurn programs between the work plan and the graphic view.
- Switches in the parameter screen between the help display and the graphic view.

**<CTRL> + <I>**

Calculates the program runtime up to or from the selected set/block and displays a graphic representation of the times.

**<CTRL> + <L>**

Scrolls the actual user interface through all installed languages one after the other.

**<CTRL> + <SHIFT> + <L>**











Scrolls the actual user interface through all installed languages in the inverse sequence.

**<CTRL> + <M>**

Selects the maximum feedrate of 120% during the simulation.

**<CTRL> + <P>**

Generates a screenshot from the actual user interface and saves it as file.

	<CTRL> + <S> Switches the single block in or out in the simulation.
	<CTRL> + <V> <ul style="list-style-type: none"> • Pastes text from the clipboard at the actual cursor position. • Pastes text from the clipboard at the position of a selected text.
	<CTRL> + <X> Cuts out the selected text. The text is located in the clipboard.
	<CTRL> + <Y> Reactivates changes that were undone (only in the program editor).
	<CTRL> + <Z> Undoes the last action (only in the program editor).
	<CTRL> + <ALT> + <C> Creates a complete standard archive (.ARC) on an external data carrier (USB-FlashDrive) Note: The complete backup via this key combination is only suitable for diagnostic purposes.
	<CTRL> + <ALT> + <S> Creates a complete Easy Archive (.ARD) on an external data carrier (USB-FlashDrive) Note: Please observe the information provided by the machine manufacturer.
	<CTRL> + <ALT> + <D> Backs up the log files on the USB-FlashDrive. If a USB-FlashDrive is not inserted, then the files are backed-up in the manufacturer's area of the CF card.
	<SHIFT> + <ALT> + <D> Backs up the log files on the USB-FlashDrive. If a USB-FlashDrive is not inserted, then the files are backed-up in the manufacturer's area of the CF card.
	<SHIFT> + <ALT> + <T> Starts "HMI Trace".
	<SHIFT> + <ALT> + <T> Exits "HMI Trace".

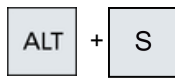

<ALT> + <S>

Opens the editor to enter Asian characters.

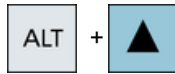

<ALT> + <Cursor up>

Moves the block start or block end up in the editor.

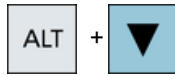

<ALT> + <Cursor down>

Moves the block start or block end down in the editor.



- Editing box
Deletes the first character to the right of the cursor.
- Navigation
Deletes all characters.

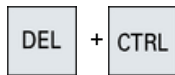

** + <CTRL>**

- Editing box
Deletes the first word to the right of the cursor.
- Navigation
Deletes all characters.



<Spacebar>

- Editing box
Inserts a space.
- Switches between several specified options in selection lists and in selection boxes.



<Plus>

- Opens a directory which contains the element.
- Increases the size of the graphic view for simulation and traces.



<Minus>

- Closes a directory which contains the element.
- Reduces the size of the graphic view for simulation and traces.



<Equals>

Opens the calculator in the entry fields.



<Asterisk>

Opens a directory with all of the subdirectories.



<Tilde>

Changes the sign of a number between plus and minus.



<INSERT>

- Opens an editing window in the insert mode. Pressing the key again, exits the window and the entries are undone.
- Opens a selection box and shows the selection possibilities.
- In the machining step program, enters an empty line for G code.
- Changes into the double editor or into the multi-channel view from the edit mode into the operating mode. You can return to the edit mode by pressing the key again.

**<INSERT> + <SHIFT>**

For G code programming, for a cycle call activates or deactivates the edit mode.

<INPUT>

- Completes input of a value in the entry field.
- Opens a directory or a program.
- Inserts an empty program block if the cursor is positioned at the end of a program block.
- Inserts a character to select a new line and the program block is split up into two parts.
- In the G code, inserts a new line after the program block.
- In the machining step program, inserts a new line for G code e
- Changes into the double editor or into the multi-channel view from the edit mode into the operating mode. You can return to the edit mode by pressing the key again.

**<ALARM> - only OP 010 and OP 010C**

Calls the "Diagnosis" operating area.

**<PROGRAM> - only OP 010 and OP 010C**

Calls the "Program Manager" operating area.

**<OFFSET> - only OP 010 and OP 010C**

Calls the "Parameter" operating area.

**<PROGRAM MANAGER> - only OP 010 and OP 010C**

Calls the "Program Manager" operating area.

**Menu forward key**

Advances in the extended horizontal softkey bar.

**Menu back key**

Returns to the higher-level menu.

**<MACHINE>**

Calls the "Machine" operating area.

**<MENU SELECT>**

Calls the main menu to select the operating area.

3.3 Machine control panels

3.3.1 Overview

The machine tool can be equipped with a machine control panel by Siemens or with a specific machine control panel from the machine manufacturer.

You use the machine control panel to initiate actions on the machine tool such as traversing an axis or starting the machining of a workpiece.

3.3.2 Controls on the machine control panel

In this example, the MCP 483C IE machine control panel is used to illustrate the operator controls and displays of a Siemens machine control panel.

Overview

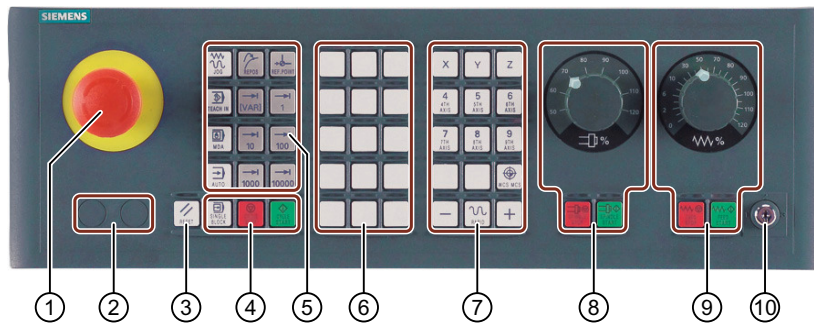

- ① EMERGENCY STOP button
- ② Installation locations for control devices (d = 16 mm)
- ③ RESET
- ④ Program control
- ⑤ Operating modes, machine functions
- ⑥ User keys T1 to T15
- ⑦ Traversing axes with rapid traverse override and coordinate switchover
- ⑧ Spindle control with override switch
- ⑨ Feed control with override switch
- ⑩ Keyswitch (four positions)

Operator controls

EMERGENCY STOP button



Press the button in situations where:

- life is at risk.
 - there is the danger of a machine or workpiece being damaged.
- All drives will be stopped with the greatest possible braking torque.



Machine manufacturer

For additional responses to pressing the EMERGENCY STOP button, please refer to the machine manufacturer's instructions.

RESET



- Stop processing the current programs.
The NCK control remains synchronized with the machine. It is in its initial state and ready for a new program run.
- Cancel alarm.

Program control



<SINGLE BLOCK>

Single block mode on/off.



<CYCLE START>

The key is also referred to as NC Start.
Execution of a program is started.



<CYCLE STOP>

The key is also referred to as NC Stop.
Execution of a program is stopped.

Operating modes, machine functions



<JOG>

Select "JOG" mode.



<TEACH IN>

Selecting the "Teach In" function



<MDI>

Select "MDI" mode.



<AUTO>

Select "AUTO" mode.



<REPOS>

Repositions, re-approaches the contour.



<REF POINT>

Approach reference point.



Inc <VAR> (Incremental Feed Variable)

Incremental mode with variable increment size.



Inc (incremental feed)

Incremental mode with predefined increment size of 1, ..., 10000 increments.

...



Machine manufacturer

A machine data code defines how the increment value is interpreted.

Traversing axes with rapid traverse override and coordinate switchover



Axis keys

Selects an axis.

...



Direction keys

Select the traversing direction.

...



<RAPID>

Traverse axis in rapid traverse while pressing the direction key.



<WCS MCS>

Switches between the workpiece coordinate system (WCS) and machine coordinate system (MCS).

Spindle control with override switch



<SPINDLE STOP>

Stop spindle.



<SPINDLE START>

Spindle is enabled.

Feed control with override switch**<FEED STOP>**

Stops execution of the running program and shuts down axis drives.

**<FEED START>**

Enable for program execution in the current block and enable for ramp-up to the feedrate value specified by the program.

3.4 Operator interface

3.4.1 Screen layout

Overview

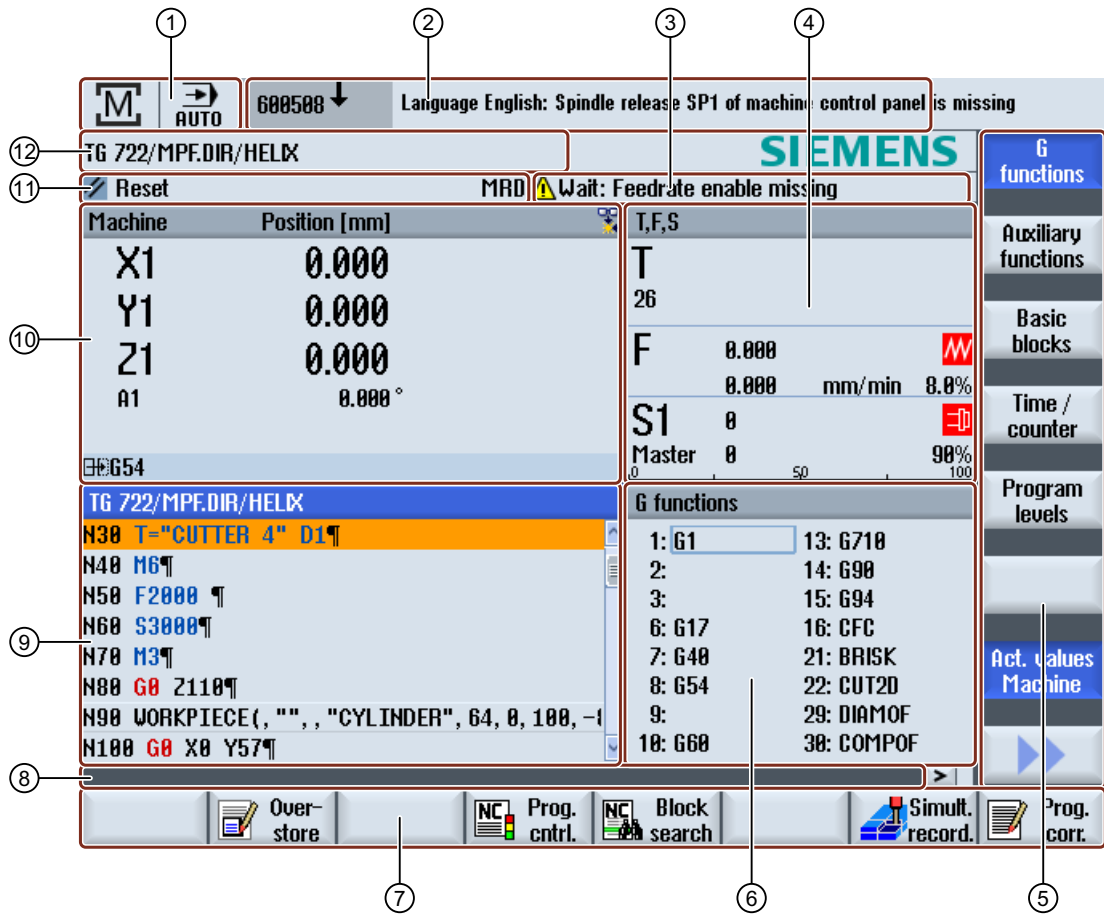

- ① Active operating area and mode
- ② Alarm/message line
- ③ Channel operational messages
- ④ Display for
 - Active tool T
 - Current feedrate F
 - Active spindle with current status (S)
 - Spindle utilization rate in percent
 - Name of active tool holder with display of a rotation in space and plane
 - Name of the active kinematic transformation
- ⑤ Vertical softkey bar

- ⑥ Display of active G functions, all G functions, auxiliary functions and input window for different functions (for example, skip blocks, program control).
- ⑦ Horizontal softkey bar
- ⑧ Dialog line to provide additional user notes.
- ⑨ Operating window with program block display
- ⑩ Position display of the axes in the actual values window
- ⑪ Channel state and program control
- ⑫ Program name

3.4.2 Status display

The status display includes the most important information about the current machine status and the status of the NCK. It also shows alarms as well as NC and PLC messages.



Depending on your operating area, the status display is made up of several lines:

- Large status display
The status display is made up of three lines in the "Machine" operating area.
- Small status display
In the "Parameter", "Program", "Program Manager", "Diagnosis" and "Start-up" operating areas, the status display consists of the first line from the large display.



Status display of "Machine" operating area



First line

Ctrl-Energy - power display







Display	Meaning
	The machine is not productive.
	The machine is productive and energy is being consumed.
	The machine is feeding energy back into the supply system.
The power display must be switched on in the status line. Additional information on configuring is provided in the Ctrl-Energy System Manual.	

Active operating area



Display	Meaning
	"Machine" operating area In touch mode you can switch over the operating area here.
	"Parameter" operating area
	"Program" operating area

Display	Meaning
	"Program manager" operating area
	"Diagnostics" operating area
	"Startup" operating area

Active mode or function

Display	Meaning
	"Jog" mode
	"MDA" mode
	"AUTO" mode
	"TEACH IN" function
	"REPOS" function
	"REF POINT" function

Alarms and messages

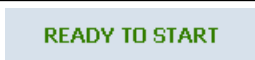
Display	Meaning
	Alarm display The alarm numbers are displayed in white lettering on a red background. The associated alarm text is shown in red lettering. An arrow indicates that several alarms are active. An acknowledgment icon shows how to acknowledge or delete the alarm.
	NC or PLC message Message numbers and texts are shown in black lettering. An arrow indicates that several messages are active.
	Messages from NC programs do not have numbers and appear in green lettering.

Second line

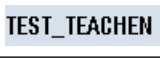
Display	Meaning
	Program path and program name





The displays in the second line can be configured.



Machine manufacturer

Please observe the information provided by the machine manufacturer.

Third line

Display	Meaning
 CHAN1 RESET	Channel status display. If the machine has several channels, then the channel name is also displayed. If there is only one channel, then only "Reset" is displayed as channel status. In touch mode you can switch over the channel here
	Channel status display: The program was canceled with "Reset". The program is executed. The program was interrupted with "Stop".
DRYPRT	Display of active program controls: PRT No axis motion DRY Dry run feedrate RG0: reduced rapid traverse M01: programmed stop 1 M101: programmed stop 2 (the designation is variable) SB1: Single block, coarse (program stops only after blocks that perform a machine function) SB2: Calculation block (program stops after each block) SB3: Single block, fine (program also only stops after blocks which perform a machine function in cycles) CST: configured stop (program stops at stop-relevant locations, which you defined before the program starts)
 Faulty NC block / user alarm  Remaining dwell time:15 Sec.	Channel operational messages: Stop: An operator action is generally required. Wait: No operator action is required.

The machine manufacturer settings determine which program controls are displayed.

**Machine manufacturer**

Please observe the information provided by the machine manufacturer.

3.4.3 Actual value window

The actual values of the axes and their positions are displayed.

Work/Machine

The displayed coordinates are based on either the machine coordinate system or the workpiece coordinate system. The machine coordinate system (Machine), in contrast to the workpiece coordinate system (Work), does not take any work offsets into consideration.

You can use the "Machine actual values" softkey to toggle between the machine coordinate system and the workpiece coordinate system.

The actual value display of the positions can also refer to the SZS coordinate system (settable zero system). However the positions are still output in the Work.

The SZS coordinate system corresponds to the Work coordinate system, reduced by certain components (\$P_TRAFRAME, \$P_PFRAME, \$P_ISO4FRAME, \$P_CYCFRAME), which are set by the system when machining and are then reset again. By using the SZS coordinate system, jumps into the actual value display are avoided that would otherwise be caused by the additional components.



Machine manufacturer

Please observe the information provided by the machine manufacturer.

Maximize display



Press the ">>" and "Zoom act. val." softkeys.

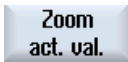

Display overview

Display	Meaning	
Header columns		
Work/Machine	Display of axes in selected coordinate system.	
Position	Position of displayed axes.	
Display of distance-to-go	The distance-to-go for the current NC block is displayed while the program is running.	
Feed/override	The feed acting on the axes, as well as the override, are displayed in the full-screen version.	
REPOS offset	The distances traversed in manual mode are displayed. This information is only displayed when you are in the "REPOS" function.	
Collision avoidance		Collision avoidance is activated for JOG, MDI and AUTO modes.
		Collision avoidance is deactivated for JOG, MDI and AUTO modes.
Footer	Display of active work offsets and transformations. The T, F, S values are also displayed in the full-screen version.	

See also



Zero offsets (Page 107)

Set collision avoidance (Page 260)

3.4.4 T,F,S window

The most important data concerning the current tool, the feedrate (path feed or axis feed in JOG) and the spindle is displayed in the T, F, S window.

In addition to the "T, F, S" window name, the following information is also displayed:

Display	Meaning
BC (example)	Name of the tool carrier
Turning (example)	Name of the active kinematic transformation
	Active tool carrier rotated in the plane
	Active tool carrier swiveled in space

Tool data





Display	Meaning
T	
Tool name	Name of the current tool
Location	Location number of the current tool
D	Cutting edge of the current tool The tool is displayed with the associated tool type symbol corresponding to the actual coordinate system in the selected cutting edge position. If the tool is swiveled, then this is taken into account in the display of the cutting edge position. In DIN-ISO mode the H number is displayed instead of the cutting edge number.
H	H number (tool offset data record for DIN-ISO mode) If there is a valid D number, this is also displayed.
∅	Diameter of the current tool
R	Radius of the current tool
L	Length of the actual tool
Z	Z value of the current tool
X	X value of the current tool

Feed data

Display	Meaning
F	
	Feed disable

Display	Meaning
	Actual feed value If several axes traverse, is displayed for: <ul style="list-style-type: none"> • "JOG" mode: Axis feed for the traversing axis • "MDA" and "AUTO" mode: Programmed axis feed
Rapid traverse	G0 is active
0.000	No feed is active
Override	Display as a percentage

Spindle data

Display	Meaning
S	
S1	Spindle selection, identification with spindle number and main spindle
Speed	Actual value (when spindle turns, display increases) Setpoint (always displayed, also during positioning)
Symbol    	Spindle status Spindle not enabled Spindle is turning clockwise Spindle is turning counterclockwise Spindle is stationary
Override	Display as a percentage
Spindle utilization rate 	Display between 0 and 100% The upper limit value can be greater than 100%. See machine manufacturer's specifications. Display of maximum remaining time of spindle use at the current spindle load. Time and symbol are displayed if the remaining time is less than 120 seconds.

Note

Display of logical spindles

If the spindle converter is active, logical spindles are displayed in the workpiece coordinate system. When switching over to the machine coordinate system, the physical spindles are displayed.



Machine manufacturer

Please observe the information provided by the machine manufacturer.

3.4.5 Current block display

The window of the current block display shows the program blocks currently being executed.

Display of current program

The following information is displayed in the running program:

- The workpiece name or program name is entered in the header line.
- The program block which is just being processed appears colored.

Display of the machining times



If you set that the machining times are to be recorded in the settings for automatic mode, the measured times are shown at the end of the line as follows:

Display	Meaning
Light green background ⊙ 17.18	Measured machining time of the program block (automatic mode)
Green background ⊙ 19.47	Measured machining time of the program group (automatic mode)
Light blue background ⊙ 17.31	Estimated machining time of the program block (simulation)
Blue background ⊙ 19.57	Estimated machining time of the program group (simulation)
Yellow background ⊙ 4.53	Wait time (automatic mode or simulation)

Highlighting of selected G code commands or keywords

In the program editor settings, you can specify whether selected G code commands are to be highlighted in color. The following colors are used as standard:

Display	Meaning
Blue font M30¶	D, S, F, T, M and H functions
Red font G0¶	"G0" motion command
Green font G1¶	"G1" motion command

Display	Meaning
Blue-green font 	"G2" or "G3" motion command
Gray font 	Comment

Machine manufacturer



You can define further highlight colors in the "sleditorwidget.ini" configuration file. Please refer to the machine manufacturer's instructions.

Editing a program directly

In the Reset state, you can edit the current program directly.



1. Press the <INSERT> key.

2. Place the cursor at the relevant position and edit the program block. Direct editing is only possible for G code blocks in the NC memory, not for external execution.



3. Press the <INSERT> key to exit the program and the edit mode again.

See also

Correcting a program (Page 146)

Settings for the automatic mode (Page 191)

3.4.6 Operation via softkeys and buttons

Operating areas/operating modes

The user interface consists of different windows featuring eight horizontal and eight vertical softkeys.

You operate the softkeys with the keys next to the softkey bars.

You can display a new window or execute functions using the softkeys.

The operating software is sub-divided into six operating areas (machine, parameter, program, program manager, diagnosis, startup), three operating modes and four functions (JOG, MDI, AUTO, TEACH IN, REF. POINT, REPOS, single block).

Changing the operating area



Press the <MENU SELECT> key and select the desired operating area using the horizontal softkey bar.

You can call the "Machine" operating area directly using the key on the operator panel.



Press the <MACHINE> key to select the "machine" operating area.

Changing the operating mode

You can select a mode or function directly with the keys on the machine control panel or the vertical softkeys in the main menu.

General keys and softkeys



When the  symbol appears to the right of the dialog line on the user interface, you can change the horizontal softkey bar within an operating area. To do so, press the menu forward key.

The  symbol indicates that you are in the expanded softkey bar.

Pressing the key again will take you back to the original horizontal softkey bar.

Use the ">>" softkey to open a new vertical softkey bar.



Use the "<<" softkey to return to the previous vertical softkey bar.



Use the "Return" softkey to close an open window.



Use the "Cancel" softkey to exit a window without accepting the entered values and return to the next highest window.



When you have entered all the necessary parameters in the parameter screen form correctly, you can close the window and save the parameters using the "Accept" softkey. The values you entered are applied to a program.



Use the "OK" softkey to initiate an action immediately, e.g. to rename or delete a program.

See also

Controls on the machine control panel (Page 38)

Channel switchover (Page 101)

3.4.7 Entering or selecting parameters

When setting up the machine and during programming, you must enter various parameter values in the entry fields. The background color of the fields provides information on the status of the entry field.

Orange background	The input field is selected
Light orange background	The input field is in edit mode
Pink background	The entered value is incorrect

Selecting parameters

Some parameters require you to select from a number of options in the input field. Fields of this type do not allow you to type in a value.

The selection symbol is displayed in the tooltip: 

Associated selection fields

There are selection fields for various parameters:

- Selection of units
- Changeover between absolute and incremental dimensions

Procedure



1. Keep pressing the <SELECT> key until the required setting or unit is selected.

The <SELECT> key only works if there are several selection options available.

- OR -



Press the <INSERT> key.

The selection options are displayed in a list.



2. Select the required setting using the <Cursor down> and <Cursor up> keys.



3. If required, enter a value in the associated input field.



4. Press the <INPUT> key to complete the parameter input.

Changing or calculating parameters

If you only want to change individual characters in an input field rather than overwriting the entire entry, switch to insertion mode.

In this mode, you can also enter simple calculation expressions, without having to explicitly call the calculator.

Note

Functions of the calculator

Function calls of the calculator are not available in the parameter screens of the cycles and functions in the "Program" operating area.



Press the <INSERT> key.

The insert mode is activated.



You can navigate within the input field using the <Cursor left> and <Cursor right> keys.



Use the <BACKSPACE> and key to delete individual characters.



Enter the value or the calculation.



Close the value entry using the <INPUT> key and the result is transferred into the field.

Accepting parameters

When you have correctly entered all necessary parameters, you can close the window and save your settings.

You cannot accept the parameters if they are incomplete or obviously erroneous. In this case, you can see from the dialog line which parameters are missing or were entered incorrectly.



Press the "OK" softkey.

- OR -



Press the "Accept" softkey.

3.4.8 Pocket calculator

The calculator allows you to calculate values for entry fields. It is possible to choose between a simple standard calculator and the extended view with mathematical functions.

Using the calculator

- You can simply use the calculator at the touch panel.
- Without a touch panel, you can use the calculator using the mouse.

Procedure

1. Position the cursor on the desired entry field.
2. Press the <=> key.
The calculator is displayed.
3. Press the <min> key if you would like to work with the standard calculator.
- OR -
Press the <extend> key to switch to the extended view.
4. Input the arithmetic statement.
You can use functions, arithmetic symbols, numbers, and commas.
5. Press the equals symbol on the calculator.

- OR -
Press the "Calculate" softkey.

- OR -
Press the <INPUT> key.
The new value is calculated and displayed in the entry field of the calculator.
6. Press the "Accept" softkey.
The calculated value is accepted and displayed in the entry field of the window.

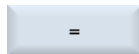

See also





Entering or selecting parameters (Page 52)

3.4.9 Pocket calculator functions

The called operations continue to be displayed in the entry field of the calculator until the value is calculated. This allows you to subsequently modify entries and to nest functions.

The following save and delete functions are provided for modifications:

Key	Function
MS	Buffer value (Memory Save)
MR	Retrieve from buffer memory (Memory Recall)

Key	Function
	Delete buffer memory contents (Memory Clear)
	Delete individual character (Backspace)
	Delete expression (Clear Element)
	Delete all entries (Clear)

Nesting functions

Various possibilities are available for the nesting of functions as follows:

- Position the cursor within the bracket of the function call and supplement the argument with an additional function.
- Highlight the expression which is to be used as an argument in the entry line and then press the desired function key.

Percentage calculation

The calculator supports the calculation of a percentage, as well as changing of a basic value by a percentage. Press the following keys in this regard:

Example: Percentage

4  50   2

Example: Change by percentage

4  50   6

Calculating trigonometric functions

1. Check whether the angles are specified in radians "RAD" or in degrees "DEG".
 2. Press the "RAD" key to calculate the trigonometric functions in degrees "DEG".
The designation of the key changes to "DEG".
- OR -
Press the "DEG" key to calculate the trigonometric functions in radian.
The designation of the key changes to "RAD".
 3. Press the key for the desired trigonometric function, e.g. "SIN".
 4. Enter the numerical value.
- ...
- 

Further mathematical functions

Press the keys in the specified order:

Square number



Num-
ber

Square root



Num-
ber

Exponential function

Base number



Exponent

Residue class calculation

Number



Divider

Absolute value



Num-
ber

Integer component



Num-
ber

Conversion between millimeters and inches



1. Enter the numerical value.
2. Press the "MM" key to convert inches to millimeters. The key is highlighted in blue.

- OR -



Press the "INCH" key to convert millimeters to inches. The button is highlighted in blue.

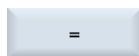

3. Press the "=" key on the calculator. The calculated value is displayed in the entry field. The key for the unit is highlighted in gray once again.

3.4.10 Context menu

When you right-click, the context menu opens and provides the following functions:

- Cut
Cut Ctrl+X
- Copy
Copy Ctrl+C
- Paste
Paste Ctrl+V

Program editor

Additional functions are available in the editor

- Undo the last change
Undo Ctrl+Z
- Redo the changes that were undone
Redo Ctrl+Y

Up to 50 changes can be undone.

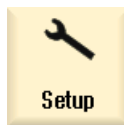
3.4.11 Changing the user interface language**Procedure**

1. Select the "Start-up" operating area.



2. Press the "Change language" softkey.
The "Language selection" window opens. The language set last is selected.

3. Position the cursor on the desired language.

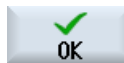

4. Press the "OK" softkey.

- OR -

Press the <INPUT> key.



The user interface changes to the selected language.

Note**Changing the language directly on the input screens**

You can switch between the user interface languages available on the controller directly on the user interface by pressing the key combination <CTRL + L>.

3.4.12 Entering Chinese characters

3.4.12.1 Function - input editor

Using the input editor IME (Input Method Editor), you can select Asian characters on classic panels (without touch operation) where you enter the phonetic notation. These characters are transferred into the user interface.

Note

Call the input editor with <Alt + S>

The input editor can only be called there where it is permissible to enter Asian characters.

The editor is available for the following Asian languages:

- Simplified Chinese
- Traditional Chinese

Input types

Input type	Description
Pinyin input	Latin letters are combined phonetically to denote the sound of the character. The editor lists all of the characters from the dictionary that can be selected.
Zhuyin input (only traditional Chinese)	Non-Latin letters are combined phonetically to denote the sound of the character. The editor lists all of the characters from the dictionary that can be selected.
Entering Latin letters	The characters that are entered are directly transferred into the input field, from where the editor was called.

Structure of the editor

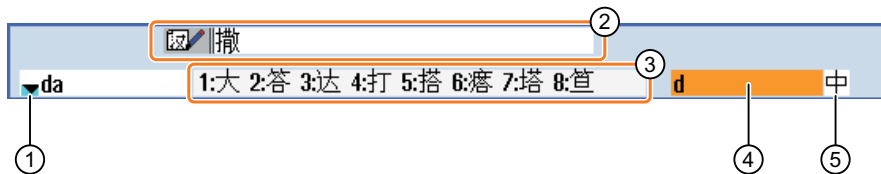

- ① Phonetic sound selection from the dictionary
- ② Learning function of the dictionary
- ③ Listed characters
- ④ Phonetic sound input
- ⑤ Function selection

Figure 3-1 Example: Pinyin input

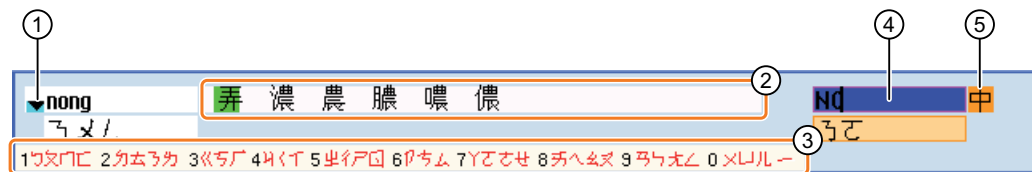

- ① Phonetic sound selection from the dictionary
- ② Listed characters (for the input field)
- ③ Listed characters (for phonetic sound input)
- ④ Phonetic sound input
- ⑤ Function selection

Figure 3-2 Example: Zhuyin input

Functions

- 中 Pinyin input
- A Entering Latin letters
-  Editing the dictionary

Dictionaries

The simplified Chinese and traditional Chinese dictionaries that are supplied can be expanded:

- If you enter new phonetic notations, the editor creates a new line. The entered phonetic notation is broken down into known phonetic notations. Select the associated character for each component. The compiled characters are displayed in the additional line. Accept the new word into the dictionary and into the input field by pressing the <Input> key.
- Using any Unicode editor, you can enter new phonetic notations into a text file. These phonetic notations are imported into the dictionary the next time that the input editor is started.

3.4.12.2 Entering Asian characters

Precondition

The control has been switched over to Chinese.

Procedure

Editing characters using the Pinyin method

+



1. Open the screen form and position the cursor on the input field.
Press the <Alt +S> keys.
The editor is displayed.
2. Enter the desired phonetic notation using Latin letters. Use the upper input field for traditional Chinese.
3. Press the <Cursor down> key to reach the dictionary.
4. Keeping the <Cursor down> key pressed, displays all the entered phonetic notations and the associated selection characters.
5. Press the <BACKSPACE> softkey to delete entered phonetic notations.
6. Press the number key to insert the associated character.
When a character is selected, the editor records the frequency with which it is selected for a specific phonetic notation and offers this character at the top of the list when the editor is next opened.

Editing characters using the Zhuyin method (only traditional Chinese)

+



1. Open the screen form and position the cursor on the input field.
Press the <Alt +S> keys.
The editor is displayed.
2. Enter the desired phonetic notation using the numerical block.
Each number is assigned a certain number of letters that can be selected by pressing the numeric key one or several times.
3. Press the <Cursor down> key to reach the dictionary.
4. Keeping the <Cursor down> key pressed, displays all the entered phonetic notations and the associated selection characters.
5. Press the <BACKSPACE> softkey to delete entered phonetic notations.



- To select the associated character, press the <cursor right> or <cursor left> keys.



- Press the <input> key to enter the character.

3.4.12.3 Editing the dictionary

Learning function of the input editor

Requirement:

The control has been switched over to Chinese.

An unknown phonetic notation has been entered into the input editor.

- The editor provides a further line in which the combined characters and phonetic notations are displayed.

The first part of the phonetic notation is displayed in the field for selecting the phonetic notation from the dictionary. Various characters are listed for this particular phonetic notation.

- Press the number key to insert the associated character into the additional line.

The next part of the phonetic notation is displayed in the field for selecting the phonetic notation from the dictionary.

- Repeat step 2 until the complete phonetic notation has been compiled.

Press the <TAB> key to toggle between the compiled phonetic notation field and the phonetic notation input.

Compiled characters are deleted using the <BACKSPACE> key.



- Press the <input> key to transfer the compiled phonetic notation to the dictionary and the input field.

Importing a dictionary

A dictionary can now be generated using any Unicode editor by attaching the corresponding Chinese characters to the pinyin phonetic spelling. If the phonetic spelling contains several Chinese characters, then the line must not contain any additional match. If there are several matches for one phonetic spelling, then these must be specified in the dictionary line by line. Otherwise, several characters can be specified for each line.

The generated file should be saved in the UTF8 format under the name dictchs.txt (simplified Chinese) or dictcht.txt (traditional Chinese).

Line structure:

Pinyin phonetic spelling <TAB> Chinese characters <LF>

OR

Pinyin phonetic spelling <TAB> Chinese character1<TAB> Chinese character2 <TAB> ... <LF>

<TAB> - tab key

<LF> - line break

Store the created dictionary in one of the following paths:

../user/sinumerik/hmi/ime/

../oem/sinumerik/hmi/ime/

When the Chinese editor is called the next time, it enters the content of the dictionary into the system dictionary.

Example:

<u>ai</u>	哎	哀	唉	埃	挨
<u>caise</u>	彩色				
<u>hongse</u>	紅色				
<u>huise</u>	灰色				
<u>heli</u>	河裏				
<u>zuihaowan</u>	最好玩				

3.4.13 Entering Korean characters

You can enter Korean characters in the input fields on classic panels (without touch operation) using the input editor IME (Input Method Editor).

Note

You require a special keyboard to enter Korean characters. If this is not available, then you can enter the characters using a matrix.

Korean keyboard

To enter Korean characters, you will need a keyboard with the keyboard assignment shown below. In terms of key layout, this keyboard is the equivalent of an English QWERTY keyboard and individual events must be grouped together to form syllables.

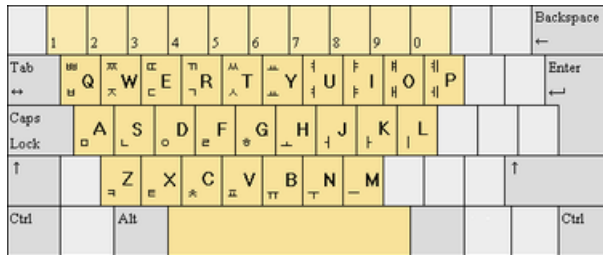

Structure of the editor

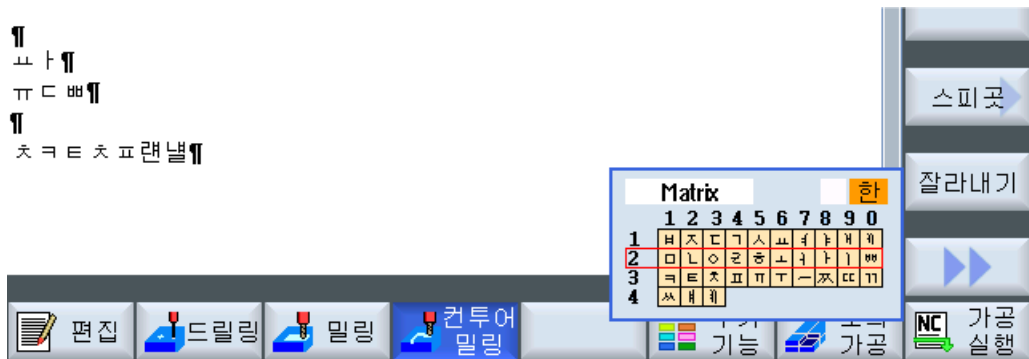

Functions

- Matrix** Editing characters using a matrix
- Beolsik 2** Editing characters using the keyboard
- 한** Entering Korean characters
- A** Entering Latin letters

Precondition

The control has been switched over to Korean.

Procedure

Editing characters using the keyboard



+



1. Open the screen form and position the cursor on the input field.
Press the <Alt +S> keys.
The editor is displayed.

2. Switch to the "Keyboard - Matrix" selection box.
3. Select the keyboard.
4. Switch to the function selection box.
5. Select Korean character input.
6. Enter the required characters.
7. Press the <input> key to enter the character into the input field.

Editing characters using a matrix



+



1. Open the screen form and position the cursor on the input field.
Press the <Alt +S> keys.
The editor is displayed.

2. Switch to the "Keyboard - Matrix" selection box.
3. Select the "matrix".
4. Switch to the function selection box.
5. Select Korean character input.
6. Enter the number of the line in which the required character is located.
The line is highlighted in color.
7. Enter the number of the column in which the required character is located.
The character will be briefly highlighted in color and then transferred to the Character field.



Press the <BACKSPACE> softkey to delete entered phonetic notations.



8. Press the <input> key to enter the character into the input field.

3.4.14 Work station safety

In order to secure machines against manipulation and protect people from accidents, proceed as follows when leaving the work station:



1. Set the keyswitch to 0 and then remove it.
2. Press the "Delete password" softkey.
Access authorization is then initiated.

You can reset the password when you return to the work station.

You can find **more information** about access levels and creating passwords in the SINUMERIK Operate Commissioning Manual.

3.4.15 Cleaning mode

In cleaning mode, you can clean the user interface of the panel without inadvertently initiating touch functions.

When you activate cleaning mode, the system does not respond when you touch the screen. Switching over to another panel and entering data at the keyboard are deactivated. The display is dimmed. The progress bar shows the remaining time in seconds.

Depending on the setting, cleaning mode lasts between 10 seconds and 1 minute. You can work as usual once this time has expired.

Note

Use a suitable cleaning agent to clean the screen.

Procedure

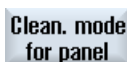
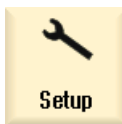

1. Select the "Start-up" operating area.
2. Press the "Cleaning mode for panel" softkey.
The system switches into cleaning mode.

3.4.16 Display live image from a camera

In SINUMERIK Operate, you can display a live image from a camera.

- The camera image allows you to track remote processes and monitor difficult-to-access areas.
- You can also document and store machine states.
- You can create and configure up to two cameras.



Machine manufacturer

Please observe the information provided by the machine manufacturer.

You configure the cameras in the "Camera configuration" window, which you call with the "Camera" softkey in the "Setup" operating area.

Note

The camera is not available for operating SINUMERIK Operate on NCU ("Embedded HMI") when using an NCU 710.

Requirement

- The cameras used meet the required criteria for resolution, frame rate, compression rate and network capability.
- You have configured the cameras used.

Displaying live images from a camera

You have the following options to call up the video stream:

- By clicking the "Camera" softkey in the "Machine" operating area
- Via the "Camera 1" and "Camera 2" widgets in the side screen
- Via the "Camera 1" and "Camera 2" apps in the Display Manager

The video stream is displayed in the first-called window.

To switch between the calling windows, the video stream must be restarted.

Note

As long as the "Camera configuration" window is open, the video stream can only be started from this window.

Note

In certain situations, disruptions to the video stream may occur in the Display Manager.

To avoid disruptions, you can reduce the frame rate and resolution.

If these parameters cannot be reduced any further, display the camera images via the "Camera 1" and "Camera 2" widgets in the side screen.

3.4.17 Online help in SINUMERIK Operate

Context-sensitive help is stored in the control system.

- A brief description is provided for each window and, if required, step-by-step instructions for the operating sequences.
- A detailed help is provided in the editor for every entered G code. You can also display all G functions and take over a selected command directly from the help into the editor.
- A help page with all parameters is provided on the input screen in the cycle programming.
- Lists of the machine data
- Lists of the setting data
- Lists of the drive parameters
- List of all alarms

Procedure

Calling context-sensitive help



1. You are in an arbitrary window of an operating area.
2. Press the <HELP> key or on an MF2 keyboard, the <F12> key.
The help page of the currently selected window is opened in a subscreen.

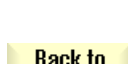

3. Press the "Full screen" softkey to use the entire user interface to display the help.
Press the "Full screen" softkey again to return to the subscreen.
4. If further help is offered for the function or associated topics, position the cursor on the desired link and press the "Follow reference" softkey.
The selected help page is displayed.
5. Press the "Back to reference" softkey to jump back to the previous help.

Calling a topic in the table of contents



1. Press the "Table of contents" softkey.
Depending on which technology is set, help is displayed for "Operate Milling", "Operate Turning", "Operate Grinding", or "Operate Universal" - as well as on the topic of "Programming".



2. Select the desired Chapter with the <Cursor down> and <Cursor up> keys.



3. Press the <Cursor right> or <INPUT> key or double-click to open the section.



4. Navigate to the desired topic with the "Cursor down" key.



5. Press the <Follow reference> softkey or the <INPUT> key to display the help page for the selected topic.



6. Press the "Current topic" softkey to return to the original help.

Searching for a topic



1. Press the "Search" softkey.
The "Search in Help for: " window appears.
2. Activate the "Full text " checkbox to search in all help pages.



3. Enter the desired keyword in the "Text" field and press the "OK" softkey.
If the checkbox is not activated, a search is performed in the table of contents and in the index.
If you enter the search term on the operator panel, replace an umlaut (accented character) by an asterisk (*) as dummy.
All entered terms and sentences are sought with an AND operation. In this way, only documents and entries that satisfy all the search criteria are displayed.



4. Press the "Keyword index" softkey to display the index.

Displaying alarm descriptions and machine data



1. If messages or alarms are active in the "Alarms", "Messages" or "Alarm Log" window, position the cursor at the appropriate display and press <HELP> or key <F12>
The associated alarm description is displayed.



2. If you are in the "Start-up" operating area in the windows for the display of the machine, setting and drive data, position the cursor on the desired machine data or drive parameter and press the <HELP> key or <F12> key. The associated data description is displayed.

Displaying and inserting a G code command in the editor



1. A program is opened in the editor.
Position the cursor on the desired G code command and press the <HELP> or the <F12> key.
The associated G code description is displayed.



2. Press the "Display all G functions" softkey.



3. Using the search function, select, for example, the desired G code command.



4. Press the "Transfer to editor" softkey.
The selected G function is taken into the program at the cursor position.



5. Press the "Exit help" softkey again to close the help.

Multitouch operation with SINUMERIK Operate

4.1 Multitouch panels

The "SINUMERIK Operate Generation 2" user interface has been optimized for multitouch operation. You can execute all actions by touch and finger gestures. Using SINUMERIK Operate is much quicker with touch operation and finger gestures.



Machine manufacturer

Please observe the information provided by the machine manufacturer.

The following operator panel fronts, handheld devices and SINUMERIK control systems can be operated with the "SINUMERIK Operate Generation 2" user interface:

- OP 015 black
- PPU 290.4
- HT 8
- HT 10
- SIMATIC ITC V3
- SIMATIC IFP
- SIMATIC panel IPC

Additional information

You can find further information on configuring the user user interface in the SINUMERIK Operate Commissioning Manual.

You can find additional information on Multitouch Panels at:

- Operator Panels Equipment Manual (OP 015 black / 019 black)

4.2 Touch-sensitive user interface

When using touch panels, wear thin gloves made of cotton or gloves for touch-sensitive glass user interfaces with capacitive touch function.

If you are using somewhat thicker gloves, then exert somewhat more pressure when using the touch panel.

Compatible gloves

You will operate the touch-sensitive glass user interface on the Operator panel optimally with the following gloves.

- Dermatril L
- Camatril Velours type 730
- Uvex Profas Profi ENB 20A
- Camapur Comfort Antistatic type 625
- Carex type 1505 / k (leather)
- Reusable gloves, medium, white, cotton: BM Polyco (RS order number 562-952)

Thicker work gloves

- Thermoplus KCL type 955
- KCL Men at Work type 301
- Camapur Comfort type 619
- Comasec PU (4342)

4.3 Finger gestures

Finger gestures



Tap

- Select window
- Select object (e.g. NC set)
- Activate entry field
 - Enter or overwrite value
 - Tap again to change the value



Tap with 2 fingers

- Call the shortcut menu (e.g. copy, paste)

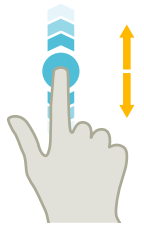

Flick vertically with one finger

- Scroll in lists (e.g. programs, tools, zero points)
- Scroll in files (e.g. NC program)

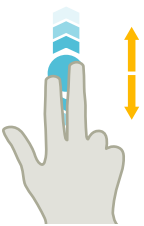

Flick vertically with two fingers

- Page-scroll in lists (e.g. ZO)
- Page-scroll in files (e.g. NC programs)



Flick vertically with three fingers

- Scroll to the start or end of lists
- Scroll to the start or end of files

4.3 Finger gestures



Flick horizontally with one finger

- Scroll in lists with many columns



Spread

- Zoom in on graphic contents (e.g. simulation, mold making view)



Pinch

- Zoom out from graphic contents (e.g. simulation, mold making view)



Pan with one finger

- Move graphic contents (e.g. simulation, mold making view)
- Move list contents



Pan with two fingers

- Rotate graphic contents (e.g. simulation, mold making view)



Tap and hold

- Open input fields to change
- Activate or deactivate edit mode (e.g. current block display)

**Tap and hold using 2 fingers**

- Open cycles line by line to change (without input screen form)

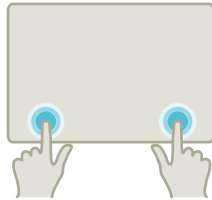
**Tap with two index fingers**

- Tap with two fingers simultaneously in the lower right- and left-hand corners to open the TCU menu.
The menu has to be opened for service purposes.

Note**Flicking gestures with several fingers**

The gestures only function reliably if you hold your fingers sufficiently far apart. The fingers should be at least 1 cm apart.

4.4 Multitouch user interface





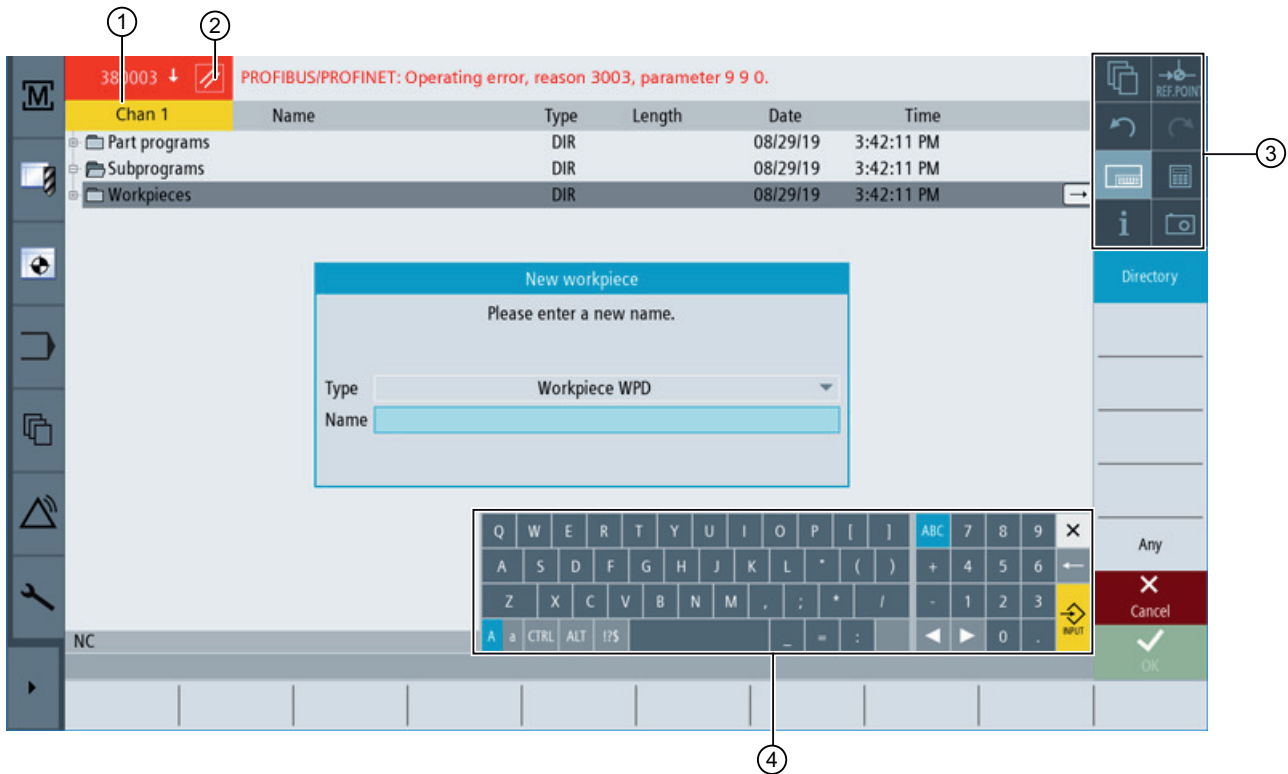





4.4.1 Screen layout

Touch and gesture operator controls for SINUMERIK Operate with the "SINUMERIK Operate Generation 2" user interface.







- ① Changing the channel
- ② Cancel alarms
- ③ Function key block
- ④ Virtual keyboard

4.4.2 Function key block

Operator control	Function
	<p>Switch operating area</p> <p>Tap the current operating area, and select the desired operating area from the operating area bar.</p>
	<p>Switch operating mode</p> <p>The operating mode is only displayed.</p> <p>To switch the operating mode, tap the operating area and select the operating area from the vertical softkey bar.</p> <p>The selection for the functions available for the operating mode is opened.</p>
	<p>Close the selection</p> <p>The selection for the functions available for the operating mode is closed.</p>
	<p>Switching the handwheel on and off</p> <p>The handwheel is switched on for axis traversing (HT10).</p> <p>The "Handwheel" operator control has three states:</p> <ul style="list-style-type: none"> • Gray: Handwheel not available or not configured. • Active (not pressed): Handwheel available and configured. • Shaded (pressed): Handwheel is assigned to the selected axis.
	<p>Undo</p> <p>Multiple changes are undone one by one.</p> <p>As soon as a change has been completed in an input field, this function is no longer available.</p>
	<p>Restoring</p> <p>Multiple changes are restored one by one.</p> <p>As soon as a change has been completed in an input field, this function is no longer available.</p>
	<p>Virtual keyboard</p> <p>Activates the virtual keyboard.</p>
	<p>Calculator</p> <p>Displays a calculator.</p>
	<p>Online help</p> <p>Opens the online help.</p>
	<p>Camera</p> <p>Generates a screenshot.</p>

4.4.3 Further operator touch controls

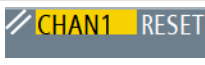
Operator control	Function
	Advances to the next horizontal softkey bar. When page 2 of the menu is called, the arrow appears on the right.
	Advances to the higher-level menu.
	Advances to the next vertical softkey bar.
	Tapping the Cancel alarm symbol clears all queued cancel alarms.
	If a channel menu has been configured, it is displayed. Tapping the channel display in the status display switches you to the next channel.

4.4.4 Virtual keyboard

If you called the virtual keyboard using the function key block, then you have the option of adapting the key assignment using the shift keys.



- ① Shift key for uppercase and lowercase letters
- ② Shift key for letters and special characters
- ③ Shift key for country-specific keyboard assignment
- ④ Shift key for full keyboard and numerical key block

Input of Chinese characters in the IME editor

You can enter Chinese characters in the IME editor, even when using the virtual keyboard.

For the input of Chinese characters via the virtual keyboard, change the language of the user interface to Chinese. To display the input field of the IME editor, click on the shift key for country-specific keyboard assignment "CHS".

Hardware keyboard

If a real keyboard is connected, the icon of a minimized keyboard appears in place of the virtual keyboard.



Use the icon to open the virtual keyboard again.

4.4.5 Special "tilde" character

If the shift key for letters and special characters is pressed, the keyboard assignment changes to the special characters.



① <Tilde>

In the Editor or in alphanumeric input fields, the special character <Tilde> is entered with the <Tilde> key. In numerical input fields, the <Tilde> key changes the sign of a number between plus and minus.

4.5 Expansion with side screen

4.5.1 Overview

Panels in widescreen format provide the possibility of using the extra area to display additional elements. In addition to the SINUMERIK Operate screen, displays and virtual keys are shown to provide faster information and operation.

This sidescreen must be activated. To do this, a navigation bar is displayed.

You can display the following elements above the navigation bar:

- Displaying (widgets)
- Virtual keys (pages)
 - ABC keyboard
 - MCP keys



Machine manufacturer

Please observe the information provided by the machine manufacturer.

Requirements

- A widescreen format multitouch panel (e.g. OP 015 black) is required to display widgets and pages.
- It is only possible to activate and configure a sidescreen when using the "SINUMERIK Operate Generation 2" user interface.

Further information

For information on activating the side screen and to configure the virtual keys, refer to the SINUMERIK Operate Commissioning Manual.







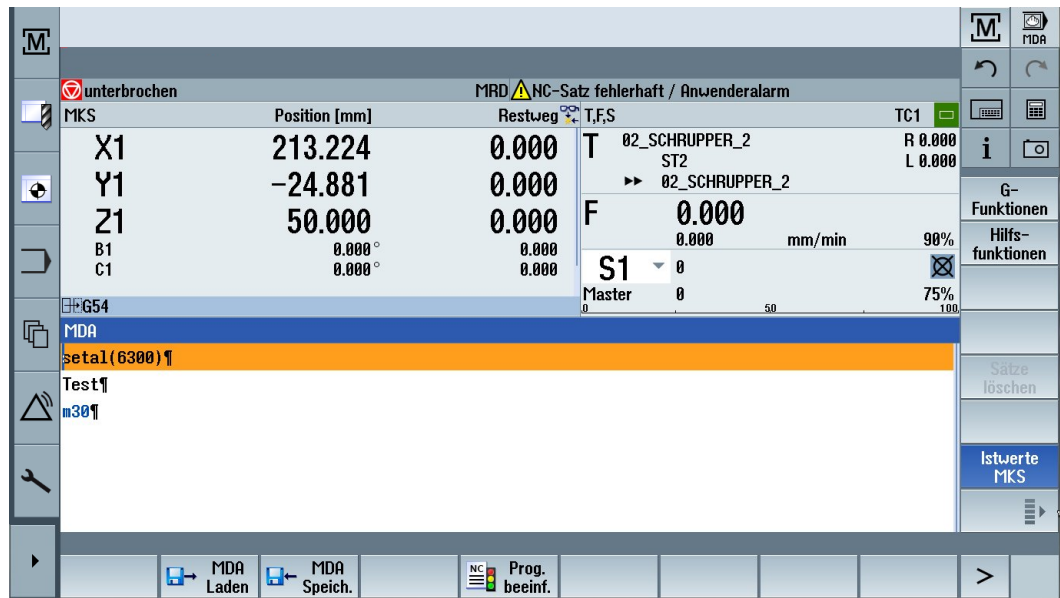

4.5.2 Sidescreen with standard windows

When the sidescreen is activated, a navigation bar is shown on the left-hand side of the user interface.

This navigation bar can be used to switch directly to the desired operating area, and to show and hide the sidescreen.



Navigation bar

Operator control	Function
	Opens the "Machinery" operating area.
	Opens the tool list in the "Parameter" operating area.
	Opens the "Work offset" window in the "Parameter" operating area.
	Opens the "Program" operating area.
	Opens the "Program manager" operating area.
	Opens the "Diagnostics" operating area.
	Opens the "Commissioning" operating area.
	Hides the sidescreen.
	Shows the sidescreen.

4.5.3 Standard widgets

Open sidescreen

- Tap the arrow on the navigation bar to show the sidescreen.
The standard widgets are displayed in minimized form as the header line.

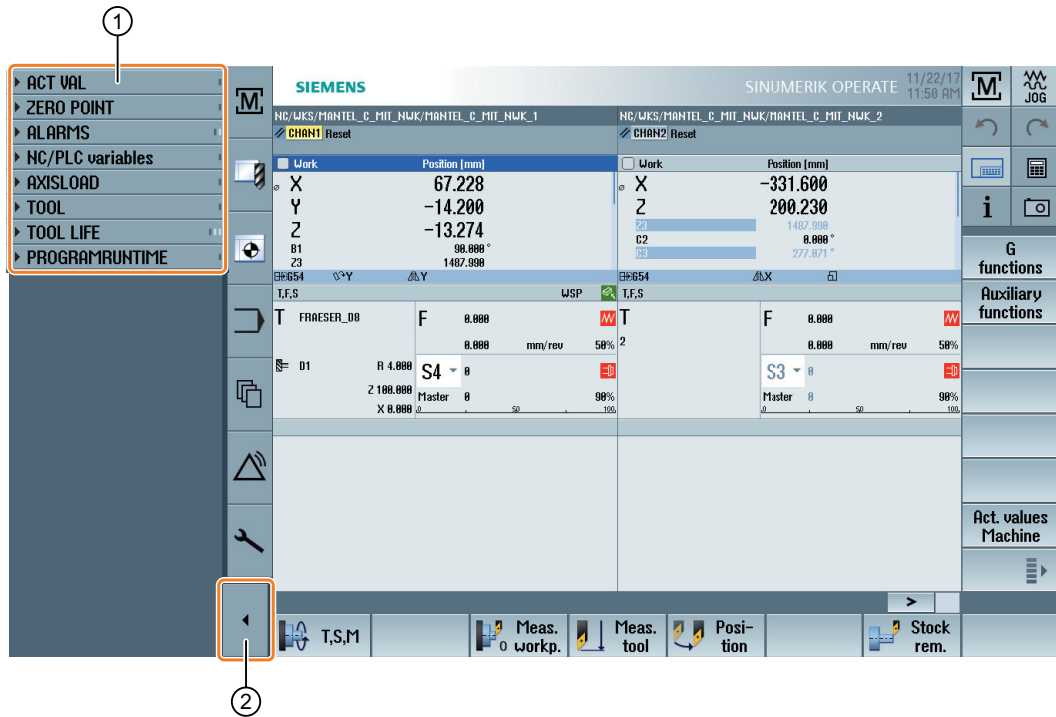

- ① Widget header lines
- ② Arrow key for showing/hiding the sidescreen

Navigating in sidescreen

- To scroll through the list of widgets, swipe vertically with 1 finger.
- OR -
- To return to the end or to the beginning of the list of widgets, swipe vertically with 3 fingers.

Open widgets

- To open a widget, tap the header line of the widget.

4.5.4 "Actual value" widget

The widget contains the position of the axes in the displayed coordinate system.

The distance-to-go for the current NC block is displayed while a program is running.

▼ ACT VAL		
Work	Position [mm]	Dist-to-go
X	67.228	0.000
Y	-14.200	0.000
Z	-13.274	0.000
B1	90.000°	0.000
Z3	1407.990	0.000

4.5.5 "Zero point" widget

The widget includes values of the active work offset for all configured axes.

The approximate and detailed offset, as well as rotation, scaling and mirroring are displayed for each axis.

▼ ZERO POINT		
G54	Coarse	Fine
X	14.230	0.216
Y	-14.200	
Z	300.000	-0.230
B1		
Z3	12.010	0.246

4.5.6 "Alarms" widget

The widget contains all the messages and alarms in the alarm list.

The alarm number and description are displayed for every alarm. An acknowledgment symbol indicates how the alarm is acknowledged or canceled.

Vertical scrolling is possible if multiple alarms are pending.

Wipe horizontally to switch between alarms and messages.

▼ ALARMS	
16906	Channel 1: Program control: action 'Start selected processing' is canceled due to an alarm
61237	Channel 1: Block 1: Retraction direction unknown. Withdraw tool manually!

4.5.7 "NC/PLC variables" widget

The "NC/PLC variables" widget displays the NC and PLC variables.

The variable name, data type and value are shown for each variable.

4.5 Expansion with side screen

▼ NC/PLC variables		
Variable	F	Value
\$AA_ACCLIMA[X1]	D	100
GUD/CHANNEL[1]	D	0
...tate/aaATol[u1, 1]	D	0
...aaSyncDiff[u1, 1]	D	0
GUD/FEED_NC_5	D	0

Only those variables that are currently displayed in the "NC/PLC variables" screen in the "Diagnostics" operating area are shown. To update the list in the "NC/PLC variables" widget following a change in the "NC/PLC variables" screen in the "Diagnostics" operating area, collapse and expand the widget again.

Vertical scrolling is possible.

4.5.8 "Axle load" widget

The widget shows the load on all axes in a bar chart.

Up to 6 axes are displayed. Vertical scrolling is possible if multiple axes are present.

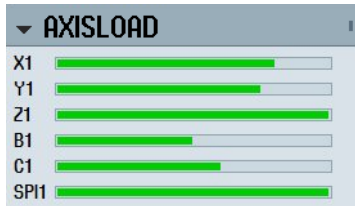

4.5.9 "Tool" widget

The widget contains the geometry and wear data for the active tool.

The following information is additionally displayed depending on the machine configuration:

- EC: Active location-dependent offset - setting up offset
- SC: Active location-dependent offset - additive offset
- TOFF: Programmed tool length offset in WCS coordinates, and programmed tool radius offset
- Override: Value of the overridden movements that were made in the individual tool directions

▼ TOOL			
FRAESER_D8			
D1	Length X	Length Z	Radius
Geometry		100.000	4.000
Wear			
EC			
SC			

4.5.10 "Service life" widget

The widget displays the tool monitoring in relation to the following values:

- Operating time of tool (standard time monitoring)
- Finished workpieces (quantity monitoring)
- Tool wear (wear monitoring)

Note

Multiple cutting edges

If a tool has multiple cutting edges, the values of the edge with the lowest residual service life, quantity and wear is displayed.

It possible to alternate between views by scrolling horizontally.

TOOL LIFE		
PLANFRAESER ST1	18:00 min	
BOHRER_12 ST1	28:00 min	
SCHRUPPSTAHL ST1	108:00 min	
BOHRER_8 ST1	108:00 min	

4.5.11 "Program runtime" widget

The widget contains the following data:

- Total runtime of the program
- Time remaining to end of program

This data is estimated for the first program run.

Additionally, progress of the program is visualized in a bar chart as a percentage.

PROGRAMRUNTIME	
Programm Rest	Gesamt
0:00:00h	0:27:12h

4.5.12 Widget "Camera 1" and "Camera 2"

You can create up to two cameras for tracking remote processes and monitoring difficult-to-access areas.

Widgets "Camera 1" and "Camera 2" are used to display camera images. There is a dedicated widget for each camera.

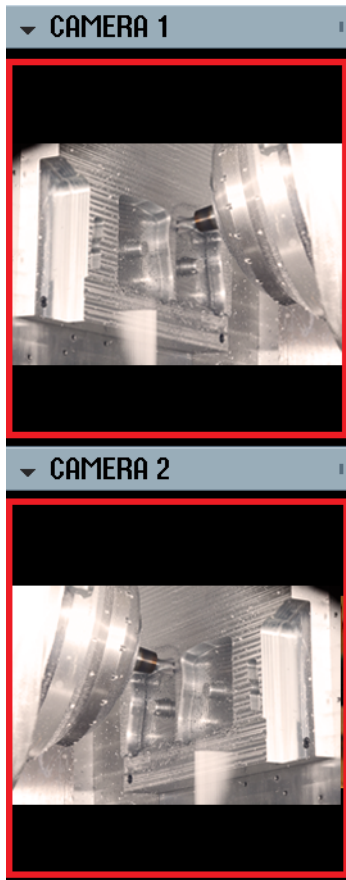

If the particular camera has been configured, start streaming by opening the widget.



Additional information on activating widgets "Camera 1" and "Camera 2" is provided in the SINUMERIK Operate Commissioning Manual.

4.5.13 Sidescreen with pages for the ABC keyboard and/or machine control panel

Not only standard widgets but also pages with ABC keyboards and machine control panels can be configured in the sidescreen of a multitouch panel.

Configure ABC keyboard and MCP

If you configured ABC keyboard and MCP keys, then the navigation bar is extended for the sidescreen:

Operator control	Function
	Display of standard widgets in the sidescreen
	Display of an ABC keyboard on the sidescreen
	Display of a machine control panel on the sidescreen

4.5.14 Example 1: ABC keyboard in the sidescreen

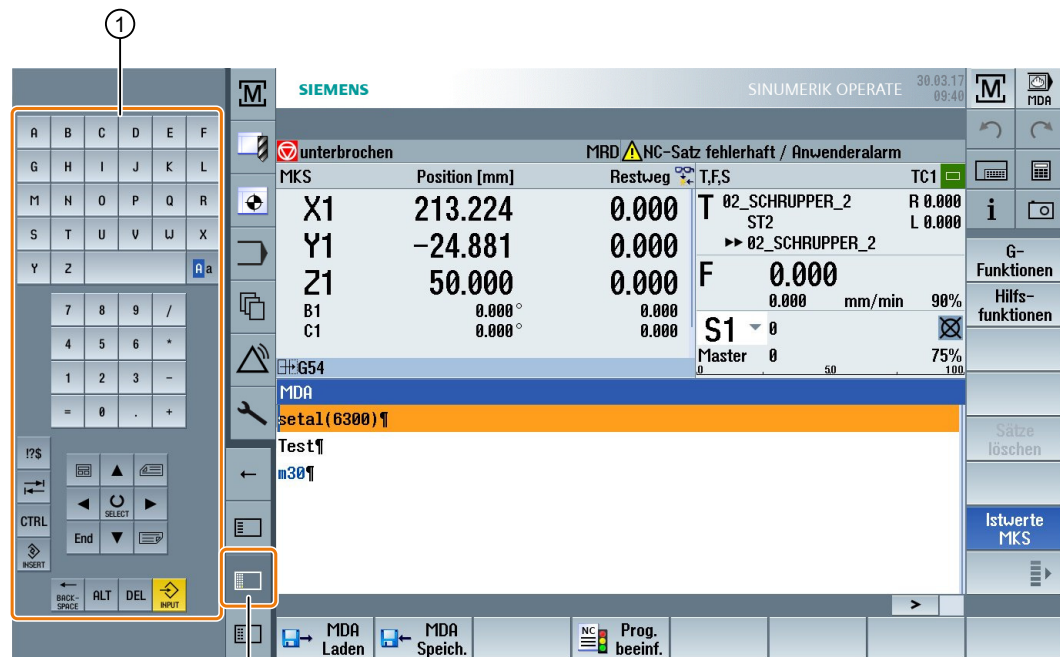

- ① ABC keyboard
- ② Key to display the keyboard

4.5.15 Example 2: Machine control panel in the sidescreen

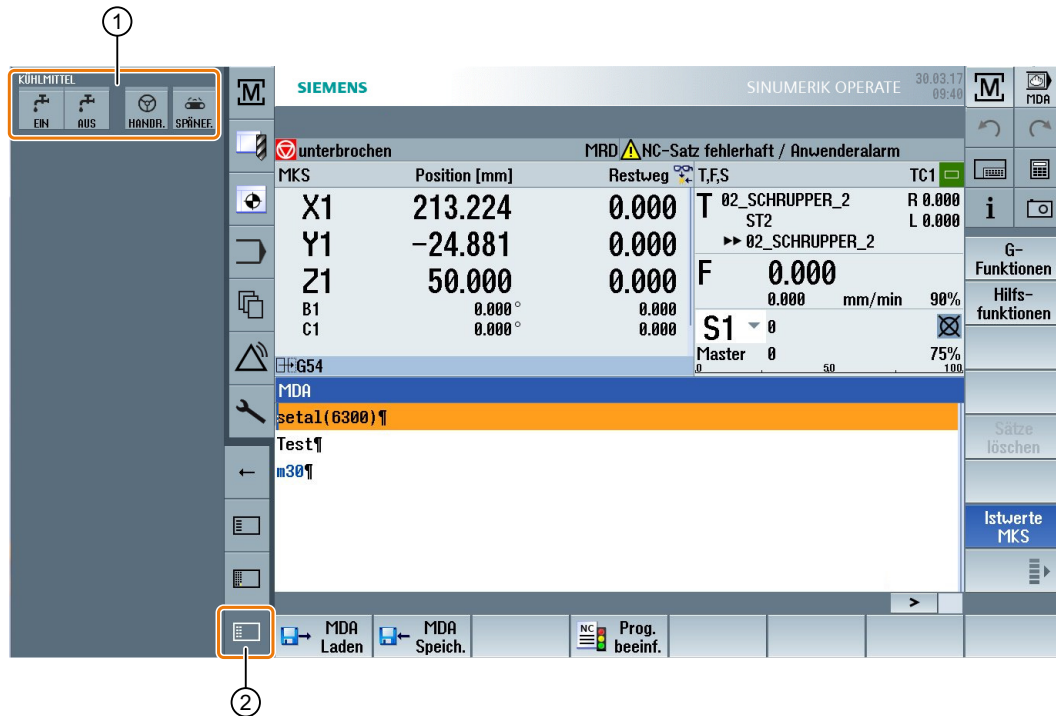

- ① Machine control panel
- ② Key to display the machine control panel

4.6 SINUMERIK Operate Display Manager

4.6.1 Overview

With a panel with full HD resolution (1920x1080), you have the possibility to work with the Display Manager.

The Display Manager allows you to see a lot of information at a glance.

With the Display Manager, the screen area is divided into several display areas.

In addition to SINUMERIK Operate, widgets, keyboards, a machine control panel and various applications are provided in the various areas.

Display Manager is available for the following configurations:

- SINUMERIK Operate on PC/PCU
- SINUMERIK Operate on NCU ("Embedded HMI") when using an NCU 720 and NCU 730.



Software option

The option "P81 – SINUMERIK Operate Display Manager" is required for the "SINUMERIK Operate Display Manager" function.

Note

The standard configuration of the Display Manager only supports the landscape orientation of the screen.

Additional information

For further information on the activation and configuration of the Display Manager, please refer to the SINUMERIK Operate Commissioning Manual.

You can find additional information about Full HD Panels in the Operator Panel Fronts Equipment Manual: TOP 1500, TOP 1900, TOP 2200.

4.6.2 Screen layout

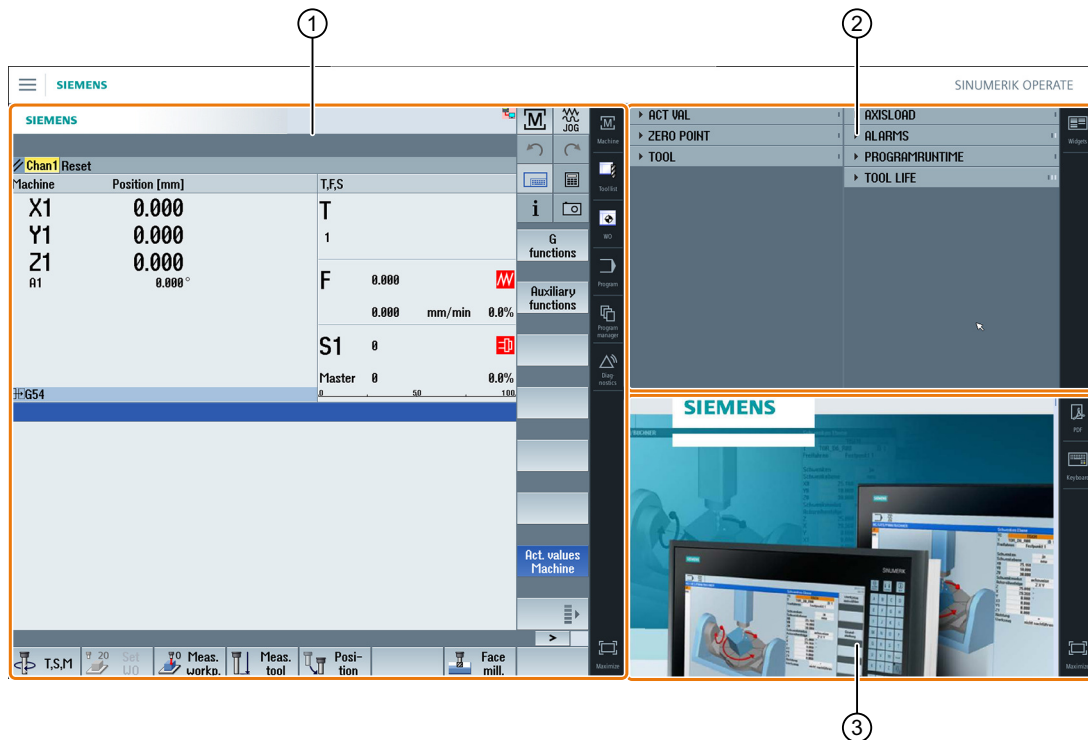

The standard supply of a SINUMERIK Operate Display Manager offers the option of choosing between 3-display areas and 4-display areas.







- ① SINUMERIK Operate with navigation bar for switchover of the operating area
- ② Display area for standard widgets
- ③ Display area for applications (e.g. PDF)





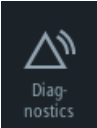

4.6.3 Operator controls

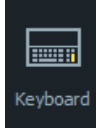
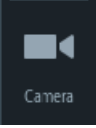

The Display Manager is activated.

Operator control	Function
	Menu Tap on the menu to select the desired arrangement of the display areas.
	3-display areas <ul style="list-style-type: none"> • SINUMERIK Operate (with function block) • Widget area • Applications area (PDF, virtual keyboard)

Operator control	Function
	<p>4-display areas</p> <ul style="list-style-type: none"> • SINUMERIK Operate (with function block) • Widget area • Applications area (PDF, virtual keyboard) • Area with virtual keyboard
	<p>Mirroring display areas</p> <p>Mirrors the selected arrangement of the display areas.</p>
 <p>Machine</p> <p>...</p>  <p>Diag- nostics</p>	<p>Navigating in SINUMERIK Operate</p> <p>Tap on the corresponding icon to directly open the desired operating area.</p>
 <p>Widgets</p>	<p>Widgets</p> <p>The following widgets are available by default:</p> <ul style="list-style-type: none"> • Actual values (Page 82) • Zero point (Page 83) • Tool (Page 84) • Axle load (Page 84) • Alarms (Page 83) • Program runtime (Page 85) • Service life (Page 85) • NC/PLC variables (Page 83)

4.6 SINUMERIK Operate Display Manager

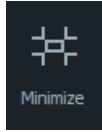
Operator control	Function
	<p>PDF</p> <p>Opens the PDF stored here.</p> <p>The following functions are available in the PDF display:</p> <ul style="list-style-type: none"> • Open (<CTRL> + <O>) • Mark (<CTRL> + <A>) • Copy (<CTRL> + <C>) • Go to (<CTRL> + <G>) • Search (<CTRL> + <F>) • Display and hide bookmarks (<CTRL> +) <p>Alternatively, use the PDF display via the animated toolbar at the top left. You optimize the read view using the following finger gestures:</p> <ul style="list-style-type: none"> • Double tap: Adapt width: • <CTRL> + double tap: Adapt height: <p>If you change the language when viewing a PDF document, the PDF document is reloaded in the respective language.</p> <p>If no PDF document is available for the language set, the English PDF document is displayed.</p> <p>The position in the PDF document is retained beyond language switchover across sessions if the PDF document contains bookmarks.</p>
 	<p>Virtual keyboard</p> <p>Displays a QWERTY keyboard in the display area for applications as well as in the 4th display area below SINUMERIK Operate.</p> <p>If the virtual keyboard is selected while the display area is maximized, the keyboard opens as a pop-up. The keyboard can be moved on the display as required by means of touch operation.</p>
	<p>Camera</p> <p>Live streaming of the configured camera:</p> <ul style="list-style-type: none"> • 1  Live streaming camera 1 • 2  Live streaming camera 2 • 1+2  Live streaming camera 1 and camera 2 <p>If a camera has been configured, you can directly view the relevant streaming process. If a camera configuration is changed or an issue with connectivity occurs, reboot the system to activate the streaming process on the camera.</p>
	<p>Maximizing the display area</p> <p>Enlarges the area with SINUMERIK Operate and the area for the applications to the full dimensions of the Panel.</p>

Operator control	Function
 Minimize	Minimizing the display area The area with SINUMERIK Operate and the area for the applications are reduced back to their original size.
 MCP	Machine control panel Shows a machine control panel. Note: Please observe the information provided by the machine manufacturer.

See also

Widget "Camera 1" and "Camera 2" (Page 85)

Setting up the machine

5.1 Switching on and switching off

Startup

The screenshot shows the Siemens CNC control main screen. At the top left, there is a 'M' icon and 'REF POINT' text. At the top right, the date '02/17/09' and time '2:36 PM' are displayed. The 'SIEMENS' logo is centered at the top. Below it, a status bar shows 'DREHEN_K1 Reset'. The main area contains a table with three columns: 'Machine', 'Position [mm]', and 'Feed/override'. The table lists four machine axes: X1, Y1, Z1, and SP1, all with positions of 0.000 and feed overrides of 80%. At the bottom right of the table area, 'F=0.000' is displayed. The bottom of the screen features a row of eight touch-sensitive buttons.

Machine	Position [mm]	Feed/override
X1	0.000	0.000 mm/min 80%
Y1	0.000	0.000 mm/min 80%
Z1	0.000	0.000 mm/min 80%
SP1	0.000 °	0.000 °/min 80%

F=0.000

When the control starts up, the main screen opens according to the operating mode specified by the machine manufacturer. This is usually the main screen for the "REF POINT" function.



Machine manufacturer

Please observe the information provided by the machine manufacturer.

5.2 Approaching a reference point

5.2.1 Referencing axes

Your machine tool can be equipped with an absolute or incremental path measuring system. An axis with incremental path measuring system must be referenced after the controller has been switched on – however, an absolute path measuring system does not have to be referenced.

For the incremental path measuring system, all the machine axes must therefore first approach a reference point, the coordinates of which are known to be relative to the machine zero-point.

Sequence

Prior to the approach, the axes must be in a position from where they can approach the reference point without a collision.

The axes can also all approach the reference point simultaneously, depending on the manufacturer's settings.



Machine manufacturer

Please refer to the machine manufacturer's specifications.

NOTICE

Risk of collision

If the axes are not in a collision-free position, you must first traverse them to safe positions in "JOG" or "MDI" mode.

You must follow the axis motions directly on the machine!

Ignore the actual value display until the axes have been referenced!

The software limit switches are not active!

Procedure



1. Press the <JOG> key.



2. Press the <REF. POINT>. key



3. Select the axis to be traversed.





4. Press the <-> or <+> key.

The selected axis moves to the reference point.



If you have pressed the wrong direction key, the action is not accepted and the axes do not move.



A symbol is shown next to the axis if it has been referenced.

The axis is referenced as soon as the reference point is reached. The actual value display is set to the reference point value.

From now on, path limits, such as software limit switches, are active.

End the function via the machine control panel by selecting operating mode "AUTO" or "JOG".

5.2.2 User agreement

If you are using Safety Integrated (SI) on your machine, you will need to confirm that the current displayed position of an axis corresponds to its actual position on the machine when you reference an axis. Your confirmation is the requirement for the availability of other Safety Integrated functions.

You can only give your user agreement for an axis after it has approached the reference point.

The displayed axis position always refers to the machine coordinate system (Machine).

Option

User agreement with Safety Integrated is only possible with a software option.

Procedure



1. Select the "Machine" operating area.



2. Press the <REF POINT> key.



3. Select the axis to be traversed.



4. Press the <-> or <+> key.

The selected axis moves to the reference point and stops. The coordinate of the reference point is displayed.



The axis is marked with



5. Press the "User enable" softkey.
The "User Agreement" window opens.
It shows a list of all machine axes with their current position and SI position.
6. Position the cursor in the "Acknowledgement" field for the axis in question.
7. Activate the acknowledgement with the <SELECT> key.



The selected axis is marked with an "x" meaning "safely referenced" in the "Acknowledgement" column.



By pressing the <SELECT> key again, you deactivate the acknowledgement again.

5.3 Modes of operation

5.3.1 General information

You can work in three different operating modes.

"JOG" mode

"JOG" mode is used for the following preparatory actions:

- Approach reference point, i.e. the machine axis is referenced
- Preparing a machine for executing a program in automatic mode, i.e. measuring tools, measuring the workpiece and, if necessary, defining the work offsets used in the program
- Traverse axes, e.g. during a program interrupt
- Positioning axes

Select "JOG"



Press the <JOG> key.

The following functions are available in "JOG" mode:

- "REF POINT"
- "REPOS"

"REF POINT" function

The "REF POINT" function is used to synchronize the control and the machine. For this purpose, you approach the reference point in "JOG" mode.

Selecting "REF POINT"



Press the <REF POINT> key.

"REPOS" function

The "REPOS" function is used for repositioning to a defined position. After a program interrupt (e.g. to correct tool wear values), move the tool away from the contour in "JOG" mode.

The path differences traversed in "JOG" mode are displayed in the actual value window as the "REPOS" offset.

"REPOS" offsets can be displayed in the machine coordinate system (MCS) or workpiece coordinate system (WCS).

Select "REPOS"



Press the <REPOS> key.

"MDI" mode (Manual Data Input)

In "MDI" mode, you can enter and execute G code commands non-modally to set up the machine or to perform a single action.

Selecting "MDI"



Press the <MDI> key.

The "TEACH IN" function is available in "MDI" mode.

"TEACH IN" function

With the "TEACH IN" function, you can create, edit and execute part programs (main programs and subroutines) for motion sequences or simple workpieces by approaching and saving positions.

Selecting "Teach In"



Press the <TEACH IN> key.

"AUTO" mode

In automatic mode, you can execute a program completely or only partially.

Select "AUTO"



Press the <AUTO> key.

The "Single block" function is available in "AUTO" mode.

"Single block" function

You can execute a program block-by-block with the "Single block" function.

Select "Single block"



Press the <SINGLE BLOCK> key.

5.3.2 Modes groups and channels

Every channel behaves like an independent NC. A maximum of one part program can be processed per channel.

- Control with 1 channel
One mode group exists.
- Control with several channels
Channels can be grouped to form several "mode groups."

Example

Control with 4 channels, where machining is carried out in 2 channels and 2 other channels are used to control the transport of the new workpieces.

Mode group 1 channel 1 (machining)

Channel 2 (transport)

Mode group 2 channel 3 (machining)

Channel 4 (transport)

Mode groups (MGs)

Technologically-related channels can be combined to form a mode group.

Axes and spindles of the same mode group can be controlled by one or more channels.

An operating mode group is in one of "Automatic", "JOG" or "MDI" operating modes, i.e., several channels of an operating mode group can never assume different operating modes.

5.3.3 Channel switchover

It is possible to switch between channels when several are in use. Since individual channels may be assigned to different mode groups, a channel switchover command is also an implicit mode switchover command.

When a channel menu is available, all of the channels are displayed on softkeys and can be switched over.

Changing the channel



Press the <CHANNEL> key.

The channel changes over to the next channel.

- OR -

If the channel menu is available, a softkey bar is displayed. The active channel is highlighted.

Another channel can be selected by pressing one of the other softkeys.

Further information

For information on configuring the channel menu, refer to the SINUMERIK Operate Commissioning Manual.

5.4 Settings for the machine

5.4.1 Switching over the coordinate system (MCS/WCS)

The coordinates in the actual value display are relative to either the machine coordinate system or the workpiece coordinate system.

By default, the workpiece coordinate system is set as a reference for the actual value display.

The machine coordinate system (MCS), in contrast to the workpiece coordinate system (WCS), does not take into account any zero offsets, tool offsets and coordinate rotation.

Procedure



1. Select the "Machine" operating area.



2. Press the <JOG> or <AUTO> key.



3. Press the "Act.vls. MCS" softkey.



The machine coordinate system is selected.

The title of the actual value window changes in the MCS.



Machine manufacturer

The softkey to changeover the coordinate system can be hidden. Please refer to the machine manufacturer's specifications.

5.4.2 Switching the unit of measurement

You can set millimeters or inches as the unit of measurement for the machine. Switching the unit of measurement always applies to the entire machine. All required information is automatically converted to the new unit of measurement, for example:

- Positions
- Tool offsets
- Work offsets

The following conditions must be met before you can switch between units of measurement:

- The corresponding machine data are set.
- All channels are in the reset state.
- The axes are not being traversed via "JOG", "DRF", and the "PLC".
- Constant grinding wheel peripheral speed (GWPS) is not active.



Machine manufacturer

Please observe the information provided by the machine manufacturer.

Further information

Additional information on the inch/metric system of measurement is provided in the Axes and Spindles Function Manual.

Procedure



1. Select the mode <JOG> or <AUTO> in the "Machine" operating area.



2. Press the menu forward key and the "Settings" softkey.
A new vertical softkey bar appears.



3. Press the "Switch to inch" softkey.
A prompt asks you whether you really want to switch over the unit of measurement.



4. Press the "OK" softkey.

The softkey label changes to "Switch to metric".

The unit of measurement applies to the entire machine.



5. Press the "Switch to metric" softkey to set the unit of measurement of the machine to metric again.

5.4.3 Setting the zero offset

You can enter a new position value in the actual value display for individual axes when a settable zero offset is active.

The difference between the position value in the machine coordinate system MCS and the new position value in the workpiece coordinate system WCS is saved permanently in the currently active zero offset (e.g. G54).

Relative actual value

Further, you also have the possibility of entering position values in the relative coordinate system.

Note

The new actual value is only displayed. The relative actual value has no effect on the axis positions and the active zero offset.

Resetting the relative actual value



Press the "Delete REL" softkey.

The actual values are deleted.

The softkeys to set the zero point in the relative coordinate system are only available if the corresponding machine data is set.



Machine manufacturer

Please refer to the machine manufacturer's specifications.

Precondition

The controller is in the workpiece coordinate system.

The actual value is set in the reset state.

Note

Setting the ZO in the Stop state

If you enter the new actual value in the Stop state, the changes made are only visible and only take effect when the program is continued.

Procedure



1. Select the "JOG" mode in the "Machine" operating area.



2. Press the "Set ZO" softkey.

- OR -



Press the ">>", "REL act. vals" and "Set REL" softkeys to set position values in the relative coordinate system.



3. Enter the new required position value for X, Y or Z directly in the actual value display (you can toggle between the axes with the cursor keys) and press the "Input" key to confirm the entries.

- OR -

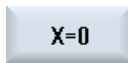

Press softkeys "X=0", "Y=0" or "Z=0" to set the relevant position to zero.

...

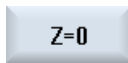

- OR -

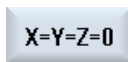

Press softkey "X=Y=Z=0" to set all axis positions to zero simultaneously.

Resetting the actual value



Press the "Delete active ZO" softkey.
The offset is deleted permanently.

Note

Irreversible active zero offset

The current active zero offset is irreversibly deleted by this action.

5.5 Zero offsets

Following reference point approach, the actual value display for the axis coordinates is based on the machine zero (M) of the machine coordinate system (Machine). The program for machining the workpiece, however, is based on the workpiece zero (W) of the workpiece coordinate system (Work). The machine zero and workpiece zero are not necessarily identical. The distance between the machine zero and the workpiece zero depends on the workpiece type and how it is clamped. This zero offset is taken into account during execution of the program and can be a combination of different offsets.

Following reference point approach, the actual value display for the axis coordinates is based on the machine zero of the machine coordinate system (Machine).

The actual value display of the positions can also refer to the SZS coordinate system (settable zero system). The position of the active tool relative to the workpiece zero is displayed.

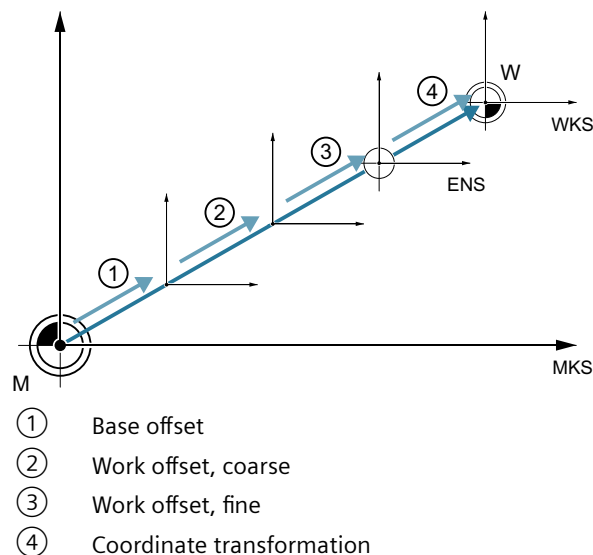

Figure 5-1 Work offsets

When the machine zero is not identical to the workpiece zero, at least one offset (base offset or zero offset) exists in which the position of the workpiece zero is saved.

Base offset

The base offset is a zero offset that is always active. If you have not defined a base offset, its value will be zero. The base offset is specified in the "Zero Offset - Base" window.

Coarse and fine offsets

Every zero offset (G54 to G57, G505 to G599) consists of a coarse offset and a fine offset. You can call the zero offsets from any program (coarse and fine offsets are added together).

You can save the workpiece zero, for example, in the coarse offset, and then store the offset that occurs when a new workpiece is clamped between the old and the new workpiece zero in the fine offset.

Note

Deselect fine offset

You have the option of deselecting the fine offset using machine data MD18600
\$MN_MM_FRAME_FINE_TRANS

5.5.1 Display active zero offset

The following zero offsets are displayed in the "Zero Offset - Active" window:

- Zero offsets, for which active offsets are included, or for which values are entered.
- Settable zero offsets
- Total zero offset

This window is generally used only for monitoring.

The availability of the offsets depends on the setting.



Machine manufacturer

Please refer to the machine manufacturer's specifications.

Procedure



1. Select the "Parameter" operating area.



2. Press the "Zero offset" softkey.
The "Zero Offset - Active" window is opened.



Note

Further details on zero offsets

If you would like to see further details about the specified offsets or if you would like to change values for the rotation, scaling or mirroring, press the "Details" softkey.

5.5.2 Displaying the zero offset "overview"

The active offsets or system offsets are displayed for all axes that have been the setup in the "Work offset - overview" window.

In addition to the offset (course and fine), the associated rotation, scaling and mirroring are also displayed.

This window is generally used only for monitoring.

Display of active work offsets

Work offsets	
MCS actual value	Display of the actual value in the Machine Coordinate System.
Kin. trans. workpiece	Displays the additional work offsets programmed with \$P_TRAFRAME_P.
Kin. trans. tool	Displays the additional work offsets programmed with \$P_TRAFRAME_T.
DRF	Displays the handwheel axis offset.
\$AA_OFF overlay	Displays the overlaid movement programmed with \$AA_OFF.
Basic reference	Displays the additional work offsets programmed with \$P_SETFRAME. Access to the system offsets is protected via a keyswitch.
External WO frame	Displays the additional work offsets programmed with \$P_EXTFRAME.
Total base WO	Displays all effective basis offsets.
G500	Displays the work offsets activated with G54 - G599. Under certain circumstances, you can change the data using "Set WO", i.e. you can correct a zero point that has been set.
Tool reference	Displays the additional work offsets programmed with \$P_TOOLFRAME.
Workpiece reference	Displays the additional work offsets programmed with \$P_WPFRAME.
Transformer reference	Displays the additional work offsets programmed with \$P_TRAFRAME.
Programmed WO	Displays the additional work offsets programmed with \$P_PFRAME.
Cycle reference	Displays the additional work offsets programmed with \$P_CYCFRAME.
Total WO	Displays the active work offset, resulting from the total of all work offsets.
T:	Displays the active tool.
WCS actual value	Displays the actual value in the Workpiece Coordinate System.

The display of the zero point offsets depends on the settings.



Machine manufacturer

Please refer to the machine manufacturer's specifications.

Procedure

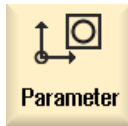

1. Select the "Parameter" operating area.



2. Press the "Work offset" and "Overview" softkeys. The "Work Offsets - Overview" window opens.



5.5.3 Displaying and editing base zero offset

The defined channel-specific and global base offsets, divided into coarse and fine offsets, are displayed for all set-up axes in the "Zero offset - Base" window.



Machine manufacturer

Please refer to the machine manufacturer's specifications.

Procedure

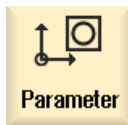

1. Select the "Parameter" operating area.



2. Press the "Zero offset" softkey.



3. Press the "Base" softkey. The "Zero Offset - Base" window is opened.
4. You can edit the values directly in the table.

Note

Activate base offsets

The offsets specified here are immediately active.

5.5.4 Displaying and editing settable zero offset

All settable offsets, divided into coarse and fine offsets, are displayed in the "Work offset - G54...G599" window.

Rotation, scaling and mirroring are displayed.

Procedure

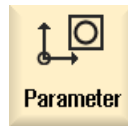

1. Select the "Parameter" operating area.



2. Press the "Work offset" softkey.



3. Press the "G54 ... G599" softkey.
The "Work offset - G54 ... G599 [mm]" window opens.

Note

The labeling of the softkeys for the settable work offsets varies, i.e. the settable work offsets configured on the machine are displayed (examples: G54 ... G57, G54 ... G505, G54 ... G599).

Please observe the information provided by the machine manufacturer.

4. You can edit the values directly in the table.

Note

Activate settable zero offsets

The settable zero offsets must first be selected in the program before they have an impact.

5.5.5 Displaying and editing details of the zero offsets

For each zero offset, you can display and edit all data for all axes. You can also delete zero offsets.

For every axis, values for the following data will be displayed:

- Coarse and fine offsets
- Rotation
- Scaling
- Mirroring



Machine manufacturer

Please refer to the machine manufacturer's specifications.

Note

Settings for rotation, scaling and mirroring are specified here and can only be changed here.

Tool details

You can display the following details for the tool and wear data for tools:

- TC
- Adapter dimension
- Length / length wear
- EC setup correction
- SC sum correction
- Total length
- Radius / radius wear



You can also change the display of the tool correction values between the Machine Coordinate System and the Workpiece Coordinate System.



Machine manufacturer

Please refer to the machine manufacturer's specifications.

Procedure

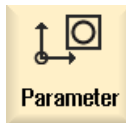

1. Select the "Parameter" operating area.



2. Press the "Zero offset" softkey.



3. Press the "Active", "Base" or "G54...G599" softkey. The corresponding window opens.



4. Place the cursor on the desired zero offset to view its details.



5. Press the "Details" softkey.

A window opens, depending on the selected zero offset, e.g. "Zero Offset - Details: G54 to G599".

6. You can edit the values directly in the table.

- OR -

Press the "Clear offset" softkey to reset all entered values.

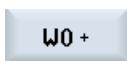

...



Press the "ZO +" or "ZO -" softkey to select the next or previous offset, respectively, within the selected area ("Active", "Base", "G54 to G599") without first having to switch to the overview window.

If you have reached the end of the range (e.g. G599), you will switch automatically to the beginning of the range (e.g. G54).

These value changes are available in the part program immediately or after "Reset".



Machine manufacturer

Please refer to the machine manufacturer's specifications.



Press the "Back" softkey to close the window.

5.5.6 Deleting a zero offset

You have the option of deleting work offsets. This resets the entered values.

Procedure



1. Select the "Parameter" operating area.



2. Press the "Work offset" softkey.



3. Press the "Overview", "Basis" or "G54...G599" softkey.

...



4. Press the "Details" softkey.

5. Position the cursor on the work offset you would like to delete.

5.5 Zero offsets



6. Press the "Clear offset" softkey.
A confirmation prompt is displayed as to whether you really want to delete the work offset.



7. Press the "OK" softkey to confirm that you wish to delete the work offset.

5.6 Monitoring axis and spindle data

5.6.1 Specify working area limitations

Using the "Working area limitation" function you can limit the range within which a tool should traverse in all channel axes. This function allows you to set up protection zones in the working area that are inhibited for tool motion.

In this way, you are able to restrict the traversing range of the axes in addition to the limit switches.

Requirements

You can only make changes in "AUTO" mode when in the RESET condition. These changes are then immediate.

You can make changes in "JOG" mode at any time. These changes, however, only become active at the start of a new motion.

Procedure

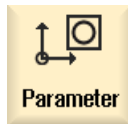

Parameter

1. Select the "Parameter" operating area.



Setting data

2. Press the "Setting data" softkey.

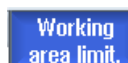

Working area limit.

The "Working Area Limitation" window appears.

3. Place the cursor in the required field and enter the new values via the numeric keyboard.
The upper or lower limit of the protection zone changes according to your inputs.
4. Click the "active" checkbox to activate the protection zone.

Note

You will find all of the setting data in the "Start-up" operating area under "Machine data" via the menu forward key.

5.6.2 Editing spindle data

The speed limits set for the spindles that must not be under- or overshoot are displayed in the "Spindles" window.

You can limit the spindle speeds in fields "Minimum" and "Maximum" within the limit values defined in the relevant machine data.

Spindle speed limitation at constant cutting rate

In field "Spindle speed limitation at G96", the programmed spindle speed limitation at constant cutting speed is displayed together with the permanently active limitations.

This speed limitation, for example, prevents the spindle from accelerating to the max. spindle speed of the current gear stage (G96) when performing tapping operations or machining very small diameters.

Note

The "Spindle data" softkey only appears if a spindle is configured.

Procedure

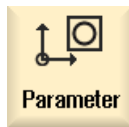

1. Select the "Parameter" operating area.



2. Press the "Setting data" and "Spindle data" softkeys.
The "Spindles" window opens.



3. If you want to change the spindle speed, place the cursor on the "Maximum", "Minimum", or "Spindle speed limitation at G96" and enter a new value.

5.7 Displaying setting data lists

You can display lists with configured setting data.



Machine manufacturer

Please refer to the machine manufacturer's specifications.

Procedure



Parameter

1. Select the "Parameter" operating area.



Setting data

2. Press the "Setting data" and "Data lists" softkeys.
The "Setting Data Lists" window opens.



Data lists



Select data list

3. Press the "Select data list" softkey and in the "View" list, select the required list with setting data.

5.8 Handwheel assignment

You can traverse the axes in the machine coordinate system (Machine) or in the workpiece coordinate system (Work) via the handwheel.

All axes are provided in the following order for handwheel assignment:

- Geometry axes
When traversing, the geometry axes take into account the current machine status (e.g. rotations, transformations). All channel machine axes, which are currently assigned to the geometry axis, are in this case simultaneously traversed.
- Channel machine axes
Channel machine axes are assigned to the particular channel. They can only be traversed individually, i.e. the current machine state has no influence.
The also applies to channel machine axes, that are declared as geometry axes.



Machine manufacturer

Please observe the information provided by the machine manufacturer.

Procedure



1. Select the "Machine" operating area.



2. Press the <JOG>, <AUTO> or <MDI> key.



3. Press the menu forward key and the "Handwheel" softkey.
The "Handwheel" window appears.



A field for axis assignment will be offered for every connected handwheel.

4. Position the cursor in the field next to the handwheel with which you wish to assign the axis (e.g. No. 1).
5. Press the corresponding softkey to select the desired axis (e.g. "X").



- OR



Open the "Axis" selection box using the <INSERT> key, navigate to the desired axis, and press the <INPUT> key.



Selecting an axis also activates the handwheel (e.g., "X" is assigned to handwheel no. 1 and is activated immediately).



6. Press the "Handwheel" softkey again.



- OR -
Press the "Back" softkey.
The "Handwheel" window closes.

Deactivate handwheel



1. Position the cursor on the handwheel whose assignment you wish to cancel (e.g. No. 1).
2. Press the softkey for the assigned axis again (e.g. "X").



- OR -
Open the "Axis" selection box using the <INSERT> key, navigate to the empty field, and press the <INPUT> key.



Clearing an axis selection also clears the handwheel selection (e.g., "X" is cleared for handwheel no. 1 and is no longer active).

5.9 MDA

In "MDI" mode (Manual Data Input mode), you can enter G-code commands or standard cycles block-by-block and immediately execute them for setting up the machine.

You have the option of loading an MDI program or a standard program with the standard cycles directly into the MDI buffer from the program manager; you can subsequently then edit it.



Machine manufacturer

Please observe the information provided by the machine manufacturer.

You can save programs, generated or modified in the MDI working window, in the program manager, e.g. in a directory specifically created for the purpose.

5.9.1 Loading an MDA program from the Program Manager

Procedure



1. Select the "Machine" operating area.



2. Press the <MDA> key.
The MDI editor opens.



3. Press the "Load MDI" softkey.
The "Load into MDI" window opens. It shows you a view of the program manager.



4. Position the cursor to the corresponding storage location, press the "Search" softkey and enter the required search term in the search dialog if you wish to search for a specific file.

Note: The place holders "*" (replaces any character string) and "?" (replaces any character) make it easier for you to perform a search.

5. Select the program that you would like to edit or execute in the MDI window.



6. Press the "OK" softkey.
The window closes and the program is ready for operation.

5.9.2 Saving an MDA program

Procedure



1. Select the "Machine" operating area.



2. Press the <MDA> key.

The MDI editor opens.

3. Create the MDI program by entering the G-code commands using the operator's keyboard.



4. Press the "Save MDI" softkey.

The "Save from MDI: Select storage location" window opens. It shows you a view of the program manager.

5. Select the drive to which you want to save the MDI program you created, and place the cursor on the directory in which the program is to be stored.

- OR -



Position the cursor to the required storage location, press the "Search" softkey and enter the required search term in the search dialog if you wish to search for a specific directory or subdirectory.

Note: The place holders "*" (replaces any character string) and "?" (replaces any character) make it easier for you to perform a search.



6. Press the "OK" softkey.

When you place the cursor on a folder, a window opens which prompts you to assign a name.

- OR -

When you place the cursor on a program, you are asked whether the file should be overwritten.



7. Enter the name for the rendered program and press the "OK" softkey.

The program will be saved under the specified name in the selected directory.

5.9.3 Editing/executing a MDI program

Procedure



1. Select the "Machine" operating area.



2. Press the <MDA> key.
The MDI editor opens.
3. Enter the desired G-code commands using the operator's keyboard.
- OR -
Enter a standard cycle, e.g. CYCLE62 ().

Editing G-code commands/program blocks

4. Edit G-code commands directly in the "MDI" window.
- OR -



Select the required program block (e.g. CYCLE62) and press the <cursor right> key, enter the required value and press "OK".



When editing a cycle, either the help screen or the graphic view can be displayed.



5. Press the <CYCLE START> key.

The control executes the input blocks.

When executing G-code commands and standard cycles, you have the option of controlling the sequence as follows:

- Executing the program block-by-block
- Testing the program
Settings under program control
- Setting the test-run feedrate
Settings under program control

See also

Program control (Page 155)

5.9.4 Deleting an MDA program

Requirement

The MDI editor contains a program that you created in the MDI window or loaded from the program manager.

Procedure



Press the "Delete blocks" softkey.

The program blocks displayed in the program window are deleted.

Working in manual mode

6.1 General

Always use "JOG" mode when you want to set up the machine for the execution of a program or to carry out simple traversing movements on the machine:

- Synchronize the measuring system of the controller with the machine (reference point approach)
- Set up the machine, i.e. activate manually-controlled motions on the machine using the keys and handwheels provided on the machine control panel.
- You can activate manually controlled motions on the machine using the keys and handwheels provided on the machine control panel while a part program is interrupted.

6.2 Selecting a tool and spindle

6.2.1 T, S, M windows

For the preparatory actions in manual mode, tool selection and spindle control are both performed centrally in a screen form.

In manual mode, you can select a tool either by its name or its location number. If you enter a number, a search is performed for a name first, followed by a location number. This means that if you enter "5", for example, and no tool with the name "5" exists, the tool is selected from location number "5".

Note

Using the location number, you can thus swing around an empty space into the machining position and then comfortably install a new tool.



Machine manufacturer

Please refer to the machine manufacturer's specifications.

Parameter	Meaning	Unit
T	Input of the tool (name or location number) You can select a tool from the tool list using the "Select tool" softkey.	
D	Cutting edge number of the tool (1 - 9)	
ST	Sister tool number (1 - 99 for sister tool strategy)	
Spindle	Spindle selection, identification with spindle number	
Spindle M function	Spindle off: Spindle is stopped	
	CCW rotation: Spindle rotates counterclockwise	
	CW rotation: Spindle rotates clockwise	
	Spindle positioning: Spindle is moved to the desired position.	
Other M functions	Input of machine functions Refer to the machine manufacturer's table for the correlation between the meaning and number of the function.	
Work offset G	Selection of the work offset (basic reference, G54 - 57) You can select work offsets from the tool list of settable work offsets via the "Work offset" softkey.	
Dimension unit	Selecting the measurement unit The setting made here has an effect on the programming.	inch mm
Machining plane	Selection of the machining plane (G17(XY), G18 (ZX), G19 (YZ))	

Parameter	Meaning	Unit
Gear stage 	Specification of the gear stage (auto, I - V)	
Stop position	Entering the spindle position	degrees

Note

Spindle positioning

You can use this function to position the spindle at a specific angle, e.g. during a tool change.

- A stationary spindle is positioned via the shortest possible route.
- A rotating spindle is positioned as it continues to turn in the same direction.

6.2.2 Selecting a tool

Procedure



1. Select the "JOG" operating mode.



2. Press the "T, S, M" softkey.

3. Enter the name or the number of the tool T in the input field.
- OR -



Press the "Select tool" softkey.

The tool selection window opens.

Place the cursor on the desired tool and press the "OK" softkey.

The tool is transferred to the "T, S, M... window" and displayed in the field of tool parameter "T".



4. Select tool edge D or enter the number directly in field "D".



5. Select the sister tool ST or enter the number directly into the "ST" field



6. Press the <CYCLE START> key.

The tool is loaded into the spindle.

6.2.3 Starting and stopping a spindle manually

Procedure



1. Select the "JOG" operating mode.



2. Press the "T, S, M" softkey.

3. Select the desired spindle (e.g. S1) and enter the desired spindle speed (rpm) or the constant cutting velocity (m/min) in the adjacent input field. The spindle remains stationary.



4. If the machine has a gearbox for the spindle, set the gear stage (e.g. auto).



5. Select a spindle direction of rotation (clockwise or counterclockwise) in the "Spindle M function" field.



6. Press the <CYCLE START> key. The spindle rotates.



7. Select the "Stop" setting in the "Spindle M function" field.



Press the <CYCLE START> key. The spindle stops.

Note

Changing the spindle speed

If you enter the speed in the "Spindle" field while the spindle is rotating, the new speed is applied.

6.2.4 Position spindle

Procedure



1. Select the "JOG" operating mode.



2. Press the "T, S, M" softkey.



3. Select the "Stop Pos." setting in the "Spindle M function" field.
The "Stop Pos." entry field appears.

4. Enter the desired spindle stop position.
The spindle position is specified in degrees.



5. Press the <CYCLE START> key.

The spindle is moved to the desired position.

Note

You can use this function to position the spindle at a specific angle, e.g. during a tool change.

- A stationary spindle is positioned via the shortest possible route.
 - A rotating spindle is positioned as it continues to turn in the same direction.
-

6.3 Traversing axes

You can traverse the axes in manual mode via the Increment or Axis keys or handwheels.

During a traverse initiated from the keyboard, the selected axis moves at the programmed setup feedrate. During an incremental traverse, the selected axis traverses a specified increment.

Set the default feedrate

Specify the feedrate to be used for axis traversal in the set-up, in the "Settings for Manual Operation" window.

6.3.1 Traverse axes by a defined increment

You can traverse the axes in manual mode via the Increment and Axis keys or handwheels.

Procedure



1. Select the "Machine" operating area.



2. Press the <JOG> key.



3. Press keys 1, 10, etc. up to 10000 in order to move the axis in a defined increment.



The numbers on the keys indicate the traverse path in micrometers or microinches.

Example: Press the "100" button for a desired increment of 100 μm (= 0.1 mm).



4. Select the axis to be traversed.



5. Press the <+> or <-> key.

Each time you press the key the selected axis is traversed by the defined increment.



Feedrate and rapid traverse override switches can be operative.

Note

When the controller is switched on, the axes can be traversed right up to the limits of the machine as the reference points have not yet been approached and the axes referenced. Emergency limit switches might be triggered as a result.

The software limit switches and the working area limitation are not yet operative!

The feed enable signal must be set.

**Machine manufacturer**

Please refer to the machine manufacturer's specifications.

6.3.2 Traversing axes by a variable increment

Procedure



Machine

1. Select the "Machine" operating area.



2. Press the <JOG> key.



3. Press the "Settings" softkey.
The "Settings for Manual Operation" window is opened.
4. Enter the desired value for the "Variable increment" parameter.
Example: Enter 500 for a desired increment of 500 μm (0.5 mm).



5. Press the <Inc VAR> key.



6. Select the axis to be traversed.
7. Press the <+> or <-> key.

Each time you press the key the selected axis is traversed by the set increment.



Feedrate and rapid traverse override switches can be operative.

6.4 Positioning axes

In manual mode, you can traverse individual or several axes to certain positions in order to implement simple machining sequences.

The feedrate / rapid traverse override is active during traversing.

Procedure



1. If required, select a tool.
2. Select the "JOG" operating mode.
3. Press the "Positions" softkey.
4. Specify the desired value for the feedrate F.
- OR -
Press the "Rapid traverse" softkey.
The rapid traverse is displayed in field "F".
5. Enter the target position or target angle for the axis or axes to be traversed.
6. Press the <CYCLE START> key.
The axis is traversed to the specified target position.

If target positions were specified for several axes, the axes are traversed simultaneously.

6.5 Manual retraction

In the following cases, the "Retract" function allows drilling tools to be retracted in the tool direction in the JOG mode:

- After interrupting a thread tapping operation (G33/331/G332),
- After interrupting machining operations using drilling tools (tools 200 to 299) as a result of power failure or a RESET at the machine control panel.

The tool and/or the workpiece remain undamaged.

Retraction is especially useful when the coordinate system is swiveled, i.e. the infeed axis is not in the vertical position.

Note

Tapping

In the case of tapping, the form fit between the tap and the workpiece is taken into account and the spindle moved according to the thread.

Use the Z axis as well as the spindle when retracting from threads.

The machine OEM sets up the "Retract" function.



Machine manufacturer

Please observe the information provided by the machine manufacturer.

Procedure



1. The power feed to the machine is interrupted.
- OR -
<RESET> interrupts an active part program.
2. After a power supply interruption, switch on the controller.
3. Select the JOG operating mode.
4. Press the Menu forward key.
5. Press the "Retract" softkey.
The "Retract Tool" window opens.
The softkey is available only when an active tool and retraction data are present.
6. Select the "WCS" coordinate system on the machine control panel.

6.5 Manual retraction



7. Use the traversing keys (e.g. Z +) to traverse the tool from the workpiece according to the retraction axis displayed in the "Retract Tool" window.



8. Press the "Retract" softkey again when the tool is at the desired position.

6.6 Default settings for manual mode

Specify the configurations for the manual mode in the "Settings for manual operation" window.

Default settings

Settings	Meaning
Type of feedrate	Here, you select the type of feedrate.
	<ul style="list-style-type: none"> G94: Axis feedrate/linear feedrate G95: Revolutional feedrate
Setup feedrate G94	Enter the desired feedrate in mm/min.
Setup feedrate G95	Enter the desired feedrate in mm/rev.
Variable increment	For variable increments, enter the desired increment when traversing axes.
Spindle speed	Here, enter the desired spindle speed in rpm.

Procedure



1. Select the "Machine" operating area.



2. Press the <JOG> key.



3. Press the menu forward key and the "Settings" softkey.
The "Settings for manual operation" window is opened.



Machining the workpiece

7.1 Starting and stopping machining

During execution of a program, the workpiece is machined in accordance with the programming on the machine. After the program is started in automatic mode, workpiece machining is performed automatically.

Preconditions

The following requirements must be met before executing a program:

- The measuring system of the controller is referenced with the machine.
- The necessary tool offsets and work offsets have been entered.
- The necessary safety interlocks implemented by the machine manufacturer are activated.

General sequence



1. Use the Program manager to select the desired program.



2. Select under "NC", "Local. Drive", "USB" or set-up network drives the desired program.



3. Press the "Select" softkey.
The program is selected for execution and automatically switched to the "Machine" operating area.



4. Press the <CYCLE START> key.
The program is started and executed.

Note

Starting the program in any operating area

If the control system is in the "AUTO" mode, you can also start the selected program when you are in any operating area.

Stopping machining



Press the <CYCLE STOP> key.

Machining stops immediately, individual blocks do not finish execution. At the next start, execution is resumed at the same location where it stopped.

Canceling machining



Press the <RESET> key.

Execution of the program is interrupted. On the next start, machining will start from the beginning.



Machine manufacturer

Please observe the information provided by the machine manufacturer.

See also

EXTCALL (Page 354)

7.2 Selecting a program

Procedure



1. Select the "Program Manager" operating area.
The directory overview is opened.



2. Select the location where the program is archived (e.g. "NC")
3. Place the cursor on the directory containing the program that you want to select.



4. Press the <INPUT> key.

- OR -

Press the <Right cursor> key.

The directory contents are displayed.



5. Place the cursor on the desired program.

6. Press the "Select" softkey.

When the program has been successfully selected, an automatic change-over to the "Machine" operating area occurs.

7.3 Program running-in

When testing a program, you can select that the system can interrupt the machining of the workpiece after each program block, which triggers a movement or auxiliary function on the machine. In this way, you can control the machining result block-by-block during the initial execution of a program on the machine.

Note

Settings for the automatic mode

Rapid traverse reduction and dry run feed rate are available to run-in or to test a program.

Move by single block





In "Program control" you may select from among several types of block processing:

SB mode	Scope
SB1 Single block, coarse	Machining stops after every machine block (except for cycles).
SB2 Data block	Machining stops after every block, i.e. also for data blocks (except for cycles)
SB3 Single block, fine	Machining stops after every machine block (also in cycles)

Precondition

A program must be selected for execution in "AUTO" or "MDA" mode.

Procedure

- 
1. Press the "Prog. ctrl." softkey and select the desired variant in the "SBL" field.
- 
2. Press the <SINGLE BLOCK> key.
- 
3. Press the <CYCLE START> key.
Depending on the execution variant, the first block will be executed. Then the machining stops.
In the channel status line, the text "Stop: Block in single block ended" appears.
- 
4. Press the <CYCLE START> key.
Depending on the mode, the program will continue executing until the next stop.
- 
5. Press the <SINGLE BLOCK> key again, if the machining is not supposed to run block-by-block.
The key is deselected again.
If you now press the <CYCLE START> key again, the program is executed to the end without interruption.

See also

Selecting a program (Page 139)

7.4 Displaying the current program block

7.4.1 Current block display

The window of the current block display shows the program blocks currently being executed.

Display of current program

The following information is displayed in the running program:

- The workpiece name or program name is entered in the header line.
- The program block which is just being processed appears colored.



Display of the machining times

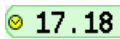
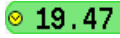
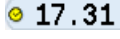
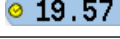
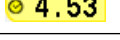

If you set that the machining times are to be recorded in the settings for automatic mode, the measured times are shown at the end of the line as follows:

Display	Meaning
Light green background 	Measured machining time of the program block (automatic mode)
Green background 	Measured machining time of the program group (automatic mode)
Light blue background 	Estimated machining time of the program block (simulation)
Blue background 	Estimated machining time of the program group (simulation)
Yellow background 	Wait time (automatic mode or simulation)

Highlighting of selected G code commands or keywords

In the program editor settings, you can specify whether selected G code commands are to be highlighted in color. The following colors are used as standard:

Display	Meaning
Blue font 	D, S, F, T, M and H functions
Red font 	"G0" motion command
Green font 	"G1" motion command

Display	Meaning
Blue-green font 	"G2" or "G3" motion command
Gray font 	Comment

Machine manufacturer



You can define further highlight colors in the "sleditorwidget.ini" configuration file. Please refer to the machine manufacturer's instructions.

Editing a program directly

In the Reset state, you can edit the current program directly.



1. Press the <INSERT> key.

2. Place the cursor at the relevant position and edit the program block. Direct editing is only possible for G code blocks in the NC memory, not for external execution.



3. Press the <INSERT> key to exit the program and the edit mode again.

See also

Settings for the automatic mode (Page 191)

7.4.2 Displaying a basic block

If you want precise information about axis positions and important G functions during testing or program execution, you can call up the basic block display. This is how you check, when using cycles, for example, whether the machine is actually traversing.

Positions programmed by means of variables or R parameters are resolved in the basic block display and replaced by the variable value.

You can use the basic block display both in test mode and when machining the workpiece on the machine. All G code commands that initiate a function on the machine are displayed in the "Basic Blocks" window for the currently active program block:

- Absolute axis positions
- G functions for the first G group
- Other modal G functions

- Other programmed addresses
- M functions



Machine manufacturer

Please observe the information provided by the machine manufacturer.

Procedure



1. A program is selected for execution and has been opened in the "Machine" operating area.
2. Press the "Basic blocks" softkey.
The "Basic Blocks" window opens.
3. Press the <SINGLE BLOCK> key if you wish to execute the program block by block.
4. Press the <CYCLE START> key to start the program execution.
The axis positions to be approached, modal G functions, etc., are displayed in the "Basic Blocks" window for the currently active program block.
5. Press the "Basic blocks" softkey once again to hide the window again.

7.4.3 Display program level

You can display the current program level during the execution of a large program with several subprograms.

Several program run throughs

If you have programmed several program run throughs, i.e. subprograms are run through several times one after the other by specifying the additional parameter P, then during processing, the program runs still to be executed are displayed in the "Program Levels" window.

Program example

N10 subprogram P25

If, in at least one program level, a program is run through several times, a horizontal scroll bar is displayed that allows the run through counter P to be viewed in the righthand window section. The scroll bar disappears if multiple run-through is no longer applicable.

Display of program level

The following information will be displayed:

- Level number
- Program name

- Block number, or line number
- Remain program run throughs (only for several program run throughs)

Precondition

A program must be selected for execution in "AUTO" mode.

Procedure



Press the "Program levels" softkey.
The "Program levels" window appears.

7.5 Correcting a program

As soon as a syntax error in the part program is detected by the controller, program execution is interrupted and the syntax error is displayed in the alarm line.

Correction options

Depending on the state of the control system, you have various options of correcting the program.

- Stop state
Only change lines that have not been executed
- Reset status
Change all lines

Note

The "program correction" function is also available for execute from external; however, when making program changes, the NC channel must be brought into the reset state.

Precondition

A program must be selected for execution in "AUTO" mode.

Procedure



1. The program to be corrected is in the Stop or Reset mode.
2. Press the "Prog. corr." softkey.

The program is opened in the editor.

The program preprocessing and the current block are displayed. The current block is also updated in the running program, but not the displayed program section, i.e. the current block moves out of the displayed program section.

If a subprogram is executed, it is not opened automatically.



3. Make the necessary corrections.
4. Press the "NC Execute" softkey.

The system switches back to the "Machine" operating area and selects "AUTO" mode.



5. Press the "CYCLE START" key to resume program execution.

Note

When you exit the editor using the "Close" softkey, you return to the "Program manager" operating area.

7.6 Repositioning axes

After a program interruption in the automatic mode (e.g. after a tool breaks), you can move the tool away from the contour in manual mode.

The coordinates of the interrupt position will be saved. The distances traversed in manual mode are displayed in the actual value window. This path difference is called "REPOS offset".

Resuming program execution

You use the "REPOS" function to return the tool to the contour of the workpiece to continue executing the program.

The interrupt position is not passed as it is blocked by the control system.

The feedrate/rapid traverse override is in effect.

NOTICE

Risk of collision

When repositioning, the axes move with the programmed feedrate and linear interpolation, i.e. in a straight line from the current position to the interrupt point. Therefore, you must first move the axes to a safe position in order to avoid collisions.

If you do not use the "REPOS" function after a program interrupt and then traversing the axes in manual mode, then on changing to automatic mode and starting the machining process, the control automatically traverses the axes in straight lines back to where they were at point of interruption.

Requirement

The following prerequisites must be met when repositioning the axes:

- The program execution was interrupted using <CYCLE STOP>.
- The axes were moved from the interrupt point to another position in manual mode.

Procedure



1. Press the <REPOS> key.



2. Select the axes to be traversed one after the other.



3. Press the <+> or <-> key for the relevant direction.
The axes are moved to the interrupt position.



7.7 Starting execution at a specific point

7.7.1 Use block search

If you want to perform only a certain section of a program on the machine, then you need not start the program from the beginning. You can start the program from a specified program block.

Applications

- Stopping or interrupting program execution
- Specify a target position, e.g. during remachining

Determining a search target

- User-friendly search target definition (search positions)
 - Direct specification of the search target by positioning the cursor in the selected program (main program)
Note:
It must be ensured during a block search that the correct tool is in the working position before commencing execution of the program.
 - Search target via text search
 - The search target is the interruption point (main program and subprogram)
The function is only available if there is an interruption point. After a program interruption (CYCLE STOP, RESET or Power Off), the controller saves the coordinates of the interruption point.
 - The search target is the higher program level of the interruption point (main program and subprogram)
A change of levels is only possible if an interruption point located in a sub-program is selected. It is thus possible to switch to the main program level and back to the level of the interruption point.
- Search pointer
 - Direct entry of the program path

Note

You can search for a specific point in subprograms with the search pointer if there is no interruption point.

Cascaded search

You can start another search from the "Search target found" state. Each time a search target is found, it is possible to continue cascading arbitrarily.

Note

Another cascaded block search can be started from the stopped program execution only if the search target has been found.

Requirements

- You have selected the desired program.
- The controller is in the reset state.
- The desired search mode is selected.

NOTICE

Risk of collision

Pay attention to a collision-free start position and appropriate active tools and other technological values.

If necessary, manually approach a collision-free start position. Select the target block considering the selected block search variant.

Toggleing between search pointer and search positions



Press the "Search pointer" softkey again to exit the "Search Pointer" window and return to the "Program" window to define search positions.

- OR -



Press the "Back" softkey.

You have now exited the block search function.

Further information

Additional information on the block search function is provided in the Basic Functions Function Manual.

See also

Selecting a program (Page 139)

Block search mode (Page 153)

7.7.2 Continuing program from search target

Press the "CYCLE START" key twice to continue the program from the desired position.

- The first CYCLE START outputs the auxiliary functions collected during the search. The program is then in the Stop state.
- Before the second CYCLE START, you can use the "Overstore" function to create states that are required, but not yet available, for the further program execution.
If the set position is not to be approached automatically after the program start, you can also traverse the tool manually from the current position to the set position by changing to JOG mode for the REPOS function

7.7.3 Simple search target definition

Requirement

The program is selected and the controller is in Reset mode.

Procedure



1. Press the "Block search" softkey.

2. Place the cursor on a particular program block.

- OR -



Press the "Find text" softkey, select the search direction, enter the search text and confirm with "OK".



3. Press the "Start search" softkey.

The search starts. Your specified search mode will be taken into account. The current block will be displayed in the "Program" window as soon as the target is found.



4. If the located target (for example, when searching via text) does not correspond to the program block, press the "Start search" softkey again until you find your target.

Press the <CYCLE START> key twice.

Processing is continued from the defined position.

7.7.4 Defining an interruption point as search target

Requirement

A program was selected in "AUTO" mode and interrupted during execution through CYCLE STOP or RESET.

Procedure



1. Press the "Block search" softkey.



2. Press the "Interrupt point" softkey.
The interruption point is loaded.



3. If the "Higher level" and "Lower level" softkeys are available, use these to change the program level.



4. Press the "Start search" softkey.

The search starts. Your specified search mode will be taken into account.
The search screen closes.

The current block will be displayed in the "Program" window as soon as the target is found.



5. Press the <CYCLE START> key twice.

The execution will continue from the interruption point.

7.7.5 Entering the search target via search pointer

Enter the program point which you would like to proceed to in the "Search Pointer" window.

Requirement

The program is selected and the controller is in the reset state.

Screen form

Each line represents one program level. The actual number of levels in the program depends on the nesting depth of the program.

Level 1 always corresponds to the main program and all other levels correspond to subprograms.

You must enter the target in the line of the window corresponding to the program level in which the target is located.

7.7 Starting execution at a specific point

For example, if the target is located in the subprogram called directly from the main program, you must enter the target in program level 2.

The target specification must always be unique. This means, for example, that if the subprogram is called in the main program in two different places, you must also specify a target in program level 1 (main program).

Procedure



1. Press the "Block search" softkey.



2. Press the "Search pointer" softkey.

3. Enter the full path of the program as well as the subprograms, if required, in the input fields.



4. Press the "Start search" softkey.

The search starts. Your specified search mode will be taken into account. The Search window closes. The current block will be displayed in the "Program" window as soon as the target is found.



5. Press the <CYCLE START> key twice.

Processing is continued from the defined location.

Note

Interruption point

You can load the interruption point in search pointer mode.

7.7.6 Parameters for block search in the search pointer

Parameter	Meaning
Number of program level	
Program:	The name of the main program is automatically entered
Ext:	File extension
P:	Number of subprogram repetitions If a subprogram is performed several times, you can enter the number of the pass here at which processing is to be continued
Line:	Is automatically filled for an interruption point

Parameter	Meaning
Type	" " search target is ignored on this level N no. Block number Label Jump label Text string Subprg. Subprogram call Line Line number
Search target	Point in the program at which machining is to start

7.7.7 Block search mode

Set the desired search variant in the "Search Mode" window.

The set mode is retained when the the controller is shut down. When you activate the "Search" function after restarting the controller, the current search mode is displayed in the title row.

Search variants

Block search mode	Meaning
With calculation - without approach	It is used in order to be able to approach a target position in any circumstance (e.g. tool change position). The end position of the target block or the next programmed position is approached using the type of interpolation valid in the target block. Only the axes programmed in the target block are moved. Note: If machine data 11450.1=1 is set, the rotary axes of the active swivel data record are pre-positioned after the block search.
With calculation - with approach	It is used to be able to approach the contour in any circumstance. The end position of the block prior to the target block is found with <CYCLE START>. The program runs in the same way as in normal program processing.
With calculation - skip extcall	This is used to speed-up a search with calculation when using EXTCALL programs: EXTCALL programs are not taken into account. Notice: Important information, e.g. modal functions, which are located in the EXTCALL program, are not taken into account. In this case, after the search target has been found, the program is not able to be executed. Information such as this should be programmed in the main program.

Block search mode	Meaning
Without calculation	<p>For a quick search in the main program.</p> <p>Calculations will not be performed during the block search, i.e. the calculation is skipped up to the target block.</p> <p>All settings required for execution have to be programmed from the target block (e.g. feedrate, spindle speed, etc.).</p>
With program test	<p>Multi-channel block search with calculation (SERUPRO).</p> <p>All blocks are calculated during the block search. Absolutely no axis motion is executed, however, all auxiliary functions are output.</p> <p>The NC starts the selected program in the program test mode. If the NC reaches the specified target block in the actual channel, it stops at the beginning of the target block and deselects program test mode again. After continuing the program with NC start (after REPOS motion) the auxiliary functions of the target block are output.</p> <p>For single-channel systems, the coordination is supported with events running in parallel, e.g. synchronized actions.</p> <p>Note</p> <p>The search speed depends on MD settings.</p>



Machine manufacturer

Please observe the information provided by the machine manufacturer.

Further information

Additional information on configuring the block search function is provided in the SINUMERIK Operate Commissioning Manual.

7.8 Controlling the program run

7.8.1 Program control

You can change the program sequence in the "AUTO" and "MDA" modes.

Abbreviation/program control	Mode of operation
PRT No axis motion	The program is started and executed with auxiliary function outputs and dwell times. In this mode, the axes are not traversed. The programmed axis positions and the auxiliary function outputs are controlled this way. Note: You can activate program execution without any axis motion using the "Dry run feedrate".
DRY Dry run feedrate	The traversing velocities programmed in conjunction with G1, G2, G3, CIP and CT are replaced by a defined dry run feedrate. The dry run feedrate also applies instead of the programmed revolutionary feedrate. Note: Do not machine any workpieces when "Dry run feedrate" is active because the altered feedrates might cause the permissible tool cutting rates to be exceeded and the workpiece or machine tool could be damaged.
RG0 Reduced rapid traverse	In the rapid traverse mode, the traversing speed of the axes is reduced to the percentage value entered in RG0. Note: You define the reduced rapid traverse in the settings for automatic operation.
M01 Programmed stop 1	The processing of the program stops at every block in which supplementary function M01 is programmed. In this way you can check the already obtained result during the processing of a workpiece. Note: In order to continue executing the program, press the <CYCLE START> key again.
Programmed stop 2 (e.g. M101)	The processing of the program stops at every block in which the "Cycle end" is programmed (e.g. with M101). Note: In order to continue executing the program, press the <CYCLE START> key again. Note: The display can be changed. Please observe the information provided by the machine manufacturer.
DRF Handwheel offset	Enables an additional incremental work offset while processing in automatic mode with an electronic handwheel. This function can be used to compensate for tool wear within a programmed block.
SB	Individual blocks are configured as follows. <ul style="list-style-type: none"> • Single block, coarse: The program stops only after blocks which perform a machine function. • Data block: The program stops after each block. • Single block, fine: The program also stops only after blocks which perform a machine function in cycles. Select the desired setting using the <SELECT> key.
SKP	Skip blocks are skipped during machining.

Abbreviation/program control	Mode of operation
MRD	In the program, the measurement results screen display is activated while machining.
CST Configured stop	<p>Program processing stops at the points you defined as relevant to stop before the program started. These may be, for example, especially critical points, at which you can check the correctness of the sequence or exclude collisions.</p> <p>The following NC function transitions can be activated as default setting in window "Program control" as stop relevant:</p> <ul style="list-style-type: none"> • Transition G1-G0 • Transition G0-G0 <p>You can also define NC functions (auxiliary functions, cycle calls, T-preselection) as NC function transitions.</p> <p>Note: Please observe the information provided by the machine manufacturer.</p>

Activating program control

You can control the program sequence however you wish by selecting and clearing the relevant checkboxes.

Display / response of active program controls

If program control is activated, the abbreviation of the corresponding function appears in the status display as feedback response.

Procedure



1. Select the "Machine" operating area.



2. Press the <AUTO> or <MDI> key.



3. Press the "Prog. ctrl." softkey.
The "Program Control" window opens.

7.8.2 Skip blocks

You can skip program blocks that are not to be executed every time the program runs.

The skip blocks are identified by placing a "/" (forward slash) or "/x" (x = number of skip level) character in front of the block number. You have the option of hiding several block sequences.

The statements in the skipped blocks are not executed. The program continues with the next block, which is not skipped.

The number of skip levels that can be used depends on a machine datum.



Machine manufacturer

Please observe the information provided by the machine manufacturer.

Skip levels, activate

Select the corresponding checkbox to activate the desired skip level.

Note

The "Program Control - Skip Blocks" window is only available when more than one skip level is set up.

7.9 Overstore

With overstore, you have the option of executing technological parameters (for example, auxiliary functions, axis feed, spindle speed, programmable instructions, etc.) before the program is actually started. The program instructions act as if they are located in a normal part program. These program instructions are, however, only valid for one program run. The part program is not permanently changed. When next started, the program will be executed as originally programmed.

After a block search, the machine can be brought into another state with overstore (e.g. M function, tool, feed, speed, axis positions, etc.), in which the normal part program can be successfully continued.

Requirement

The program to be corrected is in the Stop or Reset mode.

Procedure



1. Select the "Machine" operating area in the "AUTO" mode.



2. Press the "Overstore" softkey.
The "Overstore" window opens.
3. Enter the required data and NC block.



4. Press the <CYCLE START> key.
The blocks you have entered are stored. You can observe execution in the "Overstore" window.

After the entered blocks have been executed, you can append blocks again.

You cannot change the operating mode while you are in overstore mode.



5. Press the "Back" softkey.
The "Overstore" window closes.



6. Press the <CYCLE START> key again.
The program selected before overstore continues to run.

Note

Block-by-block execution

The <SINGLE BLOCK> key is also active in the overstore mode. If several blocks are entered in the overstore buffer, then these are executed block-by-block after each NC start

Deleting blocks



Press the "Delete blocks" softkey to delete program blocks you have entered.

7.10 Editing a program

With the editor, you are able to render, supplement, or change part programs.

Note

Maximum block length

The maximum block length is 512 characters.

Calling the editor

- The editor is started via the "Program correction" softkey in the "Machine" operating area. You can directly change the program by pressing the <INSERT> key.
- The editor is called via the "Open" softkey as well as with the <INPUT> or <Cursor right> key in the "Program manager" operating area.
- The editor opens in the "Program" operating area with the last executed part program, if this was not explicitly exited via the "Close" softkey.

Note

- Please note that the changes to programs saved in the NC memory take immediate effect.
 - If you are editing on a local drive or external drives, you can also exit the editor without saving, depending on the setting. Programs in the NC memory are always automatically saved.
 - Exit the program correction mode using the "Close" softkey to return to the "Program manager" operating area.
-

See also

Editor settings (Page 168)

Opening and closing a program (Page 325)

Correcting a program (Page 146)

7.10.1 Searching in programs

You can use the search function to quickly arrive at points where you would like to make changes, e.g. in very large programs.

Various search options are available that enable selective searching.

Search options

- **Whole words**
Activate this option and enter a search term if you want to search for texts/terms that are present as words in precisely this form.
If, for example, you enter the search term "Finishing tool", only single "Finishing tool" terms are displayed. Word combinations such as "Finishing tool_10" are not found.
- **Exact expression**
Activate this option if you wish to search for terms with characters, which can also be used as place holders for other characters, e.g. "?" and "*".

Note

Search with place holders

When searching for specific program locations, you have the option of using place holders:

- "*": Replaces any character string
 - "?": Replaces any character
-

Precondition

The desired program is opened in the editor.

Procedure



1. Press the "Search" softkey.
A new vertical softkey bar appears.
The "Search" window opens at the same time.
2. Enter the desired search term in the "Text" field.
3. Select "Whole words" if you want to search for whole words only.
- OR -



4. Position the cursor in the "Direction" field and choose the search direction (forward, backward) with the <SELECT> key.

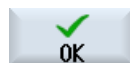

5. Press the "OK" softkey to start the search.

If the text you are searching for is found, the corresponding line is highlighted.





6. Press the "Continue search" softkey if the text located during the search does not correspond to the point you are looking for.

- OR -



Press the "Cancel" softkey when you want to cancel the search.

Further search options

Softkey	Function
	The cursor is set to the first character in the program.
	The cursor is set to the last character in the program.









7.10.2 Replacing program text

You can find and replace text in one step.

Precondition

The desired program is opened in the editor.

Procedure

1.  Press the "Search" softkey.
A new vertical softkey bar appears.
2.  Press the "Find and replace" softkey.
The "Find and Replace" window appears.
3. In the "Text" field, enter the term you are looking for and in the "Replace with" field, enter the text you would like to insert automatically during the search.
4.  Position the cursor in the "Direction" field and choose the search direction (forward, backward) with the <SELECT> key.
5.  Press the "OK" softkey to start the search.
If the text you are searching for is found, the corresponding line is highlighted.
6.  Press the "Replace" softkey to replace the text.
- OR -
 Press the "Replace all" softkey to replace all text in the file that corresponds to the search term.
- OR -
 Press the "Continue search" softkey if the text located during the search should not be replaced.
- OR -
 Press the "Cancel" softkey when you want to cancel the search.

Note**Replacing texts**

- Read-only lines (;*RO*)
If hits are found, the texts are not replaced.
 - Contour lines (;*GP*)
If hits are found, the texts are replaced as long as the lines are not read-only.
 - Hidden lines (;*HD*)
If hidden lines are displayed in the editor and hits are found, the texts are replaced as long as the lines are not read-only. Hidden lines that are not displayed, are not replaced.
-

See also

Editor settings (Page 168)

7.10.3 Copying/pasting/deleting program blocks

In the editor, you edit both basic G code as well as program steps such as cycles, blocks and subprogram calls.

Inserting program blocks

The editor responds depending on what type of program block you insert.

- If you insert a G code, then the program block is directly inserted where the write mark is located.
 - If you insert a program step, then the program block is always inserted at the next block, independent of the position of the write mark within the actual line. This is necessary as a cycle call always requires its own line.
This behavior is in all applications, irrespective of whether the program step is inserted with a screen form using "Accept" or "Insert" is used as editor function.
-

Note**Cutout program step and reinsert**

- If you cut out a program step at a specific location and you then directly reinsert it again, the sequence changes.
 - Press the shortcut (key combination) <CTRL> + <Z> to undo what you have cut out.
-

Precondition

The program is opened in the editor.

Procedure



1. Press the "Mark" softkey.

- OR -



Press the <SELECT> key.



2. Select the desired program blocks with the cursor or mouse.



3. Press the "Copy" softkey in order to copy the selection to the buffer memory.

4. Place the cursor on the desired insertion point in the program and press the "Paste" softkey.

The content of the buffer memory is pasted.

- OR -



Press the "Cut" softkey to delete the selected program blocks and to copy them into the buffer memory.

Note: When editing a program, you cannot copy or cut more than 1024 lines. While a program that is not on the NC is opened (progress display less than 100%), you cannot copy or cut more than 10 lines or insert more than 1024 characters.

Numbering the program blocks

If you have selected the "Automatic numbering" option for the editor, then the newly added program blocks are allocated a block number (N number).

The following rules apply:

- When creating a new program, the first line is allocated the "first block number".
- If, up until now, the program had no N number, then the program block inserted is allocated the starting block number defined in the "First block number" input field.
- If N numbers already exist before and after the insertion point of a new program block, then the N number before the insertion point is incremented by 1.
- If there are no N numbers before or after the insertion point, then the maximum N number in the program is increased by the "increment" defined in the settings.

Note:

After exiting the program, you have the option of renumbering the program blocks.

Note

The buffer memory contents are retained even after the editor is closed, enabling you to paste the contents in another program.

Note**Copy/cut current line**

To copy and cut the current line where the cursor is positioned, it is not necessary to mark or select it. You have the option of making the "Cut" softkey only operable for marked program sections via editor settings.

See also

Opening additional programs (Page 167)

Editor settings (Page 168)

7.10.4 Renumbering a program

You can modify the block numbering of programs opened in the editor at a later point in time.

Precondition

The program is opened in the editor.

Procedure

1. Press the ">>" softkey.
A new vertical softkey bar appears.



2. Press the "Renumber" softkey.
The "Renumbering" window appears.

3. Enter the values for the first block number and the increment to be used for numbering.



4. Press the "OK" softkey.
The program is renumbered.

Note

- If you only want to renumber a section, before the function call, select the program blocks whose block numbering you want to edit.
 - When you enter a value of "0" for the increment size, then all of the existing block numbers are deleted from the program and/or from the selected range.
-

7.10.5 Creating a program block

In order to structure programs to achieve a higher degree of transparency, you have the option of combining several G-code blocks to form program blocks.

Program blocks can be created in two stages. This means that you can form additional blocks within a block (nesting).

You then have the option of opening and closing these blocks depending on your requirement.

Settings for a program block

Display	Meaning
Text	<ul style="list-style-type: none"> Block designation
Spindle	<ul style="list-style-type: none"> Selecting the spindle Defines at which spindle a program block is to be executed.
Addit. run-in code	<ul style="list-style-type: none"> Yes For the case that the block is not executed, as the specified spindle should not be processed, then it is possible to temporarily activate a so-called "Addit. run-in code". No
Automat. Retraction	<ul style="list-style-type: none"> Yes Block start and block end are moved to the tool change point, i.e. the tool is brought into a safe range. No

Procedure



1. Select the "Program Manager" operating area.



2. Select the storage location and create a program or open a program. The program editor opens.



3. Select the required program blocks that you wish to combine to form a block.



4. Press the "Build block" softkey. The "Build Block" window opens.





5. Enter a designation for the block, assign the spindle, if required, select the additional run-in code and the automatic retraction and then press the "OK" softkey.

Opening and closing blocks



6. Press the ">>" and "View" softkeys.



- | | |
|---|--|
|  | 7. Press the "Open blocks" softkey if you wish to display the program with all blocks. |
|  | 8. Press the "Close blocks" softkey if you wish to display the program again in a structured form. |
| Remove block | |
| | 9. Open the block. |
| | 10. Position the cursor at the end of the block. |
|  | 11. Press the "Remove block" softkey. |

Note

You can also open and close blocks with the mouse or using the cursor keys:

- <Cursor right> opens the block where the cursor is positioned
- <Cursor left> closes the block if the cursor is positioned at the beginning or end of the block
- <ALT> and <Cursor left> closes the block if the cursor is located within the block

Note

DEF statements in program blocks or block generation in the DEF part of a part program / cycle are not permitted.



7.10.6 Opening additional programs

You have the option of viewing and editing several programs simultaneously in the editor.

For instance, you can copy program blocks or machining steps of a program and paste them into another program.

Opening several programs

You have the option of opening up to ten program blocks.

- | | |
|---|--|
|  | 1. In the program manager, select the programs that you wish to open and view in the multiple editor and then press on the "Open" softkey.
The editor is opened and the first two programs are displayed. |
|  | 2. Press the <NEXT WINDOW> key to change to the next opened program. |
|  | 3. Press the "Close" softkey to close the actual program. |

Note

Pasting program blocks

JobShop machining steps cannot be copied into a G code program.

Precondition

You have opened a program in the editor.

Procedure



1. Press the ">>" and "Open additional program" softkeys.



The "Select Additional Program" window is opened.

2. Select the program or programs that you wish to display in addition to the already opened program.



3. Press the "OK" softkey.

The editor opens and displays both programs next to each another.

See also

Copying/pasting/deleting program blocks (Page 163)

7.10.7 Editor settings

Enter the default settings in the "Settings" window that are to take effect automatically when the editor is opened.

Defaults

Setting	Meaning
Number automatically	<ul style="list-style-type: none"> • Yes: A new block number will automatically be assigned after every line change. In this case, the specifications provided under "First block number" and "Increment" are applicable. • No: No automatic numbering
First block number	Specifies the starting block number of a newly created program. The field is only visible when "Yes" is selected under "Number automatically".
Increment	Defines the increment used for the block numbers. The field is only visible when "Yes" is selected under "Number automatically".
Show hidden lines	<ul style="list-style-type: none"> • Yes: Hidden lines marked with "*HD" (hidden) will be displayed. • No: Lines marked with ";*HD*" will not be displayed. <p>Note: Only visible program lines are taken into account with the "Search" and "Search and Replace" functions.</p>
Display block end as symbol	The "LF" (line feed) symbol ¶ is displayed at the block end.

Setting	Meaning
Line break	<ul style="list-style-type: none"> • Yes: Long lines are broken and wrapped around. • No: If the program includes long lines, then a horizontal scrollbar is displayed. You can move the section of the screen horizontally to the end of the line.
Line break also in cycle calls	<ul style="list-style-type: none"> • Yes: If the line of a cycle call becomes too long, then it is displayed over several lines. • No: The cycle call is truncated. <p>The field is only visible if "Yes" is entered under "Line break".</p>
Visible programs	<ul style="list-style-type: none"> • 1 - 10 Select how many programs can be displayed next to one another in the editor. • Auto Specifies that the number of programs entered in a job list or up to ten selected programs will be displayed next to each other.
Width per program w. focus	Here, you enter the width of the program that has the input focus in the editor as a percentage of the window width.
Save automatically	<ul style="list-style-type: none"> • Yes: The changes are saved automatically when you change to another operating area. • No: You are prompted to save when changing to another operating area. Save or reject the changes with the "Yes" and "No" softkeys. <p>Note: Only for local and external drives.</p>
Only cut after marking	<ul style="list-style-type: none"> • Yes: Parts of programs can only be cutout when program lines have been selected, i.e. the "Cutout" softkey only then is active. • No: The program line, in which the cursor is positioned, can be cut out without having to select it.
Determine machining times	<p>Defines which program runtimes are determined in the simulation or in automatic mode:</p> <ul style="list-style-type: none"> • Off Program runtimes are not determined. • Block-by-block: The runtimes are determined for each program block. • Non-modal: The runtimes are determined at the NC block level. <p>Note: You also have the option of displaying the cumulative times for blocks. Please observe the information provided by the machine manufacturer.</p> <p>After the simulation or after executing the program, the required machining times are displayed in the editor.</p>
Save machining times	<p>Specifies how the machining times determined are processed.</p> <ul style="list-style-type: none"> • Yes A subdirectory with the name "GEN_DATA.WPD" is created in the directory of the part program. There, the machining times determined are saved in an ini file together with the name of the program. The machining times are displayed again when the program or job list are reloaded. • No The machining times that have been determined are only displayed in the editor.

Setting	Meaning
Record tools	<p>Defines whether the tool data is recorded.</p> <ul style="list-style-type: none"> • Yes Recording takes place during processing. The data is stored in a TTD file (Tool Time Data). The TTD file is located in the directory of the associated part program. • No The tool data is not recorded.
Display cycles as machining step	<ul style="list-style-type: none"> • Yes: The cycle calls in the G code programs are displayed as plain text. • No: The cycle calls in the G code programs are displayed in the NC syntax.
Highlight selected G code commands	<p>Defines the display of G code commands.</p> <ul style="list-style-type: none"> • No All G code commands are displayed in the standard color. • Yes Selected G code commands or keywords are highlighted in color. Define the rules for the color assignment in the sleditorwidget.ini configuration file. <p>Note: Please observe the information provided by the machine manufacturer.</p> <p>Note This setting also has an effect on the current block display.</p>
Font size	<p>Defines the font size for the editor and the display of the program sequence.</p> <ul style="list-style-type: none"> • auto If you open a second program, then the smaller font size is automatically used. • normal (16) - character height in pixels Standard font size that is displayed with the appropriate screen resolution. • small (14) - character height in pixels More content is displayed in the editor. <p>Note This setting also has an effect on the current block display.</p>

Note

All entries that you make here are effective immediately.

Requirement

You have opened a program in the editor.

Procedure



1. Select the "Program" operating area.



2. Press the "Edit" softkey.



3. Press the ">>" and "Settings" softkeys.
The "Settings" window opens.



4. Make the required changes.



5. Press the "Del. machining times" softkey if you wish to delete the machining times.

The machining times that have been determined are deleted from the editor as well as from the actual block display. If the machining times are saved to an ini file, then this file is also deleted.



6. Press the "OK" softkey to confirm the settings.

See also

Replacing program text (Page 162)

7.11 Display and edit user variables

The defined user data may be displayed in lists.

User variables

The following variables can be defined:

- Global arithmetic parameters (RG)
- Channel-specific arithmetic parameters (R parameters)
- Global user data (GUD) is valid in all programs
- Local user variables (LUD) are valid in the program where they have been defined.
- Program-global user variables (PUD) are valid in the program in which they have been defined, as well as in all of the subprograms called by this program

Channel-specific user data can be defined with a different value for each channel.

Entering and displaying parameter values

Up to 15 positions (including decimal places) are evaluated. If you enter a number with more than 15 places, it will be written in exponential notation (15 places + EXXX).

LUD or PUD

Only local or program-global user data can be displayed at one time.

Whether the user data are available as LUD or PUD depends on the current control configuration.



Machine manufacturer

Please observe the information provided by the machine manufacturer.

Note

Reading and writing variables protected

Reading and writing of user data are protected via a keyswitch and protection levels.

Comments

You have the option of entering a comment for global and channel-specific arithmetic parameters.

Searching for user data

You may search for user data within the lists using any character string.

Further information

Additional information on the user variables is provided in the Programming Manual NC Programming.

7.11.1 Global R parameters

Global R parameters are arithmetic parameters, which exist in the control itself, and can be read or written to by all channels.

You use global R parameters to exchange information between channels, or if global settings are to be evaluated for all channels.

These values are retained after the controller is switched off.

Comments

You can save comments in the "Global R parameters with comments" window.

These comments can be edited. You have the option of either individually deleting these comments, or using the delete function.

These comments are retained after the control is switched off.

Number of global R parameters

The number of global R parameters is defined in a machine data element.

Range: RG[0]– RG[999] (dependent on the machine data).

There are no gaps in the numbering within the range.



Machine manufacturer

Please observe the information provided by the machine manufacturer.

Procedure



1. Select the "Parameter" operating area.



2. Press the "User variable" softkey.



3. Press the "Global R parameters" softkey.
The "Global R parameters" window opens.

Display comments



1. Press the ">>" and "Display comments" softkeys.
The "Global R parameters with comments" window opens.



2. Press the "Display comments" softkey once again to return to the "Global R parameters" window.

Deleting R parameters and comments



1. Press the ">>" and "Delete" softkeys.
The "Delete global R parameters" window opens.



2. In fields "from global R parameters" and "to global R parameters", select the global R parameters whose values you wish to delete.

- OR -



Press the "Delete all" softkey.

3. Activate the checkbox "also delete comments" if the associated comments should also be automatically deleted.



4. Press the "OK" softkey.

- A value of 0 is assigned to the selected global R parameters – or to all global R parameters.
- The selected comments are also deleted.

7.11.2 R parameters

R parameters (arithmetic parameters) are channel-specific variables that you can use within a G code program. G code programs can read and write R parameters.

These values are retained after the controller is switched off.

Comments

You can save comments in the "R parameters with comments" window.

These comments can be edited. You have the option of either individually deleting these comments, or using the delete function.

These comments are retained after the control is switched off.

Number of channel-specific R parameters

The number of channel-specific R parameters is defined in a machine data element.

Range: R0-R999 (dependent on machine data).

There are no gaps in the numbering within the range.



Machine manufacturer

Please observe the information provided by the machine manufacturer.

Procedure

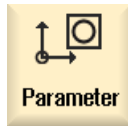

1. Select the "Parameter" operating area.



2. Press the "User variable" softkey.



3. Press the "R variables" softkey.
The "R parameters" window appears.

Display comments



1. Press the ">>" and "Display comments" softkeys.
The "R parameters with comments" window opens.



2. Press the "Display comments" softkey once again to return to the "R parameters" window.

Delete R variables



1. Press the ">>" and "Delete" softkeys.
The "Delete R parameters" window appears.



2. In fields "from R parameters" and "to R parameters", select the R parameters whose values you wish to delete.

- OR -



Press the "Delete all" softkey.

3. Activate the checkbox "also delete comments" if the associated comments should also be automatically deleted.



4. Press the "OK" softkey.

- A value of 0 is assigned to the selected R parameters or to all R parameters.
- The selected comments are also deleted.

7.11.3 Displaying global user data (GUD)

Global user variables

Global GUDs are NC global user data (Global User Data) that remains available after switching the machine off.

GUDs apply in all programs.

Definition

A GUD variable is defined with the following:

- Keyword DEF
- Range of validity NCK
- Data type (INT, REAL,)
- Variable names
- Value assignment (optional)

Example

DEF NCK INT ZAEHLER1 = 10

GUDs are defined in files with the ending DEF. The following file names are reserved for this purpose:

File name	Meaning
MGUD.DEF	Definitions for global machine manufacturer data
UGUD.DEF	Definitions for global user data
GUD4.DEF	User-definable data
GUD8.DEF, GUD9.DEF	User-definable data

Procedure

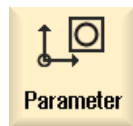

1. Select the "Parameter" operating area.



2. Press the "User variable" softkey.



3. Press the "Global GUD" softkeys.

The "Global User Variables" window is displayed. A list of the defined UGUD variables will be displayed.

- OR -



Press the "GUD selection" softkey and the "SGUD" to "GUD6" softkeys if you wish to display SGUD, MGUD, UGUD as well as GUD4 to GUD 6 of the global user variables.





- OR -

Press the "GUD selection" and ">>" softkeys as well as the "GUD7" to "GUD9" softkeys if you want to display GUD 7 to GUD 9 of the global user variables.

Note

After each start-up, a list with the defined UGUD variables is displayed in the "Global User Variables" window.

7.11.4 Displaying channel GUDs

Channel-specific user variables

Like the GUDs, channel-specific user variables are applicable in all programs for each channel. However, unlike GUDs, they have specific values.

Definition

A channel-specific GUD variable is defined with the following:

- Keyword DEF
- Range of validity CHAN
- Data type
- Variable names
- Value assignment (optional)

Example

```
DEF CHAN REAL X_POS = 100.5
```

Procedure



1. Select the "Parameter" operating area.



2. Press the "User variable" softkey.



3. Press the "Channel GUD" and "GUD selection" softkeys.



A new vertical softkey bar appears.
4. Press the "SGUD" ... "GUD6" softkeys if you want to display the SGUD, MGUD, UGUD as well as GUD4 to GUD 6 of the channel-specific user variables.



- OR -



Press the "Continue" softkey and the "GUD7" ... "GUD9" softkeys if you want to display GUD 7 and GUD 9 of the channel-specific user variables.



7.11.5 Displaying local user data (LUD)

Local user variables

LUDs are only valid in the program or subprogram in which they were defined.

The controller displays the LUDs after the start of program processing. The display is available until the end of program processing.

Definition

A local user variable is defined with the following:

- Keyword DEF
- Data type
- Variable names
- Value assignment (optional)

Procedure

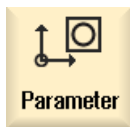

1. Select the "Parameter" operating area.



2. Press the "User variable" softkey.



3. Press the "Local LUD" softkey.

7.11.6 Displaying program user data (PUD)

Program-global user variables

PUDs are global part program variables (**Program User Data**). PUDs are valid in all main programs and subprograms, where they can also be written and read.



Machine manufacturer

Please refer to the machine manufacturer's specifications.

Procedure

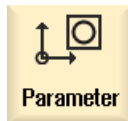

Parameter



User variable



Program PUD

1. Select the "Parameter" operating area.
2. Press the "User variable" softkey.
3. Press the "Program PUD" softkey.

7.11.7 Searching for user variables

You can search for R parameters and user variables.

Procedure

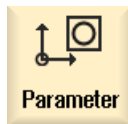

Parameter



User variable



R variables



Local LUD



Search

1. Select the "Parameter" operating area.
2. Press the "User variable" softkey.
3. Press the "R parameters", "Global GUD", "Channel GUD", "Local GUD" or "Program PUD" softkeys to select the list in which you would like to search for user variables.
4. Press the "Search" softkey.
The "Search for R Parameters" or "Search for User Variables" window opens.



5. Enter the desired search term and press "OK".

The cursor is automatically positioned on the R parameters or user variables you are searching for, if they exist.

By editing a DEF/MAC file, you can alter or delete existing definition/macro files or add new ones.

Procedure

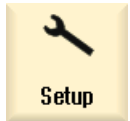

1. Select the "Start-up" operating area.



2. Press the "System data" softkey.

3. In the data tree, select the "NC data" folder and then open the "Definitions" folder.

4. Select the file you want to edit.

5. Double-click the file.

- OR -

Press the "Open" softkey.



- OR -

Press the <INPUT> key.



- OR -

Press the <Cursor right> key.

The selected file is opened in the editor and can be edited there.



6. Define the desired user variable.

7. Press the "Exit" softkey to close the editor.



Activating user variables



1. Press the "Activate" softkey.

A prompt is displayed.

2. Select whether the current values in the definition files should be retained

- OR -

Select whether the current values in the definition files should be deleted.

This will overwrite the definition files with the initial values.



3. Press the "OK" softkey to continue the process.

7.12 Display G and auxiliary functions

7.12.1 Selected G functions

16 selected G groups are displayed in the "G Function" window.

Within a G group, the G function currently active in the controller is displayed.

Some G codes (e.g. G17, G18, G19) are immediately active after switching the machine control on.

Which G codes are always active depends on the settings.



Machine manufacturer

Please observe the information provided by the machine manufacturer.

G groups displayed by default

Group	Meaning
G group 1	Modally active motion commands (e.g. G0, G1, G2, G3)
G group 2	Non-modally active motion commands, dwell time (e.g. G4, G74, G75)
G group 3	Programmable offsets, working area limitations and pole programming (e.g. TRANS, ROT, G25, G110)
G group 6	Plane selection (e.g. G17, G18)
G group 7	Tool radius compensation (e.g. G40, G42)
G group 8	Settable work offset (e.g. G54, G57, G500)
G group 9	Offset suppression (e.g. SUPA, G53)
G group 10	Exact stop - continuous-path mode (e.g. G60, G641)
G group 13	Workpiece dimensions, inch/metric (e.g. G70, G700)
G group 14	Workpiece dimensioning absolute/incremental (G90)
G group 15	Feed type (e.g. G93, G961, G972)
G group 16	Feedrate override at inside and outside curvature (e.g. CFC)
G group 21	Acceleration profile (e.g. SOFT, DRIVE)
G group 22	Tool offset types (e.g. CUT2D, CUT2DF)
G group 29	Radius/diameter programming (e.g. DIAMOF, DIAMCYCOF)
G group 30	Compressor on/off (e.g. COMPOF)

G groups displayed by default (ISO code)

Group	Meaning
G group 1	Modally active motion commands (e.g. G0, G1, G2, G3)
G group 2	Non-modally active motion commands, dwell time (e.g. G4, G74, G75)
G group 3	Programmable offsets, working area limitations and pole programming (e.g. TRANS, ROT, G25, G110)
G group 6	Plane selection (e.g. G17, G18)

Group	Meaning
G group 7	Tool radius compensation (e.g. G40, G42)
G group 8	Settable work offset (e.g. G54, G57, G500)
G group 9	Offset suppression (e.g. SUPA, G53)
G group 10	Exact stop - continuous-path mode (e.g. G60, G641)
G group 13	Workpiece dimensions, inch/metric (e.g. G70, G700)
G group 14	Workpiece dimensioning absolute/incremental (G90)
G group 15	Feed type (e.g. G93, G961, G972)
G group 16	Feedrate override at inside and outside curvature (e.g. CFC)
G group 21	Acceleration profile (e.g. SOFT, DRIVE)
G group 22	Tool offset types (e.g. CUT2D, CUT2DF)
G group 29	Radius/diameter programming (e.g. DIAMOF, DIAMCYCOF)
G group 30	Compressor on/off (e.g. COMPOF)

Procedure



1. Select the "Machine" operating area.



2. Press the <JOG>, <MDI> or <AUTO> key.

...



3. Press the "G functions" softkey.
The "G Functions" window is opened.



4. Press the "G functions" softkey again to hide the window.

The G groups selection displayed in the "G Functions" window may differ.



Machine manufacturer

Please observe the information provided by the machine manufacturer.

Further information

Additional information on configuring the displayed G groups is provided in the SINUMERIK Operate Commissioning Manual.

7.12.2 All G functions

All G groups and their group numbers are listed in the "G Functions" window.

Within a G group, only the G function currently active in the controller is displayed.

Additional information in the footer

The following additional information is displayed in the footer:

- Actual transformations

Display	Meaning
TRANSMIT	Polar transformation active
TRACYL	Cylinder surface transformation active
TRAORI	Orientation transformation active
TRAANG	Inclined axis transformation active
TRACON	Cascaded transformation active For TRACON, two transformations (TRAANG and TRACYL or TRAANG and TRANSMIT) are activated in succession.

- Current work offsets
- Spindle speed
- Path feedrate
- Active tool

7.12.3 G functions for mold making

In the window "G functions", important information for machining free-form surfaces can be displayed using the "High Speed Settings" function (CYCLE832).



Software option

You require the "Advanced Surface" software option in order to use this function.

High-speed cutting information

In addition to the information that is provided in the "All G functions" window, the following programmed values of the following specific information is also displayed:

- CTOL
- OTOL
- CTOLG0
- OTOLG0

The tolerances for G0 are only displayed if they are active.

Particularly important G groups are highlighted.

You have the option to configure which G functions are highlighted.

Further information

Additional information on the contour / orientation tolerance is provided in the Basic Functions Function Manual.

Procedure

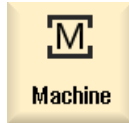

1. Select the "Machine" operating area



2. Press the <JOG>, <MDI> or <AUTO> key.



3. Press the ">>" and "All G functions" softkeys.
The "G Functions" window is opened.



7.12.4 Auxiliary functions

Auxiliary functions include M and H functions preprogrammed by the machine manufacturer, which transfer parameters to the PLC to trigger reactions defined by the manufacturer.

Displayed auxiliary functions

Up to five current M functions and three H functions are displayed in the "Auxiliary Functions" window.

Procedure



1. Select the "Machine" operating area.



2. Press the <JOG>, <MDA> or <AUTO> key.

...





3. Press the "H functions" softkey.
The "Auxiliary Functions" window opens.



4. Press the "H functions" softkey again to hide the window again.

7.13 Displaying superimpositions

You can display handwheel axis offsets or programmed superimposed movements in the "Superimpositions" window.

Input field	Meaning
Tool	Current superimposition in the tool direction
Min	Minimum value for superimposition in the tool direction
Max	Maximum value for superimposition in the tool direction
DRF	Displays the handwheel axis offset

The selection of values displayed in the "Superimposition" window may differ.



Machine manufacturer

Please observe the information provided by the machine manufacturer.

Procedure



1. Select the "Machine" operating area.



2. Press the <AUTO>, <MDI> or <JOG> key.

...



3. Press the ">>" and "Superimposition" softkeys.
The "Superimposition" window opens.



4. Enter the required new minimum and maximum values for superimposition and press the <INPUT> key to confirm your entries.

Note:

You can only change the superimposition values in "JOG" mode.



5. Press the "Superimposition" softkey again to hide the window.

7.14 Displaying status of synchronized actions

You can display status information for diagnosing synchronized actions in the "Synchronized Actions" window.

You get a list with all currently active synchronized actions.

In this list, the synchronized action programming is displayed in the same form as in the part program.

Synchronized actions

Status of synchronized actions

You can see the status of the synchronized actions in the "Status" column.

- Waiting
- Active
- Blocked

Non-modal synchronized actions can only be identified by their status display. They are only displayed during execution.

Synchronization types

Synchronization types	Meaning
ID=n	Modal synchronized actions in the automatic mode up to the end of program, local to program; n = 1... 254
IDS=n	Static synchronized actions, modally effective in every operating type, also beyond the end of program; n = 1... 254
Without ID/IDS	Non-modal synchronized actions in the automatic mode

Note

Numbers from the number range 1 to 254 can only be assigned once, irrespective of the identification number.

Display of synchronized actions

Using softkeys, you have the option of restricting the display to activated synchronized actions.

Further information: Synchronized Actions Function Manual

Procedure



1. Select the "Machine" operating area.



2. Press the <AUTO>, <MDA> or <JOG> key.



3. Press the menu forward key and the "Synchron." softkey. The "Synchronized Actions" window appears.



You obtain a display of all activated synchronized actions.



4. Press the "ID" softkey if you wish to hide the modal synchronized actions in the automatic mode.

- AND / OR -



Press the "IDS" softkey if you wish to hide static synchronized actions.

- AND / OR -



Press the "Blockwise" softkey if you wish to hide the non-modal synchronized actions in the automatic mode.



5. Press the "ID", "IDS" or "Blockwise" softkeys to re-display the corresponding synchronized actions.

...



7.15 Displaying the program runtime and counting workpieces

To gain an overview of the program runtime and the number of machined workpieces, open the "Times, Counter" window.



Machine manufacturer

Please observe the information provided by the machine manufacturer.

Displayed times

- **Program**
Pressing the softkey the first time shows how long the program has already been running. At every further start of the program, the time required to run the entire program the first time is displayed.
If the program or the feedrate is changed, the new program runtime is corrected after the first run.
- **Program remainder**
Here you can see how long the current program still has to run. In addition, you can follow how much of the current program has been completed in percent on a progress bar. The first program execution differs in the calculation of the additional program executions. When a program is executed for the first time, the progress is estimated based on the program size and the actual program offset. The larger the program and the more linear that it is executed, the more precise the first estimate. This estimate is very inaccurate as a result of the system for programs with steps and/or subprograms.
For each additional program execution, the measured overall program execution time is used as basis for the program progress display.
- **Influencing the time measurement**
The time measurement is started with the start of the program and ends with the end of the program (M30) or with an agreed M function.
When the program is running, the time measurement is interrupted with CYCLE STOP and continued with CYCLE START.
The time measurement starts at the beginning with RESET and subsequent CYCLE START.
The time measurement stops with CYCLE STOP or a feedrate override = 0.

Counting workpieces

You can also display program repetitions and the number of completed workpieces. For the workpiece count, enter the actual and planned workpiece numbers.

Workpiece count

Completed workpieces can be counted via the end of program command (M30) or an M command.

Procedure



1. Select the "Machine" operating area.



2. Press the <AUTO> key.



3. Press the "Times, Counter" softkey.
The "Times, Counter" window opens.



4. Select "Yes" under "Count workpieces" if you want to count completed workpieces.
5. Enter the number of workpieces needed in the "Desired workpieces" field.
The number of workpieces already finished is displayed in "Actual workpieces". You can correct this value when required.
After the defined number of workpieces is reached, the current workpieces display is automatically reset to zero.

7.16 Settings for the automatic mode

Before machining a workpiece, you can test the program in order to identify programming errors at an early stage. Use the dry run feedrate for this purpose.

You have the option of additionally limiting the traversing speed so that when running-in a new program with rapid traverse, no undesirably high traversing speeds occur.

Dry run feedrate

If you selected "DRY run feedrate" under program control, then the value entered in "Dry run feedrate DRY" replaces the programmed feedrate when executing/machining.

Reduced rapid traverse

If you selected "RGO reduced rapid traverse" under program control, then rapid traverse is reduced to the percentage value entered in "reduced rapid traverse RGO".

Displaying measurement results

Using an MMC command, measurement results can be displayed in a part program.

The following settings are possible:

- When it reaches the command, the control automatically jumps to the "Machine" operating area and the window with the measurement results is displayed
- The window with the measurement results is opened by pressing the "Measurement result" softkey

Recording machining times

To provide support when creating and optimizing a program, you have the option of displaying the machining times.

You define whether the time is determined while the workpiece is being machined (i.e. if the function is energized).

- Off
Machining times are not determined when machining a workpiece. No machining times are determined.
- Non-modal
The machining times are determined for each traversing block of a main program.
Note: You also have the option of displaying the cumulative times for blocks.
Please observe the information provided by the machine manufacturer.
- Block-by-block
Machining times are determined for all blocks.

Note

Utilization of resources

The more machining times are displayed, the more resources are utilized.

More machining times are determined and saved with the non-modal setting than with the block-by-block setting.

Note

Please observe the information provided by the machine manufacturer.

Save machining times

You define how the machining times determined are processed.

- Yes
A subdirectory with the name "GEN_DATA.WPD" is created in the directory of the part program. The machining times determined are saved in an ini file in the subdirectory, together with the name of the program.
- No
The machining times that have been determined are only displayed in the program block display.

Record tools

You define whether the tool data is recorded.

- Yes
Recording takes place during processing. The data is stored in a TTD file (Tool Time Data). The TTD file is located in the directory of the associated part program.
- No
The tool data is not recorded.

Procedure



1. Select the "Machine" operating area.



2. Press the <AUTO> key.



3. Press the menu forward key and the "Settings" softkey.
The "Settings for Automatic Operation" window opens.



4. In "DRY run feedrate," enter the desired dry run speed.
5. Enter the desired percentage in the "Reduced rapid traverse RGO" field.
RGO has no effect if you do not change the specified amount of 100 %.



6. Select the required entry in the "Display measurement result" field:

- "Automatic"
The measurement result window opens automatically.
- "manual"
The measurement result window is to be opened by pressing the "Measurement result" softkey.



7. Select the desired entry in the fields "Record machining time", "Save machining times" and "Record tools".

Further information

Additional information on the display of measurement result display is provided in the Measuring Cycles Programming Manual.

Note

You have the option of changing the feed velocity during operation.

See also

Current block display (Page 49)

7.17 Working with DXF files

7.17.1 Overview

The "DXF-Reader" function allows you to open files created in SINUMERIK Operate directly in a CAD system and accept and store contours directly in G-code.

The DXF file can be displayed in the Program Manager.



Software option

You require the "DXF-Reader" software option in order to use this function.



Machine manufacturer

Please observe the information provided by the machine manufacturer.

The DXF reader reads the following elements:

- "POINT"
- "LINE"
- "CIRCLE"
- "ARC"
- "TRACE"
- "SOLID"
- "TEXT"
- "SHAPE"
- "BLOCK"
- "ENDBLK"
- "INSERT"
- "ATTDEF"
- "ATTRIB"
- "POLYLINE"
- "VERTEX"
- "SEQEND"
- "3DLINE"
- "3DFACE"
- "DIMENSION"
- "LWPOLYLINE"
- "ELLIPSE"
- "LTYPE"

- "LAYER"
- "STYLE"
- "VIEW"
- "UCS"
- "VPORT"
- "APPID"
- "DIMSTYLE"
- "HEADER (\$INSUNITS, \$MEASUREMENT)"
- "TABLES"
- "BLOCKS"
- "ENTITIES"

7.17.2 Displaying CAD drawings

7.17.2.1 Open a DXF file

Procedure



1. Select the "Program Manager" operating area.



2. Choose the desired storage location and position the cursor on the DXF file that you want to display.

3. Press the "Open" softkey.

The selected CAD drawing will be displayed with all its layers, i.e. with all graphic levels.



4. Press the "Close" softkey to close the CAD drawing and to return to the Program Manager.

7.17.2.2 Cleaning a DXF file

All contained layers are shown when a DXF file is opened.

Layers that do not contain any contour- or position-relevant data can be shown or hidden.

Requirement

The DXF file is open in the Program Manager or in the editor.

Procedure



1. Press the "Clean" and "Layer selection" softkeys if you want to hide specific layers.
The "Layer Selection" window opens.

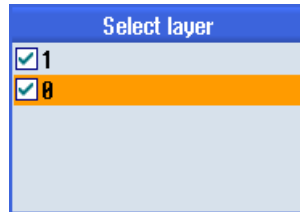

2. Deactivate the required layers and press the "OK" softkey.

- OR -



Press the "Clean automat." softkey to hide all non-relevant layers.



3. Press the "Clean automat." softkey to redisplay the layers.

7.17.2.3 Enlarging or reducing the CAD drawing

Requirement

The DXF file is opened in the Program Manager.

Procedure



1. Press the "Details" and "Zoom +" softkeys if you wish to enlarge the size of the segment.

- OR -



2. Press the "Details" and "Zoom -" softkeys if you wish to reduce the size of the segment.

- OR -



3. Press the "Details" and "Auto zoom" softkeys if you wish to automatically adapt the segment to the size of the window.



- OR -
4. Press the "Details" and "Zoom elem. selection" softkeys if you want to automatically zoom elements that are in a selection set.

7.17.2.4 Changing the section

If you want to move or change the size of a section of the drawing, for example, to view details or redisplay the complete drawing later, use the magnifying glass.
You can use the magnifying glass to determine the section and then change its size.

Requirement

The DXF file is opened in the Program Manager or in the editor.

Procedure



1. Press the "Details" and "Magnifying glass" softkeys.
A magnifying glass in the shape of a rectangular frame appears.
2. Press the <+> key to enlarge the frame.

- OR -
Press the <-> key to reduce the frame.

- OR -
Press a cursor key to move the frame up, down, left or right.
3. Press the "OK" softkey to accept the section.





7.17.2.5 Rotating the view

You can change the orientation of the drawing.

Requirement

The DXF file is open in the Program Manager or in the editor.

Procedure



-  1. Press the "Details" and "Rotate figure" softkeys.
- 
 2. Press the "Arrow right", "Arrow left", "Arrow up", "Arrow down", "Arrow clockwise" or "Arrow counter-clockwise" softkey to change the position of the drawing.
- ...
- 



7.17.2.6 Displaying/editing information for the geometric data

Precondition

The DXF file is opened in the Program Manager or in the editor.

Procedure

-  1. Press the "Details" and "Geometry info" softkeys.
The cursor takes the form of a question mark.
- 
 2. Position the cursor on the element for which you want to display its geometric data and press the "Element Info" softkey.

If, for example, you have selected a straight line, the following window opens "Straight line on layer: ...". You are shown the coordinates corresponding to the actual zero point in the selected layer: Start point for X and Y, end point for X and Y as well as the length.
-  4. If you are currently in the editor, press the "Element edit" softkey.
The coordinate values can be edited.
-  3. Press the "Back" softkey to close the display window.

Note

Editing a geometric element

You can use this function to make smaller changes to the geometry, e.g. for missing intersections.

You should make larger changes in the input screen of the editor.

You cannot undo any changes that you make with "Element Edit".

7.17.3 Importing and editing a DXF file

7.17.3.1 General procedure

- Creating/opening a G code program
- Call the "Contour" cycle and create a "New contour"
- Import the DXF file
- Select the contour in the DXF file or CAD drawing and click "OK" to accept the cycle
- Add program record with "Accept" to the G code program

7.17.3.2 Setting the tolerance

To allow even inaccurately created drawings to be used, i.e. to compensate for gaps in the geometry, you can enter a snap radius in millimeters. This relates elements.

Note

Large snap radius

The larger that the snap radius is set, the larger the number of available following elements.

Procedure

1. The DXF file is opened in the editor.
2. Press the "Details" and "Snap radius" softkeys.
The "Input" window appears.
3. Enter the desired value and press the "OK" softkey.



7.17.3.3 Assigning the machining plane

You can select the machining plane in which the contour created with the DXF reader should be located.

Procedure

1. The DXF file is opened in the editor.
2. Press the "Select plane" softkey.
The "Select Plane" window opens.
3. Select the desired plane and press the "OK" softkey.

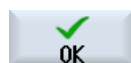

7.17.3.4 Selecting the machining range / deleting the range and element









You can select ranges in the DXF file and therefore reduce the elements. After accepting the 2nd position, only the contents of the selected rectangle are displayed. Contours are cut to the rectangle.

Requirement

The DXF file is open in the editor.

Procedure

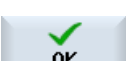
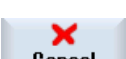

Select the machining range from the DXF file

- | | |
|---|---|
|  | 1. Press the "Reduce" and "Select range" softkeys if you want to select specific ranges of the DXF file.
An orange rectangle is displayed. |
|  | |
|  | 2. Press the "Range +" softkey to enlarge the section or press the "Range -" softkey to reduce the section. |
|  | |
|  | 3. Press the "Arrow right", "Arrow left", "Arrow up" or "Arrow down" softkey to move the selection tool. |
|  | |
|  | 4. Press the "OK" softkey.
The machining section is displayed. |
|  | Use the "Cancel" softkey to return to the previous window. |
|  | 5. Press the "Deselect range" softkey to undo the selection of the machining range.
The DXF file is reset to the original display. |

Delete selected ranges and elements of the DXF file

- | | |
|---|--------------------------------|
|  | 6. Press the "Reduce" softkey. |
|---|--------------------------------|

Delete range

- | | |
|---|---|
|  | 7. Press the "Range delete" softkey.
A blue rectangle is displayed. |
|  | 8. Press the "Range +" softkey to enlarge the section or press the "Range -" softkey to reduce the section. |
|  | |



9. Press the "Arrow right", "Arrow left", "Arrow up" or "Arrow down" softkey to move the selection tool.



- OR -

Delete element



10. Press the "Element delete" softkey, and using the selection tool, select the element that you wish to delete.

11. Press "OK".

7.17.3.5 Saving the DXF file

You can save DXF files that you have reduced and edited.

Requirement

The DXF file is open in the editor.

Procedure



1. Reduce file according to your requirements and/or select the working areas.



- OR -



2. Press the "Back" and ">>" softkeys.



3. Press the "Save DXF" softkey.



4. Enter the required name in the "Save DXF Data" window and press "OK". The "Save As" window opens.

5. Select the required storage location.



6. If required, press the "New directory" softkey, enter the required name in the "New Directory" window and press the "OK" softkey to create a directory.



7. Press the "OK" softkey.

7.17.3.6 Specifying a reference point

Because the zero point of the DXF file normally differs from the zero point of the CAD drawing, specify a reference point.

Procedure

1. The DXF file is opened in the editor.
2. Press the ">>" and "Specify reference point" softkeys.
3. Press the "Element start" softkey to place the zero point at the start of the selected element.

 - OR -
 Press the "Element center" softkey to place the zero point at the center of the selected element.

 - OR -
 Press the "Element end" softkey to place the zero point at the end of the selected element.

 - OR -
 Press the "Arc center" softkey to place the zero point at the center of an arc.

 - OR -
 Press the "Cursor" softkey to define the zero point at any cursor position.

 - OR -
 Press the "Free input" softkey to open the "Reference Point Input" window and enter the values for the positions (X, Y) there.

7.17.3.7 Accepting contours

1. The part program to be processed has been created and you are in the editor.
2. Press the "Contour" softkey.
3. Press the "New contour" softkey.

Select contour

The start and end point are specified for the contour line.

The start point and the direction are selected on a selected element. Beginning at the start point, the automatic contour line takes all subsequent elements of a contour. The contour line ends as

soon as there are no subsequent elements – or intersections with other elements of the contour occur.

Note

If a contour includes more elements than can be processed, you will be offered the option of transferring the contour to the program as pure G code.

This contour then can no longer be edited in the editor.



With the "Undo" softkey, you can undo your contour selection back to a specific point.

Procedure

Opening a DXF file



1. Enter the desired name in the "New Contour" window.



2. Press the "From DXF file" and "Accept" softkeys.

The "Open DXF File" window opens.



3. Select a storage location and place the cursor on the relevant DXF file.

You can, for example, use the search function to search directly for a DXF file in comprehensive folders and directories.



4. Press the "OK" softkey.

The CAD drawing opens and can be edited for contour selection. The cursor takes the form of a cross.

Specifying a reference point

5. If required, specify a zero point.

Contour line



6. Press the ">>" and "Automatic" softkeys if you want to accept the largest possible number of contour elements.

This makes it fast to accept contours that consist of many individual elements.



- OR -

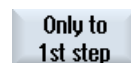

Press "Only to 1st cut" if you do not want to accept the complete contour elements at once.

The contour will be followed to the first cut of the contour element.







Defining the start point







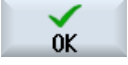

7. Press the "Select element" softkey to select the desired element.





8. Press the "Accept element" softkey.

- | | |
|---|--|
|  | 9. Press the "Element start point" softkey to place the contour start at the start point of the element.
- OR - |
|  | Press the "Element end point" softkey to place the contour start at the end point of the element.
- OR - |
|  | Press the "Element center" softkey to place the contour start at the center of the element.
- OR - |
|  | Press the "Cursor" softkey to define the start of the element with the cursor at any position. |
|  | 9. Press the "OK" softkey to confirm your selection. |
|  | 10. Press the "Accept element" softkey to accept the offered elements.
The softkey can be operated while elements are still available to be accepted. |

Specifying the end point

- | | |
|---|---|
|  | 11. Press the ">>" and "Specify end point" softkeys if you do not want to accept the end point of the selected element. |
|  | |
|  | 12. Press the "Current position" softkey if you want to set the currently selected position as end point.
- OR - |
|  | Press the "Element center" softkey to place the contour end at the center of the element.
- OR - |
|  | Press the "Element end" softkey to place the contour end at the end of the element.
- OR - |
|  | Press the "Cursor" softkey to define the start of the element with the cursor at any position. |

Transferring the contour to the cycle and to the program

- | | |
|---|---|
|  | Press the "OK" softkey.
The selected contour is transferred to the contour input screen of the editor. |
|  | Press the "Accept contour" softkey.
The program block is transferred to the program. |

Operation with mouse and keyboard

In addition to operation using softkeys, you can also operate the functions with the keyboard and with the mouse.

7.18 Mold making view

For large mold making programs such as those provided by CAD/CAM systems, you have the option to display the machining paths by using a fast view. This provides you with a fast overview of the program, and you have the possibility of correcting it.



Machine manufacturer

The mold making view has possibly been hidden.

Please observe the information provided by the machine manufacturer.

Checking the program

You can check the following:

- Does the programmed workpiece have the correct shape?
- Are there large traversing errors?
- Which program block hasn't been correctly programmed?
- How is the approach and retraction realized?

NC blocks that can be interpreted

The following NC blocks are supported for the mold making view:

- Types
 - Lines
G0, G1 with X Y Z
 - Circles
G2, G3 with center point I, J, K or radius CR, depending on the working plane G17, G18, G19, CIP with circular point I1, J1, K1 or radius CR
 - Absolute data AC and incremental data IC are possible
 - For G2, G3 and different radii at the start and end, an Archimedes spiral is used
- Orientation
 - Rotary axis programming with ORIAXES or ORIVECT using ABC for G0, G1, G2, G3, CIP, POLY
 - Orientation vector programming with ORIVECT using A3, B3, C3 for G0, G1, G2, G3, CIP
 - Rotary axes can be specified using DC
- G codes
 - Working planes (for circle definition G2, G3): G17 G18 G19
 - Incremental or absolute data: G90 G91

The following NC blocks are **not** supported for the mold making view:

- Helix programming
- Rational polynomials
- Other G codes or language commands

All NC blocks that cannot be interpreted are simply overread.

Simultaneous view of the program and mold making view

You have the option of displaying the mold making view next to the program blocks in the editor.

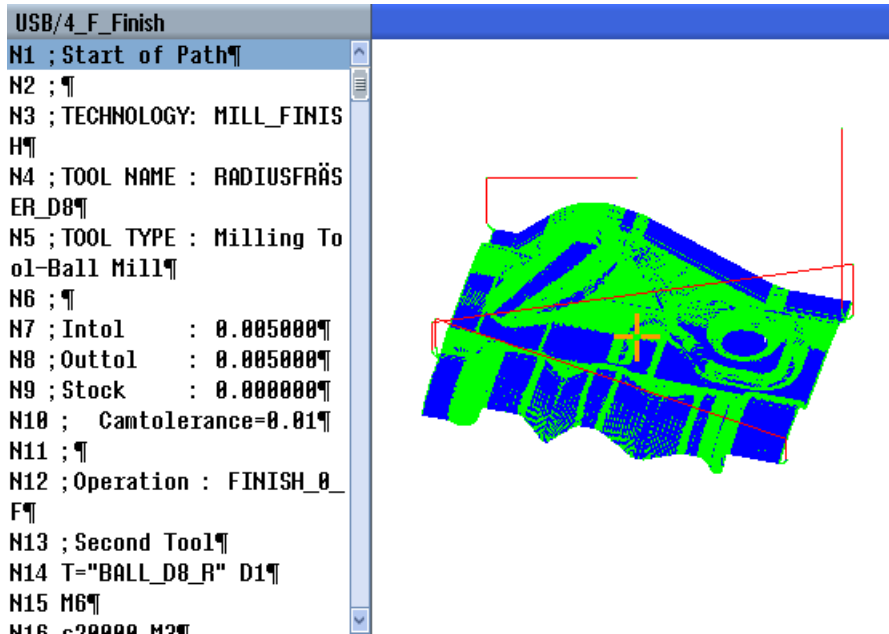

You can navigate back and forth between the NC blocks listed on the left and the associated points in the mold making view.

- On the left in the editor, if you place the cursor on an NC block with position data, then this NC block is marked in the graphic view.
- If you select a point on the right in the mold making view using the mouse, then conversely you mark the corresponding NC block on the left-hand side of the editor. This is how you jump directly to a position in the program in order to edit a program block for example.

Switch between the program window and the mold making view



Press the <NEXT WINDOW> key if you wish to toggle between the program window and the mold making view.

Changing and adapting the mold making view

Like simulation and simultaneous recording, you have the option of changing and adapting the mold making view in order to achieve the optimum view.

- Increasing or reducing the size of the graphic
- Moving the graphic
- Rotating the graphic
- Changing the section

7.18.1 Starting the mold making view

Procedure



1. Select the "Program manager" operating area.



2. Select the program that you would like to display in the mold making view.
3. Press the "Open" softkey.

The program is opened in the editor.



4. Press the ">>" and "Mold making view" softkeys.

The editor splits up into two areas.



The G code blocks are displayed in the left half of the editor.



The workpiece is displayed in the mold making view on the right-hand side of the editor. All of the points and paths programmed in the part program are represented.

7.18.2 Adapting the mold making view

You can adapt the graphic in various ways to better assess the workpiece in the mold making view.

Preconditions

- The required program is opened in the mold making view.
- The "Graphic" softkey is active.

Procedure



1. Press the softkey "Hide G1/G2/G3" if you want to conceal the machining paths.
- OR -



2. Press the softkey "Hide G0" if you want to deactivate the approach and retraction paths.
- OR -



Press softkey "Hide points" to conceal all the points in the graphic.

Note:

You have the option of simultaneously hiding G1/G2/G3 and G0 lines. In this case softkey "Hide points" is deactivated.

- OR -



Press the softkeys ">>" and "Vectors" to display all orientation vectors.



Note:

This softkey can only be operated if vectors are programmed.

- OR -



Press the softkeys ">>" and "Surface" to calculate the surface area of the workpiece.



- OR -



Press the softkeys ">>" and "Curvature".



The "Curvature" input window opens.



Enter the desired minimum and maximum value and press "OK" to confirm the entry and to highlight the curvature changes in color.

7.18.3 Specifically jump to the program block

If you notice anything peculiar in the graphic or identify an error, then from this location, you can directly jump to the program block involved where you can edit the program.

Requirements

- The required program is opened in the mold making view.
- The "Graphic" softkey is active.

Procedure

1. Press the ">>" and "Select point" softkeys.
Cross-hairs for selecting a point are shown in the diagram.

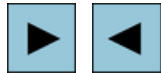

2. Using the cursor keys, move the cross-hairs to the desired position in the graphic.



3. Press the "Select NC block" softkey.
The cursor jumps to the associated program block in the editor.

7.18.4 Searching for program blocks

Using the "Search" function, you can go specifically to program blocks where you can edit programs. You can find and replace text in one step.

Precondition

- The required program is opened in the mold making view.
- The "NC blocks" softkey is active.

Procedure

1. Press the "Search" softkey.
A new vertical softkey bar appears.

7.18.5 Changing the view**7.18.5.1 Enlarging or reducing the graphical representation****Precondition**

- The mold making view has been started.
- The "Graphic" softkey is active.

Procedure



...



1. Press the <+> and <-> keys if you wish to enlarge or reduce the graphic display.
The graphic display enlarged or reduced from the center.

- OR -



Press the "Details" and "Zoom +" softkeys if you wish to increase the size of the segment.



- OR -



Press the "Details" and "Zoom -" softkeys if you wish to decrease the size of the segment.



- OR -



Press the "Details" and "Auto zoom" softkeys if you wish to automatically adapt the segment to the size of the window.



The automatic scaling function "Fit to size" takes account of the largest expansion of the workpiece in the individual axes.

Note

Selected section

The selected sections and size changes are kept as long as the program is selected.

7.18.5.2 Moving and rotating the graphic

Precondition

- The mold making view has been started.
- The "Graphic" softkey is active.

Procedure

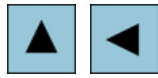

1. Press one of the cursor keys to move the mold making view up, down, left or right.

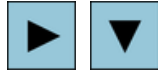

- OR -



With the <SHIFT> key pressed, rotate the mold building view in the required direction using the cursor keys.

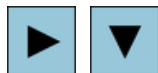

Note

Working with a mouse

Using the mouse, you have the option of rotating and shifting the mold making view.

- To do this, move the graphic with the left-hand mouse key pressed in order to reposition the mold making view.
 - To do this, move the graphic with the right-hand mouse key pressed in order to rotate the mold making view.
-

7.18.5.3 Modifying the viewport

If you want to look at the details, you can shift and change the size of the mold building view section using a magnifying glass.

Using the magnifying glass, you can define your own segment and then increase or decrease its size.

Precondition

- The mold making view has been started.
- The "Graphic" softkey is active.

Procedure



1. Press the "Details" softkey.



2. Press the "Zoom" softkey.
A magnifying glass in the shape of a rectangular frame appears.



3. Press the "Magnify +" or <+> softkey to enlarge the frame.

- OR -



Press the "Magnify -" or <-> softkey to reduce the frame.

- OR -



Press one of the cursor keys to move the frame up, down, left or right.



4. Press the "Accept" softkey to accept the section.

Simulating machining

8.1 Overview

During simulation, the current program is calculated in its entirety and the result displayed in graphic form. The result of programming is verified without traversing the machine axes. Incorrectly programmed machining steps are detected at an early stage and incorrect machining on the workpiece prevented.

Graphic display

The simulation represented on the screen uses the correct workpiece and tool proportions.

For simulation at milling machines, the workpiece is located, fixed in space. Only the tool moves, independent of the machine type.

Definition of a blank

The blank dimensions that are entered in the program editor are used for the workpiece.

The blank is clamped with reference to the coordinate system, which is valid at the time that the blank was defined. This means that before defining the blank in G code programs, the required output conditions must be established, e.g. by selecting a suitable zero offset.

Programming a blank (example)

```
G54 G17 G90
CYCLE800(0,"TABLE", 100000,57,0,0,0,0,0,0,0,0,0,-1,100,1)
WORKPIECE(,,,"Box",112,0,-50,-80,00,155,100)
T="NC-SPOTDRILL_D16
```

Note

Blank offset for a changed work offset

The blank is always created in the work offset which is presently active.

If you select another work offset, then the coordinate system is converted, however, the display of the blank is not changed.

Note

Blank clamping

If your machine has various blank clamping options, enter the required clamping in the program header or in the blank screen.

Note also the machine manufacturer's instructions in this regard.

Display of the traversing paths

The traversing paths are displayed in color. Rapid traverse is red and the feedrate is green.

Depth display

The depth infeed is color-coded. The depth display shows the depth level at which machining is currently. "The deeper, the darker" applies for the depth display.

Machine references

The simulation is implemented as workpiece simulation. This means that it is not assumed that the zero offset has already been precisely scratched or is known.

In spite of this, unavoidable machine references are in the programming, such as for example, the tool change point in the machine, the retraction position when swiveling and the table components of a swivel kinematic. Depending on the current work offset - in the worst case - these machine references can mean that collisions are shown in the simulation that would not occur for a realistic work offset - or vice versa, collisions are not shown, which could occur for a realistic work offset.

Programmable frames

All frames and work offsets are taken into account in the simulation.

Note

Manually swiveled axes

Note that swivel movement in simulation and during simultaneous recording is also displayed when the axes are swiveled manually at the start.

Simulation display

You can choose one of the following types of display:

- **Material removal simulation**
During simulation or simultaneous recording you can follow stock removal from the defined blank.
- **Path display**
You have the option of including the display of the path. The programmed tool path is displayed.

Note

Tool display in the simulation and for simultaneous recording

In order that workpiece simulation is also possible for tools that have either not been measured or have been incompletely entered, certain assumptions are made regarding the tool geometry.

For instance, the length of a miller or drill is set to a value proportional to the tool radius so that cutting can be simulated.

Note**Thread turns not displayed**

For thread and drill thread milling, the thread turns are not displayed in the simulation and for simultaneous recording.

Display variants

You can choose between three variants of graphical display:

- Simulation before machining of the workpiece
Before machining the workpiece on the machine, you can perform a quick run-through in order to graphically display how the program will be executed.
- Simultaneous recording before machining of the workpiece
Before machining the workpiece on the machine, you can graphically display how the program will be executed during the program test and dry run feedrate. The machine axes do not move if you have selected "no axis motion".
- Simultaneous recording during machining of the workpiece
You can follow machining of the workpiece on the screen while the program is being executed on the machine.

Views

The following views are available for all three variants:

- Top view
- 3D view
- Side views

Status display

The current axis coordinates, the override, the current tool with cutting edge, the current program block, the feedrate and the machining time are displayed.

In all views, a clock is displayed during graphical processing. The machining time is displayed in hours, minutes and seconds. It is approximately equal to the time that the program requires for processing including the tool change.

**Software options**

You require the "3D simulation of the finished part" option for the 3D view.

You require the "Simultaneous recording (real-time simulation)" option for the "Simultaneous recording" function.

Determining the program runtime

The program runtime is determined when executing the simulation. The program runtime is temporarily displayed in the editor at the end of the program.

Properties of simultaneous recording and simulation

Traversing paths

For the simulation, the displayed traversing paths are saved in a ring buffer. If this buffer is full, then the oldest traversing path is deleted with each new traversing path.

Optimum display

If simultaneous machining is stopped or has been completed, then the display is again converted into a high-resolution image. In some cases this is not possible. In this case, the following message is output: "High-resolution image cannot be generated".

Working zone limitation

No working zone limits and software limit switches are effective in the tool simulation.

Start position for simulation and simultaneous recording

During simulation, the start position is converted via the work offset to the workpiece coordinate system.

The simultaneous recording starts at the position at which the machine is currently located.

Restrictions

- TRAORI: 5-axis motion is linearly interpolated. More complex motion cannot be displayed.
- Referencing: G74 from a program run does not function.
- Alarm 15110 "REORG block not possible" is not displayed.
- Compile cycles are only partly supported.
- No PLC support.
- Axis containers are not supported.

Supplementary conditions

- All of the existing data records (tool carrier / TRAORI, TRACYL) are evaluated and must be correctly commissioned for correct simulation.
- The machine kinematics for TRAF00F are not taken into consideration.
- Transformations with swiveled linear axis (TRAORI 64 - 69) as well as OEM transformations (TRAORI 4096 - 4098) are not supported.
- Changes to the tool carrier or transformation data only become effective after Power On.
- Transformation change and swivel data record change are supported. However, a real kinematic change is not supported, where a swivel head is physically changed.
- The simulation of mold making programs with extremely short block change times can take longer than machining, as the computation time distribution for this application is dimensioned in favor of the machining and to the detriment of simulation.

Examples

Several examples for machine types that are supported:

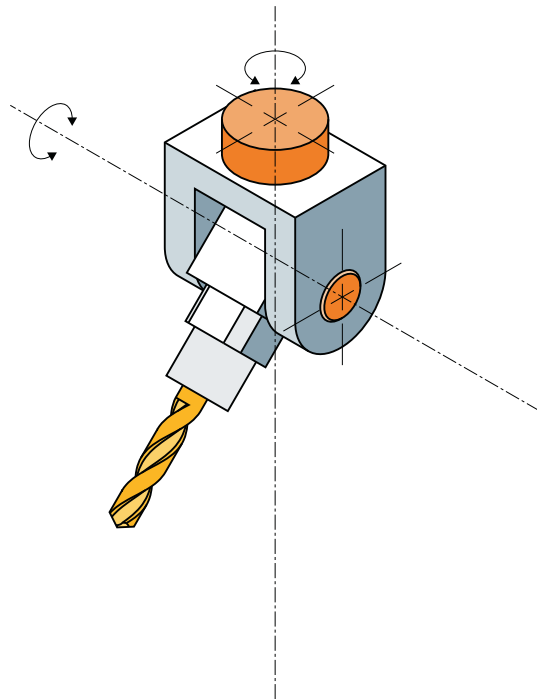

Swivel head 90°/90°

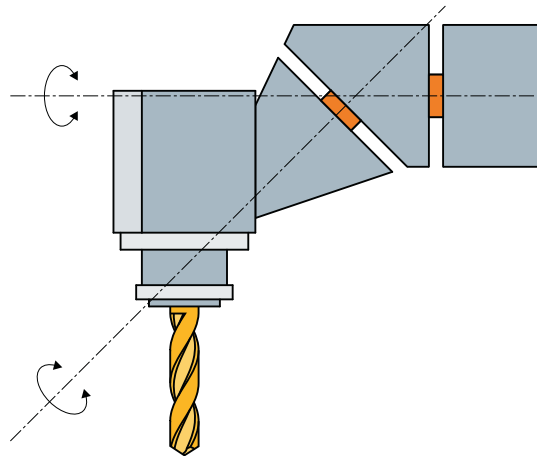

Swivel head 90°/45°

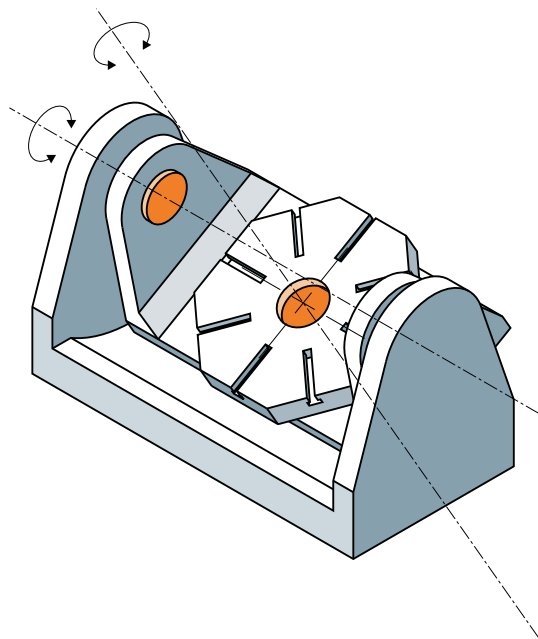

Swivel table 90°/90°

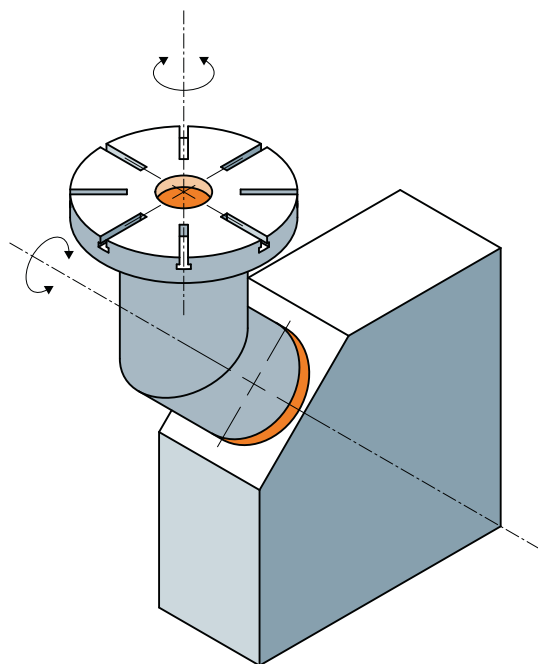

Swivel table 90°/45°

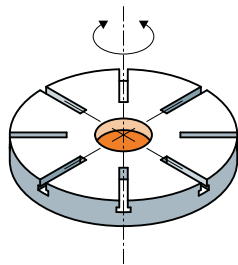
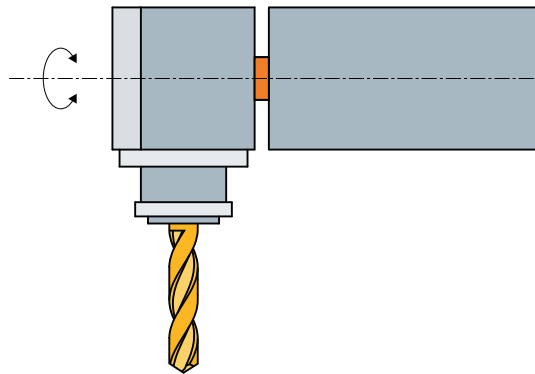

Swivel combination 90°/90°

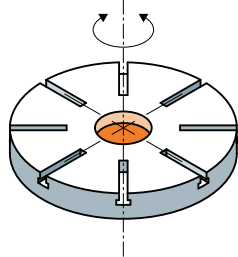
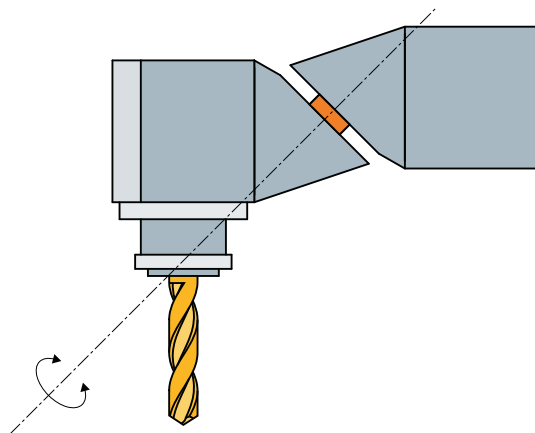

Swivel combination 45°/90°

8.2 Simulation prior to machining of the workpiece

Before machining the workpiece on the machine, you have the option of performing a quick run-through in order to graphically display how the program will be executed. This provides a simple way of checking the result of the programming.

Feedrate override

The rotary switch (override) on the control panel only influences the functions of the "Machine" operating area.

Press the "Program control" softkey to change the simulation feedrate. You can select the simulation feedrate in the range of 0 - 120%.

See also

Changing the feedrate (Page 228)

Simulating the program block by block (Page 229)

Procedure



1. Select the "Program Manager" operating area.



2. Select the storage location and position the cursor on the program to be simulated.

3. Press the <INPUT> or <Cursor right> key.



- OR -

Double-click the program.

The selected program is opened in the "Program" operating area.



4. Press the "Simulation" softkey.

The program execution is displayed graphically on the screen. The machine axes do not move.



5. Press the "Stop" softkey if you wish to stop the simulation.



- OR -

Press the "Reset" softkey to cancel the simulation.



6. Press the "Start" softkey to restart or continue the simulation.



Note

Operating area switchover

The simulation is exited if you switch into another operating area. If you restart the simulation, then this starts again at the beginning of the program.

8.3 Simultaneous recording prior to machining of the workpiece

Before machining the workpiece on the machine, you can graphically display the execution of the program on the screen to monitor the result of programming.



Software option

You require the option "Simultaneous recording (real-time simulation)" for simultaneous recording.

You can replace the programmed feedrate with a dry run feedrate to influence the speed of execution and select the program test to disable axis motion.

If you would like to view the current program blocks again instead of the graphical display, you can switch to the program view.

Procedure



1. Load a program in the "AUTO" mode.



2. Press the "Prog. ctrl." softkey and activate the checkboxes "PRT no axis movement" and "DRY run feedrate".

The program is executed without axis movement. The programmed feedrate is replaced by a dry run feedrate.



3. Press the "Sim. rec." softkey.

4. Press the <CYCLE START> key.

The program execution is displayed graphically on the screen.



5. Press the "Sim. rec." softkey again to stop the recording.

8.4 Simultaneous recording during machining of the workpiece

If the view of the work space is blocked by coolant, for example, while the workpiece is being machined, you can also track the program execution on the screen.



Software option

You require the option "Simultaneous recording (real-time simulation)" for simultaneous recording.

Procedure



1. Load a program in the "AUTO" mode.
2. Press the "Sim. rec." softkey.



3. Press the <CYCLE START> key.

The machining of the workpiece is started and graphically displayed on the screen.



4. Press the "Sim. rec." softkey again to stop the recording.

Note

- If you switch on simultaneous recording after the blank information has already been processed in the program, only traversing paths and tool are displayed.
 - If you switch off simultaneous recording during machining and then switch on the function again at a later time, the traversing paths generated in the meantime will not be displayed.
-

8.5 Different views of the workpiece

8.5.1 Overview

In the graphical display, you can choose between different views so that you constantly have the best view of the current workpiece machining, or in order to display details or the overall view of the finished workpiece.

The following views are available:

- Top view
- 3D view (with option)
- Side views
- Machine space (with "collision avoidance" option)

8.5.2 Plan view

Display as a top view



1. Simultaneous recording or the simulation is started.
2. Press the "Top view" softkey.
The workpiece is shown from above in the top view.

Changing the display

You can increase or decrease the size of the simulation graphic and move it, as well as change the segment.

See also

Enlarging or reducing the graphical representation (Page 230)

Panning a graphical representation (Page 231)

Modifying the viewport (Page 232)

8.5.3 3D view

Displaying the 3D view



1. Simultaneous recording or the simulation is started.
2. Press the "Other views" and "3D view" softkeys.



Software option

You require the option "3D simulation (finished part)" for the simulation.

Changing the display

You can increase or decrease the size of the simulation graphic, move it, turn it, or change the segment.

Displaying and moving cutting planes

You can display and move cutting planes X, Y, and Z.

See also

Enlarging or reducing the graphical representation (Page 230)

Panning a graphical representation (Page 231)

Rotating the graphical representation (Page 231)

Modifying the viewport (Page 232)

Defining cutting planes (Page 232)

8.5.4 Side view

Displaying further side views



1. Simultaneous recording or the simulation is started.
2. Press the "Other views" softkey.
3. Press the "From front" softkey if you wish to view the workpiece from the front.
- OR -
Press the "From rear" softkey if you wish to view the workpiece from the rear.



- OR -

Press the "From left" softkey if you wish to view the workpiece from the left.



- OR -

Press the "From right" softkey if you wish to view the workpiece from the right.

Changing the display

You can increase or decrease the size of the simulation graphic and move it, as well as change the segment.

8.6 Editing the simulation display

8.6.1 Blank display

You have the option of replacing the blank defined in the program or to define a blank for programs in which a blank definition cannot be inserted.

Note

The unmachined part can only be entered if simulation or simultaneous recording is in the reset state.

Procedure



1. The simulation or the simultaneous recording is started.
2. Press the ">>" and "Blank" softkeys.
The "Blank Input" windows opens and displays the pre-assigned values.



3. Enter the desired values for the dimensions.
4. Press the "Accept" softkey to confirm your entries. The newly defined workpiece is displayed.

8.6.2 Showing and hiding the tool path

The path display follows the programmed tool path of the selected program. The path is continuously updated as a function of the tool movement. The tool paths can be shown or hidden as required.

Procedure



1. The simulation or the simultaneous recording is started.
2. Press the ">>" softkey.
The tool paths are displayed in the active view.
3. Press the softkey to hide the tool paths.
The tool paths are still generated in the background and can be shown again by pressing the softkey again.
4. Press the "Delete tool path" softkey.
All of the tool paths recorded up until now are deleted.

8.7 Program control during simulation

8.7.1 Changing the feedrate

You have the capability of changing the feedrate at any time during the simulation.

You track the changes in the status bar.

Note

If you are working with the "Simultaneous recording" function, you use the rotary switch (override) on the control panel.

Procedure



1. Simulation is started.
2. Press the "Program control" softkey.



3. Press the "Override +" or "Override -" softkey to increase or decrease the feedrate by 5%, respectively.



- OR -



Press the "100% override" softkey to set the feedrate to 100%.

- OR -



Press the "<<" softkey to return to the main screen and perform the simulation with changed feedrate.

Toggling between "Override +" and "Override -"



Simultaneously press the <Ctrl> and <cursor down> or <cursor up> keys to toggle between the "Override +" and "Override -" softkeys.



Selecting the maximum feedrate





Press the <Ctrl> and <M> keys simultaneously to select the maximum feedrate of 120%.



8.7.2 Simulating the program block by block

You have the capability of controlling the program execution during the simulation, i.e. to execute a program, e.g. program block by program block.



Procedure

1. Simulation is started.
2. Press the "Program control" and "Single block" softkeys.





3. Press the "Back" and "Start SBL" softkeys. The pending program block is simulated and then stops.



4. Press "Start SBL" as many times as you want to simulate a single program block.

5. Press the "Program control" and the "Single block" softkeys to exist the single block mode.

Switching a single block on and off

- 

 Press the <CTRL> and <S> keys simultaneously to enable and disable the single block mode.

8.8 Modifying and adapting the simulation graphics

8.8.1 Enlarging or reducing the graphical representation

Precondition

The simulation or the simultaneous recording is started.

Procedure



1. Press the <+> and <-> keys if you wish to enlarge or reduce the graphic display.

The graphic display enlarged or reduced from the center.

...



- OR -



Press the "Details" and "Zoom +" softkeys if you wish to increase the size of the segment.



- OR -



Press the "Details" and "Zoom -" softkeys if you wish to decrease the size of the segment.



- OR -



Press the "Details" and "Auto zoom" softkeys if you wish to automatically adapt the segment to the size of the window.



The automatic scaling function "Fit to size" takes account of the largest expansion of the workpiece in the individual axes.

Note

Selected section

The selected sections and size changes are kept as long as the program is selected.

8.8.2 Panning a graphical representation

Precondition

The simulation or the simultaneous recording is started.

Procedure

1. Press a cursor key if you wish to move the graphic up, down, left, or right.

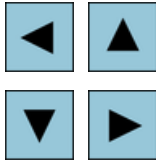

8.8.3 Rotating the graphical representation

In the 3D view you can rotate the position of the workpiece to view it from all sides.

Requirement

The simulation or simultaneous recording has been started and the 3D view is selected.

Procedure

1. Press the "Details" softkey.
2. Press the "Rotate view" softkey.
3. Press the "Arrow right", "Arrow left", "Arrow up", "Arrow down", "Arrow clockwise" and "Arrow counterclockwise" softkeys to change the position of the workpiece.



...



...



- OR -



Keep the <Shift> key pressed and then turn the workpiece in the desired direction using the appropriate cursor keys.

8.8.4 Modifying the viewport

If you would like to move, enlarge or decrease the size of the segment of the graphical display, e.g. to view details or display the complete workpiece, use the magnifying glass.

Using the magnifying glass, you can define your own section and then enlarge or reduce its size.

Precondition

The simulation or the simultaneous recording is started.

Procedure



1. Press the "Details" softkey.



2. Press the "Magnifying glass" softkey.

A magnifying glass in the shape of a rectangular frame appears.



3. Press the "Magnify +" or <-> softkey to enlarge the frame.



- OR -



Press the "Magnify -" or <-> softkey to reduce the frame.



- OR -



Press one of the cursor keys to move the frame up, down, left or right.

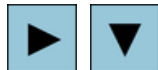

4. Press the "Accept" softkey to accept the selected section.

8.8.5 Defining cutting planes

In the 3D view, you have the option of "cutting" the workpiece and therefore displaying certain views in order to show hidden contours.

Precondition

The simulation or the simultaneous recording is started.

Procedure



1. Press the "Details" softkey.



2. Press the "Cut" softkey.



The workpiece is displayed in the cut state.

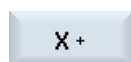

3. Press the corresponding softkey to shift the cutting plane in the required direction.

...

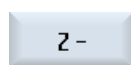

8.9 Displaying simulation alarms

Alarms might occur during simulation. If an alarm occurs during a simulation run, a window opens in the operating window to display it.

The alarm overview contains the following information:

- Date and time
- Deletion criterion
Specifies with which softkey the alarm is acknowledged
- Alarm number
- Alarm text

Precondition

Simulation is running and an alarm is active.

Procedure



1. Press the "Program control" and "Alarm" softkeys.
The "Simulation Alarms" window is opened and a list of all pending alarms is displayed.



Press the "Acknowledge alarm" softkey to reset the simulation alarms indicated by the Reset or Cancel symbol.
The simulation can be continued.

- OR -



Press the "Simulation Power On" softkey to reset a simulation alarm indicated by the Power On symbol.

Creating a G code program

9.1 Graphical programming

Functions

The following functionality is available:

- Technology-oriented program step selection (cycles) using softkeys
- Input windows for parameter assignment with animated help screens
- Context-sensitive online help for every input window
- Support with contour input (geometry processor)

Call and return conditions

- The G functions active before the cycle call and the programmable frame remain active beyond the cycle.
- The starting position must be approached in the higher-level program before the cycle is called. The coordinates are programmed in a clockwise coordinate system.

9.2 Program views

You can display a G code program in various ways.

- Program view
- Parameter screen, either with help screen or graphic view

Note

Help screens / animations

Please note that not all the conceivable kinematics can be displayed in help screens and animations of the cyclic support.

Program view

The program view in the editor provides an overview of the individual machining steps of a program.

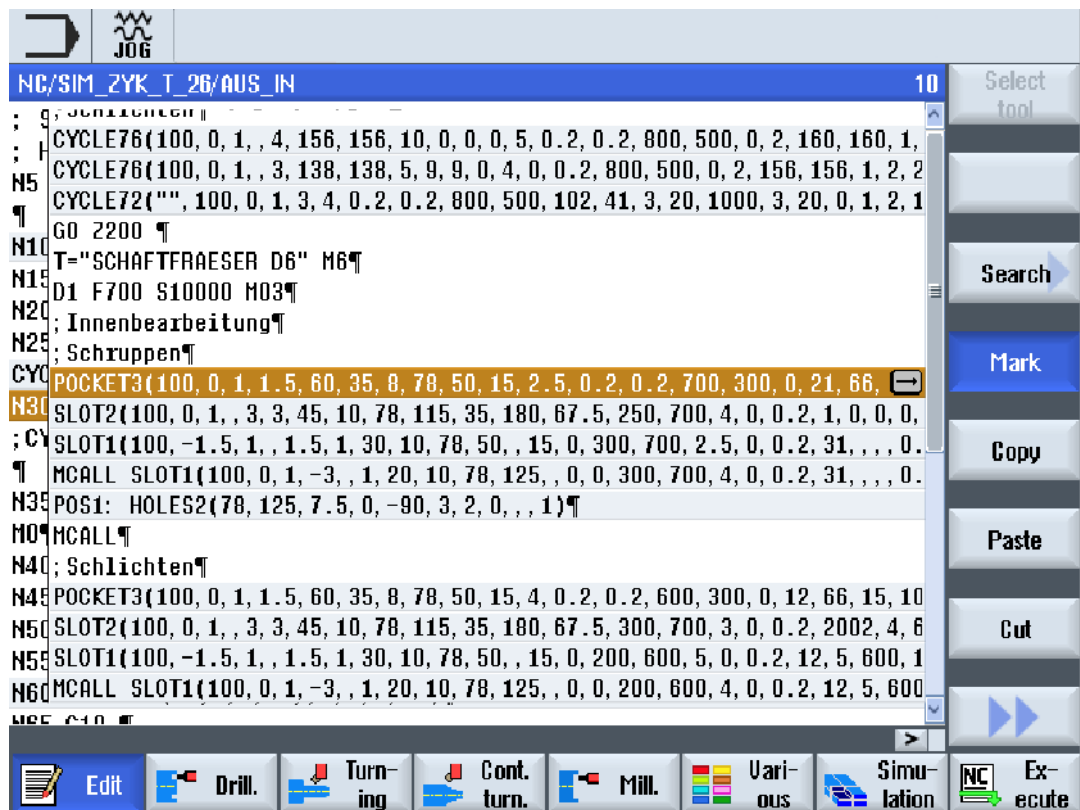
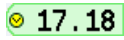
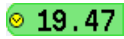
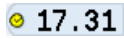
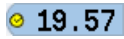
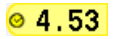

Figure 9-1 Program view of a G code program

Note





In the program editor settings, you define as to whether cycle calls are to be displayed as plain text or in NC syntax. You can also configure the recording of the machining times

Display of the machining times

Display	Meaning
Light green background 	Measured machining time of the program block (automatic mode)
Green background 	Measured machining time of the program group (automatic mode)
Light blue background 	Estimated machining time of the program block (simulation)
Blue background 	Estimated machining time of the program group (simulation)
Yellow background 	Wait time (automatic mode or simulation)

Highlighting of selected G code commands or keywords

In the program editor settings, you can specify whether selected G code commands are to be highlighted in color. The following colors are used as standard:

Display	Meaning
Blue font 	D, S, F, T, M and H functions
Red font 	"G0" motion command
Green font 	"G1" motion command
Blue-green font 	"G2" or "G3" motion command
Gray font 	Comment

Machine manufacturer



You can define further highlight colors in the "sleditorwidget.ini" configuration file. Please refer to the machine manufacturer's instructions.

Synchronization of programs on multi-channel machines

Special commands (e.g. GET and RELEASE) are used on multi-channel machines to synchronize the programs. These commands are marked with a clock symbol.

If the programs of several channels are displayed, the associated commands are displayed in one line.

Display	Meaning
☺	Synchronization command



In the program view, you can move between the program blocks using the <Cursor up> and <Cursor down> keys.



Parameter screen with help display



Press the <Cursor right> key to open a selected program block or cycle in the program view.

The associated parameter screen with help screen is then displayed.

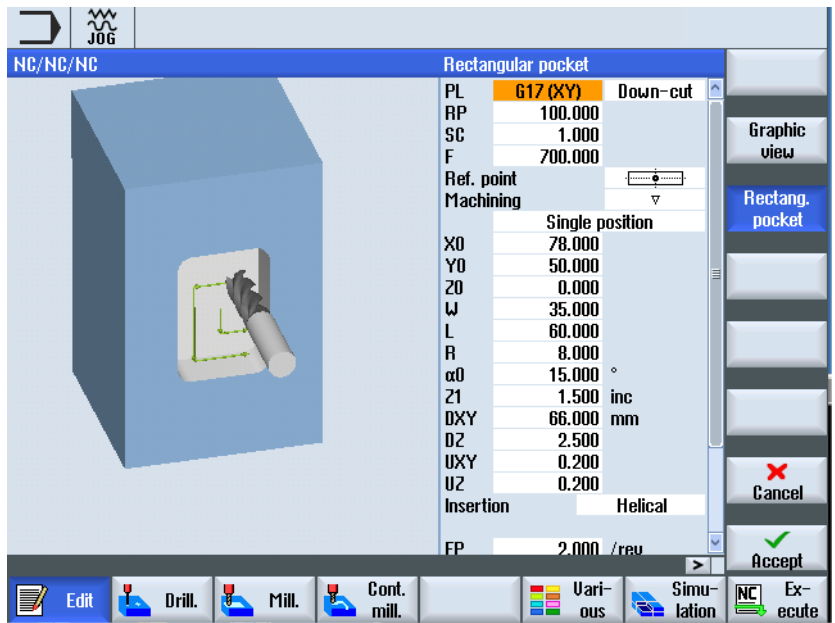

Figure 9-2 Parameter screen with help display

The animated help displays are always displayed with the correct orientation to the selected coordinate system. The parameters are dynamically displayed in the graphic. The selected parameter is displayed highlighted in the graphic.

The colored symbols

Red arrow = tool traverses in rapid traverse

Green arrow = tool traverses with the machining feedrate

Parameter screen with graphic view



Press the "Graphic view" softkey to toggle between the help screen and the graphic view.

Note

Switching between the help screen and the graphic view

The key combination <CTRL> + <G> is also available for the switchover between the help screen and the graphic view.

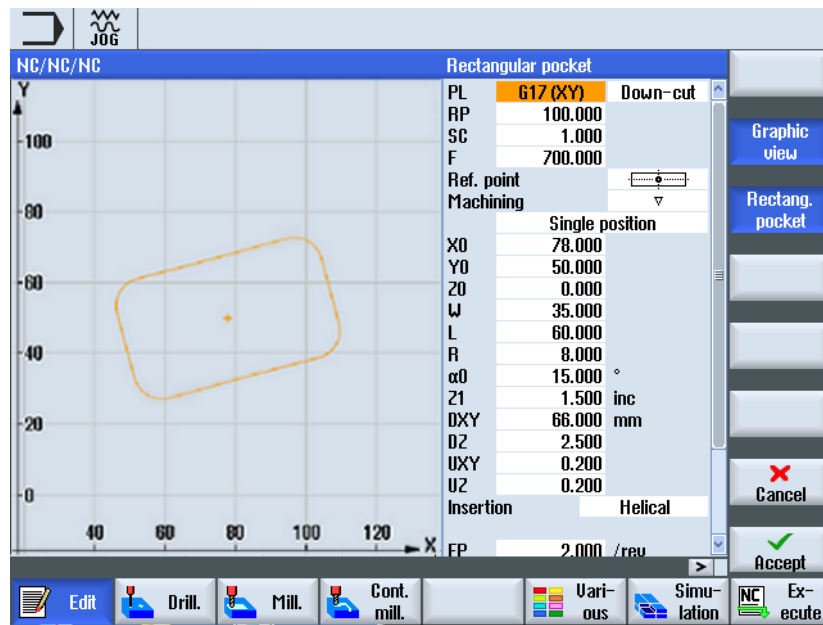

Figure 9-3 Parameter screen with a graphical view of a G code program block

9.3 Program structure

G_code programs can always be freely programmed. The most important commands that are included in the rule:

- Set a machining plane
- Call a tool (T and D)
- Call a work offset
- Technology values such as feedrate (F), feedrate type (G94, G95,...), speed and direction of rotation of the spindle (S and M)
- Positions and calls, technology functions (cycles)
- End of program

For G code programs, before calling cycles, a tool must be selected and the required technology values F, S programmed.

A blank can be specified for simulation.

9.4 Fundamentals

9.4.1 Machining planes

A plane is defined by means of two coordinate axes. The third coordinate axis (tool axis) is perpendicular to this plane and determines the infeed direction of the tool (e.g. for 2½-D machining).

When programming, it is necessary to specify the working plane so that the control system can calculate the tool offset values correctly. The plane is also relevant to certain types of circular programming and polar coordinates.

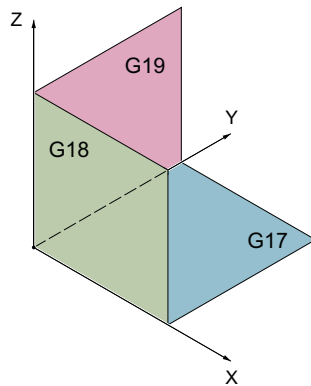

Working planes

Working planes are defined as follows:

Plane		Tool axis
X/Y	G17	Z
Z/X	G18	Y
Y/Z	G19	X

9.4.2 Current planes in cycles and input screens

Each input screen has a selection box for the planes, if the planes have not been specified by NC machine data.

- Empty (for compatibility reasons to screen forms without plane)
- G17 (XY)
- G18 (ZX)
- G19 (YZ)

There are parameters in the cycle screens whose names depend on this plane setting. These are usually parameters that refer to positions of the axes, such as reference point of a position pattern in the plane or depth specification when drilling in the tool axis.

For G17, reference points in the plane are called X0 Y0, for G18 they are called Z0 X0 - and for G19, they are called Y0 Z0. The depth specification in the tool axis for G17 is called Z1, for G18, Y1 and for G19, X1.

If the entry field remains empty, the parameters, the help screens and the broken-line graphics are displayed in the default plane (can be set via machine data):





- Turning: G18 (ZX)
- Milling: G17 (XY)

The plane is transferred to the cycles as new parameter. The plane is output in the cycle, i.e. the cycle runs in the entered plane. It is also possible to leave the plane fields empty and thus create a plane-independent program.

The entered plane only applies for this cycle (not modal)! At the end of the cycle, the plane from the main program applies again. In this way, a new cycle can be inserted in a program without having to change the plane for the remaining program.

9.4.3 Programming a tool (T)

Calling a tool

1. You are in the part program.
2. Press the "Select tool" softkey.
The "Tool selection" window is opened.

3. Position the cursor on the desired tool and press the "To program" softkey.
The selected tool is loaded into the G code editor. Text such as the following is displayed at the current cursor position in the G code editor:
T="ROUGHINGTOOL100"
- OR -
4. Press the "Tool list" and "New tool" softkeys.

5. Then select the required tool using the softkeys on the vertical softkey bar, parameterize it and then press the softkey "To program".
The selected tool is loaded into the G code editor.

6. Then program the tool change (M6), the spindle direction (M3/M4), the spindle speed (S...), the feedrate (F), the feedrate type (G94, G95,...), the coolant (M7/M8) and, if required, further tool-specific functions.

9.5 Generating a G code program

Create a separate program for each new workpiece that you would like to produce. The program contains the individual machining steps that must be performed to produce the workpiece.

Part programs in the G code can be created under the "Workpiece" folder or under the "Part programs" folder.

Procedure



1. Select the "Program Manager" operating area.



2. Select the required archiving location.

Creating a new part program



3. Position the cursor on the folder "Part programs" and press the "New" softkey.



The "New G Code Program" window opens.

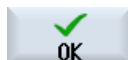

4. Enter the required name and press the "OK" softkey.

The name can contain up to 28 characters (name + dot + 3-character extension). You can use any letters (except accented), digits or the underscore symbol (_).

The program type (MPF) is set by default.

The project is created and opened in the Editor.

Creating a new part program for a workpiece



5. Position the cursor on the folder "Workpieces" and press the "New" softkey.



The "New G Code Program" window opens.

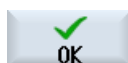

6. Select the file type (MPF or SPF), enter the desired name of the program and press the "OK" softkey.

The project is created and opened in the Editor.

7. Enter the desired G code commands.

9.6 Blank input

9.6.1 Overview

Function

The blank is used for the simulation and the simultaneous recording. A useful simulation can only be achieved with a blank that is as close as possible to the real blank.

Create a separate program for each new workpiece that you would like to produce. The program contains the individual machining steps that are performed to produce the workpiece.

For the blank of the workpiece, define the shape (cuboid, tube, cylinder, polygon or centered cuboid) and your dimensions.

Manually reclamping the blank

If the blank is to be manually reclamped from the main spindle to the counterspindle for example, then delete the blank.

Example

- Blank, main spindle, cylinder
- Machining
- M0 ; Manually reclamping the blank
- Blank, main spindle, delete
- Blank, counterspindle, cylinder
- Machining

The blank entry always refers to the work offset currently effective at the position in the program.

Note

Swiveling

For programs that use "Swiveling", a 0 swivel must first be made and then the blank defined.

9.6.2 Calling the input screen

Procedure





1. Select the "Program" operating area.







2. Press the "Misc." and "Blank" softkeys.
The "Blank Input" window opens.



9.6.3 Blank input

Parameter	Description	Unit
Data for	Selection of the spindle for blank <ul style="list-style-type: none"> Main spindle Counterspindle Note: If the machine does not have a counterspindle, then the entry field "Data for" is not applicable.	
Clamping	Selecting the clamping location of the blank <ul style="list-style-type: none"> Table All clampings are mounted on a table Note: No turning cycles can be used in the program with the "Table" selection. C1... All clampings are mounted on a rotary axis Note: please refer to the machine manufacturer's specifications.	
Blank 	Selecting the blank <ul style="list-style-type: none"> Cuboid Tube Cylinder Polygon Centered cuboid Delete 	
X0	1. Rectangular point X - (only for cuboid)	
Y0	1. Rectangular point Y - (only for cuboid)	
X1 	2. Rectangular point X (abs) or 2nd rectangular point X referred to X0 (inc) - (only for cuboid)	
Y1 	2. Rectangular point Y (abs) or 2nd rectangular point Y referred to Y0 (inc) - (only for cuboid)	

9.6 Blank input

Parameter	Description	Unit
ZA	Initial dimension	
ZI 	Final dimension (abs) or final dimension in relation to ZA (inc)	
ZB 	Machining dimension (abs) or machining dimension in relation to ZA (inc)	
XA	Outside diameter – (only for tube and cylinder)	mm
XI 	Inside diameter (abs) or wall thickness (inc) – (only for tube)	mm
N	Number of edges – (only for polygon)	
SW or L 	Width across flats or edge length – (only for polygon)	
W	Width of the blank - (only for centered cuboid)	mm
L	Length of the blank - (only for centered cuboid)	mm

9.7 Selection of the cycles via softkey

Overview of machining steps

The following softkeys are available to insert machining steps.

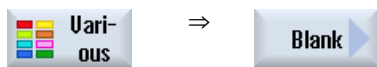

Multi-channel view

10.1 Multi-channel view

The multi-channel view allows you to simultaneously view several channels in the following operating areas:

- "Machine" operating area
- "Program" operating area

10.2 Multi-channel view in the "Machine" operating area

With a multi-channel machine, you have the option of simultaneously monitoring and influencing the execution of several programs.



Machine manufacturer

Please observe the information provided by the machine manufacturer.

Displaying the channels in the "Machine" operating area

In the "Machine" operating area, you can display 2 - 4 channels simultaneously.

Using the appropriate settings, you can define the sequence in which channels are displayed. Here, you can also select if you wish to hide a channel.

Note

The "REF POINT" function is shown only in the single-channel view.

Multi-channel view

2 - 4 channels are simultaneously displayed in channel columns on the user interface.

- Two windows are displayed one above the other for each channel.
- The actual value display is always in the upper window.
- The same window is displayed for both channels in the lower window.
- You can select the display in the lower window using the vertical softkey bar.
The following exceptions apply when making a selection using the vertical softkeys:
 - The "Actual values MCS" softkey switches over the coordinate systems of both channels.
 - The "Zoom actual value" and "All G functions" softkeys switch into the single-channel view.

Single-channel view

If you only wish to monitor one channel for your multi-channel machine, then you can set a permanent single-channel view.

Horizontal softkeys

- Block search
When selecting the block search, the multi-channel view is kept. The block display is displayed as search window.
- Program control
The "Program Control" window is displayed for the channels configured in the multi-channel view. The data entered here applies for these channels together.
- If you press an additional horizontal softkey in the "Machine" operating area (e.g. "Overstore", "Synchronized actions"), then you change into a temporary single-channel view. If you close the window again, then you return to the multi-channel view.

Switching between single- and multi-channel view



Press the <MACHINE> key in order to briefly switch between the single- and multi-channel view in the machine area.



Press the <NEXT WINDOW> key in order to switch between the upper and lower window within a channel column.

Editing a program in the block display



You can perform simple editing operations as usual with the <INSERT> key in the actual block display.

If there is not sufficient space, you switch over into the single-channel view.

Running-in a program

You select individual channels to run-in the program at the machine.

Requirement

- Several channels have been set-up.
- The setting "2 channels", "3 channels" or "4 channels" is selected.

Displaying/hiding a multi-channel view



1. Select the "Machine" operating area



2. Select the "JOG", "MDA" or "AUTO" mode.

...



3. Press the menu forward key and the "Settings" softkey.



4. Press the "Multi-channel view" softkey.

5. In the window "Settings for Multi-Channel View" in the selection box "View", select the required entry (e.g. "2 channels") and define the channels as well as the sequence in which they are to be displayed.

In the basic screen for the "AUTO", "MDA" and JOG" operating modes, the upper window of the left-hand and right-hand channel columns are occupied by the actual value window.



6. Press the "T,F,S" softkey if you wish to view the "T,F,S" window. The "T,F,S" window is displayed in the lower window of the left-hand and right-hand channel column.

Note:

The "T,F,S" softkey is present only for smaller operator panels, i.e. up to OP012.

10.3 Multi-channel view for large operator panels

On the OP015 and OP019 operator panels as well as on the PC, you have the option of displaying up to four channels next to each one. This simplifies the creation and run-in for multi-channel programs.

Constraints

- OP015 with a resolution of 1024x768 pixels: up to three channels visible
- OP019 with a resolution of 1280x1024 pixels: up to four channels visible
- The operation of a OP019 requires a PCU50.5

3- or 4-channel view in the "Machine" operating area

Use the multi-channel view settings to select the channels and specify the view.

Channel view	Display in the "Machine" operating area
3-channel view	<p>The following windows are displayed one above the other for each channel:</p> <ul style="list-style-type: none"> • Actual Value window • T,F,S window • Block Display window <p>Selecting functions</p> <ul style="list-style-type: none"> • The T,F,S window is overlaid by pressing one of the vertical softkeys.
4-channel view	<p>The following windows are displayed one above the other for each channel:</p> <ul style="list-style-type: none"> • Actual Value window • G functions (the "G functions" softkey is omitted). "All G functions" is accessed with the Menu forward key. • T,S,F window • Block Display window <p>Selecting functions</p> <ul style="list-style-type: none"> • The window showing the G codes is overlaid if you press one of the vertical softkeys.

Toggle between the channels



Press the <CHANNEL> key to toggle between the channels.



Press the <NEXT WINDOW> key to toggle within a channel column between the three or four windows arranged one above the other.

Note

2-channel display

Unlike the smaller operator panels, the T,F,S window is visible for a 2-channel view in the "Machine" operating area.

Program operating area

You can display as many as ten programs next to each other in the editor.

Displaying a program

You can define the width of the program in the Editor window using the settings in the editor. This means that you can distribute programs evenly - or you can widen the column with the active program .

Channel status

When required, channel messages are displayed in the status display.



Machine manufacturer

Please refer to the machine manufacturer's specifications.

10.4 Setting the multi-channel view

Setting	Meaning
View	Here, you specify how many channels are displayed. <ul style="list-style-type: none"> • 1 channel • 2 channels • 3 channels • 4 channels
Channel selection and sequence (for "2 - 4 channels" view)	You specify which channels in which sequence are displayed in the multi-channel view.
Visible (for "2 - 4 channels" view)	Here, you specify which channels are displayed in the multi-channel view. You can quickly hide channels from the view.

Example

Your machine has 6 channels.

You configure channels 1 - 4 for the multi-channel view and define the display sequence (e.g. 1,3,4,2).

In the multi-channel view, for a channel switchover, you can only switch between the channels configured for the multi-channel view; all others are not taken into consideration. Using the <CHANNEL> key, advance the channel in the "Machine" operating area - you obtain the following views: Channels "1" and "3", channels "3" and "4", channels "4" and "2". Channels "5" and "6" are not displayed in the multi-channel view.

In the single-channel view, toggle between all of the channels (1...6) without taking into account the configured sequence for the multi-channel view.

Using the channel menu, you can always select all channels, also those not configured for multi-channel view. If you switch to another channel, which is not configured for the multi-channel view, then the system automatically switches into the single-channel view. There is no automatic switchback into the multi-channel view, even if a channel is again selected, which has been configured for multi-channel view.

Procedure



1. Select the "Machine" operating area.



2. Select the "JOG", "MDA" or "AUTO" mode.



10.4 Setting the multi-channel view



3. Press the menu forward key and the "Settings" softkey.



4. Press the "Multi-channel view" softkey.
The "Settings for Multi-Channel View" window is opened.
5. Set the multi-channel or single-channel view and define which channels are to be seen in the "Machine" operating area - and in the editor - in which sequence.

Collision avoidance

Collision avoidance allows you to avoid collisions and damage while machining a workpiece or creating programs.



Software option

You require the "Collision Avoidance ECO (machine)" software option in order to use this function for geometrically primitive protection area elements.



Software option

You require the "Collision Avoidance (machine, working area)" software option in order to use this function additionally for protection area elements in the STL and NPP data formats.



Software option

You require the "Collision Avoidance ADVANCED (machine, workpiece)" software option in order to use this function additionally for the autonomous realization of collision avoidance application.



Machine manufacturer

Please observe the information provided by the machine manufacturer.

Collision avoidance is based on a machine model. The kinematics of the machine are described as a kinematic chain. For machine parts to be protected, protection areas are attached to these chains. The geometry of the protection areas is defined using protection area elements. The control then knows how they move in the machine coordinate system depending on the position of the machine axes. You then subsequently define the collision pairs, i.e. two protection areas, which are monitored with respect to one another.

The "Collision avoidance" function regularly calculates the clearance from these protection areas. When two protection areas approach one another and a specific safety clearance is reached, an alarm is displayed and the program is stopped before the corresponding traversing block and/or the traversing motion is stopped.

Note

The collision monitoring is only valid for single-channel machines.

Note

Referenced axes

The positions of the axes in the machine area must be known so that the protection areas can be monitored. For this reason, collision avoidance is only active after the referencing.

NOTICE
No complete machine protection
Incomplete models, e.g. machine parts, workpieces that have not been modeled or new objects in the working area, are not monitored and can therefore cause collisions.

Additional information

Further information about the kinematic chain and collision avoidance is provided in:

- Basic Functions Function Manual
- Monitoring and Compensating Function Manual

11.1 Activate collision avoidance

Precondition

- Collision avoidance is setup and an active machine model is available.
- The setting "Collision avoidance" has been selected for the AUTO operating mode or for the JOG and MDA operating modes.

Procedure



1. Select the "Machine" operating area.



2. Press the <AUTO> key.



3. Press the "Sim. rec." softkey.



4. Press the "Other views" and "Machine space" softkeys.



During simultaneous recording, an active machine model is displayed.

11.2 Set collision avoidance

Using "Settings", you have the option of separately activating or deactivating the collision monitoring for the Machine operating area (operating modes, AUTO, JOG and MDI) separately for the machine and tools.

Using machine data, you define from which protection level the collision avoidance for the machine or the tool can be activated or deactivated in the operating modes JOG/MDI or AUTO.



Machine manufacturer

Please refer to the machine manufacturer's instructions.

Setting	Effect
JOG/MDI operating mode Collision avoidance	They switch the collision avoidance for the JOG/MDI operating modes on or off.
AUTO mode Collision avoidance	They switch the collision avoidance for the AUTO operating mode on or off depending on machine data \$MN_JOG_MODE_MASK Note: Please refer to the machine manufacturer's instructions.
JOG/MDI Machine	If the collision monitoring for the JOG/MDI operating modes is activated, then as a minimum, the machine protection areas are monitored. The parameter cannot be changed.
AUTO Machine	If the collision monitoring for the AUTO operating mode is activated, then as a minimum, the machine protection areas are monitored. The parameter cannot be changed.
JOG/MDI Tools	They switch the collision avoidance of the tool protection areas for the operating modes JOG/MDI on or off.
AUTO Tools	They switch the collision avoidance of the tool protection areas for the operating mode AUTO on or off.

Procedure



1. Select the "Machine" operating area.



2. Select the "JOG", "MDI" or "AUTO" mode.





3. Press the menu forward key and the "Settings" softkey.



4. Press the "Collision avoidance" softkey.
The "Collision Avoidance" window opens.



5. In the "Collision avoidance" line for the required operating modes (e.g. for JOG/MDI), select the entry "On" to activate the collision avoidance or "Off" to deactivate collision avoidance.
6. Deactivate the "Tools" checkbox if you only want to monitor the machine protection areas.

See also

Actual value window (Page 45)

Tool management

12.1 Lists for the tool management

All tools and also all magazine locations that have been created or configured in the NC are displayed in the lists in the Tool area.

All lists display the same tools in the same order. When switching between the lists, the cursor remains on the same tool in the same screen segment.

The lists have different parameters and softkey assignments. Switching between lists is a specific change from one topic to the next.

- **Tool list**
All parameters and functions required to create and set up tools are displayed.
- **Tool wear**
All parameters and functions that are required during operation, e.g. wear and monitoring functions, are listed here.
- **Magazine**
You will find the magazine and magazine location-related parameters and functions for the tools / magazine locations here.
- **Tool data OEM**
This list can be freely defined by the OEM.

Sorting the lists

You can change the sorting within the lists according to:

- The magazine
- The name (tool identifier, alphabetic)
- The tool type
- The T number (tool identifier, numerical)
- The D number

Filtering the lists

You can filter the lists according to the following criteria:

- Only display the first cutting edge
- Only tools that are ready to use
- Only tools that have reached the pre-alarm limit
- Only locked tools
- Only tools with active code

Search functions

You have the option of searching through the lists according to the following objects:

- Tool
- Magazine location
- Empty location

12.2 Magazine management

Depending on the configuration, the tool lists support a magazine management.

Magazine management functions

- Press the "Magazine" horizontal softkey to obtain a list that displays tools with magazine-related data.
- The Magazine / Magazine location column is displayed in the lists.
- In the default setting, the lists are displayed sorted according to magazine location.
- The magazine selected via the cursor is displayed in the title line of each list.
- The "Magazine selection" vertical softkey is displayed in the tool list.
- You can load and unload tools to and from a magazine via the tool list.



Machine manufacturer

Please refer to the machine manufacturer's specifications.

12.3 Tool types

A number of tool types are available when you create a new tool. The tool type determines which geometry data is required and how it will be computed.

Tool types















New tool - favorites		
Type	Identifier	Tool position
120 -	End mill	
140 -	Facing tool	
200 -	Twist drill	
220 -	Center drill	
240 -	Tap	
710 -	3D probe	
711 -	Edge finder	
110 -	Ball nose end mill	
111 -	Conical ball end	
121 -	End mill corner rounding	
155 -	Bevelled cutter	
156 -	Bevelled cutter corner	
157 -	Tap. die-sink. cutter	
	Crosshead	
	Multitool	

Figure 12-1 Example of Favorites list















New tool - milling cutter		
Type	Identifier	Tool position
100 -	Milling tool	
110 -	Ball nose end mill	
111 -	Conical ball end	
120 -	End mill	
121 -	End mill corner rounding	
130 -	Angle head cutter	
131 -	Corn.round.ang.hd.cut	
140 -	Facing tool	
145 -	Thread cutter	
150 -	Side mill	
151 -	Saw	
155 -	Bevelled cutter	
156 -	Bevelled cutter corner	
157 -	Tap. die-sink. cutter	
160 -	Drill&thread cut.	

Figure 12-2 Available tools in the "New Tool - Milling Cutter" window











New tool - drill			
Type	Identifier		Tool position
200	Twist drill		
205	Solid drill		
210	Boring bar		
220	Center drill		
230	Countersink		
231	Counterbore		
240	Tap		
241	Fine tap		
242	Tap, Whitworth		
250	Reamer		

Figure 12-3 Available tools in the "New Tool - Drill" window











New tool - special tools			
Type	Identifier		Tool position
700	Slotting saw		
710	3D probe		
711	Edge finder		
712	Mono probe		
713	L probe		
714	Star probe		
725	Calibrating tool		
730	Stop		
900	Auxiliary tools		
	Crosshead		
	Multitool		

Figure 12-4 Available tools in the "New Tool - Special Tools" window

12.4 Tool dimensioning

This section provides an overview of the dimensioning of tools.

Tool types

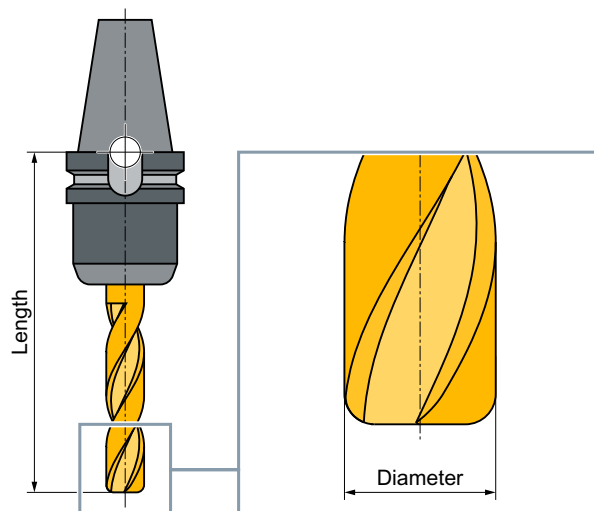

Figure 12-5 End mill (Type 120)

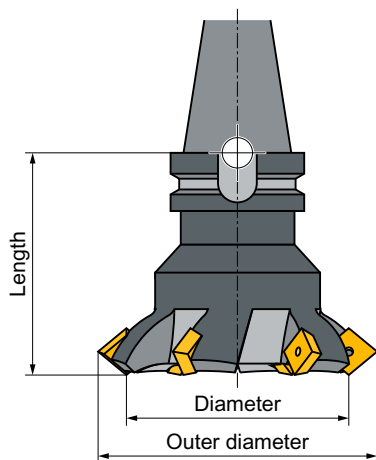

Figure 12-6 Face mill (Type 140)

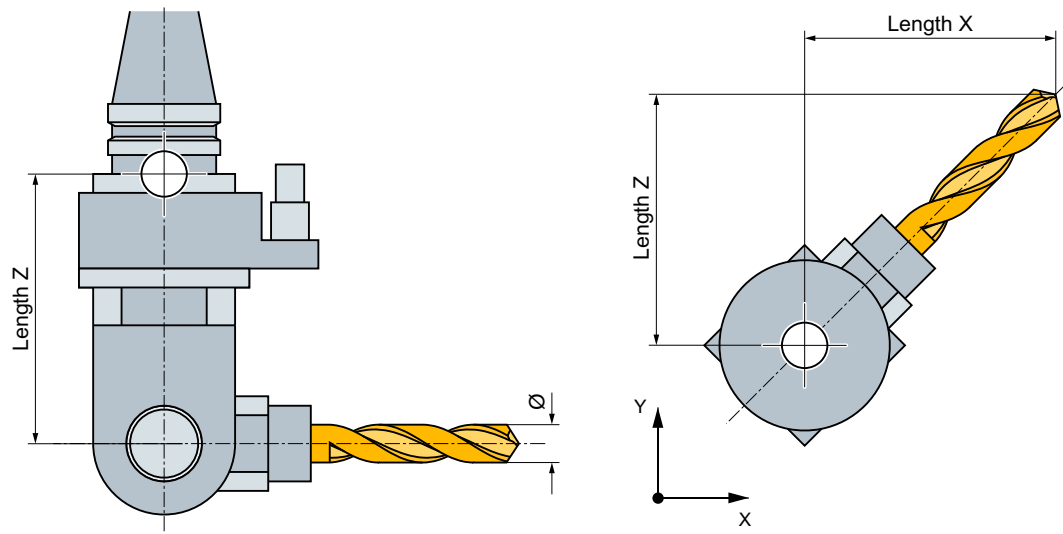

Figure 12-7 Angle head cutter (Type 130)

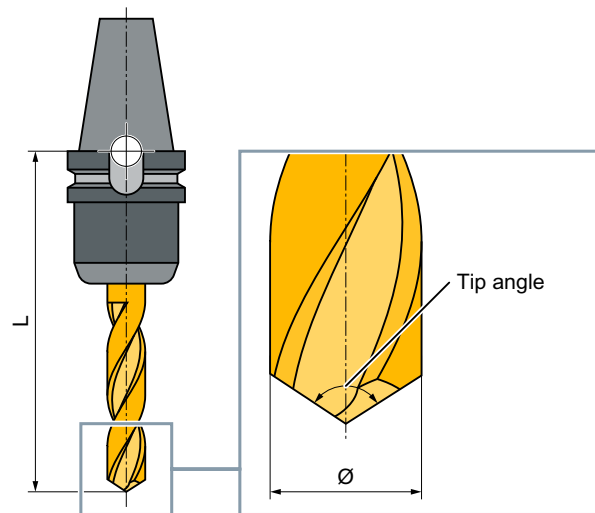

Figure 12-8 Drill (Type 200)

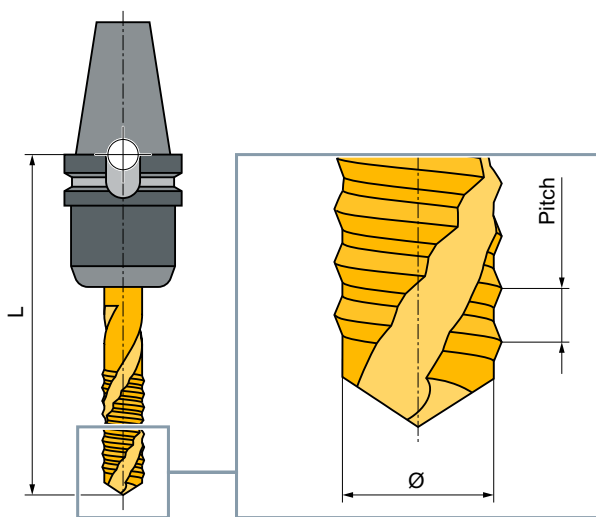

Figure 12-9 Tap (Type 240)

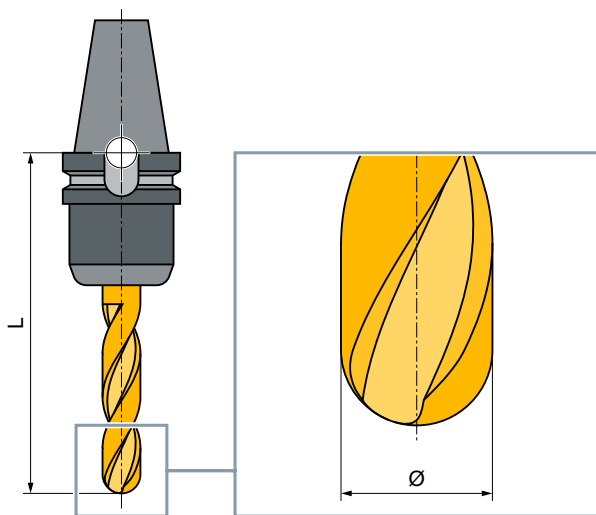

Figure 12-10 3D tool with an example of a cylindrical die-sinking cutter (Type 110)

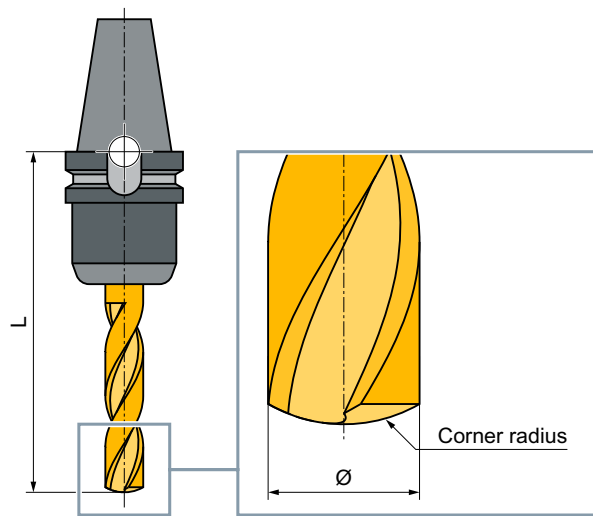

Figure 12-11 3D tool type with an example of a ballhead cutter (Type 111)

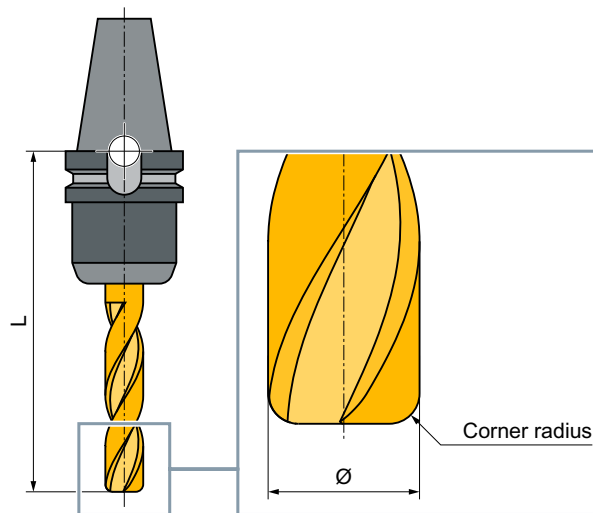

Figure 12-12 3D tool with an example of an end mill with corner rounding (Type 121)

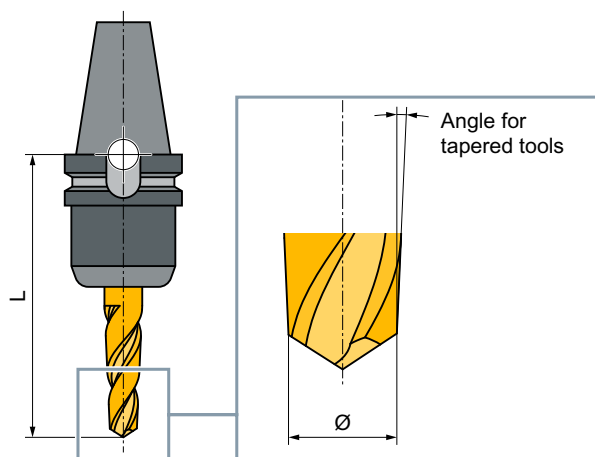

Figure 12-13 3D tool type with an example of a bevel cutter (Type 155)

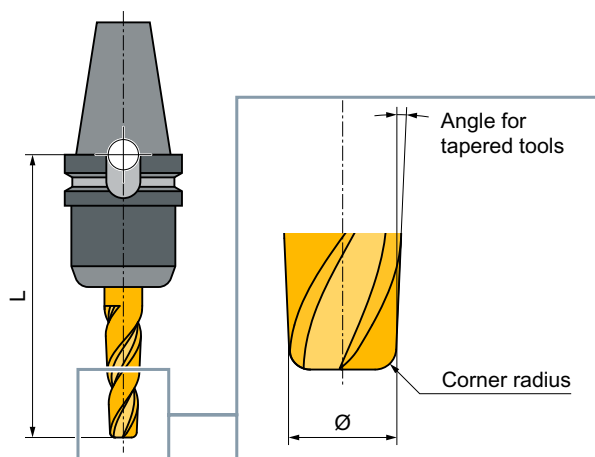

Figure 12-14 3D tool with an example of a bevel cutter with corner rounding (Type 156)

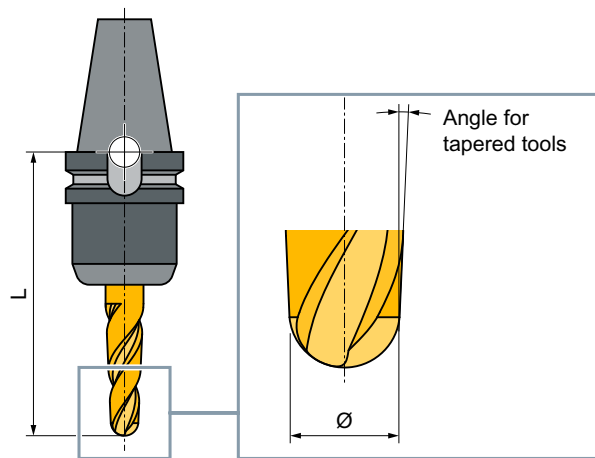
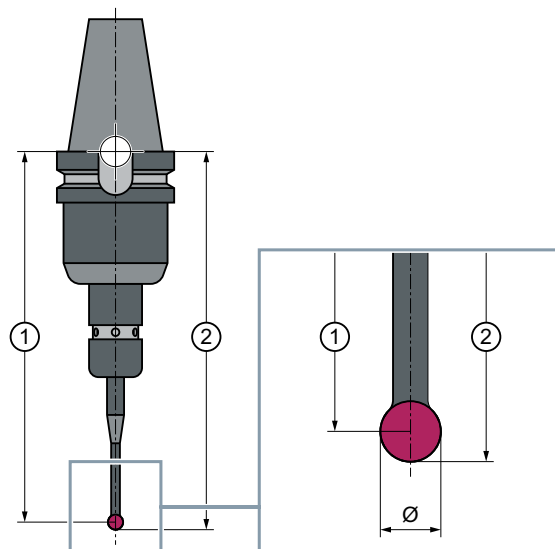

Figure 12-15 3D tool with an example of a tapered die-sinking cutter (Type 157)



- ① Length m
- ② Length u

Figure 12-16 3D probe

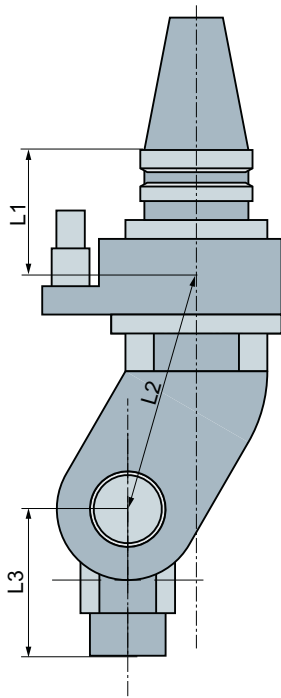

Figure 12-17 Crossover head adapter
L1, L2, L3 are offset geometry lengths.



Machine manufacturer

The tool length of the workpiece probe is measured to the center of the ball (length m) or to the ball circumference (length u).

Please observe the information provided by the machine manufacturer.

Note



An electronic workpiece probe must be calibrated before use.





12.5 Tool list

All parameters and functions that are required to create and set up the tools are displayed in the tool list.

Each tool is uniquely identified by the tool identifier and the replacement tool number.

Tool parameters

Column heading	Meaning
Location	Magazine/location number
BS	<ul style="list-style-type: none"> Magazine location numbers The magazine number is specified first, followed by the location number in the magazine. If there is only one magazine, only the location number is displayed. Load position in the load magazine
	<p>The following icons can also be displayed for other magazine types (e.g. for a chain):</p> <ul style="list-style-type: none"> Spindle location as an icon Locations for gripper 1 and gripper 2 (applies only when a spindle with dual gripper is used) as icons
	
* If activated in magazine selection	
Type	Tool type Specific tool offset data is displayed depending on the tool type (represented as an icon).
	You have the option of changing the tool type using the <SELECT> key.
Tool name	The tool is identified by the name and the replacement tool number. You may enter the names as text or numbers. Note: The maximum length of tool names is 31 ASCII characters. The number of characters is reduced for Asian characters or Unicode characters. The following special characters are not permitted: # " .
ST	Replacement tool number (for replacement tool strategy)
D	Cutting edge number
Length	Tool length Geometry data, length
Radius	Tool radius
∅	Tool diameter
Tip angle or Pitch	Tip angle for Type 200 - twist drill and Type 220 - centering tool and Type 230 countersink Pitch for Type 240 - tap

Column heading	Meaning
N	Number of teeth for Type 100 - milling tool, Type 110 - ball end mill for cylindrical die-sinking cutter, Type 111 - ball end mill or tapered die-sinking cutter, Type 120 - end mill, Type 121 - end mill with corner rounding, Type 130 - angle head cutter, Type 131 - angle head cutter with corner rounding, Type 140 - facing tool, Type 150 - side mill, Type 155 - bevel cutter, Type 156 - bevel cutter with corner rounding and Type 157 - tapered die-sinking cutter.
	Direction of spindle rotation  Spindle is not switched on  CW spindle rotation  CCW spindle rotation
	Coolant 1 and 2 (e.g. internal and external cooling) can be switched on and off. The coolant infeed at the machine does not necessarily have to be set-up.
M1 - M4	Other tool-specific functions such as additional coolant infeed, monitoring functions for speed, tool breakage

Further parameters

If you have created unique cutting edge numbers, they will be displayed in the first column.

Column heading	Meaning
D no.	Unique cutting edge number
SN	Cutting edge number
EC	Setting-up offsets
	Display of the available setup offsets

You use the configuration file to specify the selection of parameters in the list.



Machine manufacturer







Please observe the information provided by the machine manufacturer.

Further information

Additional information on configuring and setup of the tool list is provided in the Tool Management Function Manual.

Icons in the tool list

Icon/ Marking		Meaning
Tool type		
Red "X"		The tool is disabled.

Icon/ Marking		Meaning
Yellow triangle pointing downward		The prewarning limit has been reached.
Yellow triangle pointing upward		The tool is in a special state. Place the cursor on the marked tool. A tooltip provides a short description.
Green frame		The tool is preselected.
Magazine/location number		
Green double arrow		The magazine location is positioned at the change position.
Gray double arrow (configurable)		The magazine location is positioned at the loading position.
Red "X"		The magazine location is disabled.

Procedure



1. Select the "Parameter" operating area.



2. Press the "Tool list" softkey.
The "Tool List" window opens.

12.5.1 Creating a new tool

When creating a new tool, the "New tool - favorites" window offers you a number of selected tool types, known as "favorites".

If you do not find the desired tool type in the favorites list, then select the milling, drilling or special tool using the corresponding softkeys.

Procedure



1. The tool list is opened.
2. Place the cursor in the tool list at the position where the new tool should be stored.
For this, you can select an empty magazine location or the NC tool memory outside of the magazine.



- You may also position the cursor on an existing tool in the area of the NC tool memory. Data from the displayed tool will not be overwritten.
3. Press the "New tool" softkey.



The "New tool - favorites" window opens.

- OR -



If you want to create a tool that is not in the "Favorites" list, press the softkey "Cutters 100-199", "Drill 200-299", or "Spec. tool 700-900".

...

The "New tool - milling cutter", "New tool - drill", or "New tool - special tools" window opens.



4. Select the tool by placing the cursor on the corresponding icon.



5. Press the "OK" softkey.

The tool is added to the tool list with a predefined name. If the cursor is located on an empty magazine location in the tool list, then the tool is loaded to this magazine location.

The tool creation sequence can be defined differently.

Multiple load points

If you have configured several loading points for a magazine, then the "Select loading point" window appears when a tool is created directly in an empty magazine location or when the "Load" softkey is pressed.

Select the required load point and confirm with the "OK" softkey.

Additional data

If configured accordingly, the "New tool" window opens after the required tool has been selected and confirmed with "OK".

You can define the following data in this window:

- Names
- Tool location type
- Size of tool

Further information

Additional information on the configuring options is provided in the Tool Management Function Manual.

12.5.2 Additional data

The following tool types require geometry data that is not included in the tool list display.

Tools with additional geometry data

Tool type	Additional parameters
111 Conical ballhead cutter	Corner radius
121 End mill with corner rounding	Corner radius
130 Angle head cutter	Geometry length (length X, length Y, length Z) Wear length (Δ length X, Δ length Y, Δ length Z) Adapter length (length X, length Y, length Z) V (direction vector 1 - 6) Vector X, vector Y, vector Z
131 Angle head cutter with corner rounding	Geometry length (length X, length Y, length Z) Corner radius Wear length (Δ length X, Δ length Y, Δ length Z) Adapter length (length X, length Y, length Z) V (direction vector 1 - 6) Vector X, vector Y, vector Z
140 Face milling	External radius Tool angle
155 Bevel cutter	Taper angle
156 Bevel cutter with corner rounding	Corner radius Taper angle
157 Conical die-milling cutter	Taper angle
585 Calibration tool	Geometry length (length X, length Y, length Z) Wear length (Δ length X, Δ length Y, Δ length Z)
700 Slotting saw	Geometry length (length X, length Y, length Z) Wear length (Δ length X, Δ length Y, Δ length Z) Adapter length (length X, length Y, length Z) Geometry (slot width, projection) Wear (slot width, projection)
710 3D-probe milling	Geometry length (length X, length Y, length Z) Wear length (Δ length X, Δ length Y, Δ length Z)
712 Mono-probe	Geometry length (length X, length Y, length Z) Wear length (Δ length X, Δ length Y, Δ length Z)
713 L-probe	Geometry length (length X, length Y, length Z) Wear length (Δ length X, Δ length Y, Δ length Z) Boom length (length)
714 Star-type probe	Geometry length (length X, length Y, length Z) Wear length (Δ length X, Δ length Y, Δ length Z) Outer diameter (\emptyset)
Crossover head	V1 - V3: Direction vectors L1 - L3: Offset geometry length L2A, L2B: Geometry lengths

You can use the configuration file to specify the data to be displayed for specific tool types in the "Additional Data" window.



Machine manufacturer

Please observe the information provided by the machine manufacturer.

Procedure



1. The tool list is opened.
2. In the list, select an appropriate tool, e.g. an angle head cutter.
3. Press the "Additional data" softkey.
The "Additional Data - ..." window opens.
The "Additional data" softkey is only active if a tool for which the "Additional Data" window is configured is selected.

12.5.3 Managing several cutting edges

In the case of tools with more than one cutting edge, a separate set of offset data is assigned to each cutting edge. The number of possible cutting edges depends on the controller configuration.

Tool cutting edges that are not required can be deleted.

Procedure

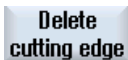

1. The tool list is opened.
2. Position the cursor on the tool for which you would like to store more cutting edges.
3. Press the "Edges" softkey in the "Tool list".
4. Press the "New cutting edge" softkey.
A new data set is stored in the list.
The cutting edge number is incremented by one and the offset data is assigned the values of the cutting edge on which the cursor is positioned.
5. Enter the offset data for the 2nd cutting edge.
6. Repeat this process if you wish to create more tool edge offset data.
7. Position the cursor on the cutting edge that you want to delete and press the "Delete cutting edge" softkey.
The data set is deleted from the list. The first tool cutting edge cannot be deleted.

12.5.4 Deleting a tool

Tools that are no longer in use can be deleted from the tool list for a clearer overview.

Procedure



1. The tool list is opened.



2. In the tool list, place the cursor on the tool that you would like to delete.

3. Press the "Delete tool" softkey.
A confirmation prompt is displayed.



4. Press the "OK" softkey if you really want to delete the selected tool.

The tool is deleted.

If the tool is in a magazine location, it is unloaded and then deleted.

Multiple loading points - tool in magazine location

If you configured several loading points for a magazine, then the "Loading Point Selection" window appears after pressing the "Delete tool" softkey.

Select the required load point and press the "OK" softkey to unload and delete the tool.

12.5.5 Loading and unloading tools

You can load and unload tools to and from a magazine via the tool list. When a tool is loaded, it is taken to a magazine location. When it is unloaded, it is removed from the magazine and stored in the NC memory.

When you are loading a tool, the application automatically suggests an empty location. You may also directly specify an empty magazine location.

You can unload tools from the magazine that you are not using at present. HMI then automatically saves the tool data in the NC memory.

Should you want to use the tool again later, simply load the tool with the tool data into the corresponding magazine location again. Then the same tool data does not have to be entered more than once.

Procedure



1. The tool list is opened.

2. Place the cursor on the tool that you want to load into the magazine (if the tools are sorted according to magazine location number you will find it at the end of the tool list).



3. Press the "Load" softkey.

The "Load to... " window opens.
The "... Location" field is defaulted with the number of the first empty magazine location.



4. Press the "OK" softkey to load the tool into the suggested location.

- OR -



Enter the location number you require and press the "OK" softkey.

- OR -



Press the "Spindle" softkey.

The tool is loaded into the specified magazine location or spindle.

Loading empty magazine location directly with tool



1. Position the cursor at an empty magazine location where you want to load a tool and press the "Load" softkey.



The "Load with ..." window opens.
Select the desired tool in the "... Tool" field and press the "OK" softkey.

Several magazines

If you have configured several magazines, the "Load to ..." window appears after pressing the "Load" softkey.

If you do not want to use the suggested empty location, then enter your desired magazine and magazine location. Confirm your selection with "OK".

Multiple load points

If you have configured several loading points for a magazine, then the "Loading Point Selection" window appears after pressing the "Load" softkey.

Select the required loading point and confirm with "OK".

Unloading tools



1. Place the cursor on the tool that you would like to unload from the magazine and press the "Unload" softkey.



2. Select the required load point in the "Loading Point Selection" window.
3. Confirm your selection with "OK".

- OR -



Undo your selection with "Cancel".

12.5.6 Selecting a magazine

You can directly select the buffer memory, the magazine, or the NC memory.

Procedure



1. The tool list is opened.



2. Press the "Magazine selection" softkey.

If there is only one magazine, you will move from one area to the next (i.e. from the buffer memory to the magazine, from the magazine to the NC memory, and from the NC memory back to the buffer memory) each time you press the softkey. The cursor is positioned at the beginning of the magazine each time.

- OR -



If there is more than one magazine, the "Magazine Selection" window opens. Position the cursor on the desired magazine in this window and press the "Go to" softkey.

The cursor jumps directly to the beginning of the specified magazine.

Hiding magazines

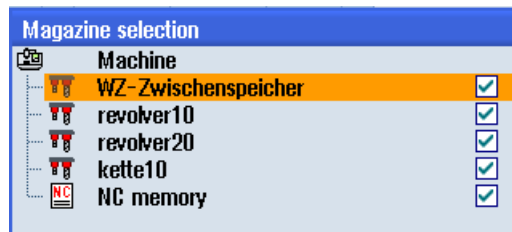

Deactivate the checkbox next to the magazines that you do not want to appear in the magazine list.

The magazine selection behavior with multiple magazines can be configured in different ways.



Machine manufacturer

Please observe the information provided by the machine manufacturer.

Further information

Additional information on the configuring options is provided in the Tool Management Function Manual.

12.5.7 Code carrier connection

You have the option of configuring a code carrier connection.

This means that the following functions are available in SINUMERIK Operate:

- Creating a new tool from code carrier
- Unloading tools on code carrier



Software option

In order to use the functions, you require the option "Tool Ident Connection".

Further information

Additional information on tool management with code carrier and the configuration of the user interface in SINUMERIK Operate is provided in the Tool Management Function Manual.

With a code carrier connection, in the list of favorites, there is also a tool available.





New tool - favorites		
Type	Identifier	Tool position
	Tool from code carrier	
120	- End mill	
140	- Facing tool	
200	- Twist drill	
220	- Center drill	
240	- Tap	
710	- 3D probe	
711	- Edge finder	
110	- Ball nose end mill	
111	- Conical ball end	
121	- End mill corner rounding	
155	- Bevelled cutter	
156	- Bevelled cutter corner	
157	- Tap. die-sink. cutter	

Figure 12-18 New tool from code carrier in the list of favorites

Creating a new tool from code carrier





1. The tool list is opened.
2. Place the cursor in the tool list at the position where the new tool should be created.
 To do this, you can select an empty magazine location or the NC tool memory outside of the magazine.
 You may also position the cursor on an existing tool in the area of the NC tool memory. Data from the displayed tool will not be overwritten.

- | | |
|---|---|
|  | 3. Press the "New tool" softkey. |
|  | The "New Tool - Favorites" window is opened. |
|  | 4. Position the cursor on the entry "Tool from code carrier" and press the "OK" softkey. |
| | The tool data is read from the code carrier, and is displayed in the "New tool" window with the tool type, tool name and possibly with certain parameters. |
|  | 5. Press the "OK" softkey. |
| | The tool is added to the tool list with the specified name. If the cursor is located on an empty magazine location in the tool list, then the tool is loaded to this magazine location. |



The tool creation sequence can be defined differently.

Unloading tool on code carrier

- | | |
|---|--|
|  | 1. The tool list is opened. |
|  | 2. Place the cursor on the tool that you would like to unload from the magazine and press the "Unload" and "On code carrier" softkeys. |
|  | The tool is unloaded and the data of the tool are written to the code carrier. |

According to the corresponding setting, the unloaded tool on the code carrier is deleted from the NC memory after reading out the code carrier.

Deleting tool on code carrier

- | | |
|---|---|
|  | 1. The tool list is opened. |
| | 2. Position the cursor on the tool on the code carrier that you want to delete. |
|  | 3. Press the "Delete tool" and "On code carrier" softkeys. |
|  | The tool is unloaded and the data of the tool are written to the code carrier. The tool is then deleted from the NC memory. |

The deletion of the tool can be set differently, i.e. the "On code carrier" softkey is not available.

12.5.8 Managing a tool in a file

If the "Enable tool in/out file" option is activated in the settings for the tool list, an additional entry is available in the list of favorites.















New tool - favorites		
Type	Identifier	Tool position
	Tool from file	
120	- End mill	
140	- Facing tool	
200	- Twist drill	
220	- Center drill	
240	- Tap	
710	- 3D probe	
711	- Edge finder	
110	- Ball nose end mill	
111	- Conical ball end	
121	- End mill corner rounding	
155	- Bevelled cutter	
156	- Bevelled cutter corner	
157	- Tap, die-sink, cutter	

Figure 12-19 New tool from file in the list of favorites

Creating a new tool from a file



1. The tool list is open.
2. Place the cursor in the tool list at the position where the new tool should be created.
To do this, you can select an empty magazine location or the NC tool memory outside of the magazine.
You may also position the cursor on an existing tool in the area of the NC tool memory. Data from the displayed tool will not be overwritten.



3. Press the "New tool" softkey.



The "New Tool - Favorites" window is opened.

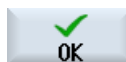

4. Position the cursor on the entry "Tool from file" and press the "OK" softkey. The "Load Tool Data" window opens.



5. Navigate to the required file and press the "OK" softkey. The tool data is read from the file, and is displayed in the "New Tool from File" window with the tool type, tool name and possibly with certain parameters.

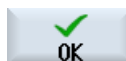

6. Press the "OK" softkey. The tool is added to the tool list with the specified name. If the cursor is located on an empty magazine location in the tool list, then the tool is loaded to this magazine location.

The tool creation sequence can be defined differently.

Unloading a tool in a file



1. The tool list is open.



2. Place the cursor on the tool that you would like to unload from the magazine and press the "Unload" and "In file" softkeys.



3. Navigate to the required directory and press the "OK" softkey.

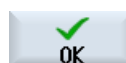

4. Enter the required file name in the "Name" field and press the "OK" softkey. The field is preassigned with tool names. The tool is unloaded and the tool data is written to the file.

According to the corresponding setting, the unloaded tool is deleted from the NC memory after it has been read out.

Deleting a tool in a file



1. The tool list is open.



2. Position the cursor on the tool that you wish to delete.

3. Press the "Delete tool" and "In file" softkeys.

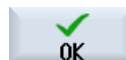

3. Navigate to the required directory and press the "OK" softkey.

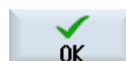

4. Enter the required file name in the "Name" field and press the "OK" softkey. The field is preassigned with tool names. The tool is unloaded and the tool data is written to the file. The tool is then deleted from the NC memory.

12.6 Tool wear

All parameters and functions that are required during operation are contained in the tool wear list.

Tools that are in use for long periods are subject to wear. You can measure this wear and enter it in the tool wear list. The controller then takes this information into account when calculating the tool length or radius compensation. This ensures a consistent level of accuracy during workpiece machining.

Monitoring types

You can automatically monitor the tools' working times via the workpiece count, tool life or wear.

Note

Combination of monitoring types

You have the option to activate the monitoring of a tool by type or any combination of monitoring types.



In addition, you can disable tools when you no longer wish to use them.



Machine manufacturer

Please refer to the machine manufacturer's specifications.

Tool parameters

Column heading	Meaning
Location	Magazine/location number
BS	<ul style="list-style-type: none"> The magazine location numbers The magazine number is specified first, followed by the location number in the magazine. If there is only one magazine, only the location number is displayed. Load position in the load magazine
  * If activated in magazine selection	The following icons can also be displayed for other magazine types (e.g. for a chain): <ul style="list-style-type: none"> Spindle location as an icon Locations for gripper 1 and gripper 2 (applies only when a spindle with dual gripper is used) as icons.
Type	Tool type Depending on the tool type (represented by an icon), certain tool offset data is enabled.



Column heading	Meaning
Tool name	The tool is identified by the name and the replacement tool number. You can enter the name as text or number. Note: The maximum length of tool names is 31 ASCII characters. The number of characters is reduced for Asian characters or Unicode characters. The following special characters are not permitted: # "
ST	Replacement tool number (for replacement tool strategy).
D	Cutting edge number
Δ Length	Length wear
Δ Radius	Radius wear
T C	Selection of tool monitoring - by tool life (T) - by count (C) - by wear (W) The wear monitoring is configured via a machine data item. Please refer to the machine manufacturer's instructions.
Tool life Workpiece count Wear * *Parameter depends on selection in TC	Tool life Number of workpieces Tool wear
Setpoint	Setpoint for tool life, workpiece count, or wear
Prewarning limit	Specification of the tool life, workpiece count or wear at which a warning is displayed.
G	The tool is disabled when the checkbox is selected.





Further parameters

If you have created unique cutting edge numbers, they will be displayed in the first column.

Column heading	Meaning
D no.	Unique cutting edge number
SN	Cutting edge number
SC	Setting-up offsets
	Display of the available setup offsets

Icons in the wear list

Icon/ Marking		Meaning
Tool type		
Red "X"		The tool is disabled.
Yellow triangle pointing downward		The prewarning limit has been reached.

Icon/ Marking		Meaning
Yellow triangle pointing upward		The tool is in a special state. Place the cursor on the marked tool. A tooltip provides a short description.
Green border		The tool is preselected.
Magazine/location number		
Green double arrow		The magazine location is positioned at the change position.
Gray double arrow (configurable)		The magazine location is positioned at the loading position.
Red "X"		The magazine location is disabled.

Procedure

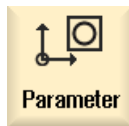

1. Select the "Parameter" operating area.



2. Press the "Tool wear" softkey.

See also

Changing a tool type (Page 302)

12.6.1 Reactivating a tool

You can replace disabled tools or make them ready for use again.

Requirements

In order to reactivate a tool, the monitoring function must be activated and a setpoint must be stored.

Procedure



1. The tool wear list is opened.
2. Position the cursor on the disabled tool which you would like to reuse.
3. Press the "Reactivate" softkey.
The value entered as the setpoint is entered as the new tool life or work-piece count.
The disabling of the tool is canceled.



Reactivating and positioning

When the "Reactivate with positioning" function is configured, the selected tool's magazine location will also be positioned at the loading point. You can exchange the tool.

Reactivation of all monitoring types

When the "Reactivation of all monitoring types" function is configured, all the monitoring types set in the NC for a tool are reset during reactivation.



Machine manufacturer

Please refer to the machine manufacturer's specifications.

Multiple load points

If you have configured several loading points for a magazine, then the "Loading Point Selection" window appears after pressing the "Load" softkey.

Select the required load point and confirm with the "OK" softkey.

Further information

Additional information on the configuring options is provided in the Tool Management Function Manual.

12.7 Tool data OEM

You have the option of configuring the list according to your requirements.

Further information

Additional information on configuring OEM tool data is provided in the Tool Management Function Manual.

Procedure

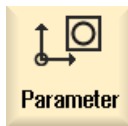

1. Select the "Parameter" operating area.





2. Press the "OEM tool" softkey.

12.8 Magazine

Tools are displayed with their magazine-related data in the magazine list. Here, you can take specific actions relating to the magazines and the magazine locations.

Individual magazine locations can be location-coded or disabled for existing tools.

Tool parameters







Column heading	Meaning
Location	Magazine/location number <ul style="list-style-type: none"> The magazine location numbers The magazine number is specified first, followed by the location number in the magazine. If there is only one magazine, only the location number is displayed. Load position in the load magazine
BS	The following icons can also be displayed for other magazine types (e.g. for a chain): <ul style="list-style-type: none"> Spindle location as an icon Locations for gripper 1 and gripper 2 (applies only when a spindle with dual gripper is used) as icons
  * If activated in magazine selection	
Type	Tool type Depending on the tool type (represented by an icon), certain tool offset data is enabled.
Tool name	The tool is identified by the name and the replacement tool number. You can enter the name as text or number. Note: The maximum length of tool names is 31 ASCII characters. The number of characters is reduced for Asian characters or Unicode characters. The following special characters are not permitted: # ".
ST	Replacement tool number (for replacement tool strategy).
D	Cutting edge number
G	Disabling of the magazine location.
Mag.loc. type	Display of magazine location type.
Tool.loc. type	Display of tool location type.
Ü	Marking of a tool as oversized. The tool occupies two half locations left, two half locations right, one half location top and one half location bottom in a magazine.
P	Fixed location coding. The tool is permanently assigned to this magazine location.

Further parameters

If you have created unique cutting edge numbers, they will be displayed in the first column.

Column heading	Meaning
D no.	Unique cutting edge number
SN	Cutting edge number

Magazine list icons

Icon/ Marking		Meaning
Tool type		
Red "X"		The tool is disabled.
Yellow triangle pointing downward		The prewarning limit has been reached.
Yellow triangle pointing upward		The tool is in a special state. Place the cursor on the marked tool. A tooltip provides a short description.
Green border		The tool is preselected.
Magazine/location number		
Green double arrow		The magazine location is positioned at the change position.
Gray double arrow (configurable)		The magazine location is positioned at the loading position.
Red "X"		The magazine location is disabled.

Procedure



1. Select the "Parameter" operating area.



2. Press the "Magazine" softkey.

See also

Changing a tool type (Page 302)

12.8.1 Position magazine

You can position magazine locations directly on the loading point.

Procedure



1. The magazine list is opened.
2. Place the cursor on the magazine location that you want to position onto the load point.
3. Press the "Position magazine" softkey.
The magazine location is positioned on the loading point.



Multiple load points

If you have configured several loading points for a magazine, then the "Loading Point Selection" window appears after pressing the "Position magazine" softkey.

Select the desired loading point in this window and confirm your selection with "OK" to position the magazine location at the loading point.

12.8.2 Relocating a tool

Tools can be directly relocated within magazines to another magazine location, which means that you do not have to unload tools from the magazine in order to load them into a different location.

When you are relocating a tool, the application automatically suggests an empty location. You may also directly specify an empty magazine location.

Buffer

You have the option of relocating the tool to buffer locations.



Machine manufacturer

Please refer to the machine manufacturer's specifications.

Procedure



1. The magazine list is opened.
2. Position the cursor on the tool that you wish to relocate to a different magazine location.



3. Press the "Relocate" softkey.
The "... relocate from location ... to location ..." window is displayed. The "Location" field is pre-assigned with the number of the first empty magazine location.



4. Press the "OK" softkey to relocate the tool to the recommended magazine location.

- OR -



Enter the required magazine, enter the location number and press the "OK" softkey.

- OR -

Enter the number "9998" or the number "9999" into the "... magazine" field in order to select the buffer as well as the required buffer location in the "Location" field.

- OR -



Press the "Spindle" softkey to load a tool into the spindle and press the "OK" softkey.



The tool is relocated to the specified magazine location, in the spindle or in the buffer.

Several magazines

If you have set up several magazines, then the "...relocate from magazine... location... to..." window appears after pressing the "Relocate" softkey.

Select the desired magazine and location, and confirm your selection with "OK" to load the tool.

12.8.3 Deleting / unloading / loading / relocating all tools

You have the option of deleting or unloading all tools in the magazine list, loading them into the magazine list or relocating them in the magazine list. With one task, the tools are deleted or unloaded from the list or loaded, relocated in the list.

Requirement

The following requirements must be satisfied so that the "Delete all", "Unload all", "Load all" or "Relocate all" softkey is displayed and available:

- Magazine management is set up
- There is no tool in the buffer / in the spindle



Machine manufacturer

Please refer to the machine manufacturer's specifications.

Procedure



1. The magazine list is open.



2. Press the "Delete all" softkey.

- OR -



Press the "Unload all" softkey.

- OR -



Press the "Load all" softkey.

- OR -



Press the "Relocate all" softkey.

A prompt is displayed as to whether you really want to delete, unload, load or relocate all tools.



3. Press the "OK" softkey to continue with deleting, unloading, loading or relocation of the tools.

The tools are deleted, unloaded, loaded or relocated in the magazine in ascending magazine location number order.

4. Press the "Cancel" softkey if you wish to cancel the unloading operation.

Multiple load points

For a magazine, if more than one loading point was set-up, using the "Select loading point" softkey, you have the option of opening a window in which you can assign a loading point to a magazine.

12.9 Tool details

12.9.1 Displaying tool details

The following parameters of the selected tool can be displayed using softkeys in the "Tool Details" window.

- Tool data
- Cutting edge data
- Monitoring data

Procedure



1. The tool list, the wear list, the OEM tool list or the magazine is opened.

...



2. Position the cursor to the desired tool.
3. If you are in the tool list or in the magazine, press the ">>" and "Details" softkey.



- OR -



If you are in the wear list or OEM tool list, press the "Details" softkey.



The "Tool Details" window is displayed.

All of the available tool data is displayed.





5. Press the softkey "Cutting edge data" if you wish to display the cutting edge data.







6. Press the softkey "Monitoring data" if you wish to display the monitoring data.

12.9.2 Cutting edge data

The "Tool Details" window provides the following data on the selected tool when the "Cutting edge data" softkey is active.

Parameter	Meaning
Magazine location	The magazine number is specified first, followed by the location number in the magazine. If there is only one magazine, only the location number is displayed.
Tool name	The tool is identified by the name and the sister tool number. You can enter the name as text or number.
ST	Sister tool number (for sister tool strategy)
D quantity	Number of created cutting edges
D	Cutting edge number
Tool type	Tool symbol with type number
	Length
Geometry	Tool length
Wear	Tool wear
	Ø (diameter)
Geometry	Tool diameter
Wear	Tool wear, diameter
Milling/turning machine For type 500 (rougner) and type 510 (finisher)	
 Cutting edge graphic	The cutting edge graphic shows the positioning defined by the holder angle, cut direction and cutting tip angle.
Reference direction 	The reference direction for the holder angle specifies the cut direction.
Holder angle	To determine the cutting edge positioning
Cutting tip angle	To determine the cutting edge positioning
Type 240 - tap	
Pitch	Height of the developed helix parallel to the screw axis
Type 200 - twist drill, type 220 - centering tool and Type 230 - countersink	
Tip angle	Angle is less than 180°
Type 520 -plunge cutter, type 530 - parting tool, type 540 - threading tool	
Cutting tip length	For displaying the tools during the simulation of the program execution.
Cutting tip width	Width of the plunge cutter
Type 110 - ball end mill for cylindrical die-sinking cutter, type 111 - ball end mill for tapered die-sinking cutter, type 120 - end mill, type 121 - end mill with corner rounding, type 130 - angle head cutter, type 140 - facing tool, type 150 - side mill, type 155 - bevel cutter, type 156 - bevel cutter with corner rounding and type 157 - tapered die-sinking cutter	
N	Number of teeth

Parameter	Meaning	
For driven tools (drills and milling tools)		
Direction of spindle rotation 		Spindle is not switched on
		CW spindle rotation
		CCW spindle rotation
	Coolant 1 and 2 (e.g. internal and external cooling) can be switched on and off. Please refer to the machine manufacturer's specifications	
Cutting edge OEM parameters 1 - 2		





Software option

In order to be able to manage the parameter spindle direction of rotation, coolant and tool-specific functions (M1-M4), you require the "ShopMill/ShopTurn" option.

12.9.3 Tool data

The "Tool Details" window provides the following data on the selected tool when the "Tool data" softkey is active.

Parameter	Meaning	
Magazine location	The magazine number is specified first, followed by the location number in the magazine. If there is only one magazine, only the location number is displayed.	
Tool name	The tool is identified by the name and the sister tool number. You can enter the name as text or number.	
ST	Sister tool number (for sister tool strategy)	
D quantity	Number of created cutting edges	
D	Cutting edge number	
Tool state	A	Activate tool
	F	Tool enabled
		G
	M	Measure tool
	V	Reaching the prewarning limit
	W	Tool being changed
	P	Tool in fixed location The tool is permanently assigned to this magazine location
	I	Tool has been in use
Tool size 	Standard	Tool does not require an additional location in a magazine.
	Oversize	The tool occupies two half locations left, two half locations right, one half location top and one half location bottom in a magazine.

Parameter	Meaning	
	Special size	
	Left	Number of half locations to the left of the tool
	Right	Number of half locations to the right of the tool
Tool OEM parameters 1 - 6	Freely available parameters	

12.9.4 Monitoring data

The "Tool Details" window provides the following data on the selected tool when the "Monitoring data" softkey is active.

Parameter	Meaning
Magazine location	The magazine number is specified first, followed by the location number in the magazine. If there is only one magazine, only the location number is displayed.
Tool name	The tool is identified by the name and the sister tool number. You can enter the name as text or number.
ST	Sister tool number (for sister tool strategy)
D quantity	Number of created cutting edges
D	Cutting edge number
Monitoring type	T - tool life  C - count W - wear The wear monitoring is configured via machine data. Please note the specifications of the machine manufacturer.
	Actual value
Tool life, count and wear	Actual value for tool life, count or wear
	Setpoint
Tool life, count and wear	Setpoint for tool life, count or wear
	Prewarning limit
Tool life, count and wear	Specification of the tool life, the count or wear at which a warning is displayed.
Monitoring OEM parameters 1 - 8	

12.10 Changing a tool type

Procedure



1. The tool list, the wear list, the OEM tool list or the magazine is opened.

...



2. Position the cursor in the column "Type" of the tool that you wish to change.



3. Press the <SELECT> key.
The "Tool types - Favorites" window opens.

4. Select the desired tool type in the list of favorites or select using the softkeys "Cutters 100-199", "Drill 200-299", or "Spec. tool 700-900".



5. Press the "OK" softkey.
The new tool type is accepted and the corresponding icon is displayed in the "Type" column.

12.11 Sorting tool management lists

When you are working with many tools, with large magazines or several magazines, it is useful to display the tools sorted according to different criteria. Then you will be able to find a specific tool more easily in the lists.

Procedure



1. Select the "Parameter" operating area.



2. Press the "Tool list", "Tool wear" or "Magazine" softkey.

...



3. Press the ">>" and "Sort" softkeys.



The lists are displayed sorted numerically according to magazine location. Tool types are used to sort tools with the same magazine location. Identical types (e.g. milling cutters), in turn, are sorted according to their radius value.



4. Press the "Acc. to type" softkey to display the tools arranged by tool type. Identical types (e.g. milling cutters) are sorted according to their radius value.

- OR -



Press the "Acc. to name" softkey to display the tool names in alphabetical order.

The replacement tool numbers are used to sort tools with the same names.

- OR -



Press the "Acc. to T number" softkey to display the tool names sorted numerically.

- OR -



Press the "Acc. to D number" softkey to display the tools sorted by D number.

The list is sorted according to the specified criteria.



Machine manufacturer

Please refer to the machine manufacturer's specifications.

12.12 Filtering the tool management lists

The filter function allows you to filter-out tools with specific properties in the tool management lists.

For instance, you have the option of displaying tools during machining that have already reached the prewarning limit in order to prepare the corresponding tools to be loaded.

Filter criteria

- Only display the first cutting edge
- Only tools that are ready to use
- Only tools with active code
- Only locked tools
- Only tools that have reached the prewarning limit
- Only tools with remaining quantity of ... to ...
- Only tools with residual tool life of ... to ...
- Only tools with unloading marking
- Only tools with loading marking



Machine manufacturer

Please observe the information provided by the machine manufacturer.

Note

Multiple selection

You have the option of selecting several criteria. You will receive an appropriate message if conflicting filter options are selected.

You can configure OR logic operations for the various filter criteria.

Procedure



1. Select the "Parameter" operating area.



2. Press the "Tool list", "Tool wear" or "Magazine" softkey.

...





3. Press the ">>" and "Filter" softkeys.
The "Filter" window opens.



4. Activate the required filter criterion and press the "OK" softkey.
The tools that correspond to the selection criteria are displayed in the list.
The active filter is displayed in the window header.

12.13 Specific search in the tool management lists

There is a search function in all tool management lists, where you can search for the following objects:

- **Tools**
 - You enter a tool name. You can narrow down your search by entering a replacement tool number.
You have the option of only entering a part of the name as search term.
 - Enter the D number and, if necessary, activate the "Active D number" checkbox.
- **Magazine locations or magazines**
If only one magazine is configured, then the search is only made for the magazine location. If several magazines are configured, then it is possible to search a specific magazine location in a specific magazine or just to search in a specific magazine.
- **Empty locations**
If the lists with the location type are used, then the empty location search is made using the location type and location size.



Machine manufacturer

Please refer to the machine manufacturer's specifications.

Procedure

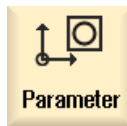

1. Select the "Parameter" operating area.



2. Press the "Tool list", "Tool wear" or "Magazine" softkey.

...



3. Press the ">>" and "Search" softkeys.

...



4. Press the "Tool" softkey if you wish to search for a specific tool.

- OR -



Press the "Magazine location" softkey if you wish to search for a specific magazine location or a specific magazine.



- OR -

Press the "Empty location" softkey if you wish to search for a specific empty location.

12.14 Multiple selection in the tool management lists

Multiple selection is available in the tool management lists.

You select several tools, e.g. to delete them from the list, load them, unload them, or move them to other magazine locations.

For multiple selection, you use either the "Select" softkey, the touch or mouse controls, or the cursor keys.

You can use multiple selection for the following tasks:

- Deleting a tool (Page 281)
- Loading and unloading a tool (Page 281)
- Relocating a tool (Page 295)
- Unloading or deleting a tool on the code carrier (Page 284)
- Equipping a multitool with tools (Page 312)
- Removing tools from a multitool (Page 313)
- Deleting a multitool (Page 314)
- Loading and unloading a multitool (Page 314)
- Relocating a multitool (Page 316)

12.15 Working with multitool

Multitool

Using a multitool you have the possibility of storing more than one tool at a magazine location.

The multitool itself has two or more locations to accept tools. The tools are directly mounted on the multitool. The multitool is located at a location in the magazine.

Geometrical arrangement of the tools on the multitool

The geometrical arrangement of the tools is defined by the clearance between the locations on the multitool.

The clearance between the locations can be defined as follows:

- Using the multitool location number or
- using the angle of the multitool location

If angle is selected here, then the value of the angle must be entered for each multitool location.

Regarding loading and unloading in a magazine, the multitool is treated as a single unit.

Further information

Additional information on the configuring options is provided in the Tool Management Function Manual.

12.15.1 Tool list for multitool

If you work with a multitool, the tool list is supplemented by the column for the multitool location number. As soon as the cursor is at a multitool in the tool list, certain column headings change.

Column header	Meaning
Location	Magazine/location number
MT loc.	Multitool location number
TYPE	Symbol for multitool
Multitool name	Name of the multitool

TOA 1 Tool list									NC memory		
Loc.	MT LO.	Type	Tool name	ST	D	Length	Ø	Pitch	↓	↺	↻
			Gewbo_M4-7G_SA	1	1	0.000	4.000	0.700	↻	<input checked="" type="checkbox"/>	<input type="checkbox"/>
			Gewbo_M8-7G_SA	1	1	0.000	8.000	1.250	↻	<input checked="" type="checkbox"/>	<input type="checkbox"/>
			Gewbo_M10-7G_SA	1	1	0.000	10.000	1.500	↻	<input checked="" type="checkbox"/>	<input type="checkbox"/>
			GEWFORM_M12	1	1	0.000	12.000	1.250	↻	<input checked="" type="checkbox"/>	<input type="checkbox"/>
		+	C-Schruppst_0.8	1	1	0.000	0.800	47.0	0	<input checked="" type="checkbox"/>	<input type="checkbox"/>

Figure 12-20 Tool list with multitool in the spindle

Procedure

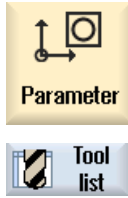

1. Select the "Parameter" operating area.
2. Press the "Tool list" softkey.
The "Tool list" window is opened.

12.15.2 Create multitool

The multitool can be selected in the list of favorites as well as in the list of special tool types.

New tool - favorites		
Type	Identifier	Tool position
120	- End mill	
140	- Facing tool	
200	- Twist drill	
220	- Center drill	
240	- Tap	
710	- 3D probe	
711	- Edge finder	
110	- Ball nose end mill	
111	- Conical ball end	
121	- End mill corner rounding	
155	- Bevelled cutter	
156	- Bevelled cutter corner	
157	- Tap, die-sink. cutter	
	Multitool	

Figure 12-21 List of favorites with multitool











New tool - special tools		
Type	Identifier	Tool position
700	- Slotting saw	
710	- 3D probe	
711	- Edge finder	
712	- Mono probe	
713	- L probe	
714	- Star probe	
725	- Calibrating tool	
730	- Stop	
900	- Auxiliary tools	
	Multitool	

Figure 12-22 Selection list for special tools with multitool

Procedure



1. The tool list is opened.

2. Position the cursor at the position where the tool is to be created. For this, you can select an empty magazine location or the NC tool storage outside the magazine.

You may also position the cursor on an existing tool in the NC tool storage area. Data from the displayed tool will not be overwritten.



3. Press the "New tool" softkey.

The "New Tool - Favorites" window opens.

- OR -



Press the softkey "Special tool 700-900".

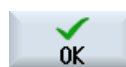

4. Select the multitool and press the "OK" softkey.

The "New Tool" window appears.



5. Enter the multitool name and define the number of multitool locations.

If you wish to define the clearance of the tools based on the angle, activate the "Angle input" checkbox, and for each multitool location, enter the clearance to the reference location as angular value.

New tool									
Multitool name	No. of locs.	Angle input	Multitool angle						
MULTITOO3	3	<input checked="" type="checkbox"/>	<table border="1"> <tr> <td>1</td> <td>0.000</td> </tr> <tr> <td>2</td> <td>120.000</td> </tr> <tr> <td>3</td> <td>230.000</td> </tr> </table>	1	0.000	2	120.000	3	230.000
1	0.000								
2	120.000								
3	230.000								

The multitool is created in the tool list.

Note

The tool creation sequence can be defined differently.



Machine manufacturer

Please refer to the machine manufacturer's specifications.

12.15.3 Equipping multitool with tools

Precondition

A multitool has been created in the tool list.

Procedure



1. The tool list is opened.

Equipping the multitool with a new tool



2. Select the required multitool, position the cursor on an empty multitool location.



3. Press the "New tool" softkey.

4. Using the appropriate selection list, e.g. favorites, select the required tool.

Loading the multitool



2. Select the required multitool, position the cursor on an empty multitool location.



3. Press the "Load" softkey.
The "Load with..." window opens.



4. Select the required tool.

Loading the tool into the multitool



2. Position the cursor on the tool that you want to load into the multitool.
3. Press the "Load" and "Multitool" softkeys.
The "Load on ..." window opens.

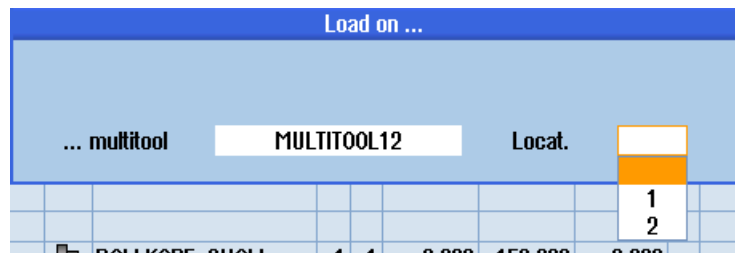

4. Select the required multitool and the multitool location to which you wish to load the tool.

12.15.4 Removing a tool from multitool

If the multitool was mechanically re-equipped, then the old tools in the tool list must be removed from the multitool.

To do this, the cursor is positioned at the line where the tool which is to be removed is located. When unloading, the tool is automatically saved in the tool list outside the magazine in the NC memory.

Procedure



1. The tool list is opened.
2. Position the cursor on the tool that you would like to unload from the multitool and press the "Unload" softkey.
- OR -
Position the cursor on the tool that you want to remove and delete from the multitool and press the "Delete tool" softkey.

12.15.5 Deleting multitool

Procedure



1. The tool list is opened.
2. Position the cursor on the multitool that you wish to delete.
3. Press the "Delete multitool" softkey.
The multitool with all of the tools that are located in it is deleted.

12.15.6 Loading and unloading multitool

Procedure



1. The tool list is opened.

Loading a multitool into the magazine

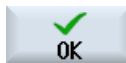

2. Position the cursor at the multitool that you wish to load into the magazine.
3. Press the "Load" softkey.
The "Load on ..." window opens.
The field "... Locat." is initialized with the number of the first empty magazine location.
4. Press the "OK" softkey if you want to load the multitool to the recommended empty location.
- OR -
Enter the location number you require and press the "OK" softkey.

The multitool together with the tools in it is loaded to the specified magazine location.

Loading a multitool into a magazine

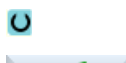

2. Position the cursor on the required empty magazine location.
3. Press the "Load" softkey.
The "Load with" window opens.
4. Select the required multitool.
5. Press the "OK" softkey.

Unloading a multitool



2. Position the cursor on the multitool that you wish to unload from the magazine.
3. Press the "Unload" softkey.
The multitool is removed from the magazine and is saved in the NC memory at the end of the tool list.

12.15.7 Reactivating the multitool

Multitool and tools located on the multitool can be disabled independently of one another.

If a multitool is disabled, then the tools of the multitool can no longer be changed in using a tool change.

If only one tool on a multitool has a set monitoring function and the lifetime or the unit quantity has expired, then the tool and the multitool on which the tool is located are disabled. The other tools on the multitool are not disabled.



Machine manufacturer

Please observe the information provided by the machine manufacturer.

If several tools with monitoring are mounted on the multitool and the lifetime or unit quantity has expired for one tool, then only this tool is disabled.

TOA 1		Tool wear		WZ-Zwischenspeic...							
Loc.	MT LQ.	Type	Tool name	ST	D	Length	$\Delta \varnothing$	T C	Quantity	Set val	Prewar limit
			MULTITOOL								
	1		Schlichtfr_10_UHM	1	1	0.000	0.000				
	2		FRAESER_D10	1	1	0.000	0.000	C	0	15	11
C											
1/1			BOHRER_G19	1	1	0.000	0.000				

Reactivating

If a tool with expired lifetime or unit quantity that is mounted on a multitool is reactivated, then for this tool, the lifetime/unit quantity is set to the setpoint and the tool and the multitool are re-enabled (disable status is removed).

If a multitool is reactivated, on which tools with monitoring are mounted, then the lifetime/unit quantity for all tools on the multitool are set to the setpoint no matter whether the tools are disabled or not.

Requirements

In order to reactivate a tool, the monitoring function must be activated and a setpoint must be stored.

Procedure

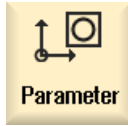

1. Select the "Parameter" operating area.
2. Press the "Tool wear" softkey.
3. Position the cursor at the multitool that is disabled and which you would like to reactivate.
- OR -
Position the cursor on the tool that you want to reactivate again.
4. Press the "Reactivate" softkey.
The value entered as the setpoint is entered as the new tool life or workpiece count.
The tool and the multitool are then no longer disabled (the disable is withdrawn).

Reactivating and positioning

When the "Reactivate with positioning" function is configured, then also the magazine location at which the selected multitool is located is positioned at the loading point. You can exchange the multitool.

Reactivation of all monitoring types

When the "Reactivation of all monitoring types" function is configured, all the monitoring types set in the NC for a tool are reset during reactivation.



Machine manufacturer

Please observe the information provided by the machine manufacturer.

12.15.8 Relocating a multitool

Multitools can be directly relocated within magazines to another magazine location, which means that you do not have to unload multitools with the associated tools from the magazine in order to relocate them to a different location.

When you are relocating a multitool, the system automatically recommends an empty location. You may also directly specify an empty magazine location.

Procedure

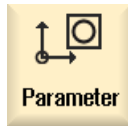

1. Select the "Parameter" operating area.



2. Press the "Magazine" softkey.

3. Position the cursor at the multitool that you wish to relocate to a different magazine location.



4. Press the "Relocate" softkey.

The "... relocate from location ... to location ..." window is displayed. The "Location" field is pre-assigned with the number of the first empty magazine location.



5. Press the "OK" softkey to locate the multitool at the recommended magazine location.

- OR -

Enter the required magazine number in the "...magazine" field and the required magazine location number in "Location" field.

Note:

Please refer to the machine manufacturer's specifications.

Press the "OK" softkey.

The multitool with the tools is relocated to the specified magazine location.



12.15.9 Positioning a multitool

You can position a magazine. In this case, a magazine location is positioned to the loading point.

Multitools that are located in a spindle can also be positioned. The multitool is rotated and therefore the multitool location involved is brought into the machining position.

Procedure



1. The magazine list is opened.
The multitool is in the spindle.

2. Position the cursor on the multitool location that you want to bring into the machining position.



3. Press the "Position multitool" softkey.

12.16 Settings for tool lists

The "Settings" window provides the following options to set the view in the tool lists:

- Display only one magazine in the magazine sorting
 - You limit the display to one magazine. The magazine is displayed with the assigned buffer locations and the not-loaded tools.
 - You use a configuration to specify whether the "Magazine selection" softkey jumps to the next magazine or whether the "Magazine Selection" dialog for changing switches to any magazine.
- Display only spindles in the buffer
 - In order to display during operation only the spindle location, the remaining locations of the buffer will be hidden.
- Enable tool in/out file
 - When creating a new tool, the tool data can be loaded from a file.
 - When deleting or unloading a tool, the tool data can be backed up in a file.
- Activating the adapter-transformed view
 - The geometry lengths and the operation offsets are displayed transformed in the tool list.
 - The wear lengths and the sum offsets are displayed transformed in the tool wear list.



Machine manufacturer

Please observe the information provided by the machine manufacturer.

Procedure

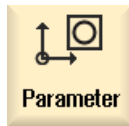

1. Select the "Parameter" operating area.



2. Press the "Tool list", "Tool wear" or "Magazine" softkey.

...



3. Press the "Continue" and "Settings" softkeys.



4. Activate the checkbox for the desired setting.

Managing programs

13.1 Overview

You can access programs at any time via the Program Manager for execution, editing, copying, or renaming.

Programs that you no longer require can be deleted to release their storage space.

NOTICE

Execution from a USB flash drive

Direct execution or simulation from a USB flash drive is not recommended.

There is no protection against contact problems, falling out, breakage through knocking or unintentional removal of the USB flash drive during operation.

Disconnecting it during operation will result in the stopping of the machining and thus to the workpiece being damaged.

Storage for programs

Possible storage locations are:

- NC
- Local drive
- Network drives
- USB drives
- FTP drives
- V24



Software options

To display the "Local drive" softkey, you require option "Additional HMI user memory on CF card of the NCU" (not for SINUMERIK Operate on PCU50 or PC/PG).

Data exchange with other workstations

You have the following options for exchanging programs and data with other workstations:

- USB drives (e.g. USB flash drive)
- Network drives
- FTP drive

Choosing storage locations

In the horizontal softkey bar, you can select the storage location that contains the directories and programs that you want to display. In addition to the "NC" softkey, via which the file system data can be displayed, additional softkeys can be displayed.

The "USB" softkey can only be used when an external storage medium is connected (e.g. USB flash drive on the USB port of the operator panel).

Displaying documents

You can display documents on all drives of the Program Manager (e.g. in the local drive or USB) and via the data tree of the system data. Various data formats are supported:

- PDF
- HTML
It is not possible to preview HTML documents.
- Various graphic formats (e.g. BMP or JPEG)
- DXF



Software options

You require the "DXF reader" option in order to display DXF files.

Note

FTP drive

It is not possible to preview documents on the FTP drive.

Structure of the directories

In the overview, the symbols in the left-hand column have the following meaning:

 Directory

 Program

All directories have a plus sign when the program manager is called for the first time.

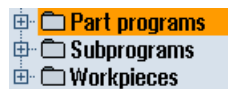

Figure 13-1 Program directory in the program manager

The plus sign in front of empty directories is removed after they have been read for the first time.

The directories and programs are always listed complete with the following information:

- Name
The name length is 24 characters.
Permissible characters include all upper-case letters (without accents), numbers, and underscores.
- Type
Directory: WPD
Program: MPF
Subprogram: SPF
Initialization programs: INI
Job lists: JOB
Tool data: TOA
Magazine assignment: TMA
Zero points: UFR
R parameters: RPA
Global user data/definitions: GUD
Setting data: SEA
Protection zones: PRO
Sag: CEC
- Size (in bytes)
- Date/time (of creation or last change)

Active programs

Selected, i.e. active programs are identified using a green symbol.

CHAN1	Name	Type	Length	Date	Time
+	Part programs	DIR		11/30/09	3:49:09 PM
+	Subprograms	DIR		12/02/09	11:24:33 AM
+	Workpieces	DIR		12/02/09	2:53:07 PM
+	DREHEN1	WPD		12/02/09	8:40:58 AM
+	GGG	WPD		12/01/09	12:03:39 PM
+	JOBSHOP_MEHRK	WPD		12/03/09	9:18:27 AM
+	MEHR	WPD		11/30/09	3:49:23 PM
+	MEHRKANAL	WPD		12/02/09	12:47:20 PM
+	SIM_CHESS_KING	WPD		11/30/09	3:49:14 PM
+	SIM_CHESS_LADY_26	WPD		11/30/09	3:49:14 PM
+	SIM_CHESS_TOWER	WPD		11/30/09	3:49:15 PM
+	SIM_ZYK_T_26	WPD		11/30/09	3:49:17 PM
+	SWOB	WPD		12/03/09	8:39:49 AM
+	UT	MPF	205	12/03/09	3:22:48 PM
+	TEMP	WPD		11/30/09	3:49:33 PM

13.1.1 NC memory

The complete NC working memory is displayed along with all tools and the main programs and subroutines.

You can create further subdirectories here.

Procedure



1. Select the "Program Manager" operating area.



2. Press the "NC" softkey.

13.1.2 Local drive

Workpieces, main and subprograms that are saved in the user memory of the CF card or on the local hard disk are displayed.

For archiving, you have the option of mapping the structure of the NC memory system or to create a separate archiving system.

You can create any number of subdirectories here, in which you can store any files (e.g. text files with notes).



Software options

To display the "Local drive" softkey, you require option "Additional HMI user memory on CF card of the NCU" (not for SINUMERIK Operate on PCU50 or PC/PG).

Procedure



1. Select the "Program Manager" operating area.



2. Press the "Local drive" softkey.

On the local drive, you have the option of mapping the directory structure of the NC memory. This also simplifies the search sequence.

Creating Directories



1. The local drive is selected.



2. Position the cursor on the main directory.



3. Press the "New" and "Directory" softkeys.
The "New Directory" window opens.



4. In the "Name" entry field, enter "mpf.dir", "spf.dir" and "wks.dir" and press the "OK" softkey.
The directories "Part programs", "Subprograms" and "Workpieces" are created below the main directory.

13.1.3 USB drives

USB drives enable you to exchange data. For example, you can copy to the NC and execute programs that were created externally.

NOTICE

Interruption of operation

Direct execution and simulation from the USB flash drive is not recommended, because machining can be undesirably interrupted, therefore resulting in workpiece damage.

Partitioned USB flash drive (TCU)

If the USB flash drive has several partitions, these are displayed in a tree structure as a subtree (01,02,...).

For EXTCALL calls, enter the partition (e.g. USB:/02/... or //ACTTCU/FRONT/02/... or //ACTTCU/FRONT,2/... or //TCU/TCU1/FRONT/02/...)

You can also configure any partition (e.g. //ACTTCU/FRONT,3).

Procedure



1. Select the "Program Manager" operating area.



2. Press the "USB" softkey.

Note

The "USB" softkey can only be operated when a USB flash drive is inserted in the front interface of the operator panel.

13.1.4 FTP drive

The FTP drive offers you the following options - to transfer data, e.g. part programs, between your control system and an external FTP server.

You have the option of archiving any files in the FTP server by creating new directories and subdirectories.

Note

Selecting a program / execution

It is not possible to select a program directly on the FTP drive, and change to execution in the "Machine" operating area.

Precondition

User name and password have been set up in the FTP server.

Procedure



1. Select the "Program manager" operating area.



2. Press the "FTP" softkey.
When selecting the FTP drive for the first time, a login window is displayed.

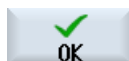

3. Enter the user name and password and press the "OK" softkey to log into the FTP server.

The content of the FTP server with its folders is displayed.



4. Press the "Log out" softkey after the required data processing has been completed.

The connection to the FTP server is disconnected. In order to reselect the FTP drive, you must log on again.

13.2 Opening and closing a program

To view a program in more detail or modify it, open the program in the editor.

With programs that are in the NCK memory, navigation is already possible when opening. The program blocks can only be edited when the program has been opened completely. You can follow the opening of the program in the dialog line.

With programs that are opened via local network, USB FlashDrive or network connections, navigation is only possible when the program has been opened completely. A progress message box is displayed when opening the program.

Note

Channel changeover in the editor

When opening the program, the editor is opened for the currently selected channel. This channel is used to simulate the program.

If you change over a channel in the editor, this does not influence the editor. Only when closing the editor do you change into the other channel.

Procedure



1. Select the "Program manager" operating area.



2. Select the desired storage location and position the cursor on the program that you would like to edit.

3. Press the "Open" softkey.

- OR -



Press the <INPUT> key.

- OR -



Press the <Cursor right> key.

- OR -

Double-click the program.

The selected program is opened in the "Editor" operating area.

4. Now make the necessary program changes.

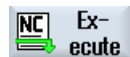

5. Press the "NC Select" softkey to switch to the "Machine" operating area and begin execution.



When the program is running, the softkey is deactivated.

Closing the program



Press the ">>" and "Exit" softkeys to close the program and editor again.



- OR -



If you are at the start of the first line of the program, press the <Cursor left> key to close the program and the editor.



To reopen a program you have exited with "Close", press the "Program" key.

Note

A program does not have to be closed in order for it to be executed.

13.3 Executing a program

When you select a program for execution, the control switches automatically to the "Machine" operating area.

Program selection

Select the workpieces (WPD), main programs (MPF) or subprograms (SPF) by placing the cursor on the desired program or workpiece.

For workpieces, the workpiece directory must contain a program with the same name. This program is automatically selected for execution (e.g. when you select the workpiece SHAFT.WPD, the main program SHAFT.MPF is automatically selected).

If an INI file of the same name exists (e.g. SHAFT.INI), it will be executed once at the first part program start after selection of the part program. Any additional INI files are executed in accordance with machine data MD11280 \$MN_WPD_INI_MODE.

MD11280 \$MN_WPD_INI_MODE=0:

The INI file with the same name as the selected workpiece is executed. For example, when you select SHAFT1.MPF, the SHAFT1.INI file is executed upon <CYCLE START>.

MD11280 \$MN_WPD_INI_MODE=1:

All files of type SEA, GUD, RPA, UFR, PRO, TOA, TMA and CEC which have the same name as the selected main program are executed in the specified sequence. The main programs stored in a workpiece directory can be selected and processed by several channels.



Machine manufacturer

Please refer to the machine manufacturer's specifications.

Procedure



1. Select the "Program manager" operating area.



2. Select the desired storage location, and position the cursor on the workpiece/program that you would like to execute.
3. Press the "Select" softkey.

The control switches automatically into the "Machine" operating area.

- OR -



If the selected program is already opened in the "Program" operating area, press the "Execute NC" softkey.



Press the <CYCLE START> key.

Machining of the workpiece is started.

Note

Program selection from external media

If you execute programs from an external drive (e.g. network drive), you require the "Execution from external storage (EES)" software option.

13.4 Creating a directory/program/job list/program list

13.4.1 File and directory names

The following rules are to be observed when assigning names to files and directories:

- All letters are permissible (with the exception of umlauts, special characters, language-specific special characters, Asian or Cyrillic characters)
- All digits
- Underscores (_).
- The name can be a maximum of 24 characters long

Note

To avoid problems with Windows applications, do **not** use the following terms as program names or directory titles:

- CON, PRN, AUX, NUL
- COM1, COM2, COM3, COM4, COM5, COM6, COM7, COM8, COM9
- LPT1, LPT2, LPT3, LPT4, LPT5, LPT6, LPT7, LPT8, LPT9

Please note that these terms, including those with extensions (e.g. LPT1.MPF, CON.INI) can lead to problems if they are transferred to a Windows environment by copying, archiving or uploading, for example.

13.4.2 Creating a new directory

Directory structures help you to manage your program and data transparently. At all storage locations, you can create subdirectories for this purpose in a directory.

In a subdirectory, in turn, you can create programs and then create program blocks for them.

Note

Restrictions

- Directory names must end in .DIR or .WPD.
 - The maximum name length is 28 characters including the extension.
 - The maximum path length for nested workpieces, including all supplementary characters, is 100 characters.
 - These names are automatically converted to upper-case letters. This limitation does not apply for work on USB/network drives.
-

Procedure



1. Select the "Program manager" operating area.



2. Select the desired storage medium, i.e. a local or USB drive.



3. If you want to create a new directory in the local network, place the cursor on the topmost folder and press the "New" and "Directory" softkeys. The "New Directory" window opens.



4. Enter the desired directory name and press the "OK" softkey.

13.4.3 Creating a new workpiece

You can set up various types of files such as main programs, initialization files, tool offsets, etc. in a workpiece.

Note

Workpiece directories

You have the option of nesting tool directories. You must note that the length of the call line is restricted. You will be informed if the maximum number of characters is reached when entering the workpiece name.

Procedure



1. Select the "Program manager" operating area.



2. Select the desired storage location and position the cursor on the folder, in which you would like to create a workpiece.



3. Press the "New" softkey. The "New Workpiece" window appears.

4. If necessary, select a template if any are available.



5. Enter the desired workpiece name and press the "OK" softkey.

The directory type (WPD) is set by default.

A new folder with the workpiece name will be created.

The "New G Code Program" window will open.



6. Press the "OK" softkey again if you want to create the program.

The program will open in the editor.

See also

Storing any new file (Page 332)

13.4.4 Creating a new G code program

You can create G code programs and then render G code blocks for them in a directory/workpiece.

Procedure



1. Select the "Program manager" operating area.

2. Select the desired storage location and position the cursor on the folder, in which you would like to store the program.



3. Press the "New" softkey.



The "New G Code Program" window appears.

4. If necessary, select a template if any are available.

5. Select the file type (MPF or SPF).

If you are in the NC memory and have selected the file "Subprograms" or "Part programs", you can create only one subprogram (SPF) or main program (MPF) respectively.

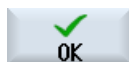

6. Enter the desired program name and press the "OK" softkey.

The program type is appropriately specified.

13.4.5 Storing any new file

In each directory or subdirectory you can create a file in any format that you specify.

Note

File extensions

In the NC memory, the extension must have 3 characters, and DIR or WPD are not permitted.

In the NC memory, you can create the following file types under a workpiece using the "Any" softkey.



Procedure



1. Select the "Program manager" operating area.



2. Select the desired storage location and position the cursor on the folder in which you would like to create the file.



3. Press the "New" and "Any" softkeys.
The "Any New Program" window opens.

4. Select a file type from the "Type" selection field (for example, "Definitions GUD") and enter the name of the file to be created when you have selected a workpiece directory in the NC memory.

The file automatically has the selected file format.

- OR -

Enter a name and file format for the file to be created (e.g. My_Text.txt).



5. Press the "OK" softkey.

13.4.6 Creating a job list

For every workpiece, you can create a job list for extended workpiece selection.

In the job list, you specify instructions for program selection in different channels.

Syntax

The job list contains the SELECT instructions.

```
SELECT <program> CH=<channel number> [DISK]
```

The SELECT instruction selects a program for execution in a specific NC channel. The selected program must be loaded into the working memory of the NC. The DISK parameter enables the selection of external execution (CF card, USB data carrier, network drive).

- <Program>
Absolute or relative path specification of the program to be selected.
Examples:
 - //NC/WCS.DIR/SHAFT.WPD/SHAFT1.MPF
 - SHAFT2.MPF
- <Channel number>
Number of the NC channel in which the program is to be selected.
Example:
CH=2
- [DISK]
Optional parameter for programs that are not in the NC memory and are to be executed "externally".
Example:
SELECT //remote/myshare/shaft3.mpf CH=1 DISK

Comment

Comments are identified in the job list by ";" at the start of the line or by round brackets.

Template

You can select a template from Siemens or the machine manufacturer when creating a new job list.

Executing a workpiece

If the "Select" softkey is selected for a workpiece, the syntax of the associated job list is checked and then executed. The cursor can also be placed on the job list for selection.

Procedure



1. Select the "Program manager" operating area.



2. Press the "NC" softkey, and in directory "Workpieces" place the cursor on the program for which you wish to create a job list.



3. Press the "New" and "Any" softkeys.
The "Any New Program" window opens.



4. Select entry "Job list JOB" from the "Type" selection field and enter a name and press the "OK" softkey.

13.4.7 Creating a program list

You can also enter programs in a program list that are then selected and executed from the PLC.
The program list may contain up to 100 entries.



Machine manufacturer

Please refer to the machine manufacturer's specifications.

Procedure



1. Select the "Program manager" operating area.



2. Press the menu forward key and the "Program list" softkey.
The "Prog.-list" window opens.



3. Place the cursor in the desired line (program number).



4. Press the "Select program" softkey.
The "Programs" window opens. The data tree of the NC memory with workpiece, part program and subprogram directory is displayed.



5. Place the cursor on the desired program and press the "OK" softkey.
The selected program is inserted in the first line of the list together with its path.
- OR -

Enter the program name directly in the list.

If you are making entries manually, check that the path is correct (e.g. //NC/WKS.DIR/MEINPROGRAMM.WPD/MEINPROGRAMM.MPF).

//NC and the extension (.MPF) may be added automatically.

With multi-channel machines, you can specify in which channel the program is to be selected.



6. To remove a program from the list, place the cursor on the appropriate line and press the "Delete" softkey.

- OR -



To delete all programs from the program list, press the "Delete all" softkey.

13.5 Creating templates

You can store your own templates to be used for creating part programs and workpieces. These templates provide the basic framework for further editing.

You can use them for any part programs or workpieces you have created.

Storage location for templates

The templates used to create part programs or workpieces are stored in the following directories:

HMI Data/Templates/Manufacturer/Part programs or Workpieces

HMI Data/Templates/User/Part programs or Workpieces

Procedure

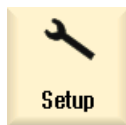

1. Select the "Start-up" operating area.



2. Press the "System data" softkey.



3. Position the cursor on the file that you wish to store as a template and press the "Copy" softkey.



4. Select the directory in which you want to store the data - "Part programs" or "Workpieces" - and press the "Paste" softkey.

Stored templates can be selected when a part program or a workpiece is being created.

13.6 Searching directories and files

You have the possibility of searching in the Program Manager for certain directories and files.

Note

Search with place holders

The following place holders simplify the search:

- "*": Replaces any character string
- "?": Replaces any character

If you use place holders, only directories and files are found that correspond exactly to the search pattern.

Without place holders, directories and files are found that contain the search pattern at an arbitrary position.

Search strategy

The search is made in all of the selected directories and their subdirectories.

If the cursor is positioned on a file, then a search is made from the higher-level directory.

Note

Searching in opened directories

Open the closed directories for a successful search.

Procedure



1. Select the "Program Manager" operating area.



2. Select the storage location in which you wish to perform the search and then press the ">>" and "Search" softkeys.



The "Find File" window opens.

3. Enter the desired search term in the "Text" field.

Note: When searching for a file with place holders, enter the complete name with extension (e.g. DRILLING.MPF).

4. When required, activate the "Observe upper and lower case" checkbox.

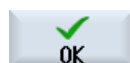

5. Press the "OK" softkey to start the search.

6. If a corresponding directory or file is found, then it is marked.

13.6 Searching directories and files



7. Press the "Continue search" and "OK" softkeys if the directory or the file does not correspond to the required result.



- OR -



Press the "Cancel" softkey when you want to cancel the search.

13.7 Displaying the program in the Preview.

You can show the content on a program in a preview before you start editing.

Procedure



1. Select the "Program manager" operating area.



2. Select a storage location and place the cursor on the relevant program.
3. Press the ">>" and "Preview window" softkeys.
The "Preview: ..." window opens.



4. Press the "Preview window" softkey again to close the window.

13.8 Selecting several directories/programs

You can select several files and directories for further processing. When you select a directory, all directories and files located beneath it are also selected.

Note

Selected files

If you have selected individual files in a directory, then this selection is canceled when the directory is closed.

If the complete directory with all of the files included in it are selected, then this selection is kept when closing the directory.

Procedure



1. Select the "Program manager" operating area.



2. Choose the desired storage location and position the cursor on the file or directory from which you would like your selection to start.



3. Press the "Select" softkey.

The softkey is active.







4. Select the required directories/programs with the cursor keys or mouse.

5. Press the "Select" softkey again to deactivate the cursor keys.



Canceling a selection

By reselecting an element, the existing selection is canceled.

Selecting via keys

Key combination	Meaning
	Renders or expands a selection. You can only select individual elements.
  	Renders a consecutive selection.
	A previously existing selection is canceled.

Selecting with the mouse

Key combination	Meaning
Left mouse	Click on element: The element is selected. A previously existing selection is canceled.
Left mouse +  Pressed	Expand selection consecutively up to the next click.
Left mouse +  Pressed	Expand selection to individual elements by clicking. An existing selection will expand to include the element you clicked.

13.9 Copying and pasting a directory/program

To create a new directory or program that is similar to an existing program, you can save time by copying the old directory or program and only changing selected programs or program blocks.

The capability of copying and pasting directories and programs can also be used to exchange data with other systems via USB/network drives (e.g. USB FlashDrive).

Copied files or directories can be pasted at a different location.

Note

You can only paste directories on local drives and on USB or network drives.

Note

Write rights

If the current directory is write-protected for the user, then the function is not listed.

Note

When you copy directories, any missing endings are added automatically.

All letters (except accented characters), numbers, and underscores are permitted when assigning names. The names are automatically converted to upper-case letters, and extra dots are converted to underscores.

Example

If the name is not changed when copying, a copy is created automatically:

MYPROGRAM.MPF is copied to MYPROGRAM__1.MPF. The next time it is copied, it is changed to MYPROGRAM__2.MPF, etc.

If the files MYPROGRAM.MPF, MYPROGRAM__1.MPF, and MYPROGRAM__3.MPF already exist in a directory, MYPROGRAM__2.MPF is created as the next copy of MYPROGRAM.MPF.

Procedure



1. Select the "Program Manager" operating area.



2. Choose the desired storage location and position the cursor on the file or directory which you would like to copy.

3. Press the "Copy" softkey.



4. Select the directory in which you want to paste your copied directory/program.

5. Press the "Paste" softkey.

An appropriate note is displayed if a directory/program with the same name exists in this directory. You are requested to assign a new name, otherwise the directory/program is assigned a name by the system.

If the name contains illegal characters or is too long, a prompt will appear for you to enter a permissible name.



6. Press the "OK" or "Overwrite all" softkey if you want to overwrite existing directories/programs.



- OR -



Press the "No overwriting" softkey if you do not want to overwrite already existing directories/programs.

- OR -



Press the "Skip" softkey if the copy operation is to be continued with the next file.

- OR -

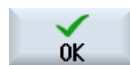

Enter another name if you want to paste the directory/program under another name and press the "OK" softkey.

Note**Copying files in the same directory**

You cannot copy files to the same directory. You must copy the file under a new name.

13.10 Deleting a directory/program

Delete programs or directories from time to time that you are no longer using to maintain a clearer overview of your data management. Back up the data beforehand, if necessary, on an external data medium (e.g. USB FlashDrive) or on a network drive.

Please note that when you delete a directory, all programs, tool data and zero point data and subdirectories that this directory contains are deleted.

Procedure



1. Select the "Program manager" operating area.



2. Choose the desired storage location and position the cursor on the file or directory that you would like to delete.

3. Press the ">>" and "Delete" softkeys.

A prompt appears as to whether you really want to delete the file or directory.



4. Press the "OK" softkey to delete the program/directory.



- OR -.



Press the "Cancel" softkey to cancel the process.

13.11 Changing file and directory properties

Information on directories and files can be displayed in the "Properties for ..." window.

Information on the creation date is displayed near the file's path and name.

You can change names.

Changing access rights

Access rights for execution, writing, listing and reading are displayed in the "Properties" window.

- Execute: Is used for the selection for execution
- Write: Controls the changing and deletion of a file or a directory

For NC files, you have the option to set the access rights from keyswitch 0 to the current access level, to be set separately for each file.

If an access level is higher than the current access level, it cannot be changed.

For external files (e.g. on a local drive), the access rights are displayed to you only if settings have been made for these files by the machine manufacturer. They cannot be changed via the "Properties" window.

Settings for the access rights to directories and files

Via a configuration file and MD 51050, access rights of the directories and file types of the NC and user memory (local drive) can be changed and pre-assigned.

Further information: SINUMERIK Operate Commissioning Manual

Procedure



1. Select the program manager.



2. Choose the desired storage location and position the cursor on the file or directory whose properties you want to display or change.



3. Press the ">>" and "Properties" softkeys.
The "Properties from ..." window appears.



4. Enter any necessary changes.
Note: You can save changes via the user interface in the NC memory.

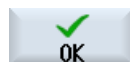

5. Press the "OK" softkey to save the changes.

13.12 Set up drives

13.12.1 Overview

Up to 21 connections to so-called logical drives (data carriers) can be configured. These drives can be accessed in the "Program manager" and "Startup" operating areas.

The following logical drives can be set up:

- USB interface
- Network drives
- CompactFlash card
- CompactFlash card of the NCU, only for SINUMERIK Operate in the NCU
- Local hard disk of the PCU, only for SINUMERIK Operate on PCU



Software option

In order to use the CompactFlash card as a data carrier, you require the option "Additional HMI user memory on CF card of NCU" (not for SINUMERIK Operate on PCU/PC).

Note

The USB interfaces of the NCU are not available for SINUMERIK Operate and can therefore not be configured.

13.12.2 Setting up drives

The "Set Up Drives" window is available in the "Start-up" operating area for configuring the softkeys in the Program Manager.

Note

Reserved softkeys

Softkeys 4, 7 and 16 are not available to be freely configured.



Machine manufacturer

Please refer to the machine manufacturer's specifications.

File

The created configuration data is stored in the "logdrive.ini" file. This file is located in the /user/sinumerik/hmi/cfg directory.

General information

Entry		Meaning
Drives 1 - 24		
Type	No drive	No drive defined
	NC program memory	Access to the NC memory
	USB local	Access to the USB interface of the active operator unit
	USB global	All of the TCUs in the plant network can access the USB memory medium.
	NW Windows	Network drive in Windows systems.
	NW Linux	Network drive in Linux systems.
	Local drive	Local drive. Hard disk or user memory on the Compact-Flash card.
	FTP	Access to an external FTP server. The drive cannot be used as global part program memory.
	User cycles	Access to the user cycle directory of the CompactFlash card
	Manufacturer cycles	Access to the manufacturer cycle directory of the CompactFlash card
	Drive Windows	Access to a local PCU/PC directory.

Specifications for USB

Entry		Description
Device		Names of the TCU to which the USB storage medium is connected, e.g. tcu1. The NCU must already know the TCU name.
Connection	Front	USB interface that is located at the front of the operator panel.
	X203/X204	USB interface X203/X204 that is located at the rear of the operator panel.
	X61/X62	For SIMATIC Thin Client, the USB interfaces are X61 and X62.
	X212/X213	TCU20.2/20.3
	X20	OP 08T
	X60.P1/P2/P3/P4	PCU
Symbolic		Symbolic drive name.
Additional parameters under Details		

Entry		Description
Partition		Partition number on the USB storage medium, e.g. 1 or all. If a USB hub is being used, then specify the USB port of the hub.
USB path		Path to the USB hub. Note: This value is not currently evaluated.

Specifications for local drives

Entry		Description
Symbolic		Symbolic drive name. Assignment of the names under Details
Additional parameters under Details		
Use drive as:	LOCAL_DRIVE	The activation of the checkbox assigns the symbolic name to the drive.
	CF_CARD	
	SYS_DRIVE	If an assignment exists already for the drive, no change can be made. All checkboxes are active as preassignment.

Specifications for network drives

Entry		Description
Computer name		Logical name of the server or the IP address.
Release name	Only for network drives in Windows systems.	Name, under which the network drive was released
Path		Start directory. The path is specified relative to the released directory.
User name Password		Enter the user name and the corresponding password for which the directory is enabled on the server. The password is displayed in encoded form as string of "*" characters and is stored in the "logdrive.ini" file.
Symbolic		Symbolic drive name. Maximum 12 characters can be entered (letters, digits, underscore). The names NC, GDIR and FTP are reserved. They are also used to label the softkey if a softkey text is not specified.

Specifications for FTP

Entry		Description
Computer name		Logical name of the FTP server or the IP address.
Path		Start directory on the FTP server. The path is specified relative to the home directory.
User name Password		User names and the associated password for login to the FTP server. The password is displayed in encoded form as string of "*" characters and is stored in the "logdrive.ini" file.
Additional parameters under Details		
Port		Interface for the FTP connection. The default port is 21.
Disconnect		After a disconnect timeout, the FTP connection is disconnected. The timeout can be between 1 and 150 s. 10 s is the default setting.

Additional specifications when using the "Execution from external storage (EES)" function





Machine manufacturer

Please refer to the machine manufacturer's specifications.

Entry		Description
Enable drive	Only for "Drive Windows (PCU)" type	The drive is enabled in the network. A user name is required. The checkbox must be activated if the local drive serves as global part program memory.
Global part program memory	Only for local drives, network drives and global USB drives	The checkbox indicates that all system nodes have access to the configured logical drive. The nodes can directly execute part programs from the drive. The setting can only be changed under Details.
Use this drive for EES program execution	Only for USB drives	Allows a local USB storage medium to be used to execute programs using EES.
Additional parameters under Details		
Windows user name Windows password	Only for USB drives, local drives and local directories	User name and the associated password for release of the configured drive. The specifications from the "Global Settings" window are used as default setting.
Global part program memory	Only for local drives, network drives and global USB drives	The checkbox defines whether all system nodes have access to the configured logical drive. Only one drive can be selected as global part program memory (GDIR). If another drive has already been defined as GDIR and the checkbox is activated, the original setting is deleted.

Specifications for the configured softkey

Entry		Description
Access level		Assign access rights to the connections: From access level 7 (keyswitch position 0) to access level 1 (manufacturer). The particular assigned access level applies to all operating areas.
Softkey text		Two lines are available as labeling text for the softkey. %n is accepted as a line separator. If the first line is too long, then a line break is automatically inserted. If a space is present, it is taken as a line separator. For language-dependent softkey texts, the text ID is entered, which is used to search in the text file. If nothing is specified in the entry field, then the symbolic drive name is used as softkey text.
Softkey icon	No icon	No icon is displayed on the softkey.
	sk_usb_front.png 	File names of the icon displayed on the softkey.
	sk_local_drive.png 	
	sk_net-work_drive_ftp.png 	
Text file	slpmdialog	
Text context	SIPmDialog	File for language-dependent softkey text. If nothing is specified in the input fields, the text appears on the softkey as was specified in the "Softkey text" input field.

Procedure

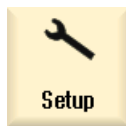





1. Select the "Start-up" operating area.



2. Press the "HMI" and "Log. drive" softkeys.
The "Set Up Drives" window opens.





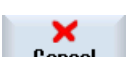

3. Select the softkey that you want to configure.

- | | | |
|---|----|---|
|  | 4. | To configure softkeys 9 to 16 or softkeys 17 to 24, click the ">> level" softkey. |
|  | 5. | To allow entry fields to be edited, press the "Change" softkey. |
|  | 6. | Select the data for the corresponding drive or enter the necessary data. |
|  | 7. | Press the "Details" softkey if you want to enter additional parameters. Press the "Details" softkey to return to the "Set Up Drives" window. |
|  | 8. | Press the "OK" softkey. The entries are checked. A window with the appropriate message opens if the data is incomplete or incorrect. Acknowledge the message with "OK" softkey. |
|  | | If you press the "Cancel" softkey, then all of the data that has not been activated is rejected. |
| | 9. | Restart the control in order to activate the configuration and to obtain the softkeys in the "Program Manager" operating area. |

Entering the default settings for drive release

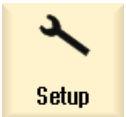
Note

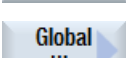
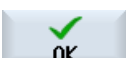
This function is available only on Windows systems when the "Execution from external storage (EES)" software option is activated.

- | | | |
|---|----|--|
|  | 1. | Select the "Start-up" operating area. |
|  | 2. | Press the "HMI" and "Log. drive" softkeys. The "Set Up Drives" window opens. |
|  | | |
|  | 3. | Press the "Glob. settings" softkey. |
|  | 4. | Enter the user name and the associated password for the configured drives to be released. |
|  | 5. | Press the "OK" softkey. The specifications are transferred as default setting for the Windows release. |
|  | | If you press the "Cancel" softkey, then all of the data that has not been activated is rejected. |

13.13 Viewing PDF documents

You have the option of displaying HTML documents, as well as PDFs, on all drives of the program manager via the data tree of the system data.

Note

A preview of the documents is only possible for PDFs.

Procedure



1. In the "Program manager" operating area, select the desired storage medium.



- OR -



Select the desired storage location in the "Commissioning" operating area in the data tree of the "System data".



2. Position the cursor on the PDF or the HTML file that you want to display, and press the "Open" softkey.

The selected file is displayed on the screen.

The storage path of the document is displayed in the status bar. The current page as well as the total number of pages of the document are displayed.



3. Press the "Zoom +" or "Zoom -" softkey to enlarge or reduce the size of the display.



Navigation and search for specific texts



1. Press the "Search" softkey.
A new vertical softkey bar is displayed.



2. Press the "Go to start" softkey to navigate to the first page of the document.



3. Press the "Go to end" softkey to navigate to the last page of the document.





4. Press the "Go to page" softkey to navigate to a specific page of the document.



5. Press the "Search" softkey if you want to search for specific texts in the PDF.



6. Enter the required term in the search form and confirm with "OK".
The cursor is positioned on the first entry that corresponds to the search term.







- | | |
|---|---|
|  | 7. Press the "Continue search" softkey if the text that is found is not the specific text that you are looking for. |
|  | 8. Press the "Back" softkey to return to the higher-level softkey bar. |

Note



If you change the language when viewing a PDF document, the PDF document is reloaded in the respective language. If no PDF document is available for the language set, the English PDF document is displayed.

The position in the PDF document is retained beyond language switchover across sessions if the PDF document contains bookmarks.

Changing the display

- | | |
|---|--|
|  | 1. Press the "View" softkey to change the representation of the PDF.
A new vertical softkey bar is displayed. |
|  | 2. Press the "Zoom page width" softkey to display the document in full width on the screen. |
| | - OR - |
|  | Press the "Zoom page length" softkey to display the document with full height on the screen. |
| | - OR - |
|  | Press the "Rotate left" softkey to rotate the document through 90 degrees to the left. |
| | - OR - |
|  | Press the "Rotate right" softkey to rotate the document through 90 degrees to the right. |
|  | 3. Press the "Back" softkey to return to the higher-level softkey bar. |

Copying text

- | | |
|---|---|
|  | 1. Press the "Mark" softkey.
The "Copy" softkey can be used. |
| | 2. Select the required text either by touching or with the mouse. |
|  | 3. Press the "Copy" softkey.
"The marked text is available for insertion in the editor" |
|  | 4. Press the "Mark" softkey again to shift the displayed section by touching.
The "Copy" softkey cannot be used. |

Closing the PDF

- | | |
|---|--|
|  | 1. Press the "Close" softkey to close the PDF. |
|---|--|

13.14 EXTCALL

The EXTCALL command can be used to access files on a local drive, USB data carriers or network drives from a part program.

The programmer can set the source directory with the setting data SD \$SC42700 EXT_PROG_PATH and then specify the file name of the subprogram to be loaded with the EXTCALL command.

Supplementary conditions

The following supplementary conditions must be taken into account with EXTCALL calls:

- You can only call files with the MPF or SPF extension via EXTCALL from a network drive.
- The files and paths must comply with the NCK naming conventions (max. 25 characters for the name, 3 characters for the identifier).
- A program is found on a network drive with the EXTCALL command if
 - with SD \$SC42700 EXT_PROG_PATH the search path refers to the network drive or a directory contained on the network drive. The program must be stored directly on that level, no subdirectories are searched.
 - without SD \$SC42700 the correct location of the program is specified in the EXTCALL call itself by means of a fully qualified path that can also point to a subdirectory of the network drive.
- For programs that were generated on external storage media (Windows system) observe upper- and lower-case syntax.

Note

Maximum path length for EXTCALL

The path length must not exceed 112 characters. The path comprises the contents of the setting data (SD \$SC42700) and the path data for EXTCALL call from the part program.

Examples of EXTCALL calls

The setting data can be used to perform a targeted search for the program.

- Call of USB drive on TCU (USB storage device on interface X203), if SD42700 is empty: e.g. EXTCALL "//TCU/TCU1 /X203 ,1/TEST.SPF"
- OR -
Call of USB drive on TCU (USB storage device on interface X203), if SD42700 "//TCU/TCU1 / X203 ,1" contains: EXTCALL "TEST.SPF"
- Call of the USB front connection (USB-FlashDrive), if SD \$SC 42700 is empty: e.g. EXTCALL "// ACTTCU/FRONT,1/TEST.SPF"
- OR -
Call of USB front connection (USB-FlashDrive), if SD42700 "//ACTTCU/FRONT,1" contains: EXTCALL "TEST.SPF"

- Call of network drive, if SD42700 is empty: e.g. EXTCALL "//computer name/enabled drive/TEST.SPF"
- OR -
Call of the network drive, if SD \$SC42700 "//Computer name/enabled drive" contains:
EXTCALL "TEST.SPF"
- Use of the HMI user memory (local drive):
 - On the local drive, you have created the directories part programs (mpf.dir), subprograms (spf.dir) and workpieces (wks.dir) with the respective workpiece directories (.wpd):
SD42700 is empty: EXTCALL "TEST.SPF"
The same search sequence is used on the CompactFlash card as in the NCK part program memory.
 - On the local drive, you have created your own directory (e.g. my.dir):
Specification of the complete path: e.g. EXTCALL "/user/sinumerik/data/prog/my.dir/TEST.SPF"
A search is performed for the specified file.

Note**Abbreviations for local drive, CompactFlash card and USB front connection**

As abbreviation for the local drive, the CompactFlash card and the USB front connection you can use the abbreviation LOCAL_DRIVE:, CF_CARD: and USB: (e.g. EXTCALL "LOCAL_DRIVE:/spf.dir/TEST.SPF").

Alternatively, you can also use the abbreviations CF_Card and LOCAL_DRIVE.

**Software options**

To display the "Local drive" softkey, you require option "Additional HMI user memory on CF card of the NCU" (not for SINUMERIK Operate on PCU50 / PC).

NOTICE**Possible interruption when executing from USB FlashDrive**

Direct execution from a USB-FlashDrive is not recommended.

There is no protection against contact problems, falling out, breakage through knocking or unintentional removal of the USB-FlashDrive during operation.

Disconnecting it during operation will result in immediate stopping of the machining and, thus, to the workpiece being damaged.

**Machine manufacturer**

Processing EXTCALL calls can be enabled and disabled.

Please observe the information provided by the machine manufacturer.

13.15 Execution from external memory (EES)

The "Execution from external storage" function allows you to directly execute any size of part program from an appropriately configured drive. The behavior is the same as that for execution from the NC part program memory without the restrictions that apply to "EXTCALL".



Software option

You require the "CNC user memory extended" software option in order to use this function in the user memory (100 MB) of the CompactFlash card.



Software option

In order to use this function without restrictions, e.g. for a network drive or a USB drive, you require the "Execution from external storage (EES)" software option.

Note

Not possible to teach-in program

When an EES program has been selected, it is not possible to teach-in programs.



Machine manufacturer

Please observe the information provided by the machine manufacturer.

You have the option of processing the G code programs saved on the configured external drives as usual in the editor.

When executing the G code programs, you obtain a current block display, as usual. You can edit the programs directly in the Reset state.

In addition to the current block display, you can also show a basic block display. You can make corrections with the "Program correction" function, as usual.

13.16 Backing up data

13.16.1 Generating an archive in the Program Manager

You have the option of archiving individual files from the NC memory and the local drive.

Archive formats

You have the option of saving your archive in the binary and punched tape format.

Save target

The archive folder of the system data in the "Startup" operating area as well as USB and network drives are available as save target.

Procedure



1. Select the "Program Manager" operating area.



2. Select the storage location for the file/files to be archived.

3. In the directories, select the required file from which you want to create an archive.

- OR -



- If you want to back up several files or directories, press the "Select" softkey. Make the selection using the cursor keys or mouse.



4. Press the ">>" and "Archive" softkeys.



5. Press the "Generate archive" softkey.

The "Generate Archive: Select archiving" window opens.



6. Position the cursor to the required storage location, press the "Search" softkey, enter the required search term in the search dialog and press the "OK" softkey if you wish to search for a specific directory or subdirectory.

Note: The place holders "*" (for any character string) and "?" (for any character) make it easier for you to perform a search.

- OR -



- Select the required storage location, press the "New directory" softkey, enter the required name in the "New directory" window and press the "OK" softkey to create a directory.

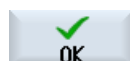



7. Press "OK".
The "Generate Archive: Name" window opens.



9. Select the format, enter the required name and press the "OK" softkey.
A message informs you if archiving was successful.

13.16.2 Generating an archive via the system data

If you only want to backup specific data, then you can select the desired files directly from the data tree and generate an archive.

Archive formats

You have the option of saving your archive in the binary and punched tape format.

You can display the content of the selected files (XML, ini, hsp, syf files, programs) using a preview.

You can display information about the file, such as path, name, date of creation and change, in a Properties window.

Precondition

The access rights depend on the relevant areas and range from protection level 7 (key switch position 0) to protection level 2 (password: Service).

Storage locations

- CompactFlash card under
/user/sinumerik/data/archive, or
/oem/sinumerik/data/archive
- All configured logical drives (USB, network drives)



Software option

In order to save archives on the CompactFlash Card in the user area you require the "Additional HMI user memory on CF card of NCU" option.

NOTICE
Possible data loss when using USB flash drives
USB-FlashDrives are not suitable as persistent memory media.

Procedure



1. Select the "Startup" operating area.



2. Press the "System data" softkey.
The data tree opens.

3. In the data tree, select the required files from which you want to generate an archive.

- OR -



If you want to back up several files or directories, press the "Select" softkey. Make the selection using the cursor keys or mouse.



4. If you press the ">>" softkey, further softkeys are displayed on the vertical bar.



5. Press the "Preview window" softkey.
The contents of the selected file are displayed in a small window. Press the "Preview window" softkey again to close the window.



6. Press the "Properties" softkey.
Information about the selected file is displayed in a small window. Press the "OK" softkey to close the window.

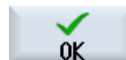

7. Press the "Search" softkey.
Enter the required search term in the search dialog and press the "OK" softkey if you wish to search for a specific directory or subdirectory.

Note: The place holders "*" (for any character string) and "?" (for any character) make it easier for you to perform a search.

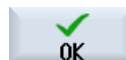

8. Press the "Archive" and "Generate archive" softkeys.
The "Generate Archive: Select Storage Location" window opens.



The "Archive" folder with the subfolders "User" and "Manufacturer" as well as the storage media (e.g. USB) are displayed.



9. Select the required location for archiving and press the "New directory" softkey to create a suitable subdirectory.
The "New Directory" window opens.

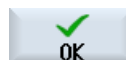

10. Enter the required name and press the "OK" softkey.
The directory is created below the selected folder.

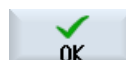

11. Press the "OK" softkey.
The "Generate Archive: Name" window opens.

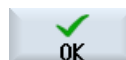

12. Select the format, enter the required name and press the "OK" softkey to archive the file/files.
A message informs you if archiving was successful.

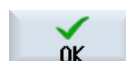

13. Press the "OK" softkey to confirm the message and end the archiving operation.
An archive file is created in the selected directory.

13.16.3 Reading in an archive in the Program Manager

In the "Program Manager" operating area, you have the option of reading in archives from the archive folder of the system data as well as from configured USB and network drives.



Software option

You require option "Additional HMI user memory on CF card of the NCU" in order to read in user archives in the "Program Manager" operating area.

Procedure



1. Select the "Program Manager" operating area.



2. Press the "Archive" and "Read in archive" softkeys. The "Read in archive: Select archive" window opens.



3. Select the archive storage location and position the cursor on the required archive.

Note: When the option is not set, the folder for user archives is only displayed if the folder contains at least one archive.

- OR -



Press the "Search" softkey and in the search dialog, enter the name of the archive file with file extension if you wish to search for a specific archive and press the "OK" softkey.



4. Press the "OK" or "Overwrite all" softkey to overwrite existing files.

...



- OR -



Press the "Do not overwrite" softkey if you do not want to overwrite already existing files.

- OR -



Press the "Skip" softkey if the read-in operation is to be continued with the next file.

The "Read In Archive" window opens and a progress message box appears for the read-in process.



- You will then obtain a "Read error log for archive" in which the skipped or overwritten files are listed.
5. Press the "Cancel" softkey to cancel the read-in process.

See also

Searching directories and files (Page 337)

13.16.4 Read in archive from system data

If you want to read in a specific archive, you can select this directly from the data tree.

Procedure

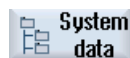
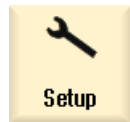

...



1. Select the "Startup" operating area.
2. Press the "System data" softkey.
3. In the data tree below the "Archive" directory, in the "User" folder, select the file that you wish to read in.
4. Press the "Read in" softkey.
5. Press the "OK" or "Overwrite all" softkey to overwrite existing files.

- OR -
Press the "Do not overwrite" softkey if you do not want to overwrite already existing files.

- OR -
Press the "Skip" softkey if the read-in operation is to be continued with the next file.

The "Read In Archive" window opens and a progress message box appears for the read-in process.

You will then obtain a "Read error log for archive" in which the skipped or overwritten files are listed.
6. Press the "Cancel" softkey to cancel the read-in process.

13.17 Setup data

Apart from programs, you can also save tool data and zero point settings.

You can use this option, for example, to backup the required tools and zero point data for a specific G code program. If you want to execute this program at a later point in time, you will then have quick access to the relevant settings.

Even tool data that you have measured on an external tool setting station can be copied easily into the tool management system using this option.

Note

Backing up setup data from part programs

Setup data from part programs can only be backed up if they have been saved in the "Workpieces" directory.

For part programs, which are located in the "Part programs" directory, "Save setup data" is not listed.

Backing up data

Data	
Tool data	<ul style="list-style-type: none"> • No • Complete tool list
Magazine assignment	<ul style="list-style-type: none"> • Yes • No
Zero points	<ul style="list-style-type: none"> • No The selection box "Basis zero point" is hidden • All
Basic zero points	<ul style="list-style-type: none"> • No • Yes
Directory	The directory is displayed, in which the selected program is located.
File name	Here you have the option of changing the suggested file names.

Note

Magazine assignment

You can only read out the magazine assignments if your system provides support for loading and unloading tool data to and from the magazine.

Procedure



1. Select the "Program Manager" operating area.



2. Position the cursor on the program whose tool and zero point data you wish to back up.

...



3. Press the ">>" and "Archive" softkeys.



4. Press the "Setup data" softkey.

The "Backup setup data" window opens.

5. Select the data you want to back up.

6. When required, change the specified name of the originally selected program here in the "File name" field.



7. Press the "OK" softkey.

The setup data will be set up in the same directory in which the selected program is stored.

The file is automatically saved as INI file.

Note

Program selection

If a main program as well as an INI file with the same name are in a directory, when selecting the main program, initially, the INI file is automatically started. In this way, unwanted tool data can be changed.



Machine manufacturer

Please refer to the machine manufacturer's specifications.

13.17.1 Reading-in set-up data

When reading-in, select which of the backed-up data you require:

- Tool data
- Magazine assignment

- Zero points
- Basic zero point

Tool data

Depending on which data you have selected, the system behaves as follows:

- Complete tool list
First, all tool management data are deleted and then the saved data are imported.
- All tool data used in the program
If at least one of the tools to be read in already exists in the tool management system, you can choose between the following options.



Select the "Replace all" softkey to import all tool data. Any existing tools will now be overwritten without a warning prompt.

- OR -



Press the "Do not overwrite" softkey if existing tools must not be overwritten.

Already existing tools are skipped, without you receiving any queries.

- OR -



Press the "Skip" softkey if already existing tools are not to be overwritten. For an already existing tool, you receive a query.

Selecting loading point

For a magazine, if more than one loading point was set-up, using the "Select loading point" softkey, you have the option of opening a window in which you can assign a loading point to a magazine.

Procedure



1. Select the "Program Manager" operating area.



2. Position the cursor on the file with the backed-up tool and zero point data (*.INI) that you wish to re-import.



3. Press the <Cursor right> key

- OR -

Double-click the file.

The "Read-in setup data" window opens.



4. Select the data (e.g. magazine assignment) that you wish to read-in.



5. Press the "OK" softkey.

13.18 Recording tools and determining the demand

13.18.1 Overview

The "Record tools and determine tool demand" function allows you to record all the tools you need when executing and simulating part programs. In this way you can determine the tool demand.



Software options

In order to use the "Record tools and determine demand" function, you need the "Determine tool demand" option.



Machine manufacturer

Please observe the information provided by the machine manufacturer.

The "Record tools and determine demand" function can be helpful in the following work steps on single-channel and multi-channel machines:

- Preparation of a new workpiece while the old workpiece is still being machined:
 - All new tools must be loaded additionally
- Change of the workpiece at the machine:
 - All old tools can be unloaded
 - All new tools must be loaded

You activate the recording of tools in the settings for automatic operation. Recording takes place during processing.

You can also activate recording for the simulation.

The recorded tool data are stored in a TTD file (Tool Time Data). The TTD file is always located with the associated part program.

Note

The recorded tool data of a tool path is only valid if the program has been run through completely. Otherwise the data will not be saved and the previous TTD file will be retained.

13.18.2 Opening tool data

Introduction

The recorded tool data are stored in a TTD file (Tool Time Data). The TTD file is always located with the associated part program and contains the following information:

- Tool data
- Magazine assignment
- Operating time, idle time, tool number, D number, ID per block

You can open the TTD file with the "Check loading" softkey.

Note

You can only open TTD files that are assigned to the active channel.

Opening a TTD file



1. Select the "Program Manager" operating area.



2. Under part programs, open the corresponding file with the extension *.TTD.



The "Tools for program" window opens.

The file contents are displayed in the form of a tool list.

Note

If the TTD file is older than the associated part program, a message informs you of this.

13.18.3 Checking the loading

When you click the "Check loading" softkey, the "Check loading" window opens.

The view in the "Check loading" window is divided into the following sections:

- Missing tools: tool not available
- Tools still to be loaded: tool available but not loaded

13.18 Recording tools and determining the demand

- Loaded tools: tools available and loaded
- Tools not required: tools available and loaded, but not required

You can adjust all tool data displayed in the "Check loading" window as required, load and unload tools individually or through multiple selection, enter the tool lengths for newly measured tools directly.

The list is updated after each action.

13.19 Backing up parameters

In addition to the programs, you can also save R-parameters and global user variables.

You can use this option, for example, to back up the required arithmetic parameters and user variables for a specific program. If you want to execute this program at a later point in time, you will then have quick access to the relevant data.

Note

Backing up parameters from part programs

Parameters from part programs can only be backed up if they have been saved in the "Workpieces" directory.

For part programs that are located in the "Part programs" or "Subprograms" directory, "Save parameters" is not listed.

Backing up data

Which data is offered for backup depends on the machine configuration:

Data	
R parameters	<ul style="list-style-type: none"> • No • Yes - all channel-specific arithmetic parameters
Global R parameters	<ul style="list-style-type: none"> • No • Yes - all global arithmetic parameters
UGUD parameters	<ul style="list-style-type: none"> • No • Yes - all channel-specific variables of the user
Global UGUD parameters	<ul style="list-style-type: none"> • No • Yes - all global variables of the user
MGUD parameters	<ul style="list-style-type: none"> • No • Yes - all channel-specific variables of the machine manufacturer
Global MGUD parameters	<ul style="list-style-type: none"> • No • Yes - all global variables of the machine manufacturer
Directory	The directory is displayed, in which the selected program is located.
File name	Here you have the option of changing the suggested file names.

For multi-channel machines, the parameters of the active channel are always backed up.

Job lists

If you select Back up parameters for a job list, the parameters of all programs that it contains are backed up.

The name of the job list does not agree with the names of the programs it contains. To nevertheless permit the unique assignment of the parameter files, they are always assigned the same name as the associated program. You cannot change these file names.

Procedure



1. Select the "Program Manager" operating area.



2. Select the drive on which the program is saved.

...



3. Position the cursor on the program whose parameters you want to back up.



4. Press the ">>" and "Archive" softkeys.



5. Press the "Save parameters" softkey.
The "Save parameters" window appears.

6. Select the data you want to back up.



7. Press the <CHANNEL> key or click on the channel display if you want to change the active channel.

- OR -



8. Change the specified name of the originally selected program in the "File name" field as required.



9. Press the "OK" softkey.
The parameters are saved in the same directory in which the selected program is stored.
The R-parameters (*.RPA) and the user variables (*.GUD) are saved in separate files.

Note

Program selection

If a directory contains a main program as well as an RPA file or a GUD file with the same name, initially these files are automatically started when the main program is selected. Tool data or parameters may accidentally be changed as a result.



Machine manufacturer

Please refer to the machine manufacturer's instructions.

13.20 RS-232-C

13.20.1 Reading-in and reading-out archives via a serial interface

You have the option of reading out and reading in archives in the "Program manager" operating area as well as in the "Startup" operating area via the V24 serial interface.

Availability of the V24 serial interface

If you want to change the availability of the V24 interface, you can adjust the following parameters in file "slpmconfig.ini":

Parameters	Description
[V24]	Describes the section in which the relevant setting parameters are located.
useV24	Setting for the availability of the V24 serial interface
= true	Interface and softkeys are available (default)
= false	Interface and softkeys are not available

Storage of file "slpmconfig.ini"

The template of the file "slpmconfig.ini" for SINUMERIK Operate is stored in the following directory:

<Installation path>/siemens/sinumerik/hmi/template/cfg

Copy the file to one of the following directories:

<Installation path>/user/sinumerik/hmi/cfg

<Installation path>/oem/sinumerik/hmi/cfg

Note

If you want to achieve a better overview of the changes you have made yourself, simply delete the unchanged parameters from the file copy "slpmconfig.ini".

Reading-out archives

The files to be sent (directories, individual files) are zipped in an archive (*.arc). If you send an archive (*.arc), this is sent directly without being additionally zipped. If you have selected an archive (*.arc) together with an additional file (e.g. directory), then these are zipped into a new archive and are then sent.

Reading-in archives

Use interface V24 if you want to read in archives. They are transferred and then subsequently unzipped.

Note

Reading in commissioning archives

When you read in a commissioning archive via the V24 interface, then this is immediately activated.

Externally processing the punched tape format

If you wish to externally process an archive, then generate this in the punched tape format.

Procedure



1. Select the "Program manager" operating area, and press the "NC" or "Local. drive" softkey.



...



- OR -

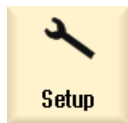

Select the "Startup" operating area and press the "System data" softkey.



Reading-out archives



2. Select the directories or the files that you wish to send to V24.
3. Press the ">>" and "Archive" softkeys.



4. Press the "V24 send" softkey.

- OR -

Reading in an archive



Press the "V24 receive" softkey if you wish to read-in files via V24.

V24 setting	Meaning
Protocol	The following protocols are supported for transfer via the V24 interface: <ul style="list-style-type: none"> • RTS/CTS (default setting) • Xon/Xoff
Transfer	Data transfer using a secured protocol (ZMODEM protocol): <ul style="list-style-type: none"> • Normal (default setting) • secure For the selected interface, secure data transfer is set in conjunction with handshake RTS/CTS.
Baud rate	Transfer rate: up to 115 kbaud data transfer rate. The baud rate that can be used depends on the connected device, the cable length and the general electrical conditions. <ul style="list-style-type: none"> • 110 • • 19200 (default) • ... • 115200
Archive format	<ul style="list-style-type: none"> • Punched tape format (default setting) • Binary format (PC format)
V24 settings (details)	
Interface	<ul style="list-style-type: none"> • COM1
Parity	Parity bits are used for error detection: The parity bits are added to the coded characters to make the number of positions set to "1" an uneven number (uneven parity) or to an even number (even parity). <ul style="list-style-type: none"> • None (default setting) • Odd • Even
Stop bits	Number of stop bits for asynchronous data transfer. <ul style="list-style-type: none"> • 1 (default) • 2
Data bits	Number of data bits for asynchronous data transfer. <ul style="list-style-type: none"> • 5 bits • ... • 8 bits (default setting)
XON (hex)	Only with protocol: Xon/Xoff
XOFF (hex)	Only with protocol: Xon/Xoff
Wait for XON for start receive V24	Only with protocol: Xon/Xoff

V24 setting	Meaning
End of data transfer (hex)	Only for punched tape format Stop with end of data transfer character The default setting for the end of data transfer character is (HEX) 1A
Time monitoring (sec)	Time monitoring For data transfer problems or at the end of data transfer (without end of data transfer character) data transfer is interrupted after the specified number of seconds. The time monitoring is controlled by a time generator (clock) that is started with the first character and is reset with each transferred character. The time monitoring can be set (seconds).

Procedure



1. Select the "Program Manager" operating area.



2. Press softkey "NC" or "Local Drive".



3. Press the ">>" and "Archive" softkeys.

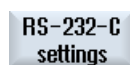

4. Select the "V24 settings" softkey.
Window "Interface: V24" is opened.

5. The interface settings are displayed.



6. Press the "Details" softkey if you wish to view and process additional settings for the interface.

Teaching in a program

14.1 Overview

The "Teach in" function can be used to edit programs in the "AUTO" and "MDA" modes. You can create and modify simple traversing blocks.

You traverse the axes manually to specific positions in order to implement simple machining sequences and make them reproducible. The positions you approach are applied.

In the "AUTO" teach-in mode, the selected program is "taught".

In the "MDA" teach-in mode, you teach to the MDA buffer.

External programs, which may have been generated offline, can therefore be adapted and modified according to your specific requirements.

Note

Not possible to teach-in program

When an EES program has been selected, it is not possible to teach-in programs.

General sequence

1. Activate teach-in mode.
2. Insert a block.
To do this, position the cursor at the desired point in the program and insert an empty line. Press the relevant softkey "Teach position", "Rapid traverse G01", "Straight line G1", or "Circle interpolation position CIP" and "Circle end position CIP".
- OR -
3. Change an existing block.
To do this, mark the desired program block, and press the corresponding softkey "Teach in position", "Rapid traverse G01", "Straight line G1", or "Circle interpolation point CIP" and "Circle end point CIP".
You can only overwrite a block with a block of the same type.
4. Traverse the axes.
5. Press the "Accept" softkey to teach-in the modified or newly created program block.

Note

Teach in multiple blocks

All defined axes are "taught in" in the first teach-in block. In all additional teach-in blocks, only axes modified by axis traversing or manual input are "taught in".

If you exit teach-in mode, this sequence begins again.

Note

Selection of axes and parameters for teach-in

You can select the axes to be included in the teach-in block in the "Settings" window.

You also specify here whether motion and transition parameters are offered for teach-in.

Operating mode or operating area switchover

If you switch to another operating mode or operating area while in teach-in mode, the position changes will be canceled and teach-in mode will be cleared.

14.2 Select teach in mode

Change to Teach in mode to adapt the current program.

Requirement

"AUTO" mode: The program to be edited is selected.

"MDI" mode: The program to be edited is loaded into the MDI buffer.

Procedure



1. Select the "Machine" operating area.



2. Press the <AUTO> or <MDA> key.



3. Press the <TEACH IN> key.



4. Press the "Teach prog." softkey.

14.3 Processing a program

14.3.1 Inserting a block

The cursor must be positioned on an empty line.

The windows for pasting program blocks contain input and output fields for the actual values in the WCS. Depending on the default setting, selection fields with parameters for motion behavior and motion transition are available.

When first selected, the input fields are empty, unless axes had already been traversed before the window was selected.

All data from the input/output fields are transferred to the program with the "Accept" softkey.

Procedure



1. Teach-in mode is active.

2. Position the cursor at the desired point in the program.
If an empty row is not available, insert one.



3. Press the softkeys "Rap. tra. G0", "Straight line G1", or "Circ. intern. pos. CIP" and "Circ. end pos. CIP".



The relevant windows with the input fields are displayed.



4. Traverse the axes to the relevant position.

5. Press the "Accept" softkey.

A new program block will be inserted at the cursor position.

- OR -



Press the "Cancel" softkey to cancel your input.

14.3.2 Editing a block

You can only overwrite a program block with a teach-in block of the same type.

The axis values displayed in the relevant window are actual values, not the values to be overwritten in the block.

Note

If you wish to change any variable in a block in the program block window other than the position and its parameters, then we recommend alphanumerical input.

Procedure



1. Teach-in mode is active.
2. Select the program block to be edited.
3. Press the relevant softkey "Teach position, "Rap. tra. GO", "Straight line G1", or "Circ. intern. pos." CIP", and "Circ. end pos. CIP".
The relevant windows with the input fields are displayed.
4. Traverse the axes to the desired position and press the "Accept" softkey.
The program block is taught with the modified values.
- OR -
Press the "Cancel" softkey to cancel the changes.

14.3.3 Selecting a block

You have the option of setting the interrupt pointer to the current cursor position. The next time the program is started, processing will resume from this point.

With teach-in, you can also change program areas that have already been executed. This automatically disables program processing.

You must press reset or select a block to resume the program.

Procedure



1. Teach-in mode is active.
2. Place the cursor on the desired program block.
3. Press the "Block selection" softkey.

14.3.4 Deleting a block

In teach-in mode, you can delete both a teach-in block and a program block entirely.

Procedure



1. Teach-in mode is active.



2. Select the program block to be deleted.

3. Press the ">>" and "Delete block" softkeys.



The program block on which the cursor is positioned is deleted.

14.4 Teach sets

Teach in position

You traverse the axes and write the current actual values directly into a positioning block.

Teach-in rapid traverse G0

You traverse the axes and teach-in a rapid traverse block with the approached positions.

Teach in straight G1

You traverse the axes and teach-in a machining block (G1) with the approached positions.

Teach in circular interpolation CIP

Enter the intermediate and end positions for the circle interpolation CIP. You teach-in each of these separately in a separate block. The order in which you program these two points is not specified.

Note

Make sure that the cursor position does not change during teach-in of the two positions.

You teach-in the intermediate position in the "Circle intermediate position CIP" window.

You teach-in the end position in the "Circle end position CIP" window.

The intermediate or interpolation point is only taught-in with geometry axes. For this reason, at least 2 geometry axes must be set up for the transfer.

Teach-in A-spline

For Akima-spline interpolation, you enter interpolation points that are connected by a smooth curve.

Enter a starting point and specify a transition at the beginning and end.

You teach-in each interpolation point via "Teach in of position".

**Software option**

You require the "Spline-Interpolation" option for A Spline interpolation.

**Machine manufacturer**

Please observe the information provided by the machine manufacturer.

Procedure



1. Teach-in mode is active.



2. Press the ">>" and "ASPLINE" softkeys.
The "Akima-spline" window opens with the input fields.



3. Traverse the axes to the required position and, if necessary, set the transition type for the starting point and end point.



4. Press the "Accept" softkey.
The new program block is inserted at the cursor-position.



- OR -
Press the "Cancel" softkey to cancel your input.

14.4.1 Input parameters for teach-in blocks

Parameters of axes for teach in

Parameter	Description
X	Axis position in the X direction
Y	Axis position in the Y direction
Z	Axis position in the Z direction
I	Coordinate of the circle intermediate points in the X direction
J	Coordinate of the circle intermediate points in the Y direction
K	Coordinate of the circle intermediate points in the Z direction

Feedrate (only for G1 and circle end position CIP)

Parameter	Description	Unit
F	Feedrate	mm/rev mm/min

Transition modes

Parameter	Description
G60	Exact stop
G64	Smoothing
G641	Programmable corner rounding
G642	Axis-specific corner rounding

Parameter	Description
G643	Block-internal corner rounding
G644	Axis dynamics corner rounding
G645	Smoothing

Motion types

Parameter	Description
CP	Path-synchronous
PTP	Point-to-point
PTPGO	Only G0 point-to-point

Transitional behavior of the spline curve

Parameter	Description
Start	Transitional behavior at the beginning <ul style="list-style-type: none"> • BAUTO - automatic calculation • BNAT - curvature is zero or natural • BTAN - tangential
End	Transitional behavior at the beginning <ul style="list-style-type: none"> • EAUTO - automatic calculation • ENAT - curvature is zero or natural • ETAN - tangential

14.5 Settings for teach-in

In the "Settings" window, you define which axes are to be included in the teach-in block and whether motion-type and continuous-path mode parameters are to be provided.

Procedure



1. Teach-in mode is active.



2. Press the ">>" and "Settings" softkeys.
The "Settings" window opens.



3. Under "Axes to be taught" and "Parameters to be taught", select the check boxes for the desired settings.



4. Press the "Accept" softkey to confirm the settings.

Handheld terminal for multi-touch-operation

15.1 HT 8

15.1.1 HT 8 overview

The mobile SINUMERIK HT 8 handheld terminal combines the functions of an operator panel and a machine control panel. You are thus provided the possibility of monitoring, operating, teaching and programming in immediate proximity to the machine.

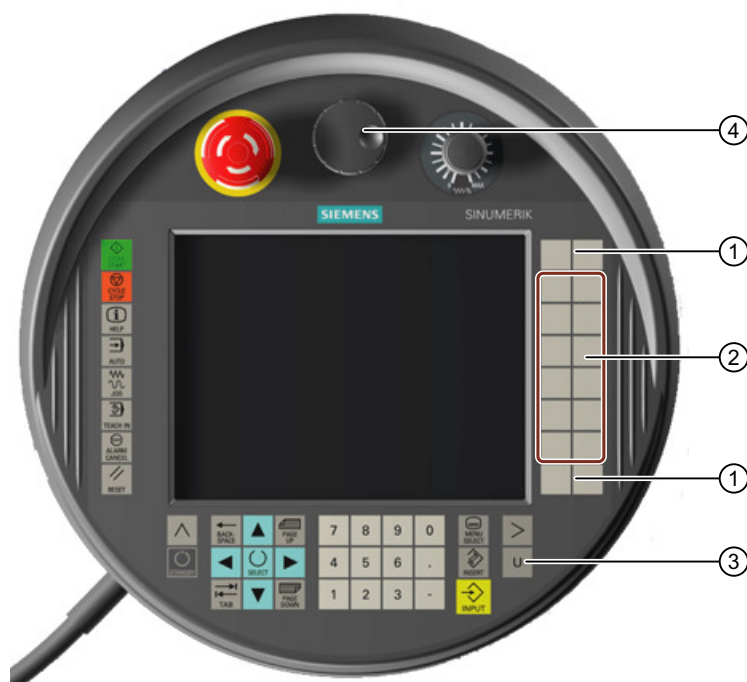

- ① Customer keys (user-defined)
- ② Traversing keys
- ③ User menu key
- ④ Handwheel (optional)

Operation

The 7.5" TFT color display provides touch operation.

Membrane keys are provided for traversing the axes, numeric input, control of the cursor, and for machine control panel functions (e.g. start and stop).

The HT 8 is equipped with an emergency stop button and two 3-stage acknowledgment buttons. You can also connect an external keyboard.

Customer keys

The four customer keys can be assigned arbitrarily and can be configured customer-specifically.



Machine manufacturer

Please observe the information provided by the machine manufacturer.

Integrated machine control panel

An MCP is integrated in the HT 8. It is comprised of keys (e.g. start and stop) as well as softkeys emulating keys.

A description of individual keys can be obtained in the chapter "Controls on the machine control panel".

Note

PLC interface signals that are triggered via the softkeys of the machine control panel menus are edge triggered.

Acknowledgment button

The HT 8 has two acknowledgment buttons. You can then activate the acknowledgement function for operator actions which require approval (e.g. showing the traversing keys) with either hand.

Acknowledgment buttons are available for the following button positions:

- Released (no activation)
- Acknowledgment (center position) - acknowledgment for channels 1 and 2 is on the same switch
- Panic (completely pushed through)

Traversing keys

To traverse the axes of your machine with the HT 8 traversing keys, "JOG" or "MDI" mode and the "REF. POINT" or "TEACH IN" functions must have been selected. You have to press the acknowledgment button depending on the setting.



Machine manufacturer

Please observe the information provided by the machine manufacturer.

Virtual keyboard

A virtual keyboard is available for the easy entry of values.

Changing the channel

- You are able to switch the channel by touch in the status display:
 - In the Machine operating area (large status display), by touch operation of the channel display in the status display.
 - In the other operating areas (no status display), by touch operation of the channel display in the screen headers (yellow field).
- The "1... n CHANNEL" softkey is available in the machine control panel menu that can be reached via the user menu key "U".

Operating area switchover

You display the operating area menu by touching the display symbol for the active operating area in the status display.

Handwheel

The HT 8 is available with a hand wheel.

Further information

Additional information about connection and commissioning is provided in the Handheld Terminal HT 8 Equipment Manual.

See also

Channel switchover (Page 101)

15.1.2 Traversing keys

The traversing keys are not labeled. However, you can display a label for the keys in place of the vertical softkey bar.

Labeling of the traversing keys is displayed for up to six axes on the touch panel by default.



Machine manufacturer

Please refer to the machine manufacturer's specifications.

Showing and hiding

You can link the showing and hiding of the label to activation of the enabling button, for example. In this case, the traversing keys are displayed when you press the enabling button.

If you release the enabling button, the traversing keys are hidden again.



Machine manufacturer

Please refer to the machine manufacturer's specifications.



All existing vertical and horizontal softkeys are covered or hidden, i.e. other softkeys cannot be used.

15.1.3 Machine control panel menu

You select keys from the machine control panel which are reproduced by the software by touch operation of the relevant softkeys.

See Section "Controls on the machine control panel" for a description of the individual keys.

Note

PLC interface signals that are triggered via the softkeys of the machine control panel menus are edge triggered.

Showing and hiding

The user menu key "U" displays the CPF softkey bar (vertical softkey bar) and the user softkey bar (horizontal softkey bar).

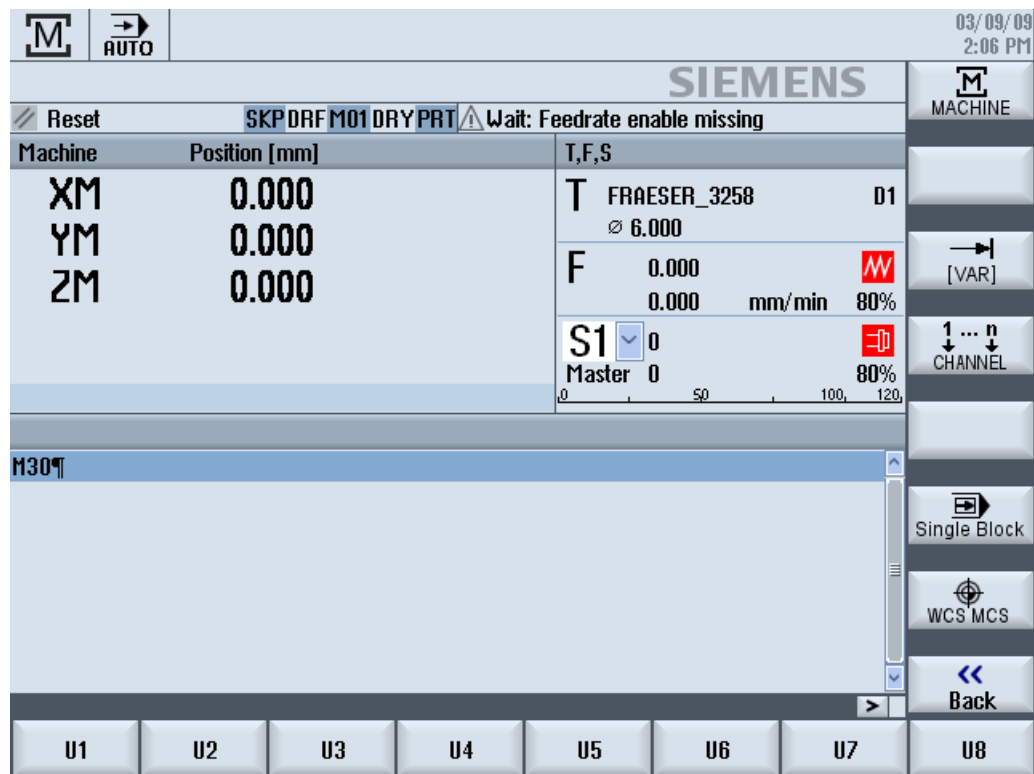

Press the menu forward key to extend the horizontal user softkey bar. There are 8 additional softkeys available.



You use the "Back" softkey to hide the menu bar again

Softkeys on the machine control panel menu

Available softkeys:

"Machine" softkey	Select the "Machine" operating area
"[VAR]" softkey	Select the axis feedrate in the variable increment
"1... n CHANNEL" softkey	Changing the channel
"Single Block" softkey	Switch single block execution on/off
"WCS MCS" softkey	Switch between WCS and MCS
"Back" softkey	Close window

Note

The window will automatically disappear when changing regions areas with the <MENU SELECT> key.

15.1.4 Virtual keyboard

The virtual keyboard is used as the input device for touch operator panels.

Open the virtual keyboard by double-clicking on an input-enabled operator control (program editor, editing fields). It is possible to position the virtual keyboard anywhere within the user interface.

You can choose between a full keyboard and a downsized keyboard featuring the numeric keypad only. With the full keyboard, it is possible to switch between English keyboard layout and the keyboard layout which corresponds with the actual language set for the respective country.

Procedure

1. Position the cursor on the desired entry field.
2. Click the input field.
The virtual keyboard is displayed.
3. Enter your values via the virtual keyboard.
4. Press the <INPUT> key.



- OR -

Position the cursor on an another operator element.
The value is accepted and the virtual keyboard is closed.

Positioning of the virtual keyboard

Press and hold the open area to the left of the icon for "Close window" with the stylus or a finger. Move the keyboard to the desired position.

Special keys on the virtual keyboard

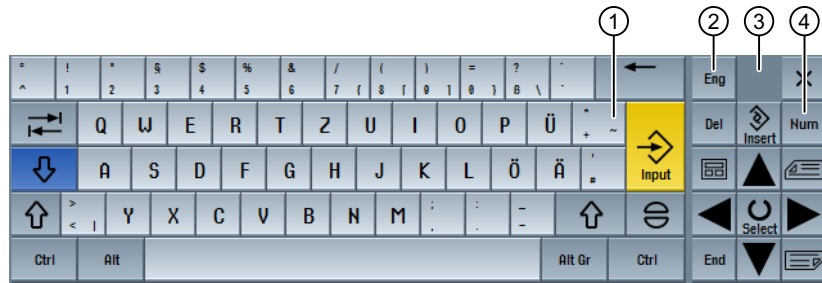

- ① "Tilde" key
 - Changes the sign in a numerical entry field.
 - A tilde character is inserted in a text box (e.g. program editor).
- ② "Eng" key
Toggles the keyboard assignment between the English keyboard assignment and the keyboard assignment for the current language setting.
- ③ Area for positioning the virtual keyboard.
- ④ "Num" key
Reduces the virtual keyboard to the number block.

Number block of the virtual keyboard



Press the "ABC" key to return to the full keyboard.

15.2 HT 10

15.2.1 HT 10: Overview

The mobile handheld terminal HT 10 combines the functions of an operator panel and a machine control panel. You are thus provided the possibility of monitoring, operating, teaching and programming in immediate proximity to the machine.

The HT 10 can be operated with user interface "SINUMERIK Operate Generation 2".



Operation

The fully graphic touch sensitive 10.1" TFT color display of the HT 10 allows touch operation. The 1280 x 800 pixel resolution is suitable for using the "Display Manager".

You can either use the handwheel or the mechanical traversing keys ("+" / "-") to traverse the axes.

The HT 10 is equipped with an EMERGENCY STOP button and a two-channel three-stage acknowledgment button.

You can also connect an external keyboard.

You can configure user-specific keys.

User-specific keys

The user-specific keys can be freely assigned. You can label the keys with your own texts in the local language.



Machine manufacturer

Please observe the information provided by the machine manufacturer.

Integrated machine control panel

The HT 10 has an integrated MCP. It comprises mechanical keys (e.g. start and stop) as well as keys emulated as softkeys.

A description of individual keys can be obtained in the chapter "Controls on the machine control panel".

Note

PLC interface signals that are triggered via the softkeys of the machine control panel menus are edge triggered.

Acknowledgment button

The HT 10 has an acknowledgment button. You can then activate the acknowledgment function for operator actions that require approval (e.g. displaying traversing keys).

Acknowledgment buttons are available for the following button positions:

- Released (no activation)
- Acknowledgment (center position) - acknowledgment for channels 1 and 2 is on the same switch
- Panic (completely pushed through)

Traversing keys

To traverse the axes of your machine using the mechanical traversing keys, "JOG" or "MDI" mode and the "REF. POINT" or "TEACH IN" functions must have been selected. You have to press the acknowledgment button depending on the setting.



Machine manufacturer

Please observe the information provided by the machine manufacturer.

Note

You can also traverse your machine axes using touch operation.

Virtual keyboard

A virtual keyboard is available for the easy entry of values.

Changing the channel

- You are able to switch the channel by touch in the status display:
 - In the Machine operating area (large status display), by touch operation of the channel display in the status display.
 - In the other operating areas (no status display), by touch operation of the channel display in the screen headers (yellow field).
- The "1... n CHANNEL" softkey is available in the machine control panel menu that can be reached via the user menu key "U".

Operating area switchover

You display the operating area menu by touching the display symbol for the active operating area in the status display.

Handwheel

The HT 10 is equipped with a handwheel.

If you are using an HT 10, then you can traverse your machine axes via the handwheel.



Machine manufacturer

Please observe the information provided by the machine manufacturer.

Further information

Additional information about connecting, commissioning and configuring user-specific keys is provided in the Handheld Terminal HT 10 Equipment Manual.

15.2.2 Machine control panel menu

You select keys from the machine control panel which are reproduced by the software by touch operation of the relevant softkeys.

See Section "Controls on the machine control panel" for a description of the individual keys.

Note

PLC interface signals that are triggered via the softkeys of the machine control panel menus are edge triggered.

Showing and hiding

The user menu key "U" displays the CPF softkey bar (vertical softkey bar) and the user softkey bar (horizontal softkey bar).

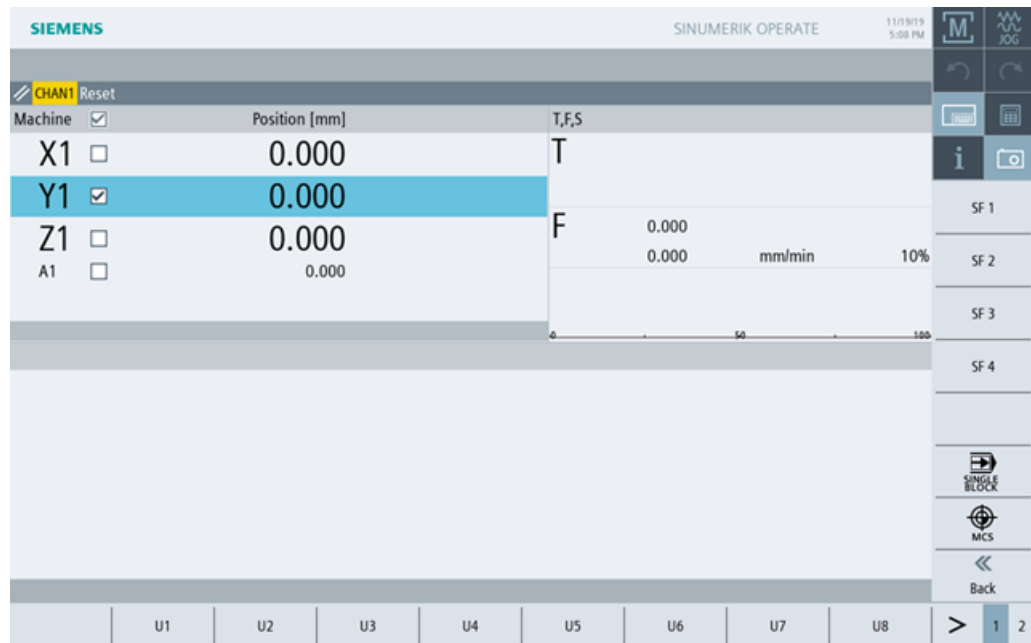

Press the menu forward key to extend the horizontal user softkey bar. This means that additional softkeys are available.

Softkeys on the machine control panel menu

Available softkeys:

SF1- SF4, U1- 8	Customer keys, can be labeled in the local language
"WCS MCS" softkey	Switching between WCS and MCS
"Single Block" softkey	Switch single block execution on/off

Note

The window will automatically disappear when changing regions areas with the <MENU SELECT> key.

Axis selection

You select an axis in the actual value window by activating the checkbox in the header line of the actual value window.

By tapping the check box, a check box is displayed next to the axis name of the axis that has been enabled for axis selection.



Machine manufacturer

Please observe the information provided by the machine manufacturer.

You select an axis by activating the appropriate checkbox.

Note

To assign an axis to the handwheel, activate the handwheel via the "Handwheel" operator control element on the touch screen, and then select the axis using the checkbox.

Note

Orientation axes cannot be assigned to the handwheel.

Then traverse the axes at fixed increments using the operator control elements.

15.2.3 Virtual keyboard

The virtual keyboard is used as the input device for touch operator panels.

Open the virtual keyboard by double-clicking on an input-enabled operator control (program editor, editing fields). It is possible to position the virtual keyboard anywhere within the user interface.

You can choose between a full keyboard and a downsized keyboard featuring the numeric keypad only. With the full keyboard, it is possible to switch between English keyboard layout and the keyboard layout which corresponds with the actual language set for the respective country.



- ① Shift key for uppercase and lowercase letters
- ② Shift key for letters and special characters
- ③ Shift key for country-specific keyboard assignment
- ④ Shift key for full keyboard and numerical key block

Accepting the entered values

The entered values are accepted using the <INPUT> key.

Positioning of the virtual keyboard

Press and hold the open area to the left of the icon for "Close window" with the stylus or a finger. Move the keyboard to the desired position.

15.3 Calibrating the touch panel

It is necessary to calibrate the touch panel upon first connection to the controller.

Note

Recalibration

If the operation is not exact, then redo the calibration.

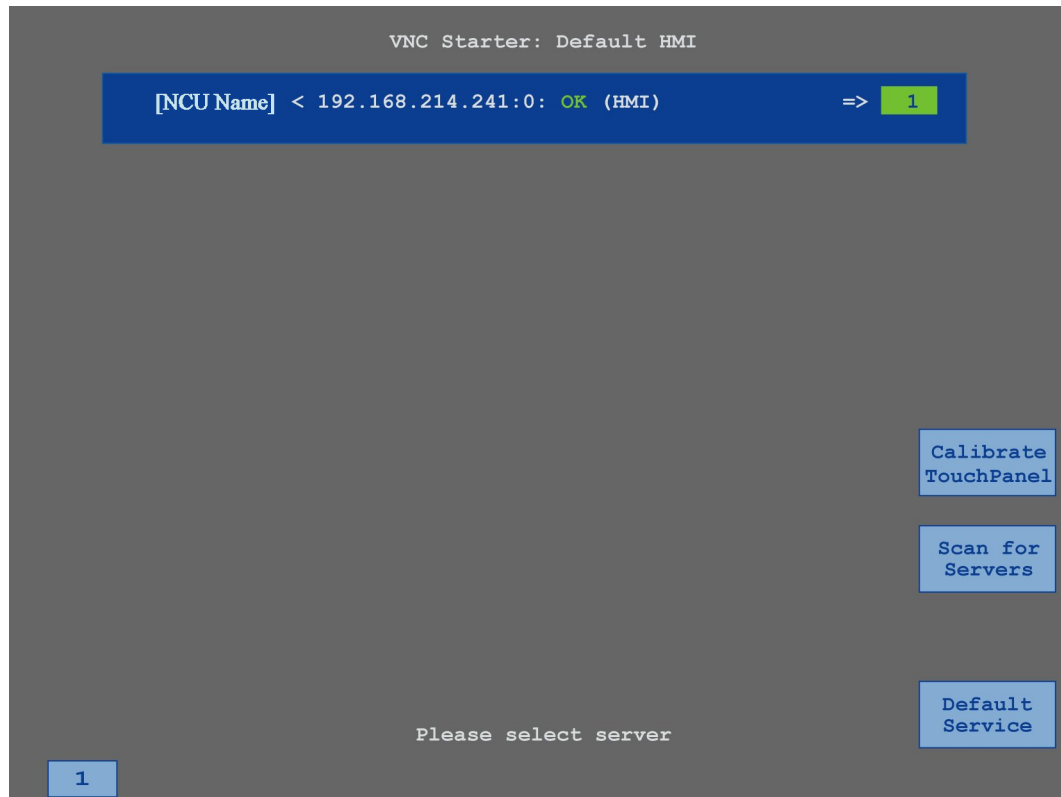

Procedure



1. Press the menu back key and the <MENU SELECT> key at the same time to start the TCU service screen.
2. Touch the "Calibrate TouchPanel" button.
The calibration process will be started.
3. Follow the instructions on the screen and touch the three calibration points one after the other.

15.3 Calibrating the touch panel

- The calibration process has terminated.
4. Touch the horizontal softkey "1" or the key with the number "1" to close the TCU service screen.

Ctrl-Energy

16.1 Functions

The "Ctrl-Energy" function provides you with the following options to improve the energy utilization of your machine.

Ctrl-E Analysis: Measuring and evaluating the energy consumption

Acquiring the actual energy consumption is the first step to achieving better energy efficiency. The energy consumption is measured and displayed at the control using the SENTRON PAC multi-function device.

Depending on the configuration and connection of the SENTRON PAC, you have the possibility of either measuring the power of the whole machine or only a specific load.

Independent of this, the power is determined directly from the drives and displayed.

Ctrl-E Profiles: Control of energy saving states of the machine

To optimize the energy consumption, you have the option of defining energy saving profiles and saving them. For instance, your machine has a basic and a more sophisticated energy-saving mode – or under certain conditions, automatically switches itself off.

These defined energy states are saved as profiles. At the user interface, you have the possibility of activating these energy-saving profiles (e.g. the so-called tea break key).

Note

Ctrl-E Deactivating profiles

Disable Ctrl-E profiles before a series commissioning in order to prevent the NCU unintentionally shutting down.



Machine manufacturer

Please observe the information provided by the machine manufacturer.

Note

Calling of the function via shortcut key

Press keys <CTRL> + <E> to call the "Ctrl Energy" function.

Further information

Additional information on configuring is provided in the Ctrl-Energy System Manual.

16.2 Ctrl-E analysis

16.2.1 Displaying energy consumption

The SINUMERIK Ctrl-Energy entry screen provides an easy-to-interpret overview of the energy consumption of the machine. To display the values and the graphical representation, a Sentron PAC must be connected and a long-term measurement configured.

This shows a consumption display with the following bar chart:

- Current power display
- Measurement of the current energy consumption
- Comparison measurement for the energy consumption

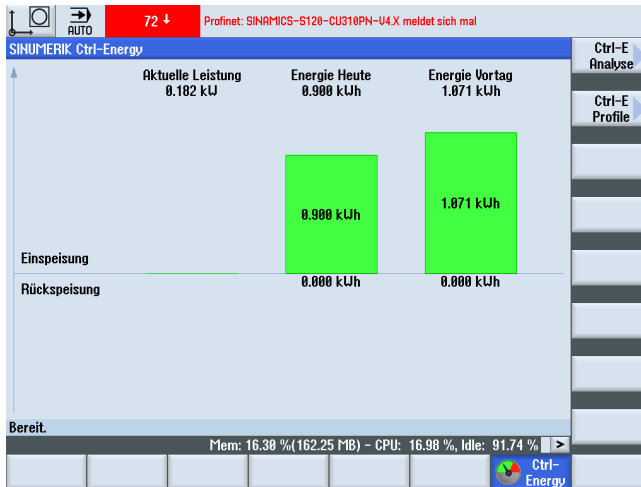

Figure 16-1 Ctrl-Energy entry screen with display of the current energy consumption

Display in the "Machine" operating area

The first row of the status display shows the current power status of the machine.

Display	Meaning
	A red bar indicates that the machine is not operating productively.
	A dark-green bar in the positive direction indicates that the machine is operating productively and consuming energy.
	A light-green bar in the negative direction indicates that the machine is feeding energy back into the power supply system.

Procedure

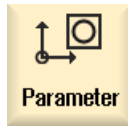

1. Select the "Parameter" operating area.



2. Press the menu forward key and then the "Ctrl-Energy" softkey.



- OR -



+

Press the <Ctrl> + <E> keys.



The "SINUMERIK Ctrl-Energy" window opens.

16.2.2 Displaying the energy analyses

You can obtain a detailed overview of the energy usage in the "Ctrl-E analyse" window.

You obtain the usage display for the following components:

- Sum of the axes
- Sum of the units, if auxiliary units are configured in the PLC
- Sentron PAC
- Sum of the machine

Detailed display of the energy usage

Further, you also have the option of listing the usage values for all drives and where relevant, all auxiliary units.

Procedure



1. You are in the "SINUMERIK Ctrl-Energy" entry window.



2. Press the "Ctrl-E analysis" softkey.

The "Ctrl-E Analysis" window opens. You obtain the summed usage values for all of the components.



3. Press the "Details", softkey to display the energy usage of individual drives and auxiliary units.

16.2.3 Measuring and saving the energy consumption

For the currently selected axes, auxiliary units, SentronPAC or the complete machine you have the option of measuring and recording the energy consumption.

Measurement of the energy consumption by part programs

The energy consumption of part programs can be measured. Single drives are taken into account for the measurement.

You specify in which channel the start and stop of the part program should be initiated and how many repetitions you want to measure.

Save measurements

Save the measured consumption values so that you can subsequently compare the data.

Note

Up to 3 data sets are saved. The oldest data set is automatically overwritten if there are more than three measurements.

Measurement duration

The measurement duration is limited. The measurement is terminated if the maximum measurement time has been reached. The corresponding message is output in the dialog line.



Machine manufacturer

Please observe the information provided by the machine manufacturer.

Requirement



You have pressed the "Ctrl-E analyse" softkey and the "Ctrl-E analyse" window has been opened.

Procedure





1. Press the "Start measurement" softkey.

The "Setting Measurement: Select Device" window opens.



2. Select the desired device in the list, possibly activate the "Measure part program" checkbox, enter the number of repetitions, select the required channel, and press the "OK" softkey.

The trace is started.

- | | |
|---|---|
|  | 3. Press the "Stop measurement" softkey.
The measurement is terminated. |
|  | 4. Press the "Save measurement" softkey to save the consumption values of the actual measurement. |

The selection of the axis to be measured depends on the configuration.

16.2.4 Tracking measurements

You have the option of graphically displaying the actual and saved measurement curves.

Precondition



You have pressed the "Ctrl-E analyse" softkey and the "Ctrl-E analyse" window has been opened.

Procedure



1. Press the "Graphic" softkey.
The actual measurement is displayed as a blue measurement curve in the "Ctrl-E analyse" window.

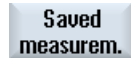

2. Press the "Saved measurements" softkey to display the measurements last saved.

In addition, measurement curves with 3 different colors paths are displayed together with the measurement time.

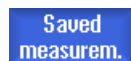

3. Press the "Saved measurements" softkey again if you only want to see the actual measurement.

16.2.5 Tracking usage values

You have the option of displaying the actual and saved usage values in a detailed table.

Display	Meaning
Start of the measurement	Shows the time at which the measurement was started by pressing the "Start measurement" softkey.
Duration of the measurement [s]	Shows the measurement duration in seconds until the "Stop measurement" softkey is pressed.
Device	Displays the selected measured component. <ul style="list-style-type: none"> • Manual (fixed value, z.B. base load, defined in the PLC) • Sentron PAC • Sum of the units (if defined in the PLC) • Sum of the axes • Total, machine

Display	Meaning
Supplied energy [kWh]	Displays the energy drawn by the selected measured component in kilowatts per hour.
Regenerated energy [kWh]	Shows the regenerated energy of the selected measured component in kilowatts per hour.
Energy totals [kWh]	Shows the total of all measured drive values or the total of all axes as well as fixed value and Sentron PAC.

Display in the "Ctrl-E analysis" window: Table"

Precondition



1. You have pressed the "Ctrl-E analyse" softkey and the "Ctrl-E analyse" window has been opened.
2. You have already saved measurements.

Procedure



Press the "Graphic" and "details" softkeys.
In the "Ctrl-E analysis" window: Details", measurement data and usage values of the last three saved measurements – and possibly an actual measurement – are displayed in a table.

16.2.6 Comparing usage values

You have the option of comparing usage values (power drawn and power fed back) of actual and saved measurements.

Precondition



1. You have pressed the "Ctrl-E analyse" softkey and the "Ctrl-E analyse" window has been opened.
2. You have already saved measurements.

Procedure



1. Press the "Graphic" softkey.
2. Press the "Compare measurements" softkey.
Window "Ctrl-E Analysis": Compare" opens.
The power drawn and the recovered power of the actual measurement are displayed in a bar diagram.



3. Press the "Saved measurements" softkey to compare the last 3 measurements that were saved.



4. Press the "Saved measurements" softkey again if you only want to see the actual comparison.

16.2.7 Long-term measurement of the energy consumption

The long-term measurement of energy consumption is performed in the PLC and saved. The values from times in which the HMI is not active are also recorded.

Measured values

The infeed and regenerative power values as well as the sum of the power are displayed for the following periods:

- Current and previous day
- Current and previous month
- Current and previous year

Precondition

SENTRON PAC is connected.

Procedure



1. The "Ctrl-E Analysis" window is open.



2. Press the "Long time measurement" softkey.
The "SINUMERIK Ctrl-Energy Analysis Long-term Measurement" window opens.

The results of the long-term measurement are displayed.



3. Press the "Back" softkey to terminate the long-term measurement.

16.3 Ctrl-E profiles

16.3.1 Using the energy-saving profile

In the "Ctrl-E profiles" window, you can display all of the defined energy-saving profiles. Here, you have the option of directly activating or inhibiting a required energy-saving profile, or re-enabling profiles.

SINUMERIK Ctrl-Energy energy-saving profiles

Display	Meaning
Energy-saving profile	All energy-saving profiles are listed.
active in [min]	The remaining time until the defined profile is reached is displayed.

Note

Disable all energy-saving profiles

For example, in order not to disturb the machine while measurements are being made, select "Disable all".

Once the pre-warning time of a profile has been reached, an alarm window that shows the remaining time is displayed. Once the energy-saving mode has been reached, then an appropriate message is displayed in the alarm line.

Predefined energy-saving profiles

Energy-saving profile	Meaning
Simple energy-saving mode (machine standby)	Machine units that are not required are either throttled or shut down. When required, the machine is immediately ready to operate again.
Full energy-saving mode (NC standby)	Machine units that are not required are either throttled or shut down. Wait times are incurred at the transition into the ready to operate state.
Maximum energy-saving mode (auto shut-off)	The machine is completely switched-off. Longer wait times are incurred at the transition into the ready to operate state.



Machine manufacturer

The selection and function of the displayed energy-saving profiles can differ. Please observe the information provided by the machine manufacturer.

Procedure

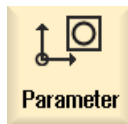

1. Select the "Parameter" operating area.



2. Press the menu forward key and then the "Ctrl-Energy" softkey.



- OR -

Press the <CTRL> + <E> keys.



+



3. Press the "Ctrl-E profile" softkey.

The "Ctrl-E Profile" window opens.



4. Position the cursor on the required energy-saving profile and press the "Activate immediately" softkey if you wish to directly activate this state.



5. Position the cursor on the required energy-saving profile and press the "Disable profile" softkey if you wish to disable this state.

The profile is inhibited and does not become active. The energy-saving profile is grayed-out and displayed without any time information.

The labeling of the "Disable profile" softkey changes to "Enable profile".



Press the "Enable profile" softkey in order to withdraw the energy-saving profile disable.



5. Press the "Disable all" softkey in order to disable all states.

All the profiles are disabled and cannot become active.

The labeling of the "Disable all" softkey changes to "Enable all".



6. Press the "Enable all" softkey to withdraw the disable for all profiles.

Alarm, error, and system messages

17.1 Displaying alarms

If the machine develops a fault in operation, an alarm is generated and machining is possibly interrupted.

The error text that is displayed together with the alarm number gives you more detailed information on the error cause.

You have the possibility of saving all of the relevant diagnostic data to a ZIP file, which you can subsequently send to the hotline for analysis.

 CAUTION
Dangers for persons and machines
Carefully check the system, based on the description of the active alarm(s). Resolve the cause of the alarms. Then acknowledge the alarms in the specified way.
Failure to observe this warning will place your machine, workpiece, saved settings and possibly even your own safety at risk.

Alarm overview

You can display all upcoming alarms and acknowledge them.

The alarm overview contains the following information:

- Date and time
- Cancel criterion
The delete criterion specifies the key or softkey that can be used to acknowledge the alarm.
- Alarm number
- Alarm text

Procedure



1. Select the "Diagnostics" operating area.



2. Press the "Alarm list" softkey.
The "Alarms" window appears.
All pending alarms are displayed.
The "Hide SI alarms" softkey is displayed if safety alarms are pending.



3. Press the "Hide SI alarms" softkey if you do not wish to display SI alarms.

17.1 Displaying alarms



4. Press the "Save diag. data" softkey if the cause of the alarm is unknown. The function collects all available LOG files of the operating software and saves them to the following directory:
 \user\sinumerik\didac\out_<Date-Time>.7z
5. If there is a problem with the system, you can send the ZIP file to the SINUMERIK hotline to help with the analysis of the problem.

Cancel alarms

In the "Cancel" column it is symbolized how you delete the pending alarms from the alarm list.

6. Position the cursor on an alarm.
7. If an NCK-POWER ON alarm is displayed, turn the unit off and back on (main switch), or press NCK-POWER ON.

- OR -

If an NC-Start alarm is displayed, press the <NC-Start> key.

- OR -

If a RESET alarm is displayed, press the <RESET> key.

- OR -

If a Cancel alarm is displayed, press the <ALARM CANCEL> key or press the "Cancel Alarm delete" softkey.



- OR -



- OR -



If an HMI alarm is displayed, press the "Delete HMI alarm" softkey.

- OR -

If a dialog alarm of the HMI is displayed, press the <RECALL> key.

- OR -

If a PLC alarm is displayed, press the key provided by the machine manufacturer.

- OR -









If a PLC alarm of the type SQ is displayed, press the "Acknowl. alarm" softkey.

The softkeys are activated when the cursor is on the corresponding alarm.

Acknowledgement symbols

Symbol	Meaning
	NCK POWER ON
	NC start

Symbol	Meaning
	RESET alarm
	Cancel alarm
	HMI alarm
	Dialog alarms of the HMI
	PLC alarm
	PLC alarm of the SQ type (alarm number from 800000)
	Safety alarms

**Machine manufacturer**

Please refer to the machine manufacturer's instructions.

17.2 Displaying an alarm log

A list of all the alarms and messages that have occurred so far are listed in the "Alarm Log" window.

Up to 500 administered, incoming and outgoing events are displayed in chronological order.



Machine manufacturer

Please refer to the machine manufacturer's specifications.

Procedure



1. Select the "Diagnostics" operating area.



2. Press the "Alarm log" softkey.

The "Alarm Log" window opens.

All of the coming and going events - that have occurred since the HMI was started - are listed.



3. Press the "Display new" softkey to update the list of displayed alarms/ messages.



4. Press the "Save Log" softkey.

The log that is currently displayed is stored as text file alarmlog.txt in the system data in directory /user/sinumerik/hmi/log/alarm_log.

17.3 Displaying messages

PLC and part program messages may be issued during machining.

These messages will not interrupt the program execution. Messages provide information with regard to a certain behavior of the cycles and with regard to the progress of machining and are usually kept beyond a machining step or until the end of the cycle.

Overview of messages

You can display all issued messages.

The message overview contains the following information:

- Date
- Message number
is only displayed for PLC messages
- Message text

Procedure



1. Select the "Diagnostics" operating area.



2. Press the "Messages" softkey.
The "Messages" window appears.

17.4 Sorting, alarms, faults and messages

If a large number of alarms, messages or alarm logs are displayed, you have the option of sorting these in an ascending or descending order according to the following criteria:

- Date (alarm list, messages, alarm log)
- Number (alarm list, messages)

As a consequence, for every extensive lists, you can obtain the required information faster.

Procedure



1. Select the "Diagnostics" operating area.



2. Press the "Alarm list", "Messages" or "Alarm log" softkey to display the requested messages and interrupts.

...



3. Press the "Sort" softkey.



The list of entries is sorted in descending order according to date, i.e. the most recent information is at the beginning of the list.



4. Press the softkey "Ascending" to sort the list in the ascending order. The most recent event is shown at the end of the list.



5. Press the "Number" softkey if you wish to sort the alarm list or the list with messages according to numbers.



6. Press the "Decreasing" softkey to display the list in decreasing/descending order again.

17.5 Creating screenshots

You can create screenshots of the current user interface.

Each screenshot is saved as a file and stored in the following folder:

`/user/sinumerik/hmi/log/screenshot`

Procedure

Ctrl + P Press the "Ctrl + P" key combination.

A screenshot of the current user interface is created in .png format.

The file names assigned by the system are in ascending order from "SCR_SAVE_0001.png" to "SCR_SAVE_9999.png". You can create up to 9,999 screenshots.

Copy file

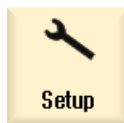

1. Select the "Commissioning" operating area.



2. Press the "System data" softkey.



3. Open the folder specified above, and select the required screenshots.
4. Press the "Copy" softkey.

- OR -



Press the "Cut" softkey.



5. Open the required archive directory, e.g. on a USB flash drive and press the "Paste" softkey.

Note

WinSCP

You can also copy the screenshots to a Windows PC using "WinSCP".

Note

Open files

Open the files in SINUMERIK Operate to view the screenshots. On a Windows PC, you can open the files using a graphic program such as "Office Picture Manager".

17.6 PLC and NC variables

17.6.1 Displaying and editing PLC and NC variables

Changes can only be made to the NC/PLC variables with the appropriate password.

WARNING

Incorrect parameterization

Changes in the states of NC/PLC variables have a considerable influence on the machine. Incorrect configuration of the parameters can endanger life and cause damage to the machine.

In the "NC/PLC Variables" window, enter the NC system variables and PLC variables that you want to monitor or change in the list:

- Variable
Address for NC/PLC variable.
Incorrect variables have a red background and are displayed with a # character in the value column.
- Comment
Any comment on the variable.
The columns can be displayed and hidden.
- Format
Specify the format in which the variable is to be displayed.
The format can be specified (e.g. floating point).
- Value
Displays the actual value of the NC/PLC variables.

PLC variables	
Inputs	<ul style="list-style-type: none"> • Input bit (Ex), input byte (EBx), input word (EWx), input double word (EDx) • Input bit (Ix), input byte (IBx), input word (IWx), input double word (IDx)
Outputs	<ul style="list-style-type: none"> • Output bit (Ax), output byte (ABx), output word (AWx), output double word (ADx) • Output bit (Qx), output byte (QBx), output word (QWx), output double word (QDx)
Bit memory	Memory bit (Mx), memory byte (MBx), memory word (MWx), memory double word (MDx)
Times	Time (Tx)
Counters	<ul style="list-style-type: none"> • Counter (Cx) • Counter (Cx)
Data	<ul style="list-style-type: none"> • Data block (DBx): Data bit (DBXx), data byte (DBBx), data word (DBWx), data double word (DBDx) • Data block (VBx): Data bit (VBXx), data byte (VBBx), data word (VBWx), data double word (VBDx)

Formats	
B	Binary
H	Hexadecimal
D	Decimal without sign
+/-D	Decimal with sign
F	Floating point (for double words)
A	ASCII character

Notation examples

Permissible notation for variables:

- PLC variables: EB2, A1.2, DB2.DBW2, VB32000002
- NC variables:
 - NC system variables: Notation \$AA_IM[1]
 - User variables / GUD: Notation GUD/MyVariable[1,3]
 - OPI notation: /CHANNEL/PARAMETER/R[u1,2]

Note

If the PLC user program writes a string into an NC/PLC variable, the string is only displayed correctly if the variable is parameterized on the NC side as a field variable of type "A" (ASCII).

Example of a field variable

Variable	Format
DBx.DBBy[<number>]	A

Inserting variables

The start value for "Filtering/searching" of variables differs. For example, to insert the variable \$R[0], enter the following start value:

- The start value is 0 if you filter according to "System variables".
- The start value is 1 if you filter according to "All (no filter)". In this case, all signals are displayed and shown in the OPI notation.

The GUD from the machine data is only displayed in the Search window for the variable selection when the associated definition file has been activated. Otherwise, the sought variables must be entered manually, e.g. GUD/SYG_RM[1]

The following machine data is representative for all variable types (INT, BOOL, AXIS, CHAR, STRING): MD18660 \$MN_MM_NUM_SYNACT_GUD_REAL[1].

Note

Display of NC/PLC variables

- System variables can be dependent on the channel. When the channel is switched over, the values from the selected channel are displayed.
You have the option of having the variables displayed channel-specifically, e.g. \$R1:CHAN1 and \$R1:CHAN2. The values of channel 1 and channel 2 are displayed, no matter in which channel you are.
- For user variables (GUD), it is not necessary to make a specification according to global or channel-specific GUD. The first element of a GUD array starts with index 0 as for NC variables.
- Using the tooltip, you can display the OPI notation for NC system variables (except for GUD).

Servo variables

Servo variables can only be selected and displayed at "Diagnostics" → "Trace".

Changing and deleting values



1. Select the "Diagnostics" operating area.



2. Press the "NC/PLC variables" softkey.

The "NC/PLC Variables" window opens.

3. Position the cursor in the "Variable" column and enter the required variable.



4. Press the <INPUT> key.

The operand is displayed with the value.



5. Press the "Details" softkey.

The "NC/PLC Variables: Details" window opens. The information for "Variable", "Comment" and "Value" is displayed in full length.



6. Position the cursor in the "Format" field and select the required format with <SELECT>.



7. Press the "Display comments" softkey.

The "Comments" column is displayed. You have the option of creating comments or editing existing comments.







Press the "Display comments" softkey once again to hide the column.

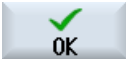

8. Press the "Change" softkey if you would like to edit the value.

The "Value" column can be edited.

- | | |
|---|---|
|  | 9. Press the "Insert variable" softkey if you wish to select a variable from a list of all existing variables and insert this.
The "Select Variable" window opens. |
|  | 10. Press the "Filter/search" softkey to restrict the display of variables (e.g. to mode group variables) using the "Filter" selection box and/or select the desired variable using the "Search" input box. |
|  | 11. Press the "Delete all" softkey if you would like to delete all the entries for the operands. |
|  | 12. Press the "OK" softkey to confirm the changes or the deletion. |
| - OR - | |
|  | Press the "Cancel" softkey to cancel the changes. |

Editing the variable list

You can edit the variable list using the "Insert line" and "Delete line" softkeys.

- | | |
|---|---|
|  | If you press the softkey, a new line inserted before the line marked by the cursor.

You can only use the "Insert line" softkey if there is at least one empty line at the end of the variable list.

The softkey is deactivated if there is no empty line. |
|  | If you press the "Delete line" softkey, the line marked by the cursor is deleted.

An empty line will be added at the bottom of the variable list. |



Changing operands

Depending on the type of operand, you can increment or decrement the address by 1 place at a time using the "Operand +" and "Operand -" softkeys.

Note

Axis names as index

For axis names, the "Operand +" and "Operand -" softkeys do not act as index, e.g. for \$AA_IM[X1].

	<p>Examples</p> <p>DB97.DBX2.5 Result: DB97.DBX2.6</p> <p>\$AA_IM[1] Result: \$AA_IM[2]</p>
	<p>MB201 Result: MB200</p> <p>/Channel/Parameter/R[u1,3] Result: /Channel/Parameter/R[u1,2]</p>

17.6.2 Saving and loading screen forms





You have the option of saving the configurations of the variables made in the "NC/PLC variables" window in a screen form that you reload again when required.

Editing screen forms

If you change a screen form that has been loaded, then this is marked using with * after the screen form name.

The name of a screen form is kept in the display after switching-off.

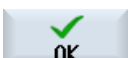
Procedure

1. You have entered values for the desired variables in the "NC/PLC variables" window.
- 
 2. Press the ">>" softkey.
- 
 3. Press the "Save screen" softkey.
The "Save screen: Select archiving" window opens.
- 
 4. Position the cursor on the template folder for variable screen forms in which your actual screen form should be saved and press the "OK" softkey.
The "Save screen: Name" window opens.
- 
 5. Enter the name for the file and press the "OK" softkey.
A message in the status line informs you that the screen form was saved in the specified folder.
If a file with the same name already exists, then you will receive a prompt.
- 
 6. Press the "Load screen" softkey.
The "Load screen" window opens and displays the sample folder for the variable screen forms.
7. Select the desired file and press the "OK" softkey.
You return to the variable view. The list of all of the predefined NC and PLC variables is displayed.

17.7 Version

17.7.1 Displaying version data

The following components with the associated version data are specified in the "Version data" window:

- System software
- PLC basic program
- PLC user program
- System expansions
- OEM applications
- Hardware

Information is provided in the "Nominal version" column as to whether the versions of the components deviate from the version supplied on the CompactFlash Card.



The version displayed in the "Actual version" column matches the version of the CF card.



The version displayed in the "Actual version" column does not match the version of the CF card.

You may save the version data. Version data saved as text files can be further processed as required or sent to the hotline in the event of an error.

Procedure



1. Select the "Diagnostics" operating area.



2. Press the "Version" softkey.
The "Version Data" window appears.
Data of the available components is displayed.



3. Select the component for which you would like more information.



4. Press the "Details" softkey, in order to receive more exact information on the components displayed.

17.7.2 Save information

All the machine-specific information of the control is combined in a configuration via the user interface. You then have the option of saving the machine-specific information on the drives that have been set up.

Procedure



1. Select the "Diagnostics" operating area.



2. Press the "Version" softkey.
It takes some time to call the version display. While the version data is being determined a progress message box and the appropriate text are displayed in the dialog line.



3. Press the "Save" softkey.
The "Save version information: Select Archive" window opens. The following storage locations are offered depending on the configuration:
 - Local drive
 - Network drives
 - USB
 - Version data (archive: Data tree in the "HMI data" directory)



4. Then press the "New directory" softkey if you wish to create your own directory.



5. Press the "OK" softkey. The directory is created.



6. Press the "OK" softkey again to confirm the storage location.
The "Save version information: Name" window opens.

7. Specify the desired settings.
 - "Name:" input field
the file name is pre-assigned with <Machine name/no.>+<CF-card number>. "_config.xml" or "_version.txt" is automatically attached to the file names.
 - "Comment:" input field
You can enter a comment that is stored with the configuration data.
 - Version data (.TXT)
Activate the checkbox if you wish to output the pure version data in the text format.
 - Configuration data (.XML)
Activate the checkbox if you wish to output the configuration data in the XML format.
The configuration file contains the data you entered under Machine identity, the license requirements, the version information and the logbook entries.

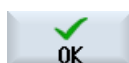

8. Press the "OK" softkey to start the data transfer.

17.8 Logbook

The logbook provides you with the machine history in an electronic form.

If service is carried out on the machine, this can be electronically saved. This means that it is possible to obtain a picture about the "History" of the control and to optimize service.

Editing the logbook

You can edit the following information:

- Editing information on the machine identity
 - Machine name/No.
 - Machine type
 - Address data
- Make logbook entries (e.g. "filter replaced")
- Deleting logbook entries

Note

Deleting logbook entries

Up to the 2nd commissioning, you have the option to delete all of the entered data up to the time of the first commissioning.

Output of the logbook

You have the possibility of exporting the logbook by generating a file using the "Save version" function in which the logbook is contained as section.

See also

Save information (Page 424)

17.8.1 Displaying and editing the logbook

Procedure



1. Select the "Diagnostics" operating area.



2. Press the "Version" softkey.



3. Press the "Logbook" softkey.
The "Machine logbook" window opens.

Editing end customer data



4. You have the option of changing the address data of the end customer using the "Change" softkey.

- OR -



Using the "Clear" softkey, you can delete all logbook entries.



All entries, except the date of the first commissioning, are deleted. Softkey "Clear" is deactivated.

Note

Deleting logbook entries

As soon as the 2nd commissioning has been completed, the "Clear" softkey to delete the logbook data is no longer available.

17.8.2 Making a logbook entry

Using the "New logbook entry" window to make a new entry into the logbook.

Enter your name, company and department and a brief description of the measure taken or a description of the fault.

Note

Setting line breaks

If you wish to make line breaks in the "Fault diagnostics/measure" field, use the key combination <ALT> + <INPUT>.

The date and entry number are automatically added.

Sorting the entries

The logbook entries are displayed numbered in the "machine logbook" window.

More recent entries are always added at the top in the display.

Procedure



1. The logbook is opened.
2. Press the "New entry" softkey.
The "New logbook entry" window opens.





3. Enter the required data and press the "OK" softkey.
You return to the "Machine logbook" window and the entry is displayed below the machine identity data.

Note**Deleting logbook entries**



Up to the completion of the 2nd commissioning, you have the option to delete the logbook entries up to the time of the first commissioning using the "Clear" softkey.

Searching for a logbook entry

You have the option for searching for specific entries using the search function.

1. The "Machine logbook" window is opened.
2. Press the "Find" softkey.

3. Enter the desired term in the search form. You can make a search according to date/time, company name/department or according to fault diagnostics/measure.
The cursor is positioned on the first entry that corresponds to the search term.
4. Press the "Continue search" softkey if the entry found is not the one that you are looking for.

Additional search option

-  Press the "Go to Beginning" softkey to start the search at the latest entry.
-  Press the "Go to End" softkey to start the search at the oldest entry.

17.9 Remote diagnostics

17.9.1 Setting remote access

You can influence the remote access to your control in the "Remote diagnostics (RCS)" window.

You set the rights for all remote operating types in this window. The selected rights are defined from the PLC and using the setting at the HMI.

The HMI can restrict the rights specified from the PLC, but however, cannot extend the rights beyond the PLC rights.

If the settings made permit access from outside, access also requires manual or automatic confirmation.

Rights for remote access

The "Specified by PLC" field shows the access rights for remote access or remote monitoring specified from the PLC.



Machine manufacturer

Follow the machine manufacturer's instructions.

In the "Selected in the HMI" selection box, you have the possibility of setting rights for remote control:

- Do not permit remote access
- Permit remote monitoring
- Permit remote control

Depending on the combination of the settings in the HMI and in the PLC, the valid status as to whether access is permitted or not is shown in the "Resulting from this" line.

Settings for the confirmation dialog box

However, if the settings made for "Specified from the PLC" and "Selected in the HMI" permit access from outside, access also requires manual or automatic confirmation.

As soon as a remote access is permitted, at all of the active operating stations, a query dialog box is displayed for the operator at the active operating station to either confirm or reject an access.

If there is no local operation, the control behavior can be set for this particular scenario. You define for how long this window will be displayed and whether remote access will be automatically rejected or accepted after the confirmation has expired.

Display of the state



Remote monitoring active



Remote control active

If remote access is active, these icons on the status line inform you whether remote access is currently active or whether only monitoring is permitted.

Procedure



1. Select the "Diagnostics" operating area.



2. Press the "Remote diag." softkey.
The "Remote diagnostics (RCS)" window opens.



3. Press the "Change" softkey.
The "Selected in the HMI" is activated.



4. If you want to use remote control, select the "Permit remote control" item.

Remote control is only possible if the "Allow remote operation" item is specified in the fields "Specified by PLC" and "Selected in HMI".

5. Enter new values in the group "Behavior for remote access confirmation" if you would like to change the behavior relating to confirming remote access.



6. Press the "OK" softkey.
The settings are accepted and saved.

Further information

You will find further information on configuration in the SINUMERIK Operate Commissioning Manual.

17.9.2 Permit modem

You can permit remote access to your control via a teleservice adapter IE connected at X127.



Machine manufacturer

Follow the machine manufacturer's instructions.



Software option

You need the "Access MyMachine /P2P" option to display the "Allow modem" softkey.

Procedure



1. The "Remote diagnostics (RCS)" window is open.
2. Press the "Allow modem" softkey.
Access to the control via modem is enabled so that a connection is established.
3. To block access again, press the "Allow modem" softkey again.

17.9.3 Request remote diagnostics

Using the "Request remote diagnostics" softkey, you have the option from your control of actively requesting remote diagnostics from your machine OEM.

Access via modem must be enabled if access is to be possible via a modem.



Machine manufacturer

Follow the machine manufacturer's instructions.

When you request remote diagnostics, a window opens with the relevant pre-assigned data and values of the ping service. If required, you can ask your machine manufacturer for this data.

Data	Meaning
IP address	IP address of the remote PC
Port	Standard port that is intended for remote diagnostics
Send duration	Duration of the request in minutes
Send interval	Cycle in which the message is sent to the remote PC in seconds
Ping send data	Message for the remote PC

Procedure



1. The "Remote diagnostics (RCS)" window is open.
2. Press the "Request remote diagnostics" softkey.
The "Request remote diagnostics" window is displayed.
3. Press the "Change" softkey if you would like to edit the values.
4. Press the "OK" softkey.
The request is sent to the remote PC.

See also

Permit modem (Page 429)

17.9.4 Exit remote diagnostics

Procedure



1. The "Remote diagnostics (RCS)" is opened and it is possible that remote monitoring or remote access is active.
2. Block the modem access if access via modem is to be blocked.
- OR -
In the "Remote Diagnostics (RCS)" window, reset the access rights to "Permit no remote access".

See also

Permit modem (Page 429)

Setting remote access (Page 428)

Index

"

- "Siemens Industry Online Support" app, 19
- "SINUMERIK Operate Gen. 2"
 - Multitouch panel, 71
- "SINUMERIK Operate Generation 2" user interface, 71
 - Function key block, 77
 - Touch operator controls, 78
 - Virtual keyboard, 78

A

- ABC keyboard, 87
- Acknowledgment button
 - HT 10, 395
 - HT 8, 388
- Actual-value display, 45
- Adapter-transformed view, 318
- Advanced Surface, 183
- Alarm log
 - display, 414
 - Sorting, 416
- Alarms
 - Backing up log data, 411
 - cancel, 412
 - Displaying, 411
 - Sorting, 416
- Any file, 332
- Archive
 - Generate in the program manager, 357
 - generating in the system data, 358
 - Punched tape format, 357
 - read in archive from system data, 361
 - reading-in in the Program Manager, 360
- Auxiliary functions
 - H functions, 184
 - M functions, 184
- Axes
 - Defined increment, 130
 - Direct positioning, 132
 - Referencing, 96
 - Repositioning, 147
 - Traversing, 130
 - Variable increment, 131

B

- Backing up
 - Data - in the Program Manager, 357
 - Data - via the system data, 358
 - Parameter, 369
 - Setup data, 362
- Base offset, 107
- Basic blocks, 143
- Binary format, 357
- Blank input
 - Function, 244
 - Parameter, 246
- Block
 - Search, 148
 - Searching - interruption point, 151
 - Searching - search pointer, 151
- Block search
 - Mode, 153
 - Program interruption, 151
 - Search pointer, 151
 - Search target parameters, 152, 153
 - Search target specification, 150
 - Using, 148

C

- Camera
 - Streaming, 66
- Channel switchover, 101
- Checking the loading, 367
- Cleaning mode, 65
- Coarse and fine offsets, 107
- Code carrier connection, 284
- Collision avoidance, 257
 - Displaying the machine model (kinematic chains), 259
 - Machine operating area, 260
 - Settings, 260
- Configured stop, 156
- Context-sensitive online help, 67
- Coordinate system
 - Switching over, 103
- Creating
 - Multitool, 310
 - Program block, 166

Ctrl-Energy

- Comparing usage values, 406
- Displaying measured curves, 405
- Displaying usage values, 405
- Energy analysis, 402, 403
- Energy-saving profiles, 408
- Functions, 401
- Measuring the energy consumption, 404
- Saved measuring curves, 405, 406

Cycles

- Current levels, 241
- Screen forms, 241

D

- Data block (SB2), 140
- Data matrix code, 20
- Delete
 - Multitool, 314
- Deleting
 - Directory, 344
 - Program, 344
- Determine demand, 366
- Dictionary
 - Importing, 61
- Directory
 - Copying, 342
 - Creating, 329
 - Deleting, 344
 - Highlight, 340
 - Inserting, 342
 - Naming convention, 329
 - Properties, 345
 - Selecting, 340
- Display Manager
 - Operator controls, 90
- DRF (handwheel offset), 155
- Drives
 - Logical drive, 346
 - Setting up, 346
- DRY (dry run feed), 155
- Duplo number, (See replacement tool number)
- DXF file
 - Changing the section, 197
 - Cleaning, 195
 - close, 195
 - Delete Element, 201
 - Delete range, 200
 - Increasing / decreasing the section, 196
 - Machining plane, 199
 - Open, 195
 - Rotating the drawing, 197

- Saving, 201
 - Select contour and accept, 202
 - Select the machining range, 200
 - Snap radius, 199
 - Specifying a reference point, 202
 - Zero point, 202
- DXF-Reader, 194

E

- Edges
 - Managing, 280
- Editor
 - Calling, 160
 - Settings, 168
- EES (execution from external storage), 349
- Energy analysis
 - Details, 403
 - Displaying, 403
 - Long time measurement, 407
- Energy consumption
 - Displaying, 402
 - Measuring, 404
- Energy-saving profiles, 408
- EXTCALL call, 354

F

- Feed data
 - Actual value window, 47
- Finger gestures, 73
- FTP drive, 324
- Function
 - REF POINT, 99
 - REPOS, 99
 - Single block, 100
 - TEACH IN, 100
- Function key block
 - "SINUMERIK Operate Generation 2" user interface, 77

G

- G code program
 - Blank input, 244
- G Code program
 - Creating, 331
- G functions
 - Display all G groups, 183
 - Displaying selected G groups, 181
 - Mold making, 183

General Data Protection Regulation, 21
 Global R parameters, 173
 Global user variables, 175
 Gloves, 72

H

Handheld terminal 10, 394
 Handheld terminal 8, 387
 Handwheel
 Assigning, 118
 Highlight
 Directory, 340
 Program, 340
 HT 10
 Acknowledgment button, 395
 Overview, 394
 Touch Panel, 399
 User menu, 396
 Virtual keyboard, 398
 HT 8
 Acknowledgment button, 388
 Overview, 387
 Touch Panel, 399
 Traversing keys, 389
 User menu, 390
 Virtual keyboard, 392

I

IME
 Chinese characters, 58
 Korean characters, 62
 Interruption point
 Approach, 151

J

Job list, 333

K

Key combinations - Simulation
 Changing the section, 232
 Enlarging/reducing a graphic, 230
 Feedrate, 228
 Moving the graphic, 231
 Override, 228
 Rotating the view, 231
 Single block mode, 229

L

Layer selection, 195
 Loading
 Multitool, 314
 Local drive, 322
 Creating an NC directory, 322
 Logbook
 Delete entries, 426
 Displaying, 425
 Edit the address data, 425
 Entry search, 427
 Making an entry, 426
 Output, 424
 Overview, 425
 Long time measurement
 Energy analysis, 407

M

Machine control panel
 in the sidescreen, 86
 Operator controls, 38
 Machine model, 257
 Machine-specific information, 424
 Machining times
 Delete, 171
 Display, 237
 Display in block display, 49, 142
 Magazine
 Deleting tools, 297
 Loading tools, 297
 Open, 293
 Positioning, 295
 Relocating tools, 297
 Selecting, 283
 Unloading tools, 297
 Magazine management, 265
 Manual mode, 125
 Positioning axes, 132
 Settings, 135
 Spindle, 128
 T, S, M windows, 126
 Tool, 127
 Traversing axes, 130
 Unit of measurement, 126
 Manual retraction, 133
 MDI
 Deleting a program, 123
 Executing a program, 122

- Loading a program, 120
- Saving a program, 121
- Messages
 - Displaying, 415
 - Sorting, 416
- Mode groups, 101
- Mold making view
 - adapting, 207
 - Changing a graphic, 209
 - Changing the section, 211
 - Editing a program block, 208
 - Programs, 205
 - Searching for program blocks, 209
 - Starting, 207
- MRD (Measuring Result Display), 156
- Multi-channel view, 249
 - "Machine" operating area, 250
 - OP015, OP019, 253
 - Settings, 255
- Multiple selection, 308
- Multitool, 309
 - Creating, 310
 - Delete, 314
 - Equipping tools, 312
 - Loading, 314
 - Parameters in the tool list, 309
 - Positioning, 317
 - Reactivating, 315
 - Relocating, 316
 - Removing tools, 313
 - Unloading, 315
- Multitouch panel
 - SINUMERIK Operate Gen. 2, 71
 - Widescreen format, 80
- mySupport documentation, 18

N

- Navigation bar
 - Sidescreen, 80
- NC memory, 321
- NC/PLC variables
 - Changing, 420
 - displaying, 418
- Number of teeth, 276

O

- Online help
 - Context-sensitive, 67
- Opening tool data, 367

- OpenSSL, 21
- Operating areas, 27
 - Changing, 50
 - Selecting, 50
- Operating mode
 - AUTO, 100
 - Changing, 50
 - JOG, 99, 125
 - MDI, 100
 - REPOS, 99
- Operator controls
 - Display Manager, 90
 - Machine control panel, 38
- Operator panel fronts, 28
 - Keys, 30

P

- Pages, 80
- Panel
 - cleaning, 65
- Parameter
 - Backing up, 369
 - Calculating, 52
 - Changing, 52
 - Entering, 52
- Pitch, 275
- Positioning
 - Multitool, 317
- Preview
 - Program, 339
- Product support, 19
- Program
 - Closing, 325
 - Copying, 342
 - Correcting, 146
 - Creating with cycle support, 243
 - Deleting, 344
 - Editing, 160
 - Executing, 327
 - Highlight, 340
 - Inserting, 342
 - Managing, 319
 - Naming convention, 329
 - Open, 325
 - opening additional programs, 167
 - Preview, 339
 - Properties, 345
 - Renumbering blocks, 165
 - Replacing text, 162
 - Running-in, 140
 - Searching for a program position, 160

- Selecting, 139, 340
- Teach-in, 377
- Program block
 - Copying and inserting, 163
 - Current, 49, 142
 - Delete, 163
 - insert, 163
 - Numbering, 164, 165
 - Search, 160
 - Selecting, 163
- Program blocks, 166
- Program control
 - activate, 156
 - Modes of operation, 155
- Program correction, 146
- Program level, 144
- Program list, 334
- Program Manager, 319
 - Displaying HTML documents, 352
 - Displaying PDF documents, 352
 - Searching for directories and files, 337
- Program runtime, 189
- Program views
 - G code, 236
- Programmed stop 1, 155
- Programmed stop 2, 155
- Properties
 - Directory, 345
 - Program, 345
- PRT (no axis motion), 155

Q

- Quantity, 289

R

- R parameters, 174
 - Backing up, 369
- Reactivating
 - Multitool, 315
- Record tools, 366
- Reference, 96
- Relocating
 - Multitool, 316
- Remote access
 - Allowing, 429
 - Setting, 428
- Remote diagnostics, 428
 - Exit, 431
 - Requesting, 430

- Replacement tool number, 275
- Repositioning, 147
- Retract, 133
- RG0 (reduced rapid traverse), 155

S

- Save
 - Parameter, 369
 - Setup data, 362
- SB (single blocks), 155
- SB1, 140
- SB2, 140
- SB3, 140
- Screen layout, 76
- Screenshots
 - Copying, 417
 - Creating, 417
 - Open, 417
- Search
 - in the Program Manager, 337
- Search mode, 153
- Search pointer, 151
- Searching
 - Logbook entry, 427
- Select, 308
- Selecting
 - Directory, 340
 - Program, 340
- Send feedback, 17
- Setting actual values, (See setting zero offsets)
- Settings
 - Collision avoidance, 260
 - Editor, 168
 - For automatic operation, 191
 - For manual operation, 135
 - Multi-channel view, 255
 - Teach-in, 386
 - Tool lists, 318
- Setup data
 - Backing up, 362
 - reading in, 363
- Shortcuts
 - Operator panel fronts, 30
- Sidescreen
 - ABC keyboard, 86
 - MCP, 86
 - Navigation bar, 80
 - Operator controls, 80
 - Overview, 80
 - Pages, 86
 - Requirements, 80

- Show, 82
- Standard widgets, 82
- Widgets, 80
- Siemens Industry Online Support
 - App, 19
- Simulation, 213
 - Alarm display, 234
 - Blank, 227
 - Canceling, 220
 - Changing the feedrate, 228
 - Changing the graphic section, 232
 - Moving the graphic, 231
 - Non-modal, 229
 - Program control, 228
 - Rotating the graphic, 231
 - Showing and hiding the path display, 227
 - Start, 220
 - stopping, 220
 - Views, 224
- Simultaneous recording, 215
 - Before machining, 222
 - Changing the graphic section, 232
 - Moving the graphic, 231
 - Rotating the graphic, 231
- Single block
 - Coarse (SB1), 140
 - Fine (SB3), 140
- SINUMERIK, 13
- SINUMERIK Operate Gen. 2
 - Screen layout, 76
- Skip blocks, 156
- SKP (skip blocks), 155
- Special characters, 29
- Spindle data
 - Actual value window, 48
- Spindle speed limitation, 116
- Standard scope, 14
- Standard widget
 - Actual values, 82
 - Alarms, 83
 - Axle load, 84
 - Camera, 86
 - Service life, 85
 - Tool, 84
 - Variables, 84
 - Zero point, 83
- Startup, 95
- Status display, 43
- Switching over
 - Coordinate system, 103
- Synchronization commands
 - Display, 238

- Synchronized actions
 - Displaying status, 187
- System data
 - Displaying HTML documents, 352
 - Displaying PDF documents, 352

T

- Teach-in, 377
 - Changing blocks, 380
 - Circle intermediate position CIP, 383
 - Continuous-path mode, 385
 - Deleting blocks, 381
 - General sequence, 377
 - Inserting a position, 383
 - Inserting blocks, 380
 - Motion type, 384
 - Parameter, 384
 - Rapid traverse G0, 383
 - Selecting, 379
 - Selecting a block, 381
 - Settings, 386
 - Traversing block G1, 383
- Technical support, 19
- Templates
 - Creating, 336
 - Storage locations, 336
- Tip angle, 275
- Tool
 - Change type, 302
 - Creating, 277
 - delete, 281
 - Details, 298
 - Dimensioning, 268
 - Loading, 281
 - Multiple edges, 280
 - Reactivating, 290
 - Relocating, 295
 - Unloading, 281
- Tool data
 - Actual value window, 47
 - Backing up, 362
 - reading in, 363
- Tool life, 289
- Tool list, 275
- Tool lists
 - Settings, 318
- Tool management, 263
 - List filtering, 304
 - Sorting lists, 303
- Tool parameters, 268
- Tool types, 266

- Tool wear, 288
- Tool wear list
 - Open, 288
- Touch operator controls
 - Cancel alarms, 78
 - Changing the channel, 78
- Touch Panel
 - calibration, 399
- Training, 19
- Transformed view, 318
- TTD file
 - Open, 367

U

- Unit of measurement
 - switching, 103
- Unloading
 - Multitool, 315
- USB drive, 323
- User agreement, 97
- User variables, 172
 - Activating, 180
 - Backing up, 369
 - Channel GUD, 177
 - Defining, 180
 - Global GUD, 175, 180
 - Global R parameters, 173
 - Local LUD, 178
 - Program PUD, 179
 - R parameters, 174
 - Searching, 179

V

- Variable screen forms, 422
- Virtual keyboard
 - "SINUMERIK Operate Generation 2" user interface, 78
 - HT 10, 398
 - HT 8, 392
- Virtual keys
 - ABC keyboard, 80
 - MCP keys, 80

W

- Wear, 289
- Websites of third-party companies, 14
- Widgets, 80

- Work offsets
 - Delete, 113
 - Overview, 107, 109
- Working area limitation, 115
- Workpiece
 - creating, 330
 - Starting machining, 137
 - Stopping machining, 137, 138
- Workpiece counter, 189

Z

- Zero offsets
 - Active ZO, 108
 - Displaying details, 111
 - Settable ZO, 111
 - Setting, 105
- Zero point
 - DXF file, 202
- Zero point settings
 - Backing up, 362
 - reading in, 363

