



RUGGEDCOM ROS v5.2

User Guide

For RSG908C

06/2018
RC1390-EN-01

Preface	
Introduction	1
Using ROS	2
Getting Started	3
Device Management	4
System Administration	5
Security	6
Layer 2	7
Redundancy	8
Traffic Control and Classification	9
Time Services	10
Network Discovery and Management	11
IP Address Assignment	12
Troubleshooting	13

Copyright © 2018 Siemens Canada Ltd

All rights reserved. Dissemination or reproduction of this document, or evaluation and communication of its contents, is not authorized except where expressly permitted. Violations are liable for damages. All rights reserved, particularly for the purposes of patent application or trademark registration.

This document contains proprietary information, which is protected by copyright. All rights are reserved. No part of this document may be photocopied, reproduced or translated to another language without the prior written consent of Siemens Canada Ltd.

» Disclaimer Of Liability

Siemens has verified the contents of this document against the hardware and/or software described. However, deviations between the product and the documentation may exist.

Siemens shall not be liable for any errors or omissions contained herein or for consequential damages in connection with the furnishing, performance, or use of this material.

The information given in this document is reviewed regularly and any necessary corrections will be included in subsequent editions. We appreciate any suggested improvements. We reserve the right to make technical improvements without notice.

» Registered Trademarks

RUGGEDCOM™ and ROS™ are trademarks of Siemens Canada Ltd.

Other designations in this manual might be trademarks whose use by third parties for their own purposes would infringe the rights of the owner.

» Third Party Copyrights

Siemens recognizes the following third party copyrights:

- Copyright © 2004 GoAhead Software, Inc. All Rights Reserved.

» Open Source

RUGGEDCOM ROS contains Open Source Software. For license conditions, refer to the associated *License Conditions* document.

» Security Information

Siemens provides products and solutions with industrial security functions that support the secure operation of plants, machines, equipment and/or networks. They are important components in a holistic industrial security concept. With this in mind, Siemens' products and solutions undergo continuous development. Siemens recommends strongly that you regularly check for product updates.

For the secure operation of Siemens products and solutions, it is necessary to take suitable preventive action (e.g. cell protection concept) and integrate each component into a holistic, state-of-the-art industrial security concept. Third-party products that may be in use should also be considered. For more information about industrial security, visit <https://www.siemens.com/industrialsecurity>.

To stay informed about product updates as they occur, sign up for a product-specific newsletter. For more information, visit <https://support.automation.siemens.com>.

» Warranty

Refer to the License Agreement for the applicable warranty terms and conditions, if any.

For warranty details, visit <https://www.siemens.com/ruggedcom> or contact a Siemens customer service representative.

» Contacting Siemens

Address

Siemens Canada Ltd
Industry Sector
300 Applewood Crescent
Concord, Ontario
Canada, L4K 5C7

Telephone

Toll-free: 1 888 264 0006
Tel: +1 905 856 5288
Fax: +1 905 856 1995

E-mail

ruggedcom.info.i-ia@siemens.com

Web

<https://www.siemens.com/ruggedcom>

Table of Contents

Preface	xv
Conventions	xv
Related Documents	xvi
System Requirements	xvii
Accessing Documentation	xvii
Training	xviii
Customer Support	xviii
 Chapter 1	
Introduction	1
1.1 Features and Benefits	1
1.2 Security Recommendations	3
1.3 Controlled vs. Non-Controlled	5
1.4 Supported Networking Standards	6
1.5 Internet Protocol Support	6
1.6 Port Numbering Scheme	8
1.7 Available Services by Port	8
 Chapter 2	
Using ROS	11
2.1 Logging In	11
2.2 Logging Out	12
2.3 Using the Web Interface	13
2.4 Using the Console Interface	14
2.5 Using the Command Line Interface	16
2.5.1 Available CLI Commands	16
2.5.2 Tracing Events	19
2.5.3 Executing Commands Remotely via RSH	20
2.5.4 Using SQL Commands	21
2.5.4.1 Finding the Correct Table	21
2.5.4.2 Retrieving Information	22
2.5.4.3 Changing Values in a Table	23
2.5.4.4 Resetting a Table	24
2.5.4.5 Using RSH and SQL	24
2.6 Selecting Ports in RUGGEDCOM ROS	25

2.7	Managing the Flash File System	25
2.7.1	Viewing a List of Flash Files	25
2.7.2	Viewing Flash File Details	26
2.7.3	Defragmenting the Flash File System	26
2.8	Accessing BIST Mode	27
Chapter 3		
	Getting Started	29
3.1	Connecting to ROS	29
3.1.1	Default IP Address	29
3.1.2	Connecting Directly	29
3.1.3	Connecting Remotely	30
3.2	Installing the RUGGEDCOM USB Serial Console Driver (Windows Only)	31
3.3	Configuring a Basic Network	32
Chapter 4		
	Device Management	33
4.1	Viewing Product Information	33
4.2	Viewing CPU Diagnostics	35
4.3	Restoring Factory Defaults	36
4.4	Uploading/Downloading Files	37
4.4.1	Uploading/Downloading Files Using XMODEM	38
4.4.2	Uploading/Downloading Files Using a TFTP Client	39
4.4.3	Uploading/Downloading Files Using a TFTP Server	40
4.4.4	Uploading/Downloading Files Using an SFTP Server	40
4.5	Managing Logs	41
4.5.1	Viewing Local and System Logs	41
4.5.2	Clearing Local and System Logs	42
4.5.3	Configuring the Local System Log	42
4.5.4	Managing Remote Logging	43
4.5.4.1	Configuring the Remote Syslog Client	43
4.5.4.2	Viewing a List of Remote Syslog Servers	44
4.5.4.3	Adding a Remote Syslog Server	45
4.5.4.4	Deleting a Remote Syslog Server	46
4.6	Managing Ethernet Ports	47
4.6.1	Controller Protection Through Link Fault Indication (LFI)	48
4.6.2	Viewing the Status of Ethernet Ports	49
4.6.3	Viewing Statistics for All Ethernet Ports	50
4.6.4	Viewing Statistics for Specific Ethernet Ports	51
4.6.5	Clearing Statistics for Specific Ethernet Ports	53
4.6.6	Configuring an Ethernet Port	54

- 4.6.7 Configuring Port Rate Limiting 57
- 4.6.8 Configuring Port Mirroring 59
- 4.6.9 Configuring Link Detection 60
- 4.6.10 Resetting Ethernet Ports 61
- 4.7 Managing IP Interfaces 62
 - 4.7.1 Managing Switch IP Interfaces 62
 - 4.7.1.1 Viewing a List of Switch IP Interfaces 63
 - 4.7.1.2 Adding a Switch IP Interface 63
 - 4.7.1.3 Deleting a Switch IP Interface 65
- 4.8 Managing IP Gateways 66
 - 4.8.1 Viewing a List of IP Gateways 67
 - 4.8.2 Adding an IP Gateway 67
 - 4.8.3 Deleting an IP Gateway 69
- 4.9 Configuring IP Services 69
- 4.10 Managing Remote Monitoring 71
 - 4.10.1 Managing RMON History Controls 72
 - 4.10.1.1 Viewing a List of RMON History Controls 72
 - 4.10.1.2 Adding an RMON History Control 72
 - 4.10.1.3 Deleting an RMON History Control 74
 - 4.10.2 Managing RMON Alarms 75
 - 4.10.2.1 Viewing a List of RMON Alarms 76
 - 4.10.2.2 Adding an RMON Alarm 77
 - 4.10.2.3 Deleting an RMON Alarm 79
 - 4.10.3 Managing RMON Events 80
 - 4.10.3.1 Viewing a List of RMON Events 81
 - 4.10.3.2 Adding an RMON Event 81
 - 4.10.3.3 Deleting an RMON Event 83
- 4.11 Upgrading/Downgrading Firmware 83
 - 4.11.1 Upgrading Firmware 84
 - 4.11.2 Downgrading Firmware 84
- 4.12 Resetting the Device 85
- 4.13 Decommissioning the Device 86

Chapter 5

- System Administration 87**
 - 5.1 Configuring the System Information 87
 - 5.2 Customizing the Login Screen 88
 - 5.3 Enabling/Disabling the Web Interface 88
 - 5.4 Managing Alarms 89
 - 5.4.1 Viewing a List of Pre-Configured Alarms 89
 - 5.4.2 Viewing and Clearing Latched Alarms 90

5.4.3	Configuring an Alarm	91
5.4.4	Authentication Related Security Alarms	94
5.4.4.1	Security Alarms for Login Authentication	94
5.4.4.2	Security Messages for Port Authentication	96
5.5	Managing the Configuration File	97
5.5.1	Configuring Data Encryption	97
5.5.2	Updating the Configuration File	99
5.6	Managing MMS Reporting	99
5.6.1	Understanding MMS Reporting	99
5.6.1.1	Reports/Data Sets	100
5.6.2	Viewing a List of Preconfigured MMS Reports	100
5.6.3	Configuring an MMS Report	101
 Chapter 6		
Security	103
6.1	Configuring Passwords	103
6.2	Clearing Private Data	106
6.3	Managing User Authentication	106
6.3.1	Configuring User Name Extensions	106
6.3.2	Managing RADIUS Authentication	107
6.3.2.1	Configuring the RADIUS Server	108
6.3.2.2	Configuring the RADIUS Client on the Device	109
6.3.3	Managing TACACS+ Authentication	110
6.3.3.1	Configuring TACACS+	110
6.3.3.2	Configuring User Privileges	112
6.4	Managing Port Security	113
6.4.1	Port Security Concepts	113
6.4.1.1	Static MAC Address-Based Authentication	114
6.4.1.2	IEEE 802.1x Authentication	114
6.4.1.3	IEEE 802.1X Authentication with MAC Address-Based Authentication	115
6.4.1.4	Assigning VLANs with Tunnel Attributes	115
6.4.2	Viewing a List of Authorized MAC Addresses	116
6.4.3	Configuring Port Security	116
6.4.4	Configuring IEEE 802.1X	118
6.5	Managing SSH and SSL Keys and Certificates	120
6.5.1	SSL Certificates	121
6.5.2	SSH Host Key	122
6.5.3	Managing SSH Public Keys	123
6.5.3.1	Public Key Requirements	123
6.5.3.2	Adding a Public Key	124
6.5.3.3	Viewing a List of Public Keys	124

6.5.3.4	Updating a Public Key	125
6.5.3.5	Deleting a Public Key	125
6.5.4	Certificate and Key Examples	126
Chapter 7		
Layer 2	129
7.1	Managing Virtual LANs	129
7.1.1	VLAN Concepts	130
7.1.1.1	Tagged vs. Untagged Frames	130
7.1.1.2	Native VLAN	130
7.1.1.3	The Management VLAN	130
7.1.1.4	Edge and Trunk Port Types	131
7.1.1.5	Ingress and Egress Rules	131
7.1.1.6	Forbidden Ports List	132
7.1.1.7	VLAN-Aware and VLAN-Unaware Modes	132
7.1.1.8	GARP VLAN Registration Protocol (GVRP)	132
7.1.1.9	PVLAN Edge	134
7.1.1.10	QinQ	134
7.1.1.11	VLAN Advantages	135
7.1.2	Viewing a List of VLANs	137
7.1.3	Configuring VLANs Globally	137
7.1.4	Configuring VLANs for Specific Ethernet Ports	138
7.1.5	Managing Static VLANs	140
7.1.5.1	Viewing a List of Static VLANs	141
7.1.5.2	Adding a Static VLAN	141
7.1.5.3	Deleting a Static VLAN	143
7.2	Managing MAC Addresses	144
7.2.1	Viewing a List of MAC Addresses	144
7.2.2	Configuring MAC Address Learning Options	145
7.2.3	Configuring MAC Address Flooding Options	146
7.2.4	Managing Static MAC Addresses	148
7.2.4.1	Viewing a List of Static MAC Addresses	148
7.2.4.2	Adding a Static MAC Address	148
7.2.4.3	Deleting a Static MAC Address	150
7.2.5	Purging All Dynamic MAC Addresses	151
7.3	Managing Multicast Filtering	152
7.3.1	Managing IGMP	152
7.3.1.1	IGMP Concepts	152
7.3.1.2	Viewing a List of Multicast Group Memberships	156
7.3.1.3	Viewing Forwarding Information for Multicast Groups	157
7.3.1.4	Configuring IGMP	157

7.3.2	Managing GMRP	159
7.3.2.1	GMRP Concepts	159
7.3.2.2	Viewing a Summary of Multicast Groups	162
7.3.2.3	Configuring GMRP Globally	162
7.3.2.4	Configuring GMRP for Specific Ethernet Ports	163
7.3.2.5	Viewing a List of Static Multicast Groups	165
7.3.2.6	Adding a Static Multicast Group	165
7.3.2.7	Deleting a Static Multicast Group	166

Chapter 8

Redundancy	169
8.1 Managing Spanning Tree Protocol	169
8.1.1 RSTP Operation	169
8.1.1.1 RSTP States and Roles	170
8.1.1.2 Edge Ports	172
8.1.1.3 Point-to-Point and Multipoint Links	172
8.1.1.4 Path and Port Costs	172
8.1.1.5 Bridge Diameter	173
8.1.1.6 eRSTP	174
8.1.1.7 Fast Root Failover	174
8.1.2 RSTP Applications	175
8.1.2.1 RSTP in Structured Wiring Configurations	175
8.1.2.2 RSTP in Ring Backbone Configurations	177
8.1.2.3 RSTP Port Redundancy	179
8.1.3 MSTP Operation	179
8.1.3.1 MSTP Regions and Interoperability	180
8.1.3.2 MSTP Bridge and Port Roles	181
8.1.3.3 Benefits of MSTP	182
8.1.3.4 Implementing MSTP on a Bridged Network	183
8.1.4 Configuring STP Globally	184
8.1.5 Configuring STP for Specific Ethernet Ports	185
8.1.6 Configuring eRSTP	188
8.1.7 Viewing Global Statistics for STP	190
8.1.8 Viewing STP Statistics for Ethernet Ports	191
8.1.9 Managing Multiple Spanning Tree Instances	193
8.1.9.1 Viewing Statistics for Global MSTIs	193
8.1.9.2 Viewing Statistics for Port MSTIs	195
8.1.9.3 Configuring the MST Region Identifier	196
8.1.9.4 Configuring a Global MSTI	197
8.1.9.5 Configuring an MSTI for an Ethernet Port	198
8.1.10 Clearing Spanning Tree Protocol Statistics	200

8.2	Managing the Media Redundancy Protocol (MRP)	200
8.2.1	Understanding MRP	200
8.2.1.1	MRM vs MRC Devices	201
8.2.1.2	MRA Devices	201
8.2.1.3	Ring Port States	201
8.2.1.4	Ring-Closed vs Ring-Open	202
8.2.2	Configuring MRP Globally	202
8.2.3	Viewing the Status of MRP Instances	203
8.2.4	Adding an MRP Instance	204
8.2.5	Deleting an MRP Instance	207
8.2.6	Example: Configuring an MRP Ring	208
8.3	Managing Link Aggregation	210
8.3.1	Link Aggregation Concepts	211
8.3.1.1	Static vs. Dynamic Link Aggregation	211
8.3.1.2	Rules and Limitations	212
8.3.1.3	Link Aggregation and Layer 2 Features	213
8.3.1.4	Link Aggregation and Physical Layer Features	213
8.3.2	Configuring Link Aggregation	213
8.3.3	Managing Link Aggregation Groups	214
8.3.3.1	Viewing a List of Link Aggregation Groups	214
8.3.3.2	Adding a Link Aggregation Group	214
8.3.3.3	Deleting a Link Aggregation Group	216
8.3.3.4	Viewing the Status of Link Aggregation Groups	217
8.3.4	Managing the Link Aggregation Control Protocol	218
8.3.4.1	Viewing Information About the LACP Partner	218
8.3.4.2	Configuring Global LACP Settings	219
8.3.4.3	Configuring LACP Per Port	220
8.3.4.4	Viewing LACP Statistics	222
8.3.5	Clearing Link Aggregation Statistics	223
Chapter 9		
	Traffic Control and Classification	225
9.1	Managing Classes of Service	225
9.1.1	Configuring Classes of Service Globally	226
9.1.2	Configuring Classes of Service for Specific Ethernet Ports	227
9.1.3	Configuring Priority to CoS Mapping	228
9.1.4	Configuring DSCP to CoS Mapping	229
Chapter 10		
	Time Services	231
10.1	Configuring the Time and Date	231

10.2	Managing the Precision Time Protocol (PTP)	233
10.2.1	Configuring PTP Globally	233
10.2.2	Configuring a Transparent Clock	236
10.2.3	Configuring the PTP Delay Request Interval	237
10.2.4	Configuring a VLAN for PTP Traffic	238
10.2.5	Viewing PTP Clock Statistics	239
10.2.6	Viewing Peer Delay Statistics	239
10.3	Configuring the Time Source	241
10.4	Managing NTP	241
10.4.1	Enabling/Disabling NTP Service	242
10.4.2	Configuring NTP Servers	242

Chapter 11

Network Discovery and Management	245	
11.1	Enabling/Disabling RCDP	245
11.2	Managing LLDP	247
11.2.1	Configuring LLDP Globally	247
11.2.2	Configuring LLDP for an Ethernet Port	249
11.2.3	Viewing Global Statistics and Advertised System Information	250
11.2.4	Viewing Statistics for LLDP Neighbors	251
11.2.5	Viewing Statistics for LLDP Ports	252
11.3	Managing SNMP	253
11.3.1	SNMP Management Interface Base (MIB) Support	253
11.3.1.1	Supported Standard MIBs	254
11.3.1.2	Supported Proprietary RUGGEDCOM MIBs	255
11.3.1.3	Supported Agent Capabilities	255
11.3.2	SNMP Traps	256
11.3.3	Managing SNMP Users	258
11.3.3.1	Viewing a List of SNMP Users	258
11.3.3.2	Adding an SNMP User	258
11.3.3.3	Deleting an SNMP User	261
11.3.4	Managing Security-to-Group Mapping	262
11.3.4.1	Viewing a List of Security-to-Group Maps	262
11.3.4.2	Adding a Security-to-Group Map	263
11.3.4.3	Deleting a Security-to-Group Map	264
11.3.5	Managing SNMP Groups	265
11.3.5.1	Viewing a List of SNMP Groups	266
11.3.5.2	Adding an SNMP Group	266
11.3.5.3	Deleting an SNMP Group	268
11.4	ModBus Management Support	268
11.4.1	ModBus Function Codes	269

11.4.2	ModBus Memory Map	270
11.4.3	Modbus Memory Formats	272
11.4.3.1	Text	272
11.4.3.2	Cmd	273
11.4.3.3	Uint16	273
11.4.3.4	Uint32	273
11.4.3.5	PortCmd	273
11.4.3.6	Alarm	274
11.4.3.7	PSStatusCmd	274
11.4.3.8	TruthValues	275
Chapter 12		
	IP Address Assignment	277
12.1	Managing DHCP	277
12.1.1	DHCP Concepts	277
12.1.1.1	DHCP Snooping	278
12.1.1.2	Trusted and Untrusted Ports	278
12.1.1.3	DHCP Relay Agent (Option 82)	278
12.1.2	Configuring the DHCP Relay Agent	279
12.1.3	Enabling DHCP Relay Agent Information (Option 82) for Specific Ports	279
12.1.4	Configuring DHCP Snooping	281
12.1.5	Configuring Trusted/Untrusted Ports	281
12.1.6	Managing the DHCP Binding Table	283
12.1.6.1	Adding Entries to the DHCP Binding Table	283
12.1.6.2	Viewing the DHCP Binding Table	284
12.1.6.3	Saving the DHCP Binding Table	286
12.1.6.4	Example: Configuring the Device as a Relay Agent	286
Chapter 13		
	Troubleshooting	289
13.1	General	289
13.2	Ethernet Ports	290
13.3	Spanning Tree	290
13.4	VLANs	292

Preface

This guide describes v5.2 of ROS (Rugged Operating System) running on the RUGGEDCOM RSG908C. It contains instructions and guidelines on how to use the software, as well as some general theory.

It is intended for use by network technical support personnel who are familiar with the operation of networks. It is also recommended for use by network and system planners, system programmers, and line technicians.

**IMPORTANT!**

Some of the parameters and options described may not be available depending on variations in the device hardware. While every attempt is made to accurately describe the specific parameters and options available, this Guide should be used as a companion to the Help text included in the software.

CONTENTS

- [“Conventions”](#)
- [“Related Documents”](#)
- [“System Requirements”](#)
- [“Accessing Documentation”](#)
- [“Training”](#)
- [“Customer Support”](#)

Conventions

This User Guide uses the following conventions to present information clearly and effectively.

>> Alerts

The following types of alerts are used when necessary to highlight important information.

**DANGER!**

DANGER alerts describe imminently hazardous situations that, if not avoided, will result in death or serious injury.

**WARNING!**

WARNING alerts describe hazardous situations that, if not avoided, may result in serious injury and/or equipment damage.

**CAUTION!**

CAUTION alerts describe hazardous situations that, if not avoided, may result in equipment damage.

**IMPORTANT!**

IMPORTANT alerts provide important information that should be known before performing a procedure or step, or using a feature.

**NOTE**

NOTE alerts provide additional information, such as facts, tips and details.

» CLI Command Syntax

The syntax of commands used in a Command Line Interface (CLI) is described according to the following conventions:

Example	Description
command	Commands are in bold.
command parameter	Parameters are in plain text.
command parameter1 parameter2	Parameters are listed in the order they must be entered.
command parameter1 <i>parameter2</i>	Parameters in italics must be replaced with a user-defined value.
command [parameter1 parameter2]	Alternative parameters are separated by a vertical bar (). Square brackets indicate a required choice between two or more parameters.
command { parameter3 parameter4 }	Curly brackets indicate an optional parameter(s).
command parameter1 parameter2 { parameter3 parameter4 }	All commands and parameters are presented in the order they must be entered.

Related Documents

» Product Notes

Document Title	Link
RUGGEDCOM ROS Release Notes v5.2	https://support.industry.siemens.com/cs/ww/en/view/109756288

» User/Reference Guides

Document Title	Link
RUGGEDCOM NMS v2.1 User Guide for Windows	https://support.industry.siemens.com/cs/ww/en/view/109737564
RUGGEDCOM NMS v2.1 User Guide for Linux	https://support.industry.siemens.com/cs/ww/en/view/109737563
RUGGEDCOM DIRECTOR v1.4 User Guide	https://support.industry.siemens.com/cs/ww/en/view/97691648
RUGGEDCOM EXPLORER v1.5 User Guide	https://support.industry.siemens.com/cs/ww/en/view/109480804
RUGGEDCOM PING v1.2 User Guide	https://support.industry.siemens.com/cs/ww/en/view/97674073

» Catalogs

Document Title	Link
RUGGEDCOM SFP Transceivers Catalog	https://support.industry.siemens.com/cs/ww/en/view/109482309

» FAQs

Document Title	Link
How Do You Configure the SMP Function in a RUGGEDCOM Switch with RUGGEDCOM ROS?	https://support.industry.siemens.com/cs/ww/en/view/109474615
How to Secure RUGGEDCOM ROS Devices Before and After Field Deployment	https://support.industry.siemens.com/cs/ww/en/view/99858806
How to Reset Passwords	https://support.industry.siemens.com/cs/ww/en/view/109738242
How to Implement Robust Ring Networks Using RSTP and eRSTP	https://support.industry.siemens.com/cs/ww/en/view/109738240
How to Implement Secure, Unattended Logging in ROS	https://support.industry.siemens.com/cs/ww/en/view/109756843

» Installation Guides

Document Title	Link
RUGGEDCOM RSG908C Installation Guide	https://support.industry.siemens.com/cs/ww/en/view/109757204

System Requirements

Each workstation used to connect to the RUGGEDCOM ROS interface must meet the following system requirements:

- Must have one of the following Web browsers installed:
 - Microsoft Internet Explorer 8.0 or higher
 - Mozilla Firefox
 - Google Chrome
 - Iceweasel/IceCat (Linux Only)
- Must have a working Ethernet interface compatible with at least one of the port types on the RUGGEDCOM device
- The ability to configure an IP address and netmask on the computer's Ethernet interface

Accessing Documentation

The latest user documentation for RUGGEDCOM ROS v5.2 is available online at <https://www.siemens.com/ruggedcom>. To request or inquire about a user document, contact Siemens Customer Support.

Training

Siemens offers a wide range of educational services ranging from in-house training of standard courses on networking, Ethernet switches and routers, to on-site customized courses tailored to the customer's needs, experience and application.

Siemens' Educational Services team thrives on providing our customers with the essential practical skills to make sure users have the right knowledge and expertise to understand the various technologies associated with critical communications network infrastructure technologies.

Siemens' unique mix of IT/Telecommunications expertise combined with domain knowledge in the utility, transportation and industrial markets, allows Siemens to provide training specific to the customer's application.

For more information about training services and course availability, visit <https://www.siemens.com/ruggedcom> or contact a Siemens Sales representative.

Customer Support

Customer support is available 24 hours, 7 days a week for all Siemens customers. For technical support or general information, contact Siemens Customer Support through any of the following methods:



Online

Visit <http://www.siemens.com/automation/support-request> to submit a Support Request (SR) or check on the status of an existing SR.

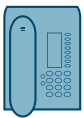

Telephone

Call a local hotline center to submit a Support Request (SR). To locate a local hotline center, visit <http://www.automation.siemens.com/mcms/aspa-db/en/automation-technology/Pages/default.aspx>.



Mobile App

Install the Industry Online Support app by Siemens AG on any Android, Apple iOS or Windows mobile device and be able to:

- Access Siemens' extensive library of support documentation, including FAQs and manuals
- Submit SRs or check on the status of an existing SR
- Contact a local Siemens representative from Sales, Technical Support, Training, etc.
- Ask questions or share knowledge with fellow Siemens customers and the support community

1 Introduction

Welcome to the RUGGEDCOM ROS v5.2 Software User Guide for the RUGGEDCOM RSG908C devices. This Guide describes the wide array of carrier grade features made available by RUGGEDCOM ROS (Rugged Operating System).

This chapter provides a basic overview of the RUGGEDCOM ROS software.

CONTENTS

- [Section 1.1, “Features and Benefits”](#)
- [Section 1.2, “Security Recommendations”](#)
- [Section 1.3, “Controlled vs. Non-Controlled”](#)
- [Section 1.4, “Supported Networking Standards”](#)
- [Section 1.5, “Internet Protocol Support”](#)
- [Section 1.6, “Port Numbering Scheme”](#)
- [Section 1.7, “Available Services by Port”](#)

Section 1.1

Features and Benefits

The following describes the many features available in RUGGEDCOM ROS and their benefits:

- **Cyber Security Features**

Cyber security is an urgent issue in many industries where advanced automation and communications networks play a crucial role in mission critical applications and where high reliability is of paramount importance. Key RUGGEDCOM ROS features that address security issues at the local area network level include:

Passwords	Multi-level user passwords secures against unauthorized configuration
SSH/SSL	Extends capability of password protection to add encryption of passwords and data as they cross the network
Enable/Disable Ports	Capability to disable ports so that traffic cannot pass
802.1Q VLAN	Provides the ability to logically segregate traffic between predefined ports on switches
SNMPv3	Encrypted authentication and access security
HTTPS	For secure access to the Web interface

- **Enhanced Rapid Spanning Tree Protocol (eRSTP)[™]**

Siemens's eRSTP allows the creation of fault-tolerant ring and mesh Ethernet networks that incorporate redundant links that are *pruned* to prevent loops. eRSTP implements both STP and RSTP to promote interoperability with commercial switches, unlike other proprietary *ring* solutions. The fast root failover feature of eRSTP provides quick network convergence in case of an RSTP root bridge failure in a mesh topology.

- **Quality of Service (IEEE 802.1p)**

Some networking applications such as real-time control or VoIP (Voice over IP) require predictable arrival times for Ethernet frames. Switches can introduce latency in times of heavy network traffic due to the internal queues that buffer frames and then transmit on a first come first serve basis. RUGGEDCOM ROS supports *Class of Service*, which allows time critical traffic to jump to the front of the queue, thus minimizing latency and reducing *jitter* to allow such demanding applications to operate correctly. RUGGEDCOM ROS allows priority classification by port, tags, MAC address, and IP Type of Service (ToS). A configurable *weighted fair queuing* algorithm controls how frames are emptied from the queues.

- **VLAN (IEEE 802.1Q)**

Virtual Local Area Networks (VLAN) allow the segregation of a physical network into separate logical networks with independent broadcast domains. A measure of security is provided since hosts can only access other hosts on the same VLAN and traffic storms are isolated. RUGGEDCOM ROS supports 802.1Q tagged Ethernet frames and VLAN trunks. Port based classification allows legacy devices to be assigned to the correct VLAN. GVRP support is also provided to simplify the configuration of the switches on the VLAN.

- **Simple Network Management Protocol (SNMP)**

SNMP provides a standardized method, for network management stations, to interrogate devices from different vendors. SNMP versions supported by RUGGEDCOM ROS are v1, v2c and v3. SNMPv3 in particular provides security features (such as authentication, privacy, and access control) not present in earlier SNMP versions. RUGGEDCOM ROS also supports numerous standard MIBs (Management Information Base) allowing for easy integration with any Network Management System (NMS). A feature of SNMP is the ability to generate *traps* upon system events. RUGGEDCOM NMS, the Siemens management solution, can record traps from multiple devices providing a powerful network troubleshooting tool. It also provides a graphical visualization of the network and is fully integrated with all Siemens products.

- **Remote Monitoring and Configuration with RUGGEDCOM NMS**

RUGGEDCOM NMS (RNMS) is Siemens's Network Management System software for the discovery, monitoring and management of RUGGEDCOM products and other IP enabled devices on a network. This highly configurable, full-featured product records and reports on the availability and performance of network components and services. Device, network and service failures are quickly detected and reported to reduce downtime.

RNMS is especially suited for remotely monitoring and configuring RUGGEDCOM routers, switches, serial servers and WiMAX wireless network equipment. For more information, contact a Siemens Sales representative.

- **NTP (Network Time Protocol)**

NTP automatically synchronizes the internal clock of all RUGGEDCOM ROS devices on the network. This allows for correlation of time stamped events for troubleshooting.

- **Port Rate Limiting**

RUGGEDCOM ROS supports configurable rate limiting per port to limit unicast and multicast traffic. This can be essential to managing precious network bandwidth for service providers. It also provides edge security for Denial of Service (DoS) attacks.

- **Broadcast Storm Filtering**

Broadcast storms wreak havoc on a network and can cause attached devices to malfunction. This could be disastrous on a network with mission critical equipment. RUGGEDCOM ROS limits this by filtering broadcast frames with a user-defined threshold.

- **Link Aggregation**

Ethernet ports can be aggregated into a single logical link either statically or dynamically to increase bandwidth and balance the traffic load.

- **Port Mirroring**

RUGGEDCOM ROS can be configured to duplicate all traffic on one port to a designated mirror port. When combined with a network analyzer, this can be a powerful troubleshooting tool.

- **Port Configuration and Status**
RUGGEDCOM ROS allows individual ports to be *hard* configured for speed, duplex, auto-negotiation, flow control and more. This allows proper connection with devices that do not negotiate or have unusual settings. Detailed status of ports with alarm and SNMP trap on link problems aid greatly in system troubleshooting.
- **Port Statistics and RMON (Remote Monitoring)**
RUGGEDCOM ROS provides continuously updating statistics per port that provide both ingress and egress packet and byte counters, as well as detailed error figures.

Also provided is full support for RMON statistics. RMON allows for very sophisticated data collection, analysis and detection of traffic patterns.
- **Multicast Filtering**
RUGGEDCOM ROS supports static multicast groups and the ability to join or leave multicast groups dynamically using IGMP (Internet Group Management Protocol) or GMRP (GARP Multicast Registration Protocol).
- **Event Logging and Alarms**
RUGGEDCOM ROS records all significant events to a non-volatile system log allowing forensic troubleshooting. Events include link failure and recovery, unauthorized access, broadcast storm detection, and self-test diagnostics among others. Alarms provide a snapshot of recent events that have yet to be acknowledged by the network administrator. An external hardware relay is de-energized during the presence of critical alarms, allowing an external controller to react if desired.
- **HTML Web Browser User Interface**
RUGGEDCOM ROS provides a simple, intuitive user interface for configuration and monitoring via a standard graphical Web browser or via a standard telcom user interface. All system parameters include detailed online help to facilitate setup and configuration. RUGGEDCOM ROS presents a common look and feel and standardized configuration process, allowing easy migration to other managed RUGGEDCOM products.
- **Brute Force Attack Prevention**
Protection against Brute Force Attacks (BFAs) is standard in RUGGEDCOM ROS. If an external host fails to log in to the Terminal or Web interfaces after a fixed number of attempts, the service will be blocked for one hour.
- **IPv4/IPv6 Support**
RUGGEDCOM ROS supports both IPv4 and IPv6 addresses (for select features). For more information about support per protocol refer to [Section 1.5, "Internet Protocol Support"](#).

Section 1.2

Security Recommendations

To prevent unauthorized access to the device, note the following security recommendations:

» Authentication

- Replace the default passwords for all user accounts and processes (where applicable) before the device is deployed.
- Use strong passwords with high randomization (i.e. entropy), without repetition of characters. Avoid weak passwords such as *password1*, *123456789*, *abcdefgh*, and any dictionary words or proper names in any combination. For more information about creating strong passwords, refer to the password requirements in [Section 6.1, "Configuring Passwords"](#).
- Make sure passwords are protected and not shared with unauthorized personnel.
- Passwords should not be re-used across different user names and systems, or after they expire.

- If RADIUS authentication is done remotely, make sure all communications are within the security perimeter or on a secure channel.
- Generate and provision a custom SSL certificate and SSH host key pair before commissioning the device. For more information, refer to [Section 6.5, “Managing SSH and SSL Keys and Certificates”](#).
- Use SSH public key authentication. For more information, refer to [Section 6.5, “Managing SSH and SSL Keys and Certificates”](#).

» Physical/Remote Access

- Do not connect the device to the Internet. Deploy the device only within a secure network perimeter.
- Restrict physical access to the device to only authorized personnel. A person with malicious intent could extract critical information, such as certificates, keys, etc. (user passwords are protected by hash codes), or reprogram the device.
- Control access to the serial console to the same degree as any physical access to the device. Access to the serial console allows for potential access to the RUGGEDCOM ROS boot loader, which includes tools that may be used to gain complete access to the device.
- Only enable services that will be used on the device, including physical ports. Unused physical ports could potentially be used to gain access to the network behind the device.
- If SNMP is enabled, limit the number of IP addresses that can connect to the device and change the community names. Also configure SNMP to raise a trap upon authentication failures. For more information, refer to [Section 11.3, “Managing SNMP”](#).
- Avoid using insecure services such as Telnet and TFTP, or disable them completely if possible. These services are available for historical reasons and are disabled by default.
- Disable RCDP if it is not intended for use.
- Limit the number of simultaneous Web Server, Telnet and SSH sessions allowed.
- Configure remote system logging to forward all logs to a central location. For more information, refer to [Section 4.5, “Managing Logs”](#).
- Configuration files are provided in the CSV (comma separated values) format for ease of use. Make sure configuration files are properly protected when they exist outside of the device. For instance, encrypt the files, store them in a secure place, and do not transfer them via insecure communication channels.
- Management of the configuration file, certificates and keys is the responsibility of the device owner. Consider using RSA key sizes of at least 2048 bits in length and certificates signed with SHA256 for increased cryptographic strength. Before returning the device to Siemens for repair, make sure encryption is disabled (to create a cleartext version of the configuration file) and replace the current certificates and keys with temporary *throwaway* certificates and keys that can be destroyed upon the device's return.
- Be aware of any non-secure protocols enabled on the device. While some protocols, such as HTTPS and SSH, are secure, others, such as Telnet and RSH, were not designed for this purpose. Appropriate safeguards against non-secure protocols should be taken to prevent unauthorized access to the device/network.
- Configure port security features on access ports to prevent an unauthorized third-party from physically connecting to the device. For more information, refer to [Section 6.4, “Managing Port Security”](#).

» Hardware/Software

- Make sure the latest firmware version is installed, including all security-related patches. For the latest information on security patches for Siemens products, visit the [Industrial Security website](https://www.siemens.com/global/en/home/company/topic-areas/future-of-manufacturing/industrial-security.html) [https://www.siemens.com/global/en/home/company/topic-areas/future-of-manufacturing/industrial-security.html]

or the [ProductCERT Security Advisories website](http://www.siemens.com/innovation/en/technology-focus/siemens-cert/cert-security-advisories.htm) [http://www.siemens.com/innovation/en/technology-focus/siemens-cert/cert-security-advisories.htm]. Updates to Siemens Product Security Advisories can be obtained by subscribing to the RSS feed on the Siemens ProductCERT Security Advisories website, or by following @ProductCert on Twitter.

- Enable BPDU Guard on ports where RSTP BPDUs are not expected.
- Use the latest Web browser version compatible with RUGGEDCOM ROS to make sure the most secure Transport Layer Security (TLS) versions and ciphers available are employed.
- Modbus can be deactivated if not required by the user. If Modbus activation is required, then it is recommended to follow the security recommendations outlined in this User Guide and to configure the environment according to defense-in-depth best practices.
- Prevent access to external, untrusted Web pages while accessing the device via a Web browser. This can assist in preventing potential security threats, such as session hijacking.
- For optimal security, use SNMPv3 whenever possible. Use strong authentication keys and private keys without repetitive strings (e.g. *abc* or *abcabc*) with this feature. For more information about creating strong passwords, refer to the password requirements in [Section 6.1, "Configuring Passwords"](#).
- Unless required for a particular network topology, the *IP Forward* setting should be set to `Disabled` to prevent the routing of packets.

**NOTE**

For configuration compatibility reasons, the configured setting will not change when upgrading from RUGGEDCOM ROS versions older than v4.2.0 to v4.2.0 and newer. This setting is always enabled and cannot be configured on versions before v4.2.0. For new units with firmware v4.2.0 or higher, this setting is configurable and disabled by default.

» Policy

- Periodically audit the device to make sure it complies with these recommendations and/or any internal security policies.
- Review the user documentation for other Siemens products used in coordination with device for further security recommendations.

Section 1.3

Controlled vs. Non-Controlled

RUGGEDCOM ROS devices are available as either Controlled (C) or Non-Controlled (NC).

- **Controlled** switches feature a variety of encryption capabilities.
- **Non-controlled** switches have limited encryption capabilities.

To determine if a device is classified as controlled or non-controlled, navigate to **Diagnostics » View Product Information**. The *Classification* parameter on the **Product Information** form indicates if the device is controlled or non-controlled.

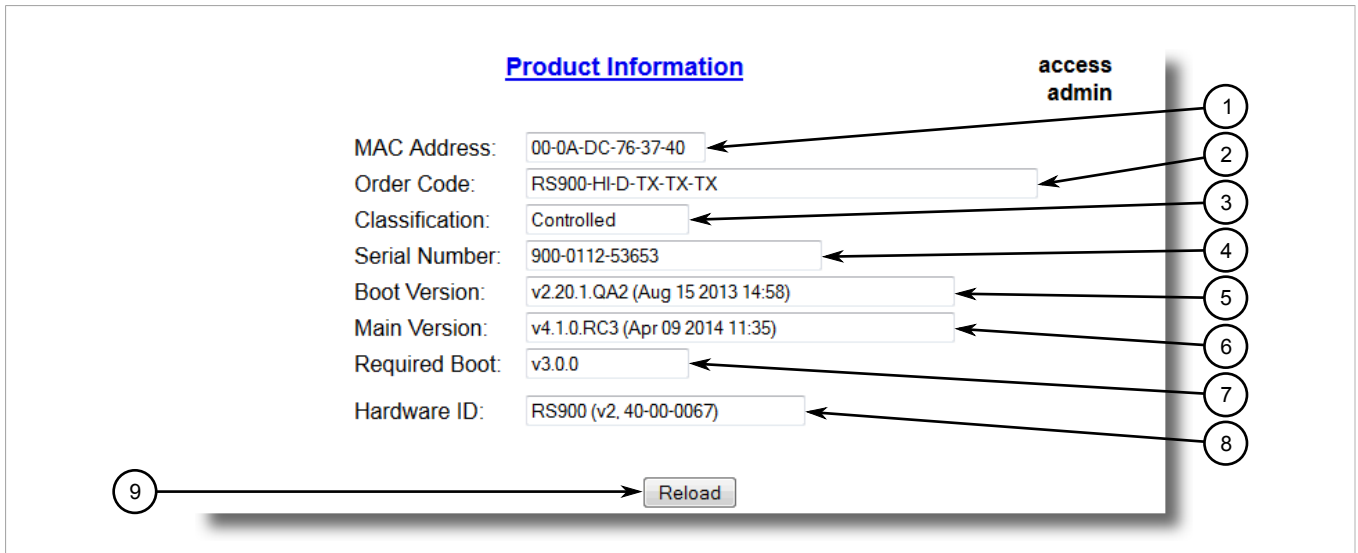

Figure 1: Product Information Form (Example)

1. MAC Address Box 2. Order Code Box 3. Classification Box 4. Serial Number Box 5. Boot Version Box 6. Main Version Box
7. Required Boot Box 8. Hardware ID Box 9. Reload Button

For information about how to convert a non-controlled device to a controlled device, contact Siemens Customer Support.

Section 1.4

Supported Networking Standards

The following networking standards are supported by RUGGEDCOM ROS:

Standard	10 Mbps Ports	100 Mbps Ports	1000 Mbps Ports	Notes
IEEE 802.3x	✓	✓	✓	Full Duplex Operation
IEEE 802.3z			✓	1000Base-LX
IEEE 802.3ab			✓	1000Base-Tx
IEEE 802.1D	✓	✓	✓	MAC Bridges
IEEE 802.1Q	✓	✓	✓	VLAN (Virtual LAN)
IEEE 802.1p	✓	✓	✓	Priority Levels

Section 1.5

Internet Protocol Support

RUGGEDCOM ROS supports both IPv4 addresses and IPv6 global unicast addresses, for select features. For more information, refer to ["Features supported by IPv4 and/or IPv6"](#).

» IPv4 Address

An IPv4 address is 32 bits in length and is written in decimal as four numbers separated by periods. Each number can be zero to 255.

Example: 192.168.0.1

» IPv6 Address

RUGGEDCOM ROS supports IPv6 global unicast addresses for management.

An IPv6 address is 128 bits in length and consists of eight, 16-bit fields. Each field must contain a hexadecimal number separated by colon.



NOTE

The double colon (::) can be used to compress leading or trailing edge zeros in an address.

- The leftmost three fields (48 bits) contain the site prefix. The prefix describes the public topology typically allocated to a site by an ISP.
- The center field is the 16-bit subnet ID, which is allocated to a specific site. The subnet ID describes the private topology, also known as the site topology, as it is internal to the site.
- The rightmost four fields (64 bits) contain the interface ID.

For example:

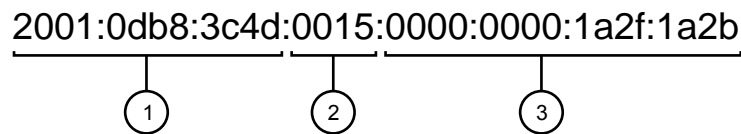

Figure 2: IPv6 Global Unicast Address Example

1. Site Prefix 2. Subnet ID 3. Interface ID

» Features supported by IPv4 and/or IPv6

Feature	IPv4	IPv6
Ping	✓	✓
Telnet Server	✓	✓
SSH Server	✓	✓
SFTP Server	✓	✓
Web Server Access	✓	✓
SNMP Client (v1, v2c, v3)	✓	✓
Radius Client	✓	✓
TACACS+ Client	✓	✓
TFTP	✓	
NTP Server/Client	✓	

Feature	IPv4	IPv6
DHCP Client	✓	
Remote Syslog Server	✓	
RSH	✓	
Serial Protocol	✓	
ARP (IPv4 only)	✓	
Network Discovery Messages (IPv6 only) ^a		✓

^a Supports Network Solicitation and Network Advertisement.

Section 1.6

Port Numbering Scheme

For quick identification, each port on a RUGGEDCOM RSG908C device is assigned a number or letter. All port numbers are silk-screened on the device.

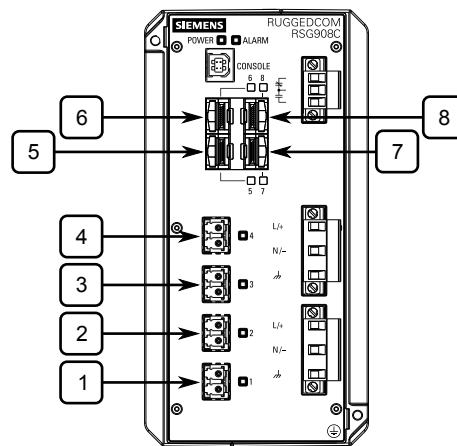

Figure 3: RUGGEDCOM RSG908C Port Numbering (Typical)

Use these numbers to configure applicable features on select ports.

Section 1.7

Available Services by Port

The following table lists the services available under RUGGEDCOM ROS. This table includes the following information:

- **Services**
The service supported by the device.
- **Port Number**
The port number associated with the service.

- **Port Open**

The port state, whether it is always open and cannot be closed, or open only, but can be configured.



NOTE

In certain cases, the service might be disabled, but the port can still be open (e.g. TFTP).

- **Port Default**

The default state of the port (i.e. open or closed).

- **Access Authorized**

Denotes whether the ports/services are authenticated during access.

Services	Port Number	Service Enabled/ Disabled	Access Authorized	Note
Telnet	TCP/23	Disabled	Yes	Only available through management interfaces.
HTTP	TCP/80	Enabled (configurable), redirects to 443	—	
HTTPS	TCP/443	Enabled (configurable)	Yes	
RSH	TCP/514	Disabled (configurable)	Yes	Only available through management interfaces.
TFTP	UDP/69	Disabled (configurable)	No	Only available through management interfaces.
SFTP	TCP/22	Enabled	Yes	Only available through management interfaces.
SNMP	UDP/161	Disabled (configurable)	Yes	Only available through management interfaces.
SNTP	UDP/123	Enabled (configurable)	No	Only available through management interfaces.
SSH	TCP/22	Enabled	Yes	Only available through management interfaces.
ICMP	—	Enabled	No	
TACACS+	TCP/49 (configurable)	Disabled (configurable)	Yes	
RADIUS	UDP/1812 to send (configurable), opens random port to listen to	Disabled (configurable)	Yes	Only available through management interfaces.
Remote Syslog	UDP/514 (configurable)	Disabled (configurable)	No	Only available through management interfaces.
TCP Modbus (Server)	TCP/502	Disabled (configurable)	No	Only available through management interfaces.
TCP Modbus (Switch)	TCP/502	Disabled (configurable)	No	
DHCP, DHCP Agent	UDP/67, 68 sending msg if enabled - if received, always come to CPU, dropped if service not configured	Disabled (configurable)	No	
RCDP	—	Enabled (configurable)	Yes	

2 Using ROS

This chapter describes how to use RUGGEDCOM ROS.

CONTENTS

- [Section 2.1, "Logging In"](#)
- [Section 2.2, "Logging Out"](#)
- [Section 2.3, "Using the Web Interface"](#)
- [Section 2.4, "Using the Console Interface"](#)
- [Section 2.5, "Using the Command Line Interface"](#)
- [Section 2.6, "Selecting Ports in RUGGEDCOM ROS"](#)
- [Section 2.7, "Managing the Flash File System"](#)
- [Section 2.8, "Accessing BIST Mode"](#)

Section 2.1

Logging In

To log in to the device, do the following:

1. Connect to the device either directly or through a Web browser. For more information about how to connect to the device, refer to [Section 3.1, "Connecting to ROS"](#).

Once the connection is established, the login form appears.



Figure 4: SSH Login Screen (Console Interface)

1. User Name Box 2. Password Box

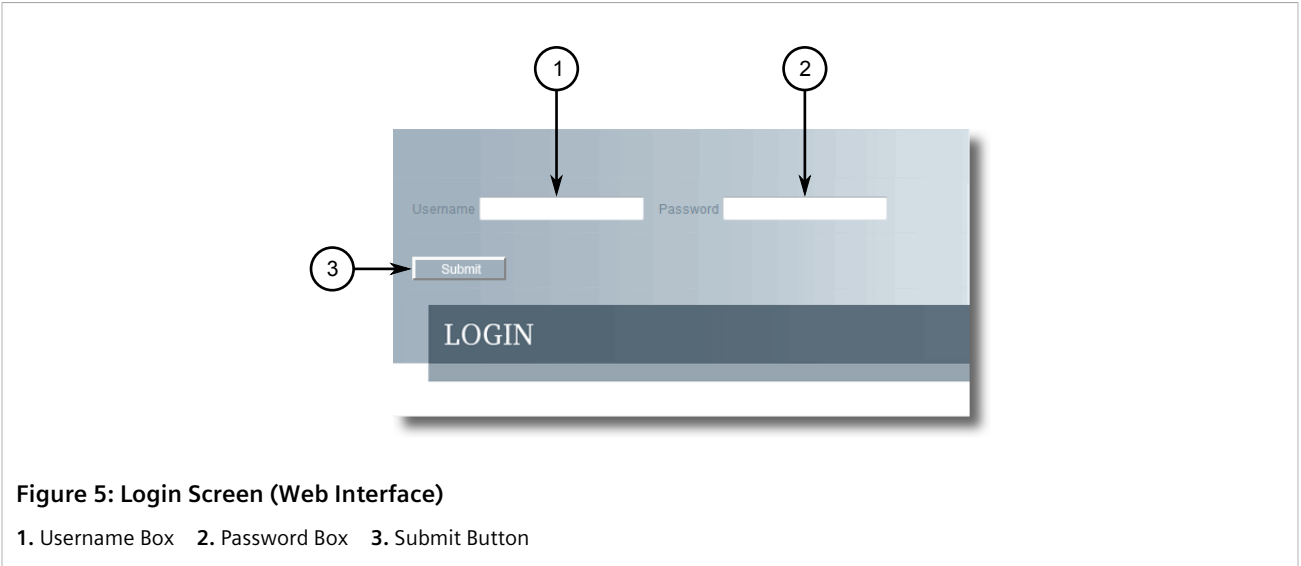

Figure 5: Login Screen (Web Interface)

1. Username Box 2. Password Box 3. Submit Button



NOTE

The following default user names and passwords are set on the device for each user type:

Guest

User Name: guest

Password: guest

Operator

User Name: operator

Password: operator

Admin

User Name: admin

Password: admin



CAUTION!

To prevent unauthorized access to the device, make sure to change the default guest, operator, and admin passwords before commissioning the device.

For more information about changing passwords, refer to [Section 6.1, "Configuring Passwords"](#).

2. In the **User Name** field, type the user name for an account setup on the device.
3. In the **Password** field, type the password for the account.
4. Click **Enter** or click **Submit** (Web interface only).

Section 2.2

Logging Out

To log out of the device, navigate to the main screen and do the following:

- To log out of the Console or secure shell interfaces, press **CTRL + X**.
- To log out of the Web interface, click **Logout**.

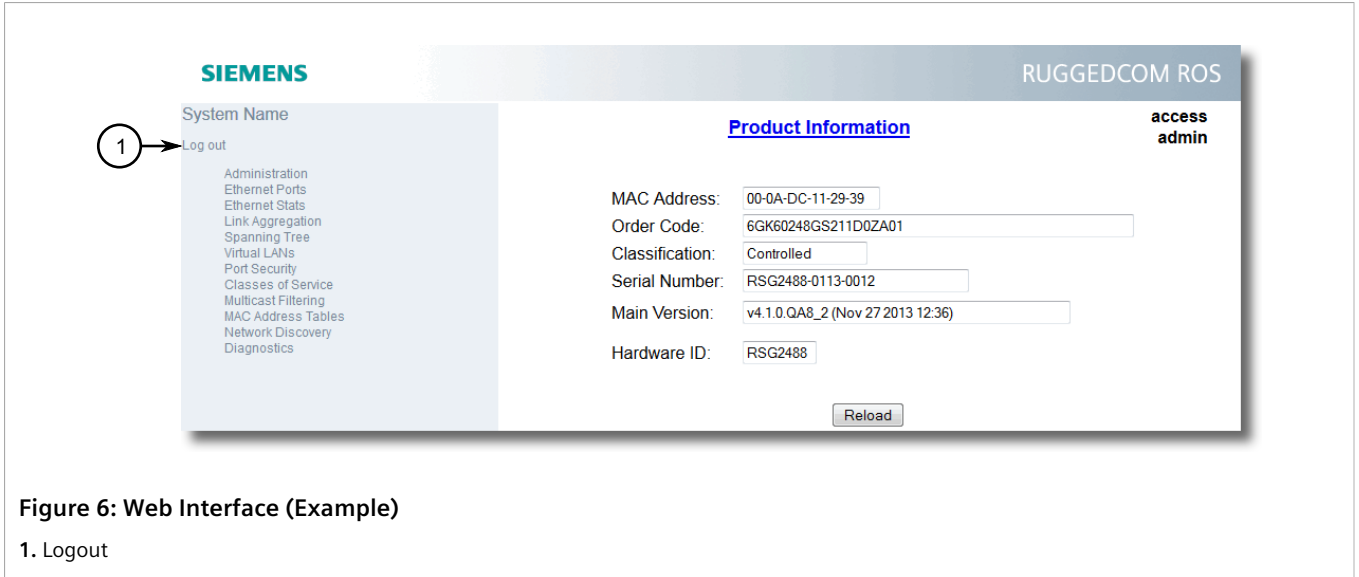

Figure 6: Web Interface (Example)

1. Logout



NOTE

If any pending configuration changes have not been committed, RUGGEDCOM ROS will request confirmation before discarding the changes and logging out of the device.

Section 2.3

Using the Web Interface

The Web interface is a Web-based Graphical User Interface (GUI) for displaying important information and controls in a Web browser. The interface is divided into three frames: the banner, the menu and the main frame.

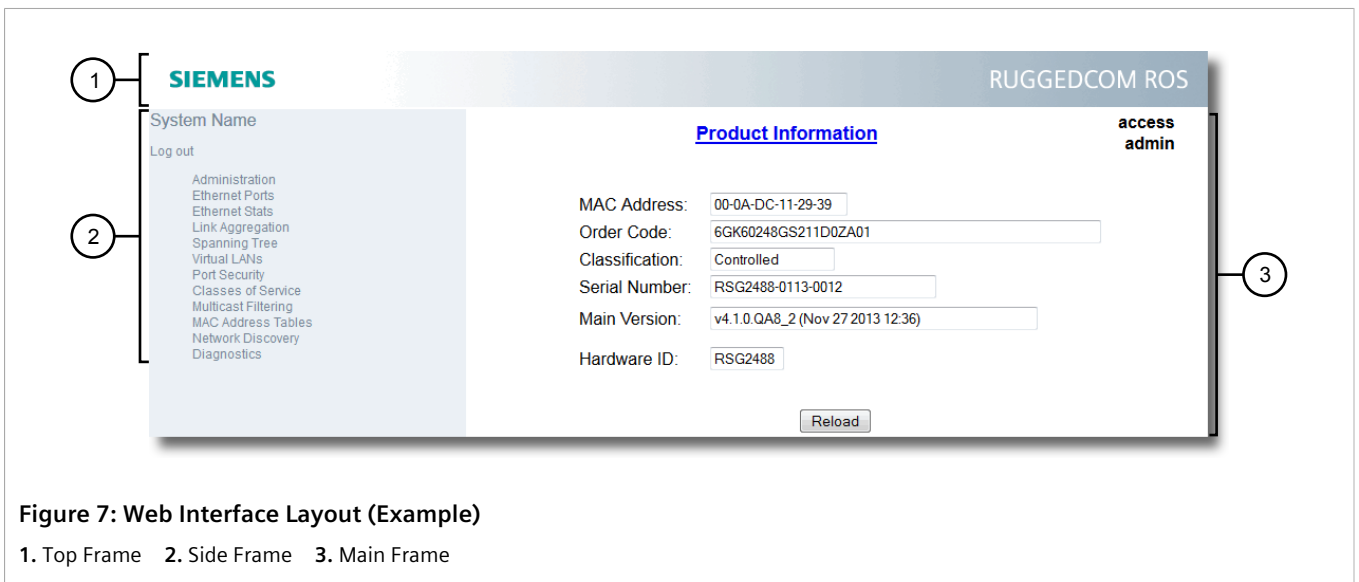

Figure 7: Web Interface Layout (Example)

1. Top Frame 2. Side Frame 3. Main Frame

Frame	Description
Top	The top frame displays the system name for the device.

Frame	Description
Side	The side frame contains a logout option and a collapsible list of links that open various screens in the main frame. For information about logging out of RUGGEDCOM ROS, refer to Section 2.2, "Logging Out" .
Main	The main frame displays the parameters and/or data related to the selected feature.

Each screen consists of a title, the current user's access level, parameters and/or data (in form or table format), and controls (e.g. add, delete, refresh, etc.). The title provides access to context-specific Help for the screen that provides important information about the available parameters and/or data. Click on the link to open the Help information in a new window.

When an alarm is generated, an alarm notification replaces the current user's access level on each screen until the alarm is cleared. The notification indicates how many alarms are currently active. For more information about alarms, refer to [Section 5.4, "Managing Alarms"](#).

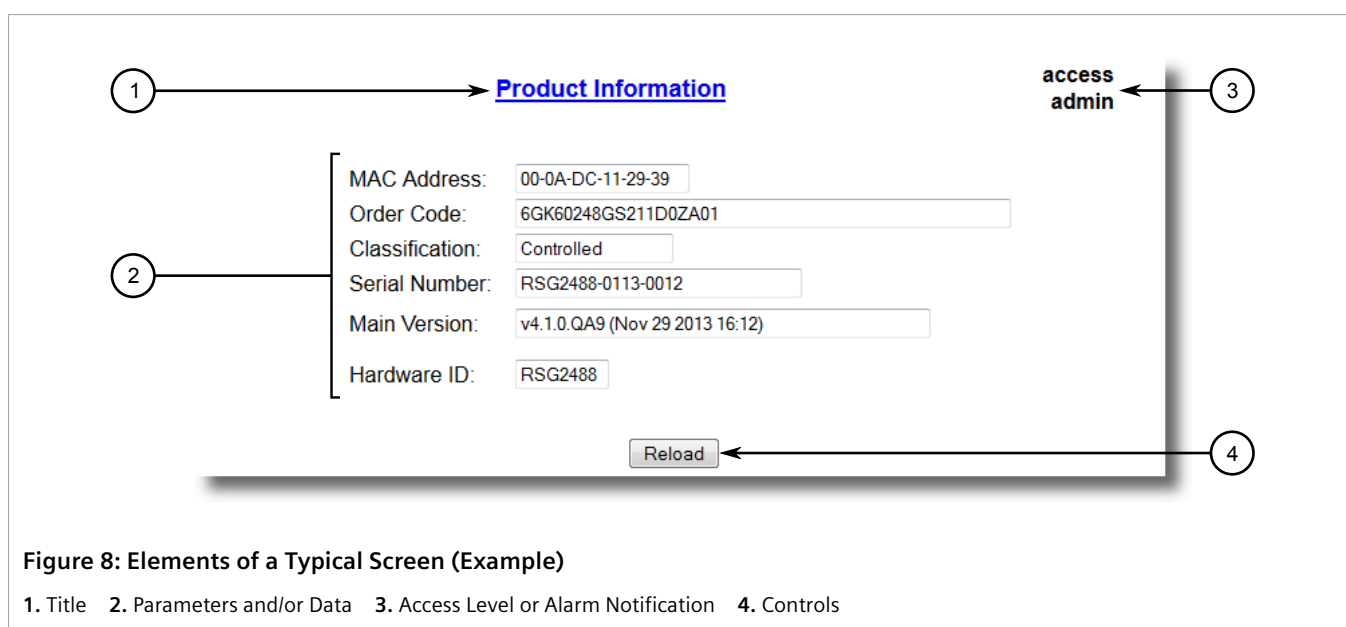

NOTE

If desired, the web interface can be disabled. For more information, refer to [Section 5.3, "Enabling/Disabling the Web Interface"](#).

Section 2.4

Using the Console Interface

The Console interface is a Graphical User Interface (GUI) organized as a series of menus. It is primarily accessible through a serial console connection, but can also be accessed through IP services, such as a Telnet, RSH (Remote Shell), SSH (Secure Shell) session, or SSH remote command execution.



NOTE

IP services can be restricted to control access to the device. For more information, refer to [Section 4.9, "Configuring IP Services"](#).

Each screen consists of a system identifier, the name of the current menu, and a command bar. Alarms are also indicated on each screen in the upper right corner.

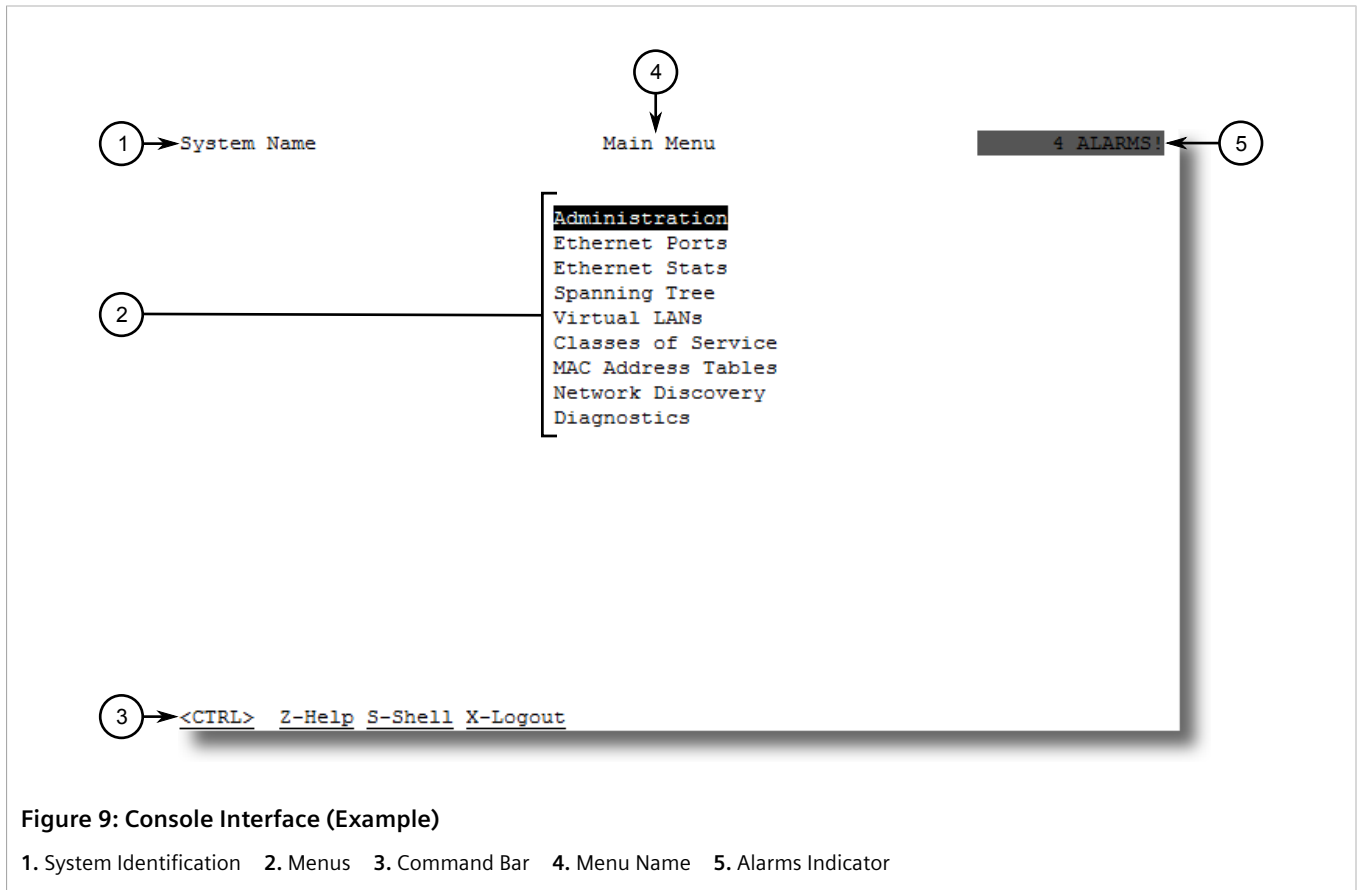

NOTE

The system identifier is user configurable. For more information about setting the system name, refer to [Section 5.1, "Configuring the System Information"](#).

» **Navigating the Interface**

Use the following controls to navigate between screens in the Console interface:

Enter	Select a menu item and press this Enter to enter the sub-menu or screen beneath.
Esc	Press Esc to return to the previous screen.

» **Configuring Parameters**

Use the following controls to select and configure parameters in the Console interface:

Up/Down Arrow Keys	Use the up and down arrow keys to select parameters.
Enter	Select a parameter and press Enter to start editing a parameter. Press Enter again to commit the change.
Esc	When editing a parameter, press Esc to abort all changes.

» Commands

The command bar lists the various commands that can be issued in the Console interface. Some commands are specific to select screens. The standard commands include the following:

Ctrl + A	Commits configuration changes made on the current screen.
	<div style="border: 1px solid gray; padding: 5px;">  NOTE <i>Before exiting a screen, RUGGEDCOM ROS will automatically prompt the user to save any changes that have not been committed.</i> </div>
Ctrl + I	Inserts a new record.
Ctrl + L	Deletes a record.
Ctrl + S	Opens the CLI interface.
Ctrl + X	Terminates the current session. This command is only available from the main menu.
Ctrl + Z	Displays important information about the current screen or selected parameter.

Section 2.5

Using the Command Line Interface

The Command Line Interface (CLI) offers a series of powerful commands for updating RUGGEDCOM ROS, generating certificates/keys, tracing events, troubleshooting and much more. It is accessed via the Console interface by pressing **Ctrl-S**.

CONTENTS

- [Section 2.5.1, "Available CLI Commands"](#)
- [Section 2.5.2, "Tracing Events"](#)
- [Section 2.5.3, "Executing Commands Remotely via RSH"](#)
- [Section 2.5.4, "Using SQL Commands"](#)

Section 2.5.1

Available CLI Commands

The following commands are available at the command line:

Command	Description	Authorized Users
alarms all	Displays a list of available alarms. Optional and/or required parameters include: <ul style="list-style-type: none"> • all displays all available alarms 	Guest, Operator, Admin
arp	Displays the IP to MAC address resolution table.	Admin
clearalarms	Clears all alarms.	Operator, Admin
clearethstats [all port]	Clears Ethernet statistics for one or more ports. Optional and/or required parameters include: <ul style="list-style-type: none"> • all clears statistics for all ports 	Operator, Admin

Command	Description	Authorized Users
	<ul style="list-style-type: none"> <i>port</i> is a comma separated list of port numbers (e.g. 1,3-5,7) 	
clearlogs	Clears the system and crash logs.	Admin
clrcblstats [<i>all</i> <i>port</i>]	Clears cable diagnostics statistics for one or more ports. Optional and/or required parameters include: <ul style="list-style-type: none"> <i>all</i> clears statistics for all ports <i>port</i> is a comma separated list of port numbers (e.g. 1,3-5,7) 	Admin
clrstpstats	Clears all spanning tree statistics.	Operator, Admin
cls	Clears the screen.	Guest, Operator, Admin
dir	Prints the directory listing.	Guest, Operator, Admin
exit	Terminates the session.	Guest, Operator, Admin
factory	<p>Enables factory mode, which includes several factory-level commands used for testing and troubleshooting. Only available to admin users.</p> <div style="border: 1px solid black; padding: 5px; background-color: #f0f0f0;">  <p>CAUTION! Misuse of the factory commands may corrupt the operational state of device and/or may permanently damage the ability to recover the device without manufacturer intervention.</p> </div>	Admin
flashfiles { <i>info filename</i> <i>defrag</i> }	<p>A set of diagnostic commands to display information about the Flash filesystem and to defragment Flash memory.</p> <p>Optional and/or required parameters include:</p> <ul style="list-style-type: none"> <i>info filename</i> displays information about the specified file in the Flash file system <i>defrag</i> defragments files in the Flash file system <p>For more information about the flashfiles command, refer to Section 2.7, "Managing the Flash File System".</p>	Admin
flashleds <i>timeout</i>	<p>Flashes the LED indicators on the device for a specified number of seconds.</p> <p>Optional and/or required parameters include:</p> <ul style="list-style-type: none"> <i>timeout</i> is the number of seconds to flash the LED indicators. To stop the LEDs from flashing, set the timeout period to 0 (zero). 	Admin
fpgacmd	Provides access to the FPGA management tool for troubleshooting time synchronization.	Admin
help <i>command</i>	<p>Displays a brief description of the specified command. If no command is specified, it displays a list of all available commands, including a description for each.</p> <p>Optional and/or required parameters include:</p> <ul style="list-style-type: none"> <i>command</i> is the command name. 	Guest, Operator, Admin
ipconfig	Displays the current IP address, subnet mask and default gateway. This command provides the only way of determining these values when DHCP is used.	Guest, Operator, Admin
loaddfmts	Loads the factory default configuration.	Admin
logout	Logs out of the shell.	Guest, Operator, Admin
logs	Displays syslog entries in CLI shell.	Admin

Command	Description	Authorized Users
<code>ping address { count timeout }</code>	<p>Sends an ICMP echo request to a remotely connected device. For each reply received, the round trip time is displayed. Use this command to verify connectivity to the next connected device. It is a useful tool for testing commissioned links. This command also includes the ability to send a specific number of pings with a specified time for which to wait for a response.</p> <p>Optional and/or required parameters include:</p> <ul style="list-style-type: none"> • <code>address</code> is the target IP address. • <code>count</code> is the number of echo requests to send. The default is 4. • <code>timeout</code> is the time in milliseconds to wait for each reply. The range is 2 to 5000 seconds. The default is 300 milliseconds. <div style="border: 1px solid black; padding: 5px; margin-top: 10px;"> <p> NOTE <i>The device to be pinged must support ICMP echo. Upon commencing the ping, an ARP request for the MAC address of the device is issued. If the device to be pinged is not on the same network as the device pinging the other device, the default gateway must be programmed.</i></p> </div>	Guest, Operator, Admin
<code>purgemac</code>	Purges the MAC Address table.	Operator, Admin
<code>random</code>	Display seeds or random numbers.	Admin
<code>reset</code>	Perform a hard reset of the switch.	Operator, Admin
<code>resetport { all ports }</code>	<p>Resets one or more Ethernet ports, which may be useful for forcing re-negotiation of speed and duplex, or in situations where the link partner has latched into an inappropriate state.</p> <p>Optional and/or required parameters include:</p> <ul style="list-style-type: none"> • <code>all</code> resets all ports • <code>ports</code> is a comma separated list of port numbers (e.g. 1,3-5,7) 	Operator, Admin
<code>rmon</code>	Displays the names of all RMON alarm eligible objects.	Guest, Operator, Admin
<code>route</code>	Displays the gateway configuration.	Guest, Operator, Admin
<code>sfp port { base alarms diag calibr thr all no parameter specified }</code>	<p>Displays SFP (Small Form Factor Pluggable) device information and diagnostics. If optional or required parameters are not used, this command displays the base and extended information.</p> <p>Optional and/or required parameters include:</p> <ul style="list-style-type: none"> • <code>port</code> is the port number for which the data are required • <code>base</code> displays the base information • <code>alarms</code> displays alarms and warning flags • <code>diag</code> displays measured data • <code>calibr</code> displays calibration data for external calibration • <code>thr</code> displays thresholds data • <code>all</code> displays all diagnostic data 	Admin
<code>sql { default delete help info insert save select update }</code>	<p>Provides an SQL-like interface for manipulating all system configuration and status parameters. All commands, clauses, table, and column names are case insensitive.</p> <p>Optional and/or required parameters include:</p> <ul style="list-style-type: none"> • <code>default</code> sets all records in a table(s) to factory defaults • <code>delete</code> allows for records to be deleted from a table • <code>help</code> provides a brief description for any SQL command or clause • <code>info</code> displays a variety of information about the tables in the database 	Admin

Command	Description	Authorized Users
	<ul style="list-style-type: none"> <code>insert</code> enables new records to be inserted into a table <code>save</code> saves the database to non-volatile memory storage <code>select</code> queries the database and displays selected records <code>update</code> enable existing records in a table to be updated For more information about the <code>sql</code> command, refer to Section 2.5.4, "Using SQL Commands" .	
<code>sshkeygen [rsa dsa] [1024 2048 3072]</code>	Generates new RSA or DSA keys in <code>ssh.keys</code> . Keys can be either 1024, 2048 or 3072 bits long.	Admin
<code>sshpubkey</code>	List, remove and update key entries in <code>sshpубkey</code> file.	Admin
<code>sslkeygen [rsa ecc] N</code>	Generates a new RSA or ECC SSL certificate in <code>ssl.crt</code> . Optional and/or required parameters include: <ul style="list-style-type: none"> <code>N</code> is the number of bits in length. For RSA keys, the allowable sizes are 1024, 2048 or 3072. For ECC keys, the allowable sizes are 192, 224, 256, 384, or 521. 	Admin
<code>telnet dest</code>	Opens a telnet session. Press Ctrl-C to close the session. Optional and/or required parameters include: <ul style="list-style-type: none"> <code>dest</code> is the server's IP address 	Guest, Operator, Admin
<code>tftp address [put get] source target</code>	Opens a TFTP session. Press Ctrl-C to close the session. Optional and/or required parameters include: <ul style="list-style-type: none"> <code>address</code> is the IP address of the remote TFTP server <code>put</code> indicates TFTP will be uploading the source file to replace the destination file <code>get</code> indicates TFTP will be downloading the source file to replace the destination file <code>source</code> is the name of the source file <code>target</code> is the name of the file that will be replaced 	Admin
<code>trace</code>	Starts event tracing. Run <code>trace ?</code> for more help.	Operator, Admin
<code>type filename</code>	Displays the contents of a text file. Optional and/or required parameters include: <ul style="list-style-type: none"> <code>filename</code> is the name of the file to be read 	Guest, Operator, Admin
<code>version</code>	Prints the software version.	Guest, Operator, Admin
<code>xmodem { send receive } filename</code>	Opens an XModem session. Optional and/or required parameters include: <ul style="list-style-type: none"> <code>send</code> sends the file to the client. <code>receive</code> receives the file from the client. <code>filename</code> is the name of the file to be read. 	Operator, Admin

Section 2.5.2

Tracing Events

The CLI trace command provides a means to trace the operation of various protocols supported by the device. Trace provides detailed information, including STP packet decodes, IGMP activity and MAC address displays.

**NOTE**

Tracing has been designed to provide detailed information to expert users. Note that all tracing is disabled upon device startup.

To trace an event, do the following:

1. Log in to the device as an admin user and access the CLI shell. For more information about accessing the CLI shell, refer to [Section 2.5, "Using the Command Line Interface"](#).
2. Determine the protocols and associated options available by typing:

```
trace ?
```

If an option such as `allon` or `alloff` is required, determine which options are available for the desired protocol by typing:

```
trace protocol ?
```

**NOTE**

If required, expand the trace scope by stringing protocols and their associated options together using a vertical bar (|).

3. Select the type of trace to run by typing:

```
trace protocol option
```

Where:

- `protocol` is the protocol to trace
- `option` is the option to use during the trace

Example:

```
>trace transport allon
      TRANSPORT: Logging is enabled
```

4. Start the trace by typing:

```
trace
```

Section 2.5.3

Executing Commands Remotely via RSH

The Remote Shell (RSH) facility can be used from a workstation to cause the product to act upon commands as if they were entered at the CLI prompt. The syntax of the RSH command is usually of the form:

```
rsh ipaddr -l auth_token command_string
```

Where:

- `ipaddr` is the address or resolved name of the device.
- `auth_token` is the user name (i.e. guest, operator or admin) and corresponding password separated by a comma. For example, `admin,secret`.
- `command_string` is the RUGGEDCOM ROS CLI command to execute.

**NOTE**

The access level (corresponding to the user name) selected must support the given command.

**NOTE**

Any output from the command will be returned to the workstation submitting the command. Commands that start interactive dialogs (such as `trace`) cannot be used.

Section 2.5.4

Using SQL Commands

RUGGEDCOM ROS provides an *SQL-like* command facility that allows expert users to perform several operations not possible under the traditional Web or CLI interface. For instance:

- Restoring the contents of a specific table, but not the whole configuration, to their factory defaults.
- Search tables in the database for specific configurations.
- Make changes to tables predicated upon existing configurations.

When combined with RSH, SQL commands provide a means to query and configure large numbers of devices from a central location.

**NOTE**

For a list of parameters available under the `sql` command, refer to [Section 2.5.1, "Available CLI Commands"](#).

**NOTE**

Read/write access to tables containing passwords or shared secrets is unavailable using SQL commands.

CONTENTS

- [Section 2.5.4.1, "Finding the Correct Table"](#)
- [Section 2.5.4.2, "Retrieving Information"](#)
- [Section 2.5.4.3, "Changing Values in a Table"](#)
- [Section 2.5.4.4, "Resetting a Table"](#)
- [Section 2.5.4.5, "Using RSH and SQL"](#)

Section 2.5.4.1

Finding the Correct Table

Many SQL commands operate upon specific tables in the database, and require the table name to be specified. Navigating the menu system in the console interface to the desired menu and pressing **Ctrl-Z** displays the name of the table. The menu name and the corresponding database table name will be cited.

Another way to find a table name is to type the following in the CLI:

```
sql info tables
```

This command also displays menu names and their corresponding database table names depending upon the features supported by the device. For example:

```
Table Description
-----
alarms Alarms
cpuDiags CPU Diagnostics
ethPortCfg Port Parameters
ethPortStats Ethernet Statistics
ethPortStatus Port Status
ipCfg IP Services
```

Section 2.5.4.2

Retrieving Information

The following describes various methods for retrieving information about tables and parameters.

» Retrieving Information from a Table

Use the following command to display a summary of the parameters within a table, as well as their values:

```
sql select from table
```

Where:

- *table* is the name of the table

Example:

```
>sql select from ipAddrtable
IP Address      Subnet          IfIndex  IfStats  IfTime  IfName
172.30.146.88   255.255.224.0  1001     17007888 2994    vlan1
1 records selected
```

» Retrieving Information About a Parameter from a Table

Use the following command to retrieve information about a specific parameter from a table:



NOTE

The parameter name must be the same as it is displayed in the menu system, unless the name contains spaces (e.g. ip address). Spaces must be replaced with underscores (e.g. ip_address) or the parameter name must be wrapped in double quotes (e.g. "ip address").

```
sql select parameter from table
```

Where:

- *parameter* is the name of the parameter
- *table* is the name of the table

Example:

```
>sql select "ip address" from ipSwitchIfCfg
IP Address
192.168.0.1
```



```
1 records selected
```

» Retrieving Information from a Table Using the *Where* Clause

Use the following command to display specific parameters from a table that have a specific value:

```
sql select from table where parameter = value
```

Where:

- *table* is the name of the table
- *parameter* is the name of the parameter
- *value* is the value of the parameter

Example:

```
>sql select from ethportcfg where media = 1000T
```

Port Name	ifName	Media	State	AutoN	Speed	Dupx	FlowCtrl	LFI	Alarm
1 Port 1	1	1000T	Enabled On	Auto	Auto	Off	Off	On	
2 Port 2	2	1000T	Enabled On	Auto	Auto	Off	Off	On	
3 Port 3	3	1000T	Enabled On	Auto	Auto	Off	Off	On	
4 Port 4	4	1000T	Enabled On	Auto	Auto	Off	Off	On	

```
4 records selected
```

Further refine the results by using *and* or *or* operators:

```
sql select from table where parameter = value [ { and | or } | parameter | = | value ...]
```

Where:

- *table* is the name of the table
- *parameter* is the name of the parameter
- *value* is the value of the parameter

Example:

```
>sql select from ethportcfg where media = 1000T and State = enabled
```

Port Name	ifName	Media	State	AutoN	Speed	Dupx	FlowCtrl	LFI	Alarm
1 Port 1	1	1000T	Enabled On	Auto	Auto	Off	Off	On	
2 Port 2	2	1000T	Enabled On	Auto	Auto	Off	Off	On	
3 Port 3	3	1000T	Enabled On	Auto	Auto	Off	Off	On	
4 Port 4	4	1000T	Enabled On	Auto	Auto	Off	Off	On	

```
4 records selected
```

Section 2.5.4.3

Changing Values in a Table

Use the following command to change the value of parameters in a table:

```
sql update table set parameter = value
```

Where:

- *table* is the name of the table

- *parameter* is the name of the parameter
- *value* is the value of the parameter

Example:

```
>sql update iplcfg set IP_Address_Type = static
1 records updated
```

Conditions can also be included in the command to apply changes only to parameters that meet specific criteria. In the following example, flow control is enabled on ports that are operating in 100 Mbps full-duplex mode with flow control disabled:

```
>sql update ethportcfg set FlowCtrl = Off where ( Media = 100TX and FlowCtrl = On )
2 records updated
```

Section 2.5.4.4

Resetting a Table

Use the following command to reset a table back to its factory defaults:

```
sql default into table
```

Where:

- *table* is the name of the table

Section 2.5.4.5

Using RSH and SQL

The combination of remote shell scripting and SQL commands offers a means to interrogate and maintain a large number of devices. Consistency of configuration across sites may be verified by this method. The following presents a simple example where the devices to interrogate are drawn from the file `Devices`:

```
C:> type Devices
10.0.1.1
10.0.1.2

C:\> for /F %i in (devices) do rsh %i -l admin,admin sql select from ipAddrtable

C:\>rsh 10.0.1.1 -l admin,admin sql select from ipAddrtable

IP Address      Subnet          IfIndex      IfStats      IfTime      IfName
192.168.0.31    255.255.255.0  1001         274409096   2218        vlan1

1 records selected

C:\>rsh 10.0.1.2 -l admin,admin sql select from ipAddrtable
0 records selected
C:\
```

Section 2.6

Selecting Ports in RUGGEDCOM ROS

Many features in ROS can be configured for one or more ports on the device. The following describes how to specify a single port, a range of ports, or all ports.

Select a single port by specifying the port number:

```
2
```

Select a range of ports using a dash (-) between the first port and the last port in the list:

```
1-4
```

Select multiple ports by defining a comma-separated list:

```
1,4,6,9
```

```
1,4
```

Use the *ALL* option to select all ports in the device, or, if available, use the *None* option to select none of the ports.

Section 2.7

Managing the Flash File System

This section describes how to manage the file system.

CONTENTS

- [Section 2.7.1, "Viewing a List of Flash Files"](#)
- [Section 2.7.2, "Viewing Flash File Details"](#)
- [Section 2.7.3, "Defragmenting the Flash File System"](#)

Section 2.7.1

Viewing a List of Flash Files

To view a list of files currently stored in Flash memory, do the following:

1. Log in to the device as an admin user and access the CLI shell. For more information about accessing the CLI shell, refer to [Section 2.5, "Using the Command Line Interface"](#).
2. Type **flashfiles**. A list of files currently in Flash memory is displayed, along with their locations and the amount of memory they consume. For example:

```
>flashfiles
-----
Filename           Base   Size  Sectors   Used
-----
boot.bin           00000000 110000  0-16     1095790
```

```
main.bin      00110000 140000 17-36 1258403
syslog.txt   00260000 140000 38-57 19222
.
.
.
-----
```

Section 2.7.2

Viewing Flash File Details

To view the details of a file currently stored in Flash memory, do the following:

1. Log in to the device as an admin user and access the CLI shell. For more information about accessing the CLI shell, refer to [Section 2.5, "Using the Command Line Interface"](#).
2. Display information about a file by typing:

```
flashfiles info filename
```

Where:

- *filename* is the name of the file stored in Flash memory

Details, similar to the following, are displayed.

```
>flashfiles info main.bin

Flash file information for main.bin:
Header version   : 4
Platform        : ROS-CF52

File name       : main.bin
Firmware version : v5.2.0
Build date      : Sep 27 2014 15:50
File length     : 2624659
Board IDs       : 3d
Header CRC      : 73b4
Header CRC Calc : 73b4
Body CRC        : b441
Body CRC Calc   : b441
```

Section 2.7.3

Defragmenting the Flash File System

The flash memory is defragmented automatically whenever there is not enough memory available for a binary upgrade. However, fragmentation can occur whenever a new file is uploaded to the unit. Fragmentation causes sectors of available memory to become separated by ones allocated to files. In some cases, the total available memory might be sufficient for a binary upgrade, but that memory may not be available in one contiguous region.

To defragment the flash memory, do the following:

1. Log in to the device as an admin user and access the CLI shell. For more information about accessing the CLI shell, refer to [Section 2.5, "Using the Command Line Interface"](#).
2. Defragment the flash memory by typing:

```
flashfiles defrag
```

Section 2.8

Accessing BIST Mode

BIST (Built-In-Self-Test) mode is used by service technicians to test and configure internal functions of the device. It should only be accessed for troubleshooting purposes.

**CAUTION!**

Mechanical hazard – risk of damage to the device. Excessive use of BIST functions may cause increase wear on the device, which may void the warranty. Avoid using BIST functions unless instructed by a Siemens Customer Support representative.

To access BIST mode, do the following:

**IMPORTANT!**

Do not connect the device to the network when it is in BIST mode. The device will generate excess multicast traffic in this mode.

1. Disconnect the device from the network.
2. Connect to RUGGEDCOM ROS through the USB console connection and a terminal application. For more information, refer to [Section 3.1.2, “Connecting Directly”](#).
3. Reset the device. For more information, refer to [Section 4.12, “Resetting the Device”](#).
4. During the boot up sequence, press **Ctrl-C** when prompted. The command prompt for BIST appears.

```
>
```

5. Type **help** to view a list of all available options under BIST.

3 Getting Started

This section describes startup tasks to be performed during the initial commissioning of the device. Tasks include connecting to the device and accessing the RUGGEDCOM ROS Web User Interface/CLI, as well as configuring a basic network.

CONTENTS

- [Section 3.1, "Connecting to ROS"](#)
- [Section 3.2, "Installing the RUGGEDCOM USB Serial Console Driver \(Windows Only\)"](#)
- [Section 3.3, "Configuring a Basic Network"](#)

Section 3.1

Connecting to ROS

This section describes the various methods for connecting to the device.

CONTENTS

- [Section 3.1.1, "Default IP Address"](#)
- [Section 3.1.2, "Connecting Directly"](#)
- [Section 3.1.3, "Connecting Remotely"](#)

Section 3.1.1

Default IP Address

The default IP address for the device is 192.168.0.1/24.

Section 3.1.2

Connecting Directly

RUGGEDCOM ROS can be accessed through a direct USB console connection for management and troubleshooting purposes. A console connection provides access to the console interface and CLI.

To establish a console connection to the device, do the following:

1. Connect a workstation (either a terminal or computer running terminal emulation software) to the USB console port on the device. For more information about the USB console port, refer to the *RSG908C Installation Guide*.



NOTE

The baud rate for the device is printed on the chassis exterior near the USB console port.

2. Configure the workstation as follows:
 - Speed (baud): 57600
 - Data Bits: 8
 - Parity: None
 - Flow Control: Off
 - Terminal ID: VT100
 - Stop Bit: 1
3. Connect to the device. Once the connection is established, the login form appears. For more information about logging in to the device, refer to [Section 2.1, “Logging In”](#).

Section 3.1.3

Connecting Remotely

RUGGEDCOM ROS can be accessed securely and remotely either through a Web browser, terminal or workstation running terminal emulation software.

» Using a Web Browser

Web browsers provide a secure connection to the Web interface for RUGGEDCOM ROS using the SSL (Secure Socket Layer) communication method. SSL encrypts traffic exchanged with its clients.

The RUGGEDCOM ROS Web server guarantees that all communications with the client are private. If a client requests access through an insecure HTTP port, the client is automatically rerouted to the secure port. Access to the Web server through SSL will only be granted to clients that provide a valid user name and password.

To establish a connection through a Web browser, do the following:

1. On the workstation being used to access the device, configure an Ethernet port to use an IP address falling within the subnet of the device. The default IP address is 192.168.0.1/24.

For example, to configure the device to connect to one of the available Ethernet ports, assign an IP address to the Ethernet port on the workstation in the range of 192.168.0.3 to 192.168.0.254.

2. Open a Web browser. For a list of recommended Web browsers, refer to [“System Requirements”](#).



IMPORTANT!

Upon connecting to the device, some Web browsers may report the Web server's certificate cannot be verified against any known certificates. This is expected behavior, and it is safe to instruct the browser to accept the certificate. Once the certificate is accepted, all communications with the Web server through that browser will be secure.



IMPORTANT!

IPv6 addresses must be wrapped in square brackets (e.g. `https://[2001:db8:123::2228]`).

3. In the address bar, type the IP address for the port that is connected to the network. For example, to access the device using its factory default IP address, type `https://192.168.0.1` and press **Enter**. Once the connection is established, the login screen for the Web interface appears.

For more information about logging in to the device, refer to [Section 2.1, "Logging In"](#). For more information about the Web interface, refer to [Section 2.3, "Using the Web Interface"](#).

» Using a Terminal or Terminal Emulation Software

A terminal or computer running terminal emulation software provides access to the console interface for RUGGEDCOM ROS through a Telnet, RSH (Remote Shell) or SSH (Secure Shell) service.



NOTE

IP services can be restricted to control access to the device. For more information, refer to [Section 4.9, "Configuring IP Services"](#).

To establish a connection through a terminal or terminal emulation software, do the following:

1. Select the service (i.e. Telnet, RSH or SSH).
2. Enter the IP address for the port that is connected to the network.
3. Connect to the device. Once the connection is established, the login form appears. For more information about logging in to the device, refer to [Section 2.1, "Logging In"](#).

Section 3.2

Installing the RUGGEDCOM USB Serial Console Driver (Windows Only)

Workstations running Microsoft Windows must have the RUGGEDCOM USB Serial Console driver installed before connecting to the console interface via the USB Type-B serial console port. This driver can be obtained from Siemens Customer Support.

To install the RUGGEDCOM USB Serial Console driver manually, do the following:

1. Obtain the installer from Siemens Customer Support. For more information about contacting Customer Support, refer to ["Customer Support"](#).
2. Uninstall all previously installed USB-to-serial drivers from the workstation.
3. Make sure the USB serial console port is not connected to the workstation.
4. Double-click `Setup.exe`. The installation wizard appears.
5. Follow the on-screen instructions to install the driver.
6. Connect the workstation to the device using a USB Standard-A to Standard-B cable.
7. Open Device Manager by clicking the **Start** button, clicking **Control Panel**, clicking **System and Security**, and then, under **System**, clicking **Device Manager**.
8. Under **Ports (COM & LPT)**, verify the USB port is recognized.

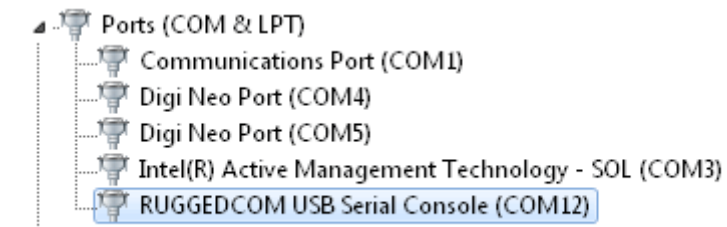

Figure 10: RUGGEDCOM USB Serial Console Port

Section 3.3

Configuring a Basic Network

To configure a basic network, do the following:

1. Connect a computer to one of the switch ports of the device and configure the computer to be on the same subnet as the port.
2. Configure the computer to use the address of VLAN1 as the default gateway.
3. Connect a second computer to a different switch port of the same device, and configure the computer to be on the same subnet as the port.
4. Configure the second computer to use the address of VLAN1 as the default gateway. The default IP address is 192.168.0.1.
5. Make sure both computers connected to the device can ping one another.

4 Device Management

This chapter describes how to configure and manage the device and its components, such as module interfaces, logs and files.

CONTENTS

- [Section 4.1, "Viewing Product Information"](#)
- [Section 4.2, "Viewing CPU Diagnostics"](#)
- [Section 4.3, "Restoring Factory Defaults"](#)
- [Section 4.4, "Uploading/Downloading Files"](#)
- [Section 4.5, "Managing Logs"](#)
- [Section 4.6, "Managing Ethernet Ports"](#)
- [Section 4.7, "Managing IP Interfaces"](#)
- [Section 4.8, "Managing IP Gateways"](#)
- [Section 4.9, "Configuring IP Services"](#)
- [Section 4.10, "Managing Remote Monitoring"](#)
- [Section 4.11, "Upgrading/Downgrading Firmware"](#)
- [Section 4.12, "Resetting the Device"](#)
- [Section 4.13, "Decommissioning the Device"](#)

Section 4.1

Viewing Product Information

During troubleshooting or when ordering new devices, Siemens personnel may request specific information about the device, such as the model, order code or serial number.

To view information about the device, navigate to **Diagnostics » View Product Information**. The **Product Information** form appears.

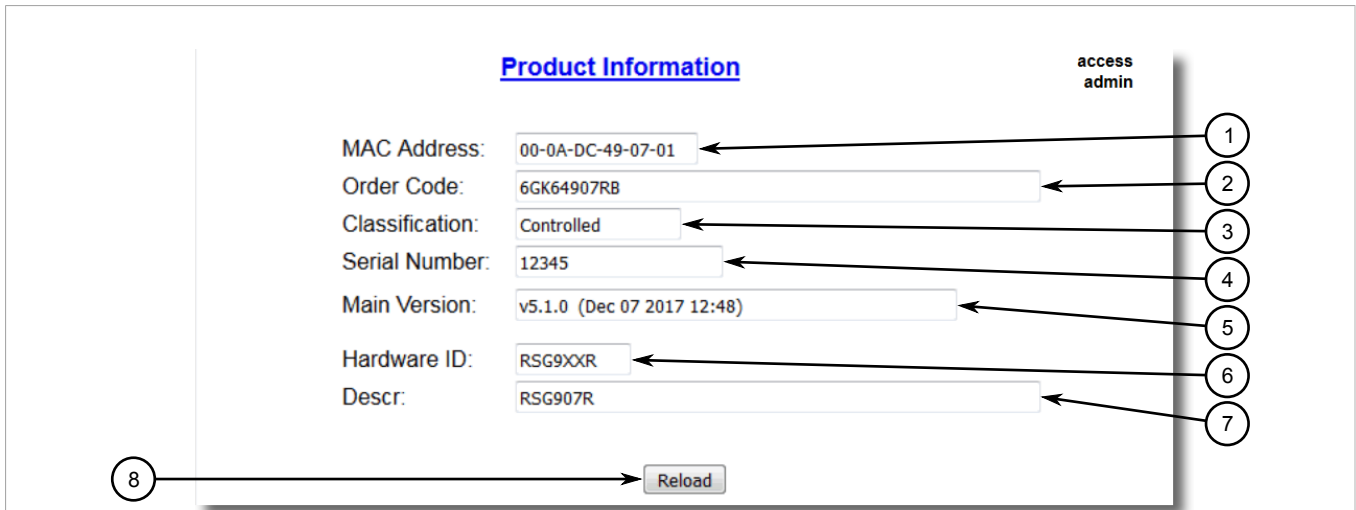

Figure 11: Product Information Form (Example)

1. MAC Address Box 2. Order Code Box 3. Classification Box 4. Serial Number Box 5. Boot Version Box 6. Main Version Box
7. Required Boot Box 8. Hardware ID Box 9. Descr Box 10. Reload Button

This screen displays the following information:

Parameter	Description
MAC Address	Synopsis: ##-##-##-##-##-## where ## ranges 0 to FF Shows the unique MAC address of the device.
Order Code	Synopsis: Any 57 characters Shows the order code of the device.
Classification	Synopsis: Any 15 characters Provides system classification. The value <i>Controlled</i> indicates the main firmware is a Controlled release. The value <i>Non-Controlled</i> indicates the main firmware is a Non-Controlled release. The <i>Controlled</i> main firmware can run on Controlled units, but it can not run on Non-Controlled units. The <i>Non-Controlled</i> main firmware can run on both Controlled and Non-Controlled units.
Serial Number	Synopsis: Any 31 characters Shows the serial number of the device.
Boot Version	Synopsis: Any 47 characters Shows the version and the build date of the boot loader software.
Main Version	Synopsis: Any 47 characters Shows the version and build date of the main operating system software.
Required Boot	Synopsis: Any 15 characters Shows the minimum boot software loader version required by running main.
Hardware ID	Synopsis: { RSMCPU (40-00-0008 Rev B1), RSMCPU2 (40-00-0026 Rev A1), RS400;RS400F (40-00-0010 Rev B2), RMC30, RS900 (40-00-0025 Rev B1), RS900 (40-00-0032 Rev B1), RS1600M, RS400;RS400F (40-00-0010 Rev C1), RSG2100;RSG2100F, RS900G;RS900GF, RSG2200;RSG2200F, RS969;RS969F, RS900 (v2, 40-00-0066), RS900 (v2, 40-00-0067), , RS416;RS416F (40-00-0078), RMC30 (v2), RS930 (40-00-0089), RS969;RS969F (v2, 40-00-0090), RS910 (40-00-0091-001 Rev A), RS920L (40-00-0102-001 Rev A), RS940G;RS940GF (40-00-0097-000 Rev A), RSi80X series CPU board, RSG2300;RSG2300F, RS416;RS416Fv2, ... }

Parameter	Description
	Shows the type, part number, and revision level of the hardware.
Descr	Synopsis: Any 57 characters The description of product based on Hardware ID, order code and classification.

Section 4.2

Viewing CPU Diagnostics

To view CPU diagnostic information useful for troubleshooting hardware and software performance, navigate to **Diagnostics » View CPU Diagnostics**. The CPU Diagnostics form appears.

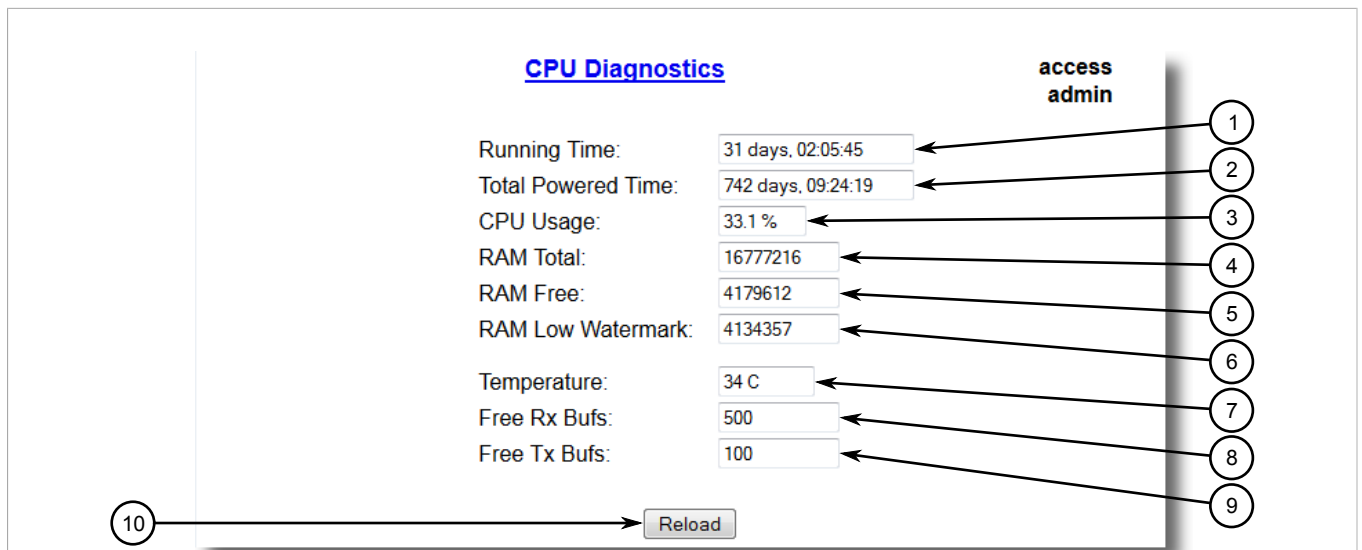

Figure 12: CPU Diagnostics Form

- 1. Running Time Box
- 2. Total Powered Time Box
- 3. CPU Usage Box
- 4. RAM Total Box
- 5. RAM Free Box
- 6. RAM Low Watermark Box
- 7. Temperature Box
- 8. Free Rx Bufs Box
- 9. Free Tx Bufs Box
- 10. Reload Button

This screen displays the following information:

Parameter	Description
Running Time	Synopsis: DDDD days, HH:MM:SS The amount of time since the device was last powered on.
Total Powered time	Synopsis: DDDD days, HH:MM:SS The cumulative powered up time of the device.
CPU Usage	Synopsis: 0.0 to 100.0% The percentage of available CPU cycles used for device operation as measured over the last second.
RAM Total	Synopsis: 0 to 4294967295 The total size of RAM in the system.
RAM Free	Synopsis: 0 to 4294967295

Parameter	Description
	The total size of RAM still available.
RAM Low Watermark	Synopsis: 0 to 4294967295 The size of RAM that have never been used during the system runtime.
Temperature	Synopsis: -32768 to 32767 C The temperature on CPU board.
Free Rx Bufs	Synopsis: 0 to 4294967295 Free Rx Buffers.
Free Tx Bufs	Synopsis: 0 to 4294967295 Free Tx Buffers.

Section 4.3

Restoring Factory Defaults

The device can be completely or partially restored to its original factory default settings. Excluding groups of parameters from the factory reset, such as those that affect basic connectivity and SNMP management, is useful when communication with the device is still required during the reset.

The following categories are not affected by a selective configuration reset:

- IP Interfaces
- IP Gateways
- SNMP Users
- SNMP Security to Group Maps
- SNMP Access
- RUGGEDCOM Discovery Protocol™ (RCDP)

In addition, the following categories are not affected by a full or selective configuration reset:

- Time Zone
- DST Offset
- DST Rule

**NOTE**

MRMs or MRAs acting as Manager must be either physically disconnected or have the ring port disabled (i.e. MRP ring open) before restoring factory defaults, otherwise default configurations may not be restored for the following parameters:

- *Port RSTP Parameters*
- *Global MRP Parameters*
- *MRP Instances*

For more information about MRP rings, refer to [Section 8.2, “Managing the Media Redundancy Protocol \(MRP\)”](#).

For more information about configuring port parameters, refer to [Section 4.6.6, “Configuring an Ethernet Port”](#).

To restore factory defaults, do the following:

1. Navigate to **Diagnostics » Load Factory Defaults**. The **Load Factory Defaults** form appears.

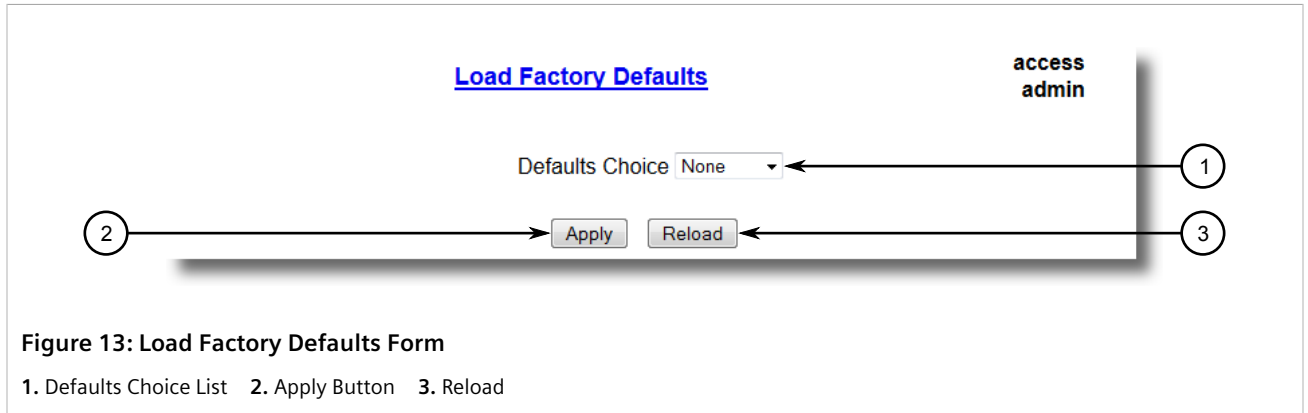

Figure 13: Load Factory Defaults Form

1. Defaults Choice List 2. Apply Button 3. Reload

2. Configure the following parameter(s) as required:

NOTE
If the VLAN ID for the Management IP interface is not 1, setting **Defaults Choice** to Selected will automatically set it to 1.

Parameter	Description
Defaults Choice	Synopsis: { None, Selected, All } Setting some records like IP Interfaces management interface, default gateway, SNMP settings to default value would cause switch not to be accessible with management applications. This parameter allows user to choose to load defaults to Selected tables, which would preserve configuration for tables that are critical for switch management applications, or to force All tables to default settings.

3. Click **Apply**.

Section 4.4

Uploading/Downloading Files

Files can be transferred between the device and a host computer using any of the following methods:

- Xmodem using the CLI shell over a Telnet or RS-232 console session
- TFTP client using the CLI shell in a console session and a remote TFTP server
- TFTP server from a remote TFTP client
- SFTP (secure FTP over SSH) from a remote SFTP client

IMPORTANT!
Scripts can be used to automate the management of files on the device. However, depending on the size of the target file(s), a delay between any concurrent write and read commands may be required, as the file may not have been fully saved before the read command is issued. A general delay of five seconds is recommended, but testing is encouraged to optimize the delay for the target file(s) and operating environment.



NOTE

The contents of the internal file system are fixed. New files and directories cannot be created, and existing files cannot be deleted. Only the files that can be uploaded to the device can be overwritten.

Files that may need to be uploaded or downloaded include:

- `main.bin` – the main RUGGEDCOM ROS application firmware image
- `boot.bin` – the boot loader firmware image
- `fpga90xr.bin` – the FPGA firmware binary image
- `config.csv` – the complete configuration database, in the form of a comma-delimited ASCII text file
- `factory.txt` – contains the MAC address, order code and serial number. Factory data must be signed.
- `banner.txt` – contains text that appears on the login screen
- `ssl.crt` – the SSL certificate. Contains both the SSL certificate and the corresponding RSA private key file.
- `ssh.keys` – the SSH keys for the device
- `ruggedcom.icd` – the IEC61850 IED Capability Description of the device
- `ruggedcom.iid` – the IEC61850 Instantiated IED Description of the device

CONTENTS

- [Section 4.4.1, “Uploading/Downloading Files Using XMODEM”](#)
- [Section 4.4.2, “Uploading/Downloading Files Using a TFTP Client”](#)
- [Section 4.4.3, “Uploading/Downloading Files Using a TFTP Server”](#)
- [Section 4.4.4, “Uploading/Downloading Files Using an SFTP Server”](#)

Section 4.4.1

Uploading/Downloading Files Using XMODEM

To upload or download a file using XMODEM, do the following:



NOTE

This method requires a host computer that has terminal emulation or Telnet software installed and the ability to perform XMODEM transfers.

1. Establish a connection between the device and the host computer. For more information, refer to [Section 3.1, “Connecting to ROS”](#).
2. Log in to the device as an admin user and access the CLI shell. For more information about accessing the CLI shell, refer to [Section 2.5, “Using the Command Line Interface”](#).
3. At the CLI prompt, type:

```
xmodem [ send | receive ] filename
```

Where:

- `send` sends the file to the host computer
- `receive` pulls the file from the host computer
- `filename` is the name of the file (i.e. `main.bin`)

**NOTE**

If available in the terminal emulation or Telnet software, select the **XModem 1K** protocol for transmission over the standard **XModem** option.

4. When the device responds with `Press Ctrl-X` to cancel, launch the XMODEM transfer from the host computer. The device will indicate when the transfer is complete.

The following is an example from the CLI shell of a successful XMODEM file transfer:

```
>xmodem receive main.bin
Press Ctrl-X to cancel
Receiving data now ...C
Received 1428480 bytes. Closing file main.bin ...
main.bin transferred successfully
```

5. If the file has been uploaded, reset the device. For more information, refer to [Section 4.12, “Resetting the Device”](#)

Section 4.4.2

Uploading/Downloading Files Using a TFTP Client

To upload or download a file using a TFTP client, do the following:

**IMPORTANT!**

TFTP does not define an authentication scheme. Any use of the TFTP client or server is considered highly insecure.

**NOTE**

This method requires a TFTP server that is accessible over the network.

1. Identify the IP address of the computer running the TFTP server.
2. Establish a connection between the device and the host computer. For more information, refer to [Section 3.1, “Connecting to ROS”](#).
3. Log in to the device as an admin user and access the CLI shell. For more information about accessing the CLI shell, refer to [Section 2.5, “Using the Command Line Interface”](#).
4. At the CLI prompt, type:

```
tftp address [ get | put ] source-filename destination-filename
```

Where:

- `get` copies files from the host computer to the device
- `put` copies files from the device to the host computer
- `address` is the IP address of the computer running the TFTP server
- `source-filename` is the name of the file to be transferred
- `destination-filename` is the name of the file (on the device or the TFTP server) that will be replaced during the transfer

The following is an example of a successful TFTP client file transfer:

```
>tftp 10.0.0.1 get ROS-CF52_Main_v5.2.0.bin main.bin
TFTP CMD: main.bin transfer ok. Please wait, closing file ...
```

```
TFTP CMD: main.bin loading successful.
```

5. If the file has been uploaded, reset the device. For more information, refer to [Section 4.12, "Resetting the Device"](#)

Section 4.4.3

Uploading/Downloading Files Using a TFTP Server

To upload or download a file using a TFTP server, do the following:



IMPORTANT!

TFTP does not define an authentication scheme. Any use of the TFTP client or server is considered highly insecure.



NOTE

This method requires a host computer that has TFTP server software installed.



IMPORTANT!

Interaction with TFTP servers is strictly controlled within the device to prevent unauthorized access. Make sure the device is configured to accept the TFTP connection. For more information, refer to [Section 4.9, "Configuring IP Services"](#).

1. Establish a connection between the device and the host computer. For more information, refer to [Section 3.1, "Connecting to ROS"](#).
2. Initialize the TFTP server on the host computer and launch the TFTP transfer. The server will indicate when the transfer is complete.

The following is an example of a successful TFTP server exchange:

```
C:\>tftp -i 10.1.0.1 put C:\files\ROS-CF52_Main_v5.2.0.bin main.bin  
Transfer successful: 1428480 bytes in 4 seconds, 375617 bytes/s
```

3. If the file has been uploaded, reset the device. For more information, refer to [Section 4.12, "Resetting the Device"](#)

Section 4.4.4

Uploading/Downloading Files Using an SFTP Server

SFTP (Secure File Transfer Protocol) is a file transfer mechanism that uses SSH to encrypt every aspect of file transfer between a networked client and server.



NOTE

The device does not have an SFTP client and, therefore, can only receive SFTP files from an external source. SFTP requires authentication for the file transfer.

To upload or download a file using an SFTP server, do the following:



NOTE

This method requires a host computer that has SFTP client software installed.

1. Establish an SFTP connection between the device and the host computer.
2. Launch the SFTP transfer. The client will indicate when the transfer is complete.

The following is an example of a successful SFTP server exchange:

```
user@host$ sftp admin@ros_ip
Connecting to ros_ip...
admin@ros_ip's password:
sftp> put ROS-CF52_Main_v5.2.0.bin main.bin
Uploading ROS-CF52_Main_v5.2.0.bin to /main.bin
ROS-CF52_Main_v5.2.0.bin 100% 2139KB 48.6KB/s 00:44
sftp> put ROS-MPC83_Main_v5.2.0.bin main.bin
Uploading ROS-MPC83_Main_v5.2.0.bin to /main.bin
ROS-MPC83_Main_v5.2.0.bin 100% 2139KB 48.6KB/s 00:44
sftp>
```

3. If the file has been uploaded, reset the device. For more information, refer to [Section 4.12, “Resetting the Device”](#)

Section 4.5

Managing Logs

The crash (`crashlog.txt`) and system (`syslog.txt`) log files contain historical information about events that have occurred during the operation of the device.

The crash log contains debugging information related to problems that might have resulted in unplanned restarts of the device or which may effect the operation of the device. A file size of 0 bytes indicates that no unexpected events have occurred.

The system log contains a record of significant events including startups, configuration changes, firmware upgrades and database re-initializations due to feature additions. The system log will accumulate information until it is full, holding approximately 2 MB of data.

CONTENTS

- [Section 4.5.1, “Viewing Local and System Logs”](#)
- [Section 4.5.2, “Clearing Local and System Logs”](#)
- [Section 4.5.3, “Configuring the Local System Log”](#)
- [Section 4.5.4, “Managing Remote Logging”](#)

Section 4.5.1

Viewing Local and System Logs

The local crash and system logs can both be downloaded from the device and viewed in a text editor. For more information about downloading log files, refer to [Section 4.4, “Uploading/Downloading Files”](#).

To view the system log through the Web interface, navigate to **Diagnostics » View System Log**. The `syslog.txt` form appears.

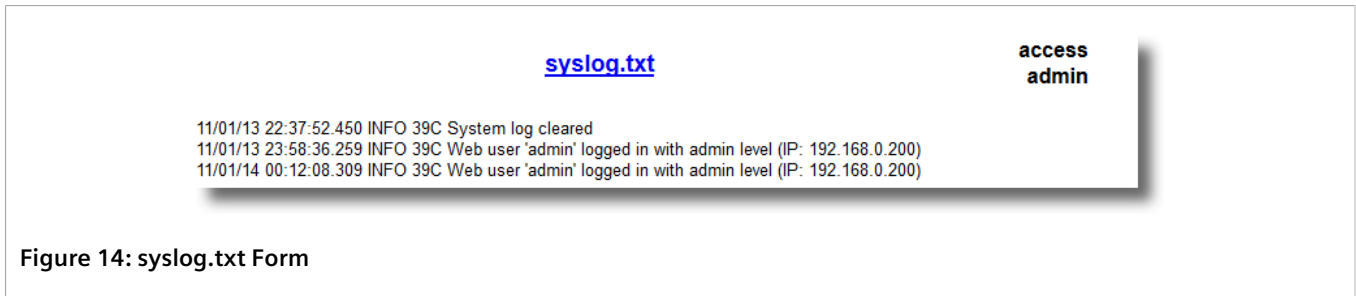

Section 4.5.2

Clearing Local and System Logs

To clear both the local crash and system logs, log in to the CLI shell and type:

```
clearlogs
```

To clear only the local system log, log in to the Web interface and do the following:

1. Navigate to **Diagnostics » Clear System Log**. The **Clear System Log** form appears.

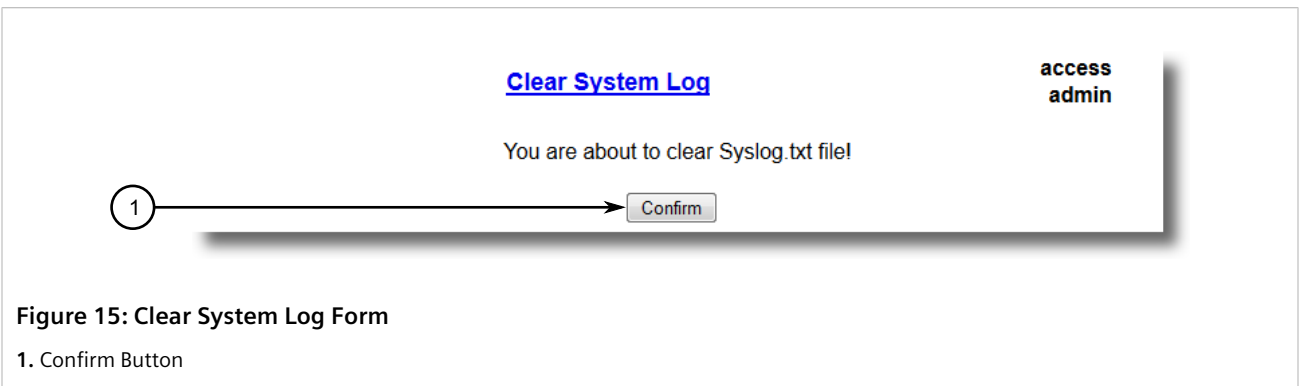

2. Click **Confirm**.

Section 4.5.3

Configuring the Local System Log

To configure the severity level for the local system log, do the following:



NOTE

For maximum reliability, use remote logging. For more information, refer to [Section 4.5.4, "Managing Remote Logging"](#).

1. Navigate to **Administration » Configure Syslog » Configure Local Syslog**. The **Local Syslog** form appears.

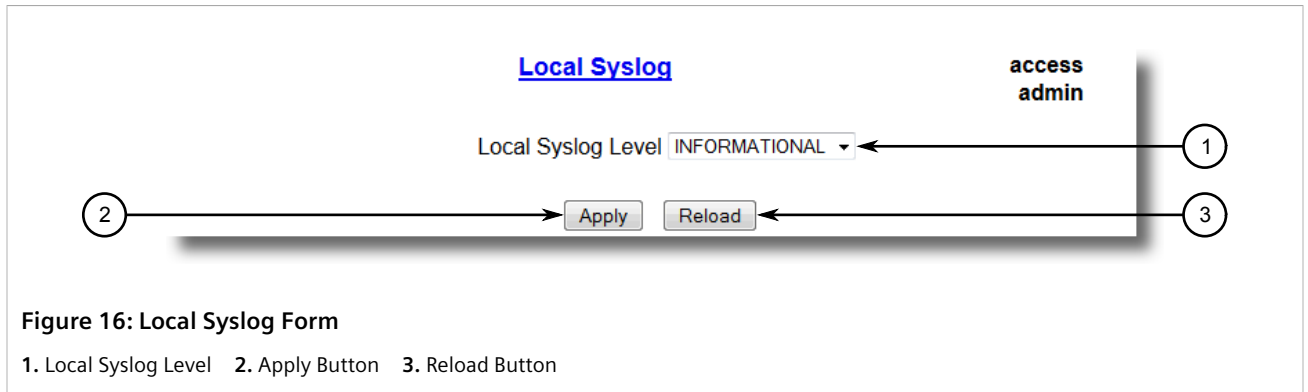

Figure 16: Local Syslog Form

1. Local Syslog Level 2. Apply Button 3. Reload Button

2. Configure the following parameter(s) as required:

Parameter	Description
Local Syslog Level	<p>Synopsis: { EMERGENCY, ALERT, CRITICAL, ERROR, WARNING, NOTICE, INFORMATIONAL, DEBUGGING }</p> <p>Default: INFORMATIONAL</p> <p>The severity of the message that has been generated. Note that the severity level selected is considered the minimum severity level for the system. For example, if ERROR is selected, the system sends any syslog messages generated by Error, Critical, Alert and Emergency.</p>

3. Click **Apply**.

Section 4.5.4

Managing Remote Logging

In addition to the local system log maintained on the device, a remote system log can be configured as well to collect important event messages. The syslog client resides on the device and supports up to 5 collectors (or syslog servers).

The remote syslog protocol, defined in RFC 3164, is a UDP/IP-based transport that enables the device to send event notification messages across IP networks to event message collectors, also known as syslog servers. The protocol is designed to simply transport these event messages from the generating device to the collector(s).

CONTENTS

- [Section 4.5.4.1, "Configuring the Remote Syslog Client"](#)
- [Section 4.5.4.2, "Viewing a List of Remote Syslog Servers"](#)
- [Section 4.5.4.3, "Adding a Remote Syslog Server"](#)
- [Section 4.5.4.4, "Deleting a Remote Syslog Server"](#)

Section 4.5.4.1

Configuring the Remote Syslog Client

To configure the remote syslog client, do the following:

1. Navigate to **Administration » Configure Syslog » Configure Remote Syslog Client**. The **Remote Syslog Client** form appears.

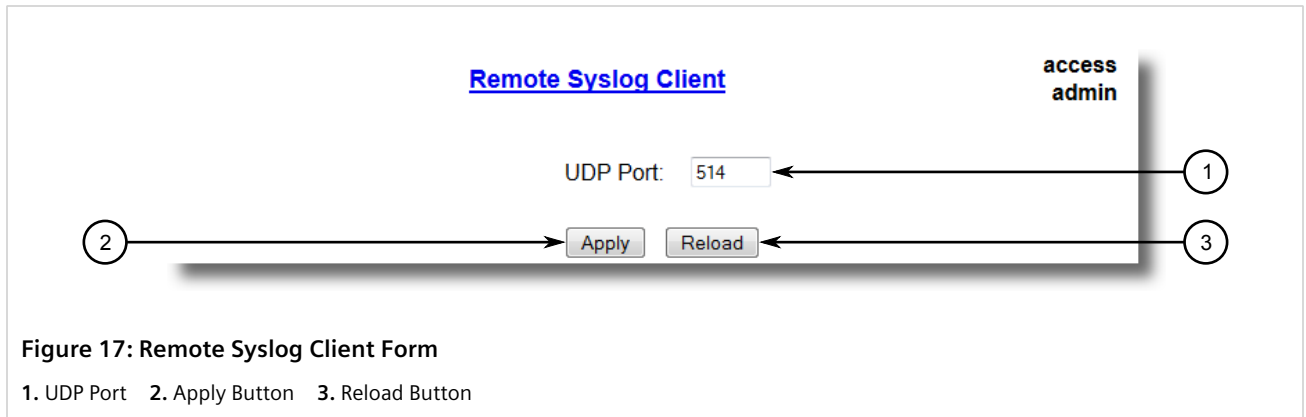

Figure 17: Remote Syslog Client Form

1. UDP Port 2. Apply Button 3. Reload Button

2. Configure the following parameter(s) as required:

Parameter	Description
UDP Port	<p>Synopsis: 1025 to 65535 or { 514 }</p> <p>Default: 514</p> <p>The local UDP port through which the client sends information to the server(s).</p>

3. Click **Apply**.

Section 4.5.4.2

Viewing a List of Remote Syslog Servers

To view a list of known remote syslog servers, navigate to **Administration » Configure Syslog » Configure Remote Syslog Server**. The **Remote Syslog Server** table appears.

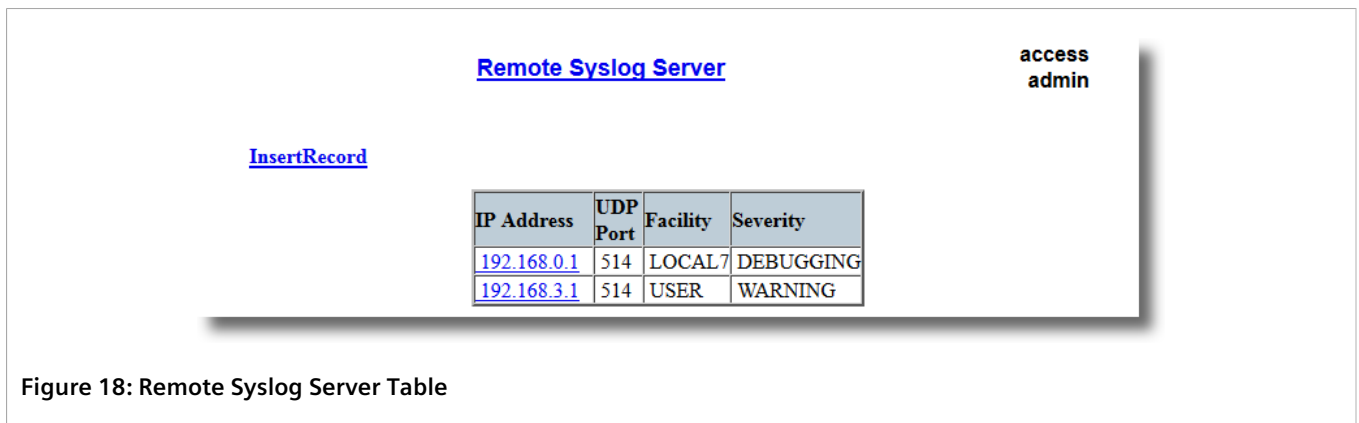

Figure 18: Remote Syslog Server Table

If remote syslog servers have not been configured, add the servers as needed. For more information, refer to [Section 4.5.4.3, “Adding a Remote Syslog Server”](#).

Section 4.5.4.3

Adding a Remote Syslog Server

RUGGEDCOM ROS supports up to 5 remote syslog servers (or collectors). Similar to the local system log, a remote system log server can be configured to log information at a specific severity level. Only messages of a severity level equal to or greater than the specified severity level are written to the log.

To add a remote syslog server to the list of known servers, do the following:

1. Navigate to **Administration » Configure Syslog » Configure Remote Syslog Server**. The **Remote Syslog Server** table appears.

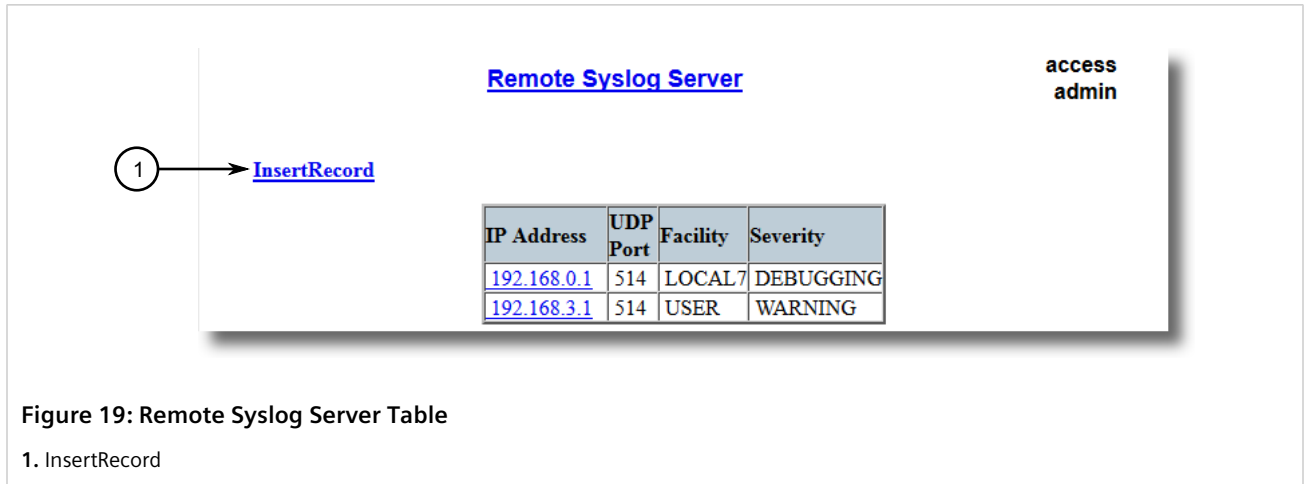

Figure 19: Remote Syslog Server Table

1. InsertRecord

2. Click **InsertRecord**. The **Remote Syslog Server** form appears.

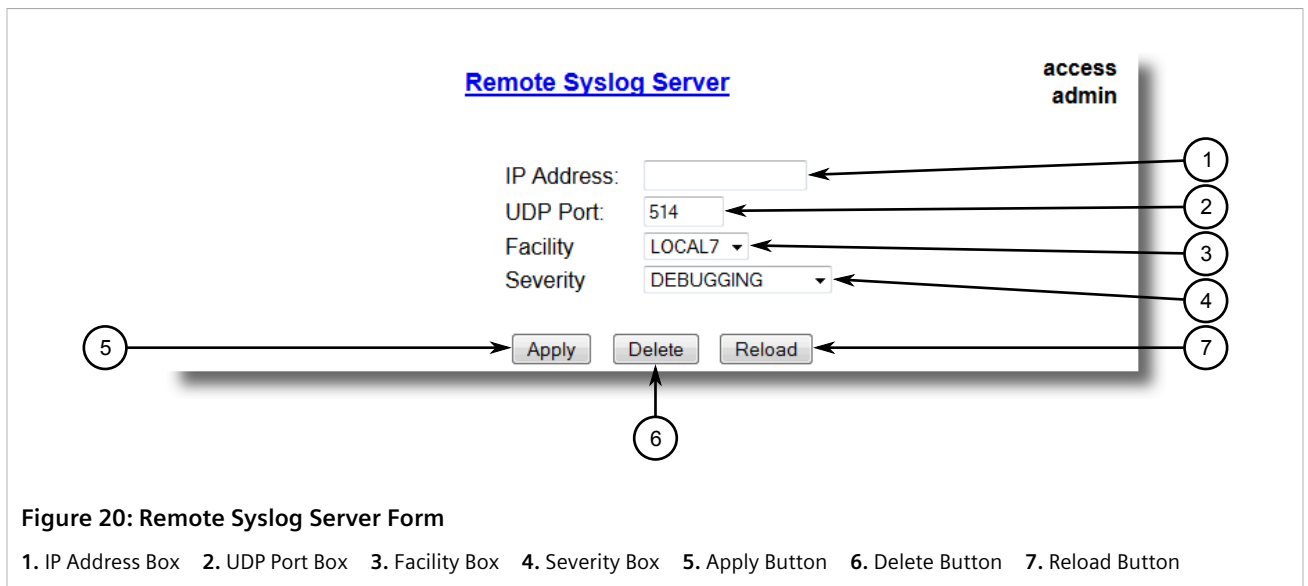

Figure 20: Remote Syslog Server Form

1. IP Address Box
2. UDP Port Box
3. Facility Box
4. Severity Box
5. Apply Button
6. Delete Button
7. Reload Button

3. Configure the following parameter(s) as required:

Parameter	Description
IP Address	Synopsis: ###.###.###.### where ### ranges from 0 to 255 Syslog server IP Address.
UDP Port	Synopsis: 1025 to 65535 or { 514 }

Parameter	Description
	<p>Default: 514</p> <p>The UDP port number on which the remote server listens.</p>
Facility	<p>Synopsis: { USER, LOCAL0, LOCAL1, LOCAL2, LOCAL3, LOCAL4, LOCAL5, LOCAL6, LOCAL7 }</p> <p>Default: LOCAL7</p> <p>Syslog Facility is one information field associated with a syslog message. The syslog facility is the application or operating system component that generates a log message. ROS map all syslog logging information onto a single facility which is configurable by user to facilitate remote syslog server.</p>
Severity	<p>Synopsis: { EMERGENCY, ALERT, CRITICAL, ERROR, WARNING, NOTICE, INFORMATIONAL, DEBUGGING }</p> <p>Default: DEBUGGING</p> <p>The severity level is the severity of the message that has been generated. Please note that the severity level user select is accepted as the minimum severity level for the system. For example, if user selects the severity level as 'Error' then the system send any syslog message originated by Error, Critical, Alert and Emergency.</p>

- Click **Apply**.

Section 4.5.4.4

Deleting a Remote Syslog Server

To delete a remote syslog server from the list of known servers, do the following:

- Navigate to **Administration » Configure Syslog » Configure Remote Syslog Server**. The **Remote Syslog Server** table appears.

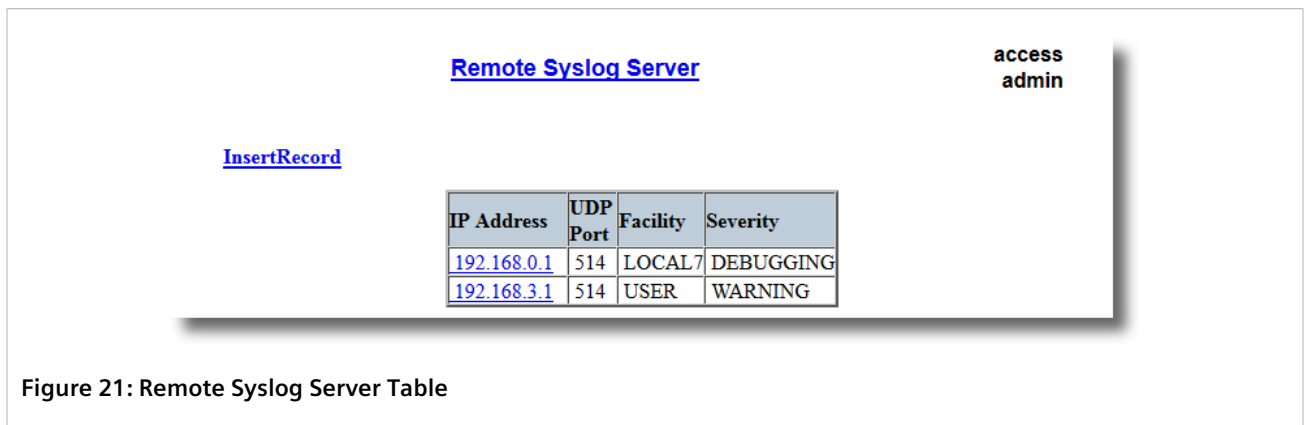

- Select the server from the table. The **Remote Syslog Server** form appears.

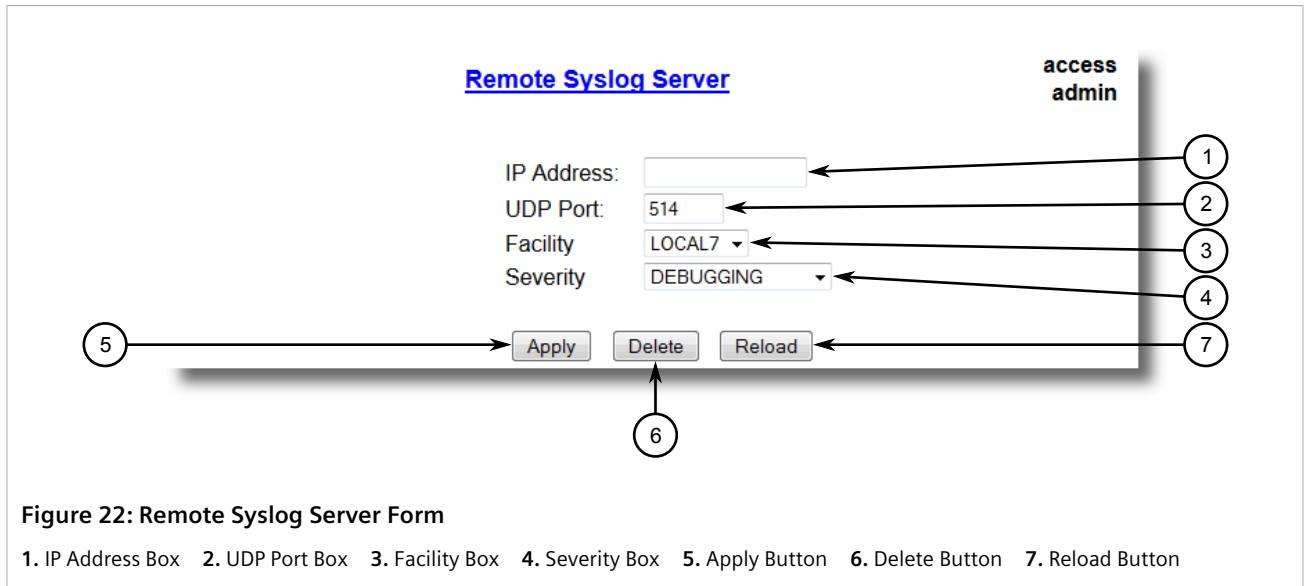

3. Click **Delete**.

Section 4.6

Managing Ethernet Ports

This section describes how to manage Ethernet ports.



NOTE

For information about configuring remote monitoring for Ethernet ports, refer to [Section 4.10](#), "Managing Remote Monitoring".

CONTENTS

- [Section 4.6.1, "Controller Protection Through Link Fault Indication \(LFI\)"](#)
- [Section 4.6.2, "Viewing the Status of Ethernet Ports"](#)
- [Section 4.6.3, "Viewing Statistics for All Ethernet Ports"](#)
- [Section 4.6.4, "Viewing Statistics for Specific Ethernet Ports"](#)
- [Section 4.6.5, "Clearing Statistics for Specific Ethernet Ports"](#)
- [Section 4.6.6, "Configuring an Ethernet Port"](#)
- [Section 4.6.7, "Configuring Port Rate Limiting"](#)
- [Section 4.6.8, "Configuring Port Mirroring"](#)
- [Section 4.6.9, "Configuring Link Detection"](#)
- [Section 4.6.10, "Resetting Ethernet Ports"](#)

Section 4.6.1

Controller Protection Through Link Fault Indication (LFI)

Modern industrial controllers often feature backup Ethernet ports used in the event of a link failure. When these interfaces are supported by media (such as fiber) that employ separate transmit and receive paths, the interface can be vulnerable to failures that occur in only one of the two paths.

Consider for instance two switches (A and B) connected to a controller. Switch A is connected to the main port on the controller, while Switch B is connected to the backup port, which is shut down by the controller while the link with Switch A is active. Switch B must forward frames to the controller through Switch A.

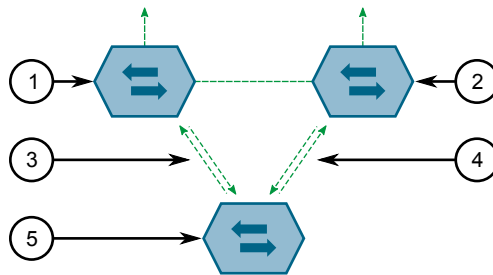

Figure 23: Example

1. Switch A 2. Switch B 3. Main Transmit Path 4. Backup Transmit Path 5. Controller

If the transmit path from the controller to Switch A fails, Switch A still generates a link signal to the controller through the receive path. The controller still detects the link with Switch A and does not failover to the backup port.

This situation illustrates the need for a notification method that tells a link partner when the link integrity signal has stopped. Such a method natively exists in some link media, but not all.

100Base-TX, 1000Base-T, 1000Base-X	Includes a built-in auto-negotiation feature (i.e. a special flag called Remote Fault Indication is set in the transmitted auto-negotiation signal).
100Base-FX Links	Includes a standard Far-End-Fault-Indication (FEFI) feature defined by the IEEE 802.3 standard for this link type. This feature includes: <ul style="list-style-type: none"> • Transmitting FEFI Transmits a modified link integrity signal in case a link failure is detected (i.e. no link signal is received from the link partner) • Detecting FEFI Indicates link loss in case an FEFI signal is received from the link partner
10Base-FL Links	No standard support.

10Base-FL links do not have a native link partner notification mechanism and FEFI support in 100Base-FX links is optional according to the IEEE 802.3 standard, which means that some links partners may not support it.

Siemens offers an advanced Link-Fault-Indication (LFI) feature for the links that do not have a native link partner notification mechanism. With LFI enabled, the device bases the generation of a link integrity signal upon its reception of a link signal. In the example described previously, if switch A fails to receive a link signal from the controller, it will stop generating a link signal. The controller will detect the link failure and failover to the backup port.



IMPORTANT!

If both link partners have the LFI feature, it **must not** be enabled on both sides of the link. If it is enabled on both sides, the link will never be established, as each link partner will be waiting for the other to transmit a link signal.

The switch can also be configured to flush the MAC address table for the controller port. Frames destined for the controller will be flooded to Switch B where they will be forwarded to the controller (after the controller transmits its first frame).

Section 4.6.2

Viewing the Status of Ethernet Ports

To view the current status of each Ethernet port, navigate to **Ethernet Ports » View Port Status**. The **Port Status** table appears.

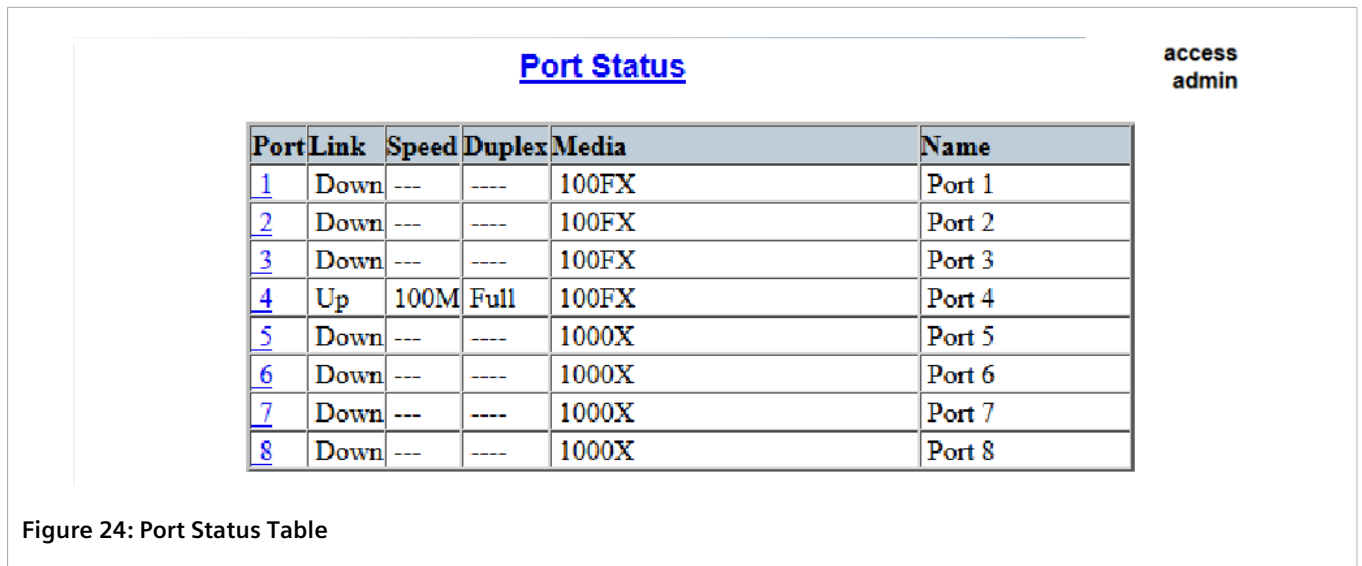

Figure 24: Port Status Table

This table displays the following information:

Parameter	Description
Port	Synopsis: 1 to maximum port number The port number as seen on the front plate silkscreen of the device.
Name	Synopsis: Any 15 characters A descriptive name that may be used to identify the device connected on that port.
Link	Synopsis: { ----, ----, Down, Up } The port's link status.
Speed	Synopsis: { ---, 10M, 100M, 1G, 10G } The port's current speed.
Duplex	Synopsis: { ----, Half, Full } The port's current duplex status.
Media	Synopsis: Any 31 characters

Parameter	Description
	Provides user with the description of installed media type on the port for modular products. Please note that fiber media may be either Single Mode(SM), Multi Mode(MM), may be Short Distance, Long Distance or Very Long Distance with connectors like LC, SC, ST, MTRJ etc. For the modules with SFP/GBICs, media description is displayed as per SFF-8472 specification, if transceiver is plugged into the module. E.g. 10/100/1000TX RJ45, 100FX SM SC, 10FX MM ST, 1000SX SFP LC S SL M5.

Section 4.6.3

Viewing Statistics for All Ethernet Ports

To view statistics collected for all Ethernet ports, navigate to **Ethernet Stats » View Ethernet Statistics**. The **Ethernet Statistics** table appears.

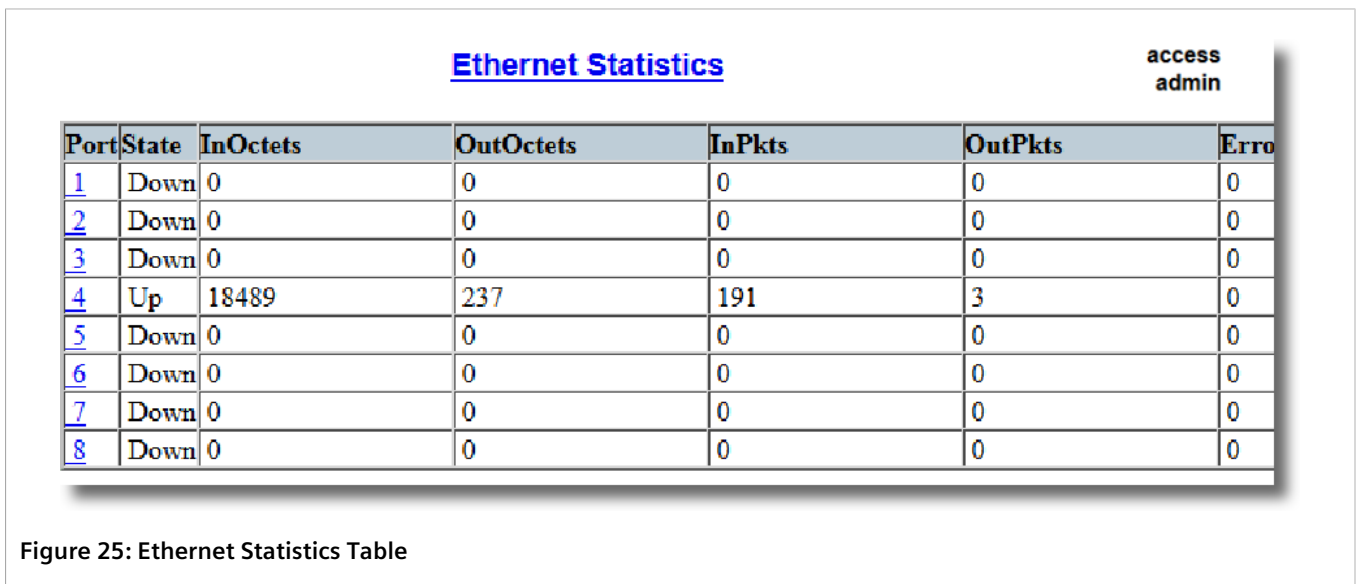

This table displays the following information:

Parameter	Description
Port	Synopsis: 1 to maximum port number The port number as seen on the front plate silkscreen of the device.
State	Synopsis: { ----, ----, Down, Up }
InOctets	Synopsis: 0 to 4294967295 The number of octets in received good packets (Unicast+Multicast+Broadcast) and dropped packets.
OutOctets	Synopsis: 0 to 4294967295 The number of octets in transmitted good packets.
InPkts	Synopsis: 0 to 4294967295 The number of received good packets (Unicast+Multicast+Broadcast) and dropped packets.
OutPkts	Synopsis: 0 to 4294967295 The number of transmitted good packets.
ErrorPkts	Synopsis: 0 to 4294967295

Parameter	Description
	The number of any type of erroneous packet.

Section 4.6.4

Viewing Statistics for Specific Ethernet Ports

To view statistics collected for specific Ethernet ports, navigate to *Ethernet Stats » View Ethernet Port Statistics*. The **Ethernet Port Statistics** table appears.

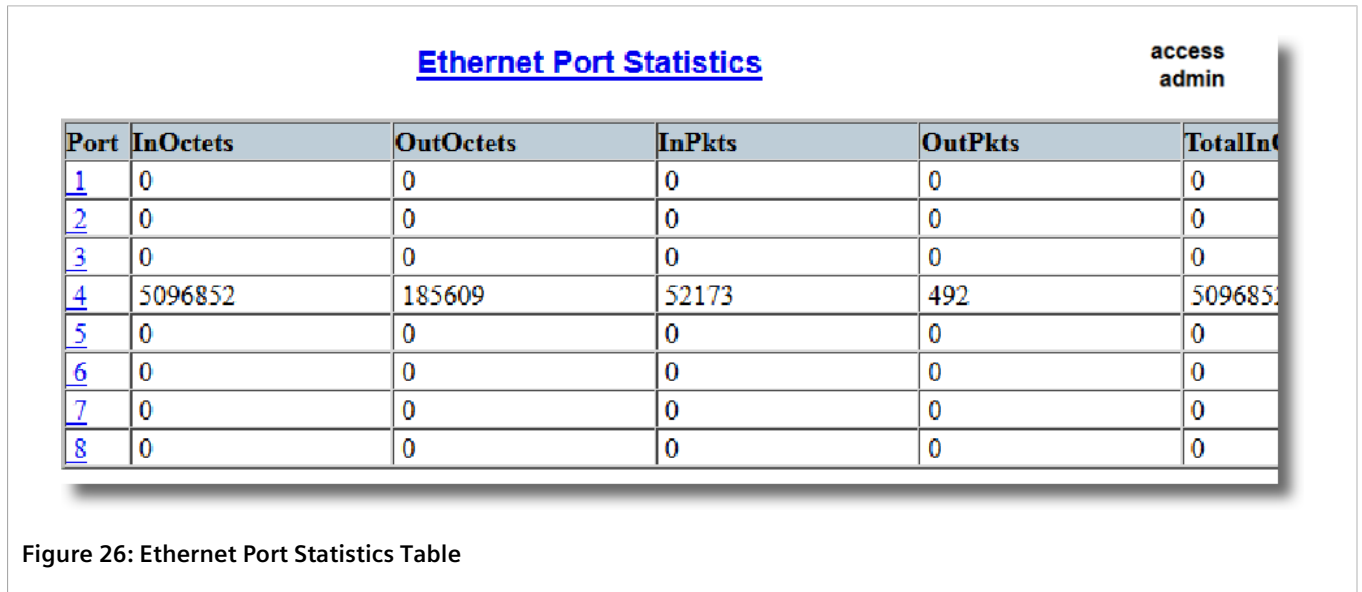

This table displays the following information:

Parameter	Description
Port	Synopsis: 1 to maximum port number The port number as seen on the front plate silkscreen of the device.
InOctets	Synopsis: 0 to 18446744073709551615 The number of octets in received good packets (Unicast+Multicast+Broadcast) and dropped packets.
OutOctets	Synopsis: 0 to 18446744073709551615 The number of octets in transmitted good packets.
InPkts	Synopsis: 0 to 18446744073709551615 The number of received good packets (Unicast+Multicast+Broadcast) and dropped packets.
OutPkts	Synopsis: 0 to 18446744073709551615 The number of transmitted good packets.
TotalInOctets	Synopsis: 0 to 18446744073709551615 The total number of octets of all received packets. This includes data octets of rejected and local packets which are not forwarded to the switching core for transmission. It should reflect all the data octets received on the line.
TotalInPkts	Synopsis: 0 to 18446744073709551615

Parameter	Description
	The number of received packets. This includes rejected, dropped local, and packets which are not forwarded to the switching core for transmission. It should reflect all packets received on the line.
InBroadcasts	Synopsis: 0 to 18446744073709551615 The number of good Broadcast packets received.
InMulticasts	Synopsis: 0 to 18446744073709551615 The number of good Multicast packets received.
CRCAAlignErrors	Synopsis: 0 to 4294967295 The number of packets received which meet all the following conditions: <ul style="list-style-type: none"> • Packet data length is between 64 and 1536 octets inclusive. • Packet has invalid CRC. • Collision Event has not been detected. • Late Collision Event has not been detected.
OversizePkts	Synopsis: 0 to 4294967295 The number of packets received with data length greater than 1536 octets and valid CRC.
Fragments	Synopsis: 0 to 4294967295 The number of packets received which meet all the following conditions: <ul style="list-style-type: none"> • Packet data length is less than 64 octets, or packet without SFD and is less than 64 octets in length. • Collision Event has not been detected. • Late Collision Event has not been detected. • Packet has invalid CRC.
Jabbers	Synopsis: 0 to 4294967295 The number of packets which meet all the following conditions: <ul style="list-style-type: none"> • Packet data length is greater than 1536 octets • Packet has invalid CRC
Collisions	Synopsis: 0 to 4294967295 The number of received packets for which Collision Event has been detected.
LateCollisions	Synopsis: 0 to 4294967295 The number of received packets for which Late Collision Event has been detected.
Pkt64Octets	Synopsis: 0 to 4294967295 The number of received and transmitted packets with size of 64 octets. This includes received and transmitted packets as well as dropped and local received packets. This does not include rejected received packets.
Pkt65to127Octets	Synopsis: 0 to 4294967295 The number of received and transmitted packets with size of 65 to 127 octets. This includes received and transmitted packets as well as dropped and local received packets. This does not include rejected received packets.
Pkt128to255Octets	Synopsis: 0 to 4294967295 The number of received and transmitted packets with size of 128 to 257 octets. This includes received and transmitted packets as well as dropped and local received packets. This does not include rejected received packets.
Pkt256to511Octets	Synopsis: 0 to 4294967295 The number of received and transmitted packets with size of 256 to 511 octets. This includes received and transmitted packets as well as dropped and local received packets. This does not include rejected received packets.

Parameter	Description
Pkt512to1023Octets	Synopsis: 0 to 4294967295 The number of received and transmitted packets with size of 512 to 1023 octets. This includes received and transmitted packets as well as dropped and local received packets. This does not include rejected received packets.
Pkt1024to1536Octets	Synopsis: 0 to 4294967295 The number of received and transmitted packets with size of 1024 to 1536 octets. This includes received and transmitted packets as well as dropped and local received packets. This does not include rejected received packets.
DropEvents	Synopsis: 0 to 4294967295 The number of received packets that are dropped due to lack of receive buffers.
OutMulticasts	Synopsis: 0 to 18446744073709551615 The number of transmitted Multicast packets. This does not include Broadcast packets.
OutBroadcasts	Synopsis: 0 to 18446744073709551615 The number of transmitted Broadcast packets.
UndersizePkts	Synopsis: 0 to 4294967295 The number of received packets which meet all the following conditions: <ul style="list-style-type: none"> • Packet data length is less than 64 octets. • Collision Event has not been detected. • Late Collision Event has not been detected. • Packet has valid CRC.

Section 4.6.5

Clearing Statistics for Specific Ethernet Ports

To clear the statistics collected for one or more Ethernet ports, do the following:

1. Navigate to **Ethernet Stats » Clear Ethernet Port Statistics**. The **Clear Ethernet Port Statistics** form appears.

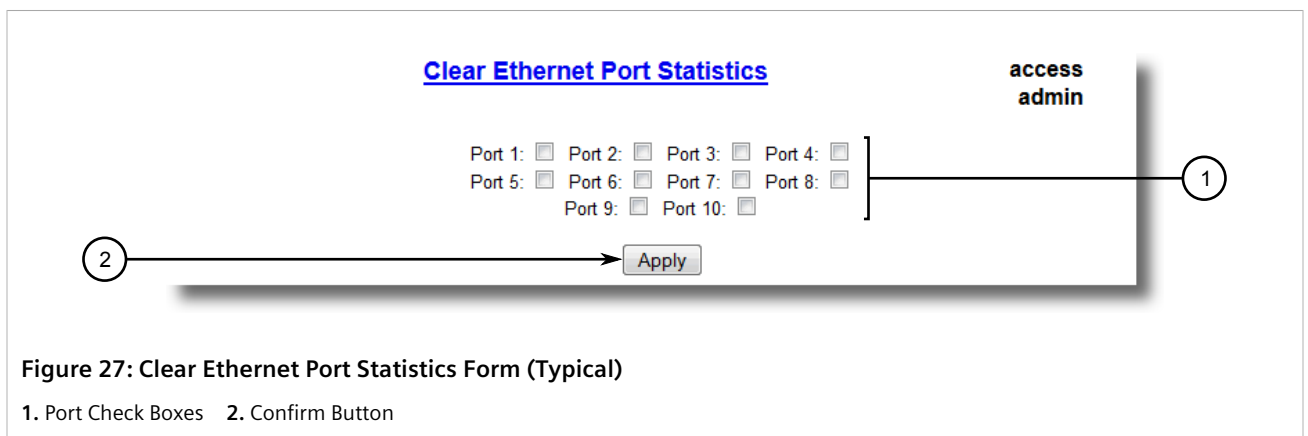

Figure 27: Clear Ethernet Port Statistics Form (Typical)

1. Port Check Boxes 2. Confirm Button

2. Select one or more Ethernet ports.
3. Click **Confirm**.

Section 4.6.6

Configuring an Ethernet Port

To configure an Ethernet port, do the following:

1. Navigate to **Ethernet Ports » Configure Port Parameters**. The **Port Parameters** table appears.

Port Parameters											access admin
Port	Name	Media	State	AutoN	Speed	Dupx	FlowCtrl	LFI	Alarm	Act on LinkDown	DownShi
1	Port 1	100FX	Enabled	Off	100M	Full	Off	Off	On	Do nothing	N/A
2	Port 2	100FX	Enabled	Off	100M	Full	Off	Off	On	Do nothing	N/A
3	Port 3	100FX	Enabled	Off	100M	Full	Off	Off	On	Do nothing	N/A
4	Port 4	100FX	Enabled	Off	100M	Full	Off	Off	On	Do nothing	N/A
5	Port 5	1000X	Enabled	On	1G	Full	Off	Off	On	Do nothing	N/A
6	Port 6	1000X	Enabled	On	1G	Full	Off	Off	On	Do nothing	N/A
7	Port 7	1000X	Enabled	On	1G	Full	Off	Off	On	Do nothing	N/A
8	Port 8	1000X	Enabled	On	1G	Full	Off	Off	On	Do nothing	N/A

Figure 28: Port Parameters Table

2. Select an Ethernet port. The **Port Parameters** form appears.

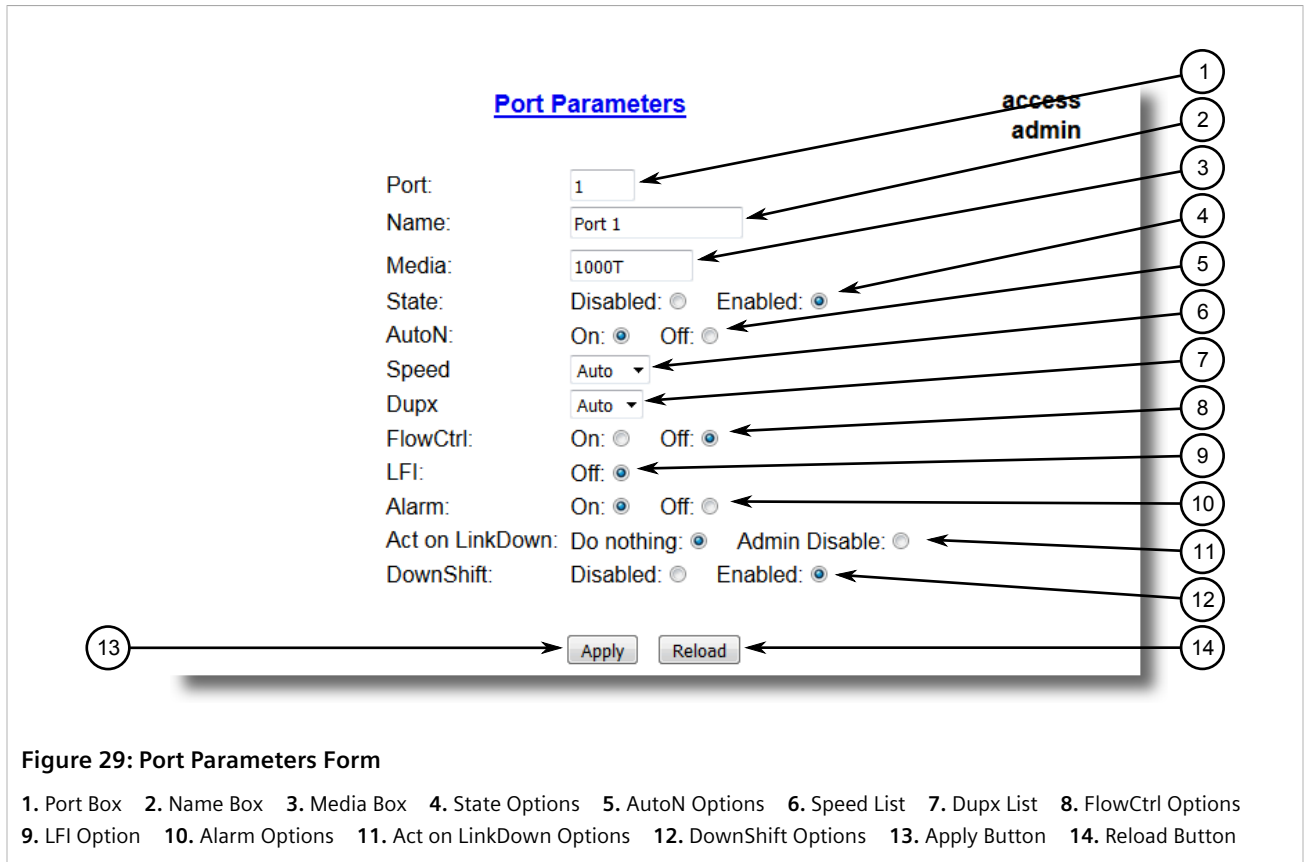



Figure 29: Port Parameters Form

1. Port Box 2. Name Box 3. Media Box 4. State Options 5. AutoN Options 6. Speed List 7. Dupx List 8. FlowCtrl Options 9. LFI Option 10. Alarm Options 11. Act on LinkDown Options 12. DownShift Options 13. Apply Button 14. Reload Button

3. Configure the following parameter(s) as required:

Parameter	Description
Port	<p>Synopsis: 1 to maximum port number Default: 1</p> <p>The port number as seen on the front plate silkscreen of the device.</p>
Name	<p>Synopsis: Any 15 characters Default: Port x</p> <p>A descriptive name that may be used to identify the device connected on that port.</p>
Media	<p>Synopsis: { 100TX, 10FL, 100FX, 1000X, 1000T, 802.11g, EoVDSL, 100TX Only, 10FL/100SX, 10GX } Default: 100TX</p> <p>The type of the port media.</p>
State	<p>Synopsis: { Disabled, Enabled } Default: Enabled</p> <p>Disabling a port will prevent all frames from being sent and received on that port. Also, when disabled link integrity signal is not sent so that the link/activity LED will never be lit. You may want to disable a port for troubleshooting or to secure it from unauthorized connections.</p> <div style="border: 1px solid black; padding: 5px; margin-top: 10px;"> <p>NOTE <i>Disabling a port whose media type is set to 802.11g disables the corresponding wireless module.</i></p> </div>
AutoN	<p>Synopsis: { Off, On } Default: On</p>

Parameter	Description
	Enable or disable IEEE 802.3 auto-negotiation. Enabling auto-negotiation results in speed and duplex being negotiated upon link detection; both end devices must be auto-negotiation compliant for the best possible results. 10Mbps and 100Mbps fiber optic media do not support auto-negotiation so these media must be explicitly configured to either half or full duplex. Full duplex operation requires that both ends are configured as such or else severe frame loss will occur during heavy network traffic.
Speed	<p>Synopsis: { Auto, 10M, 100M, 1G }</p> <p>Default: Auto</p> <p>Speed (in Megabit-per-second or Gigabit-per-second). If auto-negotiation is enabled, this is the speed capability advertised by the auto-negotiation process. If auto-negotiation is disabled, the port is explicitly forced to this speed mode.</p> <p>AUTO means advertise all supported speed modes.</p>
Dupx	<p>Synopsis: { Auto, Half, Full }</p> <p>Default: Auto</p> <p>Duplex mode. If auto-negotiation is enabled, this is the duplex capability advertised by the auto-negotiation process. If auto-negotiation is disabled, the port is explicitly forced to this duplex mode.</p> <p>AUTO means advertise all supported duplex modes.</p>
Flow Control	<p>Synopsis: { Off, On }</p> <p>Default: On</p> <p>Flow Control is useful for preventing frame loss during times of severe network traffic. Examples of this include multiple source ports sending to a single destination port or a higher speed port bursting to a lower speed port.</p> <p>When the port is half-duplex it is accomplished using 'backpressure' where the switch simulates collisions causing the sending device to retry transmissions according to the Ethernet backoff algorithm.</p> <p>When the port is full-duplex it is accomplished using PAUSE frames which causes the sending device to stop transmitting for a certain period of time.</p>
LFI	<p>Synopsis: { Off, On }</p> <p>Default: Off</p> <p>Enabling Link-Fault-Indication (LFI) inhibits transmitting link integrity signal when the receive link has failed. This allows the device at far end to detect link failure under all circumstances.</p> <div style="border: 1px solid black; padding: 5px; margin-top: 10px;"> <p> NOTE This feature must not be enabled at both ends of a fiber link.</p> </div>
Alarm	<p>Synopsis: { On, Off }</p> <p>Default: On</p> <p>Disabling link state alarms will prevent alarms and LinkUp and LinkDown SNMP traps from being sent for that port.</p>
Act on LinkDown	<p>Synopsis: { Do nothing, Admin Disable }</p> <p>Default: Do nothing</p> <p>The action to be taken upon a port LinkDown event. Options include:</p> <ul style="list-style-type: none"> • <code>Do nothing</code> – No action is taken. • <code>Admin Disable</code> – The port state is disabled. The <code>State</code> parameter must be set to <code>Enabled</code> before the link can be restored.
Downshift	<p>Synopsis: { Disabled, Enabled }</p> <p>Default: { Enabled }</p> <p>Enable or disable auto-negotiation on a gigabit (1000BASE-T) port with a two-pair twisted cable. If this option is enabled, the device is able to auto-negotiate with another</p>

Parameter	Description
	1000BASE-T link partner using a two-pair cable and establish a link at 100Mbps or 10Mbps.



NOTE

If one end of the link is fixed to a specific speed and duplex type and the peer auto-negotiates, there is a strong possibility the link will either fail to raise, or raise with the wrong settings on the auto-negotiating side. The auto-negotiating peer will fall back to half-duplex operation, even when the fixed side is full duplex. Full-duplex operation requires that both ends are configured as such or else severe frame loss will occur during heavy network traffic. At lower traffic volumes the link may display few, if any, errors. As the traffic volume rises, the fixed negotiation side will begin to experience dropped packets, while the auto-negotiating side will experience excessive collisions. Ultimately, as traffic load approaches 100%, the link will become entirely unusable. These problems can be avoided by always configuring ports to the appropriate fixed values.

4. Click **Apply**.

Section 4.6.7

Configuring Port Rate Limiting

To configure port rate limiting, do the following:

1. Navigate to **Ethernet Ports » Configure Port Rate Limiting**. The **Port Rate Limiting** table appears.

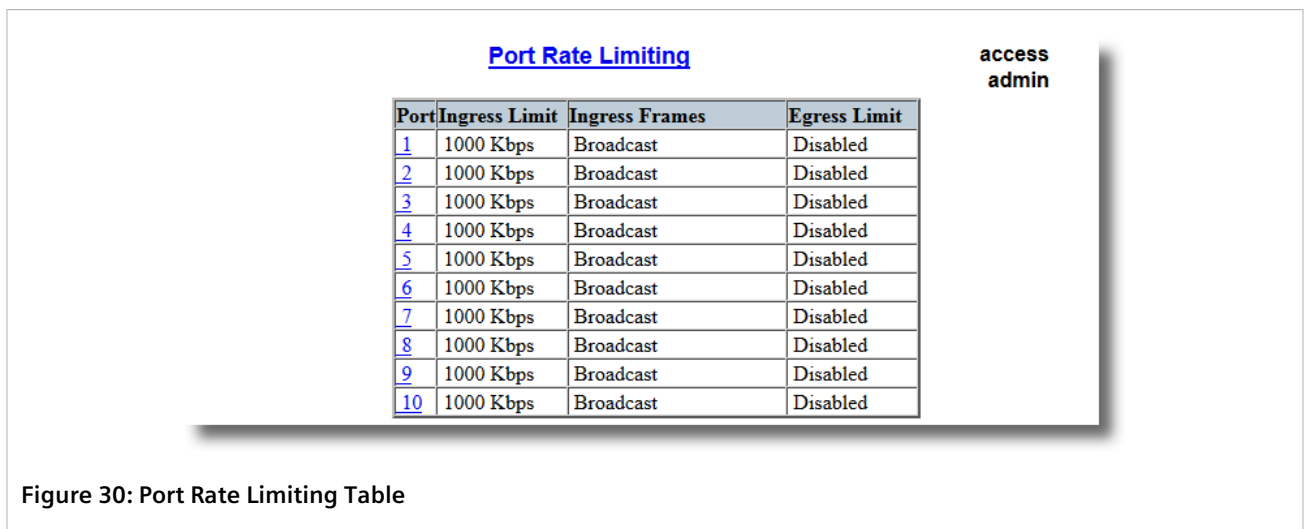

2. Select an Ethernet port. The **Port Rate Limiting** form appears.

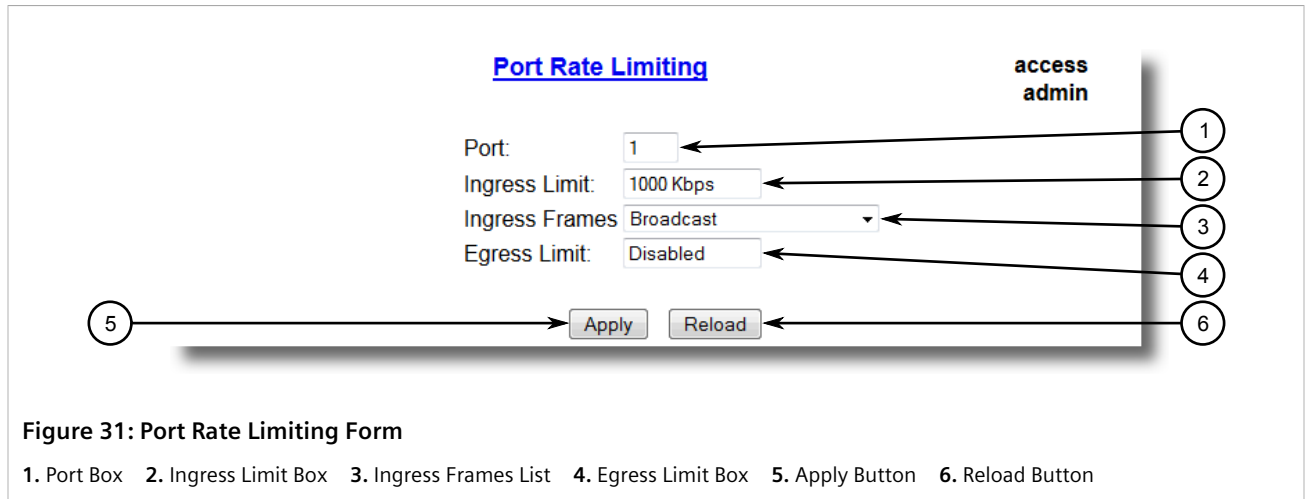

3. Configure the following parameter(s) as required:

Parameter	Description
Port	<p>Synopsis: 1 to maximum port number Default: 1</p> <p>The port number as seen on the front plate silkscreen of the device.</p>
Ingress Limit	<p>Synopsis: 62 to 256000 Kbps or { Disabled } Default: 1000 Kbps</p> <p>The rate after which received frames (of the type described by the ingress frames parameter) will be discarded by the switch.</p>
Ingress Frames	<p>Synopsis: { Broadcast, Bcast&Mcast, Bcast&Mcast&FloodUcast, Bcast&FloodUcast, FloodUcast, All } Default: Broadcast</p> <p>This parameter specifies the types of frames to be rate-limited on this port. It applies only to received frames:</p> <ul style="list-style-type: none"> • Broadcast – Only broadcast frames are limited • Bcast&Mcast – Broadcast and multicast frames are limited • Bcast&FloodUcast – Broadcast and flooded unicast frames are limited • Bcast&Mcast&FloodUcast – Broadcast, multicast and flooded unicast frames are limited • FloodUcast – Only flooded unicast frames are limited • All – All received frames are limited
Egress Limit	<p>Synopsis: { Broadcast, Multicast, Mcast&FloodUcast, All }">62 to 256000 Kbps or { Disabled } Default: Disabled</p> <p>The maximum rate at which the switch will transmit (multicast, broadcast and unicast) frames on this port. The switch will discard frames in order to meet this rate if required.</p>

4. Click **Apply**.

Section 4.6.8

Configuring Port Mirroring

Port mirroring is a troubleshooting tool that copies, or mirrors, all traffic received or transmitted on a designated port to a specified mirror port. If a protocol analyzer is attached to the target port, the traffic stream of valid frames on any source port is made available for analysis.



IMPORTANT!

Select a target port that has a higher speed than the source port. Mirroring a 100 Mbps port onto a 10 Mbps port may result in an improperly mirrored stream.



IMPORTANT!

Frames will be dropped if the full-duplex rate of frames on the source port exceeds the transmission speed of the target port. Since both transmitted and received frames on the source port are mirrored to the target port, frames will be discarded if the sum traffic exceeds the target port's transmission rate. This problem reaches its extreme in the case where traffic on a 100 Mbps full-duplex port is mirrored onto a 10 Mbps half-duplex port.



IMPORTANT!

Before configuring port mirroring, note the following:

- Traffic will be mirrored onto the target port irrespective of its VLAN membership. It could be the same as or different from the source port's membership.
- Network management frames (such as RSTP, GVRP etc.) cannot be mirrored.
- Switch management frames generated by the switch (such as Telnet, HTTP, SNMP, etc.) cannot be mirrored.



NOTE

Invalid frames received on the source port will not be mirrored. These include CRC errors, oversize and undersize packets, fragments, jabbers, collisions, late collisions and dropped events.

To configure port mirroring, do the following:

1. Navigate to **Ethernet Ports » Configure Port Mirroring**. The **Port Mirroring** form appears.

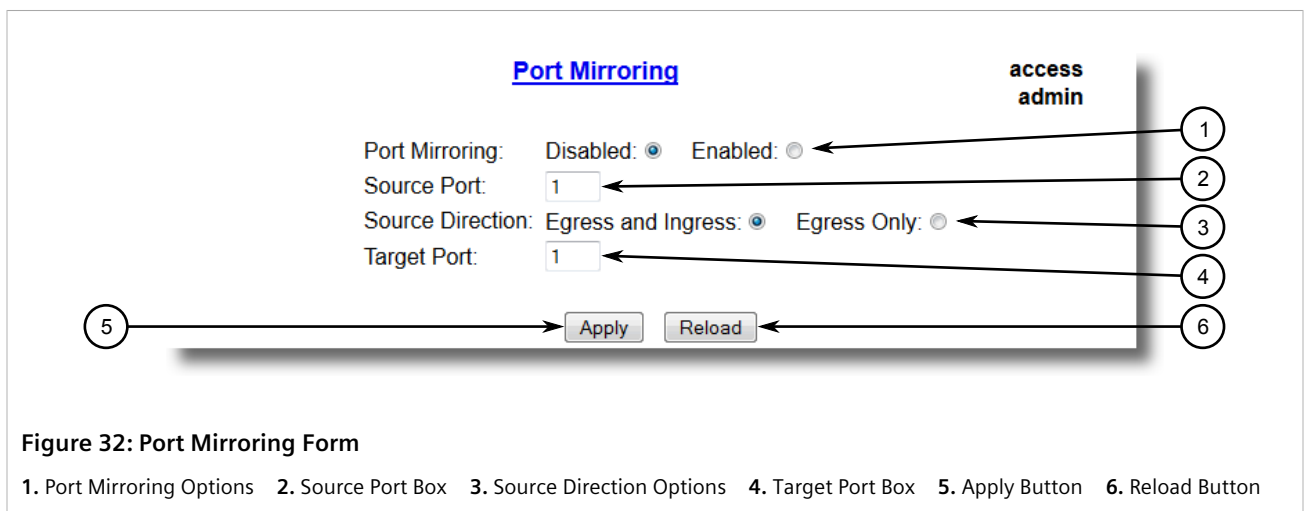

Figure 32: Port Mirroring Form

1. Port Mirroring Options
2. Source Port Box
3. Source Direction Options
4. Target Port Box
5. Apply Button
6. Reload Button

2. Configure the following parameter(s) as required:

Parameter	Description
Port Mirroring	Synopsis: { Disabled, Enabled } Default: Disabled Enabling port mirroring causes all frames received and transmitted by the source port(s) to be transmitted out of the target port.
Source Port	Synopsis: Any combination of numbers valid for this parameter The port(s) being monitored.
Source Direction	Synopsis: Egress and Ingress, Egress Only Default: Egress and Ingress Specifies monitoring whether both egress and ingress traffics or only egress traffic of the source port.
Target Port	Synopsis: 1 to maximum port number Default: 1 The port where a monitoring device should be connected.

3. Click **Apply**.

Section 4.6.9

Configuring Link Detection

To configure link detection, do the following:

1. Navigate to **Ethernet Ports » Configure Link Detection**. The **Link Detection** form appears.

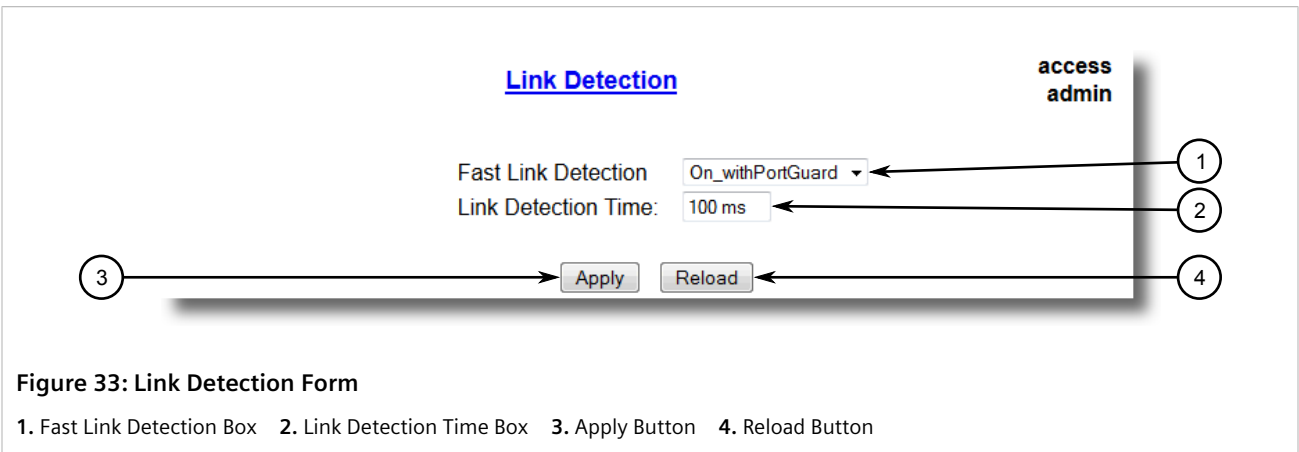

Figure 33: Link Detection Form

1. Fast Link Detection Box
2. Link Detection Time Box
3. Apply Button
4. Reload Button

2. Configure the following parameter(s) as required:



NOTE

When Fast Link Detection is enabled, the system prevents link state change processing from consuming all available CPU resources. However, if Port Guard is not used, it is possible for almost all available CPU time to be consumed by frequent link state changes, which could have a negative impact on overall system responsiveness.

Parameter	Description
Fast Link Detection	Synopsis: { Off, On, On_withPortGuard } Default: On_withPortGuard

Parameter	Description
	<p>This parameter provides protection against faulty end devices generating an improper link integrity signal. When a faulty end device or a mis-matching fiber port is connected to the unit, a large number of continuous link state changes could be reported in a short period of time. These large number of bogus link state changes could render the system unresponsive as most, if not all, of the system resources are used to process the link state changes. This could in turn cause a serious network problem as the unit's RSTP process may not be able to run, thus allowing network loop to form.</p> <p>Three different settings are available for this parameter:</p> <ul style="list-style-type: none"> • <code>Off</code> – Turning this parameter OFF will disable FAST LINK DETECTION completely. The switch will need a longer time to detect a link failure. This will result in a longer network recovery time of up to 2s. • <code>On</code> – In certain special cases where a prolonged excessive link state changes constitute a legitimate link operation, using this setting can prevent Port Guard from disabling FAST LINK DETECTION on the port in question. If excessive link state changes persist for more than 2 minutes, an alarm will be generated to warn user about the observed bouncing link. If the excessive link state changes condition is resolved later on, the alarm will be cleared automatically. Since this option does not disable FAST LINK DETECTION, a persistent bouncing link could continue affect the system in terms of response time. This setting should be used with caution. • <code>On_withPortGuard</code> – This is the recommended setting. With this setting, an extended period (~2 minutes) of excessive link state changes reported by a port will prompt Port Guard feature to disable FAST LINK DETECTION on that port and raise an alarm. By disabling FAST LINK DETECTION on the problematic port, excessive link state changes can no longer consume substantial amount of system resources. However if FAST LINK DETECTION is disabled, the port will need a longer time to detect a link failure. This may result in a longer network recovery time of up to 2s. Once Port Guard disables FAST LINK DETECTION of a particular port, user can re-enable FAST LINK DETECTION on the port by clearing the alarm.
Link Detection Time	<p>Synopsis: 100 ms to 1000 ms Default: 100 ms</p> <p>The time that the link has to continuously stay up before the "link up" decision is made by the device.</p> <p>(The device performs de-bouncing of Ethernet link detection to avoid multiple responses to an occasional link bouncing event, e.g. when a cable is shaking while being plugged-in or unplugged).</p>

3. Click **Apply**.

Section 4.6.10

Resetting Ethernet Ports

At times, it may be necessary to reset a specific Ethernet port, such as when the link partner has latched into an inappropriate state. This is also useful for forcing a re-negotiation of the speed and duplex modes.

To reset a specific Ethernet port(s), do the following:

1. Navigate to **Ethernet Ports » Reset Port(s)**. The **Reset Port(s)** form appears.

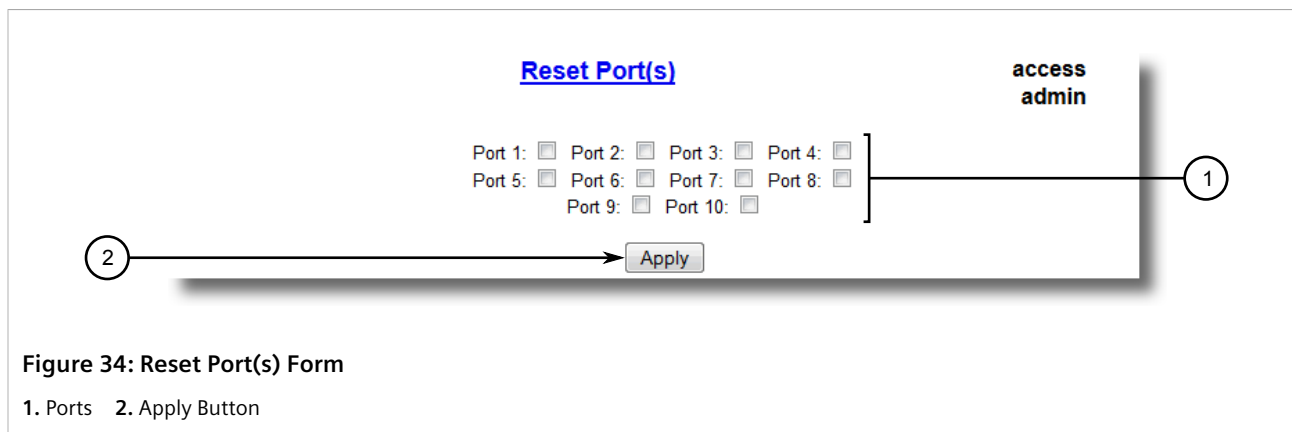

2. Select one or more Ethernet ports to reset.
3. Click **Apply**. The selected Ethernet ports are reset.

Section 4.7

Managing IP Interfaces

RUGGEDCOM ROS allows one IP interface to be configured for each subnet (or VLAN), up to a maximum of 255 interfaces. One of the interfaces must also be configured to be a management interface for certain IP services, such as DHCP relay agent.

Each IP interface must be assigned an IP address. In the case of the management interface, the IP address type can be either static, DHCP, BOOTP or dynamic. For all other interfaces, the IP address must be static.



CAUTION!

Configuration hazard – risk of communication disruption. Changing the ID for the management VLAN will break any active Raw Socket TCP connections. If this occurs, reset all serial ports.

CONTENTS

- [Section 4.7.1, “Managing Switch IP Interfaces”](#)

Section 4.7.1

Managing Switch IP Interfaces



CAUTION!

Configuration hazard – risk of communication disruption. Changing the ID for the management VLAN will break any active Raw Socket TCP connections. If this occurs, reset all serial ports.

CONTENTS

- [Section 4.7.1.1, “Viewing a List of Switch IP Interfaces”](#)
- [Section 4.7.1.2, “Adding a Switch IP Interface”](#)
- [Section 4.7.1.3, “Deleting a Switch IP Interface”](#)

Section 4.7.1.1

Viewing a List of Switch IP Interfaces

To view a list of switch IP interfaces configured on the device, navigate to **Administration » Configure IP Interfaces » Configure Switch IP Interfaces**. The **Switch IP Interfaces** table appears.

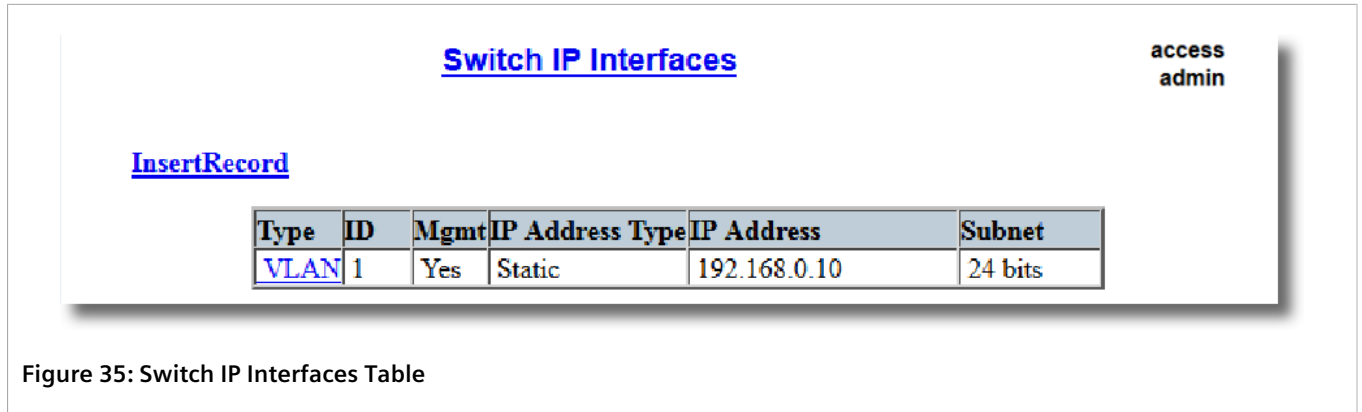

Figure 35: Switch IP Interfaces Table

If switch IP interfaces have not been configured, add IP interfaces as needed. For more information, refer to [Section 4.7.1.2, “Adding a Switch IP Interface”](#).

Section 4.7.1.2

Adding a Switch IP Interface

To add a switch IP interface, do the following:

1. Navigate to **Administration » Configure IP Interfaces » Configure Switch IP Interfaces**. The **Switch IP Interfaces** table appears.

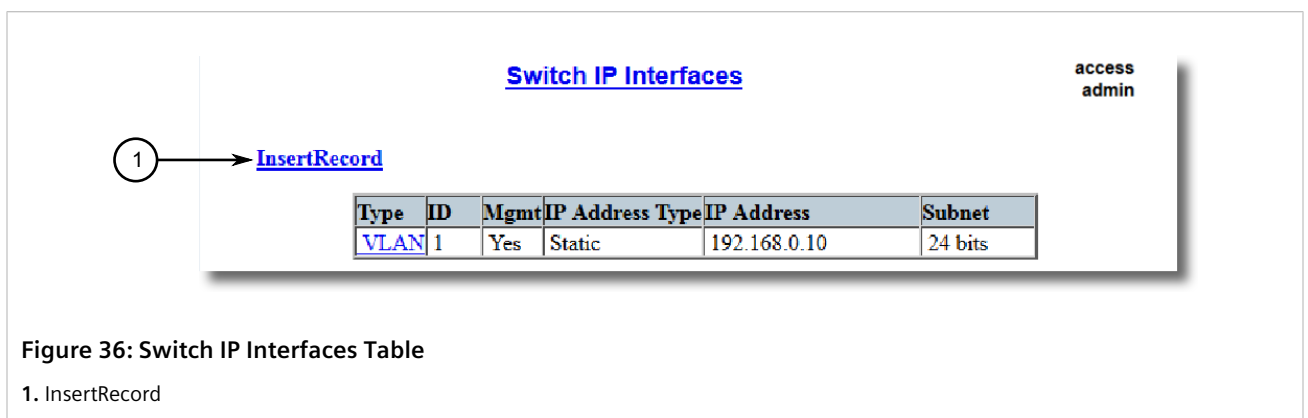

Figure 36: Switch IP Interfaces Table

1. InsertRecord

2. Click **InsertRecord**. The **Switch IP Interfaces** form appears.

Figure 37: Switch IP Interfaces Form (IPv4 Example)

- 1. Type Options
- 2. ID Box
- 3. Mgmt Options
- 4. IP Address Type Box
- 5. IP Address Box
- 6. Subnet Prefix Box
- 7. Apply Button
- 8. Delete Button
- 9. Reload Button

Figure 38: Switch IP Interfaces Form (IPv6 Example)

- 1. Type Options
- 2. ID Box
- 3. Mgmt Options
- 4. IP Address Type Box
- 5. IP Address Box
- 6. Subnet Prefix Box
- 7. Apply Button
- 8. Delete Button
- 9. Reload Button

3. Configure the following parameter(s) as required:



NOTE

The IP address and mask configured for the management VLAN are not changed when resetting all configuration parameters to defaults and will be assigned a default VLAN ID of 1. Changes to the IP address take effect immediately. All IP connections in place at the time of an IP address change will be lost.

 **NOTE**
For IPv4, if a dotted decimal notation is configured for the subnet prefix (e.g. 255.255.255.0) it will be automatically converted to the equivalent number of bits (e.g. 24 bits).

Parameter	Description
Type	<p>Synopsis: { VLAN }</p> <p>Default: VLAN</p> <p>Specifies the type of the interface for which this IP interface is created.</p>
ID	<p>Synopsis: 1 to maximum port number</p> <p>Default: 1</p> <p>Specifies the ID of the interface for which this IP interface is created. If the interface type is VLAN, this represents the VLAN ID.</p>
Mgmt	<p>Synopsis: { No, Yes }</p> <p>Default: No</p> <p>Specifies whether the IP interface is the device management interface.</p>
IP Address Type	<p>Synopsis: { Static, Dynamic, DHCP, BOOTP }</p> <p>Default: Static</p> <p>Specifies whether the IP address is static or dynamically assigned via DHCP or BOOTP. Option DYNAMIC is a common case of dynamically assigned IP address. It switches between BOOTP and DHCP until it gets the response from the relevant server.</p> <p>Must be static for non management interfaces.</p> <p>The IP address assigned by the DHCP or BOOTP server includes the subnet mask (Option 1), router (Option 3) and IP forwarding (Option 19) values. Dynamically-assigned addresses override manually-assigned gateways.</p>
IP Address	<p>Synopsis: #####:#####:#####:#####:#####:#####:#####:##### where ##### ranges from hexadecimal 0 to FFFF, or ###.###.###.### where ### ranges from decimal 0 to 255.</p> <p>Default: 192.168.0.1</p> <p>Specifies the Internet Protocol address of this interface. An IP address is a 128-bit number that is notated by using eight fields of four hexadecimal digits, for which leading zeros can be omitted, delimited by colons. Consult offline documentation for more information. A version 4 address can be encoded by four decimal numbers from 0 through 255, separated by periods. Only a unicast IP addresses is allowed, which does not begin with "FF", or ranges from 1.0.0.0 to 233.255.255.255 for version 4.</p>
Subnet Prefix	<p>Synopsis: 0 to 128 bits</p> <p>Default: 24 bits</p> <p>Specifies the IP subnet mask of this device. An IP subnet mask is a 32-bit number that is notated by using four numbers from 0 through 255, separated by periods. Typically, subnet mask numbers use either 0 or 255 as values (e.g. 255.255.255.0) but other numbers can appear.</p>

 **IMPORTANT!**
Each IP interface must have a unique network address.

- Click **Apply**.

Section 4.7.1.3

Deleting a Switch IP Interface

To delete a switch IP interface configured on the device, do the following:

1. Navigate to **Administration » Configure IP Interfaces » Configure Switch IP Interfaces**. The **Switch IP Interfaces** table appears.

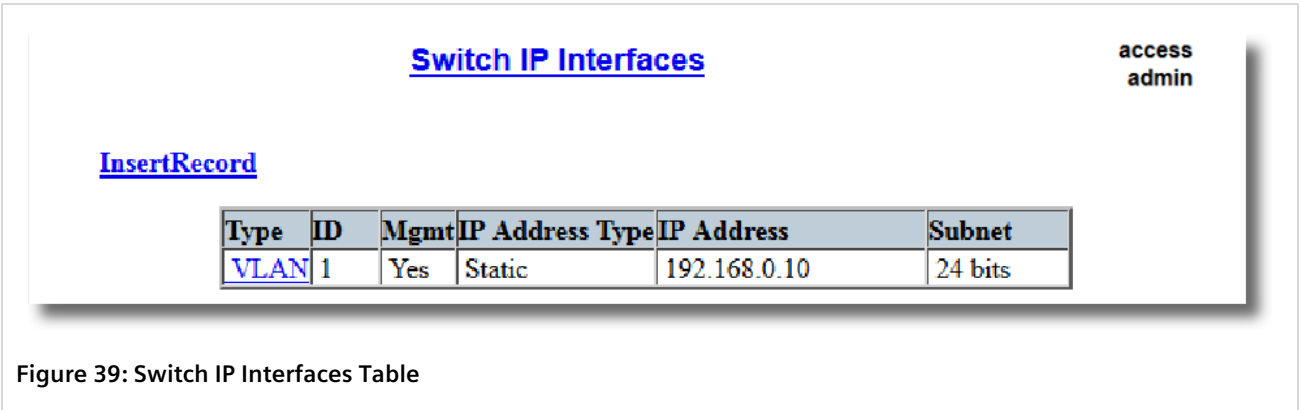

Figure 39: Switch IP Interfaces Table

2. Select the IP interface from the table. The **Switch IP Interfaces** form appears.

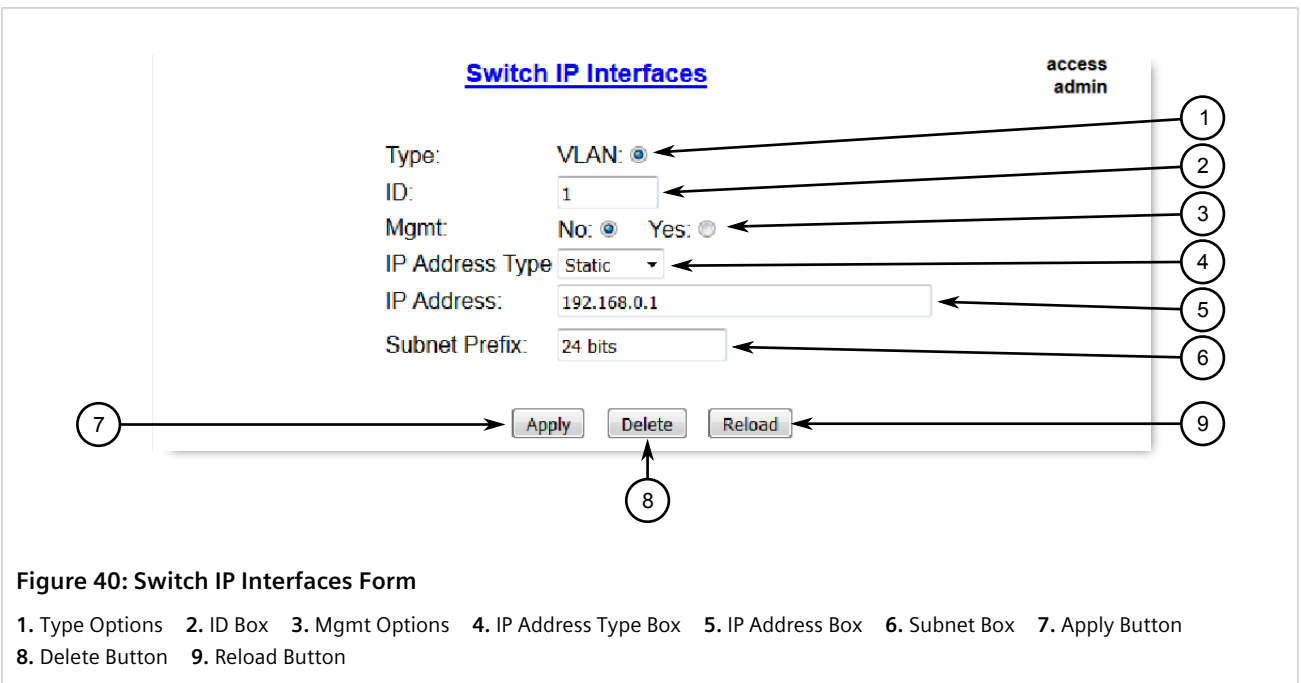

Figure 40: Switch IP Interfaces Form

1. Type Options
2. ID Box
3. Mgmt Options
4. IP Address Type Box
5. IP Address Box
6. Subnet Box
7. Apply Button
8. Delete Button
9. Reload Button

3. Click **Delete**.

Section 4.8

Managing IP Gateways

RUGGEDCOM ROS allows up to ten IP gateways to be configured. When both the **Destination** and **Subnet** parameters are blank, the gateway is considered to be a default gateway.



NOTE

The default gateway configuration will not be changed when resetting all configuration parameters to their factory defaults.

CONTENTS

- [Section 4.8.1, "Viewing a List of IP Gateways"](#)
- [Section 4.8.2, "Adding an IP Gateway"](#)
- [Section 4.8.3, "Deleting an IP Gateway"](#)

Section 4.8.1

Viewing a List of IP Gateways

To view a list of IP gateways configured on the device, navigate to **Administration » Configure IP Gateways**. The **IP Gateways** table appears.

Destination	Subnet	Gateway
		172.30.128.1

Figure 41: IP Gateways Table

If IP gateways have not been configured, add IP gateways as needed. For more information, refer to [Section 4.8.2, "Adding an IP Gateway"](#).

Section 4.8.2

Adding an IP Gateway



IMPORTANT!

DHCP-provided IP gateway addresses will override manually configured values.

To add an IP gateway, do the following:

1. Navigate to **Administration » Configure IP Gateways**. The **IP Gateways** table appears.

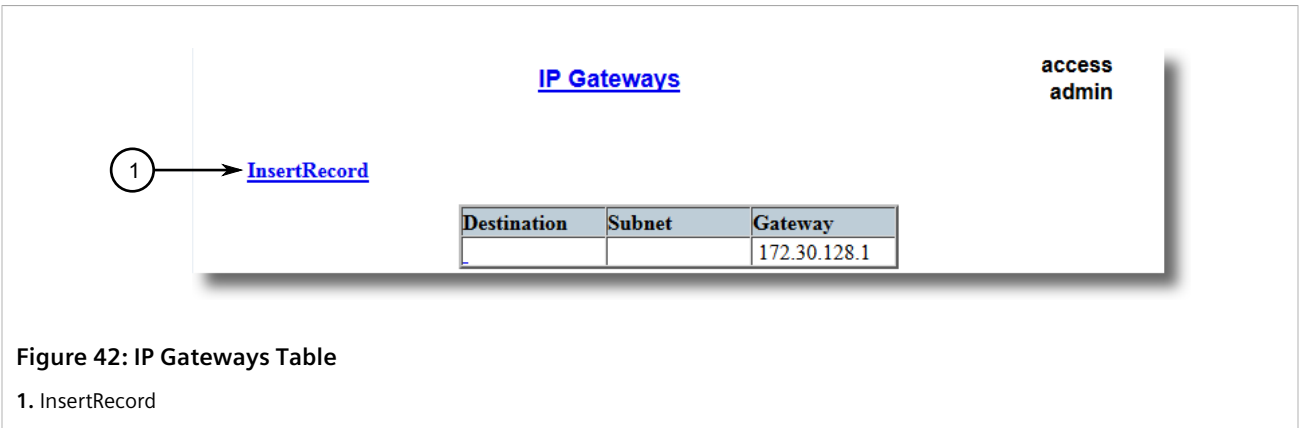

Figure 42: IP Gateways Table

1. InsertRecord

- Click **InsertRecord**. The **IP Gateways** form appears.

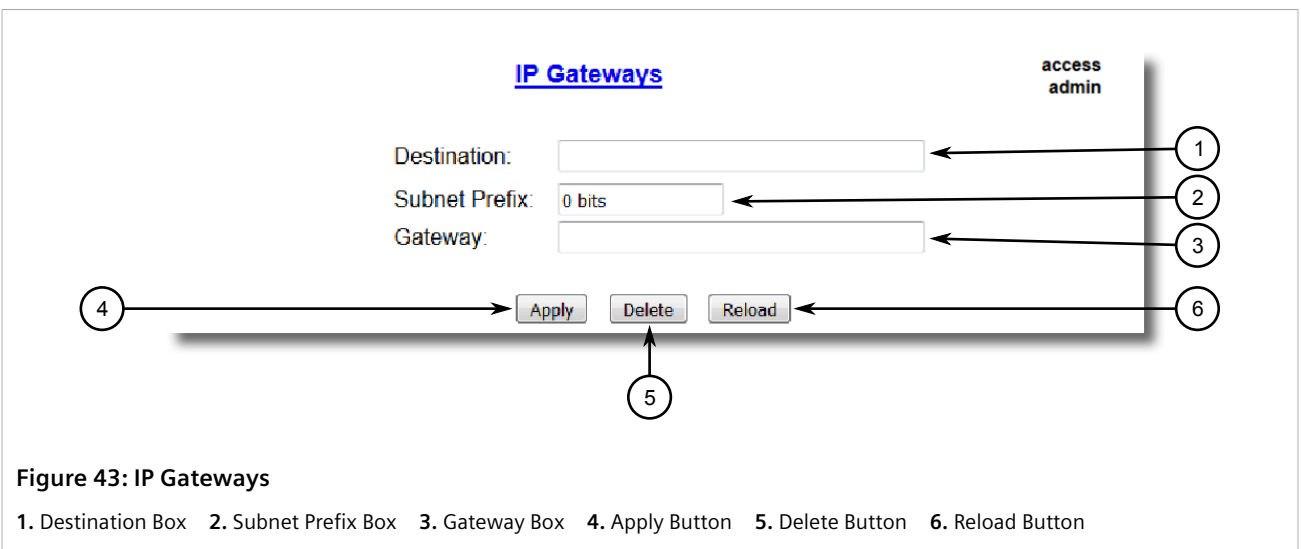

Figure 43: IP Gateways

1. Destination Box 2. Subnet Prefix Box 3. Gateway Box 4. Apply Button 5. Delete Button 6. Reload Button

- Configure the following parameter(s) as required:

Parameter	Description
Destination	Synopsis: Any valid IP address Specifies the IP address of destination network or host. For default gateway, both the destination and subnet are 0.
Subnet Prefix	Synopsis: 0 to 128 bits Default: 0 bits Specifies the destination IP subnet mask. For default gateway, both the destination and subnet are 0.
Gateway	Synopsis: Any valid IP address Specifies the gateway to be used to reach the destination.

- Click **Apply**.

Section 4.8.3

Deleting an IP Gateway

To delete an IP gateway configured on the device, do the following:

1. Navigate to **Administration » Configure IP Gateways**. The **IP Gateways** table appears.

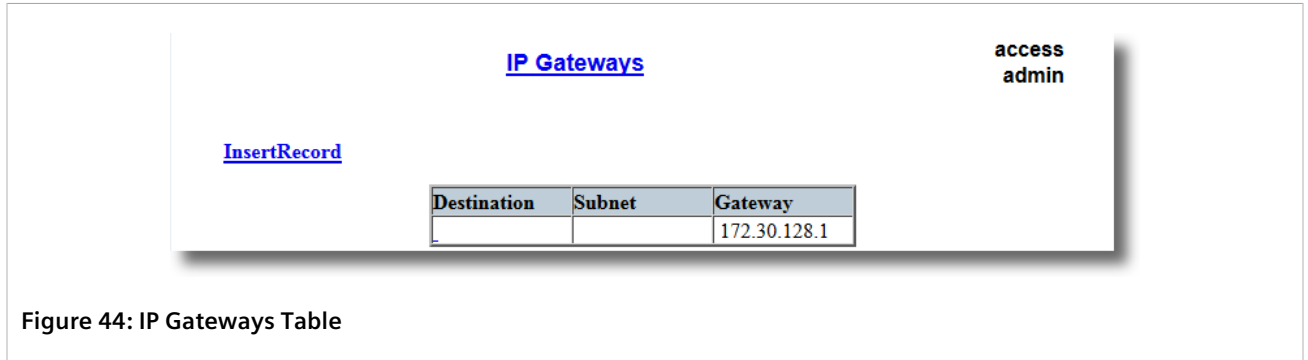

2. Select the IP gateway from the table. The **IP Gateways** form appears.

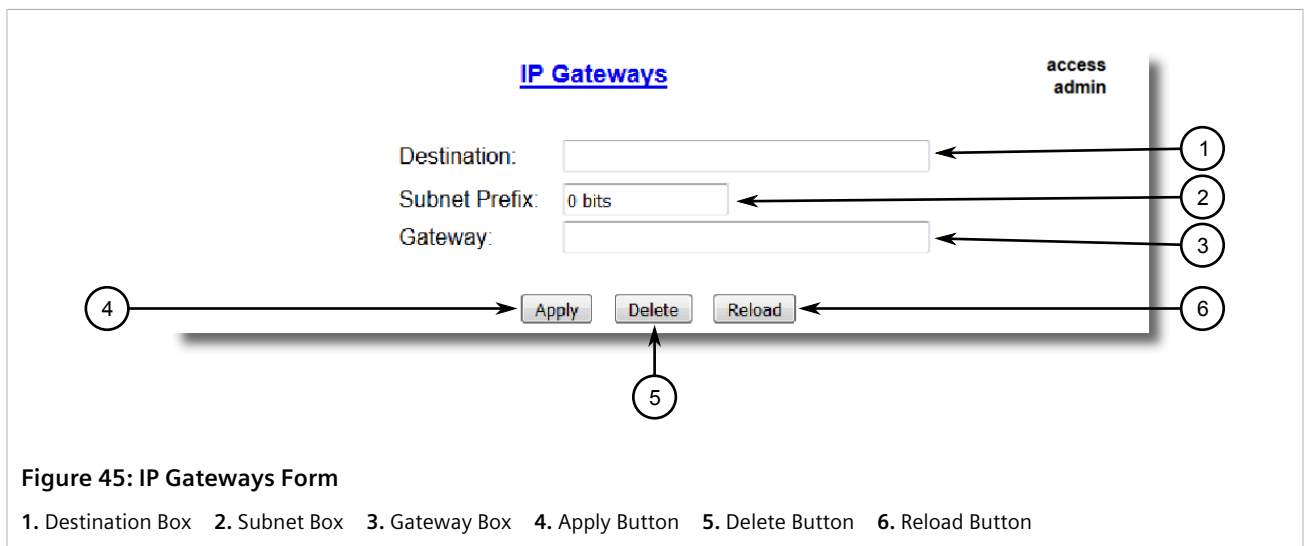

3. Click **Delete**.

Section 4.9

Configuring IP Services

To configure the IP services provided by the device, do the following:

1. Navigate to **Administration » Configure IP Services**. The **IP Services** form appears.

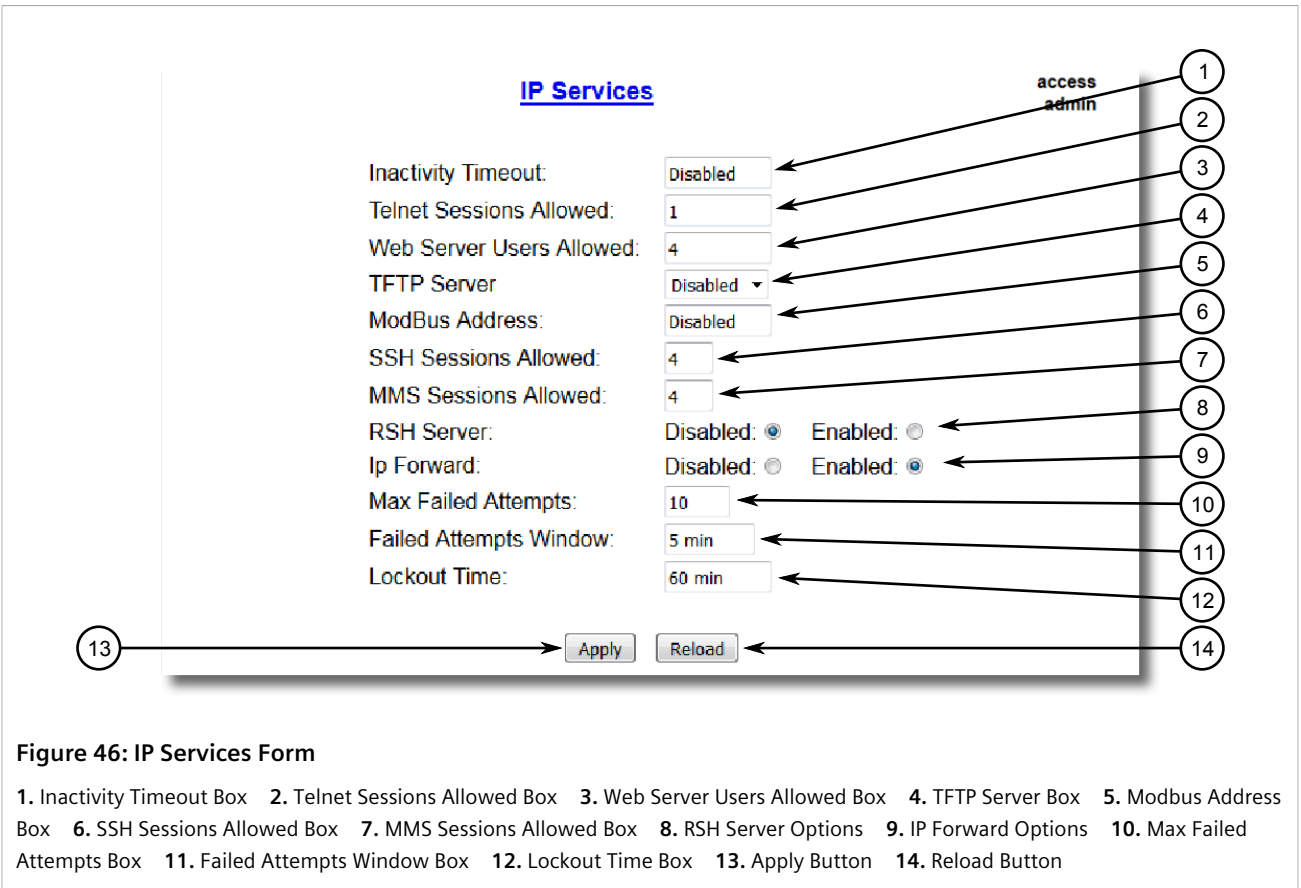



Figure 46: IP Services Form

1. Inactivity Timeout Box 2. Telnet Sessions Allowed Box 3. Web Server Users Allowed Box 4. TFTP Server Box 5. Modbus Address Box 6. SSH Sessions Allowed Box 7. MMS Sessions Allowed Box 8. RSH Server Options 9. IP Forward Options 10. Max Failed Attempts Box 11. Failed Attempts Window Box 12. Lockout Time Box 13. Apply Button 14. Reload Button

2. Configure the following parameter(s) as required:

Parameter	Description
Inactivity Timeout	Synopsis: 1 to 60 or { Disabled } Default: 5 min Specifies when the console will timeout and display the login screen if there is no user activity. A value of zero disables timeouts. For Web Server users maximum timeout value is limited to 30 minutes.
Telnet Sessions Allowed	Synopsis: 1 to 4 or { Disabled } Default: Disabled Limits the number of Telnet sessions. A value of zero prevents any Telnet access.
Web Server Users Allowed	Synopsis: 1 to 4 or { Disabled } Default: 4 Limits the number of simultaneous web server users.
TFTP Server	Synopsis: { Disabled, Get Only, Enabled } Default: Disabled As TFTP is a very insecure protocol, this parameter allows user to limit or disable TFTP Server access. Disabled – disables read and write access to TFTP Server Get Only – only allows reading of files via TFTP Server Enabled – allows reading and writing of files via TFTP Server
ModBus Address	Synopsis: 1 to 255 or { Disabled } Default: Disabled

Parameter	Description
	Determines the Modbus address to be used for Management through Modbus.
MMS Sessions Allowed	Synopsis: 1 to 4 Default: Disabled Limits the number of MMS sessions. A value of zero prevents any MMS access.
SSH Sessions Allowed (Controlled Version Only)	Synopsis: 1 to 4 Default: 4 Limits the number of SSH sessions.
RSH Server	Synopsis: { Disabled, Enabled } Default: Disabled (controlled version) or Enabled (non-controlled version) Disables/enables Remote Shell access.
IP Forward	Synopsis: { Disabled, Enabled } Default: Disabled Controls the ability of IP Forwarding between VLANs in Serial Server or IP segments. <div style="border: 1px solid black; padding: 5px; background-color: #f0f0f0;">  NOTE When upgrading to ROS v5.2, the default will be set to { Enabled }. </div>
Max Failed Attempts	Synopsis: 1 to 20 Default: 10 Maximum number of consecutive failed access attempts on service within Failed Attempts Window before blocking the service.
Failed Attempts Window	Synopsis: 1 to 30 min Default: 5 min The time in minutes (min) in which the maximum number of failed login attempts must be exceeded before a service is blocked. The counter of failed attempts resets to 0 when the specified time expires.
Lockout Time	Synopsis: 1 to 120 min Default: 60 min The time in minutes (min) the service remains locked out after the maximum number of failed access attempts has been reached.

- Click **Apply**.

Section 4.10

Managing Remote Monitoring

Remote Monitoring (RMON) is used to collect and view historical statistics related to the performance and operation of Ethernet ports. It can also record a log entry and/or generate an SNMP trap when the rate of occurrence of a specified event is exceeded.

CONTENTS

- [Section 4.10.1, “Managing RMON History Controls”](#)
- [Section 4.10.2, “Managing RMON Alarms”](#)
- [Section 4.10.3, “Managing RMON Events”](#)

Section 4.10.1

Managing RMON History Controls

The history controls for Remote Monitoring take samples of the RMON-MIB history statistics of an Ethernet port at regular intervals.

CONTENTS

- [Section 4.10.1.1, “Viewing a List of RMON History Controls”](#)
- [Section 4.10.1.2, “Adding an RMON History Control”](#)
- [Section 4.10.1.3, “Deleting an RMON History Control”](#)

Section 4.10.1.1

Viewing a List of RMON History Controls

To view a list of RMON history controls, navigate to *Ethernet Stats » Configure RMON History Controls*. The **RMON History Controls** table appears.

Index	Port	Requested Buckets	Granted Buckets	Interval	Owner
1	1	50	50	2	Monitor

Figure 47: RMON History Controls Table

If history controls have not been configured, add controls as needed. For more information, refer to [Section 4.10.1.2, “Adding an RMON History Control”](#).

Section 4.10.1.2

Adding an RMON History Control

To add an RMON history control, do the following:

1. Navigate to *Ethernet Stats » Configure RMON History Controls*. The **RMON History Controls** table appears.

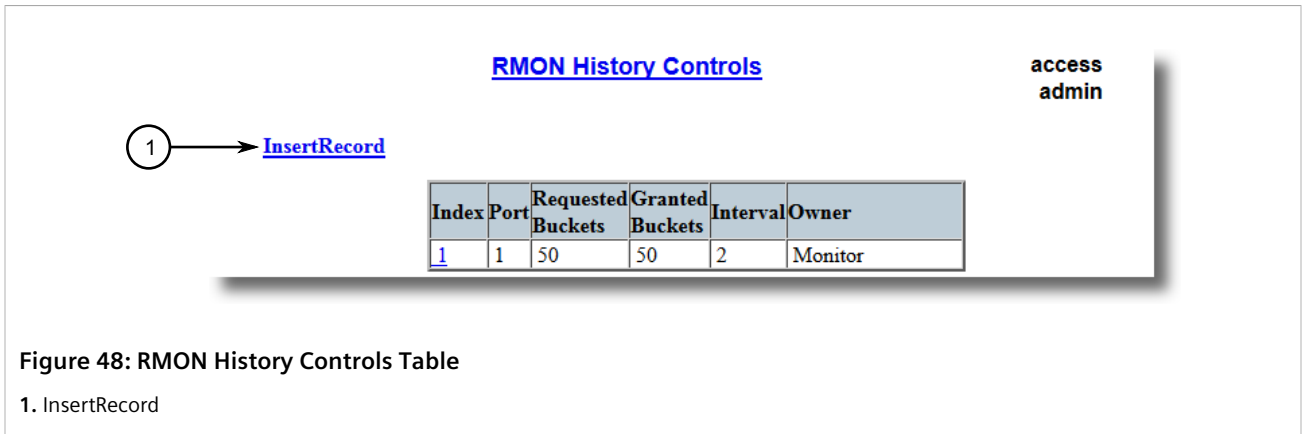

Figure 48: RMON History Controls Table

1. InsertRecord

- Click **InsertRecord**. The **RMON History Controls** form appears.

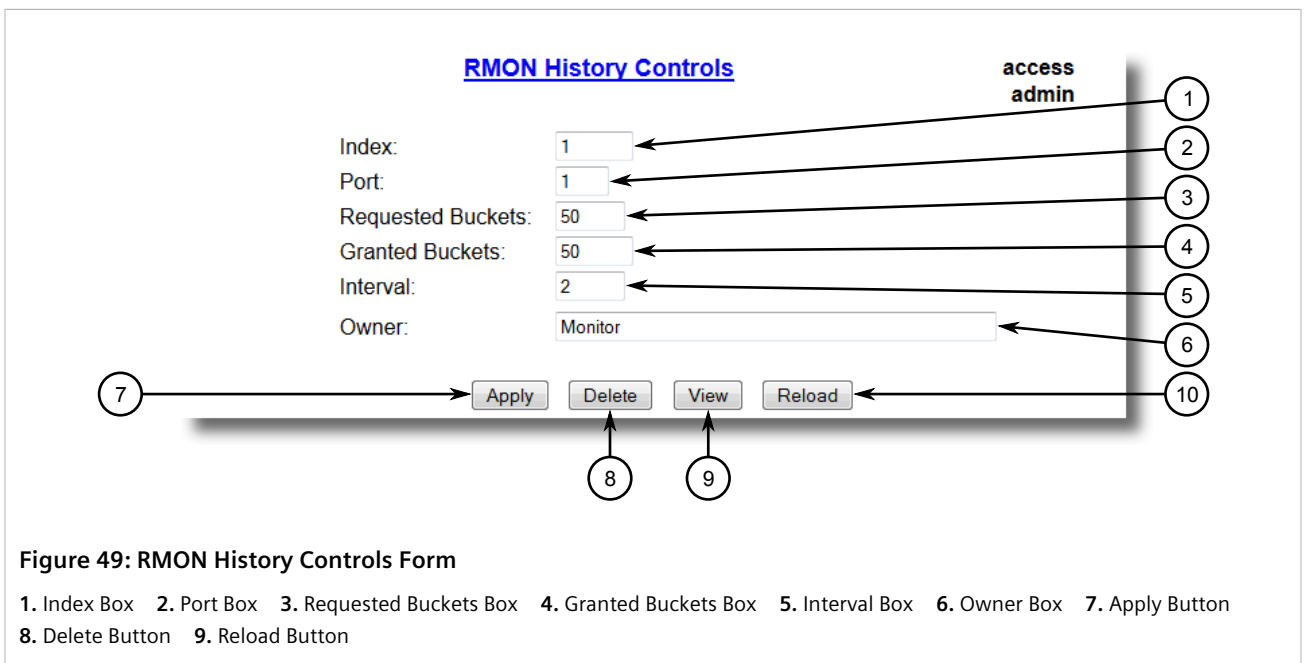

Figure 49: RMON History Controls Form

1. Index Box 2. Port Box 3. Requested Buckets Box 4. Granted Buckets Box 5. Interval Box 6. Owner Box 7. Apply Button
8. Delete Button 9. Reload Button

- Configure the following parameter(s) as required:

Parameter	Description
Index	Synopsis: 1 to 65535 Default: 1 The index of this RMON History Control record.
Port	Synopsis: 1 to maximum port number Default: 1 The port number as seen on the front plate silkscreen of the device.
Requested Buckets	Synopsis: 1 to maximum port number000 Default: 50 The maximum number of buckets requested for this RMON collection history group of statistics. The range is 1 to 4000. The default is 50.
Granted Buckets	Synopsis: 0 to 65535

Parameter	Description
	The number of buckets granted for this RMON collection history. This field is not editable.
Interval	Synopsis: 1 to 3600 Default: 1800 The number of seconds in over which the data is sampled for each bucket. The range is 1 to 3600. The default is 1800.
Owner	Synopsis: Any 127 characters Default: Monitor The owner of this record. It is suggested to start this string with word 'monitor'.

4. Click **Apply**.

Section 4.10.1.3

Deleting an RMON History Control

To delete an RMON history control, do the following:

1. Navigate to **Ethernet Stats » Configure RMON History Controls**. The **RMON History Controls** table appears.

RMON History Controls

access
admin

[InsertRecord](#)

Index	Port	Requested Buckets	Granted Buckets	Interval	Owner
1	1	50	50	2	Monitor

Figure 50: RMON History Controls Table

2. Select the history control from the table. The **RMON History Controls** form appears.

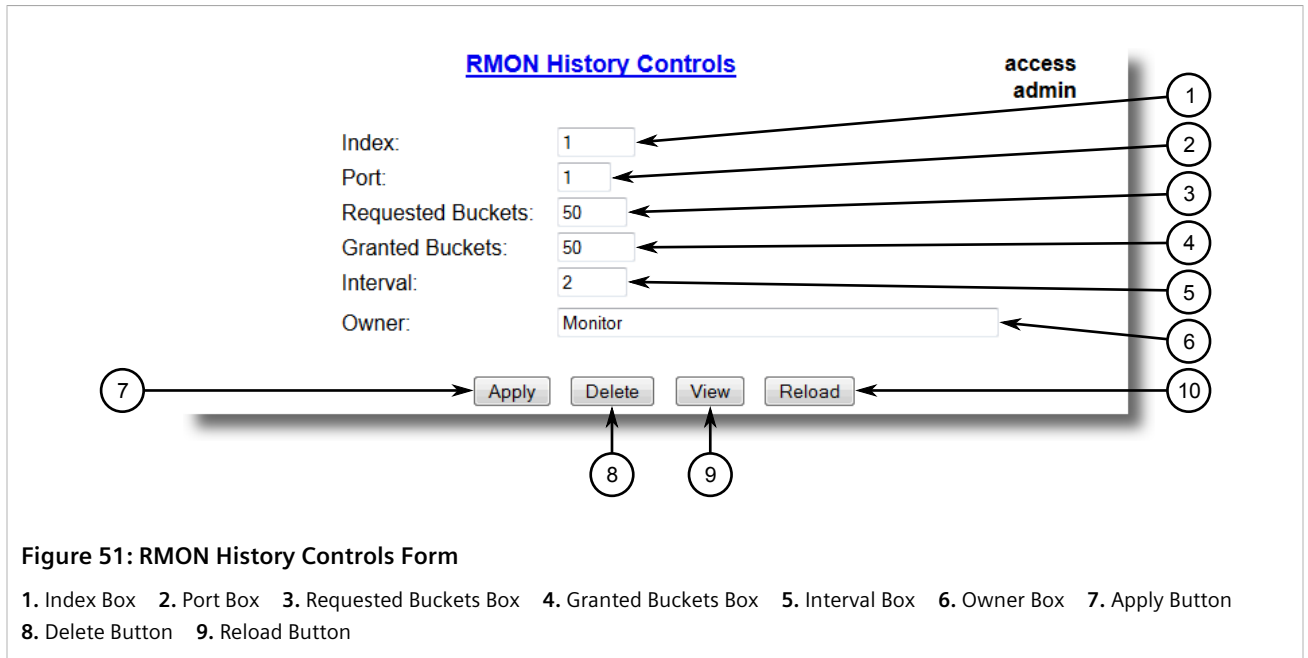

3. Click **Delete**.

Section 4.10.2

Managing RMON Alarms

When Remote Monitoring (RMON) alarms are configured, RUGGEDCOM ROS examines the state of a specific statistical variable.

Remote Monitoring (RMON) alarms define upper and lower thresholds for legal values of specific statistical variables in a given interval. This allows RUGGEDCOM ROS to detect events as they occur more quickly than a specified maximum rate or less quickly than a minimum rate.

When the rate of change for a statistics value exceeds its limits, an internal INFO alarm is always generated. For information about viewing alarms, refer to [Section 5.4.2, "Viewing and Clearing Latched Alarms"](#).

Additionally, a statistic threshold crossing can result in further activity. An RMON alarm can be configured to point to a particular RMON event, which can generate an SNMP trap, an entry in the event log, or both. The RMON event can also direct alarms towards different users defined for SNMP.

The alarm can point to a different event for each of the thresholds. Therefore, combinations such as *trap on rising threshold* or *trap on rising threshold, log and trap on falling threshold* are possible.

Each RMON alarm may be configured such that its first instance occurs only for rising, falling, or all thresholds that exceed their limits.

The ability to configure upper and lower thresholds on the value of a measured statistic provides for the ability to add hysteresis to the alarm generation process.

If the value of the measured statistic over time is compared to a single threshold, alarms will be generated each time the statistic crosses the threshold. If the statistic's value fluctuates around the threshold, an alarm can be generated every measurement period. Programming different upper and lower thresholds eliminates spurious alarms. The statistic value must *travel* between the thresholds before alarms can be generated. The following illustrates the very different patterns of alarm generation resulting from a statistic sample and the same sample with hysteresis applied.

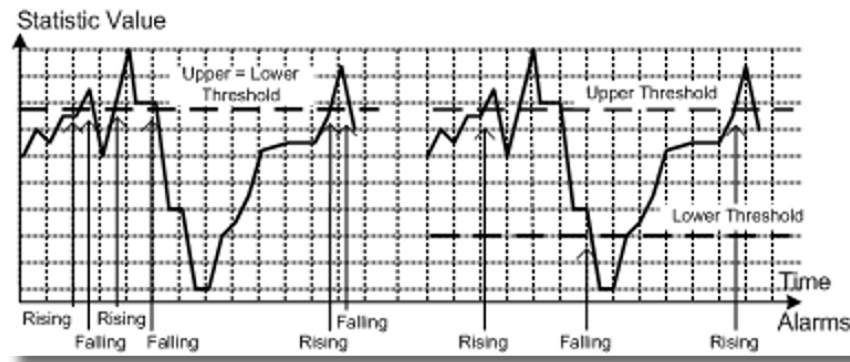

Figure 52: The Alarm Process

There are two methods to evaluate a statistic to determine when to generate an event: delta and absolute.

For most statistics, such as line errors, it is appropriate to generate an alarm when a rate is exceeded. The alarm defaults to the *delta* measurement method, which examines changes in a statistic at the end of each measurement period.

It may be desirable to alarm when the total, or absolute, number of events crosses a threshold. In this case, set the measurement period type to *absolute*.

CONTENTS

- [Section 4.10.2.1, "Viewing a List of RMON Alarms"](#)
- [Section 4.10.2.2, "Adding an RMON Alarm"](#)
- [Section 4.10.2.3, "Deleting an RMON Alarm"](#)

Section 4.10.2.1

Viewing a List of RMON Alarms

To view a list of RMON alarms, navigate to **Ethernet Stats » Configure RMON Alarms**. The **RMON Alarms** table appears.

<u>RMON Alarms</u>							access admin
InsertRecord							
Index	Variable	Rising Thr	Falling Thr	Value	Type	Interval	Star
<u>1</u>	ifInOctets.1	150	100	0	delta	1	risin

Figure 53: RMON Alarms Table

If alarms have not been configured, add alarms as needed. For more information, refer to [Section 4.10.2.2, "Adding an RMON Alarm"](#).

Section 4.10.2.2

Adding an RMON Alarm

To add an RMON alarm, do the following:

1. Navigate to **Ethernet Stats » Configure RMON Alarms**. The **RMON Alarms** table appears.

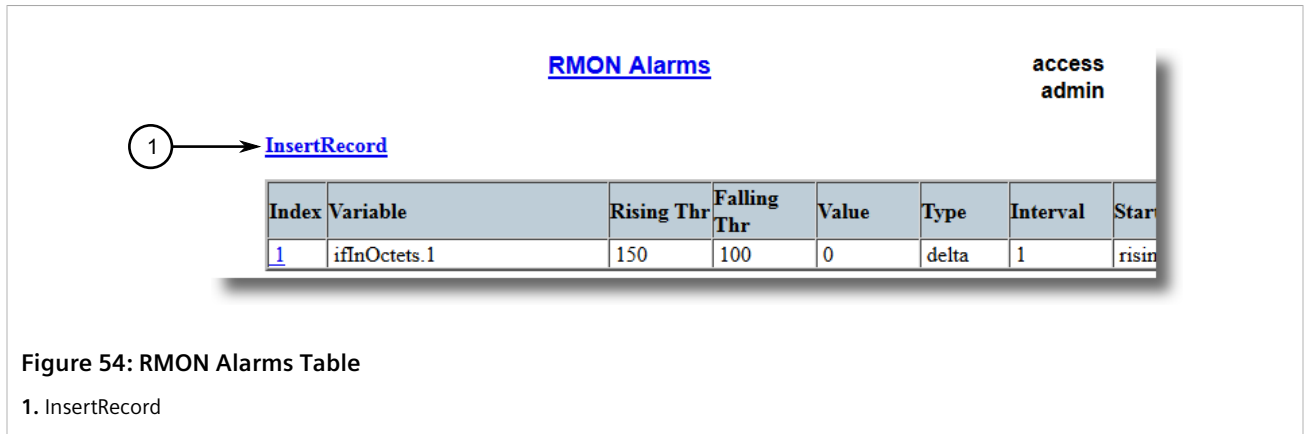

Figure 54: RMON Alarms Table

1. InsertRecord

2. Click **InsertRecord**. The **RMON Alarms** form appears.

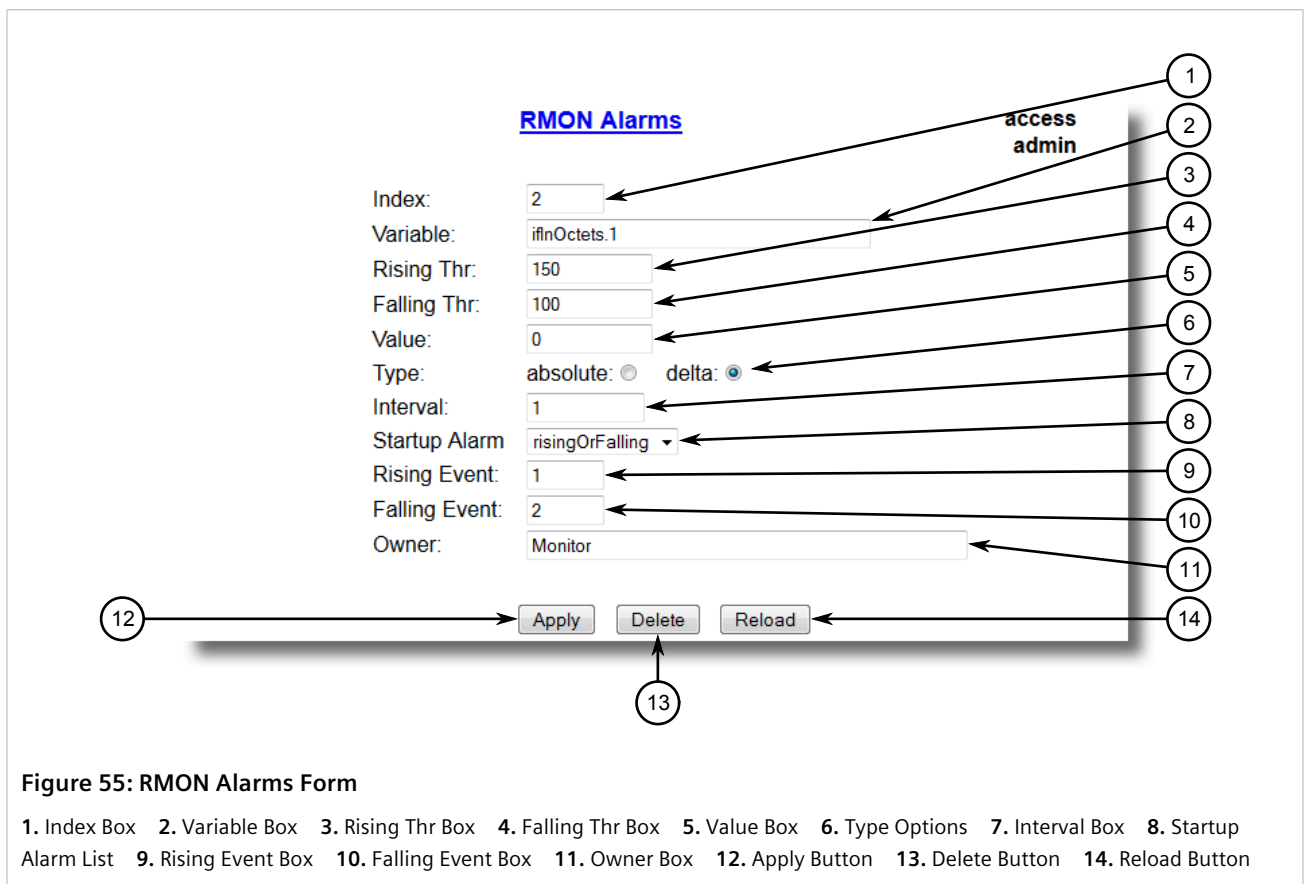

Figure 55: RMON Alarms Form

1. Index Box 2. Variable Box 3. Rising Thr Box 4. Falling Thr Box 5. Value Box 6. Type Options 7. Interval Box 8. Startup Alarm List 9. Rising Event Box 10. Falling Event Box 11. Owner Box 12. Apply Button 13. Delete Button 14. Reload Button

3. Configure the following parameter(s) as required:

Parameter	Description
Index	Synopsis: 1 to 65535

Parameter	Description
	Default: 1 The index of this RMON Alarm record.
Variable	Synopsis: SNMP Object Identifier – up to 39 characters The SNMP object identifier (OID) of the particular variable to be sampled. Only variables that resolve to an ASN.1 primitive type INTEGER (INTEGER, Integer32, Counter32, Counter64, Gauge, or TimeTicks) may be sampled. A list of objects can be printed using shell command 'rmon'. The OID format: objectName.index1.index2... where index format depends on index object type.
Rising Thr	Synopsis: -2147483647 to 2147483647 Default: 0 A threshold for the sampled variable. When the current sampled variable value is greater than or equal to this threshold, and the value at the last sampling interval was less than this threshold, a single event will be generated. A single event will also be generated if the first sample after this record is created is greater than or equal to this threshold and the associated startup alarm is equal to 'rising'. After rising alarm is generated, another such event will not be generated until the sampled value falls below this threshold and reaches the value of FallingThreshold.
Falling Thr	Synopsis: -2147483647 to 2147483647 Default: 0 A threshold for the sampled variable. When the current sampled variable value is less than or equal to this threshold, and the value at the last sampling interval was greater than this threshold, a single event will be generated. A single event will also be generated if the first sample after this record is created is less than or equal to this threshold and the associated startup alarm is equal to 'falling'. After falling alarm is generated, another such event will not be generated until the sampled value rises above this threshold and reaches the value of RisingThreshold.
Value	Synopsis: -2147483647 to 2147483647 The value of monitoring object during the last sampling period. The presentation of value depends of sample type ('absolute' or 'delta').
Type	Synopsis: { absolute, delta } Default: delta The method of sampling the selected variable and calculating the value to be compared against the thresholds. The value of sample type can be 'absolute' or 'delta'.
Interval	Synopsis: 0 to 2147483647 Default: 60 The number of seconds in over which the data is sampled and compared with the rising and falling thresholds.
Startup Alarm	Synopsis: { rising, falling, risingOrFalling } Default: risingOrFalling The alarm that may be sent when this record is first created if condition for raising alarm is met. The value of startup alarm can be 'rising', 'falling' or 'risingOrFalling'.
Rising Event	Synopsis: 0 to 65535 Default: 0 The index of the event that is used when a falling threshold is crossed. If there is no corresponding entry in the Event Table, then no association exists. In particular, if this value is zero, no associated event will be generated.
Falling Event	Synopsis: 0 to 65535 Default: 0 The index of the event that is used when a rising threshold is crossed. If there is no corresponding entry in the Event Table, then no association exists. In particular, if this value is zero, no associated event will be generated.
Owner	Synopsis: Any 127 characters

Parameter	Description
	<p>Default: Monitor</p> <p>The owner of this record. It is suggested to start this string with word 'monitor'.</p>

4. Click **Apply**.

Section 4.10.2.3

Deleting an RMON Alarm

To delete an RMON alarm, do the following:

1. Navigate to **Ethernet Stats » Configure RMON Alarms**. The **RMON Alarms** table appears.

RMON Alarms

access
admin

[InsertRecord](#)

Index	Variable	Rising Thr	Falling Thr	Value	Type	Interval	Start
1	ifInOctets.1	150	100	0	delta	1	rising

Figure 56: RMON Alarms Table

2. Select the alarm from the table. The **RMON Alarms** form appears.

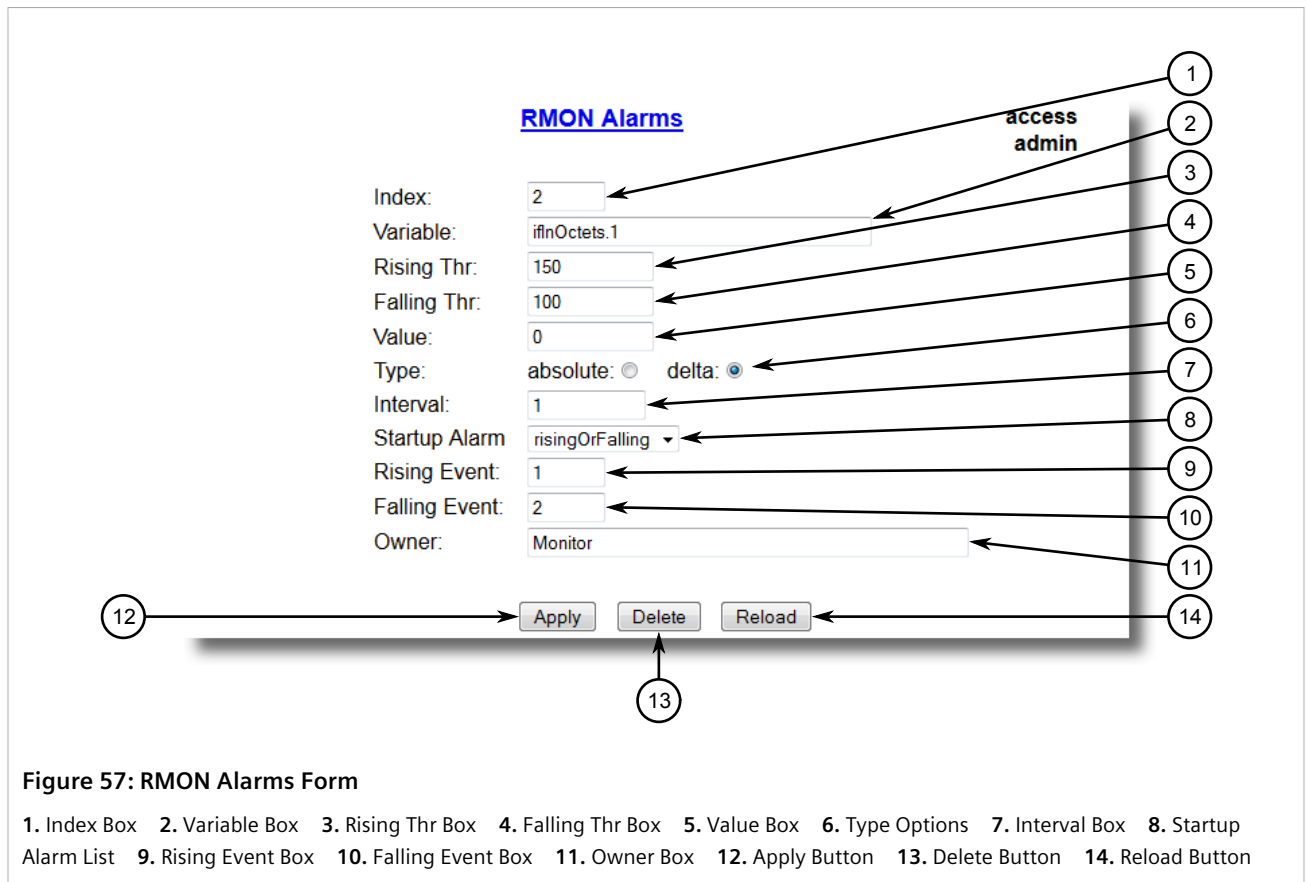

3. Click **Delete**.

Section 4.10.3

Managing RMON Events

Remote Monitoring (RMON) events define behavior profiles used in event logging. These profiles are used by RMON alarms to send traps and log events.

Each alarm may specify that a log entry be created on its behalf whenever the event occurs. Each entry may also specify that a notification should occur by way of SNMP trap messages. In this case, the user for the trap message is specified as the *Community*.

Two traps are defined: risingAlarm and fallingAlarm.

CONTENTS

- [Section 4.10.3.1, "Viewing a List of RMON Events"](#)
- [Section 4.10.3.2, "Adding an RMON Event"](#)
- [Section 4.10.3.3, "Deleting an RMON Event"](#)

Section 4.10.3.1

Viewing a List of RMON Events

To view a list of RMON events, navigate to *Ethernet Stats » Configure RMON Events*. The **RMON Events** table appears.

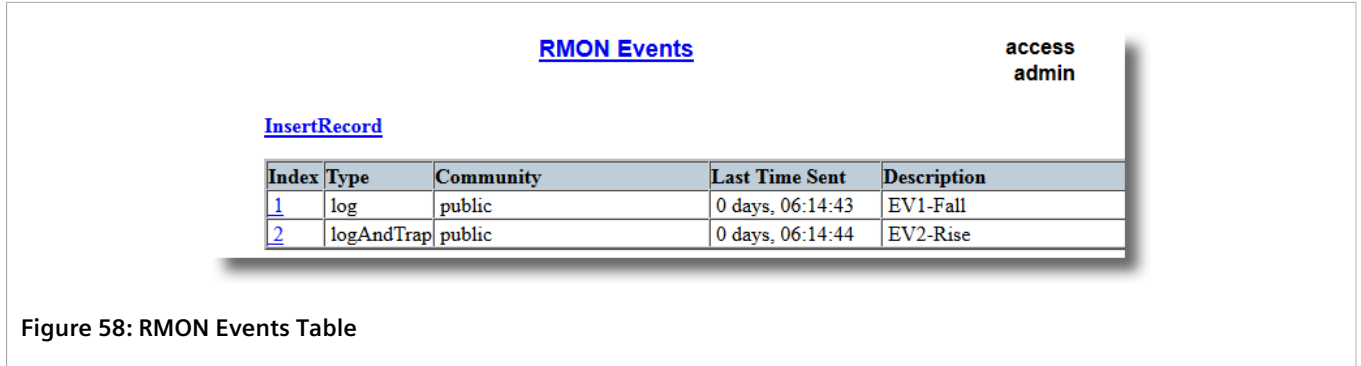

Figure 58: RMON Events Table

If events have not been configured, add events as needed. For more information, refer to [Section 4.10.3.2, "Adding an RMON Event"](#).

Section 4.10.3.2

Adding an RMON Event

To add an RMON alarm, do the following:

1. Navigate to *Ethernet Stats » Configure RMON Events*. The **RMON Events** table appears.

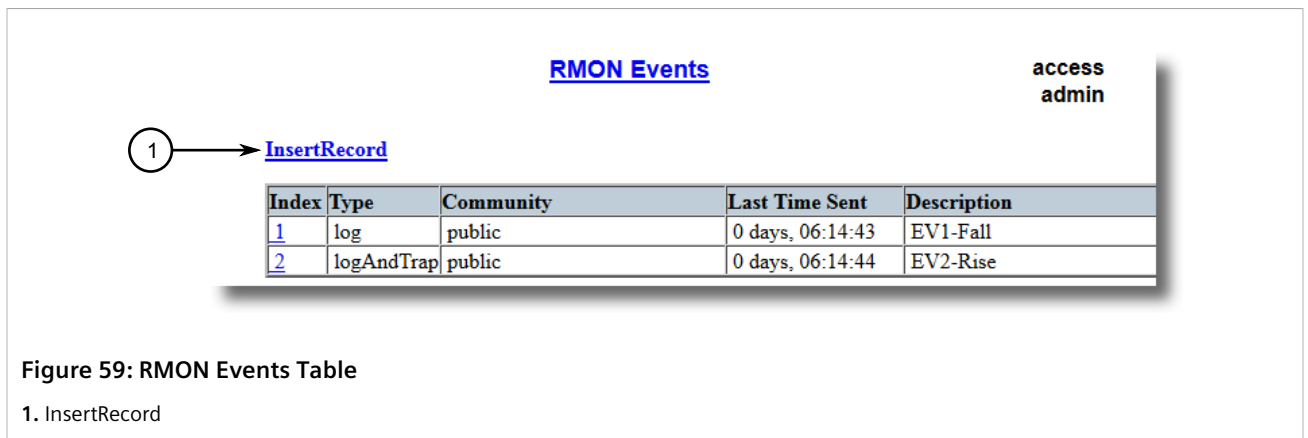

Figure 59: RMON Events Table

1. InsertRecord

2. Click **InsertRecord**. The **RMON Events** form appears.

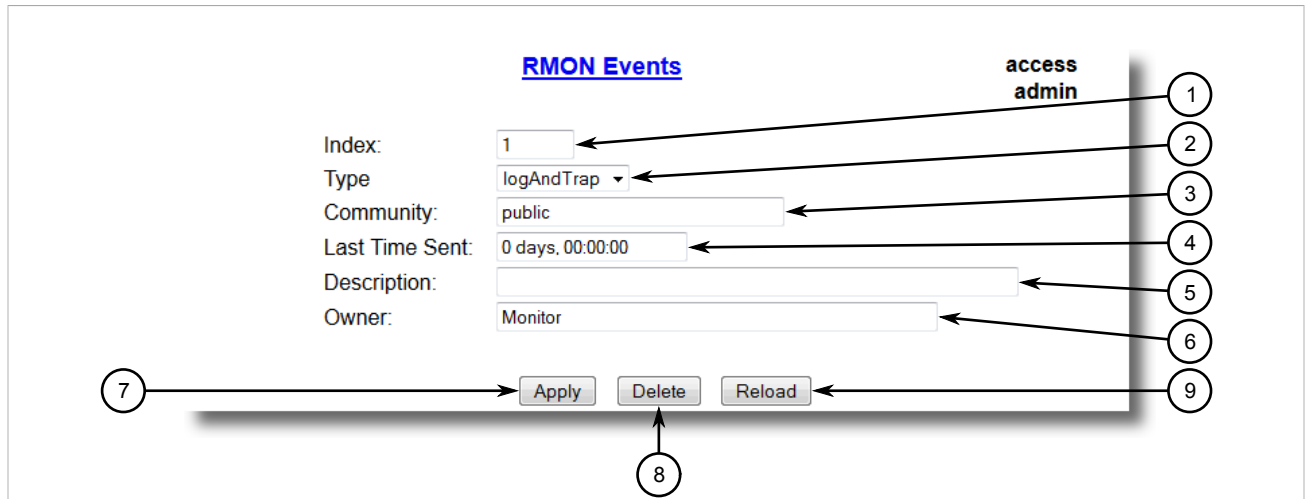

Figure 60: RMON Events Form

1. Index Box 2. Type List 3. Community Box 4. Last Time Sent Box 5. Description Box 6. Owner Box 7. Apply Button
8. Delete Button 9. View Button 10. Reload Button

3. Configure the following parameter(s) as required:

Parameter	Description
Index	Synopsis: 1 to 65535 Default: 3 The index of this RMON Event record.
Type	Synopsis: { none, log, snmpTrap, logAndTrap } Default: logAndTrap The type of notification that the probe will make about this event. In the case of 'log', an entry is made in the RMON Log table for each event. In the case of snmp_trap, an SNMP trap is sent to one or more management stations.
Community	Synopsis: Any 31 characters Default: public If the SNMP trap is to be sent, it will be sent to the SNMP community specified by this string.
Last Time Sent	Synopsis: DDDD days, HH:MM:SS The time from last reboot at the time this event entry last generated an event. If this entry has not generated any events, this value will be 0.
Description	Synopsis: Any 127 characters Default: EV2-Rise A comment describing this event.
Owner	Synopsis: Any 127 characters Default: Monitor The owner of this event record. It is suggested to start this string with word 'monitor'.

4. Click **Apply**.

Section 4.10.3.3

Deleting an RMON Event

To delete an RMON event, do the following:

1. Navigate to **Ethernet Stats » Configure RMON Events**. The RMON Events table appears.

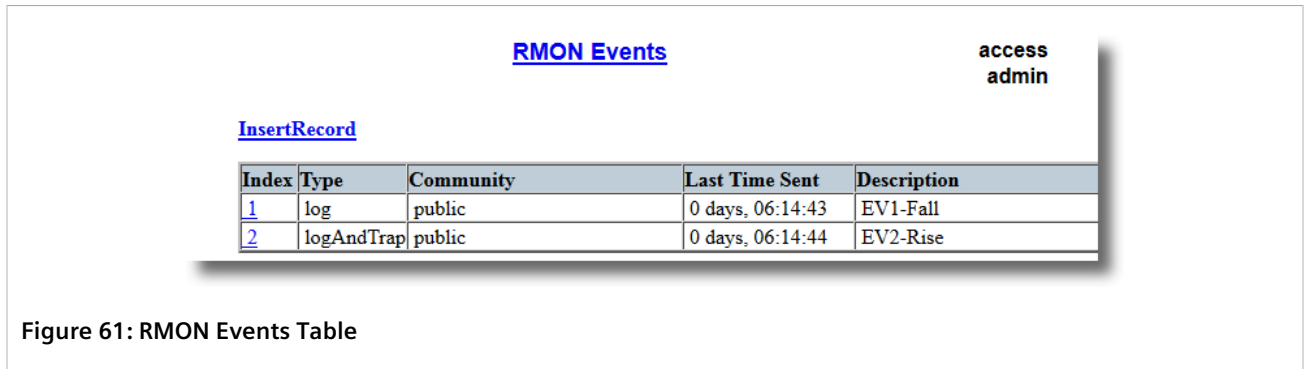

Figure 61: RMON Events Table

2. Select the event from the table. The RMON Events form appears.

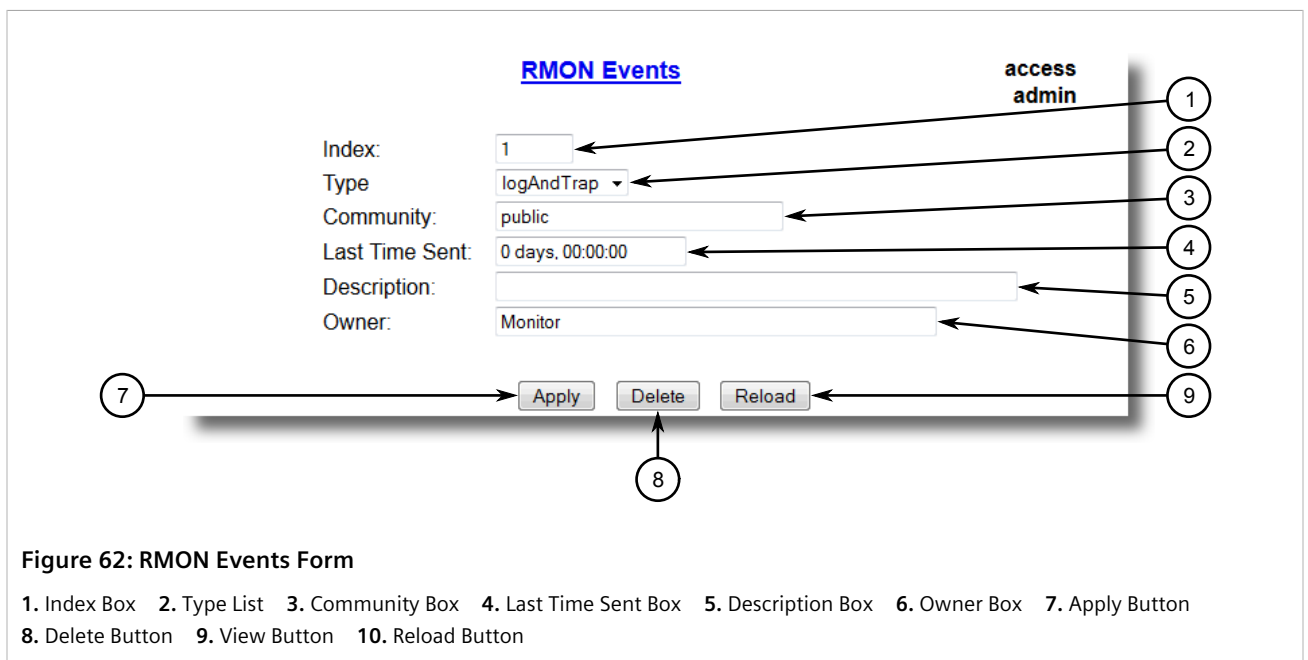

Figure 62: RMON Events Form

1. Index Box 2. Type List 3. Community Box 4. Last Time Sent Box 5. Description Box 6. Owner Box 7. Apply Button
8. Delete Button 9. View Button 10. Reload Button

3. Click **Delete**.

Section 4.11

Upgrading/Downgrading Firmware

This section describes how to upgrade and downgrade the firmware for RUGGEDCOM ROS.

CONTENTS

- [Section 4.11.1, "Upgrading Firmware"](#)

- [Section 4.11.2, "Downgrading Firmware"](#)

Section 4.11.1

Upgrading Firmware

Upgrading RUGGEDCOM ROS firmware, including the main, bootloader and FPGA firmware, may be necessary to take advantage of new features or bug fixes. Binary firmware releases, including updates, can be obtained by submitting a Support Request via the [Siemens Industry Online Support](https://support.industry.siemens.com) [https://support.industry.siemens.com] website. For more information, refer to <https://support.industry.siemens.com/My/ww/en/requests>.

Binary firmware images transferred to the device are stored in non-volatile Flash memory and require a device reset to take effect.



NOTE

The IP address set for the device will not be changed following a firmware upgrade.

To upgrade the RUGGEDCOM ROS firmware, do the following:

1. Upload a different version of the binary firmware image to the device. For more information, refer to [Section 4.4, "Uploading/Downloading Files"](#).
2. Reset the device to complete the installation. For more information, refer to [Section 4.12, "Resetting the Device"](#).
3. Access the CLI shell and verify the new software version has been installed by typing **version**. The currently installed versions of the main and boot firmware are displayed.

```
>version  
Current ROS-MPC83 Main Software v5.2.0 (Jan 01 5.2 00:01)
```

Section 4.11.2

Downgrading Firmware

Downgrading the RUGGEDCOM ROS firmware is generally not recommended, as it may have unpredictable effects. However, if a downgrade is required, do the following:



IMPORTANT!

Before downgrading the firmware, make sure the hardware and FPGA code types installed in the device are supported by the older firmware version. Refer to the Release Notes for the older firmware version to confirm.



CAUTION!

Do not downgrade the RUGGEDCOM ROS boot version.

1. Disconnect the device from the network.
2. Log in to the device as an admin user. For more information, refer to [Section 2.1, "Logging In"](#).
3. Make a local copy of the current configuration file. For more information, refer to [Section 4.4, "Uploading/Downloading Files"](#).

! **IMPORTANT!** *Never downgrade the firmware with encryption enabled to a version that does not support encryption.*

- Restore the device to its factory defaults. For more information, refer to [Section 4.3, “Restoring Factory Defaults”](#).
- Upload and apply the older firmware version and its associated FPGA files using the same methods used to install newer firmware versions. For more information, refer to [Section 4.11.1, “Upgrading Firmware”](#).
- Press **Ctrl-S** to access the CLI.
- Clear all logs by typing:

```
clearlogs
```

- Clear all alarms by typing:

```
clearalarms
```

! **IMPORTANT!** *After downgrading the firmware and FPGA files, be aware that some settings from the previous configuration may be lost or reverted back to the factory defaults (including user passwords if downgrading from a security related version), as those particular tables or fields may not exist in the older firmware version. Because of this, the unit must be configured after the downgrade.*

- Configure the device as required.

Section 4.12

Resetting the Device

To reset the device, do the following:

- Navigate to **Diagnostics » Reset Device**. The **Reset Device** form appears.

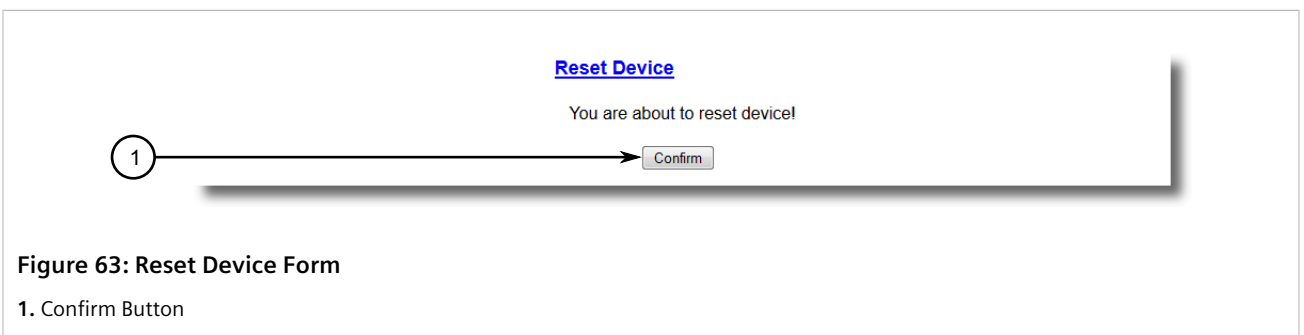

Figure 63: Reset Device Form

1. Confirm Button

- Click **Confirm**.

Section 4.13

Decommissioning the Device

Before taking the device out of service, either permanently or for maintenance by a third-party, make sure the device has been fully decommissioned. This includes removing any sensitive, proprietary information.

To decommission the device, do the following:

1. Disconnect all network cables from the device.
2. Connect to the device via the RS-232 serial console port. For more information, refer to [Section 3.1.2, "Connecting Directly"](#).
3. Restore all factory default settings for the device. For more information, refer to [Section 4.3, "Restoring Factory Defaults"](#).
4. Access the CLI. For more information, refer to [Section 2.5, "Using the Command Line Interface"](#).
5. Upload a blank version of the `banner.txt` file to the device to replace the existing file. For more information about uploading a file, refer to [Section 4.4, "Uploading/Downloading Files"](#).
6. Confirm the upload was successful by typing:

```
type banner.txt
```

7. Clear the system and crash logs by typing:

```
clearlog
```

8. Generate a random SSL certificate by typing:

```
sslkeygen
```

This may take several minutes to complete. To verify the certificate has been generated, type:

```
type syslog.txt
```

When the phrase

```
Generated ssl.crt was saved
```

appears in the log, the SSL certificate has been generated.

9. Generate random SSH keys by typing:

```
sshkeygen
```

This may take several minutes to complete. To verify the keys have been generated, type:

```
type syslog.txt
```

When the phrase

```
Generated ssh.keys was saved
```

appears in the log, the SSH keys have been generated.

10. De-fragment and erase all free flash memory by typing:

```
flashfile defrag
```

This may take several minutes to complete.

5 System Administration

This chapter describes how to perform various administrative tasks related to device identification, user permissions, alarm configuration, certificates and keys, and more.

CONTENTS

- [Section 5.1, "Configuring the System Information"](#)
- [Section 5.2, "Customizing the Login Screen"](#)
- [Section 5.3, "Enabling/Disabling the Web Interface"](#)
- [Section 5.4, "Managing Alarms"](#)
- [Section 5.5, "Managing the Configuration File"](#)
- [Section 5.6, "Managing MMS Reporting"](#)

Section 5.1

Configuring the System Information

To configure basic information that can be used to identify the device, its location, and/or its owner, do the following:

1. Navigate to **Administration » Configure System Identification**. The **System Identification** form appears.

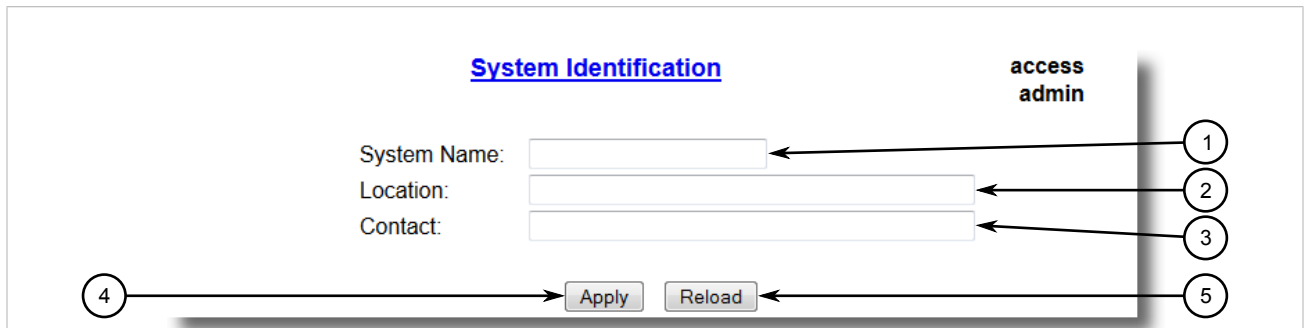

Figure 64: System Identification Form

1. System Name Box 2. Location Box 3. Contact Box 4. Apply Button 5. Reload Button

2. Configure the following parameter(s) as required:

Parameter	Description
System Name	Synopsis: Any 24 characters

Parameter	Description
	The system name is displayed in all RUGGEDCOM ROS menu screens. This can make it easier to identify the switches within your network provided that all switches are given a unique name.
Location	Synopsis: Any 49 characters The location can be used to indicate the physical location of the switch. It is displayed in the login screen as another means to ensure you are dealing with the desired switch.
Contact	Synopsis: Any 49 characters The contact can be used to help identify the person responsible for managing the switch. You can enter name, phone number, email, etc. It is displayed in the login screen so that this person may be contacted should help be required.

3. Click **Apply**.

Section 5.2

Customizing the Login Screen

To display a custom welcome message, device information or any other information on the login screen for the Web and console interfaces, add text to the `banner.txt` file stored on the device.

If the `banner.txt` file is empty, only the **Username** and **Password** fields appear on the login screen.

To update the `banner.txt` file, download the file from the device, modify it and then load it back on to the device. For information about uploading and downloading files, refer to [Section 4.4, "Uploading/Downloading Files"](#).

Section 5.3

Enabling/Disabling the Web Interface

In some cases, users may want to disable the Web interface to increase cyber security.

To disable or enable the Web interface, do the following:

**NOTE**

*The Web interface can be disabled via the Web UI by configuring the Web Server Users Allowed parameter in the **IP Services form**. For more information, refer to [Section 4.9, "Configuring IP Services"](#).*

1. Log in to the device as an admin user and access the CLI shell. For more information about accessing the CLI shell, refer to [Section 2.5, "Using the Command Line Interface"](#).
2. Navigate to **Administration » Configure IP Services » Web Server Users Allowed**.
3. Select **Disabled** to disable the Web interface, or select the desired number of Web server users allowed to enable the interface.

Section 5.4

Managing Alarms

Alarms indicate the occurrence of events of either importance or interest that are logged by the device.

There are two types of alarms:

- **Active alarms** signify states of operation that are not in accordance with normal operation. Examples include links that should be up, but are not, or error rates that repeatedly exceed a certain threshold. These alarms are continuously active and are only cleared when the problem that triggered the alarms is resolved.
- **Passive alarms** are a record of abnormal conditions that occurred in the past and do not affect the current operation state of the device. Examples include authentication failures, Remote Network MONitoring (RMON) MIB generated alarms, or error states that temporarily exceeded a certain threshold. These alarms can be cleared from the list of alarms.

**NOTE**

For more information about RMON alarms, refer to [Section 4.10.2, "Managing RMON Alarms"](#).

When either type of alarm occurs, a message appears in the top right corner of the user interface. If more than one alarm has occurred, the message will indicate the number of alarms. Active alarms also trip the Critical Failure Relay LED on the device. The message and the LED will remain active until the alarm is cleared.

**NOTE**

Alarms are volatile in nature. All alarms (active and passive) are cleared at startup.

CONTENTS

- [Section 5.4.1, "Viewing a List of Pre-Configured Alarms"](#)
- [Section 5.4.2, "Viewing and Clearing Latched Alarms"](#)
- [Section 5.4.3, "Configuring an Alarm"](#)
- [Section 5.4.4, "Authentication Related Security Alarms"](#)

Section 5.4.1

Viewing a List of Pre-Configured Alarms

To view a list of alarms pre-configured for the device, navigate to **Diagnostic » Configure Alarms**. The **Alarms** table appears.

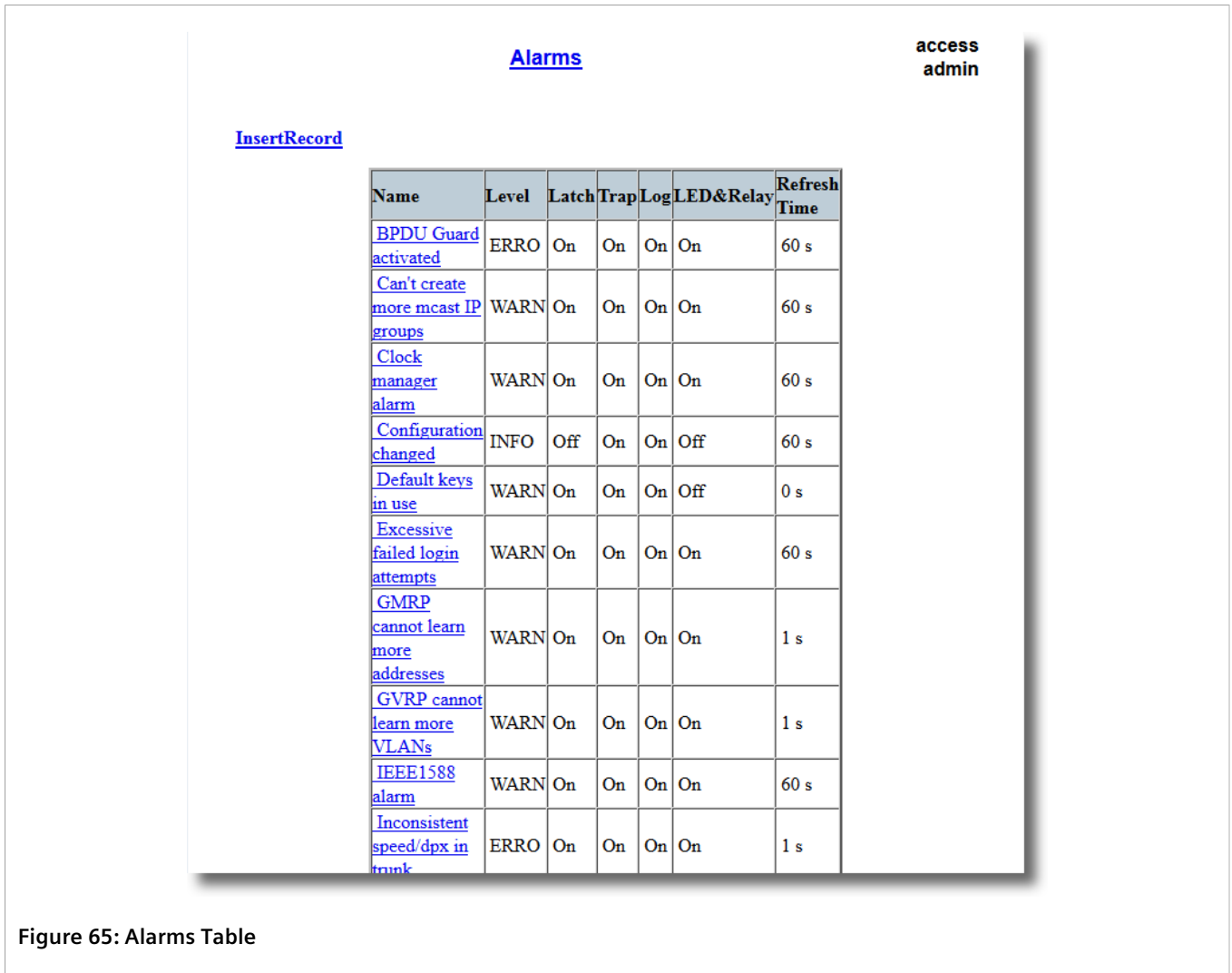



Figure 65: Alarms Table

 **NOTE**
 This list of alarms (configurable and non-configurable) is accessible through the Command Line Interface (CLI) using the **alarms**. For more information, refer to [Section 2.5.1, "Available CLI Commands"](#).

For information about modifying a pre-configured alarm, refer to [Section 5.4.3, "Configuring an Alarm"](#).

Section 5.4.2

Viewing and Clearing Latched Alarms

To view a list of alarms that are configured to latch, navigate to **Diagnostics » View Latched Alarms**. The **Latched Alarms** table appears.

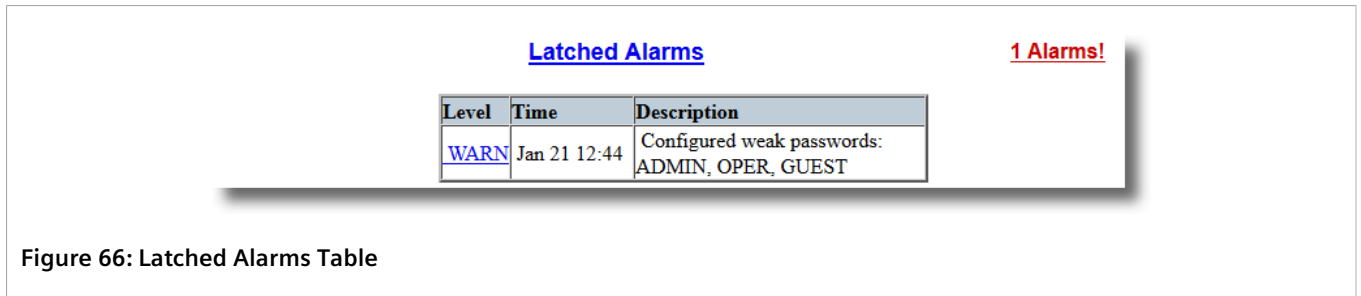

To clear the passive alarms from the list, do the following:

1. Navigate to **Diagnosics » Clear Latched Alarms**. The **Clear Latched Alarms** form appears.



2. Click **Confirm**.

Section 5.4.3

Configuring an Alarm

While all alarms are pre-configured on the device, some alarms can be modified to suit the application. This includes enabling/disabling certain features and changing the refresh time.

To configuring an alarm, do the following:



IMPORTANT!

Critical and Alert level alarms are not configurable and cannot be disabled.

1. Navigate to **Diagnostic » Configure Alarms**. The **Alarms** table appears.

[access admin](#)

[Alarms](#)

[InsertRecord](#)

Name	Level	Latch	Trap	Log	LED&Relay	Refresh Time
BPDU Guard activated	ERRO	On	On	On	On	60 s
Can't create more mcast IP groups	WARN	On	On	On	On	60 s
Clock manager alarm	WARN	On	On	On	On	60 s
Configuration changed	INFO	Off	On	On	Off	60 s
Default keys in use	WARN	On	On	On	Off	0 s
Excessive failed login attempts	WARN	On	On	On	On	60 s
GMRP cannot learn more addresses	WARN	On	On	On	On	1 s
GVRP cannot learn more VLANs	WARN	On	On	On	On	1 s
IEEE 1588 alarm	WARN	On	On	On	On	60 s
Inconsistent speed/dpx in trunk	ERRO	On	On	On	On	1 s

Figure 68: Alarms Table

2. Select an alarm. The **Alarms** form appears.

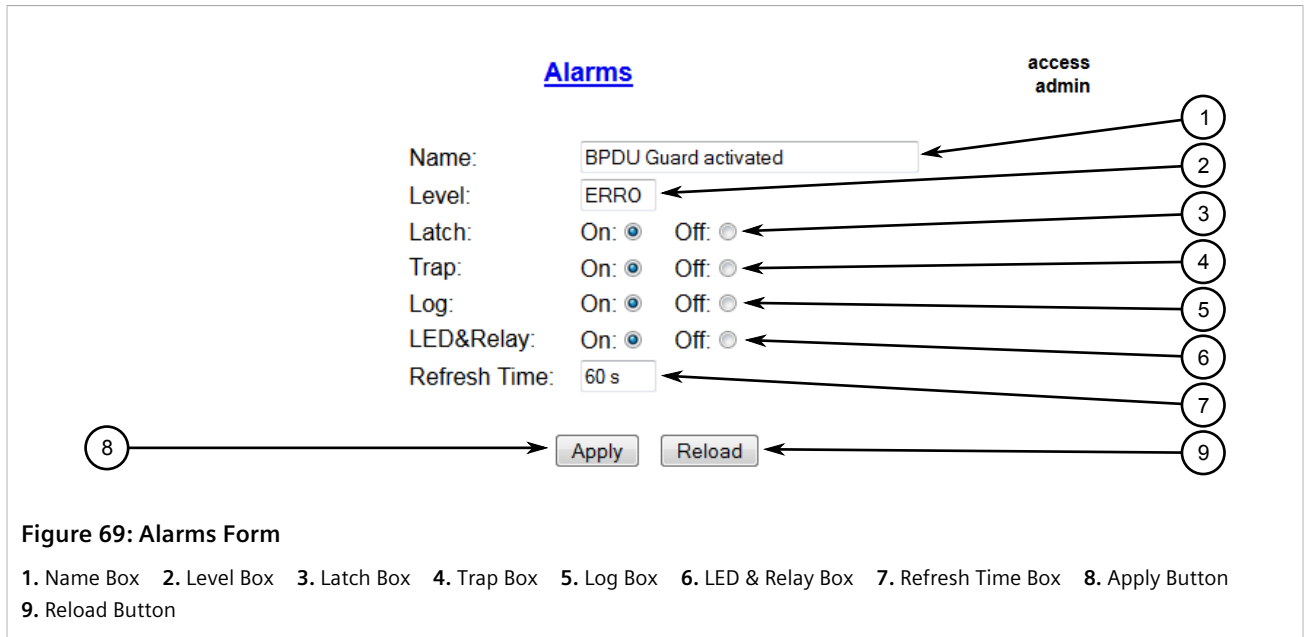

3. Configure the following parameter(s) as required:

Parameter	Description
Name	<p>Synopsis: Any 34 characters Default: sys_alarm</p> <p>The alarm name, as obtained through the alarms CLI command.</p>
Level	<p>Synopsis: { EMRG, ALRT, CRIT, ERRO, WARN, NOTE, INFO, DEBG }</p> <p>Severity level of the alarm:</p> <ul style="list-style-type: none"> • EMRG – The device has had a serious failure that caused a system reboot. • ALERT – The device has had a serious failure that did not cause a system reboot. • CRIT – The device has a serious unrecoverable problem. • ERRO – The device has a recoverable problem that does not seriously affect operation. • WARN – Possibly serious problem affecting overall system operation. • NOTE – Condition detected that is not expected or not allowed. • INFO – Event which is a part of normal operation, e.g. cold start, user login etc. • DEBG – Intended for factory troubleshooting only. <p>This parameter is not configurable.</p>
Latch	<p>Synopsis: { On, Off } Default: Off</p> <p>Enables latching occurrence of this alarm in the Alarms Table.</p>
Trap	<p>Synopsis: { On, Off } Default: Off</p> <p>Enables sending an SNMP trap for this alarm.</p>
Log	<p>Synopsis: { On, Off } Default: Off</p> <p>Enables logging the occurrence of this alarm in syslog.txt.</p>
LED & Relay	<p>Synopsis: { On, Off } Default: Off</p> <p>Enables LED and fail-safe relay control for this alarm. If latching is not enabled, this field will remain disabled.</p>

Parameter	Description
Refresh Time	Synopsis: 0 s to 60 s Default: 60 s Refreshing time for this alarm.

4. Click **Apply**.

Section 5.4.4

Authentication Related Security Alarms

This section describes the authentication-related security messages that can be generated by RUGGEDCOM ROS.

CONTENTS

- [Section 5.4.4.1, "Security Alarms for Login Authentication"](#)
- [Section 5.4.4.2, "Security Messages for Port Authentication"](#)

Section 5.4.4.1

Security Alarms for Login Authentication

RUGGEDCOM ROS provides various logging options related to login authentication. A user can log into a RUGGEDCOM ROS device via four different methods: Web, console, SSH or Telnet. RUGGEDCOM ROS can log messages in the syslog, send a trap to notify an SNMP manager, and/or raise an alarm when a successful and unsuccessful login event occurs. In addition, when a weak password is configured on a unit or when the primary authentication server for TACACS+ or RADIUS is not reachable, RUGGEDCOM ROS will raise alarms, send SNMP traps and log messages in the syslog.

The following is a list of log and alarm messages related to user authentication:

- Weak Password Configured
- Login and Logout Information
- Excessive Failed Login Attempts
- RADIUS Server Unreachable
- TACACS Server Unreachable
- TACACS Response Invalid
- SNMP Authentication Failure

**NOTE**

All alarms and log messages related to login authentication are configurable. For more information about configuring alarms, refer to [Section 5.4.3, "Configuring an Alarm"](#).

» Weak Password Configured

RUGGEDCOM ROS generates this alarm and logs a message in the syslog when a weak password is configured in the **Passwords** table.

Message Name	Alarm	SNMP Trap	Syslog
Weak Password Configured	Yes	Yes	Yes

» Default Keys In Use

RUGGEDCOM ROS generates this alarm and logs a message in the syslog when default keys are in use. For more information about default keys, refer to [Section 6.5, “Managing SSH and SSL Keys and Certificates”](#).



NOTE

For Non-Controlled (NC) versions of RUGGEDCOM ROS, this alarm is only generated when default SSL keys are in use.

Message Name	Alarm	SNMP Trap	Syslog
Default Keys In Use	Yes	Yes	Yes

» Login and Logout Information

RUGGEDCOM ROS generates this alarm and logs a message in the syslog when a successful and unsuccessful login attempt occurs. A message is also logged in the syslog when a user with a certain privilege level is logged out from the device.

Login attempts are logged regardless of how the user accesses the device (i.e. SSH, Web, Console, Telnet or RSH). However, when a user logs out, a message is only logged when the user is accessing the device through SSH, Telnet or Console.

Message Name	Alarm	SNMP Trap	Syslog
Successful Login	Yes	Yes	Yes
Failed Login	Yes	Yes	Yes
User Logout	No	No	Yes

» Excessive Failed Login Attempts

RUGGEDCOM ROS generates this alarm and logs a message in the syslog after 10 failed login attempts by a user occur within a span of five minutes. Furthermore, the service the user attempted to access will be blocked for one hour to prevent further attempts.

Message Name	Alarm	SNMP Trap	Syslog
Excessive Failed Login Attempts	Yes	Yes	Yes

» RADIUS Server Unreachable

RUGGEDCOM ROS generates this alarm and logs a message in the syslog when the primary RADIUS server is unreachable.

Message Name	Alarm	SNMP Trap	Syslog
Primary RADIUS Server Unreachable	Yes	Yes	Yes

» TACACS+ Server Unreachable

RUGGEDCOM ROS generates this alarm and logs a message in the syslog when the primary TACACS+ server is unreachable.

Message Name	Alarm	SNMP Trap	Syslog
Primary TACACS Server Unreachable	Yes	Yes	Yes

» TACACS+ Response Invalid

RUGGEDCOM ROS generate this alarm and logs a message in the syslog when the response from the TACACS+ server is received with an invalid CRC.

Message Name	Alarm	SNMP Trap	Syslog
TACACS Response Invalid	Yes	Yes	Yes

» SNMP Authentication Failure

RUGGEDCOM ROS generates this alarm, sends an authentication failure trap, and logs a message in the syslog when an SNMP manager with incorrect credentials communicates with the SNMP agent in RUGGEDCOM ROS.

Message Name	Alarm	SNMP Trap	Syslog
SNMP Authentication Failure	Yes	Yes	Yes

Section 5.4.4.2

Security Messages for Port Authentication

The following is the list of log and alarm messages related to port access control in RUGGEDCOM ROS:

- MAC Address Authorization Failure
- Secure Port X Learned MAC Addr on VLAN X
- Port Security Violated

» MAC Address Authorization Failure

RUGGEDCOM ROS generates this alarm and logs a message in the syslog when a host connected to a secure port on the device is communicating using a source MAC address which has not been authorized by RUGGEDCOM ROS, or the dynamically learned MAC address has exceeded the total number of MAC addresses configured to be learned dynamically on the secured port. This message is only applicable when the port security mode is set to *Static MAC*.

Message Name	Alarm	SNMP Trap	Syslog
MAC Address Authorization Failure	Yes	Yes	Yes

» Secure Port X Learned MAC Addr on VLAN X

RUGGEDCOM ROS logs a message in the syslog and sends a configuration change trap when a MAC address is learned on a secure port. Port X indicates the secured port number and VLAN number on that port. This message is not configurable in RUGGEDCOM ROS.

Message Name	SNMP Trap	Syslog
Secure Port X Learned MAC Addr on VLAN X	Yes	Yes

» Port Security Violated

This message is only applicable when the security mode for a port is set to "802.1X or 802.1X/MAC-Auth"

RUGGEDCOM ROS this alarm and logs a message in the syslog when the host connected to a secure port tries to communicate using incorrect login credentials.

Message Name	Alarm	SNMP Trap	Syslog
802.1X Port X Authentication Failure	Yes	Yes	Yes
802.1X Port X Authorized Addr. XXX	No	No	Yes

Section 5.5

Managing the Configuration File

The device configuration file for RUGGEDCOM ROS is a single CSV (Comma-Separate Value) formatted ASCII text file, named `config.csv`. It can be downloaded from the device to view, compare against other configuration files, or store for backup purposes. It can also be overwritten by a complete or partial configuration file uploaded to the device.

To prevent unauthorized access to the contents of the configuration file, the file can be encrypted and given a password/passphrase key.

CONTENTS

- [Section 5.5.1, "Configuring Data Encryption"](#)
- [Section 5.5.2, "Updating the Configuration File"](#)

Section 5.5.1

Configuring Data Encryption

To encrypt the configuration file and protect it with a password/passphrase, do the following:



NOTE

Data encryption is not available in Non-Controlled (NC) versions of RUGGEDCOM ROS. When switching between Controlled and Non-Controlled (NC) versions of RUGGEDCOM ROS, make sure data encryption is disabled. Otherwise, the NC version of RUGGEDCOM ROS will ignore the encrypted configuration file and load the factory defaults.

- i** **NOTE**
Only configuration data is encrypted. All comments and table names in the configuration file are saved as clear text.
- i** **NOTE**
When sharing a configuration file between devices, make sure both devices have the same passphrase configured. Otherwise, the configuration file will be rejected.
- i** **NOTE**
Encryption must be disabled before the device is returned to Siemens or the configuration file is shared with Customer Support.
- !** **IMPORTANT!**
Never downgrade the RUGGEDCOM ROS software version beyond RUGGEDCOM ROS v5.2 when encryption is enabled. Make sure the device has been restored to factory defaults before downgrading.

1. Navigate to **Administration » Configure Data Storage**. The **Data Storage** form appears.

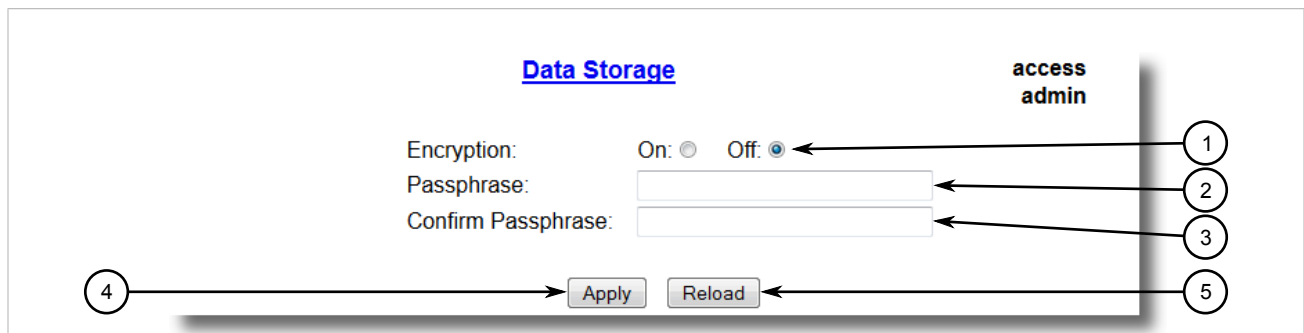

Figure 70: Data Storage Form

1. Encryption Options
2. Passphrase Box
3. Confirm Passphrase Box
4. Apply Button
5. Reload Button

2. Configure the following parameter(s) as required:

Parameter	Description
Encryption	Synopsis: { On, Off } Enable/disable encryption of data in configuration file.
Passphrase	Synopsis: 31 character ascii string This passphrase is used as a secret key to encrypt the configuration data. Encrypted data can be decrypted by any device configured with the same passphrase.
Confirm Passphrase	Synopsis: 31 character ascii string This passphrase is used as a secret key to encrypt the configuration data. Encrypted data can be decrypted by any device configured with the same passphrase.

3. Click **Apply**.

Section 5.5.2

Updating the Configuration File

Once downloaded from the device, the configuration file can be updated using a variety of different tools:

**NOTE**

For information about uploading/downloading files, refer to [Section 4.4, "Uploading/Downloading Files"](#).

- Any text editing program capable of reading and writing ASCII files
- Difference/patching tools (e.g. the UNIX *diff* and *patch* command line utilities)
- Source Code Control systems (e.g. CVS, SVN)

**CAUTION!**

Configuration hazard – risk of data loss. Do not edit an encrypted configuration file. Any line that has been modified manually will be ignored.

RUGGEDCOM ROS also has the ability to accept partial configuration updates. For example, to update only the parameters for Ethernet port 1 and leave all other parameters unchanged, transfer a file containing only the following lines to the device:

```
# Port Parameters
ethPortCfg
Port, Name, Media, State, AutoN, Speed, Dupx, FlowCtrl, LFI, Alarm,
1, Port 1, 100TX, Enabled, On, Auto, Auto, Off, Off, On,
```

Section 5.6

Managing MMS Reporting

RUGGEDCOM ROS supports the the IEC 61850 Manufacturing Message Specification (MMS) protocol.

CONTENTS

- [Section 5.6.1, "Understanding MMS Reporting"](#)
- [Section 5.6.2, "Viewing a List of Preconfigured MMS Reports"](#)
- [Section 5.6.3, "Configuring an MMS Report"](#)

Section 5.6.1

Understanding MMS Reporting

RUGGEDCOM ROS supports the IEC 61850 standard, a management and monitoring protocol for intelligent electronic devices (IEDs) at electrical substations. The standard uses the Manufacturing Message Specification (MMS) as a transport protocol, while the object model defines the objects to be polled or configured.

The MMS Report is based on the *MMS Sessions Allowed* parameter, which controls how many clients can build MMS connections simultaneously to the RUGGEDCOM ROS bridge device. For more information about configuring MMS reporting, refer to [Section 4.9, "Configuring IP Services"](#).

The IEC 61850 report functionality is used to aggregate a group of data objects from logical nodes. These data objects can be sent to the client either as an unsolicited event-driven report or a time-based report initiated by the client.

CONTENTS

- [Section 5.6.1.1, "Reports/Data Sets"](#)

Section 5.6.1.1

Reports/Data Sets

RUGGEDCOM ROS supports the following types of reports/data sets:

- **SystemStatus**
An event-driven report belonging to the logical node LPHD, indicating the device's working status. It includes two data objects: LPHD.PhyHealth (device health status) and LPHD.PwrSupAlm (device power supply alarm status).
- **RSTPStatus**
An event-driven report belonging to the logical node LBRI, indicating the device's RSTP status. It includes three data objects: LBRI.RstpRoot (device is RSTP root or not), LBRI.RstpTopoCnt (RSTP topology change count) and LBSP.RstpSt (RSTP port state).
- **PortStatistics**
A time-based report belonging to the logical node LPCP, indicating the device's physical port working status. It includes four data objects: LPCP.AutoNgt (If true, the port is auto-negotiation), LPCP.RxCnt (Number of messages received since last reset), LPCP.TxCnt (number of messages sent since last reset) and LPCP.FerPort (frame error rate on the port).
- **PortLinkStatus**
An event-driven report belonging to the logical node LPCP, indicating the device's physical port MAU status. It includes the data object LPCP.Mau (medium attachment unit link status).
- **LLDPStatus**
A time-based report belonging to the logical node LPLD, indicating the device's LLDP status. It includes three data objects: LPLD.RemPortId (remote port identifier), LPLD.RemChsId (remote port chassis identifier) and LPLD.RemAddr (remote system management address).



NOTE

The files `ruggedcom.icd` (IEC61850 IED Capability Description of the device) and `ruggedcom.iid` (IEC61850 Instantiated IED Description of the device) list the logical nodes supported by RUGGEDCOM ROS. For information about downloading these files, refer to [Section 4.4, "Uploading/Downloading Files"](#).

Section 5.6.2

Viewing a List of Preconfigured MMS Reports

To view a list of MMS Reports pre-configured for the device, navigate to **Administration » Configure MMS**. The **MMS Report Configuration** table appears.

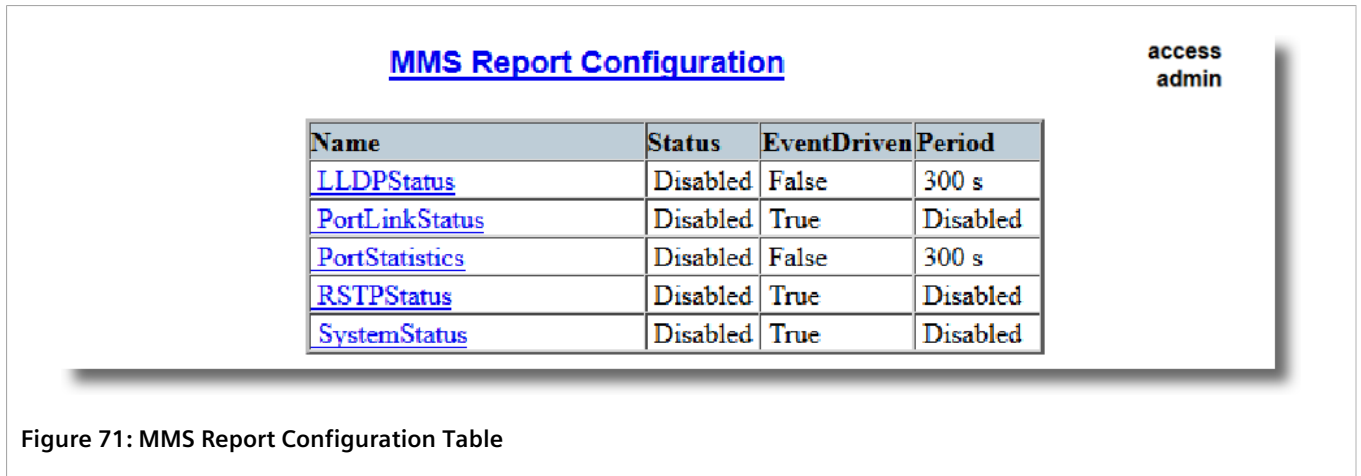

Figure 71: MMS Report Configuration Table

This table displays the following information:

Parameter	Description
Name	Synopsis: Any 32 characters Default: SysStatus The MMS report name (i.e.the data set's name).
Status	Synopsis: { Disabled, Enabled } Default: Disabled The MMS reporting status initiated or changed by the client application. If any client application enables a data set's report functionality, the status of this data set is 'Enabled'. If no client application enables the data set's report functionality, the status of this data set is 'Disabled'.
EventDriven	Synopsis: { False, True } Default: True The reporting criteria: <ul style="list-style-type: none"> • True – Reporting is event-driven • False – Reporting is time-based
Period	Synopsis: 30 to 1080 s or { Disabled } Default: 300 s The reporting interval, in seconds, for time-based reports. This parameter is 'Disabled' for event-driven reports.

For information about modifying an MMS report, refer to [Section 5.6.3, “Configuring an MMS Report”](#).

Section 5.6.3

Configuring an MMS Report

While all MMS reports are pre-configured on the device, some reports can be modified to suit the application. This includes enabling/disabling certain reports and changing the reporting interval.

To configuring an MMS report, do the following:

1. Navigate to **Administration » Configure MMS**. The **MMS Report Configuration** table appears.

access
admin

MMS Report Configuration

Name	Status	EventDriven	Period
LLDPStatus	Disabled	False	300 s
PortLinkStatus	Disabled	True	Disabled
PortStatistics	Disabled	False	300 s
RSTPStatus	Disabled	True	Disabled
SystemStatus	Disabled	True	Disabled

Figure 72: MMS Report Configuration Table

- Select a report. The **MMS Report Configuration** form appears.

access
admin

MMS Report Configuration

Name: ← 1

Status: ← 2

EventDriven: ← 3

Period: ← 4

5 → ← 6

Figure 73: MMS Report Configuration Form

- Name Box
- Status Options
- EventDriven Box
- Period Box
- Apply Button
- Reload Button

- Configure the following parameter(s) as required:

Parameter	Description
Period	<p>Synopsis: 30 to 1080 s or { Disabled }</p> <p>Default: 300 s</p> <p>The reporting interval, in seconds, for time-based reports. This parameter is 'Disabled' for event-driven reports.</p>

- Click **Apply**.

6 Security

This chapter describes how to configure and manage the security-related features of RUGGEDCOM ROS.

CONTENTS

- [Section 6.1, "Configuring Passwords"](#)
- [Section 6.2, "Clearing Private Data"](#)
- [Section 6.3, "Managing User Authentication"](#)
- [Section 6.4, "Managing Port Security"](#)
- [Section 6.5, "Managing SSH and SSL Keys and Certificates"](#)

Section 6.1

Configuring Passwords

To configure passwords for one or more of the user profiles, do the following:

1. Navigate to **Administration » Configure Passwords**. The **Configure Passwords** form appears.

The screenshot shows the 'Passwords' configuration page. On the right side, there is a vertical bar with a list of users: 'access' and 'admin'. Below this are 13 numbered callouts (1-13) with arrows pointing to specific form elements: 1 points to the 'Auth Type' dropdown (set to 'Local'); 2 points to the 'Guest Username' text box (containing 'guest'); 3 points to the 'Guest Password' text box; 4 points to the 'Confirm Guest Password' text box; 5 points to the 'Operator Username' text box (containing 'operator'); 6 points to the 'Operator Password' text box; 7 points to the 'Confirm Operator Password' text box; 8 points to the 'Admin Username' text box (containing 'admin'); 9 points to the 'Admin Password' text box; 10 points to the 'Confirm Admin Password' text box; 11 points to the 'Password Minimum Length' text box (containing '1'); 12 points to the 'Apply' button; and 13 points to the 'Reload' button.

Figure 74: Configure Passwords Form

1. Auth Type Box 2. Guest Username Box 3. Guest Password Box 4. Confirm Guest Password Box 5. Operator Username Box
6. Operator Password Box 7. Confirm Operator Password Box 8. Admin Username Box 9. Admin Password Box 10. Confirm Admin Password Box 11. Password Minimum Length box 12. Apply Button 13. Reload Button



NOTE

RUGGEDCOM ROS requires that all user passwords meet strict guidelines to prevent the use of weak passwords. When creating a new password, make sure it adheres to the following rules:

- Must not be less than 8 characters in length.
- Must not include the username or any 4 continuous characters found in the username. For example, if the username is **Subnet25**, the password may not be **subnet25admin**, **subnetadmin** or **net25admin**. However, **net-25admin** or **Sub25admin** is permitted.
- Must have at least one alphabetic character and one number. Special characters are permitted.
- Must not have more than 3 continuously incrementing or decrementing numbers. For example, **Sub123** and **Sub19826** are permitted, but **Sub12345** is not.

An alarm will generate if a weak password is configured. The weak password alarm can be disabled by the user. For more information about disabling alarms, refer to [Section 5.4, "Managing Alarms"](#).

2. Configure the following parameter(s) as required:

Parameter	Description
Auth Type	<p>Synopsis: { Local, RADIUS, TACACS+, RADIUSorLocal, TACACS+orLocal }</p> <p>Default: Local</p> <p>Password can be authenticated using locally configured values, or remote RADIUS or TACACS+ server. Setting value to any of combinations that involve RADIUS or TACACS+ require Security Server Table to be configured.</p>

Parameter	Description
	<p>Settings:</p> <ul style="list-style-type: none"> • <code>Local</code> – Authentication from the local Password Table. • <code>RADIUS</code> – Authentication using a RADIUS server for network access only (HTTP/HTTPS, SSH, RSH, Telnet). For console access, authenticate from the local Password Table. If local authentication fails, then authenticate using RADIUS server. • <code>TACACS+</code> – Authentication using a TACACS+ server for network access only (HTTP/HTTPS, SSH, RSH, Telnet). For console access, authenticate from the local Password Table. If local authentication fails, then authenticate using TACACS+ server. • <code>RADIUSOrLocal</code> – Authentication using RADIUS. If the server cannot be reached, authenticate from the local Password Table. • <code>TACACS+OrLocal</code> – Authentication using TACACS+. If the server cannot be reached, authenticate from the local Password Table.
Guest Username	<p>Synopsis: Any 15 characters Default: guest</p> <p>Related password is in field Guest Password; view only, cannot change settings or run any commands.</p>
Guest Password	<p>Synopsis: 19 character ASCII string</p> <p>Related username is in field Guest Username; view only, cannot change settings or run any commands.</p>
Confirm Guest Password	<p>Synopsis: 19 character ASCII string</p> <p>Related username is in field Guest Username; view only, cannot change settings or run any commands.</p>
Operator Username	<p>Synopsis: Any 15 characters Default: operator</p> <p>Related password is in field Oper Password; cannot change settings; can reset alarms, statistics, logs, etc.</p>
Operator Password	<p>Synopsis: 19 character ASCII string</p> <p>Related username is in field Oper Username; cannot change settings; can reset alarms, statistics, logs, etc</p>
Confirm Operator Password	<p>Synopsis: 19 character ASCII string</p> <p>Related username is in field Oper Username; cannot change settings; can reset alarms, statistics, logs, etc.</p>
Admin Username	<p>Synopsis: Any 15 characters Default: admin</p> <p>Related password is in field Admin Password; full read/write access to all settings and commands.</p>
Admin Password	<p>Synopsis: 19 character ASCII string</p> <p>Related username is in field Admin Username; full read/write access to all settings and commands.</p>
Confirm Admin Password	<p>Synopsis: 19 character ASCII string</p> <p>Related username is in field Admin Username; full read/write access to all settings and commands.</p>
Password Minimum Length	<p>Synopsis: 1 to 17 Default: 1</p> <p>Configure the password string minimum length. The new password shorter than the minimum length will be rejected.</p>

3. Click **Apply**.

Section 6.2

Clearing Private Data

When enabled, during system boot up, a user with serial console access can clear all configuration data and keys stored on the device, and restore all user names and passwords to factory default settings.

To clear private data, do the following:

**NOTE**

The commands used in the following procedure are time-sensitive. If the specified time limits are exceeded before providing the appropriate response, the device will continue normal boot up.

1. Connect to the device via the RS-232 serial console port. For more information, refer to [Section 3.1.2, "Connecting Directly"](#).
2. Cycle power to the device. As the device is booting up, the following prompt will appear:

```
Press any key to start
```

3. Within four seconds, press **CTRL + r**. The access banner will appear, followed by the command prompt:

```
>
```

4. Type the following command, then press **Enter** within 30 seconds:

```
clear private data
```

5. When prompted "Do you want to clear private data (Yes/No)?", answer yes and press **Enter** within five seconds. All configuration and keys in flash will be zeroized. An entry in the event log will be created. Crashlog.txt files (if existing) and syslog.txt files will be preserved. The device will reboot automatically.

Section 6.3

Managing User Authentication

This section describes the various methods for authenticating users.

CONTENTS

- [Section 6.3.1, "Configuring User Name Extensions"](#)
- [Section 6.3.2, "Managing RADIUS Authentication"](#)
- [Section 6.3.3, "Managing TACACS+ Authentication"](#)

Section 6.3.1

Configuring User Name Extensions

When configured to authenticate users using RADIUS or TACACS+, RUGGEDCOM ROS can be configured to add information to each user name important to the authentication server. This can include the NAS IP address, system name, system location, or any other user-defined text.

If the **Username Extension** parameter is left blank, only the user name will be sent to the authentication server.



NOTE

Extensions are ignored when IEEE 802.1x port-based authentication is enabled. RUGGEDCOM ROS will remain transparent and not make any changes to the username. For more information about IEEE 802.1x authentication, refer to [Section 6.4.1, "Port Security Concepts"](#).

To configure a username extension, do the following:

1. Navigate to **Administration » Configure Security Server » Configure Common Security Parameters**. The **Common Security Parameters** form appears.

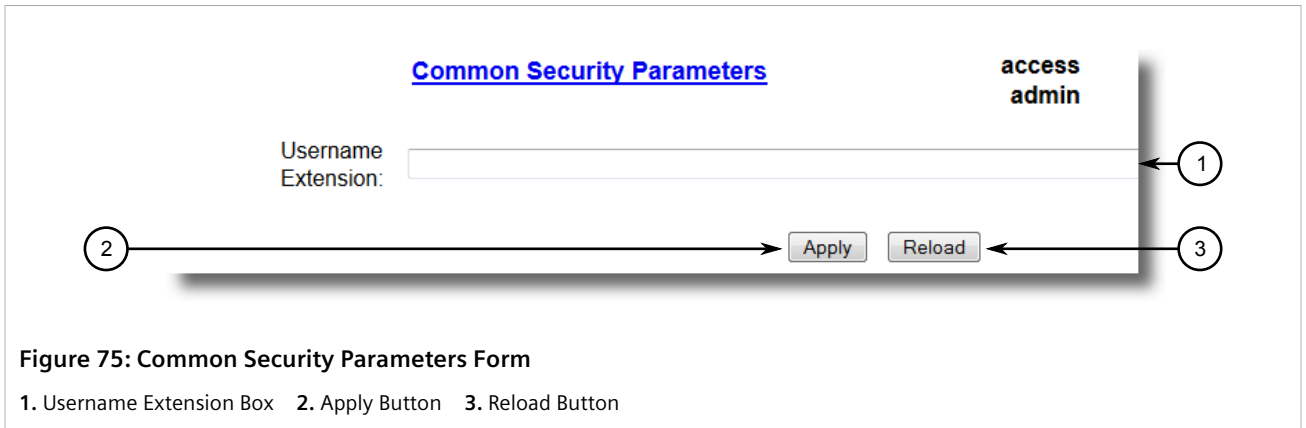

Figure 75: Common Security Parameters Form

1. Username Extension Box
2. Apply Button
3. Reload Button

2. Configure the following parameter(s) as required:

Parameter	Description
Username Extension	<p>Synopsis: Any 127 characters</p> <p>Defines the format of all user names sent to a RADIUS or TACACS+ server for authentication. A prefix or suffix can be added to the user name using predefined keywords (wrapped in % delimiters) or user-defined strings.</p> <p>Delimited values include:</p> <ul style="list-style-type: none"> %Username%: The name associated with the user profile (e.g. admin, oper, etc.) %IPaddr%: The management IP address of the switch that acts as a Network Access Server (NAS). %SysName%: The system name given to the device. %SysLocation%: The system location given to the device. <p>All pre-defined keywords are case-insensitive.</p> <p>Examples:</p> <ul style="list-style-type: none"> %Username%@ABC.com %Username%_%SysLocation% <p>If an extension is not defined, only the user name is sent to the authentication server.</p>

3. Click **Apply**.

Section 6.3.2

Managing RADIUS Authentication

RUGGEDCOM ROS can be configured to act as a RADIUS client and forward user credentials to a RADIUS (Remote Authentication Dial In User Service) server for remote authentication and authorization.

RADIUS is a UDP-based protocol used for carrying authentication, authorization and configuration information between a Network Access Server (NAS) that desires to authenticate its links and a shared authentication server. It provides centralized authentication and authorization for network access.

RADIUS is also widely used in conjunction with the IEEE 802.1X standard for port security using the Extensible Authentication Protocol (EAP).

**IMPORTANT!**

RADIUS messages are sent as UDP messages. The switch and the RADIUS server must use the same authentication and encryption key.

**IMPORTANT!**

RUGGEDCOM ROS supports both Protected Extensible Authentication Protocol (PEAP) and EAP-MD5. PEAP is more secure and is recommended if available in the supplicant.

**NOTE**

For more information about the RADIUS protocol, refer to [RFC 2865](http://tools.ietf.org/html/rfc2865) [<http://tools.ietf.org/html/rfc2865>].

For more information about the Extensible Authentication Protocol (EAP), refer to [RFC 3748](http://tools.ietf.org/html/rfc3748) [<http://tools.ietf.org/html/rfc3748>].

CONTENTS

- [Section 6.3.2.1, "Configuring the RADIUS Server"](#)
- [Section 6.3.2.2, "Configuring the RADIUS Client on the Device"](#)

Section 6.3.2.1

Configuring the RADIUS Server**NOTE**

For information about configuring the RADIUS server, refer to the manufacturer's instructions of the server being configured.

The Vendor-Specific attribute (or VSA) sent to the RADIUS server as part of the RADIUS request is used to determine the access level from the RADIUS server. This attribute may be configured within the RADIUS server with the following information:

Attribute	Value
Vendor-Specific	Vendor-ID: 15004 Format: String Number: 2 Attribute: { Guest, Operator, Admin }

**NOTE**

If no access level is received in the response packet from the RADIUS server, access is denied.

Section 6.3.2.2

Configuring the RADIUS Client on the Device

The RADIUS client can be configured to use two RADIUS servers: a primary server and a backup server. If the primary server is unavailable, the device will automatically attempt to connect with the backup server.



NOTE

The RADIUS client uses the Password Authentication Protocol (PAP) to verify access.

To configure access to either the primary or backup RADIUS servers, do the following:

1. Navigate to **Administration » Configure Security Server » Configure RADIUS Server**. The **RADIUS Server** table appears.

Server	IP Address	Auth UDP Port	Max Retry	Timeout	Reachable	Auth Key
Primary		1812	2	10000	No	
Backup		1812	2	10000	No	

Figure 76: RADIUS Server Table

2. Select either **Primary** or **Backup** from the table. The **RADIUS Server** form appears.

Figure 77: RADIUS Server Form

1. Server Box 2. IP Address Box 3. Auth UDP Port Box 4. Max Retry Box 5. Timeout Port Box 6. Reachable Box 7. Auth Key Box 8. Confirm Auth Key Box 9. Apply Button 10. Reload Button

3. Configure the following parameter(s) as required:

Parameter	Description
Server	Synopsis: Any 8 characters Default: Primary

Parameter	Description
	This field tells whether this configuration is for a Primary or a Backup Server.
IP Address	Synopsis: ###.###.###.### where ### ranges from 0 to 255 The Server IP Address.
Auth UDP Port	Synopsis: 1 to 65535 Default: 1812 The IP Port on server.
Max Retry	Synopsis: 1 to 10 Default: 2 The maximum number of times the Authenticator will attempt to contact the authentication server to authenticate the user in case of any failure.
Timeout	Synopsis: 1000 to 120000 Default: 10000 The amount of time in milliseconds the Authenticator will wait for a response from the authentication server.
Reachable	Synopsis: { No, Yes } The status of the server.
Auth Key	Synopsis: 31 character ASCII string The authentication key to be shared with server.
Confirm Auth Key	Synopsis: 31 character ASCII string The authentication key to be shared with server.

- Click **Apply**.

Section 6.3.3

Managing TACACS+ Authentication

TACACS+ (Terminal Access Controller Access-Control System Plus) is a TCP-based access control protocol that provides authentication, authorization and accounting services to routers, Network Access Servers (NAS) and other networked computing devices via one or more centralized servers.

CONTENTS

- [Section 6.3.3.1, "Configuring TACACS+"](#)
- [Section 6.3.3.2, "Configuring User Privileges"](#)

Section 6.3.3.1

Configuring TACACS+

RUGGEDCOM ROS can be configured to use two TACACS+ servers: a primary server and a backup server. If the primary server is unavailable, the device will automatically attempt to connect with the backup server.

To configure access to either the primary or backup TACACS+ servers, do the following:

- Navigate to **Administration » Configure Security Server » Configure TacPlus Server » Configure TACACS Plus Server**. The **TACACS Plus Server** table appears.

TACACS Plus Server

**access
admin**

Server	IP Address	Auth TCP Port	Max Retry	Timeout	Reachable	Auth Key
Primary		49	3	10000	No	xxxxxxxx
Backup		49	3	10000	No	xxxxxxxx

Figure 78: TACACS Plus Server Table

2. Select either **Primary** or **Backup** from the table. The **TACACS Plus Server** form appears.

TACACS Plus Server

**access
admin**

Server: (1)

IP Address: (2)

Auth TCP Port: (3)

Max Retry: (4)

Timeout: (5)

Reachable: (6)

Auth Key: (7)

Confirm Auth Key: (8)

(9) (10)

Figure 79: TACACS Plus Server Form

1. Server Box
2. IP Address Box
3. Auth TCP Port Box
4. Max Retry Box
5. Timeout Port Box
6. Reachable Box
7. Auth Key Box
8. Confirm Key Box
9. Apply Button
10. Reload Button

3. Configure the following parameter(s) as required:

Parameter	Description
Server	Synopsis: Any 8 characters Default: Primary This field tells whether this configuration is for a Primary or a Backup Server.
IP Address	Synopsis: ###.###.###.### where ### ranges from 0 to 255 The Server IP Address.
Auth TCP Port	Synopsis: 1 to 65535 Default: 49 The IP Port on server.
Max Retry	Synopsis: 1 to 10 Default: 3 The maximum number of times the Authenticator will attempt to contact the authentication server to authenticate the user in case of any failure.
Timeout	Synopsis: 1000 to 120000 Default: 10000

Parameter	Description
	The amount of time in milliseconds the Authenticator will wait for a response from the authentication server.
Reachable	Synopsis: { No, Yes } The status of the server.
Auth Key	Synopsis: 31 character ascii string Default: mySecret The authentication key to be shared with server.
Confirm Auth Key	Synopsis: 31 character ascii string The authentication key to be shared with server.

- Set the privilege levels for each user type (i.e. admin, operator and guest). For more information, refer to [Section 6.3.3.2, "Configuring User Privileges"](#).
- Click **Apply**.

Section 6.3.3.2

Configuring User Privileges

Each TACACS+ authentication request includes a *priv_lvl* attribute that is used to grant access to the device. By default, the attribute uses the following ranges:

- 15 represents the *admin* access level
- 2-14 represents the *operator* access level
- 1 represents the *guest* access level

To configure the privilege levels for each user type, do the following:

- Navigate to **Administration » Configure Security Server » Configure TacPlus Server » Configure TACPLUS Serv Privilege Config**. The **TACPLUS Serv Privilege Config** form appears.

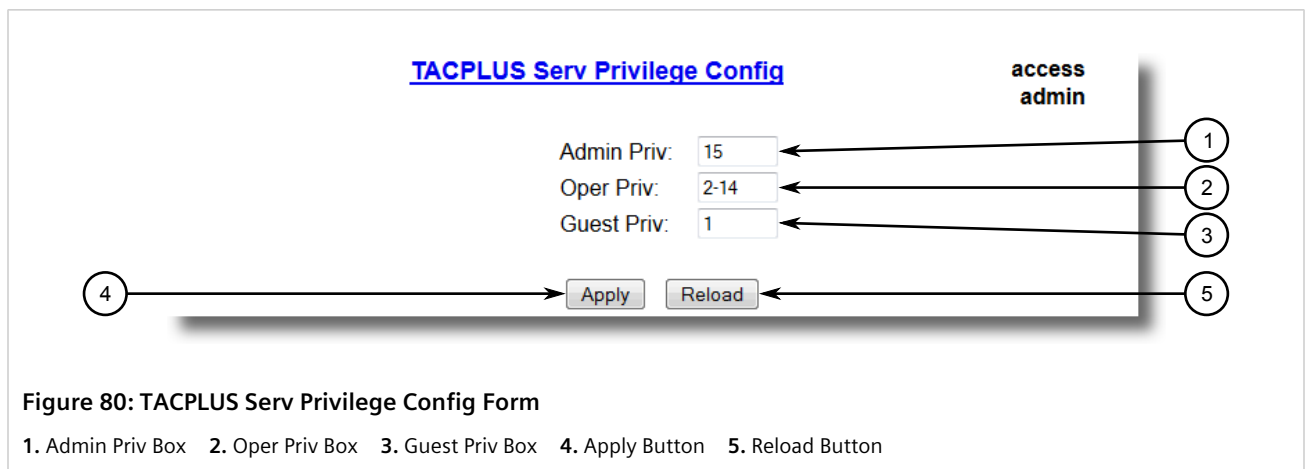

Figure 80: TACPLUS Serv Privilege Config Form

1. Admin Priv Box 2. Oper Priv Box 3. Guest Priv Box 4. Apply Button 5. Reload Button

- Configure the following parameter(s) as required:

Parameter	Description
Admin Priv	Synopsis: (0 to 15)-(0 to 15) Default: 15

Parameter	Description
	Privilege level to be assigned to the user.
Oper Priv	Synopsis: (0 to 15)-(0 to 15) Default: 2-14 Privilege level to be assigned to the user.
Guest Priv	Synopsis: (0 to 15)-(0 to 15) Default: 1 Privilege level to be assigned to the user.

3. Click **Apply**.

Section 6.4

Managing Port Security

Port security, or port access control, provides the ability to filter or accept traffic from specific MAC addresses.

Port security works by inspecting the source MAC addresses of received frames and validating them against the list of MAC addresses authorized by the port. Unauthorized frames are filtered and, optionally, the port that received the frame can be shut down permanently or for a specified period of time. An alarm will be raised indicating the detected unauthorized MAC address.

Frames to unknown destination addresses are flooded through secure ports.

CONTENTS

- [Section 6.4.1, "Port Security Concepts"](#)
- [Section 6.4.2, "Viewing a List of Authorized MAC Addresses"](#)
- [Section 6.4.3, "Configuring Port Security"](#)
- [Section 6.4.4, "Configuring IEEE 802.1X"](#)

Section 6.4.1

Port Security Concepts

This section describes some of the concepts important to the implementation of port security in RUGGEDCOM ROS.

CONTENTS

- [Section 6.4.1.1, "Static MAC Address-Based Authentication"](#)
- [Section 6.4.1.2, "IEEE 802.1x Authentication"](#)
- [Section 6.4.1.3, "IEEE 802.1X Authentication with MAC Address-Based Authentication"](#)
- [Section 6.4.1.4, "Assigning VLANs with Tunnel Attributes"](#)

Section 6.4.1.1

Static MAC Address-Based Authentication

With this method, the switch validates the source MAC addresses of received frames against the contents in the Static MAC Address Table.

RUGGEDCOM ROS also supports a highly flexible Port Security configuration which provides a convenient means for network administrators to use the feature in various network scenarios.

A Static MAC address can be configured without a port number being explicitly specified. In this case, the configured MAC address will be automatically authorized on the port where it is detected. This allows devices to be connected to any secure port on the switch without requiring any reconfiguration.

The switch can also be programmed to learn (and, thus, authorize) a pre-configured number of the first source MAC addresses encountered on a secure port. This enables the capture of the appropriate secure addresses when first configuring MAC address-based authorization on a port. Those MAC addresses are automatically inserted into the Static MAC Address Table and remain there until explicitly removed by the user.

Section 6.4.1.2

IEEE 802.1x Authentication

The IEEE 802.1x standard defines a mechanism for port-based network access control and provides a means of authenticating and authorizing devices attached to LAN ports.

Although IEEE 802.1x is mostly used in wireless networks, this method is also implemented in wired switches.

The IEEE 802.1x standard defines three major components of the authentication method: Supplicant, Authenticator and Authentication server. RUGGEDCOM ROS supports the Authenticator component.

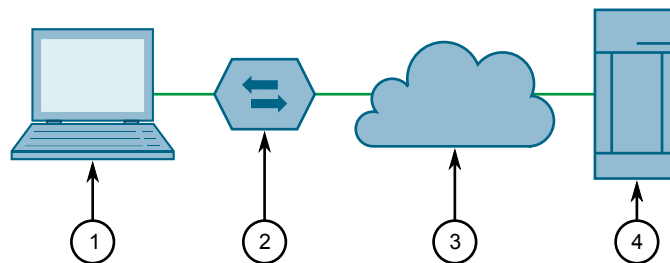

Figure 81: IEEE 802.1x General Topology

1. Supplicant 2. Authenticator Switch 3. LAN 4. Authentication Server



IMPORTANT!

RUGGEDCOM ROS supports both Protected Extensible Authentication Protocol (PEAP) and EAP-MD5. PEAP is more secure and is recommended if available in the supplicant.

IEEE 802.1x makes use of the Extensible Authentication Protocol (EAP), which is a generic PPP authentication protocol that supports various authentication methods. IEEE 802.1x defines a protocol for communication between the Supplicant and the Authenticator, referred to as EAP over LAN (EAPOL).

RUGGEDCOM ROS communicates with the Authentication Server using EAP over RADIUS.

**NOTE**

The switch supports authentication of one host per port.

**NOTE**

If the host's MAC address is configured in the Static MAC Address Table, it will be authorized, even if the host authentication is rejected by the authentication server.

Section 6.4.1.3

IEEE 802.1X Authentication with MAC Address-Based Authentication

This method, also referred to as MAB (MAC-Authentication Bypass), is commonly used for devices, such as VoIP phones and Ethernet printers, that do not support the 802.1x protocol. This method allows such devices to be authenticated using the same database infrastructure as that used in 802.1x.

IEEE 802.1x with MAC-Authentication Bypass works as follows:

1. The device connects to a switch port.
2. The switch learns the device MAC address upon receiving the first frame from the device (the device usually sends out a DHCP request message when first connected).
3. The switch sends an EAP Request message to the device, attempting to start 802.1X authentication.
4. The switch times out while waiting for the EAP reply, because the device does not support 802.1x.
5. The switch sends an authentication message to the authentication server, using the device MAC address as the username and password.
6. The switch authenticates or rejects the device according to the reply from the authentication server.

Section 6.4.1.4

Assigning VLANs with Tunnel Attributes

RUGGEDCOM ROS supports assigning a VLAN to the authorized port using tunnel attributes, as defined in [RFC 3580](http://tools.ietf.org/html/rfc3580) [<http://tools.ietf.org/html/rfc3580>], when the Port Security mode is set to 802.1x or 802.1x/MAC-Auth.

In some cases, it may be desirable to allow a port to be placed into a particular VLAN, based on the authentication result. For example:

- To allow a particular device, based on its MAC address, to remain on the same VLAN as it moves within a network, configure the switches for 802.1X/MAC-Auth mode
- To allow a particular user, based on the user's login credentials, to remain on the same VLAN when the user logs in from different locations, configure the switches for 802.1X mode

If the RADIUS server wants to use this feature, it indicates the desired VLAN by including tunnel attributes in the Access-Accept message. The RADIUS server uses the following tunnel attributes for VLAN assignment:

- Tunnel-Type=VLAN (13)
- Tunnel-Medium-Type=802
- Tunnel-Private-Group-ID=VLANID

Note that VLANID is 12-bits and takes a value between 1 and 4094, inclusive. The Tunnel-Private-Group-ID is a string as defined in [RFC 2868](http://tools.ietf.org/html/rfc2868) [<http://tools.ietf.org/html/rfc2868>], so the VLANID integer value is encoded as a string.

If the tunnel attributes are not returned by the authentication server, the VLAN assigned to the switch port remains unchanged.

Section 6.4.2

Viewing a List of Authorized MAC Addresses

To view a list of static MAC addresses learned from secure ports, navigate to **Network Access Control » Port Security » View Authorized MAC Addresses**. The **Authorized MAC Addresses** table appears.

**NOTE**

Only MAC addresses authorized on a static MAC port(s) are shown. MAC addresses authorized with IEEE 802.1X are not shown.

Authorized MAC Addresses

access
admin

Port	MAC Address	VID	Sticky
1	00-00-00-00-00-03	1	No

Figure 82: Authorized MAC Addresses Table

This table displays the following information:

Parameter	Description
Port	Synopsis: 1 to maximum port number Port on which MAC address has been learned.
MAC Address	Synopsis: ##-##-##-##-##-## where ## ranges 0 to FF Authorized MAC address learned by the switch.
VID	Synopsis: 0 to 65535 VLAN Identifier of the VLAN upon which the MAC address operates.
Sticky	Synopsis: { No, Yes } This describes whether the authorized MAC address/Device can move to another port or not: <ul style="list-style-type: none"> • Yes – authorized MAC address/Device cannot move to a different switch port • No – authorized MAC address/Device may move to another switch port

If a MAC address is not listed, do the following:

- Configure port security. For more information, refer to [Section 6.4.3, “Configuring Port Security”](#).
- Configure IEEE 802.1X. For more information, refer to [Section 6.4.4, “Configuring IEEE 802.1X”](#).

Section 6.4.3

Configuring Port Security

To configure port security, do the following:

1. Navigate to **Network Access Control » Port Security » Configure Ports Security**. The **Ports Security** table appears.

Ports Security

access admin

Port	Security	Autolearn	Sticky	Shutdown Time	Status
1	Off	None	Yes	Don't shutdown	Unsecure
2	Off	None	Yes	Don't shutdown	Unsecure
3	Off	None	Yes	Don't shutdown	Unsecure
4	Off	None	Yes	Don't shutdown	Unsecure
5	Off	None	Yes	Don't shutdown	Unsecure
6	Off	None	Yes	Don't shutdown	Unsecure
7	Off	None	Yes	Don't shutdown	Unsecure
8	Off	None	Yes	Don't shutdown	Unsecure
9	Off	None	Yes	Don't shutdown	Unsecure
10	Off	None	Yes	Don't shutdown	Unsecure

Figure 83: Ports Security Table

- Select an Ethernet port. The **Ports Security** form appears.

Ports Security

access admin

Port: ← 1

Security: ← 2

Autolearn: ← 3

Sticky: No: Yes: ← 4

Shutdown Time: ← 5

Status: ← 6

← 7 ← 8

Figure 84: Ports Security Form

1. Port Box 2. Security List 3. Autolearn Box 4. Sticky Options 5. Shutdown Time Box 6. Status Box 7. Apply Button 8. Reload Button

- Configure the following parameter(s) as required:

Parameter	Description
Port	<p>Synopsis: 1 to maximum port number</p> <p>Default: 1</p> <p>The port number as seen on the front plate silkscreen of the device.</p>
Security	<p>Synopsis: { Off, Static MAC, 802.1X, 802.1x/MAC-Auth }</p> <p>Default: Off</p> <p>Enables or disables the port's security feature. Two types of port access control are available:</p> <ul style="list-style-type: none"> Static MAC address-based. With this method, authorized MAC address(es) should be configured in the Static MAC Address table. If some MAC addresses are not known in advance (or it is not known to which port they will be connected), there is still an option to configure the switch to auto-learn certain number of MAC addresses. Once learned, they do not age out until the unit is reset or the link goes down.

Parameter	Description
	<ul style="list-style-type: none"> IEEE 802.1X standard authentication. IEEE 802.1X with MAC-Authentication, also known as MAC-Authentication Bypass. With this option, the device can authenticate clients based on the client's MAC address if IEEE 802.1X authentication times out.
Autolearn	<p>Synopsis: 1 to 16 or { None }</p> <p>Default: None</p> <p>Only applicable when the 'Security' field has been set to 'Static MAC'. It specifies maximum number of MAC addresses that can be dynamically learned on the port. If there are static addresses configured on the port, the actual number of addresses allowed to be learned is this number minus the number of the static MAC addresses.</p>
Sticky	<p>Synopsis: { No, Yes }</p> <p>Default: Yes</p> <p>Only applicable when the 'Security' field has been set to 'Static MAC'. Change the behaviour of the port to either sticky or non-sticky.</p> <p>If Sticky is 'Yes', MACs/Devices authorized on the port 'stick' to the port and the switch will not allow them to move to a different port.</p> <p>If Sticky is 'No', MACs/Devices authorized on the port may move to another port.</p>
Shutdown Time	<p>Synopsis: 1 to 86400 s or { Until reset, Don't shutdown }</p> <p>Default: Don't shutdown</p> <p>Specifies for how long to shut down the port, if a security violation occurs.</p>
Status	<p>Synopsis: Any 31 characters</p> <p>Describes the security status of the port.</p>

**NOTE**

There are a few scenarios in which static MAC addresses can move:

- *When the link is up/down on a **non-sticky** secured port*
- *When traffic switches from or to a **non-sticky** secured port*

**NOTE**

Traffic is lost until the source MAC Address of the incoming traffic is authorized against the static MAC address table.

4. Click **Apply**.

Section 6.4.4

Configuring IEEE 802.1X

To configure IEEE 802.1X port-based authentication, do the following:

1. Navigate to **Network Access Control » Port Security » Configure 802.1X**. The **802.1X Parameters** table appears.

802.1X Parameters

**access
admin**

Port	txPeriod	quietPeriod	reAuthEnabled	reAuthPeriod	reAuthMax	suppTimeout	serverTimeout	maxReq
1	30 s	60 s	No	3600 s	2	30 s	30 s	2
2	30 s	60 s	No	3600 s	2	30 s	30 s	2
3	30 s	60 s	No	3600 s	2	30 s	30 s	2
4	30 s	60 s	No	3600 s	2	30 s	30 s	2
5	30 s	60 s	No	3600 s	2	30 s	30 s	2
6	30 s	60 s	No	3600 s	2	30 s	30 s	2
7	30 s	60 s	No	3600 s	2	30 s	30 s	2
8	30 s	60 s	No	3600 s	2	30 s	30 s	2
9	30 s	60 s	No	3600 s	2	30 s	30 s	2
10	30 s	60 s	No	3600 s	2	30 s	30 s	2

Figure 85: 802.1X Parameters Table

- Select an Ethernet port. The **802.1X Parameters** form appears.

802.1X Parameters

**access
admin**

Port:

txPeriod:

quietPeriod:

reAuthEnabled: No: Yes:

reAuthPeriod:

reAuthMax:

suppTimeout:

serverTimeout:

maxReq:

Figure 86: 802.1X Parameters Form

1. Port Box 2. tx Period Box 3. quietPeriod Box 4. reAuthEnabled Options 5. reAuthPeriod Box 6. reAuthMax Box
7. suppTimeout Box 8. serverTimeout Box 9. maxReq Box 10. Apply Button 11. Reload Button

- Configure the following parameter(s) as required:

Parameter	Description
Port	Synopsis: 1 to maximum port number Default: 1 The port number as seen on the front plate silkscreen of the device.
txPeriod	Synopsis: 1 to 65535 Default: 30 s The time to wait for the Supplicant's EAP Response/Identity packet before retransmitting an EAP Request/Identity packet.
quietPeriod	Synopsis: 0 to 65535

Parameter	Description
	Default: 60 s The period of time not to attempt to acquire a Supplicant after the authorization session failed.
reAuthEnabled	Synopsis: { No, Yes } Default: No Enables or disables periodic re-authentication.
reAuthPeriod	Synopsis: 60 to 86400 Default: 3600 s The time between periodic re-authentication of the Supplicant.
reAuthMax	Synopsis: 1 to 10 Default: 2 The number of re-authentication attempts that are permitted before the port becomes unauthorized.
suppTimeout	Synopsis: 1 to 300 Default: 30 s The time to wait for the Supplicant's response to the authentication server's EAP packet.
serverTimeout	Synopsis: 1 to 300 Default: 30 s The time to wait for the authentication server's response to the Supplicant's EAP packet.
maxReq	Synopsis: 1 to 10 Default: 2 The maximum number of times to retransmit the authentication server's EAP Request packet to the Supplicant before the authentication session times out.

- Click **Apply**.

Section 6.5

Managing SSH and SSL Keys and Certificates

RUGGEDCOM ROS uses X.509v3 certificates and keys to establish secure connections for remote logins (SSH) and Web access (SSL).



IMPORTANT!

Siemens recommends the following actions before commissioning the device:

- *Replace the factory-provisioned SSL certificate with one signed by a trusted Certificate Authority (CA)*
- *Replace the factory-provisioned SSH host key pair with one generated by a trusted security authority*



NOTE

Only admin users can write certificates and keys to the device.

Each RUGGEDCOM ROS device is shipped with a unique RSA 2048-based SSH host key pair and an RSA 2048-based self-signed certificate that are generated at and provisioned by the factory. The administrator may upload a new certificate and keys to the system at any time, which will overwrite the existing ones. In addition, CLI commands are available to regenerate SSL certificate and key pair as well as the SSH host key pair.

There are three types of certificates and keys used in RUGGEDCOM ROS:

**NOTE**

Network exposure to a ROS unit operating with the default keys, although always only temporary by design, should be avoided. The best way to reduce or eliminate this exposure is to provision user-created certificate and keys as quickly as possible, and preferably before the unit is placed in network service.

**NOTE**

The default certificate and keys are common to all RUGGEDCOM ROS versions without a certificate or key files. That is why it is important to either allow the key auto-generation to complete or to provision custom keys. In this way, one has at least unique, and at best, traceable and verifiable keys installed when establishing secure communication with the unit.

• Default

A default certificate and SSL/SSH keys are built in to RUGGEDCOM ROS and are common across all RUGGEDCOM ROS units sharing the same firmware image. In the event that valid SSL certificate or SSL/SSH key files are not available on the device (as is usually only the case when upgrading from an old ROS version that does not support user-configurable keys and therefore does not ship with unique, factory-generated keys), the default certificate and keys are put into service *temporarily* so that SSH and SSL (HTTPS) sessions can be served until generated or provisioned keys are available.

• Auto-Generated

If a default SSL certificate and SSL/SSH keys are in use, RUGGEDCOM ROS immediately begins to generate a unique certificate and SSL/SSH keys for the device in the background. This process may take several minutes to complete depending on the requested key length and how busy the device is at the time. If a custom certificate and keys are loaded while auto-generated certificates and keys are being generated, the generator will abort and the custom certificate and keys will be used.

• Custom (Recommended)

Custom certificates and keys are the most secure option. They give the user complete control over certificate and key management, allow for the provision of certificates signed by a public or local certificate authority, enable strictly controlled access to private keys, and allow authoritative distribution of SSL certificates, any CA certificates, and public SSH keys.

**NOTE**

The RSA or EC private key corresponding to the SSL certificate must be appended to the certificate in the `ssl.crt` file.

CONTENTS

- [Section 6.5.1, "SSL Certificates"](#)
- [Section 6.5.2, "SSH Host Key"](#)
- [Section 6.5.3, "Managing SSH Public Keys"](#)
- [Section 6.5.4, "Certificate and Key Examples"](#)

Section 6.5.1

SSL Certificates

RUGGEDCOM ROS supports SSL certificates that conform to the following specifications:

- X.509 v3 digital certificate format
- PEM format

- For RUGGEDCOM ROS Controlled versions: RSA key pair, 1024, 2048 or 3072 bits; or NIST P-192, P-224, P-256, P-384 or P-521
- For RUGGEDCOM ROS Non-Controlled (NC) versions: RSA key pair, 512 to 2048 bits

**NOTE**

RSA keys smaller than 2048 bits in length are not recommended. Support is only included here for compatibility with legacy equipment.

Two standard PEM files are required: the SSL certificate and the corresponding RSA private key file. These are concatenated into the resulting `ssl.crt` file, which may then be uploaded to RUGGEDCOM ROS. For more information about transferring files between the device and a host computer, refer to [Section 4.4, "Uploading/Downloading Files"](#).

While RUGGEDCOM ROS is capable of using self-signed certificates created using the `sslkeygen` command, Siemens recommends using an X.509 certificate issued by an organization's own Certificate Authority (CA).

Section 6.5.2

SSH Host Key

**NOTE**

SSH is not supported in Non-Controlled (NC) versions of RUGGEDCOM ROS.

Controlled versions of RUGGEDCOM ROS support SSH public/private key pairs that conform to the following specifications:

- PEM format
- DSA key pair, 1024, 2048 or 3072 bits in length
- RSA key pair, 1024, 2048 or 3072 bits in length

**NOTE**

DSA or RSA key generation times increase depending on the key length. 1024 bit RSA keys take less than 5 minutes to generate on a lightly loaded unit, whereas 2048 bit keys may take significantly longer. A typical modern PC system, however, can generate these keys in seconds.

The following (bash) shell script fragment uses the `ssh-keygen` command line utility to generate a 2048 bit RSA key suitable for use in RUGGEDCOM ROS. The resulting `ssh.keys` file may then be uploaded to RUGGEDCOM ROS:

```
# RSA key size:
BITS=2048

# Make an SSH key pair:
ssh-keygen -t RSA -b $BITS -N '' -f ssh.keys
```

For an example of an SSH key generated by RUGGEDCOM ROS, refer to [Section 6.5.4, "Certificate and Key Examples"](#).

Section 6.5.3

Managing SSH Public Keys

RUGGEDCOM ROS allows admin users to list, add and delete SSH public keys. Public keys are added as non-volatile storage (i.e. flash) files on RUGGEDCOM ROS devices, and are retrieved at the time of SSH client authentication.

CONTENTS

- [Section 6.5.3.1, "Public Key Requirements"](#)
- [Section 6.5.3.2, "Adding a Public Key"](#)
- [Section 6.5.3.3, "Viewing a List of Public Keys"](#)
- [Section 6.5.3.4, "Updating a Public Key"](#)
- [Section 6.5.3.5, "Deleting a Public Key"](#)

Section 6.5.3.1

Public Key Requirements

Public keys are stored in a flash file, called *sshpуб.keys*. The *sshpуб.keys* file consists of ssh user public key entries. Similar to the config.csv file, each entry must be separated by an empty line. An entry has two components. They are, in sequence:

- Header
- Key

The header contains the parameters of the entry, separated by comma. The parameters are, in sequence:

- ID: A number between 0 and 9999
- Entry type: UserKey
- Access Level: (Admin, Operator or Guest)
- Revocation Status: active/inactive (always active for keys)
- User Name: This is the client's user name (not the RUGGEDCOM ROS user name). This will be used by clients to later SSH into the RUGGEDCOM ROS device.

The key must be in RFC4716 format, or in PEM format with any of the following header and footer lines:

```
-----BEGIN PUBLIC KEY-----  
-----END PUBLIC KEY-----  
  
-----BEGIN SSH2 PUBLIC KEY-----  
-----END SSH2 PUBLIC KEY-----  
  
-----BEGIN RSA PUBLIC KEY-----  
-----END RSA PUBLIC KEY-----
```

The following is an example of a valid entry in the *sshpуб.keys* file in PEM format:

```
1,userkey,admin,active,alice  
---- BEGIN SSH2 PUBLIC KEY ----  
AAAAB3NzaC1yc2EAAAABIwAAAQEA4mRrqqfk+RKXnmGRvzMyWVDSbq5VwpGGrlLQYCrjVEa  
NdbXsphqYKop8V5VUeXFRAUFz0y82yk8TF/5JxGPWq6wRNjhnYR7IY2AiMBq0+K8XeURL/  
z5K2XNRjnqTZSFwkhaUVJeduvjGg0lNN4yvgUwF3n0idU9k3E1q/na+LmYIeGhOwzCqoAc  
ipHAdR4fhD5u0jbmvjv+gDikTSZlBj9eFJfP09ekImMLHwbBry0SSBpqAKbwVdWEXIKQ47  
zz7ao2/rs3rSV16IXSq3Qe8VZh2irah0Md6JFMOX2qm9fo1I62q1DDgheCOsOiGPF4xerH  
rI2cs6FT31rAdx2JOjvw==
```

```
---- END SSH2 PUBLIC KEY ----
```

The following is an example of a valid entry in the `sshpub.keys` file in in RFC4716 format:

```
2,userkey,admin,active,bob
ssh-rsa AAAAB3NzaC1yc2EAAAADAQABAAQADH0NivR8zzbTx1ecvFPzR/
GR24NrRJa0Lc7scNsWRgi0XulHuGrRLRB5RoQ39+spdig88Y8CqhRI49XJx7uLJe0Su3RvyNYz1jkdSwHq2hSZCpukJxJ6CK95Po/
sVa5Gq2gMaHowiYDSkcx+AJywk/eM6i/jc1251RxFPdfkj74u+ob3PCvmIWz5z3WAJBrQU1IDPHDets511WMu809/
mAPZRwjqrWhRsqmcXZuv5oo54wIopCAZSo20SPzM2VmXFuUsEwDkvYMXLJK1koJPbdjH7yFFC7mwK2eMU/
oMFFn934cb05N6etsJSvplYQ4pMCw60k8Q/bB5cPSOa/rAt bob@work
```

RUGGEDCOM ROS allows only 16 user key entries to be stored. Each key entry must meet the following limits:

- Key type must be either RSA 2048 bits or RSA 3072 bits
- Key size must not exceed 4000 base64 encoded characters
- Entry Type in the header must not exceed 8 ASCII characters
- Access Level in the header must not exceed 8 ASCII characters (*operator* is maximum)
- Revocation status in the header must not exceed 8 ASCII characters (*inactive* is maximum)
- User Name must not exceed 12 ASCII characters

Section 6.5.3.2

Adding a Public Key

Administrators can add one or more public keys to RUGGEDCOM ROS.

There are two ways to update `sshpub.keys`:

- Upload a locally-created file directly to the `sshpub.keys` file. The content of the file replace the content currently stored in flash memory.
- Upload a locally-created file to the `sshaddpub.keys` file. The content of the file is appended to the existing entries in the `sshpub.keys` file.



IMPORTANT!

The content of the `sshaddpub.keys` file must follow the same syntax as the `sshpub.keys` file.

To add keys, do the following:

1. Create a public key file via a host computer.
2. Transfer the public key file to the device using SFTP or Xmodem. For more information about transferring files, refer to [Section 4.4, "Uploading/Downloading Files"](#).
3. Log in to the device as an admin user and access the CLI shell. For more information about accessing the CLI shell, refer to [Section 2.5, "Using the Command Line Interface"](#).
4. Check the system log to make sure the files were properly transferred. For more information about viewing the system log, refer to [Section 4.5.1, "Viewing Local and System Logs"](#).

Section 6.5.3.3

Viewing a List of Public Keys

Admin users can view a list of existing public keys on the device.

To view public keys, do the following:

1. Log in to the device as an admin user and access the CLI shell. For more information about accessing the CLI shell, refer to [Section 2.5, "Using the Command Line Interface"](#).
2. At the CLI prompt, type:

```
sshpubkey list
```

A list of public keys will appear, including their key ID, access level, revocation status, user name and key fingerprint.

Section 6.5.3.4

Updating a Public Key

Admin users can update public keys.

To update public keys, do the following:

1. Log in to the device as an admin user and access the CLI shell. For more information about accessing the CLI shell, refer to [Section 2.5, "Using the Command Line Interface"](#).
2. At the CLI prompt, type:

```
sshpubkey list
```

A list of public keys will appear, including their key ID, access level, revocation status, user name and key fingerprint.

3. Type the following commands to update the public keys:

Command	Description
<pre>sshpubkey update_id current_ID new_ID</pre>	Updates the ID of user public key. <div data-bbox="690 1081 1529 1197">NOTE The user public key ID must be a number between 0 and 9999.</div> <ul style="list-style-type: none">• <i>current_ID</i> is the ID currently assigned to the public key• <i>new_ID</i> is the ID that will be used to identify the public key going forward
<pre>sshpubkey update_al AL</pre>	Updates the access level of a user public key. <ul style="list-style-type: none">• <i>AL</i> is the access level (admin, operator or guest) of the public key to be updated
<pre>sshpubkey update_rs RS</pre>	Updates the revocation status (active, inactive) of a user public key. <ul style="list-style-type: none">• <i>RS</i> is the revocation status of the public key to be updated
<pre>sshpubkey update_un UN</pre>	Updates the user name of a user public key. <ul style="list-style-type: none">• <i>UN</i> is the user name of the public key to be updated

Section 6.5.3.5

Deleting a Public Key

Admin users can delete one or more public keys.

To delete a public key, do the following:

1. Log in to the device as an admin user and access the CLI shell. For more information about accessing the CLI shell, refer to [Section 2.5, "Using the Command Line Interface"](#).
2. At the CLI prompt, type:

```
vWgC+m5nmQ2SaYGz1l1zZVK3JE6qOZ/AG8k+ZEG9tsvakMliG1SoJXk=  
-----END RSA PRIVATE KEY-----
```

For SSH, DSA or RSA host key pairs must meet the requirements outlined in [Section 6.5.2, "SSH Host Key"](#).

The following is an example of a PEM formatted SSH key:

```
-----BEGIN DSA PRIVATE KEY-----  
MIIBuwIBAAKBgQD0gcGbXx/rREMu2913UW4cYo1O1cbnuUz7OZyd2mBLDx/GYbD8  
X5TnRcMraJ0RuuGK+chqQJW5k3zQmZa/BS6q9U7wYwIAx8JSxxpwfPfl/t09VwKG  
rtSJIMpLRoDq3qEwEVyR4kDUo4LFQDs1jtiyhcz1n6kd6gqsd5Xulvdh4wIVANXb  
SBi97GmZ6/9f4UCvIIBtXLEjAoGAAfmhkcCCEnRjitUTiCE+MurxdFUr3mFs/d31  
4cUDaLStQEhYmx5dbFdQuapl4Y32B7lZQkohl5q1TliUAa40/nUnJx1hFvblkYT  
8DLwxcuDAaiu0VqsaPtJ+baL2dYNp96tFisj/475PEEWBGbP6GSe5kKalZdgwue  
9LyPb+ACgYBv856v5tb9UVG5+tX5Crfv/Nd8FF1SSFkmVWW3yzguhHajg2LQg8UU  
sm1/zPSwYQ0SbQ9aOAJnpLc2HUK01ji/0oKVI7y9MMc4B+bGu4W4OnryP7oFpnp  
YYHt5PJY+zvLw/Wa+u3NOVFHkF1tGyfvBMXeV36nowPo+wrVMolAEgIVALLTnfpW  
maV6uh6RxeE1d4XoxSg2  
-----END DSA PRIVATE KEY-----
```

7 Layer 2

This chapter describes the Layer 2, or Data Link Layer (DLL), features of RUGGEDCOM ROS.

CONTENTS

- [Section 7.1, “Managing Virtual LANs”](#)
- [Section 7.2, “Managing MAC Addresses”](#)
- [Section 7.3, “Managing Multicast Filtering”](#)

Section 7.1

Managing Virtual LANs

A Virtual Local Area Network (VLAN) is a group of devices on one or more LAN segments that communicate as if they were attached to the same physical LAN segment. VLANs are extremely flexible because they are based on logical connections, rather than physical connections.

When VLANs are introduced, all traffic in the network must belong to one VLAN or another. Traffic on one VLAN cannot pass to another, except through an inter-network router or Layer 3 switch.

VLANs are created in three ways:

- **Explicitly**
Static VLANs can be created in the switch. For more information about static VLANs, refer to [Section 7.1.5, “Managing Static VLANs”](#).
- **Implicitly**
When a VLAN ID (VID) is set for a port-based VLAN, static MAC address or IP interface, an appropriate VLAN is automatically created if it does not yet exist.
- **Dynamically**
VLANs can be learned through GVRP. For more information about GVRP, refer to [Section 7.1.1.8, “GARP VLAN Registration Protocol \(GVRP\)”](#)

For more information about VLANs, refer to [Section 7.1.1, “VLAN Concepts”](#).

CONTENTS

- [Section 7.1.1, “VLAN Concepts”](#)
- [Section 7.1.2, “Viewing a List of VLANs”](#)
- [Section 7.1.3, “Configuring VLANs Globally”](#)
- [Section 7.1.4, “Configuring VLANs for Specific Ethernet Ports”](#)
- [Section 7.1.5, “Managing Static VLANs”](#)

Section 7.1.1

VLAN Concepts

This section describes some of the concepts important to the implementation of VLANs in RUGGEDCOM ROS.

CONTENTS

- [Section 7.1.1.1, "Tagged vs. Untagged Frames"](#)
- [Section 7.1.1.2, "Native VLAN"](#)
- [Section 7.1.1.3, "The Management VLAN"](#)
- [Section 7.1.1.4, "Edge and Trunk Port Types"](#)
- [Section 7.1.1.5, "Ingress and Egress Rules"](#)
- [Section 7.1.1.6, "Forbidden Ports List"](#)
- [Section 7.1.1.7, "VLAN-Aware and VLAN-Unaware Modes"](#)
- [Section 7.1.1.8, "GARP VLAN Registration Protocol \(GVRP\)"](#)
- [Section 7.1.1.9, "PVLAN Edge"](#)
- [Section 7.1.1.10, "QinQ"](#)
- [Section 7.1.1.11, "VLAN Advantages"](#)

Section 7.1.1.1

Tagged vs. Untagged Frames

VLAN tags identify frames as part of a VLAN network. When a switch receives a frame with a VLAN (or 802.1Q) tag, the VLAN identifier (VID) is extracted and the frame is forwarded to other ports on the same VLAN.

When a frame does not contain a VLAN tag, or contains an 802.1p (prioritization) tag that only has prioritization information and a VID of 0, it is considered an untagged frame.

Section 7.1.1.2

Native VLAN

Each port is assigned a native VLAN number, the Port VLAN ID (PVID). When an untagged frame ingresses a port, it is associated with the port's native VLAN.

By default, when a switch transmits a frame on the native VLAN, it sends the frame untagged. The switch can be configured to transmit tagged frames on the native VLAN.

Section 7.1.1.3

The Management VLAN

Management traffic, like all traffic on the network, must belong to a specific VLAN. The management VLAN is configurable and always defaults to VLAN 1. This VLAN is also the default native VLAN for all ports, thus allowing all ports the possibility of managing the product. Changing the management VLAN can be used to restrict management access to a specific set of users.

Section 7.1.1.4

Edge and Trunk Port Types

Each port can be configured as an edge or trunk port.

An edge port attaches to a single end device, such as a PC or Intelligent Electronic Device (IED). An edge port carries traffic on the native VLAN.

Trunk ports are part of the network and carry traffic for all VLANs between switches. Trunk ports are automatically members of all VLANs configured in the switch.

The switch can 'pass through' traffic, forwarding frames received on one trunk port out of another trunk port. The trunk ports must be members of all VLANs that the 'pass through' traffic is part of, even if none of those VLANs are used on edge ports.

Frames transmitted out of the port on all VLANs other than the port's native VLAN are always sent tagged.

**NOTE**

It may be desirable to manually restrict the traffic on the trunk to a specific group of VLANs. For example, when the trunk connects to a device, such as a Layer 3 router, that supports a subset of the available VLANs. To prevent the trunk port from being a member of the VLAN, include it in the VLAN's Forbidden Ports list.

For more information about the Forbidden Ports list, refer to [Section 7.1.1.6, "Forbidden Ports List"](#).

Port Type	VLANs Supported	PVID Format	Usage
Edge	1 (Native) Configured	Untagged	<i>VLAN Unaware Networks:</i> All frames are sent and received without the need for VLAN tags.
		Tagged	<i>VLAN Aware Networks:</i> VLAN traffic domains are enforced on a single VLAN.
Trunk	All Configured	Tagged or Untagged	<i>Switch-to-Switch Connections:</i> VLANs must be manually created and administered, or can be dynamically learned through GVRP. <i>Multiple-VLAN End Devices:</i> Implement connections to end devices that support multiple VLANs at the same time.

Section 7.1.1.5

Ingress and Egress Rules

Ingress and egress rules determine how traffic is received and transmitted by the switch.

Ingress rules are applied as follows to all frame when they are received by the switch:

- If an incoming frame is untagged or has a VID of 0 (priority tagged), the frame is associated with the ingress port's PVID
- If an incoming frame is tagged, the frame is allowed to pass, while keeping its VID
- Incoming frames are only dropped if ingress filtering is enabled and the frame is tagged with a VID that does not match any VLAN to which the ingress port is a member

Egress rules are applied as follows to all frames when they are transmitted by the switch.

- If PVID tagging is enabled, outgoing frames are tagged if they are associated with the egress port's native VLAN, regardless of the egress port's membership type (edge or trunk)
- Frames egressing on an edge interface are dropped if they are associated with a VLAN other than the egress port's native VLAN

- Frames egressing on a trunk interface are tagged if they are associated with a VLAN to which the egress port is a member

Section 7.1.1.6

Forbidden Ports List

Each VLAN can be configured to exclude ports from membership in the VLAN using the forbidden ports list. For more information, refer to [Section 7.1.5.2, "Adding a Static VLAN"](#).

Section 7.1.1.7

VLAN-Aware and VLAN-Unaware Modes

The native operation mode for an IEEE 802.1Q compliant switch is VLAN-aware. Even if a specific network architecture does not use VLANs, RUGGEDCOM ROS's default VLAN settings allow the switch to still operate in a VLAN-aware mode, while providing functionality required for almost any network application. However, the IEEE 802.1Q standard defines a set of rules that must be followed by all VLAN-aware switches:

- Valid VIDs are within the range of 1 to 4094. VIDs equal to 0 or 4095 are invalid.
- Each frame ingressing a VLAN-aware switch is associated with a valid VID.
- Each frame egressing a VLAN-aware switch is either untagged or tagged with a valid VID. Priority-tagged frames with an invalid VID will never sent out by a VLAN-aware switch.

**NOTE**

Some applications have requirements conflicting with IEEE 802.Q1 native mode of operation. For example, some applications explicitly require priority-tagged frames to be received by end devices.

To avoid conflicts and provide full compatibility with legacy (VLAN-unaware) devices, RUGGEDCOM ROS can be configured to work in VLAN-unaware mode.

In that mode:

- *Frames ingressing a VLAN-unaware device are not associated with any VLAN*
- *Frames egressing a VLAN-unaware device are sent out unmodified (i.e. in the same untagged, 802.1Q-tagged or priority-tagged format as they were received)*

Section 7.1.1.8

GARP VLAN Registration Protocol (GVRP)

GARP VLAN Registration Protocol (GVRP) is a standard protocol built on GARP (Generic Attribute Registration Protocol) to automatically distribute VLAN configuration information in a network. Each switch in a network needs only to be configured with VLANs it requires locally. VLANs configured elsewhere in the network are learned through GVRP. A GVRP-aware end station (i.e. PC or Intelligent Electronic Device) configured for a particular VID can be connected to a trunk on a GVRP-aware switch and automatically become part of the desired VLAN.

When a switch sends GVRP bridge protocol data units (BPDUs) out of all GVRP-enabled ports, GVRP BPDUs advertise all the VLANs known to that switch (configured manually or learned dynamically through GVRP) to the rest of the network.

When a GVRP-enabled switch receives a GVRP BPDU advertising a set of VLANs, the receiving port becomes a member of those advertised VLANs and the switch begins advertising those VLANs through all the GVRP-enabled ports (other than the port on which the VLANs were learned).

To improve network security using VLANs, GVRP-enabled ports may be configured to prohibit the learning of any new dynamic VLANs but at the same time be allowed to advertise the VLANs configured on the switch.

The following is an example of how to use GVRP:

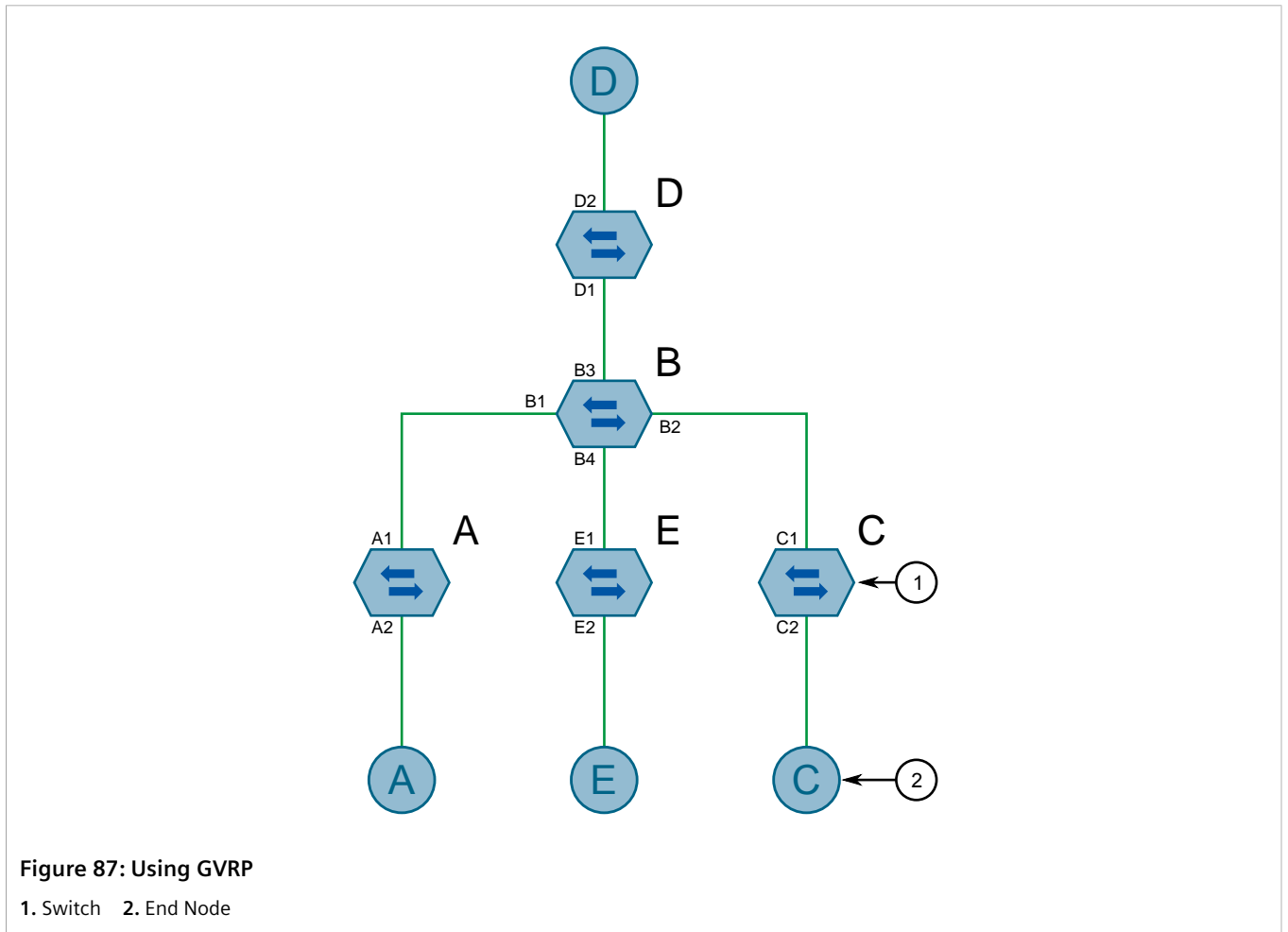

- Switch B is the core switch, all others are edge switches
- Ports A1, B1 to B4, C1, D1, D2 and E1 are GVRP aware
- Ports B1 to B4, D1 and D2 are set to advertise and learn
- Ports A1, C1 and E1 are set to advertise only
- Ports A2, C2 and E2 are edge ports
- End node D is GVRP aware
- End nodes A, E and C are GVRP unaware
- Ports A2 and C2 are configured with PVID 7
- Port E2 is configured with PVID 20
- End node D is interested in VLAN 20, hence VLAN 20 is advertised by it towards switch D
- D2 becomes a member of VLAN 20
- Ports A1 and C1 advertise VID 7
- Ports B1 and B2 become members of VLAN 7

- Ports B1, B2 and D1 advertise VID 20
- Ports B3, B4 and D1 become members of VLAN 20

For more information about how to configure GVRP, refer to [Section 7.1.4, “Configuring VLANs for Specific Ethernet Ports”](#).

Section 7.1.1.9

PVLAN Edge

Private VLAN (PVLAN) Edge isolates multiple VLAN Edge ports from each other on a single device. When VLAN Edge ports are configured as *protected*, they are prohibited from sending frames to one another, but are still permitted to send frames to other, non-protected ports within the same VLAN. This protection extends to all traffic on the VLAN, including unicast, multicast and broadcast traffic.

For more information about how to configure a port as *protected*, refer to [Section 7.1.4, “Configuring VLANs for Specific Ethernet Ports”](#).



NOTE

This feature is strictly local to the switch. PVLAN Edge ports are not prevented from communicating with ports outside of the switch, whether protected (remotely) or not.

Section 7.1.1.10

QinQ

QinQ, also referred to as Stacked VLANs, port bridging, double VLAN-tagging and Nested VLANs, is used to overlay a private Layer 2 network over a public Layer 2 network.

A large network service provider, for example, might have several clients whose networks each use multiple VLANs. It is likely the VLAN IDs used by these different client networks would conflict with one another, were they mixed together in the provider's network. Using double QinQ, each client network could be further tagged using a client-specific VID at the edges where the clients' networks are connected to the network service provider's infrastructure.

Any tagged frames ingressing an edge port of the service provider's switch are tagged with VIDs of the customer's private network. When those frames egress the switch's QinQ-enabled port into the service provider network, the switch always adds an extra tag (called an *outer tag*) on top of the frame's original VLAN tag (called an *inner tag*). The outer tag VID is the PVID of the frame's ingress edge port. This means that traffic from an individual customer is tagged with their unique VID and is thus segregated from other customers' traffic. For untagged ingress frames, the switch will only add the outer VLAN tag.

Within the service provider network, switching is based on the VID in the outer tag.

The service provider strips the outer VID from the frame on egress, leaving the frame with its original VLAN ID tag. Those frames are then forwarded on the appropriate VLANs.

The following figure shows an example of traffic flow using QinQ.

For tagged frames:

- Frames received from customer 1 with VID 100 would carry an inner tag of 100 and an outer tag of VID X (i.e. VLAN 110) which is configured on the edge port connected to customer 1.
- Next, the frames from customer 1 are forwarded through the QinQ port carrying an inner and an outer tag.
- Finally, upon arrival of the frames in the peer switch, the outer VLAN tag is removed and the frames are forwarded with the inner VLAN tag towards customer 1.

For untagged frames:

- Frames received from customer 2 would carry an outer tag of VID Y(i.e VLAN 220) which is configured on the edge port connected to customer 2.
- Next, the frames from customer 2 are forwarded through the QinQ port carrying the outer tag.
- Finally, upon arrival of the frames in the peer switch, the outer VLAN tag is removed before the frames are forwarded to customer 2.

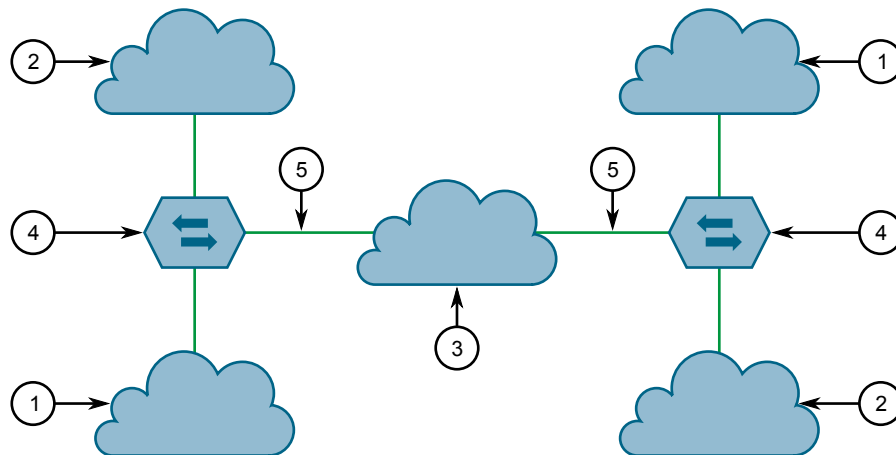

Figure 88: Using QinQ

1. Customer 1 (PVID is X) 2. Customer 2 (PVID is Y) 3. Network Service Provider Infrastructure 4. Switch 5. QinQ



NOTE

Depending on the hardware installed, some switch models allow only one switch port be configured to QinQ mode at a time.



NOTE

When QinQ is enabled, all non-QinQ ports will be untagged and cannot be changed, and all QinQ ports will be tagged, and cannot be changed.

Section 7.1.1.11

VLAN Advantages

The following are a few of the advantages offered by VLANs.

» Traffic Domain Isolation

VLANs are most often used for their ability to restrict traffic flows between groups of devices.

Unnecessary broadcast traffic can be restricted to the VLAN that requires it. Broadcast storms in one VLAN need not affect users in other VLANs.

Hosts on one VLAN can be prevented from accidentally or deliberately assuming the IP address of a host on another VLAN.

The use of creative bridge filtering and multiple VLANs can carve seemingly unified IP subnets into multiple regions policed by different security/access policies.

Multi-VLAN hosts can assign different traffic types to different VLANs.

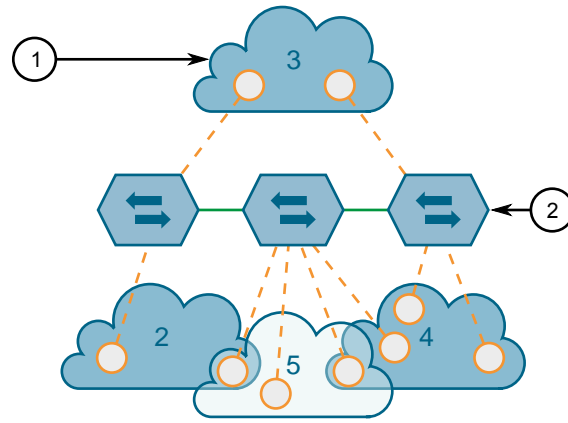

Figure 89: Multiple Overlapping VLANs

1. VLAN 2. Switch

» Administrative Convenience

VLANs enable equipment moves to be handled by software reconfiguration instead of by physical cable management. When a host's physical location is changed, its connection point is often changed as well. With VLANs, the host's VLAN membership and priority are simply copied to the new port.

» Reduced Hardware

Without VLANs, traffic domain isolation requires the use of separate bridges for separate networks. VLANs eliminate the need for separate bridges.

The number of network hosts may often be reduced. Often, a server is assigned to provide services for independent networks. These hosts may be replaced by a single, multi-horned host supporting each network on its own VLAN. This host can perform routing between VLANs.

Multi-VLAN hosts can assign different traffic types to different VLANs.

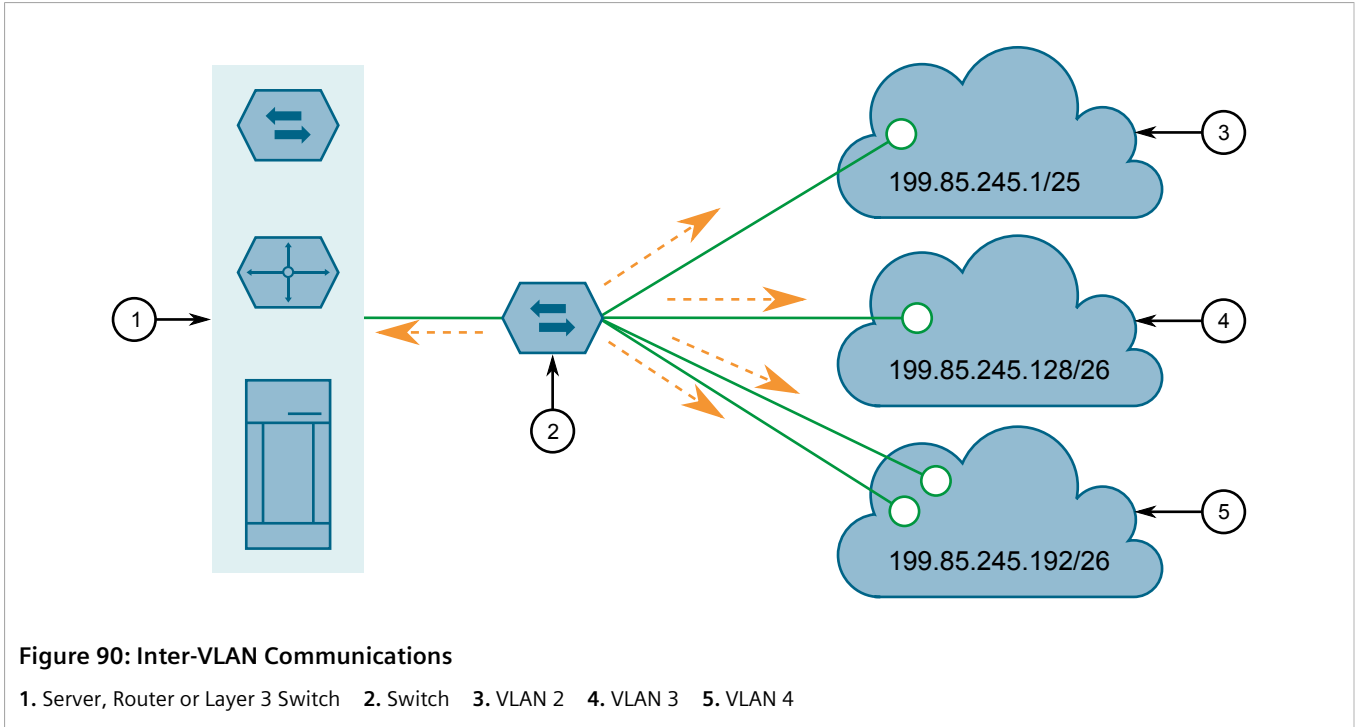

Section 7.1.2

Viewing a List of VLANs

To view a list of all VLANs, whether they were created statically, implicitly or dynamically, navigate to **Virtual LANs » View VLAN Summary**. The **VLAN Summary** table appears.

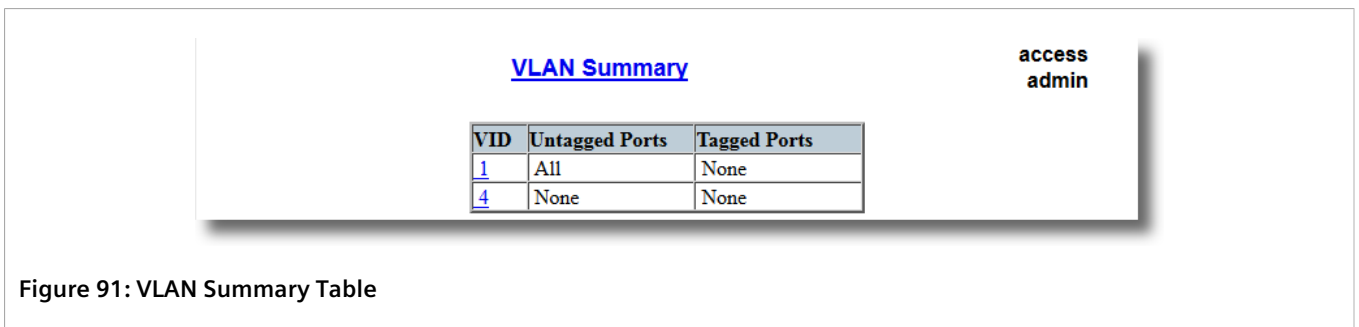

If a VLANs are not listed, add static VLANs as needed. For more information, refer to [Section 7.1.5.2, “Adding a Static VLAN”](#).

Section 7.1.3

Configuring VLANs Globally

To configure global settings for all VLANs, do the following:

1. Navigate to **Virtual LANs » Configure Global VLAN Parameters**. The **Global VLAN Parameters** form appears.

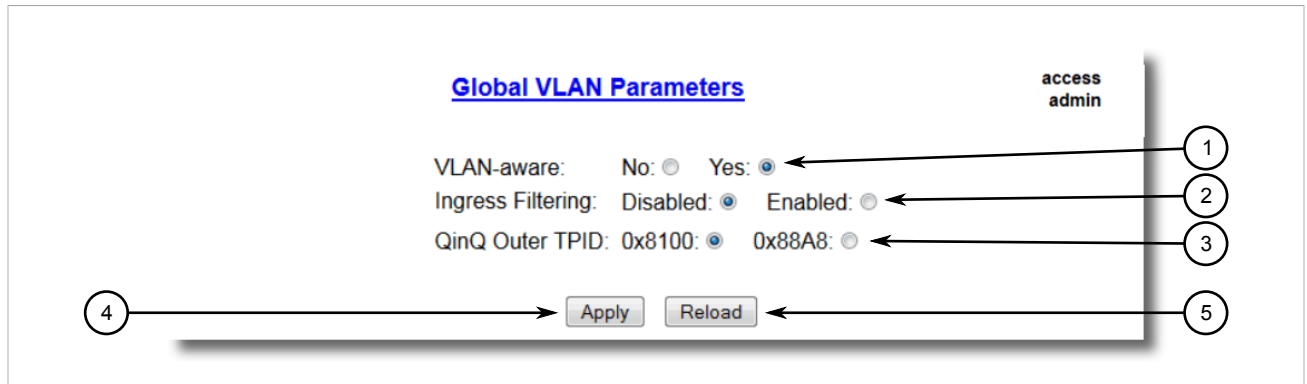

Figure 92: Global VLAN Parameters Form

1. VLAN-aware Options 2. Ingress Filtering Options 3. QinQ Outer TPID options 4. Apply Button 5. Reload Button

2. Configure the following parameter(s) as required:

Parameter	Description
VLAN-aware	<p>Synopsis: { No, Yes }</p> <p>Default: Yes</p> <p>Set either VLAN-aware or VLAN-unaware mode of operation.</p>
Ingress Filtering	<p>Synopsis: { Disabled, Enabled }</p> <p>Default: Disabled</p> <p>Enables or disables VLAN ingress filtering on all ports. When enabled, any tagged packet arriving at a port, which is not a member of a VLAN with which that packet is associated, is dropped. When disabled, packets are not dropped.</p> <div style="border: 1px solid gray; padding: 5px; margin-top: 10px;"> <p>NOTE Ingress filtering has no effect when ports are in either VLAN-unaware mode or Q-in-Q mode.</p> </div>
QinQ Outer TPID	<p>Synopsis: { 0x8100, 0x88A8 }</p> <p>Default: 0x8100</p> <p>Selects an Ethertype to be used as the Tag Protocol Identifier (TPID) on VLAN QinQ ports when QinQ is enabled. Frames that ingress a VLAN QinQ port will be identified as outer VLAN tagged if the first Ethertype matches this value; an outer VLAN tag with the TPID field assigned to this value will be inserted to frames that egress a VLAN QinQ port.</p> <div style="border: 1px solid gray; padding: 5px; margin-top: 10px;"> <p>NOTE When QinQ is enabled, all non-QinQ ports will be untagged and cannot be changed, and all QinQ ports will be tagged, and cannot be changed.</p> </div>

3. Click **Apply**.

Section 7.1.4

Configuring VLANs for Specific Ethernet Ports

When a VLAN ID is assigned to an Ethernet port, the VLAN appears in the VLAN Summary table where it can be further configured.

To configure a VLAN for a specific Ethernet port, do the following:

1. Navigate to **Virtual LANs » Configure Port VLAN Parameters**. The **Port VLAN Parameters** table appears.

Port(s)	Type	PVID	PVID Format	GVRP
1	Edge	1	Untagged	Disabled
2	Edge	1	Untagged	Disabled
3	Edge	1	Untagged	Disabled
4	Edge	1	Untagged	Disabled
5	Edge	1	Untagged	Disabled
6	Edge	1	Untagged	Disabled
7	Edge	1	Untagged	Disabled
8	Edge	1	Untagged	Disabled
9	Edge	1	Untagged	Disabled
10	Edge	1	Untagged	Disabled

access admin

Figure 93: Port VLAN Parameters Table

2. Select a port. The **Port VLAN Parameters** form appears.

Port VLAN Parameters

access admin

Port(s): 1

Type: Edge

PVID: 1

PVID Format: Untagged: Tagged:

GVRP: Disabled



Apply Reload

1. Port(s) Box 2. Type List 3. PVID Box 4. PVID Format Options 5. GVRP List 6. Apply Button 7. Reload Button

Figure 94: Port VLAN Parameters Form

3. Configure the following parameter(s) as required:

Parameter	Description
Port(s)	Synopsis: Any combination of numbers valid for this parameter The port number as seen on the front plate silkscreen of the switch (or a list of ports, if aggregated in a port trunk).
Type	Synopsis: { Edge, Trunk, PVLANEdge, QinQ } Default: Edge This parameter specifies how the port determines its membership in VLANs. There are few types of ports: <ul style="list-style-type: none"> • Edge – the port is only a member of one VLAN (its native VLAN specified by the <i>PVID</i> parameter). • Trunk – the port is automatically a member of all configured VLANs. Frames transmitted out of the port on all VLANs except the port's native VLAN will be always tagged. It can also be configured to use GVRP for automatic VLAN configuration.

Parameter	Description
	<ul style="list-style-type: none"> PVLANEdge – the port is only a member of one VLAN (its native VLAN specified by the <i>PVID</i> parameter), and does not forward traffic to other PVLANEdge ports within the same VLAN. QinQ – the port is a trunk port using double-VLAN tagging, or nested VLANs. An extra VLAN tag is always added to all frames egressing this port. VID in the added extra tag is the PVID of the frame's ingress port. VLAN tag is always stripped from frames ingressing this port. <div style="border: 1px solid gray; padding: 5px; margin-top: 10px;">  NOTE <i>Depending on the hardware installed, some switch models allow only one switch port be configured to QinQ mode at a time.</i> </div>
PVID	<p>Synopsis: 1 to maximum port number Default: 1</p> <p>The Port VLAN Identifier specifies the VLAN ID associated with untagged (and 802.1p priority tagged) frames received on this port.</p> <p>Frames tagged with a non-zero VLAN ID will always be associated with the VLAN ID retrieved from the frame tag.</p> <p>Modify this parameter with care! By default, the switch is programmed to use VLAN 1 for management and every port on the switch is programmed to use VLAN 1. If you modify a switch port to use a VLAN other than the management VLAN, devices on that port will not be able to manage the switch.</p>
PVID Format	<p>Synopsis: { Untagged, Tagged } Default: Untagged</p> <p>Specifies whether frames transmitted out of the port on its native VLAN (specified by the <i>PVID</i> parameter) will be tagged or untagged.</p> <div style="border: 1px solid gray; padding: 5px; margin-top: 10px;">  NOTE <i>When QinQ is enabled, all non-QinQ ports will be untagged and cannot be changed, and all QinQ ports will be tagged, and cannot be changed.</i> </div>
GVRP	<p>Synopsis: { Adv&Learn, Adv Only, Disabled } Default: Disabled</p> <p>Configures GVRP (Generic VLAN Registration Protocol) operation on the port. There are several GVRP operation modes:</p> <ul style="list-style-type: none"> Adv&Learn – the port will declare all VLANs existing in the switch (configured or learned) and can dynamically learn VLANs. Adv Only ONLY – the port will declare all VLANs existing in the switch (configured or learned) but will not learn any VLANs. Disabled – the port is not capable of any GVRP processing. <p>Only Trunk ports are GVRP-capable.</p>

4. Click **Apply**.

Section 7.1.5

Managing Static VLANs

This section describes how to configure and manage static VLANs.

CONTENTS

- [Section 7.1.5.1, “Viewing a List of Static VLANs”](#)
- [Section 7.1.5.2, “Adding a Static VLAN”](#)

- [Section 7.1.5.3, “Deleting a Static VLAN”](#)

Section 7.1.5.1

Viewing a List of Static VLANs

To view a list of static VLANs, navigate to *Virtual LANs » Configure Static VLANs*. The **Static VLANs** table appears.

VID	VLAN Name	Forbidden Ports	IGMP	MSTI
1	Management VLAN	None	Off	0
10	SCADA IEDs	None	On	0
11	Metering IEDs	None	On	0
12	Protection IEDs	3-6	Off	0

Figure 95: Static VLANs Table

If a static VLAN is not listed, add the VLAN. For more information, refer to [Section 7.1.5.2, “Adding a Static VLAN”](#).

Section 7.1.5.2

Adding a Static VLAN

To add a static VLAN, do the following:

1. Navigate to *Virtual LANs » Configure Static VLANs*. The **Static VLANs** table appears.

VID	VLAN Name	Forbidden Ports	IGMP	MSTI
1	Management VLAN	None	Off	0
10	SCADA IEDs	None	On	0
11	Metering IEDs	None	On	0
12	Protection IEDs	3-6	Off	0

Figure 96: Static VLANs Table

1. InsertRecord

2. Click **InsertRecord**. The **Static VLANs** form appears.

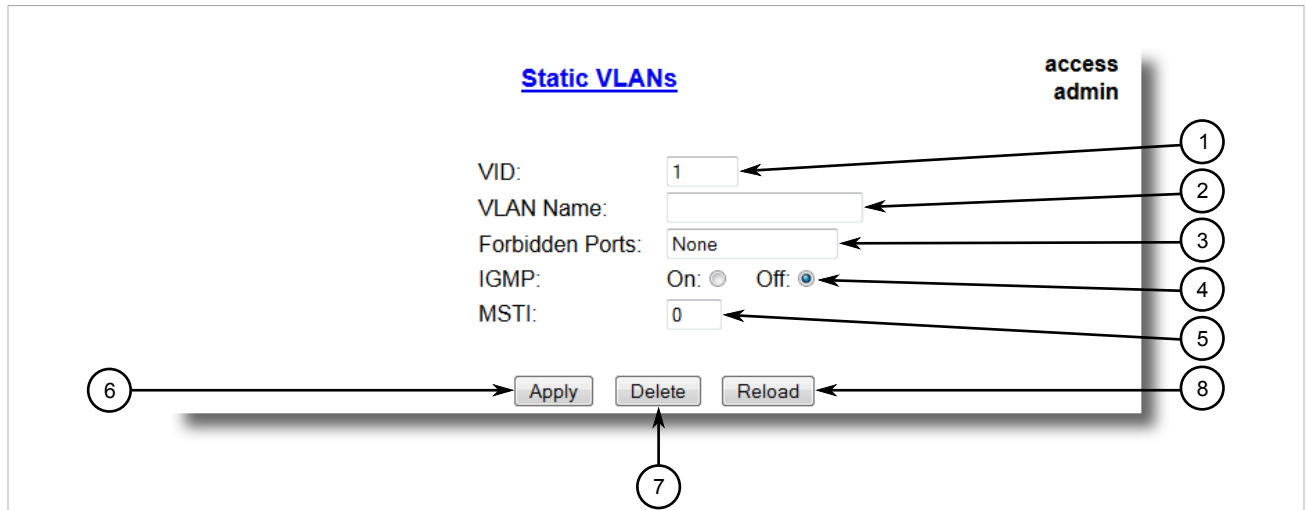

Figure 97: Static VLANs Form

1. VID Box 2. VLAN Name Box 3. Forbidden Ports Box 4. IGMP Options 5. MSTI Box 6. Apply Button 7. Delete Button 8. Reload Button

3. Configure the following parameter(s) as required:



NOTE

If IGMP Options is not enabled for the VLAN, both IGMP messages and multicast streams will be forwarded directly to all members of the VLAN. If any one member of the VLAN joins a multicast group, then all members of the VLAN will receive the multicast traffic.

Parameter	Description
VID	<p>Synopsis: 1 to 4094 Default: 1</p> <p>The VLAN Identifier is used to identify the VLAN in tagged Ethernet frames according to IEEE 802.1Q.</p>
VLAN Name	<p>Synopsis: Any 19 characters</p> <p>The VLAN name provides a description of the VLAN purpose (for example, Engineering VLAN).</p>
Forbidden Ports	<p>Synopsis: Any combination of numbers valid for this parameter or { None }</p> <p>These are ports that are not allowed to be members of the VLAN.</p> <p>Examples:</p> <ul style="list-style-type: none"> • None – all ports of the switch are allowed to be members of the VLAN • 2, 4-6, 8 – all ports except ports 2, 4, 6, 7 and 8 are allowed to be members of the VLAN
IGMP	<p>Synopsis: { Off, On }</p> <p>Default: Off</p> <p>This parameter enables or disables IGMP Snooping on the VLAN.</p>
MSTI	<p>Synopsis: 0 to 16 Default: 0</p> <p>This parameter is only valid for Multiple Spanning Tree Protocol (MSTP) and has no effect if MSTP is not used. The parameter specifies the Multiple Spanning Tree Instance (MSTI) to which the VLAN should be mapped.</p>

4. Click **Apply**.

Section 7.1.5.3

Deleting a Static VLAN

To delete a static VLAN, do the following:

1. Navigate to **Virtual LANs » Configure Static VLANs**. The **Static VLANs** table appears.

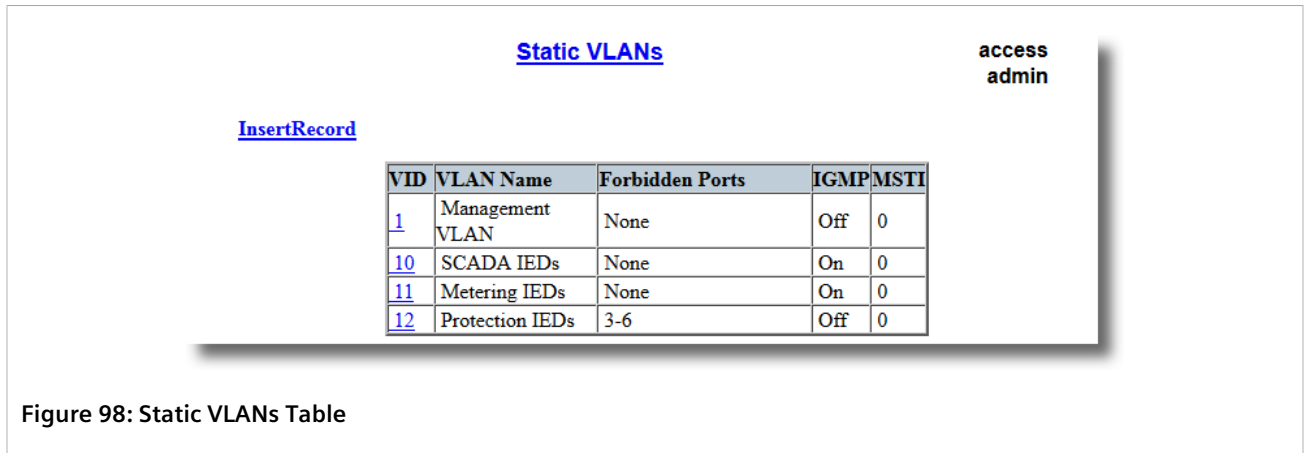

Figure 98: Static VLANs Table

2. Select the static VLAN from the table. The **Static VLANs** form appears.

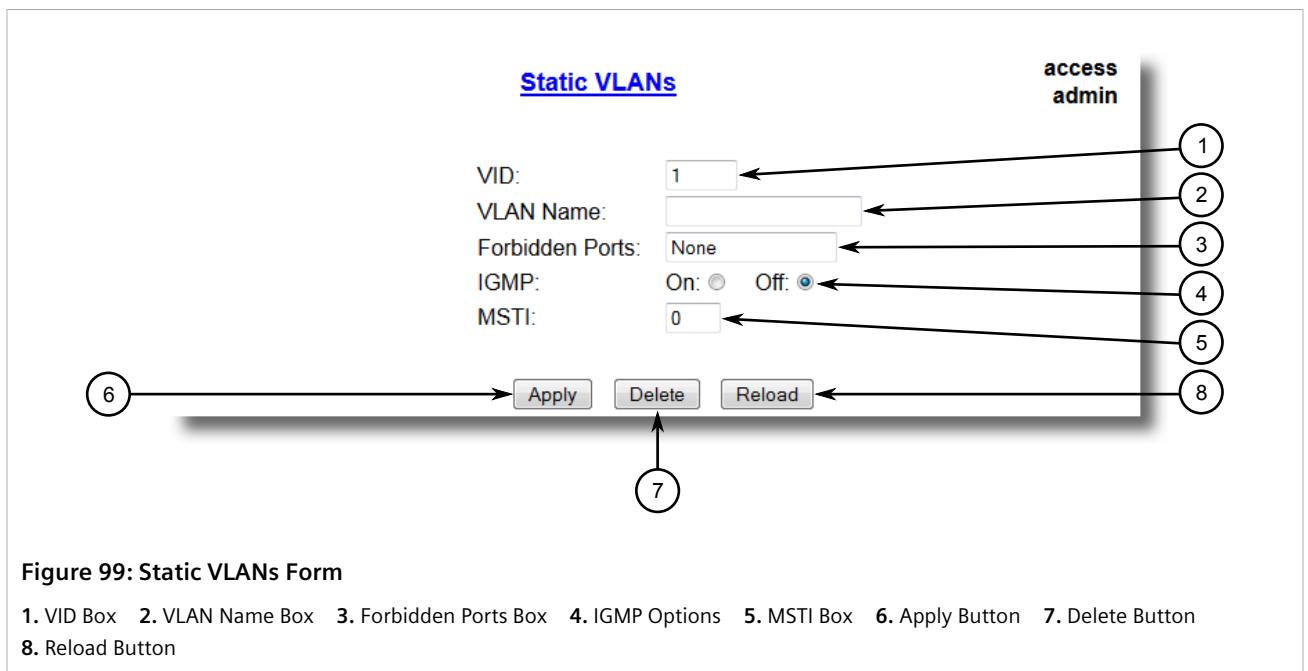

Figure 99: Static VLANs Form

1. VID Box
2. VLAN Name Box
3. Forbidden Ports Box
4. IGMP Options
5. MSTI Box
6. Apply Button
7. Delete Button
8. Reload Button

3. Click **Delete**.

Section 7.2

Managing MAC Addresses

This section describes how to manage MAC addresses.

CONTENTS

- [Section 7.2.1, “Viewing a List of MAC Addresses”](#)
- [Section 7.2.2, “Configuring MAC Address Learning Options”](#)
- [Section 7.2.3, “Configuring MAC Address Flooding Options”](#)
- [Section 7.2.4, “Managing Static MAC Addresses”](#)
- [Section 7.2.5, “Purging All Dynamic MAC Addresses”](#)

Section 7.2.1

Viewing a List of MAC Addresses

To view a list of all static and dynamically learned MAC addresses, navigate to **MAC Address Tables » View MAC Addresses**. The **MAC Addresses** table appears.

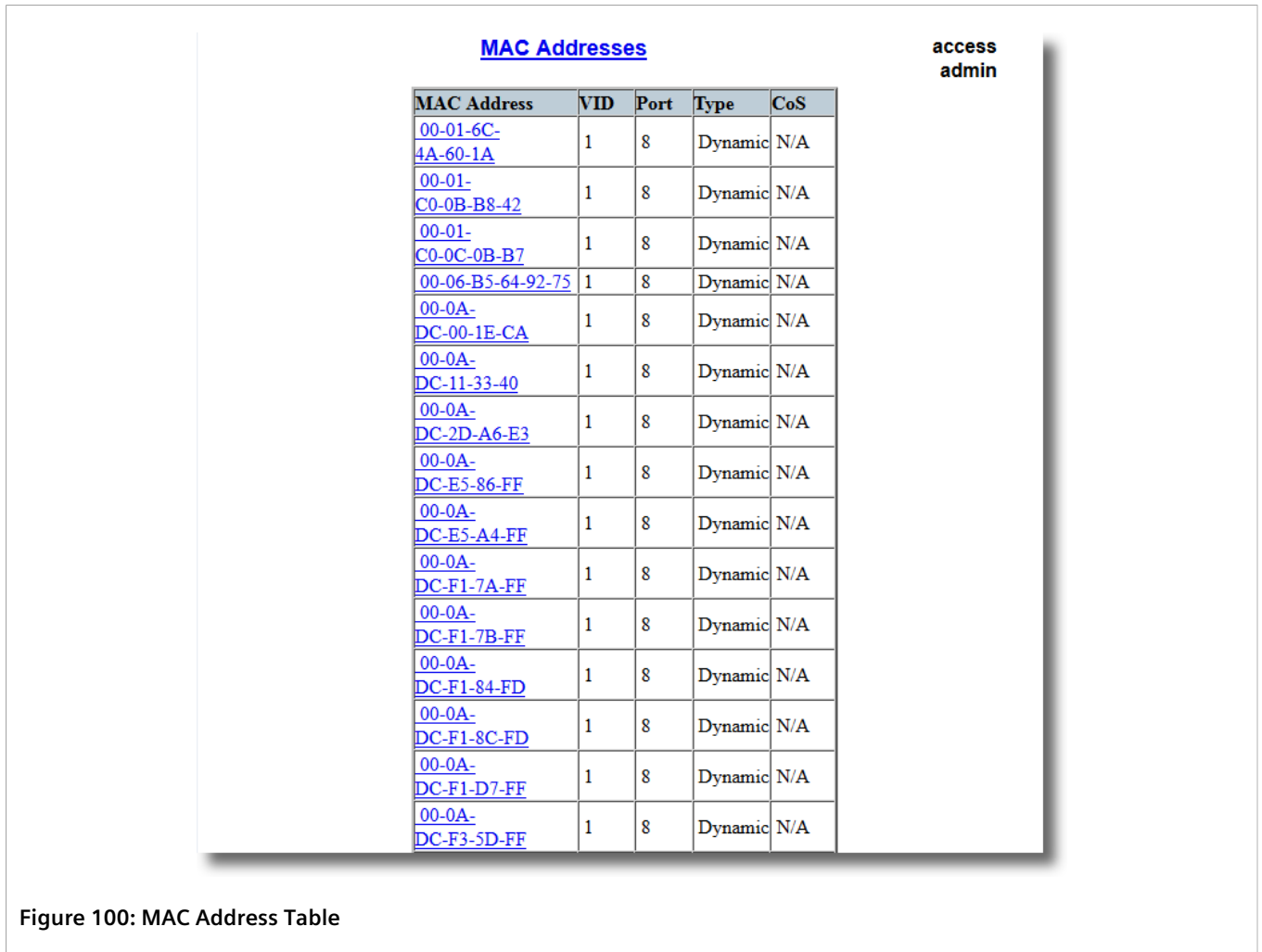

Figure 100: MAC Address Table

If a MAC address is not listed, do the following:

1. Configure the MAC address learning options to control the aging time of dynamically learned MAC addresses of other devices on the network. For more information, refer to [Section 7.2.2, "Configuring MAC Address Learning Options"](#).
2. Configure the address on the device as a static MAC address. For more information, refer to [Section 7.2.4.2, "Adding a Static MAC Address"](#).

Section 7.2.2

Configuring MAC Address Learning Options

The MAC address learning options control how and when MAC addresses are removed automatically from the MAC address table. Individual addressees are removed when the aging timer is exceeded. Addresses can also be removed when a link failure or topology change occurs.

To configure the MAC address learning options, do the following:

1. Navigate to **MAC Address Tables » Configure MAC Address Learning Options**. The **MAC Address Learning Options** form appears.

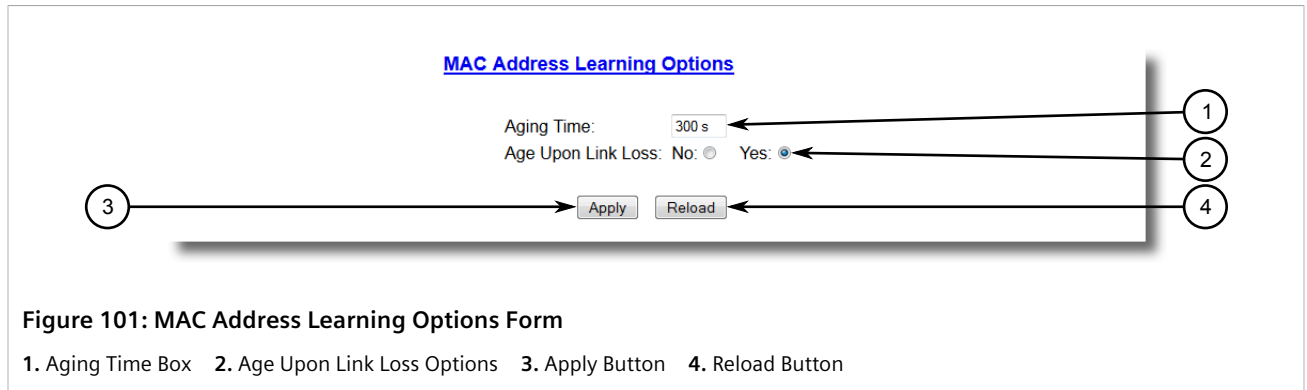

2. Configure the following parameter(s) as required:

Parameter	Description
Aging Time	<p>Synopsis: 15 to 800 Default: 300 s</p> <p>This parameter configures the time that a learned MAC address is held before being aged out.</p>
Age Upon Link Loss	<p>Synopsis: { No, Yes } Default: Yes</p> <p>When set to Yes, all MAC addresses learned on a failed port will be aged-out immediately upon link failure detection.</p> <p>When link failure occurs the switch may have some MAC addresses previously learned on the failed port. As long as those addresses are not aged-out the switch will still be forwarding traffic to that port, thus preventing that traffic from reaching its destination via the new network topology.</p> <p>Note that when a network redundancy protocol, e.g. RSTP/MSTP, is enabled on the switch, that redundancy protocol may, upon a link failure, flush MAC addresses learned on the failed port regardless of the setting of this parameter.</p>

3. Click **Apply**.

Section 7.2.3

Configuring MAC Address Flooding Options

To configure the MAC address flooding options, do the following:

1. Navigate to **MAC Address Tables » Configure MAC Address Flooding Options**. The **Flooding Options** table appears.

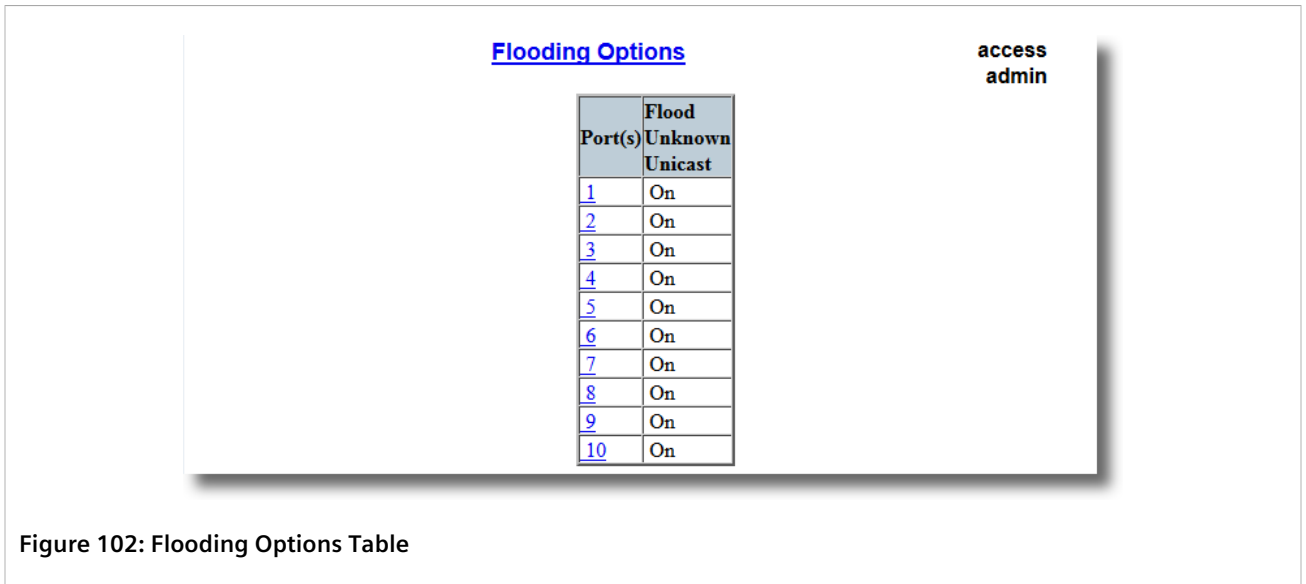

Figure 102: Flooding Options Table

- Select a port. The **Flooding Options** form appears.

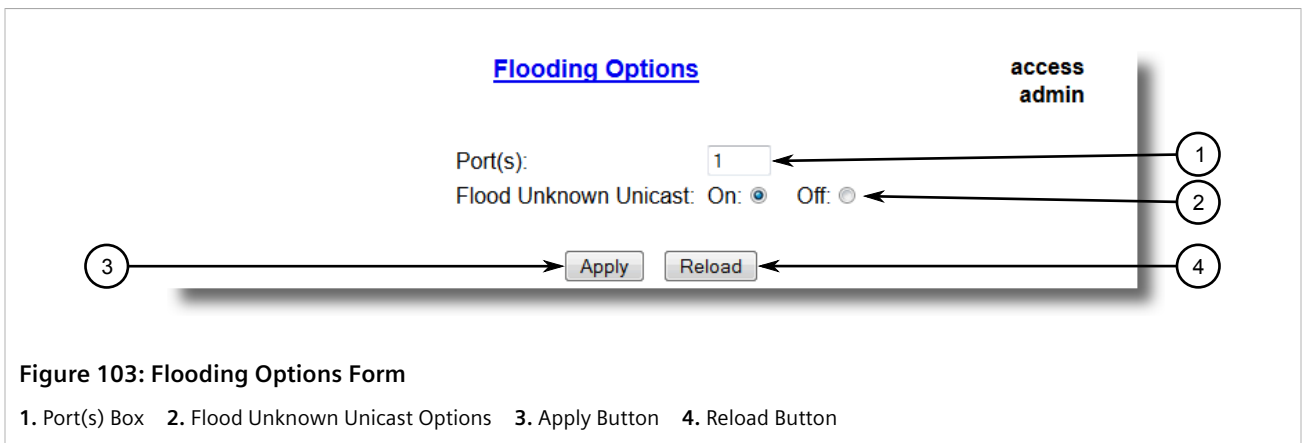

Figure 103: Flooding Options Form

- Port(s) Box
- Flood Unknown Unicast Options
- Apply Button
- Reload Button

- Configure the following parameter(s) as required:

Parameter	Description
Port(s)	Synopsis: Comma-separated list of ports The port number as seen on the front plate silkscreen of the switch (or a list of ports, if aggregated in a port trunk).
Flood Unknown Unicast	Synopsis: { On, Off } Default: On Normally, unicast traffic with an unknown destination address is flooded out of all ports. When a port is configured to turn off this kind of flooding, the unknown unicast traffic is not sent out from the selected port.

- Click **Apply**.

Section 7.2.4

Managing Static MAC Addresses

Static MAC addresses must be configured when the device is only able to receive frames, not transmit them. They may also need to be configured if port security (if supported) must be enforced.

Prioritized MAC addresses are configured when traffic to or from a specific device on a LAN segment is to be assigned a higher CoS priority than other devices on that LAN segment.

**NOTE**

A MAC address cannot be learned on a VLAN that has not been configured in the Static VLAN table. If a frame with an unknown VLAN tag arrives on a secured port, it is considered a security violation and RUGGEDCOM ROS will generate a port security alarm.

CONTENTS

- [Section 7.2.4.1, “Viewing a List of Static MAC Addresses”](#)
- [Section 7.2.4.2, “Adding a Static MAC Address”](#)
- [Section 7.2.4.3, “Deleting a Static MAC Address”](#)

Section 7.2.4.1

Viewing a List of Static MAC Addresses

To view a list of static MAC addresses configured on the device, navigate to **MAC Address Tables » Configure Static MAC Addresses**. The **Static MAC Addresses** table appears.

MAC Address	VID	Port	CoS
00-00-00-00-00-01	1	1	High
00-00-00-00-00-02	1	2	Medium
00-00-00-00-00-03	1	3	Normal

Figure 104: Static MAC Address Table

If static MAC addresses have not been configured, add addresses as needed. For more information, refer to [Section 7.2.4.2, “Adding a Static MAC Address”](#).

Section 7.2.4.2

Adding a Static MAC Address

To add a static MAC address to the Static MAC Address Table, do the following:

1. Navigate to **MAC Address Tables » Configure Static MAC Addresses**. The **Static MAC Addresses** table appears.

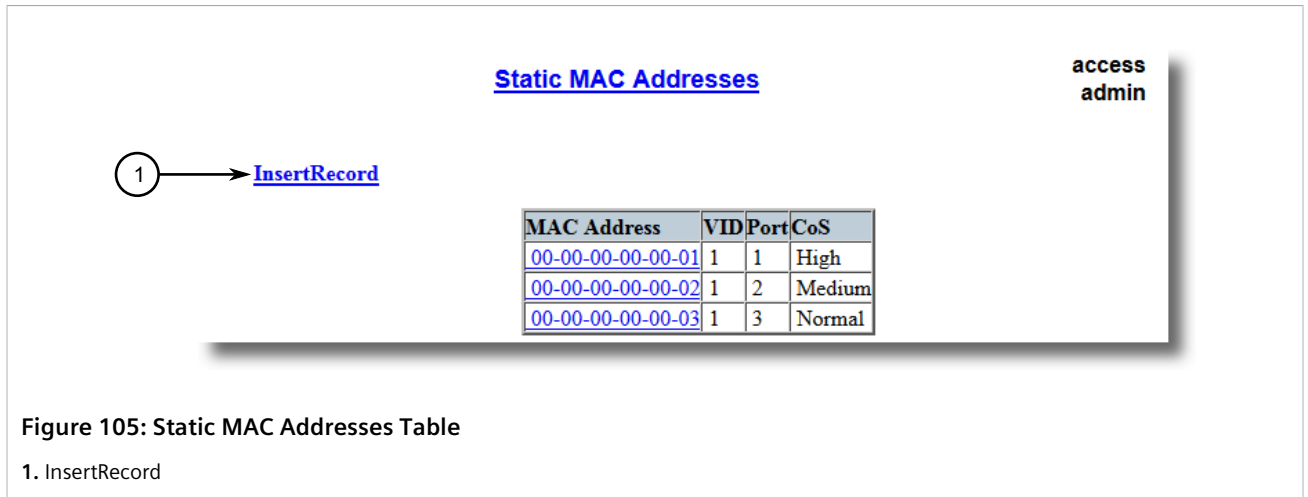

- Click **InsertRecord**. The **Static MAC Addresses** form appears.

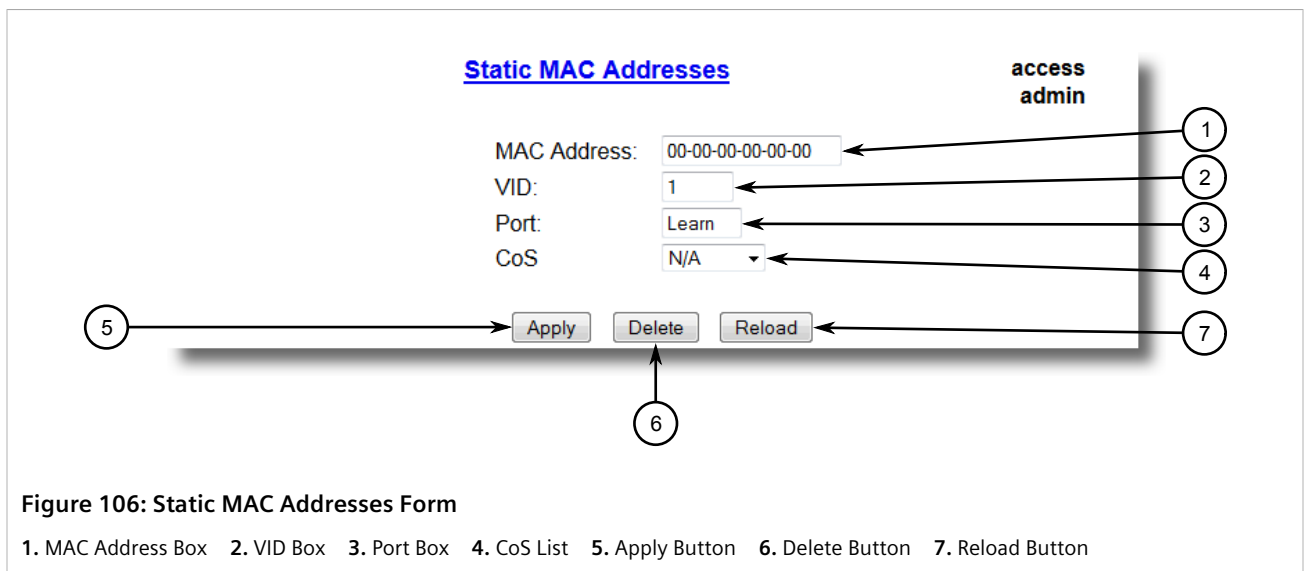

- Configure the following parameter(s) as required:

Parameter	Description
MAC Address	<p>Synopsis: ##-##-##-##-##-## where ## ranges 0 to FF</p> <p>A MAC address learned by the switch.</p> <p>Maximum of 6 wildcard characters may be used to specify a range of MAC addresses allowed to be learned by the Port Security module (when Port Security is set to 'Static MAC' mode). Wildcard must start from the right hand end and continuous.</p> <p>Examples:</p> <ul style="list-style-type: none"> 00-0A-DC-**-**-** means the entire MAC address space of RuggedCom. 00-0A-DC-12-3**-** means the range 00-0A-DC-12-30-00 to 00-0A-DC-12-3F-FF.
VID	<p>Synopsis: 1 to 4094 or { ANY }</p> <p>Default: 1</p> <p>VLAN Identifier of the VLAN upon which the MAC address operates.</p> <p>Option ANY allows learning a MAC address through the Port Security module on any VLAN's that are configured on the switch.</p>

Parameter	Description
Port	<p>Synopsis: 1 to maximum port number or { Learn }</p> <p>Default: Learn</p> <p>Enter the port number upon which the device with this address is located. The security mode of the port being selected should not be '802.1X'.</p> <p>If the port should be auto-learned, set this parameter to 'Learn'. The option 'Learn' is applicable for Port Security in 'Static MAC' mode.</p>
CoS	<p>Synopsis: { N/A, Normal, Medium, High, Crit }</p> <p>Default: N/A</p> <p>Prioritizes traffic for the specified MAC address. To not prioritize traffic based on the address, select N/A.</p>

- Click **Apply**.

Section 7.2.4.3

Deleting a Static MAC Address

To delete a static MAC address from the Static MAC Address Table, do the following:

- Navigate to **MAC Address Tables » Configure Static MAC Addresses**. The **Static MAC Addresses** table appears.

Static MAC Addresses

access
admin

[InsertRecord](#)

MAC Address	VID	Port	CoS
00-00-00-00-00-01	1	1	High
00-00-00-00-00-02	1	2	Medium
00-00-00-00-00-03	1	3	Normal

Figure 107: Static MAC Addresses Table

- Select the MAC address from the table. The **Static MAC Addresses** form appears.

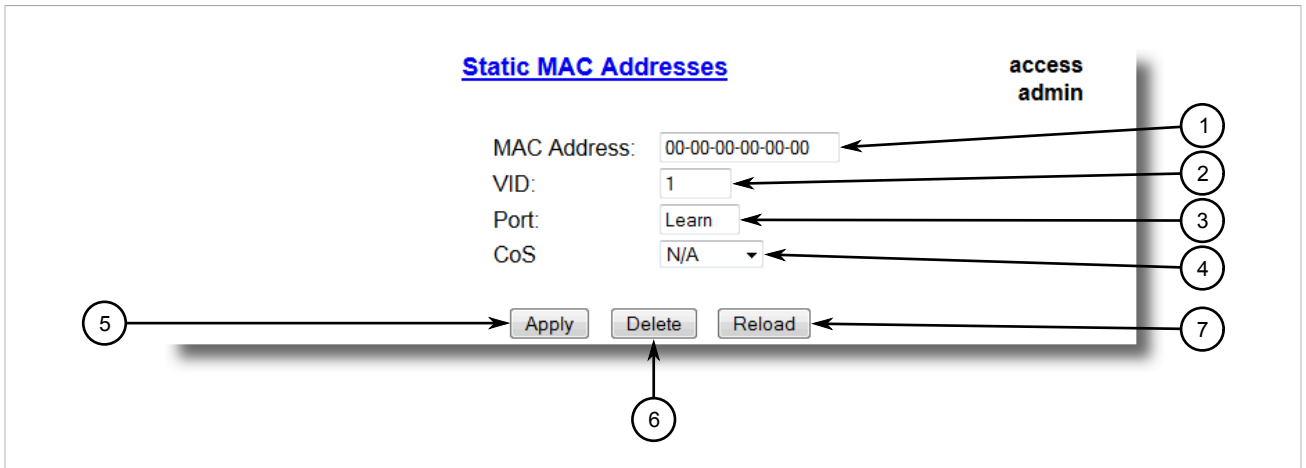

Figure 108: Static MAC Addresses Form

- 1. MAC Address Box
- 2. VID Box
- 3. Port Box
- 4. CoS List
- 5. Apply Button
- 6. Delete Button
- 7. Reload Button

- 3. Click **Delete**.

Section 7.2.5

Purging All Dynamic MAC Addresses

To purge the dynamic MAC address list of all entries, do the following:

- 1. Navigate to **MAC Address Tables » Purge MAC Address Table**. The **Purge MAC Address Table** form appears.

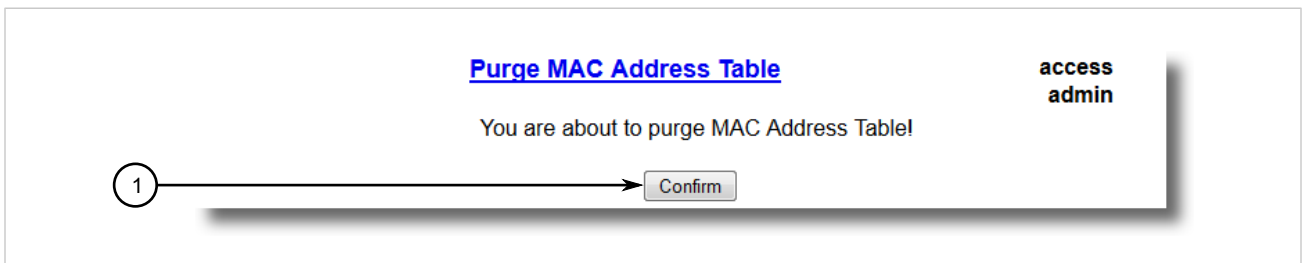

Figure 109: Purge MAC Address Table Form

- 1. Confirm Button

- 2. Click **Confirm**.

Section 7.3

Managing Multicast Filtering

Multicast traffic can be filtered using IGMP (Internet Group Management Protocol) snooping or GMRP (GARP Multicast Registration Protocol).

CONTENTS

- [Section 7.3.1, "Managing IGMP"](#)
- [Section 7.3.2, "Managing GMRP"](#)

Section 7.3.1

Managing IGMP

IGMP is used by IP hosts to report their host group memberships with multicast routers. As hosts join and leave specific multicast groups, streams of traffic are directed to or withheld from that host.

The IGMP protocol operates between multicast routers and IP hosts. When an unmanaged switch is placed between multicast routers and their hosts, the multicast streams will be distributed to all ports. This may introduce significant traffic onto ports that do not require it and receive no benefit from it.

IGMP Snooping, when enabled, will act on IGMP messages sent from the router and the host, restricting traffic streams to the appropriate LAN segments.

**IMPORTANT!**

RUGGEDCOM ROS restricts IGMP hosts from subscribing to the following special multicast addresses:

- 224.0.0.0 to 224.0.0.255
- 224.0.1.129

These addresses are reserved for routing protocols and IEEE 1588. If an IGMP membership report contains one of these addresses, the report is forwarded by the switch without learning about the host.

CONTENTS

- [Section 7.3.1.1, "IGMP Concepts"](#)
- [Section 7.3.1.2, "Viewing a List of Multicast Group Memberships"](#)
- [Section 7.3.1.3, "Viewing Forwarding Information for Multicast Groups"](#)
- [Section 7.3.1.4, "Configuring IGMP"](#)

Section 7.3.1.1

IGMP Concepts

The following describes some of the concepts important to the implementation of multicast filtering using IGMP:

>> IGMP In Operation

The following network diagram provides a simple example of the use of IGMP.

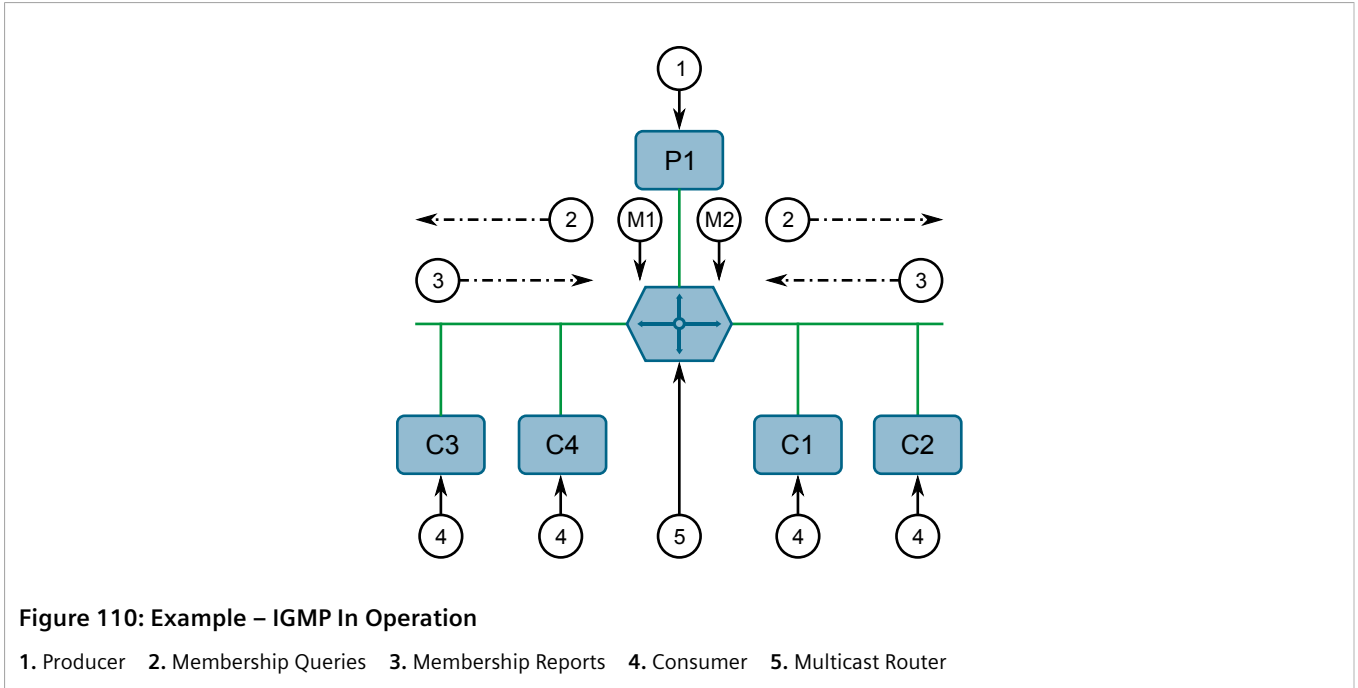

One *producer* IP host (P1) is generating two IP multicast streams, M1 and M2. There are four potential *consumers* of these streams, C1 through C4. The multicast router discovers which host wishes to subscribe to which stream by sending general membership queries to each segment.

In this example, the general membership query sent to the C1-C2 segment is answered by a membership report (or *join*) indicating the desire to subscribe to stream M2. The router will forward the M2 stream to the C1-C2 segment. In a similar fashion, the router discovers that it must forward stream M1 to segment C3-C4.

A *consumer* may join any number of multicast groups, issuing a membership report for each group. When a host issues a membership report, other hosts on the same network segment that also require membership to the same group suppress their own requests, since they would be redundant. In this way, the IGMP protocol guarantees the segment will issue only one membership report for each group.

The router periodically queries each of its segments in order to determine whether at least one consumer still subscribes to a given stream. If it receives no responses within a given time period (usually two query intervals), the router will prune the multicast stream from the given segment.

A more common method of pruning occurs when consumers wishing to unsubscribe issue an IGMP *leave group* message. The router will immediately issue a group-specific membership query to determine whether there are any remaining subscribers of that group on the segment. After the last consumer of a group has unsubscribed, the router will prune the multicast stream from the given segment.

» Switch IGMP Operation

The IGMP Snooping feature provides a means for switches to snoop (i.e. watch) the operation of routers, respond with joins/leaves on the behalf of consumer ports, and prune multicast streams accordingly. There are two modes of IGMP the switch can be configured to assume: active and passive.

- **Active Mode**

IGMP supports a *routerless* mode of operation.

When such a switch is used without a multicast router, it is able to function as if it is a multicast router sending IGMP general queries.

- **Passive Mode**

When such a switch is used in a network with a multicast router, it can be configured to run Passive IGMP. This mode prevents the switch from sending the queries that can confuse the router causing it to stop issuing IGMP queries.

**NOTE**

A switch running in passive mode requires the presence of a multicast router or it will be unable to forward multicast streams at all if no multicast routers are present.

**NOTE**

At least one IGMP Snooping switch must be in active mode to make IGMP functional.

» IGMP Snooping Rules

IGMP Snooping adheres to the following rules:

- When a multicast source starts multicasting, the traffic stream will be immediately blocked on segments from which joins have not been received.
- Unless configured otherwise, the switch will forward all multicast traffic to the ports where multicast routers are attached.
- Packets with a destination IP multicast address in the 224.0.0.X range that are not IGMP are always forwarded to all ports. This behavior is based on the fact that many systems do not send membership reports for IP multicast addresses in this range while still listening to such packets.
- The switch implements IGMPv2 *proxy-reporting* (i.e. membership reports received from downstream are summarized and used by the switch to issue its own reports).
- The switch will only send IGMP membership reports out of those ports where multicast routers are attached, as sending membership reports to hosts could result in unintentionally preventing a host from joining a specific group.
- Multicast routers use IGMP to elect a master router known as the *querier*. The *querier* is the router with the lowest IP address. All other routers become non-queriers, participating only in forwarding multicast traffic. Switches running in active mode participate in the querier election the same as multicast routers.
- When the querier election process is complete, the switch simply relays IGMP queries received from the querier.
- When sending IGMP packets, the switch uses its own IP address, if it has one, for the VLAN on which packets are sent, or an address of 0.0.0.0, if it does not have an assigned IP address.

**NOTE**

IGMP Snooping switches perform multicast pruning using a multicast frames' destination MAC multicast address, which depends on the group IP multicast address. IP address W.X.Y.Z corresponds to MAC address 01-00-5E-XX-YY-ZZ where XX is the lower 7 bits of X, and YY and ZZ are simply Y and Z coded in hexadecimal.

One can note that IP multicast addresses, such as 224.1.1.1 and 225.1.1.1, will both map onto the same MAC address 01-00-5E-01-01-01. This is a problem for which the IETF Network Working Group currently has offered no solution. Users are advised to be aware of and avoid this problem.

» IGMP and RSTP

An RSTP change of topology can render the routes selected to carry multicast traffic as incorrect. This results in lost multicast traffic.

If RSTP detects a change in the network topology, IGMP will take some actions to avoid the loss of multicast connectivity and reduce network convergence time:

- The switch will immediately issue IGMP queries (if in IGMP Active mode) to obtain potential new group membership information.
- The switch can be configured to flood multicast streams temporarily out of all ports that are not configured as RSTP Edge Ports.

» Combined Router and Switch IGMP Operation

The following example illustrates the challenges faced with multiple routers, VLAN support and switching.

Producer P1 resides on VLAN 2 while P2 resides on VLAN 3. Consumer C1 resides on both VLANs whereas C2 and C3 reside on VLANs 3 and 2, respectively. Router 2 resides on VLAN 2, presumably to forward multicast traffic to a remote network or act as a source of multicast traffic itself.

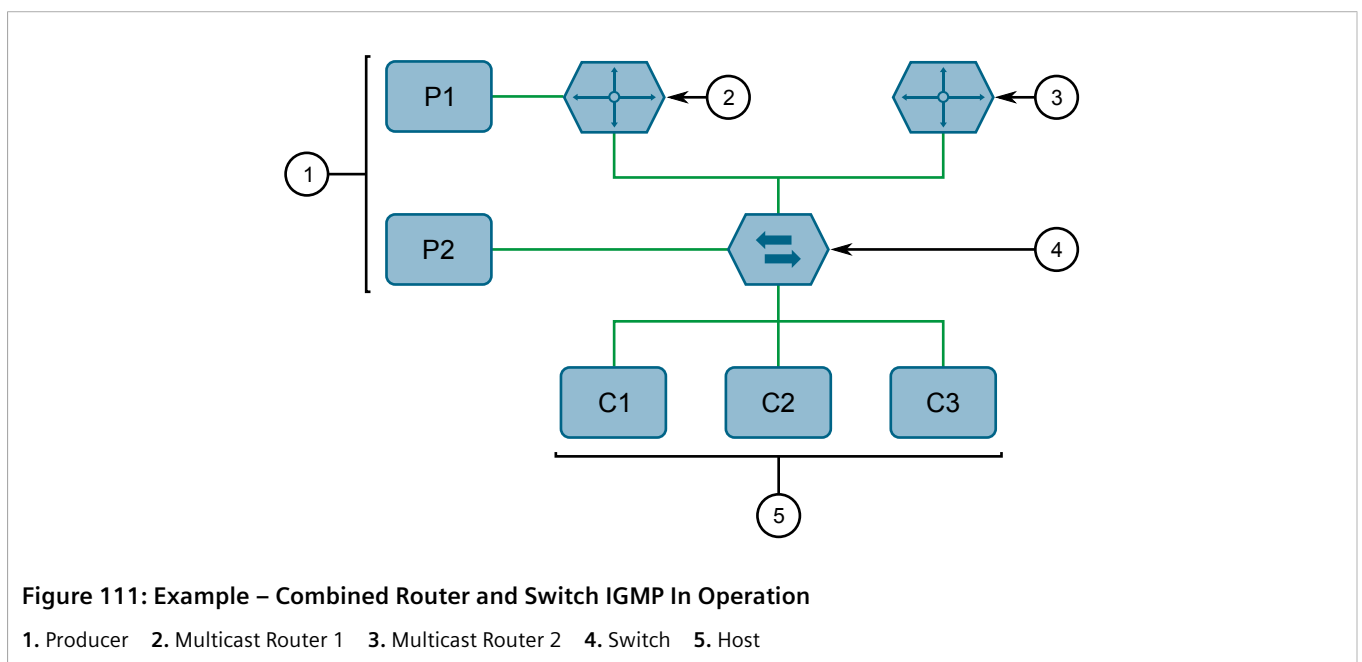

In this example:

- P1, Router 1, Router 2 and C3 are on VLAN 2
- P2 and C2 are on VLAN 3
- C1 is on both VLAN 2 and 3

Assuming that router 1 is the querier for VLAN 2 and router 2 is simply a non-querier, the switch will periodically receive queries from router 1 and maintain the information concerning which port links to the multicast router. However, the switch port that links to router 2 must be manually configured as a *router port*. Otherwise, the switch will send neither multicast streams nor joins/leaves to router 2.

Note that VLAN 3 does not have an external multicast router. The switch should be configured to operate in its *routerless* mode and issue general membership queries as if it is the router.

• Processing Joins

If host C1 wants to subscribe to the multicast streams for both P1 and P2, it will generate two membership reports. The membership report from C1 on VLAN 2 will cause the switch to immediately initiate its own membership report to multicast router 1 (and to issue its own membership report as a response to queries).

The membership report from host C1 for VLAN 3 will cause the switch to immediately begin forwarding multicast traffic from producer P2 to host C2.

• Processing Leaves

When host C1 decides to leave a multicast group, it will issue a leave request to the switch. The switch will poll the port to determine if host C1 is the last member of the group on that port. If host C1 is the last (or only) member, the group will immediately be pruned from the port.

Should host C1 leave the multicast group without issuing a leave group message and then fail to respond to a general membership query, the switch will stop forwarding traffic after two queries.

When the last port in a multicast group leaves the group (or is aged-out), the switch will issue an IGMP leave report to the router.

Section 7.3.1.2

Viewing a List of Multicast Group Memberships

Using IGMP snooping, RUGGEDCOM ROS records group membership information on a per-port basis based on membership reports it observes between the router and host.

To view a list of multicast group memberships, navigate to **Multicast Filtering » View IGMP Group Membership**. The **IGMP Group Membership** table appears.

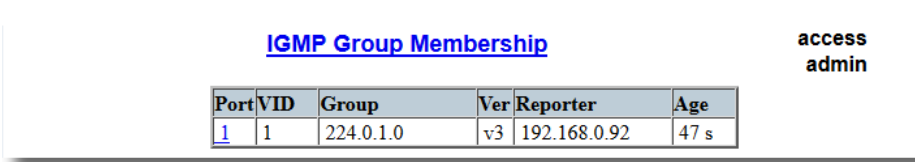

Port	VID	Group	Ver	Reporter	Age
1	1	224.0.1.0	v3	192.168.0.92	47 s

access admin

Figure 112: IGMP Group Membership Table

This table provides the following information:

Parameter	Description
Port	Synopsis: 1 to maximum port number The port number as seen on the front plate silkscreen of the device.
VID	Synopsis: 0 to 65535 VLAN Identifier of the VLAN upon which the multicast group operates.
Group	Synopsis: ###.###.###.### where ### ranges from 0 to 255 Multicast Group Address.
Ver	Synopsis: { v3, v2, v1 } Specifies the IGMP version of the learnt multicast group.
Reporter	Synopsis: ###.###.###.### where ### ranges from 0 to 255 Specifies the source IP address that is reporting subscription to the multicast group.
Age	Synopsis: 0 to 7210 s Specifies the current age of the IP multicast group learned on the port in seconds.

If the table is empty, do the following:

- Make sure traffic is being sent to the device.

- Make sure IGMP is properly configured on the device. For more information, refer to [Section 7.3.1.4, "Configuring IGMP"](#).

Section 7.3.1.3

Viewing Forwarding Information for Multicast Groups

Multicast forwarding information for every source, group and VLAN combination learned by RUGGEDCOM ROS is recorded in the IGMP Multicast Forwarding table.

To view the IGMP Multicast Forwarding table, navigate to **Multicast Filtering » View IGMP Multicast Forwarding**. The **IGMP Multicast Forwarding** table appears.

IGMP Multicast Forwarding				
VID	Group	Source	Joined Ports	Router Ports
1	239.255.255.255	*	2	1

access admin

Figure 113: IGMP Multicast Forwarding Table

This table provides the following information:

Parameter	Description
VID	Synopsis: 0 to 65535 VLAN Identifier of the VLAN upon which the multicast group operates.
Group	Synopsis: ###.###.###.### where ### ranges from 0 to 255 Multicast Group Address.
Source	Synopsis: ###.###.###.### where ### ranges from 0 to 255 or { * } Source Address. * means all possible source addresses.
Joined Ports	Synopsis: Comma-separated list of ports All ports that currently receive multicast traffic for the specified multicast group.
Router Ports	Synopsis: Comma-separated list of ports All ports that have been manually configured or dynamically discovered (by observing router specific traffic) as ports that link to multicast routers.

If the table is empty, do the following:

- Make sure traffic is being sent to the device.
- Make sure IGMP is properly configured on the device. For more information, refer to [Section 7.3.1.4, "Configuring IGMP"](#).

Section 7.3.1.4

Configuring IGMP

To configure the IGMP, do the following:

1. Make sure one or more static VLANs exist with IGMP enabled. For more information, refer to [Section 7.1.5, "Managing Static VLANs"](#).

2. Navigate to **Multicast Filtering » Configure IGMP Parameters**. The **IGMP Parameters** form appears.

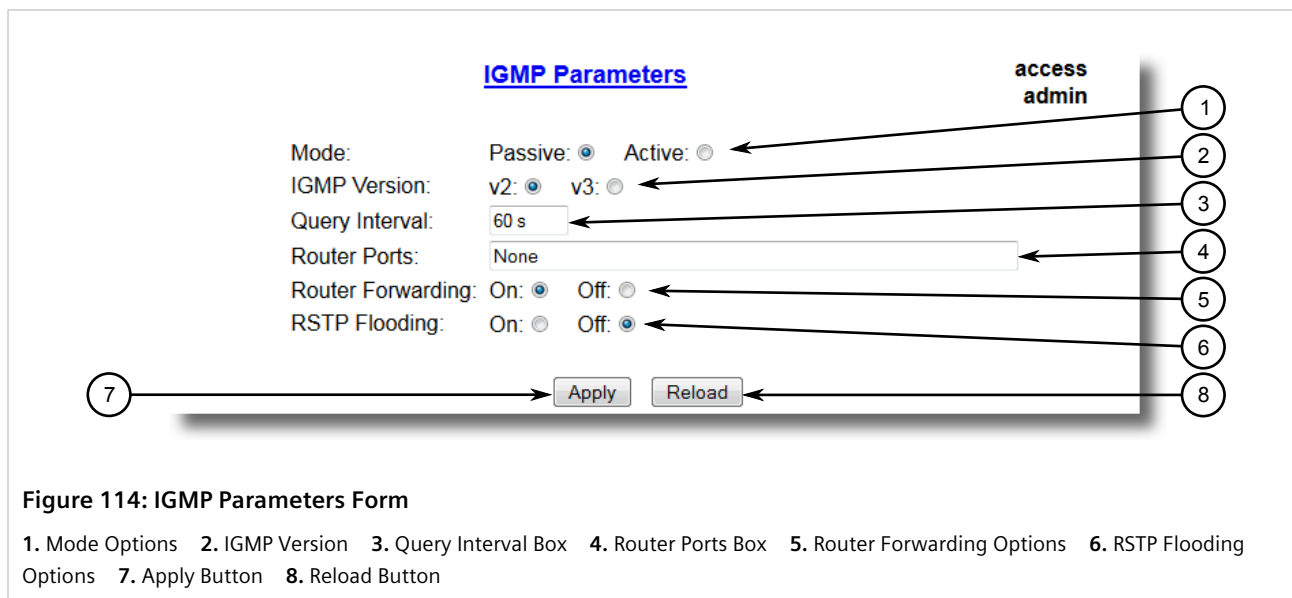

Figure 114: IGMP Parameters Form

1. Mode Options 2. IGMP Version 3. Query Interval Box 4. Router Ports Box 5. Router Forwarding Options 6. RSTP Flooding Options 7. Apply Button 8. Reload Button

3. Configure the following parameter(s) as required:

Parameter	Description
Mode	<p>Synopsis: { Passive, Active }</p> <p>Default: Passive</p> <p>Specifies the IGMP mode. Options include:</p> <ul style="list-style-type: none"> • <i>Passive</i> – the switch passively snoops IGMP traffic and never sends IGMP queries • <i>Active</i> – the switch generates IGMP queries, if no queries from a better candidate for being the querier are detected for a while.
IGMP Version	<p>Synopsis: { v2, v3 }</p> <p>Default: v2</p> <p>Specifies the configured IGMP version on the switch. Options include:</p> <ul style="list-style-type: none"> • <i>v2</i> – Sets the IGMP version to version 2. When selected for a snooping switch, all IGMP reports and queries greater than v2 are forwarded, but not added to the IGMP Multicast Forwarding table. • <i>v3</i> – Sets the IGMP version to version 3. General queries are generated in IGMPv3 format, all versions of IGMP messages are processed by the switch, and traffic is pruned based on multicast group address only.
Query Interval	<p>Synopsis: 10 to 3600</p> <p>Default: 60 s</p> <p>The time interval between IGMP queries generated by the switch.</p> <div style="border: 1px solid gray; padding: 5px; margin-top: 10px;"> <p>NOTE This parameter also affects the Group Membership Interval (i.e. the group subscriber aging time), therefore, it takes effect even in <i>PASSIVE</i> mode.</p> </div>
Router Ports	<p>Synopsis: Comma-separated list of ports</p> <p>Default: None</p> <p>This parameter specifies ports that connect to multicast routers. If you do not configure known router ports, the switch may be able to detect them, however it is advisable to pre-configure them.</p>
Router Forwarding	<p>Synopsis: { Off, On }</p> <p>Default: On</p>

Parameter	Description
	This parameter specifies whether multicast streams will be always forwarded to multicast routers.
RSTP Flooding	Synopsis: { Off, On } Default: Off This parameter specifies whether multicast streams will be flooded out of all RSTP non-edge ports upon topology change detection. Such flooding is desirable, if guaranteed multicast stream delivery after topology change is most important.

4. Click **Apply**.

Section 7.3.2

Managing GMRP

The GMRP is an application of the Generic Attribute Registration Protocol (GARP) that provides a Layer 2 mechanism for managing multicast group memberships in a bridged Layer 2 network. It allows Ethernet switches and end stations to register and unregister membership in multicast groups with other switches on a LAN, and for that information to be disseminated to all switches in the LAN that support Extended Filtering Services.

GMRP is an industry-standard protocol first defined in IEEE 802.1D-1998 and extended in IEEE 802.1Q-2005. GARP was defined in IEEE 802.1D-1998 and updated in 802.1D-2004.



NOTE

GMRP provides similar functionality at Layer 2 to what IGMP provides at Layer 3.

CONTENTS

- [Section 7.3.2.1, "GMRP Concepts"](#)
- [Section 7.3.2.2, "Viewing a Summary of Multicast Groups"](#)
- [Section 7.3.2.3, "Configuring GMRP Globally"](#)
- [Section 7.3.2.4, "Configuring GMRP for Specific Ethernet Ports"](#)
- [Section 7.3.2.5, "Viewing a List of Static Multicast Groups"](#)
- [Section 7.3.2.6, "Adding a Static Multicast Group"](#)
- [Section 7.3.2.7, "Deleting a Static Multicast Group"](#)

Section 7.3.2.1

GMRP Concepts

The following describes some of the concepts important to the implementation of multicast filtering using GMRP:

» Joining a Multicast Group

To join a multicast group, an end station transmits a GMRP *join* message. The switch that receives the *join* message adds the port through which the message was received to the multicast group specified in the message. It then propagates the *join* message to all other hosts in the VLAN, one of which is expected to be the multicast source.

When a switch transmits GMRP updates (from GMRP-enabled ports), all of the multicast groups known to the switch, whether configured manually or learned dynamically through GMRP, are advertised to the rest of network. As long as one host on the Layer 2 network has registered for a given multicast group, traffic from the corresponding multicast source will be carried on the network. Traffic multicast by the source is only forwarded by each switch in the network to those ports from which it has received join messages for the multicast group.

» Leaving a Multicast Group

Periodically, the switch sends GMRP queries in the form of a *leave all* message. If a host (either a switch or an end station) wishes to remain in a multicast group, it reasserts its group membership by responding with an appropriate *join* request. Otherwise, it can either respond with a *leave* message or simply not respond at all. If the switch receives a *leave* message or receives no response from the host for a timeout period, the switch removes the host from the multicast group.

» Notes About GMRP

Since GMRP is an application of GARP, transactions take place using the GARP protocol. GMRP defines the following two Attribute Types:

- The Group Attribute Type, used to identify the values of group MAC addresses
- The Service Requirement Attribute Type, used to identify service requirements for the group

Service Requirement Attributes are used to change the receiving port's multicast filtering behavior to one of the following:

- Forward All Multicast group traffic in the VLAN, or
- Forward All Unknown Traffic (Multicast Groups) for which there are no members registered in the device in a VLAN

If GMRP is disabled, GMRP packets received will be forwarded like any other traffic. Otherwise, GMRP packets will be processed and not forwarded.

» Establishing Membership with GMRP

The following example illustrates how a network of hosts and switches can dynamically join two multicast groups using GMRP.

In this scenario, there are two multicast sources, S1 and S2, multicasting to Multicast Groups 1 and 2, respectively. A network of five switches, including one core switch (B), connects the sources to two hosts, H1 and H2, which receive the multicast streams from S1 and S2, respectively.

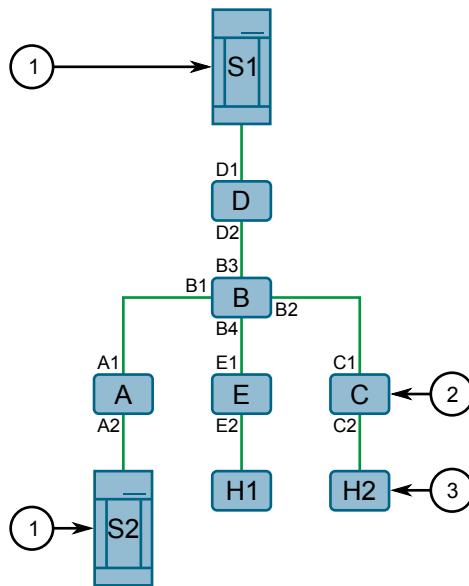

Figure 115: Example – Establishing Membership with GMRP

1. Multicast Source 2. Switch 3. Multicast Host

The hosts and switches establish membership with the Multicast Group 1 and 2 as follows:

1. Host H1 is GMRP unaware, but needs to see traffic for Multicast Group 1. Therefore, Port E2 on Switch E is statically configured to forward traffic for Multicast Group 1.
2. Switch E advertises membership in Multicast Group 1 to the network through Port E1, making Port B4 on Switch B a member of Multicast Group 1.
3. Switch B propagates the *join* message, causing Ports A1, C1 and D1 to become members of Multicast Group 1.
4. Host H2 is GMRP-aware and sends a *join* request for Multicast Group 2 to Port C2, which thereby becomes a member of Multicast Group 2.
5. Switch C propagates the *join* message, causing Ports A1, B2, D1 and E1 to become members of Multicast Group 2.

Once GMRP-based registration has propagated through the network, multicast traffic from S1 and S2 can reach its destination as follows:

- Source S1 transmits multicast traffic to Port D2 which is forwarded via Port D1, which has previously become a member of Multicast Group 1.
- Switch B forwards the Group 1 multicast via Port B4 towards Switch E.
- Switch E forwards the Group 1 multicast via Port E2, which has been statically configured for membership in Multicast Group 1.
- Host H1, connected to Port E2, thus receives the Group 1 multicast.
- Source S2 transmits multicast traffic to Port A2, which is then forwarded via port A1, which has previously become a member of Multicast Group 2.
- Switch B forwards the Group 2 multicast via Port B2 towards Switch C.
- Switch C forwards the Group 2 multicast via Port C2, which has previously become a member of Group 2.
- Ultimately, Host H2, connected to Port C2, receives the Group 2 multicast.

Section 7.3.2.2

Viewing a Summary of Multicast Groups

To view a summary of all multicast groups, navigate to **Multicast Filtering » View Multicast Group Summary**. The **Multicast Group Summary** table appears.

Multicast Group Summary			
VID	MAC Address	Static Ports	GMRP Dynamic Ports
1	01-00-5E-7F-FF-FA	None	None
1	33-33-00-01-00-02	None	None
4	01-00-5E-00-04-00	1	None

Figure 116: Multicast Group Summary Table

This table provides the following information:

Parameter	Description
VID	Synopsis: 0 to 65535 VLAN Identifier of the VLAN upon which the multicast group operates.
MAC Address	Synopsis: ##-##-##-##-##-## where ## ranges 0 to FF Multicast group MAC address.
Static Ports	Synopsis: Any combination of numbers valid for this parameter Ports that joined this group statically through static configuration in Static MAC Table and to which the multicast group traffic is forwarded.
GMRP Dynamic Ports	Synopsis: Any combination of numbers valid for this parameter Ports that joined this group dynamically through GMRP Application and to which the multicast group traffic is forwarded.

Section 7.3.2.3

Configuring GMRP Globally

To configure global settings for GMRP, do the following:

1. Navigate to **Multicast Filtering » Configure Global GMRP Parameters**. The **Global GMRP Parameters** form appears.

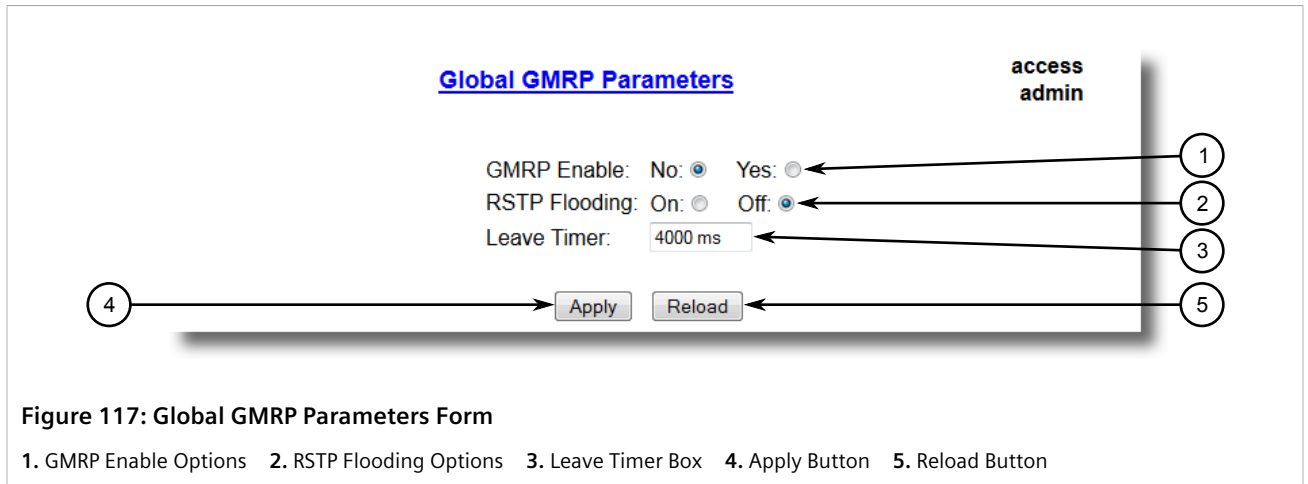

Figure 117: Global GMRP Parameters Form

1. GMRP Enable Options 2. RSTP Flooding Options 3. Leave Timer Box 4. Apply Button 5. Reload Button

2. Configure the following parameter(s) as required:

Parameter	Description
GMRP Enable	<p>Synopsis: { No, Yes }</p> <p>Default: No</p> <p>Globally enable or disable GMRP.</p> <p>When GMRP is globally disabled, GMRP configurations on individual ports are ignored. When GMRP is globally enabled, each port can be individually configured.</p>
RSTP Flooding	<p>Synopsis: { On, Off }</p> <p>Default: Off</p> <p>This parameter specifies whether multicast streams will be flooded out of all RSTP non-edge ports upon topology change detection. Such flooding is desirable, if guaranteed multicast stream delivery after topology change is most important.</p>
Leave Timer	<p>Synopsis: 600 to 300000 ms</p> <p>Default: 4000 ms</p> <p>Time (milliseconds) to wait after issuing Leave or LeaveAll before removing registered multicast groups. If Join messages for specific addresses are received before this timer expires, the addresses will be kept registered.</p>

3. Click **Apply**.

Section 7.3.2.4

Configuring GMRP for Specific Ethernet Ports

To configure GMRP for a specific Ethernet port, do the following:

1. Make sure the global settings for GMRP have been configured. For more information, refer to [Section 7.3.2.3, "Configuring GMRP Globally"](#).
2. Navigate to **Multicast Filtering » Configure Port GMRP Parameters**. The **Port GMRP Parameters** table appears.

Port GMRP Parameters

Port(s)	GMRP
1	Disabled
2	Disabled
3	Disabled
4	Disabled
5	Disabled
6	Disabled
7	Disabled
8	Disabled
9	Disabled
10	Disabled

access
admin

Figure 118: Port GMRP Parameters Table

- Select an Ethernet port. The **Port GMRP Parameters** form appears.

Port GMRP Parameters

access
admin

Port(s): ← 1

GMRP: ← 2

← 3 ← 4

Figure 119: Port GMRP Parameters Form

1. Port(s) Box 2. GMRP List 3. Apply Button 4. Reload Button

- Configure the following parameter(s) as required:

Parameter	Description
Port(s)	<p>Synopsis: Any combination of numbers valid for this parameter</p> <p>The port number as seen on the front plate silkscreen of the switch (or a list of ports, if aggregated in a port trunk).</p>
GMRP	<p>Synopsis: { Disabled, Adv Only, Adv&Learn }</p> <p>Default: Disabled</p> <p>Configures GMRP (GARP Multicast Registration Protocol) operation on the port. There are several GMRP operation modes:</p> <ul style="list-style-type: none"> • Disabled – the port is not capable of any GMRP processing. • Adv Only – the port will declare all MCAST addresses existing in the switch (configured or learned) but will not learn any MCAST addresses. • Adv&Learn – the port will declare all MCAST Addresses existing in the switch (configured or learned) and can dynamically learn MCAST addresses.

- Click **Apply**.

Section 7.3.2.5

Viewing a List of Static Multicast Groups

To view a list of static multicast groups, navigate to *Multicast Filtering » Configure Static Multicast Groups*. The **Static Multicast Groups** table appears.

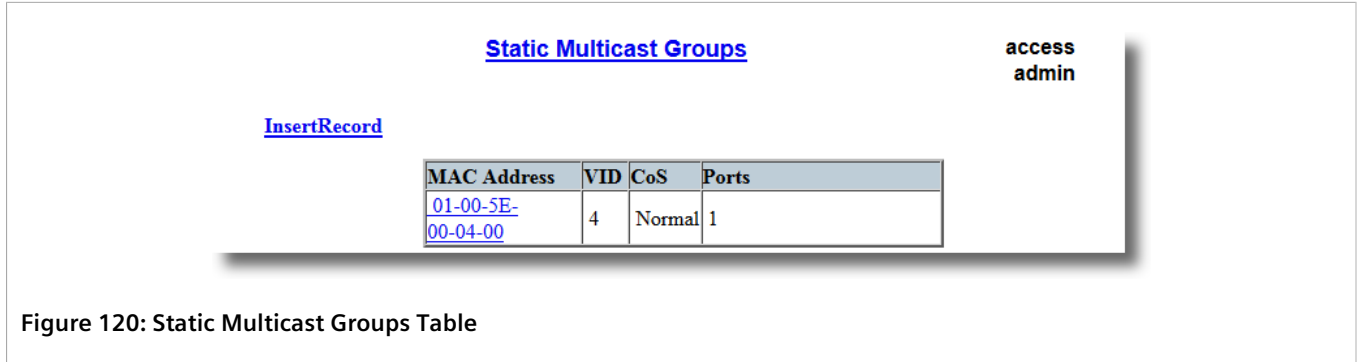

Figure 120: Static Multicast Groups Table

If a static multicast group is not listed, add the group. For more information, refer to [Section 7.3.2.6, "Adding a Static Multicast Group"](#).

Section 7.3.2.6

Adding a Static Multicast Group

To add a static multicast group from another device, do the following:

1. Navigate to *Multicast Filtering » Configure Static Multicast Groups*. The **Static Multicast Groups** table appears.

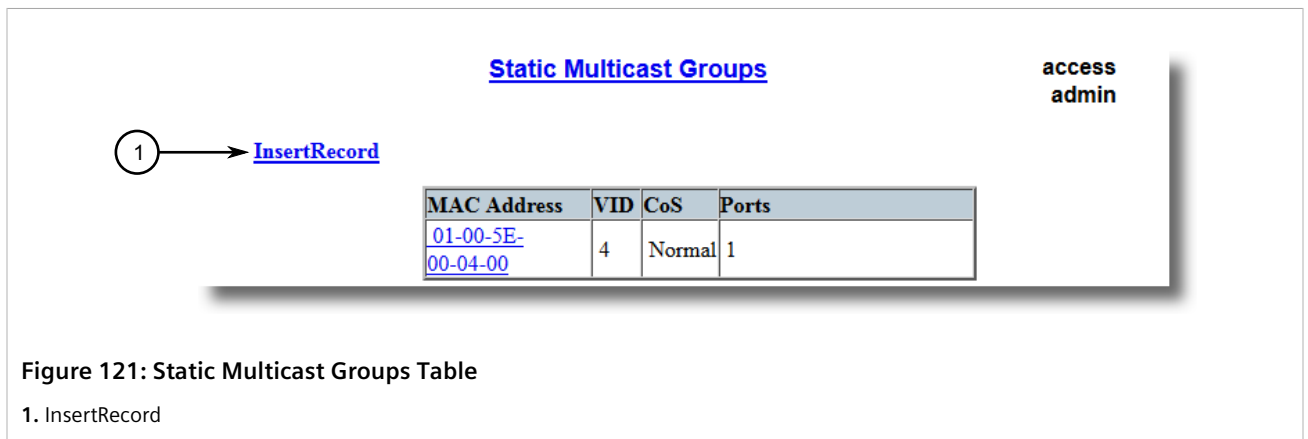
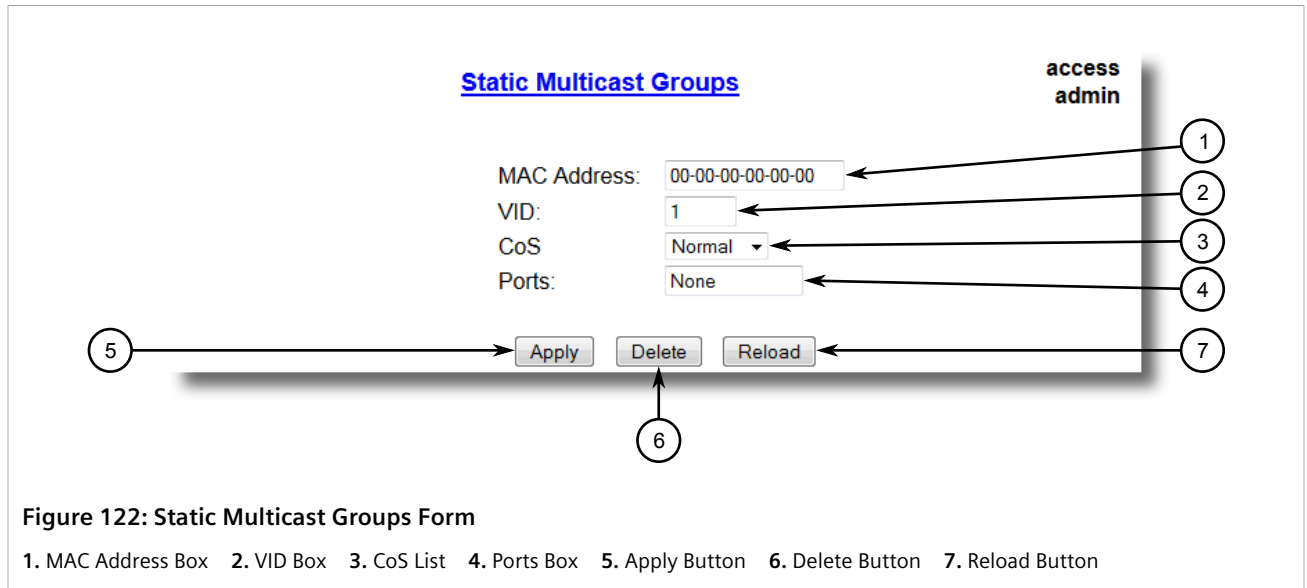

Figure 121: Static Multicast Groups Table

1. InsertRecord

2. Click **InsertRecord**. The **Static Multicast Groups** form appears.



3. Configure the following parameter(s) as required:

Parameter	Description
MAC Address	Synopsis: ##-##-##-##-##-## where ## ranges 0 to FF Default: 00-00-00-00-00-00 Multicast group MAC address.
VID	Synopsis: 1 to 4094 Default: 1 VLAN Identifier of the VLAN upon which the multicast group operates.
CoS	Synopsis: { N/A, Normal, Medium, High, Crit } Default: N/A Prioritizes traffic for the specified MAC address. To not prioritize traffic based on the address, select N/A.
Ports	Synopsis: Any combination of numbers valid for this parameter Default: None A comma-separated list of ports to which the multicast group traffic is forwarded. If a port is part of a Link Aggregation Group (LAG), or port trunk, specify all ports in the LAG.

4. Click **Apply**.

Section 7.3.2.7

Deleting a Static Multicast Group

To delete a static multicast group, do the following:

1. Navigate to **Multicast Filtering » Configure Static Multicast Groups**. The **Static Multicast Groups** table appears.

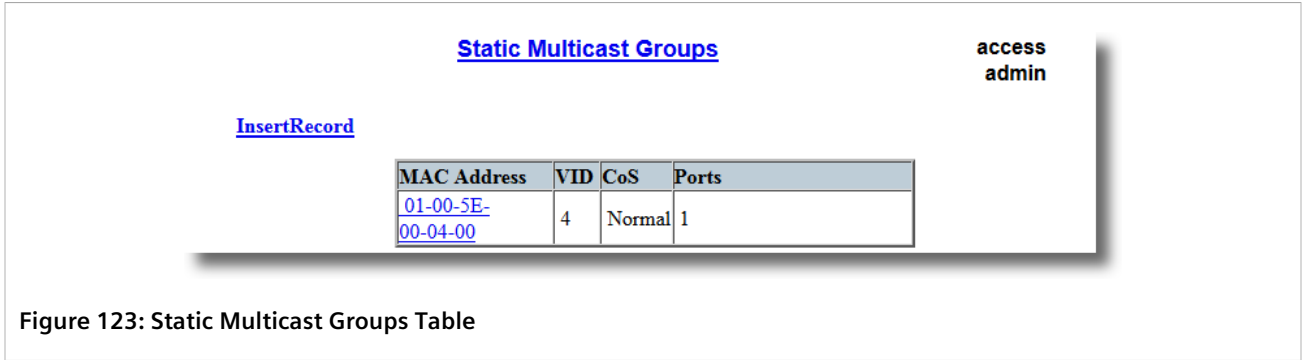

Figure 123: Static Multicast Groups Table

2. Select the group from the table. The **Static Multicast Groups** form appears.

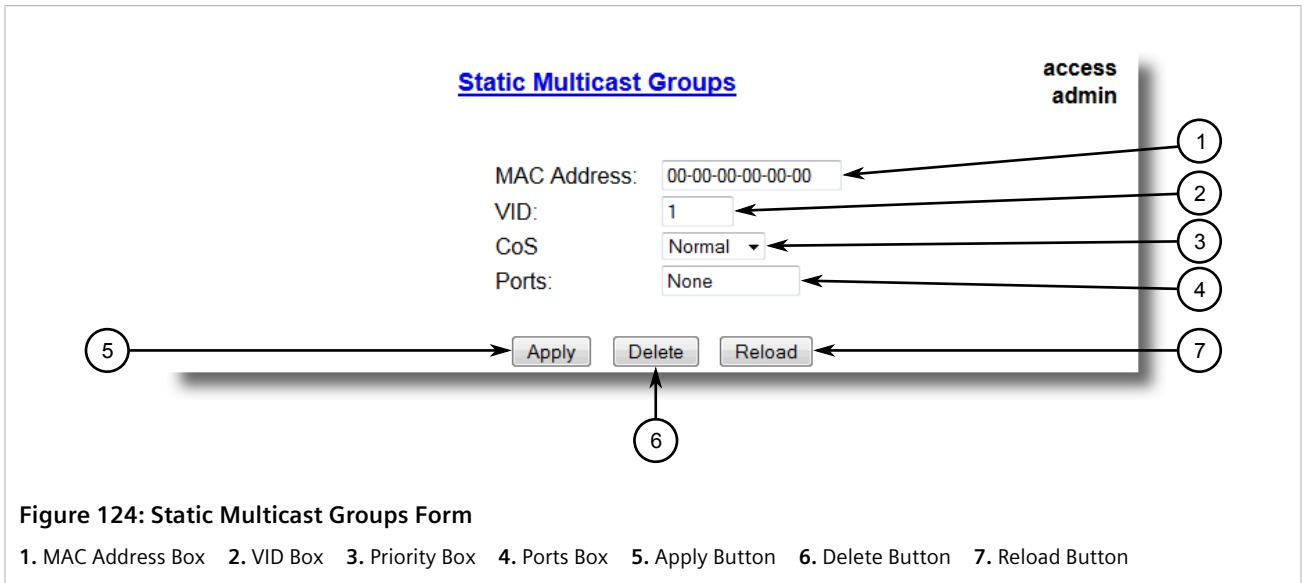

Figure 124: Static Multicast Groups Form

1. MAC Address Box 2. VID Box 3. Priority Box 4. Ports Box 5. Apply Button 6. Delete Button 7. Reload Button

3. Click **Delete**.

8 Redundancy

This chapter describes how to configure and manage the redundancy-related features of RUGGEDCOM ROS.

CONTENTS

- [Section 8.1, “Managing Spanning Tree Protocol”](#)
- [Section 8.2, “Managing the Media Redundancy Protocol \(MRP\)”](#)
- [Section 8.3, “Managing Link Aggregation”](#)

Section 8.1

Managing Spanning Tree Protocol

This section describes how to manage the spanning tree protocol.

CONTENTS

- [Section 8.1.1, “RSTP Operation”](#)
- [Section 8.1.2, “RSTP Applications”](#)
- [Section 8.1.3, “MSTP Operation”](#)
- [Section 8.1.4, “Configuring STP Globally”](#)
- [Section 8.1.5, “Configuring STP for Specific Ethernet Ports”](#)
- [Section 8.1.6, “Configuring eRSTP”](#)
- [Section 8.1.7, “Viewing Global Statistics for STP”](#)
- [Section 8.1.8, “Viewing STP Statistics for Ethernet Ports”](#)
- [Section 8.1.9, “Managing Multiple Spanning Tree Instances”](#)
- [Section 8.1.10, “Clearing Spanning Tree Protocol Statistics”](#)

Section 8.1.1

RSTP Operation

The 802.1D Spanning Tree Protocol (STP) was developed to enable the construction of robust networks that incorporate redundancy while pruning the active topology of the network to prevent loops. While STP is effective, it requires that frame transfer halt after a link outage until all bridges in the network are guaranteed to be aware of the new topology. Using the values recommended by 802.1D, this period lasts 30 seconds.

The Rapid Spanning Tree Protocol (RSTP, IEEE 802.1w) was a further evolution of the 802.1D Spanning Tree Protocol. It replaced the settling period with an active handshake between bridges that guarantees the rapid

propagation of topology information throughout the network. RSTP also offers a number of other significant innovations, including:

- Topology changes in RSTP can originate from and be acted upon by any designated bridges, leading to more rapid propagation of address information, unlike topology changes in STP, which must be passed to the root bridge before they can be propagated to the network.
- RSTP explicitly recognizes two blocking roles - Alternate and Backup Port - which are included in computations of when to learn and forward. STP, however, recognizes only one state - Blocking - for ports that should not forward.
- RSTP bridges generate their own configuration messages, even if they fail to receive any from the root bridge. This leads to quicker failure detection. STP, by contrast, must relay configuration messages received on the root port out its designated ports. If an STP bridge fails to receive a message from its neighbor, it cannot be sure where along the path to the root a failure occurred.
- RSTP offers edge port recognition, allowing ports at the edge of the network to forward frames immediately after activation, while at the same time protecting them against loops.

While providing much better performance than STP, IEEE 802.1w RSTP still required up to several seconds to restore network connectivity when a topology change occurred.

A revised and highly optimized RSTP version was defined in the IEEE standard 802.1D-2004 edition. IEEE 802.1D-2004 RSTP reduces network recovery times to just milliseconds and optimizes RSTP operation for various scenarios.

RUGGEDCOM ROS supports IEEE 802.1D-2004 RSTP.

CONTENTS

- [Section 8.1.1.1, "RSTP States and Roles"](#)
- [Section 8.1.1.2, "Edge Ports"](#)
- [Section 8.1.1.3, "Point-to-Point and Multipoint Links"](#)
- [Section 8.1.1.4, "Path and Port Costs"](#)
- [Section 8.1.1.5, "Bridge Diameter"](#)
- [Section 8.1.1.6, "eRSTP"](#)
- [Section 8.1.1.7, "Fast Root Failover"](#)

Section 8.1.1.1

RSTP States and Roles

RSTP bridges have roles to play, either root or designated. One bridge - the Root Bridge - is the logical center of the network. All other bridges in the network are Designated bridges. RSTP also assigns each port of the bridge a state and a role. The RSTP state describes what is happening at the port in relation to address learning and frame forwarding. The RSTP role basically describes whether the port is facing the center or the edges of the network and whether it can currently be used.

» State

There are three RSTP states: Discarding, Learning and Forwarding.

The discarding state is entered when the port is first put into service. The port does not learn addresses in this state and does not participate in frame transfer. The port looks for RSTP traffic to determine its role in the network. When it is determined that the port will play an active part in the network, the state will change to learning.

The learning state is entered when the port is preparing to play an active part in the network. The port learns addresses in this state but does not participate in frame transfer. In a network of RSTP bridges, the time spent in this state is usually quite short. RSTP bridges operating in STP compatibility mode will spend six to 40 seconds in this state.

After *learning*, the bridge will place the port in the forwarding state. The port both learns addresses and participates in frame transfer while in this state.



IMPORTANT!

RUGGEDCOM ROS introduces two more states - Disabled and Link Down. Introduced purely for purposes of management, these states may be considered subclasses of the RSTP Discarding state. The Disabled state refers to links for which RSTP has been disabled. The Link Down state refers to links for which RSTP is enabled but are currently down.

» **Role**

There are four RSTP port roles: Root, Designated, Alternate and Backup. If the bridge is not the root bridge, it must have a single Root Port. The Root Port is the "best" (i.e. quickest) way to send traffic to the root bridge.

A port is marked as Designated if it is the best port to serve the LAN segment it is connected to. All bridges on the same LAN segment listen to each others' messages and agree on which bridge is the Designated Bridge. The ports of other bridges on the segment must become either Root, Alternate or Backup ports.

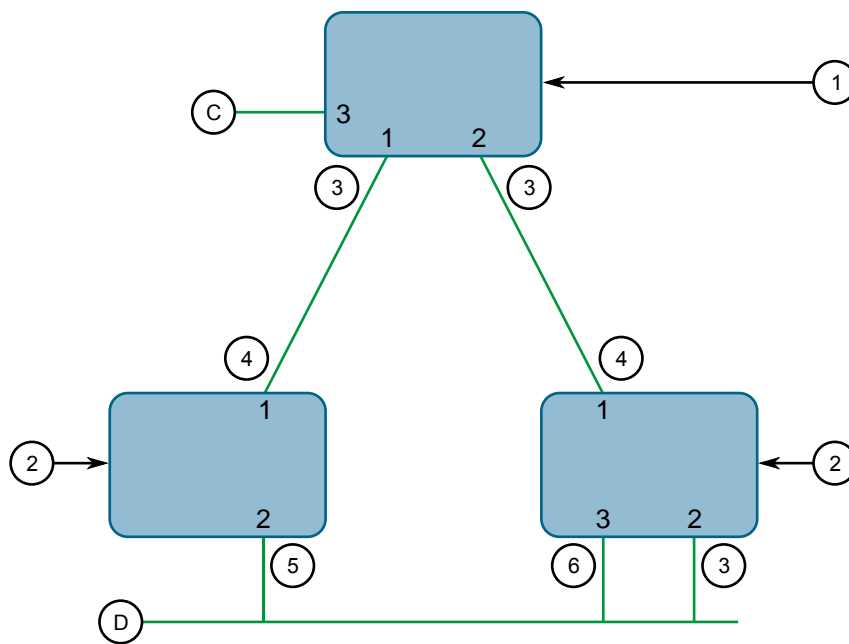

Figure 125: Bridge and Port Roles

1. Root Bridge 2. Designated Bridge 3. Designated Port 4. Root Port 5. Alternate Port 6. Backup Port

A port is alternate when it receives a better message from another bridge on the LAN segment it is connected to. The message that an Alternate Port receives is better than the port itself would generate, but not good enough to convince it to become the Root Port. The port becomes the alternate to the current Root Port and will become the new Root Port should the current Root Port fail. The Alternate Port does not participate in the network.

A port is a Backup Port when it receives a better message from the LAN segment it is connected to, originating from another port on the same bridge. The port is a backup for another port on the bridge and will become active if that port fails. The Backup Port does not participate in the network.

Section 8.1.1.2

Edge Ports

A port may be designated as an Edge Port if it is directly connected to an end station. As such, it cannot create bridging loops in the network and can thus directly transition to forwarding, skipping the listening and learning stages.

Edge ports that receive configuration messages immediately lose their Edge Port status and become normal spanning tree ports. A loop created on an improperly connected edge port is thus quickly repaired.

Because an Edge Port services only end stations, topology change messages are not generated when its link toggles.

Section 8.1.1.3

Point-to-Point and Multipoint Links

RSTP uses a peer-peer protocol called Proposing-Agreeing to ensure transitioning in the event of a link failure. This protocol is point-to-point and breaks down in multipoint situations, i.e. when more than two bridges operate on a shared media link.

If RSTP detects this circumstance (based upon the port's half duplex state after link up) it will switch off Proposing-Agreeing. The port must transition through the learning and forwarding states, spending one forward delay in each state.

There are circumstances in which RSTP will make an incorrect decision about the point-to-point state of the link simply by examining the half-duplex status, namely:

- The port attaches only to a single partner, but through a half-duplex link.
- The port attaches to a shared media hub through a full-duplex link. The shared media link attaches to more than one RSTP enabled bridge.

In such cases, the user may configure the bridge to override the half-duplex determination mechanism and force the link to be treated in the proper fashion.

Section 8.1.1.4

Path and Port Costs

The STP path cost is the main metric by which root and designated ports are chosen. The path cost for a designated bridge is the sum of the individual port costs of the links between the root bridge and that designated bridge. The port with the lowest path cost is the best route to the root bridge and is chosen as the root port.



NOTE

In actuality the primary determinant for root port selection is the root bridge ID. Bridge ID is important mainly at network startup when the bridge with the lowest ID is elected as the root bridge. After startup (when all bridges agree on the root bridge's ID) the path cost is used to select root ports. If the path costs of candidates for the root port are the same, the ID of the peer bridge is used to select the port. Finally, if candidate root ports have the same path cost and peer bridge ID, the port ID of the peer

bridge is used to select the root port. In all cases the lower ID, path cost or port ID is selected as the best.

» How Port Costs Are Generated

Port costs can be generated either as a result of link auto-negotiation or manual configuration. When the link auto-negotiation method is used, the port cost is derived from the speed of the link. This method is useful when a well-connected network has been established. It can be used when the designer is not too concerned with the resultant topology as long as connectivity is assured.

Manual configuration is useful when the exact topology of the network must be predictable under all circumstances. The path cost can be used to establish the topology of the network exactly as the designer intends.

» STP vs. RSTP Costs

The IEEE 802.1D-1998 specification limits port costs to values of 1 to 65536. Designed at a time when 9600 bps links were state of the art, this method breaks down in modern use, as the method cannot represent a link speed higher than 10 gigabits per second.

To remedy this problem in future applications, the IEEE 802.1w specification limits port costs to values of 1 to 20000000, and a link speed up to 10 Tb per second can be represented with a value of 2.

RUGGEDCOM bridges support interoperability with legacy STP bridges by selecting the style to use. In practice, it makes no difference which style is used as long as it is applied consistently across the network, or if costs are manually assigned.

Section 8.1.1.5

Bridge Diameter

The bridge diameter is the maximum number of bridges between any two possible points of attachment of end stations to the network.

The bridge diameter reflects the realization that topology information requires time to propagate hop by hop through a network. If configuration messages take too long to propagate end to end through the network, the result will be an unstable network.

There is a relationship between the bridge diameter and the maximum age parameter. To achieve extended ring sizes, Siemens eRSTP™ uses an age increment of $\frac{1}{4}$ of a second. The value of the maximum bridge diameter is thus four times the configured maximum age parameter.



NOTE

The RSTP algorithm is as follows:

- STP configuration messages contain **age** information.
- Messages transmitted by the root bridge have an age of 0. As each subsequent designated bridge transmits the configuration message it must increase the age by at least 1 second.
- When the age exceeds the value of the maximum age parameter the next bridge to receive the message immediately discards it.



IMPORTANT!

Raise the value of the maximum age parameter if implementing very large bridged networks or rings.

Section 8.1.1.6

eRSTP

Siemens's enhanced Rapid Spanning Tree Protocol (eRSTP) improves the performance of RSTP in two ways:

- Improves the fault recovery time performance (< 5 ms per hop)
- Improves performance for large ring network topologies (up to 80 switches)

eRSTP is also compatible with standard RSTP for interoperability with commercial switches.

For example, in a network comprised of 15 RUGGEDCOM hardened Ethernet switches in a ring topology, the expected fault recovery time would be less than 75 ms (i.e. 5 ms x 15). However, with eRSTP, the worst case fault recovery time is less than 26 ms.

Section 8.1.1.7

Fast Root Failover

Siemens's *Fast Root Failover* feature is an enhancement to RSTP that may be enabled or disabled. Fast Root Failover improves upon RSTP's handling of root bridge failures in mesh-connected networks.



IMPORTANT!

In networks mixing RUGGEDCOM and non-RUGGEDCOM switches, or in those mixing Fast Root Failover algorithms, RSTP Fast Root Failover will not function properly and root bridge failure will result in an unpredictable failover time. To avoid potential issues, note the following:

- *When using the Robust algorithm, all switches must be RUGGEDCOM switches*
- *When using the Relaxed algorithm, all switches must be RUGGEDCOM switches, with the exception of the root switch*
- *All RUGGEDCOM switches in the network must use the same Fast Root Failover algorithm*

Two Fast Root Failover algorithms are available:

- **Robust** – Guarantees a deterministic root failover time, but requires support from all switches in the network, including the root switch
- **Relaxed** – Ensures a deterministic root failover time in most network configurations, but allows the use of a standard bridge in the root role



NOTE

The minimum interval for root failures is one second. Multiple, near simultaneous root failures (within less than one second of each other) are not supported by Fast Root Failover.

» Fast Root Failover and RSTP Performance

- Running RSTP with Fast Root Failover disabled has no impact on RSTP performance in ring-connected networks.
- Fast Root Failover has no effect on RSTP performance in the case of failures that do not involve the root bridge or one of its links.
- The extra processing introduced by Fast Root Failover significantly decreases the worst-case failover time due to root bridge failure in mesh networks.

» Recommendations On the Use of Fast Root Failover

- It is not recommended to enable Fast Root Failover in single ring network topologies.
- It is strongly recommended to always connect the root bridge to each of its neighbor bridges using more than one link when enabled in ring-connected networks.

Section 8.1.2

RSTP Applications

This section describes various applications of RSTP.

CONTENTS

- [Section 8.1.2.1, "RSTP in Structured Wiring Configurations"](#)
- [Section 8.1.2.2, "RSTP in Ring Backbone Configurations"](#)
- [Section 8.1.2.3, "RSTP Port Redundancy"](#)

Section 8.1.2.1

RSTP in Structured Wiring Configurations

RSTP may be used to construct structured wiring systems where connectivity is maintained in the event of link failures. For example, a single link failure of any link between A and N in [Figure 126](#) would leave all the ports of bridges 555 through 888 connected to the network.

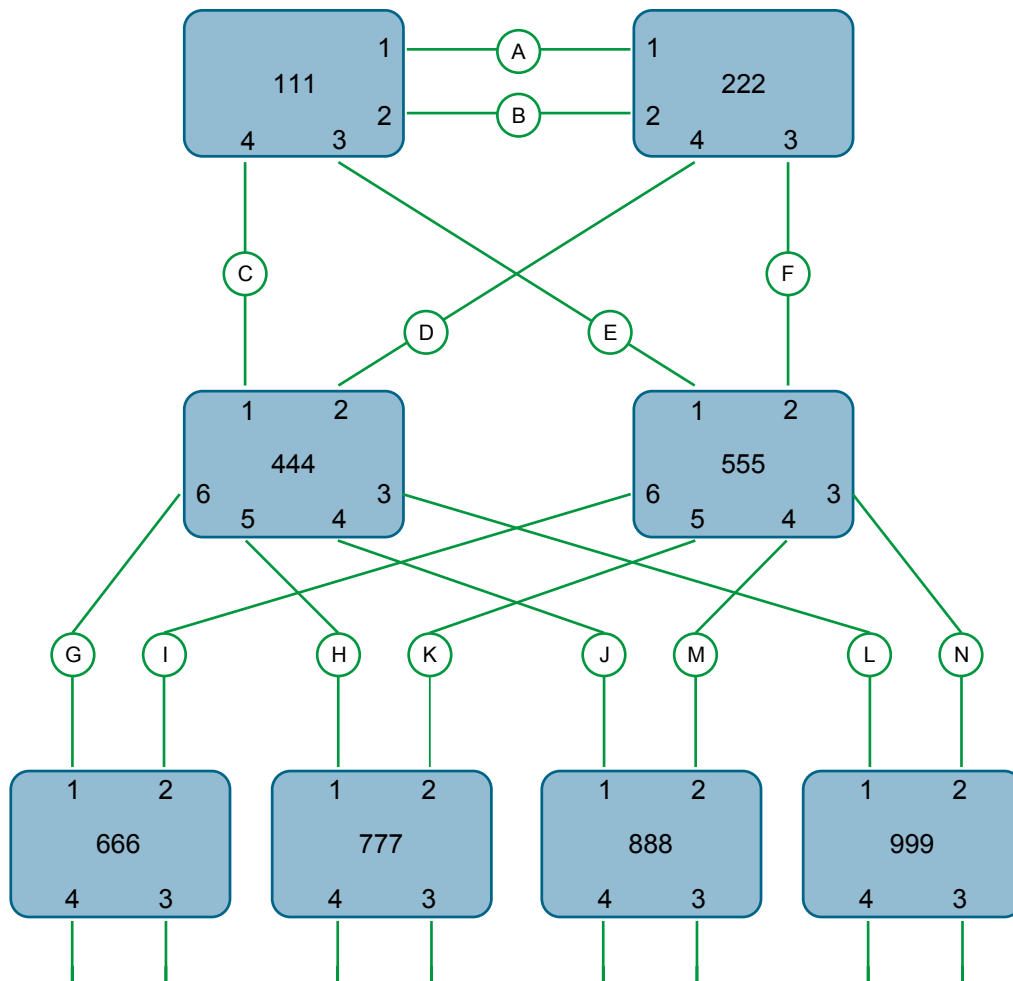

Figure 126: Example - Structured Wiring Configuration

To design a structured wiring configuration, do the following:

1. **Select the design parameters for the network.**

What are the requirements for robustness and network failover/recovery times? Are there any special requirements for diverse routing to a central host computer? Are there any special port redundancy requirements?

2. **Identify required legacy support.**

Are STP bridges used in the network? These bridges do not support rapid transitioning to forwarding. If these bridges are present, can they be re-deployed closer to the network edge?

3. **Identify edge ports and ports with half-duplex/shared media restrictions.**

Ports that connect to host computers, Intelligent Electronic Devices (IEDs) and controllers may be set to edge ports to guarantee rapid transitioning to forwarding as well as to reduce the number of topology change notifications in the network. Ports with half-duplex/shared media restrictions require special attention to guarantee that they do not cause extended fail-over/recovery times.

4. **Choose the root bridge and backup root bridge carefully.**

The root bridge should be selected to be at the concentration point of network traffic. Locate the backup root bridge adjacent to the root bridge. One strategy that may be used is to tune the bridge priority to establish the root bridge and then tune each bridge's priority to correspond to its distance from the root bridge.

5. **Identify desired steady state topology.**

Identify the desired steady state topology taking into account link speeds, offered traffic and QOS. Examine the effects of breaking selected links, taking into account network loading and the quality of alternate links.

6. **Decide upon a port cost calculation strategy.**

Select whether fixed or auto-negotiated costs should be used? It is recommended to use the auto-negotiated cost style, unless it is necessary for the network design to change the auto-negotiated cost style. Select whether the STP or RSTP cost style should be used. Make sure to configure the same cost style on all devices on the network.

7. **Enable RSTP Fast Root Failover option.**

This is a proprietary feature of Siemens. In a mesh network with only RUGGEDCOM devices in the core of the network, it is recommended to enable the RSTP Fast Root Failover option to minimize the network downtime in the event of a Root bridge failure.

8. Calculate and configure priorities and costs.

9. Implement the network and test under load.

Section 8.1.2.2

RSTP in Ring Backbone Configurations

RSTP may be used in ring backbone configurations where rapid recovery from link failure is required. In normal operation, RSTP will block traffic on one of the links, for example, as indicated by the double bars through link H in [Figure 127](#). In the event of a failure on link D, bridge 444 will unblock link H. Bridge 333 will communicate with the network through link F.

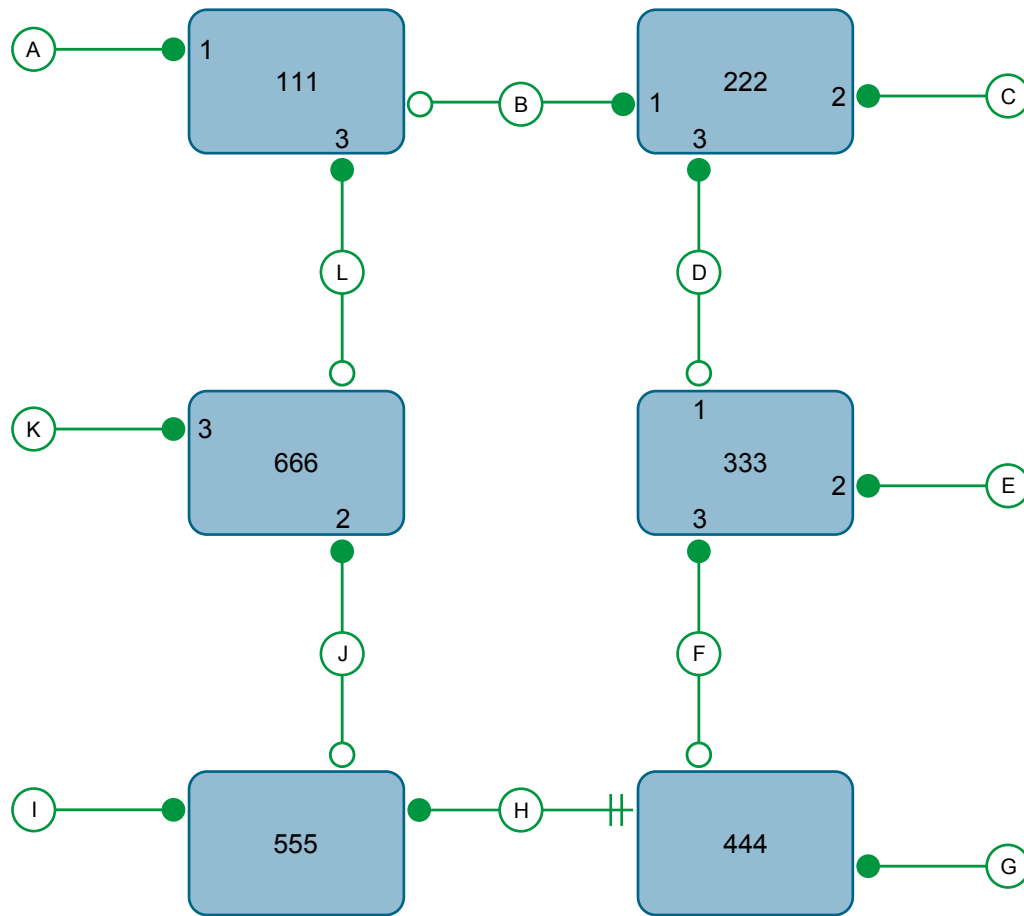

Figure 127: Example - Ring Backbone Configuration

To design a ring backbone configuration with RSTP, do the following:

1. **Select the design parameters for the network.**

What are the requirements for robustness and network fail-over/recovery times? Typically, ring backbones are chosen to provide cost effective but robust network designs.

2. **Identify required legacy support and ports with half-duplex/shared media restrictions.**

These bridges should not be used if network fail-over/recovery times are to be minimized.

3. **Identify edge ports.**

Ports that connect to host computers, Intelligent Electronic Devices (IEDs) and controllers may be set to edge ports to guarantee rapid transitioning to forwarding as well as to reduce the number of topology change notifications in the network.

4. **Choose the root bridge.**

The root bridge can be selected to equalize either the number of bridges, number of stations or amount of traffic on either of its legs. It is important to realize that the ring will always be broken in one spot and that traffic always flows through the root.

5. Assign bridge priorities to the ring.

The strategy that should be used is to assign each bridge's priority to correspond to its distance from the root bridge. If the root bridge is assigned the lowest priority of 0, the bridges on either side should use a priority of 4096 and the next bridges 8192 and so on. As there are 16 levels of bridge priority available, this method provides for up to 31 bridges in the ring.

6. Decide upon a port cost calculation strategy.

It is recommended to use the auto-negotiated cost style, unless it is necessary for the network design to change the auto-negotiated cost style. Select whether the STP or RSTP cost style should be used. Make sure to configure the same cost style on all devices on the network.

7. Disable RSTP Fast Root Failover option.

This is a proprietary feature of Siemens. In RUGGEDCOM ROS, the RSTP Fast Root Failover option is enabled by default. It is recommended to disable this feature when operating in a Ring network.

8. Implement the network and test under load.

Section 8.1.2.3

RSTP Port Redundancy

In cases where port redundancy is essential, RSTP allows more than one bridge port to service a LAN. In the following example, if port 3 is designated to carry the network traffic of LAN A, port 4 will block traffic. Should an interface failure occur on port 3, port 4 will assume control of the LAN.

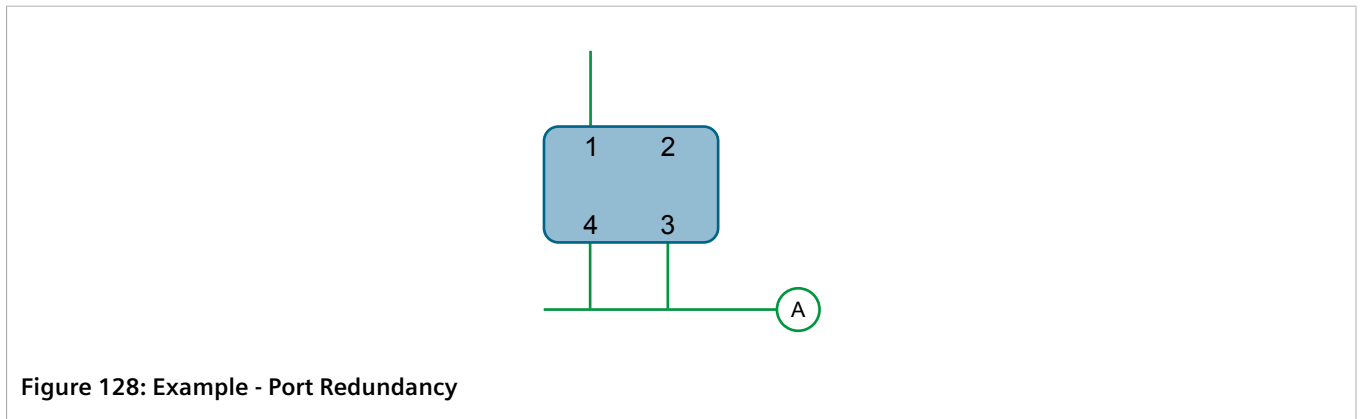

Figure 128: Example - Port Redundancy

Section 8.1.3

MSTP Operation

The Multiple Spanning Tree (MST) algorithm and protocol provide greater control and flexibility than RSTP and legacy STP. MSTP (Multiple Spanning Tree Protocol) is an extension of RSTP, whereby multiple spanning trees may be maintained on the same bridged network. Data traffic is allocated to one or another of several spanning trees by mapping one or more VLANs onto the network.

The sophistication and utility of the Multiple Spanning Tree implementation on a given bridged network is proportional to the amount of planning and design invested in configuring MSTP.

If MSTP is activated on some or all of the bridges in a network with no additional configuration, the result will be a fully and simply connected network, but at best, the result will be the same as a network using only RSTP. Taking full advantage of the features offered by MSTP requires a potentially large number of configuration variables

to be derived from an analysis of data traffic on the bridged network, and from requirements for load sharing, redundancy, and path optimization. Once these parameters have all been derived, it is also critical that they are consistently applied and managed across all bridges in an MST region.

By design, MSTP processing time is proportional to the number of active STP instances. This means that MSTP will likely be significantly slower than RSTP. Therefore, for mission critical applications, RSTP should be considered a better network redundancy solution than MSTP.

CONTENTS

- [Section 8.1.3.1, "MSTP Regions and Interoperability"](#)
- [Section 8.1.3.2, "MSTP Bridge and Port Roles"](#)
- [Section 8.1.3.3, "Benefits of MSTP"](#)
- [Section 8.1.3.4, "Implementing MSTP on a Bridged Network"](#)

Section 8.1.3.1

MSTP Regions and Interoperability

In addition to supporting multiple spanning trees in a network of MSTP-capable bridges, MSTP is capable of inter-operating with bridges that support only RSTP or legacy STP, without requiring any special configuration.

An MST region may be defined as the set of interconnected bridges whose MST Region Identification is identical. The interface between MSTP bridges and non-MSTP bridges, or between MSTP bridges with different MST Region Identification information, becomes part of an MST Region boundary.

Bridges outside an MST region will see the entire region as though it were a single (R)STP bridge; the internal detail of the MST region is hidden from the rest of the bridged network. In support of this, MSTP maintains separate *hop counters* for spanning tree information exchanged at the MST region boundary versus that propagated inside the region. For information received at the MST region boundary, the (R)STP Message Age is incremented only once. Inside the region, a separate Remaining Hop Count is maintained, one for each spanning tree instance. The external Message Age parameter is referred to the (R)STP Maximum Age Time, whereas the internal Remaining Hop Counts are compared to an MST region-wide Maximum Hops parameter.

» MSTI

An MSTI (Multiple Spanning Tree Instance) is one of sixteen independent spanning tree instances that may be defined in an MST region (not including the IST – see below). An MSTI is created by mapping a set of VLANs (in RUGGEDCOM ROS, via the VLAN configuration) to a given MSTI ID. The same mapping must be configured on all bridges that are intended to be part of the MSTI. Moreover, all VLAN to MSTI mappings must be identical for all bridges in an MST region.

RUGGEDCOM ROS supports 16 MSTIs in addition to the IST.

Each MSTI has a topology that is independent of every other. Data traffic originating from the same source and bound to the same destination but on different VLANs on different MSTIs may therefore travel a different path across the network.

» IST

An MST region always defines an IST (Internal Spanning Tree). The IST spans the entire MST region, and carries all data traffic that is not specifically allocated (by VLAN) to a specific MSTI. The IST is always computed and is defined to be MSTI zero.

The IST is also the extension inside the MST region of the CIST (see below), which spans the entire bridged network, inside and outside of the MST region and all other RSTP and STP bridges, as well as any other MST regions.

» CST

The CST (Common Spanning Tree) spans the entire bridged network, including MST regions and any connected STP or RSTP bridges. An MST region is seen by the CST as an individual bridge, with a single cost associated with its traversal.

» CIST

The CIST (Common and Internal Spanning Tree) is the union of the CST and the ISTs in all MST regions. The CIST therefore spans the entire bridged network, reaching into each MST region via the latter's IST to reach every bridge on the network.

Section 8.1.3.2

MSTP Bridge and Port Roles

MSTP supports the following bridge and port roles:

» Bridge Roles

Role	Description
CIST Root	The CIST Root is the elected root bridge of the CIST (Common and Internal Spanning Tree), which spans all connected STP and RSTP bridges and MSTP regions.
CIST Regional Root	The root bridge of the IST within an MSTP region. The CIST Regional Root is the bridge within an MSTP region with the lowest cost path to the CIST Root. Note that the CIST Regional Root will be at the boundary of an MSTP region. Note also that it is possible for the CIST Regional Root to be the CIST Root.
MSTI Regional Root	The root bridge for an MSTI within an MSTP region. A root bridge is independently elected for each MSTI in an MSTP region.

» Port Roles

Each port on an MSTP bridge may have more than one CIST role depending on the number and topology of spanning tree instances defined on the port.

Role	Description
CIST Port Roles	<ul style="list-style-type: none">The Root Port provides the minimum cost path from the bridge to the CIST Root via the CIST Regional Root. If the bridge itself happens to be the CIST Regional Root, the Root Port is also the Master Port for all MSTIs, and provides the minimum cost path to a CIST Root located outside the region.A Designated Port provides the minimum cost path from an attached LAN, via the bridge to the CIST Regional Root.Alternate and Backup Ports function the same as they do in RSTP, but relative to the CIST Regional Root.

Role	Description
MSTI Port Roles	<p>For each MSTI on a bridge:</p> <ul style="list-style-type: none"> • The Root Port provides the minimum cost path from the bridge to the MSTI Regional Root, if the bridge itself is not the MSTI Regional Root. • A Designated Port provides the minimum cost path from an attached LAN, via the bridge to the MSTI Regional Root. • Alternate and Backup Ports function the same as they do in RSTP, but relative to the MSTI Regional Root. <p>The Master Port, which is unique in an MSTP region, is the CIST Root Port of the CIST Regional Root, and provides the minimum cost path to the CIST Root for all MSTIs.</p>
Boundary Ports	<p>A Boundary Port is a port on a bridge in an MSTP region that connects to either: a bridge belonging to a different MSTP region, or a bridge supporting only RSTP or legacy STP. A Boundary Port blocks or forwards all VLANs from all MSTIs and the CIST alike.</p> <p>A Boundary Port may be:</p> <ul style="list-style-type: none"> • The CIST Root Port of the CIST Regional Root (and therefore also the MSTI Master Port). • A CIST Designated Port, CIST Alternate/Backup Port, or Disabled. At the MSTP region boundary, the MSTI Port Role is the same as the CIST Port Role. <p>A Boundary Port connected to an STP bridge will send only STP BPDUs. One connected to an RSTP bridge need not refrain from sending MSTP BPDUs. This is made possible by the fact that the MSTP carries the CIST Regional Root Identifier in the field that RSTP parses as the Designated Bridge Identifier.</p>

Section 8.1.3.3

Benefits of MSTP

Despite the fact that MSTP is configured by default to arrive automatically at a spanning tree solution for each configured MSTI, advantages may be gained from influencing the topology of MSTIs in an MST region. The fact that the Bridge Priority and each port cost are configurable per MST makes it possible to control the topology of each MSTI within a region.

» Load Balancing

MSTP can be used to balance data traffic load among sets of VLANs, enabling more complete utilization of a multiply interconnected bridged network.

A bridged network controlled by a single spanning tree will block redundant links by design, to avoid harmful loops. Using MSTP, however, any given link may have a different blocking state for MSTI, as maintained by MSTP. Any given link, therefore, might be in blocking state for some VLANs, and in forwarding state for other VLANs, depending on the mapping of VLANs to MSTIs.

It is possible to control the spanning tree solution for each MSTI, especially the set of active links for each tree, by manipulating, per MSTI, the bridge priority and the port costs of links in the network. If traffic is allocated judiciously to multiple VLANs, redundant interconnections in a bridged network which, using a single spanning tree, would have gone unused, can now be made to carry traffic.

» Isolation of Spanning Tree Reconfiguration.

A link failure in an MSTP region that does not affect the roles of Boundary ports will not cause the CST to be reconfigured, nor will the change affect other MSTP regions. This is due to the fact that MSTP information does not propagate past a region boundary.

» MSTP vs. PVST

An advantage of MSTP over the Cisco Systems Inc. proprietary Per-VLAN Spanning Tree (PVST) protocol is the ability to map multiple VLANs onto a single MSTI. Since each spanning tree requires processing and memory, the expense of keeping track of an increasing number of VLANs increases much more rapidly for PVST than for MSTP.

» Compatibility with STP and RSTP

No special configuration is required for the bridges of an MST region to connect fully and simply to non-MST bridges on the same bridged network. Careful planning and configuration is, however, recommended to arrive at an optimal network.

Section 8.1.3.4

Implementing MSTP on a Bridged Network

It is recommended the configuration of MSTP on a network proceed in the sequence outlined below.

Naturally, it is also recommended that network analysis and planning inform the steps of configuring the VLAN and MSTP parameters in particular.

Begin with a set of MSTP-capable Ethernet bridges and MSTP disabled. For each bridge in the network:



NOTE

MSTP does not need to be enabled to map a VLAN to an MSTI. However, the mapping must be identical for each bridge that belongs to the MSTP region.

1. Configure and enable STP globally and/or for specific Ethernet ports. For more information, refer to [Section 8.1.4, "Configuring STP Globally"](#) or [Section 8.1.5, "Configuring STP for Specific Ethernet Ports"](#).



NOTE

Static VLANs must be used in an MSTP configuration. GVRP is not supported.

2. Add static VLANs and map them to MSTIs. For more information, refer to [Section 7.1.5.2, "Adding a Static VLAN"](#).



NOTE

The Region Identifier and Revision Level must be the same for each bridge in the MST region.

3. Configure the revision level for the MST Region Identifier. For more information, refer to [Section 8.1.9.3, "Configuring the MST Region Identifier"](#).
4. Make sure the read-only digest for the MST Region Identifier is identical for each bridge in the MST region. If the digest is different, the set of mappings from VLANs to MSTIs differs.
5. Configure the Bridge Priority for the global MSTI. For more information, refer to [Section 8.1.9.4, "Configuring a Global MSTI"](#).

6. Configure the Port Cost and Priority per Port for each MSTI. For more information, refer to [Section 8.1.9.5, "Configuring an MSTI for an Ethernet Port"](#).
7. Set the STP Protocol Version to MSTP and enable STP. For more information, refer to [Section 8.1.4, "Configuring STP Globally"](#)

Section 8.1.4

Configuring STP Globally

To configure global settings for the Spanning Tree Protocol (STP), do the following:

1. Navigate to **Network Redundancy » Spanning Tree » Configure Bridge RSTP Parameters**. The **Bridge RSTP Parameters** form appears.

Bridge RSTP Parameters

access admin

State: Disabled: Enabled:

Version Support: RSTP

Bridge Priority: 32768

Hello Time: 2 s

Max Age Time: 20 s

Transmit Count: Unlimited

Forward Delay: 15 s

Max Hops: 20

Apply Reload

Figure 129: Bridge RSTP Parameters Form

1. State Options 2. Version Support List 3. Bridge Priority List 4. Hello Time Box 5. Max Age Time Box 6. Transmit Count Box 7. Forward Delay Box 8. Max Hops Box 9. Apply Button 10. Reload Button

2. Configure the following parameter(s) as required:

Parameter	Description
State	<p>Synopsis: { Disabled, Enabled }</p> <p>Default: Enabled</p> <p>Enable STP/RSTP/MSTP for the bridge globally. Note that STP/RSTP/MSTP is enabled on a port when it is enabled globally and along with enabling per port setting.</p>
Version Support	<p>Synopsis: { STP, RSTP, MSTP }</p> <p>Default: RSTP</p> <p>Selects the version of Spanning Tree Protocol to support, either only STP or Rapid STP or Multiple STP.</p>
Bridge Priority	<p>Synopsis: { 0, 4096, 8192, 12288, 16384, 20480, 24576, 28672, 32768, 36864, 40960, 45056, 49152, 53248, 57344, 61440 }</p> <p>Default: 32768</p> <p>Bridge Priority provides a way to control the topology of the STP connected network. The desired Root and Designated bridges can be configured for a particular topology. The bridge with the lowest priority will become root. In the event of a failure of the</p>

Parameter	Description
	root bridge, the bridge with the next lowest priority will then become root. Designated bridges that (for redundancy purposes) service a common LAN also use priority to determine which bridge is active. In this way careful selection of Bridge Priorities can establish the path of traffic flows in normal and abnormal conditions.
Hello Time	Synopsis: 1 to 10 s Default: 2 s Time between configuration messages issued by the root bridge. Shorter hello times result in faster detection of topology changes at the expense of moderate increases in STP traffic.
Max Age Time	Synopsis: 6 to 40 s Default: 20 s The time for which a configuration message remains valid after being issued by the root bridge. Configure this parameter with care when many tiers of bridges exist, or slow speed links (such as those used in WANs) are part of the network
Transmit Count	Synopsis: 3 to 100 or { Unlimited } Default: Unlimited Maximum number of BPDUs on each port that may be sent in one second. Larger values allow the network to recover from failed links/bridges more quickly.
Forward Delay	Synopsis: 4 to 30 s Default: 15 s The amount of time a bridge spends learning MAC addresses on a rising port before beginning to forward traffic. Lower values allow the port to reach the forwarding state more quickly, but at the expense of flooding unlearned addresses to all ports.
Max Hops	Synopsis: 6 to 40 Default: 20 Only applicable to MSTP. The maximum possible bridge diameter inside an MST region. MSTP BPDUs propagating inside an MST region specify a time-to-live that is decremented by every switch that propagates the BPDU. If the maximum number of hops inside the region exceeds the configured maximum, BPDUs may be discarded due to their time-to-live setting.

3. Click **Apply**.

Section 8.1.5

Configuring STP for Specific Ethernet Ports

To configure the Spanning Tree Protocol (STP) for a specific Ethernet port, do the following:

1. Navigate to **Network Redundancy » Spanning Tree » Configure Port RSTP Parameters**. The **Port RSTP Parameters** table appears.

Port RSTP Parameters

**access
admin**

Port(s)	Enabled	Priority	STP Cost	RSTP Cost	Edge Port	Point to Point	Restricted Role	Restricted TCN
1	Enabled	128	Auto	Auto	Auto	Auto	False	False
2	Enabled	128	Auto	Auto	Auto	Auto	False	False
3	Enabled	128	Auto	Auto	Auto	Auto	False	False
4	Enabled	128	Auto	Auto	Auto	Auto	False	False
5	Enabled	128	Auto	Auto	Auto	Auto	False	False
6	Enabled	128	Auto	Auto	Auto	Auto	False	False
7	Enabled	128	Auto	Auto	Auto	Auto	False	False
8	Enabled	128	Auto	Auto	Auto	Auto	False	False
9	Enabled	128	Auto	Auto	Auto	Auto	False	False
10	Enabled	128	Auto	Auto	Auto	Auto	False	False

Figure 130: Port RSTP Parameters Table

- Select an Ethernet port. The **Port RSTP Parameters** form appears.

Port RSTP Parameters

**access
admin**

Port(s): ← 1

Enabled: Disabled: Enabled: ← 2

Priority: ← 3

STP Cost: ← 4

RSTP Cost: ← 5

Edge Port: ← 6

Point to Point: ← 7

Restricted Role: ← 8

Restricted TCN: ← 9

← 10 ← 11

Figure 131: Port RSTP Parameters Form

- Port(s) Box
- Enabled Options
- Priority List
- STP Cost Box
- RSTP Cost Box
- Edge Port List
- Point to Point List
- Restricted Role Box
- Restricted TCN Box
- Apply Button
- Reload Button

- Configure the following parameter(s) as required:

Parameter	Description
Port(s)	Synopsis: Comma-separated list of ports The port number as seen on the front plate silkscreen of the switch (or a list of ports, if aggregated in a port trunk).
Enabled	Synopsis: { Disabled, Enabled } Default: Enabled

Parameter	Description
	Enabling STP activates the STP or RSTP protocol for this port per the configuration in the STP Configuration menu. STP may be disabled for the port ONLY if the port does not attach to an STP enabled bridge in any way. Failure to meet this requirement WILL result in an undetectable traffic loop in the network. A better alternative to disabling the port is to leave STP enabled but to configure the port as an edge port. A good candidate for disabling STP would be a port that services only a single host computer.
Priority	<p>Synopsis: { 0, 16, 32, 48, 64, 80, 96, 112, 128, 144, 160, 176, 194, 208, 224, 240 }</p> <p>Default: 128</p> <p>Selects the STP port priority. Ports of the same cost that attach to a common LAN will select the port to be used based upon the port priority.</p>
STP Cost	<p>Synopsis: 0 to 65535 or { Auto }</p> <p>Default: Auto</p> <p>Selects the cost to use in cost calculations, when the Cost Style parameter is set to STP in the Bridge RSTP Parameters configuration. Setting the cost manually provides the ability to preferentially select specific ports to carry traffic over others. Leave this field set to "auto" to use the standard STP port costs as negotiated (4 for 1Gbps, 19 for 100 Mbps links and 100 for 10 Mbps links).</p> <p>For MSTP, this parameter applies to both external and internal path cost.</p>
RSTP Cost	<p>Synopsis: 0 to 2147483647 or { Auto }</p> <p>Default: Auto</p> <p>Selects the cost to use in cost calculations, when the Cost Style parameter is set to RSTP in the Bridge RSTP Parameters configuration. Setting the cost manually provides the ability to preferentially select specific ports to carry traffic over others. Leave this field set to "auto" to use the standard RSTP port costs as negotiated (20,000 for 1Gbps, 200,000 for 100 Mbps links and 2,000,000 for 10 Mbps links).</p> <p>For MSTP, this parameter applies to both external and internal path cost.</p>
Edge Port	<p>Synopsis: { False, True, Auto }</p> <p>Default: Auto</p> <p>Edge ports are ports that do not participate in the Spanning Tree, but still send configuration messages. Edge ports transition directly to frame forwarding without any listening and learning delays. The MAC tables of Edge ports do not need to be flushed when topology changes occur in the STP network. Unlike an STP disabled port, accidentally connecting an edge port to another port in the spanning tree will result in a detectable loop. The "Edgeness" of the port will be switched off and the standard RSTP rules will apply (until the next link outage).</p>
Point to Point	<p>Synopsis: { False, True, Auto }</p> <p>Default: Auto</p> <p>RSTP uses a peer-to-peer protocol that provides rapid transitioning on point-to-point links. This protocol is automatically turned off in situations where multiple STP bridges communicate over a shared (non point-to-point) LAN. The bridge will automatically take point-to-point to be true when the link is found to be operating in full-duplex mode. The point-to-point parameter allows this behavior or overrides it, forcing point-to-point to be true or false. Force the parameter true when the port operates a point-to-point link but cannot run the link in full-duplex mode. Force the parameter false when the port operates the link in full-duplex mode, but is still not point-to-point (e.g. a full-duplex link to an unmanaged bridge that concentrates two other STP bridges).</p>
Restricted Role	<p>Synopsis: { True or False }</p> <p>Default: False</p> <p>A boolean value set by management. If TRUE, causes the Port not to be selected as the Root Port for the CIST or any MSTI, even if it has the best spanning tree priority vector. Such a Port will be selected as an Alternate Port after the Root Port has been selected. This parameter should be FALSE by default. If set, it can cause a lack of spanning tree connectivity. It is set by a network administrator to prevent bridges that are external to a core region of the network from influencing the spanning tree active topology. This may be necessary, for example, if those bridges are not under the full control of the administrator.</p>

Parameter	Description
Restricted TCN	<p>Synopsis: { True or False }</p> <p>Default: False</p> <p>A boolean value set by management. If TRUE, it causes the Port not to propagate received topology change notifications and topology changes to other Ports. If set, it can cause temporary loss of connectivity after changes in a spanning tree's active topology as a result of persistent, incorrectly learned, station location information. It is set by a network administrator to prevent bridges that are external to a core region of the network from causing address flushing in that region. This may be necessary, for example, if those bridges are not under the full control of the administrator or if the MAC_Operational status parameter for the attached LANs transitions frequently.</p>

- Click **Apply**.

Section 8.1.6

Configuring eRSTP

To configure eRSTP, do the following:

- Navigate to **Network Redundancy » Spanning Tree » Configure eRSTP Parameters**. The eRSTP Parameters form appears.

The screenshot shows the 'eRSTP Parameters' configuration form. It includes the following elements:

- 1:** Max Network Diameter options: MaxAgeTime (radio button), 4*MaxAgeTime (radio button).
- 2:** BPDU Guard Timeout: Don't shutdown (text box).
- 3:** Fast Root Failover: On (dropdown menu).
- 4:** IEEE802.1w Interoperability: On (radio button), Off (radio button).
- 5:** Cost Style: STP (16 bit) (radio button), RSTP (32 bit) (radio button).
- 6:** Apply button.
- 7:** Reload button.

Figure 132: eRSTP Parameters Form

1. Max Network Diameter Options 2. BPDU Guard Timeout Box 3. Fast Root Failover List 4. IEEE802.1w Interoperability Options
5. Cost Style Options 6. Apply Button 7. Reload Button

- Configure the following parameter(s) as required:

Parameter	Description
Max Network Diameter	<p>Synopsis: { MaxAgeTime, 4*MaxAgeTime }</p> <p>Default: 4*MaxAgeTime</p> <p>The RSTP standard puts a limit on the maximum network size that can be controlled by the RSTP protocol. The network size is described by the term 'maximum network diameter', which is the number of switches that comprise the longest path that RSTP BPDUs have to traverse. The standard supported maximum network diameter is equal to the value of the 'MaxAgeTime' RSTP configuration parameter.</p> <p>eRSTP offers an enhancement to RSTP which allows it to cover networks larger than ones defined by the standard.</p> <p>This configuration parameter selects the maximum supported network size.</p>
BPDU Guard Timeout	<p>Synopsis: 1 to 86400 s or { Until reset, Don't shutdown }</p> <p>Default: Don't shutdown</p>

Parameter	Description
	<p>The RSTP standard does not address network security. RSTP must process every received BPDU and take an appropriate action. This opens a way for an attacker to influence RSTP topology by injecting RSTP BPDUs into the network.</p> <p>BPDU Guard is a feature that protects the network from BPDUs received by a port where RSTP capable devices are not expected to be attached. If a BPDU is received by a port for which 'Edge' parameter is set to 'TRUE' or RSTP is disabled, the port will be shutdown for the time period specified by this parameter.</p> <ul style="list-style-type: none"> • <code>Don't shutdown</code> – BPDU Guard is disabled • <code>Until reset</code> – port will remain shutdown until the port reset command is issued by the user
Fast Root Failover	<p>Synopsis: { On, On with standard root, Off }</p> <p>Default: On</p> <p>In mesh network topologies, the standard RSTP algorithm does not guarantee deterministic network recovery time in the case of a root switch failure. Such a recovery time is hard to calculate and it can be different (and may be relatively long) for any given mesh topology.</p> <p>This configuration parameter enables Siemens's enhancement to RSTP which detects a failure of the root switch and performs some extra RSTP processing steps, significantly reducing the network recovery time and making it deterministic.</p> <div data-bbox="691 808 1524 1003" style="border: 1px solid gray; padding: 5px;"> <p> NOTE</p> <ul style="list-style-type: none"> • <i>This feature is only available in RSTP mode. In MSTP mode, the configuration parameter is ignored.</i> • <i>In a single ring topology, this feature is not needed and should be disabled to avoid longer network recovery times due to extra RSTP processing.</i> </div> <p>The Fast Root Failover algorithm must be supported by all switches in the network, including the root, to guarantee optimal performance. However, it is not uncommon to assign the root role to a switch from a vendor different from the rest of the switches in the network. In other words, it is possible that the root might not support the Fast Root Failover algorithm. In such a scenario, a "relaxed" algorithm should be used, which tolerates the lack of support in the root switch.</p> <p>These are the supported configuration options:</p> <ul style="list-style-type: none"> • <code>Off</code> – Fast Root Failover algorithm is disabled and hence a root switch failure may result in excessive connectivity recovery time. • <code>On</code> – Fast Root Failover is enabled and the most robust algorithm is used, which requires the appropriate support in the root switch. • <code>On with standard root</code> – Fast Root Failover is enabled but a "relaxed" algorithm is used, allowing the use of a standard switch in the root role.
IEEE802.1w Interoperability	<p>Synopsis: { On, Off }</p> <p>Default: On</p> <p>The original RSTP protocol defined in the IEEE 802.1w standard has minor differences from more recent, enhanced, standard(s). Those differences cause interoperability issues which, although they do not completely break RSTP operation, can lead to a longer recovery time from failures in the network.</p> <p>eRSTP offers some enhancements to the protocol which make the switch fully interoperable with other vendors' switches, which may be running IEEE 802.2w RSTP. The enhancements do not affect interoperability with more recent RSTP editions.</p> <p>This configuration parameter enables the aforementioned interoperability mode.</p>
Cost Style	<p>Synopsis: { STP (16 bit), RSTP (32 bit) }</p> <p>Default: STP (16 bit)</p> <p>The RSTP standard defines two styles of a path cost value. STP uses 16-bit path costs based upon 1x10E9/link speed (4 for 1Gbps, 19 for 100 Mbps and 100 for 10 Mbps) whereas RSTP uses 32-bit costs based upon 2x10E13/link speed (20,000 for 1Gbps, 200,000 for 100 Mbps and 2,000,000 for 10 Mbps). However, switches from some</p>

Parameter	Description
	<p>vendors keep using the STP path cost style even in RSTP mode, which can cause confusion and interoperability problems.</p> <p>This configuration parameter selects the style of link costs to employ.</p> <p>Note that RSTP link costs are used only when the bridge version support is set to allow RSTP and the port does not migrate to STP.</p>

3. Click **Apply**.

Section 8.1.7

Viewing Global Statistics for STP

To view global statistics for STP, Navigate to **Network Redundancy » Spanning Tree » View Bridge RSTP Statistics**. The **Bridge RSTP Statistics** form appears.

The screenshot shows the **Bridge RSTP Statistics** form. The fields and their values are as follows:

- 1. Bridge Status: Not Designated For Any LAN
- 2. Bridge ID: 32768/00-0A-DC-11-29-39
- 3. Root ID: 32768/00-0A-DC-00-71-57
- 4. Root Port: 3/1
- 5. Root Path Cost: 38
- 6. Configured Hello Time: 2
- 7. Learned Hello Time: 2
- 8. Configured Forward Delay: 15
- 9. Learned Forward Delay: 15
- 10. Configured Max Age: 20
- 11. Learned Max Age: 20
- 12. Total Topology Changes: 10
- 13. Time since Last TC: 0 days, 02:48:19
- 14. Reload Button

The form also includes a user name 'access admin' in the top right corner.

Figure 133: Bridge RSTP Statistics Form

1. Bridge Status Box 2. Bridge ID Box 3. Root ID Box 4. Root Port Box 5. Root Path Cost Box 6. Configure Hello Time Box 7. Learned Hello Time Box 8. Configured Forward Delay Box 9. Learned Forward Delay Box 10. Configured Max Age Box 11. Learned Max Age Box 12. Total Topology Changes Box 13. Time Since Last TC Box 14. Reload Button

This table displays the following information:

Parameter	Description
Bridge Status	<p>Synopsis: { Designated Bridge, Not Designated For Any LAN, Root Bridge }</p> <p>Spanning Tree status of the bridge. The status may be root or designated. This field may show text saying not designated for any LAN if the bridge is not designated for any of its ports.</p>

Parameter	Description
Bridge ID	Synopsis: \$\$ / ##-##-##-##-##-## where \$\$ is 0 to 65535, ## is 0 to FF Bridge Identifier of this bridge.
Root ID	Synopsis: \$\$ / ##-##-##-##-##-## where \$\$ is 0 to 65535, ## is 0 to FF Bridge Identifier of the root bridge.
Root Port	Synopsis: 1 to maximum port number or { <empty string> } If the bridge is designated, this is the port that provides connectivity towards the root bridge of the network.
Root Path Cost	Synopsis: 0 to 4294967295 Total cost of the path to the root bridge composed of the sum of the costs of each link in the path. If custom costs have not been configured. 1Gbps ports will contribute 4, 100 Mbps ports will contribute 19 and 10 Mbps ports will contribute a cost of 100 to this figure. For the CIST instance of MSTP, this is an external root path cost, which is the cost of the path from the IST root (i.e. regional root) bridge to the CST root (i.e. network "global" root) bridge.
Configured Hello Time	Synopsis: 0 to 65535 The configured Hello time from the Bridge RSTP Parameters menu.
Learned Hello Time	Synopsis: 0 to 65535 The actual Hello time provided by the root bridge as learned in configuration messages. This time is used in designated bridges.
Configured Forward Delay	Synopsis: 0 to 65535 The configured Forward Delay time from the Bridge RSTP Parameters menu.
Learned Forward Delay	Synopsis: 0 to 65535 The actual Forward Delay time provided by the root bridge as learned in configuration messages. This time is used in designated bridges.
Configured Max Age	Synopsis: 0 to 65535 The configured Maximum Age time from the Bridge RSTP Parameters menu.
Learned Max Age	Synopsis: 0 to 65535 The actual Maximum Age time provided by the root bridge as learned in configuration messages. This time is used in designated bridges.
Total Topology Changes	Synopsis: 0 to 65535 A count of topology changes in the network, as detected on this bridge through link failures or as signaled from other bridges. Excessively high or rapidly increasing counts signal network problems.
Time since Last TC	Synopsis: DDDD days, HH:MM:SS The time since the last time a topology change was detected by the bridge.

Section 8.1.8

Viewing STP Statistics for Ethernet Ports

To view STP statistics for Ethernet ports, Navigate to **Network Redundancy » Spanning Tree » View Port RSTP Statistics**. The **Port RSTP Statistics** table appears.

Port RSTP Statistics								access admin
Port(s)	Status	Role	Cost	RX RSTs	TX RSTs	RX Configs	TX Configs	RX Tcns
1	Link Down		0	0	30657	0	0	0
2	Link Down		0	2	30660	0	0	0
3	Link Down		0	0	0	0	0	0
4	Link Down		0	0	0	0	0	0
5	Link Down		0	0	0	0	0	0
6	Link Down		0	0	0	0	0	0
7	Link Down		0	0	0	0	0	0
8	Forwarding	Root	19	51851	3	0	0	0
9	Link Down		0	0	0	0	0	0
10	Link Down		0	0	0	0	0	0

Figure 134: Port RSTP Statistics Table

This table displays the following information:

Parameter	Description
Port(s)	<p>Synopsis: Comma-separated list of ports</p> <p>The port number as seen on the front plate silkscreen of the switch (or a list of ports, if aggregated in a port trunk).</p>
Status	<p>Synopsis: { Disabled, Listening, Learning, Forwarding, Blocking, Link Down, Discarding }</p> <p>Status of this port in Spanning Tree. This may be one of the following:</p> <ul style="list-style-type: none"> • Disabled – STP is disabled on this port. • Listening – This state is not used by RUGGEDCOM ROS. • Learning – The port is learning MAC addresses to prevent flooding when it begins forwarding traffic. • Forwarding – The port is forwarding traffic. • Blocking – The port is blocking traffic. • Link Down – STP is enabled on this port but the link is down. • Discarding – The link is not used in the STP topology but is standing by.
Role	<p>Synopsis: { Root, Designated, Alternate, Backup, Master }</p> <p>Role of this port in Spanning Tree. This may be one of the following:</p> <ul style="list-style-type: none"> • Designated – The port is designated for (i.e. carries traffic towards the root for) the LAN it is connected to. • Root – The single port on the bridge, which provides connectivity towards the root bridge. • Backup – The port is attached to a LAN that is serviced by another port on the bridge. It is not used but is standing by. • Alternate – The port is attached to a bridge that provides connectivity to the root bridge. It is not used but is standing by. • Master – Only exists in MSTP. The port is an MST region boundary port and the single port on the bridge, which provides connectivity for the Multiple Spanning Tree Instance towards the Common Spanning Tree root bridge (i.e. this port is the root port for the Common Spanning Tree Instance).
Cost	<p>Synopsis: 0 to 4294967295</p> <p>Cost offered by this port. If the Bridge RSTP Parameters Cost Style is set to STP, 1Gbps ports will contribute 4, 100 Mbps ports will contribute 19 and 10 Mbps ports contribute a cost of 100. If the Cost Style is set to RSTP, 1Gbps will contribute 20,000, 100 Mbps ports will contribute a cost of 200,000 and 10 Mbps ports contribute a cost of 2,000,000. Note that even if the Cost style is set to RSTP, a port that migrates to STP will have its cost limited to a maximum of 65535.</p>

Parameter	Description
RX RSTs	Synopsis: 0 to 4294967295 The count of RSTP configuration messages received on this port.
TX RSTs	Synopsis: 0 to 4294967295 The count of RSTP configuration messages transmitted on this port.
RX Configs	Synopsis: 0 to 4294967295 The count of STP configuration messages received on this port.
TX Configs	Synopsis: 0 to 4294967295 The count of STP configuration messages transmitted on this port.
RX Tcns	Synopsis: 0 to 4294967295 The count of STP topology change notification messages received on this port. Excessively high or rapidly increasing counts signal network problems.
TX Tcns	Synopsis: 0 to 4294967295 The count of STP topology change notification messages transmitted on this port.
Desig Bridge ID	Synopsis: \$\$ / ##-##-##-##-##-## where \$\$ is 0 to 65535, ## is 0 to FF Provided on the root ports of designated bridges, the Bridge Identifier of the bridge this port is connected to.
operEdge	Synopsis: True or False The port is operating as an edge port or not.

Section 8.1.9

Managing Multiple Spanning Tree Instances

This section describes how to configure and manage Multiple Spanning Tree Instances (MSTIs).

CONTENTS

- [Section 8.1.9.1, “Viewing Statistics for Global MSTIs”](#)
- [Section 8.1.9.2, “Viewing Statistics for Port MSTIs”](#)
- [Section 8.1.9.3, “Configuring the MST Region Identifier”](#)
- [Section 8.1.9.4, “Configuring a Global MSTI”](#)
- [Section 8.1.9.5, “Configuring an MSTI for an Ethernet Port”](#)

Section 8.1.9.1

Viewing Statistics for Global MSTIs

To view statistics for global MSTIs, Navigate to **Network Redundancy » Spanning Tree » View Bridge MSTI Statistics**. The **Bridge MSTI Statistics** form appears.

To view statistics for global MSTIs, Navigate to **Spanning Tree » View Bridge MSTI Statistics**. The **Bridge MSTI Statistics** form appears.

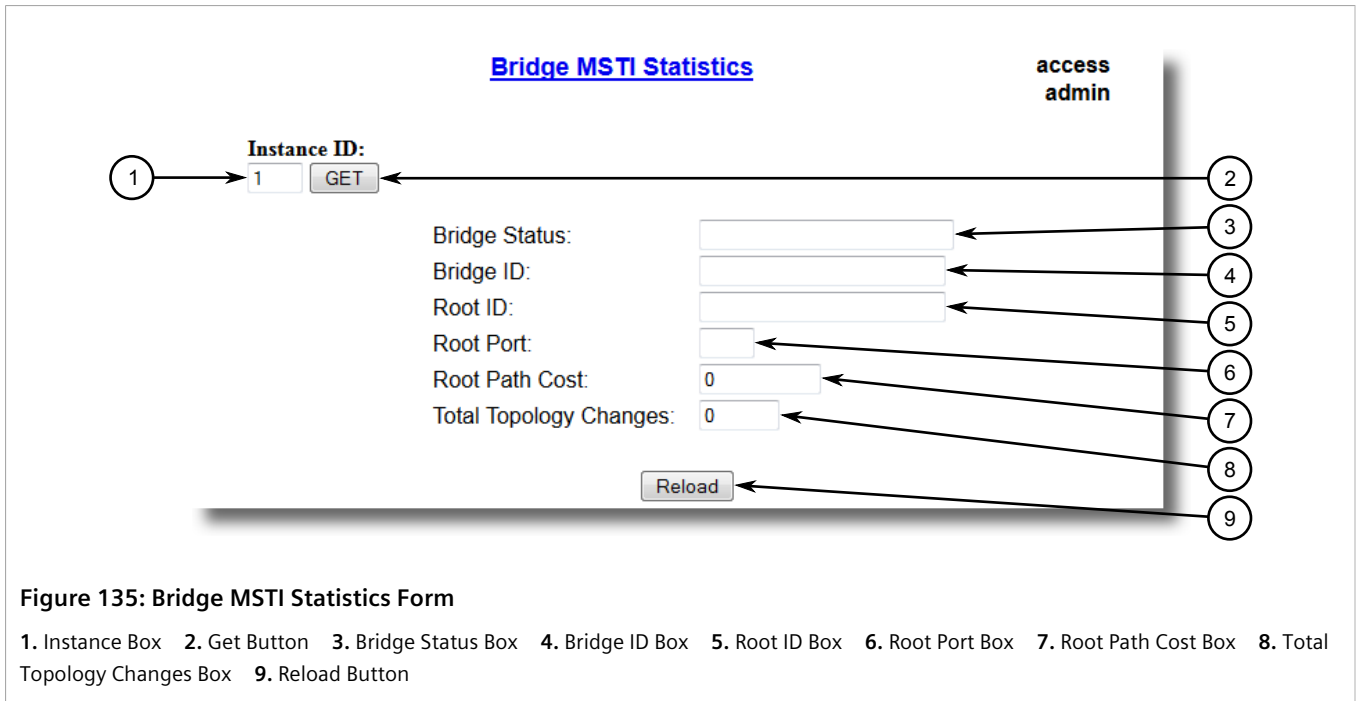

Figure 135: Bridge MSTI Statistics Form

1. Instance Box 2. Get Button 3. Bridge Status Box 4. Bridge ID Box 5. Root ID Box 6. Root Path Cost Box 7. Root Path Cost Box 8. Total Topology Changes Box 9. Reload Button

This table displays the following information:

Parameter	Description
Bridge Status	Synopsis: { Designated Bridge, Not Designated For Any LAN, Root Bridge } Spanning Tree status of the bridge. The status may be root or designated. This field may show text saying not designated for any LAN if the bridge is not designated for any of its ports.
Bridge ID	Synopsis: \$\$ / ##-##-##-##-##-## where \$\$ is 0 to 65535, ## is 0 to FF Bridge Identifier of this bridge.
Root ID	Synopsis: \$\$ / ##-##-##-##-##-## where \$\$ is 0 to 65535, ## is 0 to FF Bridge Identifier of the root bridge.
Root Port	Synopsis: 1 to maximum port number or { <empty string> } If the bridge is designated, this is the port that provides connectivity towards the root bridge of the network.
Root Path Cost	Synopsis: 0 to 4294967295 Total cost of the path to the root bridge composed of the sum of the costs of each link in the path. If custom costs have not been configured. 1Gbps ports will contribute 4, 100 Mbps ports will contribute 19 and 10 Mbps ports will contribute a cost of 100 to this figure. For the CIST instance of MSTP, this is an external root path cost, which is the cost of the path from the IST root (i.e. regional root) bridge to the CST root (i.e. network "global" root) bridge.
Total Topology Changes	Synopsis: 0 to 65535 A count of topology changes in the network, as detected on this bridge through link failures or as signaled from other bridges. Excessively high or rapidly increasing counts signal network problems.

Section 8.1.9.2

Viewing Statistics for Port MSTIs

To view statistics for port MSTIs, Navigate to **Network Redundancy » Spanning Tree » View Port MSTI Statistics**. The **Port MSTI Statistics** form appears.

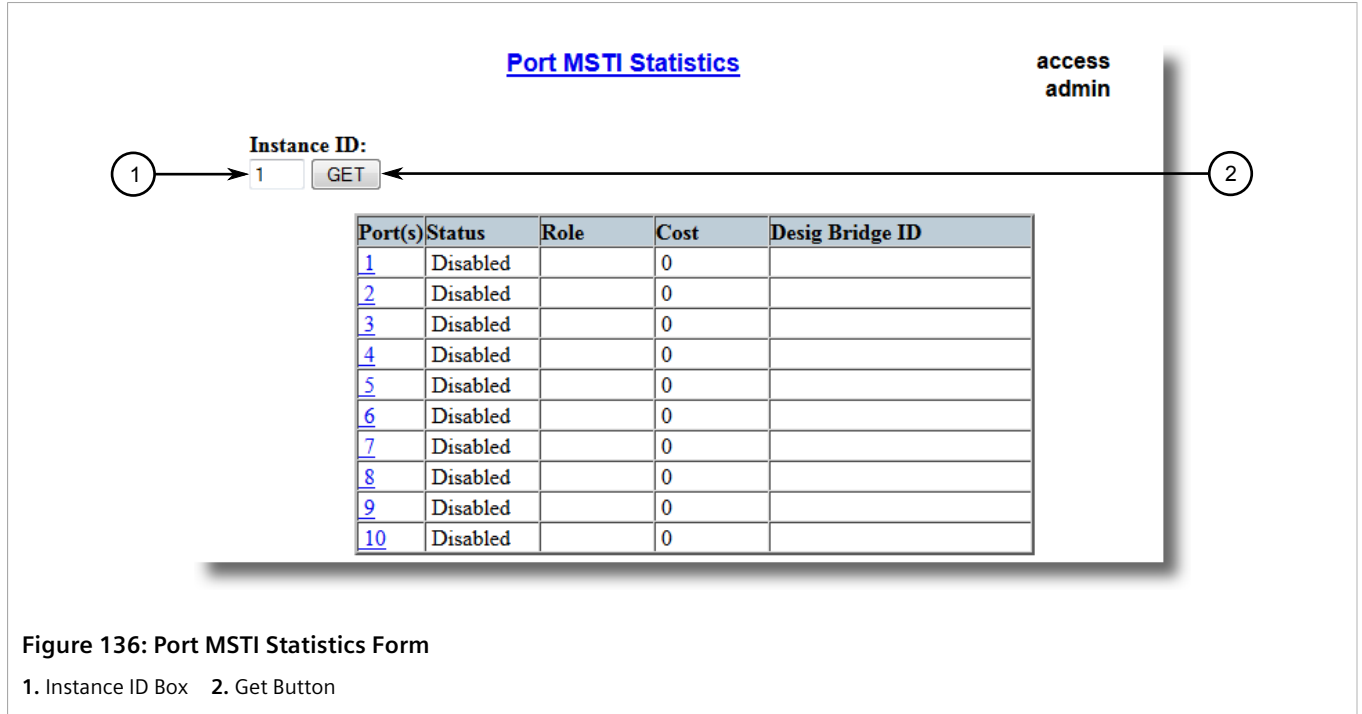

This table displays the following information:

Parameter	Description
Port(s)	Synopsis: Comma-separated list of ports The port number as seen on the front plate silkscreen of the switch (or a list of ports, if aggregated in a port trunk).
Status	Synopsis: { Disabled, Listening, Learning, Forwarding, Blocking, Link Down, Discarding } Status of this port in Spanning Tree. This may be one of the following: <ul style="list-style-type: none"> Disabled – STP is disabled on this port. Listening – This state is not used by RUGGEDCOM ROS. Learning – The port is learning MAC addresses in order to prevent flooding when it begins forwarding traffic. Forwarding – The port is forwarding traffic. Blocking – The port is blocking traffic. Link Down – STP is enabled on this port but the link is down. Discarding – The link is not used in the STP topology but is standing by.
Role	Synopsis: { Root, Designated, Alternate, Backup, Master } Role of this port in Spanning Tree. This may be one of the following: <ul style="list-style-type: none"> Designated – The port is designated for (i.e. carries traffic towards the root for) the LAN it is connected to. Root – The single port on the bridge, which provides connectivity towards the root bridge. Backup – The port is attached to a LAN that is serviced by another port on the bridge. It is not used but is standing by.

Parameter	Description
	<ul style="list-style-type: none"> Alternate – The port is attached to a bridge that provides connectivity to the root bridge. It is not used but is standing by. Master – Only exists in MSTP. The port is an MST region boundary port and the single port on the bridge, which provides connectivity for the Multiple Spanning Tree Instance towards the Common Spanning Tree root bridge (i.e. this port is the root port for the Common Spanning Tree Instance).
Cost	<p>Synopsis: 0 to 4294967295</p> <p>Cost offered by this port. If the Bridge RSTP Parameters Cost Style is set to STP, 1Gbps ports will contribute 4, 100 Mbps ports will contribute 19 and 10 Mbps ports contribute a cost of 100. If the Cost Style is set to RSTP, 1Gbps will contribute 20,000, 100 Mbps ports will contribute a cost of 200,000 and 10 Mbps ports contribute a cost of 2,000,000. Note that even if the Cost style is set to RSTP, a port that migrates to STP will have its cost limited to a maximum of 65535.</p>
Desig Bridge ID	<p>Synopsis: \$\$ / ##-##-##-##-##-## where \$\$ is 0 to 65535, ## is 0 to FF</p> <p>Provided on the root ports of designated bridges, the Bridge Identifier of the bridge this port is connected to.</p>

Section 8.1.9.3

Configuring the MST Region Identifier

Configuring the region identifier and revision level puts the MSTP bridge in a defined group. Other bridges that have the same identifier and revision level are interconnected within this region. For more information, refer to [Section 8.1.3.1, "MSTP Regions and Interoperability"](#).

To configure the Multiple Spanning Tree (MST) region identifier, do the following:

1. Navigate to **Network Redundancy » Spanning Tree » Configure MST Region Identifier**. The **MST Region Identifier** form appears.

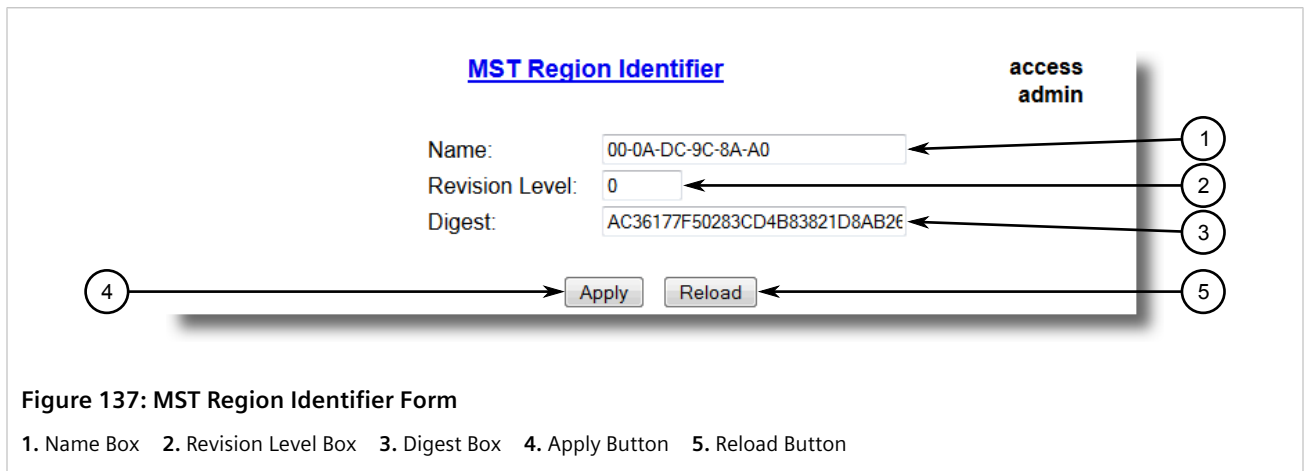

Figure 137: MST Region Identifier Form

1. Name Box 2. Revision Level Box 3. Digest Box 4. Apply Button 5. Reload Button

2. Configure the following parameter(s) as required:

Parameter	Description
Name	<p>Synopsis: Any 32 characters Default: 00-0A-DC-92-00-00</p> <p>The name of the MST region. All devices in the same MST region must have the same region name configured.</p>
Revision Level	<p>Synopsis: 0 to 65535</p>

Parameter	Description
	Default: 0 The revision level for MST configuration. Typically, all devices in the same MST region are configured with the same revision level. However, different revision levels can be used to create sub-regions under the same region name.
Digest	Synopsis: Any 32 characters Default: 0 This is a read-only parameter and should be only used for network troubleshooting. In order to ensure consistent VLAN-to-instance mapping, it is necessary for the protocol to be able to exactly identify the boundaries of the MST regions. For that pupose, the characteristics of the region are included in BPDUs. There is no need to propagate the exact VLAN-to-instance mapping in the BPDUs because switches only need to know whether they are in the same region as a neighbor. Therefore, only this 16-octet digest created from the VLAN-to-instance mapping is sent in BPDUs.

3. Click **Apply**.

Section 8.1.9.4

Configuring a Global MSTI

To configure a global Multiple Spanning Tree Instance (MSTI) for the Spanning Tree Protocol (STP), do the following:

1. Navigate to **Network Redundancy » Spanning Tree » Configure Bridge MSTI Parameters**. The **Bridge MSTI Parameters** form appears.

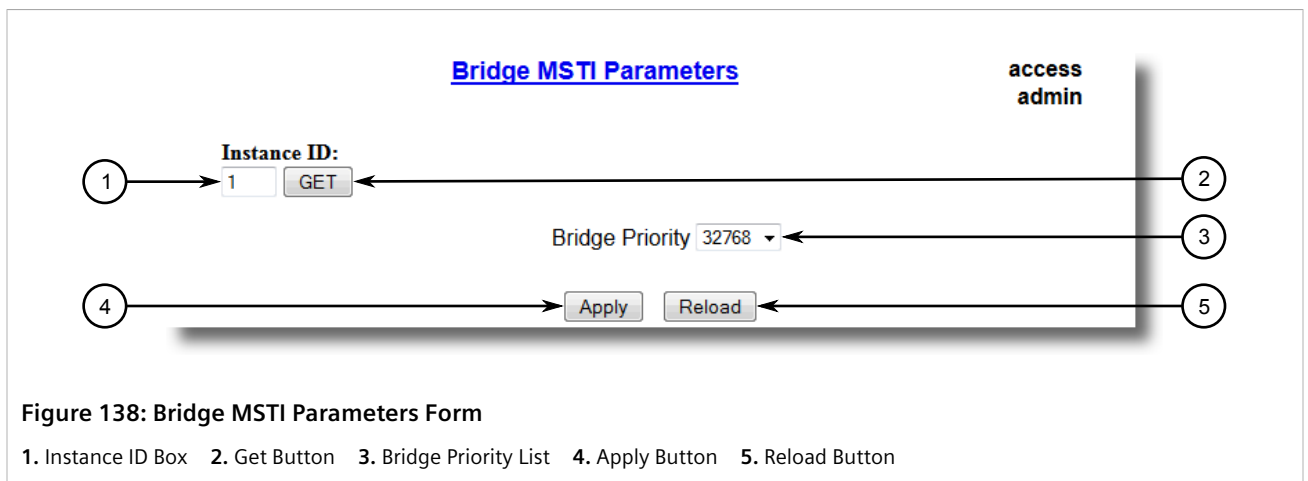

2. Under **Instance ID**, type an ID number for a Multiple Spanning Tree Instance (MSTI) and click **GET**. The settings for the MSTI are displayed. Any changes made to the configuration will be applied specifically to this instance ID.
3. Configure the following parameter(s) as required:

Parameter	Description
Bridge Priority	Synopsis: { 0, 4096, 8192, 12288, 16384, 20480, 24576, 28672, 32768, 36864, 40960, 45056, 49152, 53248, 57344, 61440 } Default: 32768 Bridge Priority provides a way to control the topology of the STP connected network. The desired Root and Designated bridges can be configured for a particular topology. The bridge with the lowest priority will become root. In the event of a failure of the

Parameter	Description
	root bridge, the bridge with the next lowest priority will then become root. Designated bridges that (for redundancy purposes) service a common LAN also use priority to determine which bridge is active. In this way careful selection of Bridge Priorities can establish the path of traffic flows in normal and abnormal conditions.

- Click **Apply**.

Section 8.1.9.5

Configuring an MSTI for an Ethernet Port

To configure a Multiple Spanning Tree Instance (MSTI) for an Ethernet port, do the following

- Navigate to **Network Redundancy » Spanning Tree » Configure Port MSTI Parameters**. The **Port MSTI Parameters** table appears.

Port MSTI Parameters

access
admin

Instance ID:

Port(s)	Priority	STP Cost	RSTP Cost
1	128	Auto	Auto
2	128	Auto	Auto
3	128	Auto	Auto
4	128	Auto	Auto
5	128	Auto	Auto
6	128	Auto	Auto
7	128	Auto	Auto
8	128	Auto	Auto
9	128	Auto	Auto
10	128	Auto	Auto

Figure 139: Port MSTI Parameters Table

- Select an Ethernet port. The **Port MSTI Parameters** form appears.

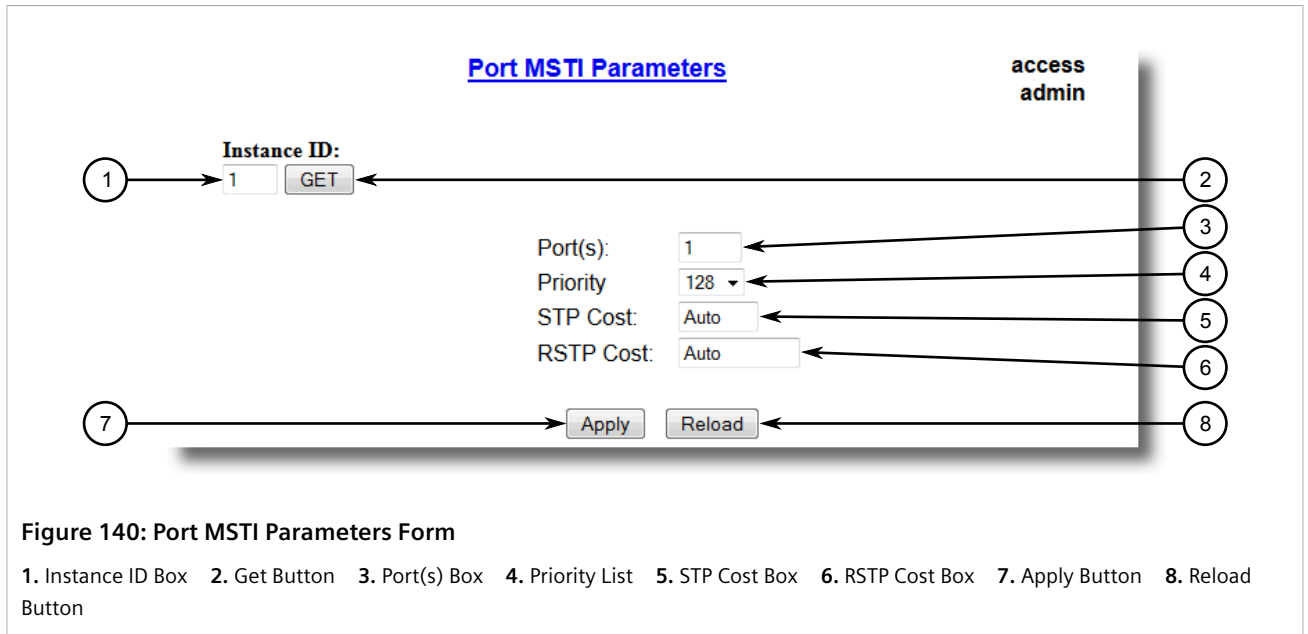

Figure 140: Port MSTI Parameters Form

1. Instance ID Box 2. Get Button 3. Port(s) Box 4. Priority List 5. STP Cost Box 6. RSTP Cost Box 7. Apply Button 8. Reload Button

- Under **Instance ID**, type an ID number for a Multiple Spanning Tree Instance (MSTI) and click **GET**. The settings for the MSTI are displayed. Any changes made to the configuration will be applied specifically to this instance ID.
- Configure the following parameter(s) as required:

Parameter	Description
Port(s)	Synopsis: Comma-separated list of ports The port number as seen on the front plate silkscreen of the switch (or a list of ports, if aggregated in a port trunk).
Priority	Synopsis: { 0, 16, 32, 48, 64, 80, 96, 112, 128, 144, 160, 176, 192, 208, 224, 240 } Default: 128 Selects the STP port priority. Ports of the same cost that attach to a common LAN will select the port to be used based upon the port priority.
STP Cost	Synopsis: 0 to 65535 or { Auto } Default: Auto Selects the cost to use in cost calculations, when the Cost Style parameter is set to STP in the Bridge RSTP Parameters configuration. Setting the cost manually provides the ability to preferentially select specific ports to carry traffic over others. Leave this field set to "auto" to use the standard STP port costs as negotiated (4 for 1Gbps, 19 for 100 Mbps links and 100 for 10 Mbps links). For MSTP, this parameter applies to both external and internal path cost.
RSTP Cost	Synopsis: 0 to 2147483647 or { Auto } Default: Auto Selects the cost to use in cost calculations, when the Cost Style parameter is set to RSTP in the Bridge RSTP Parameters configuration. Setting the cost manually provides the ability to preferentially select specific ports to carry traffic over others. Leave this field set to "auto" to use the standard RSTP port costs as negotiated (20,000 for 1Gbps, 200,000 for 100 Mbps links and 2,000,000 for 10 Mbps links). For MSTP, this parameter applies to both external and internal path cost.

- Click **Apply**.

Section 8.1.10

Clearing Spanning Tree Protocol Statistics

To clear all spanning tree protocol statistics, do the following:

1. Navigate to **Network Redundancy » Spanning Tree » Clear Spanning Tree Statistics**. The **Clear Spanning Tree Statistics** form appears.



2. Click **Confirm**.

Section 8.2

Managing the Media Redundancy Protocol (MRP)

RUGGEDCOM ROS supports the Media Redundancy Protocol (MRP).

CONTENTS

- [Section 8.2.1, "Understanding MRP"](#)
- [Section 8.2.2, "Configuring MRP Globally"](#)
- [Section 8.2.3, "Viewing the Status of MRP Instances"](#)
- [Section 8.2.4, "Adding an MRP Instance"](#)
- [Section 8.2.5, "Deleting an MRP Instance"](#)
- [Section 8.2.6, "Example: Configuring an MRP Ring"](#)

Section 8.2.1

Understanding MRP

The Media Redundancy Protocol (MRP) is a networking protocol designed to implement redundancy and recovery in a ring topology of up to 50 devices. It allows rings of Ethernet switches to quickly overcome any single failure of an inter-switch link or switch in the MRP ring or interconnection topology.

MRP operates between Layer 2 and the application layer and uses the functions of ISO/IEC/IEEE 8802-3 (IEEE 802.3) and IEEE 802.1Q, including the Filtering Database (FDB).

MRP is standardized by the International Electrotechnical Commission as IEC 62439-2.

CONTENTS

- [Section 8.2.1.1, "MRM vs MRC Devices"](#)
- [Section 8.2.1.2, "MRA Devices"](#)
- [Section 8.2.1.3, "Ring Port States"](#)
- [Section 8.2.1.4, "Ring-Closed vs Ring-Open"](#)

Section 8.2.1.1

MRM vs MRC Devices

In an MRP ring, the Media Redundancy Manager (MRM) acts as the ring manager, while Media Redundancy Clients (MRCs) act as member nodes of the ring.

The MRM periodically sends out MRP Test messages through both of its ring ports. These messages are forwarded by the MRCs between their ring ports. As the switches are connected in a ring, the MRP test messages circulate through the ring and return to the MRM. This allows the MRM to determine the state of the ring.

When the MRP test messages are returned to the MRM, redundancy is present and the ring is declared closed. If the MRP test messages fail to return, redundancy is lost and the ring is declared open.

When the ring is closed, the MRM drops (blocks) all packets on one of its two designated ring ports, while the other port forwards packets. When a link failure occurs, the MRCs send a link failure notification to the MRM, which will then unblock its blocked port, enabling communication between all of the devices.

Section 8.2.1.2

MRA Devices

Media Redundancy Manager Auto (MRA) devices automatically decide which device will take on the role of manager in the ring. This is done through an election process between all MRAs in the ring. Once the manager is elected, the rest of the MRAs act as clients.

When an MRA is present in a ring, all other devices in the ring must be either MRA or MRC (not MRM).

Section 8.2.1.3

Ring Port States

MRM and MRC ring ports support three states: *disabled*, *blocked*, and *forwarding*:

- **Disabled** ring ports drop all received packets.
- **Blocked** ring ports drop all received packets except the MRP control packets.
- **Forwarding** ring ports forward all received packets.

Section 8.2.1.4

Ring-Closed vs Ring-Open

During normal operation, the network works in the ring-closed state. In this state, one of the MRM ring ports is blocked, while the other is forwarding. Both ring ports of all MRCs are forwarding.

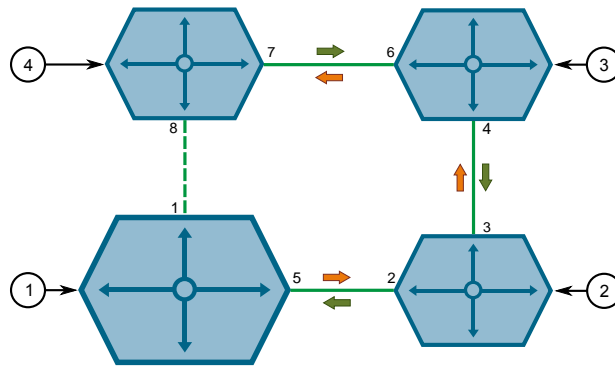

Figure 142: MRP Ring-Closed State

1. MRM or MRA acting as Manager 2. MRP Client 1 3. MRP Client 2 4. MRP Client 3

In case of failure, the network works in the ring-open state. In this state, when a link connecting two devices fails, both ring ports of the MRM are now forwarding. The MRCs adjacent to the failure have a blocked and a forwarding ring port and the other MRCs have both ring ports forwarding.

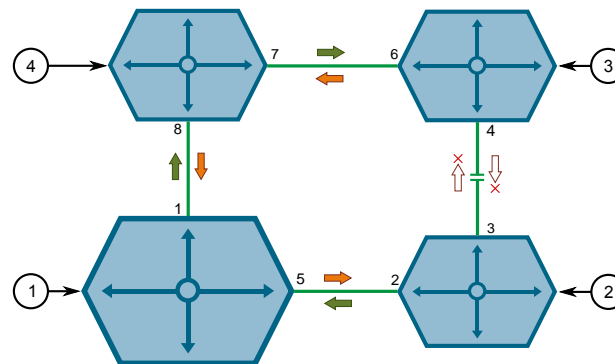

Figure 143: MRP Ring-Open State

1. MRM or MRA acting as Manager 2. MRP Client 1 3. MRP Client 2 4. MRP Client 3

Section 8.2.2

Configuring MRP Globally

To configure the Media Redundancy Protocol globally, do the following:

1. Navigate to **Network Redundancy » Ring Redundancy » Configure Global MRP Parameters**. The **Global MRP Parameters** form appears.

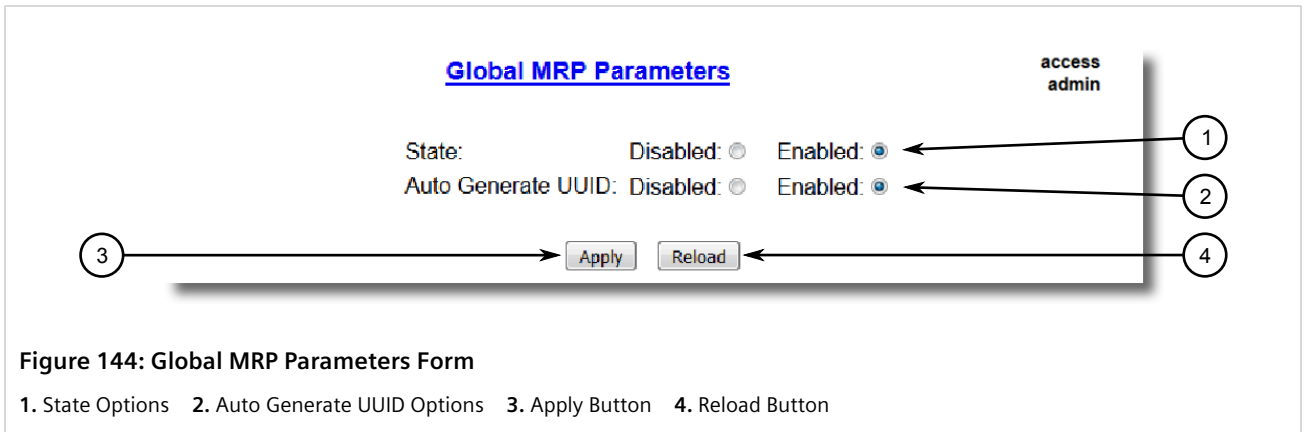

Figure 144: Global MRP Parameters Form

1. State Options
2. Auto Generate UUID Options
3. Apply Button
4. Reload Button

2. Configure the following parameter(s) as required:

Parameter	Description
State	<p>Synopsis: { Disabled, Enabled }</p> <p>Default: Disabled</p> <p>Enables/disables MRP globally. Note that MRP can be disabled on a per port basis.</p>
Auto Generate UUID	<p>Synopsis: { Disabled, Enabled }</p> <p>Default: Enabled</p> <p>Enables/disables the automatic generation of the MRP UUID (Universal Unique Identifier). If enabled, any existing user-configured domain ID will be overwritten by the UUID generated. The generated UUID is the MD5 hash of the domain name.</p>

3. Click **Apply**.

Section 8.2.3

Viewing the Status of MRP Instances

To view the status of MRP instances, navigate to **Network Redundancy » Ring Redundancy » View MRP Instance Status**. The **MRP Instance Status** table appears.

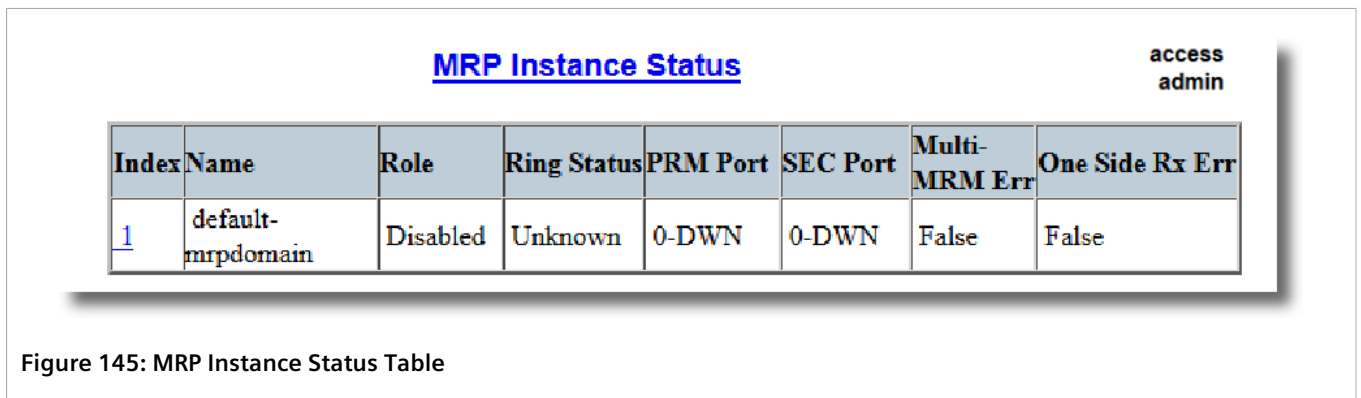

Figure 145: MRP Instance Status Table

This table displays the following information:

Parameter	Description
Index	The MRP instance number.
Name	The name of the MRP domain/ring. All MRP instances belonging to the same ring must have the same domain name.
Role	The role assigned to the MRP instance: <ul style="list-style-type: none">• <code>Disabled</code> – No role is assigned. The MRP instance is disabled.• <code>Client</code> – MRP Client.• <code>Manager</code> – MRP Manager.• <code>ManagerAuto</code> – MRP instance automatically determines the role.
Ring Status	The status of the MRP ring. Possible values include: <ul style="list-style-type: none">• <code>N/A</code> – The status of the ring is unknown. This is displayed when the device is an MRC.• <code>Open</code> – The MRP ring is open. Both ring ports are forwarding packets.• <code>Closed</code> – The MRP ring is closed. One ring port is forwarding packets, while the other is blocking packets.
PRM Port	The port number and state of the MRP ring port. Possible values include: <ul style="list-style-type: none">• <code>{port}-OFF</code> – MRP not running.• <code>{port}-DWN</code> – The ring port is down.• <code>{port}-BLK</code> – The ring port is blocking packets.• <code>{port}-FWD</code> – The ring port is forwarding packets.
SEC Port	The port number and state of the MRP ring port. Possible values include: <ul style="list-style-type: none">• <code>{port}-OFF</code> – MRP not running.• <code>{port}-DWN</code> – The ring port is down.• <code>{port}-BLK</code> – The ring port is blocking packets.• <code>{port}-FWD</code> – The ring port is forwarding packets.
Multi-MRM Err	Error indicated by an MRM when more than one MRM are active in the MRP ring. Possible values include: <ul style="list-style-type: none">• <code>false</code> – No Multi-MRM error.• <code>true</code> – More than one MRM present in the ring.
One Side Rx Err	Error indicated by an MRM when the test frames of an MRM have been seen, but only on one ring port. Possible values include: <ul style="list-style-type: none">• <code>false</code> – No One Side Rx error.• <code>true</code> – Test frame received only on one ring port.

Section 8.2.4

Adding an MRP Instance

To configure an MRP instance, do the following:

1. Navigate to **Network Redundancy » Ring Redundancy » Configure MRP Instances**. The **MRP Instances** table appears.

access
admin

1 → [InsertRecord](#)

Index	Name	Role	PRM Port	SEC Port	Priority	ID
1	default-mrpdomain	Disabled	1	1	8000	10C20ACC507B55760487569C4CD9E3B1

2 →

Figure 146: Global MRP Parameters Table

1. InsertRecord Link 2. MRP Instance Entries

2. Click **InsertRecord**. The **MRP Instances** form appears.



IMPORTANT!

RUGGEDCOM ROS only allows multiples MRP instances if all instances are Managers. A device can have up to four Manager instances.



IMPORTANT!

MRMs or MRAs acting as Manager must be either physically disconnected or have the ring port disabled (i.e. MRP ring open) before the MRM instance configuration can be changed.

For more information about configuring port parameters, refer to [Section 4.6.6, "Configuring an Ethernet Port"](#).

For more information about open and closed MRP rings, refer to [Section 8.2, "Managing the Media Redundancy Protocol \(MRP\)"](#).



NOTE

To avoid potential misconfiguration issues which can result in loss of network access, Siemens recommends disabling the ring port of an MRC before configuring it. For more information about configuring port parameters, refer to [Section 4.6.6, "Configuring an Ethernet Port"](#).

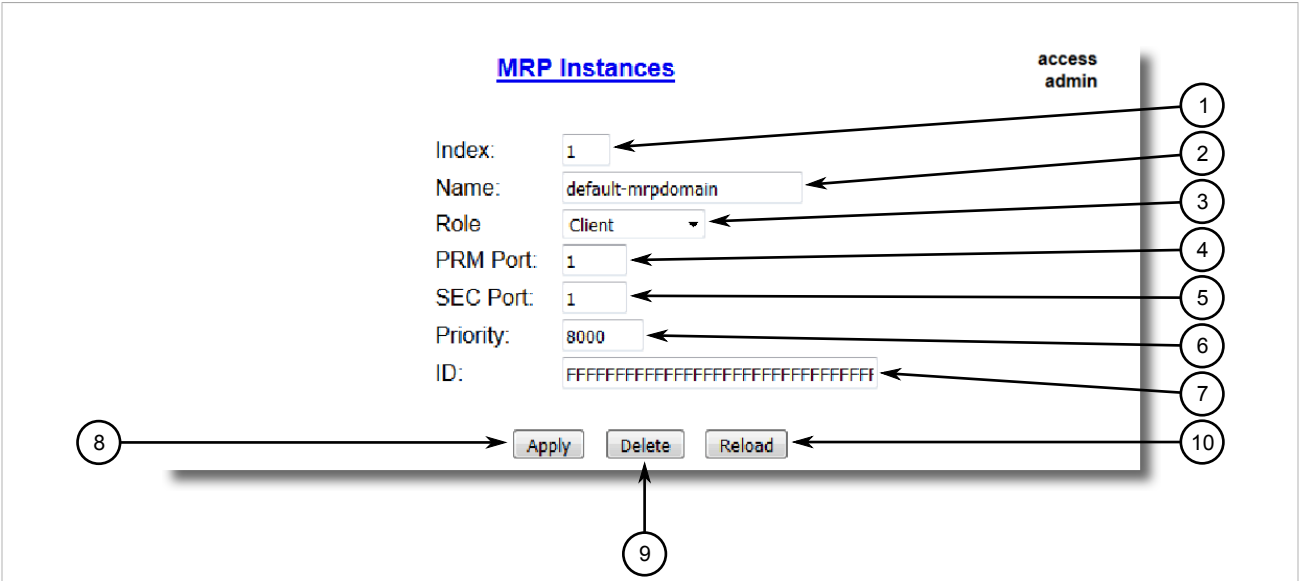

Figure 147: MRP Instances Form

1. Index Box 2. Name Box 3. Role List 4. PRM Port Box 5. SEC Port Box 6. Priority Box 7. ID Box 8. Apply Button 9. Delete Button 10. Reload Button

3. Configure the following parameters:

Parameter	Description
Index	Synopsis: 1 to 4 Default: 1 The MRP instance number.
Name	Synopsis: Any 24 characters Default: default-mrpdomain The name of the MRP domain/ring. All MRP instances belonging to the same ring must have the same domain name.
Role	Synopsis: { Disabled, Client, Manager, ManagerAuto } Default: Client The role assigned to the MRP instance: <ul style="list-style-type: none"> • Disabled – No role is assigned. The MRP instance is disabled. • Client – MRP Client. • Manager – MRP Manager. • ManagerAuto – MRP instance automatically determines the role.
PRM Port	Synopsis: 1 to maximum port number Default: 1 MRP ring port number. The port number as seen on the silkscreen of the switch.
SEC Port	Synopsis: 1 to maximum port number Default: 1 MRP ring port number. The port number as seen on the silkscreen of the switch.
Priority	Synopsis: Any 4 characters Default: 8000 The priority assigned to the MRP instance. This is used when negotiating with other MRP devices to determine which is the MRP Manager. Possible values include:

Parameter	Description
	<ul style="list-style-type: none"> • 0000 – Highest priority (Manager) • 1000 – 7000 – High priority (Manager) • 8000 – Default priority (Manager) • 9000 – 9FFF – High priority (ManagerAuto) • A000 – Default priority (ManagerAuto) • A001 – F000 – Low priority (ManagerAuto) • FFFF – Lowest priority (ManagerAuto)
ID	<p>Synopsis: Any 32 characters Default: FFFFFFFFFFFFFFFFFFFFFFFFFFFFFFFF</p> <p>128-bit domain UUID unique to a domain/ring. All MRP instances belonging to the same ring must have the same domain ID. If the Auto Generate UUID parameter is enabled, ROS automatically generates the domain ID as an MD5 hash of the domain name. In this case, any attempt to modify the domain ID will be rejected. If the Auto Generate UUID parameter is disabled, the domain ID can be modified by the user.</p>

4. Click **Apply**.

Section 8.2.5

Deleting an MRP Instance

To delete an MRP instance, do the following:

1. Navigate to **Network Redundancy » Ring Redundancy » Configure MRP Instances**. The **MRP Instances** table appears.

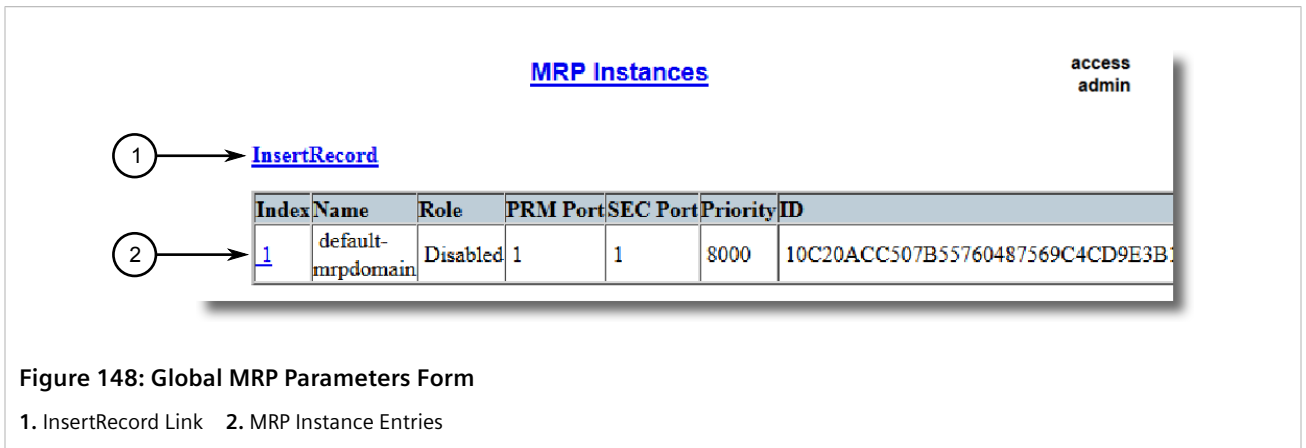

Figure 148: Global MRP Parameters Form

1. InsertRecord Link 2. MRP Instance Entries

2. Click the desired record. The **MRP Instances** form appears.

! **IMPORTANT!**
MRMs or MRAs acting as Manager must be either physically disconnected or have the ring port disabled (i.e. MRP ring open) before the MRM instance configuration can be changed.

For more information about configuring port parameters, refer to [Section 4.6.6, "Configuring an Ethernet Port"](#).

For more information about open and closed MRP rings, refer to [Section 8.2, "Managing the Media Redundancy Protocol \(MRP\)"](#).



NOTE

To avoid potential misconfiguration issues which can result in loss of network access, Siemens recommends disabling the ring port of an MRC before configuring it. For more information about configuring port parameters, refer to [Section 4.6.6, "Configuring an Ethernet Port"](#).

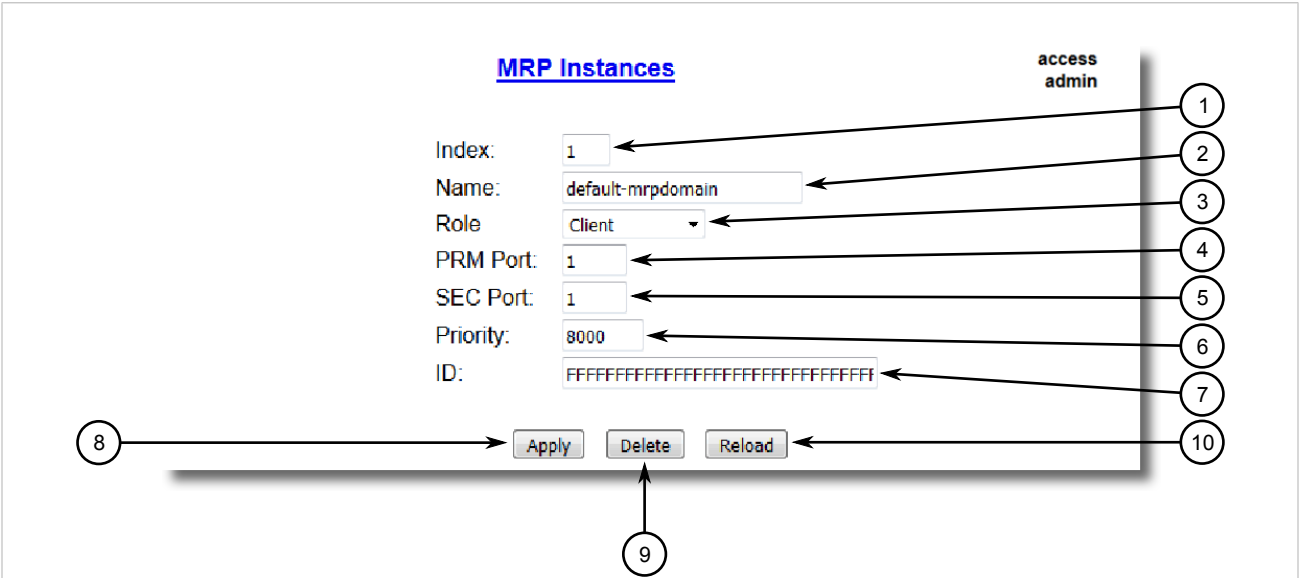

Figure 149: MRP Instances Form

- 1. Index Box
- 2. Name Box
- 3. Role Box
- 4. PRM Port Box
- 5. SEC Port Box
- 6. Priority Box
- 7. ID Box
- 8. Apply Button
- 9. Delete Button
- 10. Reload Button

3. Click **Delete**.

Section 8.2.6

Example: Configuring an MRP Ring

This example demonstrates how to configure an MRP ring using four RUGGEDCOM ROS devices.

In the following topology, the MRP ring is operating in the ring-closed state. The MRP Manager (MRM) device serves as the ring manager, while the MRP Client (MRC) devices act as member nodes of the ring. Each MRM or MRC node has two ports participating in the ring.

The MRM blocks all packets forwarding on one of its two designated ring ports. If one of two links on any other ring nodes detects a failure, the MRP ring will change to the ring-open state. In this state, the MRC sends a message to the MRM which then unblocks its blocked port, enabling communication between all of the switches.

For more information about ring-closed and ring-open states, refer to [Section 8.2, "Managing the Media Redundancy Protocol \(MRP\)"](#).



IMPORTANT!

The values shown are specific to the provided topology. Actual values can vary based on the user's configuration.

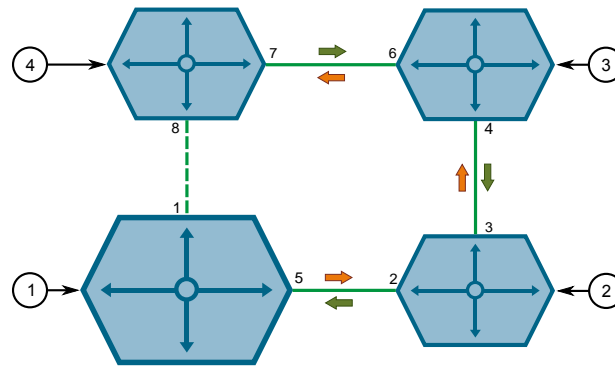

Figure 150: Topology – MRP Ring

1. MRP Manager 2. MRP Client 1 3. MRP Client 2 4. MRP Client 3

To configure an MRP ring per the topology, do the following:

1. Make sure RSTP is disabled on ports acting as PRM and SEC ports in the ring. For more information, refer to [Section 4.6.6, “Configuring an Ethernet Port”](#).
2. Enable MRP on the MRP Manager and all MRP Client devices. For more information, refer to [Section 8.2.2, “Configuring MRP Globally”](#).
3. Configure an MRP instance for the MRP Manager device as follows:

Parameter	Value
Name	{ name }
Role	Manager
PRM Port	5
SEC Port	1
Priority	1000

For more information about configuring MRP instances, refer to [Section 8.2.4, “Adding an MRP Instance”](#).

4. Configure an MRP instance for each MRP Client device as follows:



NOTE

In this example, three devices are being used. MRP is supported in ring topologies with up to 50 devices.

Device	Parameter	Value
MRP Client 1	Name	{ name }
	Role	Client
	PRM Port	2
	SEC Port	3
MRP Client 2	Priority	A000
	Name	{ name }

Device	Parameter	Value
	Role	Client
	PRM Port	4
	SEC Port	6
	Priority	A000
MRP Client 3	Name	{ name }
	Role	Client
	PRM Port	7
	SEC Port	8
	Priority	A000

For more information about configuring MRP instances, refer to [Section 8.2.4, “Adding an MRP Instance”](#).

5. To verify the configuration, make sure the MRP Instance ID is generated automatically on the MRP Manager device and each MRP client device. For more information about the MRP Instance ID, refer to [Section 8.2.4, “Adding an MRP Instance”](#).

Section 8.3

Managing Link Aggregation

Link aggregation, also referred to as *port trunking* or *port bundling*, provides the ability to aggregate or combine several Ethernet ports into one logical link (Link Aggregation Group) with higher bandwidth. This allows for highly randomized load balancing between the aggregated links based on both the source and destination MAC addresses of the forwarded frames.

Link aggregation can be used for two purposes:

- To obtain increased, linearly incremental link bandwidth.
- To improve network reliability by creating link redundancy. If one of the aggregated links fails, the switch will balance the traffic between the remaining links.

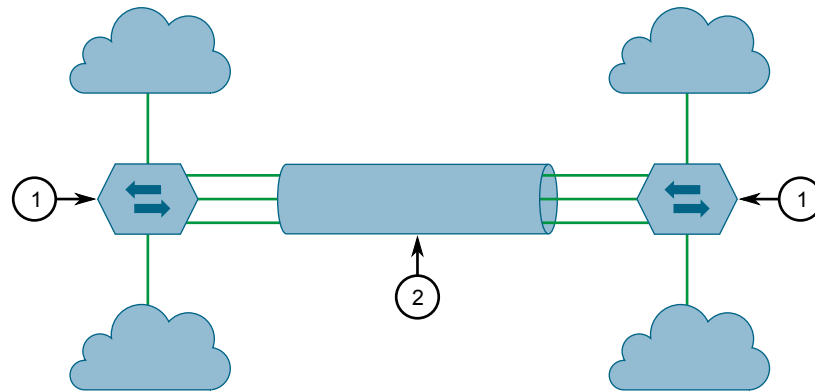

Figure 151: Basic Link Aggregation Topography

1. Device 2. Link Aggregation Group (LAG)

CONTENTS

- [Section 8.3.1, "Link Aggregation Concepts"](#)
- [Section 8.3.2, "Configuring Link Aggregation"](#)
- [Section 8.3.3, "Managing Link Aggregation Groups"](#)
- [Section 8.3.4, "Managing the Link Aggregation Control Protocol"](#)
- [Section 8.3.5, "Clearing Link Aggregation Statistics"](#)

Section 8.3.1

Link Aggregation Concepts

This section describes some of the concepts important to the implementation of link aggregation in RUGGEDCOM ROS.

CONTENTS

- [Section 8.3.1.1, "Static vs. Dynamic Link Aggregation"](#)
- [Section 8.3.1.2, "Rules and Limitations"](#)
- [Section 8.3.1.3, "Link Aggregation and Layer 2 Features"](#)
- [Section 8.3.1.4, "Link Aggregation and Physical Layer Features"](#)

Section 8.3.1.1

Static vs. Dynamic Link Aggregation

RUGGEDCOM ROS supports either static or dynamic link aggregation. In **static** link aggregation, a device is paired with a specific partner device that shares the same capabilities and configuration. The same is required for dynamic link aggregation, but with less involvement by the user. In **dynamic** link aggregation, the Link Aggregation Control Protocol (LACP) seeks a suitable partner on its own after negotiating with its peers to determine the best match.

Static link aggregation is ideal for switch-to-switch configurations, but lacks the following key features offered by dynamic link aggregation:

- **Failover**

In static link aggregation, devices are unable to communicate the status of their LAGs. Should all ports in a LAG go down and there is a media converter between both devices, the device at the other end will not know and continue to send traffic to its partner. Dynamic link aggregation, however, will detect the failed link and stop sending traffic to the other device.

- **Renegotiation**

Should all ports on the partner device go down and/or the Signal-to-Noise Ratio (SNR) be too high, LACP will automatically seek another LACP-enabled device on the network with which to form a new port channel.

- **Standby**

If more ports are added to a LAG than the device supports, LACP will automatically put the excess ports on standby. It determines which ports to put on standby based on criteria defined by the user. These standby ports will wait until an active port fails and then take its place.

- **Link Verification**

In dynamic link aggregation, both partners can mutually verify the port channel between them, making it easy for users to confirm the configuration. Static link aggregation offers no such verification.

Choosing between static or dynamic link aggregation is dependent on the capabilities of the devices available on the network.

Section 8.3.1.2

Rules and Limitations

The implementation of link aggregation must adhere to the following rules and limitations:

- A port can only belong to one Link Aggregation Group (LAG) or *port trunk* at a time.
- A port that is being mirrored (the target port) cannot belong to a LAG. However, any port that receives the mirrored traffic (the source port) can belong to a LAG.
- If only one QinQ port is supported by the device, the port working in QinQ mode cannot be a secondary member of a LAG.
- A DHCP relay agent client port cannot be a member of a LAG.
- Load balancing between the links of a bundle is randomized and may not be ideal. For instance, if three 100 Mbps links are aggregated, the resulting bandwidth of the LAG may not be precisely 300 Mbps.
- A static MAC address should not be configured to reside on an aggregated port – it may cause some frames destined for that address to be dropped.
- A secure port cannot be a member of a LAG.
- The IEEE 802.1AX (formerly IEEE 802.3ad) Link Aggregation standard requires all physical links in the LAG to run at the same speed and in full-duplex mode. If this requirement is violated, the performance of the LAG will drop. The switch will raise an appropriate alarm, if such a speed/duplex mismatch is detected.
- The Spanning Tree Protocol (STP) dynamically calculates the path cost of the LAG based on its aggregated bandwidth. However, if the aggregated ports are running at different speeds, the path cost may not be calculated correctly.
- Enabling STP is the best way for handling link redundancy in switch-to-switch connections composed of more than one physical link. If STP is enabled and increased bandwidth is not required, link aggregation should not be used, as it may lead to a longer fail-over time.

Section 8.3.1.3

Link Aggregation and Layer 2 Features

Layer 2 features (e.g. STP, VLAN, CoS, Multicast Filtering) treat a Link Aggregation Group (LAG) as a single link.

- If the Spanning Tree Protocol (STP) sets the status of an aggregated port to `Blocking` or `Forwarding`, it does it for the whole LAG.
- If one of the aggregated ports joins or leaves a multicast group (e.g. via IGMP or GMRP), all other ports in the LAG will join or leave too.
- Any port configuration parameter (e.g. VLAN, CoS) change will be automatically applied to all ports in the LAG.
- Configuration/status parameters of the secondary ports will not be shown and their port numbers will be simply listed next to the primary port number in the appropriate configuration/status user interface sessions.
- When a secondary port is added to a LAG, it inherits all the configuration settings of the primary port. When this secondary port is removed from the LAG, the settings it had previous to the aggregation are restored.

Section 8.3.1.4

Link Aggregation and Physical Layer Features

Physical layer features (e.g. physical link configuration, link status, rate limiting, Ethernet statistics) will still treat each aggregated port separately.

- Physical configuration/status parameters will NOT be automatically applied to other ports in the Link Aggregation Group (LAG) and will be displayed for each port as usual.
- Make sure only ports with the same speed and duplex settings are aggregated. If auto-negotiation is used, make sure it is resolved to the same speed for all ports in the LAG.
- To get a value of an Ethernet statistics counter for the LAG, add the values of the counters for all ports in the LAG.

Section 8.3.2

Configuring Link Aggregation

To configure static or dynamic link aggregation, do the following:

1. Disconnect or disable each port to be aggregated. For information about disabling a port, refer to [Section 4.6.6, "Configuring an Ethernet Port"](#).
2. Create one or more Link Aggregation Groups (LAGs) consisting of two or more ports. For more information, refer to [Section 8.3.3.2, "Adding a Link Aggregation Group"](#).
3. Connect or enable each port in the LAG. For information about enabling a port, refer to [Section 4.6.6, "Configuring an Ethernet Port"](#).
4. If dynamic link aggregation is required, configure the global and per port LACP settings. For more information, refer to [Section 8.3.4.2, "Configuring Global LACP Settings"](#) and [Section 8.3.4.3, "Configuring LACP Per Port"](#).
5. Repeat [Step 1](#) to [Step 4](#) for a neighboring device that has the same capabilities (i.e. port speed, media type, etc.), making sure to refer to the device's user documentation for details.

Section 8.3.3

Managing Link Aggregation Groups

RUGGEDCOM ROS allows up to 15 Link Aggregation Groups (LAGs), or *port trunks*, to be configured on a single device, with each consisting of up to eight ports.

**NOTE**

The maximum number of LAGs for each device depends on the number of ports available. At least two ports are required to configure a LAG.

**NOTE**

The aggregated port with the lowest port number is called the **Primary** port. Other ports in the LAG are called **Secondary** ports.

CONTENTS

- [Section 8.3.3.1, “Viewing a List of Link Aggregation Groups”](#)
- [Section 8.3.3.2, “Adding a Link Aggregation Group”](#)
- [Section 8.3.3.3, “Deleting a Link Aggregation Group”](#)
- [Section 8.3.3.4, “Viewing the Status of Link Aggregation Groups”](#)

Section 8.3.3.1

Viewing a List of Link Aggregation Groups

To view a list of Link Aggregation Groups (LAGs), or *port trunks*, configured on the device, navigate to **Link Aggregation » Configure Port Trunks**. The **Port Trunks** table appears.

Trunk ID	Trunk Name	Mode	Ports
1	2x100Mbs Link	Static	1-2
2	2x100Mbs Link	LACP	3-4

Figure 152: Port Trunks Table

If LAGs have not been configured, add LAGs as needed. For more information, refer to [Section 8.3.3.2, “Adding a Link Aggregation Group”](#).

Section 8.3.3.2

Adding a Link Aggregation Group

To add a Link Aggregation Group (LAG), or *port trunk*, do the following:



IMPORTANT!

The LAG must be properly configured on both sides of the port channel. In switch-to-switch connections, if the configuration of both sides does not match (i.e. some ports are mistakenly not included in the port trunk), it will result in a loop. Therefore, the following procedure is strongly recommended to configure a LAG:

- a. Disconnect or disable all the ports involved in the configuration, i.e. either being added to or removed from the LAG.
- b. Configure the LAG on both switches.
- c. Double-check the LAG configuration on both switches.
- d. Reconnect or re-enable the ports.

If the LAG is being configured while the ports are not disconnected or disabled, the port will be automatically disabled for a few seconds.



IMPORTANT!

Make sure only ports with the same speed and duplex settings are aggregated. If auto-negotiation is used, make sure it is resolved to the same speed for all ports in the LAG.

1. Navigate to **Link Aggregation » Configure Port Trunks**. The **Port Trunks** table appears.

Port Trunks

access
admin

1 → [InsertRecord](#)

Trunk ID	Trunk Name	Mode	Ports
1	2x100Mbs Link	Static	1-2
2	2x100Mbs Link	LACP	3-4

Figure 153: Port Trunks Table
1. InsertRecord

2. Click **InsertRecord**. The **Port Trunks** form appears.

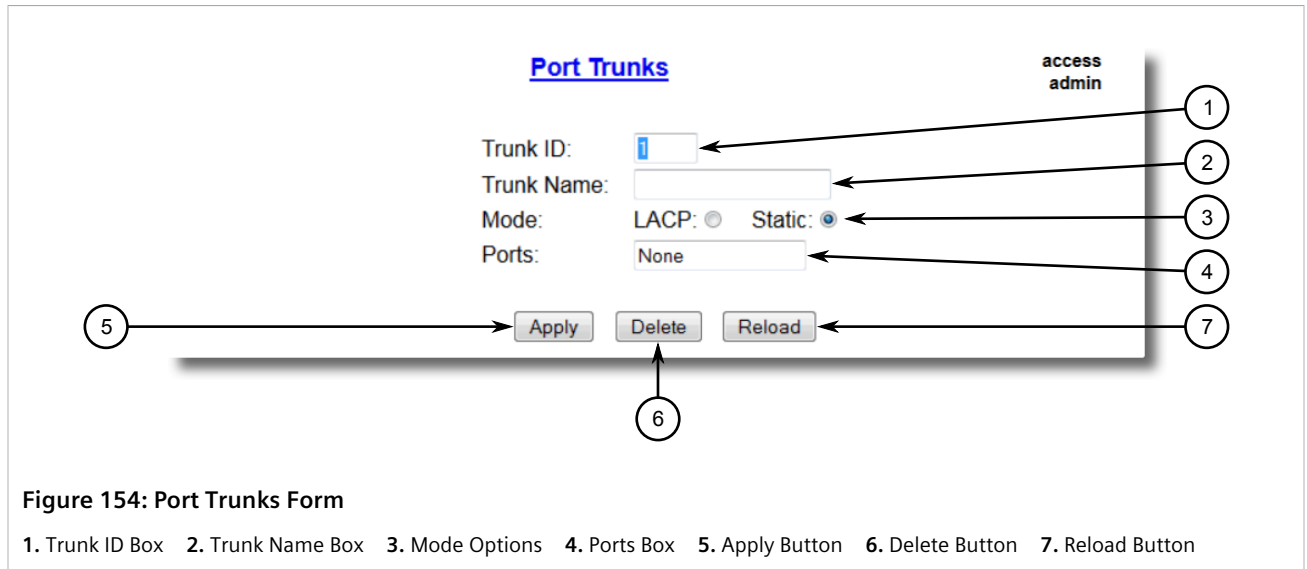

- Configure the following parameter(s) as required:

Parameter	Description
Trunk ID	Synopsis: 1 to 5 Default: 1 The ID for the Link Aggregation Group (LAG), or port trunk.
Trunk Name	Synopsis: Any 19 characters The name of the Link Aggregation Group (LAG), or port trunk. Whenever possible, include details that identify the purpose of the aggregated links.
Mode	Synopsis: { LACP, Static } Default: Static Defines how link aggregation is performed. Options include: <ul style="list-style-type: none"> LACP – Link aggregation is done dynamically using LACP for both sides of the link aggregation partnership. Static – Link aggregation settings are configured manually on both sides of the link aggregation partnership. LACP is not used.
Ports	A comma-separated list or range of ports to be aggregated in the Link Aggregation Group (LAG), or port trunk.

- Click **Apply**.

Section 8.3.3.3

Deleting a Link Aggregation Group

To delete a Link Aggregation Group (LAG), or *port trunk*, do the following:

- Navigate to **Link Aggregation » Configure Port Trunks**. The **Port Trunks** table appears.

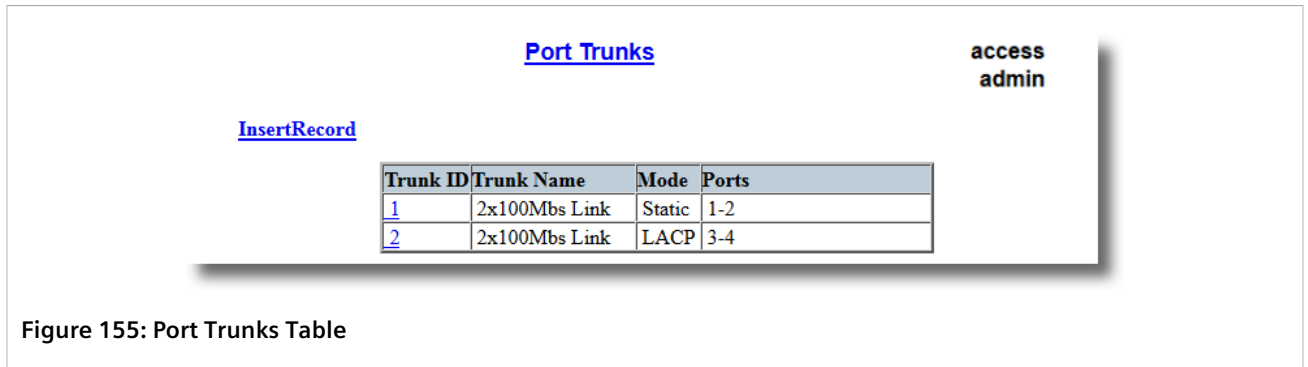

Figure 155: Port Trunks Table

- Select the desired LAG from the table. The **Port Trunks** form appears.

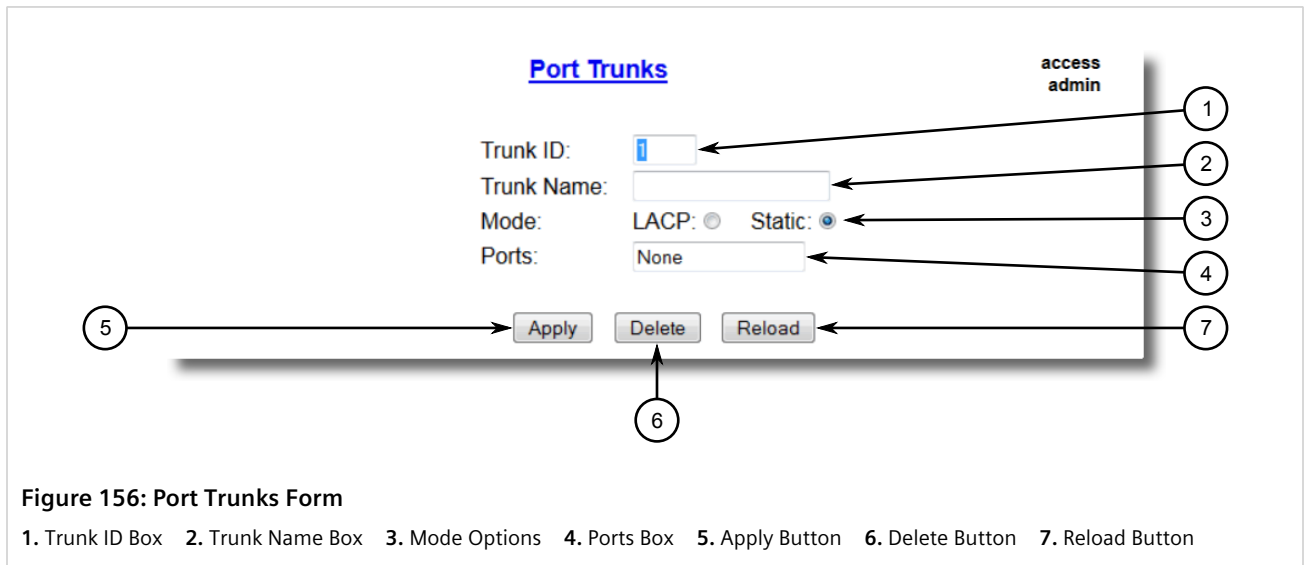

Figure 156: Port Trunks Form

- Trunk ID Box
- Trunk Name Box
- Mode Options
- Ports Box
- Apply Button
- Delete Button
- Reload Button

- Click **Delete**.

Section 8.3.3.4

Viewing the Status of Link Aggregation Groups

To view the status of each Link Aggregation Group (LAG), or *port trunk*, configured on the device, navigate to **Link Aggregation » View Port Trunk Statistics**. The **Port Trunk Statistics** table appears.

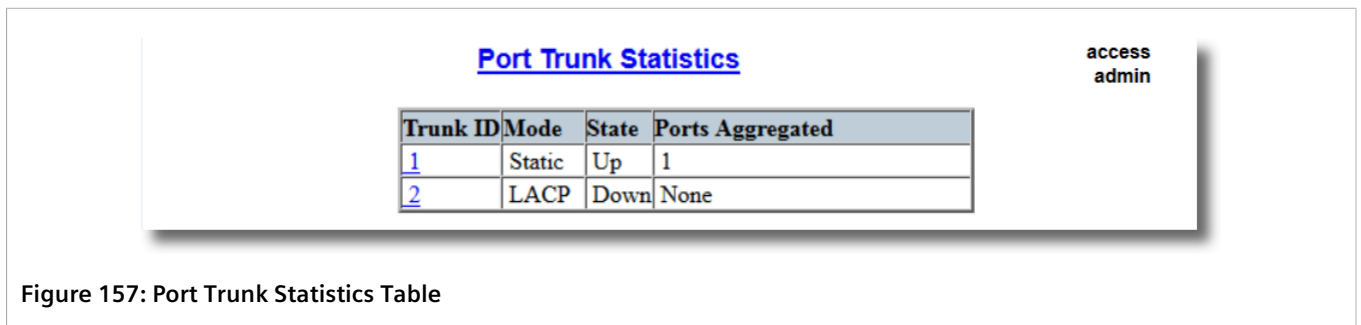

Figure 157: Port Trunk Statistics Table

This table displays the following information about each LAG:

Parameter	Description
Trunk ID	The ID for the Link Aggregation Group (LAG), or port trunk.
Mode	The link aggregation mode. Options include: <ul style="list-style-type: none">• <code>LACP</code> – Link aggregation is done dynamically using LACP for both sides of the link aggregation partnership.• <code>Static</code> – Link aggregation settings are configured manually on both sides of the link aggregation partnership. LACP is not used.
State	The operational state of the Link Aggregation Group (LAG), or port trunk..
Ports Aggregated	A comma-separated list or range of ports that are aggregated and operational in the Link Aggregation Group (LAG), or port trunk.

Section 8.3.4

Managing the Link Aggregation Control Protocol

The Link Aggregation Control Protocol (LACP) allows LACP-enabled devices to dynamically learn about each other's capabilities and automatically create port channels based on the maximum port speed and trunking state. The capabilities and configuration of each device do not need to be expressly controlled, as it would be with static link aggregation.

The capabilities of LACP-enabled devices are learned through the exchange of LACP Data Units (LACPDU). LACPDUs are distributed initially by ports configured to run LACP in `Active` mode. When these LACPDUs are received by a neighboring LACP-enabled device, an LACPDU is returned and both devices negotiate the creation of the port channel. The channel is created only if the capabilities of each device align.

**IMPORTANT!**

At least one LACP-enabled device must have a port configured to run LACP in `Active` mode. Ports configured to run in `Passive` mode participate in the negotiation process, but will not initiate it.

Configure LACP when the `Mode` parameter for any port trunk is set to `LACP`.

CONTENTS

- [Section 8.3.4.1, "Viewing Information About the LACP Partner"](#)
- [Section 8.3.4.2, "Configuring Global LACP Settings"](#)
- [Section 8.3.4.3, "Configuring LACP Per Port"](#)
- [Section 8.3.4.4, "Viewing LACP Statistics"](#)

Section 8.3.4.1

Viewing Information About the LACP Partner

To view details about the LACP partner system, navigate to **Link Aggregation » View Partner LACP Information**. The **Partner LACP Information** table appears.

Partner LACP Information

**access
admin**

Port	System Priority	System MAC	Port Priority	Port Number	Key	State	Version
1	0	00-00-00-00-00-00	0	0	0	PLIS----	1
2	0	00-00-00-00-00-00	0	0	0	PLIO----	1
3	0	00-00-00-00-00-00	0	0	0	PLIO----	1
4	0	00-00-00-00-00-00	0	0	0	PLIO----	1
5	0	00-00-00-00-00-00	0	0	0	PLIO----	1
6	0	00-00-00-00-00-00	0	0	0	PLIO----	1
7	0	00-00-00-00-00-00	0	0	0	PLIO----	1
8	0	00-00-00-00-00-00	0	0	0	PLIO----	1
9	0	00-00-00-00-00-00	0	0	0	PLIO----	1
10	0	00-00-00-00-00-00	0	0	0	PLIO----	1

Figure 158: Partner LACP Information Table

This table displays the following information:

Parameter	Description
Port	The port number as seen on the front plate silkscreen of the device.
System Priority	The LACP system priority of the partner system.
System ID	The MAC address of the partner system.
Port Priority	The LACP port priority of the partner port.
Port Number	The LACP port number of the partner port.
Key	The LACP key assigned to the partner port by the partner system.
State	<p>The LACP operational state of the partner port. The state is expressed as an eight character string. For example:</p> <pre>ASAO----</pre> <p>From left to right, each character in the string has the following meaning:</p> <ol style="list-style-type: none"> 1. LACP Activity: A=Active LACP, P=Passive LACP 2. LACP Timeout: S=Short Timeout, L=Long Timeout 3. Aggregation: A=Aggregateable, I=Individual 4. Synchronization: S=In Sync, O=Out Of Sync 5. Collecting: C=Collecting, -=Not Collecting 6. Distributing: D=Distributing, -=Not Distributing 7. Defaulted: D=Defaulted Info, -=Received Info 8. Expired: E=Expired, -=Not Expired
Version	<p>Synopsis: 0 to 255</p> <p>The version number of LACP packets sent by the partner system.</p>

Section 8.3.4.2

Configuring Global LACP Settings

To configure the global settings for the Link Aggregation Control Protocol (LACP), do the following:

1. Navigate to **Link Aggregation » Configure Global LACP Parameters**. The **Global LACP Parameters** form appears.

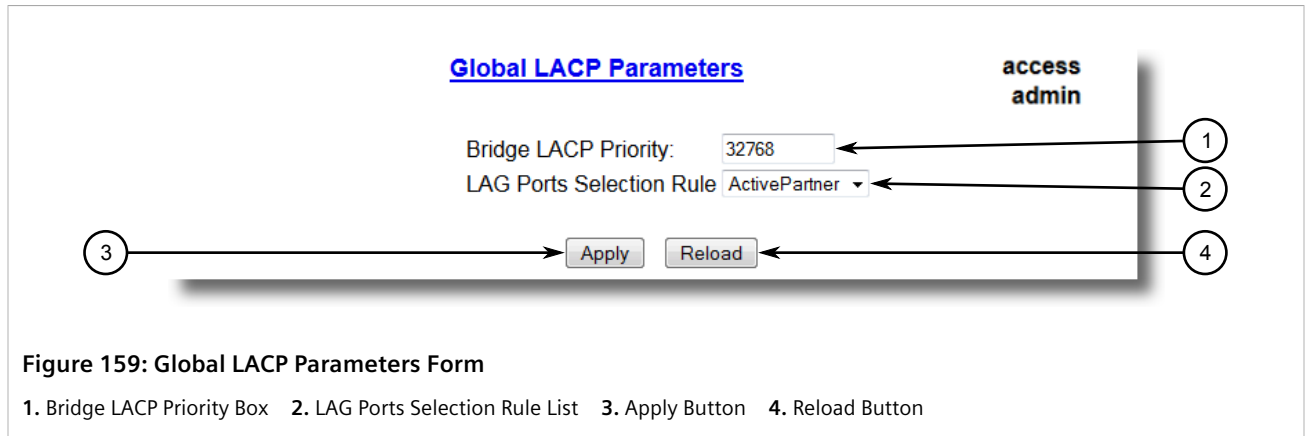

Figure 159: Global LACP Parameters Form

1. Bridge LACP Priority Box 2. LAG Ports Selection Rule List 3. Apply Button 4. Reload Button

2. Configure the following parameter(s) as required:

Parameter	Description
Bridge LACP Priority	<p>Synopsis: 0 to 65535 Default: 32768</p> <p>The LACP system priority. This is combined with the device's MAC address to form the LACP system ID, which is used in negotiations with other LACP-enabled devices.</p>
LAG Ports Selection Rule	<p>Synopsis: { ActivePartner, LinkSpeed, LinkPriority } Default: ActivePartner</p> <p>Defines the order in which ports in the Link Aggregation Group (LAG), or port trunk, are selected by LACP for aggregation. This parameter applies when ports in the LAG are connected to two or more other LAGs.</p> <p>Options include:</p> <ul style="list-style-type: none"> • ActivePartner – Select ports based on when partner ports become active. • LinkSpeed – Select ports based on link speed. The port with the higher link speed has precedence. • LinkPriority – Select ports based on LACP link priority. The port with the higher LACP link priority has precedence.

3. Click **Apply**.

Section 8.3.4.3

Configuring LACP Per Port

To configure the Link Aggregation Control Protocol (LACP) settings for a specific port, do the following:

1. Navigate to **Link Aggregation » Configure Port LACP Parameters**. The **Port LACP Parameters** table appears.

Port LACP Parameters

Port	Mode	Timeout	Individual	Priority
1	Passive	Short	False	32768
2	Passive	Short	False	32768
3	Passive	Short	False	32768
4	Passive	Short	False	32768
5	Passive	Short	False	32768
6	Passive	Short	False	32768
7	Passive	Short	False	32768
8	Passive	Short	False	32768
9	Passive	Short	False	32768
10	Passive	Short	False	32768

access
admin

Figure 160: Port LACP Parameters Table

- Select the desired port. The **Port LACP Parameters** form appears.

Port LACP Parameters

access
admin

Port: ← 1

Mode: Active: Passive: ← 2

Timeout: Short: Long: ← 3

Individual: False: True: ← 4

Priority: ← 5



← 6 ← 7

Figure 161: Port LACP Parameters Form

- Port Box
- Mode Options
- Timeout Options
- Individual Options
- Priority Box
- Apply Button
- Reload Button

- Configure the following parameter(s) as required:

Parameter	Description
Port	Synopsis: 1 to maximum port number The port number as seen on the front plate silkscreen of the device.
Mode	Synopsis: { Active, Passive } Default: Passive Defines the LACP mode for the port. Options include:: <ul style="list-style-type: none"> Active – The port actively sends LACP packets, regardless of the mode of the partner port. Passive – The port does not send LACP packets unless the partner port is in Active mode.

Parameter	Description
	<div style="border: 1px solid gray; padding: 5px;">  <p>NOTE For each physical link in the Link Aggregation Group (LAG), or port trunk, one partner port must be in Active mode.</p> </div>
Timeout	<p>Synopsis: { Short, Long }</p> <p>Default: Short</p> <p>Defines the time in seconds (s) to wait for LACP packets from the partner port. If an LACP packet is not received within the required time frame, the partner port's information is invalidated. Options include:</p> <p>Options include:</p> <ul style="list-style-type: none"> • Short – 3 s • Long – 90 s <div style="border: 1px solid gray; padding: 5px; margin-top: 10px;">  <p>NOTE The Timeout setting should be the same for all ports in a Link Aggregation Group (LAG), or port trunk.</p> </div>
Individual	<p>Synopsis: { False, True }</p> <p>Default: False</p> <p>Enables or disables Individual mode for the port. Ports in Individual mode can not be aggregated in a Link Aggregation Group (LAG), or port trunk.</p>
Priority	<p>Synopsis: 0 to 65535</p> <p>Default: 32768</p> <p>The LACP port priority. This is combined with the port number to form the LACP port identifier.</p> <p>The port priority is considered when determining if the port should be in standby.</p>

4. Click **Apply**.

Section 8.3.4.4

Viewing LACP Statistics

To view statistics collected on ports managed by the Link Aggregation Control Protocol (LACP), navigate to **Link Aggregation » View Port LACP Statistics**. The **Port LACP Statistics** table appears.

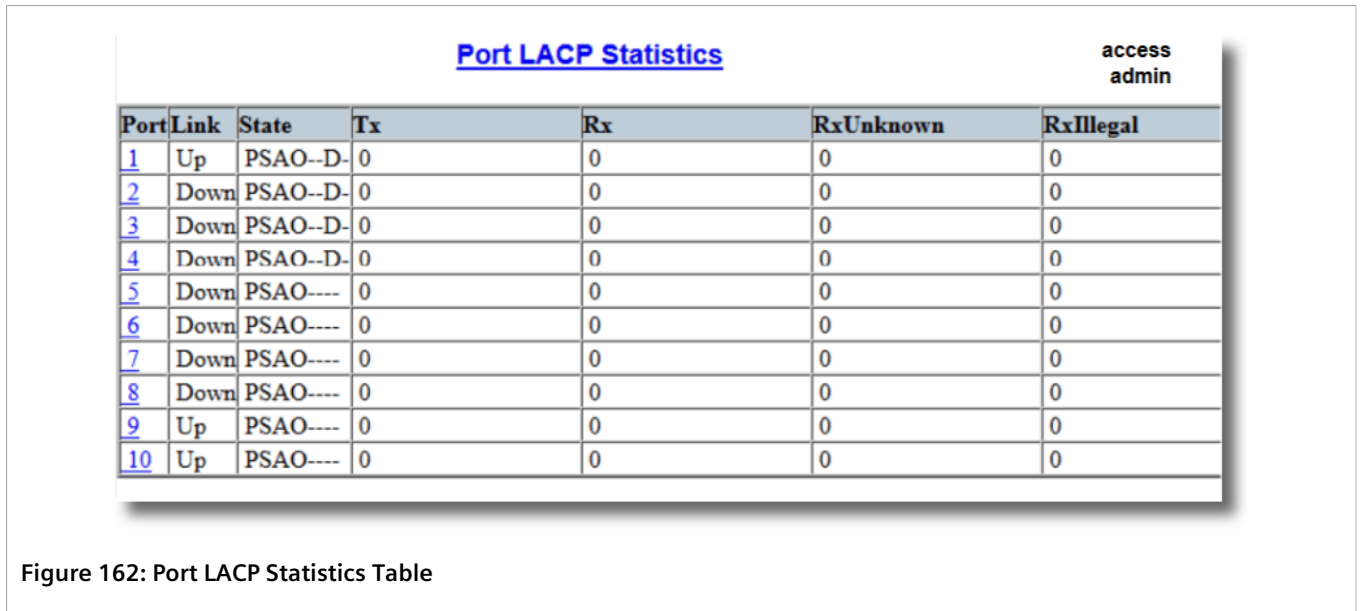

Figure 162: Port LACP Statistics Table

This table displays the following information:

Parameter	Description
Port	The port number as seen on the front plate silkscreen of the device.
Link	The link status of the port.
State	<p>Synopsis: 0 to 255</p> <p>The LACP operational state of the port. The state is expressed as an eight character string. For example:</p> <pre>ASAO----</pre> <p>From left to right, each character in the string has the following meaning:</p> <ol style="list-style-type: none"> 1. LACP Activity: A=Active LACP, P=Passive LACP 2. LACP Timeout: S=Short Timeout, L=Long Timeout 3. Aggregation: A=Aggregateable, I=Individual 4. Synchronization: S=In Sync, O=Out Of Sync 5. Collecting: C=Collecting, -=Not Collecting 6. Distributing: D=Distributing, -=Not Distributing 7. Defaulted: D=Defaulted Info, -=Received Info 8. Expired: E=Expired, -=Not Expired
Tx	The number of LACP packets transmitted by the port.
Rx	The number of good LACP packets received by the port.
RxUnknown	The number of unknown LACP packets received by the port.
RxIllegal	The number of illegal LACP packets received by the port.

Section 8.3.5

Clearing Link Aggregation Statistics

To clear all link aggregation statistics from the device, do the following:

1. Navigate to **Link Aggregation » Clear Link Aggregation Statistics**. The **Clear Link Aggregation Statistics** form appears.

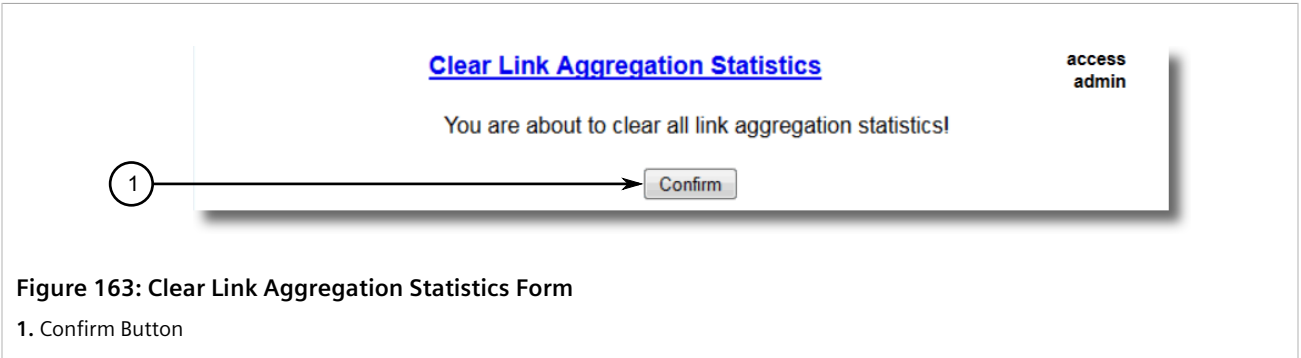

2. Click **Confirm**.

9 Traffic Control and Classification

Use the traffic control and classification subsystems to control the flow of data packets to connected network interfaces.

CONTENTS

- [Section 9.1, "Managing Classes of Service"](#)

Section 9.1

Managing Classes of Service

Classes of Service (CoS) provides the ability to expedite the transmission of certain frames and port traffic over others. The CoS of a frame can be set to Normal, Medium, High, or Critical. By default, other than the control frames, RUGGEDCOM ROS enforces Normal CoS for all incoming traffic received without a priority tag.



IMPORTANT!

Use the highest supported CoS with caution, as it is always used by the switch for handling network management traffic, such as RSTP BPDUs.

If this CoS is used for regular network traffic, upon traffic bursts, it may result in the loss of some network management frames, which in turn may result in the loss of connectivity over the network.

The process of controlling traffic based on CoS occurs over two phases:

1. Inspection Phase

In the inspection phase, the CoS priority of a received frame is determined from either:

- A specific CoS based upon the source and destination MAC address (as set in the Static MAC Address Table)
- The priority field in the IEEE 802.1Q tags
- The Differentiated Services Code Point (DSCP) component of the Type Of Service (TOS) field in the IP header, if the frame is IP
- The default CoS for the port

Each frame's CoS will be determined once the first examined parameter is found in the frame.



NOTE

*For information on how to configure the **Inspect TOS** parameter, refer to [Section 9.1.2, "Configuring Classes of Service for Specific Ethernet Ports"](#).*

Received frames are first examined to determine if their destination or source MAC address is found in the Static MAC Address Table. If they are, the CoS configured for the static MAC address is used. If neither destination or source MAC address is in the Static MAC Address Table, the frame is then examined for IEEE 802.1Q tags and the priority field is mapped to a CoS. If a tag is not present, the frame is examined to determine if it is an IP frame. If the frame is an IP frame and **Inspect TOS** is enabled in RUGGEDCOM ROS, the

CoS is determined from the DSCP field. If the frame is not an IP frame or **Inspect TOS** is disabled, the default CoS for the port is used.

After inspection, the frame is forwarded to the egress port for transmission.

2. Forwarding Phase

Once the CoS of the frame is determined, the frame is forwarded to the egress port, where it is collected into one of the priority queues according to the assigned CoS.

CoS weighting selects the degree of preferential treatment that is attached to different priority queues. The ratio of the number of higher CoS to lower CoS frames transmitted can be configured. If desired, lower CoS frames can be transmitted only after all higher CoS frames have been serviced.

CONTENTS

- [Section 9.1.1, "Configuring Classes of Service Globally"](#)
- [Section 9.1.2, "Configuring Classes of Service for Specific Ethernet Ports"](#)
- [Section 9.1.3, "Configuring Priority to CoS Mapping"](#)
- [Section 9.1.4, "Configuring DSCP to CoS Mapping"](#)

Section 9.1.1

Configuring Classes of Service Globally

To configure global settings for Classes of Service (CoS), do the following:

1. Navigate to **Classes of Service » Configure Global CoS Parameters**. The **Global CoS Parameters** form appears.

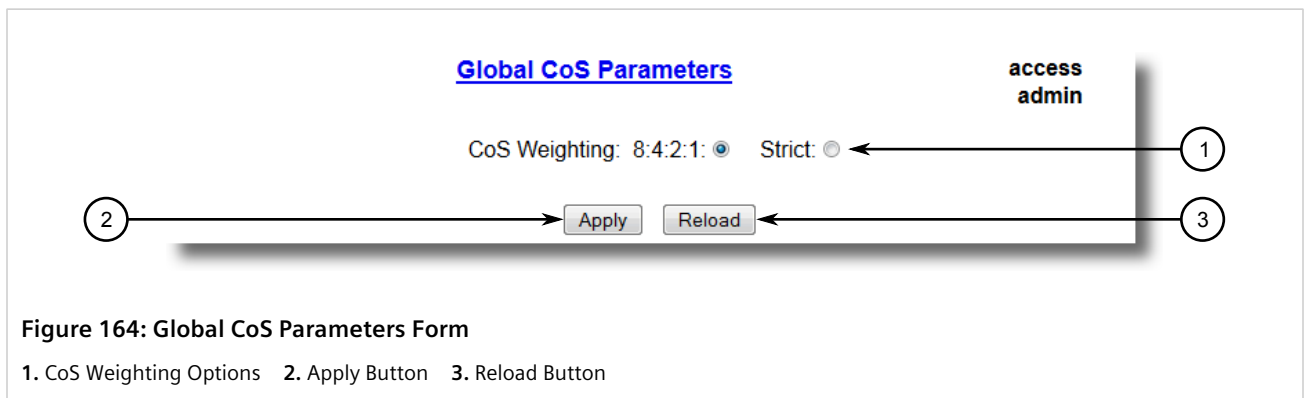

2. Configure the following parameter(s) as required:

Parameter	Description
CoS Weighting	<p>Synopsis: { 8:4:2:1, Strict }</p> <p>Default: 8:4:2:1</p> <p>During traffic bursts, frames queued in the switch pending transmission on a port may have different CoS priorities. This parameter specifies weighting algorithm for transmitting different priority CoS frames.</p> <p>Examples:</p> <ul style="list-style-type: none"> • 8:4:2:1 – 8 Critical, 4 High, 2 Medium and 1 Normal priority CoS frame • Strict – lower priority CoS frames will be only transmitted after all higher priority CoS frames have been transmitted

3. Click **Apply**.
4. If necessary, configure CoS mapping based on either the IEEE 802.1p priority or Differentiated Services (DS) field set in the IP header for each packet. For more information, refer to [Section 9.1.3, "Configuring Priority to CoS Mapping"](#) or [Section 9.1.4, "Configuring DSCP to CoS Mapping"](#).

Section 9.1.2

Configuring Classes of Service for Specific Ethernet Ports

To configure Classes of Service (CoS) for one or more Ethernet ports, do the following:

1. Navigate to **Classes of Service » Configure Port CoS Parameters**. The **Port CoS Parameters** table appears.

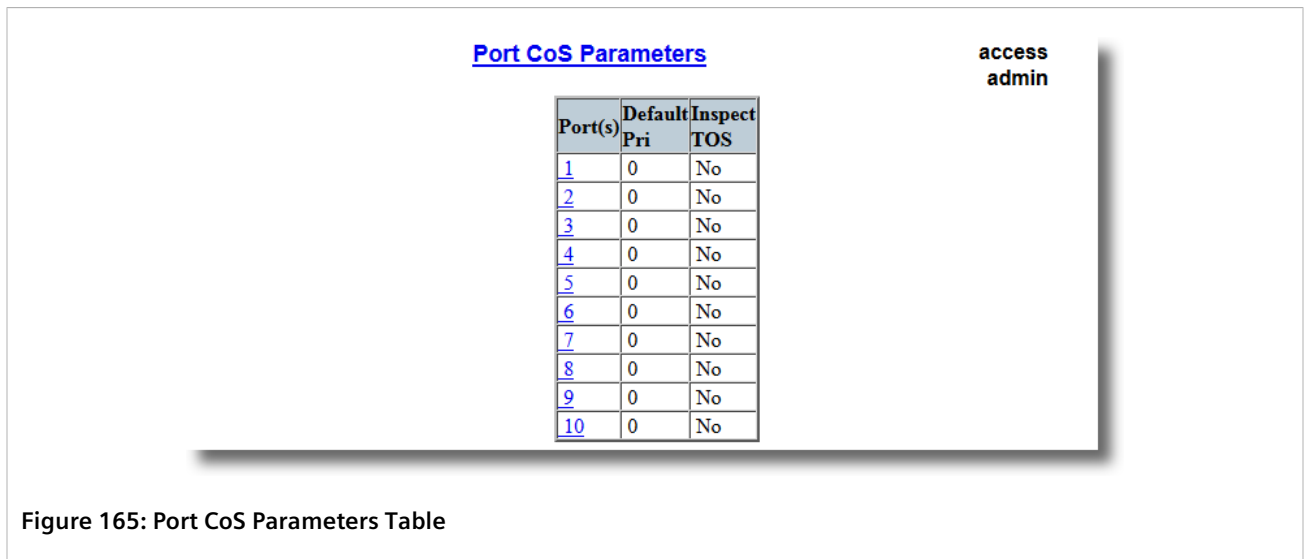

2. Select an Ethernet port. The **Port CoS Parameters** form appears.

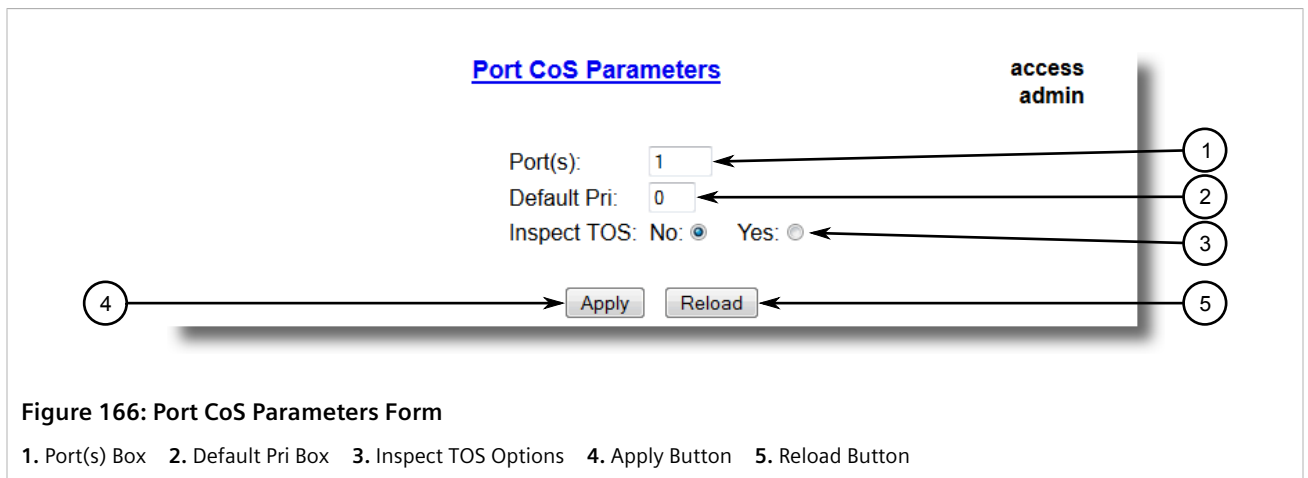

3. Configure the following parameter(s) as required:

Parameter	Description
Port(s)	Synopsis: Any combination of numbers valid for this parameter

Parameter	Description
	The port number as seen on the front plate silkscreen of the switch (or a list of ports, if aggregated in a port trunk).
Default Pri	Synopsis: 0 to 7 Default: 0 This parameter allows to prioritize frames received on this port that are not prioritized based on the frames contents (e.g. priority field in the VLAN tag, DiffServ field in the IP header, prioritized MAC address).
Inspect TOS	Synopsis: { No, Yes } Default: No This parameters enables or disables parsing of the Type-Of-Service (TOS) field in the IP header of the received frames to determine what Class of Service they should be assigned. When TOS parsing is enabled the switch will use the Differentiated Services bits in the TOS field.

- Click **Apply**.

Section 9.1.3

Configuring Priority to CoS Mapping

Frames received untagged can be automatically assigned a CoS based on their priority level.

To map a priority level to a CoS, do the following:

- Navigate to **Classes of Service » Configure Priority to CoS Mapping**. The **Priority to CoS Mapping** table appears.

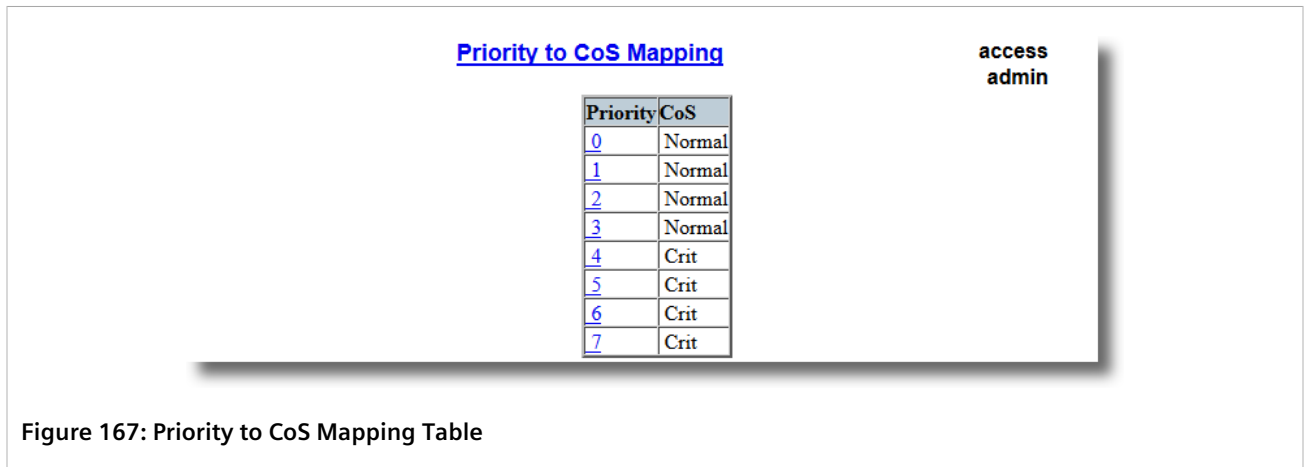

- Select a priority level. The **Priority to CoS Mapping** form appears.

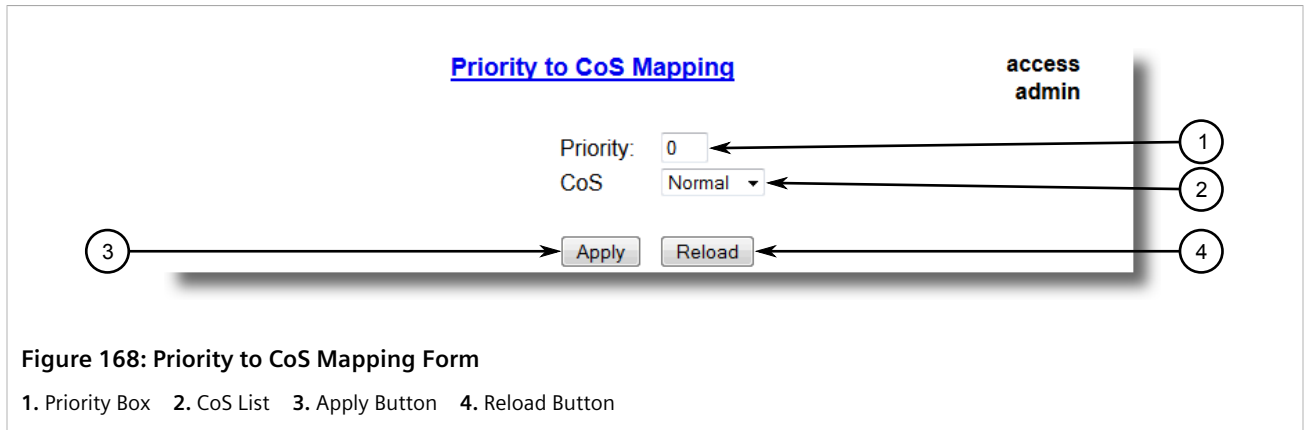

- Configure the following parameter(s) as required:

Parameter	Description
Priority	<p>Synopsis: 0 to 7</p> <p>Default: 0</p> <p>Value of the IEEE 802.1p priority.</p>
CoS	<p>Synopsis: { Normal, Medium, High, Crit }</p> <p>Default: Normal</p> <p>CoS assigned to received tagged frames with the specified IEEE 802.1p priority value.</p>

- Click **Apply**.

Section 9.1.4

Configuring DSCP to CoS Mapping

Mapping CoS to the Differentiated Services (DS) field set in the IP header for each packet is done by defining Differentiated Services Code Points (DSCPs) in the CoS configuration.

To map a DSCP to a Class of Service, do the following:

- Navigate to **Classes of Service » Configure DSCP to CoS Mapping**. The **DSCP to CoS Mapping** table appears.

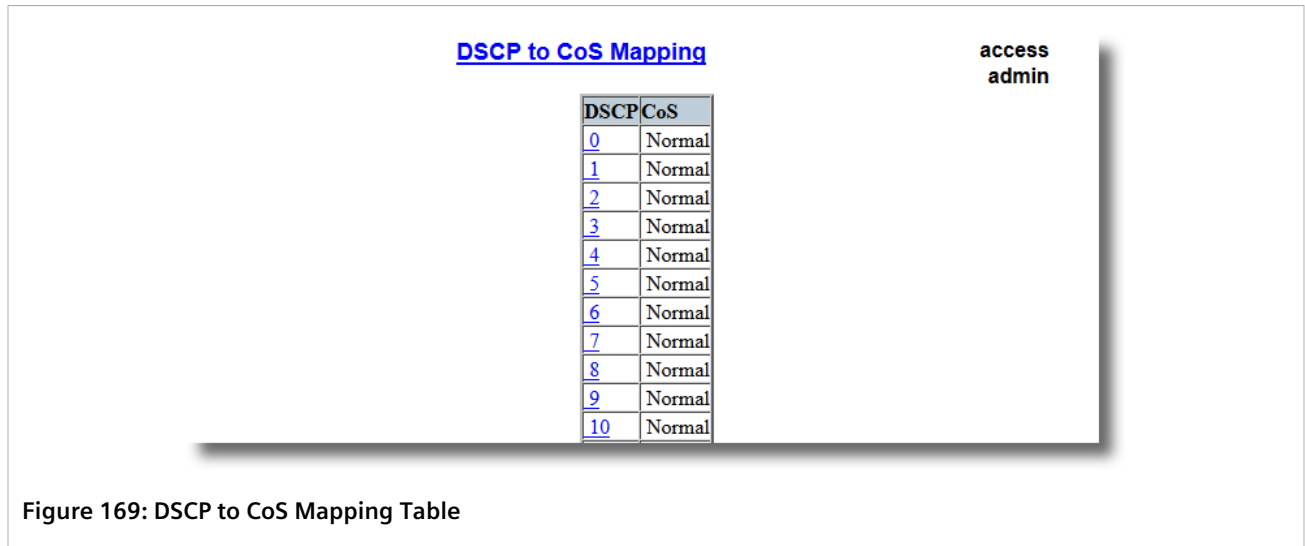

Figure 169: DSCP to CoS Mapping Table

- Select a DSCP level. The **DSCP to CoS Mapping** form appears.

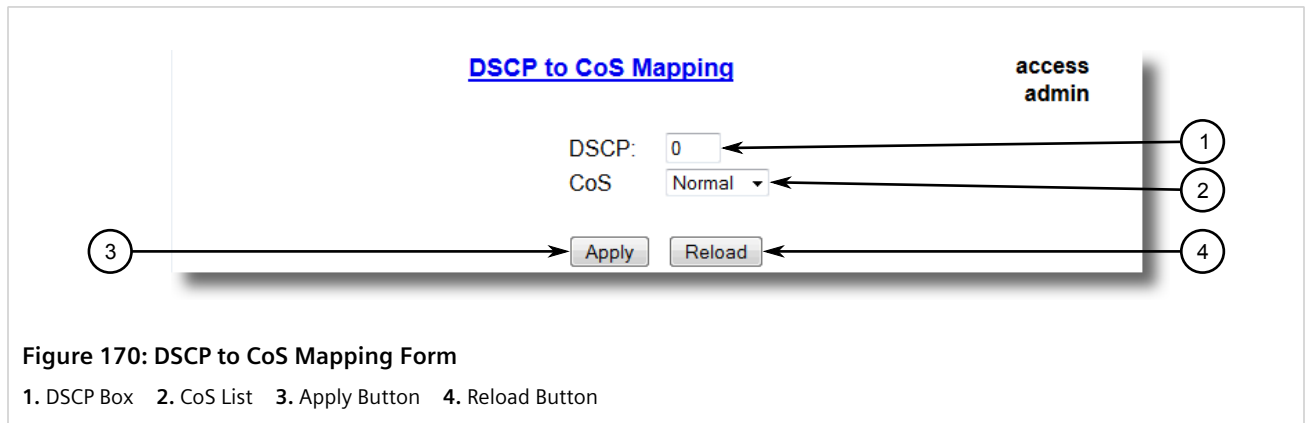

Figure 170: DSCP to CoS Mapping Form

- DSCP Box
- CoS List
- Apply Button
- Reload Button

- Configure the following parameter(s) as required:

Parameter	Description
DSCP	<p>Synopsis: 0 to 63 Default: 0</p> <p>Differentiated Services Code Point (DSCP) – a value of the 6 bit DiffServ field in the Type-Of-Service (TOS) field of the IP header.</p>
CoS	<p>Synopsis: { Normal, Medium, High, Crit }</p> <p>Default: Normal</p> <p>Class of Service assigned to received frames with the specified DSCP.</p>

- Click **Apply**.
- Configure the CoS parameters on select switched Ethernet ports as needed. For more information, refer to [Section 9.1.2, "Configuring Classes of Service for Specific Ethernet Ports"](#).

10 Time Services

This chapter describes the time-keeping and time synchronization features in RUGGEDCOM ROS.

CONTENTS

- [Section 10.1, "Configuring the Time and Date"](#)
- [Section 10.2, "Managing the Precision Time Protocol \(PTP\)"](#)
- [Section 10.3, "Configuring the Time Source"](#)
- [Section 10.4, "Managing NTP"](#)

Section 10.1

Configuring the Time and Date

To set the time, date and other time-keeping related parameters, do the following:

1. Navigate to **Administration » System Time Manager » Configure Time and Date**. The **Time and Date** form appears.

Figure 171: Time and Date Form

1. Time 2. Date 3. Time Zone 4. DST Offset 5. DST Rule 6. Current UTC Offset Box 7. Leap Second Pending Options 8. Apply Button 9. Reload Button

2. Configure the following parameter(s) as required:

Parameter	Description
Time	Synopsis: HH:MM:SS This parameter allows for both the viewing and setting of the local time.

Parameter	Description
Date	<p>Synopsis: MMM DD, YYYY</p> <p>This parameter allows for both the viewing and setting of the local date.</p>
Time Zone	<p>Synopsis: { UTC-12:00 (Eniwetok, Kwajalein), UTC-11:00 (Midway Island, Samoa), UTC-10:00 (Hawaii), UTC-9:00 (Alaska), UTC-8:00 (Los Angeles, Vancouver), UTC-7:00 (Calgary, Denver), UTC-6:00 (Chicago, Mexico City), UTC-5:00 (New York, Toronto), UTC-4:30 (Caracas), UTC-4:00 (Santiago), UTC-3:30 (Newfoundland), UTC-3:00 (Brasilia, Buenos Aires), UTC-2:00 (Mid Atlantic), UTC-1:00 (Azores), UTC-0:00 (Lisbon, London), UTC+1:00 (Berlin, Paris, Rome), UTC+2:00 (Athens, Cairo, Helsinki), ... }</p> <p>Default: UTC-5:00 (New York, Toronto)</p> <p>This setting allows for the conversion of UTC (Universal Coordinated Time) to local time.</p>
DST Offset	<p>Synopsis: HH:MM:SS</p> <p>Default: 00:00:00</p> <p>This parameter specifies the amount of time to be shifted forward/backward when DST begins and ends. For example for most part of USA and Canada, DST time shift is 1 hour (01:00:00) forward when DST begins and 1 hour backward when DST ends.</p>
DST Rule	<p>Synopsis: mm.n.d/HH:MM:SS mm.n.d/HH:MM:SS</p> <p>This parameter specifies a rule for time and date when the transition between Standard and Daylight Saving Time occurs.</p> <ul style="list-style-type: none"> • mm – Month of the year (01 – January, 12 – December) • n – nth d-day in the month (1 – 1st d-day, 5 – 5th/last d-day) • d – day of the week (0 – Sunday, 6 – Saturday) • HH – hour of the day (0 – 24) • MM – minute of the hour (0 – 59) • SS – second of the minute (0 – 59) <p>Example: The following rule applies in most part of USA and Canada:</p> <pre>03.2.0/02:00:00 11.1.0/02:00:00</pre> <p>DST begins on March's 2nd Sunday at 2:00am. DST ends on November's 1st Sunday at 2:00am.</p>
Current UTC Offset	<p>Synopsis: 0 to 1000 s</p> <p>Default: 36 s</p> <p>Coordinated Universal Time (UTC) is a time standard based on International Atomic Time (TAI) with leap seconds added at irregular intervals to compensate for the Earth's slowing rotation. Current UTC offset parameter allows user to adjust the difference between UTC and TAI. The International Earth Rotation and Reference System Service (IERS) observes the Earth's rotation and nearly six months in advance (January and July) a Bulletin-C message is sent out, which reports whether or not to add a leap second in the end of June and December.</p> <p>Please note that change in current UTC offset parameter will result in temporally disruption in the timing network.</p>
Leap Second Pending	<p>Synopsis: { No, Yes }</p> <p>Default: No</p> <p>This parameter allows user to manage the leap second event. A leap second is a second added to Coordinated Universal Time (UTC) in order to keep it synchronized with astronomical time. The International Earth Rotation and Reference System Service (IERS) observes the Earth's rotation and nearly six months in advance (January and July) a Bulletin-C message is sent out, which reports whether or not to add a leap second in the end of June and December. This parameter must set at least 5 minutes in advance before the occurrence of leap second event.</p>

Section 10.2

Managing the Precision Time Protocol (PTP)

The Precision Time Protocol (PTP) is a standard method of synchronizing network clocks over Ethernet. RUGGEDCOM ROS supports PTP v2, which is defined by the IEEE 1588 working group in the IEEE 1588-2008 standard.

PTP is a distributed protocol that allows multiple clocks in a network to synchronize with one another. These clocks are organized into a master-slave synchronization hierarchy with a *grandmaster* clock at the top of the hierarchy, which determines the reference time for the entire system. Synchronization is achieved via the exchange of PTP timing messages. *Slave* clocks use the timing information in PTP messages to adjust their time to that of the *master* in their part of the hierarchy.

The PTP protocol executes within a logical scope called a *domain*. The time established via the protocol within one domain is independent of the time in other domains.

A PTP v2 system may consist of a combination of both PTP-aware and PTP-unaware devices. There are five basic PTP device types defined in the IEEE 1588-2008 standard:

- Ordinary Clocks
- Boundary Clocks
- End-to-End Transparent Clocks
- Peer-to-Peer Transparent Clocks
- Management Nodes
- A *Peer-to-Peer Transparent Clock* forwards all messages just as a normal bridge, router, or repeater does. The difference is that a Peer-to-Peer Transparent Clock also computes the residence time (message departure time - message arrival time) and link delay (packet propagation delay between peer ports) and adds this information in PTP event messages (which carry timestamps). Ethernet ports on a Peer-to-Peer Transparent Clock use the peer delay mechanism to compute the packet propagation delay between peer ports.
- The *End-to-End Transparent Clock* supports the use of the end-to-end delay measurement mechanism between slave clocks and the master clock. It forwards all messages just as a normal bridge, router or repeater does. The difference is that an End-to-End Transparent Clock computes the residence time (message departure time - message arrival time) and adds this information to PTP event messages (messages that carry a time-stamp).

CONTENTS

- [Section 10.2.1, "Configuring PTP Globally"](#)
- [Section 10.2.2, "Configuring a Transparent Clock"](#)
- [Section 10.2.3, "Configuring the PTP Delay Request Interval"](#)
- [Section 10.2.4, "Configuring a VLAN for PTP Traffic"](#)
- [Section 10.2.5, "Viewing PTP Clock Statistics"](#)
- [Section 10.2.6, "Viewing Peer Delay Statistics"](#)

Section 10.2.1

Configuring PTP Globally

To configure the global settings for PTP, do the following:

- Navigate to **Administration » System Time Manager » Precision Time Protocol » Configure Global Parameters**. The **Global Parameters** form appears.

IMPORTANT!
Before performing SNMP get or SNMP set operations for MIBs IEEE C37.238-2011 and RUGGEDCOM-PTP1588-MIB.mib, make sure the PTP Enable parameter is set to **Yes**. For more information about supported MIBs, refer to [Section 11.3.1, "SNMP Management Interface Base \(MIB\) Support"](#).

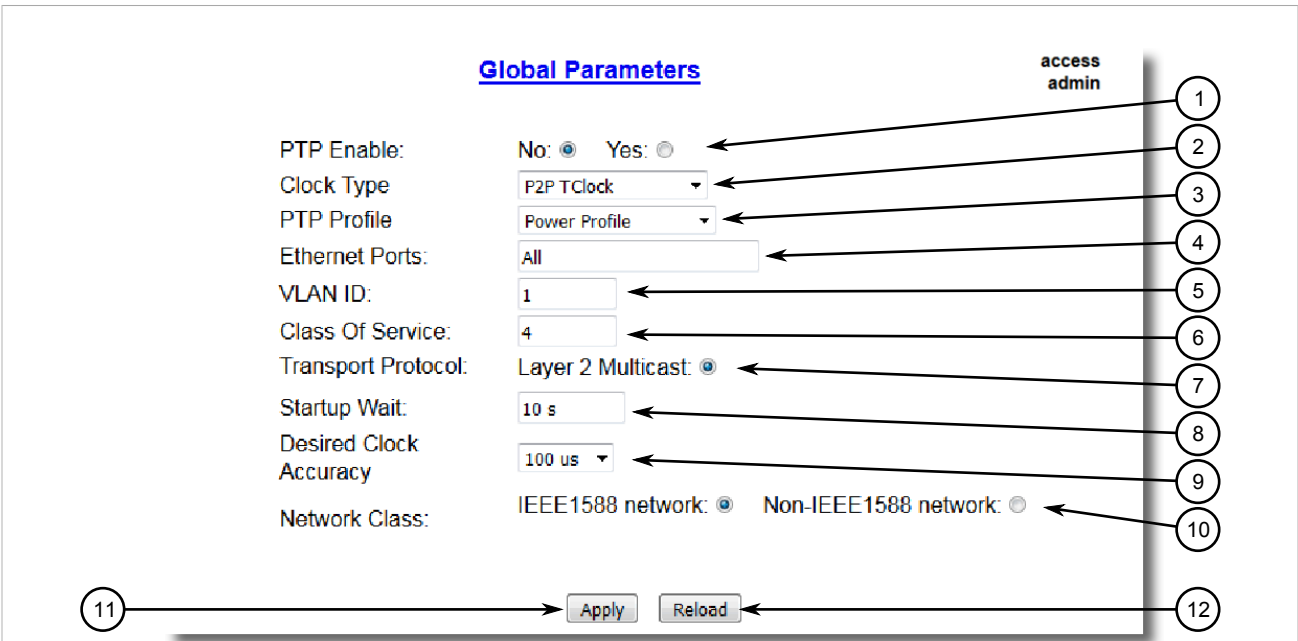





Figure 172: Global Parameters Form

- PTP Enable Options
- Clock Type Options
- PTP Profile List
- Ethernet Ports Box
- VLAN ID Box
- Class Of Service Box
- Transport Protocol Options
- Startup Wait Box
- Desired Clock Accuracy List
- Network Class Options
- Apply Button
- Reload Button

- Configure the following parameter(s) as required:

Parameter	Description
PTP Enable	Synopsis: { No, Yes } Default: No Enables PTP (Precision Time Protocol) protocol.
Clock Type	Default: { OC and P2P TClock, P2P TClock, E2E TClock } Selects PTP (Precision Time Protocol) clock type. Note that this device only operates as a PTP Slave Clock.
PTP Profile	Synopsis: { Power Profile, Default P2P Profile, Utility Profile Level 1, Default E2E Profile, Custom Profile, Power Profile v2 } Default: Power Profile Selects the PTP (Precision Time Protocol) clock profile. PTP profile represents a set of allowed PTP features applicable to specific industry.

Parameter	Description
	<div data-bbox="699 254 1524 352">  NOTE Power Profile represents C37.238.2011. </div> <div data-bbox="699 369 1524 468">  NOTE Power Profile v2 represents C37.238.2017. </div> <div data-bbox="699 485 1524 583">  NOTE Utility Profile Level 1 represents IEC/IEEE 61850-9-3 Ed.1. </div>
Ethernet Ports	<p>Synopsis: Comma-separated list of ports Default: All</p> <p>Selects Ethernet port(s) which take part in PTP (Precision Time Protocol) message exchanges.</p>
VLAN ID	<p>Synopsis: 1 to maximum port number or { Disable } Default: 1</p> <p>The VLAN ID associated with untagged (and 802.1p priority tagged) frames received on this port. Frames tagged with a non-zero VLAN ID will always be associated with the VLAN ID retrieved from the frame tag. Frames tagged with a zero VLAN ID will always be associated with the VLAN ID 1 unless this parameter is configured.</p>
Class Of Service	<p>Synopsis: 1 to 7 or { Disable } Default: 4</p> <p>Selects the PTP (Precision Time Protocol) message priority based on the IEEE 802.1p specification. IEEE 802.1p defines eight different classes of service, usually expressed using the 3-bit priority field in an IEEE 802.1Q header added to the Ethernet frame.</p>
Transport Protocol	<p>Synopsis: { Layer 2 Multicast, Layer 3 Multicast } Default: Layer 2 Multicast</p> <p>Selects network transport protocol for PTP (Precision Time Protocol) messages.</p>
Startup Wait	<p>Synopsis: 0 to 3600 s Default: 10 s</p> <p>Normally the start-up time of a non-GPS master clock is less than that of a GPS-enabled master (i.e. by the time it takes to acquire GPS lock). This parameter provides the ability to bootstrap the PTP network in an orderly fashion.</p>
Desired Clock Accuracy	<p>Synopsis: { 50 ns, 100 ns, 250 ns, 1 us, 2.5 us, 10 us, 25 us, 100 us, 250 us, 1 ms, 2.5 ms, 10 ms, 25 ms, 100 ms, 250 ms }</p> <p>This parameter allows the user to configure the desired clock accuracy. This represents the instantaneous value of the time offset between master and slave clocks. The system will generate an alarm if the time offset from the master exceeds the desired accuracy.</p>
Network Class	<p>Synopsis: { IEEE1588 network, Non-IEEE1588 network } Default: IEEE1588 network</p> <p>Clock servo stability is highly dependent on network personality. This parameter allows the user to configure a network personality to reflect a particular network environment. This might mean, for example, whether all devices in the timing plane are IEEE1588 aware (IEEE1588 network) or whether the timing plane includes non-IEEE1588 devices as well (non-IEEE1588 network). Note that a IEEE1588 network is independent of traffic load. Only the E2E mechanism is applicable to non-IEEE1588 networks.</p>

3. Click **Apply**.
4. Reset the device. For more information, refer to [Section 4.12, "Resetting the Device"](#).

Section 10.2.2

Configuring a Transparent Clock

To configure settings for a PTP transparent clock, do the following:

1. Navigate to **Administration » System Time Manager » Precision Time Protocol » Configure Clock Parameters**. The **Clock Parameters** form appears.

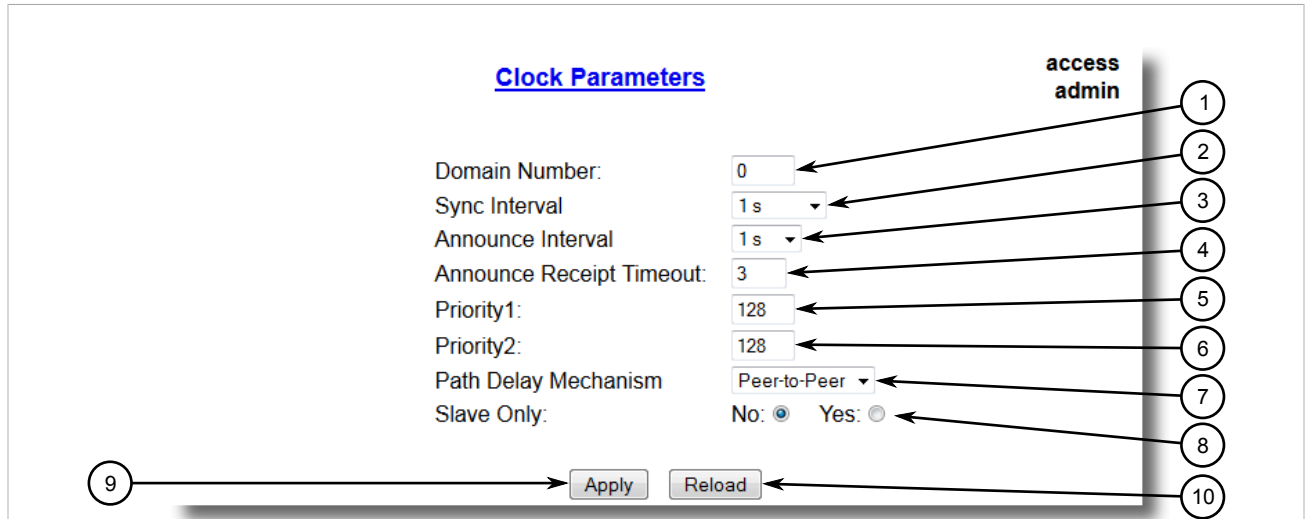

Figure 173: Clock Parameters Form

1. Domain Number Box
2. Sync Interval List
3. Announce Interval List
4. Announce Receipt Timeout Box
5. Priority 1 Box
6. Priority 2 Box
7. Path Delay Mechanism Options
8. Slave Only Options
9. Apply Button
10. Reload Button

2. Configure the following parameter(s) as required:

Parameter	Description
Domain Number	Synopsis: 0 to 127 Default: 0 Selects the PTP (Precision Time Protocol) domain number. A PTP domain is a logical grouping of PTP clocks that synchronize to each other using the PTP protocol.
Sync Interval	Synopsis: { 125 ms, 250 ms, 500 ms, 1 s, 2 s } Default: 1 s Selects the PTP (Precision Time Protocol) Sync interval (mean time interval between successive Sync messages) in seconds. Sync messages are sent periodically by the Master Clock which provide time of day information to PTP Slave Clocks.
Announce Interval	Synopsis: { 1 s, 2 s, 4 s, 8 s, 16 s, 32 s } Default: 1 s Selects the PTP (Precision Time Protocol) Announce interval (mean time interval between successive Announce messages) in seconds. Announce messages are sent periodically by the Master Clock to provide its status and characteristic information. Announce messages are used to establish the synchronization hierarchy, i.e., using the BMC (Best Master Clock) algorithm.
Announce Receipt Timeout	Synopsis: 2 to 10 Default: 3 Selects the PTP (Precision Time Protocol) Announce receipt timeout. This parameter specifies the number of intervals that may pass without receipt of an Announce message. This parameter is part of BMC (Best Master Clock) algorithm.

Parameter	Description
	Please note that a change in this parameter may be disruptive.
Priority1	<p>Synopsis: 0 to 255 Default: 128</p> <p>Selects the PTP (Precision Time Protocol) clock priority1 during the execution of the BMC (Best Master Clock) algorithm. A lower value corresponds to a higher precedence. The BMC algorithm selects clocks from a set with a lower value of priority1 over clocks from a set with a greater value</p>
Priority2	<p>Synopsis: 0 to 255 Default: 128</p> <p>Selects the PTP (Precision Time Protocol) clock priority2 during the execution of the BMC (Best Master Clock) algorithm. A lower value corresponds to a higher precedence. In the event that the operation of the BMC algorithm fails to order the clocks based on the values of priority1, clockClass, clockAccuracy and scaledOffsetLogVariance, the priority2 attribute allows the creation of up to 256 priorities to be evaluated before the tie-breaker. The tie-breaker is based on the clock identity.</p>
Path Delay Mechanism	<p>Synopsis: { Disabled, Peer-to-Peer, End-to-End } Default: Peer-to-Peer</p> <p>Selects the PTP (Precision Time Protocol) delay mechanism. There are two mechanisms used in PTP to measure the propagation delay between PTP ports: The P2P (Peer-to-Peer) delay mechanism measures the port to port propagation time such as link delay and frame residence time. The P2P mechanism is independent of whether the PTP port is acting as Master or Slave.</p> <p>The E2E (End-to-End) delay mechanism measures the message propagation time between Master and Slave clocks across the whole intervening network.</p> <p>Note that the P2P mechanism does not inter-operate with path delay measurements based on the E2E (also called request-response) delay mechanism.</p>
Slave Only	<p>Synopsis: { No, Yes } Default: No</p> <p>This option may be used to force an Ordinary Clock be a Slave only clock. A slave only clock never enters the master state. Slave only and Transparent Clock functionality may be used in combination. Please note that a Boundary Clock must not be configured as a slave only clock.</p>

3. Click **Apply**.
4. Reset the device. For more information, refer to [Section 4.12, "Resetting the Device"](#).

Section 10.2.3

Configuring the PTP Delay Request Interval

To configure the PTP delay request interval, do the following:

1. Navigate to **Administration » System Time Manager » Precision Time Protocol » Configure Path Delay**. The **Path Delay** form appears.

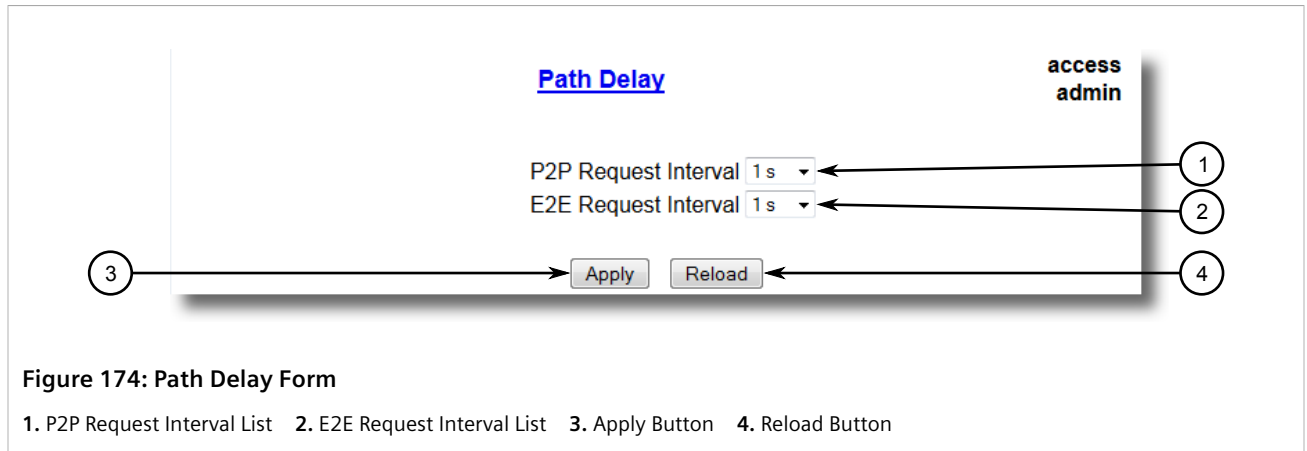

Figure 174: Path Delay Form

1. P2P Request Interval List 2. E2E Request Interval List 3. Apply Button 4. Reload Button

2. Configure the following parameter(s) as required:

Parameter	Description
P2P Request Interval	<p>Synopsis: { 1 s, 2 s, 4 s, 8 s, 16 s, 32 s }</p> <p>Default: 1 s</p> <p>Selects PTP delay request interval (mean time interval between successive delay request messages) in seconds. The peer delay mechanism measures the port-to-port propagation time, such as the link delay, between two communicating ports supporting the peer delay mechanism.</p>
E2E Request Interval	<p>Synopsis: { 1 s, 2 s, 4 s, 8 s, 16 s, 32 s }</p> <p>Default: 1 s</p> <p>Selects PTP delay request interval (mean time interval between successive delay request messages) in seconds. The E2E (also called request-response) delay mechanism measures the message propagation time between master and slave clocks.</p>

3. Click **Apply**.
4. Reset the device. For more information, refer to [Section 4.12, "Resetting the Device"](#).

Section 10.2.4

Configuring a VLAN for PTP Traffic

To configure a VLAN specifically for PTP traffic, do the following:

1. Assign a VLAN ID to all PTP traffic. For more information, refer to [Section 10.2.1, "Configuring PTP Globally"](#).
2. Add a static VLAN with the same ID. For more information about configuring a static VLAN, refer to [Section 7.1.5.2, "Adding a Static VLAN"](#).
3. For each Ethernet port that will transport PTP traffic, configure the PVID to match the VLAN ID configured in [Step 1](#). For more information, refer to [Section 7.1.4, "Configuring VLANs for Specific Ethernet Ports"](#).
4. Configure the PVID format for each affected Ethernet port to control whether PTP traffic is transported as tagged or untagged frames. Or, if necessary, configure the port to be a VLAN trunk. For more information, refer to [Section 7.1.4, "Configuring VLANs for Specific Ethernet Ports"](#).

Section 10.2.5

Viewing PTP Clock Statistics

To view statistics for the Precision Time Protocol (PTP) clock, navigate to **Administration » System Time Manager » Precision Time Protocol » View PTP Statistics » View PTP Clock Stats**. The PTP Clock Stats form appears.

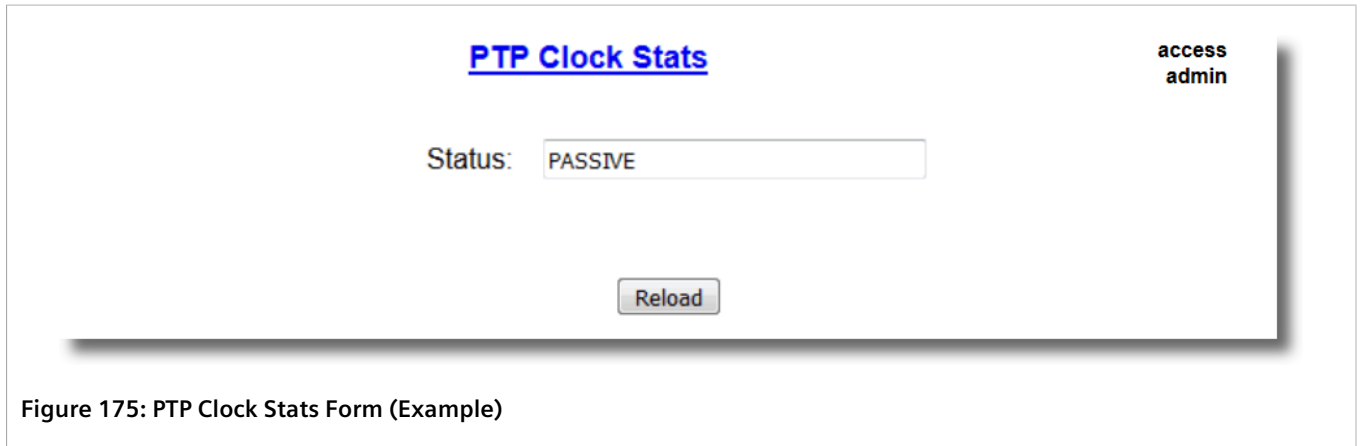

Figure 175: PTP Clock Stats Form (Example)

This form displays the following information:



NOTE

Parameters are available dependent on the status of the device.

Section 10.2.6

Viewing Peer Delay Statistics

To view statistics for the Precision Time Protocol (PTP) peer delay, do the following:

1. Navigate to **Administration » System Time Manager » Precision Time Protocol » View PTP Statistics » View Peer Delay Stats**. The PTP Delay Stats table appears.

**access
admin**

Peer Delay Stats

Port	State	PeerDelay
1	Off	0 ns
2	Off	0 ns
3	Off	0 ns
4	Off	0 ns
5	Off	0 ns
6	Off	0 ns
7	Off	0 ns
8	Off	0 ns

Figure 176: Peer Delay Stats Table

- Select an Ethernet port. The **PTP Delay Stats** form appears.

**access
admin**

Peer Delay Stats

Port: ← 1

State: ← 2

PeerDelay: ← 3

← 4

Figure 177: Peer Delay Stats Form

- Port Box
- State Box
- Peer Delay Box
- Reload Button

This table displays the following information:

Parameter	Description
Port	The port number as seen on the front plate silkscreen of the device.
State	Synopsis: { On, Off } Shows the status of PTP port with respect to P2P (Peer To Peer) delay mechanism.
PeerDelay	Synopsis: 0 to 2147483647 ns Shows peer delay in nanoseconds. The peer delay mechanism measures the port-to-port propagation time, such as the link delay, between two communicating ports supporting the peer delay mechanism.

Section 10.3

Configuring the Time Source

To configure a reference time source to be used by the device for the local clock and for all served time synchronization outputs, do the following:

1. Navigate to **Administration » System Time Manager » Configure Time Source**. The **Time Source** form appears.

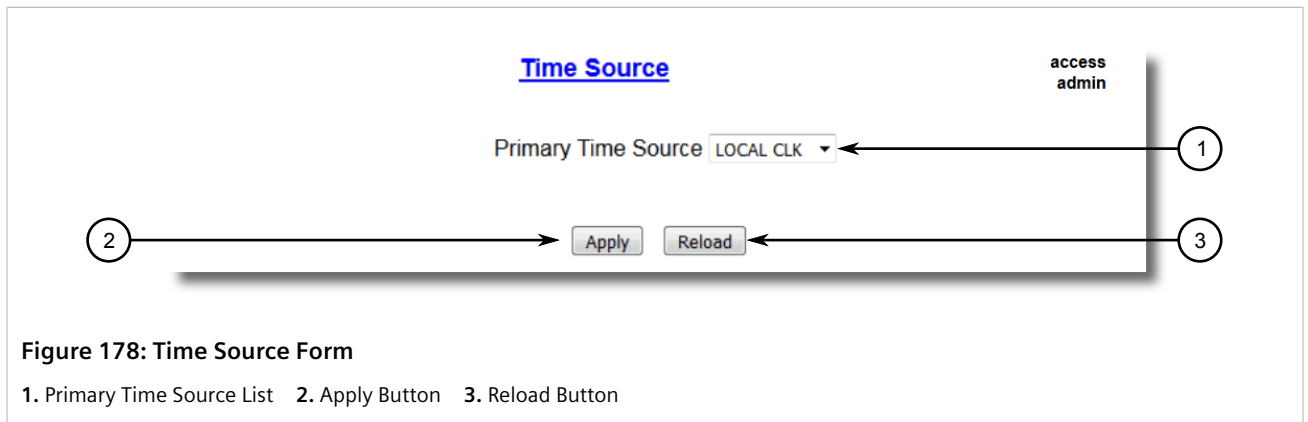

Figure 178: Time Source Form

1. Primary Time Source List
2. Apply Button
3. Reload Button

2. Configure the following parameter(s) as required:

Parameter	Description
Primary Time Source	<p>Synopsis: { LOCAL CLK, IEEE1588, NTP Server }</p> <p>Default: LOCAL CLK</p> <p>To select time source that will discipline the local clock. Note that changing the time source may produce a step change in the time seen via any of the clock outputs.</p>

3. Click **Apply**.

Section 10.4

Managing NTP

RUGGEDCOM ROS may be configured to refer periodically to a specified NTP server to correct any accumulated drift in the on-board clock. RUGGEDCOM ROS will also serve time via the Simple Network Time Protocol (SNTP) to hosts that request it.

Two NTP servers (primary and backup) may be configured for the device. The primary server is contacted first for each attempt to update the system time. If the primary server fails to respond, the backup server is contacted. If either the primary or backup server fails to respond, an alarm is raised.

CONTENTS

- [Section 10.4.1, "Enabling/Disabling NTP Service"](#)
- [Section 10.4.2, "Configuring NTP Servers"](#)

Section 10.4.1

Enabling/Disabling NTP Service

To enable or disable NTP Service, do the following:



NOTE

If the device is running as an NTP server, NTP service must be enabled.

1. Navigate to **Administration » System Time Manager » Configure NTP » Configure NTP Service**. The **SNTP Parameters** form appears.

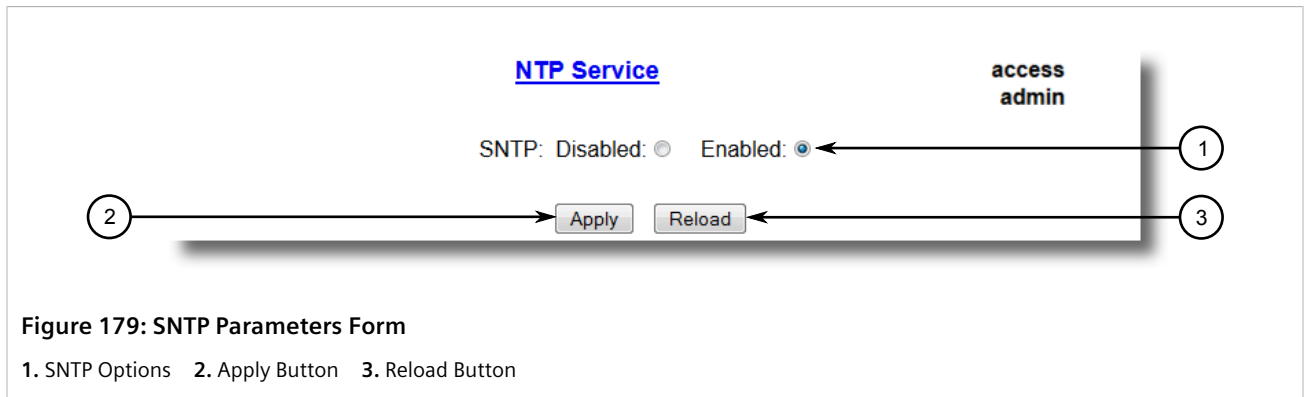

Figure 179: SNTP Parameters Form

1. SNTP Options 2. Apply Button 3. Reload Button

2. Select **Enabled** to enable SNTP, or select **Disabled** to disable SNTP.
3. Click **Apply**.

Section 10.4.2

Configuring NTP Servers

To configure either the primary or backup NTP server, do the following:

1. Navigate to **Administration » System Time Manager » Configure NTP » Configure NTP Servers**. The **NTP Servers** table appears.

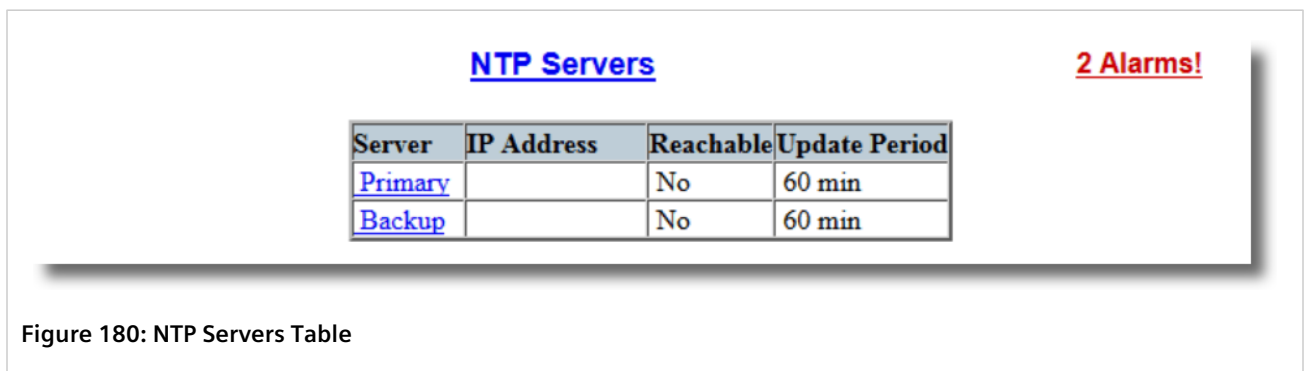

Figure 180: NTP Servers Table

2. Select either **Primary** or **Backup**. The **NTP Servers** form appears.

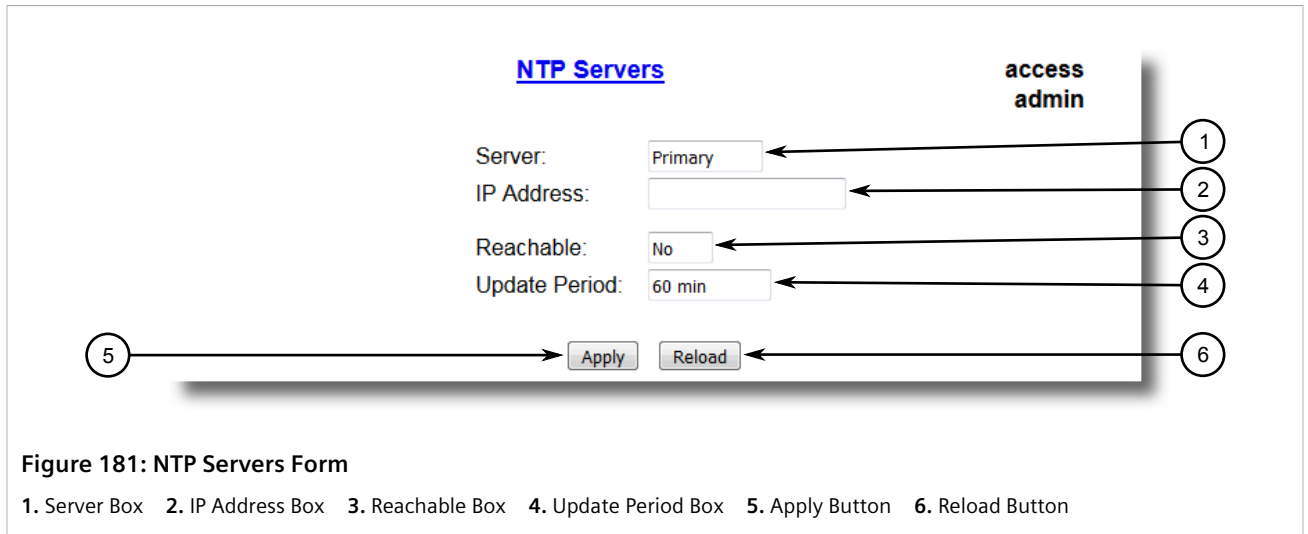

Figure 181: NTP Servers Form

1. Server Box 2. IP Address Box 3. Reachable Box 4. Update Period Box 5. Apply Button 6. Reload Button

3. Configure the following parameter(s) as required:

Parameter	Description
Server	Synopsis: Any 8 characters Default: Primary This field tells whether this configuration is for a Primary or a Backup Server.
IP Address	Synopsis: ###.###.###.### where ### ranges from 0 to 255 The Server IP Address.
Reachable	Synopsis: { No, Yes } The status of the server.
Update Period	Synopsis: 1 to 1440 min Default: 60 min Determines how frequently the (S)NTP server is polled for a time update.If the server cannot be reached in three attempts that are made at one minute intervals an alarm is generated.

4. Click **Apply**.

11 Network Discovery and Management

RUGGEDCOM ROS supports the following protocols for automatic network discovery, monitoring and device management:

- **RUGGEDCOM Discovery Protocol (RCDP)**
Use RCDP to discover RUGGEDCOM ROS-based devices over a Layer 2 network.
- **Link Layer Device Protocol (LLDP)**
Use LLDP to broadcast the device's network capabilities and configuration to other devices on the network, as well as receive broadcasts from other devices.
- **Simple Network Management Protocol (SNMP)**
Use SNMP to notify select users or groups of certain events that happen during the operation of the device, such as changes to network topology, link state, spanning tree root, etc.

CONTENTS

- [Section 11.1, "Enabling/Disabling RCDP"](#)
- [Section 11.2, "Managing LLDP"](#)
- [Section 11.3, "Managing SNMP"](#)
- [Section 11.4, "ModBus Management Support"](#)

Section 11.1

Enabling/Disabling RCDP

RUGGEDCOM ROS supports the RUGGEDCOM Discovery Protocol (RCDP). RCDP supports the deployment of RUGGEDCOM ROS-based devices that have not been configured since leaving the factory. RUGGEDCOM ROS devices that have not been configured all have the default IP (Layer 3) address. Connecting more than one of them on a Layer 2 network means that one cannot use standard IP-based configuration tools to configure them. The behavior of IP-based mechanisms such as the web interface, SSH, telnet, or SNMP will all be undefined.

Since RCDP operates at Layer 2, it can be used to reliably and unambiguously address multiple devices even though they may share the same IP configuration.

Siemens's RUGGEDCOM EXPLORER is a lightweight, standalone Windows application that supports RCDP. It is capable of discovering, identifying and performing basic configuration of RUGGEDCOM ROS-based devices via RCDP. The features supported by RCDP include:

- Discovery of RUGGEDCOM ROS-based devices over a Layer 2 network.
- Retrieval of basic network configuration, RUGGEDCOM ROS version, order code, and serial number.
- Control of device LEDs for easy physical identification.
- Configuration of basic identification, networking, and authentication parameters.

For security reasons, RUGGEDCOM EXPLORER will attempt to disable RCDP or set all devices to *Get Only* mode when EXPLORER is shut down.

Additionally, RUGGEDCOM EXPLORER will set all devices to *Get Only* mode in the following conditions:

- 60 minutes after the last RCDP frame has been received.
- The IP address, subnet, gateway or any passwords are changed for the device via SSH, RSH, Telnet, serial console or SNMP.



IMPORTANT!

For increased security, Siemens recommends disabling RCDP if it is not intended for use.



NOTE

RCDP is not compatible with VLAN-based network configurations. For correct operation of RUGGEDCOM EXPLORER, no VLANs (tagged or untagged) must be configured. All VLAN configuration items must be at their default settings.



NOTE

RUGGEDCOM ROS responds to RCDP requests only. It does not under any circumstances initiate any RCDP-based communication.

To enable or disable RCDP, do the following:

1. Navigate to **Network Discovery » RuggedCom Discovery Protocol » Configure RCDP Parameters**. The **RCDP Parameters** form appears.

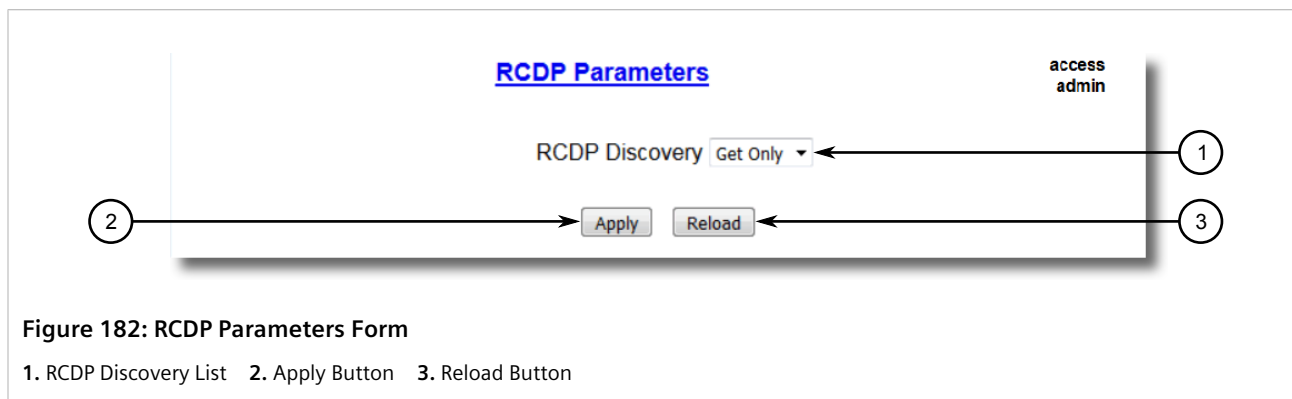

Figure 182: RCDP Parameters Form

1. RCDP Discovery List 2. Apply Button 3. Reload Button

2. Under **RCDP Discovery**, select one of the following options:



IMPORTANT!

The Enabled option is only available for devices loaded with factory default settings. This option will not be selectable once a device has been configured.

- Disabled – Disables read and write access
- Get Only – Enables only read access
- Enabled – Enables read and write access

3. Click **Apply**.

Section 11.2

Managing LLDP

The Link Layer Discovery Protocol (LLDP) defined by IEEE 802.11AB allows a networked device to advertise its own basic networking capabilities and configuration.

LLDP allows a networked device to discover its neighbors across connected network links using a standard mechanism. Devices that support LLDP are able to advertise information about themselves, including their capabilities, configuration, interconnections, and identifying information.

LLDP agent operation is typically implemented as two modules: the LLDP transmit module and LLDP receive module. The LLDP transmit module, when enabled, sends the local device's information at regular intervals, in IEEE 802.1AB standard format. Whenever the transmit module is disabled, it transmits an LLDPDU (LLDP data unit) with a time-to-live (TTL) type-length-value (TLV) containing 0 in the information field. This enables remote devices to remove the information associated with the local device in their databases. The LLDP receive module, when enabled, receives remote devices' information and updates its LLDP database of remote systems. When new or updated information is received, the receive module initiates a timer for the valid duration indicated by the TTL TLV in the received LLDPDU. A remote system's information is removed from the database when an LLDPDU is received from it with TTL TLV containing 0 in its information field.

**NOTE**

LLDP is implemented to keep a record of only one device per Ethernet port. Therefore, if there are multiple devices sending LLDP information to a switch port on which LLDP is enabled, information about the neighbor on that port will change constantly.

CONTENTS

- [Section 11.2.1, "Configuring LLDP Globally"](#)
- [Section 11.2.2, "Configuring LLDP for an Ethernet Port"](#)
- [Section 11.2.3, "Viewing Global Statistics and Advertised System Information"](#)
- [Section 11.2.4, "Viewing Statistics for LLDP Neighbors"](#)
- [Section 11.2.5, "Viewing Statistics for LLDP Ports"](#)

Section 11.2.1

Configuring LLDP Globally

To configure the global settings for LLDP, do the following:

1. Navigate to **Network Discovery » Link Layer Discovery Protocol » Configure Global LLDP Parameters**. The **Global LLDP Parameters** form appears.

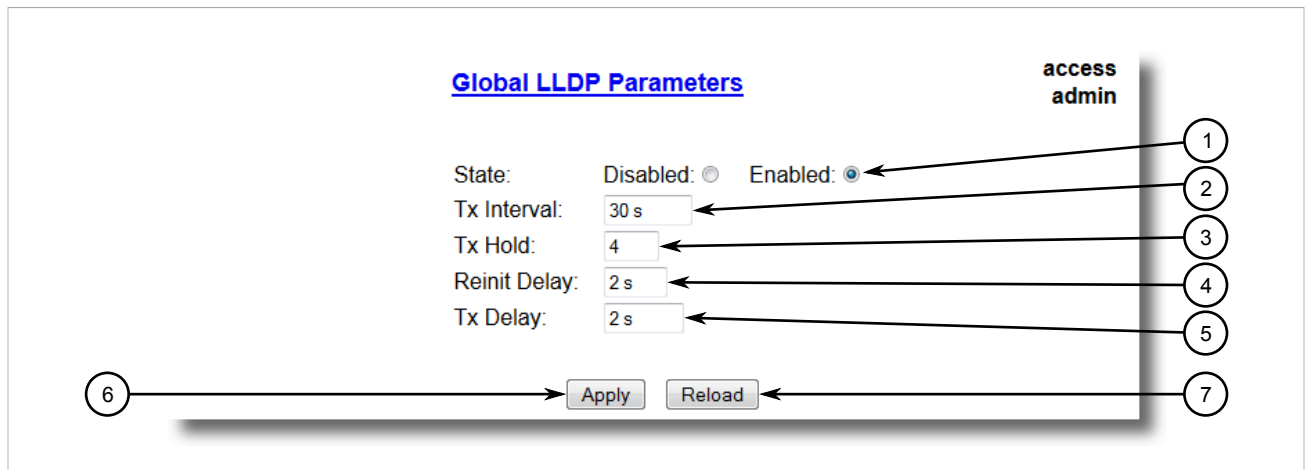

Figure 183: Global LLDP Parameters Form

1. State Options 2. Tx Interval Box 3. Tx Hold Box 4. Reinit Delay Box 5. Tx Delay Box 6. Apply Button 7. Reload Button

2. Configure the following parameter(s) as required:

Parameter	Description
State	<p>Synopsis: { Disabled, Enabled }</p> <p>Default: Enabled</p> <p>Enables LLDP protocol. Note that LLDP is enabled on a port when LLDP is enabled globally and along with enabling per port setting in Port LLDP Parameters menu.</p>
Tx Interval	<p>Synopsis: 5 to 32768 s</p> <p>Default: 30 s</p> <p>The interval at which LLDP frames are transmitted on behalf of this LLDP agent.</p>
Tx Hold	<p>Synopsis: 2 to 10</p> <p>Default: 4</p> <p>The multiplier of the Tx Interval parameter that determines the actual time-to-live (TTL) value used in a LLDPDU. The actual TTL value can be expressed by the following formula:</p> <pre>TTL = MIN(65535, (Tx Interval * Tx Hold))</pre>
Reinit Delay	<p>Synopsis: 1 to 10 s</p> <p>Default: 2 s</p> <p>The delay in seconds from when the value of Admin Status parameter of a particular port becomes 'Disabled' until re-initialization will be attempted.</p>
Tx Delay	<p>Synopsis: 1 to 8192 s</p> <p>Default: 2 s</p> <p>The delay in seconds between successive LLDP frame transmissions initiated by value or status changed. The recommended value is set by the following formula:</p> <pre>1 <= txDelay <= (0.25 * Tx Interval)</pre>

3. Click **Apply**.

Section 11.2.2

Configuring LLDP for an Ethernet Port

To configure LLDP for a specific Ethernet Port, do the following:



IMPORTANT!
LLDP is not supported on ports A and B.

1. Navigate to **Network Discovery » Link Layer Discovery Protocol » Configure Port LLDP Parameters**. The **Port LLDP Parameters** table appears.

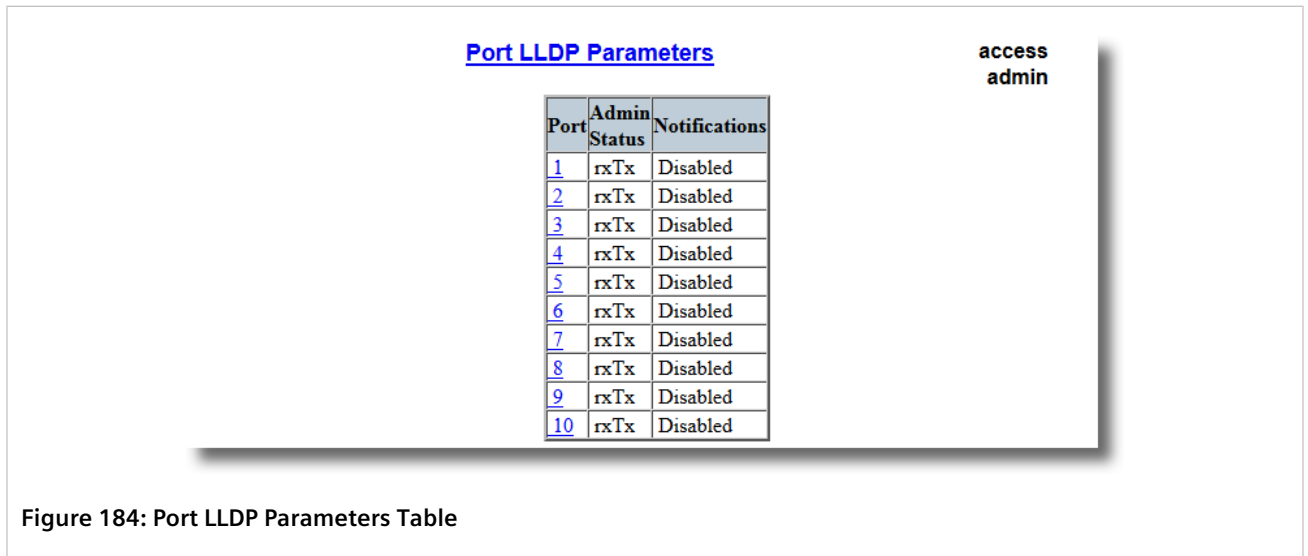

Figure 184: Port LLDP Parameters Table

2. Select a port. The **Port LLDP Parameters** form appears.

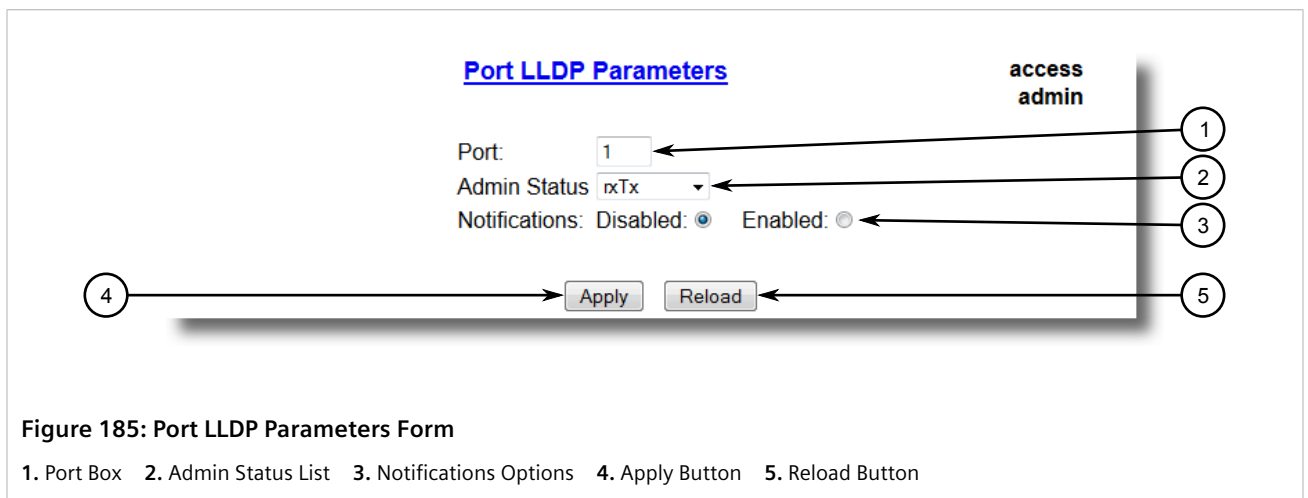

Figure 185: Port LLDP Parameters Form

1. Port Box
2. Admin Status List
3. Notifications Options
4. Apply Button
5. Reload Button

3. Configure the following parameter(s) as required:

Parameter	Description
Port	Synopsis: 1 to maximum port number Default: 1 The port number as seen on the front plate silkscreen of the device.

Parameter	Description
Admin Status	<p>Synopsis: { rxTx, txOnly, rxOnly, Disabled }</p> <p>Default: rxTx</p> <p>rxTx: the local LLDP agent can both transmit and receive LLDP frames through the port.</p> <p>txOnly: the local LLDP agent can only transmit LLDP frames.</p> <p>rxOnly: the local LLDP agent can only receive LLDP frames.</p> <p>disabled: the local LLDP agent can neither transmit or receive LLDP frames.</p>
Notifications	<p>Synopsis: { Disabled, Enabled }</p> <p>Default: Disabled</p> <p>Disabling notifications will prevent sending notifications and generating alarms for particular port from the LLDP agent.</p>

4. Click **Apply**.

Section 11.2.3

Viewing Global Statistics and Advertised System Information

To view global statistics for LLDP and the system information that is advertised to neighbors, navigate to **Network Discovery » Link Layer Discovery Protocol » View LLDP Global Remote Statistics**. The **LLDP Global Remote Statistics** form appears.

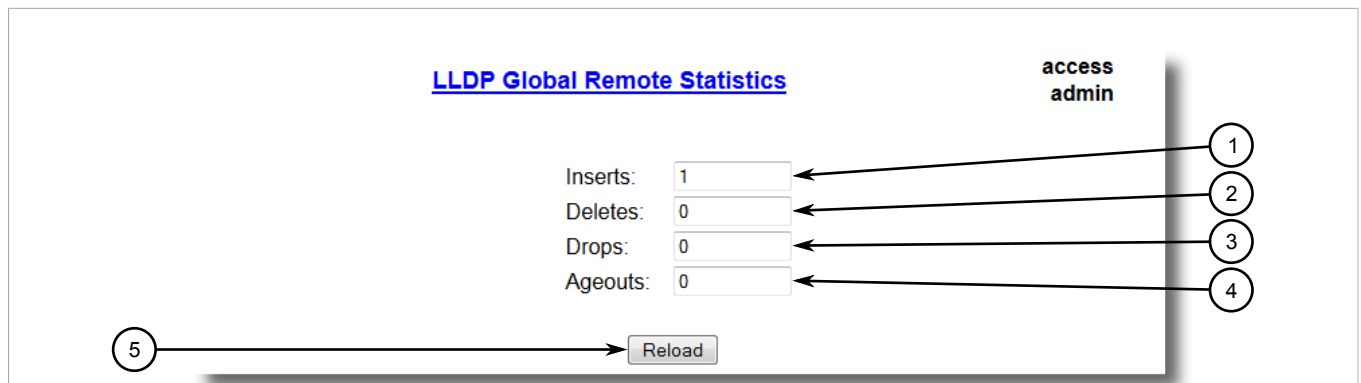

Figure 186: LLDP Global Remote Statistics Form

1. Inserts Box 2. Deletes Box 3. Drops Box 4. Ageouts Box 5. Reload Button

This form displays the following information:

Parameter	Description
Inserts	<p>Synopsis: 0 to 4294967295</p> <p>A number of times the entry in LLDP Neighbor Information Table was inserted.</p>
Deletes	<p>Synopsis: 0 to 4294967295</p> <p>A number of times the entry in LLDP Neighbor Information Table was deleted.</p>
Drops	<p>Synopsis: 0 to 4294967295</p> <p>A number of times an entry was deleted from LLDP Neighbor Information Table because the information timeliness interval has expired.</p>
Ageouts	<p>Synopsis: 0 to 4294967295</p>

Parameter	Description
	A counter of all TLVs discarded.

Section 11.2.4

Viewing Statistics for LLDP Neighbors

To view statistics for LLDP neighbors, navigate to *Network Discovery » Link Layer Discovery Protocol » View LLDP Neighbor Information*. The LLDP Neighbor Information table appears.

LLDP Neighbor Information
access admin

Port: ← 1

ChassisId: ← 2

PortId: ← 3

SysName: ← 4

SysDesc: ← 5

← 6

Figure 187: LLDP Neighbor Information Table
1. Port Box 2. ChassisId Box 3. PortId Box 4. SysName Box 5. SysDesc Box 6. Reload Button

This form displays the following information:

Parameter	Description
Port	Synopsis: 1 to maximum port number The local port associated with this entry.
ChassisId	Synopsis: Any 45 characters Chassis Id information received from remote LLDP agent.
PortId	Synopsis: Any 45 characters Port Id information received from remote LLDP agent.
SysName	Synopsis: Any 45 characters System Name information received from remote LLDP agent.
SysDesc	Synopsis: Any 45 characters System Descriptor information received from remote LLDP agent.

Section 11.2.5

Viewing Statistics for LLDP Ports

To view statistics for LLDP ports, navigate to **Network Discovery » Link Layer Discovery Protocol » View LLDP Statistics**. The LLDP Statistics table appears.

Port	FrmDrop	ErrFrm	FrmIn	FrmOut	Ageouts	TLVsDrop	TLVsUnknown
1	0	0	12274	2041	1	0	36822
2	0	0	2046	2041	1	0	0
3	0	0	0	0	0	0	0
4	0	0	0	0	0	0	0
5	0	0	0	0	0	0	0
6	0	0	0	0	0	0	0
7	0	0	0	0	0	0	0
8	0	0	1435	1433	0	0	0
9	0	0	0	0	0	0	0
10	0	0	0	0	0	0	0

Figure 188: LLDP Statistics Table

This table displays the following information:

Parameter	Description
Port	Synopsis: 1 to maximum port number The port number as seen on the front plate silkscreen of the device.
FrmDrop	Synopsis: 0 to 4294967295 A counter of all LLDP frames discarded.
ErrFrm	Synopsis: 0 to 4294967295 A counter of all LLDPDUs received with detectable errors.
FrmIn	Synopsis: 0 to 4294967295 A counter of all LLDPDUs received.
FrmOut	Synopsis: 0 to 4294967295 A counter of all LLDPDUs transmitted.
Ageouts	Synopsis: 0 to 4294967295 A counter of the times that a neighbor's information has been deleted from the LLDP remote system MIB because the txinfoTTL timer has expired.
TLVsDrop	Synopsis: 0 to 4294967295 A counter of all TLVs discarded.
TLVsUnknown	Synopsis: 0 to 4294967295 A counter of all TLVs received on the port that are not recognized by the LLDP local agent.

Section 11.3

Managing SNMP

RUGGEDCOM ROS supports versions 1, 2 and 3 of the Simple Network Management Protocol (SNMP), otherwise referred to as SNMPv1, SNMPv2c and SNMPv3 respectively. SNMPv3 provides secure access to the devices through a combination of authentication and packet encryption over the network. Security features for this protocol include:

Feature	Description
Message Integrity	Makes sure that a packet has not been tampered with in-transit.
Authentication	Determines if the message is from a valid source.
Encryption	Encrypts the contents of a packet to prevent it from being seen by an unauthorized source.

SNMPv3 provides security models and security levels. A security model is an authentication strategy setup for a user and the group in which the user resides. A security level is a permitted level of security within a security model. A combination of a security model and level will determine which security mechanism is employed when handling an SNMP packet.

Before configuring SNMPv3, note the following:

- Each user belongs to a group
- A group defines the access policy for a set of users
- An access policy defines what SNMP objects can be accessed for (i.e. reading, writing and creating notifications)
- A group determines the list of notifications its users can receive
- A group also defines the security model and security level for its users

For SNMPv1 and SNMPv2c, a community string can be configured. The string is mapped to the group and access level with a security name, which is configured as **User Name**.

CONTENTS

- [Section 11.3.1, "SNMP Management Interface Base \(MIB\) Support"](#)
- [Section 11.3.2, "SNMP Traps"](#)
- [Section 11.3.3, "Managing SNMP Users"](#)
- [Section 11.3.4, "Managing Security-to-Group Mapping"](#)
- [Section 11.3.5, "Managing SNMP Groups"](#)

Section 11.3.1

SNMP Management Interface Base (MIB) Support

RUGGEDCOM ROS supports a variety of standard MIBs, proprietary RUGGEDCOM MIBs and Agent Capabilities MIBs, all for SNMP (Simple Network Management Protocol).

CONTENTS

- [Section 11.3.1.1, "Supported Standard MIBs"](#)
- [Section 11.3.1.2, "Supported Proprietary RUGGEDCOM MIBs"](#)

- [Section 11.3.1.3, “Supported Agent Capabilities”](#)

Section 11.3.1.1

Supported Standard MIBs

RUGGEDCOM ROS supports the following standard MIBs:

Standard	MIB Name	Title
RFC 2578	SNMPv2-SMI	Structure of Management Information Version 2
RFC 2579	SNMPv2-TC	Textual conventions for SMIv2
RFC 2580	SNMPv2-CONF	Conformance statements for SMIv2
	IANAifType	Enumerated values of the ifType Object Defined ifTable defined in IF-MIB
RFC 1907	SNMPv2-MIB	Management Information Base for SNMPv2
RFC 2011	IP-MIB	SNMPv2 Management Information Base for Internet Protocol using SMIv2
RFC 2012	TCP-MIB	SNMPv2 Management Information Base for the Transmission Control Protocol using SMIv2
RFC 2013	UDP-MIB	Management Information Base for the UDP using SMIv2
RFC 1659	RS-232-MIB	Definitions of managed objects for RS-232-like hardware devices
RFC 2863	IF-MIB	The Interface Group MIB
RFC 2819	RMON-MIB	Remote Network Monitoring (RMON) management Information base
RFC 4188	BRIDGE-MIB	Definitions of managed objects for bridges
RFC 4318	RSTP-MIB	Definitions of managed objects for bridges with Rapid Spanning Tree Protocol (RSTP)
RFC 3411	SNMP-FRAMEWORK-MIB	An architecture for describing Simple Network Management Protocol (SNMP) Management Framework
RFC 3414	SNMP-USER-BASED-SM-MIB	User-based Security Model (USM) for Version 3 of the Simple Network Management Protocol (SNMPv3)
RFC 3415	SNMP-VIEW-BASED-ACM-MIB	View-based Access Control Model (VACM) for the Simple Management Protocol (SNMP)
IEEE 802.3ad	IEEE8023-LAG-MIB	Management Information Base Module for link aggregation
IEEE 802.1AB-2005	LLDP-MIB	Management Information Base Module for LLDP configuration, statistics, local system data and remote systems data components
RFC 4363	Q-BRIDGE-MIB	Definitions of Managed Objects for Bridges with traffic classes, multicast filtering, and virtual LAN extensions
IEEE C37.238-2011	IEEE37.238-MIB	IEEE Standard Profile for use of IEEE 1588 Precision Time Protocol in power system applications

Section 11.3.1.2

Supported Proprietary RUGGEDCOM MIBs

RUGGEDCOM ROS supports the following proprietary RUGGEDCOM MIBs:

File Name	MIB Name	Description
RUGGEDCOM-MIB.mib	RUGGEDCOM-MIB	RUGGEDCOM enterprise SMI
RUGGEDCOM-TRAPS-MIB.mib	RUGGEDCOM-TRAPS-MIB	RUGGEDCOM traps definition
RUGGEDCOM-SYS-INFO-MIB.mib	RUGGEDCOM-SYS-INFO-MIB	General system information about RUGGEDCOM device
RUGGEDCOM-DOT11-MIB.mib	RUGGEDCOM-DOT11-MIB	Management for wireless interface on RUGGEDCOM device
RUGGEDCOM-POE-MIB.mib	RUGGEDCOM-POE-MIB	Management for PoE ports on RUGGEDCOM device
RUGGEDCOM-SERIAL-MIB.mib	RUGGEDCOM-SERIAL-MIB	Management for serial ports on RUGGEDCOM device
RUGGEDCOM-STP-MIB.mib	RUGGEDCOM-STP-MIB	Management for RSTP protocol
RUGGEDCOM-NTP-MIB.mib	RUGGEDCOM-NTP-MIB	RUGGEDCOM proprietary MIB to control and monitor NTP module

Section 11.3.1.3

Supported Agent Capabilities

RUGGEDCOM ROS supports the following agent capabilities for the SNMP agent:

**NOTE**

For information about agent capabilities for SNMPv2, refer to [RFC 2580](http://tools.ietf.org/html/rfc2580) [<http://tools.ietf.org/html/rfc2580>].

File Name	MIB Name	Supported MIB
RC-SNMPv2-MIB-AC.mib	RC-SNMPv2-MIB-AC	SNMPv2-MIB
RC-UDP-MIB-AC.mib	RC-UDP-MIB-AC	UDP-MIB
RC-TCP-MIB-AC.mib	RC-TCP-MIB-AC	TCP-MIB
RC-SNMP-USER-BASED-SM-MIB-AC.mib	RC-SNMP-USER-BASED-SM-MIB-AC	SNMP-USER-BASED-SM-MIB-AC
RC-SNMP-VIEW-BASED-ACM-MIB-AC.mib	RC-SNMP-VIEW-BASED-ACM-MIB-AC	SNMP-VIEW-BASED-ACM-MIB-AC
RC-IF-MIB-AC.mib	RC-IF-MIB-AC	IF-MIB
RC-BRIDGE-MIB-AC.mib	RC-BRIDGE-MIB-AC	BRIDGE-MIB
RC-RMON-MIB-AC.mib	RC-RMON-MIB-AC	RMON-MIB
RC-Q-BRIDGE-MIB-AC.mib	RC-Q-BRIDGE-MIB-AC	Q-BRIDGE-MIB
RC-IP-MIB-AC.mib	RC-IP-MIB-AC	IP-MIB
RC-LLDP-MIB-AC.mib	RC-LLDP-MIB-AC	LLDP-MIB
RC-LAG-MIB-AC.mib	RC-LAG-MIB-AC	IEEE8023-LAG-MIB

File Name	MIB Name	Supported MIB
RC_RSTP-MIB-AC.mib	RC_RSTP-MIB-AC	RSTP-MIB
RC-RUGGEDCOM-DOT11-MIB-AC.mib	RC-RUGGEDCOM-DOT11-MIB-AC	RUGGEDCOM-DOT11- MIB
RC-RUGGEDCOM-POE-MIB-AC.mib	RC-RUGGEDCOM-POE-MIB-AC	RUGGEDCOM-POE-MIB
RC-RUGGEDCOM-STP-AC-MIB.mib	RC-RUGGEDCOM-STP-AC-MIB	RUGGEDCOM-STP-MIB
RC-RUGGEDCOM-SYS-INFO-MIB-AC.mib	RC-RUGGEDCOM-SYS-INFO-MIB-AC	RUGGEDCOM-SYS-INFO-MIB
RC-RUGGEDCOM-TRAPS-MIB-AC.mib	RC-RUGGEDCOM-TRAPS-MIB-AC	RUGGEDCOM-TRAPS-MIB
RUGGEDCOM_RS-232-MIB-AC.mib	RUGGEDCOM_RS-232-MIB-AC	RS-232-MIB
RC-RUGGEDCOM-SERIAL-MIB-AC.mib	RC-RUGGEDCOM-SERIAL-MIB-AC	RUGGEDCOM-SERIAL-MIB
RC-NTP-MIB-AC.mib	RC-NTP-MIB-AC	NTP-MIB

Section 11.3.2

SNMP Traps

The device generates the following traps.

» Standard Traps

Trap	MIB
linkDown	IF-MIB
linkUp	
authenticationFailure	SNMPv2-MIB
coldStart	
newRoot	BRIDGE-MIB
topologyChage	
risingAlarm	RMON-MIB
fallingAlarm	
lldpRemoteTablesChange	LLDP-MIB

» Specific Proprietary Traps

Trap	MIB
genericTrap	RUGGEDCOM-TRAPS-MIB
powerSupplyTrap	
swUpgradeTrap	
cfgChangeTrap	
weakPasswordTrap	

Trap	MIB
defaultKeysTrap	
privKeySnmpV3UserUnknwnTrap	
serialCommBlockedTrap	
unknownRouteSerialProto	
incopatableFpgaTrap	
clockMngrTrap	
ieee1588Trap	
rcLoopedBpduRcvd	
rcBpduGuardActivated	
rcGMRPCannotLearMoreAddresses	
rcGVRPCannotLearMoreAddresses	
rcMcastCpuFiltTblFull	
rclgmpGroupMembershipTblFull	
rclgmpMcastForwardTblFull	
rcMacAddressNotLearned	
excessLoginFailureTrap	
loginInfoTrap	
loginFailureTrap	
radiusServiceAvailableChange	
tacacsServiceAvailableChange	
rcDeviceError	
rcPortSecurityViolatedTrap	
rcMacAddrAuthFailedTrap	
rcRstpNewTopology	
rcNTPServiceAvailableChange	RUGGEDCOM-NTP-MIB.mib

» Generic Proprietary Traps

Generic traps carry information about events in their severity and description objects. They are sent at the same time an alarm is generated for the device. The following are examples of RUGGEDCOM generic traps:



NOTE

Information about generic traps can be retrieved using the CLI command **alarms**. For more information about the **alarms** command, refer to [Section 2.5.1, "Available CLI Commands"](#).

Trap	Severity
TACACS+ response invalid	Warning
Unable to obtain IP address	Critical

Trap	Severity
SPP is rejected on Port 1	Error
BootP client: TFTP transfer failure	Error
received two consecutive confusing BPDUs on port, forcing down	Error

Section 11.3.3

Managing SNMP Users

This section describes how to manage SNMP users.

CONTENTS

- [Section 11.3.3.1, “Viewing a List of SNMP Users”](#)
- [Section 11.3.3.2, “Adding an SNMP User”](#)
- [Section 11.3.3.3, “Deleting an SNMP User”](#)

Section 11.3.3.1

Viewing a List of SNMP Users

To view a list of SNMP users configured on the device, navigate to **Administration » Configure SNMP » Configure SNMP Users**. The **SNMP Users** table appears.

SNMP Users

**access
admin**

[InsertRecord](#)

Name	IP Address	v1/v2c Community	Auth Protocol	Priv Protocol	Auth
Manager	192.168.0.100	Manager	HMACMD5	CBC-DES	xxxx
common		common	noAuth	noPriv	
public		public	noAuth	noPriv	
read		public	noAuth	noPriv	

Figure 189: SNMP Users Table

If users have not been configured, add users as needed. For more information, refer to [Section 11.3.3.2, “Adding an SNMP User”](#).

Section 11.3.3.2

Adding an SNMP User

Multiple users (up to a maximum of 32) can be configured for the local SNMPv3 engine, as well as SNMPv1 and SNMPv2c communities.



NOTE

When employing the SNMPv1 or SNMPv2c security level, the **User Name** parameter maps the community name with the security group and access level.

To add a new SNMP user, do the following:

1. Navigate to **Administration » Configure SNMP » Configure SNMP Users**. The **SNMP Users** table appears.

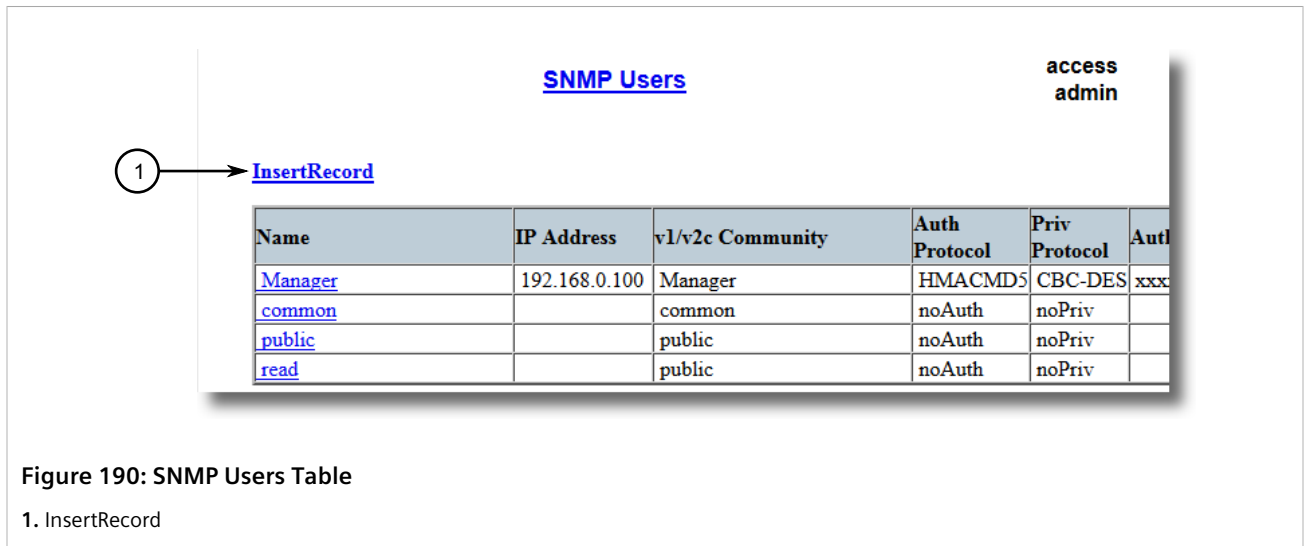

Figure 190: SNMP Users Table

1. InsertRecord

2. Click **InsertRecord**. The **SNMP Users** form appears.

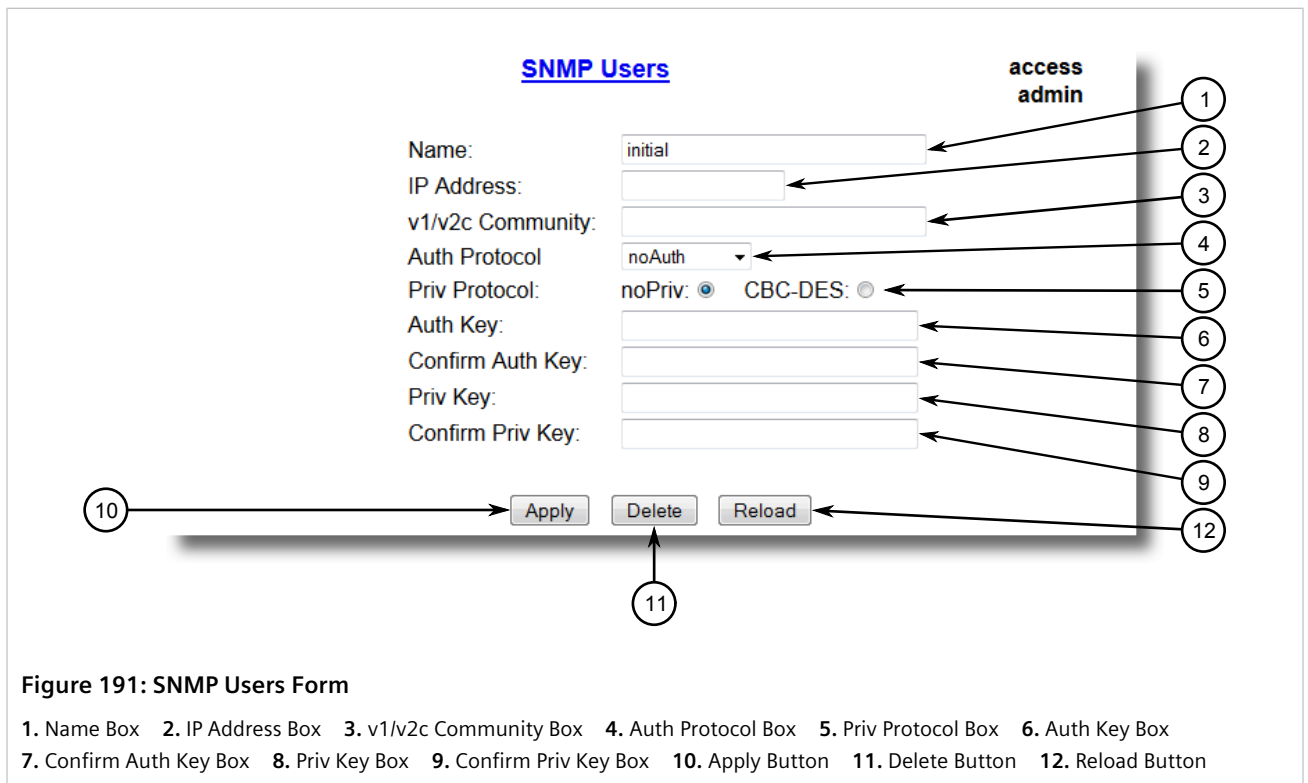

Figure 191: SNMP Users Form

1. Name Box
2. IP Address Box
3. v1/v2c Community Box
4. Auth Protocol Box
5. Priv Protocol Box
6. Auth Key Box
7. Confirm Auth Key Box
8. Priv Key Box
9. Confirm Priv Key Box
10. Apply Button
11. Delete Button
12. Reload Button



NOTE

RUGGEDCOM ROS requires that all user passwords meet strict guidelines to prevent the use of weak passwords. When creating a new password, make sure it adheres to the following rules:

- Must not be less than 6 characters in length.
- Must not include the username or any 4 continuous alphanumeric characters found in the username. For example, if the username is **Subnet25**, the password may not be **subnet25admin** or **subnetadmin**. However, **net25admin** or **Sub25admin** is permitted.
- Must have at least one alphabetic character and one number. Special characters are permitted.
- Must not have more than 3 continuously incrementing or decrementing numbers. For example, **Sub123** and **Sub19826** are permitted, but **Sub12345** is not.

An alarm will generate if a weak password is configured. The weak password alarm can be disabled by the user. For more information about disabling alarms, refer to [Section 5.4, "Managing Alarms"](#).

3. Configure the following parameter(s) as required:

Parameter	Description
Name	<p>Synopsis: Any 32 characters Default: initial</p> <p>The name of the user. This user name also represents the security name that maps this user to the security group.</p>
IP Address	<p>Synopsis: ###.###.###.### where ### ranges from 0 to 255</p> <p>The IP address of the user's SNMP management station. If IP address is configured, SNMP requests from that user will be verified by IP address as well. SNMP Authentication trap will be generated to trap receivers if request was received from this user, but from any other IP address. If IP address is empty, traps can not be generated to this user, but SNMP requests will be served for this user from any IP address.</p>
v1/v2c Community	<p>Synopsis: Any 32 characters</p> <p>The community string which is mapped by this user/security name to the security group if security model is SNMPv1 or SNMPv2c. If this string is left empty, it will be assumed to be equal to the same as user name.</p>
Auth Protocol	<p>Synopsis: { noAuth, HMACMD5, HMACSHA } Default: noAuth</p> <p>An indication of whether messages sent on behalf of this user to/from SNMP engine, can be authenticated, and if so, the type of authentication protocol which is used.</p>
Priv Protocol	<p>Synopsis: { noPriv, CBC-DES } Default: noPriv</p> <p>An Indication of whether messages sent on behalf of this user to/from SNMP engine can be protected from disclosure, and if so, the type of privacy protocol which is used.</p>
Auth Key	<p>Synopsis: 31 character ASCII string</p> <p>The secret authentication key (password) that must be shared with SNMP client. If the key is not an empty string, it must be at least 6 characters long.</p>
Confirm Auth Key	<p>Synopsis: 31 character ASCII string</p> <p>The secret authentication key (password) that must be shared with SNMP client. If the key is not an empty string, it must be at least 6 characters long.</p>
Priv Key	<p>Synopsis: 31 character ASCII string</p> <p>The secret encryption key (password) that must be shared with SNMP client. If the key is not an empty string, it must be at least 6 characters long.</p>

Parameter	Description
Confirm Priv Key	Synopsis: 31 character ASCII string The secret encryption key (password) that must be shared with SNMP client. If the key is not an empty string, it must be at least 6 characters long.

- Click **Apply**.

Section 11.3.3.3

Deleting an SNMP User

To delete an SNMP user, do the following:

- Navigate to **Administration » Configure SNMP » Configure SNMP Users**. The **SNMP Users** table appears.

SNMP Users

**access
admin**

[InsertRecord](#)

Name	IP Address	v1/v2c Community	Auth Protocol	Priv Protocol	Auth
Manager	192.168.0.100	Manager	HMACMD5	CBC-DES	xxx
common		common	noAuth	noPriv	
public		public	noAuth	noPriv	
read		public	noAuth	noPriv	

Figure 192: SNMP Users Table

- Select the user from the table. The **SNMP Users** form appears.

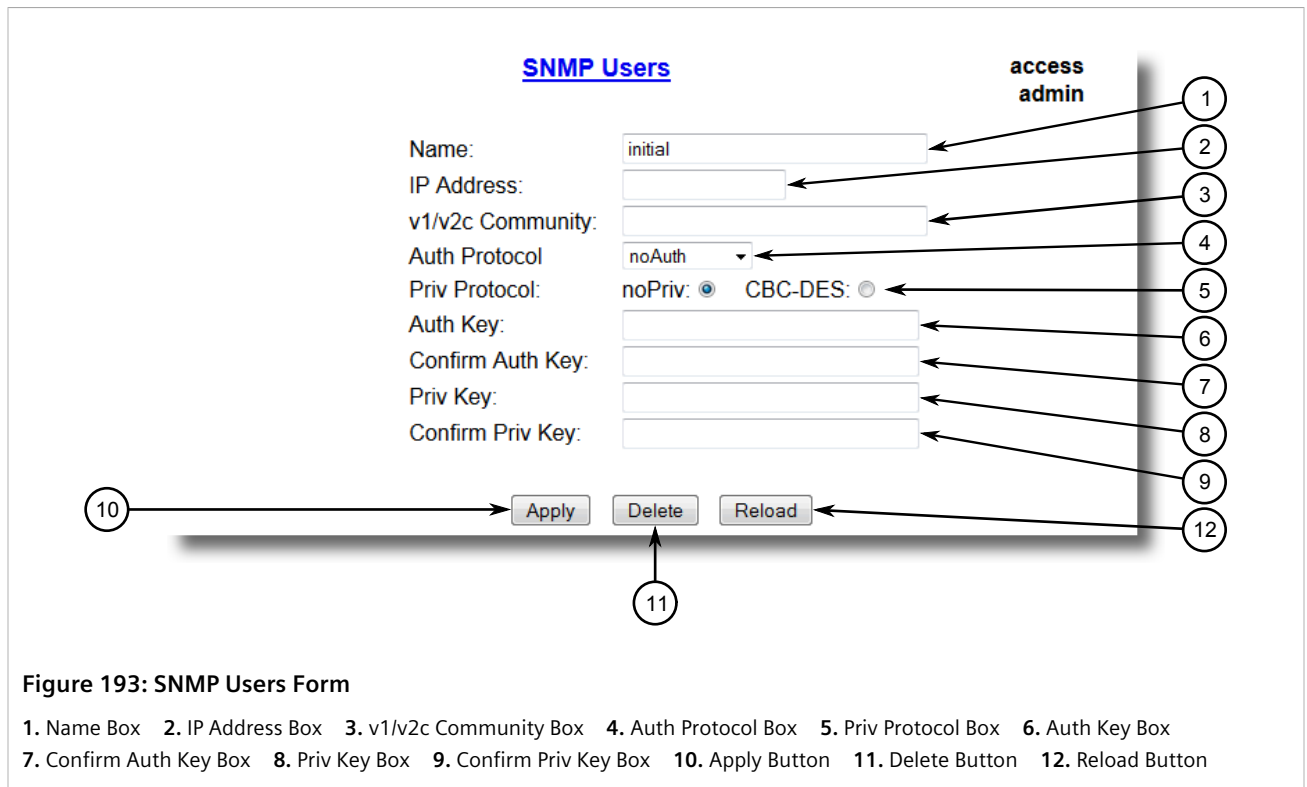

Figure 193: SNMP Users Form

1. Name Box 2. IP Address Box 3. v1/v2c Community Box 4. Auth Protocol Box 5. Priv Protocol Box 6. Auth Key Box
7. Confirm Auth Key Box 8. Priv Key Box 9. Confirm Priv Key Box 10. Apply Button 11. Delete Button 12. Reload Button

3. Click **Delete**.

Section 11.3.4

Managing Security-to-Group Mapping

This section describes how to configure and manage security-to-group maps.

CONTENTS

- [Section 11.3.4.1, "Viewing a List of Security-to-Group Maps"](#)
- [Section 11.3.4.2, "Adding a Security-to-Group Map"](#)
- [Section 11.3.4.3, "Deleting a Security-to-Group Map"](#)

Section 11.3.4.1

Viewing a List of Security-to-Group Maps

To view a list of security-to-group maps configured on the device, navigate to **Administration » Configure SNMP » Configure SNMP Security to Group Maps**. The **SNMP Security to Group Maps** table appears.

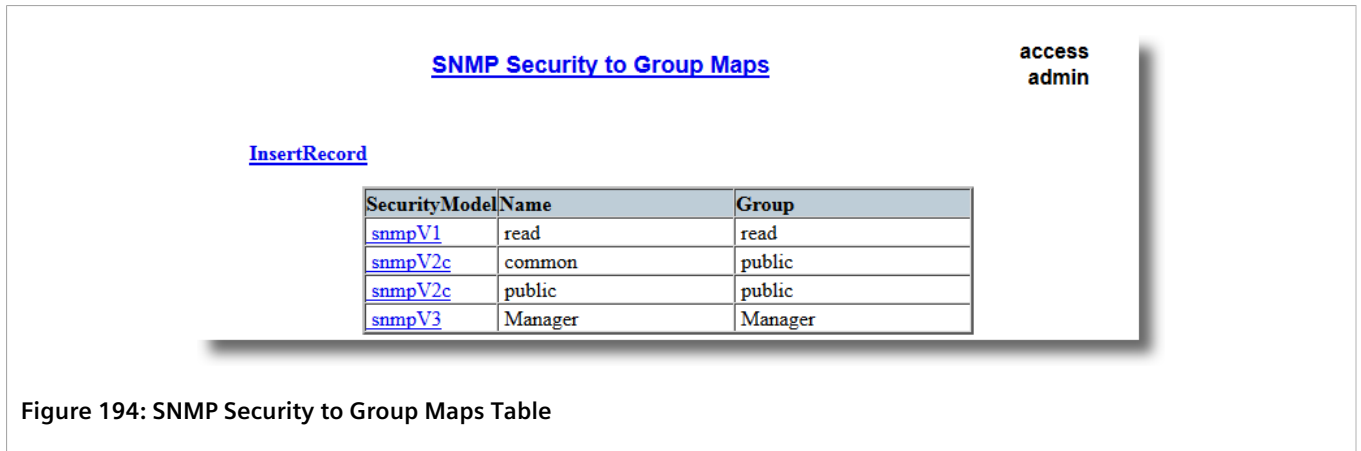

Figure 194: SNMP Security to Group Maps Table

If security-to-group maps have not been configured, add maps as needed. For more information, refer to Section 11.3.4.2, “Adding a Security-to-Group Map”.

Section 11.3.4.2

Adding a Security-to-Group Map

Multiple combinations of security models and groups can be mapped (up to a maximum of 32) for SNMP.

To add a security-to-group map, do the following:

1. Navigate to **Administration » Configure SNMP » Configure SNMP Security to Group Maps**. The **SNMP Security to Group Maps** table appears.

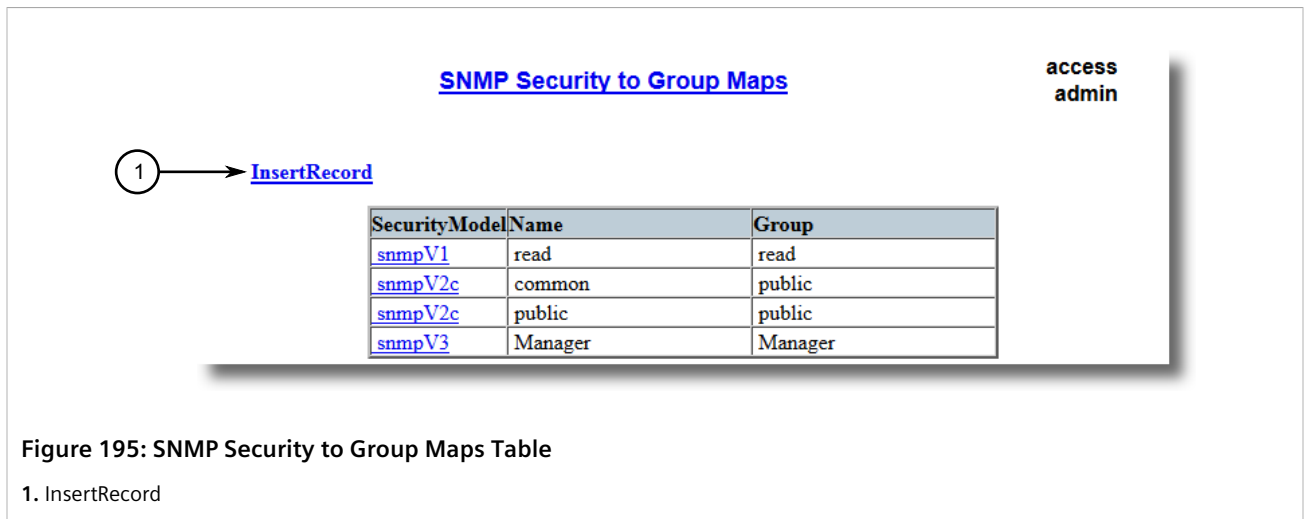

Figure 195: SNMP Security to Group Maps Table

1. InsertRecord

2. Click **InsertRecord**. The **SNMP Security to Group Maps** form appears.

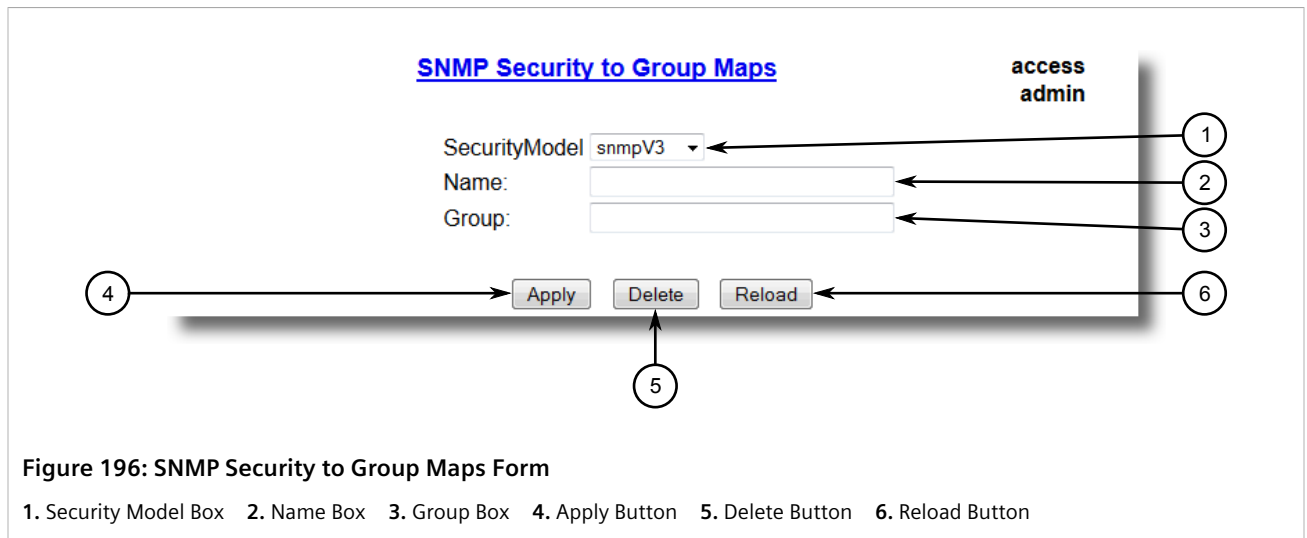

Figure 196: SNMP Security to Group Maps Form

1. Security Model Box 2. Name Box 3. Group Box 4. Apply Button 5. Delete Button 6. Reload Button

- Configure the following parameter(s) as required:

Parameter	Description
SecurityModel	Synopsis: { snmpV1, snmpV2c, snmpV3 } Default: snmpV3 The Security Model that provides the name referenced in this table.
Name	Synopsis: Any 32 characters The user name which is mapped by this entry to the specified group name.
Group	Synopsis: Any 32 characters The group name to which the security model and name belong. This name is used as an index to the SNMPv3 VACM Access Table.

- Click **Apply**.

Section 11.3.4.3

Deleting a Security-to-Group Map

To delete a security-to-group map, do the following:

- Navigate to **Administration » Configure SNMP » Configure SNMP Security to Group Maps**. The **SNMP Security to Group Maps** table appears.

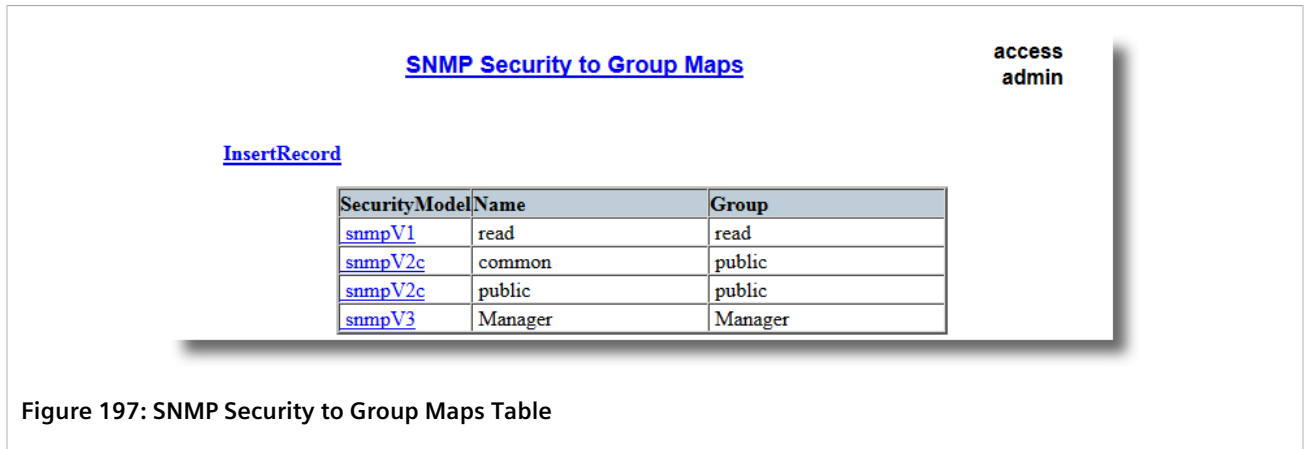

Figure 197: SNMP Security to Group Maps Table

2. Select the map from the table. The **SNMP Security to Group Maps** form appears.

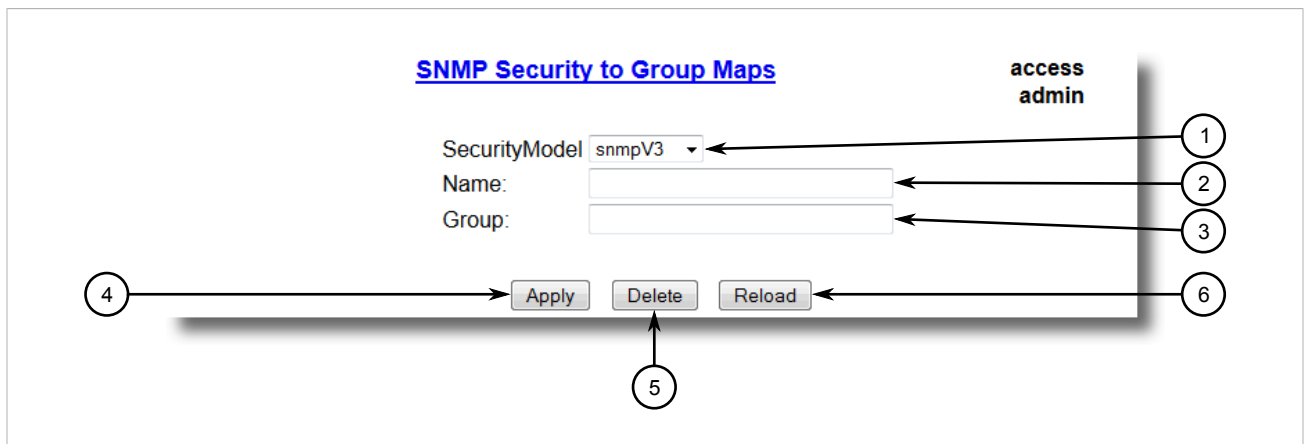

Figure 198: SNMP Security to Group Maps Form

1. Security Model Box
2. Name Box
3. Group Box
4. Apply Button
5. Delete Button
6. Reload Button

3. Click **Delete**.

Section 11.3.5

Managing SNMP Groups

Multiple SNMP groups (up to a maximum of 32) can be configured to have access to SNMP.

CONTENTS

- [Section 11.3.5.1, "Viewing a List of SNMP Groups"](#)
- [Section 11.3.5.2, "Adding an SNMP Group"](#)
- [Section 11.3.5.3, "Deleting an SNMP Group"](#)

Section 11.3.5.1

Viewing a List of SNMP Groups

To view a list of SNMP groups configured on the device, navigate to **Administration » Configure SNMP » Configure SNMP Access**. The **SNMP Access** table appears.

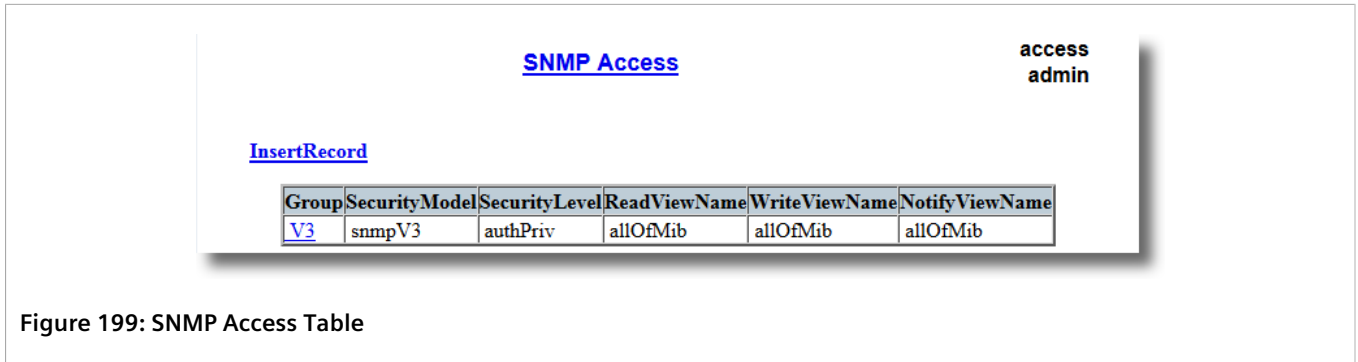

Figure 199: SNMP Access Table

If SNMP groups have not been configured, add groups as needed. For more information, refer to [Section 11.3.5.2, “Adding an SNMP Group”](#).

Section 11.3.5.2

Adding an SNMP Group

To add an SNMP group, do the following:

1. Navigate to **Administration » Configure SNMP » Configure SNMP Access**. The **SNMP Access** table appears.

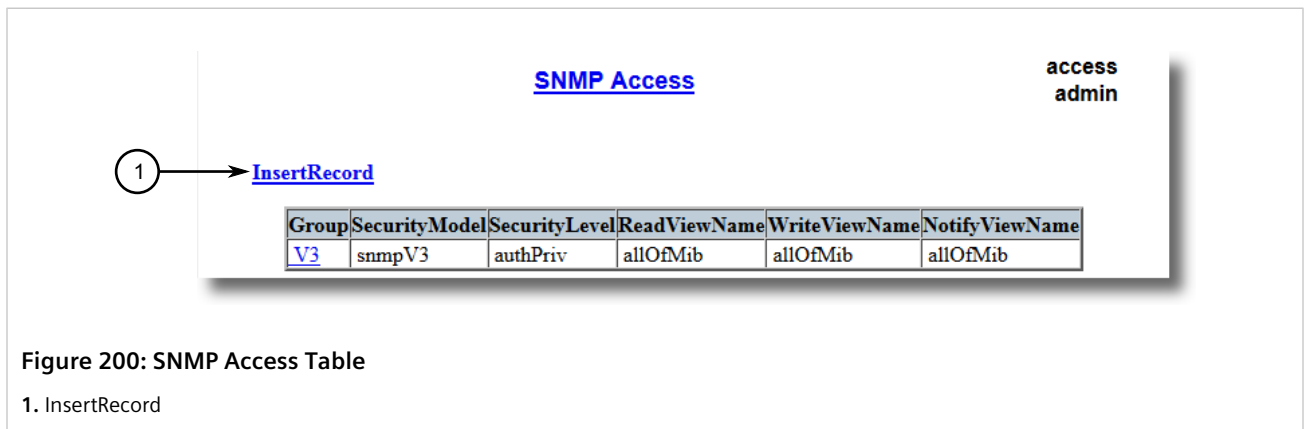

Figure 200: SNMP Access Table

1. InsertRecord

2. Click **InsertRecord**. The **SNMP Access** form appears.

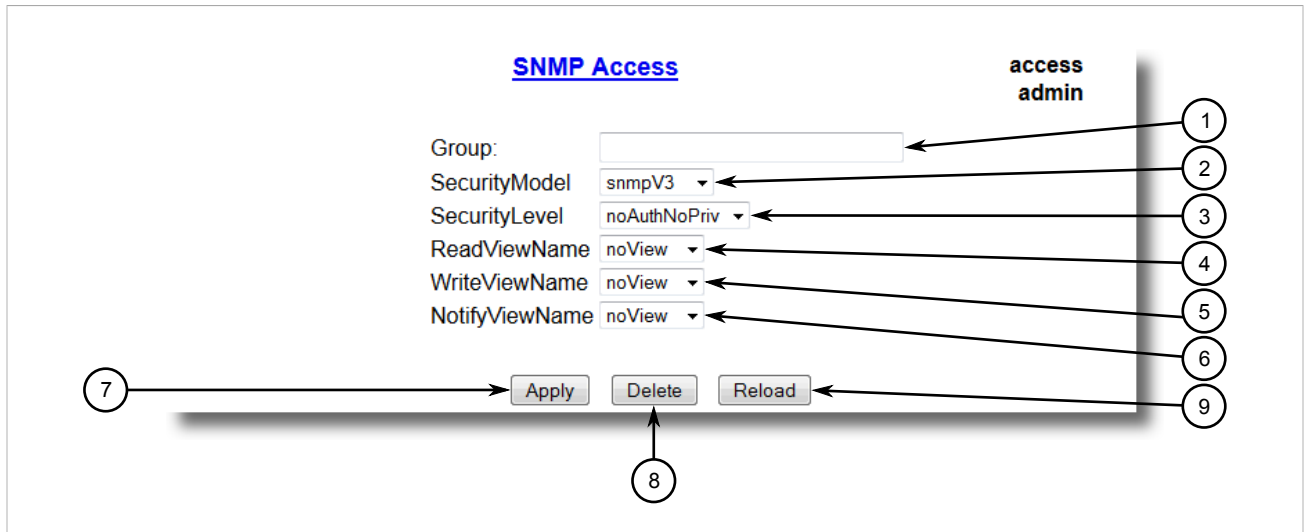

Figure 201: SNMP Access Form

1. Group Box 2. Security Model Box 3. Security Level Box 4. ReadViewName Box 5. WriteViewName Box 6. NotifyViewName Box 7. Apply Button 8. Delete Button 9. Reload Button

3. Configure the following parameter(s) as required:

Parameter	Description
Group	Synopsis: Any 32 characters The group name to which the security model and name belong. This name is used as an index to the SNMPv3 VACM Access Table.
SecurityModel	Synopsis: { snmpV1, snmpV2c, snmpV3 } Default: snmpV3 In order to gain the access rights allowed by this entry, configured security model must be in use.
SecurityLevel	Synopsis: { noAuthNoPriv, authNoPriv, authPriv } Default: noAuthNoPriv The minimum level of security required in order to gain the access rights allowed by this entry. A security level of noAuthNoPriv is less than authNoPriv, which is less than authPriv.
ReadViewName	Synopsis: { noView, V1Mib, allOfMib } Default: noView This parameter identifies the MIB tree(s) to which this entry authorizes read access. If the value is noView, then no read access is granted.
WriteViewName	Synopsis: { noView, V1Mib, allOfMib } Default: noView This parameter identifies the MIB tree(s) to which this entry authorizes write access. If the value is noView, then no write access is granted.
NotifyViewName	Synopsis: { noView, V1Mib, allOfMib } Default: noView This parameter identifies the MIB tree(s) to which this entry authorizes access for notifications. If the value is noView, then no access for notifications is granted.

4. Click **Apply**.

Section 11.3.5.3

Deleting an SNMP Group

To delete an SNMP group, do the following:

1. Navigate to **Administration » Configure SNMP » Configure SNMP Access**. The **SNMP Access** table appears.

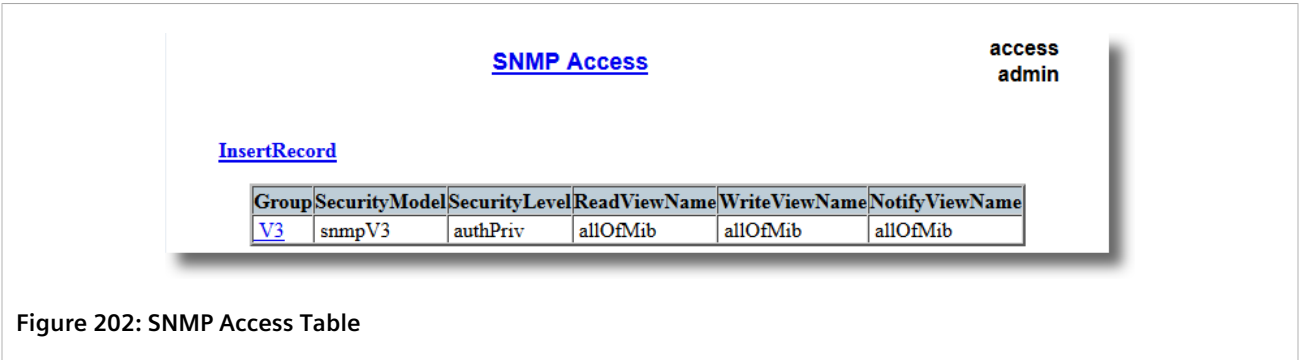

Figure 202: SNMP Access Table

2. Select the group from the table. The **SNMP Access** form appears.

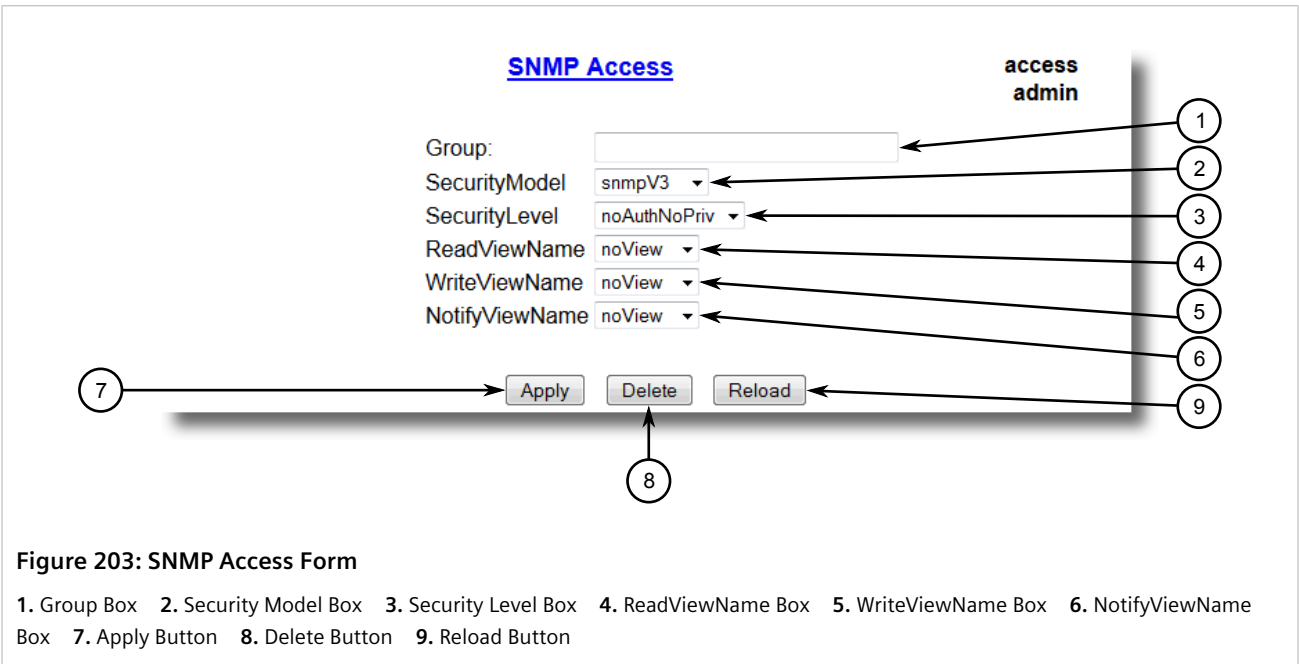

Figure 203: SNMP Access Form

1. Group Box 2. Security Model Box 3. Security Level Box 4. ReadViewName Box 5. WriteViewName Box 6. NotifyViewName Box 7. Apply Button 8. Delete Button 9. Reload Button

3. Click **Delete**.

Section 11.4

ModBus Management Support

Modbus management support in RUGGEDCOM devices provides a simple interface for retrieving basic status information. ModBus support simplifies the job of SCADA (Supervisory Control and Data Acquisition) system integrators by providing familiar protocols for retrieving RUGGEDCOM device information. ModBus provides mostly read-only status information, but there are some writeable registers for operator commands.

The ModBus protocol PDU (Protocol Data Unit) format is as follows:

Function Code	Data
---------------	------

CONTENTS

- [Section 11.4.1, “ModBus Function Codes”](#)
- [Section 11.4.2, “ModBus Memory Map”](#)
- [Section 11.4.3, “Modbus Memory Formats”](#)

Section 11.4.1

ModBus Function Codes

RUGGEDCOM devices support the following ModBus function codes for device management through ModBus:



NOTE

While RUGGEDCOM devices have a variable number of ports, not all registers and bits apply to all products.

Registers that are not applicable to a particular device return a zero (0) value. For example, registers referring to serial ports are not applicable to RUGGEDCOM switch devices.

» Read Input Registers or Read Holding Registers — 0x04 or 0x03

Example PDU Request

Function Code	1 Byte	0x04(0x03)
Starting Address	2 Bytes	0x0000 to 0xFFFF (Hexadecimal) 128 to 65535 (Decimal)
Number of Input Registers	2 Bytes	Bytes 0x0001 to 0x007D

Example PDU Response

Function Code	1 Byte	0x04(0x03)
Byte Count	1 Byte	2 x N ^a
Number of Input Registers	N ^a x 2 Bytes	

^a The number of input registers

» Write Multiple Registers — 0x10

Example PDU Request

Function Code	1 Byte	0x10
Starting Address	2 Bytes	0x0000 to 0xFFFF
Number of Input Registers	2 Bytes	Bytes 0x0001 to 0x0079
Byte Count	1 Byte	2 x N ^b
Registers Value	N ^b x 2 Bytes	Value of the register

^b The number of input registers

Example PDU Response

Function Code	1 Byte	0x10
Starting Address	2 Bytes	0x0000 to 0xFFFF
Number of Registers	2 Bytes	1 to 121 (0x79)

Section 11.4.2

ModBus Memory Map

The following details how ModBus process variable data is mapped.

» Product Info

The following data is mapped to the *ProductInfo* table:

Address	#Registers	Description (Reference Table in UI)	R/W	Format
0000	16	Product Identification	R	Text
0010	32	Firmware Identification	R	Text
0040	1	Number of Ethernet Ports	R	UInt16
0042	1	Number of Alarms	R	UInt16
0043	1	Power Supply Status	R	PSSStatusCmd
0044	1	FailSafe Relay Status	R	TruthValue
0045	1	ErrorAlarm Status	R	TruthValue

» Product Write Register

The following data is mapped to various tables:

Address	#Registers	Description (Reference Table in UI)	R/W	Format
0080	1	Clear Alarms	W	Cmd
0081	2	Reset Ethernet Ports	W	PortCmd
0083	2	Clear Ethernet Statistics	W	PortCmd

» Alarms

The following data is mapped to the *alarms* table:

Address	#Registers	Description (Reference Table in UI)	R/W	Format
0100	64	Alarm 1	R	Alarm
0140	64	Alarm 2	R	Alarm
0180	64	Alarm 3	R	Alarm
01C0	64	Alarm 4	R	Alarm

Address	#Registers	Description (Reference Table in UI)	R/W	Format
0200	64	Alarm 5	R	Alarm
0240	64	Alarm 6	R	Alarm
0280	64	Alarm 7	R	Alarm
02C0	64	Alarm 8	R	Alarm

» Ethernet Port Status

The following data is mapped to the *ethPortStats* table:

Address	#Registers	Description (Reference Table in UI)	R/W	Format
03FE	2	Port Link Status	R	PortCmd

» Ethernet Statistics

The following data is mapped to the *rmonStats* table:

Address	#Registers	Description (Reference Table in UI)	R/W	Format
0400	2	Port 1 Statistics - Ethernet In Packets	R	Uinst32
0402	2	Port 2 Statistics - Ethernet In Packets	R	Uinst32
0404	2	Port 3 Statistics - Ethernet In Packets	R	Uinst32
0406	2	Port 4 Statistics - Ethernet In Packets	R	Uinst32
0408	2	Port 5 Statistics - Ethernet In Packets	R	Uinst32
0410	2	Port 6 Statistics - Ethernet In Packets	R	Uinst32
0412	2	Port 7 Statistics - Ethernet In Packets	R	Uinst32
0414	2	Port 8 Statistics - Ethernet In Packets	R	Uinst32
0440	2	Port 1 Statistics - Ethernet Out Packets	R	Uinst32
0442	2	Port 2 Statistics - Ethernet Out Packets	R	Uinst32
0444	2	Port 3 Statistics - Ethernet Out Packets	R	Uinst32
0446	2	Port 4 Statistics - Ethernet Out Packets	R	Uinst32
0448	2	Port 5 Statistics - Ethernet Out Packets	R	Uinst32
0450	2	Port 6 Statistics - Ethernet Out Packets	R	Uinst32
0452	2	Port 7 Statistics - Ethernet Out Packets	R	Uinst32
0454	2	Port 8 Statistics - Ethernet Out Packets	R	Uinst32
0480	2	Port 1 Statistics - Ethernet In Packets	R	Uinst32
0482	2	Port 2 Statistics - Ethernet In Packets	R	Uinst32
0484	2	Port 3 Statistics - Ethernet In Packets	R	Uinst32
0486	2	Port 4 Statistics - Ethernet In Packets	R	Uinst32
0488	2	Port 5 Statistics - Ethernet In Packets	R	Uinst32

Address	#Registers	Description (Reference Table in UI)	R/W	Format
0490	2	Port 6 Statistics - Ethernet In Packets	R	Uinst32
0492	2	Port 7 Statistics - Ethernet In Packets	R	Uinst32
0494	2	Port 8 Statistics - Ethernet In Packets	R	Uinst32
04C0	2	Port 1 Statistics - Ethernet Out Packets	R	Uinst32
04C2	2	Port 2 Statistics - Ethernet Out Packets	R	Uinst32
04C4	2	Port 3 Statistics - Ethernet Out Packets	R	Uinst32
04C6	2	Port 4 Statistics - Ethernet Out Packets	R	Uinst32
04C8	2	Port 5 Statistics - Ethernet Out Packets	R	Uinst32
04C10	2	Port 6 Statistics - Ethernet Out Packets	R	Uinst32
04C12	2	Port 7 Statistics - Ethernet Out Packets	R	Uinst32
04C14	2	Port 8 Statistics - Ethernet Out Packets	R	Uinst32

Section 11.4.3

Modbus Memory Formats

This section defines the Modbus memory formats supported by RUGGEDCOM ROS.

CONTENTS

- [Section 11.4.3.1, "Text"](#)
- [Section 11.4.3.2, "Cmd"](#)
- [Section 11.4.3.3, "Uinst16"](#)
- [Section 11.4.3.4, "Uinst32"](#)
- [Section 11.4.3.5, "PortCmd"](#)
- [Section 11.4.3.6, "Alarm"](#)
- [Section 11.4.3.7, "PSStatusCmd"](#)
- [Section 11.4.3.8, "TruthValues"](#)

Section 11.4.3.1

Text

The Text format provides a simple ASCII representation of the information related to the product. The most significant register byte of an ASCII characters comes first.

For example, consider a *Read Multiple Registers* request to read Product Identification from location 0x0000.

0x04	0x00	0x00	0x00	0x08
------	------	------	------	------

The response may look like:

0x04	0x10	0x53	0x59	0x53	0x54	0x45	0x4D	0x20	0x4E	0x41	0x4D	0x45
------	------	------	------	------	------	------	------	------	------	------	------	------

0x00	0x00	0x00	0x00	0x00															
------	------	------	------	------	--	--	--	--	--	--	--	--	--	--	--	--	--	--	--

In this example, starting from byte 3 until the end, the response presents an ASCII representation of the characters for the product identification, which reads as *SYSTEM NAME*. Since the length of this field is smaller than eight registers, the rest of the field is filled with zeros (0).

Section 11.4.3.2

Cmd

The Cmd format instructs the device to set the output to either *true* or *false*. The most significant byte comes first.

- FF 00 hex requests output to be True
- 00 00 hex requests output to be False
- Any value other than the suggested values does not affect the requested operation

For example, consider a *Write Multiple Registers* request to clear alarms in the device.

0x10	0x00	0x80	0x00	0x01	2	0xFF	0x00
------	------	------	------	------	---	------	------

- FF 00 for register 00 80 clears the system alarms
- 00 00 does not clear any alarms

The response may look like:

0x10	0x00	0x80	0x00	0x01
------	------	------	------	------

Section 11.4.3.3

Uint16

The Uint16 format describes a Standard ModBus 16 bit register.

Section 11.4.3.4

Uint32

The Uint32 format describes Standard 2 ModBus 16 bit registers. The first register holds the most significant 16 bits of a 32 bit value. The second register holds the least significant 16 bits of a 32 bit value.

Section 11.4.3.5

PortCmd

The PortCmd format describes a bit layout per port, where 1 indicates the requested action is true, and 0 indicates the requested action is false.

PortCmd provides a bit layout of a maximum of 32 ports. Therefore, it uses two ModBus registers:

- The first ModBus register corresponds to ports 1 – 16
- The second ModBus register corresponds to ports 17 – 32 for a particular action

Bits that do not apply to a particular product are always set to zero (0).

A bit value of 1 indicates that the requested action is true. For example, the port is *up*.

A bit value of 0 indicates that the requested action is false. For example, the port is *down*.

» Reading Data Using PortCmd

To understand how to read data using PortCmd, consider a ModBus Request to read multiple registers from location 0x03FE.

0x04	0x03	0xFE	0x00	0x02
------	------	------	------	------

The response depends on how many ports are available on the device. For example, if the maximum number of ports on a connected RUGGEDCOM device is 20, the response would be similar to the following:

0x04	0x04	0xF2	0x76	0x00	0x05
------	------	------	------	------	------

In this example, bytes 3 and 4 refer to register 1 at location 0x03FE, and represent the status of ports 1 – 16. Bytes 5 and 6 refer to register 2 at location 0x03FF, and represent the status of ports 17 – 32. The device only has 20 ports, so byte 6 contains the status for ports 17 – 20 starting from right to left. The rest of the bits in register 2 corresponding to the non-existing ports 21 – 31 are zero (0).

» Performing Write Actions Using PortCmd

To understand how data is written using PortCmd, consider a Write Multiple Register request to clear Ethernet port statistics:

0x10	0x00	0x83	0x00	0x01	2	0x55	0x76	0x00	0x50
------	------	------	------	------	---	------	------	------	------

A bit value of 1 clears Ethernet statistics on the corresponding port. A bit value of 0 does not clear the Ethernet statistics.

0x10	0x00	0x81	0x00	0x02
------	------	------	------	------

Section 11.4.3.6

Alarm

The Alarm format is another form of text description. Alarm text corresponds to the alarm description from the table holding all of the alarms. Similar to the Text format, this format returns an ASCII representation of alarms.



NOTE

Alarms are stacked in the device in the sequence of their occurrence (i.e. Alarm 1, Alarm 2, Alarm 3, etc.).

The first eight alarms from the stack can be returned, if they exist. A zero (0) value is returned if an alarm does not exist.

Section 11.4.3.7

PSStatusCmd

The PSStatusCmd format describes a bit layout for providing the status of available power supplies. Bits 0-4 of the lower byte of the register are used for this purpose.

- Bits 0-1: Power Supply 1 Status
- Bits 2-3: Power Supply 2 Status

Other bits in the register do not provide any system status information.

Bit Value	Description
01	Power Supply not present (01 = 1)
10	Power Supply is functional (10 = 2)
11	Power Supply is not functional (11 = 3)

The values used for power supply status are derived from the RUGGEDCOM-specific SNMP MIB.

» Reading the Power Supply Status from a Device Using PSStatusCmd

To understand how to read the power supply status from a device using PSStatusCmd, consider a ModBus Request to read multiple registers from location 0x0043.

0x04	0x00	0x43	0x00	0x01
------	------	------	------	------

The response may look like:

0x04	0x02	0x00	0x0A
------	------	------	------

The lower byte of the register displays the power supply's status. In this example, both power supplies in the unit are functional.

Section 11.4.3.8

TruthValues

The Truthvalues format represents a true or false status in the device:

- 1 indicates the corresponding status for the device to be true
- 2 indicates the corresponding status for the device to be false

» Reading the FailSafe Relay Status From a Device Using TruthValue

To understand how to use the TruthValue format to read the FailSafe Relay status from a device, consider a ModBus request to read multiple registers from location 0x0044.

0x04	0x00	0x44	0x00	0x01
------	------	------	------	------

The response may look like:

0x04	0x02	0x00	0x01
------	------	------	------

The register's lower byte shows the FailSafe Relay status. In this example, the FailSafe Relay is energized.

» Reading the ErrorAlarm Status From a Device Using TruthValue

To understand how to use the TruthValue format to read the ErrorAlarm status from a device, consider a ModBus request to read multiple registers from location 0x0045.

0x04	0x00	0x45	0x00	0x01
------	------	------	------	------

The response may look like:

0x04	0x02	0x00	0x01
------	------	------	------

The register's lower byte shows the ErrorAlarm status. In this example, there is no active ERROR, ALERT or CRITICAL alarm in the device.

12 IP Address Assignment

This chapter describes features related to the assignment of IP addresses.

CONTENTS

- [Section 12.1, "Managing DHCP"](#)

Section 12.1

Managing DHCP

Dynamic Host Configuration Protocol (DHCP) is a communications protocol that allows network administrators to centrally manage and automate the network configuration of devices attached to an Internet Protocol (IP) network.

CONTENTS

- [Section 12.1.1, "DHCP Concepts"](#)
- [Section 12.1.2, "Configuring the DHCP Relay Agent"](#)
- [Section 12.1.3, "Enabling DHCP Relay Agent Information \(Option 82\) for Specific Ports"](#)
- [Section 12.1.4, "Configuring DHCP Snooping"](#)
- [Section 12.1.5, "Configuring Trusted/Untrusted Ports"](#)
- [Section 12.1.6, "Managing the DHCP Binding Table"](#)

Section 12.1.1

DHCP Concepts

The following section describes concepts important to the configuration and application of DHCP.

CONTENTS

- [Section 12.1.1.1, "DHCP Snooping"](#)
- [Section 12.1.1.2, "Trusted and Untrusted Ports"](#)
- [Section 12.1.1.3, "DHCP Relay Agent \(Option 82\)"](#)

Section 12.1.1.1

DHCP Snooping

DHCP snooping is a network security feature that protects the network from untrusted DHCP servers and untrusted clients by keeping track of ports where DHCP clients and servers reside. This information is tracked by building a DHCP binding table that contains all MAC-IP associations the switch has learned by snooping client and server DHCP communications. The binding table contains MAC-IP information which can be further utilized by DHCP snooping applications. RUGGEDCOM ROS will log messages in the syslog and/or raise an alarm when DHCP violations are detected.



NOTE

DHCP Snooping is enabled on the device on a per-VLAN basis. For more information about enabling DHCP snooping on individual VLANs, refer to [Section 7.1.5, "Managing Static VLANs"](#).

Section 12.1.1.2

Trusted and Untrusted Ports

DHCP Snooping classifies ports as trusted and untrusted. This port classification determines how a DHCP message is handled by the switch. DHCP messages received on trusted ports are forwarded without any further checking, while messages received from untrusted ports are verified to determine if the message is legitimate. The user is expected to configure the ports as trusted or untrusted.

From a deployment perspective, it is also expected the user configures network ports as trusted. Network ports typically connect to another switch or a router. This is necessary because a DHCP server may not be directly connected to a switch port.

For more information about configuring ports as trusted or untrusted, refer to [Section 12.1.5, "Configuring Trusted/Untrusted Ports"](#).

Section 12.1.1.3

DHCP Relay Agent (Option 82)

A DHCP Relay Agent is a device that forwards DHCP packets between clients and servers when they are not on the same physical LAN segment or IP subnet. The feature is enabled if the DHCP server IP address and a set of ethernet ports are configured.

DHCP Option 82 provides a mechanism for assigning an IP Address based on the location of the client device in the network. Information about the client's location can be sent along with the DHCP request to the server. Based on this information, the DHCP server makes a decision about an IP Address to be assigned.

The DHCP Relay Agent takes the broadcast DHCP requests from clients received on the configured port and inserts the relay agent information option (Option 82) into the packet. Option 82 contains the VLAN ID (2 bytes) and the port number of the client port (2 bytes: the circuit ID sub-option) and the relay agent's MAC address (the remote ID sub-option). This information uniquely defines the client's position in the network.

The DHCP Server supporting DHCP Option 82 sends a unicast reply and echoes Option 82. The DHCP Relay Agent removes the Option 82 field and forwards the packet to the port from which the original request was received.

These parameters provide the ability to configure the information based DHCP relay agent (Option 82).

For more information about configuring the DHCP Relay Agent, refer to [Section 12.1.2, "Configuring the DHCP Relay Agent"](#).

Section 12.1.2

Configuring the DHCP Relay Agent

To configure the device as a DHCP Relay Agent (Option 82), do the following:

1. Navigate to **Network Access Control » DHCP Snooping » Configure DHCP Parameters**. The **DHCP Parameters** form appears.

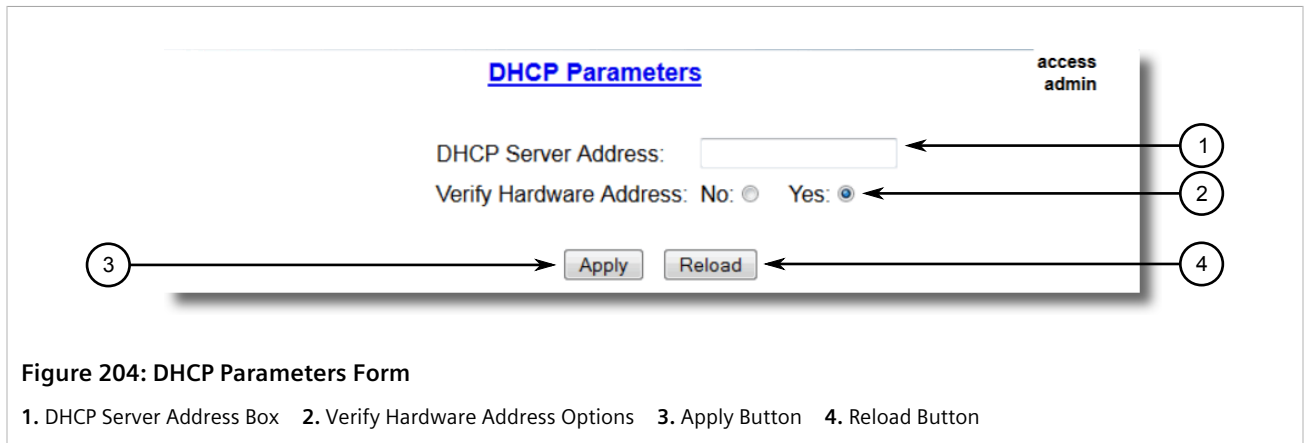

2. Configure the following parameter(s) as required:

Parameter	Description
DHCP Server Address	Synopsis: ###.###.###.### where ### ranges from 0 to 255 IP address of the DHCP server to which DHCP requests will be forwarded. DHCP server IP must be configured for Relay Agent to work.

3. Click **Apply**.
4. Enable DHCP Relay Agent (Option 82) on ports connected to a DHCP client. For more information, refer to [Section 12.1.3, "Enabling DHCP Relay Agent Information \(Option 82\) for Specific Ports"](#).

Section 12.1.3

Enabling DHCP Relay Agent Information (Option 82) for Specific Ports

DHCP Relay Agent (Option 82) can be enabled for any Ethernet port connected to a DHCP client.

To enable DHCP Relay Agent (Option 82) for a specific port, do the following:

1. Navigate to **Network Access Control » DHCP Snooping » Configure DHCP Port Parameters**. The **DHCP Port Parameters** table appears.

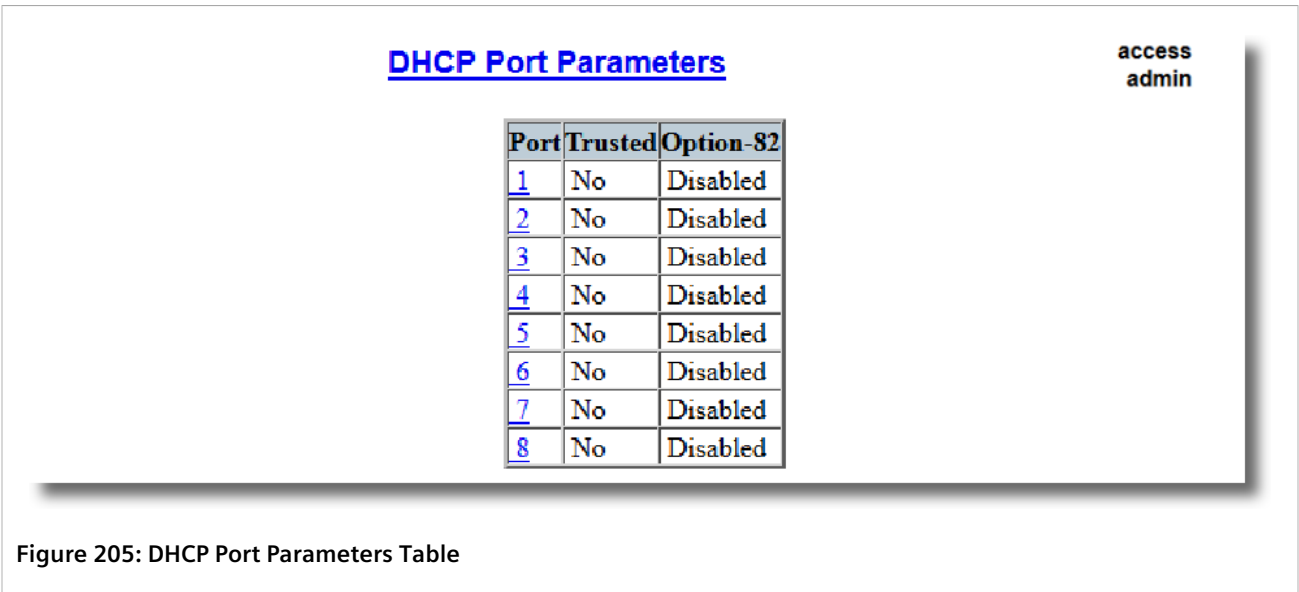

- Select a port. The DHCP Port Parameters form appears.

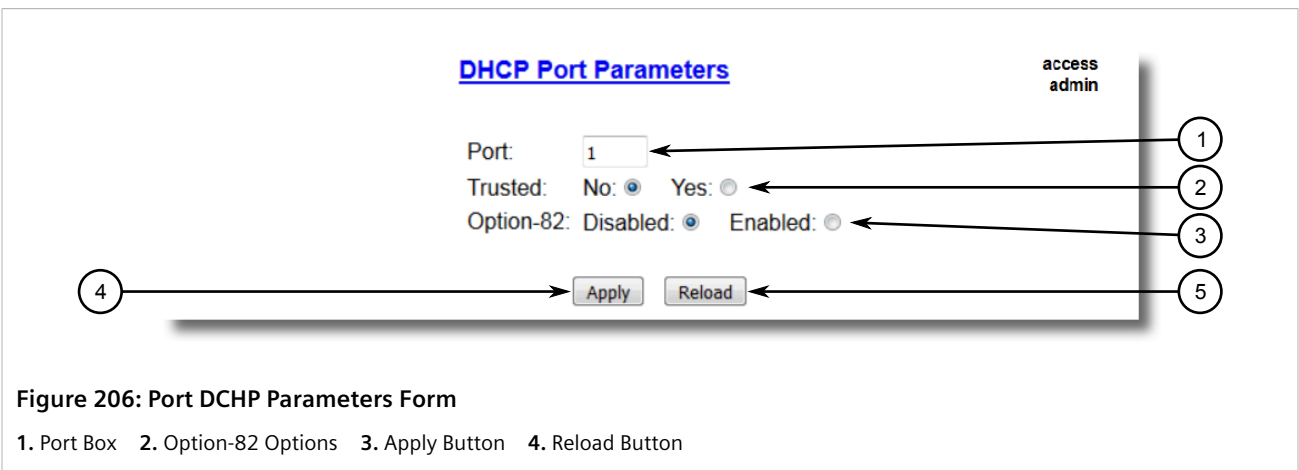

- Configure the following parameter(s) as required:

Parameter	Description
Port	Synopsis: 1 to maximum port number The port number as seen on the front plate silkscreen of the device.
Option-82	Synopsis: { Disabled, Enabled } Default: Disabled Insert DHCP Option 82.

- Click **Apply**.

Section 12.1.4

Configuring DHCP Snooping

To configure DHCP snooping, do the following:



NOTE

DHCP Snooping is enabled on the device on a per-VLAN basis. For more information about enabling DHCP snooping on individual VLANs, refer to [Section 7.1.5, "Managing Static VLANs"](#).

1. Navigate to **Network Access Control » DHCP Snooping » Configure DHCP Parameters**. The **DHCP Parameters** form appears.

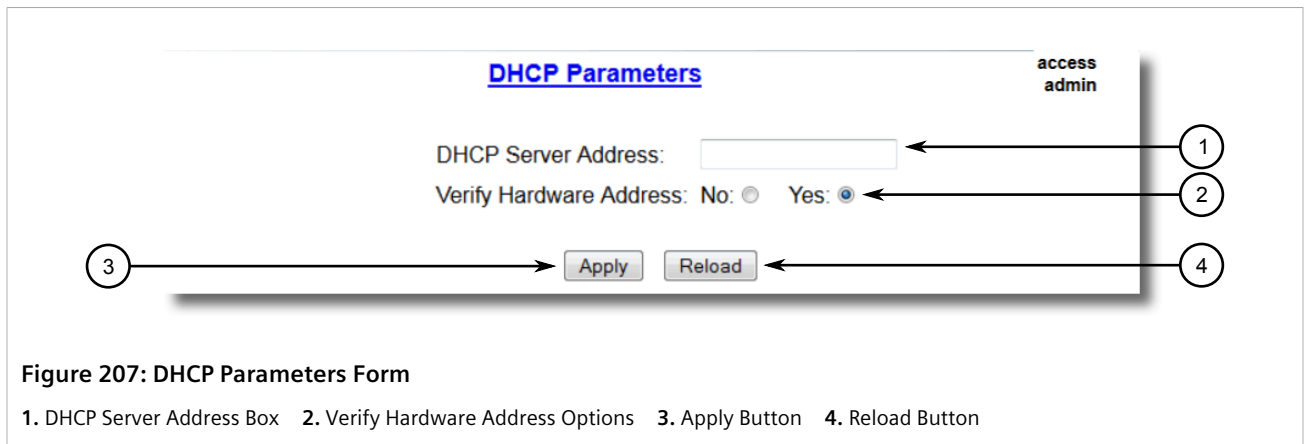

Figure 207: DHCP Parameters Form

1. DHCP Server Address Box
2. Verify Hardware Address Options
3. Apply Button
4. Reload Button

2. Configure the following parameter(s) as required:

Parameter	Description
DHCP Server Address	Synopsis: ###.###.###.### where ### ranges from 0 to 255 IP address of the DHCP server to which DHCP requests will be forwarded. DHCP server IP must be configured for Relay Agent to work.
Verify Hardware Address	Synopsis: { No, Yes } Default: Yes Verify if the Client hardware address present in the DHCP message received on untrusted port matches with the Source MAC address.

3. Click **Apply**.

Section 12.1.5

Configuring Trusted/Untrusted Ports

Once DHCP Snooping has been enabled, individual ports need to be marked as *trusted* or *untrusted*. Ports connected to the DHCP server should be *trusted*, whereas ports connected to the client or an untrusted DHCP server should be considered *untrusted*.

To configure a port as *trusted* or *untrusted*, do the following:

1. Navigate to **Network Access Control » DHCP Snooping » Configure DHCP Port Parameters**. The **DHCP Port Parameters** table appears.

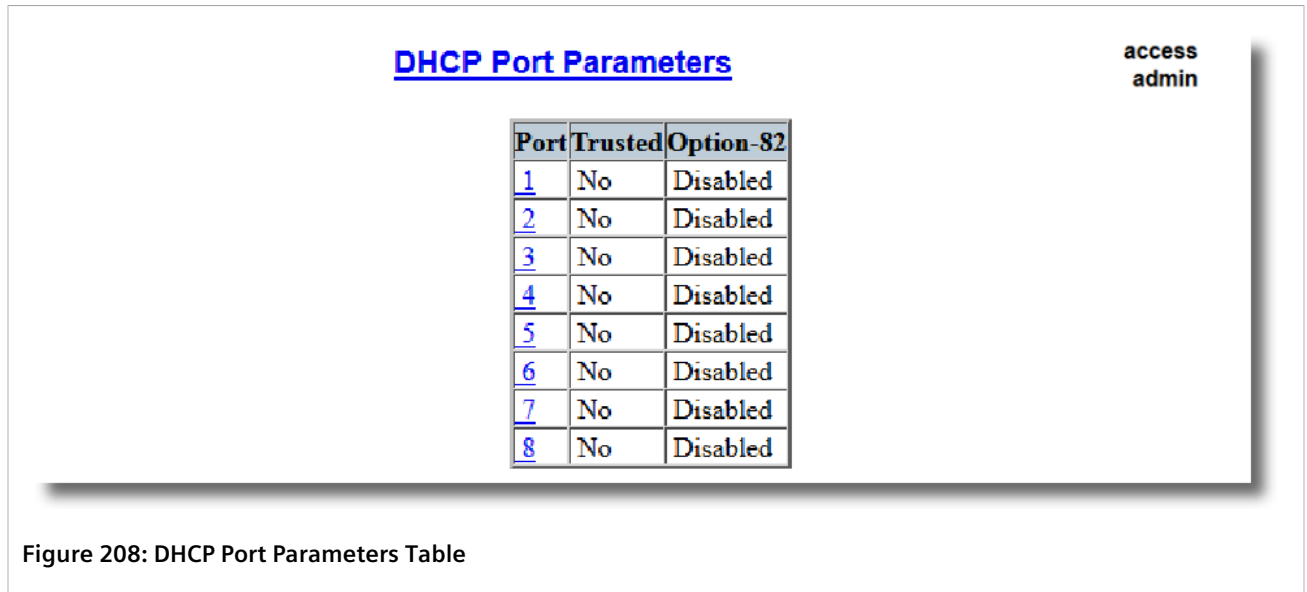

- Select an Ethernet port. The **DHCP Port Parameters** form appears.

NOTE
The *Option-82* parameter is configured as part of the DHCP Relay Agent feature. For more information, refer to [Section 12.1.3, "Enabling DHCP Relay Agent Information \(Option 82\) for Specific Ports"](#).

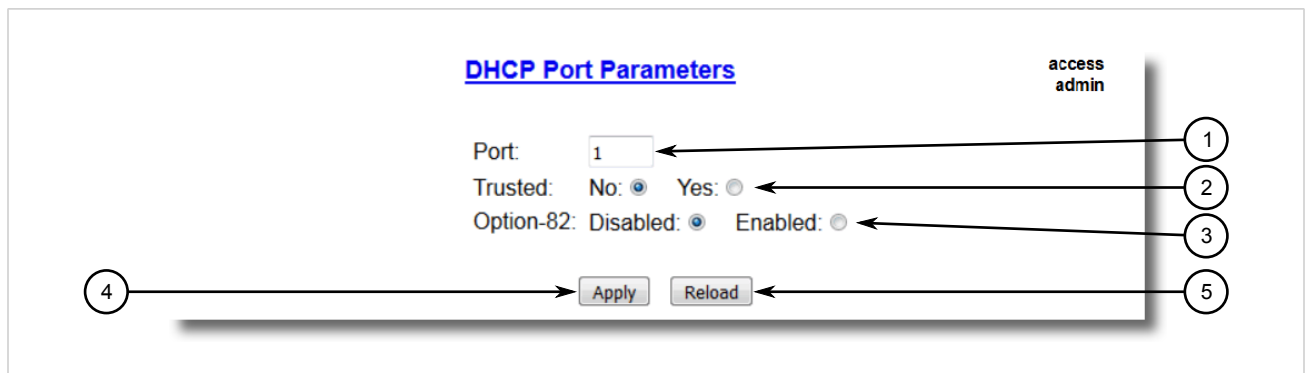

- Port Box
- Trusted Options
- Option-82 Options
- Apply Button
- Reload Button

- Configure the following parameter(s) as required:

Parameter	Description
Trusted	<p>Synopsis: { No, Yes }</p> <p>Default: No</p> <p>DHCP trust setting for the port.</p>

- Click **Apply**.

Section 12.1.6

Managing the DHCP Binding Table

This section describes how to configure and manage the DHCP binding table.

CONTENTS

- [Section 12.1.6.1, "Adding Entries to the DHCP Binding Table"](#)
- [Section 12.1.6.2, "Viewing the DHCP Binding Table"](#)
- [Section 12.1.6.3, "Saving the DHCP Binding Table"](#)
- [Section 12.1.6.4, "Example: Configuring the Device as a Relay Agent"](#)

Section 12.1.6.1

Adding Entries to the DHCP Binding Table

The DHCP binding table is populated automatically with information RUGGEDCOM ROS learns about untrusted hosts. Specific hosts can also be added to the table. Static entries do not expire and will not be removed when DHCP snooping is disabled or the device is reset.

To add a static entry to the DHCP binding table, do the following:

1. Navigate to **Network Access Control » DHCP Snooping » Configure Static DHCP Binding Table**. The **Configure Static DHCP Binding Table** appears.

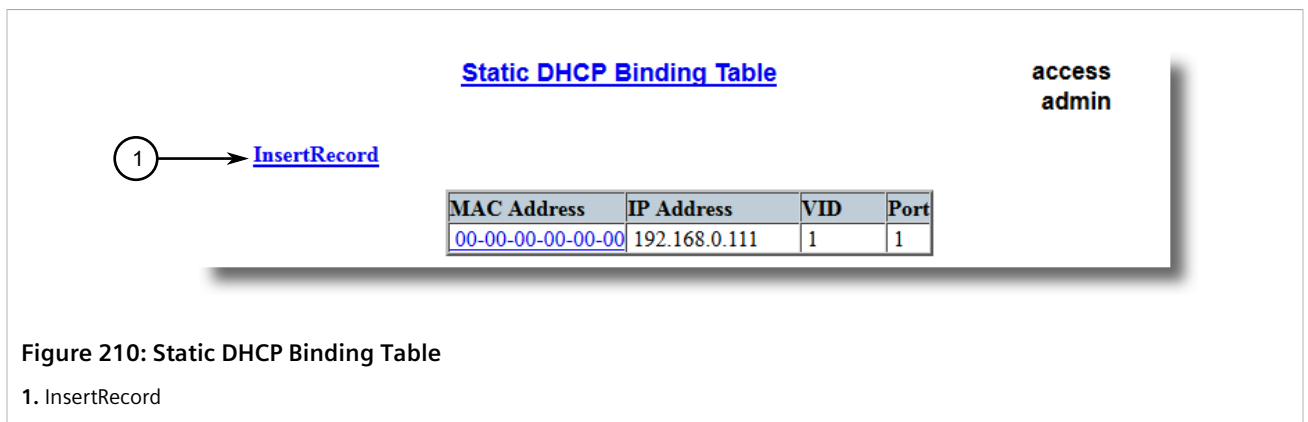

2. Click **InsertRecord**. The **Static DHCP Binding Table** form appears.

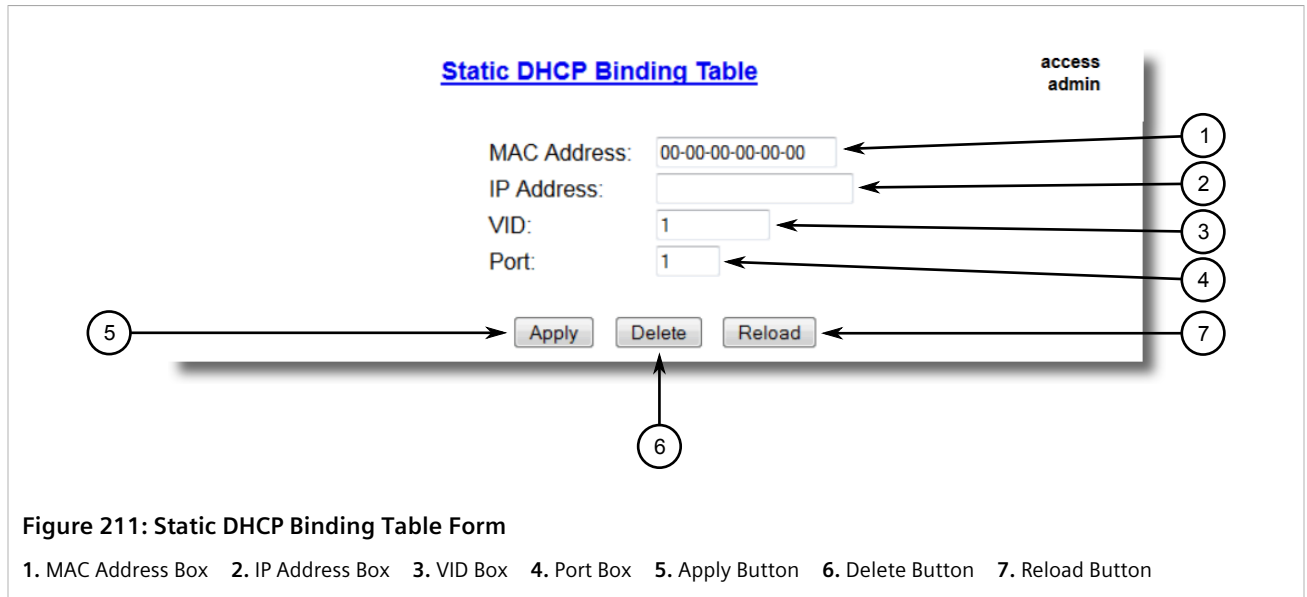

- Configure the following parameter(s) as required:

Parameter	Description
MAC Address	Synopsis: ##-##-##-##-##-## where ## ranges 0 to FF Default: 00-00-00-00-00-00 MAC Address of the DHCP Host.
IP Address	Synopsis: ##-##-##-##-##-## where ## ranges 0 to 255 IP Address assigned to the DHCP Host.
VID	Synopsis: 0 to 65535 Default: 1 VLAN where in the IP-MAC binding entry was registered.
Port	Synopsis: 1 to A/B Default: 1 Port on which IP-MAC binding entry was registered.

- Click **Apply**.

Section 12.1.6.2

Viewing the DHCP Binding Table

To view the DHCP binding table, do the following:

- Navigate to **Network Access Control » DHCP Snooping » View DHCP Binding Table**. The **View DHCP Binding Table** appears.

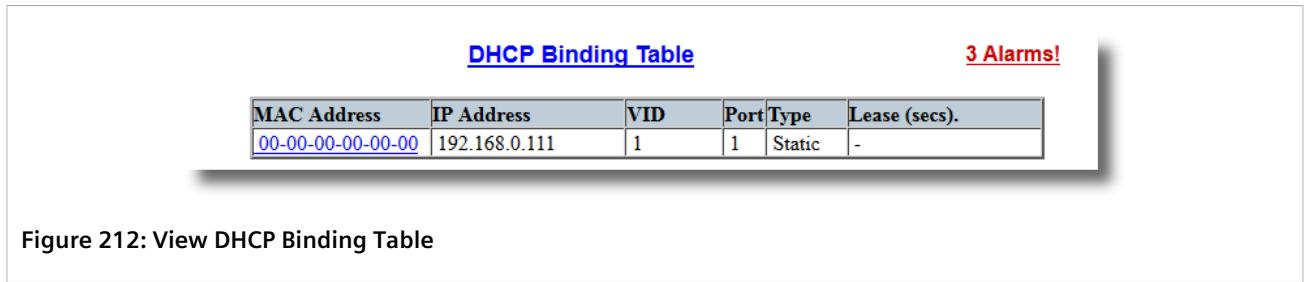

Figure 212: View DHCP Binding Table

2. Select an Ethernet port. The DHCP Binding Table form appears.

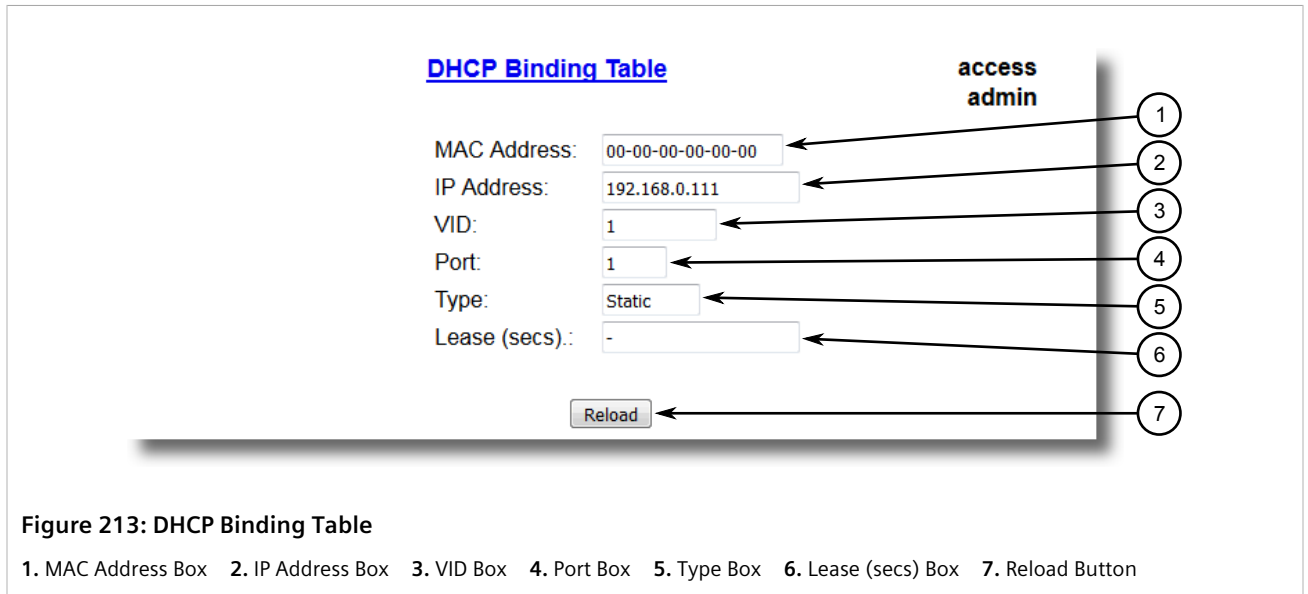

Figure 213: DHCP Binding Table

1. MAC Address Box
2. IP Address Box
3. VID Box
4. Port Box
5. Type Box
6. Lease (secs) Box
7. Reload Button

The DHCP binding table displays the following information:

Parameter	Description
MAC Address	Synopsis: ##-##-##-##-##-## where ## ranges 0 to FF MAC Address of the DHCP Host.
IP Address	Synopsis: ##-##-##-##-##-## where ## ranges 0 to 255 IP Address assigned to the DHCP Host.
VID	Synopsis: 0 to 65535 VLAN where in the IP-MAC binding entry was registered.
Port	Synopsis: 1 to A/B Port on which IP-MAC binding entry was registered.
Type	Synopsis: { Static, Dynamic } Dynamic DHCP IP-MAC Binding Entries.
Lease (secs)	Synopsis: 0 to 4294967295 or { - } Lease time assigned to a Dynamic binding entry in seconds.If the entry is Static then the lease time is infinite denoted as "-".

To refresh the table, click **Reload**.

Section 12.1.6.3

Saving the DHCP Binding Table

Information learned dynamically and added to the DHCP binding table is removed automatically when the following occurs:

- The lease expires
- DHCP snooping is disabled
- The device is reset

However, this information can be saved to the configuration file for future reference/use.

To save the DHCP binding table, do the following:

1. Navigate to **Network Access Control » DHCP Snooping » Save DHCP Binding Table**. The **Save DHCP Binding Table** table appears.

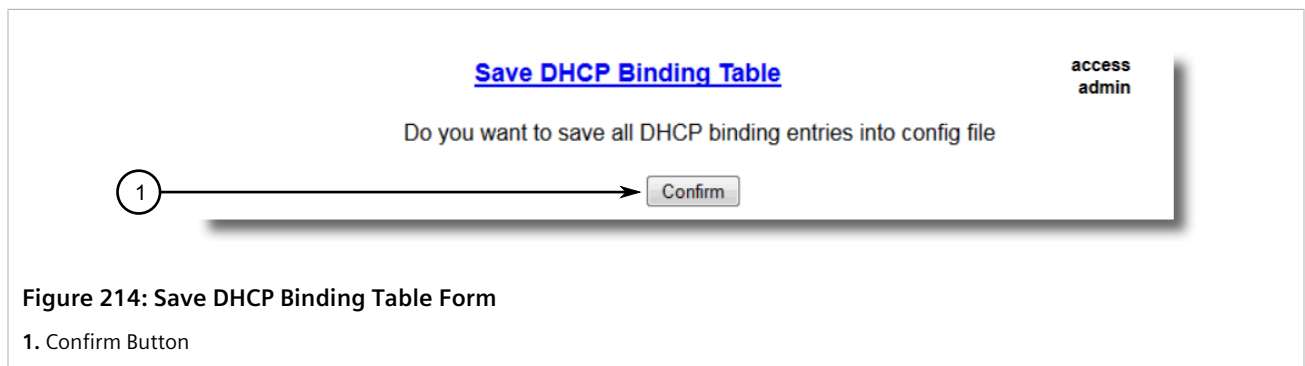

2. Click **Confirm**.

Section 12.1.6.4

Example: Configuring the Device as a Relay Agent

This example demonstrates how to configure the device as a DHCP relay agent.

The following topology depicts a scenario where two clients on separate LANs require IP addresses on different subnets from a DHCP server. Each client connects to the DHCP relay agent using different VLANs. The DHCP relay agent manages the requests and responses between the clients and the DHCP server.



IMPORTANT!

The values shown are specific to the provided topology. Actual values can vary based on the user's configuration.

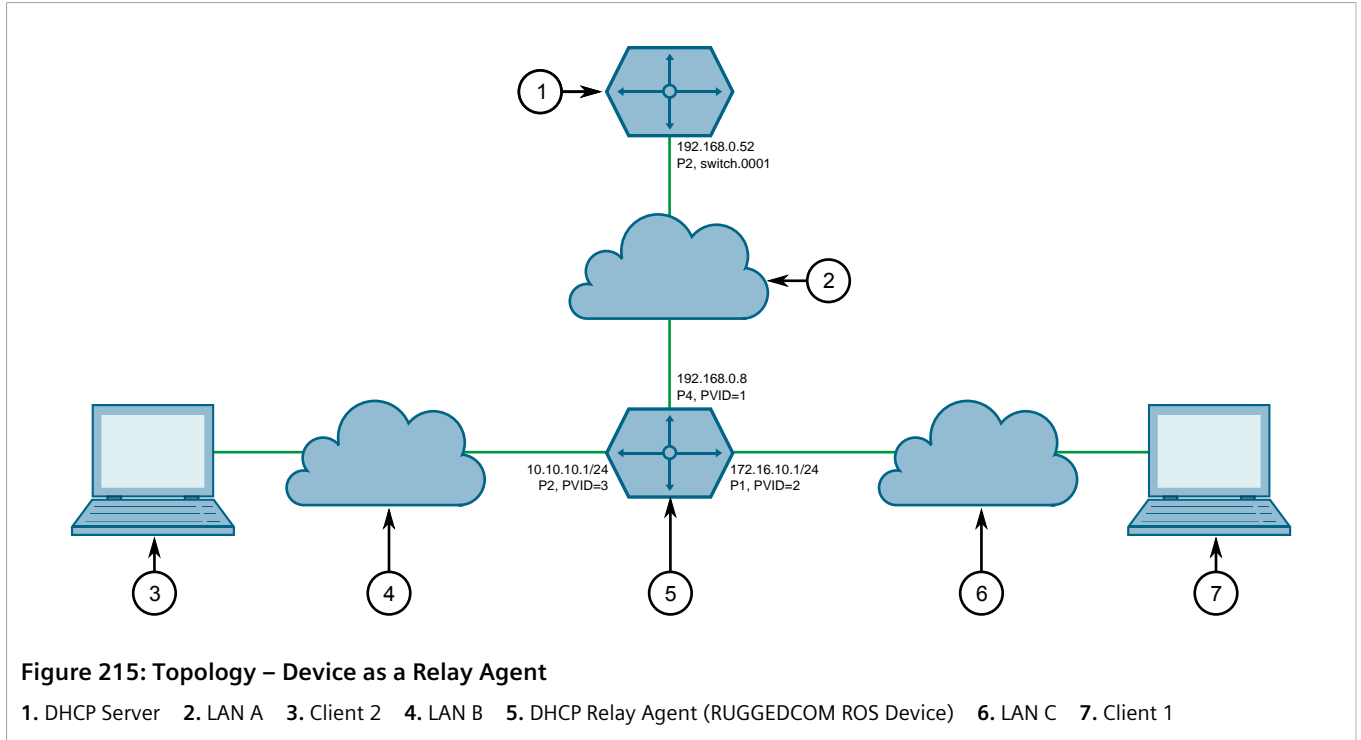

To configure the device as a DHCP relay agent per the topology, do the following:

1. Configure a separate device as the DHCP Server. If the DHCP server being used is a RUGGEDCOM ROX II device, refer to the device-specific *RUGGEDCOM ROX II User Guide* for more information.
2. Configure the RUGGEDCOM ROS device as a DHCP relay agent:
 - a. Add VLAN 2 and VLAN 3. For more information, refer to [Section 7.1.5.2, “Adding a Static VLAN”](#).
 - b. Assign IP address 192.168.0.8 to VLAN 1. For more information, refer to [Section 4.7.1.2, “Adding a Switch IP Interface”](#).
 - c. Change the PVID of port 1 to PVID 2, and change the PVID of port 2 to PVID 3. Refer to [Section 7.1.4, “Configuring VLANs for Specific Ethernet Ports”](#) for more information.
 - d. Configure 192.168.0.52 as the DHCP server address. Refer to [Section 12.1.2, “Configuring the DHCP Relay Agent”](#) for more information.
 - e. Configure DHCP client and server ports as follows:

Port	Option 82
1	Enabled
2	Enabled
4	Disabled

For more information about configuring the DHCP relay agent (Option 82) for a specific port, refer to [Section 12.1.3, “Enabling DHCP Relay Agent Information \(Option 82\) for Specific Ports”](#).

- f. To verify the configuration, make sure Client 1 has IP address 172.16.10.1/24 and Client 2 has IP address 10.10.10.1/24.

13 Troubleshooting

This chapter describes troubleshooting steps for common issues that may be encountered when using RUGGEDCOM ROS or designing a network.



IMPORTANT!

For further assistance, contact a Customer Service representative.

CONTENTS

- [Section 13.1, "General"](#)
- [Section 13.2, "Ethernet Ports"](#)
- [Section 13.3, "Spanning Tree"](#)
- [Section 13.4, "VLANs"](#)

Section 13.1

General

The following describes common problems.

Problem	Solution
<p>The switch is not responding to ping attempts, even though the IP address and gateway have been configured. The switch is receiving the ping because the LEDs are flashing and the device statistics are logging the pings. What is going on?</p>	<p>Is the switch being pinged through a router? If so, the switch gateway address must be configured as well. The following figure illustrates the problem.</p> <div data-bbox="654 1312 1531 1648" style="border: 1px solid black; padding: 10px;"> <p>Figure 216: Using a Router As a Gateway 1. Work Station 2. Router 3. Switch</p> </div>

The router is configured with the appropriate IP subnets and will forward the ping from the workstation to the switch. When the switch responds, however, it will not know which of its interfaces to use to reach the workstation and will drop the response. Programming a gateway of 10.0.0.1 will cause the switch to forward unresolvable frames to the router.

Problem	Solution
	This problem will also occur if the gateway address is not configured and the switch tries to raise an SNMP trap to a host that is not on the local subnet.

Section 13.2

Ethernet Ports

The following describes common problems related to Ethernet ports.

Problem	Solution
A link seems fine when traffic levels are low, but fails as traffic rates increase OR a link can be pinged but has problems with FTP/SQL/ HTTP/etc.	<p>A possible cause of intermittent operation is that of a 'duplex mismatch'. If one end of the link is fixed to full-duplex and the peer auto-negotiates, the auto-negotiating end falls back to half-duplex operation.</p> <p>At lower traffic volumes, the link may display few if any errors. As the traffic volume rises, the fixed negotiation side will begin to experience dropped packets while the auto-negotiating side will experience collisions. Ultimately, as traffic loads approach 100%, the link will become entirely unusable.</p> <p>The ping command with flood options is a useful tool for testing commissioned links. The command <code>ping 192.168.0.1 500 2</code> can be used to issue 500 pings each separated by two milliseconds to the next switch. If the link used is of high quality, then no pings should be lost and the average round trip time should be small.</p>
Links are inaccessible, even when using the Link Fault Indication (LFI) protection feature.	Make sure LFI is not enabled on the peer as well. If both sides of the link have LFI enabled, then both sides will withhold link signal generation from each other.

Section 13.3

Spanning Tree

The following describes common problems related to the Spanning Tree Protocol (STP).

Problem	Solution
The network locks up when a new port is connected and the port status LEDs are flashing rapidly.	Is it possible that one of the switches in the network or one of the ports on a switch in the network has STP disabled and accidentally connects to another switch? If this has occurred, then a traffic loop has been formed.
Occasionally, the ports seem to experience significant flooding for a brief period of time.	If the problem appears to be transient in nature, it is possible that ports that are part of the spanning tree have been configured as edge ports. After the link layers have come up on edge ports, STP will directly transition them (perhaps improperly) to the forwarding state. If an RSTP configuration message is then received, the port will be returned to blocking. A traffic loop may be formed for the length of time the port was in forwarding.
A switch displays a strange behavior where the root port hops back and forth between two switch ports and never settles down.	<p>If one of the switches appears to flip the root from one port to another, the problem may be one of traffic prioritization. For more information refer to "The network becomes unstable when a specific application is started."</p> <p>Another possible cause of intermittent operation is that of an auto-negotiation mismatch. If one end of the link is fixed to full-duplex mode and the peer auto-negotiates, the auto-negotiating end will fall back to half-duplex operation. At lower traffic, the volumes the link may display few if any errors. As the traffic volume rises, the fixed negotiation side will begin to experience dropped packets while the auto-negotiating side will experience collisions. Ultimately, as traffic loads approach 100%, the link will become entirely unusable. At this point, RSTP will not be able to transmit configuration messages over the link and the spanning tree topology will break down. If an alternate trunk exists, RSTP will activate it in the place of the congested port. Since activation of the alternate port often relieves the congested port of its traffic, the congested port will once again become reliable. RSTP will</p>

Problem	Solution
	promptly enter it back into service, beginning the cycle once again. The root port will flip back and forth between two ports on the switch.
A computer or device is connected to a switch. After the switch is reset, it takes a long time for it to come up.	<p>Is it possible that the RSTP edge setting for this port is set to false? If Edge is set to false, the bridge will make the port go through two forward delay times before the port can send or receive frames. If Edge is set to true, the bridge will transition the port directly to forwarding upon link up.</p> <p>Another possible explanation is that some links in the network run in half-duplex mode. RSTP uses a peer-to-peer protocol called Proposal-Agreement to ensure transitioning in the event of a link failure. This protocol requires full-duplex operation. When RSTP detects a non-full duplex port, it cannot rely on Proposal-Agreement protocol and must make the port transition the slow (i.e. STP) way. If possible, configure the port for full-duplex operation. Otherwise, configure the port's point-to-point setting to true.</p> <p>Either one will allow the Proposal-Agreement protocol to be used.</p>
When the switch is tested by deliberately breaking a link, it takes a long time before devices beyond the switch can be polled.	<p>Is it possible that some ports participating in the topology have been configured to STP mode or that the port's point-to-point parameter is set to false? STP and multipoint ports converge slowly after failures occur.</p> <p>Is it possible that the port has migrated to STP? If the port is connected to the LAN segment by shared media and STP bridges are connected to that media, then convergence after link failure will be slow.</p> <p>Delays on the order of tens or hundreds of milliseconds can result in circumstances where the link broken is the sole link to the root bridge and the secondary root bridge is poorly chosen. The worst of all possible designs occurs when the secondary root bridge is located at the farthest edge of the network from the root. In this case, a configuration message will have to propagate out to the edge and then back to reestablish the topology.</p>
The network is composed of a ring of bridges, of which two (connected to each other) are managed and the rest are unmanaged. Why does the RSTP protocol work quickly when a link is broken between the managed bridges, but not in the unmanaged bridge part of the ring?	A properly operating unmanaged bridge is transparent to STP configuration messages. The managed bridges will exchange configuration messages through the unmanaged bridge part of the ring as if it is non-existent. When a link in the unmanaged part of the ring fails however, the managed bridges will only be able to detect the failure through timing out of hello messages. Full connectivity will require three hello times plus two forwarding times to be restored.
The network becomes unstable when a specific application is started. The network returns to normal when the application is stopped.	RSTP sends its configuration messages using the highest possible priority level. If CoS is configured to allow traffic flows at the highest priority level and these traffic flows burst continuously to 100% of the line bandwidth, STP may be disrupted. It is therefore advised not to use the highest CoS.
When a new port is brought up, the root moves on to that port instead of the port it should move to or stay on.	Is it possible that the port cost is incorrectly programmed or that auto-negotiation derives an undesired value? Inspect the port and path costs with each port active as root.
An Intelligent Electronic Device (IED) or controller does not work with the device.	<p>Certain low CPU bandwidth controllers have been found to behave less than perfectly when they receive unexpected traffic. Try disabling STP for the port.</p> <p>If the controller fails around the time of a link outage, there is the remote possibility that frame disordering or duplication may be the cause of the problem. Try setting the root port of the failing controller's bridge to STP.</p>
Polls to other devices are occasionally lost.	Review the network statistics to determine whether the root bridge is receiving Topology Change Notifications (TCNs) around the time of observed frame loss. It may be possible there are problems with intermittent links in the network.
The root is receiving a number of TCNs. Where are they coming from?	Examine the RSTP port statistics to determine the port from which the TCNs are arriving. Sign-on to the switch at the other end of the link attached to that port. Repeat this step until the switch generating the TCNs is found (i.e. the switch that is itself not receiving a large number of TCNs). Determine the problem at that switch.

Section 13.4

VLANs

The following describes common problems related to the VLANs.

Problem	Solution
VLANs are not needed on the network. Can they be turned off?	Yes. Simply leave all ports set to type <i>edge</i> and leave the native VLAN set to 1. This is the default configuration for the switch.
Two VLANs were created and a number of ports were made members of them. Now some of the devices in one VLAN need to send messages to devices in the other VLAN.	If the devices need to communicate at the physical address layer, they must be members of the same VLAN. If they can communicate in a Layer 3 fashion (i.e. using a protocol such as IP or IPX), use a router. The router will treat each VLAN as a separate interface, which will have its own associated IP address space.
On a network of 30 switches, management traffic needs to be restricted to a separate domain. What is the best method for doing this while staying in contact with these switches?	<p>At the switch where the management station is located, configure a port to use the new management VLAN as its native VLAN. Configure a host computer to act as a temporary management station.</p> <p>At each switch, configure the management VLAN to the new value. Contact with each individual switch will be lost immediately as they are being configured, but it should be possible re-establish communication from the temporary management station. After all switches have been taken to the new management VLAN, configure the ports of all attached management devices to use the new VLAN.</p> <div data-bbox="609 846 1474 957" style="border: 1px solid gray; padding: 5px;"> <p> NOTE <i>Establishing a management domain is often accompanied with the establishment of an IP subnet specifically for the managed devices.</i></p> </div>