

Load Cells

Single point load cells
SIWAREX WL260 SP-S SC

Load cell

Overview



The SIWAREX WL260 SP-S SC load cells are designed for use in legal-for-trade platform scales. It is approved for use in Class III medium accuracy weighing machines with maximum divisions of n_{\max} to 4 000d. A C4 MR variant with a $Y = 40\,000$ is available for high-precision applications.

The use of stainless steel and the high IP68/IP69K degree of protection make the SIWAREX WL260 SP-S SC highly suitable for use in the food, beverages and tobacco industries or pharmaceutical industry.

Design

The load cell is made of stainless steel and is hermetically sealed.

The platform size can be up to 400 x 400 mm (15.75 x 15.75 inches) for load cells rated for 10 ... 50 kg (22.05 ... 110.23 lb). The platform size can be up to 800 x 800 mm (31.50 x 31.50 inches) for load cells rated for 100 ... 500 kg (220.46 ... 1102.31 lb).

Technical specifications

SIWAREX WL260 SP-S SC

Possible applications	<ul style="list-style-type: none"> Platform scales Small belt scales
Type of construction	Single point load cell
Loads	
Rated load E_{\max}	<ul style="list-style-type: none"> 10 kg (22.05 lb) 20 kg (44.09 lb) 50 kg (110.23 lb) 100 kg (220.46 lb) 200 kg (440.92 lb) 300 kg (661.39 lb) 400 kg (881.85 lb) 500 kg (1102.31 lb)
Minimum initial loading E_{\min}	0% E_{\max}
Maximum working load L_U	150% E_{\max}
Breaking load L_d	300% E_{\max}
Safe side load L_{iq}	100% E_{\max}
Measurement characteristic values	
Deflection s_{nom} for	
• 10 kg (22.05 lb)	0.03 mm (0.001 inch)
• 20 kg (44.09 lb)	0.08 mm (0.003 inch)
• 50 kg (110.23 lb)	0.15 mm (0.006 inch)
• 100 kg (220.46 lb)	0.12 mm (0.005 inch)
• 200 kg (440.92 lb)	0.15 mm (0.006 inch)
• 300 kg (661.39 lb)	0.18 mm (0.007 inch)
• 400 kg (881.85 lb)	0.17 mm (0.007 inch)
• 500 kg (1102.31 lb)	0.19 mm (0.008 inch)
Rated characteristic value C_n	2.0 ± 0.2 mV/V
Tolerance D_0 of zero signal	< ± 2.0% C_n
Maximum scale interval n_{ic}	
• At $E_{\max} = 10 \dots 500$ kg (22.05 ... 1102.31 lb) and accuracy classes C3, C3 MR	3 000
• At $E_{\max} = 10 \dots 50$ kg (22.05 ... 110.23 lb) and accuracy class C4 MR	4 000

SIWAREX WL260 SP-S SC

Minimum scale interval V_{\min}	
• At $E_{\max} = 10 \dots 500$ kg (22.05 ... 1102.31 lb)	C3: $E_{\max}/10\,000$ C3 MR: $E_{\max}/20\,000$ C4 MR: $E_{\max}/40\,000$
• At $E_{\max} = 10 \dots 50$ kg (22.05 ... 110.23 lb)	
Combined error F_{comb}	≤ ± 0.02% C_n
Repeatability F_V	≤ ± 0.02% C_n
Creep error F_{cr}	
• 30 min	≤ ± 0.025% C_n
Temperature coefficient	
• Zero signal T_{K0}	0.014% $C_n/10$ °C (50 °F)
• Characteristic value T_{Kc}	0.01% $C_n/10$ °C (50 °F)
Electrical characteristic values	
Recommended reference voltage U_{ref}	5 ... 12 V DC
Input resistance R_e with	
• 10 ... 50 kg (22.05 ... 110.23 lb)	380 Ω ± 15 Ω
• 100 ... 500 kg (220.46 ... 1102.31 lb)	350 Ω ± 3.5 Ω
Output resistance R_a	350 Ω ± 3.5 Ω
Insulation resistance R_{is}	5 000 MΩ at 50 V DC
Connection and environmental conditions	
Material of the load cell (DIN)	Stainless steel EN 1.4542
Maximum tightening torque of the fixing screws with	
• 10 ... 50 kg (22.05 ... 110.23 lb)	10 Nm
• 100 ... 500 kg (220.46 ... 1102.31 lb)	20 Nm
Rated temperature range B_{tn}	-10 ... +40 °C (14 ... 104 °F)
Operating temperature range B_{tu}	-35 ... +65 °C (-31 ... +149 °F)
Storage temperature range B_{ts}	-35 ... +65 °C (-31 ... +149 °F)
Degree of protection according to EN 60529; IEC 60529	IP68, IP69K
Cable connection	
Function	Color
• EXC + (supply +)	Red
• EXC - (supply -)	Black
• SIG + (measured signal +)	Green
• SIG - (measured signal -)	White
• Sense + (sensor cable +)	Blue ¹⁾
• Sense - (sensor cable -)	Yellow ¹⁾
• Shield (not connected to the load cell body)	Transparent
Certificates and approvals	
Available accuracy classes acc. to OIML R-60 at rated load	
• 10 ... 500 kg (22.05 ... 110.23 lb)	C3, C3 MR
• 10 ... 50 kg (220.46 ... 1102.31 lb)	C4 MR

¹⁾ Only with 10, 20 and 50 kg (22.05, 44.09 lb and 110.23 lb) variants.

Selection and ordering data

Article No.

Load cell, type WL260 SP-S SC

Legal-for-trade according to OIML R-60 up to 3 000d, connecting cable 3 m (9.84 ft)

Click on the Article No. for the online configuration in the PIA Life Cycle Portal.

Rated load

In accuracy class C3

- 10 kg (22.05 lb)
- 20 kg (44.09 lb)
- 50 kg (110.23 lb)
- 100 kg (220.46 lb)
- 200 kg (440.92 lb)
- 300 kg (661.91 lb)
- 400 kg (881.85 lb)
- 500 kg (1102.31 lb)

Options

In accuracy class C3 MR

Legal-for-trade according to OIML R-60 up to 3 000d and $V_{\min} = E_{\max}/20\,000$

In accuracy class C4 MR

Legal-for-trade according to OIML R-60 up to 4 000d and $V_{\min} = E_{\max}/40\,000$; only for $E_{\max} = 10, 20, 50$ kg (22.05, 44.09, 110.23 lb)

7MH5118-

0

2 A D 0

2 G D 0

2 P D 0

3 A D 0

3 G D 0

3 K D 0

3 M D 0

3 P D 0

D 5

E 5

Dimensional drawings

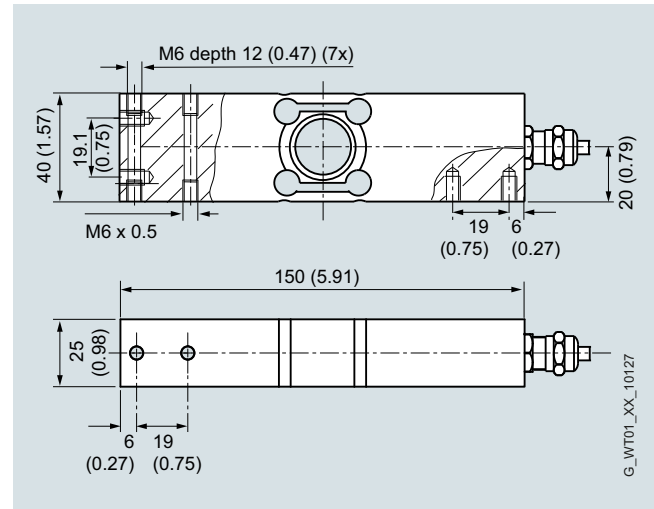

SIWAREX WL260 SP-S SC load cell, 10 ... 50 kg (22.05 ... 110.23 lb), dimensions in mm (inch)

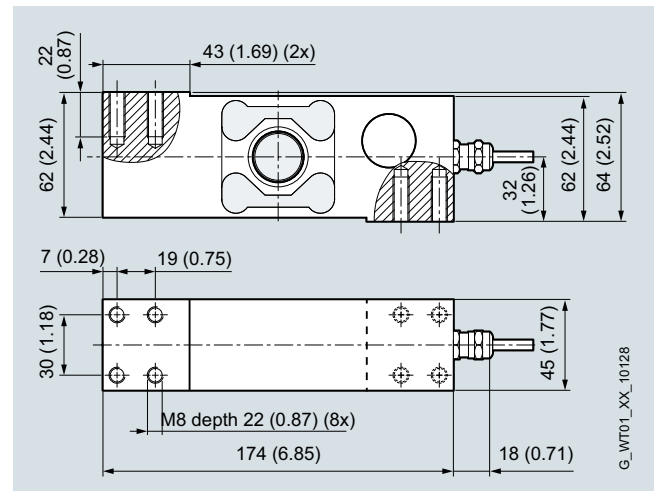

SIWAREX WL260 SP-S SC load cell 100 ... 500 kg (220.46 ... 1102.31 lb), dimensions in mm (inch)