

Overview



The compression load cell is particularly suitable for implementation in hopper scales, bin weighing equipment and vehicle scales.

Design

The measuring element is a solid cylinder made of stainless steel to which 4 strain gauges are applied. The load which acts centrally in the measuring direction causes the spring bodies and therefore the friction-locked strain gauges to be elastically deformed. This generates a measuring signal voltage that is proportional to the load.

Selection and ordering data

Load cell, type WL270 CP-S SB Legal-for-trade according to OIML R60 up to 3 000d, 20 m connecting cable	Article No. 7MH5110-			
	●	●	D 0	●
Click on the Article No. for the online configuration in the PIA Life Cycle Portal.				
Rated load				
• 100 t (98.42 tn. l.)	6	A		
Explosion protection				
• Without				0
• Explosion protection				1

Technical specifications

SIWAREX WL270 CP-S SB	
Possible applications	Hopper scales
Type of construction	Compression load cell
Rated load/maximum load E_{max}	100 t
Accuracy class according to OIML R60	C3
Max. scale interval n_{LC}	3 000
Min. scale interval V_{min}	
• $E_{max} = 100$ t	$E_{max}/9\ 000$
Minimum application range $R_{min(LC)}$	33%
Combined error F_{comb}	$\pm 0.02\% C_n$
Repeatability F_v	$\pm 0.02\% C_n$
Creep error F_{cr}	
• 30 min	$\pm 0.023\% C_n$
Temperature coefficient	
• Zero signal T_{K0}	$0.023\% C_n/5$ K
• Characteristic value T_{Kc}	$0.017\% C_n/5$ K
Min. dead load E_{min}	0 kg

Technical specifications (Continued)

SIWAREX WL270 CP-S SB	
Max. working load L_u	$150\% E_{max}$
Breaking load L_d	$300\% E_{max}$
Safe side load L_{iq}	$10\% E_{max}$
Rated displacement h_n at E_{max}	0.36 mm
Recommended supply voltage (range)	5 ... 12 V DC
Rated characteristic value C_n	2.0 ± 0.02 mV/V
Tolerance D_0 of zero signal	$\leq \pm 1.0\% C_n$
Input resistance R_e	$700 \Omega \pm 7 \Omega$
Output resistance R_s	$700 \Omega \pm 7 \Omega$
Insulation resistance R_{is}	5 000 M Ω at 50 V DC
Rated temperature range B_{tn}	-10 ... +40 °C (+14 ... +104 °F)
Operating temperature range B_{tu}	-35 ... +65 °C (-31 ... +149 °F)
Storage temperature range B_{ts}	-35 ... +65 °C (-31 ... +149 °F)
Sensor material (DIN)	Stainless steel EN 1.4542
Degree of protection according to EN 60529; IEC 60529	IP68

Load Cells

Compression load cells

SIWAREX WL270 CP-S SB Load cell

Technical specifications (Continued)

SIWAREX WL270 CP-S SB

Cable connection

Function	Color
• EXC + (supply +)	Green
• EXC – (supply -)	Black
• SIG + (measured signal +)	White
• SIG – (measured signal -)	Red
• Sense + (sensor cable +)	Yellow
• Sense – (sensor cable -)	Blue
• Shield (not connected to the load cell body)	Transparent

Certificates and approvals

Explosion protection

- EU/UK:
 - ATEX/UKEX II 1 G Ex ia IIC T4
 - ATEX/UKEX II 1 D Ex ia IIIC T200 135°C - Da
 - ATEX/UKEX II 3 G Ex ic IIC T4 Gc
 - ATEX/UKEX II 3 D Ex tc IIIC T73°C Dc
 - ATEX/UKEX II 3 G Ex ec T4 IIC Gc
- USA:
 - IS CL I, II, III, DIV 1, GP A, B, C, D, E, F, G; T4
 - IS CL I, ZN 0, AEx ia IIC T4 Ga
 - Zone 20, AEx ia IIIC T135°C Da
 - CL I, II, III, DIV 2, GP A, B, C, D, E, F, G; T4
 - CL 1, ZN 2, GP IIC T4
 - IS CL I, ZN 2, AEx ic IIC T4 Gc
- Canada:
 - IS CL I, II, III, DIV 1, GP A, B, C, D, E, F, G; T4
 - IS CL I, ZN 0, Ex ia IIC T4 Ga
 - Ex ia IIIC T135°C Da
 - CL I, II, III, DIV 2, GP A, B, C, D, E, F, G; T4
 - CL 1, ZN 2, GP IIC T4
 - Ex ic IIC T4 Gc
- China:
 - NEPSI Ex ia IIC T6 Ga; Ex iaD 20 T80

Dimensional drawings

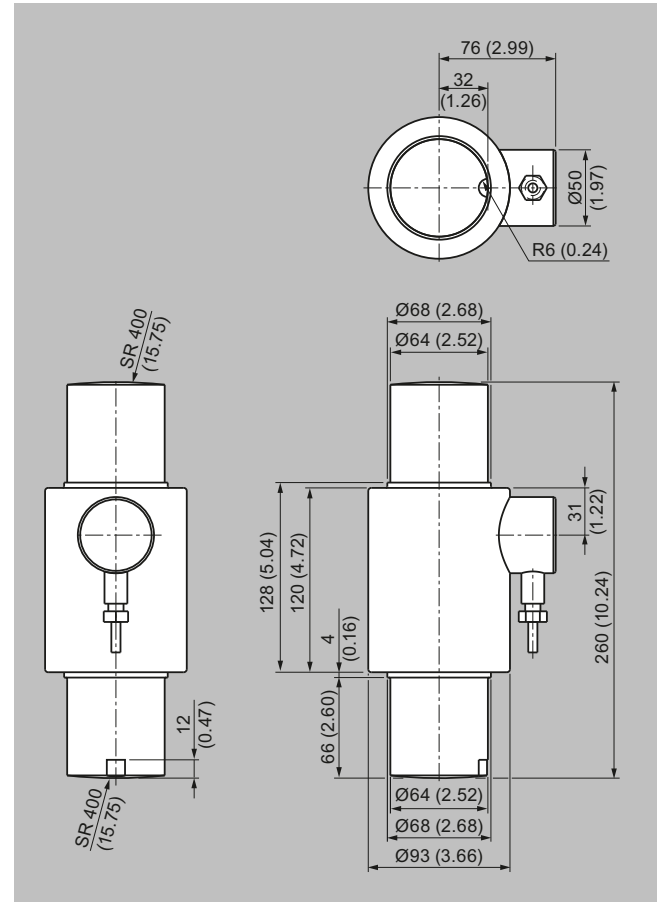

SIWAREX WL 270 CP-S SB load cell, dimensions in mm (inch)

Overview



The self-centering installation unit for SIWAREX WL270 CP-S SB load cells is particularly suitable for implementation in container scales.

Design

The mounting unit comprises a base plate and a top plate, two pressure pieces, two clamping pieces and two centering sleeves. There are threaded holes in the base plate and top plate for the subsequent flange-fitting of guide elements.

The top plate is aligned and fixed above the base plate with the two centering sleeves. This results in a stable unit. The height of the top plate is adjusted so that it is five millimeters above the installation height with load cell.

Two pressure pieces are used to mount the load cell. They are fastened flush with the head plate and base plate using the clamping pieces.

In this state, the mounting unit serves as an installation aid and can be used as a dummy for light installation jobs.

Prior to installation, the load cell is inserted into the mounting unit. Then the complete unit is installed in the scales. As a result, the load bearing implement and the mounting units are aligned. The load cells are not yet loaded.

Finally, the load bearing implement is lowered by loosening the two hexagon nuts under the centering sleeves. The weight now rests on the load cells.

In this state the load cell and the pressure pieces together form a self-centering unit. The mounting unit permits sideways displacement of the top plate, and hence of the load bearing implement, by up to eight millimeters in all directions. Two countersunk screws prevent the load bearing implement from being lifted off or toppling off.

Using the mounting unit as an installation aid results in optimum alignment of the load cells. This is essential to enable the load cells to perform at their best in terms of accuracy.

For maintenance or troubleshooting purposes, the load cell can be relieved again by tightening the hexagon nuts. Replacement of the load cell is then easy after the clamping pieces are released.

Technical specifications

Mounting unit for load cells of the SIWAREX WL270 CP-S SB series

Rated load	100 t (98.42 tn. l.)
Maximum lateral deflection with load cell	± 8 mm (0.12 inch)
Lifting path of top plate	3 ... 5 mm (0.12 ... 0.20 inch)
Restoring force per millimeter of lateral deflection of the top plate in % of the applied load with load cell	0.5%/mm
Permissible supporting load with fixed top plate	140 kN
Permissible lifting force on the top plate	140 kN
Permissible lateral force on the top plate with fixed top plate	50 kN

Selection and ordering data

	Article No.
Mounting unit For load cells of the SIWAREX WL270 CP-S SB series Material: Stainless steel EN 1.4301 and EN 1.4112 For load cells with a rated load of ¹⁾²⁾ • 100 t (98.42 tn. l.)	7MH5710-6AA00

¹⁾ The load cell is not included in the scope of delivery.

²⁾ It is highly recommendable to use a grounding cable (7MH3701-1AA1) in order to protect the load cell.

Load Cells

Compression load cells

SIWAREX WL270 CP-S SB Mounting unit

Dimensional drawings

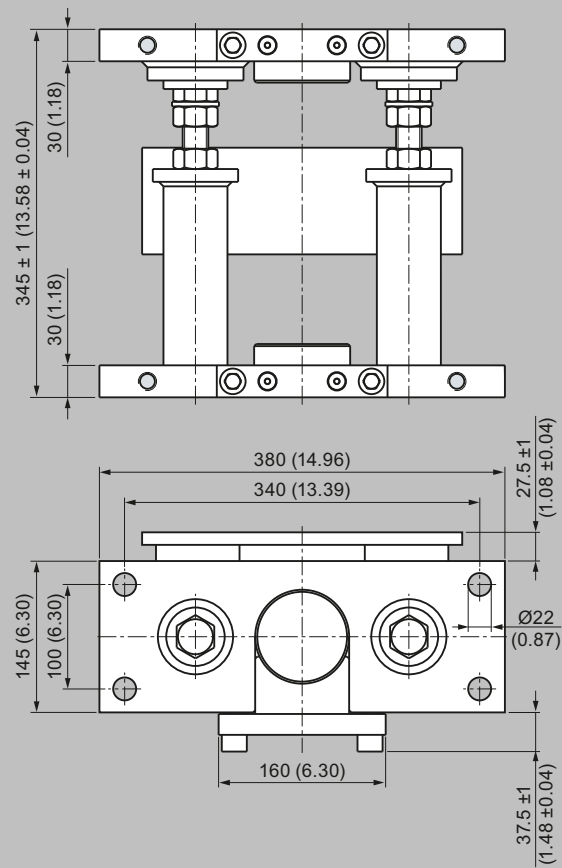

Installation unit for SIWAREX WL270 CP-S SB load cells (installation state), dimensions in mm (inch)

Overview



In combination with a pressure piece set, the SIWAREX WL270 CP-S SB load cell produces a self-centering self-aligning bearing. This unit is particularly suitable for installation in hopper scales, bin weighing equipment and vehicle scales.

Design

The pressure piece set consists of an upper and lower pressure piece. Together with the load cell the pressure piece set forms a self-centering unit with integrated torsion guard.

The self-centering, self-aligning bearing thus formed allows the load bearing element to follow horizontal displacements (e.g. due to temperature fluctuations) In this case the construction of the self-aligning bearing creates a restoring force which is dependent on the size of the displacement and the applied load.

If the load bearing implement is displaced by more than 8 mm (0.32 inch) in the horizontal direction, measures for restricting sideways play (e.g. in the form of endstops or guide elements) must be provided in the construction of the load bearing implement. Lifting of the load support must be prevented by suitable measures provided in the construction of the load bearing implement. The load cell must be ordered separately.

Selection and ordering data

	Article No.
Pressure piece sets¹⁾ For the individual installation of load cells from the SIWAREX WL270 CP-S SB series Material: Stainless steel EN 1.4112 For load cells with a rated load of ¹⁾²⁾	
<ul style="list-style-type: none"> • 100 t (98.42 tn. l.) 	7MH5710-6AD00

- ¹⁾ The principles of general mechanical engineering and safety must be observed.
- ²⁾ It is highly recommendable to use a grounding cable (7MH3701-1AA1) in order to protect the load cell.
- ³⁾ The load cell is not included in the scope of delivery.

Technical specifications

Pressure piece set for the individual installation of load cells of the type SIWAREX WL270 CP-S SB	
Rated load	100 t (98.42 tn. l.)
Maximum lateral deflection with load cell	± 8 mm (0.12 inch)
Restoring force per millimeter of lateral deflection of the top plate in % of the applied load with load cell	0.5%/mm

Dimensional drawings

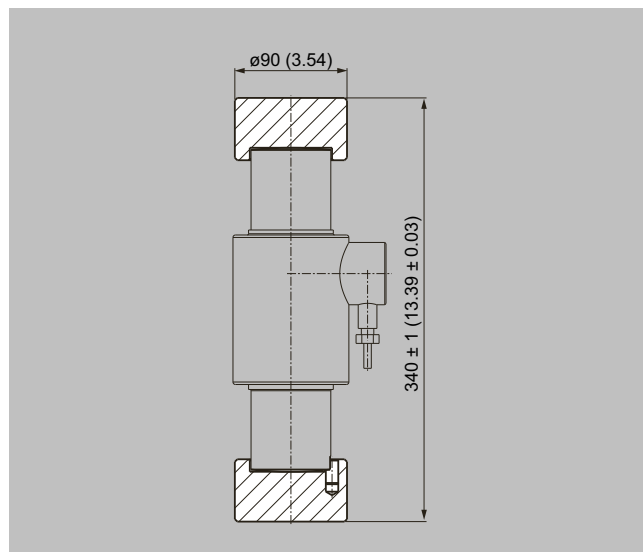

Pressure piece for SIWAREX WL270 CP-S SB load cells, dimensions in mm (inch)