

## Overview

The flowmeter systems of the SITRANS FC100 series are the precision Coriolis multi-parameter flowmeter for low flow applications. They are formed by one FCS100 sensor and one FCT transmitter:

- SITRANS FC120 is the combination of the FCS100 sensor and the FCT020 transmitter
- SITRANS FC140 is the combination of the FCS100 sensor and the FCT040 transmitter

Features:

- Compact dual curved alloy 22 measuring tubes
- Process connection: flange, thread or hygienic clamp
- Nominal sizes: DN 1 to DN 8
- Connection sizes: DN 6 to DN 40 (¼" to 1½")
- Nominal flow rates: 21 kg/h to 950 kg/h (46 lb/h to 2 094 lb/h)
- FCS100 sensors always combine with a remote transmitter via a connecting cable
- Installation of sensor and transmitter in different locations



FCS100 sensor and FCT020/040 transmitter

# Flow Measurement

## SITRANS FC (Coriolis)

### Flowmeter systems / SITRANS FC120/FC140

#### Benefits

##### Product features aligned to user value targets

	User value targets	SITRANS FC features and solutions
<b>Engineering and project management</b>	<ul style="list-style-type: none"> <li>• Reduce engineering investment</li> <li>• Cut specification effort</li> <li>• Minimize project expenditure</li> <li>• Decrease the spending on each measurement point</li> <li>• Eliminate function duplication</li> <li>• Reduce number of suppliers</li> </ul>	<ul style="list-style-type: none"> <li>• Siemens project teams offer complimentary evaluation of customer specifications, provided by regional and HQ experts</li> <li>• Simple product selection using intuitive sizing software</li> <li>• One SITRANS FC device can typically provide three to six individual measurements, all transmitted via digital communication, when planned during pre-project design</li> <li>• Added value functions: batch control, viscosity, thermal energy, concentration measurement (Fraction) of two-component solutions and pressure compensation</li> </ul>
<b>Installation</b>	<ul style="list-style-type: none"> <li>• Reduce footprint and transport outlay of OEM machinery</li> <li>• Lower installation complexity</li> <li>• Avoid costly modifications of existing plant</li> </ul>	<ul style="list-style-type: none"> <li>• Can be installed in horizontal or vertical (self-draining) pipes</li> <li>• Twin tube bend design delivers strong signal to noise characteristic resistant to external influence, so install in tight spaces with no inlet and outlet restrictions</li> <li>• Adaptable to existing pipes: typically, three or four connection sizes for each sensor size</li> <li>• Flexible selection of traditional inputs, outputs and digital communications</li> </ul>
<b>Configuration and commissioning</b>	<ul style="list-style-type: none"> <li>• Shorter commissioning schedules with lower costs</li> <li>• Faster start-up with reduced outgoings</li> </ul>	<ul style="list-style-type: none"> <li>• Easy setup wizard delivers working meters straight after start-up</li> <li>• microSD card stores sensor calibration data and default setup</li> <li>• Simple configuration using Process Device Manager (PDM)</li> <li>• Siemens device-specific faceplates simplify operation in plantwide control systems</li> </ul>
<b>Efficient plant operation</b>	<ul style="list-style-type: none"> <li>• Improve finished product consistency to reduce waste</li> <li>• Keep process performance when scaling production up or down</li> <li>• Optimize process control</li> <li>• Improve finished product quality enabling higher levels of profit</li> <li>• Reduce downtime with fast resolution of process upsets</li> <li>• Improve asset performance</li> </ul>	<ul style="list-style-type: none"> <li>• SITRANS FC meters are calibrated in rigs accredited to EN/ISO 17025 to ensure consistently high performance of flow, density, and concentration measurements</li> <li>• First-class zero-point quality maintains high accuracy into the low flow region</li> <li>• High sensitivity and intelligent dynamic range keeps the measurement active in demanding high fluid damping cases</li> <li>• Designed-in resilience to process extremes</li> <li>• Self-verification alerts to potential performance issues due to unplanned process events, for example gas or vapor breakout or solid deposits building up in the tubes</li> <li>• Diagnostic data via local menu or PDM is backed by Siemens applications experts</li> <li>• Intelligent Siemens SITRANS IQ apps for continuing asset evaluation</li> </ul>
<b>Maintenance and asset management</b>	<ul style="list-style-type: none"> <li>• Optimize technician training</li> <li>• Reduce cost of spare parts</li> <li>• Increase predictive maintenance</li> <li>• Reduce production downtime and associated costs</li> <li>• Decrease unplanned maintenance</li> <li>• Maximize asset value</li> </ul>	<ul style="list-style-type: none"> <li>• Simple product design with interchangeable modular parts</li> <li>• microSD card loads sensor-specific data to deliver fast service exchange</li> <li>• Self-verification: tube health check monitors key diagnostics, including tube stiffness, driver and pickups; the user defines verification frequency and alarm behavior</li> <li>• Verification results indicate whether preventive maintenance action is required</li> <li>• Siemens SIMATIC Maintenance Station uses cyclical acquisition to provide life cycle reports and intelligent preventive maintenance strategies</li> </ul>

## Benefits (continued)

	User value targets	SITRANS FC features and solutions
Industry compliance	<ul style="list-style-type: none"> <li>• Cut effort required to comply with Industry-specific demands</li> <li>• Reduce resource needed to maintain regulatory compliance</li> </ul>	<ul style="list-style-type: none"> <li>• Food and beverage sector covered with EHEDG and 3-A approvals, polished tubes</li> <li>• Global hazardous area approvals for international plant duplications</li> <li>• Common and emerging digital networks covered:               <ul style="list-style-type: none"> <li>•</li> <li>•</li> <li>• or</li> <li>• over (IS)</li> </ul> </li> <li>• Class-leading safety: SIL2/SIL3, secondary containment, PED,</li> </ul>

# Flow Measurement

## SITRANS FC (Coriolis)

### Flowmeter systems / SITRANS FC120/FC140

#### Application

##### Application examples for SITRANS FC multi-parameter meters across diverse industry sectors

<b>Chemical and petrochemical</b> Bulk chemicals Industrial gases Polymers Agrochemicals Fine chemicals Aroma chemicals	<ul style="list-style-type: none"> <li>• Transfer, loading and unloading of bulk chemicals</li> <li>• Concentration control of acids and alkalis (process optimization)</li> <li>• Accurate mass or volume flow of feed chemicals to in-line blending systems</li> <li>• Accurate mass flow and density (quality) of reactor fluid feeds catalyst</li> <li>• Chemical recovery</li> <li>• Mass balance optimization</li> <li>• Compressed and cryogenic gases</li> <li>• Lubricating oil blending and dosing</li> <li>• High accuracy measurement of critical fluid components</li> <li>• Low flow control in pilot plants and R&amp;D facilities</li> </ul>
<b>Food and beverage</b> Food processing Dairies Breweries Distilleries Confectionary Soft drinks Animal feed plants OEM	<ul style="list-style-type: none"> <li>• Accurate bulk transfer (mass or volume) of all dairy products: milk, cream, whey and yoghurt</li> <li>• Fat concentration in cream</li> <li>• Flow, density, temperature and concentration (Plato) during all fermentation processes</li> <li>• Flow, density, temperature and sugar concentration (Brix) in soft drink processing</li> <li>• Distilled spirits – % alcohol by volume (ABV), liters of pure alcohol, volume transfer, blending, batch and column still optimization and energy management, cask filling, tanker loading</li> <li>• Flow and density of fruit juices and pulps</li> <li>• Mixing and inventory control of confectionary ingredients, e.g. chocolate, syrup, oils, flavors</li> <li>• Metering pump control</li> <li>• Oils, fats enzymes dosing in animal feed plants</li> <li>• CO<sub>2</sub> dosing</li> <li>• CIP liquids</li> <li>• Bottling of beer, spirits, wine, soft drinks, etc.</li> <li>• Bulk sugar processing – molasses, sugar slurries, density, Brix of finished product</li> </ul>
<b>Oil and gas</b> Offshore/onshore Upstream/downstream Pipelines Distribution networks Refineries Skid manufacturers	<ul style="list-style-type: none"> <li>• Loading/unloading of hydrocarbons (e.g. crude oil, bitumen) from/to ship, road tanker, rail car</li> <li>• High pressure chemical injection</li> <li>• High pressure low flow gas</li> <li>• Net oil computing</li> <li>• Gas void fraction</li> <li>• Filling of gas bottles</li> <li>• Furnace control</li> <li>• Test separators</li> <li>• LPG, natural gas hydration</li> <li>• Well-head water-cut monitoring</li> <li>• All hydrocarbon fluids in refineries</li> <li>• Metrology, custody transfer</li> <li>• Drilling mud</li> <li>• Oil well cementing and hydrofracturing</li> </ul>

#### Application (continued)

##### Application examples for SITRANS FC multi-parameter meters across diverse industry sectors

<b>Life sciences</b> Pharmaceutical Bio	<ul style="list-style-type: none"> <li>• High accuracy flow and batching of bioreactor feeds</li> <li>• Solvent flow rate, density and batching</li> <li>• Flow of demineralized and deionized water</li> <li>• Solvents and fish oils used in high grade omega 3 oils</li> <li>• Precision coatings</li> <li>• Vacuum thin film coating</li> </ul>
<b>Household and personal care</b> Detergents Cosmetics	<ul style="list-style-type: none"> <li>• Blending and batching of detergent ingredients</li> <li>• Tanker loading and unloading</li> <li>• Salt concentration</li> <li>• Reliable measurement of aerated liquids</li> </ul>
<b>Automotive and aeronautical</b> Vehicle manufacturing Paint Engine testing OEM	<ul style="list-style-type: none"> <li>• Fuel injection nozzle and pump testing</li> <li>• Filling of under bonnet fluid reservoirs, air conditioning, coolant</li> <li>• Fuel flow and density measurement in engine test beds</li> <li>• Checking for air in oil using high accuracy density measurement</li> <li>• Paint spray robots – requires accurate and fast measurements</li> <li>• Aircraft fuel loading (kerosene)</li> <li>• High pressure flow used in turbine blade manufacture</li> </ul>
<b>Power and energy</b> Renewable Hydrogen	<ul style="list-style-type: none"> <li>• Boiler fuel flow and burner control</li> <li>• Turbine fuel flow</li> <li>• Glycol flow and concentration</li> <li>• Bioethanol</li> </ul>
<b>Marine</b> OEM Shipbuilders	<ul style="list-style-type: none"> <li>• Fuel consumption management</li> <li>• Boiler control</li> <li>• Bunkering management</li> <li>• Density used to indicate fuel quality</li> </ul>
<b>Pulp, paper and textiles</b>	<ul style="list-style-type: none"> <li>• Accurate dosing of dyes and chemicals</li> </ul>
<b>Water and environmental</b>	<ul style="list-style-type: none"> <li>• Dosing of chemicals for water treatment</li> <li>• Chemical concentration for water quality control</li> </ul>

**Design****Design options and related temperature range for FC100 series**

Design version	Process temperature range
Standard neck	Standard [-50 ... 150 °C (-58 ... 302 °F)]
Long neck	Standard [-50 ... 150 °C (-58 ... 302 °F)] Medium [-50 ... 260 °C (-58 ... 302 °F)]

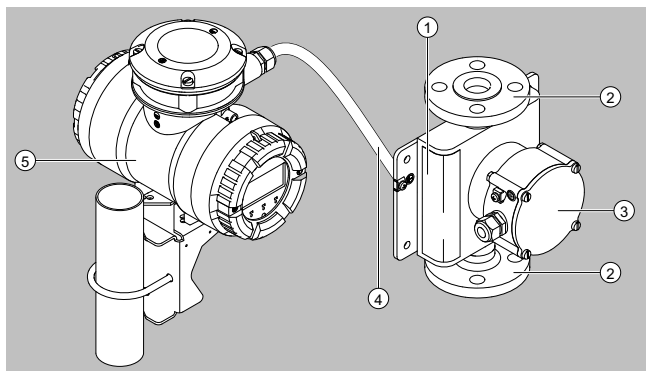

FCS100 sensor (standard neck version) and remote transmitter

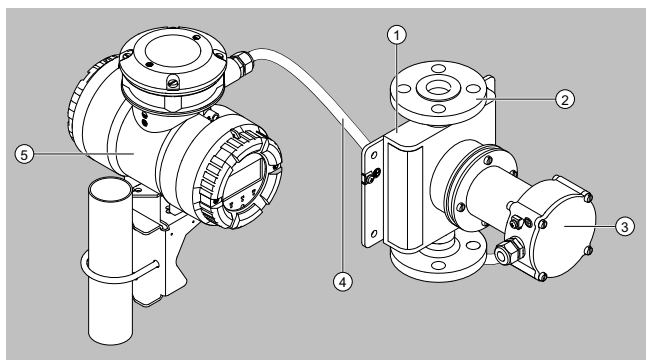

FCS100 sensor (long neck version) and remote transmitter

1	FCS100 sensor
2	Process connection
3	Sensor terminal box
4	Connecting cable
5	Transmitter

**Compatible fluids**

- Liquids
- Gases
- Mixtures, solutions, emulsions, suspensions and slurries

**Primary measured variables**

- Mass flow
- Density
- Temperature

**Design (continued)**

Based on the primary measured quantities, the transmitter also calculates

- Volume flow
- Percent concentration (fraction) of a two-component mixture (FCT040 only)
- Partial component flow rate (net flow) of a mixture consisting of two components (FCT040 only)

The mass flow, volume flow, net flow measurements can be bi-directional.

**Measurement variables for NTEP approval**

- Mass flow uni-directional
- Volume flow uni-directional

**Feature summary**

- Possibly the most compact dual curve Coriolis flowmeter for precision measurement, starting at DN 1 nominal size
- Batching function with batch leakage detection and batch control by transmitter for precise dosing
- Accurate density measurement and up to four advanced concentration measurement data sets
- Sizes to suit pilot plants, R&D labs and high value fluid additives
- Wide choice of process connections, starting with DN 6 (¼ inch) for reduced installation efforts

**Installation guidelines**

FC100 series flow meters can be mounted horizontally, vertically and at an incline. The measuring tubes should be filled with the fluid during flow measurement as entrained gas may result in errors in measurement. Straight pipe runs at inlet or outlet are usually not required.

Avoid the following installation locations and positions:

- Measuring tubes as highest point in piping when measuring liquids
- Measuring tubes as lowest point in piping when measuring gases
- Immediately in front of a free pipe outlet in a downpipe
- Lateral positions

## Flow Measurement

### SITRANS FC (Coriolis)

#### Flowmeter systems / SITRANS FC120/FC140

#### Design (continued)

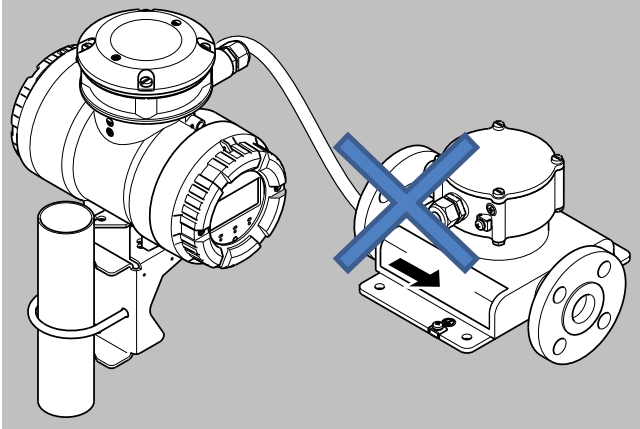

Avoid measuring tubes in sideways position resulting in possible non-homogeneous fluid separation

#### Function

##### **Compatible fluids**

- Liquids
- Gases
- Mixtures, solutions, emulsions, suspensions and slurries

##### **Primary measured variables**

- Mass flow
- Density
- Temperature

##### **Based on the primary measured quantities, the transmitter also calculates**

- Volume flow
- Percent concentration (fraction) of a two-component mixture (FCT040 only)
- Partial component flow rate (net flow) of a mixture consisting of two components (FCT040 only)

The mass flow, volume flow, net flow measurements can be bi-directional.

##### **Measurement variables for NTEP approval**

- Mass flow uni-directional
- Volume flow uni-directional

##### **Feature overview**

- Possibly the most compact dual curve Coriolis flowmeter for precision measurement, starting at DN 1 nominal size
- Batching function with batch leakage detection and batch control by transmitter for precise dosing
- Accurate density measurement and up to four advanced concentration measurement data sets
- Sizes to suit pilot plants, R&D labs and high value fluid additives
- Wide choice of process connections, starting with DN 6 (1/4 inch) for reduced installation efforts

## Selection and ordering data

SITRANS FC120/140 (Low flow)	Article No. 7ME441	Order code
Click on the Article No. for the online configuration in the PIA Life Cycle Portal.		
<b>Transmitter variant</b>		
None (spare sensor)	0	
Coriolis sensor FCS100 with transmitter FCT020	2	
Coriolis sensor FCS100 with transmitter FCT040	4	
SITRANS FC spare part transmitter, no sensor included	9	G 3 Y
<b>Sensor size / Connector size</b>		
No sensor (SITRANS FCT transmitter as spare part)	0	A
Sensor size DN 1 with connection size 1/4"	1	A
Sensor size DN 1 with connection size 3/8"	1	B
Sensor size DN 1 with connection size 1/2" DN 15	1	C
Sensor size DN 1 with connection size 3/4"	1	D
Sensor size DN 1 with special connection	1	Y
Sensor size DN 2 with connection size 1/4"	2	A
Sensor size DN 2 with connection size 3/8"	2	B
Sensor size DN 2 with connection size 1/2" DN 15	2	C
Sensor size DN 2 with connection size 3/4"	2	D
Sensor size DN 2 with connection size 1" DN 25	2	E
Sensor size DN 2 with connection size 1 1/2" DN 40	2	F
Sensor size DN 2 with special connection	2	Y
Sensor size DN 4 with connection size 1/4"	3	A
Sensor size DN 4 with connection size 3/8"	3	B
Sensor size DN 4 with connection size 1/2" DN 15	3	C
Sensor size DN 4 with connection size 3/4"	3	D
Sensor size DN 4 with connection size 1" DN 25	3	E
Sensor size DN 4 with connection size 1 1/2" DN 40	3	F
Sensor size DN 4 with special connection	3	Y
Sensor size DN 6 with connection size 1/4"	4	A
Sensor size DN 6 with connection size 3/8"	4	B
Sensor size DN 6 with connection size 1/2" DN 15	4	C
Sensor size DN 6 with connection size 3/4"	4	D
Sensor size DN 6 with connection size 1" DN 25	4	E
Sensor size DN 6 with connection size 1 1/2" DN 40	4	F
Sensor size DN 6 with special connection	4	Y
Sensor size DN 8 with connection size 1/4"	5	A
Sensor size DN 8 with connection size 3/8"	5	B
Sensor size DN 8 with connection size 1/2" DN 15	5	C
Sensor size DN 8 with connection size 3/4"	5	D
Sensor size DN 8 with connection size 1" DN 25	5	E
Sensor size DN 8 with connection size 1 1/2" DN 40	5	F
Sensor size DN 8 with special connection	5	Y
<b>Process connection</b>		
No connection (SITRANS FCT transmitter as spare part)		A 0
EN flange PN 40, suitable for EN 1092-1 type B1, raised face (RF)		A 1
EN flange PN 100, suitable for EN 1092-1 type B1, raised face (RF)		A 3
EN flange PN 40, suitable for EN 1092-1 type D, groove		A 5
EN flange PN 100, suitable for EN 1092-1 type D, groove		A 7
EN flange PN 40, suitable for EN 1092-1 type E, spigot		B 1
EN flange PN 100, suitable for EN 1092-1 type E, spigot		B 3
EN flange PN 40, suitable for EN 1092-1 type F, recess		B 5
EN flange PN 100, suitable for EN 1092-1 type F, recess		B 7
ASME flange class 600, suitable for ASME B16.5, ring joint (RJ)		C 3
ASME flange class 900, suitable for ASME B16.5, ring joint (RJ)		C 4
ASME flange class 1500, suitable for ASME B16.5, ring joint (RJ)		C 5
ASME flange class 150, suitable for ASME B16.5, raised face (RF)		D 1
ASME flange class 300, suitable for ASME B16.5, raised face (RF)		D 2
ASME flange class 600, suitable for ASME B16.5, raised face (RF)		D 3
ASME flange class 900, suitable for ASME B16.5, raised face (RF)		D 4
ASME flange class 1500, suitable for ASME B16.5, raised face (RF)		D 5

# Flow Measurement

## SITRANS FC (Coriolis)

### Flowmeter systems / SITRANS FC120/FC140

#### Selection and ordering data (continued)

SITRANS FC120/140 (Low flow)	Article No. 7ME441	Order code
Process connection with internal thread G	E 1	
Process connection with internal thread NPT	E 3	
Clamp process connection according to DIN 32676 series A	G 2	
Clamp process connection according to DIN 32676 series C (Tri-Clamp)	G 6	
JIS flange 10K, JIS B 2220	L 2	
JIS flange 20K, JIS B 2220	L 4	
Special design request	Y 1	
<b>Tube material (wetted)</b>		
<b>Process connection material and operational temperature range</b>		
None (SITRANS FCT transmitter as spare part)	0	
Tube material C22, process connection material 316L, standard: -50 ... 150 °C (-58 ... 302 °F)	1	
Tube material C22, process connection material 316L, mid-range: -50 ... 260 °C (-58 ... 500 °F)	2	
<b>Calibration</b>		
No calibration	0	
Massflow 0.1%, density 0.5 g/l	1	
Massflow 0.1%, density 1 g/l	2	
Massflow 0.1%, density 4 g/l	3	
Massflow 0.1%, density 8 g/l	4	
Massflow 0.15% density 20 g/l	5	
Massflow 0.2%, density 4 g/l	6	
Massflow 0.2%, density 8 g/l	7	
Massflow 0.2%, density 20 g/l	8	
Accuracy for gas please select below	9	
Massflow gas 0.75%		N 1 A
Massflow gas 0.5%		N 2 A
<b>Mounting style, transmitter housing and material</b>		
Remote type with "urethane-cured polyester powder coating" coated aluminum transmitter housing and standard neck sensor		C
Remote type with "urethane-cured polyester powder coating" coated aluminum transmitter housing and long neck sensor		D
Remote type with "corrosion protection coating" coated aluminum transmitter housing and standard neck sensor		E
Remote type with "corrosion protection coating" coated aluminum transmitter housing and long neck sensor		F
Remote type stainless steel transmitter and standard neck sensor		G
Remote type stainless steel transmitter and long neck sensor		H
<b>Ex approvals</b>		
None		A
ATEX, explosion group IIC and IIIC		B
ATEX, explosion group IIB and IIIC		C
IECEX, explosion group IIC and IIIC		D
IECEX, explosion group IIB and IIIC		E
EAC Ex, IIC and IIIC		F
EAC Ex, IIB and IIIC		G
FM, groups A B C D E F G		H
FM, groups C D E F G		J
INMETRO, explosion group IIC and IIIC		K
INMETRO, explosion group IIB and IIIC		L
NEPSI, explosion group IIC and IIIC		M
NEPSI, explosion group IIB and IIIC		N
Korea Ex, explosion group IIC and IIIC		P
Korea Ex, explosion group IIB and for integral type also IIIC		Q
<b>Local user interface</b>		
Spare sensor without transmitter, no display applied		0
No display		1
With display		3

## Selection and ordering data (continued)

	Order code		Order code
<b>Further designs</b> Please add "-Z" to Article No. and specify order code(s).		Certification package (C13, C18, C38, C40) including Marking Transfer and raw material certificate, Hydrostatic pressure test, Dye penetration and Quality inspection certificate	<b>C82</b>
<b>Cable entries</b> (for customer cable gland holes - no cable glands supplied)		Certification package (C13, C15, C18, C36, C38, C40) including Marking Transfer and raw material certificate, Positive material identification, Hydrostatic pressure test, Welding certificates, Dye penetration and Quality inspection certificate	<b>C83</b>
Metric, no glands (M20)	<b>A10</b>	Certification package (C15, C18, C36) including Positive material identification, Hydrostatic pressure test and Welding certificates	<b>C84</b>
NPT, no glands (1/2")	<b>A11</b>	Certification package (C34, C37, C39) including X-ray test according ASME V, Welding procedures and Certificates according ASME IX and Dye penetrant test of flange welding according ASME V	<b>C85</b>
Metric, no glands (M20) steel armored cable	<b>A20</b>	Certification package (C13, C18, C34, C37, C39, C40) including Marking Transfer and raw material certificate, Hydrostatic pressure test, X-ray test according ASME V, Welding procedures and Certificates according ASME IX, Dye penetrant test of flange welding according ASME V and Quality inspection certificate	<b>C86</b>
NPT, no glands (1/2") steel armored cable	<b>A21</b>	Certification package (C13, C15, C34, C37, C39, C40) including Marking Transfer and raw material certificate, Positive material identification, X-ray test according ASME V, Welding procedures and Certificates according ASME IX, Dye penetrant test of flange welding according ASME V and Quality inspection certificate	<b>C87</b>
<b>Sensor housing material</b>		<b>I/O Configuration Ch1</b>	
None (SITRANS FCT transmitter as spare part)	<b>B00</b>	None (SITRANS FCT transmitter as spare part)	<b>E00</b>
Stainless steel 1.4301/304, 1.4404/316L	<b>B01</b>	4-20 mA HART active	<b>E06</b>
Stainless steel 1.4404/316L	<b>B02</b>	4-20 mA HART passive	<b>E07</b>
<b>Certificates</b>		PROFIBUS PA	<b>E10</b>
Declaration of compliance with the order 2.1 according to EN 10204	<b>C11</b>	Modbus RTU RS 485	<b>E14</b>
Certificate of Marking Transfer and Raw Material Certificates (Inspection Certificate 3.1 according to EN 10204), including IGC and conform to NACE MR0175 and MR0103	<b>C13</b>	PROFINET over Ethernet-APL (IS)	<b>E15</b>
Positive Material Identification of wetted parts, including certificate (Inspection Certificate 3.1 according to EN 10204)	<b>C15</b>	<b>I/O Configuration Ch2, Ch3 and Ch4</b>	
NTEP approval accuracy class 0.3 acc. NIST	<b>C16</b>	Spare sensor without transmitter, all communication types and I/Os apply	<b>F00</b>
Hydrostatic Pressure Test Certificate (Inspection Certificate 3.1 according to EN 10204)	<b>C18</b>	1 passive current output, 1 passive pulse or status output	<b>F01</b>
Functional Safety (IEC 61508) - SIL2/3	<b>C20</b>	1 passive current output, 2 passive pulse or status outputs	<b>F02</b>
X-ray inspection of flange weld seam according to DIN EN ISO 17636-1/B, evaluation according to AD 2000 HP 5/3 and DIN EN ISO 5817/C, including certificate	<b>C33</b>	1 passive current output, 1 passive pulse or status outputs, 1 passive NAMUR pulse or status output	<b>F03</b>
X-ray test according to ASME V	<b>C34</b>	1 passive current output, 2 passive NAMUR pulse or status outputs	<b>F04</b>
WPS according to DIN EN ISO 15809-1; WPQR according to DIN EN ISO 15814-1; WQC according to DIN EN 287-1 or DIN EN ISO 8908-4	<b>C36</b>	1 passive pulse or status output	<b>F11</b>
Welding procedures and certificate according to ASME IX	<b>C37</b>	2 passive pulse or status outputs, 1 passive status output	<b>F12</b>
Dye penetrant test of process connection weld seams according to DIN EN ISO 3452-1, including certificate	<b>C38</b>	2 passive pulse or status outputs, 1 active current input	<b>F14</b>
Dye penetrant test of flange welding according to ASME V, including certificate	<b>C39</b>	2 passive pulse or status outputs, 1 passive current input	<b>F15</b>
Quality Inspection Certificate (Inspection Certificate 3.1 according to EN 10204)	<b>C40</b>	1 passive pulse or status output, 1 passive current output, 1 active current input	<b>F16</b>
Ferrite test for flange welding according to DIN EN ISO 8249	<b>C50</b>	1 passive pulse or status output, 1 passive current output, 1 passive current input	<b>F17</b>
Degreasing of wetted surfaces according to ASTM G93-03 (Level C), including test report	<b>C54</b>	1 passive pulse or status output, 1 voltage-free status input, 1 active current input	<b>F18</b>
<b>Combined certificates</b>		1 passive pulse or status output, 1 voltage-free status input, 1 passive current input	<b>F19</b>
Certification package (C13, C18, C40) including Marking Transfer and raw material certificate, Hydrostatic pressure test and Quality inspection certificate	<b>C80</b>		
Certification package (C13, C15, C40) including Marking Transfer and raw material certificate, Positive material identification and Quality inspection certificate	<b>C81</b>		

# Flow Measurement

## SITRANS FC (Coriolis)

### Flowmeter systems / SITRANS FC120/FC140

#### Selection and ordering data (continued)

	Order code
1 passive pulse or status output, 1 active pulse or status output, 1 voltage-free status input	F20
1 passive pulse or status output, 1 active pulse or status output with pull-up resistor, 1 voltage-free status input	F21
1 active current output, 2 passive pulse or status outputs	F22
1 active current output, 1 passive pulse or status output, 1 voltage-free status input	F23
1 passive pulse or status output	F31
2 passive pulse or status outputs	F32
1 passive pulse or status output, 1 active current input	F33
1 passive pulse or status output, 1 passive current input	F34
1 passive pulse or status output, 1 active pulse or status output	F35
1 passive pulse or status output, 1 active pulse or status output with pull-up resistor	F36
1 passive pulse or status output, 1 active current output	F37
1 passive pulse output	F41
Output CH1 intrinsically safe, 1 passive pulse output	F42
Output CH3 intrinsically safe, 1 passive pulse output	F50
<b>Customer selected fraction</b>	
PIA: Please select four options	
Sugar / Water 0 ... 85 °Bx, 0 ... 80 °C (32 ... 176 °F)	G01
NaOH / Water 2 ... 50 WT%, 0 ... 100 °C (32 ... 212 °F)	G02
KOH / Water 0 ... 60 WT%, 54 ... 100 °C (129 ... 212 °F)	G03
NH <sub>4</sub> NO <sub>3</sub> / Water 1 ... 50 WT%, 0 ... 80 °C (32 ... 176 °F)	G04
NH <sub>4</sub> NO <sub>3</sub> / Water 20 ... 70 WT%, 20 ... 100 °C (68 ... 212 °F)	G05
HCl / Water 22 ... 34 WT%, 20 ... 40 °C (68 ... 104 °F)	G06
HNO <sub>3</sub> / Water 50 ... 67 WT%, 10 ... 60 °C (50 ... 140 °F)	G07
H <sub>2</sub> O <sub>2</sub> / Water 30 ... 75 WT%, 4 ... 44 °C (39 ... 111 °F)	G09
Ethylene Glycol / Water 10 ... 50 WT%, -20 ... +40 °C (-4 ... 104 °F)	G10
Amylum = Starch / Water 33 ... 43 WT%, 35 ... 45 °C (95 ... 113 °F)	G11
Methanol / Water 35 ... 60 WT%, 0 ... 40 °C (32 ... 104 °F)	G12
Alcohol / Water 55 ... 100 VOL%, 10 ... 40 °C (50 ... 104 °F)	G20
Sugar / Water 40 ... 80 °Bx, 75 ... 100 °C (167 ... 212 °F)	G21
Alcohol / Water 66 ... 100 WT%, 15 ... 40 °C (59 ... 104 °F)	G30
Alcohol / Water 66 ... 100 WT%, 10 ... 40 °C (50 ... 104 °F)	G37
<b>Insulation</b>	
Insulation	J10
Insulation and heat tracing, 1/2" ASME class 150, raised face (RF)	J12
Insulation and heat tracing, 1/2" ASME class 300, raised face (RF)	J13
Insulation and heat tracing, EN DN 15, PN 40	J14
Insulation, heat tracing with ventilation, 1/2" ASME class 150, raised face (RF)	J16
Insulation heat tracing with ventilation, 1/2" ASME class 300, raised face (RF)	J17
Insulation heat tracing with ventilation, EN DN 15, PN 40	J18

	Order code
<b>Connecting cable type and length</b>	
without standard connecting cable	L50
5 meter (16.4 ft) remote connecting cable terminated standard gray / Ex blue	L51
10 meter (32.8 ft) remote connecting cable terminated standard gray / Ex blue	L54
15 meter (49.2 ft) remote connecting cable terminated standard gray / Ex blue	L57
20 meter (65.6 ft) remote connecting cable terminated standard gray / Ex blue	L60
30 meter (98.4 ft) remote connecting cable terminated standard gray / Ex blue	L63
without fire retardant connecting cable	L70
5 meter (16.4 ft) remote fire retardant connecting cable not terminated	L71
10 meter (32.8 ft) remote fire retardant connecting cable not terminated	L74
15 meter (49.2 ft) remote fire retardant connecting cable not terminated	L77
20 meter (65.6 ft) remote fire retardant connecting cable not terminated	L80
30 meter (98.4 ft) remote fire retardant connecting cable not terminated	L83
<b>SW functions</b>	
Heat measurement	S11
Tube health check	S12
Batching and filling function	S13
Netoil computing	S14
Viscosity computing function for liquids	S15
Standard concentration measurement	S16
Advanced concentration	S17
<b>Marine approval</b>	
Marine approved DNV, ABS, KR piping class 2	S22
Marine approved DNV, ABS, KR piping class 3	S23
Marine approved LR, MR, TAC piping class 2	S24
Marine approved LR, MR, TAC piping class 3	S25
Marine approved BV piping class 2	S26
Marine approved BV piping class 3	S27
<b>Mounting</b>	
2" pipe mounting bracket for sensor	S30
<b>Country specific delivery</b>	
Delivery to China including China RoHS mark	W21
Delivery to Korea including KC mark	W22
<b>Tag name</b>	
Tag name plate, SS (max. 16 characters)	Y11
HART/MODBUS software tag No. (max. 8 characters)	Y25
HART/MODBUS software tag No. (max. 32 characters)	Y26
PROFIBUS PA NODE ADDRESS (4 characters HEX)	Y28
PROFIBUS PA SOFTWARE TAG (max. 32 characters)	Y29
<b>Calibration</b>	
Predefined 6-Point Accredited Calibration: 10%, 20%, 40%, 60%, 80%, 100% of Q <sub>nom</sub> . Calibrated Output: Frequency	D62
<b>Special versions</b>	
ID-number of special design	Y99

## Technical specifications

### Mass flow rate of liquids

The mass flow rate characteristics of SITRANS FC meters are defined by the values of zero stability,  $Q_{flat}$ ,  $Q_{nom}$  and  $Q_{max}$ .

Zero stability is the maximum allowable flow rate value that can be displayed at zero flow under reference conditions. It is a good indicator of the meter performance as flow rates reduce and approach zero.

- $Q_{flat}$  is the mass flow rate above which the base accuracy is maintained (0.1% when using FCT040 transmitters).
- $Q_{nom}$  is the nominal mass flow rate of water at reference conditions that would result in a pressure drop of 1 bar (15 psi).
- $Q_{max}$  is the recommended maximum mass flow rate for each sensor size.

For questions regarding expected performance in specific applications, please contact your regional Siemens Measurement Intelligence team.

### Flow rate summary by FCS100 sensor size

Nominal size	Zero stability		$Q_{flat}$		$Q_{nom}$		$Q_{max}$	
	kg/h	lb/h	kg/h	lb/min	kg/h	lb/min	kg/h	lb/min
DN 1	0.003	0.007	2.52	0.092	21.0	0.0771	40.0	1.47
DN 2	0.005	0.011	4.50	0.165	45.0	1.65	94.0	3.45
DN 4	0.009	0.020	14.0	0.514	170	6.24	300	11.0
DN 6	0.019	0.042	30.0	1.10	370	13.6	600	22.0
DN 8	0.048	0.106	79.0	2.90	950	34.9	1 500	55.1

### Performance summary by FCS100 sensor size and transmitter type

Sensor size			DN 1	DN 2	DN 4	DN 6	DN 8
<b>Mass flow (liquids)</b>							
Accuracy	% (of rate)	FCT020	± 0.2	± 0.2	± 0.2	± 0.2	± 0.2
	% (of rate)	FCT040	± 0.2	± 0.2	± 0.1	± 0.1	± 0.1
Zero stability	kg/h (lb/h)		± 0.003 (0.007)	± 0.005 (0.011)	± 0.009 (0.02)	± 0.019 (0.042)	± 0.048 (0.106)
<b>Density (liquids)</b>							
Accuracy	kg/m <sup>3</sup> (lb/ft <sup>3</sup> )	FCT020	± 20 (1.25)	± 8 (0.5)	± 4 (0.25)	± 4 (0.25)	± 4 (0.25)
	kg/m <sup>3</sup> (lb/ft <sup>3</sup> )	FCT040	± 20 (1.25)	± 8 (0.5)	± 1 (0.06)	± 0.5 (0.03)	± 0.5 (0.03)
<b>Mass flow (gases)</b>							
Accuracy	% (of rate)	FCT020	± 0.75	± 0.75	± 0.75	± 0.75	± 0.75
	% (of rate)	FCT040	± 0.5	± 0.5	± 0.5	± 0.5	± 0.5
<b>Temperature</b>							
Accuracy	°C (°F)		± 0.5 (0.9)	± 0.5 (0.9)	± 0.5 (0.9)	± 0.5 (0.9)	± 0.5 (0.9)

The accuracy values in the table above are based on reference conditions at the time of calibration and represent the combined measurement uncertainties including sensor, electronic and pulse output interface.

Liquid density calibration is performed when density accuracy of 0.5 kg/m<sup>3</sup> (0.03 lb/ft<sup>3</sup>) is selected in the model code.

### Mass flow calibration and density adjustment for liquids

Siemens SITRANS FC Coriolis meters are calibrated in rigs accredited according to the international standard DIN EN ISO/IEC 17025:2018. Each flowmeter comes with a standard calibration certificate.

Mass flow calibration takes place at reference conditions. Specific values are listed in the standard calibration certificate.

Mass flow calibration reference conditions	
Fluid	Water
Density	900 ... 1 100 kg/m <sup>3</sup> (56 ... 69 lb/ft <sup>3</sup> )
Fluid temperature	10 ... 35 °C (50 ... 95 °F), average temperature: 22.5 °C (72.5 °F)
Ambient temperature	10 ... 35 °C (50 ... 95 °F)
Process pressure	1 ... 5 bar (15 ... 73 psi)

Density calibration reference conditions	
Flow condition	Fully developed flow profile
Fluid densities used to obtain density calibration constants	700 kg/m <sup>3</sup> (44 lb/ft <sup>3</sup> ) 1 000 kg/m <sup>3</sup> (62 lb/ft <sup>3</sup> ) 1 650 kg/m <sup>3</sup> (103 lb/ft <sup>3</sup> )
Fluid temperature	20 °C (68 °F)
Determination of temperature compensation coefficients	20 ... 80 °C (68 ... 176 °F)

### Analog output performance specification

Typical additional uncertainty when using the analog current output:

± 0.04% at a nominal mid-range current output of 12 mA, which includes the effects of:

Output adjustment, linearity, power supply variation, load resistance variation, short-term and long-term drift for one year and ambient temperature effect on the transmitter in the range 20 °C ± 30 °C (14 ... 122 °F).

### Process pressure effect on flow measurement performance

Changes in operating pressure have a small effect on the mass flow measurement performance. When the pressure changes are very large this effect can be corrected by a dynamic pressure input or a fixed process pressure.

# Flow Measurement

## SITRANS FC (Coriolis)

### Flowmeter systems / SITRANS FC120/FC140

#### Technical specifications (continued)

Sensor size	Additional flow measurement errors due to change in operating pressure from reference pressure	
	in % of rate per 1 bar variation	in % of rate per 1 psi variation
DN 1	none	none
DN 2	none	none
DN 4	none	none
DN 6	-0.0011	-0.00008
DN 8	-0.0010	-0.00007

#### Process temperature effect

For mass flow measurement, process fluid temperature effect is defined as the change in sensor flow accuracy due to process fluid temperature change, away from the 20 °C (68 °F) reference condition. Variation in process temperature influences the measuring tube characteristics and this is compensated for using the built-in PT 1000 temperature sensor.

A small flow uncertainty remains in the compensation circuit defined below.

Uncertainty due to process temperature change:  $\pm 0.001\%$  of mass flow rate per °C ( $\pm 0.00056\%$  of mass flow rate per °F)

#### Temperature effect on zero

Temperature effect on the mass flow zero-point quality can be corrected by zeroing at the process fluid temperature.

#### Process conditions

##### Process fluid temperature range

Process fluid temperature range	Nominal temperature	Design versions
-50 ... +150 °C (-58 ... +302 °F)	Standard	All process connections except DIN 32676 Class A and C hygienic clamps
-10 ... +140 °C (14 ... 284 °F)	Standard	For process connections DIN 32676 Class A and C hygienic clamps
-50 ... +260 °C (-58 ... +302 °F)	Medium	Only selectable for remote transmitters with long neck sensor: selections D, F, and H in position 14 of the order code

#### Operating pressure

The maximum allowed process pressure depends on the selected process connection and process temperature.

The given process temperature and process pressure ranges are calculated and approved without corrosion or erosion effects.

The following diagrams show the process pressure as a function of process temperature as well as the process connection used (type and size of process connection).

Calculations for ASME flanges are based on ASME B16.5 Material group 2.2 (316/316L dual certified).

#### ASME class 150

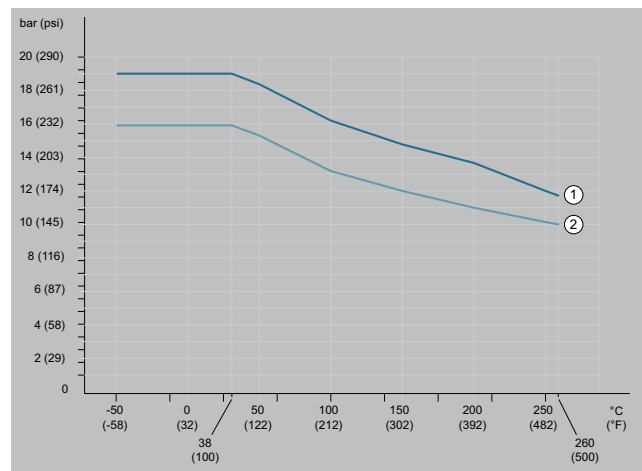

Allowed process pressure as a function of process connection temperature

- Process connection compatible to ASME B16.5 class 150
- Heat tracing connection compatible to ASME B16.5 class 150

#### ASME class 300, EN PN 40

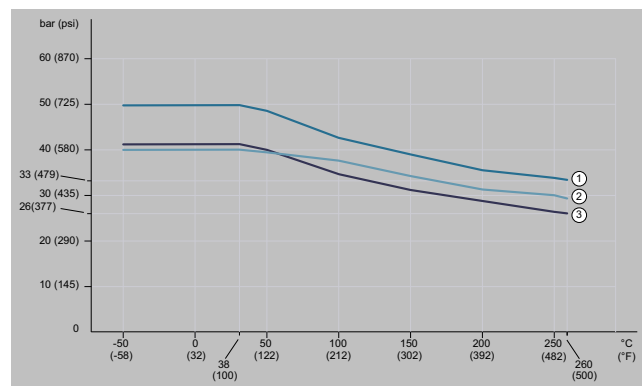

Allowed process pressure as a function of process fluid temperature

- Process connection compatible to ASME B16.5 class 300
- Process and heat tracing connection compatible to EN 1092-1 PN 40
- Heat tracing connection compatible to ASME B16.5 class 300

## Technical specifications (continued)

## ASME class 600

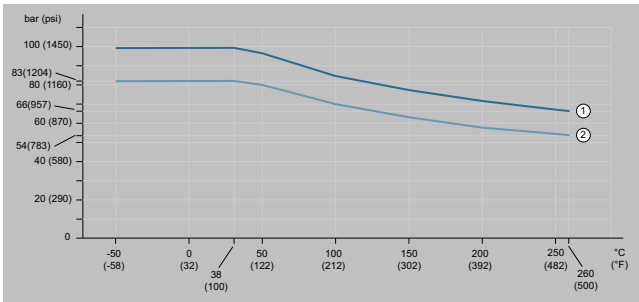

Allowed process pressure as a function of process connection temperature

- 1 Process connection compatible to ASME B16.5 class 600
- 2 Not used for this product

## ASME class 900, EN PN100

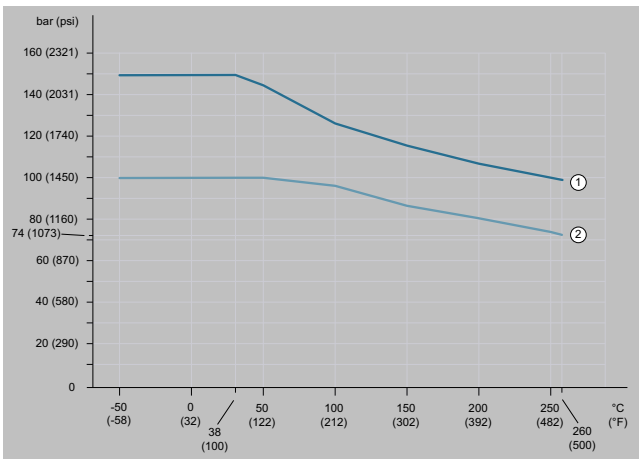

Allowed process pressure as a function of process connection temperature

- 1 Process connection compatible to ASME B16.5 class 900
- 2 Process connection compatible to EN 1092-1 PN100

## ASME class 1500 compatible to flange ASME B16.5

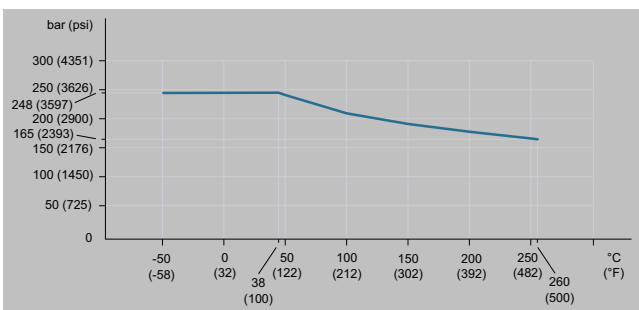

Allowed process pressure as a function of process connection temperature

## JIS 10K, JIS 20K

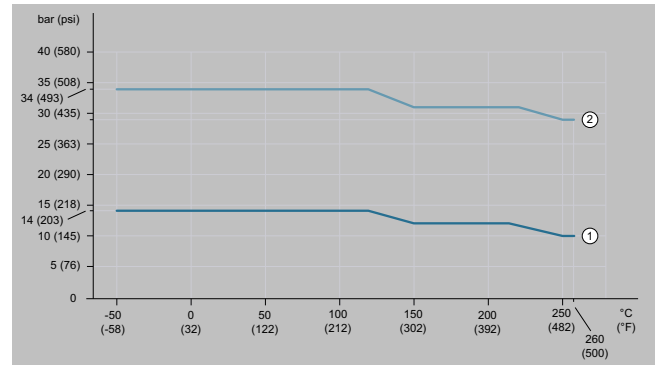

Allowed process pressure as a function of process connection temperature

- 1 Process connection compatible to JIS B 2220 10K
- 2 Process connection compatible to JIS B 2220 20K

## Clamp process connection according to DIN 32676 series A

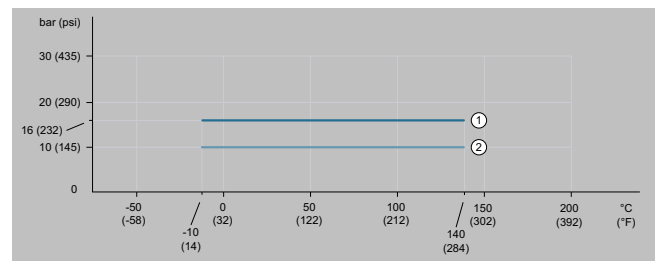

Allowed process pressure as a function of process fluid temperature

- 1 Clamp connection compatible to DIN 32676 series A up to DN 50
- 2 Clamp connection compatible to DIN 32676 series A above DN 50

## Clamp process connection according to DIN 32676 series C (Tri-Clamp)

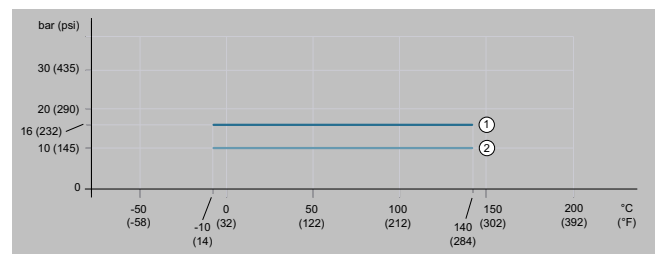

Allowed process pressure as a function of process fluid temperature

- 1 Clamp connection compatible to DIN 32676 series C up to 2"
- 2 Clamp connection compatible to DIN 32676 series C above 2"

# Flow Measurement

## SITRANS FC (Coriolis)

### Flowmeter systems / SITRANS FC120/FC140

#### Technical specifications (continued)

##### Process connection with internal thread G and NPT

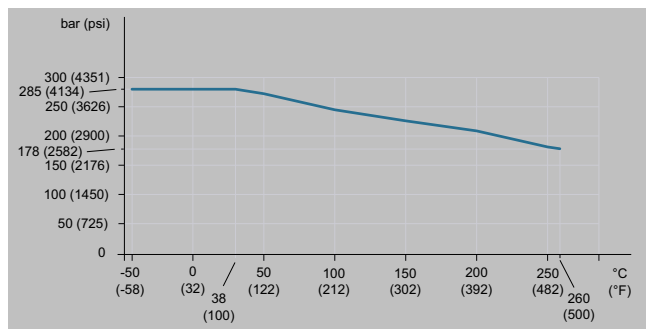

Allowed process pressure as a function of process fluid temperature

#### Ambient conditions

Allowed ambient and storage temperature of SITRANS FC100 series is influenced by the temperature specification of FCS100 sensor, FCTOX0 transmitter and the interconnecting cable.

#### Ambient temperature

Device-surrounding air temperature is considered as ambient temperature. If the device is operating outdoors make sure that the solar irradiation does not increase the surface temperature of the device higher than the allowed maximum ambient temperature. Transmitter display has limited legibility below -20 °C (-4 °F).

The sensor ambient temperature limits may also be influenced by the process fluid temperature, details shown in the chapter "Sensors" (Technical specifications).

#### Maximum ambient temperature ranges for FC100 series

Cable type	Device	Ambient temperature range
Standard cable	Sensor	-50 ... +80 °C (-58 ... +176 °F)
	Transmitter	-40 ... +60 °C (-40 ... +140 °F)
Fire retardant cable	Sensor	-35 ... +80 °C (-31 ... +176 °F)
	Transmitter	-35 ... +60 °C (-31 ... +140 °F)

#### Ambient temperature range for NTEP custody transfer approval

Cable type	Device	Ambient temperature range
Standard cable	Sensor	-50 ... +80 °C (-58 ... +176 °F)
	Transmitter	-40 ... +50 °C (-40 ... +122 °F)
Fire retardant cable	Sensor	-35 ... +80 °C (-31 ... +176 °F)
	Transmitter	-35 ... +50 °C (-31 ... +122 °F)

#### Maximum storage temperature ranges for FC100 series

Cable type	Device	Ambient temperature range
Standard cable	Sensor	-50 ... +80 °C (-58 ... +176 °F)
	Transmitter	-40 ... +60 °C (-40 ... +140 °F)
Fire retardant cable	Sensor	-35 ... +80 °C (-31 ... +176 °F)
	Transmitter	-35 ... +60 °C (-31 ... +140 °F)

#### Temperature specification of FC100 series Ex versions located in hazardous areas

Please select appropriate equipment in accordance with the laws and regulations of the relevant country/region, when it is used in a location where explosive atmospheres may be present.

The maximum ambient and process fluid temperatures depending on explosion groups and temperature classes can be determined via the SITRANS FC order code together with the Ex code (see the corresponding explosion proof type manual).

Note: The maximum process fluid temperature could be further restricted due to process connection type, refer to curves above under the heading "Allowed ambient temperature for FCS100 sensors".

#### FCS100 with standard process temperature

##### Ex approvals:

ATEX, IEC Ex, EAC Ex, NEPSI, Korea Ex

Temperature class	Maximum process temperature	Maximum ambient temperature	
		Standard cable	Fire retardant cable
T6	65 °C (149 °F)	65 °C (149 °F)	65 °C (149 °F)
T5	90 °C (194 °F)	75 °C (167 °F)	75 °C (167 °F)
T4	130 °C (266 °F)	80 °C (176 °F)	74 °C (165 °F)
T3	150 °C (302 °F)	80 °C (176 °F)	72 °C (161 °F)
T2	150 °C (302 °F)	80 °C (176 °F)	72 °C (161 °F)
T1	150 °C (302 °F)	80 °C (176 °F)	72 °C (161 °F)

##### Ex approvals:

FM

Temperature class	Maximum process temperature	Maximum ambient temperature	
		Standard cable	Fire retardant cable
T6	65 °C (149 °F)	65 °C (149 °F)	65 °C (149 °F)
T5	90 °C (194 °F)	75 °C (167 °F)	70 °C (158 °F)
T4	130 °C (266 °F)	80 °C (176 °F)	70 °C (158 °F)
T3	150 °C (302 °F)	80 °C (176 °F)	70 °C (158 °F)
T2	150 °C (302 °F)	80 °C (176 °F)	70 °C (158 °F)
T1	150 °C (302 °F)	80 °C (176 °F)	70 °C (158 °F)

## Technical specifications (continued)

## FCS100 with medium process temperature, long neck

## Ex approvals:

ATEX, IEC Ex, EAC Ex, NEPSI, Korea Ex

Temperature class	Maximum process temperature	Maximum ambient temperature		
		Standard cable	Fire retardant cable without sensor insulation	Fire retardant cable with all sensor insulation and heating options
T6	65 °C (149 °F)	65 °C (149 °F)	65 °C (149 °F)	65 °C (149 °F)
T5	90 °C (194 °F)	75 °C (167 °F)	75 °C (167 °F)	75 °C (167 °F)
T4	130 °C (266 °F)	80 °C (176 °F)	76 °C (168 °F)	75 °C (167 °F)
T3	180 °C (356 °F)	80 °C (176 °F)	75 °C (167 °F)	71 °C (159 °F)
T2	260 °C (500 °F)	80 °C (176 °F)	73 °C (163 °F)	64 °C (147 °F)
T1	260 °C (500 °F)	80 °C (176 °F)	73 °C (163 °F)	64 °C (147 °F)

## Ex approvals:

FM

Temperature class	Maximum process temperature	Maximum ambient temperature		
		Standard cable	Fire retardant cable without sensor insulation	Fire retardant cable with all sensor insulation and heating options
T6	65 °C (149 °F)	65 °C (149 °F)	65 °C (149 °F)	65 °C (149 °F)
T5	90 °C (194 °F)	75 °C (167 °F)	70 °C (158 °F)	70 °C (158 °F)
T4	130 °C (266 °F)	80 °C (176 °F)	70 °C (158 °F)	70 °C (158 °F)
T3	180 °C (356 °F)	80 °C (176 °F)	70 °C (158 °F)	70 °C (158 °F)
T2	260 °C (500 °F)	80 °C (176 °F)	70 °C (158 °F)	64 °C (147 °F)
T1	260 °C (500 °F)	80 °C (176 °F)	70 °C (158 °F)	64 °C (147 °F)

## Additional ambient and environmental specifications

Specification	Rating/level of compliance
Relative humidity	0 ... 95%
Ingress protection	IP66 or IP67 with suitable cable glands
Environmental pollution	Pollution degree 4 in accordance with EN 61010-1 whilst in operation
Maximum altitude	2 000 m (6 600 ft) above mean sea level (MSL)
Mechanical load	Transmitter: 10 ... 500 Hz, 1g acc. to IEC 60068-2-6
Electromagnetic (EMC) Immunity	<ul style="list-style-type: none"> <li>EN IEC 61326-1, Table 2</li> <li>EN IEC 61326-2-3</li> <li>EN IEC 61326-2-5</li> <li>NAMUR NE 21 recommendation</li> <li>DNV-CG-0339 section 3, chapter 14</li> </ul>
Surge Immunity Emission	<ul style="list-style-type: none"> <li>EN 61000-4-5 for lightning protection</li> <li>EN IEC 61000-3-2, Class A (harmonic current emissions)</li> <li>EN IEC 61000-3-3, Class A (voltage fluctuations)</li> </ul> <p>Immunity assessment criterion: output signal fluctuation is within ±1% of the output span</p>
Overvoltage	Category II according to EN IEC 61010-1

## Approvals and certificates – summary

Position in code, type	Order code	Description
15, Ex approval	B	ATEX, explosion group IIC and IIIC
15, Ex approval	C	ATEX, explosion group IIB and IIIC
15, Ex approval	D	IECEX, explosion group IIC and IIIC

Position in code, type	Order code	Description
15, Ex approval	E	IECEX, explosion group IIB and IIIC
15, Ex approval	H	FM, groups A, B, C, D, E, F, G
15, Ex approval	J	FM, groups C, D, E, F, G
15, Ex approval	K	INMETRO, explosion group IIC and IIIC
15, Ex approval	L	INMETRO, explosion group IIB and IIIC
15, Ex approval	M	NEPSI, explosion group IIC and dust proof
15, Ex approval	N	NEPSI, explosion group IIB and dust proof
15, Ex approval	F	EAC Ex, explosion group IIC and IIIC
15, Ex approval	G	EAC Ex, explosion group IIB and IIIC
15, Ex approval	P	Korea Ex, explosion group IIC and IIIC
15, Ex approval	Q	Korea Ex, explosion group IIB and IIIC
ZS2, Marine approval	S22	Marine approval according DNV, ABS and KR piping class 2
ZS2, Marine approval	S23	Marine approval according DNV, ABS and KR piping class 3
ZS2, Marine approval	S24	Marine approval according LR MR TAC piping class 2
ZS2, Marine approval	S25	Marine approval according LR MR TAC piping class 3
ZS2, Marine approval	S26	Marine approved BV piping class 2
ZS2, Marine approval	S27	Marine approved BV piping class 3
ZC1, Certificate	C11	Compliance with the order 2.1 EN 10204
ZC1, Certificate	C13	3.1 EN 10204 + IGC + NACE MR0175, MR0103
ZC1, Certificate	C15	PMI 3.1 according to EN 10204
ZC1, Certificate	C16	NTEP approval, accuracy class 0.3 acc. NIST Handbook 44
ZC1, Certificate	C18	Pressure Test Certificate 3.1 EN 10204
ZC1, Certificate	C20	Functional Safety (IEC 61508) - SIL2/3
ZC1, Certificate	C33	X-ray DIN EN ISO 17636-1/B

## Flow Measurement

### SITRANS FC (Coriolis)

#### Flowmeter systems / SITRANS FC120/FC140

#### Technical specifications (continued)

Position in code, type	Order code	Description
ZC1, Certificate	C34	X-ray test according to ASME V
ZC1, Certificate	C36	WPS; WPQR; WQC
ZC1, Certificate	C37	Welding procedures and Certificate ASME IX
ZC1, Certificate	C38	Dye penetration DIN EN ISO 3452-1
ZC1, Certificate	C39	Dye penetration ASME V
ZC1, Certificate	C40	Quality Inspection Certificate 3.1 EN 10204
ZC1, Certificate	C54	Degreasing ASTM G93-03, including report
ZC1, Certificate	C80	Certification package (C13, C18, C40) including Marking Transfer and raw material certificate, Hydrostatic pressure test and Quality inspection certificate
ZC1, Certificate	C81	Certification package (C13, C15, C40) including Marking Transfer and raw material certificate, Positive material identification and Quality inspection certificate

Position in code, type	Order code	Description
ZC1, Certificate	C82	Certification package (C13, C18, C38, C40) including Marking Transfer and raw material certificate, Hydrostatic pressure test, Dye penetration and Quality inspection certificate
ZC1, Certificate	C83	Certification package (C13, C15, C18, C36, C38, C40) including Marking Transfer and raw material certificate, Positive material identification, Hydrostatic pressure test, Welding certificates, Dye penetration and Quality inspection certificate
ZC1, Certificate	C84	Certification package (C15, C18, C36) including Positive material identification, Hydrostatic pressure test and Welding certificates
ZC1, Certificate	C85	Certification package (C34, C37, C39) including X-ray test according ASME V, Welding procedures and Certificates according ASME IX and Dye penetrant test of flange welding according ASME V
ZC1, Certificate	C86	Certification package (C13, C18, C34, C37, C39, C40) including Marking Transfer and raw material certificate, Hydrostatic pressure test, X-ray test according ASME V, Welding procedures and Certificates according ASME IX, Dye penetrant test of flange welding according ASME V and Quality inspection certificate
ZC1, Certificate	C87	Certification package (C13, C15, C34, C37, C39, C40) including Marking Transfer and raw material certificate, Positive material identification, X-ray test according ASME V, Welding procedures and Certificates according ASME IX, Dye penetrant test of flange welding according ASME V and Quality inspection certificate

## Dimensional drawings

## Drawings, dimensions and weight for FCS100 sensors

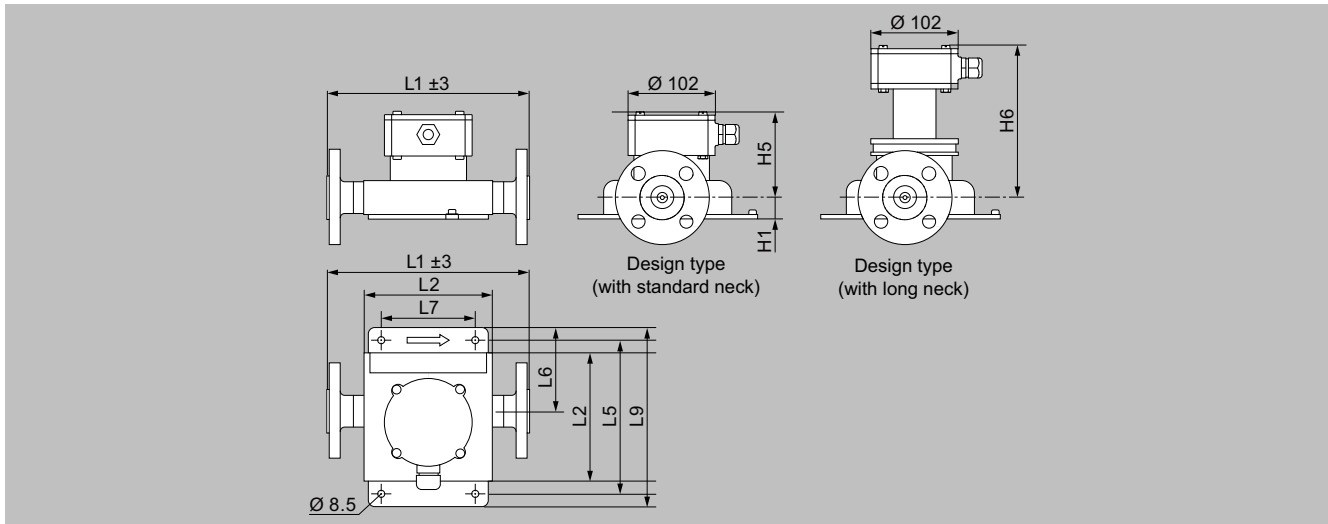

FCS100 sensor, dimensions in mm

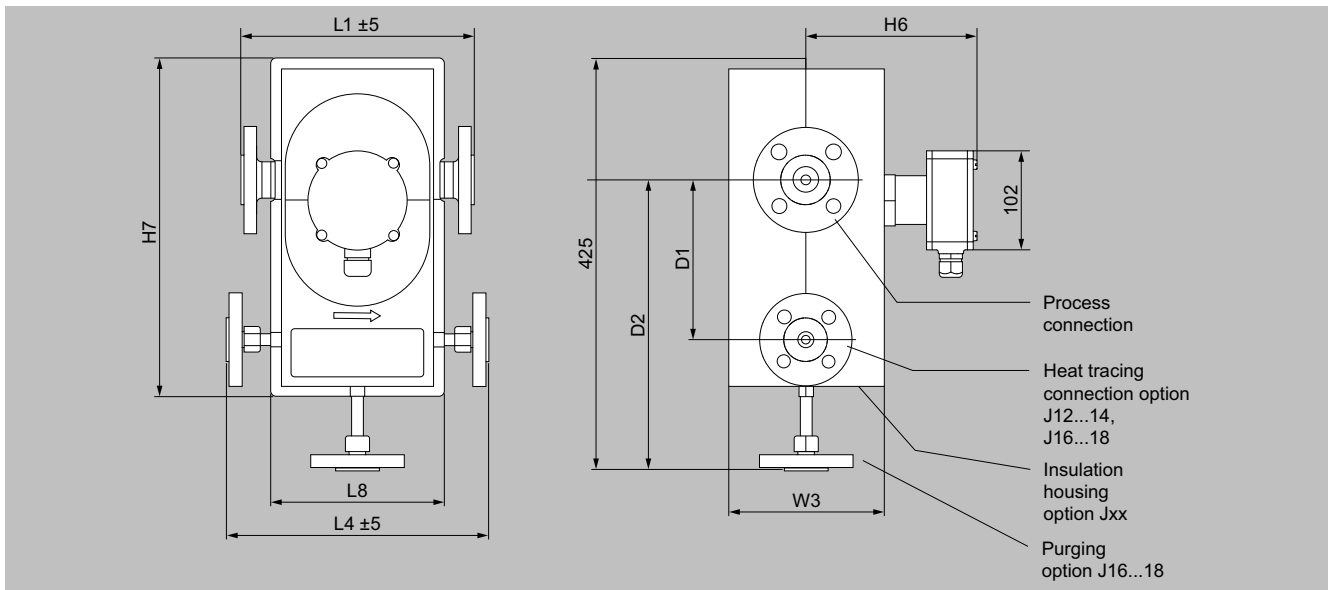

FCS100 with insulation housing, dimensions in mm

## Flow Measurement

### SITRANS FC (Coriolis)

#### Flowmeter systems / SITRANS FC120/FC140

#### Dimensional drawings (continued)

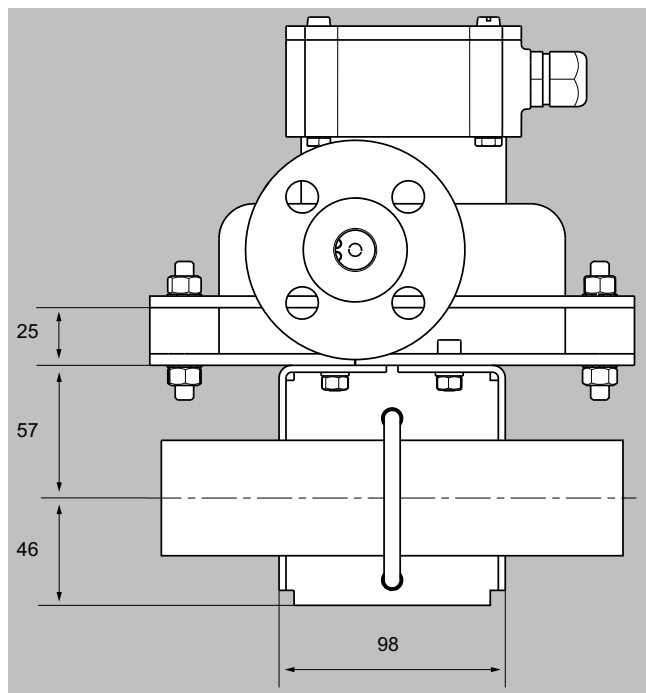

FCS100 with optional pipe mounting bracket, dimensions in mm

#### FCS100 sensor dimensions

Nominal size	L2	L4	L5	L6	L7	L8	L9
	Dimensions in mm (inch)						
DN 1	150 (5.9)	270 (10.6)	180 (7.1)	111 (4.4)	110 (4.3)	180 (7.1)	210 (8.3)
DN 2	150 (5.9)	270 (10.6)	180 (7.1)	111 (4.4)	110 (4.3)	180 (7.1)	210 (8.3)
DN 4	150 (5.9)	270 (10.6)	180 (7.1)	99 (3.9)	110 (4.3)	180 (7.1)	210 (8.3)
DN 6	150 (5.9)	270 (10.6)	180 (7.1)	89 (3.5)	110 (4.3)	180 (7.1)	210 (8.3)
DN 8	150 (5.9)	270 (10.6)	180 (7.1)	55 (2.2)	110 (4.3)	180 (7.1)	210 (8.3)

Nominal size	H1	H3	H5	H6	L7	W3	D1	D2
	Dimensions in mm (inch)							
DN 1	25 (1)	81 (3.2)	101 (4)	176 (6.9)	350 (13.8)	160 (6.3)	165 (6.5)	299 (11.8)
DN 2	25 (1)	81 (3.2)	101 (4)	176 (6.9)	350 (13.8)	160 (6.3)	165 (6.5)	299 (11.8)
DN 4	25 (1)	81 (3.2)	101 (4)	176 (6.9)	350 (13.8)	160 (6.3)	165 (6.5)	299 (11.8)
DN 6	25 (1)	81 (3.2)	101 (4)	176 (6.9)	350 (13.8)	160 (6.3)	165 (6.5)	299 (11.8)
DN 8	25 (1)	81 (3.2)	101 (4)	176 (6.9)	350 (13.8)	160 (6.3)	165 (6.5)	299 (11.8)

#### L1 dimension and weight with process connections according to ASME B16.5 (AISI 316 / AISI 316L)

Process connection size and type	FCS100 sensor nominal size									
	DN 1		DN 2		DN 4		DN 6		DN 8	
	L1 in mm (inch)	Weight in kg (lb)	L1 in mm (inch)	Weight in kg (lb)	L1 in mm (inch)	Weight in kg (lb)	L1 in mm (inch)	Weight in kg (lb)	L1 in mm (inch)	Weight in kg (lb)
ASME ½" class 150, raised face (RF)	240 (9.4)	6.2 (14)	240 (9.4)	6.2 (14)	240 (9.4)	6.2 (14)	240 (9.4)	6.2 (14)	240 (9.4)	6.2 (14)
ASME ½" class 300, raised face (RF)	240 (9.4)	6.6 (15)	240 (9.4)	6.6 (15)	240 (9.4)	6.6 (15)	240 (9.4)	6.6 (15)	240 (9.4)	6.6 (15)
ASME ½" class 600, raised face (RF)	250 (9.8)	6.9 (15)	250 (9.8)	6.9 (15)	250 (9.8)	6.9 (15)	250 (9.8)	6.9 (15)	250 (9.8)	6.9 (15)

## Dimensional drawings (continued)

Process connection size and type	FCS100 sensor nominal size									
	DN 1		DN 2		DN 4		DN 6		DN 8	
	L1 in mm (inch)	Weight in kg (lb)	L1 in mm (inch)	Weight in kg (lb)	L1 in mm (inch)	Weight in kg (lb)	L1 in mm (inch)	Weight in kg (lb)	L1 in mm (inch)	Weight in kg (lb)
ASME ½" class 600, ring joint (RJ)	250 (9.8)	6.8 (15)	250 (9.8)	6.8 (15)	250 (9.8)	6.8 (15)	250 (9.8)	6.8 (15)	250 (9.8)	6.8 (15)
ASME ½" class 900, raised face (RF)	270 (10.6)	8.8 (19)	270 (10.6)	8.8 (19)	270 (10.6)	8.8 (19)	270 (10.6)	8.8 (19)	270 (10.6)	8.8 (19)
ASME ½" class 900, ring joint (RJ)	270 (10.6)	11.3 (25)	270 (10.6)	11.3 (25)	270 (10.6)	11.3 (25)	270 (10.6)	11.3 (25)	270 (10.6)	11.3 (25)
ASME ½" class 1500, raised face (RF)	270 (10.6)	8.8 (19)	270 (10.6)	8.8 (19)	270 (10.6)	8.8 (19)	270 (10.6)	8.8 (19)	270 (10.6)	8.8 (19)
ASME ½" class 1500, ring joint (RJ)	270 (10.6)	11.3 (25)	270 (10.6)	11.3 (25)	270 (10.6)	11.3 (25)	270 (10.6)	11.3 (25)	270 (10.6)	11.3 (25)
ASME 1" class 150, raised face (RF)	n/a	n/a	240 (9.4)	7.1 (16)	240 (9.4)	7.1 (16)	240 (9.4)	7.1 (16)	240 (9.4)	7.1 (16)
ASME 1" class 300, raised face (RF)	n/a	n/a	240 (9.4)	8.1 (18)	240 (9.4)	8.1 (18)	240 (9.4)	8.1 (18)	240 (9.4)	8.1 (18)
ASME 1" class 600, raised face (RF)	n/a	n/a	260 (10.2)	8.5 (19)	260 (10.2)	8.5 (19)	260 (10.2)	8.5 (19)	260 (10.2)	8.5 (19)
ASME 1" class 600, ring joint (RJ)	n/a	n/a	260 (10.2)	8.6 (19)	260 (10.2)	8.6 (19)	260 (10.2)	8.6 (19)	260 (10.2)	8.6 (19)
ASME 1" class 900, raised face (RF)	n/a	n/a	320 (12.6)	12.7 (28)	320 (12.6)	12.7 (28)	320 (12.6)	12.7 (28)	320 (12.6)	12.7 (28)
ASME 1" class 900, ring joint (RJ)	n/a	n/a	320 (12.6)	12.8 (28)	320 (12.6)	12.8 (28)	320 (12.6)	12.8 (28)	320 (12.6)	12.8 (28)
ASME 1" class 1500, raised face (RF)	n/a	n/a	320 (12.6)	12.7 (28)	320 (12.6)	12.7 (28)	320 (12.6)	12.7 (28)	320 (12.6)	12.7 (28)
ASME 1" class 1500, ring joint (RJ)	n/a	n/a	320 (12.6)	12.8 (28)	320 (12.6)	12.8 (28)	320 (12.6)	12.8 (28)	320 (12.6)	12.8 (28)
ASME 1½" class 150, raised face (RF)	n/a	n/a	250 (9.8)	8 (18)	250 (9.8)	8 (18)	250 (9.8)	8 (18)	250 (9.8)	8 (18)
ASME 1½" class 300, raised face (RF)	n/a	n/a	250 (9.8)	10.3 (23)	250 (9.8)	10.3 (23)	250 (9.8)	10.3 (23)	250 (9.8)	10.3 (23)
ASME 1½" class 600, raised face (RF)	n/a	n/a	270 (10.6)	11.7 (26)	270 (10.6)	11.7 (26)	270 (10.6)	11.7 (26)	270 (10.6)	11.7 (26)
ASME 1½" class 600, ring joint (RJ)	n/a	n/a	270 (10.6)	11.6 (26)	270 (10.6)	11.6 (26)	270 (10.6)	11.6 (26)	270 (10.6)	11.6 (26)
ASME 1½" class 900, raised face (RF)	n/a	n/a	340 (13.4)	17.5 (39)	340 (13.4)	17.5 (39)	340 (13.4)	17.5 (39)	340 (13.4)	17.5 (39)
ASME 1½" class 900, ring joint (RJ)	n/a	n/a	340 (13.4)	17.7 (39)	340 (13.4)	17.7 (39)	340 (13.4)	17.7 (39)	340 (13.4)	17.7 (39)
ASME 1½" class 1500, raised face (RF)	n/a	n/a	340 (13.4)	17.5 (39)	340 (13.4)	17.5 (39)	340 (13.4)	17.5 (39)	340 (13.4)	17.5 (39)
ASME 1½" class 1500, ring joint (RJ)	n/a	n/a	340 (13.4)	17.7 (39)	340 (13.4)	17.7 (39)	340 (13.4)	17.7 (39)	340 (13.4)	17.7 (39)

## L1 dimension and weight with process connections according to EN 1092-1 (AISI 316L)

Process connection size and type	FCS100 sensor nominal size									
	DN 1		DN 2		DN 4		DN 6		DN 8	
	L1 in mm (inch)	Weight in kg (lb)	L1 in mm (inch)	Weight in kg (lb)	L1 in mm (inch)	Weight in kg (lb)	L1 in mm (inch)	Weight in kg (lb)	L1 in mm (inch)	Weight in kg (lb)
EN DN 15 PN 40 type B1, raised face (RF)	240 (9.4)	6.8 (15)	240 (9.4)	6.8 (15)	240 (9.4)	6.8 (15)	240 (9.4)	6.8 (15)	240 (9.4)	6.8 (15)
EN DN 15 PN 40 type D, with groove	240 (9.4)	6.6 (15)	240 (9.4)	6.6 (15)	240 (9.4)	6.6 (15)	240 (9.4)	6.6 (15)	240 (9.4)	6.6 (15)
EN DN 15 PN 40 type E, with spigot	240 (9.4)	6.5 (14)	240 (9.4)	6.5 (14)	240 (9.4)	6.5 (14)	240 (9.4)	6.5 (14)	240 (9.4)	6.5 (14)
EN DN 15 PN 40 type F, with recess	240 (9.4)	6.7 (15)	240 (9.4)	6.7 (15)	240 (9.4)	6.7 (15)	240 (9.4)	6.7 (15)	240 (9.4)	6.7 (15)
EN DN 15 PN 100 type B1, raised face (RF)	250 (9.8)	7.6 (17)	250 (9.8)	7.6 (17)	250 (9.8)	7.6 (17)	250 (9.8)	7.6 (17)	250 (9.8)	7.6 (17)
EN DN 15 PN 100 type D, with groove	250 (9.8)	13.6 (30)	250 (9.8)	13.6 (30)	250 (9.8)	13.6 (30)	250 (9.8)	13.6 (30)	250 (9.8)	13.6 (30)
EN DN 15 PN 100 type E, with spigot	250 (9.8)	7.3 (16)	250 (9.8)	7.3 (16)	250 (9.8)	7.3 (16)	250 (9.8)	7.3 (16)	250 (9.8)	7.3 (16)
EN DN 15 PN 100 type F, with recess	250 (9.8)	7.5 (17)	250 (9.8)	7.5 (17)	250 (9.8)	7.5 (17)	250 (9.8)	7.5 (17)	250 (9.8)	7.5 (17)
EN DN 25 PN 40 type B1, raised face (RF)	n/a	n/a	240 (9.4)	7.7 (17)	240 (9.4)	7.7 (17)	240 (9.4)	7.7 (17)	240 (9.4)	7.7 (17)

## Flow Measurement

## SITRANS FC (Coriolis)

## Flowmeter systems / SITRANS FC120/FC140

## Dimensional drawings (continued)

Process connection size and type	FCS100 sensor nominal size									
	DN 1		DN 2		DN 4		DN 6		DN 8	
	L1 in mm (inch)	Weight in kg (lb)	L1 in mm (inch)	Weight in kg (lb)	L1 in mm (inch)	Weight in kg (lb)	L1 in mm (inch)	Weight in kg (lb)	L1 in mm (inch)	Weight in kg (lb)
EN DN 25 PN 40 type D, with groove	n/a	n/a	240 (9.4)	7.7 (17)	240 (9.4)	7.7 (17)	240 (9.4)	7.7 (17)	240 (9.4)	7.7 (17)
EN DN 25 PN 40 type E, with spigot	n/a	n/a	240 (9.4)	7.4 (16)	240 (9.4)	7.4 (16)	240 (9.4)	7.4 (16)	240 (9.4)	7.4 (16)
EN DN 25 PN 40 type F, with recess	n/a	n/a	240 (9.4)	7.6 (17)	240 (9.4)	7.6 (17)	240 (9.4)	7.6 (17)	240 (9.4)	7.6 (17)
EN DN 25 PN 40 type B1, raised face (RF)	n/a	n/a	240 (9.4)	7.7 (17)	240 (9.4)	7.7 (17)	240 (9.4)	7.7 (17)	240 (9.4)	7.7 (17)
EN DN 25 PN 40 type D, with groove	n/a	n/a	240 (9.4)	7.7 (17)	240 (9.4)	7.7 (17)	240 (9.4)	7.7 (17)	240 (9.4)	7.7 (17)
EN DN 25 PN 40 type E, with spigot	n/a	n/a	240 (9.4)	7.4 (16)	240 (9.4)	7.4 (16)	240 (9.4)	7.4 (16)	240 (9.4)	7.4 (16)
EN DN 25 PN 40 type F, with recess	n/a	n/a	240 (9.4)	7.6 (17)	240 (9.4)	7.6 (17)	240 (9.4)	7.6 (17)	240 (9.4)	7.6 (17)
EN DN 25 PN 100 type B1, raised face (RF)	n/a	n/a	260 (10.2)	10.3 (23)	260 (10.2)	10.3 (23)	260 (10.2)	10.3 (23)	260 (10.2)	10.3 (23)
EN DN 25 PN 100 type D, with groove	n/a	n/a	260 (10.2)	10.2 (22)	260 (10.2)	10.2 (22)	260 (10.2)	10.2 (22)	260 (10.2)	10.2 (22)
EN DN 25 PN 100 type E, with spigot	n/a	n/a	260 (10.2)	9.7 (21)	260 (10.2)	9.7 (21)	260 (10.2)	9.7 (21)	260 (10.2)	9.7 (21)
EN DN 25 PN 100 type F, with recess	n/a	n/a	260 (10.2)	10.1 (22)	260 (10.2)	10.1 (22)	260 (10.2)	10.1 (22)	260 (10.2)	10.1 (22)
EN DN 40 PN 40 type B1, raised face (RF)	n/a	n/a	240 (9.4)	9.2 (20)	240 (9.4)	9.2 (20)	240 (9.4)	9.2 (20)	240 (9.4)	9.2 (20)
EN DN 40 PN 40 type D, with groove	n/a	n/a	240 (9.4)	9.1 (20)	240 (9.4)	9.1 (20)	240 (9.4)	9.1 (20)	240 (9.4)	9.1 (20)
EN DN 40 PN 40 type E, with spigot	n/a	n/a	240 (9.4)	8.8 (19)	240 (9.4)	8.8 (19)	240 (9.4)	8.8 (19)	240 (9.4)	8.8 (19)
EN DN 40 PN 40 type F, with recess	n/a	n/a	240 (9.4)	9.0 (20)	240 (9.4)	9.0 (20)	240 (9.4)	9.0 (20)	240 (9.4)	9.0 (20)
EN DN 40 PN 100 type B1, raised face (RF)	n/a	n/a	320 (12.6)	13.7 (30)	320 (12.6)	13.7 (30)	320 (12.6)	13.7 (30)	320 (12.6)	13.7 (30)
EN DN 40 PN 100 type D, with groove	n/a	n/a	320 (12.6)	13.6 (30)	320 (12.6)	13.6 (30)	320 (12.6)	13.6 (30)	320 (12.6)	13.6 (30)
EN DN 40 PN 100 type E, with spigot	n/a	n/a	320 (12.6)	13.2 (29)	320 (12.6)	13.2 (29)	320 (12.6)	13.2 (29)	320 (12.6)	13.2 (29)
EN DN 40 PN 100 type F, with recess	n/a	n/a	320 (12.6)	13.5 (30)	320 (12.6)	13.5 (30)	320 (12.6)	13.5 (30)	320 (12.6)	13.5 (30)

## L1 dimension and weight with process connections according to JIS B 2220 (AISI 316 / AISI 316L)

Process connection size and type	FCS100 sensor nominal size									
	DN 1		DN 2		DN 4		DN 6		DN 8	
	L1 in mm (inch)	Weight in kg (lb)	L1 in mm (inch)	Weight in kg (lb)	L1 in mm (inch)	Weight in kg (lb)	L1 in mm (inch)	Weight in kg (lb)	L1 in mm (inch)	Weight in kg (lb)
JIS DN 15 10K	240 (9.4)	6.5 (14)	240 (9.4)	6.5 (14)	240 (9.4)	6.5 (14)	240 (9.4)	6.5 (14)	240 (9.4)	6.5 (14)
JIS DN 15 20K	240 (9.4)	6.7 (15)	240 (9.4)	6.7 (15)	240 (9.4)	6.7 (15)	240 (9.4)	6.7 (15)	240 (9.4)	6.7 (15)
JIS DN 25 10K	n/a	n/a	240 (9.4)	7.6 (17)	240 (9.4)	7.6 (17)	240 (9.4)	7.6 (17)	240 (9.4)	7.6 (17)
JIS DN 25 20K	n/a	n/a	240 (9.4)	8 (18)	240 (9.4)	8 (18)	240 (9.4)	8 (18)	240 (9.4)	8 (18)
JIS DN 40 10K	n/a	n/a	240 (9.4)	8.4 (19)	240 (9.4)	8.4 (19)	240 (9.4)	8.4 (19)	240 (9.4)	8.4 (19)
JIS DN 40 20K	n/a	n/a	240 (9.4)	8.8 (19)	240 (9.4)	8.8 (19)	240 (9.4)	8.8 (19)	240 (9.4)	8.8 (19)

## L1 dimension and weight with process connections according to NPT internal thread

Process connection size and type	FCS100 sensor nominal size									
	DN 1		DN 2		DN 4		DN 6		DN 8	
	L1 in mm (inch)	Weight in kg (lb)	L1 in mm (inch)	Weight in kg (lb)	L1 in mm (inch)	Weight in kg (lb)	L1 in mm (inch)	Weight in kg (lb)	L1 in mm (inch)	Weight in kg (lb)
¼" NPT	260 (10.2)	5.6 (12)	260 (10.2)	5.6 (12)	260 (10.2)	5.6 (12)	260 (10.2)	5.6 (12)	260 (10.2)	5.6 (12)
⅜" NPT	260 (10.2)	5.6 (12)	260 (10.2)	5.6 (12)	260 (10.2)	5.6 (12)	260 (10.2)	5.6 (12)	260 (10.2)	5.6 (12)
½" NPT	260 (10.2)	5.6 (12)	260 (10.2)	5.6 (12)	260 (10.2)	5.6 (12)	260 (10.2)	5.6 (12)	260 (10.2)	5.6 (12)
¾" NPT	260 (10.2)	5.5 (12)	260 (10.2)	5.5 (12)	260 (10.2)	5.5 (12)	260 (10.2)	5.5 (12)	260 (10.2)	5.5 (12)

## Dimensional drawings (continued)

*L1 dimension and weight with process connections according to G internal thread*

Process connection size and type	FCS100 sensor nominal size									
	DN 1		DN 2		DN 4		DN 6		DN 8	
	L1 in mm (inch)	Weight in kg (lb)	L1 in mm (inch)	Weight in kg (lb)	L1 in mm (inch)	Weight in kg (lb)	L1 in mm (inch)	Weight in kg (lb)	L1 in mm (inch)	Weight in kg (lb)
G ¼ inch	260 (10.2)	5.6 (12)	260 (10.2)	5.6 (12)	260 (10.2)	5.6 (12)	260 (10.2)	5.6 (12)	260 (10.2)	5.6 (12)
G ⅜ inch	260 (10.2)	5.6 (12)	260 (10.2)	5.6 (12)	260 (10.2)	5.6 (12)	260 (10.2)	5.6 (12)	260 (10.2)	5.6 (12)
G ½ inch	260 (10.2)	5.6 (12)	260 (10.2)	5.6 (12)	260 (10.2)	5.6 (12)	260 (10.2)	5.6 (12)	260 (10.2)	5.6 (12)
G ¾ inch	260 (10.2)	5.5 (12)	260 (10.2)	5.5 (12)	260 (10.2)	5.5 (12)	260 (10.2)	5.5 (12)	260 (10.2)	5.5 (12)

*L1 dimension and weight with hygienic clamp process connections according to DIN 32676 series A*

Process connection size and type	FCS100 sensor nominal size									
	DN 1		DN 2		DN 4		DN 6		DN 8	
	L1 in mm (inch)	Weight in kg (lb)	L1 in mm (inch)	Weight in kg (lb)	L1 in mm (inch)	Weight in kg (lb)	L1 in mm (inch)	Weight in kg (lb)	L1 in mm (inch)	Weight in kg (lb)
DIN 32676 series A DN 15	240 (9.4)	5.3 (12)	240 (9.4)	5.3 (12)	240 (9.4)	5.3 (12)	240 (9.4)	5.3 (12)	240 (9.4)	5.3 (12)
DIN 32676 series A DN 25	n/a	n/a	240 (9.4)	5.4 (12)	240 (9.4)	5.4 (12)	240 (9.4)	5.4 (12)	240 (9.4)	5.4 (12)
DIN 32676 series A DN 40	n/a	n/a	240 (9.4)	5.4 (12)	240 (9.4)	5.4 (12)	240 (9.4)	5.4 (12)	240 (9.4)	5.4 (12)

*L1 dimension and weight with hygienic clamp process connections according to DIN 32676 series C (Tri-clamp)*

Process connection size and type	FCS100 sensor nominal size									
	DN 1		DN 2		DN 4		DN 6		DN 8	
	L1 in mm (inch)	Weight in kg (lb)	L1 in mm (inch)	Weight in kg (lb)	L1 in mm (inch)	Weight in kg (lb)	L1 in mm (inch)	Weight in kg (lb)	L1 in mm (inch)	Weight in kg (lb)
DIN 32676 series C ½ inch	240 (9.4)	5.3 (12)	240 (9.4)	5.3 (12)	240 (9.4)	5.3 (12)	240 (9.4)	5.3 (12)	240 (9.4)	5.3 (12)
DIN 32676 series C 1 inch	n/a	n/a	240 (9.4)	5.4 (12)	240 (9.4)	5.4 (12)	240 (9.4)	5.4 (12)	240 (9.4)	5.4 (12)
DIN 32676 series C 1½ inch	n/a	n/a	240 (9.4)	5.4 (12)	240 (9.4)	5.4 (12)	240 (9.4)	5.4 (12)	240 (9.4)	5.4 (12)

# Flow Measurement

## SITRANS FC (Coriolis)

### Flowmeter systems / SITRANS FC120/FC140

#### Dimensional drawings (continued)

#### Drawings, dimensions and weight for FCT020 and FCT040 transmitters

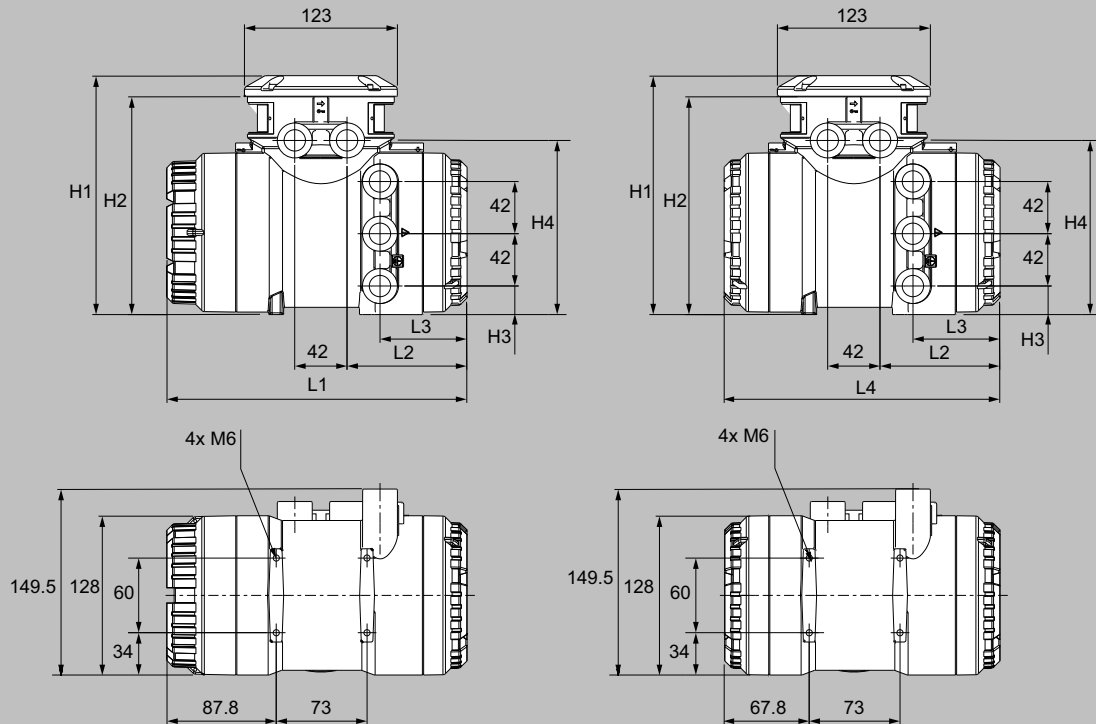

Dimensions of FCT020 or FCT040 transmitter in mm. Transmitter with display shown on the left. Transmitter without display shown on the right.

#### Dimensions L1 to L4 and H1 to H4 (material options: stainless steel, aluminum)

Material	L1 in mm (inch)	L2 in mm (inch)	L3 in mm (inch)	L4 in mm (inch)	H1 in mm (inch)	H2 in mm (inch)	H3 in mm (inch)	H4 in mm (inch)
Stainless steel	255.5 (10.06)	110.5 (4.35)	69 (2.72)	235 (9.25)	201 (7.91)	184 (7.24)	24 (0.94)	150.5 (5.93)
Aluminum	241.5 (9.51)	96.5 (3.8)	70 (2.76)	221 (8.7)	192 (7.56)	175 (6.89)	23 (0.91)	140 (5.51)

Dimensional drawings (continued)

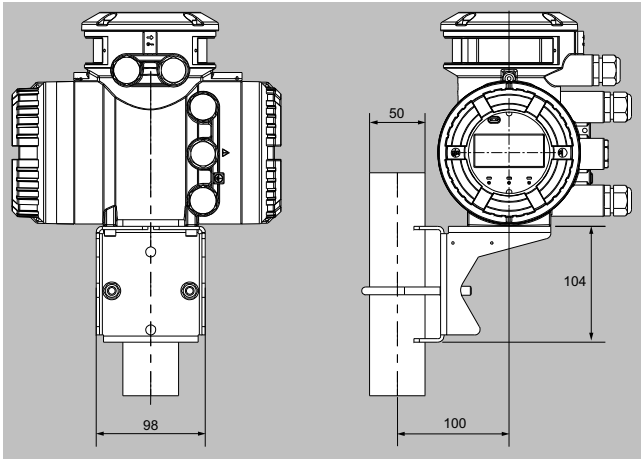

Dimensions of transmitter in mm, attached to mounting bracket.

Transmitter weights

Design type	Transmitter enclosure material	Weight in kg (lb)
Remote	Cast aluminum	4.2 (9.3)
	CF-8M stainless steel	12.5 (27.6)

Connecting cable dimensions and weights

Standard cable

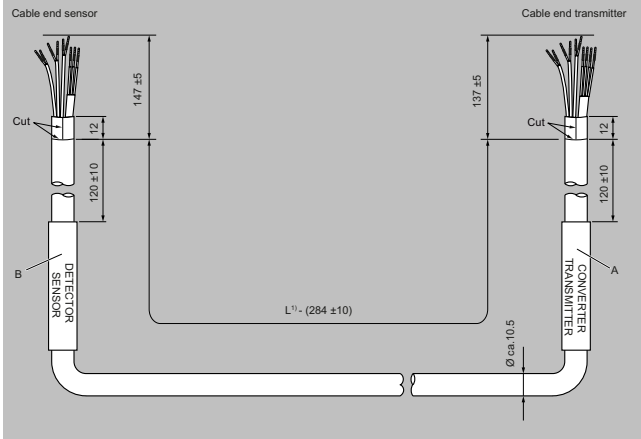

Dimensions in mm. Standard terminated cable. A and B are factory fitted labels.

Option code	Cable length, L	Cable color
L51	5 m (16.4 ft)	Non-Ex: gray / Ex: blue
L54	10 m (32.8 ft)	
L57	15 m (49.2 ft)	
L60	20 m (65.6 ft)	
L63	30 m (98.4 ft)	

Weight of cable ≤ 0.200 kg/m (0.134 lb/ft)

Standard cable with steel armored option

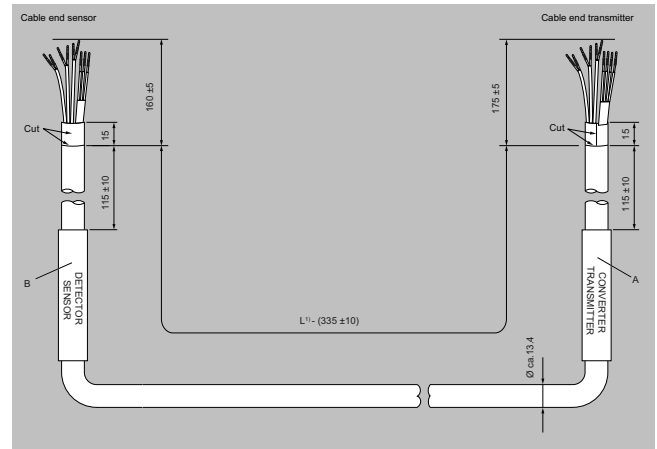

Dimensions in mm. Steel armored terminated cable. A and B are factory fitted labels.

Option code	Cable length, L	Cable color
L51 + A20/A21	5 m (16.4 ft)	Blue
L54 + A20/A21	10 m (32.8 ft)	
L57 + A20/A21	15 m (49.2 ft)	
L60 + A20/A21	20 m (65.6 ft)	
L63 + A20/A21	30 m (98.4 ft)	

Weight of cable ≤ 0.300 kg/m (0.202 lb/ft)

Fire retardant cable

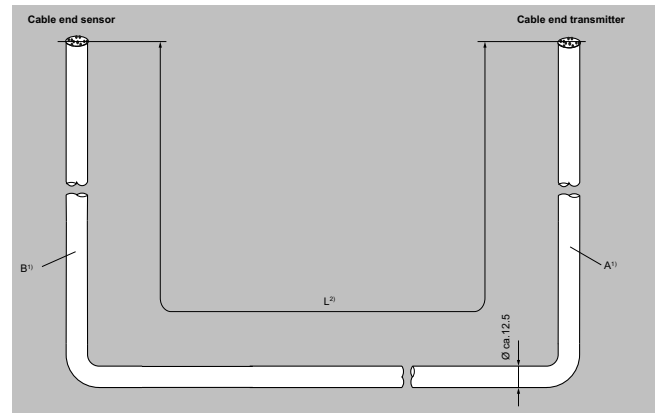

Dimensions in mm. Fire retardant unterminated cable. Labels A and B are supplied loose with termination kit.

Option code	Cable length, L	Cable color
L71	5 m (16.4 ft)	Gray
L74	10 m (32.8 ft)	
L77	15 m (49.2 ft)	
L80	20 m (65.6 ft)	
L83	30 m (98.4 ft)	

Weight of cable ≤ 0.270 kg/m (0.181 lb/ft)