

Siemens Industry, Inc.

USER'S MANUAL

UM352P-1
Rev. 6
January 2012
Supersedes Rev. 5



MODEL 352P

SINGLE-LOOP DIGITAL CONTROLLER

TABLE OF CONTENTS

SECTION AND TITLE	PAGE
PREFACE	ix
1.0 INTRODUCTION	1-1
1.1 PRODUCT DESCRIPTION	1-1
1.2 FUNCTION BLOCKS	1-6
1.2.1 LOOP Function Block Types	1-7
1.2.2 Power Up Initialization	1-8
1.2.3 Configuration	1-8
1.3 CUSTOMER/PRODUCT SUPPORT	1-9
1.4 EQUIPMENT DELIVERY AND HANDLING	1-10
1.4.1 Factory Shipment	1-10
1.4.2 Receipt of Shipment	1-10
1.4.3 Storage	1-10
1.4.4 Typical Shipment Contents	1-10
2.0 CONFIGURATION OVERVIEW	2-1
2.1 STATION FUNCTION BLOCKS	2-1
2.2 STATION HARDWARE I/O BLOCKS	2-1
2.3 LOOP FUNCTION BLOCKS	2-1
2.4 LIL GLOBAL DATA I/O FUNCTION BLOCKS	2-2
2.5 ETHERNET DATA I/O FUNCTION BLOCKS	2-3
2.6 LonWorks REMOTE I/O FUNCTION BLOCKS	2-3
2.7 CONFIGURATION PROCEDURE	2-3
2.8 OPERATION DURING LOCAL ON-LINE CONFIGURATION	2-5
3.0 FUNCTION BLOCKS	3-1
3.1 STATION FUNCTION BLOCKS	3-3
3.1.1 FCO LIB - Factory Configuration Library	3-3
3.1.2 SECUR - Security	3-3
3.1.3 STATN - Station Parameters	3-5
3.1.4 CLOCK - Real Time Clock (V2.0/2.2)	3-7
3.1.5 ETHERNET - Ethernet Communication Network (V2.4)	3-7
3.2 I/O AND LOOP FUNCTION BLOCKS	3-8
3.2.1 A/M - A/M Transfer	3-8
3.2.2 ACS - ARCCOSINE	3-10
3.2.3 ADD_ - Addition	3-10
3.2.4 AG3 - AGA 3 Orifice Metering of Natural Gas	3-11
3.2.5 AG7 - AGA 7 Measurement of Gas by Turbine Meters	3-13
3.2.6 AG8 - AGA 8 Compressibility Factors of Natural Gas	3-14
3.2.7 AIE_ - Analog Input - Ethernet (V3.0)	3-15
3.2.8 AIL_ - Analog Input - LIL	3-17
3.2.9 AIN_ - Analog Inputs	3-18
3.2.10 AINU_ - Analog Inputs, Universal	3-19
3.2.11 AIP_ - Analog Input lev_Percent	3-21
3.2.12 ALARM - Alarm	3-22
3.2.13 AND_ - AND Logic	3-24
3.2.14 AOE_ - Analog Output- Ethernet (V2.4)	3-25
3.2.15 AOL_ - Analog Output - LIL	3-25
3.2.16 AOP_ - Analog Output lev_Percent	3-26
3.2.17 AOUT_ - Analog Outputs	3-27
3.2.18 ASN_ - ARCSINE	3-28
3.2.19 ATD_ - Analog Trend Display	3-28
3.2.20 ATN_ - ARCTANGENT	3-29

3.2.21 AWE_ - Analog Write Ethernet (V3.0)	3-30
3.2.22 BATOT - Batch Totalizer	3-31
3.2.23 BATSW - Batch Switch.....	3-33
3.2.24 BIAS - Bias	3-34
3.2.25 CIE_ - Coil Inputs - Ethernet (V3.0).....	3-35
3.2.26 CHR_ - Characterizer.....	3-36
3.2.27 CMP_ - Comparator	3-37
3.2.28 COS_ - COSINE	3-37
3.2.29 CWE_ - Coil Write Ethernet (V3.0)	3-38
3.2.30 DAM_ - Deviation Amplifier	3-39
3.2.31 DID_ - Digital Input lev_Discrete.....	3-40
3.2.32 DIE_ - Digital Input - Ethernet (V3.0).....	3-41
3.2.33 DIL_ - Discrete Input _ LIL.....	3-42
3.2.34 DIN_ - Digital Inputs	3-43
3.2.35 DINU_ - Digital Inputs, Universal.....	3-44
3.2.36 DIS_ - Digital Input _ State	3-45
3.2.37 DIV_ - Division	3-46
3.2.38 DNC_ - Divide by N Counter	3-46
3.2.39 DOD_ - Digital Output lev_Discrete	3-47
3.2.40 DOE_ - Digital Output - Ethernet (V2.4).....	3-48
3.2.41 DOL_ - Discrete Output - LIL	3-48
3.2.42 DOS_ - Digital Output State	3-49
3.2.43 DOUT_ - Digital Outputs	3-50
3.2.44 DTM_ - Dead Time Table.....	3-51
3.2.45 DWE_ - Digital Write Ethernet (V3.0).....	3-52
3.2.46 DYT_ - Delay Timer.....	3-53
3.2.47 E/I - External/Internal Transfer Switch.....	3-54
3.2.48 ESL - Events Sequence Logger	3-55
3.2.49 EXP_ - NATURAL EXPONENTIATION.....	3-56
3.2.50 EXT_ - EXPONENTIATION.....	3-56
3.2.51 FTG_ - Falling Edge Trigger	3-57
3.2.52 GB_ - Gain & Bias.....	3-57
3.2.53 HLD_ - Hold	3-57
3.2.54 ID - ID Controller	3-58
3.2.55 LL_ - Lead/Lag	3-59
3.2.56 LMT_ - Limit.....	3-59
3.2.57 LN_ - NATURAL LOGARITHM	3-60
3.2.58 LOG_ - LOGARITHM BASE 10.....	3-60
3.2.59 MTH_ - Math.....	3-61
3.2.60 MUL_ - Multiplication.....	3-62
3.2.61 NND_ - NAND Logic.....	3-62
3.2.62 NOR_ - NOR Logic	3-63
3.2.63 NOT_ - NOT Logic.....	3-63
3.2.64 ODA - Operator Display for Analog indication & alarming (V2.2).....	3-64
3.2.65 ODC - Operator Display for Controllers.....	3-66
3.2.66 ODD - Operator Display for Discrete indication & control (V2.2)	3-68
3.2.67 ODP - Operator Display for PushButtons (V2.2)	3-70
3.2.68 ODS - Operator Display for Sequencer	3-72
3.2.69 ON/OFF - On/Off Controller	3-74
3.2.70 OR_ - OR Logic.....	3-75
3.2.71 ORSL - Override Selector.....	3-75
3.2.72 OST_ - One Shot Timer	3-76
3.2.73 PB1SW - PB1 Switch	3-77
3.2.74 PB2SW - PB2 Switch	3-78
3.2.75 PB3SW - PB3 Switch	3-79
3.2.76 PCOM - Phase COMMunication.....	3-80
3.2.77 PD - PD Controller.....	3-82

3.2.78 PID - PID Controller	3-84
3.2.79 PIDAG - PIDAG Controller	3-86
3.2.80 PRSEQ - Program Sequencer.....	3-88
3.2.81 QHD_ - Quickset Hold	3-90
3.2.82 RATIO - Ratio	3-91
3.2.83 RCT_ - Repeat Cycle Timer.....	3-92
3.2.84 RLM_ - Rate Limiter	3-93
3.2.85 ROT_ - Retentive On Timer	3-94
3.2.86 ROUT_ - Relay Outputs	3-94
3.2.87 RSF_ - RS Flip-Flop	3-95
3.2.88 RTG_ - Rising Edge Trigger.....	3-95
3.2.89 RTT_ - Real Time clock Trip (V2.0).....	3-95
3.2.90 SCL_ - Scaler.....	3-96
3.2.91 SEL_ - Signal Selector.....	3-96
3.2.92 SETPT - Setpoint	3-97
3.2.93 SIN_ - SINE.....	3-98
3.2.94 SPLIM - Setpoint Limit	3-99
3.2.95 SRF_ - SR Flip-Flop	3-100
3.2.96 SRT_ - Square Root	3-100
3.2.97 SUB_ - Subtraction	3-101
3.2.98 TAN_ - TANGENT	3-101
3.2.99 TH_ - Track & Hold.....	3-102
3.2.100 TOT_ - Totalizer (V2.3).....	3-102
3.2.101 TSW_ - Transfer Switch.....	3-103
3.2.102 XOR_ - Exclusive OR Logic	3-103
4.0 FACTORY CONFIGURED OPTIONS	4-1
4.1 FCO101 - Single Loop Controller w/ Tracking Setpoint.....	4-2
4.2 FCO102 - Single Loop Controller w/ Fixed Setpoint.....	4-3
4.3 FCO103 - External Set Controller with Tracking Local Setpoint	4-4
4.4 FCO104 - External Set Controller with Non-Tracking Local Setpoint	4-6
4.5 FCO105 - Ratio Set Control w/ Operator Setpoint Limits.....	4-8
4.6 FCO106 - Single Loop Controller w/ Operator Setpoint Limits	4-10
4.7 FCO107 - Dual Loop Controller.....	4-11
4.8 FCO121 - Cascade Control.....	4-13
4.9 FCO122 - Cascade Control w/ Operator Setpoint Limits	4-15
5.0 LONWORKS COMMUNICATIONS	5-1
6.0 NETWORK COMMUNICATIONS.....	6-1
6.1 MODBUS DATA MAPPING	6-1
6.2 LIL DATA MAPPING	6-3
6.2.1 Station Data.....	6-3
6.2.2 Control Loop Data	6-5
6.2.3 Sequence Loop Data	6-6
6.2.4 Analog Indicator Loop Data	6-9
6.2.5 Discrete Indicator Loop Data	6-10
6.2.6 Pushbutton Loop Data.....	6-11
7.0 DATA MAPPING.....	7-1
7.1 CONNECTING TO APACS 39ACM, MYCROADVANTAGE, ProcessSuite, i ware PC.....	7-1
7.1.1 APACS.....	7-1
7.1.2 MYCROADVANTAGE	7-1
7.1.3 ProcessSuite	7-2
7.1.4 i ware PC	7-2
7.2 STATION DATA	7-3
7.2.1 Integer Data (16-bit Integer)	7-3

7.2.2 Station String Data (8-bit ASCII Char - 2/Word)	7-5
7.2.3 Station Coil Data (1-bit).....	7-5
7.2.4 Station Status Word (SSW).....	7-5
7.3 LOOP DATA.....	7-6
7.3.1 Dynamic Loop Integer Data.....	7-7
7.3.2 Variable Loop Integer Data.....	7-8
7.3.3 Static Loop Integer Data	7-10
7.3.4 Dynamic Loop Floating Point Data (32-bit IEEE).....	7-11
7.3.5 Variable Loop Floating Point Data (32-bit IEEE)	7-12
7.3.6 Static Loop Floating Point Data (32-bit IEEE)	7-14
7.3.7 String Loop Data (8-bit ASCII Char - 2/Word).....	7-16
7.3.8 Coil Loop Data (1-bit).....	7-19
7.3.9 PCOM Block Status	7-31
7.3.10 Sequencer Loop I/O Coil Data (1-bit).....	7-33
7.3.11 LonWorks Remote I/O (Models 352P, 353, 354N)	7-35
7.3.12 Trend Data (Loop Defined by MLTP)	7-43
7.3.13 Configuration Data Sequencer Loop.....	7-46
7.3.14 LIL Alarm Type Word (ATW)	7-48
8.0 INSTALLATION	8-1
8.1 INSTALLATION CONSIDERATIONS.....	8-1
8.1.1 I/O and Communication Considerations	8-1
8.2 ENVIRONMENTAL CONSIDERATIONS	8-3
8.3 MECHANICAL INSTALLATION.....	8-4
8.3.1 Panel and Rack Mounting Guidelines.....	8-4
8.3.2 Single Station Mounting	8-4
8.3.3 Multiple Station Row Mounting	8-4
8.4 ELECTRICAL INSTALLATION	8-6
8.4.1 Wiring Guidelines	8-6
8.4.2 Analog Signal Input Wiring (4-20 mA, 1-5 Vdc, and mV)	8-11
8.4.3 Analog Output Wiring (4-20 mA, 1-5 Vdc)	8-12
8.4.4 Digital Input Wiring.....	8-13
8.4.5 Digital Output Wiring (DO1 and DO2).....	8-13
8.4.6 Option 3 I/O Wiring.....	8-14
8.4.7 Relay Output Wiring.....	8-18
8.4.8 Local Instrument Link Wiring	8-18
8.4.9 Modbus Wiring	8-19
8.4.10 SYSTEM WIRING EXAMPLES	8-21
8.4.11 Power Wiring.....	8-23
8.5 FACTORY CALIBRATION.....	8-24
9.0 LOCAL FACEPLATE OPERATION.....	9-1
9.1 NORMAL OPERATION MODE.....	9-1
9.2 CONFIGURATION MODE.....	9-3
9.3 AUTOTUNE PROCEDURE.....	9-4
9.4 REMOVABLE CONFIGURATION BOARD.....	9-7
9.5 REAL TIME CLOCK/CONFIGURATION BACKUP BOARD.....	9-7
10.0 CONTROLLER AND SYSTEM TEST.....	10-1
10.1 CONTROLLER CONFIGURATION AND TEST	10-1
10.1.1 Connections and Power.....	10-1
10.1.2 Configuration	10-2
10.1.3 Input/Output.....	10-2
10.1.4 Auto/Manual	10-2
10.1.5 Modifying an FCO	10-2
10.1.6 Alarms.....	10-4
10.1.7 TAG	10-5

10.1.8 QUICK.....	10-5
10.1.9 TUNE.....	10-6
10.1.10 View mode.....	10-7
10.2 SYSTEM CHECKOUT.....	10-7
11.0 MAINTENANCE	11-1
11.1 TOOLS AND TEST EQUIPMENT	11-2
11.2 PREVENTIVE MAINTENANCE	11-2
11.2.1 Environmental Considerations	11-2
11.2.2 Visual Inspection.....	11-2
11.2.3 Cleaning	11-2
11.2.4 Circuit Board Handling	11-3
11.3 TROUBLESHOOTING.....	11-4
11.4 ERROR CODES	11-6
11.5 ASSEMBLY REPLACEMENT	11-10
11.5.1 Power Input Fuse	11-10
11.5.2 Display Assembly	11-10
11.5.3 MPU Controller Board.....	11-12
11.5.4 I/O Expander Board	11-14
11.5.5 Accessory Boards.....	11-15
11.6 OPTION 3 I/O SELECTION.....	11-18
11.6.1 Model 352PB (no I/O Expander Board)	11-18
11.6.2 Model 352PE (with I/O Expander Board)	11-18
11.7 MPU CONTROLLER BOARD JUMPERS	11-19
12.0 CALIBRATION	12-1
12.1 ANALOG INPUT (AI1, AI2, AI4, and AI6)	12-2
12.2 ANALOG OUTPUT, AO1, AO2, AO3	12-3
12.3 ANALOG INPUT, AI5	12-4
12.4 NO. 3 INPUT, THERMOCOUPLE	12-6
12.5 NO. 3 INPUT, RTD.....	12-7
12.6 NO. 3 INPUT, VOLTAGE.....	12-9
13.0 CIRCUIT DESCRIPTION	13-1
13.1 OVERVIEW	13-1
13.2 MPU CONTROLLER BOARD	13-2
13.3 I/O EXPANDER BOARD.....	13-2
13.4 LonWorks BOARD	13-3
13.5 LOCAL INSTRUMENT LINK (LIL) NETWORK BOARD	13-3
14.0 MODEL DESIGNATION AND SPECIFICATIONS	14-1
14.1 MODEL DESIGNATION	14-1
14.2 ACCESSORIES.....	14-3
14.3 SERVICE PARTS KITS	14-4
14.4 MECHANICAL SPECIFICATIONS	14-5
14.5 POWER INPUT REQUIREMENTS	14-5
14.6 MPU CONTROLLER BOARD SPECIFICATIONS	14-6
14.7 I/O EXPANDER BOARD SPECIFICATIONS	14-7
14.8 COMMUNICATION BOARDS	14-9
14.8.1 LonWorks Board.....	14-9
14.8.2 LIL Network Board (Local Instrument Link)	14-9
14.9 ENVIRONMENTAL SPECIFICATIONS	14-10
14.10 AGENCY APPROVALS	14-10
14.10.1 CSA Hazardous Locations Precautions	14-11
14.10.2 Special Conditions for Safe Use	14-12
15.0 ABBREVIATIONS AND ACRONYMS	15-1

LIST OF ILLUSTRATIONS

FIGURE AND TITLE	PAGE
1-1 Siemens 352P, Exploded View	1-3
1-2 Analog Input 5	1-5
1-3 Computer/Pulse Input.....	1-5
1-4 Voltage Input, Option 3 I/O	1-6
2-1 Configuration Road Map.....	2-6
3-1 Logic Diagram	3-81
8-1 Forced Air Ventilation	8-3
8-2 Panel Cutout Dimension.....	8-5
8-3 Model 352P Dimensions	8-5
8-4 Conductor Installation on Rear Terminals	8-7
8-5 Case Rear Terminals	8-8
8-6 Analog Input AI1, 2-Wire Transmitter	8-11
8-7 Analog Inputs AI1 and AI2, 4-Wire Transmitters	8-11
8-8 Analog Input AI5	8-12
8-9 Analog Output AO1, Current Output.....	8-12
8-10 Analog Output AO1, Voltage Output	8-13
8-11 Digital Inputs DI1 and DI2	8-13
8-12 Digital Output DO1, Resistive and Inductive Loads.....	8-14
8-13 LonWorks.....	8-15
8-14 Thermocouple Input (AI3).....	8-15
8-15 RTD Input; 2, 3, and 4-Wire (AI3)	8-16
8-16 Digital Inputs.....	8-16
8-17 Typical Computer/Pulse Input Connections.....	8-17
8-18 Universal Relay Outputs ROUT1 and 2, Resistive Load.....	8-18
8-19 LIL Network Wiring	8-19
8-20 Modbus Communications, Model 352P to APACS ACM and Personal Computer.....	8-20
8-21 Single Loop System, 2-Wire I/O.....	8-21
8-22 Single Loop System, 4-Wire I/O.....	8-22
8-23 Model 352P to Siemens SIREC D Analog Input Wiring	8-22
8-24 Model 352P to Model 363 VIEWPAC Analog Input Wiring	8-23
8-25 Controller Power Wiring.....	8-23
8-26 Suggested Power Wiring.....	8-23
8-27 Daisy Chained Power Wiring.....	8-24
11-1 Model 352P Exploded View	11-5
11-2 MPU Controller Board.....	11-13
11-3 I/O Expander Board	11-14
11-4 Accessory Board Installation and Replacement	11-15
11-5 LIL Network Board.....	11-17
11-6 LonWorks Board.....	11-17
11-7 Real Time Clock/Configuration Backup Board	11-17
11-8 Option 3 I/O Selection Using the Option 3 I/O Jumper	11-19
11-9 MPU Controller Board Jumpers.....	11-19
11-10 W8 Real Time Clock Jumper for Hot/Warm Start and Storage	11-20
13-1 Model 352P Block Diagram.....	13-1

LIST OF TABLES

TABLE AND TITLE	PAGE
1-1 352P Rear Terminal Number and ID vs. Function Block ID	1-4
1-2 Option 3 I/O, Terminals A8, A9, A10, and B10	1-5
3-1 Security Level vs. Accessible Operations	3-4
3-2 Modbus Port Baud Rate Parameters	3-6
3-3 Board Description and ID with Example Hardware and Software Revisions	3-6
3-4 Floating Point Number Formats	3-16
3-5 Integer Default Values	3-16
3-6 FB Numbers vs. Modbus Registers	3-16
3-7 Input Types	3-20
3-8 Calibration Input Values	3-20
3-9 SEN MIN/MAX & MIN/MAX SCALE Parameters	3-20
8-1 Available I/O and Communications	8-2
8-2 Communication Options and Features	8-3
8-3 Rear Terminal Assignments	8-9
8-4 Factory Calibration	8-24
9-1 Autotune Errors	9-6
9-2 Autotune Warnings	9-6
11-1 RTC/CB and RCB Boards, Off-Line Error Codes	11-7
11-2 On-Line Error and Status Codes	11-8
11-3 Option 3 Selection, Model 352PB	11-18
11-4 Option 3 Selection, Model 352PE	11-18
14-1 Siemens 352Plus™ Model Designation	14-2

Significant Changes for Revision 6, January 2012

SECTION AND/OR TITLE	CHANGE
Cover	Update revision number and date
Introduction	Section 1.3 Customer/Product Support updated
Circuit Description	Figure 13-1 Model 352P Block Diagram revised
Throughout	Quantity of digital inputs on Controller and Expander boards corrected.

Note

At Rev. 3, the User's Manual was reorganized to move the FCO and Network Communications appendices into the body of the manual, as in the Procidia™ i|pac™ User's Manual. In Rev 3 and later manuals, the Function Block section is followed by the FCO section and the Network Communications section is followed by the Data Mapping section (previously Appendix A Network Communications).

Procidia, i|pac, i|config, i|station, i|ware PC, APACS+, PAC 353, 352Plus, and VIEWPAC are trademarks of Siemens Industry, Inc. Other trademarks are the property of their respective owners. All product designations may be trademarks or product names of Siemens Industry, Inc. or other supplier companies whose use by third parties for their own purposes could violate the rights of the owners.

Siemens Industry, Inc. assumes no liability for errors or omissions in this document or for the application and use of information included in this document. The information herein is subject to change without notice.









Procedures in this document have been reviewed for compliance with applicable approval agency requirements and are considered sound practice. Neither Siemens Industry, Inc. nor these agencies are responsible for product uses not included in the approval certification(s) or for repairs or modifications made by the user.

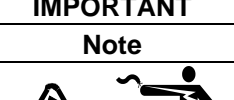

PREFACE

Conventions and Symbols

The following symbols may be used in this manual and may appear on the equipment. The reader should become familiar with the symbols and their meaning. Symbols are provided to quickly alert the reader to safety related situations, issues, and text.

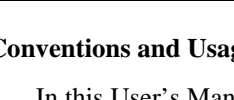
Symbol	Meaning
	Indicates an immediate hazardous situation which, if not avoided, <i>will</i> result in death or serious injury.
	Indicates a potentially hazardous situation which, if not avoided, <i>could</i> result in death or serious injury.
	Indicates a potentially hazardous situation which, if not avoided, <i>may</i> result in minor or moderate injury.
	Indicates a potentially hazardous situation which, if not avoided, may result in property damage.
	Indicates a potential situation which, if not avoided, may result in an undesirable result or state.
	Identifies an action that should be taken to avoid an undesirable result or state.
	Identifies supplemental information that should be read before proceeding.
	Electrical shock hazard – Either symbol indicates the presence of an electrical shock hazard. The associated text states the nature of the hazard, what can happen as a result of the hazard, and how to avoid the hazard..
	Explosion hazard – Symbol indicates that the danger of an explosion hazard exists. The associated text states the nature of the hazard, what can happen as a result of the hazard, and how to avoid the hazard.
	Electrostatic discharge – The presence of this symbol indicates that electrostatic discharge can damage the electronic assembly.
	Pinch hazard – Symbol indicates that a pinch hazard exists if correct procedures are not followed.

Conventions and Usage Notes:

- In this User's Manual, a Siemens 352Plus™ can be referred to using the term Siemens 352P, Model 352P, or simply 352P. The terms controller and station are also used to prevent repetition.
- Several chapters of this manual are also used in manuals for sister controllers and may contain references to those controllers.
- This manual describes the functionality provided by the current MPU Controller board firmware version. Where necessary a firmware version is identified by a phrase such as “in version x.x and higher” or simply “V1.3” or “V2.4.”

- Part numbers are for items ordered from the Process Industries Division of Siemens Industry, except as noted.
- Date format is Month-Day-Year, except as noted.
- Time format is 12 hour (a.m./p.m.), except as noted.

Warranty

The sales contract contains the entire obligation of Siemens. The warranty contained in the contract between the parties is the sole warranty of Siemens. Any statements continued herein do not create new warranties or modify the existing warranty.

Qualified Persons

The described equipment should be installed, configured, operated, and serviced only by qualified persons thoroughly familiar with this publication. A copy of this publication is shipped with the equipment. The current version, in Portable Document Format (PDF), is available at <http://www.usa.siemens.com/pi>.

For the purpose of this publication and product labels, a qualified person is one who is familiar with the installation, construction, and operation of the equipment, and the involved hazardous. In addition, he or she has the following qualifications:

- Is trained and authorized to energize, de-energize, clear, ground and tag circuits and equipment in accordance with established safety practices.
- Is trained in the proper care and use of protective equipment such as rubber gloves, hard hat, safety glasses or face shields, flash clothing, etc., in accordance with established safety practices.
- Is trained in rendering first aid.

Scope

This publication does not purport to cover all details or variations in equipment, nor to provide for every possible contingency to be met in connection with installation, operation, or maintenance. Should further information be desired or should particular problems arise which are not covered sufficiently for the purchaser's purposes, the matter should be referred to one of the support groups listed in the Product Support section of this manual.

The contents of this manual shall not become part of or modify any prior or existing agreement, commitment or relationship. The sales contract contains the entire obligation of Siemens. The warranty contained in the contract between the parties is the sole warranty of Siemens. Any statements continued herein do not create new warranties or modify the existing warranty.

General Warnings and Cautions



This equipment contains hazardous voltages, and it has been certified for use in the hazardous locations specified on the product nameplate and in the Model Designation and Specifications section. Death, serious personal injury, or property damage can result if safety instructions are not followed. Only qualified personnel should work on or around this equipment after becoming thoroughly familiar with all warning, safety notices, and maintenance procedures contained herein. The successful and safe operation of this equipment is dependent upon proper handling, installation, operation, and maintenance.

The perfect and safe operation of the equipment is conditional upon proper transport, proper storage, installation and assembly, as well as, on careful operation and commissioning.

The equipment may be used only for the purposes specified in this publication.

CAUTION

Electrostatic discharge can damage or cause the failure of semiconductor devices such as integrated circuits and transistors. The symbol at right may appear on a circuit board or other electronic assembly to indicate that special handling precautions are needed.



- A properly grounded conductive wrist strap must be worn whenever an electronics module or circuit board is handled or touched. A service kit with a wrist strap and static dissipative mat is available from on-line and local electronic supply companies.
- Electronic assemblies must be stored in anti-static protective bags when not installed in equipment.



1.0 INTRODUCTION

This User's Manual contains configuration, installation and service information for the Siemens 352Plus™ Single-Loop Digital Controller. It is divided into fifteen sections.

- Section 1, Introduction, has general information about the organization of this manual, the controller, product support, and the contents of a typical shipment.
- Section 2, Configuration Overview, contains a list of the function blocks available for use in configuring the controller and an overview procedure for controller configuration. Function block availability depends on controller model and MPU Controller board firmware version.
- Section 3, Function Blocks, contains a detailed description of each function block.
- Section 4, Factory Configured Options, provides a graphical presentation of the function blocks used in FCOs and a listing of changes made to default function block parameters.
- Section 5, LonWorks® Communications, provides an overview of LonWorks communication. (*The LonWorks option was discontinued in November 2005.*)
- Section 6, Network Communications, furnishes overviews of Modbus and Local Instrument Link (LIL) communication data.
- Section 7, Data Mapping, contains network data details for Modbus and LIL.
- Section 8, Installation, contains drawings and steps detailing mechanical and electrical installation. Electrical connections to the controller are identified and numerous wiring diagrams are included.
- Section 9, Local Faceplate Operation, describes and illustrates the Display Assembly's operator controls and displays. Use of these for on-line operation, for configurations, and for autotuning is described.
- Section 10, Controller and System Test, has procedures for testing the controller and the installation.
- Section 11, Maintenance, lists the tools and test equipment to service a controller. It also has preventive maintenance and servicing procedures, including error codes. Assembly replacement steps are included as are detailed jumper selection criteria and jumper setting steps.
- Section 12, Calibration, provides step-by-step procedures for calibration of analog input and output circuits.
- Section 13, Circuit Description, furnishes a block diagram level description of the controller's circuits.
- Section 14, Model Designation and Specifications, shows controller model numbers; a list of accessories; mechanical, electrical, and environmental specifications; and a list of current agency approvals.
- Section 15, Abbreviations and Acronyms, is a convenient reference for new users that explains many abbreviations and acronyms appearing in this manual.



1.1 PRODUCT DESCRIPTION

A Model 352Plus Single-Loop Digital Controller is a slide-in replacement for a Model 352 Single-Loop Digital Controller for upgrading and servicing existing 352 installations. The 352P is also an ideal choice when adding controllers to an existing 352 installation. The 352P houses in a 352 case the electronic circuitry and firmware developed for the Model 353 Process Automation Controller. Figure 1-1 shows an exploded view of the controller.

The 352P provides all of the I/O available with the 352 and several added features. These include:

- Modbus communications as a standard option
- PC-based remote configuration
- Local Instrument Link (LIL) option for network communication with LIL products and Procidia™ i|pac™
- LonWorks fieldbus capability for additional I/O to support advanced control capabilities

These features provide current 352 owners with a smooth transition to the powerful capabilities of the Model 353 Process Automation Controller.

Tables 1.1 and 1.2 list each case rear terminal, the terminal's identity and, for I/O, the function block identity. Figures 1-2, 1-3, and 1-4 show input details to AINU and DINU function blocks. Model 352P I/O function block identities are similar to the Model 352's. For example, a 352's analog input 1 identity is AI1. The equivalent 352P I/O function block identity is AIN1. When configuring or calibrating a 352P, the equivalent 352P I/O function blocks are active and the equivalent 352P I/O function block identities will be displayed.

At the heart of the 352P is a powerful MPU Controller board that uses the latest in microprocessor technology. It includes on-board I/O and reusable function blocks and is capable of solving a vast array of control implementations including single loop, cascade, and dual loop.

A Modbus communication port (RS485, half-duplex) is provided at rear terminals B1 and B2. The port allows network connection of up to 32 controllers (e.g., 352P, 353, 353R, i|pac, 354/354N) to an operator workstation or DCS, enabling integration of controllers into a plant-wide system.

Remote configuration uses the communication port (Modbus RS232) on the underside of the Display Assembly and the optional PC-based i|config™ Graphical Configuration Utility.

An optional I/O Expander Board can be added to the base model to increase the I/O options for improved accuracy and control. The board includes: direct thermocouple, RTD, and frequency input capability. It also has additional analog input, analog output, digital input, digital output, and relay outputs. Like the 'No. 3 Input' in a Model 352, not all I/O is available simultaneously. In the 352, a different option board was installed for the No. 3 Input. In the 352P, an 'Option 3 I/O Jumper' is set to make the I/O selection. A list of available I/O is found in Tables 1.1 and 1.2.

If more I/O is needed for multiple-loop applications, advanced control, or batch sequencing, a LonWorks remote I/O option board that uses the popular LonWorks protocol can be installed. This board provides connectivity via a high-speed digital fieldbus to a large selection of standard I/O products: analog inputs, analog outputs, and digital inputs and outputs using relay or solid state technology. The option requires that the Option 3 I/O Jumper be set to the 'LON' position.

The hardware architecture is designed to accommodate other emerging fieldbus technologies. This includes field communications that require lower power for intrinsic safety and higher speed for interplant networking.

Although the controller can be connected to and operated entirely from a central operator workstation, a controller faceplate is included. This local operator interface is for applications where loops need individual attention during startup, troubleshooting, maintenance, or emergency conditions. The convenient faceplate layout and sophisticated software allow process and configuration changes to be made quickly and easily.

The controller can be completely configured from the operator faceplate or configured remotely using the i|config Graphical Configuration Utility. An optional Real Time Clock/Configuration Backup Board is available to quickly transfer a configuration from one controller to another when downloading a configuration over a network is not available. This board also provides a real time clock function.

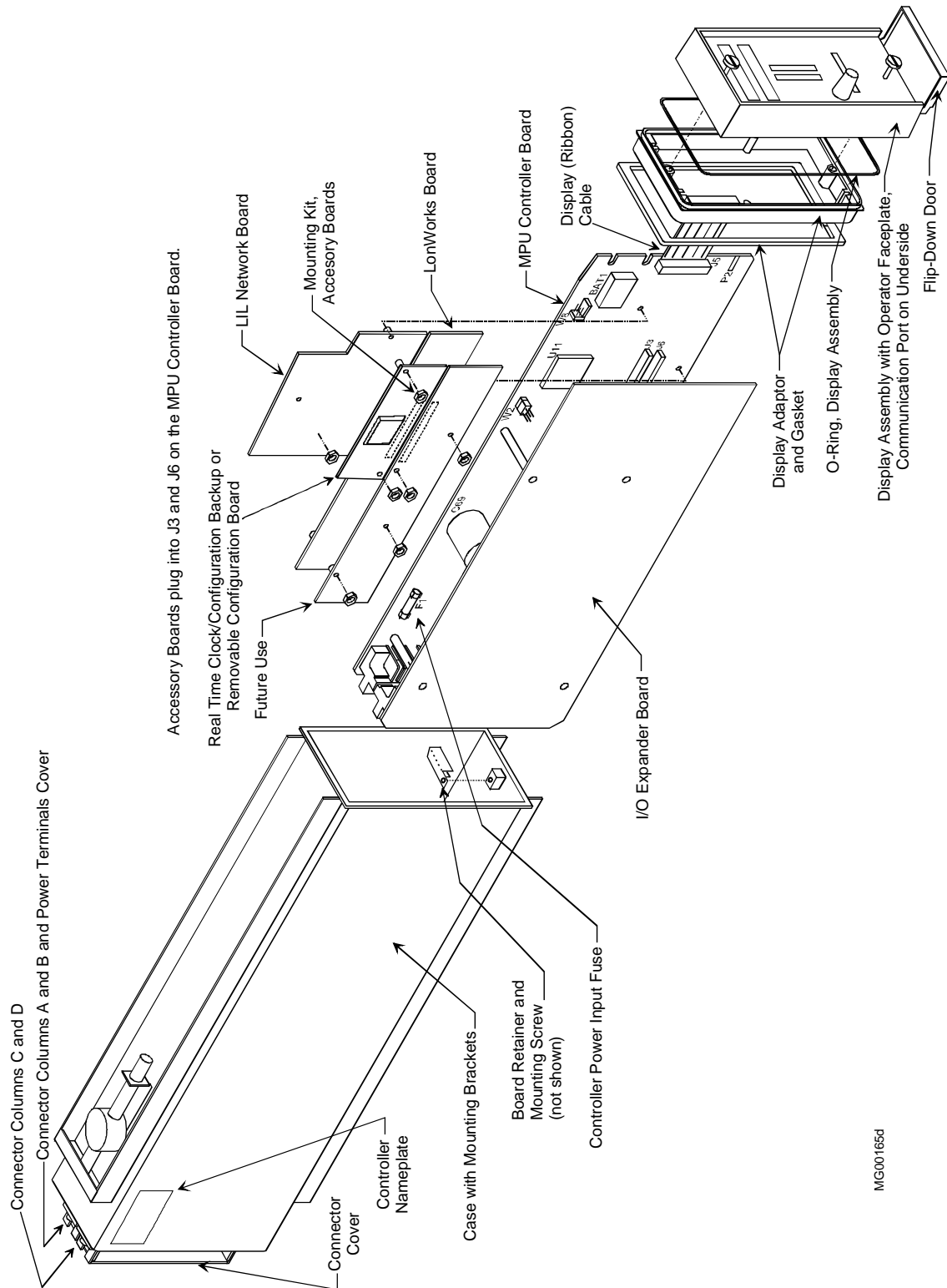

MG00165d

Figure 1-1 Siemens 352P, Exploded View

Table 1-1 352P Rear Terminal Number and ID vs. Function Block ID¹

352P Terminal	Description	352P Terminal ID	Function Block ID
A4	Analog Input 1 +	AI1+	AIN1+
A5	Analog Input Common	AIC	AINC
A6	Analog Input 2 +	AI2+	AIN2+
A7	Analog Output 1 +	AO1+	AOUT1+
A8	Analog Output Common or TC Reference Junction ²	AOC-	AOUTC
A9	<i>No. 3 Input (Table 1-2)</i>	<i>No. 3 Input (Table 1-2)</i>	<i>No. 3 Input (Table 1-2)</i>
A10	<i>No. 3 Input (Table 1-2)</i>	<i>No. 3 Input (Table 1-2)</i>	<i>No. 3 Input (Table 1-2)</i>

352P Terminal	Description	352P Terminal ID	Function Block ID
B1	Network +	Link +	----
B2	Network -	Link -	----
B3	<i>no connection</i>	n/c	----
B4	Digital Output 1 +	DO1+	DOUT1+
B5	Transmitter Power + 26 Vdc	+26 V	----
B6	Digital Output 2 +	DO2+	DOUT2+
B7	Digital Output Common	DOC-	DOUTC
B8	Digital Input 1 +	DI1+	DIN1+
B9	Digital Input 1 -	DI1 -	DIN1 -
B10	<i>No. 3 Input (Table 1-2)</i>	<i>No. 3 Input (Table 1-2)</i>	<i>No. 3 Input (Table 1-2)</i>

352P Terminal	Description	352P Terminal ID	Function Block ID
C1	Relay 1 Normally Open	R1NO	ROUT1no
C2	Relay 1 Common	R1C	ROUT1c
C3	Relay 1 Normally Closed	R1NC	ROUT1nc
C4	<i>no connection</i>	n/c	n/c
C5	Analog Output 3 +	AO3+	AOUT3+
C6	Analog Output Common	AOC -	AOUTC
C7	Digital Input 2 +	DI2+	DIN2+
C8	Digital Input 2 -	DI2 -	DIN2 -
C9	Digital Input 3 +	DI3+	DIN3+
C10	Digital Input 3 -	DI3 -	DIN3 -

352P Terminal	Description	352P Terminal ID	Function Block ID
D1	Relay 2 Normally Open	R2NO	ROUT2no
D2	Relay 2 Common	R2C	ROUT2c
D3	Relay 2 Normally Closed	R2NC	ROUT2nc
D4	Analog Input 4 +	AI4+	AIN4+
D5	Analog Input Common	AIC -	AIN4C/AINU1C
D6	Analog Input 5 +	AI5+	AINU1
D7	Analog Input 6 +	AI6+	AIN3+
D8	Analog Input Common	AIC-	AINC
D9	Analog Output 2 +	AO2+	AOUT2+
D10	Analog Output Common	AOC-	AOUTC

¹ Refer to Section 8 Installation for wiring details. Some terminal functions are jumper dependent; Refer to Sections 11.6 and 11.7 for details.² A8 - When both AO1 and T/C are needed, use another station common terminal for AOC-. See Table 1.2.

Table 1-2 Option 3 I/O, Terminals A8, A9, A10, and B10

Terminal	352PB or 352PE	352PB or 352PE	ASSOCIATED FUNCTION BLOCKS FOR OPTION 3 I/O JUMPER SELECTIONS, 352PE				
	I/O	LON	T/C, MV	RTD	FREQ	Computer/Pulse	Voltage
A8	AOUTC		AINU2a				
A9	AOUT2+	I/OBUSA	AINU2d	AINU2d		DINU1/2-	AINUc
A10	AIN3+	I/OBUSB	AINU2b+	AINU2c+	DINU1+	DINU1+	AINUb
B10	AIN3 -		AINU2c-	AINU2a-	DINU1 -	DINU2+	

Note:

LON options were discontinued November 2005. Other options require a Model 352PE.

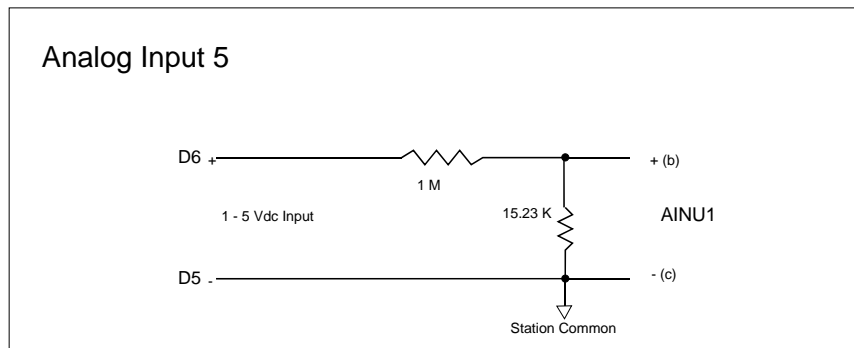

Shows resistive divider not present in Model 352's A15 circuit.

Figure 1-2 Analog Input 5

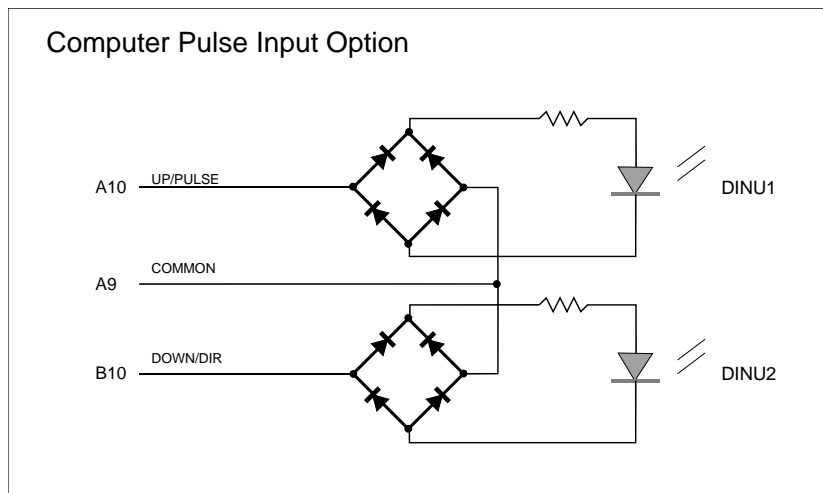

Shows computer and pulse inputs to the Model 353 function blocks.

Figure 1-3 Computer/Pulse Input

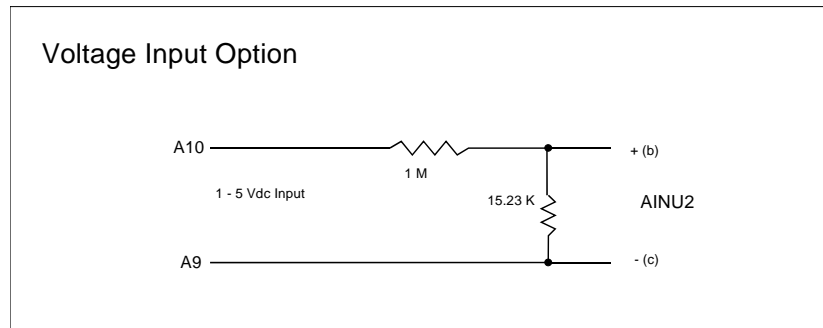

Shows resistive divider not present in Model 352.

Figure 1-4 Voltage Input, Option 3 I/O

Network communication options are listed in the following table.

Protocol (Select One)	Available	Connection (Port)	Option Board Needed
Modbus	Standard	Rear Terminals B1 and B2	None
Local Instrument Link	Optional	Rear Terminals B1 and B2	LIL Communications

Modbus communications is standard. Local Instrument Link (LIL) communications is available in place of Modbus to provide higher speed networking and peer-to-peer communication between controllers. This also provides connectivity with an array of LIL network-enabled products, including those listed below.

Current Controller Model(s)	Previous Controller Model(s)
Model 352 <i>Plus</i> Single-Loop Digital Controller Model 353 Process Automation Controller (Design Level B)	Model 353 Process Automation Controller (Design Level A) Model 353R Rack Mount Process Automation Controller Procidia™ i pac™ Internet Control System Model 352 Single-Loop Digital Controller Model 351 Triple-Loop Digital Controller Model 354/354N Universal Controller Model 382 Logic and Sequence Controller

Regardless of the selected communication option, the RS232 port on the underside of the Display Assembly will communicate using Modbus.

For small retrofit applications, the Model 352P with operator faceplate is a replacement for a simple stand-alone single loop controller. It is easily upgraded with additional I/O and communication options for advanced control strategies and plant networking.

Often in this publication, reference is made to the controller nameplate to ensure that the controller being installed has the correct power input, I/O, communication options, and approvals. This is particularly important when non-incendive requirements are present or a critical process is involved where a custom configuration or calibration has been created. Nameplate location is shown in Figure 1-1 and a typical nameplate is shown in Section 14 Model Designation and Specifications.

1.2 FUNCTION BLOCKS

Siemens 352P software is built on proven function block designs from previous LIL products and from Siemens APACS® products that support the IEC1131 standard. In many cases, the controller has been enhanced with features only now possible with state of the art technology.

Function blocks are selected for use within a LOOP. Multiple loops can be configured, and each loop can be associated with an operator faceplate. Certain blocks are used once within each loop (e.g. controller, setpoint, auto/manual), others can be used as many times as needed. Some notable features include Auto Tuning within the PID function blocks, an expandable Sequencer that allows configuration of up to 250 steps, and up to 256 discrete inputs and outputs. In addition, the i|config Graphical Configuration Utility can be used to design the logic in a ladder diagram. Combining these features with continuous control loops within the same controller offers a well-integrated solution for small batch operations.

Several function blocks are available at the station level for configuration of STATION level parameters, such as the station address and station tag name. Function blocks include the CLOCK block (when the RTC/CB option board has been included). All other function blocks are used for configuration within an individual LOOP. Control implementations are configured in the controller by first creating a loop, then entering a unique loop tag name and selecting function blocks for use within that loop. A number of loops can be configured in the controller and a number of function block types are available as described in the sections that follow.

1.2.1 LOOP Function Block Types

Local I/O Function Blocks are provided on both the MPU Controller Board and the I/O Expander Board. These blocks can be used in any LOOP, but as fixed resources are expendable. When used within a loop, the unique block name becomes <loop>.<block> (e.g. TC2053.AIN1 for Analog Input 1 used in loop TC2053).



Fixed Loop Function Blocks can be selected for use within each configured LOOP and include those blocks that define the major functions of a loop. The operator display function block (e.g. ODC Operator Display for Controllers) defines the loop type, the function of the local faceplate as well as the processing of commands coming from a remote workstation. A single controller function block can be selected from one of five available choices (ID, ON_OFF, PD, PIDAG, & PID) within each loop. When used within a loop the unique block name becomes <loop>.<block> (e.g. TC2053.PID for the PID controller used in loop TC2053).

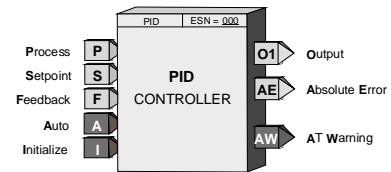

Arithmetic Function Blocks are also designated as LOOP function blocks and can be used as many times as needed in each loop. Each use of a block is automatically assigned a unique name (i.e. MATH01, MATH02) within each loop so that the unique block name becomes <loop>.<block> (e.g. TC2053.MATH01).

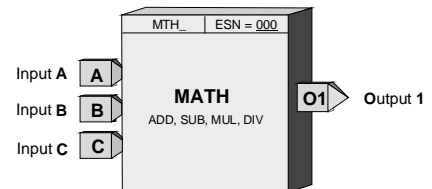

Logic Function Blocks are also designated as LOOP function blocks and can be used as many times as needed in each loop. Each use of a block is automatically assigned a unique name (i.e. AND01, AND02) within each loop so that the unique block name becomes <loop>.<block> (e.g. TC2053.AND01).

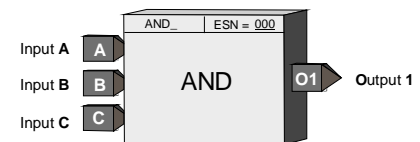

General Purpose Function Blocks are also designated as LOOP function blocks and include blocks that do not fall into the arithmetic or logic categories. These can be used as many times as needed and each use will automatically be assigned a unique name (e.g. HLD01, HLD02) within each loop so that the unique block name becomes <loop>.<block> (e.g. TC2053.HLD01).

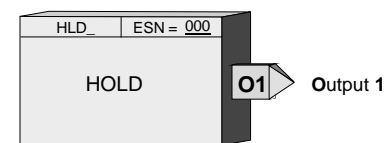

Remote I/O Bus Function Blocks can be used as needed in each LOOP when the LonWorks option is installed to provide a method for sending and receiving both analog and discrete data to and from remote devices over the remote I/O digital bus. Each use will automatically be assigned a unique name (e.g. AIP01, AOP01) within the station so that the unique block name becomes <loop>.<block> (e.g. TC2053.AIP01 for Analog Input-lev_Percent used in loop TC2053). The second AIP block used within the station will be assigned AIP02 even if in a

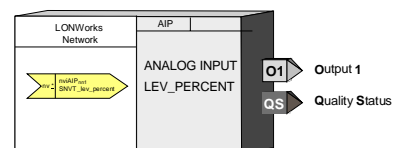

different loop so that the remote I/O blocks have unique names within the station. This will enable unique names for station variables on the LON network. (*The LonWorks option was discontinued in November 2005.*)

LIL Global Function Blocks are used as needed within a LOOP when the LIL option board is installed to enable global data communication over the LIL. They will automatically be assigned a unique name (e.g. AIL01, DIL01) within each loop when it is configured so that the unique block name becomes <loop>.<block> (e.g. TC2053.AIL01). Input and output data blocks are available as needed and will be assigned unique names as used (e.g. AIL01, AIL02 for Analog Input-LIL blocks).

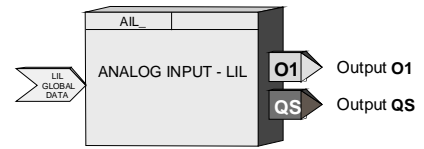

1.2.2 Power Up Initialization

The controller will retain, in the station NVRAM, calculated block values (e.g. outputs, elapsed time, last input/output logic states), including the time since power was lost. Three power up modes (hot, warm, and cold) are utilized in the controller that affect the initialization of function blocks. These modes are configured by two power up timers (warm and cold), included in STATION parameters. The station will initialize a hot start when power up occurs prior to the expiration of the warm timer. A cold start will occur when power up occurs after the expiration of the cold timer and a warm start will take place when the station powers up after the expiration of the warm timer but prior to the expiration of the cold timer.

Hot Start³ - All function block execution continues from the last state prior to power fail.

Warm Start³ - Function blocks that have a power up in a last state feature, either by design or by configuration selection, will power up as defined in the individual block descriptions. All other function blocks will initialize at cold start conditions.

Cold Start³ - All function block outputs will initialize at 0 unless otherwise stated in individual block descriptions.

1.2.3 Configuration

The controller can be configured either locally or remotely. First, the local faceplate includes buttons located behind a flip-down door for complete configuration including the addition/deletion of loops and function blocks and the editing of function block parameters. Section 2 Configuration Overview includes a road map for stepping through configuration. Certain block parameters (e.g. gains, constants) can be edited while on-line but design changes (e.g. block interconnections, block additions) will put the station in “configuration hold” which will hold outputs at the current value until the Exit button is pressed. This will enable bumpless changes to be made while on-line.

The second method is to use the `ijconfig` Graphical Configuration utility. A configuration can be downloaded to a controller either via the port on the local faceplate or over a network (either Modbus or LIL). During a download, all outputs will be held and the controller will retain all the intermediate calculations of all the blocks it had been running prior to the download. After the download, all function block parameters with the same tag name as those held will be used to initialize the downloaded function block parameters, thus providing a bumpless download under these conditions. If a loop tag name is changed, the tag names of all function blocks within that loop will change and will, therefore, require re-initialization of all of these blocks. However, the loop tag can be changed from the local faceplate without causing re-initialization, providing a bumpless tag change.

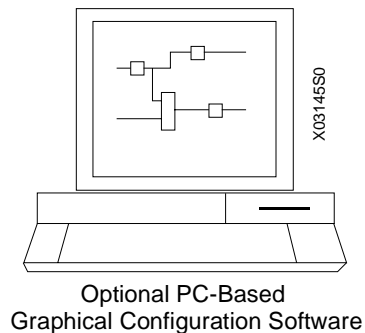

³ Set the Real Time Clock Jumper (W7 or W8) on the MPU Controller board. Refer to Section 11 Maintenance for details.

1.3 CUSTOMER/PRODUCT SUPPORT

Support is available through an online Support Request service; a link is provided in the table at the end of this section.

When contacting Siemens for support:

- Please provide complete product information:
 - For hardware, this information is provided on the product nameplate (part number or model number, serial number, and/or version).
 - For most software, this information is given in the Help > About screen.
- If there is a problem with product operation:
 - Is the problem intermittent or repeatable? What symptoms have been observed?
 - What steps, configuration changes, loop modifications, etc. were performed before the problem occurred?
 - What status messages, error messages, or LED indications are displayed?
 - What troubleshooting steps have been performed?
 - Is the installation environment (e.g. temperature, humidity) within the product's specified operating parameters? For software, does the PC meet or exceed the minimum requirements (e.g. processor, memory, operating system)?
- A copy of the product Service Instruction, User's Manual, or other technical publication should be at hand. The Siemens public Internet site (see the table) has current revisions of technical literature, in Portable Document Format, for downloading.
- To send an instrument to Siemens for warranty or non-warranty service, call Repair Service and request a Return Material Authorization (RMA).

IMPORTANT

An instrument must be thoroughly cleaned (decontaminated) to remove any process materials, hazardous materials, or blood-borne pathogens prior to return for repair. Read and complete the Siemens RMA form(s).

For the location of your local Siemens representative, visit the Siemens Process Instrumentation product support page at <http://www2.sea.siemens.com/Products/Process-Instrumentation/Support/Support/Support/Support.htm>.

For technical support refer to the following table and click the appropriate link.

Online Support Request	http://www.siemens.com/automation/support-request
Technical Support	1-800-333-7421; 8 a.m. to 4:45 p.m. eastern time, Monday through Friday (except holidays)
Customer Service & Returns	1-800-365-8766 (warranty and non-warranty)
Public Internet Site	http://www.usa.siemens.com/pi
Technical Publications in PDF	Click the above link to go to the Siemens Internet site and then click Process Instrumentation . In the column to the right, click Support > Manuals . In the column to the left, select the product line (e.g. Pressure or Temperature or Controllers) to open navigation and search panes.

1.4 EQUIPMENT DELIVERY AND HANDLING

1.4.1 Factory Shipment

Prior to shipment, a controller is fully tested and inspected to ensure proper operation. It is then packaged for shipment. Most accessories are shipped separately.

Real Time Clock Jumper - As shipped, the MPU Controller board Real Time Clock Jumper (W7 or W8) is set to maximize battery life. If the jumper is to be set to enable Hot/Warm Start, or to confirm that the jumper is properly set, refer to Section 11 Maintenance.

1.4.2 Receipt of Shipment

Inspect each carton at the time of delivery for possible external damage. Any visible damage should be immediately recorded on the carrier's copy of the delivery slip.

Carefully unpack each carton and check the contents against the enclosed packing list. Inspect each item for any hidden damage that may or may not have been accompanied by exterior carton damage.

If it is found that some items have been damaged or are missing, notify Siemens immediately and provide full details. In addition, damages must be reported to the carrier with a request for their on-site inspection of the damaged item and its shipping carton.

1.4.3 Storage

If a controller is to be stored for a period prior to installation, review the environmental specifications in Section 14 Model Designation and Specifications.

Refer to Section 11.6 Assembly Replacement to set the MPU Controller board Real Time Clock Jumper (W7 or W8) to the storage position to maximize battery life.

1.4.4 Typical Shipment Contents

The items listed below are those typically included in a shipment and are subject to change.

1. Controller, model number per order, qty. 1
2. Range Resistor Kit, qty. 1

DESCRIPTION	QUANTITY
Resistor, 250Ω, 0.1%, 3W, WW	3
Sleeving	3
Kit Installation Instruction (this instruction)	1

3. I/O Expander Board

When the I/O Expander board is factory installed it will be furnished with the following components:

DESCRIPTION	QUANTITY
Resistor, 250Ω, 0.1%, 3W, WW	3
Sleeving	3
Thermocouple Reference Junction, 100Ω	1

When the I/O Expander Board is shipped as a kit it will be furnished with the following components:

DESCRIPTION	QUANTITY
I/O Expander Board (do not remove from static bag until board is to be installed)	1
Mounting Standoffs	4
Mounting Screws	8
Resistors, 250 Ω , 0.1%, 3W, WW	3
Sleeving	3
Thermocouple Reference Junction, 100 Ω	1
Kit Installation Instruction	1

4. Printed Installation Guide IG352P-1.
 5. Process Instrumentation User Manual CD with UM352P-1, this User's Manual), qty. 1.
 6. Additional items as required by your order. Refer to the packing slip.
-

2.0 CONFIGURATION OVERVIEW

Configuration enables a user to select function blocks, stored in the controller, from an available list and enter appropriate block parameters to implement a specific control strategy. Although configuration affects the entire station, the controller partitions related control implementations into LOOPS. A maximum of 99 loops can be configured and 25 can have operator displays that are mapped to network communications⁴.

Each LOOP can contain the function blocks listed in the following paragraphs. Signals can be connected between function blocks within the LOOP as well as between loops. Also, there are several STATION function blocks that are fixed and available in the STATION menu for setting station related values.

Section 3 fully describes all available function blocks. For tuning guidelines refer to Section 9.3 Autotune Procedure or request AM-35 Digital Controller Tuning.

NOTE

This User's Manual includes the functionality provided by MPU Controller Board firmware Versions 1.3 and 2.0 through 2.40. These enhancements appear mainly in Sections 2 and 3. They are identified by the phrase "in version 1.3 and higher" or simply "V1.3" or "V2.4" in text.

2.1 STATION FUNCTION BLOCKS

Function blocks that are permanent and accessible at the STATION menu level:

FCO LIB.....Factory Configured Options **Library**
STATN.....**Station** Parameters
SECUR**Security**
CLOCKreal time **CLOCK** (requires firmware V2.2 or higher and RTC/CB board)
ETHERNET**Ethernet** Communications, Procidia and Model 353 only (requires firmware V2.4 or later and Ethernet board)

2.2 STATION HARDWARE I/O BLOCKS

Function blocks that are available during configuration depend on the hardware installed in the controller. These blocks can be selected within a LOOP but as fixed resources, once selected, are no longer available. The left column shows the minimum and maximum quantities of each block and the right column shows the quantity for each circuit board.⁵

AINI-4**Analog Input**.....MPU Controller Board (3), I/O Expander Board (1)
AINU1-2**Analog Input, Universal**I/O Expander Board (2)
AOUTI-3**Analog Output**.....MPU Controller Board (2), I/O Expander Board (1)
DINI-4**Digital Input**MPU Controller Board (3), I/O Expander Board (1)
DINU1-2**Digital Input, Universal**I/O Expander Board (2)
DOUTI-2**Digital Output**.....MPU Controller Board (2)
ROUTI-2**Relay Output**I/O Expander Board (2)

2.3 LOOP FUNCTION BLOCKS

The following blocks are available as needed within each loop in the quantities indicated (the quantity is one if no number is shown). Some blocks (e.g. A/M, BIAS) can be used only once within each LOOP. Others (e.g. ADD) are reusable within a LOOP and can be used up to the maximum number indicated. Each time a reusable block is selected within a LOOP, a new instance number will automatically be assigned (i.e. ADD01, ADD02). Each LOOP can have one operator display block (i.e. ODC or ODS). The display block defines how the loop will be displayed

⁴ Subject to available memory in the controller.

⁵ Model 352Plus™ only: Although these blocks can be selected in configuration, some may not have physical connections to the rear terminals depending upon the positioning of the Option 3 I/O Jumper.

on the local faceplate when that loop is selected and also how loop data will be mapped on the Modbus or LIL network interface. Each LOOP can have one controller function block (i.e. ID, ONOFF, PD, PID, or PIDAG).

A/MAuto/Manual	ODCOperator Display for Controllers
ACS01-99ARCCosine (V1.3)	ODSOperator Display for Sequencers
ADD01-99Addition	ODA (V2.2)Op Disp for Analog Ind. & Alarm
AG3AGA3 (V1.3)	ODD (V2.2)Op Disp for Discrete Ind & Control
AG7AGA7 (V1.3)	ODP (V2.2)Operator Display for Pushbuttons
AG8AGA8 (V1.3)	ONOFFON OFF Controller
ALARMAlarm	OR01-99OR Logic
AND01-99AND Logic	ORSLOverride Selector
ASN01-99Arcsine (V1.3)	OST01-99One Shot Timer
ATN01-99Arctangent (V1.3)	PB1SWPB1 Switch
ATD01-99Analog Trend Display (V1.3)	PB2SWPB2 Switch
BATOTBatch Totalizer	PB3SWPB3 Switch
BATSWBatch Switch	PCOMPhase Communication (V1.3)
BIASBias	PDPD Controller
CHR01-99Characterizer	PIDPID Controller
CMP01-99Comparator	PIDAGPIDAG Controller
COS01-99Cosine (V1.3)	PRSEQProgram Sequencer
DAM01-99Deviation Amplifier	QHD01-99Quickset Hold
DIV01-99Division	RATIORatio
DNC01-99Divide by N Counter	RCT01-99Repeat Cycle Timer
DTM01-99Dead Time Table	RLM01-99Rate Limiter (V3.0)
DYT01-99Delay Timer	ROT01-99Retentive On Timer
E/IExternal/Internal Transfer	RSF01-99RS Flip-Flop
ESLEvents Sequence Logger (V1.3)	RTG01-99Rising Edge Trigger
EXP01-99Natural Exponentiation (V1.3)	RTT01-99Real Time clock Trip (V2.0)
EXT01-99Exponentiation (V1.3)	SCL01-99Scaler
FTG01-99Falling Edge Trigger	SEL01-99Signal Selector
GB01-99Gain & Bias	SETPTSetpoint
HLD01-99Hold	SIN01-99Sine (V1.3)
IDID Controller	SPLIMSetpoint Limit
LL01-99Lead/Lag	SRF01-99SR Flip-Flop
LMT01-99Limit	SRT01-99Square Root
LN_01-99Natural Logarithm (V1.3)	SUB01-99Subtraction
LOG01-99Logarithm Base 10 (V1.3)	TAN01-99Tangent (V1.3)
MTH01-99Math	TH01-99Track & Hold
MUL01-99Multiplication	TOT01-99TOTalizer (V2.3)
NND01-99NAND Logic	TSW01-99Transfer Switch
NOR01-99NOR Logic	XOR01-99Exclusive OR Logic
NOT01-99NOT Logic	

2.4 LIL GLOBAL DATA I/O FUNCTION BLOCKS

These function blocks are available in the quantities indicated within each loop when the optional LIL Network board is installed. The total number of global function blocks will be limited by the number of global channels available. A controller has 256 channels. Each global data block occupies one global channel. In addition, each configured Control LOOP occupies 5 channels, each configured Sequencer LOOP 6 channels, and the Station itself the first 7 channels. See Section 6 for more information on network communications.

AIL01-99Analog Input_LIL
AOL01-99Analog Output_LIL
DIL01-99Discrete Input_LIL
DOL01-99Discrete Output_LIL

2.5 ETHERNET DATA I/O FUNCTION BLOCKS

These function blocks are available in Model 353, 353R and Procidia™ i|pac™ in the quantities indicated within a controller when the optional Ethernet Network board is installed. These blocks can be selected for use within individual loops but block names are unique station wide. *Ethernet function blocks are not available in Model 352P and Model 354/354N controllers.*

AIE01-32 Analog Input - Ethernet (V3.0)

AOE01-32 Analog Output - Ethernet (V2.4)

AWE01-32 Analog Write - Ethernet (V3.0)

CIE01-32 Coil Input - Ethernet (V3.0)

CWE01-32 Coil Write - Ethernet (V3.0)

DIE01-32 Discrete Input - Ethernet (V3.0)

DOE01-32 Digital Output - Ethernet (V2.4)

DWE01-32 Digital Write - Ethernet (V3.0)

2.6 LonWorks REMOTE I/O FUNCTION BLOCKS

These function blocks are available in the quantities indicated within a controller when the optional LonWorks Remote I/O board is installed. LonWorks is available for use with Model 352P, 353 (Design Level A) and 354 controllers. These blocks can be selected within individual loops, but block names will be unique station wide. This allows LonWorks network managers that identify variables using the block name within an individual node to be unique. For example, if LOOP01 uses AIP01 and AIP02 and an AIP block is selected in LOOP02 the name will be AIP03. Detailed information on the use of LonWorks can be found in Section 5. Model 352P only: Select LonWorks by setting the Option 3 I/O Jumper. (*The LonWorks option was discontinued November 2005.*)

AIP01-25 Analog Input lev_Percent

AOP01-25 Analog Output lev_Percent

DID1-6 Digital Input lev_Discrete, 16 Channels

DIS1-6 Digital Input_State (V1.3)

DOD1-6 Digital Output lev_Discrete, 16 Channels

DOS1-6 Digital Output_State (V1.3)

2.7 CONFIGURATION PROCEDURE

Each controller must be configured to perform the desired control strategy. The arrangement of functions and the numerical data required for a particular control circuit are referred to as the controller configuration. Local and remote configurations are accommodated.

Local configuration involves the configuration pushbuttons and the pulser knob on the Display Assembly's faceplate. Section 9.2 Configuration Mode shows the faceplate and provides brief descriptions of control functions.

Remote configuration requires a personal computer running the Siemens i|config™ Graphical Configuration Utility and either a configuration cable or a Modbus, LIL, or Ethernet network connection. The configuration can be created at and downloaded from the personal computer. A network connection is made at the controller's terminals. The configuration cable plugs into the configuration port in the underside of a 352Plus or 353 Display Assembly or into a 354N DB9 connector. The other end of this cable connects to a personal computer's serial port or to a modem.



Explosion hazard

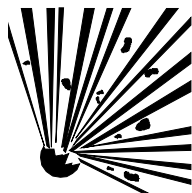

Explosion can cause death or serious injury.

In a potentially explosive atmosphere, remove power from the equipment before connecting or disconnecting power, signal or other circuits.

Comply with all pertinent regulations regarding installation in a hazardous area.

A configuration is designed by first arranging the needed function blocks in a fashion similar to that of a PI & D drawing. Parameter and calibration values are determined next and then entered on a Configuration Documentation Form or into the Graphical Configuration software. The controller may then be configured locally by entering the information on the form into the controller's configuration memory or remotely by downloading directly from the personal computer.

Nine common controller configurations have been stored in a built-in library that can be entered from the FCO LIB function block at the STATION level. Simple changes can then be made to accommodate individual needs. As an example, FCO101 Single Loop Controller includes the setpoint tracking feature but by simply disconnecting the TC input to the SETPT function block, it becomes a fixed setpoint Single Loop Controller. These FCOs are fully documented in Section 4.

- FCO101** - Single Loop Controller w/ Tracking Setpoint
- FCO102** - Single Loop Controller with Fixed Setpoint
- FCO103** - External Set Controller with Tracking Local Setpoint
- FCO104** - External Set Controller with Non-Tracking Local Setpoint
- FCO105** - Ratio Set Controller with Operator Setpoint Limits
- FCO106** - Single Loop Controller w/Operator Setpoint Limits
- FCO107** - Dual Loop Controller
- FCO121** - Cascade Loop Controller
- FCO122** - Cascade Loop Controller with Operator Setpoint Limits

Unless otherwise specified on the order, FCO101 is installed at the factory. Use the following procedure to change the factory configured option. Refer to Figure 2-1 Configuration Road Map to move to, and then through, the selected FCO and to enter or edit parameter values.

1. Press the ENTER/EXIT CONF button. LOOP will appear on the alphanumeric display.
2. Rotate the Pulser Knob until STATION appears on alphanumeric display.
3. Press the STEP DOWN button to display FCO LIB.
4. Press the STEP DOWN button to display FCO in the lower display.
5. Press the STEP DOWN button until the desired FCO number appears in numeric display.
6. Rotate the Pulser Knob to display the desired FCO number in the upper display.
7. Press the STORE button to load the new FCO.
8. Edit the FCO as needed. In addition to the material in this section, refer to:
 - Section 3 Function Blocks for details about configurable parameters
 - Section 4 Factory Configured Options for FCO diagrams and parameters
 - Sections 6 and 7 for Modbus, LIL, or Ethernet mapping
 - Section 9 Operation for operating controls and displays

Where an FCO is not suitable, a complete configuration can be designed to suit individual needs. Section 4 can be used as a guide for documenting a user-created or used-edited configuration. i|config, a PC-based Graphical Configuration Utility, can be used to design, document, and save configurations as well as download them to the controller, through either the configuration port or using a Modbus, LIL, or Ethernet network connection.

The above steps are illustrated in Figure 2-1 Configuration Road Map. The map also provides a broad overview of the configuration procedure.

- Press the ENTER CONF button to enter the configuration mode. Press the button again to exit configuration.
- After entering the configuration mode, LOOP or STATION can be selected.
- At the STATION level, a factory configured option can be loaded, station parameters can be configured, security passwords can be entered, the clock can be set, communication parameters can be configured, and inputs and outputs can be calibrated.

- Calibration can also be performed within individual loops containing the input or output function blocks used in the LOOP.
- At the LOOP level, new loops can be added, loops can be deleted, or an existing loop can be edited.

When a new loop is created, the controller will assign a default name (e.g. LOOP01). The loop name can be changed to any valid 12-character ASCII value. It is suggested that loop names be limited to six characters so that the complete tag name will appear in the alphanumeric display during normal operation.

A Loop can be edited by stepping down from the EDIT menu. If more than one loop has been configured, press the STEP DOWN button and turn the Pulser Knob to step through the list of configured loops. From the selected loop, stepping down will provide various options within the specific loop.

- The current value of all configured block outputs can be viewed.
- The current tag name of the loop and the ESN (Execution Sequence Number) can be changed. ESNs are automatically assigned by the controller in the order of creation, either a loop or individual block. An ESN should be changed when it is important that one loop be executed prior to another (e.g. cascade primary executes prior to the cascade secondary).
- Function blocks can be added to or deleted from the loop. Existing function blocks can be edited. Use the step up and step down buttons to move between the function block, parameter, and value levels within the EDIT FB menu.

If no configuration entries are made for about three minutes, the mode will time out and the controller will exit the configuration mode. The STATN function block has a CONFIG TO (Configuration Timeout) parameter to enable or disable timeout.

Loading an Earlier Firmware Version

In rare instances, replacing the installed MPU Controller board firmware with an earlier version may be desired. Before loading the earlier firmware, refer to the sections on configuration and load FCO-0 (zero) as the active configuration. This will install a minimum configuration and will reduce the number of error messages that appear during the firmware loading process.

2.8 OPERATION DURING LOCAL ON-LINE CONFIGURATION

Changing a controller's configuration parameters while the station is on-line can affect its operation and output values. Configuration parameters are divided into four types: HARD, SOFT, READ, and CALIBRATION.

HARD - When a HARD parameter is STORED the controller will suspend execution of all function blocks and will hold all outputs until the EXIT button is pressed. A HARD parameter is identified with each '(H)' notation in a function block parameter listing in Section 3. When a loop or function block is added or deleted, the station enters a HARD configuration mode.

SOFT - A SOFT function block parameter can be changed while the function blocks are executing. A SOFT parameter is identified with each '(S)' notation in a function block parameter listing in Section 3. All QUICKSET changes also fall into this category.

READ - These parameters are not changeable and therefore can be read while the station function blocks are executing. A READ parameter is identified with each '(R)' notation in a function block parameter listing in Section 3. The configuration VIEW mode also falls into this category.

CALIBRATION - To calibrate a parameter, enter CONFIGURATION mode, navigate to CAL, select a function block, and finally select a parameter to calibrate. At this point, the station will suspend execution of all function blocks and it will hold all outputs until the EXIT button is pressed. If an output block is being calibrated its output will be adjusted during the calibration procedure. A calibration parameter is identified with a '(C)' notation in a function block parameter listing in Section 3 Function Blocks.

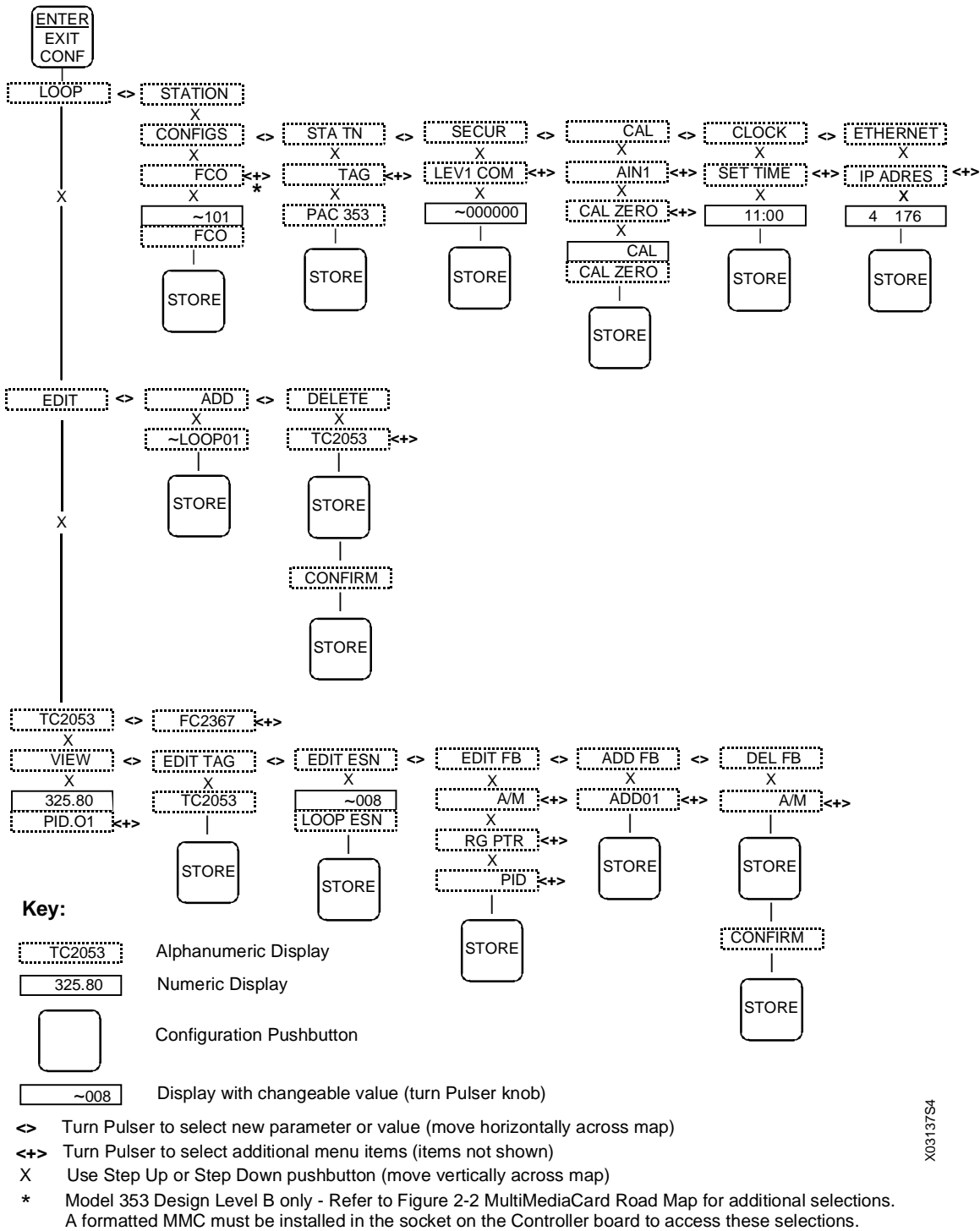

X03137S4

Figure 2-1 Configuration Road Map

3.0 FUNCTION BLOCKS

This section contains a detailed description of each function block (FB) available for configuration⁶. Each function block description is supplemented by: (1) a drawing of the block showing data inputs and outputs and control lines, (2) a block parameter table. Most blocks are further described by a block diagram that shows the block's circuitry in a simplified or equivalent circuit form.

NOTE

This User's Manual includes the additional functionality provided by MPU Controller Board firmware Versions 1.3, and 2.0 through 3.0. These enhancements appear mainly in Sections 2 and 3. They are identified by the phrase "in firmware 1.3 and higher" or the two-digit firmware version (e.g. "V1.3" or "V2.4" in text.

Keep your controller firmware current by subscribing to updates. The latest firmware version often provides performance options (e.g. additional function blocks, parameter selections) not available in an earlier version.

Ethernet function blocks described in this section are available in Model 353, Model 353R and Procidia™ i|pac™. They are not available in Model 352Plus™ and 354/354N controllers.

Function blocks have three types of inputs/outputs: digital, analog, and special data structure.

1. Arrows with dark shading and white letters are digital (outputs are displayed as 0 and 1 in the VIEW mode when using the local faceplate). Digital outputs are typically used to designate function block status, logical outputs, and on/off function block outputs. Some examples are:
 - Function block status: E/I status (IS, ES, SI), A/M status (AS, NA, MS, ES, SS), and Quality Status (QS)
 - Logical Outputs: AND (01), OR (01), NOR (01), or NOT (01)
 - On/Off function blocks: One Shot Timer (01), Retentive On Timer (01), Rising Edge Trigger (01), Alarms (A1, A2, A3, and A4), and Comparator (01)
2. Arrows with medium shading and black letters are analog. Internally they are REAL floating point numbers and outputs of these types will be displayed in the VIEW mode when using the local faceplate with the decimal point located to allow greatest resolution between 0.00000 and 999999 or -0.0000 and -99999. Numbers outside this resolution will blink.

Analog outputs are typically output (01) for analog I/O blocks and math functions. Analog outputs may also be specific to a particular function block such as the Analog Output (AO), Step Number (SN), Step Time (ST), Remaining Time (RT), and Current Recipe (CR) outputs of the Program Sequencer.

3. Arrows with medium shading and black letters but with a white tip are special data structures for range scaling information and will not be displayed in the VIEW mode). Range scaling information is used when there is a conversion of units within a function block, for example, the Alarm block scales the alarm limits into process engineering units when the range pointer is configured to the process analog input block. If unconfigured the units default to 0-100%. The output range (OR), typically used on analog output function blocks, includes MIN and MAX SCALE, the DPP (Decimal Point Position), and the ENGUNITS (Engineering Units). The analog output block is typically used for a 0-100% output to a valve where a minscale of 0 = 4 mA output and a max scale of 100 = 20 mA output.

The output range is connected to the Range Pointer (input R) of functions blocks requiring scaling other than the default 0-100. For example, an Analog input block could be scaled 0-5000 psig with output (01) connected to the AOUT input (S) and the AIN (OR) connected to the AOUT input (R). The Analog output would then output 4 mA at a minscale of 0 psig and 20 mA at a maxscale of 5000 psig. In contrast, if AOUT input (R)

⁶ The LonWorks function blocks used in Models 352P, 353 (Design Level A), and 354/354N are described in this manual. The Ubus function blocks used in Model 353R and Procidia i|pac (UAH, UAI, UAO, UDI, UDO, UEI, UER, UET, URI, USD, and UTI) are included in the firmware but are not described here since they will not operate in Models 352P, 353, and 354/354N.

were left unconfigured the output would equal 4 mA at a minscale of 0 psig, 20 mA at a maxscale of 100 psig and over ranged for any input over 100 psig.

Some users may prefer to use normalized 0-1 analog inputs for math calculations and scale outputs for display only; in this case, the Scaler function block may be used to provide an output range (OR) for the ODC (Operator display block).

Note how the range pointers are used in the following Factory Configured Options (FCOs). FCOs are described in detail in the Factory Configured Options section.

- FCO101 Single Loop Controller – The process output range AIN1 (OR) is connected to the range pointer of the SETPT block, the PID block, the ALARM block and the process variable range of the ODC block. As a result these blocks will be automatically rescaled when the minscale and the maxscale or the engineering units of the Process is changed. For example, if AIN1 is scaled 0-5000, the 0-100% bargraph on the display will represent 0-5000 when displaying the process. The A/M block, AOUT1 (Valve) output, and the Valve input of the ODC block are scaled based on the output of the PID block.
- FCO104 External-Set PID controller – The external setpoint is displayed as variable X in the ODC block. Therefore, the ODC (RX) input uses the range output of the external setpoint AIN2 (OR) for scaling. The 0-100% bargraph will represent the range of AIN1 when displaying the process variable and the range of AIN2 when displaying the X variable.
- FCO105 Ratio Set Control – AIN1 and AIN2 are scaled 0-100% of flow. The ratio of these flows is displayed on variable Y and the scaler function block is used to define the engineering units as a dimensionless ratio CF/WF scaled from 0.50 –1.50.

Connections between blocks are allowed only with similar data types.

To help you quickly locate a function block:

- In this section, function blocks are listed alphabetically by the block ID (e.g. AIN for Analog Input).
- In Section 2, function blocks are listed by broad function (e.g. station hardware I/O).

3.1 STATION FUNCTION BLOCKS

Station function blocks include factory configured options (FCOs), security, and station parameters. Each is described in the following subsections.

3.1.1 FCO LIB - Factory Configuration Library

The FCO LIB function block provides a selection of pre-configured applications. An FCO can be selected from the library and “STORED”. This loads a complete controller configuration, as defined by the FCO documentation, and erases any previously stored configuration. Station parameters and Calibration are retained when a new FCO is loaded. This enables a user to quickly configure the controller with an FCO without having to re-calibrate or re-enter the Station parameter values.

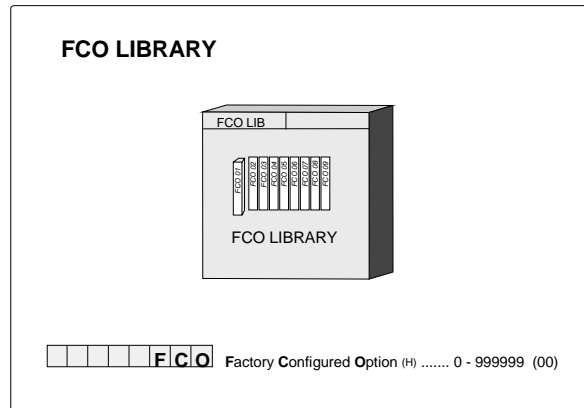

Upon stepping down to the FCO parameter, the last FCO that was loaded in the controller will be displayed. Turning the pulser knob will then display other FCOs that are available in the FCO library.

The configuration installed at the factory will be either FCO 101 or a custom configuration that was ordered and defined by the user. FCO 101 is a basic single loop PID controller.

An FCO can be loaded at any time in the field and used as is or modified (edited) to meet individual requirements. The FCO library file is not modified when the FCO selected for controller configuration is edited.

3.1.2 SECUR - Security

The SECUR function block enables a user to lock out portions or all of the faceplate configuration functions. Five levels of security are available; see Table 3-1. Each level is factory set to 000000 (no security), and can be changed by the user in the field to any number up to 999999.

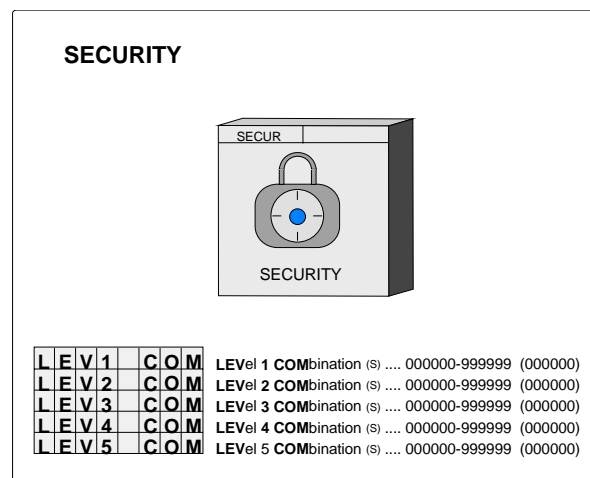

A security combination should be assigned to each security level (1-highest, 5-lowest). A level that remains at the default 000000 combination will have no security for the involved function(s) regardless of the security assigned to the other levels. For example, assume that level 1 is assigned a security combination but level 4 remains at 000000. If a controller calibration is performed, the station will not prompt the user for the security combination and anyone will be able to store new calibration values.

If security is desired, it is recommended that all 5 levels of security be set with either the same value or different values when different individuals are granted access to only certain functions.

The functions that can be accessed at the various security levels are listed in Table 3-1. The security combination will be required when the user attempts to store a parameter or attempts to view a security combination. The faceplate alphanumeric will display “ENTR COM” and allow the user to enter and store the combination. A

combination is entered by selecting one digit at a time using the ← and → keys and setting the number for that digit using the pulser. When all digits have been set, press STORE. If incorrect, the alphanumeric will display “ACCESS/DENIED” and then return to the parameter level. Once a combination has been entered correctly, access will be provided for all functions within that level until the user exits configuration. If a combination is lost, contact Siemens technical support to obtain a method to enter configuration and change the security codes. Refer to Section 1.3 for the contact information.

The PC-based Graphical Configuration Software may also have security options similar to the above. However, there is no security in the download procedure itself. At the controller there are parameters in function block STA_PARM that will lock out all downloads and all parameter writes from a PC.

Table 3-1 Security Level vs. Accessible Operations

FUNCTION	LEVEL 1	LEVEL 2	LEVEL 3	LEVEL 4	LEVEL 5
Station Function Block Edit	X	X			
Loop/Function Block Add/Delete	X	X			
Loop/Function Block Edit	X	X	X		
Security Configuration	X				
Calibration of Input/Outputs	X			X	
Quick Faceplate Access*	X	X	X		X
Configuration of NEW FCO	X	X			
Change CLOCK	X	X			

* Security does not apply, in firmware versions 1.30 and higher, to continuously adjustable quickset parameters that include RATIO, BIAS, and QHLD.

3.1.3 STATN - Station Parameters

The STATN function block enables entry of station identification and other station related information. When the station is networked using Modbus or the LIL option board the address is used by higher level devices to obtain information from the station. LIL addresses range from 1-32 or 1-64 when a Model 321 Expansion Satellite is used. Modbus can range from 1-250 but normally 1-32 is used to correspond to the total number of devices that can be installed on a single network.

Once the address has been assigned and higher level devices have been configured to access information from the station, changing the address can require reconfiguration of the higher level device. There may also be higher level devices that will query and assign addressing information based on the station tag name. In this case a tag name change will also require reconfiguration of higher level devices. Therefore, it is important not to change the station identification without being aware of system consequences.

There are two timers used during power up initialization: WARM TIM and COLD TIM. The station takes approximately 8 seconds to perform power up initialization before the power up time is evaluated. A timer should be set to a value greater than 8 seconds to be effective. A timer setting of 0 will be considered as infinite (e.g. to always power up hot, set the warm timer to 0). When the station powers up after a loss of power but prior to the expiration of the warm timer, the station will execute a Hot Start. If the station powers up after the warm timer expiration but prior to the expiration of the cold timer, the station will execute a warm start. In all other cases, the station will execute a cold start. The adjustable range of these timers is 0-18000 seconds for firmware versions prior to than 1.30 and is 0-999999 seconds for versions 1.30 and higher. **IMPORTANT:** The Real Time Clock jumper must be set for the warm and hot timers to function. See the Maintenance section for details on this jumper.

When using Modbus Network communications, the WATCHDOG timer can be set to a value other than 0 to cause a high WD output from the loop operator display function block when the station does not receive a computer command within the timer period. A value of 0 disables the watchdog. A Modbus communications DELAY time can entered for both the Display Assembly configuration port and LIL/Modbus terminals NCA/NCB (front and rear ports respectively). This may be necessary when the station responds too quickly for the modem. Modbus masters may handle IEEE floating point numbers in a different word order. The IEEE REV parameter allows matching the station to the Modbus master in use.

The CONFIG LO (Configuration Lockout) parameter (V2.40) - renamed from DWNLD LO in earlier versions - and PARAM LO (Parameter Write Lockout) parameter provide a method for locking out configuration transfers and parameter read/writes from a PC over a Modbus or LIL network. The parameter lockout does not affect the global updates on the on the LIL.

The 8-digit SERIAL # of the station is stored in memory and can be viewed when this parameter is displayed. If only seven digits are seen, assume a leading zero.

BAUD rate parameters set the Modbus port characteristics; see Table 3-2. The network Modbus port at terminals NCA and NCB, the rear port, is RS485 and uses the assigned station address. The configuration port, the front port,

STATION PARAMETERS

T A G	Station TAG (S)	12 Char ASCII	(PAC 353)
A D D R E S S	Station ADDRESS (H)	0 - 250	(0)
W A R M T I M	WARM Timer (sec) (S)	0 - 999999	(10)
C O L D T I M	COLD Timer (sec) (S)	0 - 999999	(100)
W A T C H D O G	WATCHDOG timer (sec) (S)	0 - 1000	(0)
C O N F I G L O	COnFIGuration Lock Out (S)	0/1/2/3	(0) (1)
P A R A M L O	PARAMeter Lock Out (S)	0/1/2/3	(0) (1)
S E R I A L #	SERIAL # (R)	0 to 99999999	(xxxxxxxx)
I E E E R E V	IEEE Floating Point REVERSE (S)	NO/YES	(YES)
R P B A U D	Rear Port BAUD rate (S)	(Table 3.2)	(5)
R P D E L A Y	Rear Port DELAY (S)	0 - 1000 msec	(0)
F P B A U D	Front Port BAUD rate (S)	(Table 3.2)	(6)
F P R T S	F P RTS/CTS handshaking (S)	(Table 3.2)	(1)
F P D E L A Y	Front Port DELAY (S)	0 - 1000 msec	(0)
H W P R E S	HardWare PRESENT (R)	(Table 3.3)	
C T B A S E	Cycle Time BASE msec (R)	20 to 2000	
C T B I A S	Cycle Time BIAS msec (H)	0 to 1000	(0)
C M A V A I L	Constant Mem AVAILABLE bytes(R).....	varies w/ software rev	
V M A V A I L	Volatile Mem AVAILABLE bytes(R).....	varies w/ software rev	
B A T O K	BATTery OK (R)	NO/YES	
S E R V P I N	SERVice PIN (S)	(press STORE to activate)	
C O N F I G T O	COnFIGuration Time Out (H)	NO/YES	(YES) (2)

(1) - Changed function in 2.40 0-No Lock Out, 1-Read Only, 2-Write Only, 3-Total Lock Out
 (2) - Available with Firmware version 1.30 or later

at a Model 352*Plus* or Model 353 Display Assembly's MMJ-11 connector, or a Model 354 or 354N Controllers' DB9 display/configuration port, is RS232 and uses an address of 1.

The Cycle Time of the station can be viewed as a parameter within the STATN block. In addition, a bias can be added to increase the total cycle time of the station. This may be necessary when significant communications activities are taking place, causing communication overrun errors. Adding bias will allow the processor more time during each scan cycle for completing the communication chores.

The station can be configured to time out of the configuration mode after 1 minute of no faceplate operations by setting the CONFIG TO parameter to YES (default). This parameter is in firmware versions 1.30 and higher.

Table 3-2 Modbus Port Baud Rate Parameters

PARAMETERS	SETTINGS
Data Formatting	8 bits, no parity, and 1 stop bit
Baud Rate Selections	1 - 300 2 - 1200 3 - 2400 4 - 4800 5 - 9600 6 - 19200 7 - 38400
Handshaking Selections	1. No handshaking is used. 2. The station port will turn on the RTS line when it's ready to send data but will not wait for a responding CTS from the receiving device. 3. The station port will turn on the RTS line when it's ready to send data and will wait for a responding CTS from the receiving device before transmitting.

A list of the installed controller hardware and software can be viewed within the STATN block using the HW PRES read only parameter. As shown in Table 3-3, each board has an ID and a hardware revision, and most also have a software revision. The controller's operating Kernel and operating code reside on the MPU Controller board and there is an entry in the table for each. The table lists the hardware and software revisions. For example, in Table 3-3, the MPU Controller board would be shown in the numeric display as '11 1.00'.

Table 3-3 Board Description and ID with Example Hardware and Software Revisions

BOARD DESCRIPTION	BOARD ID	HARDWARE REVISION	SOFTWARE REVISION
Kernel	0	1	1.00
MPU Controller - Models 352P, 353, and 353R	1	1	1.00
Display Assembly, Faceplate Display	2	1	1.00
I/O Expander	3	1	1.00
Ethernet Network (353, 353R and Procidia i pac)	6	1	2.40
Local Instrument Link	8	1	1.00
LonWorks	9	1	1.00
RTC/CB or RCB	b	1	1.31

Check the NVRAM battery condition by reading the BAT OK parameter. The NVRAM, on the MPU Controller Board, uses a sealed lithium battery that has a life of up to 40 years.⁷ The battery powers a portion of memory that stores operating data when external power is removed from the controller. When external power is next applied, the controller will read this data and return to the stored operating conditions. Should the battery fail, the station will power up in a Cold start using the controller configuration stored in permanent FLASH memory. Battery condition

⁷ With the Real Time Clock jumper properly set, as described in Section 11, up to 40 years for an on-line controller or for a stored MPU Controller Board or controller.

Up to 4 years for a stored MPU Controller Board or controller with the Real Time Clock jumper improperly set (i.e. clock enabled). Environmental conditions can affect battery life.

has no effect on normal operation while external power is applied. The SERV PIN is used when a LonWorks board is installed to identify this controller to the LonWorks network manager.

3.1.4 CLOCK - Real Time Clock (V2.0/2.2)

The CLOCK function block is available when the RTC/CB (Real Time Clock / Configuration Backup) option board is installed in the controller and the controller includes firmware version V2.0 or higher.

This function block enables the current time and date to be viewed when using the local faceplate. When the Step Down button is pressed to view the parameter value, the current TIME or DATE at that instant is displayed. The value can be changed using the pulser and the <-- and --> arrow buttons to enter a new value. The new value will initialize the clock when the STORE button is pressed. The time & date cannot be changed locally if the SRCE ADD parameter has been configured to a value other than 0 to have the time synchronized with a master station on the Local Instrument Link (LIL).

When the SRCE ADD parameter (version 2.2) has been configured to synchronize the time with a master controller on the LIL the controller will query the master controller at 12 midnight and synchronize its time with the master.

REAL TIME CLOCK

S E T	T I M E	SET TIME	00:00:00 to 23:59:59	(0)
S E T	D A T E	SET DATE	01011970 to 12313099	(0)
S R C E	A D D	SouRCE AdDress	0 - 64	(0)

3.1.5 ETHERNET - Ethernet Communication Network (V2.4)

Ethernet is available on Model 353, Model 353R and Procidia iipac controllers; not available on Models 352P and 354/354N.

The ETHERNET function block is available when the Ethernet Communication Network option board is installed in a controller and the controller includes firmware version V2.4 or higher.

Use this function block to configure Ethernet communication parameters. The default IP addresses shown are used for factory testing in a network environment and should be changed to meet individual system requirements. Consult your company's network administrator for assistance in determining IP addresses. Also, consider any network security issues that can arise when networking plant areas.

ETHERNET

I P	A D R E S S	IP AdDRESs (S) ..	1-nnn,2-nnn,3-nnn,4-nnn	(192.168.0.2)
I P	M A S K	IP MASK (S)	1-nnn,2-nnn,3-nnn,4-nnn	(255.255.255.0)
I P	G A T E	IP GATEway (S) ..	1-nnn,2-nnn,3-nnn,4-nnn	(192.168.0.1)
E T H	D P L X	ETHernet DuPLeX (S) .	Auto, HALF, FULL	(A)
E T H	R A T E	ETHernet RATE (S)	Auto, 10, 100	(A)
P 2 P	R A T E	Peer 2 Peer RATE (S)	.25, .5, 2, 5, 10 sec	(.5)

(Rev 2)

3.2 I/O AND LOOP FUNCTION BLOCKS

This section provides a detailed description of each input/output and loop function block. Blocks are listed alphabetically.

3.2.1 A/M - A/M Transfer

One A/M function block can be used per loop and it is normally used on the output of controller blocks to enable auto/manual operation of the loop. It is separate from the controller block allowing the option of inserting other function blocks (e.g. override, feedforward) between the controller and the A/M Transfer. If function block PB3SW has been used the A/M block is not available.

AUTO allows the signal from the controller (input A) to become the output of the A/M Transfer unless EMER MAN or STANDBY is active. Auto ONLY forces the operator pushbutton to be locked in the AUTO position, but EMEG MAN and STANDBY will function normally.

MANual allows the operator to adjust the manual value unless STANDBY is active. The manual value tracks the block output when in AUTO or STANDBY. The manual value can be adjusted when in MAN, provided the displayed variable is the process or the valve (e.g. TC2053.P or TC2053.V). When a loop is switched to MANual the display will automatically show the valve (e.g. TC2053.V). The range pointer (input Range) lets the A/M function block know the range of the auto input signal and enables the A/M block to properly process pulser changes from the operator faceplate. The range pointer also defines the range of the manual function as -10% to 110%. This can be useful to prevent inadvertent changes from an operator workstation that might set the manual value well beyond the local operator's changeable range. In most cases, the Range input (range pointer) will connect to the controller function block. An unconfigured range pointer will default the range to 0.00 - 100.00.

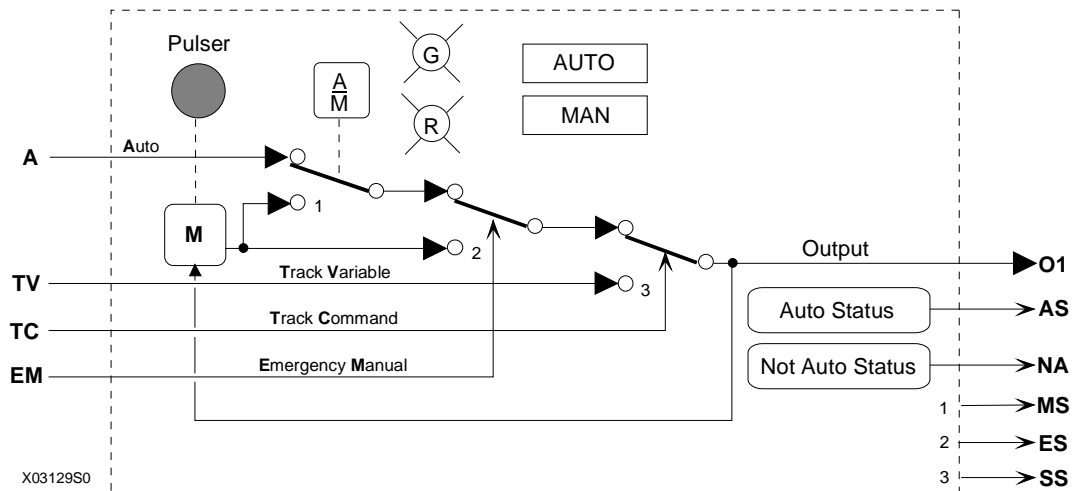
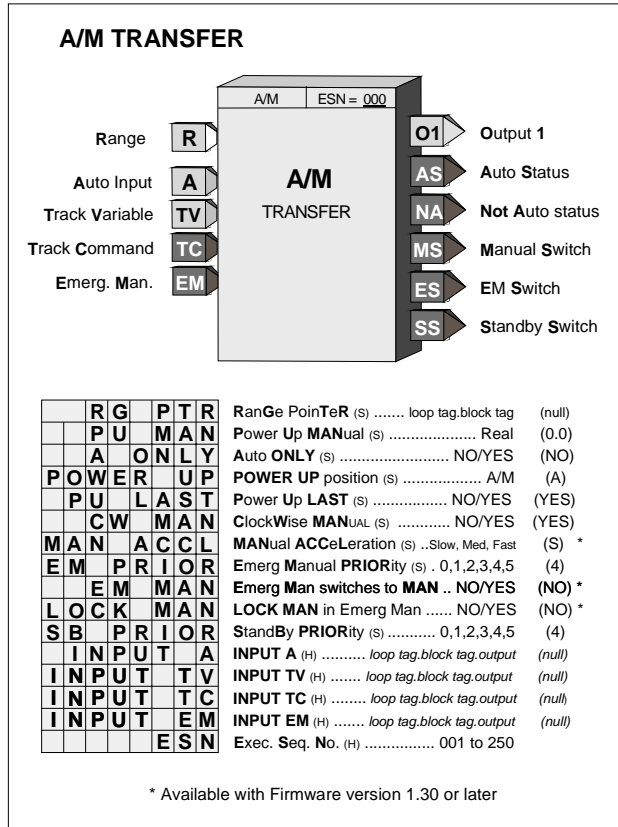

BLOCK DIAGRAM

EMERGENCY MANUAL will be asserted when input EM is high (1). This causes the output to hold at the last position and permits the operator to adjust the manual value under the conditions listed for MANUAL. It will also assert an EM MAN status, at the configured priority, to the operator display.

STANDBY will be asserted when input TC is high (1). This causes the A/M block output to track input TV thus placing the loop in a standby condition. This feature can be used to enable one loop to track another for either redundancy applications or optional control schemes. It will also assert a STANDBY status, at the configured priority, to the operator display.

STATUS OUTPUTS - Output **AS** (Auto Status) goes high (1) when output O1 is the Auto input; output **NA** will go high when output O1 is not the Auto input, output **MS** goes high when the A/M switch is in the manual position; output **ES** goes high when the Emergency Manual switch is in the manual position; and **SS** goes high when the standby switch is in the Track Variable position. Two LEDs on the display identify the position of the A/M switch.

POWER UP - The A/M function block can be configured to power up under various conditions during a warm or cold start. If **PU LAST** has been configured as **YES**, during a warm start all outputs are initialized at previous values and the block will power up in the same condition (i.e. same A/M switch position). When powering up in auto, the A/M block will execute in the manual mode for the first two scan cycles, allowing a controller block to track the last value. When **PU LAST** is set to **NO**, the A/M block does not power up in last position during a warm start and will power up as configured by the **POWER UP** parameter, either **AUTO** or **MAN**. During a cold start, the A/M block will always power up as configured by the **POWER UP** parameter. When the **POWER UP** parameter is used and the block powers up in **MAN**, the manual value can be set using the **PU MAN** parameter.

Clock Wise MANUAL configured as **YES**, the default position, will cause the manual value to increase with clockwise rotation of the knob. This feature is useful when clockwise rotation is desired to always open a valve whether the valve is direct or reverse acting.

EMERGENCY MANUAL, in firmware 1.30 and higher, allows the position of the A/M block Manual Switch (switch 1 in the block diagram) and the associated light to be configured. When the EM input goes high (1), the Emergency Manual Switch (switch 2) switches to manual. If **EM MAN** is configured as **YES**, the Manual Switch (switch 1) and the indicator light will switch to the manual position, assuming that switch 1 is in Auto, and will remain in the manual position until the operator presses the A/M button or a command is received from an HMI to switch to Auto. The EM Switch (switch 2) will remain in the manual position until the EM status clears regardless of the position of the Manual Switch (switch 1). If the **EM MAN** parameter is configured as **NO**, the Manual Switch (switch 1) and associated indicator light will not change position when the EM input goes high (1).

LOCK MAN, in V2.4, can be set to **YES** to lock the loop in manual when Emergency Manual has been activated. The operator can switch the loop to Auto only when the EM condition has cleared. This feature is available only when the **EM MAN** parameter is configured as **YES**.

The **MAN ACCL** parameter, in firmware 1.30 and higher, enables setting the acceleration rate applied to the pulser knob. It can be configured for **Slow**, **Medium**, or **Fast**. **Slow** is the default and is consistent with firmware versions less than 1.30.

PRIORITIES - The priority assigned to **EM** or **SB PRIOR** will affect the operation as follows (the outputs **ES** and **SS** will go high with all priority assignments, including 0, when event is active):

1. Bargraphs, event LEDs, and condition will flash. **ACK** button must be used to stop flashing.
2. Bargraphs, event LEDs, and condition will flash. Flashing will stop if **ACK** or if event clears.
3. Event LEDs and condition will flash. **ACK** button must be used to stop flashing.
4. Event LEDs and condition will flash. Flashing will stop if **ACK** or event clears.
5. Event LEDs and condition will turn on when event is active and off when the event clears.
0. No local display action occurs when event is active.

3.2.2 ACS - ARCCOSINE

ACS_ function blocks, in firmware 1.30 and higher, accept an input between -1.0 and 1.0. Each provides an output signal in radians of which the input is the cosine.

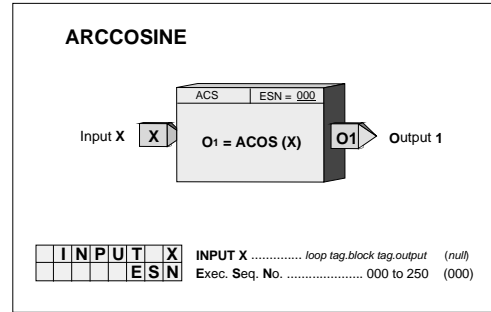
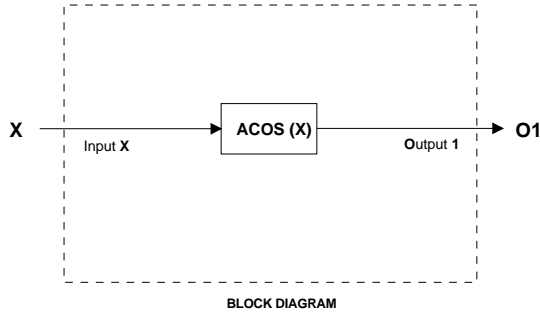

3.2.3 ADD_ - Addition

ADD_ function blocks perform arithmetic addition on three input signals. Any unused input will be set to 0.0 and will have no affect on the output.

All inputs should have the same engineering units. If units are not consistent, an SCL (Scaler) function block can be used or an alternative is to use a MATH function block that has built-in scaling functions.

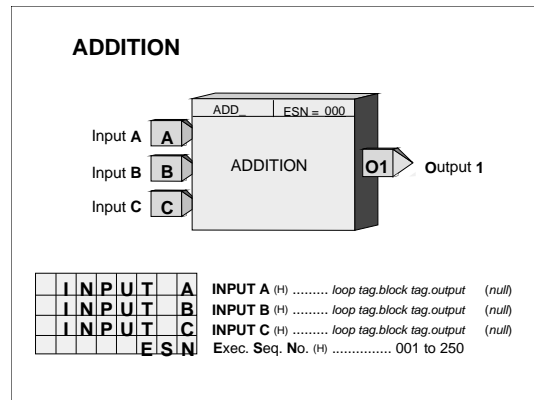
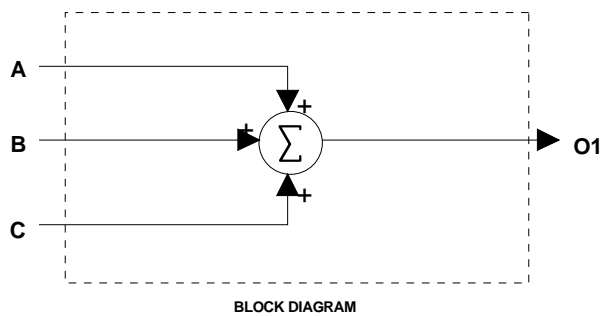

3.2.4 AG3 - AGA 3 Orifice Metering of Natural Gas

AG3 function blocks, which can be used on a one per loop basis, are available in firmware 1.30 and higher. This block uses the AGA 3 (American Gas Association Report #3) calculation to accurately measure the flow of natural gas using an orifice meter with flanged taps. The basic equations calculated by this block, in accordance with AGA Report No. 3, Orifice Metering of Natural Gas, Part 3, August 1992 (AGA Catalog No. XQ9210), are:

$$Q_b = C' \sqrt{P_{f1} h_w}$$

$$C' = F_n(F_c + F_{sl})Y_1 F_{pb} F_{tb} F_{tf} F_{gr} F_{pv}$$

where: Q_b = volume flow rate at base conditions

- C' = composite orifice flow factor
- P_{f1} = absolute flowing pressure(upstream tap)
- h_w = orifice differential pressure
- F_n = numeric conversion factor
- F_c = orifice calculation factor
- F_{sl} = orifice slope factor
- Y_1 = expansion factor (upstream tap)
- F_{pb} = base pressure factor
- F_{tb} = base temperature factor
- F_{tf} = flowing temperature factor
- F_{gr} = real gas relative density factor
- F_{pv} = supercompressibility factor

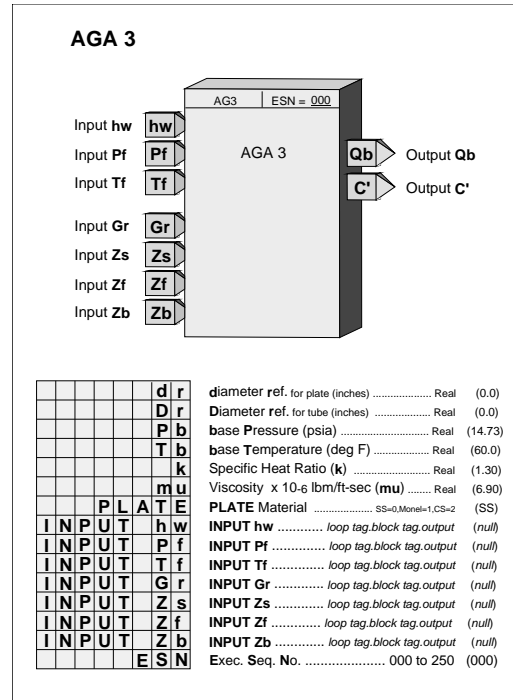

Output Q_b is updated every scan cycle. Output C' is updated continuously for temperature effects and periodically for other effects. The following conditions are considered in the calculations:

- Standard Conditions are: $P_s = 14.73$ psia, $T_s = 60^\circ\text{F}$, $Z_{sair} = 0.999590$.
- Nominal pipe size is 2" or larger, Beta is 0.1 - 0.75, and Re (Reynolds Number) is 4000 or larger.
- Y (expansion factor) and absolute flowing pressure P_f are referenced to upstream tap (i.e. Y_1 & P_{f1}).
- h_w is in inches H_2O and P_f is in psia. $0 < [h_w / (27.707 * P_f)] \leq 0.2$.

The following parameters are configuration entries:

- d_r = orifice plate bore diameter in inches at a reference temperature of 68°F
- D_r = meter tube internal diameter in inches at a reference temperature of 68°F
- P_b = base pressure (psia)
- T_b = base temperature (°F)

The following are analog inputs to the AGA 3 function block:

- h_w = orifice differential pressure (in H_2O)
- P_f = flowing pressure at upstream tap - P_{f1} (psia)
- T_f = flowing temperature (°F)

- G_r = real gas relative density (specific gravity)
- Z_s = compressibility at standard conditions
- Z_f = compressibility at flowing conditions at upstream tap - Z_{f1}
- Z_b = compressibility at base conditions

The specific gravity factor (G_r) and the compressibility factors (Z_s , Z_f , Z_b) can be entered manually using HLD (Hold) function blocks, computed, and then downloaded from a host device, or calculated in the controller using the AG8 (AGA 8 Compressibility Factors of Natural Gas) function block.

The following are analog outputs of the AGA 3 function block:

- Q_b = volume flow rate at base conditions (SCFH - Standard Cubic Feet per Hour)
- C' = composite orifice flow factor [SCFH/ $\sqrt{(\text{psia})(\text{in H}_2\text{O})}$]

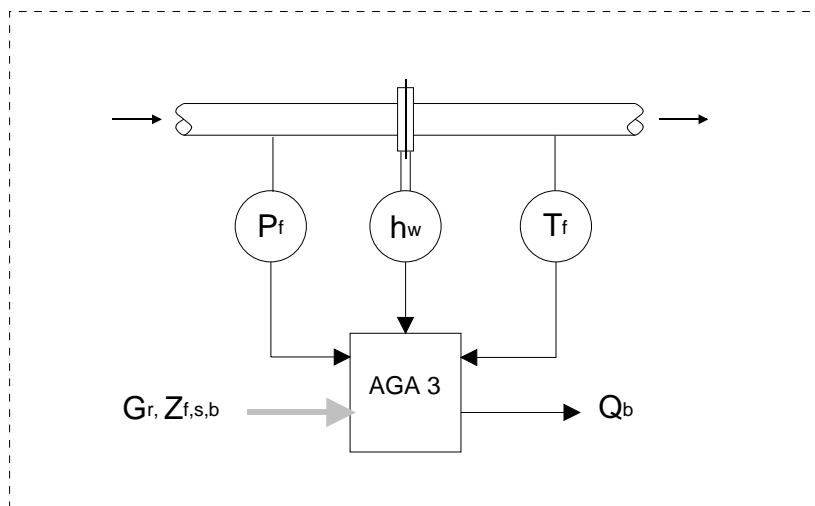

Application Diagram

3.2.5 AG7 - AGA 7 Measurement of Gas by Turbine Meters

AG7 function blocks, which can be used on a one per loop basis, are available in firmware 1.30 and higher. This block uses the AGA 7 (American Gas Association Report #7) calculation to accurately measure the volume flow of gas at base conditions using a turbine meter. The basic equations calculated by this block in accordance with AGA Turbine Meter Report No. 7, 1985 (AGA Catalog No. XQ0585) are:

$$Q_b = Q_f (T_b/T_f)(P_f/P_b)(Z_b/Z_f)$$

- where:
- Q_f = volume flow at standard conditions
 - Q_b = volume flow rate at base conditions
 - P_f = flowing pressure (psia)
 - T_f = flowing temperature
 - Z_f = compressibility at flowing conditions
 - P_b = base pressure (psia)
 - T_b = base temperature (°F)
 - Z_b = compressibility at base conditions

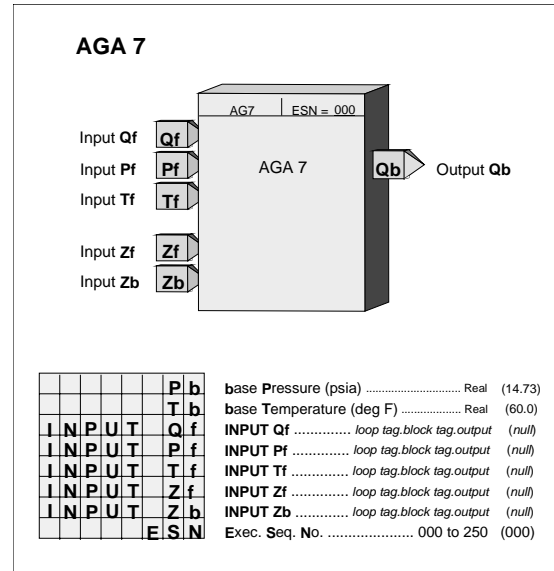

Block output Q_b is updated continuously and is the volume flow rate at base conditions in the same units as input Q_f . T_b and T_f are converted within the block from °F to °R (adds 459.67 to the °F input value) for the actual calculation. Compressibility factors (Z_f , Z_b) can be entered manually using HLD (Hold) function blocks, computed and downloaded from a host device, or calculated in the controller using the AG8 (AGA 8 Compressibility Factors of Natural Gas) function block.

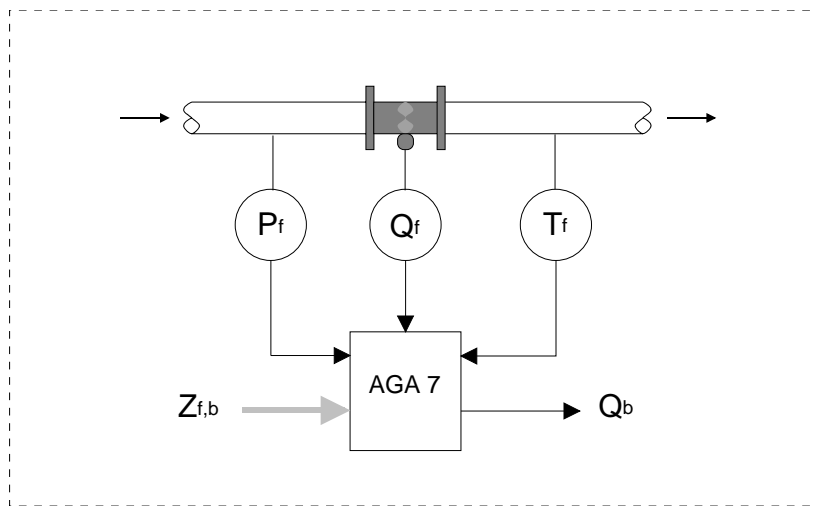

Application Diagram

3.2.6 AG8 - AGA 8 Compressibility Factors of Natural Gas

AG8 function blocks, which can be used on a one per loop basis, are available in firmware 1.30 and higher. This block calculates the compressibility factors of natural gas in accordance with AGA 8 Report No. 8, July 1994 (AGA Catalog No. XQ9212). It computes various compressibility factors and the specific gravity (relative density) using the detailed characterization method described in the report. The mole percentage of the gas components and the base temperature and pressure are entered in the configuration and the flowing temperature and pressure are provided as block inputs. Parameter **MOL% SUM** provides a read only value that is the total of all the gas compounds that have been entered. The AGA8 computation is time consuming and is calculated over a total of 100 scan cycles so as not to have any significant effect on the controller cycle time.

Z_s (compressibility at standard conditions) is calculated after a power-up or after a configuration change is made. Z_b and Z_f are calculated on a periodic basis with the actual update time dependent on the number of gas components and the scan cycle of the controller.

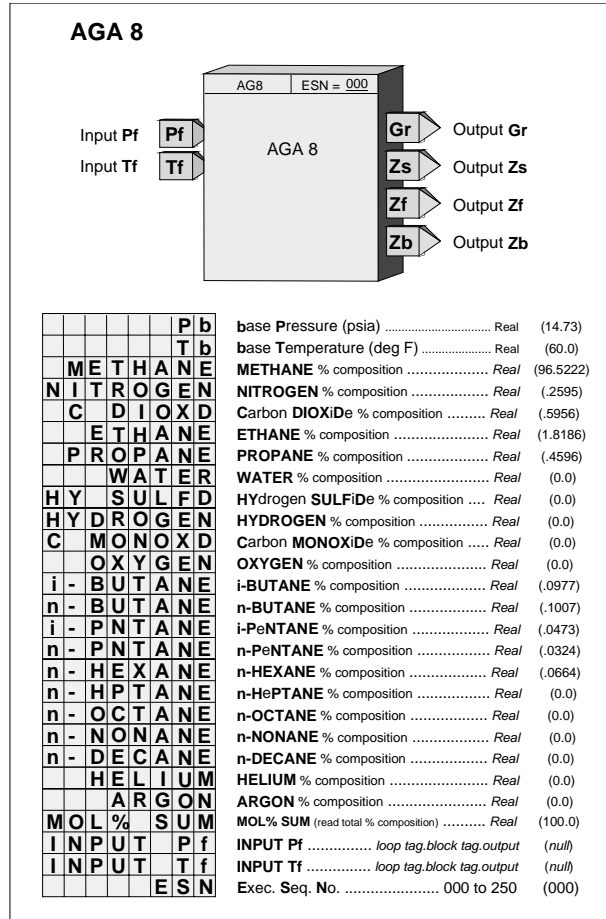

3.2.7 AIE_ - Analog Input - Ethernet (V3.0)

Ethernet is available on Model 353, Model 353R and Procidia i|pac controllers; not available on Models 352P and 354/354N

AIE_ function blocks are available when the optional Ethernet communication board⁸ is installed in the controller. It enables the controller to read analog data from other stations over the Ethernet network.

Up to 32 AIE_ blocks are available. Blocks are assigned in sequence, controller wide, with each use.

Data can be received as a real floating-point number and is passed to the block output O1 directly or it can be obtained as a 16-bit integer. A Floating Point number can be formatted in one of four methods as shown in Table 3-4 on the next page. An integer is converted to floating point as scaled by MIN INT, MAX INT, MINSCALE and MAXSCALE parameters. Both Unsigned Integer (Uint) and Signed Integer (Sint) options are available. See Table 3-5 on the next page.

When a DATA TYP is selected, range limits (see Table 3-5) are automatically selected. This ensures that the user-entered integer values fall within the correct range. MIN INT and MAX INT values must be entered whenever a DATA TYP is changed.

Output OR contains the range scaling for the floating point block output O1. The OR output is a special data type that includes the MINSCALE, MAXSCALE, DPP, and the ENGUNITS and can be connected to other blocks having a Range (RG PTR) input. Range scaling information can be automatically obtained from the source of the data over Ethernet if the device has the scaling information packaged with the data. This is a feature provided by AOE function blocks from other Siemens and Moore Products Co. controllers. AOE blocks are defined by using the Modbus Registers from Table 3-6 below. If this feature is not available, the default setting of the RANGE parameter "MAN" should be used. In this case, range parameters are entered manually. When the auto range feature is used, the range in the AIE block may be out of sync for several seconds if on line changes are made to the AOE range.

The IP ADRES parameter is used to configure the IP address of the source device. The MB ADRES parameter allows a Modbus address to be configured. When connecting to other Siemens and Moore Products Co. controllers the Modbus address is set to 1. In some cases, other devices may use a different address or when going through a Modbus TCP/IP gateway a Modbus network may have multiple devices, each having a unique address. The REG TYP parameter allows setting the source register as a Holding Register or an Input Register. For many Modbus devices, this setting does not matter since the device will treat them as identical registers. The DATA TYP parameter will enable the AIE block to acquire floating point or integer data. When floating point is selected the controller will request two consecutive registers starting with the MB REG parameter. The UD RATE parameter configures the rate at which the block will request data. The P2P setting will update the data at the rate set by the P2P RATE parameter in the ETHERNET block. The Ct setting will update the data at the cycle time of the controller. The Ct parameter should normally be used only when the analog input is the process variable in a PID control loop

Output QS indicates the quality of the received data and will go high (1) when the data is bad. This is normally associated with failure to receive data due to a communication failure or a misconfiguration of the source.

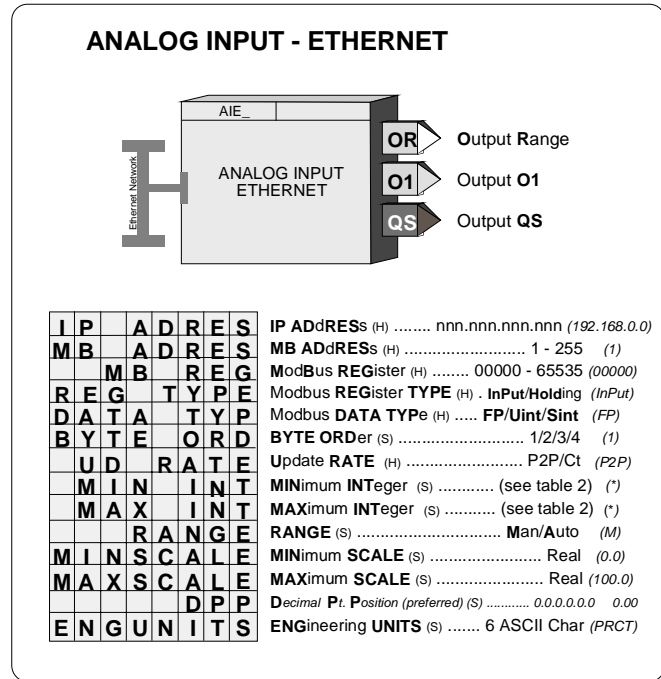

⁸ Requires Ethernet communications board firmware version 2.0 or later

Table 3-4 Floating Point Number Formats

BYTE ORD	Type Description	Byte Order	Comments
1	Big Endian FP Format	4, 3,2, 1	Standard Usage
2	Big Endian FP w/ bytes swapped	3, 4, 1, 2	
3	Little Endian FP Format	1, 2, 3, 4	
4	Little Endian FP w/ bytes swapped	2, 1, 4, 3	353 usage

Table 3-5 Integer Default Values

Selection	Parameter	Default Value
Uint	MIN INT	0
Uint	MAX INT	65535
Sint	MIN INT	-32768
Sint	MAX INT	+32767

Table 3-6 FB Numbers vs. Modbus Registers

FB Number	MB Register	FB Number	MB Register	FB Number	MB Register	FB Number	MB Register
AOE01	30961	AOE09	30977	AOE17	30993	AOE25	31009
AOE02	30963	AOE10	30979	AOE18	30995	AOE26	31011
AOE03	30965	AOE11	30981	AOE19	30997	AOE27	31013
AOE04	30967	AOE12	30983	AOE20	30999	AOE28	31015
AOE05	30969	AOE13	30985	AOE21	31001	AOE29	31017
AOE06	30971	AOE14	30987	AOE22	31003	AOE30	31019
AOE07	30973	AOE15	30989	AOE23	31005	AOE31	31021
AOE08	30975	AOE16	30991	AOE24	31007	AOE32	31023

3.2.8 AIL_ - Analog Input - LIL

AIL_ function blocks are available when the optional LIL communication board is installed. They allow the controller to obtain global data from other stations on the LIL. AIL block numbers are assigned in sequence with each use, station wide. The data is received in the LIL format having a standard range of \$80 to \$F80. The block output is a real number and is scaled in engineering units using the MIN and MAX SCALE parameters. The Output Range is a special data type that includes the MIN and MAX SCALE, the DPP, and the ENGUNITS that can be connected to other blocks having a Range (RG PTR) input.

Output QS indicates the quality of the received data and will go high (1) when the data is bad. This is normally associated with failure to receive global data due to a LIL failure or a misconfiguration of the source.

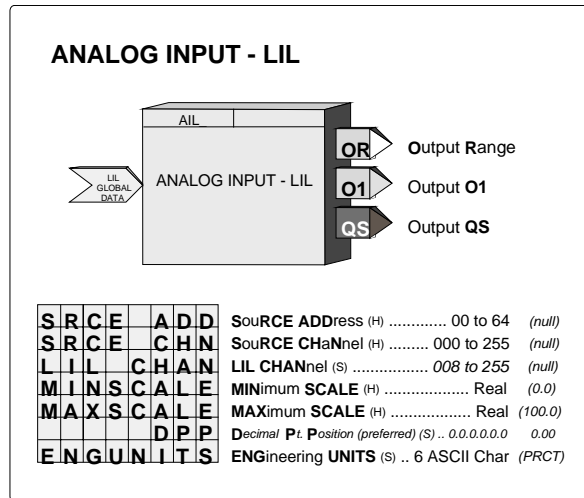

The AIL function can be assigned to a single LIL channel. It will then have certain data that will be accessible over the LIL. Parameter 1 is the received data (RD) in the \$80-\$F80 format and will be re-transmitted by this station on the assigned channel. This LIL CHAN parameter can also be set to 0. The controller will still receive global data from the other station but the received data will not be re-transmitted and the other channel data (i.e. MINSSCALE, ...) will not be accessible..

	1	2	3	4	5	6	7	8	9	10	11	12
n	RD	SA/SC	MINSSCALE	MAXSCALE	ENG UNITS			Output O1				

3.2.9 AIN_ - Analog Inputs

AIN_ function blocks convert a voltage input, having a range defined during calibration, into a block output signal that is scaled in engineering units. The output is then interconnected to other function blocks within the controller.

A 6-character ASCII value can be entered to identify the engineering units of the output signal. The scaled output range is configurable and has a factory default of 0.0 to 100.0 PRCT. Ranges such as 300.0 to 500.0, representing engineering units in degrees C, can also be configured. The Output Range is a special data type that includes the MIN and MAX SCALE, the DPP, and the ENGUNITS that can be connected to other blocks with a Range (RG PTR) input.

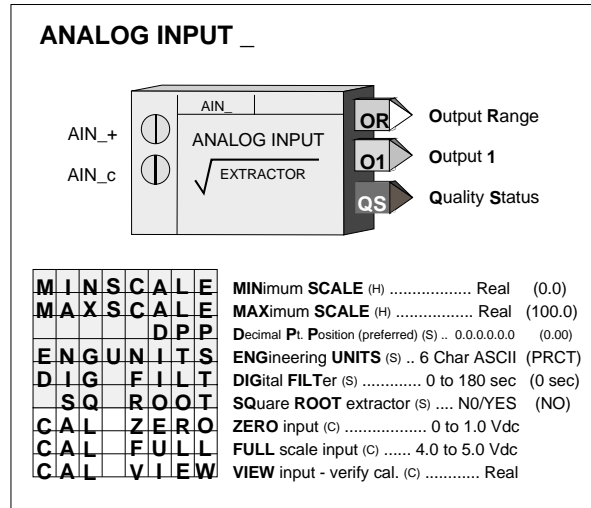

Analog Input blocks are available on the MPU Controller Board (CB) and on the I/O Expander Board (EB). Block names (IDs) are listed in Section 8.4 together with the case rear terminal numbers. Power for 2-wire transmitters is available at the rear terminals.

A digital filter (time constant) is available to dampen process noise. A square root extractor is also available to linearize a flow signal from a ΔP transmitter, allowing the block output to be configured for flow units. Output QS indicates the quality of the analog output signal O1, and will be high (1) when output O1 is bad, and low (0) when good. Bad quality signifies an A/D conversion failure or a 1-5Vdc input signal that falls below 0.6 Vdc indicating an open circuit or failure of a 2-wire transmitter.

A verify mode is available during calibration to view the analog input, in volts, over the full calibrated range. The input is factory calibrated for 1-5 Vdc and should not require field calibration. However, field calibration can be performed if another range is required or to match the exact transmitter calibration. Current inputs are accommodated using precision dropping resistors connected across the input terminals (250Ω resistors are supplied with the controller for conversion of 4-20mA inputs).

Power Up - During a hot, a warm or a cold start, the function block will temporarily by-pass the digital filter to enable the output to initialize at the actual hardware input signal.

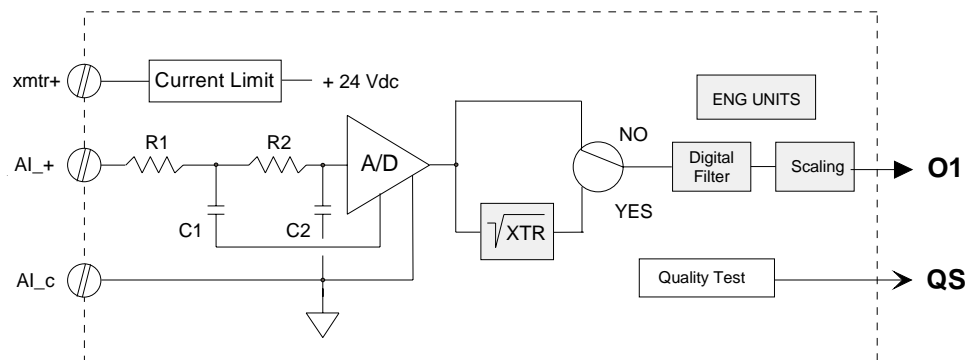

BLOCK DIAGRAM

3.2.10 AINU_ - Analog Inputs, Universal

AINU_ function blocks are available on the optional I/O Expander Board. These function blocks convert sensor inputs such as T/C (thermocouple), RTD (resistance temperature detector), millivolt, ohm, and slidewire sources into block outputs. Current inputs (i.e. 4-20 mA) are accommodated by using the WMV (wide millivolt) type. An output bias can be used to nullify any known offset in the sensor circuit and a digital filter (time constant) is included, to dampen process noise. Output QS indicates the quality status of the output signal O1 and will go high (1) when the output is of bad quality. Bad quality indicates an A/D conversion failure or an open circuit T/C, or an out of range process variable.

The scaling function is used to establish an output range, in engineering units, for the selected sensor range (e.g. 0-10 mv or 50.0-150.0 amperes). **Direct Temperature Measurements** (i.e. T/C and RTD) bypass sensor and range scaling and the block output units are selected from Table 3-7. When selected, the proper read only ASCII characters corresponding to the type units selected will automatically be placed in the ENG UNITS parameter. When OHM or MV is selected, the ENG UNITS parameter can be configured to correspond to the process engineering units. The default SEN MIN and MIN SCALE are set to the minimum operating value and SEN MAX and MAX SCALE are set to the maximum operating value. SEN MIN and SEN MAX always indicate the sensor range limits in degrees C. However, it is important to enter the actual intended operating range in the MINSCALE, MAXSCALE, and DPP parameters so that other function blocks, such as the controller, operator faceplate, and workstation interface, can point to this block for range and display informationBlock names (IDs). Input terminations (terminal numbers) are listed in Section 8.4.

All input types are factory calibrated and do not require field calibration. However, for those cases where outputs must be adjusted to meet a local standard, a field calibration feature is available to override the factory calibration for the input type selected. The factory calibration is retained so that the input can be returned to the factory calibration at any time by storing 'FAC' in the calibration selection. Table 3-8 provides the input values that are used to perform a field calibration. A verify mode is available during calibration to view the sensor input over the full range. The signal that is viewed, in the calibration verify mode, is in the basic units of measure (e.g. °C for temperature, mv for millivolts) and is not affected by the temperature units conversion, digital filter, scaling, or the output bias adjustment. The full block output with these parameters applied can be viewed in the VIEW mode within loop configuration. During a hot, a warm or a cold start, the function block will temporarily by-pass the digital filter to enable the output to initialize at the actual hardware input signal. Note that the field calibration is erased when the SENSOR TYPE is changed.

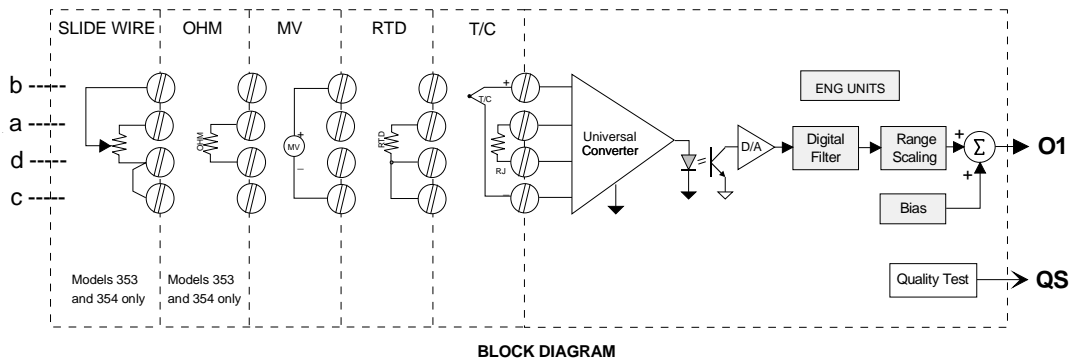
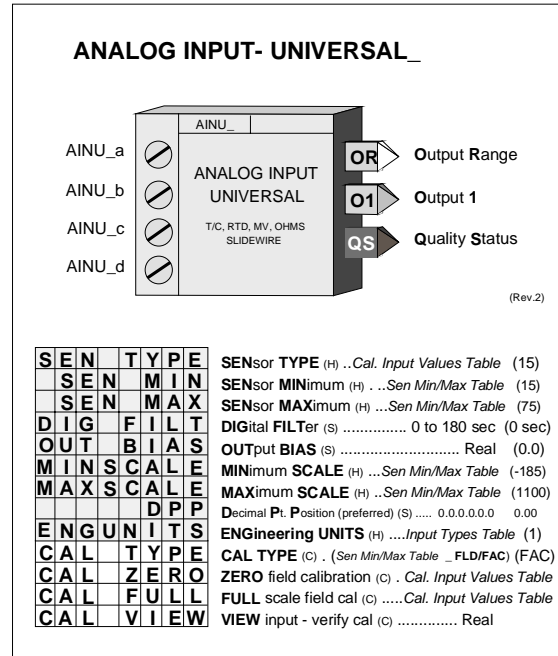

Table 3-7 Input Types

#	ENGINEERING UNITS	AVAILABLE ON INPUT TYPES
1	Deg C (degrees Celsius)	JT/C, KT/C, TT/C, ET/C, ST/C, RT/C, BT/C, NT/C, DRTD, URTD, JRTD
2	Deg F (degrees Fahrenheit)	JT/C, KT/C, TT/C, ET/C, ST/C, RT/C, BT/C, NT/C, DRTD, URTD, JRTD
3	Deg R (degrees Rankine)	JT/C, KT/C, TT/C, ET/C, ST/C, RT/C, BT/C, NT/C, DRTD, URTD, JRTD
4	K (Kelvin)	JT/C, KT/C, TT/C, ET/C, ST/C, RT/C, BT/C, NT/C, DRTD, URTD, JRTD
***** *	6 Char ASCII	OHM, SLW, NMV, WMV

Table 3-8 Calibration Input Values

#	TYPE	DESCRIPTION	OPERATING RANGE	FIELD CAL 'FLD' POINTS
1	JT/C	Type J Thermocouple	-185°C to 1100°C (-300°F to 2010°F)	0°C & 800°C
2	KT/C	Type K Thermocouple	-185°C to 1370°C (-300°F to 2500°F)	0°C & 1000°C
3	TT/C	Type T Thermocouple	-200°C to 370°C (-400°F to 698°F)	-100°C & 300°C
4	ET/C	Type E Thermocouple	-185°C to 1000°C (-300°F to 1830°F)	0°C & 800°C
5	ST/C	Type S Thermocouple	-18°C to 1650°C (0°F to 3000°F)	400°C & 1400°C
6	RT/C	Type R Thermocouple	-18°C to 1610°C (0°F to 2930°F)	400°C & 1400°C
7	BT/C	Type B Thermocouple	-18°C to 1815°C (0°F to 3300°F)	800°C & 1600°C
8	NT/C	Type N Thermocouple	-185°C to 1300°C (-300°F to 2370°F)	0°C & 1000°C
9	DRTD	DIN 43760/IEC 751 RTD alpha 0.003850	-185°C to 622°C (-300°F to 1152°F)	100Ω (0°C) & 285Ω (512.380°C)
10	URTD	US (NBS 126) RTD alpha 0.003902	-185°C to 613°C (-300°F to 1135°F)	100Ω (0°C) & 285Ω (504.84°C)
11	JRTD	JIS C-1604 RTD alpha 0.003916	-185°C to 610°C (-300°F to 1130°F)	100Ω (0°C) & 285Ω (502.94°C)
12	OHM*	Resistance	0 ohms to 5000 ohms	0 ohms & 5000 ohms
13	SLW*	Slidewire	500 ohms to 5000 ohms	<i>Field cal not available</i>
14	NMV	Narrow Millivolt	- 19.0 mv to 19.0 mv	0 mv & +15 mv
15	WMV	Wide Millivolt	-30.0 mv to 77 mv	0 mv & +75 mv

* Not available in Model 352Plus.

Table 3-9 SEN MIN/MAX & MIN/MAX SCALE Parameters

SEN TYPE (Note1)	SEN MIN	SEN MAX	MIN SCALE	MAX SCALE
1-12,14,15	[min. operating value]	[max. operating value]	[min. range scale value]	[max. range scale value]
13	0 (%)	100 (%)	0.0 PRCT (2)	100.0 PRCT (Note 2)

Note:

(1) When changing SEN TYPE, type number should blink after pressing STORE. Use STEP UP and then STEP DOWN to verify that sensor type has changed.

(2) Range scaling of the AINU output when the Slidewire sensor type is selected can be accomplished using a SCL_Scaler function block connected to the output (O1) of the AINU function block.

3.2.11 AIP_ - Analog Input lev_Percent

AIP_ function blocks convert an analog signal with a lev-percent type SNVT (Standard Network Variable Type) received from the LonWorks network into a block output, scaled in engineering units, for interconnection to other function blocks within the controller. A maximum of 25 AIP_ blocks can be used, up to the limit of nodes allowed on the Lon network or the memory limit of the controller. Each use of the block will be assigned a unique station wide ID (e.g. AIP06). These blocks are available when the LonWorks option board is installed in a 352P, 353, 353R or 354N controller. The input connection is established by 'binding' a network variable from the remote analog node to the network variable of the AIP_ function block.

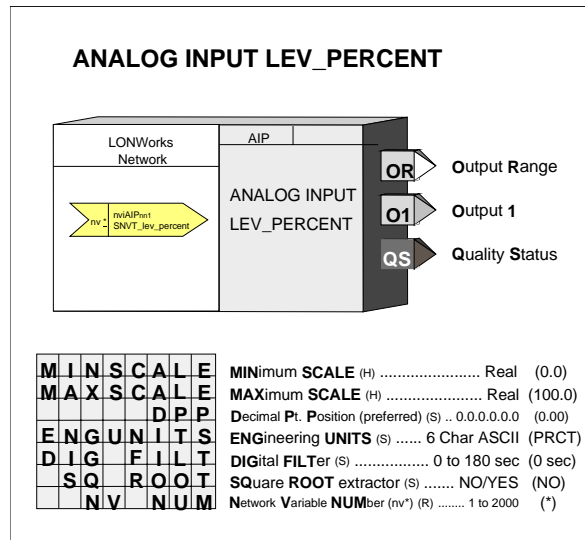

A 6-character ASCII value can be entered to identify the engineering units of the output signal. Output scaling (MINSKALE and MAXSCALE) is provided to establish an engineering range of choice. The number of the input network variable to the AIP block can be viewed in the configuration mode. This is useful when other devices need this for binding. The Output Range is a special data type that includes the MIN and MAX SCALE, the DPP, and the ENGUNITS that can be connected to other blocks with a Range (RG PTR) input.

The block output QS indicates the quality status of the output signal O1 and will go high when the output is of bad quality. Bad quality usually indicates a loss of communications within the LonWorks network.

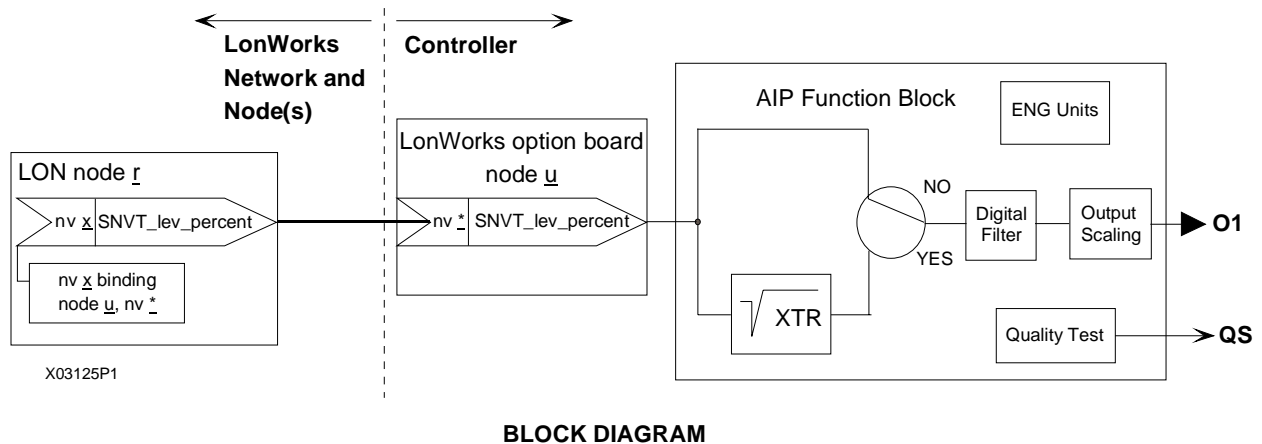

3.2.12 ALARM - Alarm

ALARM function blocks can be used on a one per loop basis and contain four (4) alarms associated with Input P (normally the process input to the controller function block). Each alarm can be configured as NONE, HI, LO, HDEV, LDEV, DEV, and OR.

Deviation type alarms compare Input P with Input D, the deviation input, normally the loop setpoint (i.e. the setpoint to the controller function block), having the same range as Input P. An Out of Range (OR) alarm compares the process input with the range limits specified by the range pointer parameter (input R). This parameter must point to a function block that includes MINSCALE and MAXSCALE configuration parameters (e.g. Analog Input) for proper scaling. If not configured, 0.0-100.0 will be used as a default range.

Alarms have priorities 1 to 5, with 1 the highest and are reported to the operator faceplate in order of priority first and then in order of occurrence. Priority 1 causes the station bargraphs and condition (e.g. A1 HI) to flash and requires acknowledgment to stop flashing. Priority 2 also flashes the bargraphs and condition but stops flashing when the alarm clears (i.e. Self Clearing). Priority 3 causes the event LEDs (L and S) and condition to flash. Flashing stops only when the alarm is acknowledged. Priority 4 also causes the event LEDs and condition to flash but stops when the alarm clears. Priority 5 displays the alarm but does not require that it be acknowledged.

Alarm limits are in engineering units. A quickset ALARM feature is also available allowing alarm limits to be set quickly during operation. The settings are in engineering units but will also be displayed in % of range on the bargraph. Alarms are displayed as defined by the range pointer parameter. Alarms can be set to any engineering value within -10% to 110% of the range defined by the pointer. If a range is changed, the current alarm settings will be changed to be the same % within the new range. For example, if a HI alarm is currently set at 100.0 with a range of 0.0 to 100.0 and the range is changed to 300.0 to 400.0, the HI alarm will be moved to 400.0.

Each alarm can be enabled or disabled when in the quickset ALARM mode. The configuration allows an alarm to be enabled or disabled on a cold start. When an alarm is disabled, it will not operate but will retain settings for return to the enabled mode. Complete operator faceplate functions, relating to alarms, are described in the sections describing the specific faceplate design. All alarms have the following features:

Deadband - requires that the signal either drop below or exceed the limit setting by the amount of the deadband before the alarm clears (goes low). The alarm deadband is set as a fixed % of the range pointer scale.

Delay-In Time - requires that the input remain above (or below) the limit setting for the delay time before the alarm trips (goes high). This can help prevent nuisance alarms that may be tripping due to process noise.

Delay-Out Time - requires that the input remain below (or above) the limit setting plus deadband for the delay time before the alarm will clear (goes low). This can help prevent inadvertent clearing of alarms due to process noise.

Ringback - causes a previously acknowledged alarm to require acknowledgment (priorities 1-4) when the alarm clears.

ALARM

	R	G	P	T	R	RanGe	PoinTeR	(S)	loop tag,block tag	(null)
A 1	L	I	M	I	T	Alarm 1	LIMIT	(S)	Real	(110.0)
A 2	L	I	M	I	T	Alarm 2	LIMIT	(S)	Real	(-10.0)
A 3	L	I	M	I	T	Alarm 3	LIMIT	(S)	Real	(100.0)
A 4	L	I	M	I	T	Alarm 4	LIMIT	(S)	Real	(0.0)
A 1	D	B	A	N	D	Alarm 1	DeadBAND	(S)	0.1/0.5/1.0/5.0%	(0.5)
A 2	D	B	A	N	D	Alarm 2	DeadBAND	(S)	0.1/0.5/1.0/5.0%	(0.5)
A 3	D	B	A	N	D	Alarm 3	DeadBAND	(S)	0.1/0.5/1.0/5.0%	(0.5)
A 4	D	B	A	N	D	Alarm 4	DeadBAND	(S)	0.1/0.5/1.0/5.0%	(0.5)
A 1	P	U	E	N		Alarm 1	Power Up ENabled	(S)	NO/YES	(YES)
A 2	P	U	E	N		Alarm 2	Power Up ENabled	(S)	NO/YES	(YES)
A 3	P	U	E	N		Alarm 3	Power Up ENabled	(S)	NO/YES	(YES)
A 4	P	U	E	N		Alarm 4	Power Up ENabled	(S)	NO/YES	(YES)
A 1	P	R	I	O	R	Alarm 1	PRIORity	(S)	1/2/3/4/5	(3)
A 2	P	R	I	O	R	Alarm 2	PRIORity	(S)	1/2/3/4/5	(3)
A 3	P	R	I	O	R	Alarm 3	PRIORity	(S)	1/2/3/4/5	(3)
A 4	P	R	I	O	R	Alarm 4	PRIORity	(S)	1/2/3/4/5	(3)
A 1			T	Y	P	A1	TYPE	(S)	none,HI,LO,HdEV,LdEV,dEV,or	(HI)
A 2			T	Y	P	A2	TYPE	(S)	none,HI,LO,HdEV,LdEV,dEV,or	(LO)
A 3			T	Y	P	A3	TYPE	(S)	none,HI,LO,HdEV,LdEV,dEV,or	(dEV)
A 4			T	Y	P	A4	TYPE	(S)	none,HI,LO,HdEV,LdEV,dEV,or	(none)
A 1			D	L	I	A1	DeLay IN	(S)	0/.4/1/2/5/15/30/60	Sec (0)
A 2			D	L	I	A2	DeLay IN	(S)	0/.4/1/2/5/15/30/60	Sec (0)
A 3			D	L	I	A3	DeLay IN	(S)	0/.4/1/2/5/15/30/60	Sec (0)
A 4			D	L	I	A4	DeLay IN	(S)	0/.4/1/2/5/15/30/60	Sec (0)
A 1			D	L	O	A1	DeLay OUT	(S)	0/.4/1/2/5/15/30/60	Sec (0)
A 2			D	L	O	A2	DeLay OUT	(S)	0/.4/1/2/5/15/30/60	Sec (0)
A 3			D	L	O	A3	DeLay OUT	(S)	0/.4/1/2/5/15/30/60	Sec (0)
A 4			D	L	O	A4	DeLay OUT	(S)	0/.4/1/2/5/15/30/60	Sec (0)
A 1			R	I	N	A1	RinGBaCK	(S)	NO/YES	(NO)
A 2			R	I	N	A2	RinGBaCK	(S)	NO/YES	(NO)
A 3			R	I	N	A3	RinGBaCK	(S)	NO/YES	(NO)
A 4			R	I	N	A4	RinGBaCK	(S)	NO/YES	(NO)
			I	N	P		INPUT P	(H)	loop tag,block tag,output	(null)
			I	N	P		INPUT D	(H)	loop tag,block tag,output	(null)
					E		ESN		Exec. Seq. No (H)	001 to 250

Alarm Types

HI compares the process input with the limit setting and it will trip the alarm status high (1) when the process is equal to or higher than the limit setting. The alarm status will clear (0) when the process is less than the limit setting minus the deadband.

LO compares the process input with the limit setting and it will trip the alarm status high (1) when the process is equal to or less than the limit setting. The alarm status will clear (0) when the process is greater than the limit setting plus the deadband.

HI DEV compares the difference between the process input and the deviation input (P-D) with the limit setting and it will trip the alarm status high (1) when (P-D) is equal to or greater than the limit setting. The alarm status will clear (0) when (P-D) is less than the limit setting minus the deadband.

LO DEV compares the difference between the deviation input and the process input (D-P) with the limit setting and it will trip the alarm status high (1) when (D-P) is equal to or greater than the limit setting. The alarm status will clear (0) when (D-P) is less than the limit setting minus the deadband.

DEV compares the absolute difference between the process input and the deviation input $|P-D|$ with the limit setting and it will trip the alarm status high (1) when $|P-D|$ is equal to or greater than the limit setting. The alarm status will clear (0) when $|P-D|$ is less than the limit setting minus the deadband.

OR compares the process input with the range limits referenced by the range pointer parameter and will trip the alarm status high (1) when the process is equal to or greater than the high limit or equal to or less than the low limit. The alarm status will clear (0) when the process is less than the high limit minus the deadband or greater than the low limit plus the deadband.

POWER UP - During a warm start, all alarms will be handled the same as during a hot start: outputs are initialized at the last state, all previously acknowledged alarms are treated as acknowledged, and any new alarms will be processed on the first scan cycle. On a cold start, all alarm outputs are initialized at 0, all alarms are reset and any new alarms, based on the block inputs, will be processed during the first scan cycle. Also, during a cold start, alarms will be enabled or disabled as determined by the PU ENable parameters.

Alarm Status

Alarm status is available with Modbus communication or the Local Instrument Link option for alarm management at a remote location. The alarm status is available in coils with Modbus communication or the same information is packed into a single word (Alarm Status Word) with LIL communication. Detailed information can be found in the Network Communications section of this document.

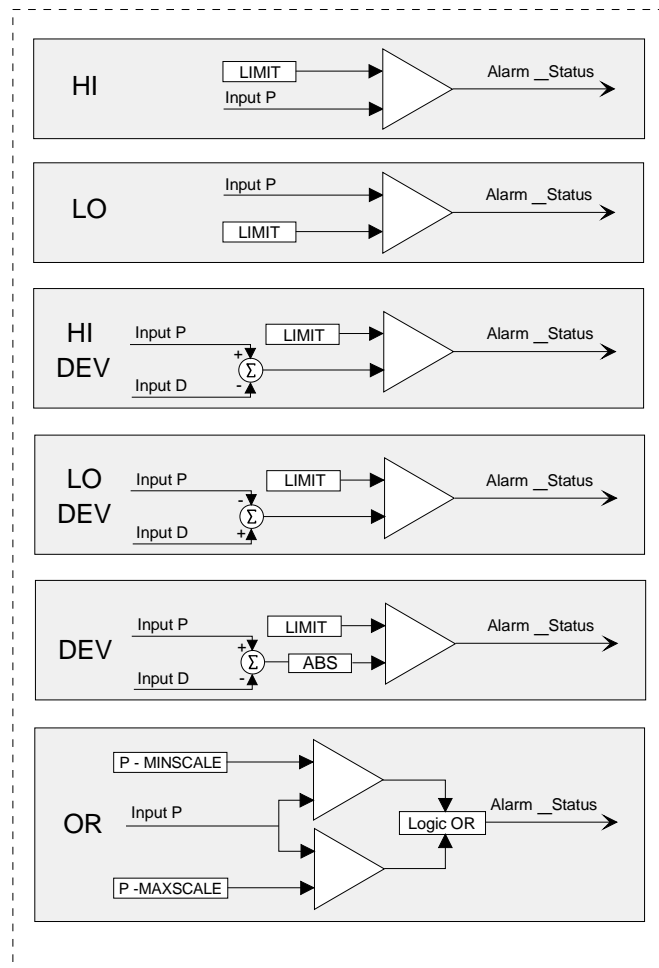

BLOCK DIAGRAM

An alarm status word is shown below.

A_=1 when the alarm is active

N_=1 when the alarm is Not acknowledged

E_=1 when the alarm is enabled (when the alarm is disabled the E, N, and A bits are set to 0)

OS=1 indicates that all alarms are identified as Out of Service which means that all alarms function normally but the OS flag indicates to a higher level device that they can be ignored. OS cannot be set locally.

CC=1 indicates a configuration change has occurred. It can be reset by a write command.

AE=1 indicates an Active Event is present within the loop. It will clear when all the loop events clear.

NA will be set to 1 when events occur and at least one within the loop has not yet been acknowledged. It can be reset to 0 which will acknowledge all events within the loop or when 0 will indicate all active events have been acknowledged

BIT	15	14	13	12	11	10	9	8	7	6	5	4	3	2	1	0
1	AE	NA	CC	OS	E4	N4	A4	E3	N3	A3	E2	N2	A2	E1	N1	A1
0																

3.2.13 AND_ - AND Logic

AND_ function blocks perform a logical AND on the three inputs. Any unused input will be set high (1).

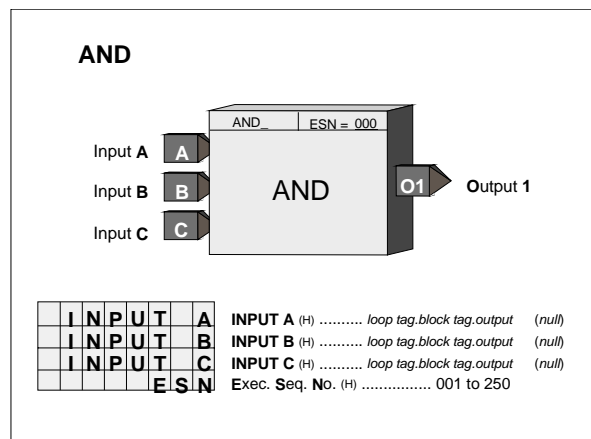
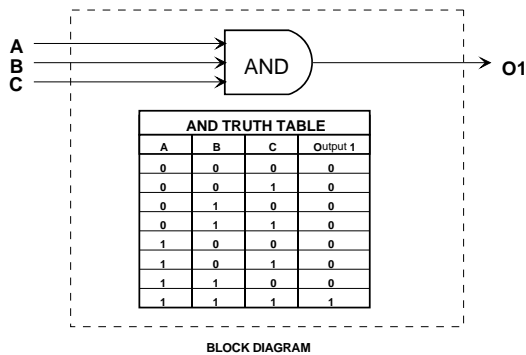

3.2.14 AOE_ - Analog Output- Ethernet (V2.4)

Ethernet is available on Model 353, Model 353R, and Procidia iJpac controllers; not available on Models 352P and 354/354N.

AOE_ function blocks are available when the optional Ethernet communication board is installed. Up to 32 AOE blocks are available and are assigned in sequence with each use, station wide.

The range pointer parameter (Input R) enables the block to pass the range scaling to AIE function blocks in other Siemens and Moore Products Co. controllers connected over the Ethernet network.

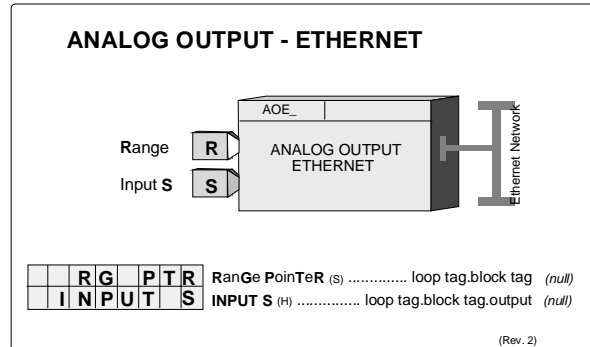

3.2.15 AOL_ - Analog Output - LIL

AOL_ function blocks are available when the optional LIL communication board is installed. They enable the station to provide a LIL global output, received as an interconnection from another function block. AOL block numbers are assigned in sequence with each use, station wide. The configuration requires the entry of a LIL Channel number to which the data is to be assigned. The range pointer parameter (input R) enables the block to scale the LIL global output (GO), in the standard \$80-\$F80 range, for the range of input S. If the pointer is not configured the value will be scaled as 0.0 to 100.0.

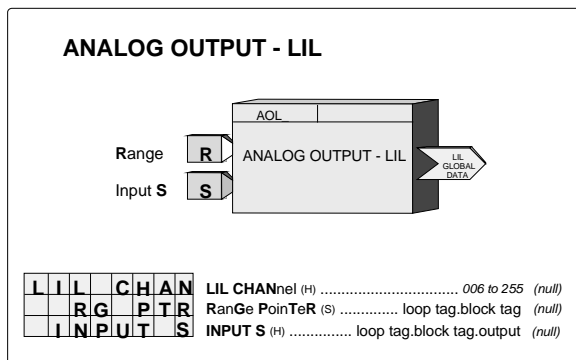

	1	2	3	4	5	6	7	8	9	10`	11	256
n	GO		MINSCALE	MAXSCALE	ENG UNITS			Input S		105		

3.2.16 AOP_ - Analog Output lev_Percent

AOP_ function blocks convert a function block interconnection signal, input S, to an output which is bound to a network variable in a node on the LonWorks network having a SNVT (Standard Network Variable Type) of lev_percent. A maximum of 25 AOP blocks can be used, up to the limit of nodes allowed on the Lon network or the memory limit of the controller. Each use of the block will be assigned a unique station wide ID (e.g. AOP13). These blocks will be available when the LonWorks option board is installed in a 352P, 353 (Design Level A), or 354N controller.

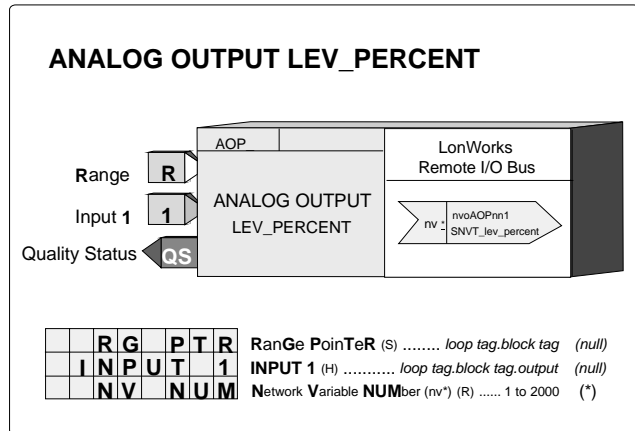

The range pointer parameter (input R) tells the function block where to obtain the signal's range scaling information. An unconfigured range pointer will use a default range of 0.00 to 100.00. The signal will be scaled and transmitted on the network as a SNVT_lev_percent (SNVT #81) data type. The NV NUM parameter enables viewing the output variable number. This may be needed when using a remote PC network manager to bind this output with the network variable in a remote node.

The block output QS indicates the quality status of the Lon output and will go high when the output is of bad quality. Bad quality usually indicates a loss of communications within the LonWorks network.

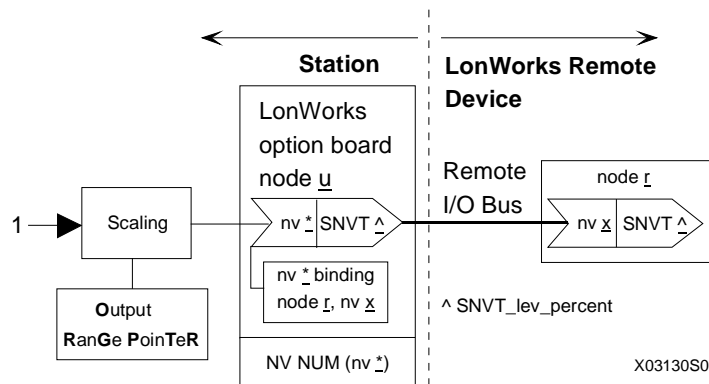

3.2.17 AOUT_ - Analog Outputs

AOUT_ function blocks convert function block interconnection signals, connected to input S, to a block output having a range of 4-20 mAdc. Input D can be used to disconnect the output from the load when asserted high (1). This feature is useful when two or more controllers are connected to a common load. When one controller is connected to the load, others are disconnected using the disconnect feature. The function block includes scaling to range the 4-20 mA output with the block input signal. The range pointer parameter (input R) tells the block where to obtain scaling information. If this parameter is not configured the block will use a range of 0.0 to 100.0.

Two analog output function blocks are available on the Controller Board and one additional on the Expander Board. Function block names and terminal identifications are listed below. The output is factory calibrated for 4-20 mAdc and should not require field calibration. However, field calibration can be performed if desired. The output is calibrated by adjusting the pulser until the desired output (i.e. 4.0 mA for zero) is obtained and then pressing the store button. A verify mode is available during calibration that will show the mA value in the numeric display as the pulser adjusts the output over the full range.

Output QS is the Quality Status output. It will go high if the output driver detects a high impedance or an open circuit. The alphanumeric will flash AOUT_.OC when an open circuit condition is detected. The QS output could also be used to switch to a second output circuit in a redundancy application.

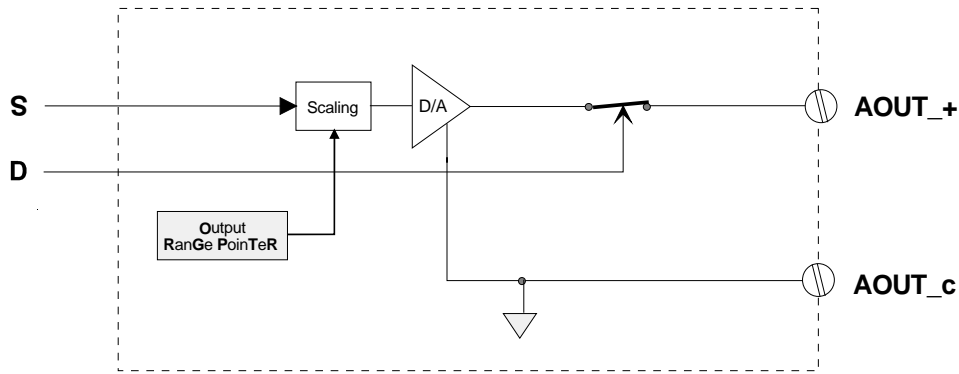
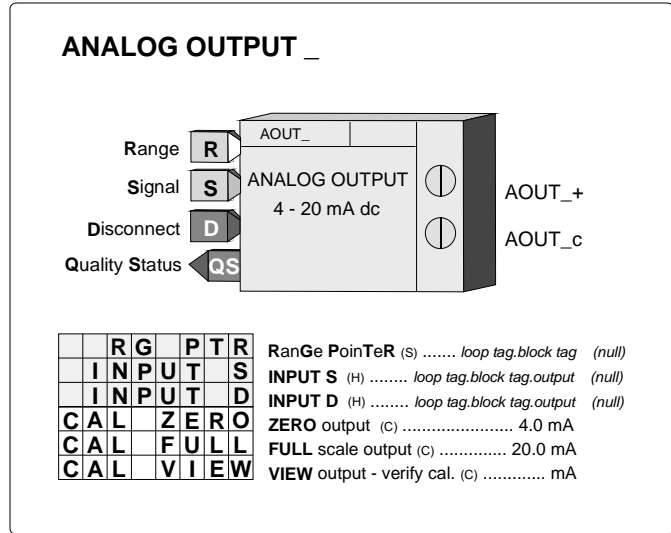

BLOCK DIAGRAM

3.2.18 ASN_ - ARCSINE

ASN_ function blocks, in firmware 1.30 and higher, accept an input between -1.0 and 1.0 and provide an output signal in radians of which the input is the sine.

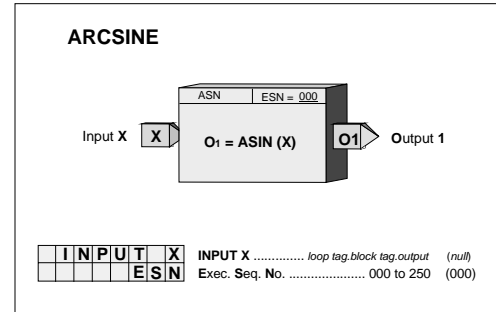
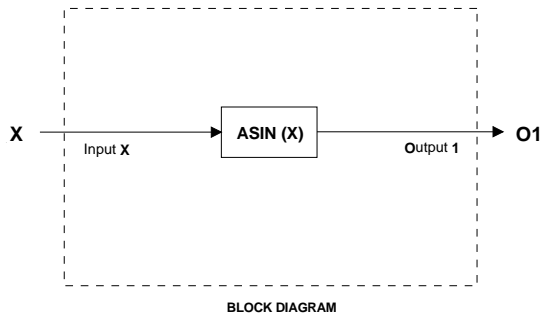

3.2.19 ATD_ - Analog Trend Display

ATD_ blocks, in firmware 1.30 and higher, can be used as needed in loops (up to a maximum of 5 per loop) to trend an analog variable connected to input A. The block can store up to 170 data points depending upon the use of the enable/disable function (see below). A trend can be displayed using Modbus commands. Data can be retrieved and displayed by a remote operator station that can retrieve, interpret, and display data packets from the station. A PC or i|station running i|ware PC operator interface software can display trend data on a Loop Detail screen or Analog Detail screen.

Parameter TRND TYP allows data to be stored in one of two formats: the average over each sample time or the peak/peak values of the data over each sample time. All data is stored in a normalized form based on the value of the RG PTR (range pointer) input. The range information will be part of the data packet when retrieved over the network communications. When this input is unconfigured, a range of 0.0 - 100.0 will be used.

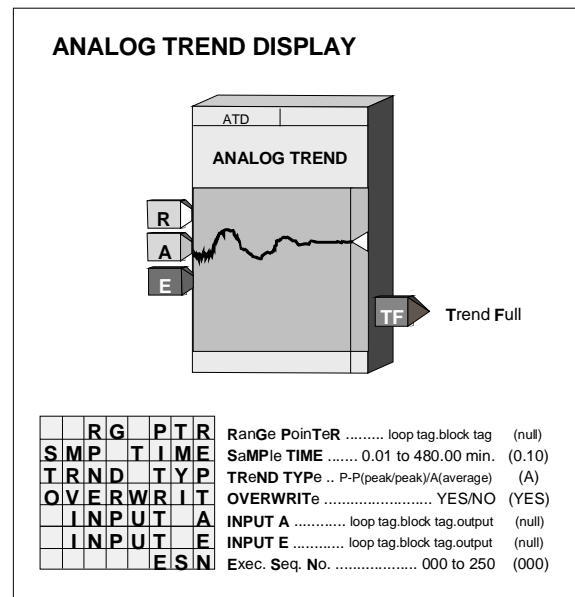

Several inputs can control the operation of the ATD function block. Input E (enable) can be used to enable the trend function when high (1) or unconfigured. Trend action can be disabled by setting E low (0). Each time the function block is enabled a new trend packet will be created.

The block also includes parameter OVERWRIT that, when set to YES, will cause the block to overwrite old data (i.e. circular file). When the parameter is set to NO, the block will stop trending when full and retain the data until reset. When the full state is reached, output TF (Trend Full) will go high (1). This function can be used to enable a second ATD block.

3.2.20 ATN_ - ARCTANGENT

ATN_ function blocks, in firmware 1.30 and higher, output a signal in radians of which the input is the tangent.

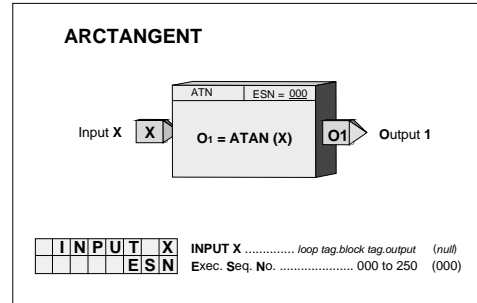
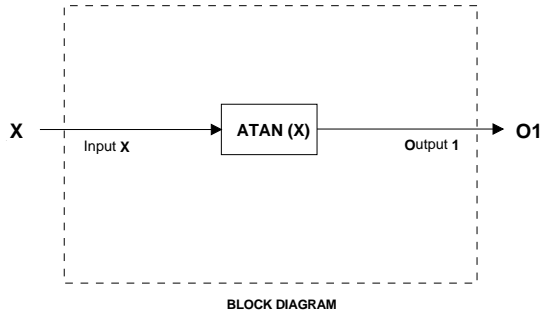

3.2.21 AWE_ - Analog Write Ethernet (V3.0)

Ethernet is available on Model 353, Model 353R and Procidia i|pac controllers; not available on Models 352P and 354/354N

AWE_ function blocks are available when the optional Ethernet communication board⁹ is installed in the controller. It enables the controller to write analog data to other Modbus devices over the Ethernet network.

Up to 32 AWE_ blocks are available. Blocks are assigned in sequence, controller wide, with each use.

Data can be written as a real floating-point number or as a 16-bit integer as configured by the DATA TYP parameter. A Floating point number can be selected to have one of four byte orders (BYTE ORD) with 1 being the most common (see Table 3-4 under AIE block description). An integer is converted from the block input S, which is a floating point number, by the MIN INT & MAX INT parameters using the range scaling information obtained from the source function block in the controller with the range pointer input R. Both Unsigned Integer (Uint) & Signed Integer (Sint) options are available. See the table listing parameters and default values below.

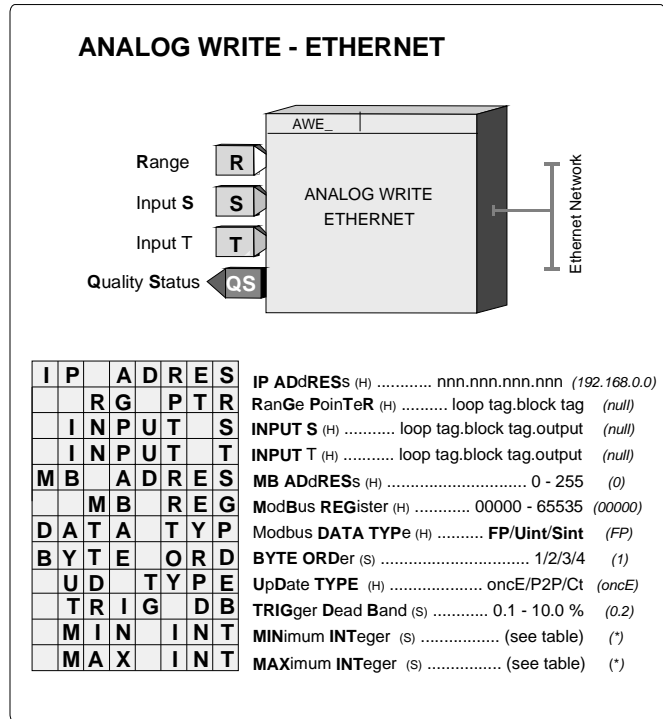

The IP ADRES parameter is used to configure the IP address of the destination Modbus device. The MB ADRES parameter allows a Modbus address to be configured. When connecting to other Siemens and Moore Products Co. controllers the Modbus address is set to 1. In some cases, other devices may use a different address or when going through a Modbus TCP/IP gateway a Modbus network may have multiple devices, each having a unique address.

Selection	Parameter	Default Value
Uint	MIN INT	0
Uint	MAX INT	65535
Sint	MIN INT	-32768
Sint	MAX INT	+32767

There are three write update options that can be configured by the UD TYPE parameter.

1. oncE will write once to the MB REG (Modbus Register). The controller will write when the input value changes by more than the value set with the TRIG DB parameter. This parameter is set based on a percentage of the range determined by the range pointer input R.
2. P2P will update at the controller peer to peer rate set in the ETHERNET block.
3. Ct will update at the cycle time of the controller.

The Ct option is normally only used when writing to I/O outputs in a PID control loop. Input T can be used to trigger a write. This would be used in cases where the oncE option has been selected, Input S does not change so as to trigger a write based on the trigger dead band, and there may be a concern that the receiving device has lost the value.

Output QS indicates the quality of the write operation and will go high (1) when the write is not completed successfully. This is normally associated with failure of the destination device to receive data due to a communication failure or a misconfiguration of the device.

⁹ Requires Ethernet communications board firmware version 2.0 or later

3.2.22 BATOT - Batch Totalizer

BATOT function blocks can be used on a one per loop basis and integrate an analog input. Each provides an output signal representing a total integrated value over the time base selected. For example, if the time base is minutes and input A is 5.0 for 60 minutes, output TL would equal 300.0. The total can be displayed on the operator faceplate as <loop tag>.T if the configuration parameter DISP TOT is set to YES. A 6-character maximum name (e.g. GAL) is entered in configuration under TOT UNIT to identify the totalizer units.

Input S asserted high (1) will stop the integrator action. Input R will cause the integrator function to reset to the initial value (INIT VAL). These inputs do not affect the PuLse output. The integrator output is summed with the INITIAL VALue entered in configuration to provide the count total. The INIT VAL is used as the total when the BATOT is reset.

DIR ACT set to YES will cause the integrator to increase its output while NO will cause the integrator output to decrease. When INIT VAL is set to a predetermined batch amount, decreasing action will provide a count down counter. This is sometimes preferred since the count output then represents the amount remaining in a batch.

ZDO is used for setting a small positive value, insuring that the integrator will stop when the flow is shut off, which might not otherwise happen if a flowmeter zero is out of calibration.

The function block has two trip presets: PRESET 1 and PRESET 2. These can be set to cause a high output (1) from A1 or A2 when the count total equals or exceeds the preset values. The preset values, entered in configuration, can also be set using the QUICK button if the parameter QUICKSET has been set to YES. The QS DPP parameter allows fixing the decimal point during quickset to speed up changes to these settings. A parameter value with no decimal point position, the default, is for applications dealing with the totalizer count as whole units. An external preset can be used by providing an input to T1 and/or T2 and when used, the internal preset will be ignored. If an external preset is used, the value can be viewed but not changed in QUICKSET.

The action of the presets is also determined by the action setting of the integrator. When DIR ACT is set to YES the presets will be direct acting and will cause outputs A1 or A2 to go high when the integrated total is equal to or higher than the preset. If set to NO the total will cause A1 or A2 to go high when the total is equal to or lower than the preset. The actual preset value is available on outputs T1 and T2.

The function block can also provide a pulse output to drive a remote counter. The pulse output function integrates the input signal using the same time base and output pulses at a rate determined by the PUL SCAL configuration parameter. This parameter determines the change to the integrator total that must occur to cause a new output pulse. In the above example, if PUL SCAL equals 10, a total of 30 pulses will have occurred in the same time period. The PUL SCAL value is also the multiplier that would be used to read the exact value of gallons to a remote counter. The pulse output function operates on the absolute value of the analog input. When both negative and positive values are to be totalized, a CoMParator block can be used to sense the polarity of the analog input and the CMP output can then indicate a direction to the counter.

Be sure that the PUL SCAL setting does not require a pulse rate output greater than the scan cycle time of the controller under the maximum input conditions. Using the same example, if the maximum A input is 60.0 and the cycle time is 0.1 sec, the maximum required pulse rate is 0.1/sec. The condition is satisfied since the maximum

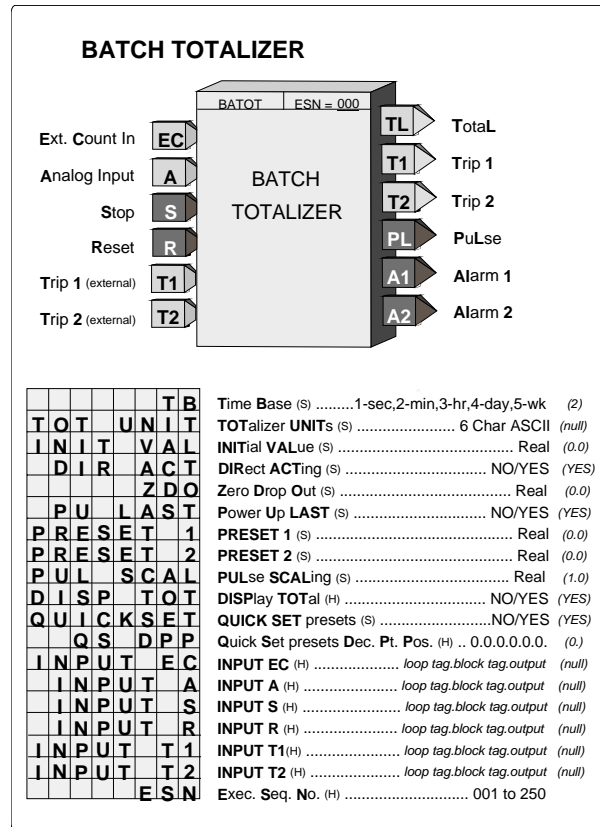

output requirement is less than the maximum pulse rate of 5/sec available with a 0.1 sec cycle time. The requirement would also be satisfied if a PUL SCAL of 1 was selected which would have required a maximum pulse rate of 1/sec.

POWER UP - During a warm start, if the configuration parameter PU LAST was set to YES, the integrator function will initialize with the last value prior to power down and all outputs will be initialized to the last value prior to power down. If set to NO, or during a cold start, the integrator and all outputs will initialize to 0.

Input EC allows the batch totalizer block to be used with another function block, such as the DINU that provides a count signal. When input A is not configured it will be set to (0.0). The EC input is summed with the initial value for use as the total. This value will now be displayed as the total on the operator faceplate and the presets will act on this value to provide outputs A1 and A2.

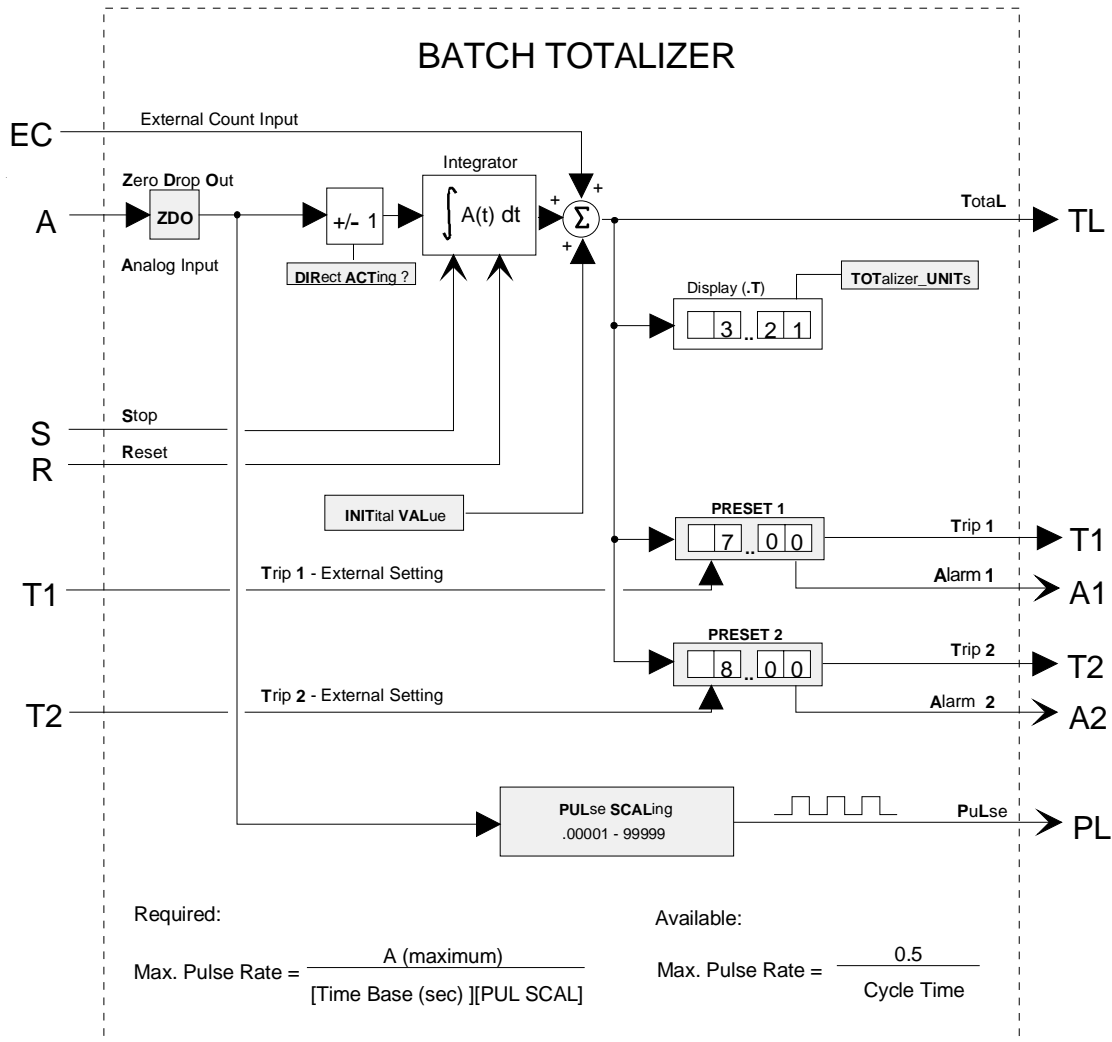

BLOCK DIAGRAM

3.2.23 BATSW - Batch Switch

BATSW function blocks can be used on a one per loop basis. Each is used with a PID function block to eliminate overshoot during startup conditions. When placed in the feedback path of the controller it causes the reset component of the controller to be reduced (if controller action is Rev). Without the use of a batch switch during startup, the controller output (O1 = GE + R) will equal full output since the reset will wind up. This requires the process to overshoot the setpoint in order to bring the controller output back down. With a batch switch in the feedback path, a lower reset value will be present when crossover occurs, thus reducing or eliminating overshoot.

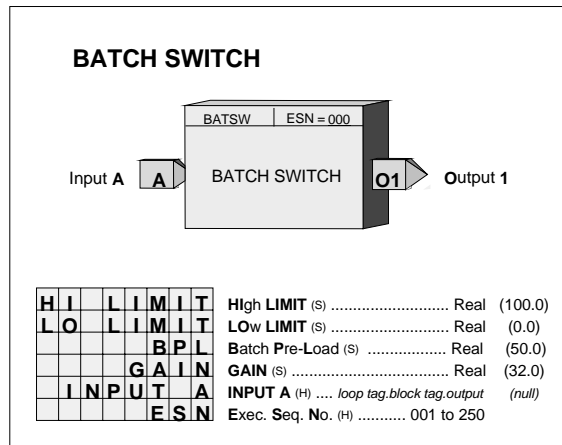

As input A equals or exceeds the HI or LO LIMIT setting, the output of the batch switch will be either decreased (HI LIMIT) or increased (LO LIMIT), changing the feedback signal and therefore the controller reset signal. This maintains controller output at the batch switch limit setting and eliminates reset windup.

If a controller has a large proportional gain setting, the reset can be modified too much, such that the process may under shoot the setpoint during a startup condition. The BPL (Batch Pre-Load) is adjusted to optimize the controller for startup conditions by limiting how much the batch switch can adjust the controller feedback signal.

When the controller output is within its normal operating output, the batch switch has no effect on the controller. This allows the controller to be tuned optimally for normal operating conditions and the batch switch to add additional compensation, very similar to derivative action, only during startup.

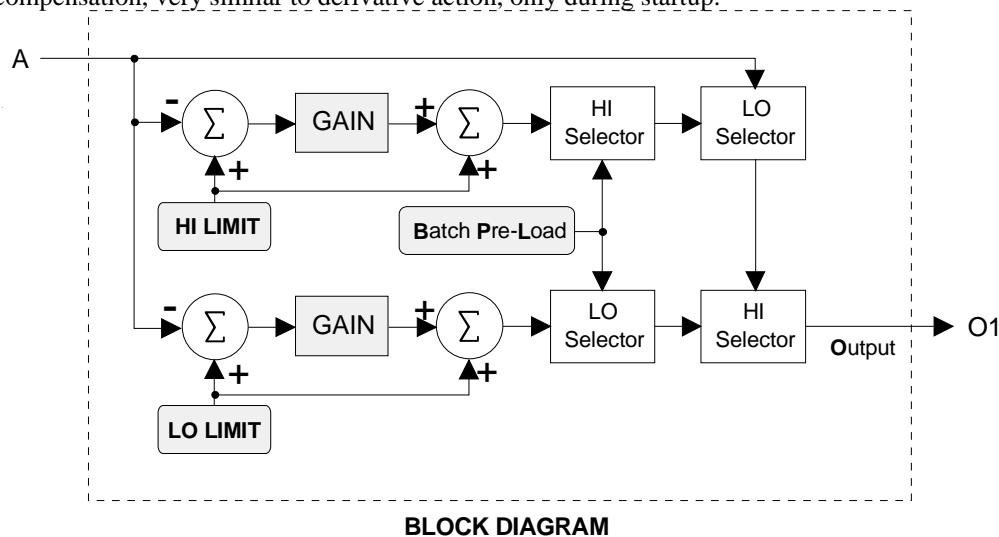

3.2.24 BIAS - Bias

BIAS function blocks can be used on a one per loop basis and provide a means to bias a signal, such as the setpoint in an external set application. Inputs A and E (external bias) are summed and then added to the operator adjustable bias B.

Track Command input TC, asserted high (1), will cause the block output to track input TV and BIAS to be recalculated as $B = TV - (A+E)$. The value of B will be clamped at the HI and LO LIMIT settings. It is important to realize that the inputs and outputs are in engineering units and the limits must be adjusted accordingly with the expected minimum and maximum required range values. The default values have been set to -150.00 and +150.00, which might be the normal expected limits when using the default range of 0.0 to 100.0. These values can be set lower but have a maximum setting of +/-150% of the range pointer value. The default range is 0.00 to 100.00 if the pointer is not configured.

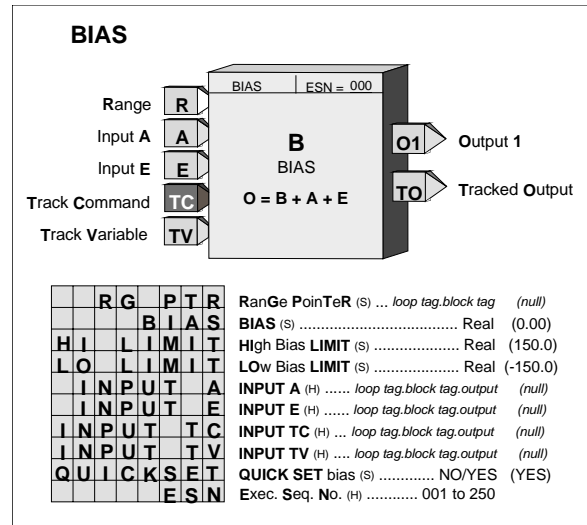

If, for example, the BIAS block is used to bias a flow setpoint with a range pointer (input R) of 0-6.00 GPM, the maximum bias adjustments would be +/-9.00. If limit adjustments of +/-50% of this range are desired, then the BIAS block LO LIMIT should be set at -3.00 and the HI LIMIT at +3.00. If a range change is made the current LIMIT settings and the current BIAS value will be changed to be the same % value within the new range.

The BIAS can be adjusted using the QUICKSET feature if the parameter QUICKSET is set to YES. The BIAS value will continuously change as the knob is adjusted but the STORE button must be pressed when the final value is reached to insure that the new BIAS setting will be retained on a Cold power up condition.

Any unused inputs to the block will be set equal to 0.

The TO (Tracked Output) is normally used in applications where an external device is being used to set a bias in place of the BIAS parameter (B is then set to 0.0). When it is desired to have the output of the BIAS block track the TV variable, the external device is forced to track TO. Input E will then equal $TV - [A+(0.0)]$ and, therefore, the BIAS block output O1 will equal TV.

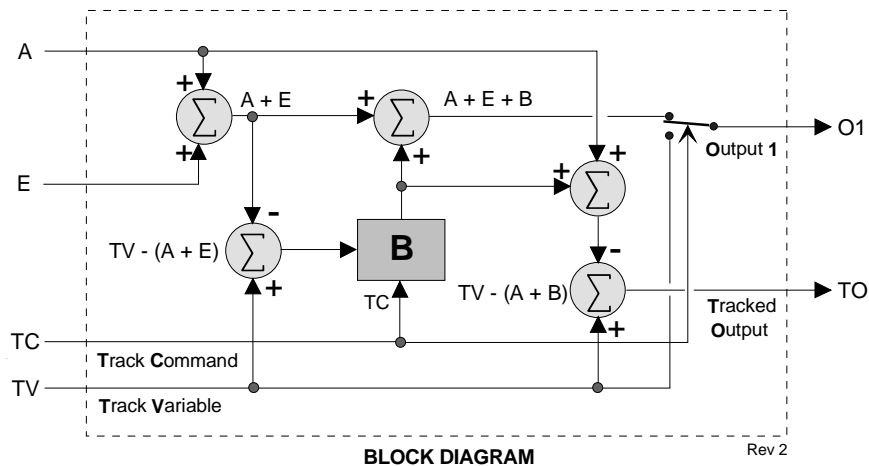

When a configuration containing the BIAS function block is edited in i|config and then downloaded to an on-line controller, the controller will ignore a change to the BIAS parameter value and continue to run with the pre-download value.

3.2.25 CIE_ - Coil Inputs - Ethernet (V3.0)

Ethernet is available on Model 353, Model 353R and Procidia i|pac controllers; not available on Models 352P and 354/354N.

CIE_ function blocks are available when the optional Ethernet communication board¹⁰ is installed in the controller. It enables the controller to obtain Coil data from other stations over the Ethernet network.

Up to 32 CIE_ blocks are available. Blocks are assigned in sequence, controller wide, with each use. Up to 16 Coils can be obtained from a Modbus device. Each Coil is assigned to block outputs C0 – CF.

The IP ADRES parameter is used to configure the IP address of the source Modbus device. The MB ADRES parameter allows a Modbus address to be configured. When connecting to other Siemens and Moore Products Co. controllers, the Modbus address is set to 1. In some cases, other Modbus devices may use a different address or when going through a Modbus TCP/IP gateway a Modbus network may have multiple devices, each having a unique address.

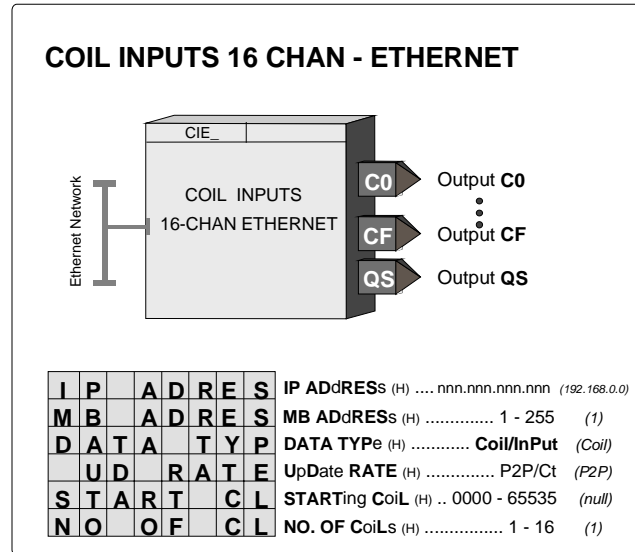

The START CL parameter identifies the location of the first Coil. Subsequent Coils, up to 16, can be obtained by setting the NO OF CL parameter to a value greater than 1. The DATA TYP parameter enables reading of Coils (Modbus Function Code 01) or Inputs (Modbus Function Code 02). Both are treated the same but the Coil type is the most common usage. The UD RATE parameter configures the rate at which the block will request data. The P2P setting will update the data at the rate set by the P2P RATE parameter in the ETHERNET block. The Ct setting will update the data at the cycle time of the controller.

Output QS indicates the quality of the received data and will go high (1) when the data is bad. This is normally associated with failure to receive data due to a communication failure or a misconfiguration of the source.

¹⁰ Requires Ethernet communications board firmware version 2.0 or later

3.2.26 CHR_ - Characterizer

CHR_ function blocks provide 10 segments that can be used to characterize the X input signal. Individual segments are configured by entering the X_n, Y_n and X_{n+1}, Y_{n+1} points for each segment. All X_{n+1} points must be greater than the associated X_n points. Input X is in engineering units and the Y points should be in the engineering units desired for the characterizer output.

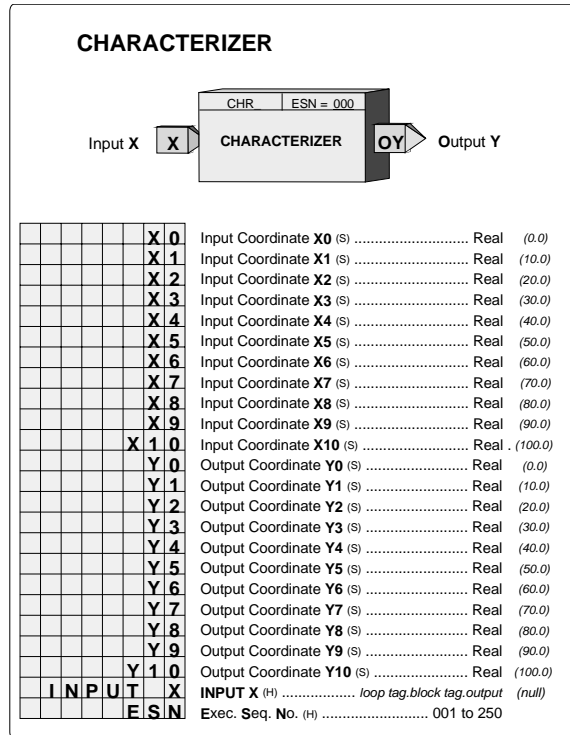
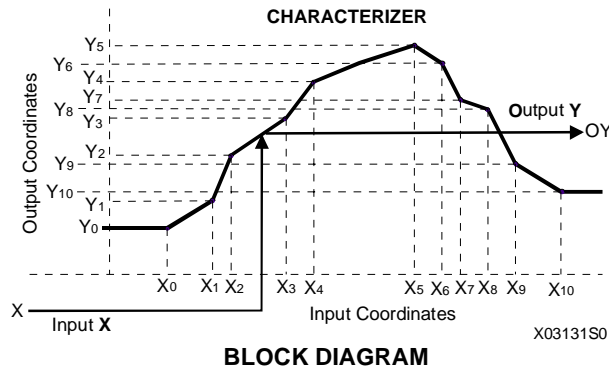

3.2.27 CMP_ - Comparator

CMP_ function blocks compare analog input A with an external or internal limit setting and provide a high (1) output when the limit is exceeded.

ACTION - the CMP block can be configured as direct or reverse action. Direct action will cause the output to go high when input A is equal to or greater than the limit. Reverse action will cause the output to go high when input A is equal to or less than the limit.

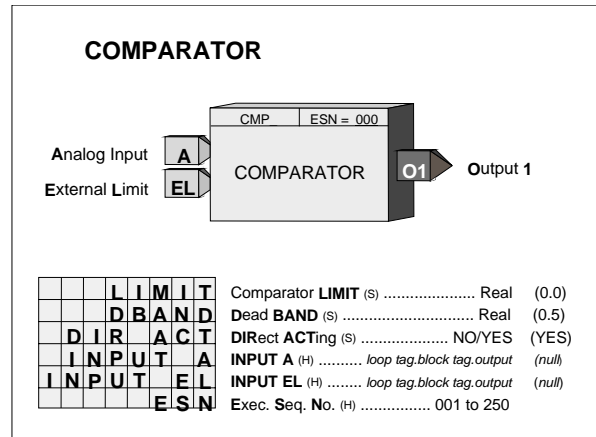
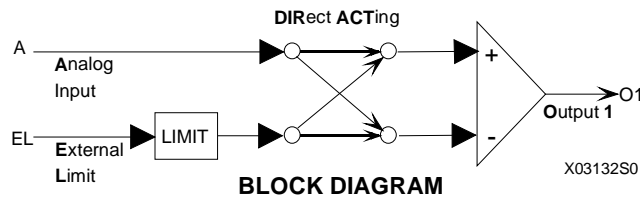

DEAD BAND - the output will return from a high (1) output to a low (0) output when input A is less than the limit - Dead BAND setting for direct action or greater than the limit + Dead BAND for reverse action.

EXTERNAL LIMIT - When input EL is configured, the LIMIT setting will be ignored and the value of input EL will be used as the limit value.

3.2.28 COS_ - COSINE

COS_ function blocks, in firmware 1.30 and higher, accept radian inputs and output the cosine of that angle.

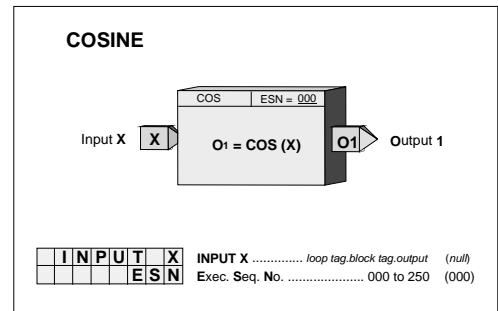
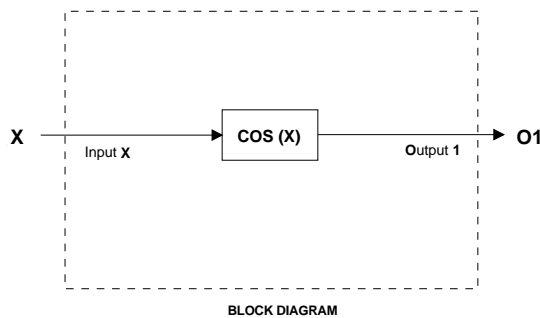

3.2.29 CWE_ - Coil Write Ethernet (V3.0)

Ethernet is available on Model 353, Model 353R and Procidia i|pac controllers; not available on Models 352P and 354/354N.

CWE_ function blocks are available when the optional Ethernet communication board¹¹ is installed in the controller. It enables the controller to write Coil data to other stations over the Ethernet network.

Up to 32 CWE_ blocks are available. Blocks are assigned in sequence, controller wide, with each use. Up to 16 ON/OFF block inputs, I0 to IF, can write to 16 consecutive coil locations in a destination Modbus device.

The IP ADRES parameter is used to configure the IP address of the destination Modbus device. The MB ADRES parameter allows a Modbus address to be configured. When connecting to other Siemens and Moore Products Co. controllers, the Modbus address is set to 1. In some cases, other Modbus devices may use a different address or when going through a Modbus TCP/IP gateway a Modbus network may have multiple devices, each having a unique address.

The START CL parameter identifies the location of the first Coil. The NO OF CL parameter identifies the total number of coils, up to 16, to write.

There are three write update options that can be configured by the UD TYPE parameter.

1. oncE will write once to the START CL (Modbus Starting Coil). The controller will write when any block input value changes state.
2. P2P will update at the controller peer to peer rate set in the ETHERNET block.
3. Ct will update at the cycle time of the controller.

The Ct option is normally only used when writing time critical changes. Input T can be used to trigger a write. This would be used in cases where the oncE option has been selected, input values do not change, and there may be a concern that the receiving device has lost the values.

Output QS indicates the quality of the write operation and will go high (1) when the write is not completed successfully. This is normally associated with failure of the destination device to receive data due to a communication failure or a misconfiguration of the device.

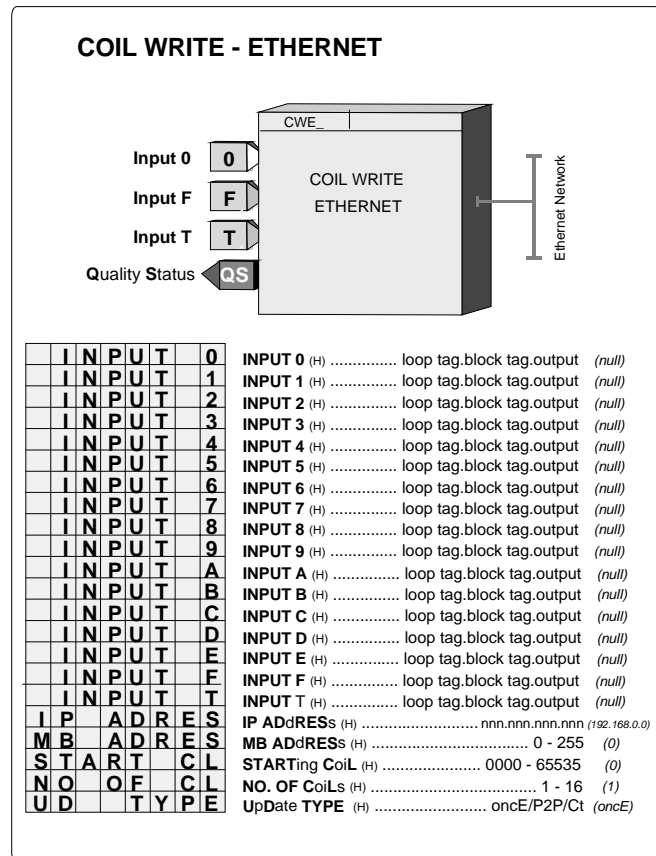

¹¹ Requires Ethernet communications board firmware version 2.0 or later

3.2.30 DAM_ - Deviation Amplifier

DAM_ function blocks compute the difference between inputs A and B, amplify the difference signal, and sum the resultant with an internal BIAS and an external signal at input C. Unused inputs are set to 0.0.

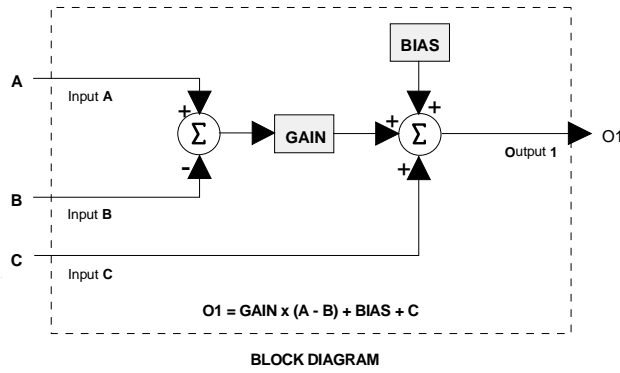

DEVIATION AMPLIFIER

Input A A
 Input B B
 Input C C

DAM | ESN = 000
 DEVIATION
 AMPLIFIER

O1 → Output 1

	GAIN	GAIN (S)	Real	(1.0)
	BIAS	BIAS (S)	Real	(0.0)
	INPUT A	INPUT A (H)	loop tag.block tag.output	(null)
	INPUT B	INPUT B (H)	loop tag.block tag.output	(null)
	INPUT C	INPUT C (H)	loop tag.block tag.output	(null)
	ESN	Exec. Seq. No. (H)	001 to 250	

3.2.31 DID_ - Digital Input lev_Discrete

DID_ function blocks convert 16 on/off signals received from a single or multiple nodes on the LonWorks network into 16 block outputs for use by other function blocks within the controller. A maximum of 6 DID blocks can be used, up to the limit of nodes allowed on the Lon network or the memory limit of the controller. Each use of the block will be assigned a unique station wide ID (e.g. DID02). Input connections are established by 'binding' each output variable of type SNVT_lev_disc (SNVT #22) in the remote node devices to each network variable in the DID function block. These blocks will be available when the LonWorks option board is installed in a 352P, 353 (Design Level A), or 354N controller.

The 0 NV NUM parameter enables the number that the station has assigned to input 0. All subsequent network variables are assigned consecutively.

Each function block output has a mode associated with it. The mode can be either NORMAL or FORCED. When using a PC capable of sending LIL or Modbus commands, the mode can be changed and the forced state can be assigned a high (1) or low (0) value. The values accessible over the network are the two switch inputs (N and F) and the position of the SPDT switch illustrated in the block diagram. A mode of '0' is Normal and '1' is Forced.

Each function block output also has a quality status associated with it. This status will go high (1) when the block determines it has lost communication with the Lon node. If any of the individual quality outputs are high the Quality Status block output will also be high.

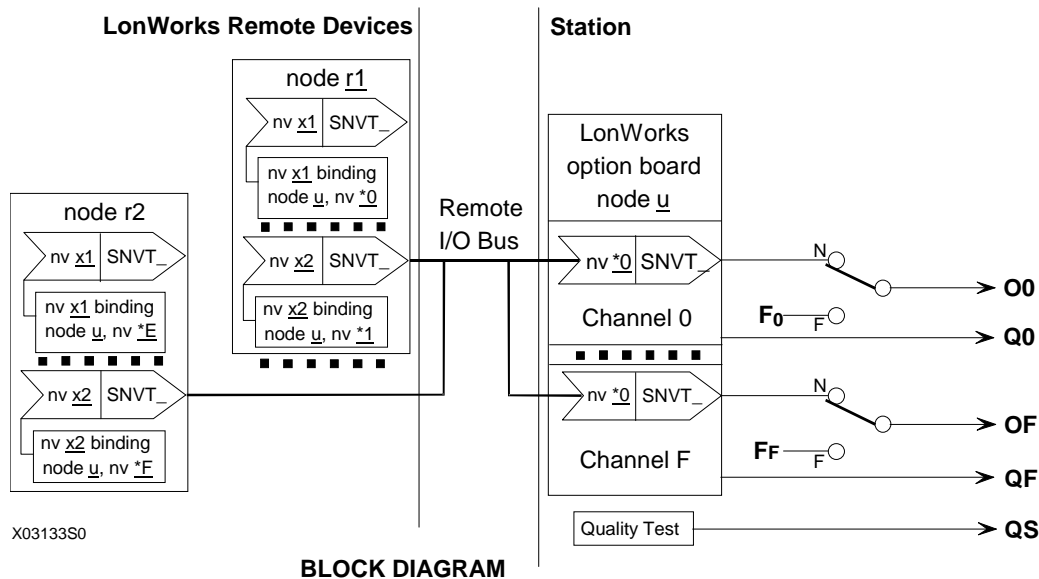
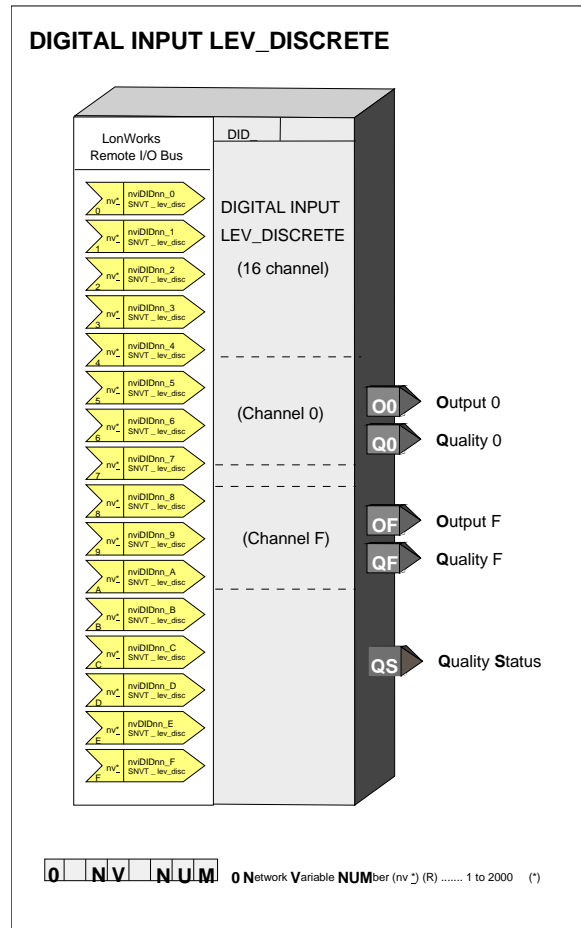

3.2.32 DIE_ - Digital Input - Ethernet (V3.0)

Ethernet is available on Model 353, Model 353R, and Procidia iJpac controllers; not available on Models 352P and 354/354N.

DIE_ function blocks are available when the optional Ethernet communication board¹² is installed in the controller. It enables the controller to read digital data from other stations over the Ethernet network.

Up to 32 DIE_ blocks are available. Blocks are assigned in sequence, controller wide, with each use. Digital data is On/Off data packed into a 16-bit word. This data is fanned out to block outputs D0 – DF.

The IP ADRES parameter is used to configure the IP address of the source device. The MB ADRES parameter allows a Modbus address to be configured. When connecting to other Siemens and Moore Products Co. controllers the Modbus address is set to 1. In some cases, other devices may use a different address or when going through a Modbus TCP/IP gateway a Modbus network may have multiple devices, each having a unique address.

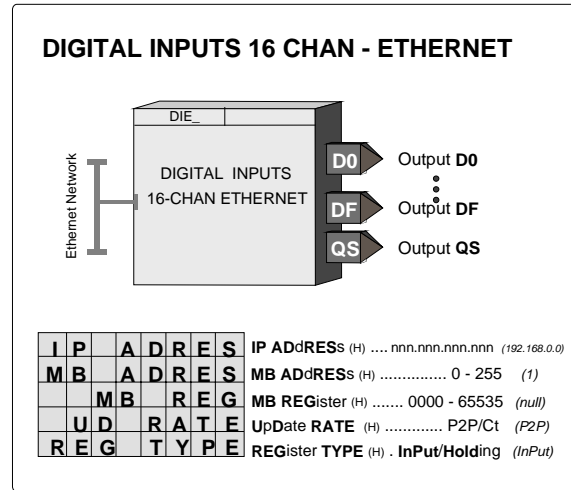

The MB REG parameter identifies the location of the digital data in the source device. The REG TYP parameter enables reading of Holding Registers (Modbus Function Code 03) or Input Registers (Modbus Function Code 04). Both are treated the same in most Modbus devices but the Input type is the most common usage. The use of DOE blocks in other Siemens and Moore Products Co. controllers as the input source is defined by using the Modbus Registers from the table below. The UD RATE parameter configures the rate at which the block will request data. The P2P setting will update the data at the rate set by the P2P RATE parameter in the ETHERNET block. The Ct setting will update the data at the cycle time of the controller.

Output QS indicates the quality of the received data and will go high (1) when the data is bad. This is normally associated with failure to receive data due to a communication failure or a misconfiguration of the source.

FB Number	MB Register	FB Number	MB Register	FB Number	MB Register	FB Number	MB Register
DOE01	31025	DOE09	31033	DOE17	31041	DOE25	31049
DOE02	31026	DOE10	31034	DOE18	31042	DOE26	31050
DOE03	31027	DOE11	31035	DOE19	31043	DOE27	31051
DOE04	31028	DOE12	31036	DOE20	31044	DOE28	31052
DOE05	31029	DOE13	31037	DOE21	31045	DOE29	31053
DOE06	31030	DOE14	31038	DOE22	31046	DOE30	31054
DOE07	31031	DOE15	31039	DOE23	31047	DOE31	31055
DOE08	31032	DOE16	31040	DOE24	31048	DOE32	31056

¹² Requires Ethernet communications board firmware version 2.0 or later

3.2.33 DIL_ - Discrete Input _ LIL

DIL_ function blocks are available when the optional LIL communication board is installed. DIL block numbers are assigned in sequence with each use, station wide. The block allows the station to obtain a global word (GW) from another station on the LIL.

The function block has 16 outputs, D0 through DF. They represent the values of bits 0-F in the global word. Output QS indicates the quality of the received data and will go high (1) when the data is bad. This is normally associated with failure to receive global data due to a LIL failure or a misconfiguration of the source.

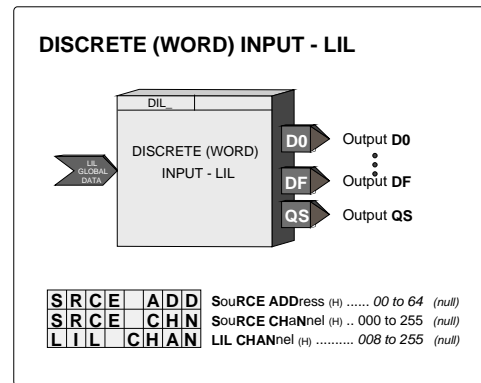

The received global word will be re-transmitted by this station as a parameter 1 value in the configured channel n.

	1	2	3	4	5	6	7	8	9	10	11	12
n	GW	SA/SC										

3.2.34 DIN_ - Digital Inputs

DIN_ function blocks can be used to sense a discrete signal from an external source and provide a block output representing the state of this signal. Blocks are available on the Controller Board and on the Expander Board. Function block names (IDs) and terminal designators are listed in Section 8.4.

The block output is high (1) when the input is on and low (0) when off.

Output QS indicates the quality status of the output signal O1 and will be high (1) when the output is of bad quality. Bad quality indicates any hardware failure of the input converter.

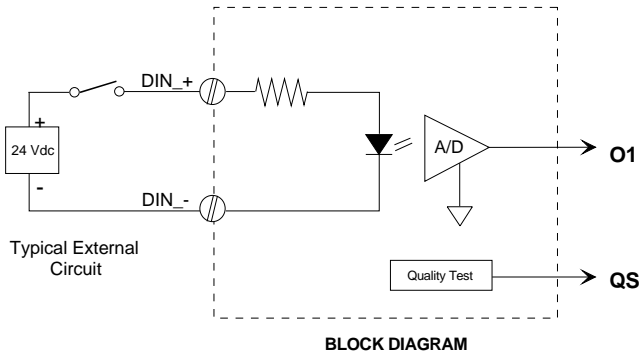
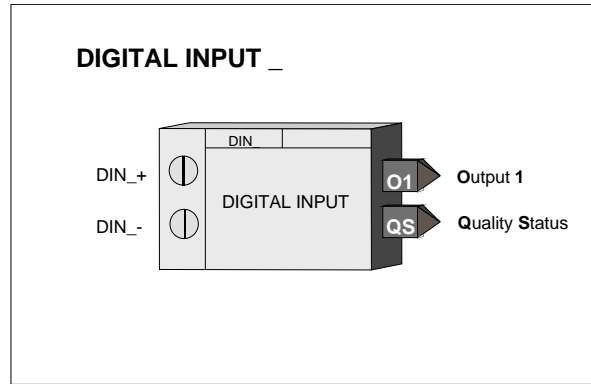

3.2.35 DINU_ - Digital Inputs, Universal

INU_ blocks have multi-function capability:

- sensing a discrete input and providing a high (1) or low (0) output representing the state of the input
- totalizing and scaling the count of input pulses
- converting the rate of input pulses to a scaled analog frequency output

Two DINU_ blocks are available on the I/O expander board. The fixed names (IDs) of these blocks and their terminal designations are listed in Section 8.4.

Output CT represents the scaled (actual count x K) total of input pulses that occurred since the last reset. This output is a real number and can be used in a number of applications, such as a direct count input to the BAT batch totalizer function block or in math operations, such as computing the difference between counts in a ratio trim circuit.

Output IS is the current state of the input at the time the block is executed at the start of each controller scan cycle. It will be low (0) when the input is low and high (1) when the input is high.

Output SF is a scaled frequency (using the FREQ MIN and MAX parameters) that can represent flow rate, speed, or other transmitter variable that has a frequency signal. When the FREQ MAX parameter is set to 25 or less, a 20 msec contact debounce is used. When contact debounce is used, a pulse input must remain on for 20 msec to be recognized as a valid pulse. Output SF is linear with frequency and can be characterized using the CHR function block if necessary. An engineering range and units are assigned to this signal using the MINSCALE, MAXSCALE, DPP, and ENGUNITS parameters. They are available to other blocks using the OR output connection.

Input R resets output CT to 0.0. Input D controls the direction of the count. When direction input D is low (0), the count will move backwards, including negative values. The direction input feature enables the use of count down counters and it allows duplication of functions performed by previous computer pulse interfaces having a Pulse/Direction format. Input TC asserted high (1) will force the scaled count to track an external signal. This can be used in applications where the CT output is being used to set a value (e.g. setpoint) that can be changed from another source.

The quality status output QS indicates the quality of the block outputs and is high (1) when outputs CT, IS, or SF are of bad quality. Bad quality indicates a failure in the hardware conversion circuit.

POWER UP - With PU LAST set to YES, the CT output will power up at the last value during a hot or warm start. If set to NO, during a warm or a cold start it will be set to 0.0. The digital filter will be temporarily bypassed during a hot, a warm or a cold start.

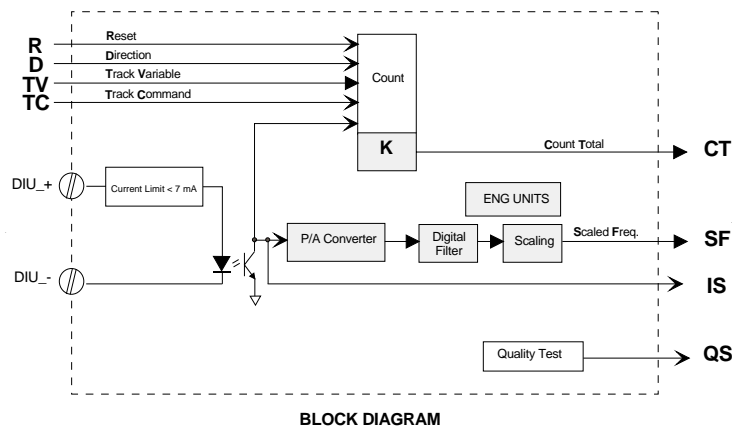
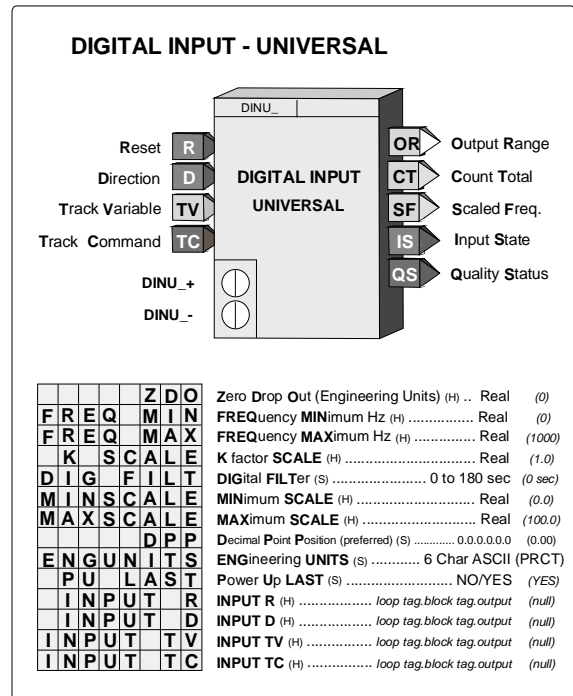

3.2.36 DIS_ - Digital Input _ State

DIS_ function blocks, in firmware 1.30 and higher, convert a 16-bit word received from a single node on the LonWorks network into 16 block outputs for interconnection to other function blocks within the controller. A maximum of 6 DIS blocks can be used, up to the limit of nodes allowed on the Lon network or the memory limit of the controller. Each use of the block will be assigned a unique station wide ID (e.g. DIS02). Input connections are established by 'binding' the output variable of type SNVT_state (SNVT #83) in the remote node to the network variable in the DIS function block. These blocks will be available when the LonWorks option board is installed in a 352P, 353 (Design Level A), or 354N controller.

The 0 NV NUM parameter enables viewing the number that the station has assigned to input 0.

Each function block output has a mode associated with it. The mode can be either NORMAL or FORCED. When using a PC capable of sending LIL or Modbus commands, the mode can be changed and the forced state can be assigned a high (1) or low (0) value. The values accessible over the network are the two switch inputs (N and F) and the position of the SPDT switch illustrated in the block diagram. A mode of '0' is Normal and '1' is Forced.

The function block also has a quality status output associated with it. This status will go high (1) when the block determines it has lost communication with the Lon node.

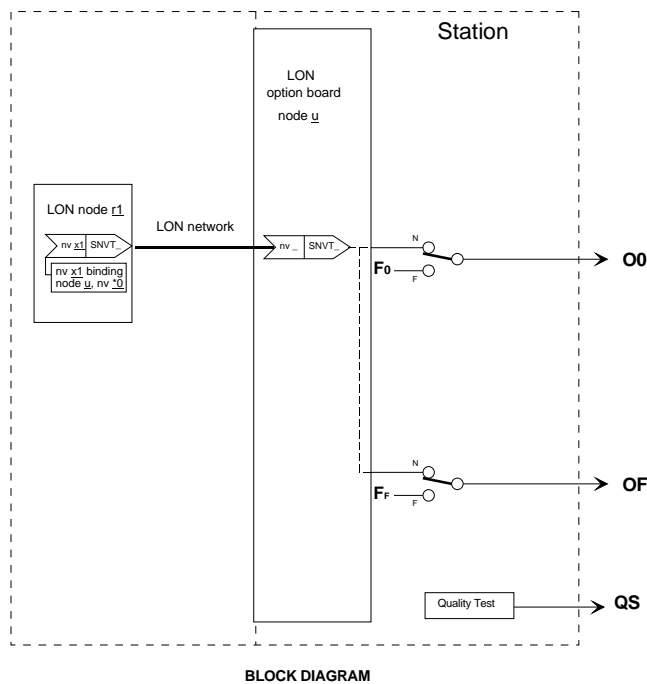
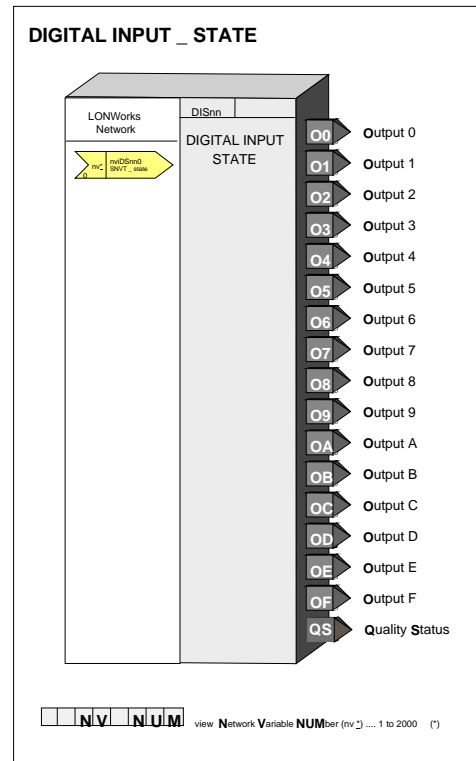

3.2.37 DIV_ - Division

DIV_ function blocks perform simple arithmetic division. The output will be the quotient of the two configured inputs N/D. The output will be limited to the maximum real number and, if the divisor is 0.0, the output will go to the maximum real number with the sign determined by the numerator. If the numerator is 0.0, the output will be 0.0.

Any unconfigured inputs will be set equal to 1.0.

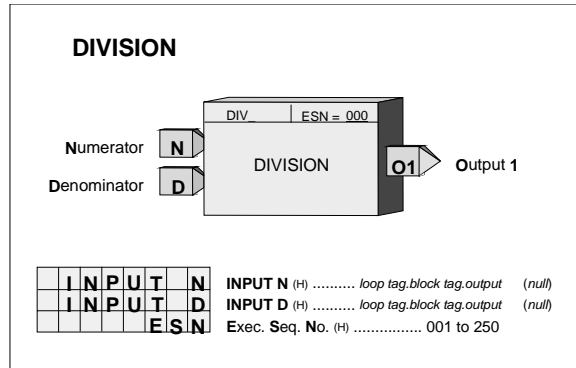
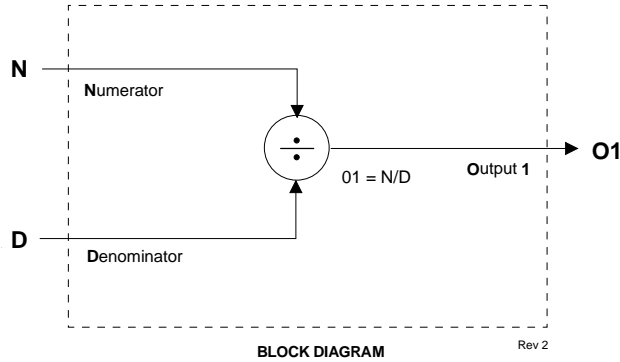

3.2.38 DNC_ - Divide by N Counter

DNC_ function blocks provide a single output pulse for a pre-selected number of input pulses. The output will go high (1) with a positive transition of the input P and will return to a low (0) output on the succeeding positive transition.

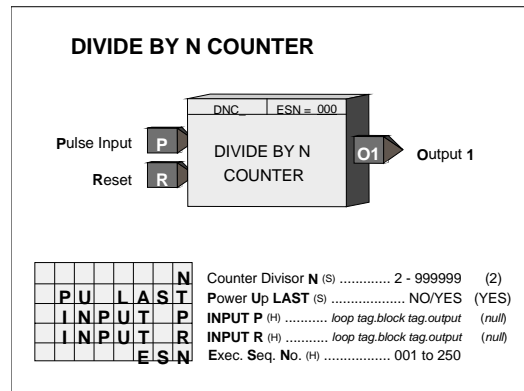
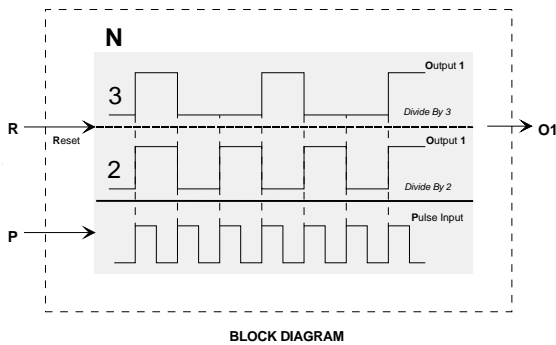

POWER UP - During a hot or a warm start, with **PU LAST** set to **YES**, the block will retain the last count and continue at the last input/output states. If set to **NO**, during a warm or a cold start, the output and count will be initialized to 0.

3.2.39 DOD_ - Digital Output lev_Discrete

DOD_ function blocks transmit up to 16 on/off signals received from a controller block interconnection to remote nodes on the LonWorks network. A maximum of 6 DOD blocks can be used, up to the limit of nodes allowed on the Lon network or the memory limit of the controller. Each use of the block will be assigned a unique station wide ID (e.g. DOD01). Each input transmitted is of type SNVT_lev_disc and can be bound to network variables in a single or multiple remote nodes that can receive network variables of this type. These blocks will be available when the LonWorks option board is installed in a 352P, 353 (Design Level A), or 354N controller. The 0 NV NUM parameter enables the number that the station has assigned to input 0 to be viewed. All subsequent network variables are assigned consecutively.

Each function block input has a mode associated with it. The mode can be either NORMAL or FORCED. When using a PC capable of sending LIL or Modbus commands, the mode can be changed and the forced state can be assigned a high (1) or low (0) value. The values accessible over the network are the two inputs (F and N) and the position of the SPDT switch illustrated in the block diagram. A mode of '0' is Normal and '1' is Forced.

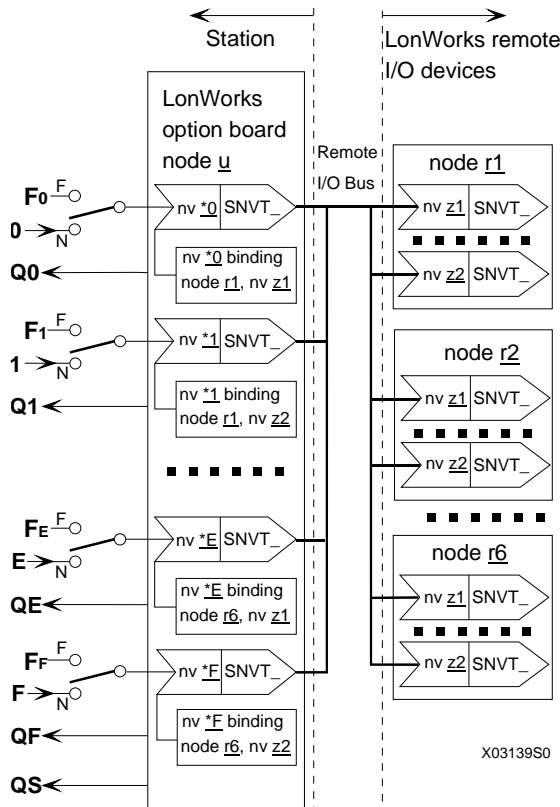

BLOCK DIAGRAM

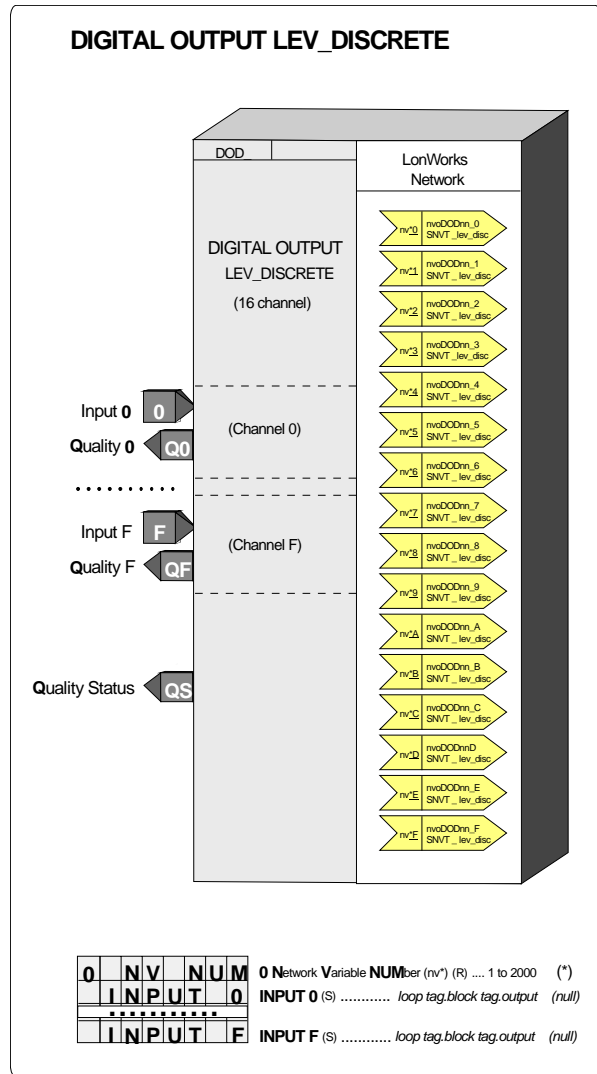

Each function block input also has a quality status associated with it. This status will go high (1) when the block determines it has lost communication with the Lon node bound to that input. If any of the individual quality inputs are high, the Quality Status block output will also be high.

3.2.40 DOE_ - Digital Output - Ethernet (V2.4)

Ethernet is available on Model 353, Model 353R and Procidia i|pac controllers; not available on Models 352P and 354/354N.

DOE_ function blocks are available when the optional Ethernet communication board is installed. Up to 32 DOE blocks are available and are assigned in sequence with each use, station wide.

Up to 16 digital inputs can be configured. The block will pack inputs I0 - IF into a single integer word which can be accessed from another controller having Ethernet communication capability.

Each DOE block is automatically assigned Modbus registers that can be accessed from any device having the Modbus Ethernet capability.

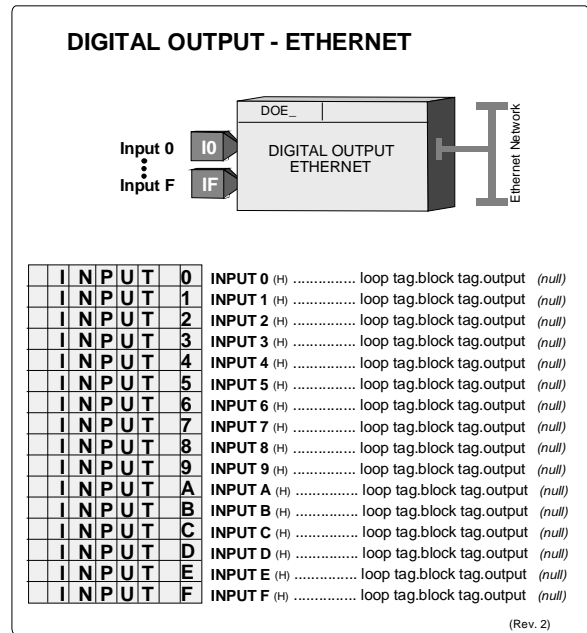

3.2.41 DOL_ - Discrete Output - LIL

DOL_ function blocks are available when the optional LIL communication board is installed. They allow the station to output a global word GW with bits 0-F representing the state 1 or 0 of each of the Boolean inputs D0 - DF. Unconfigured inputs are set to 0. DOL block numbers are assigned in sequence with each use, station wide.

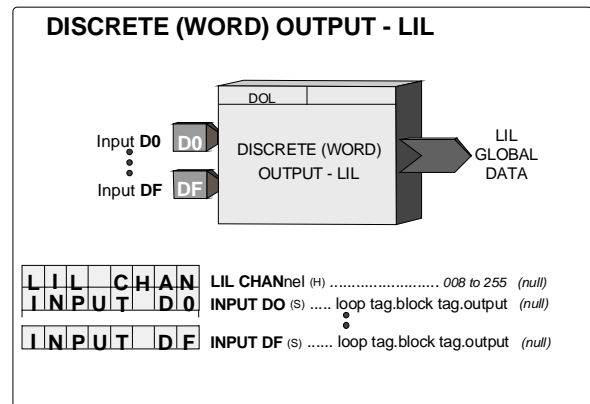

	1	2	3	4	5	6	7	8	9	10`	11	12
n	GW											

3.2.42 DOS__ - Digital Output State

DOS_ function blocks, in firmware 1.30 and higher, transmit up to 16 on/off signals received from a controller block interconnection to a remote node on the LonWorks network as a single 16-bit word value. A maximum of 6 DOS blocks can be used, up to the limit of nodes allowed on the Lon network or the memory limit of the controller. Each use of the block will be assigned a unique station wide ID (e.g. DOS01). The transmitted value is of type SNVT_state and can be bound to a network variable in a remote node that can receive a network variable of this type. These blocks will be available when the LonWorks option board is installed in a 352P, 353 (Design Level A), or 354N controller.

Each function block input has a mode associated with it. The mode can be either NORMAL or FORCED. When using a PC capable of sending LIL or Modbus commands, the mode can be changed and the forced state can be assigned a high (1) or low (0) value. The values accessible over the network are the two switch inputs (N and F) and the position of the SPDT switch illustrated in the block diagram. A mode of '0' is Normal and '1' is Forced.

The function block also has a quality status associated with it. This status will go high (1) when the block determines it has lost output communication with the Lon node bound to that input.

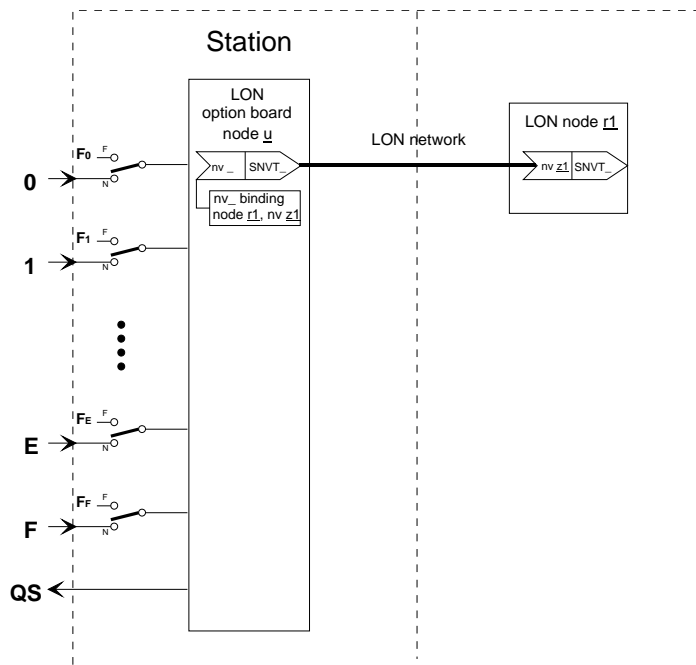
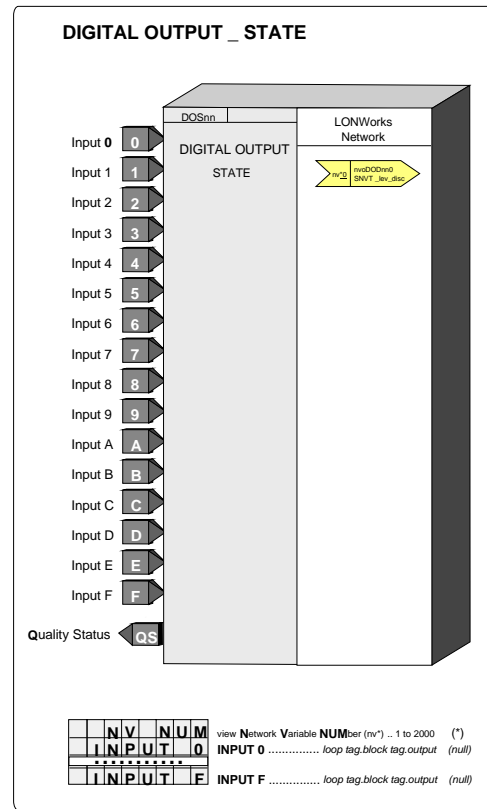

BLOCK DIAGRAM

3.2.43 DOUT_ - Digital Outputs

DOUT_ function blocks are used to turn on remote devices powered from an external source. The negative terminal of the external power source must be connected to station common. The transistor switch will turn on when the block input S is high (1) and will turn off when low (0). Two digital output function blocks are available on the Controller Board.

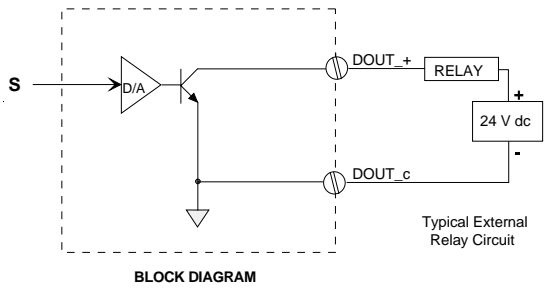

Typical External Relay Circuit

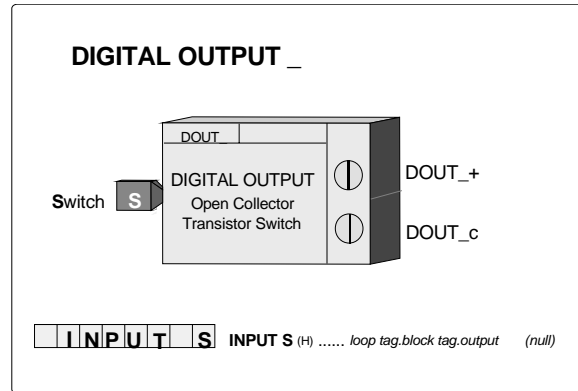

Terminal Connections:

- DOUT1** ----- DOUT1+ (8) -- DOUT1c (9)
- DOUT2** ----- DOUT2+ (10) -- DOUT2c (9)

3.2.44 DTM_ - Dead Time Table

DTM_ function blocks provide shift registers to hold the analog input signal A for a period of time and shift it from register to register to provide an overall delay between input and output as configured in parameter DEADTIME.

Input AT can be used to adapt the DEADTIME to an external signal. The actual shift register used as the block output will equal the whole value of input AT (e.g. 0.184 = register 0, 1.897 = register 1).

Output MA will provide the moving average of register 0 to the output register divided by the number of registers [e.g. output register = 50, MA = (R0+R1+R2+.....+R50)/51].

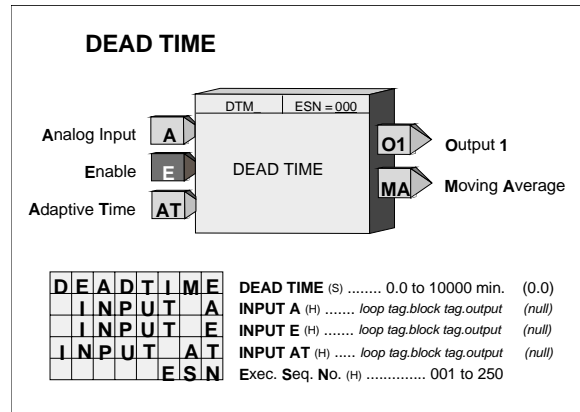

Input E asserted high (1) will enable the operation of the DTM block. When this input is not configured, it will be set high. A low (0) input will cause all registers and the outputs to equal the input A.

POWER UP - During a warm or cold start, all outputs will be initialized at 0 and all registers will be initialized to the value of the input on the first scan.

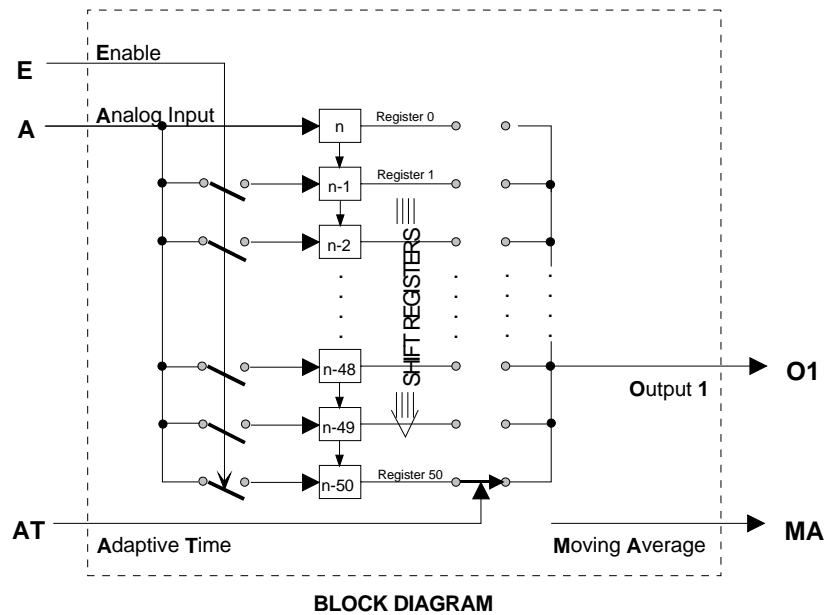

3.2.45 DWE_ - Digital Write Ethernet (V3.0)

Ethernet is available on Model 353, Model 353R and Procidia i|pac controllers; not available on Models 352P and 354/354N

DWE_ function blocks are available when the optional Ethernet communication board¹³ is installed in the controller. It enables the controller to write Digital data to other stations over the Ethernet network.

Up to 32 DWE_ blocks are available. Blocks are assigned in sequence, controller wide, with each use. Digital data is On/Off data packed into a 16-bit word.

The IP ADRES parameter is used to configure the IP address of the destination Modbus device. The MB ADRES parameter allows a Modbus address to be configured. When connecting to other Siemens and Moore Products Co. controllers the Modbus address is set to 1. In some cases, other Modbus devices may use a different address or when going through a Modbus TCP/IP gateway a Modbus network may have multiple devices, each having a unique address. The MB REG parameter identifies the location of the register in the Modbus device.

There are three write update options that can be configured by the UD TYPE parameter.

1. oncE will write once to the START CL (Modbus Starting Coil. The controller will write when any block input value changes state.
2. P2P will update at the controller peer to peer rate set in the ETHERNET block.
3. Ct will update at the cycle time of the controller. The Ct option is normally only used when writing time critical changes. Input T can be used to trigger a write. This would be used in cases where the oncE option has been selected, input values do not change, and there may be a concern that the receiving device has lost the values.

Output QS indicates the quality of the write operation and will go high (1) when the write is not completed successfully. This is normally associated with failure of the destination device to receive data due to a communication failure or a misconfiguration of the device.

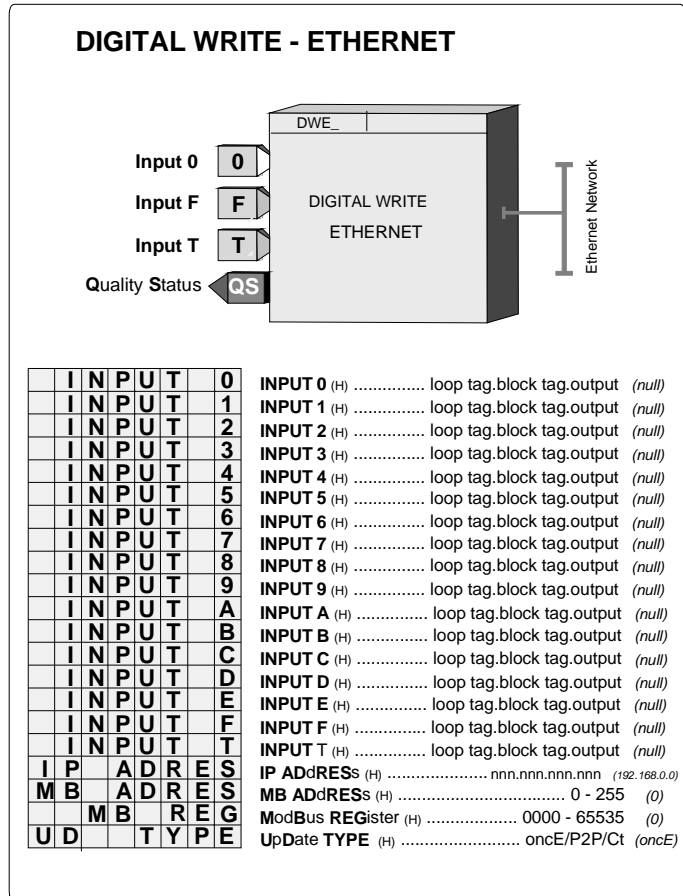

¹³ Requires Ethernet communications board firmware version 2.0 or later

3.2.46 DYT_ - Delay Timer

DYT_ function blocks perform either an ON or OFF output delay as determined by the TYPE configuration parameter.

ON Delay - When input P is low (0), output O1 is low. If P goes high (1), the elapsed timer starts and sets O1 high upon reaching the DLY TIME, provided P is still high.

OFF Delay - When input P is high (1) the output is high. If P goes low (0), the elapsed timer starts and sets O1 low upon reaching the DLY TIME, provided P is still low.

In firmware 1.30 and higher, the DLY TIME is adjustable over the full range of the display, which is 0.00000 to 999999. In earlier versions, the minimum time setting is 0.1. If the delay time is set to less than the scan time of the station, the delay time will equal the scan time.

Output ET (elapsed time) will ramp from 0.0 to the value of DLY TIME and remain there until P resets the output. Output RT (remaining time) equals DLY TIME - ET.

POWER UP - During a warm or a hot start, with PU LAST set to YES, the block will initialize with the input/output states and elapsed time in effect at the instant power down occurred. A cold start, with PU LAST set to NO, will initialize the input/output states and elapsed time to 0.

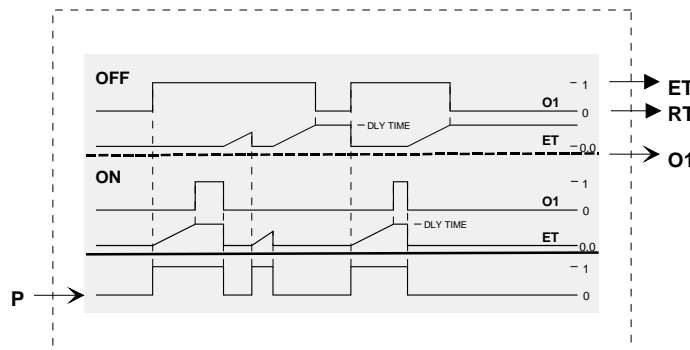
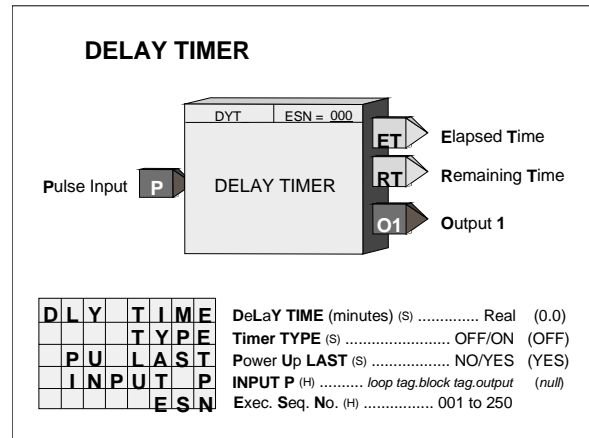

BLOCK DIAGRAM

3.2.47 E/I - External/Internal Transfer Switch

E/I function blocks can be used on a one per loop basis to select an analog signal, connected to input E (External) or input I (Internal), as a setpoint for the loop controller.

The position of the E/I switch can be changed on each positive transition of input ST and will normally be connected to the PS output of pushbutton block PB2SW, configured for momentary action. The SE output will normally be connected to the MD input of pushbutton block PB2SW. E/I switch position will be shown on the operator faceplate by a lighted LED: green for E, red for I.

The E/I switch position can also be changed by command over the Modbus or LIL network.

When PU LAST is set to YES, the E/I switch will power up in the last position during a hot or a warm start. During a cold start, it will power up in the position set by the POWER UP parameter. If PU LAST is set to NO, the E/I switch will power up in the last position during a hot start, but during a warm or cold start will power up in the position set by the POWER UP parameter.

The IO (Internal Override) input enables a HI (1) input to temporarily select the Internal Input as the function block output O1. This input does not affect the position of the E/I switch.

Outputs SE and SI indicate the actual position of the E/I switch. SE is HI (1) when in the E position and LO (0) when in the I position. SI is HI when in the I position and LO when in the E position. Outputs IS and ES indicate the actual source of the block output. IS is HI when O1 is the Internal input and is LO when O1 is the External input. ES is HI when O1 is the External input and is LO when O1 is the Internal input.

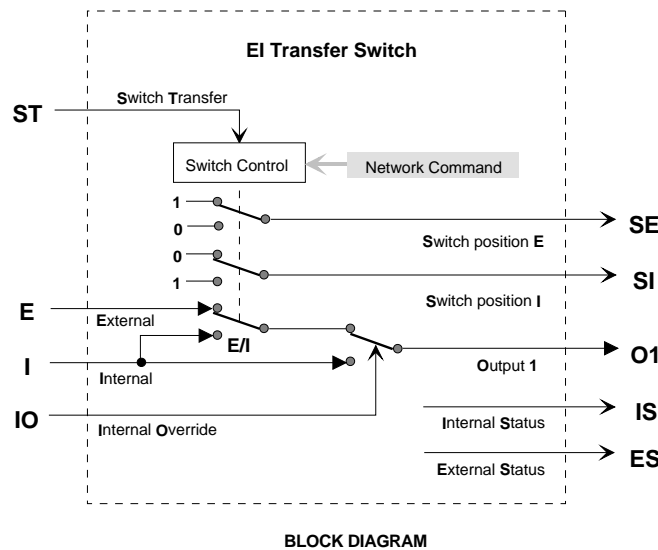
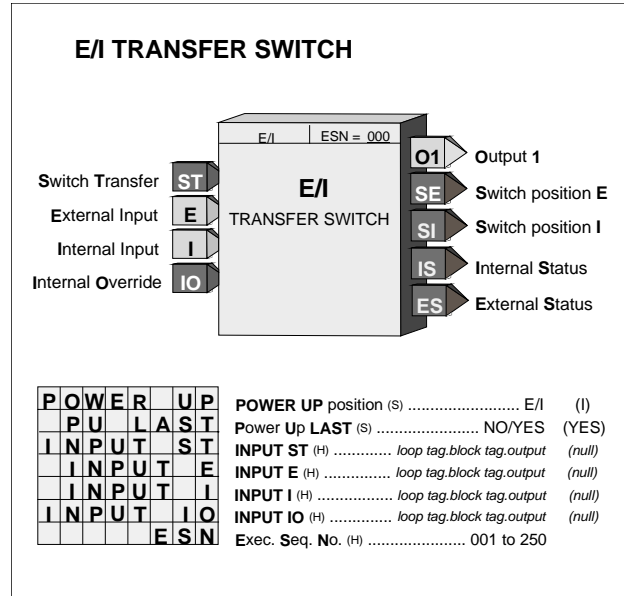

3.2.48 ESL - Events Sequence Logger

ESL function blocks, in firmware 1.30 and higher, can be used on a one per loop basis to log events within the loop. Each ESL input can be assigned a user tag (up to 8 ASCII characters) that will be displayed when viewing the logged events from the front panel. Events, once triggered by a positive transition 0>1 input, will remain in the logger until reset. Reset can be initiated either by setting input R high (this input is edge sensitive and will reset the events on the leading edge) or by entering configuration and setting the parameter RESET to YES.

Events logged to the ESL function block can be viewed at the operator faceplate by pressing the ACK pushbutton when displaying the loop containing an ESL function block having logged events. The alphanumeric display will first step through any active alarms, status conditions or errors and then all the logged events that occurred since the last reset. The configured 8-character name will be shown in the alphanumeric display and the order of occurrence (ESL-1, ESL-2...) will appear in the numeric display when stepping through the event log. Other events such as alarms, status conditions, or errors can be similarly viewed if logged to the ESL function block.

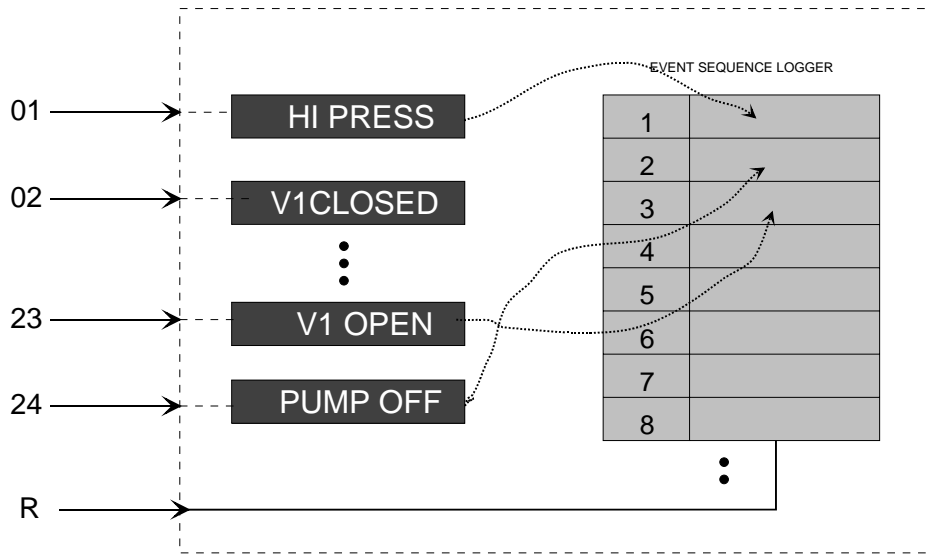
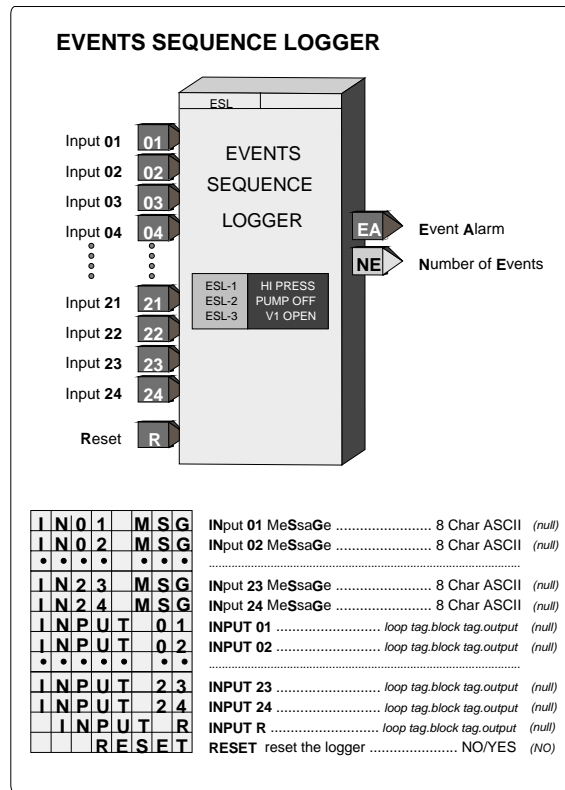

3.2.49 EXP_ - NATURAL EXPONENTIATION

EXP_ function blocks, in firmware 1.30 and higher, perform the natural exponentiation function, base “e”. The output will be the value “e” raised to the power of input X.

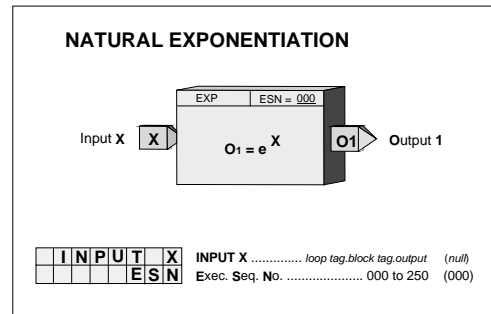
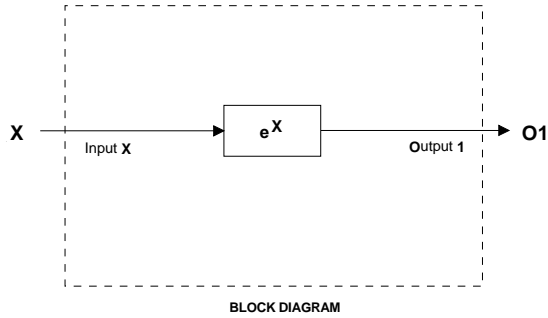

3.2.50 EXT_ - EXPONENTIATION

EXT_ function blocks, in firmware 1.30 and higher, will provide an output that equals the Y input raised to the power of X input. All negative values of input Y will be treated as 0.0. When input Y is 0.0 and X is negative, the output will be set to the maximum number (i.e. 1.17...e38).

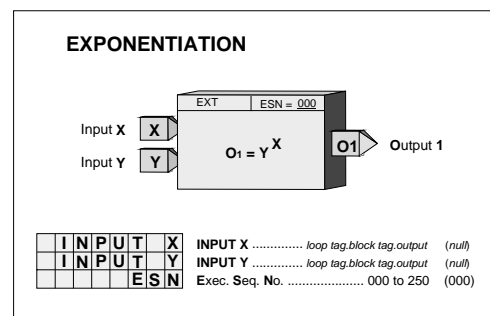
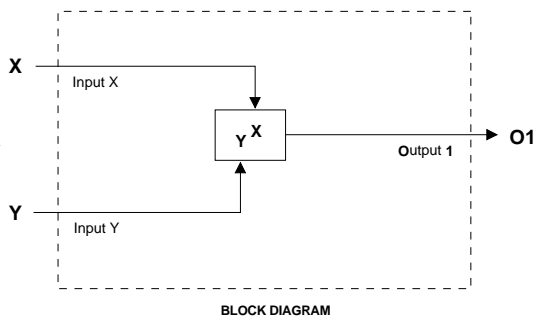

3.2.51 FTG_ - Falling Edge Trigger

FTG_ function blocks provide a high (1) output for one scan cycle each time input P transitions from a high (1) input to a low (0) input.

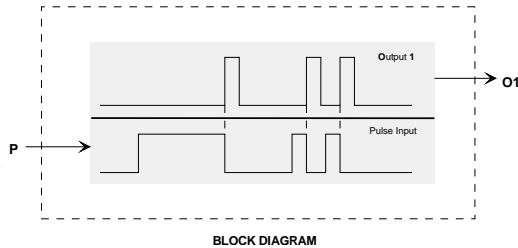

FALLING EDGE TRIGGER

I	N	P	P	E	S	N	INPUT P (H) loop tag.block tag.output (null) Exec. Seq. No. (H) 001 to 250
---	---	---	---	---	---	---	---

3.2.52 GB_ - Gain & Bias

GB_ function blocks provide action, gain, and bias adjustments to input signal A. Although this block can provide signal scaling, it should not be used if needed as a reference for a range pointer. The SCL function block should be used when scaling is required for this purpose.

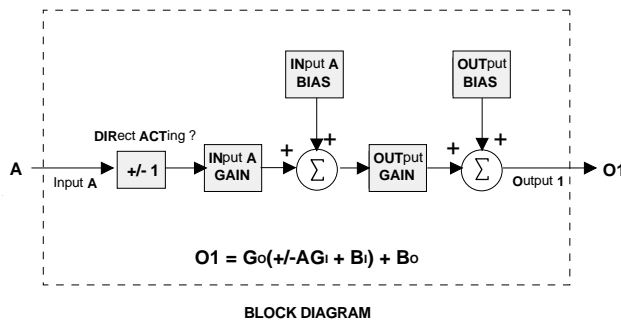

GAIN & BIAS

I	N	A	G	A	I	N	INPUT A GAIN (S) Real (1.0)
O	U	T	G	A	I	N	OUTput GAIN (S) Real (1.0)
I	N	A	B	I	A	S	INput A BIAS (S) Real (0.0)
O	U	T	B	I	A	S	OUTput BIAS (S) Real (0.0)
D	I	R	A	C	T	I	DIRect ACTing (S) NO/YES (YES)
I	N	P	U	T	A	E	INput A (H) loop tag.block tag.output (null)
E	S	N					Exec. Seq. No. (H) 001 to 250

3.2.53 HLD_ - Hold

HLD_ function blocks provide an output equal to the HOLD VAL set in configuration for interconnection to other function blocks.

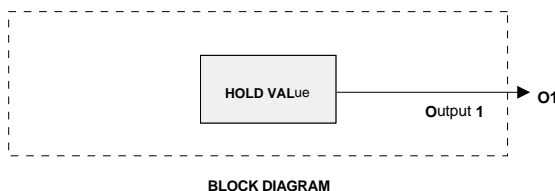

HOLD

H	O	L	D	V	A	L	HOLD VALue (S) Real (null)
---	---	---	---	---	---	---	----------------------------------

3.2.54 ID - ID Controller

ID is an integral only controller and one of five controller types that can be used on a one per loop basis. It uses external feedback to provide integral action and, therefore, allows interaction with other function blocks or external devices, such as pneumatic controllers and shutoff switches while eliminating windup that can occur with other controller types. Derivative action is provided when the parameter TD is non-zero.

When input A is high (1), the controller will operate in the normal auto mode and when low (0) will cause the output of the lag function to track the feedback signal. This will cause the controller output to track the feedback within the limits. When the controller is switched back to auto, the value at the input of the lag (GE+FB), if the GE is non-zero, will cause the output to integrate to a new output at the TI time constant.

The process range pointer parameter points to a function block that has range scaling, such as the analog input that is providing the process variable signal. This enables the controller to normalize the tuning parameters for the range of the process input. If this parameter is not configured, the controller will use a range scaling of 0.00 - 100.00.

POWER UP - During a warm or cold start, the output will be initialized to the value of the MINSCALE parameter and all dynamic states will be initialized to their current input value on the first scan cycle.

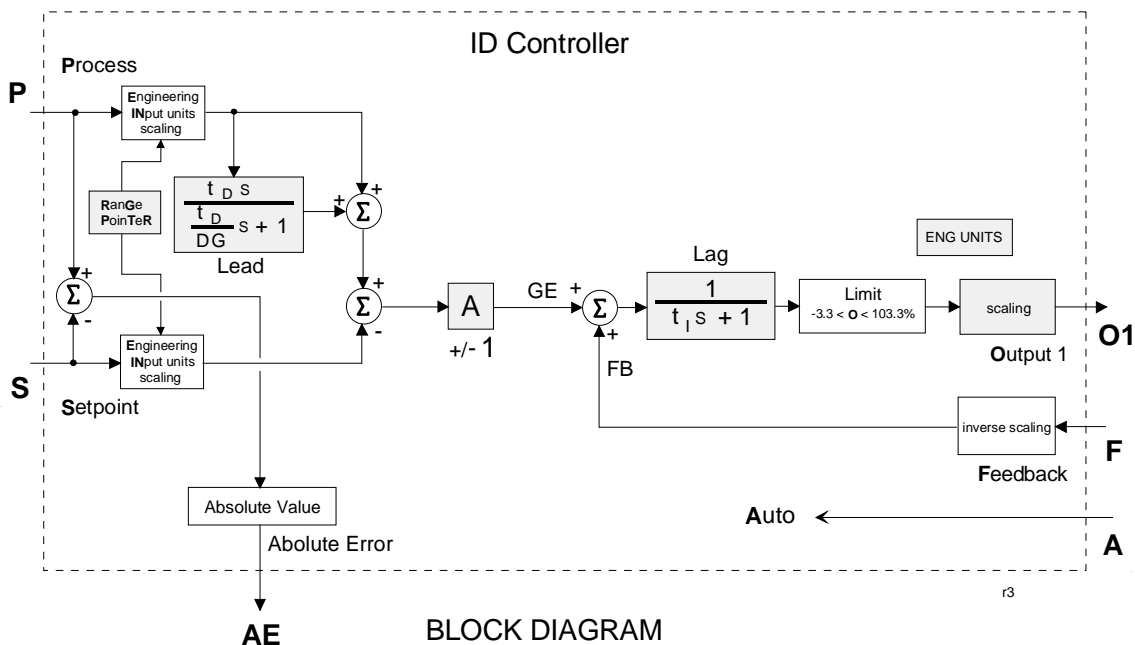
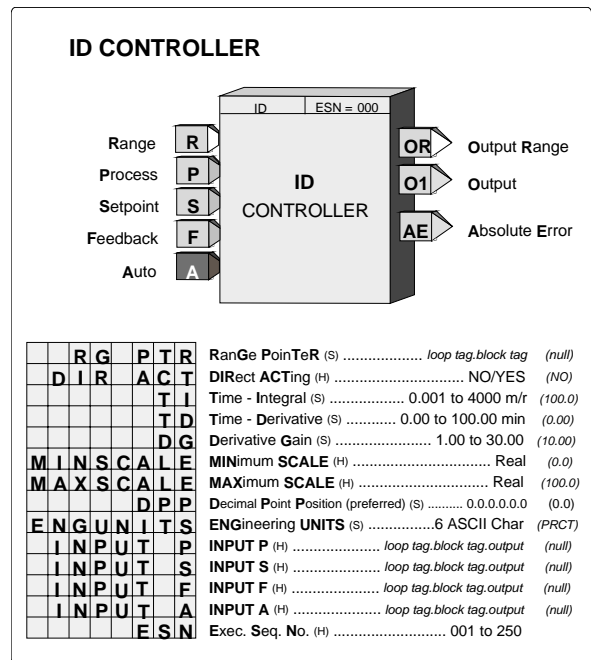

3.2.55 LL_ - Lead/Lag

LL_ function blocks provide both lead and lag functions. The block can function as lag only by setting the TLEAD time to 0.0. The lag function is always active and has a minimum setting of 0.01 minutes.

Input E asserted high (1) will enable the Lead/Lag function. When asserted low (0), the Lead/Lag function will be bypassed and the output will be set equal to the input. If input E is not configured, the block will be enabled.

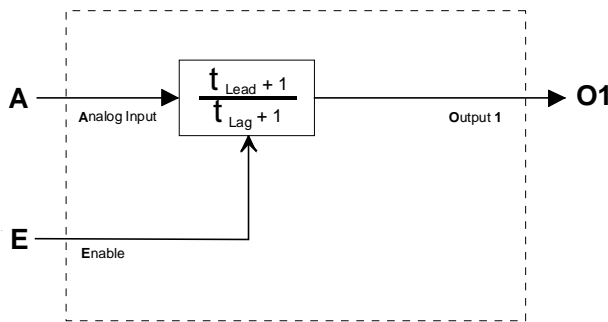

BLOCK DIAGRAM

POWER UP - During a warm or cold start, the dynamic elements and the output will be initialized to the value of the current input on the first scan.

LEAD/LAG

					T L A G	Time - LAG (min) (s)	0.01 - 10000.0	(0.10)
					T L E A D	Time - LEAD (min) (s)	0.00 - 10000.0	(0.00)
					I N P U T A	INPUT A (H)	loop tag.block tag.output	(null)
					I N P U T E	INPUT E (H)	loop tag.block tag.output	(null)
					E S N	Exec. Seq. No. (H)	001 to 250	

3.2.56 LMT_ - Limit

LMT_ function blocks are used to limit a real signal. Input A will normally pass through the function block to the output O1. If the input exceeds one of the limits, the block will output the limit value.

If the HI LIMIT is set lower than the LO LIMIT, the block will output the high limit value. The output statuses will be high (1) when the block is in a limit condition.

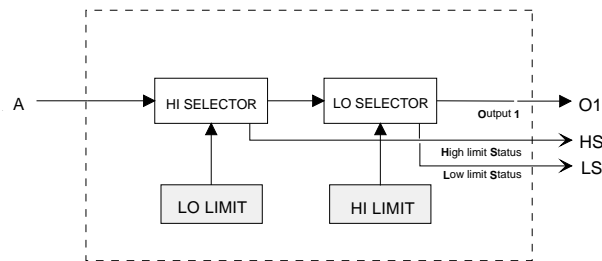

BLOCK DIAGRAM

LIMIT

					H I L I M I T	High LIMIT (s)	Real	(100.00)
					L O L I M I T	Low LIMIT (s)	Real	(0.00)
					I N P U T A	INPUT A (H)	loop tag.block tag.output	(null)
					E S N	Exec. Seq. No. (H)	001 to 250	

3.2.57 LN_ - NATURAL LOGARITHM

LN_ function blocks, in firmware 1.30 and higher, will output the natural logarithm of input X. When the input is ≤ 0.0 , the input will be treated as the smallest number greater than 0.0 (i.e. $1.17 \dots e-38$) and the LN will be computed accordingly.

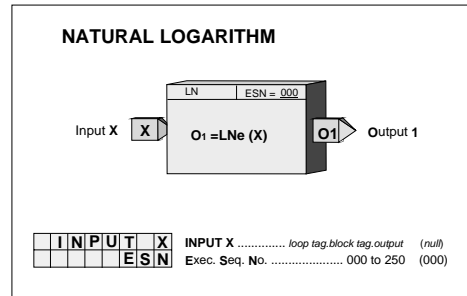
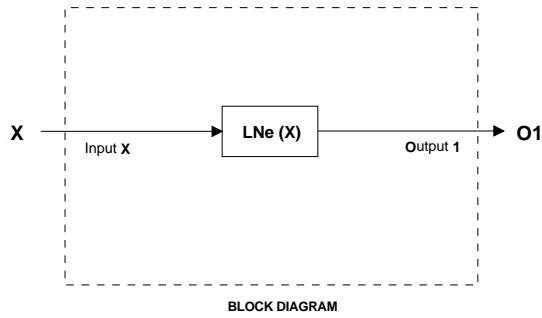

3.2.58 LOG_ - LOGARITHM BASE 10

LOG_ function blocks, in firmware 1.30 and higher, will output the logarithm to the base 10 of input X. When the input is ≤ 0.0 , the input will be treated as the smallest number greater than 0.0 (i.e. $1.17 \dots e-38$) and the LOG will be computed accordingly.

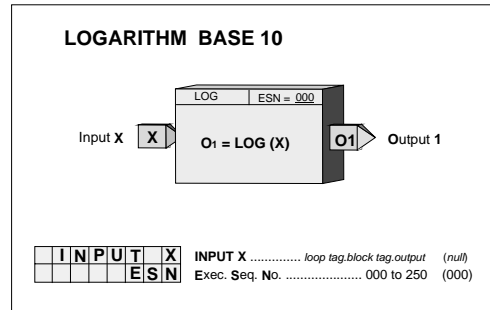
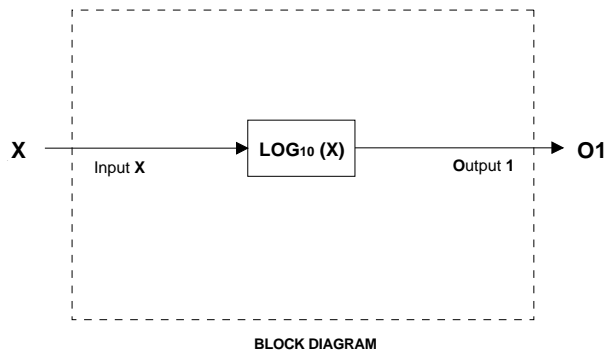

3.2.59 MTH_ - Math

MTH_ function blocks provide universal arithmetic capability. As shown in the block diagram, each input has gain and bias scaling. The resulting signals are then applied to configurable math operations (DIV, MUL, ADD and SUB). Operation A will be performed first on inputs A and B. Operation B will be performed next on the resultant and input C.

Unused inputs to a MUL or DIV operation will be set to 1.0 and those to an ADD or SUB operation will be set equal to 0.0. The operation of those inputs will function normally so it is important to insure that the bias and gain settings are set properly.

In a DIV operation, when a divisor is 0.0 the output will go to the maximum Real number with the sign determined by the numerator. If the numerator is 0 the output will be 0.

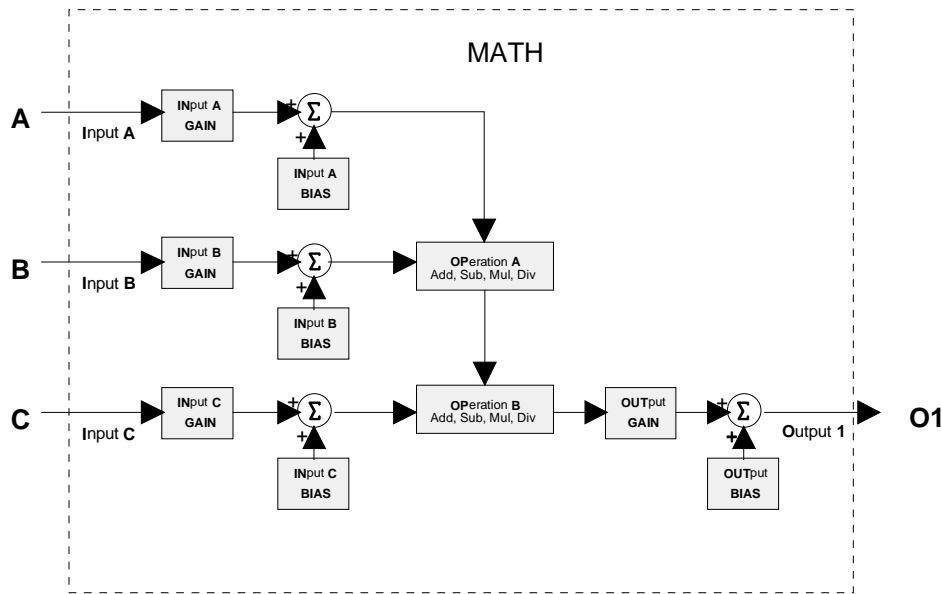
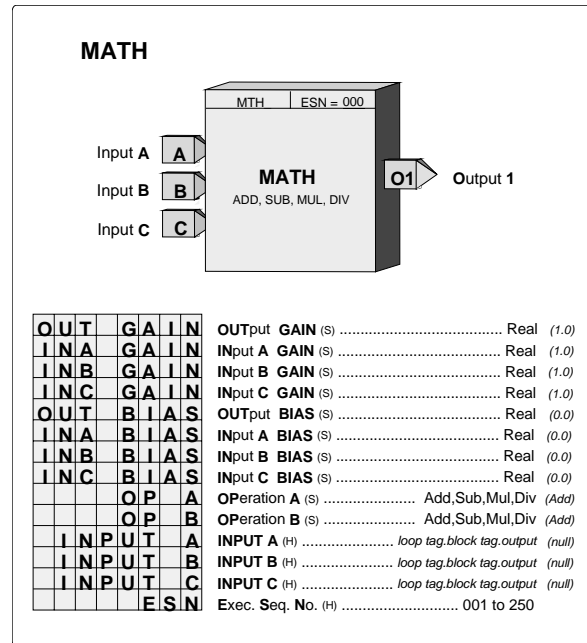

BLOCK DIAGRAM

3.2.60 MUL_ - Multiplication

MUL_ function blocks perform arithmetic multiplication on the three input signals. Any unused input will be set to 1.0 and will therefore have no affect on the output.

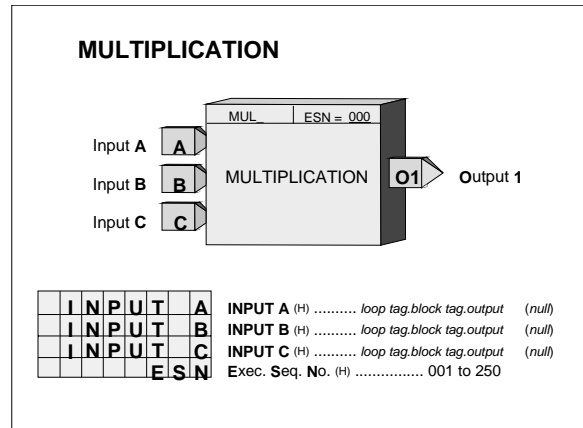
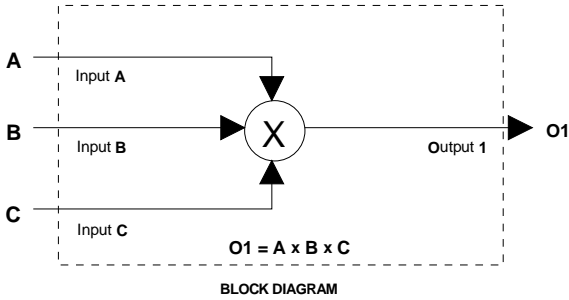

3.2.61 NND_ - NAND Logic

NND_ function blocks perform a logical NAND on the three inputs. Any unused input will be set high (1).

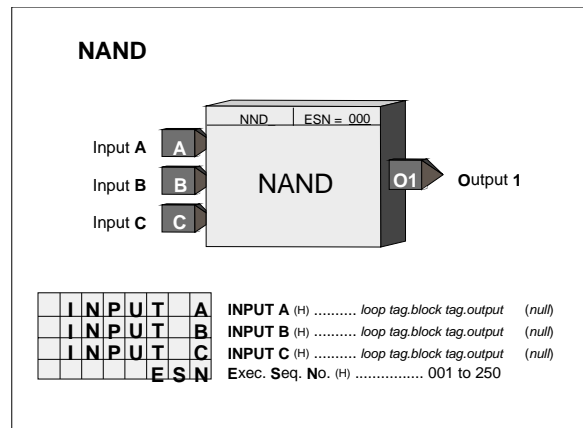
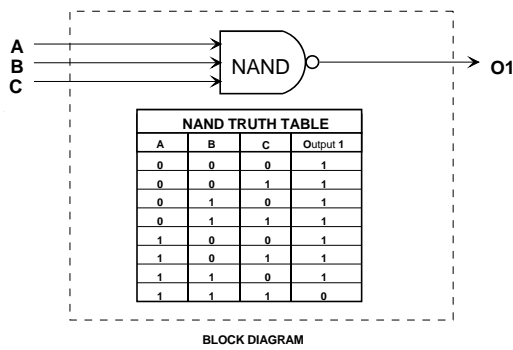

3.2.62 NOR_ - NOR Logic

NOR_ function blocks perform a logical NOR on the three inputs. Any unused input will be set low (0).

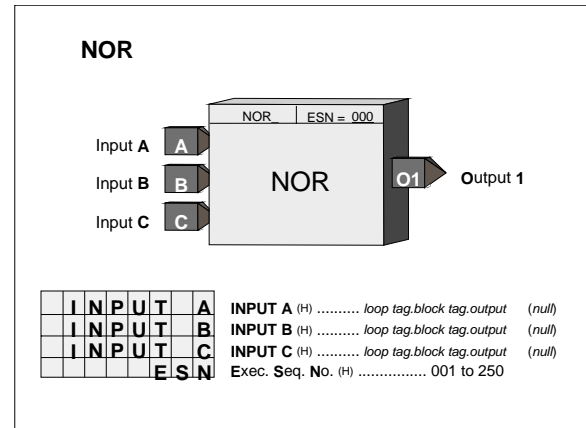
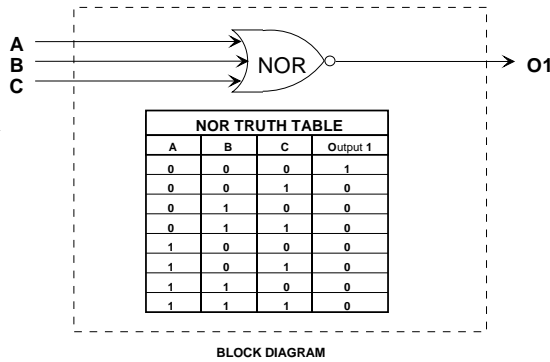

3.2.63 NOT_ - NOT Logic

NOT_ function blocks perform a logical NOT on input A. Any unused input will be set low (0).

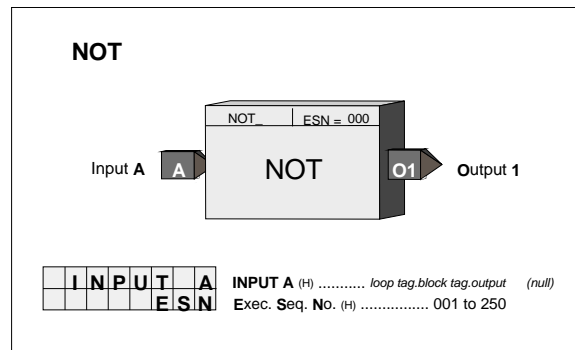
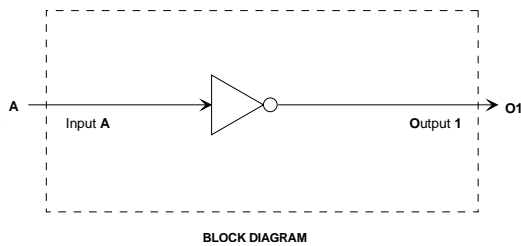

3.2.64 ODA - Operator Display for Analog indication & alarming (V2.2)

ODA blocks are one of five operator displays that are used on a one per loop basis to configure the local operator display functions and network parameters. See the i|ware PC faceplate on the next page.

The block will display up to four process variables P1 to P4 in both analog bargraph and digital form. Two alarms are associated with each process variable. They can be configured as HI or LO alarms. Each alarm function has associated block outputs that are high (1) when the alarm is active. Output LE is high (1) when a loop event is active. Output SE is high when a station error is active. LOOP # parameters are used to index reads and writes to Modbus and LIL network parameters. See Sections 6 and 7 for network parameters.

The VIEW OD parameter, when set to YES, enables the operator display to be viewed and accessed locally. In cases where it is desired to view display or operation parameters only from a network workstation, the parameter should be set to NO.

Range pointers (i.e. R1 to R4) for all four process inputs must be configured to define the range of each variable input (i.e. P1 to P4). If these parameters are not configured, the bargraphs will be scaled using the engineering range of 0.00 to 100.00. This information also defines the scaling of the loop information provided to a remote workstation over the network (i.e. Modbus or LIL).

Each process variable can be displayed on the local faceplate using the D button. When first stepping into a loop using the Loop button, the loop tag will be displayed (e.g. AnDisp1). However, if there is a point within the loop that has an unacknowledged alarm, that point will be displayed alternating between the point tag and the alarm condition (e.g. PI693/3B LO). Press the D button to scroll through the analog points displaying the point tag (e.g. TI712) in the alphanumeric and the value of the point in the digital display (e.g. 348.47). Press the UNITS button to display the units of the point. Press the Loop tag to return to displaying the loop tag.

Alarm Types

HI compares the process input with the limit setting and trips the alarm status high (1) when the process is equal to or higher than the limit setting. The alarm status will clear (0) when the process is less than the limit setting minus the deadband.

LO compares the process input with the limit setting and trips the alarm status high (1) when the process is equal to or less than the limit setting. The alarm status will clear (0) when the process is greater than the limit setting plus the deadband.

OR compares the process input with the range limits referenced by the range pointer parameter. It will trip the alarm status high (1) when the process is equal to or greater than the high limit, or equal to or less than the low limit. The alarm status will clear (0) when the process is less than the high limit minus the deadband or greater than the low limit plus the deadband.

Operator Display for Analog indication & alarming

P1	R1	PTR	Process 1 - Range Pointer (S)	loop tag.block.tag	(null)
P2	R2	PTR	Process 2 - Range Pointer (S)	loop tag.block.tag	(null)
P3	R3	PTR	Process 3 - Range Pointer (S)	loop tag.block.tag	(null)
P4	R4	PTR	Process 4 - Range Pointer (S)	loop tag.block.tag	(null)
	P1	TAG	Process 1 TAG (S)	8 ASCII Char (P1 TAG)	
	P2	TAG	Process 2 TAG (S)	8 ASCII Char (P2 TAG)	
	P3	TAG	Process 3 TAG (S)	8 ASCII Char (P3 TAG)	
	P4	TAG	Process 4 TAG (S)	8 ASCII Char (P4 TAG)	
1	A	LIMIT	Process 1 Alarm A LIMIT (S)	Real	(110.0)
1	B	LIMIT	Process 1 Alarm B LIMIT (S)	Real	(-10.0)
2	A	LIMIT	Process 2 Alarm A LIMIT (S)	Real	(110.0)
2	B	LIMIT	Process 2 Alarm B LIMIT (S)	Real	(-10.0)
3	A	LIMIT	Process 3 Alarm A LIMIT (S)	Real	(110.0)
3	B	LIMIT	Process 3 Alarm B LIMIT (S)	Real	(-10.0)
4	A	LIMIT	Process 4 Alarm A LIMIT (S)	Real	(110.0)
4	B	LIMIT	Process 4 Alarm B LIMIT (S)	Real	(-10.0)
1	A	DBAND	Process 1 Alarm A DeadBAND (S)	0.10:51:05.0%	(0.5)
1	B	DBAND	Process 1 Alarm B DeadBAND (S)	0.10:51:05.0%	(0.5)
2	A	DBAND	Process 2 Alarm A DeadBAND (S)	0.10:51:05.0%	(0.5)
2	B	DBAND	Process 2 Alarm B DeadBAND (S)	0.10:51:05.0%	(0.5)
3	A	DBAND	Process 3 Alarm A DeadBAND (S)	0.10:51:05.0%	(0.5)
3	B	DBAND	Process 3 Alarm B DeadBAND (S)	0.10:51:05.0%	(0.5)
4	A	DBAND	Process 4 Alarm A DeadBAND (S)	0.10:51:05.0%	(0.5)
4	B	DBAND	Process 4 Alarm B DeadBAND (S)	0.10:51:05.0%	(0.5)
1	A	PU EN	Process 1 Alarm A Power Up Enabled (S)	NO/YES	(YES)
1	B	PU EN	Process 1 Alarm B Power Up Enabled (S)	NO/YES	(YES)
2	A	PU EN	Process 2 Alarm A Power Up Enabled (S)	NO/YES	(YES)
2	B	PU EN	Process 2 Alarm B Power Up Enabled (S)	NO/YES	(YES)
3	A	PU EN	Process 3 Alarm A Power Up Enabled (S)	NO/YES	(YES)
3	B	PU EN	Process 3 Alarm B Power Up Enabled (S)	NO/YES	(YES)
4	A	PU EN	Process 4 Alarm A Power Up Enabled (S)	NO/YES	(YES)
4	B	PU EN	Process 4 Alarm B Power Up Enabled (S)	NO/YES	(YES)
1	A	PRIOR	Process 1 Alarm A PRIORITY (S)	1/2/3/4/5	(3)
1	B	PRIOR	Process 1 Alarm B PRIORITY (S)	1/2/3/4/5	(3)
2	A	PRIOR	Process 2 Alarm A PRIORITY (S)	1/2/3/4/5	(3)
2	B	PRIOR	Process 2 Alarm B PRIORITY (S)	1/2/3/4/5	(3)
3	A	PRIOR	Process 3 Alarm A PRIORITY (S)	1/2/3/4/5	(3)
3	B	PRIOR	Process 3 Alarm B PRIORITY (S)	1/2/3/4/5	(3)
4	A	PRIOR	Process 4 Alarm A PRIORITY (S)	1/2/3/4/5	(3)
4	B	PRIOR	Process 4 Alarm B PRIORITY (S)	1/2/3/4/5	(3)
1	A	TYPE	Process 1 Alarm A TYPE (S)	none/HILO/LO	(HI)
1	B	TYPE	Process 1 Alarm B TYPE (S)	none/HILO/LO	(LO)
2	A	TYPE	Process 2 Alarm A TYPE (S)	none/HILO/LO	(HI)
2	B	TYPE	Process 2 Alarm B TYPE (S)	none/HILO/LO	(LO)
3	A	TYPE	Process 3 Alarm A TYPE (S)	none/HILO/LO	(HI)
3	B	TYPE	Process 3 Alarm B TYPE (S)	none/HILO/LO	(LO)
4	A	TYPE	Process 4 Alarm A TYPE (S)	none/HILO/LO	(HI)
4	B	TYPE	Process 4 Alarm B TYPE (S)	none/HILO/LO	(LO)
1	A	DL IN	Proc 1 Alarm A DeLay IN (S)	0:/4/1/2/5/15/30/60	(0)
1	B	DL IN	Proc 1 Alarm B DeLay IN (S)	0:/4/1/2/5/15/30/60	(0)
2	A	DL IN	Proc 2 Alarm A DeLay IN (S)	0:/4/1/2/5/15/30/60	(0)
2	B	DL IN	Proc 2 Alarm B DeLay IN (S)	0:/4/1/2/5/15/30/60	(0)
3	A	DL IN	Proc 3 Alarm A DeLay IN (S)	0:/4/1/2/5/15/30/60	(0)
3	B	DL IN	Proc 3 Alarm B DeLay IN (S)	0:/4/1/2/5/15/30/60	(0)
4	A	DL IN	Proc 4 Alarm A DeLay IN (S)	0:/4/1/2/5/15/30/60	(0)
4	B	DL IN	Proc 4 Alarm B DeLay IN (S)	0:/4/1/2/5/15/30/60	(0)
1	A	DLOUT	Proc 1 Alarm A DeLay OUT (S)	0:/4/1/2/5/15/30/60	(0)
1	B	DLOUT	Proc 1 Alarm B DeLay OUT (S)	0:/4/1/2/5/15/30/60	(0)
2	A	DLOUT	Proc 2 Alarm A DeLay OUT (S)	0:/4/1/2/5/15/30/60	(0)
2	B	DLOUT	Proc 2 Alarm B DeLay OUT (S)	0:/4/1/2/5/15/30/60	(0)
3	A	DLOUT	Proc 3 Alarm A DeLay OUT (S)	0:/4/1/2/5/15/30/60	(0)
3	B	DLOUT	Proc 3 Alarm B DeLay OUT (S)	0:/4/1/2/5/15/30/60	(0)
4	A	DLOUT	Proc 4 Alarm A DeLay OUT (S)	0:/4/1/2/5/15/30/60	(0)
4	B	DLOUT	Proc 4 Alarm B DeLay OUT (S)	0:/4/1/2/5/15/30/60	(0)
1	A	RGBCK	Process 1 Alarm A RiNG BaCK (S)	NO/YES	(NO)
1	B	RGBCK	Process 1 Alarm B RiNG BaCK (S)	NO/YES	(NO)
2	A	RGBCK	Process 2 Alarm A RiNG BaCK (S)	NO/YES	(NO)
2	B	RGBCK	Process 2 Alarm B RiNG BaCK (S)	NO/YES	(NO)
3	A	RGBCK	Process 3 Alarm A RiNG BaCK (S)	NO/YES	(NO)
3	B	RGBCK	Process 3 Alarm B RiNG BaCK (S)	NO/YES	(NO)
4	A	RGBCK	Process 4 Alarm A RiNG BaCK (S)	NO/YES	(NO)
4	B	RGBCK	Process 4 Alarm B RiNG BaCK (S)	NO/YES	(NO)
		LOOP #	LOOP # (S)	01 to 25	(null)
		LIL CHAN	LIL starting CHANNEL (n) (H)	008 to 250	(null)
		VIEW OD	VIEW Operator Display (H)	NO/YES	(YES)
		INPUT P1	INPUT P1 (H)	loop tag.block.tag.output	(null)
		INPUT P2	INPUT P2 (H)	loop tag.block.tag.output	(null)
		INPUT P3	INPUT P3 (H)	loop tag.block.tag.output	(null)
		INPUT P4	INPUT P4 (H)	loop tag.block.tag.output	(null)

Rev. 2

Alarms have priorities 1 to 5, with 1 the highest. Alarms are reported to the operator faceplate in order of priority first and then in order of occurrence. Priority 1 causes the station bargraphs and condition (e.g. A1 HI) to flash and requires acknowledgment to stop flashing. Priority 2 also flashes the bargraphs and condition but stops flashing when the alarm clears (i.e. Self Clearing). Priority 3 causes the event LEDs (L and S) and condition to flash. Flashing stops only when the alarm is acknowledged. Priority 4 causes the event LEDs and condition to flash but flashing stops when the alarm clears. Priority 5 displays the alarm but does not require that it be acknowledged.

Alarm limits are in engineering units. A quickset ALARM feature is also available allowing alarm limits to be set quickly during operation. The settings are in engineering units but will also be displayed in % of range on the setpoint bargraph when viewing a point. Alarms are displayed as defined by the range pointer parameter. Alarms can be set to any engineering value within -10% to 110% of the range defined by the pointer. If a range is changed, the current alarm settings will be changed to be the same % within the new range. For example, if a HI alarm is currently set at 100.0 with a range of 0.0 to 100.0 and the range is changed to 300.0 to 400.0, the HI alarm will be moved to 400.0.

Each alarm can be enabled or disabled when in the quickset ALARM mode. The configuration allows an alarm to be enabled or disabled on a cold start. When an alarm is disabled, it will not operate but will retain settings for return to the enabled mode. Complete operator faceplate functions, relating to alarms, are described in the sections describing the specific faceplate design. All alarms have the following features:

Deadband - requires that the signal either drop below or exceed the limit setting by the amount of the deadband before the alarm clears (goes low). The alarm deadband is set as a fixed % of the range pointer scale.

Delay-In Time - requires that the input remain above (or below) the limit setting for the delay time before the alarm trips (goes high). This can help prevent nuisance alarms that may be tripping due to process noise.

Delay-Out Time - requires that the input remain below (or above) the limit setting plus deadband for the delay time before the alarm will clear (goes low). This can help prevent inadvertent clearing of alarms due to process noise.

Ringback - causes a previously acknowledged alarm to require acknowledgment (priorities 1-4) when the alarm clears.

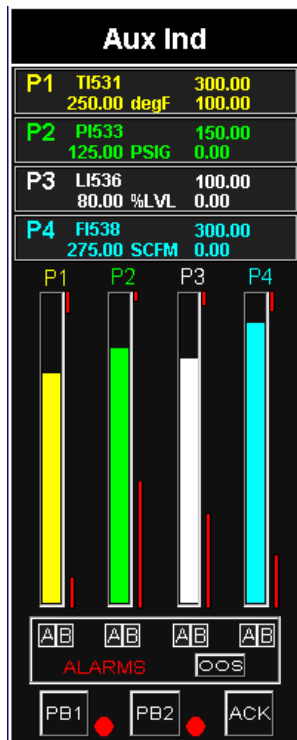

i|ware PC Faceplate Display

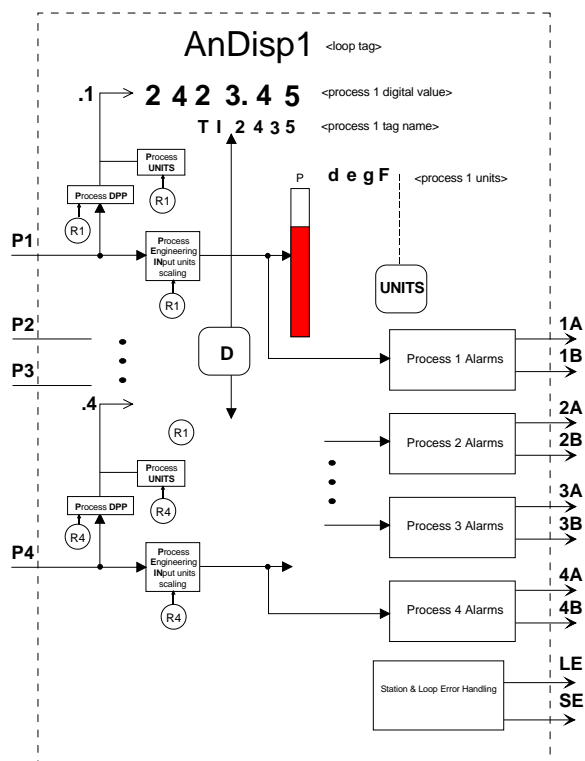

BLOCK DIAGRAM

3.2.65 ODC - Operator Display for Controllers

ODC blocks are one of five operator displays that are used on a one per loop basis to configure the local operator display functions and network parameters from a remote operator workstation associated with the loop. See the i|ware PC faceplate on the next page.

The following features are in firmware 1.30 and higher.

1. A new parameter, VIEW OD, when set to YES, the default setting, enables the operator display to be viewed and accessed locally using the LOOP button. In some cases, it may be desired to view only display or operation parameters with a network workstation and not allow operation or viewing of the control loop from the local display. Here the parameter should be set to NO.
2. Output LE is high (1) when a loop event is active. Output SE is high when a station error is active.
3. The LOOP # (this parameter was MB INDEX in version 1.21) is used to index reads and writes to Modbus parameters. The LIL has 25 parameters: C1S, C2S, C3S, C25S. When an ODC block has been selected and the LOOP # has been configured, the corresponding C#S LIL parameter will contain the LIL starting Chan (n) location. The LOOP# must be entered to enable either LIL or Modbus communications.

Range pointers for both the process/setpoint and valve bargraphs must be configured to define the range of the variable inputs to P, S, and V. If these parameters are not configured, the bargraphs will be scaled using the engineering range of 0.00 to 100.00. The range pointer for X and Y define the displayed decimal point position and the units code. This information also defines the scaling of the loop information provided to a remote workstation over the network (i.e. Modbus or LIL).

Input variables P, S, V, X, and Y are shown in the numeric display, using the engineering UNITS and the preferred DPP of the range pointer. The Total from the BATOT will also be displayed when configured within the BATOT block. If a value is greater than allowed by the DPP parameter, the decimal point will be shifted to allow the display to show the full number, until it exceeds the maximum available digits, at which time it will indicate over range.

When input U1 or U2 goes high (1), the 8-character user status (U_STATUS) will be displayed as configured by the status priority (U_PRIOR). A priority of 0 will disable that status function setting the bits in the status word to 0. See Section 9 Operation for a description of display actions using priorities 1 to 5.

The horizontal bargraph can be selected as direct or reverse acting. This feature allows it to always indicate an OPEN valve when fully lit. The labels on the basic faceplate are fixed, but paste on labels can be used to change the indications. The V NET AC parameter allows the LxVI network parameter to be set for direct or reverse action. This enables the valve bar on the HMI to operate similar to the valve bar on the faceplate. The left and right bar labels should be set accordingly (e.g. Left = "OPEN & Right = CLOSE).

An operator display must be configured to map controller loop data to network data. Loop network data is mapped into registers or coils when the standard Modbus interface is used and to channels/parameters when the optional LIL interface has been added. Mappings for both Modbus and LIL are listed in the tables included in the 'Network

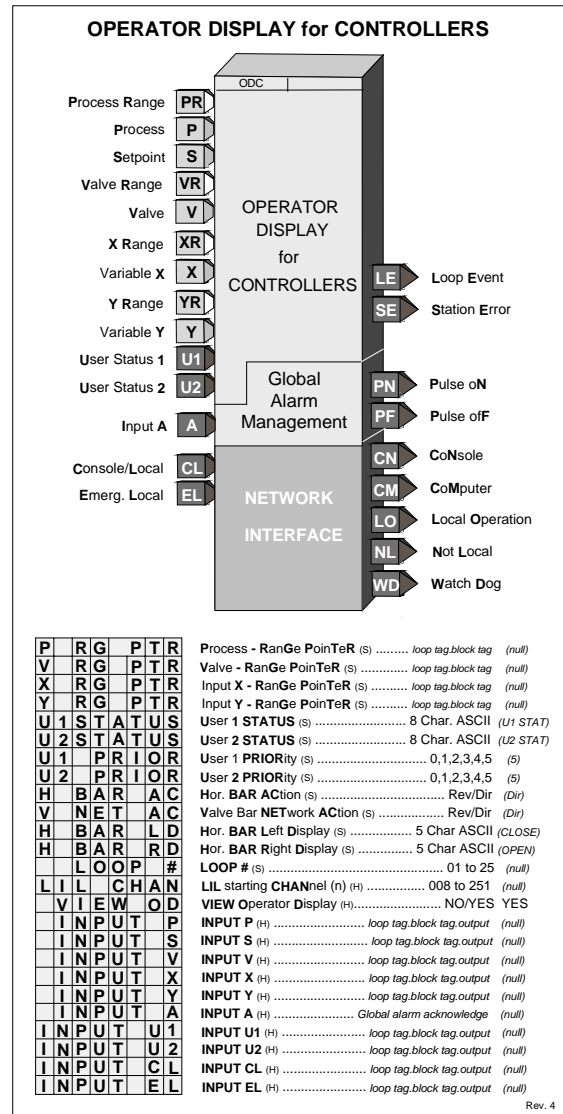

Communications' section. The 'LOOP #' and 'LIL CHAN' parameters enable configuration of a loop index number (x) for Modbus data or a starting channel (n) for LIL loop data.

Input CL controls local arbitration of changes to loop data from the network. When input CL is not configured, the three status outputs LO (in 1.21 firmware this output was named L), CN, and CM will be set high (1) and changes can be made from a network command or the local faceplate. When CL is configured, it can be changed locally from a pushbutton switch such as PB1SW output PS (configured as momentary) and will change from local to console or console/computer to local with each positive transition of the input. Also, when output LO goes high, output CN will also go high and CM will go low, indicating that the control source will change to Console whenever Local is disabled, either by a positive transition on input CL or from a network command. The Computer CM state can be set high using a network command. The NL output will normally be connected to the MD input of pushbutton block PB1SW to indicate the C/L switch position on the operator faceplate, a green LED for C and a red LED for LO.

Output WD will go high (1) when the controller fails to receive a Modbus network command within the watchdog time. The watchdog time is set in the STATN (Station Parameters) function block. Input A can be used to acknowledge all the alarms in all of the loops in a controller. Output PN (Pulse oN) will go high for 0.5 seconds (or one scan cycle whichever is longer) whenever the bargraph flashes. Bargraph flashing is controlled by the priority setting of alarms or events. Output PF (Pulse ofF) will go high for 0.5 sec when the flashing bargraph is stopped (e.g. pressing the ACK button).

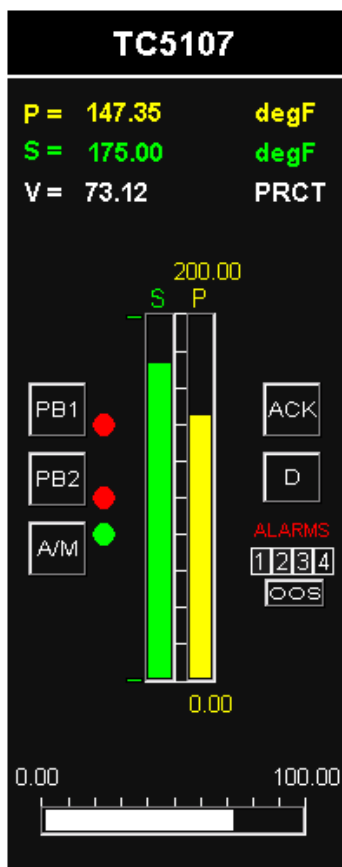

i|ware PC Faceplate Display

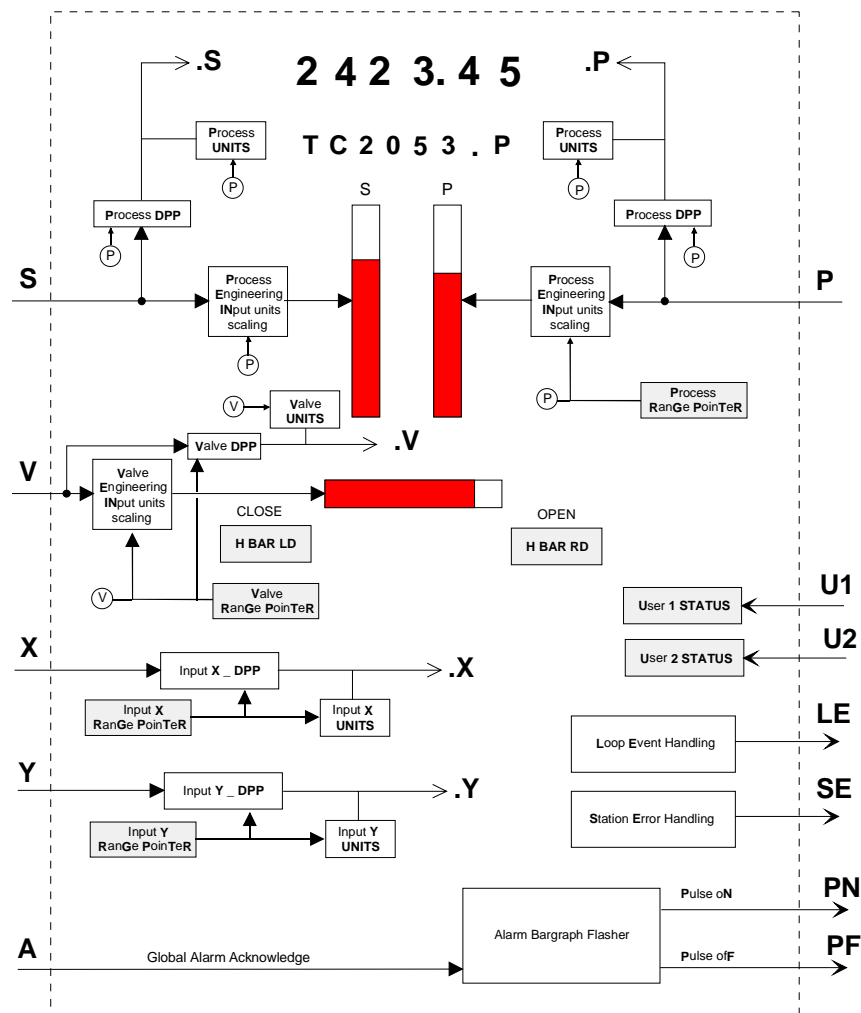

BLOCK DIAGRAM

Rev. 3

3.2.66 ODD - Operator Display for Discrete indication & control (V2.2)

ODD function blocks are one of five operator displays that can be used on a one per loop basis to configure the local operator display functions as well as network parameters. See the i|ware PC faceplate example on the next page.

The ODD function block displays up to 16 discrete variables. Each input has a corresponding block output that is equal to the input when the variable mode is in Auto. Each input variable can be assigned a mode. The value of the output can be changed while in Man by using the pulser and pressing the ACK button. When a variable is switched to Manual it will always equal the input value until changed.

The LOOP # parameter is used to index reads and writes to Modbus and LIL network parameters. When using the LIL, the LIL CHAN parameter must also be configured. See Section 6 for more information on network parameters.

The VIEW OD parameter, when set to YES enables the operator display to be viewed and accessed locally. In cases where it is desired to view display or operation parameters only from a network workstation, the parameter should be set to NO.

During a cold or warm start, each input variable will power up in the auto mode. During a hot start, the mode and manual value will equal the value prior to power down.

Each discrete input variable can be displayed on the local faceplate using the D button. When first stepping into a loop using the Loop button, the loop tag will be displayed (e.g. DigDisp1). Pressing the D button will scroll through the discrete points displaying the point tag (e.g. SV-103) in the alphanumeric and the value of the input on the left 3 positions of the digital display (e.g. On) and the output in the right most 3 positions (e.g. OFF).

The A/M button will display the point mode and enable switching the point between auto & manual using the A/M button. The manual value can be changed by turning the pulser and pressing the ACK button. If the ACK button is not pressed within 4-5 seconds, the display will return to the actual output value.

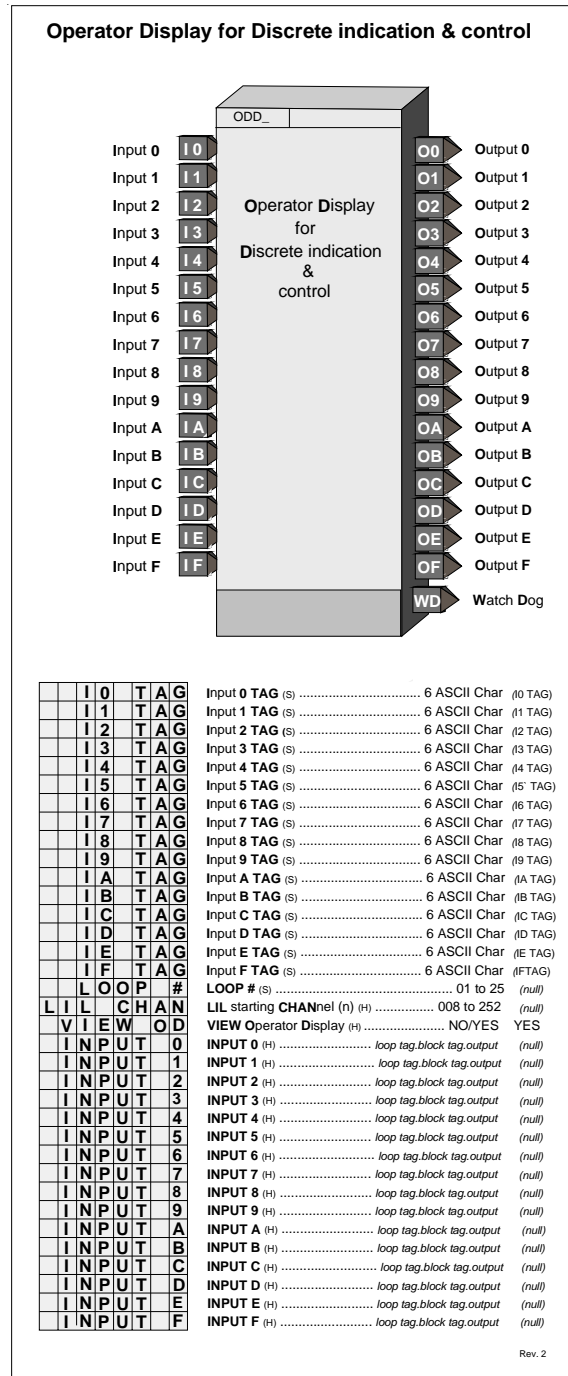

DigDisp1				
#	TAG	IN	MODE	OUT
0	SV101	ON	A	ON
1	SV102	ON	M	OFF
2	SV103	ON	M	ON
3	LS103	OFF	M	ON
4	PS105	ON	A	ON
5	MS106	ON	A	ON
6	SV107	ON	A	ON
7	LS109	OFF	A	OFF
8	SV110	ON	A	ON
9	PS115	OFF	M	ON
A	SV117	ON	A	ON
B	PS118	ON	A	ON
C	SV120	ON	A	ON
D	LS124	ON	A	ON
E	MS128	ON	A	ON
F	MS129	OFF	A	OFF

PB1	●	PB2	●
CONFIGURATION HOLD			

i|ware PC Faceplate Display

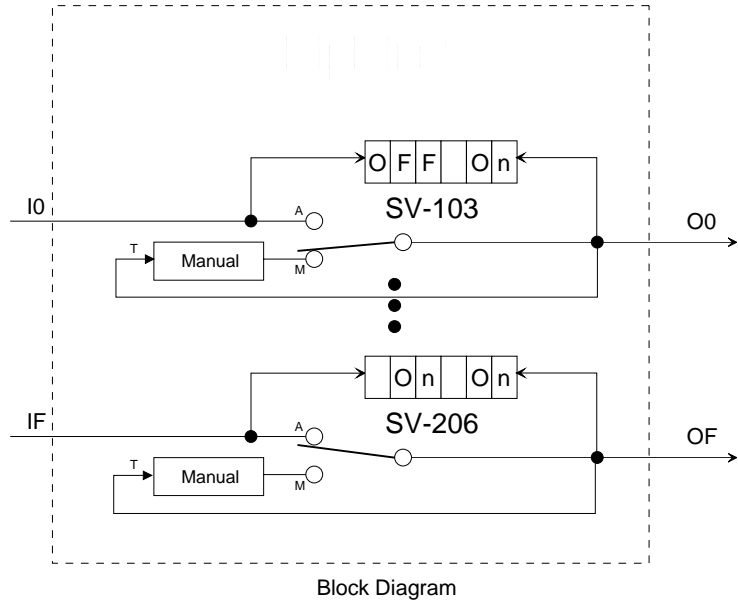

3.2.67 ODP - Operator Display for PushButtons (V2.2)

ODP function blocks are one of five operator displays that can be used on a one per loop basis to configure local operator display functions as well as network parameters. See the i|ware PC faceplate example on the next page.

The ODP function block can provide up to 8 groups of two pushbuttons and one selector switch. Each group includes:

- One normally open pushbutton, identified as PB1, on the local faceplate. It can have a 6-character tag to identify the button function on a HMI display.
- One normally closed pushbutton, identified as PB2 on the local faceplate. It can have a 6-character tag for display on an HMI.
- One two-position selector switch identified as A/M on the local faceplate. It can have a 6-character tag for switch position identification on an HMI.

Each group also has a set of 6-character messages associated with the status of a feedback signal (1/0).

Each pushbutton has a configuration parameter that controls how long the button function will be held in the pressed position. The default value is 1 second but can be set from 0.1 (or scan time if greater than 0.1) to 10 seconds.

The LOOP # parameter is used to index reads and writes to Modbus and LIL network parameters. When using the LIL, the LIL CHAN parameter must also be configured. See Sections 6 and 7 for more information on network parameters.

The VIEW OD parameter, when set to YES enables the operator display to be viewed and accessed locally. In cases where it is desired to view display or operation parameters only from a network workstation, the parameter should be set to NO.

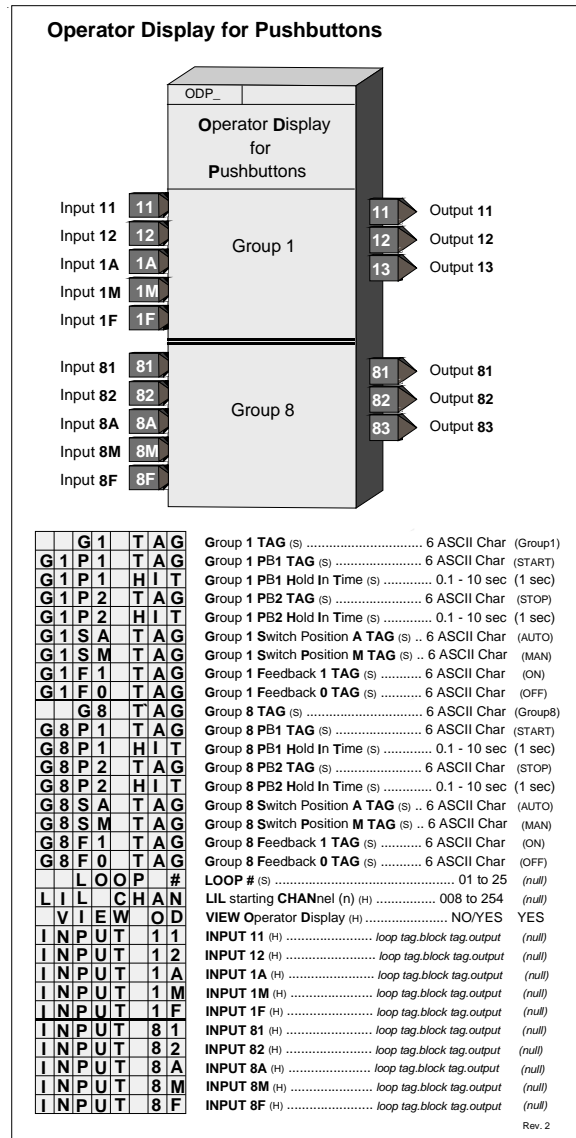

During a cold or warm start, the A/M switch will power up in the Auto position. During a hot start, the A/M switch will power up in the position prior to power down.

Each group can be displayed on the local faceplate using the D button. When first stepping into a loop using the Loop button, the loop tag will be displayed (e.g. PBD1). Pressing the D button will scroll through the groups displaying the group tag (e.g. MS1036) in the alphanumeric and the value of the feedback in the digital display (e.g. 1). The feedback message associated with this feedback value can be viewed on the local faceplate using the UNITS button. The A/M button will display the position of the group selector switch and enable switching the group selector switch between auto and manual.

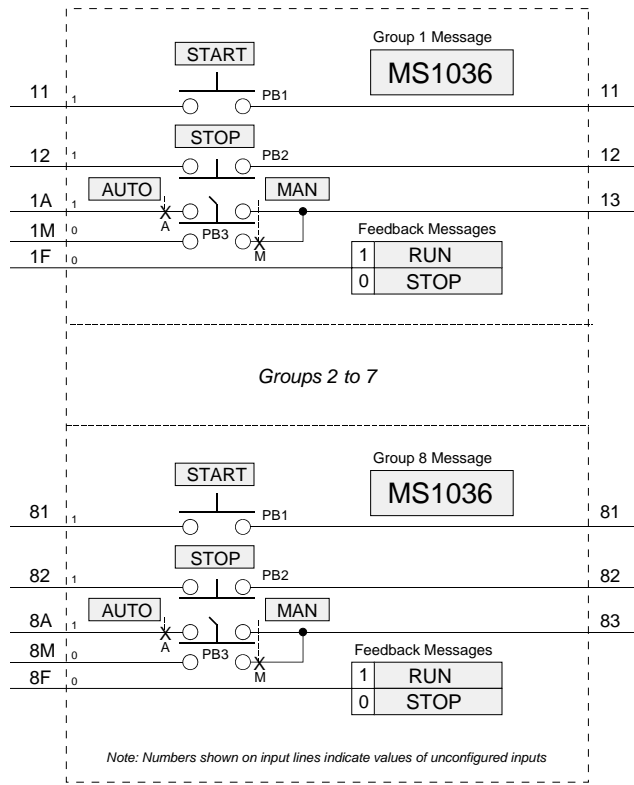
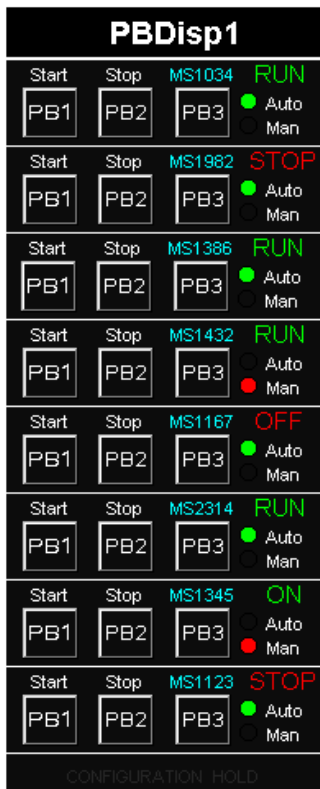

i|ware PC Faceplate Display

3.2.68 ODS - Operator Display for Sequencer

ODS function blocks are one of five operator displays available on a one per loop basis to configure the local operator display functions as well as the network commands from an operator workstation associated with the loop. See the i|ware PC faceplate example on the following page.

The following six enhancements are in firmware 1.30 and higher.

1. The VIEW OD parameter, when set to YES, the default value, enables the operator display to be viewed and accessed locally using the LOOP button. Set the parameter to NO to view the display or operation parameters only with a network workstation and not allow operation from the local display. This may be desired with a sequence/logic loop where local operation is not needed but a workstation needs access to force I/O or sequence parameters for recipe changes.
2. Messages will be available over Modbus or LIL. Refer to the Network Communication section for mapped data points.
3. The # of Recipe messages can now be set to 0 so that a Recipe Message does not appear in the message list.
4. Messages will now function as follows with the local faceplate display:

When the local display first enters a loop, the convention loop tag and sequence step number will be displayed. When the D button is pressed, the Numeric display will show MSG and the alphanumeric display will show the first message it comes to in the order shown below.

- Conditional messages will be displayed in the order in which they occurred.
- The latest message will be displayed first.
- A new message will override the current message.

The ACK button can be used to scroll through active messages. It will stay on the last message until a new message overrides it or the ACK button is again pressed. When an active message clears, the message display will loop back and start at the top and display the first message it comes to. Events that require acknowledgment will return the display to the normal mode (i.e. <loop tag>.S) and will flash the message. When events have been acknowledged they can be viewed using the ACK button. The display can be returned to the MSG mode using the D button and will then display the first message in the Queue.

5. Output LE is high (1) when a loop event is active. Output SE is high when a station error is active.
6. The LOOP # (in version 1.21 firmware this parameter was MB INDEX but they have the same function). It will be used to index reads and writes to Modbus parameters. The LIL has 25 parameters: C1S, C2S, C3S, C25S. When an ODS block has been selected and the LOOP # has been configured, the corresponding C#S

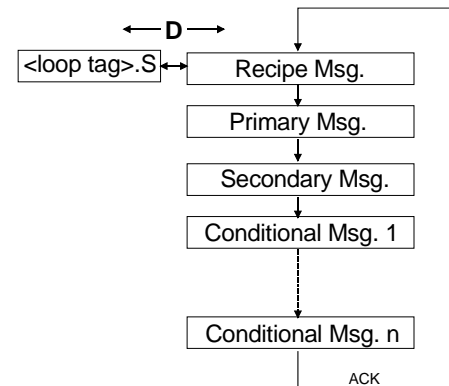
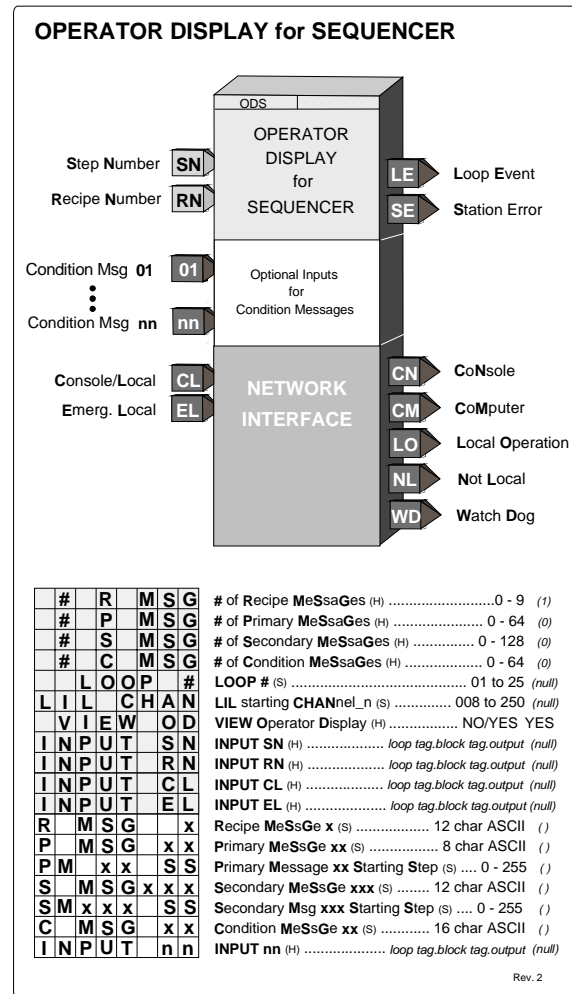

LIL parameter will contain the LIL starting Chan (n) location. . The LOOP# must be entered to enable either LIL or Modbus communications.

An operator display must be configured in order to properly map station loop data to network data. Sequencer loop network data is mapped onto registers or coils when the standard Modbus interface is used and to channels/parameters when the optional LIL interface has been added. Mappings for both Modbus and LIL are listed in tables in the ‘Network Communications’ section.

Input CL controls local arbitration of changes to loop data from the network. When input CL is not configured, the three status outputs LO (in 1.21 firmware this output was named L),, CN, and CM will be set high (1) and changes can be made from a network command or the local faceplate. When CL is configured, it can be toggled locally from a pushbutton switch, such as PB1SW (output PS), and will change from local to console or from console/computer to local each time the input is toggled. Also, when output LO goes high, output CN will also go high and CM will go low, indicating that the control source will change to Console whenever Local is disabled, either by toggling input CL or from a network command. The Computer CM state can be set high using a network command. The NL output will normally be connected to the MD input of the pushbutton block PB1SW to indicate the C/L switch position on the operator faceplate using the green LED for C and the red LED for LO.

Output WD will go high (1) when the station fails to receive a Modbus network command within the watchdog time period. The watchdog time is set in the STATN (Station Parameters) function block.

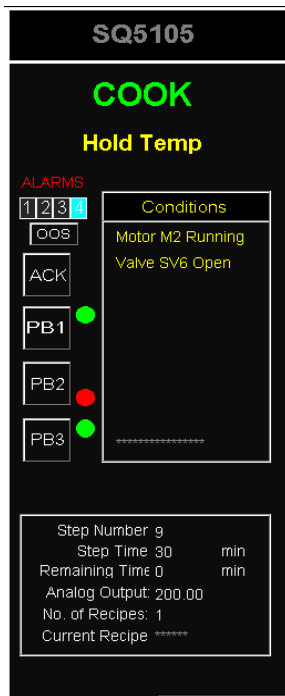

i|ware PC Faceplate Display

3.2.69 ON/OFF - On/Off Controller

ON/OFF is an on/off controller with deviation function. It is one of five controller types that can be used on a one per loop basis.

When P-S (Process - Setpoint) reaches the HDEV limit, the Boolean output HO will go high (1) and when S-P (Setpoint - Process) reaches the LDEV limit, the output LO will go high (1). When the deviation drops to less than the DEADBAND setting, the outputs will go low (0). Derivative action is added to the process variable when the TD parameter is other than 0.0.

When single ended action (gap action) is desired, set the DEADBAND equal to the gap and the HDEV parameter for half the gap. For example, if DEADBAND = 20.0, set HDEV to 10. If the setpoint S is 50.0, output HO will go high (1) when P equals 60.0 and HO will go low (0) when P equals 40.0.

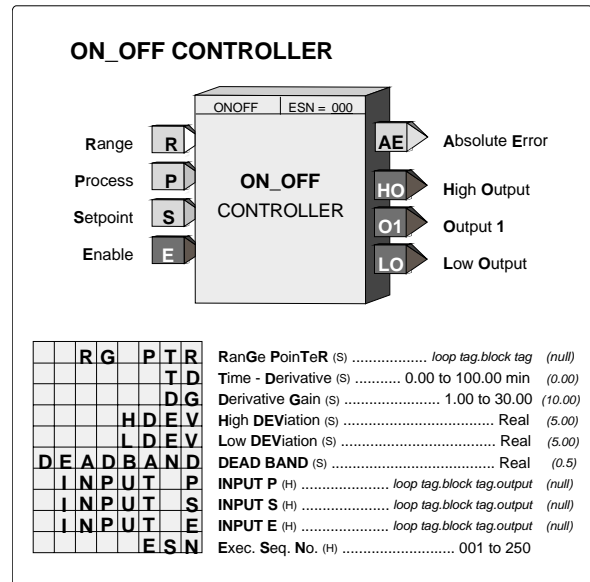

Input E asserted high (1) will enable the block outputs; when low (0) all outputs will be set low (0).

The process range pointer parameter points to another function block that has range scaling, such as the analog input that is providing the process variable. This enables the controller to normalize the tuning parameters for the range of the process input. If this parameter is not configured, the controller will use a range scaling of 0.0 - 100.0.

POWER UP - During a warm start, outputs and comparator functions will be initialized at the state prior to power down and all dynamic elements will be initialized at the current input on the first scan. During a cold start all outputs and comparator states will be set to zero, to be activated by the block functions. All dynamic elements will be initialized at the current input on the first scan.

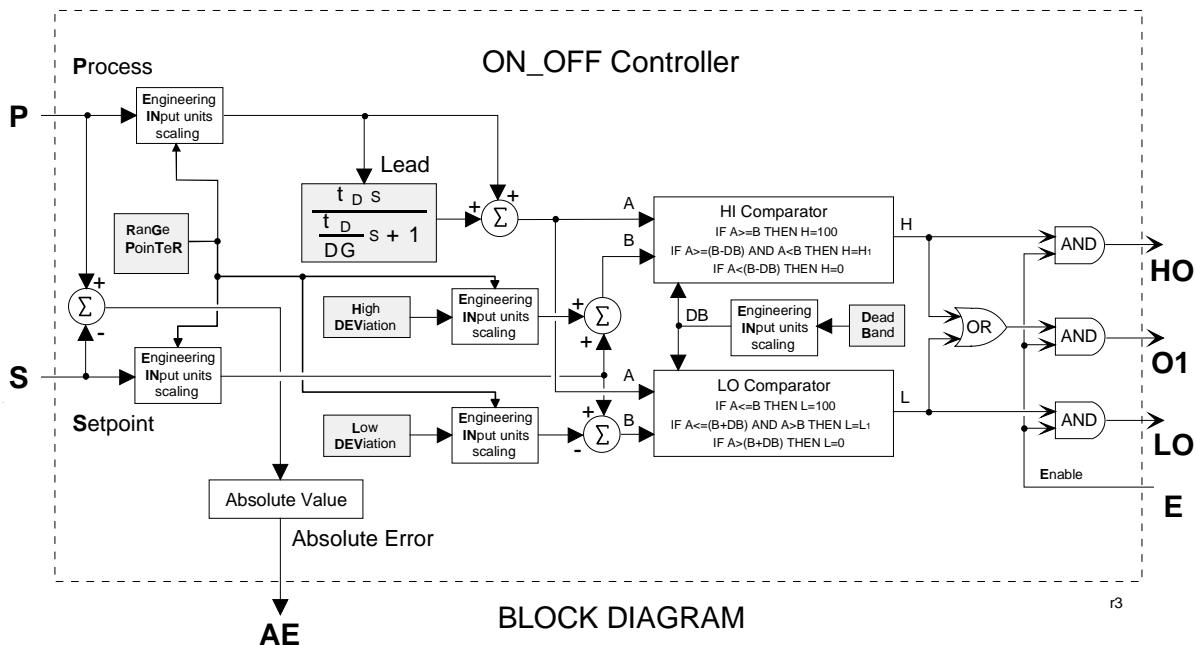

3.2.70 OR_ - OR Logic

OR_ function blocks perform a logical OR on the three inputs. Any unused input will be set low (0).

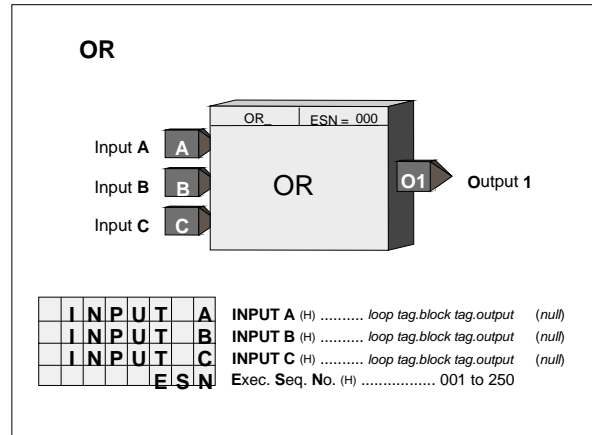
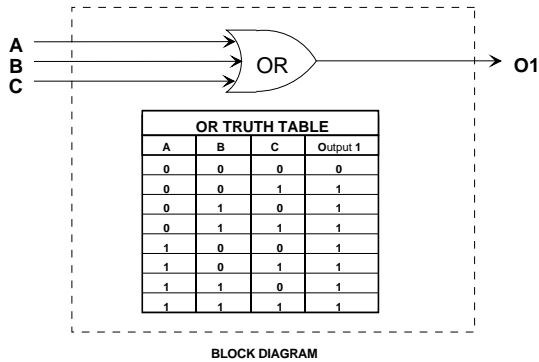

3.2.71 ORSL - Override Selector

ORSL function blocks are used on a one per loop basis and they enable a primary input signal, such as the output from a controller, to be overridden by other signals. For a selector configured as LO, the function block outputs the lower of the primary or override inputs. For a selector configured as HI, the function block will output the higher of the primary or override inputs. Override signals can be hard limits, coming from HOLD blocks, or signals coming from other controllers. Block override inputs 1 and 2 can be used as HI or LO selector functions. Additional override inputs can be accommodated by connecting these inputs to signal selector (SEL) blocks.

When the output of the ORSL block is not the primary input, the output OS will be high (1). In addition, the block can cause the operator faceplate to display 'OVERRIDE' status when a priority level higher than 0, the default, has been selected.

If an override input is not configured the individual selector will output the other input. When no inputs are configured, the block will output 0.0 and the OS status will be set low (0).

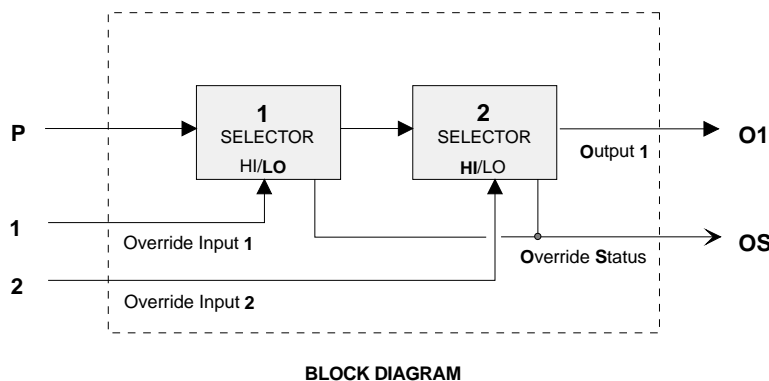
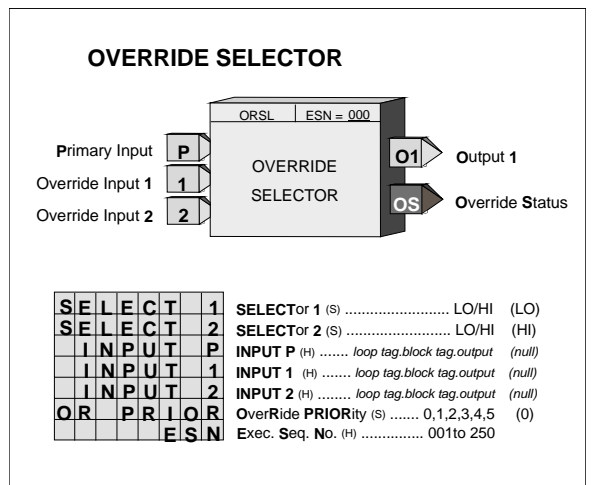

3.2.72 OST_ - One Shot Timer

OST_ function blocks provide a high (1) output for a predetermined time, set by ON TIME, when input P goes high (1). If input P goes low (0), the output will remain high until the time expires. If input P goes high during the on time, the elapsed timer will be re-triggered if RETRIG is set to YES.

With firmware 1.30 and higher the ON TIME is adjustable over the full range of the display which is 0.00000 to 999999. In earlier versions, the minimum time setting was 0.1. If the delay time is set to less than the scan time of the station the delay time will equal the scan time.

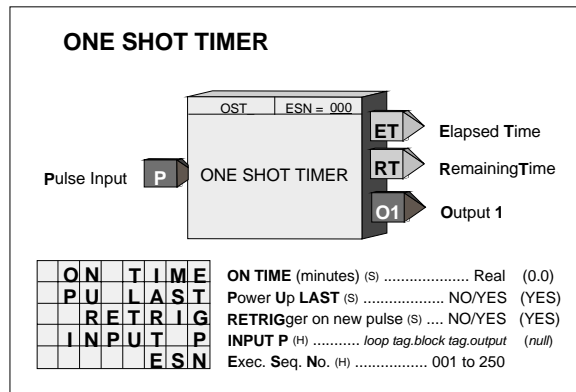

Output ET (elapsed time) will ramp from 0.0 to the value of ON TIME and remain there until P goes low (0). Output RT (remaining time) equals ON TIME - ET.

POWER UP - During a warm start, when PU LAST is set to YES, the block will initialize at the input/output states and elapsed time in effect at the instant power down occurred. A cold start will initialize the input/output states and elapsed time to 0.

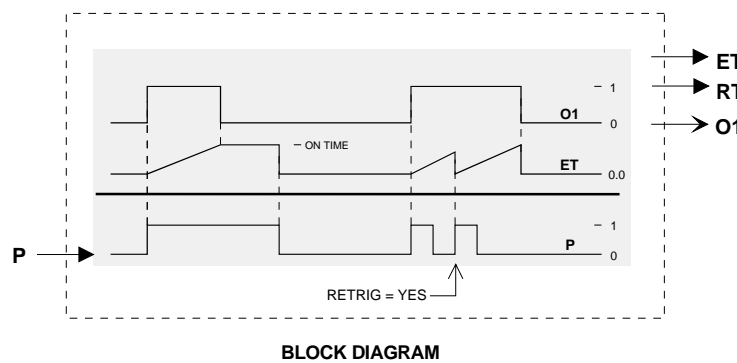

3.2.73 PB1SW - PB1 Switch

PB1SW is one of three general purpose switches available in each loop. It can be utilized for switching Boolean signals in such applications as: toggling Console/Local operation of the ODC or ODS function blocks, Start/Stop, controlling the position of a TSW (Transfer Switch) function block for switching analog signals, or other operator initiated actions.

PB1SW can be configured for momentary or sustained operation. As momentary, the switch will transfer to the NO position when the button is pressed and will return when released. Momentary action is used in toggle applications such as changing the function of the ODC or ODS function blocks. In the sustained mode, the switch will alternate positions each time the button is pressed. An unconfigured NC input defaults to 0 and an unconfigured NO input to 1. With firmware 1.30 and higher, the button can be remotely activated through a command over Modbus or LIL.

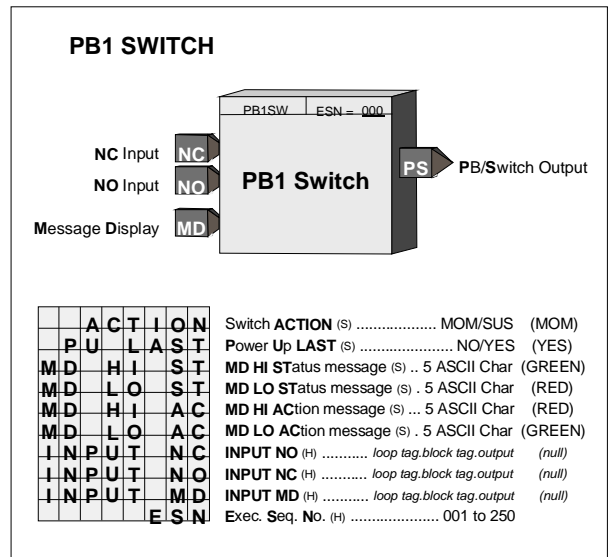

This block operates with an operator faceplate that includes green and red LEDs that are turned on using input MD. A HI (1) input will turn on the Green LED and a LO the Red LED. The default connection will be the PS output of the block but should be changed as required to display the correct status. The message parameters do not apply to the current product.

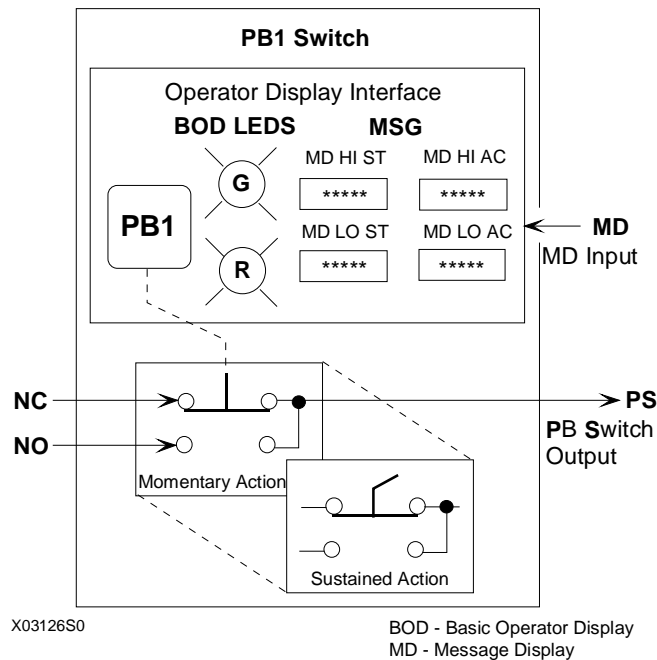

BLOCK DIAGRAM

POWER UP - When the switch is configured for momentary action, it will always power up in the NC position. For sustained action, with the **POWER UP** parameter set to YES, the switch will power up in the last position during a hot or warm start, and during a cold start will power up in the NC position. When the **POWER UP** parameter is set to NO, the switch will power up in the last position during a hot start. During a warm or cold start, it will power up in the NC position.

3.2.74 PB2SW - PB2 Switch

PB2SW is one of three general purpose switches available in each loop. It can be utilized for switching Boolean signals in such applications as: toggling the EITS (External/Internal setpoint Transfer Switch) function block, Start/Stop, controlling the position of a TSW (Transfer Switch) function block for switching analog signals, or other operator initiated actions.

The switch can be configured for momentary or sustained operation. As momentary, the switch will transfer to the NO position when the button is pressed and will return when released. Momentary action is used in toggle applications such as changing the function of the EITS function block. In the sustained mode, the switch will alternate positions each time the button is pressed. An unconfigured NC input defaults to 0 and an unconfigured NO input to 1. With firmware 1.30 and higher, the button can be remotely activated through a command over Modbus or LIL.

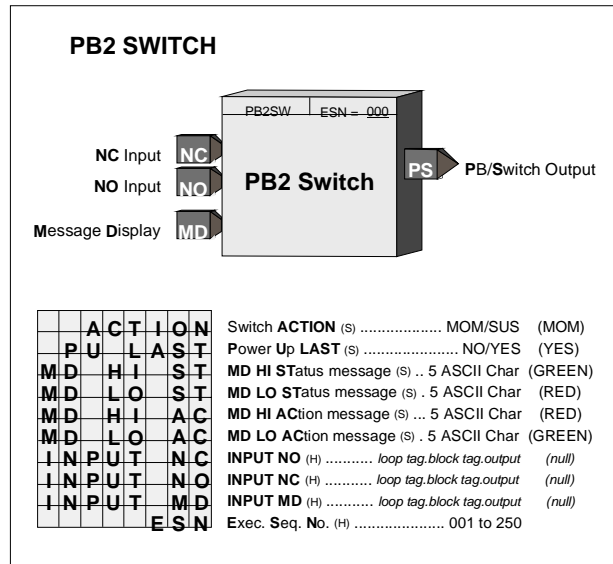

This block operates with an operator faceplate that includes green and red LEDs that are turned on using input MD. A HI (1) input will turn on the Green LED and a LO the Red LED. The default connection will be the PS output of the block but should be changed as required to display the correct status. The message parameters do not apply to the current product.

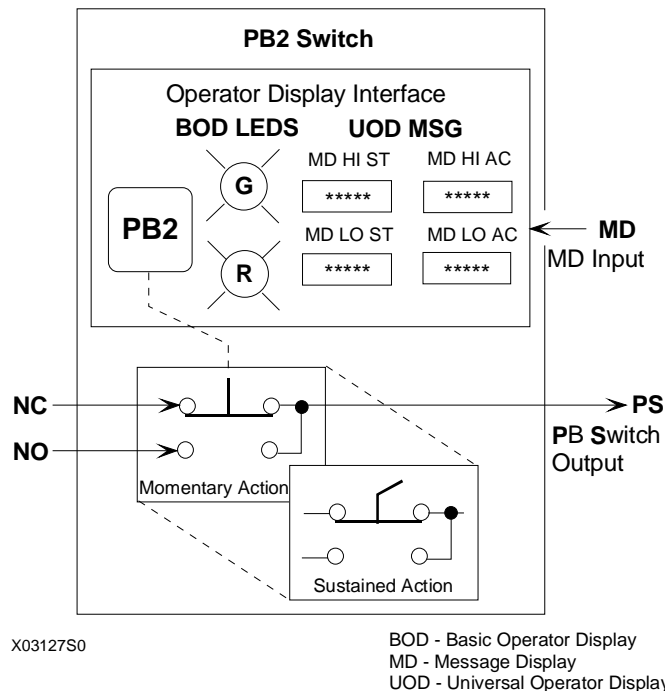

BLOCK DIAGRAM

POWER UP - When the switch is configured for momentary action, it will always power up in the NC position. For sustained action, with the **POWER UP** parameter set to YES, the switch will power up in the last position during a hot or warm start, and during a cold start will power up in the NC position. When the **POWER UP** parameter is set to NO, the switch will power up in the last position during a hot start. During a warm or cold start, it will power up in the NC position.

3.2.75 PB3SW - PB3 Switch

PB3SW is one of three general purpose switches, available in each loop. It can be utilized for switching Boolean signals in such applications as: Start/Stop, controlling the position of a TSW (Transfer Switch) function block for switching analog signals, or other operator initiated actions. PB3SW can only be operated from the front panel when the A/M function block has not been configured.

PB3SW can be configured for momentary or sustained operation. As momentary, the switch will transfer to the NO position when the button is pressed and it will return when released. In the sustained mode, the switch will alternate positions each time the button is pressed. An unconfigured NC input defaults to 0 and an unconfigured NO input to 1. With firmware 1.30 and higher, the button can be remotely activated through a command over Modbus or LIL.

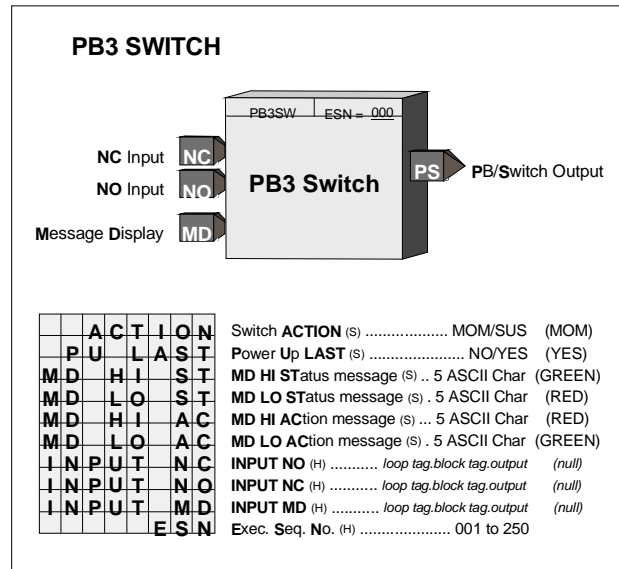

This block operates with an operator faceplate that includes green and red LEDs that are turned on using input MD. A HI (1) input will turn on the Green LED and a LO the Red LED. The default connection will be the PS output of the block but should be changed as required to display the correct status. The message parameters do not apply to the current product.

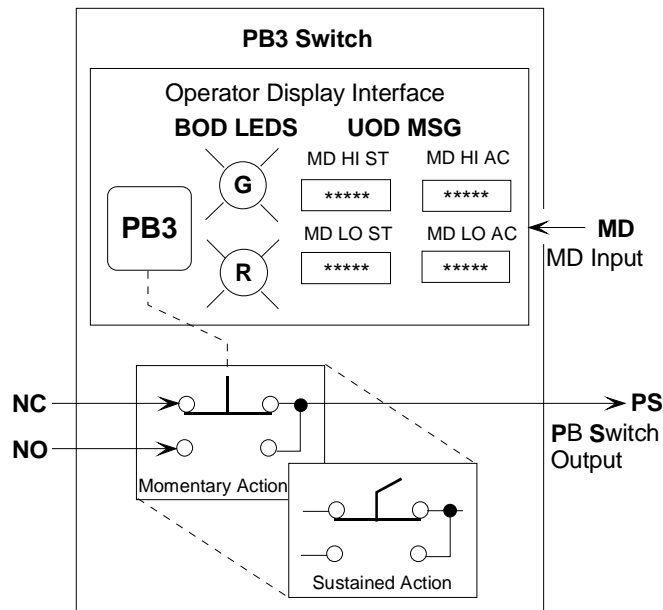

X03128S0

BOD - Basic Operator Display
 MD - Message Display
 UOD - Universal Operator Display

BLOCK DIAGRAM

POWER UP - When the switch is configured for momentary action, it will always power up in the NC position. For sustained action, with the POWER UP parameter set to YES, the switch will power up in the last position during a hot or warm start, and during a cold start it will power up in the NC position. When the POWER UP parameter is set to NO, the switch will power up in the last position during a hot start. During a warm or cold start will power up in the NC position.

3.2.76 PCOM - Phase COMMunication

The Phase Communication **PCOM** function block, in firmware 1.30 and higher, is available on a one per loop basis to enable communication with a higher level device, such as a PC running a batch management software program. When the controller configuration is structured such that logic operations are partitioned in small phase operations, the PCOM block facilitates the interface between the logic controlling the overall phase operations for the batch and the logic performing the control logic for each phase.

The logic performed by the **PCOM** block is detailed in Boolean form in Figure 3-1. Network communication can be either Modbus or LIL (Local Instrument Link). Details are listed in the Network Communications section. The LOOP # configured in the ODC or ODS function block for the loop determines the location of the status word and the status coils in the Modbus mapping. Communication states are represented in Figure 3-1, on the next page, using the symbols shown below. Modbus states are mapped in coils and LIL states mapped into two 16-bit status word as shown below. Three global channels are used to send out the two status words and an integer value from 1-7 that represents the status of the PCOM block: 1=ABORTED, 2=DONE, 3=HELD, 4=RUN, 5=INTRLK, 6=READY, 7=EMER OR. The location of the first channel is configured using the LIL CHAN parameter, represented by channel z in the LIL mapping tables.

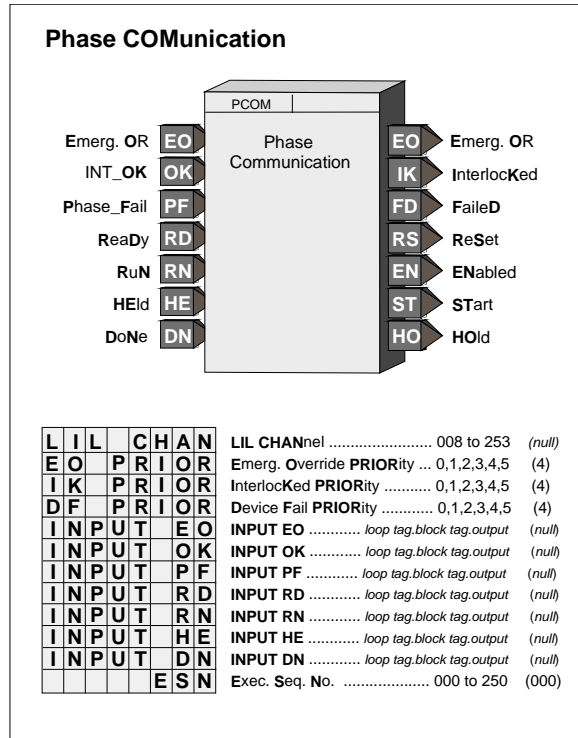

Read/Write States



Read States



Each communication state is read as a 1 or 0. Using Modbus, a write of a 1 (W1) or a 0 (W0) will affect the communication state as defined by the associated logic in Figure 3-1. The W1 or W0 is equivalent to a Mask ON or a Mask OFF using LIL commands. All unconfigured inputs will be treated as low (0) except OK, RD, RN and HE which will be treated as high (1). Three of the output states, EO (“EMERG”), IK (“INTRLK”), and FD (“FAILED”) can be configured for priorities 0-5. This will affect the flashing, etc. as previously described for other controller status conditions. These states also have unacknowledged bits as detailed in status word 2. Conditions that require acknowledging can be acknowledged by either using the local faceplate ACK button or by writing to the individual not acknowledged bit or the Not Ack’d PCOM bit.

BIT	15	14	13	12	11	10	9	8	7	6	5	4	3	2	1	0
NAME				ABORTED	DONE	HELD	RUN	READY	ABORT	PCOMP	HOLD	RESTART	START	RESET	DFAIL	INIT_OK
1				R	R	R	R	R	W	W	W	R/W	W	W	R/W	R/W
0				R	R	R	R	R	R	R	R	R/W	R	R	R/W	R/W

Status Word 1

BIT	15	14	13	12	11	10	9	8	7	6	5	4	3	2	1	0
NAME	ACTIVE PCOM	Not Ack'd PCOM									Not Ack'd FD	FAILED (FD)	Not Ack'd IK	INTRLK (IK)	Not Ack'd EO	EMERG (EO)
1	R	R									R	R	R	R	R	R
0	R	R/W									R/W	R	R/W	R	R/W	R

Status Word 2

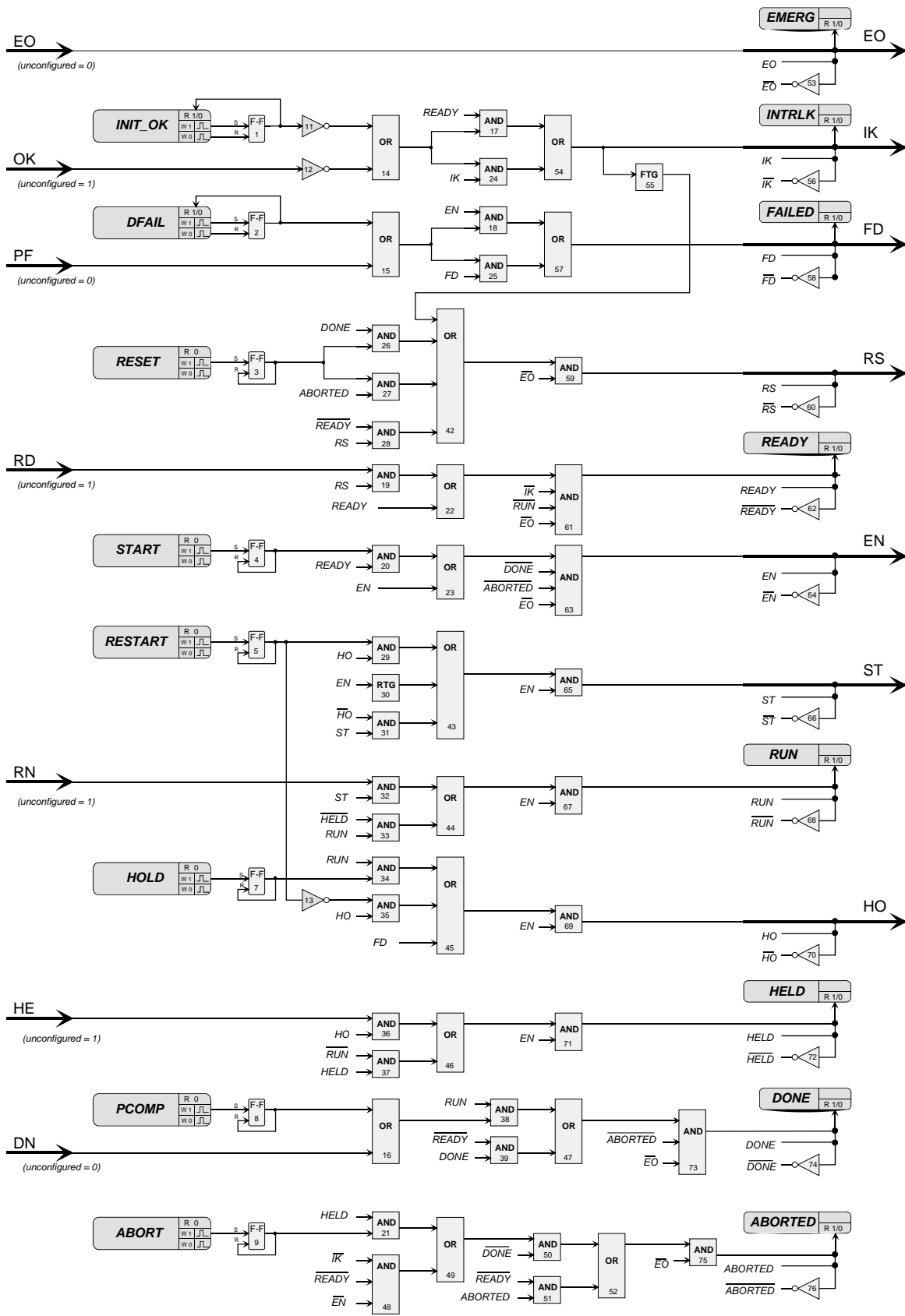

Figure 3-1 Logic Diagram

3.2.77 PD - PD Controller

PD is a proportional only controller with manual reset. It is one of five controller types that can be used on a one per loop basis.

Manual reset allows the output of the controller to be set for a normal operating value (i.e. the desired output when the process equals setpoint under a given load condition). Derivative action is provided when the parameter TD is non-zero. The controller includes an autotune feature that can be initiated from the operator faceplate using the quick TUNE feature.

When input A is high (1) the controller will operate in the normal auto mode and when low (0) causes the controller output to track the feedback signal to eliminate bumping the output when switching to auto. This is accomplished by forcing the reset component R to a value that will keep (GE+R) equal to the feedback value. When the controller is switched to auto the value of the reset component will change back to the manual reset MR value at a rate determined by the MR TLAG setting. When MRTRCK is set to YES the manual reset MR will also track the feedback signal when input A is low.

Input I, when changed from low (0) to high (1) or high to low, will cause the controller to initialize (i.e. eliminate any proportional gain action during that scan cycle). This can be used to prevent bumping the output when changes are made to the setpoint through a switch block.

PD CONTROLLER

Range **R**

Process **P**

Setpoint **S**

Feedback **F**

Auto **A**

Initialize **I**

PD
ESN = 000

**PD
CONTROLLER**

OR Output Range

O1 Output

AE Absolute Error

AW AT Warning

	R	G	P	T	R	Range PoinTeR (S) loop tag.block tag (null)
	D	I	R	A	C	DIRect ACTing (H) NO/YES (NO)
					P	Proportional Gain (S) 0.001 to 100.0 (1.000)
					T	Time - Derivative (S) 0.00 to 100.00 min (0.00)
					D	Derivative Gain (S) 1.00 to 30.00 (10.00)
					M	Manual Reset (S) 0.00 to 100.00 (0.00)
					R	Manual Reset Time LAG (S) . 0.001 to 4000 min (0.010)
					T	Manual Rest TRACKing (S) NO/YES (NO)
					M	MINimum SCALE (H) Real (0.0)
					M	MAXimum SCALE (H) Real (100.0)
					D	Decimal Point Position (preferred) (S) 0.0,0.0,0.0 (0.0)
					E	ENGINEERING UNITS (S) 6 ASCII Char (PRCT)
					A	AUTOTUNE (S) NO/YES (YES)
					%	% DEVIation during Autotune (S) ... AUTO, 2.5 to 25.0 (AUTO)
					%	% HYSteresis during Autotune (S) .. AUTO, 0.5 to 10.0 (AUTO)
					%	% output STEP on first Autotune (S) 5% to 40% (10)
					A	AT DYNAMic settings (S) Fast, Medium, Slow (M)
					A	AT RESET (S) NO/YES (YES)
					P	POST Autotune Transfer (S) NO/YES (NO)
					I	INPUT P (H) loop tag.block tag.output (null)
					I	INPUT S (H) loop tag.block tag.output (null)
					I	INPUT F (H) loop tag.block tag.output (null)
					I	INPUT A (H) loop tag.block tag.output (null)
					I	INPUT I (H) loop tag.block tag.output (null)
					E	Exec. Seq. No. (H) 001 to 250

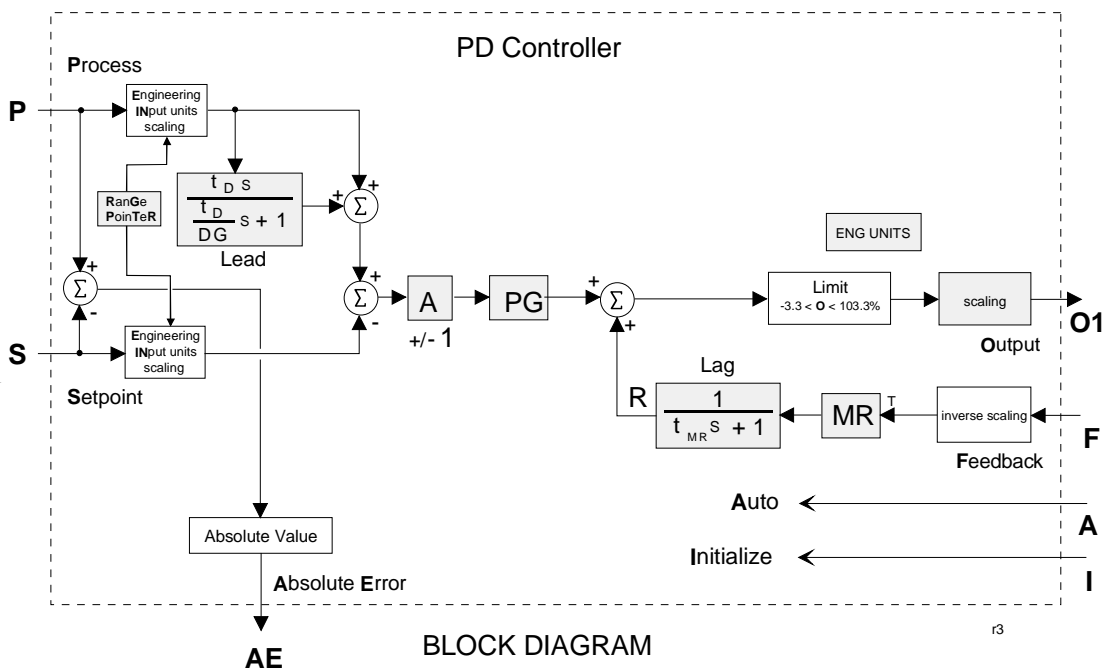

The process range pointer parameter should point to another function block that contains range scaling, such as an analog input that is the source of the process variable. This enables the controller to normalize tuning parameters for the process range. If this parameter is not configured, the controller will use a range scaling of 0.00-100.00. During a warm or cold power up the output will be initialized to MINSCALE and all dynamic elements will be initialized at the current input on the first scan.

The controller output has MINSCALE and MAXSCALE parameters allowing the output signal to be scaled for engineering ranges other than the default of 0 - 100 PRCT. This may be necessary when the controller output is the setpoint to another controller.

The Autotune feature is accessible using the TUNE pushbutton when AUTOTUNE is set to YES. It can be initiated while the loop is in Auto or Manual. The autotuner, when initiated, replaces the PD controller with an on-off control function, places the A/M block in Auto (if in Man), and cycles the control loop through six on-off cycles while learning the process dynamics which it uses to provide tuning recommendations for the PD controller.

The % DEV parameter is the maximum amount in % that the process should deviate from the setpoint during the on-off cycles. This parameter can be set manually or can be configured as AUTO. When AUTO is configured, the autotuner will set the % DEV to 4 times the % HYS. This is the minimum value needed to provide good autotuning results.

The % HYS parameter is the amount that the process must deviate from setpoint before switching the output in the opposite direction. This value must be equal to or slightly greater than any process noise band. If the noise band can not be determined, the autotuner will compute it at the start of an autotuning exercise when the % HYS parameter has been configured as AUTO.

The % STEP parameter is the amount that the valve will change on the first 1.5 on-off cycles. After the first cycles the autotuner will adjust the step to keep the process within the value of the % DEV parameter. On subsequent autotune exercises, the step will use the value computed from the previous exercise unless the AT RESET parameter is set to YES or the controller has been power cycled. The dynamic response recommended by the autotuner can be configured as Fast, Medium, or Slow. The Medium setting will normally provide a response that has no or little overshoot to a setpoint step response.

When the POST AT parameter is set to YES, the control loop will be returned to Auto using the recommended tuning values unless a warning occurred during the test.

More details on autotuning can be found in the Operation section of this manual.

3.2.78 PID - PID Controller

PID is a proportional + integral controller and one of five controller types that can be used on a one per loop basis. It uses external feedback to provide integral action. The block allows interaction with other function blocks or external devices, such as pneumatic controllers and shutoff switches, to eliminate the windup that can occur with other controller types. Derivative action is provided when the parameter TD is non-zero. The controller includes an autotune feature that can be initiated from the operator faceplate using the QUICK access feature.

When input A is high (1), the controller operates in the normal auto mode and when low (0) causes reset R to track (F-GE). This will force the controller output to track the feedback within the controller limits and allow the controller to switch back to auto without bumping the output.

The process range pointer parameter points to another function block that has range scaling, such as an analog input that is the process variable. This enables the controller to normalize the tuning parameters for the process range. If this parameter is not configured, the controller will use a range scaling of 0.00-100.00.

Input I, when changed from low (0) to high (1) or from high to low, will cause the controller to initialize (i.e. eliminate any proportional gain action during that cycle). This can be used to prevent bumping the output when changes are made to the setpoint using a switch block.

POWER UP - During a warm or cold power up, the output will be initialized to MINSCALE and all dynamic elements will be initialized at the current input on the first scan.

PID CONTROLLER

Range **R**

Process **P**

Setpoint **S**

Feedback **F**

Auto **A**

Initialize **I**

PID | ESN = 000

PID CONTROLLER

OR Output Range

O1 Output

AE Absolute Error

AW AT Warning

R	G	P	T	R	RanGe PoinTeR (S)	loop tag.block tag (null)
D	I	R	A	C	DIRect ACTing (H)	NO/YES (NO)
				P	Proportional Gain (S)	0.001 to 100.0 (1.000)
				T	Time - Integral (S)	0.001 to 4000 m/r (100.0)
				D	Time - Derivative (S)	0.00 to 100.00 min (0.00)
				D	Derivative Gain (S)	1.00 to 30.00 (10.00)
M	I	N	S	C	MINimum SCALE (H)	Real (0.0)
M	A	X	S	C	MAXimum SCALE (H)	Real (100.0)
				D	Decimal Point Position (preferred) (S)	0.0,0.0,0.0,0 (0.0)
E	N	G	U	N	ENGINEERING UNITS (S)	6 ASCII Char (PRCT)
A	U	T	O	T	AUTOTUNE (S)	NO/YES (YES)
		%	D	E	% DEVIation during Autotune (S) ...	AUTO, 2.5 to 25.0 (AUTO)
		%	H	S	% HYSteresis during Autotune (S) ..	AUTO, 0.5 to 10.0 (AUTO)
		%	S	T	% output STEP on first Autotune (S)	5% to 40% (10)
A	T	D	D	N	AT DYNAMIC settings (S)	Fast, Medium, Slow (M)
A	T	R	E	S	AT RESET (S)	NO/YES (YES)
		P	O	S	POST Autotune Transfer (S)	NO/YES (NO)
		I	N	P	INPUT P (H)	loop tag.block tag.output (null)
		I	N	S	INPUT S (H)	loop tag.block tag.output (null)
		I	N	F	INPUT F (H)	loop tag.block tag.output (null)
		I	N	A	INPUT A (H)	loop tag.block tag.output (null)
		I	N	I	INPUT I (H)	loop tag.block tag.output (null)
				E	Exec. Seq. No. (H)	001 to 250

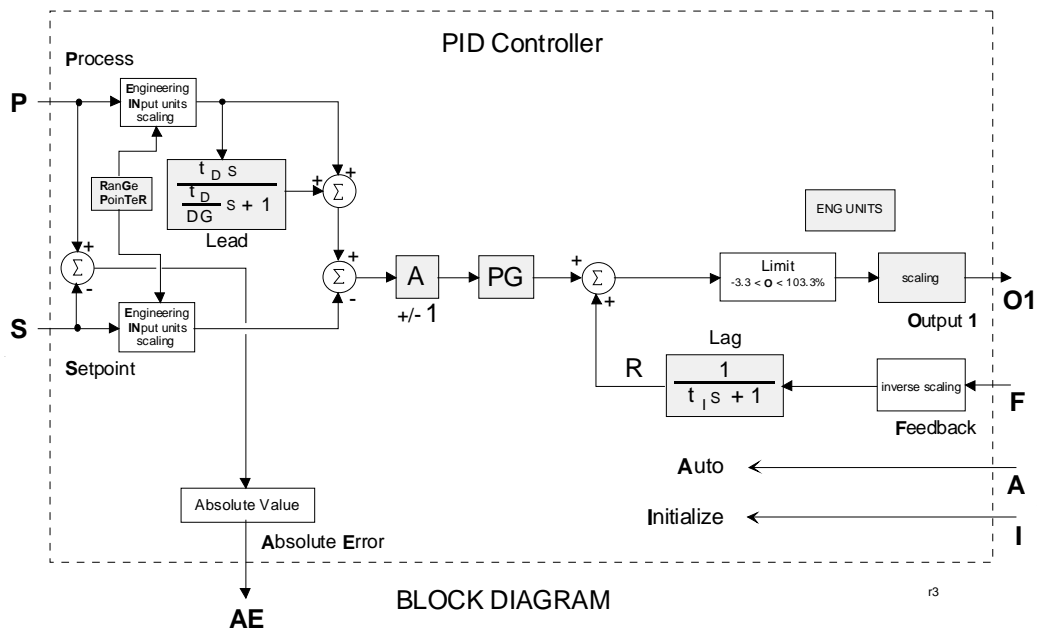

The controller output has MINSCALE and MAXSCALE parameters allowing the output signal to be scaled for engineering ranges other than the default of 0-100 PRCT. This may be necessary when the controller output is the setpoint to another controller.

The Autotune feature is accessible using the TUNE pushbutton when AUTOTUNE is set to YES and can be initiated while the loop is in Auto or Manual. The autotuner, when initiated, replaces the PID with an on-off control function, places the A/M block in Auto (if in Man) and cycles the control loop through six on-off cycles while learning the process dynamics which it uses to provide tuning recommendations for the PID controller.

The % DEV parameter is the maximum amount in % that the process should deviate from the setpoint during the on-off cycles. This parameter can be set manually or can be configured as AUTO. When AUTO is configured, the autotuner will set the % DEV to 4 times the % HYS. This is the minimum value needed to provide good autotuning results.

The % HYS parameter is the amount that the process must deviate from setpoint before switching the output in the opposite direction. This value must be at least equal to or slightly greater than any process noise band. If the noise band can not be determined, the autotuner will compute it at the start of an autotuning exercise when the % HYS parameter has been configured as AUTO.

The % STEP parameter is the amount that the valve will change on the first on-off cycle. After the first cycle, the autotuner will adjust the step to keep the process within the value of the % DEV parameter. On subsequent autotune exercises, the step will use the value computed from the previous exercise unless the AT RESET parameter is set to YES or the controller has been power cycled. The dynamic response recommended by the autotuner can be configured as Fast, Medium, or Slow. The Medium setting will normally provide a response that has no or little overshoot to a setpoint step response.

When the POST AT parameter is set to YES, the control loop will be returned to Auto using the recommended tuning values unless a warning occurred during the test.

More details on autotuning can be found in the Operation section.

3.2.79 PIDAG - PIDAG Controller

PIDAG is an adaptive gain proportional + integral controller and is one of five controller types that can be used on a one per loop basis. It uses external feedback to provide integral action that allows interaction with other function blocks or external devices, such as pneumatic controllers, shutoff switches. PIDAG eliminates windup that can occur with other controller types. Derivative action is provided when the parameter TD is non-zero. The controller includes an autotune feature that can be initiated from the operator faceplate using the quick TUNE feature.

When input A is high (1), the controller will operate in the normal auto mode and when low (0) causes reset R to track (F-GE). This forces the controller output to track the feedback within controller limits and allow the controller to be switched back to auto without bumping the output.

The process range pointer parameter (input R) points to a function block that has range scaling, such as the analog input that is providing the process variable. This enables the controller to normalize the tuning parameters for the process range. If this parameter is not configured, the controller will use a range scaling of 0.00-100.00.

Input I, when changed from low (0) to high (1) or from high to low, will cause the controller to initialize (i.e. eliminate any proportional gain action during that scan cycle). This can be used to prevent bumping the output when changes are made to the setpoint using a switch block.

PIDAG CONTROLLER

Range **R**

Process **P**

Setpoint **S**

Feedback **F**

Auto **A**

Initialize **I**

Adaptive Gain **AG**

PIDAG CONTROLLER

ESN = 000

OR Output Range

O1 Output

AE Absolute Error

AW AT Warning

R	G	P	T	R	RanGe PoiNtEr (S)	loop tag.block tag	(null)
D	I	R	A	C	DIRect ACTing (H)	NO/YES	(NO)
				P	Proportional Gain (S)	0.001 to 100.0	(1.000)
				T	Time - Integral (S)	0.001 to 4000 m/r	(100.0)
				D	Time - Derivative (S)	0.00 to 100.00 min	(0.00)
				D	Derivative Gain (S)	1.00 to 30.00	(10.00)
M	I	N	S	C	MINimum SCALE (H)	Real	(0.0)
M	A	X	S	C	MAXimum SCALE (H)	Real	(100.0)
				D	Decimal Point Position (preferred) (S)	0.0,0.0,0.0	(0.0)
E	N	G	U	N	ENGINEERING UNITS (S)	6 ASCII Char	(PRCT)
A	U	T	O	T	AUTOTUNE (S)	NO/YES	(YES)
				%	DEVIATION during Autotune (S) ... AUTO, 2.5 to 25.0		(AUTO)
				%	HYSTERESIS during Autotune (S) . AUTO, 0.5 to 10.0		(AUTO)
				%	output STEP on first Autotune (S)	5% to 40%	(10)
A	T	D	Y	N	AT DYNAMIC settings (S) .. Fast, Medium, Slow		(M)
A	T	R	E	S	AT RESET (S)	NO/YES	(YES)
				P	POST Autotune Transfer (S)	NO/YES	(NO)
I	N	P	U	T	INPUT P (H)	loop tag.block tag.output	(null)
I	N	S	U	T	INPUT S (H)	loop tag.block tag.output	(null)
I	N	F	U	T	INPUT F (H)	loop tag.block tag.output	(null)
I	N	A	U	T	INPUT A (H)	loop tag.block tag.output	(null)
I	N	I	U	T	INPUT I (H)	loop tag.block tag.output	(null)
I	N	A	G	U	INPUT AG (H)	loop tag.block tag.output	(null)
				E	Exec. Seq. No. (H)	001 to 250	

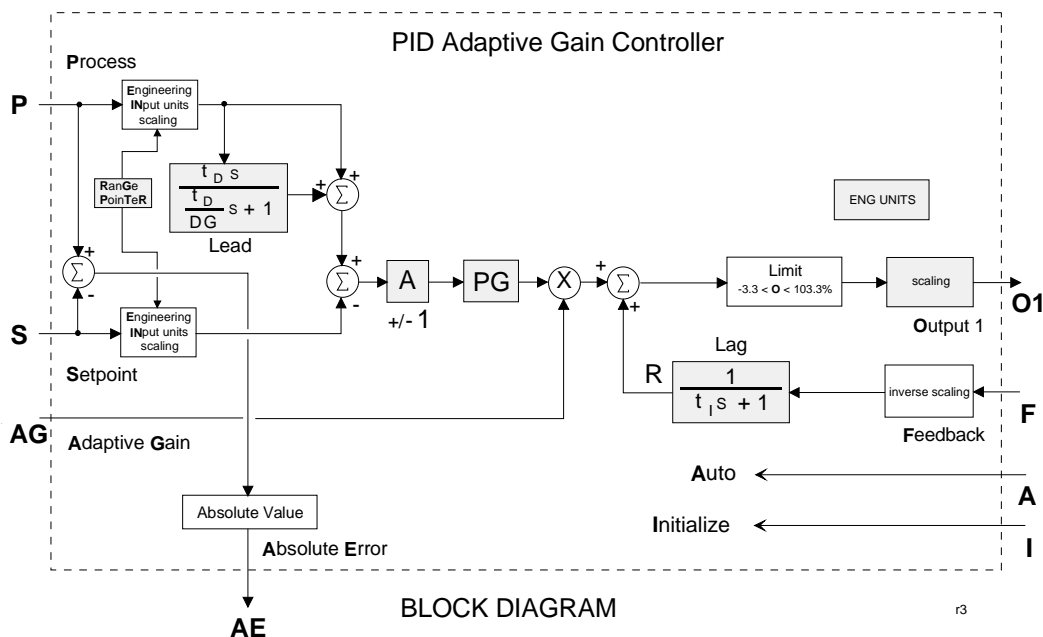

POWER UP - During a warm or cold power up, the output will be initialized to MINSCALE and all dynamic elements will be initialized at the current input on the first scan.

Input AG is multiplied by the gain error (GE). In version 1.30 of the controller firmware, an unconnected AG input will be set to 1.0. In earlier versions, it was set to 0.0 which required that the input always be connected to a source (e.g. Hold block) in order for the PIDAG block to function.

The controller output has MINSCALE and MAXSCALE parameters allowing the output signal to be scaled for engineering ranges other than the default of 0 - 100 PRCT. This may be necessary when the controller output is the setpoint to another controller.

The Autotune feature is accessible using the TUNE pushbutton when AUTOTUNE is set to YES and can be initiated while the loop is in Auto or Manual. The autotuner, when initiated, replaces the PIDAG with an on-off control function, places the A/M block in Auto (if in Man) and cycles the control loop through six on-off cycles while learning the process dynamics which it uses to provide tuning recommendations for the PIDAG controller.

The % DEV parameter is the maximum amount in % that the process should deviate from the setpoint during the on-off cycles. This parameter can be set manually or can be configured as AUTO. When AUTO is configured, the autotuner will set the % DEV to 4 times the % HYS. This is the minimum value needed to provide good autotuning results.

The % HYS parameter is the amount that the process must deviate from setpoint before switching the output in the opposite direction. This value must be at least equal to or slightly greater than any process noise band. If the noise band can not be determined, the autotuner will compute it at the start of an autotuning exercise when the % HYS parameter has been configured as AUTO.

The % STEP parameter is the amount that the valve will change on the first on-off cycle. After the first cycle, the autotuner will adjust the step to keep the process within the value of the % DEV parameter. On subsequent autotune exercises, the step will use the value computed from the previous exercise unless the AT RESET parameter is set to YES or the controller has been power cycled. The dynamic response recommended by the autotuner can be configured as Fast, Medium, or Slow. The Medium setting will normally provide a response that has no or little overshoot to a setpoint step response.

When the POST AT parameter is set to YES, the control loop will be returned to Auto using the recommended tuning values unless a warning occurred during the test.

More details on autotuning can be found in the Operation section.

3.2.80 PRSEQ - Program Sequencer

PRSEQ function blocks are available on a one per loop basis. They can be used to generate a simple setpoint profile or a complex batch sequence involving multiple discrete input and output logic operations as well as setpoint profiles.

The number of steps is configurable using the STEPS parameter and the number of discrete inputs/outputs using the GROUPS parameter. Sixteen (16) discrete inputs/outputs are provided for each group. If these parameters are increased after the function block is initially configured, the values of all previously entered step parameters will be retained. If however, a configuration is downloaded from the PC-based Graphical Configuration Software, the parameter values are determined by the download which includes the entire block configuration. The PRSEQ can store from 1 to 9 recipes. Each recipe will have the same number of steps and groups but all of the parameters can be configured differently.

Two new inputs have been added in firmware 1.30: RN (Recipe Number) and LR (Load Recipe). Input RN will accept a recipe number and input LR on a positive transition will select the recipe number which is the RN input. The RN input will round the number to the nearest integer value. A recipe number that is out of range will have no effect and the current recipe will remain. The recipe number set by the RN and LR inputs will be retained during HOT and WARM starts. During a COLD start, the recipe will revert to the recipe set by the configuration parameter "Recipe."

Input SN will accept a step number and input GS, on a positive transition, will select the step number, which is the SN input. The SN input will round the number to the nearest integer value. A step number that is out of range will have no effect and the sequencer will remain at the current step.

Output AO (analog output) will track input TV when input TC is high (1). If input TC goes low (0), AO will remain at the tracked values unless either a timed step ramps AO to the AEP (analog end point) for the step or an event completes the step at which time AO will go to the AEP value for the completed step.

The current sequencer step can be changed by any of the following six events:

1. the Reset input R going high (1) moving it to step 1
2. Goto Step input GS going high (1) forcing the sequencer to the step indicated by the whole value of input SN
3. the Step Forward input SF going high (1) moving it to the next higher step unless on the last step
4. the Step Backward input SB going high (1) moving back to the previous step unless on the first step
5. a step time expiring advancing to the next step
6. all the discrete inputs nn are True (1) that match the input mask (a mask value of '0' is a 'don't care' condition) advancing to the next step

Input H will hold the remaining time of the current step and disable advancing of the sequencer by operations 5 and 6 but will allow operations 1, 2, 3, and 4 to move the sequencer to the starting position of a new step.

When the last sequencer step is completed, SC will be set high (1). The sequencer cannot be moved past the last step unless the reset input R goes high (1) forcing it to position 1. The sequencer can be moved forward only when

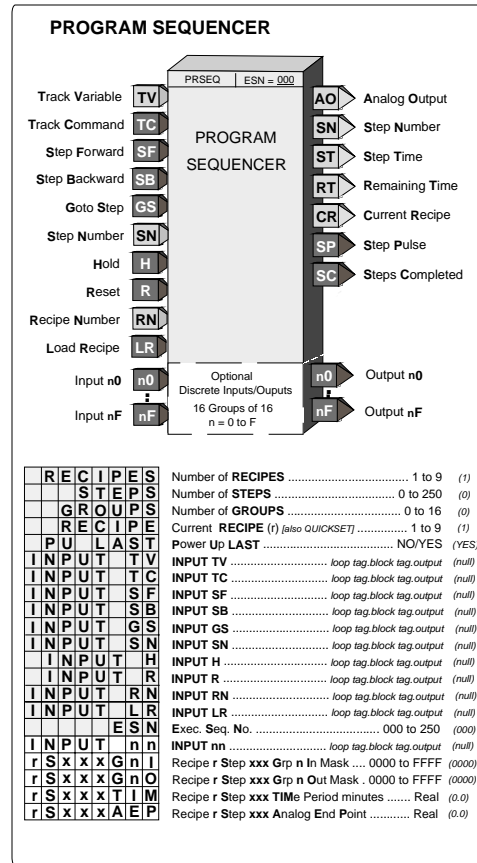

in position 1. Network communications will allow the sequencer to be moved to a new step and the remaining time of the current step to be changed to a new value.

When discrete groups are used and a step is desired as 'timed only', one discrete input should be used to prevent the input mask from moving the sequencer to the next step. This can be accomplished by requiring a high (1) input and then not connecting that input, since unconnected inputs will be treated as 0.

When discrete groups are used and a step is desired as 'event only', the TIME parameter for the step should be set to 0.0. The Analog Output will remain at the AEP value of the previous step or, if at step 1, the Analog value will be 0.0. When the sequencer advances to the next step, the Analog Output will go to the AEP value for the completed step.

POWER UP - During a warm start, if PU LAST is set to YES, all outputs, step number, track variable, and remaining step time will be initialized at the last values prior to power fail. During a cold start all outputs are initialized to 0 and the PRSEQ is in a reset condition.

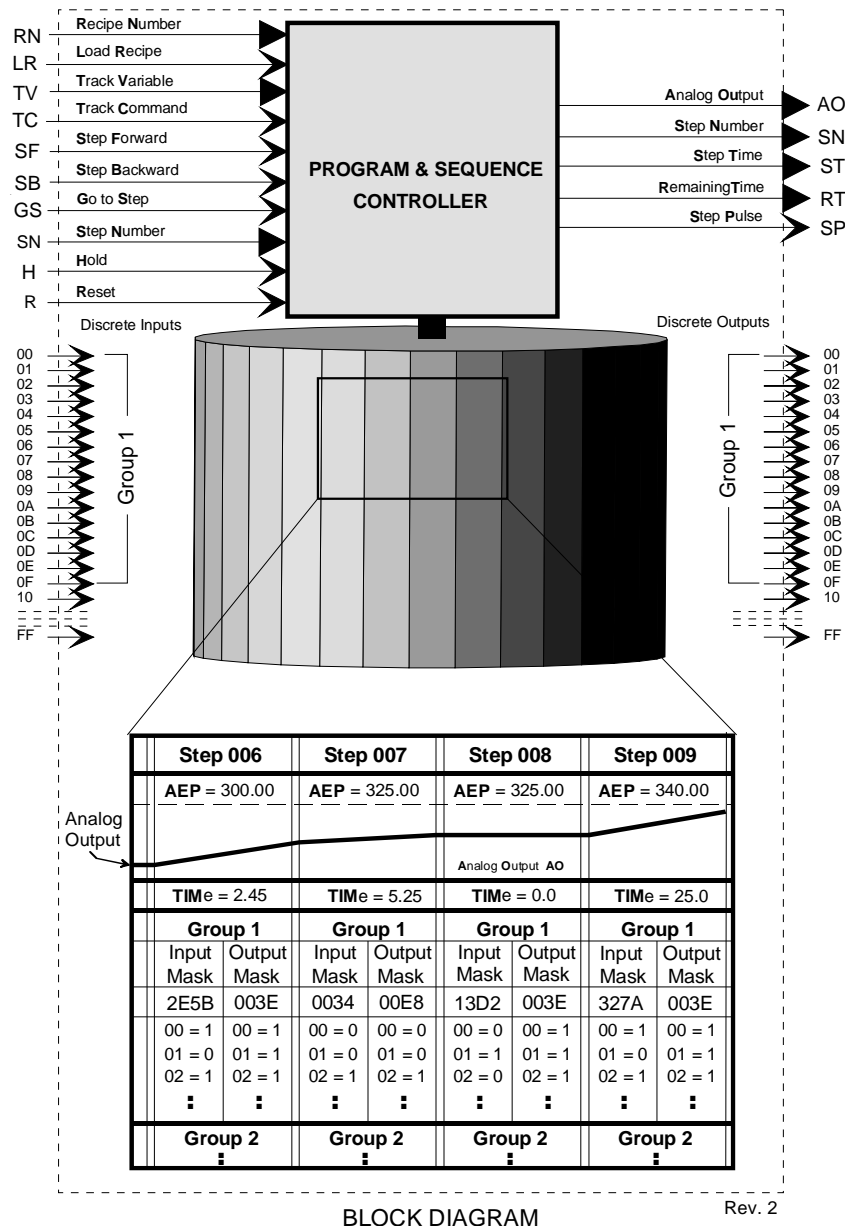

3.2.81 QHD_ - Quickset Hold

QHD_ function blocks enable a real value to be changed on-line using the QUICKSET feature. The block is identified by an 8-character name that will be displayed in the QUICKSET mode. The block is configured with a range entered as MIN SCALE and MAX SCALE to set a usable range, and a Decimal Point Position parameter can set the allowed precision. The hold value cannot be changed beyond the -10% to 110% value of these limits. The hold value will change continuously as the pulser is turned. The MAX value must always be set greater than the MIN value. The block can also be forced to track input TV by asserting input TC high (1).

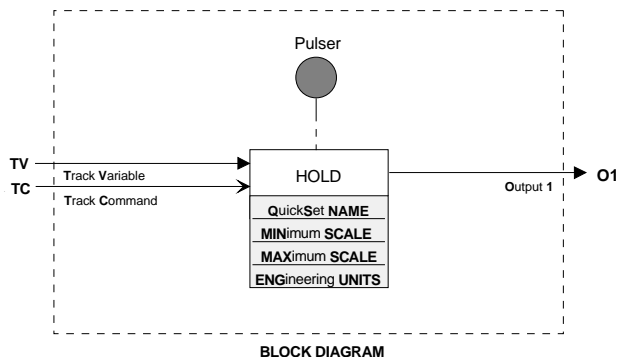

QUICKSET HOLD

Track Variable **TV**

Track Command **TC**

QHD_ ESN = 000

QUICKSET HOLD

OR Output Range

O1 Output 1

Q	S	N	A	M	E	QuickSet NAME (S)	8 ASCII Char	(null)							
M	I	N	S	C	A	L	E	MINimum SCALE (H)	Real	(0.00)					
M	A	X	S	C	A	L	E	MAXimum SCALE (H)	Real	(100.00)					
							D	P	P	Decimal Point Position (preferred) (S) ...	0.0.0.0.0.0	(0.00)			
E	N	G	U	N	I	T	S	ENGINEERING UNITS (S)	6 ASCII Char (PRCT)						
Q	S	C	H	A	N	G	E	Quick Set CHANGE ...	Continuous/Store	(C)					
P	U	V	A	L	U	E		Power Up VALUE (S)	Real	(0.00)					
								P	U	L	A	S	Power Up LAST (S)	No/Yes	(YES)
I	N	P	U	T	T	V		INPUT TV (H)	loop tag.block tag.output	(null)					
I	N	P	U	T	T	C		INPUT TC (H)	loop tag.block tag.output	(null)					
								E	S	N	Exec. Seq. No. (H)	001 to 250		Rev. 2	

Firmware 1.30 added parameter QSCHANGE. It enables the block output to either update continuously in the Quickset mode as the pulser knob is turned or to only update the output with the value in the numeric display when the STORE button is pressed.

When configuring the DPP (Decimal Point Position) it is important to keep the resolution to the minimum necessary for operation changes. It will take the operator longer turning the pulser if the resolution is too high. For example, if only 0.1% changes are needed configure a 0-100 range as 0.0 – 100.0 and not 0.000 – 100.000.

During Hot or Warm start, the QHD will power-up in the last position during a Cold start at the -10% range value.

3.2.82 RATIO - Ratio

RATIO function blocks can be used on a one per loop basis. They provide a means of setting a ratio in an external setpoint application, for example, controlling a captive flow while maintaining the ratio between a wild flow and the captive flow at the desired value. Inputs A and E (external ratio) and the operator set ratio R value are multiplied and become the function block output O1.

Track Command input TC, asserted high (1), causes the ratio block to track the input variable TV. The ratio value to be recalculated is then $R = TV / (A \times E)$. The value of R will be limited at the HI or LO LIMIT range settings. The factory default settings of the ratio limits are 0.00 - 30.00.

The RATIO can be adjusted using the QUICKSET feature if parameter QUICKSET is set to YES. The RATIO will continuously change as the knob is adjusted. Press the STORE button when the final value is reached to insure that the new RATIO setting will be retained on a Cold power up condition. The QS DPP parameter enables setting of the Ratio adjustment resolution when in the QUICKSET mode.

If input A or E is not configured, it's value will be set to 1. When input TC or TV is not configured, it's value will be set to 0.

The TO (Tracked Output) is normally used in applications where an external device is being used to set a ratio in place of the RATIO parameter (R is then set to 1.0). When it is desired to have the output of the RATIO block track the TV variable, the external device is forced to track TO. Input E will then equal $TV/[Ax(1.0)]$ and, therefore, the RATIO block output O1 will equal TV.

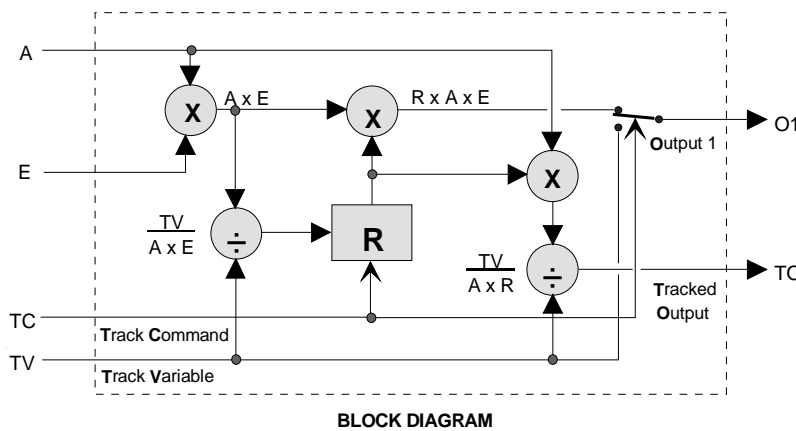
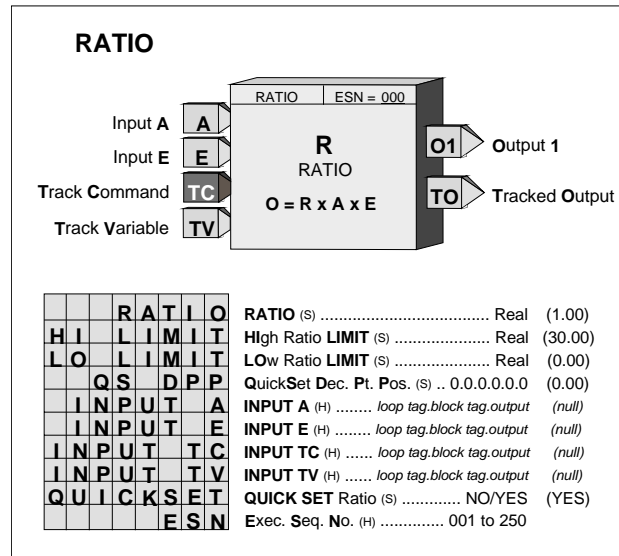

When a configuration containing the RATIO function block is edited in i/config and then downloaded to an on-line controller, the controller will ignore a change to the RATIO parameter value and continue to run with the pre-download value.

3.2.83 RCT_ - Repeat Cycle Timer

RCT_ function blocks provide repeat time cycles that can be used in logic timing operations or with PID blocks to provide adaptive on times controlled by the PID block. Output ET will provide the time in minutes that has elapsed during the current cycle (ON + OFF). Output RT is the remaining time in the current cycle and will equal the total cycle time (ON + OFF) when the timer has not been started.

With firmware 1.30 and higher, the ON and OFF TIME is adjustable over the full range of the display which is 0.00000 to 999999. In earlier firmware, the minimum time setting was 0.1. If the delay time is set to less than the scan time of the station the delay time will equal the scan time.

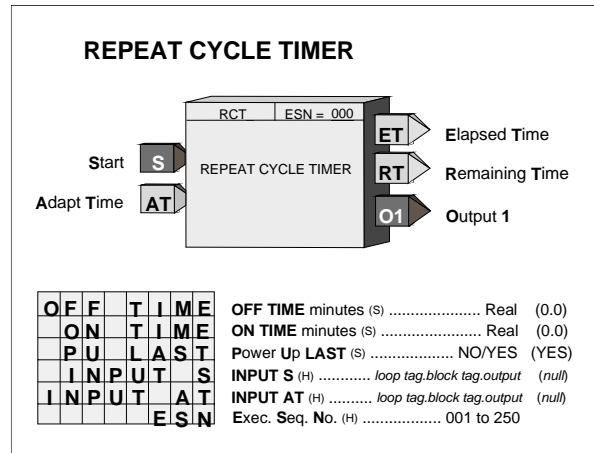

Input S, asserted high (1), will cause the RCT block to start the timing cycle. Output O1 will first go high (1) for a time set by ON TIME and then it will go low (0) for a time set by OFF TIME. It will continue to repeat this cycle until input S is asserted low (0) which forces O1 low (0) and ends the timing cycle.

ADAPTIVE ON TIME - this feature is active only when input AT is configured. It has a valid range of 0.0 to 1.0 and there are two separate modes of adaptive on time depending on the configuration of the OFF TIME parameter.

- OFF TIME = 0.0 - The time cycle will remain fixed and equal to the value of ON TIME. The output will be high for a period equal to ON TIME x AT.
- OFF TIME > 0.0 - The output will be low (0) for a period equal to OFF TIME and will be high for a period equal to ON TIME x AT. The time cycle equals [(ON TIME x AT) + OFF TIME].

POWER UP - With the PU LAST parameter set to YES, during a hot or warm power up the block will initialize the input/output states and elapsed time at the last values. During a cold start, they will be set to 0. With PU LAST set to NO, during a hot start the block will initialize the input/output states and elapsed time at the last values. During a warm or cold start, they will be set to 0.

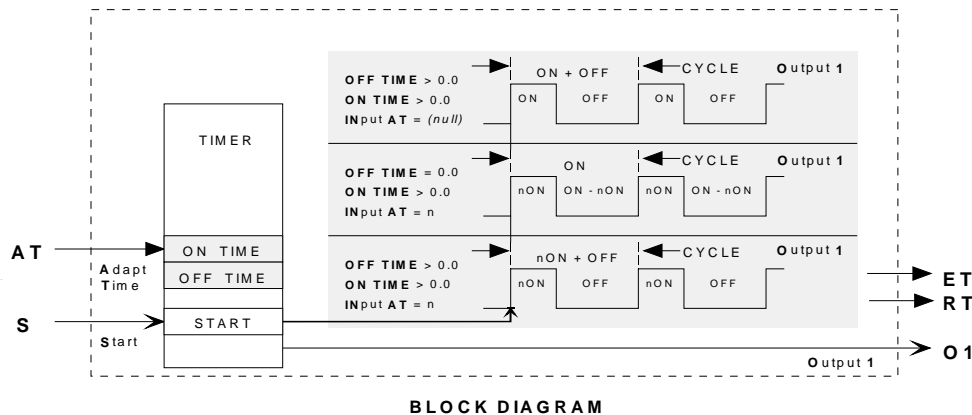

3.2.84 RLM_ - Rate Limiter

RLM_ function blocks limit the rate of change of analog input A. Separate up and down rates are entered in configuration, in engineering units per minute. Output RL will be high (1) if the block is limiting a rising input signal and output FL will be high when the block is limiting a falling input signal.

The Adaptive Rate inputs will vary the configured adaptive rate between 0 – 100% as the input varies from 0 to 100%. When the input is not configured the adaptive rate will not apply.

Input E asserted high (1) will enable the limit action of the block. When input E is low (0), the output will track the analog input. If input E is not configured, the limit action of the block will be enabled

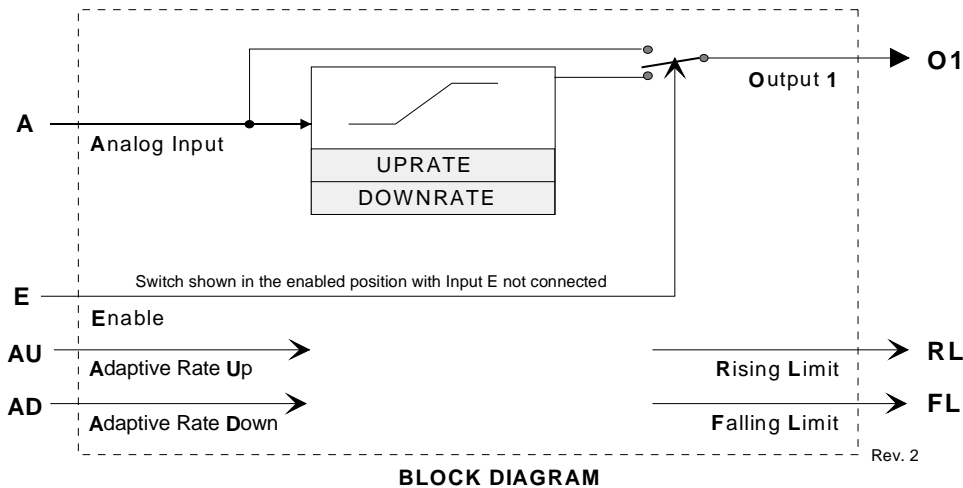
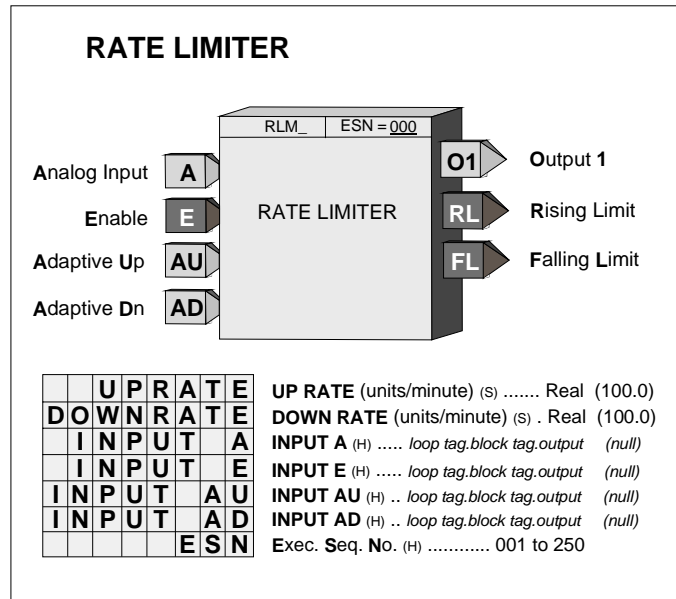

3.2.85 ROT_ - Retentive On Timer

ROT_ function blocks perform an on-delay timing function with output states determined by inputs ON and EN.

When input EN is low (0) outputs D and ND are low and when input EN is high (1), the outputs will be determined by the ON input and the elapsed time.

When ON goes high the elapsed time will start. Output D will go high after ET (elapsed time) equals or exceeds the DLY TIME. Output RT (remaining time) equals DLY TIME - ET. If ON goes low, the elapsed time will stop at the current value and will continue when ON returns to a high state. The elapsed time returns to 0.0 when input EN goes low. Output ND will be high (1) if input EN is high

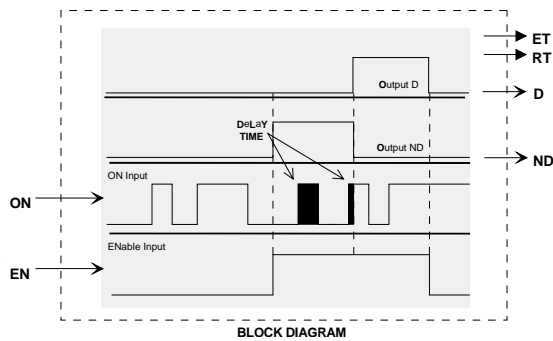
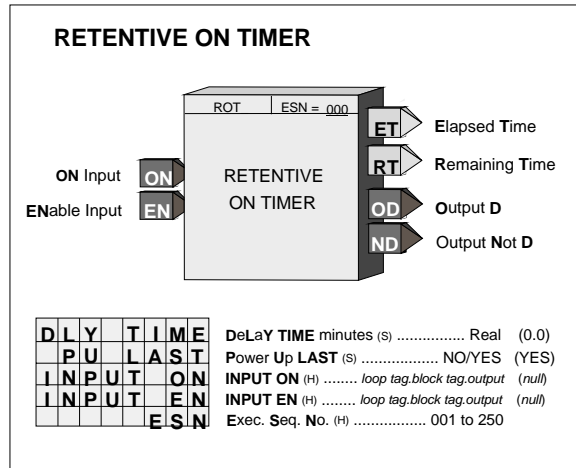

and output D is not high. With firmware 1.30 and higher, the DLY TIME is adjustable over the full range of the display which is 0.00000 to 999999. In earlier versions, the minimum time setting was 0.1. If the delay time is set to less than the scan time of the station the delay time will equal the scan time.

POWER UP - During a warm start, when PU LAST is set to YES, the block will initialize at the input/output states and elapsed time at the instant power down occurred. A cold start will initialize the input/output states and elapsed time to 0.

3.2.86 ROUT_ - Relay Outputs

ROUT_ function blocks provide SPDT contacts activated by function block input C. The relay will turn on when the block input is high (1) and will turn off when low (0). Two relay outputs are available on the Expander Board.

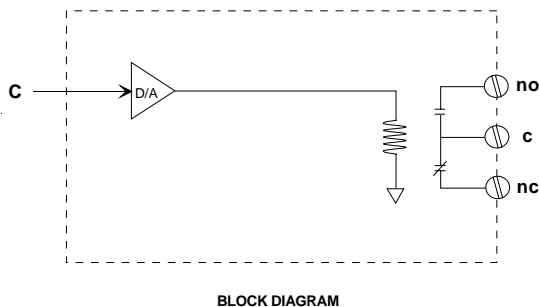
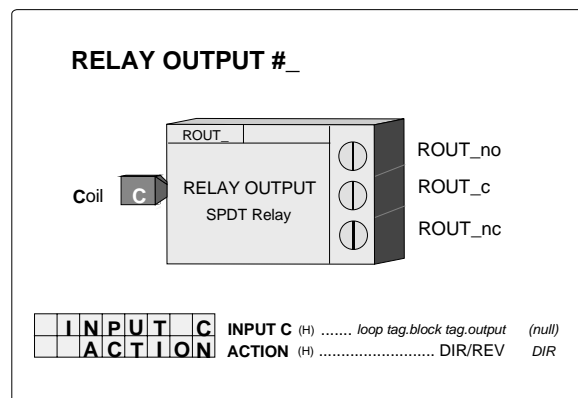

Terminal Connections are listed in Section 8.4.

3.2.87 RSF_ - RS Flip-Flop

RSF_ function blocks perform a reset dominant flip-flop function as detailed in the truth table. An unused S input will be set high (1) and an unused R input will be set low (0).

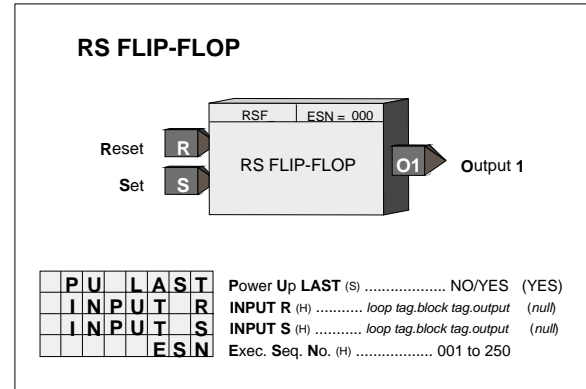
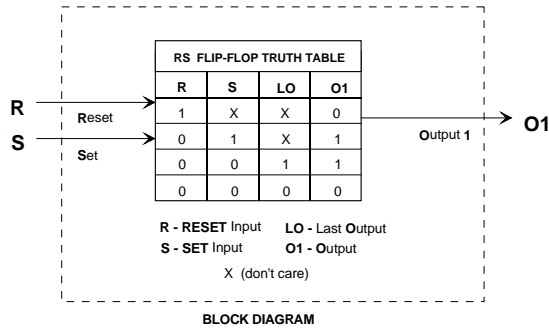

POWER UP - During a warm start, when PU LAST is set to YES, the block will initialize at the input/output states at the instant power down occurred. A cold start will initialize the input/output states to 0.

3.2.88 RTG_ - Rising Edge Trigger

RTG_ function blocks provide a high (1) output for one scan cycle each time input P transitions from a low (0) to a high (1).

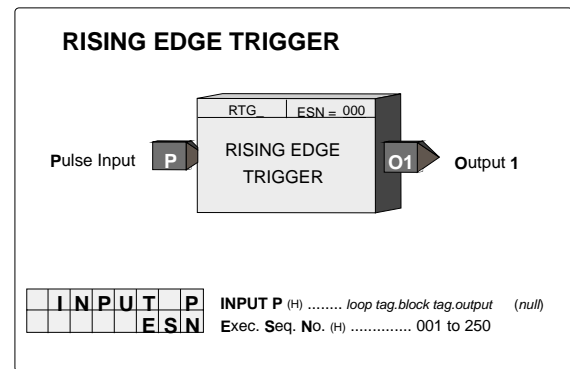
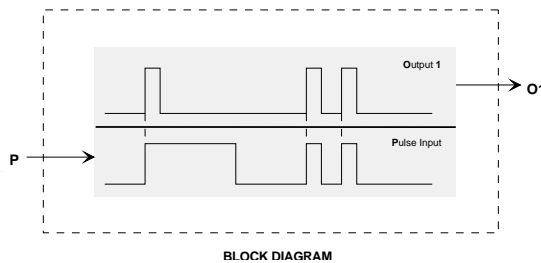

3.2.89 RTT_ - Real Time clock Trip (V2.0)

RTT_ function blocks provide high (1) outputs when time from the CLOCK block coincides with the TIME, DATE, & DAYS of the Week TRIP settings. The block outputs will remain high while the CLOCK coincides with the settings

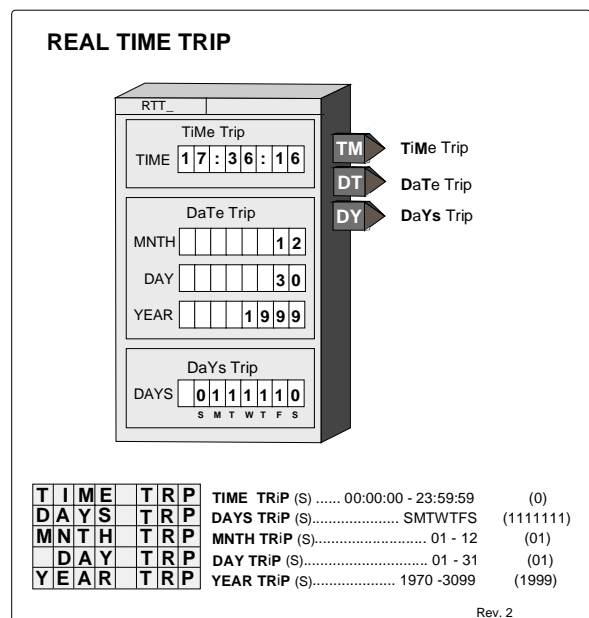

3.2.90 SCL_ - Scaler

SCL_ function blocks provide a means to scale an analog signal. It will re-range a signal by using the range pointer to reference the function block with the original range. When the range pointer (input R) is not configured, the function block will not re-scale the input signal but will pass it directly to the output. The purpose, under this situation, would be to provide minimum and maximum scale, preferred decimal point position, and units for another block (e.g. operator display) to reference.

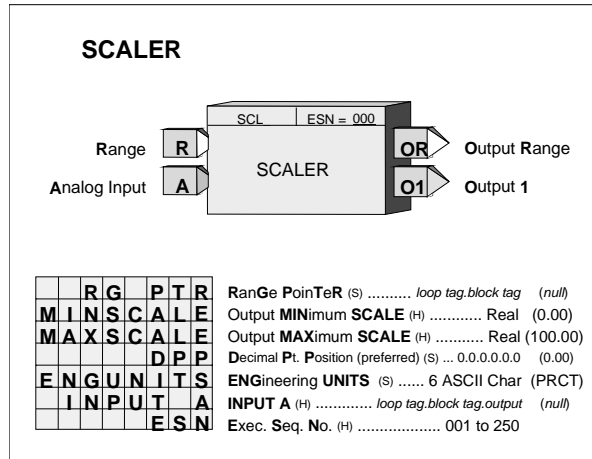
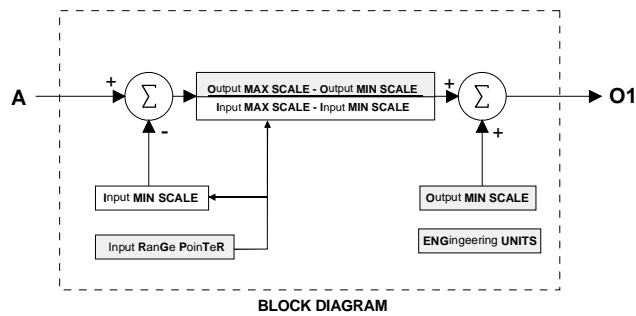

3.2.91 SEL_ - Signal Selector

SEL_ function blocks can provide a high or low signal selection on the three input signals. Unused inputs will be set equivalent to the lowest real value when configured as a HI selector and to the highest real value when configured as a LO selector.

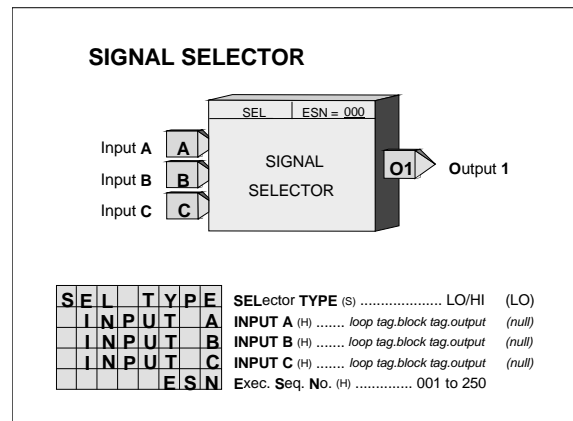
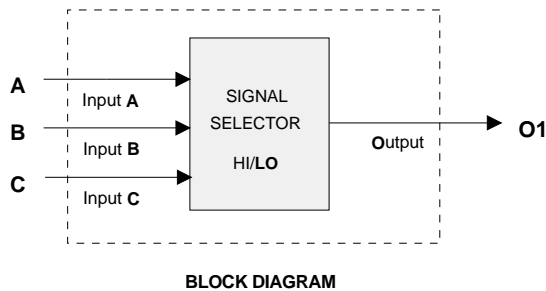

3.2.92 SETPT - Setpoint

SETPT function blocks can be used on a one per loop basis to permit operator adjustment of the controller setpoint within the loop. The on-line setpoint is adjustable, using the pulser knob, while <loop tag>.S is the displayed variable; unless the track command TC is high (1), at which time the setpoint will track the TV input.

A setpoint ramping feature allows the setpoint to ramp to a TARGET value. The start of a ramp can be initiated using a communication command asserting input SR high (the ramp starts on a positive transition of the SR input), or using the RAMP ON/OFF function in the QUICKSET mode. Both ramp RATE and ramp TIME can be set in configuration. Firmware 1.30 and higher sets the USE RATE default to NO; earlier versions are set at YES. Setting configuration parameter USE RATE to YES will cause the setpoint to change at the rate setting and ignore a configured ramp time. The RTIME or RRATE, TARGET, and PU SETPT values can be set using the QUICKSET feature if the QUICKSET parameter is set to YES.

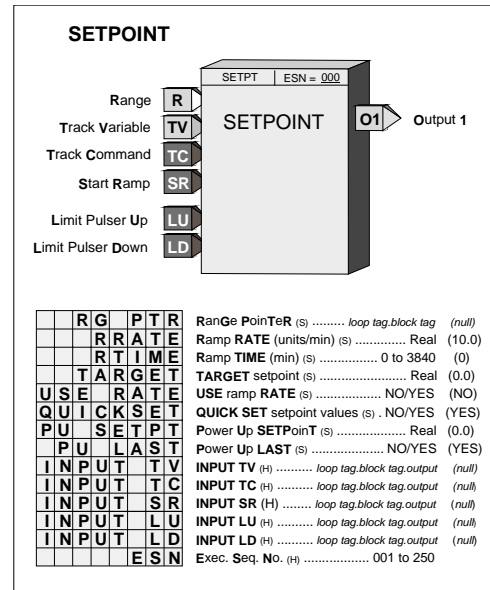

The RG PTR, range pointer, parameter determines the normal operating range of the function block. If the pointer is not configured the block will use 0.00 to 100.00. The range of the setpoint block will be limited to -10% to 110% of the range parameter. If a range change is made the current setpoint, ramp rate, target setpoint, and power up setpoint will be moved to be the same % values within the new range.

The setpoint block also has two inputs LU and LD that can be used to limit pulser changes in one direction. This can be used if another function block is limiting the setpoint and it is desired not to allow the operator to adjust the setpoint block to a value beyond the external limit.

POWER UP - The function block can be configured to power up in various conditions during a warm start. If the PU LAST parameter is set to YES, the block will power up with the last setpoint. When SETPT does not power up in last position or on a cold start, it will power up using the PU SETPT parameter.

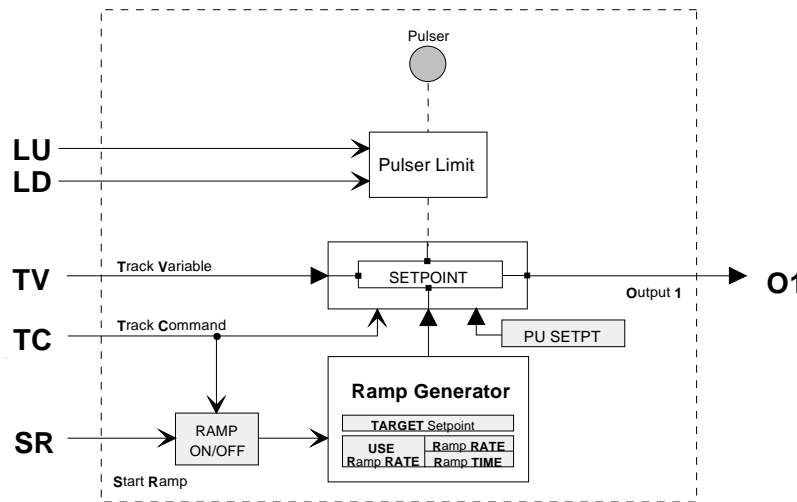

BLOCK DIAGM

3.2.93 SIN_ - SINE

SIN_ function blocks, included in firmware 1.30 and higher, accept a radian input and output the sine of that angle.

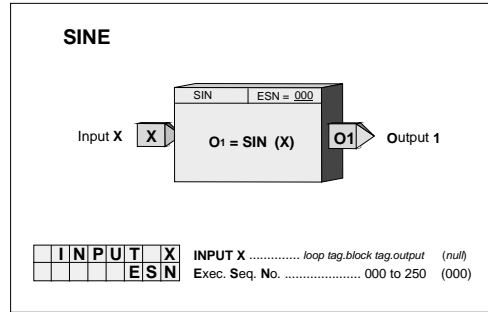
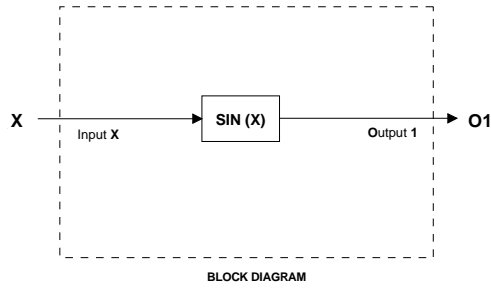

3.2.94 SPLIM - Setpoint Limit

SPLIM function blocks can be used on a one per loop basis to limit the setpoint of the loop controller. Input A will pass through the function block to output O1 unless it exceeds one of the limit settings at which time the block will output the limit value.

If the HI LIMIT is set lower than the LO LIMIT, the block will always output the high limit value.

Output status HS or LS will be high (1) if the block is in a limit condition. The status event 'S HI LIM' or 'S LO LIM' will be displayed in the alphanumeric if the SL PRIOR is greater than 0. A priority of 0 disables the reporting of the limit function and sets the bits in the status word to 0. See below for additional details regarding priorities.

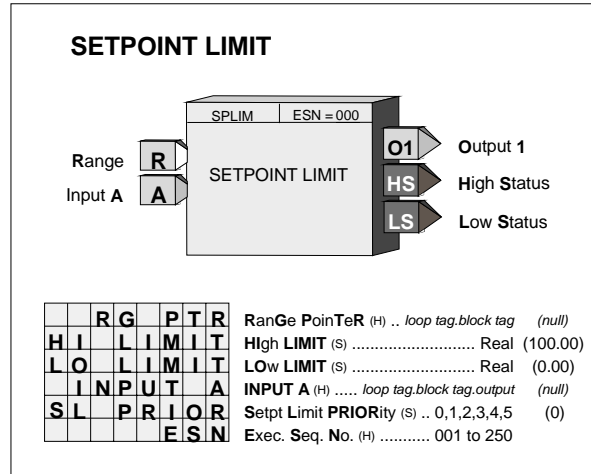

The SPLIM function block has an RG PTR parameter (input R) that defines the normal operating range of the block. Limit settings can be made within -10% to 110% of the range pointer values. If the range pointer is not configured, a range of 0.0 to 100.0 will be used. If a range change is made the current limit value will be moved to be the same % value within the new range.

PRIORITIES - The priority assigned to SL PRIOR will affect the operation as follows (the outputs HS and LS will go high with all priority assignments, including 0, when event is active):

1. Bargraphs, event LEDs, and condition will flash. ACK button must be used to stop flashing.
2. Bargraphs, event LEDs, and condition will flash. Flashing will stop if ACK or if event clears.
3. Event LEDs and condition will flash. ACK button must be used to stop flashing.
4. Event LEDs and condition will flash. Flashing will stop if ACK or event clears.
5. Event LEDs and condition will turn on when event is active and off when the event clears.
0. No display action occurs when event is active. The HL and LL status bits are always set to 0.

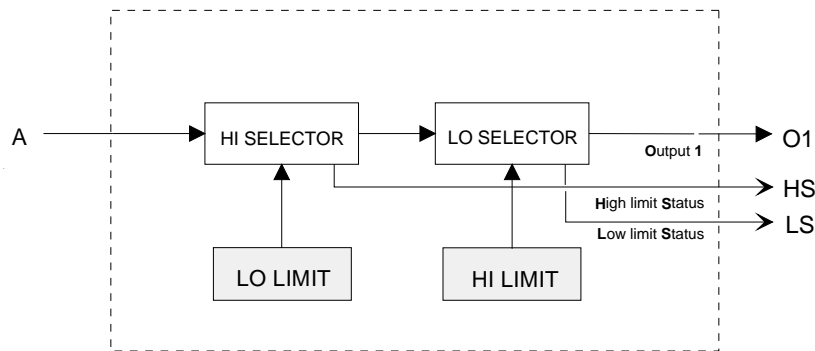

BLOCK DIAGRAM

3.2.95 SRF_ - SR Flip-Flop

SRF_ function blocks perform a set dominant flip-flop function as detailed in the truth table. An unused R input will be set high (1) and an unused S input will be set low (0).

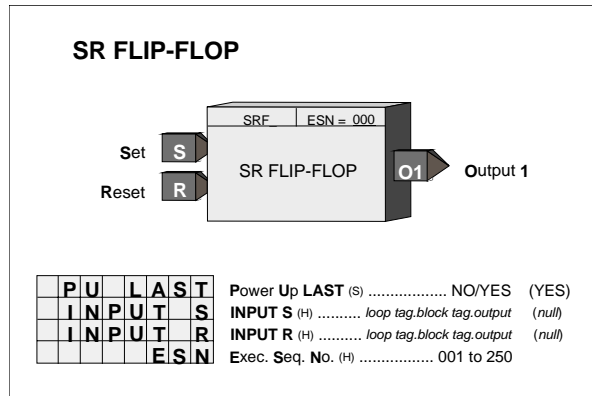
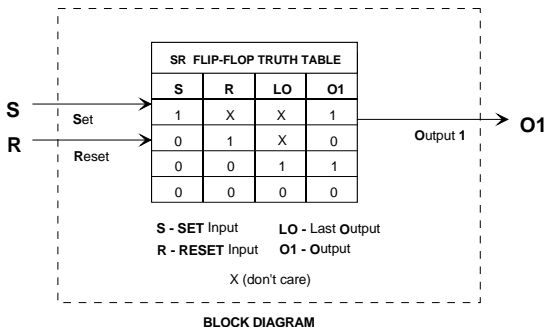

POWER UP - During a warm start, when PU LAST is set to YES, the block will initialize at the input/output states at the instant power down occurred. A cold start will initialize the input/output states to 0.

3.2.96 SRT_ - Square Root

SRT_ function blocks compute the square root of input signal A. The input has a built-in low limit that will limit the signal to the square root computation to 0.0.

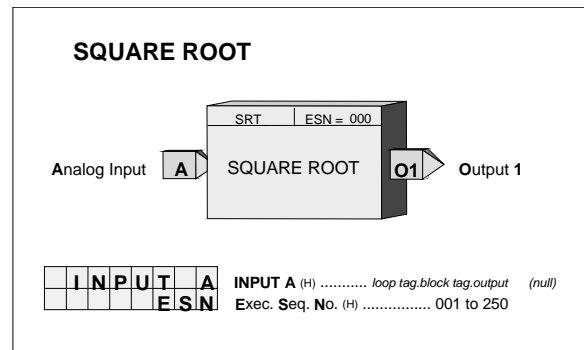
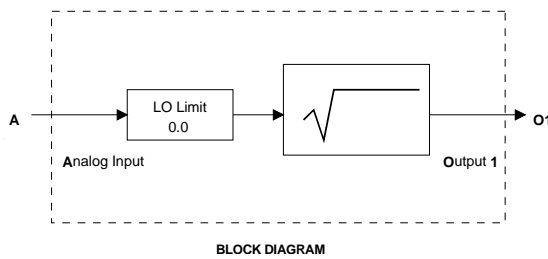

3.2.97 SUB_ - Subtraction

SUB_ function blocks perform arithmetic subtraction on the two input signals. Any unused input will be set to 0.0.

All inputs should have the same engineering units. If units are not consistent, a SCL function block can be used or an alternative is to use a MTH function block that has built-in scaling functions.

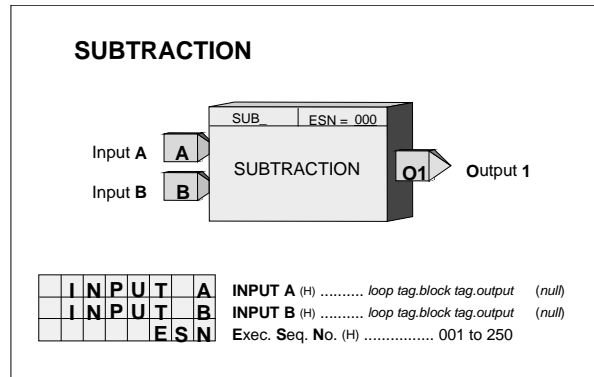
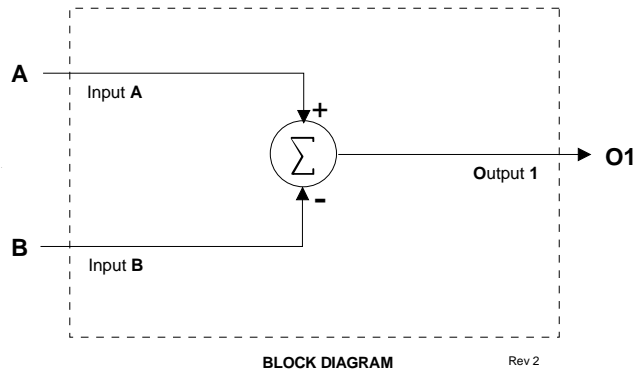

3.2.98 TAN_ - TANGENT

TAN_ function blocks, in firmware 1.30 and higher, accept a radian input and output the tangent of that angle.

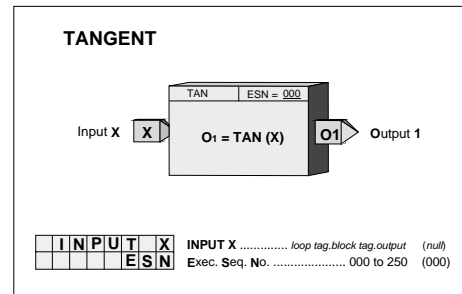
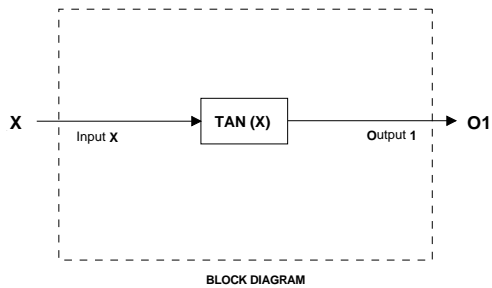

3.2.99 TH_ - Track & Hold

TH_ function blocks can hold an initial value that will transfer to the block output O1 on power up and it can be used to track the TV input when input TC is high (1).

In 1.30 firmware or greater, the HOLD value can be changed on line, using the pulser, when the TH_.O1 block output is directly connected to X or Y inputs in an ODC block. The range and resolution used by the pulser making on line changes will be determined by the X Range or Y Range inputs.

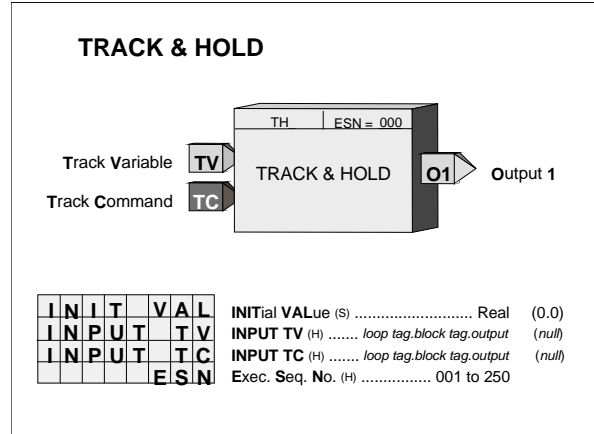
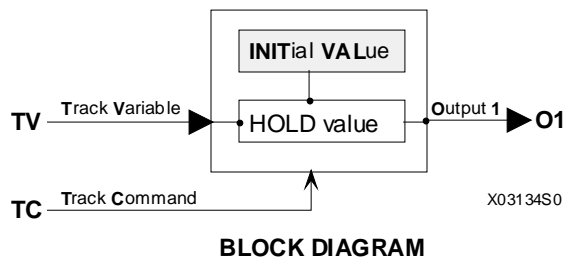

3.2.100 TOT_ - Totalizer (V2.3)

TOT_ function blocks accept a Boolean input and they will retain a running total of the input transitions as the block output as a real value for interconnection to other blocks in the controller. The running total can be reset when input R goes high (1). Input R is executed prior to reading input S on each scan cycle.

Unconfigured inputs will be set to 0. When the EDGETRIG parameter is set to 1, the total will increment on each 0 to 1 transition on input S. When the EDGETRIG parameter is set to 0, the total will increment on each 1 to 0 transition.

The total will be retained during a WARM & HOT start and will be initialized to 0.0 on a COLD start.

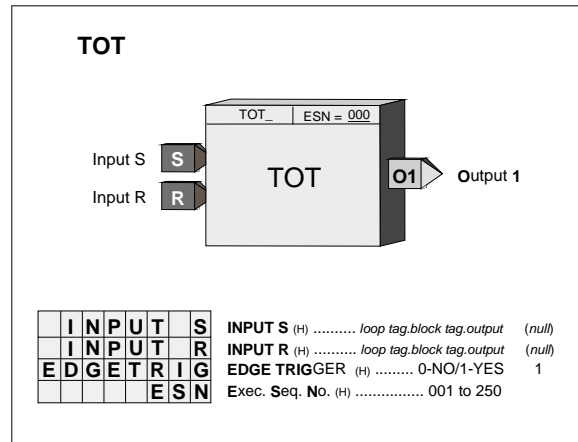
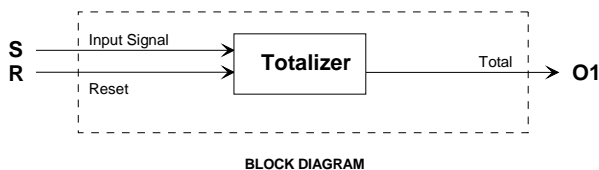

3.2.101 TSW_ - Transfer Switch

TSW_ function blocks select one of two analog input signals as the output signal. Input A becomes the output when input SC is low (0) and input B will be the output when input SC goes high (1).

Unconfigured inputs will default to SC=low(0), A=0.0, B=100.0.

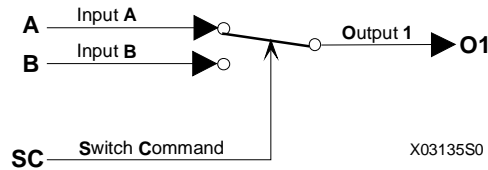

BLOCK DIAGRAM

TRANSFER SWITCH

I	N	P	U	T	A	INPUT A (H)	loop tag.block tag.output	(null)	
I	N	P	U	T	B	INPUT B (H)	loop tag.block tag.output	(null)	
I	N	P	U	T	S	C	INPUT SC (H)	loop tag.block tag.output	(null)
				E	S	N	Exec. Seq. No. (H)	001 to 250	

3.2.102 XOR_ - Exclusive OR Logic

XOR_ function blocks perform a logical exclusive OR function on all three inputs. An unused input will cause the block to function as a two input XOR. The XOR output will be low (0) when all configured inputs are low (0) or when all configured inputs are high (1).

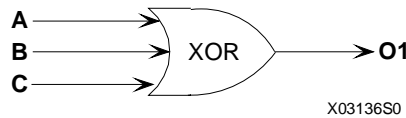

XOR TRUTH TABLE

A	B	C	Output 1
0	0	0	0
0	0	1	1
0	1	0	1
0	1	1	1
1	0	0	1
1	0	1	1
1	1	0	1
1	1	1	0

XOR

I	N	P	U	T	A	INPUT A (H)	loop tag.block tag.output	(null)
I	N	P	U	T	B	INPUT B (H)	loop tag.block tag.output	(null)
I	N	P	U	T	C	INPUT C (H)	loop tag.block tag.output	(null)
				E	S	N	Exec. Seq. No. (H)	001 to 250

4.0 FACTORY CONFIGURED OPTIONS

Factory Configured Options provide an easy way to configure a Model 352Plus™, Model 353, or Model 354. In most cases a Factory Configured Option (FCO) will provide a complete, functional loop controller, once the proper I/O connections are made. Changes can be made to an FCO to meet individual requirements. The FCO listings on the following pages document the parameters that differ from the default values listed in Section 3 Function Blocks. Some things to keep in mind when making changes are:

- a) All analog signals have been configured for an engineering range of 0.00 to 100.00. In most cases, converting to other engineering units will only require changing the range at the source (e.g. Analog Input function block). All other blocks (i.e. Controller, Operator Display, Alarm, and Setpoint) that require knowledge of the range have range pointers that point to the signal source (e.g. Analog Input block) for this information.
- b) A number of function blocks have parameters that may be affected by range pointers. The range pointer limits the setting of parameter values to within -10% to 110% of the range. If a range is changed, the current parameter values will be changed to the same % within the new range. For example, if the range is 0.0-100.0 and the Alarm 1 Limit setting is 90.0 and the range is changed to 400.0-500.0 the alarm setting will be changed to 490.0.
- c) All controller (ID, PID, PD, PIDAG) outputs have an engineering range of 0.0-100.0 which will be satisfactory in most cases since outputs normally convert to a 4-20 mA signal to drive a valve 0-100% Open or Closed. However, when a controller is used in a cascade configuration, the primary controller output must be configured for the same engineering range as the secondary controller process.
- d) FCOs do not change Station parameters or calibration.
- e) FCO 0 deletes all loops and set all parameters in the STATN & SECUR function blocks to default values. Calibration is not affected. As new loops and function blocks are added, parameters will appear at default values.

4.1 FCO101 - Single Loop Controller w/ Tracking Setpoint

Factory Configured Option FCO101 provides a single loop controller configured in Loop01. A block diagram of the loop configuration is shown below along with any *changes* to the default parameter values of the configured blocks. This configuration provides setpoint tracking which will cause the setpoint to track the process when the loop is not in Auto (NA). If the loop tag 'Loop01' is changed, all configured references within the station will automatically be changed to the new tag.

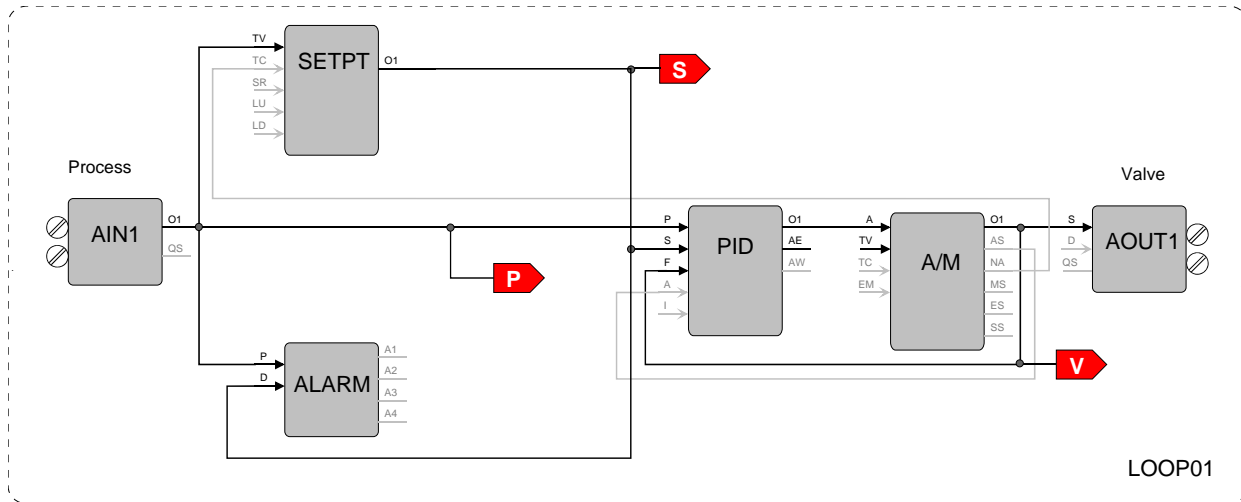

SETPT - Setpoint Function Block

RG PTR - Range Pointer ----- Loop01.AIN1.OR
 INPUT TV - Input TV ----- Loop01.AIN1.O1
 INPUT TC - Input TC ----- Loop01.A/M.NA
 ESN - Exec. Seq. No.----- 5

ALARM - Alarm Function Block

RG PTR - Range Pointer ----- Loop01.AIN1.OR
 INPUT P - Input P ----- Loop01.AIN1.O1
 INPUT D - Input D ----- Loop01.SETPT.O1
 ESN - Exec. Seq. No. ----- 10

PID - PID Controller Function Block

RG PTR - Range Pointer ----- Loop01.AIN1.OR
 INPUT P - Input P ----- Loop01.AIN1.O1
 INPUT S - Input S ----- Loop01.SETPT.O1
 INPUT F - Input F ----- Loop01.A/M.O1
 INPUT A - Input A ----- Loop01.A/M.AS
 ESN - Exec. Seq. No.----- 15

A/M - Auto/Manual Function Block

RG PTR - Range Pointer ----- Loop01.PID.OR
 INPUT A - Input A ----- Loop01.PID.O1
 ESN - Exec. Seq. No. ----- 20

AOUT1 - Analog Output 1 Function Block

RG PTR - Range Pointer ----- Loop01.PID.OR
 INPUT S - Input S ----- Loop01.A/M.O1

ODC - Operator Display for Controllers

P RG PTR - P Range Pointer ----- Loop01.AIN1.OR
 V RG PTR - V Range Pointer ----- Loop01.PID.OR
 INPUT P - Input P (Process) ----- Loop01.AIN1.O1
 INPUT S - Input S (Setpoint) ----- Loop01.SETPT.O1
 INPUT V - Input V (Valve) ----- Loop01.A/M.O1
 LOOP #- Loop # ----- 01

4.2 FCO102 - Single Loop Controller w/ Fixed Setpoint

Factory Configured Option FCO102 provides a single loop controller configured in Loop01. A block diagram of the loop configuration is shown below along with any *changes* to the default parameter values of the configured blocks. If the loop tag 'Loop01' is changed, all configured references within the station will automatically be changed to the new tag.

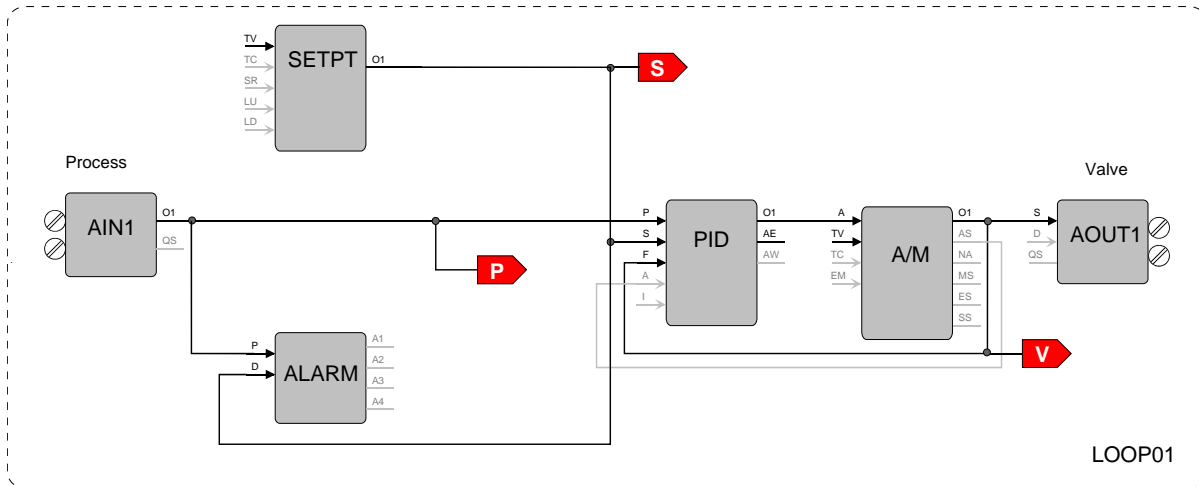

SETPT - Setpoint Function Block

RG PTR - Range Pointer ----- Loop01.AIN1.OR
 ESN - Exec. Seq. No.----- 5

ALARM - Alarm Function Block

RG PTR - Range Pointer ----- Loop01.AIN1.OR
 INPUT P - Input P ----- Loop01.AIN1.O1
 INPUT D - Input D ----- Loop01.SETPT.O1
 ESN - Exec. Seq. No. ----- 10

PID - PID Controller Function Block

RG PTR - Range Pointer ----- Loop01.AIN1.OR
 INPUT P - Input P ----- Loop01.AIN1.O1
 INPUT S - Input S ----- Loop01.SETPT.O1
 INPUT F - Input F ----- Loop01.A/M.O1
 INPUT A - Input A ----- Loop01.A/M.AS
 ESN - Exec. Seq. No.----- 15

A/M - Auto/Manual Function Block

RG PTR - Range Pointer ----- Loop01.PID.OR
 INPUT A - Input A ----- Loop01.PID.O1
 ESN - Exec. Seq. No. ----- 20

AOOUT1 - Analog Output 1 Function Block

RG PTR - Range Pointer ----- Loop01.PID.OR
 INPUT S - Input S ----- Loop01.A/M.O1

ODC - Operator Display for Controllers

P RG PTR - P Range Pointer ----- Loop01.AIN1.OR
 V RG PTR - V Range Pointer ----- Loop01.PID.OR
 INPUT P - Input P (Process) ----- Loop01.AIN1.O1
 INPUT S - Input S (Setpoint) ----- Loop01.SETPT.O1
 INPUT V - Input V (Valve) ----- Loop01.A/M.O1
 LOOP # - Loop # ----- 01

4.3 FCO103 - External Set Controller with Tracking Local Setpoint

Factory Configured Option FCO103 provides a single loop controller with external setpoint configured in Loop01. A block diagram of the loop configuration is shown below along with any *changes* to the default parameter values of the configured blocks. This configuration provides setpoint tracking. If a fixed setpoint is desired, the TC input to the SETPT function block can be set to UNCONFIG. If the loop tag 'LOOP01' is changed, all configured references will automatically be changed to the new tag.

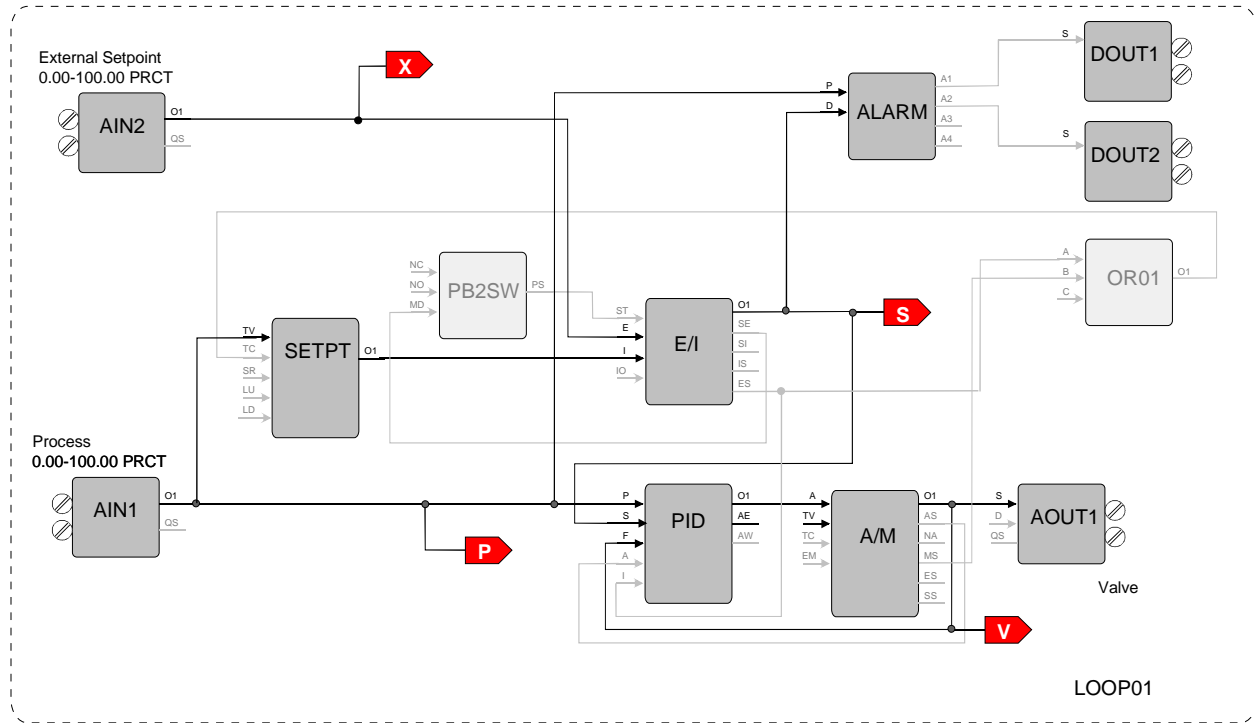

SETPT - Setpoint Function Block

RG PTR - Range Pointer ----- Loop01.AIN1.OR
 INPUT TV - Input TV ----- Loop01.AIN1.O1
 INPUT TC - Input TC ----- Loop01.OR01.O1
 ESN - Exec. Seq. No.----- 10

PB2SW - PB2 Switch Function Block

INPUT MD - Input MD ----- Loop01.E/I.SE
 ESN - Exec. Seq. No. ----- 5

ALARM - Alarm Function Block

RG PTR - Range Pointer ----- Loop01.AIN1.OR
 INPUT P - Input P ----- Loop01.AIN1.O1
 INPUT D - Input D ----- Loop01.E/I.O1
 ESN - Exec. Seq. No. ----- 20

PID - PID Controller Function Block

RG PTR - Range Pointer ----- Loop01.AIN1.OR
 INPUT P - Input P ----- Loop01.AIN1.O1
 INPUT S - Input S ----- Loop01.E/I.O1
 INPUT F - Input F ----- Loop01.A/M.O1
 INPUT A - Input A ----- Loop01.A/M.AS
 INPUT I - Input I ----- Loop01.E/I.ES
 ESN - Exec. Seq. No.----- 25

E/I - Ext/Int Transfer Switch Function Block

INPUT ST - Input ST ----- Loop01.PB2SW.PS
 INPUT E - Input E ----- Loop01.AIN2.O1
 INPUT I - Input I ----- Loop01.SETPT.O1
 ESN - Exec. Seq. No. ----- 15

A/M - Auto/Manual Function Block

RG PTR - Range Pointer ----- Loop01.PID.OR
 INPUT A - Input A ----- Loop01.PID.O1
 ESN - Exec. Seq. No. ----- 30

OR01 - OR Function Block

INPUT A - Input A ----- Loop01.E/I.ES
 INPUT B - Input B ----- Loop01.A/M.MS
 ESN - Exec. Seq. No. ----- 35

AOUT1 - Analog Output 1 Function Block

RG PTR - Range Pointer ----- Loop01.PID.OR
 INPUT S - Input S ----- Loop01.A/M.O1

ODC - Operator Display for Controllers

P RG PTR - P Range Pointer ----- Loop01.AIN1.OR
V RG PTR - V Range Pointer ----- Loop01.PID.OR
X RG PTR - X Range Pointer ----- Loop01.AIN2.OR
INPUT P - Input P (Process) ----- Loop01.AIN1.O1
INPUT S - Input S (Setpoint) ----- Loop01.E/I.O1
INPUT V - Input V (Valve) ----- Loop01.A/M.O1
INPUT X - Input X (X-Variable) - Loop01.AIN2.O1
LOOP # - Loop # ----- 01

DOUT1 - Digital Output 1 Function Block

INPUT S - Input S ----- Loop01.ALARM.A1

DOUT2 - Digital Output 2 Function Block

INPUT S - Input S ----- Loop01.ALARM.A2

4.4 FCO104 - External Set Controller with Non-Tracking Local Setpoint

Factory Configured Option FCO104 provides a single loop controller with external setpoint configured in Loop01. A block diagram of the loop configuration is shown below along with any *changes* to the default parameter values of the configured blocks. If the loop tag 'LOOP01' is changed, all configured references will automatically be changed to the new tag.

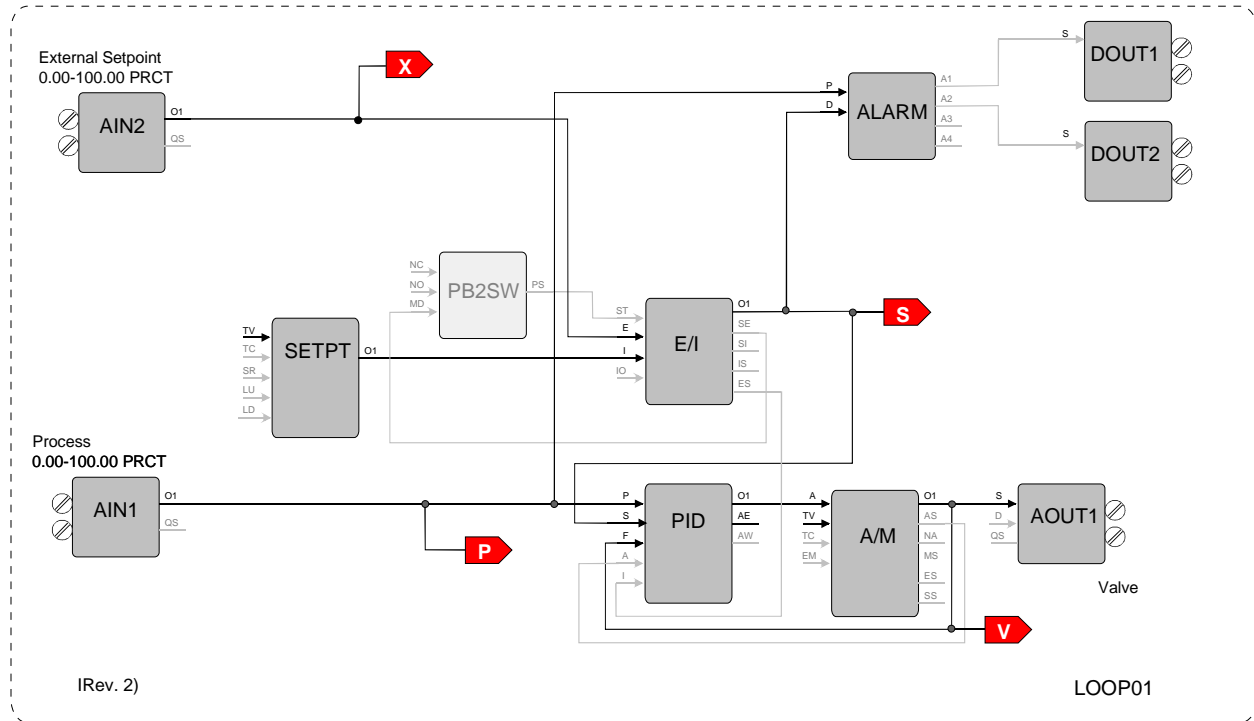

PB2SW - PB2 Switch Function Block

INPUT MD - Input MD ----- Loop01.E/I.SE
 ESN - Exec. Seq. No. ----- 5

ALARM - Alarm Function Block

RG PTR - Range Pointer ----- Loop01.AIN1.OR
 INPUT P - Input P ----- Loop01.AIN1.O1
 INPUT D - Input D ----- Loop01.E/I.O1
 ESN - Exec. Seq. No. ----- 20

PID - PID Controller Function Block

RG PTR - Range Pointer ----- Loop01.AIN1.OR
 INPUT P - Input P ----- Loop01.AIN1.O1
 INPUT S - Input S ----- Loop01.E/I.O1
 INPUT F - Input F ----- Loop01.A/M.O1
 INPUT A - Input A ----- Loop01.A/M.AS
 INPUT I - Input I ----- Loop01.E/I.ES
 ESN - Exec. Seq. No.----- 25

E/I - Ext/Int Transfer Switch Function Block

INPUT ST - Input ST ----- Loop01.PB2SW.PS
 INPUT E - Input E ----- Loop01.AIN2.O1
 INPUT I - Input I ----- Loop01.SETPT.O1
 ESN - Exec. Seq. No. ----- 15

A/M - Auto/Manual Function Block

RG PTR - Range Pointer ----- Loop01.PID.OR
 INPUT A - Input A ----- Loop01.PID.O1
 ESN - Exec. Seq. No. ----- 30

SETPT - Setpoint Function Block

RG PTR - Range Pointer ----- Loop01.AIN1.OR
 ESN - Exec. Seq. No. ----- 10

AOUT1 - Analog Output 1 Function Block

RG PTR - Range Pointer ----- Loop01.PID.OR
 INPUT S - Input S ----- Loop01.A/M.O1

ODC - Operator Display for Controllers

P RG PTR - P Range Pointer ----- Loop01.AIN1.OR
V RG PTR - V Range Pointer ----- Loop01.PID.OR
X RG PTR - X Range Pointer ----- Loop01.AIN2.OR
INPUT P - Input P (Process) ----- Loop01.AIN1.O1
INPUT S - Input S (Setpoint) ----- Loop01.E/I.O1
INPUT V - Input V (Valve) ----- Loop01.A/M.O1
INPUT X - Input X (X-Variable) - Loop01.AIN2.O1
LOOP # - Loop # ----- 01

DOU1 - Digital Output 1 Function Block

INPUT S - Input S ----- Loop01.ALARM.A1

DOU2 - Digital Output 2 Function Block

INPUT S - Input S ----- Loop01.ALARM.A2

PID - PID Controller Function Block

RG PTR - Range Pointer ----- Loop01.AIN2.OR
 INPUT P - Input P ----- Loop01.AIN2.O1
 INPUT S - Input S ----- Loop01.SPLIM.O1
 INPUT F - Input F ----- Loop01.A/M.O1
 INPUT A - Input A ----- Loop01.A/M.AS
 INPUT I - Input I ----- Loop01.E/I.ES
 ESN - Exec. Seq. No.----- 35

A/M - Auto/Manual Function Block

RG PTR - Range Pointer ----- Loop01.PID.OR
 INPUT P - Input A ----- Loop01.PID.O1
 ESN - Exec. Seq. No. ----- 40

AOUT1 - Analog Output 1 Function Block

RG PTR - Range Pointer ----- Loop01.PID.OR
 INPUT S - Input S ----- Loop01.A/M.O1

ODC - Operator Display for Controllers

P RG PTR - P Range Pointer ----- Loop01.AIN2.OR
 V RG PTR - V Range Pointer ----- Loop01.PID.OR
 X RG PTR - X Range Pointer ----- Loop01.AIN1.OR
 Y RG PTR - Y Range Pointer ----- Loop01.SCL01.OR
 INPUT P - Input P (Process) ----- Loop01.AIN2.O1
 INPUT S - Input S (Setpoint) ----- Loop01.SPLIM.O1
 INPUT V - Input V (Valve) ----- Loop01.A/M.O1
 INPUT X - Input X (X-Variable) - Loop01.AIN1.O1
 INPUT Y - Input Y (Y-Variable)-- Loop01.DIV01.O1
 LOOP # - Loop # ----- 01

DIV01 - Division Function Block

INPUT N - Input N ----- Loop01.AIN2.O1
 INPUT D - Input D ----- Loop01.AIN1.O1
 ESN - Exec. Seq. No. ----- 45

SCL01 - Scaler Function Block

MINSCALE - Output MIN ----- 0.50
 MAXSCALE - Output MAX ----- 1.50
 ENGUNITS - ENGiNEERING UNITS ---CF/WF
 ESN - Exec. Seq. No. ----- 50

OR01 - OR Function Block

INPUT A - Input A ----- Loop01.A/M.NA
 INPUT B - Input B ----- Loop01.E/I.IS
 ESN - Exec. Seq. No. ----- 55

OR02 - OR Function Block

INPUT A - Input A ----- Loop01.A/M.NA
 INPUT B - Input B ----- Loop01.E/I.ES
 ESN - Exec. Seq. No. ----- 60

4.6 FCO106 - Single Loop Controller w/ Operator Setpoint Limits

Factory Configured Option FCO106 provides a single loop controller configured in Loop01. This is similar to FCO101 but with a SPLIM block added to the output of the SETPT block. A block diagram of the loop configuration is shown below along with any *changes* to the default parameter values of the configured blocks. This configuration provides setpoint tracking. If a fixed setpoint is desired, the TC input to the SETPT function block can be set to UNCONFIG. If the loop tag 'LOOP01' is changed, all configured references will automatically be changed to the new tag.

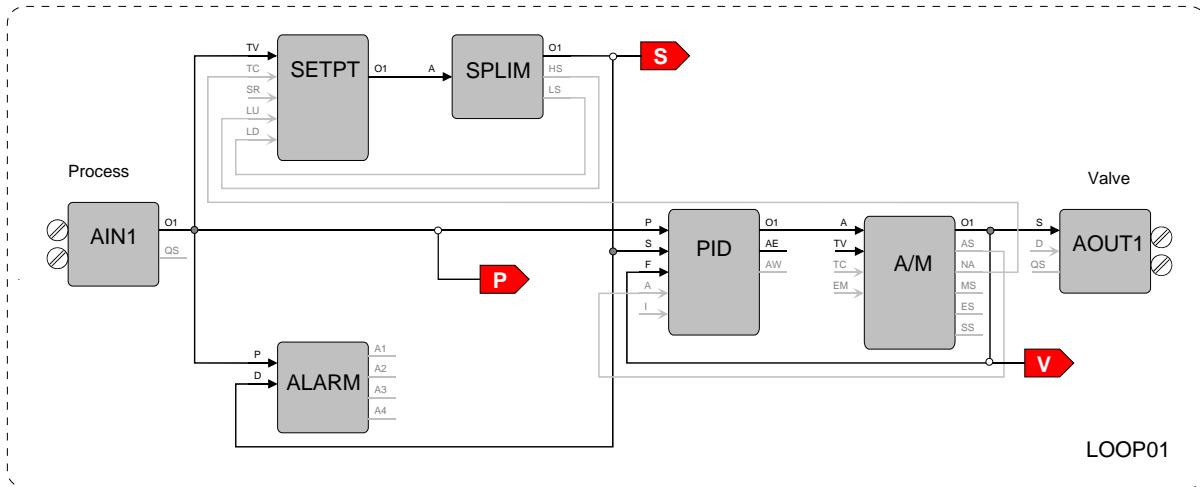

SETPT - Setpoint Function Block
 RG PTR - Range Pointer ----- Loop01.AIN1.OR
 INPUT TV - Input TV ----- Loop01.AIN1.O1
 INPUT TC - Input TC ----- Loop01.A/M.NA
 INPUT LU - Input LU ----- Loop01.SPLIM.HS
 INPUT LD - Input LD ----- Loop01.SPLIM.LS
 ESN - Exec. Seq. No.----- 5

SPLIM - Setpoint Limit Function Block
 RG PTR - Range Pointer ----- Loop01.AIN1.OR
 INPUT A - Input A ----- Loop01.SETPT.O1
 ESN - Exec. Seq. No. ----- 10

ALARM - Alarm Function Block
 RG PTR - Range Pointer ----- Loop01.AIN1.OR
 INPUT P - Input P ----- Loop01.AIN1.O1
 INPUT D - Input D ----- Loop01.SPLIM.O1
 ESN - Exec. Seq. No. ----- 15

PID - PID Controller Function Block
 RG PTR - Range Pointer - _----- Loop01.AIN1.OR
 INPUT P - Input P ----- Loop01.AIN1.O1
 INPUT S - Input S ----- Loop01.SPLIM.O1
 INPUT F - Input F ----- Loop01.A/M.O1
 INPUT A - Input A ----- Loop01.A/M.AS
 ESN - Exec. Seq. No.----- 20

A/M - Auto/Manual Function Block
 RG PTR - Range Pointer ----- Loop01.PID.OR
 INPUT A - Input A ----- Loop01.PID.O1
 ESN - Exec. Seq. No. ----- 25

AOUT1 - Analog Output 1 Function Block
 RG PTR - Range Pointer ----- Loop01.PID.OR
 INPUT S - Input S ----- Loop01.A/M.O1

ODC - Operator Display for Controllers
 P RG PTR - P Range Pointer ----- Loop01.AIN1.OR
 V RG PTR - V Range Pointer ----- Loop01.PID.OR
 INPUT P - Input P (Process) ----- Loop01.AIN1.O1
 INPUT S - Input S (Setpoint) ----- Loop01.SPLIM.O1
 INPUT V - Input V (Valve) ----- Loop01.A/M.O1
 LOOP # - Loop # ----- 01

4.7 FCO107 - Dual Loop Controller

Factory Configured Option FCO107 provides two independent loops with tracking setpoints. The block diagram of the configuration of the two loops is shown below along with the *changes* made to the default parameter values of the configured blocks. This configuration provides setpoint tracking. If a fixed setpoint is desired, the TC input to the SETPT function block can be set to UNCONFIG. The process range of the first loop can be changed in Analog Input 1 and the range of the Second loop in Analog Input 2.

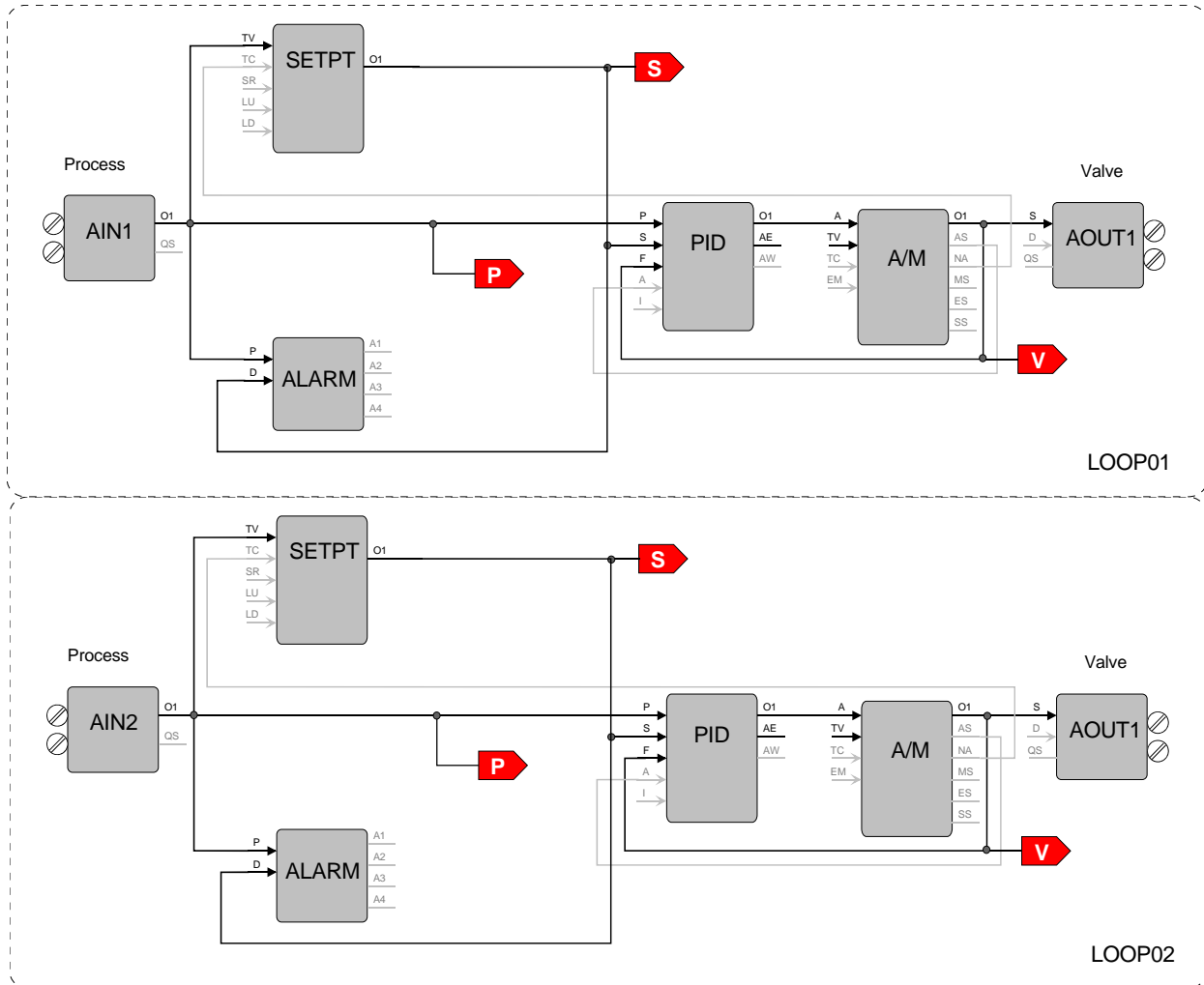

Loop 01

SETPT - Setpoint Function Block

RG PTR - Range Pointer ----- LOOP01.AIN1.OR
 INPUT TV - Input TV ----- LOOP01.AIN1.O1
 INPUT TC - Input TC ----- LOOP01.A/M.NA
 ESN - Exec. Seq. No.----- 5

ALARM - Alarm Function Block

RG PTR - Range Pointer ----- LOOP01.AIN1.OR
 INPUT P - Input P ----- LOOP01.AIN1.O1
 INPUT D - Input D ----- LOOP01.SETPT.O1
 ESN - Exec. Seq. No. ----- 10

PID - PID Controller Function Block

RG PTR - Range Pointer ----- LOOP01..AIN1.OR
 INPUT P - Input P ----- LOOP01.AIN1.O1
 INPUT S - Input S ----- LOOP01.SETPT.O1
 INPUT F - Input F ----- LOOP01.A/M.O1
 INPUT A - Input A ----- LOOP01..A/M.AS
 ESN - Exec. Seq. No.----- 15

A/M - Auto/Manual Function Block

RG PTR - Range Pointer ----- LOOP01.PID.OR
 INPUT A - Input A ----- LOOP01.PID.O1
 ESN - Exec. Seq. No. ----- 20

Loop 01 (cont)**ODC - Operator Display for Controllers**

P RG PTR - P Range Pointer ----- LOOP01.AIN1.OR
V RG PTR - V Range Pointer ---- LOOP01.PID.OR
INPUT P - Input P (Process) ----- LOOP01.AIN1.O1
INPUT S - Input S (Setpoint) ---- LOOP01.SETPT.O1
INPUT V - Input V (Valve) ----- LOOP01.A/M.O1
LOOP # - Loop# ----- 01

AOUT1 - Analog Output 1 Function Block

RG PTR - Range Pointer ----- LOOP01.PID.OR
INPUT S - Input S ----- LOOP01.A/M.O1

Loop 02**SETPT - Setpoint Function Block**

RG PTR - Range Pointer ----- LOOP02.AIN2.OR
INPUT TV - Input TV ----- LOOP02.AIN2.O1
INPUT TC - Input TC ----- LOOP02.A/M.O1
ESN - Exec. Seq. No.----- 5

ALARM - Alarm Function Block

RG PTR - Range Pointer ----- LOOP02.AIN2.OR
INPUT P - Input P ----- LOOP02.AIN2.O1
INPUT D - Input D ----- LOOP02.SETPT.O1
ESN - Exec. Seq. No. ----- 10

PID - PID Controller Function Block

RG PTR - Range Pointer ----- LOOP02.AIN2.OR
INPUT P - Input P ----- LOOP02.AIN2.O1
INPUT S - Input S ----- LOOP02.SETPT.O1
INPUT F - Input F ----- LOOP02.A/M.O1
INPUT A - Input A ----- LOOP02.A/M.AS
ESN - Exec. Seq. No.----- 15

A/M - Auto/Manual Function Block

RG PTR - Range Pointer ----- LOOP02.PID.OR
INPUT A - Input A ----- LOOP02.PID.O1
ESN - Exec. Seq. No. ----- 20

ODC - Operator Display for Controllers

P RG PTR - P Range Pointer ----- LOOP02.AIN2.OR
V RG PTR - V Range Pointer ---- LOOP02.PID.OR
INPUT P - Input P (Process) ----- LOOP02.AIN2.O1
INPUT S - Input S (Setpoint) ---- LOOP02.SETPT.O1
INPUT V - Input V (Valve) ----- LOOP02.A/M.O1
LOOP # - Loop # ----- 02

AOUT2 - Analog Output 2 Function Block

RG PTR - Range Pointer ----- LOOP02.PID.OR
INPUT S - Input S ----- LOOP02.A/M.O1

4.8 FCO121 - Cascade Control

Factory Configured Option FCO121 provides two loops configured for Cascade control. The block diagram of the configuration of the two loops is shown below along with the *changes* made to the default parameter values of the configured blocks. The process range of the Primary loop can be changed in Analog Input 1 and the range of the Secondary loop in Analog Input 2. Also, the output range of the primary PID controller must be changed to match any new range in the secondary loop. If the loop tag 'PRIM' or 'SEC' is changed, all configured references will automatically be changed to the new tag.

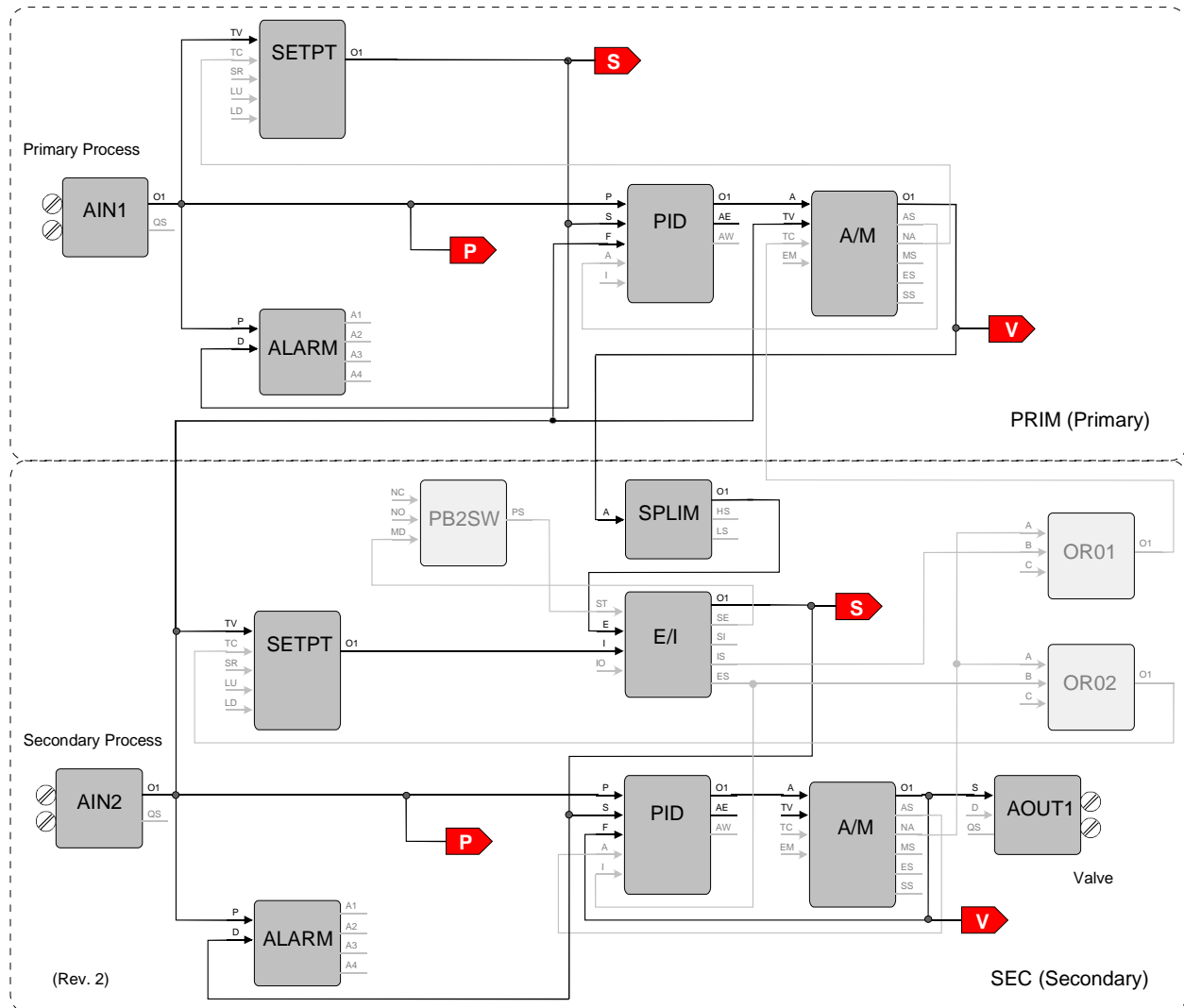

Primary Loop

SETPT - Setpoint Function Block
 RG PTR - Range Pointer ----- PRIM.AIN1.OR
 INPUT TV - Input TV ----- PRIM.AIN1.O1
 INPUT TC - Input TC ----- PRIM.A/M.NA
 ESN - Exec. Seq. No.----- 5

ALARM - Alarm Function Block
 RG PTR - Range Pointer ----- PRIM.AIN1.OR
 INPUT P - Input P ----- PRIM.AIN1.O1
 INPUT D - Input D ----- PRIM.SETPT.O1
 ESN - Exec. Seq. No. ----- 10

Primary Loop (cont)**PID - PID Controller Function Block**

RG PTR - Range Pointer ----- PRIM.AIN1.OR
 INPUT P - Input P ----- PRIM.AIN1.O1
 INPUT S - Input S ----- PRIM.SETPT.O1
 INPUT F - Input F ----- SEC.AIN2.O1
 INPUT A - Input A ----- PRIM.A/M.AS
 ESN - Exec. Seq. No.----- 15

A/M - Auto/Manual Function Block

RG PTR - Range Pointer ----- PRIM.PID.OR
 INPUT A - Input A ----- PRIM.PID.O1
 INPUT TV - Input TV ----- SEC.AIN2.O1
 INPUT TC - Input TC ----- SEC.OR01.O1
 ESN - Exec. Seq. No. ----- 20

ODC - Operator Display for Controllers

P RG PTR - P Range Pointer ---- PRIM.AIN1.OR
 V RG PTR - V Range Pointer ---- PRIM.PID.OR
 INPUT P - Input P (Process) ---- PRIM.AIN1.O1
 INPUT S - Input S (Setpoint) ---- PRIM.SETPT.O1
 INPUT V - Input V (Valve) ----- PRIM.A/M.O1
 LOOP# - Loop # ----- 01

Secondary Loop**SETPT - Setpoint Function Block**

RG PTR - Range Pointer ----- SEC.AIN2.OR
 INPUT TV - Input TV ----- SEC.AIN2.O1
 INPUT TC - Input TC ----- SEC.OR02.O1
 ESN - Exec. Seq. No.----- 5

ALARM - Alarm Function Block

RG PTR - Range Pointer ----- SEC.AIN2.OR
 INPUT P - Input P ----- SEC.AIN2.O1
 INPUT D - Input D ----- SEC.E/I.O1
 ESN - Exec. Seq. No. ----- 10

PB2SW - PB2 Switch Function Block

INPUT MD - Input MD ----- SEC.E/I.SE
 ESN - Exec. Seq. No. ----- 15

SPLIM - Setpoint Limit Function Block

RG PTR - Range Pointer ----- SEC.AIN2.OR
 INPUT A - Input A ----- PRIM.A/M.O1
 ESN - Exec. Seq. No. ----- 20

E/I - Ext/Int Transfer Switch Function Block

INPUT ST - Input ST ----- SEC.PB2SW.PS
 INPUT E - Input E ----- SEC.SPLIM.O1
 INPUT I - Input I ----- SEC.SETPT.O1
 ESN - Exec. Seq. No. ----- 25

PID - PID Controller Function Block

RG PTR - Range Pointer ----- SEC.AIN2.OR
 INPUT P - Input P ----- SEC.AIN2.O1
 INPUT S - Input S ----- SEC.E/I.O1
 INPUT F - Input F ----- SEC.A/M.O1
 INPUT A - Input A ----- SEC.A/M.AS
 INPUT I - Input I ----- SEC.E/I.ES
 ESN - Exec. Seq. No.----- 30

A/M - Auto/Manual Function Block

RG PTR - Range Pointer ----- SEC.PID.OR
 INPUT P - Input A ----- SEC.PID.O1
 ESN - Exec. Seq. No. ----- 35

OR01 - OR Function Block

INPUT A - Input A ----- SEC.A/M.NA
 INPUT B - Input B ----- SEC.E/I.IS
 ESN - Exec. Seq. No. ----- 40

OR02 - OR Function Block

INPUT A - Input A ----- SEC.A/M.NA
 INPUT B - Input B ----- SEC.E/I.ES
 ESN - Exec. Seq. No. ----- 45

AOUT1 - Analog Output 1 Function Block

RG PTR - Range Pointer ----- SEC.PID.OR
 INPUT S - Input S ----- SEC.A/M.O1

ODC - Operator Display for Controllers

P RG PTR - P Range Pointer ---- SEC.AIN2.OR
 V RG PTR - V Range Pointer ---- SEC.PID.OR
 INPUT P - Input P (Process) ---- SEC.AIN2.O1
 INPUT S - Input S (Setpoint) ---- SEC.E/I.O1
 INPUT V - Input V (Valve) ----- SEC.A/M.O1
 LOOP # - Loop # ----- 02

4.9 FCO122 - Cascade Control w/ Operator Setpoint Limits

Factory Configured Option FCO122 provides two loops configured for Cascade control. The block diagram of the configuration of the two loops is shown below along with the *changes* made to the default parameter values of the configured blocks. The process range of the Primary loop can be changed in Analog Input 1 and the range of the Secondary loop in Analog Input 2. Also, the output range of the primary PID controller must be changed to match any new range in the secondary loop. If the loop tag 'PRIM' or 'SEC' is changed, all configured references will automatically be changed to the new tag.

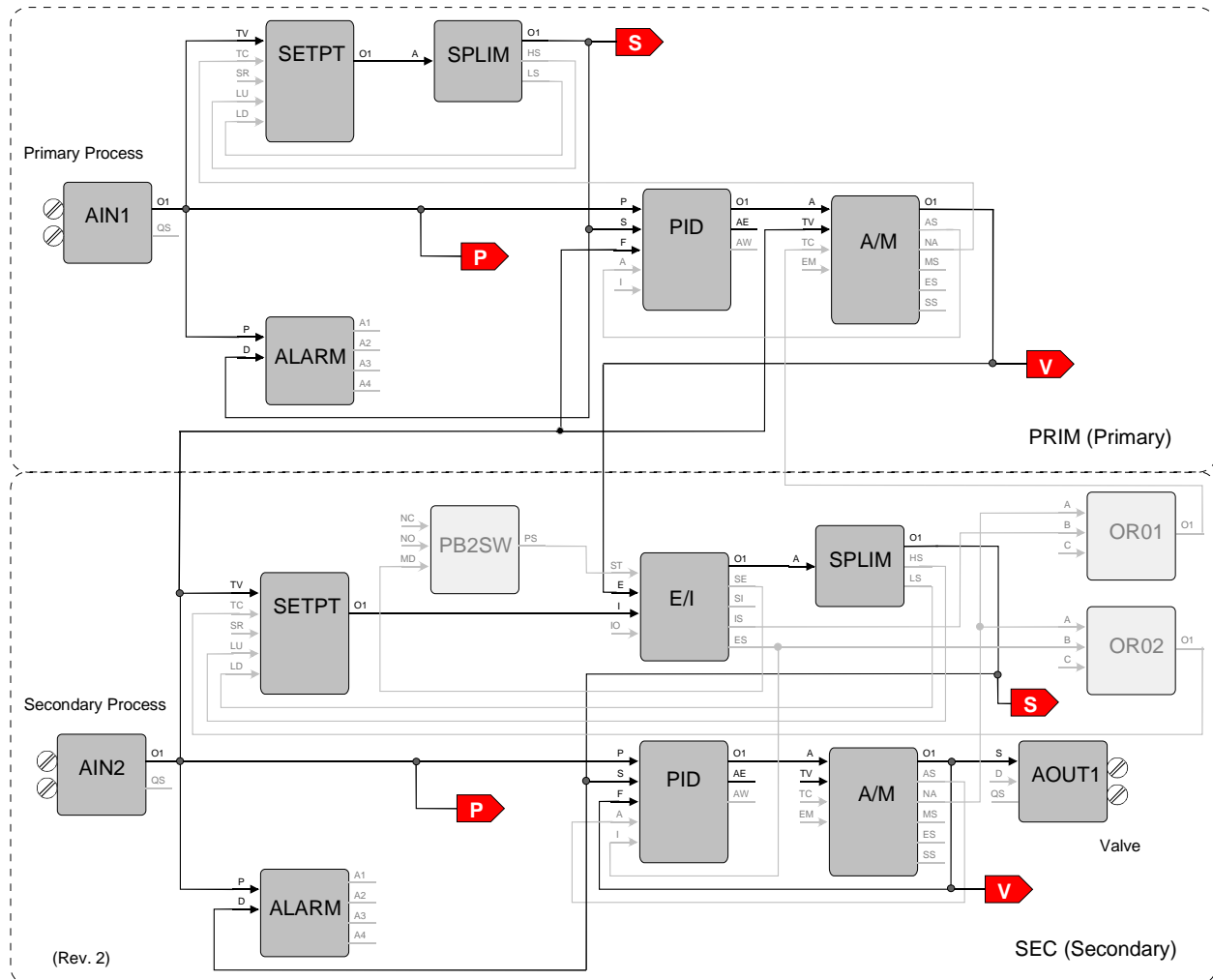

Primary Loop

SETPT - Setpoint Function Block
 RG PTR - Range Pointer ----- PRIM.AIN1.OR
 INPUT TV - Input TV ----- PRIM.AIN1.O1
 INPUT TC - Input TC ----- PRIM.A/M.NA
 INPUT LU - Input LU ----- PRIM.SPLIM.HS
 INPUT LD - Input LD ----- PRIM.SPLIM.LS
 ESN - Exec. Seq. No.----- 5

SPLIM- Setpoint Limit Function Block
 RG PTR - Range Pointer ----- PRIM.AIN1.OR
 INPUT A - Input A ----- PRIM.SETPT.O1
 ESN - Exec. Seq. No.----- 10

Primary Loop (cont)**ALARM - Alarm Function Block**

RG PTR - Range Pointer ----- PRIM.AIN1.OR
 INPUT P - Input P ----- PRIM.AIN1.O1
 INPUT D - Input D ----- PRIM.SPLIM.O1
 ESN - Exec. Seq. No. ----- 20

PID - PID Controller Function Block

RG PTR - Range Pointer ----- PRIM.AIN1.OR
 INPUT P - Input P ----- PRIM.AIN1.O1
 INPUT S - Input S ----- PRIM.SPLIM.O1
 INPUT F - Input F ----- SEC.AIN2.O1
 INPUT A - Input A ----- PRIM.A/M.AS
 ESN - Exec. Seq. No.----- 30

A/M - Auto/Manual Function Block

RG PTR - Range Pointer ----- PRIM.PID.OR
 INPUT A - Input A ----- PRIM.PID.O1
 INPUT TV - Input TV ----- SEC.AIN2.O1
 INPUT TC - Input TC ----- SEC.OR01.O1
 ESN - Exec. Seq. No. ----- 60

ODC - Operator Display for Controllers

P RG PTR - P Range Pointer ----- PRIM.AIN1.OR
 V RG PTR - V Range Pointer ----- PRIM.PID.OR
 INPUT P - Input P (Process) ----- PRIM.AIN1.O1
 INPUT S - Input S (Setpoint) ----- PRIM.SPLIM.O1
 INPUT V - Input V (Valve) ----- PRIM.A/M.O1
 LOOP # - Loop # ----- 01

Secondary Loop**SETPT - Setpoint Function Block**

RG PTR - Range Pointer ----- SEC.AIN2.OR
 INPUT TV - Input TV ----- SEC.AIN2.O1
 INPUT TC - Input TC ----- SEC.OR02.O1
 INPUT LU - Input LU ----- SEC.SPLIM.HS
 INPUT LD - Input LD ----- SEC.SPLIM.LS
 ESN - Exec. Seq. No.----- 5

ALARM - Alarm Function Block

RG PTR - Range Pointer ----- SEC.AIN2.OR
 INPUT P - Input P ----- SEC.AIN2.O1
 INPUT D - Input D ----- SEC.SPLIM.O1
 ESN - Exec. Seq. No. ----- 10

PB2SW - PB2 Switch Function Block

INPUT MD - Input MD ----- SEC.E/I.SE
 ESN - Exec. Seq. No. ----- 15

E/I - Ext/Int Transfer Switch Function Block

INPUT ST - Input ST ----- SEC.PB2SW.PS
 INPUT E - Input E ----- PRIM.A/M.O1
 INPUT I - Input I ----- SEC.SETPT.O1
 ESN - Exec. Seq. No. ----- 20

SPLIM - Setpoint Limit Function Block

RG PTR - Range Pointer ----- SEC.AIN2.OR
 INPUT A - Input A ----- SEC.E/I.O1
 ESN - Exec. Seq. No. ----- 25

PID - PID Controller Function Block

RG PTR - Range Pointer ----- SEC.AIN2.OR
 INPUT P - Input P ----- SEC.AIN2.O1
 INPUT S - Input S ----- SEC.SPLIM.O1
 INPUT F - Input F ----- SEC.A/M.O1
 INPUT A - Input A ----- SEC.A/M.AS
 INPUT I - Input I ----- SEC.E/I.ES
 ESN - Exec. Seq. No.----- 30

A/M - Auto/Manual Function Block

RG PTR - Range Pointer ----- SEC.PID.OR
 INPUT A - Input A ----- SEC.PID.O1
 ESN - Exec. Seq. No. ----- 35

OR01 - OR Function Block

INPUT A - Input A ----- SEC.A/M.NA
 INPUT B - Input B ----- SEC.E/I.IS
 ESN - Exec. Seq. No. ----- 40

OR02 - OR Function Block

INPUT A - Input A ----- SEC.A/M.NA
 INPUT B - Input B ----- SEC.E/I.ES
 ESN - Exec. Seq. No. ----- 45

AO1 - Analog Output 1 Function Block

RG PTR - Range Pointer ----- SEC.PID.OR
 INPUT S - Input S ----- SEC.A/M.O1

ODC - Operator Display for Controllers

P RG PTR - P Range Pointer ---- SEC.AIN2.OR
 V RG PTR - V Range Pointer -- SEC.PID.OR
 INPUT P - Input P (Process) ----- SEC.AIN2.O1
 INPUT S - Input S (Setpoint) ---- SEC.SPLIM.O1
 INPUT V - Input V (Valve) ----- SEC.A/M.O1
 LOOP # - Loop# ----- 02

5.0 LONWORKS COMMUNICATIONS

The LonWorks option board A-1 is added to a controller to expand the I/O capacity. The board uses the LonWorks communication protocol to communicate with remote LonWorks devices over a single twisted pair network. The diagram shows the option board added to an MPU Controller board and remote mounted LonWorks nodes.

A LonWorks Remote I/O board uses a Free Topology transceiver communicating at 78.1 Kbps.

Up to fifteen (15) physical nodes can be connected to a controller.

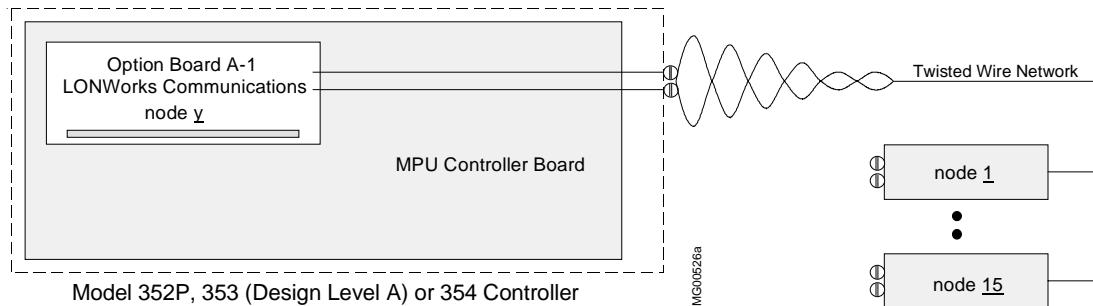

Install a LonWorks network by first wiring all the nodes to the network. Next, temporarily connect a PC-based Network Manager to the network using a SLTA (Serial Link Talk Adapter) manufactured by Echelon Corp. The Network Manager (MetaVision 3.0) and the SLTA are included in the Siemens LonWorks Startup Kit.

Each individual node is then installed by the Network Manager and saved in a Project file. The Project file is a permanent record of the network installation and must be retained for any future network maintenance. When a node is first installed, the Network Manager reads the Program ID and the Neuron ID (every LonWorks device has a Neuron chip that contains a worldwide unique ID). If a node with the same Program ID had not been previously installed, it will read all of the self-documentation from the node. The Network Manager will now have a list of all the available parameters and I/O variables within that node. Some parameters may need to be configured, but for most applications, the default settings are acceptable. The Network Manager is then used to BIND network variables (i.e. connect I/O variables from one node to another).

Network variable connections from remote nodes to the controller are used within the controller by selecting LonWorks I/O function blocks within individual loop configurations¹⁴. These function blocks, which are detailed in the Function Blocks section of this manual, enable connections to network variables to be made to other block inputs within the controller. There are a number of different block types available. Block selection depends on the types of variables to be connected. Siemens supports LonWorks Standard Network Variable Types:

- SNVT_lev_percent for analog inputs and outputs
- SNVT_lev_disc for discrete inputs and outputs
- SNVT_state for use with the Siemens 16-channel discrete input or output modules available with firmware 1.30 or higher

There is a 15 node per network limit. When large I/O counts are needed for a controller application, use physical nodes with higher I/O counts to minimize the number of physical nodes required. For example, 16-channel discrete input and output modules are available. Up to six of each can be used within a controller configuration. A 4-channel analog input module and a 2-channel analog output module are also available.

Note

The LonWorks option was discontinued in November 2005.

¹⁴ Model 352P only: the Option 3 I/O Jumper must also be used to select LonWorks.

SERVICING CONSIDERATIONS

The functioning of a LonWorks network can be affected by:

- Upgrading the MPU Controller board firmware
- Replacing a controller's MPU Controller board with a board having a different firmware version
- Moving a LonWorks board to a controller with a different MPU Controller board firmware version

Background

A LonWorks option board contains a Program ID for the controller node. A Controller MPU board will store a Program ID in the EEPROM on the LonWorks board when the combination is first powered up. When the Network Manager software installs a controller node as part of a network, it reads the Program ID when a controller is installed for the first time. The Program ID of the controller, as with all other installed nodes, is then retained by the Network Manager.

Version 1.30 Program ID was changed since function blocks DIS and DOS contain a new network variable type: SNVT_state. When controller firmware is upgraded to 1.30 or higher, the controller will store a new Program ID in the EEPROM on the LonWorks board so that a Network Manager will recognize it as a different type of node.

Considerations

- When a controller in an installed network is upgraded to 1.30 or higher, the Network Manager will not recognize the network variables added by the new version. The Network Manager will be able to bind variables present in the earlier version.
- A LonWorks board that has been used in a controller with 1.30 or higher firmware should not be used in a controller with firmware 1.21 or lower. The LonWorks board EEPROM will contain the Program ID stored in it by the 1.30 firmware.
 - If the LonWorks board is mounted in a controller with 1.21 firmware and the controller is installed by a Network Manager that had **not previously installed** a controller with 1.30 firmware, a problem will occur. The Network Manager will read out the list of network variables available but the variables will be only those that were available in 1.21. In subsequent installations of controllers with 1.30 firmware, the Network Manger will not read, and therefore will not have access to, the new 1.30 variables.
 - If the LonWorks board is mounted in a controller with 1.21 firmware and the controller is installed by a Network Manger that **had previously installed** a controller with 1.30 firmware, the Network Manager variable list will include new 1.30 variables. The controller, however, will reject an attempt to bind them.

Suggested Actions

When upgrading MPU Controller firmware:

- 1) Generate a report of all network bindings.
- 2) Uninstall the controller node from a network.
- 3) Upgrade the controller firmware
- 4) Install the controller node.
- 5) Refer to the above report and bind all network variables.

NOTE

If the 352P controller has already been upgraded, the controller node can still be uninstalled with the current version of the MetaVision 3.0x Network Manager but uninstalling prior to upgrading is recommended. Other Network Managers may not allow this.

Once a LonWorks option board is used in a 1.30 or higher controller and is uninstalled and removed from service, mark the board as **“1.30 firmware only”**.



6.0 NETWORK COMMUNICATIONS

This section provides an overview of the data that can be obtained from the station using Modbus, LIL, or Ethernet, which provides Modbus over Ethernet protocol. In the Modbus over Ethernet protocol all listed Modbus items are available but are embedded in the Modbus/Ethernet protocol frame. Refer to Section 7 for detailed list of the actual data.

NOTE

Ethernet is available on Model 353, 353R and Procidia™ i|pac™ controllers. It is not available on Model 352Plus™ and 354/354N controllers.

6.1 MODBUS DATA MAPPING

Modbus is a master/slave protocol where a master device (e.g. PC-based operator workstation) sends commands to one slave (e.g. 352P or 353) and waits for a response. Each station has a unique network address (1-32), configured as part of the station parameters, that identifies a specific controller.

Data is assigned to either a register (16-bit word) or a coil (1-bit). An IEEE floating point number (Real) is assigned to 2 consecutive registers with the first containing the most significant and the second the least significant portion of the floating point number.

The station supports Modbus function codes 01, 02, 03, 04, 05, 06, 08, and 16. Section 7 provides a listing of available data and specific locations within the Modbus map. The following is the overview for the Modbus data mapping.

Station Coils	x0001 - x0071
Loop Coils.....	x0296 - x1495
Extended Loop Coils (ODD Pushbuttons) V2.1	x8701 - x9100
Sequencer Loop I/O Coils (ref. MSLCP pointer)	x1496 - x2263
LonWorks Remote I/O Coils (Models 352P, 353, & 354/354N).....	x2401 - x3976
Ubus Discrete I/O States & Forcing V2.1 (Procidia).....	x4001 - x5500
(spares).....	x5501 - x9100
Loop PCOM Block Coils	x9101 - x9999
Station Data (16-bit integer).....	x0001 - x0100
Station String Data (ASCII).....	x0101 - x0200
Loop Dynamic Data (16-bit integer).....	x0201 - x0450
Loop Variable Data (16-bit integer).....	x0451 - x1200
Loop Static Data (16-bit integer)	x1201 - x1950
Loop Dynamic Data (32-bit floating point)	x1951 - x2450
Loop Variable Data (32-bit floating point)	x2451 - x3950
Loop Static Data (32-bit floating point).....	x3951 - x5450
Loop String Data (ASCII).....	x5451 - x7950
Ubus Module Types (Procidia)	x7951 - x8000
Loop Trend Data (ref. MLTP pointer)	x8001 - x9000
(spares).....	x9001 - x9999

EXTENDED MODBUS REGISTERS: The traditional addressing of Modbus Holding Registers has been limited to 9999. However, since the actual address is contained in a 16-bit word, addresses above 9999 are available. Many Modbus Masters support this extended addressing. Configuration data for a Sequencer & Timers contained in a single sequencer loop can be accessed in this space. The actual loop that can be accessed is contained in the Modbus parameter MSLCP Modbus Sequencer & Timers Configuration Pointer located in register 40041. This register contains the Modbus Index for the loop that can be configured with these extended parameters. A small number of these parameters have also been mapped in the areas listed within the actual loop area for those Masters that cannot access the extended area.

In addition, there are a number of registers reserved for the mappings of Modbus registers used in the peer-to-peer functionality of the Ethernet function blocks.

Sequencer Mask Configurations	x10001 – x18000
Real Time Trip Block Configurations.....	x19001 – x19021
Sequencer Time & Analog Configurations	x20001 – x20999
Timer Function Block Configurations	x21001 – x21009
Reserved -- Modbus Ethernet Block Register.....	x29001 – x29019*
Reserved – Modbus Ethernet Analog Inputs Static Data	x30001 – x30352*
Reserved – Modbus Ethernet Analog Outputs Static Data	x30353 – x30608*
Reserved – Modbus Ethernet Digital Inputs Static Data.....	x30609 – x30704*
Reserved – Modbus Ethernet Coil Inputs Static Data	x30705 – x30832*
Reserved – Modbus Ethernet Analog Inputs Dynamic Data.....	x30833 – x30896*
Reserved – Modbus Ethernet Digital Inputs Dynamic Data	x30897 – x30928*
Reserved – Modbus Ethernet Coil Inputs Dynamic Data	x30929 – x30960*
Reserved – Modbus Ethernet Analog Outputs Dynamic Data..	x30961 – x31024*/**

* Ethernet is available on Model 353, Model 353R and Procidia i|pac controllers. It is not available on Model 352P and 354/354N controllers.

** Refer to the AIE function block in the Function Blocks section for details.

6.2 LIL DATA MAPPING

LIL data is assigned to one of two data types. The first is global data which occupies parameter 1 of each channel and is transmitted by the LIL interface every 0.5 seconds. The remaining data is non-global which occupies parameters 2 through 256 and is transmitted in response to a LIL READ command or can be changed by a LIL WRITE command.

Each parameter is a 16-bit word. An IEEE floating point number (Real) is assigned to 2 consecutive parameters with the first containing the most significant and the second the least significant portion of the floating point number. String data can occupy one or more consecutive parameters. The following tables provide an overview listing of available data with descriptions located in Section 7. The acronym in the table identifies the data in Section 7. Data can be accessed using the Model 320 Independent Computer Interface. Refer to AD320-10 Model 320 ICI User Manual and AD320-20 Guidelines for Writing Application Software Using the Model 320 ICI.

Guidelines:

All individual parameters (words) can be read using the random parameter data request (CMD 7). Parameters that span multiple words, such as floating point, ASCII tags, etc., can also be read using the multiple-byte parameter data request (CMD 23) but only one variable can be requested at a time. Writes are made using the parameter data send (CMD 9). In some cases such as loop and alarm status words, the MASK ON/OFF type codes are used to identify individual bits. Not all bit mapped words support this option. See Section 7 for specific information.

6.2.1 Station Data

Station data is fixed and occupies the first seven channels.

C/P	1	2	3	4	5	6	7	8	9	10	11	12	
1	GDS	RAM	CBT	CBSR	EBT	EBSR	RBT	RBSR	NBT	NBSR	OAT	OASR	
2	ST	STAG						DRN	CFNR				
3	SSW	CWT	SA	CT	RTS	STY	STM	STD	STH	STMN	STSC		
4	SE	SN				AASEL							
5	NCL	C1S	C2S	C3S	C4S	C5S	C6S	C7S	C8S	C9S	C10S	C11S	
6	NSL	S1S	S2S	S3S	S4S	S5S	S6S	S7S	S8S	S9S	S10S	S11S	
7	LSLCP	CFN											

C/P	13	14	15	16	17	18	19	20	21	22	23	24
1	OBT	OBSR	OFT	KSR	CBDR	EBDR	RBDR	NBDR	OADR	OBDR	KDR	
2	SCR	NCR										
3												
4												
5	C12S	C13S	C14S	C15S	C16S	C17S	C18S	C19S	C20S	C21S	C22S	C23S
6	S12S	S13S	S14S	S15S	S16S	S17S	S18S	S19S	S20S	S21S	S22S	S23S
7	L1Z	L2Z	L3Z	L4Z	L5Z	L6Z	L7Z	L8Z	L9Z	L10Z	L11Z	L12Z

Ubus Address xx - Discrete I/O States & Forcing (N=Normal, M=Mode, F=Forced (see Section 7 for details))

C/P	25	26	27	28	29	30	31	32	33	34	35	36
1							UA01N	UA02N	UA03N	UA04N	UA05N	UA06N
2							UA01M	UA02M	UA03M	UA04M	UA05M	UA06M
3							UA01F	UA02F	UA03F	UA04F	UA05F	UA06F
4							UA01MT	UA02MT	UA03MT	UA04MT	UA05MT	UA06MT
5	C24S	C25S										
6	S24S	S25S										L25Z
7	L13Z	L14Z	L15Z	L16Z	L17Z	L18Z	L19Z	L20Z	L21Z	L22Z	L23Z	L24Z

C\I/P	37	38	39	40	41	42	43	44	45	46	47	48
1	UA07N	UA08N	UA09N	UA10N	UA11N	UA12N	UA13N	UA14N	UA15N	UA16N	UA17N	UA18N
2	UA07M	UA08M	UA09M	UA10M	UA11M	UA12M	UA13M	UA14M	UA15M	UA16M	UA17M	UA18M
3	UA07F	UA08F	UA09F	UA10F	UA11F	UA12F	UA13F	UA14F	UA15F	UA16F	UA17F	UA18F
4	UA07MT	UA08MT	UA09MT	UA10MT	UA11MT	UA12MT	UA13MT	UA14MT	UA15MT	UA16MT	UA17MT	UA18MT
5	NAL	A1S	A2S	A3S	A4S	A5S	A6S	A7S	A8S	A9S	A10S	A11S
6	NDL	D1S	D2S	D3S	D4S	D5S	D6S	D7S	D8S	D9S	D10S	D11S
7	NPL	P1S	P2S	P3S	P4S	P5S	P6S	P7S	P8S	P9S	P10S	P11S

C\I/P	49	50	51	52	53	54	55	56	57	58	59	60
1	UA19N	UA20N	UA21N	UA22N	UA23N	UA24N	UA25N	UA26N	UA27N	UA28N	UA29N	UA30N
2	UA19M	UA20M	UA21M	UA22M	UA23M	UA24M	UA25M	UA26M	UA27M	UA28M	UA29M	UA30M
3	UA19F	UA20F	UA21F	UA22F	UA23F	UA24F	UA25F	UA26F	UA27F	UA28F	UA29F	UA30F
4	UA19MT	UA20MT	UA21MT	UA22MT	UA23MT	UA24MT	UA25MT	UA26MT	UA27MT	UA28MT	UA29MT	UA30MT
5	A12S	A13S	A14S	A15S	A16S	A17S	A18S	A19S	A20S	A21S	A22S	A23S
6	D12S	D13S	D14S	D15S	D16S	D17S	D18S	D19S	D20S	D21S	D22S	D23S
7	P12S	P13S	P14S	P15S	P16S	P17S	P18S	P19S	P20S	P21S	P22S	P23S

C\I/P	61	62	63	64	65	66	67	68	69	70	71	72
1	UA31N											
2	UA31M											
3	UA31F											
4	UA31MT											
5	A24S	A25S										
6	D24S	D25S										
7	P24S	P25S							

LonWorks Remote Function Blocks I/O States N=Normal, M=Mode, F=Forced (see Section 7 for details)

C\I/P	100	101	102	103	104	105	106	107	108	109	110	111
1	RTT1Y	RTT1M	RTT1D	RTT1HR	RTT1MN	RTT1SC	RTT1DA					
2	RTT2Y	RTT2M	RTT2D	RTT2HR	RTT2MN	RTT2SC	RTT2DA					
3	RTT3Y	RTT3M	RTT3D	RTT3HR	RTT3MN	RTT3SC	RTT3DA					

C\I/P	202	203	204	205	206	207	208	209	210	211	212	213
1	DID1N	DID1M	DID1F	DOD1N	DOD1M	DOD1F	DIS1N	DIS1M	DIS1F	DOS1N	DOS1M	DOS1F
2	DID2N	DID2M	DID2F	DOD2N	DOD2M	DOD2F	DIS2N	DIS2M	DIS2F	DOS2N	DOS2M	DOS2F
3	DID3N	DID3M	DID3F	DOD3N	DOD3M	DOD3F	DIS3N	DIS3M	DIS3F	DOS3N	DOS3M	DOS3F
4	DID4N	DID4M	DID4F	DOD4N	DOD4M	DOD4F	DIS4N	DIS4M	DIS4F	DOS4N	DOS4M	DOS4F
5	DID5N	DID5M	DID5F	DOD5N	DOD5M	DOD5F	DIS5N	DIS5M	DIS5F	DOS5N	DOS5M	DOS5F
6	DID6N	DID6M	DID6F	DOD6N	DOD6M	DOD6F	DIS6N	DIS6M	DIS6F	DOS6N	DOS6M	DOS6F
7												

6.2.2 Control Loop Data

Control loop data occupies five LIL channels. The starting channel is entered during configuration of the ODC operator display function block for each loop, as LIL CHAN (n). The first channel for each loop can be viewed in station data starting at channel 5/parameter 2 for control loops and channel 6/parameter 2 for a sequencer loops. The station configuration entry (both local and graphical PC-based) will indicate the next available open space of five contiguous channels. Another starting channel can be entered but it is important to utilize the lowest total number of channels.

Channel locations n through n+4, in the table below, identify variables that will be available on the LIL for each control loop. All parameter 1 data (e.g. P-process) is global and is transmitted every 0.5 second. All other data is sent out on command.

CIP	1	2	3	4	5	6	7	8	9	10	11	12
n	PI	PGI	TII	TDI	DGI	MRI	RI	BI	PF		HDF	
n+1	SI	TSPI	RTI	HLI	LLI	RRI	CAI	SF		LDF		
n+2	VI	TLml	TLII	T1ml	T1II	T2ml	T2II	VF		DBF		
n+3	CLS	TAG						PUR		RHI	RLI	DPPI
n+4	ASW	A1LI	A2LI	A3LI	A4LI	A1TW	A2TW	A3TW	A4TW	ECLS		

CIP	13	14	15	16	17	18	19	20	21	22	23	24
n	PGF		TIF		TDF		DGF		MRF		RF	
n+1	TSPF		RTF		HLF		LLF		RRF			
n+2	LHM			RHM								
n+3	TLF		T1F		T2F		TLU				XI	
n+4	A1LF		A2LF		A3LF		A4LF				YI	

CIP	25	26	27	28	29	30	31	32	33	34	35	36
n	BF		PMNF		PMXF		PU		PDPPI			
n+1											BHLF	
n+2			VMNF		VMXF		VU		VDPPI		BLLF	
n+3	XF		XMNF		MXF		XU		XDPPI		BPLF	
n+4	YF		YMNF		YMXF		YU		YDPPI		BGF	

CIP	37	38	39	40	41	42	43	44	45	46	47	48
n	ADF		AHF		ASF		APGF		ATIF		ATDF	
n+1	Q1N				Q1F		Q1MNF		Q1MXF			
n+2	Q2N				Q2F		Q2MNF		Q2MXF			
n+3	Q1U				Q2U							
n+4	A1TI	A2TI	A3TI	A4TI	A1PI	A2PI	A3PI	A4PI				

CIP												256
n												102
n+1												103
n+2												104
n+3												5
n+4												7

6.2.3 Sequence Loop Data

Sequence Loop data occupies six LIL channels. The starting channel is entered during configuration of the ODS operator display function block for each loop, as LIL CHAN (n). The configuration entry (both local and graphical PC-based) will indicate the next available open space of six contiguous channels. Another starting channel can be entered but it is important to utilize the lowest total number of channels.

Channel locations n through n+5, in the table below, identify variables that will be available on the LIL for each sequencer loop. All parameter 1 data (e.g. SSN Program Sequencer Step No.) is global and is transmitted every 0.5 seconds. All other data is sent out on command.

CIP	1	2	3	4	5	6	7	8	9	10	11	12
n	SSNI	SSNF	SNSI	SNGI	SNSF	SNGF					SNRI	
n+1	SAOmF	SAOF	SAEPF			SNRF		CRNF				
n+2	SAOIF											
n+3	CRNI	SRTF	SSTF	TACM								
n+4	SLS											
n+5	ASW											

Sequencer & Remote I/O State, Mode & Forcing

CIP	13	14	15	16	17	18	19	20	21	22	23	24
n	SG0KI	SG0SI	SG0SO	SG4KI	SG4SI	SG4SO	SG8KI	SG8SI	SG8SO	SGCKI	SGCSI	SGCSO
n+1	SG1KI	SG1SI	SG1SO	SG5KI	SG5SI	SG5SO	SG9KI	SG9SI	SG9SO	SGDKI	SGDSI	SGDSO
n+2	SG2KI	SG2SI	SG2SO	SG6KI	SG6SI	SG6SO	SGAKI	SGASI	SGASO	SGEKI	SGESI	SGESO
n+3	SG3KI	SG3SI	SG3SO	SG7KI	SG7SI	SG7SO	SGBKI	SGBSI	SGBSO	SGFKI	SGFSI	SGFSO
n+4												
n+5												

CIP	25	26	27	28	29	30	31	32	33	34	35	36
n												
n+1												
n+2												
n+3												
n+4												
n+5												

CIP	37	38	39	40	41	42	43	44	45	46	47	48	
n			L#RMSG				TACM						
n+1			L#PMSG										
n+2			L#SMSG										
n+3			L#MSGa										
n+4			L#MSGb										
n+5			L#MSGc										

CIP	49	50	51	52	53	54	55	56	57	58	59	60	
n			L#MSGd										
n+1			L#MSGe										
n+2			L#MSGf										
n+3			L#MSGg										
n+4			L#MSGh										
n+5			L#MSGi										

Timers - Elapsed & Remaining Times

CIP	61	62	63	64	65	66	67	68	69	70	71	72
n	DYT01ET		DYT01RT		DYT02ET		DYT02RT		DYT03ET		DYT03RT	
n+1	OST01ET		OST01RT		OST02ET		OST02RT		OST03ET		OST03RT	
n+2	RCT01ET		RCT01RT		RCT02ET		RCT02RT		RCT03ET		RCT03RT	
n+3	ROT01ET		ROT01RT		ROT02ET		ROT02RT		ROT03ET		ROTO3RT	
n+4												
n+5												

CIP	73	74	75	76	77	78	79	80	81	82	83	84
n	DYT04ET		DYT04RT		DYT05ET		DYT05RT		DYT06ET		DYT06RT	
n+1	OST04ET		OST04RT		OST05ET		OST05RT		OST06ET		OST06RT	
n+2	RCT04ET		RCT04RT		RCT05ET		RCT05RT		RCT06ET		RCT06RT	
n+3	ROT04ET		ROT04RT		ROT05ET		ROT05RT		ROT06ET		ROTO6RT	
n+4												
n+5												

CIP	85	86	87	88	89	90	91	92	92	94	95	96
n	DYT07ET		DYT07RT		DYT08ET		DYT08RT		DYT09ET		DYT09RT	
n+1	OST07ET		OST07RT		OST08ET		OST08RT		OST09ET		OST06RT	
n+2	RCT07ET		RCT07RT		RCT08ET		RCT08RT		RCT09ET		RCT09RT	
n+3	ROT07ET		ROT07RT		ROT08ET		ROT08RT		ROT09ET		ROT09RT	
n+4												
n+5												

CIP	97	98	99	100	101	102	103	104	104	106	107	108
n	DYT10ET		DYT10RT		DYT11ET		DYT11RT		DYT12ET		DYT12RT	
n+1	OST10ET		OST10RT		OST11ET		OST11RT		OST12ET		OST12RT	
n+2	RCT10ET		RCT10RT		RCT11ET		RCT11RT		RCT12ET		RCT12RT	
n+3	ROT10ET		ROT10RT		ROT11ET		ROT11RT		ROT12ET		ROT12RT	
n+4												
n+5												

CIP	109	110	111	112	113	114	115	116	117	118	119	120
n	DYT13ET		DYT13RT		DYT14ET		DYT14RT		DYT15ET		DYT15RT	
n+1	OST13ET		OST13RT		OST14ET		OST14RT		OST15ET		OST15RT	
n+2	RCT13ET		RCT13RT		RCT14ET		RCT14RT		RCT15ET		RCT15RT	
n+3	ROT13ET		ROT13RT		ROT14ET		ROT14RT		ROT15ET		ROT15RT	
n+4												
n+5												

CIP	121	122	123	124	125	126	127	128	129	130	131	132
n	DYT16ET		DYT16RT		DYT17ET		DYT17RT		DYT18ET		DYT18RT	
n+1	OST16ET		OST16RT		OST17ET		OST17RT		OST18ET		OST18RT	
n+2	RCT16ET		RCT16RT		RCT17ET		RCT17RT		RCT18ET		RCT18RT	
n+3	ROT16ET		ROT16RT		ROT17ET		ROT17RT		ROT18ET		ROT18RT	
n+4												
n+5												

CIP	133	134	135	136	137	138	139	140	141	142	143	144
n	DYT19ET		DYT19RT		DYT20ET		DYT20RT		DYT21ET		DYT21RT	
n+1	OST19ET		OST19RT		OST20ET		OST20RT		OST21ET		OST21RT	
n+2	RCT19ET		RCT19RT		RCT20ET		RCT20RT		RCT21ET		RCT21RT	
n+3	ROT19ET		ROT19RT		ROT20ET		ROT20RT		ROT21ET		ROT21RT	
n+4												
n+5												

CIP	150	151	152	153	154	155	156	157	158	159	160	161
n												
n+1												
n+2												
n+3												
n+4												
n+5												

Sequencer and Timer Configuration Parameters:

- SxxxTIM - Step x Time Period - Real
- SxxxAEP - Step x Analog End Point..... - Real
- SxxxGnIM - Step x Group n Input Mask - 16 bit mask word
- SxxxGnOM - Step x Group n Output Mask - 16 bit mask word
- DYTxT - Delay Timer x Time - Real
- OSTxT - One Shot Timer x Time - Real
- RCTxNT - Repeat Cycle Timer x-ON Time..... - Real
- RCTxFT - Repeat Cycle Timer x-OFF Time - Real
- ROTxT - Retentive On Timer Time - Real

C/P	150	151	152	153	154	169	170	185	186	187
1	S001TIM		S001AEP		S001G0IM	S001GFIM	S001G0OM	S001GFOM		
2	S002TIM		S002AEP		S002G0IM	S002GFIM	S002G0OM	S002GFOM		
3	S003TIM		S003AEP		S003G0IM	S003GFIM	S003G0OM	S003GFOM		
4	S004TIM		S004AEP		S004G0IM	S004GFIM	S004G0OM	S004GFOM		
5	S005TIM		S005AEP		S005G0IM	S005GFIM	S005G0OM	S005GFOM		
6	S005TIM		S006AEP		S006G0IM	S006GFIM	S006G0OM	S006GFOM		
7	S007TIM		S007AEP		S007G0IM	S007GFIM	S007G0OM	S007GFOM		

C/P	150	151	152	153	154	169	170	185	186	187
244	S244TIM		S244AEP		S244G0IM	S244GFIM	S244G0OM	S244GFOM		
245	S245TIM		S245AEP		S245G0IM	S245GFIM	S245G0OM	S244GFOM		
246	S246TIM		S246AEP		S246G0IM	S246GFIM	S246G0OM	S244GFOM		
247	S247TIM		S247AEP		S247G0IM	S247GFIM	S247G0OM	S244GFOM		
248	S248TIM		S248AEP		S248G0IM	S248GFIM	S248G0OM	S244GFOM		
249	S249TIM		S249AEP		S249G0IM	S249GFIM	S249G0OM	S244GFOM		
250	S250TIM		S250AEP		S250G0IM	S250GFIM	S250G0OM	S244GFOM		

C/P	190	191	192	193	194	195	196	197	198	199	200	201
1	DYT01T		OST01T		RCT01NT		RCT01FT		ROT01T			
2	DYT02T		OST02T		RCT02NT		RCT02FT		ROT02T			
3	DYT03T		OST03T		RCT03NT		RCT03FT		ROT03T			
4	DYT04T		OST04T		RCT04NT		RCT04FT		ROT04T			
5	DYT05T		OST05T		RCT05NT		RCT05FT		ROT05T			
6	DYT06T		OST06T		RCT06NT		RCT06FT		ROT06T			
7	DYT07T		OST07T		RCT07NT		RCT07FT		ROT07T			
8	DYT08T		OST08T		RCT08NT		RCT08FT		ROT08T			
9	DYT09T		OST09T		RCT09NT		RCT09FT		ROT09T			
10	DYT10T		OST10T		RCT10NT		RCT10FT		ROT10T			
11	DYT11T		OST11T		RCT11NT		RCT11FT		ROT11T			
12	DYT12T		OST12T		RCT12NT		RCT12FT		ROT12T			
...												

6.2.4 Analog Indicator Loop Data

Analog Indicator loop data occupies six LIL channels. The starting channel is entered during configuration of the ODA operator display function block for each loop, as LIL CHAN (n). The first channel for each loop can be viewed in station data starting at channel 5/parameter 38. The station configuration entry (both local and graphical PC-based) will indicate the next available open space of six contiguous channels. Another starting channel can be entered but it is important to utilize the lowest total number of channels.

Channel locations n through n+5, in the table below, identify variables that will be available on the LIL for each analog indicator loop. All parameter 1 data (e.g. P-process) is global and is transmitted every 0.5 second. All other data is sent out on command.

CIP	1	2	3	4	5	6	7	8	9	10	11	12
n	L#P1I	L#P1F		L#P1T				L#P1U				
n+1	L#P2I	L#P2F		L#P2T				L#P2U				
n+2	L#P3I	L#P3F		L#P3T				L#P3U				
n+3	L#P4I	L#P4F		L#P4T				L#P4U				
n+4	L#SW1			L#TAG								
n+5	L#SW2											

CIP	13	14	15	16	17	18	19	20	21	22	23	24
n	L#P1ALF		L#P1BLF		L#P2ALF		L#P2BLF		L#P3ALF		L#P3BLF	
n+1	L#P1ALI	L#P1BLI	L#P2ALI	L#P2BLI	L#P3ALI	L#P3BLI	L#P4ALI	L#P4BLI			L#Q1U	
n+2	L#P1ATI	L#P1BTI	L#P2ATI	L#2BTI	L#PATI	L#P3BT	L#P4ATI	L#P4BTI			L#Q2U	
n+3	L#P1API	L#P1BPI	L#P2API	L#P2BPI	L#P3API	L#P3BPI	L#P4API	L#P4BPI			L#Q3U	
n+4											L#Q4U	
n+5												

CIP	25	26	27	28	29	30	31	32	33	34	35	36
n	L#P4ALF		L#P4BLF									
n+1		L#Q1N			L#Q1F		L#Q1MNF		L#Q1MXF			
n+2		L#Q2N			L#Q2F		L#Q2MNF		L#Q2MXF			
n+3		L#Q3N			L#Q3F		L#Q3MNF		L#Q3MXF			
n+4		L#Q4N			L#Q4F		L#Q4MNF		L#Q4MXF			
n+5												

6.2.5 Discrete Indicator Loop Data

Discrete Indicator loop data occupies four LIL channels. The starting channel is entered during configuration of the ODD operator display function block for each loop, as LIL CHAN (n). The first channel for each loop can be viewed in station data starting at channel 6/parameter 38. The station configuration entry (both local and graphical PC-based) will indicate the next available open space of six contiguous channels. Another starting channel can be entered but it is important to utilize the lowest total number of channels.

Channel locations n through n+3, in the table below, identify variables that will be available on the LIL for each analog indicator loop. All parameter 1 data (e.g. discrete input states) is global and is transmitted every 0.5 second. All other data is sent out on command.

C\P	1	2	3	4	5	6	7	8	9	10	11	12	
n	L#DISW	L#I0TAG		L#I3TAG			L#I6TAG			L#I9TAG			
n+1	L#DSSW	L#I1TAG		L#I4TAG			L#I7TAG			L#IATAG			
n+2	L#DOSW	L#I2TAG		L#I5TAG			L#I8TAG			L#IBTAG			
n+3	L#SW	L#TAG											

C\P	13	14	15	16	17	18	19	20	21	22	23	24
n			L#ICTAG									
n+1			L#IDTAG									
n+2			L#IETAG									
n+3			L#IFTAG									

6.2.6 Pushbutton Loop Data

Pushbutton loop data occupies two LIL channels. The starting channel is entered during configuration of the ODP operator display function block for each loop, as LIL CHAN (n). The first channel for each loop can be viewed in station data starting at channel 7/parameter 38. The station configuration entry (both local and graphical PC-based) will indicate the next available open space of six contiguous channels. Another starting channel can be entered but it is important to utilize the lowest total number of channels.

Channel locations n through n+1, in the table below, identify variables that will be available on the LIL for each analog indicator loop. All parameter 1 data (e.g. discrete input states) is global and is transmitted every 0.5 second. All other data is sent out on command.

C/P	1	2	3	4	5	6	7	8	9	10	11	12	
n	L#SW1	L#TAG											
n+1	L#SW2												

C/P	13	14	15	16	17	18	19	20	21	22	23	24
n	L#G1TAG			L#G1P1T			L#G1P2T			L#G1SAT		
n+1	L#G1F1T			L#G1FOT						L#G1SMT		

C/P	25	26	27	28	29	30	31	32	33	34	35	36
n	L#G2TAG			L#G2P1T			L#G2P2T			L#G2SAT		
n+1	L#G2F1T			L#G2FOT						L#G2SMT		

C/P	37	38	39	40	41	42	43	44	45	46	47	48
n	L#G3TAG			L#G3P1T			L#G3P2T			L#G3SAT		
n+1	L#G3F1T			L#G3FOT						L#G3SMT		

C/P	49	50	51	52	53	54	55	56	57	58	59	60
n	L#G4TAG			L#G4P1T			L#G4P2T			L#G4SAT		
n+1	L#G4F1T			L#G4FOT						L#G4SMT		

C/P	61	62	63	64	65	66	67	68	69	70	71	72
n	L#G5TAG			L#G5P1T			L#G5P2T			L#G5SAT		
n+1	L#G5F1T			L#G5FOT						L#G5SMT		

C/P	73	74	75	76	77	78	79	80	81	82	83	84
n	L#G6TAG			L#G6P1T			L#G6P2T			L#G6SAT		
n+1	L#G6F1T			L#G6FOT						L#G6SMT		

C/P	85	86	87	88	89	90	91	92	93	94	95	96
n	L#G7TAG			L#G7P1T			L#G7P2T			L#G7SAT		
n+1	L#G7F1T			L#G7FOT						L#G7SMT		

C/P	97	98	99	100	101	102	103	104	105	106	107	108
n	L#G8TAG			L#G8P1T			L#G8P2T			L#G8SAT		
n+1	L#G8F1T			L#G8FOT						L#G8SMT		

■

7.0 DATA MAPPING

This section provides loop and station data mapping for Modbus, Local Instrument Link, and Ethernet. Modbus is standard. A LIL option board is available to enable the Local Instrument Link communication protocol. Ethernet is available on Model 353 (standard on Design Level B), Model 353R, and Procidia™ i|pac™. With Ethernet, data is accessed using Modbus commands embedded within the TCP protocol. This is becoming known within the industry as the Open Modbus/TCP Protocol.

The controller has an RS232 port that always communicates via Modbus. It is located on the underside of the operator faceplate.

Model 352P has a multi-drop network connection that is either Modbus, LIL (when the optional LIL board is installed), or Ethernet. The Ethernet connection is made using the standard RJ45 connector. The network can connect 352*Plus*, 353, 353R, Procidia i|pac, and 354N controllers to:

- A computer running i|ware PC™, ProcessSuite™, MYCROADVANTAGE™ or other operator interface software that includes the communication driver (e.g. Modbus, LIL (320), or OPC Ethernet) in the controller
- An APACS® Model 39ACM Advanced Control Module via Modbus or LIL

The network permits data to be uploaded from the controller to the computer or workstation. This data is typically used for process control and alarm monitoring, additional processing of the data for inventory management and accounting, and process and equipment troubleshooting. Data can be downloaded to the station to change setpoint or valve value, change control mode, and acknowledge alarms.

Proprietary data transfers associated with configuration upload/download or on-line monitoring associated with the i|config Graphical Configuration Utility are not described in this manual. MPU Controller firmware versions are identified using the HW PRES parameter, as explained in Section 3.1.3 STATN – Station Parameters.

7.1 CONNECTING TO APACS 39ACM, MYCROADVANTAGE, ProcessSuite, i|ware PC

7.1.1 APACS

A Model 39ACM (Advanced Control Module) supports both Modbus and LIL connections. Use the standard Modbus Master Function Block Library to communicate with a station. When requesting Modbus data, do not exceed 48 coils or 60 registers per request. A LIL function block library (P/N 15939-625V4.00 ACM Serial Communication FB Library LIL) that provides a method for connecting the ACM to standard LIL stations is available. The library includes a 352P/353/353R/354 Loop block. The current release of the library maps the 352P/353/353R/354 as having 3-loops located at channels 8, 13, and 18. Therefore, it is necessary to configure ODC function blocks for these channels. It is expected that later releases of the library will allow multiple loops, up to maximum allowed. Also, data from additional loops can be obtained by using a combination of other library functions such as LIL_GBL, LIL_NGBL, and LIL_CMD.

7.1.2 MYCROADVANTAGE

Model 320 Driver

MYCROADVANTAGE provides a LIL (320) driver that will communicate with stations on a Local Instrument Link (LIL). Standard, predefined parameter tables for many LIL products (e.g. Models 351 and 352) are within MYCROADVANTAGE to simplify configuration. MYCROADVANTAGE release 3.32 does not include a Model 352P/353/353R/354 predefined parameter table. However, when up to three control loops are to be configured in a Model 352P, 353, 353R or 354, use the Model 351 predefined parameter table and configure the ODC blocks in the loops to channels 8, 13, and 18. This method will work since the loop data in the controller is the same as a 351 and is located at the same relative offsets as in a 351. Loops can also be configured individually. Details on the configuration can be found the MYCROADVANTAGE user manual.

Modbus Driver

MYCROADVANTAGE provides a Modbus driver for communicating with up to 32 stations through a single COM port. There are a few considerations when communicating with a Model 352P, 353, 353R or 354 using the Modbus driver.

- Loop data is available as integer or floating point. When integer is used, more data is obtained with a single command, thus improving the communication throughput. When integer data is used, ranges can be scaled using 3:Linear function $MX+B$ scaling.
- The MODBUS.DAT file must be modified. Under the section [Address Chunk Range], set “UseDefault=0”, under section [Address Size], set “itChunkSize=48” and “WordChunkSize=60”.

7.1.3 ProcessSuite

RealTime LIL I/O Server

An optional LIL RealTime I/O Server is available to communicate with the Model 320 ICI (Independent Computer Interface). The 320 communicates over the Local Instrument Link (LIL) with other stations that have the LIL option boards installed. Refer to the literature provided with the LIL RealTime I/O Server for proper operation. Optimize LIL performance by using Global Data, especially for data that is updated on each scan such as the process, setpoint, valve, loop status, and alarm I. Use individual parameter requests only to obtain data not required frequently (e.g. tuning parameters, range scaling).

Modbus I/O Server

A Modbus I/O Server comes with Process Suite and it can be used to communicate with the controller. Refer to the Modbus I/O Server instructions for operating details. Certain parameter settings are critical. In the Topic Definition, use the 584/984 slave type. Set the maximum coil reads to 48 and maximum register reads to 60. Maximum coil writes can be set to the minimum allowed value of 8 and register writes to 2.

7.1.4 i|ware PC

Modbus OPC Server

The i|ware PC Operator Interface software includes a Modbus OPC server that when connected to the controller can auto populate its database with the number and type of loops configured in the station. All tag names used in the OPC database will be the same as listed in this manual.

LIL OPC Server

The i|ware PC Operator Interface software includes an LIL OPC server that when connected to the controller can auto populate its database with the number and type of loops configured in the station. All tag names used in the LIL OPC database will be the same as listed in this manual.

Ethernet OPC Server

The i|ware PC Operator Interface software is an OPC Client and can be connected to an OPC server. An Ethernet OPC server using the Open Modbus/TCP Protocol is available to obtain data from single or multiple 353, 353R and i|pac controllers and server the data to OPC clients.

Modbus Application Note: Refer to application document AD353-108 for information on using Modbus communications with controller products.

7.2 STATION DATA

A station contains some data that pertains to the entire station and some to individual loops. Station data, available over the network, is part of the station function block (STATN) configuration and is mapped to fixed locations in Modbus registers or coils and fixed channel/parameters when the optional LIL board is installed. Loop data (detailed in the next section) can be associated with a Controller “Control Loop” or a Sequencer “Sequencer Loop” as defined by the selection of the operator display: ODC “Operator Display for Controller” or ODS “Operator Display for Sequencer”.

Much of the analog data is available in two formats. The first is 16-bit values, scaled consistent with previous LIL products, enabling integration into existing LIL systems. This data type also provides Modbus masters, unable to handle 32-bit floating point, a method for obtaining data from the station.

The second is the standard 32-bit IEEE floating point format consistent with the actual data in the station. This data type is contained in two consecutive registers or parameters.

- When using Modbus, the LSW is first and the MSW second.
- When using LIL, the first parameter contains the MSW and the second parameter the LSW.
- Boolean values are packed into 16-bit words for LIL use and are available in coils when using Modbus.
- String data, formatted as 2 ASCII characters per word with the left-most character in the most significant byte, containing tag, units, and message information is available with Modbus and LIL.

Most Station data is ‘Read Only’ except for:

- SE (Station Error) parameter that allows a write of \$0000 to reset the current error as an acknowledgment
- SSW (Station Status Word) parameter which allows writes to certain bits (coils)
- MLTP (Modbus Loop Trend Pointer, included in version 1.30 firmware) parameter
- AASEL (Active Acknowledged Station Error Log, included in version 1.30 firmware) parameter
- other items as noted below

7.2.1 Integer Data (16-bit Integer)

<u>Code</u>	<u>R/W</u>	<u>Description</u>	<u>Range</u>	<u>Register (MB)</u>	<u>C/P (LIL)</u>
GDS	R	Global Data Size (LIL)	7-256 (\$0007-\$0100)	n/a	1/1
ST	R	Station Type	6 (\$0006)	40001	2/1
SSW	R/W	Station Status Word	(see Station Status Word)	(see coils)	3/1
SE	R/W	Station Error	0-32767(\$00000-\$7FFF)	40002	4/1
NCL	R	No. of Control Loops (# of ODC)	0-255(\$0000-\$00FF)	40003	5/1
NSL	R	No. of Seq. Loops (# of ODS)	0-255(\$0000-\$00FF)	40004	6/1
RAM	R	RAM Size (size in K bytes)	0-65535(\$0000-\$FFFF)	40005	1/2
CBT	R	Controller Board Type	(see below)	40006	1/3
CBSR	R	Controller Board Software Rev. #	(see below)	40007	1/4
EBT	R	Expander I/O Board Type	(see below)	40008	1/5
EBSR	R	Exp. I/O Board Software Rev. #	(see below)	40009	1/6
RBT	R	Remote I/O Board Type (A-1)	(see below)	40010	1/7
RBSR	R	Remote I/O (A-1) Software Rev. #	(see below)	40011	1/8
NBT	R	Network Board Type (B-1)	(see below)	40012	1/9
NBSR	R	Network (B-1) Software Rev. #	(see below)	40013	1/10
OAT	R	Option Board A Type (A-2)	(see below)	40014	1/11
OASR	R	Option A (A-2) Software Rev. #	(see below)	40015	1/12
OBT	R	Option Board B Type (B-2)	(see below)	40016	1/13
OBSR	R	Option B (B-2) Rev #	(see below)	40017	1/14
OFT	R	Operator Faceplate Type	(see below)	40018	1/15
DRN	R	Model 353 Database Rev. No.	0-32767(\$0000-\$7FFF)	40019	2/8
CWT	R	Computer Watchdog Timer (sec)	0-1000 (\$0000-\$03F8)	40020	3/2

KSR	R	Kernel Software Rev. #	(see below)	40021	1/16
CT	R	Cycle Time (msec)	0-32767(\$0000-\$7FFF)	40022	3/4
LxT	R	Loop - Type	(\$0000-\$0005)	40023-40047	n/a
		(0-none, 1-controller, 2-sequencer, 3-analog ind. V2.2, 4-discrete ind. V2.2, 5-pushbuttons V2.2)			
MSLCP	R/W	Modbus Seq. Loop Config. Pt	0-25 (\$0000-\$0019)	40048	n/a
LSLCP	R/W	LIL Seq. Loop Config. Pointer	0-25 (\$0000-\$0019)	n/a	7/1
SA	R/W	Station Address	0-250 (\$0000-\$00FA)	40049	3/3
RTS	R/W	Front Port (Display Assembly) RTS	1-3 (\$0001-\$0003)	40050	3/5
		reserved		40051-40057	1/17-23
MLTP	R/W	Modbus Loop Trend Pointer (V1.3)	0-25 (\$0000-\$0019)	40058	n/a
NLTB	R	Number of Loop Trend Blocks (V1.3)	0-5 (\$0000-\$0005)	40059	n/a
AASEL	R/W	Active Ack'd Station Error Log (V1.3)	0-32767(\$0000-\$7FFF)	40060	4/6
STY	R/W (1)	Standard Time in Years	1997-	40061	3/6 (V2.0)
STM	R/W (1)	Standard Time in Months	1-12	40062	3/7 (V2.0)
STD	R/W (1)	Standard Time in Days	1-31	40063	3/8 (V2.0)
STH	R/W (1)	Standard Time in Hours	0-23	40064	3/9 (V2.0)
STMN	R/W (1)	Standard Time in Minutes	0-59	40065	3/10 (V2.0)
STSC	R/W (1)	Standard Time in Seconds	0-59	40066	3/11 (V2.0)
NAL	R	No of Analog Ind. Loops (ODA)	0-255(\$0000-\$00FF)	40067	5/37 (V2.2)
NDL	R	No of Discrete Ind. Loops (ODD)	0-255(\$0000-\$00FF)	40068	6/37 (V2.2)
NDP	R	No of Pushbutton Loops (ODP)	0-255(\$0000-\$00FF)	40069	7/37 (V2.2)
IPA1	R	IP Address (2)	1: 0-255, 2: 0-255	40070	n/a (V2.4)
IPA2	R	IP Address (2)	3: 0-255, 4: 0-255	40071	n/a (V2.4)
IPG1	R	IP Gateway Address (4)	1: 0-255, 2 0-255	40072	n/a (V2.4)
IPG2	R	IP Gateway Address (4)	3: 0-255, 4: 0-255	40073	n/a (V2.4)
IPM1	R	IP Mask (3)	1: 0-255, 2: 0-255	40074	n/a (V2.4)
IPM2	R	IP Mask (3)	3: 0-255, 4: 0-255	40075	n/a (V2.4)
EBS	R	Ethernet Board Speed	0-auto, 1-10M, 2-100M	40076	n/a (V2.4)
EBD	R	Ethernet Board Duplex	0-auto, 1-half duplex, 2-full duplex	40077	n/a (V2.4)
PPR	R	Ethernet Board Peer-to-Peer Rate	0.25, 0.5, 1, 2, 5, 10 sec	40078	n/a (V2.4)
Spares				40079-40100	
C_S	R	Control Loop Starting Chan. LIL	8-250 (\$0008-\$00FA)	n/a	5/2-5/26
S_S	R	Seq. Loop Starting Chan. LIL	8-250 (\$0008-\$00FA)	n/a	6/2-6/26
A_S	R	Analog Indicator - Starting Chan. LIL	8-250 (\$0008-\$00FA)	n/a	5/38-5/62 (V2.2)
D_S	R	Discrete Indication - Starting Chan LIL	8-250 (\$0008-\$00FA)	n/a	6/38-6/62 (V2.2)
P_S	R	PB Indication - Starting Chan LIL	8-250 (\$0008-\$00FA)	n/a	7/38-7/62 (V2.2)
SCR	R	Starting Configuration Record	0- (\$0000-)		2/13
NCR	R	Number of Configuration Records	0- (\$0000-)		2/14
LxZ	R	Loop x Param. Z Starting Channel	8-250 (\$0008-00FA)	n/a	7/16-7/36. 6/36

Software Revisions:

Development Release	MSB 128 to 255 (\$80-\$FF)
Major Rev.	MSB 1 to 127 (\$00-\$7F) (5)
Minor Rev.	LSB 0 to 255 (\$00-\$FF)

Hardware Type and Revisions:

Type	MSB1 to 15 (\$01-\$0F) (5)
Rev.	LSB 1 to 15 (\$01-\$0F)

- (1) The controller time should be changed one parameter at a time and then verified before writing the next parameter (i.e. for Modbus use command 06 and not command 16 and LIL use a single parameter send). The change to each parameter will take approximately 1 to 2 seconds each.
- (2) IP Address format (nnn.nnn.nnn.nnn) 1,2,3,4 (default 192.168.0.2)
- (3) IP Mask format (nnn.nnn.nnn.nnn) 1,2,3,4 (default 255.255.255.0)
- (4) IP Gateway format (nnn.nnn.nnn.nnn) 1,2,3,4 (default is 197.168.0.1)
- (5) A major software Rev. of 0 = no software included and a hardware type of 0 = not installed.

7.2.2 Station String Data (8-bit ASCII Char - 2/Word)

Code	R/W	Description	Range	Register (MB)	C/P (LIL)
STAG	R	Station Tag	12 ASCII Char	40101-40106	2/2-7
CFNR	R	Configuration File Name Reduced	8 ASCII Char	n/a	2/9-12
CFN	R	Configuration File Name	20 ASCII Char	40107-40116	7/2-7/12
SN	R	Station Serial No.	8 ASCII (0-99999999)	40117-40120	4/2-4/5
		Spares	0(\$0000)	40121-40199	

7.2.3 Station Coil Data (1-bit)

Code	R/W	Description	Range	Coil (MB)	C/P (LIL)
ASE	R	1-Active Station Event	1/0	00001	3/1(0)
SEN	R/W	1-Station Event Not Ack'd	1/0	00002	3/1(1)
FSB	R	1- Flashing Station Bargraph	1/0	00003	3/1(2)
SDV	R	1- Station Database Valid	1/0	00004	3/1(3)
CCL	R	Config Change Counter LSB (bit)	1/0	n/a	3/1(4)
CCH	R	Config Change Counter MSB (bit)	1/0	n/a	3/1(5)
SCH	R	1-Station Configuration Hold	1/0	00007	3/1(6)
SRB	R/W	1-Station Run Bit	1/0	00008	3/1(7)
OOS	R/W	1-Station Alarms Out of Service	1/0	00009	3/1(8) V2.0
		(spares)	0	00010-00014	3/1(9-10)
CC1	R/W	Config Change Bit #1	1/0	n/a	3/1(11)
CC2	R/W	Config Change Bit #2	1/0	n/a	3/1(12)
CC3	R/W	Config Change Bit #3	1/0	n/a	3/1(13)
SEB	R	1-Station Error Bit	1/0	00015	3/1(14)
		(spare)	0	00016	3/1(15)
		spares	0(\$0000)	00017-00071	

7.2.4 Station Status Word (SSW)

[channel 3/parameter 1]

BIT	Description	Value	Block	Read/Write	Output
0	Active Station Event (ASE)	1-Active Event		R	
1	Station Event Not Ack'd (SEN)	1-Not Acknowledged		R/W	
2	Flashing Bargraph (FSB)	1-Flashing Bargraph		R	
3	Database Valid (SDV)	1-Valid		R	
4	Config Change Counter LSB	1/0		R	
5	Config Change Counter MSB	1/0		R	
6	Configuration Hold (SCH)	1-Hold		R	
7	Station Run Bit (SRB)	1-Run		R	
8	Stations Alarms Out of Service	1-OOS		R/W	
9	(not used)	0		R	
10	(not used)	0		R	
11	Configuration Change #1	1-Config. Changed		R/W	
12	Configuration Change #2	1-Config. Changed		R/W	
13	Configuration Change #3	1-Config. Changed		R/W	
14	Station Error Bit (SEB)	1-Error		R	
15	(not used)	0		R	

7.3 LOOP DATA

Loop data is grouped into several categories. The groupings are not as significant when using the LIL option as all LIL data has been mapped consistent with previous LIL products using Global and Non-Global data. However, when using Modbus, the groupings enable single data requests (up to 60 Words/Registers or 48 Coils) to obtain similar data with a single command. The loop will have different data if assigned as a controller type (i.e. using the ODC block), a sequencer type (i.e. using the ODS block), an Analog Indicator Display (i.e. using the ODA block), or a Discrete Indicator Display (i.e. using the ODD block), or Pushbutton/Switch Operation (i.e. using the ODP block).

- a) Dynamic data may change value on each controller scan and/or is not identified as being changed by the data base change bit (coil). This category of data usually needs to be updated by a workstation every few seconds.
- b) Variable data changes periodically. It is usually associated with on-line operation at a workstation but may only need to be updated on a lower periodic basis or when a data base change is indicated.
- c) Static data is similar to variable data but has a lower update requirement. The data may only need updating when a change is indicated or to verify a previous change made to a parameter.
- d) String data contains tag names, units, and messages.

7.3.1 Dynamic Loop Integer Data

Controller [ODC]

Code	R/W	Description	Range	Register (MB)	C/P (LIL)
L#PI	R	Process (%)	-3.3 to 103.3 (\$0-\$0FFF)	40201+10(#-1)	n/1
L#SI	R/W	Setpoint (%)	-3.3 to 103.3 (\$0-\$0FFF)	40202+10(#-1)	n+1/1
L#VI	R/W	Valve (%)	-3.3 to 103.3 (\$0-\$0FFF)	40203+10(#-1)	n+2/1
L#XI	R	X Variable (%)	-3.3 to 103.3 (\$0-\$0FFF)	40204+10(#-1)	n+3/24
L#YI	R	Y Variable (%)	-3.3 to 103.3 (\$0-\$0FFF)	40205+10(#-1)	n+4/24
L#RI	R/W	Ratio	0.00 to 38.40(\$80-\$0F80)	40206+10(#-1)	n/7
L#BI	R/W	Bias	100-0-100 (\$80-\$0F80)	40207+10(#-1)	n/8
L#TImI	R	Totalizer - 3 ms (whole) digits	0-999 (\$0000-\$03E7)	40208+10(#-1)	n+2/2
L#TlI	R	Totalizer - 3 ls (whole) digits	0-999 (\$0000-\$03E7)	40209+10(#-1)	n+2/3
CLS	R/W	Control Loop Status	(see CLS)	(see coils)	n+3/1
ASW	R/W	Alarm Status Word	(see ASW)	(see coils)	n+4/1
L#PCSW	R	PCOM Block Status Word (VI.3)	1-7 (\$0001-\$0007)	40210+10(#-1)	z+2/1

Sequencer [ODS]

Code	R/W	Description	Range	Register (MB)	C/P (LIL)
L#SSNI	R	Sequencer Step No.	0-250 (\$0000-\$00FA)	40201+10(#-1)	n/1
L#SNSI	R	Sequencer Number of Steps	0-250 (\$0000-\$00FA)	40202+10(#-1)	n/4
L#SNGI	R	Sequencer Number of Groups	0-16 (\$0000-\$0010)	40203+10(#-1)	n/5
L#SLS	R/W	Sequencer Loop Status	(see SLS)	(see coils)	n+5/1
L#SNRI	R	Sequencer Number of Recipes	0-9 (\$0000-\$0009)	40204+10(#-1)	n/11
L#CRNI	R/W	Current Recipe Number	0-9 (\$0000-\$0009)	40205+10(#-1)	n+3/1
L#PCSW	R	PCOM Block Status Word (VI.3)	1-7 (\$0001-\$0007)	40206+10(#-1)	z+2/1
L#TACM	R	Total Active Conditional Msgs (VI.3)	0-64 \$0000-\$0040)	40207+10(#-1)	n/43
		(spare)	0 (\$0000)	40208+10(#-1)	
.....
		(spare)	0 (\$0000)	40210+10(#-1)	

Analog Indicator [ODA] - (V2.2)

Code	R/W	Description	Range	Register (MB)	C/P (LIL)
L#P1I	R	Process 1 (%)	-3.3 to 103.3 (\$0-\$0FFF)	40201+10(#-1)	n/1
L#P2I	R	Process 2 (%)	-3.3 to 103.3 (\$0-\$0FFF)	40202+10(#-1)	n+1/1
L#P3I	R	Process 3 (%)	-3.3 to 103.3 (\$0-\$0FFF)	40203+10(#-1)	n+2/1
L#P4I	R	Process 4 (%)	-3.3 to 103.3 (\$0-\$0FFF)	40204+10(#-1)	n+3/1
L#SW1	R/W	Status Word 1	(see SW1)	(see coils)	n+4/1
L#SW2	R/W	Status Word 2	(see SW1)	(see coils)	n+5/1

Discrete Indicator [ODD] - (V2.2)

Code	R/W	Description	Range	Register (MB)	C/P (LIL)
L#DISW	R/W	Discrete Input Status Word	(see L#DISW)	(see coils)	n/1
L#DSSW	R/W	Discrete State Status Word	(see L#DSSW)	(see coils)	n+1/1
L#DOSW	R/W	Discrete Output Status Word	(see L#DOSW)	(see coils)	n+2/1
L#SW	R/W	Status Word	(see L#SW)	(see coils)	n+3/1

Discrete Indicator [ODP] - (V2.2)

Code	R/W	Description	Range	Register (MB)	C/P (LIL)
L#SW1	R/W	Status Word 1	(see L#SW1)	(see coils)	n/1
L#SW2	R/W	Status Word 2	(see L#SW2)	(see coils)	n+1/1

7.3.2 Variable Loop Integer Data

Controller [ODC]

Code	R/W	Description	Range	Register (MB)	C/P (LIL)
L#TSPi	R/W	Target Setpoint (%)	-3.3 to 103.3 (\$0-\$0FFF)	40451+30(#-1)	n+1/2
L#HLI	R/W	Setpoint High Limit (%)	-3.3 to 103.3 (\$0-\$0FFF)	40452+30(#-1)	n+1/4
L#LLI	R/W	Setpoint Low Limit (%)	-3.3 to 103.3 (\$0-\$0FFF)	40453+30(#-1)	n+1/5
L#RTI	R/W	Setpoint Ramp Time (min)	0-3840(\$0080-\$0F80)	40454+30(#-1)	n+1/3
L#RRI	R/W	Setpoint Ramp Rate (%/min)	-3.3 to 103.3 (\$0-\$0FFF)	40455+30(#-1)	n+1/6
L#A1LI	R/W	Alarm 1 Limit (%)	-3.3 to 103.3 (\$0-\$0FFF)	40456+30(#-1)	n+4/2
L#A2LI	R/W	Alarm 2 Limit (%)	-3.3 to 103.3 (\$0-\$0FFF)	40457+30(#-1)	n+4/3
L#A3LI	R/W	Alarm 3 Limit (%)	-3.3 to 103.3 (\$0-\$0FFF)	40458+30(#-1)	n+4/4
L#A4LI	R/W	Alarm 4 Limit (%)	-3.3 to 103.3 (\$0-\$0FFF)	40459+30(#-1)	n+4/5
L#T1mI	R/W	Tot. Preset 1 - 3 ms whole digits	0-999 (\$0000-\$03E7)	40460+30(#-1)	n+2/4
L#T1Ii	R/W	Tot. Preset 1 - 3 ls whole digits	0-999 (\$0000-\$03E7)	40461+30(#-1)	n+2/5
L#T2mI	R/W	Tot. Preset 2 - 3 ms whole digits	0-999 (\$0000-\$03E7)	40462+30(#-1)	n+2/6
L#T2Ii	R/W	Tot. Preset 2 - 3 ls whole digits	0-999 (\$0000-\$03E7)	40463+30(#-1)	n+2/7
L#A1TW	R/W	Alarm 1 Type Word	(bit mapped - see ATW)	n/a	n+4/6
L#A2TW	R/W	Alarm 2 Type Word	(bit mapped - see ATW)	n/a	n+4/7
L#A3TW	R/W	Alarm 3 Type Word	(bit mapped - see ATW)	n/a	n+4/8
L#A4TW	R/W	Alarm 4 Type Word	(bit mapped - see ATW)	n/a	n+4/9
L#A1TI	R/W	Alarm 1 Type	0-6 (\$0000-\$0006)	40464+30(#-1)	n+4/37
L#A2TI	R/W	Alarm 2 Type	0-6 (\$0000-\$0006)	40465+30(#-1)	n+4/38
L#A3TI	R/W	Alarm 3 Type	0-6 (\$0000-\$0006)	40466+30(#-1)	n+4/39
L#A4TI	R/W	Alarm 4 Type	0-6 (\$0000-\$0006)	40467+30(#-1)	n+4/40
L#A1PI	R/W	Alarm 1 Priority	1-5 (\$0001-\$0005)	40468+30(#-1)	n+4/41
L#A2PI	R/W	Alarm 2 Priority	1-5 (\$0001-\$0005)	40469+30(#-1)	n+4/42
L#A3PI	R/W	Alarm 3 Priority	1-5 (\$0001-\$0005)	40470+30(#-1)	n+4/43
L#A4PI	R/W	Alarm 4 Priority	1-5 (\$0001-\$0005)	40471+30(#-1)	n+4/44
L#CAI	R/W	Controller Action	1-DIR, 0-REV	40472+30(#-1)	n+1/7
		(spare)	0 (\$0000)	40473+30(#-1)	
.....
		(spare)	0 (\$0000)	40480+30(#-1)	

Sequencer [ODS] - (MASK Configurations)

Code	R/W	Description	Range	Register (MB)	C/P (LIL)
L#S001G0I	R/W	Step 1 Group 0 Input Mask	\$0000-\$FFFF	40451+30(#-1)	1/154
L#S001G0O	R/W	Step 1 Group 0 Output Mask	\$0000-\$FFFF	40452+30(#-1)	1/170
L#S001G1I	R/W	Step 1 Group 1 Input Mask	\$0000-\$FFFF	40453+30(#-1)	1/155
L#S001G1O	R/W	Step 1 Group 1 Output Mask	\$0000-\$FFFF	40454+30(#-1)	1/171
L#S001G2I	R/W	Step 1 Group 2 Input Mask	\$0000-\$FFFF	40455+30(#-1)	1/156
L#S001G2O	R/W	Step 1 Group 2 Output Mask	\$0000-\$FFFF	40456+30(#-1)	1/172
L#S002G0I	R/W	Step 2 Group 0 Input Mask	\$0000-\$FFFF	40457+30(#-1)	2/154
L#S002G0O	R/W	Step 2 Group 0 Output Mask	\$0000-\$FFFF	40458+30(#-1)	2/170
.....
L#S005G0O	R/W	Step 5 Group 0 Output Mask	\$0000-\$FFFF	40476+30(#-1)	5/170
L#S005G1I	R/W	Step 5 Group 1 Input Mask	\$0000-\$FFFF	40477+30(#-1)	5/155
L#S005G1O	R/W	Step 5 Group 1 Output Mask	\$0000-\$FFFF	40478+30(#-1)	5/171
L#S005G2I	R/W	Step 5 Group 2 Input Mask	\$0000-\$FFFF	40479+30(#-1)	5/156
L#S005G2O	R/W	Step 5 Group 2 Output Mask	\$0000-\$FFFF	40480+30(#-1)	5/172

Analog Indicator [ODA] - (V2.2)

Code	R/W	Description	Range	Register (MB)	C/P (LIL)
L#P1ALI	R/W	Process 1 Alarm A Limit (%)	-3.3 to 103.3 (\$0-\$0FFF)	40451+30(#-1)	n+1/13
L#P1BLI	R/W	Process 1 Alarm B Limit (%)	-3.3 to 103.3 (\$0-\$0FFF)	40452+30(#-1)	n+1/14
L#P2ALI	R/W	Process 2 Alarm A Limit (%)	-3.3 to 103.3 (\$0-\$0FFF)	40453+30(#-1)	n+1/15
L#P2BLI	R/W	Process 2 Alarm B Limit (%)	-3.3 to 103.3 (\$0-\$0FFF)	40454+30(#-1)	n+1/16
L#P3ALI	R/W	Process 3 Alarm A Limit (%)	-3.3 to 103.3 (\$0-\$0FFF)	40455+30(#-1)	n+1/17
L#P3BLI	R/W	Process 3 Alarm B Limit (%)	-3.3 to 103.3 (\$0-\$0FFF)	40456+30(#-1)	n+1/18
L#P4ALI	R/W	Process 4 Alarm A Limit (%)	-3.3 to 103.3 (\$0-\$0FFF)	40457+30(#-1)	n+1/19
L#P4BLI	R/W	Process 4 Alarm B Limit (%)	-3.3 to 103.3 (\$0-\$0FFF)	40458+30(#-1)	n+1/20
L#P1ATI	R/W	Process 1 Alarm A Type	0-3 (\$0000-\$0003)	40459+30(#-1)	n+2/13
L#P1BTI	R/W	Process 1 Alarm B Type	0-3 (\$0000-\$0003)	40460+30(#-1)	n+2/14
L#P2ATI	R/W	Process 2 Alarm A Type	0-3 (\$0000-\$0003)	40461+30(#-1)	n+2/15
L#P2BTI	R/W	Process 2 Alarm B Type	0-3 (\$0000-\$0003)	40462+30(#-1)	n+2/16
L#P3ATI	R/W	Process 3 Alarm A Type	0-3 (\$0000-\$0003)	40463+30(#-1)	n+2/17
L#P3BTI	R/W	Process 3 Alarm B Type	0-3 (\$0000-\$0003)	40464+30(#-1)	n+2/18
L#P4ATI	R/W	Process 4 Alarm A Type	0-3 (\$0000-\$0003)	40465+30(#-1)	n+2/19
L#P4BTI	R/W	Process 4 Alarm B Type	0-3 (\$0000-\$0003)	40466+30(#-1)	n+2/20
L#P1API	R/W	Process 1 Alarm A Priority	1-5 (\$0001-\$0005)	40467+30(#-1)	n+3/13
L#P1BPI	R/W	Process 1 Alarm B Priority	1-5 (\$0001-\$0005)	40468+30(#-1)	n+3/14
L#P2API	R/W	Process 2 Alarm A Priority	1-5 (\$0001-\$0005)	40469+30(#-1)	n+3/15
L#P2BPI	R/W	Process 2 Alarm B Priority	1-5 (\$0001-\$0005)	40470+30(#-1)	n+3/16
L#P3API	R/W	Process 3 Alarm A Priority	1-5 (\$0001-\$0005)	40471+30(#-1)	n+3/17
L#P3BPI	R/W	Process 3 Alarm B Priority	1-5 (\$0001-\$0005)	40472+30(#-1)	n+3/18
L#P4API	R/W	Process 4 Alarm A Priority	1-5 (\$0001-\$0005)	40473+30(#-1)	n+3/19
L#P4BPI	R/W	Process 4 Alarm B Priority	1-5 (\$0001-\$0005)	40474+30(#-1)	n+3/20
.....
		(spare)	0 (\$0000)	40480+30(#-1)	

Discrete Indicator [ODD] - (V2.2)

Code	R/W	Description	Range	Register (MB)	C/P (LIL)
n/a					

Discrete Indicator [ODP] - (V2.2)

Code	R/W	Description	Range	Register (MB)	C/P (LIL)
n/a				****	

**** NOTE: Registers (40451-40480) are reserved for ASCII Tags when the ODP display has been selected in configuration.

7.3.3 Static Loop Integer Data

Controller [ODC]

Code	R/W	Description	Range	Register (MB)	C/P (LIL)
L#PGI	R/W	Proportional Gain	-9.99 to -0.01 (\$1419-\$17FF) 0.01 to 9.99 (\$1801\$1BE7) -100.0 to -10.0 (\$2418-\$279C) 10.0 to 100.0 (\$2864-\$2BE8)	41201+30(#-1)	n/2
L#TII	R/W	Integral Time (min)	0.01 to 9.99 (\$2081-\$2467) 10.0 to 99.9 (\$10E4-\$1467) 100 to 3967 (\$30E4-\$3FFF)	41202+30(#-1)	n/3
L#TDI	R/W	Derivative Time (min)	0.00 to 9.99 (\$2080-\$2467) 10.0 to 100.0 (\$10E4-\$1468)	41203+30(#-1)	n/4
L#DGI	R/W	Derivative Gain	1.00 to 39.67 (\$20E4--\$2FFF)	41204+30(#-1)	n/5
L#MRI	R/W	Manual Reset (%)	0.0 to 100.0 (\$0080-\$0F80)	41205+30(#-1)	n/6
L#RHI	R	Range High	-1 to -32768 (\$FFFF-\$8000) 0 to 32767 (\$0000-\$7FFF)	41206+30(#-1)	n+3/10
L#RLI	R	Range Low	-1 to -32768 (\$FFFF-\$8000) 0 to 32767 (\$0000-\$7FFF)	41207+30(#-1)	n+3/11
L#DPPI	R	Decimal Point Position	0 to 5 (\$0000-\$0005)	41208+30(#-1)	n+3/12
L#PDPPPI	R	Process DPP	0 to 5 (\$0000-\$0005)	41209+30(#-1)	n/34
L#VDPPPI	R	Valve DPP	0 to 5 (\$0000-\$0005)	41210+30(#-1)	n+2/34
L#XDPPPI	R	Variable X DPP	0 to 5 (\$0000-\$0005)	41211+30(#-1)	n+3/34
L#YDPPPI	R	Variable Y DPP	0 to 5 (\$0000-\$0005)	41212+30(#-1)	n+4/34
		(spare)	0 (\$0000)	41213+30(#-1)	
.....
		(spare)	0 (\$0000)	41230+30(#-1)	

Sequencer [ODS] - (MASK Configurations)

Code	R/W	Description	Range	Register (MB)	C/P (LIL)
L#S006G0I	R/W	Step 6 Group 0 Input Mask	\$0000-\$FFFF	41201+30(#-1)	6/154
L#S006G0O	R/W	Step 6 Group 0 Output Mask	\$0000-\$FFFF	41202+30(#-1)	6/170
L#S006G1I	R/W	Step 6 Group 1 Input Mask	\$0000-\$FFFF	41203+30(#-1)	6/155
L#S006G1O	R/W	Step 6 Group 1 Output Mask	\$0000-\$FFFF	41204+30(#-1)	6/171
L#S006G2I	R/W	Step 6 Group 2 Input Mask	\$0000-\$FFFF	41205+30(#-1)	6/156
L#S006G2O	R/W	Step 6 Group 2 Output Mask	\$0000-\$FFFF	41206+30(#-1)	6/172
L#S007G0I	R/W	Step 7 Group 0 Input Mask	\$0000-\$FFFF	41207+30(#-1)	7/154
L#S007G0O	R/W	Step 7 Group 0 Output Mask	\$0000-\$FFFF	41208+30(#-1)	7/170
.....
L#S009G2I	R/W	Step 9 Group 2 Input Mask	\$0000-\$FFFF	41223+30(#-1)	9/156
L#S009G2O	R/W	Step 9 Group 2 Output Mask	\$0000-\$FFFF	41224+30(#-1)	9/172
L#S010G0I	R/W	Step 10 Group 0 Input Mask	\$0000-\$FFFF	41225+30(#-1)	10/154
L#S010G0O	R/W	Step 10 Group 0 Output Mask	\$0000-\$FFFF	41226+30(#-1)	10/170
L#S010G1I	R/W	Step 10 Group 1 Input Mask	\$0000-\$FFFF	41227+30(#-1)	10/155
L#S010G1O	R/W	Step 10 Group 1 Output Mask	\$0000-\$FFFF	41228+30(#-1)	10/171
L#S010G2I	R/W	Step 10 Group 2 Input Mask	\$0000-\$FFFF	41229+30(#-1)	10/156
L#S010G2O	R/W	Step 10 Group 2 Output Mask	\$0000-\$FFFF	41230+30(#-1)	10/172

Analog, Discrete, & Pushbutton Indicators [ODA] ODD] [ODP]- (V2.1)

Code	R/W	Description	Range	Register (MB)	C/P (LIL)
n/a				****	

**** NOTE: Registers (40451-40480) are reserved for ASCII Tags when the ODP display has been selected in configuration

7.3.4 Dynamic Loop Floating Point Data (32-bit IEEE)

Controller [ODC]

Code	R/W	Description	Range	Register (MB)	C/P (LIL)
L#PF	R	Process	Real	41951+20(#-1)	n/9-10
L#SF	R/W	Setpoint	Real	41953+20(#-1)	n+1/9-10
L#VF	R/W	Valve	Real	41955+20(#-1)	n+2/9-10
L#XF	R	X Variable	Real	41957+20(#-1)	n+3/25-26
L#YF	R	Y Variable	Real	41959+20(#-1)	n+4/25-26
L#RF	R/W	Ratio	Real	41961+20(#-1)	n/23-24
L#BF	R/W	Bias	Real	41963+20(#-1)	n/25-26
L#TLF	R	Totalizer	Real	41965+20(#-1)	n+3/13-14
		(spare)	(\$00000000)	41967+20(#-1)	
		(spare)	(\$00000000)	41969+20(#-1)	

Sequencer [ODS]

Code	R/W	Description	Range	Register (MB)	C/P (LIL)
L#SSNF	R/W	Sequencer Step No.*	Real	41951+20(#-1)	n/2-3
L#SAOF	R	Sequencer Analog Output	Real	41953+20(#-1)	n+1/2-3
L#SAOmF	R	Step Analog Out (most sig. word)#	Real	n/a	n+1/1
L#SAOIF	R	Step Analog Out (least sig. word)#	Real	n/a	n+2/1
L#SAEPF	R	Step Analog End Point	Real	41955+20(#-1)	n+1/4-5
L#SRTF	R/W	Step Remaining Time*	Real	41957+20(#-1)	n+3/2-3
L#SSTF	R	Sequencer Step Time	Real	41959+20(#-1)	n+3/4-5
L#SNSF	R	Sequencer Number of Steps	Real	41961+20(#-1)	n/6-7
L#SNGF	R	Sequencer Number of Groups	Real	41963+20(#-1)	n/8-9
L#SNRF	R	Sequencer Number of Recipes	Real	41965+20(#-1)	n+1/7-8
L#CRNF		Current Recipe Number @	Real	41967+20(#-1)	n+1/9-10
R/W		(spare)	0(\$00000000)	41969+20(#-1)	

Analog Indicator [ODA] - (V2.2)

Code	R/W	Description	Range	Register (MB)	C/P (LIL)
L#P1F	R	Process 1	Real	41951+20(#-1)	n/2-3
L#P2F	R	Process 2	Real	41953+20(#-1)	n+1/2-3
L#P3F	R	Process 3	Real	41955+20(#-1)	n+2/2-3
L#P4F	R	Process 4	Real	41957+20(#-1)	n+3/2-3
		(spare)	0(\$00000000)	41959/69+20(#-1)	

Discrete Indicator [ODD] & [ODP]- (V2.2)

Code	R/W	Description	Range	Register (MB)	C/P (LIL)
					n/a

* A Write command will force the Step or Remaining Time to the write value.

@ The current recipe can be changed if the Sequencer is in the HOLD mode.

7.3.5 Variable Loop Floating Point Data (32-bit IEEE)

Controller [ODC]

<u>Code</u>	<u>R/W</u>	<u>Description</u>	<u>Range</u>	<u>Register (MB)</u>	<u>C/P (LIL)</u>
L#TSPF	R/W	Target Setpoint	Real	42451+60(#-1)	n+1/13-14
L#HLF	R/W	Setpoint High Limit	Real	42453+60(#-1)	n+1/17-18
L#LLF	R/W	Setpoint Low Limit	Real	42455+60(#-1)	n+1/19-20
L#RTF	R/W	Setpoint Ramp Time (min)	Real	42457+60(#-1)	n+1/15-16
L#RRF	R/W	Setpoint Ramp Rate (units/min)	Real	42459+60(#-1)	n+1/21-22
L#A1LF	R/W	Alarm 1 Limit	Real	42461+60(#-1)	n+4/13-14
L#A2LF	R/W	Alarm 2 Limit	Real	42463+60(#-1)	n+4/15-16
L#A3LF	R/W	Alarm 3 Limit	Real	42465+60(#-1)	n+4/17-18
L#A4LF	R/W	Alarm 4 Limit	Real	42467+60(#-1)	n+4/19-20
L#T1F	R/W	Totalizer Preset 1	Real	42469+60(#-1)	n+3/15-16
L#T2F	R/W	Totalizer Preset 2	Real	42471+60(#-1)	n+3/17-18
L#Q1F	R/W	Quickset Hold 1	Real	42473+60(#-1)	n+1/41-42
L#Q2F	R/W	Quickset Hold 2	Real	42475+60(#-1)	n+2/41-42
L#BHLF	R/W	Batch Switch High Limit	Real	42477+60(#-1)	n+1/35-36
L#BLLF	R/W	Batch Switch Low Limit	Real	42479+60(#-1)	n+2/35-36
L#BPLF	R/W	Batch Switch Pre-Load	Real	42481+60(#-1)	n+3/35-36
L#BGF	R/W	Batch Switch Gain	Real	42483+60(#-1)	n+4/35-36
		(spares)	(\$00000000)	42485-42509+60(#-1)	

Sequencer (Timers - Running Values) [ODS]

<u>Code</u>	<u>R/W</u>	<u>Description</u>	<u>Range</u>	<u>Register (MB)</u>	<u>C/P (LIL)*</u>
L#DYT01ET	R	DYT01 Elapsed Time	Real	42451+60(#-1)	n/61-62
L#DYT01RT	R/W	DYT01 Remaining Time	Real	42453+60(#-1)	n/63-64
L#OST01ET	R	OST01 Elapsed Time	Real	42455+60(#-1)	n+1/61-62
L#OST01RT	R/W	OST01 Remaining Time	Real	42457+60(#-1)	n+1/63-64
L#RCT01ET	R	RCT01 Elapsed Time	Real	42459+60(#-1)	n+2/61-62
L#RCT01RT	R/W	RCT01 Remaining Time	Real	42461+60(#-1)	n+2/63-64
L#ROT01ET	R	ROT01 Elapsed Time	Real	42463+60(#-1)	n+3/61-62
L#ROT01RT	R/W	ROT01 Remaining Time	Real	42465+60(#-1)	n+3/63-64
L#DYT02ET	R	DYT02 Elapsed Time	Real	42467+60(#-1)	n/65-66
L#DYT02RT	R/W	DYT02 Remaining Time	Real	42469+60(#-1)	n/67-68
L#OST02ET	R	OST02 Elapsed Time	Real	42471+60(#-1)	n+1/65-66
L#OST02RT	R/W	OST02 Remaining Time	Real	42473+60(#-1)	n+1/67-68
L#RCT02ET	R	RCT02 Elapsed Time	Real	42475+60(#-1)	n+2/65-66
L#RCT02RT	R/W	RCT02 Remaining Time	Real	42477+60(#-1)	n+2/67-68
L#ROT02ET	R	ROT02 Elapsed Time	Real	42479+60(#-1)	n+3/65-66
L#ROT02RT	R/W	ROT02 Remaining Time	Real	42481+60(#-1)	n+3/67-68
L#DYT03ET	R	DYT03 Elapsed Time	Real	42483+60(#-1)	n/69-70
L#DYT03RT	R/W	DYT03 Remaining Time	Real	42485+60(#-1)	n/71-72
L#OST03ET	R	OST03 Elapsed Time	Real	42487+60(#-1)	n+1/69-70
L#OST03RT	R/W	OST03 Remaining Time	Real	42489+60(#-1)	n+1/71-72
L#RCT03ET	R	RCT03 Elapsed Time	Real	42491+60(#-1)	n+2/69-70
L#RCT03RT	R/W	RCT03 Remaining Time	Real	42493+60(#-1)	n+2/71-72
L#ROT03ET	R	ROT03 Elapsed Time	Real	42495+60(#-1)	n+3/69-70
L#ROT03RT	R/W	ROT03 Remaining Time	Real	42497+60(#-1)	n+3/71-72
		(spares)		42499-42509+60(#-1)	

* In addition to the timers listed here the LIL will map 1 through 21 (see LIL overview for exact locations).

Analog Indicator [ODA]- (V2.2)

<u>Code</u>	<u>R/W</u>	<u>Description</u>	<u>Range</u>	<u>Register (MB)</u>	<u>C/P (LIL)</u>
L#P1ALF	R/W	Process 1 Alarm A Limit	Real	42451+60(#-1)	n/13-14
L#P1BLF	R/W	Process 1 Alarm B Limit	Real	42453+60(#-1)	n/15-16
L#P2ALF	R/W	Process 2 Alarm A Limit	Real	42455+60(#-1)	n/17-18
L#P2BLF	R/W	Process 2 Alarm B Limit	Real	42457+60(#-1)	n/19-20
L#P3ALF	R/W	Process 3 Alarm A Limit	Real	42459+60(#-1)	n/21-22
L#P3BLF	R/W	Process 3 Alarm B Limit	Real	42461+60(#-1)	n/23-24
L#P4ALF	R/W	Process 4 Alarm A Limit	Real	42463+60(#-1)	n/25-26
L#P4BLF	R/W	Process 4 Alarm B Limit	Real	42465+60(#-1)	n/27-28
L#Q1F	R/W	Quickset Hold 1	Real	42467+60(#-1)	n+1/29-30
L#Q2F	R/W	Quickset Hold 2	Real	42469+60(#-1)	n+2/29-30
L#Q3F	R/W	Quickset Hold 3	Real	42471+60(#-1)	n+3/29-30
L#Q4F	R/W	Quickset Hold 4 (spares)	Real (\$00000000)	42473+60(#-1) 42475-42509+60(#-1)	n+4/29-30

Discrete Indicator [ODD] - (V2.2)

<u>Code</u>	<u>R/W</u>	<u>Description</u>	<u>Range</u>	<u>Register (MB)</u>	<u>C/P (LIL)</u>
n/a					

Pushbutton/Switch Indicator [ODP] - (V2.2)

<u>Code</u>	<u>R/W</u>	<u>Description</u>	<u>Range</u>	<u>Register (MB)</u>	<u>C/P (LIL)</u>
n/a			****		

**** NOTE: Registers (40451-40480) are reserved for ASCII Tags when the ODP display has been selected in configuration

7.3.6 Static Loop Floating Point Data (32-bit IEEE)

Controller [ODC]

<u>Code</u>	<u>R/W</u>	<u>Description</u>	<u>Range</u>	<u>Register (MB)</u>	<u>C/P (LIL)</u>
L#PGF	R/W	Proportional Gain	0.001 - 100.0	43951+60(#-1)	n/13-14
L#TIF	R/W	Integral Time	0.001 - 4000.0 min	43953+60(#-1)	n/15-16
L#TDF	R/W	Derivative Time	0.00 - 100.00 min	43955+60(#-1)	n/17-18
L#MRF	R/W	Manual Reset	0.00 - 100.00	43957+60(#-1)	n/21-22
L#ADF	R/W	Autotune Deviation	auto(0), 2.5-25%	43959+60(#-1)	n/37-38
L#AHF	R/W	Autotune Hysteresis	auto(0), 0.5 - 10.0%	43961+60(#-1)	n/39-40
L#ASF	R/W	Autotune Step (initial)	5 - 40%	43963+60(#-1)	n/41-42
L#APGF	R	Autotune Proportional Gain	0.001 - 1000.0	43965+60(#-1)	n/43-44
L#ATIF	R	Autotune Integral Time	0.001 - 4000.0 min	43967+60(#-1)	n/45-46
L#ATDF	R	Autotune Derivative Time	0.00 - 100.00 min	3969+60(#-1)	n/47-48
L#HDF	R/W	On-Off Controller HI Deviation	Real	43971+60(#-1)	n/11-12
L#LDF	R/W	On-Off Controller LO Deviation	Real	43973+60(#-1)	n+1/11-12
L#DBF	R/W	On-Off Controller DEADBAND	Real	43975+60(#-1)	n+2/11-12
L#PMNF	R/W	Process MIN SCALE	Real	43977+60(#-1)	n/27-28
L#PMXF	R/W	Process MAX SCALE	Real	43979+60(#-1)	n/29-30
L#VMNF	R/W	Valve MIN SCALE	Real	43981+60(#-1)	n+2/27-28
L#VMXF	R/W	ValveMAX SCALE	Real	43983+60(#-1)	n+2/29-30
L#XMNF	R/W	X Variable MIN SCALE	Real	43985+60(#-1)	n+3/27-28
L#XMXF	R/W	X Variable MAX SCALE	Real	43987+60(#-1)	n+3/29-30
L#YMNf	R/W	Y Variable MIN SCALE	Real	43989+60(#-1)	n+4/27-28
L#YMXF	R/W	Y Variable MAX SCALE	Real	43991+60(#-1)	n+4/29-30
L#Q1MNF	R/W	Quickset 1 MIN SCALE	Real	43993+60(#-1)	n+1/43-44
L#Q1MXF	R/W	Quickset 1 MAX SCALE	Real	43995+60(#-1)	n+1/45-46
L#Q2MNF	R/W	Quickset 2 MIN SCALE	Real	43997+60(#-1)	n+2/43-44
L#Q2MXF	R/W	Quickset 2 MAX SCALE	Real	44009+60(#-1)	n+2/45-46
L#DGF	R/W	Derivative Gain	1.00 - 30.00	44001+60(#-1)	n/19-20
		(spares)	(\$00000000)	44003-44009+60(#-1)	

Sequencer [ODS]

<u>Code</u>	<u>R/W</u>	<u>Description</u>	<u>Range</u>	<u>Register (MB)</u>	<u>C/P (LIL)</u>
L#S001TIM	R/W	Step 1 Time Period (min)	Real	43951+60(#-1)	1/150-151
L#S001AEP	R/W	Step 1 Analog End Point	Real	43953+60(#-1)	1/152-153
L#S002TIM	R/W	Step 2 Time Period (min)	Real	43955+60(#-1)	2/150-151
L#S002AEP	R/W	Step 2 Analog End Point	Real	43957+60(#-1)	2/152-153
L#S003TIM	R/W	Step 3 Time Period (min)	Real	43959+60(#-1)	3/150-151
L#S003AEP	R/W	Step 3 Analog End Point	Real	43961+60(#-1)	3/152-153
L#S004TIM	R/W	Step 4 Time Period (min)	Real	43963+60(#-1)	4/150-151
L#S004AEP	R/W	Step 4 Analog End Point	Real	43965+60(#-1)	4/152-153
L#S005TIM	R/W	Step 5 Time Period (min)	Real	43967+60(#-1)	5/150-151
L#S005AEP	R/W	Step 5 Analog End Point	Real	43969+60(#-1)	5/152-153
L#S006TIM	R/W	Step 6 Time Period (min)	Real	43971+60(#-1)	6/150-151
L#S006AEP	R/W	Step 6 Analog End Point	Real	43973+60(#-1)	6/152-153
L#S007TIM	R/W	Step 7 Time Period (min)	Real	43975+60(#-1)	7/150-151
L#S007AEP	R/W	Step 7 Analog End Point	Real	43977+60(#-1)	7/152-153
L#S008TIM	R/W	Step 8 Time Period (min)	Real	43979+60(#-1)	8/150-151
L#S008AEP	R/W	Step 8 Analog End Point	Real	43981+60(#-1)	8/152-153
L#S009TIM	R/W	Step 9 Time Period (min)	Real	43983+60(#-1)	9/150-151
L#S009AEP	R/W	Step 9 Analog End Point	Real	43985+60(#-1)	9/152-153
L#S010TIM	R/W	Step 10 Time Period (min)	Real	43987+60(#-1)	10/150-151
L#S010AEP	R/W	Step 10 Analog End Point	Real	43989+60(#-1)	10/152-153
		(spares)		44991-44009+60(#-1)	

Controller [ODA] - (V2.2)

<u>Code</u>	<u>R/W</u>	<u>Description</u>	<u>Range</u>	<u>Register (MB)</u>	<u>C/P (LIL)</u>
L#Q1MNF	R/W	Quickset 1 MIN SCALE	Real	43951+60(#-1)	n+1/31-32
L#Q1MXF	R/W	Quickset 1 MAX SCALE	Real	43953+60(#-1)	n+1/33-34
L#Q2MNF	R/W	Quickset 2 MIN SCALE	Real	43955+60(#-1)	n+2/31-32
L#Q2MXF	R/W	Quickset 2 MAX SCALE	Real	43957+60(#-1)	n+2/33-34
L#Q3MNF	R/W	Quickset 3 MIN SCALE	Real	43959+60(#-1)	n+3/31-32
L#Q3MXF	R/W	Quickset 3 MAX SCALE	Real	43961+60(#-1)	n+3/33-34
L#Q4MNF	R/W	Quickset 4 MIN SCALE	Real	43963+60(#-1)	n+4/31-32
L#Q4MXF	R/W	Quickset 4 MAX SCALE	Real	43965+60(#-1)	n+4/33-34
L#P1MNF	R	Process 1 MIN SCALE	Real	43967+60(#-1)	n+4/13-14
L#P1MXF	R	Process 1 MAX SCALE	Real	43969+60(#-1)	n+5/13-14
L#P2MNF	R	Process 2 MIN SCALE	Real	43971+60(#-1)	n+4/15-16
L#P2MXF	R	Process 2 MAX SCALE	Real	43973+60(#-1)	n+5/15-16
L#P3MNF	R	Process 3 MIN SCALE	Real	43975+60(#-1)	n+4/17-18
L#P3MXF	R	Process 3 MAX SCALE	Real	43977+60(#-1)	n+5/17-18
L#P4MNF	R	Process 4 MIN SCALE	Real	43979+60(#-1)	n+4/19-20
L#P4MXF	R	Process 4 MAX SCALE	Real	43981+60(#-1)	n+5/19-20
	(spares)		(\$00000000)	43983-44009+60(#-1)	

Discrete Indicator [ODD] - (V2.2)

<u>Code</u>	<u>R/W</u>	<u>Description</u>	<u>Range</u>	<u>Register (MB)</u>	<u>C/P (LIL)</u>
n/a					

Pushbutton/Switch Indicator [ODP] - (V2.2)

<u>Code</u>	<u>R/W</u>	<u>Description</u>	<u>Range</u>	<u>Register (MB)</u>	<u>C/P (LIL)</u>
n/a					

7.3.7 String Loop Data (8-bit ASCII Char - 2/Word)

Controller [ODC]

<u>Code</u>	<u>R/W</u>	<u>Description</u>	<u>Range</u>	<u>Register (MB)</u>	<u>C/P (LIL)</u>
L#TAG	R	Loop Tag	12 ASCII Char	45451+100(#-1)	n+3/2-7
L#PUR	R/W	Process Units - Reduced	4 ASCII Char	45457+100(#-1)	n+3/8-9
L#PU	R/W	Process Units	6 ASCII Char	45459+100(#-1)	n/31-33
L#VU	R/W	Valve Units	6 ASCII Char	45462+100(#-1)	n+2/31-33
L#XU	R/W	X Variable Units	6 ASCII Char	45465+100(#-1)	n+3/31-33
L#YU	R/W	Y Variable Units	6 ASCII Char	45468+100(#-1)	n+4/31-33
L#TLU	R/W	Totalizer Units	6 ASCII Char	45471+100(#-1)	n+3/19-21
L#Q1N	R	Quickset Hold 1 Name	8 ASCII Char	45474+100(#-1)	n+1/37-40
L#Q1U	R/W	Quickset Hold 1 Units	6 ASCII Char	45478+100(#-1)	n+3/37-39
L#Q2N	R	Quickset Hold 2 Name	8 ASCII Char	45481+100(#-1)	n+2/37-40
L#Q2U	R/W	Quickset Hold 2 Units	6 ASCII Char	45485+100(#-1)	n+3/40-42
L#LHM	R/W	Left Horizontal Bar Message	5 ASCII Char	45488+100(#-1)	n+2/13-15
L#RHM	R/W	Right Horizontal Bar Message (spares)	5 ASCII Char (\$0000)	45491+100(#-1) 45492-45550+100(#-1)	n+2/16-18

Sequencer [ODS]

<u>Code</u>	<u>R/W</u>	<u>Description</u>	<u>Range</u>	<u>Register (MB)</u>	<u>C/P (LIL)</u>
L#TAG	R	Loop Tag (V2.2)	12 ASCII Char	45451+100(#-1)	n/37-42
L#PMSG	R	Primary Message (V1.3)	8 ASCII Char	45457+100(#-1)	n+1/37-41
L#SMSG	R	Secondary Message (V1.3)	12 ASCII Char	45461+100(#-1)	n+2/37-42
L#CMSGa	R	Conditional Message a *(V1.3)	16 ASCII Char	45467+100(#-1)	n+3/37-44
L#CMSGb	R	Conditional Message b *(V1.3)	16 ASCII Char	45475+100(#-1)	n+4/37-44
L#CMSGc	R	Conditional Message c *(V1.3)	16 ASCII Char	45483+100(#-1)	n+5/37-44
L#CMSGd	R	Conditional Message d *(V1.3)	16 ASCII Char	45491+100(#-1)	n/49-56
L#CMSGe	R	Conditional Message e *(V1.3)	16 ASCII Char	45499+100(#-1)	n+1/49-56
L#CMSGf	R	Conditional Message f *(V1.3)	16 ASCII Char	45507+100(#-1)	n+2/49-56
L#CMSGg	R	Conditional Message g *(V1.3)	16 ASCII Char	45515+100(#-1)	n+3/49-56
L#CMSGh	R	Conditional Message h *(V1.3)	16 ASCII Char	45523+100(#-1)	n+4/49-56
L#CMSGi	R	Conditional Message i *(V1.3)	16 ASCII Char	45531+100(#-1)	n+5/49-56
L#RMSG	R	Recipe Message (V2.2)** (spares)	12 ASCII Char (\$0000)	45539+100(#-1) 45545-45550+100(#-1)	n/25-30

* Conditional messages are stacked in the order of occurrence. The 9 most recent active conditional messages can be viewed over LIL or Modbus.

** Version 1.3 included the Recipe Message at 45451. Version 2.2 moved the Recipe Message to a new location and placed the Loop Tag in place of the Recipe Message.

Analog Indicator [ODA] - (V2.2)

<u>Code</u>	<u>R/W</u>	<u>Description</u>	<u>Range</u>	<u>Register (MB)</u>	<u>C/P (LIL)</u>
L#TAG	R	Loop Tag	12 ASCII Char	45451+100(#-1)	n+4/2-7
L#P1T	R	Process 1 Tag	6 ASCII Char	45457+100(#-1)	n/4-6
L#P1U	R/W	Process 1 Units	6 ASCII Char	45460+100(#-1)	n/7-9
L#P2T	R	Process 2 Tag	6 ASCII Char	45463+100(#-1)	n+1/4-6
L#P2U	R/W	Process 2 Units	6 ASCII Char	45466+100(#-1)	n+1/7-9
L#P3T	R	Process 3 Tag	6 ASCII Char	45469+100(#-1)	n+2/4-6
L#P3U	R/W	Process 3 Units	6 ASCII Char	45472+100(#-1)	n+2/7-9
L#P4T	R	Process 4 Tag	6 ASCII Char	45475+100(#-1)	n+3/4-6
L#P4U	R/W	Process 4 Units	6 ASCII Char	45478+100(#-1)	n+3/7-9
L#Q1N	R	Quickset Hold 1 Name	8 ASCII Char	45481+100(#-1)	n+1/25-28
L#Q1U	R/W	Quickset Hold 1 Units	6 ASCII Char	45485+100(#-1)	n+1/22-24
L#Q2N	R	Quickset Hold 2 Name	8 ASCII Char	45488+100(#-1)	n+2/25-28
L#Q2U	R/W	Quickset Hold 2 Units	6 ASCII Char	45492+100(#-1)	n+2/22-24
L#Q3N	R	Quickset Hold 3 Name	8 ASCII Char	45495+100(#-1)	n+3/25-28
L#Q3U	R/W	Quickset Hold 3 Units	6 ASCII Char	45499+100(#-1)	n+3/22-24
L#Q4N	R	Quickset Hold 4 Name	8 ASCII Char	45502+100(#-1)	n+4/25-28
L#Q4U	R/W	Quickset Hold 4 Units (spares)	6 ASCII Char (\$0000)	45506+100(#-1) 45509-45550+100(#-1)	n+4/22-24

Discrete Indicator [ODD] - (V2.2)

<u>Code</u>	<u>R/W</u>	<u>Description</u>	<u>Range</u>	<u>Register (MB)</u>	<u>C/P (LIL)</u>
L#TAG	R	Loop Tag	12 ASCII Char	45451+100(#-1)	n+3/2-7
L#I0T	R	Input 0 Tag	6 ASCII Char	45457+100(#-1)	n/2-4
L#I1T	R	Input 1 Tag	6 ASCII Char	45460+100(#-1)	n+1/2-4
L#I2T	R	Input 2 Tag	6 ASCII Char	45463+100(#-1)	n+2/2-4
L#I3T	R	Input 3 Tag	6 ASCII Char	45466+100(#-1)	n/5-7
L#I4T	R	Input 4 Tag	6 ASCII Char	45469+100(#-1)	n+1/5-7
L#I5T	R	Input 5 Tag	6 ASCII Char	45472+100(#-1)	n+2/5-7
L#I6T	R	Input 6 Tag	6 ASCII Char	45475+100(#-1)	n/8-10
L#I7T	R	Input 7 Tag	6 ASCII Char	45478+100(#-1)	n+1/8-10
L#I8T	R	Input 8 Tag	6 ASCII Char	45481+100(#-1)	n+2/8-10
L#I9T	R	Input 9 Tag	6 ASCII Char	45484+100(#-1)	n/11-13
L#IAT	R	Input A Tag	6 ASCII Char	45487+100(#-1)	n+1/11-13
L#IBT	R	Input B Tag	6 ASCII Char	45490+100(#-1)	n+2/11-13
L#ICT	R	Input C Tag	6 ASCII Char	45493+100(#-1)	n/14-16
L#IDT	R	Input D Tag	6 ASCII Char	45496+100(#-1)	n+1/14-16
L#IET	R	Input E Tag	6 ASCII Char	45499+100(#-1)	n+2/14-16
L#IFT	R	Input F Tag (spares)	6 ASCII Char (\$0000)	45502+100(#-1) 45505-45550+100(#-1)	n+3/14-16

Discrete Indicator [ODP] - (V2.2)

<u>Code</u>	<u>R/W</u>	<u>Description</u>	<u>Range</u>	<u>Register (MB)</u>	<u>C/P (LIL)</u>
L#TAG	R	Loop Tag	12 ASCII Char	45451+100(#-1)	n/2-7
L#G1Tag	R	Group 1 Tag	6 ASCII Char	45457+100(#-1)	n/13-15
L#G1P1T	R	Group 1 PB1 Tag	6 ASCII Char	45460+100(#-1)	n/16-18
L#G1P2T	R	Group 1 PB2 Tag	6 ASCII Char	45463+100(#-1)	n/19-21
L#G1SAT	R	Group 1 Switch Position A Tag	6 ASCII Char	45466+100(#-1)	n/22-24
L#G1SMT	R	Group 1 Switch Position M Tag	6 ASCII Char	45469+100(#-1)	n+1/22-24
L#G1F1T	R	Group 1 Feedback 1 Tag	6 ASCII Char	45472+100(#-1)	n+1/13-15
L#G1F0T	R	Group 1 Feedback 0 Tag	6 ASCII Char	45475+100(#-1)	n+1/16-18
L#G2Tag	R	Group 2 Tag	6 ASCII Char	45478+100(#-1)	n/25-27
L#G2P1T	R	Group 2 PB1 Tag	6 ASCII Char	45481+100(#-1)	n/28-30
L#G2P2T	R	Group 2 PB2 Tag	6 ASCII Char	45484+100(#-1)	n/31-33
L#G2SAT	R	Group 2 Switch Position A Tag	6 ASCII Char	45487+100(#-1)	n/34-36
L#G2SMT	R	Group 2 Switch Position M Tag	6 ASCII Char	45490+100(#-1)	n+1/34-36
L#G2F1T	R	Group 2 Feedback 1 Tag	6 ASCII Char	45493+100(#-1)	n+1/25-27
L#G2F0T	R	Group 2 Feedback 0 Tag	6 ASCII Char	45496+100(#-1)	n+1/28-30

L#G3Tag	R	Group 3 Tag	6 ASCII Char	45499+100(#-1)	n/37-39
L#G3P1T	R	Group 3 PB1 Tag	6 ASCII Char	45502+100(#-1)	n/40-42
L#G3P2T	R	Group 3 PB2 Tag	6 ASCII Char	45505+100(#-1)	n/43-45
L#G3SAT	R	Group 3 Switch Position A Tag	6 ASCII Char	45508+100(#-1)	n/46-48
L#G3SMT	R	Group 3 Switch Position M Tag	6 ASCII Char	45511+100(#-1)	n+1/46-48
L#G3F1T	R	Group 3 Feedback 1 Tag	6 ASCII Char	45514+100(#-1)	n+1/37-39
L#G3F0T	R	Group 3 Feedback 0 Tag	6 ASCII Char	45517+100(#-1)	n+1/40-42
L#G4Tag	R	Group 4 Tag	6 ASCII Char	45520+100(#-1)	n/49-51
L#G4P1T	R	Group 4 PB1 Tag	6 ASCII Char	45523+100(#-1)	n/52-54
L#G4P2T	R	Group 4 PB2 Tag	6 ASCII Char	45526+100(#-1)	n/55-57
L#G4SAT	R	Group 4 Switch Position A Tag	6 ASCII Char	45529+100(#-1)	n/58-60
L#G4SMT	R	Group 4 Switch Position M Tag	6 ASCII Char	45532+100(#-1)	n+1/58-60
L#G4F1T	R	Group 4 Feedback 1 Tag	6 ASCII Char	45535+100(#-1)	n+1/49-51
L#G4F0T	R	Group 4 Feedback 0 Tag	6 ASCII Char	45538+100(#-1)	n+1/52-54
L#G5Tag	R	Group 5 Tag	6 ASCII Char	40451+30(#-1)	n/61-63
L#G5P1T	R	Group 5 PB1 Tag	6 ASCII Char	40454+30(#-1)	n/64-66
L#G5P2T	R	Group 5 PB2 Tag	6 ASCII Char	40457+30(#-1)	n/67-69
L#G5SAT	R	Group 5 Switch Position A Tag	6 ASCII Char	40460+30(#-1)	n/70-72
L#G5SMT	R	Group 5 Switch Position M Tag	6 ASCII Char	40463+30(#-1)	n+1/70-72
L#G5F1T	R	Group 5 Feedback 1 Tag	6 ASCII Char	40466+30(#-1)	n+1/61-63
L#G5F0T	R	Group 5 Feedback 0 Tag	6 ASCII Char	40469+30(#-1)	n+1/64-66
		Spares		40472-40480	

Note: These Modbus groupings normally used for Variable Loop Integer Data with displays other than ODP

L#G6Tag	R	Group 6 Tag	6 ASCII Char	41201+30(#-1)	n/73-75
L#G6P1T	R	Group 6 PB1 Tag	6 ASCII Char	41204+30(#-1)	n/76-78
L#G6P2T	R	Group 6 PB2 Tag	6 ASCII Char	41207+30(#-1)	n/79-81
L#G6SAT	R	Group 6 Switch Position A Tag	6 ASCII Char	41210+30(#-1)	n/82-84
L#G6SMT	R	Group 6 Switch Position M Tag	6 ASCII Char	41213+30(#-1)	n+1/82-84
L#G6F1T	R	Group 6 Feedback 1 Tag	6 ASCII Char	41216+30(#-1)	n+1/73-75
L#G6F0T	R	Group 6 Feedback 0 Tag	6 ASCII Char	41219+30(#-1)	n+1/76-78
		spares		41222-41230	

Note: These Modbus groupings normally used for Static Loop Integer Data with displays other than ODP

L#G7Tag	R	Group 7 Tag	6 ASCII Char	42451+60(#-1)	n/85-87
L#G7P1T	R	Group 7 PB1 Tag	6 ASCII Char	42454+60(#-1)	n/88-90
L#G7P2T	R	Group 7 PB2 Tag	6 ASCII Char	42457+60(#-1)	n/91-93
L#G7SAT	R	Group 7 Switch Position A Tag	6 ASCII Char	42460+60(#-1)	n/94-96
L#G7SMT	R	Group 7 Switch Position M Tag	6 ASCII Char	42463+60(#-1)	n+1/94-96
L#G7F1T	R	Group 7 Feedback 1 Tag	6 ASCII Char	42466+60(#-1)	n+1/85-87
L#G7F0T	R	Group 7 Feedback 0 Tag	6 ASCII Char	42469+60(#-1)	n+1/88-90
L#G8Tag	R	Group 8 Tag	6 ASCII Char	42472+60(#-1)	n/97-99
L#G8P1T	R	Group 8 PB1 Tag	6 ASCII Char	42475+60(#-1)	n/100-102
L#G8P2T	R	Group 8 PB2 Tag	6 ASCII Char	42478+60(#-1)	n/103-105
L#G8SAT	R	Group 8 Switch Position A Tag	6 ASCII Char	42481+60(#-1)	n/106-108
L#G8SMT	R	Group 8 Switch Position M Tag	6 ASCII Char	42484+60(#-1)	n+1/106-108
L#G8F1T	R	Group 8 Feedback 1 Tag	6 ASCII Char	42487+60(#-1)	n+1/97-99
L#G8F0T	R	Group 8 Feedback 0 Tag	6 ASCII Char	42490+60(#-1)	n+1/100-102
		spares		42493-42509	

Note: These Modbus groupings normally used for Variable Loop Floating Point Data with displays other than ODP

7.3.8 Coil Loop Data (1-bit)

Controller [ODC]

<u>Code</u>	<u>R/W</u>	<u>Description</u>	<u>Range</u>	<u>Coil(MB)</u>	<u>C/P (LIL)</u>
L#A	R/W	1-Auto 0-Manual	1/0	00296+48(#-1)	n+3/1(0)
L#L	R/W	1-Local	1/0	00297+48(#-1)	n+3/1(1)
L#SS	R	1-AM block in STANDBY	1/0	00298+48(#-1)	n+3/1(2)
L#E	R/W	1-External Set	1/0	00299+48(#-1)	n+3/1(3)
L#CN	R/W	1-Console	1/0	00300+48(#-1)	n+3/1(4)
L#CM	R/W	1-Computer	1/0	00301+48(#-1)	n+3/1(5)
L#RS	R/W	1-Ramping Setpoint	1.0	00302+48(#-1)	n+3/1(6)
L#OR	R	1-Override	1/0	00303+48(#-1)	n+3/1(7)
L#EM	R	1-Emergency Manual	1/0	00304+48(#-1)	n+3/1(8)
L#CH	R	1-Configuration Hold	1/0	00305+48(#-1)	n+3/1(9)
L#HL	R	1-HI Setpoint Limit	1/0	00306+48(#-1)	n+3/1(10)
L#LL	R	1-LO Setpoint Limit	1/0	00307+48(#-1)	n+3/1(11)
L#OS	R/W	1-Alarms - Out of Service	1/0	00308+48(#-1)	n+3/1(12)
L#U1S	R	1-U1 Status Active	1/0	00309+48(#-1)	n+3/1(13)
L#U2S	R	1-U2 Status Active	1/0	00310+48(#-1)	n+3/1(14)
L#AT	R/W	1-Autotune	1/0	00311+48(#-1)	n+3/1(15)
L#A1	R	1-Alarm 1 is Active	1/0	00312+48(#-1)	n+4/1(0)
L#N1	R/W	1-Alarm 1 is Not Acknowledged	1/0	00313+48(#-1)	n+4/1(1)
L#E1	R/W	1-Alarm 1 is Enabled	1/0	00314+48(#-1)	n+4/1(2)
L#A2	R	1-Alarm 2 is Active	1/0	00315+48(#-1)	n+4/1(3)
L#N2	R/W	1-Alarm 2 is Not Acknowledged	1/0	00316+48(#-1)	n+4/1(4)
L#E2	R/W	1-Alarm 2 is Enabled	1/0	00317+48(#-1)	n+4/1(5)
L#A3	R	1-Alarm 3 is Active	1/0	0318+48(#-1)	n+4/1(6)
L#N3	R/W	1-Alarm 3 is Not Acknowledged	1/0	00319+48(#-1)	n+4/1(7)
L#E3	R/W	1-Alarm 3 is Enabled	1/0	00320+48(#-1)	n+4/1(8)
L#A4	R	1-Alarm 4 is Active	1/0	00321+48(#-1)	n+4/1(9)
L#N4	R/W	1-Alarm 4 is Not Acknowledged	1/0	00322+48(#-1)	n+4/1(10)
L#E4	R/W	1-Alarm 4 is Enabled	1/0	00323+48(#-1)	n+4/1(11)
L#OS2	R/W	1-Alarms - Out of Service	1/0	00324+48(#-1)	n+4/1(12)
L#CC	R	1-Configuration has Changed	1/0	00325+48(#-1)	n+4/1(13)
L#NA	R/W	1-Unacknowledged Loop Event	1/0	00326+48(#-1)	n+4/1(14)
L#AE	R	1-Active Loop Event	1/0	00327+48(#-1)	n+4/1(15)
L#NSS	R/W	1-Not Ack'd STANDBY (VI.3)	1/0	00328+48(#-1)	n+4/10(0)
L#NOR	R/W	1-Not Ack'd Override (VI.3)	1/0	00329+48(#-1)	n+4/10(1)
L#NEM	R/W	1-Not Ack'd Emergency Man (VI.3)	1/0	00330+48(#-1)	n+4/10(2)
L#NHL	R/W	1-Not Ack'd HI Setpoint Limit (VI.3)	1/0	00331+48(#-1)	n+4/10(3)
L#NLL	R/W	1-Not Ack'd LO Setpoint Limit (VI.3)	1/0	00332+48(#-1)	n+4/10(4)
L#NU1	R/W	1-Not Ack'd U1 Status (VI.3)	1/0	00333+48(#-1)	n+4/10(5)
L#NU2	R/W	1-Not Ack'd U2 Status (VI.3)	1/0	00334+48(#-1)	n+4/10(6)
L#NW1	R/W	1-Not Ack'd W1 Status (VI.3)	1/0	00335+48(#-1)	n+4/10(7)
L#NW2	R/W	1-Not Ack'd W2 Status (VI.3)	1/0	00336+48(#-1)	n+4/10(8)
L#NW3	R/W	1-Not Ack'd W3 Status (VI.3)	1/0	00337+48(#-1)	n+4/10(9)
L#NE1	R/W	1-Not Ack'd E1 Status (VI.3)	1/0	00338+48(#-1)	n+4/10(10)
L#NE2	R/W	1-Not Ack'd E2 Status (VI.3)	1/0	00339+48(#-1)	n+4/10(11)
L#NE3	R/W	1-Not Ack'd E3 Status (VI.3)	1/0	00340+48(#-1)	n+4/10(12)
L#XAT	W	1-Transfer Autotune Parameters (VI.3)	1/0	00341+48(#-1)	n+4/10(13)
L#PB1CR/W		PB1SW Input MD (*) (VI.3)	1/0	00342+48(#-1)	n+4/10(14)
L#PB2CR/W		PB2SW Input MD (*) (VI.3)	1/0	00343+48(#-1)	n+4/10(15)

* These bits indicate the status of the switch input MD. A write of a "1" will have the same effect as pressing and releasing the button on the faceplate. If the action of the switch is sustained the switch will change position. If the action is momentary the switch will close for one scan cycle.

Control Loop Status Word (L#CLS) - channel n+3/parameter 1

BIT	Description	Value	Block	Read/Write	Output
0	Auto/Manual (A)	1-Auto 0-Manual	A/M	R/W	
1	Local Loop (L)	1-Local	ODC	R/W	L
2	Standby Sync (SS)	1-Standby	A/M	R	
3	External/Internal (E)	1-External 0-Internal	E/I	R/W	ES
4	Console (CN)	1-Console	ODC	R/W	CN
5	Computer (CM)	1-Computer	ODC	R/W	CM
6	Ramping Setpoint (RS)	1-Ramping Setpoint	SETPT	R/W	RS
7	Override (OR)	1-Override	ORSL	R	OS
8	Emergency Manual (EM)	1-Emergency Manual	A/M	R	
9	Configuration Hold (CH)	1-Configuration Hold		R	
10	HI Setpoint Limit (HL)	1-HI Setpoint Limit	SPLIM	R	HS
11	LO Setpoint Limit (LL)	1-LO Setpoint Limit	SPLIM	R	LS
12	Alarms are Out of Service (OS)	1-Out of Service	ALARM	R/W	
13	U1 Status Active (U1S)	1- U1 Active	ODC	R	
14	U2 Status Active (U2S)	1- U2 Active	ODC	R	
15	Autotune is active (AT)	1-Autotune		R/W	

Control Loop Alarm Status Word (L#ASW) - channel n+4/parameter 1

BIT	Description	Value	Block	Read/Write	Output
0	Alarm 1 is Active (A1)	1-Active	ALARM	R	
1	Alarm 1 is Not Acknowledged (N1)	1-Not Acknowledged	ALARM	R/W	
2	Alarm 1 is Enabled (E1)	1-Enabled	ALARM	R/W	
3	Alarm 2 is Active (A2)	1-Active	ALARM	R	
4	Alarm 2 is Not Acknowledged (N2)	1-Not Acknowledged	ALARM	R/W	
5	Alarm 2 is Enabled (E2)	1-Enabled	ALARM	R/W	
6	Alarm 3 is Active (A3)	1-Active	ALARM	R	
7	Alarm 3 is Not Acknowledged (N3)	1-Not Acknowledged	ALARM	R/W	
8	Alarm 3 is Enabled (E3)	1-Enabled	ALARM	R/W	
9	Alarm 4 is Active (A4)	1-Active	ALARM	R	
10	Alarm 4 is Not Acknowledged (N4)	1-Not Acknowledged	ALARM	R/W	
11	Alarm 4 is Enabled (E4)	1-Enabled	ALARM	R/W	
12	Alarms are Out of Service (OS)	1-Out of Service	ALARM	R/W	
13	Configuration has Changed (CC)	1-Loop Configured		R	
14	Unacknowledged Loop Event (NA)	1-Unacknowledged Event		R/W	
15	Active Loop Event (AE)	1- Active Loop Event		R	

Extended Control Loop Status Word (L#ECLS) - channel n+4/parameter 10

BI T	Description	Value	Block	Read/Write	Output
0	Not Ack'd STANDBY	1-Not Acknowledged	A/M	R/W	
1	Not Ack'd Override	1-Not Acknowledged	A/M	R/W	
2	Not Ack'd Emergency Manual	1-Not Acknowledged	A/M	R/W	
3	Not Ack'd HI Setpoint Limit	1-Not Acknowledged	SPLIM	R/W	
4	Not Ack'd LO Setpoint Limit	1-Not Acknowledged	SPLIM	R/W	
5	Not Ack'd User 1 Status	1-Not Acknowledged	ODC	R/W	
6	Not Ack'd User 2 Status	1-Not Acknowledged	ODC	R/W	
7	Not Ack'd Autotune W1 Warning	1-Not Acknowledged	PID	R/W	
8	Not Ack'd Autotune W2 Warning	1-Not Acknowledged	PID	R/W	
9	Not Ack'd Autotune W3 Warning	1-Not Acknowledged	PID	R/W	
10	Not Ack'd Autotune E1 Warning	1-Not Acknowledged	PID	R/W	
11	Not Ack'd Autotune E2 Warning	1-Not Acknowledged	PID	R/W	
12	Not Ack'd Autotune E3 Warning	1-Not Acknowledged	PID	R/W	
13	Transfer Autotune Parameters	1-Transfer	PID	W	
14	PB1SW Input MD (*)	1-High, 0-Low	PB1SW	R/W	
15	PB2SW Input MD (*)	1-High, 0-Low	PB2SW	R/W	

* These bits indicate the status of the switch input MD. A write of a "1" will have the same effect as pressing and releasing the button on the faceplate. If the action of the switch is sustained the switch will change position. If the action is momentary, the switch will close for one scan cycle.

Sequencer Loop [ODS]

Code	R/W	Description	Range	Coil (MB)	C/P (LIL)
L#HS	R	1-Hold Sequencer	1/0	00296+48(#-1)	n+4/1(0)
L#L	R/W	1-Loop Local	1/0	00297+48(#-1)	n+4/1(1)
L#RSQ	W	1-Reset Sequencer	1/0	00298+48(#-1)	n+4/1(2)
L#TC	R	1-Track	1/0	00299+48(#-1)	n+4/1(3)
L#CN	R/W	1-Console	1/0	00300+48(#-1)	n+4/1(4)
L#CM	R/W	1-Computer	1/0	00301+48(#-1)	n+4/1(5)
L#SSF	W	1-Step Forward (normal 0)	1/0	00302+48(#-1)	n+4/1(6)
L#SSB	W	1-Step Backward (normal 0)	1/0	00303+48(#-1)	n+4/1(7)
		(spare)	1/0	00304+48(#-1)	n+4/1(8)
L#CH	R	1-Configuration Hold	1/0	00305+48(#-1)	n+4/1(9)
L#SSC	R	1-Steps Completed	1/0	00306+48(#-1)	n+4/1(10)
		(spare)	0	00307+48(#-1)	n+4/1(11)
		(spare)	0	00308+48(#-1)	n+4/1(12)
L#PB1	R	PB1SW Input MD (*) (VI.3)	1/0	00309+48(#-1)	n+4/1(13)
L#PB2	R	PB2SW Input MD (*) (VI.3)	1/0	00310+48(#-1)	n+4/1(14)
L#PB3	R	PB3SW Input MD (*) (VI.3)	1/0	00311+48(#-1)	n+4/1(15)
L#A1	R	1-Alarm 1 is Active	1/0	00312+48(#-1)	n+5/1(0)
L#N1	R/W	1-Alarm 1 is Not Acknowledged	1/0	00313+48(#-1)	n+5/1(1)
L#E1	R/W	1-Alarm 1 is Enabled	1/0	00314+48(#-1)	n+5/1(2)
L#A2	R	1-Alarm 2 is Active	1/0	00315+48(#-1)	n+5/1(3)
L#N2	R/W	1-Alarm 2 is Not Acknowledged	1/0	00316+48(#-1)	n+5/1(4)
L#E2	R/W	1-Alarm 2 is Enabled	1/0	00317+48(#-1)	n+5/1(5)
L#A3	R	1-Alarm 3 is Active	1/0	00318+48(#-1)	n+5/1(6)
L#N3	R/W	1-Alarm 3 is Not Acknowledged	1/0	00319+48(#-1)	n+5/1(7)
L#E3	R/W	1-Alarm 3 is Enabled	1/0	00320+48(#-1)	n+5/1(8)
L#A4	R	1-Alarm 4 is Active	1/0	00321+48(#-1)	n+5/1(9)
L#N4	R/W	1-Alarm 4 is Not Acknowledged	1/0	00322+48(#-1)	n+5/1(10)
L#E4	R/W	1-Alarm 4 is Enabled	1/0	00323+48(#-1)	n+5/1(11)
L#OS2	R/W	1-Alarms - Out of Service	1/0	00324+48(#-1)	n+5/1(12)
L#CC	R	1-Configuration has Changed	1/0	00325+48(#-1)	n+5/1(13)
L#NA	R/W	1-Unacknowledged Loop Event	1/0	00326+48(#-1)	n+5/1(14)
L#AE	R	1-Active Loop Event	1/0	00327+48(#-1)	n+5/1(15)
		(spare)	0	00328+48(#-1)	

* These bits indicate the status of the switch input MD. A write of a "1" will have the same effect as pressing and releasing the button on the faceplate. If the action of the switch is sustained the switch will change position. If the action is momentary the switch will close for one scan cycle.

Sequencer Loop Status Word (L#SLS) - channel n+4/parameter 1

BIT	Description	Value	Block	Read/Write	Output
0	Hold Sequencer (HS)	1-Hold	PRSEQ	R	
1	Local (L)	1-Local	ODS	R/W	L
2	Reset Sequencer (RSQ)	1-Reset	PRSEQ	W	
3	Track Command (TC)	1-Track	PRSEQ	R	
4	Console (CN)	1-Console	ODS	R/W	CN
5	Computer CM)	1-Computer	ODS	R/W	CM
6	Step Forward (SSF)	1-Step	PRSEQ	W	
7	Step Backward (SSB)	1-Step	PRSEQ	W	
8					
9	Configuration Hold (CH)	1-Configuration Hold		R	
10	Steps Completed (SSC)	1- Steps Complete	PRSEQ	R	
11					
12					
13	PB1SW Input MD (PB1)	1/0 (write of 1 presses PB)	PB1SW	R/W	
14	PB2SW Input MD (PB2)	1/0 (write of 1 presses PB)	PB2SW	R/W	
15	PB3SW Input MD (PB3)	1/0 (write of 1 presses PB)	PB2SW	R/W	

Sequencer Loop Alarm Status Word (L#ASW) - channel n+5/parameter 1

BIT	Description	Value	Block	Read/Write	Output
0	Alarm 1 is Active (A1)	1-Active	ALARM	R	
1	Alarm 1 is Not Acknowledged (N1)	1-Not Acknowledged	ALARM	R/W	
2	Alarm 1 is Enabled (E1)	1-Enabled	ALARM	R/W	
3	Alarm 2 is Active (A2)	1-Active	ALARM	R	
4	Alarm 2 is Not Acknowledged (N2)	1-Not Acknowledged	ALARM	R/W	
5	Alarm 2 is Enabled (E2)	1-Enabled	ALARM	R/W	
6	Alarm 3 is Active (A3)	1-Active	ALARM	R	
7	Alarm 3 is Not Acknowledged (N3)	1-Not Acknowledged	ALARM	R/W	
8	Alarm 3 is Enabled (E3)	1-Enabled	ALARM	R/W	
9	Alarm 4 is Active (A4)	1-Active	ALARM	R	
10	Alarm 4 is Not Acknowledged (N4)	1-Not Acknowledged	ALARM	R/W	
11	Alarm 4 is Enabled (E4)	1-Enabled	ALARM	R/W	
12	Alarms are Out of Service (OS)	1-Out of Service	ALARM	R/W	
13	Configuration has Changed (CC)	1-Loop Configured		R	
14	Unacknowledged Loop Event (NA)	1-Unacknowledged Event		R/W	
15	Active Loop Event (AE)	1- Active Loop Event		R	

Analog Indicator [ODA] - (V2.2)

Code	R/W	Description	Range	Coil(MB)	C/P (LIL)
L#P1AA	R	1-Process 1 Alarm A is Active	1/0	00296+48(#-1)	n+4/1(0)
L#P1AN	R/W	1-Process 1 Alarm A is Not Acknowledged	1/0	00297+48(#-1)	n+4/1(1)
L#P1AE	R/W	1-Process 1 Alarm A is Enabled	1/0	00298+48(#-1)	n+4/1(2)
L#P1BA	R	1-Process 1 Alarm B is Active	1/0	00299+48(#-1)	n+4/1(3)
L#P1BN	R/W	1-Process 1 Alarm B is Not Acknowledged	1/0	00300+48(#-1)	n+4/1(4)
L#P1BE	R/W	1-Process 1 Alarm B is Enabled	1/0	00301+48(#-1)	n+4/1(5)
L#P2AA	R	1-Process 2 Alarm A is Active	1/0	00302+48(#-1)	n+4/1(6)
L#P2AN	R/W	1-Process 2 Alarm A is Not Acknowledged	1/0	00303+48(#-1)	n+4/1(7)
L#P2AE	R/W	1-Process 2 Alarm A is Enabled	1/0	00304+48(#-1)	n+4/1(8)
L#P2BA	R	1-Process 2 Alarm B is Active	1/0	00305+48(#-1)	n+4/1(9)
L#P2BN	R/W	1-Process 2 Alarm B is Not Acknowledged	1/0	00306+48(#-1)	n+4/1(10)
L#P2BE	R/W	1-Process 2 Alarm B is Enabled	1/0	00307+48(#-1)	n+4/1(11)
L#OS1	R/W	1-Alarms - Out of Service	1/0	00308+48(#-1)	n+4/1(12)
L#PB1	R/W	PB1SW Input MD (*) (VI.3)	1/0	00309+48(#-1)	n+4/1(13)
L#PB2	R/W	PB2SW Input MD (*) (VI.3)	1/0	00310+48(#-1)	n+4/1(14)
L#PB3	R/W	PB3SW Input MD (*) (VI.3)	1/0	00311+48(#-1)	n+4/1(15)
L#P3AA	R	1-Process 3 Alarm A is Active	1/0	00312+48(#-1)	n+5/1(0)
L#P3AN	R/W	1-Process 3 Alarm A is Not Acknowledged	1/0	00313+48(#-1)	n+5/1(1)
L#P3AE	R/W	1-Process 3 Alarm A is Enabled	1/0	00314+48(#-1)	n+5/1(2)
L#P3BA	R	1-Process 3 Alarm B is Active	1/0	00315+48(#-1)	n+5/1(3)
L#P3BN	R/W	1-Process 3 Alarm B is Not Acknowledged	1/0	00316+48(#-1)	n+5/1(4)
L#P3BE	R/W	1-Process 3 Alarm B is Enabled	1/0	00317+48(#-1)	n+5/1(5)
L#P4AA	R	1-Process 4 Alarm A is Active	1/0	00318+48(#-1)	n+5/1(6)
L#P4AN	R/W	1-Process 4 Alarm A is Not Acknowledged	1/0	00319+48(#-1)	n+5/1(7)
L#P4AE	R/W	1-Process 4 Alarm A is Enabled	1/0	00320+48(#-1)	n+5/1(8)
L#P4BA	R	1-Process 4 Alarm B is Active	1/0	00321+48(#-1)	n+5/1(9)
L#P4BN	R/W	1-Process 4 Alarm B is Not Acknowledged	1/0	00322+48(#-1)	n+5/1(10)
L#P4BE	R/W	1-Process 4 Alarm B is Enabled	1/0	00323+48(#-1)	n+5/1(11)
L#OS	R/W	1-Alarms - Out of Service	1/0	00324+48(#-1)	n+5/1(12)
L#CC	R	1-Configuration has Changed	1/0	00325+48(#-1)	n+5/1(13)
L#NA	R/W	1-Unacknowledged Loop Event	1/0	00326+48(#-1)	n+5/1(14)
L#AE	R	1-Active Loop Event	1/0	00327+48(#-1)	n+5/1(15)

* These bits indicate the status of the switch input MD. A write of a "1" will have the same effect as pressing and releasing the button on the faceplate. If the action of the switch is sustained the switch will change position. If the action is momentary the switch will close for one scan cycle.

Analog Indicator Loop Status Word (L#W1) - channel n+4/parameter 1

BIT	Description	Value	Block	Read/Write	Output
0	P1 Alarm A is Active (A1)	1-Active	ALARM	R	
1	P1 Alarm A is Not Ack'd (N1)	1-Not Acknowledged	ALARM	R/W	
2	P1 Alarm A is Enabled (E1)	1-Enabled	ALARM	R/W	
3	P1 Alarm B is Active (A1)	1-Active	ALARM	R	
4	P1 Alarm B is Not Ack'd (N1)	1-Not Acknowledged	ALARM	R/W	
5	P1 Alarm B is Enabled (E1)	1-Enabled	ALARM	R/W	
6	P2 Alarm A is Active (A1)	1-Active	ALARM	R	
7	P2 Alarm A is Not Ack'd (N1)	1-Not Acknowledged	ALARM	R/W	
8	P2 Alarm A is Enabled (E1)	1-Enabled	ALARM	R/W	
9	P2 Alarm B is Active (A1)	1-Active	ALARM	R	
10	P2 Alarm B is Not Ack'd (N1)	1-Not Acknowledged	ALARM	R/W	
11	P2 Alarm B is Enabled (E1)	1-Enabled	ALARM	R/W	
12	Alarms are Out of Service (OS)	1-Out of Service	ALARM	R/W	
13	PB1SW Input MD (PB1)	1/0 (write of 1 presses PB)	PB1SW	R/W	
14	PB2SW Input MD (PB2)	1/0 (write of 1 presses PB)	PB2SW	R/W	
15	PB3SW Input MD (PB3)	1/0 (write of 1 presses PB)	PB2SW	R/W	

Analog Indicator Loop Alarm Status Word (L#SW2) - channel n+5/parameter 1

BIT	Description	Value	Block	Read/Write	Output
0	P3 Alarm A is Active (A1)	1-Active	ALARM	R	
1	P3 Alarm A is Not Ack'd (N1)	1-Not Acknowledged	ALARM	R/W	
2	P3 Alarm A is Enabled (E1)	1-Enabled	ALARM	R/W	
3	P3 Alarm B is Active (A1)	1-Active	ALARM	R	
4	P3 Alarm B is Not Ack'd (N1)	1-Not Acknowledged	ALARM	R/W	
5	P3 Alarm B is Enabled (E1)	1-Enabled	ALARM	R/W	
6	P4 Alarm A is Active (A1)	1-Active	ALARM	R	
7	P4 Alarm A is Not Ack'd (N1)	1-Not Acknowledged	ALARM	R/W	
8	P4 Alarm A is Enabled (E1)	1-Enabled	ALARM	R/W	
9	P4 Alarm B is Active (A1)	1-Active	ALARM	R	
10	P4 Alarm B is Not Ack'd (N1)	1-Not Acknowledged	ALARM	R/W	
11	P4 Alarm B is Enabled (E1)	1-Enabled	ALARM	R/W	
12	Alarms are Out of Service (OS)	1-Out of Service	ALARM	R/W	
13	Configuration has Changed (CC)	1-Loop Configured		R	
14	Unacknowledged Loop Event (NA)	1-Unacknowledged Event		R/W	
15	Active Loop Event (AE)	1- Active Loop Event		R	

Digital Indicator [ODD] - (V2.2)

<u>Code</u>	<u>R/W</u>	<u>Description</u>	<u>Range</u>	<u>Coil(MB)</u>	<u>C/P (LIL)</u>
L#D0I	R	Discrete 0 Input 1-ON 0-OFF	1/0	00296+48(#-1)	n/1(0)
L#D1I	R	Discrete 1 Input 1-ON 0-OFF	1/0	00297+48(#-1)	n/1(1)
L#D2I	R	Discrete 2 Input 1-ON 0-OFF	1/0	00298+48(#-1)	n/1(2)
L#D3I	R	Discrete 3 Input 1-ON 0-OFF	1/0	00299+48(#-1)	n/1(3)
L#D4I	R	Discrete 4 Input 1-ON 0-OFF	1/0	00300+48(#-1)	n/1(4)
L#D5I	R	Discrete 5 Input 1-ON 0-OFF	1/0	00301+48(#-1)	n/1(5)
L#D6I	R	Discrete 6 Input 1-ON 0-OFF	1/0	00302+48(#-1)	n/1(6)
L#D7I	R	Discrete 7 Input 1-ON 0-OFF	1/0	00303+48(#-1)	n/1(7)
L#D8I	R	Discrete 8 Input 1-ON 0-OFF	1/0	00304+48(#-1)	n/1(8)
L#D9I	R	Discrete 9 Input 1-ON 0-OFF	1/0	00305+48(#-1)	n/1(9)
L#DAI	R	Discrete A Input 1-ON 0-OFF	1/0	00306+48(#-1)	n/1(10)
L#DBI	R	Discrete B Input 1-ON 0-OFF	1/0	00307+48(#-1)	n/1(11)
L#DCI	R	Discrete C Input 1-ON 0-OFF	1/0	00308+48(#-1)	n/1(12)
L#DDI	R	Discrete D Input 1-ON 0-OFF	1/0	00309+48(#-1)	n/1(13)
L#DEI	R	Discrete E Input 1-ON 0-OFF	1/0	00310+48(#-1)	n/1(14)
L#DFI	R	Discrete F Input 1-ON 0-OFF	1/0	00311+48(#-1)	n/1(15)
L#D0S	R/W	Discrete 0 Status 1-Auto 0-Manual (*)	1/0	00312+48(#-1)	n+1/1(0)
L#D1S	R/W	Discrete 1 Status 1-Auto 0-Manual (*)	1/0	00313+48(#-1)	n+1/1(1)
L#D2S	R/W	Discrete 2 Status 1-Auto 0-Manual (*)	1/0	00314+48(#-1)	n+1/1(2)
L#D3S	R/W	Discrete 3 Status 1-Auto 0-Manual (*)	1/0	00315+48(#-1)	n+1/1(3)
L#D4S	R/W	Discrete 4 Status 1-Auto 0-Manual (*)	1/0	00316+48(#-1)	n+1/1(4)
L#D5S	R/W	Discrete 5 Status 1-Auto 0-Manual (*)	1/0	00317+48(#-1)	n+1/1(5)
L#D6S	R/W	Discrete 6 Status 1-Auto 0-Manual (*)	1/0	00318+48(#-1)	n+1/1(6)
L#D7S	R/W	Discrete 7 Status 1-Auto 0-Manual (*)	1/0	00319+48(#-1)	n+1/1(7)
L#D8S	R/W	Discrete 8 Status 1-Auto 0-Manual (*)	1/0	00320+48(#-1)	n+1/1(8)
L#D9S	R/W	Discrete 9 Status 1-Auto 0-Manual (*)	1/0	00321+48(#-1)	n+1/1(9)
L#DAS	R/W	Discrete A Status 1-Auto 0-Manual (*)	1/0	00322+48(#-1)	n+1/1(10)
L#DBS	R/W	Discrete B Status 1-Auto 0-Manual (*)	1/0	00323+48(#-1)	n+1/1(11)
L#DCS	R/W	Discrete C Status 1-Auto 0-Manual (*)	1/0	00324+48(#-1)	n+1/1(12)
L#DDS	R/W	Discrete D Status 1-Auto 0-Manual (*)	1/0	00325+48(#-1)	n+1/1(13)
L#DES	R/W	Discrete E Status 1-Auto 0-Manual (*)	1/0	00326+48(#-1)	n+1/1(14)
L#DFS	R/W	Discrete F Status 1-Auto 0-Manual (*)	1/0	00327+48(#-1)	n+1/1(15)
L#D0O	R/W	Discrete 0 Output 1-ON 0-OFF	1/0	00328+48(#-1)	n+2/1(0)
L#D1O	R/W	Discrete 1 Output 1-ON 0-OFF	1/0	00329+48(#-1)	n+2/1(1)
L#D2O	R/W	Discrete 2 Output 1-ON 0-OFF	1/0	00330+48(#-1)	n+2/1(2)
L#D3O	R/W	Discrete 3 Output 1-ON 0-OFF	1/0	00331+48(#-1)	n+2/1(3)
L#D4O	R/W	Discrete 4 Output 1-ON 0-OFF	1/0	00332+48(#-1)	n+2/1(4)
L#D5O	R/W	Discrete 5 Output 1-ON 0-OFF	1/0	00333+48(#-1)	n+2/1(5)
L#D6O	R/W	Discrete 6 Output 1-ON 0-OFF	1/0	00334+48(#-1)	n+2/1(6)
L#D7O	R/W	Discrete 7 Output 1-ON 0-OFF	1/0	00335+48(#-1)	n+2/1(7)
L#D8O	R/W	Discrete 8 Output 1-ON 0-OFF	1/0	00336+48(#-1)	n+2/1(8)
L#D9O	R/W	Discrete 9 Output 1-ON 0-OFF	1/0	00337+48(#-1)	n+2/1(9)
L#DAO	R/W	Discrete A Output 1-ON 0-OFF	1/0	00338+48(#-1)	n+2/1(10)
L#DBO	R/W	Discrete B Output 1-ON 0-OFF	1/0	00339+48(#-1)	n+2/1(11)
L#DCO	R/W	Discrete C Output 1-ON 0-OFF	1/0	00340+48(#-1)	n+2/1(12)
L#DDO	R/W	Discrete D Output 1-ON 0-OFF	1/0	00341+48(#-1)	n+2/1(13)
L#DEO	R/W	Discrete E Output 1-ON 0-OFF	1/0	00342+48(#-1)	n+2/1(14)
L#DFO	R/W	Discrete F Output 1-ON 0-OFF	1/0	00343+48(#-1)	n+2/1(15)
L#PB1	R/W	PB1SW Input MD (**)	1/0	08701+16(#-1)	n+3/1(0)
L#PB2	R/W	PB2SW Input MD (**) (spares)	1/0	08702+16(#-1) 08703-08716+16(#-1)	n+3/1(1)

(*) L#DnS - writing a "1" toggles the switch, Reading "1" indicates Auto Status; reading "0" indicate Man status.

(**) L#PB1 & L#PB2 - writing a "1" to the controller will have the same affect as pushing the button on the faceplate of the controller. If the action of the switch is sustained the switch will change position. If the action is momentary, the switch will close for one scan cycle. Reading the bits indicates the status of the switch MD input.

Digital Indicator Loop Status Word (L#DISW) - channel n/parameter 1

BIT	Description	Value	Block	Read/Write	Output
0	Discrete 0 Input Value	1 - ON 0 - OFF	ODD	R	
1	Discrete 1 Input Value	1 - ON 0 - OFF	ODD	R	
2	Discrete 2 Input Value	1 - ON 0 - OFF	ODD	R	
3	Discrete 3 Input Value	1 - ON 0 - OFF	ODD	R	
4	Discrete 4 Input Value	1 - ON 0 - OFF	ODD	R	
5	Discrete 5 Input Value	1 - ON 0 - OFF	ODD	R	
6	Discrete 6 Input Value	1 - ON 0 - OFF	ODD	R	
7	Discrete 7 Input Value	1 - ON 0 - OFF	ODD	R	
8	Discrete 8 Input Value	1 - ON 0 - OFF	ODD	R	
9	Discrete 9 Input Value	1 - ON 0 - OFF	ODD	R	
10	Discrete A Input Value	1 - ON 0 - OFF	ODD	R	
11	Discrete B Input Value	1 - ON 0 - OFF	ODD	R	
12	Discrete C Input Value	1 - ON 0 - OFF	ODD	R	
13	Discrete D Input Value	1 - ON 0 - OFF	ODD	R	
14	Discrete E Input Value	1 - ON 0 - OFF	ODD	R	
15	Discrete F Input Value	1 - ON 0 - OFF	ODD	R	

Digital Indicator Loop Status Word (L#DSSW) - channel n+1/parameter 1

BIT	Description	Value	Block	Read/Write	Output
0	Discrete 0 Status (*)	1 - AUTO 0 - MANUAL	ODD	R/W	
1	Discrete 1 Status (*)	1 - AUTO 0 - MANUAL	ODD	R/W	
2	Discrete 2 Status (*)	1 - AUTO 0 - MANUAL	ODD	R/W	
3	Discrete 3 Status (*)	1 - AUTO 0 - MANUAL	ODD	R/W	
4	Discrete 4 Status (*)	1 - AUTO 0 - MANUAL	ODD	R/W	
5	Discrete 5 Status (*)	1 - AUTO 0 - MANUAL	ODD	R/W	
6	Discrete 6 Status (*)	1 - AUTO 0 - MANUAL	ODD	R/W	
7	Discrete 7 Status (*)	1 - AUTO 0 - MANUAL	ODD	R/W	
8	Discrete 8 Status (*)	1 - AUTO 0 - MANUAL	ODD	R/W	
9	Discrete 9 Status (*)	1 - AUTO 0 - MANUAL	ODD	R/W	
10	Discrete A Status (*)	1 - AUTO 0 - MANUAL	ODD	R/W	
11	Discrete B Status (*)	1 - AUTO 0 - MANUAL	ODD	R/W	
12	Discrete C Status (*)	1 - AUTO 0 - MANUAL	ODD	R/W	
13	Discrete D Status (*)	1 - AUTO 0 - MANUAL	ODD	R/W	
14	Discrete E Status (*)	1 - AUTO 0 - MANUAL	ODD	R/W	
15	Discrete F Status (*)	1 - AUTO 0 - MANUAL	ODD	R/W	

- A mask on command will toggle the position of the Auto/Man switch

Digital Indicator Loop Status Word (L#DOSW) - channel n+2/parameter 1

BIT	Description	Value	Block	Read/Write	Output
0	Discrete 0 Output Value	1 - ON 0 - OFF	ODD	R/W	O0
1	Discrete 1 Output Value	1 - ON 0 - OFF	ODD	R/W	O1
2	Discrete 2 Output Value	1 - ON 0 - OFF	ODD	R/W	O2
3	Discrete 3 Output Value	1 - ON 0 - OFF	ODD	R/W	O3
4	Discrete 4 Output Value	1 - ON 0 - OFF	ODD	R/W	O4
5	Discrete 5 Output Value	1 - ON 0 - OFF	ODD	R/W	O5
6	Discrete 6 Output Value	1 - ON 0 - OFF	ODD	R/W	O6
7	Discrete 7 Output Value	1 - ON 0 - OFF	ODD	R/W	O7
8	Discrete 8 Output Value	1 - ON 0 - OFF	ODD	R/W	O8
9	Discrete 9 Output Value	1 - ON 0 - OFF	ODD	R/W	O9
10	Discrete A Output Value	1 - ON 0 - OFF	ODD	R/W	OA
11	Discrete B Output Value	1 - ON 0 - OFF	ODD	R/W	OB
12	Discrete C Output Value	1 - ON 0 - OFF	ODD	R/W	OC
13	Discrete D Output Value	1 - ON 0 - OFF	ODD	R/W	OD
14	Discrete E Output Value	1 - ON 0 - OFF	ODD	R/W	OE
15	Discrete F Output Value	1 - ON 0 - OFF	ODD	R/W	OF

Digital Indicator Loop Status Word (L#SW) - channel n+3/parameter 1

BIT	Description	Value	Block	Read/Write	Output
0	PB1SW Input MD (PB1)	1/0 (write of 1 presses PB)	PB1SW	R/W	
1	PB2SW Input MD (PB2)	1/0 (write of 1 presses PB)	PB2SW	R/W	
2					
3					
4					
5					
6					
7					
8					
9					
10					
11					
12					
13					
14					
15					

Pushbutton/Switch Indicator [ODP] - (V2.2)

<u>Code</u>	<u>R/W</u>	<u>Description</u>	<u>Range</u>	<u>Coil(MB) C/P (LIL)</u>
L#G1P1	W	Group 1 - Press PB1 (**)	1	00296+48(#-1) n/1(0)
L#G1P2	W	Group 1 - Press PB2 (**)	1	00297+48(#-1) n/1(1)
L#G1S3	R/W	Group 1 - Auto/Man Switch (*)	1/0	00298+48(#-1) n/1(2)
L#G1FS	R	Group 1 Feedback Status	1/0	00299+48(#-1) n/1(3)
L#G2P1	W	Group 2 - Press PB1 (**)	1	00300+48(#-1) n/1(4)
L#G2P2	W	Group 2 - Press PB2 (**)	1	00301+48(#-1) n/1(5)
L#G2S3	R/W	Group 2 - Auto/Man Switch (*)	1/0	00302+48(#-1) n/1(6)
L#G2FS	R	Group 2 - Feedback Status	1/0	00303+48(#-1) n/1(7)
L#G3P1	W	Group 3 - Press PB1 (**)	1	00304+48(#-1) n/1(8)
L#G3P2	W	Group 3 - Press PB2 (**)	1	00305+48(#-1) n/1(9)
L#G3S3	R/W	Group 3 - Auto/Man Switch (*)	1/0	00306+48(#-1) n/1(10)
L#G3FS	R	Group 3 - Feedback Status	1/0	00307+48(#-1) n/1(11)
L#G4P1	W	Group 4 - Press PB1 (**)	1	00308+48(#-1) n/1(12)
L#G4P2	W	Group 4 - Press PB2 (**)	1	00309+48(#-1) n/1(13)
L#G4S3	R/W	Group 4 - Auto/Man Switch (*)	1/0	00310+48(#-1) n/1(14)
L#G4FS	R	Group 4 - Feedback Status	1/0	00311+48(#-1) n/1(15)
L#G5P1	W	Group 5 - Press PB1 (**)	1	00312+48(#-1) n+1/1(0)
L#G5P2	W	Group 5 - Press PB2 (**)	1	00313+48(#-1) n+1/1(1)
L#G5S3	R/W	Group 5 - Auto/Man Switch (*)	1/0	00314+48(#-1) n+1/1(2)
L#G5FS	R	Group 5 - Feedback Status	1/0	00315+48(#-1) n+1/1(3)
L#G6P1	W	Group 6 - Press PB1 (**)	1	00316+48(#-1) n+1/1(4)
L#G6P2	W	Group 6 - Press PB2 (**)	1	00317+48(#-1) n+1/1(5)
L#G6S3	R/W	Group 6 - Auto/Man Switch (*)	1/0	00318+48(#-1) n+1/1(6)
L#G6FS	R	Group 6 - Feedback Status	1/0	00319+48(#-1) n+1/1(7)
L#G7P1	W	Group 7 - Press PB1 (**)	1	00320+48(#-1) n+1/1(8)
L#G7P2	W	Group 7 - Press PB2 (**)	1	00321+48(#-1) n+1/1(9)
L#G7S3	R/W	Group 7 - Auto/Man Switch (*)	1/0	00322+48(#-1) n+1/1(10)
L#G7FS	R	Group 7 - Feedback Status	1/0	00323+48(#-1) n+1/1(11)
L#G8P1	W	Group 8 - Press PB1 (**)	1	00324+48(#-1) n+1/1(12)
L#G8P2	W	Group 8 - Press PB2 (**)	1	00325+48(#-1) n+1/1(13)
L#G8S3	R/W	Group 8 - Auto/Man Switch (*)	1/0	00326+48(#-1) n+1/1(14)
L#G8FS	R	Group 8 - Feedback Status	1/0	00327+48(#-1) n+1/1(15)

* L#GnS3 - reading a "1" indicates a switch position of Auto and reading a "0" indicates Man. Writing a "1" to the controller will toggle the state of the Auto/Man switch.

** L#GnP1 & L#GnP2 - writing a "1" to the controller will have the same affect as pushing the button on the faceplate of the controller. If the action of the switch is sustained the switch will change position. If the action is momentary the switch will close for one scan cycle.

Digital Indicator Loop Status Word (L#SW1) - channel n/parameter 1

BIT	Description	Value	Block	Read/Write	Output
0	Group 1 - Press PB1	1/0 (write of 1 presses PB)	ODP	W	
1	Group 1 - Press PB2	1/0 (write of 1 presses PB)	ODP	W	
2	Group 1 - Auto/Man Switch	1 - Auto 0- Manual (*)	ODP	R/W	
3	Group 1 - Feedback Status	1 - True 0- False	ODP	R	
4	Group 2 - Press PB1	1/0 (write of 1 presses PB)	ODP	W	
5	Group 2 - Press PB2	1/0 (write of 1 presses PB)	ODP	W	
6	Group 2 - Auto/Man Switch	1 - Auto 0- Manual (*)	ODP	R/W	
7	Group 2 - Feedback Status	1 - True 0- False	ODP	R	
8	Group 3 - Press PB1	1/0 (write of 1 presses PB)	ODP	W	
9	Group 3 - Press PB2	1/0 (write of 1 presses PB)	ODP	W	
10	Group 3 - Auto/Man Switch	1 - Auto 0- Manual (*)	ODP	R/W	
11	Group 3 - Feedback Status	1 - True 0- False	ODP	R	
12	Group 4 - Press PB1	1/0 (write of 1 presses PB)	ODP	W	
13	Group 4 - Press PB2	1/0 (write of 1 presses PB)	ODP	W	
14	Group 4 - Auto/Man Switch	1 - Auto 0- Manual (*)	ODP	R/W	
15	Group 4 - Feedback Status	1 - True 0- False	ODP	R	

Digital Indicator Loop Status Word (L#SW2) - channel n+1/parameter 1

BIT	Description	Value	Block	Read/Write	Output
0	Group 5 - Press PB1	1/0 (write of 1 presses PB)	ODP	W	
1	Group 5 - Press PB2	1/0 (write of 1 presses PB)	ODP	W	
2	Group 5 - Auto/Man Switch	1 - Auto 0- Manual (*)	ODP	R/W	
3	Group 5 - Feedback Status	1 - True 0- False	ODP	R	
4	Group 6 - Press PB1	1/0 (write of 1 presses PB)	ODP	W	
5	Group 6 - Press PB2	1/0 (write of 1 presses PB)	ODP	W	
6	Group 6 - Auto/Man Switch	1 - Auto 0- Manual (*)	ODP	R/W	
7	Group 6 - Feedback Status	1 - True 0- False	ODP	R	
8	Group 7 - Press PB1	1/0 (write of 1 presses PB)	ODP	W	
9	Group 7 - Press PB2	1/0 (write of 1 presses PB)	ODP	W	
10	Group 7 - Auto/Man Switch	1 - Auto 0- Manual (*)	ODP	R/W	
11	Group 7 - Feedback Status	1 - True 0- False	ODP	R	
12	Group 8 - Press PB1	1/0 (write of 1 presses PB)	ODP	W	
13	Group 8 - Press PB2	1/0 (write of 1 presses PB)	ODP	W	
14	Group 8 - Auto/Man Switch	1 - Auto 0- Manual (*)	ODP	R/W	
15	Group 8 - Feedback Status	1 - True 0- False	ODP	R	

* A mask on command will toggle the position of the Auto/Man switch

7.3.9 PCOM Block Status

Included in MPU Controller board firmware version 1.30 and higher.

Controller/Sequencer

<u>Code</u>	<u>R/W</u>	<u>Description</u>	<u>Range</u>	<u>Coil(MB)</u>	<u>C/P (LIL)</u>
L#INIT_OK	R/W	1-INIT_OK	1/0	09101+32(#-1)	z/1(0)
L#DFAIL	R/W	1-DFAIL	1/0	09102+32(#-1)	z/1(1)
L#RESET	W	1-RESET	1/0	09103+32(#-1)	z/1(2)
L#START	W	1-START	1/0	09104+32(#-1)	z/1(3)
L#RESTART	W	1-RESTART	1/0	09105+32(#-1)	z/1(4)
L#HOLD	W	1-HOLD	1/0	09106+32(#-1)	z/1(5)
L#PCOMP	W	1-PCOMP	1/0	09107+32(#-1)	z/1(6)
L#ABORT	W	1-ABORT	1/0	09108+32(#-1)	z/1(7)
L#READY	R	1-READY	1/0	09109+32(#-1)	z/1(8)
L#RUN	R	1-RUN	1/0	09110+32(#-1)	z/1(9)
L#HELD	R	1-HELD	1/0	09111+32(#-1)	z/1(10)
L#DONE	R	1-DONE	1/0	09112+32(#-1)	z/1(11)
L#ABORTED	R	1-ABORTED	1/0	09113+32(#-1)	z/1(12)
spare	R		1/0	09114+32(#-1)	z/1(13)
spare	R		1/0	09115+32(#-1)	z/1(14)
spare	R		1/0	09116+32(#-1)	z/1(15)

<u>Code</u>	<u>R/W</u>	<u>Description</u>	<u>Range</u>	<u>Coil(MB)</u>	<u>C/P (LIL)</u>
L#EMERG (EO)	R	1-Emerg. Override	1/0	09117+32(#-1)	z+1/1(0)
L#NotAck'dEO	R/W	1-EO Not Ack'd	1/0	09118+32(#-1)	z+1/1(1)
L#INTRLK (IK)	R	1-INTRLK	1/0	09119+32(#-1)	z+1/1(2)
L#NotAck'd IK	R/W	1- IK Not Ack'd	1/0	09120+32(#-1)	z+1/1(3)
L#FAILED (FD)	R	1-FAILED	1/0	09121+32(#-1)	z+1/1(4)
L#NotAck'dFD	R/W	1- FD Not Ack'd	1/0	09122+32(#-1)	z+1/1(5)
spare	R	1/0		09123+32(#-1)	z+1/1(6)
spare	R		1/0	09124+32(#-1)	z+1/1(7)
spare	R		1/0	09125+32(#-1)	z+1/1(8)
spare	R		1/0	09126+32(#-1)	z+1/1(9)
spare	R		1/0	09127+32(#-1)	z+1/1(10)
spare	R		1/0	09128+32(#-1)	z+1/1(11)
spare	R		1/0	09129+32(#-1)	z+1/1(12)
spare	R		1/0	09130+32(#-1)	z+1/1(13)
L#NotAck'dPCOM	R/W	1-PCOM Event Not Ack'd		1/0	09131+32(#-1)
		z+1/1(14)			
L#ACTIVEPCOM	R	1-PCOM Event is Active	1/0	09132+32(#-1)	z+1/1(15)

z - LIL CHAN configured in the PCOM function block configuration.

PCOM Function Block Status Word (L#PSW1) - channel z/parameter 1

BIT	Description	Value	Block	Read/Write	Output
0	INIT_OK	1-INIT_OK	PCOM	R/W	
1	DFAIL	1-DFAIL	PCOM	R/W	
2	RESET	1-RESET	PCOM	W	
3	START	1-START	PCOM	W	
4	RESTART	1-RESTART	PCOM	W	
5	HOLD	1-HOLD	PCOM	W	
6	PCOMP	1-PCOMP	PCOM	W	
7	ABORT	1-ABORT	PCOM	W	
8	READY	1-READY	PCOM	R	
9	RUN	1-RUN	PCOM	R	
10	HELD	1-HELD	PCOM	R	
11	DONE	1-DONE	PCOM	R	
12	ABORTED	1-ABORTED	PCOM	R	
13	spare		PCOM		
14	spare		PCOM		
15	spare		PCOM		

PCOM Function Block Status Word (L#PSW2) - channel z+1/parameter 1

BIT	Description	Value	Block	Read/Write	Output
0	EMERG (EO)	1-EO is Active	PCOM	R	
1	EO Not Acknowledged	1-EO is not acknowledged	PCOM	R/W	
2	INTRLK (IK)	1-IK is Active	PCOM	R	
3	IK Not Acknowledged	1-IK is not acknowledged	PCOM	R/W	
4	FAILED (FD)	1-FD is Active	PCOM	R	
5	FD Not Acknowledged	1-FD is not acknowledged	PCOM	R/W	
6	spare		PCOM	R	
7	spare		PCOM	R	
8	spare		PCOM	R	
9	spare		PCOM	R	
10	spare		PCOM	R	
11	spare		PCOM	R	
12	spare		PCOM	R	
13	spare		PCOM	R	
14	PCOM Not Acknowledged	1-PCOM is not ack'd	PCOM	R/W	
15	ACTIVE PCOM Event (EO,IK,FD)	1- PCOM event is active	PCOM	R	

z - LIL CHAN configured in the PCOM function block configuration.

7.3.10 Sequencer Loop I/O Coil Data (1-bit)

Sequencer:

<u>Code</u>	<u>R/W</u>	<u>Description</u>	<u>Range</u>	<u>Coil (MB)</u>	<u>C/P (LIL)</u>
SG0KI0	R	Seq. Group 0 (cur. step) masK for Input 0	1/0	01496	n/13(0)
SG0KIF	R	Seq. Group 0 (cur. step) masK for Input F	1/0	01511	n/13(15)
SG0SI0	R	Seq. Group 0 (cur. step) State of Input 0	1/0	01512	n/14(0)
SG0SIF	R	Seq. Group 0 (cur. step) State of Input F	1/0	01527	n/14(15)
SG0SO0	R	Seq. Group 0 (cur. step) State of Output 0	1/0	01528	n/15(0)
SG0SOF	R	Seq. Group 0 (cur. step) State of Output F	1/0	01543	n/15(15)
SGFKI0	R	Seq. Group F (cur. step) masK for Input 0	1/0	02216	n+3/22(0)
SGFKIF	R	Seq. Group F (cur. step) masK for Input F	1/0	02231	n+3/22(15)
SGFSI0	R	Seq. Group F (cur. step) State of Input 0	1/0	02232	n+3/23(0)
SGFSIF	R	Seq. Group F (cur. step) State of Input F	1/0	02247	n+3/23(15)
SGFSO0	R	Seq. Group F (cur. step) State of Output 0	1/0	02248	n+3/24(0)
SGFSOF	R	Seq. Group F (cur. step) State of Output F	1/0	02263	n+3/24(15)

Sequencer Group n (current step) Mask Word for Inputs (SGnKI)

BIT	Description	Value	Block	Read/Write	Input
0	Group n, Input 0, Mask Config.	1-high 0-don't care	PRSEQ	R	n0
1	Group n, Input 1, Mask Config.	1-high 0-don't care	PRSEQ	R	n1
2	Group n, Input 2, Mask Config.	1-high 0-don't care	PRSEQ	R	n2
3	Group n, Input 3, Mask Config.	1-high 0-don't care	PRSEQ	R	n3
4	Group n, Input 4, Mask Config.	1-high 0-don't care	PRSEQ	R	n4
5	Group n, Input 5, Mask Config.	1-high 0-don't care	PRSEQ	R	n5
6	Group n, Input 6, Mask Config.	1-high 0-don't care	PRSEQ	R	n6
7	Group n, Input 7, Mask Config.	1-high 0-don't care	PRSEQ	R	n7
8	Group n, Input 8, Mask Config.	1-high 0-don't care	PRSEQ	R	n8
9	Group n, Input 9, Mask Config.	1-high 0-don't care	PRSEQ	R	n9
10	Group n, Input A, Mask Config.	1-high 0-don't care	PRSEQ	R	nA
11	Group n, Input B, Mask Config.	1-high 0-don't care	PRSEQ	R	nB
12	Group n, Input C, Mask Config.	1-high 0-don't care	PRSEQ	R	nC
13	Group n, Input D, Mask Config.	1-high 0-don't care	PRSEQ	R	nD
14	Group n, Input E, Mask Config.	1-high 0-don't care	PRSEQ	R	nE
15	Group n, Input F, Mask Config.	1-high 0-don't care	PRSEQ	R	nF

Sequencer Group n (current step) State Word of Inputs (SGnSI)

BIT	Description	Value	Block	Read/Write	Input
0	Group n, Input 0, State	1-high 0-low	PRSEQ	R/W(1)	n0
1	Group n, Input 1, State	1-high 0-low	PRSEQ	R/W(1)	n1
2	Group n, Input 2, State	1-high 0-low	PRSEQ	R/W(1)	n2
3	Group n, Input 3, State	1-high 0-low	PRSEQ	R/W(1)	n3
4	Group n, Input 4, State	1-high 0-low	PRSEQ	R/W(1)	n4
5	Group n, Input 5, State	1-high 0-low	PRSEQ	R/W(1)	n5
6	Group n, Input 6, State	1-high 0-low	PRSEQ	R/W(1)	n6
7	Group n, Input 7, State	1-high 0-low	PRSEQ	R/W(1)	n7
8	Group n, Input 8, State	1-high 0-low	PRSEQ	R/W(1)	n8
9	Group n, Input 9, State	1-high 0-low	PRSEQ	R/W(1)	n9
10	Group n, Input A, State	1-high 0-low	PRSEQ	R/W(1)	nA
11	Group n, Input B, State	1-high 0-low	PRSEQ	R/W(1)	nB
12	Group n, Input C, State	1-high 0-low	PRSEQ	R/W(1)	nC
13	Group n, Input D, State	1-high 0-low	PRSEQ	R/W(1)	nD
14	Group n, Input E, State	1-high 0-low	PRSEQ	R/W(1)	nE
15	Group n, Input F, State	1-high 0-low	PRSEQ	R/W(1)	nF

Sequencer Group n (current step) State Word of Outputs (SGnSO)

BIT	Description	Value	Block	Read/Write	Output
0	Group n, Output 0, State	1-high 0-low	PRSEQ	R/W(1)	n0
1	Group n, Output 1, State	1-high 0-low	PRSEQ	R/W(1)	n1
2	Group n, Output 2, State	1-high 0-low	PRSEQ	R/W(1)	n2
3	Group n, Output 3, State	1-high 0-low	PRSEQ	R/W(1)	n3
4	Group n, Output 4, State	1-high 0-low	PRSEQ	R/W(1)	n4
5	Group n, Output 5, State	1-high 0-low	PRSEQ	R/W(1)	n5
6	Group n, Output 6, State	1-high 0-low	PRSEQ	R/W(1)	n6
7	Group n, Output 7, State	1-high 0-low	PRSEQ	R/W(1)	n7
8	Group n, Output 8, State	1-high 0-low	PRSEQ	R/W(1)	n8
9	Group n, Output 9, State	1-high 0-low	PRSEQ	R/W(1)	n9
10	Group n, Output A, State	1-high 0-low	PRSEQ	R/W(1)	nA
11	Group n, Output B, State	1-high 0-low	PRSEQ	R/W(1)	nB
12	Group n, Output C, State	1-high 0-low	PRSEQ	R/W(1)	nC
13	Group n, Output D, State	1-high 0-low	PRSEQ	R/W(1)	nD
14	Group n, Output E, State	1-high 0-low	PRSEQ	R/W(1)	nE
15	Group n, Output F, State	1-high 0-low	PRSEQ	R/W(1)	nF

(1) Writes are made using a parameter data send command (CMD 9) to the entire word

7.3.11 LonWorks Remote I/O (Models 352P, 353, 354N)

DID1N-0	R	DID01 - Normal state of LON Input 0	1/0	02401	1/202(0)
DID1N-F	R	DID01 - Normal state of LON Input F	1/0	02416	1/202(15)
DID1M-0	R/W	DID01 - Mode of FB Output 0	1/0	02417	1/203(0)
DID1M-F	R/W	DID01 - Mode of FB Output F	1/0	02432	1/203(15)
DID1F-0	R/W	DID01 - Forced state 0	1/0	02433	1/204(0)
DID01F-F	R/W	DID01 - Forced state F	1/0	02448	1/204(15)
DOD01N0	R	DOD01 - Normal state of FB Input 0	1/0	02449	1/205(0)
DOD1NF	R	DOD01 - Normal state of FB Input F	1/0	02464	1/205(15)
DOD1M0	R/W	DOD01 - Mode of LON Output 0	1/0	02465	1/206(0)
DOD1MF	R/W	DOD01 - Mode of LON Output F	1/0	02480	1/206(15)
DOD1F0	R/W	DOD01 - Forced state 0	1/0	02481	1/207(0)
DOD1FF	R/W	DOD01 - Forced state F	1/0	02496	1/207(15)
DID6N0	R	DID06 - Normal state of LON Input 0	1/0	02881	6/202 (0)
DID6NF	R	DID06 - Normal state of LON Input F	1/0	02896	6/202(15)
DID6M0	R/W	DID06 - Mode of FB Output 0	1/0	02897	6/203 (0)
DID6MF	R/W	DID06 - Mode of FB Output F	1/0	02912	6/203(15)
DID6FO0	R/W	DID06 - Forced state 0	1/0	02913	6/204(0)
DID6FF	R/W	DID06 - Forced state F	1/0	02928	6/204(15)
DOD6N0	R	DOD06 - Normal state of FB Input 0	1/0	02929	6/205(0)
DOD6NF	R	DOD06 - Normal state of FB Input F	1/0	02944	65/205(15)
DOD6M0	R/W	DOD06 - Mode of LON Output 0	1/0	02945	6/206(0)
DOD6MF	R/W	DOD06 - Mode of LON Output F	1/0	02960	6/206(15)
DOD6F0	R/W	DOD06 - Forced state 0	1/0	02961	6/207(0)
DOD6FF	R/W	DOD06 - Forced state F	1/0	02976	6/207(15)

The following DIS and DOS function blocks are included in MPU Controller board firmware versions 1.30 and higher.

DIS1N0	R	DIS01 - Normal state of LON Input 0	1/0	03401	1/208(0)
DIS1NF	R	DIS01 - Normal state of LON Input F	1/0	03416	1/208(15)
DIS1M0	R/W	DIS01 - Mode of FB Output 0	1/0	03417	1/209(0)
DIS1MF	R/W	DIS01 - Mode of FB Output F	1/0	03432	1/209(15)
DIS1F0	R/W	DIS01 - Forced state 0	1/0	03433	1/210(0)
DIS1FF	R/W	DIS01 - Forced state F	1/0	03448	1/210(15)
DOS1N0	R	DOS01 - Normal state of FB Input 0	1/0	03449	1/211(0)
DOS1NF	R	DOS01 - Normal state of FB Input F	1/0	03464	1/211(15)
DOS1M0	R/W	DOS01 - Mode of LON Output 0	1/0	03465	1/212(0)
DOS1MF	R/W	DOS01 - Mode of LON Output F	1/0	03480	1/212(15)
DOS1F0	R/W	DOS01 - Forced state 0	1/0	03481	1/213(0)
DOS1FF	R/W	DOS01 - Forced state F	1/0	03496	1/213(15)
DIS6N0	R	DIS06 - Normal state of LON Input 0	1/0	03881	6/208 (0)
DIS6NF	R	DIS06 - Normal state of LON Input F	1/0	03896	6/208 (15)
DIS6M0	R/W	DIS06 - Mode of FB Output 0	1/0	03897	6/209 (0)
DIS6MF	R/W	DIS06 - Mode of FB Output F	1/0	03912	6/209(15)
DIS6F0	R/W	DIS06 - Forced state 0	1/0	03913	6/210(0)
DIS6FF	R/W	DIS06 - Forced state F	1/0	03928	6/210(15)
DOS6N0	R	DOS06 - Normal state of FB Input 0	1/0	03929	6/211(0)
DOS6NF	R	DOS06 - Normal state of FB Input F	1/0	03944	6/211(15)
DOS6M0	R/W	DOS06 - Mode of LON Output 0	1/0	03945	6/212(0)
DOS6MF	R/W	DOS06 - Mode of LON Output F	1/0	03960	6/212(15)
DOS6F0	R/W	DOS06 - Forced state 0	1/0	03961	6/213(0)
DOS6FF	R/W	DOS06 - Forced state F	1/0	03976	6/213(15)

Discrete Input Remote xx, Normal State Word of Function Block Outputs (DIDxxN)

BIT	Description	Value	Block	Read/Write	Output
0	DIDxx, Output O0 Normal State	1-high 0-low	DIDxx	R	O0
1	DIDxx, Output O1 Normal State	1-high 0-low	DIDxx	R	O1
2	DIDxx, Output O2 Normal State	1-high 0-low	DIDxx	R	O2
3	DIDxx, Output O3 Normal State	1-high 0-low	DIDxx	R	O3
4	DIDxx, Output O4 Normal State	1-high 0-low	DIDxx	R	O4
5	DIDxx, Output O5 Normal State	1-high 0-low	DIDxx	R	O5
6	DIDxx, Output O6 Normal State	1-high 0-low	DIDxx	R	O6
7	DIDxx, Output O7 Normal State	1-high 0-low	DIDxx	R	O7
8	DIDxx, Output O8 Normal State	1-high 0-low	DIDxx	R	O8
9	DIDxx, Output O9 Normal State	1-high 0-low	DIDxx	R	O9
10	DIDxx, Output OA Normal State	1-high 0-low	DIDxx	R	OA
11	DIDxx, Output OB Normal State	1-high 0-low	DIDxx	R	OB
12	DIDxx, Output OC Normal State	1-high 0-low	DIDxx	R	OC
13	DIDxx, Output OD Normal State	1-high 0-low	DIDxx	R	OD
14	DIDxx, Output OE Normal State	1-high 0-low	DIDxx	R	OE
15	DIDxx, Output OF Normal State	1-high 0-low	DIDxx	R	OF

Discrete Input Remote xx Mode Word of Function Block outputs (DIDxxM)

BIT	Description	Value	Block	Read/Write	Output
0	DIDxx, Mode of Output O0	1-forced 0-normal	DIDxx	R/W (1)	O0
1	DIDxx, Mode of Output O1	1-forced 0-normal	DIDxx	R/W (1)	O1
2	DIDxx, Mode of Output O2	1-forced 0-normal	DIDxx	R/W (1)	O2
3	DIDxx, Mode of Output O3	1-forced 0-normal	DIDxx	R/W (1)	O3
4	DIDxx, Mode of Output O4	1-forced 0-normal	DIDxx	R/W (1)	O4
5	DIDxx, Mode of Output O5	1-forced 0-normal	DIDxx	R/W (1)	O5
6	DIDxx, Mode of Output O6	1-forced 0-normal	DIDxx	R/W (1)	O6
7	DIDxx, Mode of Output O7	1-forced 0-normal	DIDxx	R/W (1)	O7
8	DIDxx, Mode of Output O8	1-forced 0-normal	DIDxx	R/W (1)	O8
9	DIDxx, Mode of Output O9	1-forced 0-normal	DIDxx	R/W (1)	O9
10	DIDxx, Mode of Output OA	1-forced 0-normal	DIDxx	R/W (1)	OA
11	DIDxx, Mode of Output OB	1-forced 0-normal	DIDxx	R/W (1)	OB
12	DIDxx, Mode of Output OC	1-forced 0-normal	DIDxx	R/W (1)	OC
13	DIDxx, Mode of Output OD	1-forced 0-normal	DIDxx	R/W (1)	OD
14	DIDxx, Mode of Output OE	1-forced 0-normal	DIDxx	R/W (1)	OE
15	DIDxx, Mode of Output OF	1-forced 0-normal	DIDxx	R/W (1)	OF

(1) Writes are made using a parameter data send command (CMD 9) to the entire word.

Discrete Input Remote xx, Forced State Word of Function Block Outputs (DIDxxF)

BIT	Description	Value	Block	Read/Write	Output
0	DIDxx, Output O0 Forced State	1-high 0-low	DIDxx	R	O0
1	DIDxx, Output O1 Forced State	1-high 0-low	DIDxx	R	O1
2	DIDxx, Output O2 Forced State	1-high 0-low	DIDxx	R	O2
3	DIDxx, Output O3 Forced State	1-high 0-low	DIDxx	R	O3
4	DIDxx, Output O4 Forced State	1-high 0-low	DIDxx	R	O4
5	DIDxx, Output O5 Forced State	1-high 0-low	DIDxx	R	O5
6	DIDxx, Output O6 Forced State	1-high 0-low	DIDxx	R	O6
7	DIDxx, Output O7 Forced State	1-high 0-low	DIDxx	R	O7
8	DIDxx, Output O8 Forced State	1-high 0-low	DIDxx	R	O8
9	DIDxx, Output O9 Forced State	1-high 0-low	DIDxx	R	O9
10	DIDxx, Output OA Forced State	1-high 0-low	DIDxx	R	OA
11	DIDxx, Output OB Forced State	1-high 0-low	DIDxx	R	OB
12	DIDxx, Output OC Forced State	1-high 0-low	DIDxx	R	OC
13	DIDxx, Output OD Forced State	1-high 0-low	DIDxx	R	OD
14	DIDxx, Output OE Forced State	1-high 0-low	DIDxx	R	OE
15	DIDxx, Output OF Forced State	1-high 0-low	DIDxx	R	OF

Discrete Output Remote xx, Normal State Word of Function Block Inputs (DODxxN)

BIT	Description	Value	Block	Read/Write	Input
0	DODxx- Input 0 Normal State	1-high 0-low	DODxx	R	0
1	DODxx- Input 1 Normal State	1-high 0-low	DODxx	R	1
2	DODxx- Input 2 Normal State	1-high 0-low	DODxx	R	2
3	DODxx- Input 3 Normal State	1-high 0-low	DODxx	R	3
4	DODxx- Input 4 Normal State	1-high 0-low	DODxx	R	4
5	DODxx- Input 5 Normal State	1-high 0-low	DODxx	R	5
6	DODxx- Input 6 Normal State	1-high 0-low	DODxx	R	6
7	DODxx- Input 7 Normal State	1-high 0-low	DODxx	R	7
8	DODxx- Input 8 Normal State	1-high 0-low	DODxx	R	8
9	DODxx- Input 9 Normal State	1-high 0-low	DODxx	R	9
10	DODxx- Input A Normal State	1-high 0-low	DODxx	R	A
11	DODxx- Input B Normal State	1-high 0-low	DODxx	R	B
12	DODxx- Input C Normal State	1-high 0-low	DODxx	R	C
13	DODxx- Input D Normal State	1-high 0-low	DODxx	R	D
14	DODxx- Input E Normal State	1-high 0-low	DODxx	R	E
15	DODxx- Input F Normal State	1-high 0-low	DODxx	R	F

Discrete Output Remote xx Mode Word of Function Block Inputs DODxxM)

BIT	Description	Value	Block	Read/Write	Input
0	DODxx, Mode of Input 0	1-forced 0-normal	DODxx	R/W (1)	0
1	DODxx, Mode of Input 1	1-forced 0-normal	DODxx	R/W (1)	1
2	DODxx, Mode of Input 2	1-forced 0-normal	DODxx	R/W (1)	2
3	DODxx, Mode of Input 3	1-forced 0-normal	DODxx	R/W (1)	3
4	DODxx, Mode of Input 4	1-forced 0-normal	DODxx	R/W (1)	4
5	DODxx, Mode of Input 5	1-forced 0-normal	DODxx	R/W (1)	5
6	DODxx, Mode of Input 6	1-forced 0-normal	DODxx	R/W (1)	6
7	DODxx, Mode of Input 7	1-forced 0-normal	DODxx	R/W (1)	7
8	DODxx, Mode of Input 8	1-forced 0-normal	DODxx	R/W (1)	8
9	DODxx, Mode of Input 9	1-forced 0-normal	DODxx	R/W (1)	9
10	DODxx, Mode of Input A	1-forced 0-normal	DODxx	R/W (1)	A
11	DODxx, Mode of Input B	1-forced 0-normal	DODxx	R/W (1)	B
12	DODxx, Mode of Input C	1-forced 0-normal	DODxx	R/W (1)	C
13	DODxx, Mode of Input D	1-forced 0-normal	DODxx	R/W (1)	D
14	DODxx, Mode of Input E	1-forced 0-normal	DODxx	R/W (1)	E
15	DODxx, Mode of Input F	1-forced 0-normal	DODxx	R/W (1)	F

Discrete Output Remote xx, Forced State Word of Function Block Inputs (DODxxF)

BIT	Description	Value	Block	Read/Write	Input
0	DODxx- Input 0 Forced State	1-high 0-low	DODxx	R/W (1)	0
1	DODxx- Input 1 Forced State	1-high 0-low	DODxx	R/W (1)	1
2	DODxx- Input 2 Forced State	1-high 0-low	DODxx	R/W (1)	2
3	DODxx- Input 3 Forced State	1-high 0-low	DODxx	R/W (1)	3
4	DODxx- Input 4 Forced State	1-high 0-low	DODxx	R/W (1)	4
5	DODxx- Input 5 Forced State	1-high 0-low	DODxx	R/W (1)	5
6	DODxx- Input 6 Forced State	1-high 0-low	DODxx	R/W (1)	6
7	DODxx- Input 7 Forced State	1-high 0-low	DODxx	R/W (1)	7
8	DODxx- Input 8 Forced State	1-high 0-low	DODxx	R/W (1)	8
9	DODxx- Input 9 Forced State	1-high 0-low	DODxx	R/W (1)	9
10	DODxx- Input A Forced State	1-high 0-low	DODxx	R/W (1)	A
11	DODxx- Input B Forced State	1-high 0-low	DODxx	R/W (1)	B
12	DODxx- Input C Forced State	1-high 0-low	DODxx	R/W (1)	C
13	DODxx- Input D Forced State	1-high 0-low	DODxx	R/W (1)	D
14	DODxx- Input E Forced State	1-high 0-low	DODxx	R/W (1)	E
15	DODxx- Input F Forced State	1-high 0-low	DODxx	R/W (1)	F

(1) Writes are made using a parameter data send command (CMD 9) to the entire word

Discrete Input Remote xx, Normal State Word of Function Block Outputs (DISxxN)

BIT	Description	Value	Block	Read/Write	Output
0	DISxx, Output O0 Normal State	1-high 0-low	DISxx	R	O0
1	DISxx, Output O1 Normal State	1-high 0-low	DISxx	R	O1
2	DISxx, Output O2 Normal State	1-high 0-low	DISxx	R	O2
3	DISxx, Output O3 Normal State	1-high 0-low	DISxx	R	O3
4	DISxx, Output O4 Normal State	1-high 0-low	DISxx	R	O4
5	DISxx, Output O5 Normal State	1-high 0-low	DISxx	R	O5
6	DISxx, Output O6 Normal State	1-high 0-low	DISxx	R	O6
7	DISxx, Output O7 Normal State	1-high 0-low	DISxx	R	O7
8	DISxx, Output O8 Normal State	1-high 0-low	DISxx	R	O8
9	DISxx, Output O9 Normal State	1-high 0-low	DISxx	R	O9
10	DISxx, Output OA Normal State	1-high 0-low	DISxx	R	OA
11	DISxx, Output OB Normal State	1-high 0-low	DISxx	R	OB
12	DISxx, Output OC Normal State	1-high 0-low	DISxx	R	OC
13	DISxx, Output OD Normal State	1-high 0-low	DISxx	R	OD
14	DISxx, Output OE Normal State	1-high 0-low	DISxx	R	OE
15	DISxx, Output OF Normal State	1-high 0-low	DISxx	R	OF

Discrete Input Remote xx Mode Word of Function Block outputs (DISxxM)

BIT	Description	Value	Block	Read/Write	Output
0	DISxx, Mode of Output O0	1-forced 0-normal	DISxx	R/W (1)	O0
1	DISxx, Mode of Output O1	1-forced 0-normal	DISxx	R/W (1)	O1
2	DISxx, Mode of Output O2	1-forced 0-normal	DISxx	R/W (1)	O2
3	DISxx, Mode of Output O3	1-forced 0-normal	DISxx	R/W (1)	O3
4	DISxx, Mode of Output O4	1-forced 0-normal	DISxx	R/W (1)	O4
5	DISxx, Mode of Output O5	1-forced 0-normal	DISxx	R/W (1)	O5
6	DISxx, Mode of Output O6	1-forced 0-normal	DISxx	R/W (1)	O6
7	DISxx, Mode of Output O7	1-forced 0-normal	DISxx	R/W (1)	O7
8	DISxx, Mode of Output O8	1-forced 0-normal	DISxx	R/W (1)	O8
9	DISxx, Mode of Output O9	1-forced 0-normal	DISxx	R/W (1)	O9
10	DISxx, Mode of Output OA	1-forced 0-normal	DISxx	R/W (1)	OA
11	DISxx, Mode of Output OB	1-forced 0-normal	DISxx	R/W (1)	OB
12	DISxx, Mode of Output OC	1-forced 0-normal	DISxx	R/W (1)	OC
13	DISxx, Mode of Output OD	1-forced 0-normal	DISxx	R/W (1)	OD
14	DISxx, Mode of Output OE	1-forced 0-normal	DISxx	R/W (1)	OE
15	DISxx, Mode of Output OF	1-forced 0-normal	DISxx	R/W (1)	OF

(1) Writes are made using a parameter data send command (CMD 9) to the entire word

Discrete Input Remote xx, Forced State Word of Function Block Outputs (DISxxF)

BIT	Description	Value	Block	Read/Write	Output
0	DISxx, Output O0 Forced State	1-high 0-low	DISxx	R	O0
1	DISxx, Output O1 Forced State	1-high 0-low	DISxx	R	O1
2	DISxx, Output O2 Forced State	1-high 0-low	DISxx	R	O2
3	DISxx, Output O3 Forced State	1-high 0-low	DISxx	R	O3
4	DISxx, Output O4 Forced State	1-high 0-low	DISxx	R	O4
5	DISxx, Output O5 Forced State	1-high 0-low	DISxx	R	O5
6	DISxx, Output O6 Forced State	1-high 0-low	DISxx	R	O6
7	DISxx, Output O7 Forced State	1-high 0-low	DISxx	R	O7
8	DISxx, Output O8 Forced State	1-high 0-low	DISxx	R	O8
9	DISxx, Output O9 Forced State	1-high 0-low	DISxx	R	O9
10	DISxx, Output OA Forced State	1-high 0-low	DISxx	R	OA
11	DISxx, Output OB Forced State	1-high 0-low	DISxx	R	OB
12	DISxx, Output OC Forced State	1-high 0-low	DISxx	R	OC
13	DISxx, Output OD Forced State	1-high 0-low	DISxx	R	OD
14	DISxx, Output OE Forced State	1-high 0-low	DISxx	R	OE
15	DISxx, Output OF Forced State	1-high 0-low	DISxx	R	OF

Discrete Output Remote xx, Normal State Word of Function Block Inputs (DOSxxN)

BIT	Description	Value	Block	Read/Write	Input
0	DOSxx- Input 0 Normal State	1-high 0-low	DOSxx	R	0
1	DOSxx- Input 1 Normal State	1-high 0-low	DOSxx	R	1
2	DOSxx- Input 2 Normal State	1-high 0-low	DOSxx	R	2
3	DOSxx- Input 3 Normal State	1-high 0-low	DOSxx	R	3
4	DOSxx- Input 4 Normal State	1-high 0-low	DOSxx	R	4
5	DOSxx- Input 5 Normal State	1-high 0-low	DOSxx	R	5
6	DOSxx- Input 6 Normal State	1-high 0-low	DOSxx	R	6
7	DOSxx- Input 7 Normal State	1-high 0-low	DOSxx	R	7
8	DOSxx- Input 8 Normal State	1-high 0-low	DOSxx	R	8
9	DOSxx- Input 9 Normal State	1-high 0-low	DOSxx	R	9
10	DOSxx- Input A Normal State	1-high 0-low	DOSxx	R	A
11	DOSxx- Input B Normal State	1-high 0-low	DOSxx	R	B
12	DOSxx- Input C Normal State	1-high 0-low	DOSxx	R	C
13	DOSxx- Input D Normal State	1-high 0-low	DOSxx	R	D
14	DOSxx- Input E Normal State	1-high 0-low	DOSxx	R	E
15	DOSxx- Input F Normal State	1-high 0-low	DOSxx	R	F

Discrete Output Remote xx Mode Word of Function Block Inputs (DOSxxM)

BIT	Description	Value	Block	Read/Write	Input
0	DOSxx, Mode of Input 0	1-forced 0-normal	DOSxx	R/W (1)	0
1	DOSxx, Mode of Input 1	1-forced 0-normal	DOSxx	R/W (1)	1
2	DOSxx, Mode of Input 2	1-forced 0-normal	DOSxx	R/W (1)	2
3	DOSxx, Mode of Input 3	1-forced 0-normal	DOSxx	R/W (1)	3
4	DOSxx, Mode of Input 4	1-forced 0-normal	DOSxx	R/W (1)	4
5	DOSxx, Mode of Input 5	1-forced 0-normal	DOSxx	R/W (1)	5
6	DOSxx, Mode of Input 6	1-forced 0-normal	DOSxx	R/W (1)	6
7	DOSxx, Mode of Input 7	1-forced 0-normal	DOSxx	R/W (1)	7
8	DOSxx, Mode of Input 8	1-forced 0-normal	DOSxx	R/W (1)	8
9	DOSxx, Mode of Input 9	1-forced 0-normal	DOSxx	R/W (1)	9
10	DOSxx, Mode of Input A	1-forced 0-normal	DOSxx	R/W (1)	A
11	DOSxx, Mode of Input B	1-forced 0-normal	DOSxx	R/W (1)	B
12	DOSxx, Mode of Input C	1-forced 0-normal	DOSxx	R/W (1)	C
13	DOSxx, Mode of Input D	1-forced 0-normal	DOSxx	R/W (1)	D
14	DOSxx, Mode of Input E	1-forced 0-normal	DOSxx	R/W (1)	E
15	DOSxx, Mode of Input F	1-forced 0-normal	DOSxx	R/W (1)	F

Discrete Output Remote xx, Forced State Word of Function Block Inputs (DOSxxF)

BIT	Description	Value	Block	Read/Write	Input
0	DOSxx- Input 0 Forced State	1-high 0-low	DOSxx	R/W (1)	0
1	DOSxx- Input 1 Forced State	1-high 0-low	DOSxx	R/W (1)	1
2	DOSxx- Input 2 Forced State	1-high 0-low	DOSxx	R/W (1)	2
3	DOSxx- Input 3 Forced State	1-high 0-low	DOSxx	R/W (1)	3
4	DOSxx- Input 4 Forced State	1-high 0-low	DOSxx	R/W (1)	4
5	DOSxx- Input 5 Forced State	1-high 0-low	DOSxx	R/W (1)	5
6	DOSxx- Input 6 Forced State	1-high 0-low	DOSxx	R/W (1)	6
7	DOSxx- Input 7 Forced State	1-high 0-low	DOSxx	R/W (1)	7
8	DOSxx- Input 8 Forced State	1-high 0-low	DOSxx	R/W (1)	8
9	DOSxx- Input 9 Forced State	1-high 0-low	DOSxx	R/W (1)	9
10	DOSxx- Input A Forced State	1-high 0-low	DOSxx	R/W (1)	A
11	DOSxx- Input B Forced State	1-high 0-low	DOSxx	R/W (1)	B
12	DOSxx- Input C Forced State	1-high 0-low	DOSxx	R/W (1)	C
13	DOSxx- Input D Forced State	1-high 0-low	DOSxx	R/W (1)	D
14	DOSxx- Input E Forced State	1-high 0-low	DOSxx	R/W (1)	E
15	DOSxx- Input F Forced State	1-high 0-low	DOSxx	R/W (1)	F

(1) Writes are made using a parameter data send command (CMD 9) to the entire word

7.3.12 Trend Data (Loop Defined by MLTP)

Included in MPU Controller board firmware version 1.30 and higher.

<u>Code</u>	<u>R/W</u>	<u>Description</u>	<u>Range</u>	<u>Register (MB)</u>	<u>C/P (LIL)</u>
A1RMN	R	ATD01 MIN SCALE	Real	48001	n/a
A1RMX	R	ATD01 MAX SCALE	Real	48003	n/a
A1DPP	R	ATD01 Decimal Point Position	0-5	48005	n/a
A1EU	R	ATD01 Engineering Units	6 ASCII Char	48006	n/a
A1YR	R	ATD01 Year V2.0 (5)	1997-	48009	n/a
A1MT	R	ATD01 Month V2.0 (5)	1-12	48010	n/a
A1DY	R	ATD01 Day V2.0 (5)	1-31	48011	n/a
A1HR	R	ATD01 Hour V2.0 (5)	0-23	48012	n/a
A1MN	R	ATD01 Minute V2.0 (5)	0-59	48013	n/a
A1SC	R	ATD01 Second V2.0 (5)	0-59	48014	n/a
A1ST	R/W*	ATD01 Sample Time x0.01=min	1-48000	48015	n/a
A1STC	R	ATD01 % Sample Time Complete	0-1000 (x.1=%)	48016	n/a
A1D1	R	ATD01 Data 1 (latest) 0-100%	128-3968	48017	n/a
A1D2	R	ATD01 Data 2 0-100%	128-3968	48018	n/a
A1D3	R	ATD01 Data 3 0-100%	128-3968	48019	n/a
.....					
A1D168	R	ATD01 Data 168 0-100%	128-3968	48184	n/a
A1D169	R	ATD01 Data 169 0-100%	128-3968	48185	n/a
A1D170	R	ATD01 Data 170 0-100%	128-3968	48186	n/a

* Writing to the sample time will reset all data points A1D1 through A1D170 to \$0.

A2RMN	R	ATD02 MIN SCALE	Real	48201	n/a
A2RMX	R	ATD02 MAX SCALE	Real	48203	n/a
A2DPP	R	ATD02 Decimal Point Position	0-5	48205	n/a
A2EU	R	ATD02 Engineering Units	6 ASCII Char	48206	n/a
A2YR	R	ATD02 Year V2.0 (5)	1997	48209	n/a
A2MT	R	ATD02 Month V2.0 (5)	1-12	48210	n/a
A2DY	R	ATD02 Day V2.0 (5)	1-31	48211	n/a
A2HR	R	ATD02 Hour V2.0 (5)	0-23	48212	n/a
A2MN	R	ATD02 Minute V2.0 (5)	0-59	48213	n/a
A2SC	R	ATD02 Second V2.0 (5)	0-59	48214	n/a
A2ST	R/W*	ATD02 Sample Time x0.01=min	1-48000	48215	n/a
A2STC	R	ATD02 % Sample Time Complete	0-1000 (x.1=%)	48216	n/a
A2D1	R	ATD02 Data 1 (latest) 0-100%	128-3968	48217	n/a
A2D2	R	ATD02 Data 2 0-100%	128-3968	48218	n/a
A2D3	R	ATD02 Data 3 0-100%	128-3968	48219	n/a
.....					
A2D168	R	ATD02 Data 168 0-100%	128-3968	48384	n/a
A2D169	R	ATD02 Data 169 0-100%	128-3968	48385	n/a
A2D170	R	ATD02 Data 170 0-100%	128-3968	48386	n/a

* Writing to the sample time will reset all data points A2D1 through A2D170 to \$0.

<u>Code</u>	<u>R/W</u>	<u>Description</u>	<u>Range</u>	<u>Register (MB)</u>	<u>C/P (LIL)</u>
A3RMN	R	ATD03 MIN SCALE	Real	48401	n/a
A3RMX	R	ATD03 MAX SCALE	Real	48403	n/a
A3DPP	R	ATD03 Decimal Point Position	0-5	48405	n/a
A3EU	R	ATD03 Engineering Units	6 ASCII Char	48406	n/a
A3YR	R	ATD03 Year V2.0 (5)	1997-	48409	n/a
A3MT	R	ATD03 Month V2.0 (5)	1-12	48410	n/a
A3DY	R	ATD03 Day V2.0 (5)	1-31	48411	n/a
A3HR	R	ATD03 Hour V2.0 (5)	0-23	48412	n/a
A3MN	R	ATD03 Minute V2.0 (5)	0-59	48413	n/a
A3SC	R	ATD03 Second V2.0 (5)	0-59	48414	n/a
A3ST	R/W*	ATD03 Sample Time x0.01=min	1-48000	48415	n/a
A3STC	R	ATD03 % Sample Time Complete	0-1000 (x.1=%)	48416	n/a
A3D1	R	ATD03 Data 1 (latest) 0-100%	128-3968	48417	n/a
A3D2	R	ATD03 Data 2 0-100%	128-3968	48418	n/a
A3D3	R	ATD03 Data 3 0-100%	128-3968	48419	n/a
.....					
A3D168	R	ATD03 Data 168 0-100%	128-3968	48584	n/a
A3D169	R	ATD03 Data 169 0-100%	128-3968	48585	n/a
A3D170	R	ATD03 Data 170 0-100%	128-3968	48586	n/a

* Writing to the sample time will reset all data points A3D1 through A3D170 to \$0.

A4RMN	R	ATD04 MIN SCALE	Real	48601	n/a
A4RMX	R	ATD04 MAX SCALE	Real	48603	n/a
A4DPP	R	ATD04 Decimal Point Position	0-5	48605	n/a
A4EU	R	ATD04 Engineering Units	6 ASCII Char	48606	n/a
A4YR	R	ATD04 Year V2.0 (5)	1997-	48609	n/a
A4MT	R	ATD04 Month V2.0 (5)	1-12	48610	n/a
A4DY	R	ATD04 Day V2.0 (5)	1-31	48611	n/a
A4HR	R	ATD04 Hour V2.0 (5)	0-23	48612	n/a
A4MN	R	ATD04 Minute V2.0 (5)	0-59	48613	n/a
A4SC	R	ATD04 Second V2.0 (5)	0-59	48614	n/a
A4ST	R/W*	ATD04 Sample Time x0.01=min	1-48000	48615	n/a
A4STC	R	ATD04 % Sample Time Complete	0-1000 (x.1=%)	48616	n/a
A4D1	R	ATD04 Data 1 (latest) 0-100%	128-3968	48617	n/a
A4D2	R	ATD04 Data 2 0-100%	128-3968	48618	n/a
A4D3	R	ATD04 Data 3 0-100%	128-3968	48619	n/a
.....					
A4D168	R	ATD04 Data 168 0-100%	128-3968	48784	n/a
A4D169	R	ATD04 Data 169 0-100%	128-3968	48785	n/a
A4D170	R	ATD04 Data 170 0-100%	128-3968	48786	n/a

* Writing to the sample time will reset all data points A4D1 through A4D170 to \$0.

Code	R/W	Description	Range	Register (MB)	C/P (LIL)
A5RMN	R	ATD05 MIN SCALE	Real	48801	n/a
A5RMX	R	ATD05 MAX SCALE	Real	48803	n/a
A5DPP	R	ATD05 Decimal Point Position	0-5	48805	n/a
A5EU	R	ATD05 Engineering Units	6 ASCII Char	48806	n/a
A5YR	R	ATD05 Year V2.0 (5)	1997-	48809	n/a
A5MT	R	ATD05 Month V2.0 (5)	1-12	48810	n/a
A5DY	R	ATD05 Day V2.0 (5)	1-31	48811	n/a
A5HR	R	ATD05 Hour V2.0 (5)	0-23	48812	n/a
A5MN	R	ATD05 Minute V2.0 (5)	0-59	48813	n/a
A5SC	R	ATD05 Second V2.0 (5)	0-59	48814	n/a
A5ST	R/W*	ATD05 Sample Time x0.01=min	1-48000	48815	n/a
A5STC	R	ATD05 % Sample Time Complete	0-1000 (x.1=%)	48816	n/a
A5D1	R	ATD05 Data 1 (latest) 0-100%	128-3968	48817	n/a
A5D2	R	ATD05 Data 2 0-100%	128-3968	48818	n/a
A5D3	R	ATD05 Data 3 0-100%	128-3968	48819	n/a
.....					
A5D168	R	ATD05 Data 168 0-100%	128-3968	48984	n/a
A5D169	R	ATD05 Data 169 0-100%	128-3968	48985	n/a
A5D170	R	ATD05 Data 170 0-100%	128-3968	48986	n/a

* Writing to the sample time will reset all data points A5D1 through A5D170 to \$0.

Notes:

1. A read of any Time Stamp Data (i.e. Year, Month, Day, Hour, Minute, Second, or Sample Time) will update all Loop data registers. Additional data reads of Trend data within the same block should only request data so as to obtain a complete set of time synchronized data.
2. The Trend data is obtained from the loop referenced by the MLTP parameter (register 40058). This parameter can also be written to change the loop.
3. Parameter NTTB will indicate the number of ATD Analog Trend Display blocks that are available in the loop specified by the MLTP.
4. Undefined data (e.g. unconfigured inputs, period station was in HOLD or powered down) is represented by a value of \$0.
5. Real time clock data requires the optional RTC/CB (Real Time Clock/Configuration Backup) board, shipped after July 1999 and Version 2.0 or higher MPU Controller firmware

7.3.13 Configuration Data Sequencer Loop

The Modbus registers or LIL parameters on this page refer to configuration parameters of function blocks within a specific loop previously defined by Modbus parameter MSLCP (40048) or LIL parameter LSLCP (7/1). For example, to read or write the Step 1 Group 0 Input Mask for the PRSEQ block that is in a loop with a Modbus Index of 3, write a 3 to 40048, then read or write to register 410001.

Sequencer (MASK Configurations)

<u>Code</u>	<u>R/W</u>	<u>Description</u>	<u>Range</u>	<u>Register (MB)</u>	<u>C/P (LIL)</u>
S001G0I	R/W	Step 1 Group 0 Input Mask	\$0000-\$FFFF	410001	1/154
S001G0O	R/W	Step 1 Group 0 Output Mask	\$0000-\$FFFF	410002	1/170
S001G1I	R/W	Step 1 Group 1 Input Mask	\$0000-\$FFFF	410003	1/155
S001G1O	R/W	Step 1 Group 1 Output Mask	\$0000-\$FFFF	410004	1/171
S001G2I	R/W	Step 1 Group 2 Input Mask	\$0000-\$FFFF	410005	1/156
S001G2O	R/W	Step 1 Group 2 Output Mask	\$0000-\$FFFF	410006	1/172
S001G3I	R/W	Step 1 Group 3 Input Mask	\$0000-\$FFFF	410007	1/157
S001G3O	R/W	Step 1 Group 3 Output Mask	\$0000-\$FFFF	410008	1/173
.....					
S250GEI	R/W	Step 250 Group E Input Mask	\$0000-\$FFFF	417997	250/168
S250GEO	R/W	Step 250 Group E Output Mask	\$0000-\$FFFF	417998	250/184
S250GFI	R/W	Step 250 Group F Input Mask	\$0000-\$FFFF	417999	250/169
S250GFO	R/W	Step 250 Group F Output Mask	\$0000-\$FFFF	418000	250/185

Real Time Trip Block Configurations

<u>Code</u>	<u>R/W</u>	<u>Description</u>	<u>Range</u>	<u>Register (MB)</u>	<u>C/P (LIL)</u>
RTT01Y	R/W	Year	1999-	419001	1/100 V 2.0
RTT01M	R/W	Month	1-12	419002	1/101 V 2.0
RTT01D	R/W	Day	1-31	419003	1/102 V 2.0
RTT01HR	R/W	Hour	0-23	419004	1/103 V 2.0
RTT01MN	R/W	Minute	0-59	419005	1/104 V 2.0
RTT01SC	R/W	Second	0-59	419006	1/105 V 2.0
RTT01DA	R/W	Day	0000 0000 0SMT WTFS	419007	1/106 V 2.0
RTT02Y	R/W	Year	1999-	419008	2/100 V 2.0
RTT02M	R/W	Month	1-12	419009	2/101 V 2.0
RTT02D	R/W	Day	1-31	419010	2/102 V 2.0
RTT02HR	R/W	Hour	0-23	419011	2/103 V 2.0
RTT02MN	R/W	Minute	0-59	419012	2/104 V 2.0
RTT02SC	R/W	Second	0-59	419013	2/105 V 2.0
RTT02DA	R/W	Day	0000 0000 0SMT WTFS	419014	2/106 V 2.0
RTT03Y	R/W	Year	1999-	419015	3/100 V 2.0
RTT03M	R/W	Month	1-12	419016	3/101 V 2.0
RTT03D	R/W	Day	1-31	419017	3/102 V 2.0
RTT03HR	R/W	Hour	0-23	419018	3/103 V 2.0
RTT03MN	R/W	Minute	0-59	419019	3/104 V 2.0
RTT03SC	R/W	Second	0-59	419020	3/105 V 2.0
RTT03DA	R/W	Day	0000 0000 0SMT WTFS	419021	3/106 V 2.0

Sequencer Time & Analog Configurations

<u>Code</u>	<u>R/W</u>	<u>Description</u>	<u>Range</u>	<u>Register (MB)</u>	<u>C/P (LIL)</u>
S001TIM	R/W	Step 1 Time Period (min)	Real	420001	1/150-151
S001AEP	R/W	Step 1 Analog End Point	Real	420003	1/152-153
S002TIM	R/W	Step 2 Time Period (min)	Real	420005	2/150-151
S002AEP	R/W	Step 2 Analog End Point	Real	420007	2/152-153
S003TIM	R/W	Step 3 Time Period (min)	Real	420009	3/150-151
S003AEP	R/W	Step 3 Analog End Point	Real	420011	3/152-153
S004TIM	R/W	Step 4 Time Period (min)	Real	420013	4/150-151
S004AEP	R/W	Step 4 Analog End Point	Real	420015	4/152-153
.....					
S246TIM	R/W	Step 246 Time Period (min)	Real	420981	246/150-151
S246AEP	R/W	Step 246 Analog End Point	Real	420983	246/152-153
S247TIM	R/W	Step 247 Time Period (min)	Real	420985	247/150-151
S247AEP	R/W	Step 247 Analog End Point	Real	420987	247/152-153
S248TIM	R/W	Step 248 Time Period (min)	Real	420989	248/150-151
S248AEP	R/W	Step 248 Analog End Point	Real	420991	248/152-153
S249TIM	R/W	Step 249 Time Period (min)	Real	420993	249/150-151
S249AEP	R/W	Step 249 Analog End Point	Real	420995	249/152-153
S250TIM	R/W	Step 250 Time Period (min)	Real	420997	250/150-151
S250AEP	R/W	Step 250 Analog End Point	Real	420999	250/152-153

Timer Function Block Configurations

<u>Code</u>	<u>R/W</u>	<u>Description</u>	<u>Range</u>	<u>Register (MB)</u>	<u>C/P (LIL)</u>
DYT01T	R/W	Delay Timer 01 Time (min)	Real	421001	1/190-1/191
OST01T	R/W	One Shot Timer 01 Time (min)	Real	421003	1/192-1/193
RCT01NT	R/W	Rept Cy Timer 01 ON Time (min)	Real	421005	1/194-1/195
RCT01FT	R/W	Rept Cy Timer 01 OFF Time (min)	Real	421007	1/196-1/197
ROT01T	R/W	Retentive On Timer 01 Time (min)	Real	421009	1/198-1/199
.....					
DYT21T	R/W	Delay Timer 21 Time (min)	Real	421201	1/190-1/191
OST21T	R/W	One Shot Timer 21 Time (min)	Real	421203	1/192-1/193
RCT21NT	R/W	Rept Cy Timer 21 ON Time (min)	Real	421205	1/194-1/195
RCT21FT	R/W	Rept Cy Timer 21 OFF Time (min)	Real	421207	1/196-1/197
ROT21T	R/W	Retentive On Timer 21 Time (min)	Real	421209	1/198-1/199

7.3.14 LIL Alarm Type Word (ATW)

BITS: 2 1 0
0 0 0 - no alarm action is required
0 0 1 - HIGH Alarm
0 1 0 - LOW Alarm
0 1 1 - HIGH DEVIATION Alarm
1 0 0 - LOW DEVIATION Alarm
1 0 1 - ABSOLUTE DEVIATION Alarm
1 1 0 - OUT OF RANGE Alarm
1 1 1 - no alarm action is required

BITS: 4 3
0 0 - 0.1 % alarm deadband
0 1 - 0.5 % alarm deadband
1 0 - 1.0 % alarm deadband
1 1 - 5.0 % alarm deadband

BITS: 7 6 5
0 0 0 - 0.0 seconds - delay time IN
0 0 1 - 0.4 seconds - delay time IN
0 1 0 - 1.0 seconds - delay time IN
0 1 1 - 2.0 seconds - delay time IN
1 0 0 - 5.0 seconds - delay time IN
1 0 1 - 15.0 seconds - delay time IN
1 1 0 - 30.0 seconds - delay time IN
1 1 1 - 60.0 seconds - delay time IN

BITS: 10 9 8
0 0 0 - 0.0 seconds - delay time OUT
0 0 1 - 0.4 seconds - delay time OUT
0 1 0 - 1.0 seconds - delay time OUT
0 1 1 - 2.0 seconds - delay time OUT
1 0 0 - 5.0 seconds - delay time OUT
1 0 1 - 15.0 seconds - delay time OUT
1 1 0 - 30.0 seconds - delay time OUT
1 1 1 - 60.0 seconds - delay time OUT

BIT: 11
0 - (ringback option is not required)
1 - RINGBACK

BITS: 12 through 15 - changes to these bits will be ignored.

■

8.0 INSTALLATION

This section describes installation of a Siemens 352Plus™ Single-Loop Digital Controller. Topics include: installation considerations, mechanical and electrical installation, and jumper settings for I/O and communication selections.

IMPORTANT

The installation must conform to the National Electrical Code and all other applicable construction and electrical codes.

Section 1.4.4 has a list of the items in a typical controller shipment. If the Display Assembly or a circuit board(s) must be installed in the case, go to Section 11.5 Assembly Replacement for installation information, including the setting of any involved jumpers.

Refer to Section 14.10 Agency Approvals as necessary. CSA Hazardous Location Precautions and Special Conditions for Safe Use are included in that section. Use of the equipment in a manner not specified by the manufacturer may impair the protection provided by the equipment.

Two warning labels, shown here, are included with the controller. Install them in a highly visible location near the controller's rear terminals to insure that personnel with access to controller terminals are aware of potential hazards.



8.1 INSTALLATION CONSIDERATIONS

The 352P is intended for flush panel mounting in a vibration free instrument panel or rack in an indoor or sheltered location. Refer to Section 8.3 Mechanical Installation to mount a single controller in a single-station panel cutout or mount several controllers in a row in a multiple-station panel cutout.

The controller can be mounted in a user-supplied enclosure located out-of-doors or in a location whose environmental parameters exceed controller operating specifications. A thin bead of silicon sealant is often placed between the controller's Display Assembly and the mounting panel to prevent air or liquid leakage at this joint. The enclosure may require heat/air conditioning to achieve an environment that does not exceed controller operating specifications.

Do not mount the controller where direct sunlight can strike the faceplate or case. Direct sunlight can make the displays difficult to read and will interfere with heat dissipation.

Mount the controller either horizontally or with a backward tilt (i.e. the front of the case higher than the rear). If the controller is to be mounted with some electronic recorders or with pneumatic recorders or stations, tilt back restrictions for these units can have a bearing on panel design and layout.

Route electrical power to the controller through a clearly labeled circuit breaker, fuse, or on-off switch that is located near the controller and is accessible by the operator. The breaker or switch should be located in a non-explosive atmosphere unless suitable for use in an explosive atmosphere.

When shipped from the factory, the Real Time Clock jumper W8 on the MPU Controller board is set in the N/C (no clock) position to conserve battery power. To enable the HOT/WARM start functions, move W8's shunt to the CLK position before going on-line. See Section 11.7 for details.

8.1.1 I/O and Communication Considerations

Table 8-1 shows the I/O and communication options available for a basic Model 352P and for an expanded 352P. The I/O is similar to that in the Model 352. Local Instrument Link, LonWorks, and Modbus communications options provide the features in Table 8-2.

Table 8-3 identifies the I/O and communication connections at the case rear terminal. If the I/O or communication is to be changed in the field, note the following:

- A 4-conductor 'Option 3 I/O Jumper' is used to select an Option 3 I/O listed in Table 8-1. Option 3 I/O is equivalent to the Model 352's Optional No. 3 Input but with additional I/O and communication selections.
- As shipped from the factory, the Option 3 I/O Jumper connections and the controller calibration are for the I/O option specified by the ordered model number.
- Changing the factory set Option 3 I/O Jumper connections in the field to select another analog input or output will require that the newly selected analog input or output be calibrated.
- Changing the factory set Option 3 I/O Jumper connections to select a communication, digital, frequency, or computer/pulse function will not require field calibration.
- See Section 11.6 for details on changing the Option 3 I/O selection.

A thermocouple input is available when an I/O Expander board and a Reference Junction temperature sensor are installed. When the TC option is specified on the order, a Reference Junction is either mounted on the case rear terminals or included in the Range Resistor and Reference Junction Installation Kit for field installation.

Table 8-1 Available I/O and Communications

CONTROLLER I/O	MODEL 352PB... (no I/O Expander)	MODEL 352PE... (with I/O Expander)
Analog Input 1	Yes	Yes
Analog Input 2	Yes	Yes
Analog Input 4	No	Yes
Analog Input 5	No	Yes
Analog Input 6	No	Yes
Analog Output 1	Yes	Yes
Analog Output 2, see Option 3 I/O below	Yes	Yes
Analog Output 3	No	Yes
Digital Input 1	Yes	Yes
Digital Input 2	No	Yes
Digital Input 3	No	Yes
Digital Output 1	Yes	Yes
Digital Output 2	Yes	Yes
Option 3 I/O	---	---
Analog I/O (AIN3* and AOUT2*)	Yes, note 1	No
LonWorks Communication	Yes, note 1	Yes, note 2
Thermocouple/Millivolt Input	No	Yes, note 2
RTD Input	No	Yes, note 2
Frequency Input	No	Yes, note 2
Computer/Pulse Input	No	Yes, note 2
Voltage Input (1-5 Vdc)	No	Yes, note 2
Relay Output 1	No	Yes
Relay Output 2	No	Yes
Local Instrument Link Communication	Yes, note 3	Yes, note 3
Modbus Communication	Yes, note 3	Yes, note 3

Notes:

1. Model 352PB - Select one of the two Option 3 I/O choices with the Option 3 I/O Jumper.
 2. Model 352PE - Select one of the six Option 3 I/O choices with the I/O Option 3 I/O Jumper.
 3. Model 352PB or 352PE - Select either communication protocol.
- * Function Block ID

Table 8-2 Communication Options and Features

PROTOCOL	OPTION BOARD NEEDED	EXPAND I/O	REMOTE CONFIGURATION
Local Instrument Link	LIL Option Board	No	Yes
LonWorks	LonWorks Option Board	Yes	No
Modbus	No	No	Yes

8.2 ENVIRONMENTAL CONSIDERATIONS

Operate a controller within its environmental specifications to help ensure reliable, trouble-free operation with minimum down-time. Refer to Section 14.8 for controller operating temperatures limits, operating humidity, and maximum moisture content.

TEMPERATURE

Keep the air surrounding an operating controller below 50°C (122°F). Check air temperature periodically to ensure that this specification is not being exceeded.

CAUTION

Exceeding the specified operating temperature limits can adversely affect performance and may cause damage to the controller.

Forced air ventilation is recommended when controllers are mounted in a partially or completely enclosed panel or cabinet (e.g. NEMA 1), as shown at right. When clean air is present, exhaust fans are often mounted across the top of a panel and louvers formed in the panel bottom. Air is then drawn upward between the station cases. When air contains particulate matter, fans and filters are generally located at the panel bottom and louvers at the top. Filtered air is now forced upward between the station cases. Filters must be serviced periodically.

Use only high quality fans that do not cause electrical noise that could interfere with electronic instruments.

A sealed cabinet (e.g. NEMA 12 or 4X) housing 352Ps must not contain other equipment that generates significant heat and must contain a fan to force air to flow around equipment and throughout the cabinet preventing hot spots from developing. Forced air conditioning may be required in high density panels or consoles. Periodically change or clean air filters.

CONTAMINANTS

The controller case is slotted to permit circulation of clean cooling air. Liquids and corrosive gases must not be allowed to enter the case. Protect the controller from rain, air conditioning condensate, and plant and process related fluids and gases. Exposure to contaminants can result in malfunction.

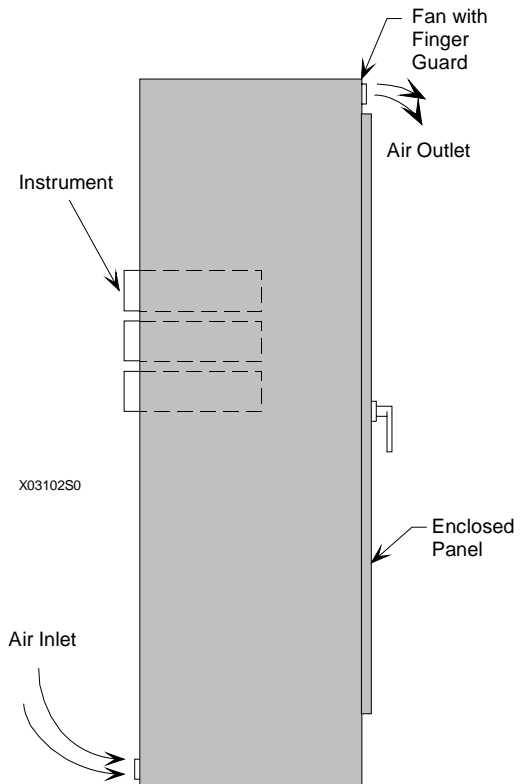

No. of Fans: One for each 16 stations or 3 ft. of panel width.

Air Inlet: 30 in² for each fan. If filters are used, they must be changed periodically (increase inlet to 50 in²).

Figure 8-1 Forced Air Ventilation

Industrial environments often contain airborne particulate contaminants. Particulate matter, usually dust and dirt, is abrasive and can cause intermittent connections. A layer of dust on circuit boards can interfere with component heat dissipation and can absorb other airborne contaminants. Extended exposure to these contaminants may result in malfunctions.

Although controller boards have a protective coating, the following steps can reduce contaminant related equipment malfunctions:

1. Identify contaminants and implement methods to reduce their presence.
2. Install protective housing for field mounted controllers.
3. When cleaning equipment and surrounding area, especially the floor, either vacuum away all dust and dirt or use a dampened rag or mop. Sweeping or dry dusting re-circulates dust and dirt.
4. Clean or replace all air conditioning filters, room air filters, and equipment filters regularly.
5. Inform all personnel with access to the equipment of the need for cleanliness.

8.3 MECHANICAL INSTALLATION

The following subsections provide guidelines and procedures for mounting controllers in a panel or rack. The installation should be structurally rigid and the controllers should be squared in the panel or rack. See Figure 8-2 for panel cutout dimensions and Figure 8-3 for controller dimensions.

8.3.1 Panel and Rack Mounting Guidelines

The panel face should provide a flat and rigid mounting surface. Reinforce the back of the panel if there is a possibility that the panel face will bow. Raceways, conduit, and wiring should not interfere with the removal or accessibility of the instruments, control devices, alarms, and related equipment.

8.3.2 Single Station Mounting

Single station mounting consists of mounting one SLDC in a single panel cutout. Use these steps to install either an empty case or a complete controller.

1. Loosen and remove the top and bottom mounting brackets from the case.
2. Insert the case into the panel cutout. Install and partially tighten the mounting brackets.
3. Square the case with the panel.
4. Alternately tighten top and bottom mounting brackets until the case is secured to the panel. Do not over tighten and distort the case.

8.3.3 Multiple Station Row Mounting

Multiple station row mounting consists of grouping a number of controllers side by side within a single panel cutout. Use these steps to install either empty cases or complete controllers.

1. Loosen and remove the top and bottom mounting brackets from all of the cases to be installed in the panel cutout.
2. Starting at one end of the row, insert a case into the panel cutout.
3. Install and partially tighten the mounting brackets.
4. Insert the next case into the panel cutout and install and partially tighten its mounting brackets.
5. Continue to install cases and mounting brackets until the panel cutout is filled.
6. Carefully square the cases with the panel and with each other.
7. Alternately tighten top and bottom mounting brackets until all cases are secured to the panel. Do not over tighten and distort the cases.

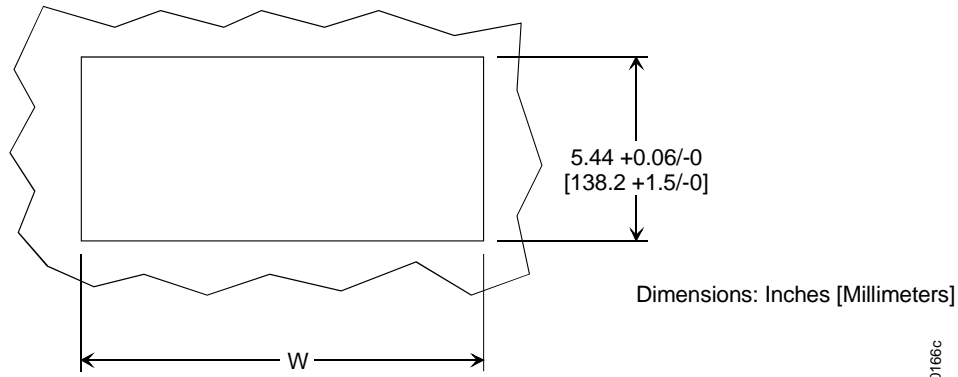

Panel Cutout Dimensions: Tolerances +0.06/-0 [+1.5/-0]
 Height= 5.44 [138.2]
 Width= (2.84 X A) - 0.16 inches
 [(72.0 X A) - 4.1] mm

Where: A= Number of 352P Stations, 353 Stations,
 353R Faceplates, and ilpac Faceplates

MG00166c

Figure 8-2 Panel Cutout Dimension

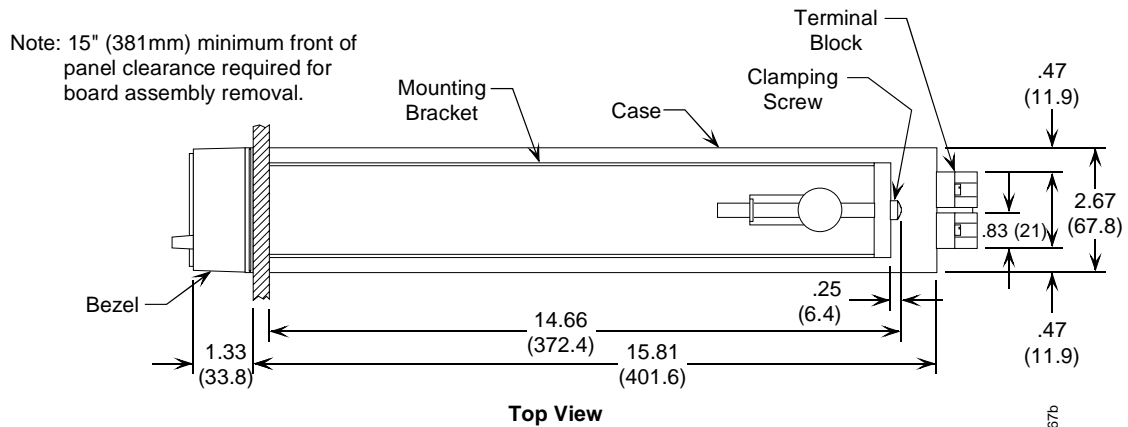

MG00167b

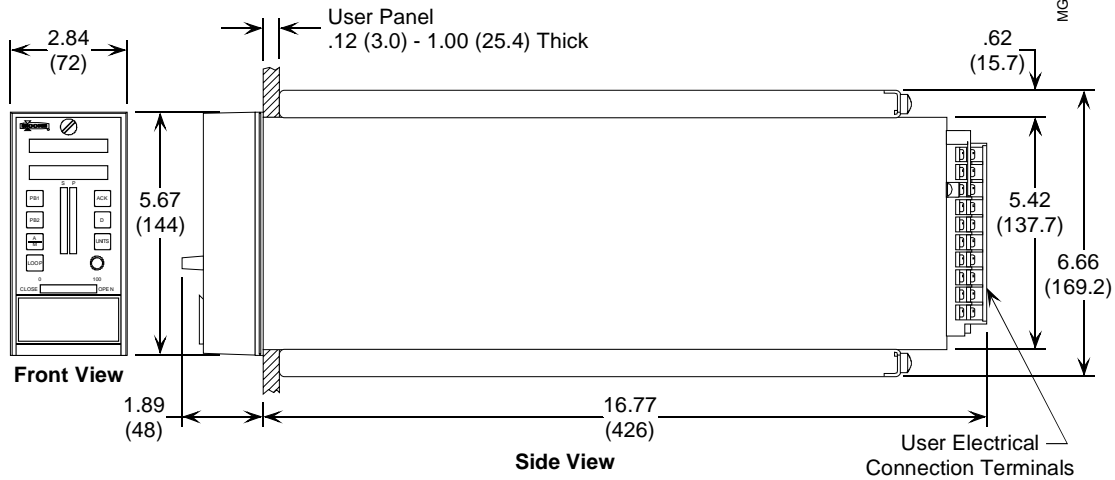





Figure 8-3 Model 352P Dimensions

8.4 ELECTRICAL INSTALLATION

These sections contain electrical connection details for wiring a Model 352P. Each case rear connector and terminal is identified. Connector styles are discussed in section 8.3 Mechanical Installation. Connector cover removal and separation of the fixed portion or a connector from the removable portion is described.

Section 8.4.2 Wiring Guidelines contains specific information about connector removal for wiring, wire size, wire stripping and other details that will be needed while wiring. Read this section before beginning to wire a controller. Sections 8.4.3 through 8.4.12 contain wiring diagrams and, where needed, step-by-step installation procedures to describe I/O and network wiring. Section 8.4.13 provides power input wiring information. Single controller and daisy chained power wiring are illustrated.

 WARNING		
	Electrical shock hazard Explosion hazard	
Can cause death, serious injury or property damage		
<ul style="list-style-type: none"> • Remove power from all wires and terminals before working on equipment. • In potentially hazardous atmosphere, remove power from equipment before connecting or disconnecting power, signal, or other circuit. • Observe all pertinent regulation regarding installation in hazardous area. 		

8.4.1 Wiring Guidelines

Electrical Connections - Power, I/O, and network connections to the controller are completed through 40 terminals in columns A, B, C and D. Figure 6-4 shows conductor connection methods to these terminals. Terminal locations are shown in Figure 6-5 and individual terminal numbers, terminal function block IDs, and terminal IDs are identified in Table 6-3.

Terminals - Each column has 10 screw terminals with #6 screws and pressure plates. Insert stripped wire ends or crimp-on connectors under the pressure plates. Each power terminal is identified by two letters: AH, Hot; AN, Neutral; and AG, Ground. Each signal I/O and communication terminal is identified by a letter and number: A9, C5.

Wire Size Recommendations:

- signal wiring - 18 AWG (0.96 mm²)
- power wiring - 18 AWG (0.96 mm²)

Wire Stripping Recommendations:

- stranded wire - 1/4" (6 mm) to 5/16" (8 mm)
- solid wire - 3/8" (10 mm) to 7/16" (11 mm)

Be careful not to nick the conductor or cut away strands.

Wire Selection - Stranded wire is recommended for most connections, however, solid wire is typically used for thermocouple extension wire. Carefully select wire size, conductor material, and insulation. Some selection considerations are:

- current and voltage to be carried
- total length of each wire run
- whether wire will be bundled or run singly
- indoor or outdoor installation
- temperature extremes
- exposure to sunlight

- vibration
- types of contaminants

Station Common, Terminal A5 - Within the Model 352P, station common is connected to:

- the transmitter (two-wire) power supply common
- digital output common (DOC-)
- all analog input and analog output commons (e.g., AI1C-)

Station common is isolated from case/safety ground and should be connected to the user's instrument bus common at only one point. Digital input commons are isolated from station common and case/safety ground.

Crimp-On (solderless) Connectors - Ring tongue or spring spade crimp-on connectors for #6 screws can be used. Connectors must have insulated barrels. Refer to the connector manufacturer's recommendations for wire stripping dimensions and crimping tools. Carefully inspect the crimped connection for mechanical strength. The stripped conductor should not be exposed and no strands of wire should be free.

Wire Routing and Conduit - DC wiring should be separated from AC wiring and away from AC powered pushbuttons, alarms, annunciators, motors, solenoids, and similar devices. Conduit and raceways are commonly used for routing panel wiring. Wiring not installed in conduit or raceway should be clamped or supported approximately every 12 inches.

Terminal Covers - There are two terminal covers: one for columns A and B and one for columns C and D. To open a cover, slip several fingers between a connector column and the outside edge of the cover and pull outward. The cover will open, pivoting on its vertical axis at the center of the case.

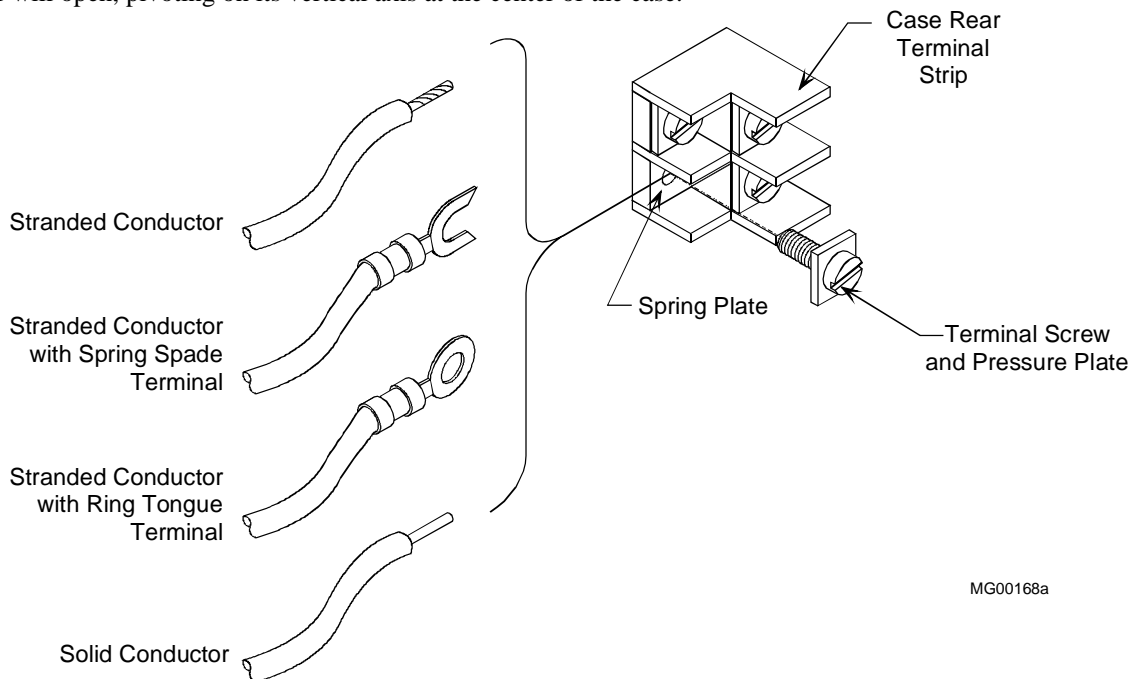
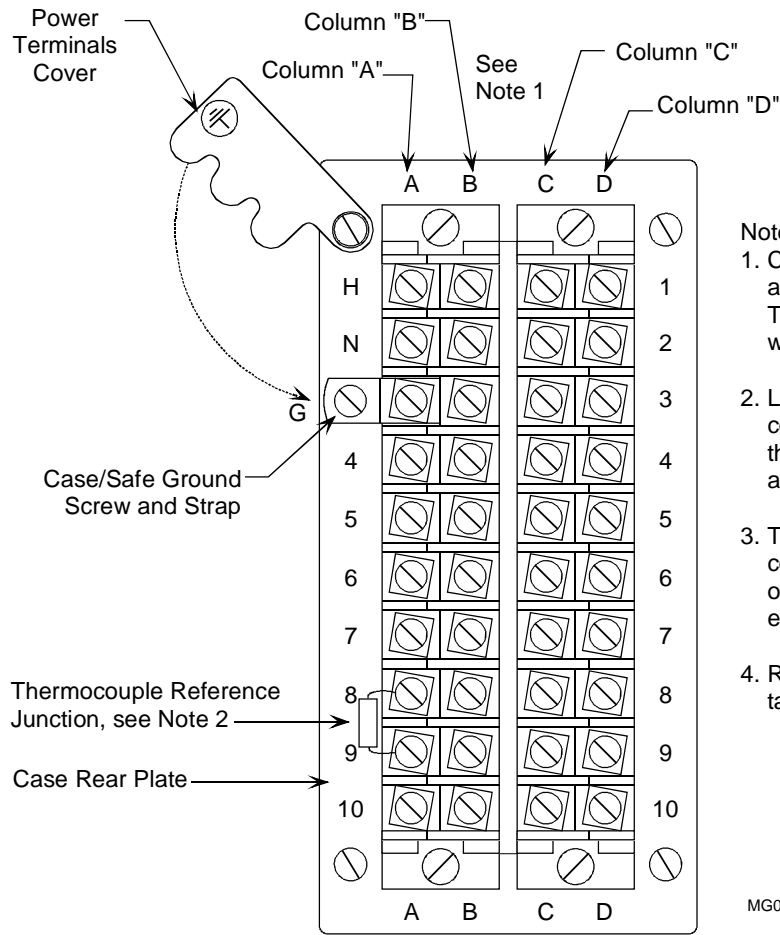

Figure 8-4 Conductor Installation on Rear Terminals



Notes:

1. Case has 40 terminals. Terminal columns A and B are used when wiring a Model 352PB. Terminal columns A, B, C and D are used when wiring a Model 352PE.
2. Locate TC Reference Junction body in the corner formed by the case rear plate and the terminal block. Leads should be short and sleeved.
3. Terminal covers are not shown. The two covers pivot at the case center and are opened by pulling outward on the outside edge of a cover.
4. Refer to the Rear Terminal Assignments table for the connection to each terminal.

MG00169b

Rear View of Case

Figure 8-5 Case Rear Terminals

Table 8-3 Rear Terminal Assignments¹⁵

REAR TERMINAL	DESCRIPTION	FUNCTION BLOCK ID	TERMINAL ID
AH	Power Input: AC Hot or DC+	-----	AH
AN	Power Input: Neutral or DC-	-----	AN
AG	Case/Safety Ground	-----	AG
A4	Analog Input 1 +	AIN1+	AI1+
A5	Analog Input Common; Station Common	AINC	AIC-
A6	Analog Input 2 +	AIN2+	AI2+
A7	Analog Output 1 +	AOUT1+	AO1+
A8	Analog Output Common or TC Ref. Jct. See Table 8-3a ¹⁶	AOUTC	AOC-
A9	Optional No. 3 Input See Tables 8.3a through 8.3h for input wiring options	-----	-----
A10	Optional No. 3 Input See Tables 8.3a through 8.3h for input wiring options	-----	-----
B1	Modbus or LIL	-----	LK+
B2	Modbus or LIL	-----	LK-
B3	Do Not Connect To This Terminal	-----	NC
B4	Digital Output 1+	DOUT1+	DO1+
B5	Transmitter Power +26 Vdc	-----	+26
B6	Digital Output 2+	DOUT2+	DO2+
B7	Digital Output 1/2 Common	DOUTC	DOC-
B8	Digital Input 1+	DIN1+	DI1+
B9	Digital Input 1-	DIN1-	DI1-
B10	Optional No. 3 Input See Tables 8.3a through 8.3h for input wiring options	-----	-----
C1	Relay 1 Output, Normally Open Contact	ROUT1no	RINO
C2	Relay 1 Common	ROUT1com	RIC
C3	Relay 1 Output, Normally Closed Contact	ROUT1nc	RINC
C4	Do Not Connect To This Terminal	NC	NC
C5	Analog Output 3+	AOUT3+	AO3+
C6	Analog Output 3 Common	AOUTC	AOC-
C7	Digital Input 2+	DIN2+	DI2+
C8	Digital Input 2-	DIN2-	DI2-
C9	Digital Input 3+	DIN3+	DI3+
C10	Digital Input 3-	DIN3-	DI3-
D1	Relay 2 Output, Normally Open Contact	ROUT2no	R2NO
D2	Relay 2 Common	ROUT2com	R2C
D3	Relay 2 Output, Normally Closed Contact	ROUT2nc	R2NC
D4	Analog Input 4+	AIN4+	AI4+
D5	Analog Input Common	AIN4C/AINU1	AIC-
D6	Analog Input 5+	AINU1b	AI5+
D7	Analog Input 6+	AIN3+	AI6+
D8	Analog Input 6 Common	AINC	AIC-
D9	Analog Output 2	AOUT2+	AO2+
D10	Analog Output Common	AOUTC	AOC-

Table continued on next page.

¹⁵ Several rear terminals are jumper dependent. Refer to Sections 11.5.3 MPU Controller Board and 11.6 Option 3 I/O Selection for jumper details.¹⁶ When a TC Reference Junction is connected to A8, use another station common terminal for Analog Out common.

TABLE 8-3a Thermocouple/Millivolt Input Option (Model 352P E ___ T...)

REAR TERMINAL	DESCRIPTION	FUNCTION BLOCK ID	MODEL 352 TERMINAL ID
A10	Analog Input 3+	AINU2b	AI3+
B10	Analog Input 3-	AINU2c	AI3-
A8	Reference Junction	AINU2a	Sens. Bd.
A9	Reference Junction	AINU2d	Sens. Bd.

TABLE 8-3b Voltage Input Option (Model 352P E ___ V...)

REAR TERMINAL	DESCRIPTION	FUNCTION BLOCK ID	MODEL 352 TERMINAL ID
A10	Analog Input 3+	AINU2b	AI3+
A9	Analog Input 3-	AINU2c	AI3-

TABLE 8-3c Computer Pulse - Pulse Direction (Model 352P E ___ C...)

REAR TERMINAL	DESCRIPTION	FUNCTION BLOCK ID	MODEL 352 TERMINAL ID
A10	UP/PULSE Input 3+	DINU1+	AI3+ (up/pulse)
B10	DOWN/DIR Input 3-	DINU2+	AI3- (down/dir)
A9	Computer Input 3 Common	DINU1-, DINU2-	AI3e

TABLE 8-3d Frequency Input Option (Model 352P E ___ F...)

REAR TERMINAL	DESCRIPTION	FUNCTION BLOCK ID	MODEL 352 TERMINAL ID
A10	Frequency Input 3+	DINU1+	AI3+
B10	Frequency Input 3-	DINU1-	AI3-

TABLE 8-3e RTD Input Option (Model 352P E ___ D...)

REAR TERMINAL	DESCRIPTION	FUNCTION BLOCK ID	MODEL 352 TERMINAL ID
A9	RTD Input 3, Excitation	AINU2d	AI3e
A10	RTD Input 3+	AINU2c	AI3+
B10	RTD Input 3-	AINU2a	AI3-

TABLE 8-3f LonWorks Option (Model 352PB/E ___ L...)

REAR TERMINAL	DESCRIPTION	FUNCTION BLOCK ID	MODEL 352 TERMINAL ID
A9	LonWorks I/O Bus A	n/a	-----
A10	LonWorks I/O Bus B	n/a	-----

TABLE 8-3g Analog I/O Option AI 3 (Model 352PB ___ A...)

REAR TERMINAL	DESCRIPTION	FUNCTION BLOCK ID	MODEL 352 TERMINAL ID
A10	Analog Input 3+	AIN3	-----
B10	Analog Input 3-	AIN3	-----

TABLE 8-3h Analog I/O AO2 Option (Model 352PB ___ A...)

REAR TERMINAL	DESCRIPTION	FUNCTION BLOCK ID	MODEL 352 TERMINAL ID
A8	Analog Output 2-	AOUTC	AO2C-
A9	Analog Output 2+	AOUT2+	AO2+

8.4.2 Analog Signal Input Wiring (4-20 mA, 1-5 Vdc, and mV)

Model 352P analog signal input terminals are connected to software function blocks AIN and AINU within the controller. Table 8-3 correlates function blocks and input terminals. These terminals will accept several input signal types with the appropriate wiring and components. A current input signal to an AIN or AINU function block must be converted to 1-5 Vdc by a range resistor. The installation kit supplied with the controller has 250Ω range resistors to convert 4-20 mA to 1-5 Vdc. Other loop currents will require other range resistor values.

Perform the following steps for each input.

1. Select an analog input terminal pair for connection of the input signal wiring. Refer to Table 8-3 and the following illustrations as necessary.

For a 4-20 mA input, go to step 2. For a 1-5 Vdc input, go to step 3.

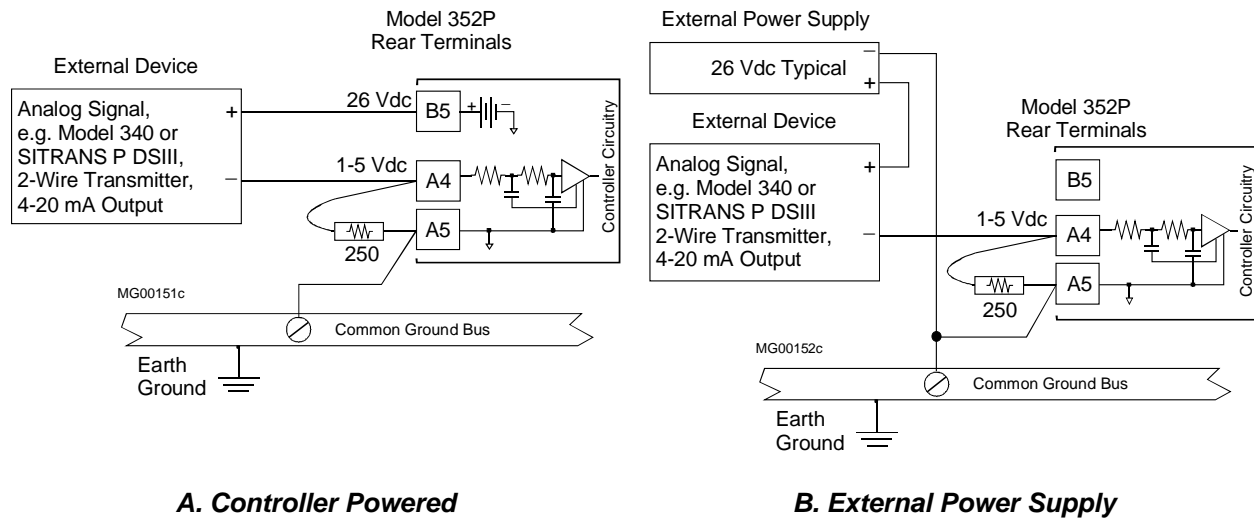

Figure 8-6 Analog Input AI1, 2-Wire Transmitter

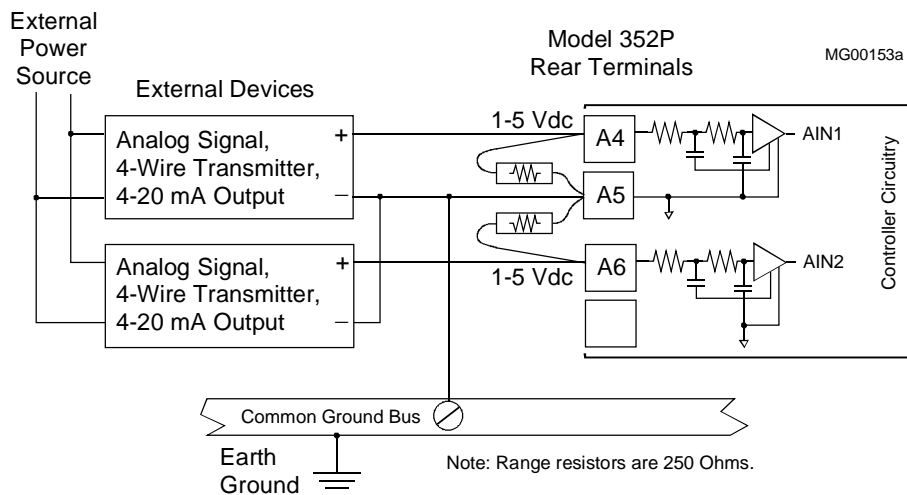

Figure 8-7 Analog Inputs AI1 and AI2, 4-Wire Transmitters

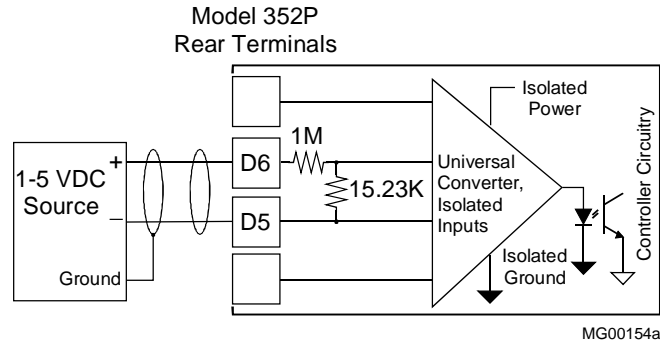

Figure 8-8 Analog Input AI5

2. 4-20 mA Input Only - Select a 250Ω resistor from the installation kit and gently form the resistor leads. Insulate each bent resistor lead with a piece of sleeving.
3. Loosen the two terminal screws. Insert signal input wires and range resistor leads under the screws and pressure plates adjacent to the selected terminal numbers.
4. Check that all involved components and station wiring are fully inserted and carefully tighten the screws. Do not over tighten.
5. Repeat steps 1-4 for each 4-20 mA and 1-5 Vdc input.
6. Carefully dress resistors and wiring so that excessive stress is not placed on a component, wire, or connection.

8.4.3 Analog Output Wiring (4-20 mA, 1-5 Vdc)

Analog output functions blocks are AOUT1, AOUT2, and AOUT3. Figure 8-9 shows connections for an external device that accepts 4-20 mA. For an external device that needs 1-5 Vdc, see Figure 8-10. Refer to Section 8.4.1 for wiring guidelines.

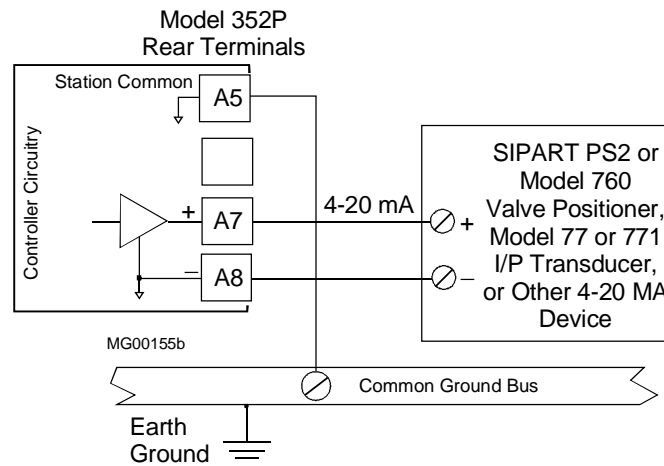

Figure 8-9 Analog Output AO1, Current Output

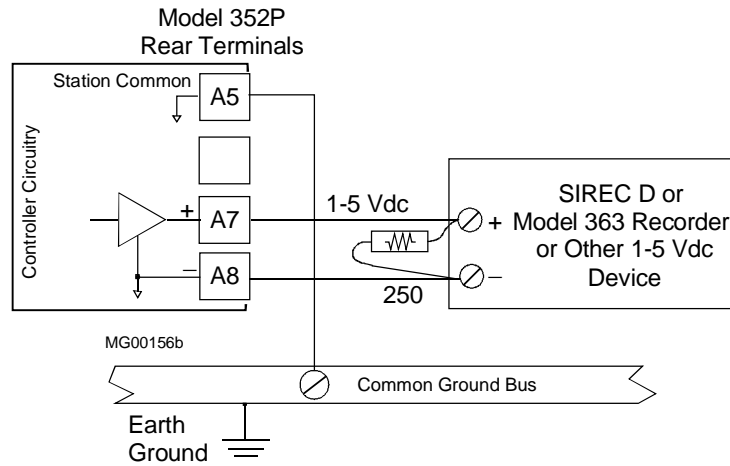

Figure 8-10 Analog Output AO1, Voltage Output

8.4.4 Digital Input Wiring

Typical connections to DIN1, DIN2, and DIN3 function blocks are shown in Figure 8-11. Wiring for internal and external power sources is shown. Semiconductor devices can replace the mechanical switches shown. Wiring guidelines are found in Section 8.4.1. For DIN3 terminals, see Table 8-3.

Digital input commons, e.g. DIN1 (-), are isolated from station common and from case/safety ground.

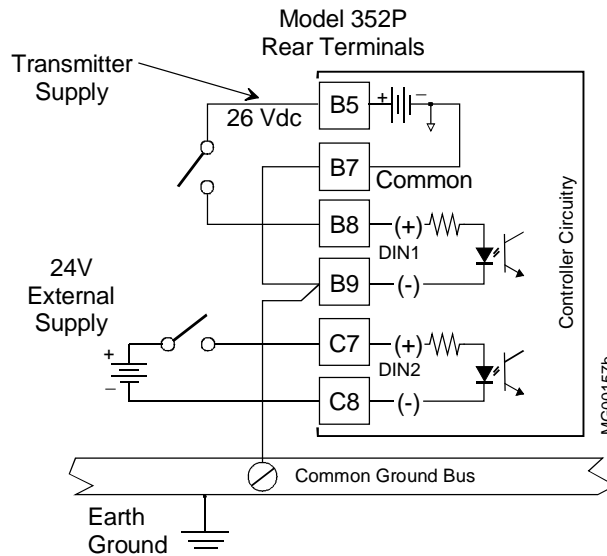

Figure 8-11 Digital Inputs DI1 and DI2

8.4.5 Digital Output Wiring (DO1 and DO2)

Digital output wiring to function blocks DOUT1 and DOUT2 is shown in Figure 8-12. Three diagrams are provided showing current and voltage outputs. Note the use of transient suppression diodes in Figure 8-12C. Always install a transient suppression component across a reactive component, such as a relay coil, to protect the semiconductor devices in the controller.

Digital output common, DOUTC, is connected to station common.

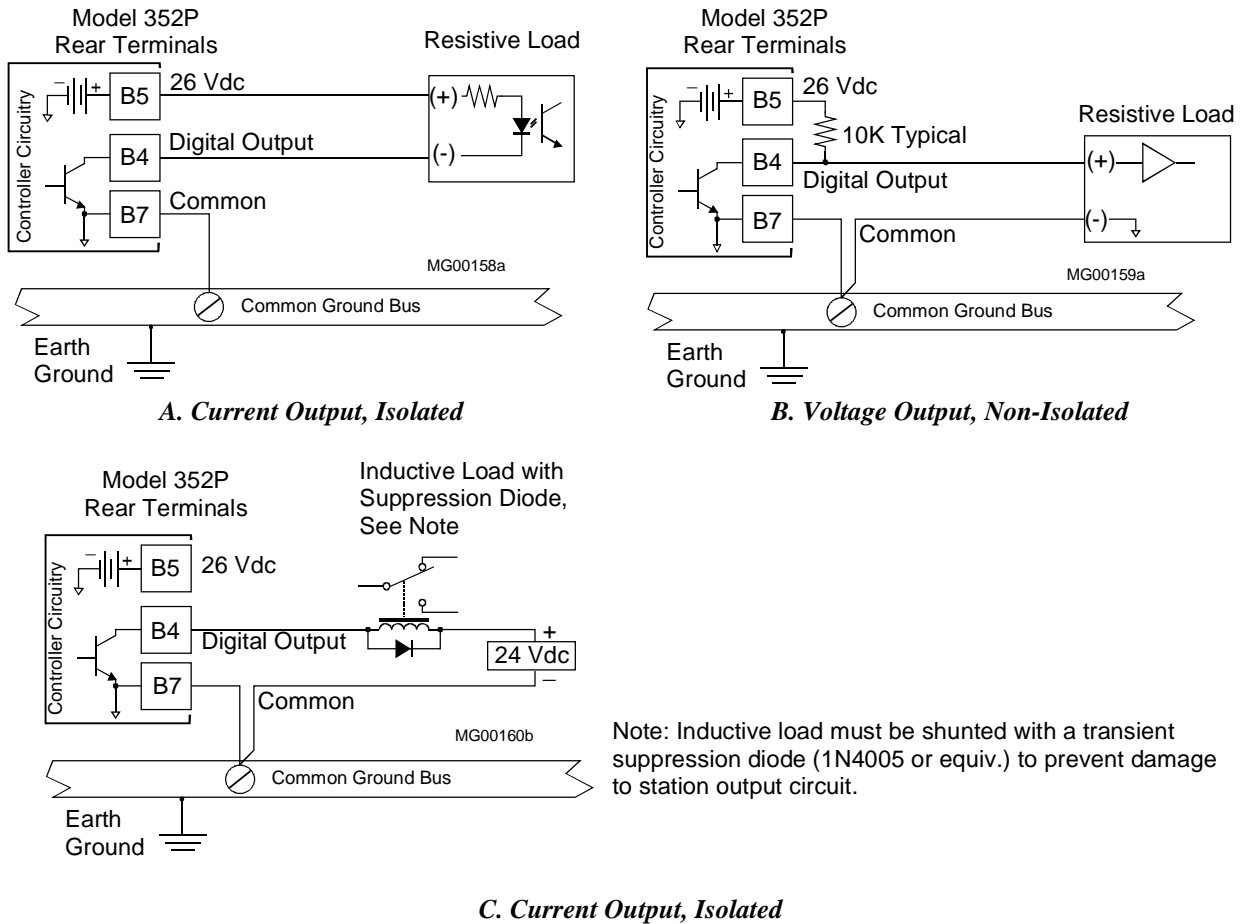

Figure 8-12 Digital Output DO1, Resistive and Inductive Loads

8.4.6 Option 3 I/O Wiring

This section contains the wiring diagrams for those Option 3 I/O selections made with the Option 3 I/O Jumper. Table 8-1 shows the I/O choices available for selection using the jumper.

8.4.6.1 Analog I/O Wiring (AI3 and AO2)

Refer to Table 8-3 for involved terminals. Refer to Section 8.4.2 to wire AI3. Refer to Section 8.4.3 to wire AO2.

8.4.6.2 LonWorks Wiring

Figure 8-13 shows typical LonWorks network wiring to the Model 352P. Connections to remote devices are described in the User's Manual supplied with each device. Refer to Section 8.4.1 for wiring guidelines.

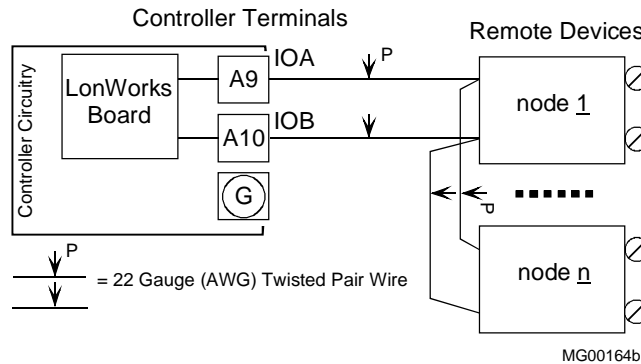

Figure 8-13 LonWorks

8.4.6.3 Thermocouple/Millivolt Input Wiring (AI3)

When the Option 3 I/O Jumper is set for a thermocouple input, function block AINU2 is connected to case rear terminals A8, A9, A10 and B10.

Wiring for a typical grounded tip thermocouple is shown in Figure 8-14. If an ungrounded thermocouple is used, the thermocouple wire shield can be grounded at the Model 352P. Thermocouple wire often has a solid conductor. Make connections as outlined in Section 8.4.1. Be sure that the solid conductor thermocouple or thermocouple extension wire is satisfactorily clamped by the terminal screw and pressure plate.

A reference junction (RJ) is either mounted on case rear terminals A8 and A9 or supplied in the I/O Expander board installation kit for field installation. When it is supplied in the kit, install the reference junction so that the body of the device rests in the corner formed by the case rear plate and the rear connector; see Figure 8-5. Reference junction leads should be as short as practical and should be sleeved.

Millivolt input wiring is connected to terminals A10 and B10. Do not install the reference junction.

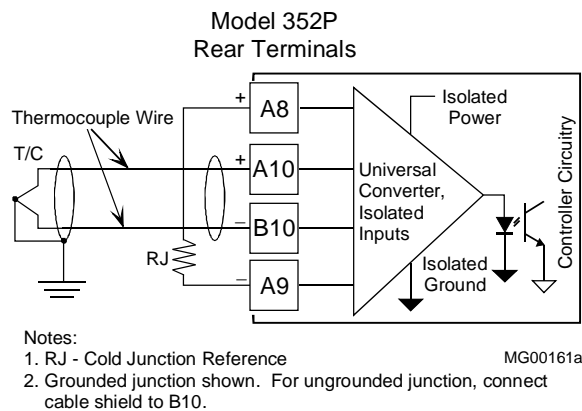

Figure 8-14 Thermocouple Input (AI3)

8.4.6.4 RTD Input Wiring (AI3)

Wiring for 2-, 3-, and 4-wire RTDs is shown in Figure 8-15. Make connections as outlined in Section 8.4.1. Note the wire jumper between terminals A9 and A10 when a 2-wire RTD is installed.

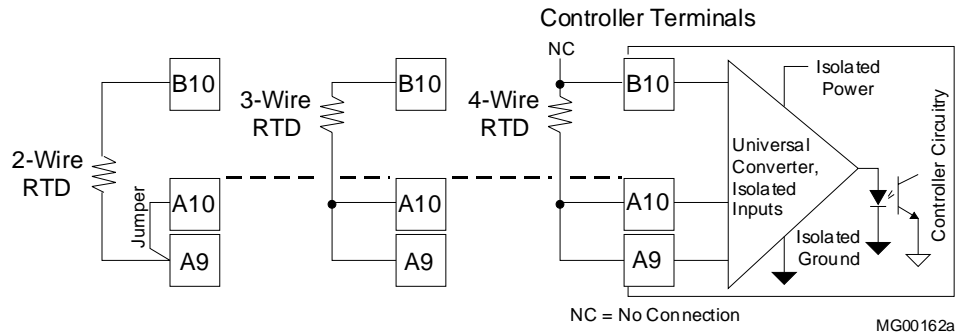

Figure 8-15 RTD Input; 2, 3, and 4-Wire (AI3)

8.4.6.5 Frequency (AI3), Computer/Pulse or Digital Input Wiring

Wiring connections to DINU1 and DINU2 function blocks are shown in Figures 8-16 and 8-17. Wiring for internal and external power sources is shown. Semiconductor devices can replace the mechanical switches shown.

Digital input commons are isolated from station common and from case/safety ground..

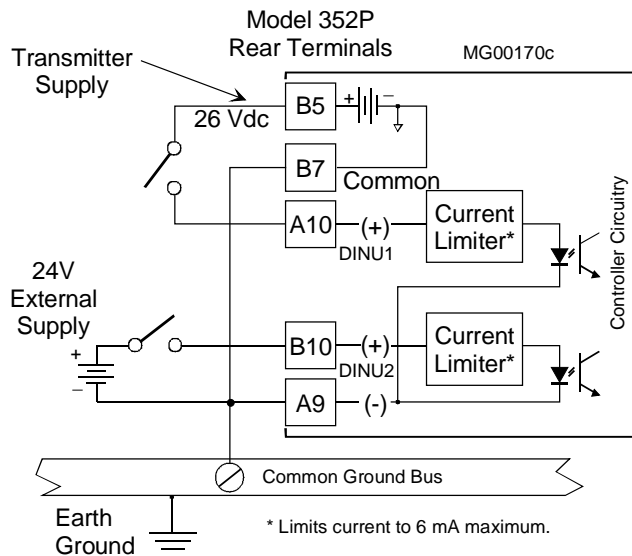

Figure 8-16 Digital Inputs

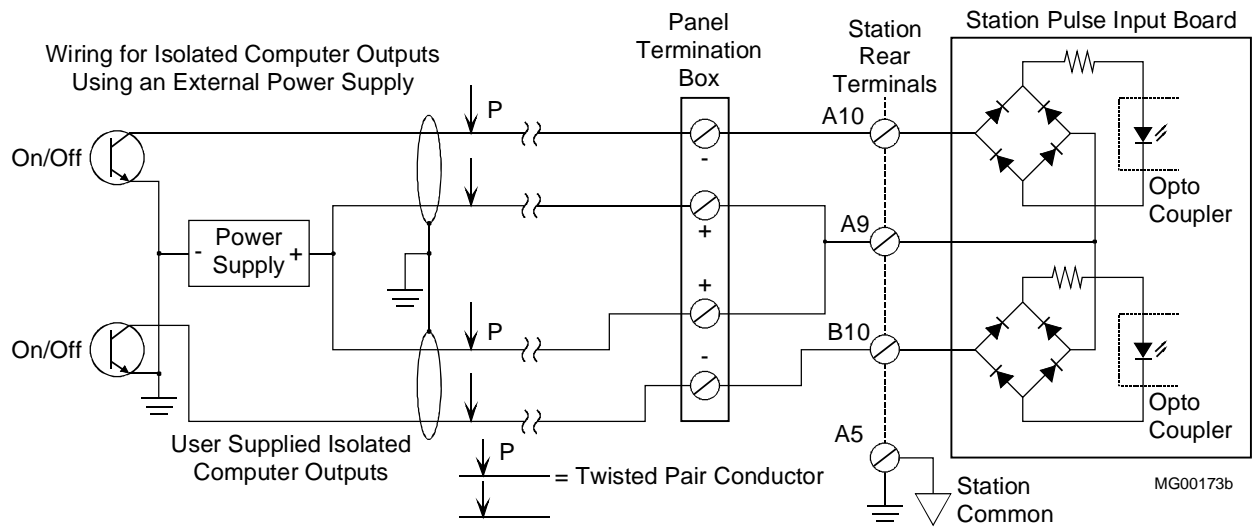
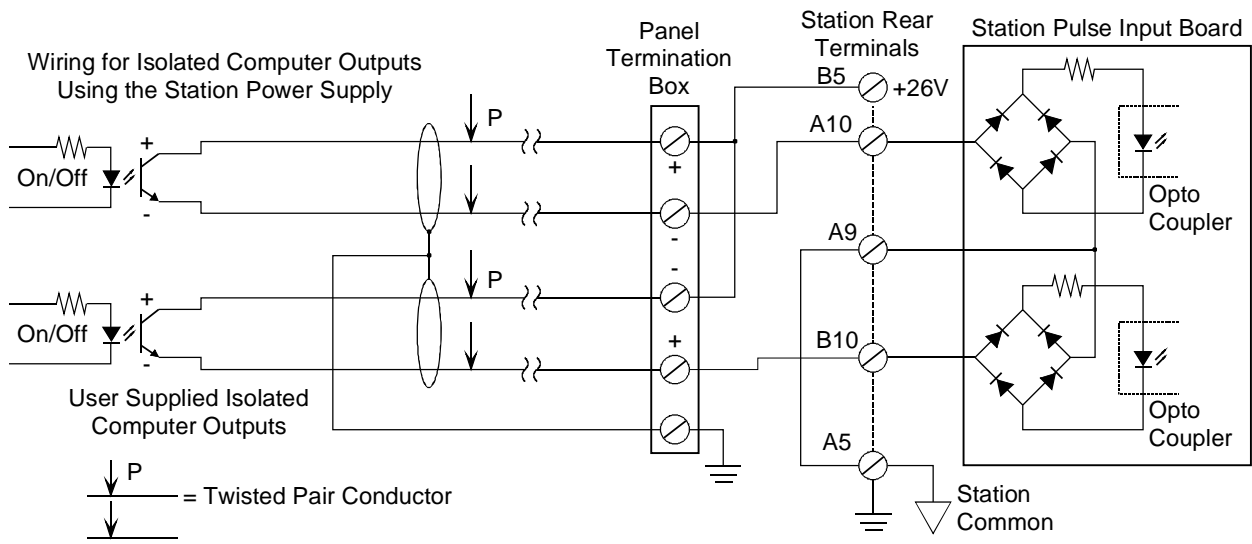
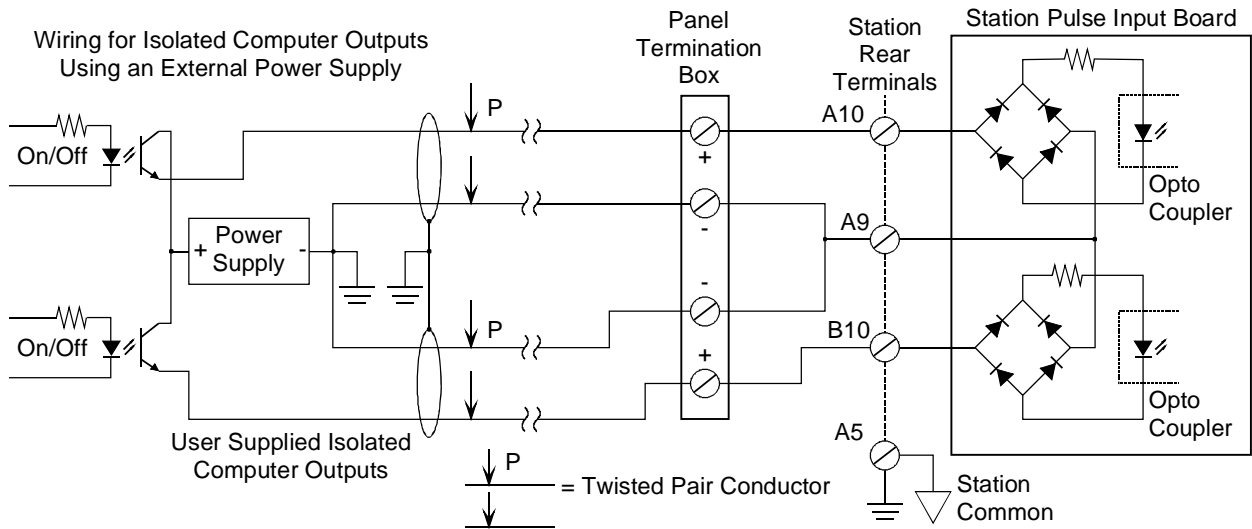

Figure 8-17 Typical Computer/Pulse Input Connections

8.4.6.6 Voltage Input Wiring (AI3)

Refer to Table 8-3 and to Section 8.4.2 to wire a 1-5 Vdc input to function block AINU2. Figure 1-4 shows the resistive divider on this input that is not present in Model 352.

8.4.7 Relay Output Wiring

Function blocks ROUT1 and ROUT2 are located on the I/O Expander board. They provide two single-pole, double-throw relay outputs, as shown in Figure 8-18. Relay contact ratings are stated in Section 14.6.

The load connected to a closed contact should draw a current between the minimum and maximum contact ratings. A resistive load is recommended. An inductive or capacitive load can cause high peak currents or contact arcing which can pit or otherwise damage contacts. The arcing associated with an inductive load can be limited by connecting a voltage transient suppressor, such as a 1N4005 diode, across the load.

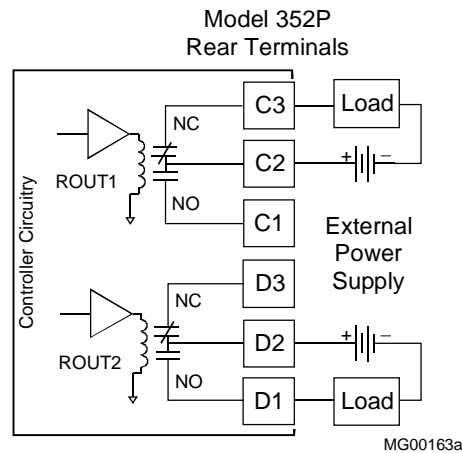

Figure 8-18 Universal Relay Outputs ROUT1 and 2, Resistive Load

8.4.8 Local Instrument Link Wiring

The Local Instrument Link (LIL) is a high performance digital data link that carries commands and responses between user-selected stations. Each station must be identified by a unique link address. This address permits commands and responses to be sent from one station to another specific station. Lower link addresses are 1 through 32. A Model 321 Expansion Satellite is used to add an upper link with addresses 33 through 64. The Station address is entered as the ADDRESS parameter in the STATN function block. Specific instructions for setting a link address in other models are available in the Installation And Service Instructions for that particular model. Refer to SD15492 for complete installation, wiring, and service instructions for the Local Instrument Link.

Figure 8-19 shows typical wiring for stations connected to the LIL. Link cabling and wiring involves twinaxial cable and twisted pair wiring. Twinaxial cable is a twisted pair, shielded cable that is used for runs of 2 feet (0.6m) or more. Unshielded twisted pair wiring is used mainly for interconnecting row mounted stations. Twisted pair wiring can also be used for runs up to 2 feet in length, for example, between rows of stations.

Two types of twinaxial cables are recommended: Belden 9182 for links up to 1500 feet (457 meters) and Belden 9860 for links up to 4000 feet (1220 meters). Either type of cable may be used on a single link. To prevent noise interference, electrically distribute stations as follows:

- no more than 8 stations may be connected within any 10 foot (3m) section of lower or upper link
- no more than 16 stations may be connected within any 100 foot (30m) section of lower or upper link
- insert 100 feet of coiled twinaxial cable between clusters of up to 8 stations

Tap boxes can be installed to serve as a connector interface between Link twinaxial cables and twisted pair wiring connected to screw terminals. Tap boxes provide over-voltage/lightening protection by including eight transient voltage suppressors and one 130V surge arrester. Link termination is also provided by two 150Ω resistors.

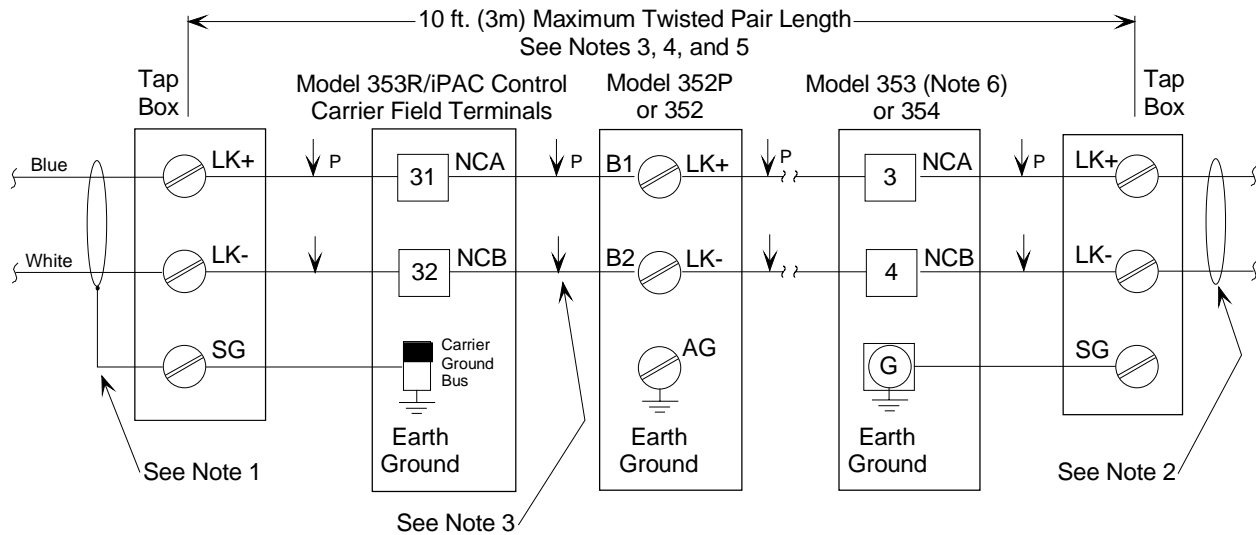

AG00270c

Notes:

1. Drain wire of shield connects to terminal SG. A short jumper of 16 AWG insulated wire grounds shield to station earth ground.
2. Drain wire of shield is cut back and insulated.
3. Twisted pair wiring is used to interconnect stations separated by up to 2 ft (0.6 meters). Twinaxial cable is used for distances greater than 2 ft (0.6 meters). The maximum twisted pair length is 10 ft (3 meters).
4. When there is no tap box at the end of a link, connect a 150 ohm, ±5%, resistor across the link conductors at the last station.
5. See Local Instrument Link Installation And Service Instruction SD15492 for details.
6. Model 353 Design Level A with LIL option board (i.e. Model 353 _____ L ____ A _).

Figure 8-19 LIL Network Wiring

8.4.9 Modbus Wiring

This section describes the wiring needed to connect a host device to a 352P’s Modbus network interface. When connected, the host can read data from and write data to a 352P in a command/response format.

Most host devices communicate using RS232 while the Modbus network interface is RS485. As shown in Figure 8-20, a 2-wire RS485 to RS232 converter is installed to perform the protocol conversion and adapt the connection hardware. A shielded RS232 cable with either DB9 or DB25 connectors is installed between the host device and the converter. An RS485 shielded, twisted-pair cable connects the converter to a 352P. Up to 32 Model 352P’s can be connected since RS485 is a multi-drop network.

Shown below are the jumper locations and identifiers for the Entelec® Isolated Converter shown in Figure 8-24.

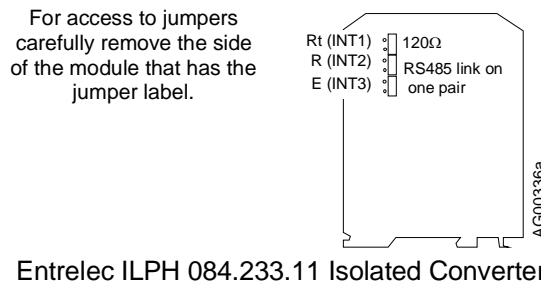

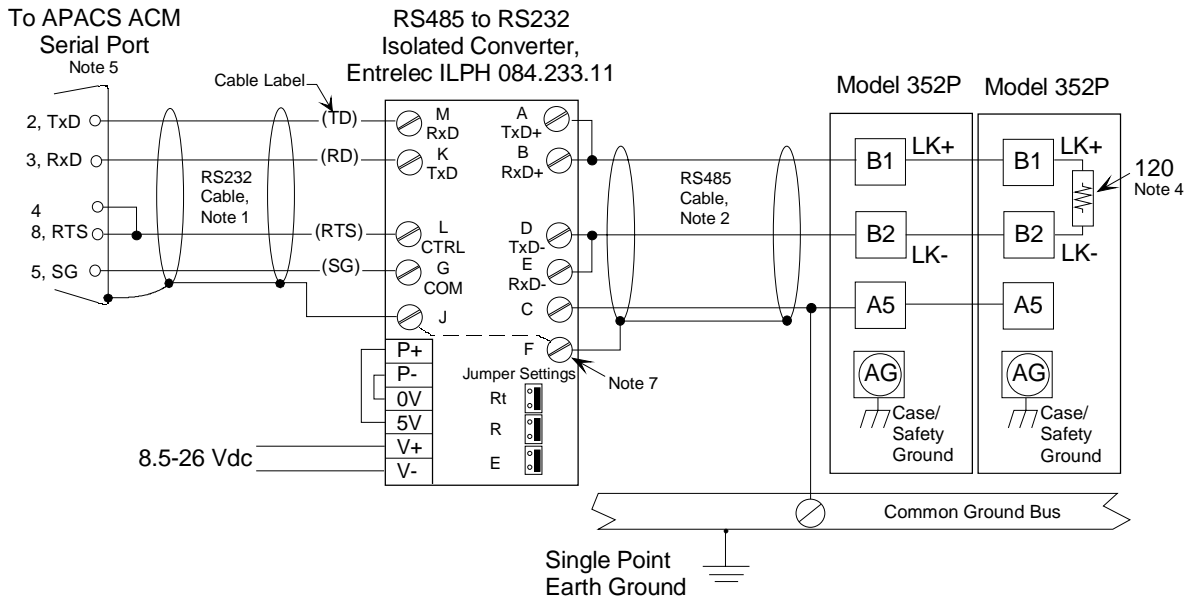

A. Modbus Communications, APACS ACM to Model 352P

MG001749

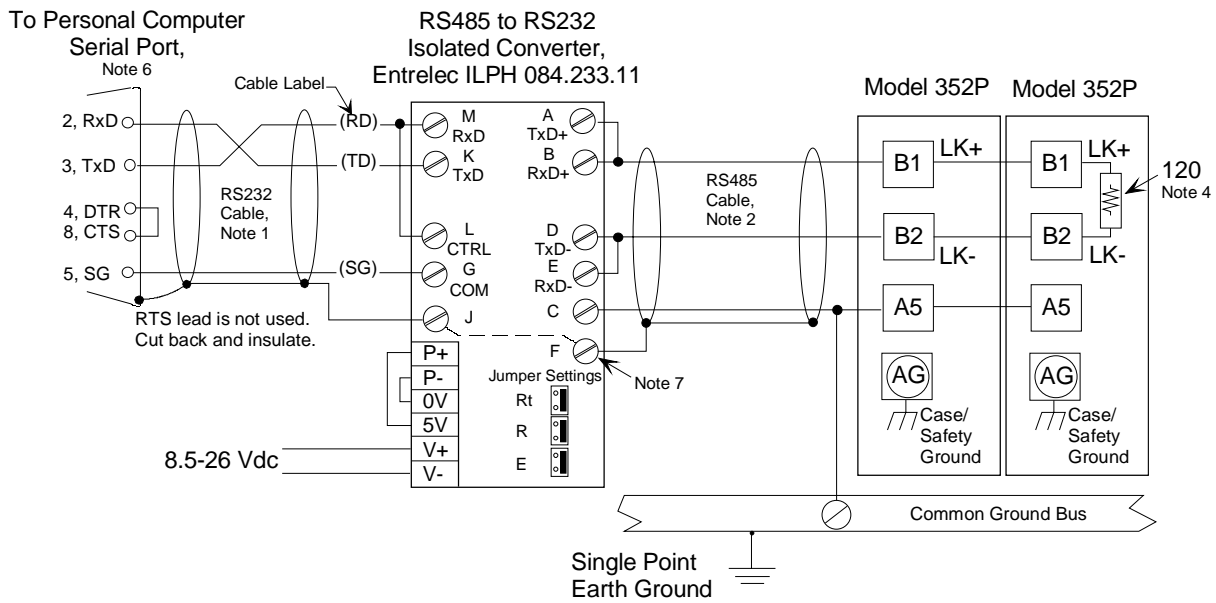

B. Modbus Communications, Personal Computer to Model 352P

Notes:

1. RS232 cable must be shielded and less than 50 feet (15 meters) in length. Recommended cable is Belden 9927, 24 AWG, or equivalent. For an assembled cable, order Siemens PN 16137-191.
2. RS485 recommended cable is Belden 9842, 24 AWG, 120 ohm or equivalent.
3. Up to 32 Model 352P's, Model 353's, Model 354's, and i|pac's can be connected.
4. A user-supplied 120 ohm network termination resistor should be installed on the last device on the network.
5. In ACM's SERIAL Function Block, set Flow Control to 1.
6. Assembled cable above has DB9 (plug) connector. Connection to computer serial port may require a DB9 (socket/receptacle) gender adapter.
7. Connection between F and J provided by Entrelec converter.

Figure 8-20 Modbus Communications, Model 352P to APACS ACM and Personal Computer

8.4.10 SYSTEM WIRING EXAMPLES

Figures 8-21, 22, 23 and 24 show a series of system wiring examples that can be used in conjunction with the other wiring diagrams in this section, each of which is dedicated to a particular function.

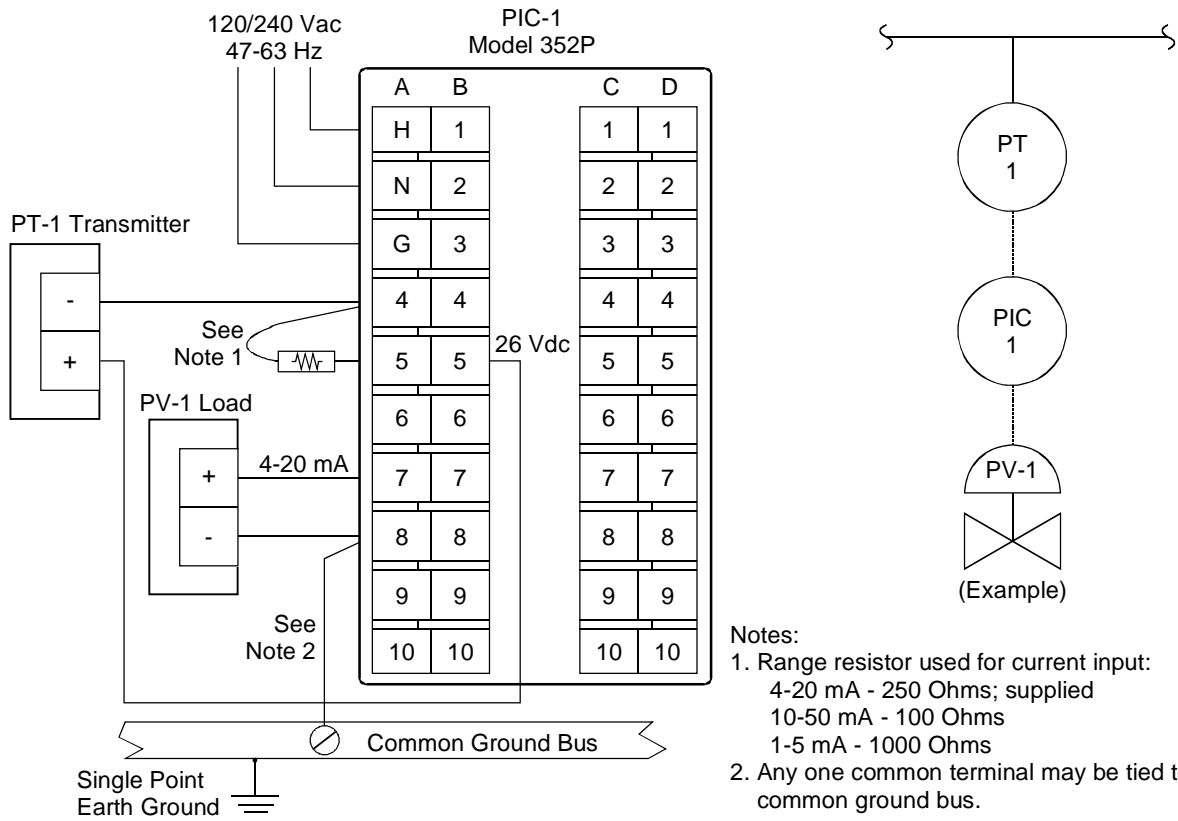

MG00171b

Figure 8-21 Single Loop System, 2-Wire I/O

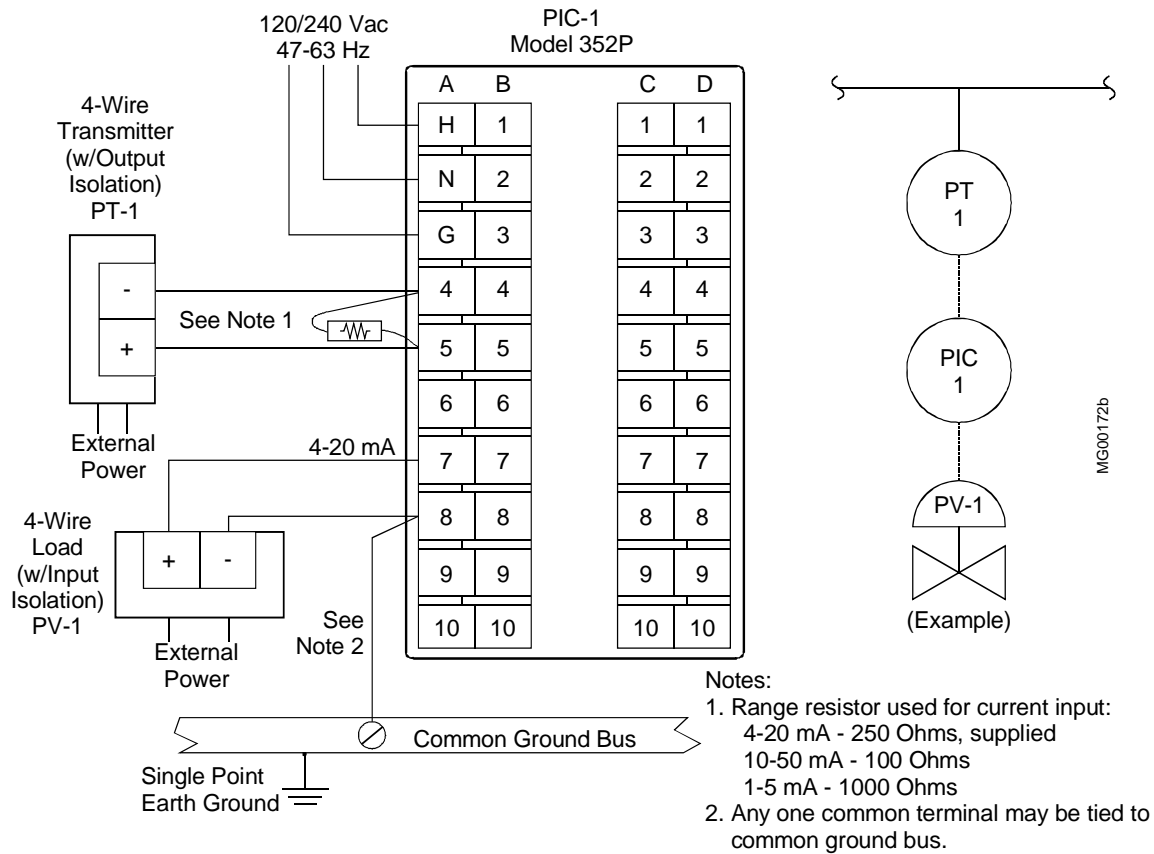

Figure 8-22 Single Loop System, 4-Wire I/O

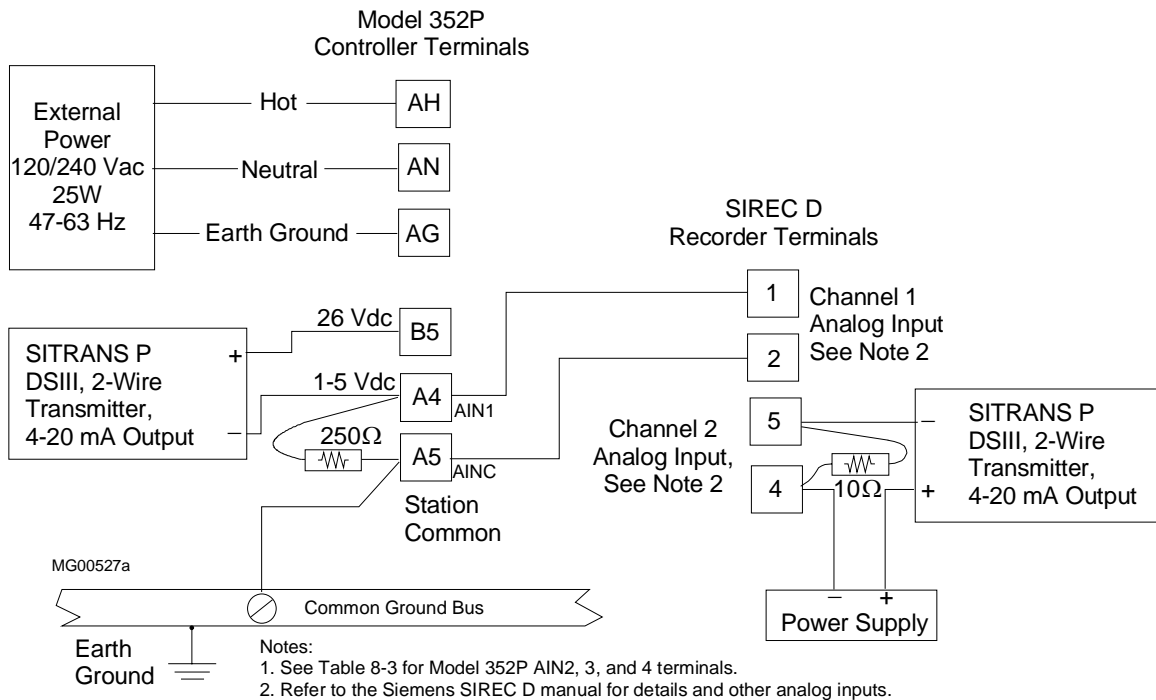

Figure 8-23 Model 352P to Siemens SIREC D Analog Input Wiring

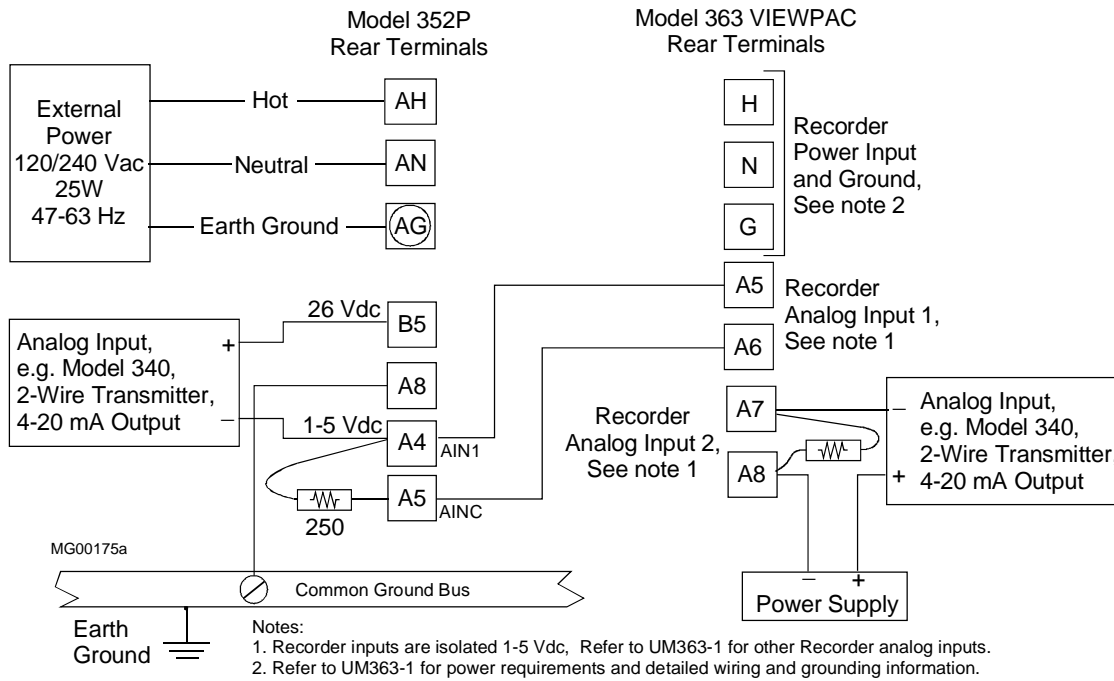
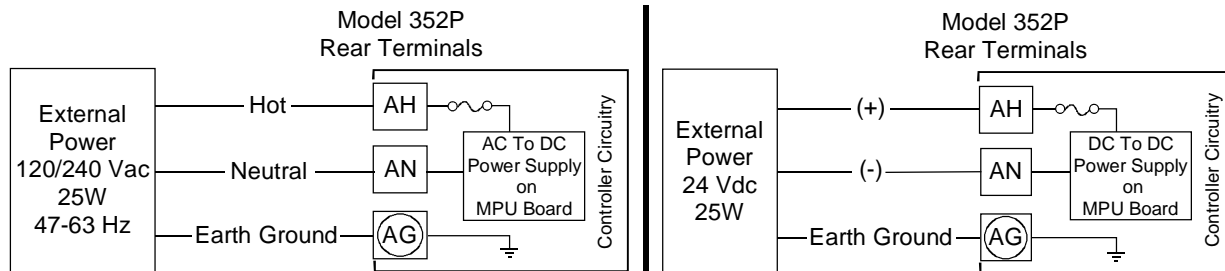

Figure 8-24 Model 352P to Model 363 VIEWPAC Analog Input Wiring

8.4.11 Power Wiring

Basic connections for AC and DC power input are shown in Figure 8-25. Wiring guidelines are given in Section 8.4.1.



MG00176a

Figure 8-25 Controller Power Wiring

Power input to a Model 352P should be routed through a clearly labeled circuit breaker, fuse or on-off switch that is located near the controller and is accessible by the operator. The protective device should be located in a non-explosive atmosphere unless suitable for use in an explosive atmosphere. This type of wiring is shown in Figure 8-26. It will permit removal of controller power without affecting the on-line status of adjacent controllers.

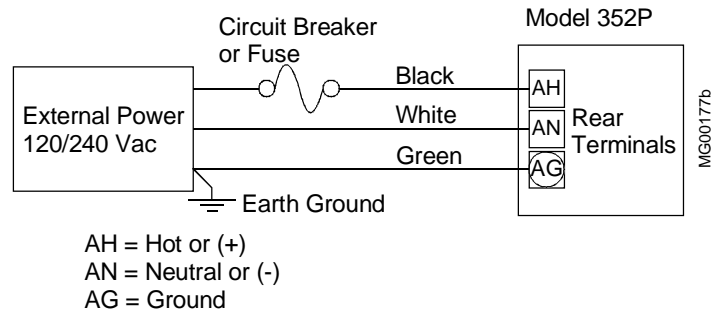

Figure 8-26 Suggested Power Wiring

Where separate wiring is not required, power input wiring can daisy chain together a series of controllers. Here, each controller, except for the last controller on the daisy chain, will have two wires (18 AWG recommended) inserted in terminal AH and in terminal AN. If a larger gauge is to be used, the two wires can be inserted in a crimp-on connector and the connector inserted in the terminal, for a more secure installation. Daisy chained wiring is shown in Figure 8-27. Perform the following steps at AH, AN, and AG terminals at each involved controller.

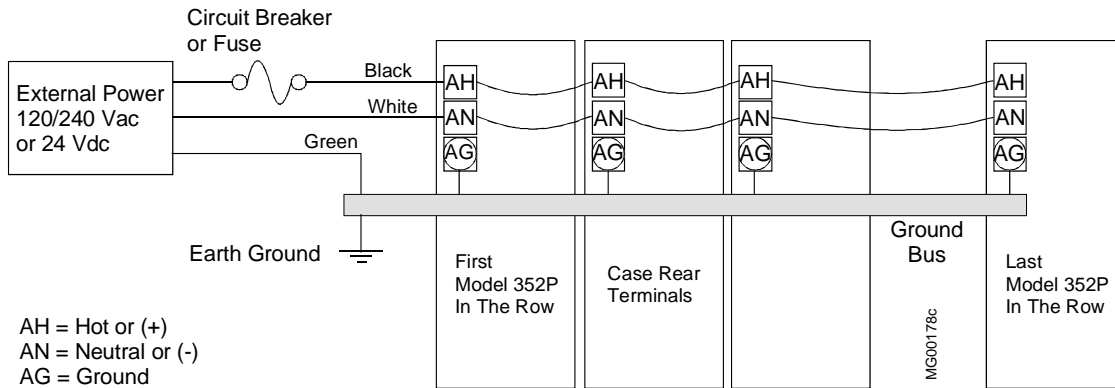

Figure 8-27 Daisy Chained Power Wiring

1. Remove 1/4" (6 mm) to 5/16" (8 mm) from each Hot, Neutral, and Ground wire to be inserted in a terminal or crimp-on connector.
2. Crimp-On Connector only - Insert the wires into the crimp-on connector until they are visible at the ring or spring spade end of the connector. Use the tool recommended by the connector manufacturer to crimp the connection. Be certain that both power input wires are fully inserted in the connector before crimping.
3. Insert the stripped wire or crimp-on connector under the pressure plate; tighten the screw.

8.5 FACTORY CALIBRATION

Unless a special calibration is ordered, the factory calibration is as follows:

Table 8-4 Factory Calibration

ANALOG INPUT OR OUTPUT	FACTORY CALIBRATION, UP TO V1.21	FACTORY CALIBRATION, V1.30 AND ABOVE
Analog input function blocks	1 to 5 Vdc	1 to 5 Vdc
Analog output function blocks	4 to 20 mA	4 to 20 mA
Thermocouple	Type J, Upscale Break	Type J, Upscale Break
RTD	CAL ZERO - 0°C CAL FULL - 500°C CAL VIEW - -3.3 to 103.3%	CAL ZERO - 0°C CAL FULL - 500°C CAL VIEW - -3.3 to 103.3%
Slidewire	CAL ZERO - 0% CAL FULL - 100% CAL VIEW - Contact factory	CAL ZERO - 0% CAL FULL - 100% CAL VIEW - Contact factory
Ohms	CAL ZERO - 0 ohms CAL FULL - 5000 ohms CAL VIEW - Contact factory	CAL ZERO - 0 ohms CAL FULL - 5000 ohms CAL VIEW - Contact factory
Millivolt	CAL ZERO - 0.0 mV CAL FULL - 10 mV CAL VIEW - 0% TO 100%	CAL ZERO - -19.0 mV CAL FULL - +19.0 mV CAL VIEW - 0% TO 100%

Section 12.0 provides calibration procedures that may be used to check or change factory calibration. ■

9.0 LOCAL FACEPLATE OPERATION

Controller operation is described in this section. Each faceplate display, pushbutton, and knob will be discussed first in normal operation mode and then in configuration mode. This section contains many references to function blocks. As necessary, refer to Section 3 for details about a function block.

Most operator controls are shown on the faceplate below. Several additional pushbuttons are located behind the flip-down door at the bottom of the faceplate. These will be discussed in the configuration mode portion of this section.

9.1 NORMAL OPERATION MODE

- 6-Digit Numeric Display** - displays the numeric value of the variable identified by the 8-character alphanumeric display. Numbers can be displayed from 0.00000 to 999999 or -0.0000 to -99999. Any input exceeding these limits will be shown as the maximum or minimum displayable value and cause the display to flash.
- 8-Character Alphanumeric Display** - normally displays the loop tag with the dot suffix of the variable currently showing in the 6-digit numeric display (e.g. **TC2053.P** is the **Process** variable for loop **TC2053**). A loop tag that is displayed is called the *Active Loop* and all operator controls (e.g. PB1, PB2, A/M, ACK, D, UNITS, ALARM, TUNE, TAG, QUICK) will affect the function blocks within the *Active Loop*.
- PB1 Pushbutton** - controls the operation of the **PB1SW (PB 1 transfer SWitch)** function block when the block has been configured for use within the *Active Loop*. See the function block details in Section 3 for more information on **PB1SW**.
- PB2 Pushbutton** - controls the operation of the **PB2SW (PB 2 transfer SWitch)** function block when the block has been configured for use within the *Active Loop*. See the function block details for more information on **PB2SW**.
- A/M Pushbutton** - controls the operation of an **A/M (Auto/Manual)** function block when the block has been configured for use within the *Active Loop*. See the function block details for more information on **A/M**. When the A/M is switched to Auto the numeric display will show the Setpoint value, as indicated by **.S** in the alphanumeric display, and when switched to Manual, the Valve value and **.V** will be shown.
- LOOP Pushbutton** - One or more loops can be configured. When more than one loop has been configured, the **LOOP** button will advance the operator display to the next *Active Loop*. All operator controls now affect the *Active Loop* that is currently shown in the alphanumeric display (e.g. **FC2367**). When a loop is first displayed, the loop tag will appear in the alphanumeric and the displayed variable will be the same as when the loop was last viewed.
- ACK Pushbutton** - this button is used together with the **L** and **S** status LEDs to manage events (e.g. alarm, status, and error conditions) within the controller. Events have user assigned priorities 1-5 (with 1 the highest) and will be organized within the controller, first by priority and then by order of occurrence.
 - S Status LED** - Indicates that event is active in the **Station**. A flashing LED indicates that the event needs to be acknowledged.
 - L Status LED** - Indicates that event is active in the displayed **Loop**. A flashing LED indicates that the event needs to be acknowledged.

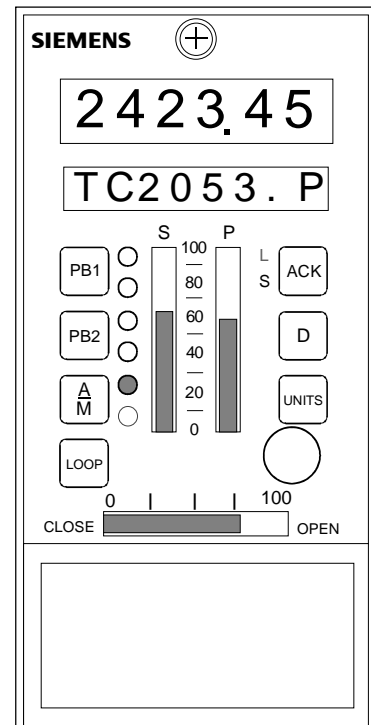

Priority:

- Priority 1 causes the station bargraphs and event LEDs to flash and requires acknowledgment to stop flashing. This is the highest priority.
- Priority 2 also flashes the bargraphs but stops flashing when the event clears (i.e. Self Clearing).
- Priority 3 causes the event LEDs L & S to flash and stops only when the event is acknowledged.
- Priority 4 also causes the event LEDs to flash but stops when the event clears.
- Priority 5 displays the event but does not require that it be acknowledged. This is the lowest priority.

If the event is in the active loop, the alphanumeric display will alternate between the loop tag and the unacknowledged condition (e.g. 'TC2053.P' <---> 'A3 HI'). Press the ACK button to acknowledge this condition and stop the flashing.

The ACK button, after all events have been acknowledged, can then be used to scroll through any active alarm or status conditions within the *Active Loop*. Pressing the ACK button will scroll through the list of active events and wrap around to the start of the list when more than one event is active. This function will time out if the ACK button is not pressed for 3 seconds and return to the normal display mode.

If an unacknowledged event is not within the active loop, press the LOOP button to page through the loops.

- **D** Pushbutton - changes the variable currently displayed. Pressing this pushbutton steps the display one position in the sequence P, S, V, X and Y from any starting point within the display select group.
- **UNITS** Pushbutton - displays the units of the variable shown in the alphanumeric display. When the button is pressed the units that apply to the displayed variable will appear in the alphanumeric (e.g. 'TC2053.P' 'deg F', 'TC2053.V' 'PRCT'). After 3 seconds, the alphanumeric display will return to the variable tag.
- **S** Bargraph - this vertical bargraph displays the scaled range of the controller setpoint in the *Active Loop*. Bargraph height shows the setpoint as the % of range value. The setpoint in engineering units can be viewed by pressing the **D** button to display the dot S parameter (e.g. **TC2053.S**).
- **P** Bargraph - this vertical bargraph displays the scaled range of the controller process in the *Active Loop*. Bargraph height shows the process as the % of range value. The process in engineering units can be viewed by pressing the **D** button to display the dot P parameter (e.g. **TC2053.P**).
- **Pulser Knob** - rotate the Pulser to change the value in the numeric display (e.g. Setpoint, Valve, or other variable configured for normal operator display changes such as **Ratio**, **Bias**). The Pulser knob is also used in configuration to change values in the alphanumeric display.

An accelerator is included. Turning the knob faster multiplies the rate of change of the displayed parameter. Large value changes then require fewer knob rotations.

- **V** Bargraph - this horizontal bargraph displays the scaled range of the controller output in the *Active Loop*. The output/valve signal is shown as the % of range value. The value in engineering units can be viewed by pressing the **D** button to display the dot V parameter (e.g. **TC2053.V**).

9.2 CONFIGURATION MODE

Configuration pushbuttons are located behind the flip-down door on the lower quarter of the faceplate. Note that many of these buttons are used in both the normal operation mode and configuration mode, as described below.

- **ENTER/EXIT CONF** - press to enter configuration when the station is in the normal operation mode or to exit configuration when in the configuration mode.
- **ALARM/STEP DOWN** - has a dual purpose. When in the normal operation mode, pressing the button will scroll through the alarm configuration parameters if the ALARM function block has been configured in the *Active Loop*. The alarm setting is displayed in engineering units and the % of range value will also be displayed on the setpoint bargraph by flashing a single segment equal to the % of range value. If security clearance is satisfied, the parameters can also be changed. See the ALARM function block description for details on the parameters. Press the ENTER/EXIT CONFIG button to return to the on-line displays.

When in the configuration mode, this button will step down to the next configuration level. See the Configuration Overview section of this manual for details on typical levels of the configuration mode.

- **TUNE/STEP UP** - has a dual purpose. When in the normal operation mode, pressing the button will scroll through the controller tuning parameters and allow activating the AUTOTUNE algorithm, if configured for the loop controller. If security clearance is satisfied, the parameters can also be changed. Press the ENTER/EXIT CONFIG button to return to the on-line displays.

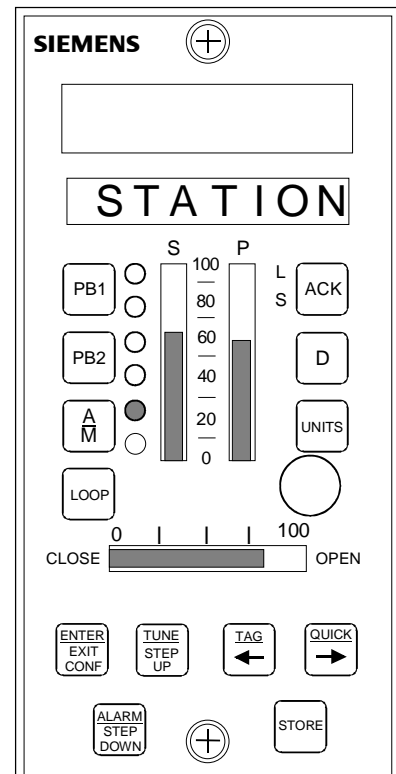

X03141S2

When in the configuration mode, this button will step up to the next configuration level.

- **TAG/<---** - has a dual purpose. When in the normal operation mode, pressing the button will scroll the complete tag name of the *Active Loop* in the alphanumeric display. The tag will scroll one character at a time starting on the right (e.g. -----T, -----TI, ----TIC).

When in the configuration mode, this button will provide a shift left function for configurable items (e.g. will shift the decimal point left).

- **QUICK/--->** - has a dual purpose. When in the normal mode this button will step through and access either previously selected configuration parameters in the quick hold blocks configured within the *Active Loop* (e.g. the HOLD value in **QHOLD03** which was labeled to display **TEMP_LIM** having a range of 300.0 to 600.0) or parameters defined as **QUICKSET**¹⁷ in certain function blocks (e.g. **RATIO**). Press the ENTER/EXIT CONFIG button to return to the on-line displays.

When in the configuration mode, this button will provide a shift right function for configurable items (e.g. will shift the decimal point right).

- **STORE** - will store the configuration parameter to memory. All configuration changes, except for **QUICK**, **BIAS**, **RATIO**, and (quickset hold), require a store before the change is applied to the configuration. However, the **QUICK** functions will also require a store for the value to be placed in permanent memory, otherwise, it will only remain in battery RAM. Values in battery will be used on a hot or warm start. A cold start will use the value in permanent memory.

¹⁷ ALARM, TUNE, and QUICK are QUICKSET functions.

9.3 AUTOTUNE PROCEDURE

If the AUTOTUNE parameter in the controller function block is set to YES, the autotune procedure can be initiated using the TUNE pushbutton located behind the flip-down door. The Autotuner will substitute an ON_OFF controller for the PD or PID function. By making +/- step changes to the valve position, the controller will control the process at the current setpoint while it learns about the process dynamics. The controller then uses this knowledge to derive recommended P, I, and, D settings.

Press the TUNE button to step through the following parameters and, if desired, initiate autotune:

PG Proportional Gain setting - (view or change)
TI Integral Time setting - PID/PIDAG controllers only (view or change)
MR Manual Reset setting - PD controller only (view or change)
TD Derivative Time setting - (view or change)
% DEV The peak/peak % process deviation that the autotuner will maintain during test
% HYS The % process change needed before the valve output will switch
AUTOTUNE Set to YES and STORE to start autotune.
 Press EXIT CONF to return to normal operator faceplate operation.
AT PG Proportional Gain setting recommended by the autotuner
AT TI Integral Time setting recommended by the autotuner
AT TD Derivative Time setting recommended by the autotuner
STORE AT Pressing STORE transfers autotuner recommended settings to controller

While autotuning, the controller will continue normal operation. Pressing the A/M button to switch the controller to Manual will terminate autotune. While in autotune, the alphanumeric display will alternate between 'AUTOTUNE' and the loop tag name and will stop alternating when the autotune program has been completed. Once completed, the controller will return to the mode prior to autotune initiation. When the POST AT (in the controller block) is set to auto transfer, the recommended tuning parameters will automatically be transferred to the controller and it will return to automatic control. To review the AT parameters before initiating autotune, press TUNE and then press STORE at the STORE AT prompt to transfer the recommended settings.

Chart 1 (0-100% range) illustrates a typical autotune exercise. Variable 1 is the Valve and 2 the Process. In this example, the process has noise with a standard deviation of less than 0.5%. The % HYS (% hysteresis band) is set to 0.75% and the % DEV (% deviation from setpoint which should be set to at least 4 times the % HYS value) is set to 3%.

The autotuner will use the initial valve step size (set as % STEP in the controller function block) during the first 1-1/2 cycles to learn the approximate gain of the process. It will then adjust the valve step size during the remainder of the autotuning exercise to maintain the % DEV setting. When this test concludes, the recommended settings are transferred to the controller and a 20% setpoint change is made to illustrate the controller tuning.

When the autotuner is started for the next autotune exercise, it will use the process gain learned during the previous exercise to determine the valve step size unless: the parameter AT RESET in the controller block has been stored as YES, warnings occurred during the first test, or the station has been power cycled.

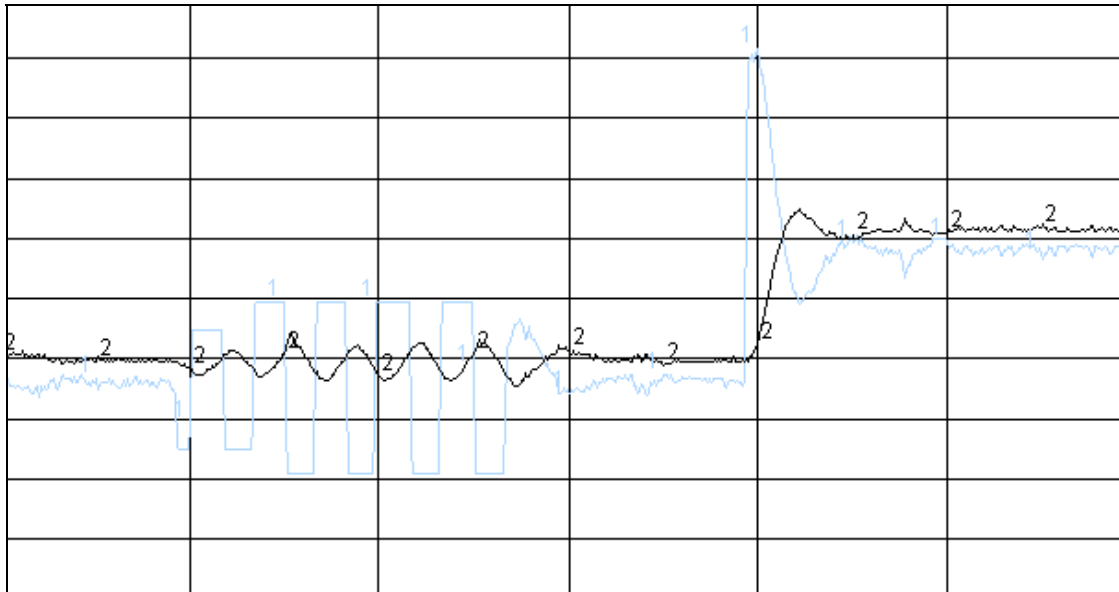
Autotuning Considerations:**Chart 1**

Process Noise - could have an effect where the autotuner will not produce periodic valve cycles. The autotuner will complete an exercise but results may not be satisfactory. This is illustrated in the first autotuning exercise in chart 2 which is the same process as chart 1 but the % HYS was set at 0.5%. If these results occur when the controller % HYS has been set to A (auto set hysteresis) the controller may be having difficulty deriving a good noise figure and manual entry of the % HYS parameter should be considered. The % HYS value should be increased to at least twice the standard deviation value of the noise. In cases where the noise amplitude is extremely large, the filter on the analog input should be increased to minimize the amplitude of the noise seen by the controller. The value of the % DEV parameter should be set to at least four times the % HYS value for best results.

Steady State Conditions - must be established for the process and controller prior to starting an autotune exercise. The autotuner can be initiated while in manual or auto. Steady state is reached when the present valve signal has brought the process to its present value, and the setpoint is equal to the process. When not at steady state, valve cycles will not be symmetrical as illustrated in the second tuning exercise in chart 2 or, as a worse case situation, the valve may not cycle at all. If the valve does cycle, although not symmetrically, adequate tuning results will still be obtained.

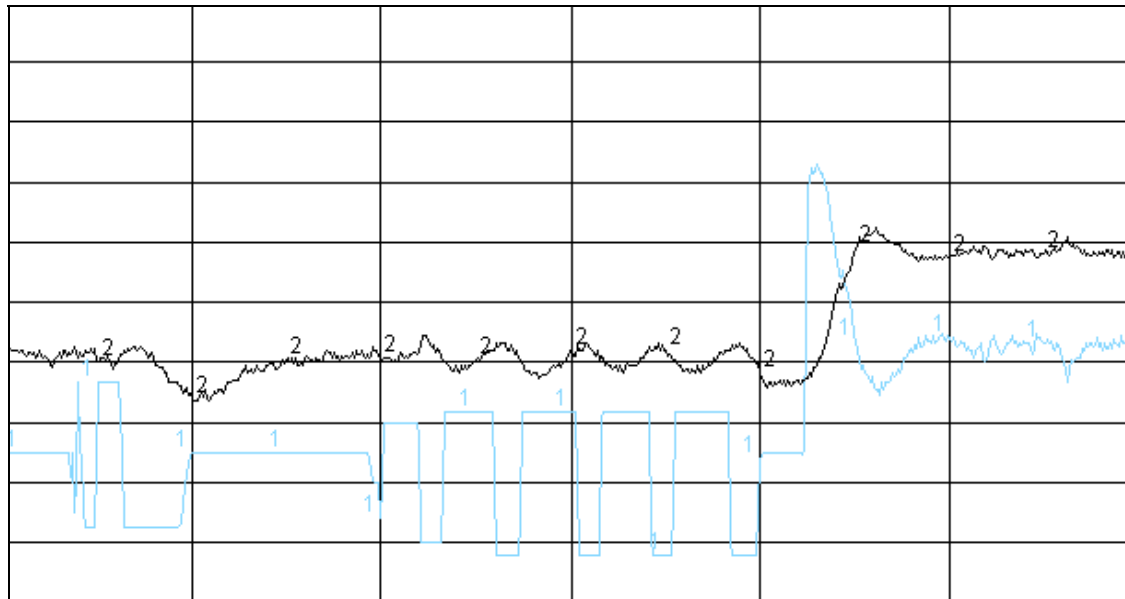

Chart 2

Autotuner Errors - terminate the autotune exercise and returns the control loop to the point prior to the start of autotune. An Error message can be cleared by pressing the ACK button. See Table 9-1.

Table 9-1 Autotune Errors

ERROR	DESCRIPTION
E1	A zero crossing did not occur within 120 minutes. Most likely caused by the control loop not being in a steady state condition when the autotuner was started.
E2	Process went out of range twice (<0%, >100%). The first time an out of range occurs, the autotuner will cut the valve step size in half and restart the exercise.
E3	When the autotune algorithm has been set to HYS = A and it calculates a required hysteresis value greater than 10%. Process filtering should be added to reduce the noise seen by the autotuner.

Autotuner Warnings - do not terminate the autotune exercise and are normally eliminated by increasing the % HYS and/or the % DEV settings. In some cases, they may have been caused by load changes that occurred during the autotune exercise. The autotuner will still derive recommended tuning values but they will not automatically be transferred to the controller, if that feature was requested. The warnings can be cleared by pressing the ACK button. See Table 9-2.

Table 9-2 Autotune Warnings

WARNING	DESCRIPTION
W1	Indicates that the % DEV setting is not greater than 4 times the % HYS setting.
W2	Indicates that the process deviations during the first one and a half cycles, where the autotuner first learns about the process gain, were inconsistent.
W3	Indicates that the average % DEV values during the final phase of the autotuning exercise were not greater than 4 times the % HYS setting. If this warning occurs while the % DEV selection was set to A (auto selection of deviation setting), the use of manual entry should be considered.

9.4 REMOVABLE CONFIGURATION BOARD

The Removable Configuration Board (RCB) can be installed in this controller¹⁸. It retains a complete copy of the configuration being used by the controller in which the RCB is installed. Should that controller fail, the RCB can be removed and installed in the replacement controller. The stored configuration can then be selected as the active configuration in the controller.

On power up, the controller will test the RCB and compare the configuration stored in the RCB to the controller's configuration. If the RCB passes all tests and the configurations are identical, the controller will power up normally and use the configuration from the MPU board. If a problem is detected or the configurations are different, an ON-LINE STATUS or OFF-LINE ERROR message will be displayed. See the Maintenance section for messages.

9.5 REAL TIME CLOCK/CONFIGURATION BACKUP BOARD

The controller is available with an optional real time clock and configuration backup board¹⁹. The configuration backup performs the same functions as the RCB described above. In addition, the board includes a real time clock. The time can be set using the built-in CLOCK function block in the STATN parameters. It can also be set over the Modbus, LIL, or Ethernet network. ■

¹⁸ RCB requires MPU Controller board firmware version 1.31 or higher.

¹⁹ RTC/CB requires MPU Controller board firmware version 2.0 or higher.

10.0 CONTROLLER AND SYSTEM TEST

This section presents a series of steps to verify controller operation and to help a user become familiar with the functionality of the controller. A new controller is shipped factory configured with either Factory Configured Option FCO101 Single Loop Controller or a user-specified custom configuration. The following procedure is for FCO101 with factory set parameter values. If a custom configuration was installed, or if you have configured the controller, it may be necessary to modify the procedure to test all function blocks in that configuration.

To determine the current configuration of a controller, either:

- refer to your configuration documentation for that controller
- upload the configuration to a PC running the Graphical Configuration Utility where the configuration can be viewed
- enter the configuration mode and step through the configuration recording the configured function blocks and entered parameter values



In the following steps, 'press' indicates a faceplate button (key).

10.1 CONTROLLER CONFIGURATION AND TEST

The purpose of this section is to configure and test the controller and to familiarize the user with the controller's faceplate pushbuttons, pulser, and displays. This section also introduces several configuration topics.

10.1.1 Connections and Power

1. Connect power to the controller. Refer to Controller nameplate for model number and then to Section 14 of this manual for power requirements. Refer to Section 8 Installation for connections.

 WARNING		
	Electrical shock hazard Explosion hazard	
Can cause death, serious injury or property damage		
<ul style="list-style-type: none"> • Remove power from all wires and terminals before working on equipment. • In potentially hazardous atmosphere, remove power from equipment before connecting or disconnecting power, signal, or other circuit. • Observe all pertinent regulation regarding installation in hazardous area. 		

2. Depending upon the configuration, connect test equipment to the I/O terminals.

FCO101 - This FCO has one 1-5 Volt analog input (AIN1), and one 4-20 mA analog output (AOUT1) configured. To verify both of these outputs, and to simulate an analog input for subsequent steps, jumper the terminals shown below. Connect a 250 ohm range resistor across the terminals shown below to convert the 4-20 mA output to a 1-5 volt input. This will tie the valve output (horizontal bargraph) back in the loop as the process input (P bargraph). Refer to Section 8 as necessary.

CONTROLLER	JUMPER TERMINAL	INSTALL 250Ω AT TERMINALS
Model 352Plus	A4 to A7	From A4 to A5
Models 353 and 354	17 to 20	From 20 to 21

Custom Configuration - Refer to Section 8 as necessary for any additional connections.

3. Apply power to the controller. Upon power up a two step test is automatically performed on the alphanumeric display to light all segments. 'WAIT' will then appear on the alphanumeric display while the controller performs power-up diagnostics.

If a power-up diagnostic test fails, an error code will be displayed on the alphanumeric display. Refer to Sections 11.3 and 11.4 for troubleshooting error codes.

If WAIT remains displayed for more than 1 minute, the controller is not powering up correctly and power connections should be checked for loose wiring.

10.1.2 Configuration

1. Determine the current configuration; refer to Section 10.0 above. Then perform one of the following steps.

To load FCO101, go to step 2.

IMPORTANT

Loading FCO101 will overwrite the current configuration and any entries made since shipment. *Skip step 2 if the installed configuration is to be retained.*

To proceed with the installed configuration, go to Section 10.1.3.

2. To load FCO101 either locally or to download it from a PC running the Graphical Configuration Utility, refer to Section 2.7 for a procedure and to Section 4 for the block diagram and parameter values.
3. Edit the configuration as desired. Refer to Section 10.1.5 Modifying an FCO.

10.1.3 Input/Output

Press the D button on the faceplate to scroll through Loop01.S (Setpoint), Loop01.V (Valve Output), and Loop01.P (Process Input). Note from the FCO101 block diagram, that INPUT P is configured as the output from function block AIN1, INPUT S is configured as the output of function block SETPT, and INPUT V is configured as the output of function block A/M.

10.1.4 Auto/Manual

In FCO101, the A/M block is configured to switch Valve control from the PID controller in AUTO, to the Pulser Knob in Manual. Press the A/M button to toggle the display between the (Loop01.S) setpoint parameter and the (Loop01.V) valve parameter. Turn the pulser knob while displaying the valve parameter in manual to change the value on the numeric display as well as the horizontal bargraph; turn the pulser knob while displaying the setpoint parameter in Auto to change the numeric value and the vertical S bargraph.

10.1.5 Modifying an FCO

In addition to FCO101, Single Loop Control, there are several other factory configured options available, such as Ratio Set Control (FCO105) and Cascade Control (FCO121). To download another FCO follow the steps in Section 2.7.

Changes to an FCO may be made either by adding and deleting function blocks or by changing the default parameter values. A Configuration Road Map is shown in Section 2. Note that an X represents pressing the STEP DOWN or STEP UP button and a <> represents turning the pulser knob. For example, to add a function block you would do the following steps:

1. Press ENTER/EXIT CONF.
2. Press STEP DOWN until VIEW is displayed.
3. Turn the pulser knob until ADD FB is displayed.
4. Press STEP DOWN for the function block menu.
5. Turn the pulser knob to scroll through the available function blocks and press STORE to add the function block to the configuration.

6. To make changes to a function block parameter turn the Pulser Knob to EDIT FB.
7. Press STEP DOWN for the function Block menu.
8. Turn the pulser knob to the desired Function Block and Press STEP DOWN.
9. The first function block parameter will be displayed. For example, RG PTR for the A/M Transfer Block or MINSCALE for the Analog Input Block. Press STEP DOWN to display current parameter value or use the pulser knob to select a different parameter. Press STORE to save any changes.
10. Press EXIT to return to normal operation mode.

Notice that the SETPT, ALARM, PID, and ODC function blocks in FCO101 all refer to AIN1 as the RG PTR (range pointer) to determine the operating range of the function block. Be aware that making changes to a configuration may require changing referenced RG PTRs. For example, in FCO105 (Ratio Set Control), the PID controller output range is determined by the range of AIN2.

Try changing the default 0-100% range of analog input #1 (AIN1) to 100.0-500.0°F using the Configuration Road Map in Section 2 or the following steps:

1. Press ENTER/EXIT CONF to display LOOP.
2. Press STEP DOWN twice to display VIEW.
3. Turn pulser knob or use arrow button to display EDIT FB.
4. Press STEP DOWN to display Function Block menu.
5. Turn the pulser knob or use right arrow button to display AIN1.
6. Press STEP DOWN to display MINSCALE.
7. Press STEP DOWN to display current 0% of range.
8. Turn the pulser knob to display 1 in the last digit. Display should read “0.00001”.
9. Now press the left arrow (TAG) button. Notice that the decimal place will move one place every time the button is pressed. Press the arrow button until the display reads “100.000” and press the STORE button.
10. Press STEP UP.
11. Turn the pulser knob or use the arrow button to display MAXSCALE.
12. Press STEP DOWN to display “100.000”.
13. Press the right arrow button until display reads “0.00001”.
14. Turn the pulser knob to change the last digit to 5. Display should read “0.00005”
15. Press left arrow button until display reads “500.000” and press store.
16. Press STEP UP.
17. Turn the pulser knob or the use arrow button to display DPP.
18. Press STEP DOWN. Notice “0.00” or 2 decimal places is the default. Turn the pulser knob to set the number of decimal places to 0.0 or to show 1 decimal place on the display and press STORE button.
19. Press STEP UP and turn the pulser knob or use the arrow button to display ENGUNITS.
20. Press STEP DOWN. Notice that the default units are PRCT.
21. Use the arrow buttons to move the flashing cursor to the space before the P. Now turn the pulser knob to display “D”. Use the arrow button to move to the next position and turn the pulser knob to select “E”. Repeat until display reads DEG F and press the STORE button.
22. Press ENTER/EXIT CONF to return to normal operation.

Try displaying the process and setpoint. Notice that these are now displayed in engineering units scaled 100 to 500 DEG F, or 300 at 50%. Press the UNITS button to display the engineering units configured above.

10.1.6 Alarms

Upon power up, FCO101 has 4 alarms enabled:

- Hi alarm at 110% on AIN1
 - Lo alarm at -10% on AIN1
 - Deviation alarm of 110% between AIN1 and SETPT
 - No alarm
1. Press the ALARM/STEP DOWN button to step through the Alarm limits and Enable/Disable Status. Notice all the alarms are enabled and the alarm limits are displayed in engineering units on the numeric display and as a percentage of range by a flashing LED on the S bargraph. If security clearance is satisfied, the alarm limits can be changed by rotating the pulser knob. Try changing the alarm limit A1 to 50% (300 DEG F) and press STORE to save the new value.
 2. Press EXIT to return to normal operation mode.
 3. Enter manual mode to display Loop01.V.
 4. Turn the pulser knob until both the valve output and process input are greater than 50%. Note that the alphanumeric display will flash "A1 HI" and the L and S LEDs will flash. Press the ACK button to acknowledge the alarm.

Alarms have a default priority of 3 (see Alarm block in Section 3.2), meaning that the alarms must be acknowledged to clear the flashing. Alarms may also be configured as self clearing. Try changing the alarm priority to 4 using the Configuration Road Map in Section 2 or the following steps:

1. Press ENTER/EXIT CONF. LOOP should be displayed.
2. Press STEP DOWN twice until VIEW appears on the display.
3. Press the right arrow button 3 times or turn the pulser knob until EDIT FB appears on the display.
4. Press STEP DOWN. A/M will be displayed.
5. Press the right arrow button 3 times or the turn pulser knob until ALARM appears on the display.
6. Press STEP DOWN to display RG PTR
7. Press the right arrow button or turn the pulser knob until A1 PRIOR appears on the display.
8. Press STEP DOWN to display 3 on the numeric display.
9. To change the priority of alarm 1 from 3 to 4, rotate the pulser knob until 4 appears on the numeric display.
10. Press STORE to save the configuration change.
11. Press ENTER/EXIT CONF to return to normal operation.

Try adjusting the process above and below 50% (300 DEG F). Notice that the alarm will clear without pressing the ACK button if the process drops below the alarm limit - deadband. Use the ALARM QUICK button to return the Alarm Limit A1 to the default 110% (540 DEG F) and press STORE to save. Other alarm parameters referenced in the ALARM function block description may be changed in a similar manner.

10.1.7 TAG

Press the TAG button. Note that Loop01.* (*= P, S, V, X or Y) will scroll across the screen. To change the tag, refer to the Configuration Road Map in Section 2 or the following instructions:

Note that although 12 characters are available for the tag, it is suggested that loop names be limited to 6 characters so that the complete tag name will be displayed during normal operation. The additional 6 characters can be displayed by scrolling the tag. The last two digits of the alphanumeric displayed during normal operation will be used to identify the variable currently being displayed, P, S, V, X or Y.

1. Press ENTER/EXIT CONF. LOOP will be displayed.
2. Press STEP DOWN twice until VIEW appears on display.
3. Press the right arrow button or the turn pulser knob until EDIT TAG appears on the display.
4. Press STEP DOWN. LOOP01 will appear on the display with the 1 digit flashing. Use the pulser knob to change the value of the flashing character and press store to save the change. Use the arrow buttons to move to another character. Try changing the TAG to TC101.
5. Press ENTER/EXIT CONF to return to normal operation mode.
6. Press TAG to view tag names longer than 6 characters.

10.1.8 QUICK

When in normal operation mode the QUICK button can be used to step through the QUICK SET parameters of any function block which has this feature enabled. In FCO101, the SETPT function block has the QUICK SET feature enabled as a default. Press the QUICK button and note that you can scroll through the following Setpoint features: RAMP ON/OFF, Ramp RATE, TARGET setpoint, and POWER UP SETPOINT. The ramp feature can either use a ramp TIME or a ramp RATE. USE RATE is set to YES as the default (see SETPT function block details in Section 3.2).

To see how the Ramp rate works, make sure the controller is in AUTO mode and do the following steps.

1. Press QUICK to display RRATE.
2. Rotate the pulser knob to set the ramp RATE to 300 and press STORE. Since the SETPT range pointer is configured for AIN1 scaled 100 to 500 DEG F, 300 will represent a ramp rate of 300 DEG F/min.
3. Press QUICK to display TARGET. Set the target to 250% and press STORE.
4. Press QUICK to display R ON OFF. Turn the pulser knob to change the setting to ON and press STORE.
5. Press ENTER/EXIT to display the setpoint on the numeric display. The setpoint should ramp to 25% in 30 seconds.

To change from a Ramp RATE to a Ramp TIME do the following steps.

1. Press ENTER/EXIT CONF to display LOOP.
2. Press STEP DOWN twice to display VIEW.
3. Press the right arrow button or turn the pulser knob to display EDIT FB.
4. Press STEP DOWN to display A/M.
5. Turn the pulser knob to display SETPT.
6. Press STEP DOWN to display RG PTR.
7. Turn the pulser knob to display USE RATE.
8. Press STEP DOWN to display YES.
9. Turn the pulser knob to change to NO, and press STORE. Press STEP UP.
10. Turn pulser knob counterclockwise or use left arrow button to display RTIME.

11. Press STEP DOWN to display ramp TIME.
12. Turn the pulser knob to set the desired Ramp TIME, and press STORE.
13. Press EXIT to return to normal operation mode.

Now press the QUICK button. Note that the RTIME parameter will now be displayed instead of the RRATE parameter. Setting R ON OFF parameter to “ON” will now ramp the setpoint to the TARGET setpoint in the specified time rather than at a particular rate. See the SETPT description in Section 3.2 for more details on setpoint functions.

Quickset parameters for other function blocks such as RATIO and BIAS may be changed in a similar fashion. See specific function block descriptions in Section 3 for more details.

10.1.9 TUNE

When in normal operation mode, pressing the TUNE button will scroll through the controller tuning parameters and allow activating the AUTOTUNE algorithm. FCO101 is configured for PID control with the AUTOTUNE feature enabled. Press the TUNE button and note that the default values for Proportional Gain (PG), Time-Integral (TI), Time-Derivative (TD), and the Derivative Gain (DG) will be displayed. In addition, the AUTOTUNE parameters % Deviation, % Hysteresis, and Autotune YES/NO will be displayed.

It is difficult to simulate the autotune feature without simulating a process signal but increasing the digital filter parameter on the AIN1 will help make the process seem more realistic. To change the digital filter to a value around 10 follow the Configuration Road Map in Section 2 or do the following steps.

1. Press ENTER/EXIT CONF.
2. Press STEP DOWN twice to display VIEW.
3. Use the right arrow button or the pulser knob to display EDIT FB.
4. Press STEP DOWN for Function Block menu.
5. Use the right arrow button or the pulser knob to display AIN1.
6. Press STEP DOWN for parameter menu.
7. Use the right arrow button or the pulser knob to display DIG FILT and Press STEP DOWN.
8. Rotate the pulser knob to set the digital filter to 10 and press STORE.
9. Press ENTER/EXIT CONF to return to normal operation.

Before initiating AUTOTUNE bring the process to steady state. This can be done by placing the instrument in manual mode and bringing the valve to approximately mid-scale using the pulser knob. Display the process and wait a minute or two for the process to stabilize.

To activate the AUTOTUNE feature:

1. Press the TUNE Quick Button to display AUTOTUNE.
2. Set this parameter to YES, press STORE, then press EXIT. The controller is now set to AUTO and “AUTOTUNE” will flash until the AUTOTUNE is finished. Tuning warnings may occur; refer to Section 9.3. Since this is only a simulation, press ACK to clear any warnings.
3. Press the TUNE button to display the default controller parameters and the resulting AUTOTUNE (ATUNE) parameters. After viewing the parameters, STORE AT will be displayed. Press the STORE button to change the controller parameters to the new values or press the ENTER/EXIT CONF button to keep the defaults.

To cancel the AUTOTUNE before the tuning operation is complete, press the A/M button to enter MANUAL mode. Refer to Section 9.3 for more details on the AUTOTUNE feature.

10.1.10 View mode

When troubleshooting a configuration, it is often helpful to be able to view the intermediate outputs of function blocks that are not configured as display variables during normal operation. This can be accomplished via the VIEW mode. To enter VIEW mode:

1. Press ENTER/EXIT CONF to display LOOP.
2. Press STEP DOWN to display VIEW.
3. Press STEP DOWN to display the first output of the first configured function block.
4. Use the pulser knob or arrow buttons to scroll through the function block outputs. Note that analog outputs are in engineering units and discrete/status outputs (represented by the black shaded arrows in the Function Block diagrams) are either low (0) or high (1).
5. Press EXIT to return to normal operation mode.

10.2 SYSTEM CHECKOUT

1. Check that the correct circuit boards are installed and fully seated in the case as follows. The controller model number on the P&I drawing should match the model number on the controller's case. Compare the model number to the Model Designation table in Section 14 to be sure the proper boards are installed.

NOTE

When power is applied to the controller, an installed hardware list can be viewed in the STATN function block. Refer to Section 3.1.2 for board description and ID.

2. Check all wiring between the controller and external equipment (e.g. transmitters, recorders, power supplies). Check for correct and secure connections, correct wire gauge and insulation, adequate support (ties, raceways, conduit), and protection from damage (sharp edges, moving equipment, chemicals, abrasion).
3. Test all equipment connected to the controller for proper operation. Refer to the equipment manufacturer's literature as necessary.
4. Apply power to the controller and note the faceplate displays during power up. See Section 10.1.1 for a description of the faceplate displays during power up.
5. Based on the controller hardware present, the current configuration in the controller, and the external equipment, exercise the system in a systematic manner to ensure proper operation.



■

11.0 MAINTENANCE

Controller maintenance requirements are minimal. Activities such as cleaning and visual inspections should be performed at regular intervals. The severity of the controller's operating environment will determine the frequency of maintenance. Additional topics including troubleshooting, assembly replacement, and software compatibility are also covered. Figure 11-1 shows an exploded view of the controller.

Before servicing or calibration the equipment, note the following statements.

- Maintenance should be performed only by qualified personnel. Failure to properly maintain the equipment can result in death, serious injury, or product failure. This manual should be carefully reviewed, understood, and followed.
- The steps in the Preventive Maintenance section should be performed regularly.
- The procedures in this section do not represent an exhaustive survey of maintenance steps necessary to ensure safe operation of the equipment. Particular applications may require further procedures. Should further information be desired or should particular problems arise which are not covered sufficiently for the purchaser's purposes, the matter should be referred to the local Siemens sales office or a Technical Support Group identified in the Product Support section of this manual.
- The use of unauthorized parts in the repair of the equipment or tampering by unqualified personnel will result in dangerous conditions that can cause death, serious injury, or equipment damage. Follow all safety instructions contained herein.

 WARNING		
	Electrical shock hazard Explosion hazard Can cause death, serious injury or property damage	
<ul style="list-style-type: none"> • Remove power from all wires and terminals before working on equipment. • In potentially hazardous atmosphere, remove power from equipment before connecting or disconnecting power, signal, or other circuit. • Observe all pertinent regulation regarding installation in hazardous area. 		

Upgrading a Controller

A controller can be upgraded in the field to add I/O or a communication option, for example. Always confirm with the factory hardware and software compatibility before upgrading a controller. To install an upgrade, you may need to:

- Refer to the Function Blocks section and develop a configuration. Refer to the HMI documentation and develop an application.
- Refer to the Kit Installation Instruction or other publications supplied with the assembly being installed.
- Refer to the Assembly Replacement subsection in the Maintenance section of this User's Manual for information about disassembling the controller, installing the assembly, and then reassembling.
- Refer to the Installation section of this manual for wiring details.
- Refer to the Controller and System Test section to ensure proper operation of the controller.

11.1 TOOLS AND TEST EQUIPMENT

The following tools and equipment are necessary for servicing:

- A. Common hand tools for servicing electronic equipment
- B. Digital Multimeter (DMM)
 - Voltmeter Section:
 - Accuracy +/-0 .01% of reading
 - Resolution 1.0 millivolt input
 - Impedance 10 Megohms
 - Ammeter section:
 - Accuracy +/- 0.1% of reading
 - Resolution 100 microamperes
- C. An anti-static service kit containing a conductive wrist strap and mat is required when a circuit board assembly is touched or otherwise handled.

11.2 PREVENTIVE MAINTENANCE

The objective for establishing a preventive maintenance program is to provide maximum operating efficiency. Every preventive maintenance operation should assist in realizing this objective. Unless a preventive measure reduces a station's down time, it is unnecessary.

11.2.1 Environmental Considerations

The controller has been designed to operate within specified environmental parameters (e.g. temperature, humidity). These parameters are listed in the Model Designation and Specifications section of this User's Manual. Additional information concerning environmental contaminants is presented in the Installation section.

11.2.2 Visual Inspection

As part of a periodic maintenance program, the controller should be visually inspected. When viewing the station, scan for abnormalities such as loose, broken or stressed ribbon cables. Look for damaged circuitry and heat stressed parts. Check for excessive dirt or dust build-up that can impede air flow and inhibit proper heat dissipation.

11.2.3 Cleaning

Circuit boards are conformally coated for protection against contaminants and should not be cleaned unless accumulated foreign material is causing a problem. If cleaning becomes necessary:

1. In a potentially hazardous area, remove power from the controller to eliminate the possibility of explosion, and eliminate the possibility of electrical shock.
2. Protect the station's electronic components from electrostatic discharge. Fasten a conductive wrist strap around your wrist and ground the strap to the station's case, the panel, or a static dissipative workmat. See the next section for circuit board handling guidelines. See Section 11.2.4. 
3. Fold down the Display Assembly's flip-down door and loosen the now accessible captive screw. Do not loosen the black screw above the numeric display. See Figure 11-1 as needed. Pull the Display Assembly from the panel about 1.5" (38 mm).
4. Look behind the Assembly and locate the display cable, then open the connector locking levers on the Assembly mounted connector to eject the cable-mounted connector. Remove the Display Assembly with the display adapter and gasket in place.
5. Clean the bezel with a mild, nonabrasive liquid cleaner and a soft, lint-free cloth - do not use a paper towel. Set the Display Assembly aside.
6. Pull individual boards or a board stack from the case. First, remove the board retainer on the inside front edge of the case. Then grasp the board by an exposed edge and pulling straight out. Do not use the display cable to pull the MPU Controller board from the case. Since the board edge connector mates with a connector at the back of the case, a moderate pull will be needed to extract the board.

MPU Controller and RTC/CB boards have a lithium battery. Refer to Section 11.2.4 for circuit board handling precautions.

7. Remove any debris from case and board(s) using a soft brush or low velocity deionized air. Be careful not to dislodge jumper shunts on the MPU Controller board.
8. Insert the removed board or board stack into the case and *carefully guide* the connector end of the board until it mates with the connector at the back of the case. Only when the connectors are mated should additional force be applied to seat the board. Install the board retainer.
9. Hold the Display Assembly with the display adapter and gasket in place close to the open case and mate the display cable with the connector on the Display Assembly circuit board. The cable is keyed. Check that the connector locking levers are fully engaged.
10. Align the Display Assembly with the case and *finger-tighten* the faceplate screw. To ensure water tightness, use a torque screwdriver set to 6 inch-pounds (0.7 N-m) to tighten the screw. Alternatively, use a screwdriver to tighten the screw until a slight resistance is felt, then tighten an additional ½ turn. **DO NOT OVERTIGHTEN.**
11. Remove the wrist strap.
12. Apply power to the controller and test as necessary to ensure proper operation.

11.2.4 Circuit Board Handling

ELECTROSTATIC DISCHARGE, ALL ELECTRONIC ASSEMBLIES



Semiconductor devices must be protected from electrostatic discharge. A properly grounded conductive wrist strap must be worn whenever a circuit board assembly is touched or otherwise handled. A service kit with a conductive wrist strap and static dissipative workmat is available from electronic supply sources, local as well as on-line.

LITHIUM BATTERY PRECAUTIONS

Each MPU Controller board and Real Time Clock/Configuration Backup board has a lithium battery that is not field replaceable. Note the following when handling or disposing of either board.

- Properly dispose of an un-repairable circuit board with a lithium battery
- Do not burn the battery
- Do not place the circuit board on a metal surface or otherwise short circuit battery terminals
- Do not attempt to charge the battery
- If electrolyte is exposed, wear safety glasses and rubber gloves when handling the battery
- For details contact the battery manufacturer

11.3 TROUBLESHOOTING

Troubleshooting the controller is primarily done by error codes. An error code will appear on the alphanumeric display in response to a failed power-up diagnostic test or an on-line controller error. Section 11.4 has error code details: the type of test or error check, controller response, problem confirmation, and corrective action.

In the event a malfunction within the controller is suspected, troubleshooting by assembly substitution is recommended to get the controller back on-line in the shortest possible time. The plug-in design of controller assemblies permits rapid removal and replacement to isolate a defect. Figure 11-1 shows controller assemblies.

If a problem appears upon initial installation of the controller, carefully check the installation wiring and the controller's configuration. Also, check the wiring of associated external process devices (e.g. process transmitters, LonWorks modules, valve positioners). Field servicing experience indicates that most initial service incidents are of this nature.

Additional troubleshooting avenues are also possible. For example, a series of test configurations may be created and implemented to 'exercise' different function blocks within the controller. Section 3 describes each function block. This type of troubleshooting analysis is intended to be implemented in an off-line test bench situation.

On-line checks of the controller input and output signals (i.e. analog and digital) can be performed without affecting station operation. However, this type of signal tracing is usually carried out behind an instrument panel. Refer to the Installation section, Table 8-3, for rear terminal assignments.

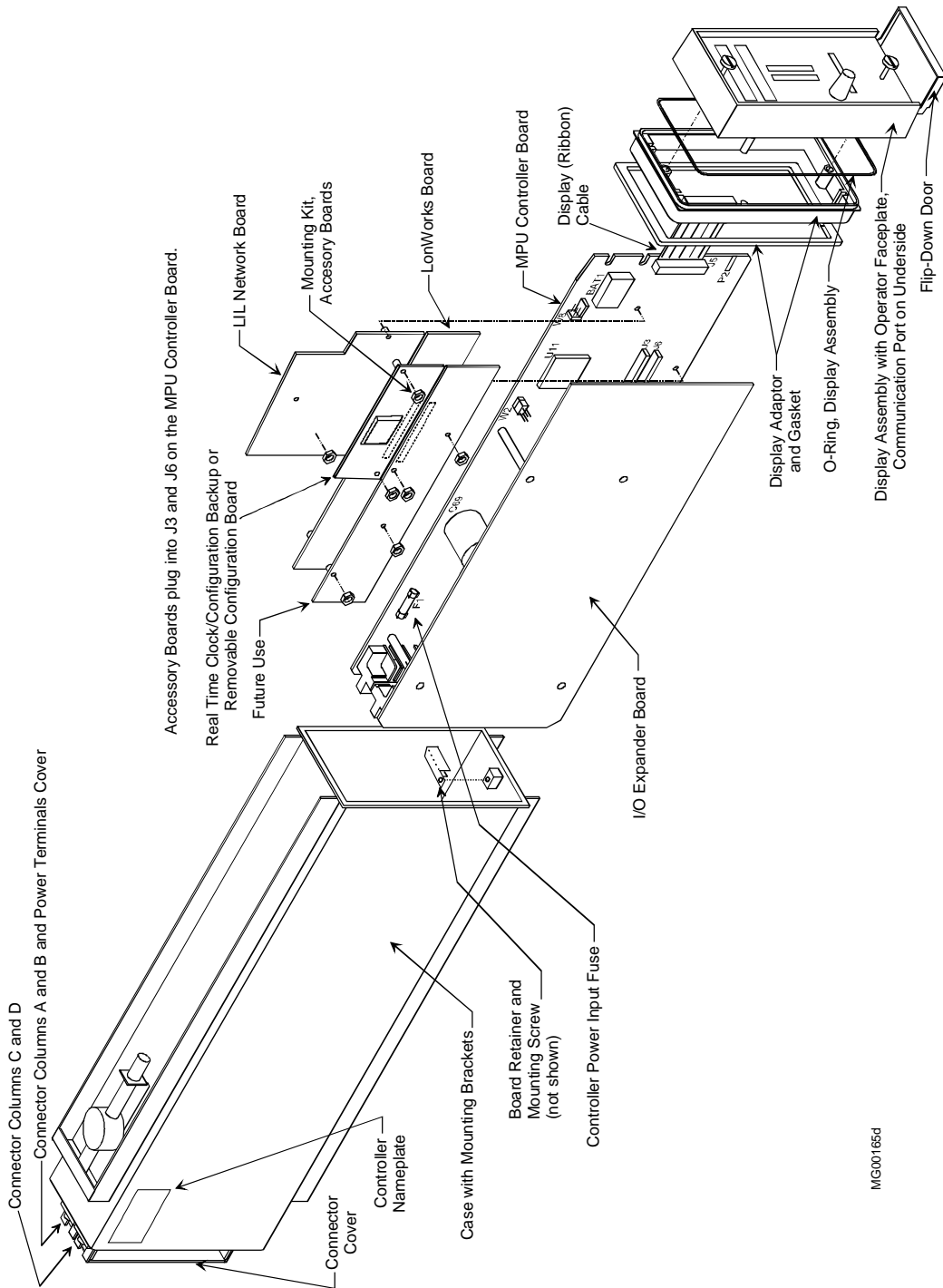

MG00165d

Figure 11-1 Model 352P Exploded View

11.4 ERROR CODES

This section describes off-line error codes, on-line error codes, and on-line status codes. Typically, a code will point to a failed internal assembly or a failed peripheral device. Note that a configuration error can also cause an error code or multiple error codes to be produced.

OFF-LINE ERROR CODES

Off-line error messages are displayed while the 353 is powered but not running function block code and, therefore, not actively controlling a process. Depending on the message, user intervention will most likely be required.

Corrective action can be initiated by way of the LIL or Modbus ports, as appropriate. LIL parameter “SE” located at channel 4, parameter 1 (Modbus register 40002) will contain the hexadecimal form of the error number currently displayed (e.g., ERR: 213 would be sent as \$00D5). An Error message can be acknowledged over the network by writing a 0 to the Modbus register or LIL parameter. Messages will be displayed one at a time in order of occurrence and cannot be cleared until the error condition is corrected.

Display Format:

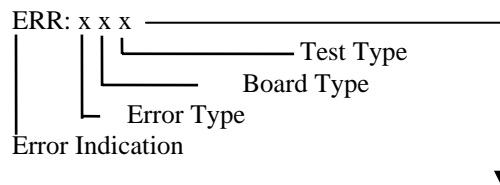

Error Type:

1	Fatal	The station cannot operate until the source of the error has been corrected.
2	Non-Fatal	Correct error from faceplate or communication port.

Board Type:

0	MPU Controller
1	I/O Expander
2	LIL Network
3	LonWorks Remote I/O
8	RCB or RTC/CB
9	Ethernet Network

Test Type:

0	RAM Test	- MPU Controller board - Fatal error, replace board. Press ENTER to repeat test. - Option Board - Station operation suspended. Pressing ENTER will cause all references to blocks relating to the option board to be removed from the configuration and removal of the board from the availability list.
1	Flash CRC Test	- MPU Controller board - Station operation suspended until new code is downloaded. Press ENTER to repeat test. - Option Board - Station operation suspended until new code is downloaded. Pressing ENTER will cause all references to blocks relating to the option board to be removed from the configuration and removal of the board from the availability list.
2	Constant Data CRC Test	Station operation suspended until new constant data is downloaded. Press ENTER to load board specific default constant data.
3	Calibration Data CRC Test	Station operation suspended until ENTER is pressed to load default calibration data.
4	Software Compatibility Test	Station operation suspended until new code is downloaded. Pressing ENTER will cause all references to blocks relating to the option board to be removed from the configuration and removal of the board from the availability list.
5	Database Compatibility Test	Station operation suspended until new constant data is downloaded. Press ENTER to, if possible, convert the database or load board specific default constant data.

6	Board Not Present Error	Station operation suspended. Install the missing board or press ENTER to remove from the configuration all references to the missing board.
7	Hardware Communication (QSPI) Test	Fatal error. Repair or replace as necessary. Press ENTER to repeat test.
8	Board Compatibility Test	Remove the board causing the error and install a compatible board. Ethernet Board - Upgrade Ethernet firmware to V3.0 or higher.

Real Time Clock/Configuration Backup board and Removable Configuration Board (RCB) off-line error codes are listed in Table 11-1. RTC/CB and RCB on-line status codes are located in Table 11.2 and listed as “RCB” errors.

Table 11-1 RTC/CB and RCB Boards, Off-Line Error Codes

ERROR CODE	DESCRIPTION	CORRECTIVE ACTION
ERR280	Board failed NVRAM test	<ol style="list-style-type: none"> 1) Power down and replace Board. 2) Press ENTER to ACK error. Controller will go on-line using configuration in MPU memory.
ERR282	Configuration on Board failed checksum test and is corrupted.	<ol style="list-style-type: none"> 1) Power down and install a Board containing a valid configuration. 2) Press ENTER to ACK error. Controller will go on-line using configuration in MPU memory that will also be loaded into the Board.
ERR284	Configuration on Board is not compatible with MPU Controller board firmware level. <i>This will occur only when the Board comes from a controller with a different MPU Controller board firmware level than the current controller and some functions in the configuration database cannot be supported by the current firmware.</i>	<ol style="list-style-type: none"> 1) Install MPU firmware compatible with the Board configuration 2) Press ENTER to ACK error. Controller will go on-line using configuration in MPU memory. The configuration will remain intact until a parameter is STOREd, at which time the MPU configuration will be transferred to the Board.
ERR285	Configuration on Board is not compatible with MPU Controller board database. <i>This will occur only when the Board comes from a controller with a higher MPU Controller firmware level than the current controller. Controller firmware can convert a database created with a lower firmware revision level but not a higher level.</i>	<ol style="list-style-type: none"> 1) Install MPU firmware compatible with the Board configuration 2) Press ENTER to ACK error. Controller will go on-line using configuration in MPU memory. The configuration will remain intact until a parameter is STOREd, at which time the MPU configuration will be transferred to the Board.
ERR286	The controller powered down with a Board installed but could not identify it on power up. <i>The board may have been removed or the board ID may be corrupted.</i>	<ol style="list-style-type: none"> 1) Install a Board or new Board. 2) Press ENTER to ACK error. Controller will go on-line using configuration in MPU memory.
ERR288	The LonWorks circuit board currently installed is not compatible with the LonWorks configuration contained on the Board.	<ol style="list-style-type: none"> 1) Power down and install the LonWorks board from the same controller that the Board came from. 2) Press ENTER to ACK error. Controller will go on-line. Any existing LonWorks network data will be used if it is valid, otherwise, it will be set to default values. In either case, the LonWorks network manager will be required to re-establish the network bindings.

ON-LINE ERROR CODES AND STATUS CODES

These codes can be produced while the controller is running function block and may be actively controlling a process. Depending on the message and its priority level, user intervention may be required or the message may simply be informational in nature. LIL parameter “SE” located at channel 4, parameter 1 (Modbus register \$40002) will reflect unacknowledged error or status messages present in the controller. Messages are displayed according to priority until all active messages have been acknowledged. If no link code has been assigned to the active message, the “SE” code will remain at its last value.

Table 11-2 lists on-line error and status codes. For most error codes, replace the involved circuit board to repair the controller. For most status codes, acknowledge or otherwise respond to the situation.

Table 11-2 On-Line Error and Status Codes

DISPLAYED CODE	LINK/MODBUS CODE (Hex/Dec)	DESCRIPTION
MPU A/D	\$0001 1	MPU Controller board A/D Error
EXP A/D	\$0002 2	I/O Expander Board A/D Error
AOUT1 OC	\$0003 3	MPU Controller board D/A #1 Open Circuit
AOUT2 OC	\$0004 4	MPU Controller board D/A #2 Open Circuit
AOUT3 OC	\$0005 5	MPU Controller board D/A #3 Open Circuit
AINU1 AD	\$0006 6	I/O Expander Board Universal Analog Input #1 A/D Error
AINU1 TC	\$0007 7	I/O Expander Board Universal Analog Input #1 T/C Burnout
AINU1 RJ	\$0008 8	I/O Expander Board Universal Analog Input #1 Reference Junction Error
AINU2 AD	\$0009 9	I/O Expander Board Universal Analog Input #2 A/D Error
AINU2 TC	\$000A 10	I/O Expander Board Universal Analog Input #2 T/C Burnout
AINU2 RJ	\$000B 11	I/O Expander Board Universal Analog Input #1 Reference Junction Error
DINU1 E1	\$000C 12	I/O Expander Board Universal Digital Input #1 Underflow Error
DINU2 E1	\$000D 13	I/O Expander Board Universal Digital Input #2 Underflow Error
LIL ERR	\$000E 14	LIL Port Error
LIL NUI	\$000F 15	LIL Non Updating Input Error
MOD ERR	\$0010 16	Modbus Port Error
LON ERR	\$0011 17	LON Port Error
LON NUI	\$0012 18	LON Non Updating Error
Watchdog	\$0013 19	Watchdog Timeout
LOW BAT	\$0014 20	Low NVRAM Battery Voltage
RCB → MEM	\$0015 21	Press STORE to load RCB configuration into MPU memory
CYCLTIME	\$0016 22	Cycle Time Overrun – see STATN block – add Cycle Time bias
BURNFAIL	\$0017 23	Flash Memory burn failed
RCB FAIL	\$0018 24	Press ENTER to ACK error and replace RCB
NO EXPBD	\$0019 25	Expander board is not installed
PEB FAIL	\$001A 26	Ethernet Board failure
IP OVRUN	\$001B 27	Ethernet board TCP communication error
MB OVRUN	\$001C 28	Modbus communication error
A1 HI	None	Alarm A1 High
A1 LO	None	Alarm A1 Low
A1 HI D	None	Alarm A1 High Deviation
A1 LO D	None	Alarm A1 Low Deviation
A1 DEV	None	Alarm A1 Deviation
A1 OR	None	Alarm A1 Overrange
A2 HI	None	Alarm A2 High
A2 LO	None	Alarm A2 Low
A2 HI D	None	Alarm A2 High Deviation
A2 LO D	None	Alarm A2 Low Deviation
A2 DEV	None	Alarm A2 Deviation
A2 OR	None	Alarm A2 Overrange
A3 HI	None	Alarm A3 High

DISPLAYED CODE	LINK/MODBUS CODE (Hex/Dec)	DESCRIPTION
A3 LO	None	Alarm A3 Low
A3 HI D	None	Alarm A3 High Deviation
A3 LO D	None	Alarm A3 Low Deviation
A3 DEV	None	Alarm A3 Deviation
A3 OR	None	Alarm A3 Overrange
A4 HI	None	Alarm A4 High
A4 LO	None	Alarm A4 Low
A4 HI D	None	Alarm A4 High Deviation
A4 LO D	None	Alarm A4 Low Deviation
A4 DEV	None	Alarm A4 Deviation
A4 OR	None	Alarm A4 Overrange
B1 HI	None	Alarm B1 High
B1 LO	None	Alarm B1 Low
B1 OR	None	Alarm B1 Out of Range
B2 HI	None	Alarm B2 High
B2 LO	None	Alarm B2 Low
B2 OR	None	Alarm B2 Out of Range
B3 HI	None	Alarm B3 High
B3 LO	None	Alarm B3 Low
B3 OR	None	Alarm B3 Out of Range
B4 HI	None	Alarm B4 High
B4 LO	None	Alarm B4 Low
B4 OR	None	Alarm B4 Out of Range
Emeg Man	None	Emergency Manual
Em Local	None	Emergency Local
Standby	None	Standby Sync
Override	None	Override
EMERG OR	None	Emergency Override - PCOM block
INTRLK	None	Interlocked – PCOM block
DFAIL	None	Device Failed – PCOM block
MAX LOOP	None	Maximum Loop Size
S HI Lim	None	Setpoint HI Limit
S LO Lim	None	Setpoint LO Limit
U1 Status	None	User Status #1
U2 Status	None	User Status #2
ATUNE W1	None	Autotuner Warning: hys/desamp >0.2; see Section 9.3 for 'W#' details
ATUNE W2	None	Autotuner Warning: Deviation Ratio is HI; see Autotune procedure
ATUNE W3	None	Autotuner Warning: Avg. Deviating is LO; see Autotune procedure
ATUNE E1	None	Autotuner Error: limit cycle timeout
ATUNE E2	None	Autotuner Error: process out of range
ATUNE E3	None	Autotuner Error: Only applies when % HYS set to A. Process too noisy.
E In RAM	None	Insufficient Volatile Memory Available
E In Con	None	Insufficient Constant Memory Available
E Db CRC	None	Database CRC/Checksum Error
E P Qual	None	Poor I/O quality
iOOn NC	None	Ubus Module #n Not Communicating
AIEnn NU	None	AIEnn Function Block Not Updating
CIEnn NU	None	CIEnn Function Block Not Updating
DIEnn NU	None	DIEnn Function Block Not Updating

11.5 ASSEMBLY REPLACEMENT

Spare and replacement part numbers are provided in Section 14.3 Service Parts Kits. The following describes replacement of the controller's assemblies. Common hand tools for electronic equipment servicing are needed and a torque screwdriver, calibrated in inch-pounds, is recommended. Before handling an assembly, refer to Section 11.2.4 for electrostatic discharge prevention procedures. See Figure 11-1 for an exploded view of the controller that shows field replaceable assemblies and individual parts.

MPU Controller Board Jumpers

There are several jumpers on the MPU Controller board. When replacing an MPU Controller board, simple set the jumpers on the replacement board to match those on the board being replaced. If controller or board functionality must be changed, jumper locations are shown in Figure 11-2 and the settings described in Sections 11.5.3 and 11.6.

11.5.1 Power Input Fuse

A power input fuse is located on the MPU Controller board, as shown in Figure 11-1. This is the controller's power input fuse. A replacement fuse can be obtained from a local electronics supplier or can be ordered from the factory. See the Section 14.3 Service Parts Kits for fuse part number and description.

To replace the fuse:

1. Refer to section 11.5.2 and remove the Display Assembly
2. Refer to Section 11.5.3 and remove the MPU Controller board.
3. While the controller is apart, visually inspect the assemblies for overheated or otherwise damaged components.
4. Remove the failed fuse and read fuse ratings. Install a replacement fuse:
 - 120/240 Vac MPU Controller board – A 0.5A fuse may be replaced with a 0.4A or 0.5A, 250V, SloBlo fuse. However, a 0.4A fuse must be replaced with a 0.4A, 250V, SloBlo fuse.
 - 24 Vdc MPU Controller board – Install a 2A, 250V, SloBlo fuse.
5. Reassemble the controller. Refer to the above referenced sections as necessary.
6. Apply power to the controller. Operate the controller off-line for several minutes to be sure that a condition does not exist that will cause the replacement fuse to fail.

11.5.2 Display Assembly

The following steps describe replacing a Display Assembly. To replace the bezel or the circuit board, perform the procedures in Sections 11.5.2 and 11.5.2.1.

REMOVAL:

1. In a hazardous area, remove power from the Controller.
2. Protect the station's electronic components from electrostatic discharge. Fasten a conductive wrist strap around your wrist and ground the strap to the ground screw on the Controller's case, an unpainted area on the panel, or a grounded static dissipative workmat. 
3. Loosen the Display Assembly faceplate screw behind the flip-down door. The screw above the numeric display should not be loosened.
4. Pull the Assembly from the panel about 1.5" (38 mm).
5. Look behind the Assembly and locate the display cable from the MPU Controller board. Open the connector locking levers on the Assembly mounted connector to eject the cable-mounted connector.

6. Loosen the faceplate screw above the numeric display to remove the display adapter. Save the adapter and gasket.
7. Place the Display Assembly in a static shielding bag and set it aside.
8. Go to the following sections to remove a circuit board or replace the power input fuse.

INSTALLATION

1. Place the display adapter on the Display Assembly and tighten the faceplate screw above the numeric display. Use a torque screwdriver set to 6 inch-pounds (0.7 N-m) to tighten the screw. Alternatively, use a screwdriver to tighten the screws until a *slight resistance* is felt, then tighten an additional ½ turn. **DO NOT OVERTIGHTEN.**
2. Hold the Display Assembly with display adapter and gasket in place close to the open case and mate the display cable with the connector on the Display Assembly circuit board. Check that the locking levers on the connector fully engaged the cable-mounted connector. The cable is keyed.
3. Align the Display Assembly with the case. To ensure water tightness, use a torque screwdriver set to 6 inch-pounds (0.7 N-m) to tighten the faceplate screw behind the flip-down door. Alternatively, use a screwdriver to tighten the screws until a *slight resistance* is felt, then tighten an additional ½ turn. **DO NOT OVERTIGHTEN.**
4. Remove the wrist strap.

NOTE

When changing a Display Assembly with the controller powered-up and an error code present, the displays will light in a random pattern except for the alphanumeric display, which will show the error code. Clear the error to clear the displays.

11.5.2.1 Replace the Bezel or Circuit Board

REMOVAL

1. Place a properly grounded wrist strap on your wrist and remove the Display Assembly as described above.
2. Refer to the figure below. Notice that the circuit board is captured by a Fixed Retainer at the top of the bezel and a Flexible Retainer at the bottom. Grasp the body of the black connector at “A” and at the same time press the Flexible Retainer downward slightly. Pull gently on the connector to lift the bottom edge of the board above the Flexible Retainer.



Note

The board is a snug fit. Do not squeeze the bezel sides and make removal more difficult.

3. Remove the board from the bezel by carefully continuing to lift board while pulling the board out from under to Fixed Retainer at the top of the assembly.
4. If the bezel is being replaced:
 - 1) Remove the two Display Assembly mounting screws. Turn the assembly face up and lift each mounting screw upward until the threaded portion contacts the bezel. Turn each screw counterclockwise to unscrew it from the bezel. A screwdriver may be needed once a screw is started.
 - 2) Remove the flip-down door by pressing on the door near its pivot point to free the door from the bezel.

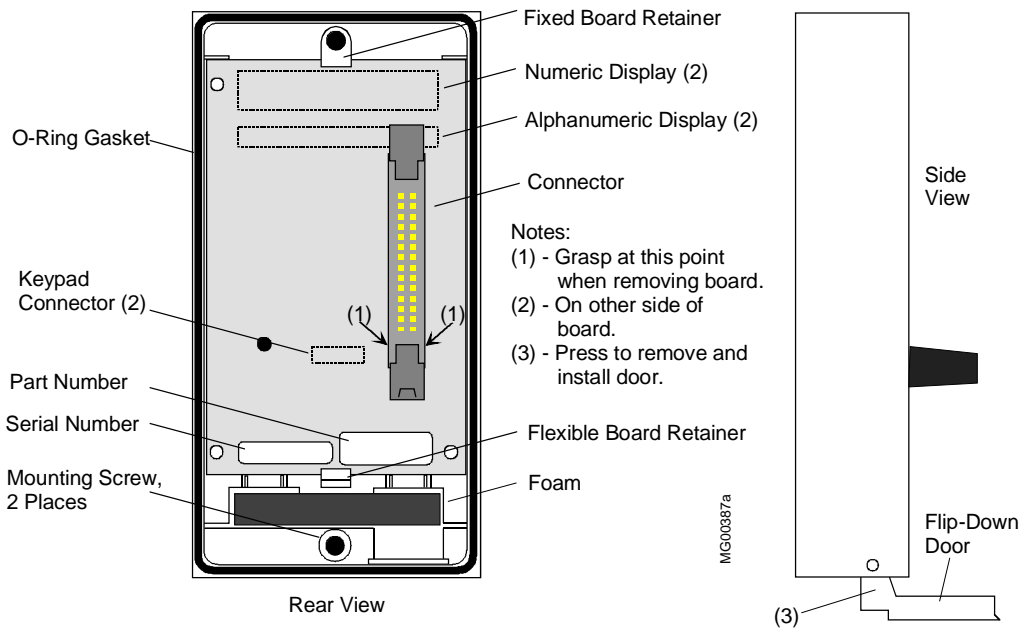

INSTALLATION

1. Place an anti-static wrist strap on your wrist and connect the ground lead.
2. Get the replacement bezel, or get the replacement circuit board and remove it from the anti-static bag.
3. If the bezel is being replaced, start threading each Faceplate mounting screw into the bezel. Use a screwdriver to complete screw installation. Install the flip-down door; see the figure.
4. Turn the bezel over.
5. Install the circuit board in the bezel by slightly inserting the top edge of board under the Fixed Retainer. The top edge is nearest the Numeric and Alphanumeric Displays.
6. Continue to ease the board under the Fixed Retainer while lowering the bottom edge of the board into the bezel. Be sure that the keypad connector mates with the connector on the keypad. The board is fully inserted when it snaps under the Flexible Retainer.
7. Install the Display Assembly on the case as described above.

11.5.3 MPU Controller Board

This board has a lithium battery; refer to Section 11.2.4 Board Handling Precautions. When replacing an MPU Controller board, configuration parameters must be re-entered. Refer to Sections 2 and 3 and to Section 12 Calibration as needed. Factory repaired controllers must also be configured.

Use the following procedure to replace the MPU Controller board, remove the MPU Controller board for access to physically connected boards, or to replace the main power fuse.

REMOVAL:

1. Remove input power from the Controller.
2. Remove the Display Assembly as described in the previous section.
3. Remove the board retainer bracket and screw.
4. Pivot the extractor tab at the top edge of the MPU Controller board to loosen the board. Carefully pull the board out of the case and then lower the outer most end of the board so the board's rear connector clears the retainer block on the floor of the case. If the board does not easily slide out of the case be sure the Option 3 I/O Jumper has not snagged on the retainer block.

IMPORTANT

If the board is to be shipped or stored, pull the W8 shunt from the CLK position and place it in the N/C position.

5. If the main fuse is being replaced, go to Section 11.5.1, step 4.

If board is to be replaced or added, as appropriate, remove the I/O Expander board (See Section 11.5.4) and accessory boards (See Section 11.5.5 and Figure 11-4). Note the positions of all jumpers, particularly the Option 3 I/O Jumper. Refer to Sections 11.6 and 11.7 for jumper identification and location. Remove and retain the 4-wire Option 3 I/O Jumper for use during installation of a replacement board.

6. Place the MPU Controller board in a static shielding bag.

INSTALLATION:

1. While wearing a grounded anti-static wrist strap, remove MPU Controller board from static shielding bag.
2. Refer to Section 11.7 and check and change MPU Controller board jumper settings as needed. Set W8 to CLK if HOT/WARM Start is desired.
3. Fasten needed I/O Expander board and accessory boards to the MPU Controller board. Refer to Sections 11.5.4 and 11.5.5.
4. Refer to Section 11.6 and set the Option 3 I/O Jumpers.
5. To insert the MPU Controller board into the case:
 - 1) Align the lower edge of the board with the card guide on the floor of the case.
 - 2) Lower the outer-most end of the board so the board's rear connector clears the retainer block on the floor of the case and carefully guide the connector end of the board into the case
 - 3) Push the board into the case until it mates with the connector at the back of the case. Only when the connectors are mated should additional force be applied to seat the board.
6. Disconnect wrist strap.
7. Install Display Assembly as described in the previous section.

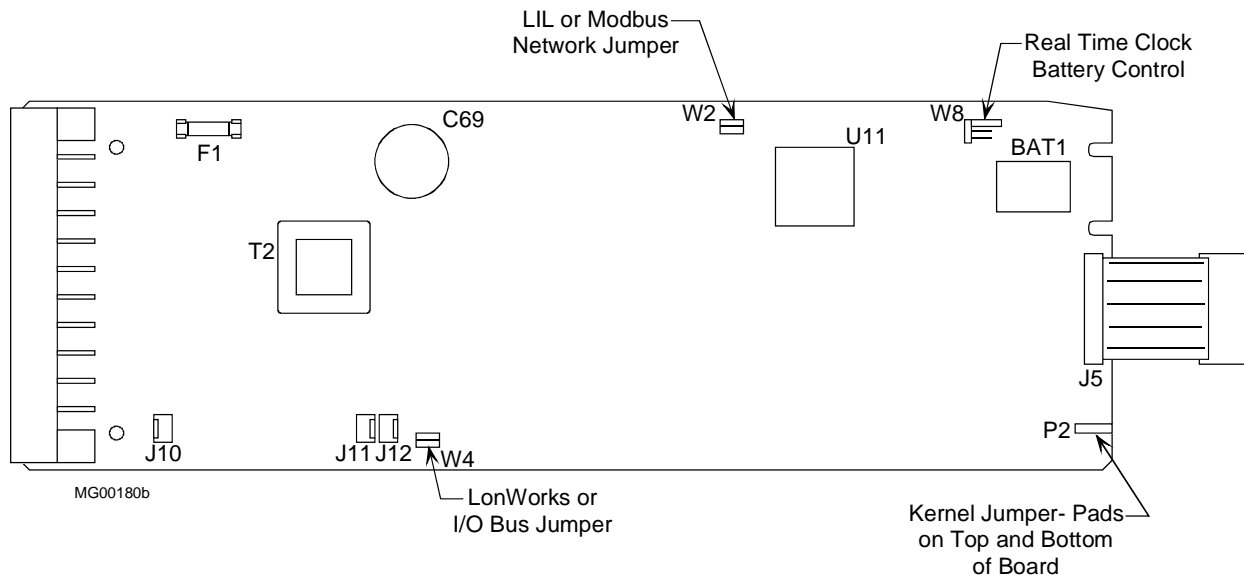

Figure 11-2 MPU Controller Board

11.5.4 I/O Expander Board

REMOVAL:

1. In a hazardous area, remove input power from Controller.
2. Remove Display Assembly and MPU Controller board as described in previous sections. Note the positions of Option 3 I/O Jumper and W1.
3. Remove the 4 screws securing the I/O Expander board to the MPU Controller board. Disconnect the ribbon cable connecting the two boards by opening the ejector levers on the MPU Controller board connector.
4. Place the board in a static shielding bag.

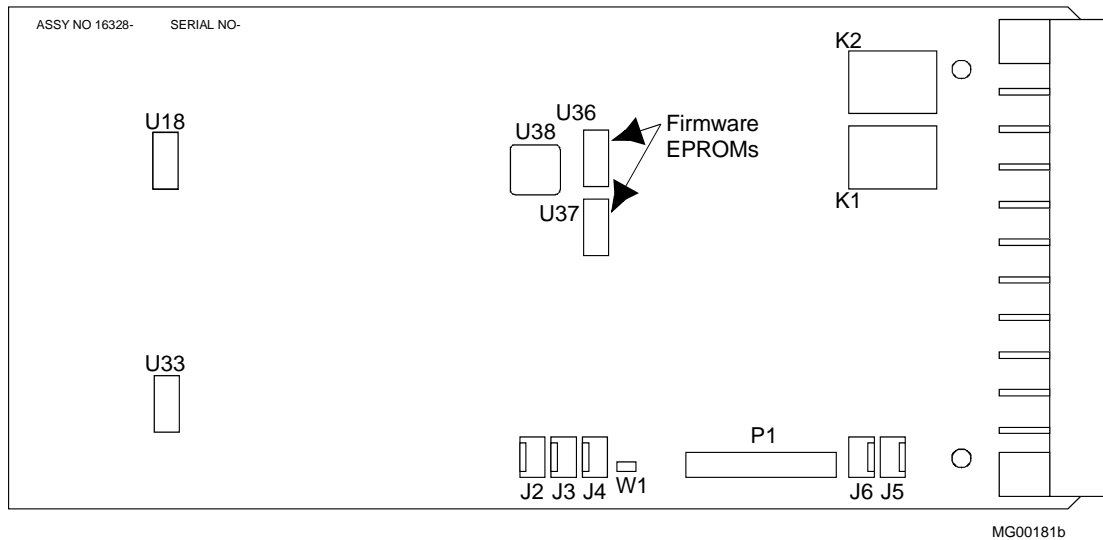

Figure 11-3 I/O Expander Board

INSTALLATION

1. If one or more communication boards must be attached to the MPU Controller board, refer to the next section and then return here.
2. While wearing a grounded anti-static wrist strap, remove I/O Expander board from static shielding bag.
3. Secure the I/O Expander board to the MPU Controller board using eight screws and lockwashers and four standoffs.
4. Refer to Section 11.6 to set the jumpers: (e.g. option 3 I/O jumper).
5. Insert the board stack into the case and carefully guide the connector end of the board until it mates with the connector at the back of the case. Only when the connectors are mated should additional force be applied to seat the board stack.
6. Disconnect the wrist strap.
7. Install the Display Assembly as described in a previous section.

IMPORTANT

After **replacing** an I/O Expander board in a controller whose configuration includes an AINU function block: assemble the controller, apply power, ENTER configuration and STORE the SEN TYPE parameter. This must be done even if the SEN TYPE displays the desired type to ensure that the function block loads the correct calibration from the new Expander board. If desired, a FIELD CAL can then be performed.

11.5.5 Accessory Boards

These boards mechanically fasten and electrically connected to the MPU Controller board as shown in Figure 9-4. Individual boards are shown in Figure 9-5, 6, and 7. Carefully align connectors before applying force to seat a board. There are jumpers on the MPU Controller board that may need to be set when installing an Accessory Board. Refer to Sections 11.6 and 11.7 for information about setting these jumpers.

If the controller is receiving one of these boards for the first time, ERR 232 may be displayed when power is first applied. Simply press the ENTER/EXIT configuration button to clear the error. Edit the configuration to activate the board and connect I/O or network wiring as needed.

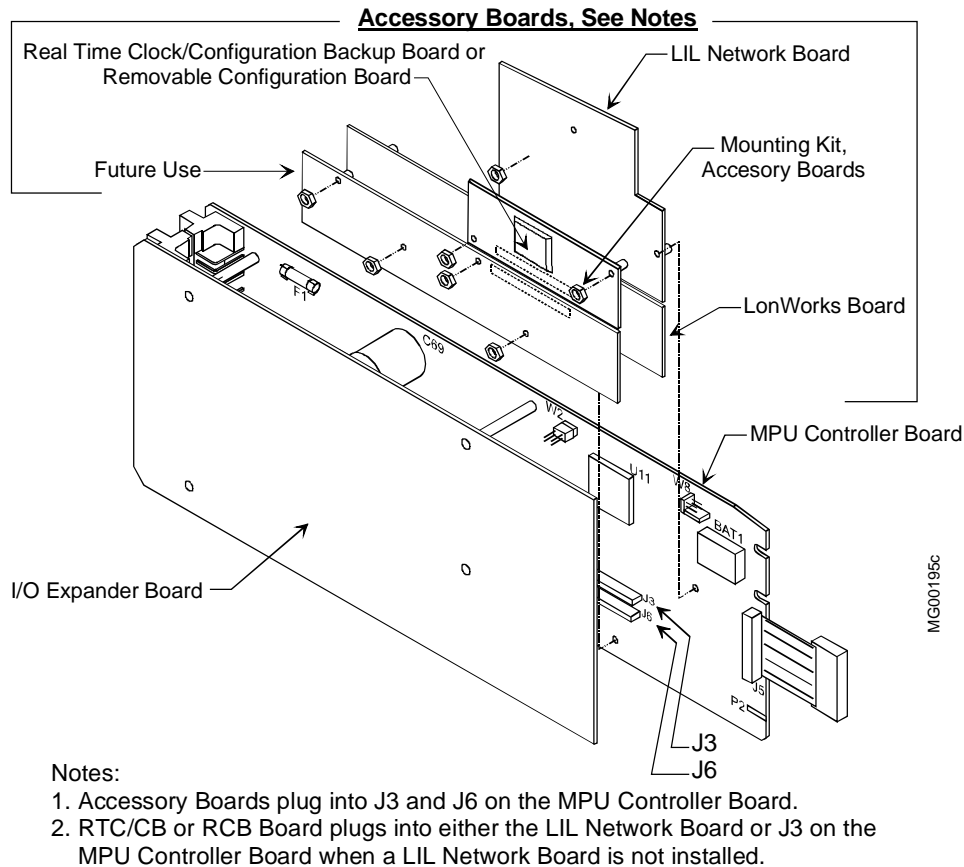

Figure 11-4 Accessory Board Installation and Replacement

RTC/CB and RCB Boards

Refer to Figure 11-4 for board location and assembly hardware; the RCB and RTC/CB board mount in the same location and use the same hardware. The board typically mounts on and electrically connects to either a LIL Network board or an Ethernet board. If either of these boards is not installed, the RTC/CB board will mount directly on and electrically connect to the MPU Controller.

IMPORTANT

Before powering the controller after installing an RTC/CB board, connect a local faceplate to the controller. The controller will power up in a hold state and the faceplate is needed to select the controller configuration as described in the following procedure.

Board Installation

1. To install a board, fasten a grounded wrist strap on your wrist.
2. The MPU Controller board may have several attached boards secured by spacers and screws. Refer to Figure 11-4 for board location and fasteners. Refer to the board comments above for jumpering and other information before attaching a board to the MPU Controller board.
3. Insert the board or board stack into the case card guides and carefully guide the connector end of the board until it mates with the connector(s) on the case. Only when the connectors are mated should additional force be applied to seat the board. Install board retaining hardware. (Refer to Section 11.5.3 as needed.)
4. Install the Display Assembly. Refer to Section 11.5.2.
5. Remove the wrist strap.
6. When power is applied, an RCB->MEM message will appear in the local faceplate's alphanumeric display. This message is prompting you to select the controller's operating configuration. Read the two bulleted items below and select the desired configuration.
 - To copy the configuration stored on the RTC/CB or RCB board to the MPU Controller board: rotate the pulser to display YES and press the STORE pushbutton. This option is typically selected when a configuration is being transferred from one controller to another by moving the RTC/CB or RCB board from one controller to another.
 - To retain the configuration stored on the MPU Controller board: rotate the pulser to display NO and press the STORE pushbutton. The configuration stored on the MPU Controller board will be the operating configuration and it will be copied to the RTC/CB or RCB board when a change is made to the configuration.

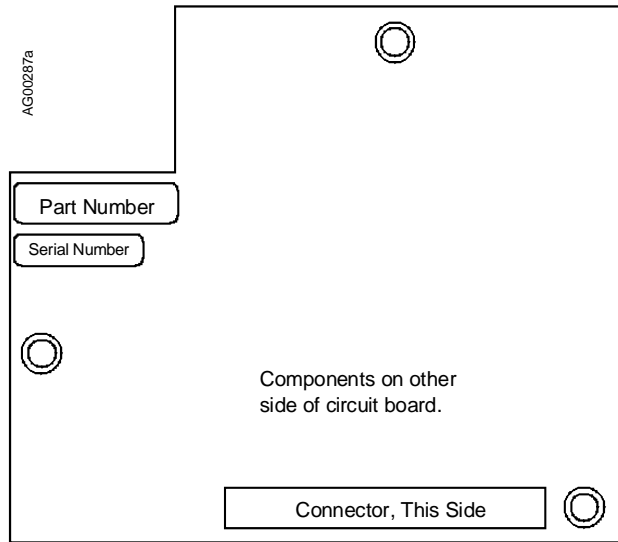

Figure 11-5 LIL Network Board

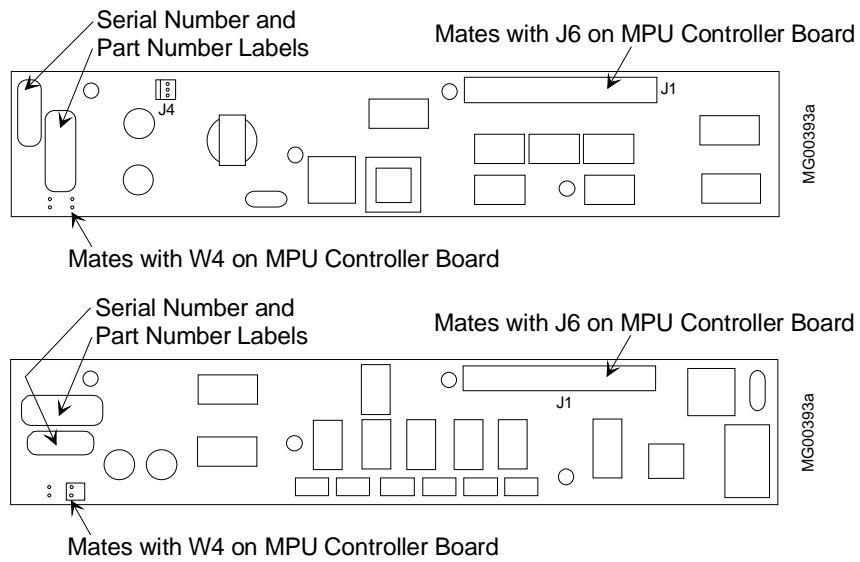

Figure 11-6 LonWorks Board

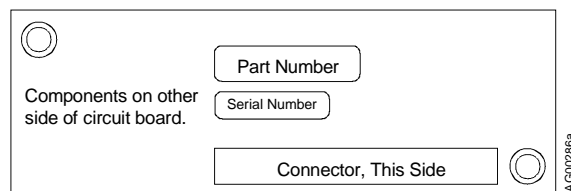

Figure 11-7 Real Time Clock/Configuration Backup Board

11.6 OPTION 3 I/O SELECTION

Table 11-3 shows the available I/O and communication selections available depending upon the controller's model number and the presence of any field installed circuit boards.

11.6.1 Model 352PB (no I/O Expander Board)

In addition to the basic I/O (see Table 8-1), a Model 352PB can have either a 3rd analog input and a 2nd analog output or a LonWorks connection. This selection is made on the MPU Controller board by positioning the Option 3 I/O Jumper as described in Table 11-3 and Figure 11-5.

Table 11-3 Option 3 Selection, Model 352PB

SELECTION	FROM	TO
Added I/O: AIN3 and AOUT2	J10	J11
LonWorks Communication	J10	J12

11.6.2 Model 352PE (with I/O Expander Board)

With an Expander Board installed, an Option 3 I/O type may be selected; see Table 11-4 and Figure 11-8.

Factory Selection

As shipped from the factory, the Option 3 I/O type is specified by the ordered model number and jumpers are set and calibration performed accordingly.

Field Selection

Installing an Expander Board in the field or selecting a new Option 3 I/O type in the field will involve:

- selecting the Option 3 I/O type as shown in Table 11-4 and Figure 11-8 [When LonWorks is field selected the factory selected Option 3 I/O type will be disabled but all other non-Option 3 I/O Expander inputs and outputs at connectors 'C' and 'D' (e.g. relay outputs) will remain available.]
- configuring the Option 3 I/O type either locally from the Display Assembly or remotely using the Graphical Configuration Utility
- calibrating an analog input when a new analog Option 3 I/O type is selected (e.g., the controller was ordered and shipped for use with a thermocouple input but an RTD input is now needed)

Field selection of an Option 3 I/O type is as follows:

1. Place a static dissipative workmat on the bench or other surface. Ground the workmat. Fasten an anti-static wrist strap on your wrist and connect the ground lead to a convenient ground or to the workmat.
2. Refer to Section 11.5 Assembly Replacement and remove the Display Assembly and MPU Controller board and any attached boards from the case. Place them on the static dissipative workmat.
3. Re-install the circuit boards and Display Assembly.

Table 11-4 Option 3 Selection, Model 352PE

OPTION 3 TYPE	CONNECT 'OPTION 3 I/O JUMPER'		RELATED JUMPER, SHUNT POSITION, ON
	FROM JUMPER, ON	TO JUMPER, ON	
TC/MV	J10, MPU Controller	J2, I/O Expander	W1, One Pin*, I/O Expander
RTD	J10, MPU Controller	J3, I/O Expander	W1, One Pin*, I/O Expander
Voltage	J10, MPU Controller	J4, I/O Expander	W1, Two Pins*, I/O Expander
Frequency	J10, MPU Controller	J5, I/O Expander	W1, One Pin*, I/O Expander
Computer Pulse	J10, MPU Controller	J6, I/O Expander	W1, One Pin*, I/O Expander
LonWorks	J10, MPU Controller	J12, MPU Controller	W4, MPU Controller, See Section 11.7

* 2-Pin Jumper - Place shunt on either one pin or both pins according to the input type.

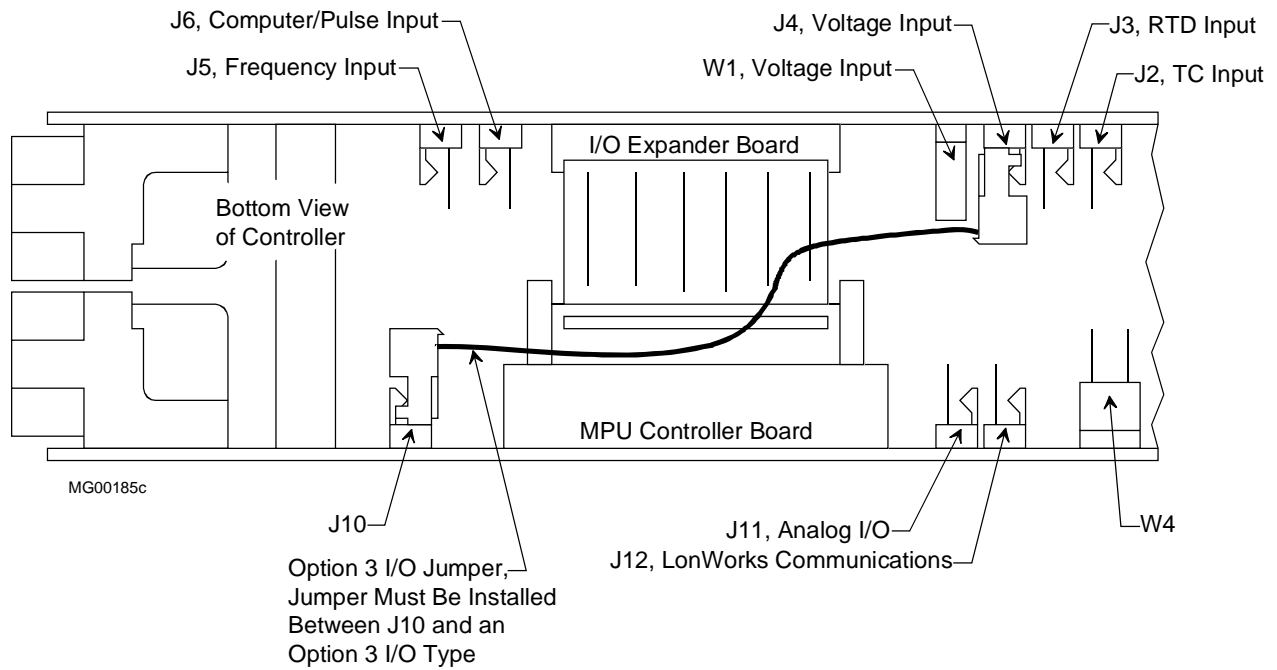

Figure 11-8 Option 3 I/O Selection Using the Option 3 I/O Jumper

11.7 MPU CONTROLLER BOARD JUMPERS

Figure 11-9 shows MPU Controller Board jumpers. These jumpers are factory set but W2, W4, and W8 may need to be changed in the field. To preserve battery life when storing a controller or an MPU Controller board, be sure to set W8 in the N/C position, as described below.

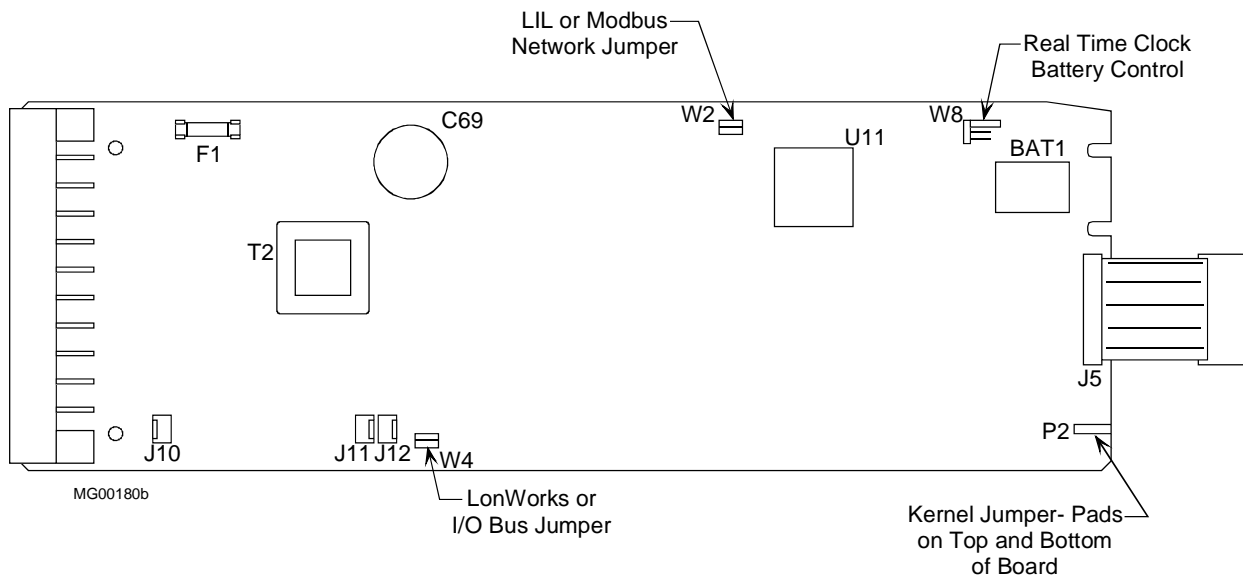

Figure 11-9 MPU Controller Board Jumpers

W2, LIL/Modbus Network Jumper (see drawing at right):

- Install shunt(s) when network connections at rear terminals B1 and B2 are wired for Modbus.
- Remove shunt(s) when network connections at rear terminals B1 and B2 are wired for LIL.

W4, LonWorks I/O Bus Jumper (see drawing at right):

- Install shunt(s) when LonWorks Board is NOT installed.
- Remove shunt(s) when installing a LonWorks Board.

W8, Real Time Clock Jumper (see Figure 11-10):

- CLK (Clock)- Install shunt on both CLK pins to enable HOT/WARM Start functions. For HOT/WARM Start details, see Section 3.1.3 STATN Station Parameters.
- N/C (No Clock) - Place shunt on both N/C pins when storing the MPU Controller board or a Model 352P. Storing with the shunt in the CLK position will shorten NVRAM battery life. A Model 352P or an individual MPU Controller board is shipped from the factory with this jumper in the N/C position.
- WDT - For factory use only; do not use in the field.

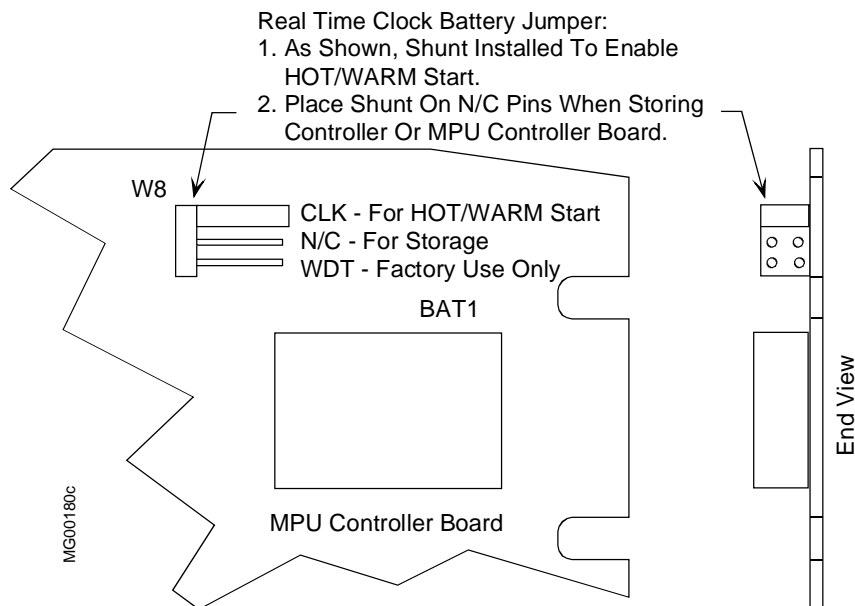
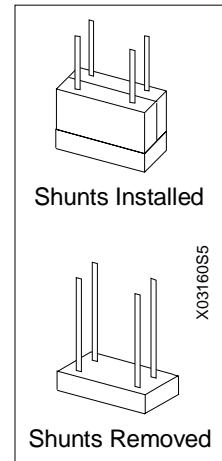

Figure 11-10 W8 Real Time Clock Jumper for Hot/Warm Start and Storage

12.0 CALIBRATION

A controller is factory calibrated either to the standard values listed in Section 8.5 or to values specified by the purchaser at time of order. Field calibration should not be necessary.

For those cases where inputs or outputs must be adjusted either to meet a local standard or for a more critical application, a field calibration can be performed. The field calibration becomes the default calibration.

A CAL VIEW mode is available in calibration to view the sensor input over the full range. The signal that is viewed, in the calibration verify mode, is 0 to 100% of span in basic units of measure (e.g., °C for temperature, mv for millivolts) and is not affected by the temperature units conversion, digital filter, scaling, or the output bias adjustment. The full block output in engineering units with these parameters applied can be seen in the VIEW mode within loop configuration.

This section describes calibration and verification of the analog inputs (1-5 Vdc) and outputs (4-20 mA) listed in Table 12-1. The bold IDs are the actual terminal identifications for the 352Plus™ and match those of the Model 352. The IDs in parenthesis are the *equivalent Model 353 function block identifications* that are displayed and used when you select a function block in the calibration mode.

TABLE 12.1 Analog I/O

352P (353) ANALOG INPUT AND OUTPUT IDs	SECTION
AI1 (AIN1), AI2 (AIN2), AI4 (AIN4), AI6* (AIN3)	10.1 ANALOG INPUTS
AO1 (AOUT 1), AO2* (AOUT2), AO3 (AOUT3)	10.2 ANALOG OUTPUTS
AI5 (AINU1)	10.3 ANALOG INPUT

* NOTES for **AI6** (AIN3) and **AO2** (AOUT2)

1. AI6 and AO2 calibration can be performed only when the I/O is physically connected to case rear terminals when either an I/O Expander board (Model 352PE) is installed or the Option 3 I/O Jumper is placed to select the I/O option (Model 352PB).
2. Model 352PE - AI6 and AO2 are standard. They are connected to the rear terminals used in the 352 for the AI6 input and AO2 output. AI6 and AO2 must not be selected as the Option 3 I/O option when the I/O Expander board is installed.
3. Model 352PB - AI6 and AO2 can be selected as an option using the Option 3 I/O Jumper and the Option 3 I/O terminals, since the I/O circuits are physically located on the MPU Controller board.

When field calibrating a controller for a critical application, consider the following:

- If the input is a current signal (e.g., 4-20 mA), use a precision current source. The 250 ohm precision range resistor installed across the input terminals for calibration should remain with the station, connected across that set of terminals, to eliminate the voltage drop variation due to resistor tolerance.
- Allow the Station to warm-up for an hour prior to calibration. The ambient temperature should be close to normal operating conditions.

The controller must be off-line during calibration. Factory calibration values are listed in Section 8.5.

Refer to Table 8-3 and to the installation wiring figures in Section 8.4 for power input, signal input, signal output, and communication terminals.

Security, Calibration of Inputs/Outputs: If level 1 and level 4 security are enabled, the user-determined six-digit security combination (e.g. 000025) for either level 1 or level 4 must be entered before new calibration parameters can be stored. Once the security combination has been entered, access will be provided to all functions with that security level until the user exits configuration. For additional information, refer to function block SECUR - Security in Section 3.

Bargraphs: The bargraphs on the Display Assembly are not used during the calibration procedure. Ignore any bargraph indications during calibration.

Calibration and calibration verification are described in the following procedures.

WARNING

Electrical shock hazard



Hazardous voltage can cause death or serious injury.

Remove power from all wires and terminals before working on this equipment.

12.1 ANALOG INPUT (AI1, AI2, AI4, and AI6)

Analog input function blocks have been factory calibrated for 1 to 5 Vdc inputs. Field calibration should not be required unless calibration parameters are to be changed. Periodic calibration should not be necessary. To calibrate an analog input, use the following procedure.

1. At the controller's rear terminals, connect an electronic calibrator or precision reference source capable of supplying a voltage between 0.000 and 5.000 Vdc to the selected analog input terminals (e.g. AI1, AI2, AI4, or AI6). Refer to Section 8.4 Electrical Installation for terminal numbers and wiring guidelines. Ensure that terminal screws are tight.
2. If security is enabled, a level 1 or level 4 security combination will be needed to store the results of a calibration. Refer to SECUR-Security in Section 3 for additional information.
3. Apply power to the station.
4. Press the ENTER CONF button to enter the configuration mode at the MENU level.
5. Rotate the Pulser Knob to select 'STATION' on the alphanumeric (lower) display.
6. Press the STEP DOWN button to choose options at the station level and rotate the Pulser Knob to select 'CAL' on the alphanumeric display.
7. Press the STEP DOWN button to enter the FUNCTION BLOCK level.
8. Rotate the Pulser Knob to select the desired input (e.g. AIN1, AIN2, AIN4 or AIN3).
9. Press the STEP DOWN button to enter the PARAMETER level.
10. Rotate the Pulser Knob to select the desired parameter, CAL ZERO, shown on the alphanumeric display.
11. Press the STEP DOWN button to enter the VALUE level ('CAL' appears on upper display).
12. Set the precision voltage source to the zero input value (0.000 to 1.000 Vdc).
13. Press STORE to lock-in the desired value. If ENTER COM appears in the alphanumeric display, security is enabled and steps 1) through 5) must be performed to store the calibration. Otherwise, go to step 14.
 - 1) The numeric display shows 000000 with the right-most digit flashing. Rotate the pulser knob to set the units digit to the correct number.
 - 2) Press the TAG/← key to select the next digit, the tens digit.
 - 3) Rotate the pulser knob to select a number for that digit.
 - 4) Move to and select the needed number for each remaining digit.
 - 5) Press ENTER. If the combination entered is incorrect, "ACCESS/DENIED" will be displayed and the controller will return to the parameter level. Otherwise, go to step 14.

14. Press the STEP UP button.
15. Rotate the Pulser Knob to select the 'CAL FULL' parameter.
16. Press the STEP DOWN button to enter the VALUE level ('CAL' appears on upper display).
17. Set the voltage source to the full scale input value (4.000 to 5.000 Vdc).
18. Press STORE.
19. For verification perform the following steps:
 - 1) Press STEP UP button.
 - 2) Rotate Pulser Knob to select 'CAL VIEW' parameter.
 - 3) Press STEP DOWN button to enter VALUE level.
 - 4) Set precision voltage source to zero input voltage. The display should read 0%.
 - 5) Set source to full scale voltage. The display should read 100%.
20. If all points have been calibrated and verified, press EXIT button to leave the calibration mode and enter the operation mode. If additional function blocks are to be calibrated and verified, press the STEP UP button to enter the FUNCTION BLOCK level. Perform steps 8-19 for each function block.

If security is enabled, exiting the configuration mode will lock out the calibration mode until the security combination is again entered.

12.2 ANALOG OUTPUT, AO1, AO2, AO3

Analog output function blocks have been factory calibrated to 4-20 mA outputs. If calibration is necessary, use the following procedure.

1. At the controller's rear terminals, connect an electronic calibrator or digital multimeter capable of displaying 4.00 and 20.00 mA to the selected analog output terminals (AO1, AO2, or AO3). Refer to Section 6.4 Electrical Installation for terminal numbers and wiring guidelines. Ensure that terminal screws are tight.
2. If security is enabled, a level 1 or level 4 security combination will be needed to store the results of a calibration. Refer to SECUR-Security in Section 3 for additional information.
3. Apply power to the station.
4. Press the ENTER CONF button to enter the configuration mode at the MENU level.
5. Rotate the Pulser Knob to select 'STATION' on the alphanumeric (lower) display.
6. Press the STEP DOWN button to choose options at the station level and rotate the Pulser Knob to select 'CAL' on the alphanumeric display.
7. Press the STEP DOWN button to enter the FUNCTION BLOCK level.
8. Rotate the Pulser Knob to select the desired output: AOUT1, AOUT2, or AOUT3
9. Press the STEP DOWN button to enter the PARAMETER level.
10. Rotate the Pulser Knob to select the desired parameter, CAL ZERO, shown on the alphanumeric display.
11. Press the STEP DOWN button to enter the VALUE level ('CAL' appears on display).
12. Rotate the Pulser Knob to set the zero output to 4.00 mA on the digital multimeter or electronic calibrator.
13. Press the STORE button to lock-in the desired value. (If "ENTER COM" appears in the alphanumeric display, go to Section 10.1, step 13 for entering a level 1 or level 4 security combination.)
14. Press the STEP UP button.
15. Rotate the Pulser Knob to select the 'CAL FULL' parameter.
16. Press the STEP DOWN button to enter the VALUE level ('CAL' appears on display).

17. Rotate the Pulser Knob to set the full scale output to 20.00 mA.
18. Press STORE.
19. For verification perform the following steps:
 - 1) Press STEP UP button.
 - 2) Rotate Pulser Knob to select 'CAL VIEW' parameter.
 - 3) Press STEP DOWN button to enter VALUE level.
 - 4) Rotate Pulser Knob to set display to 0.0%. Output current should be 4.00 mA.
 - 5) Rotate Pulser Knob to set 100.0%. Output current should be 20.00 mA.
 - 6) If all points have been calibrated and verified, press EXIT button to leave the calibration mode and enter the operation mode. If additional function blocks are to be calibrated and verified, press the STEP UP button to enter the FUNCTION BLOCK level. Perform steps 8-18 for each function block

12.3 ANALOG INPUT, AI5

This analog input uses the AINU1 function block which is a Universal Analog Input. In this application the Wide Millivolt option (15) must be selected in the AINU1 function block. The 1-5 Vdc input is connected to the input of the function block through a resistor network that attenuates the 1-5V input to 15-75 mV. This input has been factory calibrated with this network installed and, therefore, should not require field calibration. For those cases where the calibration needs to be corrected to meet plant conditions, a field calibration of the AINU1 function block can be performed.

1. At the controller's rear terminals, connect an electronic calibrator or precision reference source capable of supplying a voltage between 0.000 and 5.000 Vdc to the selected analog input terminals (e.g. **AI5**). Refer to Section 8.4 Electrical Installation for terminal numbers and wiring guidelines. Ensure that terminal screws are tight.
2. If security is enabled, a level 1 or level 4 security combination will be needed to store the results of a calibration. Refer to SECUR-Security in Section 3 for additional information.
3. Apply power to the station.
4. Press the ENTER CONF button to enter the configuration mode at the MENU level.
5. Rotate the Pulser Knob to select 'STATION' on the alphanumeric (lower) display.
6. Press the STEP DOWN button to choose options at the station level and rotate the Pulser Knob to select 'CAL' on the alphanumeric display.
7. Press the STEP DOWN button to enter the FUNCTION BLOCK level.
8. Rotate the Pulser Knob to select the desired input (e.g. AINU1).
9. Press the STEP DOWN button to enter the PARAMETER level.
10. Rotate the Pulser Knob to select SEN TYPE.
11. Press the STEP DOWN button and verify that the sensor type is 15.
12. If the sensor type is not 15, rotate the Pulser Knob to select 15 and then press STORE.
13. Press the STEP UP button to return the PARAMETER level.
14. Rotate the Pulser Knob to select CAL TYPE.
15. Press the STEP DOWN button to view the cal type, select FLD (field cal), press STORE.
16. Press the STEP UP button to return the PARAMETER level.
17. Rotate the Pulser Knob to select the desired parameter, CAL ZERO, shown on the alphanumeric display.
18. Press the STEP DOWN button to enter the VALUE level ('CAL' appears on upper display).
19. Set the precision voltage source to the zero input value (0.000 Vdc).

20. Press STORE to lock-in the desired value. If ENTER COM appears in the alphanumeric display, security is enabled and steps 1) through 5) must be performed to store the calibration. Otherwise, go to step 21.
 - 1) The numeric display shows 000000 with the right-most digit flashing. Rotate the pulser knob to set the units digit to the correct number.
 - 2) Press the TAG/← key to select the next digit, the tens digit.
 - 3) Rotate the pulser knob to select a number for that digit.
 - 4) Move to and select the needed number for each remaining digit.
 - 5) Press ENTER. If the combination entered is incorrect, "ACCESS/DENIED" will be displayed and the controller will return to the parameter level. Otherwise, go to step 21.
21. Press the STEP UP button.
22. Rotate the Pulser Knob to select the 'CAL FULL' parameter.
23. Press the STEP DOWN button to enter the VALUE level ('CAL' appears on upper display).
24. Set the voltage source to the full scale input value (5.000 Vdc).
25. Press STORE.
26. For verification perform the following steps:
 - 1) Press STEP UP button.
 - 2) Rotate Pulser Knob to select 'CAL VIEW' parameter.
 - 3) Press STEP DOWN button to enter VALUE level.
 - 4) Set precision voltage source to 1.00 Vdc. The display should read 15.00 (mv)
 - 5) Set source to 5.00 Vdc. The display should read 75.00 (mv).
27. When input has been calibrated and verified, press EXIT button to leave the calibration mode and enter the operation mode. If security is enabled, exiting the configuration mode will lock out the calibration mode until the security combination is re-entered.

12.4 NO. 3 INPUT, THERMOCOUPLE

This analog input uses the AINU2 function block which is a Universal Analog Input. In this application, a thermocouple type 1-8 is selected in the AINU2 function block. The thermocouple input has been factory calibrated and should not require calibration. However, a field calibration feature is available that enables calibration in the field for the selected thermocouple type. The calibration can always be returned to the values stored at the factory by selecting FAC (Factory Calibration) using the AINU2 parameter CAL TYPE. The minimum and maximum calibration values are listed in the AINU function block information in Section 3 Function Blocks.

1. At the controller's rear terminals, connect a precision thermocouple source, for the type thermocouple type selected, to the + and - input terminals. Also, make sure the reference junction sensor is installed across terminals A8 and A9. Refer to Section 8.4 Electrical Installation for terminal numbers and wiring guidelines. Ensure that terminal screws are tight.
2. If security is enabled, a level 1 or level 4 security combination will be needed to store the results of a calibration. Refer to SECUR-Security in Section 3.1 for additional information.
3. Apply power to the station.
4. Press the ENTER CONF button to enter the configuration mode at the MENU level.
5. Rotate the Pulser Knob to select 'STATION' on the alphanumeric (lower) display.
6. Press the STEP DOWN button to choose options at the station level and rotate the Pulser Knob to select 'CAL' on the alphanumeric display.
7. Press the STEP DOWN button to enter the FUNCTION BLOCK level.
8. Rotate the Pulser Knob to select the desired input (e.g. AINU2).
9. Press the STEP DOWN button to enter the PARAMETER level.
10. Rotate the Pulser Knob to select SEN TYPE.
11. Press the STEP DOWN button and verify that the sensor type is the type required (e.g. 2 for type K T/C).
12. If the sensor type is not the type required, rotate the Pulser Knob to select it and then press STORE.
13. Press the STEP UP button to return to the PARAMETER level.
14. Rotate the Pulser Knob to select CAL TYPE.
15. Press the STEP DOWN button to view the cal type, select FLD (field cal), and press STORE.
16. Press the STEP UP button to return to the PARAMETER level.
17. Rotate the Pulser Knob to select the desired parameter, CAL ZERO, shown on the alphanumeric display.
18. Press the STEP DOWN button to enter the VALUE level ('CAL' appears on upper display).
19. Set the precision thermocouple source to the zero input value (e.g. 0.0 °C for a type K thermocouple).
20. Press STORE to lock-in the desired value. If ENTER COM appears in the alphanumeric display, security is enabled and steps 1) through 5) must be performed to store the calibration. Otherwise, go to step 21.
 - 1) The numeric display shows 000000 with the right-most digit flashing. Rotate the pulser knob to set the units digit to the correct number.
 - 2) Press the TAG/← key to select the next digit, the tens digit.
 - 3) Rotate the pulser knob to select a number for that digit.
 - 4) Move to and select the needed number for each remaining digit.
 - 5) Press ENTER. If the combination entered is incorrect, "ACCESS/DENIED" will be displayed and the controller will return to the parameter level. Otherwise, go to step 21.
21. Press the STEP UP button.
22. Rotate the Pulser Knob to select the 'CAL FULL' parameter.

23. Press the STEP DOWN button to enter the VALUE level ('CAL' appears on upper display).
24. Set the thermocouple source to the full input value (e.g. 1000.0 °C for a type K thermocouple).
25. Press STORE.
26. For verification perform the following steps:
 - 1) Press STEP UP button.
 - 2) Rotate Pulser Knob to select 'CAL VIEW' parameter.
 - 3) Press STEP DOWN button to enter VALUE level.
 - 4) Set precision thermocouple source to minimum field calibration value (e.g. 0.0 °C for a type K T/C.. The display should read 0.00).
 - 5) Set precision thermocouple source to maximum field calibration value (e.g. 1000.0 °C for a type K T/C.. The display should read 1000.00).
27. When the input has been calibrated and verified, press the EXIT button to leave the calibration mode and enter the operation mode. If security is enabled, exiting the configuration mode will lock out the calibration mode until the security combination is again entered.

12.5 NO. 3 INPUT, RTD

This analog input uses the AINU2 function block, a Universal Analog Input. In this application, an RTD type 9-11 is selected in the AINU2 function block. The RTD input has been factory calibrated and should not require calibration. However, a field calibration feature is available that enables calibration in the field for the selected RTD type. The calibration can always be returned to the values stored at the factory by selecting FAC (Factory Calibration) using the AINU2 parameter CAL TYPE. The minimum and maximum calibration values are listed in the AINU function block information in Section 3 Function Blocks.

1. At the controller's rear terminals, connect a precision RTD source, for the type selected, to the input terminals. Refer to Section 8.4 Electrical Installation for terminal numbers and wiring guidelines. Ensure that terminal screws are tight.
2. If security is enabled, a level 1 or level 4 security combination will be needed to store the results of a calibration. Refer to SECUR-Security in Section 3.1 for additional information.
3. Apply power to the station.
4. Press the ENTER CONF button to enter the configuration mode at the MENU level.
5. Rotate the Pulser Knob to select 'STATION' on the alphanumeric (lower) display.
6. Press the STEP DOWN button to choose options at the station level and rotate the Pulser Knob to select 'CAL' on the alphanumeric display.
7. Press the STEP DOWN button to enter the FUNCTION BLOCK level.
8. Rotate the Pulser Knob to select the desired input (e.g. AINU2).
9. Press the STEP DOWN button to enter the PARAMETER level.
10. Rotate the Pulser Knob to select SEN TYPE.
11. Press the STEP DOWN button and verify that the sensor type is the type required (e.g. 9 for type DIN RTD).
12. If the sensor type is not the type required, rotate the Pulser Knob to select it and then press STORE.
13. Press the STEP UP button to return to the PARAMETER level.
14. Rotate the Pulser Knob to select CAL TYPE.
15. Press the STEP DOWN button to view the cal type, select FLD (field cal), and press STORE.
16. Press the STEP UP button to return to the PARAMETER level.
17. Rotate the Pulser Knob to select the desired parameter, CAL ZERO, shown on the alphanumeric display.

18. Press the STEP DOWN button to enter the VALUE level ('CAL' appears on upper display).
19. Set the precision RTD source to the minimum calibration value (e.g. 100.00 Ω (0.0 °C) for a type DIN RTD).
20. Press STORE to lock-in the desired value. If ENTER COM appears in the alphanumeric display, security is enabled and steps 1) through 5) must be performed to store the calibration. Otherwise, go to step 21.
 - 1) The numeric display shows 000000 with the right-most digit flashing. Rotate the pulser knob to set the units digit to the correct number.
 - 2) Press the TAG/← key to select the next digit, the tens digit.
 - 3) Rotate the pulser knob to select a number for that digit.
 - 4) Move to and select the needed number for each remaining digit.
 - 5) Press ENTER. If the combination entered is incorrect, "ACCESS/DENIED" will be displayed and the controller will return to the parameter level. Otherwise, go to step 21.
21. Press the STEP UP button.
22. Rotate the Pulser Knob to select the 'CAL FULL' parameter.
23. Press the STEP DOWN button to enter the VALUE level ('CAL' appears on upper display).
24. Set the precision RTD source to the maximum calibration value (e.g. 280.90 Ω (500.0 °C) for a type DIN RTD).
25. Press STORE.
26. For verification perform the following steps:
 - 1) Press STEP UP button.
 - 2) Rotate Pulser Knob to select 'CAL VIEW' parameter.
 - 3) Press STEP DOWN button to enter VALUE level.
 - 4) Set precision RTD source to the minimum field calibration value. The display should read 0.00.
 - 5) Set precision RTD source to the maximum field calibration value. The display should read 500.00.
27. When input been calibrated and verified, press EXIT button to leave the calibration mode and enter the operation mode. If security is enabled, exiting the configuration mode will lock out the calibration mode until the security combination is again entered.

12.6 NO. 3 INPUT, VOLTAGE

This analog input uses the AINU2 function block which is a Universal Analog Input. In this application, a wide MV type 15 is selected in the AINU2 function block. This input has been factory calibrated for 15 to 75 mv and may require field calibration to offset any slight error caused by the attenuating circuit that drops the 1-5 Vdc input to 15 to 75 mv.

1. At the controller's rear terminals, connect a precision voltage source. Refer to Section 8.4 Electrical Installation for terminal numbers and wiring guidelines. Ensure that terminal screws are tight.
2. If security is enabled, a level 1 or level 4 security combination will be needed to store the results of a calibration. Refer to SECUR-Security in Section 3 for additional information.
3. Apply power to the station.
4. Press the ENTER CONF button to enter the configuration mode at the MENU level.
5. Rotate the Pulser Knob to select 'STATION' on the alphanumeric (lower) display.
6. Press the STEP DOWN button to choose options at the station level and rotate the Pulser Knob to select 'CAL' on the alphanumeric display.
7. Press the STEP DOWN button to enter the FUNCTION BLOCK level.
8. Rotate the Pulser Knob to select the desired input (e.g. AINU2).
9. Press the STEP DOWN button to enter the PARAMETER level.
10. Rotate the Pulser Knob to select SEN TYPE.
11. Press the STEP DOWN button and verify that the sensor type is 15.
12. If the sensor type is not 15, rotate the Pulser Knob to select it and then press STORE.
13. Press the STEP UP button to return to the PARAMETER level.
14. Rotate the Pulser Knob to select CAL TYPE.
15. Press the STEP DOWN button to view the cal type, select FLD (field cal), and press STORE.
16. Press the STEP UP button to return to the PARAMETER level.
17. Rotate the Pulser Knob to select the desired parameter, CAL ZERO, shown on the alphanumeric display.
18. Press the STEP DOWN button to enter the VALUE level ('CAL' appears on upper display).
19. Set the precision voltage source to 0.0 Vdc. If a current input (4-20 mA) using a 250 Ω dropping resistor is connected, set the precision current source to 4.00 mA.
20. Press STORE to lock-in the desired value. If ENTER COM appears in the alphanumeric display, security is enabled and steps 1) through 5) must be performed to store the calibration. Otherwise, go to step 21.
 - 1) The numeric display shows 000000 with the right-most digit flashing. Rotate the pulser knob to set the units digit to the correct number.
 - 2) Press the TAG/← key to select the next digit, the tens digit.
 - 3) Rotate the pulser knob to select a number for that digit.
 - 4) Move to and select the needed number for each remaining digit.
 - 5) Press ENTER. If the combination entered is incorrect, "ACCESS/DENIED" will be displayed and the controller will return to the parameter level. Otherwise, go to step 21.
21. Press the STEP UP button.
22. Rotate the Pulser Knob to select the 'CAL FULL' parameter.
23. Press the STEP DOWN button to enter the VALUE level ('CAL' appears on upper display).

24. Set the precision voltage source to 5.0 Vdc. If a current input (4-20 mA) using a 250 Ω dropping resistor is connected, set the precision current source to 20.00 mA.
25. Press STORE.
26. For verification perform the following steps:
 - 1) Press STEP UP button.
 - 2) Rotate Pulser Knob to select 'CAL VIEW' parameter.
 - 3) Press STEP DOWN button to enter VALUE level.
 - 4) Set precision source to the minimum field calibration value. The display should read 15.00.
 - 5) Set precision source to the maximum field calibration value. The display should read 75.00.
27. When input been calibrated and verified, press the EXIT button to leave the calibration mode and enter the operation mode. If security is enabled, exiting the configuration mode will lock out the calibration mode until the security combination is re-entered.



13.0 CIRCUIT DESCRIPTION

This section provides a block diagram level circuit description of the Siemens 352Plus™.

13.1 OVERVIEW

Controller hardware architecture is shown in Figure 13-1. Notice that all major plug-in assemblies interact with the Controller Board.

The Display Assembly is used for operation and configuration. The MPU-based Controller Board performs many of the controller’s signal processing and process control functions in addition to overseeing internal operations. The Controller Board’s on-board power supply furnishes DC operating voltages to all plug-in assemblies and to external process transmitters connected to the rear terminals. The I/O Expander board provides additional I/O. Networking options include Modbus, Local Instrument Link and Ethernet (Ethernet available on Model 353, Model 353R, and Procidia™ i|pac™).

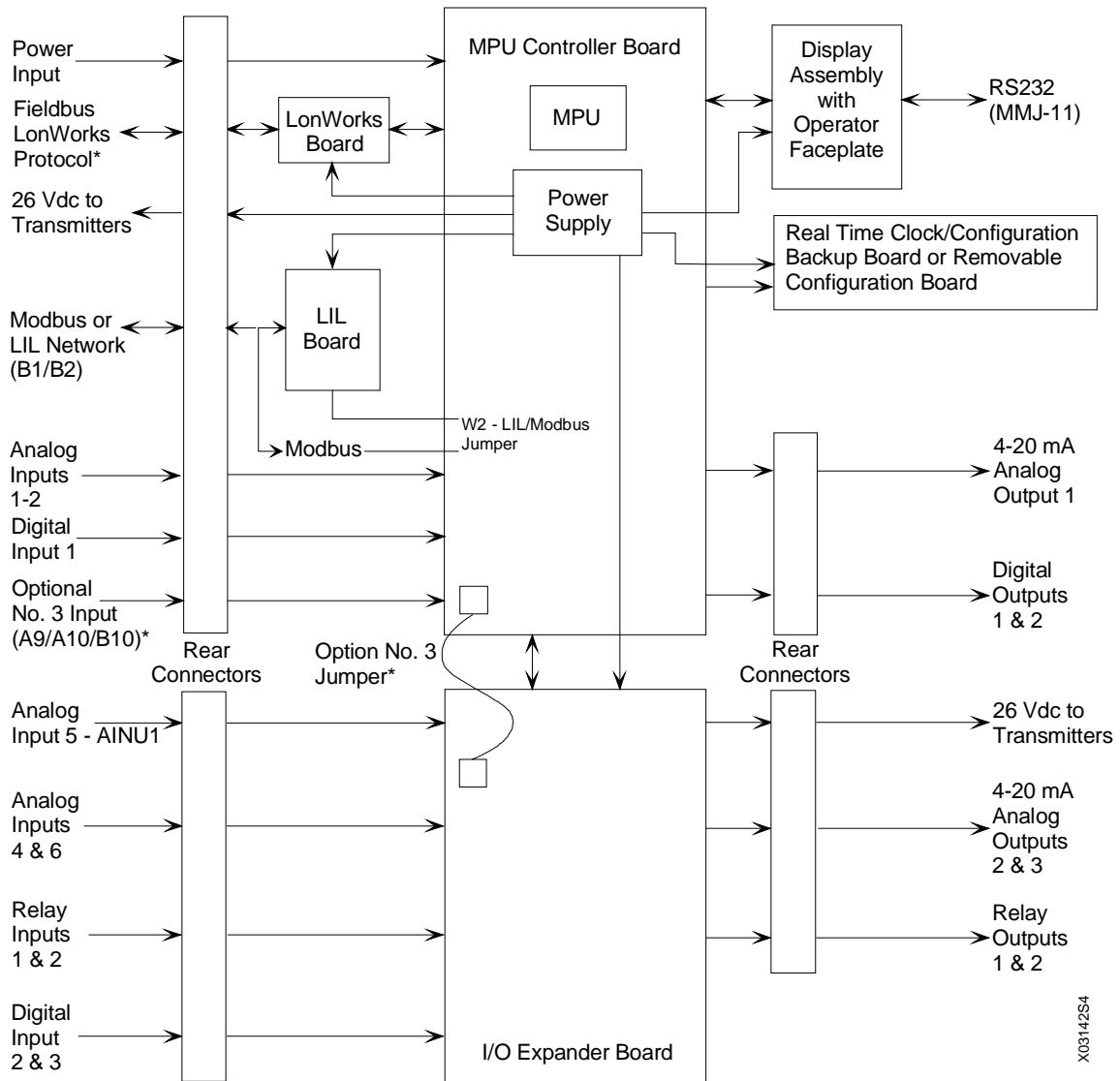

* Optional No. 3 Input (A9, A10 & B10): Expander Board required for most options. Refer to Section 8 Installation, Tables 8.1, 8.2, and 8.3 for a list of input types. Also see Section 11.6 Option 3 I/O Selection for jumpering.

Figure 13-1 Model 352P Block Diagram

13.2 MPU CONTROLLER BOARD

The heart of the controller is the powerful, microprocessor-based MPU Controller Board. The flexible software supports reusable function blocks beneficial in solving a vast array of control strategies such as single loop, cascade and dual loop.

The Controller Board assembly contains both analog and digital circuits. The analog circuitry operates in real time while the microprocessor based digital circuitry operates at high speed under program control. The MPU (microprocessor unit) contains a CPU32 core, System Integration Module (SIM), a queued SPI module (QSPI), timer module and two general-purpose 8-bit ports. The MPU is capable of arithmetic, logical, and support circuit control functions and interacts with surrounding on-board and off-board circuitry to control the internal operation of the controller. The MPU Board also contains 16-bit RAM, 16-bit ROM, a 2-wire RS485 connection, and an RS232 connection.

The CPU32 communicates with the RAM, ROM and external communications boards via the SIM. All communication between the MPU and the I/O, display and expander board is done via the QSPI. The QSPI is a full-duplex, synchronous serial interface with a queue for receive and transmit data. Communication consists of timing, control, data, and sequencing information.

The Controller Board has three analog inputs, 1 digital input, 2 analog outputs and 2 digital outputs. The configuration in use determines the active inputs and outputs. For example, Factory Configured Option FCO101 is configured to accept one analog input for the process signal and one analog output for the valve signal. The two analog outputs are 4 to 20 mA current sources with shutdown control for use in redundant control systems. The two digital outputs are open collector devices with over-voltage protection.

Two serial ports, A and B, are available for bi-directional asynchronous communications. Serial Port A is an RS485 connection, accessed via the rear terminals, available for network communications. Serial port B, an RS232 connection accessed via the connector on the display board, is available for creating and editing configurations using `ijconfig`, the optional PC-Based Graphical Configuration program. Since both ports are independent UARTs, communications with one serial port will not interfere with communications to the other. Parameters in the STATN function block allow setting of the front and rear port baud rate and other transmission characteristics for Modbus. (See STATN-Station Parameters in section 3.) Additional information on Modbus network communications and data mapping can be found in Sections 6 and 7.

The RS-232 connection uses a DEC MMJ connector with the following six connections:

- RTS - Handshaking output from MPU
- TXD - Data output from MPU
- Common
- Common
- RXD - Data input to MPU
- CTS - Handshaking input to MPU

The on-board Power Supply circuit provides the power sources necessary for system power, internal analog output power and transmitter power. Transmitter power is +26 Vdc at 0.125 amperes, to power up six process transmitters.

13.3 I/O EXPANDER BOARD

The I/O Expander Board communicates with the Controller Board and contains hardware that increases station capability. Additional direct connected I/O includes two isolated universal analog inputs with thermocouple, RTD, resistance, slidewire, mA and voltage conversions, two additional digital inputs that can be used as discrete or frequency inputs, an additional analog output and two relay outputs. All calibration data for the Expander Board is stored in the board's nonvolatile EEPROM making recalibration unnecessary when interchanging Expander and Controller Boards.

Expander circuitry operates under the control of the MPU-based Controller Board, and like the Controller Board, it contains both analog and digital circuitry. The analog circuitry operates in real time while the digital circuitry operates at high speed under program control.

Relay 1 and Relay 2 are triggered by the off-board MPU to provide relay contact type outputs. Each SPDT relay output can be connected in a normally open or normally closed contact state.

13.4 LonWorks BOARD

The LonWorks Board provides additional I/O when needed for multiple-loop applications, advanced control, or batch sequencing. This board uses the popular LonWorks (LON stands for Local Operating Network) protocol for high connectivity via a high-speed digital fieldbus to a large selection of standard I/O products. LonWorks remote I/O products include many analog input and output options as well as digital inputs and outputs using relay or solid state technology. This board plugs into the Controller Board via two connectors. An 80 pin pass-through connector is also available for stacking additional option boards.

The LonWorks Board has an integrated circuit containing three processors, two timers, RAM, EEPROM, parallel and serial ports and a network communication port. The board communicates with the Controller Board via a parallel MIP interface. The MIP interface uses a token passing scheme so only the token holder can initiate a data transfer. The board also connects directly to a remote network using a free topology transceiver that operates at a rate of 78 kbps and connects up to 64 nodes over a twisted pair (see Section 5.0). The network wiring may be in a bus configuration or wired in any combination of bus, star or loop topologies.

13.5 LOCAL INSTRUMENT LINK (LIL) NETWORK BOARD

An optional Local Instrument Link (LIL) Network Board is available in place of the Modbus communication network to provide higher speed networking and peer-to-peer communication between controllers. The hardware architecture is designed to accommodate other emerging fieldbus technologies. This includes both field communications that may require lower power for intrinsic safety and also higher speed for interplant networking.

The LIL Board plugs into the controller board via two connectors. An 80-pin pass-through connector is also available for stacking additional option boards. The LIL Board communicates with the main Controller Board via a 32K, 8-bit Dual Port RAM. Two LED's on the LIL Board indicate serial transmit and line activity.

Global LIL function blocks (AIL, AOL, DIL, DOL) can be configured to provide communication between 353 controllers as well as connectivity to other LIL products, such as the Models 352, 351 and 382, over a twisted pair network. The total number of global function blocks will be limited by the number of global channels available. Information on LIL network communications and Data Mapping can be found in Sections 6 and 7. ■



14.0 MODEL DESIGNATION AND SPECIFICATIONS

This section provides model designation information, lists of controller accessories and service parts, detailed controller specifications and hazardous area installation information.

IMPORTANT

Before installing or servicing a controller, refer to the controller labels and the applicable specifications and hazardous area classifications in this section to ensure that the correct model with the needed certifications is at hand.

Every controller is identified by a nameplate located on the case. Inside the drop-down door on the Display Assembly is a warning label. A typical nameplate is shown here.

SIEMENS Siemens Industry, Inc.		CE
MODEL NO.	352PBA21ANNNNAW	
SER NO.	99999999	
SALES NO.	9999999999/999999	
	CL I, DIV2, GPS A, B, C, & D SUBSTITUTION OF COMPONENTS OR OTHER EQUIPMENT MODIFICATIONS MAY IMPAIR THE ELECTRICAL SAFETY OF THE INSTRUMENT.	 LR38024 ABS TYPE APPROVED
MAX AMB TEMP 50°C TEMP CODE T4A (120/240 VAC)		

14.1 MODEL DESIGNATION

Table 14-1 shows the controller's model number sequence. The model designation is shown on a nameplate on the top of the case. The nameplate and other labels carry important information about the controller, such as Model Number, Bill of Material number (P/N No.), Serial Number, and Certifications.

IMPORTANT

Confirm a controller's model number and hazardous area certifications before installing, applying power, or servicing.

When circuit boards are added to a controller in the field, nameplate information will not reflect the current physical configuration.

Table 14-1 Siemens 352Plus™ Model Designation

352P B Basic SLDC Plus

352P E Expanded SLDC Plus

Power Supply

A 120/240 Vac (80-264 Vac), 47-63 Hz.

C 24 Vdc, +20%, -15%

Mounting Case

1 -----

2 Terminal Connections, 40

N Not Required

Operator's Display Panel

1 Analog & Digital Displays (required option with LonWorks I/O)

N Not Required - Includes Blank Panel

D Delete - Panel Not Included [furnished only with mounting option N]

No. 3 Input Options

A Additional Analog Input & Output [352PB]

L LonWorks Remote I/O Fieldbus [352PB or 352PE] (LonWorks option discontinued November 2005.)

F Frequency Input [352PE required]

C Computer Pulse [352PE required]

V Isolated Voltage Input [352PE required]

T Thermocouple/MV Input [352PE required]

D RTD Input (DIN Curve, US Curve) [352PE required]

Link Interface

1 LIL RS-422 - Half Duplex

N Not Required

Removable Configuration Board (RCB)

N Not Required

R RCB Option Installed

T Real Time Clock/Configuration Backup

Reserved for Future Use

N Reserved for Future Use

Modification Options

N Not Required

X Controller Modified as detailed in order bill of material

Design Level

A Design Level A

Electrical Approval*

N Not Required

4 FM/CSA (non-incendive Class I, Div. 2, Groups A, B, C & D)

W FM/CSA (non-incendive Class I, Div. 2, Groups A, B, C & D), ABS, CE*

X FM/CSA (non-incendive Class I, Div. 2, Groups A, B, C & D), ABS

I/O available to user determined by:

1. Model selected.
2. Option 3 I/O jumper placement
3. Controller configuration

Contact the Process Industries Division of Siemens Industry, Inc. for the latest model designation information, availability of some options, and current electrical approvals. Always refer to the nameplate on the controller case and MPU Controller board for approvals and certifications applicable to that instrument.

352P B A 2 1 A N N N N A X Sample Model No.

* CE discontinued July 2009

14.2 ACCESSORIES

The following two tables list the accessories currently available.

ACCESSORY	PART NUMBER	DESCRIPTION
i config Graphical Configuration Utility	iCONFIG-Vn.nn	For PC-based controller configuration and creation of function block diagram. Transfer configurations via the Display Assembly connector, Modbus network, or LIL network. Microsoft® Windows® operating system required. Vn.nn - the latest software version will be supplied.
Transmitter Power Supply	15124-1	Acopian Model B24G210M, 24 Vdc, 2.0A
Adapter Bezel	15738-123	A panel cutout adapter for mounting a Model 352P in a 3"x6" panel cutout.
Blank Filler Panel	15738-168	Enhances control room appearance by covering a panel cutout intended for future mounting of a controller.
Loop Identification Card	-----	Custom printed loop identification for flip-down access door. Specify up to 5 lines with 24 characters per line.
Permanent Instrument Tag	-----	Stainless steel tag permanently attached to the controller's case. One line with up to 24 characters can be specified.
Communications Cable	16353-61	Connects MMJ11 on adapter (connected to a personal computer's serial port) to MMJ11 on controller's Display Assembly. Select one of the following adapters.
Adapter, DB25 to MMJ11	16353-62	Adapts personal computer serial port to above Communications Cable.
Adapter, DB9 to MMJ11	16353-63	
Industrial Module Rack/6	16052-38	Industrial rack that holds six controllers.
Adapter for 16052-15 Module Rack	16052-22	Adapter to mount up to six controllers in the rack.
LonWorks I/O Modules	-----	See the following table or consult the factory or your nearest Siemens, Process Industries Division sales office or subsidiary for the latest information

LONWORKS ACCESSORY	PART NUMBER	DESCRIPTION
LonWorks Protocol Startup Kit	16353-65	LonWorks Startup Kit; includes: 27005-1 Adapter - see description below 15939-70Vn.nn Driver - see description below 16353-66 Cable - see description below
Echelon 73000-1-600-6 SLTA/2	27005-1	Serial PC Interface Adapter
Echelon SLTA/2 Device Driver	15939-70Vn.nn	PC software (latest version will be supplied)
SLTA/2 to LonWorks Network Cable	16260-27	Cable assembly to connect DB9 on PC serial port to DB9 on SLTA Adapter
Configuration Software	27005-2	Acromag 50SW-CFS-M03-1.44MB
1-Channel T/C, RTD Input Module	27005-4	Acromag 550L3-502-TEMPR-10-NCR
Quad V/mAdc Input Module, +/- 1 Volt ²⁰	27005-5	Acromag 550L3-503-4V1-10-NCR
Quad V/mAdc Input Module, +/- 1 Volt, with Factory Calibration	27005-6	Acromag 550L3-503-4V1-10-NCR-C

²⁰ For 4-20 mA input module, order 72005-6 calibrated to 0.2 to 1V. (Replaces part 27005-3.)

LONWORKS ACCESSORY	PART NUMBER	DESCRIPTION
4-Channel High Level DC Input Module, +/- 10; +/- 100 Volts	27005-7	Acromag 550L3-504-4V2-10-NCR
4-Channel High Level DC Input Module, +/- 10; +/- 100 Volts, with Factory Calibration	27005-8	Acromag 550L3-504-4V2-10-NCR-C
2-Channel 4-20 mA Output Module	27005-9	Acromag 570L3-701-C1-10-NCR
3-Channel Isolated DC Discrete Input Module	27005-10	Acromag 540L3-401-3DC-10-NCR
3-Channel Isolated AC Discrete Input Module	27005-11	Acromag 540L3-401-3AC-10-NCR
8-Channel DC Discrete Input Module	27005-12	Acromag 540L3-410-8D1-10-NCR
3-Channel Mechanical Relay Output Module	27005-13	Acromag 560L3-601-3MR-10-NCR
3-Channel Solid State Relay Output Module	27005-14	Acromag 560L3-601-3SS-10-NCR
8-Channel DC Discrete Output Module	27005-15	Acromag 560L3-610-8DO-10-NCR
4-Input/4-Output DC Discrete Module	27005-16	Acromag 580L3-810-4I4O-10-NCR
16 Digital Inputs, DC Powered Module	16802-3	Discontinued
16 Digital Outputs, DC Powered Module	16802-4	Discontinued
Power Supply, Input 115-230 Vac, Output 24 Vdc @ 2.1A	27005-24	idec PS5R-D24

14.3 SERVICE PARTS KITS

An exploded view drawing of the Siemens 352P appears in Section 1 Introduction and in Section 11 Maintenance.

PART NO.	SERVICE PART DESCRIPTION
	- FIRMWARE UPDATE KITS -
15939-71V4.00 Contact Siemens for current version.	Controller Upgrade Utility and Controller Firmware for Models 352P, 353, 353R, 354 and iPAC. Download file fw400.zip (the file/firmware revision at the time this manual was prepared) or order a firmware CD.
	- ELECTRONIC ASSEMBLIES AND RELATED PARTS -
16356-31	Display Assembly Kit includes Display Assembly Adapter and Gasket; Model 352P___1_____
16353-163	Display Assembly Bezel Replacement Kit Includes gray bezel, keypad, pulsar knob, and kit installation instruction.
16356-27	MPU Controller Board Kit, for 120/240 Vac Power Input; Model 352P_A_____
16356-28	MPU Controller Board Kit, for 24 Vdc Power Input; Model 352P_C_____
16356-29	I/O Expander Board Kit; NOT for No. 3 Input Option "V" – Contains I/O Expander Board and Range Resistor and Reference Junction Kit; requires 40 terminal case; Model 352PE_____

PART NO.	SERVICE PART DESCRIPTION
16356-44	I/O Expander Board Kit; for all No. 3 Input Options – Contains I/O Expander Board and Range Resistor and Reference Junction Kit; requires 40 terminal case; Model 352PE_ _ _ V _ _ _ _ _
16297-22	Local Instrument Link Network Board Kit with mounting hardware; Model 352P_ _ _ _ _ 1 _ _ _ _ _
16356-37	LonWorks Board Kit with mounting hardware; Model 352P_ _ _ L _ _ _ _ _
16353-143	Removable Configuration Board Kit with mounting hardware - For MPU Controller board firmware version 1.31 or higher; Model 352P_ _ _ _ _ R _ _ _ _ _
16357-34	Real Time Clock/Configuration Backup Board - Requires MPU Controller board firmware version 2.20 or higher; Model 352P_ _ _ _ _ T _ _ _ _ _
	- INSTALLATION AND SPARE PARTS KITS -
16356-33	Range Resistor Kit - Supplied with each Model 352PB and 352PE - Contains: Range Resistor, 250 Ohm, 0.1%, 3W, WW, qty 3 Sleeving, Insulating Kit Installation Instruction
16356-34	Range Resistor and Reference Junction Kit - Supplied with each Model 352PE and I/O Expander Board Kit – Contains: Range Resistor, 250 Ohm, 0.1%, 3W, WW, qty 3 Sleeving, Insulating Reference Junction, 100 Ohm, for TC inputs, qty 1 Kit Installation Instruction
16356-35	Spare Parts Kit - Contains: Range Resistor, 250 Ohm, 0.1%, 3W, WW, qty 3 Gasket, Display Assembly Adapter, qty 2 Range Resistor Kit, PN16356-33, see above for contents O-Ring, Display Assembly, qty 2 Fuse, 120/240 Vac MPU Cont. Board: 0.4A or 0.5A, 250V, SlowBlo, qty 3 Fuse, 24 Vdc MPU Controller Board: 2A, 250V, SlowBlo, qty 3 Kit Installation Instruction
	- CASE -
16356-23	Case, with Mounting Brackets and 40 Terminals

14.4 MECHANICAL SPECIFICATIONS

Panel Cutout DimensionsSee Figure 8-2
 Controller Dimensions.....See Figures 8-3

14.5 POWER INPUT REQUIREMENTS

Voltage Input
 Model 352P_ A85-264 Vac, 47-63 Hz
 AC power ride through time.....25 msec. (minimum)
 Model 352P_ C24 Vdc, +20%, -15%

Power25 Watts, 40 VA (maximum)

Wire Size, Recommended18 AWG (0.96 mm²)

Rear TerminalsAH - Hot; AN - Neutral; AG - Case/Safety Ground

Over-current Protection.....20A maximum fuse or circuit breaker

14.6 MPU CONTROLLER BOARD SPECIFICATIONS

Analog Inputs: (3)

Input Range	0-5 Vdc (standard calibration 1-5 Vdc)
Zero	0-1 Vdc
Span	4-5 Vdc
Type	Single ended
Accuracy	0.10 %
Resolution	0.024 %
Software Output Type	Analog [configurable (default 0.0-100.0)]
Normal Mode Rejection	>50dB @ 60Hz.
Input Impedance	>1 megohm
Maximum Continuous Input	
Without Crosstalk	+7, -30 Vdc
Without Damage	±30 Vdc

Analog Outputs: (2)

Standard Calibration	4-20 mAdc
Zero	4 mAdc +/- trim
Span	16 mAdc +/- trim
Current Limits	2.4 mA to 21.6 mA
Accuracy:	0.1%
Resolution:	0.003%
Software Input Type	Analog [configurable (default 0.0-100.0)]
Signal Reference	Neg. (-) output tied to station common
Output Load	800 Ohms
Over-voltage Protection	30 Vdc

Digital Input: (1)

Logic "1" Range	15-30 Vdc
Logic "0" Range	0-1 Vdc
Over-voltage	+/-30 Vdc
Minimum Required ON time	>Scan Time
Software Output Type	Digital
Isolation	100 Vdc

Digital Outputs: (2)

Type	Open Collector Transistor (emitter tied to station common)
Load Voltage	+30Vdc maximum
Load Current	100 mA maximum
Off State Leakage Current	< 200 uA @ 30 Vdc

Transmitter Power

.....	25 Vdc +/-3V, 120 mA, short circuit protected
-------	---

14.7 I/O EXPANDER BOARD SPECIFICATIONS

Analog Inputs, Universal: (2)

Type 'J' Thermocouple:

Range Limits-185°C to 1100°C (-300°F to 2010°F)
 Performance Range0 to 1100°C
 Accuracy+/-0.5°C
 Conformity<= 0.06°C
 Software Output Type.....Analog (configurable °C, °F, °R, °K)
 Ambient Temperature Effect:+/- 0.08°C/°C

Type 'K' Thermocouple:

Range Limits-185°C to 1370°C (-300°F to 2500°F)
 Performance Range0 to 1370°C
 Accuracy+/-0.6°C
 Conformity<= 0.06°
 Software Output Type.....Analog (configurable °C, °F, °R, °K)
 Ambient Temperature Effect:+/- 0.10°C/°C

Type 'T' Thermocouple:

Range Limits-240°C to 370°C (-400°F to 698°F)
 Performance Range-100 to 370°C
 Accuracy+/-0.5°C
 Conformity<= 0.06°
 Software Output Type.....Analog (configurable °C, °F, °R, °K)
 Ambient Temperature Effect:+/- 0.07°C/°C

Type 'E' Thermocouple:

Range Limits-185°C to 1000°C (-300°F to 1830°F)
 Performance Range0 to 1000°C
 Accuracy+/-0.5°C
 Conformity<= 0.06°
 Software Output Type.....Analog (configurable °C, °F, °R, °K)
 Ambient Temperature Effect:+/- 0.07°C/°C

Type 'S' Thermocouple:

Range Limits-18°C to 1650°C (0°F to 3000°F)
 Performance Range200 to 1650°C
 Accuracy+/-0.7°C
 Conformity<= 0.06°
 Software Output Type.....Analog (configurable °C, °F, °R, °K)
 Ambient Temperature Effect:+/- 0.14°C/°C

Type 'R' Thermocouple:

Range Limits-18°C to 1610°C (0°F to 2930°F)
 Performance Range200 to 1610°C
 Accuracy+/-0.7°C
 Conformity<= 0.06°
 Software Output Type.....Analog (configurable °C, °F, °R, °K)
 Ambient Temperature Effect:+/- 0.15°C/°C

Type 'B' Thermocouple:

Range Limits-18°C to 1815°C (0°F to 3300°F)
 Performance Range800 to 1815°C
 Accuracy+/-0.7°C
 Conformity<= 0.06°
 Software Output Type.....Analog (configurable °C, °F, °R, °K)

Ambient Temperature Effect: +/- 0.15°C/°C

Type 'N' Thermocouple:

Range Limits -200°C to 1300°C (-325°F to 2370°F)
 Performance Range 0 to 1300°C
 Accuracy +/- 0.5°C
 Conformity <= 0.06°
 Software Output Type Analog (configurable °C, °F, °R, °K)
 Ambient Temperature Effect: +/- 0.10°C/°C

Type DIN 43760/ IEC 751 RTD (α = 0.003850):

Range Limits -185°C to 622°C (-300°F to 1152°F)
 Accuracy +/- 0.4 °C
 Software Output Type Analog (configurable °C, °F, °R, °K)
 Ambient Temperature Effect: +/- 0.04°C/°C

Type US (NBS126) RTD (α = 0.003902):

Range Limits 185°C to 613°C (-300°F to 1135°F)
 Accuracy +/- 0.4°C
 Software Output Type Analog (configurable °C, °F, °R, °K)
 Ambient Temperature Effect: +/- 0.04°C/°C

Type JIS C-1604 RTD (α = 0.003916):

Range Limits -185°C to 610°C (-300°F to 1130°F)
 Accuracy +/- 0.4°C
 Software Output Type Analog (configurable °C, °F, °R, °K)
 Ambient Temperature Effect: +/- 0.04°C/°C

Millivolt

Narrow Range -19.0 to 19.0 mVdc
 Accuracy +/- 5.0 uV
 Ambient Temperature Effect 1.0 uV/°C
 Wide Range -30.0 to 77 mVdc
 Accuracy +/- 8.0 uV
 Ambient Temperature Effect 2.5 uV/°C
 Software Output Type Analog (millivolts)

Analog Input: (1)

Input Range 0-5 Vdc (standard calibration 1-5 Vdc)
 Zero 0-1 Vdc
 Span 4-5 Vdc
 Type Single ended
 Accuracy 0.10 %
 Resolution 0.024 %
 Software Output Type Analog [configurable (default 0.0 - 100.0)]
 Normal Mode Rejection >50dB @ 60Hz.
 Input Impedance >1 megohm
 Maximum Continuous Input +/- 30 Vdc

Analog Output: (1)

Standard Calibration 4-20 mA dc
 Zero 4 mA dc +/- trim
 Span 16 mA dc +/- trim
 Accuracy 0.10 %
 Resolution 0.003 %
 Software Input Type Analog [configurable (default 0.0 - 100.0)]
 Current Range Limits 2.4 to 21.6 mA dc

Signal ReferenceNeg. (-) output tied to station common
 Output Load800 Ohms
 Overvoltage Protection.....30 Vdc

Digital Inputs: (2)

Logic "1" Range.....15-30 Vdc
 Logic "0" Range.....0-1 Vdc
 Overvoltage+/-30 Vdc
 Minimum Required ON Time>Scan Time
 Software Output TypeDigital
 Isolation.....100 Vdc

Universal Digital Inputs: (2)

Logic "1" Range.....4-30 Vdc
 Input Current<7 mA @ 30 V
 Logic "0" Range.....0-1 Vdc
 Overvoltage+/-30 Vdc
 Frequency Range.....0 to 25,000 Hz.
 Accuracy0.03 % of reading
 Minimum Operating Frequency0.05 Hz.
 Pulse Width20 μ sec (minimum)
 Signal Types.....Sine Square, Pulse, Triangle, or Contact Closure
 (contacts require external power)
 Software Output Types:(a) Scaled Frequency: Analog
(b) Scaled Count: Analog
(c) Current Input State: Digital
 Isolation.....100 Vdc

Relay Outputs: (2)

TypeSealed (meets requirements of Division 2 applications)
 Software Input Type.....Digital
 Contact ConfigurationSPDT
 Contact Rating.....5A @ 115 Vac; 2.5A @ 230 Vac (resistive load)
 Minimum Current.....100 mA @ 10 mVdc or 150 mA @ 50 mVac

14.8 COMMUNICATION BOARDS

Communication boards plug into the Controller Board and provide digital communication as required by the application. These boards provide digital communication for remote I/O and NETWORK communication for interstation/workstation/APACS networking. Two communication boards plug into the MPU controller board: a LonWorks board and a LIL Network board.

14.8.1 LonWorks Board

This board provides for additional I/O, remote from the controller. The communication method allows various configurations of analog and discrete signal types, both input and output, for use in control and/or sequencing applications within the station.

14.8.2 LIL Network Board (Local Instrument Link)

This board provides network communication, mapping station variables to the standard LIL channel/parameter communication map. When this board is used, Modbus communication is not available. The local configuration port under the faceplate is still available for configuration and diagnostic applications.

14.9 ENVIRONMENTAL SPECIFICATIONS

Mounting, Typical Location:Control room or other protected area

Temperature Limits:

Operating:.....0 to 50°C (32 to 122°F)

Storage:-40 to 85°C (-40 to 185°F)

Climatic Conditions:.....IEC654-1 (Class B3)

Corrosive Conditions:.....IEC654-4 (Class 2)
IEC801-2 (Electrostatic Discharge)
IEC801-3 (RFI)
IEC801-4 (Electrical Transients)

14.10 AGENCY APPROVALS

The Model 352P has been designed to meet various agency approvals. Contact the factory or your local Siemens (Process Industries Division) representative for current approvals. Labels on each 352P list the agency approvals that apply to that particular instrument.

FM/CSA

Class I, Division 2, Groups A, B, C, and D

CE - see Section 14.10.2

ABS TYPE Approval

14.10.1 CSA Hazardous Locations Precautions

This section provides CSA hazardous location precautions that should be observed by the user when installing or servicing the equipment described in this Instruction. These statements supplement those given in the preceding section.



Explosion Hazard

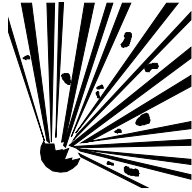

Explosion can cause death or serious injury.

In a potentially explosive atmosphere, remove power from the equipment before connecting or disconnecting power, signal or other wiring.

All pertinent regulations regarding installation in a hazardous area must be observed.

Precautions - English

For Class I, Division 1 and Class I, Division 2 hazardous locations,

- Use only factory-authorized replacement parts. Substitution of components can impair the suitability of this equipment for hazardous locations.

For Division 2 hazardous locations:

When the equipment described in this Instruction is installed without safety barriers, the following precautions should be observed. Switch off electrical power at its source (in non-hazardous location) before connecting or disconnecting power, signal, or other wiring.

Précautions - Français

Emplacements dangereux de classe I, division 1 et classe I, division 2:

- Les pièces de rechange doivent être autorisées par l'usine. Les substitutions peuvent rendre cet appareil impropre à l'utilisation dans les emplacements dangereux.

Emplacement dangereux de division 2:

Lorsque l'appareil décrit dans la notice ci-jointe est installé sans barrières de sécurité, on doit couper l'alimentation électrique à la source (hors de l'emplacement dangereux) avant d'effectuer les opérations suivantes branchement ou débranchement d'un circuit de puissance, de signalisation ou autre.

14.10.2 Special Conditions for Safe Use

Always refer to the labels on the controller case for approvals and certifications applicable to that instrument.

CE

- Use of the equipment in a manner not specified by the manufacturer may impair the protection provided by the equipment.
- Route electrical power to the station through a clearly labeled circuit breaker or on-off switch that is located near the station and is accessible by the operator. The breaker or switch should be located in a non-explosive atmosphere unless suitable for use in an explosive atmosphere.
- Local Instrument Link twinaxial cable must be shielded.
- Environmental Conditions, Per IEC 664, Installation Category II, Pollution Degree 2
- A representative unit was tested in accordance with EN50082-2. Test results are available upon request.
- CSA electrical classification approval as non-incendive for Division 2 service applies to installations in North America and where recognized. Check local approval requirements.

FM, Enclosure Requirements:

- The apparatus must be mounted within an enclosure or assembly to prevent personal injury resulting from accessibility to live parts. The enclosure is typically user-supplied and, therefore, was not examined as part of this Approval but shall comply with the requirements of this section.
- Accessibility - The system must be installed within the enclosure so that its circuits are accessible by the use of a tool only. A part is accessible when either a.) the IEC articulate accessibility probe applied in every possible position to the exterior or exposed surfaces, including the bottom; or b.) the IEC rigid accessibility probe applied with a maximum force of 30 Newtons (6.75 lbs force) in every possible position to the exterior or exposed surface, including the bottom, touches the part.
- Protection from Fire - If the enclosure is non-metallic, it shall have the proper flammability rating.
- Grounding - A metallic enclosure must have a protective grounding terminal and be marked as such. All accessible non-current conductive parts must be bonded to the protective grounding terminal.
- General Construction - The equipment enclosure, or parts of the enclosure, required to be in place to comply with the requirements for protection from electric shock, personal injury, protection of internal parts and wiring and external cord and cable assembly strain relief shall comply with the following tests for mechanical strength:
 - Impact Tests - The equipment shall be held firmly against a rigid support and shall be subjected to sets of three blows with 6.6 Joules (4.9 pound force-inch) from a spring-operated impact hammer. The hammer shall be applied to any external part that when broken is likely to expose live parts. A window of an indicating device shall withstand an impact of 0.085 Newton-meter (0.753 pound force-inch) from a hollow steel impact sphere 50.8 mm (2 inches) in diameter and an approximate mass of 113.4 grams (4 ounces).
 - Pressure Tests - A force of 90 Newtons (20 pounds) shall be applied from a metal rod 12.7 mm (0.50 inch) in diameter, the end of which is rounded. The force shall be applied for one minute to any point on the overall enclosure except the bottom. The bottom shall sustain a force of 65 Newtons (15 pounds).
 - Tip Stability Test - Equipment having a weight of 11 kilograms (24 pounds) or more shall not tip over when placed at the center of an inclined plane that makes an angle of 10 degrees with the horizontal and then turned to the position (with all doors, drawers, and other openable and sliding parts in the least stable position) most likely to cause tip-over.
 - Sharp Edges - An accessible edge, projection, or corner of an enclosure, opening, frame, guard, handle, or the like shall be smooth and well rounded, and shall not cause a cut-type injury during normal use of the equipment.

15.0 ABBREVIATIONS AND ACRONYMS

This section contains definitions for many of the abbreviations and acronyms that frequently appear in this User's Manual. Less frequently used terms are defined where they appear. Where a term has more than one meaning, context will usually indicate the meaning. Terms that identify a function block are indicated by (FB).

A - ampere(s)	DLY - delay
AC - action, alternating current	DMM - digital multimeter
ACS - Arccosine (FB)	DNC - Divide by N Counter (FB)
ACT - acting	DOD - Digital Output Discrete (FB)
ADD - Addition (FB), address	DOE - Digital Output -Ethernet (FB)
AIE - Analog Input - Ethernet (FB)	DOL - Discrete Output - LIL (FB)
AIN - Analog Input (FB)	DOS - Digital Output_State (FB)
AINU - Analog Input Universal (FB)	DOUT - Digital Output (FB)
A/M - auto/manual	DPP - decimal point position
AOE - Analog Output - Ethernet (FB)	DTM - Dead Time Table (FB)
APACS - Advanced Process Automation and Control System	DWNLD - download
ASCII - American Standard Code for Information Interchange	DYT - Delay Timer (FB)
ASN - Arcsine (FB)	E/I - External/Internal Transfer Switch (FB)
AT - adaptive time, autotune transfer	EM - EMER MAN - emergency manual
ATD - Analog Trend Display (FB)	EN - enable, enabled
ATN - Arctangent (FB)	ENG - engineering (units)
AWG - American Wire Gauge	ERR - error
	ESL - Events Sequence Logger (FB)
BAT - battery	ESN - Execution Sequence Number
BATSW - Batch Switch (FB)	ET - elapsed time
BATOT - Batch Totalizer (FB)	EXP - Natural Exponent (FB)
BPL - batch pre-load	EXT - Exponentiation (FB)
BOD - Basic Operator Display	
	F - Fahrenheit
C - centigrade	FAC - factory
CAL - calibrate, calibration	FB - function block
CHN - channel	FCO - Factory Configured Option
CHR - Characterizer (FB)	FREQ - frequency
CHAN - channel	ft. - feet
CIE - Coil Input - Ethernet (FB)	FTG - Falling Edge Trigger (FB)
CL - console/local	
CMP - Comparator (FB)	GB - Gain & Bias (FB)
COS -Cosine (FB)	GS - go to step
	GW - global word (LIL)
D - deviation, denominator	
DAM - Deviation Amplifier (FB)	H - hold
DC - direct current	HART - Highway Addressable Remote Transducer
DEG - degrees	HI - high
DEV - deviation	HLD - Hold (FB)
DG - derivative gain	HYS - hysteresis
DIE - Digital Input -Ethernet (FB)	Hz - Hertz
DID - Digital Input Discrete (FB)	
DIG - digital	ICI - Independent Computer Interface (Model 320)
DIL - Discrete Input LIL (FB)	ID - ID Controller (FB), identity
DIN - Digital Input (FB)	in. - inch
DINU - Digital Input Universal (FB)	INIT - initial
DIR - direct	I/O - input/output
DIS - Digital Input_State	IO - internal override
DISP - display	k - kilo (prefix) 10 ⁺³
DIV - Division (FB)	K - Kelvin

lb. - pound(s)
 LED - Light Emitting Diode
 LIB - library
 LIL - Local Instrument Link
 LL - Lead/Lag (FB)
 LMT - Limit (FB)
 LN_ - Natural Logarithm (FB)
 LO - low, lockout
 LOG - Logarithm Base 10 (FB)

m - milli (prefix) 10^{-3} , meter
 M - mega (prefix) 10^{+6}
 MA - moving average
 MAX - maximum
 MB - Modbus
 MD - Message Display
 MIN - minimum
 MR - manual reset
 MSG - Message
 MTH - Math (FB)
 MUL - Multiplication (FB), multiply, multiplication

N - number, numerator
 NC - normally closed
 NND - NAND Logic (FB)
 NO - normally open
 NOR - NOR Logic (FB)
 NOT - NOT Logic (FB)
 NUM - number
 NV - network variable
 NVRAM - non-volatile random access memory

ODC - Operator Display for Controllers (FB)
 ODS - Operator Display for Sequencer (FB)
 ON/OFF - On/Off Controller (FB)
 OP - operation
 OR - OR Logic (FB), override
 ORSL - Override Select (FB)
 OST - One Shot Timer (FB)

P - process
 PAC - Process Automation Controller
 PARM - parameter
 PB - Pushbutton
 PB#SW - Pushbutton # Switch (FB)
 PC - personal computer
 PCOM - Phase Communication (FB)
 PD - PD Controller (FB)
 PG - proportional gain
 PID - PID Controller (FB),
 proportional/integral/derivative
 PIDAG - PIDAG Controller (FB),
 proportional/integral/derivative/adaptive gain
 PRSEQ - Program Sequencer (FB)
 PTR - pointer
 PU - Power Up
 PUL - pulse

Q - quality
 QHD - Quickset Hold (FB)
 QS - quick set, quality status
 QSPI - Queued Serial Peripheral Interface

R - reset, Rankine
 RCB - Removable Configuration Board
 RCT - Repeat Cycle Timer (FB)
 RD - received data
 Rev - revision
 RG - range
 RLM - Rate Limiter (FB)
 RN - recipe number
 ROT - Retentive On Timer (FB)
 ROUT - Relay Output (FB)
 RSF - RS Flip-Flop (FB)
 RT - remaining time
 RTD - resistance temperature detector
 RTG - Rising Edge Trigger (FB)

S - setpoint, set
 SCL - Scaler (FB)
 SEN - sensor
 SB - step backward
 SEL - Signal Selector (FB)
 SETPT - Setpoint (FB)
 SF - step forward
 SIN_ - Sine (FB)
 SL - setpoint limit
 SLTA - Serial Link Talk Adapter
 SN - step number
 SPLIM - Setpoint Limit (FB)
 SQ - square root
 SR - start ramp
 SRF - SR Flip-Flop (FB)
 SRT - Square Root (FB)
 SS - stainless steel, standby synchronization
 ST - status
 STA - station
 STATN - station
 SUB - Subtraction (FB), subtract
 SW - switch

TAN_ - Tangent (FB)
 TC - thermocouple, track command
 TD - time derivative
 TH - Track & Hold (FB)
 TI - time integral
 TIM - timer
 TO - tracked output
 TOT - totalizer
 TSW - Transfer Switch (FB)
 TV - track variable

V - valve, volt(s)
 VAL - value

W - watts
WD - watchdog

ZDO - zero drop out

XMTR - transmitter
XOR - Exclusive OR Logic (FB)



**Procidia™ Controller Models 352P, 353, 354, and 354N
Design Level “A”
MPU Controller Board Firmware, Version 3.00**

PRODUCTS INVOLVED

Model 353 Process Automation Controller, Design Level A¹, (e.g. 353_-----A_)
Model 352*Plus*™ Single-Loop Digital Controller
Model 354 Universal Control Station
Model 354N Universal Loop Controller

INTRODUCTION

This Software Release memo discusses the enhancements and operational considerations for version 3.00 of MPU Controller board firmware (software).

ENHANCEMENTS

Model 353, Design Level “A” controllers: V3.00 firmware adds Ethernet communication function blocks and V2.00 Ethernet Communication board firmware to the features provided by earlier firmware versions. An Ethernet Communication option board with V2.00 firmware must be installed in a Model 353 controller for the added blocks to be available. Of the four listed controllers, Ethernet communications is available only in the Model 353.

V3.00 firmware will add the following enhancements to a Model 353.

- AWE Function Block – The AWE (Analog Write Ethernet) block allows the controller to write analog data to other Modbus devices over the Ethernet network.
- CWE Function Block – The CWE (Coil Write Ethernet) block allows the controller to write coil data to other Modbus devices over the Ethernet network.
- DWE Function Block – The DWE (Digital Write Ethernet) block allows the controller to write digital data to other Modbus devices over the Ethernet network.
- V2.00 Ethernet Communication board firmware (included in this release)
- V3.00 Controller firmware enhances AIE, CIE, and DIE function blocks through the inclusion of additional parameters for data type selection.

All listed controllers: The RLM block now accepts an adaptive rate input.

¹ The design level is indicated by the next to last character in the model number. The characters shown are those required to identify an involved instrument. See the Siemens Process Instruments catalog or the instrument’s User’s Manual (e.g. UM353-1) for complete model designation information.

OPERATIONAL CONSIDERATIONS

- 353 with Ethernet - Before installing MPU Controller board firmware 3.00, if the controller contains an Ethernet Board with firmware version 1, first upgrade Ethernet Board firmware to version 2. To display the firmware version, refer to the STATN – Station Parameters section in the Function Blocks chapter of UM353-1, the controller’s User’s Manual.
- Critical configurations² only – Before upgrading to MPU Controller board firmware 3.00:
 - 1) Save the current configuration using i|config™.
 - 2) Using the Display Assembly/Local Faceplate, select and store FCO-0 (zero) as the controller configuration -- FCO-0 will overwrite the installed configuration.
 - 3) Update the MPU Controller board firmware.
 - 4) Create a new configuration using the saved configuration for a reference.
- Before installing MPU Controller board firmware that is a lower level than that presently installed in the controller:
 - 1) Save the current configuration using i|config.
 - 2) Using the Display Assembly/Local Faceplate, select and store FCO-0 (zero) as the controller configuration -- FCO-0 will overwrite the installed configuration.
 - 3) Install the Controller board firmware.
 - 4) Create a new configuration using the saved configuration for a reference.
- RTC/CB Option Board - After downloading a configuration to a controller that has an RTC/CB board installed, an “RTC->MEM” message may appear following a power interruption. If the "RTC->MEM" message appears, the controller is asking for permission to transfer the configuration data from the RTC/CB to the MPU board. The presently selected choice (YES or NO) is shown in the 5-digit display. Select "NO" using the pulser knob and press the "STORE" button, which will allow the controller to operate. To stop the "RTC-MEM" message from appearing on future power cycles, you should now store a configuration parameter using the controller’s Display Assembly/Local Faceplate.
- 353 with Ethernet - After installing MPU Controller board firmware 3.00, if the controller configuration includes an AIE function block connected to an AOE block, the BYTE ORD parameter must be changed to 4 from the default setting of 1. Refer to function blocks “STATN- Station Parameter” and “AIE_ - Analog Input – Ethernet” in UM353-1 for details.
- ALARM - Alarm Block – When an ALARM block is placed in a loop configuration (either at the controller faceplate or in i|config™), Alarm 3 is configured as a Deviation alarm. The displayed default value of Alarm 3 Limit is 100%. However, the alarm will actually trip at 110%. To reset the default Limit value to 100%, display the Alarm 3 Limit value and press STORE (faceplate) or click Accept (i|config).

When Alarm 3 Limit is user configured, the user entered value over writes the default value and the default trip point error has no effect.

The above also occurs when creating a new configuration from a Factory Configured Option (FCO) that contains an ALARM - Alarm Block, for example, FCO101. If the selected FCO has two loops, the Alarm Block in each loop should be reset.

² For the purpose of this Software Release memo, a critical configuration may be any configuration that would be very difficult to recreate in the unlikely event that the upgrade process fails or is interrupted.

- In the STATN - Station Parameters function block, parameters CONFIG LO and PARAM LO can have a value of either 0 or 1, 2, or 3: a 0 allows writes, a 1, 2, or 3 prevents writes. (There is no difference in operation in selecting a 1, 2, or 3.) Early User's Manuals list write values as YES/NO which was correct for earlier firmware. Later User's Manuals incorrectly list different functions for selections 1, 2, and 3. Reads are always enabled.

UPGRADE CONSIDERATIONS AND MATERIALS

1. Check the current MPU Controller Board firmware version before upgrading. To display the firmware version, refer to the STATN – Station Parameters section in the Function Blocks chapter of the controller's User's Manual.
2. A personal computer running Microsoft® Windows® 95, 98, NT, 2000 or XP is needed.
3. Upgrading requires the following items:
 - 1) Communications Cable - P/N 16353-61
 - 2) Communications Cable Adapter; select one to mate with your computer's COM port:
DB25 to MMJ11 - P/N 16353-62
DB9 to MMJ11 - P/N 16353-63
 - 3) Model 352P/353/354 Firmware Upgrade Utility P/N15939-77V3.00 (*upgrades 1.xx to 3.00*). Kit contents:
 - CD-ROM with the multiple versions of the controller firmware
 - Software license disk created for the station (by serial number) to be upgraded
 - Software registration card

INSTALLING VERSION 3.00

1. Read the Operational Considerations and the Upgrade Considerations and Materials sections of this publication.
2. Follow the instructions on the label of the supplied CD-ROM to install the utility.
3. Read the supplied HELP file for information about downloading firmware (kernel and code) to a controller.
4. Complete and mail the software registration card.

CUSTOMER/PRODUCT SUPPORT

For support and the location of your local Siemens representative, refer to the table below for the URL of the Process Instrumentation (PI) portion of the Siemens public Internet site. Once at the site, click **Support** in the right column and then **Product Support**. Next select the type of support desired: sales, technical (see the table below), documentation, or software.

Online Support Request	http://www.siemens.com/automation/support-request
Technical Support	1-800-333-7421; 8 a.m. to 4:45 p.m. eastern time, Monday through Friday (except holidays)
Customer Service & Returns	1-800-365-8766 (warranty and non-warranty)
Public Internet Site	http://www.usa.siemens.com/pi
Technical Publications in PDF	Click the above link to go to the PI home page. Click Support and then Manuals and then, under "Additional Manuals," select the product line (e.g. Control Solutions)

All product designations may be trademarks or product names of Siemens Industry, Inc. or other supplier companies whose use by third parties for their own purposes could violate the rights of the owners.

Siemens Industry, Inc. assumes no liability for errors or omissions in this document or for the application and use of information in this document. The information herein is subject to change without notice.

Procedures in this document have been reviewed for compliance with applicable approval agency requirements and are considered sound practice. Neither Siemens Industry, Inc. nor these agencies are responsible for product uses not included in the approval certification(s) or for repairs or modifications made by the user.

© Copyright 2010, Siemens Industry, Inc. All rights reserved.