

SIEMENS



Motion Control Drives

SINAMICS V90 Basic Servo Drive System

Catalog
D 33

Edition
May
2018

siemens.com/drives

Related catalogs

| | | | |
|--|---|--|---|
| <p>Motion Control Drives D 31.1 SINAMICS Inverters for Single-Axis Drives Built-In Units</p> <p>E86060-K5531-A111-A1-7600</p> |  | <p>Industrial Controls IC 10 SIRIUS</p> <p>E86060-K1010-A101-A7-7600</p> |  |
| <p>SINAMICS Drives D 35 SINAMICS G120P and SINAMICS G120P Cabinet pump, fan, compressor converters</p> <p>E86060-K5535-A101-A4-7600</p> |  | <p>Industrial Controls IC 10 AO SIRIUS Classic</p> <p>PDF (E86060-K1010-A191-A5-7600)</p> |  |
| <p>SINAMICS S120 D 21.3 Chassis Format Converter Units Cabinet Modules</p> <p>SINAMICS S150 Converter Cabinet Units E86060-K5521-A131-A6-7600</p> |  | <p>Low-Voltage Power Distribution and Electrical Installation Technology LV 10 SENTRON • SIVACON • ALPHA Protection, Switching, Measuring and Monitoring Devices, Switchboards and Distribution Systems PDF (E86060-K8280-A101-A7-7600) Print (E86060-K8280-A101-A6-7600)</p> |  |
| <p>Motion Control Drives D 21.4 SINAMICS S120 and SIMOTICS</p> <p>E86060-K5521-A141-A1-7600</p> |  | <p>SIMATIC ST 70 Products for Totally Integrated Automation</p> <p>E86060-K4670-A101-B6-7600</p> |  |
| <p>SIMOTICS S-1FG1 Servo geared motors D 41 Helical, Parallel shaft, Bevel and Helical worm geared motors</p> <p>E86060-K5541-A101-A3-7600</p> |  | <p>SIMATIC HMI / PC-based Automation ST 80/ST PC Human Machine Interface Systems PC-based Automation</p> <p>E86060-K4680-A101-C5-7600</p> |  |
| <p>SIMOTICS GP, SD, XP, DP Low-Voltage Motors D 81.1 Type series 1FP1, 1LE1, 1LE5, 1MB1 and 1PC1 Frame sizes 63 to 355 Power range 0.09 to 500 kW E86060-K5581-A111-B2-7600</p> |  | <p>Industrial Communication IK PI SIMATIC NET</p> <p>E86060-K6710-A101-B8-7600</p> |  |
| <p>FLENDER Couplings MD 10.1 Standard Couplings</p> <p>E86060-K5710-A111-A5-7600</p> |  | <p>SITRAIN Training for Industry</p> <p>www.siemens.com/sitrain</p> |  |
| <p>SIMOGEAR Geared Motors MD 50.1 Helical, parallel shaft, bevel, helical worm and worm geared motors</p> <p>E86060-K5250-A111-A5-7600</p> |  | <p>Products for Automation and Drives CA 01 Interactive Catalog Download</p> <p>www.siemens.com/ca01download</p> |  |
| <p>Motion Control System PM 21 SIMOTION Equipment for Production Machines</p> <p>E86060-K4921-A101-A4-7600</p> |  | <p>Industry Mall Information and Ordering Platform on the Internet:</p> <p>www.siemens.com/industrymall</p> |  |

SIEMENS

SINAMICS V90

Basic Servo Drive System

Motion Control Drives

Catalog D 33 · May 2018

Dear Customer,

We are pleased to present you with the new Catalog D 33 · May 2018. The catalog provides a comprehensive overview of the SINAMICS V90 basic servo drive system consisting of a SINAMICS V90 servo drive, a SIMOTICS S-1FL6 servomotor and a matching MOTION-CONNECT connection system.

The products listed in this catalog are also included in the Industry Mall. Please contact your local Siemens office for additional information.

Up-to-date information about SINAMICS V90 is available online at www.siemens.com/sinamics-v90

You can access our Interactive Catalog and our Industry Mall online at www.siemens.com/industrymall

Your personal contact is keen to receive your suggestions and recommendations for improvement. You can find your contact in our contact database at www.siemens.com/automation-contact

We hope that you will often enjoy using Catalog D 33 · May 2018 as a selection and ordering reference document and wish you every success with our products and solutions.

With kind regards,



Achim Peltz
Vice President
General Motion Control
Siemens AG, Digital Factory Division, Motion Control

SINAMICS V90 Basic Servo Drive System

Motion Control Drives



Catalog D 33 · May 2018

Refer to the Industry Mall for current updates of this catalog:

www.siemens.com/industrymall

The products contained in this catalog can also be found in the Interactive Catalog CA 01.

Article No.: E86060-D4001-A510-D8-7500

Please contact your local Siemens branch.

NEW

Click on an Article No. in the catalog PDF to call it up in the Industry Mall and to obtain all the information.

Article No.

6SL3070-0AA00-0AG0
6SL3072-0AA00-0AG0



Or directly on the Internet, e.g.

www.siemens.com/product?6SL3070-0AA00-0AG0



The products and systems described in this catalog are manufactured/distributed under application of a certified quality management system in accordance with EN ISO 9001.

The certificate is recognized by all IQNet countries.

System overview

1

SINAMICS V90 servo drive

2

SIMOTICS S-1FL6 servomotors

3

MOTION-CONNECT connection systems

4

Engineering tools

5

Services and documentation

6

Appendix

7

Digital Enterprise

The building blocks that ensure everything works together perfectly in the digital enterprise

Digitalization is already changing all areas of life and existing business models. It is placing greater pressure on industry while at the same time creating new business opportunities. Today, thanks to scalable solutions from Siemens, companies can already become a digital enterprise and ensure their competitiveness.



Industry faces tremendous challenges



Reduce time-to-market

Today manufacturers have to bring products to market at an ever-increasing pace despite the growing complexity of these products. In the past, a major manufacturer would push aside a small one, but now it is a fast manufacturer that overtakes a slow one.



Boost flexibility

Consumers want customized products, but at a price they would pay for a mass-produced item. That only works if production is more flexible than ever before.



Improve quality

To ensure a high level of quality while meeting legal requirements, companies have to establish closed quality loops and enable the traceability of products.

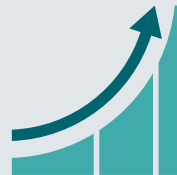

Boost efficiency

Today the product itself needs to be sustainable and environmentally friendly, while energy efficiency in production has become a competitive advantage.



Increase security

Increasing networking escalates the threat to production facilities of cyberattacks. Today more than ever, companies need suitable security measures.



The digital enterprise has already become a reality

To fully benefit from all the advantages of digitalization, companies first have to achieve complete consistency of their data. Fully digitally integrated business processes, including those of suppliers, can help to create a digital representation of the entire value chain. This requires

- the integration of industrial software and automation,
- expansion of the communication networks,
- security in automation,
- and the use of business-specific industrial services.

MindSphere

The cloud-based open IoT operating system from Siemens

With MindSphere, Siemens offers a cost-effective and scalable cloud platform as a service (PaaS) for the development of applications. The platform, designed as an open operating system for the Internet of Things, makes it possible to improve the efficiency of plants by collecting and analyzing large volumes of production data.

Totally Integrated Automation (TIA) Where digitalization becomes reality

Totally Integrated Automation (TIA) ensures the seamless transition from the virtual to the real world. It already encompasses all the necessary conditions for transforming the benefits of digitalization into true added value. The data that will form the digital twin for actual production is generated from a common base.

Digital Plant

Learn more about the digital enterprise for the process industry
www.siemens.com/digitalplant

Digital Enterprise Suite

Learn more about the digital enterprise for the discrete industry
www.siemens.com/digital-enterprise-suite

Integrated Drive Systems

Faster on the market and in the black with Integrated Drive Systems

Integrated Drive Systems are Siemens' trendsetting answer to the high degree of complexity that characterizes drive and automation technology today. The world's only true one-stop solution for entire drive systems is characterized in particular by its threefold integration: Horizontal, vertical, and lifecycle integration ensure that every drive system component fits seamlessly into the whole system, into any automation environment, and even into the entire lifecycle of a plant.

The outcome is an optimal workflow – from engineering all the way to service that entails more productivity, increased efficiency, and better availability. That's how Integrated Drive Systems reduce time to market and time to profit.

Horizontal integration

Integrated drive portfolio: The core elements of a fully integrated drive portfolio are frequency converters, motors, couplings, and gear units. At Siemens, they're all available from a single source. Perfectly integrated, perfectly interacting. For all power and performance classes. As standard solutions or fully customized. No other player in the market can offer a comparable portfolio. Moreover, all Siemens drive components are perfectly matched, so they are optimally interacting.

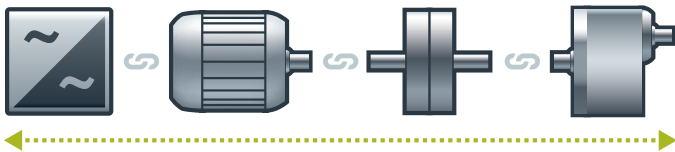

You can boost the availability of your application or plant to up to

99%*
*e.g., conveyor application

Vertical integration

Thanks to **vertical integration**, the complete drive train is seamlessly integrated in the entire automation environment – an important prerequisite for production with maximum value added. Integrated Drive Systems are part of Totally Integrated Automation (TIA), which means that they are perfectly embedded into the system architecture of the entire industrial production process. This enables optimal processes through maximum communication and control.

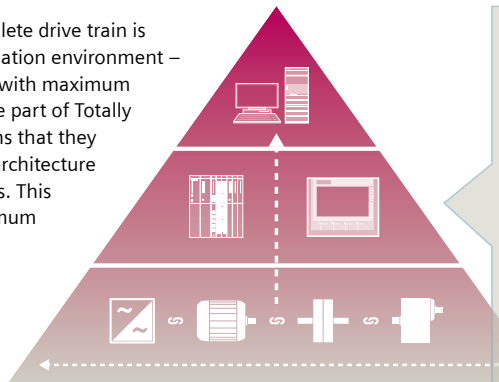

With TIA Portal you can cut your engineering time by up to

30%

Lifecycle integration

Lifecycle integration adds the factor of time: Software and service are available for the entire lifecycle of an Integrated Drive System. That way, important optimization potential for maximum productivity, increased efficiency, and highest availability can be leveraged throughout the system's lifecycle – from planning, design, and engineering to operation, maintenance, and all the way even to modernization.

With Integrated Drive Systems, assets become important success factors. They ensure shorter time to market, maximum productivity and efficiency in operation, and shorter time to profit.

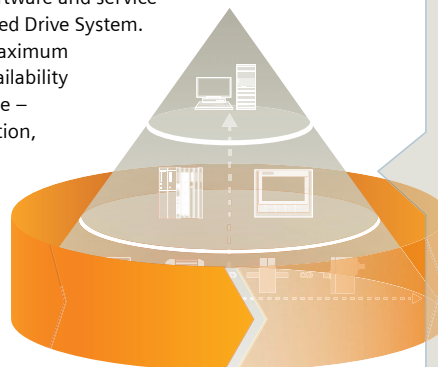

With Integrated Drive Systems you can reduce your maintenance costs by up to

15%

System overview



| | |
|-------------|--|
| 1/2 | The SINAMICS drive family |
| 1/2 | Overview |
| 1/6 | Drive selection |
| 1/6 | Overview |
| 1/6 | More information |
| 1/7 | SINAMICS V90 basic servo drive system |
| 1/7 | Overview |
| 1/7 | Benefits |
| 1/8 | Application |
| 1/8 | Design |
| 1/9 | Selection and ordering data |
| 1/12 | Accessories |
| 1/13 | Function |
| 1/14 | Configuration |
| 1/14 | Technical specifications |
| 1/14 | More information |
| 1/15 | Integration |
| 1/18 | SINAMICS V90 Starter Kit |
| 1/18 | Overview |
| 1/18 | Benefits |
| 1/18 | Selection and ordering data |
| 1/19 | Recommended SIMATIC S7 controller |
| 1/19 | Selection and ordering data |

System overview

The SINAMICS drive family

Overview

Integration in automation

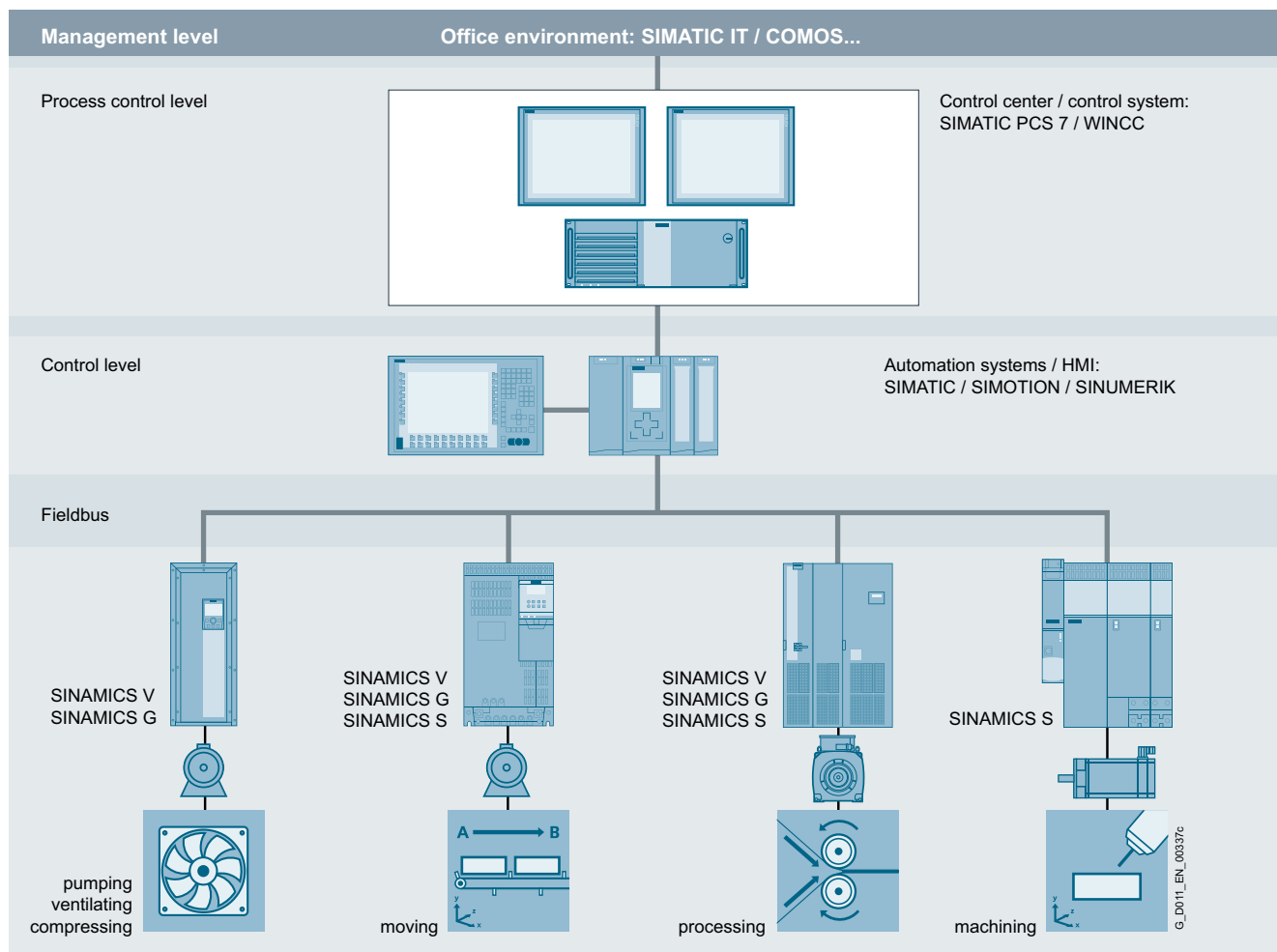

Totally Integrated Automation and communication

SINAMICS is an integral component of the Siemens "Totally Integrated Automation" concept. Integrated SINAMICS systems covering configuration, data storage, and communication at automation level ensure low-maintenance solutions with the SIMATIC, SIMOTION and SINUMERIK control systems.

Depending on the application, the appropriate variable frequency drives can be selected and incorporated in the automation concept. With this in mind, the drives are clearly subdivided into their different applications. A wide range of communication options (depending on the drive type) are available for establishing a communication link to the automation system:

- PROFINET
- PROFIBUS
- EtherNet/IP
- Modbus TCP
- Modbus RTU
- AS-Interface
- BACnet MS/TP

Applications

SINAMICS is the comprehensive family of drives from Siemens designed for machine and plant engineering applications. SINAMICS offers solutions for all drive tasks:

- Simple pump and fan applications in the process industry
- Demanding single drives in centrifuges, presses, extruders, elevators, as well as conveyor and transport systems
- Drive line-ups in textile, plastic film, and paper machines as well as in rolling mill plants
- Highly dynamic servo drives for machine tools, as well as packaging and printing machines

Overview (continued)*SINAMICS as part of the Siemens modular automation system***Innovative, energy-efficient and reliable drive systems and applications as well as services for the entire drive train**

The solutions for drive technology place great emphasis on the highest productivity, energy efficiency and reliability for all torque ranges, performance and voltage classes.

Siemens offers not only the right innovative variable frequency drive for every drive application, but also a wide range of energy-efficient low voltage motors, geared motors, explosion-protected motors and high-voltage motors for combination with SINAMICS.

Furthermore, Siemens supports its customers with global pre-sales and after-sales services, with over 295 service points in 130 countries – and with special services e.g. application consulting or motion control solutions.

Energy efficiencyEnergy management process

Efficient energy management consultancy identifies the energy flows, determines the potential for making savings and implements them with focused activities.

Almost two thirds of the industrial power requirement is from electric motors. This makes it all the more important to use drive technology permitting energy consumption to be reduced effectively even in the configuration phase, and consequently to optimize plant availability and process stability. With SINAMICS, Siemens offers powerful energy efficient solutions which, depending on the application, enable a significant reduction in electricity costs.

System overview

The SINAMICS drive family

Overview (continued)

Up to 70 % potential for savings using variable speed operation

SINAMICS enables great potential for savings to be realized by controlling the motor speed. In particular, huge potential savings can be recovered from pumps, fans and compressors which are operated with mechanical throttle and valves. Here, changing to variable-speed drives brings enormous economic advantages. In contrast to mechanical control systems, the power consumption at partial load operation is always immediately adjusted to the demand at that time. So energy is no longer wasted, permitting savings of up to 60 % – in exceptional cases even up to 70 %. Variable-speed drives also offer clear advantages over mechanical control systems when it comes to maintenance and repair. Current spikes when starting up the motor and strong torque surges become things of the past – and the same goes for pressure waves in pipelines, cavitation or vibrations which cause sustainable damage to the plant. Smooth starting and ramp-down relieve the load on the mechanical system, ensuring a significantly longer service life of the entire drive train.

Regenerative feedback of braking energy

In conventional drive systems, the energy produced during braking is converted to heat using braking resistors. Energy produced during braking is efficiently recovered to the supply system by versions of SINAMICS G and SINAMICS S drives with regenerative feedback capability and these devices do not therefore need a braking resistor. This permits up to 60 % of the energy requirement to be saved, e.g. in lifting applications. Energy which can be reused at other locations on a machine. Furthermore, this reduced power loss simplifies the cooling of the system, enabling a more compact design.

Energy transparency in all configuration phases

Early on, in the configuration phase, the SIZER for Siemens Drives engineering tool provides information on the specific energy requirement. The energy consumption across the entire drive train is visualized and compared with different plant concepts.

SINAMICS in combination with energy-saving motors

Engineering integration stretches beyond the SINAMICS drive family to higher-level automation systems, and to a broad spectrum of energy-efficient motors with a wide range of performance classes, which, compared to previous motors, are able to demonstrate up to 10 % greater efficiency.

Variants

Depending on the application, the SINAMICS range offers the ideal variant for any drive task.

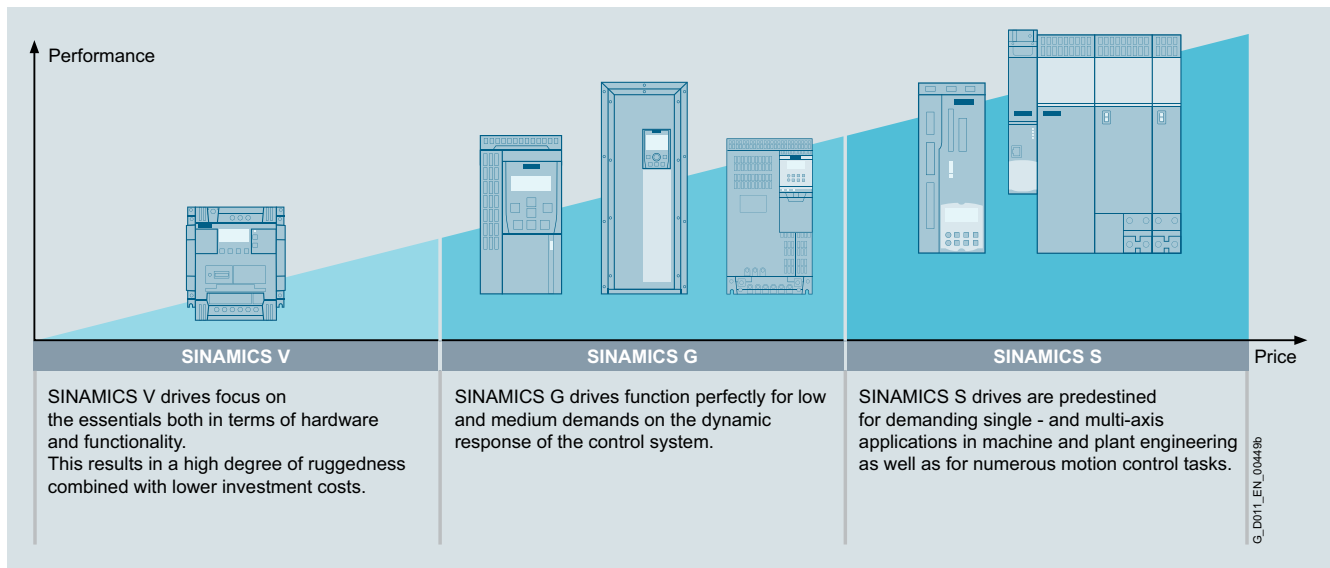

Overview (continued)

Platform concept

All SINAMICS variants are based on a platform concept. Joint hardware and software components, as well as standardized tools for dimensioning, configuration, and commissioning tasks ensure high-level integration across all components. SINAMICS handles a wide variety of drive tasks with no system gaps. The different SINAMICS variants can be easily combined with each other.











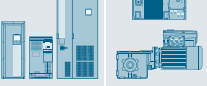

Quality management according to EN ISO 9001

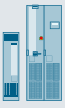
SINAMICS conforms to the most exacting quality requirements. Comprehensive quality assurance measures in all development and production processes ensure a consistently high level of quality.

Of course, our quality management system is certified by an independent authority in accordance with EN ISO 9001.

IDS – Integration at its very best

The Siemens Integrated Drive Systems (IDS) solution offers perfectly matched drive components with which you can meet your requirements. The drive components reveal their true strengths as an Integrated Drive System over the full range from engineering and commissioning through to operation: Integrated system configuration is performed using the Drive Technology Configurator: Just select a motor and an inverter and design them with the SIZER for Siemens Drives engineering tool. The STARTER and SINAMICS Startdrive commissioning tools integrate the motor data and at the same time simplify efficient commissioning. Integrated Drive Systems are incorporated in the TIA Portal – this simplifies engineering, commissioning and diagnostics.

| Low voltage | | | | | | | | | | DC voltage | Medium voltage |
|---|--|--|--|--|---|--|---|---|--|--|--|
| Basic performance | | General performance | | | | | High performance | | | DC applications | Applications with high outputs |
|  |  |  |  |  |  |  |  |  |  |  |  |
| SINAMICS V20 | SINAMICS V90 | SINAMICS G120C G120 G120P G120P Cabinet | SINAMICS G110D G120D G110M SIMATIC ET 200pro FC-2 | SINAMICS G130 G150 | SINAMICS G180 | SINAMICS S110 | SINAMICS S210 | SINAMICS S120 S120M | SINAMICS S150 | SINAMICS DCM | SINAMICS GH150 GH180 GM150 SM150 GL150 SL150 SM120CM |
| 0.12 kW to 30 kW | 0.05 kW to 7 kW | 0.37 kW to 630 kW | 0.37 kW to 7.5 kW | 75 kW to 2700 kW | 2.2 kW to 6600 kW | 0.55 kW to 132 kW | 0.05 kW to 0.75 kW | 0.55 kW to 5700 kW | 75 kW to 1200 kW | 6 kW to 30 MW | 0.15 MW to 85 MW |
| Pumps, fans, compressors, conveyor belts, mixers, mills, spinning machines, textile machines, refrigerated display counters, fitness equipment, ventilation systems | Handling machines, packaging machines, automatic assembly machines, metal forming machines, printing machines, winding and unwinding units | Pumps, fans, compressors, conveyor belts, mixers, mills, extruders, building management systems, process industry, HVAC, single-axis positioning applications in machine and plant engineering | Conveyor technology, single-axis positioning applications (G120D) | Pumps, fans, compressors, conveyor belts, mixers, mills, extruders | Sector-specific for pumps, fans, compressors, conveyor belts, extruders, mixers, mills, kneaders, centrifuges, separators | Single-axis positioning applications in machine and plant engineering | Packaging machines, handling equipment, feed and withdrawal devices, stacking units, automatic assembly machines, laboratory automation, wood, glass and ceramics industry, digital printing machines | Production machines (packaging, textile and printing machines, paper machines, plastic processing machines), machine tools, plants, process lines and rolling mills, marine drives, test bays | Test bays, cross cutters, centrifuges | Rolling mill drives, wire-drawing machines, extruders and kneaders, cableways and lifts, test bay drives | Pumps, fans, compressors, mixers, extruders, mills, crushers, rolling mills, conveyor technology, excavators, test bays, marine drives, blast furnace fans, retrofit |
| Catalog D 31.1 | Catalog D 33 | Catalogs D 31.1, D 35 | Catalog D 31.2 | Catalog D 11 | Catalog D 18.1 | Catalog D 31.1 | Catalog D 32 | Catalogs D 21.3, D 21.4 NC 62 | Catalog D 21.3 | Catalog D 23.1 | Catalogs D 15.1, D 12 |

Engineering tools (e.g. Drive Technology Configurator, SIZER for Siemens Drives, STARTER and SINAMICS Startdrive)

G_D011_EN_00450k





System overview

Drive selection

1

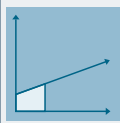
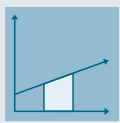
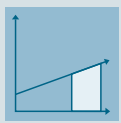
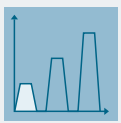
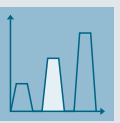
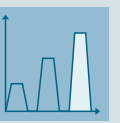
Overview

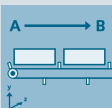
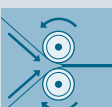
SINAMICS selection guide – typical applications

| Use | Requirements for torque accuracy/speed accuracy/position accuracy/coordination of axes/functionality | | | | | |
|---|---|--|--|---|---|--|
| | Continuous motion | | | Non-continuous motion | | |
| | Basic | Medium | High | Basic | Medium | High |
| |  |  |  |  |  |  |
| Pumping, ventilating, compressing  | Centrifugal pumps Radial / axial fans Compressors V20 G120C G120P | Centrifugal pumps Radial / axial fans Compressors G120P G130/G150 G180 ¹⁾ | Eccentric screw pumps S120 | Hydraulic pumps Metering pumps G120 | Hydraulic pumps Metering pumps S110 | Descaling pumps Hydraulic pumps S120 |
| Moving  | Conveyor belts Roller conveyors Chain conveyors V20 G110D G110M G120C ET 200pro FC-2 ²⁾ | Conveyor belts Roller conveyors Chain conveyors Lifting/lowering devices Elevators Escalators/moving walkways Indoor cranes Marine drives Cable railways G120 G120D G130/G150 G180 ¹⁾ | Elevators Container cranes Mining hoists Excavators for open-cast mining Test bays S120 S150 DCM | Acceleration conveyors Storage and retrieval machines V90 G120 G120D | Acceleration conveyors Storage and retrieval machines Cross cutters Reel changers S110 S210 DCM | Storage and retrieval machines Robotics Pick & place Rotary indexing tables Cross cutters Roll feeds Engagers/disengagers S120 S210 DCM |
| Processing  | Mills Mixers Kneaders Crushers Agitators Centrifuges V20 G120C | Mills Mixers Kneaders Crushers Agitators Centrifuges Extruders Rotary furnaces G120 G130/G150 G180 ¹⁾ | Extruders Winders/unwinders Lead/follower drives Calenders Main press drives Printing machines S120 S150 DCM | Tubular bagging machines Single-axis motion control such as • Position profiles • Path profiles V90 G120 | Tubular bagging machines Single-axis motion control such as • Position profiles • Path profiles S110 S210 | Servo presses Rolling mill drives Multi-axis motion control such as • Multi-axis positioning • Cams • Interpolations S120 S210 DCM |
| Machining  | Main drives for • Turning • Milling • Drilling S110 | Main drives for • Drilling • Sawing S110 S120 | Main drives for • Turning • Milling • Drilling • Gear cutting • Grinding S120 | Axis drives for • Turning • Milling • Drilling S110 | Axis drives for • Drilling • Sawing S110 S120 | Axis drives for • Turning • Milling • Drilling • Lasering • Gear cutting • Grinding • Nibbling and punching S120 |

Using the SINAMICS selection guide

The varying range of demands on modern variable frequency drives requires a large number of different types. Selecting the optimum drive has become a significantly more complex process. The application matrix shown simplifies this selection process considerably, by suggesting the ideal SINAMICS drive for examples of typical applications and requirements.

- The application type is selected from the vertical column
 - Pumping, ventilating, compressing
 - Moving
 - Processing
 - Machining
- The quality of the motion type is selected from the horizontal row
 - Basic
 - Medium
 - High

More information

Further information about SINAMICS is available on the Internet at www.siemens.com/sinamics

Practical application examples and descriptions are available on the Internet at www.siemens.com/sinamics-applications

¹⁾ Industry-specific inverters.

²⁾ Information on the SIMATIC ET 200pro FC-2 frequency converter is available in Catalog D 31.2 and at www.siemens.com/et200pro-fc

Overview

SINAMICS V90 servo drive system



The performance-optimized, user-friendly servo drive system comprises a SINAMICS V90 servo drive and a SIMOTICS S-1FL6 servomotor. Different frame sizes and motor shaft heights cover a wide range of applications for operation on single and three-phase line supplies. There are eight servo drive frame sizes and seven motor shaft heights with power ratings ranging from 0.05 to 7.0 kW, to realize a wide range of applications, with the focus on dynamic motion and processing - for example positioning, transporting and winding.

In addition to operation in the TIA Portal V14 with the new SIMATIC 1500 T-CPU Advanced Controller, the servo drive system is also suitable for use with the SIMATIC S7-1500 Advanced Controller and the SIMATIC S7-1200 Basic Controller.

Benefits

Cost-effective - many integrated functions to reduce machine costs

Integrated control modes

Pulse train input position control mode (PTI), internal position control mode (IPos) with traversing block or Modbus, speed control mode and torque control are all integrated in the SINAMICS V90.

The drive has various integrated control modes to address a wide range of applications.

Integrated PROFINET – the industrial Ethernet standard for automation

SINAMICS V90 PROFINET version features PROFINET, enabling real-time transmission of user/process data and diagnostic data with a single cable.

This solution offers wide-ranging functions with reduced complexity.

Integrated positioning function

- Positioning function is integrated in the drive. Target positions and respective speeds can be stored in the drive during commissioning or changed via communication.
- Absolute or relative positioning
- Rotary or linear axes
- Referencing in the drive

Point-to-point positioning possible using a PLC without positioning functionality.

Integrated braking resistor for all frame sizes and max. motor power ≥ 0.2 kW

All frame sizes with max. motor power ≥ 0.2 kW have an integrated braking resistor to dissipate the regenerative power for fast braking.

Most applications can be realized without an additional braking resistor.

Integrated holding brake switch (SINAMICS V90, 400 V version)

Integrated holding brake switch - the brake can be directly connected to the drive if a motor with holding brake is used.

Holding brake can be connected without requiring an external relay (only for SINAMICS V90, 400 V version).

Easy to use - Simple tuning and quick commissioning

Easy servo tuning and machine optimization

The system can be automatically optimized using the auto tuning function and automatic suppression of machine resonances.

Simply plug & play, no in-depth servo know-how required.

Easy commissioning using the SINAMICS V-ASSISTANT engineering tool

Graphic user interface guides the user when setting application-specific parameters; intuitive drive and motor status check; integrated trace and measuring functionality.

SINAMICS V-ASSISTANT makes commissioning and diagnostics quick and easy.

<https://www.siemens.com/sinamics-v-assistant>

Simple connection to a control system

- Two-channel pulse train for position setpoint, one exclusively for 5 V differential (RS422 standard), one for 24 V single ended signal (for pulse train version)
- Standard RS485 interface supports USS and Modbus RTU (pulse train version)
- Industrial Ethernet standard PROFINET with PROFIdrive (PROFINET version)

Standard interface makes it easy to connect the drive with PLCs and motion controller.

Easy, all from a single source

- Predefined drive/motor bundles and accessories, easy to select
- Tested with SIMATIC PLC/HMI and ready-to-run application examples for connecting a SINAMICS V90 drive to a controller
- Different application examples can be downloaded free of charge from the Online Support Portal

Parameter cloning

SINAMICS V90 servo drives are equipped with a standard SD card slot (400 V version) and a Micro SD card slot (200 V version), so that parameter settings can be easily transferred between drive devices.

Efficient commissioning of machine series.

System overview

SINAMICS V90 basic servo drive system

1

Application

Application examples

SINAMICS V90 servo drive system

| 200 V ... 240 V 1 AC/3 AC | | 380 V ... 480 V 3 AC | |
|--|---|---|---|
| Low Inertia for high dynamic performance | | High Inertia for smooth operational performance | |
| Electronic assembly industry, for example | <ul style="list-style-type: none"> • Pick and place machine • Stencil cutting machine • PCB assembly machine • IC handling machine • Chip sorting machine • Bonding machine | Metal forming machinery, for example | <ul style="list-style-type: none"> • Punching machine • Engraving machine • Edging press |
| Converting/printing industry, for example | <ul style="list-style-type: none"> • Labeling machine • Slitter machine • Laminating/coating machine • Screen printing machine | Converting/printing industry, for example | <ul style="list-style-type: none"> • Winders • Slitter machine • Laminating/coating machine • Screen printing machine • Wire drawing machine |
| Packaging industry, for example | <ul style="list-style-type: none"> • Filling and sealing machine • Blister machine (pharmaceutical packaging) • Bag packing machine | Packaging industry, for example | <ul style="list-style-type: none"> • Filling machine • Blister machine (pharmaceutical packaging) • Bag packing machine |
| Material handling machinery, for example | <ul style="list-style-type: none"> • Automatic palletizers | Material handling machinery, for example | <ul style="list-style-type: none"> • Storage and warehouse systems • Conveyor systems |

Design

System topology

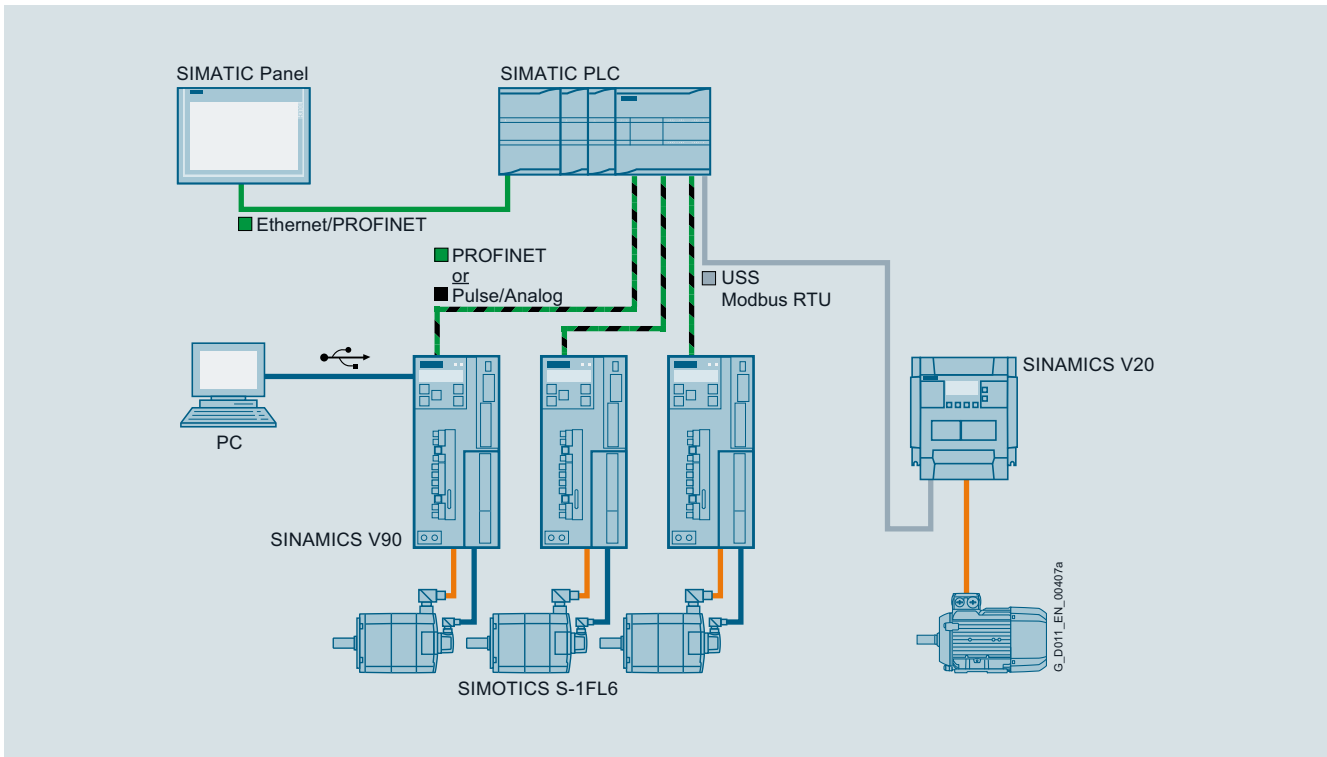

SINAMICS V90 basic servo drive system

SINAMICS V90 basic servo drive system

Selection and ordering data

| SIMOTICS S-1FL6 servomotors Further info in section SIMOTICS S-1FL6 servomotors. | | | | | | | | | | | | | | SINAMICS V90 servo drive Further info in section SINAMICS V90 servo drive. | | | | MOTION-CONNECT connection systems Further info in section MOTION-CONNECT connection systems. | | | | | | MOTION-CONNECT connection systems | | | Line filter | | | Recommended standard fuse | | | Recommended circuit breaker | | | | | | | | |
|---|--|----------------------------------|--|---------------------------|--|--------------|-----------------|----------------------------|---|----------------------|-------------------|------------|--|---|--|--|---------------------------------|--|----------------------|-------------|---|-------------------------------|------------------------------|--|-----------------|-------------|---------------|--|---------------|---------------------------|---------------------|--------------------|-----------------------------|-----------|----|-------------|---------------|--|--|--|--|
| Max. speed | Rated power ¹⁾ | Static torque | Rated torque ¹⁾ | Max. torque ¹⁾ | Rated current | Max. current | Torque constant | Moment of inertia of rotor | Recom- mended load to motor inertia ratio, max. | Weight ²⁾ | Max. motor power | Frame size | No. of cores x conductor cross-section | SINAMICS V90 – Incremental encoder on the 1FL6 servomotor | SINAMICS V90 – Absolute encoder on the 1FL6 servomotor | SINAMICS V90 – Brake on the 1FL6 servomotor with holding brake | Motor side for power connection | Motor side for incremental encoder | for absolute encoder | for brake | With one of the recommended line filters, EN 61008-3 category C2 can be reached in combination with SINAMICS V90. For more information please refer to SINAMICS V90 Operating instructions. | corresponding to IEC standard | corresponding to UL standard | corresponding to IEC standard/ UL standard | | | | | | | | | | | | | | | | | |
| n_{max} | P_{rated} at $\Delta T=100\text{ K}$ | M_N at $\Delta T=100\text{ K}$ | M_{rated} at $\Delta T=100\text{ K}$ | M_{max} | I_{rated} at $\Delta T=100\text{ K}$ | I_{max} | | $J_{without\ brake}$ | $J_{with\ brake}$ | $m_{without\ brake}$ | $m_{with\ brake}$ | | | | | | Motor side for power connection | Motor side for incremental encoder | for absolute encoder | for brake | Line supply voltage | I_{rated} | I_{rated} | Class | | | | | | | | | | | | | | | | | |
| rpm | kW (hp) | Nm | Nm | Nm | A | A | Nm/A | 10^{-4} kgm^2 | | kg | kg | | mm ² | Article No. | Article No. | Article No. | Article No. | Article No. | Article No. | Article No. | V | A | Article No. | A | Article No. | Article No. | | | | | | | | | | | | | | | |
| SIMOTICS S-1FL6 Low Inertia servomotors – High dynamic performance | | | | | | | | | | | | | | SINAMICS V90 servo drive | | | | | | | | | | | | | | MOTION-CONNECT connection systems | | | | | | | | | | | | | |
| Shaft height 20 – Rated speed n_{rated} 3000 rpm | | | | | | | | | | | | | | Line supply 200 ... 240 V 1 AC/3 AC | | | | | | | | | | | | | | | | | | | | | | | | | | | |
| 5000 | 0.05 (0.07) | 0.16 | 0.16 | 0.48 | 1.2 | 3.6 | | 0.14 | 0.031 | 0.038 | 30x | 0.47 | 0.7 | 0.10 (0.14) | 6SL3210-5FB10-1U | 1 | FSA | 4 x 0.75 | 6FX3002-5CK01-1 | 0 | 6FX3002-2CT20-1 | 0 | 6FX3002-2DB20-1 | 0 | 6FX3002-5BK02-1 | 0 | 6FX2003-0LL12 | 6FX2003-OSL12 | 6FX2003-0DB12 | 6FX2003-0LL52 | 1 AC 200 ... 240 18 | 6SL3203-0BB21-8VA0 | 6 | 3NA3801 | 6 | Listed JDDZ | 3RV2011-1EA10 | | | | |
| 5000 | 0.10 (0.14) | 0.32 | 0.32 | 0.96 | 1.2 | 3.6 | | 0.29 | 0.052 | 0.059 | 30x | 0.63 | 0.86 | | | | | | | | | | | | | | | | | | | | | | | | | | | | |
| Shaft height 30 – Rated speed n_{rated} 3000 rpm | | | | | | | | | | | | | | Line supply 200 ... 240 V 1 AC/3 AC | | | | | | | | | | | | | | | | | | | | | | | | | | | |
| 5000 | 0.20 (0.27) | 0.64 | 0.64 | 1.91 | 1.4 | 4.2 | | 0.48 | 0.214 | 0.245 | 30x | 1.02 | 1.48 | 0.20 (0.27) | 6SL3210-5FB10-2U | 1 | FSA | 4 x 0.75 | 6FX3002-5CK01-1 | 0 | 6FX3002-2CT20-1 | 0 | 6FX3002-2DB20-1 | 0 | 6FX3002-5BK02-1 | 0 | 6FX2003-0LL12 | 6FX2003-OSL12 | 6FX2003-0DB12 | 6FX2003-0LL52 | 1 AC 200 ... 240 18 | 6SL3203-0BB21-8VA0 | 6 | 3NA3801 | 6 | Listed JDDZ | 3RV2011-1EA10 | | | | |
| 5000 | 0.40 (0.54) | 1.27 | 1.27 | 3.82 | 2.6 | 7.8 | | 0.49 | 0.351 | 0.381 | 30x | 1.46 | 1.92 | 0.40 (0.54) | 6SL3210-5FB10-4U | 1 | FSB | | | | | | | | | | | | | | | | | | | | | | | | |
| Shaft height 40 – Rated speed n_{rated} 3000 rpm | | | | | | | | | | | | | | Line supply 200 ... 240 V 1 AC/3 AC | | | | | | | | | | | | | | | | | | | | | | | | | | | |
| 5000 | 0.75 (1.02) | 2.39 | 2.39 | 7.2 | 4.7 | 14.2 | | 0.51 | 0.897 | 1.06 | 20x | 2.8 | 3.68 | 0.75 (1.02) | 6SL3210-5FB10-8U | 0 | FSC | 4 x 0.75 | 6FX3002-5CK01-1 | 0 | 6FX3002-2CT20-1 | 0 | 6FX3002-2DB20-1 | 0 | 6FX3002-5BK02-1 | 0 | 6FX2003-0LL12 | 6FX2003-OSL12 | 6FX2003-0DB12 | 6FX2003-0LL52 | 1 AC 200 ... 240 18 | 6SL3203-0BB21-8VA0 | 16 | 3NA3805 | 20 | Listed JDDZ | 3RV2011-1KA10 | | | | |
| 5000 | 1.00 (1.36) | 3.18 | 3.18 | 9.54 | 6.3 | 18.9 | | 0.51 | 1.15 | 1.31 | 20x | 3.39 | 4.2 | 1.00 (1.36) | 6SL3210-5FB11-0U | 1 | FSD | 4 x 0.75 | 6FX3002-5CK01-1 | 0 | 6FX3002-2CT20-1 | 0 | 6FX3002-2DB20-1 | 0 | 6FX3002-5BK02-1 | 0 | 6FX2003-0LL12 | 6FX2003-OSL12 | 6FX2003-0DB12 | 6FX2003-0LL52 | 3 AC 200 ... 240 12 | 6SL3203-0BE21-2VA0 | 16 | 3NA3805 | 20 | Listed JDDZ | 3RV2011-1JA10 | | | | |
| Shaft height 50 – Rated speed n_{rated} 3000 rpm | | | | | | | | | | | | | | Line supply 200 ... 240 V 3 AC | | | | | | | | | | | | | | | | | | | | | | | | | | | |
| 5000 | 1.50 (2.04) | 4.78 | 4.78 | 14.3 | 10.6 | 31.8 | | 0.46 | 2.04 | 2.24 | 15x | 5.45 | 6.96 | 1.50 (2.04) | 6SL3210-5FB11-5U | 0 | FSD | 4 x 2.5 | 6FX3002-5CK32-1 | 0 | 6FX3002-2CT12-1 | 0 | 6FX3002-2DB12-1 | 0 | 6FX3002-5BL03-1 | 0 | 6FX2003-0LL13 | 6FX2003-OSL13 | 6FX2003-0DB13 | 6FX2003-0LL53 | 3 AC 200 ... 240 12 | 6SL3203-0BE21-2VA0 | 25 | 3NA3810 | 25 | Listed JDDZ | 3RV2011-4AA10 | | | | |
| 5000 | 2.00 (2.72) | 6.37 | 6.37 | 19.1 | 11.6 | 34.8 | | 0.55 | 2.62 | 2.82 | | 6.66 | 8.2 | 2.00 (2.72) | 6SL3210-5FB12-0U | 0 | | | | | | | | | | | | | | | | | | | | | | | | | |
| SIMOTICS S-1FL6 High Inertia servomotors – Smooth operational performance | | | | | | | | | | | | | | SINAMICS V90 servo drive | | | | | | | | | | | | | | MOTION-CONNECT connection systems | | | | | | | | | | | | | |
| Shaft height 45 – Rated speed n_{rated} 3000 rpm | | | | | | | | | | | | | | Line supply 380 ... 480 V 3 AC | | | | | | | | | | | | | | | | | | | | | | | | | | | |
| 4000 | 0.4 (0.54) | 1.9 | 1.27 | 3.8 | 1.2 | 3.6 | | 1.1 | 2.7 | 3.2 | 10x | 3.4 | 4.8 | 0.4 (0.54) | 6SL3210-5FE10-4U | 0 | FSA | 4 x 1.5 | 6FX3002-5CL02-1 | 0 | 6FX3002-2CT12-1 | 0 | 6FX3002-2DB10-1 | 0 | 6FX3002-5BL03-1 | 0 | 6FX2003-0LL13 | 6FX2003-OSL13 | 6FX2003-0DB11 | 6FX2003-0LL53 | 3 AC 380 ... 480 5 | 6SL3203-0BE15-0VA0 | 6 | 3NA3801-6 | 10 | Listed JDDZ | 3RV2021-1DA10 | | | | |
| 4000 | 0.75 (1.02) | 3.5 | 2.39 | 7.2 | 2.1 | 6.3 | | 1.2 | 5.2 | 5.7 | | 5.2 | 6.6 | 0.75 (1.02) | 6SL3210-5FE10-8U | 0 | FSA | | | | | | | | | | | | | | | | | | | | | | | | |
| Shaft height 65 – Rated speed n_{rated} 2000 rpm | | | | | | | | | | | | | | Line supply 380 ... 480 V 3 AC | | | | | | | | | | | | | | | | | | | | | | | | | | | |
| 3000 | 0.75 (1.02) | 4 | 3.58 | 10.7 | 2.5 | 7.5 | | 1.5 | 8 | 9.1 | 5x | 5.7 | 8.8 | 1 (1.36) | 6SL3210-5FE11-0U | 0 | FSA | 4 x 1.5 | 6FX3002-5CL02-1 | 0 | 6FX3002-2CT12-1 | 0 | 6FX3002-2DB10-1 | 0 | 6FX3002-5BL03-1 | 0 | 6FX2003-0LL13 | 6FX2003-OSL13 | 6FX2003-0DB11 | 6FX2003-0LL53 | 3 AC 380 ... 480 5 | 6SL3203-0BE15-0VA0 | 10 | 3NA3803-6 | 10 | Listed JDDZ | 3RV2021-1FA10 | | | | |
| 3000 | 1 (1.36) | 6 | 4.78 | 14.3 | 3 | 9 | | 1.7 | 11.7 | 13.5 | | 7 | 10.1 | | | | | | | | | | | | | | | | | | | | | | | | | | | | |
| 3000 | 1.5 (2.04) | 8 | 7.16 | 21.5 | 4.6 | 13.8 | | 1.6 | 15.3 | 16.4 | | 8.4 | 11.5 | 1.75 (2.38) | 6SL3210-5FE11-5U | 0 | FSB | 4 x 2.5 | 6FX3002-5CL12-1 | 0 | | | | | | | | | | | | | | | | | | | | | |
| 3000 | 1.75 (2.38) | 11 | 8.36 | 25.1 | 5.3 | 15.9 | | 1.7 | 22.6 | 23.7 | | 11.1 | 14.2 | | | | | | | | | | | | | | | | | | | | | | | | | | | | |
| 3000 | 2 (2.72) | 15 | 9.55 | 28.7 | 5.9 | 17.7 | | 1.7 | 29.9 | 31 | | 13.7 | 16.8 | 2.5 (3.40) | 6SL3210-5FE12-0U | 0 | | | | | | | | | | | | | | | | | | | | | | | | | |
| Shaft height 90 – Rated speed n_{rated} 2000 rpm | | | | | | | | | | | | | | Line supply 380 ... 480 V 3 AC | | | | | | | | | | | | | | | | | | | | | | | | | | | |
| 3000 | 2.5 (3.40) | 15 | 11.9 | 35.7 | 7.8 | 23.4 | | 1.6 | 47.4 | 56.3 | 5x | 15.4 | 21.5 | 2.5 (3.40) | 6SL3210-5FE12-0U | 0 | FSB | 4 x 2.5 | 6FX3002-5CL12-1 | 0 | 6FX3002-2CT12-1 | 0 | 6FX3002-2DB10-1 | 0 | 6FX3002-5BL03-1 | 0 | 6FX2003-0LL13 | 6FX2003-OSL13 | 6FX2003-0DB11 | 6FX2003-0LL53 | 3 AC 380 ... 480 12 | 6SL3203-0BE21-2VA0 | 16 | 3NA3805-6 | 15 | Listed JDDZ | 3RV2021-4AA10 | | | | |
| 3000 | 3.5 (4.76) | 22 | 16.7 | 50 | 11 | 33 | | 1.6 | 69.1 | 77.9 | | 19.8 | 25.9 | 3.5 (4.76) | 6SL3210-5FE13-5U | 0 | FSC | | | | | | | | | | | | | | | | | | | | | | | | |
| 2500 | 5 (6.80) | 30 | 23.9 | 70 | 12.6 | 36.9 | | 2.0 | 90.8 | 99.7 | | 24.4 | 30.5 | 5 (6.80) | 6SL3210-5FE15-0U | 0 | | | | | | | | | | | | | | | | | | | | | | | | | |
| 2000 | 7 (9.52) | 40 | 33.4 | 90 | 13.2 | 35.6 | | 2.7 | 134.3 | 143.2 | | 33.3 | 39.3 | 7 (9.52) | 6SL3210-5FE17-0U | 0 | | | | | | | | | | | | | | | | | | | | | | | | | |

Detailed information on SINAMICS V90 is available on the Internet at: www.siemens.com/sinamics-v90

In addition, the Drive Technology Configurator (DT Configurator) can be used on the Internet: www.siemens.com/dt-configurator

¹⁾ Rated torque, rated power and maximum torque listed in the table above allow for a production tolerance of 10 %.

²⁾ Motor weight with incremental encoder.

System overview

SINAMICS V90 basic servo drive system

Accessories

Connecting cables and connectors for SIMATIC S7 controller

| For SINAMICS V90 pulse train (PTI) version | | For SINAMICS V90 PROFINET (PN) version | |
|---|---------------------------|---|---------------------------|
| Description | Article No. | Description | Article No. |
| Setpoint cable with connector (MDR 50-pin connector, free pins to controller side), length: 1 m | 6SL3260-4NA00-1VB0 | I/O cable with 20-pin MDR connector (free pins to controller side), length: 1 m | 6SL3260-4MA00-1VB0 |
| Setpoint cable with connectors on both sides and separate terminal block (MDR 50-pin connector, terminal block to controller side), length: 0,5 m | 6SL3260-4NA00-1VA5 | Connector for I/O cable, 20-pin | 6SL3260-2MA00-0VA0 |
| 50-pin MDR connector for setpoint cable | 6SL3260-2NA00-0VA0 | Pre-assembled PROFINET cable with two RJ45 180° plugs, length: 1 m | 6XV1871-5BH10 |
| | | RJ45 data plug-in connector with 180° (straight) cable outlet | 6GK1901-1BB10-2AA0 |
| | | Standard PROFINET cable, 4-core, sold by the meter, not assembled | 6XV1840-2AH10 |

For further information about PROFINET cables refer to Catalog IK PI or on the Internet at:
www.siemens.com/simatic-net

Requirements for external braking resistor

When the internal braking resistor is not sufficient, select a standard braking resistor according to the table.

| Frame size | Resistance Ω | Max. power kW | Rated power W | Max. energy kJ |
|---|------------------------|------------------|------------------|-------------------|
| Line voltage 200 ... 240 V 1 AC/3 AC | | | | |
| FSA, 0,2 kW | 150 | 1.09 | 20 | 0.8 |
| FSB | 100 | 1.64 | 21 | 1.23 |
| FSC | 50 | 3.28 | 62 | 2.46 |
| FSD, 1 kW | 50 | 3.28 | 62 | 2.46 |
| FSD, 1.5 ... 2 kW | 25 | 6.56 | 123 | 4.92 |
| Line voltage 380 ... 480 V 3 AC | | | | |
| FSAA | 533 | 1.2 | 30 | 2.4 |
| FSA | 160 | 4 | 100 | 8.0 |
| FSB | 70 | 9.1 | 229 | 18.3 |
| FSC | 27 | 23.7 | 1185 | 189.6 |

Supplementary system components

| Description | Article No. |
|--|---------------------------|
| SINAMICS SD card, 512 MB for SINAMICS V90 400 V version | 6SL3054-4AG00-2AA0 |
| Replacement connector kit for SINAMICS V90 400 V version FSAA | 6SL3200-0WT00-0AA0 |
| Replacement connector kit for SINAMICS V90 400 V version FSA | 6SL3200-0WT01-0AA0 |
| Replacement connector kit for SINAMICS V90 200 V version FSA and FSB | 6SL3200-0WT02-0AA0 |
| Replacement connector kit for SINAMICS V90 200 V version FSC and FSD | 6SL3200-0WT03-0AA0 |
| Replacement fan for SINAMICS V90 200 V version FSD and 400 V version FSB | 6SL3200-0WF00-0AA0 |
| Replacement fan for SINAMICS V90 400 V version FSC | 6SL3200-0WF01-0AA0 |

SINAMICS V90 Starter Kit

| Description | Article No. |
|---|---------------------------|
| Starter Kit – SINAMICS V90 with SIMOTICS S-1FL6 Low Inertia | 6SL3200-0AE40-0AA0 |

SINAMICS V90 training case

| Description | Article No. |
|--|---------------------------|
| SINAMICS V90 training case 1-axis pulse train (PTI) version consisting of 1 x servo drive SINAMICS V90 pulse train (PTI) version, 1 x servomotor SIMOTICS S-1FL6 Low Inertia and 1 x controller SIMATIC S7-12000 | 6AG1067-2AA00-0AC0 |
| SINAMICS V90 training case 1-axis pulse train (PTI) version consisting of 1 x servo drive SINAMICS V90 pulse train (PTI) version and 1 x servomotor SIMOTICS S-1FL6 High Inertia | 6AG1067-3AA00-0AB0 |
| SINAMICS V90 training case 2-axis PROFINET (PN) version consisting of 2 x servo drive SINAMICS V90 PROFINET (PN) version and 2 x servomotor SIMOTICS S-1FL6 Low Inertia | 6AG1067-1AA32-0AA0 |

Function

Optimized servo performance - quick, smooth and precise positioning

Advanced one-button tuning and real-time auto tuning

Control loop parameters are optimized automatically. One-button tuning can be used when commissioning. This allows machines to achieve a high dynamic performance and smooth operation in a wide range of applications.

Automatic suppression of machine resonances

When this function is activated the drive identifies mechanical resonance frequencies and automatically suppresses these using a filter. Vibration and noise during operation are reduced. This ensures a high dynamic response of the machine while decreasing machine vibration levels.

Sufficient encoder resolution and high data transfer rates

The encoder is available up to 21-bit resolution (approx. 2.1 billion pulses per motor rotation).

Fast data transfer:

- Signaling rate up to 1 MHz (pulse train version)
- 100 Mbit/s transfer rate (PROFINET version)

This allows machines to achieve a high positioning accuracy with low speed ripple.

Optimized system performance

Fast acceleration and braking while maintaining smooth operation to ensure high machine productivity.

- 300 % overload capability of drive and motor
- Low motor torque ripple
- Motor and drive are perfectly harmonized

Reliable operation - Robust design and safe choice

Suitable for harsh environments

- Wide range of line voltages
 - 200 V ... 240 V 1 AC/3 AC (-15 %/+10 %)
 - 380 V ... 480 V 3 AC, (-15 %/+10 %)
- Coated PCB increases robustness of the drive to cope with harsh environments
- Motor is equipped with high-quality bearings

High degree of motor protection

- SIMOTICS S-1FL6 servomotors have degree of protection IP65 as standard
- Oil seal at shaft end as standard
- High-quality metal motor connector (SIMOTICS S-1FL6 High Inertia servomotors)

Integrated safety function STO (safe torque off)

The STO function is a standard feature of all SINAMICS V90 servo drives. This function prevents the motor from moving unexpectedly and complies with safety standard SIL 2 according to EN 61508 resp. PL d, Cat 3 according to EN ISO 13849. This safety functionality can be realized without additional components (activation only via terminals of SINAMICS V90, not supported via PROFINET/PROFIsafe).

Complete motion control solutions from Siemens

SINAMICS V90 System and SIMATIC – Siemens offers comprehensive solutions from a single source for general motion control applications with different SINAMICS application examples.

Siemens application examples comprise the following:

- Ready-to-run application example including wiring diagram and parameter description
- Sample configuration to connect SINAMICS V90 drives to the appropriate SIMATIC controller – this includes hardware and software, a corresponding wiring example, installation instructions for the S7 project provided, drive parameterization and a HMI sample project

Benefits for the customer:

- An operational project is configured properly
- A motor is quickly made operational
- Basis for a customer-specific configuration
- TIA advantages are optimally leveraged

Can be downloaded free of charge via the Online Support Portal:

<https://siemens.com/sinamics-applications>

System overview

SINAMICS V90 basic servo drive system

Configuration

The following electronic configuring aids and engineering tools are available for the SINAMICS V90 basic servo drive system:

Drive Technology Configurator (DT Configurator) within the Catalog CA 01

The Interactive Catalog CA 01 – the offline Industry Mall of Siemens – contains over 100 000 products with approximately 5 million possible drive system product variants. The Drive Technology Configurator (DT Configurator) has been developed to facilitate selection of the correct motor and/or converter from the wide spectrum of drives. It is integrated as a selection tool in Catalog CA 01.

Online DT Configurator

In addition, the DT Configurator can be used on the Internet without requiring any installation. The DT Configurator can be found in the Siemens Industry Mall at the following address:

www.siemens.com/dt-configurator

SINAMICS V-ASSISTANT – Easy-to-use engineering tool for commissioning and diagnostics

A PC with installed SINAMICS V-ASSISTANT software tool can be connected to SINAMICS V90 via a standard USB port. It is used for setting parameters, test operation, troubleshooting – and has powerful monitoring functions.

SINAMICS V-ASSISTANT can be downloaded free of charge from the SINAMICS V90 Internet page:

<https://siemens.com/sinamics-v90>

You can find further information about the SINAMICS V-ASSISTANT in the Engineering tools section.

Technical specifications

General technical specifications

SINAMICS V90 servo drive system 200 V ... 240 V 1 AC/3 AC Low Inertia for high dynamic performance

| SINAMICS V90 servo drive | |
|---|--|
| Line supply and power | 200 V ... 240 V 1 AC (–15 % / +10 %), 0.05 kW ... 0.75 kW 200 V ... 240 V 3 AC (–15 % / +10 %), 0.05 kW ... 2 kW |
| Control mode Pulse train (PTI) version | Positioning with pulse train, internal positioning, speed, torque |
| Control mode PROFINET (PN) version | Speed control, basic positioner control (EPos) |
| Degree of protection | IP20 |
| SIMOTICS S-1FL6 servomotors | |
| Shaft height | 20, 30, 40, 50 |
| Rated torque | 0.16 ... 6.37 Nm |
| Rated speed | 3000 rpm |
| Max. speed | 5000 rpm |
| Encoder | <ul style="list-style-type: none"> Incremental encoder TTL 2500 S/R ¹⁾; Absolute encoder 21-bit single-turn |
| Degree of protection | IP65, natural cooling |

SINAMICS V90 servo drive system 380 V ... 480 V 3 AC High Inertia for smooth operational performance

| SINAMICS V90 servo drive | |
|---|--|
| Line supply and power | 380 V ... 480 V 3 AC (–15 % / +10 %), 0.4 kW ... 7 kW |
| Control mode Pulse train (PTI) version | Positioning with pulse train, internal positioning, speed, torque |
| Control mode PROFINET (PN) version | Speed control, basic positioner control (EPos) |
| Degree of protection | IP20 |
| SIMOTICS S-1FL6 servomotors | |
| Shaft height | 45, 65, 90 |
| Rated torque | 1.27 ... 33.40 Nm |
| Rated speed | 2000 rpm / 3000 rpm |
| Max. speed | 4000 rpm |
| Encoder | <ul style="list-style-type: none"> Incremental encoder TTL 2500 S/R; Absolute encoder 20-bit + 12-bit multi-turn |
| Degree of protection | IP65, natural cooling |

More information

Detailed information on SINAMICS V90, the latest technical documentation (brochures, dimension drawings, certificates, manuals and operating instructions) is available on the Internet at:

www.siemens.com/sinamics-v90

In addition, the Drive Technology Configurator (DT Configurator) can be used on the Internet. The DT Configurator can be found in the Siemens Industry Mall at the following address:

www.siemens.com/dt-configurator

¹⁾ For very low speed, high accuracy or high dynamic application TTL encoder is not recommended.

Integration

Pulse train version (PTI)

- RS485 interface for Modbus RTU/USS to communicate with a PLC

PROFINET version (PN)

- 2 RJ45 connectors for PROFINET communication with a PLC

Status indicator

- RDY indicates servo ready/alarm state
- COM indicates communication with PC

Standard mini USB socket

- To connect a PC with engineering

Integrated operator panel

- 6 digits, 7-segment LED
- 5 buttons

SD card slot

- To copy parameters
- Standard SD card slot (SINAMICS V90, 400 V version)
- Micro SD card slot (SINAMICS V90, 200 V version)

High-quality connectors

Safe Torque Off

Motor holding brake

(only SINAMICS V90, 400 V version)

Control/status interface

Pulse train version (PTI) Setpoint interface

- 50 pins
- Pulse train input
- Encoder emulation pulse output
- DI/DO, AI/AO
- Motor holding brake¹⁾ (only SINAMICS V90, 200 V version)

Braking resistor

- If the internal braking resistor is not sufficient, disconnect DCP and R2, then connect DCP and R1 with an external braking resistor

PROFINET version (PN) I/O interface

- 20 pins
- DI/DO
- Motor holding brake¹⁾ (only SINAMICS V90, 200 V version)

Shield plate

- Easy shield connection to cables and improved EMC behavior

Motor encoder connector

¹⁾ Motor holding brake signal (only SINAMICS V90, 200 V version). The SINAMICS V90, 200 V version requires an external relay to connect the motor holding brake.

G_D011_EN_00499a

SIMOTICS S-1FL6, High Inertia

- High-quality metal connector
- IP65 degree of protection standard for all motors
- High-quality bearings
- High-wear-resistant oil seal material
- Shaft sleeve protection

G_D011_EN_00479b

SIMOTICS S-1FL6, Low Inertia

- Compact cable connection
- IP65 degree of protection standard for all motors
- High-quality bearings
- High-wear-resistant oil seal material

G_D011_EN_00482b

System overview

SINAMICS V90 basic servo drive system

Integration (continued)

System connection diagram for SINAMICS V90 pulse train version

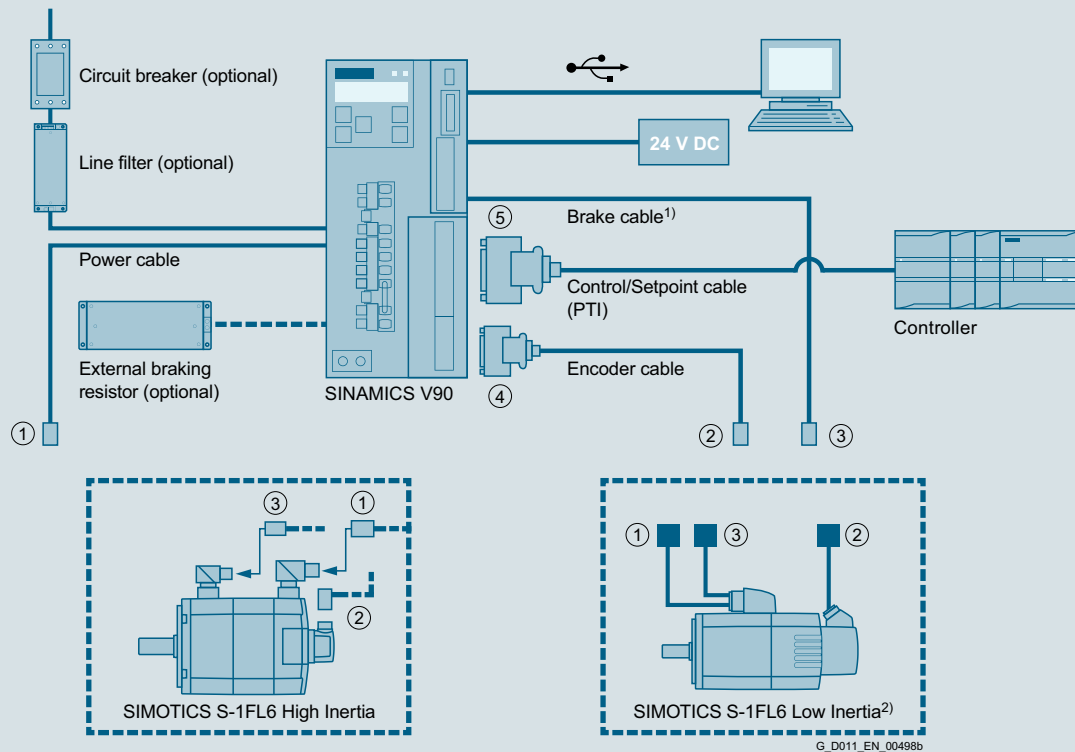

¹⁾ Brake cable connection shown here is for SINAMICS V90 400 V version only. The SINAMICS V90 200 V version requires an external relay to connect the motor brake cable. The relay has to be connected via the setpoint cable for the SINAMICS V90 pulse train version. For more information, refer to the SINAMICS V90 operating instructions.

²⁾ SIMOTICS S-1FL6 Low Inertia servomotors in shaft heights 20/30/40 use outlet connection concept with pre-mounted cable end and plastic connection plug-in system.

- ① Power connector (motor side)
- ② Encoder connector (motor side)
- ③ Brake connector (motor side)
- ④ Encoder connector (drive side)
- ⑤ Setpoint connector

Integration (continued)

System connection diagram for SINAMICS V90 PROFINET version

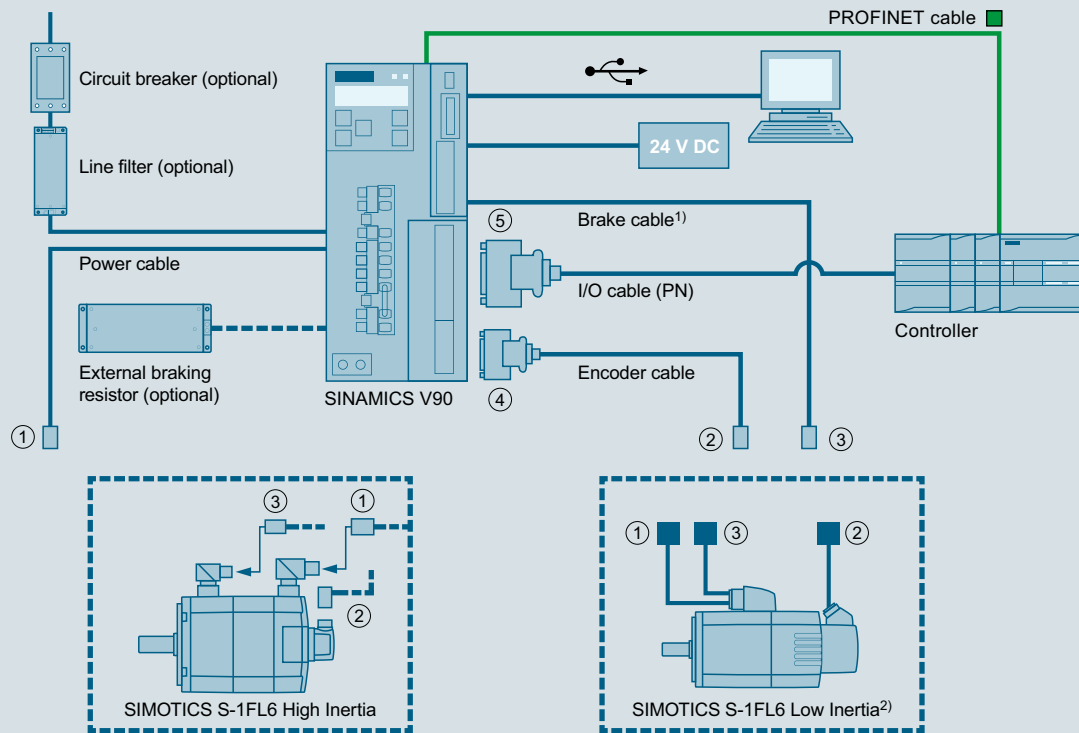

- ¹) Brake cable connection shown here is for SINAMICS V90 400 V version only. The SINAMICS V90 200 V version requires an external relay to connect the motor brake cable. The relay has to be connected via I/O cable for the SINAMICS V90 PROFINET version. For more information, refer to the SINAMICS V90 operating instructions.
- ²) SIMOTICS S-1FL6 Low Inertia servomotors in shaft heights 20/30/40 use outlet connection concept with pre-mounted cable end and plastic connection plug-in system.

- ① Power connector (motor side)
 ② Encoder connector (motor side)
 ③ Brake connector (motor side)
 ④ Encoder connector (drive side)
 ⑤ I/O connector

System overview

1

SINAMICS V90 Starter Kit

Overview

The SINAMICS V90 Starter Kit can be perfectly combined with the SIMATIC Starter Kits. This allows to quickly implement basic drive tasks through to Motion Control applications.

Benefits

- Easy entry in the world of SINAMICS drives
- The major components required for operation are already included
- One article number

Selection and ordering data

| Description | Article No. |
|--|---------------------------|
| SINAMICS V90 Starter Kit with SIMOTICS S-1FL6 Low Inertia Scope of delivery <ul style="list-style-type: none"> • SINAMICS V90 PROFINET version 0.4 kW frame size FSB without filter • SIMOTICS S-1FL6 0.4 kW, shaft height 30, TTL encoder, without brake • Power and signal cable, length: 3 m (9.84 ft) • I/O cable, length: 1 m (3.28 ft) | 6SL3200-0AE40-0AA0 |

Selection and ordering data

Recommended controller for SINAMICS V90 pulse train (PTI) version – pulse train (PTI), Modbus RTU or USS

| SIMATIC S7-1200 Basic Controller for SINAMICS V90 pulse train (PTI) version | | | | | | | |
|---|-----------------------|----------------|-----------------|--|-------------|--------------------|---------------------------|
| Compact CPU expandable with Signal board or communication board | Communication modules | Signal Modules | Digital outputs | of which high-speed outputs (Pulse Train Output) | Work memory | CPU | Article No. |
| 1 | 3 | – | 4 | 4 (100 kHz) | 50 KB | CPU 1211C DC/DC/DC | 6ES7211-1AE40-0XB0 |
| | | 2 | 6 | 4 (100 kHz) | 75 KB | CPU 1212C DC/DC/DC | 6ES7212-1AE40-0XB0 |
| | | 8 | 10 | 4 (100 kHz) | 100 KB | CPU 1214C DC/DC/DC | 6ES7214-1AG40-0XB0 |
| | | | | | 125 KB | CPU 1215C DC/DC/DC | 6ES7215-1AG40-0XB0 |
| | | | | | 4 (1 MHz) | 150 KB | CPU 1217C DC/DC/DC |

One SIMATIC S7-1200 CPU can control up to 4 SINAMICS V90 axes. Each axis requires 2 high-speed digital outputs for the pulse train interface. The SIMATIC S7-1500 compact CPUs can also be connected to SINAMICS V90 via “pulse train”.

| Expansion for Modbus RTU and USS | | | Expansion for control of more than 2 axes | | | |
|---|---------|---------------------------|--|---------------|---------|---------------------------|
| For serial data exchange via point-to-point connection | | | Signal boards, 0.1 A, 200 kHz, can be plugged directly into the CPU. One axis requires 2 high-speed digital outputs for controlling. | | | |
| Designation | Type | Article No. | Digital outputs | Input voltage | Type | Article No. |
| Communication Board RS485, can be plugged directly into the CPU | CB 1241 | 6ES7241-1CH30-1XB0 | 2 | 5 V DC | SB 1223 | 6ES7223-3AD30-0XB0 |
| | | | | 24 V DC | | 6ES7223-3BD30-0XB0 |
| Communication Module RS422/RS485 | CM 1241 | 6ES7241-1CH32-0XB0 | 4 | 5 V DC | SB 1222 | 6ES7222-1AD30-0XB0 |
| | | | | 24 V DC | | 6ES7222-1BD30-0XB0 |

Recommended controller for SINAMICS V90 PROFINET (PN) version

| Version | Integrated interfaces | PROFINET | PROFIBUS DP | CPU Processing times for bit operations | Max. number of axes | Work memory | CPU | Article No. |
|--|-------------------------------|----------|-------------|---|---------------------|-------------|--------------------|---------------------------|
| SIMATIC S7-1200 Basic Controller for SINAMICS V90 PROFINET (PN) version | | | | | | | | |
| Standard CPUs | 1 x PN IO | – | – | 85 ns | 2 | 50 KB | CPU 1211C DC/DC/DC | 6ES7211-1AE40-0XB0 |
| | | – | – | 85 ns | 2 | 75 KB | CPU 1212C DC/DC/DC | 6ES7212-1AE40-0XB0 |
| | | – | – | 85 ns | 2 | 100 KB | CPU 1214C DC/DC/DC | 6ES7214-1AG40-0XB0 |
| | 1 x PN IO (2-port switch) | – | – | 85 ns | 2 | 125 KB | CPU 1215C DC/DC/DC | 6ES7215-1AG40-0XB0 |
| | | – | – | 85 ns | 2 | 150 KB | CPU 1217C DC/DC/DC | 6ES7217-1AG40-0XB0 |
| SIMATIC S7-1500 Advanced Controller for SINAMICS V90 PROFINET (PN) version | | | | | | | | |
| Standard CPUs | 1 x PN IO IRT (2-port switch) | – | – | 60 ns | 10 | 150 KB | CPU 1511-1 PN | 6ES7511-1AK02-0AB0 |
| | | – | – | 40 ns | 10 | 300 KB | CPU 1513-1 PN | 6ES7513-1AL02-0AB0 |
| | | 1 x PN | – | 30 ns | 30 | 500 KB | CPU 1515-2 PN | 6ES7515-2AM01-0AB0 |
| | | 1 x PN | 1 x DP | 10 ns | 30 | 1 MB | CPU 1516-3 PN/DP | 6ES7516-3AN01-0AB0 |
| | | 1 x PN | 1 x DP | 2 ns | 96 | 2 MB | CPU 1517-3 PN/DP | 6ES7517-3AP00-0AB0 |
| | | 2 x PN | 1 x DP | 1 ns | 128 | 4 MB | CPU 1518-4 PN/DP | 6ES7518-4AP00-0AB0 |
| Compact CPUs | 1 x PN IO IRT (2-port switch) | – | – | 60 ns | 10 | 175 KB | CPU 1511C-1 PN | 6ES7511-1CK01-0AB0 |
| | | – | – | 48 ns | 10 | 250 KB | CPU 1512C-1 PN | 6ES7512-1CK01-0AB0 |
| Technology CPUs | 1 x PN IO IRT (2-port switch) | – | – | 60 ns | 10 | 225 KB | CPU 1511T-1 PN | 6ES7511-1TK01-0AB0 |
| | | 1 x PN | – | 30 ns | 30 | 750 KB | CPU 1515T-2 PN | 6ES7515-2TM01-0AB0 |
| | | 1 x PN | 1 x DP | 10 ns | 80 | 1.5 MB | CPU 1516T-3 PN/DP | 6ES7516-3TN00-0AB0 |
| | | 1 x PN | 1 x DP | 2 ns | 128 | 3 MB | CPU 1517T-3 PN/DP | 6ES7517-3TP00-0AB0 |
| Fail-safe CPUs | 1 x PN IO IRT (2-port switch) | – | – | 60 ns | 10 | 225 KB | CPU 1511F-1 PN | 6ES7511-1FK02-0AB0 |
| | | – | – | 40 ns | 10 | 450 KB | CPU 1513F-1 PN | 6ES7513-1FL02-0AB0 |
| | | 1 x PN | – | 30 ns | 30 | 750 KB | CPU 1515F-2 PN | 6ES7515-2FM01-0AB0 |
| | | 1 x PN | 1 x DP | 10 ns | 30 | 1.5 MB | CPU 1516F-3 PN/DP | 6ES7516-3FN01-0AB0 |
| | | 1 x PN | 1 x DP | 2 ns | 96 | 3 MB | CPU 1517F-3 PN/DP | 6ES7517-3FP00-0AB0 |
| | | 2 x PN | 1 x DP | 1 ns | 128 | 6 MB | CPU 1518F-4 PN/DP | 6ES7518-4FP00-0AB0 |
| Fail-safe Technology CPUs | 1 x PN IO IRT (2-port switch) | – | – | 60 ns | 10 | 225 KB | CPU 1511TF-1 PN | 6ES7511-1UK01-0AB0 |
| | | 1 x PN | – | 30 ns | 14 | 750 KB | CPU 1515TF-2 PN | 6ES7515-2UM01-0AB0 |
| | | 1 x PN | 1 x DP | 10 ns | 80 | 1.5 MB | CPU 1516TF-3 PN/DP | 6ES7516-3UN00-0AB0 |
| | | 1 x PN | 1 x DP | 2 ns | 128 | 3 MB | CPU 1517TF-3 PN/DP | 6ES7517-3UP00-0AB0 |

For SINAMICS V90 PROFINET (PN) version, the AC/DC/RLY and DC/DC/RLY versions of SIMATIC S7-1200 are also possible (CPU 1211C, CPU 1212C, CPU 1214C and CPU 1215C).

SINAMICS V90 as a PROFINET I/O device with PROFIdrive supports technology objects and function blocks of SIMATIC S7-1200, SIMATIC S7-1500 and SIMATIC S7-1500 Technology CPU for speed and positioning control.

For further information about SIMATIC controllers please refer to Catalog ST 70 or to web page: www.siemens.com/simatic-controller

System overview

Notes

1

SINAMICS V90 servo drive



| | |
|-------------|---|
| 2/2 | SINAMICS V90 servo drive |
| 2/2 | Overview |
| 2/2 | Benefits |
| 2/3 | Function |
| 2/4 | Integration |
| 2/5 | Technical specifications |
| 2/7 | Dimensional drawings |
| 2/10 | Line filters |
| 2/10 | Overview |
| 2/10 | Recommended line-side overcurrent protection devices |
| 2/10 | Overview |
| 2/10 | External braking resistor |
| 2/10 | Overview |
| 2/10 | Connecting cables for SIMATIC S7 controller |
| 2/10 | Overview |
| 2/10 | Supplementary system components |
| 2/10 | Overview |

For **Selection and Ordering Data** please refer to section "System overview" "SINAMICS V90 basic servo drive system" from page 1/9.

Detailed technical information on SINAMICS V90 is available on the Internet at:
www.siemens.com/sinamics-v90/documentation

In addition, the Drive Technology Configurator (DT Configurator) can be used on the Internet at the following address:
www.siemens.com/dt-configurator

SINAMICS V90 servo drive

SINAMICS V90 servo drive

Overview

SINAMICS V90 - optimized servo drive solution for motion control applications



SINAMICS V90 servo drive, 200 ... 240 V 1 AC/3 AC, frame sizes FSA, FSB, FSC and FSD

SINAMICS V90 servo drive

SINAMICS V90 can be integrated into a wide range of applications, either using the pulse train version (pulse/direction, analog, USS/Modbus RTU) or the PROFINET version.

The SINAMICS V90 pulse train version features internal positioning, positioning with pulse train as well as speed and torque control modes.

The SINAMICS V90 PROFINET version supports PROFINET for linking the drive to an automation system via PROFIdrive profile.



SINAMICS V90 servo drive, 380 ... 480 V 3 AC, frame sizes FSA, FSB and FSC

With integrated real-time auto tuning and automatic suppression of machine resonances, the system automatically optimizes itself to achieve high dynamic performance and smooth operation.

For Selection and Ordering Data please refer to section "System overview" "SINAMICS V90 basic servo drive system" from page 1/9.

Benefits

Optimized servo performance

- Advanced one-button tuning and real-time auto tuning enable machines to achieve a high dynamic performance
- Automatic suppression of machine resonances
- 1 MHz high-frequency pulse train input
- Different encoder types to address the requirements of your applications

Cost-effective

- Integrated control modes: Pulse train positioning, internal positioning with traversing block or Modbus, speed and torque control modes
- Integrated internal positioning function
- Integrated braking resistor in all frame sizes with max. motor power ≥ 0.2 kW
- Integrated holding brake switch (for the 400 V version), no external relay necessary

Easy to use

- Simple connection to a control system
- Easy, all from a single source
- Easy servo tuning and machine optimization
- Easy commissioning with SINAMICS V-ASSISTANT
- Parameter cloning
- Easy integration via PTI, PROFINET, USS, Modbus RTU

Reliable operation

- High-quality motor bearings
- All motors have IP65 degree of protection and are equipped with oil seal
- Integrated safe torque off (STO)

Function

| | | SINAMICS V90 Pulse train version (PTI) | SINAMICS V90 PROFINET version (PN) |
|--|---|--|---|
| Control modes | | | |
| Control modes | | <ul style="list-style-type: none"> Pulse train input position control (PTI) Internal position control (IPos), setpoints selected using a combination of digital inputs, or Modbus/US\$ Speed control (S) Torque control (T) Compound controls, switches between position control, speed control, and torque control Jog using buttons on the integrated operator panel | <ul style="list-style-type: none"> Speed control mode: position and speed control in combination with a motion function (TO axis) of SIMATIC S7-1500/S7-1200 and PROFINET Basic positioner control (EPos) |
| Speed control | Speed input | External analog input or internal speed setpoint | PROFINET or internal speed setpoint |
| | Torque limit | External analog input or set using a parameter | PROFINET or set using a parameter |
| Pulse train input position control | Max. pulse frequency | <ul style="list-style-type: none"> Differential line driver (5 V), 1 MHz Optical coupler (24 V), 200 kHz | – |
| | Multiplying factor | Electronic gear ratio (A/B), A:1-65535, B:1-65535, 1/50<A/B<200 | – |
| | Torque limit | External analog input or set using a parameter | – |
| Torque control mode | Torque input | External analog input or internal torque setpoint | – |
| | Speed limit | Prevents speed limits from being violated, set using a parameter for analog input | Set using a parameter |
| Control features | | | |
| Real time auto tuning | Estimates the machine characteristic and sets the closed-loop control parameters (gain, integral time, etc.) continuously in real time without any user intervention | | |
| Resonance suppression | Suppresses mechanical resonance, such as workpiece and foundation vibration | | |
| One-button auto tuning | Estimates the machine load inertia and mechanical characteristics with internal movement command (pre-configured for SINAMICS V90) This feature can be initiated using the SINAMICS V-ASSISTANT engineering tool. | | |
| Gain switch and PI/P switch | Switches between gains or from PI to P control using an external signal or internal operating conditions | | |
| Torque limit | Limits motor speed using an external analog input or internal torque limit | Motor torque is internally limited | |
| Travel to fixed stop | Can be used to move an axis to a fixed stop at a specified torque without a signal fault | | |
| DI/DO parameterization | Freely assigns the control signals to digital inputs and digital outputs | | |
| External braking resistor | An external braking resistor can be used when the internal braking resistor is not capable of handling the regenerative energy. | | |
| Measure machine | The machine frequency characteristics are analyzed using SINAMICS V-ASSISTANT | | |
| Parameter cloning and Firmware update | Optionally via memory card <ul style="list-style-type: none"> For 400 V version: SD card; recommended SINAMICS SD card For 200 V version: Micro SD card Maximum supported capacity: 32 GB | | |
| Safety functions | Safe Torque Off (STO) via terminal, complies with safety standard SIL 2 according to EN 61508 resp. PL d, Cat 3 according to EN ISO 13849 (activation only via terminals of SINAMICS V90, not supported via PROFINET/PROFIsafe) | | |
| Basic Operator Panel (BOP) | Integrated, 6-digit/7-segment display, 5 buttons | | |
| Engineering PC tool | <ul style="list-style-type: none"> SINAMICS V-ASSISTANT engineering tool exclusively for SINAMICS V90 SINAMICS V90 in combination with S7-1500 and STEP 7 Professional engineering via TIA Portal V14 possible. | | |

SINAMICS V90 servo drive

SINAMICS V90 servo drive

Integration

2

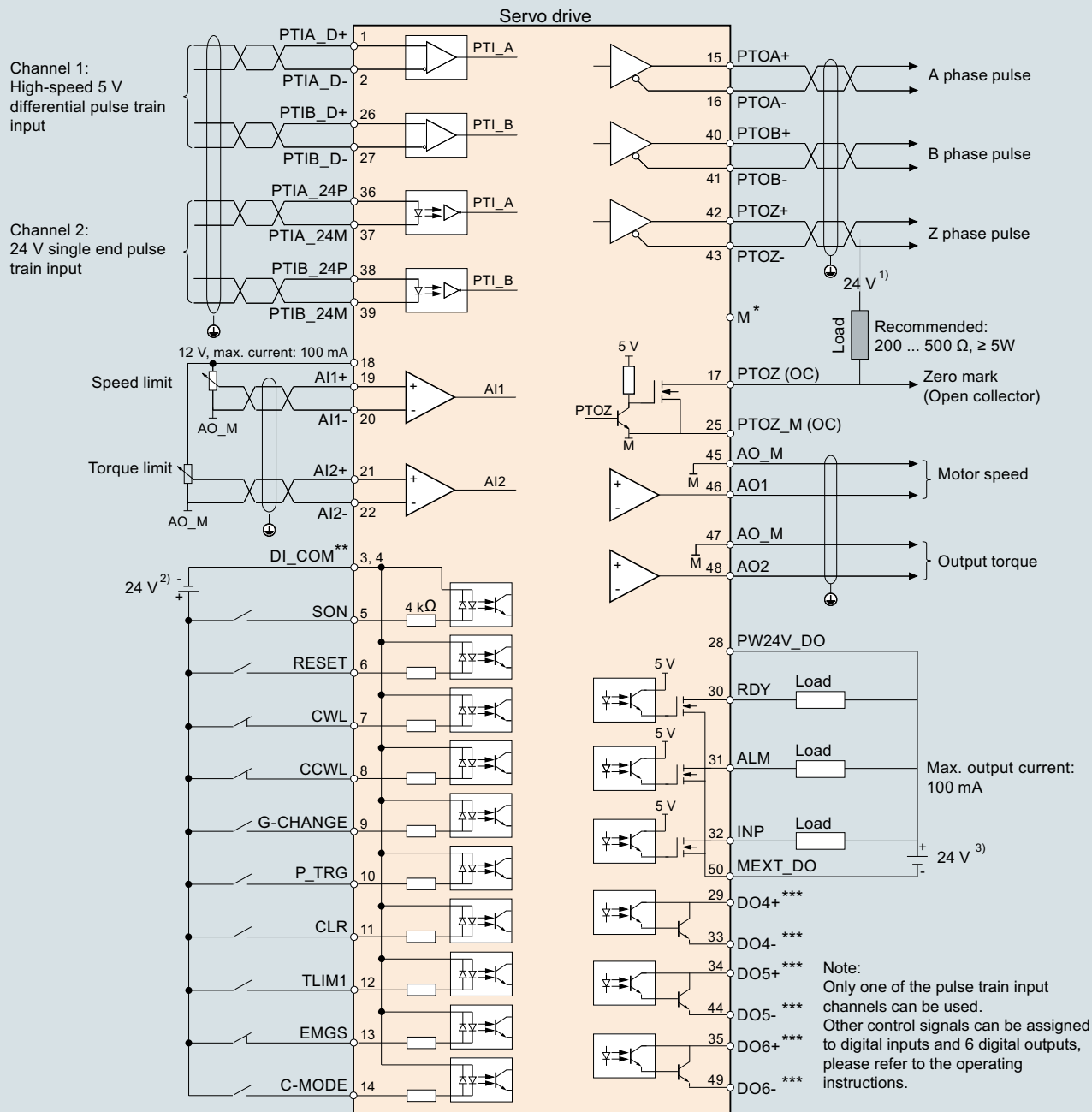

The 24 V power supplies in the connection diagram are as follows:

- 1) 24 V power supply for SINAMICS V90. All the PTO signals must be connected to the controller with the same 24 V power supply as SINAMICS V90.
- 2) Isolated digital input power supply. The controller power supply can be used.
- 3) Isolated digital output power supply. The controller power supply can be used.

Shielded cable

Twisted-pair wires

* PTO and PTI_D reference ground, connected to the reference ground of the host controller.

** Digital inputs, supporting both the PNP and the NPN types.

*** Digital outputs, supporting both the PNP and the NPN types.

For detailed information, please refer to the operating instructions.

G_D011_EN_00463b

Standard wiring for pulse train input (PTI) position control mode (for detailed information and connection diagram for other control modes, please refer to the operating instructions). The diagram is given as a reference for selecting the drive type.

When commissioning the selected servo drive system, establish the wiring connections according to the connection diagram and the instructions provided in the operating instructions.

Technical specifications

General technical specifications

| SINAMICS V90 servo drive | |
|------------------------------|---|
| Control power supply | |
| • Voltage | 24 V DC (-15 %/+20 %) When SINAMICS V90 controls a motor equipped with brake, the tolerance of the 24 V DC power supply must be -10 % to +10 % to comply with the voltage required by the brake. |
| • Current ¹⁾ | |
| -without holding brake | 1.6 A |
| -with holding brake | 1.6 A + rated current motor holding brake For more information please refer to section „SIMOTICS S-1FL6 servomotors“ „Technical Data“ from page 3/3. |
| Line supply system | TN, TT, IT, TT earthed line |
| Overload capacity | 300 % × rated current for 300 ms every 10 s |
| Control system | Servo control |
| Braking resistor | Integrated for all frame sizes with max. motor power ≥ 0.2 kW |
| Ambient temperature | |
| • Operation | 0 ... 45 °C (32 ... 113 °F) 45 ... 55 °C (113 ... 131 °F) with derating |
| • Storage | -40 ... +70 °C (-40 ... +158 °F) |
| Ambient humidity | |
| • Operation | <90 % (no condensation) |
| • Storage | 90 % (no condensation) |
| Pollution class | 2 |
| Vibration | |
| • Operation | Operational area II 10 Hz ... 58 Hz: 0.075 mm deflection 58 Hz ... 200 Hz: 1 g vibration |
| • Product packaging | 2 Hz ... 9 Hz: 3.5 mm deflection 9 Hz ... 200 Hz: 1 g vibration Quantity of cycles: 10 per axis Sweep speed: 1 octave/min |
| Shock | Operational area II Peak acceleration: 5 g, 30 ms; 15 g, 11 ms Quantity of shocks: 3 per direction × 6 directions Duration of shock: 1 s |
| Degree of protection | IP20 |
| Installation altitude | Up to 1000 m (3281 ft) above sea level without derating, > 1000 m ... 5000 m (> 3281 ft ... 16405 ft) with derating |
| Standards | CE, KC, EAC, cULus, RCM |

¹⁾ SINAMICS V90 PROFINET version requires a 24 V DC supply with max. 1.5 A (without a holding brake), or 3.5 A (with a holding brake). Refer to the operating instructions for detailed information.

SINAMICS V90 servo drive

SINAMICS V90 servo drive

Technical specifications (continued)

| Line voltage 200 ... 240 V 1 AC/3 AC | | SINAMICS V90 servo drive | | | | | | |
|---|---------------|---|---|---|---|--------------------------------------|--------------------------------------|--------------------------------------|
| Pulse train version: | 6SL3210-5F... | B10-1UA1 | B10-2UA1 | B10-4UA1 | B10-8UA0 | B11-0UA1 | B11-5UA0 | B12-0UA0 |
| PROFINET version: | 6SL3210-5F... | B10-1UF1 | B10-2UF1 | B10-4UF1 | B10-8UF0 | B11-0UF1 | B11-5UF0 | B12-0UF0 |
| Frame size | | FSA | FSA | FSB | FSC | FSD | FSD | FSD |
| Max. motor power | kW | 0.1 | 0.2 | 0.4 | 0.75 | 1 | 1.5 | 2 |
| Output current | | | | | | | | |
| • Rated current I_{rated} | A | 1.2 | 1.4 | 2.6 | 4.7 | 6.3 | 10.6 | 11.6 |
| • Max. current I_{max} | A | 3.6 | 4.2 | 7.8 | 14.1 | 18.9 | 31.8 | 34.8 |
| Line supply voltage | | 200 ... 240 V 1 AC/3 AC -15 %/+10 % | 200 ... 240 V 1 AC/3 AC -15 %/+10 % | 200 ... 240 V 1 AC/3 AC -15 %/+10 % | 200 ... 240 V 1 AC/3 AC -15 %/+10 % | 200 ... 240 V 3 AC -15 %/+10 % | 200 ... 240 V 3 AC -15 %/+10 % | 200 ... 240 V 3 AC -15 %/+10 % |
| Line frequency | Hz | 50/60 -10 %/+10 % | 50/60 -10 %/+10 % | 50/60 -10 %/+10 % | 50/60 -10 %/+10 % | 50/60 -10 %/+10 % | 50/60 -10 %/+10 % | 50/60 -10 %/+10 % |
| Line supply capacity | | | | | | | | |
| • 1 AC | kVA | 0.5 | 0.7 | 1.2 | 2 | – | – | – |
| • 3 AC | kVA | 0.5 | 0.7 | 1.1 | 1.9 | 2.7 | 4.2 | 4.6 |
| Cooling | | Natural cooling | Natural cooling | Natural cooling | Natural cooling | Fan cooling | Fan cooling | Fan cooling |
| Dimensions | | | | | | | | |
| • Width | mm (in) | 45 (1.77) | 45 (1.77) | 55 (2.17) | 80 (3.15) | 95 (3.74) | 95 (3.74) | 95 (3.74) |
| • Height | mm (in) | 170 (6.69) | 170 (6.69) | 170 (6.69) | 170 (6.69) | 170 (6.69) | 170 (6.69) | 170 (6.69) |
| • Depth | mm (in) | 170 (6.69) | 170 (6.69) | 170 (6.69) | 195 (7.68) | 195 (7.68) | 195 (7.68) | 195 (7.68) |
| Weight, approx. | kg (lb) | 1.07 (2.4) | 1.07 (2.4) | 1.20 (2.6) | 1.94 (4.3) | 2.49 (5.5) | 2.49 (5.5) | 2.49 (5.5) |

| Line voltage 380 ... 480 V 3 AC | | SINAMICS V90 servo drive | | | | | | | |
|------------------------------------|---------------|--------------------------------------|--------------------------------------|--------------------------------------|--------------------------------------|--------------------------------------|--------------------------------------|--------------------------------------|--------------------------------------|
| Pulse train version: | 6SL3210-5F... | E10-4UA0 | E10-8UA0 | E11-0UA0 | E11-5UA0 | E12-0UA0 | E13-5UA0 | E15-0UA0 | E17-0UA0 |
| PROFINET version: | 6SL3210-5F... | E10-4UF0 | E10-8UF0 | E11-0UF0 | E11-5UF0 | E12-0UF0 | E13-5UF0 | E15-0UF0 | E17-0UF0 |
| Frame size | | FSA | FSA | FSA | FSB | FSB | FSC | FSC | FSC |
| Max. motor power | kW | 0.4 | 0.75 | 1 | 1.75 | 2.5 | 3.5 | 5 | 7 |
| Output current | | | | | | | | | |
| • Rated current I_{rated} | A | 1.2 | 2.1 | 3 | 5.3 | 7.8 | 11 | 12.6 | 13.2 |
| • Max. current I_{max} | A | 3.6 | 6.3 | 9 | 15.9 | 23.4 | 33 | 37.8 | 39.6 |
| Line supply voltage | | 380 ... 480 V 3 AC -15 %/+10 % | 380 ... 480 V 3 AC -15 %/+10 % | 380 ... 480 V 3 AC -15 %/+10 % | 380 ... 480 V 3 AC -15 %/+10 % | 380 ... 480 V 3 AC -15 %/+10 % | 380 ... 480 V 3 AC -15 %/+10 % | 380 ... 480 V 3 AC -15 %/+10 % | 380 ... 480 V 3 AC -15 %/+10 % |
| Line frequency | Hz | 50/60 -10 %/+10 % | 50/60 -10 %/+10 % | 50/60 -10 %/+10 % | 50/60 -10 %/+10 % | 50/60 -10 %/+10 % | 50/60 -10 %/+10 % | 50/60 -10 %/+10 % | 50/60 -10 %/+10 % |
| Line supply capacity | kVA | 1.7 | 3 | 4.3 | 6.6 | 11.1 | 15.7 | 18 | 18.9 |
| Cooling | | Natural cooling | Natural cooling | Natural cooling | Natural cooling | Fan cooling | Fan cooling | Fan cooling | Fan cooling |
| Dimensions | | | | | | | | | |
| • Width | mm (in) | 60 (2.36) | 80 (3.15) | 80 (3.15) | 100 (3.94) | 100 (3.94) | 140 (5.51) | 140 (5.51) | 140 (5.51) |
| • Height | mm (in) | 180 (7.09) | 180 (7.09) | 180 (7.09) | 180 (7.09) | 180 (7.09) | 260 (10.24) | 260 (10.24) | 260 (10.24) |
| • Depth | mm (in) | 200 (7.87) | 200 (7.87) | 200 (7.87) | 220 (8.66) | 220 (8.66) | 240 (9.45) | 240 (9.45) | 240 (9.45) |
| Weight, approx. | kg (lb) | 1.45 (3.2) | 2.09 (4.6) | 2.09 (4.6) | 2.73 (6.0) | 2.73 (6.0) | 5.95 (13.1) | 5.95 (13.1) | 5.95 (13.1) |

| Interfaces | | SINAMICS V90 Pulse train version (PTI) | SINAMICS V90 PROFINET version (PN) |
|-----------------------------------|--|---|---|
| USB | | Mini USB | Mini USB |
| Pulse train input | | 2 channels, one exclusively for 5 V differential signal, one for 24 V single end signal | – |
| Pulse train encoder output | | 5 V differential signal, A, B, Z phase | – |
| Digital inputs/outputs | | 10 inputs, NPN/PNP; 6 outputs, NPN | 4 inputs, NPN/PNP; 2 outputs, NPN/PNP |
| Analog outputs | | 2 analog outputs, output voltage range ± 10 V, 10 bit | – |
| Communication | | USS/Modbus RTU (RS485) | PROFINET RT/IRT interface with 2 ports (RJ45 sockets) |
| SD card slot | | <ul style="list-style-type: none"> Standard SD card with 400 V version Micro SD card with 200 V version | <ul style="list-style-type: none"> Standard SD card with 400 V version Micro SD card with 200 V version |
| Safety functions | | Safe Torque Off (STO) via terminal, SIL 2 | Safe Torque Off (STO) via terminal, SIL 2 |

Dimensional drawings

Dimensions in mm

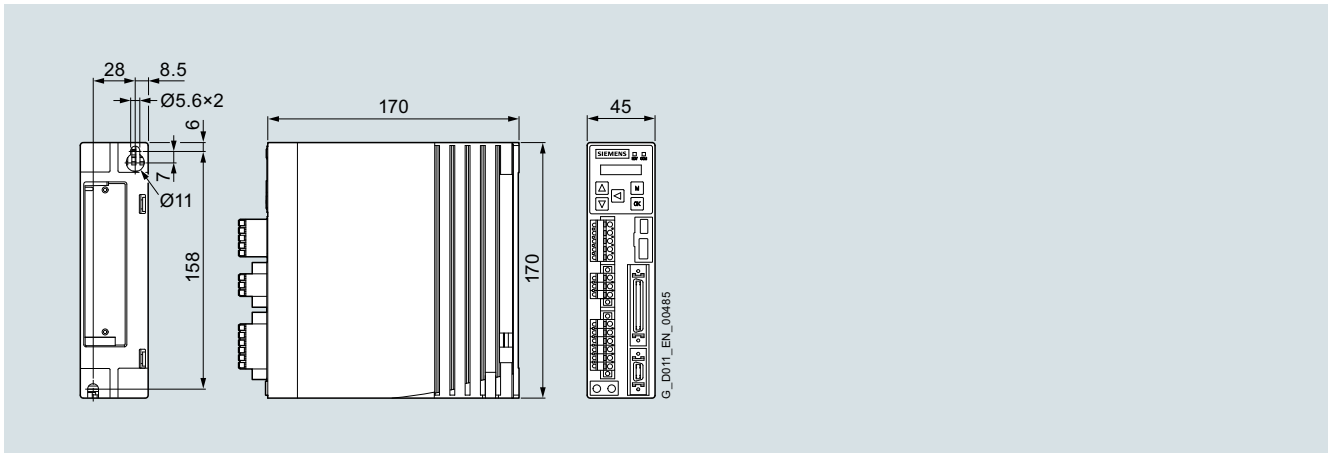

SINAMICS V90, 200 ... 240 V 1 AC/3 AC, frame size FSA

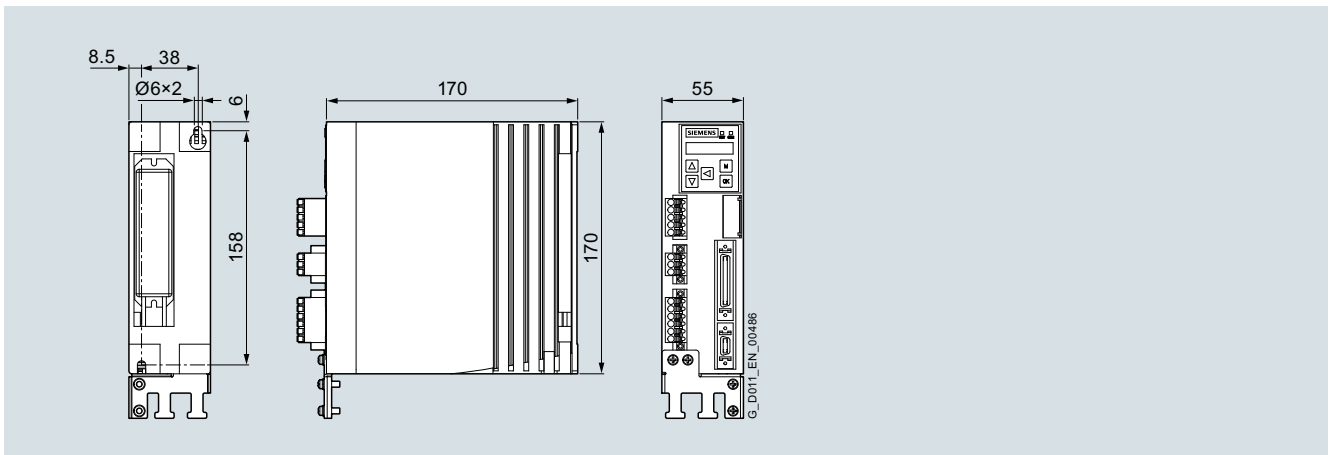

SINAMICS V90, 200 ... 240 V 1 AC/3 AC, frame size FSB

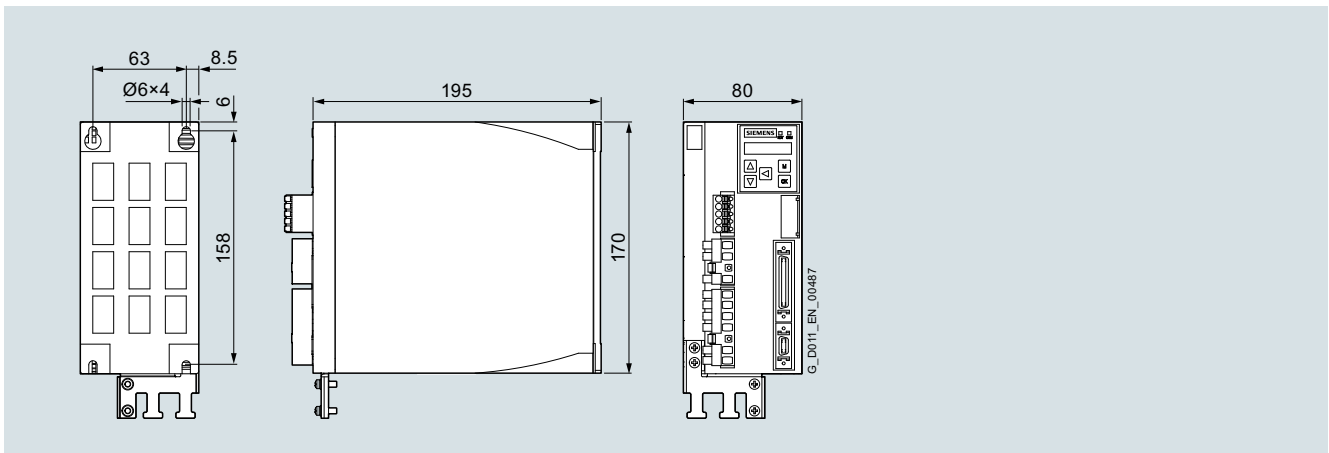

SINAMICS V90, 200 ... 240 V 1 AC/3 AC, frame size FSC

SINAMICS V90 servo drive

SINAMICS V90 servo drive

Dimensional drawings (continued)

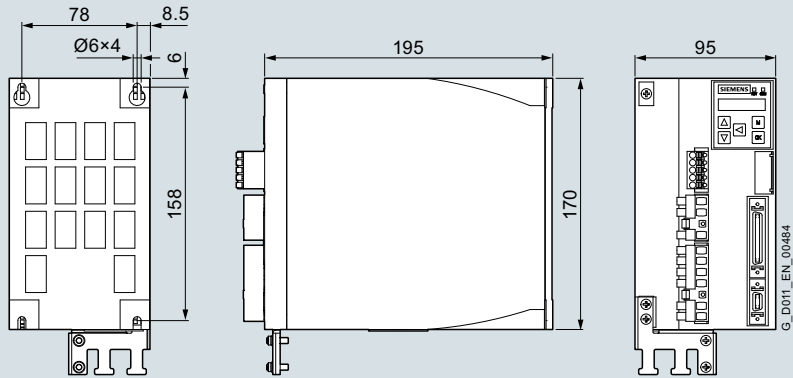

SINAMICS V90, 200 ... 240 V 3 AC, frame size FSD

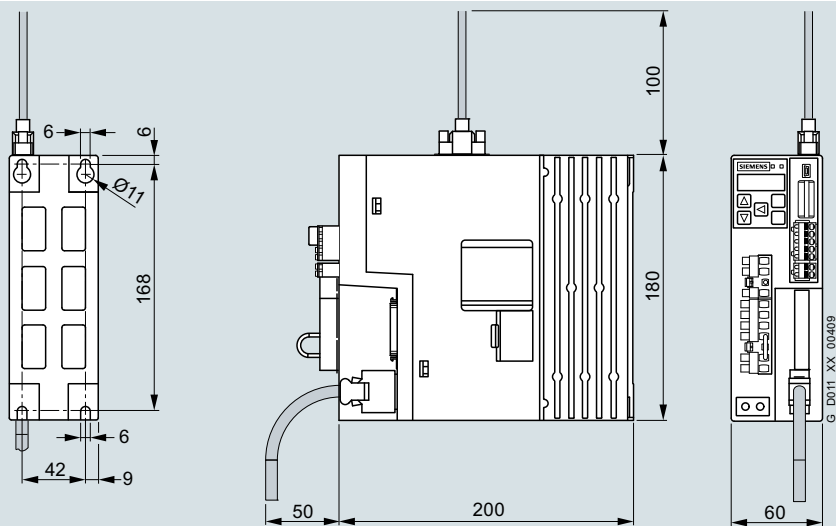

SINAMICS V90, 380 ... 480 V 3 AC, frame size FSAA

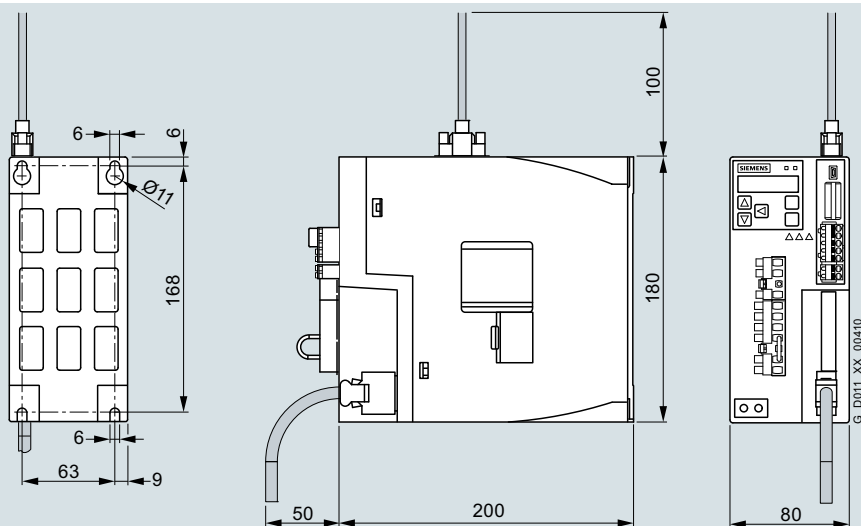

SINAMICS V90, 380 ... 480 V 3 AC, frame size FSA

Dimensional drawings (continued)

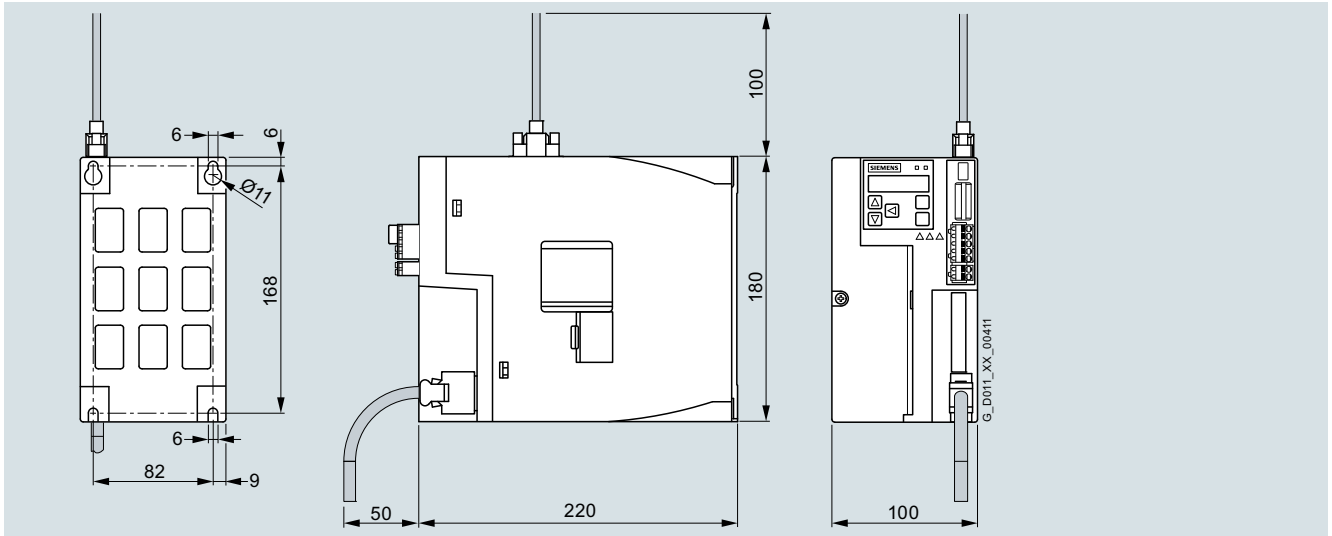

SINAMICS V90, 380 ... 480 V 3 AC, frame size FSB

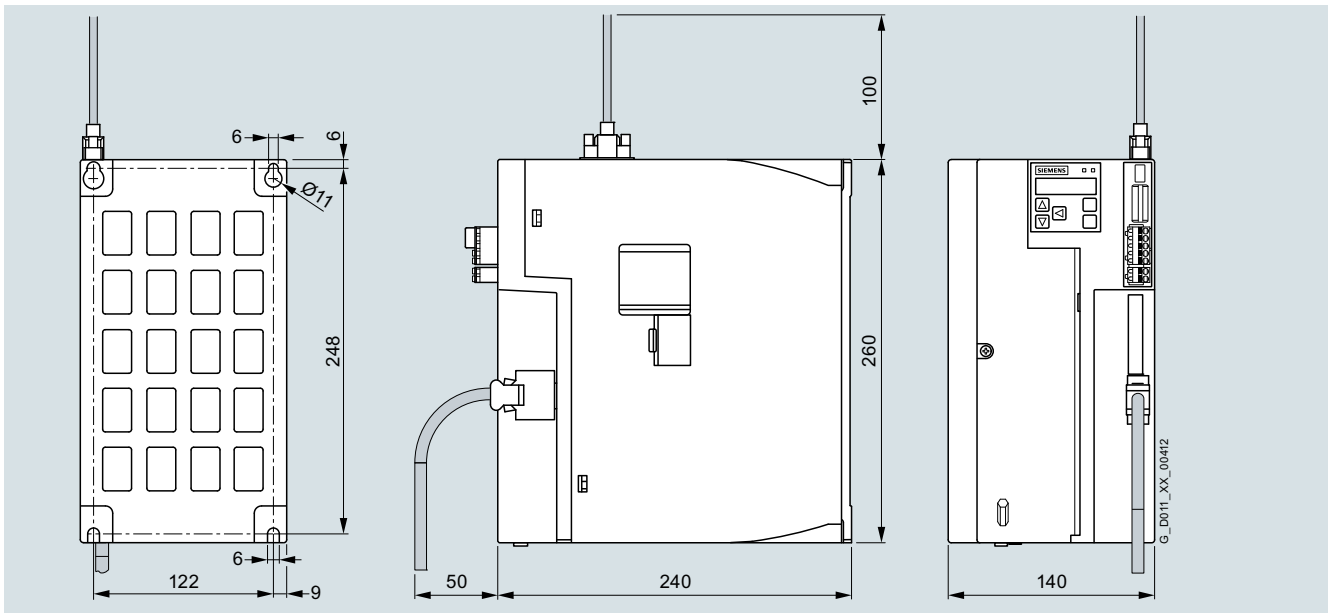

SINAMICS V90, 380 ... 480 V 3 AC, frame size FSC

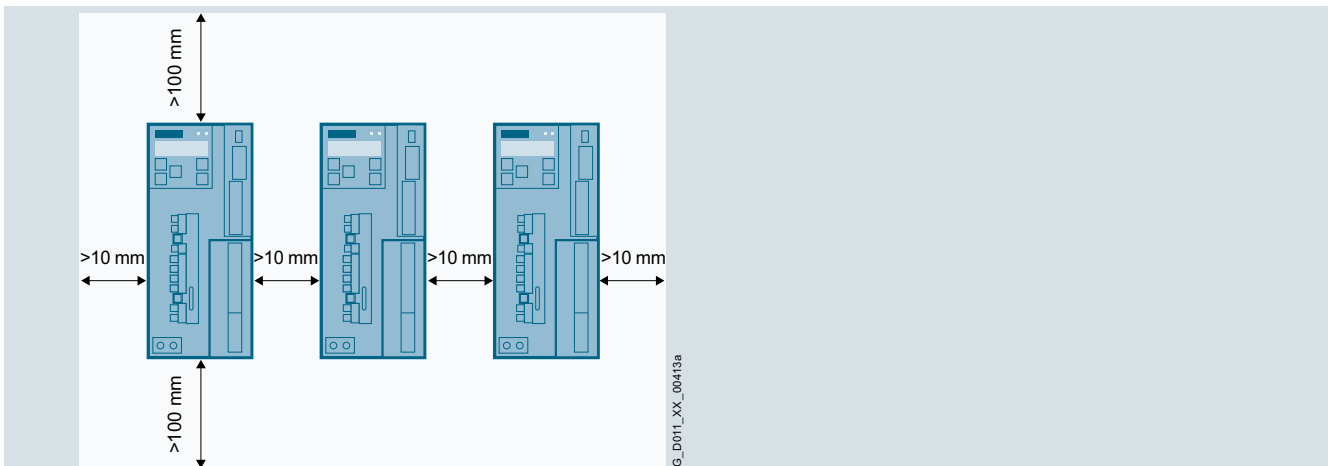

Mounting clearances

SINAMICS V90 servo drive

Line filters

Overview

It is recommended to use a line filter to protect the system from high frequency noise.

With one of the recommended line filters, EN 61800-3 category C2 can be reached in combination with SINAMICS V90.

For Selection and Ordering Data please refer to section "System overview" "SINAMICS V90 basic servo drive system" from page 1/9.

Recommended line-side overcurrent protection devices

Overview

A fuse/circuit breaker can be used to protect the system.

For Selection and Ordering Data please refer to section "System overview" "SINAMICS V90 basic servo drive system" from page 1/9.

External braking resistor

Overview

When the internal braking resistor cannot meet the braking requirements, an external braking resistor can be used to transform the regenerative electrical energy into heat, thus giving greatly improved braking and deceleration capabilities.

The following table contains the technical data for selecting a standard braking resistor.

| Frame size | Resistance Ω | Max. power kW | Rated power W | Max. energy kJ |
|---|------------------------|------------------|------------------|-------------------|
| Line voltage 200 ... 240 V 1 AC/3 AC | | | | |
| FSA | 150 | 1.09 | 20 | 0.8 |
| FSB | 100 | 1.64 | 21 | 1.23 |
| FSC | 50 | 3.28 | 62 | 2.46 |
| FSD, 1 kW | 50 | 3.28 | 62 | 2.46 |
| FSD, 1.5 ... 2 kW | 25 | 6.56 | 123 | 4.92 |
| Line voltage 380 ... 480 V 3 AC | | | | |
| FSA | 533 | 1.2 | 30 | 2.4 |
| FSA | 160 | 4 | 100 | 8.0 |
| FSB | 70 | 9.1 | 229 | 18.3 |
| FSC | 27 | 23.7 | 1185 | 189.6 |

Connecting cables for SIMATIC S7 controller

Overview

Connecting cables for SIMATIC S7 controller are available for

- SINAMICS V90 pulse train (PTI) version
- SINAMICS V90 PROFINET (PN) version

For Selection and Ordering Data please refer to section "System overview" "SINAMICS V90 basic servo drive system" page 1/12.

Supplementary system components

Overview

Memory card

Optionally an SD card can be used for SINAMICS V90 380 ... 480 V 3 AC variants to copy drive parameters or perform a firmware update. You are recommended to use the SINAMICS SD card.

For Selection and Ordering Data please refer to section "System overview" "SINAMICS V90 basic servo drive system" page 1/12.

Replacement connector kits

Replacement connector kits for the power and signal cables are available for SINAMICS V90.

Replacement fans

Replacement fans are available for SINAMICS V90 200 ... 240 V 3 AC frame size FSD and 380 ... 480 V 3 AC frame sizes FSB and FSC.

SIMOTICS S-1FL6 servomotors

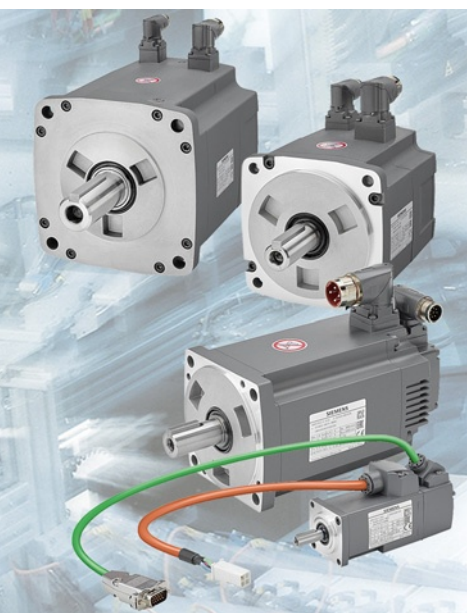

3/2

SIMOTICS S-1FL6 servomotors for SINAMICS V90

3/2 Overview

3/2 Benefits

3/2 Application

3/2 Function

3/3 Technical specifications

3/6 Characteristic curves

3/8 Dimensional drawings

For **Selection and Ordering Data** please refer to section "System overview" "SINAMICS V90 basic servo drive system" from page 1/9.

Detailed technical information on SINAMICS V90 is available on the Internet at:
www.siemens.com/sinamics-v90/documentation

In addition, the Drive Technology Configurator (DT Configurator) can be used on the Internet at the following address:
www.siemens.com/dt-configurator

SIMOTICS S-1FL6 servomotors

SIMOTICS S-1FL6 servomotors for SINAMICS V90

Overview

Optimized servomotor solution for motion control applications



SIMOTICS S-1FL6 Low Inertia servomotors

SIMOTICS S-1FL6 servomotors are permanent-magnet synchronous motors and designed for operation without external cooling. The heat is dissipated through the motor surface.

The motors have a 300 % overload capability and can be combined with the SINAMICS V90 servo drives to create a powerful servo system with high functionality. Incremental or absolute encoders can be selected depending on the application.

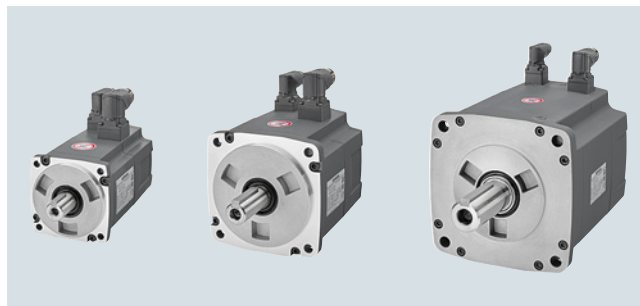

SIMOTICS S-1FL6 High Inertia servomotors

SIMOTICS S-1FL6 motors have a high degree of dynamic performance, wide speed control range and high shaft end and flange precision.

For Selection and Ordering Data please refer to section "System overview" "SINAMICS V90 basic servo drive system" from page 1/9.

3

Benefits

- High-performance magnet material
- Rugged design with IP65 degree of protection for complete motor including connectors
- Smooth running quality thanks to low torque ripple
- High rated speed for some variants
- High acceleration due to the 300 % overload capacity
- Rotatable connectors
- Maximum flexibility due to variants with incremental encoder/absolute encoder, with/without brake and plain shaft/feather key

Application

Typical applications

- Handling machines, e.g. pick & place machines
- Packaging machines, e.g. labeling machines, horizontal packaging machines
- Automatic assembly machines
- Metal forming machines
- Printing machines, e.g. screen printing machines
- Winders and unwinders

Function

| SIMOTICS S-1FL6 servomotors | | |
|------------------------------|---|--|
| | Low Inertia | High Inertia |
| Shaft height | 20, 30, 40, 50 | 45, 65, 90 |
| Rated torque | 0.16 Nm ... 6.37 Nm | 1.27 Nm ... 33.4 Nm |
| Rated speed | 3000 rpm | 2000 rpm/3000 rpm |
| Maximum speed | 5000 rpm | 4000 rpm |
| Encoders, integrated | <ul style="list-style-type: none"> • Incremental encoder 2500 S/R • Absolute encoder 21 bit single-turn | <ul style="list-style-type: none"> • Incremental encoder 2500 S/R • Absolute encoder 20 bit + 12 bit multi-turn |
| Additional advantages | <ul style="list-style-type: none"> • High dynamic performance High acceleration for shorter cycle times as a result of the very low moment of inertia • High speed Maximum speed up to 5000 rpm can increase machine productivity • Compact size The reduced motor length/height compared to High Inertia variants and compact drive size can address critical mounting requirements. | <ul style="list-style-type: none"> • Smooth operation Higher torque accuracy and low speed ripple as a result of the higher moment of inertia ensures a better product quality. • Robust design High-quality metal connector and standard motor oil seal can withstand harsh environment. • Sufficient torque output Wide range of rated torques up to 33.4 Nm |

Technical specifications

General technical specifications

| SIMOTICS S-1FL6 servomotors | |
|---|--|
| Type of motor | Permanent-magnet synchronous motor |
| Magnet material | High-performance magnetic material |
| Cooling | Natural cooling |
| Insulation of the stator winding in accordance with EN 60034-1 (IEC 60034-1) | Temperature class 130 (B) |
| Temperature class | B (130 °C/266 °F) |
| Type of construction in accordance with EN 60034-7 (IEC 60034-7) | IM B5 (IM V1, IM V3) |
| Degree of protection in accordance with EN 60034-5 (IEC 60034-5) | IP65 |
| Shaft extension in accordance with IEC 60072-1 | Plain shaft/feather key (C type) |
| Shaft and flange accuracy in accordance with IEC 60072-1 ¹⁾ | Tolerance N |
| Vibration severity in accordance with IEC 60034-14 | Grade A |
| Sound pressure level, max. | |
| • 1FL602 | 60 dB |
| • 1FL603 | 60 dB |
| • 1FL604 | |
| -Low Inertia | 60 dB |
| -High Inertia | 65 dB |
| • 1FL605 | 60 dB |
| • 1FL606 | 70 dB |
| • 1FL609 | 70 dB |
| Ambient temperature | |
| • Storage/transport | -20 ... +65 °C (-4 ... +149 °F) |
| • Operation | |
| -SIMOTICS S-1FL6 Low Inertia 1FL6052-2AF.../1FL6054-2AF... | 0 ... 30 °C (32 ... 86 °F) without derating |
| -SIMOTICS S-1FL6 Low Inertia 1FL6022/1FL6024/1FL6032/1FL6034/1FL6042/1FL6044 | 0 ... 40 °C (32 ... 104 °F) without derating |
| -SIMOTICS S-1FL6 High Inertia | 0 ... 40 °C (32 ... 104 °F) without derating |
| Relative atmospheric humidity | |
| • Storage/transport | 90 % at 30 °C (86 °F) (no condensation) |
| • Operation | 90 % at 30 °C (86 °F) (no condensation) |
| Installation altitude | Up to 1000 m (3281 ft) above sea level without derating > 1000 m ... 5000 m (3281 ... 16405 ft) with derating |
| Paint finish | Black |
| Certificate of suitability | CE, EAC |

¹⁾ Shaft extension run-out, concentricity of centering ring and shaft, and perpendicularity of flange to shaft.

SIMOTICS S-1FL6 servomotors

SIMOTICS S-1FL6 servomotors for SINAMICS V90

Technical specifications (continued)

| | | SIMOTICS S-1FL6 Low Inertia | | | | | | | |
|--|-----------------------------------|--|----------------|----------------|----------------|----------------|----------------|----------------|----------------|
| | | 1FL6022-2AF... | 1FL6024-2AF... | 1FL6032-2AF... | 1FL6034-2AF... | 1FL6042-2AF... | 1FL6044-2AF... | 1FL6052-2AF... | 1FL6054-2AF... |
| Shaft height | | 20 | 20 | 30 | 30 | 40 | 40 | 50 | 50 |
| Rated power ¹⁾ | kW | 0.05 | 0.10 | 0.20 | 0.40 | 0.75 | 1.00 | 1.50 | 2.00 |
| | hp | 0.07 | 0.14 | 0.27 | 0.54 | 1.02 | 1.36 | 2.04 | 2.72 |
| Rated torque ¹⁾ | Nm | 0.16 | 0.32 | 0.64 | 1.27 | 2.39 | 3.18 | 4.78 | 6.37 |
| Rated speed | rpm | 3000 | 3000 | 3000 | 3000 | 3000 | 3000 | 3000 | 3000 |
| Maximum torque ¹⁾ | Nm | 0.48 | 0.96 | 1.91 | 3.82 | 7.2 | 9.54 | 14.3 | 19.1 |
| Maximum speed | rpm | 5000 | 5000 | 5000 | 5000 | 5000 | 5000 | 5000 | 5000 |
| Rated current | A | 1.2 | 1.2 | 1.4 | 2.6 | 4.7 | 6.3 | 10.6 | 11.6 |
| Maximum current | A | 3.6 | 3.6 | 4.2 | 7.8 | 14.2 | 18.9 | 31.8 | 34.8 |
| Torque constant | Nm/A | 0.14 | 0.29 | 0.48 | 0.49 | 0.51 | 0.51 | 0.46 | 0.55 |
| Moment of inertia | | | | | | | | | |
| • without brake | 10 ⁻⁴ kgm ² | 0.031 | 0.052 | 0.214 | 0.351 | 0.897 | 1.15 | 2.04 | 2.62 |
| • with brake | 10 ⁻⁴ kgm ² | 0.038 | 0.059 | 0.245 | 0.381 | 1.06 | 1.31 | 2.24 | 2.82 |
| Recommended load to motor inertia ratio, max. | | 30x | 30x | 30x | 30x | 20x | 20x | 15x | 15x |
| Encoder types | | <ul style="list-style-type: none"> Incremental encoder TTL, 2500 S/R Absolute encoder 21 bit single-turn | | | | | | | |
| Weight ²⁾ | | | | | | | | | |
| • without brake | kg | 0.47 | 0.63 | 1.02 | 1.46 | 2.8 | 3.39 | 5.45 | 6.66 |
| • with brake | kg | 0.70 | 0.86 | 1.48 | 1.92 | 3.68 | 4.20 | 6.96 | 8.20 |
| Holding brake ³⁾ | | | | | | | | | |
| Holding torque | Nm | 0.32 | 0.32 | 1.27 | 1.27 | 3.18 | 3.18 | 6.37 | 6.37 |
| Rated voltage | V DC | 24 ±10 % | 24 ±10 % | 24 ±10 % | 24 ±10 % | 24 ±10 % | 24 ±10 % | 24 ±10 % | 24 ±10 % |
| Opening time | ms | 35 | 35 | 75 | 75 | 105 | 105 | 90 | 90 |
| Closing time | ms | 10 | 10 | 10 | 10 | 15 | 15 | 35 | 35 |
| Rated current | A | 0.25 | 0.25 | 0.3 | 0.3 | 0.35 | 0.35 | 0.57 | 0.57 |

| | | SIMOTICS S-1FL6 High Inertia | | | | | | |
|--|-----------------------------------|--|----------------|----------------|----------------|----------------|----------------|----------------|
| | | 1FL6042-1AF... | 1FL6044-1AF... | 1FL6061-1AC... | 1FL6062-1AC... | 1FL6064-1AC... | 1FL6066-1AC... | 1FL6067-1AC... |
| Shaft height | | 45 | 45 | 65 | 65 | 65 | 65 | 65 |
| Rated power ¹⁾ | kW | 0.40 | 0.75 | 0.75 | 1.00 | 1.50 | 1.75 | 2.00 |
| | hp | 0.54 | 1.02 | 1.02 | 1.36 | 2.04 | 2.38 | 2.72 |
| Rated torque ¹⁾ | Nm | 1.27 | 2.39 | 3.58 | 4.78 | 7.16 | 8.36 | 9.55 |
| Rated speed | rpm | 3000 | 3000 | 2000 | 2000 | 2000 | 2000 | 2000 |
| Maximum torque ¹⁾ | Nm | 3.8 | 7.2 | 10.7 | 14.3 | 21.5 | 25.1 | 28.7 |
| Maximum speed | rpm | 4000 | 4000 | 3000 | 3000 | 3000 | 3000 | 3000 |
| Rated current | A | 1.2 | 2.1 | 2.5 | 3.0 | 4.6 | 5.3 | 5.9 |
| Maximum current | A | 3.6 | 6.3 | 7.5 | 9.0 | 13.8 | 15.9 | 17.7 |
| Torque constant | Nm/A | 1.1 | 1.2 | 1.5 | 1.7 | 1.6 | 1.7 | 1.7 |
| Moment of inertia | | | | | | | | |
| • without brake | 10 ⁻⁴ kgm ² | 2.7 | 5.2 | 8.0 | 11.7 | 15.3 | 22.6 | 29.9 |
| • with brake | 10 ⁻⁴ kgm ² | 3.2 | 5.7 | 9.1 | 13.5 | 16.4 | 23.7 | 31.0 |
| Recommended load to motor inertia ratio, max. | | 10x | 10x | 5x | 5x | 5x | 5x | 5x |
| Encoder types | | <ul style="list-style-type: none"> Incremental encoder TTL, 2500 S/R Absolute encoder 20 bit single-turn + 12 bit multi-turn | | | | | | |
| Weight ²⁾ | | | | | | | | |
| • without brake | kg | 3.4 | 5.2 | 5.7 | 7.0 | 8.4 | 11.1 | 13.7 |
| • with brake | kg | 4.8 | 6.6 | 8.8 | 10.1 | 11.5 | 14.2 | 16.8 |
| Holding brake ³⁾ | | | | | | | | |
| Holding torque | Nm | 3.5 | 3.5 | 12.0 | 12.0 | 12.0 | 12.0 | 12.0 |
| Rated voltage | V DC | 24 ±10 % | 24 ±10 % | 24 ±10 % | 24 ±10 % | 24 ±10 % | 24 ±10 % | 24 ±10 % |
| Opening time | ms | 60 | 60 | 180 | 180 | 180 | 180 | 180 |
| Closing time | ms | 45 | 45 | 60 | 60 | 60 | 60 | 60 |
| Rated current | A | 0.9 | 0.9 | 1.5 | 1.5 | 1.5 | 1.5 | 1.5 |

¹⁾ Rated torque, rated power and maximum torque listed in the table above allow for a production tolerance of 10 %.

²⁾ Motor weight with incremental encoder.

³⁾ It is not permissible to use the holding brake for an emergency stop.

Technical specifications (continued)

| | | SIMOTICS S-1FL6 High Inertia | | | |
|--|-----------------------------------|--|----------------|----------------|------------------------------|
| | | 1FL6090-1AC... | 1FL6092-1AC... | 1FL6094-1AC... | 1FL6096-1AC... ⁴⁾ |
| Shaft height | | 90 | | | |
| Rated power¹⁾ | kW | 2.5 | 3.5 | 5 | 7 |
| | hp | 3.40 | 4.76 | 6.80 | 9.52 |
| Rated torque¹⁾ | Nm | 11.90 | 16.70 | 23.90 | 33.40 |
| Rated speed | rpm | 2000 | 2000 | 2000 | 2000 |
| Maximum torque¹⁾ | Nm | 35.7 | 50.0 | 70.0 | 90.0 |
| Maximum speed | rpm | 3000 | 3000 | 2500 | 2000 |
| Rated current | A | 7.8 | 11.0 | 12.6 | 13.2 |
| Maximum current | A | 23.4 | 33.0 | 36.9 | 35.6 |
| Torque constant | Nm/A | 1.6 | 1.6 | 2.0 | 2.7 |
| Moment of inertia | | | | | |
| • without brake | 10 ⁻⁴ kgm ² | 47.4 | 69.1 | 90.8 | 134.3 |
| • with brake | 10 ⁻⁴ kgm ² | 56.3 | 77.9 | 99.7 | 143.2 |
| Recommended load to motor inertia ratio, max. | | 5× | | | |
| Encoder types | | <ul style="list-style-type: none"> • Incremental encoder TTL, 2500 S/R • Absolute encoder 20 bit single-turn + 12 bit multi-turn | | | |
| Weight²⁾ | | | | | |
| • without brake | kg | 15.4 | 19.8 | 24.4 | 33.3 |
| • with brake | kg | 21.5 | 25.9 | 30.5 | 39.3 |
| Holding brake³⁾ | | | | | |
| Holding torque | Nm | 30.0 | | | |
| Rated voltage | V DC | 24 ±10 % | | | |
| Opening time | ms | 220 | | | |
| Closing time | ms | 115 | | | |
| Rated current | A | 1.9 | | | |

¹⁾ Rated torque, rated power and maximum torque listed in the table above allow for a production tolerance of 10 %.

²⁾ Motor weight with incremental encoder.

³⁾ It is not permissible to use the holding brake for an emergency stop.

⁴⁾ For SIMOTICS S-1FL6096-... servomotors with brake, when the ambient temperature exceeds 30 °C (86 °F), the power should be derated by 10 %. Power derating is not required for other motors.

SIMOTICS S-1FL6 servomotors

SIMOTICS S-1FL6 servomotors for SINAMICS V90

Characteristic curves

Torque-speed characteristic for SIMOTICS S-1FL6 Low Inertia when connected to SINAMICS V90

3

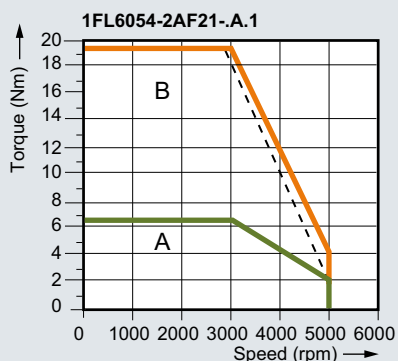
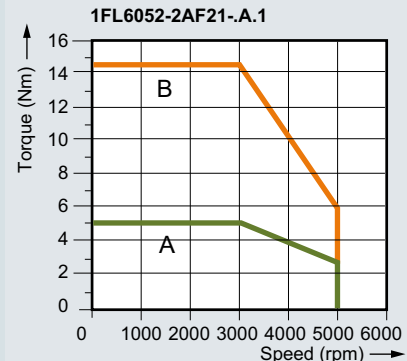
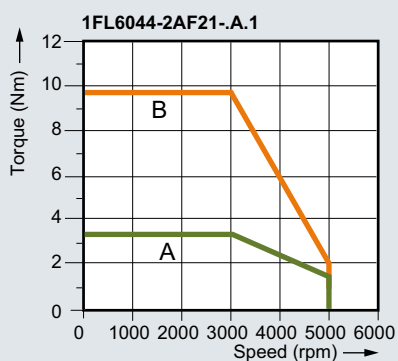
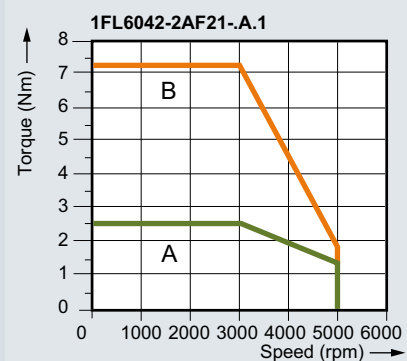
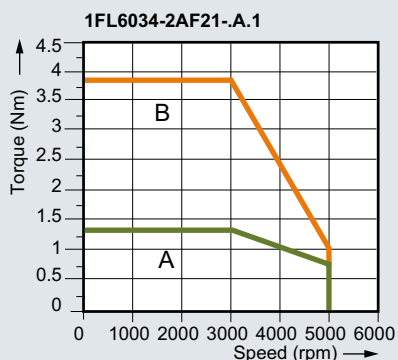
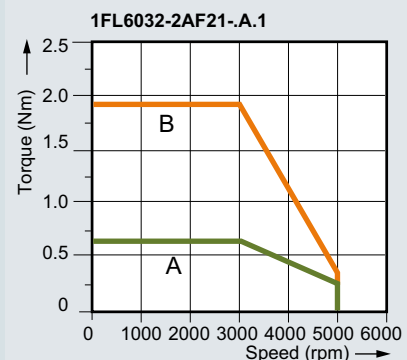
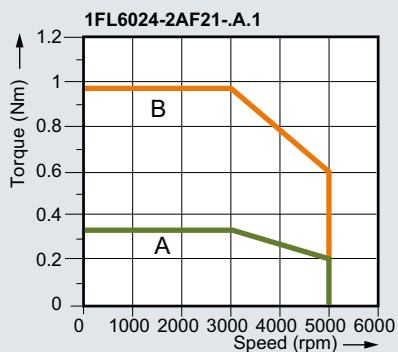
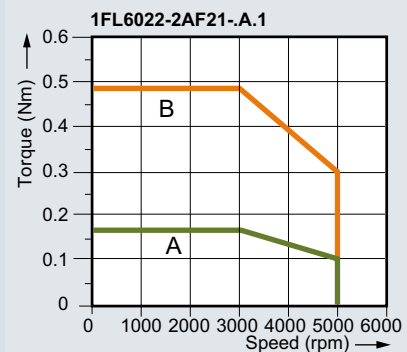

220 V AC supply voltage
 A: Continuous operating area
 B: Short-term operating area

— Supply voltage 220 V
 - - - Supply voltage 198 V

G_D011_EN_00483

Characteristic curves (continued)

Torque-speed characteristic for SIMOTICS S-1FL6 High Inertia when connected to SINAMICS V90

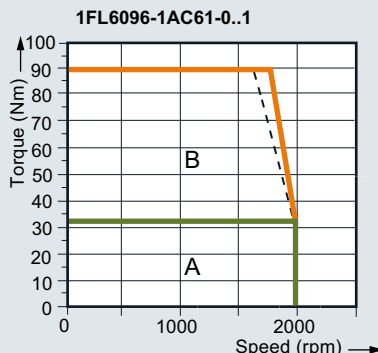
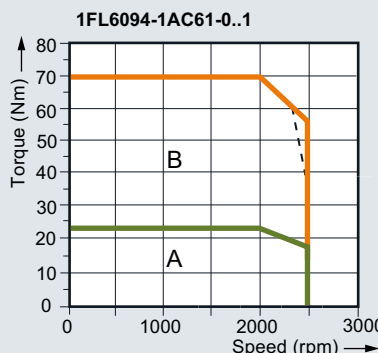
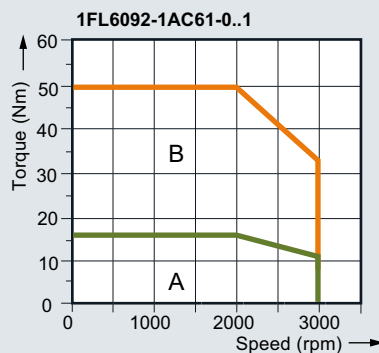
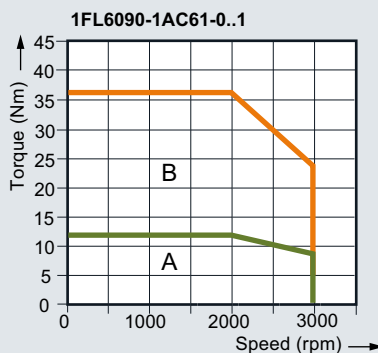
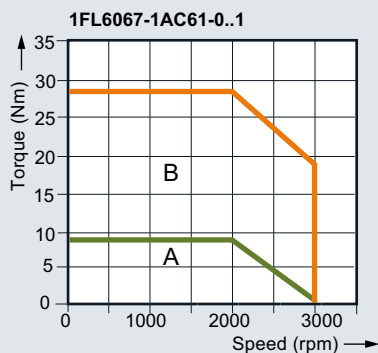
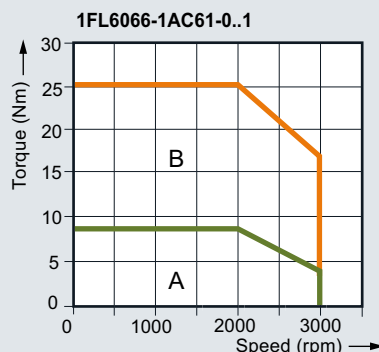
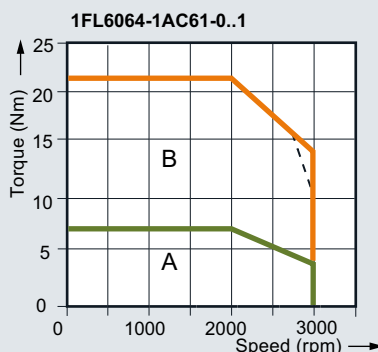
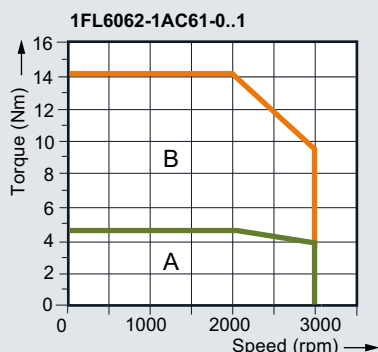
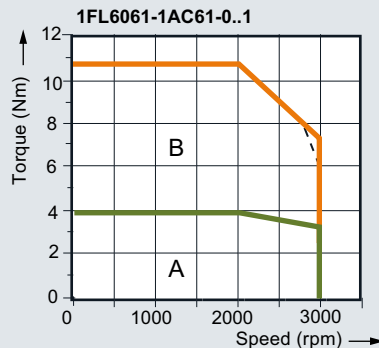
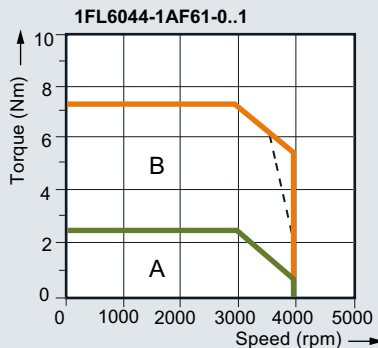
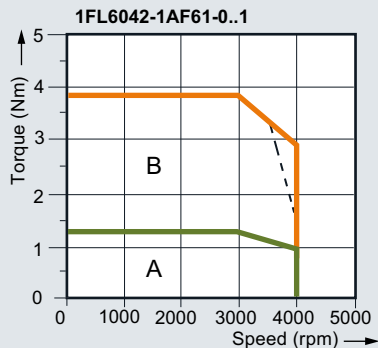

G_D011_EN_00414

Notes:

- A: Continuous operating area
- B: Short-term operating area

- Supply voltage 400 V
- - - Supply voltage 380 V

SIMOTICS S-1FL6 servomotors

SIMOTICS S-1FL6 servomotors for SINAMICS V90

Dimensional drawings

SIMOTICS S-1FL6 Low Inertia

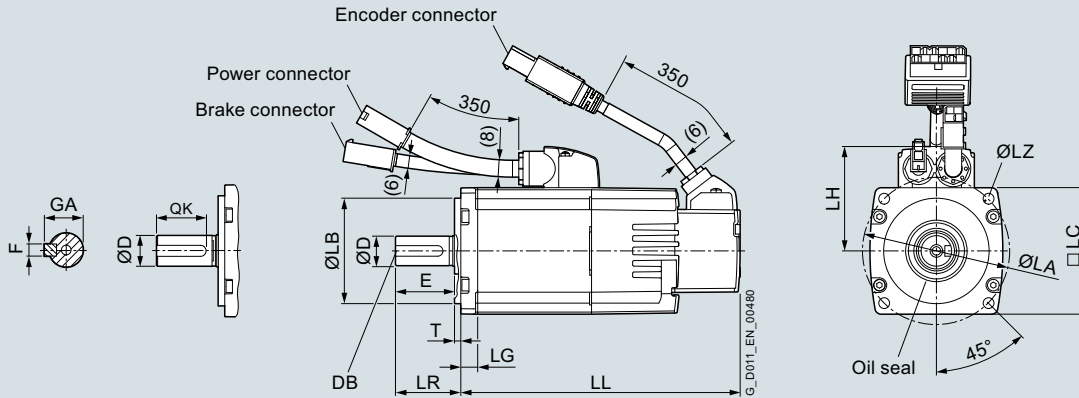

SIMOTICS S-1FL6 Low Inertia servomotors, shaft heights 20, 30, 40

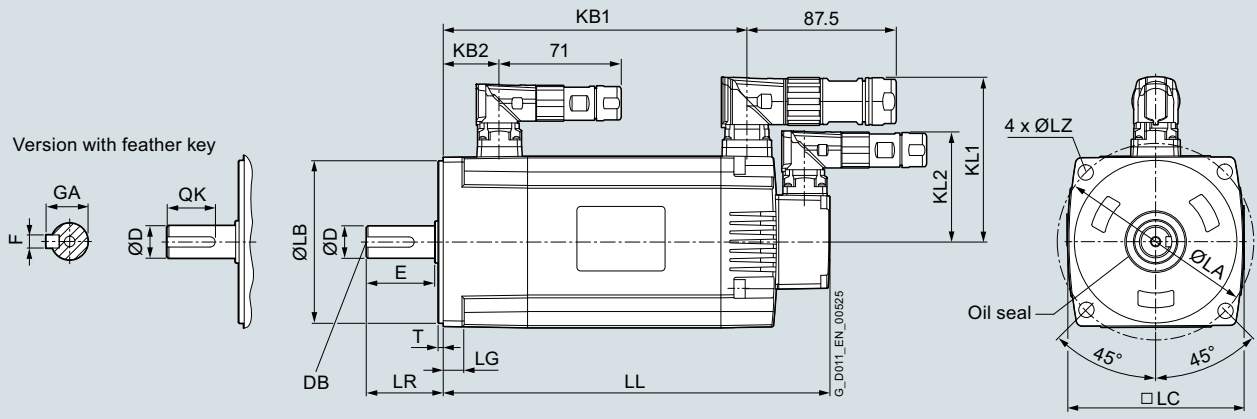

SIMOTICS S-1FL6 Low Inertia servomotor, shaft height 50

| For motor | | Dimensions in mm | | | | | | | | | | | | | | | | | | | | |
|---|-------------|------------------|-----|-----|----|----|----|-----|----|--------------------|-------|----|------|------|---------------|-------|------------|-------|-------|------|-----|------|
| Shaft height | Type | LC | LA | LZ | LB | LH | LR | T | LG | DE shaft extension | | | | | Without brake | | With brake | | | | | |
| | | | | | | | | | | D | DB | E | QK | GA | F | LL | KB1 | LL | KB1 | KB2 | KL1 | KL2 |
| SIMOTICS S-1FL6 Low Inertia, natural cooling, without/with brake | | | | | | | | | | | | | | | | | | | | | | |
| 20 | 1FL6022-2AF | 40 | 46 | 4.5 | 30 | 40 | 25 | 2.5 | 6 | 8 | M3×8 | 22 | 17.5 | 9 | 3 | 86 | – | 119 | – | – | – | – |
| | 1FL6024-2AF | 40 | 46 | 4.5 | 30 | 40 | 25 | 2.5 | 6 | 8 | M3×8 | 22 | 17.5 | 9 | 3 | 106 | – | 139 | – | – | – | – |
| 30 | 1FL6032-2AF | 60 | 70 | 5.5 | 50 | 50 | 31 | 3 | 8 | 14 | M4×15 | 26 | 22.5 | 16 | 5 | 98 | – | 132.5 | – | – | – | – |
| | 1FL6034-2AF | 60 | 70 | 5.5 | 50 | 50 | 31 | 3 | 8 | 14 | M4×15 | 26 | 22.5 | 16 | 5 | 123 | – | 157.5 | – | – | – | – |
| 40 | 1FL6042-2AF | 80 | 90 | 7 | 70 | 60 | 35 | 3 | 8 | 19 | M6×16 | 30 | 28 | 21.5 | 6 | 139 | – | 178.3 | – | – | – | – |
| | 1FL6044-2AF | 80 | 90 | 7 | 70 | 60 | 35 | 3 | 8 | 19 | M6×16 | 30 | 28 | 21.5 | 6 | 158.8 | – | 198.1 | – | – | – | – |
| 50 | 1FL6052-2AF | 100 | 115 | 9 | 95 | – | 45 | 3 | 12 | 19 | M6×16 | 40 | 28 | 21.5 | 6 | 192 | 143.5 | 226 | 177.5 | 32.5 | 98 | 65.5 |
| | 1FL6054-2AF | 100 | 115 | 9 | 95 | – | 45 | 3 | 12 | 19 | M6×16 | 40 | 28 | 21.5 | 6 | 216 | 167.5 | 250 | 201.5 | 32.5 | 98 | 65.5 |

Dimensional drawings (continued)

SIMOTICS S-1FL6 High Inertia with incremental encoder

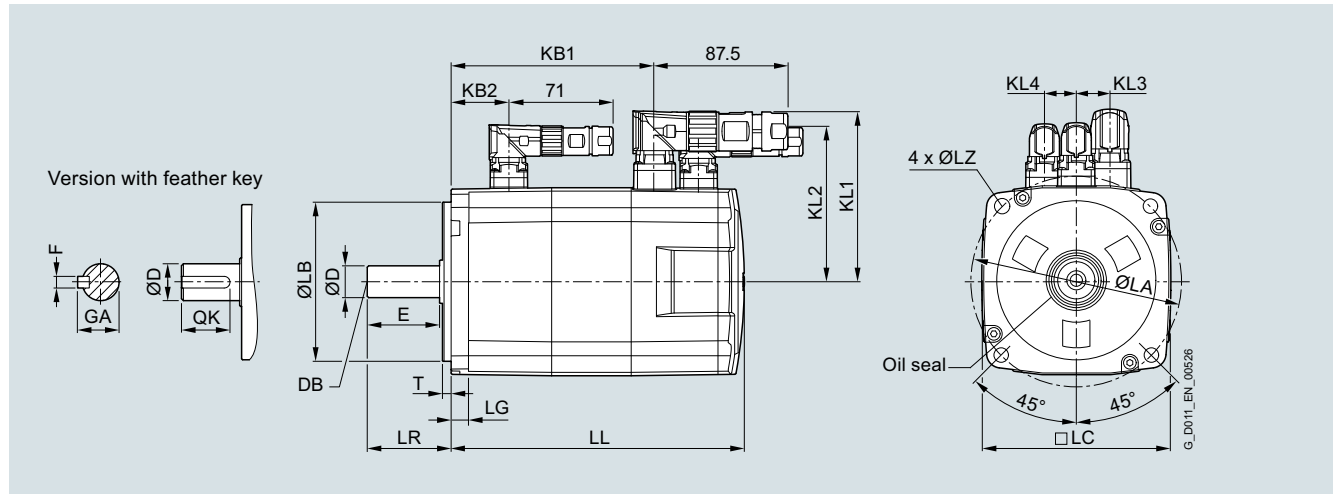

SIMOTICS S-1FL6 High Inertia servomotors, with incremental encoder

| For motor | | Dimensions in mm | | | | | | | | | | | | | | Encoder system: Incremental encoder 2500 S/R | | | | | | | | |
|--|---------|------------------|-----|------|-------|----|---|----|----|--------|----|----|------|----|---------------|--|------------|-------|-------|------|------|------|-----|-----|
| Shaft height | Type | LC | LA | LZ | LB | LR | T | LG | D | DB | E | QK | GA | F | without brake | | with brake | | KL1 | KL2 | KL3 | KL4 | | |
| | | | | | | | | | | | | | | | LL | KB1 | KB2 | LL | | | | | KB1 | KB2 |
| SIMOTICS S-1FL6 High Inertia, natural cooling, without/with brake | | | | | | | | | | | | | | | | | | | | | | | | |
| 45 | 1FL6042 | 90 | 100 | 7 | 80 | 35 | 4 | 10 | 19 | M6×16 | 30 | 25 | 21.5 | 6 | 154.5 | 93.5 | - | 201 | 140 | 31.5 | 96.2 | 84.6 | 13 | 14 |
| | 1FL6044 | 90 | 100 | 7 | 80 | 35 | 4 | 10 | 19 | M6×16 | 30 | 25 | 21.5 | 6 | 201.5 | 140.5 | - | 248 | 187 | 31.5 | 96.2 | 84.6 | 13 | 14 |
| 65 | 1FL6061 | 130 | 145 | 9 | 110 | 58 | 6 | 12 | 22 | M8×16 | 50 | 44 | 25 | 8 | 148 | 85.5 | - | 202.5 | 140 | 39.5 | 118 | 108 | 23 | 22 |
| | 1FL6062 | 130 | 145 | 9 | 110 | 58 | 6 | 12 | 22 | M8×16 | 50 | 44 | 25 | 8 | 164 | 101.5 | - | 219 | 156.5 | 39.5 | 118 | 108 | 23 | 22 |
| | 1FL6064 | 130 | 145 | 9 | 110 | 58 | 6 | 12 | 22 | M8×16 | 50 | 44 | 25 | 8 | 181 | 118.5 | - | 235.5 | 173 | 39.5 | 118 | 108 | 23 | 22 |
| | 1FL6066 | 130 | 145 | 9 | 110 | 58 | 6 | 12 | 22 | M8×16 | 50 | 44 | 25 | 8 | 214 | 151.5 | - | 268.5 | 206 | 39.5 | 118 | 108 | 23 | 22 |
| 90 | 1FL6067 | 130 | 145 | 9 | 110 | 58 | 6 | 12 | 22 | M8×16 | 50 | 44 | 25 | 8 | 247 | 184.5 | - | 301.5 | 239 | 39.5 | 118 | 108 | 23 | 22 |
| | 1FL6090 | 180 | 200 | 13.5 | 114.3 | 80 | 3 | 18 | 35 | M12×25 | 75 | 60 | 38 | 10 | 189.5 | 140 | - | 255 | 206 | 44.5 | 143 | 143 | 34 | 34 |
| | 1FL6092 | 180 | 200 | 13.5 | 114.3 | 80 | 3 | 18 | 35 | M12×25 | 75 | 60 | 38 | 10 | 211.5 | 162 | - | 281 | 232 | 44.5 | 143 | 143 | 34 | 34 |
| | 1FL6094 | 180 | 200 | 13.5 | 114.3 | 80 | 3 | 18 | 35 | M12×25 | 75 | 60 | 38 | 10 | 237.5 | 188 | - | 307 | 258 | 44.5 | 143 | 143 | 34 | 34 |
| | 1FL6096 | 180 | 200 | 13.5 | 114.3 | 80 | 3 | 18 | 35 | M12×25 | 75 | 60 | 38 | 10 | 289.5 | 240 | - | 359 | 310 | 44.5 | 143 | 143 | 34 | 34 |

SIMOTICS S-1FL6 servomotors

SIMOTICS S-1FL6 servomotors for SINAMICS V90

Dimensional drawings (continued)

SIMOTICS S-1FL6 High Inertia with absolute encoder

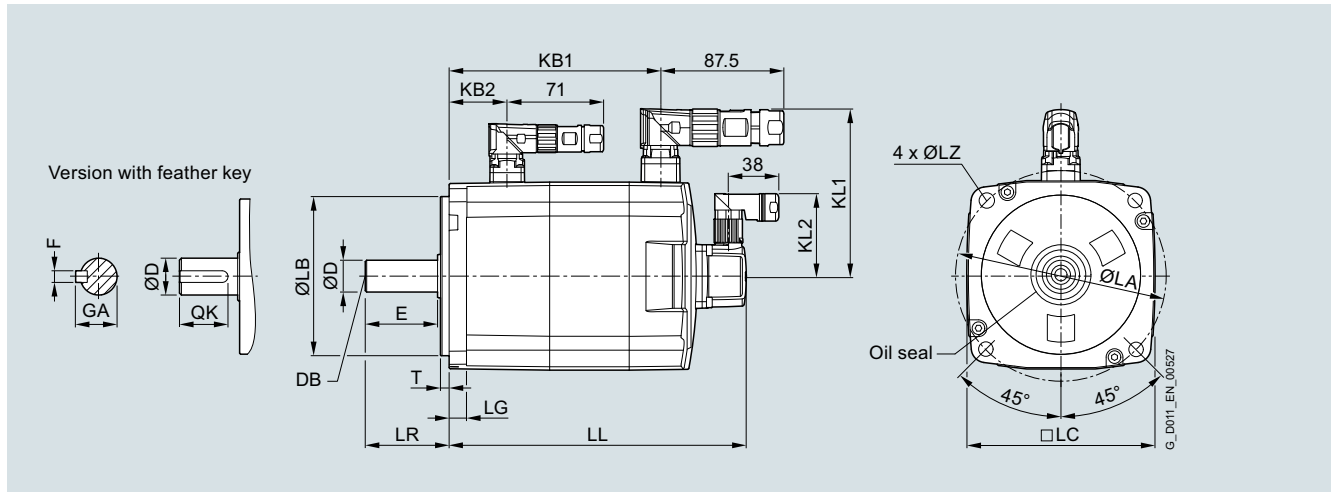

SIMOTICS S-1FL6 High Inertia servomotors, with absolute encoder

| For motor | | Dimensions in mm | | | | | | | | | | | | | Encoder system: Absolute encoder 20 bit | | | | | | | |
|--|---------|------------------|-----|------|-------|----|---|----|--------------------|--------|----|----|---------------|----|---|-------|-----|-------|-------|------|-------|-----|
| Shaft height | Type | LC | LA | LZ | LB | LR | T | LG | DE shaft extension | | | | without brake | | with brake | | KL1 | KL2 | | | | |
| | | | | | | | | | D | DB | E | QK | GA | F | LL | KB1 | | | KB2 | LL | KB1 | KB2 |
| SIMOTICS S-1FL6 High Inertia, natural cooling, without/with brake | | | | | | | | | | | | | | | | | | | | | | |
| 45 | 1FL6042 | 90 | 100 | 7 | 80 | 35 | 4 | 10 | 19 | M6×16 | 30 | 25 | 21.5 | 6 | 157 | 100 | – | 203.5 | 146.5 | 31.5 | 96.2 | 60 |
| | 1FL6044 | 90 | 100 | 7 | 80 | 35 | 4 | 10 | 19 | M6×16 | 30 | 25 | 21.5 | 6 | 204 | 147 | – | 250.5 | 193.5 | 31.5 | 96.2 | 60 |
| 65 | 1FL6061 | 130 | 145 | 9 | 110 | 58 | 6 | 12 | 22 | M8×16 | 50 | 44 | 25 | 8 | 151 | 92 | – | 205.5 | 146.5 | 39.5 | 117.5 | 60 |
| | 1FL6062 | 130 | 145 | 9 | 110 | 58 | 6 | 12 | 22 | M8×16 | 50 | 44 | 25 | 8 | 167.5 | 108.5 | – | 222 | 163 | 39.5 | 117.5 | 60 |
| | 1FL6064 | 130 | 145 | 9 | 110 | 58 | 6 | 12 | 22 | M8×16 | 50 | 44 | 25 | 8 | 184 | 125 | – | 238.5 | 179.5 | 39.5 | 117.5 | 60 |
| | 1FL6066 | 130 | 145 | 9 | 110 | 58 | 6 | 12 | 22 | M8×16 | 50 | 44 | 25 | 8 | 217 | 158 | – | 271.5 | 212.5 | 39.5 | 117.5 | 60 |
| 90 | 1FL6067 | 130 | 145 | 9 | 110 | 58 | 6 | 12 | 22 | M8×16 | 50 | 44 | 25 | 8 | 250 | 191 | – | 304.5 | 245.5 | 39.5 | 117.5 | 60 |
| | 1FL6090 | 180 | 200 | 13.5 | 114.3 | 80 | 3 | 18 | 35 | M12×25 | 75 | 60 | 38 | 10 | 197 | 135 | – | 263 | 201 | 45 | 143 | 60 |
| | 1FL6092 | 180 | 200 | 13.5 | 114.3 | 80 | 3 | 18 | 35 | M12×25 | 75 | 60 | 38 | 10 | 223 | 161 | – | 289 | 227 | 45 | 143 | 60 |
| | 1FL6094 | 180 | 200 | 13.5 | 114.3 | 80 | 3 | 18 | 35 | M12×25 | 75 | 60 | 38 | 10 | 249 | 187 | – | 315 | 253 | 45 | 143 | 60 |
| | 1FL6096 | 180 | 200 | 13.5 | 114.3 | 80 | 3 | 18 | 35 | M12×25 | 75 | 60 | 38 | 10 | 301 | 239 | – | 367 | 305 | 45 | 143 | 60 |

Further information is available in the Drive Technology Configurator (DT Configurator) which can be used on the Internet.

The DT Configurator can be found in the Siemens Industry Mall at the following address:

www.siemens.com/dt-configurator

MOTION-CONNECT connection systems



| | |
|------------|---|
| 4/2 | MOTION-CONNECT 300 |
| 4/2 | Overview |
| 4/3 | Pre-assembled power cables for SINAMICS V90 |
| 4/3 | Overview |
| 4/3 | Technical specifications |
| 4/4 | Pre-assembled signal cables for SINAMICS V90 |
| 4/4 | Overview |
| 4/4 | Technical specifications |
| 4/6 | Connectors for SINAMICS V90 |
| 4/6 | Overview |

For **Selection and Ordering Data** please refer to section "System overview" "SINAMICS V90 basic servo drive system" from page 1/9.

Detailed technical information on SINAMICS V90 is available on the Internet at:
www.siemens.com/sinamics-v90/documentation

In addition, the Drive Technology Configurator (DT Configurator) can be used on the Internet at the following address:
www.siemens.com/dt-configurator

MOTION-CONNECT connection systems

MOTION-CONNECT 300

Overview

The use of pre-assembled MOTION-CONNECT 300 cables ensures high quality and system-tested, problem-free operation.

Degree of protection of pre-assembled power and signal cables and their extensions is IP65 when closed and connected unless otherwise stated.

MOTION-CONNECT 300 cables are not suitable for outdoor use.

MOTION-CONNECT 300 cables are approved for a maximum horizontal travel distance of 5 m without support.

The cables must be unwound without twisting.

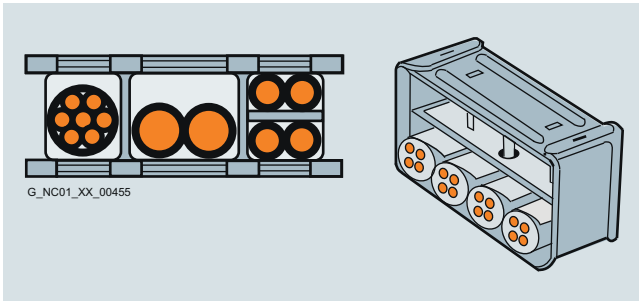

To maximize the service life of the cable carrier and cables, cables in the carrier made from different materials must be separated in the cable carrier using spacers. The spacers must be filled evenly to ensure that the position of the cables does not change during operation. The cables should be distributed as symmetrically as possible according to their weights and dimensions. Cables with different outer diameters should be separated by spacers as well.

When inserting pre-assembled cables into the cable carrier, do not pull at the connector, as this may damage the strain relief or cable clamping.

The cables must not be fixed in the cable carrier. They must be freely movable.

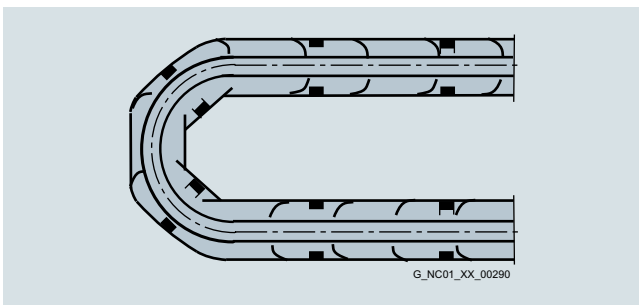

The cables must be able to be moved without applying force, specifically in the bending radii of the carrier. The specified minimum bending radii must be adhered to.

The cable fixings must be attached at both ends at an appropriate distance from the end points of the moving parts in a dead zone.

Cables must be installed in accordance with the instructions supplied by the cable carrier manufacturer.

In case of vibration load and with horizontal or vertical cable entries, we recommend that the cable is additionally fixed if between the cable strain relief on the cable carrier and the terminal at the motor part of the cable is hanging loose or is not routed. To prevent machine vibrations being transmitted to the connectors, the cable should be fixed at the moving part where the motor is mounted.

Derating factors for power and signal cables

| Ambient air temperature °C (°F) | Derating factor according to EN 60204-1 Table D.1 |
|------------------------------------|--|
| 30 (86) | 1.15 |
| 35 (95) | 1.08 |
| 40 (104) | 1.00 |
| 45 (113) | 0.91 |
| 50 (122) | 0.82 |
| 55 (131) | 0.71 |
| 60 (140) | 0.58 |

Overview



Example: MOTION-CONNECT 300, power cable for SIMOTICS S-1FL6 Low Inertia servomotors



Example: MOTION-CONNECT 300, power cable for SIMOTICS S-1FL6 High Inertia servomotors

For Selection and Ordering Data please refer to section "System overview" "SINAMICS V90 basic servo drive system" from page 1/9.

Technical specifications

| | | |
|--|--|--|
| Product name | MOTION-CONNECT 300 power cable SINAMICS V90 200 ... 240 V 1 AC/3 AC – SIMOTICS S-1FL6 Low Inertia, 0.05 kW ... 1 kW | SINAMICS V90 200 ... 240 V 1 AC/3 AC – SIMOTICS S-1FL6 Low Inertia, 1.5 kW ... 2 kW SINAMICS V90 380 ... 480 V 3 AC – SIMOTICS S-1FL6 High Inertia, 0.4 kW ... 7 kW |
| Type | 6FX3002-5CK01-.... | 6FX3002-5CL02-.... 6FX3002-5CL12-.... 6FX3002-5CK32-.... |
| No. of cores | 4 | 4 |
| Degree of protection motor side (when closed and connected) | IP20 | IP65 |
| Certificate of suitability | | |
| • RoHS | Yes | Yes |
| • UL | cURus | No UL for motor side connector |
| • CE | Yes | Yes |
| Rated voltage U_0/U | 300 V/500 V | 600 V/1000 V |
| Test voltage, rms | 4 kV | 4 kV |
| Operating temperature on the surface | | |
| • Fixed installation | -25 ... +80 °C | -25 ... +80 °C |
| Tensile stress, max. | | |
| • Fixed installation | 50 N/mm ² | 50 N/mm ² |
| • Flexible installation | 20 N/mm ² | 20 N/mm ² |
| Smallest bending radius | | |
| • Fixed installation | 6 × diameter | 6 × diameter |
| • Flexible installation | 155 mm | 155 mm |
| Torsional stress | Absolute 30°/m | Absolute 30°/m |
| Bending | 100000 | 100000 |
| Insulation material, incl. jacket | PVC | PVC |
| Oil resistance | EN 60811-2-1 | EN 60811-2-1 |
| Outer jacket | PVC | PVC |
| Flame-retardant | EN 60332-1-1 to 1-3 | EN 60332-1-1 to 1-3 |

MOTION-CONNECT connection systems

Pre-assembled signal cables for SINAMICS V90

Overview

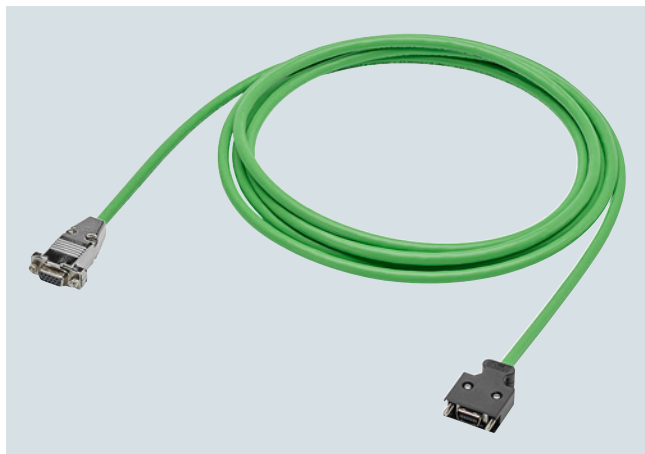

Example: MOTION-CONNECT 300, signal cable for encoder connection on SIMOTICS S-1FL6 Low Inertia servomotors



Example: MOTION-CONNECT 300, signal cable for encoder connection for SIMOTICS S-1FL6 High Inertia servomotors

For Selection and Ordering Data please refer to section "System overview" "SINAMICS V90 basic servo drive system" from page 1/9.

Technical specifications

| Product name | MOTION-CONNECT 300 signal cable for encoder connection | |
|--|---|--|
| | SINAMICS V90 200 ... 240 V 1 AC/3 AC – SIMOTICS S-1FL6 Low Inertia, 0.05 kW ... 1 kW | SINAMICS V90 200 ... 240 V 1 AC/3 AC – SIMOTICS S-1FL6 Low Inertia, 1.5 kW ... 2 kW SINAMICS V90 380 ... 480 V 3 AC – SIMOTICS S-1FL6 High Inertia, 0.4 kW ... 7 kW |
| Type | 6FX3002-2DB20-.... 6FX3002-2CT20-.... | 6FX3002-2DB10-.... 6FX3002-2DB12-.... 6FX3002-2CT12-.... |
| No. of cores | 10 | 10 |
| Degree of protection motor side (when closed and connected) | IP20 | IP65 |
| Certificate of suitability | | |
| • RoHS | Yes | Yes |
| • UL | cURus | cURus (for 6FX3002-2CT12-.... no UL for motor side connector) |
| • CE | Not required | Not required |
| Rated voltage U_0/U | 30 V/30 V | 30 V/30 V |
| Test voltage, rms | 500 V | 500 V |
| Operating temperature on the surface | | |
| • Fixed installation | -25 ... +80 °C | -25 ... +80 °C |
| Tensile stress, max. | | |
| • Fixed installation | 50 N/mm ² | 50 N/mm ² |
| • Flexible installation | 20 N/mm ² | 20 N/mm ² |
| Smallest bending radius | | |
| • Fixed installation | 6 × diameter | 6 × diameter |
| • Flexible installation | 155 mm | 155 mm |
| Torsional stress | Absolute 30°/m | Absolute 30°/m |
| Bending | 100000 | 100000 |
| Insulation material, incl. jacket | PVC | PVC |
| Oil resistance | EN 60811-2-1 | EN 60811-2-1 |
| Outer jacket | PVC | PVC |
| Flame-retardant | EN 60332-1-1 to 1-3 | EN 60332-1-1 to 1-3 |

Overview (continued)



Example: MOTION-CONNECT 300, signal cable for brake connection on SIMOTICS S-1FL6 Low Inertia servomotors



Example: MOTION-CONNECT 300, signal cable for brake connection on SIMOTICS S-1FL6 High Inertia servomotors

For Selection and Ordering Data please refer to section "System overview" "SINAMICS V90 basic servo drive system" from page 1/9.











Technical specifications (continued)

| Product name | MOTION-CONNECT 300 signal cable for brake connection | |
|--|---|--|
| | SINAMICS V90 200 ... 240 V 1 AC/3 AC – SIMOTICS S-1FL6 Low Inertia, 0.05 kW ... 1 kW | SINAMICS V90 200 ... 240 V 1 AC/3 AC – SIMOTICS S-1FL6 Low Inertia, 1.5 kW ... 2 kW SINAMICS V90 380 ... 480 V 3 AC – SIMOTICS S-1FL6 High Inertia, 0.4 kW ... 7 kW |
| Type | 6FX3002-5BK02-.... | 6FX3002-5BL03-.... |
| No. of cores | 2 | 2 |
| Degree of protection motor side (when closed and connected) | IP20 | IP65 |
| Certificate of suitability | | |
| • RoHS | Yes | Yes |
| • UL | cURus | No UL for motor side connector |
| • CE | Not required | Not required |
| Rated voltage U_0/U | 30 V/30 V | 30 V/30 V |
| Test voltage, rms | 500 V | 500 V |
| Operating temperature on the surface | | |
| • Fixed installation | -25 ... +80 °C | -25 ... +80 °C |
| Tensile stress, max. | | |
| • Fixed installation | 50 N/mm ² | 50 N/mm ² |
| • Flexible installation | 20 N/mm ² | 20 N/mm ² |
| Smallest bending radius | | |
| • Fixed installation | 6 × diameter | 6 × diameter |
| • Flexible installation | 155 mm | 155 mm |
| Torsional stress | Absolute 30°/m | Absolute 30°/m |
| Bending | 100000 | 1000000 |
| Insulation material, incl. jacket | PVC | PVC |
| Oil resistance | EN 60811-2-1 | EN 60811-2-1 |
| Outer jacket | PVC | PVC |
| Flame-retardant | EN 60332-1-1 to 1-3 | EN 60332-1-1 to 1-3 |

MOTION-CONNECT connection systems

Connectors for SINAMICS V90

Overview

| Shaft height | Connectors motor side | | | |
|---|---|--|--|---|
| | for power connection | for incremental encoder | for absolute encoder | for brake |
| MOTION-CONNECT connectors for SIMOTICS S-1FL6 Low Inertia servomotors | | | | |
| 20, 30, 40 | 6FX2003-0LL12 | 6FX2003-0SL12 | 6FX2003-0DB12 | 6FX2003-0LL52 |
| |  |  |  |  |
| 50 | 6FX2003-0LL13 | 6FX2003-0SL13 | 6FX2003-0DB13 | 6FX2003-0LL53 |
| |  |  |  |  |
| MOTION-CONNECT connectors for SIMOTICS S-1FL6 High Inertia servomotors | | | | |
| 45, 65, 90 | 6FX2003-0LL13 | 6FX2003-0SL13 | 6FX2003-0DB11 | 6FX2003-0LL53 |
| |  |  |  |  |
| Frame size | Connectors drive side | | | |
| | for power connection | for incremental encoder | for absolute encoder | for brake |
| MOTION-CONNECT connectors for SINAMICS V90 servo drive | | | | |
| FSA, FSB, FSC, FSD | – | 6FX2003-0SB14 | 6FX2003-0SB14 | – |
| | |  | | |

For Selection and Ordering Data please refer to section "System overview" "SINAMICS V90 basic servo drive system" from page 1/9.

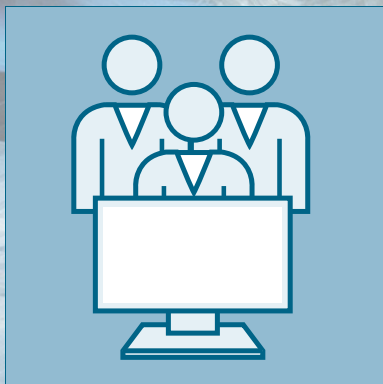

Security information

Siemens provides products and solutions with industrial security functions that support the secure operation of plants, systems, machines and networks.

In order to protect plants, systems, machines and networks against cyber threats, it is necessary to implement – and continuously maintain – a holistic, state-of-the-art industrial security concept. Siemens' products and solutions constitute one element of such a concept.

Customers are responsible for preventing unauthorized access to its plants, systems, machines and networks. Such systems, machines and components should only be connected to an enterprise network or the internet if and to the extent such a connection is necessary and only when appropriate security measures (e.g. firewalls and/or network segmentation) are in place.

For additional information on industrial security measures that may be implemented, please visit

<https://www.siemens.com/industrialsecurity>

Siemens' products and solutions undergo continuous development to make them more secure. Siemens strongly recommends that product updates are applied as soon as they are available and that the latest product versions are used. Use of product versions that are no longer supported, and failure to apply latest updates may increase customer's exposure to cyber threats.

To stay informed about product updates, subscribe to the Siemens Industrial Security RSS Feed under

<https://www.siemens.com/industrialsecurity>

5/2

5/2

5/2

5/2

Drive Technology Configurator

Overview

Selection and ordering data

More information

5/3

5/3

SINAMICS V-ASSISTANT

Overview

Engineering tools

Drive Technology Configurator

Overview

The Drive Technology Configurator (DT Configurator) helps you to configure the optimum drive technology products for your application – starting with gear units, motors, inverters as well as the associated options and components and ending with controllers, software licenses and connection systems. Whether with little or detailed knowledge of products: preselected product groups, deliberate navigation through selection menus and direct product selection through entry of the article number support quick, efficient and convenient configuration.

In addition, comprehensive documentation comprising technical data sheets, 2D dimensional drawings/3D CAD models, operating instructions, certificates, etc. can be selected in the DT Configurator. Immediate ordering is possible by simply transferring a parts list to the shopping cart of the Industry Mall.

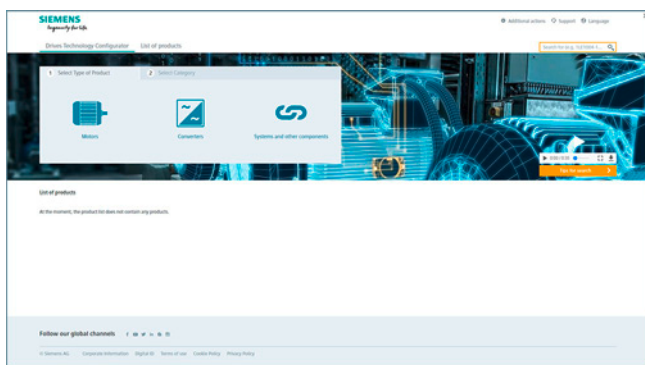

Drive Technology Configurator for efficient drive configuration with the following functions

- Quick and easy configuration of drive products and associated components – gear units, motors, inverters, controllers, connection systems
- Configuration of drive systems for pumps, fans and compressor applications from 1 kW to 2.6 MW
- Retrievable documentation for configured products and components, such as
 - Data sheets in up to 9 languages in PDF or RTF format
 - 2D dimensional drawings/3D CAD models in various formats
 - Terminal box drawing and terminal connection diagram
 - Operating instructions
 - Certificates
 - Start-up calculation for SIMOTICS motors
 - EPLAN macros
- Support with retrofitting in conjunction with Spares On Web (www.siemens.com/sow)
- Ability to order products directly through the Siemens Industry Mall

Access to the Drive Technology Configurator

The Drive Technology Configurator can be called up without registration and without a login:

www.siemens.com/dt-configurator

Selection and ordering data

| Description | Article No. |
|---|----------------------------------|
| Interactive Catalog CA 01 including Drive Technology Configurator | |
| • German (DVD-ROM – Edition Germany) | E86060-D4001-A500-D8 |
| • German, English, French, Spanish (Download - without prices) | E86060-D4001-A510-D8-7500 |

More information

[Online access to the Drive Technology Configurator](#)

More information about the Drive Technology Configurator is available on the Internet at

www.siemens.com/dtconfigurator

[Offline access to the Drive Technology Configurator in the Interactive Catalog CA 01](#)

In addition, the Drive Technology Configurator is also included in the Interactive Catalog CA 01 – the offline version of the Siemens Industry Mall.

The Interactive Catalog CA 01 can be ordered from the relevant Siemens sales office or via the Internet:

www.siemens.com/automation/CA01

Overview

SINAMICS V-ASSISTANT – Easy-to-use engineering tool for commissioning and diagnostics

A PC with installed SINAMICS V-ASSISTANT software tool can be connected to SINAMICS V90 via a standard USB port. It is used for setting parameters, test operation, troubleshooting – and has powerful monitoring functions.

SINAMICS V-ASSISTANT can be downloaded free of charge from the SINAMICS V90 Internet page: <https://siemens.com/sinamics-v90>

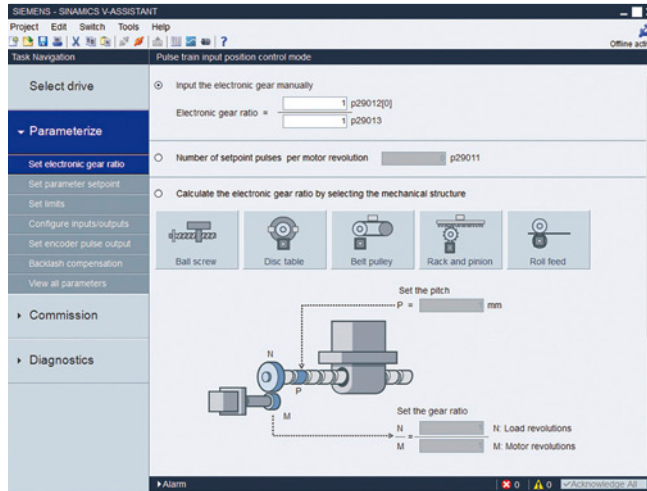

User task-centric design for prompted machine commissioning

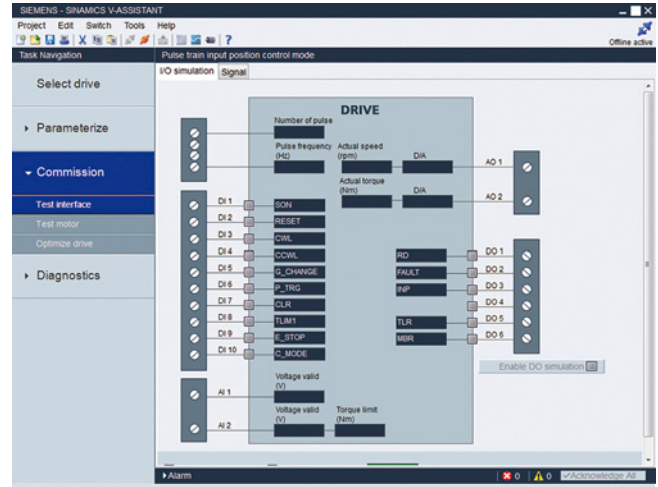

Graphic view to monitor the digital inputs/outputs and other control signals

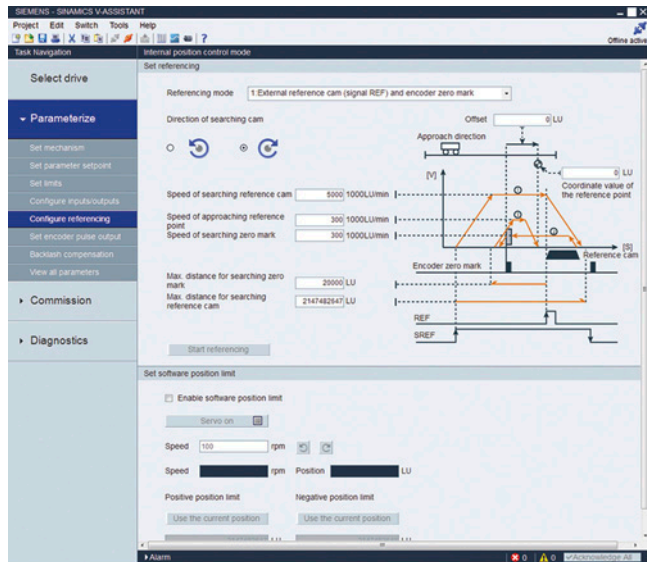

Graphic screen so that users can quickly and simply configure machines

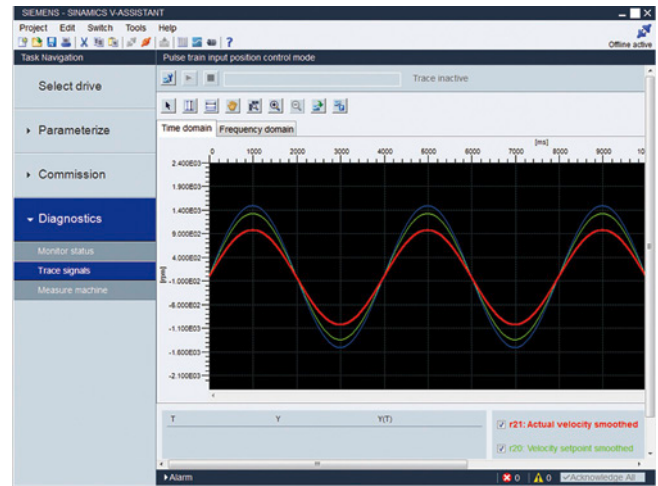

Trace function to monitor the drive and motor status

Engineering tools

Notes

Services and documentation



| | |
|------|--|
| 6/2 | Partner at Siemens |
| 6/2 | Easy product selection and ordering in the Industry Mall and with the Interactive Catalog CA 01 |
| 6/2 | Industry Mall |
| 6/2 | Interactive Catalog CA 01 – Products for Automation and Drives |
| 6/3 | Information and Download Center |
| 6/3 | Downloading catalogs |
| 6/4 | Industry Services |
| 6/4 | Overview |
| 6/4 | Industry Services – Portfolio overview |
| 6/5 | Overview |
| 6/6 | Online Support |
| 6/6 | Overview |
| 6/7 | Training |
| 6/7 | SITRAIN – Training for Industry |
| 6/8 | SINAMICS V90 training case |
| 6/8 | Overview |
| 6/8 | Technical specifications |
| 6/8 | Selection and ordering data |
| 6/9 | Applications |
| 6/9 | Overview |
| 6/10 | Documentation |
| 6/10 | General documentation |
| 6/10 | Overview |
| 6/10 | Application |
| 6/10 | Selection and ordering data |

Services and documentation

Partner · Industry Mall and Interactive Catalog CA 01

Partner at Siemens

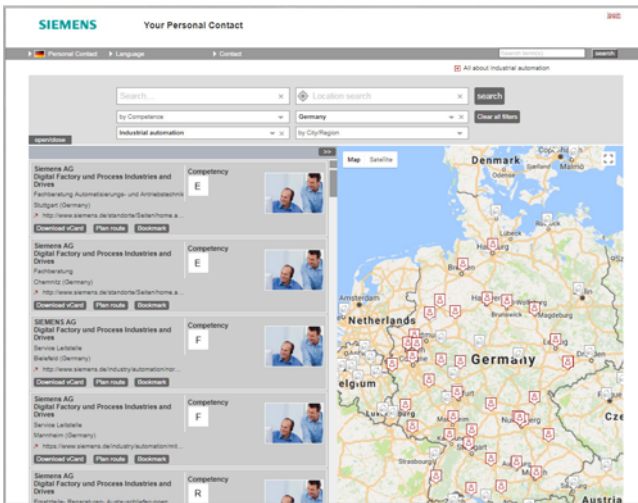

At your service locally, around the globe for consulting, sales, training, service, support, spare parts on the entire portfolio of Digital Factory and Process Industries and Drives.

Your partner can be found in our Personal Contacts Database at: www.siemens.com/automation-contact

You start by selecting

- the required competence,
 - products and branches,
 - a country and a city
- or by a
- location search or free text search.

Easy product selection and ordering in the Industry Mall and with the Interactive Catalog CA 01

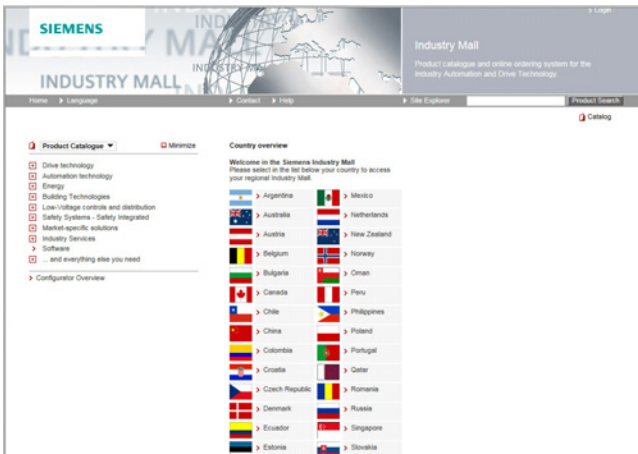

Industry Mall

The Industry Mall is a Siemens Internet ordering platform. Here you have a clear and informative online access to a huge range of products.

Powerful search functions make it easy to select the required products. Configurators enable you to configure complex product and system components quickly and easily. CAx data types are also provided here.

Data transfer allows the whole procedure, from selection through ordering to tracking and tracing, to be carried out online. Availability checks, customer-specific discounts and bid creation are also possible.

www.siemens.com/industrymall



Interactive Catalog CA 01 – Products for Automation and Drives

The Interactive Catalog CA 01 combined with the Siemens Industry Mall unites the benefits of offline and online media in one application – the performance of an offline catalog with the availability of manifold and up-to-date information on the Internet.

Select products and assemble orders with the CA 01, determine the availability of the selected products and track & trace via the Industry Mall.

More information and download:
www.siemens.com/automation/ca01

Downloading catalogs

The screenshot displays the Siemens Information and Download Center interface. At the top, there is a navigation bar with the Siemens logo and a search bar. Below the navigation bar, the page is titled "Information and Download Center". The main content area is divided into several sections:

- Navigation and Search:** Includes tabs for "Catalogs (362)", "Brochures (810)", "Customer Magazines (8)", and "Demo Software (15)". There is a search filter set to "10" and a language dropdown set to "English".
- Product Listings:** Two catalog items are visible:
 - Catalog D 11 - 2015 (13 MB):** Order number: 6ES730-1A10-1A6-7000. Includes SINAMICS G130 Drive Converter Chassis Units and SINAMICS G150 Drive Converter Cabinet Units.
 - Catalog D 12 - 2017 with dimension drawings:** Order number: keine (Bestellnummer vorhanden). Includes Medium voltage drives, SINAMICS GM150, and SINAMICS SM150 with dimension drawings.
- Filtering and Sharing:** A "Text Size" selector and a "Share this Page" button with social media icons are present.
- Product & Service Filter:** A list of categories with checkboxes:
 - Building Technologies (2)
 - Drive technology (294)
 - Energy (11)
 - Industrial automation (922)
 - Low-voltage controls and distribution (32)
 - Safety systems - Safety Integrated (31)
 - Services (8)
 - Software (1)
- All about Products & Services:** A list of links:
 - Presses info
 - Catalog and ordering system online
 - Technical info
 - Support
 - Service offer

In the Information and Download Center you can download catalogs and brochures in PDF format without having to register. The filter dialog makes it possible to carry out targeted searches.

www.siemens.com/industry/infocenter

Services and documentation

Industry Services

Overview

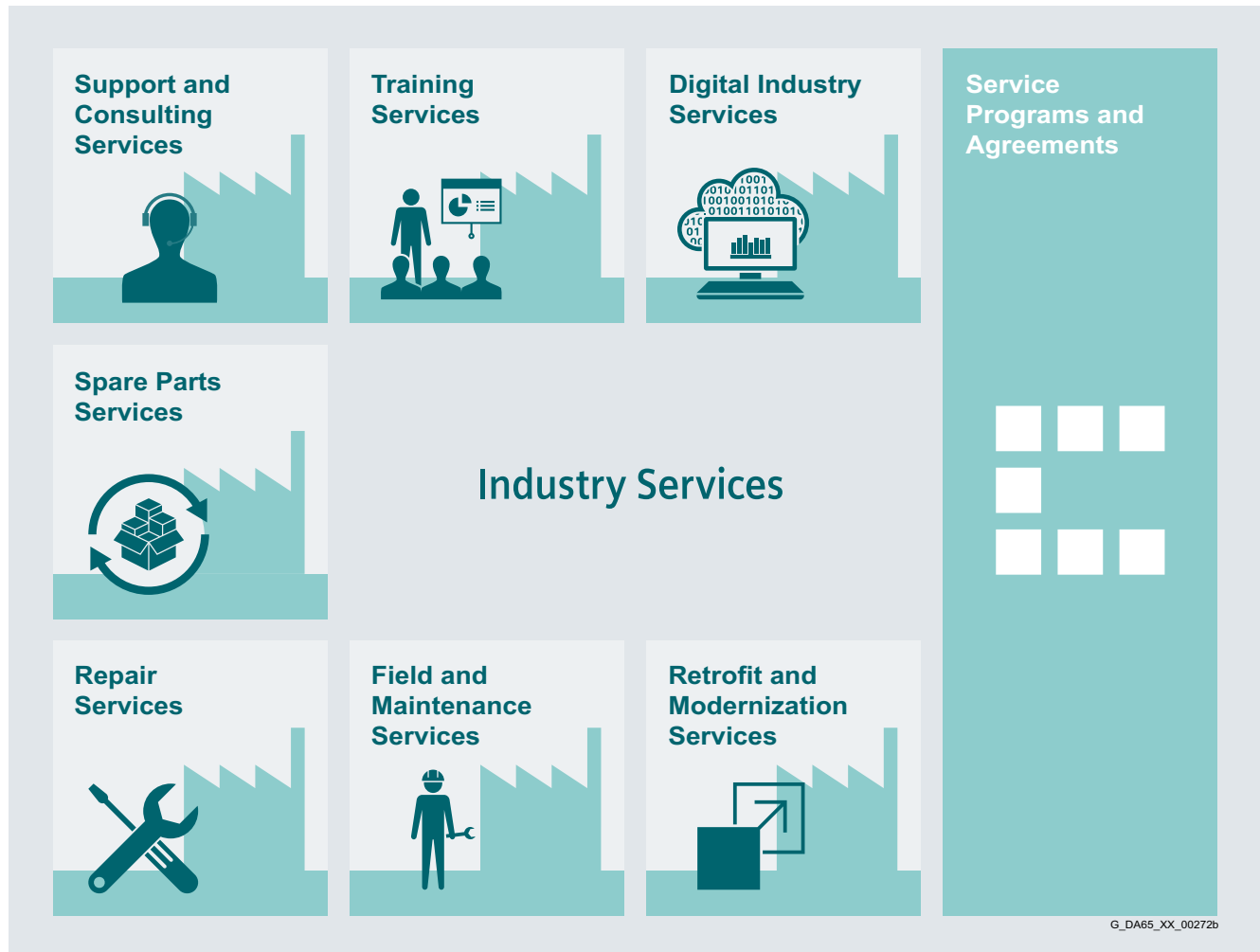

Keep your business running and shaping your digital future – with Industry Services

Optimizing the productivity of your equipment and operations can be a challenge, especially with constantly changing market conditions. Working with our service experts makes it easier. We understand your industry's unique processes and provide the services needed so that you can better achieve your business goals.

You can count on us to maximize your uptime and minimize your downtime, increasing your operations' productivity and reliability. When your operations have to be changed quickly to meet a new demand or business opportunity, our services give you the flexibility to adapt. Of course, we take care that your production is protected against cyber threats. We assist in keeping your operations as energy and resource efficient as possible and reducing your total cost of ownership. As a trendsetter, we ensure that you can capitalize on the opportunities of digitalization and by applying data analytics to enhance decision making: You can be sure that your plant reaches its full potential and retains this over the longer lifespan.

You can rely on our highly dedicated team of engineers, technicians and specialists to deliver the services you need – safely, professionally and in compliance with all regulations. We are there for you, where you need us, when you need us.

www.siemens.com/industryservices

Overview



Digital Industry Services

Digital Industry Services

Digital Industry Services make your industrial processes transparent to gain improvements in productivity, asset availability, and energy efficiency.

Production data is generated, filtered and translated with intelligent analytics to enhance decision-making.

This is done whilst taking data security into consideration and with continuous protection against cyber-attack threats.

<https://www.siemens.com/global/en/home/products/services/industry/digital-services.html>

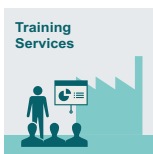

Training Services

Training Services

From the basics and advanced to specialist skills, SITRAIN courses provide expertise right from the manufacturer – and encompass the entire spectrum of Siemens products and systems for the industry.

Worldwide, SITRAIN courses are available wherever you need a training course in more than 170 locations in over 60 countries.

<https://support.industry.siemens.com/cs/ww/en/sc/2226>

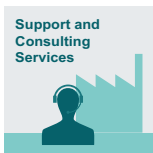

Support and Consulting Services

Support and Consulting Services

Industry Online Support site for comprehensive information, application examples, FAQs and support requests.

Technical and Engineering Support for advice and answers for all inquiries about functionality, handling, and fault clearance. The Service Card as prepaid support for value added services such as Priority Call Back or Extended Support offers the clear advantage of quick and easy purchasing.

Information & Consulting Services, e.g. SIMATIC System Audit; clarity about the state and service capability of your automation system or Lifecycle Information Services; transparency on the lifecycle of the products in your plants.

<https://support.industry.siemens.com/cs/ww/en/sc/2235>



Spare Parts Services

Spare Parts

Spare Parts Services are available worldwide for smooth and fast supply of spare parts – and thus optimal plant availability. Genuine spare parts are available for up to ten years. Logistic experts take care of procurement, transport, custom clearance, storage and order management.

Reliable logistics processes ensure that components reach their destination as needed.

Since not all spare parts can be kept in stock at all times, Siemens offers a preventive measure for spare parts provisioning on the customer's premises with optimized **Spare Parts Packages** for individual products, custom-assembled drive components and entire integrated drive trains – including risk consulting.

Asset Optimization Services help you design a strategy for parts supply where your investment and carrying costs are reduced and the risk of obsolescence is avoided.

<https://support.industry.siemens.com/cs/ww/en/sc/2110>



Repair Services

Repair Services

Repair Services are offered on-site and in regional repair centers for fast restoration of faulty devices' functionality.

Also available are extended repair services, which include additional diagnostic and repair measures, as well as emergency services.

<https://support.industry.siemens.com/cs/ww/en/sc/2154>



Field and Maintenance Services

Field and Maintenance Services

Siemens specialists are available globally to provide expert field and maintenance services, including commissioning, functional testing, preventive maintenance and fault clearance.

All services can be included in customized service agreements with defined reaction times or fixed maintenance intervals.

<https://support.industry.siemens.com/cs/ww/en/sc/2265>



Retrofit and Modernization Services

Retrofit and Modernization Services

Provide a cost-effective solution for the expansion of entire plants, optimization of systems or upgrading existing products to the latest technology and software, e.g. migration services for automation systems.

Service experts support projects from planning through commissioning and, if desired over the entire extended lifespan, e.g. Retrofit for Integrated Drive Systems for an extended lifetime of your machines and plants.

<https://support.industry.siemens.com/cs/ww/en/sc/2286>



Service Programs and Agreements

Service Programs and Agreements

A technical Service Program or Agreement enables you to easily bundle a wide range of services into a single annual or multi-year agreement.

You pick the services you need to match your unique requirements or fill gaps in your organization's maintenance capabilities.

Programs and agreements can be customized as KPI-based and/or performance-based contracts.

<https://support.industry.siemens.com/cs/ww/en/sc/2275>

Services and documentation

Industry Services

Online Support

Overview

Online Support – fast, intuitive, whenever you want, wherever you need

Web

support.industry.siemens.com

App

Scan the QR code for information on our Online Support app.

- FAQ / Application examples**
Information about industrial products, programming and configuration as well as application examples
- Technical Information**
Videos, documentation, manuals, updates, product notes, compatibility tool, certificates, planning data such as dimensional drawings, product data, 3D models
- Forum**
Exchange information and experience with other users and experts

Online Support for Siemens Products for Industry

Siemens Industry and Online Support with some 1.7 million visitors per month is one of the most popular web services provided by Siemens. It is the central access point for comprehensive technical know-how about products, systems and services for automation and drives applications as well as for process industries.

In connection with the challenges and opportunities related to digitalization you can look forward to continued support with innovative offerings.



Your benefit from practical training directly from the manufacturer

SITRAIN – Training for Industry – provides you with comprehensive support in solving your tasks.

Training directly from the manufacturer enables you to make correct decisions with confidence.

Increased profits and lower costs:

- Shorter times for commissioning, maintenance and servicing
- Optimized production operations
- Reliable configuration and commissioning
- Shortened startup times, reduced downtimes, and faster troubleshooting
- Exclude expensive faulty planning right from the start.
- Flexible plant adaptation to market requirements
- Compliance with quality standards in production
- Increased employee satisfaction and motivation
- Shorter familiarization times following changes in technology and staff

Contact

Visit our site on the Internet at:
www.siemens.com/sitrain

or let us advise you personally:

SITRAIN – Training for Industry
SITRAIN Customer Support Germany:

Tel.: +49 911 895-7575

Fax: +49 911 895-7576

Email: info@sitrain.com

Your benefits with SITRAIN – Training for Industry

Certified top trainers

Our trainers are skilled specialists with practical experience. Course developers have close contact with product development, and pass on their knowledge to the trainers and then to you.

Practical application with practice

Practice, practice, practice! We have designed the trainings with an emphasis on practical exercises. They take up to half of the course time in our trainings. You can therefore implement your new knowledge in practice even faster.

300 courses in more than 60 countries

We offer a total of about 300 classroom-based courses. You can find us at more than 50 locations in Germany, and in 62 countries worldwide. You can find which course is offered at which location at:

www.siemens.com/sitrain

Skills development

Do you want to develop skills and fill in gaps in your knowledge? Our solution: We will provide a program tailored exactly to your personal requirements. After an individual requirements analysis, we will train you in our training centers near you or directly at your offices. You will practice on the most modern training equipment with special exercise units. The individual training courses are optimally matched to each other and help with the continuous development of knowledge and skills. After finishing a training module, the follow-up measures make success certain, as well as the refreshment and deepening of the knowledge gained.

Services and documentation

Training

SINAMICS V90 training case

Overview



Example: SINAMICS V90 training case, pulse train version (PTI) without SIMATIC controller

The SINAMICS V90 training cases are convincing demonstration systems thanks to their compact design. They are suitable for direct customer presentations as well as for tests in technical departments. These training cases enable the functions of SINAMICS V90 to be demonstrated and tested quickly and easily.

The following training cases are available: 1-axis pulse train version (PTI) with and without SIMATIC controller and 2-axis PROFINET version (PN).

Depending on the version, the training cases contain the following components:

- SINAMICS V90 servo drive
- SIMOTICS S-1FL6 servomotor
- SIMATIC S7-1200 controller

The SINAMICS V90 training case is supplied in the form of a stackable Tanos Systainer case (size depending on training case version).

Technical specifications

| SINAMICS V90 training case | 6AG1067-2AA00-0AC0 | 6AG1067-3AA00-0AB0 | 6AG1067-1AA32-0AA0 |
|----------------------------|---|--|---|
| Supply voltage | 230 V 1 AC | 230 V 1 AC | 230 V 1 AC |
| Version | 1-axis version Pulse train version (PTI) comprising <ul style="list-style-type: none"> • SINAMICS V90 servo drive frame size FSA, 0.2 kW • SIMOTICS S-1FL6 Low Inertia servomotor • SIMATIC S7-1200 CPU1211C controller | 1-axis version Pulse train version (PTI) comprising <ul style="list-style-type: none"> • SINAMICS V90 servo drive frame size FSAA, 0.4 kW • SIMOTICS S-1FL6 High Inertia servomotor | 2-axis version PROFINET version (PN) comprising <ul style="list-style-type: none"> • 2 × SINAMICS V90 servo drive frame size FSAA, 0.2 kW • 2 × SIMOTICS S-1FL6 Low Inertia servomotor |
| Dimensions | | | |
| • Width | 400 mm (15.75 in) | 400 mm (15.75 in) | 340 mm (13.39 in) |
| • Height | 315 mm (12.40 in) | 315 mm (12.40 in) | 470 mm (18.50 in) |
| • Depth | 300 mm (11.81 in) | 300 mm (11.81 in) | 400 mm (15.75 in) |
| Weight, approx. | 7.7 kg (17.0 lb) | 12 kg (26.5 lb) | 19.2 kg (42.3 lb) |
| Delivery state | Tanos Systainer size 3 | Tanos Systainer size 4 | Tanos Systainer size 4 |

Selection and ordering data

| Description | Article No. |
|--|---------------------------|
| SINAMICS V90 training case | |
| • Pulse train version (PTI), 1-axis version with SIMATIC controller | 6AG1067-2AA00-0AC0 |
| • Pulse train version (PTI), 1-axis version without SIMATIC controller | 6AG1067-3AA00-0AB0 |
| • PROFINET version (PN), 2-axis version without SIMATIC controller | 6AG1067-1AA32-0AA0 |

Overview



Our understanding of an application is the customer-specific solution of an automation task based on standard hardware and software components. In this respect, industry knowledge and technological expertise are just as important as expert knowledge about how our products and systems work. We are setting ourselves this challenge with more than 280 application engineers in 20 countries.

Application centers

We currently have application centers in:

- Germany: Head Office in Erlangen and in other German regions, e.g. in Munich, Nuremberg, Stuttgart, Mannheim, Frankfurt, Chemnitz, Cologne, Bielefeld, Bremen, Hanover, Hamburg
- Belgium: Brussels
- Brazil: Sao Paulo
- China: Beijing and 12 regions
- Denmark: Ballerup
- France: Paris
- Great Britain: Manchester
- India: Mumbai
- Italy: Bologna, Milan
- Japan: Tokyo, Osaka
- The Netherlands: The Hague
- Austria: Vienna
- Poland: Warsaw
- Sweden: Göteborg
- Switzerland: Zurich, Lausanne
- Spain: Madrid
- South Korea: Seoul
- Taiwan: Taipeh
- Turkey: Istanbul
- USA: Atlanta

These application centers specialize in the use of SIMATIC/SIMOTION/SINAMICS. You therefore can rely on automation and drive specialists for implementing successful applications. By involving your personnel at an early stage in the process, we can provide a solid basis for rapid knowledge transfer, maintenance and further development of your automation solution.

Advice on applications and implementation

We offer a variety of consultation services to help you find the optimum solution for the SIMATIC/SIMOTION/SINAMICS application you want to implement:

The quotation phase includes

- clarification of technical questions,
- discussion of machine concepts and customer-specific solutions,
- selection of suitable technology and
- suggestions for implementation.

A technical feasibility study is also performed at the outset. In this way, difficult points of the application can be identified and solved early on. We can also configure and implement your application as a complete solution from a single source.

A large number of proven standard applications are available for use during the implementation phase. This saves engineering costs.

The system can be commissioned by experienced, competent personnel, if required. This saves time and trouble.

If servicing is required, we can support you on site or remotely. For further information about servicing, please see the section "Industry Services".

On-site application training

Training for the implemented applications can also be organized and carried out on site. This training for machine manufacturers and their customers does not deal with individual products, but the entire hardware and software system (for example, automation, drives and visualization).

From an initial concept to successful installation and commissioning: We provide complete support for SIMATIC/SIMOTION/SINAMICS! Contact your Siemens representative.

You can find further information at www.siemens.com/machinebuilding

Services and documentation

Documentation

General documentation

Overview

A high-quality programmable control or drive system can be used to maximum effect only if the user is aware of the performance of the products used as a result of intensive training and good technical documentation.

This is becoming more important due to the shorter innovation cycles of modern automation products and the convergence of electronics and mechanical engineering.

A comprehensive range of documentation is available which includes a Getting Started guide, operating instructions, installation manuals and a list manual.

The documents are available in hardcopy form or as a PDF file for downloading from the Internet.

Information and documentation relating to SINUMERIK, SINAMICS, SIMOTION and SIMOTICS are available on the Internet at <https://support.industry.siemens.com/cs/document/109476679>

In addition to many other useful documents, the Information and Download Center also contains catalogs about the following systems:

- SINUMERIK: NC 62, NC 81.1, NC 82
- SINAMICS: D 11, D 12, D 21.3, D 21.4, D 23.1, D 23.2, D 31.1, D 31.2, D 32, D 33, D 35
- SIMOTION: PM 21
- SIMOTICS: D 21.4, D 41, D 81.1, D 81.8, D 83.1
- You can download these catalogs in PDF format – you don't need to log on. You can perform a targeted search using the filter box above the first displayed catalog. By entering the search term "NC 8", for example, you can locate Catalog NC 81.1 and Catalog NC 82, and by entering "ST 70" you will find Catalog ST 70 as well as the relevant news and add-ons (if available).
www.siemens.com/industry/infocenter

Application

Explanations of the manuals:

- **Operating Instructions**
contain all the information needed to install the device and make electrical connections, information about commissioning and a description of the inverter functions.
Phases of use: Control cabinet construction, commissioning, operation, maintenance and servicing.
- **Hardware Installation Manual**
contains all relevant information about the intended use of the components of a system (technical specifications, interfaces, dimensional drawings, characteristics, or possible applications), information about installation and electrical connections and information about maintenance and servicing.
Phases of use: Control cabinet configuration/construction, maintenance and servicing.
- **Operating and Installation Instructions**
(for inverter and accessories)
contain all relevant information about the intended use of the components, such as technical specifications, interfaces, dimensional drawings, characteristics, or possible applications.
Phases of use: Control cabinet configuration/construction.
- **Manual/Configuration Manual**
contains all necessary information about the intended use of the components of a system, e.g. technical specifications, interfaces, dimensional drawings, characteristics, or possible applications.
Phases of use: Cabinet configuration/setup, circuit diagram configuration/drawing.

- **Commissioning Manual**

contains all information relevant to commissioning after installation and wiring. It also contains all safety and warning notices relevant to commissioning in addition to overview drawings.

Phases of use: Commissioning of components that have already been connected, configuration of system functions.

- **List Manual**

contains all parameters, function diagrams, and faults/alarms for the product/system as well as their meanings and setting options. It contains parameter data and fault/alarm descriptions with functional correlations.

Phases of use: Commissioning of components that have already been connected, configuration of system functions, fault cause/diagnosis.

- **Getting Started**

provides information about getting started for the first-time user as well as references to additional information. It contains information about the basic steps to be taken during commissioning. The information in the other documentation should be carefully observed for all of the other work required.

Phases of use: Commissioning of components that have already been connected.

- **Function Manual Drive Functions**

contains all the relevant information about individual drive functions: Description, commissioning and integration in the drive system.

Phases of use: Commissioning of components that have already been connected, configuration of system functions.

Selection and ordering data

| Description | Article No. |
|---|-------------------------------|
| Decentralization with PROFIBUS DP/DPV1 | Via bookstore |
| • German | ISBN 978-3-89578-189-6 |
| • English | ISBN 978-3-89578-218-3 |
| Automating with PROFINET: Industrial Communication Based on Industrial Ethernet | Via bookstore |
| • German | ISBN 978-3-89578-293-0 |
| • English | ISBN 978-3-89578-294-7 |
| Configuration Manual EMC Installation Guideline SIMOCRANE, SIMOTICS, SIMOTION, SINAMICS, SINUMERIK | |
| • German | 6FC5297-0AD30-0AP3 |
| • English | 6FC5297-0AD30-0BP3 |
| • Italian | 6FC5297-0AD30-0CP3 |
| • French | 6FC5297-0AD30-0DP3 |
| • Spanish | 6FC5297-0AD30-0EP3 |
| • Chinese Simplified | 6FC5297-0AD30-0RP3 |

Appendix



| | |
|------|--|
| 7/2 | Certificates of suitability |
| 7/4 | Software licenses |
| 7/6 | Conversion tables |
| 7/8 | Metal surcharges |
| 7/11 | Conditions of sale and delivery |

Appendix

Certificates of suitability







Overview

Many of the products in this Catalog fulfill requirements, e.g. for UL, CSA or FM and are labeled with the corresponding approval designation.

All of the certificates of suitability, approvals, certificates, declarations of conformity, test certificates, e.g. CE, UL, Safety Integrated etc. have been performed with the associated system components as they are described in the Catalogs and Configuration Manuals.

The certificates are only valid if the products are used with the described system components, are installed according to the Installation Guidelines and used for their intended purpose.

In other cases, the vendor of these products is responsible for arranging for the issue of new certificates.

| Test code | Tested by | Device series/ Component | Test standard | Product category/ File-No. |
|---|---------------------------------------|-----------------------------|---|---|
| UL: Underwriters Laboratories <i>Independent public testing body in North America</i> | | | | |
|  | UL according to UL standard | SINUMERIK | Standard UL 508, CSA C22.2 No. 142 | NRAQ/7.E164110 NRAQ/7.E217227 |
| | | SIMOTION | Standard UL 508, CSA C22.2 No. 142 | NRAQ/7.E164110 |
|  | UL according to CSA standard | SINAMICS | Standard UL 508, 508C, 61800-5-1 CSA C22.2 No. 142, 274 | NRAQ/7.E164110, NMMS/2/7/8.E192450, NMMS/2/7/8.E203250, NMMS/7.E214113, NMMS/7.E253831 |
| | | | | NMMS/2/7/8.E121068 NMMS/7.E355661 NMMS/7.E323473 |
|  | UL according to UL and CSA standards | SIMODRIVE | Standard UL 508C, CSA C22.2 No. 274 | NMMS/2/7/8.E192450 NMMS/7.E214113 |
| | | SIMOTICS | Standard UL 1004-1, 1004-6, 1004-8, CSA C22.2 No. 100 | PRGY2/8.E227215 PRHZ2/8.E93429 PRHJ2/8.E342747 PRGY2/8.E253922 PRHZ2/8.E342746 |
|  | UL according to UL standard | Line/motor reactors | Standard UL 508, 506, 5085-1, 5085-2, 1561, CSA C22.2 No. 14, 47, 66.1-06, 66.2-06 | XQNX2/8.E257859 NMTR2/8.E219022 NMMS2/8.E333628 XPTQ2/8.E257852 XPTQ2/8.E103521 NMMS2/8.E224872 XPTQ2/8.E354316 XPTQ2/8.E198309 XQNX2/8.E475972 |
| | | | | Line filters, dv/dt filters, sine-wave filters |
|  | UL according to CSA standard | Resistors | UL 508, 508C, CSA C22.2 No. 14, 274 | NMTR2/8.E224314 NMMS2/8.E192450 NMTR2/8.E221095 NMTR2/8.E226619 |
| | | | |  |
| TUV: TÜV Rheinland of North America Inc. <i>Independent public testing body in North America, Nationally Recognized Testing Laboratory (NRTL)</i> | | | | |
| TÜV: TÜV SÜD Product Service <i>Independent public testing body in Germany, Nationally Recognized Testing Laboratory (NRTL) for North America</i> | | | | |
|  | TUV according to UL and CSA standards | SINAMICS | NRTL listing according to standard UL 508C | U7V 12 06 20078 013 U7 11 04 20078 009 U7 11 04 20078 010 U7 11 04 20078 011 |
| | | SIMOTION | NRTL listing according to standard UL 508 | U7V 13 03 20078 01 |
| | | SIMODRIVE | NRTL listing according to standard UL 508C, CSA C22.2. No. 14 | CU 72090702 |
| | | Motion Control Encoder | NRTL listing according to UL 61010-1 CSA C22.2 No. 61010-1 | U8V 10 06 20196 024 |

Overview (continued)

| Test code | Tested by | Device series/ Component | Test standard | Product category/ File-No. |
|--|--|-----------------------------------|--|-------------------------------|
| CSA: Canadian Standards Association <i>Independent public testing body in Canada</i> | | | | |
|  | CSA according to CSA standard | SINUMERIK | Standard CSA C22.2 No. 142 | 2252-01 : LR 102527 |
| FMRC: Factory Mutual Research Corporation <i>Independent public testing body in North America</i> | | | | |
|  | FM according to FM standard | SINUMERIK | Standard FMRC 3600, FMRC 3611, FMRC 3810, ANSI/ISA S82.02.1 | – |
| EAC: Ivanovo-Certificate <i>Independent public testing body in the Russian Federation</i> | | | | |
|  | EAC in accordance with the EAC Directive | SINAMICS SINUMERIK SIMOTION | Standard IEC 61800-5-1/-2, IEC 61800-3 | – |
| RCM: Australian Communications and Media Authority <i>Independent public testing body in Australia</i> | | | | |
|  | RCM according to EMC standard | SINAMICS SINUMERIK SIMOTION | Standard IEC AS 61800-3, EN 61800-3 | – |
| KC: National Radio Research Agency <i>Independent public testing body in South Korea</i> | | | | |
|  | KC according to EMC standard | SINAMICS SINUMERIK SIMOTION | Standard KN 11 | – |
| BIA <i>Federal Institute for Occupational Safety</i> | | | | |
| – | Functional safety | SINAMICS SINUMERIK SIMOTION | Standard EN 61800-5-2 | – |
| TÜV SÜD Rail | | | | |
| – | Functional safety | SINAMICS SINUMERIK SIMOTION | Standard EN 61800-5-2 | – |

More information about certificates can be found online at:
<https://support.industry.siemens.com/cs/ww/en/ps/cert>

Appendix

Software licenses

Overview

Software types

Software requiring a license is categorized into types. The following software types have been defined:

- Engineering software
- Runtime software

Engineering software

This includes all software products for creating (engineering) user software, e.g. for configuring, programming, parameterizing, testing, commissioning or servicing.

Data generated with engineering software and executable programs can be duplicated for your own use or for use by third-parties free-of-charge.

Runtime software

This includes all software products required for plant/machine operation, e.g. operating system, basic system, system expansions, drivers, etc.

The duplication of the runtime software and executable programs created with the runtime software for your own use or for use by third-parties is subject to a charge.

You can find information about license fees according to use in the ordering data (e.g. in the catalog). Examples of categories of use include per CPU, per installation, per channel, per instance, per axis, per control loop, per variable, etc.

Information about extended rights of use for parameterization/configuration tools supplied as integral components of the scope of delivery can be found in the readme file supplied with the relevant product(s).

License types

Siemens Industry Automation & Drive Technologies offers various types of software license:

- Floating license
- Single license
- Rental license
- Rental floating license
- Trial license
- Demo license
- Demo floating license

Floating license

The software may be installed for internal use on any number of devices by the licensee. Only the concurrent user is licensed. The concurrent user is the person using the program. Use begins when the software is started. A license is required for each concurrent user.

Single license

Unlike the floating license, a single license permits only one installation of the software per license.

The type of use licensed is specified in the ordering data and in the Certificate of License (CoL). Types of use include for example per instance, per axis, per channel, etc.

One single license is required for each type of use defined.

Rental license

A rental license supports the "sporadic use" of engineering software. Once the license key has been installed, the software can be used for a specific period of time (the operating hours do not have to be consecutive).

One license is required for each installation of the software.

Rental floating license

The rental floating license corresponds to the rental license, except that a license is not required for each installation of the software. Rather, one license is required per object (for example, user or device).

Trial license

A trial license supports "short-term use" of the software in a non-productive context, e.g. for testing and evaluation purposes. It can be transferred to another license.

Demo license

The demo license support the "sporadic use" of engineering software in a non-productive context, for example, use for testing and evaluation purposes. It can be transferred to another license. After the installation of the license key, the software can be operated for a specific period of time, whereby usage can be interrupted as often as required.

One license is required per installation of the software.

Demo floating license

The demo floating license corresponds to the demo license, except that a license is not required for each installation of the software. Rather, one license is required per object (for example, user or device).

Certificate of License (CoL)

The CoL is the licensee's proof that the use of the software has been licensed by Siemens. A CoL is required for every type of use and must be kept in a safe place.

Downgrading

The licensee is permitted to use the software or an earlier version/release of the software, provided that the licensee owns such a version/release and its use is technically feasible.

Delivery versions

Software is constantly being updated. The following delivery versions

- PowerPack
- Upgrade

can be used to access updates.

Existing bug fixes are supplied with the ServicePack version.

PowerPack

PowerPacks can be used to upgrade to more powerful software. The licensee receives a new license agreement and CoL (Certificate of License) with the PowerPack. This CoL, together with the CoL for the original product, proves that the new software is licensed.

A separate PowerPack must be purchased for each original license of the software to be replaced.

Overview (continued)**Upgrade**

An upgrade permits the use of a new version of the software on the condition that a license for a previous version of the product is already held.

The licensee receives a new license agreement and CoL with the upgrade. This CoL, together with the CoL for the previous product, proves that the new version is licensed.

A separate upgrade must be purchased for each original license of the software to be upgraded.

ServicePack

ServicePacks are used to debug existing products. ServicePacks may be duplicated for use as prescribed according to the number of existing original licenses.

License key

Siemens Industry Automation & Drive Technologies supplies software products with and without license keys.

The license key serves as an electronic license stamp and is also the "switch" for activating the software (floating license, rental license, etc.).

The complete installation of software products requiring license keys includes the program to be licensed (the software) and the license key (which represents the license).

Software Update Service (SUS)

As part of the SUS contract, all software updates for the respective product are made available to you free of charge for a period of one year from the invoice date. The contract will automatically be extended for one year if it is not canceled three months before it expires.

The possession of the current version of the respective software is a basic condition for entering into an SUS contract.

You can download explanations concerning license conditions from www.siemens.com/automation/salesmaterial-as/catalog/en/terms_of_trade_en.pdf

Appendix

Conversion tables

Rotary inertia (to convert from A to B, multiply by entry in table)

| A \ B | lb-in ² | lb-ft ² | lb-in-s ² | lb-ft-s ² slug-ft ² | kg-cm ² | kg-cm-s ² | gm-cm ² | gm-cm-s ² | oz-in ² | oz-in-s ² |
|--|------------------------|-----------------------|-----------------------|--|---------------------|------------------------|---------------------|-----------------------|-----------------------|-----------------------|
| lb-in ² | 1 | 6.94×10^{-3} | 2.59×10^{-3} | 2.15×10^{-4} | 2.926 | 2.98×10^{-3} | 2.92×10^3 | 2.984 | 16 | 4.14×10^{-2} |
| lb-ft ² | 144 | 1 | 0.3729 | 3.10×10^{-2} | 421.40 | 0.4297 | 4.21×10^5 | 429.71 | 2304 | 5.967 |
| lb-in-s ² | 386.08 | 2.681 | 1 | 8.33×10^{-2} | 1.129×10^3 | 1.152 | 1.129×10^6 | 1.152×10^3 | 6.177×10^3 | 16 |
| lb-ft-s ² slug-ft ² | 4.63×10^3 | 32.17 | 12 | 1 | 1.35×10^4 | 13.825 | 1.355×10^7 | 1.38×10^4 | 7.41×10^4 | 192 |
| kg-cm ² | 0.3417 | 2.37×10^{-3} | 8.85×10^{-4} | 7.37×10^{-5} | 1 | 1.019×10^{-3} | 1000 | 1.019 | 5.46 | 1.41×10^{-2} |
| kg-cm-s ² | 335.1 | 2.327 | 0.8679 | 7.23×10^{-2} | 980.66 | 1 | 9.8×10^5 | 1000 | 5.36×10^3 | 13.887 |
| gm-cm ² | 3.417×10^{-4} | 2.37×10^{-6} | 8.85×10^{-7} | 7.37×10^{-8} | 1×10^{-3} | 1.01×10^{-6} | 1 | 1.01×10^{-3} | 5.46×10^{-3} | 1.41×10^{-5} |
| gm-cm-s ² | 0.335 | 2.32×10^{-3} | 8.67×10^{-4} | 7.23×10^{-5} | 0.9806 | 1×10^{-3} | 980.6 | 1 | 5.36 | 1.38×10^{-2} |
| oz-in ² | 0.0625 | 4.34×10^{-4} | 1.61×10^{-4} | 1.34×10^{-5} | 0.182 | 1.86×10^{-4} | 182.9 | 0.186 | 1 | 2.59×10^{-3} |
| oz-in-s ² | 24.13 | 0.1675 | 6.25×10^{-2} | 5.20×10^{-3} | 70.615 | 7.20×10^{-2} | 7.09×10^4 | 72.0 | 386.08 | 1 |

Torque (to convert from A to B, multiply by entry in table)

| A \ B | lb-in | lb-ft | oz-in | N-m | kg-cm | kg-m | gm-cm | dyne-cm |
|---------|------------------------|------------------------|------------------------|------------------------|-------------------------|------------------------|------------------------|---------------------|
| lb-in | 1 | 8.333×10^{-2} | 16 | 0.113 | 1.152 | 1.152×10^{-2} | 1.152×10^3 | 1.129×10^6 |
| lb-ft | 12 | 1 | 192 | 1.355 | 13.825 | 0.138 | 1.382×10^4 | 1.355×10^7 |
| oz-in | 6.25×10^{-2} | 5.208×10^{-3} | 1 | 7.061×10^{-3} | 7.200×10^{-2} | 7.200×10^{-4} | 72.007 | 7.061×10^4 |
| N-m | 8.850 | 0.737 | 141.612 | 1 | 10.197 | 0.102 | 1.019×10^4 | 1×10^7 |
| kg-cm | 0.8679 | 7.233×10^{-2} | 13.877 | 9.806×10^{-2} | 1 | 10^{-2} | 1000 | 9.806×10^5 |
| kg-m | 86.796 | 7.233 | 1.388×10^3 | 9.806 | 100 | 1 | 1×10^5 | 9.806×10^7 |
| gm-cm | 8.679×10^{-4} | 7.233×10^{-5} | 1.388×10^{-2} | 9.806×10^{-5} | 1×10^{-3} | 1×10^{-5} | 1 | 980.665 |
| dyne-cm | 8.850×10^{-7} | 7.375×10^{-8} | 1.416×10^{-5} | 10^{-7} | 1.0197×10^{-6} | 1.019×10^{-8} | 1.019×10^{-3} | 1 |

Length (to convert from A to B, multiply by entry in table)

| A \ B | inches | feet | cm | yd | mm | m |
|--------|---------|---------|-------|-----------------------|-------|--------|
| inches | 1 | 0.0833 | 2.54 | 0.028 | 25.4 | 0.0254 |
| feet | 12 | 1 | 30.48 | 0.333 | 304.8 | 0.3048 |
| cm | 0.3937 | 0.03281 | 1 | 1.09×10^{-2} | 10 | 0.01 |
| yd | 36 | 3 | 91.44 | 1 | 914.4 | 0.914 |
| mm | 0.03937 | 0.00328 | 0.1 | 1.09×10^{-3} | 1 | 0.001 |
| m | 39.37 | 3.281 | 100 | 1.09 | 1000 | 1 |

Force (to convert from A to B, multiply by entry in table)

| A \ B | lb | oz | gm | dyne | N |
|-------|------------------------|-----------------------|-------|-----------------------|---------|
| lb | 1 | 16 | 453.6 | 4.448×10^5 | 4.4482 |
| oz | 0.0625 | 1 | 28.35 | 2.780×10^4 | 0.27801 |
| gm | 2.205×10^{-3} | 0.03527 | 1 | 1.02×10^{-3} | N.A. |
| dyne | 2.248×10^{-6} | 3.59×10^{-5} | 980.7 | 1 | 0.00001 |
| N | 0.22481 | 3.5967 | N.A. | 100000 | 1 |

Mass (to convert from A to B, multiply by entry in table)

| A \ B | lb | oz | gm | kg | slug |
|-------|------------------------|------------------------|---------------------|-----------|------------------------|
| lb | 1 | 16 | 453.6 | 0.4536 | 0.0311 |
| oz | 6.25×10^{-2} | 1 | 28.35 | 0.02835 | 1.93×10^{-3} |
| gm | 2.205×10^{-3} | 3.527×10^{-2} | 1 | 10^{-3} | 6.852×10^{-5} |
| kg | 2.205 | 35.27 | 10^3 | 1 | 6.852×10^{-2} |
| slug | 32.17 | 514.8 | 1.459×10^4 | 14.59 | 1 |

Rotation (to convert from A to B, multiply by entry in table)

| A \ B | rpm | rad/s | degrees/s |
|-----------|-------|------------------------|-----------|
| rpm | 1 | 0.105 | 6.0 |
| rad/s | 9.55 | 1 | 57.30 |
| degrees/s | 0.167 | 1.745×10^{-2} | 1 |

Power (to convert from A to B, multiply by entry in table)

| A \ B | hp | Watts |
|------------------|------------------------|------------------------|
| hp (English) | 1 | 745.7 |
| (lb-in) (deg./s) | 2.645×10^{-6} | 1.972×10^{-3} |
| (lb-in) (rpm) | 1.587×10^{-5} | 1.183×10^{-2} |
| (lb-ft) (deg./s) | 3.173×10^{-5} | 2.366×10^{-2} |
| (lb-ft) (rpm) | 1.904×10^{-4} | 0.1420 |
| Watts | 1.341×10^{-3} | 1 |

Temperature Conversion

| °F | °C | °C | °F |
|---|-------|--------------------------------------|------|
| 0 | -17.8 | -10 | 14 |
| 32 | 0 | 0 | 32 |
| 50 | 10 | 10 | 50 |
| 70 | 21.1 | 20 | 68 |
| 90 | 32.2 | 30 | 86 |
| 98.4 | 37 | 37 | 98.4 |
| 212 | 100 | 100 | 212 |
| subtract 32 and multiply by $\frac{5}{9}$ | | multiply by $\frac{9}{5}$ and add 32 | |

Mechanism Efficiencies

| | |
|-----------------------------|------------|
| Acme-screw with brass nut | ~0.35–0.65 |
| Acme-screw with plastic nut | ~0.50–0.85 |
| Ball-screw | ~0.85–0.95 |
| Chain and sprocket | ~0.95–0.98 |
| Preloaded ball-screw | ~0.75–0.85 |
| Spur or bevel-gears | ~0.90 |
| Timing belts | ~0.96–0.98 |
| Worm gears | ~0.45–0.85 |
| Helical gear (1 reduction) | ~0.92 |

Friction Coefficients

| Materials | μ |
|--------------------------|------------|
| Steel on steel (greased) | ~0.15 |
| Plastic on steel | ~0.15–0.25 |
| Copper on steel | ~0.30 |
| Brass on steel | ~0.35 |
| Aluminum on steel | ~0.45 |
| Steel on steel | ~0.58 |
| Mechanism | μ |
| Ball bushings | <0.001 |
| Linear bearings | <0.001 |
| Dove-tail slides | ~0.2++ |
| Gibb ways | ~0.5++ |

Material Densities

| Material | lb-in ³ | gm-cm ³ |
|---------------------------------|--------------------|--------------------|
| Aluminum | 0.096 | 2.66 |
| Brass | 0.299 | 8.30 |
| Bronze | 0.295 | 8.17 |
| Copper | 0.322 | 8.91 |
| Hard wood | 0.029 | 0.80 |
| Soft wood | 0.018 | 0.48 |
| Plastic | 0.040 | 1.11 |
| Glass | 0.079–0.090 | 2.2–2.5 |
| Titanium | 0.163 | 4.51 |
| Paper | 0.025–0.043 | 0.7–1.2 |
| Polyvinyl chloride | 0.047–0.050 | 1.3–1.4 |
| Rubber | 0.033–0.036 | 0.92–0.99 |
| Silicone rubber, without filler | 0.043 | 1.2 |
| Cast iron, gray | 0.274 | 7.6 |
| Steel | 0.280 | 7.75 |

Wire Gauges¹⁾

| Cross-section mm ² | Standard Wire Gauge (SWG) | American Wire Gauge (AWG) |
|----------------------------------|------------------------------|------------------------------|
| 0.2 | 25 | 24 |
| 0.3 | 23 | 22 |
| 0.5 | 21 | 20 |
| 0.75 | 20 | 19 |
| 1.0 | 19 | 18 |
| 1.5 | 17 | 16 |
| 2.5 | 15 | 13 |
| 4 | 13 | 11 |
| 6 | 12 | 9 |
| 10 | 9 | 7 |
| 16 | 7 | 6 |
| 25 | 5 | 3 |
| 35 | 3 | 2 |
| 50 | 0 | 1/0 |
| 70 | 000 | 2/0 |
| 95 | 00000 | 3/0 |
| 120 | 0000000 | 4/0 |
| 150 | – | 6/0 |
| 185 | – | 7/0 |

¹⁾ The table shows approximate SWG/AWG sizes nearest to standard metric sizes; the cross-sections do not match exactly.

Appendix

Metal surcharges

Explanation of the raw material/metal surcharges ¹⁾

Surcharge calculation

To compensate for variations in the price of the raw materials silver, copper, aluminum, lead, gold, dysprosium ²⁾ and/or neodym ²⁾, surcharges are calculated on a daily basis using the so-called metal factor for products containing these raw materials. A surcharge for the respective raw material is calculated as a supplement to the price of a product if the basic official price of the raw material in question is exceeded.

The surcharges are calculated in accordance with the following criteria:

- Basic official price of the raw material
Basic official price from the day prior to receipt of the order or prior to release order (daily price) for ³⁾
- Silver (sales price, processed)
- Gold (sales price, processed)
and for ⁴⁾
- Copper (lower DEL notation + 1 %)
- Aluminum (aluminum in cables)
- Lead (lead in cables)
- Metal factor of the products
Certain products are displayed with a metal factor. The metal factor determines the official price (for those raw materials concerned) as of which the metal surcharges are applied and the calculation method used (weight or percentage method). An exact explanation is given below.

Structure of the metal factor

The metal factor consists of several digits; the first digit indicates whether the percentage method of calculation refers to the list price or a possible discounted price (customer net price) (L = list price / N = customer net price).

The remaining digits indicate the method of calculation used for the respective raw material. If no surcharge is added for a raw material, a "-" is used.

| | |
|-----------|--|
| 1st digit | List or customer net price using the percentage method |
| 2nd digit | for silver (AG) |
| 3rd digit | for copper (CU) |
| 4th digit | for aluminum (AL) |
| 5th digit | for lead (PB) |
| 6th digit | for gold (AU) |
| 7th digit | for dysprosium (Dy) ²⁾ |
| 8th digit | for neodym (Nd) ²⁾ |

Weight method

The weight method uses the basic official price, the daily price and the raw material weight. In order to calculate the surcharge, the basic official price must be subtracted from the daily price. The difference is then multiplied by the raw material weight.

The basic official price can be found in the table below using the number (1 to 9) of the respective digit of the metal factor. The raw material weight can be found in the respective product descriptions.

Percentage method

Use of the percentage method is indicated by the letters A-Z at the respective digit of the metal factor.

The surcharge is increased - dependent on the deviation of the daily price compared with the basic official price - using the percentage method in "steps" and consequently offers surcharges that remain constant within the framework of this "step range". A higher percentage rate is charged for each new step. The respective percentage level can be found in the table below.

Metal factor examples

| | |
|------------------------|---|
| L E A - - - - | <ul style="list-style-type: none"> Basis for % surcharge: List price Silver Basis 150 €, Step 50 €, 0.5 % Copper Basis 150 €, Step 50 €, 0.1 % No surcharge for aluminum No surcharge for lead No surcharge for gold No surcharge for dysprosium No surcharge for neodym |
| N - A 6 - - - - | <ul style="list-style-type: none"> Basis for % surcharge: Customer net price No surcharge for silver Copper Basis 150 €, Step 50 €, 0.1 % Aluminum acc. to weight, basic offic. price 225 € No surcharge for lead No surcharge for gold No surcharge for dysprosium No surcharge for neodym |
| - - 3 - - - - | <ul style="list-style-type: none"> No basis necessary No surcharge for silver Copper acc. to weight, basic official price 150 € No surcharge for aluminum No surcharge for lead No surcharge for gold No surcharge for dysprosium No surcharge for neodym |

1) Refer to the separate explanation on the next page regarding the raw materials dysprosium and neodym (= rare earths).

2) For a different method of calculation, refer to the separate explanation for these raw materials on the next page.

3) Source: Umicore, Hanau (www.metalsmanagement.umicore.com).

4) Source: Schutzvereinigung DEL-Notiz e.V. (www.del-notiz.org).

Explanation of the raw material/metal surcharges for dysprosium and neodym (rare earths)

Surcharge calculation

To compensate for variations in the price of the raw materials silver ¹⁾, copper ¹⁾, aluminum ¹⁾, lead ¹⁾, gold ¹⁾, dysprosium and/or neodym, surcharges are calculated on a daily basis using the so-called metal factor for products containing these raw materials. The surcharge for dysprosium and neodym is calculated as a supplement to the price of a product if the basic official price of the raw material in question is exceeded.

The surcharge is calculated in accordance with the following criteria:

- Basic official price of the raw material ²⁾
Three-month basic average price (see below) in the period before the quarter in which the order was received or the release order took place (= average official price) for
- dysprosium (Dy metal, 99 % min. FOB China; USD/kg)
- neodym (Nd metal, 99 % min. FOB China; USD/kg)
- Metal factor of the products
Certain products are displayed with a metal factor. The metal factor indicates (for those raw materials concerned) the basic official price as of which the surcharges for dysprosium and neodym are calculated using the weight method. An exact explanation of the metal factor is given below.

Three-month average price

The prices of rare earths vary according to the foreign currency, and there is no freely accessible stock exchange listing. This makes it more difficult for all parties involved to monitor changes in price. In order to avoid continuous adjustment of the surcharges, but to still ensure fair, transparent pricing, an average price is calculated over a three-month period using the average monthly foreign exchange rate from USD to EUR (source: European Central Bank). Since not all facts are immediately available at the start of each month, a one-month buffer is allowed before the new average price applies.

Examples of calculation of the average official price:

| Period for calculation of the average price: | Period during which the order/release order is effected and the average price applies: |
|--|--|
| Sep 2012 - Nov 2012 | Q1 in 2013 (Jan - Mar) |
| Dec 2012 - Feb 2013 | Q2 in 2013 (Apr - Jun) |
| Mar 2013 - May 2013 | Q3 in 2013 (Jul - Sep) |
| Jun 2013 - Aug 2013 | Q4 in 2013 (Oct - Dec) |

Structure of the metal factor

The metal factor consists of several digits; the first digit is not relevant to the calculation of dysprosium and neodym.

The remaining digits indicate the method of calculation used for the respective raw material. If no surcharge is added for a raw material, a "-" is used.

| | |
|-----------|--|
| 1st digit | List or customer net price using the percentage method |
| 2nd digit | for silver (AG) ¹⁾ |
| 3rd digit | for copper (CU) ¹⁾ |
| 4th digit | for aluminum (AL) ¹⁾ |
| 5th digit | for lead (PB) ¹⁾ |
| 6th digit | for gold (AU) ¹⁾ |
| 7th digit | for dysprosium (Dy) |
| 8th digit | for neodym (Nd) |

Weight method

The weight method uses the basic official price, the average price and the raw material weight. In order to calculate the surcharge, the basic official price must be subtracted from the average price. The difference is then multiplied by the raw material weight.

The basic official price can be found in the table below using the number (1 to 9) of the respective digit of the metal factor. Your Sales contact can inform you of the raw material weight.

Metal factor examples

| | |
|-----------|---|
| ----- 7 1 | |
| ↑ | No basis necessary |
| ↑ | No surcharge for silver |
| ↑ | No surcharge for copper |
| ↑ | No surcharge for aluminum |
| ↑ | No surcharge for lead |
| ↑ | No surcharge for gold |
| ↑ | Dysprosium acc. to weight, basic official price 300 € |
| ↑ | Neodym acc. to weight, basic official price 50 € |

1) For a different method of calculation, refer to the separate explanation for these raw materials on the previous page.

2) Source: Asian Metal Ltd (www.asianmetal.com)

Appendix

Metal surcharges

Values of the metal factor

| Percentage method | Basic official price in € | Step range in € | % surcharge 1st step | % surcharge 2nd step | % surcharge 3rd step | % surcharge 4th step | % surcharge per additional step | |
|--------------------------------|---|--|----------------------|----------------------|----------------------|----------------------|---------------------------------|--|
| | | | Price in € | Price in € | Price in € | Price in € | | |
| | | | 150.01 - 200.00 | 200.01 - 250.00 | 250.01 - 300.00 | 300.01 - 350.00 | | |
| A | 150 | 50 | 0.1 | 0.2 | 0.3 | 0.4 | 0.1 | |
| B | 150 | 50 | 0.2 | 0.4 | 0.6 | 0.8 | 0.2 | |
| C | 150 | 50 | 0.3 | 0.6 | 0.9 | 1.2 | 0.3 | |
| D | 150 | 50 | 0.4 | 0.8 | 1.2 | 1.6 | 0.4 | |
| E | 150 | 50 | 0.5 | 1.0 | 1.5 | 2.0 | 0.5 | |
| F | 150 | 50 | 0.6 | 1.2 | 1.8 | 2.4 | 0.6 | |
| G | 150 | 50 | 1.0 | 2.0 | 3.0 | 4.0 | 1.0 | |
| H | 150 | 50 | 1.2 | 2.4 | 3.6 | 4.8 | 1.2 | |
| I | 150 | 50 | 1.6 | 3.2 | 4.8 | 6.4 | 1.6 | |
| J | 150 | 50 | 1.8 | 3.6 | 5.4 | 7.2 | 1.8 | |
| | | | 175.01 - 225.00 | 225.01 - 275.00 | 275.01 - 325.00 | 325.01 - 375.00 | | |
| O | 175 | 50 | 0.1 | 0.2 | 0.3 | 0.4 | 0.1 | |
| P | 175 | 50 | 0.2 | 0.4 | 0.6 | 0.8 | 0.2 | |
| R | 175 | 50 | 0.5 | 1.0 | 1.5 | 2.0 | 0.5 | |
| | | | 225.01 - 275.00 | 275.01 - 325.00 | 325.01 - 375.00 | 375.01 - 425.00 | | |
| S | 225 | 50 | 0.2 | 0.4 | 0.6 | 0.8 | 0.2 | |
| U | 225 | 50 | 1.0 | 2.0 | 3.0 | 4.0 | 1.0 | |
| V | 225 | 50 | 1.0 | 1.5 | 2.0 | 3.0 | 1.0 | |
| W | 225 | 50 | 1.2 | 2.5 | 3.5 | 4.5 | 1.0 | |
| | | | 150.01 - 175.00 | 175.01 - 200.00 | 200.01 - 225.00 | 225.01 - 250.00 | | |
| Y | 150 | 25 | 0.3 | 0.6 | 0.9 | 1.2 | 0.3 | |
| | | | 400.01 - 425.00 | 425.01 - 450.00 | 450.01 - 475.00 | 475.01 - 500.00 | | |
| Z | 400 | 25 | 0.1 | 0.2 | 0.3 | 0.4 | 0.1 | |
| Price basis (1st digit) | | | | | | | | |
| L | Calculation based on the list price | | | | | | | |
| N | Calculation based on the customer net price (discounted list price) | | | | | | | |
| Weight method | Basic official price in € | | | | | | | |
| 1 | 50 | Calculation based on raw material weight | | | | | | |
| 2 | 100 | | | | | | | |
| 3 | 150 | | | | | | | |
| 4 | 175 | | | | | | | |
| 5 | 200 | | | | | | | |
| 6 | 225 | | | | | | | |
| 7 | 300 | | | | | | | |
| 8 | 400 | | | | | | | |
| 9 | 555 | | | | | | | |
| Miscellaneous | | | | | | | | |
| - | No metal surcharge | | | | | | | |

1. General Provisions

By using this catalog you can acquire hardware and software products described therein from Siemens AG subject to the following Terms and Conditions of Sale and Delivery (hereinafter referred to as "T&C"). Please note that the scope, the quality and the conditions for supplies and services, including software products, by any Siemens entity having a registered office outside Germany, shall be subject exclusively to the General Terms and Conditions of the respective Siemens entity. The following T&C apply exclusively for orders placed with Siemens Aktiengesellschaft, Germany.

1.1 For customers with a seat or registered office in Germany

For customers with a seat or registered office in Germany, the following applies subordinate to the T&C:

- for installation work the "General Conditions for Erection Works – Germany"¹⁾ ("Allgemeine Montagebedingungen – Deutschland" (only available in German at the moment)) and/or
- for Plant Analytics Services the "Standard Terms and Conditions for Plant Analytics Services – for Customer in Germany"¹⁾ ("Allgemeine Geschäftsbedingungen für das Plant Analytics Services – für Kunden in Deutschland" (only available in German at the moment)) and/or
- for stand-alone software products and software products forming a part of a product or project, the "General License Conditions for Software Products for Automation and Drives for Customers with a Seat or registered Office in Germany"¹⁾ and/or
- for other supplies and/or services the "General Conditions for the Supply of Products and Services of the Electrical and Electronics Industry"¹⁾.

In case such supplies and/or services should contain Open Source Software, the conditions of which shall prevail over the "General Conditions for the Supply of Products and Services of the Electrical and Electronics Industry"¹⁾. A notice will be contained in the scope of delivery in which the applicable conditions for Open Source Software are specified. This shall apply mutatis mutandis for notices referring to other third party software components.

1.2 For customers with a seat or registered office outside Germany

For customers with a seat or registered office outside Germany, the following applies subordinate to the T&C:

- for Plant Analytics Services the "Standard Terms and Conditions for Plant Analytics Services"¹⁾ and/or
- for services the "International Terms & Conditions for Services"¹⁾ supplemented by "Software Licensing Conditions"¹⁾ and/or
- for other supplies of hard- and/or software the "International Terms & Conditions for Products"¹⁾ supplemented by "Software Licensing Conditions"¹⁾

1.3 For customers with master or framework agreement

To the extent our supplies and/or services offered are covered by an existing master or framework agreement, the terms and conditions of that agreement shall apply instead of T&C.

2. Prices

The prices are in € (Euro) ex point of delivery, exclusive of packaging.

The sales tax (value added tax) is not included in the prices. It shall be charged separately at the respective rate according to the applicable statutory legal regulations.

Prices are subject to change without prior notice. We will charge the prices valid at the time of delivery.

To compensate for variations in the price of raw materials (e.g. silver, copper, aluminum, lead, gold, dysprosium and neodym), surcharges are calculated on a daily basis using the so-called metal factor for products containing these raw materials. A surcharge for the respective raw material is calculated as a supplement to the price of a product if the basic official price of the raw material in question is exceeded.

The metal factor of a product indicates the basic official price (for those raw materials concerned) as of which the surcharges on the price of the product are applied, and with what method of calculation.

You will find a detailed explanation of the metal factor on the page headed "Metal surcharges".

To calculate the surcharge (except in the cases of dysprosium and neodym), the official price from the day prior to that on which the order was received or the release order was effected is used.

To calculate the surcharge applicable to dysprosium and neodym ("rare earths"), the corresponding three-month basic average price in the quarter prior to that in which the order was received or the release order was effected is used with a one-month buffer (details on the calculation can be found in the explanation of the metal factor).

3. Additional Terms and Conditions

The dimensions are in mm. In Germany, according to the German law on units in measuring technology, data in inches apply only to devices for export.

Illustrations are not binding.

Insofar as there are no remarks on the individual pages of this catalog - especially with regard to data, dimensions and weights given - these are subject to change without prior notice.

¹⁾ The text of the Terms and Conditions of Siemens AG can be downloaded at www.siemens.com/automation/salesmaterial-as/catalog/en/terms_of_trade_en.pdf

Appendix

Conditions of sale and delivery

4. Export regulations

We shall not be obligated to fulfill any agreement if such fulfillment is prevented by any impediments arising out of national or international foreign trade or customs requirements or any embargoes and/or other sanctions.

Export may be subject to license. We shall indicate in the delivery details whether licenses are required under German, European and US export lists.

Our products are controlled by the U.S. Government (when labeled with "ECCN" unequal "N") and authorized for export only to the country of ultimate destination for use by the ultimate consignee or end-user(s) herein identified. They may not be resold, transferred, or otherwise disposed of, to any other country or to any person other than the authorized ultimate consignee or end-user(s), either in their original form or after being incorporated into other items, without first obtaining approval from the U.S. Government or as otherwise authorized by U.S. law and regulations.

The export indications can be viewed in advance in the description of the respective goods on the Industry Mall, our online catalog system. Only the export labels "AL" and "ECCN" indicated on order confirmations, delivery notes and invoices are authoritative.

Products labeled with "AL" unequal "N" are subject to European / national export authorization. Products without label, with label "AL:N" / "ECCN:N", or label "AL:9X9999" / "ECCN: 9X9999" may require authorization from responsible authorities depending on the final end-use, or the destination.

If you transfer goods (hardware and/or software and/or technology as well as corresponding documentation, regardless of the mode of provision) delivered by us or works and services (including all kinds of technical support) performed by us to a third party worldwide, you must comply with all applicable national and international (re-)export control regulations.

If required for the purpose of conducting export control checks, you (upon request by us) shall promptly provide us with all information pertaining to the particular end customer, final disposition and intended use of goods delivered by us respectively works and services provided by us, as well as to any export control restrictions existing in this relation.

The products listed in this catalog may be subject to European/German and/or US export regulations. Any export requiring approval is therefore subject to authorization by the relevant authorities.

Errors excepted and subject to change without prior notice.

Further information can be obtained from our branch offices listed at www.siemens.com/automation-contact

| | | | |
|---|----------------|--|-----------------|
| Interactive Catalog | <i>Catalog</i> | Process Instrumentation and Analytics | <i>Catalog</i> |
| Products for Automation and Drives | CA 01 | <i>Digital: Field Instruments for Process Automation</i> | FI 01 |
| Building Control | | <i>Digital: Display Recorders SIREC D</i> | MP 20 |
| GAMMA Building Control | ET G1 | <i>Digital: SIPART Controllers and Software</i> | MP 31 |
| Drive Systems | | Products for Weighing Technology | WT 10 |
| SINAMICS G130 Drive Converter Chassis Units | D 11 | <i>Digital: Process Analytical Instruments</i> | AP 01 |
| SINAMICS G150 Drive Converter Cabinet Units | | <i>Digital: Process Analytics, Components for Continuous Emission Monitoring</i> | AP 11 |
| SINAMICS GM150, SINAMICS SM150 Medium-Voltage Converters | D 12 | Low-Voltage Power Distribution and Electrical Installation Technology | |
| <i>Digital: SINAMICS PERFECT HARMONY GH180 Medium-Voltage Air-Cooled Drives (Germany Edition)</i> | D 15.1 | SENTRON · SIVACON · ALPHA Protection, Switching, Measuring and Monitoring Devices, Switchboards and Distribution Systems | LV 10 |
| SINAMICS G180 Converters – Compact Units, Cabinet Systems, Cabinet Units Air-Cooled and Liquid-Cooled | D 18.1 | Standards-Compliant Components for Photovoltaic Plants | LV 11 |
| SINAMICS S120 Chassis Format Converter Units | D 21.3 | Electrical Components for the Railway Industry | LV 12 |
| SINAMICS S120 Cabinet Modules | | Power Monitoring Made Simple | LV 14 |
| SINAMICS S150 Converter Cabinet Units | | Components for Industrial Control Panels according to UL Standards | LV 16 |
| SINAMICS S120 and SIMOTICS | D 21.4 | <i>Digital: Air circuit breakers and molded case circuit breakers with UL certification</i> | LV 18 |
| SINAMICS DCM DC Converter, Control Module | D 23.1 | 3WT Air Circuit Breakers up to 4000 A | LV 35 |
| SINAMICS Inverters for Single-Axis Drives · Built-In Units | D 31.1 | 3VT Molded Case Circuit Breakers up to 1600 A | LV 36 |
| SINAMICS Inverters for Single-Axis Drives · Distributed Inverters | D 31.2 | <i>Digital: SIVACON System Cubicles, System Lighting and System Air-Conditioning</i> | LV 50 |
| <i>Digital: SINAMICS S210 Servo Drive System</i> | D 32 | <i>Digital: ALPHA Distribution Systems</i> | LV 51 |
| <i>Digital: SINAMICS V90 Basic Servo Drive System</i> | D 33 | ALPHA FIX Terminal Blocks | LV 52 |
| <i>Digital: SINAMICS G120P and SINAMICS G120P Cabinet pump, fan, compressor converters</i> | D 35 | SIVACON S4 Power Distribution Boards | LV 56 |
| LOHER VARIO High Voltage Motors Flameproof, Type Series 1PS4, 1PS5, 1MV4 and 1MV5 Frame Size 355 to 1000, Power Range 80 to 7100 kW | D 83.2 | SIVACON 8PS Busbar Trunking Systems | LV 70 |
| <i>Digital: Three-Phase Induction Motors SIMOTICS HV, SIMOTICS TN</i> | D 84.1 | <i>Digital: DELTA Switches and Socket Outlets</i> | ET D1 |
| <i>Digital: Three-Phase Induction Motors SIMOTICS HV</i> | D 84.3 | Vacuum Switching Technology and Components for Medium Voltage | HG 11.01 |
| High Voltage Three-phase Induction Motors SIMOTICS HV Series A-compact PLUS | D 84.9 | Power Supply | |
| <i>Digital: Modular Industrial Generators SIGENTICS M</i> | D 85.1 | SITOP Power supply | KT 10.1 |
| Three-Phase Induction Motors SIMOTICS HV, Series H-compact | D 86.1 | Safety Integrated | |
| Synchronous Motors with Permanent-Magnet Technology, HT-direct | D 86.2 | Safety Technology for Factory Automation | SI 10 |
| DC Motors | DA 12 | SIMATIC HMI / PC-based Automation | |
| SIMOVERT PM Modular Converter Systems | DA 45 | Human Machine Interface Systems/ PC-based Automation | ST 80/ ST PC |
| MICROMASTER 420/430/440 Inverters | DA 51.2 | SIMATIC Ident | |
| MICROMASTER 411/COMBIMASTER 411 | DA 51.3 | Industrial Identification Systems | ID 10 |
| <u>Low-Voltage Three-Phase-Motors</u> | | SIMATIC Industrial Automation Systems | |
| SIMOTOCS S-1FG1 Servo geared motors | D 41 | Products for Totally Integrated Automation | ST 70 |
| SIMOTICS Low-Voltage Motors | D 81.1 | SIMATIC PCS 7 Process Control System System components | ST PCS 7 |
| SIMOTICS FD Low-Voltage Motors | D 81.8 | SIMATIC PCS 7 Process Control System Technology components | ST PCS 7 T |
| LOHER Low-Voltage Motors | D 83.1 | Add-ons for the SIMATIC PCS 7 Process Control System | ST PCS 7 AO |
| <i>Digital: MOTOX Geared Motors</i> | D 87.1 | SIMATIC S7-400 advanced controller | ST 400 |
| SIMOGEAR Geared Motors | MD 50.1 | SIMATIC NET | |
| SIMOGEAR Electric-monorail geared motors Light-load and heavy-load applications | MD 50.8 | Industrial Communication | IK PI |
| SIMOGEAR Gearboxes with adapter | MD 50.11 | SIRIUS Industrial Controls | |
| <u>Mechanical Driving Machines</u> | | <i>Digital: SIRIUS Industrial Controls</i> | IC 10 |
| FLENDER Standard Couplings | MD 10.1 | | |
| FLENDER High Performance Couplings | MD 10.2 | | |
| FLENDER Backlash-free Couplings | MD 10.3 | | |
| FLENDER SIP Standard industrial planetary gear units | MD 31.1 | | |
| Motion Control | | | |
| SINUMERIK 840 Equipment for Machine Tools | NC 62 | | |
| SINUMERIK 808 Equipment for Machine Tools | NC 81.1 | | |
| SINUMERIK 828 Equipment for Machine Tools | NC 82 | | |
| SIMOTION Equipment for Production Machines | PM 21 | | |
| <i>Digital: Drive and Control Components for Cranes</i> | CR 1 | | |

*Digital: These catalogs are only available as a PDF.***Information and Download Center**

Digital versions of the catalogs are available on the Internet at:
www.siemens.com/industry/infocenter
 There you'll find additional catalogs in other languages.

Get more information

The drives family SINAMICS:
www.siemens.com/sinamics

SIMOTICS electric motors:
www.siemens.com/simotics

Motion Control Systems and Solutions for production machine and machine tool equipment:
www.siemens.com/motioncontrol

Local partners worldwide:
www.siemens.com/automation-contact

Siemens AG
Digital Factory Division
Motion Control
Postfach 31 80
91050 ERLANGEN
GERMANY

© Siemens AG 2018
Subject to change without prior notice
PDF (Article No. E86060-K5533-A101-A1-7600)
V6.MKKATA.GMC.181
KG 0918 76 En
Produced in Germany

The information provided in this catalog contains merely general descriptions or characteristics of performance which in case of actual use do not always apply as described or which may change as a result of further development of the products. An obligation to provide the respective characteristics shall only exist if expressly agreed in the terms of contract. Availability and technical specifications are subject to change without notice.

All product designations may be trademarks or product names of Siemens AG or supplier companies whose use by third parties for their own purposes could violate the rights of the owners.

Security information

Siemens provides products and solutions with industrial security functions that support the secure operation of plants, systems, machines and networks.

In order to protect plants, systems, machines and networks against cyber threats, it is necessary to implement – and continuously maintain – a holistic, state-of-the-art industrial security concept. Siemens' products and solutions constitute one element of such a concept.

Customers are responsible for preventing unauthorized access to their plants, systems, machines and networks. Such systems, machines and components should only be connected to an enterprise network or the internet if and to the extent such a connection is necessary and only when appropriate security measures (e.g. firewalls and/or network segmentation) are in place.

For additional information on industrial security measures that may be implemented, please visit <https://www.siemens.com/industrialsecurity>.

Siemens' products and solutions undergo continuous development to make them more secure. Siemens strongly recommends that product updates are applied as soon as they are available and that the latest product versions are used. Use of product versions that are no longer supported, and failure to apply the latest updates may increase customer's exposure to cyber threats.

To stay informed about product updates, subscribe to the Siemens Industrial Security RSS Feed under <https://www.siemens.com/industrialsecurity>.

Discover the advantages of Integrated Drive Systems at a glance

