

Industrial Controls

Soft Starter SIRIUS Soft Starter 3RW5 PCS 7 Library V9.0 SP2



Programming and Operating Manual

<u>Introduction</u>	1
<u>Information about the library</u>	2
<u>Templates</u>	3
<u>Block icons and faceplate views</u>	4
<u>Description of the blocks</u>	5
<u>Maintenance station</u>	6
<u>Module drivers of Soft Starter</u>	7
<u>Parameters</u>	A
<u>Technical data</u>	B
<u>Abbreviations</u>	C

Legal information

Warning notice system

This manual contains notices you have to observe in order to ensure your personal safety, as well as to prevent damage to property. The notices referring to your personal safety are highlighted in the manual by a safety alert symbol, notices referring only to property damage have no safety alert symbol. These notices shown below are graded according to the degree of danger.

 DANGER
indicates that death or severe personal injury will result if proper precautions are not taken.
 WARNING
indicates that death or severe personal injury may result if proper precautions are not taken.
 CAUTION
indicates that minor personal injury can result if proper precautions are not taken.
NOTICE
indicates that property damage can result if proper precautions are not taken.

If more than one degree of danger is present, the warning notice representing the highest degree of danger will be used. A notice warning of injury to persons with a safety alert symbol may also include a warning relating to property damage.

Qualified Personnel

The product/system described in this documentation may be operated only by **personnel qualified** for the specific task in accordance with the relevant documentation, in particular its warning notices and safety instructions. Qualified personnel are those who, based on their training and experience, are capable of identifying risks and avoiding potential hazards when working with these products/systems.

Proper use of Siemens products

Note the following:

 WARNING
Siemens products may only be used for the applications described in the catalog and in the relevant technical documentation. If products and components from other manufacturers are used, these must be recommended or approved by Siemens. Proper transport, storage, installation, assembly, commissioning, operation and maintenance are required to ensure that the products operate safely and without any problems. The permissible ambient conditions must be complied with. The information in the relevant documentation must be observed.

Trademarks

All names identified by ® are registered trademarks of Siemens AG. The remaining trademarks in this publication may be trademarks whose use by third parties for their own purposes could violate the rights of the owner.

Disclaimer of Liability

We have reviewed the contents of this publication to ensure consistency with the hardware and software described. Since variance cannot be precluded entirely, we cannot guarantee full consistency. However, the information in this publication is reviewed regularly and any necessary corrections are included in subsequent editions.

Table of contents

1	Introduction	9
1.1	Security information	9
1.2	Product specific security information	10
1.3	Version overview.....	10
1.4	Components of the software package	11
1.5	Installation	11
1.6	Configuration steps	12
1.6.1	Configuring in HW Config	12
1.6.2	Configuring in CFC	14
1.7	Driver generator	15
1.8	Example Configurations.....	16
1.9	Parametrization softwares	18
1.10	Further documentation.....	18
2	Information about the library	19
2.1	Block overview	19
2.2	Faceplates	19
3	Templates	23
3.1	Overview of the templates	23
3.2	Using templates	25
3.3	3RW5 Soft Starter templates	28
4	Block icons and faceplate views	29
4.1	Block icons	29
4.1.1	3RW5Oprn block icon	30
4.1.2	3RW5Ctrl block icon	31
4.2	Faceplates	33
4.2.1	Batch view.....	33
4.2.2	Trend view	34
4.2.3	Alarm view	36
4.2.4	Memo view.....	37
4.2.5	Scalable faceplates.....	38
4.3	Supported functions	40
4.3.1	Central color management	40
4.3.2	Web Navigator	40
4.4	APL Operator Trend Control (AOTC)	41

5	Description of the blocks	43
5.1	Functions for all blocks	43
5.1.1	Calling OBs	43
5.1.2	Called blocks.....	44
5.1.3	Worst signal status.....	45
5.1.4	Quality code	47
5.1.5	Error numbers	49
5.1.6	Reading and writing data records	51
5.1.7	Read Record error status.....	53
5.1.8	Write Record error status.....	53
5.1.9	Overview of the measuring point browser window	54
5.1.10	Configurable response using the feature I/O	54
5.1.10.1	Start-up characteristics	54
5.1.10.2	Response for Out of service mode	55
5.1.10.3	Resets the commands for switching between modes.....	56
5.1.10.4	Enabling resetting of commands for the control settings	56
5.1.10.5	Setting switch or button mode.....	57
5.1.10.6	Set switching mode.....	58
5.1.10.7	Enabling direct changeover between forward and reverse	58
5.1.10.8	Status handling for values.....	59
5.1.10.9	Resetting via input signals in the event of interlocking (Protection) or errors.....	59
5.1.10.10	Changes Signal status of outputs in OOS (Out of service)	60
5.1.10.11	Exit local mode.....	60
5.1.10.12	Condition Monitoring	61
5.1.10.13	Enable runtime for feedback signals.....	61
5.1.10.14	Separate monitoring time for stopping the motor.....	62
5.1.10.15	Enabling rapid stop via faceplate	62
5.1.10.16	Activate bumpless changeover to automatic mode	63
5.1.10.17	Activate fault status for external control system fault.....	63
5.1.10.18	Suppression of one or more alarm messages	64
5.1.10.19	Reset even in locked state.....	64
5.1.10.20	Enable feedback monitoring when motor OFF	65
5.1.10.21	Disable Feedback Tracking LocalSetting 2 & 4	65
5.1.10.22	Suppress reading DS.....	66
5.1.10.23	Bumpless switchover to automatic mode	66
5.1.10.24	Update acknowledgement and error status of the alarm	67
5.1.10.25	Message display	67
5.1.10.26	Local operator authorization	68
5.1.10.27	Activate local operator permission	68
5.1.10.28	Suppression of all messages	69
5.1.10.29	Suppression of all messages - 3RW5Ctrl	69
5.1.10.30	Suppression Parameter set reading	70
5.1.10.31	Evaluate the first run	70
5.1.10.32	Active parameter set reading	71
5.1.10.33	Interlock display with LocalSetting 2 or 4.....	71
5.1.10.34	Changes Signal status of outputs in OOS (Out of service)	72
5.1.10.35	Update Data exchange with the status information	72
5.1.10.36	Write Output value low in Simulation mode	73
5.1.10.37	Define reset as a function of the mode	73
5.1.10.38	Enable reset of interlocks in manual mode	74
5.1.10.39	Separate evaluation for excluded and simulated interlock signals	75
5.1.10.40	Resetting control in case of invalid command	75

5.1.10.41	Setting switch or button mode for local commands	76
5.1.10.42	Evaluation of the signal status of the interlock signals	77
5.1.10.43	Forcing operating modes in the "Local" mode	77
5.1.10.44	Button Mode with Triggered local control commands.....	78
5.1.10.45	Considering bad quality of automatic commands or external values	78
5.1.10.46	Suppress MsgLock and "Out of service" mode for a connected message block	79
5.1.10.47	Separate interlock for each direction or position	80
5.2	Diagnostics block	81
5.2.1	3RW5Diag block description.....	81
5.2.2	Message characteristics	81
5.2.3	Driver generator	83
5.2.4	Start-up characteristics	83
5.2.5	Module error.....	83
5.2.6	Failure of the DP master/DP slave/PROFINET IO station.....	84
5.2.7	PROFIBUS connection error	85
5.2.8	Diagnostics of the 3RW5	87
5.2.9	Malfunction when loading the OB	87
5.2.10	Interconnections of the 3RW5Diag block.....	88
5.2.11	Reading the device diagnosis	88
5.3	Operation block.....	89
5.3.1	3RW5Oprn block description	89
5.3.2	Parametrizable functions via the Feature connection 3RW5Oprn	90
5.3.3	Operating modes	92
5.3.4	Process image input and output	95
5.3.5	Diagnostics information.....	97
5.3.6	Group error	98
5.3.7	Trip reset.....	98
5.3.8	Emergency start.....	99
5.3.9	Self-test.....	100
5.3.10	Output 1, Output 2 and Output 3	100
5.3.11	Active parameter sets	101
5.3.12	Status of the device in Local mode.....	102
5.3.13	Disable Quick Stop	103
5.3.14	Pump cleaning	103
5.3.15	Use alternative stopping mode	104
5.3.16	Motor standstill.....	105
5.3.17	Motor current display	105
5.3.18	Current limits.....	106
5.3.19	Substitute value	107
5.3.20	Message characteristics	107
5.3.21	System text libraries for warning and trip.....	108
5.3.22	Reading and writing data records	110
5.3.23	Fault handling	111
5.3.24	Invalid input signals.....	111
5.3.25	Operator permissions.....	111
5.3.26	Enable measurement and statistics.....	113
5.3.27	Status information	113
5.3.28	Faceplate views	116
5.3.28.1	3RW5Oprn - Standard	116
5.3.28.2	3RW5Oprn - Diagnostics	119
5.3.28.3	Direct control from block icons.....	123

5.3.28.4	3RW52	125
5.3.28.5	3RW55	129
5.4	Measurement block.....	136
5.4.1	3RW5Meas block description	136
5.4.2	Parametrizable functions via the Feature connection 3RW5Meas.....	137
5.4.3	Operating modes.....	138
5.4.4	Read cyclic float values	139
5.4.5	Read measured values	139
5.4.6	Message characteristics	142
5.4.7	System text libraries for warning and trip.....	144
5.4.8	Start-up characteristics	145
5.4.9	Status information	145
5.4.10	Enabled operations	146
5.4.11	Faceplate views	147
5.4.11.1	3RW5Meas - Standard	147
5.4.11.2	3RW5Meas - Diagnostics	148
5.4.11.3	3RW5Meas - Preview	149
5.4.11.4	3RW52	150
5.4.11.5	3RW55	152
5.5	Statistical block	155
5.5.1	3RW5Stat block description.....	155
5.5.2	Parametrizable functions via the Feature connection 3RW5Stat	156
5.5.3	Operating modes.....	157
5.5.4	Statistical values	158
5.5.5	Read statistical values	159
5.5.6	Message characteristics	160
5.5.7	Start-up characteristics	161
5.5.8	Status information	162
5.5.9	Enabled operations	163
5.5.10	Faceplate views	164
5.5.10.1	3RW5Stat - Standard view.....	164
5.5.10.2	3RW5Stat - Maximum pointer 1.....	165
5.5.10.3	3RW5Stat - Preview.....	167
5.5.10.4	3RW52	168
5.5.10.5	3RW55	171
5.6	Channel block	175
5.6.1	3RW5Chn block description.....	175
5.6.2	Parametrizable functions via the Feature connection 3RW5Chn	175
5.6.3	Configuration.....	176
5.6.4	Control word.....	177
5.7	Control commands block	178
5.7.1	3RW5Ctrl block description.....	178
5.7.2	Neutral Position.....	179
5.7.3	Output signal as a pulse signal or static signal.....	180
5.7.4	Generating instance-specific messages	182
5.7.5	Operating modes.....	183
5.7.6	Mode changeover error.....	185
5.7.7	Forcing operating modes	186
5.7.8	Control functions for directions	187
5.7.9	Parameterizable functions via the Feature connection 3RW5Ctrl.....	188

5.7.10	Output signal for ready to start	190
5.7.11	Resetting of the block	191
5.7.12	Rapid stop	193
5.7.13	Specify warning times for controls	193
5.7.14	Issuing maintenance release	194
5.7.15	Suppressing messages using the MsgLock parameter	194
5.7.16	Simulation	195
5.7.17	Monitoring functions	196
5.7.18	Monitoring the motor status during pump cleaning	198
5.7.19	Motor Protection	198
5.7.20	Interlocking	199
5.7.21	Disabling interlocks	202
5.7.22	Group fault	202
5.7.23	User-defined auxiliary values and user-defined status	203
5.7.24	Message characteristics	204
5.7.25	Connection of the time-stamped messages from EventTs or Event16Ts	205
5.7.26	Opening additional faceplates	205
5.7.27	Fault handling	206
5.7.28	Enabled operations	206
5.7.29	Status information	207
5.7.30	Restart lock after changing direction of rotation or switching off the motor using idle time	210
5.7.31	Selecting a unit of measure	211
5.7.32	Faceplate views	212
5.7.32.1	3RW5Ctrl - Standard	212
5.7.32.2	3RW5Ctrl - Maintenance	215
5.7.32.3	3RW5Ctrl - Preview	217
6	Maintenance station	221
6.1	Identification data for 3RW5 objects	221
6.2	Maintenance Station	222
7	Module drivers of Soft Starter	225
7.1	Released modules	225
7.2	Object lists and action lists	226
7.3	Driver blocks	226
A	Parameters	229
A.1	3RW5Diag block parameters	229
A.2	Structure of UDTs for 3RW5Diag	232
A.3	3RW5Meas block parameters	238
A.4	3RW5Stat block parameters	246
A.5	3RW5Oprn block parameters	256
A.6	3RW5Chn block parameters	269
A.7	3RW5Ctrl block parameters	277

B	Technical data	289
	B.1 Technical data.....	289
C	Abbreviations.....	291
	C.1 Abbreviations	291

Introduction

1.1 Security information

Siemens provides products and solutions with industrial security functions that support the secure operation of plants, systems, machines and networks.

In order to protect plants, systems, machines and networks against cyber threats, it is necessary to implement – and continuously maintain – a holistic, state-of-the-art industrial security concept. Siemens' products and solutions constitute one element of such a concept.

Customers are responsible for preventing unauthorized access to their plants, systems, machines and networks. Such systems, machines and components should only be connected to an enterprise network or the internet if and to the extent such a connection is necessary and only when appropriate security measures (e.g. firewalls and/or network segmentation) are in place.

For additional information on industrial security measures that may be implemented, please visit

<https://www.siemens.com/industrialsecurity>.

Siemens' products and solutions undergo continuous development to make them more secure. Siemens strongly recommends that product updates are applied as soon as they are available and that the latest product versions are used. Use of product versions that are no longer supported, and failure to apply the latest updates may increase customer's exposure to cyber threats.

To stay informed about product updates, subscribe to the Siemens Industrial Security RSS Feed under

<https://www.siemens.com/industrialsecurity>.

1.2 Product specific security information

Product specific security information

This library is designed to be integrated inside of SIMATIC PCS 7 environment. Therefore, it is recommended to follow the security principles for SIMATIC PCS 7 to support a secure operation, such as:

- User rights
- Password protection of
 - WinCC

For more information, click here

(<https://support.industry.siemens.com/cs/document/60119725>).

Note

Security settings of the 3RW5 device (user account administration) must be setup correctly to work with this library.

Please ensure that the configured user role and rights are fitting to the requirements for the PCS 7 user.

1.3 Version overview

Please find an overview of all versions, manuals, readmes, readme_oss and additional information on the internet (<https://support.industry.siemens.com/cs/document/109770336>).

1.4 Components of the software package

This library integrates PROFIBUS and PROFINET 3RW5 Soft Starters into the PCS 7 environment.

The software package includes the following components:

No.	Function block description	Name	FB no.
1	Soft Starter diagnostic block	3RW5Diag	FB1335
2	Soft Starter operation block	3RW5Oprn	FB1336
3	Soft Starter measurement block	3RW5Meas	FB1337
4	Soft Starter statistic block	3RW5Stat	FB1338
5	Soft Starter channel block	3RW5Chn	FB1339
6	Soft Starter control command block	3RW5Ctrl ⁵⁵	FB1340

⁵⁵ Applicable only for 3RW55

- Online help in German and English
- Installation program
- Readme file for installation
- Readme_OSS

1.5 Installation

Getting started

For Getting started please check on the internet (<https://support.industry.siemens.com/cs/document/109770336>).

Installation

Please find instructions for the installation in the latest Readme for this library.

1.6 Configuration steps

1.6.1 Configuring in HW Config

The 4 bytes of the process image inputs (PII) are transferred from the Soft Starter 3RW5 device based on the logical address configured in the module. This is a manual configuration and user has to configure inputs.

In addition to 4 bytes, there are 12 bytes of cyclic data that can be configured manually. These 12 bytes contain 3 real values which can be either measurement values or statistical value.

3RW5 Soft Starter on the master system (PROFIBUS)

- Drag and drop the desired Soft Starter 3RW5 object (GSD only) out of the HW Catalog into the "Station" window of HW Config and connect it to the desired field bus (PROFIBUS).
- HW Config assigns the logical address to the object which will be used for setting up of the CFC template.

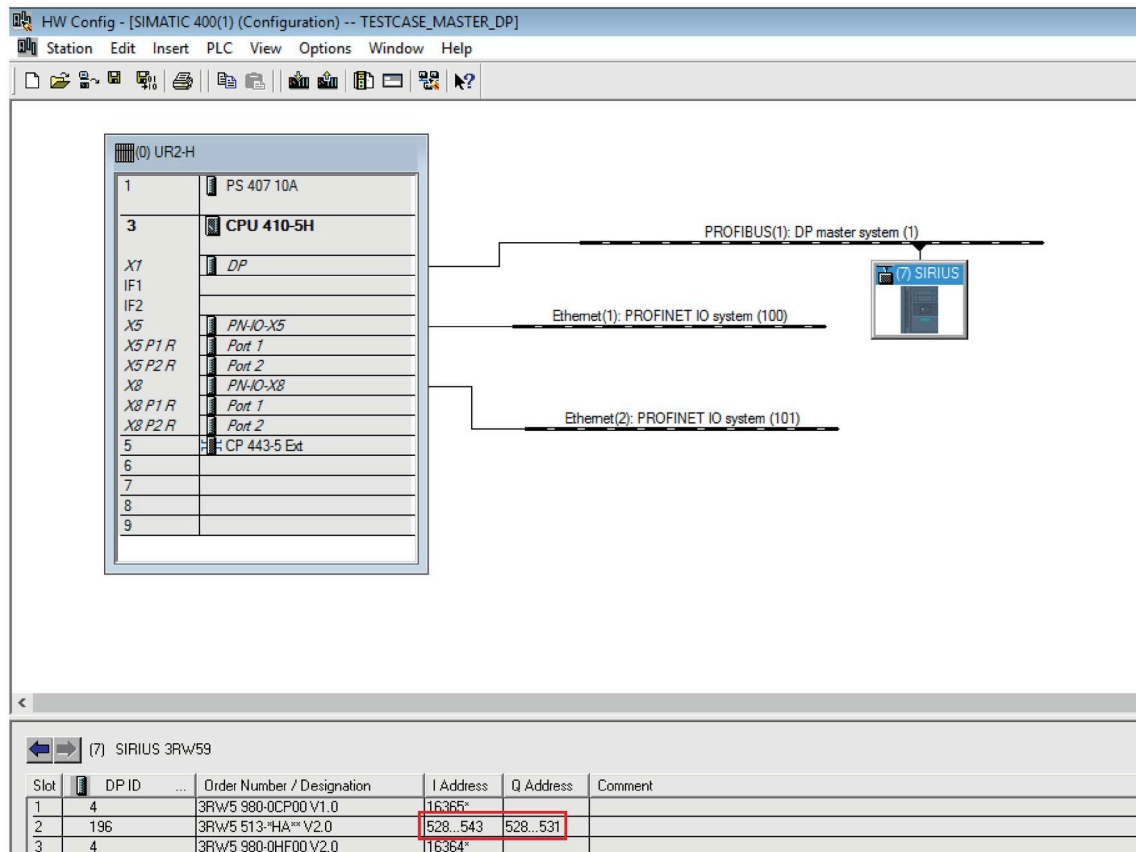

Figure 1-1 Hardware configuration

Note

It is required to have input address lesser then or equal to output address.

For more information, refer the table below.

Example	Input address (I Address)	Output address (Q Address)	Remark
1	528..543	528..531	Correct
2	528..543	538..541	Incorrect
3	528..543	518..521	Incorrect

Symbolic name in HW Config

The PZDI_{n03} input parameter of the block is interconnected with the corresponding input of the logical address of the device (LAddr).

The logical double word address can be assigned to a symbolic name (*).

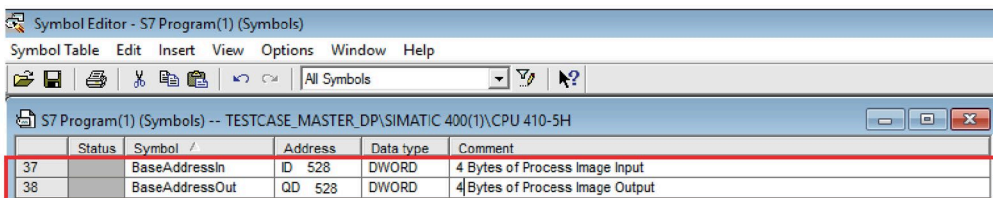
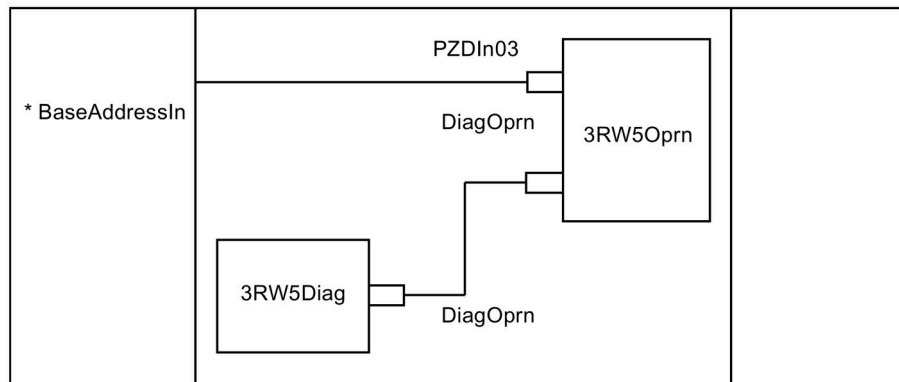

1.6.2 Configuring in CFC

The 4 bytes of the Process Image Inputs (PII) are transferred from the Soft Starter device based on the logical address configured for the module. This is a manual configuration that a user has to configure.

Procedure

1. Configure the Soft Starter 3RW52 / 3RW55 at HW config.
2. Open CFC-Editor.
3. If not yet done, instantiate an appropriate template.
4. Refer to the input address of the Soft Starter 3RW52 / 3RW55 device at HW Config and assign this address to the interconnectable chart I/O "PZDIIn03" (Input address of 3RW52 / 3RW55 Softstarter device).

Compile the CFC chart using the "Generate Module Driver" function.

Refer "Using templates (Page 25)" for further information on interconnections.

Reference

Additional information is available in the "Process Control System PCS 7 Compendium Part A - Configuration Guidelines" Operating Manual on the Internet (<https://support.industry.siemens.com/cs/document/109756485>).

1.7 Driver generator

The "Generate Module Driver" function is available for signal processing in PCS 7. Once the hardware has been configured in HW Config and the technological functions have been configured in the CFC, this function automatically generates, interconnects, and parameterizes the required module drivers. These module drivers are responsible for diagnosing and reporting errors during signal processing.

The Setup program installs XML files for the connection between the 3RW5 Soft Starter and the installed driver generator.

Supported modules and configurations

The driver concept includes operation of Soft Starter 3RW5 control function:

- As a DP slave direct on the DP master system (connection via GSD)
- As a DP slave behind a Y-link (connection via GSD)
- As a PROFINET I/O system on single PLC (connection via GSDML)
- As a DP slave behind an IE / PB Link (connection via GSD)
- As a DP slave behind an external card (connection via GSD)
- As a PROFINET I/O device behind an external card (connection via GSDML)

More information

Files for the integration of the 3RW5 Soft Starters are available as download in the internet.

PROFINET GSDML file (<https://support.industry.siemens.com/cs/document/109757789>)

PROFIBUS GSD file (<https://support.industry.siemens.com/cs/document/109757790>)

Purpose of the driver generator

The signal-processing blocks, the technological blocks, and the channel block are inserted in the CFC for each Soft Starter, and the connection to the hardware is established using symbolic address / base address.

The "Generate Module Driver" option inserts the driver and diagnostic block, and then connects and assigns the corresponding parameters.

1.8 Example Configurations

In HW Config, the 3RW52 / 3RW55 Soft Starter is inserted and configured with the associated components (GSD / GSDML files).

Note

The following diagrams show example configurations and illustrate the configuration in HW Config.

3RW5 Soft Starter on the master system (PROFIBUS)

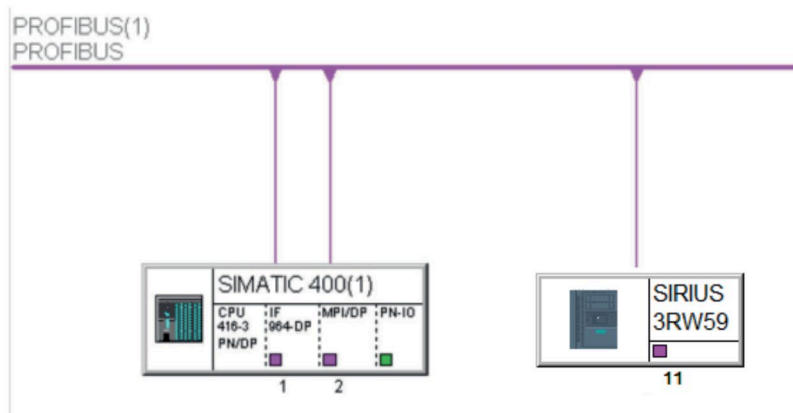

3RW5 Soft Starter on the master system (PROFINET)

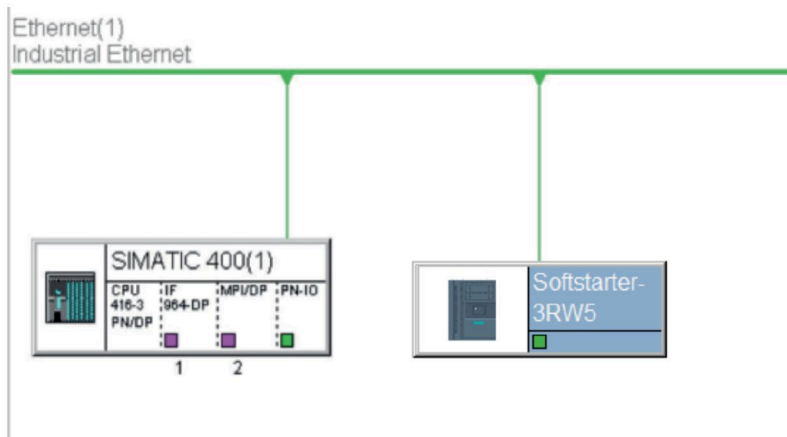

Note

PROFINET port monitoring settings are made mandatory.

When multiple devices are connected to the CPU / CP card interface, used and unused PROFINET port settings are required to distinguish between actual rack failure and device failure.

3RW5 Soft Starter on PROFIBUS DP behind a Y-link

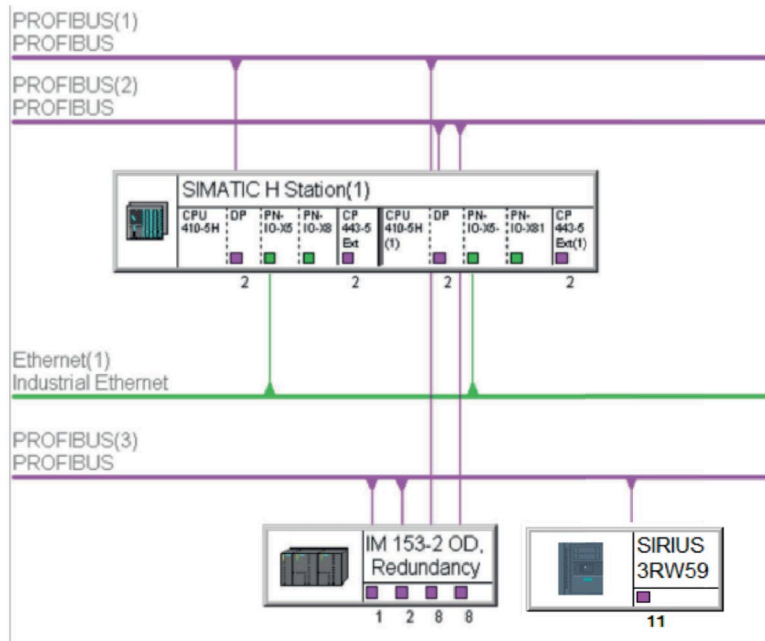

3RW5 Soft Starter on PROFIBUS DP behind IE / PB link

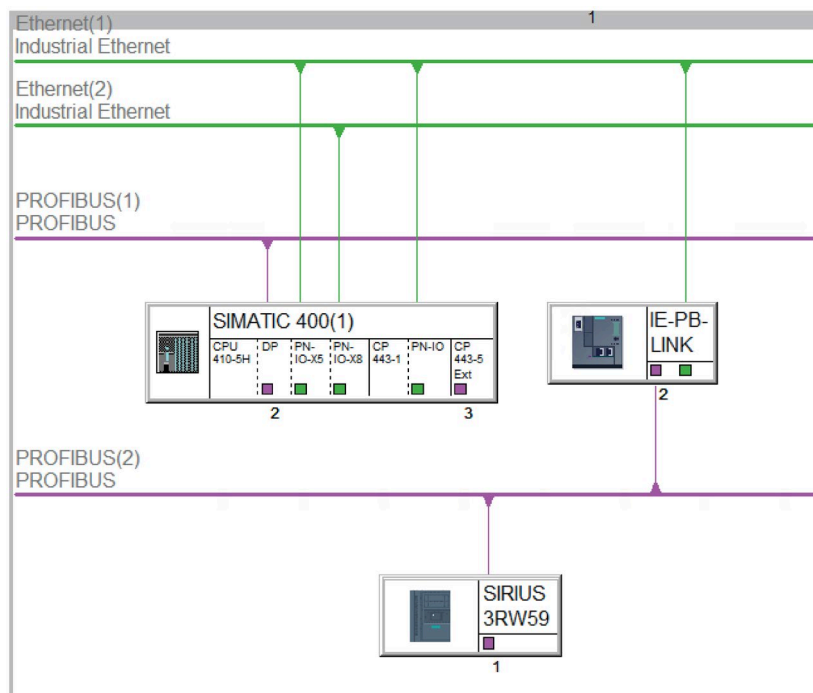

1.9 Parametrization softwares

The following software is available:

- Soft Starter ES V15.1 (TIA portal)

1.10 Further documentation

Overview

You can find more information here:

- Online help for PCS 7 Advanced Process Library.
- Online help for SIMATIC PCS 7 Process Control System
- Function manuals for SIMATIC PCS 7 Process Control System (<https://support.industry.siemens.com/cs/document/109760968>)
- System Manual for SIRIUS 3RW52 Soft Starter (<https://support.industry.siemens.com/cs/document/109753751>)
- System Manual for SIRIUS 3RW55 Soft Starter (<https://support.industry.siemens.com/cs/document/109753752>)
- System Manual for SIRIUS 3RW5 PROFINET communication module (<https://support.industry.siemens.com/cs/document/109753754>)
- System Manual for SIRIUS 3RW5 PROFIBUS communication module (<https://support.industry.siemens.com/cs/document/109753753>)
- Getting Started (<https://support.industry.siemens.com/cs/document/109770336>)
- Version overview for SIRIUS Soft Starter 3RW5 PCS 7 Libraries (<https://support.industry.siemens.com/cs/document/109770336>)

Information about the library

2.1 Block overview

The following blocks can be used with the 3RW5 Soft Starters:

Name	FB no.	Description	3RW55	3RW52
3RW5Diag	FB1335	Soft Starter diagnostic block (Page 81)	X	X
3RW5Oprn	FB1336	Soft Starter operation block (Page 89)	X	X
3RW5Meas	FB1337	Soft Starter measurement block (Page 136)	X	X
3RW5Stat	FB1338	Soft Starter statistic block (Page 155)	X	X
3RW5Chn	FB1339	Soft Starter channel block (Page 175)	X	X
3RW5Ctrl	FB1340	Soft Starter control commands block (Page 178)	X	-

2.2 Faceplates

A faceplate displays all elements of a block graphically. The faceplate is displayed in a separate window on the Operator Station (OS). You can open the faceplate:

- Using picture selection keys
- From the process tag list
- By clicking the specific block icon

Typical structure of a faceplate

The file name of the faceplate is structured as follows:

"@<PG>_<XXX>_<YYY>.pdl"

Table 2- 1 Meaning of tags

Tag	Replaced with
<PG>	<ul style="list-style-type: none"> • PG for block-specific elements • PCS7 for elements provided by PCS 7
<XXX>	Name of the block, e.g. 3RW5Oprn
<YYY>	Name of view

2.2 Faceplates

Example: "@PG_3RW5Oprn_Standard.pdl"

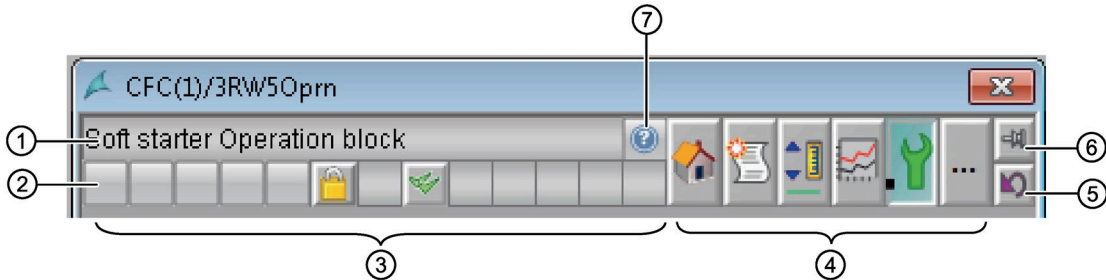

- ① Name of block
- ② Comment, e.g., name of starter
- ③ Overview window
- ④ Toolbar for selecting the view
- ⑤ "Back to Process Picture" button:
You can use this button to return to the original process picture.
- ⑥ "Pin faceplate" button:
You can use this button to secure the faceplate when switching the faceplate.
- ⑦ Help button

Toolbar

Every button in the toolbar represents a view. Click on the appropriate button to open the view. Right-click on the name of the view in the toolbar to open the view in a separate window.

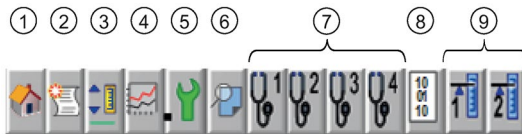



- | | | |
|------------|---------------|--------------------|
| ① Standard | ④ Trend | ⑦ Diagnostics |
| ② Alarm | ⑤ Maintenance | ⑧ Process image |
| ③ Limits | ⑥ Preview | ⑨ Maximum pointers |

Overview window

The overview window shows the overall status of the block:



- ① Group display:
Indicates whether unacknowledged alarms and warnings are pending.
- ② Status LOCK for messages, authorization level 5 and higher
- ③  Message suppression¹
-  Individual Message suppression²
- ④ Message acknowledgement, authorization level 5 and higher
- ⑤ Signal status of the block
- ⑥ Batch Display:
This function indicates whether the block instance of SIMATIC BATCH is occupied.
- ⑦ Maintenance state

¹) The symbol appears in overview window of 3RW5Oprn, 3RW5Stat and 3RW5Meas. The messages of the blocks are suppressed when `MsgLock = 1` and `Feature bit 25 = 1`.

²) The symbol appears in overview window of 3RW5Oprn (`Feature bit 11 to bit 18`), 3RW5Stat (`Feature bit 11 to bit 18`) and 3RW5Meas (`Feature bit 11 to bit 18`), if one or more alarm message is suppressed using respective `Feature bit`.

Expanded command area

For inputs in the dialog window that require confirmation by the operator, the command area is expanded in the faceplate. The corresponding options are then available, depending on the selection.

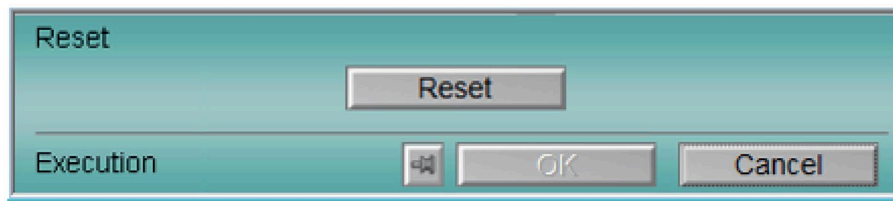

The expanded command area can be programmed with a 2- or 3-level access concept for the operator. The access can be changed in the WinCC Explorer using the internal `@APLCommandExecutionSteps` variable.

Level 2: The operator only needs to press the command to execute.

Level 3: The operator must also press the OK button to execute the command.

Authorization levels

Some commands are subject to permission with authorization levels via WinCC. The authorization levels are updated when a view is opened. The user can only execute the commands that are enabled for him.

The authorization levels are created for the project by means of a user ID.

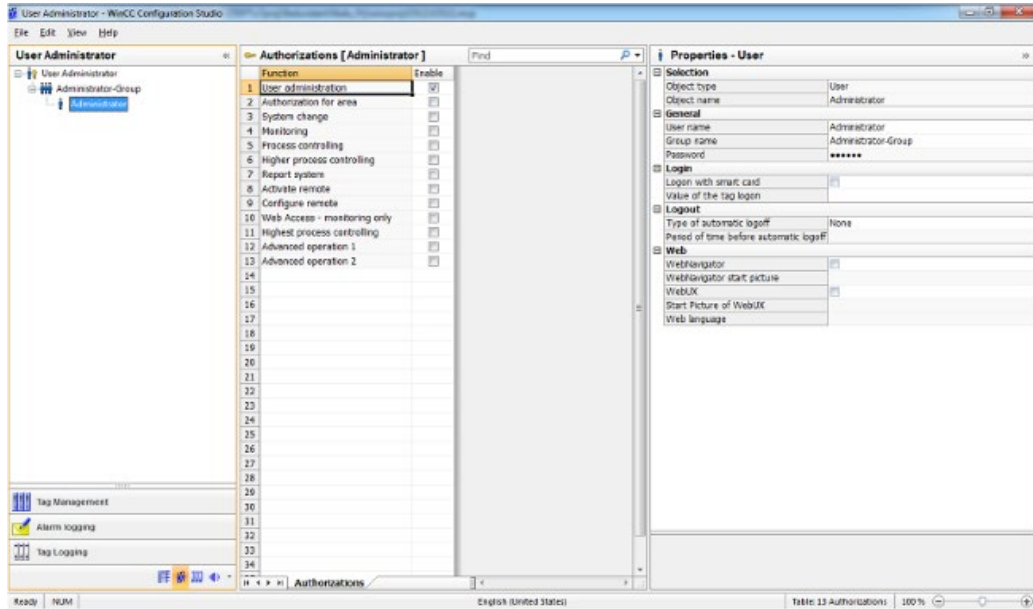

Configuration aids

The following software and templates are available for configuring the faceplates:

- In WinCC Explorer: the Graphics Designer
- Templates available from the Faceplate Designer
- PCS 7-specific standard views
 - Trend
 - Alarms
- Additionally required views, user objects, and functions

More information

The faceplates described are available as functional, tested components. Along with the faceplates, you receive a description that enables you to adapt the faceplates:

- Description of the interface to the blocks
- Description of the operator input functions and the display functions.

See also

Alarm view (Page 36)

Templates

3.1 Overview of the templates

Templates in this library can be used to simplify the engineering for configuring the blocks. You can modify the templates or create completely new ones. The interconnections that must then be created manually can be found in the available templates.

Note

The templates of this library have been built using the function blocks of PCS7 APL. When this library is installed, the respective Drive block (MotL) of PCS7 APL would need to be imported by the user at the templates.

To update the existing project, please refer the respective readme version under the topic "Steps to be done for updating existing PCS 7 projects" for detailed information.

Template for the Soft Starter

Softstarter Device	Template	APL blocks	Soft Starter blocks
3RW55 PROFIBUS / PROFINET	3RW55_Soft_Starter	Event16Ts	3RW5Ctrl ¹ 3RW5Oprn ¹ 3RW5Chn 3RW5Meas 3RW5Stat
3RW52 PROFIBUS / PROFINET	3RW52_Soft_Starter	MotL ¹ Event16Ts	3RW5Oprn ¹ 3RW5Chn 3RW5Meas 3RW5Stat

¹ Block icon available

For more information about the APL blocks, refer to the Function Manual "PCS 7 Process Control System, PCS 7 Advanced Process Library" on the Internet (<https://support.industry.siemens.com/cs/document/109760968>).

Reference

3RW5Diag Block (Page 81)

3RW5Oprn Block (Page 89)

3RW5Meas Block (Page 136)

3RW5Stat Block (Page 155)

3RW5Chn Block (Page 175)

3RW5Ctrl Block (Page 178)

3.2 Using templates

The template for the control function Direct starter is located in the 3RW5 Soft Starter Library under:

3RW5_PCS7_LibV90SP2 > Blocks + Templates\Templates >

Select the template, e.g. *3RW55_Soft_Starter* and drag-and-drop onto the CFC.

Alternatively, you can also copy the template direct to the chart container or to the required location in the technological hierarchy view.

Manual interconnections

In the CFC, connect "PZDIn03 (Input address of 3RW52 / 3RW55 Soft Starter device)".

There are two ways of doing this:

- Via the already created symbolic name
- Via direct input of the calculated address

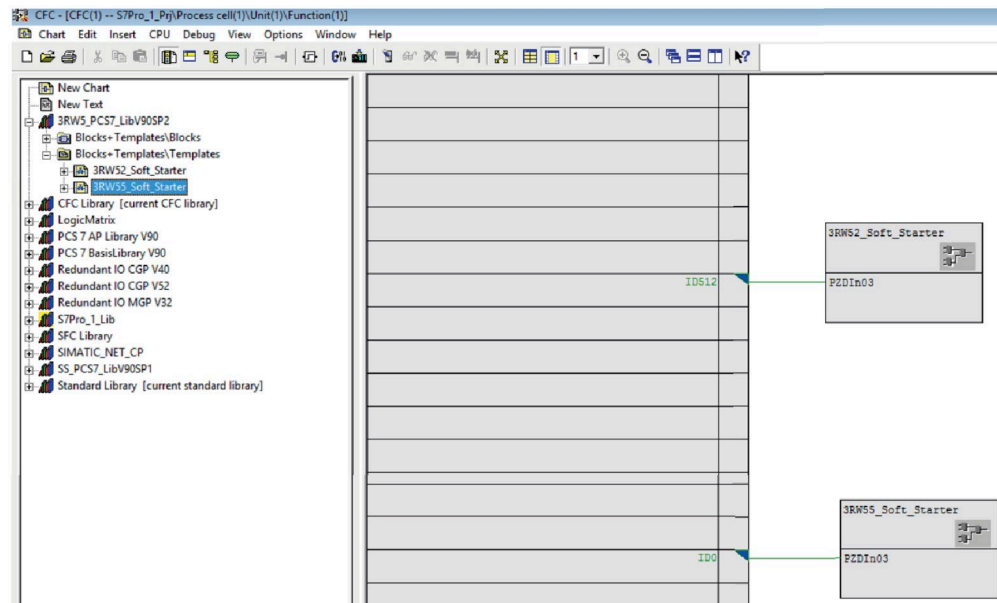

Automatic interconnections

If the option "Generate Block Driver" is activated in the "Compile Program" dialog, interconnections that are not yet available but that are necessary will be automatically executed.

In addition to the interconnections, the driver generator automatically inserts the following blocks and connects them with the template:

- SUBNET
- OB_DIAG1 / OB_DIAG1_PN
- RACK
- 3RW5Diag
- MOD_SWT
- OR
- AND

The textual interconnections supplied in the template can be deleted individually or entirely. The driver generator replaces the textual interconnections automatically.

You can control deletion of the textual interconnections using the menu command Options → Delete Textual Interconnections.

Note

To view generated interconnections after executing the driver generator, hit F5 to refresh or close the CFC and open it again.

Assigning the starting logical address is enough to start the driver generation through which the `PZDIIn03` values are passed to the other dependent blocks, also the `PZDOut03` address is fetched automatically from the HW config.

Remove unused blocks

The following blocks (at CFC Sheet 2) are not absolutely necessary for operating 3RW5 Soft Starters:

- 3RW5Meas
- 3RW5Stat

They provide further functions such as measured values (e.g. temperature) and statistical data.

These blocks can be deleted (right mouse key → delete or select block → Del). After renewed compiling and downloading to the PLC, these functionalities are no longer available for the user program.

Note

Once the OS compilation is also done, there will be only one block icon created for each template. The block icon for MotL for 3RW52 and block icon for 3RW5Ctrl for 3RW55 will be created. However, if the user desires to have a block icon for the 3RW5Oprn block, it can be enabled manually by the user before OS compilation. Refer the screenshot below.

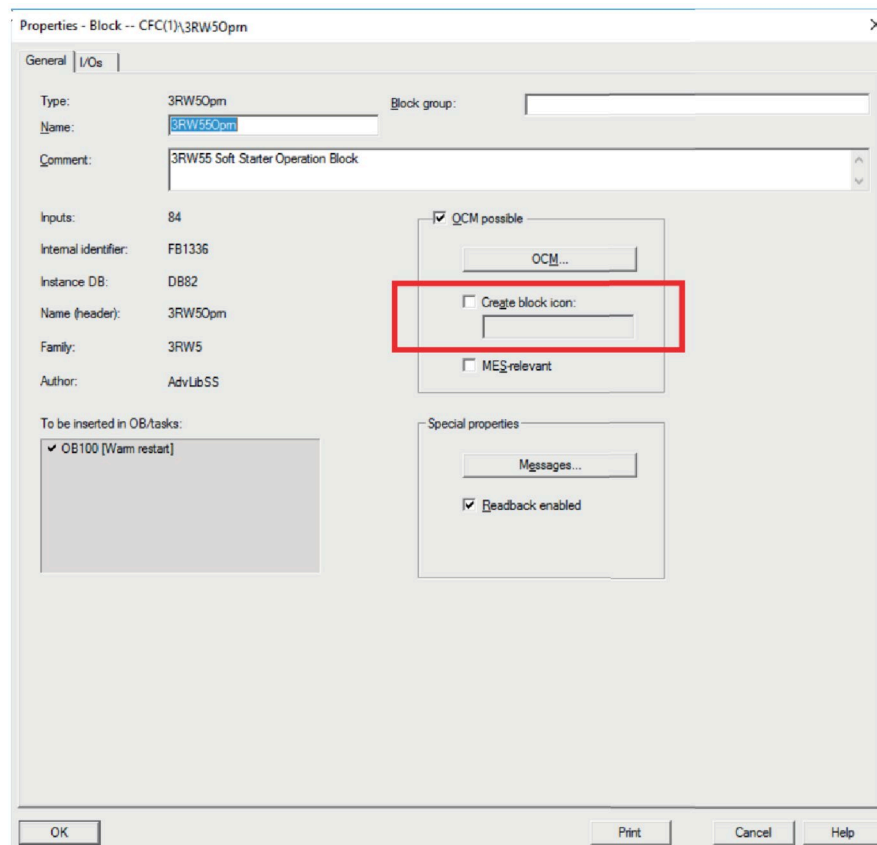

3.3 3RW5 Soft Starter templates

This template supports the control and operation of 3RW5 Soft starters

Blocks available in 3RW5 Soft starter template is mentioned in the below table:

Blocks	3RW55	3RW52
MotL	–	X
Event16Ts	X	X
Or04	X	X
And04	X	–
3RW5Oprn	X	X
3RW5Meas	X	X
3RW5Stat	X	X
3RW5Chn	X	X
3RW5Ctrl	X	–

Note

3RW55: `Feature Bit7` should be set to "1" for starting the motor in the opposite direction i.e. when motor is running in forward direction if operator needs to change the direction (reverse direction) without stopping motor. Same condition is applicable for creep speeds (creep forward and creep reverse).

3RW52: Starting the Motor in the opposite direction is not possible.

Block icons and faceplate views

4.1 Block icons

The block symbols are contained in the following file: "@PCS7Typicals3RW5V9.pdf"

The 3RW5Oprn block can be displayed by a block icon.

The availability of block icons for blocks is mentioned below:

Block icons	3RW55	3RW52
3RW5Diag	–	–
3RW5Meas	–	–
3RW5Stat	–	–
3RW5Chn	–	–
3RW5Oprn	X	X
3RW5Ctrl	X	–

Structure

Structure of a block icon:

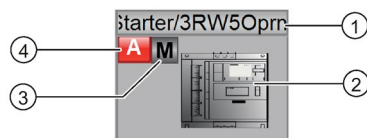

- ① Process type
- ② Device status display
- ③ Operating mode
- ④ Error messages

Figure 4-1 Structure of a block icon, example 3RW5Oprn

4.1.1 3RW5Oprn block icon

Creating block icons in CFC

To create a block icon, select the number for the appropriate block icon in the object properties of the block.

During the AS-OS compilation, the block icons are extracted from the file @PCS7Typicals3RW5V9.pdl to the picture file of the current project.

Clicking on the block icon opens the corresponding faceplate and the block icon remains highlighted as long as this faceplate is opened.

To create a block icon select "create block icon" check box in the object properties of the block

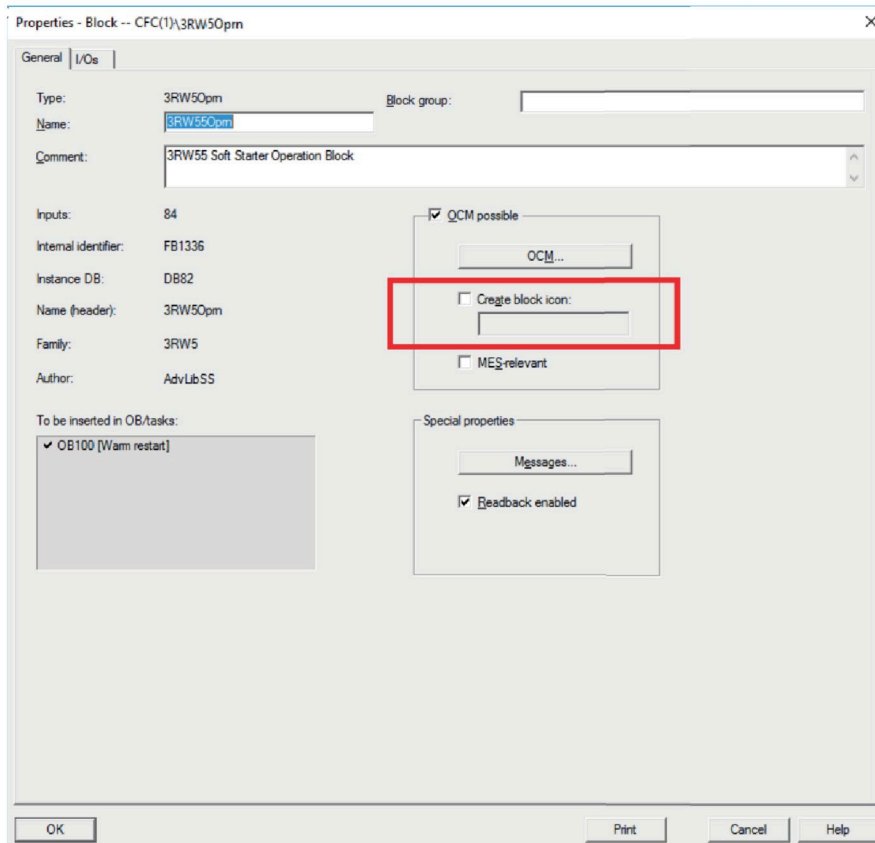

3RW5Oprn block icon

The block icon of the 3RW5Oprn block is displayed below:

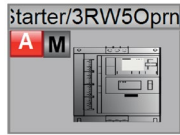

4.1.2 3RW5Ctrl block icon

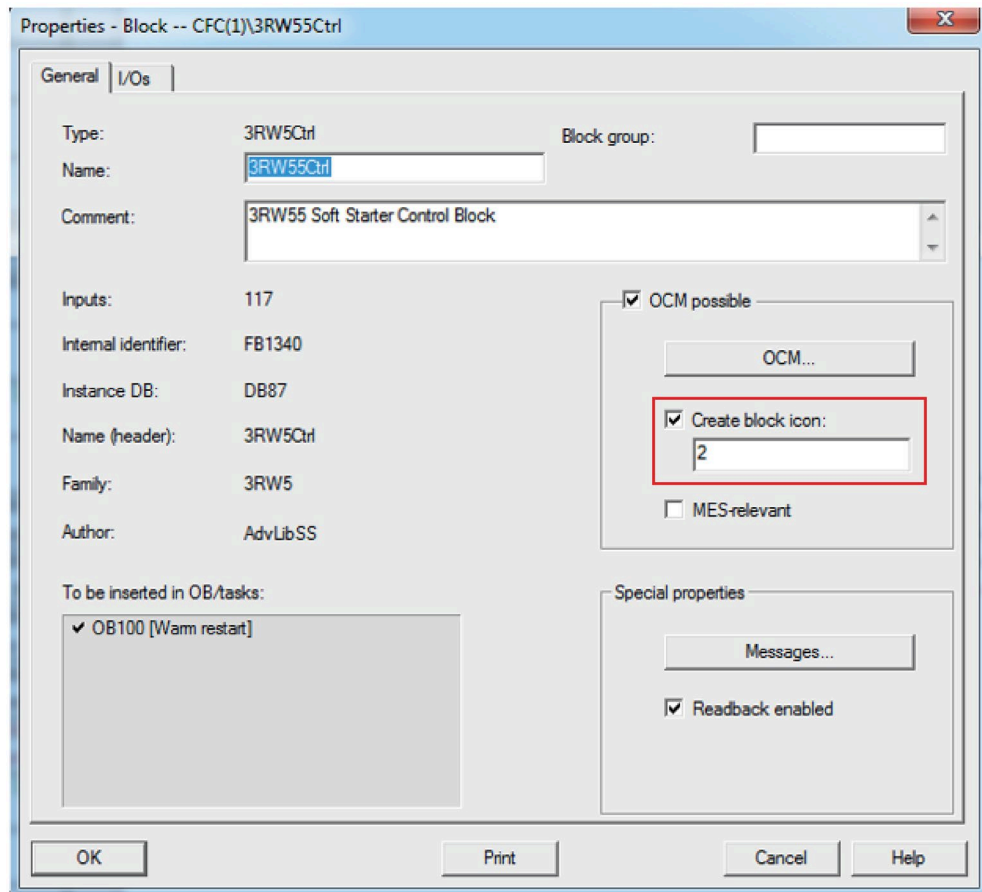

Changing block icons in CFC

When 3RW55 template is used, the motor block icon is created (Refer table "3RW5Ctrl block icons"). To change / switch the block icon of 3RW5Ctrl block, enter the number for the appropriate block icon in the object properties of the block (Input field underneath check box "Create block icon"). Please follow the below procedure "creating block icons in CFC" for the same.



3RW5Ctrl block icon

The 3RW5Ctrl block provides 2 block icons as displayed below:

No.	Icon
1	 The icon shows a grey square with a red 'A' and black 'M' in the top left. A circular symbol with a double-headed horizontal arrow is in the center. The text '3RW5Ctrl/1' is in the top right.
2	 The icon shows a grey square with a red 'A' and black 'M' in the top left. A circular symbol with a double-headed vertical arrow is in the center. The text '3RW5Ctrl/2' is in the top right.

4.2 Faceplates

4.2.1 Batch view

The "Batch" view is available for all signal blocks.

Batch view

- | | | |
|---|------------------------|---|
| ① | Enabled (BatchEn) | This area shows you if the block is enabled for operation via SIMATIC BATCH (Status1.Bit1) |
| ② | Allocated (Occupied) | This area shows if the block is currently in use by SIMATIC BATCH (Status1.Bit0) |
| ③ | Batch name (BatchName) | This area shows the name of the batch that is currently running |
| ④ | Batch ID (BatchID) | This area shows the identification number of the batch that is currently running (BatchID).
The batch view is disabled if BatchID = 16#00000000. |
| ⑤ | Batch step (StepNo) | This area shows the step number of the batch that is currently running. |

4.2.2 Trend view

The "Trend" view is available in blocks in which curves are generated online from measured values, for example, the motor current.

Trend view

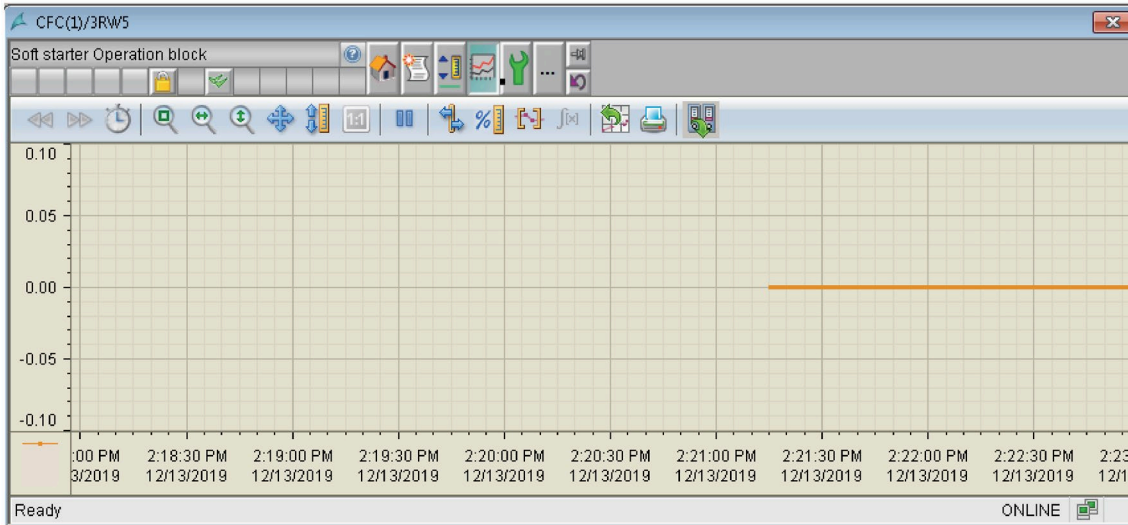

Configuring the view

The block parameters that are evaluated for the trend are configured in the block icon of the block.

To configure the view, use the properties TrendPictureName, TrendConfiguration and Trend color. Up to 10 parameters can be used for the view

1. The file name TrendPictureName is identical for all the blocks in the library: "@PCS7_APL_Trend.PDL".
2. TrendConfiguration is entered in the following format:
<ParameterName>;<TrendControl>;<Reserved>;<Name of the Curve>
For example, MotCurr#Value;_TrendCtrl1_;Reserved;MotorCurrent
3. Trend color determines the color of the curve.

Object properties TrendConfiguration

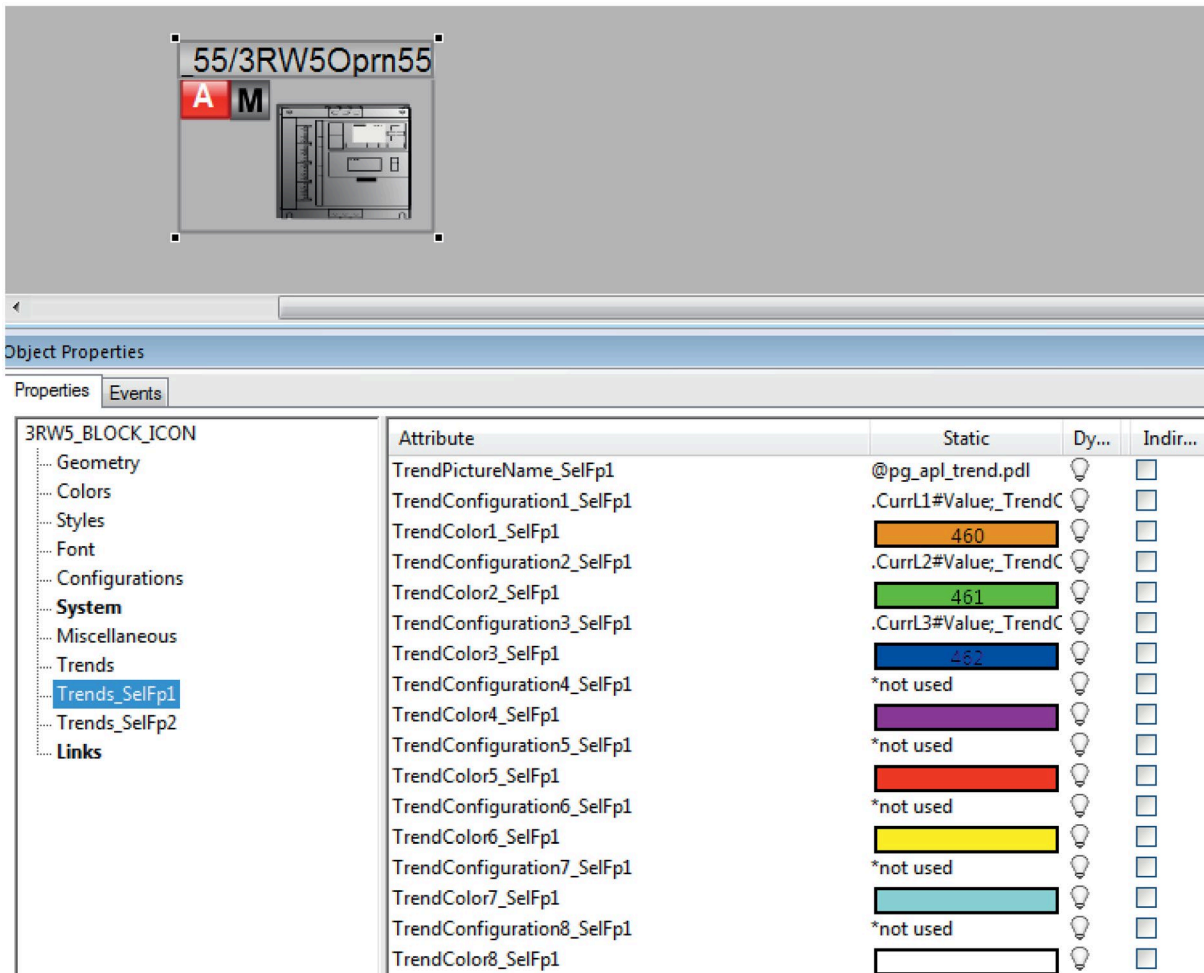

Attribute	Static	Dy...	Indir...
TrendPictureName_SelfFp1	@pg_apl_trend.pdl	💡	<input type="checkbox"/>
TrendConfiguration1_SelfFp1	.CurrL1#Value;_TrendC	💡	<input type="checkbox"/>
TrendColor1_SelfFp1	460	💡	<input type="checkbox"/>
TrendConfiguration2_SelfFp1	.CurrL2#Value;_TrendC	💡	<input type="checkbox"/>
TrendColor2_SelfFp1	461	💡	<input type="checkbox"/>
TrendConfiguration3_SelfFp1	.CurrL3#Value;_TrendC	💡	<input type="checkbox"/>
TrendColor3_SelfFp1	482	💡	<input type="checkbox"/>
TrendConfiguration4_SelfFp1	*not used	💡	<input type="checkbox"/>
TrendColor4_SelfFp1		💡	<input type="checkbox"/>
TrendConfiguration5_SelfFp1	*not used	💡	<input type="checkbox"/>
TrendColor5_SelfFp1		💡	<input type="checkbox"/>
TrendConfiguration6_SelfFp1	*not used	💡	<input type="checkbox"/>
TrendColor6_SelfFp1		💡	<input type="checkbox"/>
TrendConfiguration7_SelfFp1	*not used	💡	<input type="checkbox"/>
TrendColor7_SelfFp1		💡	<input type="checkbox"/>
TrendConfiguration8_SelfFp1	*not used	💡	<input type="checkbox"/>
TrendColor8_SelfFp1		💡	<input type="checkbox"/>

Trends Trend curves configuration for the 3RW5Oprn block

Trends_SelfFp1 Trend curves configuration for the block connected via the parameter Trends_SelfFp1 (e.g. 3RW5Meas).

Trends_SelfFp2 Trend curves configuration for the block connected via the parameter Trends_SelfFp2 (e.g. 3RW5Stat).

4.2.3 Alarm view

The "Alarm" view is available for all signal blocks.

Alarm view

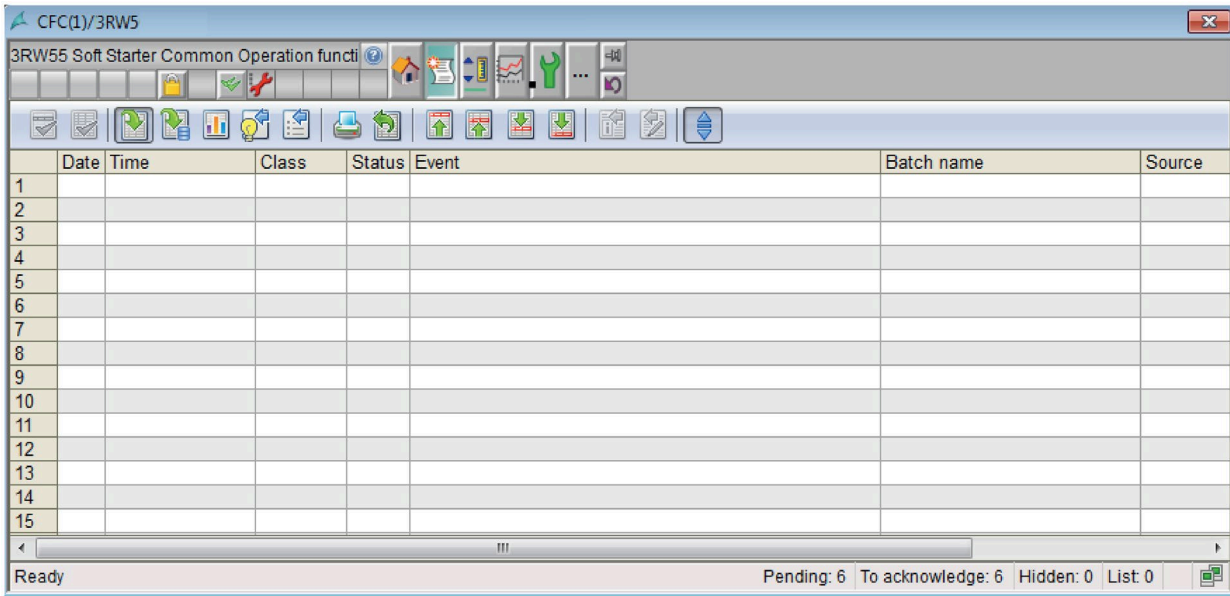
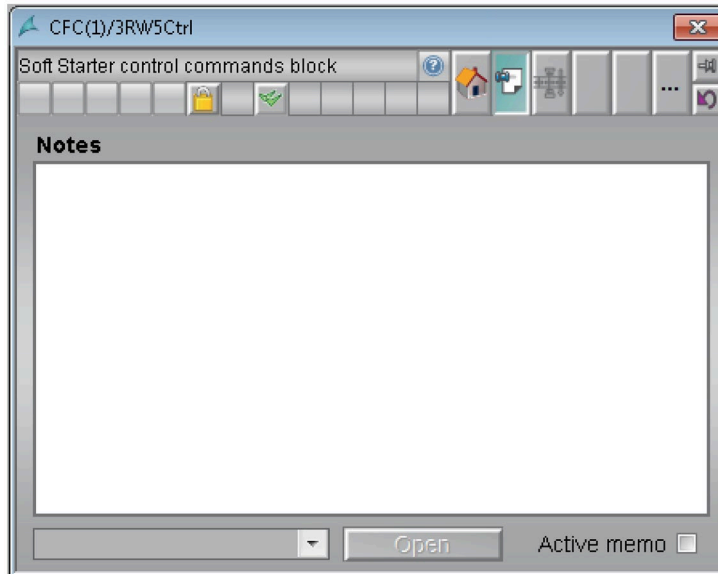

Figure 4-2 Alarm view, 3RW5Oprn example

4.2.4 Memo view

The Memo view is available only for 3RW5Ctrl block.

Memo view







Note

Refer APL Memo view to know more about configuring Note View.

4.2.5 Scalable faceplates

The faceplates will be scaled from 50% to 200%. The value to scale will be given in the internal variable "@APLFaceplateScaleFactor". Default value is 100. The faceplates will be scaled up from 101% to 200%, by providing a value in a range of 101-200 in internal variable. Similarly the faceplates will be scaled down from 50% to 99%, by providing a value in the range 50-99. The reference for calculation is default size of the faceplates which is 100(%). It means if the value given is 150, the faceplates will be scaled up by 50% of the default size.

The faceplate can also be scaled up or down using buttons. The button can do the following function

	Button to increase zoom factor by 5%.
	Button to decrease zoom factor by 5%.
	Button to reset zoom factor to 100%.
	An Object to display current zoom factor value in runtime.

This Object changes the value of tag **@APLFaceplateScaleFactor**.

The buttons are available in @PCS7TypicalsAPLV8.PDL and @TemplateAPLV8.PDL files and it should be copied to plant view to process the image in order to use them.

Note

Faceplate must be reopened after changing the scale value. Already opened faceplate cannot be scaled up if the scale value is changed.

Example: The screenshot below shows the faceplates scaled up by providing the value of 200, scaled down by providing the value of 50 for the internal variable.

Scaling factor is 50%

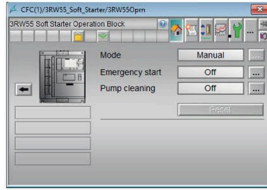

Scaling factor is 100% (Default value)

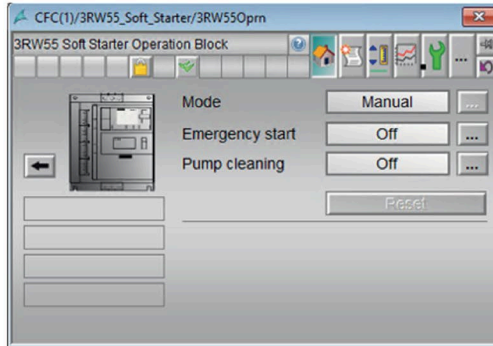

Scaling factor is 200%

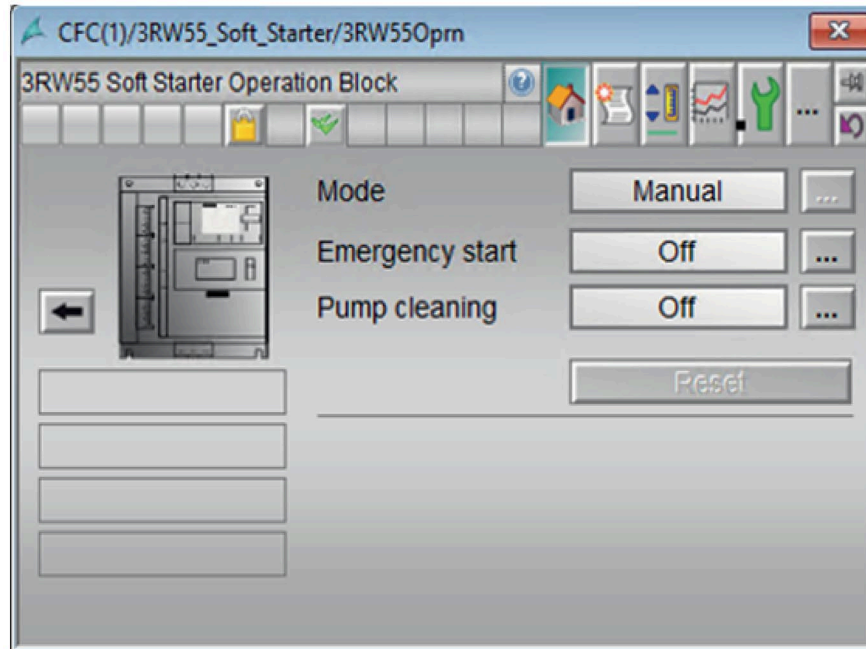

4.3 Supported functions

4.3.1 Central color management

Central color management

The central color palette from the APL Library underlies this "3RW5 Soft Starter PCS 7 Library".

The colors in the faceplates and block icons can be changed via this central color palette in WinCC. The color palette is located on the "User interface and design" tab of the project properties.

For more information about the parameterizable functions, refer to the Function Manual "Process Control System PCS 7, PCS 7 Advanced Process Library" on the Internet (<https://support.industry.siemens.com/cs/document/109760968>).

4.3.2 Web Navigator

This library supports the Web Navigator functions.

You can find additional information on configuring the Web Navigator functions in the manual "PCS 7 - OS Web Option" under C:\Program Files\SIEMENS\Documentation\English.

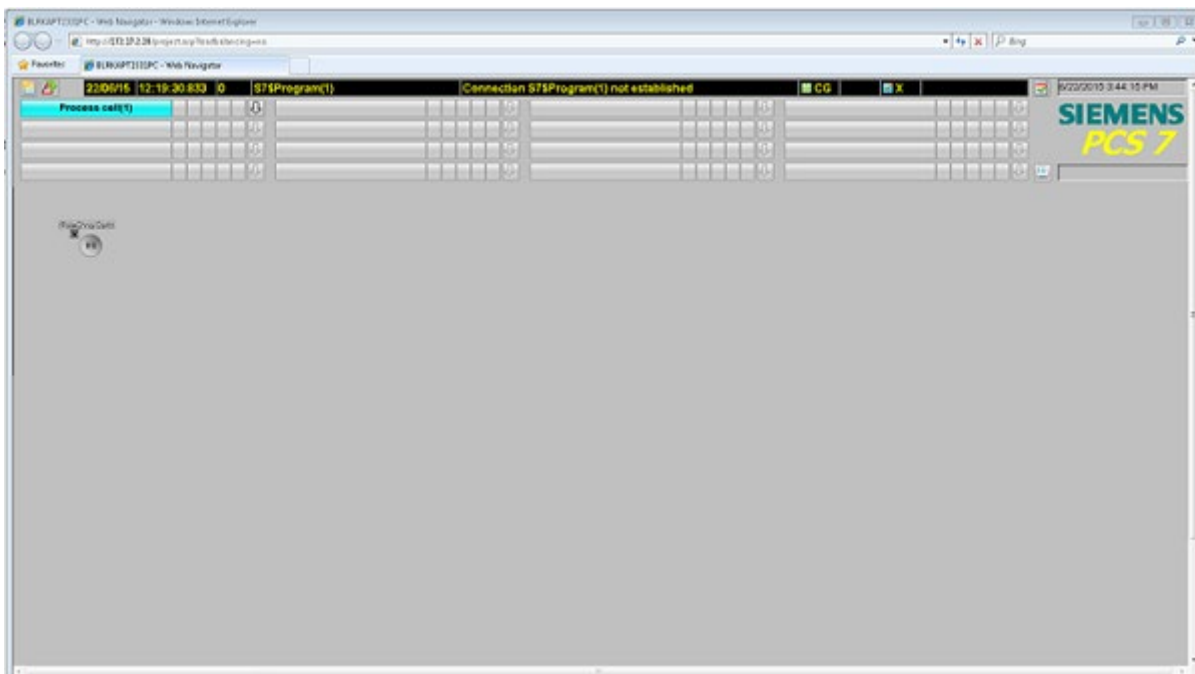
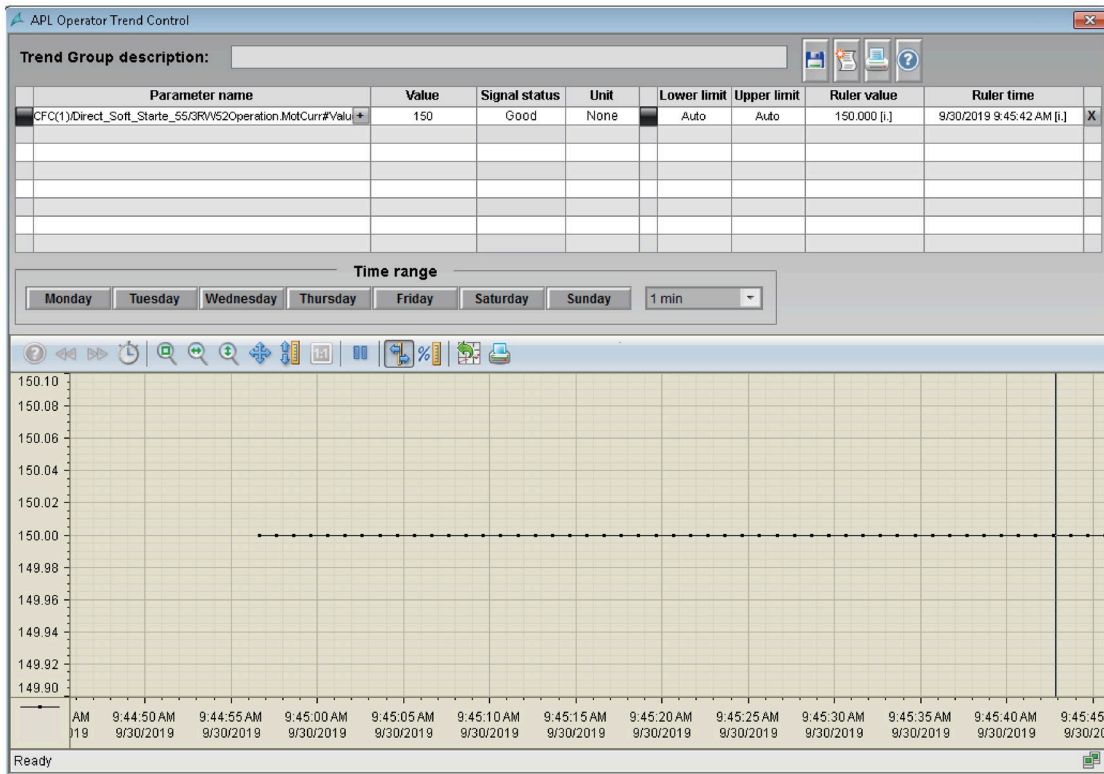

Figure 4-3 Web Navigator

4.4 APL Operator Trend Control (AOTC)

Opening the AOTC window

Press and hold the `Ctrl` key and left-click the block icon to open the AOTC window. Status of parameters are added to the Trend Control and the detailed information is displayed in the each row of the overview area.



Note

Refer APL Operator Trend Control section to know more details.

Description of the blocks

5.1 Functions for all blocks

5.1.1 Calling OBs

The "Generate Module Driver" function automatically inserts the Soft Starter blocks into the following organization blocks within the run sequence of the CFC:

Table 5- 1 Organization blocks

OB	Description	3RW5Diag	3RW5Meas	3RW5Stat	3RW5Oprn	3RW5Chn	3RW5Ctrl ⁵⁵
OB1	Cyclic program	X	–	–	–	–	–
OB30...OB38 ¹	Cyclic alarms	–	X	X	X	X	X
OB82	Diagnostics alarm	X	–	–	–	–	–
OB83	Insert/remove interrupt	X	–	–	–	–	–
OB85	Program execution error	X	–	–	–	–	–
OB86	Rack fault	X	–	–	–	–	–
OB100	Restart (warm restart)	X	X	X	X	X	X

¹ Insert the block into the OB32, if read / write access is slow.

⁵⁵ Applicable only for 3RW55

"X" = OB calls the block; "–" = OB does not call the block.

Reference

You can obtain further information on organization blocks in the "Process Control System PCS 7 System Functions" manual and in the system and standard functions reference manual for S7-300/400 on the Internet

(<https://support.industry.siemens.com/cs/document/44240604>).

5.1.2 Called blocks

The Soft Starter blocks call the following blocks:

Table 5- 2 Called blocks

Block		Description	3RW5Diag	3RW5Meas	3RW5Stat	3RW5Oprn	3RW5Chn	3RW5Ctrl ⁵⁵
SFB35	ALARM_8P	Generates block-specific messages with values for eight signals	X	X	X	X	–	X
SFB52	RDREC	Read data set	X	X	X	X	–	–
SFB53	WRREC	Writes a data record	–	–	X	X	–	–
SFB54	RALRM	Receives alarm	X	–	–	X	–	–
SFC6	RD_SINFO	Reading of OB start information	X	X	X	X	X	X
SFC13	DPNRM_DG	Reads the diagnostic data of the DP slave	X	–	–	–	–	–
SFC20	BLKMOV	Used to Copy the content of a memory area to another Memory area	–	X	X	X	X	X
SFC51	RDSYSST	Reads the system status list or the sublist	X	–	–	–	–	–
FC369	SeIst16	Output of the best or worst signal status	X	X	X	X	–	X

"X" = The block calls this block.

⁵⁵ Applicable only for 3RW55

"—" = The block does not call this block.

5.1.3 Worst signal status

Worst Signal Status ST_{Worst} is formed from the following parameters:

Block	Parameter	3RW55	3RW52
3RW5Oprn	ModFact.ST	X	X
	RackFact.ST	X	X
	GrpFlt.ST	X	X
	GrpWarn.ST	X	X
	TrpRstLi.ST	X	X
	SlfTstLi.ST	X	X
	RdDataLi.ST	X	X
	GrpErr.ST	X	X
	RdErr.ST	X	X
	WrErr.ST	X	X
	EmrgStAut.ST	X	-
	DsQkSpAut.ST	X	-
	Out1Aut.ST	X	-
	Out2Aut.ST	X	-
	Out3Aut.ST	X	-
	PmpClnAut.ST	X	-
AltStpAut.ST	X	-	
MtrStdAut.ST	X	-	
3RW5Meas	RackFact.ST	X	X
	ModFact.ST	X	X
	GrpErr.ST	X	X
	RdErr.ST	X	X
	RdDataLi.ST	X	X
3RW5Stat	RackFact.ST	X	X
	ModFact.ST	X	X
	GrpErr.ST	X	X
	RdErr.ST	X	X
	WrErr.ST	X	X
	RdDataLi.ST	X	X
3RW5Diag	RackFact.ST	X	X
	ModFact.ST	X	X
	GrpErr.ST	X	X
	Rack1Err.ST	X	X
	Rack2Err.ST	X	X
	RdErr.ST	X	X

Block	Parameter	3RW55	3RW52
3RW5Ctrl ⁵⁵	FbkCrpFwdOut.ST	X	-
	FbkCrpRevOut.ST	X	-
	FbkFFwdOut.ST	X	-
	FbkFRevOut.ST	X	-
	LocalLi.ST	X	-
	CrpFwdAut.ST	X	-
	CrpRevAut.ST	X	-
	StopLocal.ST	X	-
	FwdAut.ST	X	-
	RevAut.ST	X	-
	Trip.ST	X	-
	FwdChnST.ST	X	-
	RevChnST.ST	X	-
	CrpFwdChnST.ST	X	-
	CrpRevChnST.ST	X	-

⁵⁵ Applicable only for 3RW55 Soft Starter

"X" : Applicable

"-" : Not applicable

5.1.4 Quality code

The status and quality of a rack is checked by means of the quality code.

Table 5- 3 Quality code

Quality code	Priority ¹	Occurs when...	Meaning	3RW5Diag	3RW5Meas	3RW5Stat	3RW5Oprn	3RW5Ctrl ⁵⁵
16#80	6	No error	Good	X	X	X	X	X
16#60	–	SimOn	Simulated value	–	–	–	–	X
16#00	0	<ul style="list-style-type: none"> • RackFAct • ModFAct • BusFlt 	Bad, device related, value not valid	X	X	X	X	X
16#28	1	<ul style="list-style-type: none"> • Subnet error Rack1Err or Rack2Err • OB not loaded. 	Bad, device related	X	–	–	–	–
16#28	2	From preceding blocks	Bad, process-specific	–	X	X	X	X
16#68	3	Group warning	Bad	X				X
		From preceding blocks	Uncertain, device related		X	X	X	
16#A4	–		Maintenance demand	–	–	–	–	X

¹ 0 = high; 6 = low.

⁵⁵ Applicable only for 3RW55.







"X" = The quality code occurs in this block.

"–" = The quality code does not occur in this block.

Icons

The icons for the quality code are displayed in the block icon and in the overview window of the faceplates.

Table 5- 4 Icons for quality code display

Quality code	Symbol	Meaning
16#80		Good
16#60		Local function check / simulation
16#00 ¹		Bad, device related, value not valid
16#28 ¹		Bad, process-specific
16#68		Uncertain, device related
16#A4		Maintenance demand

¹ Active Quality Codes for the Trip, Intlock, Permit, and Protect parameters in the interlock status.

Reference

You can find more information on quality code display in the Programming Manual PCS 7 Libraries APL Styleguide on the Internet

(<https://support.industry.siemens.com/cs/document/65601446>).

5.1.5 Error numbers

Table 5- 5 Error numbers per block

Error number	Error type	Description	3RW5Diag	3RW5Meas	3RW5Stat	3RW5Oprn	3RW5Chn	3RW5Ctrl ⁵⁵
-1	–	Predefined value when inserting the block; the block is not processed.	X	X	X	X	X	X
0	–	No error	X	X	X	X	X	X
1	System error	Rack failure	X	X	X	X	–	–
3	System error	The module does not respond.	X	X	X	X	–	–
4	System error	Subnet 1 or subnet 2 error	X	–	–	–	–	–
41	Programming error	The value for LocalSetting I/O is not within the permissible limits of 0 to 4.	–	–	–	–	–	X
42	Programming error	LocalSetting = 0 or LocalSetting = 3 or LocalSetting = 4 and LocalLi = 1	–	–	–	–	–	X
51	Programming error	Error number for invalid signal state e.g. FwdLocal = 1 and StopLocal = 1 FwdAut = 1 and StopAut = 1 AutModLi = 1 and ManModLi = 1 FwdForce = 1 and RevForce = 1	–	–	–	X	–	X
52	Programming error	LocalAct = 1 and LocalSetting = 2 or 4 and SimOn = 1	–	–	–	–	–	X
53	Programming error	Active parameter set = 2 Feature bit 26 = 1 Feature bit 28 = 0	–	–	–	X	–	–
54	Programming error	Active parameter set = 3 Feature bit 27 = 1 Feature bit 28 = 0	–	–	–	X	–	–

Description of the blocks

5.1 Functions for all blocks

Error number	Error type	Description	3RW5Diag	3RW5Meas	3RW5Stat	3RW5Oprn	3RW5Chn	3RW5Ctrl ⁵⁵
55	Programming error	Active parameter set = 2 Feature bit 26 = 1 Feature bit 28 = 1	-	-	-	X	-	-
56	Programming error	Active parameter set = 3 Feature bit 27 = 1 Feature bit 28 = 1	-	-	-	X	-	-

"X" = Error occurs in this block.

"-" = Error does not occur in this block.

⁵⁵ Applicable only for 3RW55.

5.1.6 Reading and writing data records

The blocks use SFB 52 "RDREC" function to read and process values from data records, and The SFB 53 "WRREC" functions to process and write values to data records of the Soft Starter device.

The "Read Data" button in the faceplates is used to update the displayed values by calling the "RDREC" at the function block.

Note

Reading can only be performed successfully if the function "WRREC" (Write data) is not executed at the same time.

Read parameter data record

Reading data records are performed irrespective of the current mode.

Write function

It is only possible to write data records if the block is in REMOTE mode.

Parameter Read data set

Reading data sets is performed irrespective of the current mode.

Reading is performed with the following parameters:

Table 5- 6 Parameter Read data set

Parameter	Value	Meaning
RdDataOp ¹	1	Read data from data set
RdDataLi ¹	0 → 1	Read data set via link or SFC
RdWrEn	1	Enable read / write record
RdErr	1	Error when reading
WrErr	1	Error when writing
RdWrAct	1	Reading / writing data set ended

¹ not in Out of service mode and in case of rack failure

Errors when reading / writing data record

The following errors can occur when reading / writing the data record:

Error code (W#16#...)	Description
8085	Due to a problem in the system, information is not currently available (for example, due to a lack of resources).
80A2	DP protocol error at layer 2
80A3	<ul style="list-style-type: none">PROFIBUS DP: DP protocol error with Direct-Data-Link-Mapper or user interface / userPROFINET IO: General CM error
80A4	Bus communication disrupted
80A9	Application - Feature / Function is not supported. DPV1 service <> DS-Read / DS-Write
80C0	The module has the data record, however there are no read data yet.
80C2	The module currently processes the maximum possible jobs for a CPU.
80C3	The required operating resources (memory, etc.) are currently occupied.
80C4	Internal temporary error. Job could not be carried out. Repeat the job. If this error occurs often, check your installation for sources of electrical interference.
80C6	Data record transfer was canceled due to priority class cancellation.
80C7	Job cancelled due to restart (warm restart) or cold restart of DP master.

Note

Automatic function call for 300 cycles if error is detected

If any of these errors is detected, the function calls to read or write data record is executed again. The maximum counts of these repetitive calls is set to 300 beyond which an error is reported as a read error or write error at the `RdErr` or `WrErr` output parameter respectively.

5.1.7 Read Record error status

The "Read Record" error status function is available for the 3RW5Diag, 3RW5Oprn, 3RW5Meas and 3RW5Stat blocks.

Displaying the error status in the "Alarm" view

The "Read Record" error status is shown at the output parameter `RdErrStat`.

To display the error status as a message in the "Alarm" view, proceed as follows:

1. Interconnect the output parameter `RdErrStat` with one of the pins of the external values (`ExtVaXXX`).
2. Interconnect the output parameter `RdErr` with one of the pins of the external messages (`ExtMsgX`).
3. Configure the message in the auxiliary value `ALARM_8P` accordingly.
4. Compile and download the CFCs.
5. Recompile the OS.

5.1.8 Write Record error status

The "Write Record" error status function is available for the 3RW5Oprn and 3RW5Stat blocks.

Displaying the error status in the "Alarm" view

The "Write Record" error status is shown at the output parameter `WrErrStat`.

To display the error status as a message in the "Alarm" view, proceed as follows:

1. Connect the output parameter `WrErrStat` with one of the pins of the external values (`ExtVaXXX`).
2. Connect the output parameter `WrErr` with one of the pins of the external messages (`ExtMsgX`).
3. Configure the message in the auxiliary value `ALARM_8P` accordingly.
4. Compile and download the CFCs.
5. Recompile the OS.

5.1.9 Overview of the measuring point browser window

For more information on measuring point browser, refer SIMATIC PCS 7 APL Function Manual (<https://support.industry.siemens.com/cs/document/109760968>).

5.1.10 Configurable response using the feature I/O

5.1.10.1 Start-up characteristics

Number of the `Feature` bit: 0

Feature bit purpose

The alarm messages are suppressed in the OB100 for the `RunUpCyc` number of times. During warm restart, the `RdyToReset` will be reset to zero.

When in the "Out of service mode", the block will continue to be in the same mode after a warm restart.

Applicable for blocks

- 3RW5Stat
- 3RW5Oprn
- 3RW5Ctrl

The message classes alarm, warning and tolerance are not valid for user-configured message classes. Take into consideration the validity of terms for user-configured message classes.

Note

During 'Run-Stop-Run' transition of the CPU, the internally pending messages, non-stuck-through messages with time stamps and auxiliary values beginning with `RunUpCycle` occur for blocks with the startup characteristic `Feature` bit = 0 and after the expiration of the `RunUpCycle` counter in the following cases:

- Alarm, warning or tolerance messages from the operating points
- Feedback errors

This causes an outgoing message when initializing Alarm_8P in OB100 and an incoming message after expiration of the `RunUpCycle` counter on the cyclic interrupt level.

Set startup characteristics

Bit = 0: Starting the block in manual mode and in neutral position. With controllers, the setpoint is set to (SP_Int) internally.

Bit = 1: Starting the block with the last stored values, in other words in the last operating mode set (manual, automatic or local mode) and at the last valid position.

Note

Special note following complete download to the CPU

Following a complete download to the CPU, the motor protection signal Trip is evaluated during the initial run as good (=1). When a motor protection signal is pending, this causes a non-struck-through message with time stamp and auxiliary values beginning with `RunUpCycle` after the complete download and after expiration of the `RunUpCycle` counter.

5.1.10.2 Response for Out of service mode

Number of the `Feature` bit: 1

Feature bit purpose

Define the reaction of the technologic block based on the linked input parameter `OosLi = 1`.

The default setting is 0.

Applicable for blocks

- 3RW5Stat
- 3RW5Oprn
- 3RW5Meas
- 3RW5Ctrl

Set startup characteristics

Bit = 0: The symbol for the "In progress" status appears in the block icon and in the faceplate of the assigned technologic block. A 0-1 edge transition at the input parameter `OosLi` has no further influence on the reaction of the technological block; the previous status is retained.

No switch to the "Out of service" mode is performed.

Bit = 1: The mode switches to "Out of service" assuming that the block is "On" or "Manual" mode. If this is not the case, the mode does not change. The symbol for the "In progress" status also appears in the block icon and in the faceplate of the assigned technologic block regardless of the mode change. If no message display on the faceplate then this indicates whether the mode change has occurred or not.

5.1.10.3 Resets the commands for switching between modes

Number of the Feature bit: 2

Feature bit purpose

Define how the block handles the incoming control commands AutModLi and ManModLi .

The default setting is 0.

Applicable for blocks

- 3RW5Oprn
- 3RW5Ctrl

Set startup characteristics

Bit = 0: The control commands are not reset by the block. If there are two pending control commands for changing mode, the mode is not changed. In this case, the note text "Invalid command" is displayed in the faceplate.

Bit = 1: The control commands are reset by the block. This, for example, ensures that if a control command is sent from the SFC, the command is reset automatically after a step is exited.

5.1.10.4 Enabling resetting of commands for the control settings

Number of the Feature bit: 3

Feature bit purpose

With this Feature bit, you select how the block handles commands for the control settings (for example motor on) via the interconnected input parameters.

The default setting is 0.

Applicable for blocks

- 3RW5Ctrl

Set startup characteristics

Bit = 0: The control commands are not reset by the block. If there are two commands relating to the control settings at the same time, the status of the control settings is retained. In this case, the "Invalid signal" message is displayed in the standard view of the faceplate.

Bit = 1: The control commands are reset by the block. This, for example, ensures that if a control command is sent from the SFC, the command is reset automatically after a step is exited.

5.1.10.5 Setting switch or button mode

Number of the **Feature bit**: 4

Feature bit purpose

Determine whether a separate interconnectable 1-active control input has to be used for every automatic command of the block or two automatic commands are assigned to a control input (input signal as pulse signal or as static signal).

The Feature bit affects the following control inputs:

- starting and stopping a motor
- switching modes (parameters `AutModLi` and `ManModLi`)

Setpoint specification internal and external is given in the form of a pulse (pushbutton operation) or a static signal (switching mode).

You can find the commands for controlling the block in the relevant section on block operating modes. These are the parameters that are always used for the automatic operation of a block.

The default setting is 0.

Applicable for blocks

- 3RW5Oprn
- 3RW5Ctrl

Set startup characteristics

Bit = 0: Button mode: Each automatic command is assigned to a control input. This has a latching reaction and is 1-active.

Example with a motor 3RW5Ctrl: In this case, use the interconnectable input parameters.

- `FwdAut` = 1 for the command "Start forward"
- `RevAut` = 1 for the command "Start backwards"
- `StopAut` = 1 for the stop command and
- `AutModLi` = 1 for setting "Automatic" operating mode
- `ManModLi` = 1 for setting "Manual" operating mode

Bit = 1: Switching mode: two static automatic commands are assigned to a control input.

Example with a motor 3RW5Ctrl: In this case, use the interconnectable input parameters.

- `FwdAut` = 1 for the command "Start forward"
- `RevAut` = 1 for the command "Start backwards" and
- `FwdAut` = 0 and `RevAut` = 0 for the stop command
- `AutModLi` = 1 for setting "Automatic" operating mode
- `AutModLi` = 0 for setting "Manual" operating mode

The `StopAut` and `ManModLi` control inputs are irrelevant in this case.

5.1.10.6 Set switching mode

Number of the `Feature` bit: 5

Feature bit purpose

Use this Feature bit to specify switching mode for the motor block.

The default setting is 0.

Applicable for blocks

- 3RW5Ctrl

Set startup characteristics

Bit = 0: Switching mode "On over creep Speed" with the `SwOverTi` > 0 parameter.

Bit = 1: Switching mode "Off over creep Speed" with the `SwOverTi` > 0 parameter.

5.1.10.7 Enabling direct changeover between forward and reverse

Number of the `Feature` bit: 7

Feature bit purpose

Use this Feature bit to enable direct reversal of the direction of motors.

The default setting is 0.

Applicable for blocks

- 3RW5Ctrl

Set startup characteristics

Bit = 0: Direct changeover of the direction is disabled.

You can only change the direction of the motor by first stopping and starting the motor again in the required direction. The motor can only be started again after the time set in the `IdleTime` parameter has elapsed.

Bit = 1: Direct changeover is enabled.

You can reverse the motor direction directly. The motor block reverses the direction automatically. The motor is stopped and is started in the other direction when the time set in the `IdleTime` parameter has elapsed.

5.1.10.8 Status handling for values

Number of the `Feature` bit: 7

Feature bit purpose

This Feature enables faceplate to show Last valid value (maintenance release) instead of Bad value (rackfault).

The default setting is 0.

Applicable for blocks

- 3RW5Chn

Set startup characteristics

Bit = 0: Bad value (ST: =16#00).

Bit = 1: Last valid value (ST: =16#68).

5.1.10.9 Resetting via input signals in the event of interlocking (Protection) or errors

Number of the `Feature` bit: 8

Feature bit purpose

Define how the automatic control is to be re-enabled after an active interlock.

The default setting is 0.

Applicable for blocks

- 3RW5Ctrl

Set startup characteristics

Bit = 0: After an interlock (only Protection: Input parameter `Protect`) or errors, the system can only be restarted using a reset command. Reset is initiated either by operator input in the faceplate or via the interconnectable input parameter (`RstLi = 1`) in the block. Thereafter, the currently pending command takes effect in automatic mode.

Bit = 1: It is also possible to reset with a 0-1 edge change in the control signal in automatic mode.

5.1.10.10 Changes Signal status of outputs in OOS (Out of service)

Number of the `Feature` bit: 9

Feature bit purpose

This Feature bit changes the signal status of outputs in "Out of service" mode to 16#60.

The default setting is 0.

Applicable for blocks

- 3RW5Oprn

Set startup characteristics

Bit = 0: Signal status will be last frozen values.

Bit = 1: Signal status of outputs in OOS to 16#60.

Example

Status of `MotorOn`, `MotorCW` & `MotorCCW` parameters

5.1.10.11 Exit local mode

Number of the `Feature` bit: 10

Feature bit purpose

Define how "Local mode" is either departed or will be departed with `LocalSetting = 1` or `LocalSetting = 2`, and if the mode is not specified by `AutModLi` or `ManModLi`.

The default setting is 0.

Applicable for blocks

- 3RW5Oprn

Set startup characteristics

Bit = 0: Exiting local mode in manual mode.

Bit = 1: When local mode is departed, the mode changes back to the last mode that was active prior to local mode.

5.1.10.12 Condition Monitoring

Number of the Feature bit: 10

Feature bit purpose

Transferring condition monitoring information to the Maintenance Station.

The default setting is 0.

Applicable for blocks

- 3RW5Chn

Set startup characteristics

Bit = 0: No Condition Monitoring.

Bit = 1: Condition Monitoring.

5.1.10.13 Enable runtime for feedback signals

Number of the Feature bit: 11

Feature bit purpose

To activate the runtime of feedback signals.

The default setting is 0.

Applicable for blocks

- 3RW5Ctrl

Set startup characteristics

Bit = 0: Deactivated - Tracking of feedback for simulation immediately after the trigger signal.

Bit = 1: Activated - Tracking of feedback for simulation after the trigger signal and expiration of the monitoring time (MonTiDynamic). The feedback signals are generated after expiration of the monitoring time.

5.1.10.14 Separate monitoring time for stopping the motor

Number of the Feature bit: 13

Feature bit purpose

To activate a separate monitoring time for stopping the motor.

The default setting is 0.

Applicable for blocks

- 3RW5Ctrl

Set startup characteristics

Bit = 0: A monitoring time for starting and stopping the motor.

Bit = 1: Separate monitoring time for stopping the motor.

5.1.10.15 Enabling rapid stop via faceplate

Number of the Feature bit: 14

Feature bit purpose

Specify if the OS operator can use rapid stop for the block via the standard view of the faceplate.

The default setting is 0.

Applicable for blocks

- 3RW5Ctrl

Set startup characteristics

Bit = 0: The "Rapid stop" button is not visible in the faceplate.

Bit = 1: The OS operator can use the button for rapid stop.

5.1.10.16 Activate bumpless changeover to automatic mode

Number of the Feature bit: 17

Feature bit purpose

To enable the bumpless switchover from local / manual mode to automatic mode.

The default setting is 0.

Applicable for blocks

- 3RW5Ctrl

Set startup characteristics

Bit = 0: Bumpless switchover is disabled. You can switch from local / manual mode to automatic mode at any time.

Bit = 1: Bumpless switchover from local / manual mode to automatic mode is enabled. A switchover from local / manual mode to automatic mode is possible if the control settings of the local / manual mode and automatic modes match. If switchover occurs at a different point in any time, the "Switchover error" text is indicated on the faceplate.

5.1.10.17 Activate fault status for external control system fault

Number of the Feature bit: 18

Feature bit purpose

Specify whether the block should switch to the error state at an external process control error CSF = 1.

The default setting is 0.

Applicable for blocks

- 3RW5Ctrl

Set startup characteristics

Bit = 0: Block does not go to error state with process control error CSF = 1.

Bit = 1: Activated - Block goes to error state with process control error CSF = 1.

5.1.10.18 Suppression of one or more alarm messages

Number of the Feature bit: 11-18

Feature bit purpose

One or more alarm messages can be suppressed using Feature Bits (Bit11... Bit18). These bits are used to suppress any particular message(s) which is of no interest.

The default setting is 0.

Applicable for blocks

- 3RW5Stat
- 3RW5Oprn
- 3RW5Meas

Set startup characteristics

Bit = 0: Alarm message(s) is not suppressed.

Bit = 1: Single alarm message(s) is suppressed.

5.1.10.19 Reset even in locked state

Number of the Feature bit: 19

Feature bit purpose

You can specify if it is possible to perform a reset with an active "Protection" or "Motor protection" type interlock. This can be used, for example, to reset hardware interlocks.

The default setting is 0.

Applicable for blocks

- 3RW5Ctrl

Set startup characteristics

Bit = 0: No reset is possible with a "Protection" type interlock or with active motor protection.

Bit = 1: Reset is possible with a "Protection" type interlock or with active motor protection.

5.1.10.20 Enable feedback monitoring when motor OFF

Number of the Feature bit: 19

Feature bit purpose

Enables feedback monitoring at 3RW5Ctrl block when motor is set to OFF state.

The default setting is 0.

Applicable for blocks

- 3RW5Oprn

Set startup characteristics

Bit = 0: Enable/disable feedback monitoring irrespective of the motor running status.

Bit = 1: Enable/disable feedback monitoring only when the motor is running,

When the motor is in OFF state the feedback monitoring stays enabled.

5.1.10.21 Disable Feedback Tracking LocalSetting 2 & 4

Number of the Feature bit: 20

Feature bit purpose

To disable the tracking of feedback signals in the "Local" mode setting 2 and 4.

The default setting is 0.

Applicable for blocks

- 3RW5Ctrl

Set startup characteristics

Bit = 0: Calculation of impulse controls in LocalSetting 2 and 4.

Bit = 1: Disable calculation of impulse controls in LocalSetting 2 and 4.

5.1.10.22 Suppress reading DS

Number of the `Feature` bit: 20-21

Feature bit purpose

Suppress reading statistical data (DS95) for `Feature bit 20`. Suppress reading Maximum pointer data (DS96) for `Feature bit 21`.

The default setting is 0.

Applicable for blocks

- 3RW5Stat

Set startup characteristics

Bit = 0: Enable data set reading.

Bit = 1: Disable data set reading.

5.1.10.23 Bumpless switchover to automatic mode

Number of the `Feature` bit: 21

Feature bit purpose

Specify whether bumpless switchover to automatic mode for motors can be enabled only if switching via the faceplate is in effect, or whether switching using interconnectable inputs `AutModLi` and `ManModLi` (`ModLiOp = 1`) is also possible.

The default setting is 0.

Applicable for blocks

- 3RW5Stat

Set startup characteristics

Bit = 0: The function "Bumpless switchover to automatic mode for motors" works when switching via the faceplate and switching using interconnectable inputs `AutModLi` and `ManModLi` (`ModLiOp = 1`).

Bit = 1: The "Bumpless switchover in automatic mode for motors" function only works for switching via the faceplate. Bumping switchover can be activated via the inputs `AutModLi` and `ManModLi` (`ModLiOp = 1`).

5.1.10.24 Update acknowledgement and error status of the alarm

Number of the `Feature` bit: 22

Feature bit purpose

To determine if the acknowledgement and error status of the message call at the block output should be updated.

The default setting is 0.

Applicable for blocks

- 3RW5Ctrl
- 3RW5Opn
- 3RW5Stat
- 3RW5Meas

Set startup characteristics

Bit = 0: The `MsgErr`, `MsgStat` and `MsgAckn` block outputs are set to the default settings and not updated. The block will run faster with this setting.

Bit = 1: The `MsgErr`, `MsgStat` and `MsgAckn` block outputs are updated based on the feedback from the lower level message blocks. The lower level message blocks are called every other cycle as long as an acknowledgement is expected or error information is pending.

5.1.10.25 Message display

Number of the `Feature` bit: 23

Feature bit purpose

This Feature will decide whether the messages are displayed on APL motor block only or on 3RW5Opn / 3RW5Meas block.

The default setting is 0.

Applicable for blocks

- 3RW5Opn
- 3RW5Meas

Set startup characteristics

Bit = 0: Messages are forwarded via an `EventTS` block to the APL motor block (e.g. MotL / 3RW5Ctrl).

Bit = 1: Messages are displayed on 3RW5Opn / 3RW5Meas block.

5.1.10.26 Local operator authorization

Number of the Feature bit: 24

Feature bit purpose

Local operator authorization for technological blocks.

The default setting is 0.

Applicable for blocks

- 3RW5Stat
- 3RW5Oprn
- 3RW5Meas

Set startup characteristics

Bit = 0: "Local operator authorization" function is deactivated.

Bit = 1: "Local operator authorization" function is activated.

5.1.10.27 Activate local operator permission

Number of the Feature bit: 24

Feature bit purpose

To enable local operator permission for a technologic block.

The default setting is 0.

Applicable for blocks

- 3RW5Ctrl

Set startup characteristics

Bit = 0: Disabled

Bit = 1: Enabled.

5.1.10.28 Suppression of all messages

Number of the `Feature` bit: 25

Feature bit purpose

All messages of technological block are suppressed if this `Feature bit 25 = 1` and `MsgLock = 1`.

The default setting is 0.

Applicable for blocks

- 3RW5Stat
- 3RW5Oprn
- 3RW5Meas

Set startup characteristics

Bit = 0: All messages are not suppressed.

Bit = 1: All messages are suppressed.

5.1.10.29 Suppression of all messages - 3RW5Ctrl

Number of the `Feature` bit: 25

Feature bit purpose

To determine whether all messages of the block are to be suppressed.

Applicable for blocks

- 3RW5Ctrl

Set startup characteristics

Bit = 0: Messages are not suppressed.

Bit = 1: Messages are suppressed.

5.1.10.30 Suppression Parameter set reading

Number of the Feature bit: 26-27

Feature bit purpose

Reading Parameter set 2 and 3 can be disabled using this feature bits.

DS141 and 142 for parameter set 2 applicable for Feature bit 26

DS151 and 152 for parameter set 3 applicable for Feature bit 27.

The default setting is 0.

Applicable for blocks

- 3RW5Oprn

Set startup characteristics

Bit = 0: Enable parameter set reading.

Bit = 1: Disable parameter set reading.

5.1.10.31 Evaluate the first run

Number of the Feature bit: 27

Feature bit purpose

To evaluate the first run of the diagnostic block, which means that first run information should be regarded.

The default setting is 0.

Applicable for blocks

- 3RW5Chn

Set startup characteristics

Bit = 0: Evaluate the first run of the diagnostic blocks.

Bit = 1: Do not evaluate the first run of the diagnostic blocks.

5.1.10.32 Active parameter set reading

Number of the `Feature` bit: 28

Feature bit purpose

Reading Parameter set which is active. This feature bit suppress other two parameter sets which are not active.

The default setting is 0.

Applicable for blocks

- 3RW5Oprn

Set startup characteristics

Bit = 0: Read all parameter set.

Bit = 1: Read only active parameter set.

5.1.10.33 Interlock display with LocalSetting 2 or 4

Number of the `Feature` bit: 27

Feature bit purpose

To specify the display of interlocks with LocalSetting 2 or 4 at the faceplate and at the faceplate output `LockAct`.

The default setting is 0.

Note

A decreasing motor protection (`Trip.Value=0`) is displayed at the output parameter `LockAct`, regardless of the `Feature` bit setting.

Applicable for blocks

- 3RW5Ctrl

Set startup characteristics

Bit = 0: LocalSetting 2 and 4 crossed out locks are displayed in the standard view. `LockAct` is not set with interlock.

Bit = 1: LocalSetting 2 and 4 locks are displayed in the standard view according to the interlock. `LockAct` is set according to interlock. This setting is used for hardware interlock.

5.1.10.34 Changes Signal status of outputs in OOS (Out of service)

Number of the Feature bit: 28

Feature bit purpose

This feature bit changes the signal status of outputs in Out of service mode.

The default setting is 0.

Applicable for blocks

- 3RW5Ctrl

Set startup characteristics

Bit = 0: Default state of the block.

Bit = 1: Signal status of the respective output parameters changes to 16#60.

5.1.10.35 Update Data exchange with the status information

Number of the Feature bit: 29

Feature bit purpose

The status information is transferred to maintenance station.

The default setting is 1.

Applicable for blocks

- 3RW5Chn

Set startup characteristics

Bit = 0: DataXchg is updated without the status information.

Bit = 1: DataXchg is updated with the status information.

5.1.10.36 Write Output value low in Simulation mode

Number of the `Feature` bit: 30

Feature bit purpose

The output value is written if the block is not in simulation.

The default setting is 1.

Applicable for blocks

- 3RW5Chn

Set startup characteristics

Bit = 0: Output is lowest value at a block-external simulation.

Bit = 1: Output is last valid value.

5.1.10.37 Define reset as a function of the mode

Number of the `Feature` Bit: 30

Feature bit purpose

When the "Protection" interlock, feedback error ("Status error", "Control error") or "Motor protection" signal is present again, this `Feature` bit is used to specify if a reset can be made depending on the mode, only by the operator in manual mode or by the automatic I/Os in automatic mode.

Resetting to manual mode is enabled with `Feature` Bit 31 (Activating reset of protection / error in manual mode). Also refer to the Resetting the block in case of interlocks or errors chapter.

The default setting is 0.

Applicable for blocks

- 3RW5Ctrl

Set startup characteristics

Bit = 0: Reset does not depend on the operating mode.

Bit = 1: In manual mode, manual reset by the operator is only possible if **Feature Bit 31** is set, otherwise no reset is required in manual mode.

In automatic mode, reset can only be made with automatic I/Os, regardless of **Feature Bit 31**. This is performed either with a 0-1 edge transition at the **RstLi** input or, when **Feature Bit 9** is set, with a 0-1 edge transition at the automatic inputs, for example **OpenAut**, **CloseAut**.

Note

Rapid stop is unlocked for all operating modes using the "Reset" button in the faceplate (**RstOp** = 1); in CFC it is unlocked using the **RstLi** = 1 input parameter.

Note

The local operating mode does not depend on this **Feature Bit** and has a separate reset mechanism.

5.1.10.38 Enable reset of interlocks in manual mode

Number of the **Feature bit**: 31

Feature bit purpose

Specify whether a reset is necessary once the "Protection" interlock signal, feedback errors ("Runtime error", "Control deviation"), or "Motor protection" are present again. See also the following section, 'Resetting via input signal in the event of interlocking or errors' (Page 59).

The default setting is 0.

Applicable for blocks

- 3RW5Ctrl

Set startup characteristics

Bit = 0: No reset required in manual mode.

Bit = 1: Reset required in manual mode. The reset is performed using the "Reset" button (**RstOp** = 1) or, in CFC, using the input parameter **RstLi**.

Note

Rapid stop is unlocked for all operating modes using the "Reset" button in the faceplate (**RstOp** = 1); in CFC it is unlocked using the **RstLi** = 1 input parameter.

Note

The local operating mode has a separate reset mechanism.

5.1.10.39 Separate evaluation for excluded and simulated interlock signals

Number of the `Feature2` bit: 2

Feature2 bit purpose

You can use this feature bit to set the reaction of the block to an interlock signal of an interlock block that is excluded or simulated.

The default setting is 0.

Applicable for blocks

- 3RW5Ctrl

Set startup characteristics

Bit = 0: Switch-relevant excluded and simulated interlock signals are processed with the status 16#60 and are displayed as simulated or excluded, depending on the interlock status.

Bit = 1: Excluded and simulated interlock signals are evaluated separately. All excluded interlock signals in a sequence of interlock blocks are displayed as excluded. Switch-relevant simulated interlock signals are processed with the status 16#60 and displayed as simulated.

Note

If the feature bit is enabled, the signal cannot be inverted via CFC during interconnections at the inputs, as, otherwise, the bypass display would not update.

5.1.10.40 Resetting control in case of invalid command

Number of the `Feature2` bit: 3

Feature bit purpose

To define the control priority in the event of an invalid input command.

The default setting is 0.

Applicable for blocks

- 3RW5Ctrl

Set startup characteristics

Bit = 0: In the event of an invalid input command, the control output is retained.

Bit = 1: In the event of an invalid input command, the control output switches to the "neutral position".

5.1.10.41 Setting switch or button mode for local commands

Number of the `Feature2` bit: 4

Feature2 bit purpose

To determine whether a separate interconnectable 1 - active control input has to be used for every local command of the block or two local commands are assigned to a control input.

The `Feature2` bit affects starting and stopping a motor control inputs for local mode in the form of a pulse (pushbutton operation) or a static signal (switching mode).

Applicable for blocks

- `3RW5Ctrl`

Set startup characteristics

Bit = 0: Button mode: Each local command is assigned to a control input. This has a latching reaction and is 1-active.

Example with a motor `MotRevL`: In this case, use the interconnectable input parameters.

- `FwdLocal = 1` for the command "Start forward"
- `RevLocal = 1` for the command "Start backward"
- `StopLocal = 1` for the stop command

Bit = 1: Switching mode: Two static local commands are assigned to a control input.

Example with a motor `MotRevL`: In this case, use the interconnectable input parameters.

- `FwdLocal = 1` for the command "Start forward"
- `RevLocal = 1` for the command "Start backwards"
- `FwdLocal = 0` and `RevLocal = 0` for the stop command

Note

The `StopLocal` control input is irrelevant in this case.

5.1.10.42 Evaluation of the signal status of the interlock signals

Number of the `Feature2` bit: 5

Feature2 bit purpose

You can use this `Feature2.bit` to specify if the signal status of the interlock inputs is to be checked for the values `16#00` or `16#28`.

The signal status of the inputs itself remains unchanged here.

The default setting is 0.

Applicable for blocks

- 3RW5Ctrl

Set startup characteristics

Bit = 0: The signal status is determined, an input with `ST = 16#00` or `16#28` is forwarded with value = 0.

Bit = 1: No evaluation of the signal status for `16#00` or `16#28`.

5.1.10.43 Forcing operating modes in the "Local" mode

Number of the `Feature2` bit: 8

Feature2 bit purpose

Specify whether forcing operating modes is possible in the "Local" mode.

The default setting is 0.

Applicable for blocks

- 3RW5Ctrl

Set startup characteristics

Bit = 0: In the "Local" mode, forcing operating modes is not possible.

Bit = 1: In the "Local" mode, forcing operating modes is possible.

5.1.10.44 Button Mode with Triggered local control commands

Number of the `Feature2` bit: 9

Feature2 bit purpose

Execute local commands only if new command and no reset request.

The default setting is 0.

Applicable for blocks

- 3RW5Ctrl

Set startup characteristics

Bit = 0: Local command is issued again even if there is an existing Local command.

Bit = 1: Only new local command is issued.

5.1.10.45 Considering bad quality of automatic commands or external values

Number of the `Feature2` bit: 10

Feature2 bit purpose

Use this bit to consider the bad signal status (16#00 or 16#28) in the parameter for the automatic commands or external values to move the block into the neutral position.

The default setting is 0.

Applicable for blocks

- 3RW5Ctrl

Set startup characteristics

Bit = 0: The bad signal status will not be considered.

Bit = 1: The bad signal status (16#00 or 16#28) in the automatic commands or external values will be considered from the block. The block goes to a defined neutral position.

5.1.10.46 Suppress MsgLock and "Out of service" mode for a connected message block

Number of the `Feature2` bit: 10

Feature2 bit purpose

With this Feature / Feature2 bit, you can suppress the message lock with the parameter `MsgLock` and the switchover to the "Out of service" mode for a connected message block (`EventTs`, `Event16Ts`). Only the connected block over the parameter `EventTsIn` is concerned. This allows generating messages also in the case of `MsgLock` = 1 or during a switchover to the "Out of Service" mode in the main block.

For example, if the main block goes to the "Out of service" mode, the switchover can be messaged over a connection from the main block output `OosAct` to an input `Inx` of `EventTs` / `Event16Ts`.

The default setting is 0.

Applicable for blocks

- 3RW5Ctrl

Set startup characteristics

Bit = 0: No suppression.

Bit = 1: A message lock with the parameter `MsgLock` and a switchover to the "Out of service" mode are suppressed for connected message block over `EventTsIn`.

5.1.10.47 Separate interlock for each direction or position

Number of the `Feature2` bit: 16

Feature2 bit purpose

With this Feature / Feature2 bit, you can suppress the message lock with the parameter `MsgLock` and the switchover to the "Out of service" mode for a connected message block (`EventTs`, `Event16Ts`). Only the connected block over the parameter `EventTsIn` is concerned. This allows generating messages also in the case of `MsgLock = 1` or during a switchover to the "Out of Service" mode in the main block.

For example, if the main block goes to the "Out of service" mode, the switchover can be messaged over a connection from the main block output `OosAct` to an input `Inx` of `EventTs` / `Event16Ts`.

The default setting is 0.

Applicable for blocks

- 3RW5Ctrl

Set startup characteristics

Bit = 0: One interlock for each direction or position.

Bit = 1: Separate interlock for each direction or position.

5.2 Diagnostics block

5.2.1 3RW5Diag block description

Purpose of the block

The 3RW5Diag block handles the diagnostics for 3RW52 / 3RW55 Soft Starters.

The functions of the block are described below:

- It evaluates the acyclic events:
 - Start
 - DP station failure
 - Module fault
- It signals module failure on the DP / PN master system (`RackF`) and behind the Y-link (`ModF`).
- It generates the associated Quality Codes.
- It reads the messages of the station diagnostics and device diagnostics.
- It transmits the status information to the signal processing block via the `RackFAct` and `ModFAct` parameter outputs.
- It identifies the connected device with add-on modules. The same information is shared with technological and channel blocks by `DevType` output.

Views

The 3RW5Diag block does not support views.

5.2.2 Message characteristics

3RW5Diag signals the following errors:

- DP station fault (`Rack1Err`, `Rack2Err`)
- Rack failure (`RackFAct`)
- Module fault (`ModFAct`)
- Connection fault (`BusFlt`)

An error generates a group error in output parameter `GrpErr`.

The `Subn1_Id` and `Subn2_Id` parameters of the SUBNET function block (FB106) are combined with the `Subn1Id` and `Subn2Id` parameters of the 3RW5Diag block. These parameters forward the error information of the primary and redundant master system. This information is provided to output parameters `Rack1Err` and `Rack2Err` of the 3RW5Diag block.

Message block MsgEvid1

Table 5- 7 Output 3RW5Diag messages

Message block	Message No.	Block parameters	Message text	Message class *
MsgEvId1	1	Rack1Err	\$\$BlockComment\$\$ Subnet1@1%d@: Fault	S
	2	Rack2Err	\$\$BlockComment\$\$ Subnet2@2%d@: Fault	S
	3	RackFAct	\$\$BlockComment\$\$ Device @1%d@/@5%d@/@3%d@: Failure	S
	4	ModFAct	\$\$BlockComment\$\$ Device @1%d@/@5%d@/@3%d@: Module error	S
	5	BusFlt	\$\$BlockComment\$\$ Device @1%d@/@5%d@/@3%d@: Not reachable	S
	6	ExtMsg1 **	\$\$BlockComment\$\$ External message 1	S
	7	ExtMsg2 **	\$\$BlockComment\$\$ External message 2	S
	8	ExtMsg3 **	\$\$BlockComment\$\$ External message 3	S

* S = AS, OS process control fault; A = Alarm

** User-definable message

Auxiliary values

Table 5- 8 Structure of the auxiliary values ALARM_8P

Message No.	Auxiliary value	Block parameters	Meaning
1	1	Subn1ID	ID of the primary DP master system
2	2	Subn2ID	ID of the redundant DP master system
3	3	RackNo	Field device address
4	4	SlotNo	Slot number
5	5	SnSubnLnkID	ID of Master system on the Link
6	6	ExtVal06	Auxiliary value 6, user-definable
7	7	ExtVal07	Auxiliary value 7, user-definable
8	8	ExtVal08	Auxiliary value 8, user-definable
9	9	ExtVal09	Auxiliary value 9, user-definable
10	10	ExtVal10	Auxiliary value 10, user-definable

The MsgStat1, MsgAckn1, and MsgErr1 parameters transfer the following information:

- Message status
- Message error
- Message acknowledgment status

5.2.3 Driver generator

The "Generate Module Driver" function inserts the 3RW5Diag block into the following organization blocks within the run sequence:

- OB1 (cyclic program)
- OB82 (diagnostics alarm)
- OB83 (pull / plug alarm)
- OB85 (program execution error)
- OB86 (rack failure)
- OB100 (warm restart)

The block is inserted downstream of the OB_DIAG1/OB_DIAG1_PN block in the CFC chart.

The `RackNo`, `SlotNo`, `HmiDAddr`, `DAddr`, `LAddr`, `Subn1ID`, `Subn2ID` and `SubnTyp` inputs are configured using the information from HW Config.

5.2.4 Start-up characteristics

In OB100, the identifier for "Start up" is entered in output `OMODE` (`OMODE = 16#xx01xxxx`).

The messages are suppressed in OB100 for the number of cycles that have been programmed for runup in parameter `RunUpCyc`.

Acknowledge the errors `GrpErr`, `RackFact`, `ModFact`, `Rack1Err`, and `Rack2Err`.

5.2.5 Module error

Following a restart and when `AccID = TRUE`, a check of the module addressed with `LAddr` is carried out. The SZL ID xC91 is read for this purpose. If the module addressed with `LAddr` is missing, the `ModFact` output is set and the identifier for "higher-level fault" is entered for the `OMODE` output (`OMODE = 16#40xxxxxx`).

The module fault is detected by the event number 16#61 in PROFIBUS for event class 16#39.

The module fault is detected while the Soft Starter is configured behind a Y-link.

The logical address of the module (`LAddr`) is derived from the geographical address of the module, e.g. from `Subn1ID`, `RackNo` and `SlotNo`.

Note

The "module rack fault" takes precedence over the module fault.

5.2.6 Failure of the DP master/DP slave/PROFINET IO station

The OB_DIAG1 block detects the failure of DP master and DP slave, OB_DIAG1_PN detects the failure of PROFINET IO station and evaluates it via the inputs `RackF`, `Subn1ID` and `Subn2ID`.

In case of an error, the identifier for "Higher-level fault" (`OMODE = 16#40xxxxxx`) is entered in the `OMODE` output.

Fault	Event number	Event class
Distributed I/O devices: Failure of the DP master system (<code>RackFact</code>)	16#C3	16#39
PROFIBUS DP station failure (<code>RackFact</code>)	16#C4	16#39
PROFIBUS DP station return	16#C4	16#38
PROFIBUS DP station fault	16#C5	16#39
Reset PROFIBUS DP station fault	16#C5	16#38
PROFIBUS DP station return, but error in assignment of the module parameters	16#C6, 16#C7	16#38
PROFINET IO system failure	16#CA	16#39
PROFINET IO system failure	16#CA	16#38
PROFINET IO system failure	16#CB	16#39
PROFINET IO system failure	16#CB	16#38
PROFINET IO station return	16#CC	16#38
PROFINET IO station operational again, but expected configuration does not match actual	16#CD	16#39
PROFINET IO station operational again, but error(s) in module parameter assignment	16#CE	16#39

If "Rack failure" error (`RackFact = 1`) occurs, the PROFIBUS / PROFINET connection to the device is lost (`BusFlt = 1`).

5.2.7 PROFIBUS connection error

Failure of the PROFIBUS connection to the DP slave (3RW5 device) is detected by reading out the diagnostics information of the device. The information is saved in bit 0 of byte 0 of the device.

The diagnostics information is read from SFC13 (DPNRM_DG) and saved in a temporary buffer.

The PROFIBUS connection error is reported at the `BusFlt` output of the 3RW5Diag block and as an alarm in WinCC.

Table 5- 9 Possible reasons for the connection error

Byte 0	Meaning	Reason or remedy
Bit 0	1: DP slave cannot be accessed by the DP master.	<ul style="list-style-type: none"> • DP slave cannot be accessed by the DP master. • Is the station address of the DP slave set correctly? • Is the bus connection plug connected? • Is voltage applied to the DP slave? • Is the RS 485 Repeater secured correctly? • Has a reset been performed on the DP slave?

DiagOprn

DiagOprn transfers the following information:

Table 5- 10 Diagnostic information in DiagOprn.DIAG for each bit

DiagOprn.DIAG Bit	Diagnostic message
0	DP slave cannot be accessed by DP master. ¹
1	DP slave is not yet ready for data exchange.
2	Config data to DP slave from DP master does not match.
3	External diagnostics pending (Group diagnostics display)
4	The function is not supported by the DP slave, e.g. node address change by the software.
5	DP master cannot interpret DP slave response.
6	DP slave type does not match the software configuration.
7	DP slave parameterized by a different DP master
8	DP slave parameters must be reassigned.
9	Static diagnostic message: A diagnostics message is pending. DP slave will not function until the error is corrected.
10	Bit is set to "1" as long as DP slave address exists.
11	Watchdog function activated for DP slave
12	DP slave has received "FREEZE" command.
13	DP slave has received "SYNC" command.
14	The DP slave has been deactivated, e.g. it is not included in the current processing.
15	More diagnostic messages than DP slave can store. The DP master cannot write all diagnostic messages to its diagnostic buffer that were sent by the DP slave.
16...31	Not used

¹ The lost connection is signaled with `BusFlt` and as an alarm in WinCC.

5.2.8 Diagnostics of the 3RW5

The following system function and diagnostic interrupt calls read the diagnostic information of the 3RW5 slave.

Block	Description	
SFC 13	DPNRM_DG	Reads the diagnostic data of the PROFIBUS DP slave.
SFB 52	RDREC	If diagnostic interrupt 82 occurs, this block reads a process data set.

Diagnostic messages that relate to communication and operation are read:

- If interrupt OB 82 occurs.

This diagnostic information is mapped onto the `DiagOprn` and `DiagMeas` output parameters. These parameters are interconnected with the `3RW5Oprn` and `3RW5Meas` blocks.

Table 5- 11 Status of the station

Byte	Meaning
1	Station status 1
2	Station status 2
3	Station status 3

5.2.9 Malfunction when loading the OB

Interrupt OB85 sets or resets the priority class error `GrpErr` (malfunction when loading OBs).

Table 5- 12 Events during which OB 85 `GrpErr` is reset

Fault	Event number	Event class
Error when creating a start event for an OB. This is not loaded to the CPU.	16#A1, 16#A2 or 16#A3	16#35
Error when the operating system accesses a module.	16#B1, 16#B2	16#39
	16#B3 or 16#B4	16#39 AND NOT 16#38
PROFINET Interface DB cannot be addressed	16#A4	16#35
PROFINET Interface DB can be addressed again	16#A4	16#34

`GrpErr` is only triggered once for one execution cycle of the block.

5.2.10 Interconnections of the 3RW5Diag block

The "Generate module driver" function generates the driver blocks and creates all the required interconnections between the driver blocks automatically.

Use the templates provided with this library. The templates contain all basic blocks required for operating the Soft Starter.

For additional information, refer to the section Templates (Page 23).

Diagnostic information

The 3RW5Diag block reads the diagnostic information and transfers it to the 3RW5Oprn and 3RW5Meas blocks using the `DiagOprn` and `DiagMeas` output parameter.

5.2.11 Reading the device diagnosis

The 3RW5Diag block reads diagnostic data via data set DS92, slot 2.

Table 5- 13 Data set table

Data set number	Read access/write access	Number of bytes	Description	3RW55	3RW52
DS92	R	94	Read Soft Starter diagnostic data	X	X

The values are read from the Soft Starter with RDREC function. This information is written to the output parameters.

Reading and writing data records

For more information about reading and writing data records, refer section (Page 51).

5.3 Operation block

5.3.1 3RW5Oprn block description

Purpose of the block

The Advanced Process Library (APL) offers fundamental control functionality that can be expanded by the 3RW5Oprn block.

- Via the block, commands such as emergency start, self-test, pump cleaning, trip reset are started because these functions are not supported by the APL themselves.
- The block reads data sets.
- The 3RW5Oprn block faceplates can be displayed via the "Operation" button on the standard view of the 3RW5Ctrl (for 3RW55 device) block or MotL (for 3RW52 device) block used in the template.

The block icon for the 3RW5Oprn block can also be enabled at the CFC as described in section (Page 19).

Views

The 3RW5Oprn block supports the following parameters:

- Standard (Page 116)
- Alarm (Page 36)
- Limits (Page 132)
- Trend (Page 34)
- Maintenance (Page 129)
- Parameter (Page 131)
- Diagnostics (Page 119)
- Preview (Page 37)
- Process image input (Page 134)
- Process image output (Page 134)
- Batch (Page 33)

5.3.2 Parametrizable functions via the Feature connection 3RW5Oprn

The modules of the library have an input named `Feature`. You can influence various responses of the block via this input.

The Feature Bits are assigned in the following order:

Meaning of the 3RW5Oprn Feature.Bits

Feature.Bit	Meaning ¹
Feature.Bit0 (Page 54)	Set startup characteristics 0 = Switch substitute value (OB100) 1 = Retain last value
Feature.Bit1 (Page 56)	1 = Input "OosLi" can be used to switch to the "Out of Service" mode.
Feature.Bit2 (Page 56)	1 = Reset commands for switching the operating mode
Feature.Bit4 (Page 57)	Set switch mode or pushbutton mode 0 = Pushbutton mode 1 = Switch mode
Feature.Bit9 (Page 59)	Change signal status of outputs in "OOS" to 16#60
Feature.Bit10 (Page 60)	Exit local mode 1 = When Manual LOCAL mode is exited, switch to the last setting of AUTO / MANUAL mode.
Feature.Bit11 (Page 64)	1 = Suppress Group Warning Alarm message
Feature.Bit12 (Page 64)	1 = Suppress Group Fault Alarm message
Feature.Bit13 (Page 64)	1 = Suppress Control System Fault Alarm message
Feature.Bit14 (Page 64)	1 = Suppress switching element overload
Feature.Bit15 (Page 64)	1 = Suppress device error
Feature.Bit16 (Page 64)	1 = Suppress External message 1
Feature.Bit17 (Page 64)	1 = Suppress External message 2
Feature.Bit18 (Page 64)	1 = Suppress External message 3
Feature.Bit19 (Page 65)	1 = Enable feedback monitoring when motor OFF
Feature.Bit22 (Page 67)	1 = Update acknowledgment and error status of the message call
Feature.Bit23 (Page 67)	0 = Messages are forwarded via an EventTS block to the 3RW5Ctrl (3RW55 device) block or MotL (3RW52 device) block alarm view. 1 = Messages are displayed at the alarm view of 3RW5Oprn block
Feature.Bit24 (Page 68)	1 = "Local operator authorization" function is activated

Feature.Bit	Meaning ¹
Feature.Bit25 (Page 69)	1 = Suppression of all messages is activated if <code>MsgLock = 1</code>
Feature.Bit26* (Page 70)	1 = Suppress parameter set 2 reading
Feature.Bit27* (Page 70)	1 = Suppress parameter set 3 reading
Feature.Bit28* (Page 71)	0 = Read all parameter set; 1 = Read only active parameter set

* Not applicable for 3RW52

¹ The standard setting is 0 if no other value is specified.

For more information about the parameterizable functions, refer to the function manual "Process Control System PCS 7, PCS 7 Advanced Process Library" in the Internet (<https://support.industry.siemens.com/cs/document/109760968>).

5.3.3 Operating modes

The following modes are available for the 3RW5Oprn block:

- Local
- Automatic
- Manual
- Out of Service

In conjunction with drive (3RW5Ctrl, MotL) APL blocks, this block is used, for example, for the emergency start and test modes.

An APL block is interconnected with 3RW5Oprn to control the Automatic / Manual mode when the device is in Remote mode..

Dependent on the value of the process image input at PZDIIn03, the block is switched to Local mode.

Note

In this library mode switchover to local mode is only via TIA / HMI

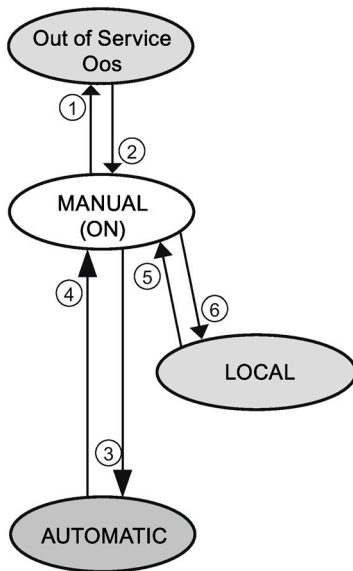

Conditions for changing the mode

Table 5- 14 Conditions for changing the mode

No.	Conditions
①	MANUAL (ON) → Out of service (OoS) <ul style="list-style-type: none"> • Via faceplate ($OoSOp = 1$) if $ModLiOp = 0$ or • on an edge transition $0 \rightarrow 1$ from $OosLi$, if $Feature.Bit1 = 1$ (response for Out of service mode)
②	Out of service (OoS) → MANUAL (ON) <ul style="list-style-type: none"> • Via faceplate ($ManModOp = 1$)
③	MANUAL → AUTOMATIC <ul style="list-style-type: none"> • Via faceplate ($AutModOp = 1$) if $ModLiOp = 0$ or • via $AutModLi = 1$ if $ModLiOp = 1$
④	AUTOMATIC → MANUAL <ul style="list-style-type: none"> • Via faceplate ($ManModOp = 1$) if $ModLiOp = 0$ or • via $ManModLi = 1$ if $ModLiOp = 1$ and $Feature.Bit4 = 0$ (pushbutton mode) or • via $AutModLi = 0$ if $ModLiOp = 1$ and $Feature.Bit4 = 1$ (switch mode)
⑤	LOCAL → MANUAL <ul style="list-style-type: none"> • $PII\ 1.6 = 0$ • Mode changes from local to manual mode.
⑥	MANUAL → LOCAL <ul style="list-style-type: none"> • $PII\ 1.6 = 1$ • Mode changes from Manual mode to local mode.

If $ModLiOp = 1$, the enabled operations for all mode changes will be deactivated.

If the block is in local mode, no other mode can be activated for it.

Switching between the operating modes

The switchover between "Manual and Automatic mode" takes place as shown in the following schematic:

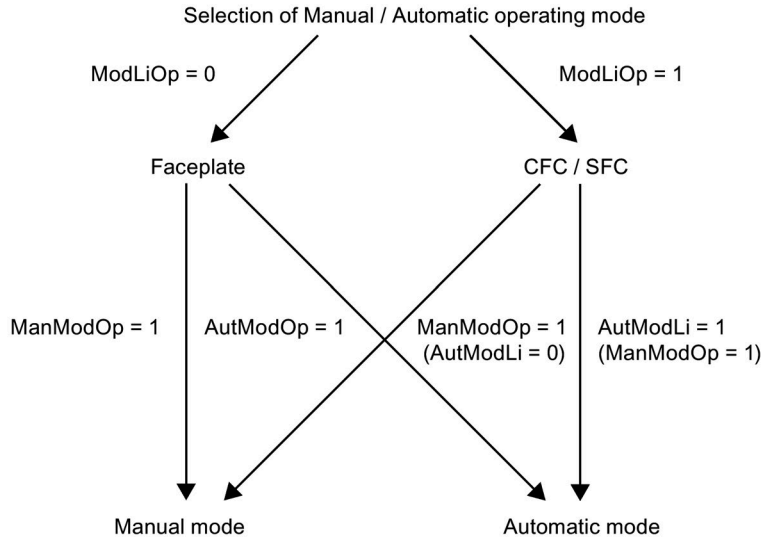

Reference

You will find more information in the function manual "Process Control System PCS7, PCS7 Advanced Process Library" on the Internet.

<https://support.industry.siemens.com/cs/document/109760968>

5.3.4 Process image input and output

Bit assignment

Table 5- 15 Process image input (PII): Bit assignment of byte 0 and byte 3

Byte.Bit	Process image	3RW55	3RW52
0.0	Ready to start (automatic)	X	X
0.1	Motor ON	X	X
0.2	Group error	X	X
0.3	Group warning	X	X
0.4	Input 1	X	X
0.5	Input 2	X	-
0.6	Input 3	X	-
0.7	Input 4	X	-
1.0	Motor current lact-bit 0	X	X
1.1	Motor current lact-bit 1	X	X
1.2	Motor current lact-bit 2	X	X
1.3	Motor current lact-bit 3	X	X
1.4	Motor current lact-bit 4	X	X
1.5	Motor current lact-bit 5	X	X
1.6	Manual operation local	X	X
1.7	Ramp operation	X	X
2.0	Motor CW	X	X
2.1	Motor CCW	X	-
2.1	Start mode active	X	X
2.5	Operation / bypass active	X	X
2.6	Stop mode active	X	X
2.7	Test operation active	X	X
3.0	Thermal motor model overload	X	X
3.1	Temperature sensor overload	X	X
3.2	Switching element overload	X	X
3.3	Cooling time active	X	X
3.4	Device error	X	X
3.5	Automatic parameterization active	X	-
3.6	New Ex parameter values detected	X	-

Process image output (PIO): Bit assignment of byte 0 and byte 3

Byte.Bit	Process image	3RW55	3RW52
0.0	Motor CW	X	X
0.1	Motor CCW	X	-
0.3	Reset	X	X
0.4	Emergency start	X	-
0.5	Self-test (user-test)	X	X
0.6	Creep speed	X	-
1.0	Output 1	X	-
1.1	Output 2	X	-
1.2	Parameter set bit 0	X	-
1.3	Parameter set bit 1	X	-
1.7	Disable quick-stop	X	-
2.0	Output 3	X	-
2.3	Pump cleaning	X	-
3.0	Manual operation local - input controlled	X	X
3.1	Use alternative stopping mode	X	-
3.2	Motor standstill	X	-

Note

Process image output (PIO) data will not be updated in the Local operating mode.

5.3.5 Diagnostics information

The diagnostic information is displayed at WinCC, in the related faceplates.

The following diagnostic information is available for Soft Starters:

- 3RW5 Soft Starters PROFIBUS DP slave diagnostics, output via the parameter output `DiagStn`
- Diagnostics communication, switching and controlling, output via parameter output `DiagCom`
- Diagnostics parameter and device function, output via the parameter output `DiagPar`
- Diagnostics error parameter number, output via parameter output `FltPar`

Bit assignment DiagStn

Table 5- 16 Bit assignment DiagStn

Output parameter	Auxiliary variable	DiagStn Bit	Message
DiagStn 3RW5 PROFIBUS DP slave diagnostics	DiagStn	0	DP slave cannot be accessed by DP master.
	DiagStn	1	DP slave is not yet ready for data exchange.
	DiagStn	2	Config data to DP slave from DP master does not match.
	DiagStn	3	External diagnostics pending (Group diagnostics display)
	DiagStn	4	The function is not supported by DP slave, e.g. node address change by the software
	DiagStn	5	DP master cannot interpret DP slave response.
	DiagStn	6	DP slave type does not match the software configuration.
	DiagStn	7	DP slave parameterized by a different DP master
	DiagStn	8	DP slave parameters must be reassigned.
	DiagStn	9	Static diagnostic message: A diagnostics message is pending. DP slave will not function until the error is corrected.
	DiagStn	10	Bit is set to "1" as long as DP slave address exists.
	DiagStn	11	Watchdog function activated for DP slave
	DiagStn	12	DP slave has received "FREEZE" command.
	DiagStn	13	DP slave has received "SYNC" command.
	DiagStn	14	The DP slave has been deactivated, e.g. it is not included in the current processing.
	DiagStn	15	More diagnostic messages than DP slave can store. The DP master cannot write all diagnostic messages to its diagnostic buffer that were sent by the DP slave.
DiagStn	16...31	Not used	

5.3.6 Group error

The output parameter `GrpErr` is set when one of the errors listed below is detected. The Standard view displays these errors as a group error in plain text.

- Group error: Process image bit (PII) 0.2
- Module failure
- Rack failure

5.3.7 Trip reset

Soft Starters can be reset with the trip reset command in the following situations:

- No contact block supply voltage.
- Motor overload.
- `RdyToReset` generated in the previous APL / 3RW5Ctrl block.

A "Trip reset" set the process image output (PIO) 0.3.

Reset trip

A trip can be reset as follows:

Table 5- 17 Trip reset

Operating mode	Input parameter	Value	Output	Assigned PIO bits (<code>TrpRstOn</code>)
AUTO	<code>TrpRstLi</code>	0 → 1	<code>TrpRstOn</code>	PIO 0.3 = 1
MANUAL	<code>TrpRstOp</code> ^{1,2}	1	<code>TrpRstOn</code>	PIO 0.3 = 1

¹ The command is reset at the end of the execution cycle of the block.

² In the Standard view if the operation has been enabled (`OS_Perm = 1`).

Note

Trip reset is applicable for 3RW55 and 3RW52 Soft starter devices.

5.3.8 Emergency start

Purpose of emergency start

The emergency start function sets the process image output (PIO) 0.4, that issues the emergency start command to the Soft Starter.

The following parameters are active in the various operating modes of the block:

Table 5- 18 Emergency start

Operating mode	Input parameter	Value	Output	Assigned PIO bits
AUTO	EmrgStAut	0 → 1 1 → 0	EmrgStOn	PIO 0.4 = 1
MANUAL	EmrgStMan ^{1,2}	0 → 1 1 → 0	EmrgStOn	PIO 0.4 = 1



¹ In the Standard view if the operator control enable exists (OS_Perm).

² The emergency start command of MANUAL mode monitors the respective command in AUTO mode to guarantee bumpless transfer of the command state during mode switchover from AUTO to MANUAL.

Status displays with activated Emergency start function

While the 3RW5Oprn icon displays an active group error, the 3RW5Ctrl icon shows the current operating state of the motor when the Emergency start function is active.

Table 5- 19 Example: Status displays with activated Emergency start function

3RW5Oprn faceplate		3RW5Ctrl faceplate	
Status display	Symbol	Status display	Symbol
Group error		Motor is running	
		Motor stationary	

Note

When used as a template, the group error is not forwarded to the 3RW5Ctrl block when the emergency start function is activated. Only when the emergency start function is active, it is possible to send start and stop commands to the Soft Starter via 3RW5Ctrl block while a group error is active.

Note

- 3RW55: Emergency start status is not updated in the Local operating mode.
- 3RW52: Emergency start function is not applicable for 3RW52.

5.3.9 Self-test

The Self-test function allows LED test, current measurement test and electronic motor overload protection test.

The following parameters are active in the various operating modes of the block:

Operating mode	Input parameter	Assigned PIO bits	Control via
Manual Local	—	PIO 0.5	Soft Starter ES
Auto	SlfTstLi = 1	PIO 0.5	Automation system
Manual	SlfTstOp = 1	PIO 0.5	Automation system

SlfTstOn = 1 indicates that Self-test is activated.

Note

- The SlfTstOn output parameter will be reset at the end of block execution cycle.
- Possible only if an HMI is connected.

5.3.10 Output 1, Output 2 and Output 3

The following parameters are active in the various operating modes (Page 92) of the block:

Table 5- 20 Output 1, Output 2 and Output 3

Operating mode Manual Input parameter	Operating mode Auto Input parameter	Value	Output parameter	Process image output Bits
Out1Man	Out1Aut	0 → 1	Out1On	PIO 1.0
Out2Man	Out2Aut	0 → 1	Out2On	PIO 1.1
Out3Man	Out3Aut	0 → 1	Out3On	PIO 2.0

Note

- 3RW55: Output 1, Output 2 and Output 3 status is not updated in the local operating mode.
- 3RW52: This is not applicable for 3RW52.

5.3.11 Active parameter sets

The process images of the outputs bit PIO 1.2 and PIO 1.3 correspond to the settings that the operator makes for the active parameter sets. For this purpose, parameter sets 1, 2 and 3 are assigned via the parameter `ParaSet = 1, 2 or 3`.

PIO 1.3	PIO 1.2	Paraset
FALSE	FALSE	1
FALSE	TRUE	2
TRUE	FALSE	3

Note

Active parameter set status is not updated in the Local operating mode.

This is not applicable for 3RW52.

5.3.12 Status of the device in Local mode

If the Soft Starter is in the "Local" operation mode, then there is no information available in the cyclic data (process image output).

The below listed parameters also do not update the status in Local mode:

- Trip reset
- Pump cleaning
- Emergency start
- Self test
- Output 1
- Output 2
- Output 3
- Active parameter set
- Disable quick stop
- Use alternative stopping mode
- Motor standstill

The motor running in creep speed / pump cleaning status is shown with a plain green color symbol as shown below at 3RW5Oprn block icon and 3RW5Oprn Standard view faceplate

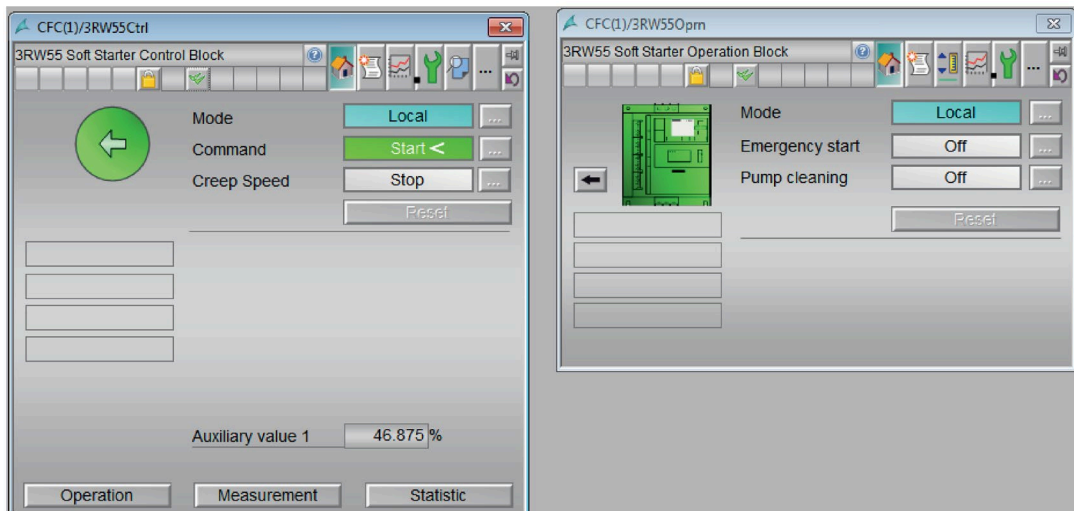
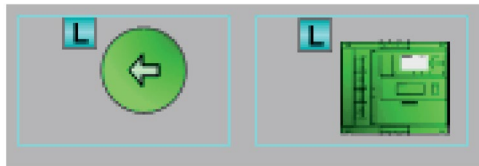

5.3.13 Disable Quick Stop

The "Quick Stop" function enables the motor and switches off the brake output without a group error. This function can be disabled.

The following parameters are active in the various operating modes of the block:

Table 5- 21 Disable quick stop

Operating mode Manual Input parameter	Operating mode Auto Input parameter	Value	Output	Process image output Bit	Output parameter
DsQkSpMan	DsQkSpAut	0 → 1	DsQkSpOn	PIO 1.7	DsQkSpOn

Note

- 3RW55: Disable quick stop status is not updated in the Local operating mode.
- 3RW52: Disable quick stop is not applicable for 3RW52.

5.3.14 Pump cleaning

Purpose of pump cleaning

The pump cleaning function can prevent an imminent blockage and clear an existing blockage. The pump cleaning function sets the process image output (PIO) 2.3, that issues the pump cleaning command to the soft starter.

- No internal trip command - Pump cleaning is possible if the motor or pump is switched ON and if one of the control commands Motor CW or Motor CCW is present.
- If Internal trip command active - Pump cleaning is possible if the motor or pump is switched ON, if one of the control commands Motor CW or Motor CCW is present, and emergency start is active.
- After successful completion of pump cleaning function, user has to switch OFF pump cleaning command manually as status of pump cleaning is not available in PII.
- Pump cleaning command will be reset once the stop command for the motor is issued from the 3RW5Ctrl block.

WARNING

Pump cleaning operation can be activated only when the feedback monitoring is disabled.
After successful completion of pump cleaning, user should ensure that feedback monitoring is enabled during normal operation of the motor.

5.3 Operation block

Operating mode Manual Input parameter	Operating mode Auto Input parameter	Value	Output parameter	Process image output Bits
PmpClnMan	PmpClnAut	0 → 1	PmpClnOn	PIO 2.3

Note

- 3RW55: Pump cleaning status is not updated in the local operating mode.
- 3RW52: Pump cleaning function is not applicable for 3RW52 device.

5.3.15 Use alternative stopping mode

Purpose of use alternative stopping mode

The use alternative stopping mode function can switch from the parameterized stopping mode to a parameterizable stopping mode. The use alternative stopping mode function sets the process image output (PIO) 3.1, that enable an alternative stopping mode at the soft starter. The alternative stopping mode will take effect only if it is enabled before stop command is issued.

Operating mode Manual Input parameter	Operating mode Auto Input parameter	Value	Output parameter	Process image output Bits
AltStpMan	AltStpAut	0 → 1	AltStpOn	PIO 3.1

Note

- 3RW55: Alternative stopping mode status is not updated in the local operating mode
- 3RW52: Alternative stopping mode function is not applicable for 3RW52 device.

5.3.16 Motor standstill

The soft starter supports the motor standstill detection function that senses that the motor shaft is at a standstill.

The motor standstill function sets the process image output (PIO) 3.2, that issues the motor standstill command to the soft starter.

Operating mode Manual Input parameter	Operating mode Auto Input parameter	Value	Output parameter	PIO Bits
MtrStdMan	MtrStdAut	0 → 1	MtrStdOn	PIO 3.2

Note

- 3RW55: Motor standstill status is not updated in the local operating mode.
- 3RW52: Motor standstill function is not applicable for 3RW52.

5.3.17 Motor current display

Display for motor current

The process image input (PII) bits 1.0 to 1.5 of the process image input describe the current consumption when the motor is connected. The current value is displayed in the Limits view as a percentage via the `MotCurr` output parameter.

Calculation of the motor current

PII						
1.5	1.4	1.3	1.2	1.1	1.0	Max.
2^0	2^{-1}	2^{-2}	2^{-3}	2^{-4}	2^{-5}	
1	0,5	0,25	0,125	0,0625	0,03125	1,96875
Example						
0	1	0	1	0	1	0,65625 *

* The sum of the values is the motor current:

$$\text{Ratio} = 0.5 + 0.125 + 0.03125 = 0.65625$$

$$\text{MotCurr} = 0.65625 * 100 \text{ (current in \%)}$$

5.3.18 Current limits

Note

Not applicable for 3RW52.

Current limit range and acceptance criteria is described in the table below.

Parameter	Current limit (range)	Value acceptance criteria
Upper limit error (PSX _{CurHi})	50 - 400	$PSX_{CurMH} \leq PSX_{CurHi} \leq 400$
Upper limit maintenance demand (PSX _{CurMH})	50 - 400	$PSX_{CurML} < PSX_{CurMH} \leq PSX_{CurHi}$ or $50 \leq PSX_{CurMH} \leq PSX_{CurHi}$
Lower limit maintenance demand (PSX _{CurML})	19 - 100	$PSX_{CurLo} \leq PSX_{CurML} < PSX_{CurMH}$ or $PSX_{CurLo} \leq PSX_{CurML} \leq 100$
Lower limit error (PSX _{CurLo})	19 - 100	$19 \leq PSX_{CurLo} \leq PSX_{CurML}$

Activate / Deactivate limit

The limits can be activated or deactivated via faceplate.

On re-activating the limit parameters the parameters values will be set as below:

- $PSX_{CurHi} \geq PSX_{CurMH}$ or 50, whichever is higher.
- $PSX_{CurMH} > PSX_{CurML}$ or 50, whichever is higher.
- $PSX_{CurML} \geq PSX_{CurLo}$ or 19, whichever is higher.
- $PSX_{CurLo} \leq PSX_{CurML}$ or 19, whichever is higher.

Note

In this section, "PSX" refers to parameter set (1, 2, 3).

Parameter limit values will be $PSX_{CurLo} \leq PSX_{CurML} < PSX_{CurMH} \leq PSX_{CurHi}$.

5.3.19 Substitute value

The operator parameterizes the substitute value. The `SubValue` parameter has 4 bytes. The data contained are written to the Soft Starter via data set 131. If the response to CPU / master stop event occurs, the Soft Starter is switched to the substitute value parameterized in `SubValue` or it retains the last value.

Note

Substitute value is only applicable for 3RW52 soft starter.

5.3.20 Message characteristics

3RW5Oprn reports the following errors at the block output:

- Rack failure (`RackFAct`)
- Module fault (`ModFAct`)

An error generates a group error in output parameter `GrpErr`.

These errors are not signaled as alarms as they are already part of the 3RW5Diag block.

The alarms are output using the ALARM_8P function.

The messages can be enabled or disabled using the `MsgLock` input. The alarms are suppressed when the block is in Out of service mode.

Message block MsgEvd1

Table 5- 22 Output messages

Message block	Message No.	Block parameter	Message text	Message class *
MsgEvd1	1	GenWarn	\$\$BlockComment\$\$ Group warning : @4W%t#3RW5Oprn_WRN@	W
	2	GenFlt	\$\$BlockComment\$\$ Group error : @5W%t#3RW5Oprn_TRP@	S
	3	CSF	\$\$BlockComment\$\$Control System Fault	S
	4	StcswPZDIn03.SwtElmOvl	\$\$BlockComment\$\$ Switching element overload	S
	5	StcswPZDIn03.DevErr	\$\$BlockComment\$\$ Device error	S
	6	ExtMsg1	\$\$BlockComment\$\$External message 1	S
	7	ExtMsg2	\$\$BlockComment\$\$External message 2	S
	8	ExtMsg3	\$\$BlockComment\$\$External message 3	S

* W = Warning

S = AS, OS process control fault

Auxiliary values

The block supports 10 programmable auxiliary values.

Table 5- 23 Structure of the auxiliary values ALARM_8P

Message No.	Auxiliary value	Block parameter	Meaning
1	1	SarBatchName	Batch name
2	2	SdwStepNoLoc	Batch step
3	3	SdwBatchId	Batch ID
4	4	SnWrnNo	General warning
5	5	SnTrpNo	General fault
6	6	ExtVal06	External value 6, user-defined
7	7	ExtVal07	External value 7, user-defined
8	8	ExtVal08	External value 8, user-defined
9	9	ExtVal09	External value 9, user-defined
10	10	ExtVal10	External value 10, user-defined

The `MsgStat1`, `MsgAckn1`, and `MsgErr1` parameters transfer the following information:

- Message status
- Message error
- Message acknowledgment status

5.3.21 System text libraries for warning and trip

System text libraries are created if 3RW5Opn blocks are inserted into the CFC chart. They are assigned to the numbers of the warnings and trips.

Table 5- 24 Numbers for trips

TripNo	Text
1	Switching element defective
2	No supply voltage
3	Electronics supply voltage too low
4	Bus error
5	Process image error
6	Invalid parameter
7	No external start parameter received
8	Error during self-test
9	Preset unequal actual configuration
10	Type of motor connection wrong
11	Load missing
12	Phase failure L1

TripNo	Text
13	Phase failure L2
14	Phase failure L3
15	Bypass defective
16	Bypass protective trip
17	Switching element L1 defective
18	Switching element L2 defective
19	Switching element L3 defective
20	FW update unsuccessful
21	Switching frequency time not kept
22	Main power rotation faulty
23	Supply voltage not permitted for test
24	Supply voltage required for test
25	Operating temperature too high

Table 5- 25 Numbers for warnings

WrngNo	Text
1	Connection abort in manual mode
2	Preset unequal actual configuration
3	New Ex parameter values detected
4	Switching frequency time not kept
5	2-phase control with defective thyristor active
6	Main power rotation faulty
7	Check fan
8	Starting time limit – maintenance demanded exceeded
9	Starting time limit – maintenance demanded undershot

5.3.22 Reading and writing data records

Read function

The RDREC (SFB 52) function is used to read and process values from the data sets.

Reading can only be performed successfully if the function Write to data sets (WRREC) is not executed at the same time.

Table 5- 26 Parameter Read/write data set

Parameter	Value	Meaning
RdDataOp ¹	1	Read data from data set
RdDataLi ¹	0 → 1	Read data set via link or SFC
EnRdWr	1	Enable reading/writing data set
RdErr**	1	Error when reading
WrErr	1	Error when writing
RdWrAct	1	Reading / writing data set ended

¹ not in Out of service mode and in case of rack failure

** Refer section reading and writing data record for the detailed error code description.

Data set table

No.	Data set number	Number of bytes	Description	3RW52	3RW55
1	DS131	200	Parameter basic functions - Set 1	R	R/W
2	DS132	200	Parameter extended functions 1 - Set 1	-	R/W
3	DS141	200	Technology parameter 2 - Set 2	-	R/W
4	DS142	200	Parameter extended functions 1 - Set 2	-	R/W
5	DS151	200	Technology parameter 2 - Set 3	-	R/W
6	DS152	200	Parameter extended functions 1 - Set 3	-	R/W

Write function

Writing of data sets is only possible when the block is in REMOTE mode.

The WRREC (SFB 53) function is used to process and write commands and values to the Soft Starter.

Note

After complete download of CFC, the read data command has to be executed at least once (e.g. by pushing "Read data" button at 3RW5Oprn faceplate or by giving a value "1" at "RdDataOp" input parameter at 3RW5Oprn block) before writing current limit values at 3RW5Oprn.

5.3.23 Fault handling

The following errors can be displayed for this block:

- Error numbers (Page 49)
- Mode changeover error
- Invalid input signals
- Suppressed parameter set 2 reading
- Suppressed parameter set 3 reading
- Suppressed active parameter set reading

5.3.24 Invalid input signals

The "Invalid input signals" error occurs if there are inconsistencies between associated inputs and outputs. For example, you cannot issue start commands and stop commands to the motor simultaneously.

If the block algorithm detects an invalid combination of input signals, it will issue an error number at the `ErrorNum` output, depending on the block.

5.3.25 Operator permissions

Operator permissions 3RW5Oprn

The operator permissions for control commands are configured in the `OS_Perm` structured parameters. These are transferred to WinCC via the `OS_PermOut` and `OS_PermLog` parameters.

The operator permissions control operation only in the faceplate.

Table 5- 27 Operator permissions – 3RW5Oprn

OS_Perm Bit	OS_PermOut Bit	OS_PermLog Bit	Description
0	0	0	Operator can switch to automatic mode
1	1	1	Operator can switch to manual mode
2	2	2	Reserved
3	3	3	Operator can switch to OOS
4...6	4...6	4...6	Reserved
7	7	7	Operator enabled to monitor feedback at control block
8	8	8	Operator enabled to trip reset
9	9	9	Operator enabled for Output1
10	10	10	Operator enabled for Output2
11	11	11	Operator enabled for Output3

5.3 Operation block

OS_Perm Bit	OS_PermOut Bit	OS_PermLog Bit	Description
12	12	12	Operator enabled to change Parameter set
13	13	13	Operator enabled for Disable Quick stop
14	14	14	Operator enabled to emergency start the motor
15	15	15	Operator enabled to pump cleaning
16	16	16	Operator enable to self-test
17	17	17	Operator enabled to use alternative stopping mode
18	18	18	Operator enabled to motor standstill
19	19	19	Operator can alter the current upper limit maintenance demand of PS1
20	20	20	Operator can alter the current lower limit maintenance demand of PS1
21	21	21	Operator enabled to read data
22	22	22	Operator can alter the current upper limit of PS1
23	23	23	Operator can alter the current lower limit of PS1
24	24	24	Operator can alter the current upper limit of PS2
25	25	25	Operator can alter the current lower limit of PS2
26	26	26	Operator can alter the current upper limit of PS3
27	27	27	Operator can alter the current lower limit of PS3
28	28	28	Operator can alter the current upper limit maintenance demand of PS2
29	29	29	Operator can alter the current lower limit maintenance demand of PS2
30	30	30	Operator can alter the current upper limit maintenance demand of PS3
31	31	31	Operator can alter the current lower limit maintenance demand of PS3

OS_PermOut contains the permission information of all the parameters.

OS_PermLog contains the permission evaluated based on the current operating states.

5.3.26 Enable measurement and statistics

You can open the Standard view of the 3RW5Meas and 3RW5Stat blocks using buttons in the Standard view of the 3RW5Oprn block when using 3RW52.

You can open the Standard view of the 3RW5Meas and 3RW5Stat blocks using buttons in the Standard view of the 3RW5Ctrl block when using 3RW55.

To display buttons in the faceplate, connect the `selFp1` and `selFp2` input parameters to any output parameter of the 3RW5Meas and 3RW5Stat blocks in the CFC chart.

5.3.27 Status information

Status information 3RW5Oprn

Table 5- 28 Status1 – 3RW5Oprn

Status1 Bit	Description
0	Occupied
1	BatchEn
2	Slave Type 0 = PROFIBUS 1 = PROFINET
3	1 = Out of service
4	1 = Out of service via interconnection
5	0 = MANUAL mode active 1 = AUTO mode active
6	1 = Local active
7	1 = Forward command (PIO)
8	1 = Disable Quick stop (PIO)
9	1 = Reverse command (PIO)
10	1 = Creep speed (PIO)
11	1 = Output 1 (PIO)
12	1 = Output 2 (PIO)
13	0 = Emergency start inactive (PIO) 1 = Emergency start active,
14	1 = Parameter set bit0 (PIO)
15	1 = Parameter set bit1 (PIO)
16	0 = Trip reset inactive (PIO) 1 = Trip reset active;
17	1 = Motor ON feedback
18	1 = Input 1 (PII)
19	1 = Input 2 (PII)
20	1 = Input 3 (PII)

5.3 Operation block

Status1 Bit	Description
21	1 = Input 4 (PII)
22	1 = Ramp mode (PII)
23	1 = Status – Group fault (PII)
24	1 = Status – Group warning (PII)
25	1 = current upper limit error violation
26	1 = current lower limit error violation
27	Startup with OB100
28	0 = No error 1 = Group fault
29	MsgLock activated
30	0 = Rack failure 1 = No error
31	Invalid signal status

Status2 Bit	Description
0	Last successful read data time stamp read
1	All alarm message suppressed
2	One alarm message suppressed
3	1 = Self test (PIO)
4	1 = Output 3 (PIO)
5	1 = Pump cleaning (PIO)
6	1 = Manual operation local-input controlled (PIO)
7	1 = Use alternative stopping mode (PIO)
8	1 = Motor standstill (PIO)
9	1 = Motor CW (PII)
10	1 = Motor CCW (PII)
11	1 = Starting mode active (PII)
12	1 = Operation / bypass active (PII)
13	1 = Stop mode active (PII)
14	1 = Test operation active (PII)
15	1 = Thermal motor model overload (PII)
16	1 = Temperature sensor overload (PII)
17	1 = Switching element overload (PII)
18	1 = Cooling time active (PII)
19	1 = Device error (PII)
20	1 = Automatic parameterization active (PII)
21	1 = New ex parameter value detected (PII)
22	1 = parameter set 1 suppressed
23	1 = parameter set 2 suppressed
24	1 = parameter set 3 suppressed
25	Configuration fault
26...29	Reserve
30	3RW52 configured
31	3RW55 configured

5.3.28 Faceplate views

5.3.28.1 3RW5Oprn - Standard

Standard view (3RW55)

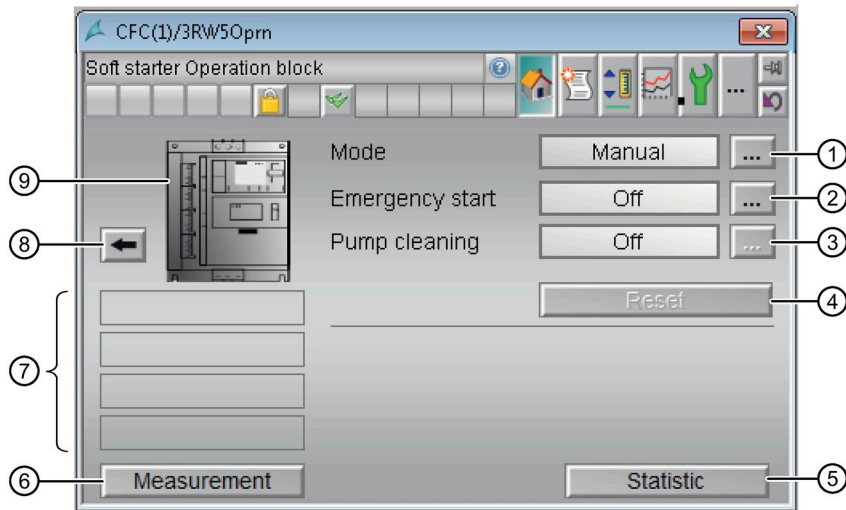





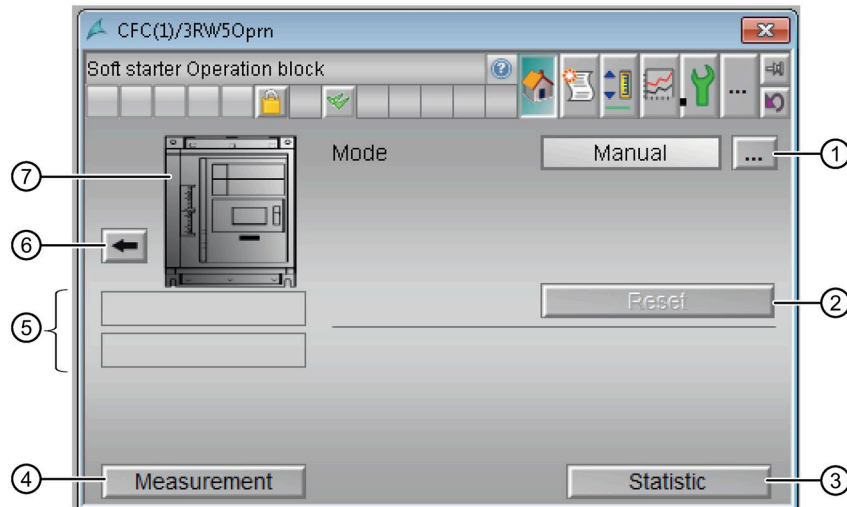



- ① Button for changing the operating mode (`AutoModOp`, `ManModOp`, `OosOp`)
Opens the expanded command area; authorization level 5 and higher, authorization level 6 for `OosOp`.
- ② Emergency start (Page 99) button (`EmrgStMan`);
Opens the expanded command area; authorization level 6.
- ③ Pump cleaning (Page 103) button (`PmpClnMan`)
Opens the expanded command area; authorization level 6.
Pump cleaning status:
 - On - Pump cleaning is active
 - Off - Motor/Pump is Off
 - Disable monitor - Motor is On and feedback monitoring is enabled (User should disable monitoring before starting the pump cleaning).
- ④ Button for resetting the trip (`TrpRstOp`)
Opens the expanded command area; authorization level 5.
- ⑤ Button for switching to the Standard view of Statistics faceplate; visible if the `SelFp2` input parameter of the `3RW5Oprn` block is configured. (By default this option is not available in template)
- ⑥ Button for switching to the Standard view of Measurement faceplate; visible if the `SelFp1` input parameter of the `3RW5Oprn` block is configured. (By default this option is not available in template)
- ⑦ Status display of the block, e.g. Rack fault, Config fault, Self Test active, Disable quick stop, Invalid signal, Output active
- ⑧ **Navigation button**
The button to navigate to the connected `3RW5Ctrl` block.
- ⑨ **Device status** (see table)

Standard view (3RW52)



- ① Button for changing the operating mode (`AutoModOp`, `ManModOp`, `OosOp`)
Opens the expanded command area; authorization level 5 and higher, authorization level 6 for `OosOp`.
- ② Button for resetting the trip (`TrpRstOp`)
opens the expanded command area; authorization level 5.
- ③ Button for switching to the Standard view of Statistics faceplate; visible if the `selFp2input` parameter of the `3RW50prn` block is configured.
- ④ Button for switching to the Standard view of Measurement faceplate; visible if the `selFp1input` parameter of the `3RW50prn` block is configured.
- ⑤ Status display of the block, e.g. Invalid signal, Rack fault, Config fault, Group error, Self test active
- ⑥ **Navigation button**
The button to navigate to the connected `MotL` block.
- ⑦ **Device status** (see table)

Device status icons

Status	Symbol	Symbol
	3RW55	3RW52
Motor ON		
Motor OFF		
Error		
OoS		

5.3.28.2 3RW5Oprn - Diagnostics

For the 3RW5Oprn block there are diagnostics views for station, control, device and parameters.

All the available diagnostics messages are displayed in the Diagnostics view.

Note

In case of Rack fault/ Module fault of the device, all of the diagnostic messages will be suppressed except the station diagnostics messages.

Station diagnostics (DiagStn)

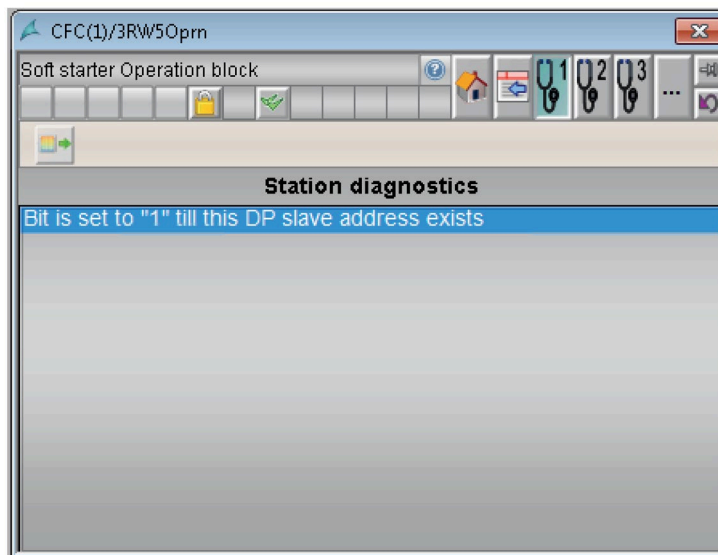

Note

Only applicable for PROFIBUS Soft starter devices.

Control diagnostics (DiagCom)

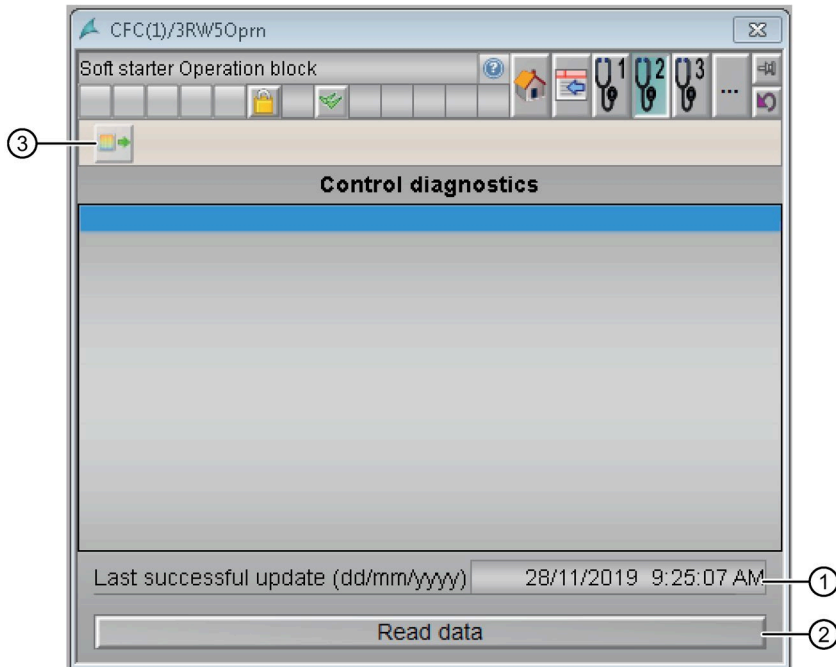

- ① Last successful Timestamp of Read Data
- ② Button for updating the data (`RdDataOp`); opens the expanded command range; authorization level 5.
Button is deactivated if `RackFAct = 1`.
- ③ Export button - Button exports available diagnostic messages in a .csv file format to the project folder.
This button is disabled for operation at web navigator view.

Device diagnostics (DiagDev)

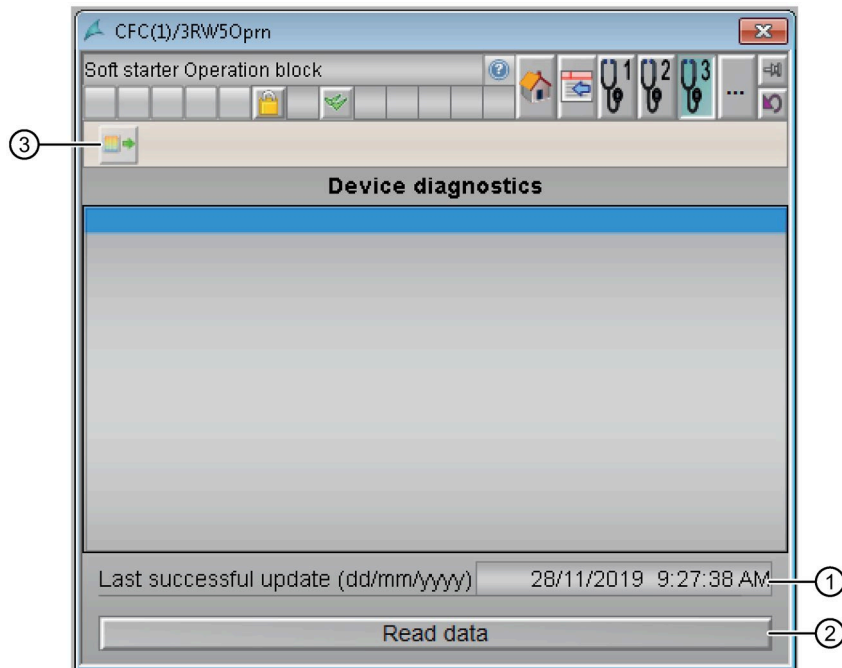

- ① Last successful Timestamp of Read Data
- ② Button for updating the data (`RdDataOp`); opens the expanded command range; authorization level 5.
Button is deactivated if `RackFAct = 1`.
- ③ Export button - Button exports available diagnostic messages in a .csv file format to the project folder.
This button is disabled for operation at web navigator view.

Parameter diagnostics (DiagPar)

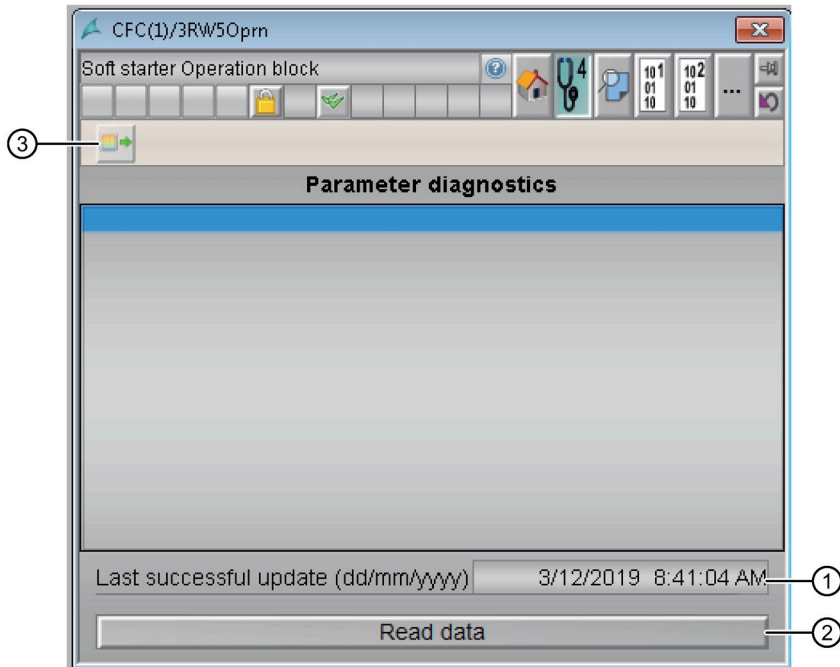

- ① Last successful Timestamp of Read Data
- ② Button for updating the data (`RdDataOp`); opens the expanded command range; authorization level 5.
Button is deactivated if `RackFAct = 1`.
- ③ Export button - Button exports available diagnostic messages in a .csv file format to the project folder.
This button is disabled for operation at web navigator view.

5.3.28.3 Direct control from block icons

Reading configuration data

Access	Direct control Read Data functionality can be accessed by right clicking the Soft Starter block icon.
Function	The "Read Data" ($RdDataOp$) button in the faceplates is used to update the current device configuration by calling the "RDREC" at the 3RW5Oprn function block.
Precondition	Read Data Button will be disabled when dataset is suppressed using feature bit or device is in out of service mode.

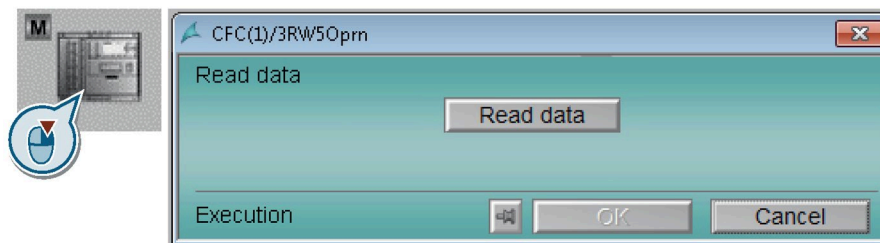

Resetting the trip

Access	Direct control Reset functionality can be accessed by right clicking the "Error symbol" at Soft Starter block icon.
Function	The Reset button in the faceplate is used for resetting the trip ($TrpRstOp$).
Precondition	The Reset button is enabled only when Ready to reset ($RdyToReset$) is available. The Reset command area is not visible when the device is in healthy mode or if the required authorization level is not available.

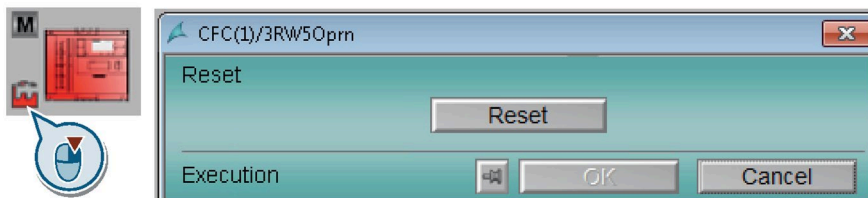

Mode change

Access	Direct control mode change functionality can be accessed by right clicking the mode symbol "M" at Soft Starter block icon.
Function	The Mode change button in the faceplate is used for changing the modes between Automatic (<code>AutModOp</code>), Manual (<code>ManModOp</code>) and Out of service (<code>OosOp</code>).
Precondition	The Mode change button is enabled only when <code>ModLiOp = 0</code> .

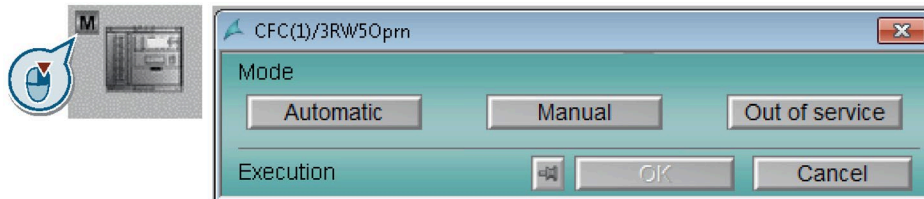



5.3.28.4 3RW52

3RW5Oprn - Maintenance

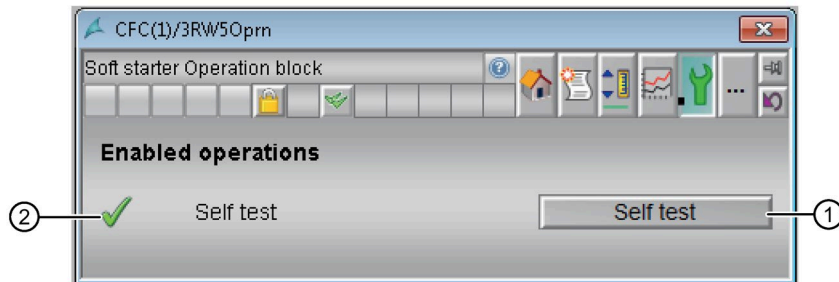
Maintenance view



- ① Button to issue self test command (`SlfTstOp`)
Opens the expanded command area; authorization level 5.
- ② Operator control enable
-  • The operator may execute the command.
 -  • The operator cannot execute the command because the command is currently blocked by a process.
 -  • The operator is not permitted to execute the command (`OS_Perm`).

The displays are dependent on the bit values in the `OS_PermOut` and `OS_PermLog` parameters.

3RW5Oprn - Parameter

Parameter view

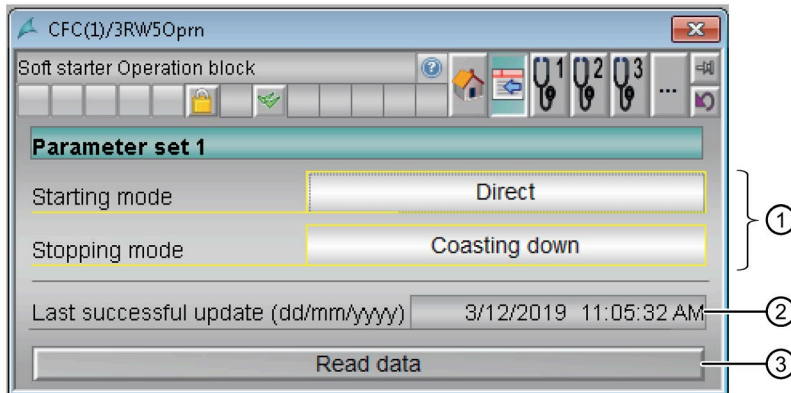

- ① Starting mode ($PS1StrMod$)
Stopping mode ($PS1StpMod$)
- ② Last successful timestamp of Read data
- ③ Button for updating the values ($RdDataOp$)
Button is deactivated on Rack fault ($RackFact = 1$)

Note

The Starting, Stopping and Alternative stopping mode parameters are only read and displayed on the faceplate. Changing the mode is not possible via faceplate.

3RW5Oprn - Limits

Limits view

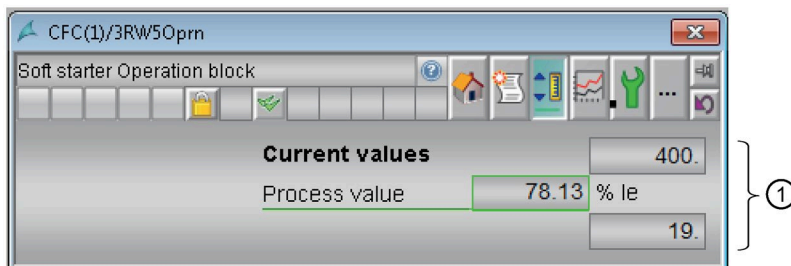

- ① **Current values**
Display of the drawn motor current under the selected parameter set (shown in blue) and its limit values ($MotCurr$).
Upper and lower limits for motor current ($PS1OpScale$).
The values show the display range of the process value. The scale range is defined in the Engineering Station.

3RW5Oprn - Process image

The Process image view displays the values for:

- Process image inputs (PII)
- Process image outputs (PIO)

Process image – Soft starter 3RW52

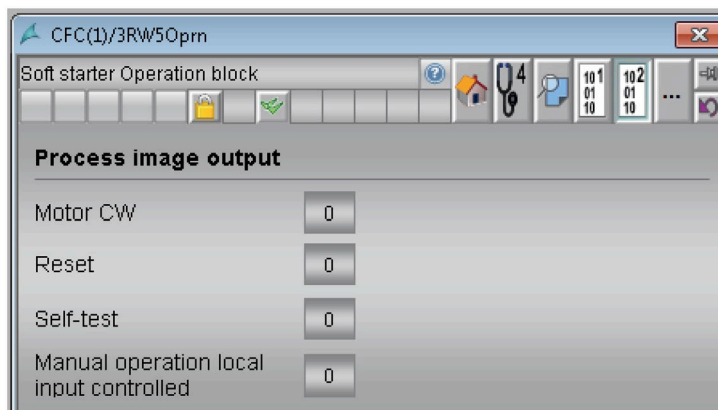
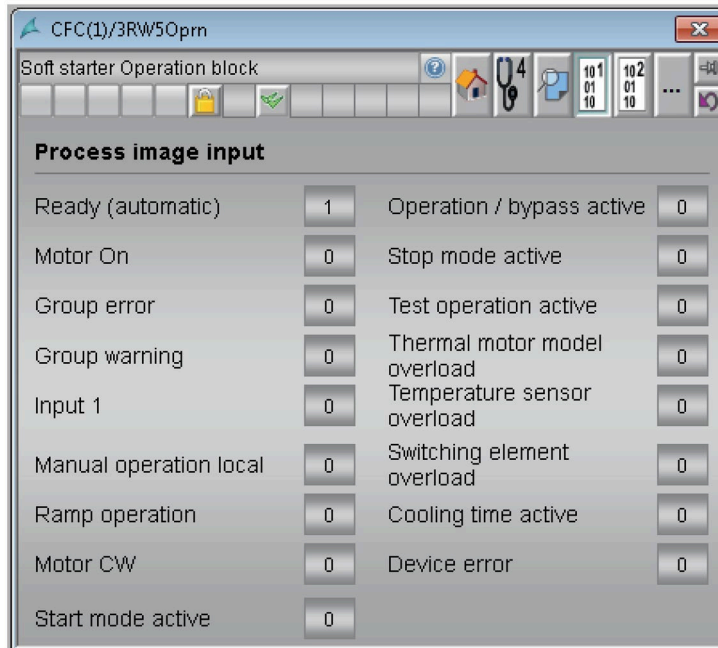

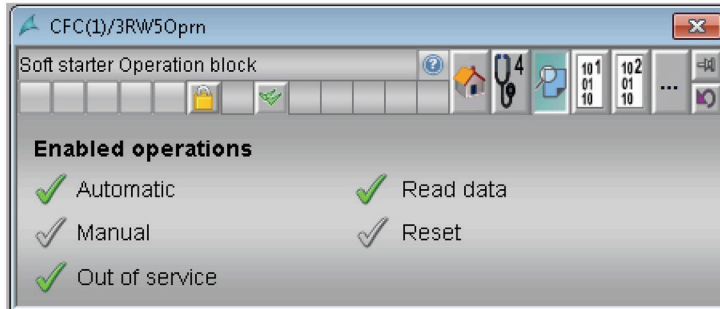

3RW5Oprn - Preview

Preview (3RW52)



Operator control enable

-  • The operator may execute the command.
-  • The operator cannot execute the command because the command is currently blocked by a process.
-  • The operator is not permitted to execute the command.

5.3.28.5 3RW55

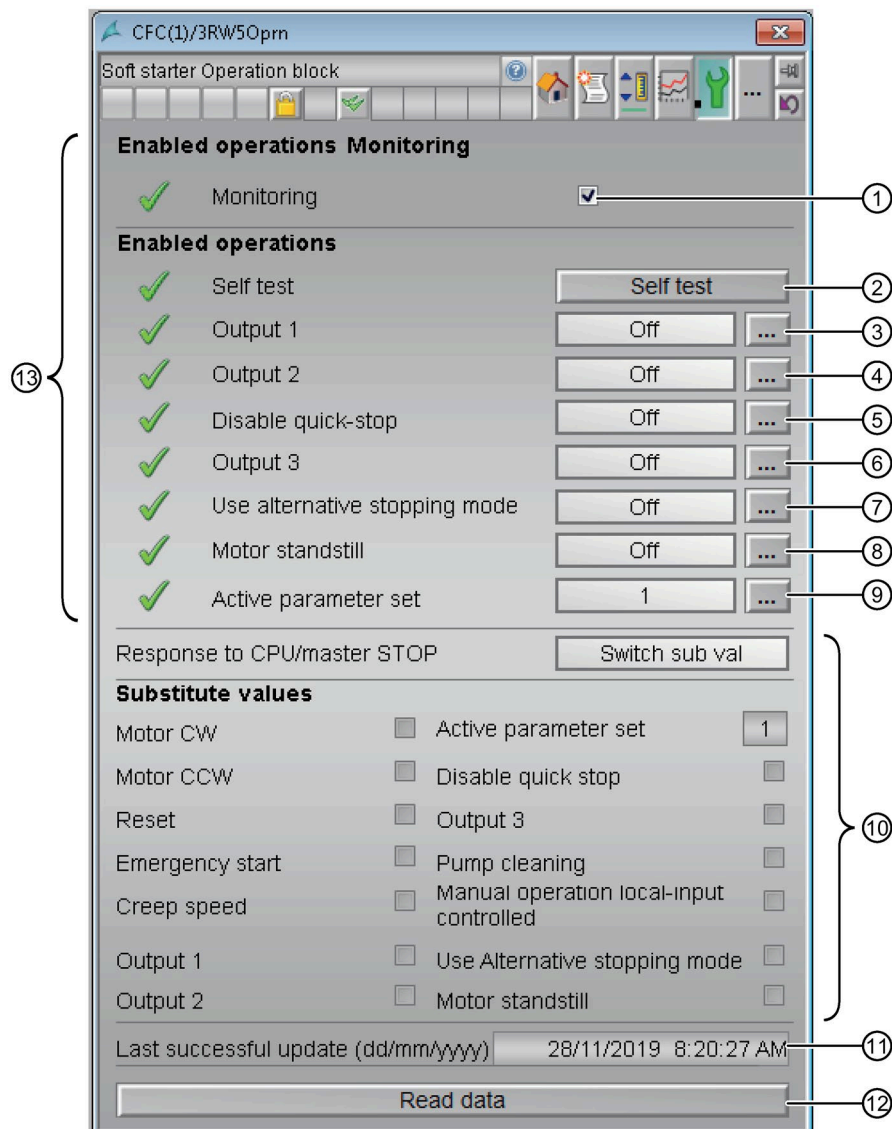

3RW5Oprn - Maintenance

Maintenance view



- ① Monitoring (Monitor)
- ② Button to issue self test command (SlfTstOp)
Opens the expanded command area; authorization level 5.
- ③ Button to issue Output1 command (Out1Man)
Opens the expanded command area; authorization level 5.
- ④ Button to issue Output2 command (Out2Man)
Opens the expanded command area; authorization level 5.

5.3 Operation block

- ⑤ Button to Disable quick-stop command (DsQkSpMan)
Opens the expanded command area; authorization level 5.
- ⑥ Button to issue Output3 command (Out3Man)
Opens the expanded command area; authorization level 5.
- ⑦ Button to enable alternative stopping mode (AltStpMan)
Opens the expanded command area; authorization level 5.
- ⑧ Button to issue Motor standstill command (MtrStdMan)
Opens the expanded command area; authorization level 5.
- ⑨ Activate parameter set (ParaSet)
Opens the expanded command area; authorization level 5.
- ⑩ Substitute values
This can be activated / deactivated.
- ⑪ Last successful timestamp of Read data
- ⑫ Button for updating the values (RdDataOp)
Button is deactivated on Rack fault (RackFAct = 1)
- ⑬ Operator control enable
 -  • The operator may execute the command.
 -  • The operator cannot execute the command because the command is currently blocked by a process.
 -  • The operator is not permitted to execute the command (OS_Perm).

The displays are dependent on the bit values in the OS_PermOut and OS_PermLog parameters.

3RW5Oprn - Parameter

Parameter view

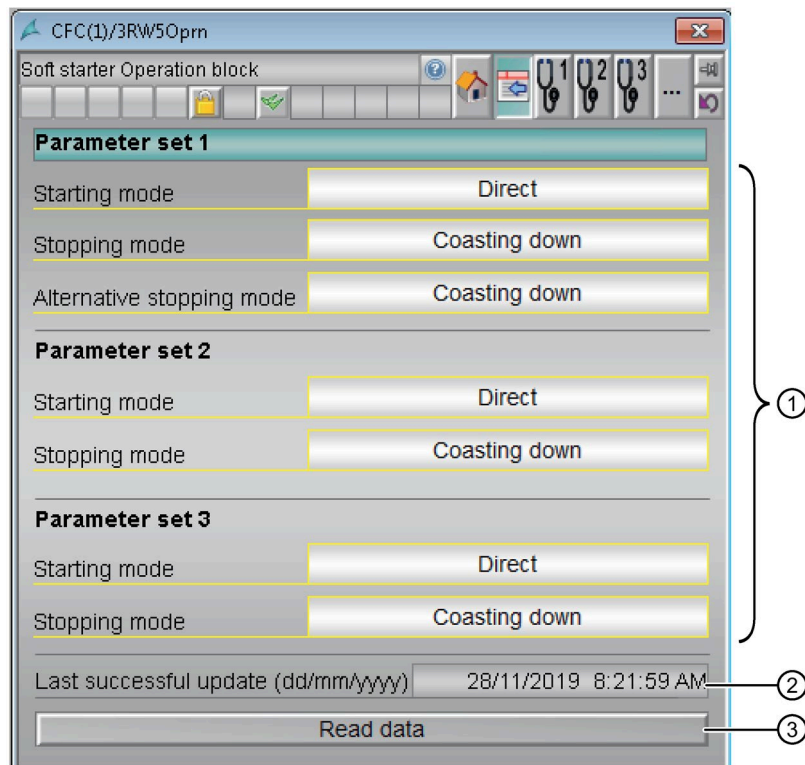

- ① Starting mode ($PS1StrMod$, $PS2StrMod$, $PS3StrMod$)
 Stopping mode ($PS1StpMod$, $PS2StpMod$, $PS3StpMod$)
 Alternative stopping mode ($AltStpMod$)
- ② Last successful timestamp of Read data
- ③ Button for updating the data ($RdDataOp$); opens the expanded command range; authorization level 5.
 Button is deactivated if $RackFAct = 1$

Note

The Starting, Stopping and Alternative stopping mode parameters are only read and displayed on the faceplate. Changing the mode is not possible via faceplate.

3RW5Oprn - Limits

Limits view

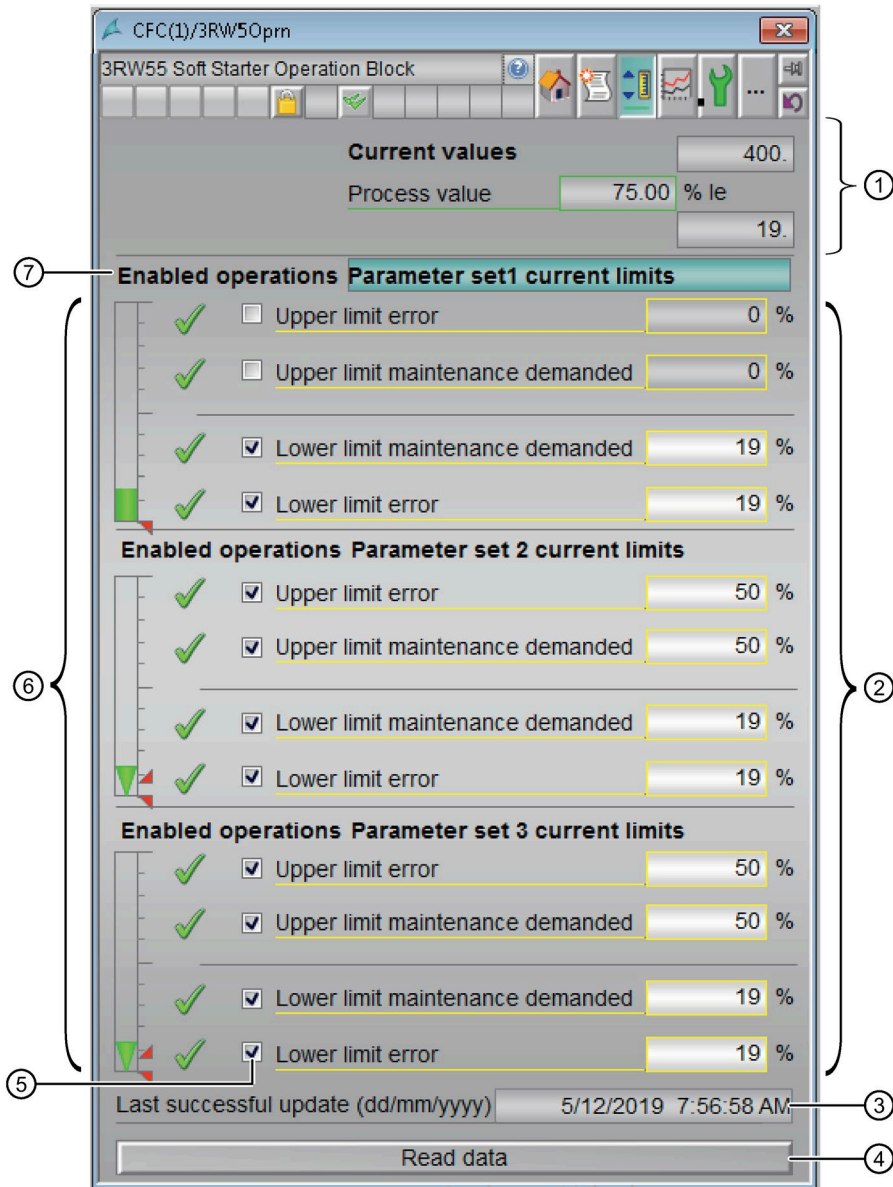

- ① **Current values**
 Display of the drawn motor current under the selected parameter set and its limit values (MotCurr).
 Upper and lower limits for motor current (PS1_OpScale, PS2_OpScale, PS3_OpScale).
 The values show the display range of the process value. The scale range is defined in the Engineering Station.

② **Parameter set 1–3 - Current limits** (Page 106)

- Deactivate upper limit error / lower limit error
- Upper limit error (PS1CurHi, PS2CurHi, PS3CurHi)
- Lower limit error (PS1CurLo, PS2CurLo, PS3CurLo)
- Deactivate upper limit maintenance demand / lower limit maintenance demand
- Upper limit maintenance demand (PS1CurMH, PS2CurMH, PS3CurMH)
- Lower limit maintenance demand (PS1CurML, PS2CurML, PS3CurML)

If the background color of the field is white, you can change the value in the expanded operating area in 3 ways (authorization level 6):

- Entry in the input box
- Setting using the slider
- Entry by direct operation

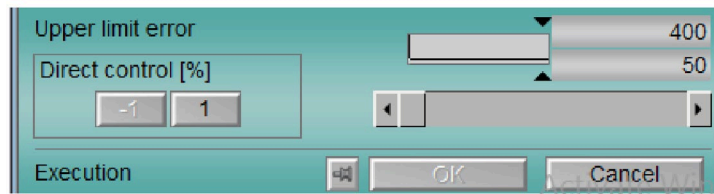

③ Last successful Timestamp of Read Data

④ Button for updating the data (RdDataOp); opens the expanded command range; authorization level 5.

Button is deactivated if RackFAct = 1.

⑤ The limits can be activated or deactivated using check box.

⑥ **Bar graph for current - Parameter set 1–3**

The visible range in the bar graph depends on the configuration in the Engineering Station.

The colored triangles show the specified limits:

- Red: Alarm
- Yellow: Warning

⑦ **Operator control enable**

- The operator may execute the command.
- The operator cannot execute the command because the command is currently blocked by a process.
- The operator is not permitted to execute the command (OS_Perm).

The displays are dependent on the bit values in the OS_PermOut and OS_PermLog parameters.

3RW5Oprm - Process image

The Process image view displays the values for the process image inputs (PII) and the process image outputs (PIO).

Process image – Soft Starter 3RW55

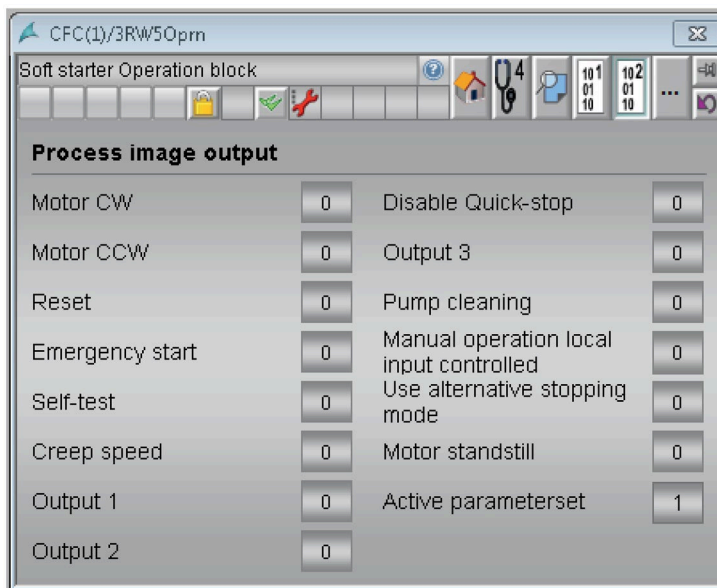
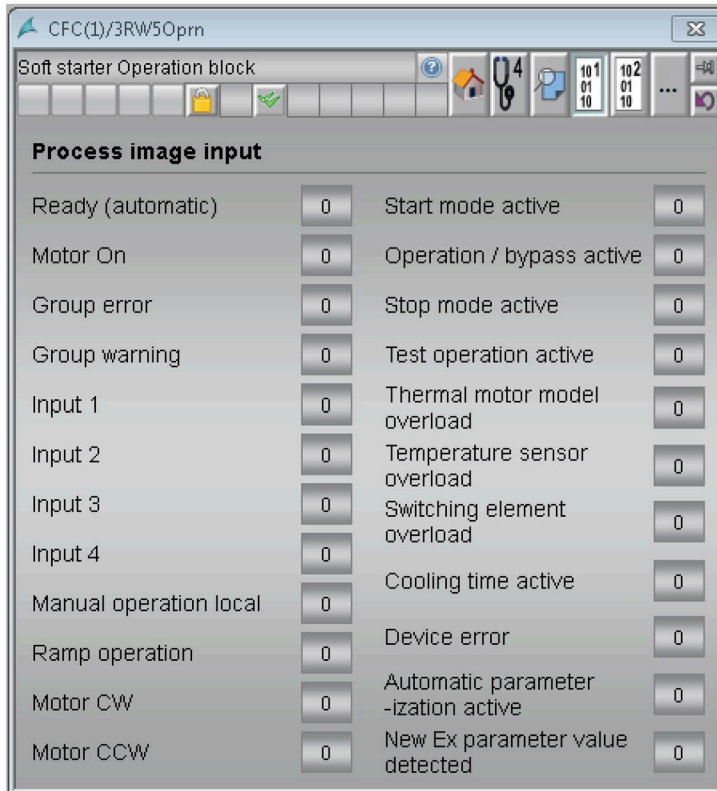

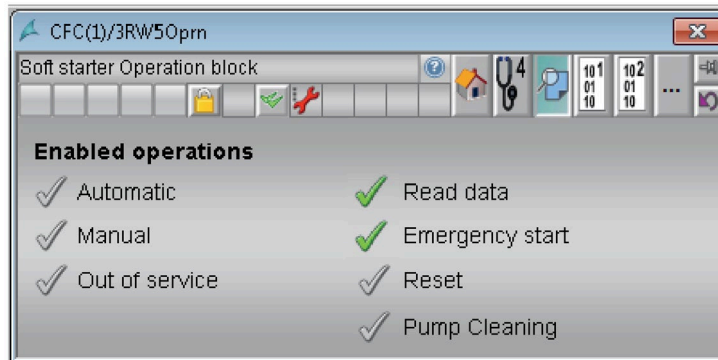

3RW5Oprn - Preview

Preview (3RW55)



Operator control enable

-  • The operator may execute the command.
-  • The operator cannot execute the command because the command is currently blocked by a process.
-  • The operator is not permitted to execute the command.

5.4 Measurement block

5.4.1 3RW5Meas block description

Purpose of the block

The 3RW5Meas block provides the following measurement information:

Measurement information	3RW55	3RW52
Phase current values	X	X
Voltage values	X	-
Output frequency	X	-
Line frequency	X	-
Output power	X	-
Temperature	X	X
Asymmetry	X	X
Power factor	X	X
Average phase current	X	X
Switching frequency time	X	X

"X" : Applicable

"-" : Not applicable

The block receives the diagnostic information from the 3RW5Diag block.

Views

The 3RW5Meas block supports the following views:

- Standard (Page 147)
- Alarm (Page 36)
- Trend (Page 34)
- Preview (Page 37)
- Batch (Page 33)
- Diagnostics (Page 148)

5.4.2 Parametrizable functions via the Feature connection 3RW5Meas

The modules of the library have an input named `Feature`. You can influence various responses of the block via this input.

The feature bits are assigned in the following order:

Table 5- 29 Meaning of the 3RW5Meas Feature.Bits

Feature.Bit	Meaning ¹
Feature.Bit1 (Page 55)	1 = Input "OosLi" can be used to switch to the "Out of Service" mode
Feature.Bit11 (Page 64)	1 = Suppress General Fault Alarm message
Feature.Bit12 (Page 64)	1 = Suppress General Warning Alarm message
Feature.Bit13 (Page 64)	1 = Suppress Temperature sensor overload Fault Alarm message
Feature.Bit14 (Page 64)	1 = Suppress Temperature sensor overload Warning Alarm message
Feature.Bit15 (Page 64)	1 = Suppress External Message 1
Feature.Bit16 (Page 64)	1 = Suppress External Message 2
Feature.Bit17 (Page 64)	1 = Suppress External Message 3
Feature.Bit18 (Page 64)	1 = Suppress External Message 4
Feature.Bit22 (Page 67)	1 = Enable message state actualization
Feature.Bit23 (Page 67)	0 = Message Handling at APL block 1 = Message Handling at 3RW5Oprn block
Feature.Bit24 (Page 68)	1 = Local authorization active
Feature.Bit25 (Page 69)	1 = Suppress all messages if <code>MsgLock = 1</code>

¹ The standard setting is 0 if no other value is specified.

For more information about the parameterizable functions, refer to the function manual "Process Control System PCS 7, PCS 7 Advanced Process Library" in the Internet (<https://support.industry.siemens.com/cs/document/109760968>).

5.4.3 Operating modes

The following modes are available for the block:

- Local
- ON
- Out of service (OoS)

Note

In this library mode switchover to local mode is only via Soft Starter TIA / HMI.

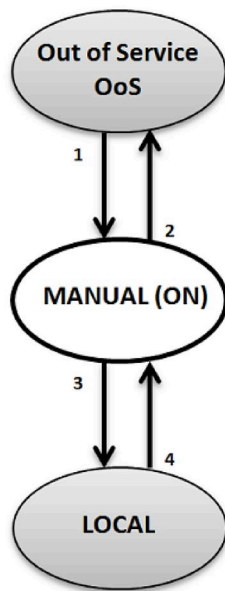

Conditions for changing the mode

No.	Conditions
①	Out of service (OoS) → MANUAL <ul style="list-style-type: none"> • Via faceplate (OnOp = 1)
②	MANUAL → Out of service (OoS) <ul style="list-style-type: none"> • Via faceplate (OosOp = 1) • On an edge transition 0 → 1 from OosLi, If Feature.Bit=1 (Response for Out of service mode)
③	MANUAL → LOCAL <ul style="list-style-type: none"> • PII 1.6 = 1
④	LOCAL → MANUAL <ul style="list-style-type: none"> • PII 1.6 = 0

Reference

You will find more information in the Function Manual "Process Control System PCS7, PCS7 Advanced Process Library" on the Internet (<https://support.industry.siemens.com/cs/document/109760968>).

5.4.4 Read cyclic float values

The 3RW5Meas block reads measured values via data set DS94.

No.	Data set number	Read access/write access	Number of bytes	Description
1	DS94	R	100	Read measured values

The values are read from the Soft Starter with the `RDREC` function. This information is written to the output parameters.

5.4.5 Read measured values

Input Mode

The `PZDInxxxx` inputs are assigned to the `ModeInxx` parameter inputs. These determine whether the measured values are read acyclically from data records (`ModeInxx = 0`) or Cyclically updated (`ModeInxx <> 0`) through process image wiring.

ModeInxx	Meaning	3RW55	3RW52
0	Measured value is read from data record.	X	-
1	Phase current I L1 (A) (CurrL1E)	X	X
2	Phase current I L2 (A) (CurrL2E)	X	X
3	Phase current I L3 (A) (CurrL3E)	X	X
4	Power factor L1..3 (PwrFact)	X	-
5	Active Power (ActPwr)	X	-
6	Phase current average(rms) in A (PhsCurAvgE)	X	-

"X" : Applicable

"-" : Not applicable

Note

3RW55 Soft Starter device can have `ModeInxx` values from 0-6.

3RW52 Soft Starter device can have `ModeInxx` values from 1-3, these values are fixed and cannot be modified.

Reading cyclic float values

Cyclic reading of float values is applicable for 3RW5 devices. `ModeInxx` values ranges from 0 to 6 and corresponds to the different float values which can be read using the above device combination. If the cyclic float value is configured it occupies double word (two word), i.e. Double word (DWord) input have to be configured with `PZDInxxxx` and its corresponding `ModeInxx` should be given at the first instance.

Note

3RW52 will support pre-defined parameters.

In 3RW55, cyclic parameters can be configured at Soft Starter TIA.

Example

If phase current `CurrL1 (A)` is configured in `Byte 4_7` then corresponding double word address needs to be given at `PZDIn47` and `ModeIn01` needs to be configured with '1' which corresponds to `Phase current CurrL1 (A)`.

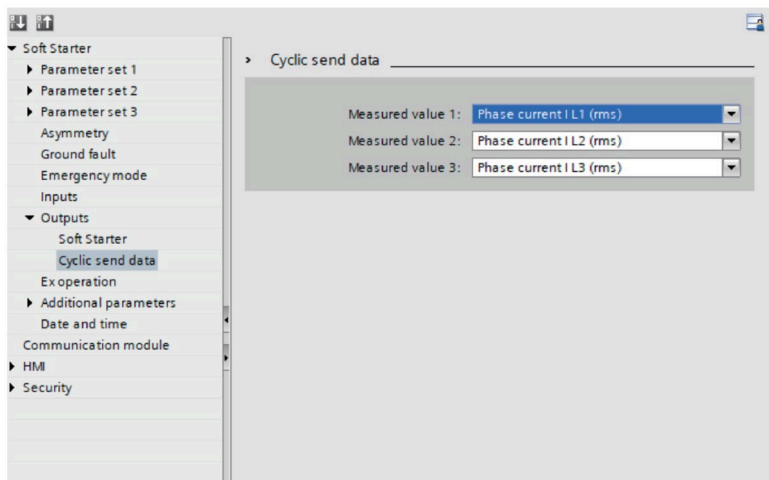
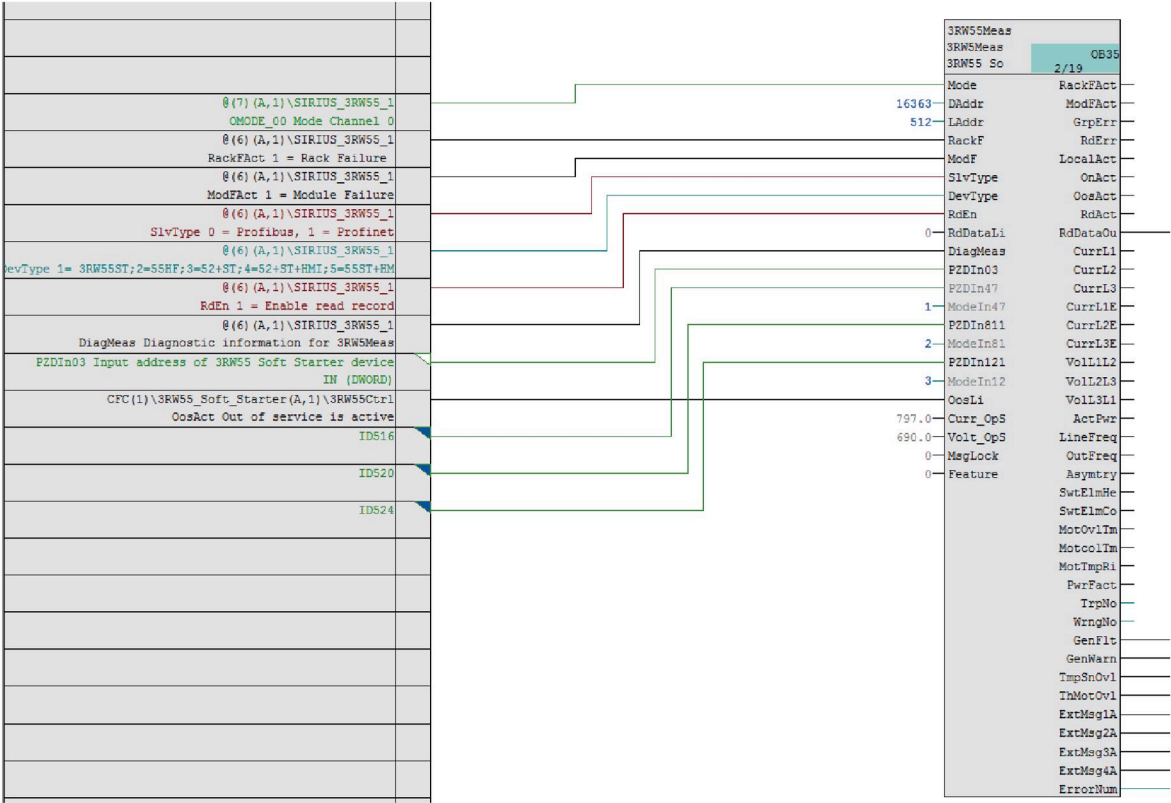

Figure 5-1 Configuring cyclic views from Soft Starter ES for TIA



5.4.6 Message characteristics

3RW5Meas reports the following errors at the block output:

- Rack failure (`RackFAct`)
- Module fault (`ModFAct`)

An error generates a group error in output parameter `GrpErr`.

These errors are not signaled as alarms as they are already part of the 3RW5Diag block (both on the DP master system and behind the Y-link). The alarms are output using the `ALARM_8P` function.

The messages can be enabled or disabled using the `MsgLock` input.

The alarms are suppressed when the block is in Out of service mode.

Furthermore, individual message can also be disabled with use of `feature bits 11-18`.

Message block MsgEvid1

Table 5- 30 Output messages

Message block	Message No.	Block parameters	Message text	Message class *
MsgEvId1	1	GenFit.Value	\$\$BlockComment\$\$ Group fault : @4W%t#3RW5Meas_TRP@	S
	2	GenWarn.Value	\$\$BlockComment\$\$ Group warning : @5W%t#3RW5Meas_WRN@	W
	3	TmpSnOvIF.Value	\$\$BlockComment\$\$ Temperature sensor overload Fault Alarm	S
	4	ThMotOvl.Value	\$\$BlockComment\$\$ Thermal motor model overload	S
	5	ExtMsg1.Value	\$\$BlockComment\$\$ External message 1	S
	6	ExtMsg2.Value	\$\$BlockComment\$\$ External message 2	S
	7	ExtMsg3.Value	\$\$BlockComment\$\$ External message 3	S
	8	ExtMsg4.Value	\$\$BlockComment\$\$ External message 4	S

* S = AS, OS process control fault; W = Warning

Auxiliary values

The block supports 10 programmable auxiliary values.

Table 5- 31 Structure of the auxiliary values ALARM_8P

Message No.	Auxiliary value	Block parameter	Meaning
1	1	SarBatchName	Batch name
2	2	SdwStepNoLoc	Batch step
3	3	SdwBatchId	Batch ID
4	4	SnTrpNo	Trip number
5	5	SnWrnNo	Warning number
6	6	ExtVal06	External value 6, user-definable
7	7	ExtVal07	External value 7, user-definable
8	8	ExtVal08	External value 8, user-definable
9	9	ExtVal09	External value 9, user-definable
10	10	ExtVal10	External value 10, user-definable

The `MsgStat1`, `MsgAckn1`, and `MsgErr1` parameters transfer the following information:

- Message status
- Message error
- Message acknowledgment status

5.4.7 System text libraries for warning and trip

System text libraries are created if 3RW5Meas blocks are inserted into the CFC chart. They are assigned to the numbers of the warnings and trips.

Table 5- 32 Numbers for trips

Message No.	Message text
1	Temperature sensor wire break
2	Temperature sensor short-circuit
3	Thermal motor model trip
4	Asymmetry limit error exceeded
5	Asymmetry trip
6	Current limit exceeded
7	Current limit undershot
8	Current limit error trip
9	Ground fault limit error exceeded
10	Current measuring range overshoot
11	Active power error limit exceeded
12	Active power error limit undershot
13	Active power error limit trip
14	Phase angle control failure

Table 5- 33 Numbers for warnings

Message No.	Message text
1	Temperature sensor overload
2	Temperature sensor wire break
3	Temperature sensor short-circuit
4	Switching element for Start too hot
5	Remaining time for tripping warning limit undershot
6	Motor heating warning limit exceeded
7	Current limit - maintenance demanded exceeded
8	Current limit - maintenance demanded undershot
9	Asymmetry limit warning exceeded
10	Ground fault limit warning exceeded
11	Active power limit - maintenance demanded exceeded
12	Active power limit - maintenance demanded undershot
13	Generator operation

5.4.8 Start-up characteristics

The alarm messages are suppressed in the OB100 for the `RunUpCyc` number of times.

5.4.9 Status information

Status information 3RW5Meas

The status information is passed to WinCC for display in the faceplates.

Table 5- 34 Status information – 3RW5Meas

Status1 Bit	Description
0	Occupied
1	BatchEn
2	Slave Type; 0 = PROFIBUS 1 = PROFINET
3	OosAct.Value
4	OosLi active
5	Reserved
6	Operating Mode 0 = ON mode 1 = Local mode
7...27	Reserved
28	Group error
29	MsgLock
30	1 = No error 0 = Rack failure
31	Reserved

Status2 Bit	Description
0	Last successful Timestamp of Read Data
1	All alarm message suppressed
2	At least one alarm message is suppressed
3...29	Reserved
30	Configured Device is 3RW52
31	Configured Device is 3RW55

5.4.10 Enabled operations

Operator permissions

The operator permissions for control commands are configured in the `OS_Perm` structured parameters. These are transferred to WinCC via the `OS_PermOut` and `OS_PermLog` parameters.

The operator permissions control operation only in the faceplate.

Table 5- 35 Operator permissions – 3RW5Meas

OS_Perm Bit	OS_PermOut Bit	OS_PermLog Bit	Description
0	0	0	Reserved
1	1	1	1 = Operator is permitted to change to ON mode.
2	2	2	Reserved
3	3	3	1 = Operator is permitted to change to "Out of service" (OoS) mode.
4...20	4...20	4...20	Reserved
21	21	21	1 = Operator is permitted to read data from the device.
22...31	22...31	22...31	Reserved

`OS_PermOut` contains the release information of all parameters.

`OS_PermLog` contains the release based on the current modes.

5.4.11 Faceplate views

5.4.11.1 3RW5Meas - Standard

Standard View

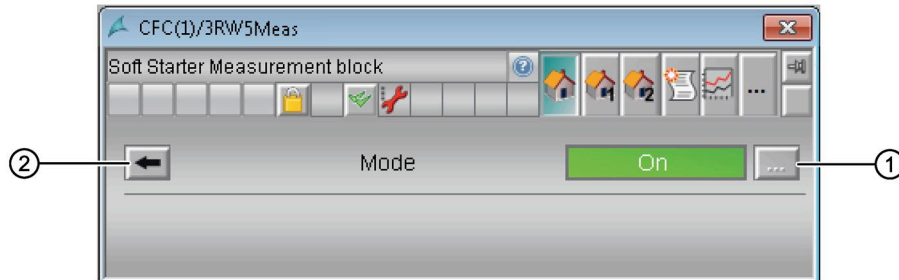

- ① Display of the operating mode
- ② **Navigation button**
Navigation to the connected 3RW5Ctrl / 3RW5Oprn block.

Icons



- ① 3RW55 / 3RW52 Measured value set 1
- ② 3RW55 Measured values set 2
- ③ 3RW52 Measured values set 2 - Disabled
- ④ Protection Diagnostic

5.4.11.2 3RW5Meas - Diagnostics

Diagnostics view

All the available diagnostics messages are displayed in this view.

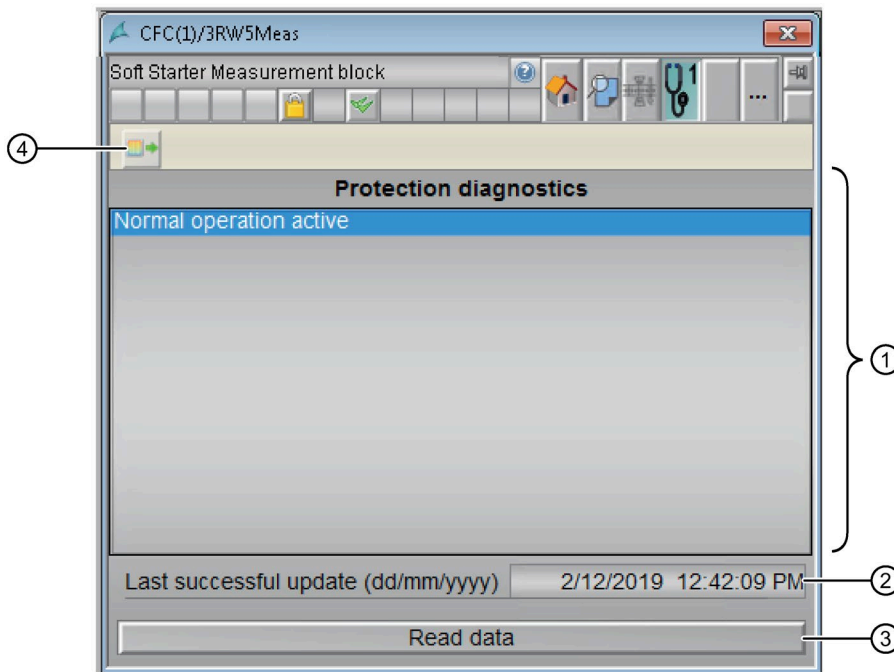

- ① Diagnostic message view
- ② Last successful Timestamp of Read Data
- ③ Button for updating the data (RdDataOp). Button is deactivated if $RackFact = 1$.
User authorization level 5.
- ④ Export button - Button exports available diagnostic messages in a .csv file format to the project folder.
This button is disabled for operation at web navigator view.

5.4.11.3 3RW5Meas - Preview

Preview (3RW55)

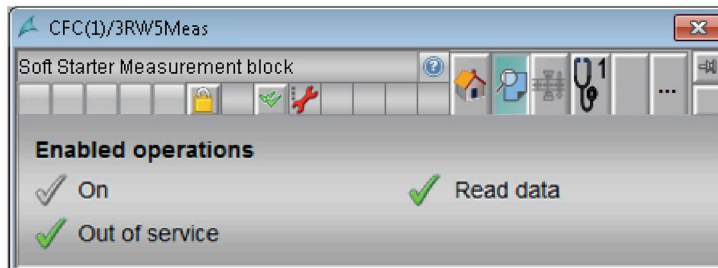

The operator may execute the command.



The operator cannot execute the command because the command is currently blocked by a process.



The operator is not permitted to execute the command (OS_Perm).

The displays are dependent on the bit values in the OS_PermOut and OS_PermLog parameters.

5.4.11.4 3RW52

3RW5Meas - Standard 1

Standard 1 view

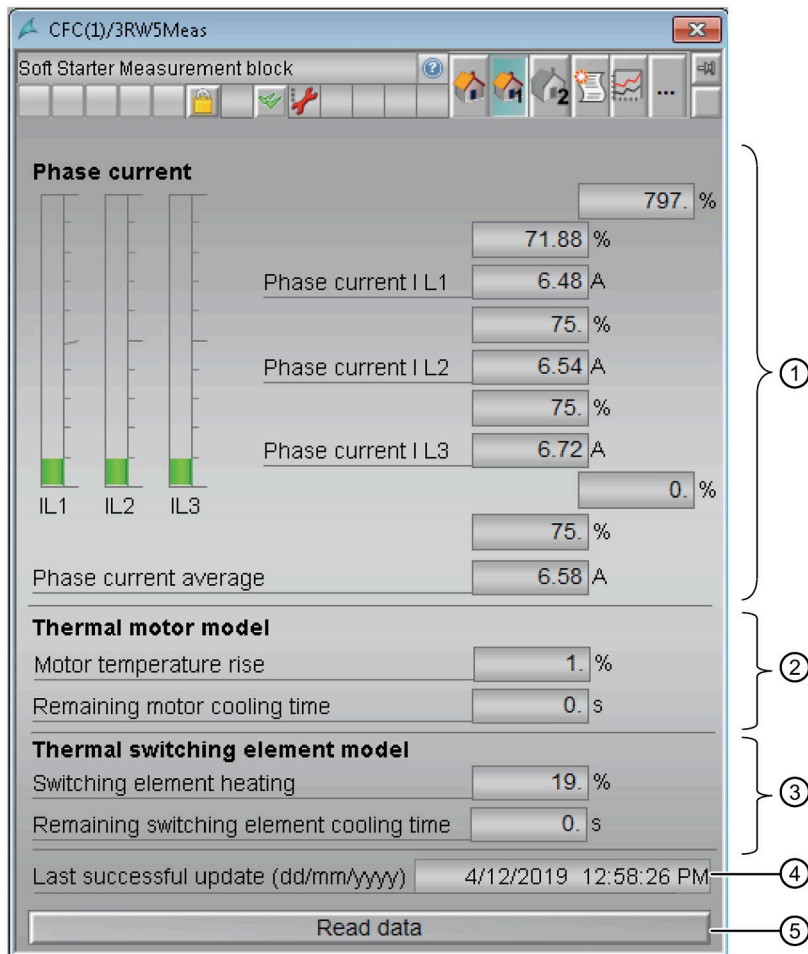

- ① **Phase current**
 - Current values as bars (Curr_OpScale high value, low value)
 - Phase current in % and amperes (CurrL1, CurrL2, CurrL3, CurrL1E, CurrL2E, CurrL3E)
 - Phase current average in % and amperes (PhsCurAvg and PhsCurAvgE)
 - Phase current max in amperes (MaxPhsCur)
- ② **Thermal motor model**
 - Motor temperature rise (MotTmpRis)
 - Remaining time for motor overload protection (MotOvlTm)
 - Remaining motor cooling time (MotcolTm)

- ③ **Thermal switching element model**
Switching element heating (`SwtElmHeat`)
Remaining switching element cooling time (`SwtElmColTm`)

- ④ Last successful Timestamp of Read Data
- ⑤ Button for updating the data (`RdDataOp`).
Button is deactivated if `RackFact = 1`.
User authorization level 5.

5.4.11.5 3RW55

3RW5Meas - Standard 1

Standard 1 view

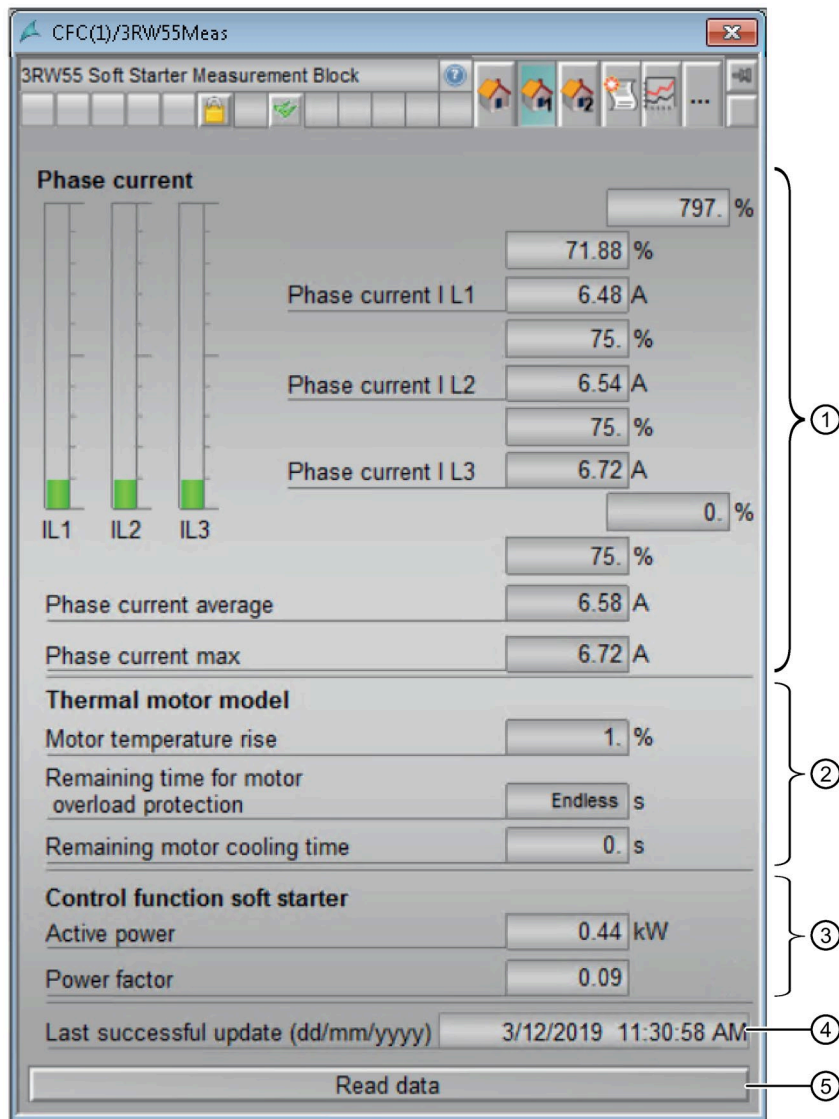

- ① **Phase current**
 Current values as bars (Curr_OpScale high value, low value)
 Phase current in % and amperes (CurrL1, CurrL2, CurrL3, CurrL1E, CurrL2E, CurrL3E)
 Phase current average in % and amperes (PhsCurAvg and PhsCurAvgE)
 Phase current max in amperes (MaxPhsCur)

- ② **Thermal motor model**
 - Motor temperature rise (`MotTmpRis`)
 - Remaining time for motor overload protection (`MotOvlTm`)
 - Remaining motor cooling time (`MotcolTm`)
- ③ **Control function soft starter**
 - Active Power (`ActPwr`)
 - Power Factor (`PwrFact`)
- ④ Last successful Timestamp of Read Data
- ⑤ Button for updating the data (`RdDataOp`).
 - Button is deactivated if `RackFact = 1`.
 - User authorization level 5.

3RW5Meas - Standard 2

Standard 2 view

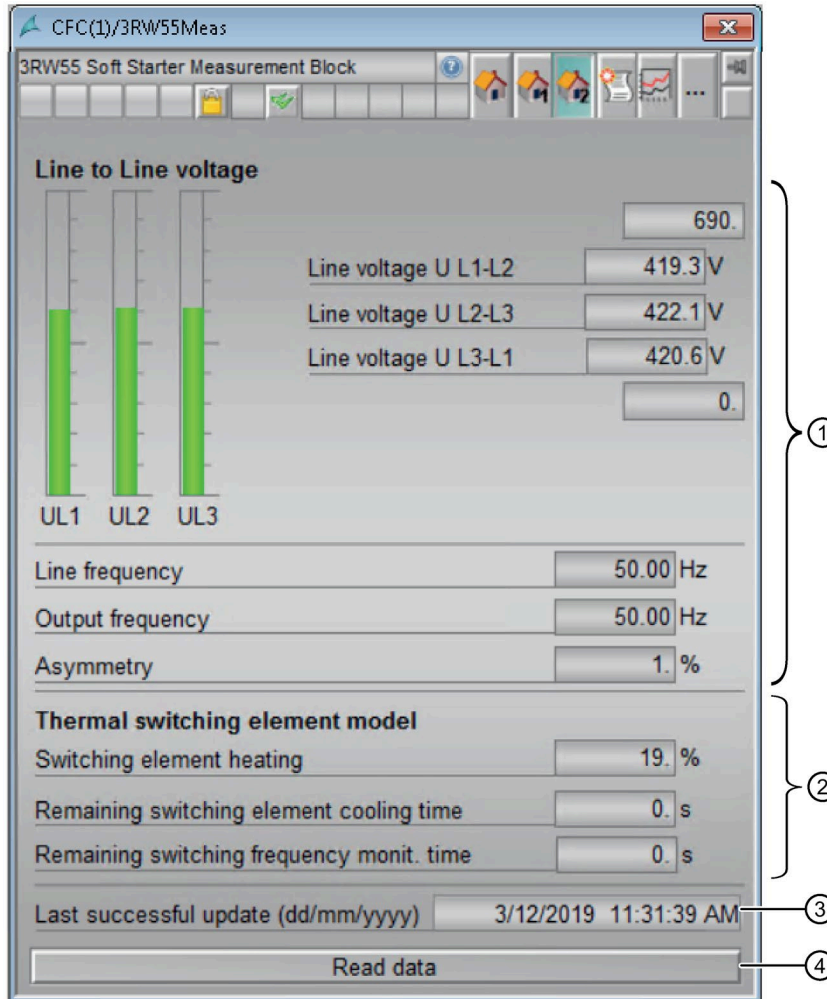

- ① **Line to Line voltage**
 Voltage values as bars (Volt_OpScale high value, low value)
 Voltage values in volts (VolL1L2, VolL2L3, VolL3L1)
 Line frequency (LineFreq)
 Output frequency (OutFreq)
 Asymmetry (Asymtry)
- ② **Thermal switching element model**
 Switching element heating in % (SwtElmHeat)
 Remaining cooling time for switching element (SwtElmColTm)
 Remaining switching frequency monitoring time (SwtFrqMon)
- ③ Last successful Timestamp of Read Data
- ④ Button for updating the data (RdDataOp).
 Button is deactivated if RackFact = 1.
 User authorization level 5.

5.5 Statistical block

5.5.1 3RW5Stat block description

Purpose of the block

The 3RW5Stat block gathers statistical data from data set 95.

The 3RW5Stat block provides information about the following topics:

- Device operating hours
- Motor hours run
- Operating cycles
- Fault statistics
- Current measuring
- Active energy

Views

The 3RW5Stat faceplate supports the following views:

- Standard (Page 164)
- Alarm (Page 36)
- Maximum pointer (Page 165)
- Preview (Page 167)
- Batch (Page 33)

5.5.2 Parametrizable functions via the Feature connection 3RW5Stat

The modules of the library have an input named `Feature`. You can influence various responses of the block via this input.

The Feature Bits are assigned in the following order:

Meaning of the 3RW5Stat Feature.Bits

Feature.Bit	Meaning ¹
Feature.Bit1 (Page 55)	1 = Input "OosLi" can be used to switch to the "Out of Service" mode.
Feature.Bit11 (Page 64)	1 = Suppress External Message 1
Feature.Bit12 (Page 64)	1 = Suppress External Message 2
Feature.Bit13 (Page 64)	1 = Suppress External Message 3
Feature.Bit14 (Page 64)	1 = Suppress External Message 4
Feature.Bit15 (Page 64)	1 = Suppress External Message 5
Feature.Bit16 (Page 64)	1 = Suppress External Message 6
Feature.Bit17 (Page 64)	1 = Suppress External Message 7
Feature.Bit18 (Page 64)	1 = Suppress External Message 8
Feature.Bit20 (Page 66)	1 = Suppress Reading statistical data
Feature.Bit21 (Page 66)	1 = Suppress Reading Maximum pointers
Feature.Bit22 (Page 67)	1 = Enable message state actualization
Feature.Bit24 (Page 68)	1 = "Local operator authorization" function is activated
Feature.Bit25 (Page 69)	1 = Suppression of all messages is activated if <code>MsgLock = 1</code>

¹ The standard setting is 0 if no other value is specified.

For more information about the parameterizable functions, refer to the function manual "Process Control System PCS 7, PCS 7 Advanced Process Library" in the Internet (<https://support.industry.siemens.com/cs/document/109760968>).

5.5.3 Operating modes

The following modes are available for the block:

- Local
- ON
- Out of service (OoS)

Note

In this library mode switchover to local mode is only via Soft Starter TIA / HMI.

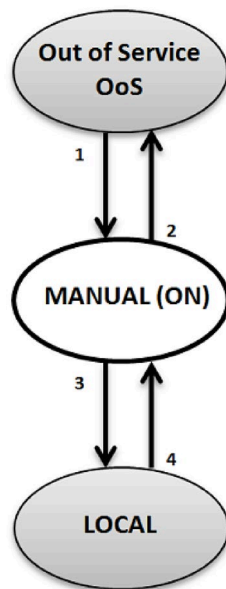

Conditions for changing the mode

No.	Conditions
①	Out of service (OoS) → MANUAL <ul style="list-style-type: none"> • Via faceplate ($OnOp = 1$)
②	MANUAL → Out of service (OoS) <ul style="list-style-type: none"> • Via faceplate ($OosOp = 1$) • On an edge transition $0 \rightarrow 1$ from $OosLi$, If $Feature.Bit=1$ (Response for Out of service mode)
③	MANUAL → LOCAL <ul style="list-style-type: none"> • $PII\ 1.6 = 1$
④	LOCAL → MANUAL <ul style="list-style-type: none"> • $PII\ 1.6 = 0$

Reference

You will find more information in the Function Manual "Process Control System PCS7, PCS7 Advanced Process Library" on the Internet (<https://support.industry.siemens.com/cs/document/109760968>).

5.5.4 Statistical values

The DS93 Data set has write capability. The necessary function to Write (WRREC) is executed to write the command (Delete Maximum Pointer) to the Soft Starter Device. Data set 95 reads statistical information, and data set 96 reads the maximum pointer. The values are read from the Soft Starter with the RDREC function. This information is written to the output parameters.

Table 5- 36 Data set table

No.	Data set number	Read access/write access	Number of bytes	Description
1	DS93	W	10	Write command - Delete Maximum Pointer
2	DS95	R	200	Read statistics data
3	DS96	R	126	Read maximum pointer

5.5.5 Read statistical values

Reading cyclic float values

Cyclic reading of statistical values is applicable for 3RW55 devices only. In statistical block, only "Active energy import total" value can be read cyclically. If the cyclic float value is configured it occupies DWORD i.e. Double word.

The cyclic input must be configured with PZDIn1215.

Example

If "512" is the starting address, PZDIn1215 should be interconnected with ID524.

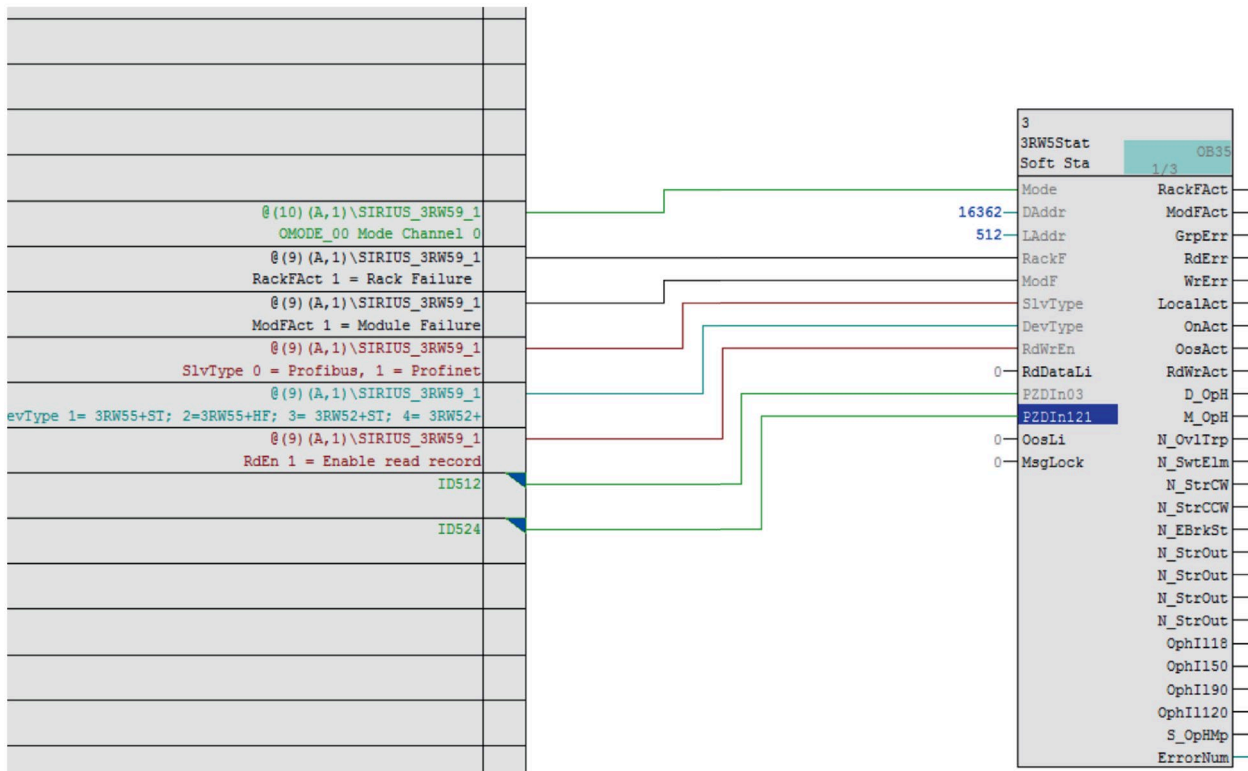
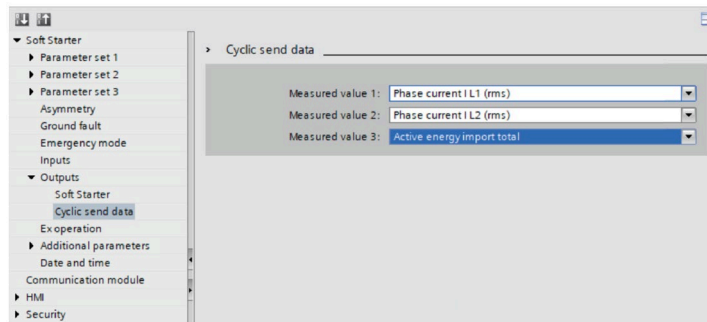

5.5.6 Message characteristics

3RW5Stat reports the following errors at the block output:

- Rack failure (`RackFAct`)
- Module fault (`ModFAct`)

An error generates a group error in output parameter `GrpErr`.

These errors are not signaled as alarms as they are already part of the 3RW5Diag block. The alarms are output using the ALARM_8P function.

The messages can be enabled or disabled using the `MsgLock` input. The alarms are suppressed when the block is in `Oos` (Out of service) mode.

Message block MsgEvid1

Table 5- 37 Output messages

Message block	Message No.	Block parameters	Message text	Message class *
MsgEvId1	1	ExtMsg1 **	\$\$BlockComment\$\$External Message 1	S
	2	ExtMsg2 **	\$\$BlockComment\$\$External Message 2	S
	3	ExtMsg3 **	\$\$BlockComment\$\$External Message 3	S
	4	ExtMsg4 **	\$\$BlockComment\$\$External Message 4	S
	5	ExtMsg5 **	\$\$BlockComment\$\$External Message 5	S
	6	ExtMsg6 **	\$\$BlockComment\$\$External Message 6	S
	7	ExtMsg7 **	\$\$BlockComment\$\$External Message 7	S
	8	ExtMsg8 **	\$\$BlockComment\$\$External Message 8	S

* S = AS, OS process control fault

** User-definable message

Auxiliary values

The block supports 10 programmable auxiliary values.

Table 5- 38 Structure of the auxiliary values ALARM_8P

Message No.	Auxiliary value	Block parameter	Meaning
1	1	SarBatchName	Batch name
2	2	SdwStepNoLoc	Batch step
3	3	SdwBatchId	Batch ID
4	4	ExtVal104	External value 4, user-definable
5	5	ExtVal105	External value 5, user-definable
6	6	ExtVal106	External value 6, user-definable
7	7	ExtVal107	External value 7, user-definable
8	8	ExtVal108	External value 8, user-definable
9	9	ExtVal109	External value 9, user-definable
10	10	ExtVal110	External value 10, user-definable

The `MsgStat1`, `MsgAckn1`, and `MsgErr1` parameters transfer the following information:

- Message status
- Message error
- Message acknowledgment status

5.5.7 Start-up characteristics

The alarm messages are suppressed in the OB100 for the `RunUpCyc` number of times.

5.5.8 Status information

Status information 3RW5Stat

The status information is passed to WinCC for display in the faceplates.

Table 5- 39 Status information – 3RW5Stat

Status1 Bit	Description
0	Occupied
1	BatchEn
2	Slave Type; 0 = PROFIBUS 1 = PROFINET
3	OosAct.Value
4	OosLi active
6	Operating Mode 0 - ON 1 - Local
7...27	Reserved
28	Group error
29	Message lock
30	Enable / Disable <code>RdDataOp</code> button 1 = No error 0 = Rack failure/Module Failure
31	1 = Cyclic data reading for active energy import total active

Status2 Bit	Description
0	Last successful Timestamp of Read Data
1	All alarm message suppressed
2	At least one alarm message is suppressed
3...29	Reserved
30	Configured Device is 3RW52
31	Configured Device is 3RW55

5.5.9 Enabled operations

Operator permissions

The operator permissions for control commands are configured in the `OS_Perm` structured parameters. These are transferred to WinCC via the `OS_PermOut` and `OS_PermLog` parameters.

The permission for control operation in the faceplate are described in the table:

Table 5- 40 Operator permissions – 3RW5Stat

OS_Perm Bit	OS_PermOut Bit	OS_PermLog Bit	Description
0	0	0	Reserved
1	1	1	1 = Operator is permitted to change to ON mode.
2	2	2	Reserved
3	3	3	1 = Operator is permitted to change to "Out of service" (OoS) mode.
4...19	4...19	4...19	Reserved
20	20	20	1 = Operator is permitted to delete the maximum pointer.
21	21	21	1 = Operator is permitted to read data from the device.
22...31	22...31	22...31	Reserved

`OS_PermOut` contains the release information of all parameters.

`OS_PermLog` contains the release based on the current modes.

5.5.10 Faceplate views

5.5.10.1 3RW5Stat - Standard view

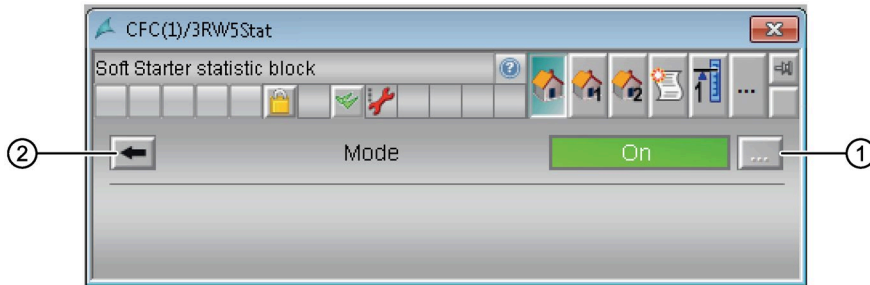

- ① Operating mode
- ② **Navigation button**
Navigation to the connected 3RW5Ctrl / 3RW5Oprn block



- ① 3RW55 / 3RW52 Statistic values set 1
- ② 3RW52 Statistic values set 2 - Disabled
- ③ Maximum pointer 1
- ④ Maximum pointer 2

5.5.10.2 3RW5Stat - Maximum pointer 1

Maximum pointer 1

This Maximum pointer 1 view displays statistical data of the 3RW5Stat block.

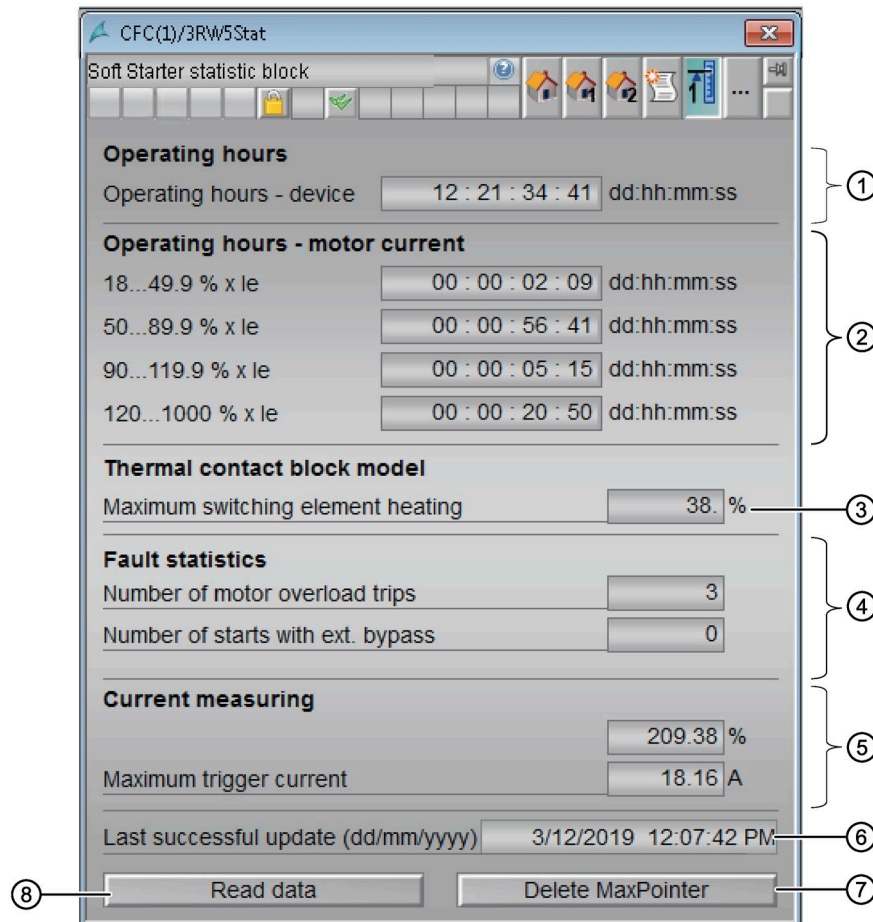

- ① **Operating hours**
Operating hours Device (s_OpHMP)
- ② **Operating hours - motor current**
Motor current ($OhI118Mp$, $OhI150Mp$, $OhI190Mp$, $OhI1120Mp$)
- ③ **Thermal contact block model**
Maximum contact block heating ($CntBlkMp$)
- ④ **Fault statistics**
Number of motor overload trips ($N_Ov1TrpMp$)
Number of starts with ext bypass ($N_BypOv1Trp$)
- ⑤
- ⑥
- ⑦
- ⑧





5.5 Statistical block

- ⑤ **Current measuring**
Maximum tripping current in % and amperes (MaxTrgI , MaxTrgIE)
- ⑥ Last successful Timestamp of Read Data
- ⑦ Button for deleting the maximum pointer, only in REMOTE mode, authorization level 6.
Button is deactivated if $\text{RackFact} = 1$
- ⑧ Button for updating the data, button is deactivated, if $\text{RackFact} = 1$.
User authorization level 5.

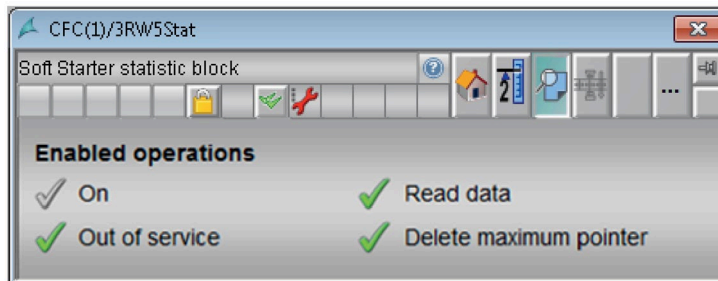
5.5.10.3 3RW5Stat - Preview

Preview (3RW55)



-  The operator may execute the command.
-  The operator cannot execute the command because the command is currently blocked by a process.
-  The operator is not permitted to execute the command (OS_Perim).
- 

The displays are dependent on the bit values in the OS_PerimOut and OS_PerimLog parameters.

5.5.10.4 3RW52

3RW5Stat - Standard 1

Standard 1 view (3RW52)

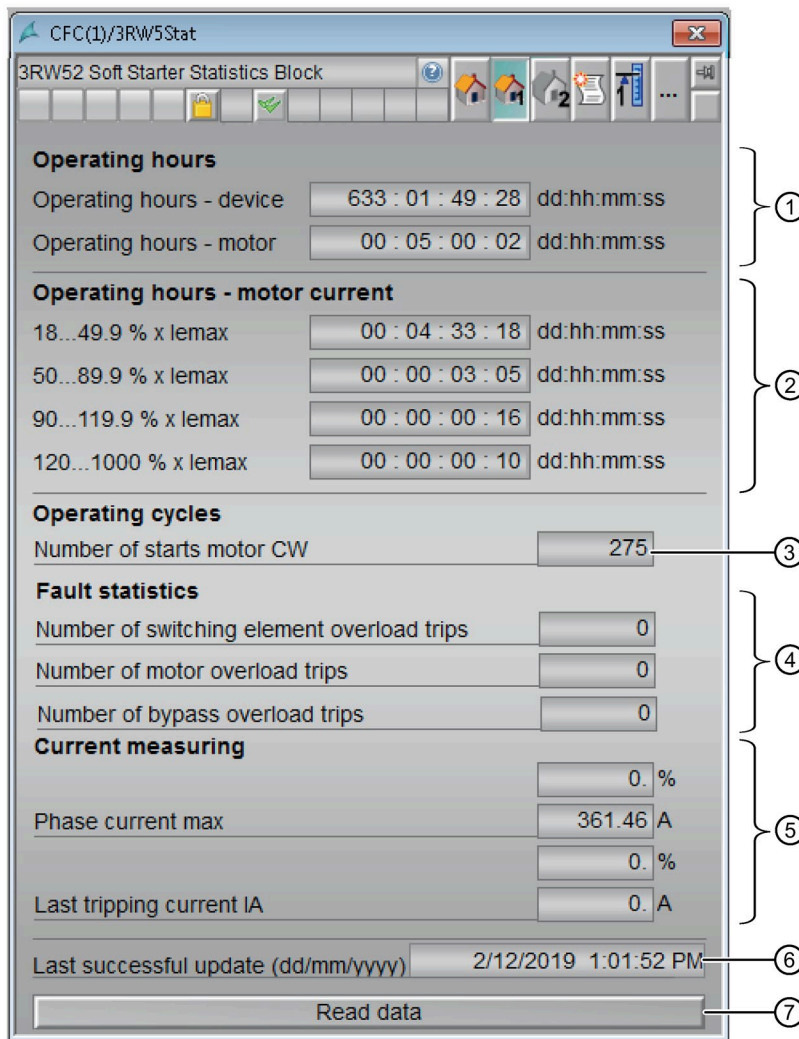

- ① **Operating hours**
Device (D_OpH), motor (M_OpH)
- ② **Operating hours - motor current**
Motor current (OphI118, OphI150, OphI190, OphI1120)
- ③ **Operating cycles**
Number of motor starts CW (N_StrCW)
- ④ **Fault statistics**
Number of switching element overload trips (N_SwtElmTrp)
Number of motor overload trips (N_Ov1Trp)
Number of bypass overload trips (N_BypOv1Trp)

- ⑤ **Current measuring**
Maximum motor current I_{max} in % and amperes (Ph_IMax, Ph_IMaxE)
Last tripping current in % and amperes (LTrpCur, LTrpCurE)
- ⑥ Last successful Timestamp of Read Data
- ⑦ Button for updating the data (RdDataOp).
Button is deactivated if RackFact = 1.
User authorization level 5.

3RW5Stat - Maximum Pointer 2

Maximum pointer 2

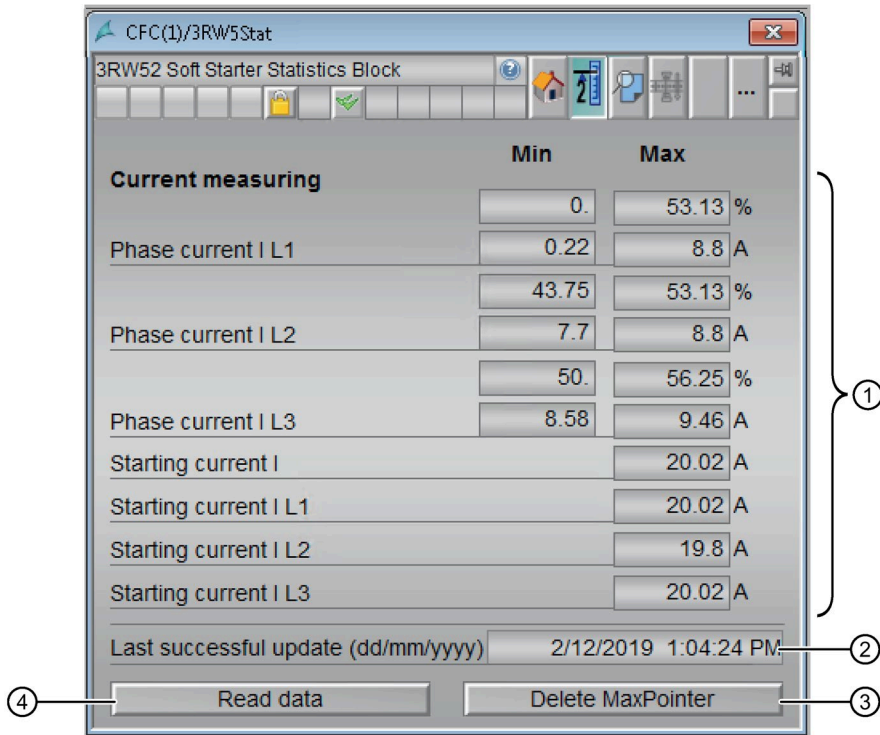

- ① Current measuring
Phase current IL1, IL2, IL3 in amperes and %
(CurL1MnE, CurL1MxE, CurL1Mn, CurL1Mx,
CurL2MnE, CurL2MxE, CurL2Mn, CurL2Mx,
CurL3MnE, CurL3MxE, CurL3Mn, CurL3Mx)
Starting current I in amperes (StrCurIMax)
Starting current IL1, IL2, IL3 in amperes (StrCurIMax1, StrCurIMax2, StrCurIMax3)
- ② Last successful Timestamp of Read Data
- ③ Button for deleting the maximum pointer, only in REMOTE mode, authorization level 6.
- ④ Button for updating the data (RdDataOp), authorization level 5 and higher.
Button is deactivated if RackFAct = 1.
User authorization level 5.

5.5.10.5 3RW55

3RW5Stat - Standard 1

3RW55 Standard 1 view

- ① **Operating hours**
Device (D_OpH), motor (M_OpH)
- ② **Operating hours - motor current**
Motor current ($OphI118$, $OphI150$, $OphI190$, $OphI1120$)
- ③ **Operating cycles**
Number of motor starts CW / CCW (N_StrCW , N_StrCCW)
Number of electrical braking Stops ($N_EBrkStp$)
Number of starts output 1- 4 ($N_StrOut1$, $N_StrOut2$, $N_StrOut3$, $N_StrOut4$)
- ④ Last successful Timestamp of Read Data
- ⑤ Button for updating the data ($RdDataOp$).
Button is deactivated if $RackFAct = 1$.
User authorization level 5.

3RW5Stat - Standard 2

Standard 2 view

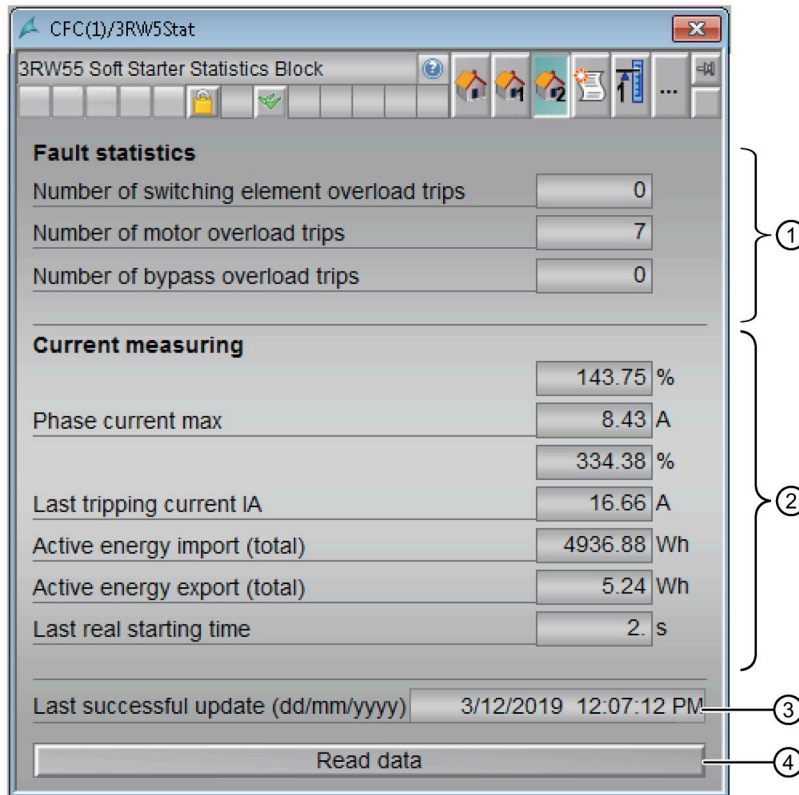

- ① **Fault statistics**
 - Number of switching element overload trips ($N_{SwtElmTrp}$)
 - Number of motor overload trips (N_{OvlTrp})
 - Number of bypass overload trips ($N_{BypOvlTrp}$)
- ② **Current measuring**
 - Maximum motor current I_{max} in % and amperes (Ph_{IMax} , Ph_{IMaxE})
 - Last tripping current in % and amperes ($LTrpCur$, $LTrpCurE$)
 - Total Active energy import ($ActEImpT$) - When the operator has interconnects the respective PII ($ActEImpT$) will read cyclically and the cyclic symbol is updated in the faceplate.
 - Total Active energy export ($ActEExpT$)
 - Last real starting time ($LstStrTm$)
- ③ Last successful Timestamp of Read Data
- ④ Button for updating the data ($RdDataOp$).
Button is deactivated if $RackFAct = 1$.
User authorization level 5.

3RW5Stat - Maximum pointer 2

Maximum pointer 2

	Min	Max
Main energy monitoring		
Line frequency	49.00	63.00 Hz
Voltage measurement		
Line-to-line voltage U L1-L2	414.1	435.3 V
Line-to-line voltage U L2-L3	415.2	436.6 V
Line-to-line voltage U L3-L1	415.2	437.4 V
Current measuring		
Phase current I L1	68.75	140.63 %
Phase current I L2	5.86	7.06 A
Phase current I L2	65.63	137.5 %
Phase current I L2	5.82	6.95 A
Phase current I L3	71.88	143.75 %
Phase current I L3	6.3	7.19 A
Starting current I max		58.41 A
Starting current I L1 max		55.64 A
Starting current I L2 max		56.64 A
Starting current I L3 max		58.41 A
Last successful update (dd/mm/yyyy)	3/12/2019 12:08:11 PM	

- ① **Main energy monitoring**
Line frequency ($L_{FreqMin}$, $L_{FreqMax}$)
- ② **Voltage measurement**
Line-to-line voltage in volts ($U_{L1L2Min}$, $U_{L1L2Max}$, $U_{L2L3Min}$, $U_{L2L3Max}$, $U_{L3L1Min}$, $U_{L3L1Max}$)
- ③ **Current measuring**
Phase current I_{L1} , I_{L2} , I_{L3} in amperes and %
(Cur_{L1MnE} , Cur_{L1MxE} , Cur_{L1Mn} , Cur_{L1Mx} , Cur_{L2MnE} , Cur_{L2MxE} , Cur_{L2Mn} , Cur_{L2Mx} , Cur_{L3MnE} , Cur_{L3MxE} , Cur_{L3Mn} , Cur_{L3Mx})

5.5 Statistical block

- ④ Last successful Timestamp of Read Data
- ⑤ Button for deleting the maximum pointer, only in REMOTE mode, authorization level 6. Button is deactivated if `RackFAct = 1`
- ⑥ Button for updating the data (`RdDataOp`), authorization level 5 and higher.
Button is deactivated if `RackFAct = 1`.
User authorization level 5.

5.6 Channel block

5.6.1 3RW5Chn block description

Purpose of the block

The 3RW5Chn channel block is used for processing 3RW55 / 3RW52 Soft Starter process input and process output image values.

The block has no operating modes.

Views

The 3RW5Chn block does not support faceplate views.

5.6.2 Parametrizable functions via the Feature connection 3RW5Chn

The modules of the library have an input named `Feature`. You can influence various responses of the block via this input.

The Feature Bits are assigned in the following order:

Feature.Bit	Meaning ¹
Feature.Bit7 (Page 59)	Status handling for values 0 = BAD value (ST:=16#00) 1 = Last valid value (ST:=16#68)
Feature.Bit10 (Page 61)	Condition Monitoring, status transfer to maintenance station 0 = No Condition Monitoring 1 = Condition Monitoring
Feature.Bit27 (Page 70)	1 = Do not evaluate the first run of the diagnostic blocks
Feature.Bit29 (Page 72)	1 = DataXchg is updated with the status information (Motor ready, Motor on, Group fault and Group warning)
Feature.Bit30 (Page 73)	1 = De-energized (lowest) value is output in the case of block-external simulation (standard setting = 1)

¹ The standard setting is 0 if no other value is specified.

For more information about the parameterizable functions, refer to the function manual "Process Control System PCS 7, PCS 7 Advanced Process Library" in the Internet (<https://support.industry.siemens.com/cs/document/109760968>).

5.6.3 Configuration

Interconnection of the 3RW5Chn channel block

The interconnection is made symbolically to the first input double word.

Use the CFC editor to install the block in a cyclic interrupt OB (OB30 to OB38).

The block is automatically installed in the startup OB (OB100).

Use the templates supplied. These contain all the necessary interconnections between the blocks.

Note

Refer the information in Chapter Templates (Page 23).

5.6.4 Control word

If the control word stw is formed and the signal status stw_st is good (16#80), the control inputs listed in the table are ineffective. The control word stw is set at process value output $PZDOut03$ depending on the device type used.

If the signal status stw_st has a bad value, the data of the control inputs are used.

Signal status Stw_ST	Control inputs (PIO)	Additional condition for 3RW55	Additional condition for 3RW52	3RW55	3RW52
Motor CW	Control word Bit 0	MotCW.Value or MotCpCW.Value	MotCW.Value	X	X
Motor CCW	Control word Bit 1	MotCCW.Value or MotCpCCW.Value	–	X	–
Reset	Control word Bit 3 or (STW1ST=16#80 AND STW1 control word bit 3)	–	–	X	X
Emergency start	Control word Bit 4	–	–	X	–
Selftest (user test)	Control word Bit 5	–	–	X	X
Creep speed	Control word Bit 6	CrpSpeed.Value OR MotCpCW.Value OR MotCpCCW.Value	–	X	–
Output 1	Control word Bit 8	–	–	X	–
Output 2	Control word Bit 9	–	–	X	–
Parameter set bit 0	Control word Bit 10	–	–	X	–
Parameter set bit 1	Control word Bit 11	–	–	X	–
Disable quickstop	Control word Bit 15	–	–	X	–
Output 3	Control word Bit 16	–	–	X	–
Pump cleaning	Control word Bit 19	PmpCln.Value AND FbMotOn.Value	–	X	–
Manual operation local	Control word Bit 24	–	–	X	X
Use alternative stopping mode	Control word Bit 25	–	–	X	–
Motor standstill	Control word Bit 26	–	–	X	–

Note

Remaining control word bits are reserved for future use.

5.7 Control commands block

5.7.1 3RW5Ctrl block description

Purpose of the block

The 3RW5Ctrl motor block controls the operation of a 3RW55 Softstarter.

The following commands are available in automatic mode and manual mode:

- Forward
- Creep Forward
- Reverse
- Creep Reverse
- Stop

Use

In AUTO mode, the commands can be given based on the `Feature.Bit4` : 0 = pushbutton mode, 1 = switch mode.

The commands for starting and stopping the motor (`FwdMan`, `CrpFwdMan`, `StopMan`, `RevMan`, `CrpRevMan`) are reset at the end of the execution cycle of the block because the commands are pulse signals in manual operation.

At the `ErrorNum` parameter, error "Invalid signal status" is indicated if `FwdAut = 1` and `StopAut = 1`, provided that `Feature.Bit4 = 0`.

Block icons and faceplates

The 3RW5Ctrl motor block can be indicated via 2 block icons (Page 31).

The commands can be issued from the faceplate if the operator permission has been programmed at the `OS_Perm` parameter.

Views

The 3RW5Ctrl motor block supports the following views:

- Batch
- Trend
- Alarm
- Memo
- Standard (Page 212)
- Maintenance (Page 215)
- Preview (Page 217)

Reference

3RW5Ctrl block parameter (Page 277)

Functions for all blocks (Page 43)

Overview of the templates, control functions and blocks (Page 23)

5.7.2 Neutral Position

This block provides the standard function "Neutral position" for motors. The neutral position always represents the de-energized state.

Neutral position for motors

The neutral position for motors is always the stopped motor.

The neutral position is adopted when:

- the function monitoring (Page 196) the feedbacks were triggered
- one of the interlock (Page 199) conditions is active (see Interlocks)
- an external error via `FaultExt` or `CSF` was triggered (see Fault handling (Page 206))
- the motor protection (Page 198) function was triggered
- the function "Rapid stop (Page 193)" for motors was triggered
- the "Out of service" mode is active
- one of the automatic commands has bad signal status (16#00 or 16#28)
- the `Feature2 bit 10` is set to 1 considering bad quality of automatic commands or external values (Page 78).

5.7.3 Output signal as a pulse signal or static signal

This block provides the standard function "Output signal as a static signal or pulse signal".

Description

You can output the control signals for motors as:

- Static signal or
- Pulse signal with configurable pulse length.

You can find the signals in the I/O table of the individual blocks.

Output signal as a static signal

The control settings are made available as a static signal in the blocks in the form of interconnectable output parameters. The 3RW5Ctrl block provides these as static signals via the alternative output parameters `Fwd`, `Rev`, `CrpFwd` and `CrpRev`.

Output signal as a pulse signal

The control is made available as pulse signals at the blocks using interconnectable output parameters.

You can specify the pulse length of the output signals in seconds using the input parameter `PulseWidth`. The 3RW5Ctrl block provides these as pulse signals

via the output parameters `P_Fwd`, `P_Rev`, `P_CrpRev` and `P_CrpFwd`.

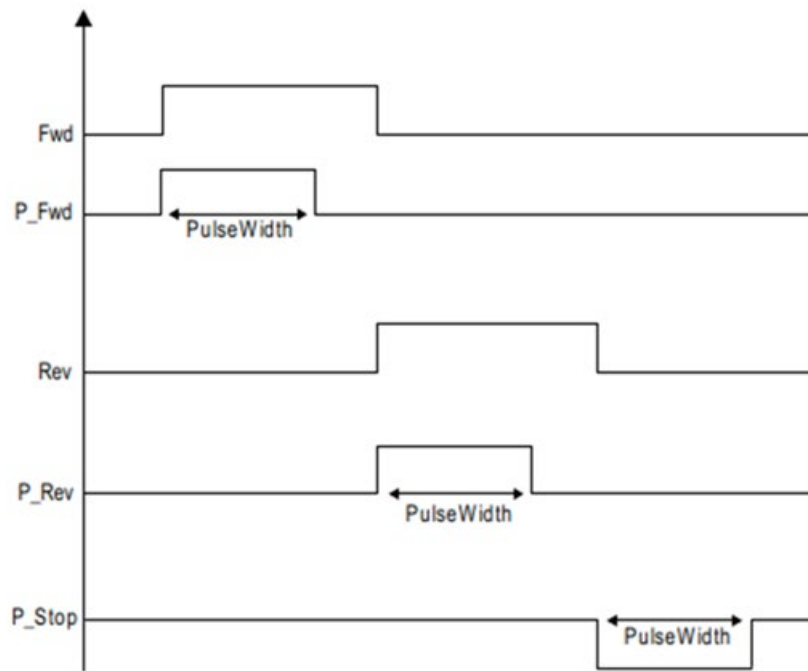

Note

Almost all output parameters for pulse control, for example `P_Fwd`, `P_Rev`, `P_CrpRev`, `P_CrpFwd` have a positive effective direction, i.e. a `0 → 1 → 0` pulse triggers activation.

The only exception is the `P_Stop` output parameter with a negative effective direction, i.e. a `1 → 0 → 1` pulse triggers activation.

5.7.4 Generating instance-specific messages

This block provides the standard function "Generating instance-specific messages".

You can generate instance-specific messages for a binary signal. The number of interconnectable input parameters that can be used freely varies with relation to the blocks. The "X" in the parameter name designates the position.

You can specify the following messages for these instance-specific messages:

- Message class
- Priority of the message
- Message text
- Message auxiliary value
- Acknowledge behavior

Reference

Additional information is available in the descriptions of the message functionality of the individual blocks and in the PCS 7 Configuration Manual Operator Station under "How to configure the user-specific messages".

5.7.5 Operating modes

The following modes are available for the 3RW5Ctrl block:

- Local
- Automatic
- Manual
- Out of service (OoS)

Note

In this library mode switchover to local mode is only via TIA / HMI

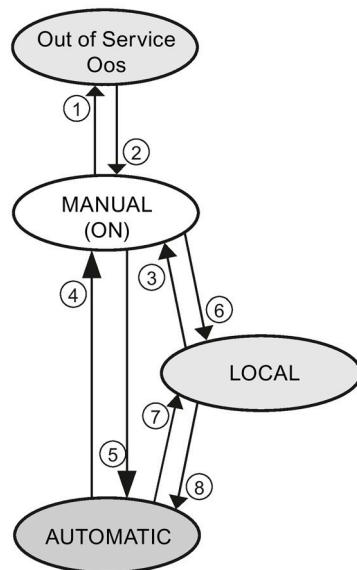

Conditions for changing the mode

Note

Local mode changeover for both 3RW55 via 3RW5Ctrl and 3RW52 via MotL is currently not supported as part of 3RW5 Soft starter Library V9.0 SP2.

Local mode changeover is only to be carried out through Soft Starter ES V15.1 (TIA Portal) or 3RW55/52 HMI-HF.

No.	Conditions
①	<p>MANUAL (ON) → Out of service (OoS)</p> <ul style="list-style-type: none"> via faceplate ($OosOp = 1$) if $ModLiOp = 0$ or on an edge transition $0 \rightarrow 1$ from $OosLi$, if $Feature.Bit1 = 1$ (response for Out of service mode)
②	<p>Out of service (OoS) → MANUAL (ON)</p> <p>Via faceplate ($ManModOp = 1$)</p>
③	<p>Local → MANUAL</p> <ul style="list-style-type: none"> via faceplate ($ManModOp = 1$) if $ModLiOp = 0$ and $LocalSetting = 3$ or $LocalSetting = 4$ or via $LocalLi = 0$, if $LocalSetting = 1$, $LocalSetting = 2$
④	<p>AUTOMATIC → MANUAL</p> <ul style="list-style-type: none"> via faceplate ($ManModOp = 1$) if $ModLiOp = 0$ or via $ManModLi = 1$ if $ModLiOp = 1$ and $Feature.Bit4 = 0$ (pushbutton mode) or via $AutModLi = 0$ if $ModLiOp = 1$ and $Feature.Bit4 = 1$ (switch mode)
⑤	<p>MANUAL → AUTOMATIC</p> <ul style="list-style-type: none"> via faceplate ($AutModOp = 1$) if $ModLiOp = 0$ or via $AutModLi = 1$ if $ModLiOp = 1$
⑥	<p>Manual → Local</p> <ul style="list-style-type: none"> via faceplate ($LocalOp = 1$) if $ModLiOp = 0$ and $LocalSetting = 3$ or $LocalSetting = 4$ or via $LocalLi = 1$, if $LocalSetting = 1$, $LocalSetting = 2$
⑦	<p>AUTOMATIC → Local</p> <ul style="list-style-type: none"> via faceplate ($LocalOp = 1$) if $ModLiOp = 0$ and $LocalSetting = 3$ or $LocalSetting = 4$ or via $LocalLi = 1$, if $LocalSetting = 1$, $LocalSetting = 2$
⑧	<p>Local → AUTOMATIC</p> <ul style="list-style-type: none"> via faceplate ($AutModOp = 1$) if $ModLiOp = 0$ and $LocalSetting = 3$ or $LocalSetting = 4$ or via $LocalLi = 0$, if $LocalSetting = 1$, $LocalSetting = 2$

If $ModLiOp = 1$, the enabled operations for all mode changes will be deactivated.

If the block is in local mode, no other mode can be activated for it.

Switching between the operating modes

The switchover between "manual and automatic mode" takes place as shown in the following schematic:

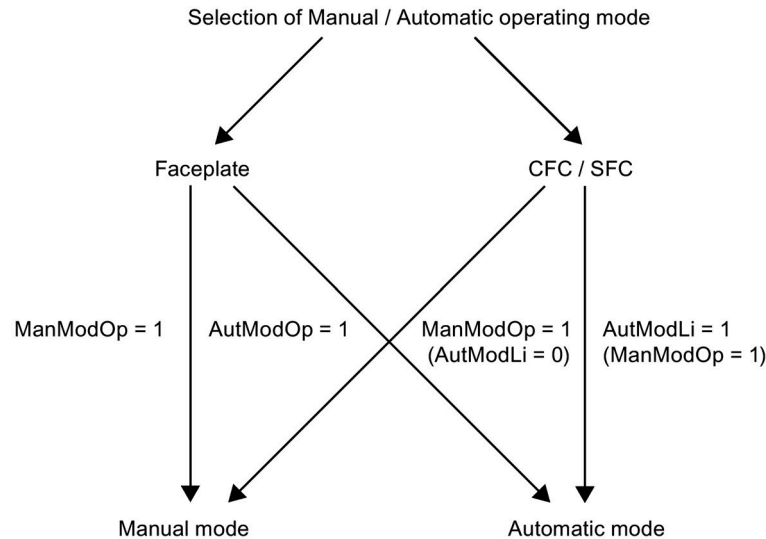

Reference

For more information, refer Function Manual "Process Control System PCS7, PCS7 Advanced Process Library V9.0 SP2" on the Internet (<https://support.industry.siemens.com/cs/document/109760968>).

5.7.6 Mode changeover error

- Mode changeover error occurs when you change the mode of the block from manual to automatic mode or local to automatic mode and the previous state does not match the target state (e.g. Bumpless switchover: This refers to motor state before and after mode switchover.)
- You can change the mode only if the subsequent state and previous state are same.
- Bumpless switchover can be activated / deactivated using the connection `Feature.Bit17` (bumpless switchover to automatic mode).
- Bumpless switchover from local to automatic mode is performed with the `LocalSetting` parameter.
- In the standard view of the faceplate, the text "Error switchover" is displayed when unwanted non-bumpless switchover occur.
- If operator initiates switchover from local to automatic mode the error occurs and the block will remain in local mode.

5.7.7 Forcing operating modes

The "Forcing operating modes" function enables you to put the function block into another operating state via interconnectable input parameters, independent of the current control.

Table 5- 41 Parameters for "Forced operating states"

Parameter	Value	Meaning
StopForce	1	Stop motor (forced)
FwdForce	1	Start motor forward (forced)
CrpFwdForce	1	Start motor creep forward (forced)
RevForce	1	Start motor in reverse (forced)
CrpRevForce	1	Start motor in creep reverse (forced)

Inconsistent input parameters generate the `ErrorNum` parameter, the control remains unchanged.

Note

- The function can be performed in MANUAL and AUTO mode.
If you have parameterized the prewarning time `WarnTiMan` and the waiting time `IdleTime` is greater than 0, the control becomes effective after the set times have elapsed.
- When operating states are forced, the Enable direct changeover between forward and reverse operation feature bit has no effect. Direct changeover between forward and reverse operation is always possible.

Display in the faceplate and block icon

If an operating state is forced, this is displayed in the block icon and in the standard view of the faceplate.

In the block symbol: Display with a red F and the crossed-out lock.

In the standard view of the faceplate: Display of a text for the forced operating state, e.g. "Forced stop" for motors. This is additionally displayed with the crossed-out lock.

5.7.8 Control functions for directions

In local, manual, and automatic mode, the commands for the change of direction are controlled via:

- Feature.Bit5 = 1
- Feature.Bit7 = 1

The switchover time cannot be applied to Force control commands.

Commands for change of direction	Off	Fwd	Rev	CrpFwd	CrpRev
OFF	–	Feature.Bit5*	Feature.Bit5*	–	–
Fwd	Feature.Bit5*	–	Feature.Bit5* Feature.Bit7	–	Feature.Bit5* Feature.Bit7
Rev	Feature.Bit5*	Feature.Bit5* Feature.Bit7	–	Feature.Bit5* Feature.Bit7	–
CrpFwd	–	–	Feature.Bit5* Feature.Bit7	–	Feature.Bit7
CrpRev	–	Feature.Bit5* Feature.Bit7	–	Feature.Bit7	–

* Also possible without Feature bit.

For more details, refer Section "Step control mode for the speed change" in Advanced Process Library Function Manual.

Note

When the motor is running in local mode with creep speed there won't be indication at faceplates.

5.7.9 Parameterizable functions via the Feature connection 3RW5Ctrl

The modules of the library have an input named `Feature`. You can influence various responses of the block via this input.

The Feature Bits are assigned in the following order:

Table 5- 42 Meaning of Feature.Bits

Feature.Bit	Meaning
Feature.Bit0 (Page 54)	Set startup characteristics
Feature.Bit1 (Page 55)	Response for Out of Service mode
Feature.Bit2 (Page 56)	Resets the commands for switching between modes
Feature.Bit3 (Page 56)	Enable resetting of the commands for the control setting
Feature.Bit4 (Page 57)	Set switch mode or pushbutton mode
Feature.Bit5 (Page 58)	Set switching mode
Feature.Bit7 (Page 58)	Enable direct changeover between forward and reverse operation
Feature.Bit9 (Page 59)	Reset via input signals in the event of interlocking (protection) or errors
Feature.Bit10 (Page 60)	Exit local mode
Feature.Bit11 (Page 61)	Enable runtime for feedback signals
Feature.Bit13 (Page 62)	Separate monitoring time for stopping the motor
Feature.Bit14 (Page 62)	Enable rapid stop via faceplate
Feature.Bit17 (Page 63)	Activate bumpless changeover to automatic mode
Feature.Bit18 (Page 63)	Activate fault status for external control system fault (CSF)
Feature.Bit19 (Page 64)	Reset even in locked state
Feature.Bit20 (Page 65)	Disable Feedback Tracking Local Setting 2 & 4
Feature.Bit21 (Page 66)	Bumpless switchover to automatic mode
Feature.Bit22 (Page 67)	Update acknowledgment and error status of the alarm call
Feature.Bit24 (Page 68)	Activate local operator permission
Feature.Bit25 (Page 69)	Suppression of all messages

Feature.Bit	Meaning
Feature.Bit27 (Page 71)	Interlock display with LocalSetting 2 or 4
Feature.Bit28 (Page 72)	Changes Signal status of outputs in OOS to 16#60
Feature.Bit30 (Page 73)	Define reset as a function of the mode
Feature.Bit31 (Page 74)	Enable reset of interlocks in manual mode

The default setting is 0 in each case.

For more information about the parameterizable functions, refer to the function manual "Process Control System PCS 7, PCS 7 Advanced Process Library V9.0 SP2" on the Internet (<https://support.industry.siemens.com/cs/document/109760968>).

Note

Irrespective of the value of Feature bit 0, the corresponding block in the Out of Service mode will continue to remain in the same mode after a warm restart.

Table 5- 43 Meaning of Feature2.Bits

Feature2.Bit	Meaning
Feature2.Bit2 (Page 75)	Separate evaluation for excluded and simulated interlock signals
Feature2.Bit3 (Page 75)	Control priority in the event of an invalid input command
Feature2.Bit4 (Page 76)	Setting switch or button mode for local commands
Feature2.Bit5 (Page 77)	Evaluation of the signal status of the interlock signals
Feature2.Bit8 (Page 77)	Forcing operating modes in the "Local" mode
Feature2.Bit9 (Page 78)	Triggered local button mode
Feature2.Bit10 (Page 78)	Considering bad quality of automatic commands or external values
Feature2.Bit11 (Page 79)	Suppress MsgLock and "Out of service" mode for a connected message block
Feature2.Bit16 (Page 80)	Separate interlock for each direction or position

The default setting is 0 in each case.

5.7.10 Output signal for ready to start

The `RdyToStart = 1` output parameter displays whether a start is possible in AUTO mode.

Readiness to start is displayed if the following conditions are fulfilled:

- No general fault is pending.
- No interlock is active
- No forcing of operating states and the setting value is active
- No rapid stop is active
- The block is in automatic mode
- The waiting time for the restart must have elapsed

5.7.11 Resetting of the block

Resetting the block is necessary if an interlock occurred via the input `Protect, Trip` or an error ("runtime" or "control") has occurred.

The `RdyToReset` output signals if resetting is possible via the `RstLi` input parameter or via the automatic commands.

The block can be reset in different ways:

- Resetting by interconnection (`RstLi` input).
- Resetting by the operator via pushbutton in the faceplate (`RstOp` input).
- Resetting by a 0-1 edge transition of the corresponding automatic or local signal (except for motor protection).

To reset via the faceplate, the operator must have the appropriate authorization (`OS_Perm`). After a reset, the `P_Rst` output is set for one cycle.

Note

- The reset via input `RstLi` or `RstOp` does not depend on the selected operating mode.
 - The operator must have the appropriate authorization to use the reset function in the faceplate (`OS_Perm`). After a reset, the output parameter `P_Rst` is set for a cycle.
-

Resetting monitoring errors and interlocks in manual and automatic mode

You can influence the reaction using the following Feature Bits:

Feature.bit	Message
Feature.Bit19 (Page 64)	Resetting via input signals in the event of interlocking (Protection) or errors
Feature.Bit30 (Page 73)	Define reset as a function of the mode.
Feature.Bit31 (Page 74)	Enable reset of interlocks in manual mode.

Resetting monitoring errors, external errors and interlocks in local mode

The monitoring error can occur in local mode if you have set 1 or 3 for the input parameter LocalSetting (for detailed information on **Local Mode** refer to APL manual (<https://support.industry.siemens.com/cs/document/109760968>)). When LocalSetting is set to 2 or 4, a monitoring error can only occur when a rapid stop is triggered.

The following applies with LocalSetting 1 or 3:

- The monitoring error, the external error and the interlocks cannot be reset when the control and feedback signals do not match.
- When the control and feedback signals match, the monitoring error, external error and the interlocks are reset by stopping (`StopLocal = 1`) the drive.

Resetting motor protection (Trip) in local mode

In local mode, the "Motor protection" display is reset in the faceplate and not using the reset button available there. The display disappears as soon as Trip = 1, the activation signals and feedback match and a command for stopping the drive has been issued.

Note

A motor protection signal (Trip parameter) with signal status 16#00 or 16#28 is used to activate motor protection. This is indicated by "Motor protection" in the standard view of the faceplates.

Resetting monitoring errors, external errors and interlocks using the "Forcing operating states" function

With "Forcing operating states", monitoring errors, external errors, interlocks or the motor protection function are reset under the following conditions and a reset pulse is output at the P_Rst output:

- The block is in an operating mode in which a reset is necessary and
- a monitoring error, an external error, a "Protection" interlock or the motor protection function is ready to be reset. This can be seen in the faceplate with the reset button or with the Request 0/1 indicator in the faceplate. When `Feature2.Bit8 = 1`, the block is ready to reset as soon as the protection (Protect = 0) or motor protection (Trip = 0) interlock is set, whereby enabled motor protection prevents the motor from starting.

For further information on **Resetting for Interlocks and errors** refer APL manual. (<https://support.industry.siemens.com/cs/document/109760968>)

5.7.12 Rapid stop

Rapid stop has the highest priority in manual and automatic mode, and in all other operating states (e.g. forcing of states). The function is activated via the faceplate. This depends on the parameterization in the Enable rapid stop via faceplate feature bit.

You enter the command for rapid stop via the `RapidStp = 1` input parameter.

The drive is stopped immediately by clicking the "Rapid stop" button in the faceplate. This is displayed in the faceplate and is shown below.

Rapid Stop

Release of the rapid stop for all modes is performed in the faceplate via the "Reset" button (`RstOp = 1`). In the CFC, release is performed via the `RstLi = 1` input parameter. In the automatic mode, release can also be performed via a 0-1 edge transition of the control if the `Feature.Bit9 = 1`.

Rapid stop can also be selected in the stop state of the motor. This prevents the motor from starting.

NOTICE
Damage can occur while using rapid stop function.

5.7.13 Specify warning times for controls

The 3RW5Ctrl block supports the "Specify warning times" for controls function.

You can generate warning signals when motors are started. Warning signals can be generated in the following modes:

- Manual mode (`WarnTiMan` input parameter)
- Automatic mode (`WarnTiAut` input parameter)

You can specify the warning times in seconds using the input parameters `WarnTiMan` and `WarnTiAut`. If a motor is started, warning time is displayed in the output parameter with `WarnAct = 1`. The motor then starts after the set warning time has elapsed and `WarnAct` is reset (`WarnAct = 0`).

A corresponding warning will not be displayed if you set a value smaller than the `SampleTime` parameter for the warning times (`WarnTiMan`, `WarnTiAut`).

Note

In this case, the warning time is only active if the block is controlled from the de-energized state.

Disabling warnings:

Configure each parameter with 0 seconds to generate no warnings.

5.7.14 Issuing maintenance release

The maintenance release provides information about a measuring point at which maintenance, service, or calibration work is to be performed. You can use the signal for the maintenance release to convey information about release of a measuring point from the OS to the maintenance station.

You can issue the maintenance release in the parameter view via operation of the `MS_RelOp = 1` input parameter (operator control permission "high-value process operation" required). A maintenance release is then provided via the interconnectable output parameter `MS_Release = 1` for further processing. An Operation message is generated.

Note

The block must be in either "Manual" or "Out of service" mode to set the release for maintenance.

5.7.15 Suppressing messages using the `MsgLock` parameter

The `3RW5Ctrl` block supports the standard function message suppression. The function is executed via the `MsgLock` parameter.

With the `Feature.Bit25`, you can determine which messages are suppressed via the `MsgLock = 1` parameter:

- All messages on the block
- All messages on the block except for process control messages, the message class that is released by the default setting (e.g. CSF, motor protection, feedback error) and external messages.

Pending messages are given the "output" status with `MsgLock = 1`.

5.7.16 Simulation

Simulation is the manipulation of a signal, independently of the actual source of the signal or logic that generates this signal.

Simulation can only be activated / deactivated with the operator control permission level for system authorization via $SimOn = 1$, if $SimLiOp = 0$ or from the CFC via $SimOnLi = 1$, if $SimLiOp = 1$.

During simulation, the Quality Code (ST_Worst) is set to 16#60. The icons for the Quality Code are displayed in the block icon and in the overview window of the faceplates.

Simulation is triggered during runtime in the faceplate's parameter view by clicking on the "Simulation" button.

The simulation is characterized as follows:

- Simulation can only be activated / deactivated with the operator control permission level for system authorization.
- The technological functions are not influenced
- All process-relevant output signals, such as Fwd , Rev , $CrpFwd$, and $CrpRev$ are given "Simulation" status.
- In the case of blocks with operator control or monitoring functions (for example, faceplates), these signals are identified in the faceplate with the status for the simulation as follows:



- The group status of the block is displayed in the status bar of the block icon and of the operator block with the simulation status as follows:



- The interlocking functions of the block are activated in accordance with the input parameter $BypProt = 0$ or deactivated $BypProt = 1$.
- Auxiliary values (e.g. UserAna1) cannot be simulated.
- When the control function of the block can be manipulated, the read-back and feedback values (for example, $FbkFwd$) are adjusted according to the manipulation of the control settings

5.7.17 Monitoring functions

The monitoring function can be released or blocked via the operator in the faceplate.

The `Monitor` parameter indicates whether the feedback for the monitoring function is activated:

- `Monitor = 1` (default): Monitoring function ON
- `Monitor = 0`: Monitoring function OFF

If the block is in Local mode, no check is made for monitoring errors.

If the "Forward" / "Stop" command is output and no correct feedback signal is received within the defined time (`MonTiDynamic`), the block will issue an error signal (`MonDynErr`) and the output signal will issue the "Stop" command.

The monitoring time is specified in seconds. If the monitoring time is less than the sampling time, the monitoring time will be calibrated to the sampling time. The time can be entered in the faceplate in the expanded command area in day-hour-minute-second format.

The function is not available in Out of Service mode.

Note

The monitoring functions are functions of the block.

Once 'monitor' function is activated, the current monitoring time will be shown at `CurrMon` output parameter and the same will be shown in preview faceplate.

The monitoring time should be equal to or more than the starting time specified at the device via TIA or HMI.

Monitoring of the starting and stopping characteristics for motors

The monitoring of the starting and stopping characteristics is implemented via the `MonTiDynamic` and `MonTiDyStop` parameter. The monitoring time states the period in which the associated feedback value for a control signal, e.g. `FbkFwd` must be present in the motor. If this is not the case, the text "Feedback error" is displayed in the standard view of the faceplate.

At the same time, an error message is output. The block then enters its neutral position. In motors, this is always the stop state. The block signals this on the relevant output parameter of the error message with 1, e.g. on the motor with `MonDynErr = 1`.

The parameters are set in seconds.

Note

The monitoring functions are functions of the block.

Monitoring of the running characteristics for motors

The monitoring of the running characteristics is implemented via the `MonTiStatic` parameter. The monitoring time states the period in which the feedback value can change its value quickly without an error message being output.

Example: A running motor with the feedback via the `FbkFwd` input parameter. This parameter should be static in accordance with the control, but may change its value within the monitoring time.

If change of the `FbkFwd` parameter is longer than the monitoring time, the "Runtime error" text will be displayed in the standard view of the faceplate.

At the same time, an error message is output. The block then enters its neutral position. For motors, this is always the stop state. The block signals this on the relevant output parameter of the error message with 1, e.g. on the motor with `MonStaErr = 1`.

The parameters are set in seconds.

Note

The monitoring functions are functions of the block.

Please note that $\text{MonTiDynamic} \geq \text{MonTiStatic}$ and $\text{MonTiDynamic} \geq \text{SampleTime}$ have to be configured. If something is set outside these limits, the block always returns the respective limit at the input.

If `SampleTime` changes, `MonTiDynamic` may be tracked to the new value for `SampleTime`. `MonTiStatic` is tracked if $\text{MonTiDynamic} < \text{MonTiStatic}$ changes. With `MonTiStatic = 0`, each feedback change without change of the control immediately results in a runtime error.

Reference

3RW5Ctrl - Maintenance

5.7.18 Monitoring the motor status during pump cleaning

When pump cleaning is in progress (Initiated via 3RW5Oprn Block (Page 103)), feedback of the actual operating direction and speed of the motor will not match with the actual control command output from the 3RW5Ctrl block for a few cycles until pump cleaning is completed. To ensure that the motor does not trip while monitoring the feedback (`MonDynErrr`), the monitoring function needs to be disabled at the 3RW5Ctrl block.

Status is Runtime

During pump cleaning the block icon status in runtime will alternate between flashing in reverse direction and motor running forward direction until the pump cleaning is completed. The status display of the command button will retain the last valid state of the command.

5.7.19 Motor Protection

The motor protection function is used to switch off the motor on a thermal overload (`Trip = 0`, interconnectable input parameters).

If the motor is switched off via the motor protection function, a message is generated (process control message). This is displayed in the faceplate with the text "Motor protection."

You can influence the reset via various `Feature.Bits`. For more details, refer to the section "Resetting the block in case of interlocks or errors" in the APL manual (<https://support.industry.siemens.com/cs/document/109760968>).

5.7.20 Interlocking

Interlocks

This block provides the following interlocks:

Feature 2 bit 16 = 0:

- Activation enable
- Interlock without reset ("Interlock")
- Interlock with reset ("Protection")

Feature 2 bit 16 = 1:

- Activation enable forward
- Activation enable reverse
- Interlock forward without reset ("Interlock forward")
- Interlock reverse without reset ("Interlock reverse")
- Interlock forward with reset ("Protection interlock forward")
- Interlock reverse with reset ("Protection interlock reverse")

Interlocking with Permit, Intlock and Protect

A maximum of three types of interlock can be used for the 3RW5Ctrl block. Three separate inputs named `Permit`, `Intlock` and `Protect` are available for these functions.



Table 5- 44 Interlock types

Input	Value	Meaning
<code>Permit</code>	1	Activation enable ("Permission"): The activation enable makes it possible to leave the neutral position of the block in response to operator input or a command from the program (CFC). The activation enable has no effect if the block is not in the neutral position.
<code>Intlock</code>	0	Interlock without reset ("Interlock"): An active interlock condition brings the block to the neutral position. After the interlock condition has gone, the currently active control function becomes active again in automatic or local mode. In manual mode the faceplate can be operated again after the interlock condition has gone.
<code>Protect</code>	0	Interlock with reset ("Protection"): An active interlock condition brings the block to the neutral position. After the interlock conditions are cleared, the operator or an activation sequence must perform a reset to once again enable activation of the control according to the input parameters.

Display of interlock

The state of the interlock is visualized in the faceplates and in the block icons.

Table 5- 45 Icons for interlock

Icon	Meaning
	No interlock is active
	One or more interlocks are pending
No lock	Individual interlocks are not active (the input parameters are inactive; the button in the faceplate is invisible): <ul style="list-style-type: none"> • Perm_En = 0 OR Permit.ST = 16#FF • PermRevEn = 0 OR PermRev.ST = 16#FF OR Feature2.Bit16 = 0 • Prot_En = 0 OR Protect.ST = 16#FF • ProtRev_En = 0 OR ProtRev.ST = 16#FF OR Feature2.Bit16 = 0 • Intl_En = 0 OR Intllock.ST = 16#FF • IntlRev_En = 0 OR IntlRev.ST = 16#FF OR Feature2.Bit16 = 0

The faceplate visualizes the state of each interlock type separately.

Note

No safe position

Motors and values are not put into the safe position if one of the interlock inputs is active (e.g., Intllock = 0) and the corresponding signal status is 16#FF (Intllock.ST = 16#FF).

The padlock is not shown in the block icon, if all the parameters for enabling button are set to 0 or all parameters have the signal status 16#FF.

"Interlock active" output via the LockAct parameter

The LockAct parameter is always set automatically if an interlock is set in the following parameters:



- Intllock
- Permit
- Protect
- Trip
- IntlRev (only for blocks with directional interlock and Feature2.Bit16 = 1)
- PermRev (only for blocks with directional interlock and Feature2.Bit16 = 1)
- ProtRev (only for blocks with directional interlock and Feature2.Bit16 = 1)

The LockAct = 0 parameter if the interlock is canceled and the interlocks that require acknowledgments have been acknowledged.

You can bypass the interlock using BypProt = 1 in local mode and during simulation. This also makes LockAct = 0.

How the signal status affects the interlocks

There are three ways in which the signal status affects the interlocks:

No.	Icon	Signal status
1		Simulation (16#60): <ul style="list-style-type: none"> If the interlock signal with the status 16#60 brings about a cancelation of the interlock, this is processed as a bypass of the interlock in the block.
		<ul style="list-style-type: none"> If the interlock signal with status 16#60 does not bring about a cancelation of the interlock, this is processed in the block as simulation.
2		"bad, device-related" (16#28) or " bad, process-related" (16#00) → The signal status is used to activate the motor to stop.
3	–	Signal status ≠ Simulation , "bad, device-related" and " bad, process-related" → No change in the block

Reference

3RW5 - Standard (Page 212)

5.7.21 Disabling interlocks

Disabling individual interlocks

You can disable the block interlocks that are implemented using the input parameters `Permit`, `Intlock` and `Protect`.

This is done by setting the following parameters:

- `Perm_En = 0` or `Permit.ST = 16#FF`: The `Permit` input parameter has no effect
- `PermRevEn = 0` or `PermRev.ST = 16#FF` or `Feature2.Bit16 = 0`: The input parameter `PermRev` has no effect
- `Prot_En = 0` or `Protect.ST = 16#FF`: The `Protect` input parameter has no effect
- `ProtRevEn/Prot = 0` or `ProtRev.ST = 16#FF` or `Feature2.Bit16 = 0`: The input parameter `ProtRev` has no effect
- `Intl_En = 0` or `Intlock.ST = 16#FF`: The `Intlock` input parameter has no effect
- `IntlRevEn = 0` or `IntlRev.ST = 16#FF` or `Feature2.Bit16 = 0`: The input parameter `IntlRev` has no effect

Deactivation of all interlocks

You can use the input parameter `BypProt = 1` to disable all the interlocks, irrespective of the parameter assignment of the individual interlock, in local mode as well as for the "simulation" function.

5.7.22 Group fault

GrpErr

The output parameter for group error `GrpErr` is set when one of the errors listed below is detected.

The Standard view displays these errors as a "group error" in plain text.

- Control System Fault (`CSF`)
- Trip (`Trip`)
- Feedback error due to control change (`MonDynErr`)
- Feedback error due to unexpected feedback change (`MonStaErr`)

5.7.23 User-defined auxiliary values and user-defined status

For the 3RW5Ctrl block, auxiliary values and status bits are available that are displayed in the Standard view and that the user can define.

User-defined auxiliary values

Use the auxiliary values to display values such as motor velocity, temperature.

To do so, connect the value to be displayed with input parameters `UserAna1` or `UserAna2`.

In the CFC chart, you can define the text for the displayed values in the object properties of the block (Connections > Identifiers).

User-defined status

Use the `UserStatus` parameter to display information using user-defined status bits.

To do so, connect the signal (byte) to be displayed with the `UserStatus` input parameter.

Displaying auxiliary values

Up to two auxiliary values can be displayed in the standard view of some faceplates. This feature can be used, for example, with motors to indicate the motor current and winding temperature.

To do so interconnect the value that you want to have displayed with the input parameters `UserAna1` or `UserAna2`.

In the object properties (I/Os > Identifier) of the block in CFC, you can specify the text to be displayed for these parameters in the standard view of the faceplate.

Note

For Selecting a Unit of Measure/Customer specific units for the Auxillary values refer APL manual. (<https://support.industry.siemens.com/cs/document/109760968>)

5.7.24 Message characteristics

The alarms are output using the ALARM_8P function.

Block messages can be enabled or disabled using the `MsgLock` input.

The alarms are also suppressed if the block is in Out of service mode.

The alarms are suppressed on warm restart for the number of cycles set for power up in the `RunUpCyc` parameter.

Message block MsgEvd1

Table 5- 46 Output messages

Message block	Message No.	Block parameters	Message text	Message class *
MsgEvd1	1	Message-1	\$\$BlockComment\$\$Monitoring Error or Starter tripped	S
	2	Message-2	\$\$BlockComment\$\$Motor protection triggered	S
	3	CSF	\$\$BlockComment\$\$Control System Fault	S
	4	ExtMsg1 **	\$\$BlockComment\$\$External message 1	S
	5	ExtMsg2 **	\$\$BlockComment\$\$External message 2	S
	6	ExtMsg3 **	\$\$BlockComment\$\$External message 3	S
	7	–	–	–
	8	–	–	–

* S = AS, OS process control fault

** User-definable message

Table 5- 47 Structure of the auxiliary values ALARM_8P

Message No.	Auxiliary value	Block parameters	Meaning
1	1	SarBatchName	Name of batch
2	2	SdwStepNoLoc	Step number
3	3	SdwBatchId	ID of the batch
4	4	ExtVal04	External value 4, user-definable
5	5	ExtVal05	External value 5, user-definable
6	6	ExtVal06	External value 6, user-definable
7	7	ExtVal07	External value 7, user-definable
8	8	ExtVal08	External value 8, user-definable
9	9	ExtVal09	Reserved
10	10	ExtVal10	Reserved

The `MsgStat1`, `MsgAckn1` and `MsgErr1` parameters transfer the following information:

- Message status
- Message error
- Message acknowledgment status

5.7.25 Connection of the time-stamped messages from EventTs or Event16Ts

If the output parameter `EventTsOut` of the block `EventTs` or `Event16Ts` is connected to the input parameter `EventTsIn` of another block, the time-stamped messages of the block `EventTs` or `Event16Ts` will be displayed at the connected block. The following functionalities or parameters of the block are transferred to the connected message blocks:

- Maintenance release status (`MS_Release`)
- Operating mode "Out of service" (depends on `Feature2.Bit11`)
- Message lock with the parameter `MsgLock` (depends on `Feature2.Bit11`)
- Batch parameters (`BatchEn`, `Occupied`, `BatchID`, `BatchName`, and `StepNo`)

With `Feature2.Bit11 Suppress MsgLock` and "Out of service" mode for a connected message block (Page 79), you can suppress the change to the "Out of service" mode and the message lock over `MsgLock`.

5.7.26 Opening additional faceplates

You can open standard views of other faceplates from the standard view of the Control block.

In the CFC you need to interconnect the `SelFp1`, `SelFp2`, `SelMeas` and `SelStat` input parameter for the enabling the button in the standard view.

By default, in the 3RW55 Soft Starter template `SelFp1` of the Control block (`3RW5Ctrl`) is connected with `3RW5Opn` Block.

`SelFp2` button is available in the preview view. You can use this button to open the standard view of a block that can be selected freely. In order to use this function, in the CFC you need to interconnect `SelFp2` for the button in the preview to any given output parameter of the block whose faceplate is to be opened.

You can change the button labels in the "OS additional text" attribute to "SelFp2"

Enable for measurement and statistics

`SelMeas` and `SelStat` are connected with Measurement and statistics blocks respectively.

Note

Configure `3RW5Meas` and `3RW5Stat` blocks in the same CFC as the `3RW5Ctrl` block.

Refer to the section **Button Label** in the APL manual (<https://support.industry.siemens.com/cs/document/109760968>) to know more about alternative solutions for labelling the buttons.

5.7.27 Fault handling

The following errors can be displayed for this block:

- Error numbers
- Mode changeover error
- Invalid input signals

5.7.28 Enabled operations

The operator permissions for control commands are configured in the `OS_Perm` structured parameters. These are transferred to WinCC via the `OS_PermOut` and `OS_PermLog` parameters. The block parameters are controlled via the FBs in CFC.

The activated parameter allows the operator to enter the desired commands.

The operator permissions control operation only in the faceplate.

Table 5- 48 Operator permissions – 3RW5Ctrl

OS_Perm bit	OS_PermOut bit	OS_PermLog bit	Description
0	0	0	1 = Operator is permitted to change to AUTO mode.
1	1	1	1 = Operator is permitted to change to MANUAL mode.
2	2	2	1 = Operator is permitted to change to Local mode.
3	3	3	1 = Operator is permitted to change to "Out of service" mode
4	4	4	1 = Operator is permitted to stop the motor
5	5	5	1 = Operator is permitted to start the motor (forward) On→
6	6	6	1 = Operator is permitted to start the motor (reverse) On←
7	7	7	1 = Operator is permitted to start the motor (creep forward) On →
8	8	8	1 = Operator is permitted to start the motor (creep reverse) On←
9	9	9	1 = Operator is permitted to reset the motor
10	10	10	1 = Operator is permitted to define the monitoring time for startup
11	11	11	1 = Operator is permitted to define the monitoring time for runtime
12	12	12	1 = Operator is permitted to activate the monitoring time function (Bit10, Bit11)
13	13	13	1 = Operator is permitted to activate the simulation function
14	14	14	1 = Operator is permitted to activate the maintenance release function
15...25	15...25	15...25	Reserved
26	26	26	1 = Operator can change the simulation value SimAV
27...30	27...30	27...30	Reserved
31	31	31	1 = Operator can execute the rapid stop

5.7.29 Status information

The status information is passed to WinCC for display in the faceplates.

Status1

Table 5- 49 Status1 – 3RW5Ctrl

Status1 bit	Description
0	Occupied
1	BatchEn
2	Set the Simulation bit On
6	1 = Local Active
7	0 = Open padlock in the block icon 1 = Closed padlock in the block icon
8	1 = Fwd Command
9	0 = Stop Command 1 = Run Command
10	1 = Rev Command
11	1 = CrpFwd Command
12	1 = CrpRev Command
13	1 = Static Monitoring Error
14	1 = Dynamic Monitoring Error
15	Cross pad protection inputs
16	Invalid signal status
17	Error in mode change
18	1 = Interlock is active
19	1 = Permit is active
20	1 = Protect is active
21	Trip.Value
22	Creep FwdForce
23	StopForce
24	Creep RevForce
25	FwdForce
26	Reverse Force
27	"Interlock" button activated
28	Reset request with input signal
29	WarnAct.Value or IdleTime is active
30	Bypass information from previous function block
31	"Permission" button is enabled

Status2

Table 5- 50 Status2 – 3RW5Ctrl

Status2 bit	Description
0	MsgLock
1	Show automatic preview in the standard view
2	Automatic preview for forward mode
3	Automatic preview for stop mode
4	Automatic preview for reverse mode
5	Automatic preview for creep forward mode
6	Automatic preview for creep reverse mode
7	Motor is stopped
8	Motor is stopping in forward
9	Motor is stopping in reverse
10	Motor is stopping in creep forward
11	Motor is stopping in creep reverse
12	Motor is starting in forward
13	Motor running forward
14	Motor is starting in reverse
15	Motor is running in reverse
16	Motor is starting in creep forward
17	Motor is running in creep forward
18	Motor is starting in creep reverse
19	Motor is running in creep reverse
20	No influence on the local command inputs
21	Error on stopping the motor
22	Error in motor running forward
23	Error in motor running reverse
24	Error in motor running creep forward
25	Error in motor running creep reverse
26	Show padlocks in block icon
27	"Protect" button activated
28	Hidden bypass signal in Permit Reverse
29	Hidden bypass signal in Interlock Reverse
30	Hidden bypass signal in Protect Reverse
31	MS_RelOp

Status3

Table 5- 51 Status3 – 3RW5Ctrl

Status3 bit	Description
0...7	Not used
8	Indication of motor protection (Trip.Status ≠ 16#FF)
9	1 = Input parameter FbkFwd is connected
10	1 = Input parameter FbkRev is connected
11	1 = Input parameter FbkCrpFwd is connected
12	1 = Input parameter FbkCrpRev is connected
13	SimLiOp.Value
14	1 = Enable rapid stop
15	Rapid stop
16	Start motor forward
17	Start motor in reverse
18	Start motor creep forward
19	Start motor in creep reverse
20	GrpErr.Value
21	RdyToStart.Value
22	Auxiliary value 1 visible
23	Auxiliary value 2 visible
24	External error generated by FaultExt or external control system fault from CSF with set Feature bit 18 Activating error state for external process control error CSF
25	Hidden bypass signal in Permit
26	Hidden bypass signal in Interlock
27	Hidden bypass signal in Protect
28	Feature2 bit 2: Separate bypass signal
29	MonDynStopErr.Value Dynamic Monitoring Error Stop
30	Feature2 bit 16: Separate interlock for each direction or position
31	Separate monitoring of shutdown of the motor (Feature bit 13)(Feature2 Bit 16)

Status4

Table 5- 52 Status4 – 3RW5Ctrl

Status4 bit	Description
0	"Permission Forward" button is enabled
1	"Permission Reverse" button is enabled
2	"Interlock Forward" button is enabled
3	"Interlock Reverse" button is enabled
4	"Protect Forward" button is enabled
5	"Protect Reverse" button is enabled
6	1 = Permission Reverse is active
7	1 = Interlock Reverse is active
8	1 = Protect Reverse is active
9	FwdChnST is connected
10	RevChnST is connected
11	CrpFwdChnST is connected
12	CrpRevChnST is connected
13...16	Not used
17	Monitor
18...31	Not used

5.7.30 Restart lock after changing direction of rotation or switching off the motor using idle time

Use the input parameter `IdleTime` to enter a restart lock for changing the direction of rotation or restarting the motor. Use the `Feature Bit` 'Enabling direct changeover between forward and reverse' to define how switchover is to be performed. When the "Stop" command is given, the motor goes immediately into "Stop" mode, and `IdleTime` starts after the feedback (`FbkFwd` and `FbkRev` = 0) is given. The motor cannot be started again until the `IdleTime` has expired. For example, the `IdleTime` can be changed (increase / decrease) when the block has entered `IdleTime` from the "Stop" mode.

The `IdleTime` parameter can be set independently of the `MonTiDynamic` parameter.

Note

Idle time is not applicable during speed transitions.

5.7.31 Selecting a unit of measure

Customer-specific units

It is possible to use the units which differ from the IEC 611582 standard. User can define units in the range 1 to 199 in an XML file. The name of the XML should be 'APLCustomerUnits.xml' and should be placed in the project path in the folder "GraCS" on both server and client. An example to describe the content of the XML file 'APLCustomerUnits.xml' is shown below:

```
<?xml version="1.0" encoding="utf-8"?>
  <UserDefinedUnits> <!-- Root node start -->
    <!-- Define the first unit for different languages -->
    <Unit id="1"> <!-- first node with unit ID 1 start -->
      <Name lcid="1031">German1</Name> <!-- unit value (e.g. German1) in
German -->
      <Name lcid="1033">English1</Name> <!-- unit value (e.g. English1)
in English -->
      <Name lcid="1034">Spanish1</Name> <!-- unit value (e.g. Spanish1)
in Spanish -->
      <Name lcid="1036">French1</Name> <!-- unit value (e.g. French1) in
French -->
      <Name lcid="1040">Italian1</Name> <!-- unit value (e.g. Italian1)
in Italian -->
      <Name lcid="1041">Japanes1</Name> <!-- unit value (e.g. Japanes1)
in Japanese -->
      <Name lcid="2052">Chines1</Name> <!-- unit value (e.g. Chines1)
in Chinese -->
    </Unit> <!-- first node with unit ID 1 end -->
    <!-- Define the second unit for different languages -->
    <Unit id="2">
      <Name lcid="1031">German2</Name> <!-- lcid="1031" is for German -->
      <Name lcid="1033">English2</Name> <!-- lcid="1033" is for
English -->
      <Name lcid="1034">Spanish2</Name> <!-- lcid="1034" is for
Spanish -->
      <Name lcid="1036">French2</Name> <!-- lcid="1036" is for French -->
      <Name lcid="1040">Italian2</Name> <!-- lcid="1040" is for
Italian -->
      <Name lcid="1041">Japanese2</Name> <!-- lcid="1041" is for
Japanese -->
      <Name lcid="2052">Chinese2</Name> <!-- lcid="2052" is for
Chinese -->
    </Unit>
```

The "Unit id" value should be given to XXX_Unit parameter in the function blocks.

Note

The XML is read only once when WinCC runtime is activated. If any changes are done in the XML later, user must deactivate, close, and activate the WinCC runtime again to reflect the changes.

5.7.32 Faceplate views

5.7.32.1 3RW5Ctrl - Standard

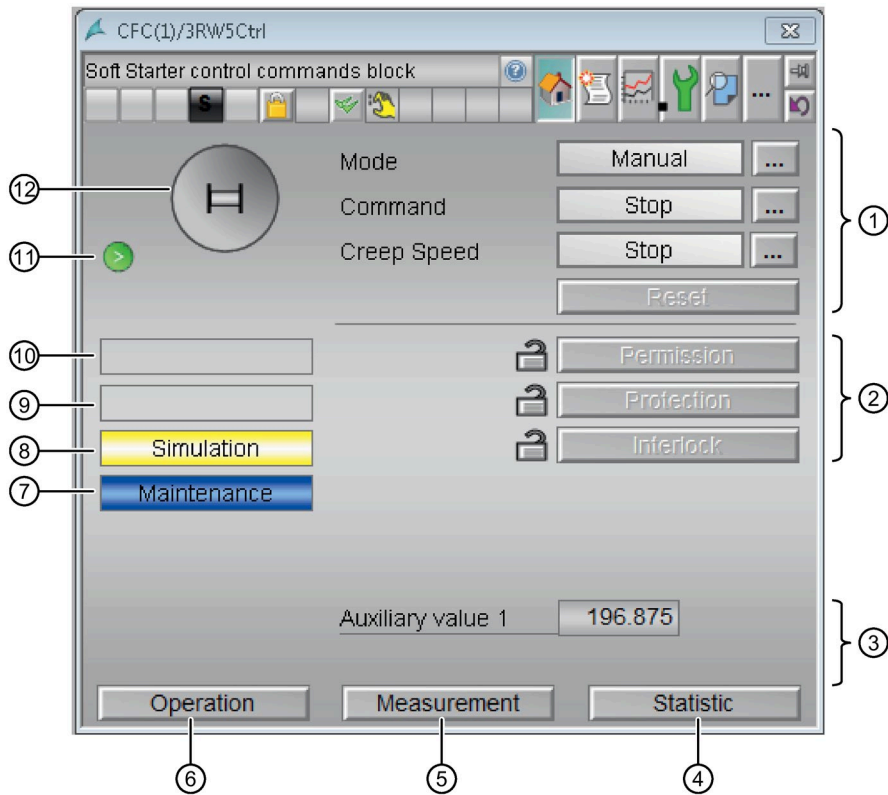

- ① Buttons
- For switching between modes (`AutoModOp`, `ManModOp`, `LocalOp`, `OosOp`)
 - For starting and stopping the motor (`FwdMan`, `RevMan`, `StopMan`, `RapidStp`)
 - For starting and stopping the motor in Creep Mode (`CrpFwdMan`, `CrpRevMan`, `StopMan`)
 - For resetting the trip (`TrpRstOp`)
- The buttons open the expanded command area; authorization level 5 and higher
- ② Interlocks and Bypass conditions
- Enable status (`Permit`, `Perm_En`, `PermRev`)
 - Protection status (`Protect`, `Prot_En`, `ProtRev`)
 - Interlocking status (`IntLock`, `Intl_En`, `IntlRev`)
- This display is only visible when the corresponding block input is connected. You can use this button to control the interlock functions of the block. You can find additional information in the section Interlocking functions (Page 199).
- ③ Analog user-defined auxiliary values (`UserAna1`, `UserAna2`)

- ④ Button to navigate to faceplate 3RW5Stat
Visible if the input parameter `Se1Stat` is logically connected with an output parameter of 3RW5Stat.
- ⑤ Button to navigate to faceplate 3RW5Meas
Visible if the input parameter `SeMeas` is logically connected with an output parameter of 3RW5Meas
- ⑥ Button to switch the standard view of 3RW5Oprn faceplate.
Display is only visible when the corresponding block input is connected to `Se1FP1`.
- ⑦ Display area for block states. This area provides additional information on the operating state of the "Maintenance" block.
- ⑧ Display area for block states. This area provides additional information on the operating state of the block "Simulation" and "Delay".
- ⑨ Display area for block states. This area provides additional information on the operating state of the blocks:
 - Forced stop
 - Forced start >
 - Forced start |>
- ⑩ This display is only visible in "manual mode", "local mode", or with a reset request in "automatic mode", when the current output signals are not identical to the control in "automatic mode".
The display shows what state the motor presume if you:
 - switch from "manual" or "local" mode to "automatic mode"
 - perform a reset to "automatic mode".
- ⑪ Automatic preview : This display is only visible in "manual mode", in "local mode", or with a reset request in "automatic mode", when the current output signals are not identical to the control in "automatic mode". The display shows what state the motor would assume if you switched from "manual" or "local" mode to "automatic mode", or performed a reset to "automatic mode".
- ⑫ Motor status (see table below)

Motor status icons

Status	Symbol
Motor running forward	
Motor running reverse	
Motor running creep forward	
Motor running creep reverse	
Motor fault	
Motor stops	

Refer "Monitoring the motor status during pump cleaning (Page 198)" section for the motor block icon status during pump cleaning.

Note

When the motor is running in local mode with creep speed there wont be indication in the faceplate.

5.7.32.2 3RW5Ctrl - Maintenance

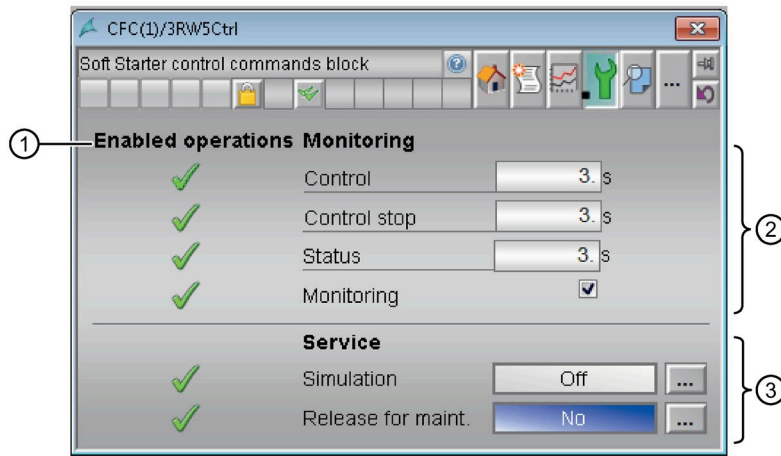

① Operator control enable



- The operator may execute the command.
- The operator cannot execute the command because the command is currently blocked by a process.
- The operator is not permitted to execute the command (OS_Perm).

The displays are dependent on the bit values in the OS_PermOut and OS_PermLog parameters.

② Monitoring

Control and runtime in seconds, monitoring time (MonTiDynamic, MonTiStatic)

Activation of monitoring (Monitor) opens the expanded command area; authorization level 6 and higher

You can influence the following parameters:

"Control": Monitoring time during startup and shutdown of the motor (dynamic)

"Control stop": Monitoring time during shutdown of the motor (dynamic) with Feature.Bit13 = 1

"Control start": Monitoring time during startup of the motor (dynamic) with Feature.Bit13 = 1

"Status": Monitoring time during permanent operation of the motor (static)

③ Monitoring (Monitor)

④ Service

Activation of simulation (SimOn) Maintenance enable (MS_ReLOp)

The buttons open the expanded command area; authorization level 7 and higher

Note

Monitoring function cannot be disabled by the user when using 3RW55_Soft_Starter template.

It will be remain in enabled state except in pump cleaning mode

5.7.32.3 3RW5Ctrl - Preview

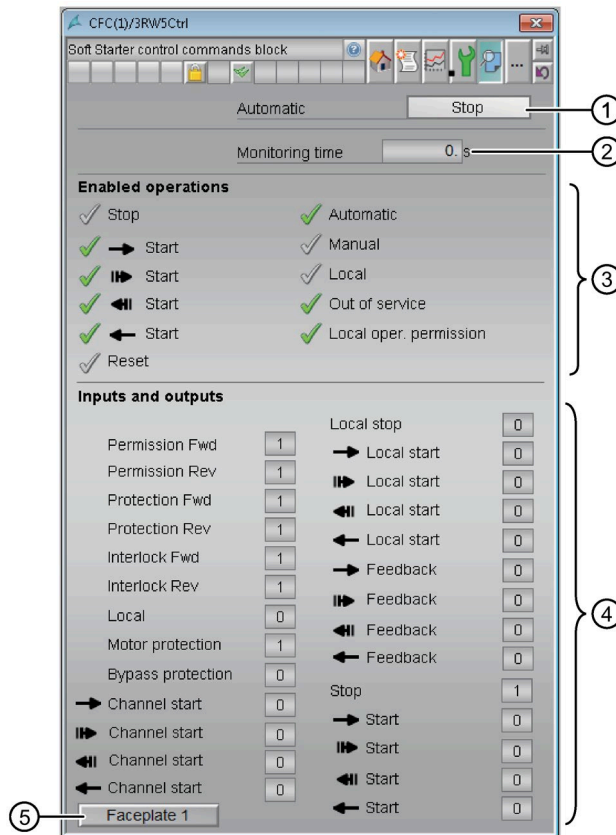



① **"Automatic" display**

If the block is in "Automatic" mode, the current status of the block will be displayed (e.g. "Start →")

② **Monitoring time**

③ **Enabled operations**

-  • The operator may execute the command.
-  • The operator cannot execute the command because the command is currently blocked by a process.
-  • The operator is not permitted to execute the command.

The displays are dependent on the bit values in the OS_PermOut and OS_PermLog parameters.

- ④ **Displays the current control signals (Inputs and outputs)**
 - Permission ***
 - Permission Forward 1 = Enable for starting the / stopping towards forward direction from neutral position
 - Permission reverse 1 = Enable for starting / stopping towards reverse direction from neutral position
 - Protection ***
 - 0 = Protection interlock is active; if the interlock condition disappears, you must perform a reset for the block
 - 1 = Protection interlock is not active
 - Interlock ***
 - 0 = Interlocking without reset is active; you may operate the block without reset once the interlocking condition is cleared
 - 1 = Interlock is not active
 - Local:** 1 = Block operating in Local mode
 - Motor protection:** 1 = Motor is in "good" state
 - Interlock deactivated**
 - 0 = Bypassing deactivated
 - 1 = Bypassing of the interlock in Local mode and during simulation

For more details on "Inputs and outputs", refer table below.
 - ⑤ **Navigation button for switching to the standard view of any faceplate**
 - This display is only visible when the corresponding block input is connected.
- * Display is only visible when the corresponding block input is connected.

Inputs and outputs

Local stop :1	Stop motor in Local mode
Start Local →: 1	Start motor in forward in Local mode
Start Local ∥→: 1	Start motor in creep forward in Local mode
Start Local←∥ : 1	Start motor in creep reverse in Local mode
Start Local ←: 1	Start motor in reverse in Local mode
Feedback →: 1	Motor has started and is running forward
Feedback ∥→: 1	Motor has started and is running creep forward
Feedback ←∥: 1	Motor has started and is running in creep reverse
Feedback ←: 1	Motor has started and is running in reverse
Stop: 1	Stop motor
Start →:1	Start motor forward
Start ∥→: 1	Start motor creep forward
Start ←∥: 1	Start motor in creep reverse
Start ←: 1	Start motor in reverse
Channel Start →: 1	Signal from the output channel block for "forward"
Channel ∥→: 1	Signal from the output channel block for "creep forward"
Channel ←∥: 1	Signal from the output channel block for "creep reverse"
Channel ←: 1	Signal from the output channel block for "reverse"

Maintenance station

6.1 Identification data for 3RW5 objects

In the case of the faceplate for 3RW5 objects, the identification data is read from the properties of each slot of the 3RW5 device.

The first object created for 3RW5 device will be for the communication module slot. LID, Address, Device Type, Manufacturer, HW revision and SW revision data displayed will be based on the properties of this communication module.



The second level object is created for the Device Module Slot. Here LID, Device Type, Order number, HW revision and SW revision data displayed will be based on the properties of Basic Unit Module.



Note

- For PROFINET Devices HW revision is not displayed at both for the device slot and communication module slot. In the GSDML file the HW revision is not contained, it has no influence on the HW configuration.
 - For PROFIBUS Devices since a single GSD can hold only one HW/SW revision for a device, the HW revision and SW revision is not displayed for the Basic Unit module slot.
-

6.2 Maintenance Station

This library supports the function of the Maintenance Station and via GSD / GSDML.

Soft Starter PROFIBUS / PROFINET – Maintenance Station

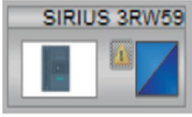
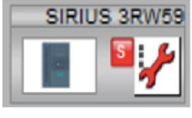
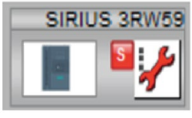
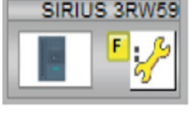
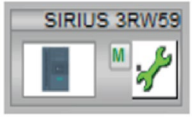
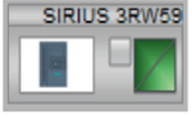
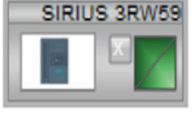
Display	Remark	Message	Caused by
	Unknown / untested	-	PLC in Standby
	Trip	Device [Subnet No.] / [Address]: Bad, maintenance alarm	Tripping *) <ul style="list-style-type: none"> • General Fault • Controller Fault • Protection has tripped • Level monitoring low/high • Miscellaneous
	Failure	Device [Subnet No.] / [Address]: Failure	Failure of PROFIBUS connection or Rack Fault or Module Fault
	Warning	Device [Subnet No.] / [Address]: Uncertain, maintenance demanded	Warnings *) <ul style="list-style-type: none"> • Protection has tripped • Level monitoring low/high • Miscellaneous
	Signaling	Device [Subnet No.] / [Address]: Good, maintenance required	Status signaling *) <ul style="list-style-type: none"> • Signaling by controller • Protection has tripped • Signaling caused by parameterization
	Good	-	-
	Message is locked	-	Message lock is enabled in maintenance view faceplate

Messages

Messages for an incoming signaling, warning and tripping event can be found using:















Tool	Dialog/Alarm logging
For WinCC	Alarm logging or at the faceplates diagnosis view of the device
For Soft Starter TIA	TIA Project: Select Device Configuration > Go Online > Select Commissioning Option > Soft Starter > Diagnosis > Faults And Warnings. You will find details for: <ul style="list-style-type: none"> • Faults • Warnings

Further status information according to control and protection can be found:

Tool	Dialog
For Soft Starter TIA	TIA Project: Select Device Configuration > Go Online > Select Commissioning Option > Soft Starter > Diagnosis > Current Status. You will find details for: <ul style="list-style-type: none"> • Control • Motor Protection

Correlation Maintenance Status and Maintenance Job

The following table provides an overview:

Meaning	Maintenance job	Status maintenance job
Maintenance required has been requested, maintenance engineer has not yet created a maintenance job		
Maintenance demanded has been requested, maintenance engineer has not yet created a maintenance job		
Maintenance alarm has been requested, maintenance engineer has not yet created a maintenance job		
Maintenance required has been requested, maintenance job was set to status "In progress"		
Maintenance demanded has been requested, maintenance job was set to status "In progress"		
Maintenance alarm has been requested, maintenance job was set to status "In progress"		
Maintenance job canceled Maintenance engineer has canceled the maintenance job	Maintenance status see table above	
Maintenance job completed	Maintenance status see table above	

Module drivers of Soft Starter

7.1 Released modules

The following Soft Starters are available for this library:

Article number	Compatible modules
3RW5 2**-**C**	Yes
3RW5 513-*HA**	
3RW5 514-*HA**	
3RW5 515-*HA**	
3RW5 521-*HA*6	
3RW5 516-*HA**	
3RW5 517-*HA**	
3RW5 524-*HA**	
3RW5 525-*HA**	
3RW5 526-*HA**	
3RW5 527-*HA**	
3RW5 534-*HA**	
3RW5 535-*HA**	
3RW5 536-*HA**	
3RW5 543-*HA**	
3RW5 544-*HA**	
3RW5 545-*HA**	
3RW5 546-*HA**	
3RW5 547-*HA**	
3RW5 548-*HA**	
3RW5 552-*HA**	
3RW5 553-*HA**	
3RW5 554-*HA**	
3RW5 556-*HA**	
3RW5 558-*HA**	

7.2 Object lists and action lists

Hardware modules, among other things, are configured in HW Config.

Description

The object lists and the action lists are used to generate the module drivers for these hardware modules.

The object list contains a unique object identification number for each of these hardware modules. Each object list is assigned to a particular hardware configuration.

The action list contains a list of actions. These actions must be executed for the object identification numbers that appear in the object list. Examples of such actions include:

- Assigning the device address
- Interconnecting the input and output parameters of the driver block

The "Generate Module Driver" function generates the module drivers when the CFC is compiled.

7.3 Driver blocks

3RW5 Soft Starter PROFINET directly on the PROFINET IO master system - Configuration using GSDML file

The following driver blocks are generated when the CFC is compiled:

- 3RW5Diag - Soft Starter diagnostics block
- OB_DIAG1_PN - OB diagnostics function
- OB_BEGIN - CPU function block
- MOD_SWT - Message diagnostic of SWITCH

3RW5 Soft Starter directly on the DP master system - Configuration using GSD file

The following driver blocks are generated when the CFC is compiled:

- 3RW5Diag - Soft Starter diagnostics block
- OB_DIAG1 - OB diagnostics function
- OB_BEGIN - CPU function block
- MOD_SWT - Message diagnostic of SWITCH

3RW5 Soft Starter behind a Y-link - Configuration using the Object Manager

This configuration cannot be applied.

3RW5 Soft Starter following a Y-link - Configuration using GSD file

The following driver blocks are generated when the CFC is compiled:

- 3RW5Diag - Soft Starter diagnostics block
- OB_DIAG1 - OB diagnostics function
- OB_BEGIN - CPU function block
- MOD_SWT - Message diagnostic of SWITCH

3RW5 Soft Starter behind a IE/PB-link - Configuration using the Object Manager

This configuration cannot be applied.

3RW5 Soft Starter behind a IE/PB-link - Configuration using GSD file

The following driver blocks are generated when the CFC is compiled:

- 3RW5Diag - Soft Starter diagnostics block
- OB_DIAG1_PN - OB diagnostics function
- OB_BEGIN - CPU function block
- MOD_SWT - Message diagnostic of SWITCH

Parameters

A.1 3RW5Diag block parameters

Input parameters

Table A- 1 3RW5Diag input parameters

Parameter	Data format	Default setting	Meaning
EnDiag	BOOL	FALSE	1 = Enable reading of diagnostic data
Mode	DWORD	16#00	OMODE from MOD_SWT
DAddr	INT	0	Diagnostic address of module
HmiDAddr	INT	0	Diagnostic address of HMI-HF
DevTyp	INT	0	1 = 3RW55+ST; 2 = 3RW55+HF; 3 = 3RW52+ST; 4 = 3RW52+ST+HMI; 5 = 3RW55ST+HMI; 6 = 3RW55HF+HMI
RdData	BOOL	0	1 = Read diagnostic data
DPALink	BOOL	FALSE	Device connection: 0 = DP-MASTER 1 = DP-LINK
SubnTyp	BOOL	FALSE	1 = External DP-Interface
SlvTyp	BOOL	FALSE	0 = PROFIBUS 1 = PROFINET
Subn1ID	BYTE	16#FF	ID of Primary Subnet
Subn2ID	BYTE	16#FF	ID of Redundant Subnet
SubnLnkID	WORD	16#FFFF	ID of MasterSystem on the Link
RackNo	BYTE	16#FF	Rack number
SlotNo	BYTE	16#FF	Slot number
LAddr	WORD	16#0000	Logical address of the starter module
RackF	BOOL	FALSE	1 = Rack failure
Subn1Err	BOOL	FALSE	1 = Subnet 1 error
Subn2Err	BOOL	FALSE	1 = Subnet 2 error
RunUpCyc	INT	3	Number of cycles for which all messages are suppressed
MsgEvid1	DWORD	16#FF	Message Event ID
AccID	BOOL	TRUE	1 = Accept new Mode settings

Parameters

A.1 3RW5Diag block parameters

Parameter	Data format	Default setting	Meaning
ExtMsg1	STRUCT • Value: BOOL • ST: BYTE	– • 0 • 16#80	External Message 1
ExtMsg2	STRUCT • Value: BOOL • ST: BYTE	– • 0 • 16#80	External Message 2
ExtMsg3	STRUCT • Value: BOOL • ST: BYTE	– • 0 • 16#80	External Message 3
ExtVa106	ANY	–	Associated External Value 6 for Messages (MsgEvID1)
ExtVa107	ANY	–	Associated External Value 7 for Messages (MsgEvID1)
ExtVa108	ANY	–	Associated External Value 8 for Messages (MsgEvID1)
ExtVa109	ANY	–	Associated External Value 9 for Messages (MsgEvID1)
ExtVa110	ANY	–	Associated External Value 10 for Messages (MsgEvID1)
ReserveIn	WORD	–	Reserved

Output parameters

Table A-2 3RW5Diag output parameters

Parameter	Data format	Default setting	Meaning
GrpErr	STRUCT • Value: BOOL • ST: BYTE	– • 0 • 16#80	1 = Group error is active
RackFAct	STRUCT • Value: BOOL • ST: BYTE	– • 0 • 16#80	1 = Rack Failure
ModFAct	STRUCT • Value: BOOL • ST: BYTE	– • 0 • 16#80	1 = Module Failure
Rack1Err	STRUCT • Value: BOOL • ST: BYTE	– • 0 • 16#80	1 = DP slave / IO system failure (primary)
Rack2Err	STRUCT • Value: BOOL • ST: BYTE	– • 0 • 16#80	1 = DP slave / IO system failure (redundant)
RdErr	STRUCT • Value: BOOL • ST: BYTE	– • 0 • 16#80	1 = Error read record

Parameter	Data format	Default setting	Meaning
RdErrStat	WORD	16#00	Status of Read record error
RdStatus	WORD	16#00	Status of RDSYSST return code
BusFlt	BOOL	FALSE	1 = Connection Fault
RdEn	BOOL	FALSE	1 = Enable read record
SlvTyp	BOOL	FALSE	0 = PROFIBUS 1 = PROFINET
DevType	INT	0	1 = 3RW55ST; 2 = 55HF; 3 = 52+ST; 4 = 52+ST+HMI; 5 = 55ST+HMI; 6 = 55HF+HMI
PADiag	DWORD	0	Diagnostic information for maintenance
DiagOprn	DIAGOPRN3RW5	–	Diagnostic information for 3RW5Oprn
DiagMeas	DIAGMEAS3RW5	–	Diagnostic information for 3RW5Meas
ST_Worst	BYTE	16#80	Worst Signal Status
OMode	DWORD	16#00	Status MODE
ErrorNum	INT	-1	Error Number
MsgErr1	BOOL	FALSE	1 = Messaging Error Occurs
MsgStat1	WORD	16#00	ALARM_8P: Status Output
MsgAckn1	WORD	16#00	ALARM_8P: ACK_STATE Output
ReserveOut	WORD	–	Reserved

Structure of OMODE

Table A- 3 Structure of OMODE – 3RW5Diag

Byte	Value	Meaning
Byte 1; 0	16#0000	–
Byte 2	16#01:	Warm restart (OB100)
Byte 3	16#80:	Valid data
	16#40:	Invalid data
	16#20:	Redundancy error

A.2 Structure of UDTs for 3RW5Diag

UDTs for diagnostic information

The following diagnostic information is available for 3RW5 Soft Starters:

- 3RW5DiagOprn – Status, output via the `DiagOprn` parameter output
- 3RW5DiagMeas – Status, output via the `DiagMeas` parameter output

3RW5DiagOprn and 3RW5DiagMeas are structured parameters for diagnostic information. They are composed of a number of elements.

DIAGOPRN3RW5

Table A- 4 Diagnostic information

Element	Data format	Message	Diagnostic type
DIAG ¹	DWORD	3RW5 PROFIBUS DP Slave diagnostics	Station diagnostics
BUSERR	BOOL	Bus error	Communication
CPUMSTRSTOP	BOOL	CPU / master Stop	
AUTOPLCCNTRL	BOOL	Automatic mode (PLC controlled)	
OPRMODMANBUS	BOOL	Operating mode manual	
OPRMODMANLOC	BOOL	Operating mode manual - local	
CONABRMANMOD	BOOL	Connection abort in manual mode	
PIERROR	BOOL	Process image error	
NOEXTSTPAR	BOOL	No external start-up parameters received	
MANBUSPCCTRL	BOOL	Manual operation bus - PC controlled	
MANLOCINCTRL	BOOL	Manual operation local - input controlled	
MANLOCOMCTRL	BOOL	Manual operation local - HMI controlled	
MANLOCPCCTRL	BOOL	Manual operation local - PC controlled	
MANLOCWBCTRL	BOOL	Manual operation local - Webserver controlled	

Element	Data format	Message	Diagnostic type
READY	BOOL	Ready (automatic)	Switching and Control
MOTCW	BOOL	Motor clockwise (right)	
MOTCCW	BOOL	Motor counter-clockwise (left)	
SWTELMTOVLD	BOOL	Switching element overload	
SWTELMTDFCT	BOOL	Switching element defective	
EMGSTARTACT	BOOL	Emergency start is active	
GRPWARN	BOOL	Group warning	
GRPERR	BOOL	Group error	
NOSUPVOLT	BOOL	No supply voltage	
STRTMODACT	BOOL	Start Mode active	
STPMODACT	BOOL	Stopping Mode active	
ELEBRKACT	BOOL	Electrical braking procedure is active	
CRSPDACT	BOOL	Creep speed active	
INPUTCTRL	BOOL	Input control	
QCKSTPACT	BOOL	Quick stop active	
ELEVELTLO	BOOL	Electronics supply voltage too low	
RDYMOTON	BOOL	Ready to start for motor ON	
BYPDEFCT	BOOL	Bypass defective	
BYPPROTRP	BOOL	Bypass protective trip	
SWELE1DFCT	BOOL	Switching element 1 defective	
SWELE2DFCT	BOOL	Switching element 2 defective	
SWELE3DFCT	BOOL	Switching element 3 defective	
SWFRQTIMRUN	BOOL	Switching frequency time running	
SWFRQNTKPWRN	BOOL	Switching frequency time not kept (warning)	
SWFRQNTKPFLT	BOOL	Switching frequency time not kept (fault)	
SWEFRQLOCACT	BOOL	Switching frequency lock active	
EMGSTRENB	BOOL	Emergency start enabled	
EMGRUNENB	BOOL	Emergency run enabled	
EMGRUNACT	BOOL	Emergency run active	
PHCTDEFTHYAT	BOOL	2-phase control with defective thyristor active	
ALTSTPMODACT	BOOL	Alternative stopping mode active	
REVDCBRKACT	BOOL	Reversing DC braking active	
MANPOWROTWRN	BOOL	Main power rotation faulty (warning)	
MANPOWROTFLT	BOOL	Main power rotation faulty (fault)	
CHKFAN	BOOL	Check fan	
SUPVOLNTTST	BOOL	Supply voltage not permitted for test	
SUPVOLREQTST	BOOL	Supply voltage required for test	
SIMACT	BOOL	Simulation active	
TSTSMLLODACT	BOOL	Test with small load active	
OPRTEMPHI	BOOL	Operating temperature too high	
AUTPARACT	BOOL	Automatic parameterization active	

Element	Data format	Message	Diagnostic type
STRTIMLIM	BOOL	Starting time limit - maintenance demanded exceeded	
STRTIMANUSH	BOOL	Starting time limit - maintenance demanded undershot	
LOGBKAPERDEL	BOOL	Logbook application - errors deleted	
LOGBKAPWRDEL	BOOL	Logbook application - warnings deleted	
LOGBKAPEVDEL	BOOL	Logbook application - events deleted	
LOGBKSRERDEL	BOOL	Logbook service - errors deleted	
MAXPNTRST	BOOL	Maximum pointer reset	Parameter
PSACTIVE	BOOL	Parameter assignment active	
INVALPARA	BOOL	Invalid parameter	
PARACNTCHNG	BOOL	Parameters cannot be changed in ON state	
PSDISCPUACT	BOOL	Parameterization disable CPU/master active	
SELFTESTACT	BOOL	Self-test active	
ERRSLFTEST	BOOL	Error during self-test	
FACTSETRSTR	BOOL	Factory settings restored	
PARNUMERRL	BOOL	Parameter number error (low byte)	
PARNUMERRH	BOOL	Parameter number error (high byte)	
PRSUNQACTCNF	BOOL	Preset unequal actual configuration	
PS1ACTIVE	BOOL	Parameter set 1 active	
PS2ACTIVE	BOOL	Parameter set 2 active	
PS3ACTIVE	BOOL	Parameter set 3 active	
PSCHNGNTPOS	BOOL	Parameter set change not possible	
PRSUNQACCNF	BOOL	Preset unequal actual configuration	
MOTCONWRNG	BOOL	Type of motor connection wrong	
MOTHEATACT	BOOL	Motor heating active	
DCBRKACT	BOOL	DC braking active	
DYNDCBRK	BOOL	Dynamic DC braking active	
MOTCONSTD	BOOL	Type of motor connection standard	
MOTCONDELT	BOOL	Inside-delta motor connection	
MOTCONUNKW	BOOL	Motor connection type unknown	
LOADMISS	BOOL	Load missing	
PHASFAIL1	BOOL	Phase failure L1	
PHASFAIL2	BOOL	Phase failure L2	
PHASFAIL3	BOOL	Phase failure L3	
MANPOWRGHT	BOOL	Main power rotation right	
MANPOWLFT	BOOL	Main power rotation left	
OUT1ACT	BOOL	Output 1 active	
OUT2ACT	BOOL	Output 2 active	
OUT3ACT	BOOL	Output 3 active	
OUT4ACT	BOOL	Output 4 active	
OUT1TIMACT	BOOL	Output 1 - Time active	

Element	Data format	Message	Diagnostic type
OUT2TIMACT	BOOL	Output 2 - Time active	
OUT4TIMACT	BOOL	Output 4 - Time active	
FWUPDTACT	BOOL	FW update active	
FWUPDTSCFL	BOOL	FW update successful	
FWUPDTFLT	BOOL	FW update faulty	
FWUPDTREJ	BOOL	FW update rejected	
OPRFACT	BOOL	Operation / bypass active	
EXAPPACT	BOOL	EX application active	
NEWEXPARETC	BOOL	New EX parameter values detected	
RLSWRNPARCRC	BOOL	Release denied due to wrong F-parameter CRC	
ANLOUTUNDFLW	BOOL	Analog output underflow	
ANLOUTOVRFLW	BOOL	Analog output overflow	
MISINTAFMNT	BOOL	Missing initialization after maintenance	

¹ The information of the station diagnostics is mapped to the `DiagOprtn.DIAG` parameter.

DIAGMEAS3RW5

Table A- 5 Diagnostic information

Element	Data format	Meaning	Diagnostic type
TMPSNSOVLDF	BOOL	Temperature sensor overload (fault)	Protective function motor/cable/short-circuited
TMPSNSWIRBRKF	BOOL	Temperature sensor wire break(fault)	
TMPSNSSHORTF	BOOL	Temperature sensor short-circuit(fault)	
TMPSNSOVLDF	BOOL	Temperature sensor overload(warning)	
TMPSNSWIRBRKW	BOOL	Temperature sensor wire break(warning)	
TMPSNSSHORTW	BOOL	Temperature sensor short-circuit(warning)	
THMMOTOVLD	BOOL	Thermal motor Model overload	
THMMOTMDTRP	BOOL	Thermal motor model trip	
IDLETRACT	BOOL	Idle time active	
COOLTRACT	BOOL	Cooling time active	
CURLTRACT	BOOL	Current limiting active	
GENOPRTN	BOOL	Generator operation	
ASYMLIMEXED	BOOL	Asymmetry limit error exceeded	
ASYMTRP	BOOL	Asymmetry trip	
CURHI	BOOL	Current limit error exceeded	
CURLO	BOOL	Current limit error undershot	
CURLMERRTRP	BOOL	Current limit error trip	
INPUT1	BOOL	Input 1 active	
INPUT2	BOOL	Input 2 active	
INPUT3	BOOL	Input 3 active	
INPUT4	BOOL	Input 4 active	
GNDFLTLIMEXE	BOOL	Ground fault limit error exceeded	
TMMDEACT	BOOL	Thermal motor model deactivated	
PHCTRFIL	BOOL	Phase angle control failure	
SWELMCOLACT	BOOL	Switching element cooling time active	
SWELMHOTSTR	BOOL	Switching element for Start too hot	
CURMESRNGOVR	BOOL	Current measuring range overshoot	
DEVICERR	BOOL	Device error	
STRPAUACT	BOOL	Start pause pending	
ENRGSAVMACT	BOOL	Energy saving mode active	
NRMLOPRACT	BOOL	Normal operation active	
TESTOPRRACT	BOOL	Test operation active	
REMTRPWRNUDR	BOOL	Remaining time for tripping warning limit undershot	
MOTHETWRNEXE	BOOL	Motor heating warning limit exceeded	
CURLMTMNTEXE	BOOL	Current limit - maintenance demanded exceeded	
CURLMTMNTUST	BOOL	Current limit - maintenance demanded undershot	
ASTLMTWRNEXE	BOOL	Asymmetry limit warning exceeded	

Element	Data format	Meaning	Diagnostic type
GNDFLTLMTEXE	BOOL	Ground fault limit warning exceeded	
PMPCLNACT	BOOL	Pump cleaning active	
ACTPWMANEXE	BOOL	Active power limit - maintenance demanded exceeded	
ACTPWMANUSHT	BOOL	Active power limit - maintenance demanded undershot	
ACTPWEREXE	BOOL	Active power error limit exceeded	
ACTPWERUSHT	BOOL	Active power error limit undershot	
ACTPWERLMTRP	BOOL	Active power error limit trip	

A.3 3RW5Meas block parameters

Input parameters

Table A- 6 3RW5Meas input parameters

Parameter	Data format	Default setting	Meaning
Mode	DWORD	16#8000FFFF	OMODE information from MOD_SWT block
DAddr	INT	0	Diagnostic address of Soft starter
LAddr	INT	0	Logical address of Soft starter
RackF	STRUCT • Value : BOOL • Value ST : BYTE END_STRUCT	– • FALSE • 16#80	1 = Rack failure information from 3RW5Diag block
ModF	STRUCT • Value : BOOL • Value ST : BYTE END_STRUCT	– • FALSE • 16#80	1 = Module Failure information from 3RW5Diag block
SlvType	BOOL	0	0 = Profibus, 1 = Profinet
DevType	INT	0	1, 2, 5, 6 = 3RW55; 3, 4 = 3RW55
RdEn	BOOL	TRUE	1 = Enable read record
RdDataLi	STRUCT • Value : BOOL • Value ST : BYTE END_STRUCT	– • FALSE • 16#80	Input 0->1: Read record via Link or SFC
RdDataOp	BOOL	FALSE	1 = Read data from datasets
DiagMeas	DIAGMEAS3RW5	–	Diagnostic information from 3RW5Diag block
PZDIn03	DWORD	16#00	Process value DP 0.0-3.7
PZDIn47	DWORD	16#00	Process value DP 4.0-7.7
Modeln47	INT	0	Mode for Analog Input PZDIn47
PZDIn811	DWORD	16#00	Process value DP 8.0-11.7
Modeln811	INT	0	Mode for Analog Input PZDIn811
PZDIn1215	DWORD	16#00	Process value DP 12.0-15.7
Modeln1215	INT	0	Mode for Analog Input PZDIn1215
OnOp	BOOL	FALSE	1 = On Mode: On Mode by Operator
OosOp	BOOL	FALSE	1 = Oos Mode: Oos Mode by Operator
OosLi	STRUCT • Value : BOOL • Value ST : BYTE END_STRUCT	– • FALSE • 16#80	1 = Oos Mode: Oos Mode by Field Signal

Parameter	Data format	Default setting	Meaning
RunUpCyc	INT	3	Number of cycles for which all messages are suppressed
Curr_OpScale	STRUCT • High : REAL • Low : REAL END_STRUCT	– • 797.0 • 0.0	Current Bar Display Limits for OS
Volt_OpScale	STRUCT • High : REAL • Low : REAL END_STRUCT	– • 1500.0 • 0.0	Voltage Bar Display Limits for OS
MsgEvid1	DWORD	16#FF	Message Event ID
MsgLock	STRUCT • Value : BOOL • Value ST : BYTE END_STRUCT	– • FALSE • 16#80	Inhibit process message
BatchEn	BOOL	FALSE	Enable Remote Operation of Controller by Batch Recipe
BatchID	DWORD	16#00	Current Batch ID (number)
BatchName	STRING [32]	–	Current Batch Name
StepNo	DWORD	16#00	Batch Step Number
Occupied	BOOL	FALSE	Occupied by Batch
ExtMsg1	STRUCT • Value : BOOL • Value ST : BYTE END_STRUCT	– • FALSE • 16#80	External Message 1
ExtMsg2	STRUCT • Value : BOOL • Value ST : BYTE END_STRUCT	– • FALSE • 16#80	External Message 2
ExtMsg3	STRUCT • Value : BOOL • Value ST : BYTE END_STRUCT	– • FALSE • 16#80	External Message 3
ExtMsg4	STRUCT • Value : BOOL • Value ST : BYTE END_STRUCT	– • FALSE • 16#80	External Message 4
ExtVa106	ANY	–	Associated External Value 6 for Messages (MsgEvid1)
ExtVa107	ANY	–	Associated External Value 7 for Messages (MsgEvid1)
ExtVa108	ANY	–	Associated External Value 8 for Messages (MsgEvid1)
ExtVa109	ANY	–	Associated External Value 9 for Messages (MsgEvid1)
ExtVa110	ANY	–	Associated External Value 10 for Messages (MsgEvid1)

Parameters

A.3 3RW5Meas block parameters

Parameter	Data format	Default setting	Meaning
OS_Perm	STRUCT	–	Operator Permissions
OpSt_In	DWORD	16#0	Enabled operator stations
Feature	STRUCT <ul style="list-style-type: none">• Bit 0: BOOL• ...• Bit 31: BOOL	– <ul style="list-style-type: none">• 0• 0• 0	Status of various features
ReserveIn	WORD	–	Reserved

Output parameters

Table A- 7 3RW5Meas output parameters

Parameter	Data format	Default setting	Meaning
RackFact	STRUCT • Value : BOOL • Value ST : BYTE END_STRUCT	– • FALSE • 16#80	1 = Rack Failure
ModFact	STRUCT • Value : BOOL • Value ST : BYTE END_STRUCT	– • FALSE • 16#80	1 = Module Failure
GrpErr	STRUCT • Value : BOOL • Value ST : BYTE END_STRUCT	– • FALSE • 16#80	1 = Group error is active
RdErr	STRUCT • Value : BOOL • Value ST : BYTE END_STRUCT	– • FALSE • 16#80	1 = Error read record
LocalAct	STRUCT • Value : BOOL • Value ST : BYTE END_STRUCT	– • FALSE • 16#80	1 = Motor in Local Operation Mode: Local Mode Indicator
OnAct	STRUCT • Value : BOOL • ST : BYTE END_STRUCT	– • TRUE • 16#80	On Mode is active
OosAct	STRUCT • Value : BOOL • Value ST : BYTE END_STRUCT	– • FALSE • 16#80	Out of service is active
RdAct	STRUCT • Value : BOOL • Value ST : BYTE END_STRUCT	– • FALSE • 16#80	1 = Enable read record
RdDataOut	STRUCT • Value : BOOL • Value ST : BYTE END_STRUCT	– • FALSE • 16#80	1 = Triggers Read operation of DS92 at 3RW5Diag
RdErrStat	WORD	16#00	Status of read record error

Parameter	Data format	Default setting	Meaning
DiagProt01	DWORD	16#00	Measurement parameter diagnostics
DiagProt02	DWORD	16#00	Measurement parameter diagnostics
CurrL1	STRUCT • Value : REAL • Value ST : BYTE END_STRUCT	– • 0.0 • 16#80	Phase current I L1 (%)
CurrL2	STRUCT • Value : REAL • Value ST : BYTE END_STRUCT	– • 0.0 • 16#80	Phase current I L2 (%)
CurrL3	STRUCT • Value : REAL • Value ST : BYTE END_STRUCT	– • 0.0 • 16#80	Phase current I L3 (%)
CurrL1E	STRUCT • Value : REAL • Value ST : BYTE END_STRUCT	– • 0.0 • 16#80	Phase current I L1 (rms)
CurrL2E	STRUCT • Value : REAL • Value ST : BYTE END_STRUCT	– • 0.0 • 16#80	Phase current I L2 (rms)
CurrL3E	STRUCT • Value : REAL • Value ST : BYTE END_STRUCT	– • 0.0 • 16#80	Phase current I L3 (rms)
Voil1L2	STRUCT • Value : REAL • Value ST : BYTE END_STRUCT	– • 0.0 • 16#80	Line-to-Line voltage U L1-L2 (rms)
Voil2L3	STRUCT • Value : REAL • Value ST : BYTE END_STRUCT	– • 0.0 • 16#80	Line-to-Line voltage U L2-L3 (rms)
Voil3L1	STRUCT • Value : REAL • Value ST : BYTE END_STRUCT	– • 0.0 • 16#80	Line-to-Line voltage U L3-L1 (rms)
ActPwr	STRUCT • Value : REAL • Value ST : BYTE END_STRUCT	– • 0.0 • 16#80	Active Power

Parameter	Data format	Default setting	Meaning
LineFreq	STRUCT • Value : REAL • Value ST : BYTE END_STRUCT	– • 0.0 • 16#80	Line Frequency in Hz
OutFreq	STRUCT • Value : REAL • Value ST : BYTE END_STRUCT	– • 0.0 • 16#80	Output Frequency in Hz
Asymtry	STRUCT • Value : INT • Value ST : BYTE END_STRUCT	– • 0 • 16#80	Asymmetry
SwtElmHeat	STRUCT • Value : INT • Value ST : BYTE END_STRUCT	– • 0 • 16#80	Switching element heating
SwtElmCoITm	STRUCT • Value : REAL • Value ST : BYTE END_STRUCT	– • 0.0 • 16#80	Remaining switching element cooling time in s
MotOvlTm	STRUCT • Value : REAL • Value ST : BYTE END_STRUCT	– • 0.0 • 16#80	Remaining time for motor overload protection in s
MotcolTm	STRUCT • Value : REAL • Value ST : BYTE END_STRUCT	– • 0.0 • 16#80	Remaining cool down time of the motor in s
MotTmpRis	STRUCT • Value : INT • Value ST : BYTE END_STRUCT	– • 0 • 16#80	Motor temperature rise
PwrFact	STRUCT • Value : REAL • Value ST : BYTE END_STRUCT	– • 0.0 • 16#80	Power factor L1..3
SwtFrqMon	STRUCT • Value : INT • Value ST : BYTE END_STRUCT	– • 0 • 16#80	Remaining switching frequency monitoring time in s

Parameters

A.3 3RW5Meas block parameters

Parameter	Data format	Default setting	Meaning
PhsCurAvg	STRUCT • Value : REAL • Value ST : BYTE END_STRUCT	– • 0.0 • 16#80	Phase current average (%)
PhsCurAvgE	STRUCT • Value : REAL • Value ST : BYTE END_STRUCT	– • 0.0 • 16#80	Phase current average (rms) in A
MaxPhsCur	STRUCT • Value : REAL • Value ST : BYTE END_STRUCT	– • 0.0 • 16#80	Maximum Phase current (rms) in A
TrpNo	INT	0	Trip Diagnostic number
WrngNo	INT	0	Warning diagnostic number
GenFit	STRUCT • Value : BOOL • Value ST : BYTE END_STRUCT	– • FALSE • 16#00	Group Fault
GenWarn	STRUCT • Value : BOOL • Value ST : BYTE END_STRUCT	– • FALSE • 16#00	Group Warning
TmpSnOvIF	STRUCT • Value : BOOL • Value ST : BYTE END_STRUCT	– • FALSE • 16#80	Temperature sensor overload Fault alarm
ThMotOvl	STRUCT • Value : BOOL • Value ST : BYTE END_STRUCT	– • FALSE • 16#80	Thermal motor model overload alarm
ExtMsg1Act	STRUCT • Value : BOOL • Value ST : BYTE END_STRUCT	– • FALSE • 16#80	External Message 1 Active
ExtMsg2Act	STRUCT • Value : BOOL • Value ST : BYTE END_STRUCT	– • FALSE • 16#80	External Message 2 Active
ExtMsg3Act	STRUCT • Value : BOOL • Value ST : BYTE END_STRUCT	– • FALSE • 16#80	External Message 3 Active

Parameter	Data format	Default setting	Meaning
ExtMsg4Act	STRUCT • Value : BOOL • Value ST : BYTE END_STRUCT	- • FALSE • 16#80	External Message 4 Active
OS_PermOut	DWORD	16#FFFFFFFF	Operator Permission: Output for OS
OS_PermLog	DWORD	16#FFFFFFFF	Operator Permission: Output for OS
OpSt_Out	DWORD	16#0	Enabled operator stations
ST_Worst	BYTE	16#80	Worst Signal Status
Status1	DWORD	16#00000000	Status 1 information
Status2	DWORD	16#00000000	Status 2 information
ErrorNum	INT	-1	Error Number
MsgErr1	BOOL	FALSE	1 = Messaging Error Occurs
MsgStat1	WORD	16#00	ALARM_8P: Status Output
MsgAckn1	WORD	16#00	ALARM_8P: ACK_STATE Output

A.4 3RW5Stat block parameters

Input parameters

Table A- 8 3RW5Stat input parameters

Block parameters	Data format	Default setting	Meaning
Mode	DWORD	16#8000FFFF	OMODE information from MOD_SWT block
DAddr	INT	0	Diagnostic address of Soft starter
LAddr	INT	0	Logical address of Soft starter
RackF	STRUCT • Value : BOOL • Value ST : BYTE END_STRUCT	– • FALSE • 16#80	1 = Rack failure information from 3RW5Diag block
ModF	STRUCT • Value : BOOL • Value ST : BYTE END_STRUCT	– • FALSE • 16#80	1 = Module Failure information from 3RW5Diag block
SlvType	BOOL	0	0 = PROFIBUS, 1 = PROFINET
DevType	INT	0	1, 2, 5, 6 = 3RW55; 3, 4 = 3RW52
RdWrEn	BOOL	TRUE	1 = Enable read / write record
RdDataLi	STRUCT • Value : BOOL • Value ST : BYTE END_STRUCT	– • FALSE • 16#80	Input 0->1: Read record via Link or SFC
RdDataOp	BOOL	FALSE	1 = Read data from datasets
PZDIn03	WORD	16#00	Process value DP 0.0-3.7
PZDIn1215	DWORD	16#00	Process value DP 12.0-15.7
OnOp	BOOL	FALSE	1 = On Mode: On Mode by Operator
OosOp	BOOL	FALSE	1 = Oos Mode: Oos Mode by Operator
OosLi	STRUCT • Value : BOOL • Value ST : BYTE END_STRUCT	– • FALSE • 16#80	1 = Oos Mode: Oos Mode by Field Signal
DelMaxPtr	BOOL	FALSE	Delete maximum pointer
RunUpCyc	INT	3	Number of cycles for which all messages are suppressed
MsgEvId1	DWORD	16#FF	Message Event ID 1

Block parameters	Data format	Default setting	Meaning
MsgLock	STRUCT • Value : BOOL • Value ST : BYTE END_STRUCT	– • FALSE • 16#80	Inhibit process message
BatchEn	BOOL	FALSE	Enable Remote Operation of Controller by Batch Recipe
BatchID	DWORD	16#00	Current Batch ID (number)
BatchName	STRING [32]	–	Current Batch Name
StepNo	DWORD	16#00	Batch Step Number
Occupied	BOOL	FALSE	Occupied by Batch
ExtMsg1	STRUCT • Value : BOOL • Value ST : BYTE END_STRUCT	– • FALSE • 16#80	External Message 1
ExtMsg2	STRUCT • Value : BOOL • Value ST : BYTE END_STRUCT	– • FALSE • 16#80	External Message 2
ExtMsg3	STRUCT • Value : BOOL • Value ST : BYTE END_STRUCT	– • FALSE • 16#80	External Message 3
ExtMsg4	STRUCT • Value : BOOL • Value ST : BYTE END_STRUCT	– • FALSE • 16#80	External Message 4
ExtMsg5	STRUCT • Value : BOOL • Value ST : BYTE END_STRUCT	– • FALSE • 16#80	External Message 5
ExtMsg6	STRUCT • Value : BOOL • Value ST : BYTE END_STRUCT	– • FALSE • 16#80	External Message 6
ExtMsg7	STRUCT • Value : BOOL • Value ST : BYTE END_STRUCT	– • FALSE • 16#80	External Message 7
ExtMsg8	STRUCT • Value : BOOL • Value ST : BYTE END_STRUCT	– • FALSE • 16#80	External Message 8

Parameters

A.4 3RW5Stat block parameters

Block parameters	Data format	Default setting	Meaning
ExtVa104	ANY	–	Associated External Value 4 for Messages (MsgEvID1)
ExtVa105	ANY	–	Associated External Value 5 for Messages (MsgEvID1)
ExtVa106	ANY	–	Associated External Value 6 for Messages (MsgEvID1)
ExtVa107	ANY	–	Associated External Value 7 for Messages (MsgEvID1)
ExtVa108	ANY	–	Associated External Value 8 for Messages (MsgEvID1)
ExtVa109	ANY	–	Associated External Value 9 for Messages (MsgEvID1)
ExtVa110	ANY	–	Associated External Value 10 for Messages (MsgEvID1)
OS_Perm	STRUCT	–	Operator Permissions
OpSt_In	DWORD	16#0	Enabled operator stations
Feature	STRUCT <ul style="list-style-type: none"> • Bit 0: BOOL • ... • Bit 31: BOOL 	– <ul style="list-style-type: none"> • 0 • 0 • 0 	Status of various features
ReserveIn	WORD	–	Reserved

Output parameters

Table A- 9 3RW5Stat output parameters

Block parameters	Data format	Default setting	Meaning
RackFact	STRUCT • Value : BOOL • Value ST : BYTE END_STRUCT	– • FALSE • 16#80	1 = Rack Failure
ModFact	STRUCT • Value : BOOL • Value ST : BYTE END_STRUCT	– • FALSE • 16#80	1 = Module Failure
GrpErr	STRUCT • Value : BOOL • Value ST : BYTE END_STRUCT	– • FALSE • 16#80	1 = Group error is active
RdErr	STRUCT • Value : BOOL • Value ST : BYTE END_STRUCT	– • FALSE • 16#80	1 = Error read record
WrErr	STRUCT • Value : BOOL • Value ST : BYTE END_STRUCT	– • FALSE • 16#80	1 = Error write record
LocalAct	STRUCT • Value : BOOL • Value ST : BYTE END_STRUCT	– • FALSE • 16#80	1 = Motor in Local Operation Mode: Local Mode Indicator
OnAct	STRUCT • Value : BOOL • ST : BYTE END_STRUCT	– • TRUE • 16#80	On Mode is active
OosAct	STRUCT • Value : BOOL • ST : BYTE END_STRUCT	– • TRUE • 16#80	Out of service is active
RdWrAct	STRUCT • Value : BOOL • ST : BYTE END_STRUCT	– • TRUE • 16#80	1 = Enable read / write record
RdErrStat	WORD	16#00	Status of read record error

Parameters

A.4 3RW5Stat block parameters

Block parameters	Data format	Default setting	Meaning
WrErrStat	WORD	16#00	Status of write record error
D_OpH	STRUCT • Value : DWORD • ST : BYTE END_STRUCT	– • 16#00000000 • 16#80	Operating hours - device
M_OpH	STRUCT • Value : DWORD • ST : BYTE END_STRUCT	– • 16#00000000 • 16#80	Operating hours - motor
N_OvITrp	STRUCT • Value : DINT • ST : BYTE END_STRUCT	– • 0 • 16#80	No. of overload trips
N_SwtElmTrp	STRUCT • Value : DINT • ST : BYTE END_STRUCT	– • 0 • 16#80	No. of switching element overload trips
N_StrCW	STRUCT • Value : DINT • ST : BYTE END_STRUCT	– • 0 • 16#80	No. of motor starts CW
N_StrCCW	STRUCT • Value : DINT • ST : BYTE END_STRUCT	– • 0 • 16#80	No. of motor starts CCW
N_EBrkStp	STRUCT • Value : DINT • ST : BYTE END_STRUCT	– • 0 • 16#80	No. of electrical braking Stops
N_StrOut1	STRUCT • Value : DINT • ST : BYTE END_STRUCT	– • 0 • 16#80	No. of starts output1
N_StrOut2	STRUCT • Value : DINT • ST : BYTE END_STRUCT	– • 0 • 16#80	No. of starts output2
N_StrOut3	STRUCT • Value : DINT • ST : BYTE END_STRUCT	– • 0 • 16#80	No. of starts output3

Block parameters	Data format	Default setting	Meaning
N_StrOut4	STRUCT • Value : DINT • ST : BYTE END_STRUCT	– • 0 • 16#80	No. of starts output4
Ph_I _{max}	STRUCT • Value : REAL • Value ST : BYTE END_STRUCT	– • 0.0 • 16#80	Phase Current max in %
Ph_I _{MaxE}	STRUCT • Value : REAL • Value ST : BYTE END_STRUCT	– • 0.0 • 16#80	Maximum phase current (rms) in A
LTrpCur	STRUCT • Value : REAL • Value ST : BYTE END_STRUCT	– • 0.0 • 16#80	Last tripping current I _A in %
LTrpCurE	STRUCT • Value : REAL • Value ST : BYTE END_STRUCT	– • 0.0 • 16#80	Last tripping current I _A (rms) in A
OphI18	STRUCT • Value : DWORD • ST : BYTE END_STRUCT	– • 16#00000000 • 16#80	Operating hours - motor current = 18...49.9% x I _e (max)
OphI50	STRUCT • Value : DWORD • ST : BYTE END_STRUCT	– • 16#00000000 • 16#80	Operating hours - motor current = 50...89.9% x I _e (max)
OphI90	STRUCT • Value : DWORD • ST : BYTE END_STRUCT	– • 16#00000000 • 16#80	Operating hours - motor current = 90...1199.9% x I _e (max)
OphI120	STRUCT • Value : DWORD • ST : BYTE END_STRUCT	– • 16#00000000 • 16#80	Operating hours - motor current = 120...1000% x I _e (max)
S_OpHMp	STRUCT • Value : DWORD • ST : BYTE END_STRUCT	– • 16#00000000 • 16#80	Operating hours - device

Parameters

A.4 3RW5Stat block parameters

Block parameters	Data format	Default setting	Meaning
MaxSwEleHe	STRUCT • Value : INT • Value ST : BYTE END_STRUCT	– • 0 • 16#80	Maximum switching element heating
N_OvITrpMp	STRUCT • Value : INT • Value ST : BYTE END_STRUCT	– • 0 • 16#80	No. of motor overload trips
N_BypOvITrp	STRUCT • Value : INT • Value ST : BYTE END_STRUCT	– • 0 • 16#80	No. of bypass overload trips
ActEImpT	STRUCT • Value : REAL • Value ST : BYTE END_STRUCT	– • 0.0 • 16#80	Active energy import total
ActEExpT	STRUCT • Value : REAL • Value ST : BYTE END_STRUCT	– • 0.0 • 16#80	Active energy export total
LstStrTm	STRUCT • Value : INT • Value ST : BYTE END_STRUCT	– • 0 • 16#80	Last real starting time
LFreqMin	STRUCT • Value : REAL • Value ST : BYTE END_STRUCT	– • 0.0 • 16#80	Minimum line frequency
LFreqMax	STRUCT • Value : REAL • Value ST : BYTE END_STRUCT	– • 0.0 • 16#80	Maximum Line frequency
UI1I2Min	STRUCT • Value : REAL • Value ST : BYTE END_STRUCT	– • 0.0 • 16#80	Line-to-line voltage U L1-L2 min
UI2I3Min	STRUCT • Value : REAL • Value ST : BYTE END_STRUCT	– • 0.0 • 16#80	Line-to-line voltage U L2-L3 min

Block parameters	Data format	Default setting	Meaning
UI311Min	STRUCT • Value : REAL • Value ST : BYTE END_STRUCT	– • 0.0 • 16#80	Line-to-line voltage U L3-L1 min
UI112Max	STRUCT • Value : REAL • Value ST : BYTE END_STRUCT	– • 0.0 • 16#80	Line-to-line voltage U L1-L2 max
UI213Max	STRUCT • Value : REAL • Value ST : BYTE END_STRUCT	– • 0.0 • 16#80	Line-to-line voltage U L2-L3 max
UI311Max	STRUCT • Value : REAL • Value ST : BYTE END_STRUCT	– • 0.0 • 16#80	Line-to-line voltage U L3-L1 max
CurL1Mn	STRUCT • Value : REAL • Value ST : BYTE END_STRUCT	– • 0.0 • 16#80	Minimum phase current I L1 in %
CurL2Mn	STRUCT • Value : REAL • Value ST : BYTE END_STRUCT	– • 0.0 • 16#80	Minimum phase current I L2 in %
CurL3Mn	STRUCT • Value : REAL • Value ST : BYTE END_STRUCT	– • 0.0 • 16#80	Minimum phase current I L3 in %
CurL1Mx	STRUCT • Value : REAL • Value ST : BYTE END_STRUCT	– • 0.0 • 16#80	Maximum phase current I L1 in %
CurL2Mx	STRUCT • Value : REAL • Value ST : BYTE END_STRUCT	– • 0.0 • 16#80	Maximum phase current I L2 in %
CurL3Mx	STRUCT • Value : REAL • Value ST : BYTE END_STRUCT	– • 0.0 • 16#80	Maximum phase current I L3 in %

Block parameters	Data format	Default setting	Meaning
CurL1MnE	STRUCT • Value : REAL • Value ST : BYTE END_STRUCT	– • 0.0 • 16#80	Minimum phase current I L1 (rms) in A
CurL2MnE	STRUCT • Value : REAL • Value ST : BYTE END_STRUCT	– • 0.0 • 16#80	Minimum phase current I L2 (rms) in A
CurL3MnE	STRUCT • Value : REAL • Value ST : BYTE END_STRUCT	– • 0.0 • 16#80	Minimum phase current I L3 (rms) in A
CurL1MxE	STRUCT • Value : REAL • Value ST : BYTE END_STRUCT	– • 0.0 • 16#80	Maximum phase current I L1 (rms) in A
CurL2MxE	STRUCT • Value : REAL • Value ST : BYTE END_STRUCT	– • 0.0 • 16#80	Maximum phase current I L2 (rms) in A
CurL3MxE	STRUCT • Value : REAL • Value ST : BYTE END_STRUCT	– • 0.0 • 16#80	Maximum phase current I L3 (rms) in A
MaxTrgl	STRUCT • Value : REAL • Value ST : BYTE END_STRUCT	– • 0.0 • 16#80	Maximum trigger current in %
MaxTrglE	STRUCT • Value : REAL • Value ST : BYTE END_STRUCT	– • 0.0 • 16#80	Maximum trigger current (rms) in A
OhI18Mp	STRUCT • Value : DWORD • ST : BYTE END_STRUCT	– • 16#00000000 • 16#80	Maximum pointer: Operating hours - motor current =18...49.9% x Ie
OphI50Mp	STRUCT • Value : DWORD • ST : BYTE END_STRUCT	– • 16#00000000 • 16#80	Maximum pointer: Operating hours - motor current =50...89.9% x Ie

Block parameters	Data format	Default setting	Meaning
OphI190Mp	STRUCT • Value : DWORD • ST : BYTE END_STRUCT	– • 16#00000000 • 16#80	Maximum pointer: Operating hours - motor current =90...1199.9% x Ie
OphI120Mp	STRUCT • Value : DWORD • ST : BYTE END_STRUCT	– • 16#00000000 • 16#80	Maximum pointer: Operating hours - motor current =120...1000% x Ie
StrCurlMax	STRUCT • Value : REAL • Value ST : BYTE END_STRUCT	– • 0.0 • 16#80	Starting current I max (rms) in A
StrCurlMax1	STRUCT • Value : REAL • Value ST : BYTE END_STRUCT	– • 0.0 • 16#80	Starting current I L1 max (rms) in A
StrCurlMax2	STRUCT • Value : REAL • Value ST : BYTE END_STRUCT	– • 0.0 • 16#80	Starting current I L2 max (rms) in A
StrCurlMax3	STRUCT • Value : REAL • Value ST : BYTE END_STRUCT	– • 0.0 • 16#80	Starting current I L3 max (rms) in A
N_StrExtByP	STRUCT • Value : INT • Value ST : BYTE END_STRUCT	– • 0 • 16#80	Number of starts with ext. bypass
OS_PermOut	DWORD	16#FFFFFFFF	Operator Permission: Output for OS
OS_PermLog	DWORD	16#FFFFFFFF	Operator Permission: Output for OS
OpSt_Out	DWORD	16#0	Enabled operator stations
ST_Worst	BYTE	16#80	Worst Signal Status
Status1	DWORD	16#00000000	Status 1 information
Status2	DWORD	16#00000000	Status 2 information
ErrorNum	INT	-1	Error Number
MsgErr1	BOOL	FALSE	1 = Messaging Error Occurs
MsgStat1	WORD	16#00	ALARM_8P: Status Output
MsgAckn1	WORD	16#00	ALARM_8P: ACK_STATE Output

A.5 3RW5Oprn block parameters

Input parameters

Table A- 10 3RW5Oprn input parameters

Parameter	Data format	Default setting	Meaning
Mode	DWORD	16#8000FFFF	OMODE information from MOD_SWT block
DAddr	INT	0	Diagnostic address of Soft Starter module
LAddr	INT	0	Logical address of Soft Starter module
Slv_Typ	BOOL	FALSE	0 = PROFIBUS 1 = PROFINET
DevType	INT	1	1 = 3RW55ST; 2 = 55HF; 3 = 52+ST; 4 = 52+ST+HMI; 5 = 55ST+HMI; 6 = 55HF+HMI
RackF	STRUCT • Value: BOOL • ST: BYTE	– • FALSE • 16#80	1 = Rack failure information from 3RW5Diag block
ModF	STRUCT • Value: BOOL • ST: BYTE	– • FALSE • 16#80	1 = Module failure information from 3RW5Diag block
RdWrEn	BOOL	TRUE	1 = Enable read / write record
RdDataLi	STRUCT • Value: BOOL • ST: BYTE	– • FALSE • 16#80	Input 0->1: Read record via Link or SFC
RdDataOp	BOOL	FALSE	1 = Read data from datasets
DiagOprn	DIAGOPRN3RW5	–	Diagnostic information from 3RW5Diag block
PZDIn03	DWORD	16#00	Process Image Input DP 0.0-3.7
PZDOut03	DWORD	16#00	Process image output DP 0.0-3.7
ModLiOp	STRUCT • Value: BOOL • ST: BYTE	– • FALSE • 16#80	Input to Auto/Manual commands: 0 = Manual 1 = Link/Auto
AutModOp	BOOL	FALSE	1 = Auto Mode: Auto Mode by Operator
ManModOp	BOOL	TRUE	1 = Manual Mode: Manual Mode by Operator

Parameter	Data format	Default setting	Meaning
AutModLi	STRUCT • Value: BOOL • ST: BYTE	– • FALSE • 16#80	1 = Auto Mode: Auto Mode by Linked or SFC
ManModLi	STRUCT • Value: BOOL • ST: BYTE	– • 0 • 16#80	1 = Manual Mode: Manual Mode by Linked or SFC
OosOp	BOOL	FALSE	1 = Oos Mode: Oos Mode by Operator
OosLi	STRUCT • Value: BOOL • ST: BYTE	– • FALSE • 16#80	1 = Oos Mode: Oos Mode by Field Signal
TrpRstLi	STRUCT • Value: BOOL • ST: BYTE	– • FALSE • 16#80	1 = Trip Reset Active, by Linked or SFC
TrpRstOp	BOOL	FALSE	1 = Trip Reset Active, Manual Mode Command
RdyToRst	STRUCT • Value: BOOL • ST: BYTE	– • FALSE • 16#80	1 = Ready to trip reset active
EmrgStMan	BOOL	FALSE	1 = Emergency Start Active, Manual Mode Command
EmrgStAut	STRUCT • Value: BOOL • ST: BYTE	– • FALSE • 16#80	1 = Emergency Start Active, Auto Mode Command
SltTstOp	BOOL	FALSE	1 = Self-test, Manual Mode Command
SltTstLi	STRUCT • Value: BOOL • ST: BYTE	– • FALSE • 16#80	1 = Self-test, Auto Mode Command
Out1Man	BOOL	FALSE	1 = Output1 Active, Manual Mode Command
Out1Aut	STRUCT • Value: BOOL • ST: BYTE	– • FALSE • 16#80	1 = Output1 Active, Auto Mode Command
Out2Man	BOOL	FALSE	1 = Output2 Active, Manual Mode Command
Out2Aut	STRUCT • Value: BOOL • ST: BYTE	– • FALSE • 16#80	1 = Output2 Active, Auto Mode Command
DsQkSpMan	BOOL	FALSE	1 = Disable quick stop Active, Manual Mode Command
DsQkSpAut	STRUCT • Value: BOOL • ST: BYTE	– • FALSE • 16#80	1 = Disable quick stop Active, Auto Mode Command

Parameter	Data format	Default setting	Meaning
Out3Man	BOOL	FALSE	1 = Output3 Active, Manual Mode Command
Out3Aut	STRUCT • Value: BOOL • ST: BYTE	– • FALSE • 16#80	1 = Output3 Active, Auto Mode Command
ParaSet	INT	1	Parameter Set Active
PmpClnMan	BOOL	FALSE	1 = Pump cleaning command, Manual Mode Command
PmpClnAut	STRUCT • Value: BOOL • ST: BYTE	– • FALSE • 16#80	1 = Pump cleaning command, Auto Mode Command
AltStpMan	BOOL	FALSE	1 = Alternative stopping mode active, Manual Mode Command
AltStpAut	STRUCT • Value: BOOL • ST: BYTE	– • FALSE • 16#80	1 = Alternative stopping mode active, Auto Mode Command
MtrStdMan	BOOL	FALSE	1 = Motor stand still command, Manual Mode Command
MtrStdAut	STRUCT • Value: BOOL • ST: BYTE	– • FALSE • 16#80	1 = Motor stand still command, Auto Mode Command
PS1_OpScale	STRUCT • High: REAL • Low: REAL	– • 400.0 • 19.0	Parameter set 1 Op_scale
PS2_OpScale	STRUCT • High: REAL • Low: REAL	– • 400.0 • 19.0	Parameter set 2 Op_scale
PS3_OpScale	STRUCT • High: REAL • Low: REAL	– • 400.0 • 19.0	Parameter set 3 Op_scale
PS1CurHi	STRUCT • Value: INT • ST: BYTE	– • 50 • 16#80	Para. Set1: Current upper limit error
PS1CurMH	STRUCT • Value: INT • ST: BYTE	– • 50 • 16#80	Para. Set1: Current upper limit maintenance demanded
PS1CurLo	STRUCT • Value: INT • ST: BYTE	– • 19 • 16#80	Para. Set1: Current lower limit error

Parameter	Data format	Default setting	Meaning
PS1CurML	STRUCT • Value: INT • ST: BYTE	– • 19 • 16#80	Para. Set1: Current lower limit maintenance demanded
PS2CurHi	STRUCT • Value: INT • ST: BYTE	– • 50 • 16#80	Para. Set2: Current upper limit error
PS2CurMH	STRUCT • Value: INT • ST: BYTE	– • 50 • 16#80	Para. Set2: Current upper limit maintenance demanded
PS2CurLo	STRUCT • Value: INT • ST: BYTE	– • 19 • 16#80	Para. Set2: Current lower limit error
PS2CurML	STRUCT • Value: INT • ST: BYTE	– • 19 • 16#80	Para. Set2: Current lower limit maintenance demanded
PS3CurHi	STRUCT • Value: INT • ST: BYTE	– • 50 • 16#80	Para. Set3: Current upper limit error
PS3CurMH	STRUCT • Value: INT • ST: BYTE	– • 50 • 16#80	Para. Set3: Current upper limit maintenance demanded
PS3CurLo	STRUCT • Value: INT • ST: BYTE	– • 19 • 16#80	Para. Set3: Current lower limit error
PS3CurML	STRUCT • Value: INT • ST: BYTE	– • 19 • 16#80	Para. Set3: Current lower limit maintenance demanded
SubValue	DWORD	16#00	Substitute Value on Response to CPU/master stop
CSF	STRUCT • Value: BOOL • ST: BYTE	– • FALSE • 16#80	Control System Fault Message - External Fault
BatchEn	BOOL	FALSE	Enable Remote Operation of Controller by Batch Recipe
BatchID	DWORD	16#00	Current Batch ID (number)
BatchName	STRING[32]	–	Current Batch Name
StepNo	DWORD	16#00	Batch Step Number
Occupied	BOOL	FALSE	Occupied by Batch

Parameters

A.5 3RW5Oprn block parameters

Parameter	Data format	Default setting	Meaning
MsgLock	STRUCT • Value: BOOL • ST: BYTE	– • FALSE • 16#80	Inhibit process message
RunUpCyc	INT	3	Number of cycles for which all messages are suppressed
MsgEvid	DWORD	16#00000000	Message Event ID
ExtMsg1	STRUCT • Value: BOOL • ST: BYTE	– • FALSE • 16#80	External Message 1
ExtMsg2	STRUCT • Value: BOOL • ST: BYTE	– • FALSE • 16#80	External Message 2
ExtMsg3	STRUCT • Value: BOOL • ST: BYTE	– • FALSE • 16#80	External Message 3
ExtVa106	ANY	–	Associated External Value 6 for Messages (MsgEVID1)
ExtVa107	ANY	–	Associated External Value 7 for Messages (MsgEVID1)
ExtVa108	ANY	–	Associated External Value 8 for Messages (MsgEVID1)
ExtVa109	ANY	–	Associated External Value 9 for Messages (MsgEVID1)
ExtVa110	ANY	–	Associated External Value 10 for Messages (MsgEVID1)
SelFp1	ANY	–	Select Faceplate 1
SelFp2	ANY	–	Select Faceplate 2
OS_Perm	STRUCT • Bit 0: BOOL • ... • Bit 31: BOOL	– • 1 • 1 • 1	Operator Permissions
OpSt_In	DWORD	16#0	Enabled operator stations
Feature	STRUCT • Bit 0: BOOL • ... • Bit 31: BOOL	– • 0 • 0 • 0	Status of various features
Monitor	BOOL	TRUE	Feedback monitor for control block
ReserveIn	WORD	–	Reserved

Output parameters

Table A- 11 3RW5Oprn output parameters

Parameter	Data format	Default setting	Meaning
RackFact	STRUCT • Value: BOOL • ST: BYTE	– • FALSE • 16#80	1 = Rack Failure
ModFact	STRUCT • Value: BOOL • ST: BYTE	– • FALSE • 16#80	1 = Module Failure
GrpErr	STRUCT • Value: BOOL • ST: BYTE	– • FALSE • 16#80	1 = Group error is active
RdErr	STRUCT • Value: BOOL • ST: BYTE	– • FALSE • 16#80	1 = Error read record
WrErr	STRUCT • Value: BOOL • ST: BYTE	– • FALSE • 16#80	1 = Error write record
RdWrAct	STRUCT • Value: BOOL • ST: BYTE	– • FALSE • 16#80	1 = Operator enabled for read / write record
RdDataOut	STRUCT • Value: BOOL • ST: BYTE	– • FALSE • 16#80	1 = Triggers Read operation of diagnostic data at 3RW5Diag
RdErrStat	WORD	16#00	Status of read record error
WrErrStat	WORD	16#00	Status of write record error
LocalAct	STRUCT • Value: BOOL • ST: BYTE	– • FALSE • 16#80	Local mode on
AutAct	STRUCT • Value: BOOL • ST: BYTE	– • FALSE • 16#80	1 = Auto: Automatic Mode Indicator
ManAct	STRUCT • Value: BOOL • ST: BYTE	– • TRUE • 16#80	Manual Mode is active
OutIn03	DWORD	16#00	Process Image Input PZDIn03

Parameters

A.5 3RW5Oprn block parameters

Parameter	Data format	Default setting	Meaning
OosAct	STRUCT • Value: BOOL • ST: BYTE	– • FALSE • 16#80	Out of service is active
SubAct	STRUCT • Value: BOOL • ST: BYTE	– • FALSE • 16#80	Substitute value is active
SubFwd	STRUCT • Value: BOOL • ST: BYTE	– • FALSE • 16#80	Substitute value Motor CW active
SubRev	STRUCT • Value: BOOL • ST: BYTE	– • FALSE • 16#80	Substitute value Motor CCW active
SubTrpRst	STRUCT • Value: BOOL • ST: BYTE	– • FALSE • 16#80	Substitute value Trip Reset
SubEmgStr	STRUCT • Value: BOOL • ST: BYTE	– • FALSE • 16#80	Substitute value Emergency start
SubCrpSpd	STRUCT • Value: BOOL • ST: BYTE	– • FALSE • 16#80	Substitute value Creep speed
SubOut1	STRUCT • Value: BOOL • ST: BYTE	– • FALSE • 16#80	Substitute value Output 1
SubOut2	STRUCT • Value: BOOL • ST: BYTE	– • FALSE • 16#80	Substitute value Output 2
SubPSBit0	STRUCT • Value: BOOL • ST: BYTE	– • FALSE • 16#80	Substitute value Parameter set bit 0
SubPSBit1	STRUCT • Value: BOOL • ST: BYTE	– • FALSE • 16#80	Substitute value Parameter set bit 1
SubDQkSp	STRUCT • Value: BOOL • ST: BYTE	– • FALSE • 16#80	Substitute value Disable quick stop

Parameter	Data format	Default setting	Meaning
SubOut3	STRUCT • Value: BOOL • ST: BYTE	– • FALSE • 16#80	Substitute value Output 3
SubPmpCln	STRUCT • Value: BOOL • ST: BYTE	– • FALSE • 16#80	Substitute value pump cleaning
SubOprLocl	STRUCT • Value: BOOL • ST: BYTE	– • FALSE • 16#80	Substitute value Manual operation local-input controlled
SubAltStp	STRUCT • Value: BOOL • ST: BYTE	– • FALSE • 16#80	Substitute value use alternative stopping mode
SubMtrstd	STRUCT • Value: BOOL • ST: BYTE	– • FALSE • 16#80	Substitute value Motor standstill
SlfTstOn	STRUCT • Value: BOOL • ST: BYTE	– • FALSE • 16#80	Self test active
Out1On	STRUCT • Value: BOOL • ST: BYTE	– • FALSE • 16#80	Output 1 active
Out2On	STRUCT • Value: BOOL • ST: BYTE	– • FALSE • 16#80	Output 2 active
MotorOn	STRUCT • Value: BOOL • ST: BYTE	– • FALSE • 16#80	Motor running status active (PII Bit 0.1 status)
TrpRstOn	STRUCT • Value: BOOL • ST: BYTE	– • FALSE • 16#80	Trip Reset
EmrgStOn	STRUCT • Value: BOOL • ST: BYTE	– • FALSE • 16#80	Emergency start
PSBit0	STRUCT • Value: BOOL • ST: BYTE	– • FALSE • 16#80	Parameter set bit 0

Parameters

A.5 3RW5Oprn block parameters

Parameter	Data format	Default setting	Meaning
PSBit1	STRUCT • Value: BOOL • ST: BYTE	– • FALSE • 16#80	Parameter set bit 1
DsQkSpOn	STRUCT • Value: BOOL • ST: BYTE	– • FALSE • 16#80	Disable quick stop active
Out3On	STRUCT • Value: BOOL • ST: BYTE	– • FALSE • 16#80	Output 3 active
PmpClnOn	STRUCT • Value: BOOL • ST: BYTE	– • FALSE • 16#80	Pump Cleaning mode active
AltStpOn	STRUCT • Value: BOOL • ST: BYTE	– • FALSE • 16#80	Alternative stopping mode active
MtrStdOn	STRUCT • Value: BOOL • ST: BYTE	– • FALSE • 16#80	Motor standstill on
DiagStn	DWORD	16#00	3RW5 PROFIBUS DP slave diagnostics
DiagCom1	DWORD	16#00	Communication and switching and controlling diagnostics
DiagCom2	DWORD	16#00	Communication and switching and controlling diagnostics
DiagPar	DWORD	16#00	Parameter diagnostics
DiagDev	DWORD	16#00	Device function diagnostics
FltPar	WORD	16#00	Diagnostic of faulty parameter number
RampOn	STRUCT • Value: BOOL • ST: BYTE	– • FALSE • 16#80	Ramp Operation Active (PII Bit 1.7 Status)
MotorCW	STRUCT • Value: BOOL • ST: BYTE	– • FALSE • 16#80	Motor running state CW active (PII Bit 2.0 Status)
MotorCCW	STRUCT • Value: BOOL • ST: BYTE	– • FALSE • 16#80	Motor running state CCW active (PII Bit 2.1 Status)
StrModAct	STRUCT • Value: BOOL • ST: BYTE	– • FALSE • 16#80	Start mode active (PII Bit 2.4 Status)

Parameter	Data format	Default setting	Meaning
BypassAct	STRUCT • Value: BOOL • ST: BYTE	– • FALSE • 16#80	Start mode active (PII Bit 2.5 Status)
StpModAct	STRUCT • Value: BOOL • ST: BYTE	– • FALSE • 16#80	Stop mode active (PII Bit 2.6 Status)
TstOpAct	STRUCT • Value: BOOL • ST: BYTE	– • FALSE • 16#80	Test operation active (PII Bit 2.7 Status)
ThrMotOvl	STRUCT • Value: BOOL • ST: BYTE	– • FALSE • 16#80	Thermal motor model overload (PII Bit 3.0 Status)
TmpSenOvl	STRUCT • Value: BOOL • ST: BYTE	– • FALSE • 16#80	Temperature sensor overload (PII Bit 3.1 Status)
SwtElmOvl	STRUCT • Value: BOOL • ST: BYTE	– • FALSE • 16#80	Switching overload (PII Bit 3.2 Status)
ColTmAct	STRUCT • Value: BOOL • ST: BYTE	– • FALSE • 16#80	Cooling time active (PII Bit 3.3 Status)
DevErr	STRUCT • Value: BOOL • ST: BYTE	– • FALSE • 16#80	Device error (PII Bit 3.4 Status)
AutParAct	STRUCT • Value: BOOL • ST: BYTE	– • FALSE • 16#80	Automatic parameterization active (PII Bit 3.5 Status)
ExParDet	STRUCT • Value: BOOL • ST: BYTE	– • FALSE • 16#80	New Ex parameter values detected (PII Bit 3.6 Status)
GrpFlt	STRUCT • Value: BOOL • ST: BYTE	– • FALSE • 16#80	Group fault (PII Bit 0.2 Status)
CSFlt	STRUCT • Value: BOOL • ST: BYTE	– • FALSE • 16#80	1 = Control system fault active

Parameters

A.5 3RW5Oprn block parameters

Parameter	Data format	Default setting	Meaning
GenWarn	STRUCT • Value: BOOL • ST: BYTE	– • FALSE • 16#00	General warning
GenFit	STRUCT • Value: BOOL • ST: BYTE	– • FALSE • 16#00	General fault
GrpWarn	STRUCT • Value: BOOL • ST: BYTE	– • FALSE • 16#80	Group warning (PII Bit 0.3 Status)
MotCurr	STRUCT • Value: REAL • ST: BYTE	– • 0.0 • 16#80	Actual motor current (%)
MotCurrE	STRUCT • Value: REAL • ST: BYTE	– • 0.0 • 16#80	Actual motor current in Amps
OS_PermOut	DWORD	16#FFFFFFFF	Operator Permission: Output for OS
OS_PermLog	DWORD	16#FFFFFFFF	Operator Permission: Output for OS
OpSt_Out	DWORD	16#0	Enabled operator stations
ST_Worst	BYTE	16#80	Worst Signal Status
Status1	DWORD	16#00000000	Status 1 Word
Status2	DWORD	16#00000000	Status 2 Word
ErrorNum	INT	-1	Error Number
TrpNo	INT	0	Trip Diagnostic number
WrngNo	INT	0	Warning diagnostic number
MsgErr1	BOOL	FALSE	1 = Messaging Error Occurs
MsgStat1	WORD	16#00	ALARM_8P: Status Output
MsgAckn1	WORD	16#00	ALARM_8P: ACK_STATE Output
ExtMsg1Act	STRUCT • Value: BOOL • ST: BYTE	– • FALSE • 16#80	External Message 1 Active
ExtMsg2Act	STRUCT • Value: BOOL • ST: BYTE	– • FALSE • 16#80	External Message 2 Active
ExtMsg3Act	STRUCT • Value: BOOL • ST: BYTE	– • FALSE • 16#80	External Message 3 Active

Parameter	Data format	Default setting	Meaning
PS1CurHiOut	STRUCT • Value: INT • ST: BYTE	– • 0 • 16#80	Parameter Set1: Current upper limit Out
PS1CurMHOu	STRUCT • Value: INT • ST: BYTE	– • 0 • 16#80	Parameter Set1: Current upper limit maintenance demand out
PS1CurLoOut	STRUCT • Value: INT • ST: BYTE	– • 0 • 16#80	Parameter Set1: Current lower limit Out
PS1MntLoOut	STRUCT • Value: INT • ST: BYTE	– • 0 • 16#80	Parameter Set1: Current lower limit maintenance demand Out
PS2CurHiOut	STRUCT • Value: INT • ST: BYTE	– • 0 • 16#80	Parameter Set2: Current upper limit Out
PS2CurMHOu	STRUCT • Value: INT • ST: BYTE	– • 0 • 16#80	Parameter Set2: Current upper limit maintenance demand out
PS2CurLoOut	STRUCT • Value: INT • ST: BYTE	– • 0 • 16#80	Parameter Set2: Current lower limit Out
PS2MntLoOut	STRUCT • Value: INT • ST: BYTE	– • 0 • 16#80	Parameter Set2: Current lower limit maintenance demand Out
PS3CurHiOut	STRUCT • Value: INT • ST: BYTE	– • 0 • 16#80	Parameter Set3: Current upper limit out
PS3CurMHOu	STRUCT • Value: INT • ST: BYTE	– • 0 • 16#80	Parameter Set3: Current upper limit maintenance demand out
PS3CurLoOut	STRUCT • Value: INT • ST: BYTE	– • 0 • 16#80	Parameter Set3: Current lower limit Out
PS3MntLoOut	STRUCT • Value: INT • ST: BYTE	– • 0 • 16#80	Parameter Set3: Current lower limit maintenance demand Out

Parameters

A.5 3RW5Oprn block parameters

Parameter	Data format	Default setting	Meaning
PS1StrMod	BYTE	16#5	Starting mode of soft starter
PS1StpMod	BYTE	16#0	Stopping mode of soft starter
PS2StrMod	BYTE	16#5	Starting mode of soft starter
PS2StpMod	BYTE	16#0	Stopping mode of soft starter
PS3StrMod	BYTE	16#5	Starting mode of soft starter
PS3StpMod	BYTE	16#0	Stopping mode of soft starter
AltStpMod	BYTE	16#0	Alternative stopping mode of soft starter
MonitorOn	BOOL	TRUE	Enable / disable monitoring for control block
ReserveOut	WORD	-	Reserved

A.6 3RW5Chn block parameters

Input parameters

Table A- 12 3RW5Chn input parameters

Parameter	Data format	Default setting	Meaning
PZDIn03	DWORD	16#00	Input word 0.0-3.7
MS_Release	STRUCT • Value : BOOL • Value ST : BYTE END_STRUCT	- • FALSE • 16#80	Maintenance release
MS	DWORD	0	Maintenance state
MS_Ext	DWORD	-	External Maintenance state
TextRef	WORD	0	Text reference external messages
DevType	INT	0	1,2,5,6 = 3RW55; 3,4= 3RW52
FlutEn	BOOL	0	1 = Flutter suppress active
FlutTmln	INT	0	Flutter suppress time
Stw	DWORD	16#00	Control word 0.0-3.7
Stw_ST	BYTE	16#00	Control word status
MotCW	STRUCT • Value : BOOL • Value ST : BYTE END_STRUCT	- • FALSE • 16#80	PIQ 0.0 Motor CW Command
MotCpCW	STRUCT • Value : BOOL • Value ST : BYTE END_STRUCT	- • FALSE • 16#80	Motor CW Creep Command (Input from 3RW5Ctrl to derive Creep speed direction)
MotCpCCW	STRUCT • Value : BOOL • Value ST : BYTE END_STRUCT	- • FALSE • 16#80	Motor CCW Creep Command (Input from 3RW5Ctrl to derive Creep speed direction)
MotCCW	STRUCT • Value : BOOL • Value ST : BYTE END_STRUCT	- • FALSE • 16#80	PIQ 0.1 Motor CCW Command
ResIn01	STRUCT • Value : BOOL • Value ST : BYTE END_STRUCT	- • FALSE • 16#80	PIQ 0.2 Reserved for future use

Parameters

A.6 3RW5Chn block parameters

Parameter	Data format	Default setting	Meaning
TrpRst	STRUCT • Value : BOOL • Value ST : BYTE END_STRUCT	– • FALSE • 16#80	PIQ 0.3 Trip Reset
EmrgSt	STRUCT • Value : BOOL • Value ST : BYTE END_STRUCT	– • FALSE • 16#80	PIQ 0.4 Emergency start
SlfTest	STRUCT • Value : BOOL • Value ST : BYTE END_STRUCT	– • FALSE • 16#80	PIQ 0.5 Self test (User-test)
CrpSpeed	STRUCT • Value : BOOL • Value ST : BYTE END_STRUCT	– • FALSE • 16#80	PIQ 0.6 Creep Speed
ResIn02	STRUCT • Value : BOOL • Value ST : BYTE END_STRUCT	– • FALSE • 16#80	PIQ 0.7 Reserved for future use
Out_1	STRUCT • Value : BOOL • Value ST : BYTE END_STRUCT	– • FALSE • 16#80	PIQ 1.0 Output1
Out_2	STRUCT • Value : BOOL • Value ST : BYTE END_STRUCT	– • FALSE • 16#80	PIQ 1.1 Output2
PSBit0	STRUCT • Value : BOOL • Value ST : BYTE END_STRUCT	– • FALSE • 16#80	PIQ 1.2 Parameter set bit 0
PSBit1	STRUCT • Value : BOOL • Value ST : BYTE END_STRUCT	– • FALSE • 16#80	PIQ 1.3 Parameter set bit 1
ResIn03	STRUCT • Value : BOOL • Value ST : BYTE END_STRUCT	– • FALSE • 16#80	PIQ 1.4 Reserved for future use

Parameter	Data format	Default setting	Meaning
ResIn04	STRUCT • Value : BOOL • Value ST : BYTE END_STRUCT	– • FALSE • 16#80	PIQ 1.5 Reserved for future use
ResIn05	STRUCT • Value : BOOL • Value ST : BYTE END_STRUCT	– • FALSE • 16#80	PIQ 1.6 Reserved for future use
DsQkStp	STRUCT • Value : BOOL • Value ST : BYTE END_STRUCT	– • FALSE • 16#80	PIQ 1.7 Disable quick-stop
Out_3	STRUCT • Value : BOOL • Value ST : BYTE END_STRUCT	– • FALSE • 16#80	PIQ 2.0 Output3
ResIn06	STRUCT • Value : BOOL • Value ST : BYTE END_STRUCT	– • FALSE • 16#80	PIQ 2.1 Reserved for future use
ResIn07	STRUCT • Value : BOOL • Value ST : BYTE END_STRUCT	– • FALSE • 16#80	PIQ 2.2 Reserved for future use
PmpCln	STRUCT • Value : BOOL • Value ST : BYTE END_STRUCT	– • FALSE • 16#80	PIQ 2.3 Pump cleaning
ResIn08	STRUCT • Value : BOOL • Value ST : BYTE END_STRUCT	– • FALSE • 16#80	PIQ 2.4 Reserved for future use
ResIn09	STRUCT • Value : BOOL • Value ST : BYTE END_STRUCT	– • FALSE • 16#80	PIQ 2.5 Reserved for future use
ResIn10	STRUCT • Value : BOOL • Value ST : BYTE END_STRUCT	– • FALSE • 16#80	PIQ 2.6 Reserved for future use

Parameters

A.6 3RW5Chn block parameters

Parameter	Data format	Default setting	Meaning
ResIn11	STRUCT • Value : BOOL • Value ST : BYTE END_STRUCT	– • FALSE • 16#80	PIQ 2.7 Reserved for future use
MnOpLocl	STRUCT • Value : BOOL • Value ST : BYTE END_STRUCT	– • FALSE • 16#80	PIQ 3.0 Manual operation local - input controlled
AltStpMo	STRUCT • Value : BOOL • Value ST : BYTE END_STRUCT	– • FALSE • 16#80	PIQ 3.1 Use alternative stopping mode
MotStdsl	STRUCT • Value : BOOL • Value ST : BYTE END_STRUCT	– • FALSE • 16#80	PIQ 3.2 Motor standstill
ResIn12	STRUCT • Value : BOOL • Value ST : BYTE END_STRUCT	– • FALSE • 16#80	PIQ 3.3 Reserved for future use
ResIn13	STRUCT • Value : BOOL • Value ST : BYTE END_STRUCT	– • FALSE • 16#80	PIQ 3.4 Reserved for future use
ResIn14	STRUCT • Value : BOOL • Value ST : BYTE END_STRUCT	– • FALSE • 16#80	PIQ 3.5 Reserved for future use
ResIn15	STRUCT • Value : BOOL • Value ST : BYTE END_STRUCT	– • FALSE • 16#80	PIQ 3.6 Reserved for future use
ResIn16	STRUCT • Value : BOOL • Value ST : BYTE END_STRUCT	– • FALSE • 16#80	PIQ 3.7 Reserved for future use
IScale	STRUCT • High : REAL • Low : REAL END_STRUCT	– • 100.0 • 0.0	Measurement End

Parameter	Data format	Default setting	Meaning
IUnit	INT	1342	Unit for the line measured current
Feature	STRUCT <ul style="list-style-type: none"> • Bit 0: BOOL • ... • Bit 31: BOOL 	– <ul style="list-style-type: none"> • 0 • 0 • 0 	Status of various features
ReserveIn	WORD	–	Reserved

Input and output parameters

Table A- 13 3RW5Chn input and output parameters

Parameter	Data format	Default setting	Meaning
Mode	DWORD	16#00000030	Quality and Mode
DataXchg	DWORD	0	Data exchange
DataXchg1	DWORD	0	Data exchange
MS_Xchg	DWORD	0	Maintenance State exchange

Output parameters

Table A- 14 3RW5Chn output parameters

Parameter	Data format	Default setting	Meaning
PZDOut03	DWORD	16#00	Output word 0.0-3.7
Bad	STRUCT <ul style="list-style-type: none"> • High : REAL • Low : REAL END_STRUCT	– <ul style="list-style-type: none"> • FALSE • 16#80 	1: Invalid Process values
ErrorNum	INT	0	Error Number
ModErr	STRUCT <ul style="list-style-type: none"> • High : REAL • Low : REAL END_STRUCT	– <ul style="list-style-type: none"> • FALSE • 16#80 	1: Drive out of order
OosAct	STRUCT <ul style="list-style-type: none"> • High : REAL • Low : REAL END_STRUCT	– <ul style="list-style-type: none"> • FALSE • 16#80 	Out of service is active
Zsw1	DWORD	–	Status word
FbMotRdy	STRUCT <ul style="list-style-type: none"> • High : REAL • Low : REAL END_STRUCT	– <ul style="list-style-type: none"> • FALSE • 16#80 	PII 0.0 Feedback of Motor Ready

Parameter	Data format	Default setting	Meaning
FbMotOn	STRUCT • High : REAL • Low : REAL END_STRUCT	– • FALSE • 16#80	PII 0.1 Feedback of Motor On
FbMotCW	STRUCT • High : REAL • Low : REAL END_STRUCT	– • FALSE • 16#80	PII 2.0 Feedback of Motor CW Running
FbCrpCW	STRUCT • High : REAL • Low : REAL END_STRUCT	– • FALSE • 16#80	Feedback of Motor running in Creep CW for 3RW5Ctrl block
FbCrpCCW	STRUCT • High : REAL • Low : REAL END_STRUCT	– • FALSE • 16#80	Feedback of Motor running in Creep CCW for 3RW5Ctrl block
FbMotCCW	STRUCT • High : REAL • Low : REAL END_STRUCT	– • FALSE • 16#80	PII 2.1 Feedback of Motor CCW Running
GrpErr	STRUCT • High : REAL • Low : REAL END_STRUCT	– • FALSE • 16#80	PII 0.2 Group error
GrpWar	STRUCT • High : REAL • Low : REAL END_STRUCT	– • FALSE • 16#80	PII 0.3 Group warning
Input_1	STRUCT • High : REAL • Low : REAL END_STRUCT	– • FALSE • 16#80	PII 0.4 Input1 activated
Input_2	STRUCT • High : REAL • Low : REAL END_STRUCT	– • FALSE • 16#80	PII 0.5 Input2 activated
Input_3	STRUCT • High : REAL • Low : REAL END_STRUCT	– • FALSE • 16#80	PII 0.6 Input3 activated

Parameter	Data format	Default setting	Meaning
Input_4	STRUCT • High : REAL • Low : REAL END_STRUCT	– • FALSE • 16#80	PII 0.7 Input4 activated
Imax	STRUCT • High : REAL • Low : REAL END_STRUCT	– • FALSE • 16#80	PII (1.0 - 1.5) Actual current in %
ManOpLoc	STRUCT • High : REAL • Low : REAL END_STRUCT	– • FALSE • 16#80	PII 1.6 Manual operation local active
RampOp	STRUCT • High : REAL • Low : REAL END_STRUCT	– • FALSE • 16#80	PII 1.7 Ramping Operation active
ResOu01	STRUCT • High : REAL • Low : REAL END_STRUCT	– • FALSE • 16#80	PII 2.2 Reserved for future use
ResOu02	STRUCT • High : REAL • Low : REAL END_STRUCT	– • FALSE • 16#80	PII 2.3 Reserved for future use
StrModAct	STRUCT • High : REAL • Low : REAL END_STRUCT	– • FALSE • 16#80	PII 2.4 Start mode active
BypAct	STRUCT • High : REAL • Low : REAL END_STRUCT	– • FALSE • 16#80	PII 2.5 Operation / bypass active
StpModAct	STRUCT • High : REAL • Low : REAL END_STRUCT	– • FALSE • 16#80	PII 2.6 Stop mode active
TstOprAct	STRUCT • High : REAL • Low : REAL END_STRUCT	– • FALSE • 16#80	PII 2.7 Test Operation active

Parameters

A.6 3RW5Chn block parameters

Parameter	Data format	Default setting	Meaning
ThMotOvl	STRUCT • High : REAL • Low : REAL END_STRUCT	– • FALSE • 16#80	PII 3.0 Thermal motor model overload active
TmpSnOvl	STRUCT • High : REAL • Low : REAL END_STRUCT	– • FALSE • 16#80	PII 3.1 Temperature sensor overload active
SwtEIOvl	STRUCT • High : REAL • Low : REAL END_STRUCT	– • FALSE • 16#80	PII 3.2 Switching element overload active
ColTmAct	STRUCT • High : REAL • Low : REAL END_STRUCT	– • FALSE • 16#80	PII 3.3 Cooling time active
DevErr	STRUCT • High : REAL • Low : REAL END_STRUCT	– • FALSE • 16#80	PII 3.4 Device error
AutPmAct	STRUCT • High : REAL • Low : REAL END_STRUCT	– • FALSE • 16#80	PII 3.5 Automatic parameterization active
NExParDet	STRUCT • High : REAL • Low : REAL END_STRUCT	– • FALSE • 16#80	PII 3.6 New Ex parameter values detected
ResOu03	STRUCT • High : REAL • Low : REAL END_STRUCT	– • FALSE • 16#80	PII 3.7 Reserved for future use
IScaleOut	STRUCT • High : REAL • Low : REAL END_STRUCT	– • FALSE • 16#80	Scale for the line measured current
IUnitOut	INT	0	Unit for the line measured current
ReserveOut	WORD	–	Reserved
MS_Req	STRUCT • High : REAL • Low : REAL END_STRUCT	– • FALSE • 16#80	Maintenance request

A.7 3RW5Ctrl block parameters

Input parameters

Parameter	Data format	Default setting	Meaning
CrpFwdAut	STRUCT <ul style="list-style-type: none"> Value: BOOL ST: BYTE 	– <ul style="list-style-type: none"> 1 16#80 	1 = Start: Creep Forward Start Command in Auto Mode
FwdAut	STRUCT <ul style="list-style-type: none"> Value: BOOL ST: BYTE 	– <ul style="list-style-type: none"> 1 16#FF 	1 = Start: Forward Start Command in Auto Mode
StopAut	STRUCT <ul style="list-style-type: none"> Value: BOOL ST: BYTE 	– <ul style="list-style-type: none"> 1 16#FF 	1 = Stop: Stop Command in Auto Mode
RevAut	STRUCT <ul style="list-style-type: none"> Value: BOOL ST: BYTE 	– <ul style="list-style-type: none"> 1 16#FF 	1 = Start: Reverse Start Command in Auto Mode
CrpRevAut	STRUCT <ul style="list-style-type: none"> Value: BOOL ST: BYTE 	– <ul style="list-style-type: none"> 1 16#FF 	1 = Start: Creep Reverse Command in Auto Mode
CrpFwdMan	BOOL	FALSE	1 = Start: Creep Forward Command in Manual Mode
FwdMan	BOOL	FALSE	1 = Start: Forward Start Command in Manual Mode
StopMan	BOOL	FALSE	1 = Stop: Stop Command in Manual Mode
RevMan	BOOL	FALSE	1 = Start: Reverse Start Command in Manual Mode
CrpRevMan	BOOL	FALSE	1 = Start: Creep Reverse Command in Manual Mode
ModLiOp	STRUCT <ul style="list-style-type: none"> Value: BOOL ST: BYTE 	– <ul style="list-style-type: none"> 0 16#80 	1 = Link / Auto, 0 = Manual: Input to Auto / Manual Commands
ManModLi	STRUCT <ul style="list-style-type: none"> Value: BOOL ST: BYTE 	– <ul style="list-style-type: none"> 0 16#80 	1 = Manual Mode: Manual Mode by Linked or SFC
AutModLi	STRUCT <ul style="list-style-type: none"> Value: BOOL ST: BYTE 	– <ul style="list-style-type: none"> 0 16#80 	1 = Auto Mode: Auto Mode by Linked or SFC

Parameter	Data format	Default setting	Meaning
LocalLi	STRUCT <ul style="list-style-type: none"> Value: BOOL ST: BYTE 	– <ul style="list-style-type: none"> 0 16#80 	1 = Local Mode: Local Operation by Field Signal
LocalOp	BOOL	FALSE	1 = Local Mode: Local Operation by Operator
AutModOp	BOOL	FALSE	1 = Auto Mode: Auto Mode by Operator
ManModOp	BOOL	FALSE	1 = Manual Mode: Manual Mode by Operator
MS_RelOp	BOOL	FALSE	Operator input for MS Release, 1: MS release requirement
OosOp	BOOL	FALSE	1 = Oos Mode: Oos Mode by Operator
OosLi	STRUCT <ul style="list-style-type: none"> Value: BOOL ST: BYTE 	– <ul style="list-style-type: none"> 0 16#80 	1 = Oos Mode: Oos Mode by Field Signal
CrpFwdLocal	STRUCT <ul style="list-style-type: none"> Value: BOOL ST: BYTE 	– <ul style="list-style-type: none"> 0 16#80 	1 = Start Local: Field Creep Forward Start Signal
FwdLocal	STRUCT <ul style="list-style-type: none"> Value: BOOL ST: BYTE 	– <ul style="list-style-type: none"> 0 16#80 	1 = Start Local: Field Forward Start Signal
StopLocal	STRUCT <ul style="list-style-type: none"> Value: BOOL ST: BYTE 	– <ul style="list-style-type: none"> 0 16#80 	1 = Stop Local: Field Stop Signal
RevLocal	STRUCT <ul style="list-style-type: none"> Value: BOOL ST: BYTE 	– <ul style="list-style-type: none"> 0 16#80 	1 = Start Local: Field Reverse Start Signal
CrpRevLocal	STRUCT <ul style="list-style-type: none"> Value: BOOL ST: BYTE 	– <ul style="list-style-type: none"> 0 16#80 	1 = Start Local: Field Creep Reverse Start Signal
LocalSetting	INT	0	Local Mode Behavior
FbkCrpFwd	STRUCT <ul style="list-style-type: none"> Value: BOOL ST: BYTE 	– <ul style="list-style-type: none"> 0 16#80 	Feedback of Control Creep Forward 1 = Run 0 = Stop
FbkFwd	STRUCT <ul style="list-style-type: none"> Value: BOOL ST: BYTE 	– <ul style="list-style-type: none"> 0 16#80 	Feedback of Control Forward: 0 = Stop 1 = Run

Parameter	Data format	Default setting	Meaning
FbkRev	STRUCT <ul style="list-style-type: none"> Value: BOOL ST: BYTE 	– <ul style="list-style-type: none"> 0 16#80 	Feedback of Control Reverse: 0 = Stop 1 = Run
FbkCrpRev	STRUCT <ul style="list-style-type: none"> Value: BOOL ST: BYTE 	– <ul style="list-style-type: none"> 0 16#80 	Feedback of Control Creep Reverse: 0 = Stop 1 = Run
Monitor	BOOL	TRUE	Feedback Monitor 0 = Monitor OFF 1 = Monitor ON
MonTiStatic	REAL	3.0	Monitoring Time of Feedback [s]
MonTiDynamic	REAL	3.0	Monitoring time of feedback error after operation in [s]
MonTiDyStop	REAL	3.0	Monitoring time of feedback on stopping in control output
SwOverTi	REAL	0.0	Switch over time to Creep Forward / Creep Reverse [s]
IdleTime	REAL	5.0	Offdelay Monitoring Time On Change Direction [s]
PulseWidth	REAL	3.0	Control Output Start / Stop Pulse Width [s]
WarnTiMan	REAL	0.0	Warning Time Prior to Motor Start [s]
WarnTiAut	REAL	0.0	Warning Time Prior to Motor Start in AUTO mode in [s]
RapidStp	BOOL	0	1 = Motor Rapid Stop command
RstOp	BOOL	0	Operator Reset Signal
RstLi	STRUCT <ul style="list-style-type: none"> Value: BOOL ST: BYTE 	– <ul style="list-style-type: none"> 0 16#80 	1 = ready to reset via RstLi or automatic commands
ByProt	BOOL	FALSE	Bypass Protection in Sim/Local Modes
Trip	STRUCT <ul style="list-style-type: none"> Value: BOOL ST: BYTE 	– <ul style="list-style-type: none"> 1 16#FF 	1 = Motor Healthy State, 0 = Motor Tripped Signal
Permit	STRUCT <ul style="list-style-type: none"> Value: BOOL ST: BYTE 	– <ul style="list-style-type: none"> 1 16#FF 	0 = Not Allowed to Activate Motor 1 = Permit is OK
Perm_En	BOOL	TRUE	0 = Permit disabled 1 = Permit enabled
PermRev	STRUCT <ul style="list-style-type: none"> Value: BOOL ST: BYTE 	– <ul style="list-style-type: none"> 1 16#FF 	1 = Permit Rev / CrpRev is OK, 0 = Not Allowed to Activate Motor Rev / CrpRev

Parameter	Data format	Default setting	Meaning
PermRevEn	BOOL	TRUE	0 = Permit Rev / CrpRev disabled 1 = Permit Rev / CrpRev enabled
Intlock	STRUCT <ul style="list-style-type: none"> Value: BOOL ST: BYTE 	– <ul style="list-style-type: none"> 1 16#FF 	0 = Motor / Motor Fwd / CrpFwd is Interlocked, 1 = Motor / Motor Fwd / CrpFwd is Not Interlocked
Intl_En	BOOL	TRUE	0 = Interlock disabled 1 = Interlock enabled
IntlRev	STRUCT <ul style="list-style-type: none"> Value: BOOL ST: BYTE 	– <ul style="list-style-type: none"> 1 16#FF 	0 = Motor Rev / CrpRev is Interlocked, 1 = Motor Rev / CrpRev is Not Interlocked
IntlRevEn	BOOL	TRUE	0 = Interlock Rev / CrpRev disabled 1 = Interlock Rev / CrpRev enabled
Protect	STRUCT <ul style="list-style-type: none"> Value: BOOL ST: BYTE 	– <ul style="list-style-type: none"> 1 16#FF 	0 = Protect. / Prot. Fwd / CrpFwd is active, 1 = Protect. / Prot. Fwd / CrpFwd is not active
Prot_En	BOOL	TRUE	0 = Protection disabled 1 = Protection enabled
ProtRev	STRUCT <ul style="list-style-type: none"> Value: BOOL ST: BYTE 	– <ul style="list-style-type: none"> 1 16#FF 	0 = Protection Rev / CrpRev is active, 1 = Protection Rev / CrpRev is not active
ProtRevEn	BOOL	TRUE	0 = Protection Rev / CrpRev disabled 1 = Protection Rev / CrpRev enabled
CrpFwdForce	STRUCT <ul style="list-style-type: none"> Value: BOOL ST: BYTE 	– <ul style="list-style-type: none"> 0 16#80 	1 = Start: Creep Forward Start Command in Forced Operation
FwdForce	STRUCT <ul style="list-style-type: none"> Value: BOOL ST: BYTE 	– <ul style="list-style-type: none"> 0 16#80 	1 = Start: Forward Start Command in Forced Operation
StopForce	STRUCT <ul style="list-style-type: none"> Value: BOOL ST: BYTE 	– <ul style="list-style-type: none"> 0 16#80 	1 = Stop: Stop Command in Forced Operation
RevForce	STRUCT <ul style="list-style-type: none"> Value: BOOL ST: BYTE 	– <ul style="list-style-type: none"> 0 16#80 	1 = Start: Reverse Start Command in Forced Operation
CrpRevForce	STRUCT <ul style="list-style-type: none"> Value: BOOL ST: BYTE 	– <ul style="list-style-type: none"> 0 16#80 	1 = Start: Creep Reverse Command in Forced Operation
UserAna1	STRUCT <ul style="list-style-type: none"> Value: REAL ST: BYTE 	– <ul style="list-style-type: none"> 0.0 16#80 	User Analog Input 1

Parameter	Data format	Default setting	Meaning
UA1unit	INT	0	Unit of UserAna1
UserAna2	STRUCT <ul style="list-style-type: none"> Value: REAL ST: BYTE 	– <ul style="list-style-type: none"> 0 16#FF 	User Analog Input 2
UA2unit	INT	0	Unit of UserAna2
FwdChnST	STRUCT <ul style="list-style-type: none"> Value: BOOL ST: BYTE 	– <ul style="list-style-type: none"> 0.0 16#FF 	Output channel state of Forward
RevChnST	STRUCT <ul style="list-style-type: none"> Value: BOOL ST: BYTE 	– <ul style="list-style-type: none"> 0 16#80 	Output channel state of Reverse
CrpFwdChnST	STRUCT <ul style="list-style-type: none"> Value: BOOL ST: BYTE 	– <ul style="list-style-type: none"> 0 16#FF 	Output channel state of CrpFwd
CrpRevChnST	STRUCT <ul style="list-style-type: none"> Value: BOOL ST: BYTE 	– <ul style="list-style-type: none"> 0 16#80 	Output channel state of Creep Reverse
MsgLock	STRUCT <ul style="list-style-type: none"> Value: REAL ST: BYTE 	– <ul style="list-style-type: none"> 0.0 16#80 	Inhibit process message
SampleTime	REAL	0.1	Sampling Time [s]
SimLiOp	STRUCT <ul style="list-style-type: none"> Value: REAL ST: BYTE 	– <ul style="list-style-type: none"> 0.0 16#80 	Simulation on / off via 0 = Operator, 1 = Interconnection or SFC
SimOnLi	STRUCT <ul style="list-style-type: none"> Value: REAL ST: BYTE 	– <ul style="list-style-type: none"> 0.0 16#80 	1 = Simulation activated by interconnection or SFC (controlled by SimLiOp = 1)
SimOn	BOOL	FALSE	Simulation On / Off
RunUpCyc	INT	3	Number of cycles for which all messages are suppressed
MsgEvId1	DWORD	16#00	Message Event ID 1
MsgEvId2	DWORD	16#00	Message Event ID 2
BatchEn	BOOL	FALSE	Enable Remote Operation of Controller by Batch Recipe
Occupied	BOOL	FALSE	Occupied by Batch
BatchID	DWORD	16#00	Current Batch ID (number)
BatchName	STRING[32]	–	Current Batch Name
StepNo	DWORD	16#00	Batch step number

Parameter	Data format	Default setting	Meaning
CSF	STRUCT <ul style="list-style-type: none"> Value: REAL ST: BYTE 	– <ul style="list-style-type: none"> 0.0 16#80 	Control System Fault Message - External Error
ExtMsg1	STRUCT <ul style="list-style-type: none"> Value: REAL ST: BYTE 	– <ul style="list-style-type: none"> 0.0 16#80 	External Message 1
ExtMsg2	STRUCT <ul style="list-style-type: none"> Value: REAL ST: BYTE 	– <ul style="list-style-type: none"> 0.0 16#80 	External Message 2
ExtMsg3	STRUCT <ul style="list-style-type: none"> Value: REAL ST: BYTE 	– <ul style="list-style-type: none"> 0.0 16#80 	External Message 3
ExtMsg4	STRUCT <ul style="list-style-type: none"> Value: REAL ST: BYTE 	– <ul style="list-style-type: none"> 0.0 16#80 	External Message 4
ExtMsg5	STRUCT <ul style="list-style-type: none"> Value: REAL ST: BYTE 	– <ul style="list-style-type: none"> 0.0 16#80 	External Message 5
ExtMsg6	STRUCT <ul style="list-style-type: none"> Value: REAL ST: BYTE 	– <ul style="list-style-type: none"> 0.0 16#80 	External Message 6
ExtMsg7	STRUCT <ul style="list-style-type: none"> Value: REAL ST: BYTE 	– <ul style="list-style-type: none"> 0.0 16#80 	External Message 7
ExtMsg8	STRUCT <ul style="list-style-type: none"> Value: REAL ST: BYTE 	– <ul style="list-style-type: none"> 0.0 16#80 	External Message 8
ExtMsg9	STRUCT <ul style="list-style-type: none"> Value: REAL ST: BYTE 	– <ul style="list-style-type: none"> 0.0 16#80 	External Message 9
ExtMsg10	STRUCT <ul style="list-style-type: none"> Value: REAL ST: BYTE 	– <ul style="list-style-type: none"> 0.0 16#80 	External Message 10
ExtMsg11	STRUCT <ul style="list-style-type: none"> Value: REAL ST: BYTE 	– <ul style="list-style-type: none"> 0.0 16#80 	External Message 11

Parameter	Data format	Default setting	Meaning
ExtVa104	ANY	–	Associated value 4 for messages (MsgEvID1)
ExtVa105	ANY	–	Associated value 5 for messages (MsgEvID1)
ExtVa106	ANY	–	Associated value 5 for messages (MsgEvID1)
ExtVa107	ANY	–	Associated value 7 for messages (MsgEvID1)
ExtVa108	ANY	–	Associated value 8 for messages (MsgEvID1)
ExtVa204	ANY	–	Associated value 4 for messages (MsgEvID2)
ExtVa205	ANY	–	Associated value 5 for messages (MsgEvID2)
ExtVa206	ANY	–	Associated value 6 for messages (MsgEvID2)
ExtVa207	ANY	–	Associated value 7 for messages (MsgEvID2)
ExtVa208	ANY	–	Associated value 8 for messages (MsgEvID2)
UserStatus	BYTE	16#00	User Status Bits
SelFp1	ANY	–	Select Faceplate 1
SelFp2	ANY	–	Select Faceplate 2
SelMeas	ANY	–	Select Measurement Faceplate
SelStat	ANY	–	Select Statistic Faceplate
OS_Perm	STRUCT <ul style="list-style-type: none"> • Bit 0: BOOL • ... • Bit 31: BOOL 	<ul style="list-style-type: none"> • 1 • ... • 1 	Operator Permissions
OpSt_In	DWORD	16#00000000	Enabled operator stations
Feature	STRUCT <ul style="list-style-type: none"> • Bit 0: BOOL • ... • Bit 31: BOOL 	<ul style="list-style-type: none"> • 0 • 0 • 0 	Status of various features
Feature2	STRUCT <ul style="list-style-type: none"> • Bit 0: BOOL • ... • Bit 31: BOOL 	<ul style="list-style-type: none"> • 0 • 0 • 0 	Status of various features
FaultExt	STRUCT <ul style="list-style-type: none"> • Value: BOOL • ST: BYTE 	<ul style="list-style-type: none"> • 0 • 16#80 	External error
EventTsln	ANY	-	Timestamp parameters
ReserveIn	WORD	16#00	Reserved

Output parameter

Parameter	Data format	Default setting	Meaning
CurrMon	DINT	0	Current monitoring time [s]
MS_Release	STRUCT • Value: BOOL • ST: BYTE	– • 0 • 16#80	1: MS release
MonDynErr	STRUCT • Value: BOOL • ST: BYTE	– • 0 • 16#80	Feedback Error on change in control output
MonStaErr	STRUCT • Value: BOOL • ST: BYTE	– • 0 • 16#80	Feedback Error on unexpected feedback change
MonDynStopErr	STRUCT • Value: BOOL • ST: BYTE	– • 0 • 16#80	1 = Feedback stop error due to control change
R_StpAct	STRUCT • Value: BOOL • ST: BYTE	– • 0 • 16#80	1 = Rapid stop is active
LockAct	STRUCT • Value: BOOL • ST: BYTE	– • 0 • 16#80	1 = Interlock (Permit, Interlock or Protect) or Trip is active
GrpErr	STRUCT • Value: BOOL • ST: BYTE	– • 0 • 16#80	1 = Group error is active
RdyToStart	STRUCT • Value: BOOL • ST: BYTE	– • 0 • 16#80	1 = Ready to start
RdyToReset	STRUCT • Value: BOOL • ST: BYTE	– • 0 • 16#80	1 = Ready to reset via RstLi or automatic commands
WarnAct	STRUCT • Value: BOOL • ST: BYTE	– • 0 • 16#80	Warning Prior to Motor Start in Auto/Manual Mode
CrpSpd	STRUCT • Value: BOOL • ST: BYTE	– • 0 • 16#80	Control Output to Start in Creep (For 3RW5Chn block)
CrpFwd	STRUCT • Value: BOOL • ST: BYTE	– • 0 • 16#80	Control Output to Start Creep Forward

Parameter	Data format	Default setting	Meaning
Fwd	STRUCT • Value: BOOL • ST: BYTE	– • 0 • 16#80	Control Output to Start Motor Forward
Rev	STRUCT • Value: BOOL • ST: BYTE	– • 0 • 16#80	Control Output to Start Motor Reverse
CrpRev	STRUCT • Value: BOOL • ST: BYTE	– • 0 • 16#80	Control Output to Start Creep Reverse
P_CrpSpd	STRUCT • Value: BOOL • ST: BYTE	– • 0 • 16#80	Pulsive Control Output to Start in Creep Speed (For 3RW5Chn block)
P_CrpFwd	STRUCT • Value: BOOL • ST: BYTE	– • 0 • 16#80	Pulsive Control Output to Start Motor Forward
P_Fwd	STRUCT • Value: BOOL • ST: BYTE	– • 0 • 16#80	Pulsive Control Output to Start Motor Forward
P_Stop	STRUCT • Value: BOOL • ST: BYTE	– • 1 • 16#80	Pulsive Control Output to Stop
P_Rev	STRUCT • Value: BOOL • ST: BYTE	– • 0 • 16#80	Pulsive Control Output to Start Motor Reverse
P_CrpRev	STRUCT • Value: BOOL • ST: BYTE	– • 0 • 16#80	Pulsive Control Output to Start Motor Reverse
P_Rst	STRUCT • Value: BOOL • ST: BYTE	– • 0 • 16#80	Reset Impulse
LocalAct	STRUCT • Value: BOOL • ST: BYTE	– • 0 • 16#80	1 = Motor in Local Operation Mode: Local Mode Indicator
AutAct	STRUCT • Value: BOOL • ST: BYTE	– • 0 • 16#80	1 = Auto: Automatic Mode Indicator

Parameter	Data format	Default setting	Meaning
ManAct	STRUCT • Value: BOOL • ST: BYTE	– • 1 • 16#80	Manual value is active
OosAct	STRUCT • Value: BOOL • ST: BYTE	– • 0 • 16#80	Out of service is active
FbkCrpFwdOut	STRUCT • Value: BOOL • ST: BYTE	– • 0 • 16#80	Feedback of Control Creep Forward 0 = Stop 1 = Creep Forward
FbkFwdOut	STRUCT • Value: BOOL • ST: BYTE	– • 0 • 16#80	Feedback of Control Forward 0 = Stop 1 = Run
FbkRevOut	STRUCT • Value: BOOL • ST: BYTE	– • 0 • 16#80	Feedback of Control Reverse 0 = Stop 1 = Run
FbkCrpRevOut	STRUCT • Value: BOOL • ST: BYTE	– • 0 • 16#80	Feedback of Control Creep Reverse 0 = Stop 1 = Creep Reverse
RunCrpFwd	STRUCT • Value: BOOL • ST: BYTE	– • 0 • 16#80	1 = Motor running with Creep Forward
RunCrpSpd	STRUCT • Value: BOOL • ST: BYTE	– • 0 • 16#80	1 = Motor running with Creep Speed
RunFwd	STRUCT • Value: BOOL • ST: BYTE	– • 0 • 16#80	1 = Motor running forward
Stop	STRUCT • Value: BOOL • ST: BYTE	– • 0 • 16#80	1 = Motor STOP
RunRev	STRUCT • Value: BOOL • ST: BYTE	– • 0 • 16#80	1 = Motor running reverse
RunCrpRev	STRUCT • Value: BOOL • ST: BYTE	– • 0 • 16#80	1 = Motor running with Creep Reverse

Parameter	Data format	Default setting	Meaning
Starting	STRUCT <ul style="list-style-type: none"> Value: BOOL ST: BYTE 	– <ul style="list-style-type: none"> 0 16#80 	1 = Motor starting
Stopping	STRUCT <ul style="list-style-type: none"> Value: BOOL ST: BYTE 	– <ul style="list-style-type: none"> 0 16#80 	1 = Motor stopping
OS_PermOut	DWORD	16#FFFFFFFF	Operator Permission: Output for OS
OS_PermLog	DWORD	16#FFFFFFFF	Operator Permission: Output for OS
OpSt_Out	DWORD	16#00000000	Enabled operator stations
Status1	DWORD	16#00000000	Status1 Word
Status2	DWORD	16#00000000	Status2 Word
Status3	DWORD	16#00000000	Status3 Word
Status4	DWORD	16#00000000	Status4 Word
ST_Worst	BYTE	16#80	Worst Signal Status
AutoST	BYTE	16#80	Worst Signal Status of the Automatic Commands
ErrorNum	INT	-1	Error Number
MsgErr1	BOOL	FALSE	1 = Messaging Error Occurs
MsgStat1	WORD	16#00	Message status 1
MsgAckn1	WORD	16#00	Message acknowledgement status 1
MsgErr2	BOOL	FALSE	1 = Messaging Error Occurs
MsgStat2	WORD	16#00	Message status 2
MsgAckn2	WORD	16#00	Message acknowledgement status 2
ReserveOut	WORD	16#00	Reserved

Technical data

B.1 Technical data

Table B- 1 Memory requirement, FB number, and called blocks, per block type

Name of block ¹⁾	FB no. ²⁾	Length of block in the load memory, in bytes ³⁾	Length of block in the work memory, in bytes ³⁾	Length of instance data in the load memory, in bytes ⁴⁾	Length of instance data in the work memory, in bytes ⁴⁾	Temporary memory, in bytes ⁵⁾	Blocks called ⁶⁾
3RW5Diag	FB 1335	8734	7462	1490	498	438	SFB 35 SFB 52 SFB 54 FC 369 SFC 13 SFC 51 SFC 6
3RW5Oprn	FB 1336	32502	28478	5370	2494	238	SFB 35 SFB 52 SFB 53 SFB 54 FC 369 SFC 6 SFC 20
3RW5Meas	FB 1337	10386	8674	2086	784	104	SFB 35 SFB 52 FC 369 SFC 6 SFC 20
3RW5Stat	FB 1338	9680	8110	2582	1232	94	SFB 35 SFB 52 SFB 53 FC 369 SFC 6 SFC 20

B.1 Technical data

Name of block ¹⁾	FB no. ²⁾	Length of block in the load memory, in bytes ³⁾	Length of block in the work memory, in bytes ³⁾	Length of instance data in the load memory, in bytes ⁴⁾	Length of instance data in the work memory, in bytes ⁴⁾	Temporary memory, in bytes ⁵⁾	Blocks called ⁶⁾
3RW5Chn	FB 1339	4638	3726	1070	286	32	-
3RW5Ctrl ⁵⁵	FB 1340	28466	25814	2842	936	130	SFB 35 FC 369 SFC 20 SFC 6

- 1) The symbolic designator in the symbol table of the library for the respective function block (FB). It must be unique within the project.
- 2) Composed of the block type, e.g., FB for function block and the number.
- 3) Memory requirement of program code, once per block type
- 4) Memory requirement for an instance data block.
- 5) The memory required for the local data when the block is called in an execution level. This is limited according to the specific CPU. If this amount is exceeded, you must check the setting in the CPU configuration and redistribute it among the organization blocks based on the actual requirement.
- 6) The relevant driver block uses these blocks. They are now located in the user program. They are stored in the same library.
- 55 Applicable only for 3RW55.

Abbreviations

C.1 Abbreviations

Table C- 1 Meaning of abbreviations

Abbreviation	Meaning
AS	Automation station
CFC	Continuous Function Chart
CCW	Counter-clockwise
CW	Clockwise
CSF	Control System Fault
DC	Direct-current voltage
DP	Distributed Peripherals
ES	Engineering system
FB	Function block
GSD	Generic Station Description
HW Config	"Hardware configuration" module in SIMATIC Manager
HMI	Human Machine Interface
ID	Identification number
OB	Organization block
OM	Object Manager
OoS	Out of Service
OS	Operator station
PCS 7	Process Control System 7
PIO	Process image output
PII	Process image input
PDM	Process Device Manager
PG	Programming device
PS	Parameter set
SFB	System function block
SFC	System function call
SSL	System status list
TIA	Totally Integrated Automation

