

# SIEMENS

## SITOP power supply

### SITOP PSU8200 1ph

#### Manual

#### Overview

---

Safety instructions

1

Description, device design,  
dimension drawing

2

Mounting/removal

3

Mounting position, mounting  
clearances

4

Installation

5

Technical data

6

Safety, approvals, EMC

7

Ambient conditions

8

Applications

9

Environment

10

Service & Support

11

SITOP PSU8200 24 V/5 A  
6EP3333-8SB00-0AY0  
SITOP PSU8200 24 V/10 A  
6EP3334-8SB00-0AY0  
SITOP PSU8200 24 V/20 A  
6EP1336-3BA10

11.2014

C98130-A7633-A1-3-7629

## Legal information

### Warning notice system

This manual contains notices you have to observe in order to ensure your personal safety, as well as to prevent damage to property. The notices referring to your personal safety are highlighted in the manual by a safety alert symbol, notices referring only to property damage have no safety alert symbol. These notices shown below are graded according to the degree of danger.

#### **DANGER**

indicates that death or severe personal injury **will** result if proper precautions are not taken.

#### **WARNING**

indicates that death or severe personal injury **may** result if proper precautions are not taken.

#### **CAUTION**

indicates that minor personal injury can result if proper precautions are not taken.

#### **NOTICE**

indicates that property damage can result if proper precautions are not taken.

If more than one degree of danger is present, the warning notice representing the highest degree of danger will be used. A notice warning of injury to persons with a safety alert symbol may also include a warning relating to property damage.

### Qualified Personnel

The product/system described in this documentation may be operated only by **personnel qualified** for the specific task in accordance with the relevant documentation, in particular its warning notices and safety instructions. Qualified personnel are those who, based on their training and experience, are capable of identifying risks and avoiding potential hazards when working with these products/systems.

### Proper use of Siemens products

Note the following:

#### **WARNING**

Siemens products may only be used for the applications described in the catalog and in the relevant technical documentation. If products and components from other manufacturers are used, these must be recommended or approved by Siemens. Proper transport, storage, installation, assembly, commissioning, operation and maintenance are required to ensure that the products operate safely and without any problems. The permissible ambient conditions must be complied with. The information in the relevant documentation must be observed.

### Trademarks

All names identified by ® are registered trademarks of Siemens AG. The remaining trademarks in this publication may be trademarks whose use by third parties for their own purposes could violate the rights of the owner.

### Disclaimer of Liability

We have reviewed the contents of this publication to ensure consistency with the hardware and software described. Since variance cannot be precluded entirely, we cannot guarantee full consistency. However, the information in this publication is reviewed regularly and any necessary corrections are included in subsequent editions.

# Overview



1-phase SITOP PSU820 power supplies from the SITOP modular product line are high-performance, regulated technology power supplies for automated systems and machines.

In addition to the basic functions required, these low-profile power supply units have an outstanding overload behavior.

The key benefits of the product include:

- Suitable for connecting to almost any 1-phase line supply around the world
- AC and DC input voltages possible (only for 6EP1336-3BA10)
- Output voltage can be adjusted in the range 24..28.8 V
- Power boost during operation with 300% rated current for 25 ms
- Extra-Power with 1.5x rated current for 5 seconds for switching on loads with a high inrush current
- Especially low width without requiring any lateral mounting clearances
- Ambient temperature -25 ...+70° C (derating from +60° C)
- Selectable short-circuit response (constant current or latching shutdown)
- A soft characteristic can be selected for a parallel connection (for uniform load distribution of power supply units of the same type)

- Display of the operating state using 3 LEDs
- "24 V O.K." signaling contact
- Remote "ON/OFF" contact for switching the power supply output in a no current condition (only for 6EP3333-8SB00-0AY0 and 6EP3334-8SB00-0AY0)
- To increase the system availability, these reliable power supplies can be expanded using SITOP supplementary modules (redundancy module, selectivity module, buffer module), as well as SITOP DC-UPS modules

### Ordering data

The following device versions are available:

Regulated power supply unit SITOP PSU-8200 1ph	
Type	Order number
120/230 VAC input, 24 V / 5 A output	6EP3333-8SB00-0AY0
120/230 VAC input, 24 V / 10 A output	6EP3334-8SB00-0AY0
Input, 1 and 2-phase AC or DC, Output 24 V DC / 20 A	6EP1336-3BA10

Accessories	
Type	Order number
Device identification labels 20 mm × 7 mm, Ti grey	3RT2900-1SB20

# Table of contents

	Overview.....	3
<b>1</b>	<b>Safety instructions.....</b>	<b>7</b>
<b>2</b>	<b>Description, device design, dimension drawing.....</b>	<b>9</b>
2.1	Device description.....	9
2.2	Connections and terminal designation.....	11
2.3	Potentiometer.....	13
2.4	Status displays and signaling.....	14
2.5	Change-over switch.....	16
2.6	Remote contact.....	18
2.7	Block diagram.....	19
2.8	Dimensions and weight.....	21
<b>3</b>	<b>Mounting/removal.....</b>	<b>23</b>
<b>4</b>	<b>Mounting position, mounting clearances.....</b>	<b>25</b>
4.1	Standard mounting position.....	25
4.2	Other mounting positions.....	27
4.2.1	6EP3333-8SB00-0AY0.....	27
4.2.2	6EP3334-8SB00-0AY0.....	29
4.2.3	6EP1336-3BA10.....	31
<b>5</b>	<b>Installation.....</b>	<b>33</b>
5.1	Line-side connection.....	33
5.2	Output-side connection.....	35
<b>6</b>	<b>Technical data.....</b>	<b>37</b>
6.1	Input.....	37
6.2	Output.....	39
6.3	Efficiency.....	44
6.4	Closed-loop control.....	45
6.5	Protection and monitoring.....	46
6.6	MTBF.....	46
6.7	Mechanical system.....	46
6.8	Accessories.....	47
6.9	Dimension drawing.....	47

<b>7</b>	<b>Safety, approvals, EMC .....</b>	<b>49</b>
7.1	Safety .....	49
7.2	Test voltage.....	50
7.3	Approvals .....	51
7.4	EMC .....	52
<b>8</b>	<b>Ambient conditions.....</b>	<b>53</b>
<b>9</b>	<b>Applications .....</b>	<b>55</b>
9.1	Parallel connection to increase power rating .....	55
9.2	Parallel connection for redundancy .....	57
9.3	Series connection for increased voltage.....	58
9.4	Overload protection in the 24 V output circuit.....	59
9.5	Protection against short-time voltage dips.....	60
9.6	Protecting against longer power failures.....	61
<b>10</b>	<b>Environment .....</b>	<b>63</b>
<b>11</b>	<b>Service &amp; Support.....</b>	<b>65</b>

# Safety instructions

# 1

 **WARNING**

**Correct handling of the devices**

When operating electrical devices, it is inevitable that certain components will carry dangerous voltages.

Therefore, failure to handle the units properly can result in death or serious physical injury as well as extensive property damage.

Only appropriately qualified personnel may work on or in the vicinity of this equipment.

Perfect, safe, and reliable operation of this equipment is dependent on proper transportation, storage, installation and mounting.

Before installation or maintenance work can begin, the system's main switch must be switched off and measures taken to prevent it being switched on again.

If this instruction is not observed, touching live parts can result in death or serious injury.





## Description, device design, dimension drawing

### 2.1 Device description

SITOP PSU8200 1 ph is a primary-clocked power supply for connection to a 1-phase AC line supply. An electronically regulated DC voltage that can be set via a potentiometer is available at the output of the device. The output of the device is isolated, no-load proof and short-circuit proof. The LED displays indicate the operating state. The operating state of the device can be processed via the signaling contact. The device can be switched ON/OFF remotely using a remote contact.

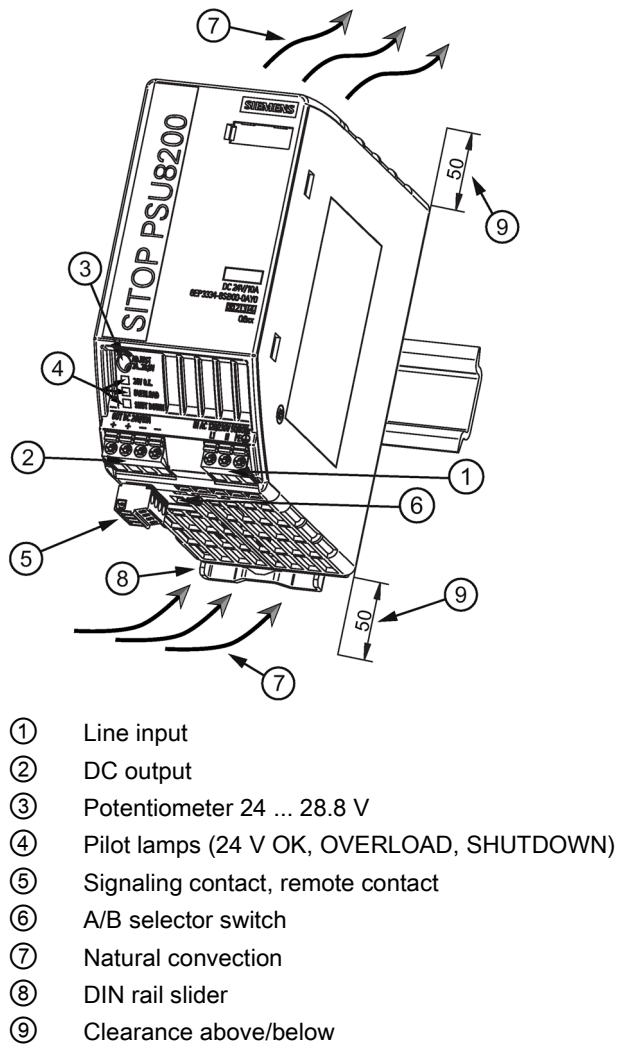
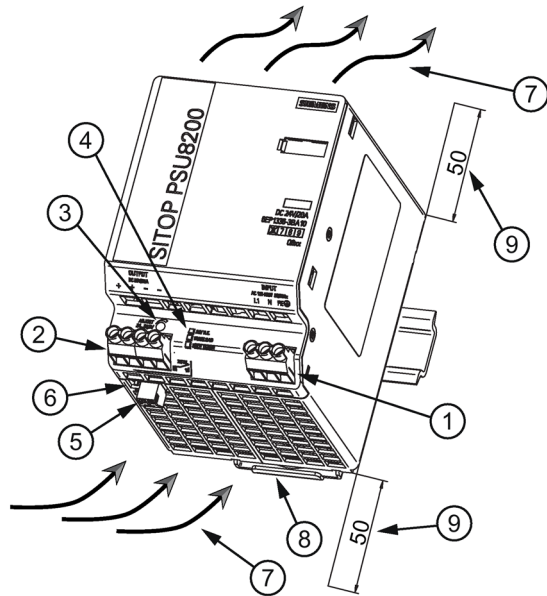

Figure 2-1 Design (example: 6EP3334-8SB00-0AY0)

2.1 Device description

SITOP PSU8200 20A 1ph is a primary-clocked power supply for connection to a 1-phase/2-phase AC line supply or a DC supply. An electronically regulated DC voltage that can be set via a potentiometer is available at the output of the device. The output of the device is isolated, no-load proof and short-circuit proof. The LED displays indicate the operating state. The operating state of the device can be processed via the signaling contact.





- ① Line input
- ② DC output
- ③ Potentiometer 24 ... 28.8 V
- ④ Pilot lamps (24 V OK, OVERLOAD, SHUTDOWN)
- ⑤ Signaling contact, remote contact
- ⑥ A/B selector switch
- ⑦ Natural convection
- ⑧ DIN rail slider
- ⑨ Clearance above/below

Figure 2-2 Design 6EP1336-3BA10

## 2.2 Connections and terminal designation

The line input terminals ① can be used to establish the connection to the supply voltage. The output terminals ② are used to connect to the loads to be supplied (see also Section Installation (Page 33)).

Connections and terminal designations for 6EP3333-8SB00-0AY0 and 6EP3334-8SB00-0AY0	
① Line input L1, N, PE	One screw terminal each
② output "+"	2 screw terminals
② output "-"	2 screw terminals
⑤ signaling contacts 13, 14	One screw terminal each
⑤ remote contacts 15, 16	One screw terminal each

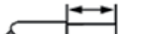



	① + ②	③	⑤
	SZS 0,6 x 3,5 / PZ1 / PH1	SZS 0,6 x 3,5 max. Ø 3,5 mm	SZS 0,4 x 2,5
	1 x 0,2 - 2,5 mm <sup>2</sup>	-	1 x 0,14 - 1,5 mm <sup>2</sup>
	1 x 0,2 - 2,5 mm <sup>2</sup>	-	1 x 0,14 - 1,5 mm <sup>2</sup>
AWG	24 - 12	-	28 - 16
Nm	0,5 - 0,6 Nm	0,04 Nm * <sup>1)</sup>	0,22 Nm
	6,5 mm	-	7 mm

\*<sup>1)</sup> Do not subject the end stop to higher loads

Figure 2-3 Terminal data for 6EP3333-8SB00-0AY0 and 6EP3334-8SB00-0AY0

2.2 Connections and terminal designation

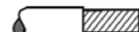
Connections and terminal designations for the 6EP1336-3BA10	
① Line input L1, N, PE	One screw terminal each
② output "+"	2 screw terminals
② output "-"	2 screw terminals
③ signaling contacts 13, 14	One screw terminal each

	① + ②	③	⑤
	SZS 0,6 x 3,5 / PZ1 / PH1	SZS 0,6 x 3 / PZ1 / PH1 max. Ø 3,5 mm	SZS 0,6 x 3,5
	1 x 0,2 - 6 mm <sup>2</sup>	-	1 x 0,14 - 1,5 mm <sup>2</sup>
	1 x 0,2 - 4 mm <sup>2</sup>	-	1 x 0,14 - 1,5 mm <sup>2</sup>
AWG	24 - 10	-	28 - 16
Nm	0,5 - 0,6 Nm	0,04 Nm * <sup>1)</sup>	0,22 Nm
	8 mm	-	7 mm

\*<sup>1)</sup> Do not subject the end stop to higher loads

Figure 2-4 Terminal data for 6EP1336-3BA10

## 2.3 Potentiometer

The potentiometer ③ on the front of the device is used to adjust the output voltage. The output voltage is set to 24 V in the factory, and can be adjusted in the range 24 ... 28.8 V; for example, to compensate voltage drops across long supply lines to the connected load.

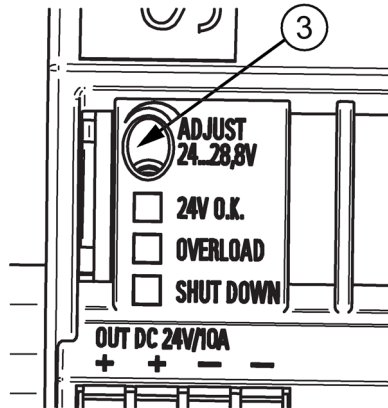

Figure 2-5 Potentiometer (example: 6EP3334-8SB00-0AY0)

### NOTICE

#### Thermal overload possible

When adjusting the output voltage to >24 V, the output current must be derated by 4 %/V, or the permissible ambient temperature must be taken into account with 3° C/V.

### Note

It is only permissible to use an insulated screwdriver when actuating the potentiometer.

For information on actuating the potentiometer (screwdriver, torque), see Figure 2-4 Terminal data for 6EP1336-3BA10 (Page 12). and Figure 2-3 Terminal data for 6EP3333-8SB00-0AY0 and 6EP3334-8SB00-0AY0 (Page 11)

## 2.4 Status displays and signaling

	6EP3333-8SB00-0AY0 (24 V/5 A) 6EP3334-8SB00-0AY0 (24 V/10 A)
Operating display ④	LED green for "24 V O.K." Yellow LED for overload in "constant current" mode Red LED for latching shutdown in "shut down" mode
Signaling contacts (13, 14) ⑤	Relay contact (NO contact, contact rating 30 V AC / 0.5 A, 60 V DC / 0.3 A, 30 V DC / 1 A) for "24 V O.K."

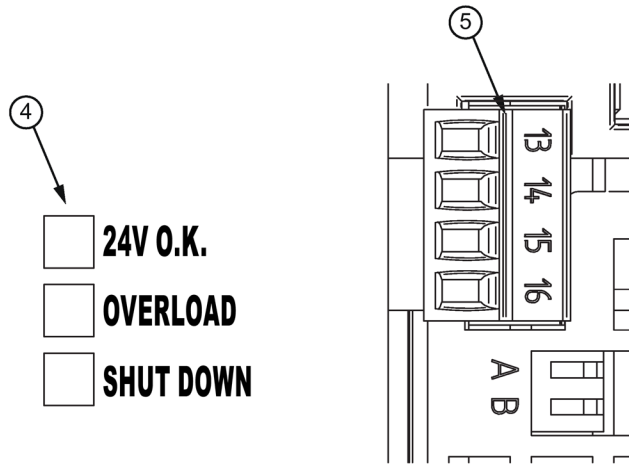

Figure 2-6 Operating display and signaling contact for 6EP3333-8SB00-0AY0 and 6EP3334-8SB00-0AY0

Signaling	6EP3333-8SB00-0AY0 (24 V/5 A) 6EP3334-8SB00-0AY0 (24 V/10 A)
Green LED lit Signaling contact, contacts 13-14 closed	Normal operation, output voltage $>20\text{ V} \pm 0.5\text{ V}$
LED off Signaling contact, contacts 13-14 open (quiescent position)	No supply voltage
Yellow LED lit Signaling contact, contacts 13-14 open (quiescent position)	Overload, output voltage $<20\text{ V} \pm 0.5\text{ V}$ (only in "constant current" mode)
Red LED lit Signaling contact, contacts 13-14 open (quiescent position)	Latching shut down or remote OFF

6EP1336-3BA10 (24 V/20 A)	
Operating display ④	LED green, lit for "24 V O.K." Yellow LED lit for overload condition ( $U_a < 20 \text{ V} \pm 0.5 \text{ V}$ ) Red LED lit for latching shutdown as a result of overload (only for selector switch B in the "ON" position)
Signaling contact ⑤	Relay contact (NO contact, contact rating 30 V AC/0.5 A, 30 V DC/1 A) for "24 V O.K."

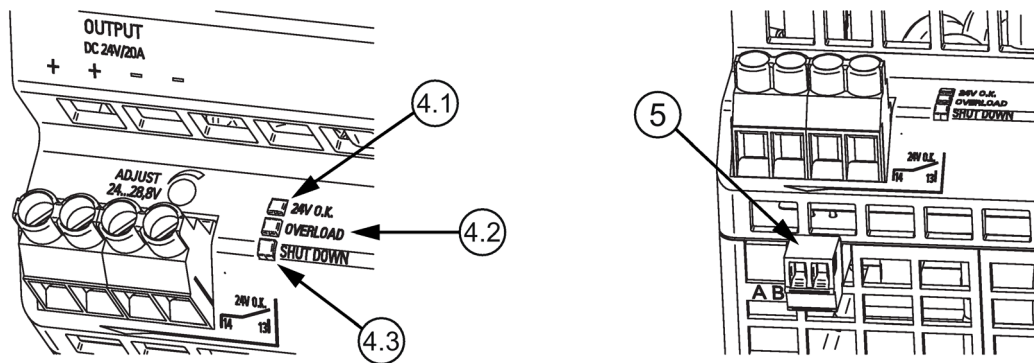

Figure 2-7 Operating display and signaling contact for 6EP1336-3BA10

Signaling	6EP1336-3BA10 (24 V/20 A)
LED green (4.1) off Signaling contact (5), contacts 13-14 open (quiescent position)	No supply voltage
Green LED (4.1) lit Signaling contact (5), contacts 13-14 closed	Normal operation, output voltage $> 20 \text{ V} \pm 0.5 \text{ V}$
Yellow LED (4.2) lit Signaling contact (5), contacts 13-14 open (quiescent position)	Overload ( $U_a < 20 \text{ V} \pm 0.5 \text{ V}$ )
Red LED (4.3) lit Signaling contact (5), contacts 13-14 open (quiescent position)	Latching shutdown due to overload

## 2.5 Change-over switch

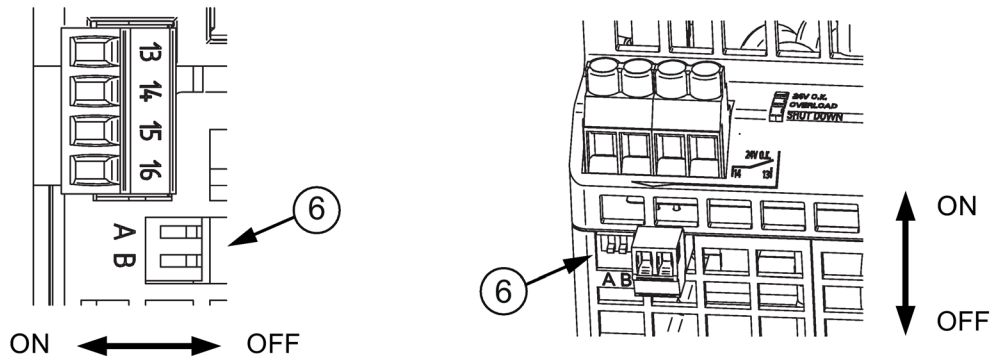

Figure 2-8 Selector switch

The two switches A and B are used to influence the output characteristic curve:

Switch	ON	OFF
<b>A</b> influences the output characteristic in the load range	<b>Parallel operation:</b> 'Soft' characteristic curve (see, e.g. Figure 6-6 Output characteristic curve 6EP3333-8SB00-0AY0 parallel operation (Page 42)) for the parallel operation of two or more devices: The output voltage falls with increasing output current (namely, also for the overcurrent pulse!). This means that for full output current the highest output voltage can normally no longer be attained.	<b>Single operation:</b> <i>Delivery state</i> "Hard" characteristic curve (see, e.g. Figure 6-3 Output characteristic curve 6EP3333-8SB00-0AY0 stand-alone operation (Page 41)) for normal operation (single operation): The output voltage is independent of the output current.
<b>B</b> influences the output characteristic in the overload range	<b>Latching shutdown:</b> If the output current rises above the rated value and above the current limit, the device reduces the output voltage (see, e.g. Figure 6-9 Output characteristic curve 6EP3333-8SB00-0AY0 latching shutdown (Page 43)). If the output voltage falls below 20 V, the device shuts down latching, the red LED lights up. This limit voltage of 20 V is independent of the set output voltage. The "Short-term overload current" feature is not available in this operating mode. 6EP3333-8SB00-0AY0 and 6EP3334-8SB00-0AY0 are reset using power supply OFF for a minimum of 60 s or remote OFF and ON at the remote contact. 6EP1336-3BA10 is reset by switching the power supply OFF for at least 5 s. To also guarantee that large capacitances can be charged at the output in this operating mode, a non-latching shutdown is not performed during the first 10 s after power ON or remote ON. During these first 10 s, the device responds for overload as if the switch is OFF.	<b>Constant current:</b> <i>Delivery state</i> If the output current rises above the rated value and above the current limit, the device reduces the output voltage. The yellow LED lights up if the output voltage falls below 20 V.



Delivery state: A-OFF; B-OFF

---

**Note**

Selector switches may only be activated when the device is switched off.

---

## 2.6 Remote contact

---

6EP3333-8SB00-0AY0 (24 V/5 A)

6EP3334-8SB00-0AY0 (24 V/10 A)

---

Remote contacts (15, 16) ⑤ Non-isolated input for remote ON/OFF switching of the power supply.  
Function: The device is remotely switched off when contacts 15, 16 are short-circuited ( $R < 8 \text{ k}\Omega$ ). If the power supply is shut down and latched in the "latching shutdown" mode as a result of an overload, then it can be restarted using remote OFF followed by remote ON.

---



Figure 2-9 Remote contact for 6EP3333-8SB00-0AY0 and 6EP3334-8SB00-0AY0

## 2.7 Block diagram

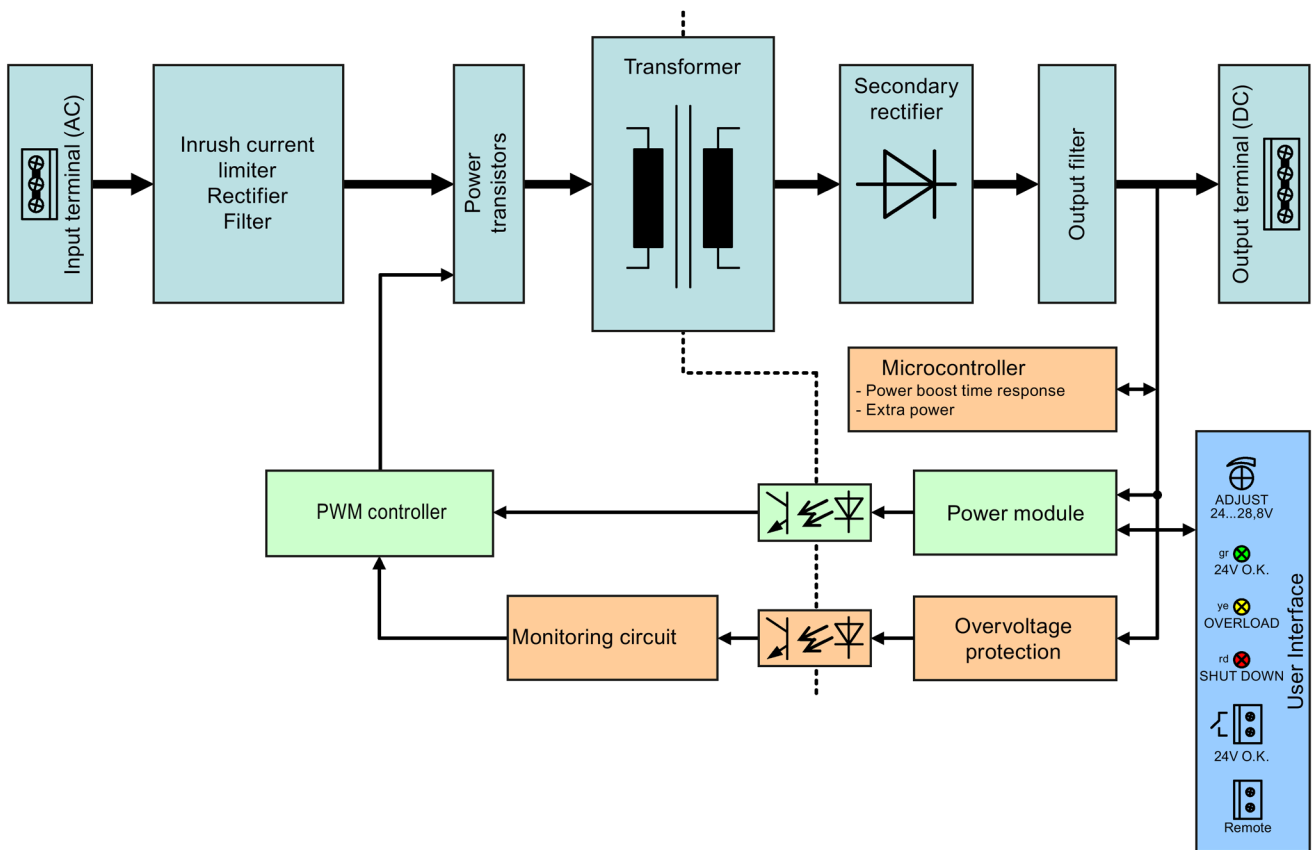

Figure 2-10 Block diagram for 6EP3333-8SB00-0AY0 and 6EP3334-8SB00-0AY0

2.7 Block diagram

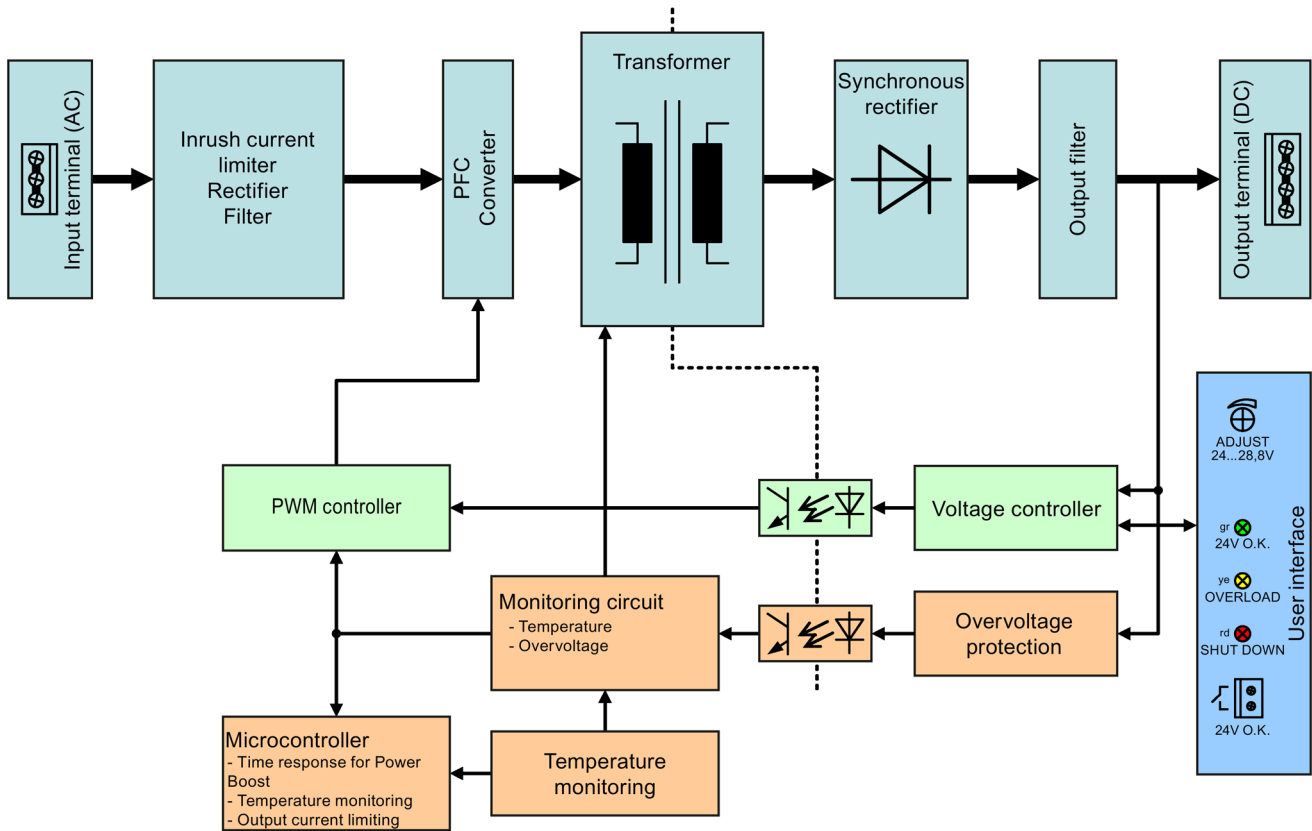

Figure 2-11 Block diagram for 6EP1336-3BA10

## 2.8 Dimensions and weight

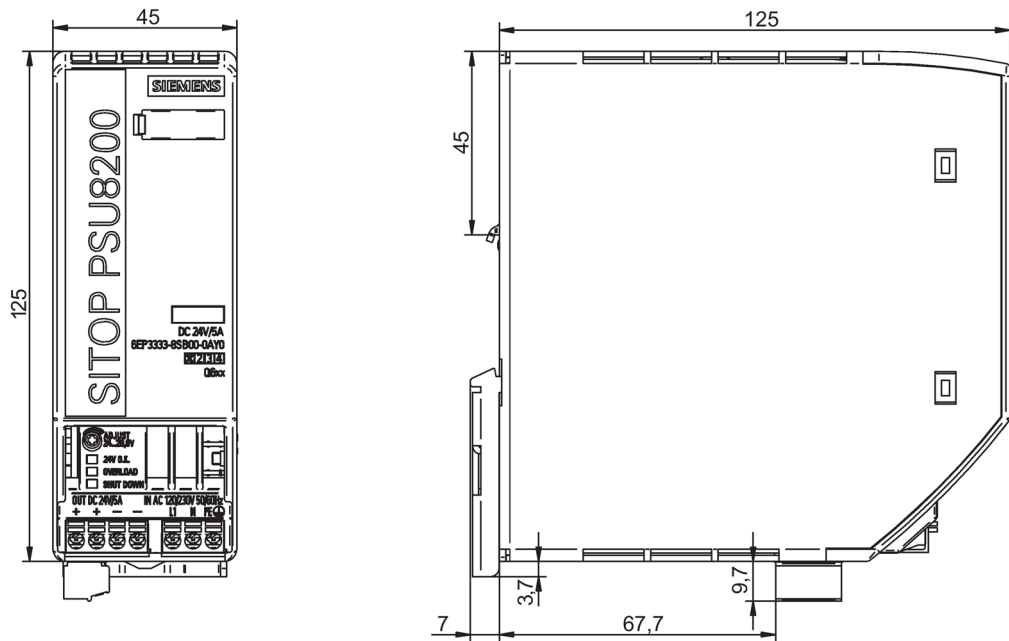

Figure 2-12 Dimension drawing 6EP3333-8SB00-0AY0

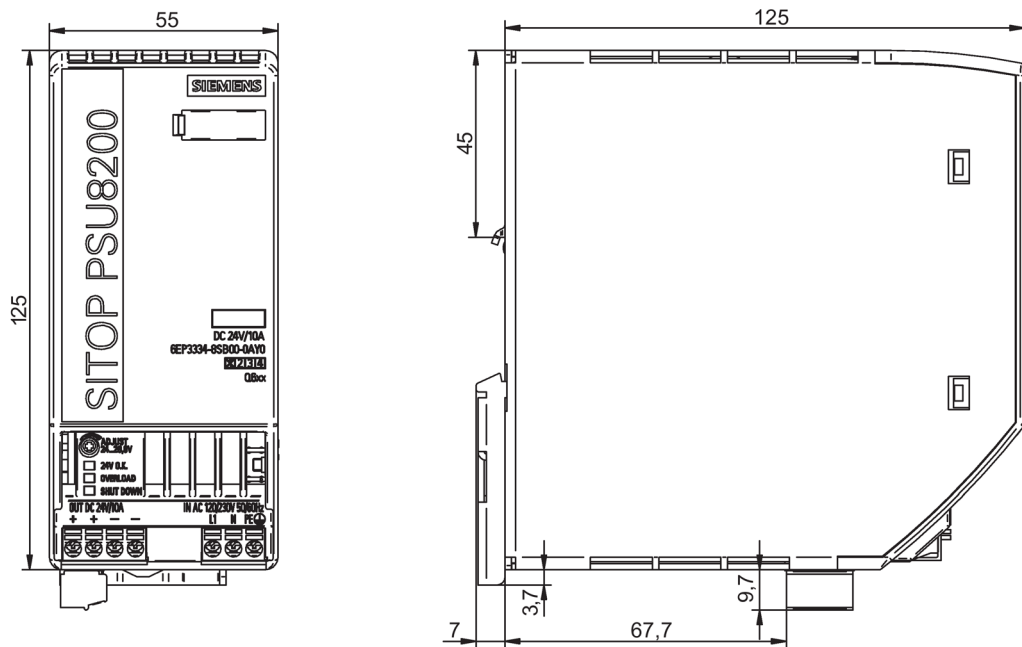

Figure 2-13 Dimension drawing 6EP3334-8SB00-0AY0

2.8 Dimensions and weight

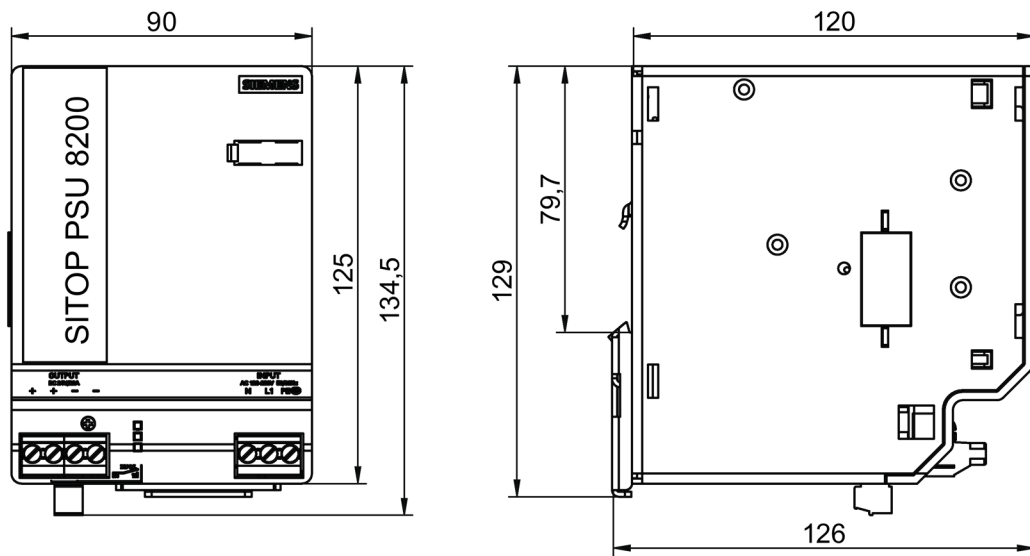

Figure 2-14 Dimension drawing for 6EP1336-3BA10

	6EP3333-8SB00-0AY0 (24 V/5 A)	6EP3334-8SB00-0AY0 (24 V/10 A)	6EP1336-3BA10 (24 V/20 A)
Dimensions (W × H × D) in mm	45 × 125 × 125	55 × 125 × 125	90 × 125 × 120
Weight	approx. 0.8 kg	approx. 1.0 kg	approx. 1.2 kg

## Mounting/removal

### WARNING

#### Installing the device in a housing or a control cabinet

The SITOP PSU8200 1ph power supply is a built-in device. It must be installed in a housing or control cabinet, to which only qualified personnel have access.

The device can be mounted in a control cabinet on standard mounting rails according to EN 60715.

#### Mounting

To mount the device, position it with the mounting rail guide at the upper edge of the standard mounting rail and press down to lock it into place. If this is too difficult, press slider ⑧ at the same time, as described under "Removal".

#### Removal

To remove, pull up the slider ⑧ using a screwdriver and disengage the device at the bottom edge of the standard mounting rail. Then you can remove the device from the upper edge of the standard mounting rail.

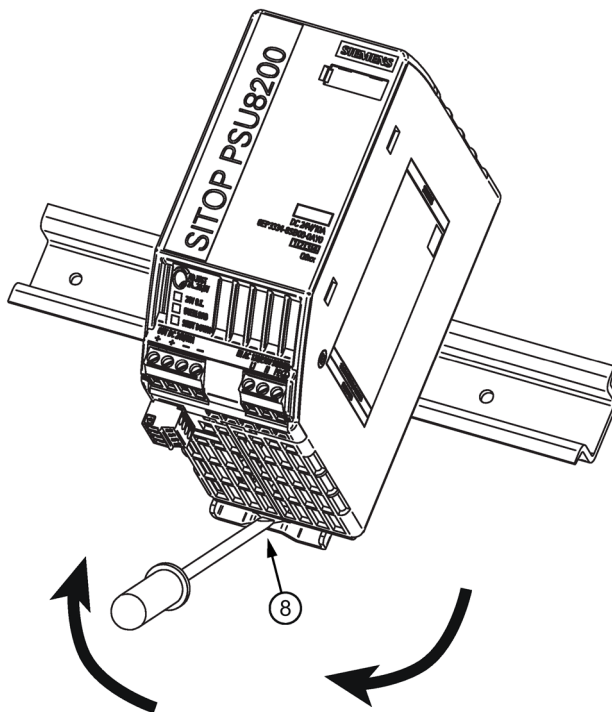

Figure 3-1 Mounting/removal (example): 6EP3334-8SB00-0AY0)

 **WARNING**

**Use in hazardous zones**

If the devices are to be used in hazardous zones (II 3G Ex nA nC IIC T3 Gc or II 3G Ex nA nC IIC T4 Gc), they must be installed in a distribution box with degree of protection IP54 or higher.



## Mounting position, mounting clearances

### 4.1 Standard mounting position

The device is mounted on standard mounting rails according to EN 60715. The device must be mounted vertically in such a way that the input terminals and the output terminals are at the bottom to ensure correct cooling.

A clearance of at least 50 mm should be maintained above and below the device (maximum depth of the cable duct, 50 mm).

No space is required at the side.

### Output current as a function of the ambient temperature and mounting height

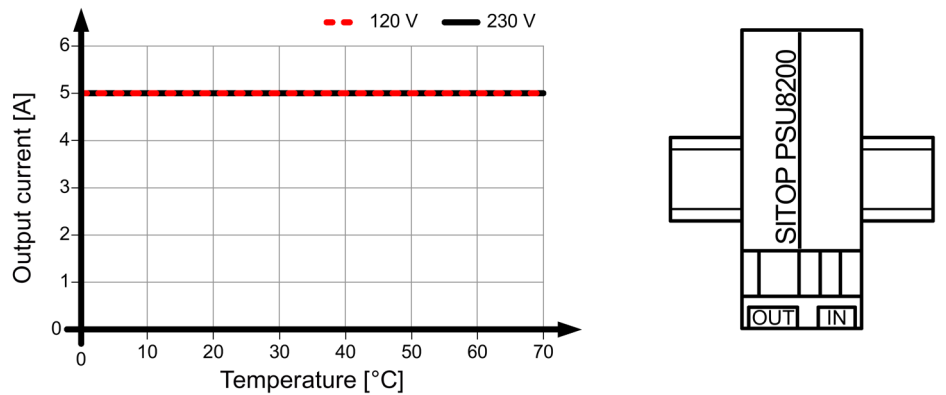

Figure 4-1 6EP3333-8SB00-0AY0 standard mounting position

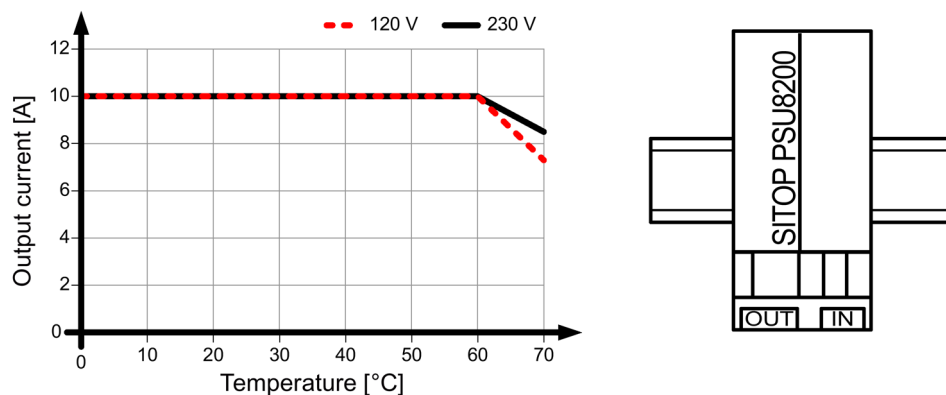

Figure 4-2 6EP3334-8SB00-0AY0 standard mounting position

4.1 Standard mounting position

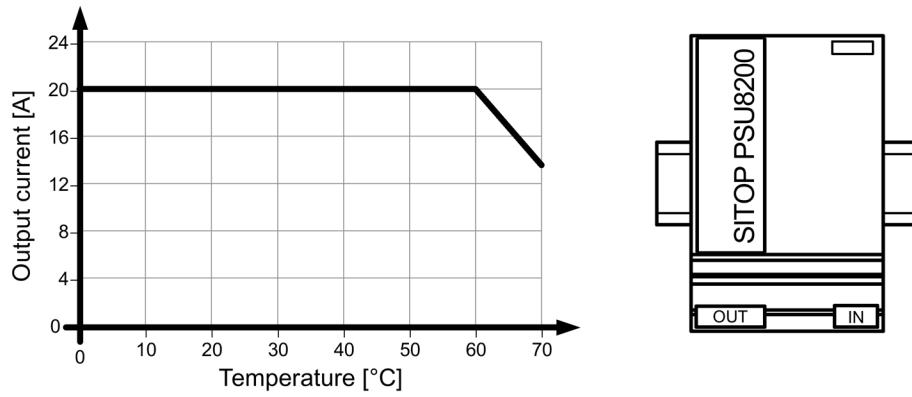

Figure 4-3 6EP1336-3BA10 standard mounting position

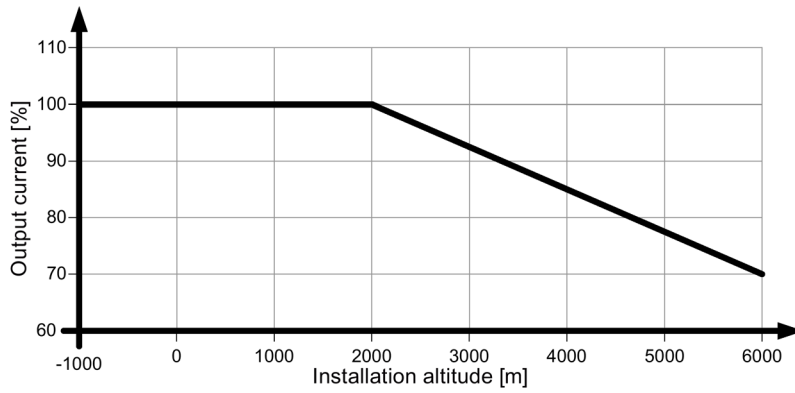

Figure 4-4 Mounting height derating

For details, see Ambient conditions (Page 53)

## 4.2 Other mounting positions

For mounting positions that deviate from the standard mounting position, derating factors (reduction of the output power or the permissible ambient temperature) must be observed in accordance with the following diagrams.

### Note

In the case of mounting positions that deviate from the standard mounting position, reduced mechanical resistance of the devices against vibration and shock must be expected.

Particularly when installing on a vertically fastened standard mounting rail, additional measures may be required, e.g. to prevent the device from slipping on the standard mounting rail.

### 4.2.1 6EP3333-8SB00-0AY0

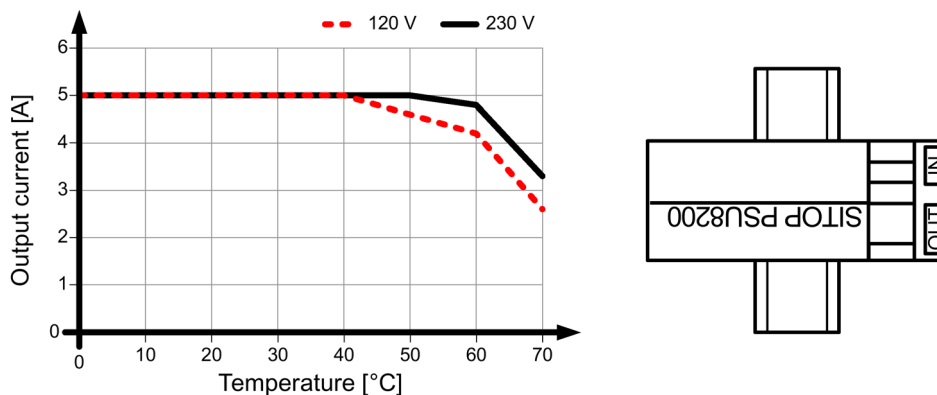

Figure 4-5 6EP3333-8SB00-0AY0 mounting position (1)

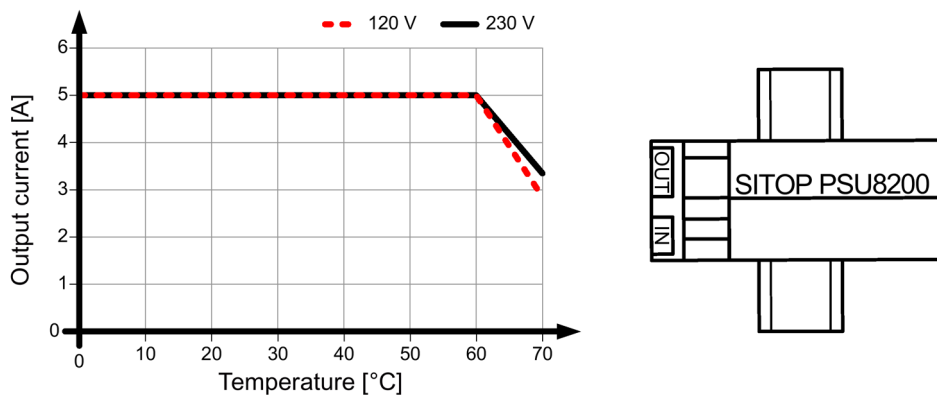

Figure 4-6 6EP3333-8SB00-0AY0 mounting position (2)

4.2 Other mounting positions

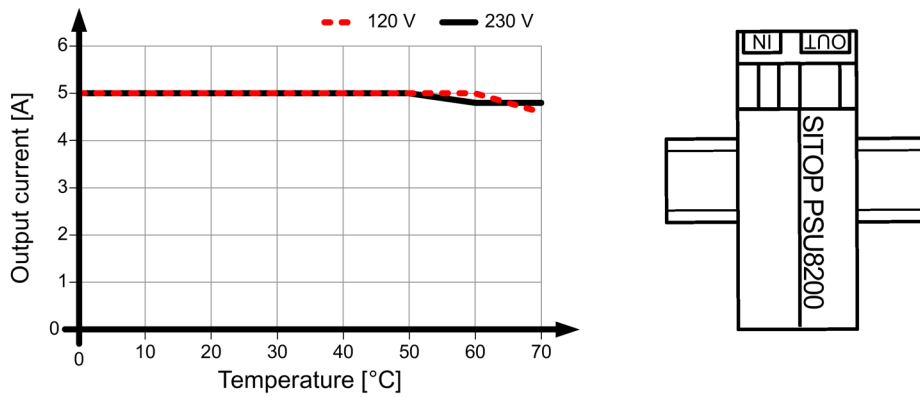

Figure 4-7 6EP3333-8SB00-0AY0 mounting position (3)

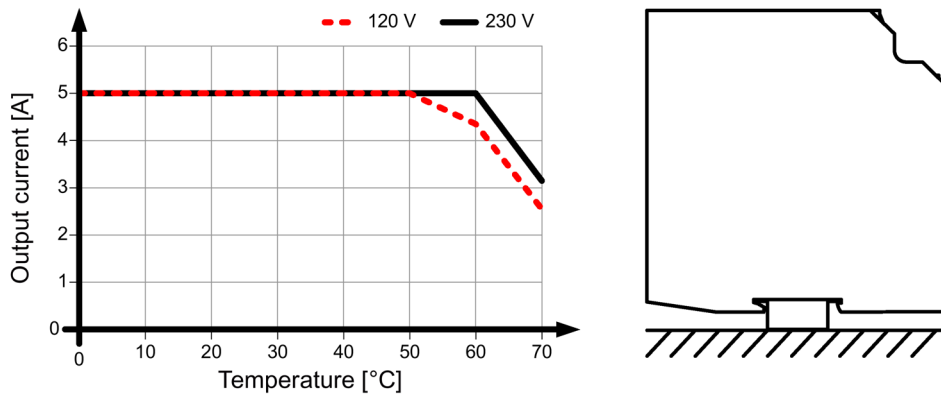

Figure 4-8 6EP3333-8SB00-0AY0 mounting position (4)

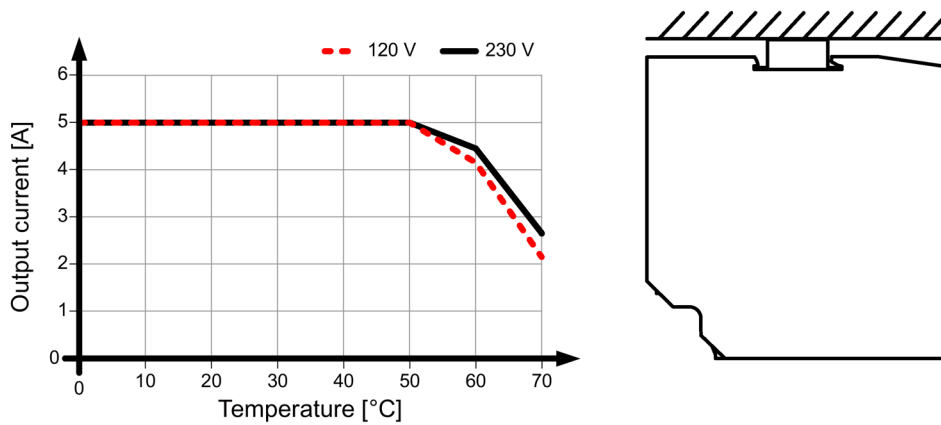

Figure 4-9 6EP3333-8SB00-0AY0 mounting position (5)

4.2.2 6EP3334-8SB00-0AY0

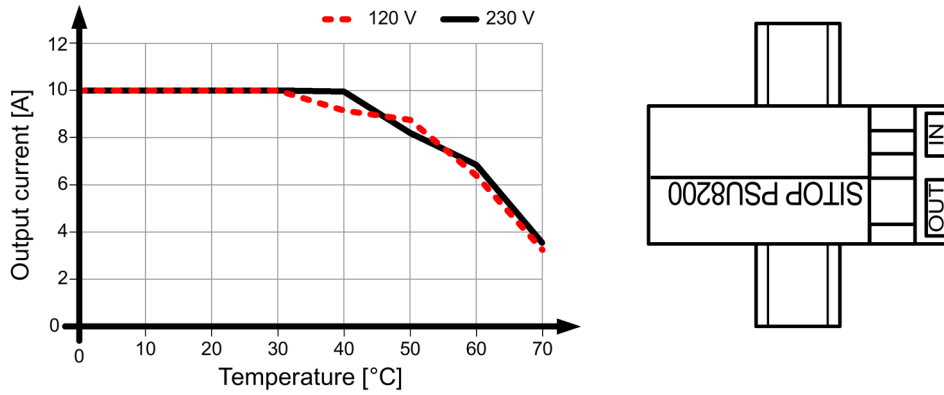

Figure 4-10 6EP3334-8SB00-0AY0 mounting position (1)

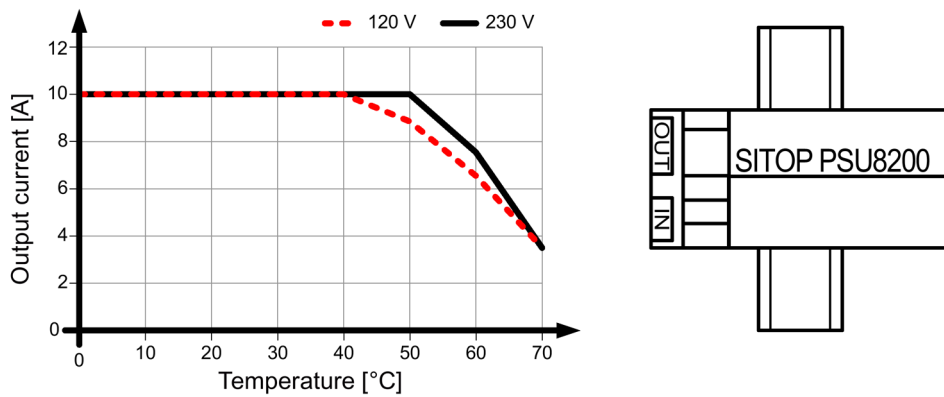

Figure 4-11 6EP3334-8SB00-0AY0 mounting position (2)

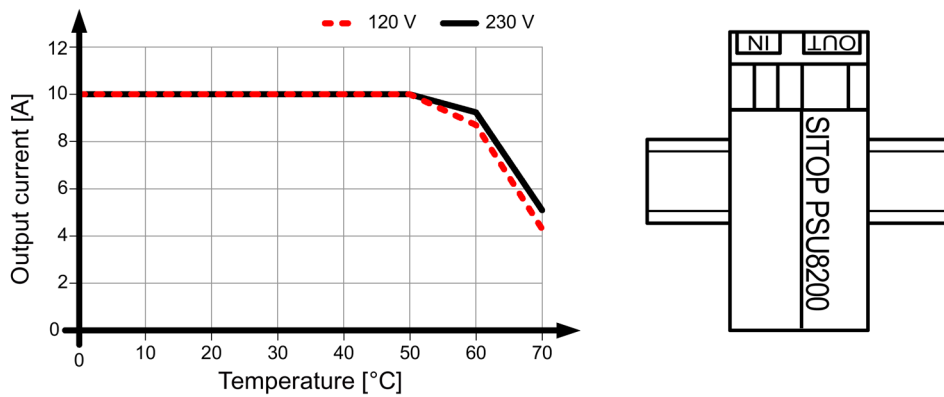

Figure 4-12 6EP3334-8SB00-0AY0 mounting position (3)

4.2 Other mounting positions

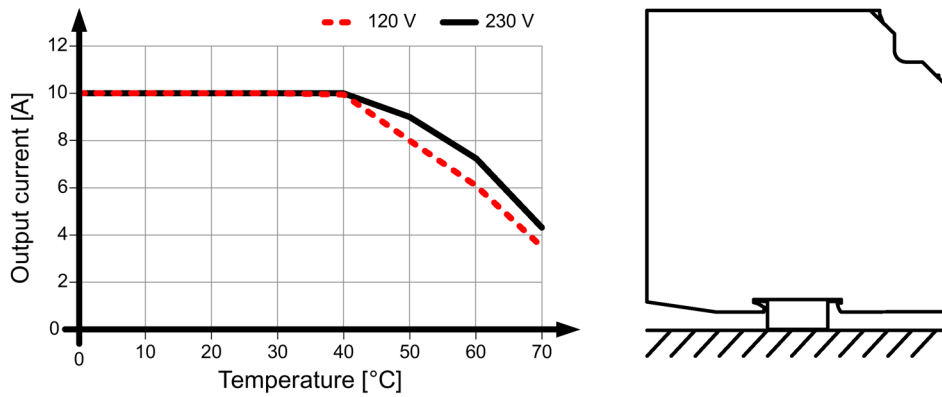

Figure 4-13 6EP3334-8SB00-0AY0 mounting position (4)

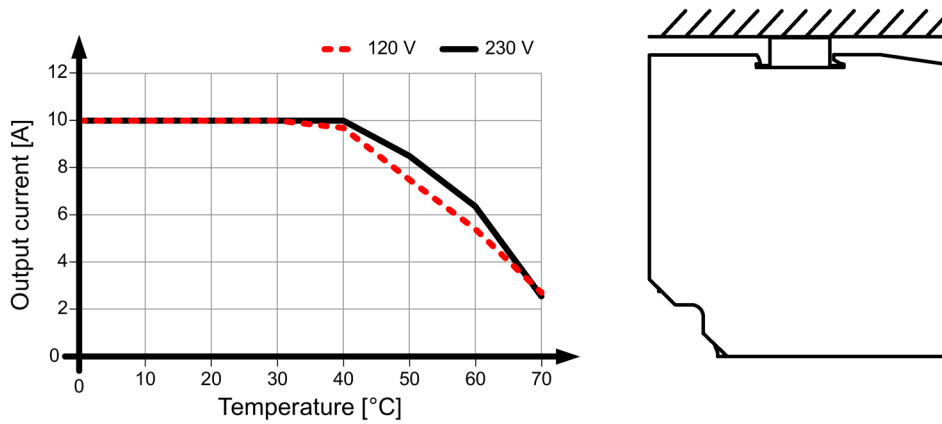

Figure 4-14 6EP3334-8SB00-0AY0 mounting position (5)

4.2.3 6EP1336-3BA10

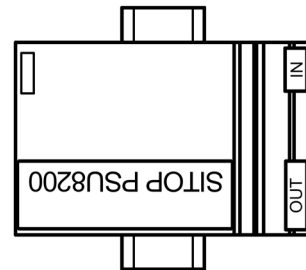
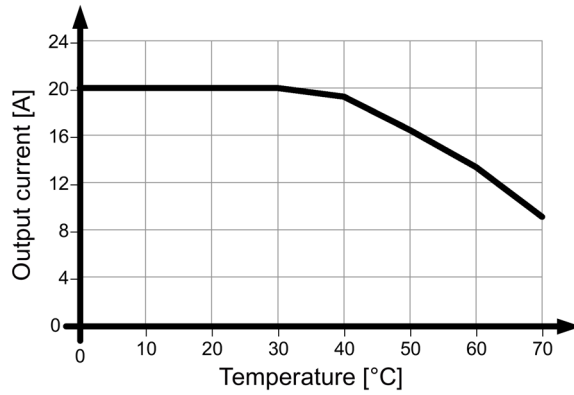

Figure 4-15 6EP1336-3BA10 mounting position (1)

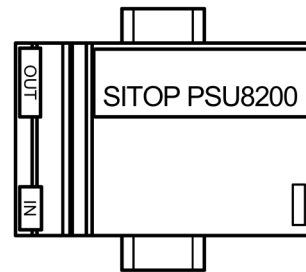
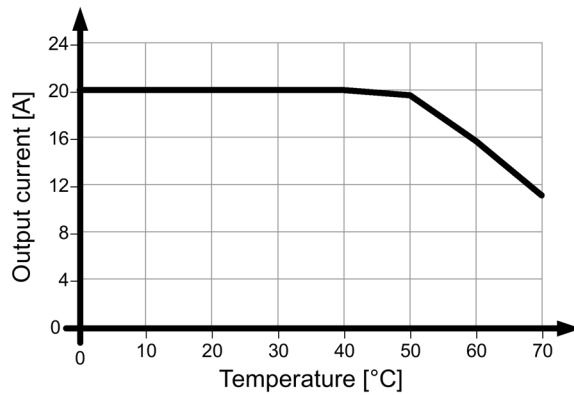

Figure 4-16 6EP1336-3BA10 mounting position (2)

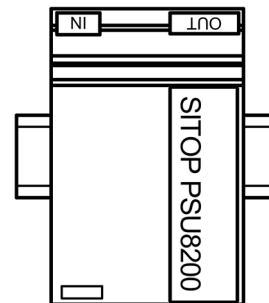
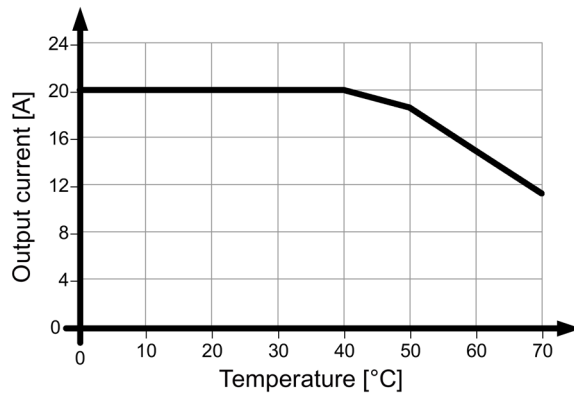

Figure 4-17 6EP1336-3BA10 mounting position (3)

4.2 Other mounting positions

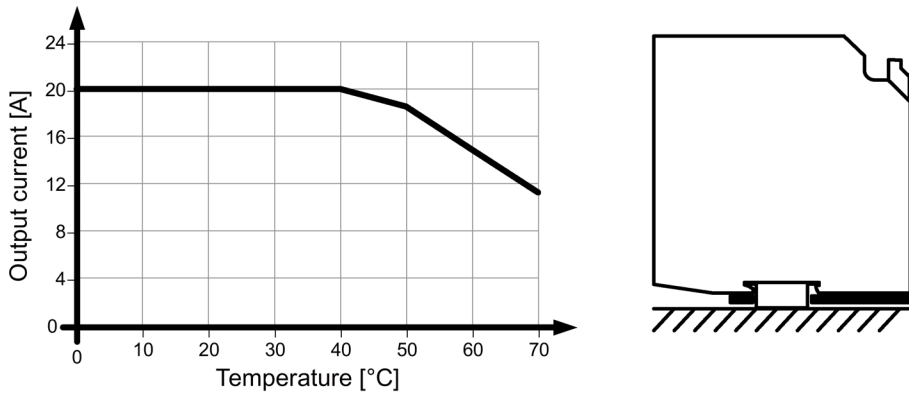

Figure 4-18 6EP1336-3BA10 mounting position (4)

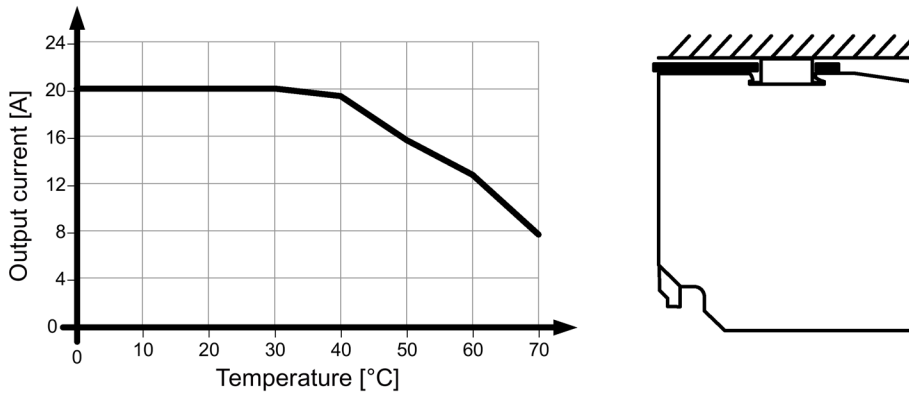

Figure 4-19 6EP1336-3BA10 mounting position (5)



<p><b>⚠ WARNING</b></p> <p><b>Hazard due to electric shock</b></p> <p>Before installation or maintenance work can begin, the system's main switch must be switched off and measures taken to prevent it being switched on again. If this instruction is not observed, touching live parts can result in death or serious injury.</p>
--

## 5.1 Line-side connection

The SITOP PSU8200 1ph (6EP3333-8SB00-0AY0 and 6EP3334-8SB00-0AY0) power supply is designed for connection to a 1-phase AC line supply with a rated voltage of 120/230 V AC, 50/60 Hz.



Figure 5-1 Line connection for 6EP3333-8SB00-0AY0 and 6EP3334-8SB00-0AY0

SITOP PSU8200 1ph (6EP1336-3BA10) power supplies are designed to be connected to a 1-phase AC line voltage or to 2 line conductors of three-phase line supplies (TN, TT or IT system according to VDE 0100 T 300 / IEC 364-3) with a rated voltage of 120-230 V AC, 50/60 Hz or a DC voltage.

5.1 Line-side connection

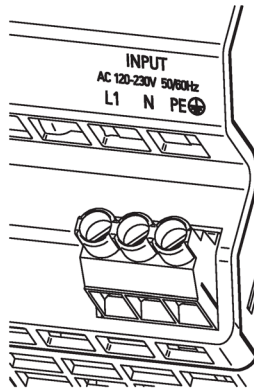

Figure 5-2 Line connection for 6EP1336-3BA10

The line supply is connected via terminals L1, N and PE (see Figure 5-1 Line connection for 6EP3333-8SB00-0AY0 and 6EP3334-8SB00-0AY0 (Page 33)) or (Figure 5-2 Line connection for 6EP1336-3BA10 (Page 34)) – and must be implemented according to IEC 60364 and EN 50178 .

A protective device (miniature circuit breaker or circuit breaker) and a disconnection unit for the power supply must be provided. A ground-fault circuit interrupter is not permissible against indirect contact as the only protective measure. This applies for the complete line supply protected by the ground-fault circuit interrupter.

**Protection**

SITOP PSU8200 1ph	Line-side protection
6EP3333-8SB00-0AY0 (24 V/5 A)	<b>Recommended:</b> Miniature circuit breaker (IEC 898) characteristic C, 6 A
6EP3334-8SB00-0AY0 (24 V/10 A)	<b>Recommended:</b> Miniature circuit breaker (IEC 898) characteristic C, 10 A
6EP1336-3BA10 (24 V/20 A)	<b>Recommended:</b> miniature circuit breaker for single-phase operation: 10 A, characteristic C; required for two-phase operation: Miniature circuit breaker, two-pole coupled or circuit breaker (8 or 4 A) according to UL 489: 3RV2711-1HD10 (120 V) or 3RV2711-1ED10 (230 V)

The protective conductor of the line supply must be connected at the PE terminal.

Other country-specific regulations may have to be observed when installing the device.

## 5.2 Output-side connection

At its output, the SITOP PSU8200 1ph power supply provides an isolated (= non-grounded) SELV output voltage (Safety Extra Low Voltage). The output of the power supply is no-load, overload, and short-circuit proof. If an overload occurs, the electronic current limiting function limits the output current to a maximum value (see Section Technical data (Page 37)).

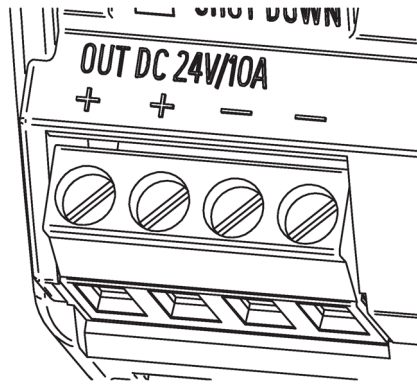

Figure 5-3 Output connection (example: 6EP3334-8SB00-0AY0)

The output voltage is connected via the + and - terminals at the output of the power supply (see Figure 5-3 Output connection (example: 6EP3334-8SB00-0AY0) (Page 35)). Ensure that the output cables are dimensioned correctly for the maximum output current rms value and fused accordingly.

---

### Note

If the safety concept of the plant or system specifies that the DC output circuit should be grounded (PELV, Protected Extra Low Voltage), then it is permissible that the output voltage of the SITOP power supply is grounded. In this case, ideally, the grounding at the output should be directly connected from terminal "-" of the power supply to a suitable connection point of the protective conductor system (PE) of the plant or system.

---



## Technical data

### Note

Technical data is applicable for a rated input voltage, rated load and +25° C ambient temperature (if nothing else is specified).

## 6.1 Input

	6EP3333-8SB00-0AY0 (24 V/5 A)	6EP3334-8SB00-0AY0 (24 V/10 A)	6EP1336-3BA10 (24 V/20 A)
Input	1-phase, AC	1-phase, AC	1 and 2-phase AC or DC
Rated voltage value U <sub>e</sub> rated	120/230 V	120/230 V	120...230 V
Rated voltage U <sub>e</sub> rated for DC	-	-	110/220 V
Voltage range for AC	85 ... 132/170 ... 264 V	85 ... 132/170 ... 264 V	85 ... 275 V
• Remark	Automatic current switchover	Automatic current switchover	Temperature derating for U <sub>e</sub> < 100 V for 50 °C necessary
Voltage range for DC	-	-	88 ... 350 V
• Remark			Temperature derating for U <sub>e</sub> < 100 V for 50 °C necessary
Wide-range input	No	No	Yes
Overvoltage strength	-	-	2.3 × U <sub>e</sub> rated, 1.3 ms
Power failure buffering at I <sub>a</sub> rated, min at 230 V	35 ms	35 ms	20 ms
Rated line frequency	50/60 Hz	50/60 Hz	50/60 Hz
Line frequency range	47 ... 63 Hz	47 ... 63 Hz	45 ... 65 Hz
Input current / at rated value of input voltage 120 V	2.1 A	4 A	4.6 A
Input current / at rated value of input voltage 230 V	1.2 A	1.9 A	2.5 A
Switch-on current limitation (+ 25° C), max.	10 A	10 A	20 A
I <sup>2</sup> t, max	0.2 A <sup>2</sup> s	0.3 A <sup>2</sup> s	5 A <sup>2</sup> s

6.1 Input

	6EP3333-8SB00-0AY0 (24 V/5 A)	6EP3334-8SB00-0AY0 (24 V/10 A)	6EP1336-3BA10 (24 V/20 A)
Integrated input fuse	Fuse T 3.15 A	Fuse T 6.3 A	Fuse T 10 A
Protection in the line feeder cable (IEC 898)	Recommended: Miniature circuit breaker (IEC 898), characteristic C, 6 A	Recommended: Miniature circuit breaker (IEC 898), characteristic C, 10 A	Recommended miniature circuit breaker for single-phase operation: 10 A, characteristic C; required for two-phase operation: Miniature circuit breaker, two-pole coupled or circuit breaker (8 or 4 A) according to UL 489: 3RV2711-1HD10 (120 V) or 3RV2711-1ED10 (230 V)

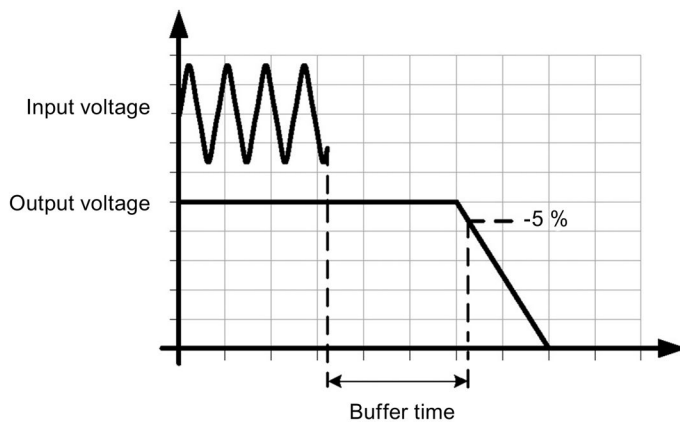

Figure 6-1 Power failure buffering

## 6.2 Output

	6EP3333-8SB00-0AY0 (24 V/5 A)	6EP3334-8SB00-0AY0 (24 V/10 A)	6EP1336-3BA10 (24 V/20 A)
Output	Regulated isolated DC voltage	Regulated isolated DC voltage	regulated isolated DC voltage
Rated voltage value U <sub>a</sub> rated DC	24 V	24 V	24 V
Total tolerance, static ±	3 %	3 %	3 %
Static line regulation, approx.	0,03 %	0,05 %	0,1 %
Static load regulation, approx.	0,2 %	0,3 %	0,3 %
Residual ripple in the load range Peak-peak, max.	50 mV	50 mV	100 mV
Spikes peak-peak, max. (bandwidth, approx. 20 MHz)	200 mV	200 mV	200 mV
Adjustment range	24 ... 28.8 V	24 ... 28.8 V	24 ... 28.8 V
Product function / output voltage can be adjusted	Yes	Yes	Yes
Output voltage setting	Via potentiometer	Via potentiometer	Via potentiometer
• Remark	Max. 120 W	Max. 240 W	Max. 480 W
Operating display	LED green for "24 V O.K."	LED green for "24 V O.K."	LED green for "24 V O.K."
Signaling	Relay contact (NO contact, rating 60 V DC / 0.3 A) for "24 V O.K."	Relay contact (NO contact, rating 60 V DC / 0.3 A) for "24 V O.K."	Relay contact (NO contact, contact rating 60 V DC/0.3 A, 30 V DC/1 A) for "24 V O.K."
Response when switching on/off	Overshoot of U <sub>a</sub> approx. 3%	Overshoot of U <sub>a</sub> approx. 3%	No overshoot of U <sub>a</sub> (soft start)
Starting delay, max.	1 s	1 s	0.25 s
Voltage rise, typ.	30 ms	70 ms	50 ms
Voltage rise time of the output voltage, maximum	500 ms	500 ms	150 ms
Rated current value I <sub>a</sub> rated	5 A	10 A	20 A
Current range	0 ... 5 A	0 ... 10 A	0 ... 20 A
• Remark	At U <sub>e</sub> <100 V / <200 V: 80% I <sub>a</sub> rated	+60 to +70 °C derating: approx. 2% I <sub>a</sub> rated/K At U <sub>e</sub> <100 V / <200 V: 80% I <sub>a</sub> rated	+60..+70 °C Derating: 3 % I <sub>a</sub> rated/K
Output active power / typical	120 W	240 W	480 W
Constant overload current for a short circuit when powering up, typical	6 A	12 A	30 A
Short-time overload current for a short circuit during operation, typical	15 A	30 A	60 A

6.2 Output

	6EP3333-8SB00-0AY0 (24 V/5 A)	6EP3334-8SB00-0AY0 (24 V/10 A)	6EP1336-3BA10 (24 V/20 A)
Duration of the current over-load capability / for a short circuit while powering up	150 ms	150 ms	150 ms
Duration of the current over-load capability for a short circuit during operation	25 ms	25 ms	25 ms
• Remark	per 1 min	per 1 min	per 1 min
Can be connected in parallel to increase the power rating	Yes	Yes	Yes
• Remark	Switchable characteristic	Switchable characteristic	Switchable characteristic
Number of devices that can be connected in parallel to increase the power rating, units	2	2	2
Output characteristic	See Figure 6-3 Output characteristic curve 6EP3333-8SB00-0AY0 stand-alone operation (Page 41)	See Figure 6-4 Output characteristic curve 6EP3334-8SB00-0AY0 stand-alone operation (Page 41)	See Figure 6-5 6EP1336-3BA10 single operation output characteristic (Page 41)

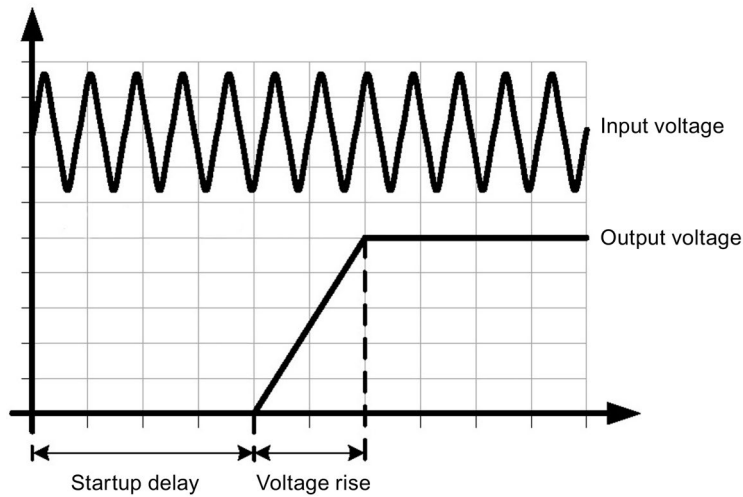

Figure 6-2 Starting delay/voltage rise



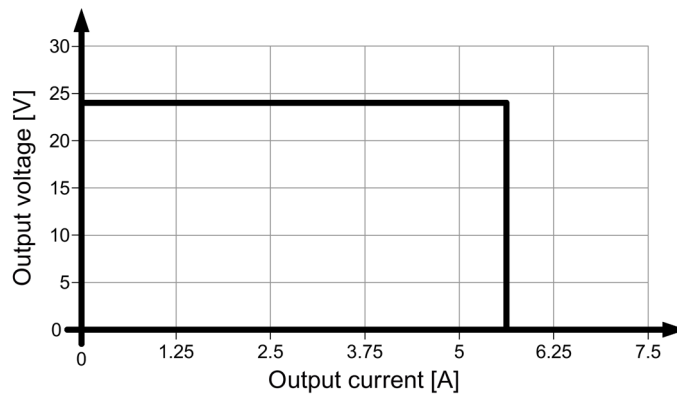

Figure 6-3 Output characteristic curve 6EP3333-8SB00-0AY0 stand-alone operation

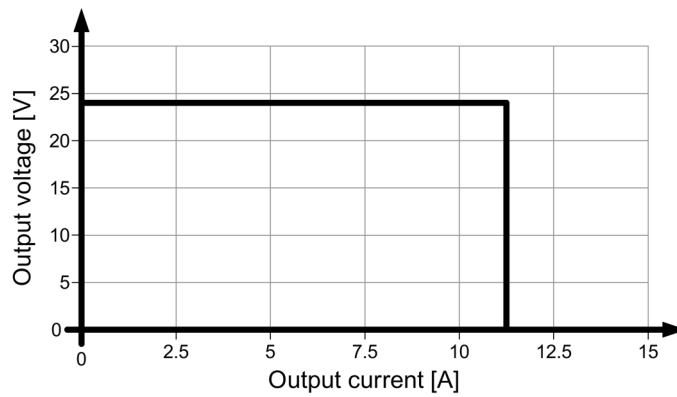

Figure 6-4 Output characteristic curve 6EP3334-8SB00-0AY0 stand-alone operation

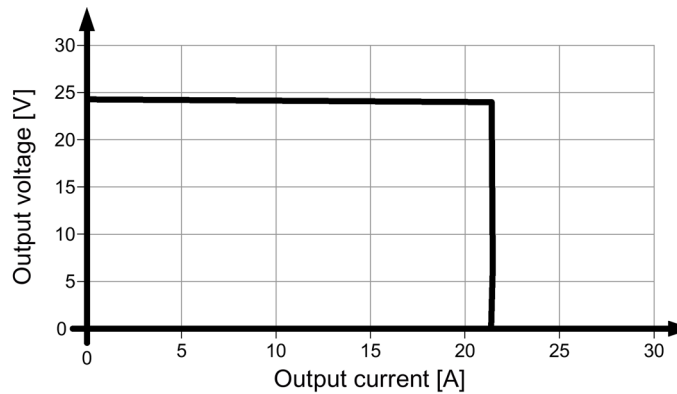

Figure 6-5 6EP1336-3BA10 single operation output characteristic

The device supplies a constant output voltage until the current limit is reached. In the event of an overload, the output current and the output voltage are reduced.

**Selector switch A on (parallel operation):**

The output voltage falls with increasing output current.

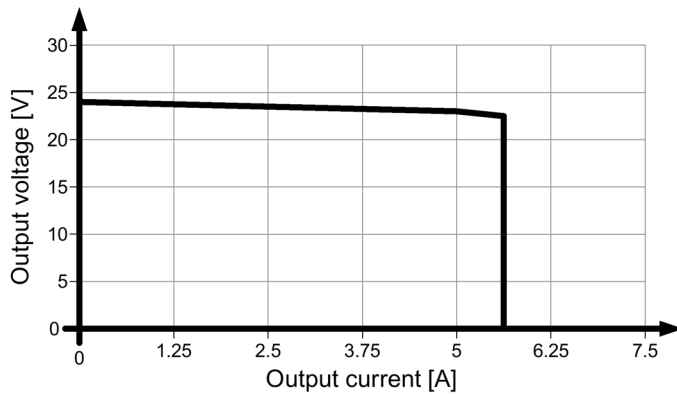

Figure 6-6 Output characteristic curve 6EP3333-8SB00-0AY0 parallel operation

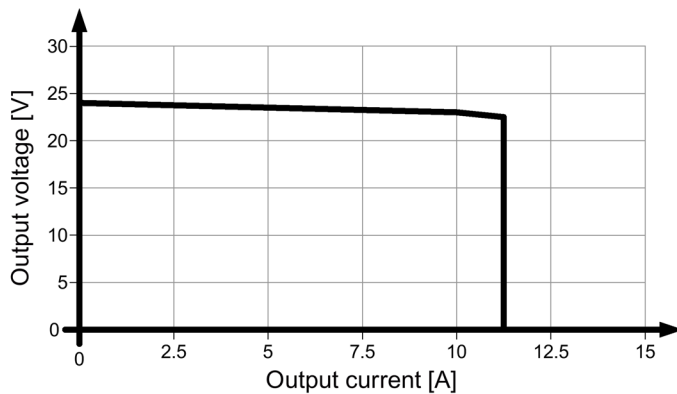

Figure 6-7 Output characteristic curve 6EP3334-8SB00-0AY0 parallel operation

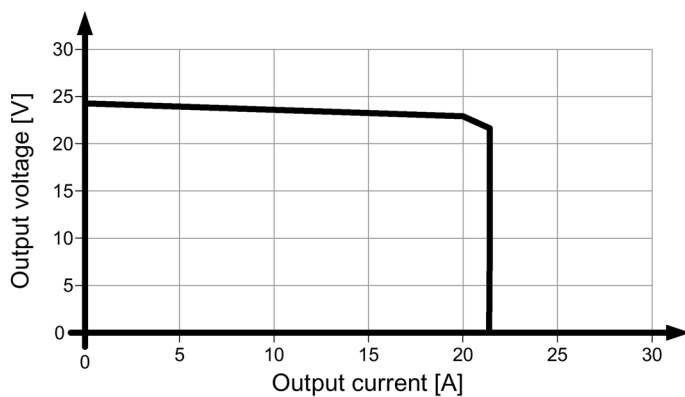

Figure 6-8 6EP1336-3BA10 parallel operation output characteristic

**Selector switch B on (latching shutdown):**

The device is shutdown if the overload lasts longer than 100 ms. 6EP3333-8SB00-0AY0 and 6EP3334-8SB00-0AY0 are reset using power supply OFF for a minimum of 60 s or remote OFF and ON at the remote contact. 6EP1336-3BA10 is reset using power supply OFF for a minimum of 5 s or remote OFF and ON at the remote contact. 6EP1336-3BA10 is reset by switching off the power supply for longer than 5 s.

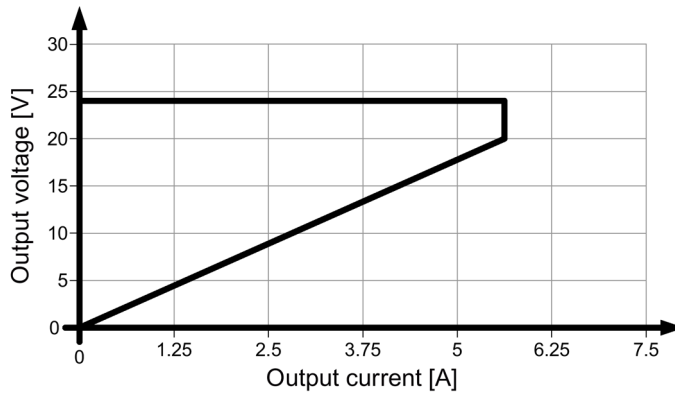

Figure 6-9 Output characteristic curve 6EP3333-8SB00-0AY0 latching shutdown

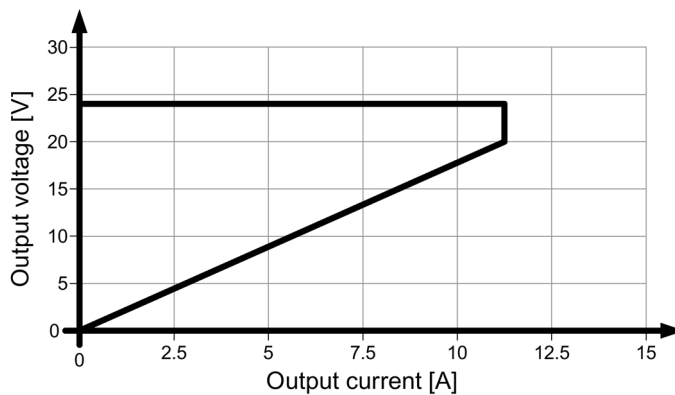

Figure 6-10 Output characteristic curve 6EP3334-8SB00-0AY0 latching shutdown

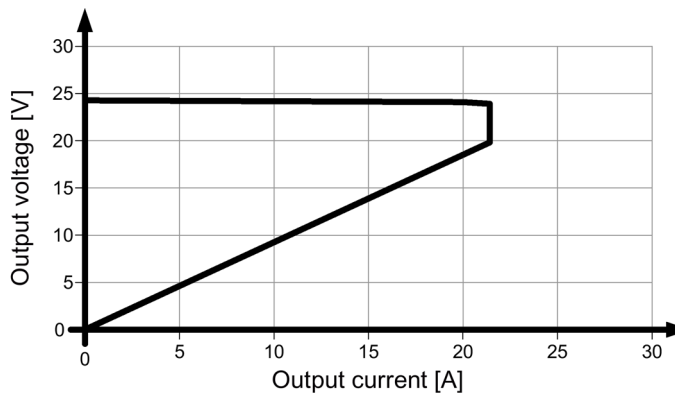

Figure 6-11 6EP1336-3BA10 latching shutdown output characteristic

## 6.3 Efficiency

	6EP3333-8SB00-0AY0 (24 V/5 A)	6EP3334-8SB00-0AY0 (24 V/10 A)	6EP1336-3BA10 (24 V/20 A)
Efficiency at $U_a$ rated, $I_a$ rated, approx.	93 %	94 %	93 %
Power loss at $U_a$ rated, $I_a$ rated, approx.	9 W	18 W	42 W
No-load operation power loss, approx.	1.5 W	1.5 W	10 W
Power loss in the "latching shut-down" state	1.2 W	1.2 W	6.5 W

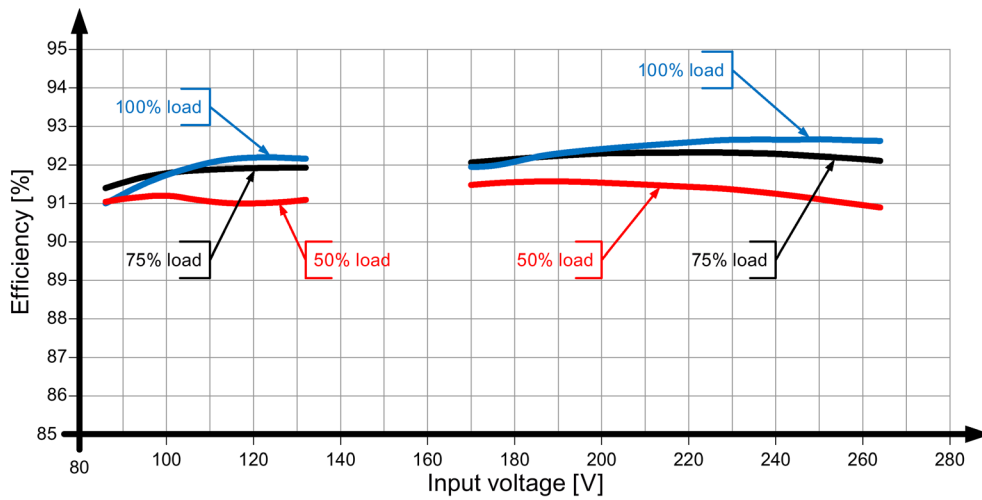

Figure 6-12 Power efficiency 6EP3333-8SB00-0AY0

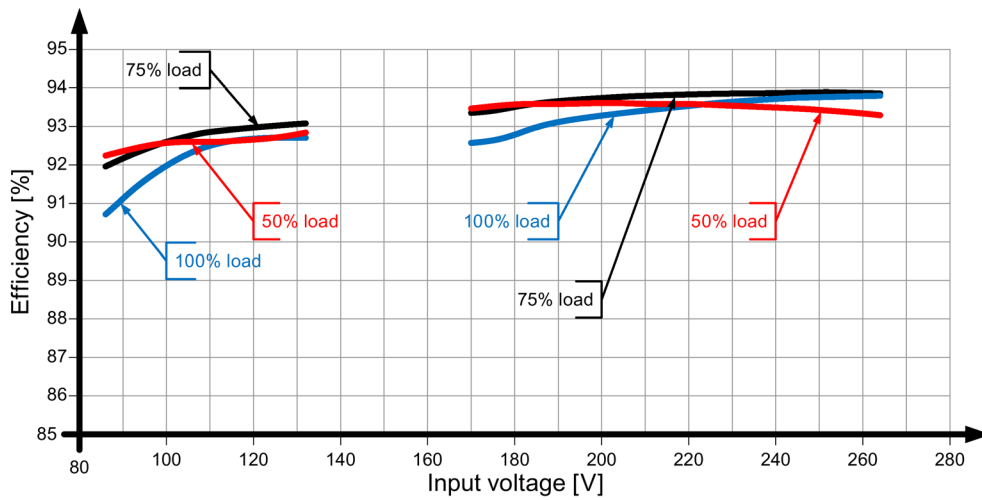

Figure 6-13 Power efficiency 6EP3334-8SB00-0AY0

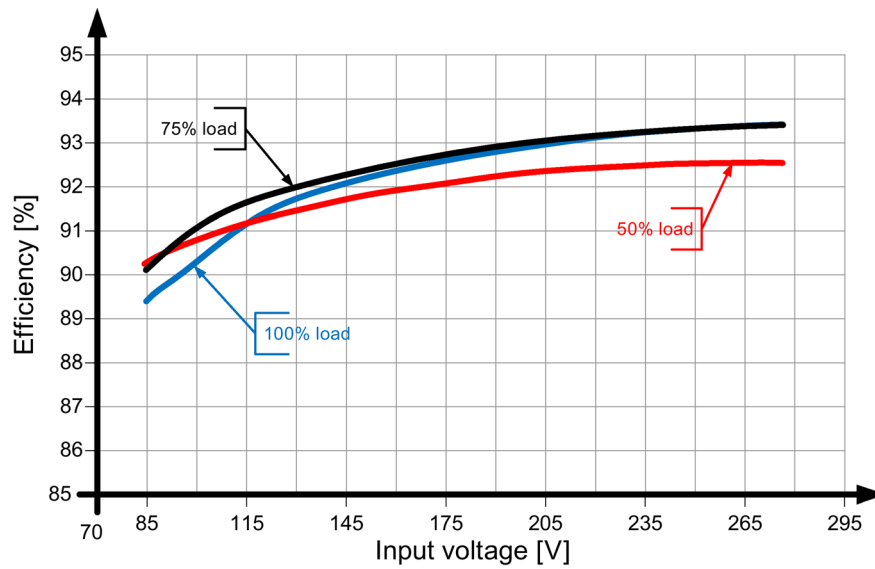

Figure 6-14 Efficiency 6EP1336-3BA10

## 6.4 Closed-loop control

	6EP3333-8SB00-0AY0 (24 V/5 A)	6EP3334-8SB00-0AY0 (24 V/10 A)	6EP1336-3BA10 (24 V/20 A)
Dyn. line regulation ( $U_e$ rated $\pm 15\%$ ), max.	0,1 %	0,1 %	1 %
Dyn. load regulation ( $I_a$ : 50/100/50%), $U_a \pm \text{typ.}$	2 %	4 %	1 %
Load step regulation time 50 to 100%, typ.	250 $\mu\text{s}$	250 $\mu\text{s}$	1 ms
Load step regulation time 100 to 50%, typ.	500 $\mu\text{s}$	500 $\mu\text{s}$	1 ms
Regulation time / maximum	1 ms	1 ms	5 ms
Dyn. load regulation ( $I_a$ : 10/90/10 %), $U_a \pm \text{typ.}$	-	-	2 %
Load step regulation time 10 to 90 %, typ.	-	-	1 ms
Load step regulation time 90 to 10 %, typ.	-	-	1 ms

## 6.5 Protection and monitoring

	<b>6EP3333-8SB00-0AY0 (24 V/5 A)</b>	<b>6EP3334-8SB00-0AY0 (24 V/10 A)</b>	<b>6EP1336-3BA10 (24 V/20 A)</b>
Output overvoltage protection	< 33 V	< 33 V	< 33 V
Current limitation, typ.	6 A	12 A	21.5 A
Property of the output / short-circuit proof	Yes	Yes	Yes
Short-circuit protection	Optional constant current characteristic curve or latching shutdown	Optional constant current characteristic curve or latching shutdown	Optional constant current characteristic approx. 23 A or latching shutdown
Continuous short-circuit current / rms value / typical	3.5 A	7 A	23 A
• Remark	Overload capability 150% Ia rated up to 5 s/min	Overload capability 150% Ia rated up to 5 s/min	Overload capability 150% Ia rated up to 5 s/min
Overload / short-circuit indicator	Yellow LED for "overload", red LED for "latching shutdown"		

## 6.6 MTBF

	<b>6EP3333-8SB00-0AY0 (24 V/5 A)</b> <b>6EP3334-8SB00-0AY0 (24 V/10 A)</b>	<b>6EP1336-3BA10 (24 V/20 A)</b>
Mean Time Between Failures	SN29500: >1200000 hours at 40 °C, rated load, 24-hour operation	SN29500: >620000 hours at 40 °C, rated load, 24-hour operation

## 6.7 Mechanical system

	<b>6EP3333-8SB00-0AY0 (24 V/5 A)</b>	<b>6EP3334-8SB00-0AY0 (24 V/10 A)</b>	<b>6EP1336-3BA10 (24 V/20 A)</b>
Connection system	Screw-type terminal	Screw-type terminal	Screw-type terminal
Connections / line supply	L1, N, PE: 1 screw terminal each for 0.2 ... 2.5 mm <sup>2</sup> solid (finely stranded)	L1, N, PE: 1 screw terminal each for 0.2 ... 2.5 mm <sup>2</sup> solid (finely stranded)	L, N, PE: 1 screw terminal each for 0.2 ... 6 (4) mm <sup>2</sup> solid (finely stranded)
Connections / output	+, -: 2 screw terminals each for 0.2 ... 2.5 mm <sup>2</sup> solid (finely stranded)	+, -: 2 screw terminals each for 0.2 ... 2.5 mm <sup>2</sup> solid (finely stranded)	+, -: 2 screw terminals each for 0.2 ... 6 (4) mm <sup>2</sup> solid (finely stranded)
Width of the housing	45 mm	55 mm	90 mm
Height of the housing	125 mm	125 mm	125 mm
Depth of the housing	125 mm	125 mm	125 mm
Mounting width	45 mm	55 mm	90 mm

	6EP3333-8SB00-0AY0 (24 V/5 A)	6EP3334-8SB00-0AY0 (24 V/10 A)	6EP1336-3BA10 (24 V/20 A)
Mounting height	225 mm	225 mm	225 mm
Weight, approx.	0.8 kg	1.0 kg	1.2 kg
Product feature of the housing / housing that can be lined up next to one another	Yes	Yes	Yes
Type of mounting / panel mounting	No	No	No
Type of mounting / rail mounting	Yes	Yes	Yes
Type of mounting / S7-300 rail mounting	No	No	No
Mounting	Can be snapped onto standard EN 60715 35x7,5/15 mounting rails	Can be snapped onto standard EN 60715 35x7,5/15 mounting rails	Can be snapped onto standard EN 60715 35x7,5/15 mounting rails

## 6.8 Accessories

	6EP3333-8SB00-0AY0 (24 V/5 A) 6EP3334-8SB00-0AY0 (24 V/10 A) 6EP1336-3BA10 (24 V/20 A)
Electrical accessories	Buffer module, redundancy module
Mechanical accessories	Device identification label 20mm × 7mm, Ti grey 3RT2900-1SB20

## 6.9 Dimension drawing

See Section Dimensions and weight (Page 21)

CAD data that can be downloaded from the Internet:

6EP3333-8SB00-0AY0

([http://www.automation.siemens.com/bilddb/index.aspx?objKey=G\\_KT01\\_XX\\_00963](http://www.automation.siemens.com/bilddb/index.aspx?objKey=G_KT01_XX_00963))

6EP3334-8SB00-0AY0

([http://www.automation.siemens.com/bilddb/index.aspx?objKey=G\\_KT01\\_XX\\_00966](http://www.automation.siemens.com/bilddb/index.aspx?objKey=G_KT01_XX_00966))

6EP1336-3BA10

([http://www.automation.siemens.com/bilddb/index.aspx?objKey=G\\_KT01\\_XX\\_00385](http://www.automation.siemens.com/bilddb/index.aspx?objKey=G_KT01_XX_00385))





## Safety, approvals, EMC

### 7.1 Safety

	6EP3333-8SB00-0AY0 (24 V/5 A)
	6EP3334-8SB00-0AY0 (24 V/10 A)
	6EP1336-3BA10 (24 V/20 A)
Primary/secondary galvanic isolation	Yes
Electrical isolation	SELV output voltage $U_a$ according to EN 60950-1 and EN 50178
Protection class	Class I
Degree of protection (EN 60529)	IP20
Leakage current, typ.	1 mA
Leakage current, max.	3.5 mA
Test voltage	See Table 7-1 Test voltage for 6EP3333-8SB00-0AY0 and 6EP3334-8SB00-0AY0 (Page 50) and Table 7-2 Test voltage for 6EP1336-3BA10 (Page 51)

## 7.2 Test voltage

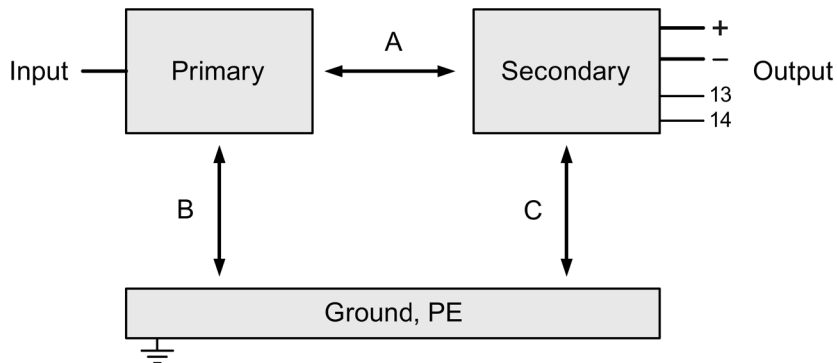

Figure 7-1 Test voltage diagram

Only the manufacturer can perform the type test and production test; users can also perform the field test.

Preconditions for performing the field test:

Tests (A) & (B)

- Connect the input terminals with one another
- Connect the output terminals, signaling contact and PE with one another

Test (C)

- Connect the output terminals and signaling contact with one another and measure with respect to PE

Table 7- 1 Test voltage for 6EP3333-8SB00-0AY0 and 6EP3334-8SB00-0AY0

	Test time	Prim ↔ sec (A)	Prim ↔ PE (B)	Sec ↔ PE (C)
Type test	60 s	4200 VDC	2200 VDC	700 VDC
	60 s	3000 VAC	1500 VAC	500 VAC
Production test	1 s	4200 VDC	4200 VDC	500 VDC
	1 s	3000 VAC	3000 VAC	350 VAC
Field test	1 s	2200 VDC	2200 VDC	500 VDC
	1 s	1500 VAC	1500 VAC	350 VAC

Note:

Tripping current for DC measurement: 0 mA

Tripping current for AC measurement: <100 mA

Table 7- 2 Test voltage for 6EP1336-3BA10

	Test time	Prim ↔ sec (A)	Prim ↔ PE (B)	Sec ↔ PE (C)
Type test	60 s	4200 VDC	2200 VDC	700 VDC
	60 s	3000 VAC	1500 VAC	500 VAC
Production test	1 s	2200 VDC	2200 VDC	500 VDC
	1 s	1500 VAC	1500 VAC	350 VAC
Field test	1 s	2200 VDC	2200 VDC	500 VDC
	1 s	1500 VAC	1500 VAC	350 VAC

Remark:

Tripping current for DC measurement: 0 mA

Tripping current for AC measurement: <100 mA

## 7.3 Approvals

	6EP3333-8SB00-0AY0 (24 V/5 A) 6EP3334-8SB00-0AY0 (24 V/10 A)	6EP1336-3BA10 (24 V/20 A)
CE marking	Yes, (2004/108/EG and 2006/95/EG)	Yes, (2004/108/EG and 2006/95/EG)
UL/cUL (CSA) approval	cULus-Listed (UL 508, CSA C22.2 No. 107.1), File E197259	cULus-Listed (UL 508, CSA C22.2 No. 107.1), File E197259
Explosion protection	EPS 12 ATEX 1 640 X IECEX EPS 14.0057X II 3G Ex nA nC IIC T4 Gc cCSAus HazLoc Class I, Div 2, Group A,B,C,D T4	EPS 12 ATEX 1 442 X IECEX EPS 14.0062X II 3G Ex nA nC IIC T3 Gc cCSAus HazLoc Class I, Div 2, Group A,B,C,D T3
CB approval	Yes, (IEC 60950-1)	No
SEMI F47 compliance	Fulfilled	-
Marine approvals	GL, ABS	GL, ABS

## 7.4 EMC

		<b>6EP3333-8SB00-0AY0 (24 V/5 A)</b>	<b>6EP1336-3BA10 (24 V/20 A)</b>
		<b>6EP3334-8SB00-0AY0 (24 V/10 A)</b>	
Electrostatic discharge	EN 61000-4-2	8 kV contact, 8 kV air	8 kV contact, 8 kV air
Electromagnetic fields	EN 61000-4-3	80 ... 1000 MHz 25 V/m 1000 ... 2700 MHz 10 V/m	80 ... 1000 MHz 25 V/m 1000 ... 2700 MHz 10 V/m
High-speed transient disturbance variables (burst)	EN 61000-4-4	4 kV at line supply connections 2 kV at the DC output	4 kV at line supply connections 2 kV at the DC output
Surge voltages	EN 61000-4-5	3 kV symmetrical at the line supply connections 6 kV symmetrical at the line supply connections 500 V symmetrical/asymmetrical on DC output cables	3 kV symmetrical at the line supply connections 5 kV asymmetrical at the line supply connections 500 V symmetrical/asymmetrical on DC output cables
High-frequency fields	EN 61000-4-6	10 V; 0.15 ... 80 MHz	10 V; 0.15 ... 80 MHz
Magnetic fields	EN 61000-4-8	30 A/m; 50 Hz	30 A/m; 50 Hz
Voltage dips	EN 61000-4-11	-	100 % for 20 ms 60 % for 200 ms 30 % for 500 ms
Voltage interruptions	EN 61000-4-11	-	100 % for 5000 ms
Emitted interference	EN 55022	Class B	
Line harmonics limit	EN 61000-3-2	Class A	
Generic standards	EN61000-6-2	Noise immunity for industrial environments	
	EN61000-6-3	Emission for residential areas	

## Ambient conditions

<b>6EP3333-8SB00-0AY0 (24 V/5 A)</b> <b>6EP3334-8SB00-0AY0 (24 V/10 A)</b> <b>6EP1336-3BA10 (24 V/20 A)</b>	
Ambient temperature	-25 ... +70° C with natural convection Tested according to: <ul style="list-style-type: none"> <li>• EN 60068-2-1 cold</li> <li>• EN 60068-2-2 dry heat</li> <li>• EN 60068-2-78 humid heat, constant</li> <li>• EN 60068-2-14 temperature change</li> </ul>
Transport and storage temperature	-40 ...+85 °C Tests (packed for shipping) according to: <ul style="list-style-type: none"> <li>• EN 60068-2-1 cold</li> <li>• EN 60068-2-2 dry heat</li> <li>• EN 60068-2-30 humid heat, cyclic</li> </ul>
Humidity class	Climatic class 3K3 according to EN 60721, without condensation
Degree of pollution	2
Mechanical stressing during operation	Tested according to: <ul style="list-style-type: none"> <li>• EN 60068-2-6 vibration, test Fc: 7 mm deflection in the range 5 ... 8.4 Hz 2 g acceleration in the range 8.4 ... 150 Hz</li> <li>• EN 60068-2-27 shock, test Ea: Acceleration 150 m/s<sup>2</sup>, test duration 11 ms</li> </ul>
Damaging gases	Tested according to: <ul style="list-style-type: none"> <li>• EN 60068-2-42 sulfur dioxide</li> <li>• EN 60068-2-43 hydrogen sulfide</li> </ul>
Atmospheric pressure	Operation: <ul style="list-style-type: none"> <li>• 1080 ... 795 hPa (-1000 ... +2000 m)</li> <li>• For operation at installation altitudes from 2000 m up to 6000 m: Output power derating of -7.5 % / 1000 m or reduction of the ambient temperature by 5 K / 1000 m see Figure 4-4 Mounting height derating (Page 26)</li> <li>• Overvoltage category: III to 2000 m (EN 50178) II from 2000 m to 6000 m (EN 50178) II to 2000 m (EN 60950-1) I from 2000 m to 6000 m (EN 60950-1)</li> </ul> Storage: <ul style="list-style-type: none"> <li>• 1080 ... 660 hPa (-1000 ... +3500 m)</li> </ul>



# Applications

## 9.1 Parallel connection to increase power rating

To increase the power rating, SITOP PSU8200 power supplies of the same type can be directly connected in parallel.

The following must be observed:

- The cables connected to each power supply at terminals "+" and "-" must have identical lengths and the same cable cross-sections (or the same impedance) up to a common external connection point (terminal strip) if possible.
- The power supplies connected in parallel must be switched on simultaneously with a common switch in the line feeder cable (e.g. with the main switch available in control cabinets).
- The output voltages measured in no-load operation for the power supplies that are not yet connected in parallel should not deviate more than a maximum of 50 mV. This usually corresponds to the factory setting. If the output voltage is changed, you should connect the "-" terminals and then, in no-load operation, measure the voltage difference between the "+" terminals that have not yet been connected. The voltage difference should not exceed 50 mV.
- Switch selector switch "A" (see Figure 2-8 Selector switch (Page 16)) to "Parallel operation".

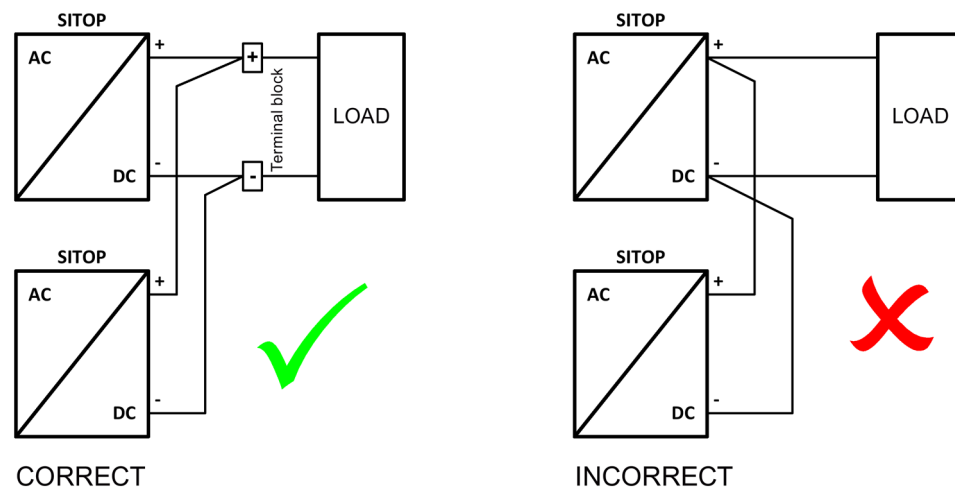

Figure 9-1 Parallel connection

**NOTICE**

**Protective circuit for the parallel connection of more than two power supplies**

When connecting more than two power supplies in parallel, additional measures must be taken to prevent high backward feeding currents in the event of a secondary device fault. For this purpose, a suitable protective circuit (e.g. decoupling diode or DC-conform circuit breaker) must be installed between each "+" terminal of the power supply and the common connection point.



## 9.2 Parallel connection for redundancy

Connecting several SITOP PSU8200 power supplies in parallel for redundancy purposes is required if especially high demands are placed regarding the availability of a reliable 24 V power supply.

Using the SITOP PSE202U redundancy module, two 24 V power supplies of the same type up to 20 A can be decoupled (Figure 9-2 Redundant configuration with two power supplies and SITOP PSE202U redundancy module (Page 57)). When one of the devices fails, then the other automatically takes over the power supply. If one of the power supplies fails, then this is signaled using an LED on the redundancy module as well as an isolated relay contact.

When dimensioning the system, it must be ensured that  $n+1$  redundant connected power supplies can handle the total power requirement of the remaining  $n$  power supplies.

---

### Note

For a high reliability of the supply, it is recommended that the redundant switched power supplies are fused separately on the line-side and, if possible, connected to different power supply networks.

---

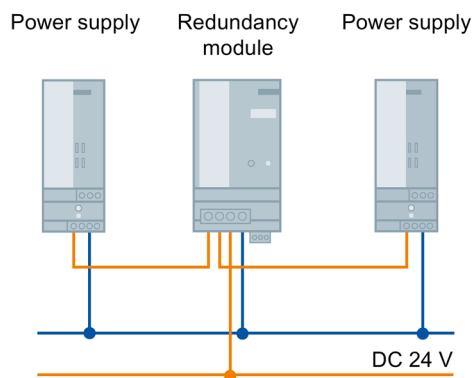

Figure 9-2 Redundant configuration with two power supplies and SITOP PSE202U redundancy module

You can find additional information in the:

SITOP PSE202U manual (<http://support.automation.siemens.com/WW/view/en/42248598>)

### 9.3 Series connection for increased voltage

To achieve an output voltage of 48 V DC, two 24 V SITOP PSU8200 power supplies of the same type can be connected in series. In this case, connect the "-" terminal of the first power supply to the "+" terminal of the second power supply. The "+" terminal of the first power supply and the "-" terminal of the second power supply are routed to the load.

Depending on the grounding point of the secondary output voltages, voltages of +48 V,  $\pm 24$  V or -48 V can be realized.

In the case of an asymmetric load distribution, it is not possible to guarantee correct functionality.

 <b>WARNING</b>
<b>SELV is not guaranteed in the case of a fault</b>
When connecting two power supplies in series, the continuous, permissible SELV voltage of a maximum of 60 VDC according to EN 60950 cannot be guaranteed in the case of a fault.

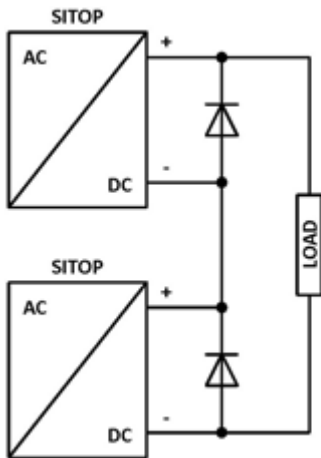

Figure 9-3 Series connection

## 9.4 Overload protection in the 24 V output circuit

If an overload occurs, the electronic current limiting function limits the SITOP PSU8200 output current to a maximum value (see Section Technical data (Page 37)). The output cables are protected against a thermal overload if they are dimensioned corresponding to the maximum rms output current, or protected using additional components (for example, miniature circuit breaker, fuses).

However, a load circuit that fails as a result of overload, for instance, should frequently be reliably and quickly identified and specifically switched off before the power supply goes into current-limiting mode (in current-limiting mode, the supply voltage would also be reduced for all of the remaining 24 V loads).

The SITOP PSE200U selectivity module with 4 outputs (versions with adjustable output current range for each output from 0.5-3 A and 3-10 A) is available for this purpose; this monitors the 24 V branches for overload and short-circuit (Figure 9-4 Electronic protection of 24 V consumers with the SITOP PSE200U selectivity module (Page 59)). Brief current peaks, e.g. as a result of a high inrush current, are permitted, and branches with a longer overload are switched into a no-current condition. This is also ensured for cables in a high-ohmic condition and for short-circuits that slowly develop over time.

When an output fails, the fault is signaled using a group signal contact or as a single channel signal, and the branch of the module involved is displayed using an LED.

For versions with single-channel signaling, function blocks for evaluation purposes are available at no charge for SIMATIC S7-1200/1500/300/400, for STEP 7 and TIA Portal as well as for SIMOTION CPUs and SIMOTION SCOUT.

You can find additional information at:

SITOP PSE200U selectivity module manuals

(<http://support.automation.siemens.com/WW/view/en/10807226/130000>)

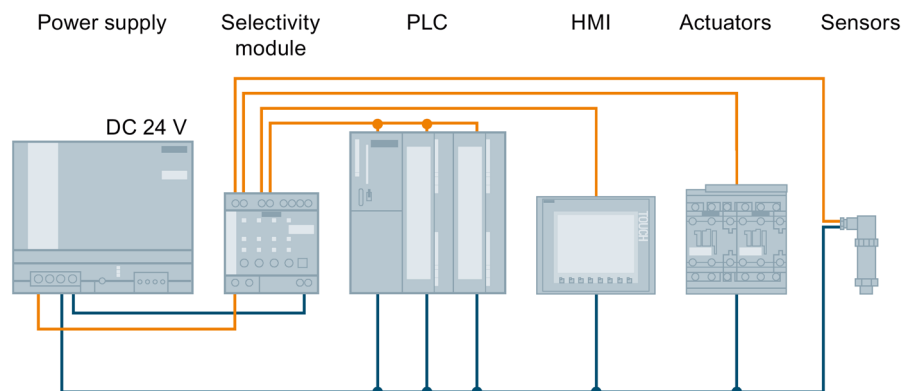

Figure 9-4 Electronic protection of 24 V consumers with the SITOP PSE200U selectivity module

## 9.5 Protection against short-time voltage dips

In the case of a drop in the line-side supply voltage, the SITOP PSU8200 power supply can still maintain the output voltage for a short time in the millisecond range (see section Technical data (Page 37)).

For line supplies that manifest frequent brief voltage dips, in order to increase the power supply reliability, it may make sense to increase the line buffering time in the device using an additional SITOP PSE201U buffer module.

The SITOP PSE201U buffer module, based on electrolytic capacitors, is connected in parallel to the 24 V power supply output (Figure 9-5 Buffering brief power failures using the SITOP PSE201U buffer module (Page 60)). The buffer time is 200 ms at 40 A up to 1.6 s for a load current of 5 A. This time can be increased a multiple number of times by connecting buffer modules in parallel; the maximum buffer time is 10 s.

You can find additional information at:

SITOP PSE201U manual (<http://support.automation.siemens.com/WW/view/en/41129219>)

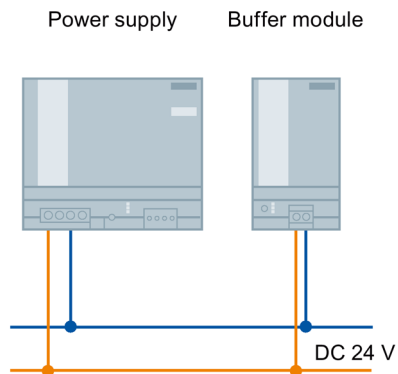

Figure 9-5 Buffering brief power failures using the SITOP PSE201U buffer module

## 9.6 Protecting against longer power failures

Sudden and longer failures of the line supply voltage can result in undefined states and significant danger as a result of the associated failure of the plant or system control. The SITOP power supply product portfolio includes various DC-UPS solutions to prevent the failure of the 24 V power supply voltage.

Power supply failures up into the minutes range can be buffered using the maintenance-free SITOP UPS500 DC-UPS modules based on capacitors (Figure 9-6 24 V buffering to allow the saving of process data and controlled shutdown of PCs (Page 61)).

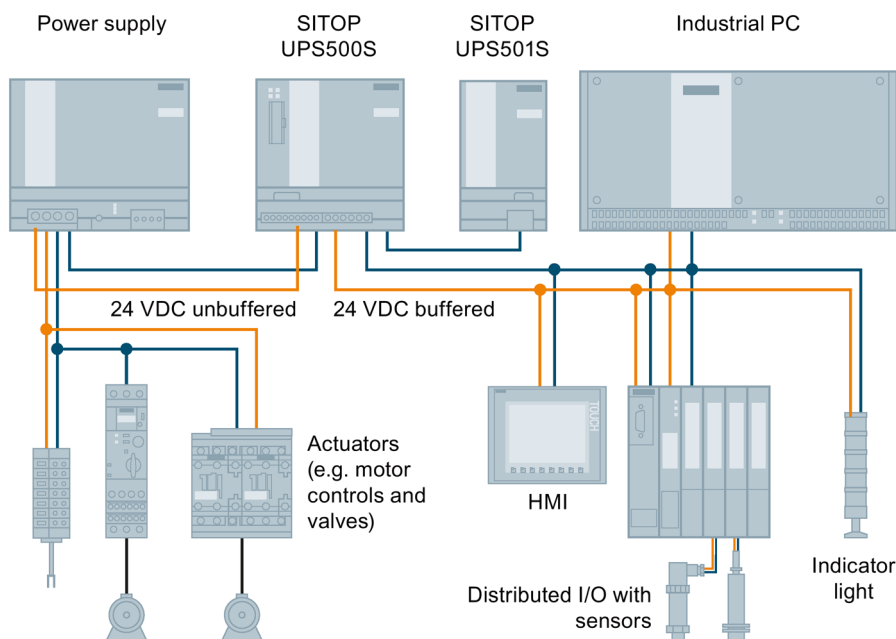

Figure 9-6 24 V buffering to allow the saving of process data and controlled shutdown of PCs

Using the free-of-charge SITOP DC-UPS software tool, DC-UPS systems can be simply integrated into PC-based automation solutions. This supports further processing of the status signals and safely running down the PC.

You can find additional information at:

Manual, DC UPS with capacitors

(<http://support.automation.siemens.com/WW/view/en/48932766/133300>)

Using DC UPS SITOP UPS1600 and SITOP UPS1100 battery modules, buffer times in the range of hours can be implemented. Intelligent battery management using Energy Storage Link automatically detects the UPS1100 energy storage device, and ensures optimum temperature-controlled charging and continuous monitoring. The UPS1600 can be flexibly integrated into the widest range of automation applications with its digital inputs/outputs as well as optional USB interface or Ethernet/PROFINET port.

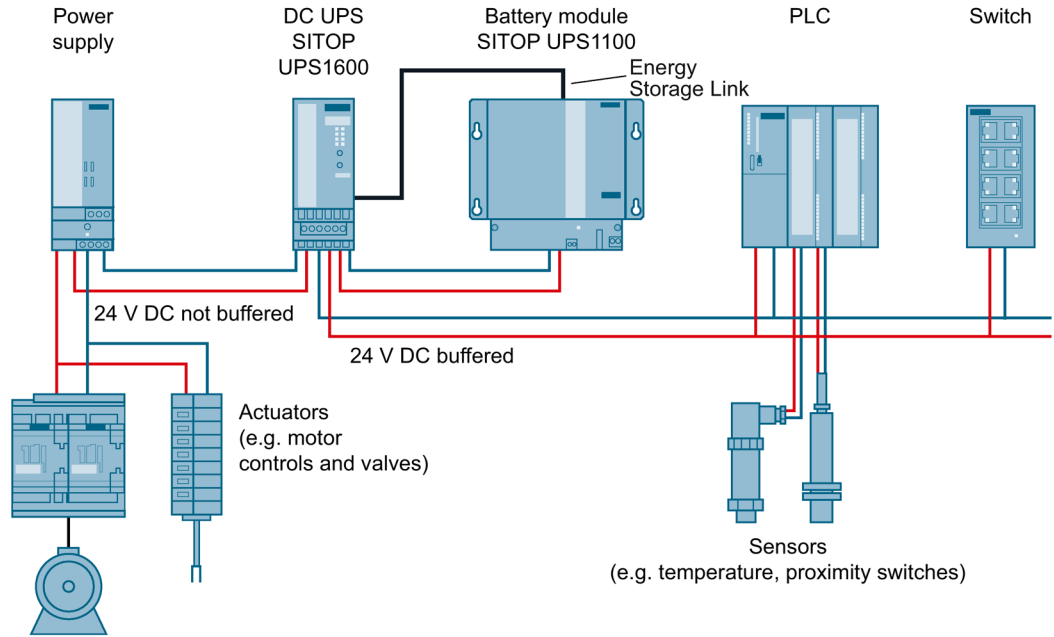

Figure 9-7 24 V buffering with SITOP UPS1600 to maintain communication, signaling functions, sensor measured values and position values

For open, PC-based automation systems, configuration and monitoring is realized using the SITOP UPS Manager PC software, which is available at no charge. This allows PC responses to the operating states of the DC UPS to be freely selected – and offers comprehensive diagnostic functions.

For TIA-based automation systems, the UPS1600 is engineered using the TIA Portal. Special function blocks for SIMATIC S7-300/400/1200 and S7-1500 – available at no charge – make it easy to integrate operating and diagnostics information into STEP 7 user programs. Preconfigured UPS faceplates for WinCC visualization can be downloaded at no charge.

You can find additional information at:

DC UPS SITOP UPS1600/UPS1100 Manual  
<http://support.automation.siemens.com/WW/view/en/84977415>

## Environment

The devices are in conformance with RoHS.

As a rule, only non-silicon precipitating materials are used.

### Disposal guidelines



Packaging and packaging aids can and should always be recycled. The product itself may not be disposed of as domestic refuse.





## Service & Support

### Technical support

Technical support for all IA/DT products can be accessed through the following communication channels:

- Phone: + 49 (0) 911 895 7222
- E-Mail (<mailto:support.automation@siemens.com>)
- Internet:  
Online support request form (<http://www.siemens.de/automation/support-request>)

### Technical documentation on the Internet

Operating instructions and manuals for SITOP are available in the Internet:  
Operating instructions/manuals (<http://www.siemens.de/sitop/manuals>)

### SITOP power supply homepage

General news about our power supplies is available in the Internet at the SITOP homepage:  
SITOP (<http://www.siemens.de/sitop>)

### Information material

SITOP information can be downloaded from the Internet:  
Information and download center (<http://www.siemens.de/sitop-infomaterial>)

### CAX data

2D/3D data and circuit diagram macros can be downloaded from the Internet:  
Siemens image database (<http://www.siemens.de/sitop-cax>)

Request all CAX data via the CAX download manager:  
CAX shopping cart (<http://www.siemens.de/cax>)

### SITOP Selection Tool

Simply and quickly select the optimum the power supply or DC-UPS:  
SITOP Selection Tool (<http://www.siemens.de/sitop-selection-tool>)

### Online catalog and ordering system

The online catalog and the online ordering system are available through the Industry Mall homepage:  
Industry Mall (<http://www.siemens.com/industrymall/de>)

**Contact persons**

If you have any questions regarding the use of our products, then contact the Siemens contact person in your regional Siemens sales office.

You can find these addresses as follows:

- On the Internet (<http://www.siemens.de/automation/partner>)
- In Catalog CA 01