

SIEMENS



SENTRON

Residual Current Protective Devices

Technology primer

Answers for infrastructure and cities.

Preface

Whether for protecting, switching, monitoring or measuring – low-voltage circuit protection devices from Siemens perform a wide range of functions for all applications in the area of electrical installation technology. They are suitable for use in residential buildings, non-residential buildings or industrial applications and thus allow you to maintain control over all electrical circuits.

This is especially important when it comes to selecting and installing the appropriate residual current protective device. With this primer, we provide you with a simple tool for perfectly adapting the respective residual current protective device to the requirements of the electrical installation in question. Apart from general information on residual current protective devices, it contains important details regarding installation and use. You can therefore be assured that you will always choose the right device.

Your team
Low-Voltage Circuit Protection

Contents

Introduction	6
1 Protection through residual current protective devices	7
1.1 Additional protection (previously "Protection against direct contact") with $I_{\Delta n} \leq 30 \text{ mA}$	7
1.2 Fault protection (protection against indirect contact)	10
1.3 Fire protection	11
2 Residual current protective devices	12
2.1 Types of residual current protective devices	12
2.1.1 Type AC	14
2.1.2 Type A	14
2.1.3 Type F	14
2.1.4 Type B	16
2.1.5 Type B+	16
2.2 Classification of residual current protective devices	16
2.3 Basic design and method of operation	18
2.3.1 Type A RCCB	18
2.3.2 SIQUENCE universal current-sensitive RCCB Type B and Type B+	20
2.4 Features and application areas	21
2.4.1 RCCB	21
2.4.2 RCBO (Type AC/Type A, Type F) • Installation with a central RCCB • Installation with RCBOs	22 23
2.4.3 SIQUENCE universal current-sensitive RCCB Type B and Type B+	24
2.4.4 SIQUENCE universal current-sensitive RCBO Type B and Type B+	28
2.4.5 RC units for installation on miniature circuit breakers	28
2.4.6 SIGRES RCCB (for harsh ambient conditions)	29
2.4.7 Type K , super-resistant	29
2.4.8 Type S , selective	31
2.4.9 Versions for 50 to 400 Hz	32
2.4.10 Versions for 500 V operational voltage	32
2.4.11 Residual current operated circuit breaker with N-connection on the left side	32
2.5 Additional components for residual current operated circuit breakers	33
2.5.1 Remote controlled operating mechanism (RC)	33
2.5.2 Auxiliary switch	33

3	Notes on installation and use	34
3.1	General notes	34
3.1.1	Selection of protective devices	34
3.1.2	Use of residual current protective devices	35
3.2	Choosing the right residual current protective device	38
3.2.1	Type A, Type F or Type B/Type B+?	39
3.2.2	What protection goal must be achieved?	39
	• Additional protection	39
	• Fault protection	39
	• Fire protection	40
3.2.3	What electrical interference occurs and how is it handled?	41
3.2.3.1	Leakage currents	41
	• Static leakage currents	41
	• Dynamic leakage currents	41
3.2.3.2	High load currents	42
3.2.3.3	Overvoltages and surge current load	42
3.3	Special features regarding the use of SIQUENCE universal current-sensitive residual current protective devices (Type B and Type B+)	43
3.3.1	Applications	43
3.3.2	Residual currents at different fault locations, with a frequency converter (FC) as an example	44
	• Fault locations in section 1 (upstream of the FC)	44
	• Fault locations in section 2 (in the FC)	45
	• Fault locations in section 3 (downstream of the FC)	46
	• Frequency components in the residual current of a frequency converter	47
3.3.3	Configuration	48
3.3.4	Causes of excessive leakage currents and possibilities of reducing them	49
3.4	Back-up protection	51
3.5	Protection against thermal overload	54
3.6	Troubleshooting	54
3.7	Leakage current measurement	55
3.8	4-pole residual current operated circuit breakers in a 3-pole network	57
4	Residual current monitoring devices (RCM)	57
5	Outlook	59
	Appendix	60
	Index of figures and tables	70

Residual current operated circuit breaker (RCCB)



5SM3

- Type AC, Type A and Type F
- $I_n = 16 \dots 125 \text{ A}$
- $I_{\Delta n} = 10 \text{ mA} \dots 1 \text{ A}$
- 2-pole (1+N) and 4-pole (3+N)
- N connection at left and right
- SIGRES for harsh ambient conditions
- Version **K** and **S**
- 500 V version
- 50 ... 400 Hz version

SIQUENCE universal current-sensitive residual current operated circuit breaker (RCCB)



5SM3

- Type B, Type B+
- $I_n = 16 \dots 80 \text{ A}$
- $I_{\Delta n} = 30, 300 \text{ and } 500 \text{ mA}$
- 2-pole (1+N) and 4-pole (3+N)
- Version **K** and **S**

SIQUENCE RCBO



5SU1

- Type B, Type B+
- $I_n = 100 \dots 125 \text{ A}$
- $I_{\Delta n} = 30, 300 \text{ mA and } 1 \text{ A}$
- 4-pole
- Circuit breaker characteristic C and D
- Rated switching capacity 10 kA
- Version **K** and **S**

RC unit for combination with a miniature circuit breaker



5SM2

- For mounting on a miniature circuit breaker
- Combined electric shock and line protection
- Type AC, Type A and Type F
- $I_n = 0.3 \dots 100 \text{ A}$
- $I_{\Delta n} = 10 \text{ mA} \dots 1 \text{ A}$
- 2-, 3- and 4-pole
- Version **K** and **S**

RCBO; combination units



5SU1

- Combined electric shock and line protection
- Type AC, Type A and Type F
- $I_n = 6 \dots 40 \text{ A}$
- $I_{\Delta n} = 10 \dots 300 \text{ mA}$
- Circuit breaker characteristic B and C
- Rated switching capacity 4.5 kA, 6 kA and 10 kA
- 1+N-pole, 2-pole
- N connection at right and left

Residual current monitoring devices (RCM)



5SV8

- Residual current monitoring
- Type AC and Type A
- $I_{\Delta n} = 0.03 \dots 30 \text{ A}$
- Response time 0.02 ... 10 s
- Summation current transformer 20 ... 210 mm

Introduction

When dealing with electricity, safety has top priority. Every electrician must be particularly conscientious when safety is concerned and must apply the required protective measures correctly.

In consumer's installations, residual current protective devices must be given unreserved preference over alternative protective devices.

In addition to fault protection (protection in cases of indirect contact), residual current protective devices with rated residual currents up to 30 mA also provide "additional protection" in cases of direct contact. Fires caused by ground-fault currents can also be prevented at a very early stage.

In many cases, the DIN VDE standards require the use of residual current protective devices. Electricians should therefore make sure that they are fully informed about residual current protective devices.

In addition to information on the protective effect of residual current protective devices, an understanding of how the devices function is also conveyed.

In order to optimally adapt the use of residual current protective devices to the requirements of the electrical installation, the functionality of the different versions of residual current protective devices is discussed and the user is given practical installation and application tips.

1 Protection through residual current protective devices

The basic prerequisite for use of a residual current protective device in order to automatically disconnect the power supply as a protective measure is that an appropriately grounded protective conductor is connected to the system components and equipment to be protected. Current can then pass through a human body only when two faults occur (interruption of the PE conductor in addition to a fault in the insulation) or when there is unintentional contact between live parts.

1.1 Additional protection (previously "Protection against direct contact") with $I_{\Delta n} \leq 30 \text{ mA}$

Additional protection is understood to mean protection which takes effect if there is direct contact of a human body with a part normally live during operation in the event of basic and/or fault protection failing. When a human body touches live parts, two resistors connected in series determine the intensity of the flowing current – the internal resistance of the human body R_m and the transfer resistance of the location R_{st} (Figure 1).

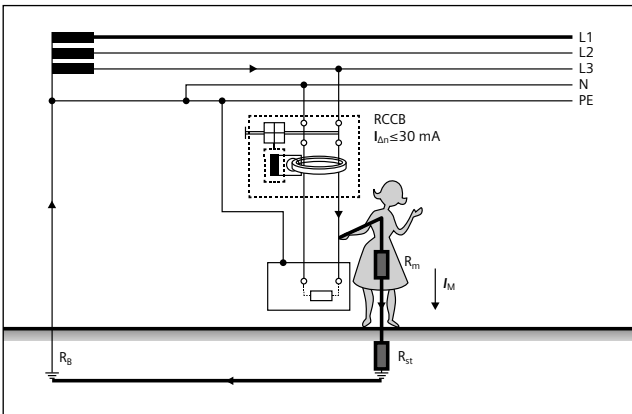
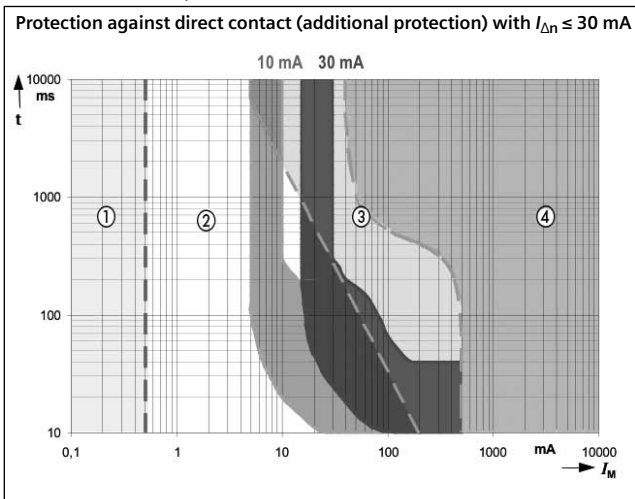

Figure 1: Additional protection: Residual current protective device with $I_{\Delta n} \leq 30 \text{ mA}$ in the TN system

In order to consider the accident properly, the worst case scenario where the transfer resistance of the location is near zero must be assumed.

The resistance of the human body depends on the current path and the contact resistance of the skin. Measurements have shown e.g. approximately 1,000 Ω for the flow of current from hand to hand or from hand to foot. Under these assumptions, a touch voltage of 230 V results in a dangerous shock current of 230 mA. Figure 2 shows the current intensity/exposure time curves in relation to the physiological reactions of the human body. Dangerous current intensities and exposure times are those which reach as far as zone 4, as they can cause death due to ventricular fibrillation. It also shows the tripping ranges of the residual current protective devices with rated residual currents of 10 mA and 30 mA. It also shows the maximum permissible tripping times according to VDE 0664-10.

As can be seen from the tripping curves, residual current protective devices do not limit the intensity of the residual current but provide protection due to fast disconnection of the power and therefore a minimal time of exposure to the current.



Zone ①: Exposure is normally imperceptible.

Zone ②: There are generally no injurious effects or muscle spasms.

Zone ③: Muscle cramps can occur. There is normally no danger of ventricular fibrillation.

Zone ④: Ventricular fibrillations may occur

Figure 2: Effects of 50/60 Hz alternating current on the human body

The tripping curve of residual current protective devices with a rated residual current of $I_{\Delta n} \leq 10$ mA is in zone 2 below the release limit. Medically damaging effects and muscle cramps do not usually occur (see Figure 2). They are therefore suitable for sensitive areas, such as bathrooms.

Residual current protective devices with a rated residual current of $I_{\Delta n} \leq 30$ mA fulfill the conditions for additional protection against electric shock (see Figure 2):

- in the event of unintentional, direct contact with parts that are live when operational (e.g. failure of the basic insulation, operation for other than the intended purpose, ineffective basic protection)
- in the event of carelessness on the part of the user (e.g. use of defective equipment, incorrectly repaired components and equipment)
- in the event of contact with defective live parts (e.g. loss of protection against faults due to interruption of the protective conductor).

The use of residual current protective devices with a rated residual current of up to 30 mA has proven to be effective as additional protection in the event of failure of the basic protection precautions (protection against direct contact) and/or fault protection precautions (protection against indirect contact) as well as in the event of carelessness on the part of the user when using electrical equipment. However, this should not be the only way of providing protection against electric shock. This does not replace the need for further protective measures as required by DIN VDE 0100-410.

The requirement for "additional protection" with residual current protective devices according to sections 411.3.3 and 415.1 of DIN VDE 0100-410 does not mean that how this protection is used is up to the user. This additional protection can be required in conjunction with other protection measures under certain external influences and in certain special areas.

In several parts of the standards of sections 4 and 7 of DIN VDE 0100, this additional protection is required or expressly recommended (see Appendix). Some important requirements are explained below in more detail as examples.

In the generally applicable standard for protection against electric shock (DIN VDE 0100-410:2007-06, the use of residual current protective devices with a rated residual current of ≤ 30 mA is required as additional protection for

- all socket outlets with a rated current of ≤ 20 A if they are intended for use by non-experts and for general use
- final circuits for portable items of equipment used outdoors with a rated current of ≤ 32 A.

Note:

In DIN VDE 0100-410:06-2007, two exceptions from these requirements are indicated but they are not usually applicable in the majority of applications.

The requirement of the standard for additional protection can be avoided only in the case of socket outlets which are only used by qualified electricians and persons who have received appropriate technical instruction (e.g. in electrical workshops) or if it has been ensured that the socket outlet is only used permanently for a "specific item of equipment".

According to standard DIN VDE 0100-723:2005-06 "Requirements for special installations, locations or plants - classrooms with experimental equipment", Type B residual current protective devices with a rated residual current of ≤ 30 mA must be used for supplying power to the experimental equipment and its circuits in TN or TT systems.

1.2 Fault protection (previously "Protection against indirect contact")

Fault protection is understood to mean the contact of a human body with a part that is not live in operation but is electrically conductive. In these cases, the demand is for automatic disconnection of the power supply when a fault can pose a risk due to the intensity and duration of the touch voltage.

Residual current protective devices with rated residual currents of over 30 mA are also suitable for this purpose. The tripping conditions must be complied with to achieve the protective effect. In addition, the dangerous touch voltage must not be present for an impermissible length of time, taking into consideration the grounding resistance and the rated residual current.

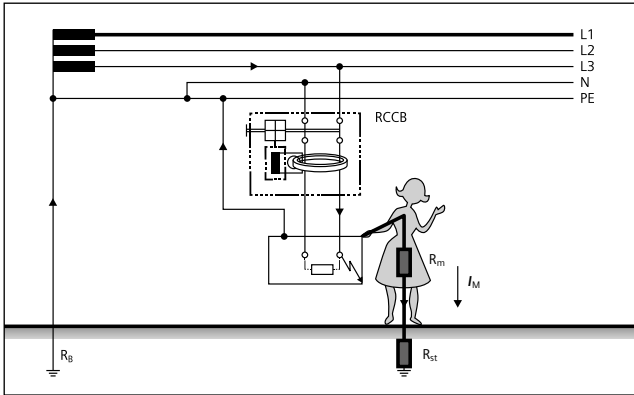

Figure 3: Fault protection in the TN system

1.3 Fire protection

DIN VDE 0100-482 requires measures for the prevention of fires which can be caused by insulation faults in “locations exposed to fire hazards”. This stipulates that cables and conductors in TN and TT systems must be protected by means of residual current protective devices with a rated residual current of $I_{\Delta n} \leq 300 \text{ mA}$. This does not include mineral-insulated cables and busbar systems.

In applications in which resistive faults can cause a fire (e.g. radiant ceiling heating with panel heating elements), the rated residual current must be $I_{\Delta n} = 30 \text{ mA}$.

The fire protection provided by residual current protective devices, however, should not be limited to locations exposed to fire hazards but should always be provided.

2 Residual current protective devices

2.1 Types of residual current protective devices

Residual current protective devices are distinguished from one another in respect of their suitability for detecting different forms of residual current (Figure 4).







Current waveform	Correct functioning of residual current protective devices of Type					Tripping current
	AC	A	F	B	B+	
	•	•	•	•	•	0.5 to 1.0 $I_{\Delta n}$
	-	•	•	•	•	0.35 to 1.4 $I_{\Delta n}$
	-	•	•	•	•	Start angle 90° 0.25 to 1.4 $I_{\Delta n}$ Start angle 135° 0.11 to 1.4 $I_{\Delta n}$
	- A)	•	•	•	•	max. 1.4 $I_{\Delta n}$ + 6 mA (Type + 10 mA (Type F) + 0.4 $I_{\Delta n}$ (Type B/B+)
	-	-	•	•	•	0.5 to 1.4 $I_{\Delta n}$
	-	-	-	•	•	0.5 to 2.0 $I_{\Delta n}$

Figure 4: Classification of residual current protective devices into different types with tripping ranges

Residual current with different waveforms can occur depending on the electronic switching in the circuit. Since residual current protective devices differ in their suitability for detecting residual current waveforms, the relevant load input circuit must be taken into account when such a device is chosen.

Table 1 shows electronic circuits and their possible load and residual currents, along with the suitable types of residual current protective device in each case.

Suitable RCD type	Circuit	Load current	Residual current
B F A AC B+ kHz			

Table 1: Possible residual current waveforms and suitable residual current protective devices

2.1.1 Type AC

Type AC residual current protective devices are suitable only for detecting sinusoidal AC residual currents (see circuits 1 to 3 in Table 1). This device type is not authorized in every country (e.g. Germany as per DIN VDE 0100-530) for residual current protection and cannot carry the VDE mark of conformity.

2.1.2 Type A

Type A residual current protective devices detect pulsating DC residual currents in addition to sinusoidal AC residual currents.

This type of device is the most commonly used pulse current-sensitive residual current protective device in Germany. It can therefore also handle the residual current waveforms which can occur in the power supply units of single-phase loads with electronic components (e.g. ECG, dimmer switches). Smooth DC residual currents up to 6 mA do not affect the trip properties unacceptably. This type of residual current protective device is suitable for electronic equipment with input current circuits 1 to 6 in Table 1.

2.1.3 Type F

Type F residual current protective devices detect all residual current types as do Type A. Additionally, they are suitable for detecting residual currents from mixed frequencies of up to 1 kHz.

This will also be able to cope with the possible residual current waveforms on the output side of single-phase connected frequency converters (e.g. in washing machines, pumps). Smooth DC residual currents up to 10 mA do not affect the trip properties unacceptably. Type F residual current protective devices additionally have short-time delayed tripping and enhanced current withstand capability. They are suitable for electronic equipment with input current circuits 1 to 7 in Table 1.

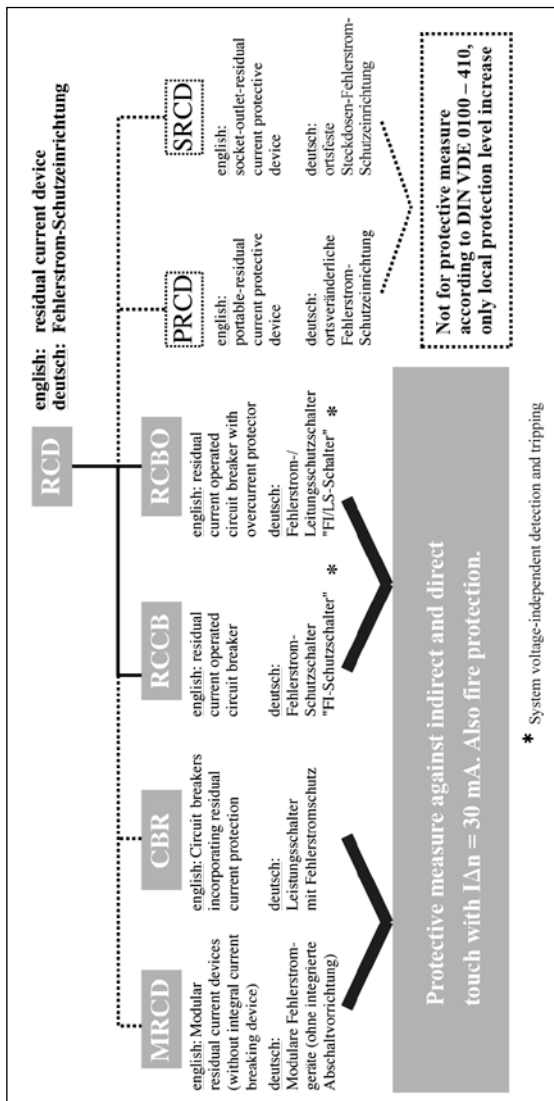

Figure 5: Classification of residual current protective devices (RCDs)

2.1.4 Type B

In addition to detecting residual current waveforms of Type F, residual current protective devices of Type B are used to detect smooth DC residual currents. Residual current protective devices of this type are suitable for use in 50/60 Hz three-phase AC systems, but not in DC voltage systems or where frequencies differ from 50/60 Hz as on the output side of frequency converters. They can be used for all input current circuits listed in Table 1, i.e. also for those identified with numbers 8 to 13. Tripping values defined up to 2 kHz.

2.1.5 Type B+

The same conditions apply for Type B+ residual current protective devices as for Type B residual current protective devices. It is only that the frequency range for the detection of residual currents is extended to 20 kHz: The device will trip within this frequency range below 420 mA.

2.2 Classification of residual current protective devices

Residual current protective devices are classified according to their various versions (see Figure 5).

- **RCD** is the generic term for all types of residual current protective device.
- **RCCBs** are residual current operated circuit breakers without integral overcurrent protection known in Germany as Fehlerstrom-Schutzschalter (FI-Schutzschalter).
- **RCBOs** are devices which feature an integrated overcurrent protection unit for overload and short-circuit protection in addition to protection against residual currents. Another version in this device group is the residual current unit (RC unit). The customer can then mount the miniature circuit breaker versions suitable for a particular application (characteristic, rated current, switching capacity) on these RC units. Once assembled, these devices perform the same functions as an RCBO. The RC unit provides residual-current detection but has no contacts of its own; in the event of a fault, it trips the miniature circuit breaker which opens the contacts and interrupts the circuit.

Given their tripping conditions, only versions of RCCBs and RCBOs which are independent of the supply voltage are approved for AC residual currents and pulsating residual currents (Type A) in Germany and in most other European countries as a means of providing protection with disconnection of the supply. Only such RCCBs and RCBOs are permitted to bear the VDE mark of conformity.

- **CBRs** are miniature circuit breakers with residual current protection in accordance with EN 60947-2 (VDE 0660-101), Appendix B. In this case, a residual-current detector is permanently installed on a miniature circuit breaker, thus ensuring residual current protection.
- **MRCDs** are modular devices, i.e. separate modules are provided for residual current detection (via current transformers), evaluation and tripping (via miniature circuit breakers) (in accordance with EN 60947-2 (VDE 0660-101), Appendix M).

CBRs and MRCDs are especially intended for applications with higher rated currents (> 125 A).

- **PRCDs** are portable residual current protective devices which are integrated, for example, in connectors or in multiple socket outlets.
- **SRCDs** are, according to DIN VDE 0662, non-portable residual current protective devices which are integrated in a socket outlet or form a single unit with a socket outlet.

PRCDs and SRCDs can be used to raise the level of protection for applications in which the required protective measure is ensured in some other manner. They are not permissible as a protective measure with disconnection of the supply.

2.3 Basic design and method of operation

2.3.1 RCCB Type A

A residual current operated circuit breaker of Type A essentially consists of the following function groups:

- Summation current transformer for residual current detection
- Tripping circuit with components for evaluation and holding magnet release for converting the electrical measured variable into a mechanical latch release
- Breaker mechanism with contacts

Note: With the exception of the tripping circuit, the design of the Type AC and Type F RCCBs is identical to that of Type A.

The summation current transformer comprises all conductors of the circuit to be protected, including the neutral conductor. In a fault-free system, the magnetic effects of the current-carrying conductors are cancelled out in the summation current transformer. There is no residual magnetic field which could induce voltage onto the secondary winding of the transformer.

A residual magnetic field remains in the transformer core only if residual current is flowing, e.g. due to an insulation fault in the system to be protected (from the electrical point of view, downstream of the residual current operated circuit breaker). This generates a voltage in the secondary winding, effecting disconnection of the circuit with the excessive touch voltage by means of the holding magnet release and the breaker mechanism (Figure 6).

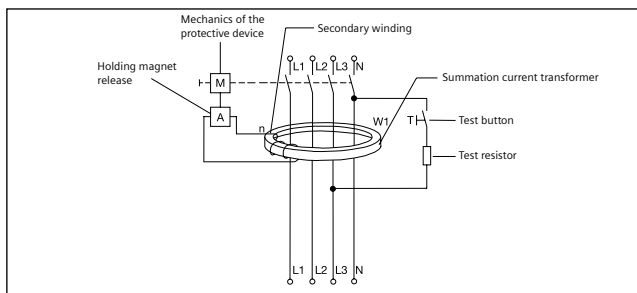

Figure 6: Schematic representation of a residual current operated circuit breaker

In accordance with the device standard EN 61008-1 (VDE 0664-10), the device must disconnect within 300 ms at the rated residual current.

In accordance with the product standard applicable in Germany, Type A and Type F residual current operated circuit breakers must function independently of supply voltage and auxiliary voltage in all function groups (detection, evaluation, disconnection) in order to achieve a consistently high level of reliability of the device protection function.

The function of the trip element, which works independently of the supply or auxiliary voltage, is shown in Figure 7.

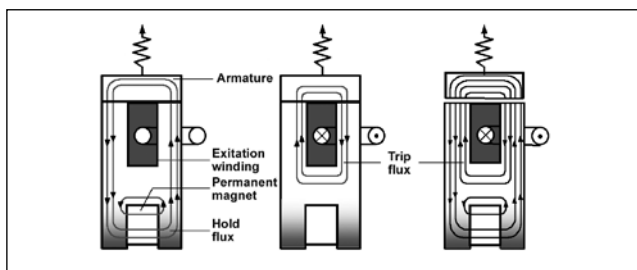

Figure 7: Principle of operation of a holding magnet release







Immediately above the permanent magnet lies a magnetic shunt whose primary task is to stabilize the permanent magnet's magnetic flux. On one pole core, there is an excitation winding, which is connected to the secondary winding of the summation current transformer. If there is a ground fault in the main circuit, a voltage is induced in the secondary winding of the summation current transformer. The left part of the illustration shows the rest position when the system is in a fault-free state. The permanent magnet drives a magnetic flux between two cores of magnetically soft material and stabilizes the armature through counteraction of a spring force.

When a voltage is generated in the secondary winding of the transformer (middle part of the illustration), this voltage drives a current through the excitation winding. This generates a second magnetic flux. The effect of the permanent magnetic field is cancelled out in a half-wave by the second magnetic field (right-hand part of the illustration).

This allows the spring to pull the armature from the pole face. The armature triggers the separation of the contacts by means of the breaker mechanism. The transformer need only generate the small amount of energy needed to cancel out the holding flux, which trips the latch release of the energy store in the breaker mechanism by means of the falling armature, and not the large amount of energy needed to open the contacts.

The functionality of the residual current protective device can be tested using the test button available on any device. Pressing the test button generates an artificial residual current which must trip the residual current protective device. In order to guarantee protection against dangerous shock currents, the reliability of the RCCB must be tested when the installation is commissioned and at regular intervals, at least half-yearly (e.g. upon transition from daylight savings time to standard time).

2.3.2 SIQUENCE universal current-sensitive RCCB

Type B    and **Type B+**    kHz

This type of device has two detection systems. In accordance with the DIN VDE 0664-100 specification applicable in Germany, detection, evaluation and disconnection according to Type A requirements are independent of the supply voltage. For physical reasons, a voltage supply is required only for the detection of smooth DC residual currents. The voltage is supplied by all line supply cables.

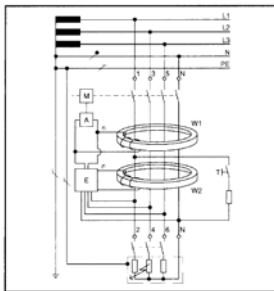



- A Holding magnet release
- M Mechanics of the protective device
- E Electronics for tripping in the event of smooth DC residual currents
- T Test equipment
- n Secondary winding
- W1 Summation current transformer for detection of sinusoidal residual currents 
- W2 Summation current transformer for detection of smooth DC residual currents 

Figure 8: Structure of a SIQUENCE Type B and Type B+ universal current-sensitive RCCB

2.4 Features and application areas

2.4.1 RCCB

RCCBs are residual current protective devices without integrated protection against overcurrent (overload and/or short circuit). A corresponding overcurrent protective device must therefore be assigned to them for overcurrent protection. The expected operational current of the circuit can be used as a basis for assessing the level of overload protection needed. The overcurrent protective device must be selected according to the information provided by the manufacturer of the residual current operated circuit breaker.

In order to meet these requirements regarding the availability of the electrical installation (see section 3.1.2), final circuits are to be divided up among several residual current protective devices.

If the protective device trips in the event of a fault or if manual disconnection is necessary, all the circuits downstream from the RCCB are disconnected from the power supply, whereby the phase conductor and the neutral conductor are disconnected. This is an advantage when troubleshooting is carried out in an installation with fault-laden neutral conductors.

If residual current operated circuit breakers with a rated residual current of 30 mA or less are used for additional protection, fault protection is to be provided with an upstream selective residual current protective device with a higher rated residual current or with an overcurrent protection device. The protective device must be installed at the beginning of the circuit.

2.4.2 RCBO Type AC , Type A , Type F

Residual current operated circuit breakers with overcurrent protection (RCBOs) include residual current detection and overcurrent protection in one device and thus enable a combination of electric-shock protection, fire protection and line protection in one device. The use of RCBOs has a series of advantages:

- Each circuit is assigned its own RCBO:
 - If the device is tripped due to a residual current, only the affected circuit is disconnected. This is done in the same way as it has been for years when the miniature circuit-breaker exclusively assigned to a circuit trips due to overcurrent.
- Due to division of the circuits, the user profits from increased operational safety and equipment availability because leakage currents produced by electronic equipment, such as parts of power supply systems, for operating reasons do not add up to produce non-permissible values and exceed the tripping value of the RCCB.

- Planning is simplified in that demand factors as in the case of loads on residual current operated circuit breakers do not have to be taken into account. The RCBO protects itself against overload.
- In the event of a fault, all poles are disconnected from the power supply. All live parts are thus reliably disconnected from the supply and troubleshooting is simplified.

These advantages led to a note in DIN VDE 0100-410 recommending the use of RCBOs as additional protection in final circuits for outdoors and for socket outlets.

The requirements indicated in 3.1.2, namely that the circuits in an electrical installation must always be divided up among several residual current protective devices, can also be complied with optimally by using RCBOs. In the following comparison of the different methods of installation, the differences are described.

Installation with a central RCCB

Figure 9 shows a frequent type of installation with a central RCCB, downstream of which several miniature circuit breakers are connected for each phase conductor.

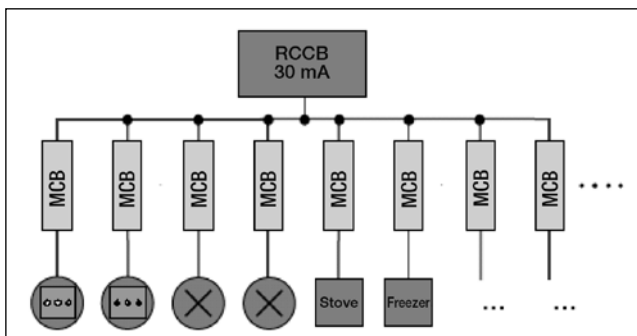

Figure 9: Installation with a central RCCB and miniature circuit breakers for feeders

The RCCB provides electric-shock protection and fire protection as well as the additional protection with $I_{\Delta n} \leq 30 \text{ mA}$ against direct contact as required for certain circuits (e.g. in bathrooms). The miniature circuit breaker prevents damage due to overloads or short circuits. If the RCCB is tripped in one of the downstream circuits due to a ground fault, all other circuits, even the fault-free circuits, are disconnected from the voltage supply. Operation of these parts of the installation can only be resumed after the fault has been eliminated. The following factors must be taken into account with this type of installation:

- For correct dimensioning of the installation in respect of the residual current operated circuit breaker (RCCB), it must be ensured that the RCCB is not overloaded due to excessively high load currents (see section 3.5).
- In the de-energized state, the single-pole miniature circuit breakers only disconnect the phase conductor from the network. The neutral conductor remains connected to the load side.

Installation with RCBOs

Figure 10 contains an example of a future-oriented installation, which meets all the requirements of the installation regulations and planning stipulations.

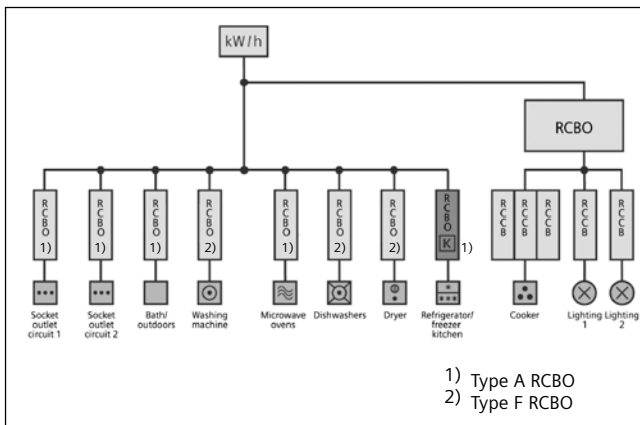



Figure 10: Example of an installation with RCBOs

Each individual socket-outlet circuit now has its own RCBO, which provides complete fault, fire and line protection as well as additional protection against direct contact. In the event of a fault, only the affected circuit is disconnected from the supply. The use of Type F RCBOs is recommended for washing machine, dryer and dishwasher circuits. In the event of a fault in such appliances, currents with frequencies other than 50 Hz can occur for which Type A RCBOs are not designed. In order to obtain increased safety against inadvertent disconnection from the supply, e.g. due to lightning overvoltages, the use of a super resistant RCBO, Type **K**, is recommended for protection of socket outlet circuits for refrigerators and freezers. If RCBOs with a rated residual current of 30 mA or less are used, the additional protection and fault protection can be provided with the same RCBO. The RCBO must be installed at the beginning of the circuit to be protected.

As an option, a selective RCCB with $I_{\Delta n} = 300$ mA can be connected upstream of the entire installation. This RCCB protects installations with branches against faults and fire. If the stipulations of DIN 18015-2:2000-08 and RAL RG 678:2004-09 are taken as the basis for the same extent of equipment and for the same living area, the additional space required in the circuit distribution board when the recommended RCBOs are used is only slightly more than the space required in an installation with separate RCCBs and miniature circuit breakers.

2.4.3 SIQUENCE universal current-sensitive RCCB

Type B  and **Type B+**  kHz

Type A residual current protective devices – for sinusoidal AC residual currents and pulsating DC residual currents – are not capable of detecting possible smooth DC residual currents. Due to pre-magnetization of the transformer, DC residual currents can even result in the inability of Type A residual current protective devices to detect AC residual currents.

For these reasons, Siemens introduced the universal current-sensitive Type B residual current operated circuit breaker, which is also used for smooth DC residual currents, in 1994, the first manufacturer to do so. Since then, the required residual current operated circuit breaker technology can be used in many applications in which smooth DC residual currents occur.

As universal current-sensitive residual current operated circuit breakers are used for the widest variety of applications, these are always also designed for use under harsh ambient conditions like our SIGRES version (see paragraph 2.4.6).

In addition to the residual current waveforms described above, AC residual currents of different frequencies can originate in the case of electronic components, for instance on the outgoing side of a frequency converter (also see section 3.3.2).

Type A RCCBs are not designed for this purpose.

The Type B residual current operated circuit breakers intended for use in three-phase systems (not in DC voltage systems) are therefore specified in draft DIN VDE 0664-100 (for RCCBs) and draft DIN VDE 0664-200 (for RCBOs) in the extended tripping conditions up to 2 kHz. The tripping characteristics of the SIQUENCE universal current-sensitive Type B RCCBs with rated residual currents of 30 mA and 300 mA are shown in Figure 11.

The tripping value of the circuit breaker always lies within the limit values of the device specification and, for 30 mA rated residual current, is well below the limit curve for dangerous ventricular fibrillation (according to IEC 60479-2).

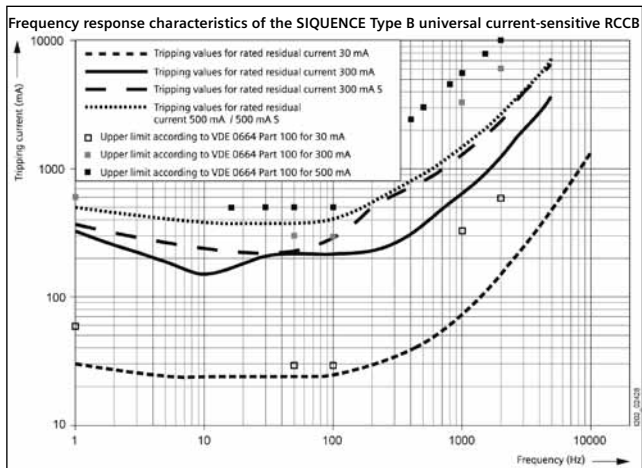

Figure 11: Type B frequency-dependent tripping current

Note: The lines illustrated are typical patterns. Deviations up to the limit values of the standard are possible.

To protect against fires caused by ground-fault currents, the use of residual current protective devices with a rated residual current of up to 300 mA has proven itself to be effective.

This is derived from the assumption that approximately 70 W is sufficient to cause a fire. The tripping values of the SIQUENCE universal current-sensitive Type B RCCB increase with higher frequencies. However, since residual current contains high-frequency and low-frequency components (see section 3.3.2), an effective contribution to fire protection in the case of ground-fault currents can also be achieved with a tripping characteristic which rises with the frequency. The positive effect of the increasing tripping current is a higher degree of operational safety for the system as a whole, since leakage currents from capacitors can lead to a reduced level of unwanted tripping of the RCCB.

The dimensioning of the SIQUENCE universal current-sensitive Type B RCCB's frequency response takes these boundary conditions into account, and represents a solid compromise between fire protection and operational safety. Since the influence of existing capacitive leakage currents on the tripping of the RCCB is clearly limited, the RCCB can be used in a significantly larger number of applications.

The use of Type B+ residual current protection devices is recommended if the use of residual current protection devices with rated residual currents of max. 300 mA is required in accordance with DIN VDE 0100-482 "Fire protection against special risks or hazards" in connection with DIN VDE 0100-530. They meet all requirements of the well-known Type B, but remain below the tripping value of 420 mA at up to 20 kHz in accordance with product standards DIN VDE 0664-400 (RCCBs) and DIN VDE 0664-401 (RCBOs) as well as VdS Guideline 3501, thus offering an increased level of preventive fire protection.

High-intensity leakage currents can occur briefly when capacitors connected to the PE protective conductor are switched on (e.g. in the case of EMC filters in conjunction with frequency converters). In order to ensure trouble-free operation in such cases, the SIQUENCE universal current-sensitive Type B and Type B+ RCCBs are always super-resistant and feature short-time delayed tripping (Type **K**).

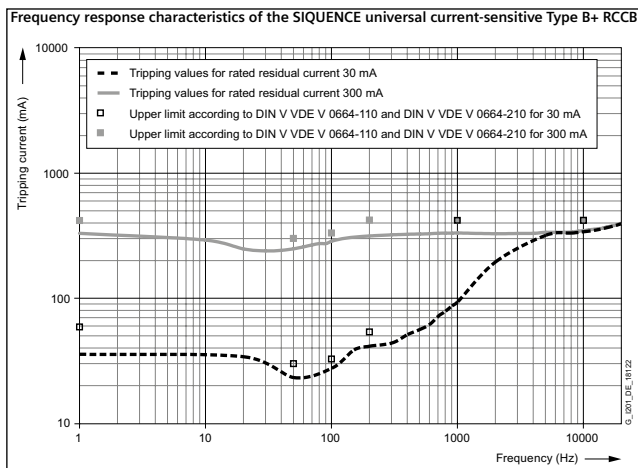

Figure 12: Type B+ frequency-dependent tripping current

Note: The lines illustrated are typical patterns. Deviations up to the limit values of the standard are possible.

In order to fulfill the tripping conditions for protection against indirect contact (fault protection) using the SIQUENCE universal current-sensitive RCCB, its tripping characteristics at different frequencies and the frequency spectra occurring in the application at the fault location must be taken into account.



On the assumption of unfavorable conditions (high clock pulse rate of a frequency converter; also see section 3.3.2), the maximum permissible grounding resistances listed below are recommended:

Rated residual current	Maximum permissible grounding resistance at touch voltage	
	50 V	25 V
30 mA	120 Ω	60 Ω
300 mA	16 Ω ¹⁾	8 Ω ¹⁾
500 mA	10 Ω	5 Ω

¹⁾ The value may be up to 120 Ω at 50 V and 60 Ω at 25 V for Type B+

Table 2: Recommended maximum grounding resistances for SIQUENCE universal current-sensitive Type B and Type B+ RCCBs

2.4.4 SIQUENCE universal current-sensitive RCBO

Type B  and Type B+ 

The principle of detection on which the SIQUENCE Type B universal current-sensitive RCBO is based is identical to that on which the SIQUENCE universal current-sensitive RCCB is based and operates in accordance with VDE 0664-200 (applicable standard in Germany) and DIN V VDE V 0664-210 (Type B+) independently of the supply voltage with regard to the requirements for Type A.

With regard to the response to residual currents and the protective functions, the same statements and specifications which apply to the SIQUENCE Type B / Type B+ universal current-sensitive RCCB are applicable.

RCBOs combine in one unit the protection functions of electric-shock and fire protection along with line protection.

Thanks to the integrated overcurrent protection feature, intrinsic thermal protection of the device is ensured automatically without further adaptation to upstream/downstream overload protection systems.

In addition to those advantages mentioned in section 2.4.2, direct allocation of a SIQUENCE Type B universal current-sensitive RCBO to a circuit offers the following special advantages over an RCCB and multiple miniature circuit breakers in the outgoing circuit:

- the maximum possible leakage current ($0.3 * I_{\Delta n}$) can be used in each feeder.
- As in the case of overcurrent, tripping due to residual current disconnects only the affected branch from the supply voltage
- High system availability, since the fault-free part of the system is still supplied with power.

2.4.5 RC units for installation on miniature circuit breakers

RC units are suitable for installation on miniature circuit breakers in accordance with EN 61009-1 (VDE 0664-20):2000-09, Appendix G. The customer can combine these RC units with an appropriate miniature circuit breaker to generate the same functionality as the factory-built RCBOs.

A large number of different combinations can be made up from the available RC unit and miniature circuit breaker product ranges without having to stock a large number of products. This results in important advantages:

- High degree of application flexibility

- Customized combination of device features from RC unit (rated residual current, instantaneous or selective) and miniature circuit breaker (rated current, characteristic, switching capacity)
- The device combination offers all advantages of an RCBO as regards electric-shock, fire and line protection

2.4.6 SIGRES RCCB (for harsh ambient conditions)

When residual current protective devices are used under severe environmental conditions with increased emissions of corrosive gases, for instance in

- indoor swimming pools (chlorine gas; ozone),
- farming (ammonia),
- industry (sulfur dioxide),

they are subject to a significantly higher load.

These gases, in conjunction with humidity, have a corrosive effect on all metal components and therefore also on the metal surfaces of the holding magnet release.

The SIGRES residual current operated circuit breakers are suitable for such applications and their patented active condensation protection feature gives them a significantly longer service life. Direct heating of the holding magnet release produces a slightly higher temperature on the metal components with only minimum power required. Since condensation of the humid air enriched with corrosive gases is thereby avoided, corrosion cannot take place, resulting in a longer service life of the devices.

A power supply is required for heating. If the RCCB is also used for a longer period of time while in a disconnected state, the direction of the incoming supply (from below) must be observed. This ensures that heating is possible in this case as well. The protective function of the RCCB continues to remain absolutely independent of the supply voltage as required by the product standard.

2.4.7 Type K, super-resistant

Leakage currents and residual currents arising from the operation of electrical equipment cannot be distinguished. The reaction to both is the same. If a temporary high leakage current occurs, it is neither necessary nor desirable to disconnect the load from the supply. If electronic equipment is used with capacitors connected against the protective conductor in order to eliminate faults, inadvertent tripping of the RCCB can occur when the equipment is switched on.

In order to avoid this disconnection, the use of super-resistant residual current protective devices is recommended. They trip with a time delay and are designated as Type **K** devices.

As far as the product standards EN 61008-1 (RCCBs) and EN 61009-1 (RCBOs) are concerned, there are only two types of device:

- Standard
- Selective

For these types of device, the limit values for the break times are defined. In accordance with the standard, the super-resistant residual current protective devices are instantaneous versions.

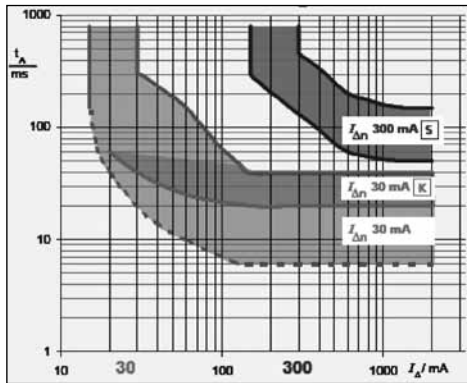

Figure 13: Break time t_A as a function of the tripping current I_Δ

Figure 13 shows the tripping range of the different versions of residual current protective devices. It can be clearly seen that the tripping ranges of the standard version and the super-resistant version are identical in terms of the maximum value. Only the minimum value is higher in the case of Type **K**. The Type **S** responds selectively to these two versions.

The Type **K** super-resistant residual current protective devices exploit the maximum permissible tripping range of the standard. They have a minimum time delay of approximately 10 ms. In other words, short-time leakage currents and high surge currents ($8/20 \mu\text{s}$) are ignored for this length of time. Only when a residual current flows for longer than the delay time is disconnection from the supply initiated. Protection against electric shock is provided by this residual current protective device too.

The devices can be used without restriction for all the protective measures (with disconnection from the supply) required in the installation conditions. The installation is not disconnected unnecessarily and its availability is considerably increased.

2.4.8 Type **S**, selective

In order to achieve selective tripping in the case of series-connected residual current protective devices in the event of a fault scenario, both the rated residual current $I_{\Delta n}$ and the tripping time of the devices must be staggered. The different permissible break times of the standard and selective residual current protective devices can be taken from Figure 14. Appropriate staggering of the rated residual currents can also be seen in Figure 14.

Type **S** selective residual current protective devices also have a very high current withstand capability of 5 kA (8/20 μ s current waveform). They are identified by the symbol **S**.

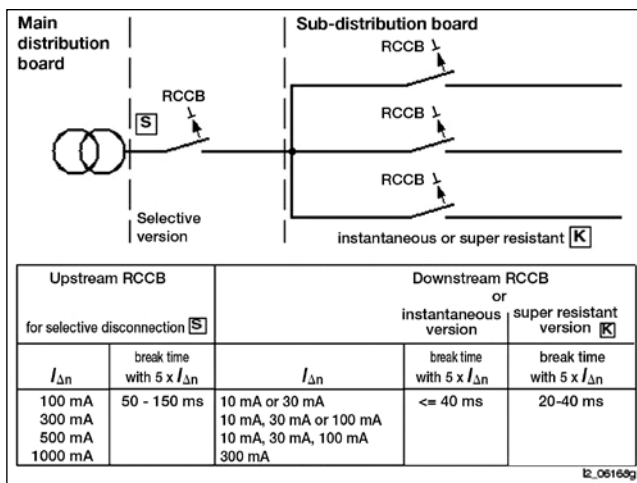

Figure 14: Layout of different residual current protective devices and their tripping times

■ **2.4.9 Versions for 50 to 400 Hz**

Because of the principle according to which they function, residual current protective devices in their standard version are designed for maximum efficiency in a 50/60 Hz network. The device specifications and tripping conditions also relate to this frequency. With increasing frequency, sensitivity normally decreases.

In order to be able to implement effective residual current protection in networks up to 400 Hz (e.g. industrial systems), suitable devices must be used.

Such residual current operated circuit breakers fulfill the tripping conditions up to the specified frequency and provide corresponding protection.

■ **2.4.10 Versions for 500 V operational voltage**

The standard versions of residual current protective devices, with their creepage and clearances, are designed for networks up to 240/415 V alternating voltage.

Suitable residual current protective devices are available for networks up to 500 V.

■ **2.4.11 Residual current operated circuit breaker with N-connection on the left side**

Residual current operated circuit breakers, particularly in Germany, are normally placed at the left of the miniature circuit breakers but have the N-conductor connection on the right. This causes problems with regard to integrated busbar connection. Residual current operated circuit breakers in conjunction with miniature circuit breakers therefore require a special busbar.

In order to make it possible use standard busbars whenever required, four-pole residual current operated circuit breakers with the N-connection on the left are also available.

The habit of installing the residual current operated circuit breakers at the left of the miniature circuit breakers and using standard busbar connections can thus be maintained.

2.5 Additional components for residual current operated circuit breakers

2.5.1 Remote-controlled operating mechanism (RC)

Favored locations for remote-controlled operating mechanisms are spacious or not continually manned work areas, such as water-treatment plants or radio stations as well as automated plants for energy and operations management.

The use of a remote-controlled operating mechanism allows the user direct and immediate access to the installation even in remote or hard-to-access locations. Fast reconnection to the supply following a fault, in particular, saves considerable time and costs.

The remote-controlled operating mechanism is controlled by means of a mechanical function selection switch. In the "OFF" position, the remote-controlled mechanism is disabled and can also be closed.

"RC OFF" prevents remote switching and allows only manual actuation of the RCCB. This prevents unauthorized remote switching during service assignments, for instance. In the "RC ON" position, "Remote ON" and "Remote OFF" switching as well as local operation are possible. If a fault trip occurs, the connected handles on the RCCB and the remote-controlled operating mechanism are set to the "OFF" position. The circuit breaker must only be reclosed if the hazardous situation no longer exists. To reclose the breaker, the operator must also acknowledge disconnection of the supply with a RESET (OFF command) for the remote-controlled operating mechanism.

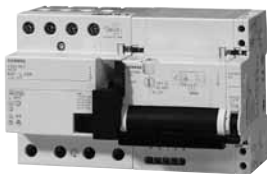

Figure 15: Remote-controlled operating mechanism with RCCB

2.5.2 Auxiliary switch

Auxiliary switches can usually be retrofitted on the residual current operated circuit breaker by the customer. They indicate the circuit breaker's switching state.

Three variants are possible (1 NO/1 NC; 2 NCs; 2 NOs).

3 Notes on installation and use

3.1 General notes

3.1.1 Selection of protective devices

When selecting a suitable protective device for the protective measure "automatic disconnection of the power supply" in accordance with DIN VDE 0100-410 for fault protection the conditions of disconnection depending on the supply system must be taken into account.

Table 3 summarizes the relevant characteristic variables for the conditions of disconnection from the supply.

Characteristics	Values in the TN system	Values in the TT system
Impedance of the fault loop Z_s (measured values)	several 10 m Ω to approx. 2 Ω	up to 100 Ω
Residual current $I_f = \frac{230V}{Z_s}$	Approx. 115 A to several 1000 A	At least 2.3 A
Maximum permissible break time t_b , according to Table 41.1. in IEC 60364-4-41 or EN 60364-4-41 ¹⁾	0.4 s	0.2 s
Touch voltage U_T (empirical values)	80 V up to 115 V	160 V up to 230 V
Touch current $I_T = \frac{U_T}{1000\Omega}$ <small>Impedance of the human body in case of hand-to-foot flow of current (guide value)</small>	80 mA up to 115 mA	160 mA up to 230 mA

¹⁾ For final circuits with a rated current not greater than 32 A in a 230/400 V system (50 Hz)

Table 3: Characteristic variables for the conditions of disconnection in TN and TT systems with rated voltages of 230/400 V AC

Table 3 shows the clear differences in respect of touch voltages and the resulting touch currents in TN and TT systems. These differences explain why the maximum permissible break times in the TT system must be shorter than in the TN system in order to provide the same protection.

Suitable protective devices are to be selected on this basis.

Table 4 provides an overview.

	TN system			TT system		
Trip currents I_a of overcurrent protective devices for ensuring the required disconnecting time t_a	$I_a \leq \frac{230V}{Z_s}$			$I_a \leq \frac{230V}{Z_s}$		
	Protective device	I_a	$t_a^{(1)}$	The necessary trip currents I_a of overcurrent protection devices are generally not reached by the residual currents I_r .		
	MCB type B	$\geq 5 I_n$	< 0.1 s			
	MCB type C	$\geq 10 I_n$	< 0.1 s			
Melting fuse gG	ca. $> 14 I_n$	< 0.4 s				
Tripping conditions I_a of residual current protective devices for ensuring the required disconnecting time t_a	$I_a \leq \frac{230V}{Z_s}$			$I\Delta n \leq \frac{50V}{R_a}$		
	In the TN system, the residual currents I_r are considerably higher than $5 I_n$.			In the event of a fault, there is 230 V at the fault location. The following therefore applies to the trip current I_a : $I_a = \frac{230V}{50V} I\Delta n = 4,6 I\Delta n$		
	Type	I_a	$t_a^{(1)}$	Type	I_a	$t_a^{(1)}$
	RCCB general	$> 5 I_{s,n}$	≤ 0.04 s	RCCB general	$> 2 I_{s,n}$	≤ 0.15 s
RCCB selective	$> 5 I_{s,n}$	≤ 0.15 s	RCCB selective	$> 2 I_{s,n}$	≤ 0.2 s	
<p>1) The values for t_a relate to the stipulations in the relevant product standards.</p> <p>R_a - the sum of the resistances in Ω of the ground electrode and the protective conductor of the bodies;</p> <p>$I_{s,n}$ - the rated residual current in A of the residual current protective device.</p>						

Table 4: Selection of protective devices in TN systems and in TT systems with rated voltages of 230/400 V AC

3.1.2 Use of residual current protective devices

Residual current protective devices can be combined with any other protective devices. Even if other protective measures are already installed in an existing system, residual current protection can still be used for this system or parts of it.

Almost any type of protective measure can be converted to residual current protection with comparatively little effort.

According to the standard DIN VDE 0100-530, it is permissible, where a residual current protection device with a rated residual current of $I_{\Delta n} \leq 30$ mA is being used, to also use this simultaneously to provide fault protection in the form of automatic disconnection of the power supply and additional protection in the event of direct contact. However, because this additional protection by means of residual current protective devices with a rated residual current that does not exceed 30 mA is envisaged as additional protection for the event that precautions for

basic protection and/or precautions for fault protection are not successful, it is nevertheless recommended that the protective functions be split up among different devices in order to fulfill both of these protection goals.

In order to achieve maximum availability and operational safety, the circuits must be divided up appropriately among several residual current protective devices. These requirements are specified in different documents:

- According to DIN VDE 0100-300 (VDE 0100-300):1996-01, the circuits must be divided up in order to avoid hazards, limit the consequences of faults, facilitate inspection, testing and maintenance and take into account hazards which can be caused by a fault in only one circuit, e.g. lighting failure.
- DIN 18015-1:2007-09 "Electrical Installations in Residential Buildings Part 1: Planning Principles" requires that connection points for items of current-using equipment be assigned to a circuit in such a way that automatic tripping of the protective device assigned to this circuit (e.g. overcurrent protective device, residual current protective device) in the event of a fault or necessary manual disconnection from the power supply only cause a small part of the customer's installation to be disconnected from the supply.
- TAB 2007 (Technical Connecting Conditions) states that when circuits are divided up, connection points for items of current-using equipment be assigned to a circuit in such a way that automatic tripping of the protective device assigned to this circuit in the event of a fault or necessary manual disconnection from the power supply only cause a part of the customer's installation to be disconnected from the supply.

This means that: except when selective residual current protective devices are used, the circuits are to be divided up in such a way that tripping of a residual current protective device does not lead to the failure of all circuits.

If a residual current protective device for other protection tasks (fault protection, fire protection) is connected upstream of an RCD for additional protection (rated residual current ≤ 30 mA), this second RCD should always have a selective tripping characteristic (e.g. Type **S**).

As shown in table 4, selective and standard residual current protective devices achieve the maximum permissible tripping times in both power supply systems. The following points must be noted when residual current protective devices are used in Germany for fault protection, fire protection and (in accordance with DIN VDE 0100-530) additional protection:

- All poles of all active conductors – i.e. including the neutral conductor – must always be disconnected.
- Only voltage-independent residual current protective devices (Type A) are allowed.
- Purely AC-sensitive residual current protective devices (Type AC) are not allowed.

3.2 Choosing the right residual current protective device

Figure 16 can help users to select a suitable residual current protective device.

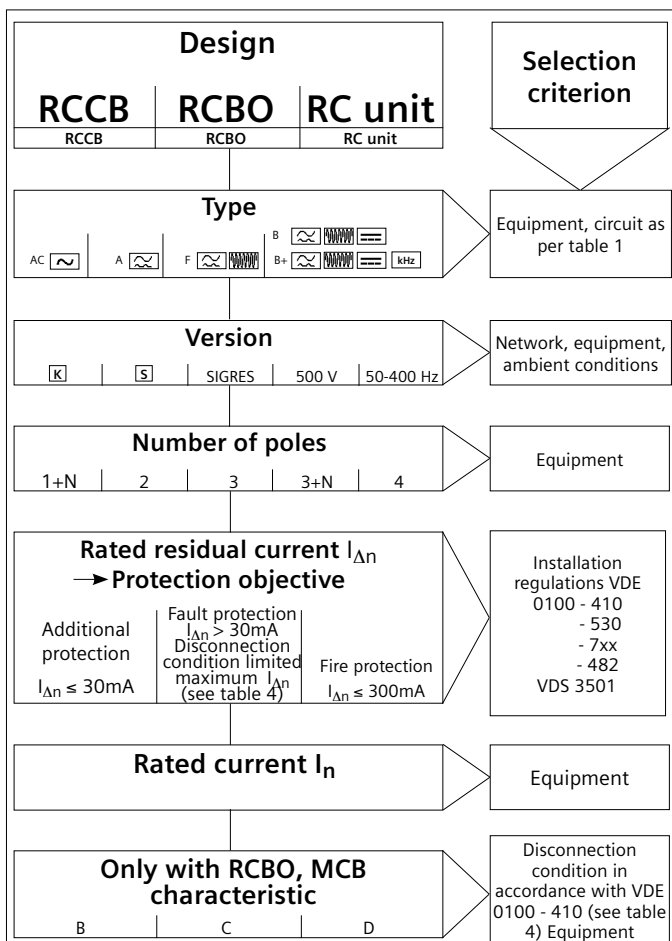

Figure 16: Selection aid for finding the suitable residual current protective device

Details are explained below.

3.2.1 Type A, Type F or Type B/Type B+?

The correct type of residual current protective device for each application can be selected with the help of Table 1 (in accordance with EN 50178/VDE 0160 "Electronic equipment for use in power installations" and DIN VDE 0100-530 Section 531.3.1).

If the electronic equipment (e.g. a frequency converter) is operated directly on the three-phase system and input circuits 8 to 13 are connected (see Table 1), universal current-sensitive residual current operated circuit breakers (Type B or B+) must be used. Type F residual current protective devices shall be used (input current circuit 7 in the table) if higher frequencies are to be expected in the residual current (e.g. frequency converter in a 1+N network). It is sufficient to use Type A residual current protective devices (sensitive to pulsating current) for all other applications.

3.2.2 What protection goal must be achieved?

Various protection goals must be achieved depending on the application and location of use:

- Additional protection with a rated residual current of $I_{\Delta n} \leq 30$ mA: These RCDs are intended to provide additional protection against electric shock in case of a failure of the other basic protective measures (protection against direct contact) and/or for protection against faults (protection against indirect contact) or in the event of carelessness by the user. Their protection is effective up to a maximum frequency of 100 Hz. All statements concerning the risk of ventricular fibrillation (up to 1 kHz) are at present only of limited validity at higher frequencies. No reliable evidence is available regarding the impact of other effects (thermal, electrolytic) on the human organism.
- Fault protection with a rated residual current of $I_{\Delta n} > 30$ mA: Protection against electric shock can be provided with these rated residual currents under fault conditions. The tripping conditions of the respective power system must be complied with. At frequencies higher than 100 Hz, protection in the event of indirect touching must be provided and account must be taken of the frequency response of the residual current operated circuit breaker, the maximum permissible touch voltage (e.g. 50 V), the critical frequency components in the residual current and the maximum permissible grounding resistance determined from these components (see also Section 2.4.3).

- Fire protection with a rated residual current $I_{\Delta n} \leq 300$ mA:
In installations
 - at particular risk of fire (premises exposed to fire hazards),
 - primarily made of flammable construction materials,
 - containing irreplaceable goods of great value the installation of residual current protection devices with rated residual currents of no more than 300 mA is required in accordance with DIN VDE 0100-482 in connection with DIN VDE 0100-530. Exceptions are only permitted if mineralized lines and busbar systems are used.Type B+ residual current protection devices must be used in the above-mentioned systems to increase the preventative fire protection of electrical equipment with input current circuits no. 8 through no. 13 (see Table 1).

3.2.3 What electrical interference occurs and how is it handled?

3.2.3.1 Leakage currents

Leakage currents are currents that are leaked to ground although the insulation is not faulty. They can be either static or dynamic, and they trip the RCCB if the tripping value is exceeded.

These currents must therefore be taken into account when the rated residual current $I_{\Delta n}$ of an RCCB is selected and, if necessary, minimized, in order to ensure that the specified protection requirements are met.

- Static leakage currents

Static leakage currents are continuously leaked to ground or the PE conductor during normal operation of the load, even though the insulation is not faulty. These currents are mainly leaked from line and filter capacitors.

Stationary leakage currents in an existing system can be measured with the 5SM1 930-0 leakage current measurement device (see also Section 3.7).

For problem-free use of residual current protective devices in practical applications, the stationary leakage current should be $\leq 0.3 * I_{\Delta n}$.

- Dynamic leakage currents

Dynamic leakage currents are transient currents to ground or the PE conductor. They occur in the range from a few μs to a few ms, especially when devices with filter circuits are switched. Their duration depends on the time constant that is derived from the circuit impedances, and above all on the switching device that is used to connect the filter to the power supply.

Depending on the design of the filter circuit, short-time high capacitance values to PE can arise because of the non-uniform contact of the various switching contacts which are reduced to low residual values to PE owing to the star connection of the capacitors after the device has been fully closed.

These dynamic leakage currents can have a magnitude of a few amperes and hence also trip instantaneous RCCBs with $I_{\Delta n} = 300 \text{ mA}$. The peak value of the dynamic leakage current must be determined in the PE conductor by means of an oscilloscope.

The equipment must be arranged in an insulated setup, so that the complete leakage current is able to flow back along the measurement path.

The use of super-resistant residual current protective devices (Type **K**) is recommended to prevent unwanted tripping in these kinds of application.

3.2.3.2 High load currents

Even if no leakage currents are present, an RCCB can still be spuriously tripped as a result of high load currents ($> 6x I_N$). These high load current peaks can lead to different magnetizations in the magnetic strip core because the arrangement of the primary conductors is not absolutely symmetrical and the secondary winding on the circumference of the summation current transformer for residual current detection is not completely closed, so that a tripping signal is produced. Tripping can also result if the magnetic field around the current carrying conductor is directly irradiated onto the holding magnet release. High load current peaks are especially common in conjunction with the direct-on-line start of motors, lamp loads, heater windings, capacitive loads (capacitances between L and N), and medical equipment such as CT machines or X-ray equipment.

According to the product standard, RCCBs are resistant to spurious tripping at up to six times the rated current.

3.2.3.3 Overvoltages and surge current load

During thunderstorms, atmospheric overvoltages in the form of traveling waves can penetrate the installation via the supply system and inadvertently trip residual current protective devices. To prevent these spurious tripping operations, our residual current protective devices must pass a test with the standardized 8/20 μ s surge current wave (see Figure 17). In the product standard EN 61008 (VDE 0664), this test is only stipulated for selective residual current protective devices ($i = 3$ kA).

All versions of our Type A and B residual current operated circuit breakers offer a significantly higher current withstand capability. They consequently have a greatly reduced tendency to trip falsely in practice.

The current withstand capability of the individual product series is as follows:

- instantaneous at least 1 kA
- Type F and super-resistant Type **[K]** at least 3 kA
- selective (Type **[S]**) at least 5 kA

Even in the standard versions, these values ensure good resistance to false tripping, and this form of protective measure with rated currents up to 30 mA can also be used for sensitive load circuits (e.g. refrigerators).

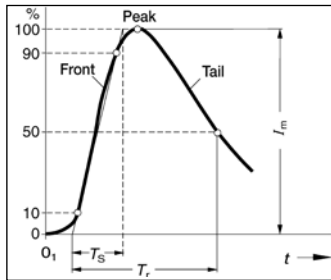

Characteristics of a current impulse acc. to DIN VDE 0432-2
 T_S Front time in s
 T_r Virtual time to half value on tail in s
 O_1 Virtual origin
 I_m Peak value

Figure 17: Surge current characteristic 8/20 μ s

3.3 Special features regarding the use of SIQUENCE universal current-sensitive residual current protective devices (Type B and Type B+)

3.3.1 Applications

Typical applications that are vulnerable to smooth DC residual currents:

- Frequency converters with a three-phase connection
- Medical equipment such as X-ray equipment or CT machines
- Photovoltaic or UPS systems
- Connection points (wall boxes, charging stations) for electric vehicles
- Elevator controllers
- Pipeline trace heating
- Test setups in laboratories
- Construction sites in accordance with BGI 608 information leaflet (Electronic equipment on construction sites)
- Charging stations for battery-powered forklift trucks
- Cranes of all kinds
- Mixing plants if relevant loads are connected
- Variable-speed machine tools, such as milling and grinding machines or lathes

3.3.2 Residual currents at different fault locations, with a frequency converter (FC) as an example

A frequency converter (FC) is considered below as a typical example of equipment where different residual current waveforms can occur depending on the fault location (see Figure 18).

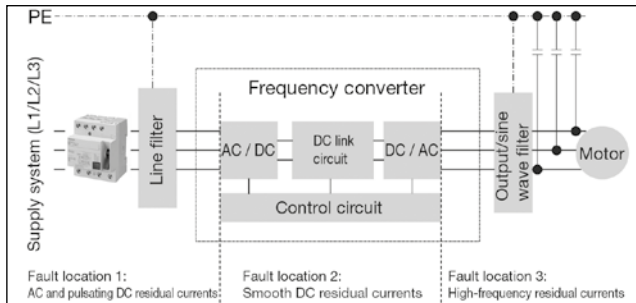

Figure 18: Circuit with a SIQUENCE universal current-sensitive RCCB and a frequency converter

Fault locations in section 1 (upstream of the FC)

Line-frequency AC residual currents occur between the RCCB and the frequency converter (see Fig. 19). Protection against these purely sinusoidal 50 Hz residual currents is provided by all RCCBs (types AC, A, F and B). The section at risk is disconnected when the tripping value in the range 0.5 to 1 $I_{\Delta n}$ is reached.

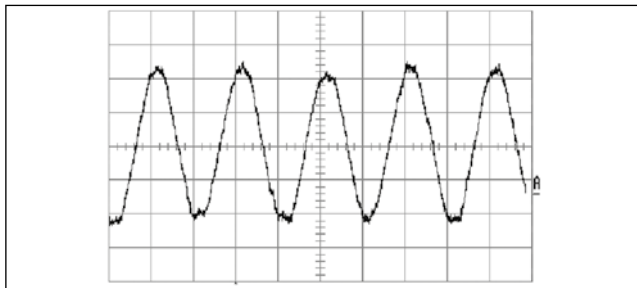

Figure 19: Residual current waveform at fault location 1

Fault locations in section 2 (in the FC)

Practically smooth DC residual currents occur in the frequency converter (between the input rectifier and the output electronics, i.e. in the DC link circuit) (see Fig. 20). There is reliable disconnection in the range from 0.5 to 2 $I_{\Delta n}$ if a Type B universal current-sensitive RCCB is used.

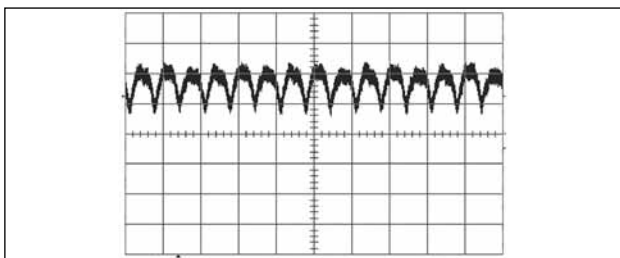

Figure 20: Residual current waveform at fault location 2

Types AC, A and F residual current protective devices are unable to offer protection in these cases. The device does not trip because the DC residual current does not cause any change over time in the transformer induction of the RCCB which operates according to the induction principle. A smooth DC residual current (or leakage current) due to a creeping insulation fault leads to pre-magnetization of the transformer material of Type AC, A and F residual current protective devices. Figure 21 shows the difference between a transformer signal without and with DC residual current superimposition. Without DC residual current (I_{Δ} d.c.), an AC residual current (I_{Δ} a.c.) causes modulation on the field strength axis H of magnitude I. In accordance with characteristic magnetization curve M of the transformer a voltage of magnitude II is induced. A DC residual current (I_{Δ} d.c.) flowing via the residual current protective device shifts the working point of the transformer on the H axis. An AC residual current (I_{Δ} a.c.) with the same value as in the case without DC residual current causes modulation of the same magnitude on the field strength axis H of magnitude III. Although the change III has the same value as I, a significantly smaller voltage of magnitude IV is induced in the transformer. If it is assumed that a signal of size II is necessary for tripping, it becomes clear that the considerably smaller signal IV is not sufficient for this.

Only much higher AC residual currents would lead to attainment of the necessary signal level. This shows that Type AC, A or F residual current protective devices are no longer able to trip if a purely sinusoidal residual current, which could otherwise be tripped without any problems, occurs simultaneously. The desired protective function of the residual current protective device is therefore no longer guaranteed.

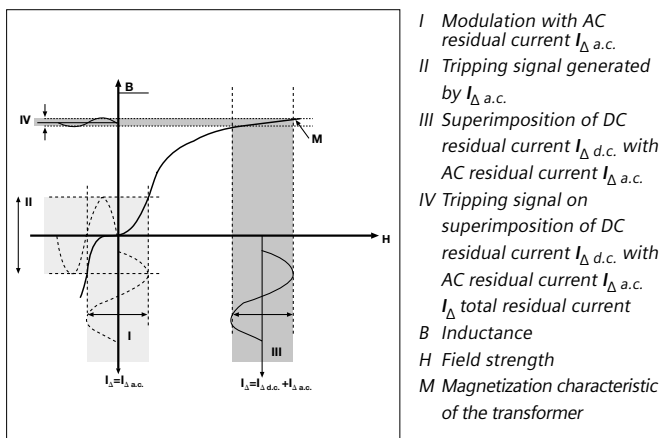

Figure 21: Pre-magnetization due to DC residual current

Fault locations in section 3 (downstream of the FC)

AC residual currents which deviate from the line frequency and the sinusoidal waveform occur between the outgoing terminal of the frequency converter and the motor. These currents represent a frequency spectrum with different frequency components (see Fig. 22). Smooth DC residual currents can also occur, depending on the operating mode of the frequency converter (e.g. as a DC brake or a DC pre-heater)

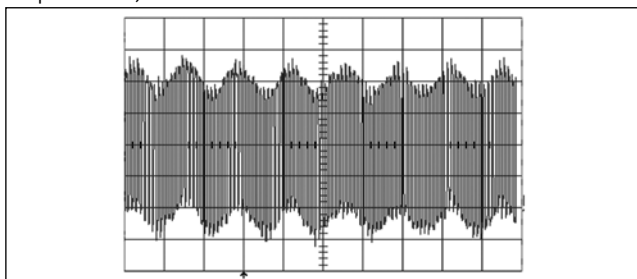

Figure 22: Residual current waveform at fault location 3

According to the product standard, Type AC, A and F RCCBs are only designed to detect residual currents at 50/60 Hz. The tripping value is therefore increased in an undefined way for higher frequency components of the residual current. The intended protective effect is usually lost as a result. Tripping conditions for frequencies up to 2 kHz are defined for Type B RCCBs.

Frequency components in the residual current of a frequency converter

The frequency components in the residual current must be taken into account in addition to the tripping characteristics of the RCCB in order to assess the protective effect of this RCCB in conjunction with a frequency converter. The following critical frequency components occur at fault location 3:

- Clock frequency of the frequency converter (a few kHz)
- Motor frequency (normally 0 to 50 Hz, maximum frequency 1 kHz)
- 3rd harmonic of 50 Hz (150 Hz if the frequency converter has a three-phase connection)

Figure 23 shows a typical example of the frequency components that can flow across a fault impedance of 1 k Ω in the area of fault location 3 (see Figure 22).

The clock frequency accounts for a smaller percentage of the total residual current as the motor frequency increases, while the motor frequency accounts for a correspondingly higher percentage.

This behavior is characteristic of many different frequency converter versions.

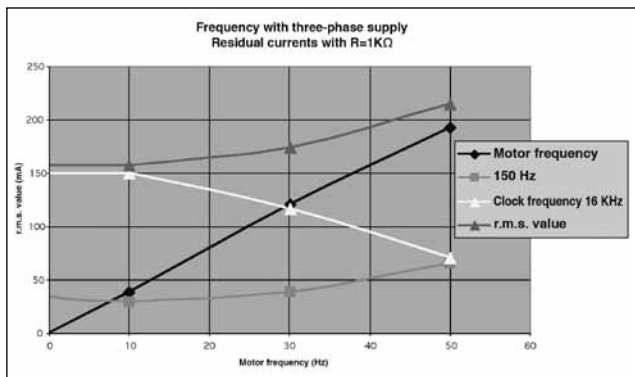

Figure 23: Frequency components in the residual current based on the example of a frequency converter

3.3.3 Configuration

Type B / Type B+ universal current-sensitive residual current protective devices must be used if smooth or nearly smooth DC residual currents can occur in the event of a fault when electronic equipment is operated (input circuits 8 to 13 in Table 1).

In these cases, Type AC, A or F residual current protective devices may not be used to provide protection, as their tripping function can be impaired by the potential smooth DC residual currents to the extent that they are no longer able to trip even when those residual currents for which they are designed occur.

For this reason, it is essential to ensure that if Type A or F residual current protective devices are coordinated with Type B (or B+) in installations with several load circuits, a Type B or B+ residual current protective device is always connected upstream of each Type A or Type F residual current protective device. Figure 24 shows an example configuration.

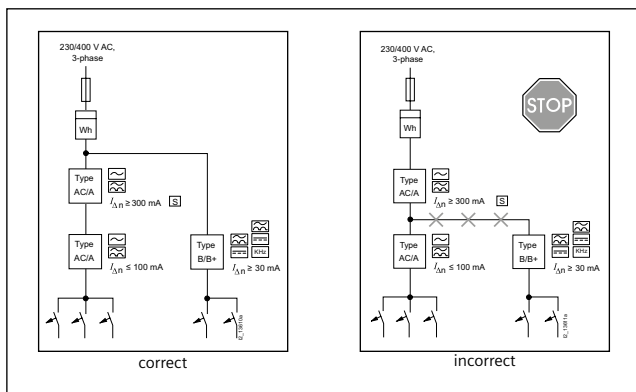

Figure 24: Configuration example with Type A and B residual current protective devices

3.3.4 Causes of excessive leakage currents and possibilities of reducing them

Causes of leakage currents	Consequences
EMC (input) filter capacitances between phase conductor and PE conductor	Highly dynamic and static leakage currents
Conductor capacitances	Mainly static leakage currents
Making/breaking asymmetries	Highly dynamic leakage currents possible
Summation of leakage currents due to connection of several loads (especially frequency converters) to an RCCB	Highly dynamic and static leakage currents
Clock frequency of frequency converters	Static leakage currents via cable capacitance
Grounding conditions	Static leakage currents
Harmonic component of the output voltage of the frequency converter	Static leakage currents via cable capacitance

Corrective measures

- Use low leakage current filters.
 - Clarify with converter manufacturer whether filters with lower degree of interference suppression (class B or C3/C4 instead of class A or C1) are possible or EMC input filters can be dispensed with if, for instance, output-side sinewave filters or dv/dt filters or motor chokes can be used.
-
- Minimize cable lengths
(the overall capacity and thus the leakage current flowing to PE increase with the length of the cable corresponding to the capacitance per meter – leakage current of shielded cables from approximately 0.2 mA/m to 1 mA/m).
 - Select cables with low conductor-ground capacitance. Symmetrical cables achieve favorable values. Single conductor configuration yields higher leakage currents.
 - The use of shielded cables can be dispensed with if the EMC requirements are also met with unshielded cables, for instance (i.e. with sinewave filters at the output).
 - Connect existing cable shield according to the manufacturer's information regarding the frequency converter.
-
- Avoid the use of manually operated switchgear for normal switching in order to reduce the duration of making and breaking asymmetries to a minimum.
 - Use all-pole contactors or switchgear with a snap-action mechanism.
 - Own power supply connection for the actuator
(asymmetry in the network causes additional leakage currents)
 - Inrush current limitation can reduce the dynamic leakage currents upon making.
-
- Distribute the circuits over a number of RCCBs
(keep the number of actuators after an RCCB as low as possible).
 - Avoid switching on several frequency converters downstream of one RCCB simultaneously (or at least use inrush current limitation).
 - Use a common EMC filter for several loads
(leakage current is usually lower than the sum of individual filters).

Select as low a clock frequency as possible, in particular for Type B+ residual current protection devices (if usable for the application). Depending on the circumstances, an overall more favorable behavior can be achieved with higher clock frequencies with Type B residual current protection devices which exhibit a tripping value which increases with the frequency, in spite of higher capacitive leakage currents. In any case, care must be taken to avoid resonance frequency ranges when setting EMC filters.

If possible, return all leakage currents to the frequency converter via the PE connection in order to maximize the effect of the filtering measures and prevent the occurrence of undefined leakage currents.

Sinewave filters in the outgoing feeder of the frequency converter reliably filter out the switching frequency and its harmonics to produce almost sinusoidal output voltages and currents. EMC requirements can then usually also be satisfied with unshielded cables. This leads to a significant reduction in capacitive leakage currents downstream of the frequency converter (e.g. due to the cable capacitance per unit length). In some cases, it is even possible to dispense with the line filter on the input side and thus reduce the stationary and dynamic leakage currents still further. Output reactors, dv/dt filters, or Nanoperm filters can be used as an alternative to sinewave filters, although they are less effective.

3.4 Back-up protection

Short circuit and residual currents can be up to several hundred amperes, depending on the network and system configuration. Thus, for instance, in the event of an insulation fault to the grounded exposed conductive parts of electrical equipment with a correspondingly low resistance, a short circuit-like current flows via the residual current protective device. The contacts that open in this event must be able to withstand this stress.

This requires a correspondingly high rated switching capacity.

The rated switching capacity I_m of residual current operated circuit breakers shall, according to the applicable device standards (EN 61008-1/VDE 0664-10) be at least 500 A or $10 \cdot I_n$, whichever is the higher. The rated switching capacity of our residual current operated circuit breakers is predominately 800 A and hence clearly exceeds the minimum requirements of 500 A or 630 A (see Table 5) for devices of up to 63 A rated current.

Rated current of the residual current protective device	Rated switching capacity I_m in accordance with IEC/EN 61008 (VDE 0664) at a grid distance of 35 mm			Maximum permissible short-circuit back-up fuse NH, DIAZED, NEOZED	
	gG operational class for RCCB				
				125 V AC ... 400 V	500 V AC
	A	TE	A	A	A
Type AC					
Type A					
Type F					
Type B					
Type B+					
16-40	2.0	500	63	-	
63, 80	2.5	800	100	-	
100, 125	2.0	1250	125	-	
25, 40 (400 Hz)	4.0	800	80	-	
25-63	4.0	800	100	63	
80	4.0	800	100	-	
100	4.0	1000	100	-	
125	4.0	1250	125	-	

Table 5: Rated switching capacity and maximum permissible short-circuit back-up fuses

In accordance with the installation regulations (VDE 0100-410; DIN VDE 0100-530), residual current protective devices can be installed in all system types (TT, NT and IT). Residual currents that are in excess of the rated switching capacity of the residual current operated circuit breaker can occur alongside short-circuit currents in a TN system in particular. An overcurrent device shall be connected as a back-up protective device to restrict the energy and strength of the short-circuit current to compatible levels.

The conditional rated short-circuit current is stated on the residual current operated circuit breaker in the form of a symbol in conjunction with a maximum permissible rated current for the fuse (gG operational class melting fuses).

This will be explained based on the following example:

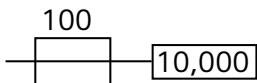

The conditional rated short-circuit current of the residual current operated circuit breaker where a fuse rated at a maximum of 100 A is used is 10 kA.

In cases in which no rated fuse current is stated, a minimum value of 63 A applies automatically in Germany. A minimum value of 6 kA is required for the conditional rated short-circuit current.

In the case of Siemens residual current protective devices, rated switching capacity and rated residual switching capacity are not differentiated and nor are rated conditional short-circuit current and rated conditional residual short-circuit current. The reason for this is that the values for the residual and short-circuit currents can be identical in the relevant cases.

The use of miniature circuit breakers or circuit breakers instead of the specified fuses will result in markedly lower rated values in some cases due to the higher throughput values until the circuit is disconnected. A direct specification for the permissible rated current of these circuit breakers cannot be given here due to the great differences in design and tripping characteristics. But the maximum permissible rated current of the allocated overcurrent protective device can be determined in consideration of the

maximum permissible limit values of the residual current operated circuit breaker. The rated current of the allocated overcurrent protective device can be determined based on the maximum permissible short-circuit back-up fusing according to Table 5 specified on the residual current operated circuit breakers. In the process, the following maximum values must be complied with for series 5SM3 residual current operated circuit breakers:

maximum permissible short-circuit back-up fuse	maximum I^2t value	maximum current peak value
63 A	25,000 A ² s	6.0 kA
80 A	40,000 A ² s	7.0 kA
100 A	70,000 A ² s	7.5 kA
125 A	94,000 A ² s	8.0 kA

The rated switching capacity of RCBOs is considerably higher than that for residual current operated circuit breakers as the MCB component, which is specially provided for short-circuit protection, performs short-circuit clearing. Should this switching capacity not be adequate, a back-up protection shall also be provided here in accordance with the manufacturer's information.

3.5 Protection against thermal overload

Protection against thermal overloading of an RCCB shall primarily be provided by careful planning of the load circuits downstream of the RCCB taking the manufacturer's information into consideration.

A note in DIN VDE 0100-530 states that it is permissible to use the expected operational current as a rating selection criterion to prevent overloading of residual current operated circuit breakers as long as the instructions of the manufacturer regarding the rated current and type of overcurrent protective device are used to form the basis for the estimation.

The following points must be noted in order to avoid overloading the residual current operated circuit breaker:

- The rated current of the RCCB is the maximum permissible uninterrupted load current and must not be permanently exceeded.
- The back-up fuse value indicated on the rating plate (63 A to 125 A) only provides back-up protection for the RCCB (see Section 3.4).

The considerations regarding thermal loading no longer apply if RCBOs are used as the MCB part provides overload protection through its thermal release.

3.6 Troubleshooting

If a residual current protective device trips, the first troubleshooting step should be to follow the procedure outlined in the diagram below (Figure 25).

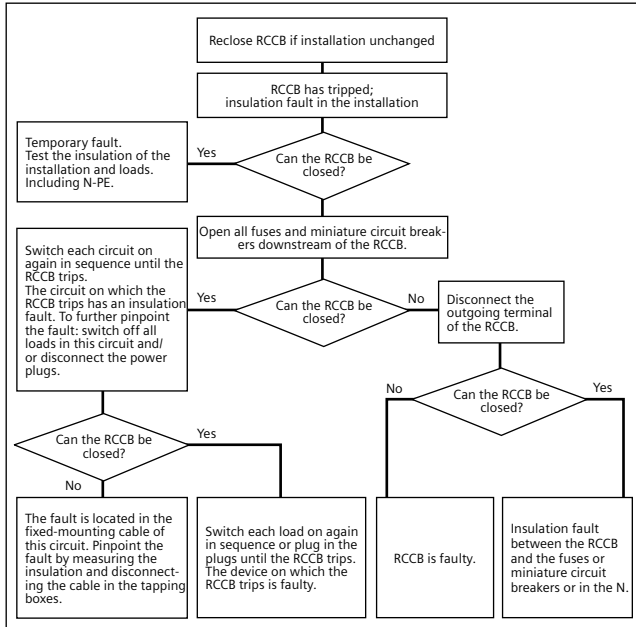

Figure 25: Troubleshooting flowchart

3.7 Leakage current measurement

If leakage currents occur frequently in normal operation or if electrical loads with high leakage currents are used because the system has not been optimally configured, for instance if there are too many electrical loads, the tripping current of the upstream residual current protective device may be exceeded, depending on the operational status of the electrical installation. Spurious tripping results.

To prevent residual current protective devices from inadvertently tripping in practice, the leakage current that flows in the system during normal operation should always be less than 0.3 times the rated residual current.

A leakage current measurement device (see Figure 26) can be connected into the system in series with the residual current protective device to facilitate recording, and if necessary monitoring, of the status of the installation. This device measures the leakage current flowing during normal system operation.

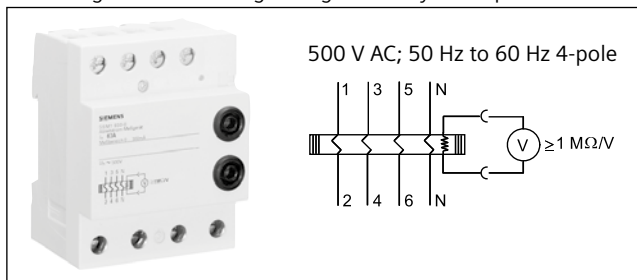

Figure 26: 5SM1 930-0 leakage current measurement device

The leakage current measurement device functions according to the same principle as the residual current protective device. Instead of the device tripping, however, the leakage current is converted via the test sockets on the front to a voltage that can be read off on a high-impedance voltmeter. The calibration curve supplied with the unit provides a rough indication of the leakage current.

3.8 4-pole residual current operated circuit breakers in a 3-pole network

The 4-pole (3+N) version of the residual current operated circuit breakers can also be operated in 3-pole systems. In this case, the 3-pole connection must be at terminals 1, 3, 5 and 2, 4, 6.

The device function is not impaired as a result. Functioning of the test circuit is only ensured if a jumper is fitted between terminals 3 and N (this is also described in the operating instructions).

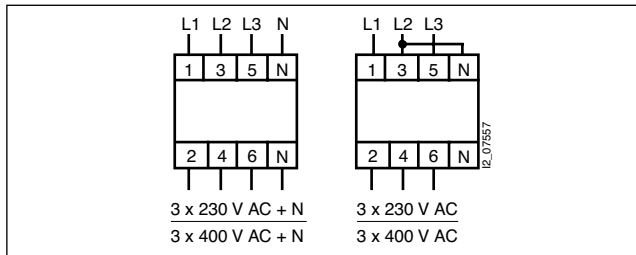

Figure 27: 4-pole RCCB in a 3-pole network

4 Residual current monitoring devices (RCM)

In addition to personal protection by means of residual current protection devices (RCD), permanent residual current monitoring is becoming increasingly important in terms of increasing system and operational safety and power supply monitoring.

Residual current monitoring devices, also known as residual current monitors (RCM), monitor residual currents in electrical systems and report when they exceed a determined value. RCMs are not approved for implementing the “automatic power supply shutoff” protective measure according to the product standard for residual current monitoring devices EN 62020 (VDE 0663) and/or IEC 62020. However, an RCM can be used in conjunction with protective devices.

Continuous residual current monitoring can already detect and signal faults before the protective device responds. Sudden system disconnection can frequently be avoided this way. For that reason, residual current monitoring devices are primarily used in systems in which a signal, but not a disconnection, should be carried out in the event of a fault. In addition, the residual current monitoring counts as a preventative maintenance measure in electrical systems.

The residual current monitoring devices function the same way as residual current protective devices do. The summation current transformer covers all conductors needed to carry current, i.e. the neutral conductor as well, if necessary. In a fault-free system, the magnetizing effects of the current-carrying conductors are cancelled out for the transformer, and the sum of all currents is equivalent to zero (Kirchhoff's 1st law of circuits). A residual magnetic field will only remain in the transformer core if a residual current is flowing as a result of an insulation fault and is generating voltage. The voltage will be evaluated by the RCM electronics and the switched contact can be used to control such elements as an acoustic/optical signaling device, a higher-level control system or a circuit breaker. RCMs are not equipped with a direct shut-off function.

RCMs are widely available with both integral current transformers and external summation current transformers. External summation current transformers are available with different inside diameters. This even makes it possible to monitor installations with rated currents of several hundred amperes. Furthermore, residual current monitoring devices are also associated with adjustable values for response residual current, response time and, if applicable, the display of the current residual current value.

The ability to adjust the response residual current and time behavior constitutes a significant advantage of the RCMs. This enables system-specific adjustment and makes it possible to take leakage currents which are permanently present into account. These leakage currents are caused by capacities in the cables and lines or in electrical equipment, for instance.

RCMs as additional fire protection

In accordance with DIN VDE 0100-530, RCMs coupled with switchgear with an isolating function can be used as an alternative to fire protection if residual current protective devices (RCDs) cannot be used for fire protection, because the operating current of the circuit to be protected is greater than the greatest rated current of the residual current protective devices (RCDs). A prerequisite for this is that the response residual current does not exceed 300 mA and that the monitored network is disconnected in the event of a failure in the residual current monitoring device's (RCM) control supply voltage.

5 Outlook

There is a growing demand for residual current protective devices in electrical installations owing to the high level of protection they afford.

At the same time, the widespread use of residual current protective devices to protect a large variety of different loads means that even more complex functional requirements need to be met. The use of Type B universal current-sensitive residual current protective devices as well as super-resistant devices or variants for harsh ambient conditions exemplify how requirements have increased. This trend is predicted to continue in future.

Combinations of RCBOs are also increasing in popularity – either as a compact unit or as an RC unit in conjunction with miniature circuit breakers that can be installed where required.

These RCBO combination units are installed in all circuits of modern electrical installations, combining maximum operating safety with electric shock and line protection.

Appendix

A.1 Key terms and definitions

(according to DIN VDE 0100-200)

- *Phase conductors (symbol L1, L2, L3),*
Conductors that connect current sources to current-using equipment but that do not originate at the center point or neutral point.
- *Neutral conductor (symbol N)*
Conductor that is connected to the center point or neutral point and that is suitable for transmitting electricity.
- *Protective conductor (symbol PE)*
Conductor required for certain protective measures against hazardous electric shock currents in order to establish an electrical connection with one of the following parts:
 - Exposed conductive part of the electrical equipment
 - External conductive parts
 - Main ground terminal
 - Ground electrode
 - Ground point of the current source or artificial neutral point
- *PEN conductor*
Grounded conductor that simultaneously functions as the protective conductor and the neutral conductor.
- *Rated voltage (in an installation)*
Voltage that characterizes an installation or part of an installation.
- *Touch voltage*
Voltage that may be present between simultaneously touchable parts in the event of an insulation fault.
- *Live part*
Conductor or conductive part that is intended to be live during normal operation, including the neutral conductor but (according to agreement) not the PEN conductor.

- *Exposed conductive part (of electrical equipment)*
Touchable, conductive part of the electrical equipment that is not normally live but that may be live in the event of a fault.
- *Electric shock*
Pathophysiological effect caused by an electric current flowing through the body of a person or animal.
- *Additional protection*
Supplementary measure to reduce the risks that may arise to persons and livestock if the basic and/or fault protection is rendered ineffective.
- *Basic protection*
Protection against electric shock in a non-faulty system. *Basic protection usually corresponds to the protection against direct contact described in DIN VDE 0100-410.*
- *Fault protection*
Protection against electric shock if a single fault occurs (e.g. faulty basic insulation). *Fault protection usually corresponds to the protection against indirect contact described in DIN VDE 0100-410.*
- *Dangerous body current*
Current flowing through the body of a person or animal with characteristics that are likely to trigger a pathophysiological (harmful) effect.
- *Leakage current (in an installation)*
Current flowing in a non-faulty circuit to ground or to an external conductive part.

■ *Residual current*

Sum of the instantaneous values of all currents flowing through all active conductors in a circuit at a defined point in the electrical system.

In connection with residual current protective devices, the differential current is referred to as "residual current" in accordance with the standards in the DIN VDE 0664 (VDE 0664) series.

■ *Operational current*

Current that should flow in the circuit during normal operation.

■ *Ground*

Conductive mass of ground whose electric potential is set to zero at all points according to agreement.

■ *Ground electrode*

Conductive part or parts that make good contact with ground and form an electrical connection with it.

■ *Total grounding resistance*

Resistance between the main ground terminal/busbar and ground.

■ **A.2 Power systems and protective devices**

The various power systems are defined in DIN VDE 0100-300. The permissible protective devices for these systems are listed in DIN VDE 0100-410.

The power systems are identified by means of codes where the individual characters have the following meanings:

1st character = Relationship of power system to ground

T Direct grounding of a point

I Either insulation of all live parts from ground or connection of one point with ground via impedance

2nd character = Relationship of the exposed conductive part of the installation to ground

- T Exposed conductive part directly connected to ground, independently of the grounding of any point of the power system
- N Exposed conductive part directly connected with the ground electrode (the grounded point in AC networks is generally the neutral point)

Subsequent characters = Arrangement of the neutral and protective conductors in a TN system

- S Separate conductors for neutral and protective earth functions
- C Neutral and protective conductor functions combined in a single conductor (PEN conductor)

A.2.1 TN system

All exposed conductive parts in the system must be connected by protective conductors to the grounded point of the supply network, which must be grounded on or in the vicinity of the associated transformer or generator. The various versions of TN system are shown in Figures A1, A2, and A3.

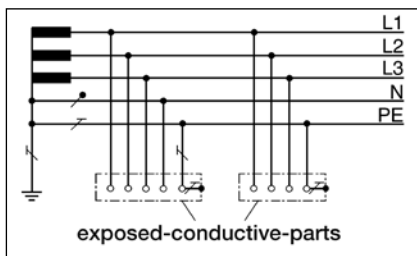

Figure A1: TN-S system

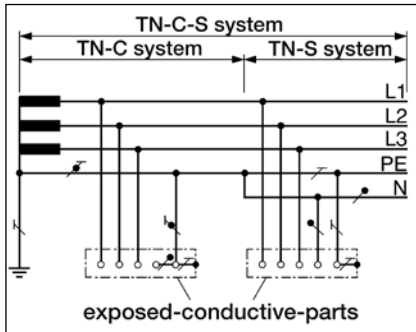

Figure A2: TN-C-S system

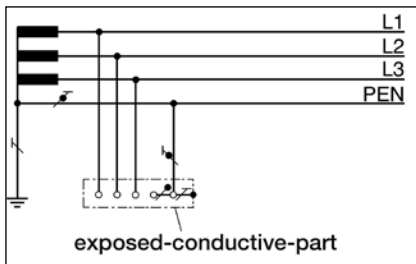

Figure A3: TN-C system

Permissible protective measures in TN systems:

- Overcurrent protective devices
- Residual current protective devices
(but not in the TN-C system)

A.2.2 TT system

All exposed conductive parts protected by the same protective device must be connected to a common ground electrode by means of protective conductors (see Figure A4).

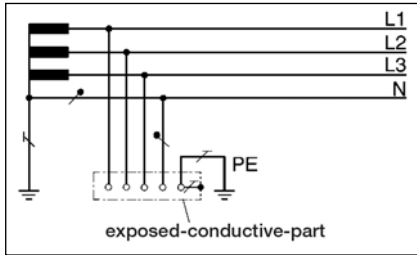

Figure A4: TT system

Permissible protective measures:

- Residual current protective devices
- Overcurrent protective devices

Where residual current protective devices are used different maximum permissible grounding resistances are specified for Type AC and Type A as a function of the rated residual current to meet the disconnection conditions (see Table A1).

Rated residual current $I_{\Delta n}$	Maximum permissible grounding resistance at a maximum permissible touch voltage of	
	50 V	25 V
10 mA	5000 Ω	2500 Ω
30 mA	1660 Ω	830 Ω
100 mA	500 Ω	250 Ω
300 mA	170 Ω	85 Ω
500 mA	100 Ω	50 Ω
1 A	50 Ω	25 Ω

Table A1: Maximum permissible grounding resistances as a function of $I_{\Delta n}$

The specifications of section 2.4.3 shall be observed for SIQUENCE Type B and Type B+ universal current-sensitive RCCBs if the equipment used has different frequency components in the possible residual current.

A.2.3 IT system

Live parts in IT systems (see Figure A5) must either be insulated to ground or designed with a sufficiently high impedance. The exposed conductive parts must be grounded individually, or in groups, or with a common ground.

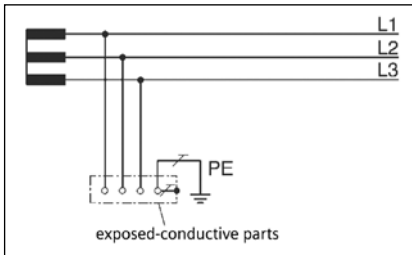

Figure A5: IT system

Permissible protective measures:

- Insulation monitoring devices
- Overcurrent protective devices
- Residual current protective devices

Tripping is not required for the first fault. However, measures must be taken to preclude all risk of pathophysiological effects on persons when the second fault occurs.

It is essential that an insulation monitoring device is fitted to enable the first fault to be indicated by an acoustic or visual signal and eliminated as quickly as possible.

Certain conditions must be satisfied after the first fault, depending on how the loads are grounded (individually, in groups, or with a common ground). If these conditions cannot be met with overcurrent protective devices, either separate residual current protective devices must be provided for each item of current-using equipment or additional equipotential bonding must be provided.

No mutual interference results if insulation monitoring devices and residual current protective devices are used in the same system.

A.2.4 Summary

Residual current protective devices can be used in all network AC or three-phase systems (TN, TT, or IT system, see Figure A6). The protection afforded by residual current protective devices is superior to that offered by other approved protective devices, because in addition to fault protection (protection in case of indirect contact) when residual current protective devices with $I_{\Delta n} \leq 30 \text{ mA}$ are used, they also provide additional protection (protection in the event of direct contact), and with their $I_{\Delta n} \leq 300 \text{ mA}$ play an important role in preventive protection against electrically ignited fires caused by ground fault currents.

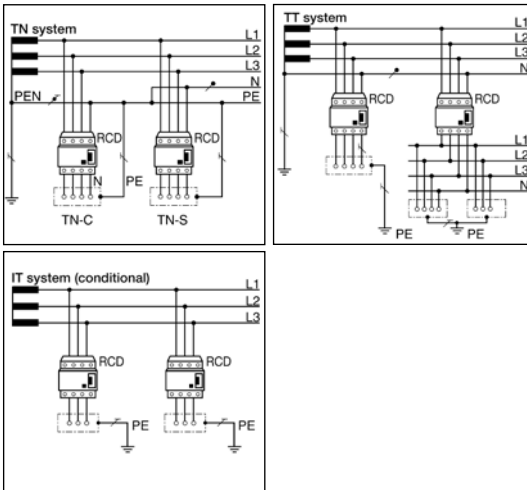

Figure A6: Residual current protective devices in all network systems

A.3 Key terms and definitions for specifying the switching capacity

- Rated switching capacity I_m of the RCCB (EN 61008-1):
Prospective rms value of the short-circuit current which a residual current operated circuit breaker can make, carry and break under defined conditions.
- Rated switching capacity I_{cn} of an RCBO (EN 61009-1):
The rated switching capacity of an RCBO is the limit short-circuit breaking capacity specified by the manufacturer.
- Rated residual switching capacity $I_{\Delta m}$ (EN 61008-1, EN 61009-1):
Prospective rms value of the residual current which the residual current protective device can make, carry and break under defined conditions.
- Rated conditional short-circuit current I_{nc} (EN 61008-1):
Prospective current which the residual current operated circuit breaker protected by a short-circuit back-up fuse can withstand without suffering functional impairment.
- Rated conditional residual short-circuit current $I_{\Delta c}$ (EN 61008-1):
Prospective residual current which the residual current operated circuit breaker protected by a short-circuit back-up fuse can withstand without subsequent functional impairment.

A.4 Installation standards for electrical installations with residual current protective devices

Standard (DIN VDE ... or BGI ...)	Application	Required $I_{\Delta n}$ [mA]	Recommended Siemens RCCB (taking into consideration possible nature of the residual currents in the equipment)			
			Type A	Type F	SIQUENCE Type B / Type B+	SIGRES
0100-410	Protection against electric shock	30 ... 500	+	+	+	+
	Socket outlets up to 20 A, outdoor installations	10 ... 30	+	+		
0100-482	Fire protection for particular risks or safety hazards	30 and 300	+	+	+	
0100-701	Rooms with baths or showers, socket outlets in zone 3	10 ... 30	+	+		
0100-702	Pools in swimming baths and other pools	10 ... 30	+			+
0100-703	Rooms and cabins with sauna heating systems	10 ... 30	+			+
0100-704 and BGI 608	Construction sites, socket outlet circuits up to 32 A and for hand-held tools, plugs and sockets $I_n > 32$ A	≤ 30 mA	+	+	+	+
		≤ 500 mA	+	+	+	+
0100-705	Agricultural and horticultural, general, socket outlet circuits	≤ 300	+	+		+
		10 ... 30	+	+		+
0100-706	Conductive areas with limited freedom of movement, fixed equipment	10 ... 30	+			
0100-708	Electrical installations on camping sites, each socket outlet individually and each branch circuit for a fixed connection to the supply	10 ... 30	+			+
0100-710	Medical premises with a TN-S system, depending on application group 1 or 2 and equipment	10 ... 30 or ≤ 300	+		+	+
0100-712	Solar PV power supply systems (without simple isolation)	≤ 300			+	
0100-723	Classrooms with experiment equipment	10 ... 30			+	
0100-739	Additional protection against direct contact in homes	10 ... 30	+			
EN 50178 (VDE 0160)	Fitting of power installations with electronic equipment	General requirements for correct selection when using res. current protection	+	+	+	
0832-100	Traffic signals Class T1 Class U1	≤ 300 ≤ 30	+			+
	Foodstuffs and chemical industry	recommended ≤ 30 mA	+			+

Note:

For reasons of basic fire protection, we recommend a maximum rated residual current of 300 mA for residual current protection devices.

List of figures and tables

- Page 7, Figure 1: Additional protection: Residual current protective device with $I_{\Delta n} \leq 30$ mA in the TN system
- Page 8, Figure 2: Effects of 50/60 Hz alternating current on the human body
- Page 11, Figure 3: Fault protection in the TN system
- Page 12, Figure 4: Classification of residual current protective devices into different types with tripping ranges
- Page 13, Table 1: Possible residual current waveforms and suitable residual current protective devices
- Page 15, Figure 5: Classification of residual current protective devices (RCDs)
- Page 18, Figure 6: Schematic representation of a residual current operated circuit breaker
- Page 19, Figure 7: Principle of operation of a holding magnet release
- Page 20, Figure 8: Structure of a SIQUENCE Type B and Type B+ universal current-sensitive RCCB
- Page 22, Figure 9: Installation with a central RCCB and miniature circuit breakers for feeders
- Page 23, Figure 10: Example of an installation with RCBOs
- Page 25, Figure 11: Type B frequency-dependent tripping current
- Page 27, Figure 12: Type B+ frequency-dependent tripping current
- Page 27, Table 2: Recommended maximum grounding resistances for SIQUENCE universal current-sensitive Type B RCCBs
- Page 30, Figure 13: Break time t_A as a function of the tripping current I_{Δ}
- Page 31, Figure 14: Layout of different residual current protective devices and their tripping times
- Page 33, Figure 15: Remote-controlled operating mechanism with RCCB
- Page 34, Table 3: Characteristic variables for the conditions of disconnection in TN and TT systems with rated voltages of 230/400 V AC
- Page 35, Table 4: Selection of protective devices in TN systems and in TT systems with rated voltages of 230/400 V AC
- Page 38, Figure 16: Selection aid for finding the suitable residual current protective device.
- Page 43, Figure 17: Surge current characteristic 8/20 μ s
- Page 44, Figure 18: Circuit with a SIQUENCE universal current-sensitive RCCB and a frequency converter
- Page 44, Figure 19: Residual current waveform at fault location 1

- Page 45, Figure 20: Residual current waveform at fault location 2
- Page 46, Figure 21: Pre-magnetization due to DC residual current
- Page 46, Figure 22: Residual current waveform at fault location 3
- Page 47, Figure 23: Frequency components in the residual current based on the example of a frequency converter
- Page 48, Figure 24: Configuration example with Type A and B residual current protective devices
- Page 51, Table 5: Rated switching capacity and maximum permissible short-circuit back-up fuses
- Page 55, Figure 25: Troubleshooting flowchart
- Page 56, Figure 26: 5SM1 930-0 leakage current measurement device
- Page 57, Figure 27: 4-pole RCCB in a 3-pole network
- Page 63, Figure A1: TN-S system
- Page 64, Figure A2: TN-C-S system
- Page 64, Figure A3: TN-C system
- Page 65, Figure A4: TT system
- Page 65, Table A1: Maximum permissible grounding resistances as a function of $I_{\Delta n}$
- Page 66, Figure A5: IT system
- Page 67, Figure A6: Residual current protective devices in all network systems

Siemens AG
Infrastructure & Cities Sector
Low and Medium Voltage Division
Low Voltage & Products
P.O. Box 10 09 53
93009 Regensburg
Germany

Order No. E10003-E38-2B-G0090-7600
Dispo 25601 • 1212 • 3.0
Printed in Germany

Subject to change.

The information provided in this brochure contains descriptions or characteristics of performance which in case of actual use do not always apply as described or which may change as a result of further development of the products. An obligation to provide the respective characteristics shall only exist if expressly agreed in the terms of contract.

All rights reserved.

All product names may be brand names of Siemens Ltd or another supplier whose use by third-parties for their own purposes may violate the owner's rights.

© Siemens AG 2012