

Flow Measurement

SITRANS FC (Coriolis)

Sensors / SITRANS FCS100

Overview

SITRANS FCS100 sensor is the precision Coriolis flow sensor for low flow applications.

Features:

- Possibly the most compact dual curve Coriolis flow sensor
- Nominal sizes: DN 1 to DN 8
- Process connection: flange, thread, or hygienic clamp
- Install in tight spaces with no inlet and outlet restrictions
- Sizes to suit pilot plants, R&D labs, and high value fluid additives
- FCS100 sensors always combine with a remote transmitter via a connecting cable
- Installation of sensor and transmitter in different locations

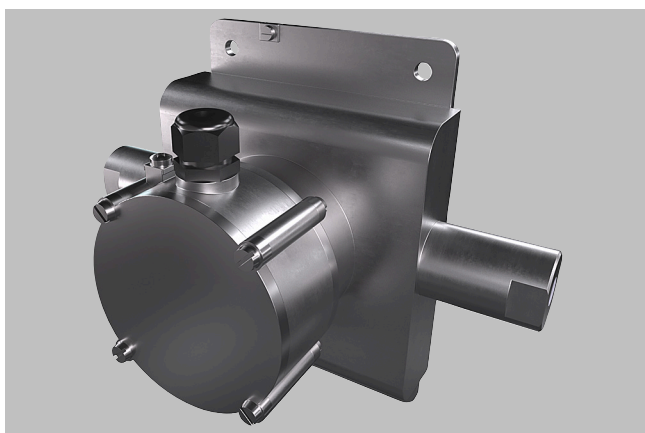

FCS100 sensor

Design

Sensor installation position related to type of fluid

Installation position	Fluid	Description
Position 1 	Liquid	<ul style="list-style-type: none"> • Horizontal • Measuring tubes below process pipe • Avoids accumulation of entrained gas
Position 2 	Gas	<ul style="list-style-type: none"> • Horizontal • Measuring tubes above process pipe • Accumulation of liquid or condensate is less likely
Position 3 	Gas / Liquid	<ul style="list-style-type: none"> • Vertical • Upwards direction of flow • In liquid application accumulation of entrained gas is avoided • This position allows self-draining in liquid flow

Technical specifications

Allowed ambient temperature for FCS100 sensors

The allowed combinations of process fluid and ambient temperature for the sensor are illustrated as light areas in the diagrams below.

Standard temperature specification, remote type

(except versions with hygienic clamp process connections)

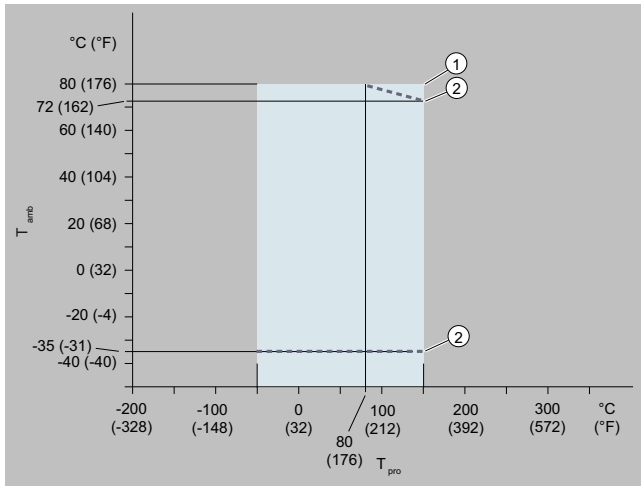

Allowed process fluid and ambient temperatures, remote type (except hygienic clamp process connections)

1	Standard cable option
2	Limitation for fire retardant cable option
T_{amb}	Ambient temperature
T_{pro}	Process fluid temperature

Standard temperature specification, remote type

(versions with hygienic clamp process connection versions only)

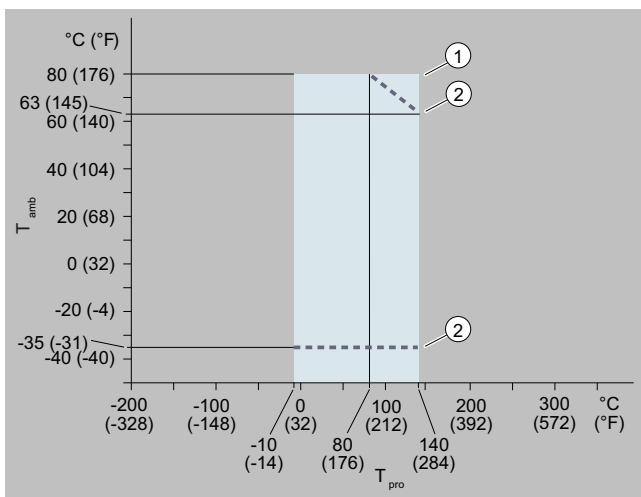

Allowed process fluid and ambient temperatures, remote type (hygienic clamp process connections only)

1	Standard cable option
2	Limitation for fire retardant cable option
T_{amb}	Ambient temperature
T_{pro}	Process fluid temperature

Medium temperature specification, remote type

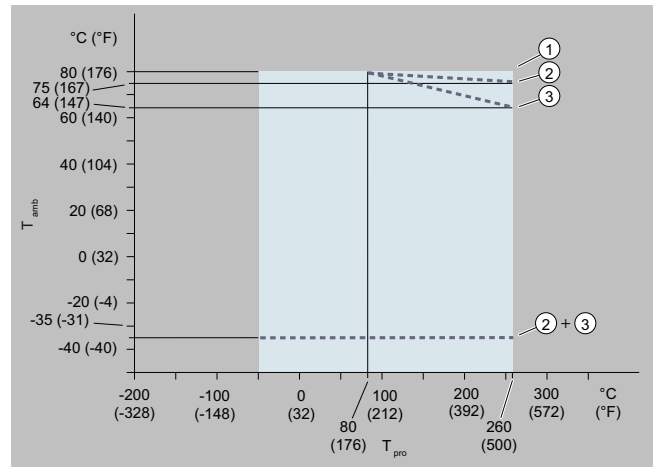

Allowed process fluid and ambient temperatures

1	Standard cable option
2	Fire retardant cable without insulation options
3	Fire retardant cable with insulation options JXX
T_{amb}	Ambient temperature
T_{pro}	Process fluid temperature

Mechanical specifications of FCS100 sensors

The FCS100 sensor is available in standard neck and long neck designs. The neck can also be described as the pedestal connecting the sensor body to the terminal housing.

When configuring FCS100 sensors with medium range temperature specification (up to 260 °C (500 °F)), it is compulsory to select long neck options. Order code position 14 (Mounting style, Transmitter housing and material) includes the neck options.

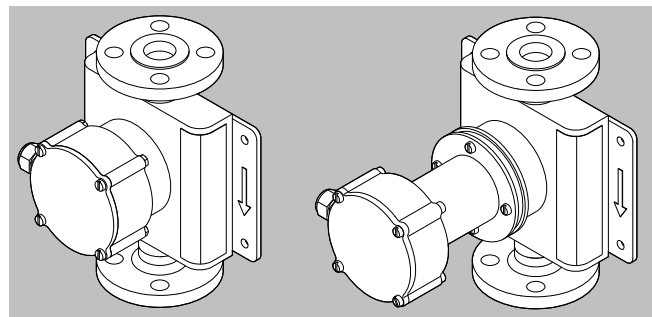

FCS100 sensor with standard neck and long neck designs

Flow Measurement

SITRANS FC (Coriolis)

Sensors / SITRANS FCS100

Technical specifications (continued)

Materials

Material specifications		
Wetted parts¹⁾		
Process connections	AISI 316L stainless steel, mat. no. 1.4404	
Measuring tubes	alloy 22/2.4602	
Sensor housing		
Junction box	AISI 316L stainless steel	Mat. no. 1.4404
Neck	similar to ASTM CF-8 cast stainless steel	Mat. no. 1.4308
Body	AISI 304 stainless steel	Mat. no. 1.4301 (order code option B01)
	AISI 316L stainless steel	Mat. no. 1.4404 (order code option B02)
Nameplates²⁾		
Sensor with AISI 304 stainless steel housing	Process temperature range	Material
Sensor with AISI 304 stainless steel housing	Standard, up to 150 °C (302 °F)	Polyester film
Sensor with AISI 316L stainless steel housing	Medium, up to 260 °C (500 °F)	AISI 316L ss
Sensor with AISI 316L stainless steel housing	All	AISI 316L ss

¹⁾ The user is responsible to ensure chemical compatibility of the material of the wetted parts with the measured process fluid.

²⁾ Nameplate material depends on the materials selected for SITRANS FC sensors.

Secondary containment

Some applications or environment conditions require secondary containment retaining the process pressure for increased safety. SITRANS FCS100 sensors have a secondary containment filled with inert gas.

Typical burst pressure at room temperature for sizes 65 bar (942 psi)

1	Heating tracing connection
2	Insulation
3	Sensor terminal box
4	Process connection
5	Purging connection

Maximum temperature of heat carrier

Order code position 12	Process temperature range	Temperature range of heat carrier
1	Standard, up to 150 °C (302 °F)	0 ... 150 °C (32 ... 302 °F)
2	Medium, up to 260 °C (500 °F)	0 ... 200 °C (32 ... 392 °F)

Insulation and heat tracing

In cases where fluid temperature deviates more than 80 °C from ambient temperature, sensor insulation is recommended to avoid negative effects from temperature fluctuations.

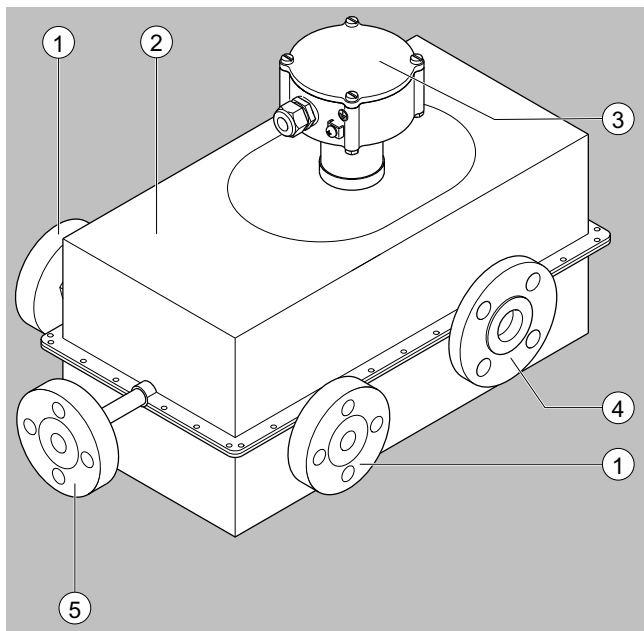

Configuration of FCS100 sensor with insulation and heat tracing

Insulation and heat tracing may be installed by the user but not in hazardous areas and the following must be noted:

- Do not insulate sensor terminal box.
- Do not expose transmitters to ambient temperatures exceeding 60 °C (140 °F)
- The preferred insulation is 60 mm (2.36 inch) thick with a heat transfer coefficient of 0.4 W/m² K (0.07 Btu/ ft² °F)

Dimensional drawings

Drawings, dimensions and weight for FCS100 sensors

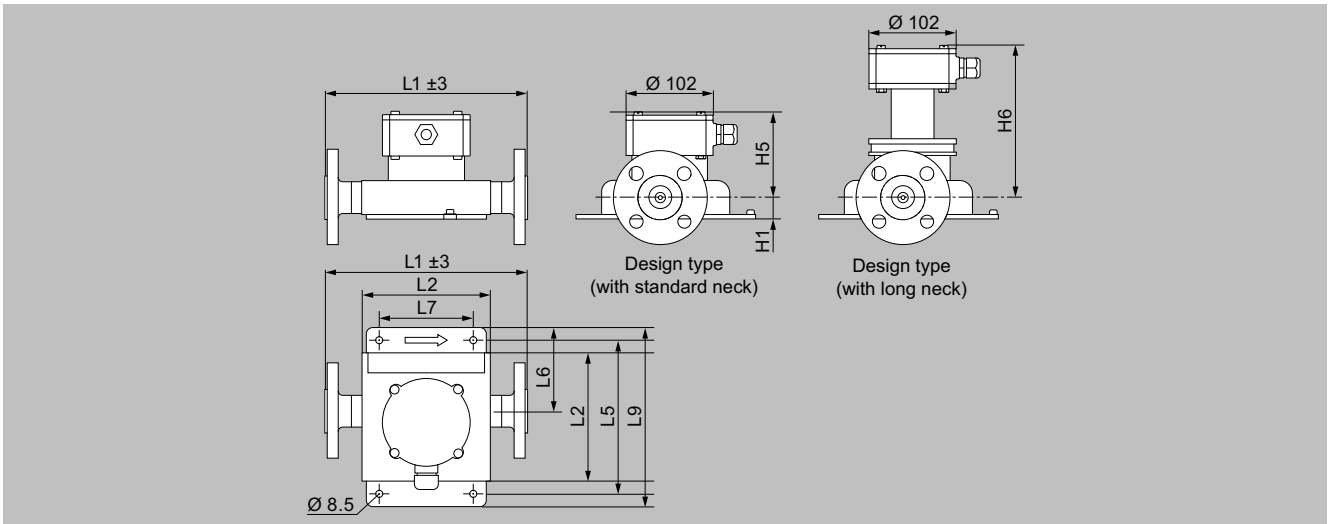

FCS100 sensor, dimensions in mm

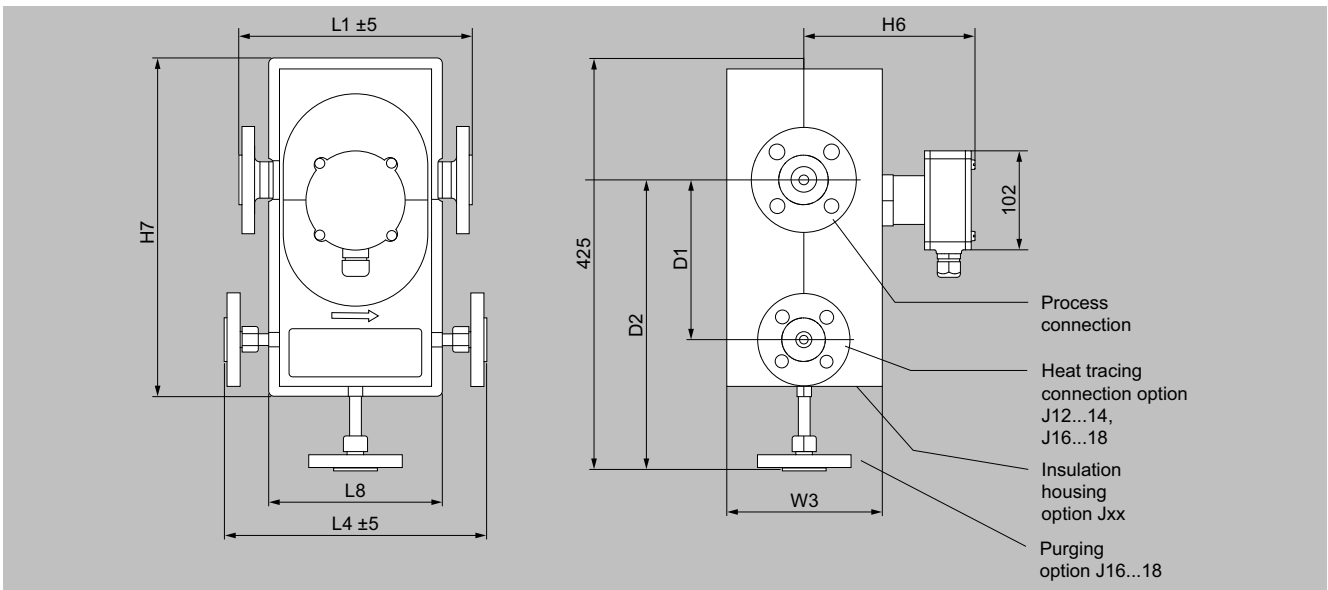

FCS100 with insulation housing, dimensions in mm

Flow Measurement

SITRANS FC (Coriolis)

Sensors / SITRANS FCS100

Dimensional drawings (continued)

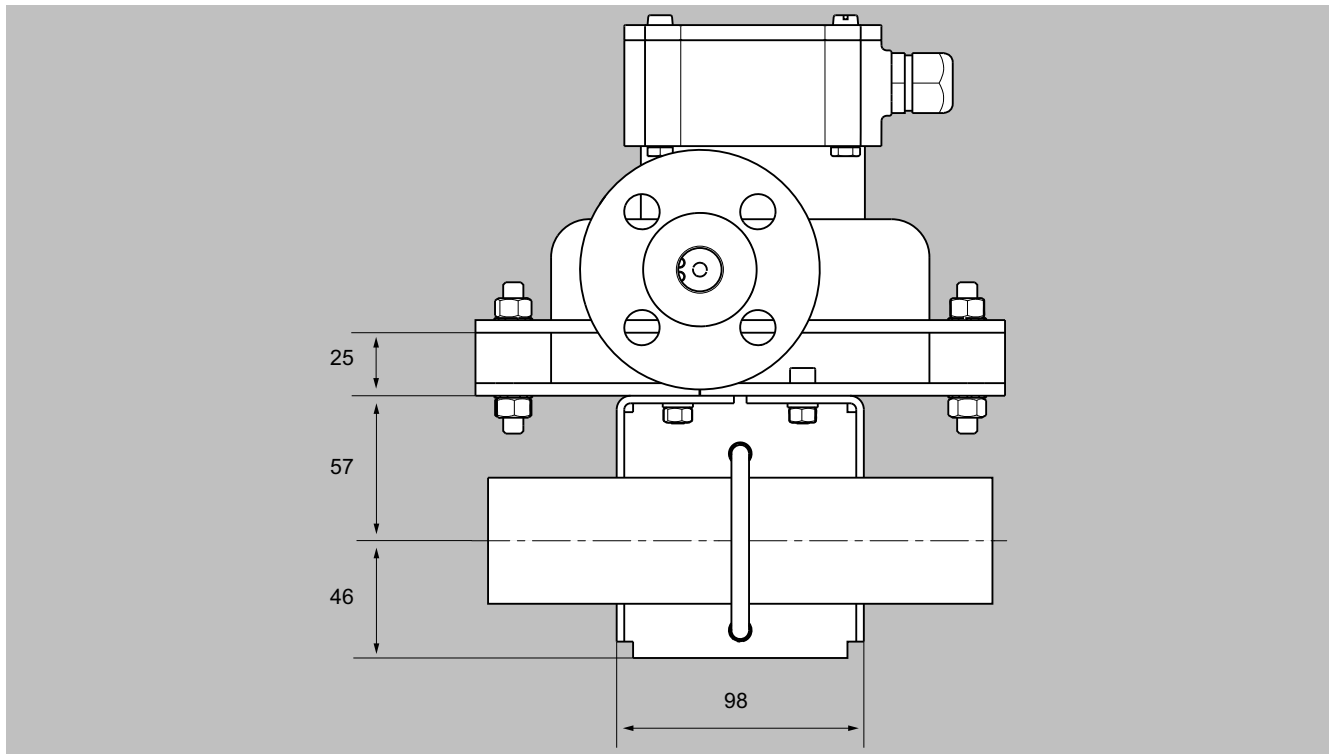

FCS100 with optional pipe mounting bracket, dimensions in mm

FCS100 sensor dimensions

Nominal size	L2	L4	L5	L6	L7	L8	L9
Dimensions in mm (inch)							
DN 1	150 (5.9)	270 (10.6)	180 (7.1)	111 (4.4)	110 (4.3)	180 (7.1)	210 (8.3)
DN 2	150 (5.9)	270 (10.6)	180 (7.1)	111 (4.4)	110 (4.3)	180 (7.1)	210 (8.3)
DN 4	150 (5.9)	270 (10.6)	180 (7.1)	99 (3.9)	110 (4.3)	180 (7.1)	210 (8.3)
DN 6	150 (5.9)	270 (10.6)	180 (7.1)	89 (3.5)	110 (4.3)	180 (7.1)	210 (8.3)
DN 8	150 (5.9)	270 (10.6)	180 (7.1)	55 (2.2)	110 (4.3)	180 (7.1)	210 (8.3)

Nominal size	H1	H3	H5	H6	H7	W3	D1	D2
Dimensions in mm (inch)								
DN 1	25 (1)	81 (3.2)	101 (4)	176 (6.9)	350 (13.8)	160 (6.3)	165 (6.5)	299 (11.8)
DN 2	25 (1)	81 (3.2)	101 (4)	176 (6.9)	350 (13.8)	160 (6.3)	165 (6.5)	299 (11.8)
DN 4	25 (1)	81 (3.2)	101 (4)	176 (6.9)	350 (13.8)	160 (6.3)	165 (6.5)	299 (11.8)
DN 6	25 (1)	81 (3.2)	101 (4)	176 (6.9)	350 (13.8)	160 (6.3)	165 (6.5)	299 (11.8)
DN 8	25 (1)	81 (3.2)	101 (4)	176 (6.9)	350 (13.8)	160 (6.3)	165 (6.5)	299 (11.8)

L1 dimension and weight with process connections according to ASME B16.5 (ISI 216 / AISI 316L)

Process connection size and type	FCS100 sensor nominal size									
	DN 1		DN 2		DN 4		DN 6		DN 8	
	L1 in mm (inch)	Weight in kg (lb)	L1 in mm (inch)	Weight in kg (lb)	L1 in mm (inch)	Weight in kg (lb)	L1 in mm (inch)	Weight in kg (lb)	L1 in mm (inch)	Weight in kg (lb)
ASME ½" class 150, raised face (RF)	240 (9.4)	6.2 (14)	240 (9.4)	6.2 (14)	240 (9.4)	6.2 (14)	240 (9.4)	6.2 (14)	240 (9.4)	6.2 (14)
ASME ½" class 300, raised face (RF)	240 (9.4)	6.6 (15)	240 (9.4)	6.6 (15)	240 (9.4)	6.6 (15)	240 (9.4)	6.6 (15)	240 (9.4)	6.6 (15)
ASME ½" class 600, raised face (RF)	250 (9.8)	6.9 (15)	250 (9.8)	6.9 (15)	250 (9.8)	6.9 (15)	250 (9.8)	6.9 (15)	250 (9.8)	6.9 (15)

Dimensional drawings (continued)

Process connection size and type	FCS100 sensor nominal size									
	DN 1		DN 2		DN 4		DN 6		DN 8	
	L1 in mm (inch)	Weight in kg (lb)	L1 in mm (inch)	Weight in kg (lb)	L1 in mm (inch)	Weight in kg (lb)	L1 in mm (inch)	Weight in kg (lb)	L1 in mm (inch)	Weight in kg (lb)
ASME ½" class 600, ring joint (RJ)	250 (9.8)	6.8 (15)	250 (9.8)	6.8 (15)	250 (9.8)	6.8 (15)	250 (9.8)	6.8 (15)	250 (9.8)	6.8 (15)
ASME ½" class 900, raised face (RF)	270 (10.6)	8.8 (19)	270 (10.6)	8.8 (19)	270 (10.6)	8.8 (19)	270 (10.6)	8.8 (19)	270 (10.6)	8.8 (19)
ASME ½" class 900, ring joint (RJ)	270 (10.6)	11.3 (25)	270 (10.6)	11.3 (25)	270 (10.6)	11.3 (25)	270 (10.6)	11.3 (25)	270 (10.6)	11.3 (25)
ASME ½" class 1500, raised face (RF)	270 (10.6)	8.8 (19)	270 (10.6)	8.8 (19)	270 (10.6)	8.8 (19)	270 (10.6)	8.8 (19)	270 (10.6)	8.8 (19)
ASME ½" class 1500, ring joint (RJ)	270 (10.6)	11.3 (25)	270 (10.6)	11.3 (25)	270 (10.6)	11.3 (25)	270 (10.6)	11.3 (25)	270 (10.6)	11.3 (25)
ASME 1" class 150, raised face (RF)	n/a	n/a	240 (9.4)	7.1 (16)	240 (9.4)	7.1 (16)	240 (9.4)	7.1 (16)	240 (9.4)	7.1 (16)
ASME 1" class 300, raised face (RF)	n/a	n/a	240 (9.4)	8.1 (18)	240 (9.4)	8.1 (18)	240 (9.4)	8.1 (18)	240 (9.4)	8.1 (18)
ASME 1" class 600, raised face (RF)	n/a	n/a	260 (10.2)	8.5 (19)	260 (10.2)	8.5 (19)	260 (10.2)	8.5 (19)	260 (10.2)	8.5 (19)
ASME 1" class 600, ring joint (RJ)	n/a	n/a	260 (10.2)	8.6 (19)	260 (10.2)	8.6 (19)	260 (10.2)	8.6 (19)	260 (10.2)	8.6 (19)
ASME 1" class 900, raised face (RF)	n/a	n/a	320 (12.6)	12.7 (28)	320 (12.6)	12.7 (28)	320 (12.6)	12.7 (28)	320 (12.6)	12.7 (28)
ASME 1" class 900, ring joint (RJ)	n/a	n/a	320 (12.6)	12.8 (28)	320 (12.6)	12.8 (28)	320 (12.6)	12.8 (28)	320 (12.6)	12.8 (28)
ASME 1" class 1500, raised face (RF)	n/a	n/a	320 (12.6)	12.7 (28)	320 (12.6)	12.7 (28)	320 (12.6)	12.7 (28)	320 (12.6)	12.7 (28)
ASME 1" class 1500, ring joint (RJ)	n/a	n/a	320 (12.6)	12.8 (28)	320 (12.6)	12.8 (28)	320 (12.6)	12.8 (28)	320 (12.6)	12.8 (28)
ASME 1½" class 150, raised face (RF)	n/a	n/a	250 (9.8)	8 (18)	250 (9.8)	8 (18)	250 (9.8)	8 (18)	250 (9.8)	8 (18)
ASME 1½" class 300, raised face (RF)	n/a	n/a	250 (9.8)	10.3 (23)	250 (9.8)	10.3 (23)	250 (9.8)	10.3 (23)	250 (9.8)	10.3 (23)
ASME 1½" class 600, raised face (RF)	n/a	n/a	270 (10.6)	11.7 (26)	270 (10.6)	11.7 (26)	270 (10.6)	11.7 (26)	270 (10.6)	11.7 (26)
ASME 1½" class 600, ring joint (RJ)	n/a	n/a	270 (10.6)	11.6 (26)	270 (10.6)	11.6 (26)	270 (10.6)	11.6 (26)	270 (10.6)	11.6 (26)
ASME 1½" class 900, raised face (RF)	n/a	n/a	340 (13.4)	17.5 (39)	340 (13.4)	17.5 (39)	340 (13.4)	17.5 (39)	340 (13.4)	17.5 (39)
ASME 1½" class 900, ring joint (RJ)	n/a	n/a	340 (13.4)	17.7 (39)	340 (13.4)	17.7 (39)	340 (13.4)	17.7 (39)	340 (13.4)	17.7 (39)
ASME 1½" class 1500, raised face (RF)	n/a	n/a	340 (13.4)	17.5 (39)	340 (13.4)	17.5 (39)	340 (13.4)	17.5 (39)	340 (13.4)	17.5 (39)
ASME 1½" class 1500, ring joint (RJ)	n/a	n/a	340 (13.4)	17.7 (39)	340 (13.4)	17.7 (39)	340 (13.4)	17.7 (39)	340 (13.4)	17.7 (39)

L1 dimension and weight with process connections according to EN 1092-1 (AISI 316L)

Process connection size and type	FCS100 sensor nominal size									
	DN 1		DN 2		DN 4		DN 6		DN 8	
	L1 in mm (inch)	Weight in kg (lb)	L1 in mm (inch)	Weight in kg (lb)	L1 in mm (inch)	Weight in kg (lb)	L1 in mm (inch)	Weight in kg (lb)	L1 in mm (inch)	Weight in kg (lb)
EN DN 15 PN 40 type B1, raised face (RF)	240 (9.4)	6.8 (15)	240 (9.4)	6.8 (15)	240 (9.4)	6.8 (15)	240 (9.4)	6.8 (15)	240 (9.4)	6.8 (15)
EN DN 15 PN 40 type D, with groove	240 (9.4)	6.6 (15)	240 (9.4)	6.6 (15)	240 (9.4)	6.6 (15)	240 (9.4)	6.6 (15)	240 (9.4)	6.6 (15)
EN DN 15 PN 40 type E, with spigot	240 (9.4)	6.5 (14)	240 (9.4)	6.5 (14)	240 (9.4)	6.5 (14)	240 (9.4)	6.5 (14)	240 (9.4)	6.5 (14)
EN DN 15 PN 40 type F, with recess	240 (9.4)	6.7 (15)	240 (9.4)	6.7 (15)	240 (9.4)	6.7 (15)	240 (9.4)	6.7 (15)	240 (9.4)	6.7 (15)
EN DN 15 PN 100 type B1, raised face (RF)	250 (9.8)	7.6 (17)	250 (9.8)	7.6 (17)	250 (9.8)	7.6 (17)	250 (9.8)	7.6 (17)	250 (9.8)	7.6 (17)
EN DN 15 PN 100 type D, with groove	250 (9.8)	13.6 (30)	250 (9.8)	13.6 (30)	250 (9.8)	13.6 (30)	250 (9.8)	13.6 (30)	250 (9.8)	13.6 (30)
EN DN 15 PN 100 type E, with spigot	250 (9.8)	7.3 (16)	250 (9.8)	7.3 (16)	250 (9.8)	7.3 (16)	250 (9.8)	7.3 (16)	250 (9.8)	7.3 (16)
EN DN 15 PN 100 type F, with recess	250 (9.8)	7.5 (17)	250 (9.8)	7.5 (17)	250 (9.8)	7.5 (17)	250 (9.8)	7.5 (17)	250 (9.8)	7.5 (17)
EN DN 25 PN 40 type B1, raised face (RF)	n/a	n/a	240 (9.4)	7.7 (17)	240 (9.4)	7.7 (17)	240 (9.4)	7.7 (17)	240 (9.4)	7.7 (17)

Flow Measurement

SITRANS FC (Coriolis)

Sensors / SITRANS FCS100

Dimensional drawings (continued)

Process connection size and type	FCS100 sensor nominal size									
	DN 1		DN 2		DN 4		DN 6		DN 8	
	L1 in mm (inch)	Weight in kg (lb)	L1 in mm (inch)	Weight in kg (lb)	L1 in mm (inch)	Weight in kg (lb)	L1 in mm (inch)	Weight in kg (lb)	L1 in mm (inch)	Weight in kg (lb)
EN DN 25 PN 40 type D, with groove	n/a	n/a	240 (9.4)	7.7 (17)	240 (9.4)	7.7 (17)	240 (9.4)	7.7 (17)	240 (9.4)	7.7 (17)
EN DN 25 PN 40 type E, with spigot	n/a	n/a	240 (9.4)	7.4 (16)	240 (9.4)	7.4 (16)	240 (9.4)	7.4 (16)	240 (9.4)	7.4 (16)
EN DN 25 PN 40 type F, with recess	n/a	n/a	240 (9.4)	7.6 (17)	240 (9.4)	7.6 (17)	240 (9.4)	7.6 (17)	240 (9.4)	7.6 (17)
EN DN 25 PN 100 type B1, raised face (RF)	n/a	n/a	260 (10.2)	10.3 (23)	260 (10.2)	10.3 (23)	260 (10.2)	10.3 (23)	260 (10.2)	10.3 (23)
EN DN 25 PN 100 type D, with groove	n/a	n/a	260 (10.2)	10.2 (22)	260 (10.2)	10.2 (22)	260 (10.2)	10.2 (22)	260 (10.2)	10.2 (22)
EN DN 25 PN 100 type E, with spigot	n/a	n/a	260 (10.2)	9.7 (21)	260 (10.2)	9.7 (21)	260 (10.2)	9.7 (21)	260 (10.2)	9.7 (21)
EN DN 25 PN 100 type F, with recess	n/a	n/a	260 (10.2)	10.1 (22)	260 (10.2)	10.1 (22)	260 (10.2)	10.1 (22)	260 (10.2)	10.1 (22)
EN DN 40 PN 40 type B1, raised face (RF)	n/a	n/a	240 (9.4)	9.2 (20)	240 (9.4)	9.2 (20)	240 (9.4)	9.2 (20)	240 (9.4)	9.2 (20)
EN DN 40 PN 40 type D, with groove	n/a	n/a	240 (9.4)	9.1 (20)	240 (9.4)	9.1 (20)	240 (9.4)	9.1 (20)	240 (9.4)	9.1 (20)
EN DN 40 PN 40 type E, with spigot	n/a	n/a	240 (9.4)	8.8 (19)	240 (9.4)	8.8 (19)	240 (9.4)	8.8 (19)	240 (9.4)	8.8 (19)
EN DN 40 PN 40 type F, with recess	n/a	n/a	240 (9.4)	9.0 (20)	240 (9.4)	9.0 (20)	240 (9.4)	9.0 (20)	240 (9.4)	9.0 (20)
EN DN 40 PN 100 type B1, raised face (RF)	n/a	n/a	320 (12.6)	13.7 (30)	320 (12.6)	13.7 (30)	320 (12.6)	13.7 (30)	320 (12.6)	13.7 (30)
EN DN 40 PN 100 type D, with groove	n/a	n/a	320 (12.6)	13.6 (30)	320 (12.6)	13.6 (30)	320 (12.6)	13.6 (30)	320 (12.6)	13.6 (30)
EN DN 40 PN 100 type E, with spigot	n/a	n/a	320 (12.6)	13.2 (29)	320 (12.6)	13.2 (29)	320 (12.6)	13.2 (29)	320 (12.6)	13.2 (29)
EN DN 40 PN 100 type F, with recess	n/a	n/a	320 (12.6)	13.5 (30)	320 (12.6)	13.5 (30)	320 (12.6)	13.5 (30)	320 (12.6)	13.5 (30)

L1 dimension and weight with process connections according to JIS B 2220 (AISI 316 / AISI 316L)

Process connection size and type	FCS100 sensor nominal size									
	DN 1		DN 2		DN 4		DN 6		DN 8	
	L1 in mm (inch)	Weight in kg (lb)	L1 in mm (inch)	Weight in kg (lb)	L1 in mm (inch)	Weight in kg (lb)	L1 in mm (inch)	Weight in kg (lb)	L1 in mm (inch)	Weight in kg (lb)
JIS DN 15 10K	240 (9.4)	6.5 (14)	240 (9.4)	6.5 (14)	240 (9.4)	6.5 (14)	240 (9.4)	6.5 (14)	240 (9.4)	6.5 (14)
JIS DN 15 20K	240 (9.4)	6.7 (15)	240 (9.4)	6.7 (15)	240 (9.4)	6.7 (15)	240 (9.4)	6.7 (15)	240 (9.4)	6.7 (15)
JIS DN 25 10K	n/a	n/a	240 (9.4)	7.6 (17)	240 (9.4)	7.6 (17)	240 (9.4)	7.6 (17)	240 (9.4)	7.6 (17)
JIS DN 25 20K	n/a	n/a	240 (9.4)	8 (18)	240 (9.4)	8 (18)	240 (9.4)	8 (18)	240 (9.4)	8 (18)
JIS DN 40 10K	n/a	n/a	240 (9.4)	8.4 (19)	240 (9.4)	8.4 (19)	240 (9.4)	8.4 (19)	240 (9.4)	8.4 (19)
JIS DN 40 20K	n/a	n/a	240 (9.4)	8.8 (19)	240 (9.4)	8.8 (19)	240 (9.4)	8.8 (19)	240 (9.4)	8.8 (19)

L1 dimension and weight with process connections according to NPT internal thread

Process connection size and type	FCS100 sensor nominal size									
	DN 1		DN 2		DN 4		DN 6		DN 8	
	L1 in mm (inch)	Weight in kg (lb)	L1 in mm (inch)	Weight in kg (lb)	L1 in mm (inch)	Weight in kg (lb)	L1 in mm (inch)	Weight in kg (lb)	L1 in mm (inch)	Weight in kg (lb)
¼" NPT	260 (10.2)	5.6 (12)	260 (10.2)	5.6 (12)	260 (10.2)	5.6 (12)	260 (10.2)	5.6 (12)	260 (10.2)	5.6 (12)
⅜" NPT	260 (10.2)	5.6 (12)	260 (10.2)	5.6 (12)	260 (10.2)	5.6 (12)	260 (10.2)	5.6 (12)	260 (10.2)	5.6 (12)
½" NPT	260 (10.2)	5.6 (12)	260 (10.2)	5.6 (12)	260 (10.2)	5.6 (12)	260 (10.2)	5.6 (12)	260 (10.2)	5.6 (12)
¾" NPT	260 (10.2)	5.5 (12)	260 (10.2)	5.5 (12)	260 (10.2)	5.5 (12)	260 (10.2)	5.5 (12)	260 (10.2)	5.5 (12)

L1 dimension and weight with process connections according to G internal thread

Process connection size and type	FCS100 sensor nominal size									
	DN 1		DN 2		DN 4		DN 6		DN 8	
	L1 in mm (inch)	Weight in kg (lb)	L1 in mm (inch)	Weight in kg (lb)	L1 in mm (inch)	Weight in kg (lb)	L1 in mm (inch)	Weight in kg (lb)	L1 in mm (inch)	Weight in kg (lb)
G ¼ inch	260 (10.2)	5.6 (12)	260 (10.2)	5.6 (12)	260 (10.2)	5.6 (12)	260 (10.2)	5.6 (12)	260 (10.2)	5.6 (12)
G ⅜ inch	260 (10.2)	5.6 (12)	260 (10.2)	5.6 (12)	260 (10.2)	5.6 (12)	260 (10.2)	5.6 (12)	260 (10.2)	5.6 (12)
G ½ inch	260 (10.2)	5.6 (12)	260 (10.2)	5.6 (12)	260 (10.2)	5.6 (12)	260 (10.2)	5.6 (12)	260 (10.2)	5.6 (12)
G ¾ inch	260 (10.2)	5.5 (12)	260 (10.2)	5.5 (12)	260 (10.2)	5.5 (12)	260 (10.2)	5.5 (12)	260 (10.2)	5.5 (12)

Dimensional drawings (continued)

L1 dimension and weight with hygienic clamp process connections according to DIN 32676 series A

Process connection size and type	FCS100 sensor nominal size									
	DN 1		DN 2		DN 4		DN 6		DN 8	
	L1 in mm (inch)	Weight in kg (lb)	L1 in mm (inch)	Weight in kg (lb)	L1 in mm (inch)	Weight in kg (lb)	L1 in mm (inch)	Weight in kg (lb)	L1 in mm (inch)	Weight in kg (lb)
DIN 32676 series A DN 15	240 (9.4)	5.3 (12)	240 (9.4)	5.3 (12)	240 (9.4)	5.3 (12)	240 (9.4)	5.3 (12)	240 (9.4)	5.3 (12)
DIN 32676 series A DN 25	n/a	n/a	240 (9.4)	5.4 (12)	240 (9.4)	5.4 (12)	240 (9.4)	5.4 (12)	240 (9.4)	5.4 (12)
DIN 32676 series A DN 40	n/a	n/a	240 (9.4)	5.4 (12)	240 (9.4)	5.4 (12)	240 (9.4)	5.4 (12)	240 (9.4)	5.4 (12)

L1 dimension and weight with hygienic clamp process connections according to DIN 32676 series C (Tri-clamp)

Process connection size and type	FCS100 sensor nominal size									
	DN 1		DN 2		DN 4		DN 6		DN 8	
	L1 in mm (inch)	Weight in kg (lb)	L1 in mm (inch)	Weight in kg (lb)	L1 in mm (inch)	Weight in kg (lb)	L1 in mm (inch)	Weight in kg (lb)	L1 in mm (inch)	Weight in kg (lb)
DIN 32676 series C ½ inch	240 (9.4)	5.3 (12)	240 (9.4)	5.3 (12)	240 (9.4)	5.3 (12)	240 (9.4)	5.3 (12)	240 (9.4)	5.3 (12)
DIN 32676 series C 1 inch	n/a	n/a	240 (9.4)	5.4 (12)	240 (9.4)	5.4 (12)	240 (9.4)	5.4 (12)	240 (9.4)	5.4 (12)
DIN 32676 series C 1½ inch	n/a	n/a	240 (9.4)	5.4 (12)	240 (9.4)	5.4 (12)	240 (9.4)	5.4 (12)	240 (9.4)	5.4 (12)