

Flow Measurement

SITRANS FC (Coriolis)

Sensors / SITRANS FCS600

Overview

SITRANS FCS600 sensor is the resistant Coriolis flow sensor for extreme conditions and corrosive fluids.

Features:

- Dual curved AISI 316L or alloy 22 tubes with optimum decoupling from external influences
- Nominal sizes from DN 2 to DN 65
- Process connection: flange, thread, or high pressure autoclave
- Temperatures from -196 °C (for cryogenic fluids), up to +350 °C
- Insulation and heat tracing options for viscous and molten liquids
- Combination with compact or remote transmitters.

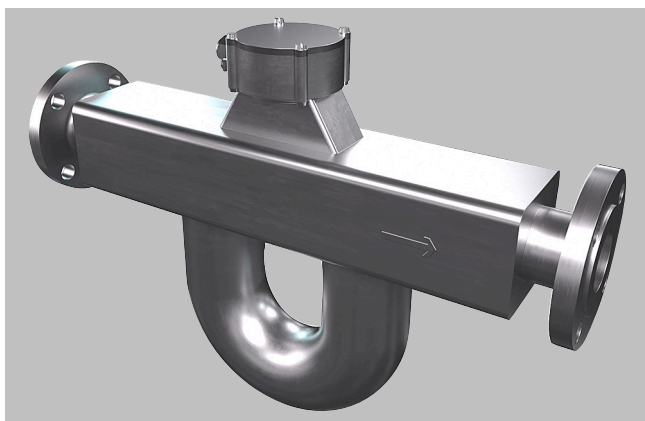

FCS600 sensor

Design

Sensor installation position related to type of fluid

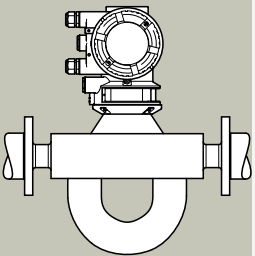
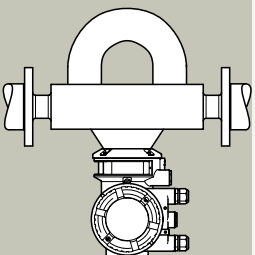
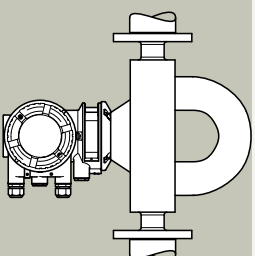
Installation position	Fluid	Description
Position 1 	Liquid	<ul style="list-style-type: none"> • Horizontal • Measuring tubes below process pipe • Avoids accumulation of entrained gas
Position 2 	Gas	<ul style="list-style-type: none"> • Horizontal • Measuring tubes above process pipe • Accumulation of liquid or condensate is less likely
Position 3 	Gas / Liquid	<ul style="list-style-type: none"> • Vertical • Upwards direction of flow • In liquid application accumulation of entrained gas is avoided • This position allows self-draining in liquid flow

Technical specifications

Allowed ambient temperature for FCS600 sensors

The allowed combinations of process fluid and ambient temperature for the sensor are illustrated as light areas in the diagrams below.

Standard temperature specification, compact transmitter

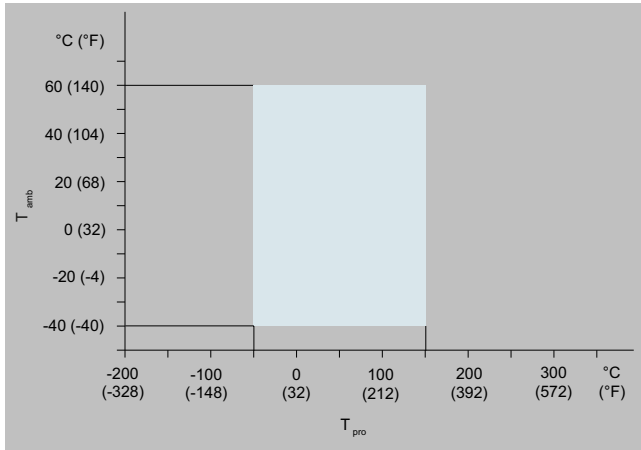

Allowed process fluid and ambient temperatures, compact transmitter

T_{amb}	Ambient temperature
T_{pro}	Process fluid temperature

Standard temperature specification with hygienic clamp connections, compact transmitter

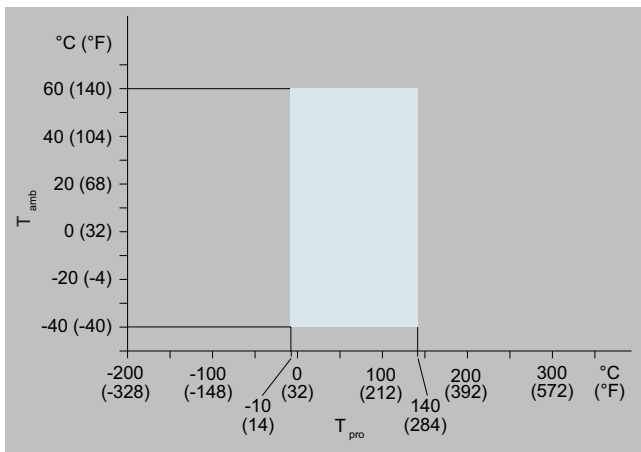

Allowed process fluid and ambient temperatures, hygienic clamp connections, compact transmitter

T_{amb}	Ambient temperature
T_{pro}	Process fluid temperature

Low temperature specification, remote transmitter

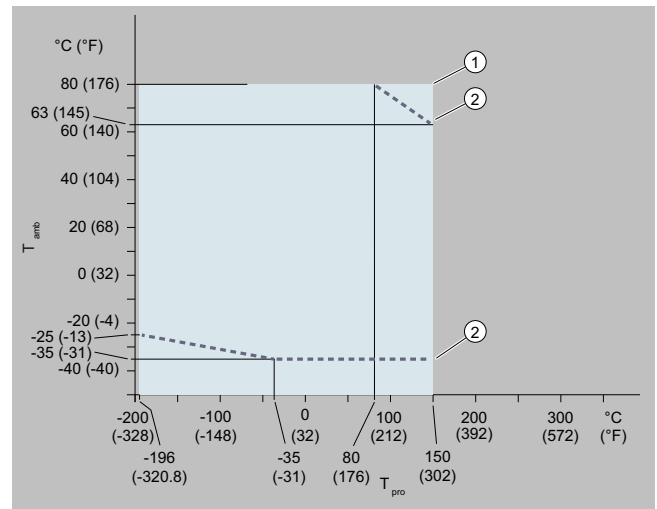

Allowed process fluid and ambient temperatures, remote transmitter

1	Standard cable option
2	Limitation for fire retardant cable option
T_{amb}	Ambient temperature
T_{pro}	Process fluid temperature

Standard temperature specification, remote transmitter

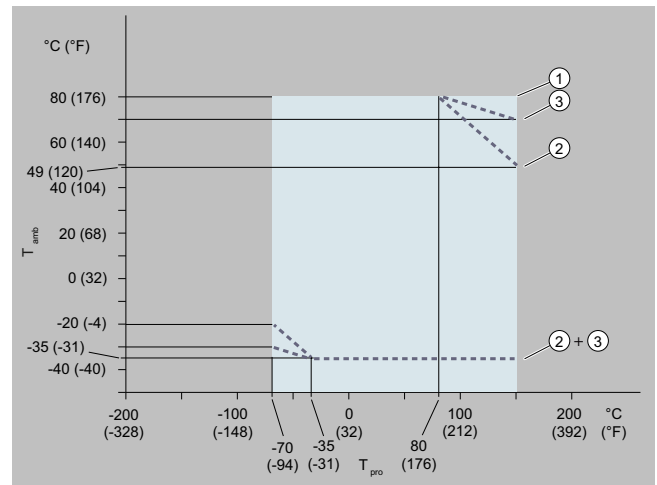

Allowed process fluid and ambient temperatures, remote transmitter

1	Standard cable option
2	Limitation for fire retardant cable option and standard neck
3	Limitation for fire retardant cable option and long neck
T_{amb}	Ambient temperature
T_{pro}	Process fluid temperature

Flow Measurement

SITRANS FC (Coriolis)

Sensors / SITRANS FCS600

Technical specifications (continued)

Standard temperature specification with hygienic clamp connections, remote transmitter

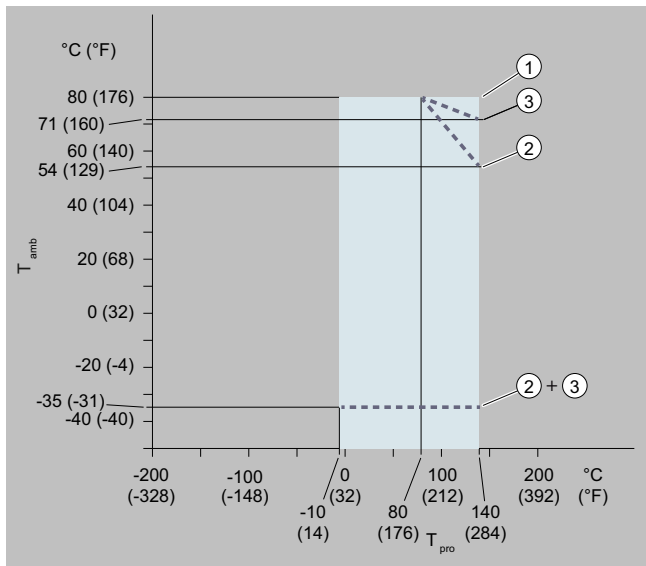

Allowed process fluid and ambient temperatures, hygienic clamp connections, remote transmitter

1	Standard cable option
2	Limitation for fire retardant cable option and standard neck
3	Limitation for fire retardant cable option and long neck
T_{amb}	Ambient temperature
T_{pro}	Process fluid temperature

Medium temperature specification, remote transmitter

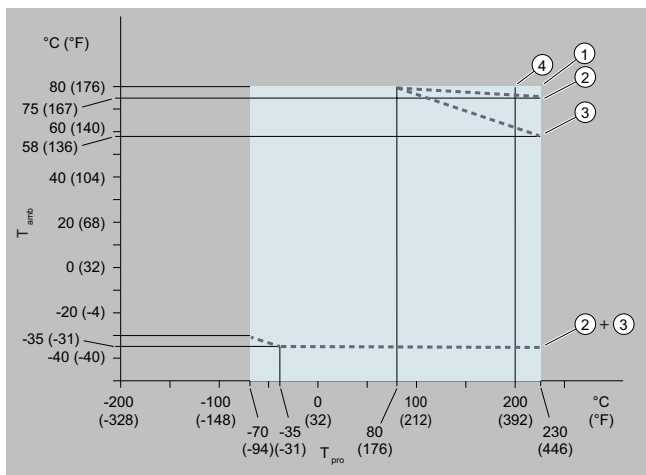

Allowed process fluid and ambient temperatures, remote transmitter

1	Standard cable option
2	Limitation for fire retardant cable without insulation/tracing option
3	Limitation for fire retardant cable option with insulation/tracing option
T_{amb}	Ambient temperature
T_{pro}	Process fluid temperature

High temperature specification, remote transmitter

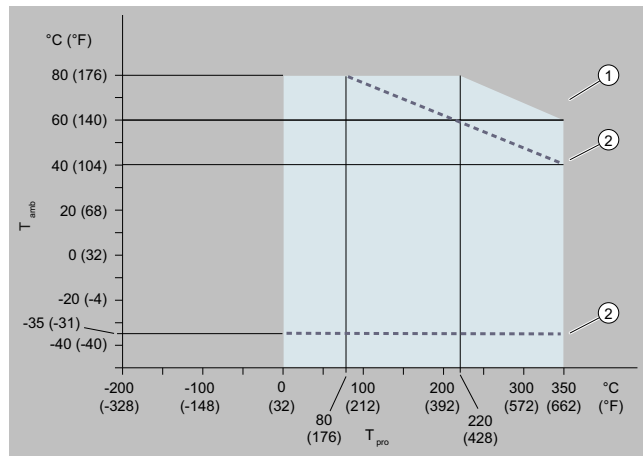

Allowed process fluid and ambient temperatures, remote transmitter

1	Standard cable option
2	Limitation for fire retardant cable option
T_{amb}	Ambient temperature
T_{pro}	Process fluid temperature

Mechanical specifications of FCS600 sensors

FCS600 sensors are available with standard neck or long neck design and can be combined with compact or remote transmitters. The neck can also be described as the pedestal connecting the sensor body to the transmitter or terminal housing.

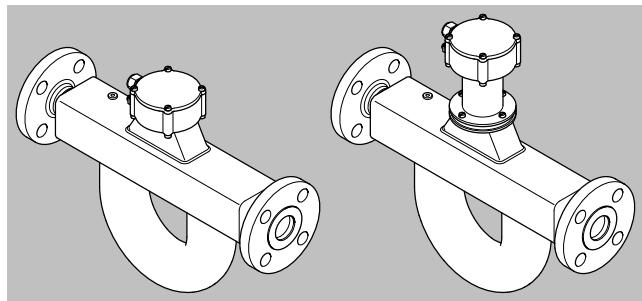

FCS600 sensors (for remote transmitter) in sizes DN 15, DN 25, DN 40 and DN 65, standard neck and long neck

Technical specifications (continued)

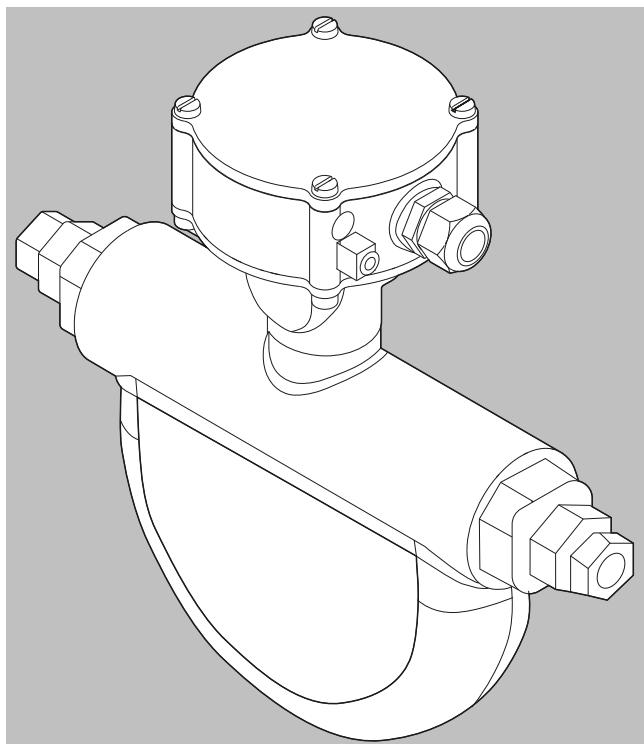

FCS600 sensors (for remote transmitter) in sizes DN 2 and DN 4 standard neck

Material specifications

Wetted parts¹⁾

Sensor size DN 2	Alloy 22 dual measuring tubes with AISI 316L stainless steel process connections
Sensor size DN 4	Alloy 22 dual measuring tubes with AISI 316L stainless steel process connections
Sensor size DN 15	AISI 316L stainless steel or alloy 22
Sensor size DN 25	AISI 316L stainless steel or alloy 22
Sensor size DN 40	AISI 316L stainless steel or alloy 22
Sensor size DN 65	AISI 316L stainless steel

Sensor housing

Junction box	AISI 316L stainless steel	All sensors with remote transmitters
Neck (pedestal)	ASTM A351 CF3M stainless steel	DN 2 and DN 4 sensors only (short neck)
Neck (pedestal)	AISI 316L stainless steel	All sensors, except sizes DN 2 and DN 4
Body (outer casing)	AISI 304 stainless steel	All versions, except sizes DN 2 and DN 4
Body (outer casing)	AISI 316L stainless steel	All versions

Nameplates²⁾

	Process temperature range	Material
Sensor with AISI 304 stainless steel housing	Standard, up to 150 °C (302 °F)	Polyester film
Sensor with AISI 304 stainless steel housing	Low, medium or high	AISI 316L ss
Sensor with AISI 316L stainless steel housing	All versions	AISI 316L ss

¹⁾ The user is responsible to ensure chemical compatibility of the material of the wetted parts with the measured process fluid.

²⁾ Nameplate material depends on the materials selected for SITRANS FC sensors.

Secondary containment

Some applications or environment conditions require secondary containment retaining the process pressure for increased safety. SITRANS FCS600 sensors have a secondary containment filled with inert gas.

Flow Measurement

SITRANS FC (Coriolis)

Sensors / SITRANS FCS600

Technical specifications (continued)

Typical burst pressure at room temperature for sizes DN 2 and DN 4	49 bar (710 psi)
Typical burst pressure at room temperature for sizes DN 15, DN 25 and DN 40: 120 bar (1 740 psi)	120 bar (1 740 psi)
Typical burst pressure at room temperature for size DN 65	80 bar (1 160 psi)

Insulation and heat tracing (not available for sizes DN 2 and DN 4)

In cases where fluid temperature deviates more than 80 °C (176 °F) from ambient temperature, sensor insulation is recommended to avoid negative effects from temperature fluctuations.

Maximum temperature of heat carrier

Process temperature range	Temperature range of heat carrier
Standard, up to 150 °C (302 °F)	0 ... 150 °C (32 ... 302 °F)
Medium, up to 260 °C (500 °F)	0 ... 230 °C (32 ... 446 °F) ¹⁾
High, up to 350 °C (662 °F)	0 ... 350 °C (32 ... 662 °F)

¹⁾ With Ex Approval 0 ... 220 °C (32 ... 428 °F)

Insulation and heat tracing may be installed by the user but not in hazardous areas and the following must be noted:

- Do not insulate sensor terminal box.
- Do not expose transmitters to ambient temperatures exceeding 60 °C (140 °F).
- The preferred insulation is 60 mm (2.36") thick with a heat transfer coefficient of 0.4 W/m² K (0.07 Btu/ft² °F).

Dimensional drawings

Drawings, dimensions and weight for FCS600 sensors

FCS dimensions and weight (excluding high pressure versions)

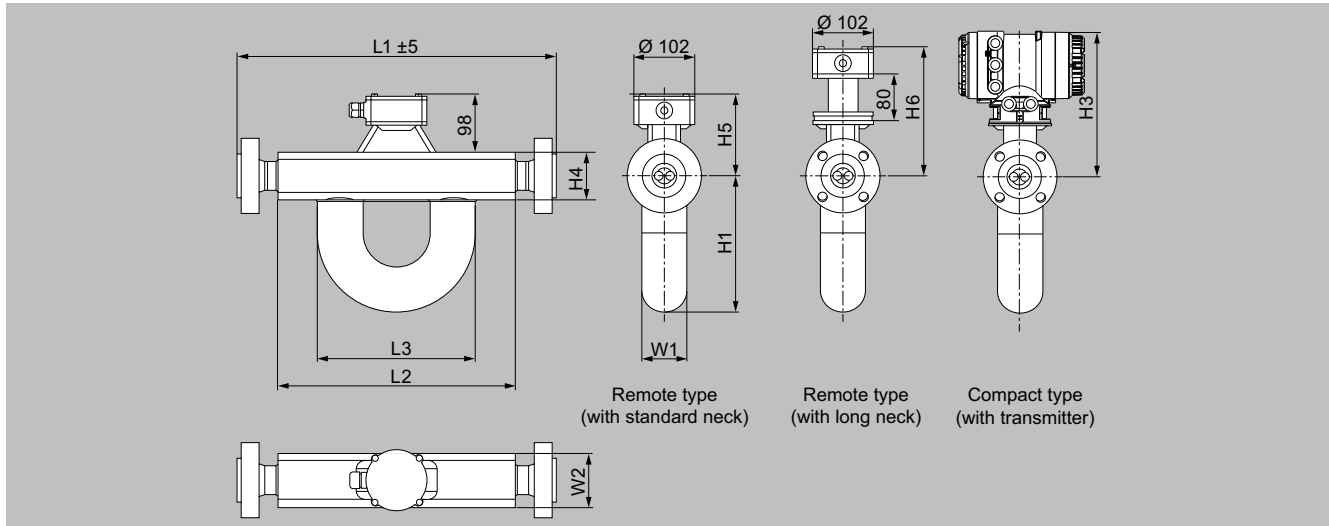

Dimensions in mm

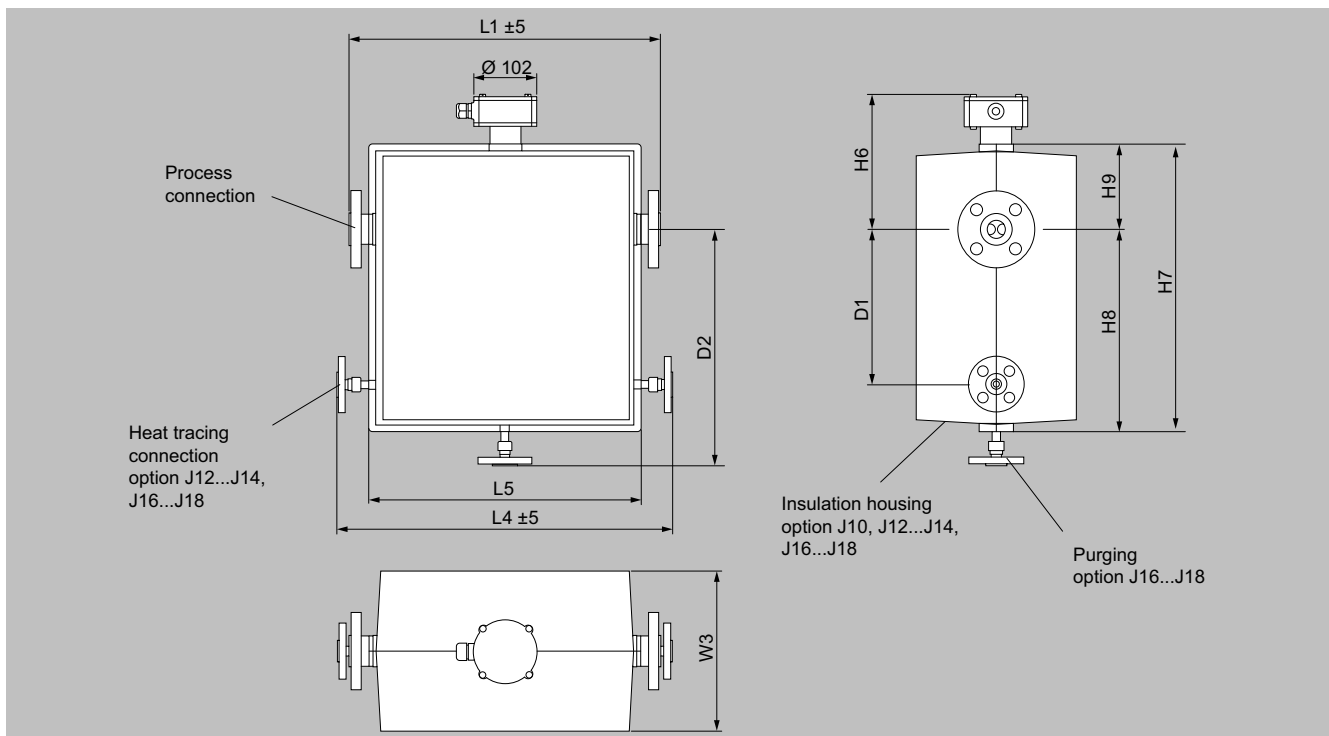

Dimensions in mm (with insulation and heating options)

Flow Measurement

SITRANS FC (Coriolis)

Sensors / SITRANS FCS600

Dimensional drawings (continued)

FCS600 sensor dimensions without L1

Nominal size	L2	L3	L4	L5	W1	W2	W3	D1	D2
Dimensions in mm (inch)									
DN 15	272 (10.7)	212 (8.3)	420 (16.5)	310 (12.2)	60 (2.4)	80 (3.1)	240 (9.4)	200 (7.9)	330 (13)
DN 25	400 (15.7)	266 (10.5)	540 (21.3)	439 (17.3)	76 (3)	90 (3.5)	260 (10.2)	250 (9.8)	380 (15)
DN 40	490 (19.3)	267 (10.5)	640 (25.2)	530 (20.9)	89 (3.5)	110 (4.3)	260 (10.2)	250 (9.8)	430 (16.9)
DN 65	850 (33.5)	379 (14.9)	1000 (39.4)	894 (35.2)	129 (5.1)	160 (6.3)	302 (11.9)	350 (13.8)	545 (21.5)

Nominal size	H1	H3	H4	H5	H6	H7	H8	H9
Dimensions in mm (inch)								
DN 15	177 (7)	267 (10.5)	80 (3.1)	138 (5.4)	218 (8.6)	411 (16.2)	273 (10.7)	138 (5.4)
DN 25	230 (9.1)	267 (10.5)	80 (3.1)	138 (5.4)	218 (8.6)	464 (18.3)	326 (12.8)	138 (5.4)
DN 40	268 (10.6)	277 (10.9)	100 (3.9)	148 (5.8)	228 (9)	524 (20.6)	376 (14.8)	148 (5.8)
DN 65	370 (14.6)	294.5 (11.6)	135 (5.3)	165 (6.5)	246 (9.7)	668 (26.3)	503 (19.8)	165 (6.5)

Overall length L1 and weight

The overall length of the sensor depends on the selected process connection (type and size). The following tables list the overall length and weight as functions of the individual process connection.

The weights in the tables are for the remote type. Additional weight for the compact type: up to 3.2 kg (7.1 lb).

L1 dimension and weight with process connections according to ASME B16.5, AISI 316L wetted parts

Process connection size and type	FCS600 sensor nominal size							
	DN 15 L1 in mm (inch)	Weight in kg (lb)	DN 25 L1 in mm (inch)	Weight in kg (lb)	DN 40 L1 in mm (inch)	Weight in kg (lb)	DN 65 L1 in mm (inch)	Weight in kg (lb)
ASME ½" class 150, raised face (RF)	370 (14.6)	10 (22)	n/a	n/a	n/a	n/a	n/a	n/a
ASME ½" class 300, raised face (RF)	370 (14.6)	10.4 (23)	n/a	n/a	n/a	n/a	n/a	n/a
ASME ½" class 600, raised face (RF)	380 (15)	10.6 (23)	n/a	n/a	n/a	n/a	n/a	n/a
ASME ½" class 600, ring joint (RJ)	380 (15)	10.6 (23)	n/a	n/a	n/a	n/a	n/a	n/a
ASME 1" class 150, raised face (RF)	370 (14.6)	10.8 (24)	500 (19.7)	14.8 (33)	n/a	n/a	n/a	n/a
ASME 1" class 300, raised face (RF)	370 (14.6)	11.8 (26)	500 (19.7)	15.8 (35)	n/a	n/a	n/a	n/a
ASME 1" class 600, raised face (RF)	390 (15.4)	12.2 (27)	520 (20.5)	16.2 (36)	n/a	n/a	n/a	n/a
ASME 1" class 600, ring joint (RJ)	390 (15.4)	12.4 (27)	520 (20.5)	16.2 (36)	n/a	n/a	n/a	n/a
ASME 1½" class 150, raised face (RF)	380 (15)	11.8 (26)	500 (19.7)	15.8 (35)	600 (23.6)	25 (56)	n/a	n/a
ASME 1½" class 300, raised face (RF)	380 (15)	14.2 (31)	510 (20.1)	18.2 (40)	600 (23.6)	27.2 (60)	n/a	n/a
ASME 1½" class 600, raised face (RF)	400 (15.7)	15.4 (34)	530 (20.9)	19.2 (42)	620 (24.4)	28.2 (62)	n/a	n/a
ASME 1½" class 600, ring joint (RJ)	400 (15.7)	15.4 (34)	530 (20.9)	19.4 (43)	620 (24.4)	28.2 (62)	n/a	n/a
ASME 2" class 150, raised face (RF)	n/a	n/a	510 (20.1)	17.4 (38)	600 (23.6)	26.4 (58)	n/a	n/a
ASME 2" class 300, raised face (RF)	n/a	n/a	510 (20.1)	19 (42)	600 (23.6)	28 (62)	n/a	n/a
ASME 2" class 600, raised face (RF)	n/a	n/a	540 (21.3)	20.8 (46)	630 (24.8)	29.8 (66)	n/a	n/a
ASME 2" class 600, ring joint (RJ)	n/a	n/a	540 (21.3)	21.2 (47)	630 (24.8)	29.8 (66)	n/a	n/a
ASME 2½" class 150, raised face (RF)	n/a	n/a	n/a	n/a	610 (24)	29.6 (65)	n/a	n/a
ASME 2½" class 300, raised face (RF)	n/a	n/a	n/a	n/a	610 (24)	31 (68)	n/a	n/a
ASME 2½" class 600, raised face (RF)	n/a	n/a	n/a	n/a	640 (25.2)	33.4 (74)	n/a	n/a
ASME 2½" class 600, ring joint (RJ)	n/a	n/a	n/a	n/a	640 (25.2)	34.4 (76)	n/a	n/a
ASME 3" class 150, raised face (RF)	n/a	n/a	n/a	n/a	610 (24)	30.6 (67)	1 000 (39.4)	60.2 (133)

Dimensional drawings (continued)

Process connection size and type	FCS600 sensor nominal size							
	DN 15		DN 25		DN 40		DN 65	
	L1 in mm (inch)	Weight in kg (lb)	L1 in mm (inch)	Weight in kg (lb)	L1 in mm (inch)	Weight in kg (lb)	L1 in mm (inch)	Weight in kg (lb)
ASME 3" class 300, raised face (RF)	n/a	n/a	n/a	n/a	620 (24.4)	34.6 (76)	1 000 (39.4)	63.4 (140)
ASME 3" class 600, raised face (RF)	n/a	n/a	n/a	n/a	640 (25.2)	38 (84)	1 000 (39.4)	65.8 (145)
ASME 3" class 600, ring joint (RJ)	n/a	n/a	n/a	n/a	640 (25.2)	38.6 (85)	1 000 (39.4)	65.8 (145)
ASME 4" class 150, raised face (RF)	n/a	n/a	n/a	n/a	n/a	n/a	1 000 (39.4)	64 (141)
ASME 4" class 300, raised face (RF)	n/a	n/a	n/a	n/a	n/a	n/a	1 000 (39.4)	71.4 (157)
ASME 4" class 600, raised face (RF)	n/a	n/a	n/a	n/a	n/a	n/a	1 030 (40.6)	82.6 (182)
ASME 4" class 600, ring joint (RJ)	n/a	n/a	n/a	n/a	n/a	n/a	1 030 (40.6)	82.8 (183)
ASME 5" class 150, raised face (RF)	n/a	n/a	n/a	n/a	n/a	n/a	1 000 (39.4)	66 (146)
ASME 5" class 300, raised face (RF)	n/a	n/a	n/a	n/a	n/a	n/a	1 000 (39.4)	78.4 (173)
ASME 5" class 600, raised face (RF)	n/a	n/a	n/a	n/a	n/a	n/a	1 030 (40.6)	102.8 (227)
ASME 5" class 600, ring joint (RJ)	n/a	n/a	n/a	n/a	n/a	n/a	1 030 (40.6)	103.6 (228)

L1 dimension and weight with process connections according to ASME B16.5, alloy 22 wetted parts

Process connection size and type	FCS600 sensor nominal size							
	DN 15		DN 25		DN 40			
	L1 in mm (inch)	Weight in kg (lb)	L1 in mm (inch)	Weight in kg (lb)	L1 in mm (inch)	Weight in kg (lb)	L1 in mm (inch)	Weight in kg (lb)
ASME 1" class 150, raised face (RF)	390 (15.4)	11.4 (25)	n/a	n/a	n/a	n/a	n/a	n/a
ASME 1" class 300, raised face (RF)	390 (15.4)	12.6 (28)	n/a	n/a	n/a	n/a	n/a	n/a
ASME 1" class 600, raised face (RF)	390 (15.4)	12.4 (27)	n/a	n/a	n/a	n/a	n/a	n/a
ASME 1½" class 150, raised face (RF)	390 (15.4)	12.6 (28)	520 (20.5)	16.5 (35)	n/a	n/a	n/a	n/a
ASME 1½" class 300, raised face (RF)	390 (15.4)	15.4 (34)	520 (20.5)	19.1 (42)	n/a	n/a	n/a	n/a
ASME 1½" class 600, raised face (RF)	400 (15.7)	15.6 (34)	530 (20.9)	19.6 (43)	n/a	n/a	n/a	n/a
ASME 2" class 150, raised face (RF)	390 (15.4)	14.8 (33)	520 (20.5)	18.5 (41)	620 (24.4)	27.3 (60)	620 (24.4)	29.1 (64)
ASME 2" class 300, raised face (RF)	390 (15.4)	16 (35)	520 (20.5)	20.5 (45)	620 (24.4)	29.1 (64)	620 (24.4)	29.1 (64)
ASME 2" class 600, raised face (RF)	410 (16.1)	17.6 (39)	540 (21.3)	21.6 (48)	630 (24.8)	29.7 (66)	630 (24.8)	29.7 (66)
ASME 2½" class 150, raised face (RF)	n/a	n/a	n/a	n/a	620 (24.4)	30.9 (68)	620 (24.4)	30.9 (68)
ASME 2½" class 300, raised face (RF)	n/a	n/a	n/a	n/a	620 (24.4)	32.5 (72)	620 (24.4)	32.5 (72)
ASME 2½" class 600, raised face (RF)	n/a	n/a	n/a	n/a	640 (25.2)	33.9 (75)	640 (25.2)	33.9 (75)
ASME 3" class 150, raised face (RF)	n/a	n/a	n/a	n/a	620 (24.4)	32.8 (72)	620 (24.4)	32.8 (72)
ASME 3" class 300, raised face (RF)	n/a	n/a	n/a	n/a	620 (24.4)	36.6 (81)	620 (24.4)	36.6 (81)
ASME 3" class 600, raised face (RF)	n/a	n/a	n/a	n/a	640 (25.2)	38.9 (86)	640 (25.2)	38.9 (86)

Flow Measurement

SITRANS FC (Coriolis)

Sensors / SITRANS FCS600

Dimensional drawings (continued)

L1 dimension and weight with process connections according to EN 1092-1, AISI 316L wetted parts

Process connection size and type	FCS600 sensor nominal size		DN 25		DN 40		DN 65	
	DN 15 L1 in mm (inch)	Weight in kg (lb)	L1 in mm (inch)	Weight in kg (lb)	L1 in mm (inch)	Weight in kg (lb)	L1 in mm (inch)	Weight in kg (lb)
EN DN 15 PN 40 type B1, raised face (RF)	370 (14.6)	10.6 (23)	n/a	n/a	n/a	n/a	n/a	n/a
EN DN 15 PN 40 type D, with groove	370 (14.6)	10.4 (23)	n/a	n/a	n/a	n/a	n/a	n/a
EN DN 15 PN 40 type E, with spigot	370 (14.6)	10.4 (23)	n/a	n/a	n/a	n/a	n/a	n/a
EN DN 15 PN 40 type F, with recess	370 (14.6)	10.4 (23)	n/a	n/a	n/a	n/a	n/a	n/a
EN DN 15 PN 100 type B1, raised face (RF)	380 (15)	11.4 (25)	n/a	n/a	n/a	n/a	n/a	n/a
EN DN 15 PN 100 type D, with groove	380 (15)	11.4 (25)	n/a	n/a	n/a	n/a	n/a	n/a
EN DN 15 PN 100 type E, with spigot	380 (15)	11.2 (25)	n/a	n/a	n/a	n/a	n/a	n/a
EN DN 15 PN 100 type F, with recess	380 (15)	11.4 (25)	n/a	n/a	n/a	n/a	n/a	n/a
EN DN 25 PN 40 type B1, raised face (RF)	370 (14.6)	11.6 (26)	500 (19.7)	15.6 (34)	n/a	n/a	n/a	n/a
EN DN 25 PN 40 type D, with groove	370 (14.6)	11.4 (25)	500 (19.7)	15.4 (34)	n/a	n/a	n/a	n/a
EN DN 25 PN 40 type E, with spigot	370 (14.6)	11.2 (25)	500 (19.7)	15.2 (34)	n/a	n/a	n/a	n/a
EN DN 25 PN 40 type F, with recess	370 (14.6)	11.4 (25)	500 (19.7)	15.4 (34)	n/a	n/a	n/a	n/a
EN DN 25 PN 100 type B1, raised face (RF)	390 (15.4)	14 (31)	520 (20.5)	18.2 (40)	n/a	n/a	n/a	n/a
EN DN 25 PN 100 type D, with groove	390 (15.4)	14 (31)	520 (20.5)	18 (40)	n/a	n/a	n/a	n/a
EN DN 25 PN 100 type E, with spigot	390 (15.4)	13.6 (30)	520 (20.5)	17.6 (39)	n/a	n/a	n/a	n/a
EN DN 25 PN 100 type F, with recess	390 (15.4)	14 (31)	520 (20.5)	18 (40)	n/a	n/a	n/a	n/a
EN DN 40 PN 40 type B1, raised face (RF)	370 (14.6)	13 (29)	500 (19.7)	17 (37)	600 (23.6)	26.2 (58)	n/a	n/a
EN DN 40 PN 40 type D, with groove	370 (14.6)	13 (29)	500 (19.7)	17 (37)	600 (23.6)	26 (57)	n/a	n/a
EN DN 40 PN 40 type E, with spigot	370 (14.6)	12.6 (28)	500 (19.7)	16.6 (37)	600 (23.6)	25.8 (57)	n/a	n/a
EN DN 40 PN 40 type F, with recess	370 (14.6)	12.8 (29)	500 (19.7)	16.8 (37)	600 (23.6)	26 (57)	n/a	n/a
EN DN 40 PN 100 type B1, raised face (RF)	450 (17.7)	17.6 (39)	560 (22)	21.2 (47)	620 (24.4)	29.8 (66)	n/a	n/a
EN DN 40 PN 100 type D, with groove	450 (17.7)	17.4 (38)	560 (22)	21.2 (47)	620 (24.4)	29.6 (65)	n/a	n/a
EN DN 40 PN 100 type E, with spigot	450 (17.7)	17 (37)	560 (22)	20.8 (46)	620 (24.4)	29.2 (64)	n/a	n/a
EN DN 40 PN 100 type F, with recess	450 (17.7)	17.4 (38)	560 (22)	21 (46)	620 (24.4)	29.6 (65)	n/a	n/a
EN DN 50 PN 40 type B1, raised face (RF)	n/a	n/a	500 (19.7)	18.4 (41)	600 (23.6)	27.4 (60)	n/a	n/a
EN DN 50 PN40 type D, with groove	n/a	n/a	500 (19.7)	18.2 (40)	600 (23.6)	27.4 (60)	n/a	n/a
EN DN 50 PN 40 type E, with spigot	n/a	n/a	500 (19.7)	18 (40)	600 (23.6)	27 (60)	n/a	n/a
EN DN 50 PN 40 type F, with recess	n/a	n/a	500 (19.7)	18.2 (40)	600 (23.6)	27.2 (60)	n/a	n/a
EN DN 50 PN 63 type B1, raised face (RF)	n/a	n/a	520 (20.5)	21.6 (48)	620 (24.4)	30.6 (67)	n/a	n/a
EN DN 50 PN 63 type D, with groove	n/a	n/a	520 (20.5)	21.4 (47)	620 (24.4)	30.4 (67)	n/a	n/a
EN DN 50 PN 63 type E, with spigot	n/a	n/a	520 (20.5)	21 (46)	620 (24.4)	30 (66)	n/a	n/a
EN DN 50 PN 63 type F, with recess	n/a	n/a	520 (20.5)	21.2 (47)	620 (24.4)	30.2 (67)	n/a	n/a
EN DN 50 PN 100 type B1, raised face (RF)	n/a	n/a	590 (23.2)	25.2 (56)	660 (26)	33.6 (74)	n/a	n/a

Dimensional drawings (continued)

Process connection size and type	FCS600 sensor nominal size							
	DN 15		DN 25		DN 40		DN 65	
	L1 in mm (inch)	Weight in kg (lb)	L1 in mm (inch)	Weight in kg (lb)	L1 in mm (inch)	Weight in kg (lb)	L1 in mm (inch)	Weight in kg (lb)
EN DN 50 PN 100 type D, with groove	n/a	n/a	590 (23.2)	25 (55)	660 (26)	33.4 (74)	n/a	n/a
EN DN 50 PN 100 type E, with spigot	n/a	n/a	590 (23.2)	24.4 (54)	660 (26)	33 (73)	n/a	n/a
EN DN 50 PN 100 type F, with recess	n/a	n/a	590 (23.2)	24.8 (56)	660 (26)	33.4 (74)	n/a	n/a
EN DN 80 PN 40 type B1, raised face (RF)	n/a	n/a	n/a	n/a	610 (24)	31 (68)	1 000 (39.4)	60.4 (133)
EN DN 80 PN 40 type D, with groove	n/a	n/a	n/a	n/a	610 (24)	30.8 (68)	1 000 (39.4)	60.2 (133)
EN DN 80 PN 40 type E, with spigot	n/a	n/a	n/a	n/a	610 (24)	30.4 (67)	1 000 (39.4)	59.8 (132)
EN DN 80 PN 40 type F, with recess	n/a	n/a	n/a	n/a	610 (24)	30.6 (67)	1 000 (39.4)	60 (132)
EN DN 80 PN 63 type B1, raised face (RF)	n/a	n/a	n/a	n/a	620 (24.4)	34.4 (76)	1 000 (39.4)	63.4 (140)
EN DN 80 PN 63 type D, with groove	n/a	n/a	n/a	n/a	620 (24.4)	34.2 (75)	1 000 (39.4)	63.2 (139)
EN DN 80 PN 63 type E, with spigot	n/a	n/a	n/a	n/a	620 (24.4)	33.6 (74)	1 000 (39.4)	62.8 (138)
EN DN 80 PN 63 type F, with recess	n/a	n/a	n/a	n/a	620 (24.4)	33.8 (75)	1 000 (39.4)	63 (139)
EN DN 80 PN 100 type B1, raised face (RF)	n/a	n/a	n/a	n/a	730 (28.7)	41.8 (92)	1 000 (39.4)	67.2 (148)
EN DN 80 PN 100 type D, with groove	n/a	n/a	n/a	n/a	730 (28.7)	41.6 (92)	1 000 (39.4)	67 (148)
EN DN 80 PN 100 type E, with spigot	n/a	n/a	n/a	n/a	730 (28.7)	41 (90)	1 000 (39.4)	66.4 (146)
EN DN 80 PN 100 type F, with recess	n/a	n/a	n/a	n/a	730 (28.7)	41.4 (91)	1 000 (39.4)	66.6 (147)
EN DN 100 PN 40 type B1, raised face (RF)	n/a	n/a	n/a	n/a	n/a	n/a	1 000 (39.4)	63.6 (140)
EN DN 100 PN 40 type D, with groove	n/a	n/a	n/a	n/a	n/a	n/a	1 000 (39.4)	63.2 (139)
EN DN 100 PN 40 type E, with spigot	n/a	n/a	n/a	n/a	n/a	n/a	1 000 (39.4)	62.4 (138)
EN DN 100 PN 40 type F, with recess	n/a	n/a	n/a	n/a	n/a	n/a	1 000 (39.4)	62.6 (138)
EN DN 100 PN 63 type B1, raised face (RF)	n/a	n/a	n/a	n/a	n/a	n/a	1 000 (39.4)	68 (150)
EN DN 100 PN 63 type D, with groove	n/a	n/a	n/a	n/a	n/a	n/a	1 000 (39.4)	67.8 (149)
EN DN 100 PN 63 type E, with spigot	n/a	n/a	n/a	n/a	n/a	n/a	1 000 (39.4)	67 (148)
EN DN 100 PN 63 type F, with recess	n/a	n/a	n/a	n/a	n/a	n/a	1 000 (39.4)	67.4 (149)
EN DN 100 PN 100 type B1, raised face (RF)	n/a	n/a	n/a	n/a	n/a	n/a	1 050 (41.3)	76.6 (169)
EN DN 100 PN 100 type D, with groove	n/a	n/a	n/a	n/a	n/a	n/a	1 050 (41.3)	76.2 (168)
EN DN 100 PN 100 type E, with spigot	n/a	n/a	n/a	n/a	n/a	n/a	1 050 (41.3)	75.4 (166)
EN DN 100 PN 100 type F, with recess	n/a	n/a	n/a	n/a	n/a	n/a	1 050 (41.3)	75.8 (167)
EN DN 125 PN 40 type B1, raised face (RF)	n/a	n/a	n/a	n/a	n/a	n/a	1 000 (39.4)	67.6 (149)
EN DN 125 PN 40 type D, with groove	n/a	n/a	n/a	n/a	n/a	n/a	1 000 (39.4)	67.2 (148)
EN DN 125 PN 40 type E, with spigot	n/a	n/a	n/a	n/a	n/a	n/a	1 000 (39.4)	66.4 (146)
EN DN 125 PN 40 type F, with recess	n/a	n/a	n/a	n/a	n/a	n/a	1 000 (39.4)	66.6 (147)
EN DN 125 PN 63 type B1, raised face (RF)	n/a	n/a	n/a	n/a	n/a	n/a	1 000 (39.4)	77.8 (172)
EN DN 125 PN 63 type D, with groove	n/a	n/a	n/a	n/a	n/a	n/a	1 000 (39.4)	77.4 (171)

Flow Measurement

SITRANS FC (Coriolis)

Sensors / SITRANS FCS600

Dimensional drawings (continued)

Process connection size and type	FCS600 sensor nominal size							
	DN 15		DN 25		DN 40		DN 65	
	L1 in mm (inch)	Weight in kg (lb)	L1 in mm (inch)	Weight in kg (lb)	L1 in mm (inch)	Weight in kg (lb)	L1 in mm (inch)	Weight in kg (lb)
EN DN 125 PN 63 type E, with spigot	n/a	n/a	n/a	n/a	n/a	n/a	1 000 (39.4)	76.4 (168)
EN DN 125 PN 63 type F, with recess	n/a	n/a	n/a	n/a	n/a	n/a	1 000 (39.4)	76.8 (169)
EN DN 125 PN 100 type B1, raised face (RF)	n/a	n/a	n/a	n/a	n/a	n/a	1 100 (43.3)	93.2 (205)
EN DN 125 PN 100 type D, with groove	n/a	n/a	n/a	n/a	n/a	n/a	1 100 (43.3)	92.8 (205)
EN DN 125 PN 100 type E, with spigot	n/a	n/a	n/a	n/a	n/a	n/a	1 100 (43.3)	91.4 (202)
EN DN 125 PN 100 type F, with recess	n/a	n/a	n/a	n/a	n/a	n/a	1 100 (43.3)	92.4 (204)

L1 dimension and weight with process connections according to EN 1092-1, alloy 22 wetted parts

Process connection size and type	FCS600 sensor nominal size							
	DN 15		DN 25		DN 40			
	L1 in mm (inch)	Weight in kg (lb)	L1 in mm (inch)	Weight in kg (lb)	L1 in mm (inch)	Weight in kg (lb)	L1 in mm (inch)	Weight in kg (lb)
EN DN 25 PN 40, type B1, raised face (RF)	390 (15.4)	11.7 (26)	520 (20.5)	15.7 (35)	n/a	n/a	n/a	n/a
EN DN 40 PN 40, type B1, raised face (RF)	390 (15.4)	13.7 (30)	520 (20.5)	17.5 (39)	n/a	n/a	n/a	n/a
EN DN 50 PN 40, type B1, raised face (RF)	n/a	n/a	520 (20.5)	19.3 (43)	620 (24.4)	28 (62)	n/a	n/a
EN DN 80 PN 40, type B1, raised face (RF)	n/a	n/a	n/a	n/a	620 (24.4)	32.6 (72)	n/a	n/a

L1 dimension and weight with process connections according to JIS B 2220, AISI 316L wetted parts

Process connection size and type	FCS600 sensor nominal size							
	DN 15		DN 25		DN 40		DN 65	
	L1 in mm (inch)	Weight in kg (lb)	L1 in mm (inch)	Weight in kg (lb)	L1 in mm (inch)	Weight in kg (lb)	L1 in mm (inch)	Weight in kg (lb)
JIS DN 15 10 K	370 (14.6)	10.4 (23)	n/a	n/a	n/a	n/a	n/a	n/a
JIS DN 15 20 K	370 (14.6)	10.4 (23)	n/a	n/a	n/a	n/a	n/a	n/a
JIS DN 25 10 K	370 (14.6)	11.4 (25)	500 (19.7)	15.6 (34)	n/a	n/a	n/a	n/a
JIS DN 25 20 K	370 (14.6)	11.8 (26)	500 (19.7)	15.8 (35)	n/a	n/a	n/a	n/a
JIS DN 40 10 K	370 (14.6)	12.2 (27)	500 (19.7)	16.2 (36)	600 (23.6)	25.4 (56)	n/a	n/a
JIS DN 40 20 K	370 (14.6)	12.6 (28)	500 (19.7)	16.6 (37)	600 (23.6)	25.8 (57)	n/a	n/a
JIS DN 50 10 K	n/a	n/a	500 (19.7)	17 (37)	600 (23.6)	26 (57)	n/a	n/a
JIS DN 50 20 K	n/a	n/a	500 (19.7)	17.2 (38)	600 (23.6)	26.2 (58)	n/a	n/a
JIS DN 80 10 K	n/a	n/a	n/a	n/a	600 (23.6)	27.8 (61)	1 000 (40.2)	57.8 (127)
JIS DN 80 20 K	n/a	n/a	n/a	n/a	610 (24)	30.4 (67)	1 000 (40.2)	60 (132)
JIS DN 100 10 K	n/a	n/a	n/a	n/a	n/a	n/a	1 000 (40.2)	59 (130)
JIS DN 100 20 K	n/a	n/a	n/a	n/a	n/a	n/a	1 000 (40.2)	63 (139)
JIS DN 125 10 K	n/a	n/a	n/a	n/a	n/a	n/a	1 000 (40.2)	62.8 (138)
JIS DN 125 20 K	n/a	n/a	n/a	n/a	n/a	n/a	1 000 (40.2)	69 (152)

Dimensional drawings (continued)

L1 dimension and weight with process connections according to JIS B 2220, alloy 22 wetted parts

Process connection size and type	FCS600 sensor nominal size					
	DN 15		DN 25		DN 40	
	L1 in mm (inch)	Weight in kg (lb)	L1 in mm (inch)	Weight in kg (lb)	L1 in mm (inch)	Weight in kg (lb)
JIS DN 25 10 K	390 (15.4)	12.1 (27)	n/a	n/a	n/a	n/a
JIS DN 25 20 K	390 (15.4)	12.5 (28)	n/a	n/a	n/a	n/a
JIS DN 40 10 K	390 (15.4)	13.6 (30)	520 (20.5)	17.4 (38)	n/a	n/a
JIS DN 40 20 K	390 (15.4)	14 (31)	520 (20.5)	17.6 (39)	n/a	n/a
JIS DN 50 10 K	n/a	n/a	520 (20.5)	18.6 (41)	620 (24.4)	27.3 (60)
JIS DN 50 20 K	n/a	n/a	520 (20.5)	18.8 (41)	620 (24.4)	27.3 (60)
JIS DN 80 10 K	n/a	n/a	n/a	n/a	620 (24.4)	30.8 (68)
JIS DN 80 20 K	n/a	n/a	n/a	n/a	620 (24.4)	33.3 (73)

L1 dimension and weight with G threaded process connections, AISI 316L wetted parts

Process connection size and type	FCS600 sensor nominal size							
	DN 15		DN 25		DN 40		DN 65	
	L1 in mm (inch)	Weight in kg (lb)	L1 in mm (inch)	Weight in kg (lb)	L1 in mm (inch)	Weight in kg (lb)	L1 in mm (inch)	Weight in kg (lb)
G 3/8"	390 (15.4)	9.4 (21)	n/a	n/a	n/a	n/a	n/a	n/a
G 1/2"	390 (15.4)	9.4 (21)	n/a	n/a	n/a	n/a	n/a	n/a
G 3/4"	390 (15.4)	9.4 (21)	n/a	n/a	n/a	n/a	n/a	n/a

L1 dimension and weight with NPT threaded process connections, AISI 316L wetted parts

Process connection size and type	FCS600 sensor nominal size							
	DN 15		DN 25		DN 40		DN 65	
	L1 in mm (inch)	Weight in kg (lb)	L1 in mm (inch)	Weight in kg (lb)	L1 in mm (inch)	Weight in kg (lb)	L1 in mm (inch)	Weight in kg (lb)
3/8" NPT	390 (15.4)	9.4 (21)	n/a	n/a	n/a	n/a	n/a	n/a
1/2" NPT	390 (15.4)	9.4 (21)	n/a	n/a	n/a	n/a	n/a	n/a
3/4" NPT	390 (15.4)	9.4 (21)	n/a	n/a	n/a	n/a	n/a	n/a

L1 dimension and weight with hygienic clamp process connections to DIN 32676 Series A, AISI 316L wetted parts

Process connection size and type	FCS600 sensor nominal size							
	DN 15		DN 25		DN 40		DN 65	
	L1 in mm (inch)	Weight in kg (lb)	L1 in mm (inch)	Weight in kg (lb)	L1 in mm (inch)	Weight in kg (lb)	L1 in mm (inch)	Weight in kg (lb)
DIN 32676 series A, DN 25	370 (14.8)	9.2 (20)	n/a	n/a	n/a	n/a	n/a	n/a
DIN 32676 series A, DN 40	370 (14.8)	9.2 (20)	500 (19.7)	13.2 (29)	n/a	n/a	n/a	n/a
DIN 32676 series A, DN 50	n/a	n/a	500 (19.7)	13.2 (29)	600 (23.6)	22.4 (49)	n/a	n/a
DIN 32676 series A, DN 65	n/a	n/a	n/a	n/a	600 (23.6)	22.5 (50)	n/a	n/a
DIN 32676 series A, DN 100	n/a	n/a	n/a	n/a	n/a	n/a	1 000 (39.4)	52.1 (115)

L1 dimension and weight with hygienic clamp process connections to DIN 32676 Series C (Tri-clamp), AISI 316L wetted parts

Process connection size and type	FCS600 sensor nominal size							
	DN 15		DN 25		DN 40		DN 65	
	L1 in mm (inch)	Weight in kg (lb)	L1 in mm (inch)	Weight in kg (lb)	L1 in mm (inch)	Weight in kg (lb)	L1 in mm (inch)	Weight in kg (lb)
DIN 32676 series C, 1"	370 (14.8)	9.2 (20)	n/a	n/a	n/a	n/a	n/a	n/a
DIN 32676 series C, 1 1/2"	370 (14.8)	9.2 (20)	500 (19.7)	13.2 (29)	n/a	n/a	n/a	n/a
DIN 32676 series C, 2"	n/a	n/a	500 (19.7)	13.2 (29)	600 (23.6)	22.4 (49)	n/a	n/a
DIN 32676 series C, 3"	n/a	n/a	n/a	n/a	600 (23.6)	22.5 (50)	n/a	n/a
DIN 32676 series C, 4"	n/a	n/a	n/a	n/a	n/a	n/a	1 000 (39.4)	52.2 (115)

Flow Measurement

SITRANS FC (Coriolis)

Sensors / SITRANS FCS600

Dimensional drawings (continued)

L1 dimension and weight with hygienic clamp process connections to JIS/ISO 2852, AISI 316L wetted parts

Process connection size and type	FCS600 sensor nominal size DN 15		DN 25		DN 40		DN 65	
	L1 in mm (inch)	Weight in kg (lb)	L1 in mm (inch)	Weight in kg (lb)	L1 in mm (inch)	Weight in kg (lb)	L1 in mm (inch)	Weight in kg (lb)
JIS/ISO 2852, 1"	370 (14.8)	9.2 (20)	n/a	n/a	n/a	n/a	n/a	n/a
JIS/ISO 2852, 1½"	370 (14.8)	9.2 (20)	500 (19.7)	13.2 (29)	n/a	n/a	n/a	n/a
JIS/ISO 2852, 2"	n/a	n/a	500 (19.7)	13.3 (29)	600 (23.6)	22.4 (49)	n/a	n/a
JIS/ISO 2852, 3"	n/a	n/a	n/a	n/a	600 (23.6)	22.5 (50)	n/a	n/a

FCS600 dimensions and weight (high pressure versions)

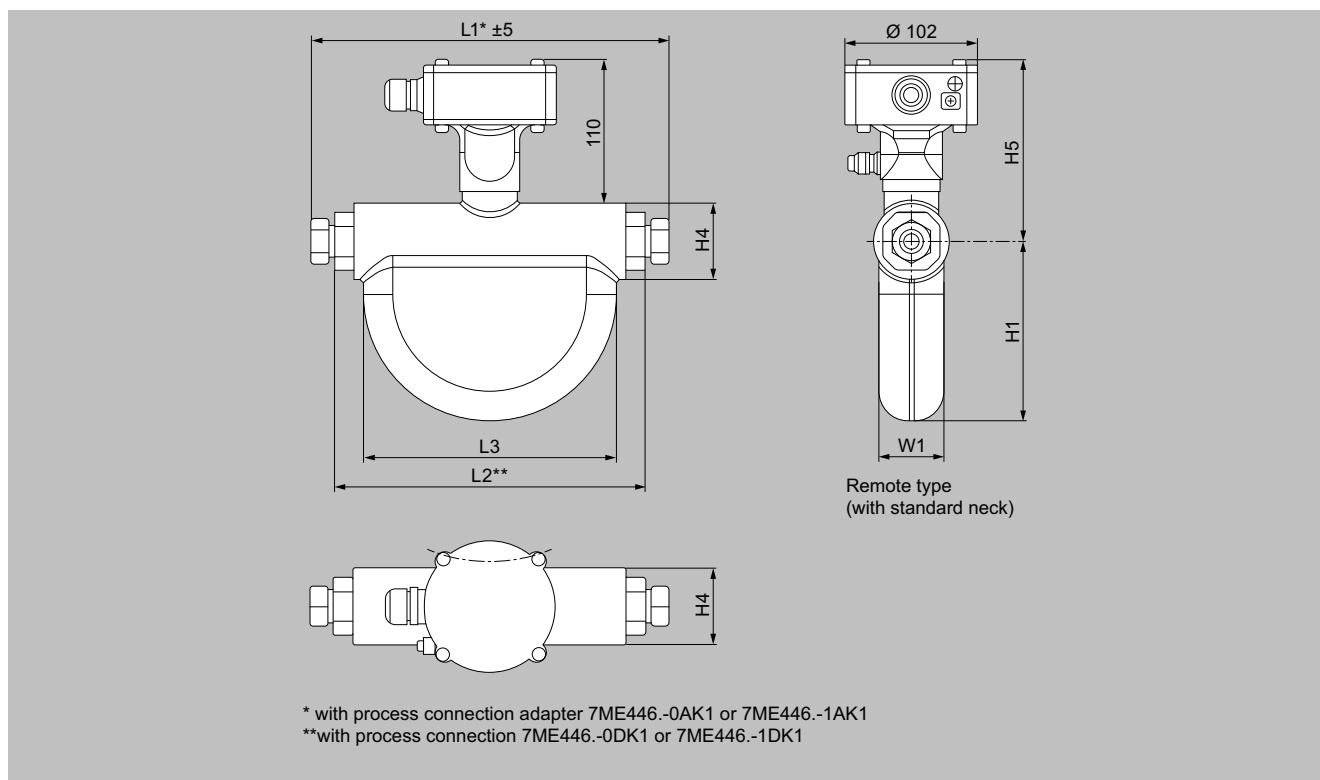

Dimensions in mm for sizes DN 2 and DN 4

Dimensional drawings (continued)

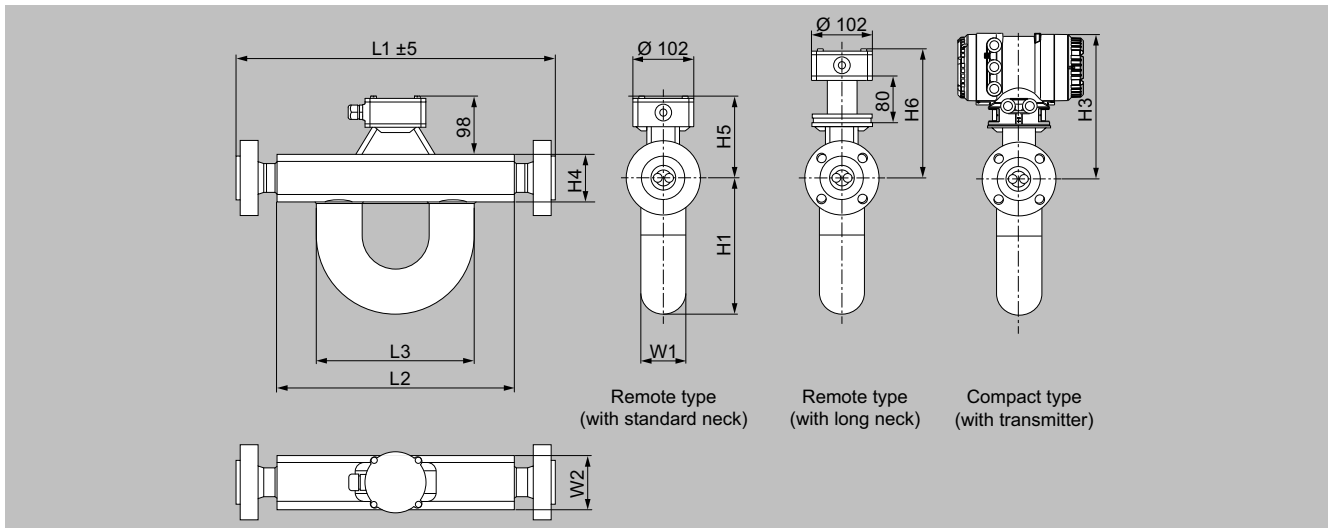

Dimensions in mm for sizes DN 15, DN 25 and DN 40

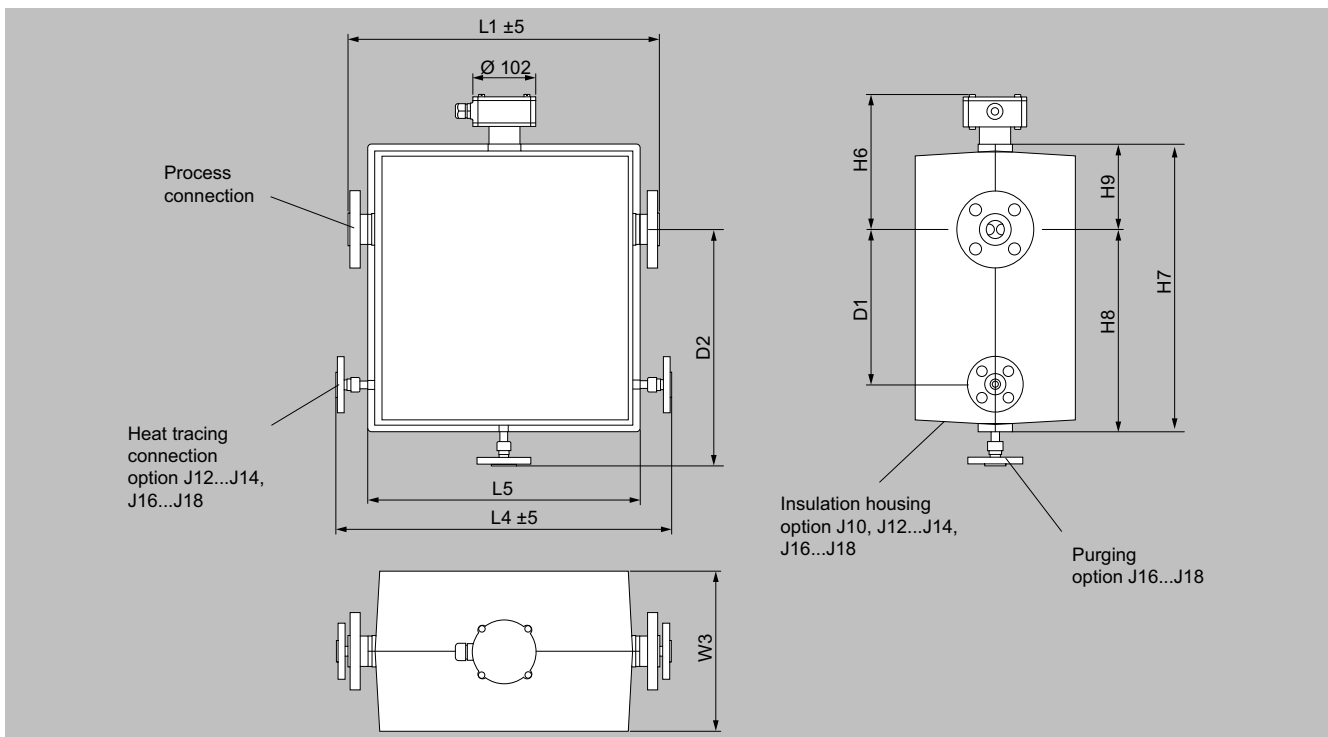

Dimensions in mm, version with insulation housing for sizes DN 15, DN 25 and DN 40 only

Dimensions without length L1

Nominal size	L2	L3	L4	L5	W1	W2	W3	D1	D2
Dimensions in mm (inch)									
DN 2	240 (9.5)	195 (7.7)			50 (2.0)				
DN 4	240 (9.5)	195 (7.7)			50 (2.0)				
DN 15	272 (10.7)	212 (8.3)	420 (16.5)	310 (12.2)	60 (2.4)	80 (3.1)	240 (9.4)	200 (7.9)	330 (13)
DN 25	400 (15.7)	266 (10.5)	540 (21.3)	439 (17.3)	76 (3)	90 (3.5)	260 (10.2)	250 (9.8)	380 (15)
DN 40	490 (19.3)	267 (10.5)	640 (25.2)	530 (20.9)	89 (3.5)	110 (4.3)	260 (10.2)	250 (9.8)	430 (16.9)

Flow Measurement

SITRANS FC (Coriolis)

Sensors / SITRANS FCS600

Dimensional drawings (continued)

Nominal size	H1	H3	H4	H5	H6	H7	H8	H9
Dimensions in mm (inch)								
DN 2	138 (5.4)		59 (2.3)	140 (5.5)				
DN 4	138 (5.4)		59 (2.3)	140 (5.5)				
DN 15	177 (7)	267 (10.5)	80 (3.1)	138 (5.4)	218 (8.6)	411 (16.2)	273 (10.7)	138 (5.4)
DN 25	230 (9.1)	267 (10.5)	80 (3.1)	138 (5.4)	218 (8.6)	464 (18.3)	326 (12.8)	138 (5.4)
DN 40	268 (10.6)	277 (10.9)	100 (3.9)	148 (5.8)	228 (9)	524 (20.6)	376 (14.8)	148 (5.8)

Overall length L1 and weight

The overall length of the sensor depends on the selected process connection (type and size). The following tables list the overall length and weight as functions of the individual process connection.

The weights in the tables are for the remote type. Additional weight for the compact type: up to 3.2 kg (7.1 lb).

L1 dimension and weight for medium pressure autoclave process connections

Wetted parts AISI 316L stainless steel and alloy 22

Process connection size and type	FCS600 sensor nominal size DN 2		DN 4	
	L1 in mm (inch)	Weight in kg (lb)	L1 in mm (inch)	Weight in kg (lb)
Autoclave 9/16" adapter	275 (10.8)	7 (15.4)	275 (10.8)	7 (15.4)
Autoclave 3/4"	240 (9.5)	7 (15.4)	240 (9.5)	7 (15.4)

L1 dimension and weight for process connections compatible to ASME B16.5, AISI 316L wetted parts

Process connection size and type	FCS600 sensor nominal size DN 15		DN 25		DN 40	
	L1 in mm (inch)	Weight in kg (lb)	L1 in mm (inch)	Weight in kg (lb)	L1 in mm (inch)	Weight in kg (lb)
ASME 1/2" class 900, raised face (RF)	400 (15.7)	12.6 (28)	n/a	n/a	n/a	n/a
ASME 1/2" class 900, ring joint (RJ)	400 (15.7)	13 (29)	n/a	n/a	n/a	n/a
ASME 1/2" class 1 500, raised face (RF)	400 (15.7)	12.6 (28)	n/a	n/a	n/a	n/a
ASME 1/2" class 1 500, ring joint (RJ)	400 (15.7)	13 (29)	n/a	n/a	n/a	n/a
ASME 1" class 900, raised face (RF)	450 (17.7)	16.4 (36)	540 (21.3)	20.6 (45)	n/a	n/a
ASME 1" class 900, ring joint (RJ)	450 (17.7)	16.6 (37)	540 (21.3)	20.4 (45)	n/a	n/a
ASME 1" class 1500, raised face (RF)	450 (17.7)	16.4 (36)	n/a	n/a	n/a	n/a
ASME 1" class 1500, ring joint (RJ)	450 (17.7)	16.6 (37)	n/a	n/a	n/a	n/a
ASME 2" class 900, raised face (RF)	n/a	n/a	660 (26)	35.2 (78)	720 (28.3)	43 (95)
ASME 2" class 900, ring joint (RJ)	n/a	n/a	660 (26)	35.6 (78)	720 (28.3)	43.4 (96)

Dimensional drawings (continued)

L1 dimension and weight for process connections compatible to ASME B16.5, alloy 22 wetted parts

Process connection size and type	FCS600 sensor nominal size		DN 25		DN 40	
	DN 15 L1 in mm (inch)	Weight in kg (lb)	L1 in mm (inch)	Weight in kg (lb)	L1 in mm (inch)	Weight in kg (lb)
ASME 1" class 900, raised face (RF)	400 (15.7)	16.4 (36)	n/a	n/a	n/a	n/a
ASME 1" class 900, ring joint (RJ)	n/a	n/a	580 (23)	21 (46)	n/a	n/a
ASME 1" class 1 500, raised face (RF)	400 (15.7)	16.4 (36)	n/a	n/a	n/a	n/a
ASME 1" class 1 500, ring joint (RJ)	n/a	n/a	580 (23)	21 (46)	n/a	n/a
ASME 2" class 900, raised face (RF)	n/a	n/a	580 (23)	34 (75)	710 (28)	44 (97)
ASME 2" class 900, ring joint (RJ)	n/a	n/a	580 (23)	36 (80)	710 (28)	44 (97)
ASME 2" class 1 500, ring joint (RJ)	n/a	n/a	580 (23)	36 (80)	710 (28)	44 (97)
ASME 3" class 900, raised face (RF)	n/a	n/a	n/a	n/a	710 (28)	50 (110)
ASME 3" class 900, ring joint (RJ)	n/a	n/a	n/a	n/a	710 (28)	52 (115)

L1 dimension and weight for process connections with internal thread G

Process connection size and type	FCS600 sensor nominal size		DN 25		DN 40	
	DN 15 L1 in mm (inch)	Weight in kg (lb)	L1 in mm (inch)	Weight in kg (lb)	L1 in mm (inch)	Weight in kg (lb)
G 3/8"	390 (15.4)	9.4 (21)	n/a	n/a	n/a	n/a
G 1/2"	390 (15.4)	9.4 (21)	n/a	n/a	n/a	n/a
G 3/4"	390 (15.4)	9.4 (21)	n/a	n/a	n/a	n/a

L1 dimension and weight for process connections with internal thread NPT

Process connection size and type	FCS600 sensor nominal size		DN 25		DN 40	
	DN 15 L1 in mm (inch)	Weight in kg (lb)	L1 in mm (inch)	Weight in kg (lb)	L1 in mm (inch)	Weight in kg (lb)
3/8" NPT	390 (15.4)	9.4 (21)	n/a	n/a	n/a	n/a
1/2" NPT	390 (15.4)	9.4 (21)	n/a	n/a	n/a	n/a
3/4" NPT	390 (15.4)	9.4 (21)	n/a	n/a	n/a	n/a