

**SIEMENS**

*Ingenuity for life*



## SIMATIC RF600:

The powerful UHF-RFID system for transparent processes in the Digital Enterprise

IF Design  
Award  
2016 + 2019



German  
Design  
Award  
Special 2017



[siemens.com/rf600](https://www.siemens.com/rf600)



# SIMATIC RF600

The high-performance system for global production and supply-chain solutions



A digital infrastructure for industry is the key variable for companies that want to fully exploit the opportunities of digitalization. Behind the scenes, it provides the necessary connections between all objects, systems, and applications, transforming a plant into a smart plant, things into the Industrial Internet of Things, and ideas into reality.

As an essential core element of the digital infrastructure, SIMATIC Ident offers an efficient and economical solution: a uniquely consistent, end-to-end, and scalable portfolio of RFID and optical identification systems for manufacturing and logistics. Along with locating systems, network solutions, industrial security, and future key technologies, you benefit from a powerful foundation for all present and future IoT applications.

### Identification with RFID

Would you like a contactless and highly reliable identification of your products? Then opt for solutions that cover a variety of demands in terms of performance, range, and frequency range: the SIMATIC RF RFID systems from Siemens, which have proven their worth even in harsh industrial environments.

### Transparency builds bridges

SIMATIC RF600, the high-performance UHF-RFID system, connects factory automation to the logistics environment, thereby creating seamless supply-chain solutions. The product range consists of a scalable portfolio of readers, antennas, and transponders for various areas of application in production and logistics.



## SIMATIC RF600 RFID system

<b>Read/write distance</b>	Up to 8 m
<b>Frequency</b>	865–868 MHz (ETSI for Europe) 902–928 MHz (FCC for USA) 920–925 MHz (CMIIT for China) 920–924 MHz (ARIB for Japan)
<b>Standards</b>	EPCglobal Class 1 Gen 2 ISO 18000-63 ISO 18000-62
<b>Communication protocols</b>	XML, PROFINET, OPC UA, and EtherNet/IP integrated via Industrial Ethernet PROFIBUS via ASM456

## Highlights

- Scalable portfolio of high-performance RFID readers – now includes compact versions
- Large selection of labels and tags for industrial applications
- Wide range of external antennas for all ambient conditions
- Transparency in production and logistics, thanks to simple cloud connection via OPC UA
- Reduced project expenditures, thanks to quick and easy access to proven configuration, commissioning, and diagnostic tools via a Web browser
- Proven “UHF for Industry” algorithms
- Reduced engineering costs due to easy integration into the SIMATIC automation environment: for example, into the TIA Portal

## Innovations



**SIMATIC RF610R**   **SIMATIC RF615R**

Highly compact readers with internal, circularly polarized antenna



**SIMATIC RF615A**

Highly compact antenna with linear antenna polarization

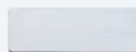

**SIMATIC RF642L**

Smart label for direct mounting on metal



**SIMATIC RF645T**

Tag for direct mounting on metal



**SIMATIC RF682T**

Tag for high-temperature applications



# Diverse applications with SIMATIC RF600

Quality and efficiency across  
the value chain

Experience the combined benefits of having all hardware and software in a single system: customized solutions for all applications, reliable tag reading, and easy commissioning, maintenance, and service.



## Sample application: Conveyor system

### Requirements

Transport similar types of objects (such as containers, workpiece carriers) via extensive, modular, and space-saving conveyor systems.

### Solution

- The SIMATIC RF615R compact reader is integrated into a conveyor system module and combined with the SIMATIC RF650A UHF antenna to form a small gate.
- The trigger for the read point and the separator setting element are connected to the reader's digital input or output.
- A SIMATIC RF610R compact reader on the conveyor system is connected directly to a PC as an island solution.

### Benefits

- Easy integration of compact readers for limited space.
- Local response to trigger signals and read events, thanks to digital I/Os integrated into the reader.
- Cost-effective gate configuration, thanks to integrated antenna and external antenna connection.

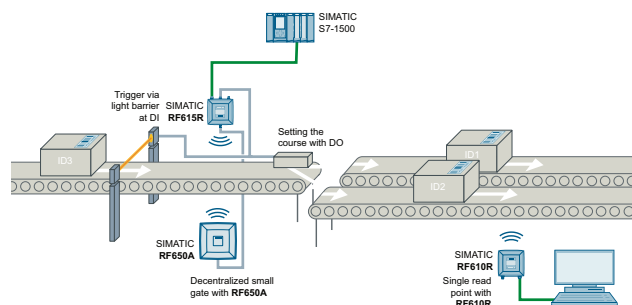

## Sample application: Assembly line production

### Requirements

Equip each workstation with one read point to track objects on the line.

### Solution

- The SIMATIC RF680R and R685R readers are mounted along the line and can be networked with each other via two integrated PROFINET connections each.

### Benefits

- The linear structure of the PROFINET network prevents a star structure, which would be unfavorable in this case, and reduces the number of Industrial Ethernet switches that would otherwise be necessary.
- Enables easy implementation: for example, of production control, quality assurance, and individualized production according to customer specifications.

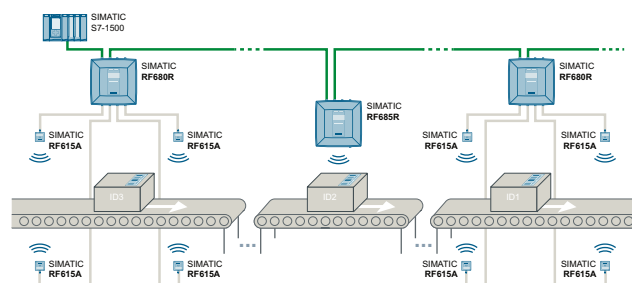

## Sample application: Supply-chain management

### Requirements

Monitor incoming and outgoing goods, distribution of goods.

### Solution

- A SIMATIC RF680R reader with four antennas monitors the incoming goods gate.
- The incoming data from the RFID tag that is attached to each pallet is sent wirelessly to the reader and then passed onto the higher-level systems.
- The individual packages are removed from the newly delivered pallets, order-picked per customer orders, and furnished with new tags where the package data is stored.
- After the packages are checked and depending on the read results, the outgoing gate for outgoing goods opens or an alarm is issued.

### Benefits

- A high level of automation saves time, prevents errors, and thereby increases throughput.
- The OPC UA interface integrated into the reader permits standardized communication with higher-level systems – with low integration effort.

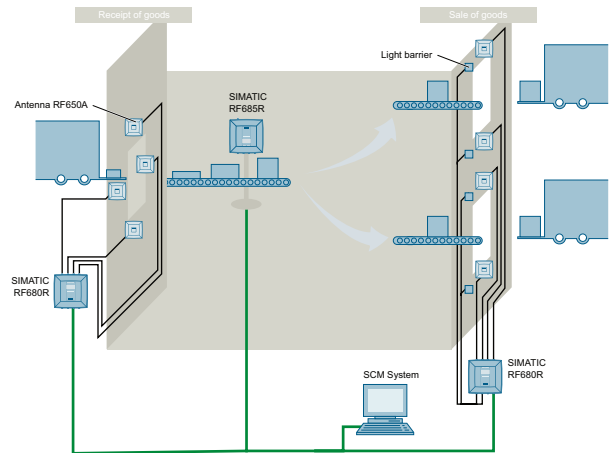

## Sample application: Track and trace

### Requirements

Automatic, cross-location tracking and tracing of goods.

### Solution

- A SIMATIC RF650R reader with up to four antennas, sensors, and traffic light permanently mounted on a gate.
- The process of reading the tags mounted on the goods is initiated, and if appropriate, ended by the sensors.
- A traffic light is set to red for "error" or green for "passage and loading permitted."
- The data automatically acquired is forwarded to a cloud platform via an Industrial IoT gateway.

### Benefits

- Transparency of material flow, error prevention, and a high level of automation.
- Worldwide availability of data that is always up to date – including across company boundaries.

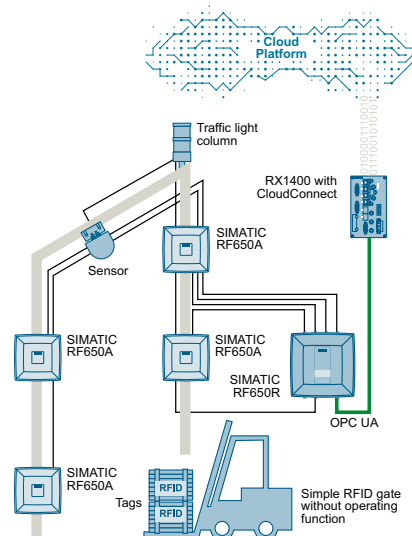



## Sample application: Production control

### Requirements

Consistent, end-to-end identification of car bodies, from shell construction to final assembly.

### Solution

- A heat-resistant SIMATIC RF680L SmartLabel is attached to the automobile body and contains custom product data such as automobile paint color, wheel options, stereo options, and other customization options.
- The SIMATIC RF685R reader can be connected directly by PROFINET or by ASM456 via PROFIBUS.
- An additional SIMATIC RF680A adaptive antenna ensures reliable read results even in a complex, metallic environment.

### Benefits

- Cost reduction, thanks to a uniform identification system mounted directly on the car body.
- Increased quality/productivity, thanks to continuous identification at every workstation.

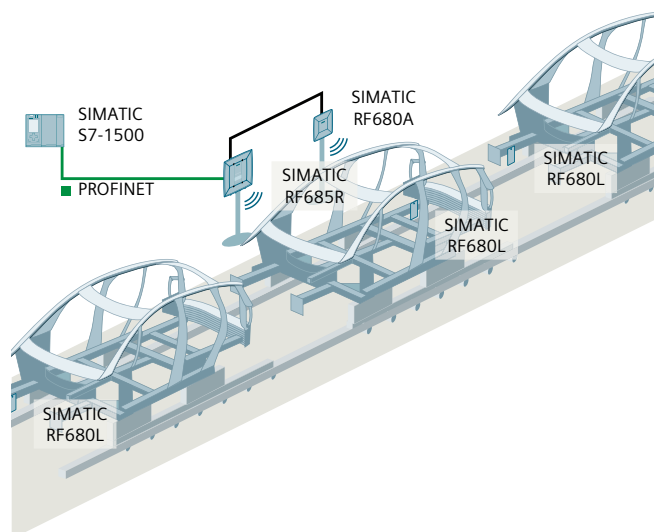

## Sample application: Asset/container management

### Requirements

Up-to-date information at all times on location, status, contents, and degree of utilization of assets like containers.

### Solution

- RFID gates and read points at the individual production process stations supply information on the location or area where the assets are situated.
- This generates comprehensive documentation for each process step.
- Information on asset status and contents is written to the tags.

### Benefits

- Transparency of inventory and degree of utilization.
- Comprehensive documentation on product quality and legal requirements.

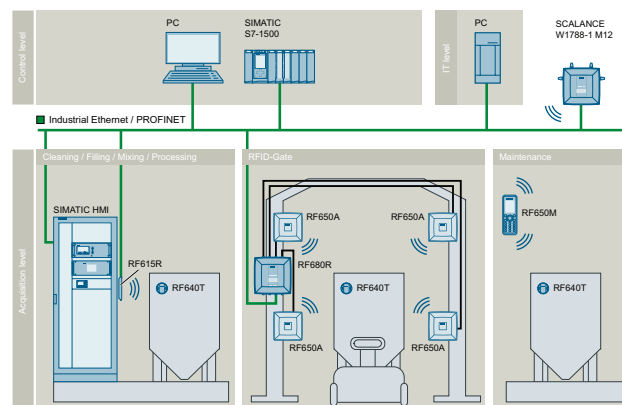

# The future is digital:

## SIMATIC RF600 incorporates with and supplies data to the cloud

Digitalization is changing everything: Billions of smart devices and machines throughout the Internet of Things (IoT) are generating staggering volumes of data that flow together in the virtual cloud. The analysis and utilization of this data is unleashing unimagined potential. Siemens has developed MindSphere, a cloud-based open IoT operating system that allows this potential to be fully exploited. MindSphere supports the digital transformation of enterprises of any size and in any sector – in the shortest possible time.

### Greater efficiency through data analysis

Our SIMATIC RF600 UHF-RFID system supports OPC UA as an IoT interface, thereby enabling manufacturer-independent, secure communication in automation and a standardized connection to cloud applications via an Industrial IoT gateway like RUGGEDCOM RX1400 with CloudConnect.

Another path to the cloud is provided by the SIMATIC S7-1500 controller and CP 1545-1. Thanks to the simple connection of the SIMATIC RF600 RFID system to cloud applications, the data obtained from the RFID transponders can be reused. As a link between the physical and digital worlds, SIMATIC RF600 allows operating resources like containers, pallets, and products that could not previously be mapped to now be registered and tracked.

The analysis of the data provided to the cloud via SIMATIC RF600 allows for more transparency among KPIs such as plant availability, utilization of asset, and energy-saving potential. This will allow the targeted optimization of production processes and supply chains for the purpose of improving efficiency and quality in production, logistics, asset management, and other areas – in all industries.

## Highlights

- Simple, standardized and secure connection to cloud applications via:
  - An Industrial IoT gateway: for example, RUGGEDCOM RX1400 with CloudConnect
  - SIMATIC S7-1500 and CP1545-1
- Support for Siemens MindSphere, Amazon Web Services, Microsoft Azure, and IBM Cloud thanks to standardized MQTT transport protocol
- Worldwide availability of KPIs thanks to the Web-based concept
- Complete solution, from the sensor and connection to digital services and cloud-based applications

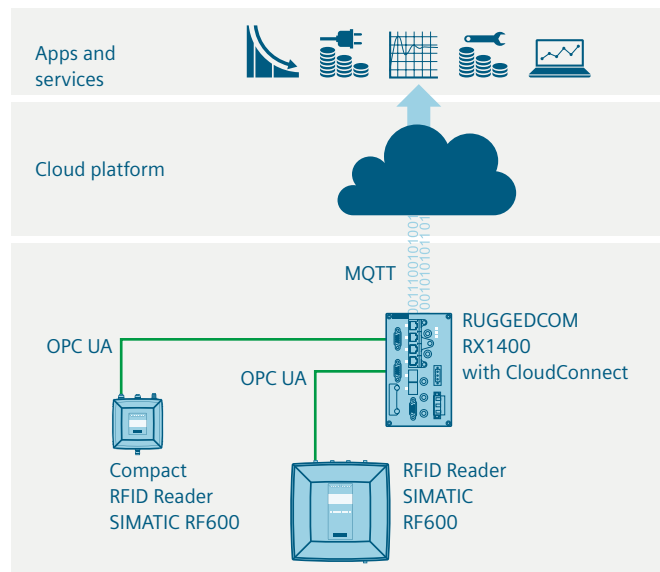

SIMATIC RF600 and a future-ready cloud infrastructure are essential components of a successful digitalization strategy and the foundation for enterprise-wide, data-based services for predictive maintenance and the management of energy data, assets, and supply chains.





# Components of the SIMATIC RF600 RFID system

Our portfolio of SIMATIC RF600 equipment provides you with a wide range of components for almost all identification tasks. Regardless of capacity, design, or degree of protection, you'll always find the right device to meet your requirements.

## Readers

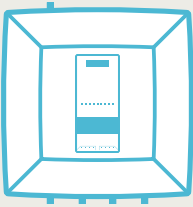

- A variety of rugged designs and capacities – now available in an extremely compact version
- Integrated and/or external antennas optional
- Mobile handheld terminal with integrated antenna
- Suitable for use in many countries

## Tags



- Available in various designs, including with large storage capacities
- For harsh, industrial environments (versions also available for metallic environments or high-temperature applications)
- ATEX approval available
- Maintenance-free and passive
- Globally usable

## External antennas

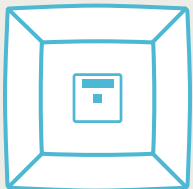

- Powerful antennas in various designs down to the smallest version suitable for industry
- From linear and circular versions to a version that can be changed
- Globally usable

## Communications modules



- Communications modules supplement the interfaces already integrated into the reader: for example, PROFIBUS

## Labels



- Available in various designs, including with large storage capacities
- For harsh, industrial environments (versions also available for metallic environments and high-temperature applications)
- Cost-effective, maintenance-free, and passive
- Globally usable

## Maximum efficiency in integration

- Direct integration of RF680R/RF685R in PROFINET networks, in PROFIBUS infrastructure with ASM456
- Device selection in hardware catalog in the TIA Portal
- Programming via standard function block (Ident profile)
- Direct access to Web-based management from the TIA Portal when connected via PROFINET

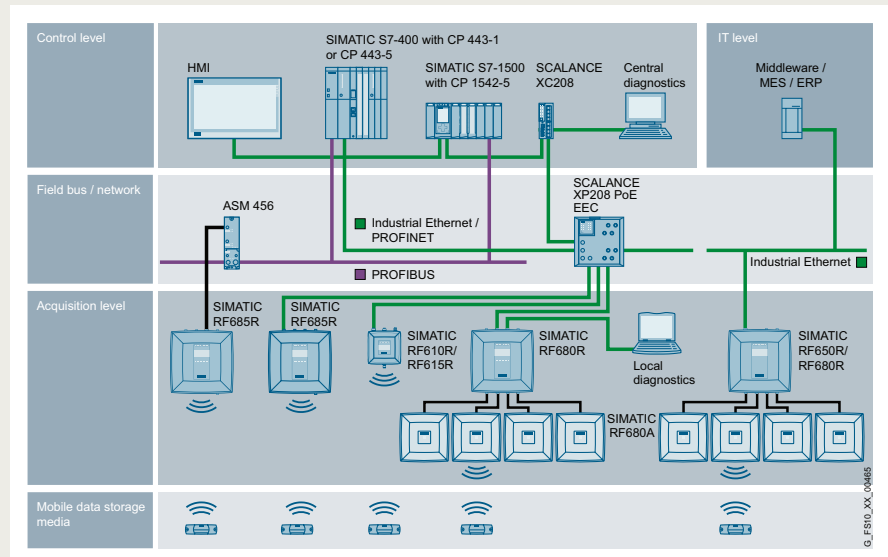

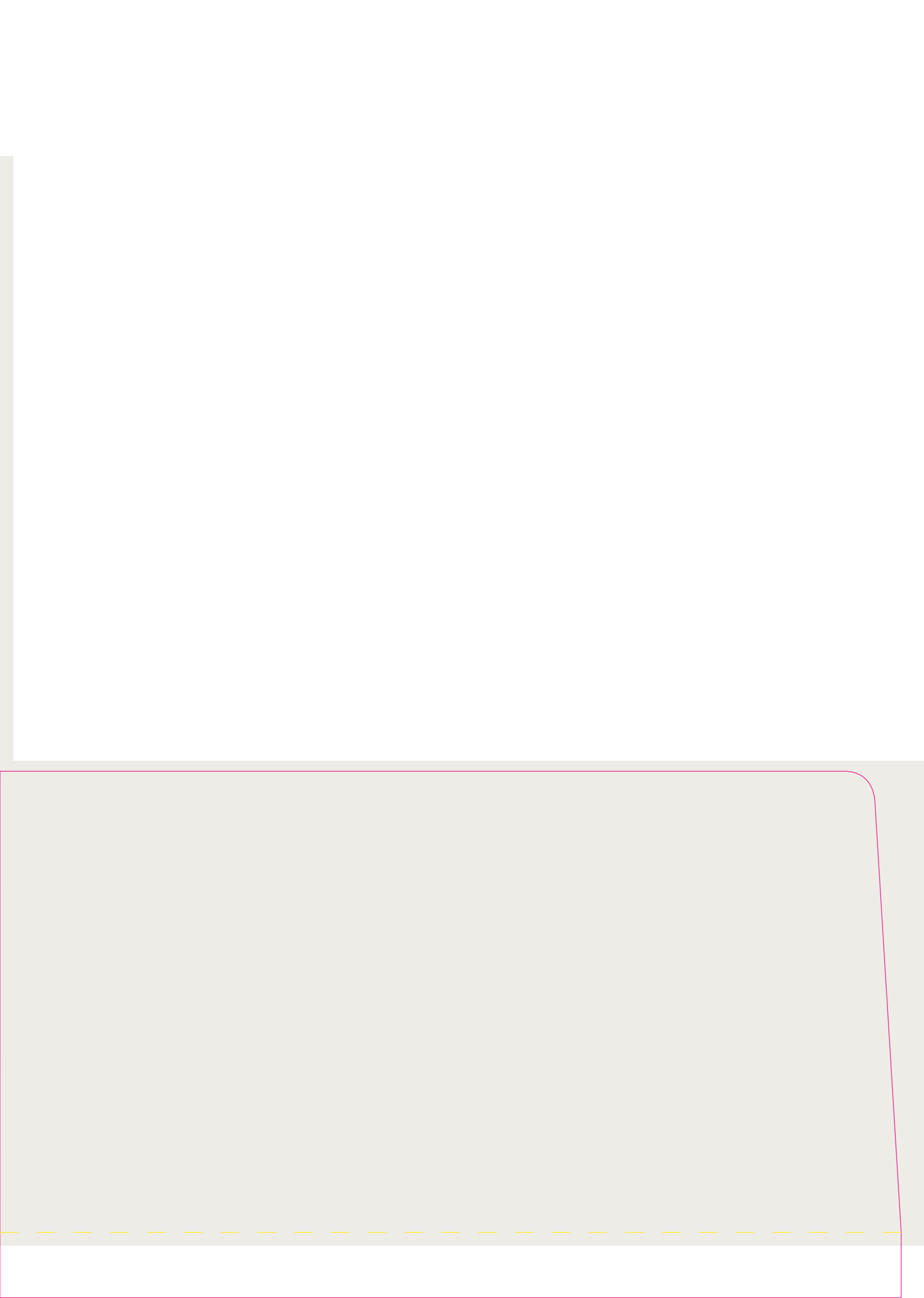

See the ordering overview "RFID Systems for the HF range" for precise type descriptions and technical data.

**Published by  
Siemens AG**

Digital Industries  
Process Automation  
Östliche Rheinbrückenstr. 50  
76187 Karlsruhe, Germany

Article no. PDPA-B10480-00-7600  
Dispo 06353  
WS 03192.0  
Printed in Germany  
© Siemens 2019

Subject to changes and errors. The information provided in this brochure contains descriptions or performance characteristics which, in case of actual use, do not always apply as described or which may change as a result of further development of the products. The desired performance characteristics are only binding if expressly agreed in the contract. Availability and technical specifications are subject to change without notice.

All product designations may be trademarks or product names of Siemens AG or supplier companies, the use of which by third parties for their own purposes may violate the rights of the owners.

**Security information**

Siemens provides products and solutions with industrial security functions that support the secure operation of plants, systems, machines and networks.

In order to protect plants, systems, machines and networks against cyber threats, it is necessary to implement – and continuously maintain – a holistic, state-of-the-art industrial security concept. Siemens' products and solutions constitute one element of such a concept.

Customers are responsible for preventing unauthorized access to their plants, systems, machines and networks. Such systems, machines and components should only be connected to an enterprise network or the internet if and to the extent such a connection is necessary and only when appropriate security measures (e.g. firewalls and/or network segmentation) are in place.

For additional information on industrial security measures that may be implemented, please visit [siemens.com/industrialsecurity](https://www.siemens.com/industrialsecurity)

Siemens' products and solutions undergo continuous development to make them more secure. Siemens strongly recommends that product updates are applied as soon as they are available and that the latest product versions are used. Use of product versions that are no longer supported, and failure to apply the latest updates may increase customer's exposure to cyber threats.

To stay informed about product updates, subscribe to the Siemens Industrial Security RSS Feed under [siemens.com/industrialsecurity](https://www.siemens.com/industrialsecurity)

**Learn more:**

[siemens.com/rf600](https://www.siemens.com/rf600)

- › Industry Mall for electronic ordering:  
[siemens.com/industrymall](https://www.siemens.com/industrymall)
- › Contact:  
[siemens.de/automation/partner](https://www.siemens.de/automation/partner)

**Additional information**

- › Intelligent data management with industrial identification: SIMATIC Ident  
[siemens.de/ident](https://www.siemens.de/ident)
- › SIMATIC RTLS real-time locating system  
Seamless localization of all relevant objects anywhere on the company premises:  
[siemens.de/rtls](https://www.siemens.de/rtls)