

PXC Compact 16/24

Description

The PXC Compact Series communicates with other field panels or workstations on a peer-to-peer Automation Level Network (ALN). The following communication options are supported:

- Native BACnet/IP communications over 10/100 MB Ethernet networks
- Native BACnet MS/TP on RS-485
- Ethernet TCP/IP ALN
- RS-485 ALN or FLN

The PXC Compact is available in 16- or 24-point versions with optional support for FLN devices (requires additional license and PXC Compact model with both an Ethernet and an RS-485 port). Selected models also support ability to reside as a P1 FLN device.

NOTE: For information on the PXC Compact Series with an extended temperature range for use in rooftop and other uncontrolled spaces, see the *PXC Compact Series Extended Temperature Range Option Installation Instructions (553-170)*.

Product Numbers

PXC16.2-E.A	PXC Compact, 16 point, BACnet/IP ALN
PXC16.2-EF.A	PXC Compact, 16 point, BACnet/IP ALN, RS-485 FLN supported with additional license
PXC16.2-EF32.A	PXC Compact, 16 point, BACnet/IP ALN, RS-485 Enabled
PXC16.2-P.A	PXC Compact, 16 point, RS-485 ALN
PXC16.2-PE.A	PXC Compact, 16 point, Ethernet/IP ALN
PXC24.2-E.A	PXC Compact, 24 point, BACnet/IP ALN
PXC24.2-EF.A	PXC Compact, 24 point, BACnet/IP ALN, RS 485 FLN supported with additional license
PXC24.2-EF32.A	PXC Compact, 24 point, BACnet/IP ALN, RS-485 Enabled
PXC24.2-P.A	PXC Compact, 24 point, RS-485 ALN
PXC24.2-PE.A	PXC Compact, 24 point, Ethernet/IP ALN
PXC24.2-PEF.A	PXC Compact, 24 point, Ethernet/IP or RS-485 ALN, RS 485 FLN supported with additional license
PXC24.2-PEF32.A	PXC Compact, 24 point, P2 IP ALN, RS-485 Enabled

PXA-DIN16KIT

Accessory kit with four 16" (406 mm) DIN rails

Warning/Caution Notations

WARNING:  Personal injury or property damage may occur if you do not follow a procedure as specified.

CAUTION:  Equipment damage or loss of data may occur if you do not follow a procedure as specified.

Required Tools and Materials

- Wire stripper/side cutter
- Small flat-blade screwdriver
- Phillips screwdriver
- Electric drill and Phillips driver bit
- Level
- Tape measure
- Digital multimeter (DMM)
- Black marker
- Masonry drill bit (to mount on concrete or masonry)
- Four wall anchors (to mount on concrete or masonry)
- Optional DIN rail (1.38" W x 0.276" H x 0.04" D (35 mm W x 7 mm H x 1 mm D))

Included Materials

The following screws are included for mounting the PXC Compact without a DIN rail:

- Four No. 8-18 x 3/8" self-tapping Phillips screws
- Four No. 8-18 x 3/4" self-drilling Phillips screws
- Two No. 8-18 x 1-3/4" self-drilling Phillips screws

Expected Installation Time

20 minutes

Prerequisites



CAUTION:

No power wiring is connected to the PXC Compact at this time.

- If mounting in an enclosure:
 - Enclosure is installed.
 - The power source is installed, as applicable.
 - The power is OFF.
- All necessary wiring is pulled and terminated per the layout drawing.
- Power and communication wiring is terminated to the removable plugs supplied with the devices.

CE Compliance Requirements

Must be installed inside a metal enclosure rated at IP20 minimum.

Energy Management Applications

For energy management only (low voltage Class 2), the PXC Compact may be mounted on a flat surface.

Applications Requiring a Secure Enclosure

Mount the PXC Compact inside a listed enclosure along with a Service Box and Sidewall Kit, if needed.

Smoke Control Application Requirements



CAUTION:

The 115V or 230V PX Series Service Box is required for UL864 and NFPA92A compliant installations. For more information, see the *PX Series Service Box Assemblies Installation Instructions* (553-131).

For non-UL864 and non-NFPA92A applications, any 24 Vac UL Listed Class 2 transformer may be used.

NOTE: For smoke control applications over Ethernet or BACnet/IP, the PXC Compact must be connected to the Automation Level Network (ALN) through an Ethernet switch that is UL Listed for Fire Signaling. ALN and FLN circuits are supervised.

For smoke control applications, mount the PXC Compact inside a 19" or 34" PX Series enclosure (PXA-ENC19 or PXA-ENC34). For more information, see the *19" and 34" PX Series Enclosure Assemblies Installation Instructions* (553-130).

Service Modem Kit (538-915) is required for remote connection to the HMI of a PXC Compact running smoke control applications. The modem, serial cable, and surge suppressor must be installed inside the 19" or 34" PX Series Enclosure with a Service Box.

For Ethernet communications, the UL Listed surge protector (Ditek model DTK-MRJ45C5E) is required for Ethernet or BACnet/IP networks. The surge protector must be located in the same enclosure as the controller.

Installation Instructions



WARNING:

Turn OFF AC power at the circuit breaker panel.

CAUTION:



UL Listings require that NEC Class I and Class II wiring be kept separate from each other. Use separate conduit and cable tie bars to separate Class I DO wires from all other Class II wiring.

NOTE: Securely fasten the PXC Compact so that it does not come loose when point connectors are removed.

NOTE: If you need to reinsert one of the mounting tabs, see the *PXC Compact Series Owner's Manual* (553-104) for instructions.

The PXC Compact may be mounted either vertically (with 24 Vac and DOs on the right) or horizontally (with 24 Vac and DOs at the top).

Options for Mounting the PXC Compact

- Select one of the following options for installation:
 - Mount the controller on a DIN rail by using the four slide-out mounting tabs.
 - Fasten the controller to a surface or enclosure backplane with screws

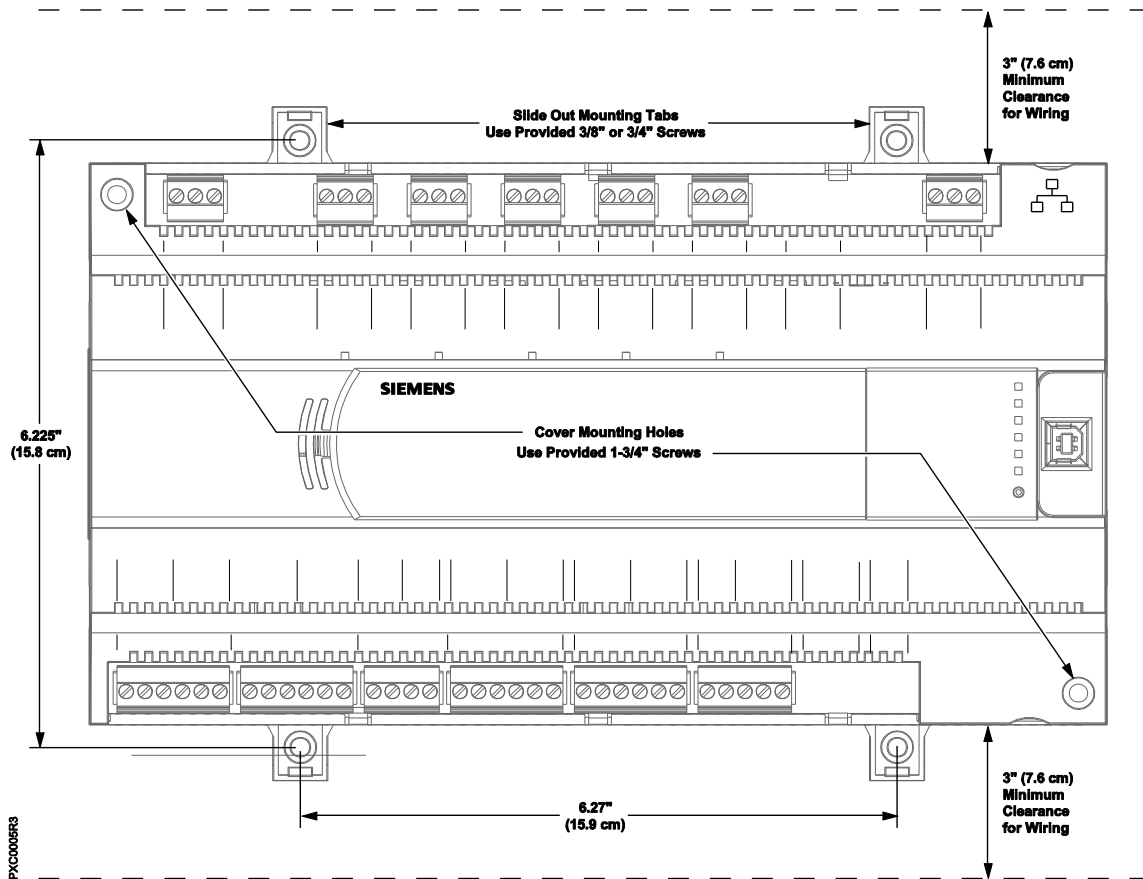

Figure 1. Front View of the PXC Compact Series (PXC-24 shown).

Option 1: Mounting the Controller on a DIN Rail

NOTE: To provide a minimum clearance for wiring, allow 6 inches (15 cm) from the center of the DIN rail to obstructions on either side.

Installing the DIN Rail

Do the following if the DIN rail is not already installed:

1. Align and level the DIN rail on the mounting surface or the backplane of the enclosure.
2. Mark the position of the mounting holes at either end of the DIN rail.
3. Using wall anchors, if necessary, attach the DIN rail to the surface or the backplane.

NOTE: For longer DIN rails, use one mounting screw per running foot of DIN rail.

Installing the PXC Compact

1. Slide out the mounting tabs.
2. Align the channel on the back of the device with the DIN rail.
3. Using a flat-blade screwdriver, push in each mounting tab until it clips onto the DIN rail.
4. Continue with *Completing the Installation*.

Option 2: Fastening the Controller with Screws

NOTE: Allow a minimum clearance of 3 inches (7.6 cm) around the controller ports and connectors for terminating wires.

1. Select one of the following options for fastening the controller:
 - Drive screws through the four slide-out mounting tabs.
 - Drive screws through the two mounting holes in the controller cover and through two mounting tabs at the opposite corners (see Figure 1).

NOTE: For installation in an enclosure backplane, use the 3/8" self-tapping screws and, if necessary, the 1-3/4" self-drilling screws.

NOTE: For mounting on a surface, use the 3/4" self-drilling screws and, if necessary, the 1-3/4" self-drilling screws.

2. Slide out the required mounting tabs.
3. Align the PXC Compact on the mounting surface and mark the position of the mounting holes.
4. For installation in an enclosure, align the mounting holes of the PXC Compact with holes in the perforated backplane.
5. Using wall anchors if necessary secure the controller using the provided screws.
6. Continue with *Completing the Installation*.

Completing the Installation



CAUTION:

For PXC Compacts with an RS-485 port do not connect the shield wire to the connector.

For installation as either an ALN device or FLN controller, terminate only one end of the shield wire on the enclosure earth ground.

For installation as an FLN device, connect the shields together and tape back



For a 3-wire system, ↓ terminal is connected to reference wire. Protective ground terminal may be connected to earth ground.

For a 2-wire system, ↓ terminal is not connected. Protective ground terminal must be connected to earth ground.

NOTE: Do not connect the power or network communication cable until instructed to do so during start-up.

1. Terminate power wiring to the 24 Vac removable plug.
2. If required, remove the RS-485 plug and terminate the communication wiring.
3. Terminate point wiring to the appropriate connectors (Figure 2).



CAUTION:

Adjacent point connections on the PXC Compact share a Common termination.

For specific wiring diagrams, see the *APOGEE Wiring Guidelines for Field Panels and Equipment Controllers* (125-3002).

The installation is now complete.

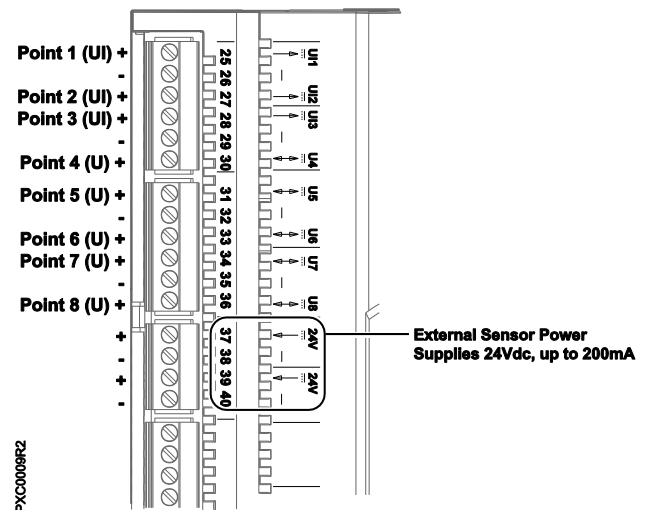

Figure 2. Polarity for Point Connections.

NOTE: The combined total of the external sensor power outputs cannot exceed 200 mA.

Information in this document is based on specifications believed correct at the time of publication. The right is reserved to make changes as design improvements are introduced. APOGEE and Insight are registered trademarks of Siemens Industry, Inc. Other product or company names mentioned herein may be the trademarks of their respective owners. © 2017 Siemens Industry, Inc.