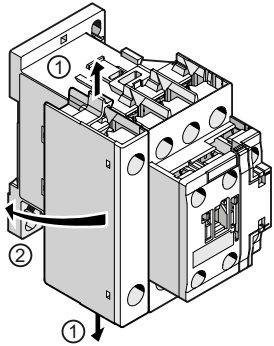
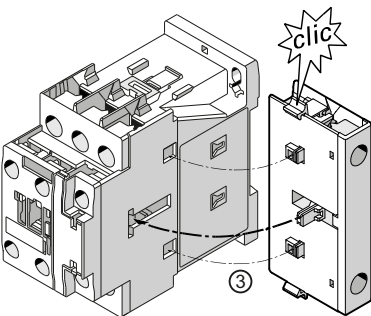
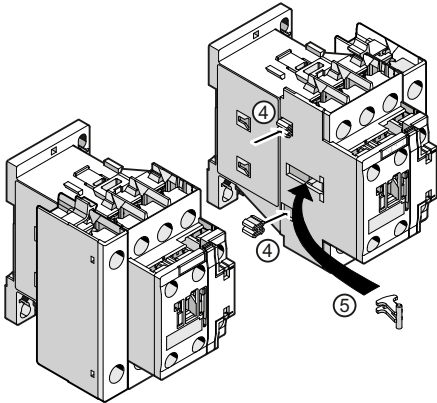
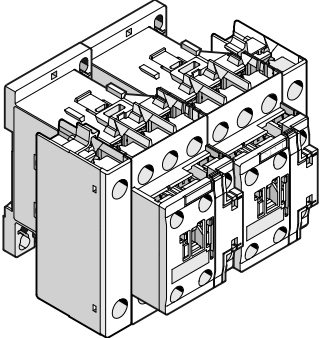

4-pole reversing contactor assembly

The illustrations below show how to mount the 4-pole reversing contactor assembly in size S0.

Table 2- 71 Mounting the 4-pole reversing contactor assembly with screw-type connection (size S0)

Step	Operating instruction	Figure
1 / 2	Remove the 4th pin from one of the two contacts by releasing the snap hooks.	
3	Attach the 4th pin to the other side of the same contactor by hooking it into the openings on the contactor and snapping the pin to the contactor.	
4	Insert the connecting clips into the openings on contactor Q12.	
5	Secure the mechanical interlock on the left-hand side of contactor Q12.	

Step	Operating instruction	Figure
6	Connect contactors Q11 and Q12 together.	

Note

As there are no wiring kits for 4-pole reversing contactor assemblies, the main and control circuits are wired using a cable.