

Extractive continuous process gas analytics

ULTRAMAT 23

Overview



The ULTRAMAT 23 is an innovative multi-component gas analyzer for measuring up to three infrared-sensitive gases using the NDIR principle. Use of a UV photometer enables you to measure even smaller concentrations of SO₂ and NO₂.

Measurement of oxygen (O₂) is also possible through the use of electrochemical oxygen sensors or measuring cells operating according to the paramagnetic measuring principle ("dumbbell"). The use of an additional electrochemical H₂S measuring cell permits use in biogas applications.

Up to four gas components can be measured continuously at the same time with the ULTRAMAT 23 gas analyzer. The device can be equipped with the following sensors:

- IR detector for IR-active gases
- UV photometer for UV-active gases
- H₂S sensor (electrochemical)
- O₂ sensor (electrochemical)
- O₂ sensor (paramagnetic)
- With the ULTRAMAT 23 gas analyzer for use in biogas plants, up to four gas components can be measured continuously: Two infrared-sensitive gases (CO₂ and CH₄), plus O₂ and H₂S with electrochemical measuring cells.
- Up to four gas components can be measured continuously using the ULTRAMAT 23 gas analyzer with paramagnetic oxygen cell: Three infrared-sensitive gases, plus O₂ ("dumbbell" measuring cell).
- With the ULTRAMAT 23 gas analyzer with UV photometer, one infrared-sensitive gas, UV-active gases (SO₂, NO₂) as well as O₂ can be measured with an electrochemical sensor.

Benefits

- AUTOCAL with ambient air (depending on the measured component)
 - Highly cost-effective as calibration gases are not required
- High selectivity thanks to multi-layer detectors, e.g. low cross-sensitivity to water vapor
- Analyzer cells can be cleaned on site as required
 - Cost savings due to reuse after contamination
- Menu-assisted operation in plain text
 - No manual required for operation, high level of operator safety
- Service information and logbook
 - Preventive maintenance; help for service and maintenance personnel; cost savings
- Coded input levels protect against unauthorized access
 - Increased safety
- Open interface architecture (RS 485, RS 232, PROFIBUS, SIPROM GA)
 - Simplified process integration; remote operation and control

Special benefits when used in biogas plants

- Continuous measurement of all four key components, including H₂S
- Long service life of the H₂S sensor even at increased concentrations; no diluting or backflushing necessary
- Introduction and measurement of flammable gases as occurring in biogas plants (e.g. 70% CH₄) is permissible (German Technical Inspectorate/TÜV certificate)

Application

- Optimization of small firing systems
- Monitoring of exhaust gas concentration from firing systems with all types of fuel (oil, gas and coal) as well as operational measurements with thermal incineration plants
- Room air monitoring
- Monitoring of air in fruit stores, greenhouses, fermenting cellars and warehouses
- Monitoring of process control functions
- Atmosphere monitoring during heat treatment of steel

Application areas in biogas plants

- Monitoring of fermenters for generating biogas (input and pure sides)
- Monitoring of gas-driven motors (power generation)
- Monitoring of feeding of biogas into the commercial gas network

Application area of paramagnetic oxygen sensor

- Flue gas analysis
- Inerting plants
- Room air monitoring
- Medical engineering

Further applications

- Environmental protection
- Chemical plants
- Cement industry

Special versions

Separate gas paths

The ULTRAMAT 23 with 2 IR components without pump is also available with two separate gas paths. This allows the measurement of two measuring points as used e.g. for the NO_x measurement before and after the NO_x converter.

The ULTRAMAT 23 gas analyzer can be used in emission measuring devices and for process and safety monitoring.

Versions conforming to EN 14181 and EN 15267

According to EN 14181, which is standardized in the EU and required in many European countries, a QAL1 qualification test, i.e. certification of the complete measuring device including gas paths and conditioning, is required for continuous emission monitoring systems (CEMS). In accordance with EN 15267, this must be performed by an independent accredited authority. In Germany, for example, the test is performed by the German Technical Inspectorate (TÜV) and the test report is submitted to the Federal/State Workgroup for Emission Control (Bund/Länder-Arbeitsgemeinschaft für Immissionsschutz - LAI) for examination/approval. Notification is then issued by the German Federal Environment Agency (Umweltbundesamt - UBA) in the Federal Gazette (Bundesanzeiger) as well as by the German Technical Inspectorate (TÜV) here:

<https://www.qal1.de/en>.

In the UK, the QAL1 test reports are prepared by Sira Environmental of the Environmental Agency in accordance with the MCERTS scheme and submitted for approval and publication on the SIRA Environmental websites. The other European countries rely either on the German or English certification scheme.

For use in EN 14181 applications, the devices with the article numbers 7MB235X in the Set CEM CERT (7MB1957) have undergone

Application (continued)

qualification testing according to German standards of EN 15267. These German Technical Inspectorate (TÜV) versions of ULTRAMAT are suitable for measurement of CO, NO, SO₂ and O₂ according to sections 13, 17 and 27 of the BImSchV (Federal Emission Law of Germany) and TA Luft. Smallest measuring range tested and approved by the German Technical Inspectorate:

1 and 2-component analyzer

- CO: 0 to 50 mg/m³
- NO: 0 to 50 mg/m³
- SO₂: 0 to 70 mg/m³

3-component analyzer

- CO: 0 to 250 mg/m³
- NO: 0 to 250 mg/m³
- SO₂: 0 to 70 mg/m³

Also tested as additional measuring ranges in accordance with EN 15267-3:

- CO: 0 to 1 250 mg/m³
- NO: 0 to 2 000 mg/m³
- SO₂: 0 to 7 000 mg/m³

Determination of the analyzer drift according to EN 14181 (QAL3) can be carried out manually or also with a PC using the SIPROM GA maintenance and servicing software. In addition, selected manufacturers of emission evaluation computers offer the possibility to read the drift data via the analyzer's serial interface and automatically record and process it in the evaluation computer. For devices in applications requiring a certified measuring range of less than 0 ... 100 mg/m³, compensation of the CO₂ cross-interference for CO and NO and of the O₂ cross-interference for NO is necessary.

Version with faster response time

The connection between the two condensation traps is equipped with a stopper to lead the complete flow through the measuring cell (otherwise only 1/3 of the flow), i.e. the response time is 2/3 faster. The functions of all other components remain unchanged.

Chopper purge

Consumption 100 ml/min (upstream pressure setting: approx. 3 000 hPa).

Extractive continuous process gas analytics

ULTRAMAT 23

Design

- 19" rack unit with 4 U for installation
 - In hinged frame
 - In cabinets
- Flow indicator for sample gas on front plate;
option: integrated sample gas pump (standard for bench-top version)
- Gas connections for sample gas inlet and outlet as well as zero gas; pipe diameter 6 mm or 1/4"
- Gas and electrical connections at the rear of the device (portable version: sample gas inlet at front)

Display and operator panel

- Operation based on NAMUR recommendation
- Simple, fast parameterization and commissioning of analyzer
- Large, backlit LCD for measured values
- Menu-driven operator functions for parameterization, test functions and calibration
- Washable membrane keyboard
- User help in plain text
- 6-language operating software

Inputs/outputs

- Three digital inputs for sample gas pump On/Off, triggering of AUTOCAL and synchronization of several devices
- Eight relay outputs can be freely configured for fault, maintenance demanded, maintenance switch, limits, measuring range identification and external solenoid valves
- Eight additional digital inputs and relay outputs as an option
- Electrically isolated analog outputs

Communication

RS 485 present in basic unit (connection from the rear).

Options

- RS 485/RS 232 converter
- RS 485/Ethernet converter
- RS 485/USB converter
- Incorporation in networks via PROFIBUS DP/PA interface
- SIPROM GA software as service and maintenance tool

Design (continued)

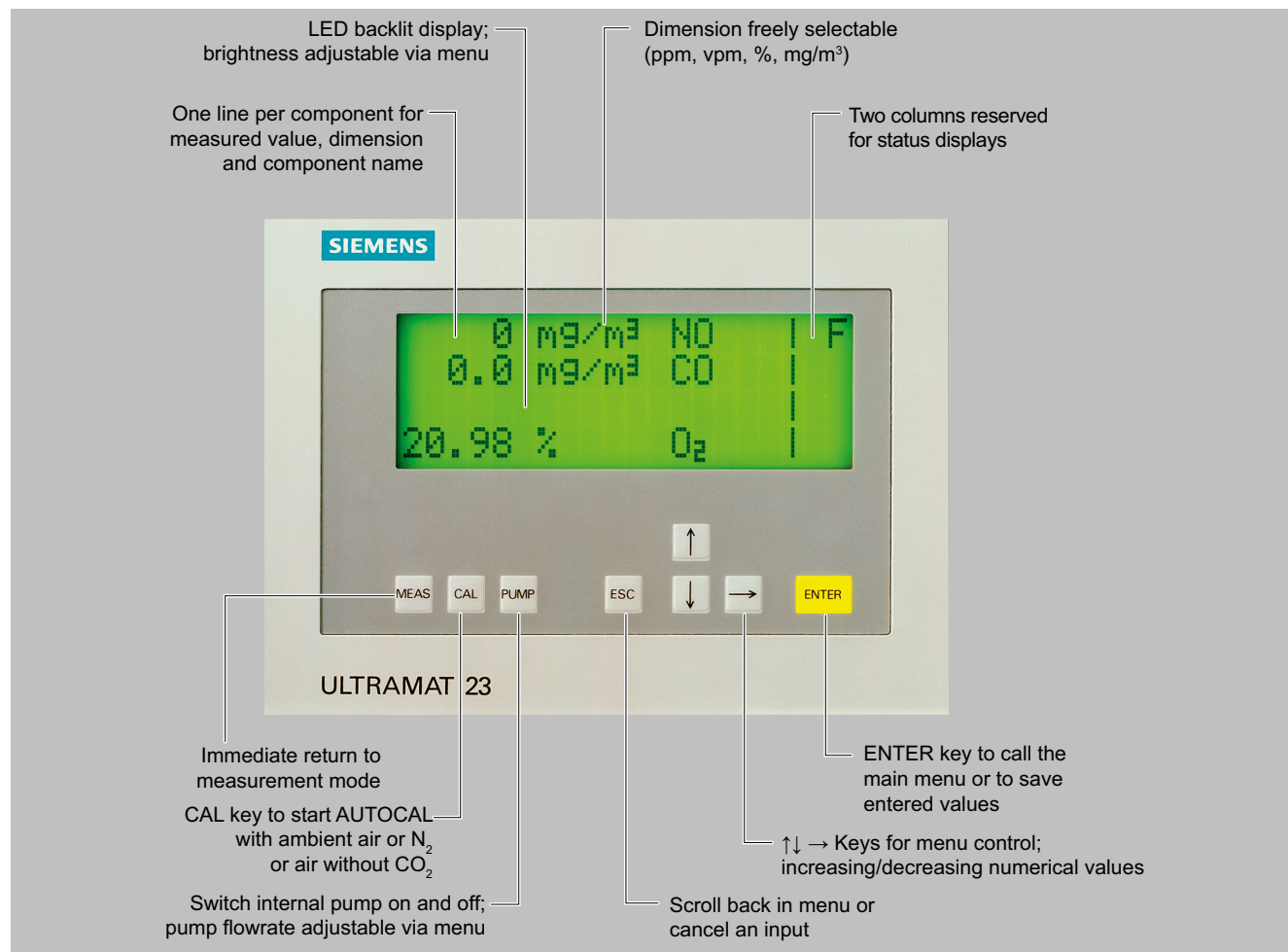

ULTRAMAT 23, membrane keyboard and graphic display

Extractive continuous process gas analytics

ULTRAMAT 23

Design (continued)

ULTRAMAT 23 also available as bench-top unit:

- 2 handles
- 4 rubber feet for setting up
- No mounting frame

80-digit display
(4 lines/20 characters)

Dust-tight and washable
membrane keypad

Flowmeter in conjunction with
pressure switch for monitoring
the sample gas flow

Gas and electrical
connections on rear
panel (portable version
simple gas at front)

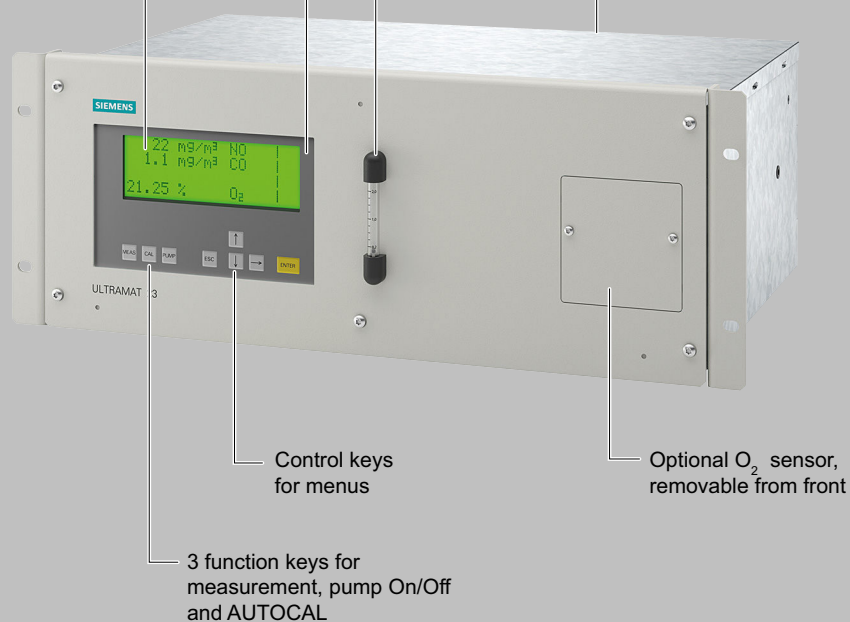

ULTRAMAT 23, design

Designs – parts wetted by sample gas

Gas path	19" rack unit	Desktop unit
With hoses		
Condensation trap/gas inlet	-	PA (polyamide)
Condensation trap	-	PE (polyethylene)
Gas connections 6 mm	PA (polyamide)	PA (polyamide)
Gas connections ¼"	Stainless steel, mat. no. 1.4571	Stainless steel, mat. no. 1.4571
Hose	FPM (Viton)	FPM (Viton)
Pressure switch	FPM (Viton) + PA6-3-T (Trogamide)	FPM (Viton) + PA6-3-T (Trogamide)
Flowmeter	PDM/Duran glass/X10CrNiTi1810	PDM/Duran glass/X10CrNiTi1810
Angle units/T-pieces	PA6	PA6
Internal pump, option	PVDF/PTFE/EPDM/FPM/Trolene/stainless steel, mat. no. 1.4571	PVDF/PTFE/EPDM/FPM/Trolene/stainless steel, mat. no. 1.4571

Design (continued)

Designs – parts wetted by sample gas			
Gas path		19" rack unit	Desktop unit
With hoses	Solenoid valve	FPM70/Ultramide/stainless steel, mat. no. 1.4310/1.4305	FPM70/Ultramide/stainless steel, mat. no. 1.4310/1.4305
	Safety condensation trap	PA66/NBR/PA6	PA66/NBR/PA6
	Analyzer chamber		
	• Body	Aluminum	Aluminum
	• Lining	Aluminum	Aluminum, black anodized
	• Fitting	Stainless steel, black anodized, mat. no. 1.4571	Stainless steel, mat. no. 1.4571
	• Window	CaF ₂ , quartz	CaF ₂
• Adhesive	E353	E353	
• O-ring	FPM (Viton)	FPM (Viton)	
With pipes, only available in version "without pump"	Gas connections 6 mm/¼"	Stainless steel, mat. no. 1.4571	-
	Pipes	Stainless steel, mat. no. 1.4571	-
	Analyzer chamber		
	• Body	Aluminum	-
	• Lining	Aluminum	-
	• Fitting	Stainless steel, mat. no. 1.4571	-
	• Window	CaF ₂	-
• Adhesive	E353	-	
• O-ring	FPM (Viton)	-	

Gas path

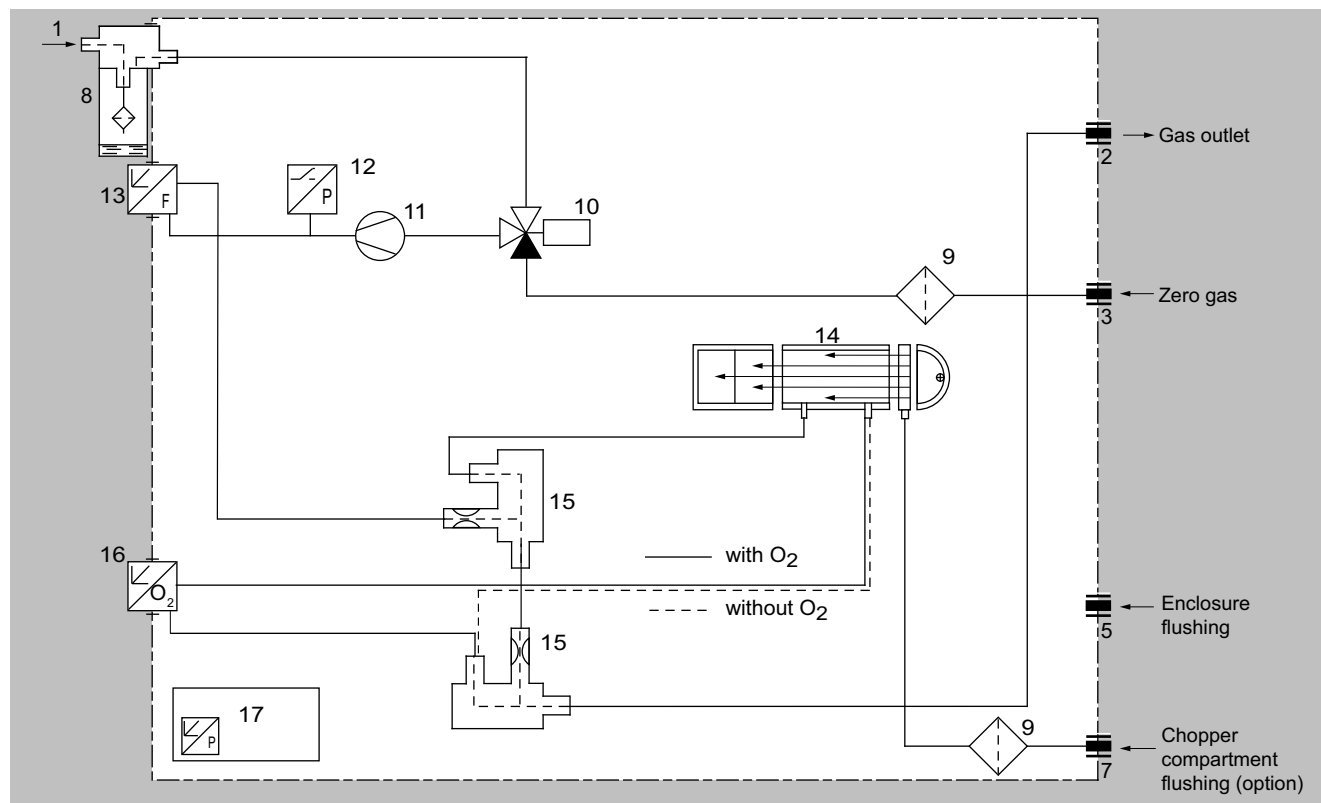

ULTRAMAT 23, portable, in sheet-steel housing with internal sample gas pump, condensation trap with safety filter on front plate, optional oxygen measurement

Extractive continuous process gas analytics

ULTRAMAT 23

Design (continued)

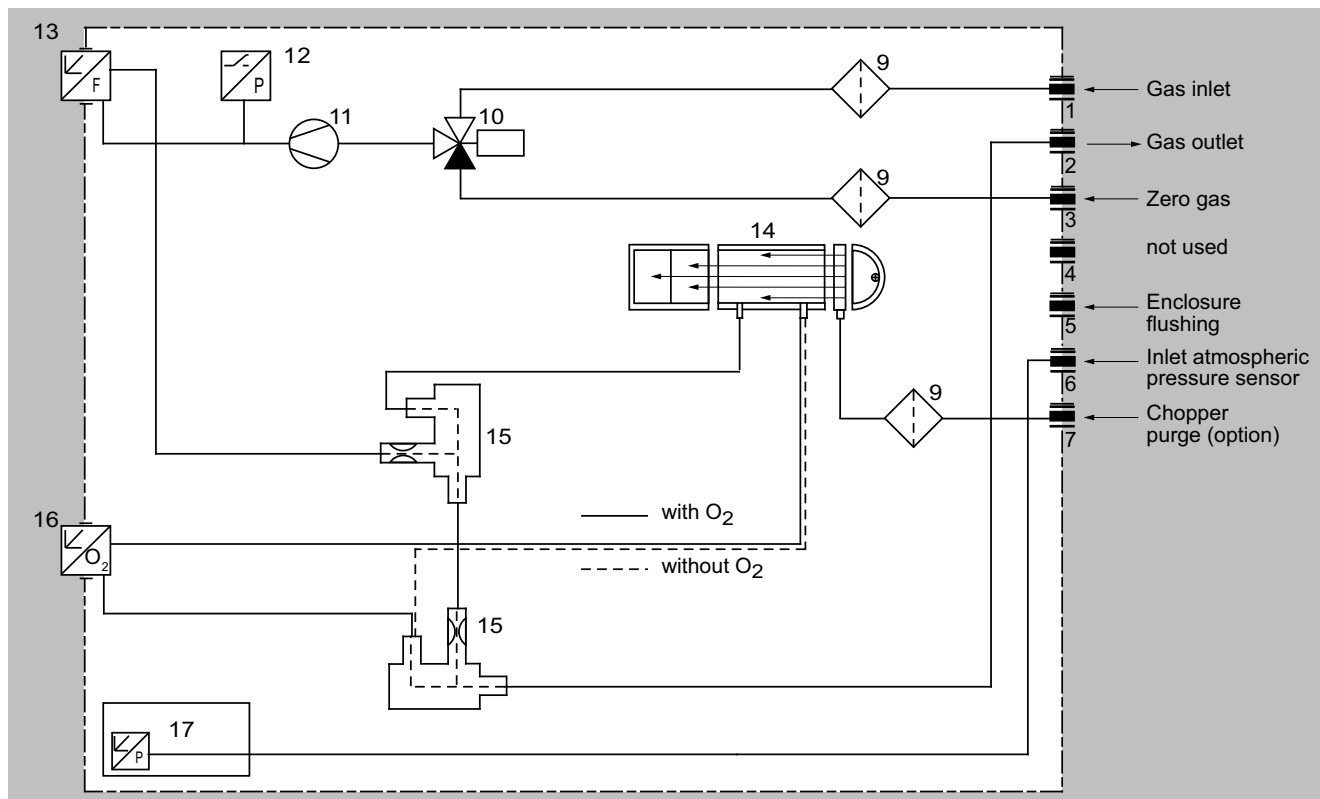

ULTRAMAT 23, 19" rack-mounted enclosure with internal sample gas pump; optional oxygen measurement

Design (continued)

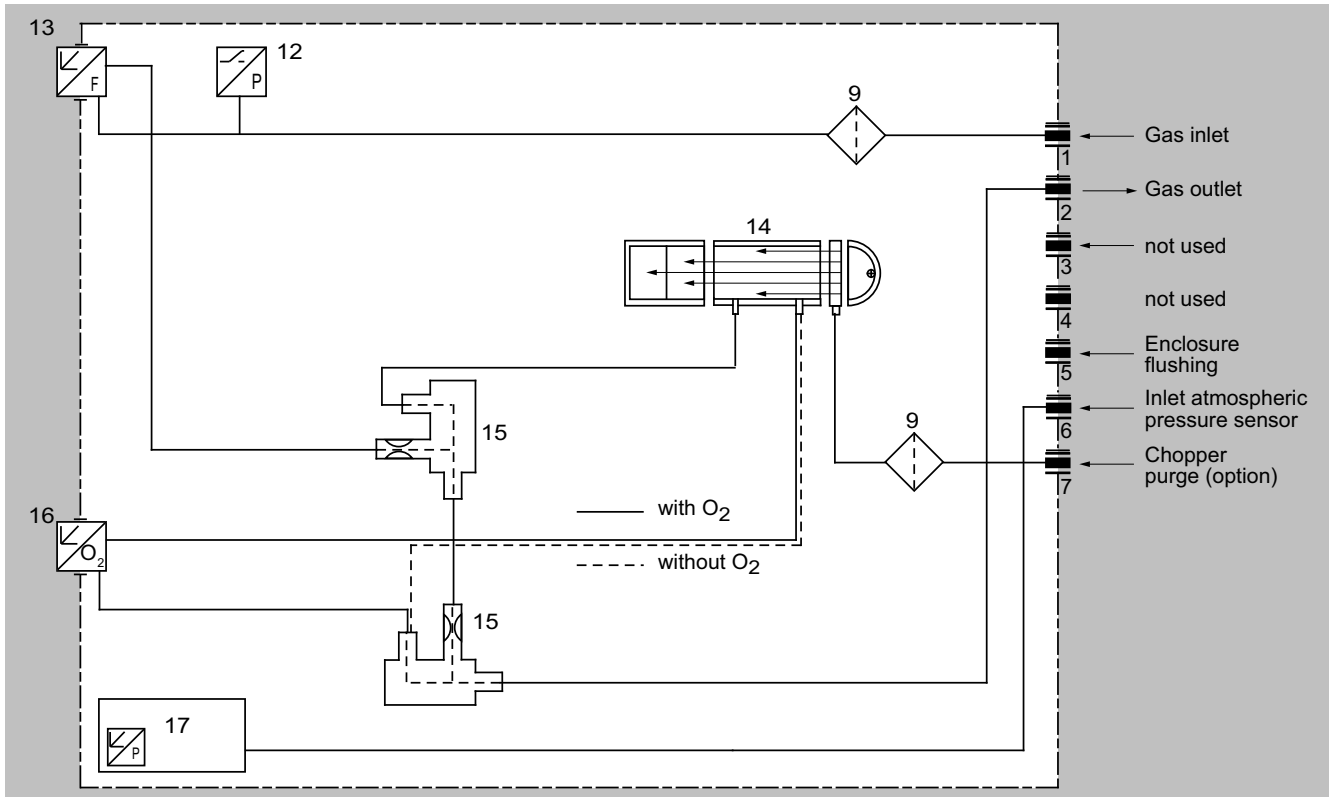

ULTRAMAT 23, 19" rack-mounted enclosure without internal sample gas pump; optional oxygen measurement

Extractive continuous process gas analytics

ULTRAMAT 23

Design (continued)

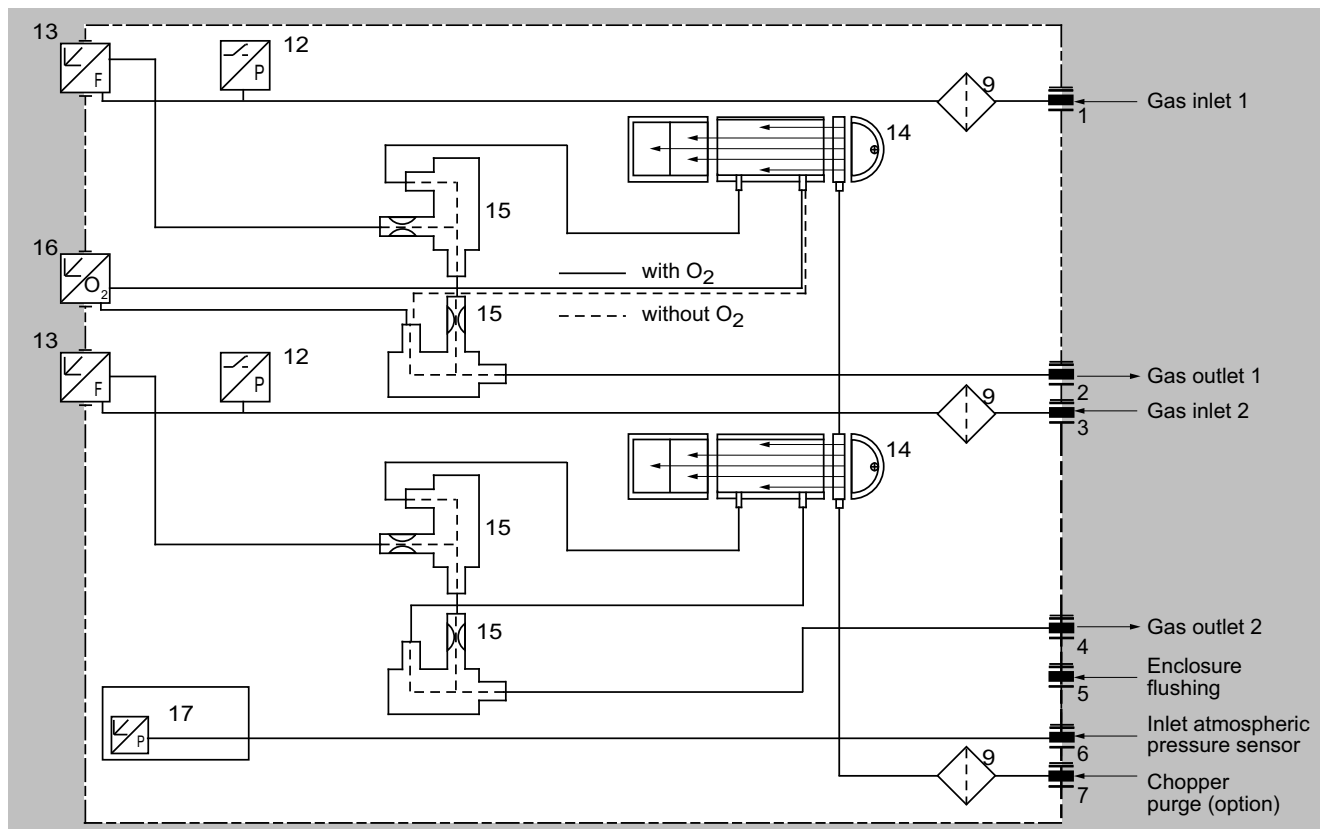

ULTRAMAT 23, 19" rack unit housing without internal sample gas pump, with separate gas path for the 2nd measured component or for the 2nd and 3rd measured component, optional oxygen measurement

Design (continued)

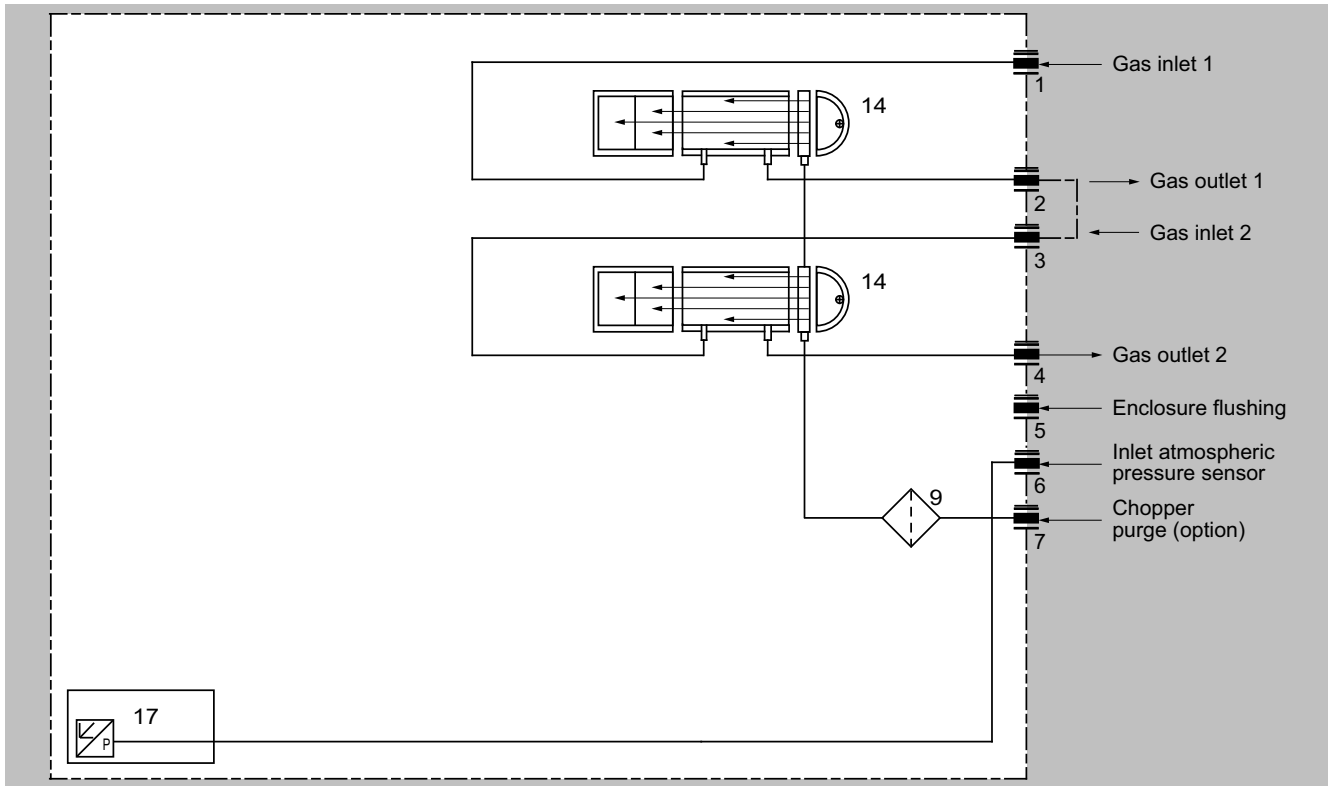

ULTRAMAT 23, 19" rack-mounted enclosure, sample gas path version in pipes, separate gas path, always without sample gas pump, without safety filter and without safety condensation trap

Extractive continuous process gas analytics

ULTRAMAT 23

Design (continued)

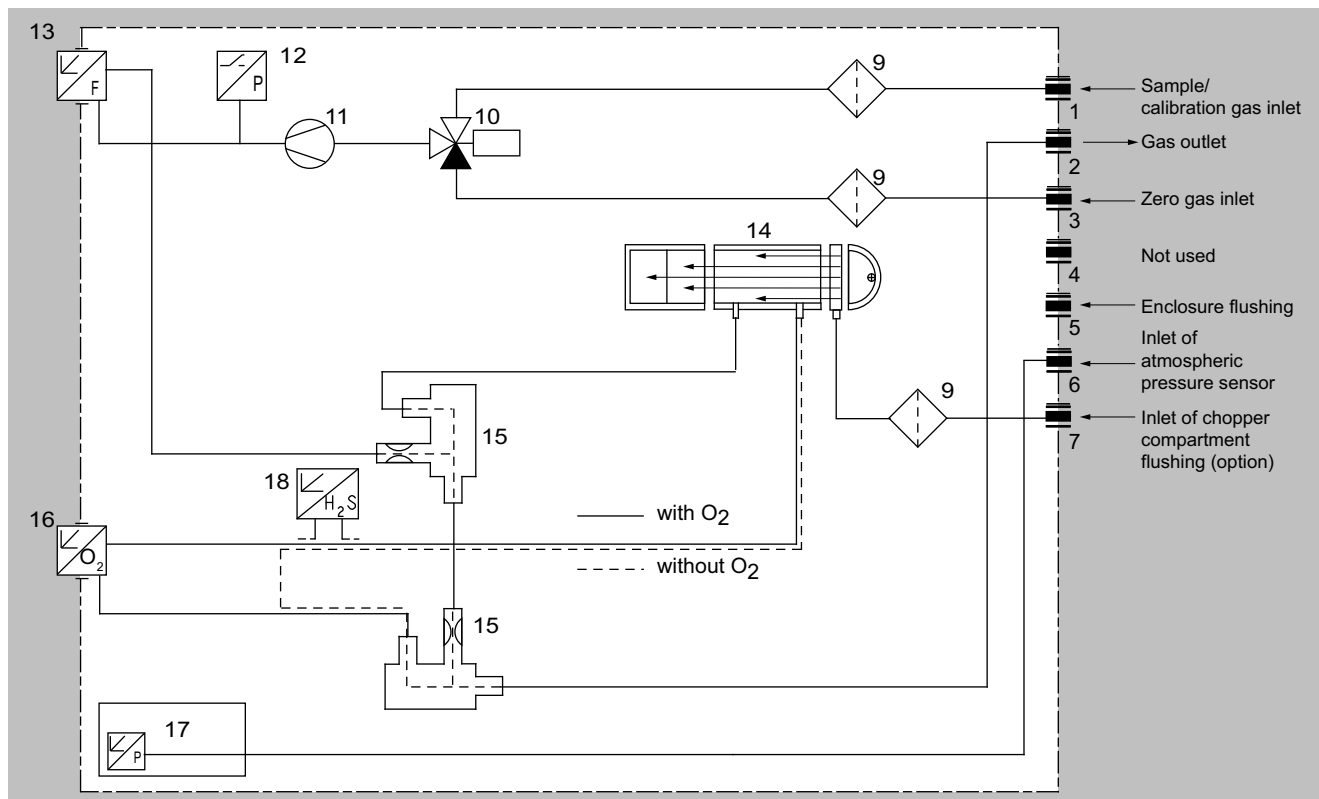
ULTRAMAT 23, 19" rack-mounted enclosure with internal sample gas pump and H₂S sensor

Design (continued)

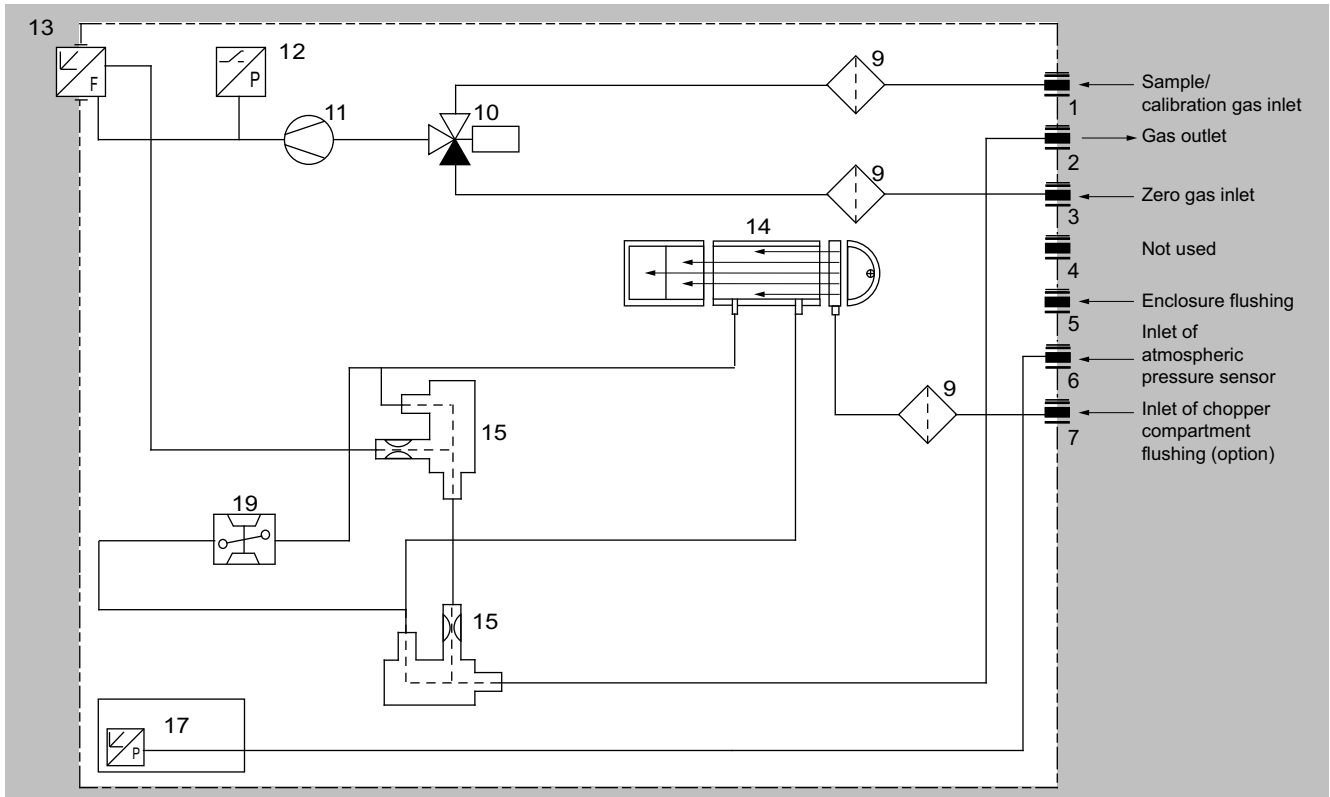

ULTRAMAT 23, 19" rack-mounted enclosure with internal sample gas pump and paramagnetic oxygen measurement

Extractive continuous process gas analytics

ULTRAMAT 23

Design (continued)

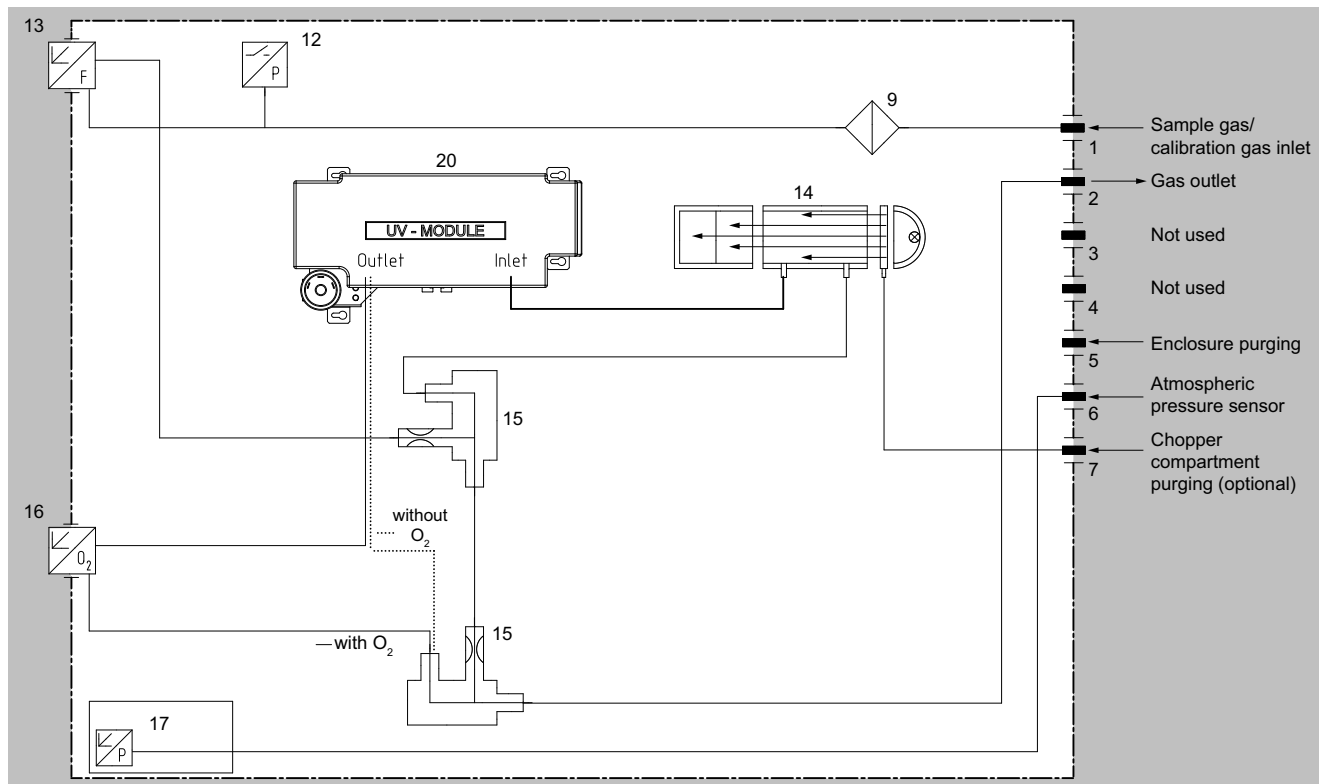

ULTRAMAT 23, 19" rack unit enclosure with IR detector, UV photometer (UV module); optional oxygen measurement

Design (continued)

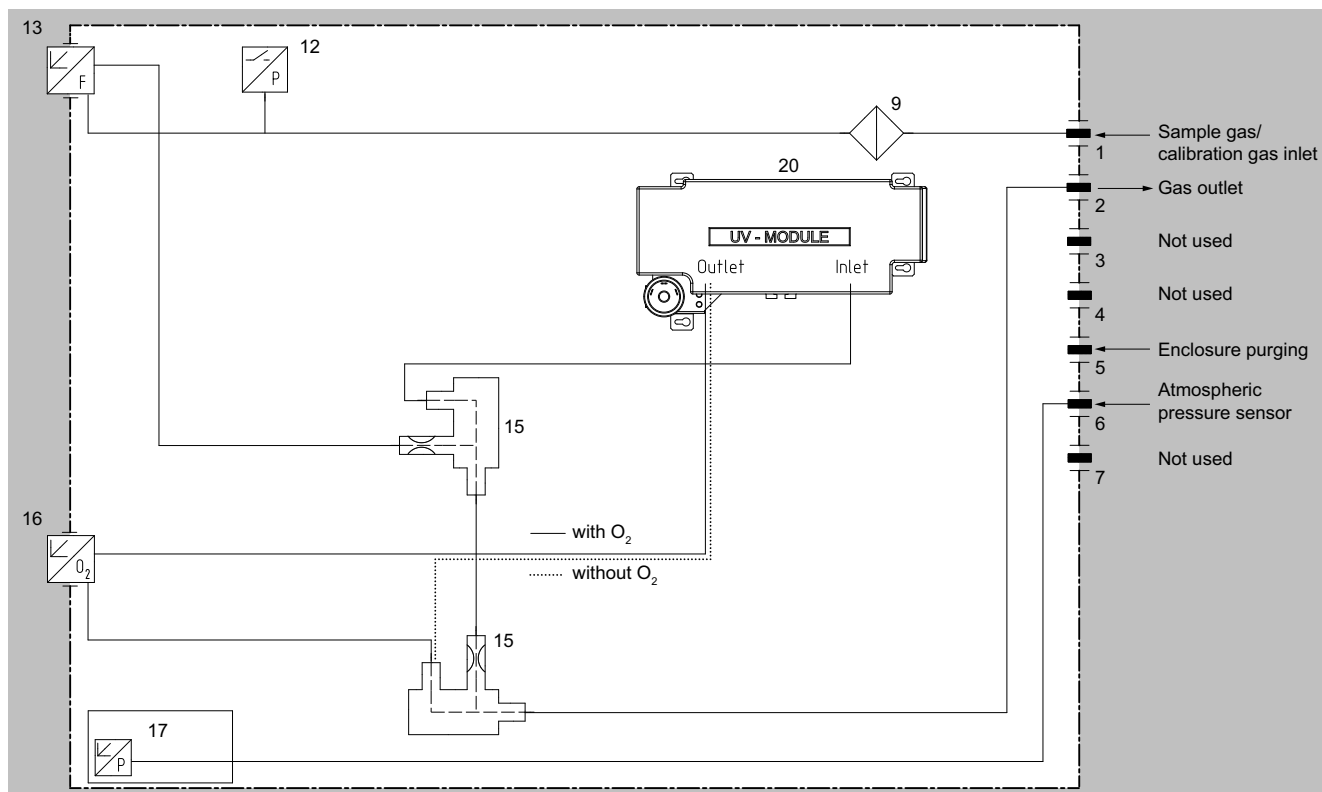

ULTRAMAT 23, 19" rack-mounted enclosure with UV photometer (UV module); optional oxygen measurement

Legend for the gas path figures

1	Inlet for sample gas/calibration gas	11	Sample gas pump
2	Gas outlet	12	Pressure switch
3	Inlet for AUTOCAL/zero gas or inlet for sample gas/calibration gas (channel 2)	13	Flow indicator
4	Gas outlet (channel 2)	14	Analyzer unit
5	Enclosure purging	15	Safety condensation trap
6	Inlet of atmospheric pressure sensor	16	Oxygen sensor (electrochemical)
7	Inlet/chopper purge	17	Atmospheric pressure sensor
8	Condensation trap with filter	18	Hydrogen sulfide sensor
9	Safety fine filter	19	Oxygen measuring cell (paramagnetic)
10	Solenoid valve	20	UV photometer (UV module)

Extractive continuous process gas analytics

ULTRAMAT 23

Mode of operation

The ULTRAMAT 23 uses multiple independent measuring principles which work selectively.

Infrared measurement

The measuring principle of the ULTRAMAT 23 is based on the molecule-specific absorption of bands of infrared radiation, which in turn is based on the "single-beam procedure". A radiation source (7) operating at 600 °C emits infrared radiation, which is then modulated by a chopper (5) at 8 1/3 Hz.

The IR radiation passes through the sample chamber (4), into which sample gas is flowing, and its intensity is weakened as a function of the concentration of the measured component.

The detector chamber - set up as a two- or three-layer detector chamber - is filled with the component to be measured.

The first detector layer (11) primarily absorbs energy from the central sections of the sample gas IR bands. Energy from the peripheral sections of the bands is absorbed by the second (2) and third (12) detector layers.

The microflow sensor generates a pneumatic connection between the upper layer and the lower layers. Negative feedback from the upper and lower layers leads to an overall narrowing of the spectral sensitivity band. The volume of the third layer and, therefore, the absorption

of the bands, can be varied using a "slide switch" (10), thereby increasing the selectivity of each individual measurement.

The rotating chopper (5) generates a pulsating flow in the detector chamber that the microflow sensor (3) converts into an electrical signal.

The microflow sensor consists of two nickel-plated grids heated to approximately 120 °C, which, along with two supplementary resistors, form a Wheatstone bridge. The pulsating flow together with the dense arrangement of the Ni grids causes a change in resistance. This leads to an offset in the bridge, which is dependent on the concentration of the sample gas.

Note

The sample gases must be fed into the analyzers free of dust. Condensation in the sample chambers must be prevented. Therefore, the use of gas modified for the measuring task is necessary in most application cases.

As far as possible, the ambient air of the analyzer unit should also not have a large concentration of the gas components to be measured.

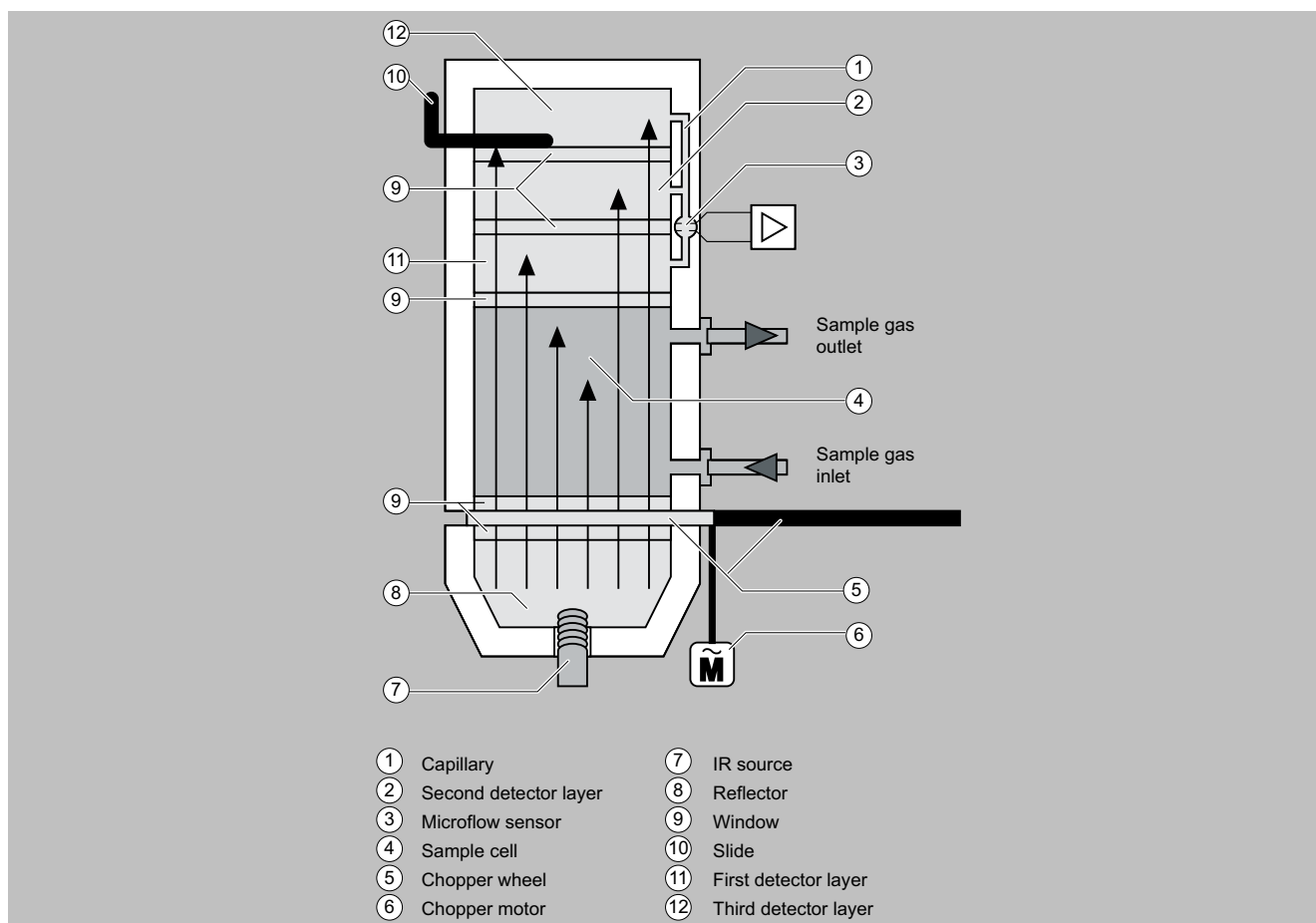

ULTRAMAT 23, mode of operation of the infrared channel (example with three-layer detector)

Mode of operation (continued)

Automatic calibration with air (AUTOCAL)

The ULTRAMAT 23 can be calibrated using, for example, ambient air. During this process (adjustable between 1 and 24 hours, 0 = no AUTOCAL), the chamber is purged with air. The detector then generates the largest signal U_0 (no pre-absorption in the sample chamber). This signal is used as the reference signal for zero point calibration, and also serves as the initial value for calculating the full-scale value in the manner described below.

As the concentration of the measured component increases, so too does absorption in the sample chamber. As a result of this pre-absorption, the detectable radiation energy in the detector decreases, and thus also the signal voltage. For the single-beam procedure of the ULTRAMAT 23, the mathematical relationship between the concentration of the measured component and the measured voltage can be approximately expressed as the following exponential function:

$$U = U_0 \cdot e^{-kc}$$

Legend	
c	Concentration
k	Device-specific constant
U_0	Basic signal with zero gas (sample gas without measured component)
U	Detector signal

Changes in the radiation power, contamination of the sample chamber, or aging of the detector components have the same effect on both U_0 and U, and result in the following:

$$U' = U'_0 \cdot e^{-kc}$$

Apart from being dependent on concentration c, the measured voltage thus changes continuously as the IR source ages, or with persistent contamination.

Each AUTOCAL thus tracks the total characteristic curve according to the currently valid value. Temperature and pressure influences are also compensated in this way.

The influences of contamination and aging, as mentioned above, have a negligible influence on the measurement as long as U' remains in a certain tolerance range monitored by the device.

The tolerance range between two or more AUTOCALS can be individually configured on the ULTRAMAT 23 and an alarm message output. An alarm message is output when the value falls below the original factory setting of $U_0 < 50\% U$. In most cases, this is due to the sample chamber being contaminated.

Calibration

The devices can be set to automatically calibrate the zero point every 1 to 24 hours, using ambient air or nitrogen. The calibration point for the IR-sensitive components is calculated mathematically from the newly determined U'_0 and the device-specific parameters stored as default values. We recommend checking the calibration point once a year using a calibration gas. (For details on German Technical Inspectorate/TÜV measurements, see Table "Calibration intervals (TÜV versions)" under Selection and ordering data).

If an electrochemical sensor is installed, it is recommendable to use air for the AUTOCAL. In addition to calibration of the zero point of the IR-sensitive components, it is then also possible to simultaneously calibrate the calibration point of the electrochemical O_2 sensor automatically. The characteristic curve of the O_2 sensor is sufficiently stable following the single-point calibration. The zero point of the electrochemical sensor only needs be checked once a year by connecting nitrogen.

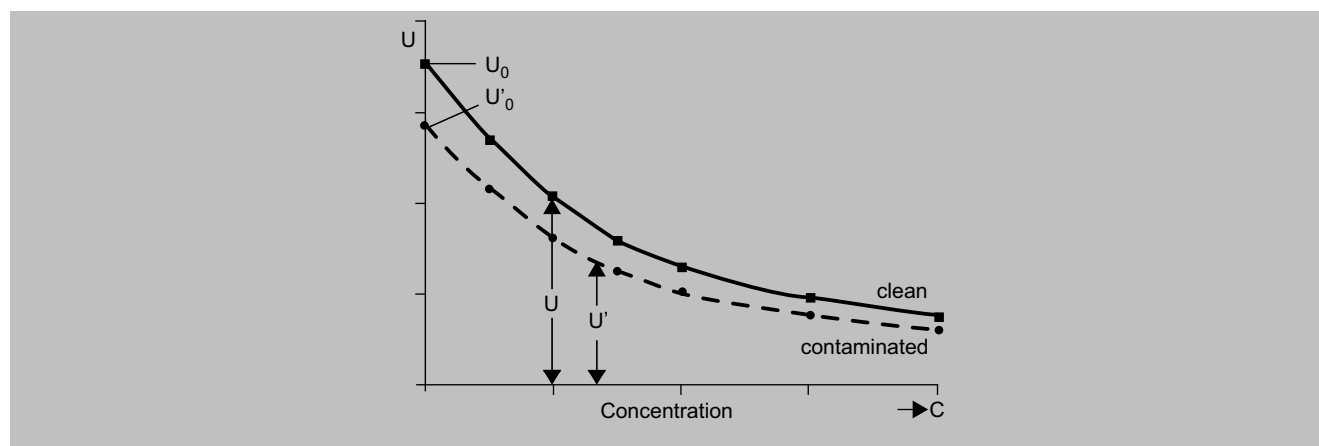

Calibration

Extractive continuous process gas analytics

ULTRAMAT 23

Mode of operation (continued)

Ultraviolet measurement

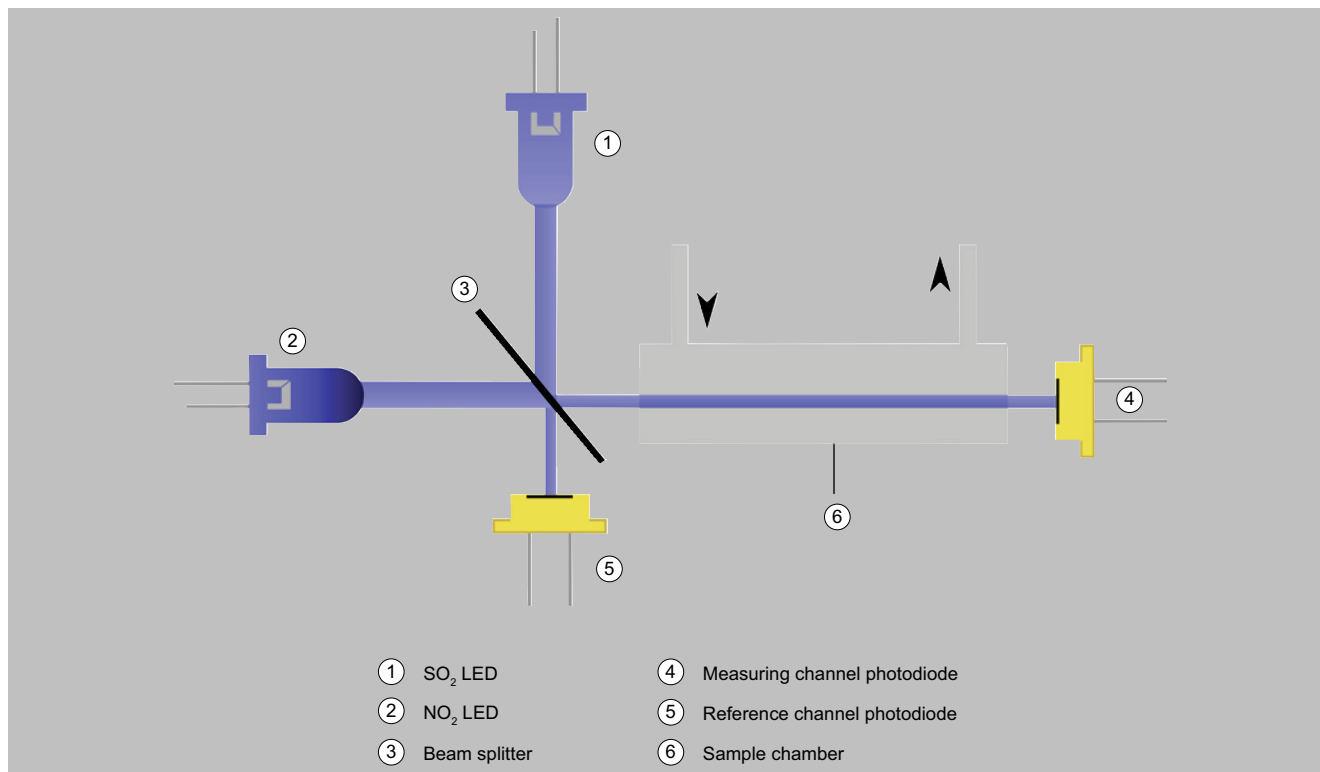

ULTRAMAT 23, ultraviolet measurement mode of operation

This measuring principle is also based on the molecule-specific absorption of bands of ultraviolet radiation using a double-beam photometer.

The light source is a solid-state diode (LED) based on AlGaN or InGaN semiconductors (1). To improve the signal evaluation, the light source is operated as a pulsed light source.

The ultraviolet radiation is collimated and first passes through a beam splitter (3), which generates two identically sized ray bundles (measuring and reference radiation). The measuring ray bundle passes through the sample chamber (6) into which the sample gas is flowing, and is attenuated as a function of the concentration of the measured component. This attenuation is evaluated according to the Lambert-Beer absorption law.

The measuring radiation is recorded by a photodiode (4) downstream of the sample chamber into which the sample gas is flowing (measuring signal). Likewise, the reference radiation is recorded by a second photodiode (5, reference signal). The ratio of measured signal and reference signal is used to calculate the concentration of the gas component.

The beam splitter also enables the coupling of a second light source (2) for measuring a second gas component. In this way, the absorption of sulfur dioxide (SO₂) and nitrogen dioxide (NO₂) is measured in alternating cycles and converted into continuous concentration values in sensor-level electronics. Additional sample gas applications are possible through a suitable selection of LEDs.

Oxygen measurement

The oxygen sensor operates according to the principle of a fuel cell. The oxygen is converted at the boundary layer between the cathode and electrolyte. An electron emission current flows between the lead

anode and cathode and via a resistance, where a measured voltage is present. This measured voltage is proportional to the concentration of oxygen in the sample gas.

The oxygen electrolyte used is less influenced by interference influences (particularly CO₂, CO, H₂ and CH₄) than other sensor types.

Note

The oxygen sensor can be used for concentrations of both > 1% and < 1% O₂. In the event of sudden changes from high concentrations to low concentrations (< 1%), the sensor will, however, require longer running-in times to get a constant measured value. This is to be taken into consideration when switching between measuring points in particular, and appropriate purging times are to be set.

Mode of operation (continued)

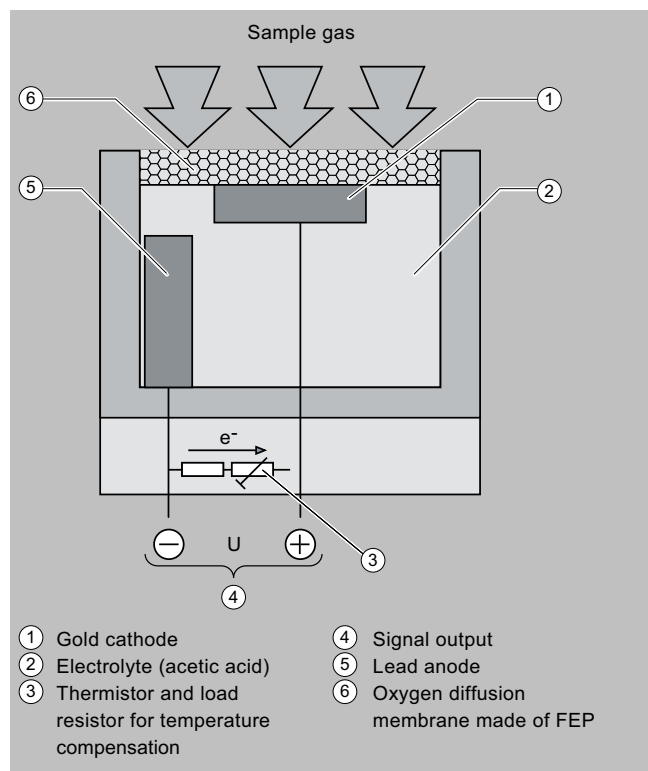

ULTRAMAT 23, oxygen sensor mode of operation

Electrochemical sensor for H_2S determination

The hydrogen sulfide enters through the diffusion barrier (gas diaphragm) into the sensor and is oxidized at the working electrode. A

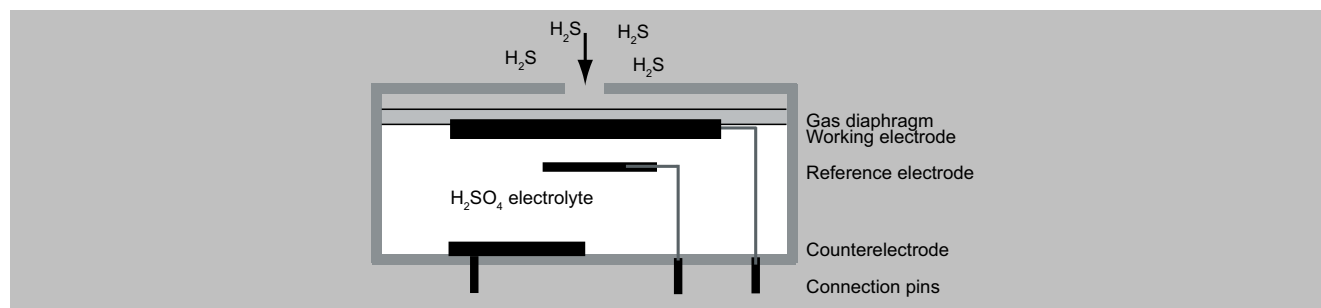
Operating principle of the H_2S sensor

Paramagnetic oxygen cell

In contrast to other gases, oxygen is highly paramagnetic. This property is used as the basis for the method of measurement.

Two permanent magnets generate an inhomogeneous magnetic field in the measuring cell. If oxygen molecules flow into the measuring cell (1), they are drawn into the magnetic field. This results in the two diamagnetic hollow spheres (2) being displaced out of the magnetic field. This rotary motion is recorded optically, and serves as the input variable for control of a compensation flow. This generates a torque opposite to the rotary motion around the two hollow spheres by means of a wire loop (3). The compensation current is proportional to the concentration of oxygen.

reaction in the form of a reduction of atmospheric oxygen takes place on the counter electrode. The transfer of electrons can be tapped on the connector pins as a current which is directly proportional to the gas concentration.

Calibration

The zero point is automatically recalibrated by the AUTOCAL function when connecting e.g. nitrogen or air. It is recommendable to check the calibration point monthly using calibration gas (45 to 50 vpm).

The AUTOCAL (with ambient air, for example) must be performed every hour. In so doing, you must ensure that the ambient air is saturated in accordance with a dew point of 11 °C.

If this cannot be constantly ensured with dry ambient air, the adjustment gas must be fed through a humidifier and subsequently through a cooler (dew point 11 °C).

If the accompanying gas contains the following components, the hydrogen sulfide sensor must not be used:

- Compounds containing chlorine
- Compounds containing fluorine
- Heavy metals
- Aerosols
- Alkaline components
- $NH_3 > 5$ vpm

Calibration

The calibration point is calibrated with the AUTOCAL function when processing air (corresponding to calibration with the electrochemical O_2 sensor). In order to comply with the technical data, the zero point of the paramagnetic measuring cell must be calibrated with nitrogen weekly in the case of measuring ranges < 5% or every two months in the case of larger measuring ranges.

Alternatively, inert gases (such as nitrogen) can be used for AUTOCAL. As the limit point of the measuring range remains largely stable, an annual limit point adjustment will suffice.

Extractive continuous process gas analytics

ULTRAMAT 23

Mode of operation (continued)

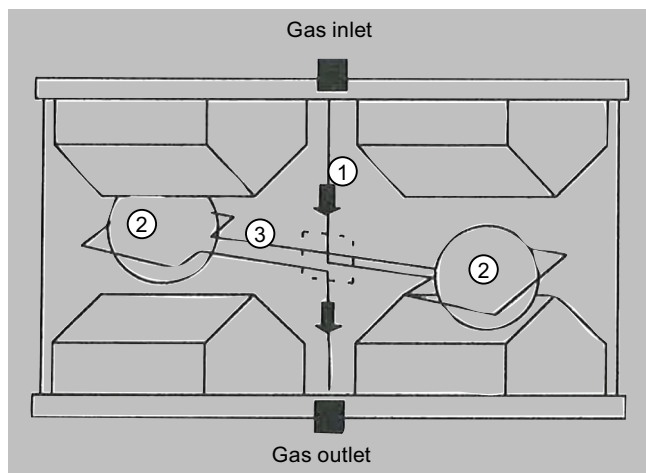

Operating principle of the paramagnetic oxygen cell

Cross-interferences, paramagnetic oxygen cells

Accompanying gas	Formula	Deviation at 20 °C	Deviation at 50 °C
Acetaldehyde	C ₂ H ₄ O	-0.31	-0.34
Acetone	C ₃ H ₆ O	-0.63	-0.69
Acetylene, ethyne	C ₂ H ₂	-0.26	-0.28
Ammonia	NH ₃	-0.17	-0.19
Argon	Ar	-0.23	-0.25
Benzene	C ₆ H ₆	-1.24	-1.34
Bromine	Br ₂	-1.78	-1.97
Butadiene	C ₄ H ₆	-0.85	-0.93
n-butane	C ₄ H ₁₀	-1.1	-1.22
Isobutylene	C ₄ H ₈	-0.94	-1.06
Chlorine	Cl ₂	-0.83	-0.91
Diacetylene	C ₄ H ₂	-1.09	-1.2
Dinitrogen monoxide	N ₂ O	-0.2	-0.22
Ethane	C ₂ H ₆	-0.43	-0.47
Ethyl benzene	C ₈ H ₁₀	-1.89	-2.08
Ethylene, ethene	C ₂ H ₄	-0.2	-0.22
Ethylene glycol	C ₂ H ₆ O ₂	-0.78	-0.88
Ethylene oxide	C ₂ H ₄ O	-0.54	-0.6
Furan	C ₄ H ₄ O	-0.9	-0.99
Helium	He	0.29	0.32
n-hexane	C ₆ H ₁₄	-1.78	-1.97
Hydrogen chloride, hydrochloric acid	HCl	-0.31	-0.34
Hydrogen fluoride, hydrofluoric acid	HF	0.12	0.14
Carbon dioxide	CO ₂	-0.27	-0.29
Carbon monoxide	CO	-0.06	-0.07
Krypton	Kr	-0.49	-0.54
Methane	CH ₄	-0.16	-0.17
Methanol	CH ₄ O	-0.27	-0.31
Methylene chloride	CH ₂ Cl ₂	-1	-1.1
Monosilane, silane	SiH ₄	-0.24	-0.27
Neon	Ne	0.16	0.17
n-octane	C ₈ H ₁₈	-2.45	-2.7
Phenol	C ₆ H ₆ O	-1.4	-1.54

Mode of operation (continued)

Accompanying gas	Formula	Deviation at 20 °C	Deviation at 50 °C
Propane	C ₃ H ₈	-0.77	-0.85
Propylene, propene	C ₃ H ₆	-0.57	-0.62
Propylene chloride	C ₃ H ₇ Cl	-1.42	-1.44
Propylene oxide	C ₃ H ₆ O	-0.9	-1
Oxygen	O ₂	100	100
Sulfur dioxide	SO ₂	-0.18	-0.2
Sulfur hexafluoride	SF ₆	-0.98	-1.05
Hydrogen sulfide	H ₂ S	-0.41	-0.43
Nitrogen	N ₂	0	0
Nitrogen dioxide	NO ₂	5	16
Nitrogen monoxide	NO	42.7	43
Styrene	C ₈ H ₈	-1.63	-1.8
Toluene	C ₇ H ₈	-1.57	-1.73
Vinyl chloride	C ₂ H ₃ Cl	-0.68	-0.74
Vinyl fluoride	C ₂ H ₃ F	-0.49	-0.54
Water (vapor)	H ₂ O	-0.03	-0.03
Hydrogen	H ₂	0.23	0.26
Xenon	Xe	-0.95	-1.02

Cross-sensitivities (with accompanying gas concentration 100%)

Function**Main features**

- Practically maintenance-free thanks to AUTOCAL with ambient air (or with N₂, only for devices without an oxygen sensor); both the zero point and the sensitivity are calibrated in the process
- Calibration with calibration gas only required every twelve months, depending on the application
- Two measuring ranges per component can be set within specified limits; all measuring ranges linearized; autoranging with measuring range identification
- Automatic correction of variations in atmospheric pressure
- Sample gas flow monitoring; error message output if flow < 1 l/min (only with Viton sample gas path)
- Maintenance demanded
- Two freely configurable undershooting or overshooting limits per measured component

Extractive continuous process gas analytics

ULTRAMAT 23

19" rack unit and portable version

Selection and ordering data

ULTRAMAT 23 gas analyzer			Article No.			
For measuring 1 infrared component, UV components, oxygen and hydrogen sulfide			7MB2335- ● ● ● ● ● - ● A A ●			
Click on the Article No. for online configuration in the PIA Life Cycle Portal.						
<i>Unavailable combinations are shown in PIA Life Cycle Portal as "not permitted".</i>						
Enclosure, version and gas paths						
19" rack unit for installation in cabinets ¹²						
<u>Gas connections</u>	<u>Gas paths</u>	<u>Internal sample gas pump</u>				
6 mm pipe	Viton	Without ²⁾				0
¼" pipe	Viton	Without ^{2), 14)}				1
6 mm pipe	Viton	With				2
¼" pipe	Viton	With ¹³⁾				3
6 mm pipe	Stainless steel, mat. No. 1.4571, separate	Without ²⁾				6
¼" pipe	Stainless steel, mat. No. 1.4571, separate	Without ²⁾				7
Portable, in sheet-steel enclosure, 6 mm gas connections, Viton gas path, with integrated sample gas pump, condensation trap with safety filter on the front plate.						8
<u>Infrared measured component</u>						
<u>Measured component</u>	<u>Possible with measuring range identification</u>					
CO	A, C, D, E, F, G ... R, T, U, X					A
CO ₂ ¹⁾	D ⁵⁾ , G ⁵⁾ , H ⁵⁾ , J ⁵⁾ , K ... R					C
CH ₄	E, H, L, N, P, R					D
C ₂ H ₄	K					F
C ₆ H ₁₄	K					M
SO ₂ ¹⁰⁾	B ⁷⁾ , F ... L, S ⁹⁾ , T ⁸⁾ , W					N
NO	A, C, E, G ... J, T, U, V, W					P
N ₂ O ⁶⁾	E					S
SF ₆	H					V
<u>Smallest measuring range</u>	<u>Largest measuring range</u>					
0 ... 50 mg/m ³	0 ... 500 mg/m ³					A
0 ... 200 mg/m ³	0 ... 1 000 mg/m ³					B
0 ... 100 mg/m ³	0 ... 1 000 mg/m ³					C
0 ... 50 vpm	0 ... 250 vpm					D
0 ... 100 vpm	0 ... 500 vpm					E
0 ... 150 vpm	0 ... 750 vpm					F
0 ... 200 vpm	0 ... 1 000 vpm					G
0 ... 500 vpm	0 ... 2 500 vpm					H
0 ... 1 000 vpm	0 ... 5 000 vpm					J
0 ... 2 000 vpm	0 ... 10 000 vpm					K
0 ... 0.5%	0 ... 2.5%					L
0 ... 1%	0 ... 5%					M
0 ... 2%	0 ... 10%					N
0 ... 5%	0 ... 25%					P
0 ... 10%	0 ... 50%					Q
0 ... 20%	0 ... 100%					R
0 ... 50 mg/m ^{3 11)}	0 ... 1 250 mg/m ^{3 11)}					S
0 ... 100 mg/m ³	0 ... 750 mg/m ³					T
0 ... 150 mg/m ³	0 ... 750 mg/m ³					U
0 ... 250 mg/m ³	0 ... 1 250 mg/m ³					V
0 ... 400 mg/m ³	0 ... 2 000 mg/m ³					W
0 ... 50 vpm	0 ... 2 500 vpm					X
<u>Oxygen measurement⁴⁾</u>						
Without O ₂ sensor						0
With electrochemical O ₂ sensor						1
With paramagnetic oxygen measuring cell						8
<u>Hydrogen sulfide measurement</u>						
Without						6
With H ₂ S sensor 0 ... 5 / 50 vpm						7
<u>Auxiliary power</u>						
100 V AC, 50 Hz						0
120 V AC, 50 Hz						1

Selection and ordering data (continued)

ULTRAMAT 23 gas analyzer For measuring 1 infrared component, UV components, oxygen and hydrogen sulfide	Article No. 7MB2335- ● ● ● ● ● - ● A A ●
200 V AC, 50 Hz	2
230 V AC, 50 Hz	3
100 V AC, 60 Hz	4
120 V AC, 60 Hz	5
230 V AC, 60 Hz	6
Language of the operating software³⁾	
German	0
English	1
French	2
Spanish	3
Italian	4

- 1) For measuring ranges below 1%, a CO₂ absorber cartridge can be used for zero point adjustment (see Accessories).
- 2) Without separate zero gas input or solenoid valve.
- 3) Language for operation can be changed.
- 4) O₂ sensor/O₂ measuring cell in gas path of infrared measured component 1.
- 5) With chopper compartment purging (N₂ approx. 3 000 hPa required for measuring ranges below 0.1% CO₂), to be ordered separately (see order code C02 or C03).
- 6) Not suitable for use with emission measurements since cross-sensitivity too high.
- 7) Maximum possible AUTOCAL cycle ≤ 6 h, constant ambient conditions (max. deviation ±1 °C (1.8 °F)): see table "Calibration intervals, standard devices" under "More information".
- 8) Maximum possible AUTOCAL cycle ≤ 3 h, constant ambient conditions (max. deviation ±1 °C (1.8 °F)): see table "Calibration intervals, standard devices" under "More information".
- 9) Measured with UV technology
- 10) When measuring range identification "S" selected: Parallel measurement of SO₂ and NO₂ with UV photometer.
- 11) The measuring ranges of the two components differ slightly: For SO₂: 0 ... 50/1 250 mg/m³, for NO₂: 0 ... 50/1 000 mg/m³.
- 12) E21 only for options 1, 3 and 5
- 13) In combination with the E21 option (CSA for measuring flammable gases) without pump, flow indicator, pressure switch and S-vessel. The solenoid valve is present. However, the gas path corresponds to this setup.
- 14) In combination with the E21 option (CSA for measuring flammable gases) without flow indicator, pressure switch and S-vessel. However, the gas path corresponds to this setup.

Options	Order code
Add "-Z" to article number and then add order code	
Settings	
Add-on electronics with 8 digital inputs/outputs, PROFIBUS PA interface	A12
Add-on electronics with 8 digital inputs/outputs, PROFIBUS DP interface	A13
IEC plug, 37-pin D-sub connector, 9-pin D-sub connector	A33
Tag plates (customized inscription)	B03
Clean for O ₂ service (specially cleaned gas path)	B06
Gas path for short response time ³⁾	C01
Chopper compartment purging for 6 mm gas connection	C02
Chopper compartment purging for 1/4" gas connection	C03
Selection of the conversion mg/m ³ in ppm at 293K or 273K	D15
ATEX: II 3G Ex ec ic nC IIC T4 Gc; BVS 16 ATEX E 061 X IECEx: Ex ec ic nC IIC T4 Gc; IECEx BVS 16.0041X FM/CSA: Class I, Zone 2 A/Ex ec ic nC IIC T4 Gc Class I, Division 2, Groups A, B, C, D T4	E20
CSA: Class I, Zone 2 A/Ex ec ic nC IIC T4 Gb/Gc Class I, Division 2, Groups A, B, C, D T4	E21

Options	Order code
Calibration interval 5 months (TÜV, QAL) measuring ranges: CO 0 - 150/750 mg/m ³ ; NO 0 - 100/750 mg/m ³	E50
Measuring range indication in plain text ¹⁾	Y11
Measurement of CO ₂ in forming gas ²⁾ (only in conjunction with measuring range 0 ... 20 / 0 ... 100%)	Y14

- 1) Default setting: smallest measuring range, largest measuring range.
- 2) CO₂ measurement in accompanying gas Ar or Ar/He (3:1); forming gas.
- 3) Only for version with Viton hose.

Accessories	Article No.
CO ₂ absorber cartridge	7MB1933-8AA
RS 485/Ethernet converter	A5E52327218
RS 485/RS 232 converter	A5E52327214
RS 485/USB converter	A5E52327216
Add-on electronics with 8 digital inputs/outputs and PROFIBUS PA	A5E00056834
Add-on electronics with 8 digital inputs/outputs and PROFIBUS DP	A5E00057159
Set of Torx screwdrivers	A5E34821625

Extractive continuous process gas analytics

ULTRAMAT 23

19" rack unit and portable version

Selection and ordering data (continued)

ULTRAMAT 23 gas analyzer For measuring 2 infrared components, UV components, oxygen and hydrogen sulfide			Article No. 7MB2337- ● ● ● ● ● - ● ● ● ●
Click on the Article No. for online configuration in the PIA Life Cycle Portal.			
<i>Unavailable combinations are shown in PIA Life Cycle Portal as "not permitted".</i>			
Enclosure, version and gas paths			
19" rack unit for installation in cabinets ¹⁴			
Gas connections	Gas paths	Internal sample gas pump	
6 mm pipe	Viton, not separate	Without ²⁾	0
¼" pipe	Viton, not separate	Without ^{2), 16)}	1
6 mm pipe	Viton, not separate	With	2
¼" pipe	Viton, not separate	With ¹⁵⁾	3
6 mm pipe	Viton, separate	Without ²⁾	4
¼" pipe	Viton, separate	Without ^{2), 16)}	5
6 mm pipe	Stainless steel, mat. No. 1.4571, separate	Without ²⁾	6
¼" pipe	Stainless steel, mat. No. 1.4571, separate	Without ²⁾	7
Portable, in sheet-steel enclosure, 6 mm gas connections, Viton gas path, with integrated sample gas pump, condensation trap with safety filter on the front plate.			8
1st infrared measured component			
Measured component	Possible with measuring range identification		
CO	A, C, D, E, F, G ... R, T, U, X		A
CO ₂ ¹⁾	D ⁵⁾ , G ⁵⁾ , H ⁵⁾ , J ⁵⁾ , K ... R		C
CH ₄	E, H, L, N, P, R		D
C ₂ H ₄	K		F
C ₆ H ₁₄	K		M
SO ₂	B ⁸⁾ , F ... L, T ⁹⁾ , W		N
NO	A, C, E, G ... J, T, U, V, W		P
N ₂ O ⁶⁾	E		S
SF ₆	H		V
Smallest measuring range	Largest measuring range		
0 ... 50 mg/m ³	0 ... 500 mg/m ³		A
0 ... 200 mg/m ³	0 ... 1 000 mg/m ³		B
0 ... 100 mg/m ³	0 ... 1 000 mg/m ³		C
0 ... 50 vpm	0 ... 250 vpm		D
0 ... 100 vpm	0 ... 500 vpm		E
0 ... 150 vpm	0 ... 750 vpm		F
0 ... 200 vpm	0 ... 1 000 vpm		G
0 ... 500 vpm	0 ... 2 500 vpm		H
0 ... 1 000 vpm	0 ... 5 000 vpm		J
0 ... 2 000 vpm	0 ... 10 000 vpm		K
0 ... 0.5%	0 ... 2.5%		L
0 ... 1%	0 ... 5%		M
0 ... 2%	0 ... 10%		N
0 ... 5%	0 ... 25%		P
0 ... 10%	0 ... 50%		Q
0 ... 20%	0 ... 100%		R
0 ... 100 mg/m ³	0 ... 750 mg/m ³		T
0 ... 150 mg/m ³	0 ... 750 mg/m ³		U
0 ... 250 mg/m ³	0 ... 1 250 mg/m ³		V
0 ... 400 mg/m ³	0 ... 2 000 mg/m ³		W
0 ... 50 vpm	0 ... 2 500 vpm		X
Oxygen measurement⁴⁾			
Without O ₂ sensor			0
With electrochemical O ₂ sensor			1
With paramagnetic oxygen measuring cell			8
Hydrogen sulfide measurement			
Without			6
With H ₂ S sensor 0 ... 5 / 50 vpm			7

Selection and ordering data (continued)

ULTRAMAT 23 gas analyzer For measuring 2 infrared components, UV components, oxygen and hydrogen sulfide		Article No. 7MB2337- ● ● ● ● ● - ● ● ● ●
Auxiliary power		
100 V AC, 50 Hz		0
120 V AC, 50 Hz		1
200 V AC, 50 Hz		2
230 V AC, 50 Hz		3
100 V AC, 60 Hz		4
120 V AC, 60 Hz		5
230 V AC, 60 Hz		6
2nd infrared measured component		
Measured component	Possible with measuring range identification	
CO	A, C, D, E, F, G ... R, T, U, X	A
CO ₂ ¹⁾	D ⁵⁾ , G ⁵⁾ , H ⁵⁾ , J ⁵⁾ , K ... R	C
CH ₄	E, H, L, N, P, R	D
C ₂ H ₄	K	F
C ₆ H ₁₄	K	M
SO ₂ ¹¹⁾	B ⁸⁾ , F ... L, S ¹⁰⁾ , T ⁹⁾ , W	N
NO	C, E, G ... J, T, U, V, W	P
N ₂ O	E ⁶⁾ , Y ⁷⁾	S
SF ₆	H	V
Smallest measuring range	Largest measuring range	
0 ... 50 mg/m ³ ¹²⁾	0 ... 500 mg/m ³ ¹²⁾	A
0 ... 200 mg/m ³	0 ... 1 000 mg/m ³	B
0 ... 100 mg/m ³	0 ... 1 000 mg/m ³	C
0 ... 50 vpm	0 ... 250 vpm	D
0 ... 100 vpm	0 ... 500 vpm	E
0 ... 150 vpm	0 ... 750 vpm	F
0 ... 200 vpm	0 ... 1 000 vpm	G
0 ... 500 vpm	0 ... 2 500 vpm	H
0 ... 1 000 vpm	0 ... 5 000 vpm	J
0 ... 2 000 vpm	0 ... 10 000 vpm	K
0 ... 0.5%	0 ... 2.5%	L
0 ... 1%	0 ... 5%	M
0 ... 2%	0 ... 10%	N
0 ... 5%	0 ... 25%	P
0 ... 10%	0 ... 50%	Q
0 ... 20%	0 ... 100%	R
0 ... 50 mg/m ³ ¹³⁾	0 ... 1 250 mg/m ³ ¹³⁾	S
0 ... 100 mg/m ³	0 ... 750 mg/m ³	T
0 ... 150 mg/m ³	0 ... 750 mg/m ³	U
0 ... 250 mg/m ³	0 ... 1 250 mg/m ³	V
0 ... 400 mg/m ³	0 ... 2 000 mg/m ³	W
0 ... 50 vpm	0 ... 2 500 vpm	X
0 ... 500 vpm	0 ... 5 000 vpm	Y
Language of the operating software³⁾		
German		0
English		1
French		2
Spanish		3
Italian		4

1) For measuring ranges below 1%, a CO₂ absorber cartridge can be used for zero point adjustment (see Accessories).

2) Without separate zero gas input or solenoid valve.

3) Language for operation can be changed.

4) O₂ sensor/O₂ measuring cell in gas path of infrared measured component 1.

5) With chopper compartment purging (N₂ approx. 3 000 hPa required for measuring ranges below 0.1% CO₂), to be ordered separately (see order code C02 or C03).

6) Not suitable for use with emission measurements since cross-sensitivity too high.

7) Only in conjunction with CO₂ measuring range 0 to 5% to 0 to 25% (CP).

8) Maximum possible AUTOCAL cycle ≤ 6 h, constant ambient conditions (max. deviation ±1 °C (1.8 °F)): see table "Calibration intervals, standard devices" under "More information".

9) Maximum possible AUTOCAL cycle ≤ 3 h, constant ambient conditions (max. deviation ±1 °C (1.8 °F)): see table "Calibration intervals, standard devices" under "More information".

Extractive continuous process gas analytics

ULTRAMAT 23

19" rack unit and portable version

Selection and ordering data (continued)

¹⁰⁾ Measured with UV technology

¹¹⁾ When measuring range identification "S" selected: Parallel measurement of SO₂ and NO₂ with UV photometer.

¹²⁾ For devices in applications requiring a certified measuring range of less than 0 ... 100 mg/m³, compensation of the CO₂ cross-interference for CO and NO and of the O₂ cross-interference for NO is necessary.

¹³⁾ The measuring ranges of the two components differ slightly: For SO₂: 0 ... 50/1 250 mg/m³, for NO₂: 0 ... 50/1 000 mg/m³.

¹⁴⁾ E21 only for options 1, 3 and 5

¹⁵⁾ In combination with the E21 option (CSA for measuring flammable gases) without pump, flow indicator, pressure switch and S-vessel. The solenoid valve is present. However, the gas path corresponds to this setup.

¹⁶⁾ In combination with the E21 option (CSA for measuring flammable gases) without flow indicator, pressure switch and S-vessel. However, the gas path corresponds to this setup.

Options	Order code
Add "-Z" to article number and then add order code	
Settings	
Add-on electronics with 8 digital inputs/outputs, PROFIBUS PA interface	A12
Add-on electronics with 8 digital inputs/outputs, PROFIBUS DP interface	A13
Stainless steel connection pipe (mat. No. 1.4571), 6 mm, complete with screw connection (cannot be combined with Viton hose)	A27
Stainless steel connection pipe (mat. No. 1.4571), 1/4", complete with screw connection (cannot be combined with Viton hose)	A29
IEC plug, 37-pin D-sub connector, 9-pin D-sub connector	A33
Tag plates (customized inscription)	B03
Clean for O ₂ service (specially cleaned gas path)	B06
Gas path for short response time ³⁾	C01
Chopper compartment purging for 6 mm gas connection	C02
Chopper compartment purging for 1/4" gas connection	C03
Application with paramagnetic oxygen measuring cell and separate gas path	C11
Selection of the conversion mg/m ³ in ppm at 293K or 273K	D15
ATEX: II 3G Ex ec ic nC IIC T4 Gc; BVS 16 ATEX E 061 X	E20
IECEX: Ex ec ic nC IIC T4 Gc; IECEX BVS 16.0041X FM/CSA: Class I, Zone 2 A/Ex ec ic nC IIC T4 Gc Class I, Division 2, Groups A, B, C, D T4	
CSA: Class I, Zone 2 A/Ex ec ic nC IIC T4 Gb/Gc Class I, Division 2, Groups A, B, C, D T4	E21

Options	Order code
Calibration interval 5 months (TÜV, QAL) measuring ranges: CO 0 - 150/750 mg/m ³ ; NO 0 - 100/750 mg/m ³	E50
DNV-GL statement of conformity for use in marine CEMS according to MEPC.259(68)	E60
Measuring range indication in plain text ¹⁾	Y11
Measurement of CO ₂ in forming gas ²⁾ (only in conjunction with measuring range 0 ... 20 / 0 ... 100%)	Y14

¹⁾ Default setting; smallest measuring range, largest measuring range.

²⁾ CO₂ measurement in accompanying gas Ar or Ar/He (3:1); forming gas.

³⁾ Only for version with Viton hose.

Accessories	Article No.
CO ₂ absorber cartridge	7MB1933-8AA
RS 485/Ethernet converter	A5E52327218
RS 485/RS 232 converter	A5E52327214
RS 485/USB converter	A5E52327216
Add-on electronics with 8 digital inputs/outputs and PROFIBUS PA	A5E00056834
Add-on electronics with 8 digital inputs/outputs and PROFIBUS DP	A5E00057159
Set of Torx screwdrivers	A5E34821625

ULTRAMAT 23 gas analyzer			Article No.
For measuring 3 infrared components, UV components, oxygen or 2 infrared components and UV components			7MB2338- ● ● ● ● 6 - ● ● ● ●
Click on the Article No. for online configuration in the PIA Life Cycle Portal.			
<i>Unavailable combinations are shown in PIA Life Cycle Portal as "not permitted".</i>			
Enclosure, version and gas paths			
19" rack unit for installation in cabinets ¹³⁾			
Gas connections	Gas paths	Internal sample gas pump	
6 mm pipe	Viton, not separate	Without ²⁾	0
1/4" pipe	Viton, not separate	Without ²⁾ , ¹⁵⁾	1
6 mm pipe	Viton, not separate	With	2
1/4" pipe	Viton, not separate	With ¹⁴⁾	3
6 mm pipe	Viton, separate	Without ²⁾	4
1/4" pipe	Viton, separate	Without ²⁾ , ¹⁵⁾	5
6 mm pipe	Stainless steel, mat. No. 1.4571, separate	Without ²⁾	6

Selection and ordering data (continued)

ULTRAMAT 23 gas analyzer For measuring 3 infrared components, UV components, oxygen or 2 infrared components and UV components			Article No. 7MB2338- ● ● ● ● 6 - ● ● ● ●			
1/4" pipe	Stainless steel, mat. No. 1.4571, separate	Without ²⁾	7			
Portable, in sheet-steel enclosure, 6 mm gas connections, Viton gas path, with integrated sample gas pump, condensation trap with safety filter on the front plate.			8			
1st and 2nd infrared measured component						
Measured component	Smallest measuring range	Largest measuring range				
CO and NO	0 ... 500 vpm	0 ... 2 500 vpm	A	A		
CO and NO	0 ... 2 000 vpm (CO) 0 ... 1 000 vpm (NO)	0 ... 10 000 vpm (CO) 0 ... 5 000 vpm (NO)	A	B		
CO and NO	0 ... 1 000 vpm	0 ... 5 000 vpm	A	C		
CO and NO	0 ... 1% (CO) 0 ... 1 000 vpm (NO)	0 ... 5% (CO) 0 ... 5 000 vpm (NO)	A	D		
CO and NO	0 ... 250 mg/m ³ (CO) 0 ... 400 mg/m ³ (NO)	0 ... 1 250 mg/m ³ (CO) 0 ... 2 000 mg/m ³ (NO)	A	K		
CO and NO	0 ... 50 vpm (CO) 0 ... 100 vpm (NO)	0 ... 250 vpm (CO) 0 ... 500 vpm (NO)	A	P		
CO and NO	0 ... 100 vpm	0 ... 500 vpm	A	R		
CO and CO ₂	0 ... 10%	0 ... 50%	B	A		
CO and CO ₂	0 ... 10% (CO) 0 ... 0.5% (CO ₂)	0 ... 50% (CO) 0 ... 2.5% (CO ₂)	B	B		
CO and CO ₂	0 ... 20%	0 ... 100%	B	D		
CO and CO ₂	0 ... 100 vpm (CO) 0 ... 5% (CO ₂)	0 ... 500 vpm (CO) 0 ... 25% (CO ₂)	B	J		
CO and CO ₂	0 ... 0.5% (CO) 0 ... 10% (CO ₂)	0 ... 2.5% (CO) 0 ... 50% (CO ₂)	B	K		
CO and CO ₂	0 ... 75 mg/m ³ (CO) 0 ... 5% (CO ₂)	0 ... 750 mg/m ³ (CO) 0 ... 25% (CO ₂)	B	L		
CO and CO ₂	0 ... 50 mg/m ³ (CO) 0 ... 5% (CO ₂)	0 ... 500 mg/m ³ (CO) 0 ... 25% (CO ₂)	B	M		
CO ₂ and CH ₄	0 ... 5% (CO ₂) 0 ... 1% (CH ₄)	0 ... 25% (CO ₂) 0 ... 5% (CH ₄)	C	A		
CO ₂ and CH ₄	0 ... 5% (CO ₂) 0 ... 2% (CH ₄)	0 ... 25% (CO ₂) 0 ... 10% (CH ₄)	C	B		
CO ₂ and NO	0 ... 5% (CO ₂) 0 ... 500 vpm (NO)	0 ... 25% (CO ₂) 0 ... 2 500 vpm (NO)	D	C		
Oxygen measurement⁴⁾						
Without O ₂ sensor						0
With electrochemical O ₂ sensor						1
With paramagnetic oxygen measuring cell						8
Auxiliary power						
100 V AC, 50 Hz						0
120 V AC, 50 Hz						1
200 V AC, 50 Hz						2
230 V AC, 50 Hz						3
100 V AC, 60 Hz						4
120 V AC, 60 Hz						5
230 V AC, 60 Hz						6
3rd infrared measured component						
Measured component	Possible with measuring range identification					
CO	A, C, D, E, F, G ... R, U, X					
CO ₂ ¹⁾	D ⁵⁾ , G ⁵⁾ , H ⁵⁾ , J ⁵⁾ , K ... R					
CH ₄	E, H, L, N, P, R					
C ₂ H ₄	K					
C ₆ H ₁₄	K					
SO ₂ ¹⁰⁾	PIA B ⁸⁾ , F ... L, S, T ⁹⁾ , W					
NO	C, E, G ... J, T, U, V, W					
N ₂ O	E ⁶⁾ , Y ⁷⁾					
SF ₆	H					
Smallest measuring range	Largest measuring range					
0 ... 50 mg/m ³ ¹¹⁾	0 ... 500 mg/m ³ ¹¹⁾					
0 ... 200 mg/m ³	0 ... 1 000 mg/m ³					
						A
						B

Extractive continuous process gas analytics

ULTRAMAT 23

19" rack unit and portable version

Selection and ordering data (continued)

ULTRAMAT 23 gas analyzer For measuring 3 infrared components, UV components, oxygen or 2 infrared components and UV components		Article No. 7MB2338- ● ● ● ● 6 - ● ● ● ●									
0 ... 100 mg/m ³	0 ... 1 000 mg/m ³										C
0 ... 50 vpm	0 ... 250 vpm										D
0 ... 100 vpm	0 ... 500 vpm										E
0 ... 150 vpm	0 ... 750 vpm										F
0 ... 200 vpm	0 ... 1 000 vpm										G
0 ... 500 vpm	0 ... 2 500 vpm										H
0 ... 1 000 vpm	0 ... 5 000 vpm										J
0 ... 2 000 vpm	0 ... 10 000 vpm										K
0 ... 0.5%	0 ... 2.5%										L
0 ... 1%	0 ... 5%										M
0 ... 2%	0 ... 10%										N
0 ... 5%	0 ... 25%										P
0 ... 10%	0 ... 50%										Q
0 ... 20%	0 ... 100%										R
0 ... 50 mg/m ³ 12)	0 ... 1 250 mg/m ³ 12)										S
0 ... 100 mg/m ³	0 ... 750 mg/m ³										T
0 ... 150 mg/m ³	0 ... 750 mg/m ³										U
0 ... 250 mg/m ³	0 ... 1 250 mg/m ³										V
0 ... 400 mg/m ³	0 ... 2 000 mg/m ³										W
0 ... 50 vpm	0 ... 2 500 vpm										X
0 ... 500 vpm	0 ... 5 000 vpm										Y
Language of the operating software³⁾											
German											0
English											1
French											2
Spanish											3
Italian											4

1) For measuring ranges below 1%, a CO₂ absorber cartridge can be used for zero point adjustment (see Accessories).

2) Without separate zero gas input or solenoid valve.

3) Language for operation can be changed.

4) O₂ sensor/O₂ measuring cell in gas path of infrared measured component 1.

5) With chopper compartment purging (N₂ approx. 3 000 hPa required for measuring ranges below 0.1% CO₂), to be ordered separately (see order code C02 or C03).

6) Not suitable for use with emission measurements since cross-sensitivity too high.

7) Only in conjunction with CO₂/NO, measuring range 0 to 5/25%, 0 to 500/5 000 vpm [-DC-].

8) Maximum possible AUTOCAL cycle ≤ 6 h, constant ambient conditions (max. deviation ±1 °C (1.8 °F)): see table "Calibration intervals, standard devices" under "More information".

9) Maximum possible AUTOCAL cycle ≤ 3 h, constant ambient conditions (max. deviation ±1 °C (1.8 °F)): see table "Calibration intervals, standard devices" under "More information".

10) When measuring range identification "S" selected: Parallel measurement of SO₂ and NO₂ with UV photometer.

11) For devices in applications requiring a certified measuring range of less than 0 ... 100 mg/m³, compensation of the CO₂ cross-interference for CO and NO and of the O₂ cross-interference for NO is necessary.

12) The measuring ranges of the two components differ slightly: For SO₂: 0 ... 50/1 250 mg/m³, for NO₂: 0 ... 50/1 000 mg/m³.

13) E21 only for options 1, 3 and 5

14) In combination with the E21 option (CSA for measuring flammable gases) without pump, flow indicator, pressure switch and S-vessel. The solenoid valve is present. However, the gas path corresponds to this setup.

15) Present in combination with the E21 option (CSA for measuring flammable gases) without flow indicator, pressure switch and S-vessel. However, the gas path corresponds to this setup.

Options	Order code
Add "-Z" to article number and then add order code	
Settings	
Add-on electronics with 8 digital inputs/outputs, PROFIBUS PA interface	A12
Add-on electronics with 8 digital inputs/outputs, PROFIBUS DP interface	A13

Options	Order code
Stainless steel connection pipe (mat. No. 1.4571), 6 mm, complete with screw connection (cannot be combined with Viton hose)	A27
Stainless steel connection pipe (mat. No. 1.4571), ¼", complete with screw connection (cannot be combined with Viton hose)	A29
IEC plug, 37-pin D-sub connector, 9-pin D-sub connector	A33
Tag plates (customized inscription)	B03
Clean for O ₂ service (specially cleaned gas path)	B06
Gas path for short response time ³⁾	C01

Selection and ordering data (continued)

Options	Order code
Chopper compartment purging for 6 mm gas connection	C02
Chopper compartment purging for 1/4" gas connection	C03
Application with paramagnetic oxygen measuring cell and separate gas path	C11
Selection of the conversion mg/m ³ in ppm at 293K or 273K	D15
ATEX: II 3G Ex ec ic nC IIC T4 Gc; BVS 16 ATEX E 061 X IECEX: Ex ec ic nC IIC T4 Gc; IECEX BVS 16.0041X FM/CSA: Class I, Zone 2 A/Ex ec ic nC IIC T4 Gc Class I, Division 2, Groups A, B, C, D T4	E20
CSA: Class I, Zone 2 A/Ex ec ic nC IIC T4 Gb/Gc Class I, Division 2, Groups A, B, C, D T4	E21
Measuring range indication in plain text ¹⁾	Y11
Measurement of CO ₂ in forming gas ²⁾ (only in conjunction with measuring range 0 ... 20 / 0 ... 100%)	Y14

- 2) CO₂ measurement in accompanying gas Ar or Ar/He (3:1); forming gas.
3) Only for version with Viton hose.

Accessories	Article No.
CO ₂ absorber cartridge	7MB1933-8AA
RS 485/Ethernet converter	A5E52327218
RS 485/RS 232 converter	A5E52327214
RS 485/USB converter	A5E52327216
Add-on electronics with 8 digital inputs/outputs and PROFIBUS PA	A5E00056834
Add-on electronics with 8 digital inputs/outputs and PROFIBUS DP	A5E00057159
Set of Torx screwdrivers	A5E34821625

1) Default setting: smallest measuring range, largest measuring range.

ULTRAMAT 23 gas analyzer - German Technical Inspectorate version For measuring 1 infrared component, UV components and oxygen		Article No.	
		7MB2355-	● ● ● ● 6 - ● A A ●
Click on the Article No. for online configuration in the PIA Life Cycle Portal.			
<i>Unavailable combinations are shown in PIA Life Cycle Portal as "not permitted".</i>			
Enclosure, version and gas paths 19" rack unit for installation in cabinets			
Gas connections	Gas path	Internal sample gas pump	
6 mm	FPM (Viton)	Without	0
Measured component	Possible with measuring range identification		
CO	G, J		A
CO ₂	P		C
SO ₂ ¹⁾	F, G, H, S, W		N
NO	A, F, G, H, U, V, W		P
Smallest measuring range³⁾	Largest measuring range³⁾		
NO: 0 ... 50 mg/m ³ ⁴⁾	NO: 0 ... 500 mg/m ³ ⁴⁾		A
SO ₂ : 0 ... 400 mg/m ³	SO ₂ : 0 ... 2 000 mg/m ³		F
NO: 0 ... 200 mg/m ³	NO: 0 ... 1 000 mg/m ³		
CO: 0 ... 200 mg/m ³	CO: 0 ... 1 250 mg/m ³		G
SO ₂ : 0 ... 500 mg/m ³	SO ₂ : 0 ... 2 500 mg/m ³		
NO: 0 ... 250 mg/m ³	NO: 0 ... 1 250 mg/m ³		
NO: 0 ... 600 mg/m ³	NO: 0 ... 3 000 mg/m ³		H
SO ₂ : 0 ... 1 400 mg/m ³	SO ₂ : 0 ... 7 000 mg/m ³		
0 ... 1 250 vpm	0 ... 6 000 vpm		J
0 ... 5% ²⁾	0 ... 25% ²⁾		P
0 ... 50 mg/m ³ 2) 5)	0 ... 1 250 mg/m ³ 2) 5)		S
0 ... 150 mg/m ³ 2)	0 ... 750 mg/m ³ 2)		U
0 ... 250 mg/m ³ 2)	0 ... 1 250 mg/m ³ 2)		V
0 ... 400 mg/m ³ 2)	0 ... 2 000 mg/m ³ 2)		W
Oxygen measurement			
Without O ₂ sensor	0		
With electrochemical O ₂ sensor	1		
With paramagnetic oxygen measuring cell	8		
Auxiliary power			
230 V AC, 50 Hz	3		
Language of the operating software			
German	0		
English	1		

Extractive continuous process gas analytics

ULTRAMAT 23

19" rack unit and portable version

Selection and ordering data (continued)

ULTRAMAT 23 gas analyzer - German Technical Inspectorate version For measuring 1 infrared component, UV components and oxygen		Article No. 7MB2355- ● ● ● ● 6 - ● A A ●	
French			2
Spanish			3
Italian			4

- When measuring range identification "S" selected: Parallel measurement of SO₂ and NO₂ with UV photometer.
- Only in conjunction with order code T13/T23/T33.
- German Technical Inspectorate: see table "TÜV/German Technical Inspectorate, 1 and 2-component analyzer" under "More information".
- For devices in applications requiring a certified measuring range of less than 0 ... 100 mg/m³, compensation of the CO₂ cross-interference for CO and NO and of the O₂ cross-interference for NO is necessary.
- The measuring ranges of the two components differ slightly: For SO₂: 0 ... 50/1 250 mg/m³, for NO₂: 0 ... 50/1 000 mg/m³.

Options	Order code
Add "-Z" to article number and then add order code.	
Settings	
Add-on electronics with 8 digital inputs/outputs, PROFIBUS PA interface	A12
Add-on electronics with 8 digital inputs/outputs, PROFIBUS DP interface	A13
IEC plug, 37-pin D-sub connector, 9-pin D-sub connector	A33
O ₂ paramagnetic, suitability-tested EN 15267, IR measuring range in mg/m ³	T13
O ₂ paramagnetic, suitability-tested EN 15267, IR measuring range in mg/m ³ , wide measuring range	T14

Options	Order code
O ₂ electrochemical, suitability-tested EN 15267, IR measuring range in mg/m ³	T23
O ₂ electrochemical, suitability-tested EN 15267, IR measuring range in mg/m ³ , wide measuring range	T24
O ₂ electrochemical cell	T25
Without O ₂ , suitability-tested EN 15267, IR measuring range in mg/m ³	T33
Without O ₂ , suitability-tested EN 15267, IR measuring range in mg/m ³ , wide measuring range	T34
No O ₂ cell integrated	T35
Measuring range indication in plain text	Y11
SO ₂ with measuring range 0 ... 400/7 000 mg/m ³	Y15

ULTRAMAT 23 gas analyzer - German Technical Inspectorate version For measuring 2 infrared components, UV components and oxygen		Article No. 7MB2357- ● ● ● ● 0 - ● ● ● ●	
Click on the Article No. for online configuration in the PIA Life Cycle Portal.			
<i>Unavailable combinations are shown in PIA Life Cycle Portal as "not permitted".</i>			
Enclosure, version and gas paths 19" rack unit for installation in cabinets			
Gas connections	Gas path	Internal sample gas pump	
6 mm	FPM (Viton, not separate)	Without	0
1st infrared measured component			
Measured component	Possible with measuring range identification		
CO	G, J		A
CO ₂	P		C
SO ₂	F, G, H, W		N
NO	A, F, G, H, U, V, W		P
Smallest measuring range³⁾	Largest measuring range³⁾		
NO: 0 ... 50 mg/m ³⁴⁾	NO: 0 ... 500 mg/m ³⁴⁾		A
SO ₂ : 0 ... 400 mg/m ³	SO ₂ : 0 ... 2 000 mg/m ³		F
NO: 0 ... 200 mg/m ³	NO: 0 ... 1 000 mg/m ³		
CO: 0 ... 200 mg/m ³	CO: 0 ... 1 250 mg/m ³		G
SO ₂ : 0 ... 500 mg/m ³	SO ₂ : 0 ... 2 500 mg/m ³		
NO: 0 ... 250 mg/m ³	NO: 0 ... 1 250 mg/m ³		
NO: 0 ... 600 mg/m ³	NO: 0 ... 3 000 mg/m ³		H
SO ₂ : 0 ... 1 400 mg/m ³	SO ₂ : 0 ... 7 000 mg/m ³		
0 ... 1 250 vpm	0 ... 6 000 vpm		J
0 ... 5% ²⁾	0 ... 25% ²⁾		P
0 ... 150 mg/m ^{3 2)}	0 ... 750 mg/m ^{3 2)}		U
0 ... 250 mg/m ^{3 2)}	0 ... 1 250 mg/m ^{3 2)}		V
0 ... 400 mg/m ^{3 2)}	0 ... 2 000 mg/m ^{3 2)}		W
Oxygen measurement			
Without O ₂ sensor			0
With electrochemical O ₂ sensor			1

Selection and ordering data (continued)

		Article No.									
ULTRAMAT 23 gas analyzer - German Technical Inspectorate version		7MB2357- ● ● ● ● 0 - ● ● ● ●									
For measuring 2 infrared components, UV components and oxygen											
With paramagnetic oxygen measuring cell		8									
Auxiliary power											
230 V AC, 50 Hz		3									
2nd infrared measured component											
Measured component	Possible with measuring range identification										
CO	A, G, J	A									
CO ₂	P	C									
SO ₂ ¹⁾	F, G, H, S, W	N									
NO	F, G, H, U, V, W	P									
Smallest measuring range³⁾	Largest measuring range³⁾										
CO: 0 ... 50 mg/m ^{3 4)}	CO: 0 ... 500 mg/m ^{3 4)}	A									
SO ₂ : 0 ... 400 mg/m ³	SO ₂ : 0 ... 2 000 mg/m ³	F									
NO: 0 ... 200 mg/m ³	NO: 0 ... 1 000 mg/m ³	G									
CO: 0 ... 200 mg/m ³	CO: 0 ... 1 250 mg/m ³	G									
SO ₂ : 0 ... 500 mg/m ³	SO ₂ : 0 ... 2 500 mg/m ³	H									
NO: 0 ... 250 mg/m ³	NO: 0 ... 1 250 mg/m ³	H									
NO: 0 ... 600 mg/m ³	NO: 0 ... 3 000 mg/m ³	H									
SO ₂ : 0 ... 1 400 mg/m ³	SO ₂ : 0 ... 7 000 mg/m ³	H									
0 ... 1 250 vpm	0 ... 6 000 vpm	J									
0 ... 5% ²⁾	0 ... 25% ²⁾	P									
0 ... 50 mg/m ^{3 2) 5)}	0 ... 1 250 mg/m ^{3 2) 5)}	S									
0 ... 150 mg/m ^{3 2)}	0 ... 750 mg/m ^{3 2)}	U									
0 ... 250 mg/m ^{3 2)}	0 ... 1 250 mg/m ^{3 2)}	V									
0 ... 400 mg/m ^{3 2)}	0 ... 2 000 mg/m ^{3 2)}	W									
Language of the operating software											
German		0									
English		1									
French		2									
Spanish		3									
Italian		4									

1) When measuring range identification "S" selected: Parallel measurement of SO₂ and NO₂ with UV photometer.

2) Only in conjunction with order code T13/T23/T33.

3) German Technical Inspectorate: see table "TÜV/German Technical Inspectorate, 1 and 2-component analyzer" under "More information".

4) For devices in applications requiring a certified measuring range of less than 0 ... 100 mg/m³, compensation of the CO₂ cross-interference for CO and NO and of the O₂ cross-interference for NO is necessary.

5) The measuring ranges of the two components differ slightly: For SO₂: 0 ... 50/1 250 mg/m³, for NO₂: 0 ... 50/1 000 mg/m³.

Options	Order code
Add "-Z" to article number and then add order code.	
Settings	
Add-on electronics with 8 digital inputs/outputs, PROFIBUS PA interface	A12
Add-on electronics with 8 digital inputs/outputs, PROFIBUS DP interface	A13
IEC plug, 37-pin D-sub connector, 9-pin D-sub connector	A33
O ₂ paramagnetic, suitability-tested EN 15267, IR measuring range in mg/m ³	T13
O ₂ paramagnetic, suitability-tested EN 15267, IR measuring range in mg/m ³ , wide measuring range	T14

Options	Order code
O ₂ electrochemical, suitability-tested EN 15267, IR measuring range in mg/m ³	T23
O ₂ electrochemical, suitability-tested EN 15267, IR measuring range in mg/m ³ , wide measuring range	T24
O ₂ electrochemical, suitability-tested EN 15267, measuring range in mg/m ³ with UV photometer	T25
Without O ₂ , suitability-tested EN 15267, IR measuring range in mg/m ³	T33
Without O ₂ , suitability-tested EN 15267, IR measuring range in mg/m ³ , wide measuring range	T34
Suitability-tested EN 15267, measuring range in mg/m ³ with UV photometer	T35
Measuring range indication in plain text	Y11
SO ₂ with measuring range 0 ... 400/7 000 mg/m ³	Y15

Extractive continuous process gas analytics

ULTRAMAT 23

19" rack unit and portable version

Selection and ordering data (continued)

ULTRAMAT 23 gas analyzer - German Technical Inspectorate version For measuring 3 infrared components, UV components, oxygen or 2 infrared components and UV components			Article No. 7MB2358- ● ● ● ● 6 - ● ● ● ●			
Click on the Article No. for online configuration in the PIA Life Cycle Portal. <i>Unavailable combinations are shown in PIA Life Cycle Portal as "not permitted".</i>						
Enclosure, version and gas paths 19" rack unit for installation in cabinets						
Gas connections	Gas path	Internal sample gas pump				
6 mm	FPM (Viton, not separate)	Without	0			
1st and 2nd infrared measured component						
Measured component	Smallest measuring range	Largest measuring range				
CO and NO	0 ... 250 mg/m ³ (CO) 0 ... 400 mg/m ³ (NO)	0 ... 1 250 mg/m ³ (CO) 0 ... 2 000 mg/m ³ (NO)	A K			
CO and NO	0 ... 200 mg/m ³ (CO) 0 ... 150 mg/m ³ (NO)	0 ... 1 250 mg/m ³ (CO) 0 ... 750 mg/m ³ (NO)	A S			
CO and CO ₂	0 ... 50 mg/m ³ (CO) 0 ... 5% (CO ₂)	0 ... 500 mg/m ³ (CO) 0 ... 25% (CO ₂)	B M			
Oxygen measurement						
Without O ₂ sensor			0			
With electrochemical O ₂ sensor			1			
With paramagnetic oxygen measuring cell			8			
Auxiliary power						
230 V AC, 50 Hz			3			
3rd infrared measured component						
Measured component	Possible with measuring range identification					
SO ₂ ¹⁾	F, G, H, S, W		N			
Smallest measuring range²⁾	Largest measuring range²⁾					
0 ... 400 vpm	0 ... 2 000 vpm		F			
0 ... 500 vpm	0 ... 2 500 vpm		G			
0 ... 1 400 vpm	0 ... 7 000 vpm		H			
0 ... 50 mg/m ³ ³⁾	0 ... 1 250 mg/m ³ ³⁾		S			
0 ... 400 mg/m ³	0 ... 2 000 mg/m ³		W			
Language of the operating software						
German			0			
English			1			
French			2			
Spanish			3			
Italian			4			

1) When measuring range identification "S" selected: Parallel measurement of SO₂ and NO₂ with UV photometer.

2) German Technical Inspectorate: see table "TÜV/German Technical Inspectorate, 3-component analyzer" under "More information".

3) The measuring ranges of the two components differ slightly: For SO₂: 0 ... 50/1 250 mg/m³, for NO₂: 0 ... 50/1 000 mg/m³.

Options	Order code
Add "-Z" to article number and then add order code.	
Settings	
Add-on electronics with 8 digital inputs/outputs, PROFIBUS PA interface	A12
Add-on electronics with 8 digital inputs/outputs, PROFIBUS DP interface	A13

Options	Order code
IEC plug, 37-pin D-sub connector, 9-pin D-sub connector	A33
O ₂ paramagnetic, suitability-tested EN 15267, IR measuring range in mg/m ³	T13
O ₂ electrochemical, suitability-tested EN 15267, IR measuring range in mg/m ³	T23
Without O ₂ , suitability-tested EN 15267, IR measuring range in mg/m ³	T33
Without O ₂ , suitability-tested EN 15267, IR measuring range in mg/m ³ , with UV photometer	T35
Measuring range indication in plain text	Y11
SO ₂ with measuring range 0 ... 400/7 000 mg/m ³	Y15

Note

See tables for German Technical Inspectorate (TÜV), component analyzer and order examples under "More information".

Technical specifications

ULTRAMAT 23, 19" rack unit and portable version	
General information	
Measured components	Maximum of 4
Measuring ranges	2 per measured component
Display	LCD with LED backlighting and contrast control; function keys; 80 characters (4 lines/20 characters)
Operating position	Front wall, vertical
Conformity	CE marking EN 61000-6-2, EN 61000-6-4
Design, enclosure	
Weight	Approximately 10 kg
Degree of protection, 19" rack unit and desktop model	<ul style="list-style-type: none"> 7MB2335, 7MB2337 and 7MB2338: IP20 according to EN 60529 7MB2355, 7MB2357 and 7MB2358: IP40 according to EN 60529
Electrical characteristics	
EMC interference immunity (electromagnetic compatibility)	In accordance with standard requirements of NAMUR NE21 or EN 61326-1
Safety extra-low voltage (SELV) with safe isolation	
Auxiliary power	<ul style="list-style-type: none"> 100 V AC, +10%/-15%, 50 Hz 120 V AC, +10%/-15%, 50 Hz 200 V AC, +10%/-15%, 50 Hz 230 V AC, +10%/-15%, 50 Hz 100 V AC, +10%/-15%, 60 Hz 120 V AC, +10%/-15%, 60 Hz 230 V AC, +10%/-15%, 60 Hz
Power consumption	Approx. 60 VA
Electrical inputs and outputs	
Analog output	Per component, 0/2/4 ... 20 mA, NAMUR, floating, max. load 750 Ω
Relay outputs	8, with changeover contacts, freely configurable, e.g. for measuring range identification; 24 V AC/DC/1 A load rating, floating, non-sparking
Digital inputs	3, dimensioned for 24 V, potential-free <ul style="list-style-type: none"> Pump AUTOCAL Synchronization
Serial interface	RS 485
AUTOCAL function	Automatic device calibration with ambient air (depending on measured component); adjustable cycle time from 0 (1) ... 24 hours
Options	Add-on electronics, each with 8 additional digital inputs and relay outputs, e.g. for triggering of automatic calibration and for PROFIBUS PA or PROFIBUS DP
Climatic conditions	
Permissible ambient temperature	
• During operation	<ul style="list-style-type: none"> +5 ... 45 °C (IR detector, O₂) +5 ... 40 °C (H₂S sensor) +15 ... 35 °C (UV photometer)
• During storage and transportation	<ul style="list-style-type: none"> -25 ... 60 °C (IR detector, O₂, UV photometer) -10 ... 60 °C (H₂S sensor)
Permissible ambient humidity	< 90% RH (relative humidity) during storage and transportation
Permissible pressure fluctuations	<ul style="list-style-type: none"> 600 ... 1 200 hPa (IR detector, O₂, UV photometer) 750 ... 1 200 hPa (H₂S sensor)
Gas inlet conditions	
Sample gas pressure	
• Without pump	Depressurized (< 1 200 hPa, absolute)

Technical specifications (continued)

ULTRAMAT 23, 19" rack unit and portable version	
• With pump	Depressurized suction mode, factory preset with 2 m hose at sample gas outlet; measuring range end value calibration necessary under different restrictor conditions (800 ... 1 050 hPa, absolute)
Sample gas flow	72 ... 120 l/h (1.2 ... 2 l/min)
Sample gas temperature	Min. 0 ... max. 50 °C, but above the dew point
Sample gas humidity	< 90% RH (relative humidity), non-condensing

ULTRAMAT 23, infrared channel¹⁾

Measuring ranges	See ordering data
Chopper purge	Primary pressure approximately 3 000 hPa; purging gas consumption approximately 100 ml/min
Time response	
Warm-up period	Approx. 30 min (at room temperature), (the technical specification will be met after 2 h)
Delayed display (T ₉₀ time)	Dependent on length of analyzer chamber, sample gas line and configurable damping
Damping (electrical time constant)	Configurable from 0 ... 99.9 s
Measuring response	
Output signal fluctuation	< ± 1% of the current measuring range (see nameplate)
Detection limit	1% of the current measuring range
Linearity error	<ul style="list-style-type: none"> In the largest possible measuring range: < ± 1% of the measuring range end value In the smallest possible measuring range: < ± 2% of the measuring range end value
Repeatability	± 1% of the current measuring range
Drift	
Zero point	≤ 1% of the current measuring range/week
Full-scale value drift	≤ 1% of the current measuring range/week
Influencing variables	
Temperature	Based on sample gas pressure 1 013 hPa absolute, 1.0 l/min sample gas flow and 25 °C ambient temperature
Atmospheric pressure	Max. 2% of the smallest possible measuring range according to nameplate per 10 K with an AUTOCAL cycle time of 6 h
Auxiliary power	< 0.2% of the current measuring range per 1% pressure variation
	< 0.1% of the current measuring range with a change of ± 10%

¹⁾ To ensure compliance with the technical specifications, a cycle time of ≤ 24 hours must be activated for the AUTOCAL. The cycle time of the AUTOCAL function must be ≤ 6 hours when measuring small NO and SO₂ measuring ranges (≤ 400 mg/m³) on German Technical Inspectorate/QAL-certified systems.

ULTRAMAT 23, oxygen channel (electrochemical)

Measuring ranges	0 ... 5% to 0 ... 25% O ₂ , configurable
Service life	Approx. 2 years with 21% O ₂
Detection limit	1% of the current measuring range
Time response	
Delayed display (T ₉₀ time)	Dependent on dead time and configurable damping, not > 30 s at approximately 1.2 l/min sample gas flow
Measuring response	
Output signal fluctuation	< ± 0.5% of the current measuring range
Linearity error	< ± 0.2% of the current measuring range

Extractive continuous process gas analytics

ULTRAMAT 23

19" rack unit and portable version

Technical specifications (continued)

ULTRAMAT 23, oxygen channel (electrochemical)	
Repeatability	≤ 0.05% O ₂
Drift	
• With AUTOCAL	Negligible
Influencing variables	Based on sample gas pressure 1 013 hPa absolute, 1.0 l/min sample gas flow and 25 °C ambient temperature
Temperature	< ± 0.5% O ₂ per 20 K, relating to a measured value at 20 °C
Atmospheric pressure	< 0.2% of the measured value per 1% pressure variation
Accompanying gases	The oxygen sensor must not be used if the accompanying gas contains the following components: Chlorine or fluorine compounds, heavy metals, aerosols, mercaptans, alkaline components (such as NH ₃ in % range)
Typical combustion exhaust gases	Influence: < 0.05% O ₂
Humidity	H ₂ O dew point ≥ 2 °C; the oxygen sensor must not be used with dry sample gases (however, no condensation either)

ULTRAMAT 23, ultraviolet photometer ²⁾	
Measuring ranges	The measuring ranges are calibrated with a certified calibration gas, whereby a concentration specification in ppm in accordance with EN 1343 must be converted to the unit mg/m ³ at a reference temperature of 0 °C and a reference pressure of 1 013 hPa.
SO ₂	
• Smallest measuring range	0 ... 50 mg/m ³
• Largest measuring range	0 ... 1 250 mg/m ³
NO ₂	
• Smallest measuring range	0 ... 50 mg/m ³
• Largest measuring range	0 ... 1 250 mg/m ³
Time response	
Warm-up period	30 min The technical specification will be met after 2 h
Delayed display (T ₉₀ time)	Dependent on the external gas preparation, the length of the sample gas line and the configurable damping (see below) of the device. Note: SO ₂ is highly soluble in water! ≤ 30 s after sample gas inlet at a damping of ≤ 12 s
Damping (electronic time constant)	0 ... 99.9 s, can be set
Measuring response	
Output signal fluctuation	≤ 1% of set full-scale value
Detection limit	1% of set full-scale value or: • 1 mg/m ³ (SO ₂) • 0.8 mg/m ³ (NO ₂) This corresponds to 0.4 ppm for both components
Linearity error	
• In the largest measuring range	≤ 1% of set full-scale value
• In the smallest measuring range	≤ 2% of set full-scale value
Repeatability	≤ 1% of set full-scale value
Influencing variables	
Temperature error	≤ 4% of smallest full-scale value/10 K in ambient temperature range of 5 ... 45 °C
Atmospheric pressure	≤ 1% of set full-scale value per 1% pressure variation
Auxiliary power	≤ 0.1% of set full-scale value with a change of ±10%
Drift (zero point and full-scale value)	
• AUTOCAL activated	Negligible depending on the cycle time setting

Technical specifications (continued)

ULTRAMAT 23, ultraviolet photometer ²⁾	
• AUTOCAL deactivated	
- NO ₂	3% of the smallest measuring range
- SO ₂	3% of the smallest measuring range
Note	It can take up to 12 hours after the device is put into operation before these values are reached.
Accompanying gases	
• Humidity up to 20 °C dew point	Negligible
• CO ₂ ≤ 16% vol	Negligible
• Exclusions	<ul style="list-style-type: none"> Sulfur compounds other than SO₂ Halogen compounds Chlorine Acetone Ozone

³⁾ To ensure compliance with the technical specifications, a cycle time of ≤ 24 hours must be activated for the AUTOCAL. The technical specifications are based on a sample gas pressure of 1 013 ± 5 hPa absolute, a sample gas flow of 1.2 ± 0.2 l/min and an ambient temperature of 25 ± 2 °C. They apply to the SO₂ and NO₂ sample gas components.

ULTRAMAT 23, H ₂ S channel for measuring ranges of 5 ... 50 vpm	
Measured components	Maximum of 4, comprising up to 2 infrared-sensitive gases, an oxygen component and a hydrogen sulfide component
Measuring ranges	
• Smallest measuring range	0 ... 5 vpm
• Largest measuring range	0 ... 50 vpm
Service life of the sensor	Approx. 12 months
Permissible atmospheric pressure	750 ... 1 200 hPa
Permissible operating temperature	5 ... 40 °C (41 ... 104 °F)
Operation mode	<ul style="list-style-type: none"> Continuous measurement between 0 and 12.5 vpm Discontinuous measurement between 12.5 and 50 vpm
Influencing variables	
Accompanying gases	The hydrogen sulfide sensor must not be used if the accompanying gas contains the following components: <ul style="list-style-type: none"> Compounds containing chlorine Compounds containing fluorine Heavy metals Aerosols Alkaline components (e.g. NH₃ > 5 vpm)
Interference gases	1 360 vpm SO ₂ result in a cross-interference of < 20 vpm H ₂ S 180 vpm NO result in a cross-interference of < 150 vpm H ₂ S No cross-interference of CH ₄ , CO ₂ and H ₂ (1 000 vpm)
Temperature	< 3%/10 K referred to full-scale value
Atmospheric pressure	< 0.2% of the measured value per 1% pressure variation
Measuring response	
Delayed display (T ₉₀ time)	< 40 s with sample gas flow of approx. 1 ... 1.2 l/min
Output signal noise	< 2% of smallest measuring range with a damping constant of 30 s
Display resolution	< 0.01 vpm H ₂ S
Output signal resolution	< 1% of smallest measuring range with a damping constant of 30 s
Repeatability	< 4% of smallest measuring range
Drift	< 1% of the current measuring range per month

Technical specifications (continued)

ULTRAMAT 23, paramagnetic oxygen cell	
Measured components	Maximum of 4, comprising up to 3 infrared-sensitive gases and an oxygen component
Measuring ranges	2 per component <ul style="list-style-type: none"> • Min. 0 ... 2% vol O₂ • Max. 0 ... 100% vol O₂ • Suppressed measuring range possible; e.g. 95 ... 100%
Permissible operating temperature	5 ... 45 °C (41 ... 113 °F)
Interference gases	See "Paramagnetic oxygen cell cross-interference" table
Zero point drift	<ul style="list-style-type: none"> • Measuring range 2%: max. 0.1% with weekly zero-point calibration • Measuring range 5%: max. 0.1% with weekly zero-point calibration • Measuring range 25% or more: max. 0.5% with monthly zero-point calibration
Measured-value drift	Negligible with AUTOCAL
Temperature error	<ul style="list-style-type: none"> < 2%/10 K referred to measuring range 5% < 5%/10 K referred to measuring range 2%
Humidity error for N ₂ with 90% relative humidity after 30 min	< 0.6% at 50 °C
Atmospheric pressure	< 0.2% of measured value per 1% pressure variation
Delayed display (T90 time)	< 60 s
Output signal noise	< 1% of smallest measuring range
Repeatability	< 1% of the current measuring range

Extractive continuous process gas analytics

ULTRAMAT 23

19" rack unit and portable version

Dimensional drawings

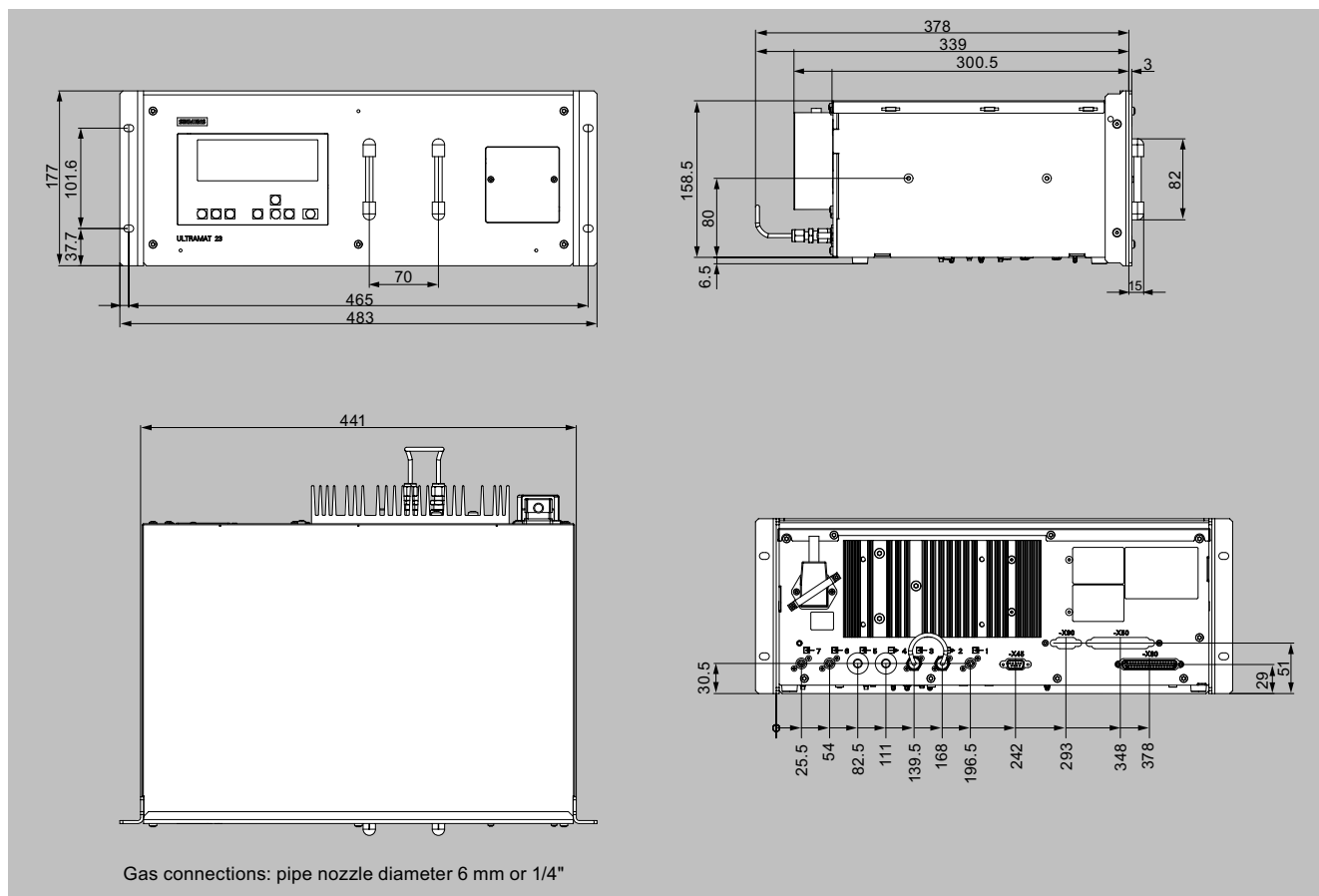

ULTRAMAT 23, 19" rack unit, dimensions in mm

Dimensional drawings (continued)

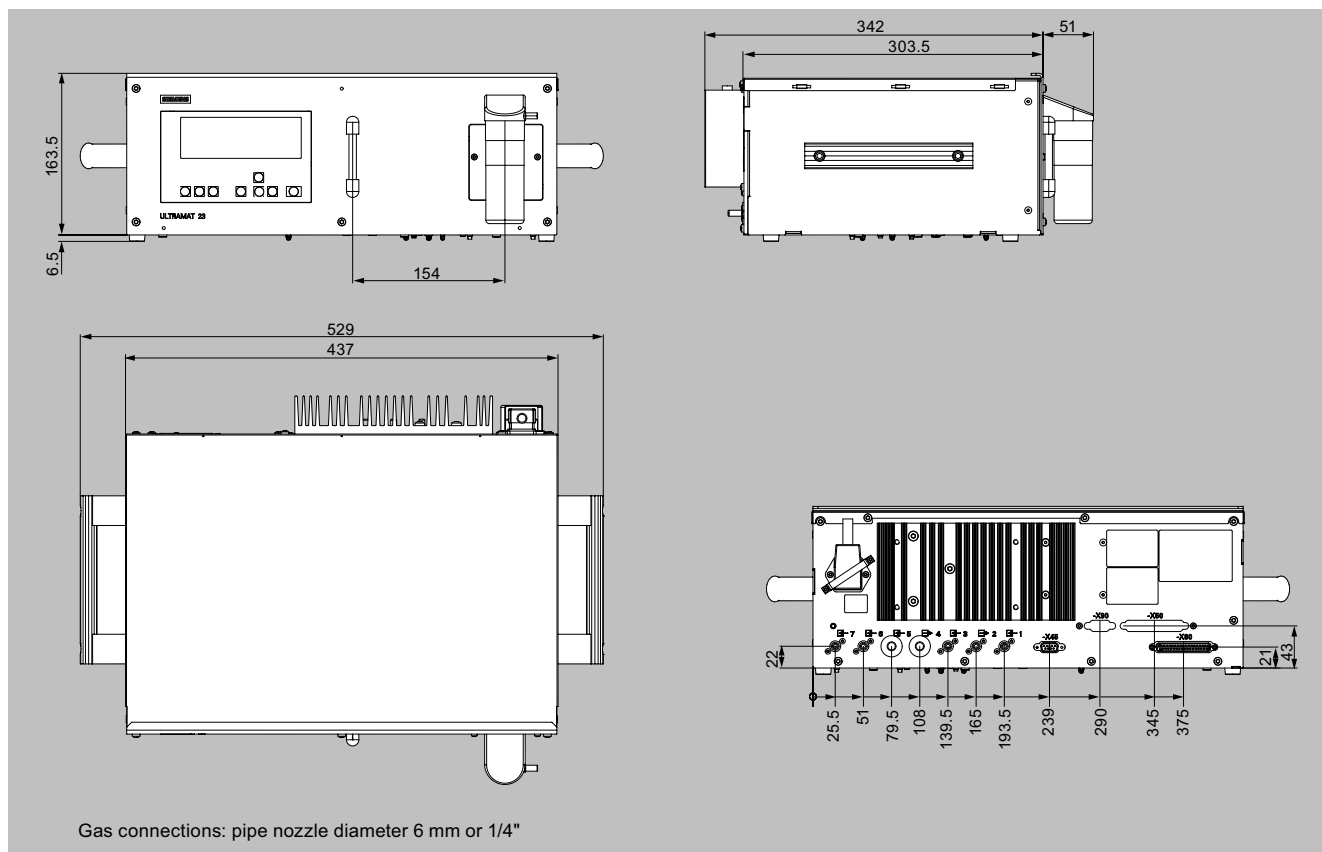

ULTRAMAT 23, bench-top unit, dimensions in mm

Circuit diagrams (continued)

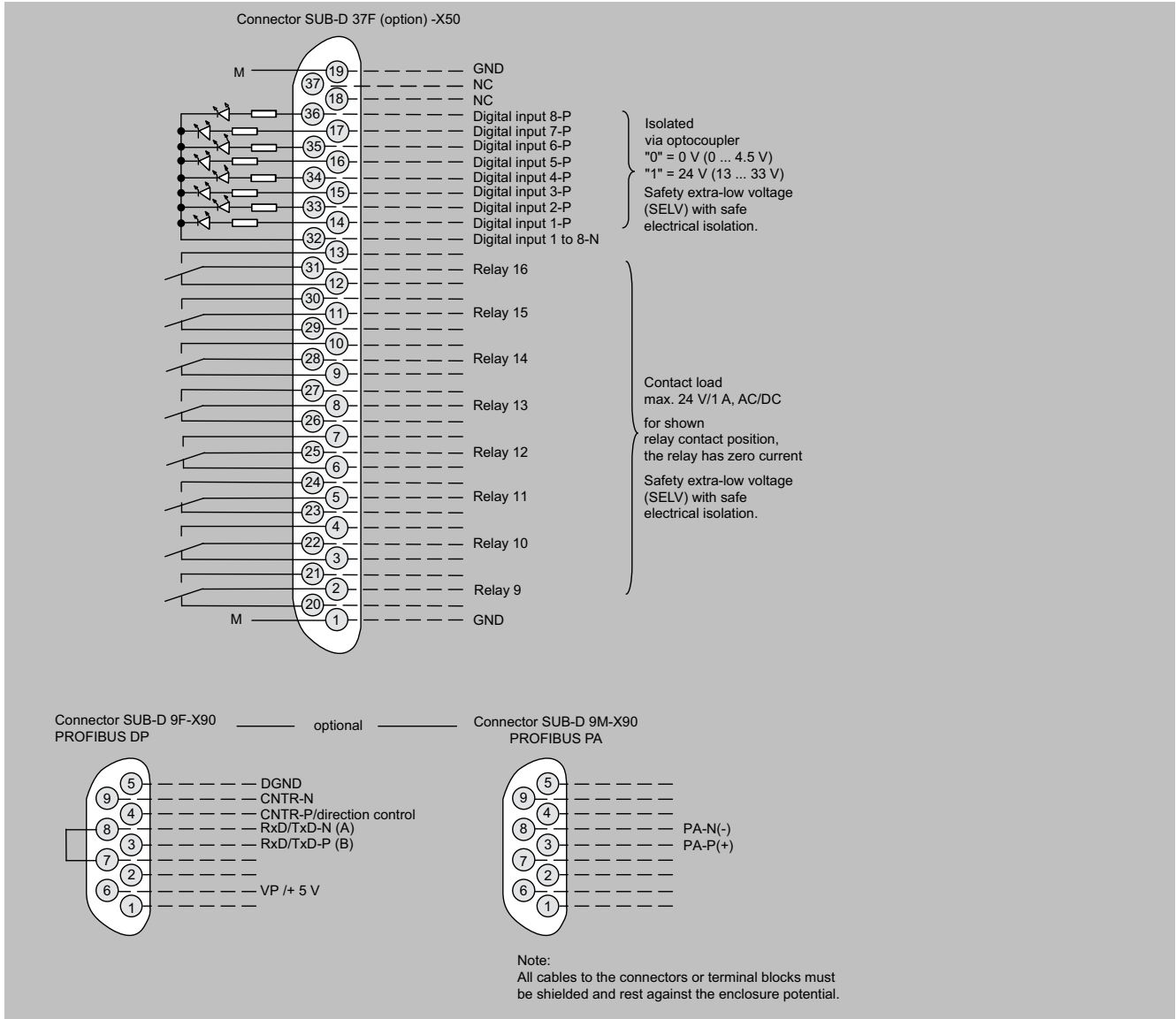

ULTRAMAT 23, pin assignment of optional PROFIBUS interface card

Extractive continuous process gas analytics

ULTRAMAT 23

19" rack unit and portable version

Circuit diagrams (continued)

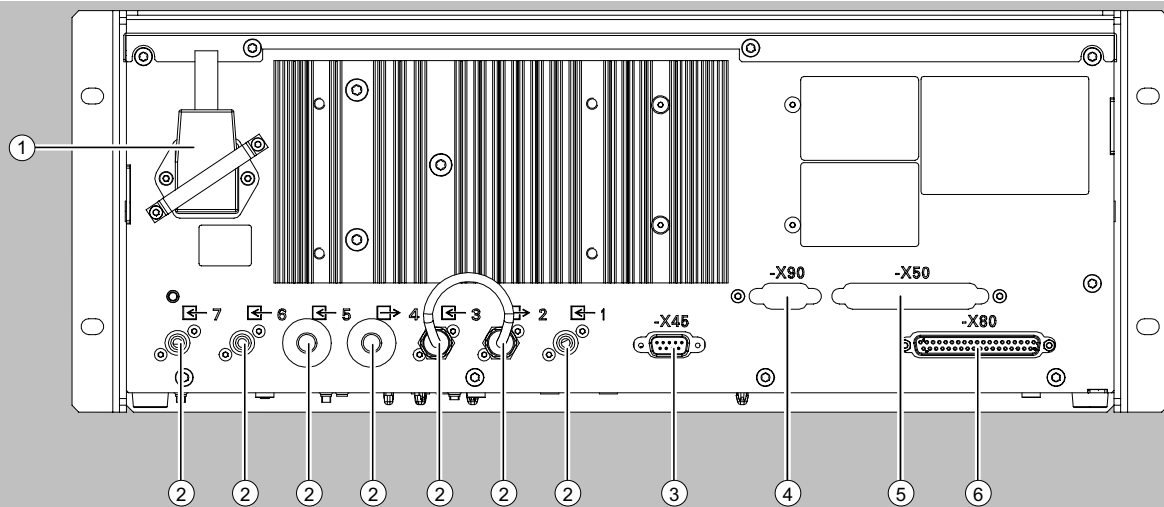

- ① Auxiliary power and fine fuse
- ② Gas connections: nozzles 6 mm or ¼"
- ③ -X45: ELAN (RS485) 9-pin connector
- ④ -X90: 9-pin interface connector (option board with PROFIBUS-DP/PA)
- ⑤ -X50: 37-pin connector: Option board; digital inputs/relay outputs
- ⑥ -X80: 37-pin connector: Analog and digital inputs and outputs

When installing in a cabinet: mount analyzer on support rails.

ULTRAMAT 23, 19" rack unit, e.g. an IR measured component with oxygen measurement

Circuit diagrams (continued)

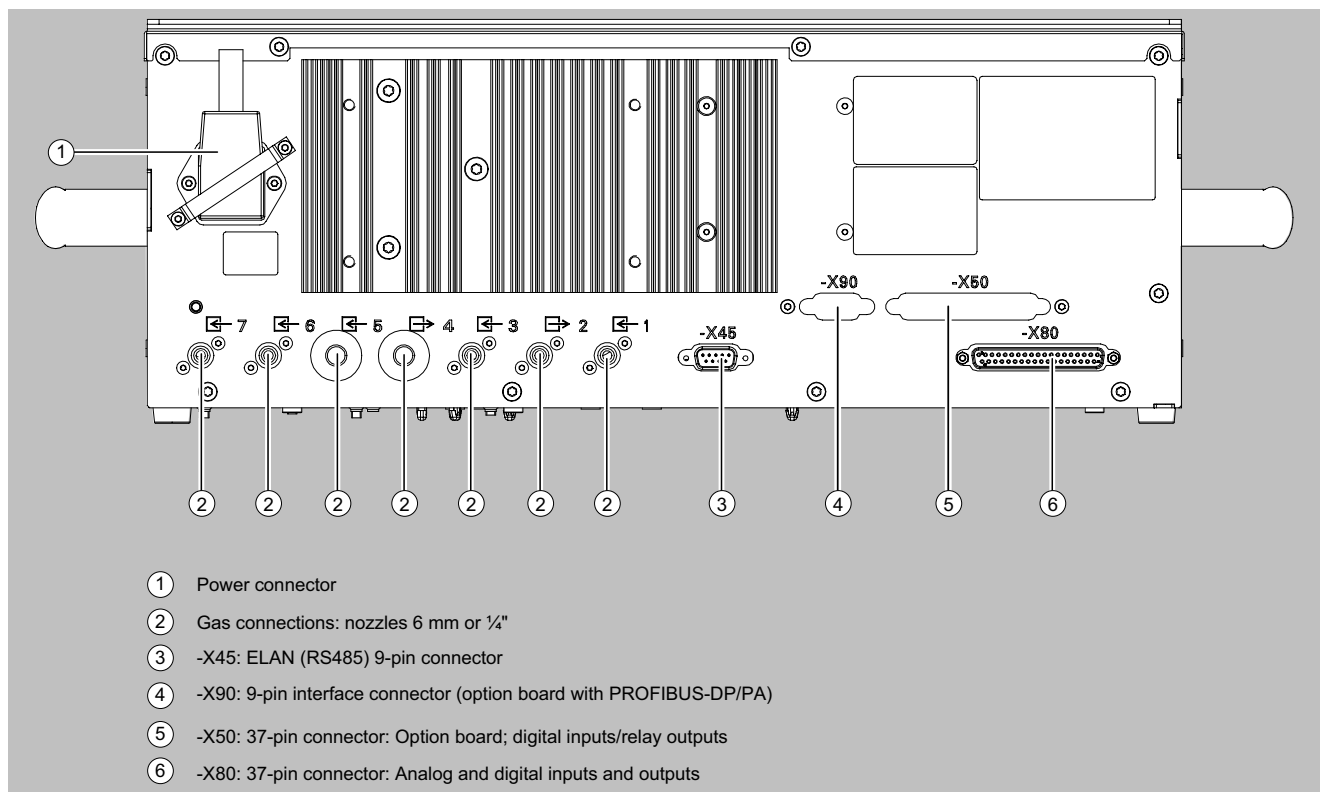

ULTRAMAT 23 portable, in sheet-steel enclosure, gas connections and electrical connections

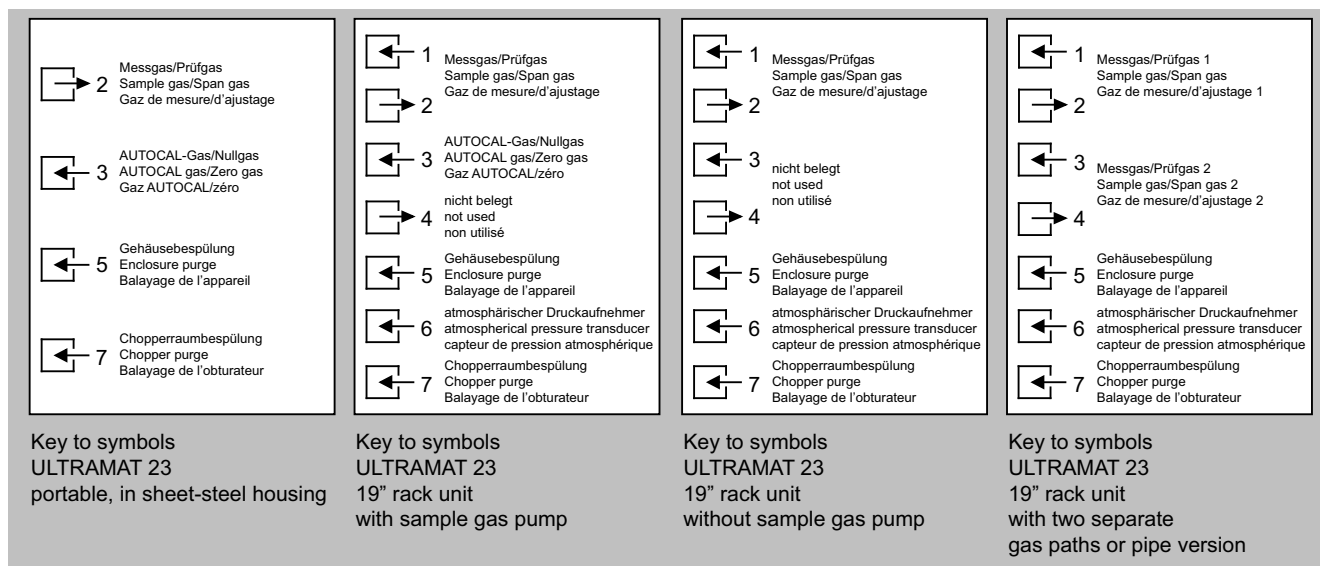

ULTRAMAT 23, designation of the different labels

Extractive continuous process gas analytics

ULTRAMAT 23

19" rack unit and portable version

More information

German Technical Inspectorate (TÜV), 1 and 2-component analyzer

Only in conjunction with order code T13/T23/T33

Component	CO (TÜV)		SO ₂ (TÜV)		NO (TÜV)	
	Smallest measuring range from 0 to ...	Largest measuring range from 0 to ...	Smallest measuring range from 0 to ...	Largest measuring range from 0 to ...	Smallest measuring range from 0 to ...	Largest measuring range from 0 to ...
F	-	-	400 mg/m ³	2 000 mg/m ³	200 mg/m ³	1 000 mg/m ³
G	200 mg/m ³	1 250 mg/m ³	500 mg/m ³	2 500 mg/m ³	250 mg/m ³	1 250 mg/m ³
H	-	-	1 400 mg/m ³	7 000 mg/m ³	-	-
S	-	-	75 mg/m ³	1 250 mg/m ³	-	-

Only in conjunction with order code T14/T24/T34

Component	CO (TÜV)		SO ₂ (TÜV)		NO (TÜV)	
	Smallest measuring range from 0 to ...	Largest measuring range from 0 to ...	Smallest measuring range from 0 to ...	Largest measuring range from 0 to ...	Smallest measuring range from 0 to ...	Largest measuring range from 0 to ...
H	-	-	-	-	600 mg/m ³	3 000 mg/m ³
J	1 250 mg/m ³	6 000 mg/m ³	-	-	-	-

Ordering example

ULTRAMAT 23, German Technical Inspectorate (TÜV)

IR component: CO

Measuring range: 0 to 200 / 1 250 mg/m³

with electrochemical O₂ sensor

230 V AC; German

7MB2355-0AG16-3AA0-Z +T23

German Technical Inspectorate (TÜV), 3-component analyzer

Only in conjunction with order code T13/T23/T33

Component	CO (TÜV)		SO ₂ (TÜV)		NO (TÜV)	
	Smallest measuring range from 0 to ...	Largest measuring range from 0 to ...	Smallest measuring range from 0 to ...	Largest measuring range from 0 to ...	Smallest measuring range from 0 to ...	Largest measuring range from 0 to ...
F	-	-	400 mg/m ³	2 000 mg/m ³	-	-
G	-	-	500 mg/m ³	2 500 mg/m ³	-	-
H	-	-	1 400 mg/m ³	7 000 mg/m ³	-	-

Ordering example

ULTRAMAT 23, German Technical Inspectorate (TÜV)

IR component: CO/NO + SO₂

Measuring range: CO: 0 to 250 / 1 250 mg/m³, NO: 0 to 400 /

2 000 mg/m³, SO₂: 0 to 400 / 2 000 mg/m³

with paramagnetic oxygen measuring cell

230 V AC; German

7MB2358-0AK86-3NF0-Z +T13

Ordering notes

Special selection rules must be observed when measuring some components.

Measured component N₂O

7MB2335, 7MB2337 and 7MB2338

(application: Si chip production)

- Measuring range 0 to 100 / 500 vpm (MB designation "E")

- Can only be used to measure N₂O in ultra-pure gases

7MB2337 and 7MB2338

(application: measurement in accordance with the requirements of the Kyoto protocol)

- Measuring range 0 to 500 / 5 000 vpm (MB designation "Y")

- Requires simultaneous measurement of CO₂ for correction of cross-interference

7MB2337-CP*6-*SY* or

7MB2338-DC*6-*SY* (incl. NO measurement)

7MB2337 and 7MB2338 (application with paramagnetic oxygen measuring cell and separate gas path)

7MB2337-4**86-**** - Z + C11

7MB2337-5**86-**** - Z + C11

7MB2338-4**86-**** - Z + C11

7MB2338-5**86-**** - Z + C11

Measured component SF₆

7MB2335, 7MB2337 and 7MB2338

(application: Si chip production)

- Measuring range 0 to 500 / 2 500 vpm (MB designation "H")

- Can only be used to measure SF₆ in ultra-pure gases

More information (continued)*Calibration intervals, standard devices*

	Calibration with calibration gas [weeks]		Comments (Comply with technical specifications)
	Zero point	Calibration point	
IR components	●	52	-
O ₂ - electrochemical sensor	52	●	-
O ₂ paramagnetic cell	1	●	At MB < 5%
	8	●	At MB > 5%
O ₂ paramagnetic cell	●	52	At MB < 5%
	●	52	At MB > 5%
H ₂ S sensor	●	4	-

● = with AUTOCAL, with ambient air or N₂, 3 ... 24h – depending on measuring range.

Extractive continuous process gas analytics

ULTRAMAT 23

Suggestion for spare parts

Selection and ordering data

Description	2 years (unit)	5 years (unit)	Article No.
Analyzer unit			
O-ring for analyzer chamber: 180, 90, 60, 20 mm	2	4	C71121-Z100-A99
Chopper			
• With motor, for 1 IR channel (7MB23X5-...)	1	1	C79451-A3468-B515
• With motor, for 2 IR channels (7MB23X7-..., 7MB23X8-...)	1	1	C79451-A3468-B516
Electronics			
Motherboard, with firmware	-	1	C79451-A3494-D501
Keypad	1	1	C79451-A3492-B605
LCD module	1	1	C79451-A3494-B16
Plug-in filter	-	1	W75041-E5602-K2
Line switch (portable analyzer)	-	1	W75050-T1201-U101
Fusible element 220 ... 240 V	2	4	W79054-L1010-T630
Fusible element 100 ... 120 V	2	4	W79054-L1011-T125
Other			
Safety filter (zero gas), internal	2	2	C79127-Z400-A1
Safety filter (sample gas), internal	2	3	C79127-Z400-A1
Pressure switch	1	2	C79302-Z1210-A2
Flowmeter	1	2	C79402-Z560-T1
Set of gaskets for sample gas pump	2	5	C79402-Z666-E20
Condensation trap (for portable device, in sheet steel enclosure)	1	2	C79451-A3008-B43
Filter (for portable device, in sheet steel enclosure)	1	2	C79451-A3008-B60
Oxygen sensor	1	1	C79451-A3458-B55
Sample gas pump 50 Hz	1	1	C79451-A3494-B10
Sample gas pump 60 Hz	1	1	C79451-A3494-B11
Solenoid valve	1	1	C79451-A3494-B33