



Description of the Measurement • 12/2016

Help and Explanations to – “SIMATIC OPC UA Transfer Time Measurements”

OPC ID32

Table of Contents

1	Scope of the Measurement	3
1.1	Objective.....	3
1.2	Performance data provided.....	4
1.3	Parameters of the measurement.....	5
1.4	Scope of validity and technical data.....	5
2	How to Use the User Interface	9
2.1	Overview of the user interface.....	9
2.2	How to use the user interface.....	10
2.2.1	Initial situation when starting the application.....	11
2.2.2	Entering the desired configuration.....	13
2.2.3	Entering the performance requirements.....	15
2.2.4	View of the selected configuration.....	15
2.2.5	Performance data table.....	16
3	Performing the Measurements	18
3.1	Method of measurement and measurement setup/sequence.....	18
3.2	Measurement setup.....	19
3.1	Method of measurement of the “Monitoring via UA subscription/cpu subscription” transfer time.....	22
3.2	Method of measurement of the “UA Read” transfer time.....	26
3.3	Method of measurement of the “UA Write” transfer time.....	28
3.4	Measurement: Cycle time/cycle control time.....	30
3.5	Measured variables and statistics.....	31
3.6	Explanatory notes on the OPC UA test client.....	35
3.7	Explanatory notes on the STEP 7 program.....	37
3.7.1	Variable structure in the S7 CPUs.....	37
3.7.2	Overview of the STEP 7 programs.....	40
3.7.3	Measuring program.....	40
3.7.4	Load program.....	41
4	Version	42

1 Scope of the Measurement

1.1 Objective

Automation projects often require intensive data exchange between SIMATIC S7 controllers and PC systems. Nowadays, the usual way is to use the standardized OPC server that acts as a data collector for the S7 stations.

This approach focuses on the measurement of the transfer time of the data through the entire system. This means from the S7 station via the SIMATIC NET OPC Server to the OPC test client. The OPC test client can be located either locally (i.e., on the SIMATIC NET OPC Server PC) or remotely (i.e., on a different PC).

Important questions

The planner's primary interest is how long the system needs to log the change of a large to very large number of variables (OPC items).

Using the use cases, a user wants to retrieve the following information from the system:

- **Update time of n OPC items (monitoring variables)**
Use case: Process values must always be present in the client
 - In the worst case, all variables (OPC items) change in 1 to n S7 CPUs
 - How long is the response time until all changes of the monitored items have been logged by the "local" or "remote" OPC client?
 - How big are the differences between UA subscription and CPU subscription?
- **Read time of n OPC items (reading variables)**
Use case: How long does requesting the data from the "local" or "remote" client take?
 - n variables (OPC items) are read from 1 to n S7 CPUs
 - How long is the read time until all values exist in the OPC client?
- **Operating time of OPC items (writing variables)**
Use case: Update duration from "local" or "remote" client to n CPUs
 - In 1 to n S7 CPUs, n items are written to from the OPC client
 - How long does it take until the changes of the items have been logged in all receive CPUs (end time)?
- **OB1 cycle time**
 - How strongly do the OB1 cycle times in the S7 CPUs differ during active communication with the OPC server?
- **Distribution of nodes**
Use case: How does the distribution of variables (nodes) in the PLC's DBs affect the transfer rate and what is the influence of optimized DBs versus standard DBs?

To answer these questions, Siemens Industry Automation regularly performs extensive measurements with typical SIMATIC NET OPC UA systems. To conveniently access the measurement results, you can set up your desired configuration using the interactive user interface.

- Which S7 components are best suited for the planned automation project?
- Which transfer times can be expected for typical configurations?
- Which statistical fluctuations can occur?
- Which effects can be expected?

1.2 Performance data provided

The following performance data or measured variables are available to you in this measurement:

Table 1-1

Measured variable	Definition
Transfer time – monitoring variables (monitoring)	How long is the average update time of n variables (nodes) for 1 to m S7 stations if all configured items (variables) have changed virtually synchronously in all S7 stations?
Transfer time – asynchronous read (UA Read)	How long is the average read time of n variables (nodes) from 1 to m S7 stations for a synchronous trigger in the OPC UA client?
Transfer time – asynchronous write (UA Write)	How long is the average write time of n variables to 1 to m S7 stations for a synchronous trigger in the OPC UA client?
Cycle time in the S7 controller	This is the interval between two process image updates in the S7 controller.

Note For a detailed description of the method of measurement, please refer to Chapter 3 Performing the Measurements.

1.3 Parameters of the measurement

This measurement was performed with the following parameters:

Table 1-2

Component	Parameter	Explanation
S7 station	CPU	Selection of the S7 CPU type
	Load due to program	Setting of the load implemented in the S7 station by an additional STEP 7 program.
	Communication path	Selection of the interface via which communication takes place (integrated interface of the CPU or via Ethernet CP/CM).
	User data length	Setting of the data volume (number of bytes per S7 station).
	Number of S7 stations	Number of S7 stations that simultaneously communicate with the OPC UA server.
	Distribution of variables (nodes)	Continuous array of bytes (one subscription for one node) Distributed variables (n subscriptions for n nodes)
OPC server/client	OPC server cycle time	Polling cycle of the OPC UA server (50ms/100ms)
	Localization	Position of the client station in the network (locally on the OPC server station or remotely).
	OPC service method	Setting of the access method to the nodes (UA subscription monitoring variables, cpu subscription monitoring variables, UA Read, UA Write).

Note The ranges of values of the individual parameters that can be set may vary depending on the configuration. This is indicated by the respective displays in the user interface.

1.4 Scope of validity and technical data

Scope of validity

The measurement covers a typical range of components. The selection follows the most current and most frequently used products as at "early 2016".

The measured values apply provided that the network has been configured correctly. Due to system-internal error control, an incorrect or incomplete configuration causes significantly deviating times.

Boundary conditions of the measurement

All measured values were acquired under specific boundary conditions (configuration and parameterization).

All the settings essential to the measurement can be found in the following table. STEP 7 default values are used for all the settings that are not listed.

Area	Parameter	Range of values	Constraint
OPC client	Implementation	C#/ .NET stack on OPC UA interface via UA TCP	.NET Framework V4 UA stack version 1.02
	OPC client location	OPC server and client on one machine OPC server and client on different machines	
	Ethernet interface	Standard IE interface	
	Security in "remote" mode (client in the LAN)	OPC UA <ul style="list-style-type: none"> - Security Policy: yes - Message Security: yes - Authentication: yes 	Via secure channel only
	Item Update Rate	Always the minimum possible polling rate offered by the UA method.	The minimum is always the OPC server cycle rate.
	Subscription Publishing Rate	The minimum possible rate allowed by the OPC server.	For the SIMATIC NET OPC Server, the minimum possible value is 50ms
	Item structuring for UA polling & cpu subscriptions	The following applies per S7 station: <ul style="list-style-type: none"> • one subscription for contiguous item arrays (one symbol) • multiple subscriptions when distributing the variables to single symbols 	Limit of cpu subscription for PLCs
	Subscription Cycle Time	Set the best possible value for which the UA subscription itself does not poll all the data again.	The smallest possible value allowed by this method is 100ms .
OPC server	Interface	OPC UA	
	OPC server cycle time	Cycle time: 50 ms, 100 ms	
Communication functions	OPC PLC protocol	OPC UA: S7 OPT protocol only	OPC server: active partner S7 CPU/CP: passive partner
	Connections	One S7 connection from the OPC server to each S7 station involved	
	Services	Variable services <ul style="list-style-type: none"> • Monitoring Variables (via polling & cpu subscription) • UA Write • UA Read 	Async Meth.(UA) Async Meth.(UA)
		Maximum of 2 parallel OPC read jobs	Default value

1 Scope of the Measurement

Area	Parameter	Range of values	Constraint
OPC server PC load	CPU load	Except the Windows 7 default services, no other PC programs run as a load.	
Network load		No other network loads (PGs, HMI devices, VPN tunnels, etc.) are connected to the test object.	
S7 controller	S7 communication load	S7-1500: 50% S7-1200: 20%	TIA Portal default values
	Distributions of OPC items/nodes	Continuously in an array (one symbol) With gaps (approx. 30% memory gaps) with n symbols	Access to distribution with gaps is not used for 100000 bytes.

Components used

The following table contains all components that were used in this measurement.

Table 1-3

Component		Type	Article no.	Version
S7 stations	S7-1200	CPU-1212C	6ES7212-1AE40-0XB0	V4.1.2
		CP1243-1	6GK7243-1BX30-0XE0	V2.1
	S7-1500	CPU-1511-1PN	6ES7511-1AK01-0AB0	V1.8
		CPU-1516-3PN/DP	6ES7516-3AN01-0AB0	V1.8
		CPU-1518-4PN/DP	6ES7518-4AP00-0AB0	V1.8
		ET 200SP CPU 1512SP-1 PN	6ES7512-1DK00-0AB0	V1.0
		CM1542-1	6GK7542-1AX00-0XE0	V1.0
	Software controller	ET 200SP Open Controller CPU 1515SP PC	6ES7677-2AA41-0FB0	V1 4GB RAM, WES7 P 64; 8GB CFAST
		CPU1507S	6ES7672-7AC00-0YA0	V1.8
IPC 427D & CPU1507S		6AG4140-3BL05-3HA0	Core i3 1.6 GHz, 8GB NVRAM, Win7 Embedded 64, CFAST 8GB, 80GB SSD	
OPC server/local client station	PC hardware	Industrial rack PC IPC547E	6AG4104-3KA32-0BX0	Core i7, 500GB HDD, 8GB SDRAM
		Operating system		Windows 7 Ultimate 64-bit
	PC CP	Standard Ethernet interface		
	Communications protocol software	SOFTNET S7	SIMATIC NET CD V13 SP1	
	SIMATIC NET OPC Server	OPC Server station	SIMATIC NET CD V13 SP1	OPC Server version >= V13
Remote client station	PC hardware	IPC647C		Windows 7 Ultimate 64-bit
SIMATIC S7 configuration software		TIA Portal V13 SP1		

2 How to Use the User Interface

The following chapters provide you with information on how to operate the measurement via the path user interface.

2.1 Overview of the user interface

The user interface is divided into four areas: Selection area, Performance Requirements, Chosen topology and performance data table. All areas, except the performance data table, can be collapsed and expanded.

Selection area

Figure 2-1

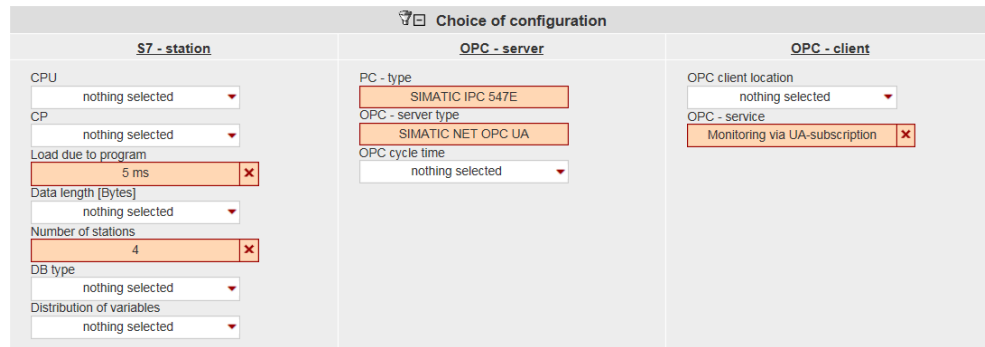

In this area, you can enter your desired configuration using the appropriate operator controls. The system supports you through various automatic functions.

Table 2-1

Icon	Explanation
	The "filter icon" indicates that at least one filter is active in the selection area.
	+ : expand input area - : collapse input area
	These controls allow you to select components or values.
	A selection has been made by you and can be undone by clicking "X".
	Due to the selection of another control, the system has made an automatic selection for you.

Performance Requirements

Figure 2-2

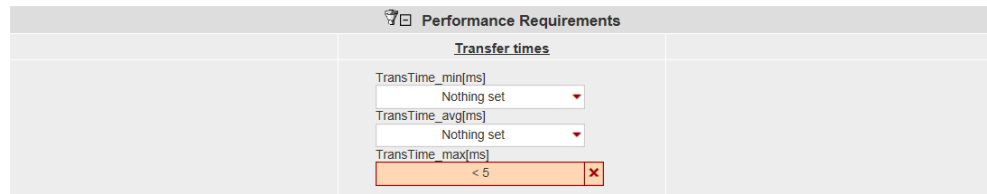

In this area, numerical filter conditions that appear when clicking the appropriate control allow you to additionally restrict the measured values of the results table.

In this example, the maximum transfer time is to be less than 5 ms. In addition to the filters of the selection area, this filter will now be used for the results table.

Chosen topology

Figure 2-3

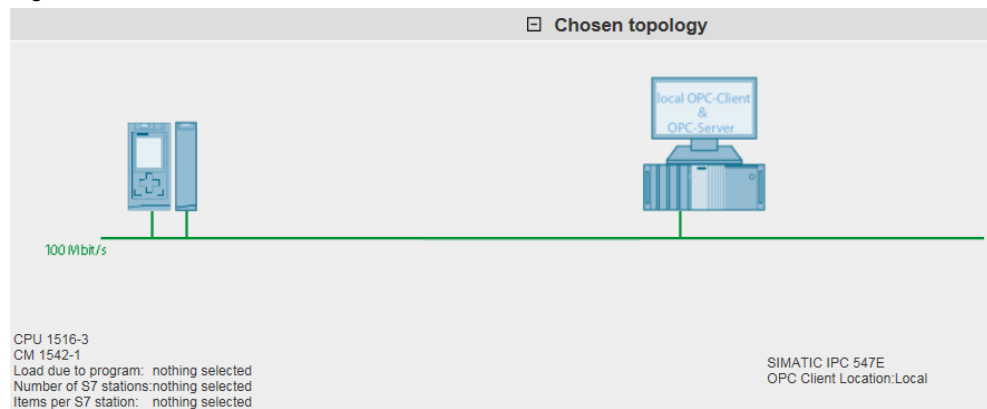

In the “Chosen topology” area, the system displays the graphical structure of your configuration. If nothing has been entered for one or more controls in the selection

area, this is indicated by a question mark  or “---” in the specific area.

Performance data table

Figure 2-4

Results: 3 of 7272 [Download results \(*.csv\)](#) [Show columns](#)

Prg-Load	CP	Num S7-stations	Num Items	OPC-Service	TransTime_min[ms]	TransTime_avg[ms]	TransTime_max[ms]
5 ms	---	1	100	Read	2,3	3,3	4,8
5 ms	---	1	100	Read	2,4	3,3	4,9
10 ms	---	1	100	Read	2,5	3,3	4,9

This area displays the measured performance data with all the filters you have selected. More columns can be shown or hidden using a dialog box by clicking “Show columns”. Clicking “Download results (*.csv)” allows you to export the displayed selection as an Excel csv spreadsheet. This allows you to make more sorts for your applications.

2.2 How to use the user interface

The following chapters provide you with information on how to use the user interface:

2.2.1 Initial situation when starting the application

When calling the web application for the first time, the status of the application is as follows:

User interface

Figure 2-5

The screenshot shows the user interface with a top navigation bar containing 'Performance data on OPC', 'Language', 'Contact', and 'help'. Below this is a 'Choice of configuration' section with three columns: 'S7 - station', 'OPC - server', and 'OPC - client'. Each column contains several dropdown menus for configuration. Below the configuration section are two hidden sections: 'Performance Requirements' and 'Chosen topology'. At the bottom, there is a table titled 'Results: 7272 of 7272' with a 'Download results (*.csv)' link and a 'Show columns' link. The table has columns for CPU, Prg-Load, CP, Num S7-stations, Num Items, OPC-ClientLoc, OPC-Service, TransTime_min[ms], TransTime_avg[ms], and TransTime_max[ms]. The table contains 20 rows of data.

CPU	Prg-Load	CP	Num S7-stations	Num Items	OPC-ClientLoc	OPC-Service	TransTime_min[ms]	TransTime_avg[ms]	TransTime_max[ms]
CPU 1518-4	10 ms	CM 1542-14	1	10000	Remote (LAN)	Monitoring via CPU-subscription	0	0	0
CPU 1518-4	5 ms	CM 1542-14	1	10000	Remote (LAN)	Monitoring via CPU-subscription	0	0	0
CPU 1518-4	10 ms	CM 1542-14	1	10000	Remote (LAN)	Monitoring via CPU-subscription	0	0	0
CPU 1518-4	5 ms	CM 1542-14	1	10000	Remote (LAN)	Monitoring via CPU-subscription	0	0	0
CPU 1515SP PC	10 ms	---	4	10000	Remote (LAN)	Monitoring via UA-subscription	0	0	0
CPU 1515SP PC	5 ms	---	4	10000	Remote (LAN)	Monitoring via UA-subscription	0	0	0
CPU 1507S (IPC 427D)	10 ms	---	1	10000	Remote (LAN)	Monitoring via UA-subscription	0	0	0
CPU 1515SP PC	10 ms	---	4	100000	Remote (LAN)	Monitoring via UA-subscription	0	0	0
CPU 1518-4	1 ms	---	1	100	Local	Write	1,2	1,3	3,3
CPU 1518-4	10 ms	---	1	100	Local	Write	1,6	1,6	4,3
CPU 1518-4	10 ms	---	1	100	Local	Read	1,6	1,6	4,3
CPU 1518-4	1 ms	---	1	100	Local	Read	1,5	1,6	4,4
CPU 1518-4	10 ms	---	1	100	Local	Read	1,6	1,6	4,4
CPU 1518-4	1 ms	---	1	100	Local	Read	1,5	1,6	4,6
CPU 1518-4	5 ms	---	4	100	Local	Read	1,6	1,6	4,5
CPU 1518-4	10 ms	---	1	100	Local	Write	1,5	1,6	4,7
CPU 1518-4	5 ms	---	4	100	Local	Read	1,6	1,6	4
CPU 1518-4	5 ms	---	1	100	Local	Read	1,6	1,6	4,7
CPU 1518-4	5 ms	---	4	100	Local	Read	1,6	1,6	5,8
CPU 1518-4	10 ms	---	1	100	Local	Write	1,6	1,6	4,3

Figure 2-6

This screenshot is similar to Figure 2-5 but shows the 'Performance Requirements' and 'Chosen topology' sections hidden, leaving only the 'Choice of configuration' section visible.

The selection area and the performance data table are always visible. The “Performance Requirements” and “Chosen topology” areas are hidden.

Description of the menu items

The following section explains the items of the application menu bar.

Figure 2-7



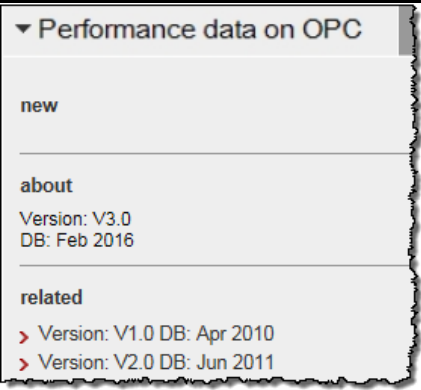
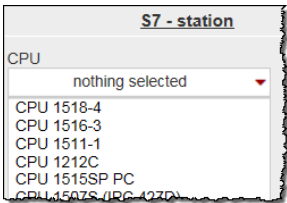
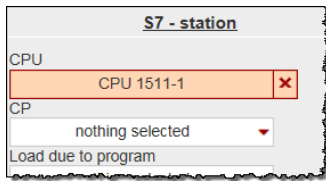

Table 2-2

Menu item	Description
	<p>Clicking the Performance data on OPC menu item opens a dialog where</p> <ul style="list-style-type: none"> • clicking the new menu item restores the user interface to its initial state. • the about area displays the version of the measurement and the database. • the related area allows you to directly switch to other versions of this measurement type.
Language	The user interface is implemented in German and English.
Contact	Links to Online Support
help	Allows you to open these help pages

2.2.2 Entering the desired configuration

In the “Choice of configuration” area, you can specify the desired hardware configuration.

Table 2-3

No.	Operator action	System response																																																																																																																					
1.	<p>Select a configuration by clicking the various parameter controls and selecting a component. Example: Select a CPU in the <u>S7 station</u> area</p> 	<p>The system has applied your desired CPU (here: CPU 1511-1) and at the same time, where applicable, automatically made the next selection, the CP, for you.</p> 																																																																																																																					
	<p>The system has immediately sent a query with the currently active filter to the database and displayed it in the performance data table.</p> <p>Results: 1764 of 7272  Download results (*.csv)</p> <table border="1"> <thead> <tr> <th>Prg-Load</th> <th>CP</th> <th>Num S7-stations</th> <th>Num Items</th> <th>OPC-ClientLoc</th> <th>OPC-Service</th> <th>TransTime_min[ms]</th> <th>TransTime_avg[ms]</th> <th>T</th> </tr> </thead> <tbody> <tr><td>5 ms</td><td>---</td><td>4</td><td>100</td><td>Remote (LAN)</td><td>Write</td><td>2,1</td><td>2,4</td><td>4,2</td></tr> <tr><td>10 ms</td><td>---</td><td>1</td><td>100</td><td>Local</td><td>Read</td><td>2,3</td><td>3,1</td><td>5,6</td></tr> <tr><td>5 ms</td><td>---</td><td>1</td><td>100</td><td>Local</td><td>Read</td><td>2,3</td><td>3,3</td><td>4,8</td></tr> <tr><td>10 ms</td><td>---</td><td>1</td><td>100</td><td>Local</td><td>Read</td><td>2,4</td><td>3,3</td><td>6,4</td></tr> <tr><td>10 ms</td><td>---</td><td>1</td><td>100</td><td>Local</td><td>Read</td><td>2,3</td><td>3,3</td><td>5,9</td></tr> <tr><td>5 ms</td><td>---</td><td>1</td><td>100</td><td>Local</td><td>Read</td><td>2,4</td><td>3,3</td><td>4,9</td></tr> <tr><td>10 ms</td><td>---</td><td>1</td><td>100</td><td>Local</td><td>Read</td><td>2,5</td><td>3,3</td><td>4,9</td></tr> <tr><td>10 ms</td><td>---</td><td>1</td><td>100</td><td>Local</td><td>Read</td><td>2,5</td><td>3,4</td><td>8</td></tr> <tr><td>5 ms</td><td>---</td><td>1</td><td>100</td><td>Local</td><td>Read</td><td>2,5</td><td>3,4</td><td>6,8</td></tr> <tr><td>10 ms</td><td>---</td><td>1</td><td>100</td><td>Local</td><td>Write</td><td>2,5</td><td>3,4</td><td>5,9</td></tr> <tr><td>5 ms</td><td>---</td><td>1</td><td>100</td><td>Local</td><td>Read</td><td>2,3</td><td>3,5</td><td>6,2</td></tr> <tr><td>10 ms</td><td>---</td><td>1</td><td>100</td><td>Local</td><td>Read</td><td>2,5</td><td>3,5</td><td>6,1</td></tr> </tbody> </table>	Prg-Load	CP	Num S7-stations	Num Items	OPC-ClientLoc	OPC-Service	TransTime_min[ms]	TransTime_avg[ms]	T	5 ms	---	4	100	Remote (LAN)	Write	2,1	2,4	4,2	10 ms	---	1	100	Local	Read	2,3	3,1	5,6	5 ms	---	1	100	Local	Read	2,3	3,3	4,8	10 ms	---	1	100	Local	Read	2,4	3,3	6,4	10 ms	---	1	100	Local	Read	2,3	3,3	5,9	5 ms	---	1	100	Local	Read	2,4	3,3	4,9	10 ms	---	1	100	Local	Read	2,5	3,3	4,9	10 ms	---	1	100	Local	Read	2,5	3,4	8	5 ms	---	1	100	Local	Read	2,5	3,4	6,8	10 ms	---	1	100	Local	Write	2,5	3,4	5,9	5 ms	---	1	100	Local	Read	2,3	3,5	6,2	10 ms	---	1	100	Local	Read	2,5	3,5	6,1	
Prg-Load	CP	Num S7-stations	Num Items	OPC-ClientLoc	OPC-Service	TransTime_min[ms]	TransTime_avg[ms]	T																																																																																																															
5 ms	---	4	100	Remote (LAN)	Write	2,1	2,4	4,2																																																																																																															
10 ms	---	1	100	Local	Read	2,3	3,1	5,6																																																																																																															
5 ms	---	1	100	Local	Read	2,3	3,3	4,8																																																																																																															
10 ms	---	1	100	Local	Read	2,4	3,3	6,4																																																																																																															
10 ms	---	1	100	Local	Read	2,3	3,3	5,9																																																																																																															
5 ms	---	1	100	Local	Read	2,4	3,3	4,9																																																																																																															
10 ms	---	1	100	Local	Read	2,5	3,3	4,9																																																																																																															
10 ms	---	1	100	Local	Read	2,5	3,4	8																																																																																																															
5 ms	---	1	100	Local	Read	2,5	3,4	6,8																																																																																																															
10 ms	---	1	100	Local	Write	2,5	3,4	5,9																																																																																																															
5 ms	---	1	100	Local	Read	2,3	3,5	6,2																																																																																																															
10 ms	---	1	100	Local	Read	2,5	3,5	6,1																																																																																																															
	<p>In this example, 1764 out of a total of 7272 measured values are available that were measured with this exact CPU. As the PLC has now been permanently assigned, this column has been removed from the results table.</p>																																																																																																																						
2.	<p>Proceed in the same way to enter the parameters of your choice for the “OPC client” area. Example: Selection of the “Monitoring via UA subscription” OPC service</p>	<p>The system has applied your desired entries.</p>																																																																																																																					
	<p>As in 1, the system has performed another database query with the advanced filter settings and therefore further narrowed down the number of relevant measured values.</p> <p>Results: 540 of 7272  Download results (*.csv)</p> <table border="1"> <thead> <tr> <th>Prg-Load</th> <th>CP</th> <th>Num S7-stations</th> <th>Num Items</th> <th>OPC-ClientLoc</th> <th>TransTime_min[ms]</th> <th>TransTime_avg[ms]</th> <th>T</th> </tr> </thead> <tbody> <tr><td>5 ms</td><td>CP1543-1</td><td>1</td><td>100</td><td>Remote (LAN)</td><td>9,1</td><td>29,3</td><td>58</td></tr> <tr><td>5 ms</td><td>---</td><td>1</td><td>100</td><td>Remote (LAN)</td><td>9,4</td><td>30,3</td><td>96</td></tr> <tr><td>10 ms</td><td>CP1543-1</td><td>4</td><td>100</td><td>Local</td><td>17,5</td><td>30,6</td><td>59</td></tr> <tr><td>5 ms</td><td>---</td><td>1</td><td>100</td><td>Remote (LAN)</td><td>9,7</td><td>31,8</td><td>56</td></tr> <tr><td>10 ms</td><td>CP1543-1</td><td>4</td><td>100</td><td>Local</td><td>18,6</td><td>32,2</td><td>10</td></tr> <tr><td>10 ms</td><td>CP1543-1</td><td>1</td><td>100</td><td>Remote (LAN)</td><td>9,6</td><td>32,4</td><td>89</td></tr> <tr><td>10 ms</td><td>CP1543-1</td><td>1</td><td>100</td><td>Remote (LAN)</td><td>8,4</td><td>32,5</td><td>60</td></tr> <tr><td>5 ms</td><td>CP1543-1</td><td>1</td><td>100</td><td>Remote (LAN)</td><td>7,7</td><td>33</td><td>58</td></tr> <tr><td>5 ms</td><td>CP1543-1</td><td>1</td><td>100</td><td>Remote (LAN)</td><td>8</td><td>34,2</td><td>10</td></tr> <tr><td>5 ms</td><td>---</td><td>4</td><td>100</td><td>Remote (LAN)</td><td>11,7</td><td>35,5</td><td>61</td></tr> <tr><td>10 ms</td><td>CP1543-1</td><td>4</td><td>100</td><td>Local</td><td>17,4</td><td>37,5</td><td>11</td></tr> <tr><td>10 ms</td><td>CM 1542-1</td><td>4</td><td>100</td><td>Local</td><td>13,9</td><td>37,5</td><td>11</td></tr> </tbody> </table>	Prg-Load	CP	Num S7-stations	Num Items	OPC-ClientLoc	TransTime_min[ms]	TransTime_avg[ms]	T	5 ms	CP1543-1	1	100	Remote (LAN)	9,1	29,3	58	5 ms	---	1	100	Remote (LAN)	9,4	30,3	96	10 ms	CP1543-1	4	100	Local	17,5	30,6	59	5 ms	---	1	100	Remote (LAN)	9,7	31,8	56	10 ms	CP1543-1	4	100	Local	18,6	32,2	10	10 ms	CP1543-1	1	100	Remote (LAN)	9,6	32,4	89	10 ms	CP1543-1	1	100	Remote (LAN)	8,4	32,5	60	5 ms	CP1543-1	1	100	Remote (LAN)	7,7	33	58	5 ms	CP1543-1	1	100	Remote (LAN)	8	34,2	10	5 ms	---	4	100	Remote (LAN)	11,7	35,5	61	10 ms	CP1543-1	4	100	Local	17,4	37,5	11	10 ms	CM 1542-1	4	100	Local	13,9	37,5	11														
Prg-Load	CP	Num S7-stations	Num Items	OPC-ClientLoc	TransTime_min[ms]	TransTime_avg[ms]	T																																																																																																																
5 ms	CP1543-1	1	100	Remote (LAN)	9,1	29,3	58																																																																																																																
5 ms	---	1	100	Remote (LAN)	9,4	30,3	96																																																																																																																
10 ms	CP1543-1	4	100	Local	17,5	30,6	59																																																																																																																
5 ms	---	1	100	Remote (LAN)	9,7	31,8	56																																																																																																																
10 ms	CP1543-1	4	100	Local	18,6	32,2	10																																																																																																																
10 ms	CP1543-1	1	100	Remote (LAN)	9,6	32,4	89																																																																																																																
10 ms	CP1543-1	1	100	Remote (LAN)	8,4	32,5	60																																																																																																																
5 ms	CP1543-1	1	100	Remote (LAN)	7,7	33	58																																																																																																																
5 ms	CP1543-1	1	100	Remote (LAN)	8	34,2	10																																																																																																																
5 ms	---	4	100	Remote (LAN)	11,7	35,5	61																																																																																																																
10 ms	CP1543-1	4	100	Local	17,4	37,5	11																																																																																																																
10 ms	CM 1542-1	4	100	Local	13,9	37,5	11																																																																																																																



2 How to Use the User Interface

No.	Operator action	System response																																																																																															
3.	<p>Proceed in the same way to enter the parameters of your choice for the number of S7 stations the number of items (variables) to be monitored and the type of the data block.</p> <p>Example: Selection of 4 S7 stations with 1000 items (bytes) each in a standard DB</p>	<p>The system has applied your entries.</p>																																																																																															
<p>Once again, the system has performed a database query with the advanced filter settings and removed the now defined columns from the results table.</p>																																																																																																	
<p>Results: 18 of 7272 <input type="button" value="Download results (*.csv)"/></p>																																																																																																	
<table border="1"> <thead> <tr> <th data-bbox="316 616 459 629">Prg-Load</th> <th data-bbox="459 616 603 629">CP</th> <th data-bbox="603 616 927 629">TransTime_min[ms]</th> <th data-bbox="927 616 1241 629">TransTime_avg[ms]</th> <th data-bbox="1241 616 1375 629">TransTi</th> </tr> </thead> <tbody> <tr><td>50 ms</td><td>--</td><td>39,3</td><td>85,9</td><td>138,6</td></tr> <tr><td>5 ms</td><td>CP1543-1</td><td>69,2</td><td>108,6</td><td>166,1</td></tr> <tr><td>5 ms</td><td>--</td><td>68,7</td><td>111</td><td>169,8</td></tr> <tr><td>10 ms</td><td>CM 1542-1</td><td>75,7</td><td>120,5</td><td>175,5</td></tr> <tr><td>50 ms</td><td>CP1543-1</td><td>77,8</td><td>123,2</td><td>176,8</td></tr> <tr><td>5 ms</td><td>CM 1542-1</td><td>76,3</td><td>126,5</td><td>174,7</td></tr> <tr><td>5 ms</td><td>CP1543-1</td><td>75,6</td><td>126,7</td><td>187,6</td></tr> <tr><td>10 ms</td><td>CP1543-1</td><td>77,7</td><td>128,8</td><td>176,9</td></tr> <tr><td>50 ms</td><td>CM 1542-1</td><td>81,5</td><td>130,4</td><td>172,4</td></tr> <tr><td>10 ms</td><td>CM 1542-1</td><td>81,6</td><td>133,7</td><td>197,9</td></tr> <tr><td>5 ms</td><td>CM 1542-1</td><td>84,5</td><td>133,9</td><td>193,4</td></tr> <tr><td>50 ms</td><td>CM 1542-1</td><td>86,6</td><td>135,7</td><td>179,3</td></tr> <tr><td>10 ms</td><td>CP1543-1</td><td>87,2</td><td>136,6</td><td>187,6</td></tr> <tr><td>50 ms</td><td>CP1543-1</td><td>84,8</td><td>141,6</td><td>194,2</td></tr> <tr><td>50 ms</td><td>--</td><td>100,6</td><td>148,4</td><td>188,4</td></tr> <tr><td>10 ms</td><td>--</td><td>92,9</td><td>151,3</td><td>182,5</td></tr> <tr><td>5 ms</td><td>--</td><td>100,9</td><td>160</td><td>210,2</td></tr> <tr><td>10 ms</td><td>--</td><td>100,8</td><td>160</td><td>203,2</td></tr> </tbody> </table>			Prg-Load	CP	TransTime_min[ms]	TransTime_avg[ms]	TransTi	50 ms	--	39,3	85,9	138,6	5 ms	CP1543-1	69,2	108,6	166,1	5 ms	--	68,7	111	169,8	10 ms	CM 1542-1	75,7	120,5	175,5	50 ms	CP1543-1	77,8	123,2	176,8	5 ms	CM 1542-1	76,3	126,5	174,7	5 ms	CP1543-1	75,6	126,7	187,6	10 ms	CP1543-1	77,7	128,8	176,9	50 ms	CM 1542-1	81,5	130,4	172,4	10 ms	CM 1542-1	81,6	133,7	197,9	5 ms	CM 1542-1	84,5	133,9	193,4	50 ms	CM 1542-1	86,6	135,7	179,3	10 ms	CP1543-1	87,2	136,6	187,6	50 ms	CP1543-1	84,8	141,6	194,2	50 ms	--	100,6	148,4	188,4	10 ms	--	92,9	151,3	182,5	5 ms	--	100,9	160	210,2	10 ms	--	100,8	160	203,2
Prg-Load	CP	TransTime_min[ms]	TransTime_avg[ms]	TransTi																																																																																													
50 ms	--	39,3	85,9	138,6																																																																																													
5 ms	CP1543-1	69,2	108,6	166,1																																																																																													
5 ms	--	68,7	111	169,8																																																																																													
10 ms	CM 1542-1	75,7	120,5	175,5																																																																																													
50 ms	CP1543-1	77,8	123,2	176,8																																																																																													
5 ms	CM 1542-1	76,3	126,5	174,7																																																																																													
5 ms	CP1543-1	75,6	126,7	187,6																																																																																													
10 ms	CP1543-1	77,7	128,8	176,9																																																																																													
50 ms	CM 1542-1	81,5	130,4	172,4																																																																																													
10 ms	CM 1542-1	81,6	133,7	197,9																																																																																													
5 ms	CM 1542-1	84,5	133,9	193,4																																																																																													
50 ms	CM 1542-1	86,6	135,7	179,3																																																																																													
10 ms	CP1543-1	87,2	136,6	187,6																																																																																													
50 ms	CP1543-1	84,8	141,6	194,2																																																																																													
50 ms	--	100,6	148,4	188,4																																																																																													
10 ms	--	92,9	151,3	182,5																																																																																													
5 ms	--	100,9	160	210,2																																																																																													
10 ms	--	100,8	160	203,2																																																																																													

2.2.3 Entering the performance requirements

In addition to specifying the hardware components, you can restrict the range of tolerable transmission delay times in the “Performance Requirements” filter area.

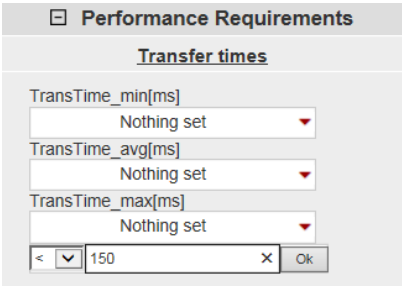
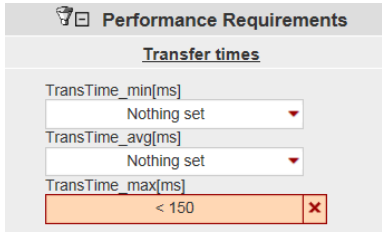
Table 2-4

No.	Operator action	System response
1.	<p>Enter the minimum, average or maximum values required in your plant. For a description of the different measured values, please refer to Chapter 1.2; a tooltip directly on the control provides a brief explanation.</p> <p><u>Example:</u> You want the maximum tolerable transmission time of the system to be 150 ms.</p>  <p>Confirm your entry by clicking the OK button.</p>	<p>The system has applied your desired entry.</p>  <p>The system has sent a query with the now active filters to the database and displayed it in the performance data table.</p>  <p>With the selected sample filter settings, the system has found only 1 data record that meets all default criteria.</p>

© Siemens AG 2016 All rights reserved

2.2.4 View of the selected configuration

Expanding the “Chosen topology” area allows you to view the hardware configuration diagram for this topology.

Figure 2-8

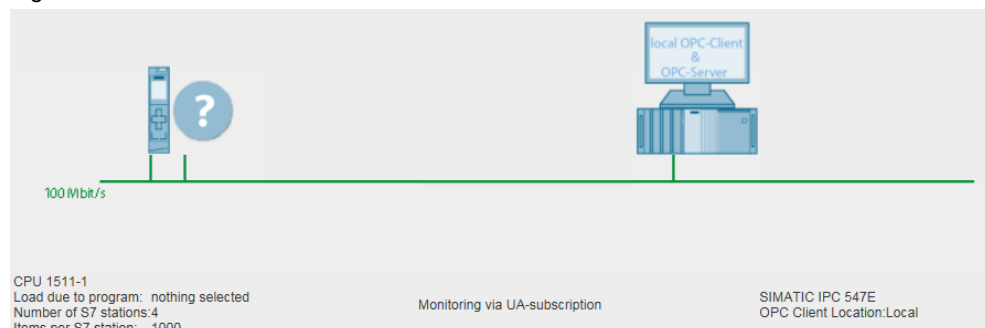

Components that have not been selected are indicated by a question mark icon



in the graphic and “---” in the text.

2.2.5 Performance data table

The performance data table shows the database contents of the respective measurement restricted by the previous filters. This area is permanently visible. By default, the table displays only a selection of the columns available in the database for this measurement. A dialog box allows you to select or deselect individual columns.

Control elements of the table

Figure 2-9

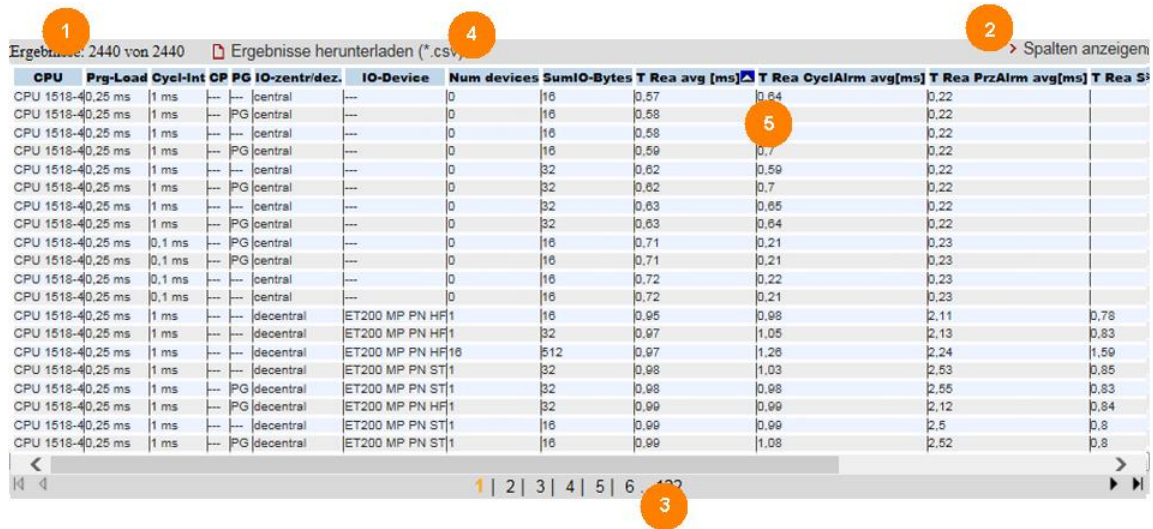

Explanation of the control elements

The following table describes the control elements shown in Figure 1-8.

Table 2-5

No.	Explanation
1	The table control displays <ul style="list-style-type: none"> the number of results the maximum number of data records of this measurement
2	Clicking the “> Show columns” control element opens a dialog box where you can select or deselect individual columns.
3	Provided that there are multiple results pages, the control bar elements of the table control allow you to select the individual results pages and go to the next, previous, last or first page.
4	When you click “Download results (*.csv)”, the web server uploads all contents of the results table to the client browser as a csv file. Depending on the browser and the installed Excel version, the data is immediately displayed in an Excel spreadsheet.

No.	Explanation
5	<p>Clicking the column header of the measured values (in this example – TransTime_avg) triggers a sorting of the table by this criterion. Clicking a column header changes the sort state of the appropriate column.</p> <p>TransTime_min[ms] Values unsorted</p> <p>TransTime_min[ms]▲ Values sorted in ascending order</p> <p>TransTime_min[ms]▼ Values sorted in descending order</p> <p>Note: You can only sort one column at a time!</p>

Meaning of the columns

Tooltips provide more detailed explanations of all column headers.

Table 2-6

Column name	Explanation
CPU	CPU type
CPUFW	CPU firmware version
CP	CP type
CPFW	CP firmware version
Prg-Load	Load due to program in OB1
Num Items	Number of bytes per S7 station
Num S7 stations	Number of SIMATIC stations
DB Type	Data block type (standard/optimized)
Var. distribution	Distribution of OPC variables
Server PC	OPC server PC type (not changeable)
OPC-ServerType	OPC server type (not changeable)
OPC-Server Cycle	OPC server cycle time
OPC-ClientLoc	OPC client location
OPC-Service	OPC service
TransTime_min[ms]	Minimum transfer time [ms]
TransTime_Q25[ms]	25% quartile of transfer time [ms]
TransTime_avg[ms]	Average transfer time [ms]
TransTime_Q75[ms]	75% quartile of transfer time [ms]
TransTime_max[ms]	Maximum transfer time [ms]
Cycle time min[ms]	Minimum OB1 cycle time [ms]
Cycle time avg[ms]	Average OB1 cycle time [ms]
Cycle time max[ms]	Maximum OB1 cycle time [ms]

3 Performing the Measurements

The following chapters provide information on how to perform the measurements.

3.1 Method of measurement and measurement setup/sequence

Measuring sequence

The basic sequence of a measurement is as follows:

1. Configuring a configuration, including the download to all stations involved.
2. Measuring all measured variables (each measurement is repeated several times).
3. Evaluating the measurements and determining the statistical position parameters.

Method of measurement for the performance data

- **Transfer time:**

- “Monitoring via UA subscription” or “Monitoring via cpu subscription” variant:

How long is the average update time of n items (variables) for 1 to m S7 stations if all configured items (variables) have changed virtually synchronously in all S7 stations?

- “UA Read” variant:

How long is the average read time of n items from 1 to m S7 stations for a synchronous trigger in the OPC client?

- “UA Write” variant:

How long is the average write time of n items to 1 to m S7 stations for a synchronous trigger in the OPC client?

- **Cycle times:**

The cycle time is the interval between two process image updates of the IO controller in OB1. This value is measured with system-internal functions. The cycle time is measured during operation: The S7 controller communicates with the distributed stations or its central modules.

3.2 Measurement setup

The figure below shows the basic measurement setup for the different OPC UA methods of measurement. It does not show components and signals for the gauges (e.g., ready signals) used only to perform the measurement.

The measurement takes place under the following boundary conditions:

- The communication program in the S7 stations (if necessary) is called cyclically in OB1 of the S7 controller.
- Exactly one S7 connection is established from the server PC (OPC server) to each S7 station.
- Source/destination of the data in the S7 station are each located in data blocks.
- Source/destination of the data in the OPC TestClient are each data structures in the PC memory.
- The connection between the test OPC client and the gauge is established via an interrupt-capable PCI IO PC card.

Measurement setup: "Monitoring Variables"

Client station
Remote OPC test client

Server PC
Local OPC test client
SIMATIC NET OPC UA Server
SOFTNET IE

S7 stations

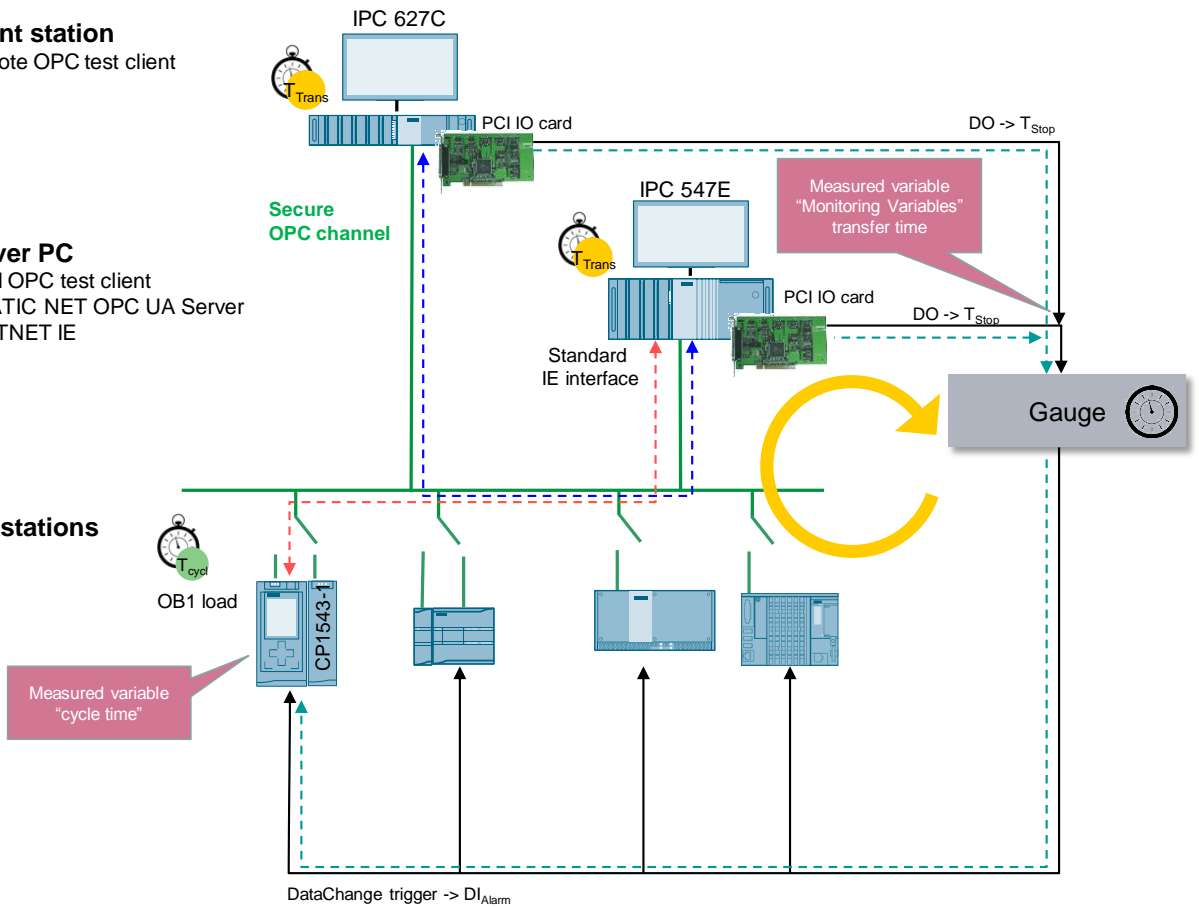

- - - Net transmission path – S7 stations to OPC server/local OPC client
- - - Net transmission path – OPC server to remote OPC client
- - - Measurement control transmission time

Note

For this measurement, the average absolute measuring error, due to the propagation time of the trigger signal by the PCI IO card, is approx. 2.6 ms.
For the explanation, please see Chapter 3.10.

Measurement setup: "OPC UA Read/Write"

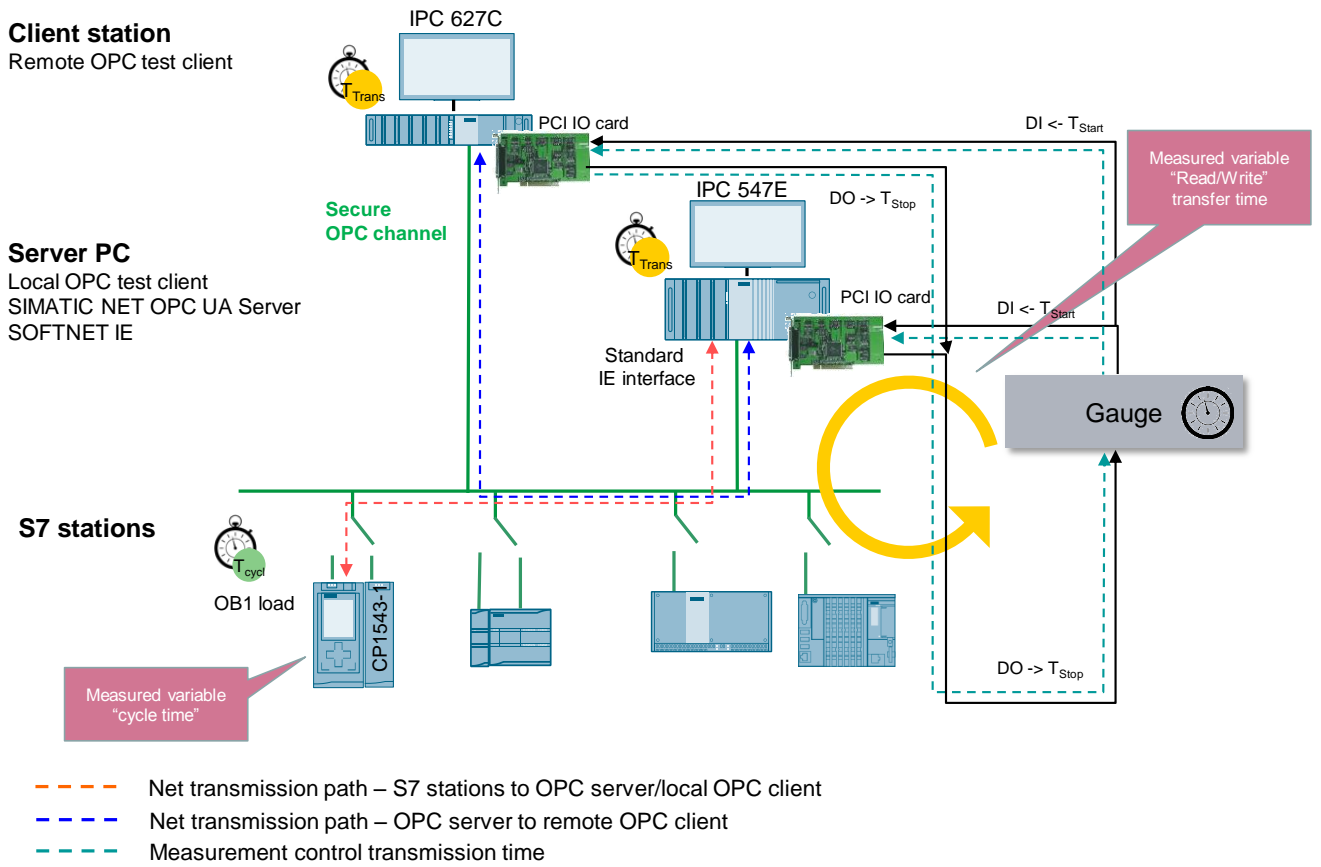

Note For this measurement, the average absolute measuring error, due to the propagation time of the trigger signals by the PCI IO card, is approx. 5.2 ms. For the explanation, please see Chapter 3.10.

Note When the appropriate hardware interface of the S7 CPU is available, the gigabit port is always used.

3.1 Method of measurement of the “Monitoring via UA subscription/cpu subscription” transfer time

This section describes the two variants “Monitoring via UA subscription” and “Monitoring via cpu subscription”.

Measuring principle

The transfer time in “Monitoring via UA/cpu subscription” mode indicates how long it takes until the OPC server, that permanently monitors a number of n items in the active S7 stations for changes, has stored this data in a data structure of the OPC test client.

The transfer time is acquired in a gauge:

- **Start of time measurement:**
The measuring station triggers **all** S7 stations for synchronous change of their variables in the data block (OPC items);
i.e., for the OPC server: all the configured data has changed “virtually” simultaneously.
- **Stop of time measurement:**
The OPC test client has received all DataChange events of all items to be monitored from all S7 stations from the OPC server.

The ready signal (T3) indicates that the changed data (here always the maximum number of configured items) has been fully stored in a data structure in the OPC TestClient and is available for possible further processing in the PC.

The SIMATIC NET OPC Server polls the S7 stations for all measurements with the maximum update rate of 100 ms.

The measurement is repeated several times for each configuration (measurement setup) ($\Delta T_1.. \Delta T_n$). The most important statistical position parameters are then determined from this data.

Functional model of the measurement

The following functional model explains the basic method of measurement:

Figure 3-1 Measuring principle: “Monitoring Variables”

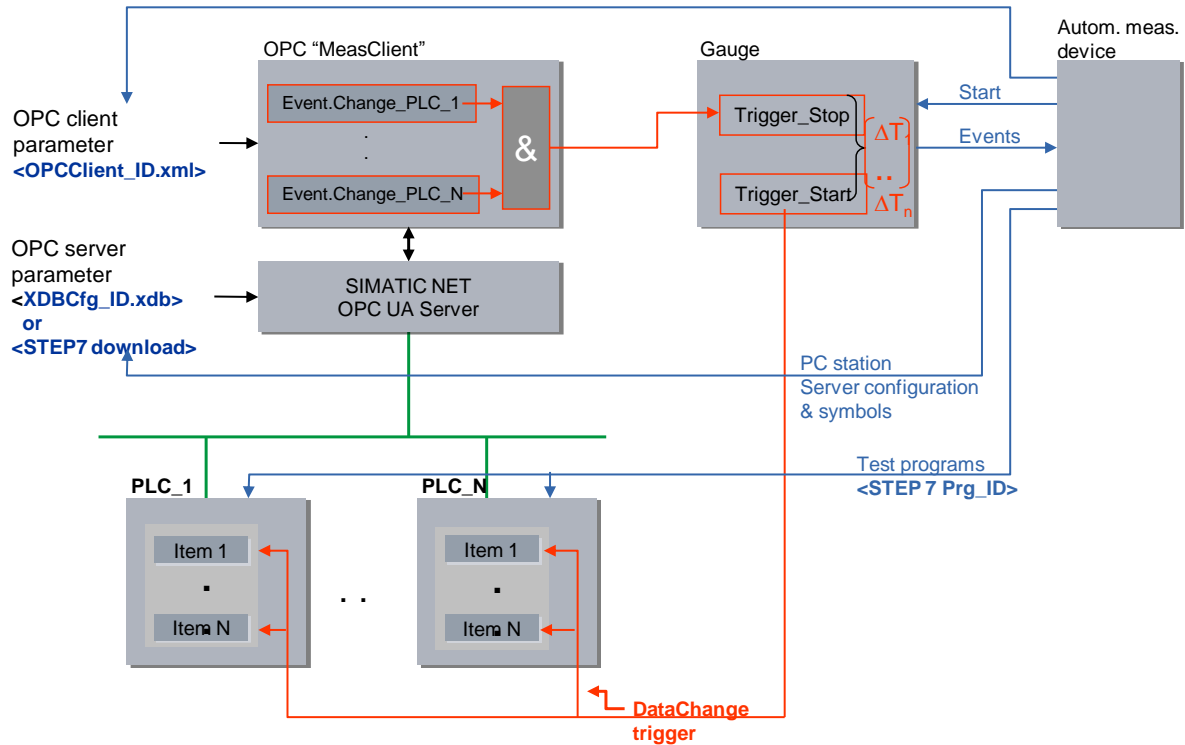

The following table describes the individual time intervals T_x :

Table 3-1

Time	Description	
T1	From	Gauge sets start signal to all configured S7 stations
	To	Start signal of all S7 stations acquired via a process interrupt
T2	From	S7 stations synchronously change the configured send data (items)
	To	Items are polled for changes by the OPC server and copied to data structures on the OPC server
T3	From	The OPC test client logs the DataChange events of all configured data fields.
	To	All DataChange signals have been acquired in the OPC test client and trigger the stop signal of the gauge via a PCI IO card

Note

The mere transfer time corresponds to the time T2. Systematic measuring errors are minimized by time-optimized programming of the OPC client and interrupt-controlled programming of the PCI IO card.

Asynchronous correlations between the components of the transfer

The following figure shows the internal correlations between the S7 CPU and the OPC server/client for the two cases **UA subscription** and **cpu subscription**.

Figure 3-2

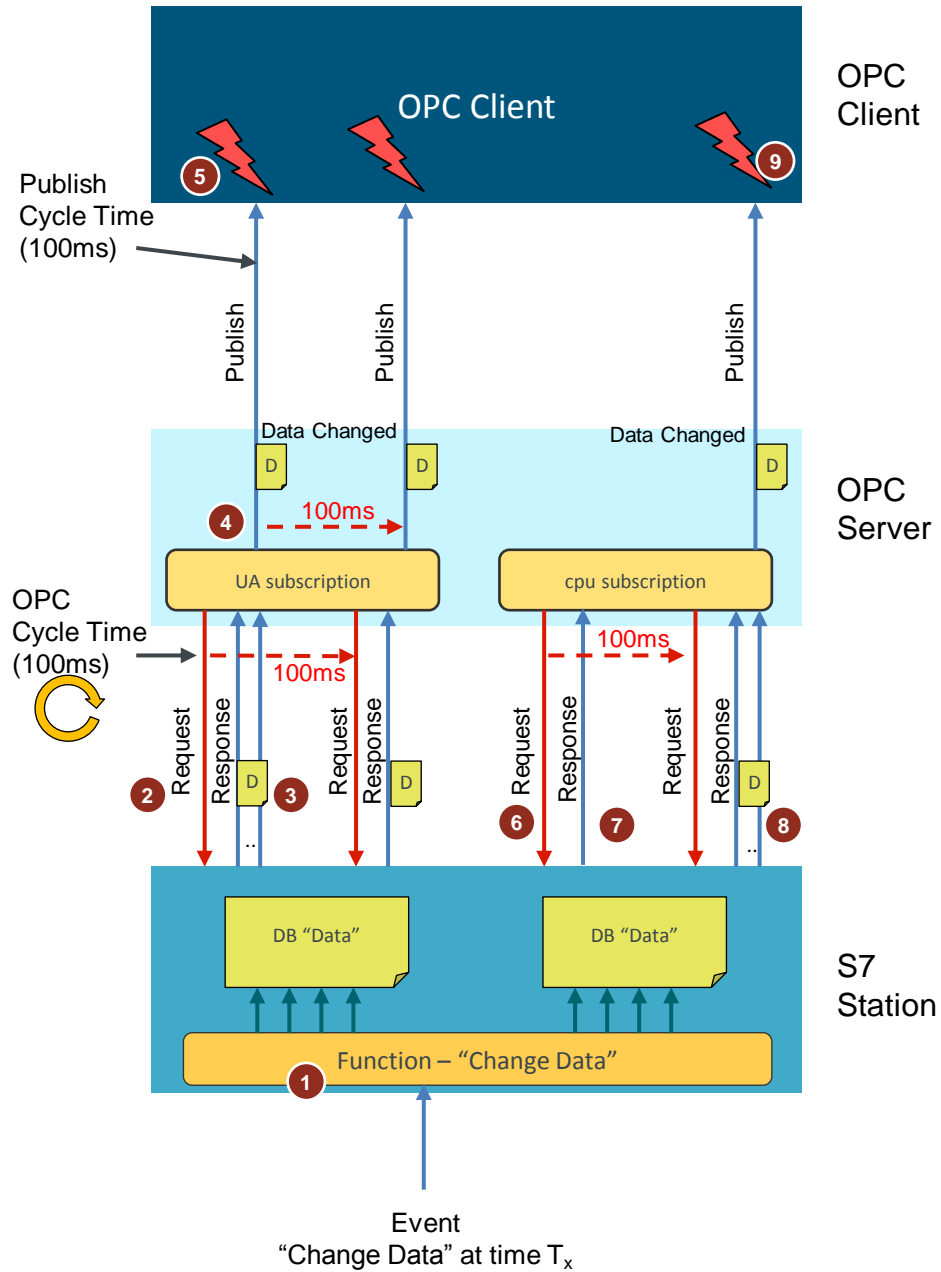

OPC UA subscription: The SIMATIC NET OPC UA Server must permanently receive all variables, determine the changes compared to the previous OPC server cycle and then inform the OPC client.

Table 3-2 Processes for UA subscription

No.	Explanation
1	The digital input signal from the gauge causes a change of the monitored variables at a time Tx. After a time Ty, new values have been written to all variables.
2	The UA subscription configured to these variables polls them every 100/50 ms.
3	After each polling request, the S7 station sends all variables of this UA subscription to the OPC server in n frames (S7 protocol).
4	The OPC UA server checks the received data for changes compared to the previous polling cycle and if there is a change, it sends the variables to the OPC client in a publish event.
5	The OPC client receives the publish frame and triggers a notification method that then provides the data to the user program.

cpu subscription: The S7 CPU must determine the changes compared to the previous OPC server cycle and inform the SIMATIC NET OPC UA Server. This server then forwards the information to the OPC client via a publish frame. In this case, the net network load is significantly lower.

Table 3-3 Processes for cpu subscription

No.	Explanation
1	The digital input signal from the gauge causes a change of the monitored variables at a time Tx. After a time Ty, new values have been written to all variables.
6	The UA subscription configured to these variables polls them every 100/50 ms.
7	If the data in the S7 station has not changed, the S7 station sends a small acknowledgment frame of this cpu subscription to the OPC UA server.
8	If the data in the S7 CPU has changed compared to the last polling cycle, the S7 CPU sends all changed variables to the OPC UA server in this step.
9	The OPC client receives the publish frame and triggers a notification method that then provides the data to the user program.

Evaluations

From a maximum of 200 single measurements, the gauge calculates the statistical position parameters of the measured values. (See Chapter 3.5 Measured variables and statistics.)

3.2 Method of measurement of the “UA Read” transfer time

This section describes the “OPC UA Read” variant.

Measuring principle

The transfer time in “Async Read/UA Read” mode indicates how long it takes to read a number of n items from the user area (data block) of the active S7 stations and provide them in a data structure on the OPC test client.

The transfer time is acquired in a gauge:

- **Start of time measurement:**
Via an interrupt of the PCI IO card, the measuring station triggers the OPC test client to read **all** configured items from the active S7 stations.
- **Stop of time measurement:**
The OPC test client has received all ReadComplete events from the OPC server -> the data is available for possible further processing.

The ready signal (T3) indicates that the data (here always the maximum number of configured items) has been fully stored in the data structure of the OPC TestClient. The S7 protocol used here ensures this with a layer 7 acknowledgment to the OPC server.

The measurement is repeated several times for each configuration (measurement setup) ($\Delta T_1.. \Delta T_n$). The most important statistical position parameters are then determined from this data.

Functional model of the measurement

The following functional model explains the basic method of measurement:

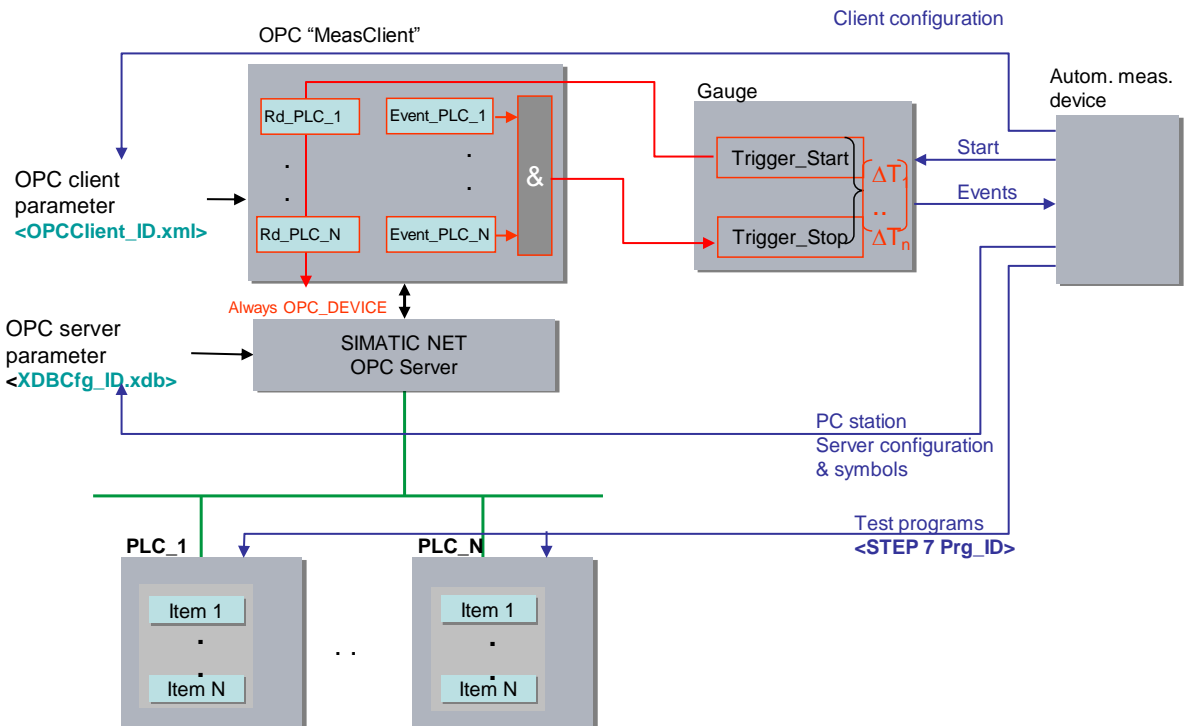

The following table describes the individual time intervals T_x :

Table 3-4

Time	Description	
T1	From	Gauge sets start signal to OPC test client
	To	All asynchronous read jobs were sent from the OPC test client to the OPC server.
T2	From	The OPC server forwards the read jobs to all S7 stations via the S7 protocol.
	To	The read data asynchronously arrives back at the OPC server.
T3	From	The OPC server reports each arrival of a data packet to the OPC test client via a ReadComplete event.
	To	If all ReadComplete events have been received by the OPC TestClient, the OPC test client triggers the stop signal of the gauge via the PCI IO card.

3.3 Method of measurement of the “UA Write” transfer time

This section describes the “OPC UA Write” variant.

Measuring principle

The transfer time in “Async Write/UA Write” mode indicates how long it takes to write a number of n items from a data structure in the OPC test client to the user area (data block) of the active S7 stations. The transfer time is acquired in a gauge:

- **Start of time measurement:**
Via an interrupt of the PCI IO card, the measuring station triggers the OPC test client to write **all** configured items to the active S7 stations.
- **Stop of time measurement:**
The OPC test client has received all WriteComplete events from the OPC server.

The ready signal (T3) indicates that the changed data (here always the maximum number of configured items) has completely arrived in the data block of the configured S7 stations. The S7 protocol used here ensures this with a layer 7 acknowledgment to the OPC server.

The measurement is repeated several times for each configuration (DT1.. DTn). The most important statistical position parameters are then determined from this data.

Functional model of the measurement

The following functional model explains the basic method of measurement:

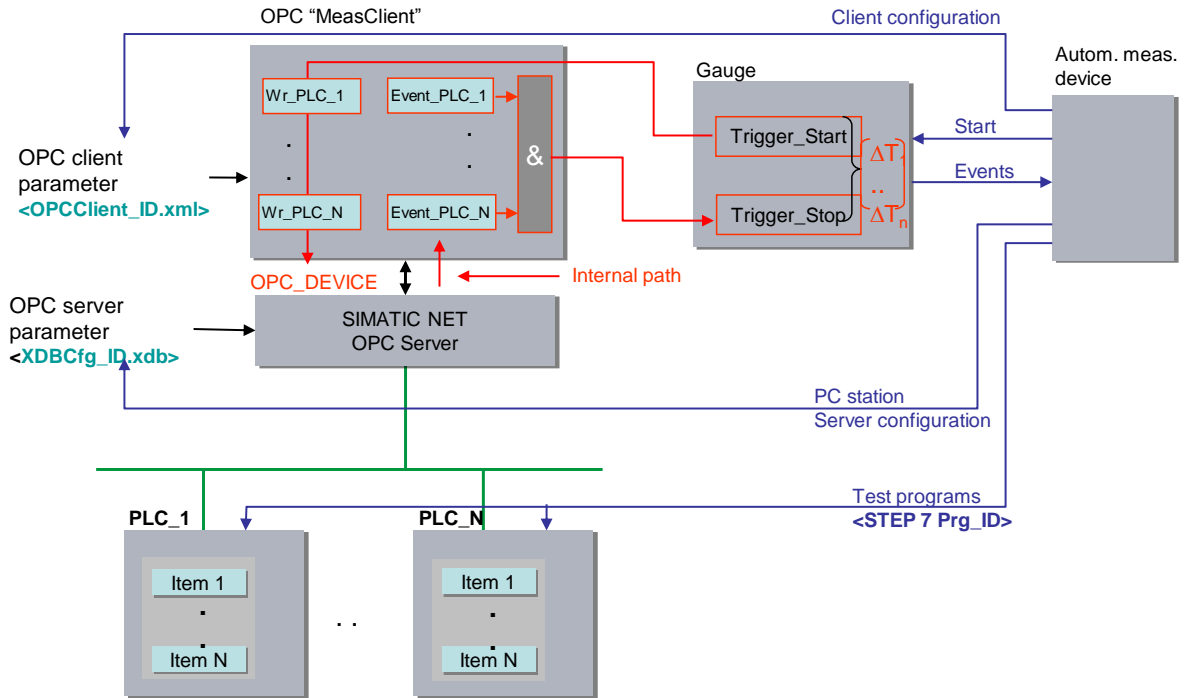

The following table describes the individual time intervals T_x :

Table 3-5

Time	Description	
T1	From	Gauge sets start signal to OPC test client
	To	All asynchronous write jobs were sent from the OPC test client to the OPC server.
T2	From	The OPC server forwards the write jobs to all S7 stations via the S7 protocol.
	To	The data arrives asynchronously at the S7 stations.
T3	From	The OPC server reports each arrival of a data packet at the respective S7 station to the OPC test client via a WriteComplete event.
	To	If all WriteComplete events have been received by the OPC TestClient, the OPC test client triggers the stop signal of the gauge via the PCI IO card.

3.4 Measurement: Cycle time/cycle control time

Principle

The cycle time in the sending and receiving stations is determined via system functions (S7-1500) and separate measuring programs (S7-1200). From the repeated measurements, the S7 controller automatically determines the statistical position parameters of the cycle time.

Measurement period

- From the start of the PN IO response time measurement
- To the end of the PN IO response time measurement with X repetitions

Evaluation

From a maximum of 500 single measurements, the gauge calculates the statistical position parameters of the measured values. (See Chapter 3.5 Measured variables and statistics.)

3.5 Measured variables and statistics

Position parameters

In order to make an assessment regarding the significance of the mean (median), the other statistical position parameters should also be considered. To this end, all measured variables are measured multiple times (up to 200 individual measurements). From all measured values, the gauge calculates the following statistical values that can be selected by the user in the results table.

Table 3-6

Position parameter	Definition
TransTime_min	The smallest measured value in the series of measurements
TransTime_Q25	The first quartile (Q25) indicates that 25% of the measured values are below this number
TransTime_avg	The median (Q50) indicates the measured value that divides the number of sorted measured values into two halves of equal size. This position parameter is the most important one in the measured value table.
TransTime_Q75	The third quartile (Q75) indicates that 75% of the measured values are below this number.
TransTime_max	The largest measured value in the series of measurements

50% of all measured values are in the so-called interquartile range (IQR), i.e., the range between TransTime_Q25 and TransTime_Q75. This range provides the user with a statement on the spread and reliability of the mean (median).

Note

In OPC UA Read/Write mode, the significance of the median is very precise for the number of single measurements selected here. In "Monitoring Variables" mode, the minimum and maximum values of the measurement require greater attention. In this case, the median strongly depends on the number of single measurements.

Interpretation of the measured values

The box plot representation standardized in statistics indicates, for example, the spread of the measured values.

Table 3-7

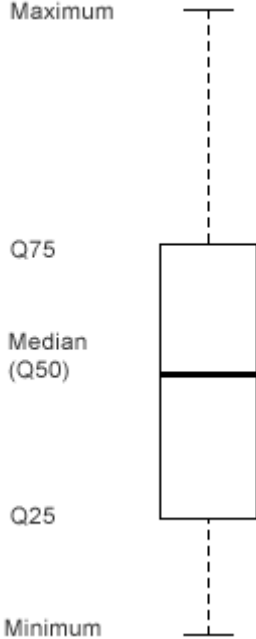
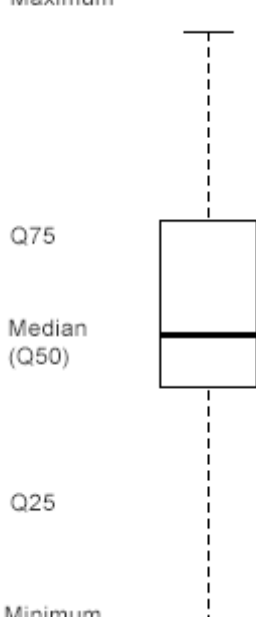
Box plot	Position parameter	Interpretation
	<p>Here the maximum of the measured values is slightly asymmetric to the rest.</p> <p>50% of all measured values are in the IQR range (Q25 to Q75). In this example, this range is relatively large compared to the second example.</p> <p>The median (Q50 value) is fairly symmetrical in the IRQ range.</p>	<p>In this measurement, there is a slight upward deviation.</p> <p>50% of all measured values are spread relatively widely, i.e., the entire IRQ range is more likely for this measurement.</p>
	<p>50% of all measured values are in the IQR range (Q25 to Q75). Compared to the first example, this measurement is much narrower.</p>	<p>The spread of 50% of all measured values is relatively narrow. For this configuration, the results and the value of the median are very meaningful and probable.</p>

NOTICE Especially for non-deterministic Windows PC systems, extreme outliers regarding the maximum value may occasionally occur. For PC measurements, the median value is the most meaningful value!

Special aspects of “Monitoring Variables”

All n single measurements are collected by the gauge and then evaluated statistically.

Especially in “Monitoring Variables” mode, the shape of the distribution of the transfer times strongly depends on the number of single measurements. For a theoretically infinitely long measurement duration, a constant polling rate of the OPC UA server results in an ideal Gaussian bell curve. This depends on the asynchronous, cyclic systems involved in the data transfer (S7 CPU, OPC server, OPC client).

Example: “Monitoring Variables” mode, 1000 bytes, one S7 CPU, OB1 cycle: 10 ms, OPC server cycle: 100 ms, approx. 400 single measurements

Figure 3-3

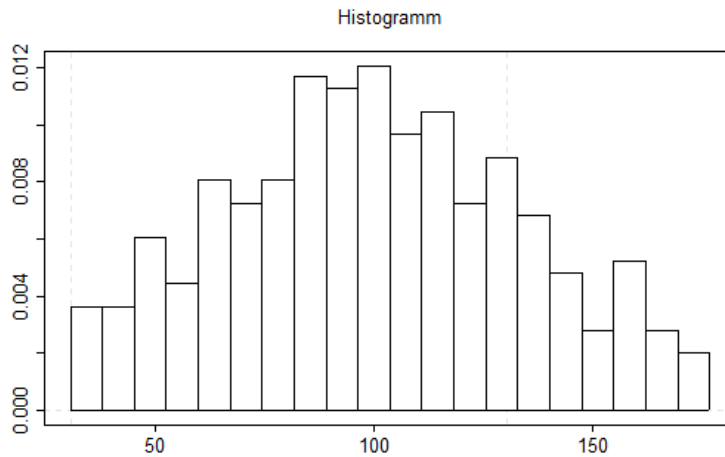

Corresponding box plot:

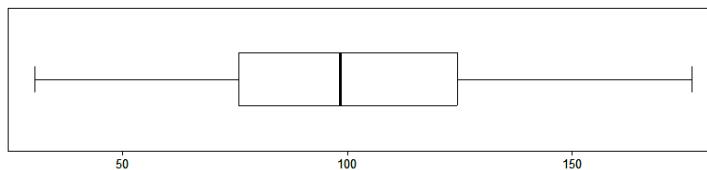

If the measurement is completed after only 80 single measurements with the other boundary conditions being the same, this results in different distributions. In this case, for example, the value 100 ms also visibly affects the distribution of the transfer times (the difference between the two maximum values is 100 ms).

Figure 3-4

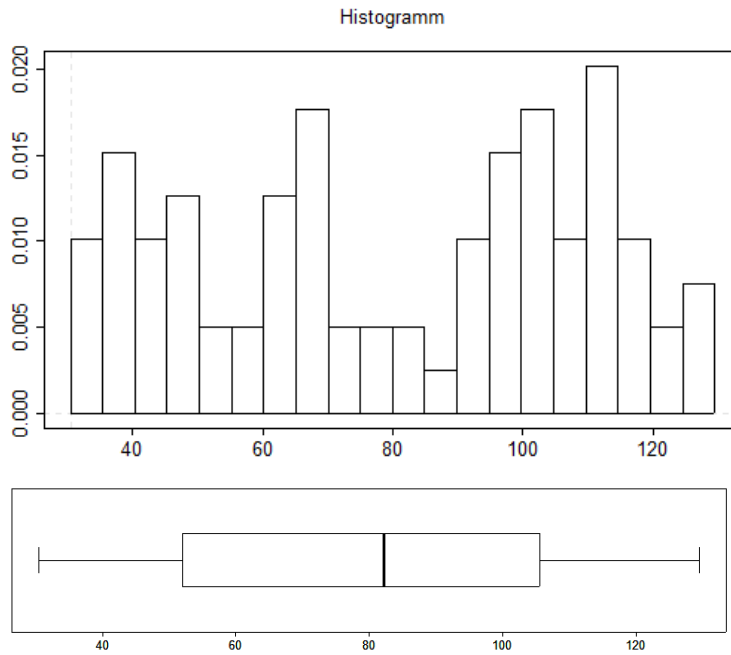

However, when performing less single measurements, this ideal histogram may differ considerably, especially in “Monitoring Variables” mode, resulting in a different median.

Note

Therefore, the median value in “Monitoring Variables” mode reflects the true (for infinite measured values) value only to a limited extent. In this case, the minimum and maximum value should rather be used for interpretation.

3.6 Explanatory notes on the OPC UA test client

Apart from the S7 stations, the test OPC client is the central measurement object in the entire sequence. The following section provides an overview of its properties.

Overview

For the measurements, there are two options available for the location of the OPC client.

- Local: The OPC client is on the same computer as the SIMATIC NET OPC Server.
- Remote: The OPC client and the OPC server are installed on different computers.

Functions of the OPC TestClients

The automatic measuring device provides the OPC TestClient with the configurations to be measured.

- It dynamically adjusts to the quantity frameworks to be received,
- collects all callbacks from the registered OPC objects,
- receives the appropriate trigger signals from the gauge via a digital IO card in the PC and informs it of the ready signals for determining the runtime.

Program properties of the OPC TestClients

Access to the OPC server is runtime-optimized for the OPC UA server in the C#/.NET programming language.

Runtime-optimized programming of the OPC client.

Communication with the PCI IO card is part of the OPC TestClient.

Development environment:

.NET Framework V4.0 with Microsoft Visual Studio 2014

Image of the S7 stations in the OPC client (local & remote)

Each S7 station with its variables is mapped in the object of the OPC UA subscription class. Depending on the measurement configuration, the number of OPC subscription objects is dynamically generated by the OPC TestClient in the initialization phase. Each object of the OPC-data Monitored Item class maps the variables from the S7 station in an array or a defined single symbol arrangement.

Communication with PCI IO card

To exchange the control signals with the gauge and the automatic measuring device, the interrupt-capable PCI IO card APCI-1500 from ADDI-DATA was used.

Latency time of the measurement system:

The propagation time of the trigger signal from and to the OPC test client via the PCI IO card was determined by a mirror routine in the OPC test client. To this end, the time from the digital input of the PCI IO card to the test OPC client and the instant mirroring of the signal and output at a digital output of the PCI IO card was determined. The measurement was repeated 500 times.

Results of the latency time measurement:

T latency_{Min}: 1.01 ms

T latency_{Avg}: 5.2 ms

T latency_{Max}: 6.82 ms

This means a trigger signal from the digital input of the card to the OPC TestClient needs T latency/2 (here: on average approx. 2.6 ms).

Note

These values have to be seen as an estimate and apply only to the IPC environment used. For other PC systems, the values may vary.

3.7 Explanatory notes on the STEP 7 program

The STEP 7 program directly affects the measured values. The following chapters provide you with an overview of the STEP 7 program on which the measured values are based:

3.7.1 Variable structure in the S7 CPUs

The test variables in the S7 CPUs are arranged for the different variants in the following types

- Optimized data blocks
- Standard data blocks
- In a contiguous array of bytes (without gaps) (addressing as an item)
- In a distributed structure (addressing of n items)

The time response of the measured values differs when accessing the different variables.

OPC UA variable structure for distribution without gaps

In the “without gaps” case, the bytes to be transferred are created in an **optimized** and **standard data block** as an **array [0..max-1] of bytes**.

Symbolic access only via the NodeIDs of the variables.

Figure 5 DB objects contiguous arrays

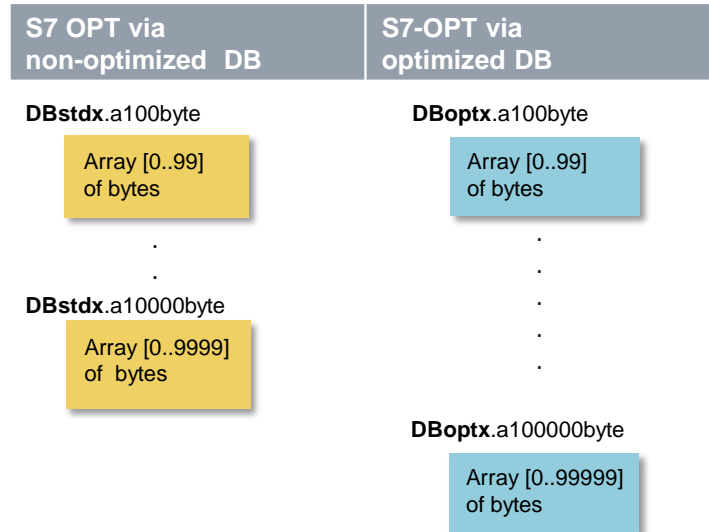

SYM:Stationx.PLCx.DBstdx.a100byte **SYM:Stationx.PLCx.DBoptx.a100byte**

OPC UA variable structure for distribution with gaps

In the “with gaps” case, the bytes to be transferred are created in an **optimized** and **standard data block** as an **array [0..max-1] of typeMix**.

The **typeMix** data type is defined so that – due to the placement of elementary data types > 1 byte at each word boundary of non-optimized DBs – a “**gap degree**” of approx. **30%** can be used. In this case, the **single symbols** are used for addressing.

PLC type: typeMix

Element	Abs. byte address	Variable type	Net bytes
EL_1	0	Byte	1
	1	-	
EL_2	2	WORD	
	3		3
EL_3	4	BYTE	4
	5	-	
EL_4	6	WORD	
	7		6
EL_5	8	BYTE	7
	9	-	
EL_6	10	WORD	9
	11		
EL_7	12	BYTE	10

The **typeMix** type with its 13 bytes in an array is expanded to 14 bytes.

In the data array, **10 bytes of net data variables** have 14 bytes of used memory, which corresponds to a “**gap degree**” of **approx. 29%**.

Figure 6 - DB objects single objects with gaps Figure 3-7

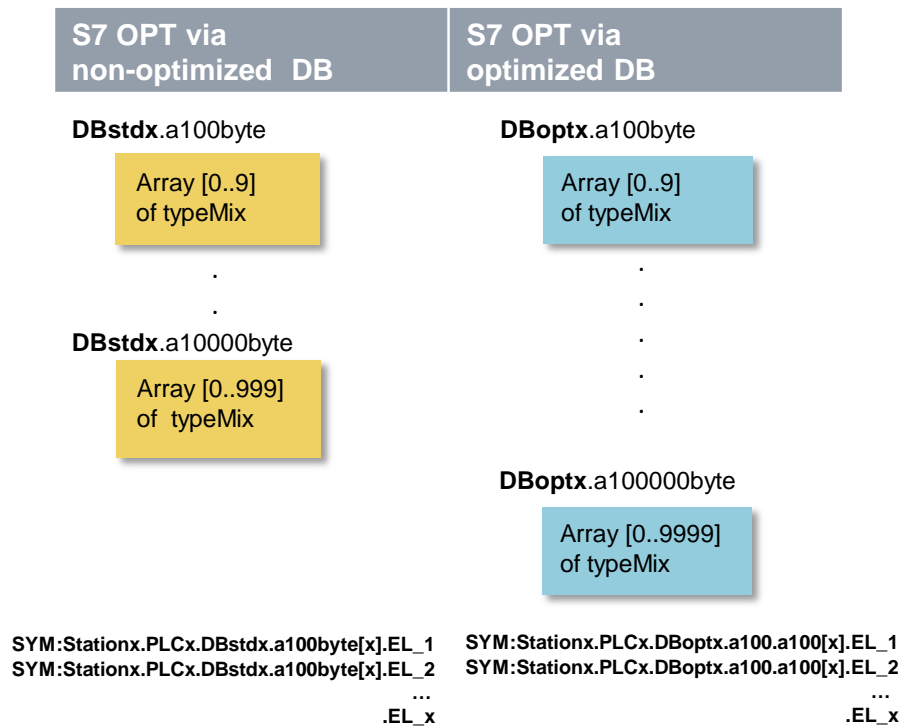

3.7.2 Overview of the STEP 7 programs

The following table shows the function of the individual program parts. During a measurement, all program parts are loaded.

The user program contains primarily STEP 7 blocks for automating the measurement and communicating with the distributed stations.

Table 3-8

STEP 7 program part		Task in the S7 controller
Measuring program	Function program	Program parts that have nothing to do with the actual measured-value acquisition. (e.g., call of communication blocks, HMI program, etc.)
	Acquisition program	Program parts used exclusively to acquire the measured values and generate the control signals. <ul style="list-style-type: none"> • Acquire start/stop measurement signal • Measure cycle time
Load program		The load program does not perform specific tasks; the program itself has no function. It is merely used to increase the size of the STEP 7 program and thus extend the cycle time.

3.7.3 Measuring program

The following table provides an overview of the possible measuring programs:

Table 3-9 Measuring program in the S7 PLC

Measuring program		Purpose	Execution in the S7 CPU
Function program	I/O trigger program	Read/write signal via central or distributed digital I/O to change and acquire the defined time of item variables via the gauges.	Via a hardware interrupt OB (OB40), the gauge signals are acquired in a time-optimized manner.
	Communication program	--	For the S7-1500 and S7-1200 CPs, explicit S7 communication blocks are no longer necessary.
Acquisition program		Acquisition and evaluation of measured values.	In all series of measurements. Concerns only the cycle time .

I/O trigger program

Mode: Monitoring Variables

The I/O trigger program (start measurement action) changes **all** variables monitored by the OPC server in the S7 CPU within **one** cycle.

It is **initiated** by a process interrupt triggered by the gauge on a digital module with interrupt capability in the central rack of the S7 station. (Exception: The Microbox with the CPU 1507S requires that the trigger signal be picked up via a distributed I/O station.)

In this case, the start signal to the S7 CPUs is the time when the gauge starts measuring. For the small S7 CPUs and large data volumes that need to be changed, this process takes very long in some cases (> 100 ms). This time is nonetheless included in the transfer time as the transfer to the OPC server starts continuously already during this time interval.

Communication program in OB1

In the case of optimized S7 communication between the CP and the OPC UA server (OPC server active, S7 CPU/CP passive), **no** communication blocks are required in the OB1 program.

Acquisition program in OB1

The acquisition program is used for acquisition and evaluation

- of the cycle time in the OB1 cycle.
- The average, minimum and maximum OB1 cycle time of the S7 CPU is determined using the RD_SINFO system block.

3.7.4 Load program

The load program is part of the STEP 7 program in the S7 controller. The size (length) of the load program is selected such that a default “cycle time without communication” results in the S7 controller.

Definition of “cycle time without communication”

The “cycle time without communication” is the cycle time set in the S7 controller when the S7 controller is **not** subject to influences of the communication. For the S7 controller, this means that no data is sent and no communication blocks are processed.

Setting a defined “cycle time without communication”

To be able to define the “cycle time without communication”, a load program is downloaded to the S7 controller. This load program allows the user to simulate the case occurring in practice that other control tasks are performed in the S7 controller simultaneously with the communication. The load program is implemented with a simple loop that does not influence the remaining program. The variation of the executed loops can therefore be used to set the “cycle time without communication”.

Selecting the “cycle time without communication”

For this measurement, the length of the load program has always been selected such that there is a no-load cycle time (“cycle time without communication”) of **250us** (low CPU load due to control tasks) or **50ms** (high CPU load due to control tasks). This implies that the length of the load program varies per S7 controller to ensure that the desired no-load cycle time is set.

Structure of the load program

The load program consists of a combination of different types of STEP 7 statements. The number of STEP 7 statements of a type is selected such that this type has a defined percentage of the total execution time of the load program.

Table 3-10

Type of STEP 7 assignment	Percentage of the execution time	e.g., in the case of a cycle time = 10 ms
Binary statements	approx. 60%	approx. 6ms
Time / counter statements	approx. 20%	approx. 2ms

Type of STEP 7 assignment	Percentage of the execution time	e.g., in the case of a cycle time = 10 ms
Data word commands	approx. 10%	approx. 1ms
Floating-point arithmetic	approx. 10%	approx. 1ms

4 Version

Table 4-1

Measurement version	Measurement setup	Publication	Description
V 3.0	Early 2016	January 2017	Repeated measurement
V 2.0	Late 2012	March 2012	Repeated measurement
V 1.0	Mid-2010	October 2010	First measurement