

Overview

The measuring principle of the OXYMAT 61 gas analyzers is based on the paramagnetic alternating pressure method and is used to measure oxygen in gases in standard applications.

Benefits

- Integrated pump for reference gas (option, e.g. ambient air)
- High linearity
- Compact design
- Physically suppressed zero possible

Application**Application areas**

- Environmental protection
- Boiler control in firing systems
- Quality monitoring (e.g. in ultra-pure gases)
- Process exhaust monitoring
- Process optimization

Further applications

- Chemical plants
- Gas manufacturers
- Research and development

Design

- 19" slide-in module with 4 HU for installation
 - In hinged frame
 - In cabinets with or without telescope rails
- Front plate can be swung down for servicing purposes (laptop connection)
- Gas connections for sample gas inlet and outlet; pipe diameter 6 mm or 1/4"
- Gas and electrical connections at the rear

Display and control panel

- Large LCD field for simultaneous display of
 - Measured value
 - Status bar
 - Measuring ranges
- Contrast of LCD panel adjustable using menu
- Permanent LED backlighting
- Washable membrane keyboard with five softkeys
- Menu-driven operation for parameterization, test functions, adjustment
- User help in plain text
- Graphic display of concentration trend; programmable time intervals
- Bilingual operating software German/English, English/Spanish, French/English, Spanish/English, Italian/English

Input and outputs

- One analog output per medium (from 0, 2, 4 to 20 mA; NAMUR parameterizable)
- Six digital inputs freely configurable (e.g. for measurement range switchover, processing of external signals from sample preparation)
- Six relay outputs freely configurable (failure, maintenance demanded, maintenance switch, threshold alarm, external magnetic valves)
- Two analog inputs configurable (e.g. correction of cross-interference, external pressure sensor)
- Expansion by eight additional digital inputs and eight additional relay outputs for autocalibration with up to four calibration gases

Communication

RS 485 present in basic unit (connection from the rear).

Options

- RS 485/RS 232 converter
- RS 485/Ethernet converter
- RS 485/USB converter
- Connection to networks via PROFIBUS DP/PA interface
- SIPROM GA software as service and maintenance tool

Extractive continuous process gas analysis

Series 6

OXYMAT 61

General information

LED backlit graphic display and membrane keyboard with noticeable click

Status line to display the analyzer status (programmable)

Two code levels according to NAMUR (maintenance and specialist level)

Display of concentrations as numbers and bargraph

Display of start-of-scale and full-scale values

Keyboard to enter values

CLEAR key to delete inputs

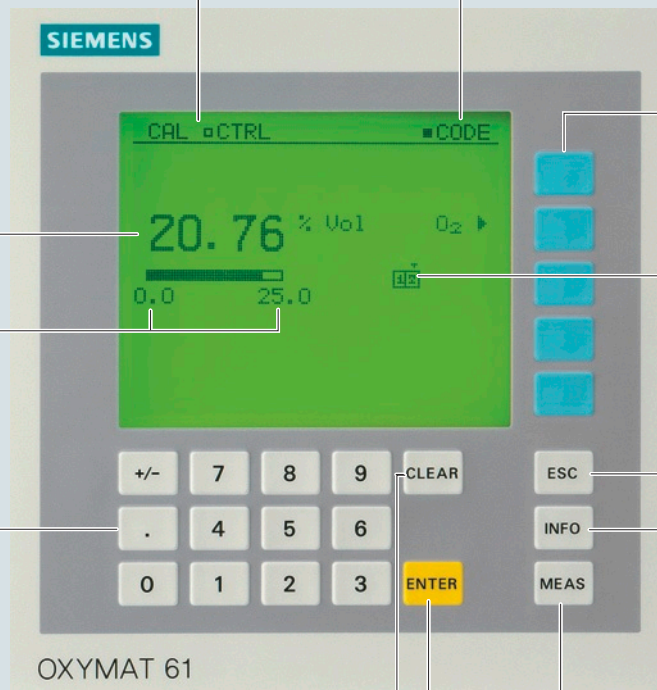

Easy operation menu controlling the softkeys

Display of current measuring ranges

ESC key to abort inputs

INFO key for help in plain text

MEAS key to return to measurement mode

ENTER key to accept input values

OXYMAT 61, membrane keyboard and graphic display

Designs – Parts wetted by sample gas, standard

Gas path		19" rack unit
With hoses	Bushing	Stainless steel. Mat. no. 1.4571
	Hose	FKM (Viton)
	Sample chamber	Stainless steel. Mat. no. 1.4571
	Fittings for sample chamber	Stainless steel. Mat. no. 1.4571
	Restrictor	PTFE (Teflon)
	O-rings	FKM (Viton)
	Hose coupling	Polyamide 6
Options		
Flow indicator	Measurement pipe	Duran glass
	Variable area	Duran glass, black
	Suspension boundary	PTFE (Teflon)
	Angle pieces	FKM (Viton)
Pressure switch	Diaphragm	FKM (Viton)
	Enclosure	PA 6.3 T

Gas path

Legend for the gas path figures

1	Sample gas inlet	8	Pressure switch in sample gas channel (option)
2	Sample gas outlet	9	Restrictor in reference gas path (outlet)
3	Not used	10	Pressure switch for reference gas monitoring
4	Reference gas inlet	11	Pump
5	Restrictor in reference gas path	12	Filter
6	O ₂ physical system	13	Flow indicator in sample gas channel (optional)
7	Restrictor in sample gas path	14	Pressure sensor

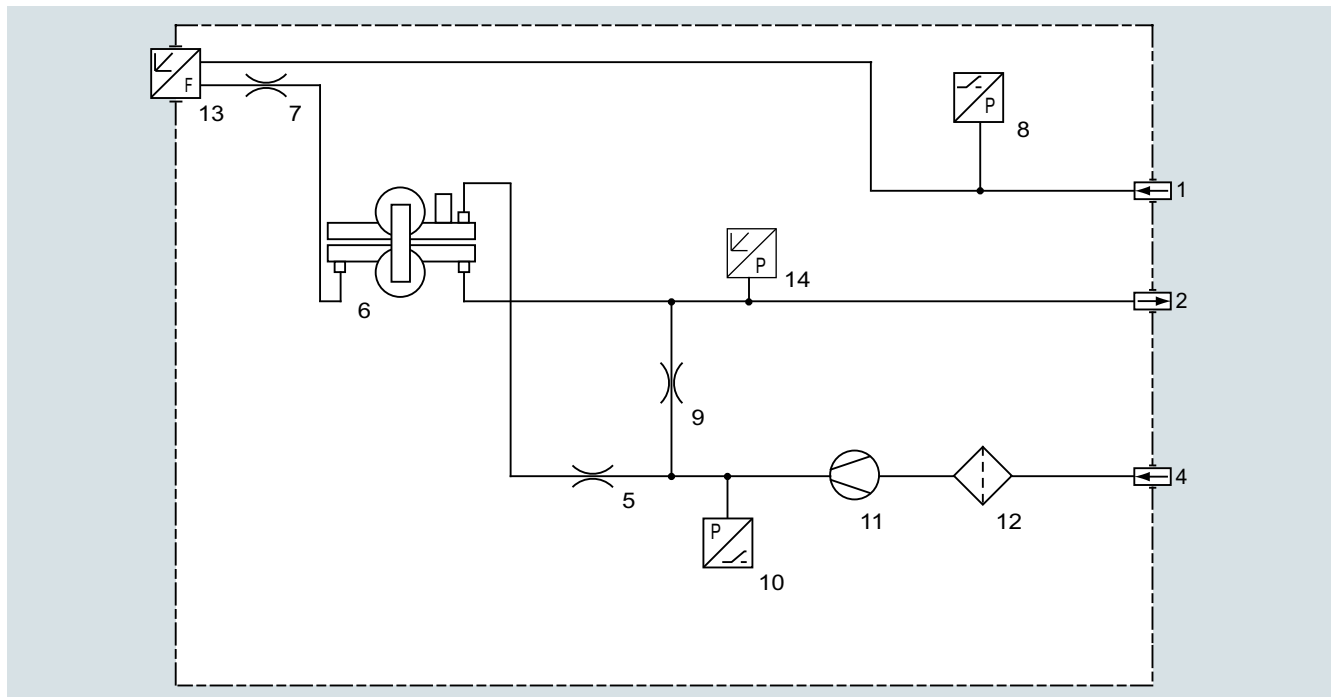

Gas path OXYMAT 61 with integrated reference gas pump (connection for 1 100 hPa, absolute)

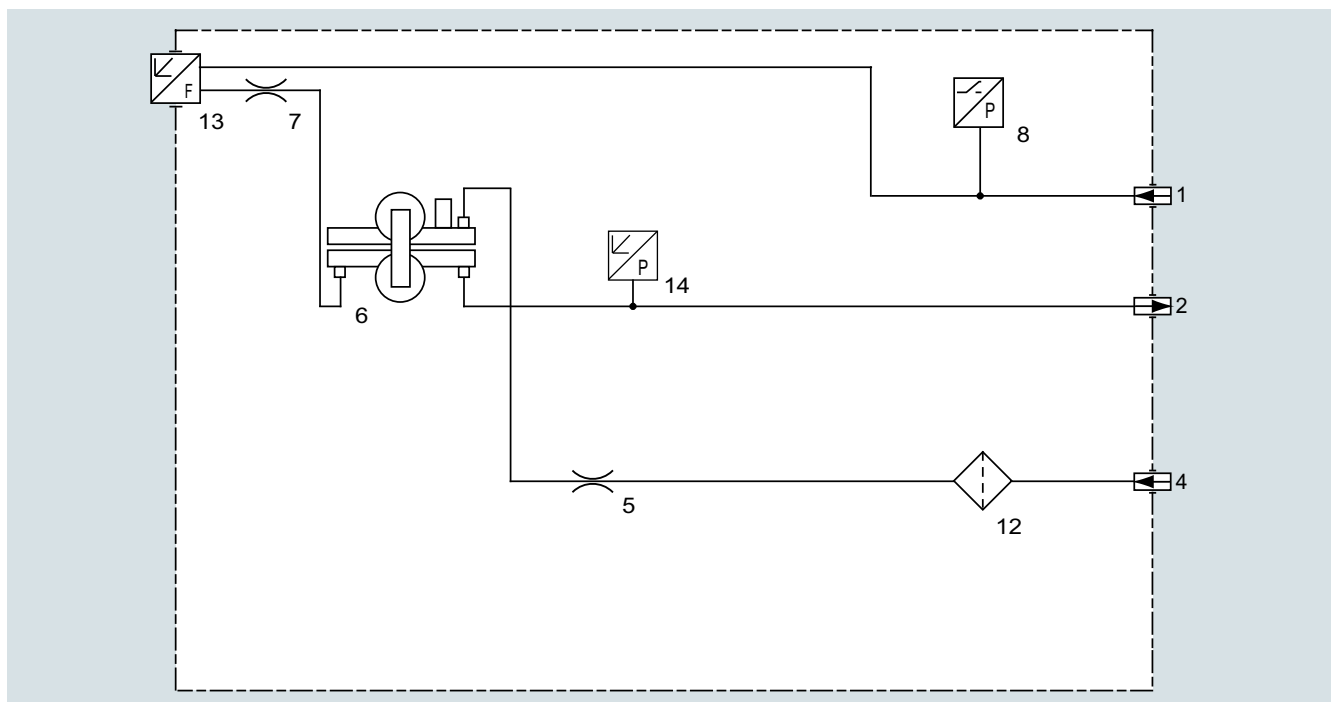

Gas path OXYMAT 61 with reference gas connection 3 000 to 5 000 hPa, absolute

Extractive continuous process gas analysis

Series 6

OXYMAT 61

General information

Function

In contrast to almost all other gases, oxygen is paramagnetic. This property is utilized as the measuring principle by the OXYMAT 61 gas analyzers.

Oxygen molecules in an inhomogeneous magnetic field are drawn in the direction of increased field strength due to their paramagnetism. When two gases with different oxygen contents meet in a magnetic field, a pressure difference is produced between them.

In the case of OXYMAT 61, one gas (1) is a reference gas (N_2 , O_2 or air), the other is the sample gas (5). The reference gas is introduced into the sample chamber (6) through two channels (3). One of these reference gas streams meets the sample gas within the area of a magnetic field (7). Because the two channels are connected, the pressure, which is proportional to the oxygen content, causes a cross flow. This flow is converted into an electric signal by a microflow sensor (4).

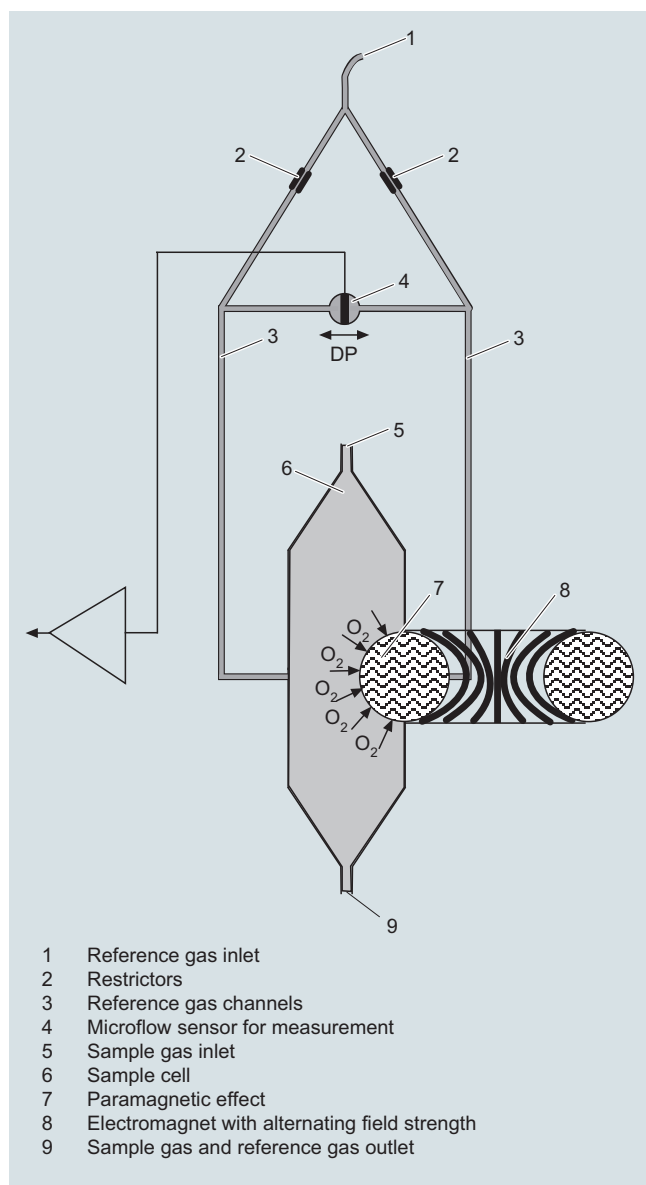

OXYMAT 61, principle of operation

The microflow sensor consists of two nickel-plated grids heated to approximately 120 °C, which, along with two supplementary resistors, form a Wheatstone bridge. The pulsating flow results in a change in the resistance of the Ni grids. This leads to an offset in the bridge which is dependent on the oxygen concentration of the sample gas.

Because the microflow sensor is located in the reference gas stream, the measurement is not influenced by the thermal conductivity, the specific heat or the internal friction of the sample gas. This also provides a high degree of corrosion resistance because the microflow sensor is not exposed to the direct influence of the sample gas.

By using a magnetic field with alternating strength (8), the effect of the background flow in the microflow sensor is not detected, and the measurement is thus independent of the instrument's operating position.

The sample chamber is directly in the sample path and has a small volume, and the microflow sensor is a low-lag sensor. This results in a very short response time for the OXYMAT 61.

Note

The sample gases must be fed into the analyzers free of dust. Condensation in the sample chambers must be prevented. Therefore, gas modified for the measuring tasks is necessary in most application cases.

Essential characteristics

- Four measuring ranges which can be freely configured, even with suppressed zero point, all measuring ranges are linear
- Galvanically isolated measured-value output 0/2/4 to 20 mA (also inverted)
- Autoranging possible; remote switching is also possible
- Storage of measured values possible during adjustments
- Wide range of selectable time constants (static/dynamic noise suppression); i.e. the response time of the device can be adapted to the respective measuring task
- Easy handling thanks to menu-driven operation
- Low long-term drift
- Two control levels with their own authorization codes for the prevention of accidental and unauthorized operator interventions
- Automatic measuring range calibration can be configured
- Operation based on the NAMUR recommendation
- Monitoring of sample gas (option)
- Customer-specific analyzer options such as:
 - Customer acceptance
 - TAG labels
 - Drift recording
- Simple handling using a numerical membrane keyboard and operator prompting
- Short response time
- Reference gas supply either externally (N_2 , O_2 or air, approx. 3 000 hPa) or via built-in reference gas pump (ambient air, approx. 1 100 hPa abs.)
- Monitoring of reference gas with reference gas connection; only on version with built-in reference gas pump
- Different smallest measuring ranges, depending on version 2.0% or 5.0% O_2
- Internal pressure sensor for correction of fluctuations in the sample gas pressure

Correction of zero error / cross-sensitivities

Accompanying gas (concentration 100 vol.%)	Deviation from zero point in vol.% O ₂ absolute	Accompanying gas (concentration 100 vol.%)	Deviation from zero point in vol.% O ₂ absolute
Organic gases		Inert gases	
Ethane C ₂ H ₆	-0.49	Helium He	+0.33
Ethene (ethylene) C ₂ H ₄	-0.22	Neon Ne	+0.17
Ethine (acetylene) C ₂ H ₂	-0.29	Argon Ar	-0.25
1.2 butadiene C ₄ H ₆	-0.65	Krypton Kr	-0.55
1.3 butadiene C ₄ H ₆	-0.49	Xenon Xe	-1.05
n-butane C ₄ H ₁₀	-1.26	Inorganic gases	
iso-butane C ₄ H ₁₀	-1.30	Ammonia NH ₃	-0.20
1-butene C ₄ H ₈	-0.96	Hydrogen bromide HBr	-0.76
iso-butene C ₄ H ₈	-1.06	Chlorine Cl ₂	-0.94
Dichlorodifluoromethane (R12) CCl ₂ F ₂	-1.32	Hydrogen chloride HCl	-0.35
Acetic acid CH ₃ COOH	-0.64	Dinitrogen monoxide N ₂ O	-0.23
n-heptane C ₇ H ₁₆	-2.40	Hydrogen fluoride HF	+0.10
n-hexane C ₆ H ₁₄	-2.02	Hydrogen iodide HI	-1.19
Cyclo-hexane C ₆ H ₁₂	-1.84	Carbon dioxide CO ₂	-0.30
Methane CH ₄	-0.18	Carbon monoxide CO	+0.07
Methanol CH ₃ OH	-0.31	Nitrogen oxide NO	+42.94
n-octane C ₈ H ₁₈	-2.78	Nitrogen N ₂	0.00
n-pentane C ₅ H ₁₂	-1.68	Nitrogen dioxide NO ₂	+20.00
iso-pentane C ₅ H ₁₂	-1.49	Sulfur dioxide SO ₂	-0.20
Propane C ₃ H ₈	-0.87	Sulfur hexafluoride SF ₆	-1.05
Propylene C ₃ H ₆	-0.64	Hydrogen sulfide H ₂ S	-0.44
Trichlorofluoromethane (R11) CCl ₃ F	-1.63	Water H ₂ O	-0.03
Vinyl chloride C ₂ H ₃ Cl	-0.77	Hydrogen H ₂	+0.26
Vinyl fluoride C ₂ H ₃ F	-0.55		
1.1 vinylidene chloride C ₂ H ₂ Cl ₂	-1.22		

Table 1: Zero error due to diamagnetism or paramagnetism of some accompanying gases with nitrogen as the reference gas at 60 °C and 1 000 hPa absolute (according to IEC 1207/3)

Conversion to other temperatures:

The deviations from the zero point listed in Table 1 must be multiplied by a correction factor (k):

- with diamagnetic gases: $k = 333 \text{ K} / (\varphi [^{\circ}\text{C}] + 273 \text{ K})$
- with paramagnetic gases: $k = [333 \text{ K} / (\varphi [^{\circ}\text{C}] + 273 \text{ K})]^2$

All diamagnetic gases have a negative deviation from zero point.

Reference gases

Measuring range	Recommended reference gas	Reference gas connection pressure	Remarks
0 to ... vol.% O ₂	N ₂	2 000 ... 4 000 hPa above sample gas pressure (max. 5 000 hPa absolute)	The reference gas flow is set automatically to 5 ... 10 ml/min.
... to 100 vol.% O ₂ (suppressed zero point with full-scale value 100 vol.% O ₂)	O ₂		
Around 21 vol.% O ₂ (suppressed zero point with 21 vol.% O ₂ within the measuring span)	Air	Atm. pressure with internal reference gas pump	

Extractive continuous process gas analysis

Series 6

OXYMAT 61

19" rack unit

1

Technical specifications

General information		Measuring response	
Measuring ranges	4, internally and externally switchable; autoranging is also possible	Output signal fluctuation	Based on sample gas pressure 1 013 hPa absolute, 0.5 l/min sample gas flow and 25 °C ambient temperature
Smallest possible span (relating to sample gas pressure 1 000 hPa absolute, 0.5 l/min sample gas flow and 25 °C ambient temperature)	2 vol.% or 5 vol.% O ₂	Zero point drift	< ± 0.5%/month of the smallest possible span according to rating plate
Largest possible measuring span	100 vol.% O ₂	Measured-value drift	< ± 0.5%/month of the current measuring range
Measuring ranges with suppressed zero point	Any zero point within 0 ... 100 vol.% can be implemented, provided that a suitable reference gas is used	Repeatability	< 1% of the current measuring range
Operating position	Front wall, vertical	Detection limit	1% of the current measuring range
Conformity	CE mark in accordance with EN 50081-1 and EN 50082-2	Linearity error	< 1% of the current measuring range
Design, enclosure		Influencing variables	
Degree of protection	IP20 according to EN 60529	Ambient temperature	Based on sample gas pressure 1 013 hPa absolute, 0.5 l/min sample gas flow and 25 °C ambient temperature
Weight	Approx. 13 kg	Sample gas pressure (with air (100 hPa) as internal reference gas supply, correction of the atmospheric pressure fluctuations is only possible if the sample gas can vent to ambient air.)	< 1% of the current measuring range/10 K Zero offset: < 0.1 vol.% O ₂ absolute/10 K
Electrical characteristics		Accompanying gases	<ul style="list-style-type: none"> • With disabled pressure compensation: < 2% of the current measuring range/1% pressure change • With enabled pressure compensation: < 0.2% of the current measuring range/1% pressure change
Auxiliary power	100 ... 120 V AC (nominal range of use 90 ... 132 V), 48 ... 63 Hz or 200 ... 240 V AC (nominal range of use 180 ... 264 V), 48 ... 63 Hz	Sample gas flow at zero point	< 1% of the current measuring range according to rating plate with a change in flow of 0.1 l/min within the permissible flow range
Power consumption	Approx. 45 VA	Auxiliary power	< 0.1% of the current measuring range with rated voltage ± 10%
EMC (electromagnetic compatibility)	In accordance with standard requirements of NAMUR NE21 (08/98)	Electrical inputs and outputs	
Electrical safety	According to EN 61010-1, overvoltage category III	Analog output	0/2/4 ... 20 mA, floating; max. load 750 Ω
Fuse values	100 ... 120 V: 1.0 T/250 200 ... 240 V: 0.63 T/250	Relay outputs	6, with changeover contacts, freely configurable, e.g. for measuring range identification; load: 24 V AC/DC/1 A, floating
Gas inlet conditions		Analog inputs	2, dimensioned for 0/2/4 ... 20 mA for external pressure sensor and accompanying gas influence correction (correction of cross-interference)
Permissible sample gas pressure	800 ... 1 200 hPa absolute Atmospheric pressure ± 50 hPa	Digital inputs	6, designed for 24 V, floating, freely configurable, e.g. for measuring range switchover
• External reference gas supply		Serial interface	RS 485
• With integrated pump		Options	AUTOCAL function each with 8 additional digital inputs and relay outputs, also with PROFIBUS PA or PROFIBUS DP
Sample gas flow	18 ... 60 l/h (0.3 ... 1 l/min)	Climatic conditions	
Sample gas temperature	Min. 0 to max. 50 °C, but above the dew point	Permissible ambient temperature	-30 ... +70 °C during storage and transportation 5 ... 45 °C during operation
Sample gas humidity	< 90% relative humidity	Permissible humidity	< 90% relative humidity as annual average, during storage and transportation (must not fall below dew point)
Reference gas pressure (high-pressure version)	2 000 to 4 000 hPa above sample gas pressure, but max. 5 000 hPa absolute (version without reference gas pump)		
Reference gas pressure (low-pressure version) with external pump	Min. 100 hPa above sample gas pressure		
Dynamic response			
Warm-up period	At room temperature < 30 min (the technical specification will be met after 2 hours)		
Delayed display (T ₉₀)	3.5 s		
Damping (electrical time constant)	0 ... 100 s, configurable		
Dead time (purging time of the gas path in the unit at 1 l/min)	Approximately 0.5 ... 2.5 s, depending on version		
Time for device-internal signal processing	< 1 s		
Pressure correction range			
Pressure sensor internal	500 ... 2 000 hPa, absolute (see gas inlet conditions for permissible sample gas pressure)		

Selection and ordering data	Article No.	
OXYMAT 61 gas analyzer 19" rack unit for installation in cabinets Click on the Article No. for the online configuration in the PIA Life Cycle Portal.	7MB2001- A 0 0 -	Cannot be combined
<u>Gas connections for sample gas and reference gas</u> Pipe with 6 mm outer diameter Pipe with 1/4" outer diameter	0 1	
<u>Smallest possible measuring span O₂</u> 2 % Reference gas pressure 3 000 hPa 2 % reference gas supply with internal pump 5 % Reference gas pressure 3 000 hPa 5 % reference gas supply with internal pump	C D E F	D → Y02 F → Y02
<u>Power supply</u> 100 ... 120 V AC, 48 ... 63 Hz 200 ... 240 V AC, 48 ... 63 Hz	0 1	
<u>Sample gas monitoring</u> Without With (incl. flow indicator and pressure switch)	A D	
<u>Add-on electronics</u> Without AUTOCAL function <ul style="list-style-type: none"> With 8 additional digital inputs/outputs With serial interface for the automotive industry (AK) With 8 additional digital inputs/outputs and PROFIBUS PA interface With 8 additional digital inputs/outputs and PROFIBUS DP interface 	A B D E F	
<u>Language</u> German English French Spanish Italian	0 1 2 3 4	
Additional versions	Order code	
Add "-Z" to Article No. and specify Order code		
Telescopic rails (2 units)	A31	
TAG labels (specific lettering based on customer information)	B03	
Attenuation element for sample gas	B04	→ Y02
SIL conformity declaration (SIL 2) Functional Safety according to IEC 61508 and IEC 61511	C20	
Clean for O ₂ service (specially cleaned gas path)	Y02	
Measuring range indication in plain text, if different from the standard setting ¹⁾	Y11	
Accessories	Article No.	
RS 485/Ethernet converter	A5E00852383	
RS 485/RS 232 converter	C79451-Z1589-U1	
RS 485/USB converter	A5E00852382	
AUTOCAL function each with 8 digital inputs/outputs	C79451-A3480-D511	
AUTOCAL function 8 digital inputs/outputs each and PROFIBUS PA	A5E00057307	
AUTOCAL function 8 digital inputs/outputs each and PROFIBUS DP	A5E00057312	
Set of Torx screwdrivers	A5E34821625	

¹⁾ Standard setting:
Measuring range 1: 0 to smallest measuring span
Measuring range 2: 0 to 10 %
Measuring range 3: 0 to 25 %
Measuring range 4: 0 to 100 %

Extractive continuous process gas analysis

Series 6

OXYMAT 61

19" rack unit

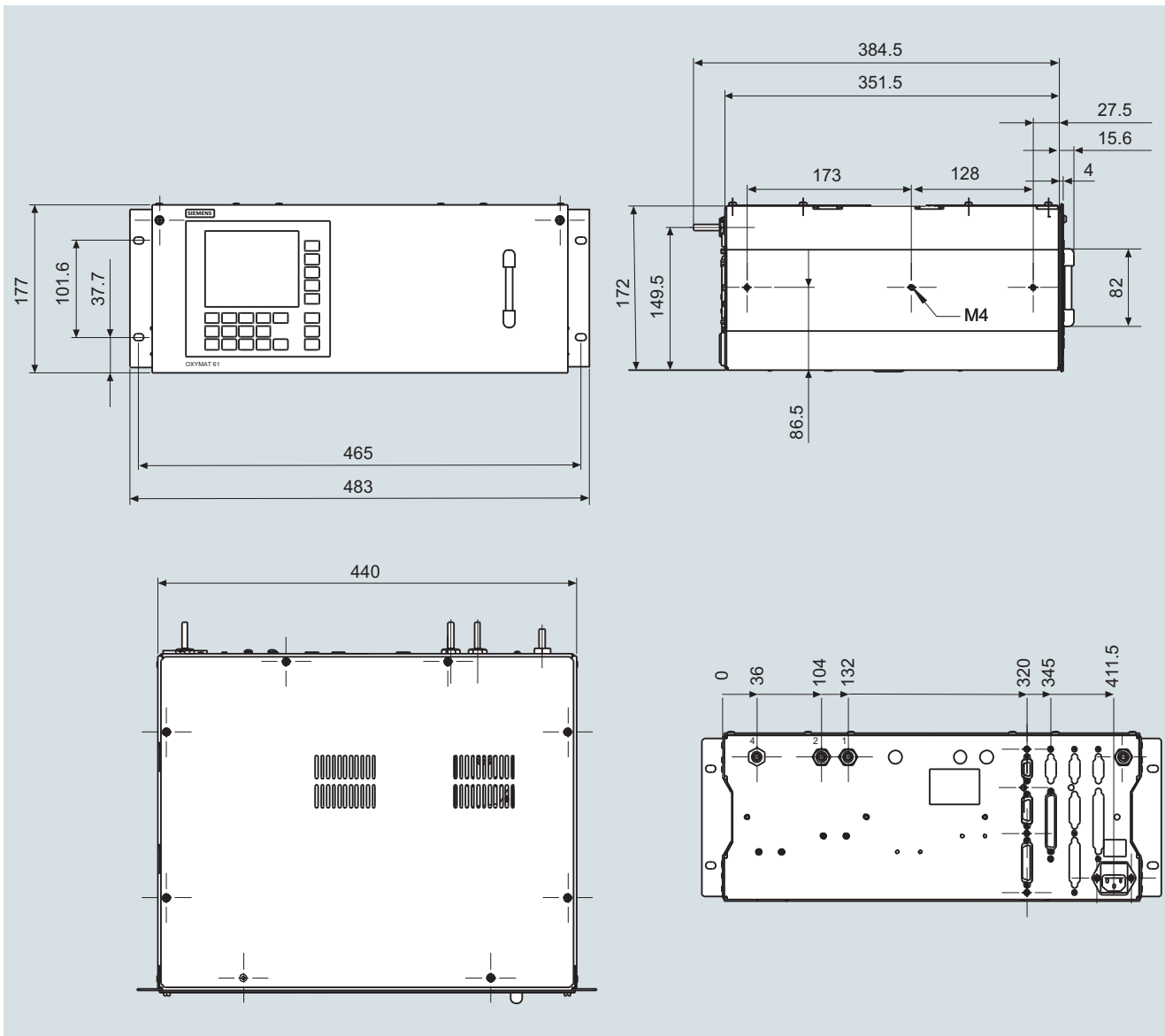
Dimensional drawings

OXYMAT 61, 19" unit, dimensions in mm

Circuit diagrams

Pin assignment (electrical connections)

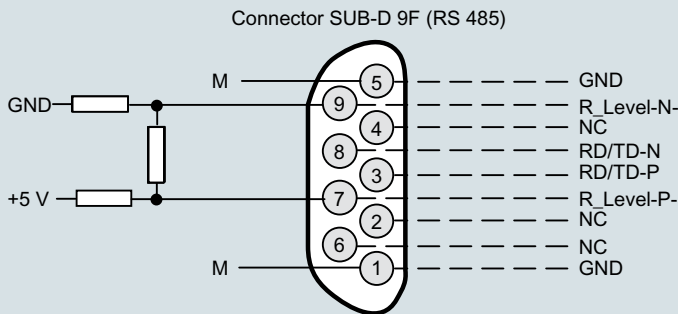

It is possible to connect bus terminating resistors to pins 7 and 9.

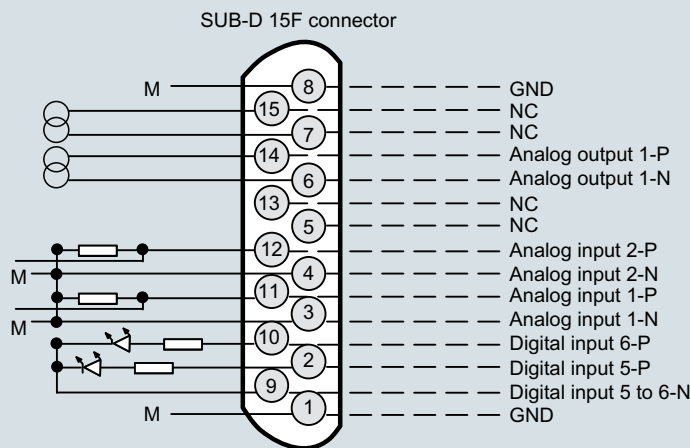

Analog outputs isolated (also from each other), $R_i \leq 750 \Omega$

Pressure correction } Non-isolated analog inputs,
 Pressure correction } 0 ... 20 mA/500 Ω or
 Correction of cross-interference } 0 ... 10 V (low resistance)
 Correction of cross-interference }

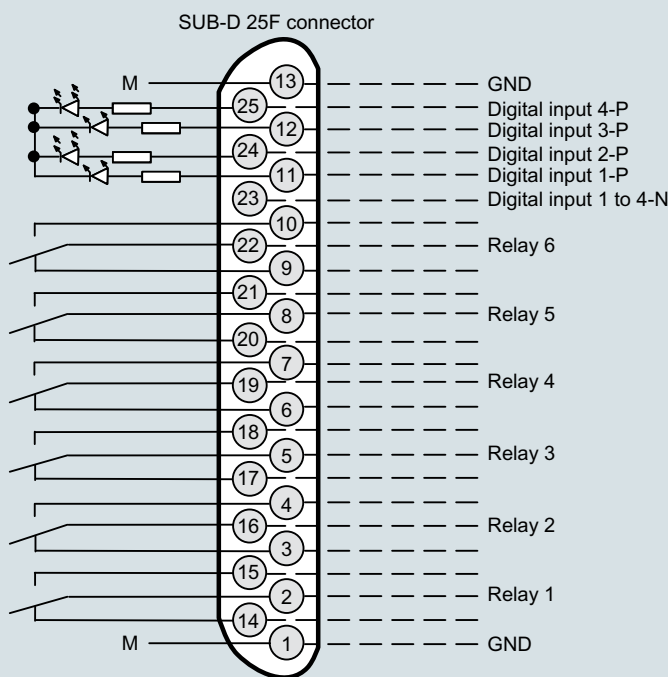

Isolated via optocoupler
 "0" = 0 V (0 ... 4.5 V)
 "1" = 24 V (13 ... 33 V)

Contact load max. 24 V/1 A, AC/DC
 The relay is current-free for the relay contact position shown

Note:
 All cables to the connectors or terminal blocks must be shielded and rest against the enclosure potential.

OXYMAT 61, 19" unit, pin assignment

Extractive continuous process gas analysis

Series 6
OXYMAT 61

19" rack unit

Pin assignment (electrical connections)

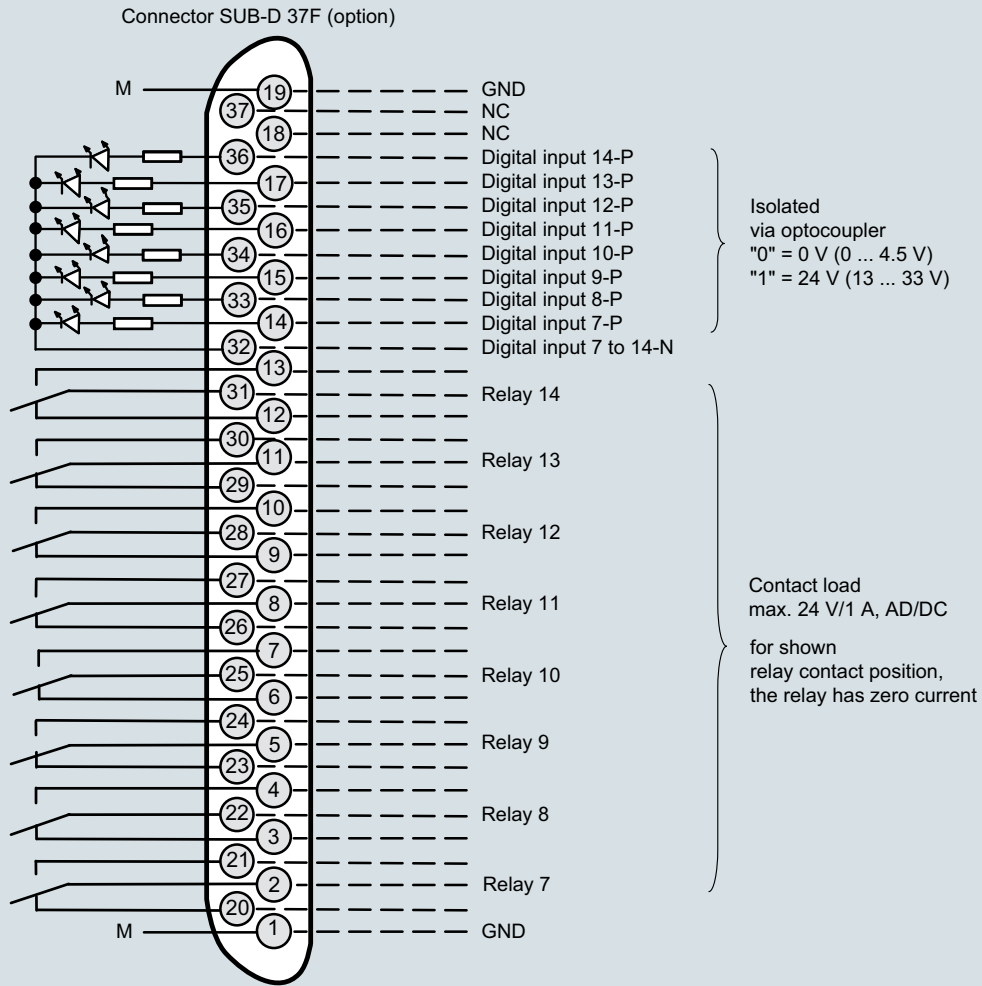

Connector SUB-D 9F-X90
PROFIBUS DP

Optional

Connector SUB-D 9M-X90
PROFIBUS PA

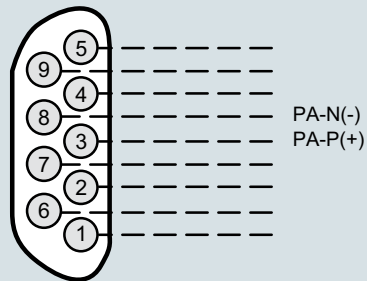
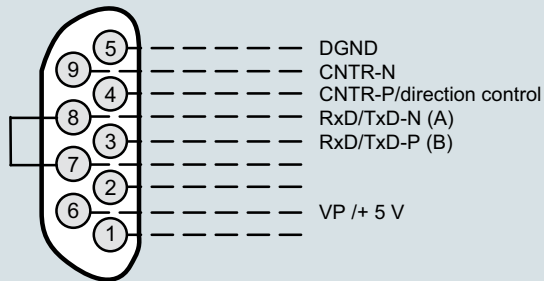

Note:
All cables to the connectors or terminal blocks must be shielded and rest against the enclosure potential.

OXYMAT 61, 19" unit, pin assignment of the AUTOCAL board and PROFIBUS connectors

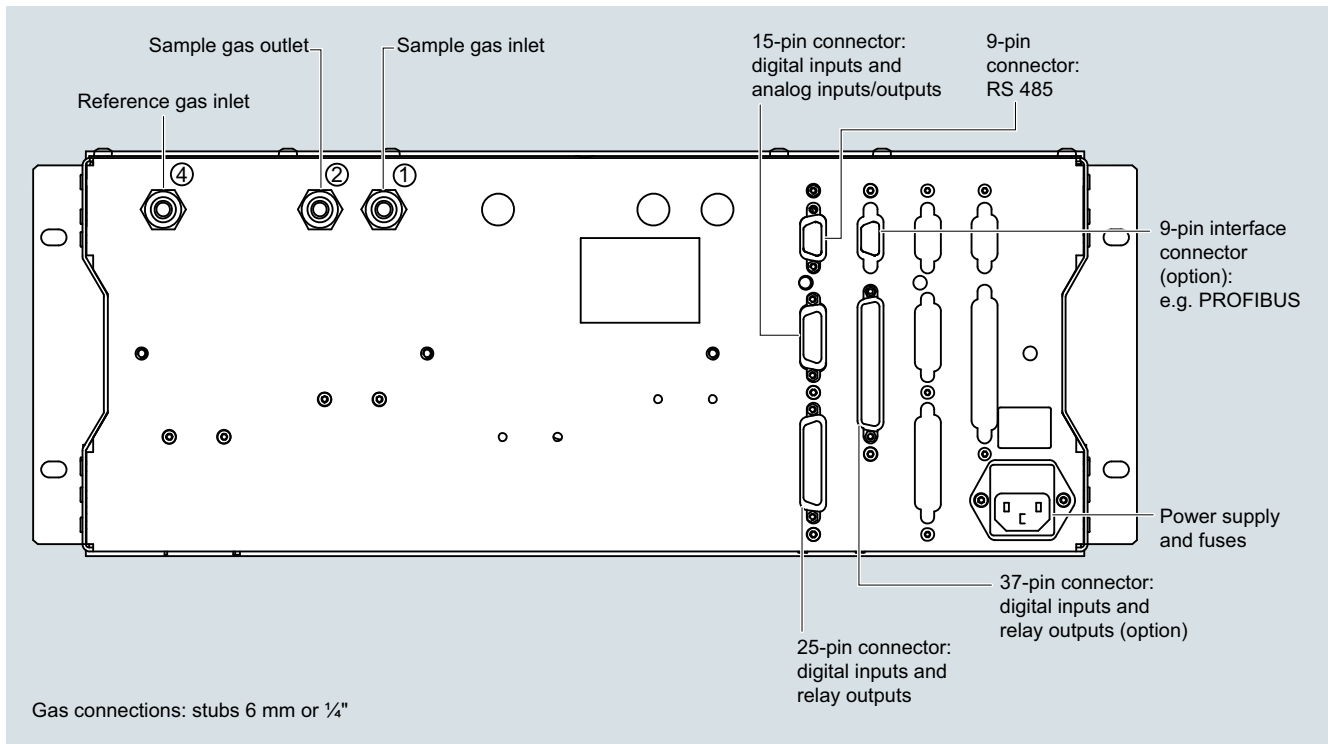
Gas and electrical connections

OXYMAT 61, 19" unit, gas and electrical connections

Extractive continuous process gas analysis

Series 6

OXYMAT 61

Documentation, suggestions for spare parts

1

Selection and ordering data

Operating instructions	Article No.
OXYMAT 61 Gas analyzer for measurement of oxygen	
<ul style="list-style-type: none"> German 	A5E00123066
<ul style="list-style-type: none"> English 	A5E00123067
<ul style="list-style-type: none"> French 	A5E00123068
<ul style="list-style-type: none"> Spanish 	A5E00123069
<ul style="list-style-type: none"> Italian 	A5E00123070

More information

The complete documentation is available in various languages for downloading free of charge:

<http://www.siemens.com/processanalytics/documentation>

Selection and ordering data

Description	Quantity for 2 years	Quantity for 5 years	Article No.
Analyzer unit			
Reference gas supply (pump, restrictor, pressure switch, hose)	1	1	A5E00114838
Set of gaskets for sample gas pump	2	5	A5E35875733
O-ring	1	2	C74121-Z100-A6
Pressure switch (sample gas)	1	2	C79302-Z1210-A2
Flowmeter	1	2	C79402-Z560-T1
Sample chamber			
<ul style="list-style-type: none"> Stainless steel, mat. no. 1.4571; non-flow-type compensation branch 	-	1	C79451-A3277-B535
<ul style="list-style-type: none"> O-ring (measuring head) 	2	4	C79121-Z100-A32
<ul style="list-style-type: none"> O ring (fitting) 	2	4	C71121-Z100-A159
Measuring head (non-flow-type compensation branch)	1	1	C79451-A3460-B525
Restrictor for sample gas path, hose	2	2	C79451-A3480-C10
Reference gas path, 3000 hPa (set of parts)	1	1	C79451-A3480-D518
Electronics			
Front plate with keyboard	1	1	A5E00259978
Motherboard, with firmware: see spare parts list	-	1	
Adapter plate, LCD/keyboard	1	1	C79451-A3474-B605
Magnetic field connection plate	-	1	C79451-A3474-B606
LC display	1	1	A5E31474846
Connector filter	-	1	W75041-E5602-K2
Fuse			
<ul style="list-style-type: none"> 0.63 A/250 V (230 V version) 	2	3	W79054-L1010-T630
<ul style="list-style-type: none"> 1.0 A/250 V (110 V version) 	2	3	W79054-L1011-T100

If the OXYMAT 61 was supplied with a specially cleaned gas path for high oxygen context ("Clean for O₂ service"), please ensure that you specify this when ordering spare parts. This is the only way to guarantee that the gas path will continue to comply with the special requirements for this version.