

# SIEMENS

## SIMATIC

### S7-300 Automation System, Hardware and Installation: CPU 312IFM - 318-2 DP

#### Installation Manual

#### Contents

---

Preface	1
Guide to the S7-300 Documentation	2
Installation Order	3
S7-300 Modules	4
Configuring	5
Installation	6
Wiring	7
Addressing	8
Commissioning	9
Maintenance	10
Testing functions and Diagnostics	11
Appendix	12
Glossary	13
Index	



This documentation can **no longer** be ordered under the given number!

This manual is part of the documentation package with the order number:  
**6ES7398-8FA10-8BA0**

**Edition 06/2003**  
A5E00203919-01

## Safety Guidelines

This manual contains notices intended to ensure personal safety, as well as to protect the products and connected equipment against damage. These notices are highlighted by the symbols shown below and graded according to severity by the following texts:



---

### Danger

indicates that death, severe personal injury or substantial property damage will result if proper precautions are not taken.

---



---

### Warning

indicates that death, severe personal injury or substantial property damage can result if proper precautions are not taken.

---



---

### Caution

indicates that minor personal injury can result if proper precautions are not taken.

---

---

### Caution

indicates that property damage can result if proper precautions are not taken.

---

---

### Notice

draws your attention to particularly important information on the product, handling the product, or to a particular part of the documentation.

---

## Qualified Personnel

Only **qualified personnel** should be allowed to install and work on this equipment. Qualified persons are defined as persons who are authorized to commission, to ground and to tag circuits, equipment, and systems in accordance with established safety practices and standards.

## Correct Usage

Note the following:



---

### Warning

This device and its components may only be used for the applications described in the catalog or the technical description, and only in connection with devices or components from other manufacturers which have been approved or recommended by Siemens.

This product can only function correctly and safely if it is transported, stored, set up, and installed correctly, and operated and maintained as recommended.

---

## Trademarks

SIMATIC®, SIMATIC HMI® and SIMATIC NET® are registered trademarks of SIEMENS AG.

Third parties using for their own purposes any other names in this document which refer to trademarks might infringe upon the rights of the trademark owners.

### Copyright © Siemens AG 2002 All rights reserved

The reproduction, transmission or use of this document or its contents is not permitted without express written authority. Offenders will be liable for damages. All rights, including rights created by patent grant or registration of a utility model or design, are reserved.

### Disclaimer of Liability

We have checked the contents of this manual for agreement with the hardware and software described. Since deviations cannot be precluded entirely, we cannot guarantee full agreement. However, the data in this manual are reviewed regularly and any necessary corrections included in subsequent editions. Suggestions for improvement are welcomed.

Siemens AG  
Bereich Automation and Drives  
Geschäftsgebiet Industrial Automation Systems  
Postfach 4848, D- 90327 Nuernberg

Siemens Aktiengesellschaft

©Siemens AG 2003  
Technical data subject to change.

A5E00203919-01



# Contents

<b>1</b>	<b>Preface .....</b>	<b>1-1</b>
<b>2</b>	<b>Guide to the S7-300 Documentation .....</b>	<b>2-1</b>
<b>3</b>	<b>Installation Order .....</b>	<b>3-1</b>
<b>4</b>	<b>S7-300 Modules .....</b>	<b>4-1</b>
<b>5</b>	<b>Configuring.....</b>	<b>5-1</b>
5.1	Summary of the Content .....	5-1
5.2	Basic Principles of Planning .....	5-2
5.3	Component Dimensions .....	5-4
5.4	Arranging modules on a single rack .....	5-7
5.5	Arranging Modules on Multiple Racks .....	5-9
5.6	Selection and installation of cabinets .....	5-12
5.7	Example: Selecting a Cabinet .....	5-15
5.8	Electrical assembly, protective measures and grounding .....	5-17
5.8.1	Grounding concept and overall structure .....	5-17
5.8.2	Installing the S7-300 with grounded reference potential (except for CPU 312 IFM) .....	5-19
5.8.3	Isolated or non-isolated modules .....	5-22
5.8.4	Grounding measures .....	5-25
5.8.5	Overview: Grounding.....	5-28
5.9	Selecting the Load Power Supply .....	5-30
5.10	Planning Subnets .....	5-32
5.10.1	Extending and networking subnets .....	5-32
5.10.2	Basic principles of MPI and DP subnets .....	5-34
5.10.3	Interfaces.....	5-37
5.10.4	Network Components .....	5-39
5.10.5	Cable length .....	5-42
5.10.6	Sample networks .....	5-44
<b>6</b>	<b>Installation .....</b>	<b>6-1</b>
6.1	Installing an S7-300.....	6-1
6.2	Installing the rail.....	6-3
6.3	Installing modules on the rail.....	6-7
6.4	Label the modules .....	6-9

<b>7</b>	<b>Wiring</b> .....	<b>7-1</b>
7.1	Wiring .....	7-1
7.2	Connecting the Protective Conductor to the Rail .....	7-4
7.3	Adjusting the Power Supply Module to the Mains Voltage .....	7-5
7.4	Wiring the power supply module and the CPU .....	7-6
7.5	Wiring Front Connectors .....	7-8
7.6	Inserting Front Connectors into Modules .....	7-12
7.7	Labeling the Module I/O .....	7-13
7.8	Connecting shielded cables to the shielding contact element .....	7-14
7.9	Wiring the Bus Connector .....	7-17
<b>8</b>	<b>Addressing</b> .....	<b>8-1</b>
8.1	Addressing.....	8-1
8.2	Slot-defined addressing of modules .....	8-1
8.3	User-defined addressing of modules .....	8-3
8.4	Addressing Signal Modules.....	8-3
8.5	Addressing the Integrated I/O of the CPU.....	8-6
8.6	Consistent Data .....	8-7
<b>9</b>	<b>Commissioning</b> .....	<b>9-1</b>
9.1	In this Chapter .....	9-1
9.2	Commissioning procedure.....	9-1
9.3	Commissioning Checklist .....	9-4
9.4	Insert the back-up battery or rechargeable battery .....	9-5
9.5	Inserting and replacing a memory card.....	9-7
9.6	Commissioning the modules .....	9-8
9.6.1	Connecting the PG .....	9-8
9.6.2	Initial power on. ....	9-12
9.6.3	Memory reset by means of the CPU mode selector switch .....	9-13
9.6.4	Starting SIMATIC Manager .....	9-17
9.6.5	Monitoring and controlling I/Os.....	9-18
9.7	Commissioning PROFIBUS DP .....	9-23
9.7.1	Commissioning PROFIBUS DP .....	9-23
9.7.2	Commissioning the CPU as DP master .....	9-24
9.7.3	Commissioning the CPU as DP slave.....	9-27
9.7.4	Direct Data Exchange .....	9-33
<b>10</b>	<b>Maintenance</b> .....	<b>10-1</b>
10.1	In this Chapter .....	10-1
10.2	Backup of the CPU operating system .....	10-1
10.3	Updating the Operating System .....	10-3
10.4	Module replacement.....	10-4
10.5	Replacing the back-up battery or rechargeable battery (CPUs with MC only) .....	10-9
10.6	Digital output module AC 120/230 V: Replacing the fuses .....	10-11

<b>11</b>	<b>Testing functions and Diagnostics .....</b>	<b>11-1</b>
11.1	In this Chapter .....	11-1
11.2	Overview: Testing functions .....	11-1
11.3	Overview: Diagnostics .....	11-4
11.4	Diagnostic options with STEP 7 .....	11-6
11.5	Diagnostics with LEDs.....	11-7
11.6	Diagnostics of DP CPUs .....	11-12
11.6.1	Diagnostics of DP CPUs operating as DP master .....	11-12
11.6.2	Reading Slave Diagnostic Data.....	11-15
11.6.3	Interrupts on the DP Master .....	11-21
11.6.4	Structure of the slave diagnostic data when the CPU is used as an intelligent slave .....	11-22
<b>12</b>	<b>Appendix.....</b>	<b>12-1</b>
12.1	Assembly.....	12-1
12.1.1	General Rules and Regulations for S7-300 Operation.....	12-1
12.2	Protection against electromagnetic interference .....	12-3
12.2.1	Basic Points for System Installations Conforming with EMC Requirements...	12-3
12.2.2	Five Basic Rules for Ensuring EMC .....	12-5
12.2.3	EMC Compatible Installation of PLC .....	12-7
12.2.4	Examples of an EMC Compatible Installation .....	12-8
12.2.5	Shielding of Cables .....	12-11
12.2.6	Equipotential bonding.....	12-12
12.2.7	Cable Routing inside Buildings.....	12-14
12.2.8	Outdoor cable routing.....	12-16
12.3	Lightning and Surge Voltage Protection.....	12-17
12.3.1	In the following sections ... ..	12-17
12.3.2	Lightning Protection Zone Concept.....	12-17
12.3.3	Rules for the Transition Point between Lightning Protection Zones 0 <-> 1 .....	12-19
12.3.4	Rules for the Transition Points between Lightning Protection Zones 1 <-> 2 and Higher .....	12-21
12.3.5	Sample of a Surge Protection Circuit for Networked S7-300 PLCs.....	12-24
12.3.6	1 How to Protect Digital Output Modules against Inductive Surge Voltage ..	12-26
12.4	Safety of electronic control equipment .....	12-28
<b>13</b>	<b>Glossary.....</b>	<b>13-1</b>

**Index**

**Figures**

1-1	Information Landscape of an S7-300 .....	1-3
1-2	Additional Documentation .....	1-4
1-3	SIMATIC Technical Support.....	1-5
3-1	Installing an S7 system .....	3-1
4-1	Example configuration: S7-300 components .....	4-1
5-1	Horizontal and vertical installation .....	5-3
5-2	Shielding contact element.....	5-5
5-3	Clearance.....	5-6
5-4	Maximum configuration on one rack.....	5-8
5-5	Full assembly using racks.....	5-11
5-6	Power loss dissipated .....	5-16
5-7	S7-300 configuration with grounded reference potential (CPU 313 – 318-2 DP) .....	5-20
5-8	S7-300 configuration with floating reference potential (CPU 313 – 318-2 DP) .....	5-21
5-9	Configuration with isolated modules .....	5-23
5-10	Configuration with non-isolated modules .....	5-24
5-11	Grounding concept for the S7-300 with CPU 312 IFM .....	5-28
5-12	Grounding concept for the S7-300 with CPU 31 x.....	5-29
5-13	Example: S7-300 with load power supply from PS 307.....	5-31
5-14	Example of an MPI subnet.....	5-44
5-15	Example: Maximum distance in the MPI subnet.....	5-45
5-16	Example of a PROFIBUS subnet.....	5-46
5-17	Example: CPU 314C-2 DP as MPI and PROFIBUS nodes.....	5-47
5-18	Example of PG access across network boundaries (routing) .....	5-48
5-19	Installing the terminating resistors in an MPI subnet .....	5-49
6-1	Holes for mounting the 2 m rail .....	6-4
6-2	Free space required for an S7-300 installation.....	6-6
6-3	Inserting slot numbers in modules .....	6-10
7-1	connecting the protective conductor to the rail .....	7-4
7-2	Setting the mains voltage selector switch for the PS 307.....	7-5
7-3	Wiring the power supply module and the CPU .....	7-7
7-4	Move the front connector into wiring position .....	7-10
7-5	Slide the labeled strips into the front panel.....	7-13
7-6	Shielding contact element underneath two signal modules.....	7-15
7-7	Connecting 2-wire cables to the shielding contact element.....	7-16
7-8	Bus connector: Enabled and disabled terminating resistor.....	7-18
8-1	S7-300 slots and the associated module start addresses .....	8-2
8-2	Addresses of the I/O of digital modules .....	8-4
8-3	I/O Addresses of a digital module in Slot 4 .....	8-5
8-4	I/O addresses of an analog module in Slot 4.....	8-6
9-1	Insert a back-up battery into CPUs 313/314.....	9-6
9-2	Insert the memory card into the CPU.....	9-7
9-3	Connecting a PG to an S7-300 .....	9-8
9-4	Connecting a PG to multiple S7 devices.....	9-9
9-5	Connecting a PG to a subnet.....	9-10
9-6	PG connected to an ungrounded S7-300 .....	9-11
9-7	Operation of mode selector switch for memory reset .....	9-14
9-8	Using the mode selector switch for a cold start (CPU 318-2 DP only) .....	9-15
9-9	Transfer memory in the CPUs 31x-2 DP acting as DP slave .....	9-29
9-10	Direct data exchange with CPUs 31x-2 DP .....	9-34
10-1	Unlocking the front connector and removing the module .....	10-5

10-2	Removing the front connector coding pin .....	10-6
10-3	Installing a new module.....	10-7
10-4	Inserting the front connector .....	10-8
10-5	Replacing the back-up battery in CPU 313/314.....	10-9
10-6	Location of fuses in the digital output module 120/230 VAC .....	10-12
11-1	Principle of Forcing with S7-300 CPUs (all CPUs except 318-2 DP) .....	11-3
11-2	Diagnostics with CPU 31x-2 .....	11-12
11-3	Diagnostic addresses for DP masters and DP slaves .....	11-13
11-4	Diagnostic address for the receiving node with direct data exchange.....	11-15
11-5	Diagnostic addresses for DP masters and DP slaves .....	11-18
11-6	Structure of slave diagnostic data.....	11-22
11-7	Structure of the ID-specific diagnostics for CPU 31x-2.....	11-25
11-8	Structure of the module status .....	11-26
11-9	Structure of the interrupt status.....	11-27
11-10	Bytes y+4 to y+7 for a diagnostic interrupt (operating status change by intelligent slave).....	11-28
12-1	Possible paths of electromagnetic interference .....	12-3
12-2	Example of an EMC compatible cabinet installation.....	12-8
12-3	Example of EMC compatible wall-mounting .....	12-10
12-4	Mounting cable shielding.....	12-12
12-5	Equipotential bonding.....	12-13
12-6	Lightning protection zones of a building.....	12-18
12-7	Sample circuit for networked S7-300 PLCs .....	12-24
12-8	EMERGENCY-OFF relay contact in the output circuit.....	12-26
12-9	Circuit for coils operated with DC voltage .....	12-27
12-10	Circuit for coils operated with AC voltage .....	12-27

**Tables**

2-1	Influence of the ambient conditions on the automation system (AS).....	2-1
2-2	Electrical isolation.....	2-1
2-3	Communication between sensors/actuators and the automation system....	2-2
2-4	Use of centralized and decentralized peripherals .....	2-2
2-5	Configuration consisting of the central processing unit (CPU) and expansion modules (EMs).....	2-2
2-6	CPU performance.....	2-3
2-7	Communication .....	2-3
2-8	Software .....	2-3
2-9	Supplementary features .....	2-3
5-1	Components of an S7-300: .....	4-2
4-1	Rails - overview .....	5-4
4-2	Module width .....	5-4
4-3	Shielding terminals - overview .....	5-5
4-4	Interface modules - Overview .....	5-9
4-5	Types of cabinet .....	5-14
4-6	Choice of cabinets.....	5-16
4-7	VDE specifications for the installation of a PLC system .....	5-18
4-8	Protective grounding measures .....	5-25
4-9	Connection of the load voltage reference potential.....	5-27
4-10	Connection of the load voltage reference potential.....	5-28
4-11	Connection of the load voltage reference potential.....	5-29
4-12	Characteristics of load power supply units.....	5-30
4-13	Nodes on the subnet .....	5-34
4-14	MPI/PROFIBUS DP addresses .....	5-35
4-15	MPI addresses of CPs/FMs in an S7-300 .....	5-36
4-16	The following devices may be connected .....	5-38
4-17	Available bus cables.....	5-39
4-18	Marginal conditions for wiring interior bus cables .....	5-40
4-19	Bus connector .....	5-40
4-20	RS 485 repeater .....	5-41
4-21	PG patch cord .....	5-42
4-22	Permitted cable lengths in an MPI subnet segment.....	5-42
4-23	Permitted cable lengths in a PROFIBUS subnet segment.....	5-43
4-24	Stub cable lengths per segment.....	5-43
6-1	Module accessories.....	6-2
6-2	Installation tools and materials.....	6-3
6-3	Mounting holes for rails .....	6-5
6-4	Slot numbers for S7 modules.....	6-9
7-1	Wiring accessories .....	7-1
7-2	Conditions for connecting the PS and CPU .....	7-2
7-3	Wiring conditions for front connectors.....	7-3
7-4	Wiring accessories .....	7-7
7-5	Assignment of front connectors to modules.....	7-8
7-6	Assignment of front connectors to modules.....	7-10
7-7	Wiring the front connector .....	7-10
7-8	Assigning the labeling strips to modules .....	7-13
7-9	Assigning the shielding diameter to shielding terminals .....	7-14
8-1	Integrate inputs and outputs on the CPU 312 IFM.....	8-6
8-2	Integrate inputs and outputs on the CPU 314 IFM.....	8-7
9-1	Recommended commissioning procedure - part I: Hardware .....	9-2
9-2	Recommended commissioning procedure - part II: software .....	9-3



9-3	Possible causes for the CPU memory reset request .....	9-13
9-4	Procedure for resetting the CPU memory .....	9-14
9-5	Operations in the CPU during a memory reset .....	9-16
9-6	Software requirements .....	9-23
9-7	DP address areas of the CPUs .....	9-23
9-8	Event recognition by CPUs 31x-2 DP acting as the DP master .....	9-25
9-9	Event recognition by CPUs 31x-2 DP acting as DP slave .....	9-28
9-10	Configuration example for the address areas in transfer memory .....	9-30
10-1	Backup of the operating system on MC .....	10-2
10-2	Updating the operating system with MC/MMC .....	10-3
11-1	The differences between forcing and controlling variables .....	11-3
11-2	Status and error displays .....	11-7
11-3	Evaluation of the SF LED (software error) .....	11-8
11-4	Evaluation of the SF LED (hardware error) .....	11-9
11-5	The BUSF, BUSF1 and BUSF2 LEDs .....	11-10
11-6	The BUSF LED lights up. ....	11-11
11-7	The BUSF LED flashes .....	11-11
11-8	Event recognition by CPUs 31x-2 as the DP master .....	11-14
11-9	Evaluation in the DP master of RUN to STOP transitions by the DP slave .....	11-14
11-10	Reading the diagnostic information using STEP 5 and STEP 7 in the masters system .....	11-16
11-11	Event recognition by CPUs 31x-2 acting as the DP slave .....	11-19
11-12	Evaluation of RUN to STOP transitions in the DP master/DP slave .....	11-20
11-13	Structure of station status 1 (byte 0) .....	11-23
11-14	Structure of station status 2 (byte 1) .....	11-23
11-15	Structure of station status 3 (byte 2) .....	11-24
11-16	Structure of the master PROFIBUS address (byte 3) .....	11-24
11-17	Structure of the vendor ID (byte 4, 5) .....	11-24
12-1	Starting the system after specific events .....	12-1
12-2	Mains voltage .....	12-2
12-3	Protection against external electrical interference .....	12-2
12-4	Protection against external electrical interference .....	12-2
12-5	Coupling mechanisms .....	12-4
12-6	Key to example 1 .....	12-9
12-7	Routing cables inside buildings .....	12-14
12-8	High-voltage protection of cables with surge voltage protection components .....	12-20
12-9	Surge voltage protection components for lightning protection zones 1 <-> 2 .....	12-22
12-10	Surge voltage protection components for lightning protection zones 2 <-> 3 .....	12-23
12-11	Example of a lightning-protected structure (key to figure above) .....	12-25



# Preface

# 1

## Purpose of this manual

To get you started, this manual contains the information you will need to plan, assemble, wire up, address and commission a S7-300.

You will then get to know the tools you can use to diagnose and eliminate errors in hardware and software.

## Basic knowledge required

To understand this manual you will require a general knowledge of automation technology, backed up by a knowledge of the STEP 7 basic software. You may find it useful to read the Programming with STEP 7 V5.1 manual first.

## Scope of the Manual

This manual is valid for CPUs with the following hardware and software versions:

CPU	Order No.	As of version	
		Firmware	Hardware
CPU 312 IFM	6ES7 312-5AC02-0AB0 6ES6 312-5AC82-0AB0	1.0.0	01
CPU 313	6ES7 312-1AD03-0AB0	1.0.0	01
CPU 314	6ES7 314-1AE04-0AB0 6ES7 314-1AE84-0AB0	1.0.0	01
CPU 314 IFM	6ES7 314-5AE03-0AB0 6ES7 314-5AE83-0AB0	1.0.0	01
CPU 314 IFM	6ES7 314-5AE10-0AB0	1.0.0	01
CPU 315	6ES7 315-1AF03-0AB0	1.0.0	01
CPU 315-2 DP	6ES7 315-2AF03-0AB0 6ES7 315-2AF83-0AB0	1.0.0	
CPU 316-2 DP	6ES7 316-2AG00-0AB0	1.0.0	01
CPU 318-2 DP	6ES7 318-2AJ00-0AB0	3.0.0	03

## Approvals

The SIMATIC S7-300 product series has the following approvals:

- Underwriters Laboratories, Inc.: UL 508 (Industrial Control Equipment)
- Canadian Standards Association: CSA C22.2 No. 142, (Process Control Equipment)
- Factory Mutual Research: Approval Standard Class Number 3611

## CE mark

The SIMATIC S7-300 product series conforms to the requirements and safety specifications of following EU directives:

- EU directive 73/23/EWE "Low-voltage directive"
- EU directive 89/336/EEC "EMC directive"

## C tick mark

The SIMATIC S7-300 product series is compliant with AS/NZS 2064 (Australia).

## Standards

The SIMATIC S7-300 product series is compliant with the requirements and criteria for IEC 61131-2.

## Documentation required

This manual is part of the documentation package for the S7-300.

<p><b>Reference Manual</b></p> <ul style="list-style-type: none"> <li>☐ CPU Data CPU 312 IFM to 318-2 DP</li> <li>☐ CPU Data CPU 31xC and CPU 31x</li> </ul>	<p>Description of the operation, the functions and the technical data of the CPU</p>
<p><b>Manual</b></p> <ul style="list-style-type: none"> <li>☐ CPU 31xC: Technological Functions</li> <li>⦿ Examples</li> </ul>	<p>Description of the individual technological functions:</p> <ul style="list-style-type: none"> <li>- Positioning</li> <li>- Counting</li> <li>- Point-to-point connection</li> <li>- Control</li> </ul> <p>The CD contains examples of the technological functions.</p>
<p><b>Installation Manual</b></p> <div style="display: flex; align-items: center;"> <div style="writing-mode: vertical-rl; transform: rotate(180deg); font-size: small; margin-right: 5px;">You are reading this manual →</div> <ul style="list-style-type: none"> <li>☐ S7-300 Automation System, Hardware and Installation: CPU 312 IFM - 318-2 DP</li> <li>☐ S7-300 Automation System, Hardware and Installation: CPU 31xC and CPU 31x</li> </ul> </div>	<p>Configuration, installation, wiring, network and commissioning descriptions of a S7-300</p>
<p><b>Reference Manual</b></p> <ul style="list-style-type: none"> <li>☐ S7-300 Programmable Controller Module Specifications</li> </ul>	<p>Function descriptions and the technical data of the signal modules, power supply modules and the interface modules</p>
<p><b>Instruction List</b></p> <ul style="list-style-type: none"> <li>☐ CPU 312 IFM to 318-2 DP</li> <li>☐ CPU 31xC and CPU 31x IM 151-7 CPU, BM 147-1 CPU, BM 147-2 CPU</li> </ul>	<p>List of stored instructions of the CPUs and their execution times. List of executable blocks (OBs/SFCs/SFBs) and their execution times.</p>
<p><b>Getting Started</b></p> <ul style="list-style-type: none"> <li>☐ Getting Starteds take you through each commissioning step up to a functioning application by running through a concrete example.</li> </ul> <p>The following Getting Starteds are available to you:</p>	<ul style="list-style-type: none"> <li>- CPU 31xC: Commission</li> <li>- CPU 31x: Commission</li> <li>- CPU 31xC: Positioning with Analog Output</li> <li>- CPU 31xC: Positioning with Digital Output</li> <li>- CPU 31xC: Counting</li> <li>- CPU 31xC: Point-to-Point Connection</li> <li>- CPU 31xC: Controlling</li> </ul>

Figure 1-1 Information Landscape of an S7-300

You also require the following manuals in addition to this documentation package:



<p><b>Manual Integrated Functions CPU 312 IFM/314 IFM</b></p> <p> Manual</p>	<p>Description of the technological functions of the CPUs 312 IFM/314 IFM.</p>
<p><b>Reference Manual System Software for S7-300/400 System and Standard Functions</b></p> <p> Reference Manual part of the STEP 7 documentation package</p>	<p>Description of the SFCs, SFBs and OBs of the CPUs. You can also find the description in the STEP 7 Online Help.</p>

Figure 1-2 Additional Documentation

## Recycling and Disposal

The units described in this manual are recyclable, due to the low levels of harmful substances they contain. For correct recycling and disposal of your old unit, contact a certified disposal facility for electronic scrap.

## Further Support

If you still have questions about how to use the products described in this manual, then please contact your local Siemens dealer.

<http://www.siemens.com/automation/partner>

## Training Center

We can provide training courses to help you get started with your S7-300 PLC. Please contact your local Training Center or the Central Training Center in Nuremberg, D-90327, Germany

Phone +499 (911) 895-3200..

<http://www.sitrain.com>

## A&D Technical Support

In addition to your local dealer, you can also contact one of three Support Centers:

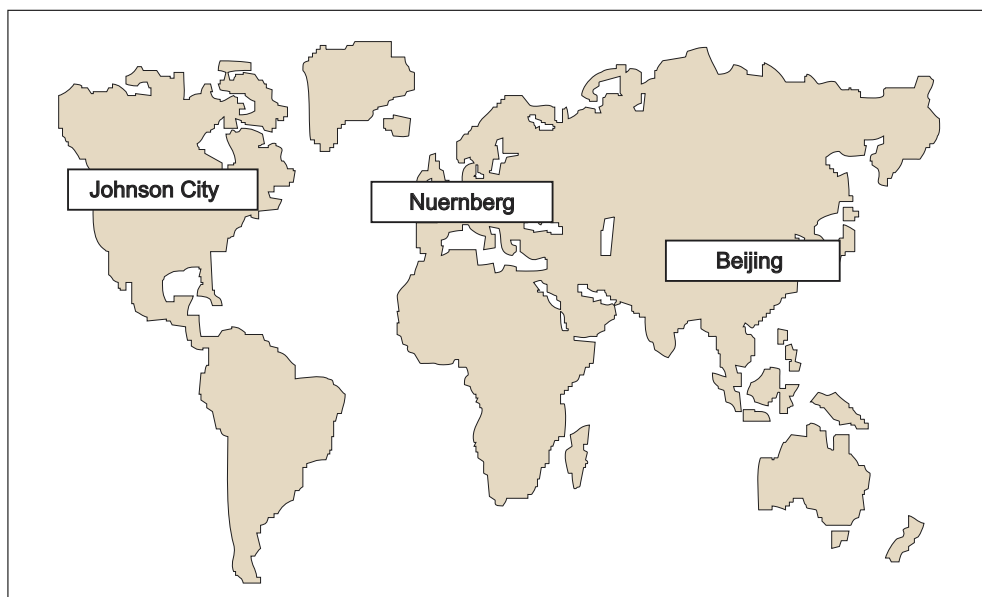

Figure 1-3 SIMATIC Technical Support

<p><b>Worldwide (Nuremberg) Technical Support</b></p> <p>Local time: 0:00 to 24:00 / 365 days a year          Phone: +49 (0) 180 5050 222          Fax: +49 (0) 180 5050 223          E-mail: adsupport@siemens.com          GMT: +1:00</p>		
<p><b>Europe / Africa (Nuremberg) Authorization</b></p> <p>Local time: Mo.-Fr. 8:00 to 17:00          Phone: +49 (0) 180 5050-222          Fax: +49 (0) 180 5050-223          E-mail: adsupport@siemens.com          GMT: +1:00</p>	<p><b>America (Johnson City) Technical Support and Authorization</b></p> <p>Local time: Mo.-Fr. 8:00 to 17:00          Phone: +1 (0) 770 740 3505          Fax: +1 (0) 770 740 3699          E-mail: isd-callcenter@sea.siemens.comn          GMT: -5:00</p>	<p><b>Asia / Australia (Peking) Technical Support and Authorization</b></p> <p>Local time: Mo.-Fr. 8:00 to 17:00          Phone: +65 (0) 740-7000          Fax: +65 (0) 740-7001          E-mail: simatic.hotline@sea.siemens.com.sg          GMT: +8:00</p>
<p>Technical Support and Authorization personnel generally speak both German and English.</p>		

## **Service & Support on the Internet**

We offer you our complete knowledge base online on the Internet as a supplement to our documentation.

<http://www.siemens.com/automation/service&support>

There you can find:

- Up-to-date product information (What's new), FAQs (Frequently Asked Questions), Downloads, Tips and Tricks.
- Our Newsletter always offers you the latest information on your products.
- The Knowledge Manager finds the documents you require.
- Users and specialists all over the world share their experience in our Forum.
- You can find your local service partner for Automation & Drives in our Partner Database.
- Information relating to on-site service, repairs, spare parts and lots more is available to you in the "Service" section.



# Guide to the S7-300 Documentation

# 2

## In this Chapter

you will find a guide to the documentation for the S7-300.

## Selecting and configuring

Table 2-1 Influence of the ambient conditions on the automation system (AS)

Information on ...	is available in ...
What provisions do I have to make for PLC installation space?	Chapter <i>Configuring; Mounting dimensions of modules, and Mounting; mounting the rail</i> , in the <i>Installation Manual</i>
How do environmental conditions influence the PLC?	<i>Appendix of the Installation Manual</i>

Table 2-2 Electrical isolation

Information on ...	is available in ...
Which modules can I use if electrical isolation is required between sensors/actuators?	Chapter <i>Configuring; Electrical assembly, protective measures and grounding</i> , in the <i>Installation Manual</i> Reference Manual <i>Module Data</i>
When do I need to isolate the potential of individual components? How do I wire that?	Chapter <i>Configuring; Electrical assembly, protective measures and grounding</i> , in the <i>Installation Manual</i> Chapter <i>Wiring</i> , in the <i>Installation Manual</i>
When do I need to isolate the potential of specific stations? How do I wire that?	Chapter <i>Configuring; Configuring a subnet</i> , in the <i>Installation Manual</i> Chapter <i>Wiring</i> , in the <i>Installation Manual</i>

Table 2-3 Communication between sensors/actuators and the automation system

Information on ...	is available in ...
Which module is suitable for my sensor/actuator?	for CPU: in applicable <i>CPU Data Reference Manual</i> for signal modules: <i>Module Data Reference Manual</i>
How many sensors/actuators can I connect to the module?	for CPU: in applicable <i>CPU Data Reference Manual</i> for signal modules: <i>Module Data Reference Manual</i>
To connect my sensors/actuators to the PLC, how do I wire the front connector ?	Chapter <i>Wiring; Wiring front connectors, in the Installation Manual</i>
When do I require expansion modules (EM), and how are they connected?	Chapter <i>Configuring, optional expansions and networking, in the Installation Manual</i>
How do I mount modules in module racks / on profile rails?	Chapter <i>Mounting; Mounting modules on a rail, in the Installation Manual</i>

Table 2-4 Use of centralized and decentralized peripherals

Information on ...	is available in ...
Which range of modules do I want to use?	for local I/O / expansion modules (EMs): <i>Module Data Reference Manual</i> for distributed I/Os / PROFIBUS DP: Manual of the relevant I/O device, e.g. <i>Manual ET 200B</i>

Table 2-5 Configuration consisting of the central processing unit (CPU) and expansion modules (EMs)

Information on ...	is available in ...
Which rack / rail is best suited to my application?	Chapter <i>Configuring, in the Installation Manual</i>
Which Interface modules (IM) do I need to connect EMs to the CPU?	Chapter <i>Configuring, Arranging modules on multiple racks, in the Installation Manual</i>
What is the right power supply (PS) for my application?	Chapter <i>Configuring, in the Installation Manual</i>

Table 2-6 CPU performance

Information on ...	is available in ...
Which memory concept is best suited for my application?	in applicable <i>CPU Data Reference Manual</i>
How do I insert and remove Micro Memory Cards?	Chapter <i>Commissioning; Removing/Installing Micro Memory Cards, in the Installation Manual</i>
Which CPU meets my requirements on performance ?	<i>Instruction list; Reference Manual CPU Data</i>
How fast is the response / processing time of the CPU?	in applicable <i>CPU Data Reference Manual</i>
Which technological functions are implemented?	<i>Technological functions Manual</i>
How can I use these technological functions?	<i>Technological functions Manual</i>

Table 2-7 Communication

Information on ...	is available in ...
Which principles do I have to take into account?	<i>Communication with SIMATIC Manual</i>
Which options and resources are available on the CPU ?	in applicable <i>CPU Data Reference Manual</i>
How do I optimize communication with the help of communication processors (CPs)?	the respective manual
Which type of communication network is best suited to my application?	Chapter <i>Configuring; Configuring a subnet, in the Installation Manual</i> <i>Communication with SIMATIC Manual</i>
How do I network the individual components?	Chapter <i>Configuring and wiring, in the Installation Manual</i>

Table 2-8 Software

Information on ...	is available in ...
Which software do I require for my S7-300 system?	Chapter <i>Technical Specification; applicable CPU Data Reference Manual</i>

Table 2-9 Supplementary features

Information on ...	is available in ...
How do I implement operator control and monitoring? (Human Machine Interface)	for text-based display units: the relevant device manual for OPs: the relevant device manual for WinCC: the relevant device manual
How can I integrate process control modules?	for PCS 7: the respective device manual
What options are offered by redundant and fail-safe systems?	<i>Manual S7-400H - Redundant Systems; Manual Fail-safe Systems</i>



# Installation Order

# 3

## In this Chapter

We will show you the sequence of steps you must follow to install your SIMATIC-S7 system.

We shall then go on to explain the basic rules that you should follow, and how you can modify an existing system.

## Procedure for installing an S7-300 system

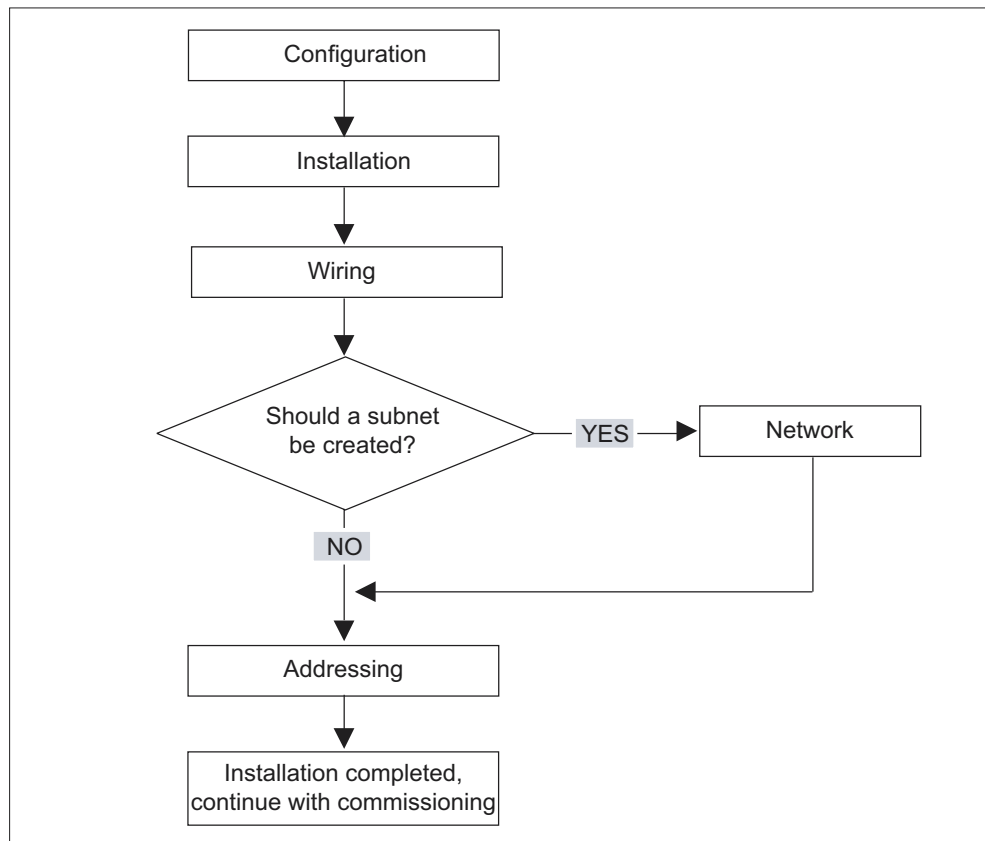

Figure 3-1 Installing an S7 system

### **Basic rules for trouble-free operation of S7**

An S7 system can be used in many different ways, so we can only provide basic rules for the electrical and mechanical installation in this section.

You must at least keep to these basic rules if you want your S7 system to operate correctly.

### **Modifying the structure of an existing S7 system**

If you want to modify the configuration of an existing system at a later time, proceed using the steps indicated above.

---

#### **Note**

If you want to install a signal module at a later time, consult the relevant information for the respective module.

---

### **Cross-reference**

Also note the description of your specific module in the *SIMATIC S7-300 PLCs* manual and the *Module Data Reference Manual*.

# S7-300 Modules

# 4

## Which modules can you use to create an S7-300?

An S7-300 consists of several modules. The following diagram illustrates a possible configuration:

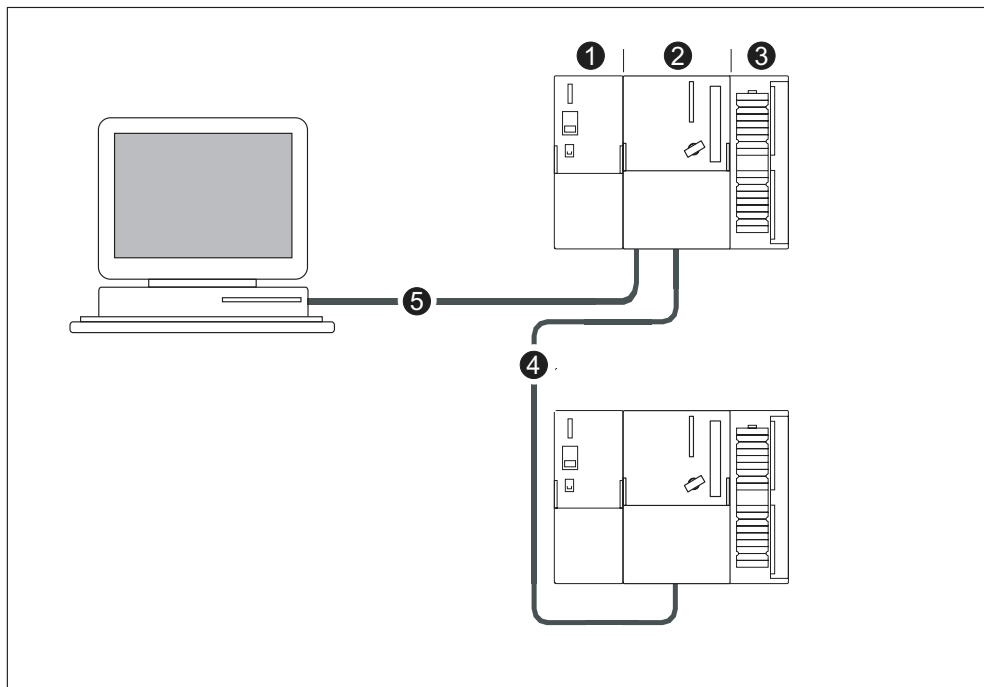

Figure 4-1 Example configuration: S7-300 components

The diagram illustrates under number	the following modules of an S7-300
(1)	Power supply
(2)	Central processing unit
(3)	Signal module
(4)	PROFIBUS bus cable
(5)	Cable for connecting a programming device (PG)

A programming device (PG) is used to program the S7-300 PLC. Use a PG cable to connect the PG and the CPU.

Several S7-300 CPUs can communicate with one another and with other SIMATIC S7 PLCs via the PROFIBUS cable. You can connect several S7-300s using a PROFIBUS bus cable.



**S7-300 Modules**

There is a whole range of components available for creating and using an S7-300. The table below shows the major modules and their functions.

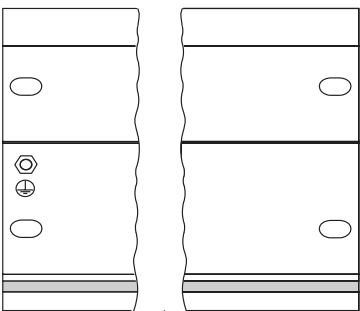
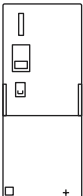
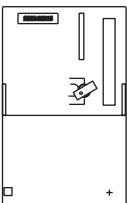
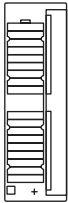
Table 4-1 Components of an S7-300:

Components	Function	Illustration
Mounting rail (rack) Accessory: Shielding contact element	This is the rack for an S7-300	
Power supply (PS)	This converts the line voltage (120/230 VAC) to 24 VDC operating voltage and is used to supply the S7-300 and 24 VDC load circuits	
CPU Accessory: Front connectors (for CPUs with integrated peripherals)	This runs the user program, provides a 5 V supply to the S7-300 backplane bus and communicates with other MPI network nodes via the MPI interface.  In addition, a CPU can also be a DP master or a DP slave in a PROFIBUS subnet.	 <p data-bbox="997 1541 1294 1570">CPUs 312 IFM to 318-2 DP</p>
Signal modules (SM) (Digital input modules, digital output modules, digital I/O modules, analog input modules, analog output modules, analog I/O modules) Accessory: Front connectors	They match different process signal levels to the S7-300.	

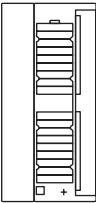
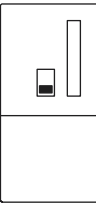
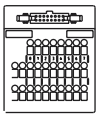
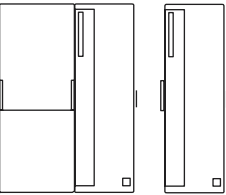

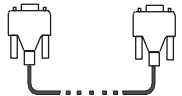
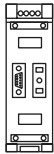
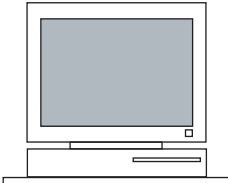
Components	Function	Illustration
Function modules (FM) Accessory: Front connectors	These perform time-critical and memory-intensive process signal processing tasks, such as positioning or regulation.	
Communication processor (CP). Accessory: Connecting cable	This performs communication for the CPU, e.g. CP 342-5 DP connection to PROFIBUS DP	
SIMATIC TOP connect Accessory: Front connector module with ribbon cable terminals	Use for wiring the digital I/O modules	
Interface module (IM) Accessory: Connecting cable	Connects the individual rows in an S7-300	
PROFIBUS cable with bus connector	Connect the nodes of an MPI or PROFIBUS subnet to one another	
PG cable	Connects a PG/PC to a CPU	
RS485 Repeater	Used to amplify the signals in an MPI or PROFIBUS subnet and for coupling segments of an MPI or PROFIBUS subnet	
Programming device (PG) or PC with the STEP 7 software package	You will need a PG to configure, set parameters, program and test your S7-300	



# Configuring

# 5

## 5.1 Summary of the Content

### In this Chapter

we will provide you with all the information you need

- Mechanical configuration of an S7-300
- Electrical configuration of an S7-300
- Considerations for networking

### Further information on networking

For information on network topics we recommend the *Communication with SIMATIC* Manual. This manual contains important notes on networking for SIMATIC professionals as well as the basics for newcomers.

### Cross-reference

Information on ambient conditions is in the Appendix: see *Ambient Conditions*

Information on special protective measures is in the Appendix: see *Electrical Protective Measures*

## 5.2 Basic Principles of Planning

### Important information about planning



---

#### Warning

##### Open equipment

The modules that make up an S7-300 are regarded as open equipment. This means that you must always install the S7-300 in a cubicle, cabinet or electrical control room that can only be accessed using a key or tool. Only trained or authorized personnel are allowed access to such cubicles, cabinets or electrical operating rooms.

---



---

#### Caution

Depending on the field of application, the operation of an S7-300 in a plant or system is defined by special rules and regulations. Note the safety and accident prevention regulations relating to specific applications, e.g. machine protection directives. This chapter and the appendix *General rules and regulations on S7-300 operation* provide an overview of the most important rules you need to consider when integrating an S7-300 into a plant or a system.

---

### Central unit (CU) and expansion module (EM)

An S7-300 PLC consists of a central unit (CU) and – if required – one or multiple expansion modules (EMs).

The rack containing the CPU is referred to as the central unit (CU). Racks equipped with modules form the expansion modules (EMs) connected to the system's CU.

### When should I use expansion modules?

You can use EMs if the number of CU slots is insufficient for your application.

When using EMs, you might require further power supply modules in addition to the extra racks and interface modules (IM). When using interface modules you must ensure compatibility of the partner stations.

### Module racks

The rack for your S7-300 is a rail. You can use this rail to mount all modules of your S7-300 system.

### Horizontal and vertical installation

You can mount an S7-300 either vertically or horizontally. The following ambient air temperatures are permitted:

- Vertical installation: from 0 °C to 40 °C
- Horizontal installation: from 0 °C to 60 °C.

Always install the CPU and power supply on the left or at the bottom.

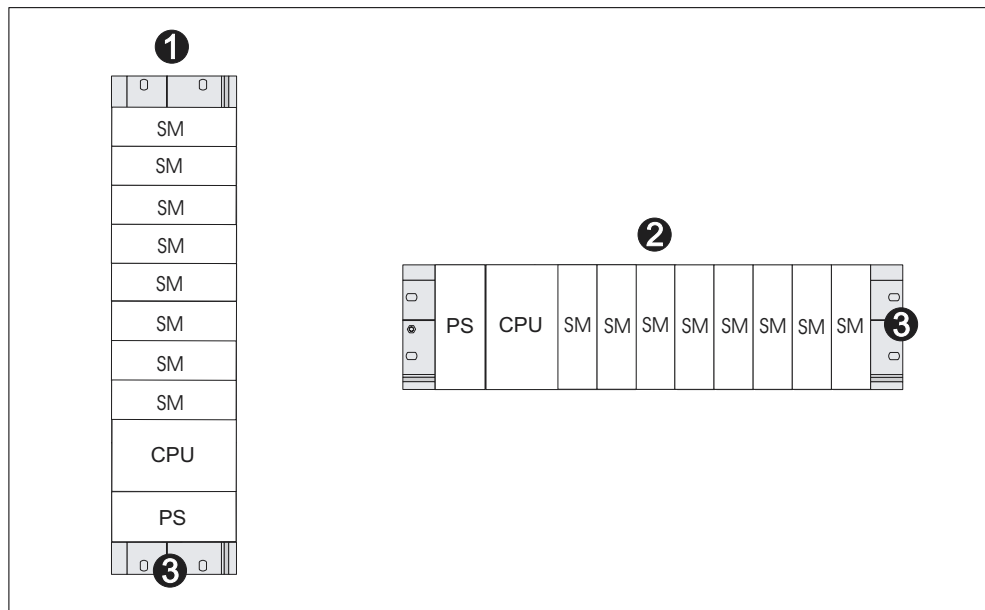

Figure 5-1 Horizontal and vertical installation

The diagram illustrates under number	
(1)	Vertical installation of an S7-300
(2)	Horizontal installation of an S7-300
(3)	Rail

### Further information

- the selection and dimensions of rails (racks) can be found in Chapter *Module dimensions*.
- connections and interfaces (IMs) are found in Chapter *Arranging modules on multiple racks*.
- the most important rules on S7-300 operation are found in the Appendix *General rules and regulations on S7-300 operation*.

### 5.3 Component Dimensions

#### Length of the rails

The following rails are available.

Table 5-1 Rails - overview

Rail length	Usable length for modules	Order No.
160 mm	120 mm	ES7 390-1AB60-0AA0
482.6 mm	450 mm	ES7 390-1AE80-0AA0
530 mm	480 mm	ES7 390-1AF30-0AA0
830 mm	780 mm	ES7 390-1AJ30-0AA0
2,000 mm	cut to length if required.	ES7 390-1BC00-0AA0

In contrast to other rails, the 2-meter rail is not equipped with any mounting holes. These must be drilled, allowing optimal adaptation of the 2-meter rail to your application.

#### Installation dimensions of modules

Table 5-2 Module width

Module	Width
Power supply PS 307, 2 A	50 mm
Power supply PS 307, 5 A	80 mm
Power supply PS 307, 10 A	200 mm
CPU	The installation dimensions are listed in the Technical Data section of your <i>CPU Data Reference Manual</i> .
Analog I/O modules	40 mm
Digital I/O modules	40 mm
Simulator module SM 374	40 mm
Interface modules IM 360 and IM 365	40 mm
Interface module IM 361	80 mm

- Module height: 125 mm
- Module height with **shielding contact element**: 185 mm
- Maximum mounting depth: 130 mm
- Maximum mounting depth with open hinged front panel (CPU): 180 mm

Dimensions of other modules such as CPs, FMs etc. are found in the relevant manuals.

## Shielding contact element

The direct contact between the shielding contact element and the rail enables you to connect all shielded cables of your S7 modules to ground.

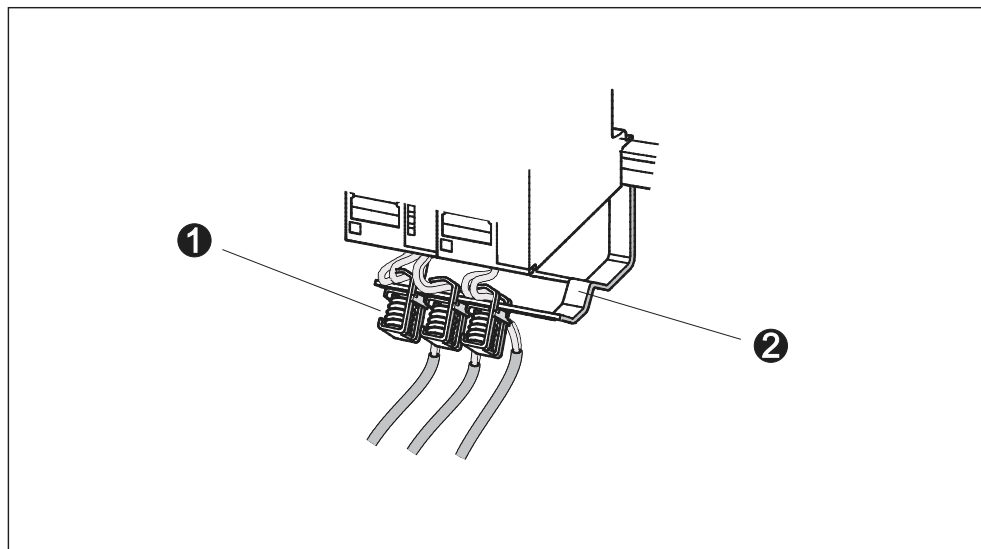

Figure 5-2 Shielding contact element

The diagram illustrates under number	
(1)	the shielding terminals
(2)	the retaining bracket

Mount the bracket (Order No. 6ES5 390-5AA0-0AA0) to the rail using the two screw bolts.

If you use a shielding contact element, the specified dimensions apply from the lower edge of the module.

- Width of the shielding contact element: 80 mm
- Number of mountable shielding terminals per shielding contact element: max 4

Table 5-3 Shielding terminals - overview

Cable with shielding diameter	Shielding terminal order no.
Cable shielding diameter 2 mm to 6 mm	6ES7 390-5AB00-0AA0
Cable shielding diameter 3 mm to 8 mm	6ES7 390-5BA00-0AA0
Cable shielding diameter 4 mm to 13 mm	6ES7 390-5CA00-0AA0

### Required clearances

You must maintain the clearance shown in the figure in order to provide sufficient space to install the modules and to dissipate the heat generated by the modules.

This figure illustrates the clearances between multiple racks, as well as between nearby equipment, cable channels, cabinet walls, etc.

For example, if you wire your modules using a cable duct, the clearance between the bottom edge of the shielding contact element and the cable duct must be 40 mm.

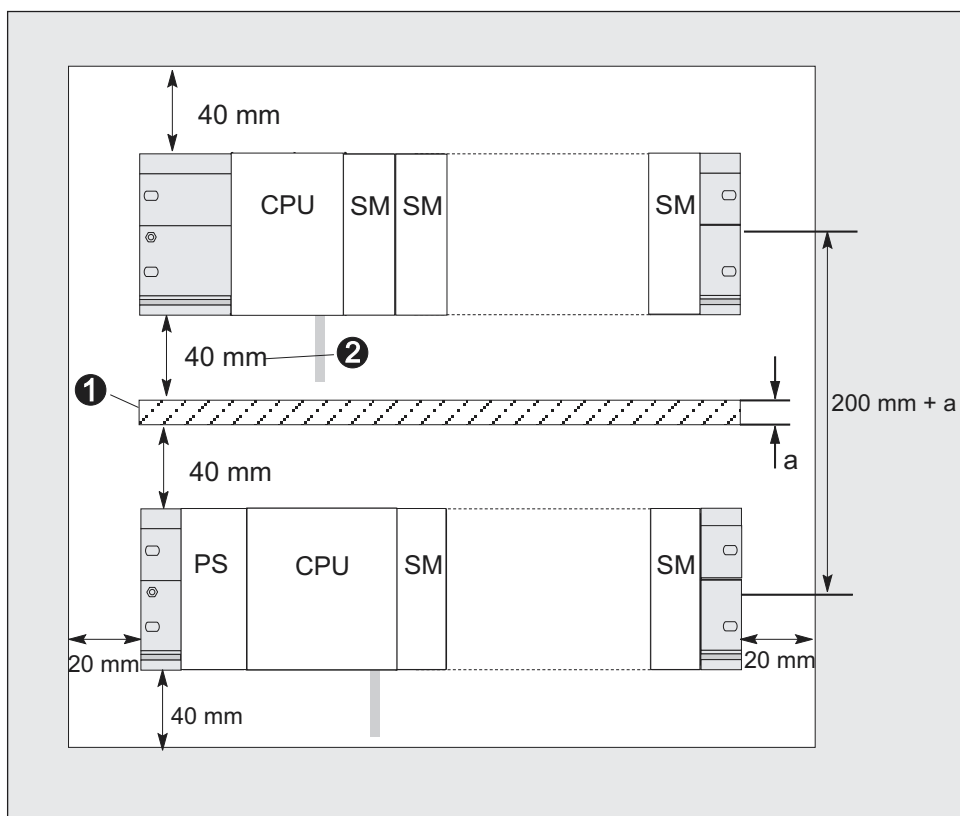

Figure 5-3 Clearance

The diagram illustrates under number	
(1)	Wiring using a cable duct
(2)	Clearance between cable channel and bottom edge of shielding contact element must be 40 mm

### Cross-reference

You will find information on how to install an S7-300 in the chapter entitled *Installation*.



## 5.4 Arranging modules on a single rack

### Use of one or more racks

You will use either one rack or multiple racks, depending on your planned application.

### Reasons for using a single rack:

- Compact, space-saving use of all your modules
- Centralized use of your modules
- Fewer signals to be processed

#### Tip:

If you opt for installation on a single rack, insert a dummy module to the right of the CPU (order no.: 6ES7 370-0AA01-0AA0). This gives you the option of inserting a second rack for your application in the future, simply by replacing the dummy module with an interface module and without having to reinstall and rewire the first rack.

### Reasons for using multiple racks

- More signals to be processed
- Insufficient slots available

### Rules: Arranging modules on a single rack

For arranging modules on a single rack, the following rules apply:

- No more than eight modules (SM, FM, CP) may be installed to the right of the CPU.
- All modules that you have installed on one rack may not exceed a total current consumption of 1.2 A (312 IFM: 0.8 A) from the S7-300 backplane bus.

**Example:**

The figure below shows the arrangement of eight signal modules on one rack.

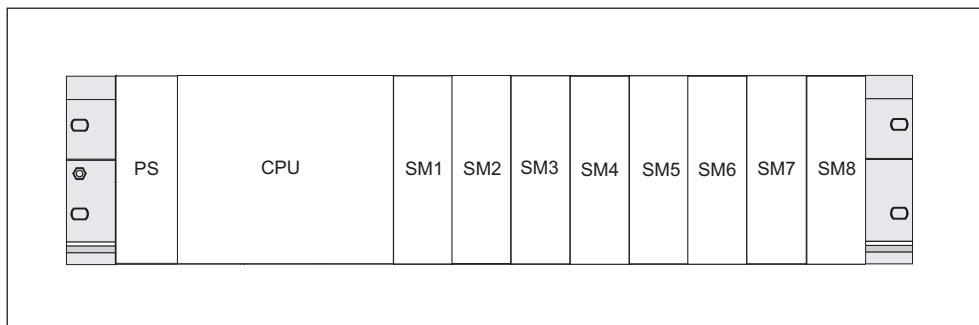

Figure 5-4 Maximum configuration on one rack

**Cross-reference**

You will find information about the current consumption of modules in the technical specifications, for example, in the *S7-300 Module Data Reference Manual* or in the *Reference Manual* of the CPU you are using.

## 5.5 Arranging Modules on Multiple Racks

### Exceptions

With the CPU 312 IFM and the CPU 313, only one row is permitted on a rack.

### Using interface modules

If you are planning a structure distributed between multiple racks then you will need interface modules (IM). An interface module routes the backplane bus of an S7-300 to the next rack.

The CPU is always located on rack 0.

Table 5-4 Interface modules - Overview

Characteristics	Two or more rows	Low-cost 2-row configuration
Send IM in rack 0	IM 360 Order No.: 6ES7 360-3AA01-0AA0	IM 365 Order No.: 6ES7 365-0AB00-0AA0
Receive IM in rack 1 to 3	IM 361 Order No.: 6ES7 361-3CA01-0AA0	IM 365 (hardwired to send IM 365)
Maximum number of expansion modules	3	1
Length of the connecting cables	1 m (6ES7 368-3BB01-0AA0) 2.5 m (6ES7 368-3BC51-0AA0) 5 m (6ES7 368-3BF01-0AA0) 10 m (6ES7 368-3CB01-0AA0)	1 m (hardwired)
Remarks	-	Rack 1 can only receive signal modules; the total current consumption is limited to 1.2 A (for the 312 IFM: 0.8 A), whereby the maximum for rack 1 is 0.8 A.  These restrictions do not apply to operation with interface modules IM 360/IM 361

### **Rules: Arranging modules on multiple racks**

Please note the following points if you wish to arrange your modules on multiple racks:

- The interface module always uses slot 3 (slot 1: power supply; slot 2: CPU, slot 3: interface module)
- It is always on the left before the first signal module.
- No more than 8 modules (SM, FM, CP) are permitted per rack.
- The number of modules (SM, FM, CP) is limited by the permitted current consumption on the S7-300 backplane bus. The total current consumption may not exceed 1.2 A per row (if 312 IFM CPU is used: 0.8 A).

### **Cross-reference**

Information about the power consumption of individual modules is provided in the *Module Data Reference Manual*.

### **Rules: Interference-proof installation of the connection**

Special shielding and grounding measures are not required if you interconnect the central units and expansion modules using suitable interface modules (Send IM and Receive IM).

However, you must ensure the following:

- all racks are interconnected with low impedance,
- the racks of a grounded assembly are grounded in a star pattern,
- the contact springs on the racks are clean and not bent, thus ensuring that interference currents can be dissipated.

### Example of a full assembly

The figure shows the arrangement of modules in an S7-300 assembly on 4 racks.



Figure 5-5 Full assembly using racks

The diagram illustrates under number	
(1)	Rack 0 (central unit)
(2)	Rack 1 (expansion module)
(3)	Rack 2 (expansion module)
(4)	Rack 3 (expansion module)
(5)	Connection cable 368
(6)	Limitation for the CPU 314 IFM. when this CPU is used, you must not insert Signal Module 8 on Rack 4.

## 5.6 Selection and installation of cabinets

### Reasons for installing an S7-300 in a cabinet

You should install your S7-300 in a cabinet when any of the following apply:

- If you plan a larger system
- You are using your S7-300s in an environment subject to interference or contamination
- In order to meet UL/CSA requirements, which require installation in cabinets

### Selecting and dimensioning cabinets

Take the following criteria into account:

- Ambient conditions at the cabinet's place of installation
- The specified mounting clearance for racks (rails)
- Total power loss of all components in the cabinet

The ambient conditions (temperature, humidity, dust, chemical influence, explosion hazard) at the cabinet's place of installation determine the degree of protection (IP xx) required for the cabinet.

### Reference for degrees of protection

Further information on degree of protection can be found in IEC 529 and DIN 40050.

### The cabinet's power dissipation

The power dissipation capability of a cabinet depends on its type, ambient temperature and on the internal arrangement of devices.

### Reference for power loss

Siemens catalogs NV21 and ET1 contain more detailed information about power dissipation.

**Specifications for cabinet dimensions**

Note the following specifications when you determine the dimensions of a cabinet suitable for an S7-300 installation:

- Space required for racks (rails)
- Minimum clearance between the racks and cabinet walls
- Minimum clearance between the racks
- Space required for cable ducts or fans
- Position of the stays

**Warning**

Modules may get damaged if exposed to inadmissible ambient temperatures.

---

**Reference for ambient temperatures**

Information on permissible ambient temperatures is in the Appendix: see *Ambient Conditions*

### Overview of typical cabinet types

The table below gives you an overview of the commonly used cabinet types. It shows you the applied principle of heat dissipation, the calculated maximum power loss and the degree of protection.

Table 5-5 Types of cabinet

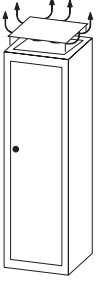
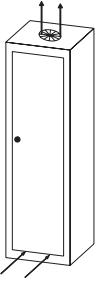
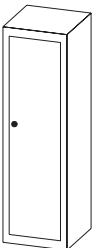
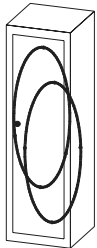
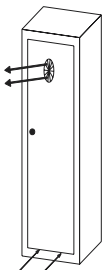
Open cabinets		Closed cabinets		
Enclosed ventilation via natural convection	Increased enclosed ventilation	Natural convection	Forced convection with rack fan, improvement of natural convection	Forced convection with heat exchanger, internal and external auxiliary ventilation
				
Mainly inherent heat dissipation, with a small portion across the cabinet wall.	Higher heat dissipation with increased air movement.	Heat dissipation only across the cabinet wall; only low power losses permitted. In most cases heat concentration develops at the top of the cabinet interior.	Heat dissipation only across the cabinet wall. Forced convection of the interior air improves heat dissipation and prevention of heat concentration.	Heat dissipation by heat exchange between heated internal air and cool external air. The increased surface of the pleated profile of the heat exchanger wall and forced convection of internal and external air provide good heat dissipation.
Degree of protection IP 20	Degree of protection IP 20	Degree of protection IP 54	Degree of protection IP 54	Degree of protection IP 54
Typical power dissipation under following marginal conditions:				
<ul style="list-style-type: none"> <li>• Cabinet size: 600 mm x 600 mm x 2,200 mm</li> <li>• Difference between the outer and inner temperature of the cabinet is 20 °C (for other temperature differences refer to the temperature charts of the cabinet manufacturer)</li> </ul>				
up to 700 W	up to 2,700 W (with fine filter up to 1,400 W)	up to 260 W	up to 360 W	up to 1,700 W



## 5.7 Example: Selecting a Cabinet

### Introduction

The sample below clearly shows the maximum permitted ambient air temperature at a specific power loss for different cabinet designs.

### Assembly

The following device configuration should be installed in a cabinet:

- Central unit, 150 W
- Expansion modules, each with 150 W
- Load power supply under full load, 200 W

This results in a total power loss of 650 W.

### Power loss dissipated

The diagram in the figure below shows guide values for the permitted ambient air temperature of a cabinet with the dimensions 600 mm x 600 mm x 2,000 mm, depending on power loss. these values only apply if you maintain the specified installation and clearance dimensions for racks (rails).

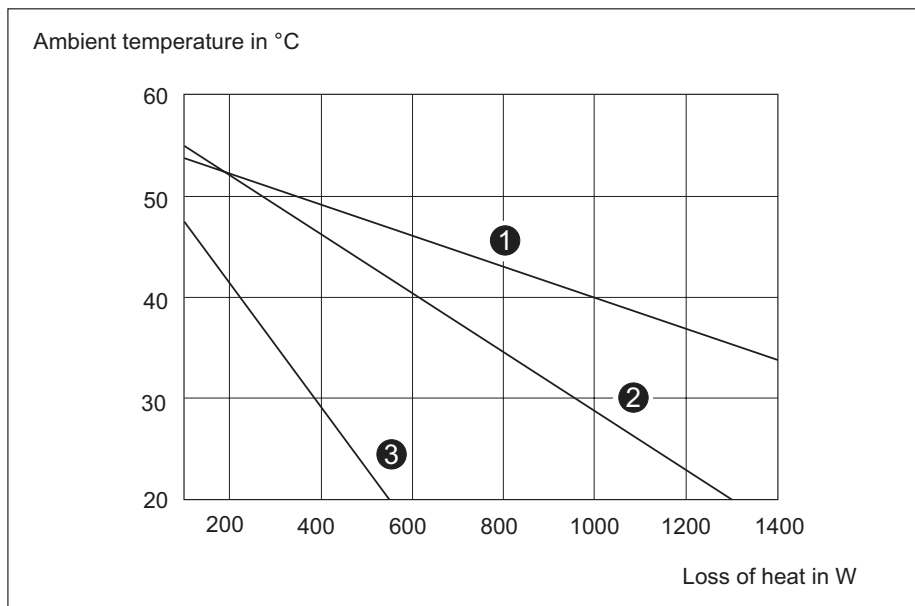

Figure 5-6 Power loss dissipated

Curve	Cabinet Type
(1)	Closed cabinet with heat exchanger (heat exchanger size 11/6 (920 mm x 460 mm x 111 mm))
(2)	Cabinet with through-ventilation by natural convection
(3)	Closed cabinet with natural convection and forced ventilation by equipment fans

**Result:**

From the diagram we can see that the following ambient temperatures are obtained for a total power loss of 650 W:

Table 5-6 Choice of cabinets

Cabinet design	Maximum permitted ambient temperature
Closed with natural convection and forced ventilation (Curve 3)	Operation not possible
Open with through-ventilation (Curve 2)	approx. 38 °C
Closed with heat exchanger (Curve 1)	approx. 45 °C

If you install the S7-300 horizontally, you can use the following types of cabinet:

- open, with closed ventilation
- closed, with heat exchanger

**see also**

Selection and installation of cabinets

## 5.8 Electrical assembly, protective measures and grounding

### 5.8.1 Grounding concept and overall structure

#### In this Chapter

This section contains information about the overall configuration of an S7-300 on a grounded incoming supply (TN-S network):

- Circuit-breaking devices, short-circuit and overload protection to VDE 0100 and VDE 0113
- Load power supplies and load circuits
- Grounding concept

---

#### Note

An S7-300 can be used in many different ways, so we can only describe the basic rules for the electrical installation in this document. You must observe at least these basic rules if you want your S7-300 to operate free of trouble.

---

#### Definition: Grounded power supply (PEN)

The neutral is grounded in a grounded power supply system (PEN). A single short-circuit to ground between a live conductor or a grounded part of the system trips the protective devices.

## Specified components and protective measures

A number of components and protective measures are prescribed for plant installations. The type of components and the degree of compulsion pertaining to the protective measures will depend on the VDE specification applicable to your particular plant.

The table below shows components and protective measures.

Table 5-7 VDE specifications for the installation of a PLC system

Compare ...	1)	VDE 0100	VDE 0113
Disconnecting devices for control systems, sensors and actuators	(1)	... Part 460: Master switch	... Part 1: Circuit breaker
Short-circuit/overload protection: In groups for sensors and actuators	(2)	... Part 725: Single-pole fusing of circuits	... Part 1: <ul style="list-style-type: none"> <li>• In the case of a grounded secondary circuit: Provide single-pole protection</li> <li>• Otherwise: Provide all-pole protection</li> </ul>
Load power supply for AC load circuits with more than five electromagnetic devices	(3)	Electrical isolation by transformer recommended	Electrical isolation by transformer mandatory

1) This column refers to the numbers in the diagram in the Summary diagram: Grounding section.

## Cross-reference

Additional information on protective measures is in the Appendix.

## see also

General Rules and Regulations for S7-300 Operation

## 5.8.2 Installing the S7-300 with grounded reference potential (except for CPU 312 IFM)

### Definition

In an S7-300 configuration with grounded reference potential occurring interference current is dissipated to the ground conductor/ to ground.

### Note

Your CPU already is supplied complete with a grounded reference potential,

so if you wish to install an S7-300 with grounded reference potential, then you do not need to make any changes to your CPU.

### Grounded reference potential on CPUs 313 – 318-2 DP

This connection diagram applies to the following CPUs

CPU	Order No.	As of hardware version
CPU 313	6ES7 313-1AD03-0AB0	01
CPU 314	6ES7 314-1AE04-0AB0 6ES7 314-1AE84-0AB0	01
CPU 314 IFM	6ES7 314-5AE03-0AB0	01
CPU 314 IFM	6ES7 314-5AE83-0AB0	01
CPU 315	6ES7 315-1AF03-0AB0	01
CPU 315-2 DP	6ES7 315-2AF03-0AB0 6ES7 315-2AF83-0AB0	01
CPU 316-2 DP	6ES7 316-2AG00-0AB0	01
CPU 318-2 DP	6ES7 318-2AJ00-0AB0	03

The diagram illustrates an S7-300 configuration with grounded reference potential (implemented with a jumper)

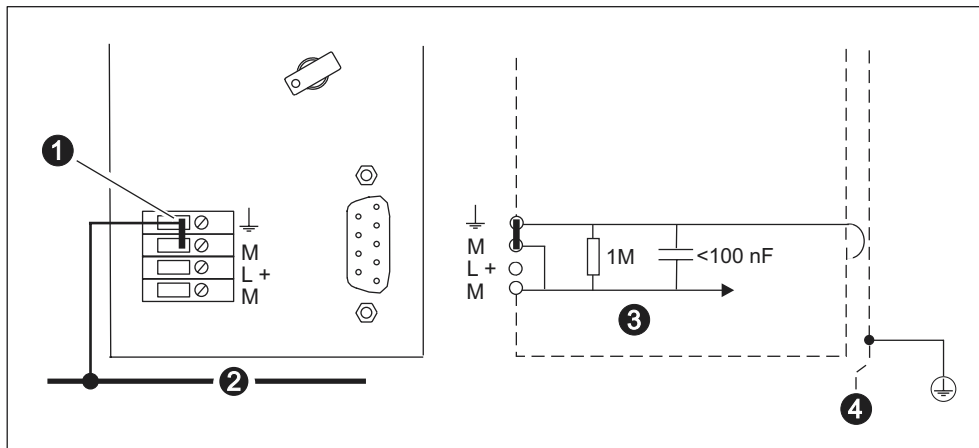

Figure 5-7 S7-300 configuration with grounded reference potential (CPU 313 – 318-2 DP)

The diagram illustrates under number	
1	The removable jumper
2	The grounding bus cable
3	The reference potential of the CPU interconnection
4	Rail

**Note**

If you wish to install an S7-300 with grounded reference potential, you must NOT remove the jumper from the CPU.

**5.8.2.1 Installing the S7-300 with floating reference potential (except for CPU 312 IFM)**

**Definition**

If you install an S7-300 with ungrounded reference potential, any interference currents that occur are dissipated via an RC system to the ground conductor/local ground integrated into the CPU.

**Note**

Floating potential installation of an S7-300 with CPU 312 IFM or CPU 31xC is not possible.

## Application

In larger plants, it might prove necessary to install the S7-300 with floating reference potential because of short-circuit to ground monitoring. This is the case, for example, in chemical industry and power stations.

### Floating reference potential on CPUs 313 – 318-2 DP

This connection diagram applies to the

CPU	Order No.	As of hardware version
CPU 313	6ES7 313-1AD03-0AB0	01
CPU 314	6ES7 314-1AE04-0AB0 6ES7 314-1AE84-0AB0	01
CPU 314 IFM	6ES7 314-5AE03-0AB0	01
CPU 314 IFM	6ES7 314-5AE83-0AB0	01
CPU 315	6ES7 315-1AF03-0AB0	01
CPU 315-2 DP	6ES7 315-2AF03-0AB0 6ES7 315-2AF83-0AB0	01
CPU 316-2 DP	6ES7 316-2AG00-0AB0	01
CPU 318-2 DP	6ES7 318-2AJ00-0AB0	03

The diagram illustrates an S7-300 configuration with floating reference potential (jumper has been removed)

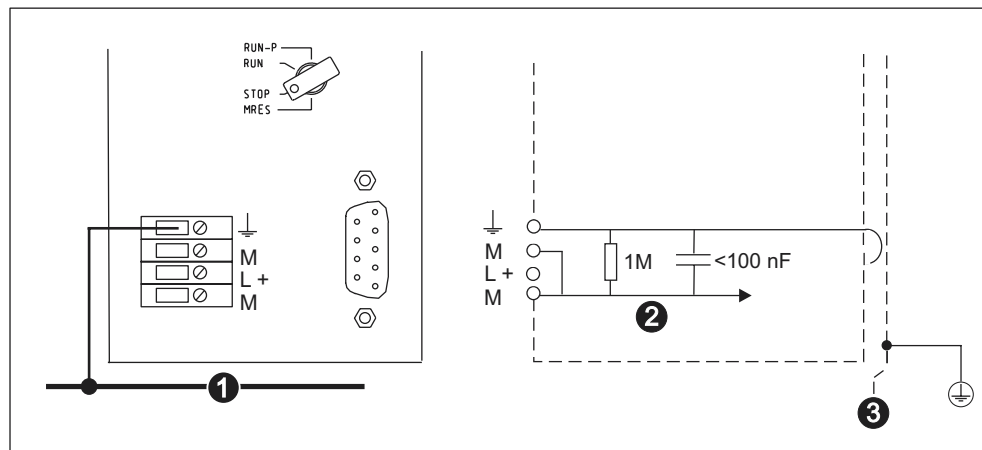

Figure 5-8 S7-300 configuration with floating reference potential (CPU 313 – 318-2 DP)

The diagram illustrates under number	
1	The grounding bus cable
2	The reference potential of the CPU interconnection
3	The mounting rail

If the jumper is not installed, the reference potential of the S7-300 is connected internally to the ground conductor via an RC system and the rail. This discharges radio-frequency interference current and avoids static charge.

---

**Note**

To create a floating reference potential, remove the jumper from the CPU between the M terminals and functional ground.

---

### 5.8.3 Isolated or non-isolated modules

#### Isolated modules

In configurations with isolated modules, the reference potentials of the control circuit ( $M_{\text{internal}}$ ) and the load circuit ( $M_{\text{external}}$ ) are galvanically isolated.

#### Application range for isolated modules

Use isolated modules for:

- All AC load circuits
- DC load circuits with a separate reference potential, for example:
  - DC load circuits whose sensors have different reference potentials (for example if grounded sensors are located at some considerable distance from the control system and no equipotential bonding is possible)
  - DC load circuits with grounded positive pole (L+) (battery circuits).

#### Isolated modules and grounding concept

You can use isolated modules, regardless of whether or not the control system's reference potential is grounded.





### Non-isolated modules

In configurations with non-isolated modules, the reference potentials of the control circuit ( $M_{\text{internal}}$ ) and load circuit ( $M_{\text{external}}$ ) are not electrically isolated (see the figure below).

### Example of non-isolated modules

For operation with an SM 334 AI 4/AO 2 analog I/O module you must connect one of the grounding terminals  $M_{\text{analog}}$  to the CPU's chassis ground.

The figure below shows a sample configuration of an S7-300 CPU with non-isolated modules.

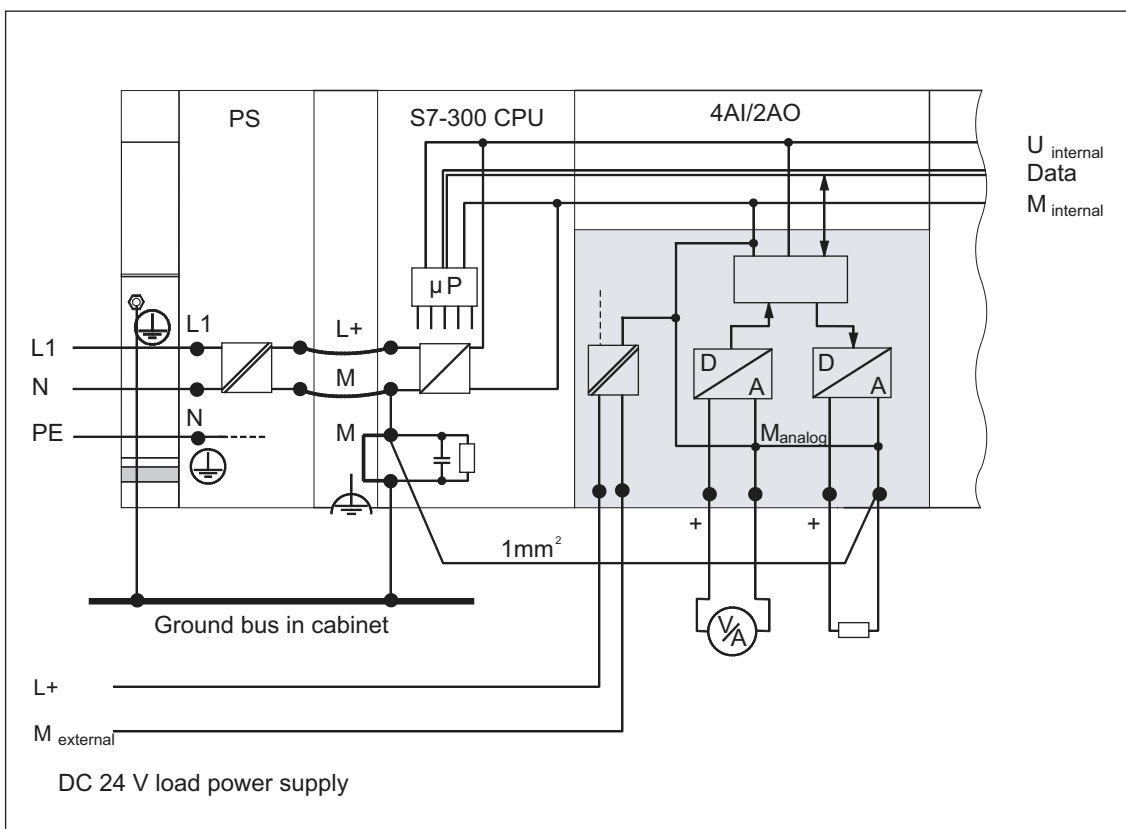

Figure 5-10 Configuration with non-isolated modules

## 5.8.4 Grounding measures

### Bonding

Low-resistance connections to ground reduce the risk of electric shock in case of a short-circuit or system fault. Low-impedance connections (large surface, large-surface contact) reduces the effects of interference on the system or the emission of interference signals. Here, effective shielding of cables and devices is also a significant contribution.



#### Warning

Connect all protection class 1 devices and all larger metal parts to protective ground. This is the only way to protect users from electric shock. It also deflects interference which is emitted from external power supply cables and signal cables to cables connected to I/O devices.

### Measures for protective grounding

The table below shows an overview of the most important measures for protective grounding.

Table 5-8 Protective grounding measures

Device	Measures
Cabinet/mounting structure	Connection to central ground (e.g. equipotential bus line) via cables with protective conductor quality
Rack / rail	Connection to central ground with cable of minimum cross-section of 10 mm <sup>2</sup> , if the rails are not installed in the cabinet and not interconnected with larger metallic parts.
Module	None
I/O Device	Grounding via Schuko plug
Sensors and actuators	Grounding in accordance with regulations applying to the system

### Rule: Ground the cable shielding

You should always connect both ends of the cable shielding to ground/functional ground, since this is the only way to achieve good interference suppression in the higher frequency range.

If you connect only one end of the shielding (that is, at one or the other end of the cable) to ground, you will merely achieve an attenuation in the lower frequency range. One-sided shielding connections could be more favorable in situations

- not allowing the installation of an equipotential bonding conductor,
- if analog signals (some mA or  $\mu$ A) are transmitted,
- or if foil shielding is used (static shielding).

---

#### Note

Potential differences between two grounding points might cause an equipotential current flow across shielding connected at both ends. In this case you should install an additional equipotential bonding conductor..

---



---

#### Caution

Always avoid the flow of operating current to ground.

---

### Additional information on cable shielding and equipotential bonding

are found in the Appendix under the same topic.

### Rule: Ground the load circuits

You should always ground the load circuits. This common reference potential (earth) ensures proper functioning.

**Tip:** (except for CPU 312 IFM)

If you want to locate a fault to ground, provide your load power supply (Terminal L– or M) or the isolating transformer with a removable connection to the protective conductor (see *Overview: Grounding* Number 4).

## Connecting the reference potential of the load voltage

Numerous output modules require an additional load voltage for switching control devices.

The table below shows how to connect the load voltage reference potential  $M_{\text{external}}$  for the various configuration versions.

Table 5-9 Connection of the load voltage reference potential

Installation	Non-isolated modules	Isolated modules	Remarks
grounded	Connect $M_{\text{external}}$ with M on the CPU	Connect or do not connect $M_{\text{external}}$ to the common grounding line	-
ungrounded	Connect $M_{\text{external}}$ with M on the CPU	Connect or do not connect $M_{\text{external}}$ to the common grounding line	ungrounded operation of CPU 312 IFM is not possible

### 5.8.5 Overview: Grounding

#### CPU 312 IFM

The figure below shows you the complete assembly of an S7-300 with CPU 312 IFM with a power supply from TN-S power supply. Apart from powering the CPU, the PS 307 also supplies the load current for the 24 VDC modules. Note: The arrangement displayed does not correspond with the physical arrangement; it was merely selected to give you a clear overview.

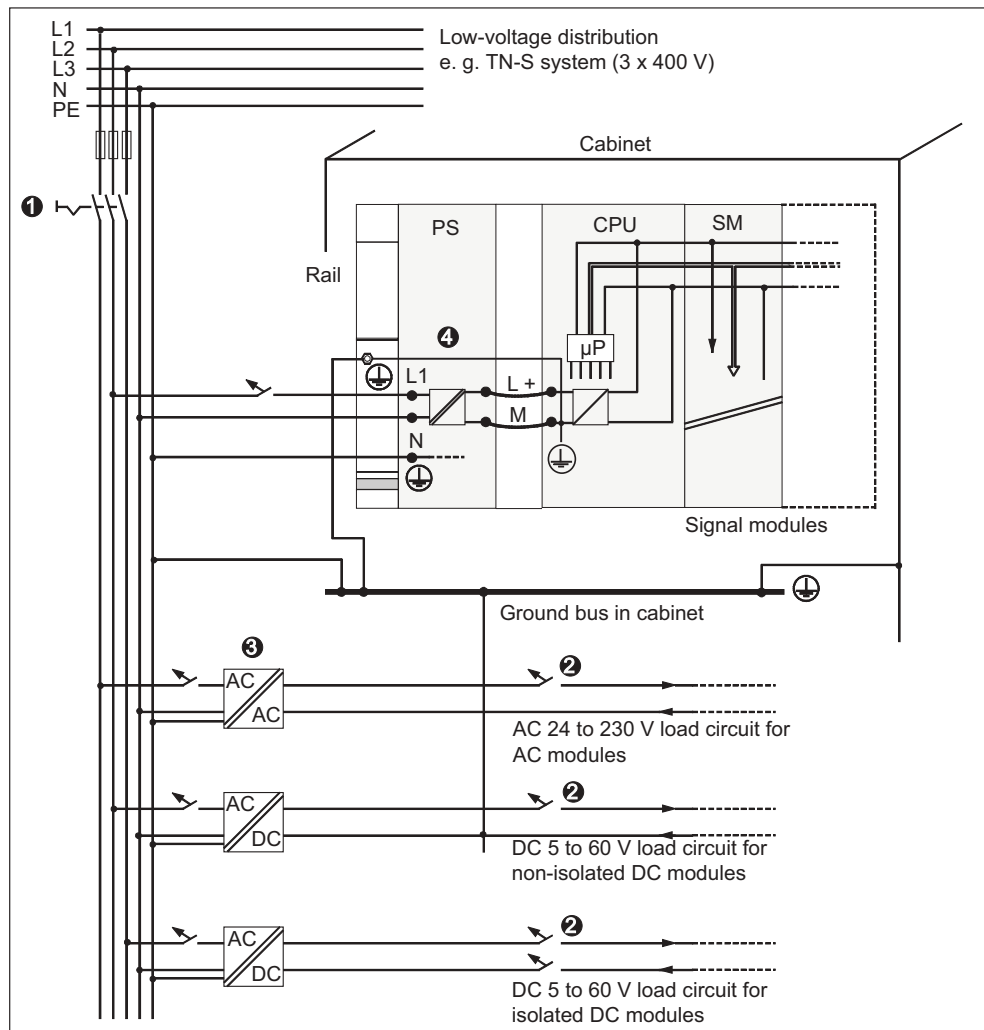

Figure 5-11 Grounding concept for the S7-300 with CPU 312 IFM

Table 5-10 Connection of the load voltage reference potential

The diagram illustrates under number	
(1)	The main switch
(2)	Short-circuit/overload protection
(3)	The load current supply (galvanic isolation)
(4)	This connection is established automatically with the CPU 312 IFM.

### All CPUs except for CPU 312 IFM

The figure below shows you an overall S7-300 configuration with TN-S power supply. Apart from powering the CPU, the PS 307 also supplies the load current for the 24 VDC modules.

Note: The arrangement displayed does not correspond with the physical arrangement; it was merely selected to give you a clear overview.

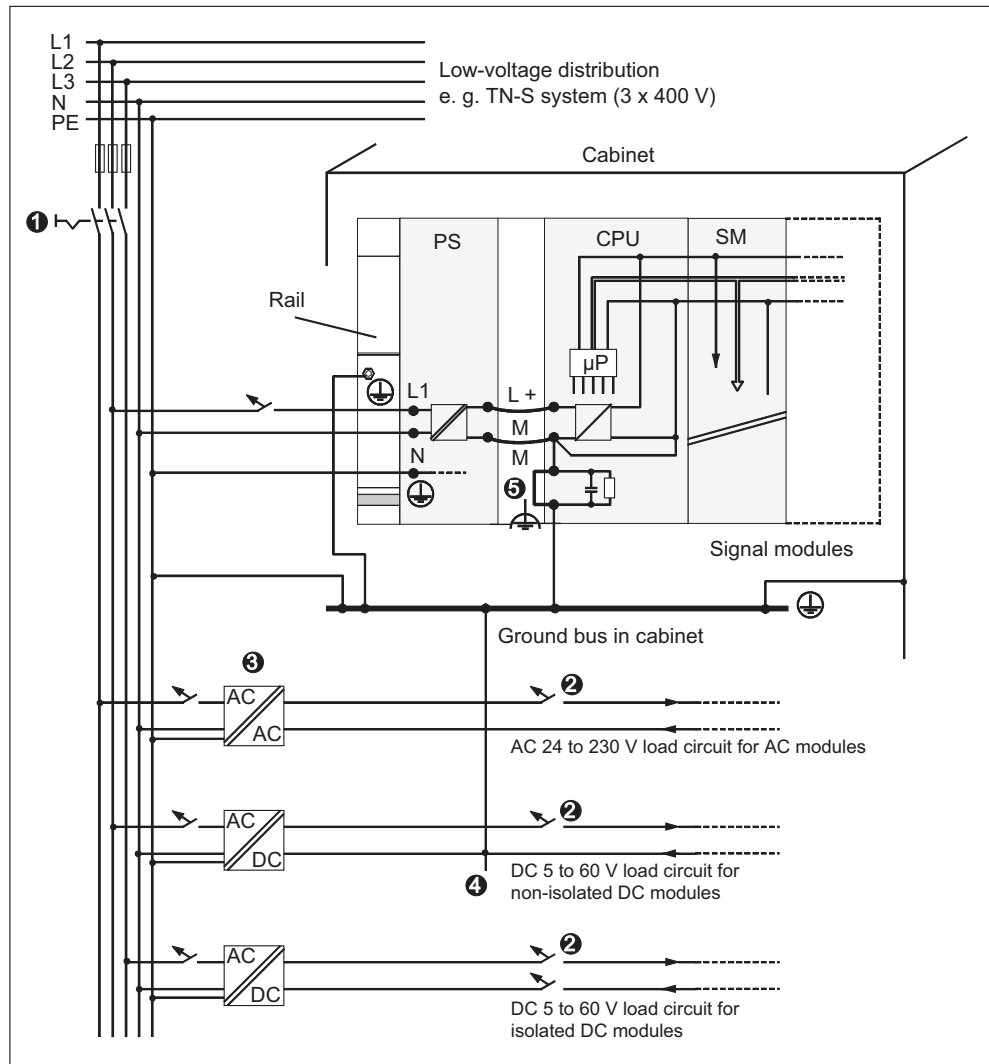

Figure 5-12 Grounding concept for the S7-300 with CPU 31 x

Table 5-11 Connection of the load voltage reference potential

The diagram illustrates under number	
(1)	The main switch
(2)	Short-circuit/overload protection
(3)	The load current supply (galvanic isolation)
(4)	The removable connection to the equipment grounding conductor cable for ground fault localization
(5)	Grounding brackets of the CPU (removable jumper)

## 5.9 Selecting the Load Power Supply

### Task of load power supply

The load power supply feeds the input and output circuits (load circuits), and the sensors and actuators.

### Characteristics of load power supply units

You will have to adapt the load power supply unit to your specific application. The following table compares the various load power supply units and their characteristics to help you make your choice:

Table 5-12 Characteristics of load power supply units

Mandatory for ...	Characteristics of the load power supply	Remarks
Modules requiring voltage supplies of $\leq 60$ VDC or $\leq 25$ VAC. 24 VDC load circuits	Protective separation	These characteristics apply to Siemens power supplies of the series PS 307 and to SITOP power (series 6EP1).
24 VDC load circuits 48 VDC load circuits 60 VDC load circuits	Output voltage tolerances: 20.4 V to 28.8 V 40.8 V to 57.6 V 51 V to 72 V	-

### Requirements for load power supplies

It must provide an extra-low voltage of  $\leq 60$  VDC and be safely isolated from mains. Safe isolation from mains can be realized, for example, in accordance with VDE 0100 Part 410 / HD 384-4-41 / IEC 364-4-41 (as functional extra-low voltage with safe isolation) or VDE 0805 / EN 60950 / IEC 950 (as safety extra-low voltage SELV) or VDE 0106 Part 101.

### How to determine load current

The required load current is determined by the sum load current of all sensors and actuators connected to the outputs.

In case of short-circuit the DC outputs are briefly loaded with twice to three times the rated output current before the clocked electronic short-circuit protection comes into effect. Thus, you must consider this increased short-circuit current when selecting your load power supply unit. Uncontrolled load power supplies usually provide this excess current. With controlled load power supplies - especially for low output power (up to 20 A) - you must ensure that the supply can handle this excess current.



### Example: S7-300 with load power supply from PS 307

The figure below shows the overall S7-300 configuration (load power supply unit and grounding concept), with TN-S mains supply.

Apart from powering the CPU, the PS 307 also supplies the load current for the 24 VDC modules.

#### Note

The arrangement of supply connections displayed does not correspond with the physical arrangement; it was merely selected to give you a clear overview.

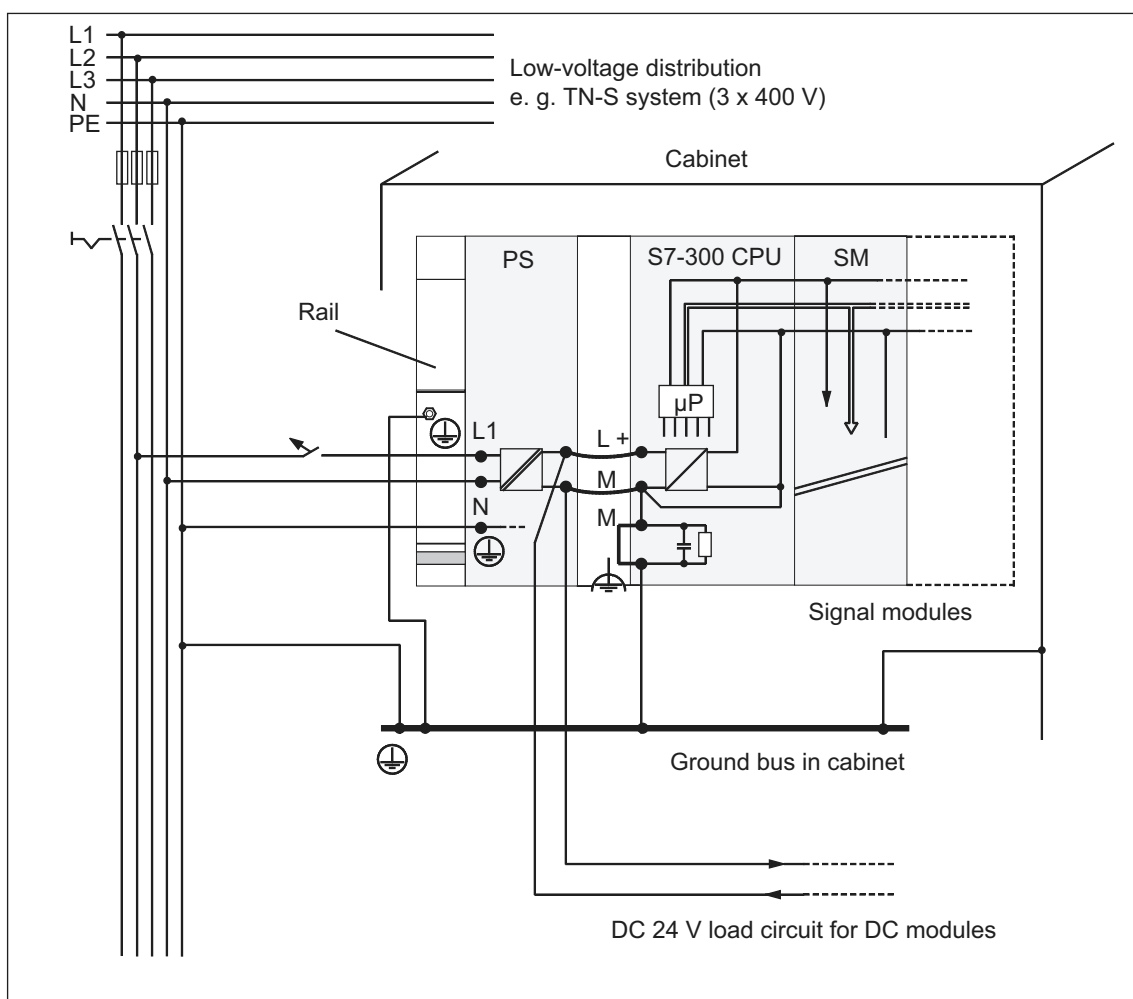

Figure 5-13 Example: S7-300 with load power supply from PS 307

## 5.10 Planning Subnets

### 5.10.1 Extending and networking subnets

#### Overview: Subnets with SIMATIC

SIMATIC offers the following subnets, according to different automation levels (process, cell, field and actuator/sensor level ):

- Multi-Point Interface (MPI)
- PROFIBUS
- Point-to-point communication (PtP)
- Industrial Ethernet
- Actuator/Sensor Interface (ASI)

#### Multi-Point Interface (MPI)

**Availability: In all the CPUs described in this document.**

MPI is a small subnet with just a few nodes at the field/cell level. It is a multipoint-capable interface in SIMATIC S7/M7 and C7, intended for operation as PG interface for networking just a few CPUs or for exchanging small volumes of data with PGs.

MPI always retains the last configuration of the transmission rate, node number and highest MPI address, even after memory reset, voltage failure or deletion of the CPU parameter configuration.

#### PROFIBUS

**Availability: CPUs with the letters "DP" after the number have a DP interface as their second interface (e.g. 315-2 DP)**

PROFIBUS in the SIMATIC open, multivendor communication system represents the network at the cell and field level.

PROFIBUS is available in two versions:

1. PROFIBUS DP field bus for fast cyclic data exchange, and PROFIBUS-PA for the intrinsically safe area.
2. The cell level as PROFIBUS (FDL or PROFIBUS-FMS) for fast data exchange with communication partners equipped with equal rights.

However, you can also implement PROFIBUS DP and PROFIBUS-FMS with communication processors (CP).

## Industrial Ethernet

### Implementation using communication processors (CP).

Industrial Ethernet in an open multivendor communication system represents the SIMATIC network at the process and cell level. Industrial Ethernet is suitable for fast and high-volume data exchange and offers offsite networking options via gateway.

The CPUs described in this manual can only be connected to Industrial Ethernet by means of communication processors.

## Actuator/sensor interface (ASI)

### Implementation using communication processors (CP).

The ASI, or actuator/sensor interface, represents a subnet system on the lowest process level for automation systems. It is used especially for networking digital sensors and actuators. The maximum data volume is 4 bit per slave station.

With S7-300 CPUs, you can connect to an ASI only with the help of communication processors.

## Same configuration for MPI and PROFIBUS DP

For your MPI network configuration, we recommend you use the same network components as in a PROFIBUS DP network configuration. The same configuration rules apply in this case.

## Cross-reference

You will find more information about communication in the *Communication with SIMATIC* Manual.

## 5.10.2 Basic principles of MPI and DP subnets

### MPI/PROFIBUS DP

These subnets are the most frequently used for S7-300 CPUs, so they are discussed in detail below.

#### Convention: Device = Node

In the following, all networked devices are referred to as nodes.

#### Segment

A segment is a bus link between two terminating resistors. A segment can include up to 32 nodes. It is also limited by the permitted line length, depending on the transmission rate.

#### Transmission rate

These maximum transmission rates are possible:

- MPI
  - 12 Mbps with CPU 318-2 DP
  - 187.5 Kbps with all other CPUs
- PROFIBUS DP: 12 Mbps

#### Number of nodes

Maximum possible number of nodes per subnet:

Table 5-13 Nodes on the subnet

Parameters	MPI	PROFIBUS DP
Number	127	126 <sup>1)</sup>
Addresses	0 to 126	0 to 125
Remarks	Default: 32 addresses Reserved are: <ul style="list-style-type: none"> <li>• address 0 for PG</li> <li>• address 1 for OP</li> </ul>	of those: 1 Master (reserved) 1 PG connection (address 0 reserved) 125 slaves or other masters

1) Note the CPU-specific maximum specifications in the CPU manual.

## MPI/PROFIBUS DP addresses

To ensure that all nodes can intercommunicate, you must assign them an address:

- In the MPI network: an “MPI address“
- In the PROFIBUS DP network: a “PROFIBUS DP address“

On the PG you can specify individual MPI/PROFIBUS addresses for each one of the nodes (on some of the PROFIBUS DP slaves this is also possible per selector switch).

## Default MPI/PROFIBUS DP addresses

The table below shows you the factory setting of the MPI/PROFIBUS DP addresses and the highest default MPI/PROFIBUS DP addresses for the devices.

Table 5-14 MPI/PROFIBUS DP addresses

Node (device)	Default MPI/PROFIBUS DP address	Default highest MPI address	Default highest PROFIBUS DP address
PG	0	32	126
OP	1	32	126
CPU	2	32	126

## Rules: Assigning MPI/PROFIBUS DP addresses

Note the following rules before assigning MPI/PROFIBUS addresses:

- All MPI/PROFIBUS addresses in a subnet must be unique.
- The highest MPI/PROFIBUS address must be  $\geq$  of the physical MPI/PROFIBUS address, and it must be identical for each node. (Exception: Connecting a PG to multiple nodes; refer to the next Chapter).

### Differences in the case of MPI addresses of CPs/FMs in an S7-300

Table 5-15 MPI addresses of CPs/FMs in an S7-300

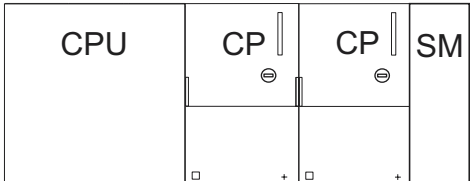
Options	Example:			
<p>Example: An S7-300 CPU and 2 CPs in one unit. You have two options for assigning MPI addresses of CPs/FMs installed in one unit:</p>				
<p><b>First option:</b> The CPU adopts the CP MPI addresses you specify in STEP 7.</p>	MPI address	MPI address +x	MPI address .+y	
<p><b>Second option:</b> The CPU automatically determines the MPI addresses of the CPs in their configuration as follows: MPI address of CPU; MPI address +1; MPI address +2. (Default)</p>	MPI address	MPI address +1	MPI address +2	
<p><b>Special features: CPU 318-2 DP</b></p>	<p>This CPU uses only one MPI address, including the CPs connected.</p>			

### Recommendations for the MPI address n

Reserve MPI address “0” for a service PG or “1” for a service OP. You can later connect them temporarily to the subnet. Also, assign other MPI addresses to PGs/OPs operating on the MPI subnet.

Recommended MPI address for the CPU in case of replacement or service:

Reserve MPI address “2” for the CPU. This prevents duplication of MPI addresses after you connect a CPU with default settings to the MPI subnet (for example, when replacing a CPU). That is, you must assign an MPI address greater than “2” to CPUs on the MPI subnet.

### Recommended MPI address n

Reserve PROFIBUS address “0” for a service PG that you can subsequently connect briefly to the PROFIBUS subnet if required. Therefore, assign unique PROFIBUS addresses to PGs integrated in the PROFIBUS subnet.

## PROFIBUS DP: Electrical conductor or fiber optic cable?

Use fiber optic cables instead of copper conductors if you want your field bus to cover greater distances regardless of the transmission rate and be insensitive to external noise fields.

## Equipotential bonding

For information on what to take into account relating to equipotential bonding when you configure your network, refer to the corresponding chapter in the appendix.

## Also note ...

the section referring to communication in the relevant CPU manual.

## 5.10.3 Interfaces

### MPI interface

**Availability: In all the CPUs described in this document.**

MPI (Multi-Point Interface) represents the interface between the CPU and a PG/OP or for communication in an MPI Subnet.

The typical (default) transmission rate is 187.5 Kbps. You can also set the rate to 19.2 Kbps for communication with an S7-200. Other baud rates are not possible (exception CPU 318-2DP: up to 12 Mbps).

The CPU automatically broadcasts its bus parameter configuration (e.g. transmission rate) via MPI interface. A programming device, for example, can then automatically retrieve the correct parameters and connect to an MPI Subnet.

---

### Note

In RUN mode, you may only connect PGs to the MPI Subnet. Other stations (e.g.. OP, TP, ...) should not be connected to the MPI subnet while the PLC is in run mode. Otherwise, transferred data might be corrupted as a result of interference or global data packages may get lost.

---

## PROFIBUS DP interface

### Availability: CPU types with the identifier "DP" (used as a DP master)

The PROFIBUS DP interface is mainly used to connect distributed I/Os. PROFIBUS DP allows you to create large, extended subnets, for example.

The PROFIBUS DP interface can be configured as either master or slave, and offers a transmission speed of up to 12 Mbps.

The CPU sends its bus parameters (e.g. the baud rate) to the PROFIBUS DP interface (if it is used as the master). A programming device, for example, can then automatically retrieve the correct parameters and connect to a PROFIBUS subnet. In your configuration, you can disable this bus parameter broadcast.

### Reference (CPU 318-2DP only)

You will find information about the DPV1 functionality in the chapter of the same name of the *CPU Data CPU 312 IFM – 318-2DP Reference Manual*.

### Which devices can I connect to which interface?

Table 5-16 The following devices may be connected

MPI	PROFIBUS-DP
<ul style="list-style-type: none"> <li>• PG/PC</li> <li>• OP/TP</li> <li>• S7-300/400 with MPI interface</li> <li>• S7-200 (19.2 Kbps only)</li> </ul>	<ul style="list-style-type: none"> <li>• PG/PC</li> <li>• OP/TP</li> <li>• DP slaves</li> <li>• DP master</li> <li>• Actuators/Sensors</li> <li>• S7-300/400 with PROFIBUS DP interface</li> </ul>

### Further information

Further information on specific connections can be found in the *Communication with SIMATIC* manual.

Details on PtP communication is found in the *Technological Functions* Manual.



## 5.10.4 Network Components

### PROFIBUS bus cable

For PROFIBUS DP or MPI networking we offer you the following bus cables for diverse fields of application:

Table 5-17 Available bus cables

Bus cable	Order No.
PROFIBUS cable	6XV1 830-0AH10
PROFIBUS cable, halogen-free	6XV1 830-0CH10
PROFIBUS underground cable	6XV1 830-3AH10
PROFIBUS trailing cable	6XV1 830-3BH10
PROFIBUS cable with PUR sheath for environments subject to chemical and mechanical stress	6XV1 830-0DH10
PROFIBUS bus cable with PE sheath for the food and beverages industry	6XV1 830-0BH10
PROFIBUS bus cable for festooning	6XV1 830-3CH10

### Properties of PROFIBUS cables

The PROFIBUS cable is a shielded twisted-pair cable with copper conductors. It is used for line transmission in accordance with US Standard EIA RS485.

The table below lists the characteristics of these bus cables.

Table 5-18 Properties of PROFIBUS cables

Characteristics of the bus cables for PROFIBUS Properties	Values
Impedance level	approx. 135 $\Omega$ to 160 $\Omega$ (f = 3 MHz to 20 MHz)
Loop resistance	$\leq 115 \Omega/\text{km}$
Effective capacitance	30 nF/km
Attenuation	0.9 dB/100 m (f = 200 kHz)
permitted conductor cross-sections	0.3 mm <sup>2</sup> to 0.5 mm <sup>2</sup>
permitted cable diameter	8 mm $\pm$ 0.5 mm

### Rules for installing bus cables

When wiring PROFIBUS cables, you must not

- twist,
- stretch
- or compress them.

When wiring indoor bus cables, also maintain the following marginal conditions ( $d_A$  = outer cable diameter):

Table 5-19 Marginal conditions for wiring interior bus cables

Characteristics	Condition
Bending radius (one-off)	$\geq 80 \text{ mm } (10 \times d_A)$
Bending radius (multiple times)	$\geq 160 \text{ mm } (20 \times d_A)$
permitted temperature range during installation	-5 °C to +50 °C
Shelf and stationary operating temperature range	-30 °C to +65 °C

### Cross-reference

If you want to use fiber optic cable cables for PROFIBUS, you can find further information on this topic in the SIMATIC NET, PROFIBUS Networks Manual.

### RS485 bus connector

Table 5-20 Bus connector

Type	Order No.
RS485 bus connector, up to 12 Mbps, with 90° cable exit, without PG interface, with PG interface	6ES7 972-0BA11-0XA0 6ES7 972-0BB11-0XA0
Fast Connect RS485 bus connector, up to 12 Mbps, with 90° cable exit, with insulation displacement technology , without PG interface, with PG interface	6ES7 972-0BA50-0XA0 6ES7 972-0BB50-0XA0
RS 485 bus connector up to 12 Mbps with 35° cable exit (not CPU 31xC, 312, 314 (6ES7314-1AF10-0AB0) or 315-2 DP (6ES7315-2AG10-0AB0)) without PG interface with PG interface	6ES7 972-0BA40-0XA0 6ES7 972-0BB40-0XA0

## Application

You require these bus connectors to connect the PROFIBUS cable to an MPI or PROFIBUS-DP interface

You do **not** require a bus connector for:

- DP slaves with degree of protection IP 65 (e.g. ET 200C)
- RS485 Repeater.

## RS485 repeater

Table 5-21 RS 485 repeater

Type	Order No.
RS485 repeater	6ES7 972-0AA00-0XA0

## Task of the RS 485 repeater

An RS485 repeater amplifies data signals on bus lines and interconnects bus segments.

You require this RS485 Repeater in the following situations:

- for operation with more than 32 network nodes
- when interconnecting a grounded and an ungrounded segment
- when exceeding the maximum line length in a segment

## The maximum cable lengths for RS485 Repeaters ...

... can be found in the Chapter *Cable lengths*.

## Longer cable lengths

If you want to implement cable lengths above those permitted in a segment, you must use RS485 repeaters. The maximum cable length possible between two RS485 repeaters corresponds to the cable length of a segment (see the following Chapter). Please note that these maximum cable lengths only apply if no other node is interconnected between the two RS485 repeaters. You can connect up to nine RS485 repeaters in series.

Please note that you have to add the RS485 repeater when you determine the number of nodes in your subnet, even if it is not assigned its own MPI/PROFIBUS address.

## Technical data and installation instructions are found ...

... in the RS485 Repeater product information.

## PG patch cord

Table 5-22 PG patch cord

Type	Order No.
PG patch cord	6ES7 901-4BD00-0XA0

## Stub cables

If bus nodes are connected to a bus segment via stub cables (e.g. PG via a normal PG cable), then you must consider the maximum possible length of the stub cable.

You can use a PROFIBUS bus cable with bus connector as the stub cable for up to 3 Mbps.

Use the patch cord to connect the PG or PC when operating above 3 Mbps. In your bus configuration you can use multiple PG patch cords with this order no. Do not use other types of stub cable.

## The maximum cable lengths for PG patch cords ...

... can be found in the Chapter *Cable lengths*.

### 5.10.5 Cable length

#### MPI Subnet Segment

You can implement cable lengths of up to 50 m in an MPI subnet segment. This 50 m applies from the first node to the last node in the segment.

Table 5-23 Permitted cable lengths in an MPI subnet segment

Transmission rate	S7-300 CPUs (without CPU 318-2 DP) (non-isolated MPI interface)	CPU 318-2 DP (isolated MPI interface)
19.2 Kbps	50 m	1,000 m
187.5 Kbps		
1.5 Mbps	-	M 200
3.0 Mbps		M 100
6.0 Mbps		
12.0 Mbps		

## Segment in the PROFIBUS subnet

The cable length in a segment of a PROFIBUS subnet depends on the transmission rate.

Table 5-24 Permitted cable lengths in a PROFIBUS subnet segment

Transmission rate	Maximum cable length in a segment
9.6 Kbps to 187.5 Kbps	1,000 m
500 Kbps	M 400
1.5 Mbps	M 200
3 Mbps to 12 Mbps	M 100

## Longer cable lengths

If you want to implement cable lengths above those permitted in a segment, you must use RS485 repeaters. Information on this topic can be found in the RS485 repeater product information.

## Length of the stub cables

If bus nodes are connected to a bus segment via stub cables (e.g. PG via a normal PG cable), then you must consider the maximum possible length of the stub cable.

The following table lists the maximum permitted lengths of stub cables per segment:

Table 5-25 Stub cable lengths per segment

Transmission rate	Max. length of stub cables per segment	Number of nodes with stub cable length of ...	
		1.5 m or 1.6 m	M 3
9.6 Kbps to 93.75 Kbps	M 96	32	32
187.5 Kbps	M 75	32	25
500 Kbps	M 30	20	10
1.5 Mbps	M 10	6	3
3 Mbps to 12 Mbps	<sup>1)</sup>	<sup>1)</sup>	<sup>1)</sup>

<sup>1)</sup> At 3 Mbps and higher, use the PG patch cord (Order No. 6ES7 901-4BD00-0XA0) to connect the PG or PC. You can use multiple PG patch cords of this number in an installation. Do not use any other type of stub cable.

### 5.10.6 Sample networks

#### Example: Installing an MPI subnet

The figure below shows you the block diagram of an MPI subnet.

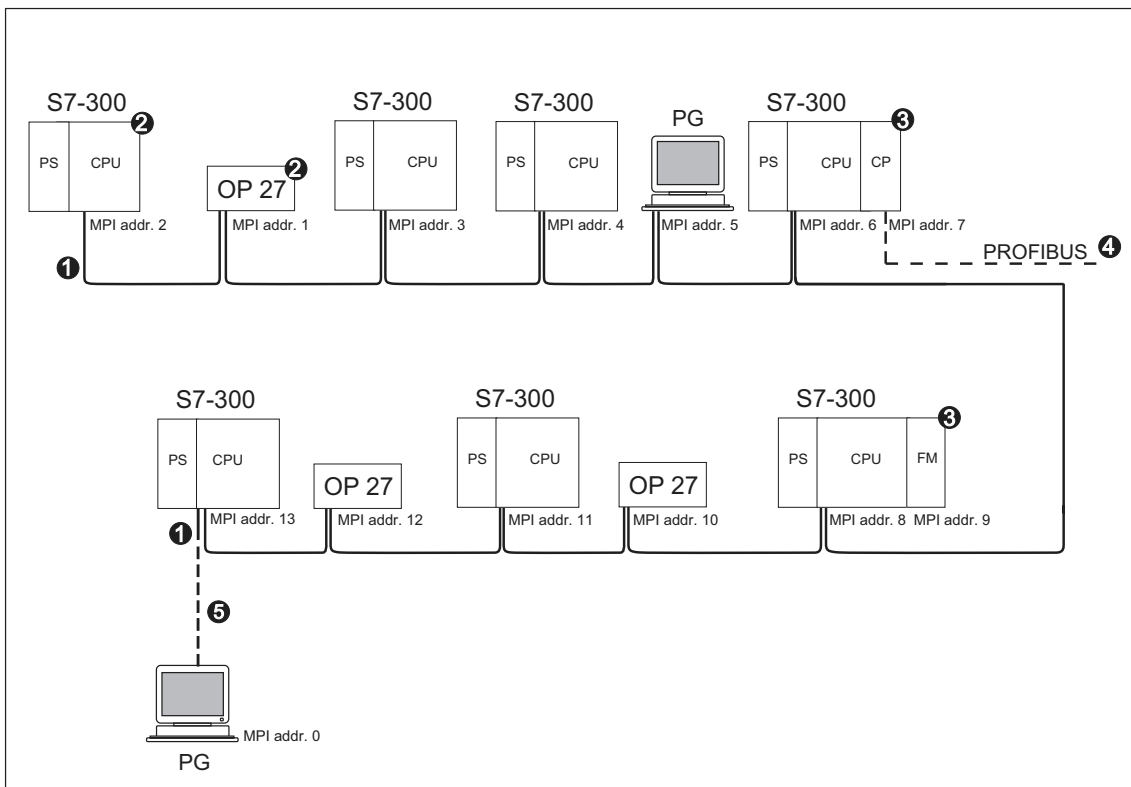

Figure 5-14 Example of an MPI subnet

Key to numbers in the figure	
(1)	Terminating resistor inserted
(2)	S7-300 and OP 27 have subsequently been connected to the MPI subnet using their MPI default address.
(3)	With CPU 318-2 DP, a separate MPI address is not assigned to CPs or FMs. With S7-300 CPUs (without CPU 318-2 DP), you can also freely assign MPI addresses for the CPs/ FMs.
(4)	In addition to the MPI address, the CP also has a PROFIBUS address (7 in this case).
(5)	Connected via a stub cable using the default MPI address for commissioning/maintenance only

**Example: Maximum distances in the MPI subnet**

The figure below shows you:

- a possible MPI Subnet configuration
- maximum distances possible in an MPI subnet
- the principle of “Line extension” using RS485 repeaters

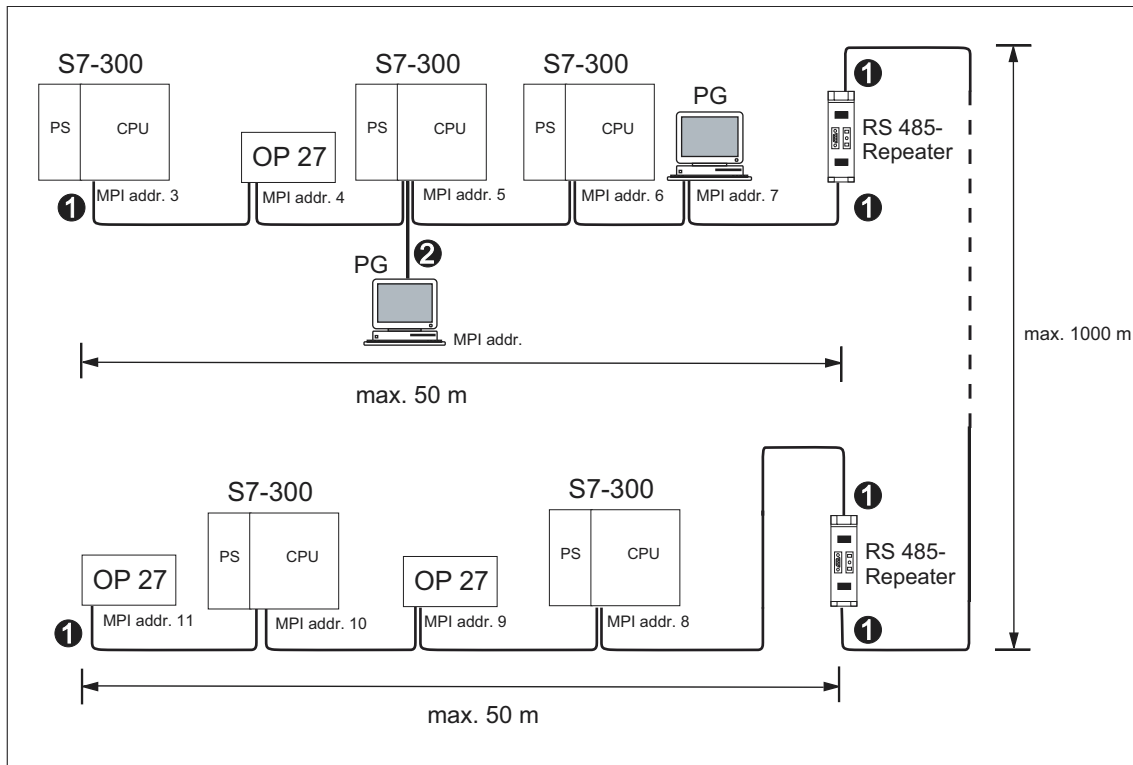

Figure 5-15 Example: Maximum distance in the MPI subnet

Key to numbers in the figure	
(1)	Terminating resistor inserted
(2)	PG connected by means of a stub cable for maintenance purposes

### Example: Installing a PROFIBUS subnet

The figure below shows you the block diagram of a PROFIBUS subnet.

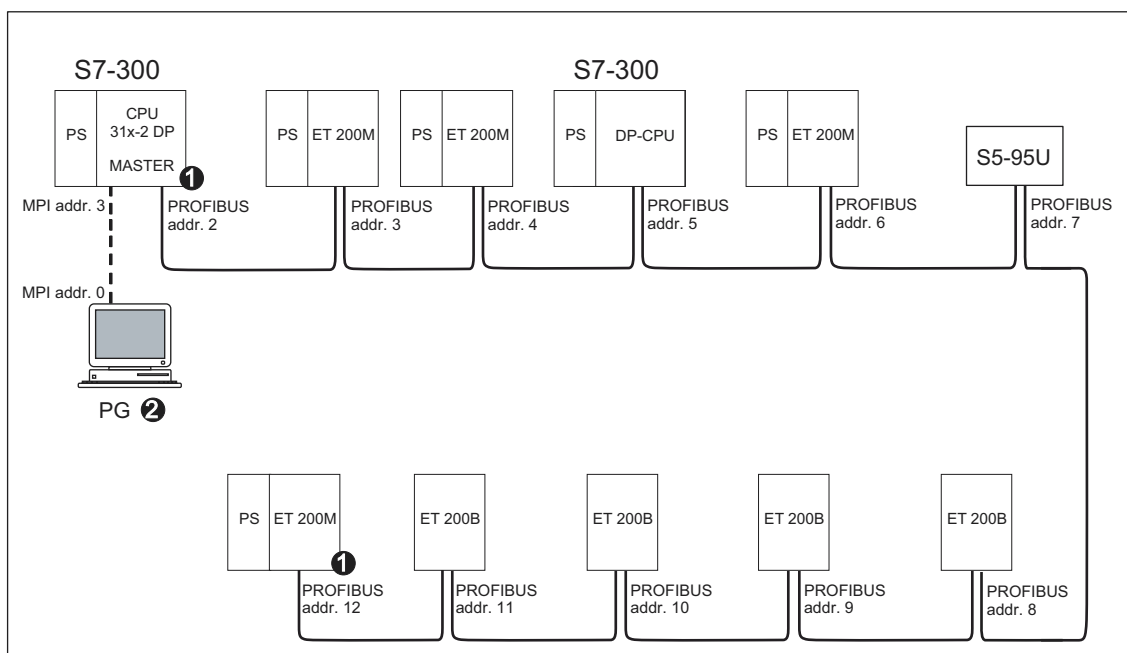

Figure 5-16 Example of a PROFIBUS subnet

Key to numbers in the figure	
(1)	Terminating resistor inserted
(2)	PG connected by means of a stub cable for maintenance purposes



**Example: CPU 31x-2 DP as MPI and PROFIBUS nodes**

The figure below shows you an assembly with a CPU 31x-2 DP integrated in an MPI subnet and at the same time operated as DP master in a PROFIBUS subnet.

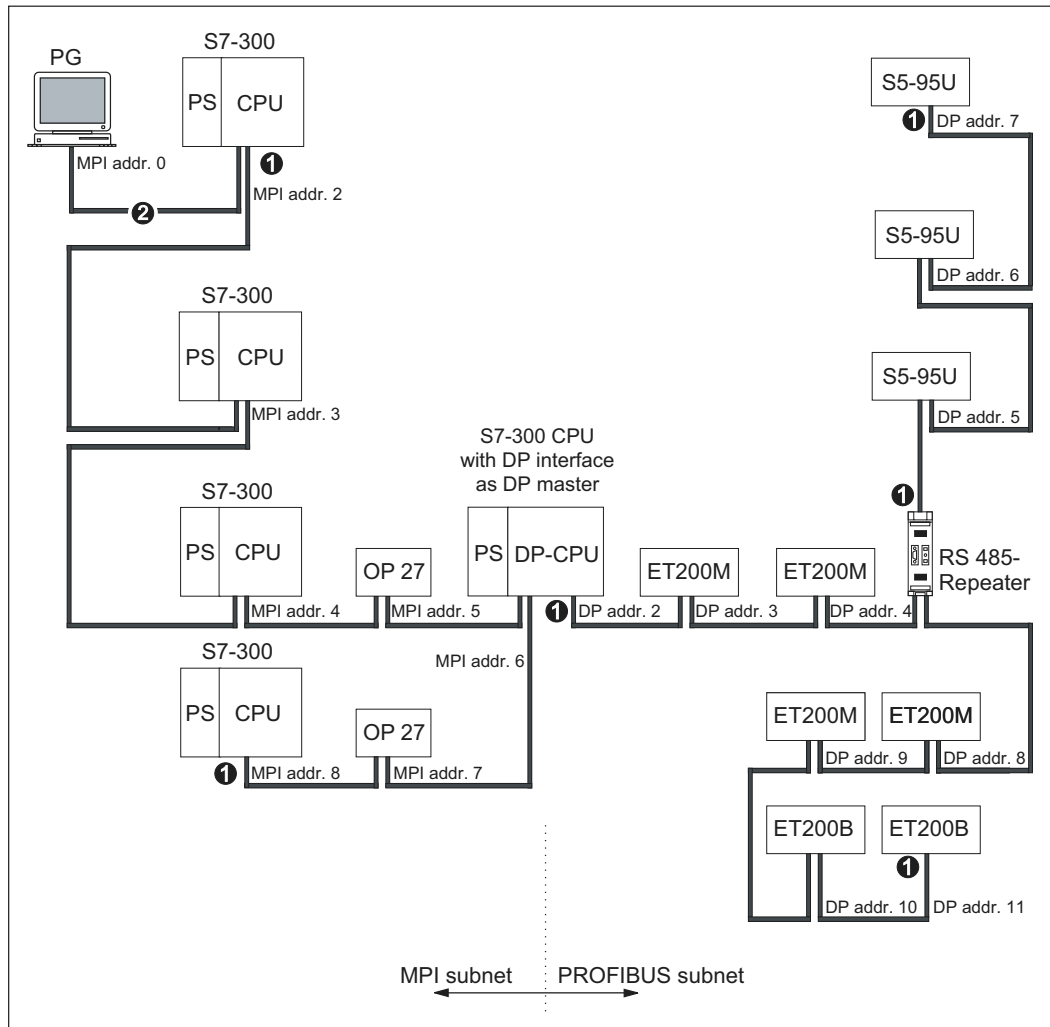

Figure 5-17 Example: CPU 314C-2 DP as MPI and PROFIBUS nodes

Key to numbers in the figure	
(1)	Terminating resistor inserted
(2)	PG connected by means of a stub cable for maintenance purposes

### Example: PG access across network boundaries (routing)

With a programming device you can access all modules across network boundaries.

#### Requirements

- You must use STEP 7, Version 5.0 or higher.
- You must assign the PG/PC to a network in your STEP 7 project (SIMATIC Manager, assigning a PG/PC).
- The network boundaries must be bridged by modules with routing capability.
- After having configured all networks in NETPRO, you have initiated a new compilation for all stations and downloaded the configuration to every module capable of routing. This also applies to all changes made in the network.

Thus, every router knows all possible paths to a target node.

This example illustrates routing beyond network limits with two MPI networks and one PROFIBUS-DP network.

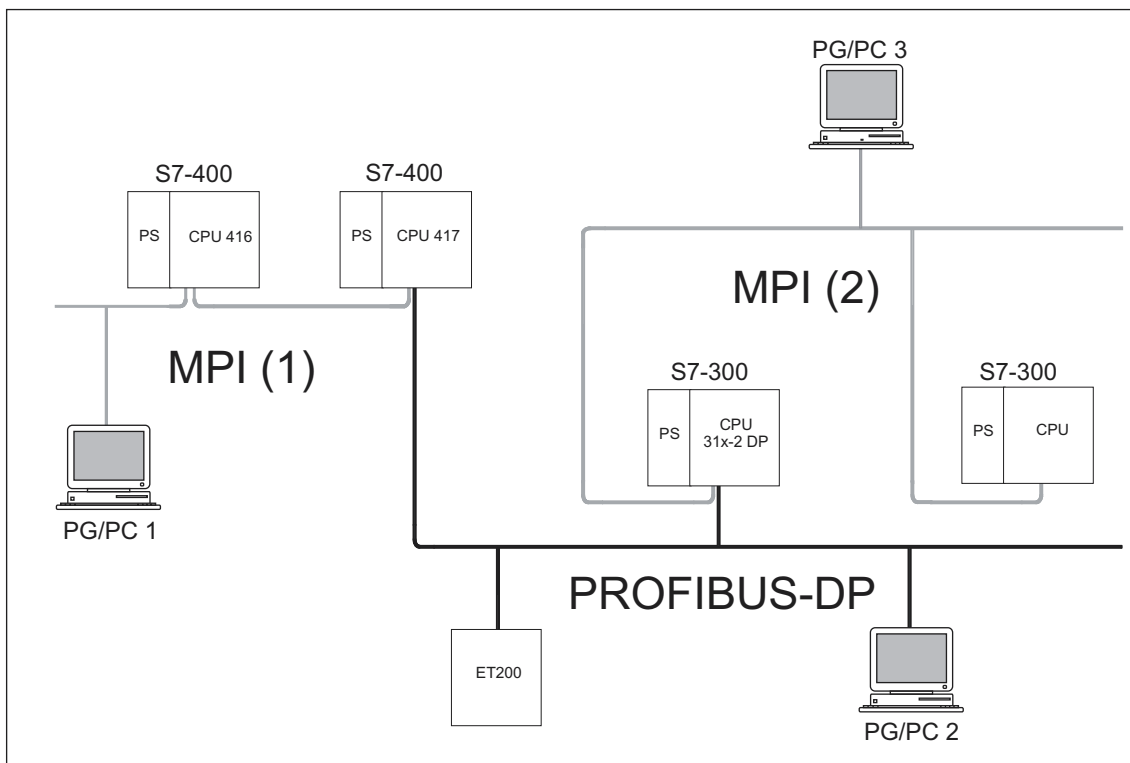

Figure 5-18 Example of PG access across network boundaries (routing)

**Information on routing can be found in the ...**

- CPU Data CPU 312 IFM – 318-2DP Reference Manual
- In the *Communication with SIMATIC* manual.

**Example: Terminating resistor in the MPI subnet**

The following figure shows you where to connect the terminating resistors on the MPI subnet **(1)**. In this example, the programming device (PG) is connected by means of a stub cable only during commissioning or servicing **(2)**.

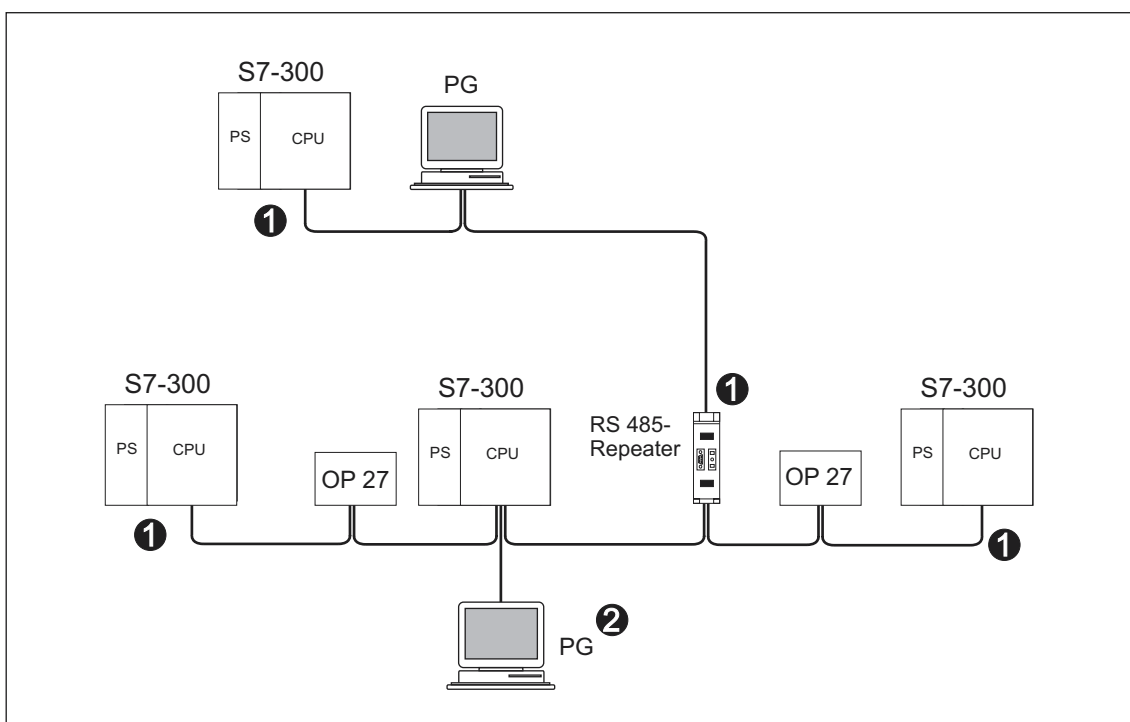

Installing Figure 5-19 the terminating resistors in an MPI subnet

Key to numbers in the figure	
(1)	Terminating resistor inserted
(2)	PG connected by means of a stub cable for maintenance purposes



**Warning**

Disturbance of data traffic might occur on the bus.

A bus segment must always be terminated at both ends with the terminating resistor. This, for example, is not the case if the last slave with bus connector is off power.

Since the bus connector draws its power from the station, the terminating resistor has no effect.

Please make sure that power is always supplied to stations on which the terminating resistor is active.

As an alternative, you can also use the PROFIBUS Terminator as active bus termination.



# Installation

# 6

## 6.1 Installing an S7-300

### In this Chapter

we shall explain the steps required for the mechanical assembly of an S7-300.

---

#### Note

Note the installation guidelines and notes on safety in this manual when mounting, commissioning and operating S7-300 systems.

---

### Open components

S7-300 modules are "Open Components" according to IEC 61131-2 and EU directive 73/23/EEC (Low-Voltage directive), and to UL/CSA Approval an "open type".

In order to conform with specifications on safe operation relating to mechanical strength, inflammability, stability and touch-protection, the following alternative installation modes are prescribed:

- Installation in a suitable cubicle
- Installation in a suitable cabinet
- Installation in an appropriately equipped and closed operating area

Access to these areas must only be possible with a key or tool. Only trained or authorized personnel is allowed access to these cubicles, cabinets or electrical operating rooms.

## Accessories included

Installation accessories are included with the module package. The appendix contains a list of accessories and spare parts together with the corresponding order numbers.

Table 6-1 Module accessories

Module	Accessories included	Description
CPU	1 x Slot number label	For assigning slot numbers
	2 keys (only for CPUs with a key switch, such as the CPU 318-2 DP)	The key is used for operating the CPU's mode selector switch
	Inscription labels	For labeling the integrated inputs and outputs (CPU 312 IFM, 314 IFM) with the MPI address and firmware version  Tip: Templates for labeling strips are available on the Internet at <a href="http://www.ad.siemens.de/cs/info">http://www.ad.siemens.de/cs/info</a> under article ID 11978022.
Signal module (SM) Function Module (FM)	1 bus connector	For electrical interconnection of modules
	1 labeling strip	for labeling module I/Os  Tip: Templates for labeling strips are available on the Internet at <a href="http://www.ad.siemens.de/cs/info">http://www.ad.siemens.de/cs/info</a> under article ID 406745.
Communication module (CP)	1 bus connector	For electrical interconnection of modules
	1 inscription label (only CP 342-2)	for labeling the connection to the PLC interface  Tip: Templates for labeling strips are available on the Internet at <a href="http://www.ad.siemens.de/cs/info">http://www.ad.siemens.de/cs/info</a> under article ID 406745.
Interface module (IM)	1 x Slot number label (only IM 361 and IM 365)	For assigning slot numbers on racks 1 to 3

## Tools and material required

For your S7-300 installation you require the tools and materials listed in the table below.

Table 6-2 Installation tools and materials

You require ...	for ...
cutting the 2 m rail to length	Standard tool
scribing and drilling holes on the 2 m rail	Standard tool, 6.5 mm diameter drill bit
screw-mounting the rail	wrench or screwdriver, matching the selected fixing screws  diverse M6 screws (length depends on the place of installation) with nuts and spring lock washers
screw-fastening the modules on the rail	screwdriver with 3.5 mm blade width (cylindrical design)
pulling out the grounding slide contact in the floating state	screwdriver with 3.5 mm blade width (cylindrical design)

## 6.2 Installing the rail

### Introduction

rails are available in two versions:

- Ready-to-use, in four standard lengths (with 4 holes for fixing screws and 1 ground conductor bolt)
- Meter rail  
This may be shortened to any length if unusual size attachments are required. It has no holes for fixing screws and no ground conductor screw.

### Requirement

You have prepared the 2 m rail for installation.

### Preparing the 2 m rail for installation

1. Cut the 2 m rail to the required length.
2. Mark out:
  - four bores for the fixing screws (for dimensions refer to "Dimensions for fixing holes")
  - one hole for the protective conductor bolt.
3. If the length of your rail exceeds 830 mm, you must stabilize it by providing additional holes for fixing it with more screws.

Mark out these holes along the groove in the middle section of the rail (see the Figure below). The pitch should be approx. 500 mm.

4. Drill the marked holes to a diameter of  $6.5^{+0.2}$  mm for M6 screws.
5. Attach an M6 screw for fixing the ground conductor.

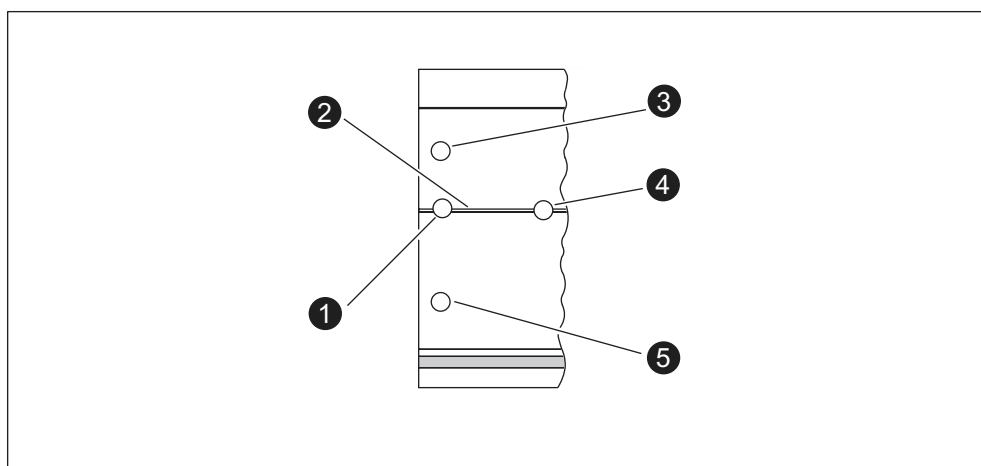

Figure 6-1 Holes for mounting the 2 m rail

Key to numbers in the figure	
(1)	Hole for ground conductor screw
(2)	Groove for drilling additional holes for mounting screws
(3)	Hole for mounting screw
(4)	Additional hole for mounting screw
(5)	Hole for mounting screw



### Dimension of the mounting holes

The mounting hole dimensions for the rail are shown in the table below.

Table 6-3 Mounting holes for rails

"Standard" rail			2 m rail
Length of rail	Dimension a	Dimension b	-
160 mm	10 mm	140 mm	
482.6 mm	8.3 mm	466 mm	
530 mm	15 mm	500 mm	
830 mm	15 mm	800 mm	

### Fixing screws

You can use the following type of screw to mount the rails:

For ...	Type of screw	Description
Lateral fixing screws	Cylindrical head screw M6 to ISO 1207/ISO 1580 (DIN 84/DIN 85)	Choose a suitable screw length for your assembly. You also need size 6.4 washers to ISO 7092 (DIN 433)
	M6 hexagonal head screw to ISO 4017 (DIN 4017)	
additional fixing screws (only 2 m rail)	Cylindrical head screw M6 to ISO 1207/ISO 1580 (DIN 84/DIN 85)	

### Installing the rail

1. When you mount the rails, allow sufficient space for mounting modules and heat elimination (at least 40 mm above and below the modules. See the figure below).
2. Mark up the mounting holes on the mounting surface. Drill the holes to a diameter of  $6.5^{+0.2}$  mm.
3. Screw on the rail (M6 screws).

---

#### Note

Take care to create a low-impedance connection between the rail and a mounting surface which is a grounded metal plate or equipment mounting plate. In the case of varnished or anodized metals, for instance, use a suitable contacting agent or contact washers.

---

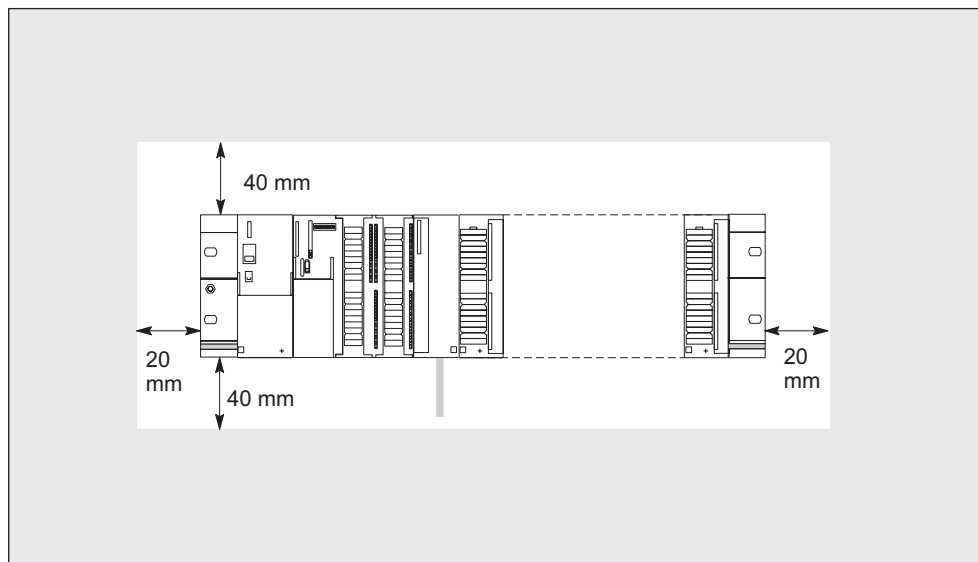

Figure 6-2 Free space required for an S7-300 installation

## 6.3 Installing modules on the rail

### Requirements for module installation

- Configuration of the automation system is complete.
- The rail is installed.

### Order of the modules

Snap the modules onto the rail, starting at the left and in the following order:

1. Power supply module
2. CPU
3. signal modules, function modules, communication modules, interface modules

---

#### Note

If you install SM 331 analog input modules, please check **before** installation whether you have to reposition the measuring range submodules at the side of the module. See Chapter 4 on analog modules in the *Module Data Reference Manual*.

---

---

#### Note

If you want to create the S7-300 with a floating reference potential, you must establish this state on the CPU, ideally before you attach it to the rail. The section entitled *Creating an S7-300 with floating reference potential* contains the necessary instructions.

---

### Installation steps

The steps for installing the modules are described below.

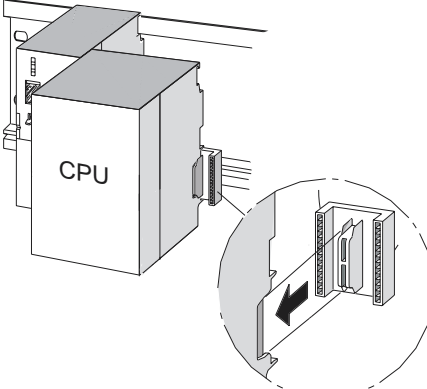
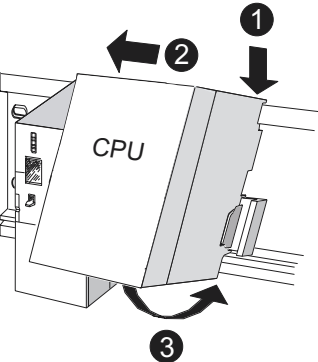
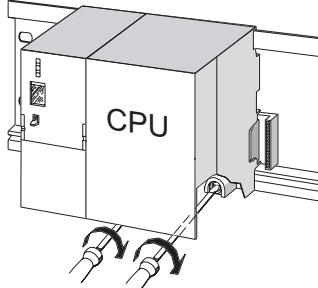
<p>1.</p>	<p>Plug the bus connectors into the CPU and signal/function/communication/interface modules. One bus connector is included per module, but not for the CPU.</p> <ul style="list-style-type: none"> <li>• Always start at the CPU when you plug in the bus connectors. Here, take the bus connector of the "last" module in the row.</li> <li>• Insert the bus connectors into the other modules. The "last" module is not equipped with a bus connector.</li> </ul>	
<p>2.</p>	<p>Add all modules in their specified sequence to the rail (1), slide them up to the module on the left (2), then swing them down (3).</p>	
<p>3.</p>	<p>Manually tighten the module screws.</p>	

### Insert the key (CPUs with key switch only)

Once you have installed the modules, you can insert the key into the CPU mode selector switch.

## 6.4 Label the modules

### Assigning slot numbers

After installation, you should assign a slot number to each module. This makes it easier to assign the modules in the configuration table in *STEP 7*. The table below shows the slot number assignment.

Table 6-4 Slot numbers for S7 modules

Slot number	Module	Remarks
1	Power supply (PS)	–
2	CPU	–
3	Interface module (IM)	To the right of the CPU
4	1st signal module	To the right of the CPU or IM
5	2nd signal module	–
6	3rd signal module	–
7	4th signal module	–
8	5th signal module	–
9	6th signal module	–
10	7th signal module	–
11	8th signal module	–

### Inserting slot numbers

1. Hold the corresponding slot number in front of the relevant module.
2. Insert the pin into the opening on the module (1).
3. Press the slot number into the module (2). The slot number breaks off from the wheel.

The figure below illustrates this procedure. The slot number labels are included with the CPU.

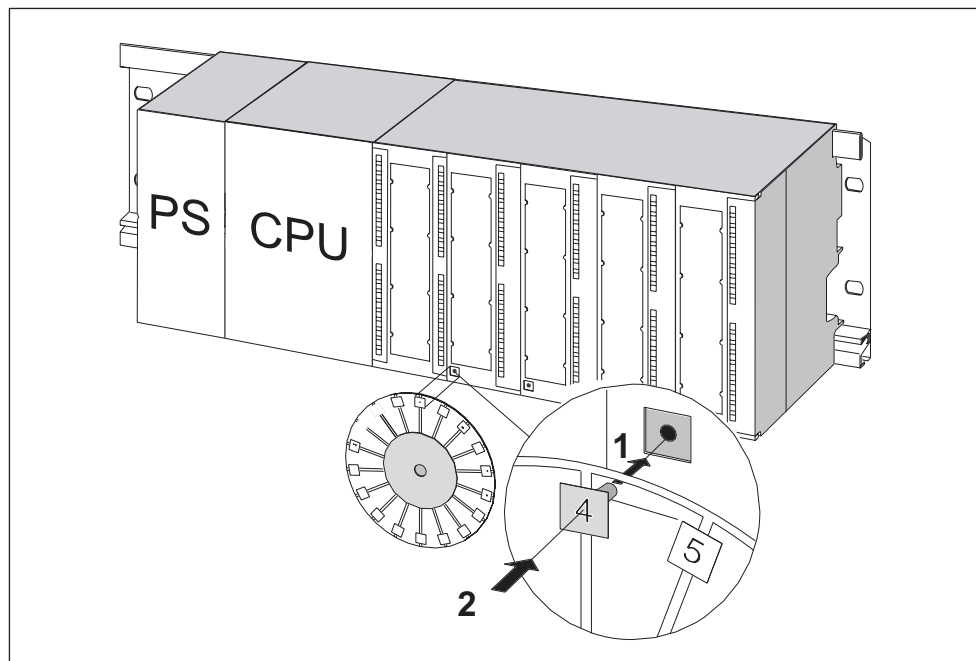

Figure 6-3 Inserting slot numbers in modules

# Wiring

# 7

## 7.1 Wiring

### In this Chapter

we shall explain the procedures for wiring an S7-300.

### Accessories required

To wire the S7-300, you require the accessories listed in the table below.

Table 7-1 Wiring accessories

<b>Accessories</b>	<b>Description</b>
Connection comb (included with the PS)	for the connection between the power supply module and the CPU
Front connector	for the connection of system sensors/actuators to the S7-300
Labeling strips	for labeling the module I/Os
Shielding contact element, shielding terminals (matching the shielding diameter)	for connecting cable shielding

## Tools and material required

To wire the S7-300, you require the tools and materials listed in the table below.

Table 7-2 Tools and materials for wiring

Wiring tools and materials You require ...	for ...
connecting the protective conductor to the rail	Wrench (size 10) Protective conductor cable (cross-section $\geq 10 \text{ mm}^2$ ) with M6 cable lug M6 nut, washer, spring lock washer
Adjusting the power supply module to mains voltage	Screwdriver with a blade width of 4.5 mm
Wiring the power supply module and the CPU	Screwdriver with a blade width of 3.5 mm, side-cutter, wire stripping tool Flexible cable, e.g. sheathed flexible cable $3 \times 1.5 \text{ mm}^2$ If required, wire end ferrules to DIN 46228
Wiring the front connector	Screwdriver with a blade width of 3.5 mm, side-cutter, wire stripping tool Flexible cable $0.25 \text{ mm}^2$ to $0.75/1.5 \text{ mm}^2$ If required, shielded cables If required, wire end ferrules to DIN 46228

## Brief overview of the power supply module and CPU

Table 7-3 Conditions for connecting the PS and CPU

Connectable cables	to PS and CPU
solid conductors	No
flexible conductors	
• Without wire end ferrule	$0.25 \text{ mm}^2$ to $2.5 \text{ mm}^2$
• With wire end ferrule	$0.25 \text{ mm}^2$ to $1.5 \text{ mm}^2$
Number of conductors per terminal	1 conductor, or 2 conductors up to $1.5 \text{ mm}^2$ (total) in a common wire end ferrule
Diameter of the conductor insulation	max. 3.8 mm
Stripped length	11 mm
Wire end ferrules to DIN 46228	
• Without insulating collar	Version A, 10 mm to 12 mm length
• With insulating collar	Version E, up to 12 mm length



## Brief overview of front connectors

Table 7-4 Wiring conditions for front connectors

Connectable cables	Front connector	
	20-pin	40-pin
solid conductors	No	No
flexible conductors <ul style="list-style-type: none"> <li>Without wire end ferrule</li> <li>With wire end ferrule</li> </ul>	0.25 mm <sup>2</sup> to 1.5 mm <sup>2</sup> 0.25 mm <sup>2</sup> to 1.5 mm <sup>2</sup>	0.25 mm <sup>2</sup> to 0.75 mm <sup>2</sup> 0.25 mm <sup>2</sup> to 0.75 mm <sup>2</sup> <ul style="list-style-type: none"> <li>Potential supply: 1.5 mm<sup>2</sup></li> </ul>
Number of conductors per terminal	1 conductor, or 2 conductors up to 1.5 mm <sup>2</sup> (total) in a common wire end ferrule	1 conductor, or 2 conductors up to 0.75 mm <sup>2</sup> (total) in a common wire end ferrule
Diameter of the conductor insulation	max. 3.1 mm	<ul style="list-style-type: none"> <li>max. 2.0 mm for 40 conductors</li> <li>max. 3.1 mm for 20 conductors</li> </ul>
Stripped length	6 mm	6 mm
Wire end ferrules to DIN 46228 <ul style="list-style-type: none"> <li>Without insulating collar</li> <li>With insulating collar</li> </ul>	Version A, 5 mm to 7 mm length Version E, up to 6 mm long	Version A, 5 mm to 7 mm length Version E, up to 6 mm long

## 7.2 Connecting the Protective Conductor to the Rail

### Requirement

The rail is fixed to the mounting surface.

### Connecting the protective conductor

1. Connect the protective conductor to the rail, using the M6 protective conductor bolt.

Minimum cross-section of the protective conductor: 10 mm<sup>2</sup>.

The figure below shows how the protective conductor must be bonded to the rail.

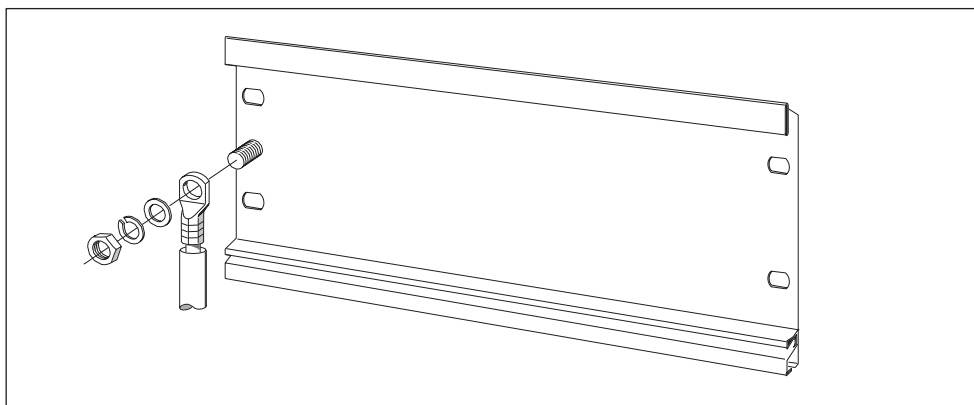

Figure 7-1 connecting the protective conductor to the rail

---

### Note

Always ensure a low-impedance connection of the protective conductor. You can achieve this by bonding a cable with low impedance and as short as possible to a large contact surface.

For example, if the S7-300 is mounted on a hinged frame you must use a flexible ground strap.

---

## 7.3 Adjusting the Power Supply Module to the Mains Voltage

### Introduction

You can operate the S7-300 power supply on 120 VAC or on 230 VAC. Factory setting for PS 307 is always 230 VAC.

### Setting the mains voltage selector switch

Check to see whether the selector switch is set to the correct mains voltage.

You can change the selector switch setting as follows:

1. Remove the protective cap with a screwdriver.
2. Set the selector switch to the available line voltage.
3. Replace the cover.

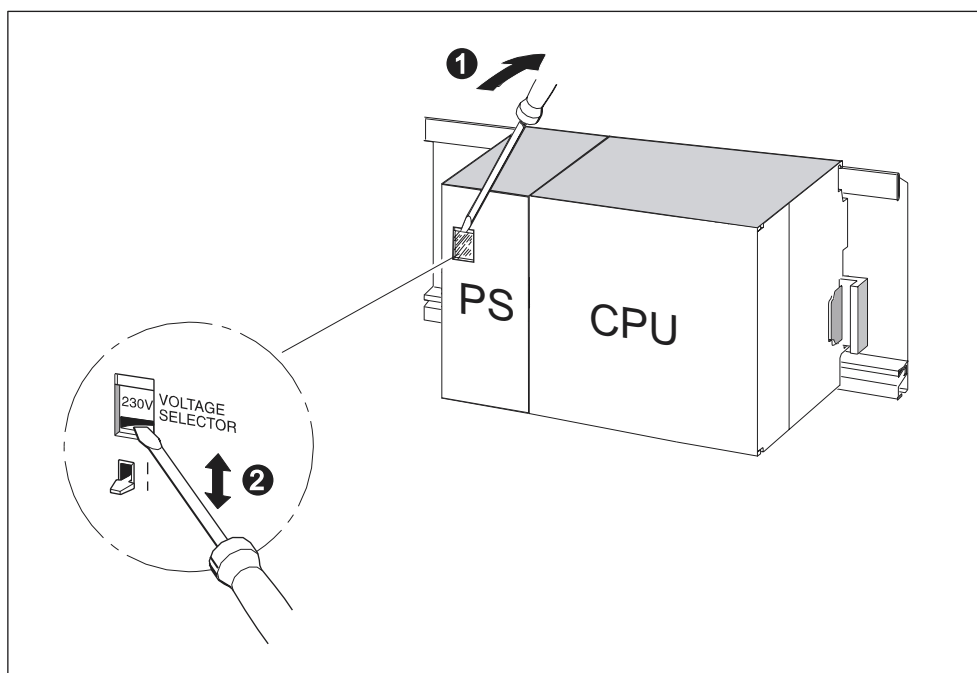

Figure 7-2 Setting the mains voltage selector switch for the PS 307

Key to numbers in the figure	
(1)	Remove protective cap with screwdriver.
(2)	Set selector switch to mains voltage

## 7.4 Wiring the power supply module and the CPU

### Requirement

The modules are mounted on the rail.

### Connection comb (except for CPU 312 IFM)

The power supply (PS) module is supplied with a connection comb to facilitate connection of the power supply module and the CPU.

### PS and CPU wiring

---

#### Note

The PS 307 power supply module is equipped with two additional DC 24 V connections (L+ and M) for the supply of I/O modules.

---



---

#### Warning

You may come into contact with live wires if the power supply module and any additional load power supply units are connected to the mains.

You should therefore disconnect the S7-300 from the power supply before starting the wiring. Only use ferrules with insulating collars to press-fit onto the ends of the cables. Once you have wired the modules, close all the front panels. You can then switch on the S7-300 again.

---

1. Open the front panels of the power supply module and CPU.
2. Remove the strain relief clamp from the power supply module.
3. Strip the power cable to a length of approximately 11 mm and connect it to L1, N, and to the ground conductor terminal of the power supply module.
4. Screw-tighten the strain relief clamp again.
5. You can now wire your CPU:
  - With **CPU 312 IFM** , the power supply terminal connection is located on the front panel of the integrated I/O.

Connect the lower terminal M of the power supply module to terminal M of the CPU and the lower terminal L+ of the power supply module to terminal L+ of the CPU.

  - **CPU 313/314/314 IFM/315/315-2 DP/316-2 DP/318-2 DP**: Insert the connection comb and screw-tighten it.
6. Close the front panel.

The figure below illustrates the procedures described above.

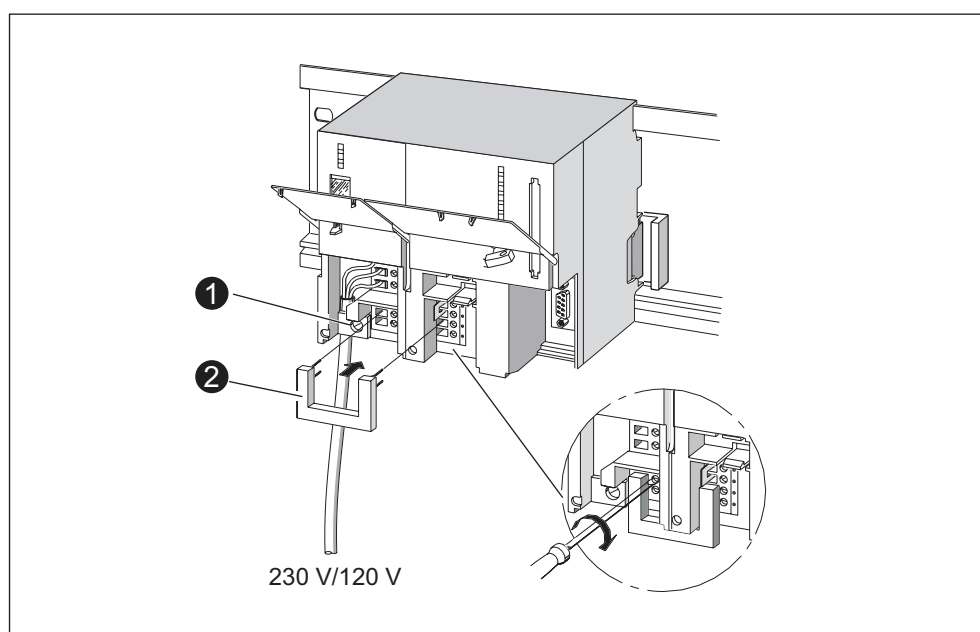

Figure 7-3 Wiring the power supply module and the CPU

Table 7-5 Wiring accessories

<b>The numbers have the following meanings:</b>	
<b>(1)</b>	Cable grip of the power supply
<b>(2)</b>	Connection comb (accessory for power supply)

#### Note

The PS 307 power supply module is equipped with two additional DC 24 V connections (L+ and M) for the supply of I/O modules.

## 7.5 Wiring Front Connectors

### Introduction

The front connector is used to connect the sensors and actuators of your system to the S7-300 automation system. Wire the sensors and actuators to this front connector and then plug it into the module.

### Front connector versions

Front connectors come in 20-pin and 40-pin versions, each with screw contacts or spring terminals. The 40-pin front connector is required for 32-channel signal modules.

You must use the following front connectors, depending on the module:

Table 7-6 Assignment of front connectors to modules

Module	Front connectors with screw terminals; Order No.:	Front connectors with spring terminals; Order No.:
Signal modules (not 32-channel), Function modules, Communication module CP 342-2 CPU 312 IFM	6ES7 392-1AJ00-0AA0	6ES7 392-1BJ00-0AA0
Signal modules (32 channel) and CPUs 314 IFM	6ES7 392-1AM00-0AA0	6ES7 392-1BM01-0AA0

### Termination with spring terminals

To terminate a conductor in a front connector with spring terminals, simply insert the screwdriver vertically into the opening with the red opening mechanism, insert the wire into the terminal and remove the screwdriver.



#### Warning

You can damage the spring-based opening mechanism of the front connector if the screwdriver slips sideways or if you insert the wrong size of screwdriver. Always slide a suitable screwdriver vertically into the desired opening until it reaches the stop. This will ensure that the spring terminal is fully open.

**Tip:**

There is a separate opening for test probes up to 2 mm in diameter to the left of the opening for the screwdriver.

**Requirement**

The modules (SM, FM, CP 342-2) are mounted on the rail.

**Preparing the front connector and the cables****Warning**

You may come into contact with live wires if the power supply module and any additional load power supply units are connected to the mains.

You should therefore disconnect the S7-300 from the power supply before starting the wiring. Once you have wired the modules, close all the front panels. You can then switch on the S7-300 again.

---

1. Switch off the power supply **(1)**.
2. Open the front panel of the module **(2)**.
3. Move the front connector into wiring position **(3)**.  
Slide the front connector into the signal module until it latches. The front connector still protrudes from the module in this position.  
Advantage of the wiring position: Easy wiring.  
In this wiring position the front connector does not contact the module.
4. Strip the leads to a length of 6 mm.
5. Crimp on the cable end sleeves, e.g. for terminating 2 conductors on 1 terminal.

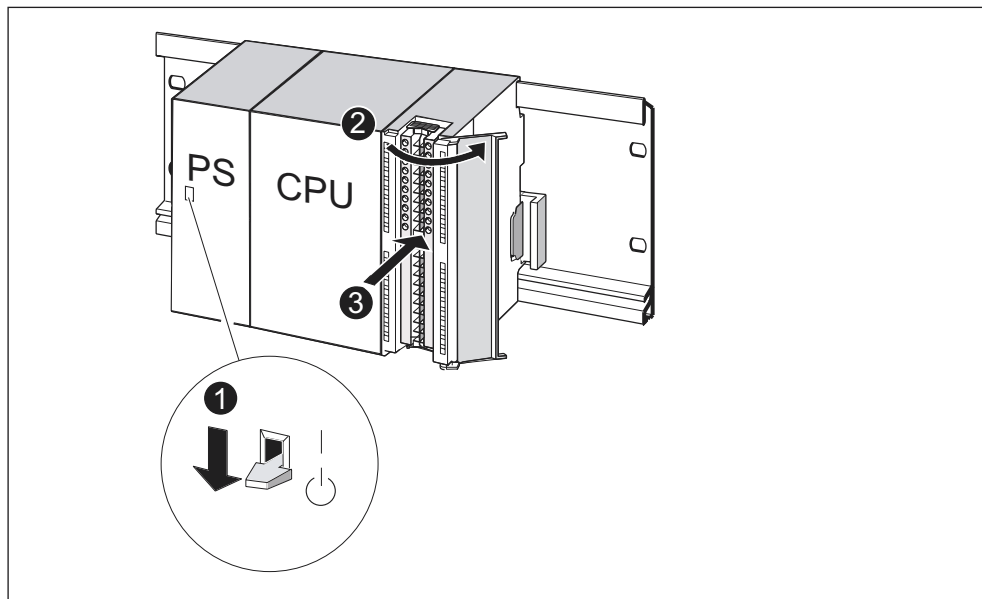

Figure 7-4 Move the front connector into wiring position

Table 7-7 Assignment of front connectors to modules

The diagram illustrates under number	
(1)	Power supply switched off (PS)
(2)	Opened module
(3)	Front connector in wiring position

### Wiring the front connector

Table 7-8 Wiring the front connector

Step	20-pin front connector	40-pin front connector
(1)	Thread the cable strain relief into the front connector.	–
(2)	Do you want to exit the cables at the bottom of the module?	
	<p><b>If yes:</b></p> <p>Starting at terminal 20, work your way down to terminal 1.</p>	<p>Starting at terminal 40 or 20, wire the connector, working in alternating passes from terminals 39, 19, 38, 18 etc. until you have reached terminals 21 and 1.</p>
	<p><b>If not:</b></p> <p>Starting at terminal 1, work your way up to terminal 20.</p>	<p>Starting at terminal 1 or 21, wire the connector, working in alternating passes from terminals 2, 22, 3, 23 etc. until you have reached terminals 20 and 40.</p>

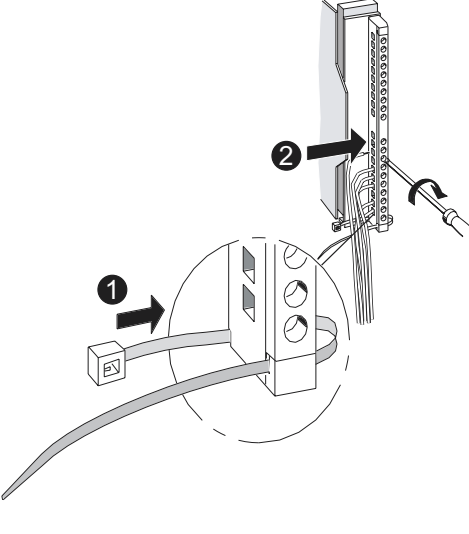
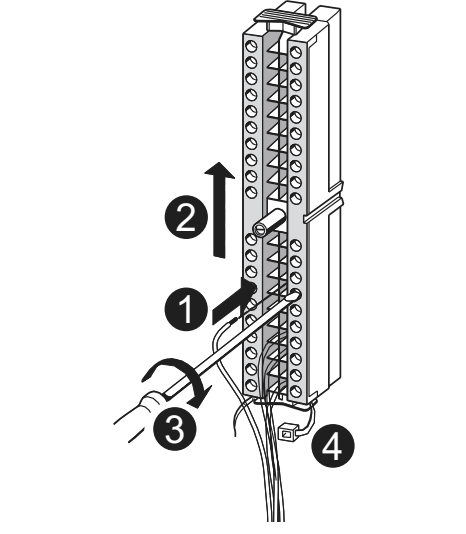

Step	20-pin front connector	40-pin front connector
(3)	<b>Front connectors with screw terminals:</b>	
(4)	–	Attach the cable strain-relief assembly around the cable and the front connector.
–	Pull the cable strain-relief assembly tight. Push in the strain relief retainer to the left to improve utilization of the available cable space.	
–		
–	The work step numbers are shown in the figure above	
–	<b>(1)</b> Thread the strain relief. <b>(2)</b> Wire the terminals.	<b>(1) to (3)</b> Wire the terminals. <b>(4)</b> Tighten the strain relief clamp.

## 7.6 Inserting Front Connectors into Modules

### Requirement

The front connectors are completely wired.

### Inserting the front connector

Table 7-9 Inserting front connectors

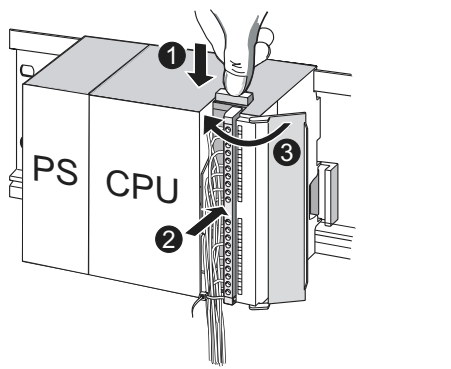
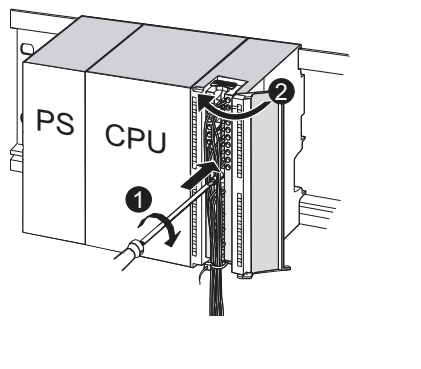
Inserting the front connect or Step	with 20-pin front connector	with 40-pin front connector
<p>1.</p>	<p>Push in the unlocking mechanism on top of the module.</p> <p>Keeping the locking mechanism pressed, insert the front connector into the module.</p> <p>Provided the front connector is seated correctly in the module, the unlocking mechanism automatically returns to initial position when you release it.</p> <p><b>Note</b></p> <p>When you insert the front connector into the module, an encoding mechanism engages in the front connector, thus ensuring that the connector can only be inserted in modules of the same type.</p>	<p>Tighten the mounting screw in the center of the connector.</p> <p>This pulls the front connector completely into contact with the module.</p>
<p>2.</p>	<p>Close the front panel.</p>	<p>Close the front panel.</p>
		
	<p>The work step numbers are shown in the figure above</p>	
	<p>(1) Keep unlocking mechanism pressed.</p> <p>(2) Insert front connector.</p> <p>(3) Then close the front door.</p>	<p>(1) Tighten mounting screw.</p> <p>(2) You can now close the front panel</p>

## 7.7 Labeling the Module I/O

### Introduction

The labeling strips are used to document the assignment between inputs/outputs of the modules and the sensors/actuators of your plant.

You must use the labeling strips, depending on the module:

Table 7-10 Assigning the labeling strips to modules

Module	Labeling strip Order No.:
Signal modules (not 32-channel), Function modules, Communication module CP 342-2	6ES7 392-2XX00-0AA0
Signal modules (32-channel)	6ES7 392-2XX10-0AA0

### Labeling and inserting labeling strips

1. Label the strips with the addresses of the sensors/actuators.
2. Slide the labeled strips into the front panel.

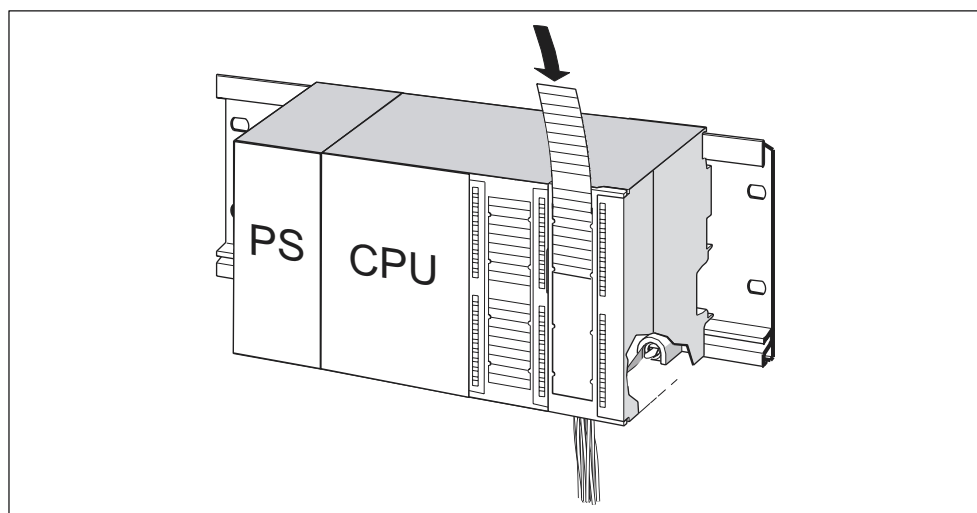

Figure 7-5 Slide the labeled strips into the front panel

### Tip:

Templates for labeling strips are available on the Internet at <http://www.ad.siemens.de/csinfo> under article ID 11978022.

## 7.8 Connecting shielded cables to the shielding contact element

### Application

With the shielding contact element, you can easily connect all shielded cables of S7 modules to ground by means of a mounting rail.

### Design of the shielding contact element

The shielding contact element consists of:

- a bracket for screw-mounting (with two screws) it onto the rail (Order No.: 6ES5 390-5AA00-0AA0) and
- the shielding terminals.

You must use the following shielding terminals, depending on the shielding diameter of your cables:

Table 7-11 Assigning the shielding diameter to shielding terminals

Cable with shielding diameter	Shielding terminal Order No.
2 cables each one with a shielding diameter of 2 to 6 mm	6ES7 390-5AB00-0AA0
1 cable with a shielding diameter of 3 to 8 mm	6ES7 390-5BA00-0AA0
1 cable with a shielding diameter of 4 to 13 mm	6ES7 390-5CA00-0AA0

The shielding contact element width is 80 mm. It provides termination space in two rows, each one for 4 shielding terminals.

### Mounting the shielding contact element

1. Push the two screw bolts of the fixing bracket into the guide on the underside of the rail.
2. Position the bracket underneath the modules whose shielded cables are to be terminated.
3. Screw-tighten the bracket onto the rail.
4. The shielding terminal is equipped with a slotted web underneath. Place this part of the shielding terminal on the edge of the mounting bracket. Now push the shielding terminal down and pivot it into the desired position.

The two rows of the shielding contact element allow you install a maximum of 4 shielding terminals.

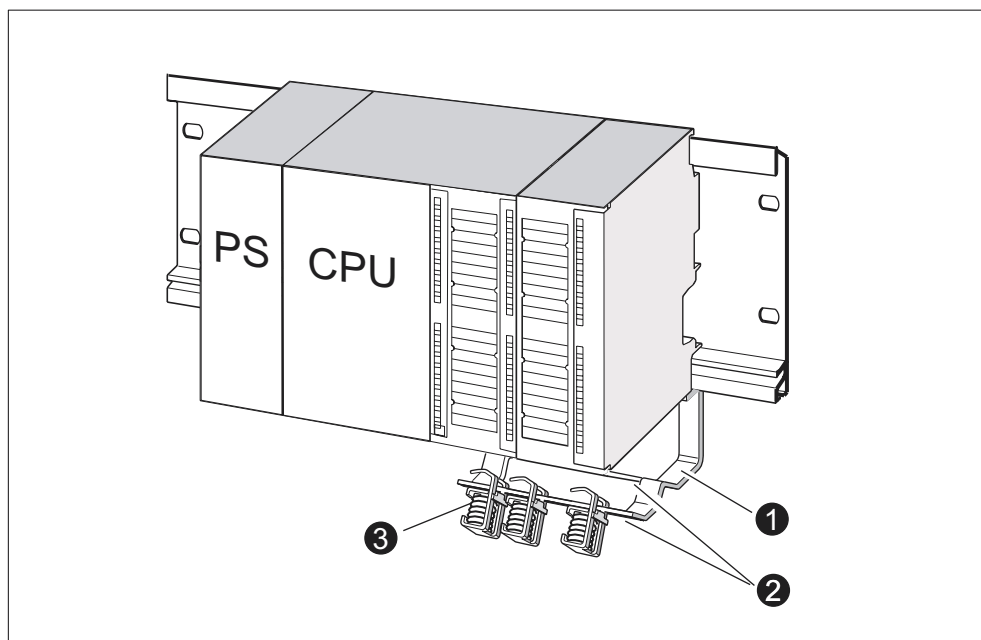

Figure 7-6 Shielding contact element underneath two signal modules

The diagram illustrates under number	
(1)	Bracket of shielding contact element
(2)	Edge of mounting bracket, where the shield connection terminal(s) must rest
(3)	Shielding terminals

### Terminating cables

Only one or two shielded cables may be clamped per shielding terminal. The cable is clamped in at the stripped cable shielding.

1. First, strip the cable shield to a length of at least 20 mm.
2. Now clamp in the stripped cable shield underneath the shielding terminal. Push the shielding terminal towards the module and feed the cable through underneath the clamp.

If you need more than four shielding terminals, start wiring at the rear row of the shielding contact element.

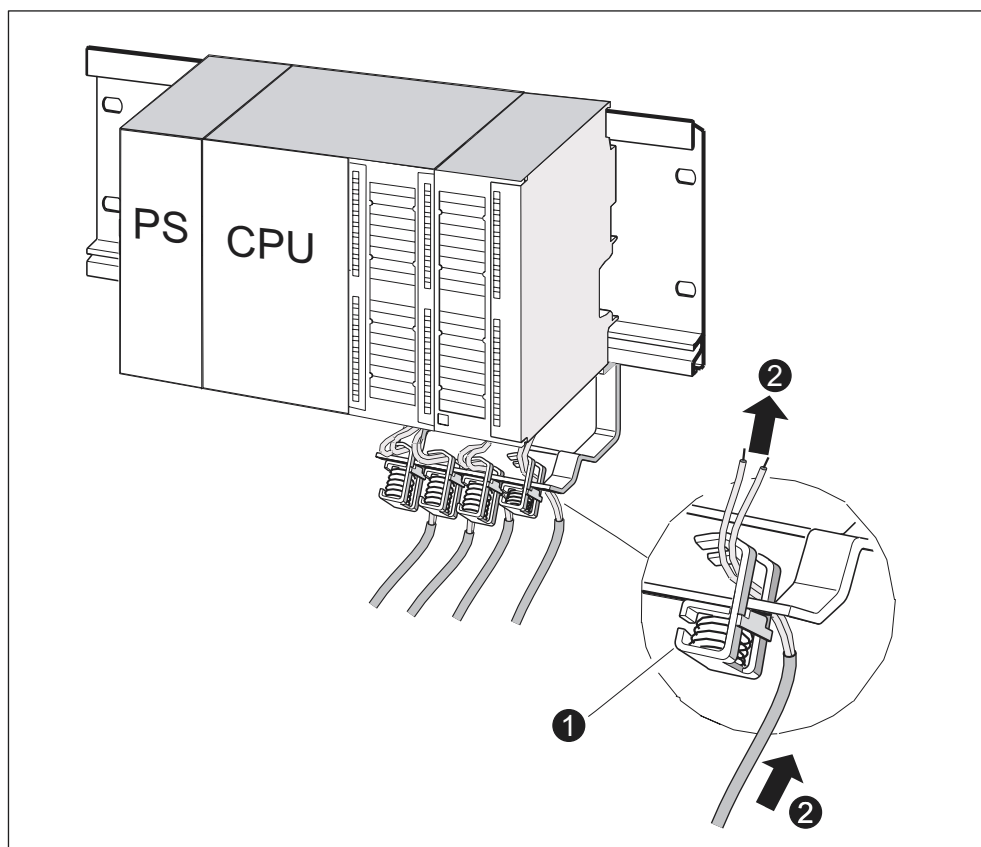

Figure 7-7 Connecting 2-wire cables to the shielding contact element

The diagram illustrates under number	
(1)	Magnified view of shielding terminal
(2)	Wiring of shielding terminal

**Tip:**

For your connection to the front connector, leave a sufficient cable length behind the shielding terminal. This allows you to disconnect the front connector, e.g. for repairs, without having to open the shielding contact element.

## 7.9 Wiring the Bus Connector

### Introduction

You need to network the nodes if you want to create a multiple-node subnet. The components you require here are listed in the Chapter *Configuring, Configuring a Subnet*.

Information on how to wire the bus connector can be found in the article below.

### Wiring the bus cable to the bus connector

#### Bus connector with screw terminals:

1. Strip the bus cable.

Details on stripped lengths are found in the product information included with the bus connector.

2. Open the bus connector housing.
3. Insert the green and the red wire into the screw-terminal block.

Note that you always have to connect the same wires to the same terminal (e.g. always wire green to terminal A and red to terminal B).

4. Press the cable sheath into the clamp. Take care that the bare shielding contacts the shielding contact surface.
5. Screw-tighten the wire terminals.
6. Close the bus connector housing.

#### Fast Connect bus connector:

1. Strip the bus cable.

Details on stripped lengths are found in the product information included with the bus connector.

2. Open the strain relief of the bus connector.
3. Insert the green and red wire into the open contacting covers.

Note that you always have to connect the same wires to the same terminal (e.g. always wire green to terminal A and red to terminal B).

4. Close the contacting cover.

This presses the wires down into the insulation displacement terminals .

5. Screw-tighten the strain relief clamp. Take care that the bare shielding contacts the shielding contact surface.

### Inserting the bus connector into the module

1. Insert the wired bus connector into the module.
2. Screw-tighten the bus connector on the module.
3. If the bus connector is at the start or end of a segment, you have to enable the terminating resistor (Switch position "ON" see figure below)

#### Note

6ES7 972-0BA30-0XA0 bus connectors are not equipped with a terminating resistor. You cannot connect it at the beginning or end of a segment.

Please make sure during start-up and normal operation that power is always supplied to nodes where the terminating resistor is active.

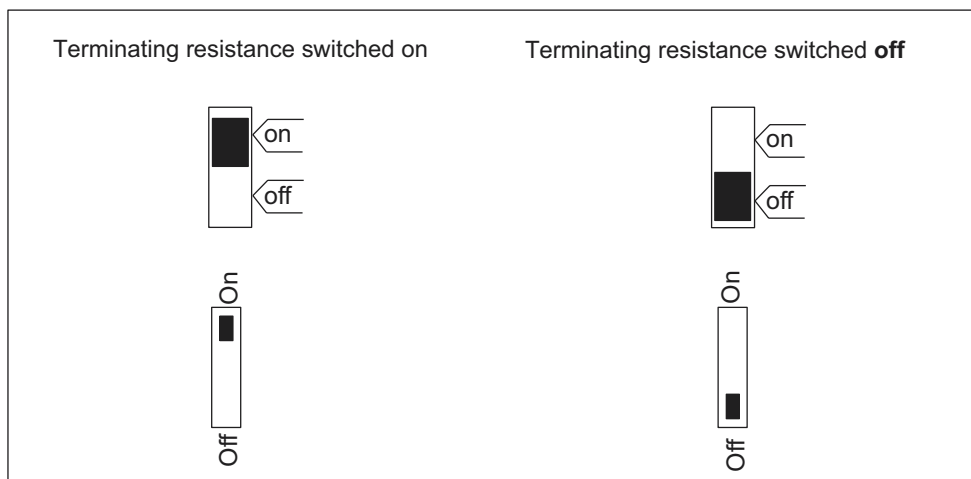

Figure 7-8 Bus connector: Enabled and disabled terminating resistor

### Removing bus connectors

With a looped-through bus cable, you can unplug the bus connector from the PROFIBUS-DP interface at any time, without interrupting data communication on the network.

### Possible data traffic errors



#### Warning

Data traffic error might occur on the bus!  
 A bus segment must always be terminated at both ends with the terminating resistor. This, for example, is not the case if the last slave with bus connector is off power. Since the bus connector draws its power from the station, the terminating resistor has no effect.

Please make sure that power is always supplied to stations on which the terminating resistor is active.



# Addressing

# 8

## 8.1 Addressing

### In this Chapter

You will learn how you can address the individual channels of your modules.

### Slot-based addressing

Slot-based addressing is the default setting, that is, *STEP 7* assigns each slot number a defined module start address.

### User-defined addressing

With user-defined addressing, you can assign any module address from the address area managed by the CPU. For the S7-300, user-defined addressing is only possible with CPUs 315, 315-2 DP, 316-2 DP, and 318-2 DP.

## 8.2 Slot-defined addressing of modules

### Introduction

In slot-based addressing (default addressing), a module start address is allocated to each slot number. This is a digital or analog address, depending on the type of module.

This section shows you which module start address is assigned to which slot number. You need this information to determine the start addresses of the installed modules.

### Maximum assembly and the corresponding module start addresses

The figure below shows you an S7-300 assembly on four racks and the optional slots with their module start addresses.

The input and output addresses for I/O modules start from the same module start address.

---

#### Note

With CPU 314 IFM, you **cannot** insert a module in slot 11 of module 3. The address area is reserved for the integrated I/O.

---

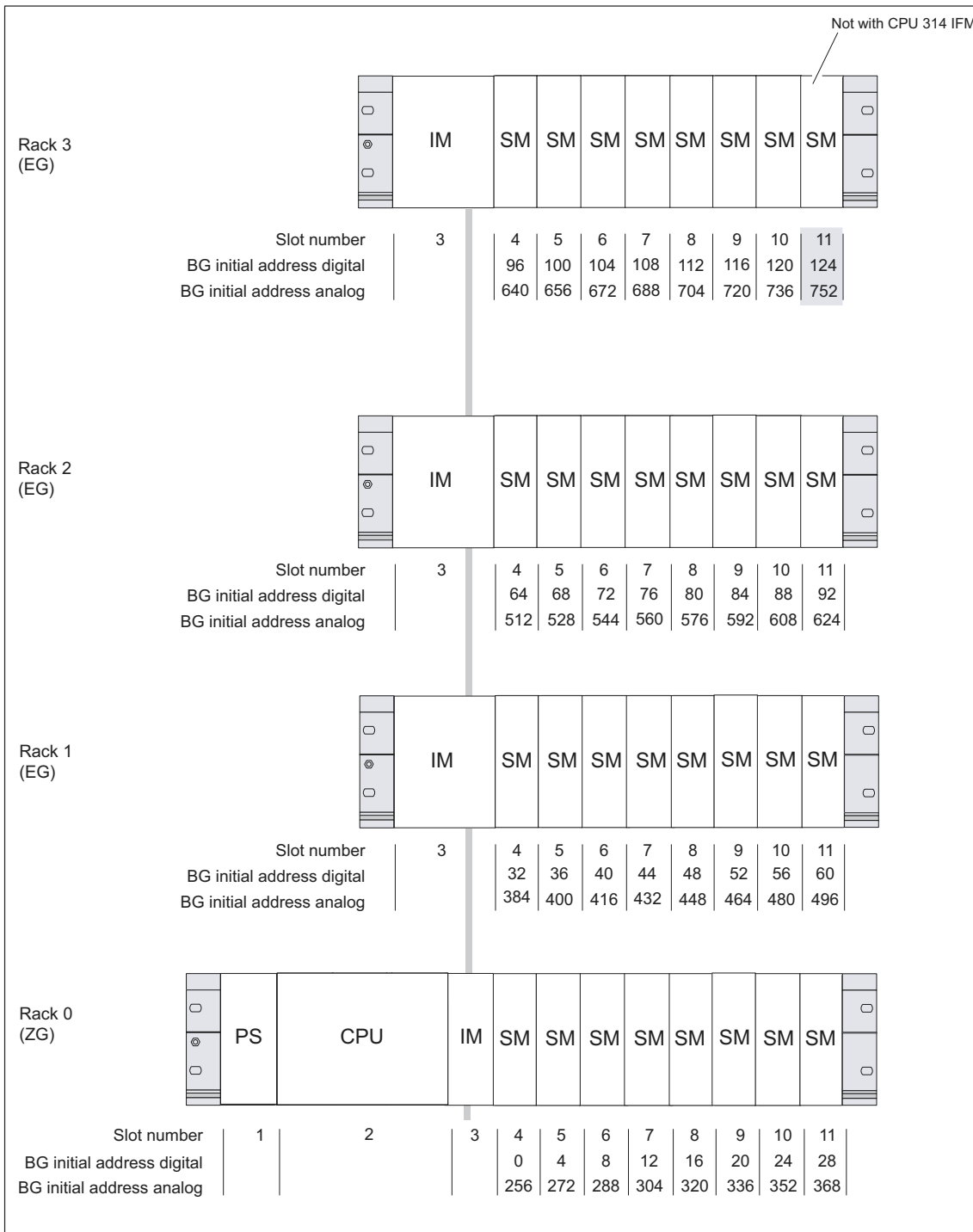

Figure 8-1 S7-300 slots and the associated module start addresses

## 8.3 User-defined addressing of modules

The following CPUs support free addressing

CPU	Order No.	As of version	
		Firmware	Hardware
CPU 315	6ES7 315-1AF03-0AB0	V1.0.0	01
CPU 315-2 DP	6ES7 315-2AF03-0AB0 6ES7 315-2AF83-0AB0	V1.0.0	01
CPU 316-2 DP	6ES7 316-2AG00-0AB0	V1.0.0	01
CPU 318-2 DP	6ES7 318-2AJ00-0AB0	V3.0.0	03

### User-defined addressing

User-defined addressing means that you can assign an address of your choice to any module (SM/FM/CP). The addresses are assigned in *STEP 7*. Here, you specify the module start address that forms the basis for all other addresses of the module.

### Advantages of user-defined addressing:

- Optimization of the address areas available, since “address gaps” will not occur between the modules.
- When creating standard software, you can program addresses which are independent of the relevant S7-300 configuration.

## 8.4 Addressing Signal Modules

### Introduction

This section shows you how to address signal modules. You need this information in order to be able to address the channels of the signal modules in your user program.

### Addresses of digital modules

The address of an input or output of a digital module consists of a byte address and a bit address.

Example: **I 1.2**

This example consists of: input **I**, byte address **1**, and bit address **2**

The byte address depends on the module start address.

The bit address is the number printed on the module.

Insert the first digital module into slot 4 so that it has default start address 0. The start address of every subsequent digital module will be incremented by 4 per slot (see diagram under *Slot-based module addressing*).

The figure below shows you how the addresses of the individual channels of a digital module are obtained.

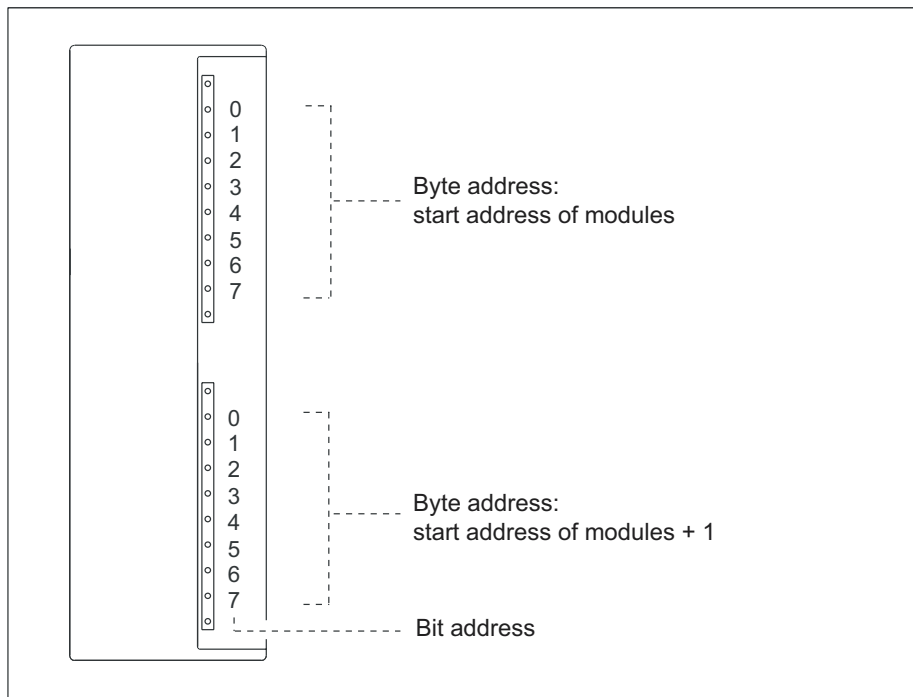

Figure 8-2 Addresses of the I/O of digital modules

### An example for digital modules

The example in the figure below shows which default addresses are obtained if a digital module is inserted in slot 4 (that is, when the module start address is 0).

Slot number 3 has not been assigned since there is no interface module in the example.

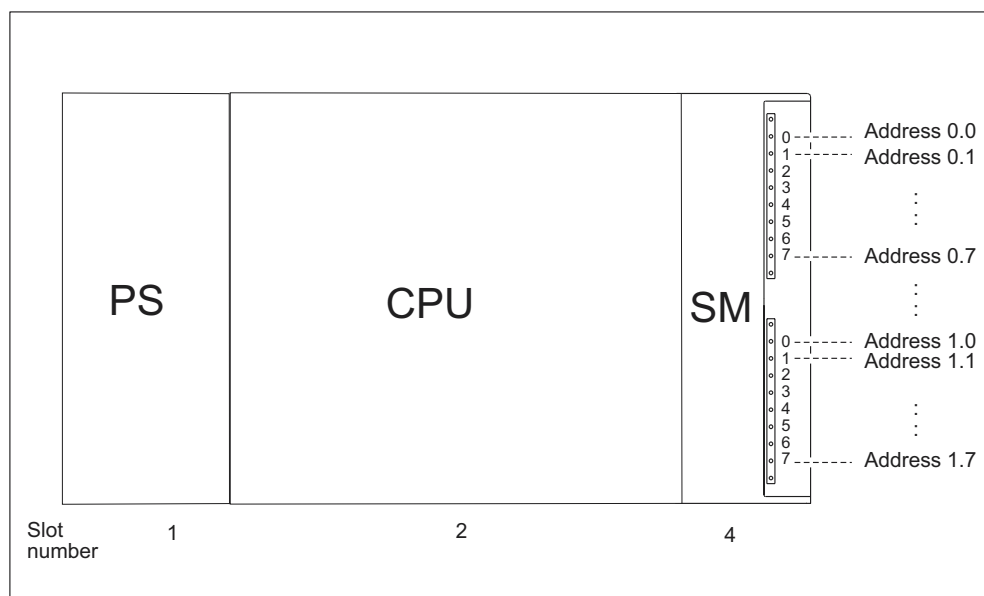

Figure 8-3 I/O Addresses of a digital module in Slot 4

### Addresses of the analog modules

The address of an analog input or output channel is always a word address.

The channel address depends on the module start address.

Insert the first analog module into slot 4 so that it has default start address 256. The start address of every subsequent analog module will be incremented by 16 per slot (see diagram under *Slot-based module addressing*).

An analog I/O module has the same start addresses for its input and output channels.

### An example for analog modules

The example in the figure below shows you which default channel addresses are obtained if an analog module is inserted in slot 4. As you can see, the input and output channels of an analog I/O module are addressed starting at the same address, namely the module start address.

Slot number 3 has not been assigned since there is no interface module in the example.

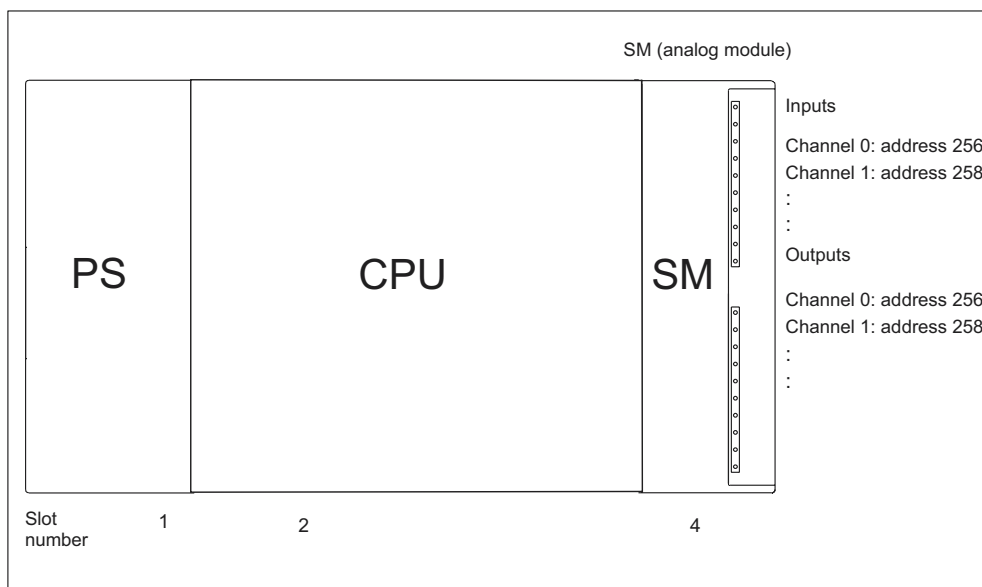

Figure 8-4 I/O addresses of an analog module in Slot 4

## 8.5 Addressing the Integrated I/O of the CPU

### CPU 312 IFM

The following addresses are assigned to the integrated I/O of CPU 312 IFM:

Table 8-1 Integrate inputs and outputs on the CPU 312 IFM

Inputs/Outputs	Addresses	Remarks
10 digital inputs	124.0 to 125.1 of those are 4 Inputs for integrated functions: 124.6 to 125.1	Optional utilization of Inputs for integrated functions: <ul style="list-style-type: none"> <li>• Counting</li> <li>• Frequency measurement</li> <li>• Interrupt input</li> </ul> See <i>Integrated Functions</i> manual
6 digital outputs	124.0 to 124.5	–

## CPU 314 IFM

The following addresses are assigned to the integrated I/O of CPU 314 IFM:

Table 8-2 Integrate inputs and outputs on the CPU 314 IFM

Inputs/Outputs	Addresses	Remarks
20 digital inputs	124.0 to 126.3 of those are 4 Inputs for integrated functions: 126.0 to 126.3	Optional utilization of Inputs for integrated functions: <ul style="list-style-type: none"> <li>• Counting</li> <li>• Counting A/B</li> <li>• Frequency measurement</li> <li>• Positioning</li> <li>• Interrupt input</li> </ul> See <i>Integrated Functions</i> manual
16 digital outputs	124.0 to 125.7	–
4 analog inputs	128 to 135	–
1 analog output	128 to 129	–

## 8.6 Consistent Data

### Consistent data

The table below illustrates the points to consider with respect to communication **in a DP master system** if you want to transfer I/O areas with "Total length" consistency.

CPU 315-2 DP CPU 316-2 DP CPU 318-2 DP (Firmware < V3.0)	CPU 318-2 DP (firmware version ≥ V3.0)
Even if they exist in the process image, consistent data is not automatically updated.	You can choose whether or not to update the address area of consistent data in the process image.
To read and write consistent data, you must use SFC14 and 15.	To read and write consistent data, you can also use SFC14 and 15.  If the address area of consistent data is not in the process image, you must use SFC14 and 15 to read and write consistent data.  Direct access to consistent areas is also possible (e.g. L PEW or T PAW).

You can transfer a maximum of 32 bytes of consistent data.





# Commissioning

# 9

## 9.1 In this Chapter

### In this Chapter

There are notes on commissioning which you should take into account in order to avoid personal injury or damage to machines.

---

#### Note

Since your commissioning phase is determined primarily by your application, we can only offer you general information, without claiming completeness of this topic.

---

### Cross-reference

Note the information about commissioning provided in the descriptions of your plant section and equipment.

## 9.2 Commissioning procedure

### Software requirements

You need STEP, V 5.x or higher to use the full functional scope of the CPUs.

### Requirements for commissioning

- S7-300 is installed
- S7-300 is wired
- With networked S7-300:
  - MPI/PROFIBUS addresses are configured
  - The segments are terminated with active terminating resistors

### Recommended procedure - Part I: Hardware

With its modular structure and many different upgrade options, the S7-300 can be very large and extremely complex. It is therefore inappropriate to initially start up an S7-300 with multiple racks and all inserted (installed) modules. Rather, we recommend a step-by-step commissioning procedure.

We recommend the following initial commissioning procedure for an S7-300:

Table 9-1 Recommended commissioning procedure - part I: Hardware

Tasks	Remarks	Information can be found in ...
an installation and wiring check according to checklist	-	in the following Chapter
Disabling connections to drive aggregates and control elements	This prevents negative effects on your system as a result of program errors. <b>Tip:</b> Redirecting output data from your outputs to a data block, allows you to check the status of the outputs at any time	-
Preparing the CPU	Connecting the PG	in the Chapter <i>Connecting the PG</i>
Central unit (CU): commission the CPU and power supply, check the LEDs	Commission the CU with inserted power supply module and CPU. First, switch on the expansion modules (EMs) which are equipped with an auxiliary power supply module and then switch on the power supply module of the CD.	in Chapter <i>Initial Power On</i>
	Check the LED displays on both modules.	in Chapter <i>Testing Functions, Diagnostics and Fault Elimination</i>
Initialize the CPU and check the LEDs	-	in Chapter <i>Resetting CPU memory</i>
CU: commission all other modules	Insert further modules into the CU and commission them in succession.	Reference Manual <i>Module Data</i>
Expansion module (EM): Connecting	If required, interconnect the CU and the EMs: Insert only one Send IM into the CU and the matching receiver IM into the EM.	Chapter <i>Mounting</i>
EM: Commissioning	Insert further modules into the EMs and commission them in succession.	See above.

## Recommended procedure - Part II: Software

Table 9-2 Recommended commissioning procedure - part II: software

Tasks	Remarks	Information can be found in ...
<ul style="list-style-type: none"> <li>Switch on the PG and start SIMATIC Manager</li> <li>Download the configuration and the program to the CPU</li> </ul>	-	in the <i>STEP 7 Programming Manual</i>
Testing the I/O	Helpful functions are here: <ul style="list-style-type: none"> <li>Monitoring and controlling of variables</li> <li>Testing with program status</li> <li>Force</li> <li>Modifying outputs in STOP mode (PO enable)</li> </ul> <b>Tip:</b> Test the signals at the inputs and outputs using the simulation module SM 374, for example.	<ul style="list-style-type: none"> <li>in the <i>STEP 7 Programming Manual</i></li> <li>in Chapter <i>Testing Functions, Diagnostics and Fault Elimination</i></li> </ul>
Commission PROFIBUS DP or other networks	-	in Chapter <i>Commissioning PROFIBUS DP</i>
Connect the outputs	Commissioning the outputs successively.	-



### Danger

Proceed step-by-step. Do not go to the next step unless you have completed the previous one without error/error message.

### Response to errors

React to errors as follows:

- Check the system with the help of the Checklist in the chapter below.
- Check the LED displays on all modules. Notes on their significance can be found in the chapters describing the relevant modules.
- If required, remove individual components to trace the error.

### Important notes are also found ...

in Chapter *Testing Functions, diagnostics and fault elimination*

### see also

Commissioning Checklist

## 9.3 Commissioning Checklist

### Introduction

After you have mounted and wired your S7-300, we recommend you check all previous steps once again.

The checklist tables below are a guide for your examination of the S7-300. They also provide cross-references to chapters containing further information on the relevant topic.

### Module racks

Points to be Examined	S7-300: Hardware and Installation, Chapters
Are the rails mounted firmly to the wall, in the frame or in the cabinet?	Configuring, Installation
Have you maintained free space required?	Configuring, Installation
Are the cable ducts installed properly?	Configuring
Is the air convection OK?	Installation

### Concept of grounding and chassis ground

Points to be Examined	S7-300: Hardware and Installation, Chapters
Have you established a low-impedance connection (large surface, large contact area) to local ground?	Configuring, Appendix
Are all racks (rails) properly connected to reference potential and local ground (electrical connection or isolated operation)?	Configuring, Wiring, Appendix
Are all grounding points of electrically connected modules and of the load power supply units connected to reference potential ?	Configuring, Appendix

### Module installation and wiring

Points to be Examined	S7-300: Hardware and Installation, Chapters
Are all modules properly inserted and screwed in?	Installation
Are all front connectors properly wired, plugged, screw-tightened or latched to the correct module?	Installation, Wiring

## Mains voltage

Points to be examined	S7-300: Hardware and Installation, Chapters	See reference manual; Section ...
Is the correct mains voltage set for all component?	Wiring	Module Specifications

## Power supply module

Points to be examined	S7-300: Hardware and Installation, Chapters	See reference manual; Section ...
Is the mains plug wired correctly?	Wiring	-
Is mains voltage connected?	-	-

## 9.4 Insert the back-up battery or rechargeable battery

### Rechargeable battery and storage battery

Rechargeable battery: If the CPU is operated without a back-up battery and you only wish to back up the time against power failures on CPUs with a hardware clock, you can insert a rechargeable battery in place of the back-up battery in the back-up battery compartment. In this case only the time is maintained. The RAM and RAM loading memory are not maintained in this case, so a memory card is absolutely essential. A limited number (CPU-specific) of bytes may also be maintained in a data block or by flags, timers and counters.

If you insert the back-up battery (buffered CPU mode), the RAM, the RAM loading memory of the CPU and the clock are maintained even if power fails. In this case, all the data blocks and any flags, timers and counters defined in the parameter settings are also maintained.

### Exceptions

- **CPU 312 IFM** is not equipped with a back-up battery or rechargeable battery (it is not buffered).
- **CPU 313** has a software rather than a hardware clock, so it does not need a rechargeable battery (just a back-up battery is needed)

## Inserting the back-up/rechargeable battery

Insert a back-up/rechargeable battery in the CPU as follows:

---

### Note

Do not insert the back-up battery in the CPU until after POWER ON.  
If you insert the back-up battery before POWER ON, the CPU requests a memory reset.

---

1. Open the front panel of the CPU.
2. Plug the connector of the back-up/rechargeable battery into the corresponding socket in the battery compartment of the CPU. The notch on the connector must show towards the left hand side.
3. Insert the back-up/rechargeable battery into the battery compartment of the CPU.
4. Close the front door of the CPU.

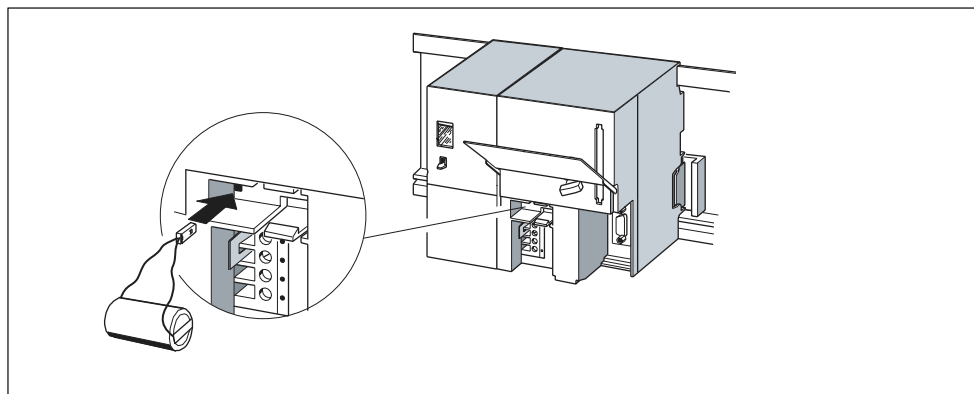

Figure 9-1 Insert a back-up battery into CPUs 313/314

## 9.5 Inserting and replacing a memory card

### CPUs without a memory card

You cannot insert a memory card into the CPUs 312 IFM and 314 IFM (314-5AE0x). These CPUs are equipped with an integrated FEPRM load memory.

### Inserting / replacing a memory card

#### Note

If you insert the memory card in a CPU mode other than STOP, the CPU will switch to STOP mode and the STOP LED will flash at 2-second intervals to request a memory reset.

1. Switch the CPU to STOP.
2. Is a Memory Card inserted? If so, ensure that it is not accessed by read or write operations. If required, disconnect all communication connections or switch to POWER OFF state. Then pull the memory card out of its slot in the CPU.
3. Insert the ("new") memory card into the slot in the CPU, making sure that the insertion mark on the memory card points toward the mark on the top side of the module slot (**1**).
4. Reset the CPU memory (see *Commissioning the modules, resetting the CPU memory*).

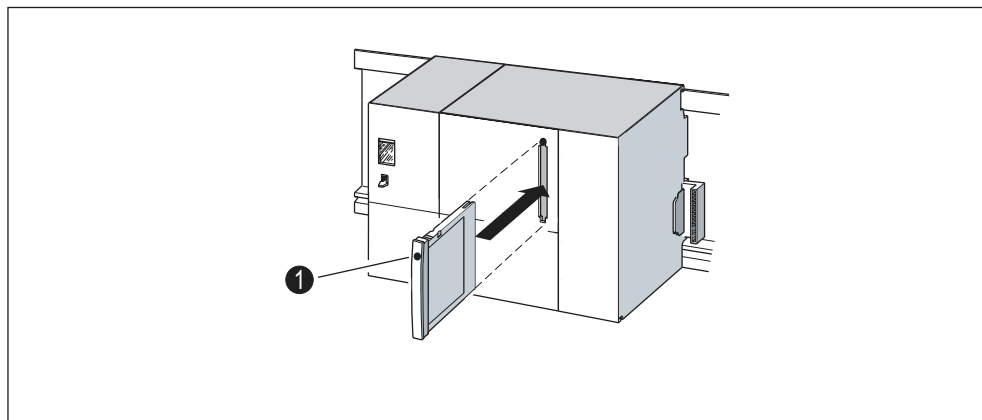

Figure 9-2 Insert the memory card into the CPU

### Inserting and removing a memory card (FEPRM) in POWER OFF Mode

If you remove a memory card in POWER OFF mode and insert another memory card with identical contents, the following happens after POWER ON:

CPU 318-2 (buffered)	CPUs 312 IFM to 316-2 DP
The CPU 318-2 goes into STOP mode and requests memory reset.	The CPU switches to the mode it was in prior to POWER OFF, that is, RUN or STOP.

## 9.6 Commissioning the modules

### 9.6.1 Connecting the PG

#### Requirement

The programming device must be equipped with an integrated MPI interface or an MPI card in order to connect it to the MPI interface of your CPU.

#### Cross-reference

For information on possible cable lengths refer to the Chapter *Configuring; Cable Lengths*.

#### Connecting a PG to an S7-300

1. Connect the programming device (PG) to the MPI interface of your CPU by means of a preassembled PG cable (1).

Alternatively, you can produce the connecting leads with PROFIBUS cable and bus connectors yourself (refer to Chapter *Wiring, Connecting Bus Connectors*).

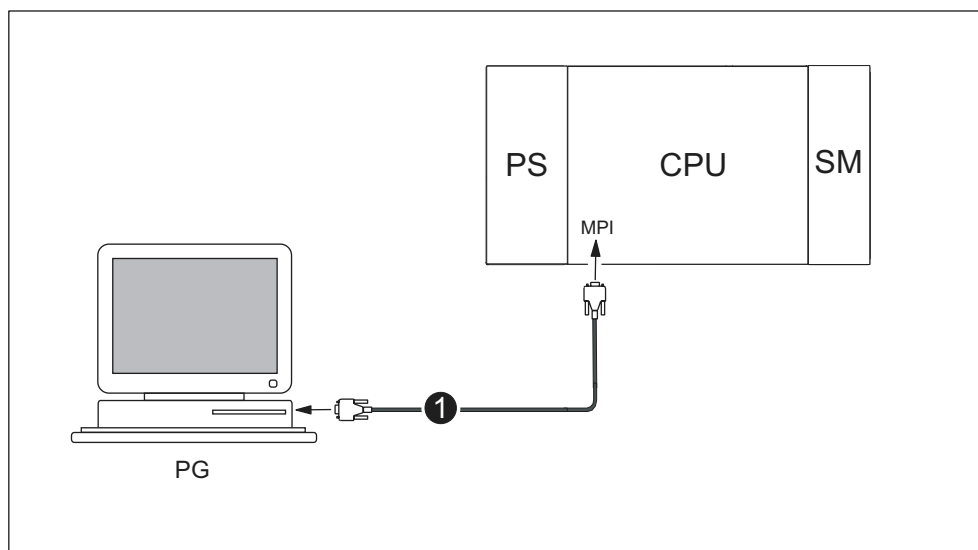

Figure 9-3 Connecting a PG to an S7-300



## Connecting the PG to Several Nodes

### Stationary PG

1. Use bus connectors to connect a stationary PG in the MPI subnet to the other nodes of the MPI subnet.

The following figure shows you two S7-300 connected by means of PROFIBUS bus cables. The bus cable connectors have integrated terminating resistors. These must be energized on the CPUs for the outgoing bus cable connectors.

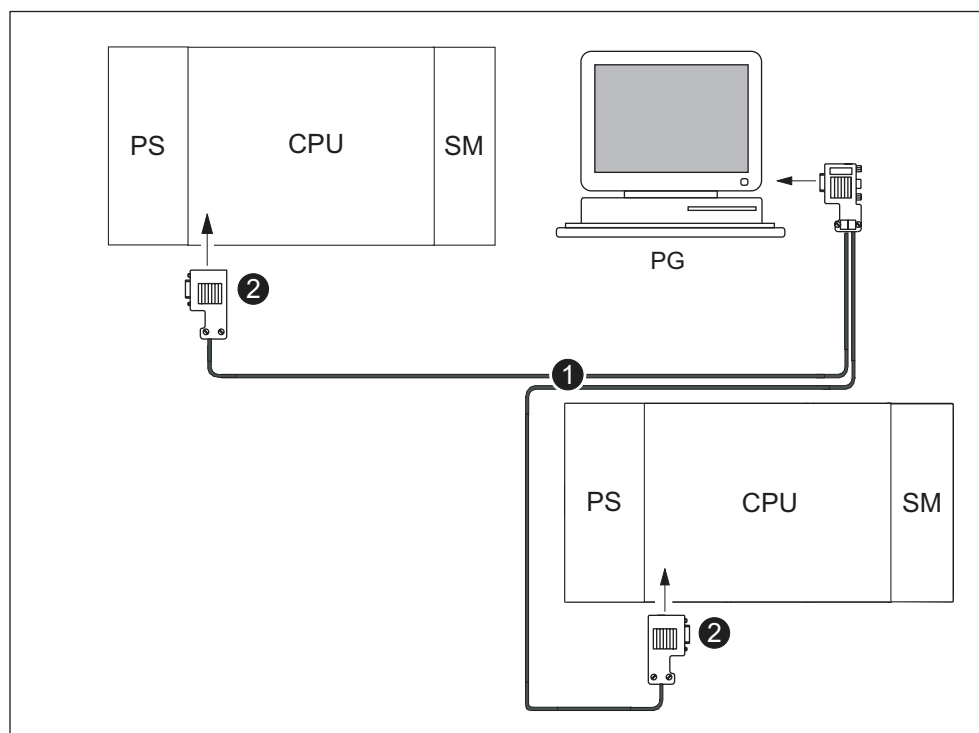

Figure 9-4 Connecting a PG to multiple S7 devices

The diagram illustrates under number	
(1)	PROFIBUS bus cable
(2)	Cable connector with energized terminating resistors

**PG for commissioning or maintenance**

1. For commissioning or service, connect the programming device (PG) to a subnet node by means of a stub cable. The bus connector of this node must be equipped with a PG socket.
2. You must energize the terminating resistor for the bus cable connectors going into the CPU.
3. You use a PROFIBUS bus cable to network the CPUs.

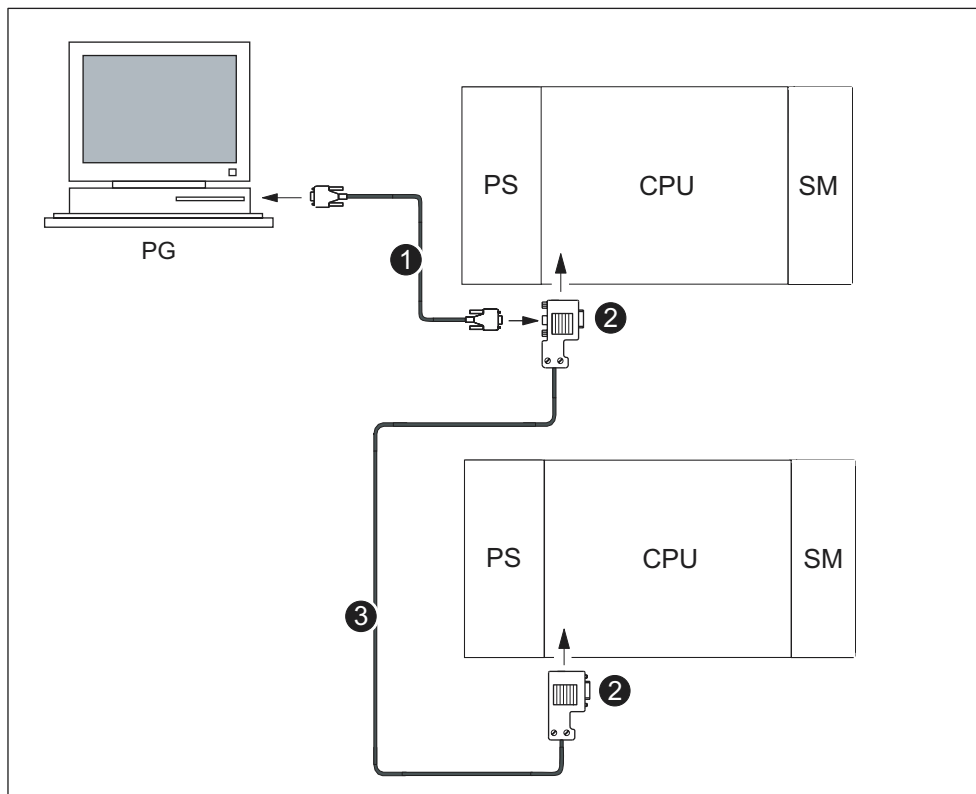

Figure 9-5 Connecting a PG to a subnet

The diagram illustrates under number	
(1)	Stub cable used to create connection between PG and CPU
(2)	Energized terminating resistor of the bus cable connector
(3)	PROFIBUS bus cable used to network both CPUs

## MPI addresses for service PGs

If there is no stationary PG, we recommend:

To connect it to an MPI subnet with "unknown" node addresses, set the following addresses on the service PG:

- MPI address: 0
- Highest MPI address: 126.

Using *STEP 7*, you then determine the highest MPI address in the MPI subnet and adapt the highest MPI address in the PG to that of the MPI subnet.

## Connecting PG to an ungrounded node configuration on an MPI subnet

### Connecting a PG to ungrounded nodes

Always connect an ungrounded PG to ungrounded MPI subnet nodes or S7-300 PLCs.

### Connecting a grounded PG to the MPI

You want to operate with ungrounded nodes. If the MPI at the PG is grounded, you must interconnect the nodes and the PG with an RS485 repeater. You must connect the ungrounded nodes to bus segment 2 if the PG is connected to bus segment 1 (connections A1 B1), or the PG/OP interface.

The figure below shows an RS485 repeater as interface between grounded and ungrounded nodes of an MPI subnet.

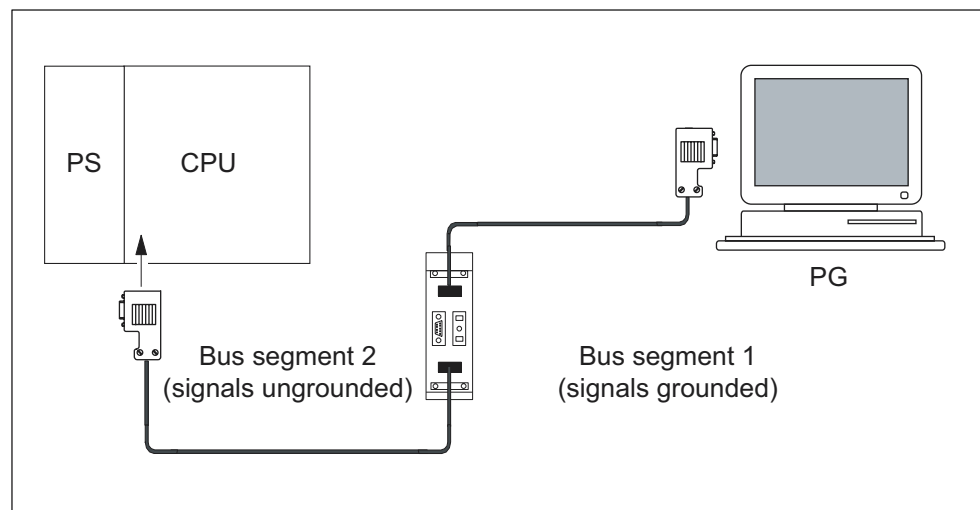

Figure 9-6 PG connected to an ungrounded S7-300

## 9.6.2 Initial power on.

### Requirements

- You must have installed and wired up the S7-300.
- Your CPU's mode selector switch must be set to STOP.

### Initial power up for a CPU with memory card (MC)

The CPU 312 IFM has no memory card, but it is covered in this section.

Switch on the PS 307 power supply module.

#### Result:

- The 24 VDC LED on the power supply module is lit.
- The 5 VDC LED on the CPU
  - is lit.
  - The STOP LED flashes at 2 Hz when the CPU executes an automatic memory reset.
  - The STOP LED is lit after memory reset.

The BATF LED is lit if the back-up battery is missing in the CPU (not with CPU 312 IFM, since not buffered).

---

#### Note

If you insert a Memory Card and a back-up battery before power is on, the CPU also requests a memory reset after start-up.

---

### 9.6.3 Memory reset by means of the CPU mode selector switch

#### When should you reset the CPU memory?

You must reset CPU memory,

- Before you download a (completely) new user program to the CPU
- If the CPU requests memory reset with its STOP LED flashing at 0.5 Hz intervals

Table 9-3 Possible causes for the CPU memory reset request

Causes of a CPU request to reset memory	Remarks
The memory card has been replaced.	Does not apply to CPU 312 IFM / 314 IFM (314-5AE0x)
RAM error in CPU	–
Main memory is too small, that is not all user program blocks on a memory card can be loaded.	CPU with inserted 5 V-FEPROM memory card. With these causes the CPU requests one memory reset. After that, the CPU ignores the contents of the memory card, enters the error reasons in the diagnostics buffer and goes to STOP. You can erase or reprogram 5 V FEPROM Memory Card in the CPU.
Attempts to load faulty blocks; e.g. if the wrong instruction was programmed.	

#### Memory reset by means of mode selector or PG

There are two ways to perform a memory reset on your CPU:

- In this chapter, we will show you how to perform a direct memory reset by means of the mode selector of your CPU.
- A memory reset by means of your PG can only be performed with STEP 7 in CPU STOP mode.

#### Cross-reference

You can find information on how to perform a memory reset of your CPU with a PG in *STEP 7 Online Help*.

### CPU memory reset with the mode selector switch

The table below shows the steps required for resetting CPU memory.

Table 9-4 Procedure for resetting the CPU memory

Step	Resetting CPU memory
1.	Turn the key to STOP position
2.	Turn the key to MRES position Hold the key in this position until the STOP LED lights up for the second time and remains on (this takes 3 seconds). Then release the key.
3.	You must turn the key back to the MRES position, push it in within three seconds and hold it there until the STOP LED flashes (at 2 Hz). You can now release the switch. When the CPU has completed memory reset, the STOP LED stops flashing and remains lit. The CPU has reset the memory.

The procedure described in the table above is only required if the user wishes to reset the CPU memory without being requested by the CPU to reset the memory (STOP LED flashing slowly). If the memory reset is requested by the CPU, simply turn the mode selector switch to MRES briefly to start the reset.

The figure below shows you the sequence of operation.

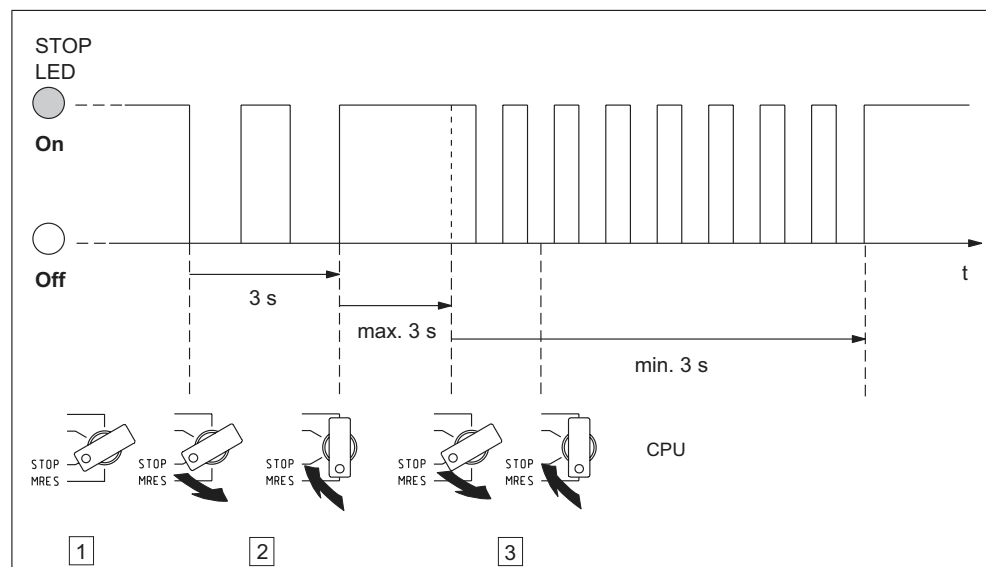

Figure 9-7 Operation of mode selector switch for memory reset

### STOP LED does not flash during the memory reset

What should I do if the STOP LED does not flash during the memory reset or if other LEDs are lit (Exception: BATF LED)?

1. You must repeat steps 2 and 3.
2. If the CPU still does not reset memory, evaluate the diagnostic buffer of the CPU.

## Cold restart with CPU 318-2 DP

With a CPU 318-2DP you can also perform a cold start instead of resetting the memory.

Cold start means:

- The data blocks in the working memory created by SFC 22 are deleted. The remaining data blocks have the default value from load memory.
- The process image and all timers, counters and memory bits are reset - irrespective of whether they were configured as retentive.
- OB 102 is processed.
- The process image of the inputs is read before the first instruction in OB1 is executed.

Step	Performing a Cold Start
1.	Turn the key to STOP position
2.	Turn the key to MRES position Hold the key in this position until the STOP LED lights up for the second time and remains on (this takes 3 seconds). Then release the key.
3.	You have to turn the switch to the RUN position within 3 seconds. During start-up the RUN LED flashes at 2 Hz.

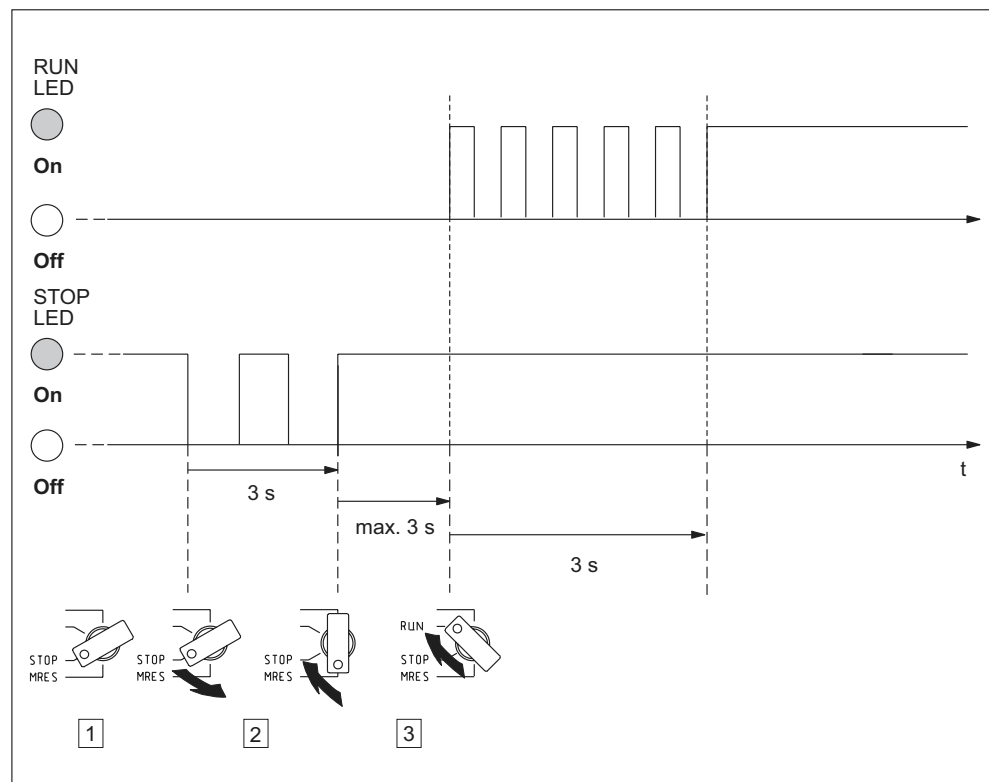

Figure 9-8 Using the mode selector switch for a cold start (CPU 318-2 DP only)

### What happens in the CPU during memory reset?

Table 9-5 Operations in the CPU during a memory reset

Event	CPU 313 / 314 IFM (314-5AE10) / 315 / 31x-2 DP	CPU 312 IFM / 314 IFM (314-5AE0x)	
CPU activities	1.	The CPU deletes the complete user program in main memory and RAM load memory.	
	2.	The CPU deletes the retentive data.	
	3.	The CPU tests its own hardware.	
	4.	If a memory card is inserted, the CPU copies its sequence-relevant data to the main memory. <b>Tip:</b> If the CPU cannot copy the data on Memory Card or MMC and requests memory reset: <ul style="list-style-type: none"> <li>• Remove the memory card</li> <li>• Resetting CPU memory</li> <li>• Read the diagnostic buffer.</li> </ul>	The CPU copies runtime relevant data from EPROM memory to main memory
Memory contents after reset	The status of CPU memory space is "0". If a memory card has been inserted, the user program is transferred back to the main memory.	The user program is loaded back into the RAM from the integrated retentive EPROM of the CPU.	
What's left?	Data in the diagnostics buffer. You can read the diagnostic buffer with the PG (see <i>STEP 7 Online Help</i> ).		
	The MPI parameters (MPI address and highest MPI address, transmission rate, configured MPI addresses of CPs/FMs in an S7-300).		
	The contents of the operating hours counter (not for CPU 312 IFM).		

### Special feature: MPI parameters

MPI parameters hold a special position when memory is reset. The table below describes MPI parameters remaining valid after memory reset.

Memory reset ...	MPI parameters
With inserted memory card	... located on the memory card or on the integrated FEPRM of the CPU are valid. If this location does not contain parameter data (SDB), the previously set parameters stay valid.
With integrated FEPRM load memory (CPU 312 IFM / 314 IFM (314-5AE0x))	



## CPU 312 IFM and 314 IFM: Erasing the integrated EPROM

If you wish to erase the contents of the integrated EPROM, proceed as follows:

1. Use menu command **View > online** to open the online window for viewing an open project  
or  
open the window **Available nodes** with a click on the **Available nodes** toolbar button or select the menu command **PLC > Show available nodes** .
2. Select the MPI number of the target CPU (double-click).
3. Select the **Modules** container.
4. Select the menu item **Edit > Select all**.
5. Then select the menu command **File > Delete** or press the DEL key. This deletes all selected blocks from target memory.
6. Select the MPI number of the target CPU.
7. Select the menu command **PLC > Copy RAM to ROM**.

These commands delete all blocks online and overwrite the EPROM with the blank contents of the RAM.

### 9.6.4 Starting SIMATIC Manager

#### Introduction

SIMATIC Manager is a GUI for online/offline editing of S7 objects (projects, user programs, blocks, hardware Stations and Tools).

The SIMATIC Manager lets you

- manage projects and libraries,
- call STEP 7 Tools,
- access the PLC (AS) online,
- edit Memory Cards.

#### Starting SIMATIC Manager

After installation, the Windows desktop displays the **SIMATIC Manager** icon and in the Start menu under **SIMATIC** it displays the program item **SIMATIC Manager**.

1. Start SIMATIC Manager with a double-click on the icon or via Start menu (same as with all other Windows applications).

## User interface

A corresponding editing tool pops up when you open the relevant objects. Double-click on a program block starts the program editor; the block can be edited (object-oriented start).

## Online Help

The Online Help for the active window is always called with the F1 function key.

## 9.6.5 Monitoring and controlling I/Os

### The tool "Monitoring and Controlling a Variable"

The STEP 7 tool "Monitoring and Controlling a Variable" lets you

- monitor program variables in any format,
- edit the status or data of variables in the CPU (controlling).

### Create a variable table

You have two options for creating a variable table (VAT):

- in the ladder diagram/sequential function chart/statement list editor via menu item **PLC > Monitor/control variable**

This table is also available directly online

- in SIMATIC Manager with the **Blocks** container open via menu item **Insert new object > Variable table**

This table created offline can be saved for future retrieval. You can also test it after switching to online mode.

**VAT structure:**

In the VAT, every address to be monitored or modified (e.g. inputs, outputs) occupies one row.

The meaning of the VAT columns is as follows:

Column text	This field ...
Operand	contains the absolute address of the variable
Symbol	contains the symbolic descriptor of the variable This is identical to the specification in the Symbol Table.
Symbol comment	shows the symbol comment of the Symbol Table
Status format	contains the default format setting, e.g. HEX You can change the format as follows: <ul style="list-style-type: none"> <li>• Right-click on the format field. The Format List pops up.</li> <li>or</li> <li>• Left-click on the format field until the desired format appears</li> </ul>
Status value	shows the content of the variable at the time of update
Control value	is used to enter the new variable value (control value)

**Monitoring variables**

You have two options for monitoring variables:

- updating the status values once via menu item **Variable > Update status values**
- or
- continuous update of status values via menu item **Variable > Monitor**

## Controlling variables

To control variables, proceed as follows:

1. Left-click the field **Control value** of the relevant variable.
2. Enter the control value according to the data type.
3. To update control values once, select the menu item **Variable > Enable control values** .

or

Enable control values permanently via menu item **Variable > Control** .

4. In the **Monitor** test function, verify the control value entry in the variable.

### Is the control value valid?

You can disable the control value entered in the table. An invalid value is displayed same as a comment. You can re-enable the control value.

Only valid control values can be enabled.

## Setting the trigger points

### Trigger points:

- The "Trigger point for monitoring" determines the time of update for values of variables to be monitored.
- The "Trigger point for controlling" determines the time for assigning the control values to the variables to be controlled.

### Trigger condition:

- The "Trigger condition for monitoring" determines whether to update values once when the trigger point is reached or continuously every time the trigger point is reached.
- The "Trigger condition for controlling" determines whether to assign control values once or permanently to the variable to be controlled.

You can customize the trigger points using the tool "Monitor and control variable" in menu item **Variable > Set Trigger ...** start.

### Special features

- If "Trigger condition for monitoring" is set to **once** , the menu items **Variable > Update status value** or **Variable > Monitor** have the same effect, namely a single update.
- If "Trigger condition for controlling" is set to **once** , the menu items **Variable > Update control value** or **Variable > Control** have the same effect, namely a one-time assignment.
- If trigger conditions are set to **permanent** , the said menu items have different effects as described above.
- If monitoring and controlling is set to the same trigger point, monitoring is executed first.
- With some CPU versions (e.g. CPU 314-1AE03) values are not assigned at every cycle when **permanent control** is set.  
Remedy: Use the testing function **Force**.

## Saving/Opening the Variable Table

### Saving the VAT

1. After you abort or complete a test phase, you can save the variable table to memory. The name of a variable table starts with the letters VAT, followed by a number from 0 to 65535; e.g. VAT5.

### Opening the VAT

1. Select the menu item **Table > Open** .
2. Select the project name in the **Open** dialog.
3. In the project window below, select the relevant program and mark the **Blocks** container.
4. In the block window, select the desired table.
5. Confirm with **OK**.

## Establishing a connection to the CPU

The variables of a VAT represent variable quantities of a user program. In order to monitor or control variables it is required to establish a connection to the relevant CPU. Every variable tables can be linked to another CPU.

In menu item **PLC > Connect to ...** , establish a connection to one of the following CPUs:

- configured CPU
- directly connected CPU
- available CPU ...

The table below lists the display of variables.

CPUs	The CPU variables are displayed, ...
configured CPU	in their S7 program (Hardware Station) in which the VAT is stored.
directly connected CPU	that is connected directly to the PG.
available CPU.	that is selected in the dialog window. Menu item <b>PLC &gt; Connect to ... &gt; Available CPU ...</b> is used to establish a connection to any CPU available on the network.

### Controlling outputs in CPU STOP mode

The function **Enable PO** switches off output disable for the peripheral outputs (PO), thus enabling control of the PO in CPU STOP mode.

In order to enable the POs, proceed as follows:

1. In menu item **Table > Open the variable table (VAT)**, open the VAT that contains the PO you want to control, or activate the window containing the corresponding VAT.
2. To control the PO of the active VAT, select the CPU connection in menu command **PLC > Connect to ...** .
3. Use menu command **PLC > Operating Mode** to open the **Operating Mode** dialog and switch the CPU to STOP mode.
4. Enter your values in the "Control value" column for the PO you want to control.

Example:

```
PO: POB 7 control value: 2#0100 0011
   POW 2 W#16#0027
   POD 4 DW#16#0001
```

5. Use menu item **Variable > Enable PO** to switch to "Enable PO" mode.
6. Control the PO via menu item **Variable > Enable control values** . "Enable PO" mode remains active until switched off again via **Variable > Enable PO** .  
"Enable PO" is also terminated when the connection to the PG goes down.
7. Return to step 4 if you want to specify new values.

---

#### Note

For example, a message pops up to indicate CPU mode transition from STOP to RUN or START-UP.  
A message also pops up indicating that the "Enable PO" function is selected while the CPU is in RUN mode.

---

## 9.7 Commissioning PROFIBUS DP

### 9.7.1 Commissioning PROFIBUS DP

#### Requirements

Before you commission a PROFIBUS DP network, the following requirements must be met:

- A PROFIBUS DP network has been configured.
- In *STEP 7*, you have configured the PROFIBUS DP network and you have assigned a PROFIBUS DP address and memory area to all Nodes (see the manual *SIMATIC, STEP 7 V5.x; Configuring Hardware and Connections with STEP 7 V5.x*).
- Note that you must also set address switches in some of the DP slaves (see the description of the relevant DP slave).
- Depending on your CPU, you need the following software:

Table 9-6 Software requirements

CPU	Order No.	Software required
315-2 DP	6ES7315-2AF03-0AB0	<i>STEP 7 V 3.1</i> or later
	6ES7315-2AF83-0AB0	<i>COM PROFIBUS V 3.0</i> or later
316-2 DP	6ES7316-2AG00-0AB0	<i>STEP 7 V 5.x</i> or later
318-2 DP	6ES7318-2AJ00-0AB0	<i>COM PROFIBUS V 5.0</i> or later

#### DP address areas of the CPUs

Table 9-7 DP address areas of the CPUs

Address area	315-2 DP (6ES7 315-2AF03-0AB0)	316-2 DP	318-2 DP
DP address area for I/Os	1024 bytes	2048 bytes	8192 bytes
Number of those in the I/O process image	Bytes 0 to 127	Bytes 0 to 127	Byte 0 to 255 (default), configurable up to byte 2047

**DP diagnostic addresses** occupy 1 byte per DP master and DP slave in the input address area. For example, at these addresses DP standard diagnostics can be called for the relevant node ( LADDR parameter of SFC13). The DP diagnostic addresses are specified in your configuration. If you do not specify any DP diagnostic addresses, *STEP 7* assigns these DP diagnostic addresses, starting at the highest byte address downwards .

With CPU318 >= V3.0 as a master with a DPV1 configuration, you assign two different diagnostic addresses for S7 slaves:

- Diagnostic address of the slave (address for slot 0)  
At this address all slave events are reported in the DP master (Node representative), e.g. Node failure.
- Diagnostic address of the module (address for slot 2)  
This address is used to report events (OB82) in the master that affect the module. With a CPU as DP-Slave, for example, diagnostic interrupts for operating mode transitions are reported at this address.

## 9.7.2 Commissioning the CPU as DP master

### Requirements for commissioning

- The PROFIBUS subnet has been configured.
- The DP slaves are ready for operation (see relevant DP slave manual).
- An MPI/DP interface as DP interface must be configured accordingly (only CPU 318-2).
- You must configure the CPU as DP master prior to commissioning. That is, in *STEP 7* you must:
  - configure the CPU as a DP master,
  - assign a PROFIBUS address to the CPU,
  - assign a master diagnostic address to the CPU,
  - integrate the DP slaves into the DP master system.

Is a CPU 31x-2 DP a DP slave?

If so, you will find that DP slave in the PROFIBUS-DP catalog as **already configured Node**. In the DP master, assign a slave diagnostic address to this DP slave CPU. You must interconnect the DP master with the DP slave CPU and specify the address areas for data exchange with the DP slave CPU.

### Commissioning

Commission CPU 31x-2 DP as DP master in the PROFIBUS subnet as follows:

1. Download the PROFIBUS subnet configuration (preset configuration) you have created in *STEP 7* from the PG to CPU 31x-2 DP.
2. Switch on all of the DP slaves.
3. Switch CPU 31x-2 DP from STOP to RUN mode.



## Start-up of CPU 31x-2 DP as DP master

During start-up, CPU 31x-2 DP compares the preset configuration of your DP master system to the actual configuration.

If preset configuration = actual configuration, the CPU switches to RUN mode.

If the preset configuration  $\neq$  to the actual configuration, the configuration of parameter **start-up if preset configuration  $\neq$  actual configuration** determines the start-up behavior of the CPU.

<b>start-up with preset configuration <math>\neq</math> actual configuration = yes (Default setting)</b>	<b>start-up with preset configuration <math>\neq</math> actual configuration = no</b>
CPU 31x-2 DP switches to RUN mode. (BUSF LED flashes if any of the DP slaves cannot be addressed)	CPU 31x-2 DP remains in STOP mode. When the <b>Monitoring time for parameter transfer to modules</b> runs out, the BUSF LED starts flashing.  The flashing BUSF LED indicates that at least one DP slave cannot be accessed. In this case, check whether all DP slaves are switched on or correspond with your configuration, or read out the diagnostic buffer with <i>STEP 7</i> .

## Recognizing the operating state of DP slaves (Event recognition)

The table below shows how CPU 31x-2 DP operating as a DP master recognizes operating mode transitions of a CPU operating as a DP slave and data exchange interruptions.

Table 9-8 Event recognition by CPUs 31x-2 DP acting as the DP master

<b>Event</b>	<b>What happens in the DP master?</b>
Bus failure interrupt (short-circuit, connector unplugged)	<ul style="list-style-type: none"> <li>• Call of OB86 with the message <b>Station failure</b> (coming event; diagnostic address of the DP slave assigned to the DP master)</li> <li>• with I/O access: Call of OB122 (I/O access error)</li> </ul>
DP slave: RUN $\rightarrow$ STOP	<ul style="list-style-type: none"> <li>• Call of OB82 with the message <b>Module error</b> (incoming event; diagnostic address of the DP slave assigned to the DP master; Variable OB82_MDL_STOP=1)</li> </ul>
DP slave: STOP $\rightarrow$ RUN	<ul style="list-style-type: none"> <li>• Call of OB82 with the message <b>Module OK</b> (outgoing event; diagnostic address of the DP-Slave assigned to the DP master; Variable OB82_MDL_STOP=0)</li> </ul>

### Tip:

When commissioning the CPU as DP master, always program OB 82 and 86. This helps you to recognize and evaluate data exchange errors or interruption.

### Programming, status/control via PROFIBUS

As an alternative to the MPI interface, you can program the CPU or execute the Status and Modify functions of the PG via the PROFIBUS-DP interface.

---

#### Note

The use of the Status and Modify functions via the PROFIBUS-DP interface extends the DP cycle.

---

### Constant Bus Cycle Time

As of *STEP 7 V 5.x* you can configure equidistant lengths for PROFIBUS subnet (constant bus cycle time) bus cycles. Details on equidistance are found in the *Step 7 Online Help*.

### Start-up of the DP master system

CPU 315-2 DP / 316-2 DP is the DP master	CPU 318-2 DP is DP master
Customize the start-up monitoring time for DP slaves in parameter <b>Monitoring time for parameter transfer to modules</b> .	Customize the start-up monitoring time for DP slaves in parameters <b>Monitoring time for parameter transfer to modules</b> and <b>Module reports ready</b> .
That is, the DP slaves must start up within the set time and be configured by the CPU (as DP master).	

### PROFIBUS address of the DP master

With CPU 31x-2 DP, do not set "**126**" as PROFIBUS address.

### 9.7.3 Commissioning the CPU as DP slave

#### Requirements for commissioning

- The DP master is configured and programmed.
- If the MPI/DP interface of CPU 318-2 DP is to be operated as DP interface, you must configure the interface accordingly.
- You must program and configure CPU 31x-2 DP as a DP slave prior to commissioning. That is, in *STEP 7* you must:
  - "switch on" the CPU as DP slave,
  - assign a PROFIBUS address to the CPU,
  - assign a slave diagnostic address to the CPU,
  - specify whether the DP master is an S7 DP master or another DP master,
  - specify the address areas for data exchange with the DP master.
- All other DP slaves are programmed and configured.

#### GSD files

When working on an IM 308-C or non-Siemens system, you require a device database (GSD) file to be able to configure CPU 31x-2 DP as a DP slave in a DP master system.

*COM PROFIBUS* as of V 4.0 includes this GSD file.

When working with an older version or another configuration tool, you can download the GSD file at:

- Internet URL <http://www.ad.siemens.de/csi/gsd>
- or
- via modem from the **SSC (Interface Center)** Fürth, Germany; Phone number (0911) 911/737972

#### Configuration and parameter assignment message frame

*STEP 7* supports you in configuring/programming CPU 31x-2 DP. Should you require a description of the configuration and parameter assignment frame, in order to use a bus monitor for example, you can find it on the Internet at <http://www.ad.siemens.de/csinfo> under article ID 1452338.

## Commissioning

Commission CPU 31x-2 DP as a DP slave in the PROFIBUS subnet as follows:

1. Switch on power, but hold the CPU in STOP mode.
2. First, switch on all other DP masters/slaves.
3. Now switch the CPU to RUN mode.

## Start-up of CPU 31x-2 DP as DP slave

When the CPU 31x-2x DP is switched to RUN, two independent operating mode transitions are executed:

- The **CPU** switches from STOP to RUN mode.
- At the **PROFIBUS-DP interface** the CPU starts data transfer with the DP master.

## Recognizing the Operating State of the DP master (Event Recognition)

The table below shows how CPU 31x-2 operating as a DP slave recognizes operating state transitions or data exchange interruptions.

Table 9-9 Event recognition by CPUs 31x-2 DP acting as DP slave

Event	What happens in the DP slave?
Bus failure interrupt (short-circuit, connector unplugged)	<ul style="list-style-type: none"> <li>• Call of OB86 with the message <b>Station failure</b> (coming event; diagnostic address of the DP slave, assigned to the DP slave)</li> <li>• with I/O access: Call of OB122 (I/O access error)</li> </ul>
DP master. RUN → STOP	<ul style="list-style-type: none"> <li>• Call of OB82 with the message <b>Module error</b> (coming event; diagnostic address of the DP slave, assigned to the DP slave; Variable OB82_MDL_STOP=1)</li> </ul>
DP master STOP → RUN	<ul style="list-style-type: none"> <li>• Call of OB82 with the message <b>Module OK</b> (outgoing event; diagnostic address of the DP slave, assigned to the DP slave; Variable OB82_MDL_STOP=0)</li> </ul>

### Tip:

When commissioning the CPU as DP slave, always program OB 82 and 86. This helps you to recognize and evaluate the respective operating states or data exchange errors.

## 9.8 Programming, status/control via PROFIBUS

As an alternative to the MPI interface, you can program the CPU or execute the Status and Modify functions of the PG via the PROFIBUS-DP interface. To do so, you must enable these functions when configuring the CPU as a DP slave in STEP7.

### Note

The use of Status and Control function via the PROFIBUS-DP interface extends the DP cycle.

### Data Transfer via Intermediate Memory

CPU 31x-2 DP operating as a DP slave provides a transfer memory for PROFIBUS DP communication. All data exchange between the CPU as DP slave and the DP master takes place via this transfer memory. You can configure up to 32 address areas for this function.

That is, the DP master writes its Data to these intermediate memory address areas and the CPU reads these data in the user program, and vice versa.

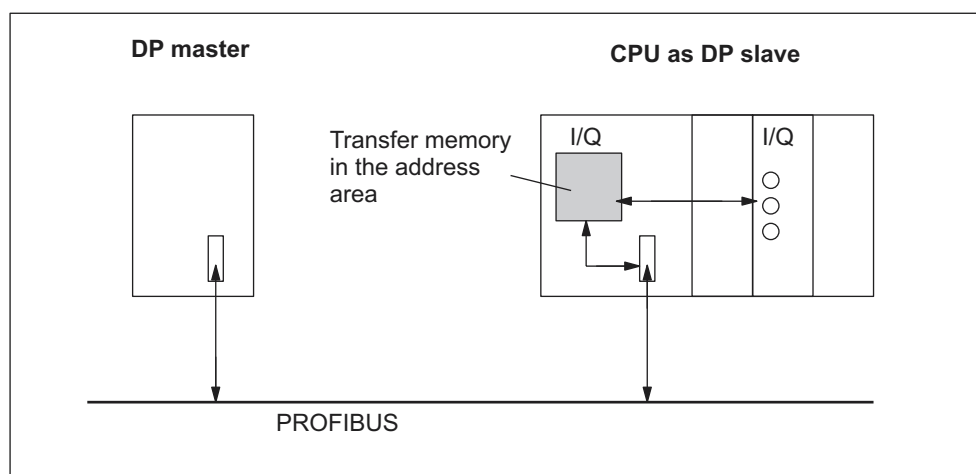

Figure 9-9 Transfer memory in the CPUs 31x-2 DP acting as DP slave

### Address areas in intermediate memory

In *STEP 7*, configure the I/O address areas:

- You can configure up to 32 I/O address areas.
- Maximum length per address area is 32 bytes.
- You can configure a maximum of 244 input bytes and 244 outputs bytes.

The table below shows the principle of address areas. You can also find this figure in the *STEP 7* configuration.

Table 9-10 Configuration example for the address areas in transfer memory

	Type	Master address	Type	Slave address	Length	Unit	Consistency
1	E	222	A	310	2	Byte	Unit
2	A	0	E	13	10	Word	Total length
:							
32							
	Address areas in the DP master CPU		Address areas in the DP slave CPU		These address area parameters must be identical for DP master and DP slave		

## Sample program

Below you will see a small sample program for data exchange between DP master and DP slave. The addresses used in the example are found in the table above.

In the DP slave CPU				In the DP master CPU			
L	2		//Data pre-				
T	MB	6	processing in				
L	IB	0	the				
			DP slave				
T	MB	7					
L	MW	6	// Forward data				
T	PQW	310	to the				
			DP master				
				L	PIB	222	// processing data
							received
				T	MB	50	
				L	PIB	223	in the DP master
							in the DP master
				L	B#16#3		
				+	I		
				T	MB	51	
				L	10		//Data preparation in
							DP master
				+	3		
				T	MB	60	
				CALL	SFC	15	//Send data to
							DP slave
							LADDR:= W#16#0
							RECORD:= P#M60.0 Byte 20
							RET_VAL:=MW 22
CALL	SFC	14	//receive data				
			from DP master				
L	MB	30	//Reprocess				
			received data				
L	MB	7					
+	I						
T	MW	100					

## Working with transfer memory

Note the following rules when working with intermediate memory:

- Assignment of address areas:
  - Input data of DP slaves are **always** output data of the DP master
  - Output data of DP slaves are **always** input data of the DP master
- The user can define these addresses. In the user program, access data with load/transfer instructions or with SFC 14 and 15. You can also specify addresses from the input/output process image (refer to Chapter *Addressing, User-defined Addressing of Modules*).
- The lowest address of specific address areas is their respective area start address.
- The length, unit and consistency of the address areas for DP master and DP slave must be identical.

---

### Note

Assign transfer memory addresses taken from the DP address area of CPU 31x-2 DP.  
Addresses assigned to transfer memory cannot be assigned again to I/O modules of CPU 31x-2 DP. When using consistent data areas in transfer memory, note the section on *Consistent Data* in Chapter *Addressing*.

---

## S5 DP master

When exchanging consistent data with IM 308-C operating as DP master and CPU 31x-2 DP as DP slave, note that:

You must program FB192 in IM 308-C to enable exchange of consistent data between a DP master and the DP slave. FB192 reads or outputs CPU 31x-2 DP data only in a single continuous block.

## S5-95 as DP master

Bus parameters of an AG S5-95 operated as DP master must also be set in CPU 31x-2 DP operating as DP slave.

## Data transfer in STOP mode

The DP slave CPU goes into STOP mode: Data in CPU intermediate memory are overwritten with "0". That is, the DP master reads "0".

The DP master goes into STOP mode: Actual data in CPU intermediate memory is maintained and can still be read by the CPU.



## PROFIBUS Address

With CPU 31x-2 DP, do not set "**126**" as PROFIBUS address.

### 9.8.1 Direct Data Exchange

#### Requirement

In *STEP 7 V 5.x* or later, you can configure "Direct data exchange" for PROFIBUS nodes. CPUs with a DP interface can take part in direct data exchange as senders and receivers.

#### Definition

"Direct data exchange" is a special communication relationship between PROFIBUS-DP nodes.

Characteristic of direct data exchange is that PROFIBUS DP nodes "listen" on the bus for data a DP slave returns to its DP master. This mechanism allows "Listening stations" (receivers) direct access to modified input data of remote DP slaves.

#### Address Areas

In your *STEP 7* configuration of the relevant peripheral input addresses, specify which address area of the receiving node is to receive data requested from the sending node.

The following types of DP-CPU are possible:

- DP slave sending station
- receiving station, as DP slave or DP master, or as CPU not integrated in a master system.

**Example:**

The sample in the figure below shows the relationships you can configure for direct data exchange. In the figure, all DP masters and DP slaves are a CPU 31x-2 DP. Note that other DP slaves (ET 200M, ET 200X, ET 200S) can only operate as sending node.

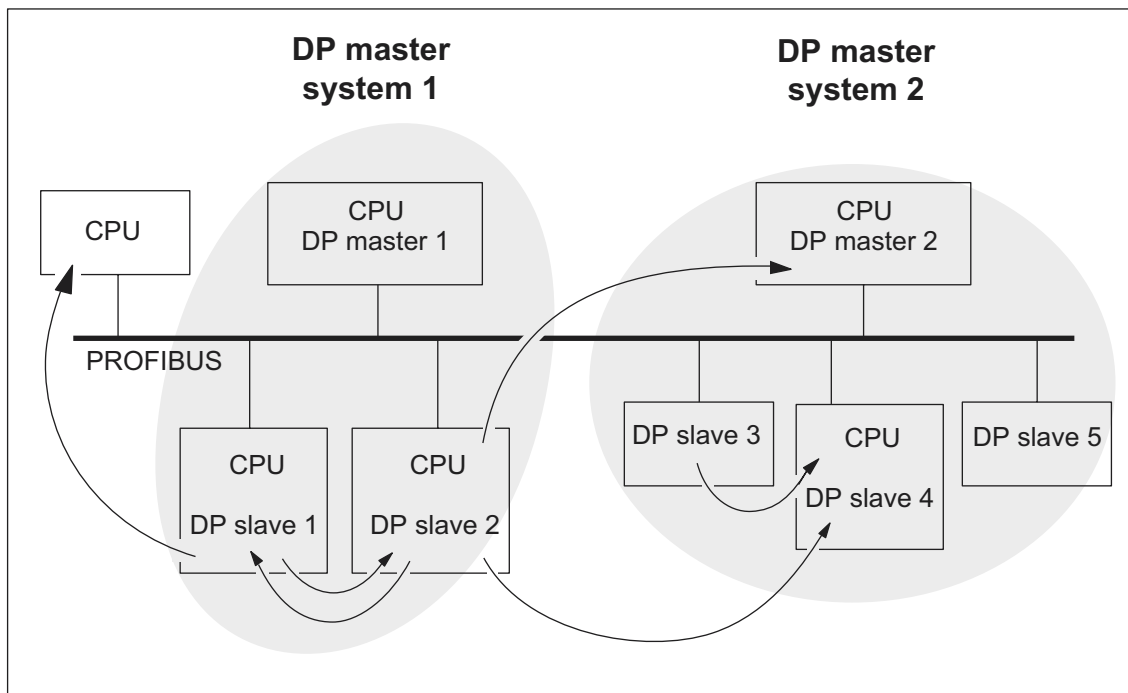

Figure 9-10 Direct data exchange with CPUs 31x-2 DP

## 10.1 In this Chapter

### **Maintenance = operating system back-up/update, replacement of modules and fuses**

S7-300 is a maintenance-free automation system.

Thus, by maintenance we mean

- Backup of the operating system on memory card (MC) and update of the MC operating system
- Replacement of modules
- Replacement of backup battery/rechargeable battery
- Replacement of the fuses in digital output modules

### **In this Chapter**

we show you how to back-up or update your operating system and to replace modules, the back-up/rechargeable battery and the 120/230 VAC fuse of the digital output module.

## 10.2 Backup of the CPU operating system

### **When should you back up the operating system of your CPU?**

In some cases, we recommend that you back up your CPU's operating system:

For example, you might want to replace the CPU in your plant with a CPU from store. In this case, you should make sure that the CPU from store has the same operating system that is used in the plant.

We also recommend that you create a back-up copy of the operating system for emergency situations.

## Which CPUs allow me to back up the operating system?

You can back-up the operating system as of the following CPU versions:

CPU	Order No.	Firmware	Required MC/MMC
313	from 6ES7313-1AD03-0AB0	V 1.0.0 or later	MC ≥ 1 MB
314	from 6ES7314-1AEx4-0AB0	V 1.0.0 or later	MC ≥ 1 MB
314 IFM	from 6ES7314-5AE10-0AB0	V 1.1.0 or later	MC ≥ 2 MB
315	from 6ES7315-1AF03-0AB0	V 1.0.0 or later	MC ≥ 1 MB
315-2 DP	from 6ES7315-2AFx3-0AB0	V 1.0.0 or later	MC ≥ 2 MB
316-2 DP	from 6ES73136-2AG00-0AB0	V 1.0.0 or later	MC ≥ 2 MB

### Note

A back-up of the operating system is not possible with CPU 318-2 DP.

## Backup of the operating system on memory card

How to back up the operating system:

Table 10-1 Backup of the operating system on MC

Step	Action required	CPU Response
1.	Insert a new memory card into the CPU	The CPU requests memory reset
2.	Turn the mode selector switch to MRES position and hold it there.	-
3.	POWER OFF / POWER ON. Hold the mode selector switch in MRES position until ...	... the STOP, RUN and FRCE LEDs start flashing.
4.	Mode selector switch to STOP position.	-
5.	Mode selector switch briefly to MRES position, then let it return to STOP.	<ul style="list-style-type: none"> <li>The CPU starts backing up the operating system to the MC.</li> <li>All LEDs are lit during the back-up.</li> <li>When backup is complete, the STOP-LED flashes. The CPU is requesting a memory reset.</li> </ul>
6.	Remove the memory card	-

## 10.3 Updating the Operating System

### In which situations should I update the operating system?

After (compatible) function expansions or after an enhancement of operating system performance the operating system should be upgraded to the latest version (update).

### Where do I get the latest version of the operating system?

You can obtain the latest operating system versions from your Siemens partner or from the Internet (Siemens home page; Automation and Drives, Customer Support).

### Tip: back-up your operating system before you update it

If you back up your existing operating system to an empty MC before you start the update, you can reload the "old" operating system in case you encounter any problems.

## Updating the Operating System

How to update the operating system (OS):

Table 10-2 Updating the operating system with MC/MMC

Step	Action required	CPU Response
1.	Using STEP 7 and your programming device, transfer the update files to an empty MC.	-
2.	Remove the back-up/rechargeable battery from relevant CPUs.	-
3.	Switch off the CPU power supply and insert the MC that contains the OS update.	-
4.	POWER ON.	<ul style="list-style-type: none"> <li>• The CPU automatically recognizes the MC and the OS update, and it starts the update.</li> <li>• All LEDs are lit during OS update.</li> <li>• When the OS update is complete, the STOP-LED flashes. The CPU is requesting a memory reset.</li> </ul>
5.	Switch off the CPU power supply and remove the MC that contains the OS update.	-
6.	Reinsert the back-up/rechargeable battery into the relevant CPUs.	-

## 10.4 Module replacement

### Rules for Installation and Wiring

The table below shows you points to follow when wiring, installing or removing of S7-300 modules.

Rules governing	... Power supply	... CPU	... SM/FM/CP
Blade width of screwdriver	3.5 mm (cylindrical model)		
Tightening torque			
<ul style="list-style-type: none"> <li>• Attaching modules to the rail</li> <li>• Connecting cables</li> </ul>	from 0.8 N/m to 1.1 N/m		from 0.8 N/m to 1.1 N/m
	from 0.5 N/m to 0.8 N/m		–
POWER OFF when replacing the ...	Yes		Yes
S7-300 operating mode when replacing ...	–		STOP
Load voltage OFF when replacing the ...	Yes		Yes

### Initial Situation

The module you want to replace is still installed and wired. You want to install the same type of module.



#### Warning

Disturbances can corrupt data if you insert or remove S7-300 modules while data is being transferred via MPI. Do not replace S7-300 modules while there is data traffic on the MPI. If you are not certain whether or not data transfer is active on the MPI, unplug the connector on the MPI before you replace the module.

## Removing a module (SM/FM/CP)

Remove the module as follows:

Step	20-pin front connector	40-pin front connector
1.	Switch the CPU to STOP.	
2.	Switch off the load voltage to the module.	
3.	Remove the labeling strip from the module.	
4.	Open the front panel.	
5.	Unlock the front connector and remove it.	
	Press down the unlocking mechanism with one hand and with the other hand, pull out the front connector at the grips.	Remove the fixing screw from the middle of the front connector. Pull the front connector out, holding it at the grips.
6.	Undo the module fixing screw(s).	
7.	Swing the module out.	

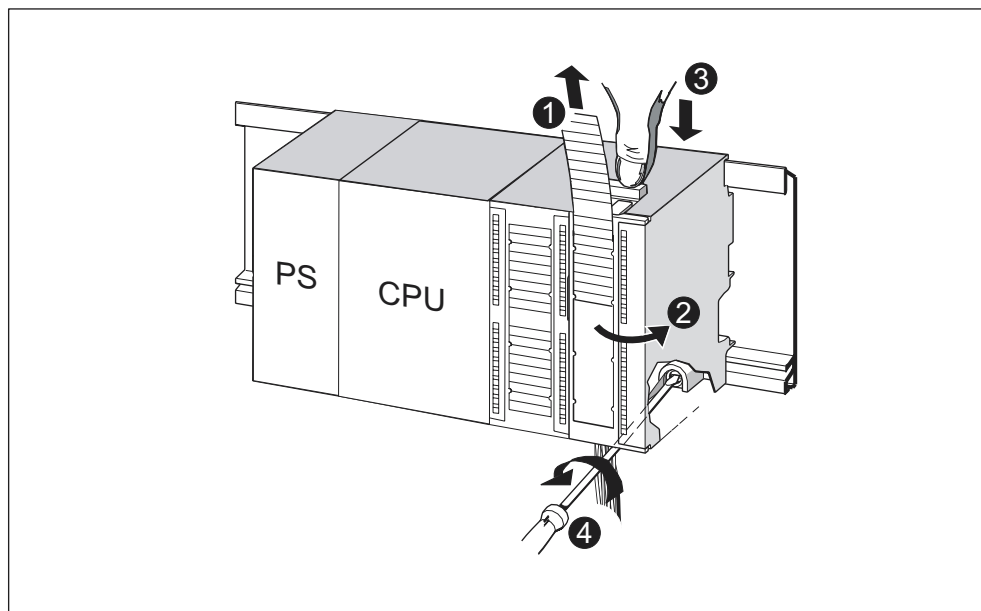

Figure 10-1 Unlocking the front connector and removing the module

This figure illustrates the steps described:	
(1)	Remove labeling strips.
(2)	Open module.
(3)	Press unlocking mechanism/loosen mounting screw, and pull out front connector.
(4)	Remove mounting screw of module and tilt module out.

### Removing the front connector coding pin from the module

Before you start installing the new module, remove the upper part of the front connector coding pin from this module.

Reason: This part is already inserted in the wired front connector.

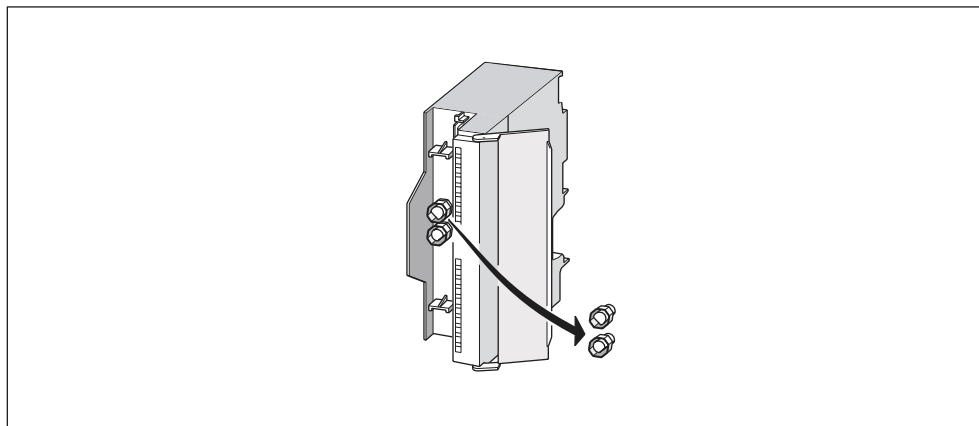

Figure 10-2 Removing the front connector coding pin



## Installing a new module

Install the new module as follows:

1. Install new module of same type.
2. Pivot the module down into place.
3. Screw-tighten the module.
4. Slide the labeling strips into the module.

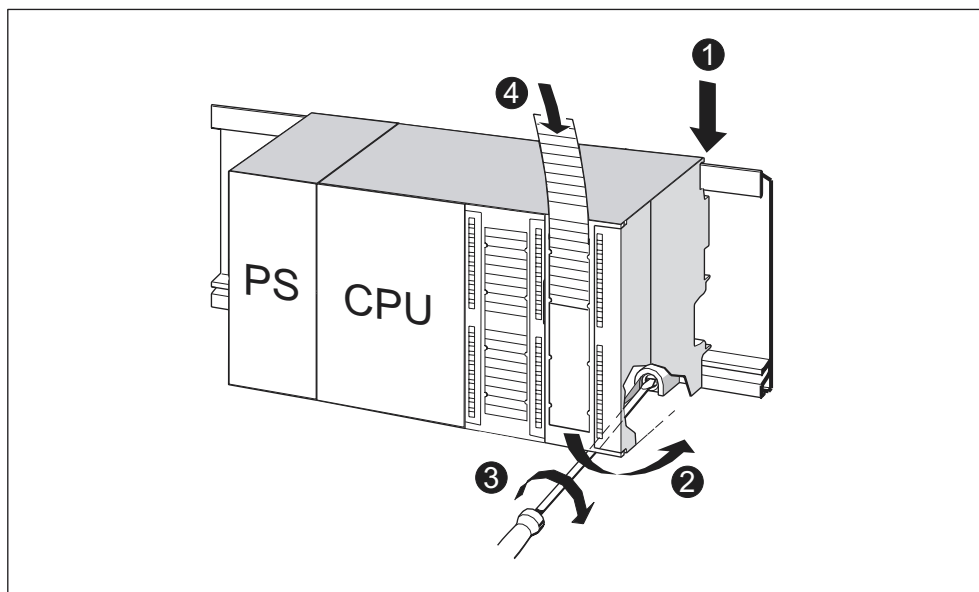

Figure 10-3 Installing a new module

The figure illustrates the described steps:	
(1)	Lower module onto rail.
(2)	Tilt module down.
(3)	Screw the module in tightly.
(4)	Insert labeling strips.

## Removing the Front Connector Coding

If you want to take a "used" front connector to wire another module, you can remove its coding mechanism:

Simply push out the front connector coding with a screwdriver.

This upper part of the coding key must then be plugged back into the old module.

### Putting a New Module into Service

Proceed as follows to put the new module into service:

1. Open the front panel.
2. Reinstall the front connector.
3. Close the front panel.
4. Switch the load voltage back on.
5. Set the CPU to RUN mode again.

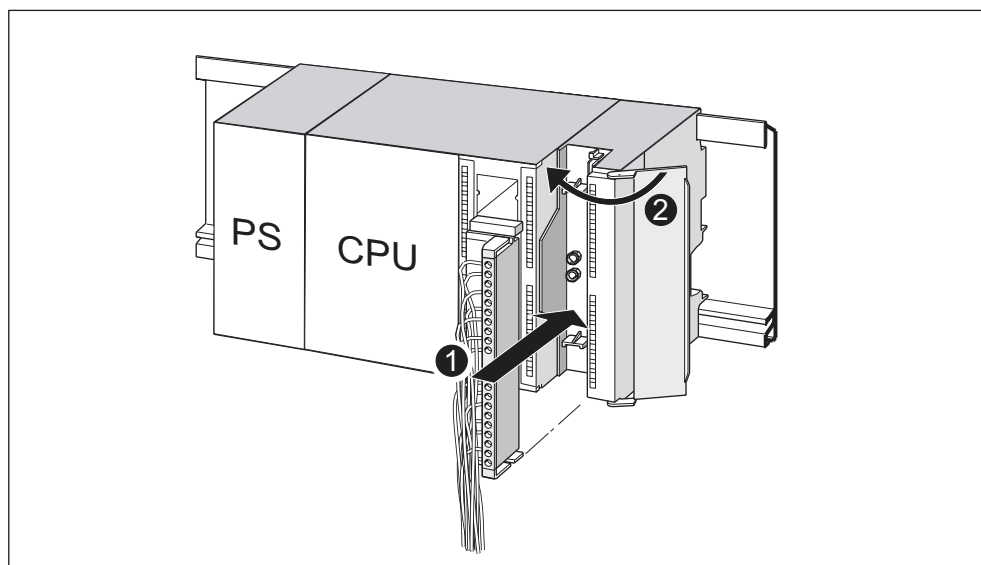

Figure 10-4 Inserting the front connector

The figure illustrates the described steps:	
(1)	Move the front connector into operating position
(2)	Close front panel.

### Behavior of S7-300 after module replacement

After module replacement the CPU switches to run mode, provided no error has occurred. If the CPU maintains STOP status, you can view the cause of error with *STEP 7* (refer to the *STEP 7* User Manual).

## 10.5 Replacing the back-up battery or rechargeable battery (CPUs with MC only)

### Replacing backup battery or rechargeable battery

**Always** replace the back-up/rechargeable battery in POWER ON state of the CPU, in order to avoid data loss in internal memory or stopping the real-time clock.

#### Note

Data in internal main memory will be lost if you replace the back-up battery in POWER OFF state of the CPU.

Always replace the back-up battery in POWER ON state!

Replace the back-up/rechargeable battery as follows:

Step	CPU 313/314	CPU 314 IFM/315/315-2 DP/ 316-2 DP/318-2 DP
1.	Open the front panel of the CPU.	
2.	Pull the back-up battery/accumulator out of the compartment with a screwdriver.	Pull the back-up/rechargeable battery out of the compartment with its cable.
3.	Plug the connector of the new back-up/rechargeable battery into the corresponding socket in the battery compartment of the CPU. The notch on the battery connector must show towards the left hand side.	
4.	Insert the new back-up/rechargeable battery into the battery compartment of the CPU.	
5.	Close the front door of the CPU.	

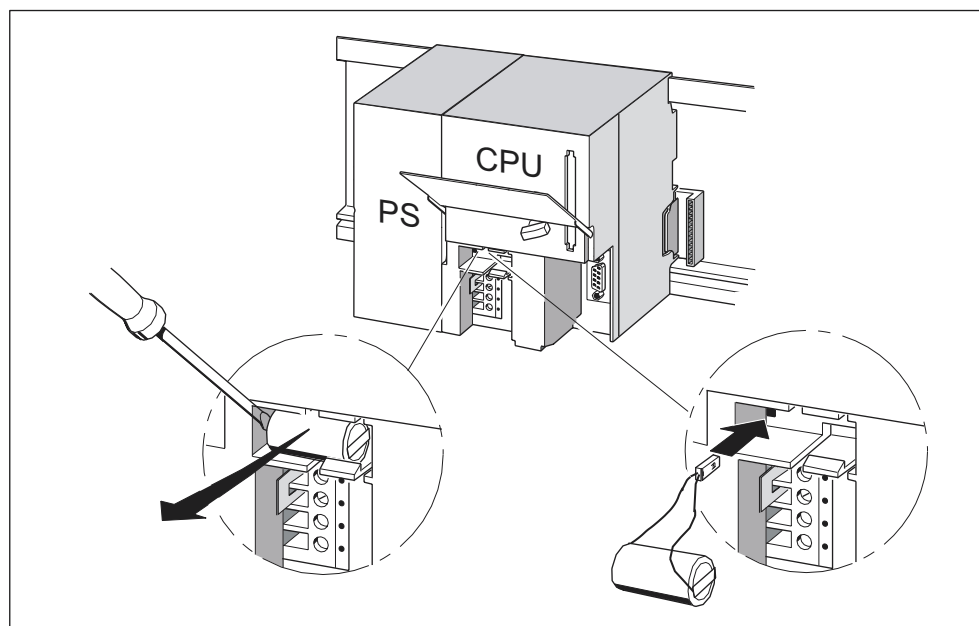

Figure 10-5 Replacing the back-up battery in CPU 313/314

### How often do I have to replace it?

**back-up battery:** We recommend an annual replacement

**Rechargeable battery:** Never needs to be replaced.

### Disposal

Note your local regulations/directives on battery disposal.

### Storing back-up batteries

Store back-up batteries in a dry and cool place.

The shelf life of back-up batteries is five years.



#### Warning

If heated or damaged, back-up batteries can ignite or explode and cause severe burning injury.

Store back-up batteries in a dry and cool place.

---

### Rules for the handling of back-up batteries

To avoid risk of danger when handling back-up batteries, note the following rules:



#### Warning

Improper handling of back-up batteries could result in injury or damage to property. Improperly handled back-up batteries can explode and cause severe burns.

Do not

- charge
  - heat up
  - incinerate
  - drill through
  - squash
  - short-circuit back-up batteries.
- 

### Rules for handling the rechargeable battery

Do not charge rechargeable batteries in devices other than the CPU. The rechargeable battery must always be charged in the CPU, in POWER ON state of the CPU.

## 10.6 Digital output module AC 120/230 V: Replacing the fuses

### Fuses for Digital Outputs

the digital outputs of the following digital output modules are short-circuit protected by individual fusing of the channel groups:

- Digit output module SM 322; DO 16 × A 120 V
- Digit output module SM 322; DO 8 × A 120 230 V

### System check

Eliminate the causes of fuse tripping.

### Replacement fuses

If replacement is required, you can use the following fuses:

- 8 A, 250 V fuse
  - Wickmann 19 194-8 A
  - Schurter SP001.013
  - Littlefuse 217.008
- Fuse holder
  - Wickmann 19 653



---

#### Warning

Improper handling of digital output modules could result in injury or damage to property.

Under the covers on the right side of the module, there are dangerous voltages > 25 VAC or > 60 VDC.

Before opening these covers, ensure that the front connector of the module is removed or that the module is disconnected from the supply voltage.

---



---

#### Warning

Improper handling of front connectors could result in injury or damage to property.

When you remove the front connector during operation, beware of dangerous live voltage > 25 VAC or > 60 VDC across the pins.

If the front connector is wired to such voltages, hot swapping of modules must always be carried out by skilled or instructed electrical staff, in order to avoid unintentional contact with the module pins.

---

## Position of the Fuses

Digital output modules are equipped with 1 fuse per channel group. The fuses are located at the left side of the digital output module. The figure below shows you the location of the fuses on digital output modules.(1)

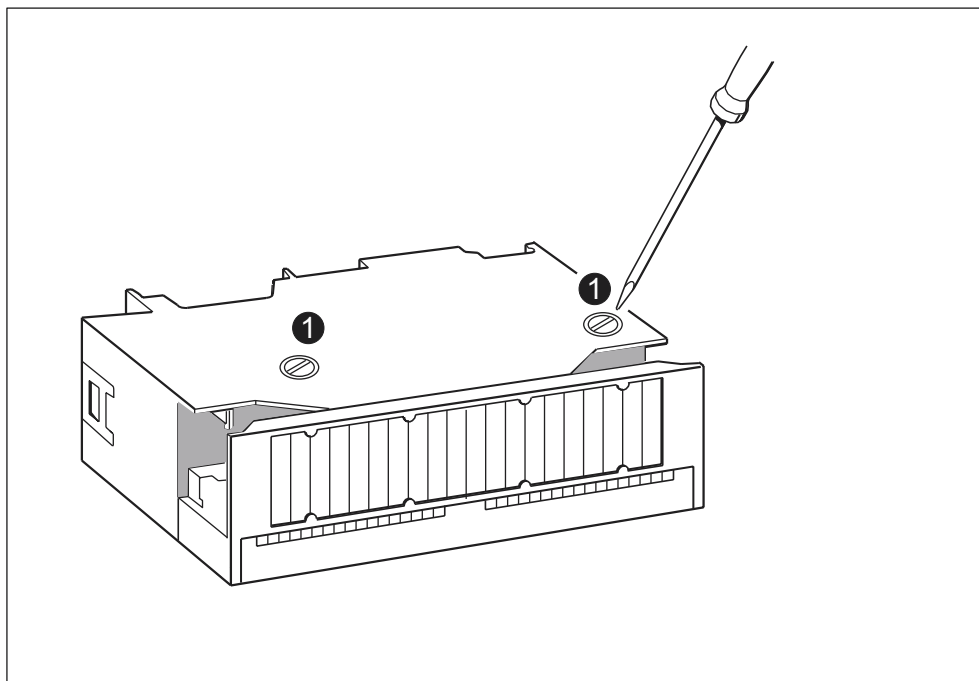

Figure 10-6 Location of fuses in the digital output module 120/230 VAC

## Replacing fuses

The fuses are located at the left side of the module. Replace the fuses as follows:

1. Switch the CPU to STOP.
2. Switch off the load voltage of the digital output module.
3. Remove the front connector from the digital output module.
4. Loosen the fixing screw of the digital output module.
5. Swing out the digital output module.
6. Remove the fuse holder from the digital output module (1).
7. Replace the fuse.
8. Screw the fuse holder back into the digital output module.
9. Reinstall the digital output module.

# Testing functions and Diagnostics

# 11

## 11.1 In this Chapter

### Introduction

This Chapter helps you to get acquainted with tools you can use to carry out the following tasks:

- Hardware/software error diagnostics.
- Elimination of hardware/software errors.
- Testing the hardware/software - for example, during commissioning.

---

#### Note

It would go beyond the scope of this manual to provide detailed descriptions of all the tools you can use for diagnostics, testing and troubleshooting functions. Further notes are found in the relevant hardware/software manuals.

---

## 11.2 Overview: Testing functions

### Software testing functions: Monitoring and controlling of variables, single-step mode

STEP 7 offers you the following testing functions you can also use for diagnostics:

- Monitoring and controlling of variables

Can be used for PG/PC monitoring of specific CPU or user program variables. You can also declare permanent values for the variables.

- Testing with program status

You can test your program by viewing the program status of each function (result of logical links, status bit) or the data of specific registers in real-time mode.

For example, if you have selected the programming language LAD in STEP 7 for your presentation, the color of the symbol will indicate a closed switch or an active circuit.

---

### Note

The STEP 7 testing function with program status extends the CPU cycle time! In STEP 7 you can customize the maximum permitted increase in cycle time (not for CPU 318-2 DP). In this case, set process mode for the CPU parameters in STEP 7.

---

- Single-step Mode

When testing in single-step mode, you can process your program instructions in sequence (= single-step) and set break points. This is only possible in testing mode and not in process mode.

### Testing functions of the software: Forcing variables

The Force function can be used to declare permanent values in specific variables of a user program or CPU (also: inputs and outputs) which cannot be overwritten subsequently by the user program.

For example, you can use it to jumper sensors or switch outputs permanently, irrespective of the user program.



#### Danger

This could result in severe injury or even death, and damage to property. Incorrect use of the Force function could result in death or severe injury, and damage to machinery or even the entire plant. Always follow the safety instructions in the *STEP 7 manuals*.

---



#### Danger

##### Forcing with S7-300 CPUs (not CPU 318-2 DP)

The forced values in the **inputs** process image can be overwritten by write commands (such as T EB x, = E x.y, copy with SFC, etc.) and by read I/O commands (such as L PEW x) in the user program, or by write PG/OP function.

**Outputs** initialized with forced values only return the forced value if not accessed by the user program via peripheral write instructions (e.g. TPQB x) or by PG/OP write functions!

Always ensure that forced values in the I/O process image cannot be overwritten by the user program or PG/OP functions!

---



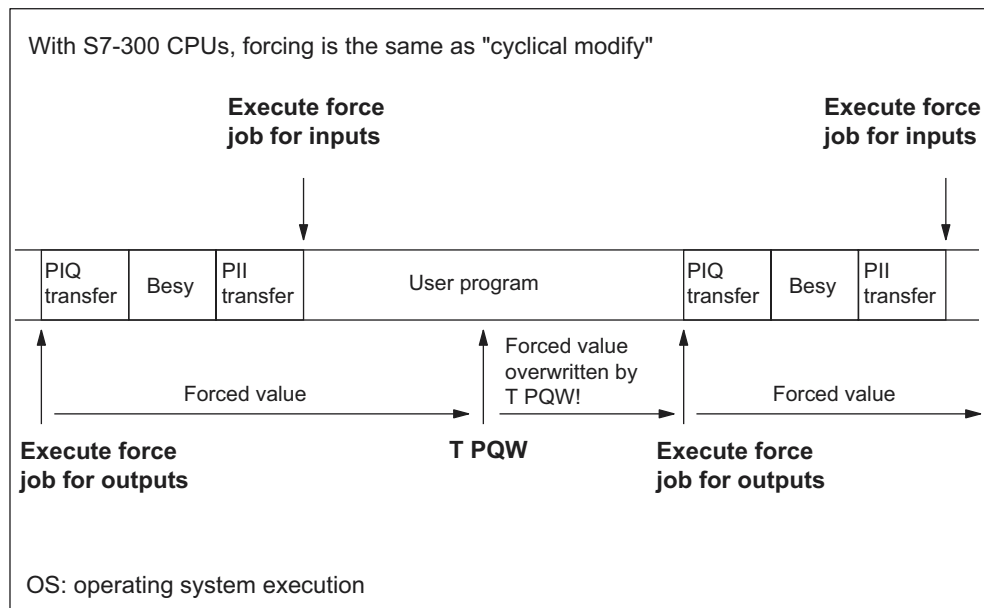

Figure 11-1 Principle of Forcing with S7-300 CPUs (all CPUs except 318-2 DP)

### The differences between forcing and controlling variables

Table 11-1 The differences between forcing and controlling variables

Characteristics/Function	Forcing with CPU 318-2 DP and S7-400	Forcing with S7-300 without 318-2 DP	Controlling Variables
Memory bit (M)	Yes	-	Yes
Timers and counters (T, C)	-	-	Yes
Data Blocks (DB)	-	-	Yes
Inputs and outputs (I, Q)	Yes	Yes	Yes
Peripheral Inputs (PI)	Yes	-	-
Peripheral Outputs (PO)	Yes	-	Yes
User program can overwrite modify/force values	-	Yes	Yes
Maximum number of force values	256	10	-

### Cross-reference

Details on test functions of the software are found in the *STEP 7 Online Help* and in the *STEP 7 Programming Manual*.

## 11.3 Overview: Diagnostics

### Introduction

System errors can occur especially in the **Commissioning** phase. Tracking these errors might be a time-consuming effort, since they can occur likewise on hardware and on software side. Here, the multitude of testing functions ensures commissioning without problems.

---

#### Note

Faults **during operation** are almost always caused by hardware errors or damage.

---

### Types of Error

Errors the S7 CPUs can recognize and to which you can react with the help of organization blocks (OBs) can be split into the following two categories:

- Synchronous errors: Errors you can relate to a specific point in the user program (e.g. error when accessing a peripheral module).
- Asynchronous errors: Errors you can **not** relate to a specific point in the user program (e.g. cycle time exceeded, module error).

### Error Handling

Programming with foresight and, above all, knowledge and proper handling of diagnostic tools puts you into an advantageous position in error situations:

- You can reduce the effects of errors.
- It makes it easier for you to locate errors (e.g. by programming error OBs).
- You can limit downtimes.

### Diagnostics with LED display

SIMATIC S7 hardware offers diagnostics with LEDs.

These LEDs are implemented in three colors:

- Green LEDs report regular operation (e.g. supply voltage is applied).
- Yellow LEDs indicate special operating states (e.g. "Force" is active).
- Red LEDs report errors (e.g. bus error)

A flashing LED also indicates a special event (e.g. memory reset).

## Cross-reference

Notes on diagnostics with LEDs are found in the Chapter below.

Notes on diagnostics of I/O modules capable of diagnostics are found in the relevant Manual.

## Diagnostic buffer

If an error occurs, the CPU writes the cause of error to the diagnostic buffer. In *STEP 7* you can read the diagnostic buffer with your PG. This location holds error information in plain text.

Other modules capable of diagnostics can be equipped with their own diagnostic buffer. In *STEP 7* (HW Config > Hardware diagnostics) you can read out his buffer on your PG.

diagnosable modules without diagnostic buffer write their error information to the CPU's diagnostic buffer.

When an error or an interrupt event occurs, (e.g. time-of-day interrupt), the CPU switches to STOP mode, or you can react in the user program via error/interrupt OBs. This would be OB82 in the above example.

## Diagnostics with system functions for CPU 318-2 DP

If you are using CPU 318-2 DP with a firmware version  $\geq$  V 3.0.0, we recommend the easy-to-use SFB 54 RALRM (call up diagnostic OB82) for diagnostic evaluation of centralized or distributed modules or DP slaves. In addition, the following system functions can also be used:

## Diagnostics with system functions for all CPUs

- Using SFC 51 "RDSYSST" to read an SSL partial list or an extract thereof.
- Reading the diagnostic data (Slave diagnostics) of a DP slave, using SFC13 "DPNRM\_DG"

Every DP slave provides slave diagnostic data according to EN 50 170 Volume 2, PROFIBUS. You can use SFC 13 "DPNRM\_DG" to read these diagnostic data. Error information is stored in hex code. Refer to the relevant module manual for information on the meaning of the read code.

For example, the entry of the value 50H (= dual 0101 0000) in byte 7 of the slave diagnostics for the distributed I/O module ET 200B indicates a faulty fuse or missing load voltage in channel group 2 and 3.

- Reading a data record with SFC59 "RD\_REC"

You can use SFC59 "RD\_REC" (read record) to read a specific data record from the addressed module. Data records 0 and 1 are especially suitable for reading diagnostic information from a diagnosable module.

Data record 0 contains 4 bytes of diagnostic data describing the current state of a signal module. Data record 1 contains the 4 bytes of diagnostic data also stored in data record 0, plus module-specific diagnostic data.

- Reading out the start information of the current OB, using SFC6 "RD\_SINFO"

Error information is also found in the start information of the relevant error OB.

You can use SFC6 "RD\_SINFO" (read start information) to read the start information of the OB that was last called and not yet processed completely, and of the start-up OB that was last called.

## 11.4 Diagnostic options with STEP 7

### The "Hardware diagnostics" function

Locate the cause of a module error by viewing the online information on the module. You can locate the cause of an error in the user program cycle with the help of the diagnostic buffer and of the stack content. You can also check whether a user program will run on a specific CPU.

Hardware diagnostics give you an overview of the PLC status. In an overview symbols can display the error status of every module. A double-click on the faulty module opens detailed error information. The scope of this information depends on the specific module. You can view the following information:

- Display of general information on the module (e.g. order No., version, designation) and module status (e.g. error).
- Display of module errors (e.g. channel error) in the central I/O and DP slave.
- Display of messages from the diagnostic buffer.

For CPUs you can also view the following module status information:

- Cause of an error in the user program cycle.
- Display of the cycle time (longest, shortest and last cycle).
- Options and utilization of MPI communication.
- Display of performance data (number of possible I/Os, memory bits, counters, timers and blocks).

Details on diagnostic options in STEP 7 and procedures are found in the *Programming with STEP 7 Manual* and in the *HW Config Online Help*.

## 11.5 Diagnostics with LEDs

### Introduction

Diagnostics with LEDs is an initial tool for error localization. Usually you evaluate the diagnostic buffer for further error localization.

The buffer contains plain text information on the error that has occurred. For example, you will find the number of the appropriate error OB here. If you generate this information, you can prevent the CPU from switching to STOP mode.

### For further information on status and error displays,

see the *Status and error displays* section of the appropriate *CPU Data Reference Manual*.

### Status and error displays of all CPUs

Table 11-2 Status and error displays

LED					Description
SF	5 VDC	FRCE	RUN mode	STOP	
LED off	LED off	LED off	LED off	LED off	CPU power supply missing. Remedy: Check whether the power supply module is connected to mains and switched on. Check whether the CPU is connected to the power supply module and switched on.
LED off	On	X (see the description)	LED off	On	The CPU is in STOP mode. Remedy: Start the CPU.
On	On	X	LED off	On	The CPU is in STOP mode as a result of error. Remedy: refer to the tables below, evaluate the SF LED
X	On	X	LED off	Flashes (0.5 Hz)	The CPU requests memory reset.
X	On	X	LED off	Flashes (2 Hz)	The CPU executes memory reset.
X	On	X	Flashes (2 Hz)	On	The CPU is in start-up mode.
X	On	X	Flashes (0.5 Hz)	On	The CPU was halted by a programmed break point. For details refer to the Programming Manual <i>Programming with STEP 7</i> .
On	On	X	X	X	Hardware or software error Remedy: refer to the tables below, evaluate the SF LED
X	X	On	X	X	You have activated the Force function For details refer to the Programming Manual <i>Programming with STEP 7</i> .

**Description of status X:**

This status has no effect on the current CPU function.

Table 11-3 Evaluation of the SF LED (software error)

Possible Errors	response of the CPU	Remedies
TOD interrupt is enabled and triggered. However, a matching block is not loaded. (Software/configuration error)	Calls OB 85. CPU does not STOP if OB 85 is loaded.	Load OB 10 or 11 (CPU 318-2 only) (OB number can be viewed in the diagnostic buffer).
Start time of the enabled TOD interrupt was jumped, e.g. by advancing the internal clock.	Calls OB 80. CPU does not STOP if OB 80 is loaded.	Disable the TOD interrupt before you set the time-of-day with SFC29.
Delay interrupt triggered by SFC 32. However, a matching block is not loaded. (Software/configuration error)	Calls OB 85. CPU does not STOP if OB 85 is loaded.	Load OB 20 or 21 (CPU 318-2 only) (the OB number can be viewed in the diagnostic buffer).
Process interrupt is enabled and triggered. However, a matching block is not loaded. (Software/configuration error)	Calls OB 85. CPU does not STOP if OB 85 is loaded.	Load OB 40 or 41 (CPU 318-2 only) (the OB number can be viewed in the diagnostic buffer).
<b>(CPU 318-2 DP only)</b> Status interrupt is generated, however, an appropriate OB55 is not loaded.	Calls OB85. CPU does not STOP if OB85 is loaded.	Load OB55
<b>(CPU 318-2 DP only)</b> Update interrupt is generated, however, an appropriate OB56 is not loaded.	Calls OB85. CPU does not STOP if OB85 is loaded.	Load OB 56
<b>(CPU 318-2 DP only)</b> Manufacturer-specific interrupt is generated, however, an appropriate OB57 is not loaded.	Calls OB85. CPU does not STOP if OB85 is loaded.	Load OB 57
Attempt to access a missing or faulty module. (Software or hardware error)	Calls OB 85. CPU does not STOP if OB 85 is loaded or, if OB 80 is loaded, the cycle time is exceeded a second time without being triggered again.	Generate OB 85, the start information of the OB contains the address of the relevant module. Replace the relevant module or eliminate the program error.
The cycle time was exceeded. Probably too many interrupt OBs called simultaneously.	Calls OB 80. CPU does not STOP if it is OB 80 is loaded or called for a second time.	Extension of the cycle time (STEP 7 – Hardware configuration), changing the program structure. Remedy: if required, retrigger cycle time monitoring via SFC 43

Possible Errors	response of the CPU	Remedies
Programming error <ul style="list-style-type: none"> <li>• Block not loaded</li> <li>• Wrong block number</li> <li>• Wrong timer/counter number</li> <li>• Read/write access to wrong area</li> <li>• Etc.</li> </ul>	Calls OB 121. CPU does not STOP if OB 121 is loaded.	Eliminate the programming error. The STEP 7 testing function helps you to locate the error.
I/O access error An error has occurred when module data was accessed	Calls OB122. CPU does not STOP if OB122 is loaded.	Check module addressing in HW Config or whether a module/DP slave has failed.
Global data communication error, e.g. insufficient length of the DB for global data communication.	Calls OB 87. CPU does not STOP if OB 87 is loaded.	Check global data communication in STEP 7. If required, correct the DB size.

Table 11-4 Evaluation of the SF LED (hardware error)

Possible Errors	response of the CPU	Remedies
A module was removed or inserted during operation.	CPU goes into STOP	Screw-tighten the modules and restart the CPU.
A diagnosable module reports a diagnostic interrupt.	Calls OB 82. CPU does not STOP if OB 82 is loaded.	response to the diagnostic event, depending on the module's configuration.
Attempt to access a missing or faulty module. Loose connector (Software or hardware error).	Call of OB 85, if access was attempted during update of the process image (here, the OB85 call must be enabled accordingly in the parameters). Call of OB122 with direct I/O access. CPU switches to STOP if the OB is not loaded.	Generate OB 85, the start information of the OB contains the address of the relevant module. Replace the relevant module, tighten the plug or eliminate the program error.
Faulty Memory Card.	The CPU goes into STOP mode and requests memory reset.	Replace the Memory Card, reset CPU memory, transfer the program again and set the CPU to RUN mode.

Tip: You can use SFC 39 to disable all interrupts and asynchronous error events.

Tip on OB 32 and OB 35: You can set the times in watchdog OB 32 and OB 35, starting from 1 ms.

**Note**

The shorter the selected watchdog interrupt period, the more likely it is that watchdog interrupt errors will occur. You must take into account the operating system times of the CPU in question, the user program runtime and extension of the cycle time by active PG functions, for example.

**Cross-reference**

Details on the OBs and on SFCs required for their evaluation can be found in the *STEP 7 Online Help* and in the Manual *System Software for S7-300/400 - System and Standard Functions*.

**Status and error display of DP-compliant CPUs**

Table 11-5 The BUSF, BUSF1 and BUSF2 LEDs

SF	LED				Description
	5 VDC	BUSF	BUSF1	BUSF2	
On	On	On/ flashes	-	-	PROFIBUS DP interface error. Remedy: Refer to the table below
On	On	-	On/ flashes	X	Error at the first PROFIBUS DP interface of CPU 318-2 DP. Remedy: Refer to the table below
On	On	-	X	On/ flashes	Error at the second PROFIBUS DP interface of CPU 318-2 DP. Remedy: Refer to the table below

Description of status X:

The LED can assume the status On or Off, but this status has no effect on the current CPU function. For example, the states Force On or Off do not influence the STOP status of the CPU



Table 11-6 The BUSF LED lights up.

Possible Errors	response of the CPU	Remedies
<ul style="list-style-type: none"> <li>• Bus fault (hardware fault).</li> <li>• DP interface error.</li> <li>• Different transmission rates in multiple DP master mode.</li> <li>• Bus short-circuit has occurred.</li> </ul>	<p>Calls OB86 (when CPU is in RUN mode). CPU switches to STOP if OB 86 is not loaded.</p>	<ul style="list-style-type: none"> <li>• Check the bus cable for short or interruption.</li> <li>• Evaluate the diagnostic data. Reconfigure, or correct the configuration.</li> </ul>

Table 11-7 The BUSF LED flashes

Possible Errors	response of the CPU	Remedies
<p>CPU is the DP master</p> <ul style="list-style-type: none"> <li>• Failure of a connected station</li> <li>• At least one of the configured slaves cannot be accessed.</li> <li>• Incorrect configuration</li> </ul>	<p>Calls OB86 (when CPU is in RUN mode). CPU switches to STOP if OB 86 is not loaded.</p>	<p>Ensure that the bus cable is connected to the CPU and that the bus is not interrupted.</p> <p>Wait until the CPU has started. If the LED does not stop flashing, check the DP slaves or evaluate the diagnostic data for the DP slaves.</p>
<p>The CPU is the DP slave CPU 31x was programmed incorrectly. Possible causes:</p> <ul style="list-style-type: none"> <li>• The response monitoring time has expired.</li> <li>• PROFIBUS DP communication is interrupted.</li> <li>• Wrong PROFIBUS address.</li> <li>• Incorrect configuration</li> </ul>	<p>Calls OB 86 (when CPU is in RUN mode).</p> <p>CPU switches to STOP if OB 86 is not loaded.</p>	<ul style="list-style-type: none"> <li>• Check the CPU.</li> <li>• Check to make sure that the bus connector is properly inserted.</li> <li>• Check for interruptions in the bus cable to the DP master.</li> <li>• Check configuration data and the parameters.</li> </ul>

## 11.6 Diagnostics of DP CPUs

### 11.6.1 Diagnostics of DP CPUs operating as DP master

#### Diagnostics evaluation in the user program

The figure below illustrates the procedure for evaluating the diagnostics in the user program.

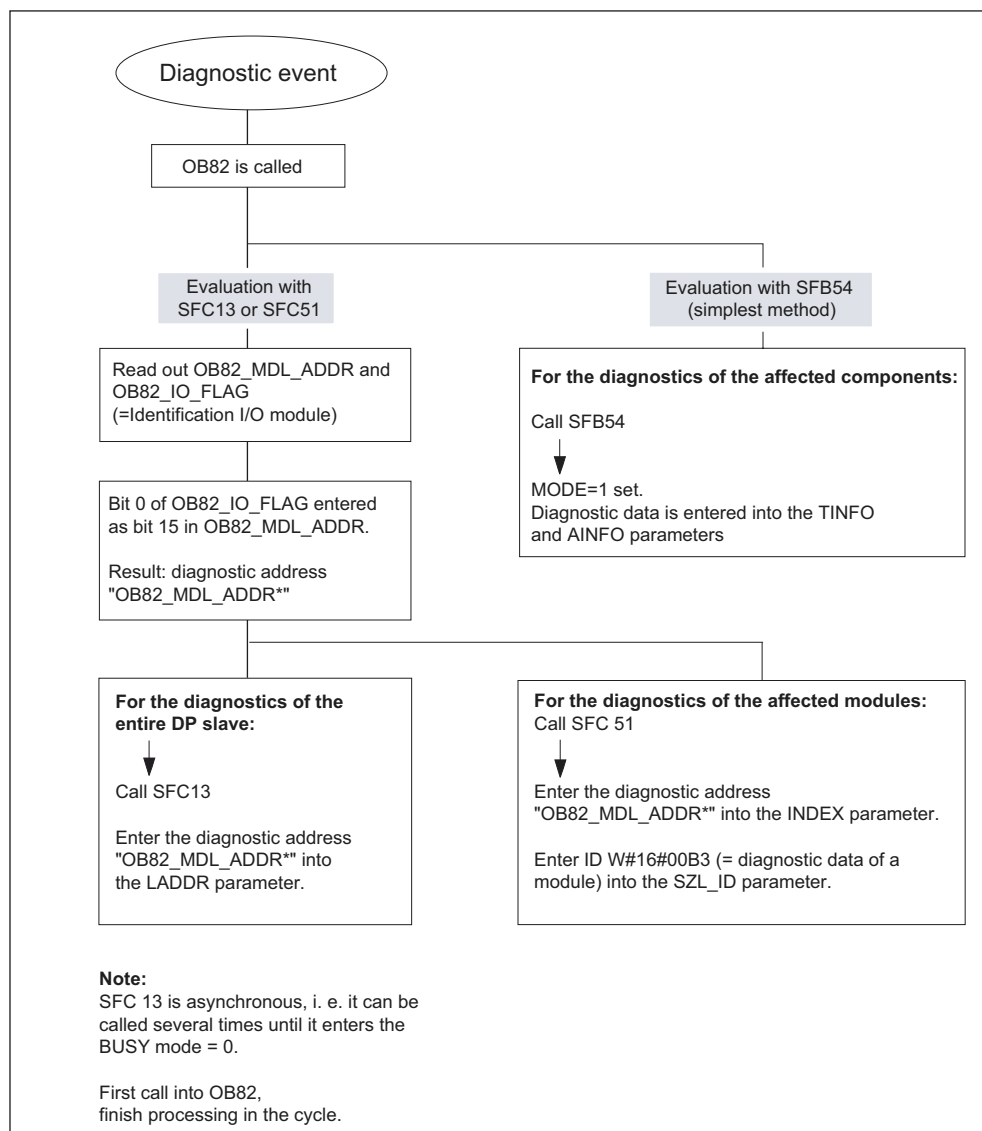

Figure 11-2 Diagnostics with CPU 31x-2

## Diagnostic addresses

With CPU 31x-2 you assign diagnostic addresses for the PROFIBUS DP. Make sure DP diagnostic addresses are assigned once to the DP master and to the DP slave during configuration.

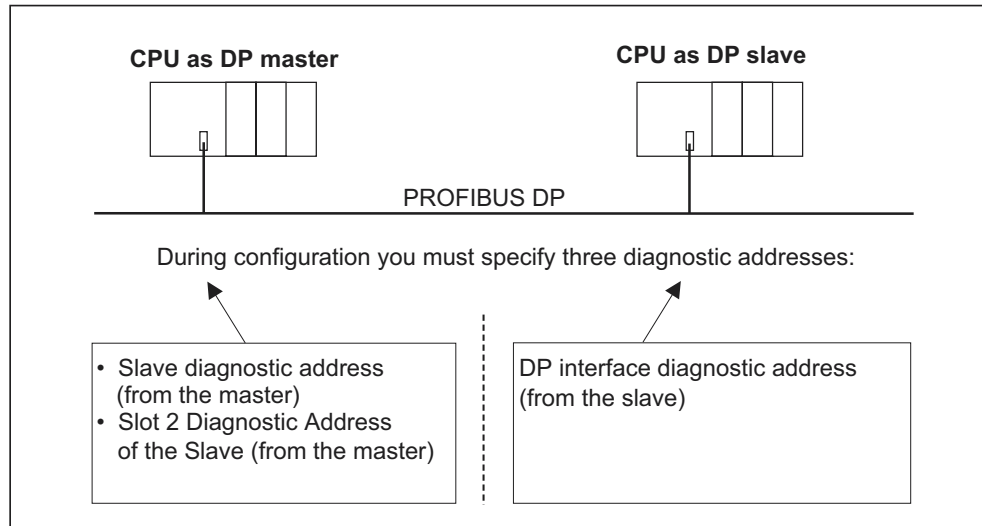

Figure 11-3 Diagnostic addresses for DP masters and DP slaves

Description of DP master configuration	Description of DP slave configuration
<p>When configuring the DP master, define a diagnostic address for the DP slave (in the associated project of the DP master). Below, this diagnostic address is labeled <i>Assigned to DP master</i> . The DP master receives information about the status of the DP slave or about a bus interruption by means of this diagnostic address.</p>	<p>During configuration of the DP slave, you also specify a diagnostic address assigned to the DP slave (in the associated project of the DP slave). Below, this diagnostic address is labeled <i>Assigned to DP slave</i>. This diagnostic addresses is used by the DP slave to obtain information on the status of the DP master or a bus interruption.</p>

## Special features of CPU 318-2 DP (≥ V3.0.0)

When CPU318-2 DP act as a master in DPV1 mode, you assign two different diagnostic addresses for an I-Slave, one diagnostic address for Slot 0 and one for Slot 2. Both addresses have the following functions:

- The diagnostic address for slot 0 reports in the master all events relating to the complete slave (node representative), e.g. node failure.
- The diagnostic address for slot 2 is used to report events that affect this slot. For example, if the CPU is acting as an intelligent slave, it returns the diagnostic interrupts for operating state transitions.

## Event recognition

The table below shows how CPU 31x-2 operating as DP master recognizes operating mode transitions of a CPU operating as DP slave or data exchange interruptions.

Table 11-8 Event recognition by CPUs 31x-2 as the DP master

Event	What happens in the DP slave?
Bus failure interrupt (short-circuit, connector unplugged)	<ul style="list-style-type: none"> <li>• Calls OB 86 with the message <b>Node failure</b> (coming event; diagnostic address of the DP slave assigned to the DP master)</li> <li>• with I/O access: Call of OB122 (I/O access error)</li> </ul>
DP slave: RUN → STOP	<ul style="list-style-type: none"> <li>• Call of OB82 with the message <b>Module error</b> (incoming event; diagnostic address of the DP slave assigned to the DP master; Variable OB82_MDL_STOP=1)</li> </ul>
DP slave: STOP → RUN	<ul style="list-style-type: none"> <li>• Call of OB82 with the message <b>Module OK</b> (outgoing event; diagnostic address of the DP-Slave assigned to the DP master; Variable OB82_MDL_STOP=0)</li> </ul>

## Evaluation in the user program

The table below shows how you can, for example, evaluate RUN to STOP transitions of the DP slave in the DP master.

Table 11-9 Evaluation in the DP master of RUN to STOP transitions by the DP slave

In the DP master	In the DP slave (CPU 31x-2DP)
Diagnostic addresses: (Example) Master diagnostic address = <b>1023</b> Slave diagnostic address = <b>1022</b>	Diagnostic addresses: (Example) Slave diagnostic address = <b>422</b> Master diagnostic address = irrelevant
The CPU calls OB 82 with the following information: <ul style="list-style-type: none"> <li>• OB 82_MDL_ADDR:=<b>1022</b></li> <li>• OB82_EV_CLASS:=B#16#39 (incoming event)</li> <li>• OB82_MDL_DEFECT: = Module error</li> </ul> Tip: The CPU diagnostic buffer also contains this information  In the user program you should also include SFC13 "DPNRM_DG" for reading out DP slave diagnostic data.	← CPU: RUN -> STOP  The CPU generates a DP slave diagnostics message frame

## 11.6.2 Reading Slave Diagnostic Data

The slave diagnostic data is compliant with EN 50170, Volume 2, PROFIBUS. Depending on the DP master, diagnostic data for all DP slaves conforming to standard can be read with *STEP 7*.

### Diagnostic addresses with direct data exchange

For direct data exchange, you assign a diagnostic address in the receiver:

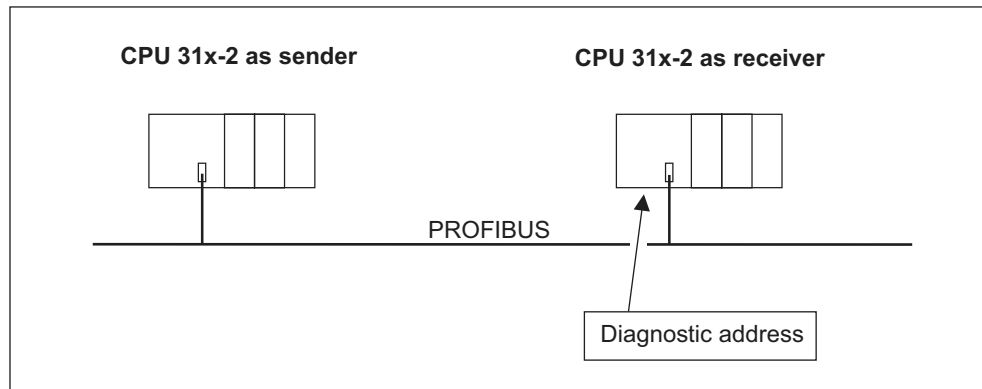

Figure 11-4 Diagnostic address for the receiving node with direct data exchange

In this figure, you see that for configuration in the receiver, you define a diagnostic address that is assigned to the receiver. The receiver obtains information about the status of the sender or about a bus interruption by means of this diagnostic address.

### Reading out the diagnostic data

The table below shows you how the various DP master systems can read diagnostic information from a slave.

Table 11-10 Reading the diagnostic information using STEP 5 and STEP 7 in the masters system

PLC with DP master	Blocks or registers in STEP 7	Application	Further information
SIMATIC S7/M7	"DP slave diagnostics" register	Displaying slave diagnostic data as plain text on a STEP 7 user interface	Found under the keyword <i>Hardware diagnostics</i> in the STEP 7 Online Help and in the <i>Programming STEP 7 Manual</i>
	SFC 13 "DP_NRM_DG"	Reading slave diagnostic data (stored in the data area of the user program)	<i>System and Standard Functions Reference Manual</i>
	SFC 51 "RDSYSST"	Reading SSL sublists. In the diagnostic interrupt, call SFC 51 with the system status list ID W#16#00B4 and read out the SSL of the slave CPU.	<i>System and Standard Functions Reference Manual</i>
	<b>(CPU 318-2 DP only)</b> SFB 54 "RALRM"	Reading additional interrupt information from a DP slave or a centralized module from the relevant OB.	<i>System and Standard Functions Reference Manual</i>
	SFC 59 "RD_REC"	Reading data records of the S7 diagnosis (stored in the data area of the user program)	<i>System and Standard Functions Reference Manual</i>
	FB 125/FC 125	Evaluating slave diagnostic data	On the Internet URL <a href="http://www.ad.siemens.de/simatic-cs">http://www.ad.siemens.de/simatic-cs</a> , Article ID 387 257
SIMATIC S5 with IM 308-C operating as DP master	FB 192 "IM308C"	Reading slave diagnostic data (stored in the data area of the user program)	Manual <i>Distributed I/O System ET 200</i>
SIMATIC S5 with S5-95U PLC operating as DP master	FB 230 "S_DIAG"		

### Example of reading slave diagnostic data, using FB192 "IM 308C"

Here you will find an example of how to use FB192 to read out DP slave diagnostic data in the 192 **STEP 5** user program.

#### Agreement for the STEP 5 user program

For this **STEP 5** user program it is assumed that:

- The IM 308-C operating as DP master uses page frame 0 to 15 (number 0 of IM 308-C).
- The DP slave has the PROFIBUS address 3.
- Slave diagnostics data should be stored in DB 20. Here you can also use any other data block.
- Slave diagnostic data has a length of 26 bytes.

#### STEP 5 user program

	STL	Description
	:A DB 30	
	:SPA FB 192	
Name	:IM308C	
DPAD	: KH F800	Default address area of IM 308-C
IMST	: KY 0, 3	//IM no. = 0, PROFIBUS address of the DP slave = 3
FCT	: KC SD	//Function: Read slave diagnosis
GCGR	: KM 0	//not evaluated
TYP	: KY 0, 20	//S5 data area: DB 20
STAD	: KF +1	//Diagnostic data as of data word 1
LENG	: KF 26	//Length of diagnostic data = 26 bytes
ERR	: DW 0	//Error code storage in DW 0 of DB 30

### Example of reading out S7 diagnostic data with SFC 59 "RD REC"

Here you will find an example of how to use SFC 59 in the **STEP 7** user program to read S7 diagnostics data records for a DP slave. The process of reading the slave diagnostics is similar to SFC 13.

#### Assumptions regarding the STEP 7 user program

For this **STEP 7** user program it is assumed that:

- Diagnostic data for the input module at address 200<sub>H</sub> is to be read.
- Data record 1 is to be read out.
- Data record 1 is to be stored in DB 10.

## STEP 7 user program

STL	Description
CALL SFC 59	
REQ :=TRUE	//Request to read
IOID :=B#16#54	//Identifier of the address area, here the I/O input
LADDR:= W#16#200	//Logical address of the module
RECNUM :=B#16#1	//Data record 1 is to be read
RET_VAL :=MW2	//An error code is output if an error occurs
BUSY :=MO.0	//Read operation not finished
RECORD :=P# DB10.DBX 0.0 BYTE 240	//DB 10 is target area for the read data record 1

### Note

Data is only returned to the target area if BUSY is reset to 0 and if no negative RET\_VAL has occurred.

## Diagnostic addresses

With CPU 31x-2 you assign diagnostic addresses for the PROFIBUS DP. Make DP diagnostic addresses are assigned to the DP master and to the DP slave sure during configuration.

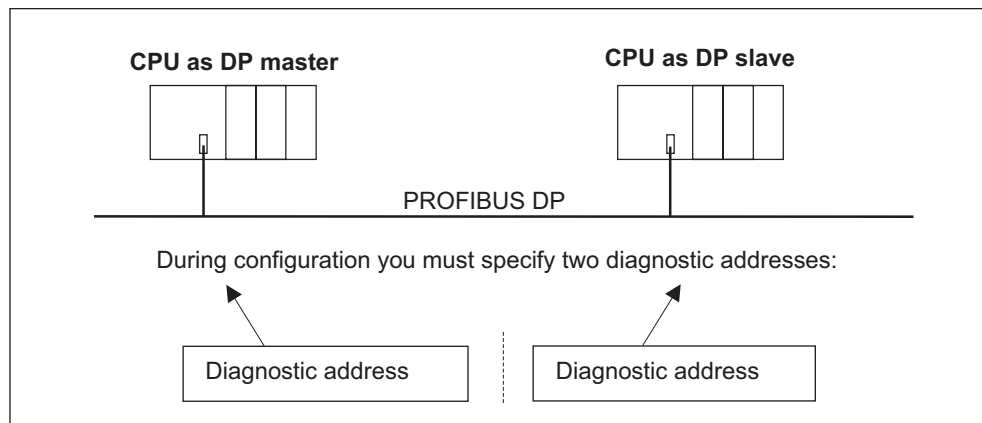

Figure 11-5 Diagnostic addresses for DP masters and DP slaves



Description of DP master configuration	Description of DP slave configuration
<p>When configuring the DP master, define a diagnostic address for the DP slave (in the associated project of the DP master).</p> <p>Below, this diagnostic address is labeled <i>Assigned to DP master</i>.</p> <p>The DP master receives information about the status of the DP slave or about a bus interruption by means of this diagnostic address.</p>	<p>During configuration of the DP slave, you also specify a diagnostic address assigned to the DP slave (in the associated project of the DP slave).</p> <p>Below, this diagnostic address is labeled <i>Assigned to DP slave</i>.</p> <p>This diagnostic addresses is used by the DP slave to obtain information on the status of the DP master or a bus interruption.</p>

### Special features of CPU 318-2 DP

Applies to the following CPUs	As of firmware version
CPU 318-2 DP	>= V 3.0.0

When CPU318-2 DP act as a master in DPV1 mode, you assign two different diagnostic addresses for an I-Slave, one diagnostic address for Slot 0 and one for Slot 2. Both addresses have the following functions:

- The diagnostic address for slot 0 reports in the master all events relating to the complete slave (node representative), e.g. node failure.
- The diagnostic address for slot 2 is used to report events that affect this slot. For example, if the CPU is acting as an intelligent slave, it returns the diagnostic interrupts for operating state transitions.

### Event recognition

The table below shows how CPU 31x-2 operating as DP slave recognized operating state transitions or data exchange interruptions.

Table 11-11 Event recognition by CPUs 31x-2 acting as the DP slave

Event	What happens in the DP slave?
Bus failure interrupt (short-circuit, connector unplugged)	<ul style="list-style-type: none"> <li>• Calls OB 86 with the message <b>Station failure</b> (incoming event; diagnostic address of the DP slave, assigned to the DP slave)</li> <li>• with I/O access: Call of OB122 (I/O access error)</li> </ul>
DP master: RUN → STOP	<ul style="list-style-type: none"> <li>• Calls OB 82 with the message <b>Module error</b> (incoming event; diagnostic address of the DP slave assigned to the DP slave; Variable OB82_MDL_STOP=1)</li> </ul>
DP master: STOP → RUN	<ul style="list-style-type: none"> <li>• Call of OB82 with the message <b>Module OK</b>(outgoing event; diagnostic address of the DP slave, assigned to the DP slave; Variable OB82_MDL_STOP=0)</li> </ul>

### Evaluation in the user program

The table below shows you how you can, for example, evaluate RUN-STOP transitions of the DP master in the DP slave (see also the previous table).

Table 11-12 Evaluation of RUN to STOP transitions in the DP master/DP slave

In the DP master	In the DP slave
Diagnostic addresses: (Example) Master diagnostic address = <b>1023</b> Slave diagnostic address in the master system= <b>1022</b>	Diagnostic addresses: (Example) Slave diagnostic address = <b>422</b> Master diagnostic address = irrelevant
CPU: RUN " STOP	→ The CPU calls OB82 with the following information: <ul style="list-style-type: none"> <li>• OB82_MDL_ADDR:=422</li> <li>• OB82_EV_CLASS:=B#16#39 (incoming event)</li> <li>• OB82_MDL_DEFECT: = Module error</li> </ul> Tip: The CPU diagnostic buffer also contains this information

### 11.6.3 Interrupts on the DP Master

#### Interrupts with S7 DP master

If the CPU 31x-2 is used as the DP slave, you can trigger a process interrupt on the DP master from the user program.

When you call SFC 7 "DP\_PRAL", you trigger an OB40 in the user program on the DP master. The SFC 7 allows you to forward interrupt information to the DP master in a double word. This information can then be evaluated in the OB40\_POINT\_ADDR variable in the OB 40. The interrupt information can be freely programmed as required. The *System software for S7-300/400 - System and Standard Functions - Reference Manual* contains a detailed description of SFC 7 "DP\_PRAL".

#### Interrupts with another DP master

When CPU 31x-2 operates with another DP master, an image of these interrupts is created in the device-specific diagnostic data of CPU 31x-2. You must post-process the relevant diagnostic events in the DP master's user program.

---

#### Note

Before you can evaluate diagnostic and process interrupts using the device-specific diagnostics function on another DP master, you must make sure that:

The DP master is able to store the diagnostic messages, i.e. the diagnostic messages should be stored in a ring buffer on the DP master. For example, if the DP master can not store diagnostic messages, only the last incoming diagnostic message would be stored.

In your user program, you must query the relevant bits in device-specific diagnostic data. Here you must take the PROFIBUS DP cycle time into account, for example, to be able to query these bits at least once and in synchronism to bus cycle time.

With an IM 308-C operating as DP master you cannot utilize process interrupts in device-specific diagnostics, because only incoming events are reported rather than outgoing events.

---

### 11.6.4 Structure of the slave diagnostic data when the CPU is used as an intelligent slave

#### Structure of the diagnostics message frame

The figure below shows the structure of the diagnostics message frame for slave diagnostics.

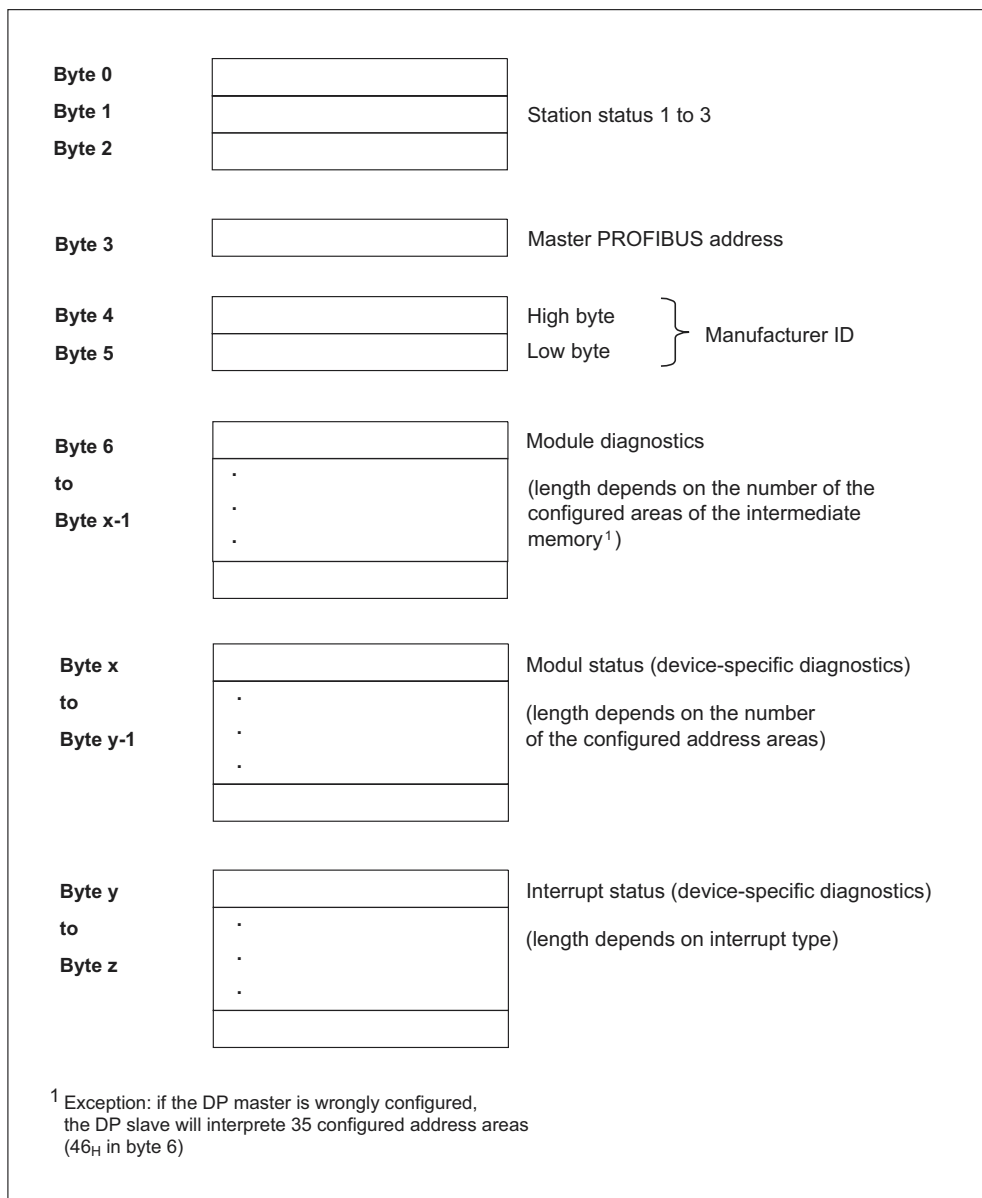

Figure 11-6 Structure of slave diagnostic data

## Station status 1

Table 11-13 Structure of station status 1 (byte 0)

Bit	Description	Remedy
0	<b>1:</b> DP slave cannot be addressed by DP master.	<ul style="list-style-type: none"> <li>Is the correct DP address set on the DP slave?</li> <li>Is the bus connector in place?</li> <li>Does the DP slave have power?</li> <li>Correct configuration of the RS485 Repeater?</li> <li>Perform a reset on the DP slave.</li> </ul>
1	<b>1:</b> DP slave is not ready for data exchange.	<ul style="list-style-type: none"> <li>Wait for the slave to complete start-up.</li> </ul>
2	<b>1:</b> Configuration data sent by DP master to the DP slave is inconsistent with slave configuration.	<ul style="list-style-type: none"> <li>Was the software set for the correct station type or DP slave configuration?</li> </ul>
3	<b>1:</b> Diagnostic interrupt, generated by a RUN to STOP transition on the CPU or by the SFB 75 <b>0:</b> Diagnostic interrupt, generated by a STOP to RUN transition on the CPU or by the SFB 75	<ul style="list-style-type: none"> <li>You can read the diagnostic data.</li> </ul>
4	<b>1:</b> Function not supported; e.g. changing the DP address at software level	<ul style="list-style-type: none"> <li>Check configuration data.</li> </ul>
5	<b>0:</b> This bit is always "0".	<ul style="list-style-type: none"> <li>-</li> </ul>
6	<b>1:</b> DP slave type inconsistent with software configuration.	<ul style="list-style-type: none"> <li>Was the software set for the right station type? (parameter assignment error)</li> </ul>
7	<b>1:</b> DP slave was configured by a DP master other than the master currently accessing the slave.	<ul style="list-style-type: none"> <li>The bit is always 1 if, for example, you are currently accessing the DP slave via PG or a different DP master.</li> </ul> <p>The configuring master's DP address is located in the "Master PROFIBUS address" diagnostics byte.</p>

## Station Status 2

Table 11-14 Structure of station status 2 (byte 1)

Bit	Description
0	<b>1:</b> The DP slave requires new parameters and configuration.
1	<b>1:</b> A diagnostic message was received. The DP slave cannot resume operation until the error has been cleared (static diagnostic message).
2	<b>1:</b> This bit is always "1" if a DP slave exists with this DP address.
3	<b>1:</b> The watchdog monitor is enabled on this DP slave.
4	<b>1:</b> DP slave has received control command "FREEZE".
5	<b>1:</b> DP slave has received control command "SYNC".
6	<b>0:</b> This bit is always "0".
7	<b>1:</b> DP slave is disabled, that is, it has been excluded from cyclic processing.

### Station Status 3

Table 11-15 Structure of station status 3 (byte 2)

Bit	Description
0 to 6	<b>0:</b> These bits are always "0"
7	<b>1:</b> The incoming diagnostic messages exceeds the memory capacity of the DP slave. The DP master cannot write all diagnostic messages sent by the DP slave to its diagnostic buffer.

### Master PROFIBUS address

The "Master PROFIBUS address" diagnostic byte stores the DP address of the DP master:

- that has configured the DP slave and
- has read and write access to the DP slave.

Table 11-16 Structure of the master PROFIBUS address (byte 3)

Bit	Description
0 to 7	DP address of the DP master that has configured the DP slave and has read/write access to that DP slave.
	FFH: DP slave was not configured by a DP master

### vendor ID

The vendor ID contains a code specifying the DP slave's type.

Table 11-17 Structure of the vendor ID (byte 4, 5)

Byte 4	Byte 5	Vendor ID for the CPU
80 <sub>H</sub>	2F <sub>H</sub>	CPU 315-2 DP (6ES7315-2AF03-0AB0) CPU 315-2 DP (6ES7315-2AF83-0AB0)
80 <sub>H</sub>	6F <sub>H</sub>	CPU 316-2-DP
80 <sub>H</sub>	7F <sub>H</sub>	CPU 318-2 DP

### Module diagnostics

Module diagnostics indicate the configured address area of transfer memory that has received an entry.

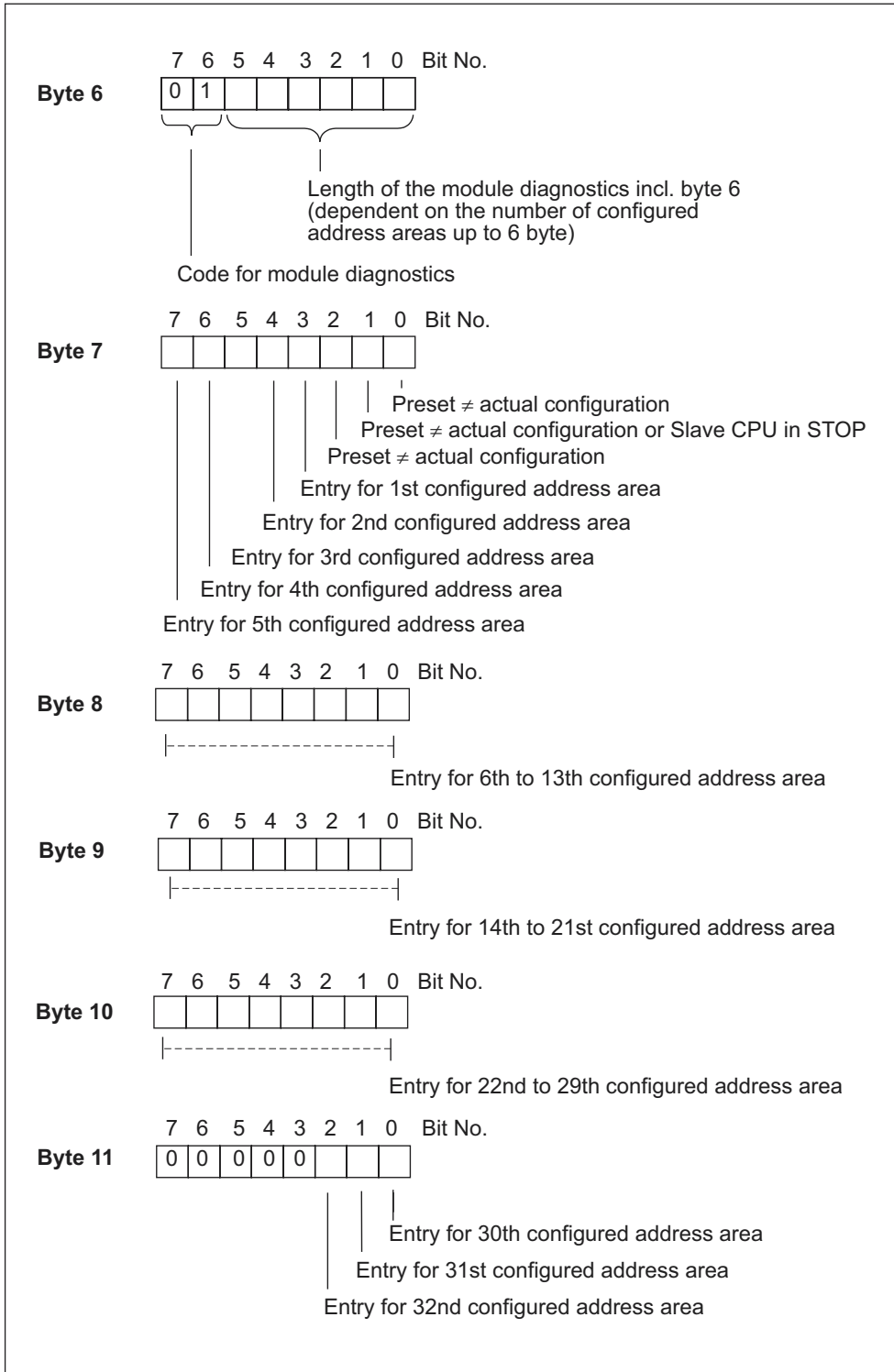

Figure 11-7 Structure of the ID-specific diagnostics for CPU 31x-2

### Module status

The module status reflects the status of the configured address areas, and provides detailed ID-specific diagnostics with respect to the configuration. Module status starts with module diagnostics and consists of a maximum of 13 bytes.

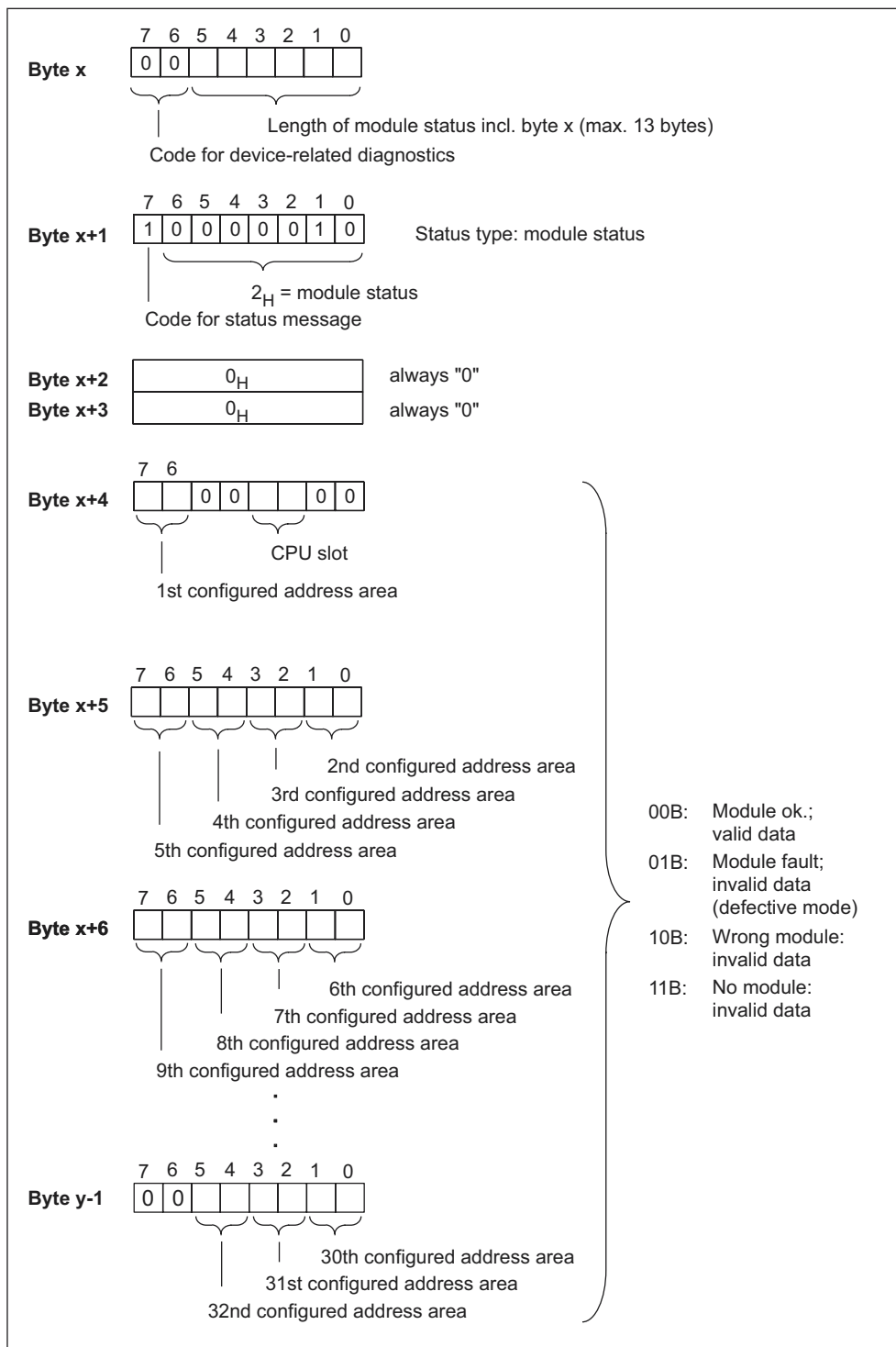

Figure 11-8 Structure of the module status



### Interrupt status

The interrupt status of module diagnostics provides details on a DP slave. The maximum length of module diagnostics starting at byte y is 20 bytes.

The following figure describes the structure and content of the bytes for a configured address area of transfer memory.

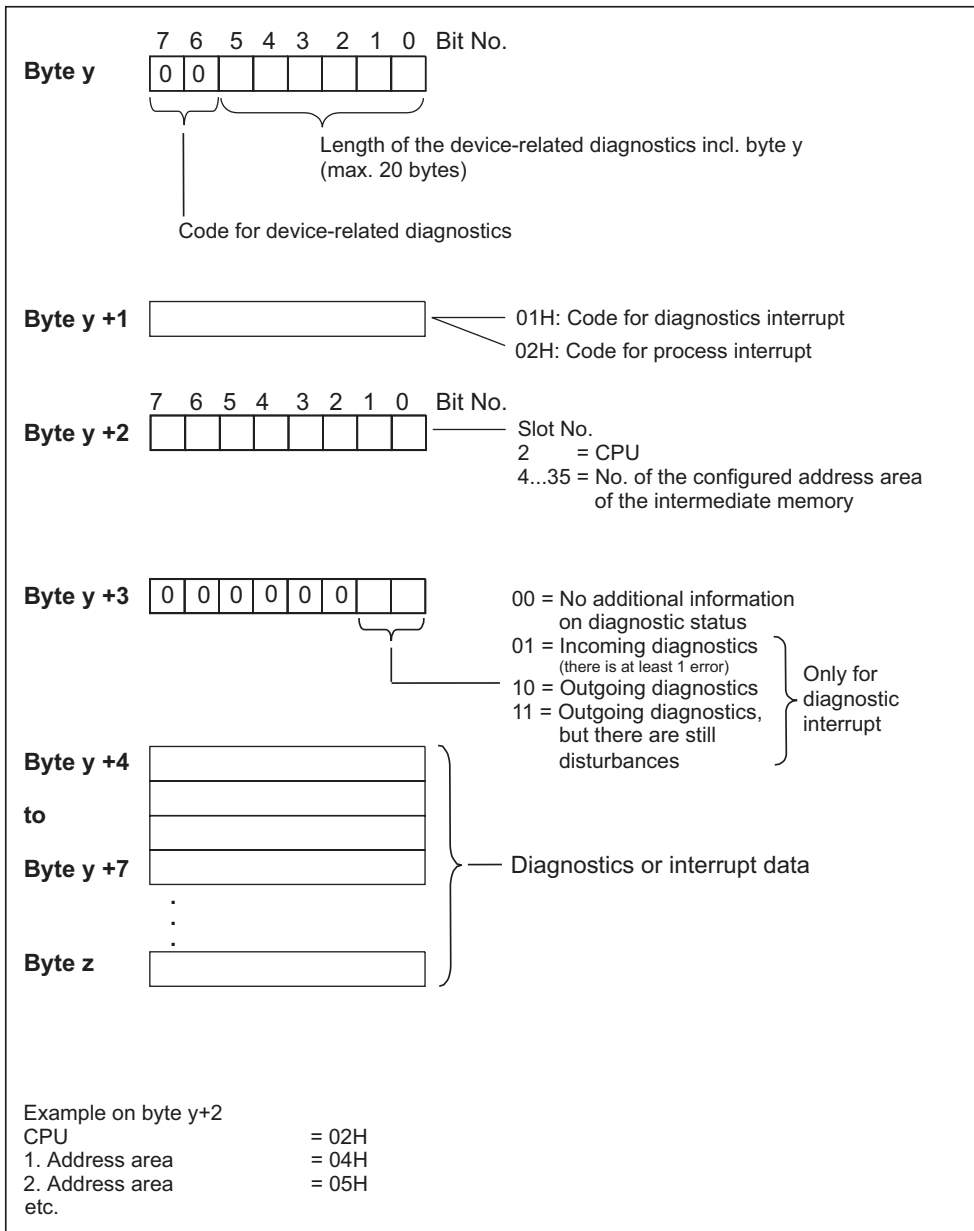

Figure 11-9 Structure of the interrupt status

### Structure of the interrupt data for a process interrupt (from byte y+4)

When a process interrupt occurs (code 02<sub>H</sub> for process interrupt in byte y+1), 4 bytes of interrupt information after byte y+4 are transferred. These 4 bytes are transferred to the intelligent slave using SFC 7 "DP\_PRAL" when the process interrupt for the master is generated.

### Structure of the interrupt data when a diagnostic interrupt is generated in response to an operating status change by the intelligent slave (after byte y+4)

Byte y+1 contains the code for a diagnostic interrupt (01<sub>H</sub>). The diagnostic data contains the 16 bytes of status information from the CPU. The figure below shows the allocation of the first four bytes of diagnostic data. The next 12 bytes are always 0.

The data in these bytes corresponds to the contents of data record 0 of diagnostic data in **STEP 7** (in this case, not all bits are used).

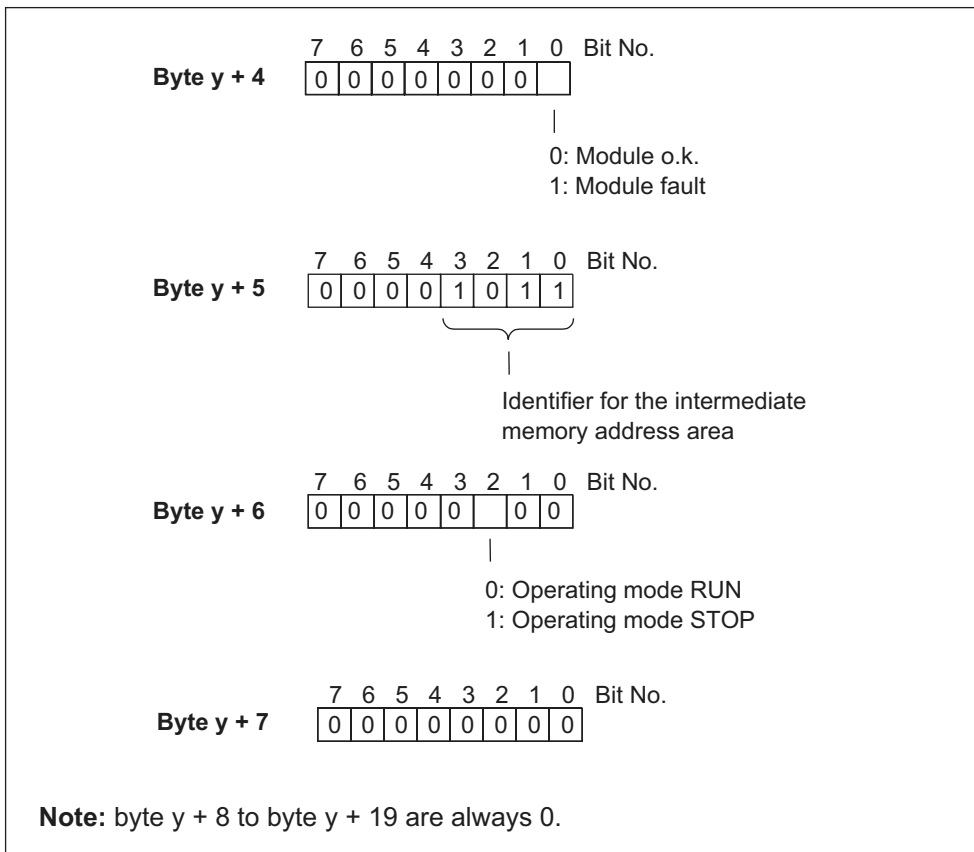

Figure 11-10 Bytes y+4 to y+7 for a diagnostic interrupt (operating status change by intelligent slave)

## 12.1 Assembly

### 12.1.1 General Rules and Regulations for S7-300 Operation

#### Introduction

In view of the many and versatile S7-300 applications, this chapter can only describe the basic rules on its electrical configuration. You must observe at least these basic rules if you want your S7-300 to operate free of trouble.

#### EMERGENCY-OFF devices

EMERGENCY-OFF devices to IEC 204 (corresponds to VDE 113) must remain effective in all operating modes of the plant or system.

#### Start-up of the system after specific events

The following table shows you what you have to observe when starting up a plant again following specific events.

Table 12-1 Starting the system after specific events

<b>If there is...</b>	<b>What must not happen ...</b>
Restart following a voltage dip or power failure,	No dangerous operating states may occur. If necessary, force EMERGENCY-OFF.
Start-up after releasing the EMERGENCY OFF device:	An uncontrolled or undefined start-up must be avoided.

## Mains voltage

The following table shows you what to watch with respect to the mains voltage.

Table 12-2 Mains voltage

In the case of ...	is ...
For stationary systems or systems without all-pole mains disconnect switch	Installation of a mains disconnect switch or a fuse in the building installation system.
For load power supplies, power supply modules	The set rated voltage range must correspond to the local power supply voltage.
For all circuits of the S7-300	Rated mains voltage fluctuation/deviation must lie within the permitted tolerance (refer to Technical Data of S7-300 modules).

## 24 VDC Power Supply

The table below shows what you must observe in connection with the 24 VDC power supply.

Table 12-3 Protection against external electrical interference

In the case of ...	Measures to take	
Buildings	External lightning protection	Install lightning protection (e.g. lightning conductors).
24 VDC power supply cables, signal cables	Internal lightning protection	
24 VDC Power Supply	Safe (electrical) extra-low voltage isolation	

## Protection against external electrical interference

The table below shows how you must protect your system against electrical interference or faults.

Table 12-4 Protection against external electrical interference

In the case of ...	Make sure that ...
All plants or system with an S7-300 installation	the plant or system is connected to a protective conductor for the suppression of electromagnetic interference.
Supply/signal/bus cables	The conductor routing and installation is correct.
Signal and bus cables	a cable/conductor break does not result in undefined plant or system states.

## Information on EMC and surge protection ...

can be found in the following Chapters.

## 12.2 Protection against electromagnetic interference

### 12.2.1 Basic Points for System Installations Conforming with EMC Requirements

#### Definition: EMC

EMC (electromagnetic compatibility) describes the capability of electrical equipment to operate free of errors in a given electromagnetic environment, without being subject to external influence and without influencing external devices in any way.

#### Introduction

Although your S7-300 and its components are developed for an industrial environment and high electromagnetic compatibility, you should draw up an EMC installation plan before you install the controller under consideration of all possible interference sources.

#### Possible effects of interference

Electromagnetic noise can influence a PLC in various ways:

- Electromagnetic fields having a direct influence on the system
- Interference via bus signals (PROFIBUS DP etc.)
- Interference coupling via the system wiring
- Interference influencing the system via the power supply and/or protective ground

The figure below shows the likely paths of electromagnetic interference.

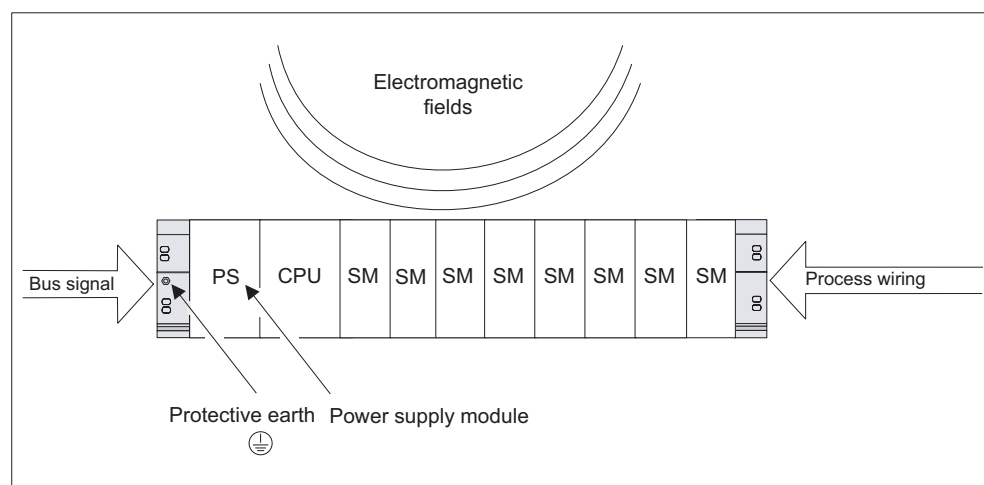

Figure 12-1 Possible paths of electromagnetic interference

## Coupling mechanisms

Depending on the emitting media (line or isolated) and the distance between the interference source and the device, four different coupling mechanisms can influence the PLC.

Table 12-5 Coupling mechanisms

Coupling mechanisms	Cause	Typical interference sources
Electrical coupling	Galvanic or mechanical coupling always occurs when two circuits use one common cable.	<ul style="list-style-type: none"> <li>• Clocked devices (influence on the network due to converters and third-party power supply modules)</li> <li>• Starting motors</li> <li>• Potential differences on component enclosures with common power supply</li> <li>• Static discharge</li> </ul>
Capacitive coupling	Capacitive or electrical coupling occurs between conductors connected to different potentials.  The coupling effect is proportional to voltage change over time.	<ul style="list-style-type: none"> <li>• Interference coupling due to parallel routing of signal cables</li> <li>• Static discharge of the operator</li> <li>• Contactors</li> </ul>
Inductive coupling	Inductive or magnetic coupling occurs between two current circuit loops. Current flow in magnetic fields induces interference voltages.  The coupling effect is proportional to current change over time.	<ul style="list-style-type: none"> <li>• Transformers, motors, arc welding devices</li> <li>• Power supply cables routed in parallelism</li> <li>• Switched cable current</li> <li>• High-frequency signal cable</li> <li>• Coils without suppression circuit</li> </ul>
Radio frequency coupling	Radio frequency coupling occurs when an electromagnetic wave reaches a conductor system. This wave coupling induces currents and voltages.	<ul style="list-style-type: none"> <li>• Neighboring transmitters (e.g. radio phones)</li> <li>• Sparking (sparkplugs, collectors of electrical motors, welding devices)</li> </ul>

## 12.2.2 Five Basic Rules for Ensuring EMC

### If you comply with these five basic rules ...

you can ensure EMC in many cases!

#### Rule 1: Large-area grounding

When you install the automation equipment, make sure that surfaces of inactive metal parts are well bonded to chassis ground (see the following sections).

- Bond all passive metal parts to chassis ground, ensuring large area and low-impedance contact.
- When using screw connections on varnished or anodized metal parts, support contact with special contact washers or remove the protective insulating finish on the points of contact.
- Wherever possible, avoid the use of aluminum parts for ground bonding. Aluminum oxidizes very easily and is therefore less suitable for ground bonding.
- Create a central connection between chassis ground and the equipotential grounded/protective conductor system.

#### Rule 2: Proper cable routing

Ensure proper cable routing when you wire your system (see the section below on *Indoor/outdoor cable routing*).

- Sort your wiring system into groups (high-voltage/power supply/signal/data cables).
- Always route high-voltage, signal or data cables through separated ducts or in separate bundles.
- Install the signal and data cables as close as possible to grounded surfaces (e.g. supporting beams, metal rails, steel cabinet walls ).

### Rule 3: Mounting the cable shielding

Take care that all cable shielding is properly fastened (refer to the section on *Shielding of cables*).

- Always use shielded data cable. Always connect both ends of the shielding to ground on a large area.
- Analog cables must always be shielded. For the transmission of low-amplitude signals it might prove to be more efficient to have only one side of the shielding connected to ground.
- Directly behind the cable entry in the cabinet or enclosure, terminate the shielding on a large area of the shielding/protective ground bar and fasten it with the help of a cable clamp. Then, route the cable to the module; however, do not connect the shielding once again to ground in this place.
- Connections between the shielding/protective ground busbar and the cabinet/enclosure must be of a low impedance.
- Always install shielded data cables in metal/metallized connector housings.

### Rule 4: Special EMC measures

Some special applications might require special EMC measures (refer to the section on *How to protect digital output modules against inductive surge voltage*).

- Connect anti-surge elements to all inductive devices not controlled by S7-300 modules.
- For cabinet or cubicle lighting in the immediate range of your controller, use incandescent lamps or interference suppressed fluorescent lamps .

### Rule 5: Homogeneous reference potential

Create a homogeneous reference potential and ground electrical equipment whenever possible (refer to the section on *Equipotential bonding*).

- Route your equipotential conductors over a wide area if potential differences exist or are expected between your system components.
- Make sure you carefully direct your grounding measures. Grounding measures protect the controller and its functions.

Form a star circuit to connect the equipment in your system and the cabinets containing central/expansion units to the grounding/protective conductor system. This prevents the formation of ground loops.

#### see also

Grounding concept and overall structure

Outdoor cable routing

EMC Compatible Installation of PLC



## 12.2.3 EMC Compatible Installation of PLC

### Introduction

Quite often it is the case that interference suppression measures are not taken until corruption of user signals is detected after the controller is actually in operation.

Frequently, the causes of such interference are found in inadequate reference potentials as a result of faulty installation. This section shows you how to avoid such errors.

### Inactive metal parts

Inactive parts are referred to as electrically conductive elements, separated from active elements by a basic insulating and only subject to electrical potential if an error occurs.

### Installation and ground bonding of inactive metal parts

Bond all inactive metal parts to a large-surface ground when you install the S7-300. Proper ground bonding ensures a homogeneous reference potential for the controller and reduces the effect of interference coupling.

The ground connection establishes an electrically conductive interconnection of all inactive parts. The sum of all interconnected inactive parts is referred to as chassis ground.

This chassis ground must never develop a hazardous potential even if a fault occurs. Therefore, chassis ground must be connected to the protective conductor using cables with an adequate conductor cross-section. To avoid ground loops, physically separate chassis ground elements (cabinets, parts of the building construction or machine) must be bonded to the protective conductor system in a star circuit.

### Observe the following for ground connection:

- In the same way as with active elements, exercise meticulous care to interconnect inactive metal elements.
- Always make sure that you have a low-impedance interconnection between metal elements (e.g. large and highly conductive contact surface).
- The protective insulating finish on varnished or anodized metal elements must be pierced or removed. Use special contact washers or completely remove the finish on the point of contact.
- Protect your connecting elements against corrosion (e.g. with a suitable grease)
- Interconnect moving chassis ground elements (e.g. cabinet doors) with flexible ground straps. Always use short ground straps with a large surface (the surface is decisive for the diversion of high-frequency currents).

## 12.2.4 Examples of an EMC Compatible Installation

### Introduction

Below you can find two examples of an EMC compatible PLC installation.

#### Example 1: EMC compatible cabinet installation

The figure below shows a cabinet installation with the measures described above (bonding of inactive metal parts to chassis ground and connecting the cable shielding to ground). This sample applies only to grounded operation. Note the points in the figure when you install your system.

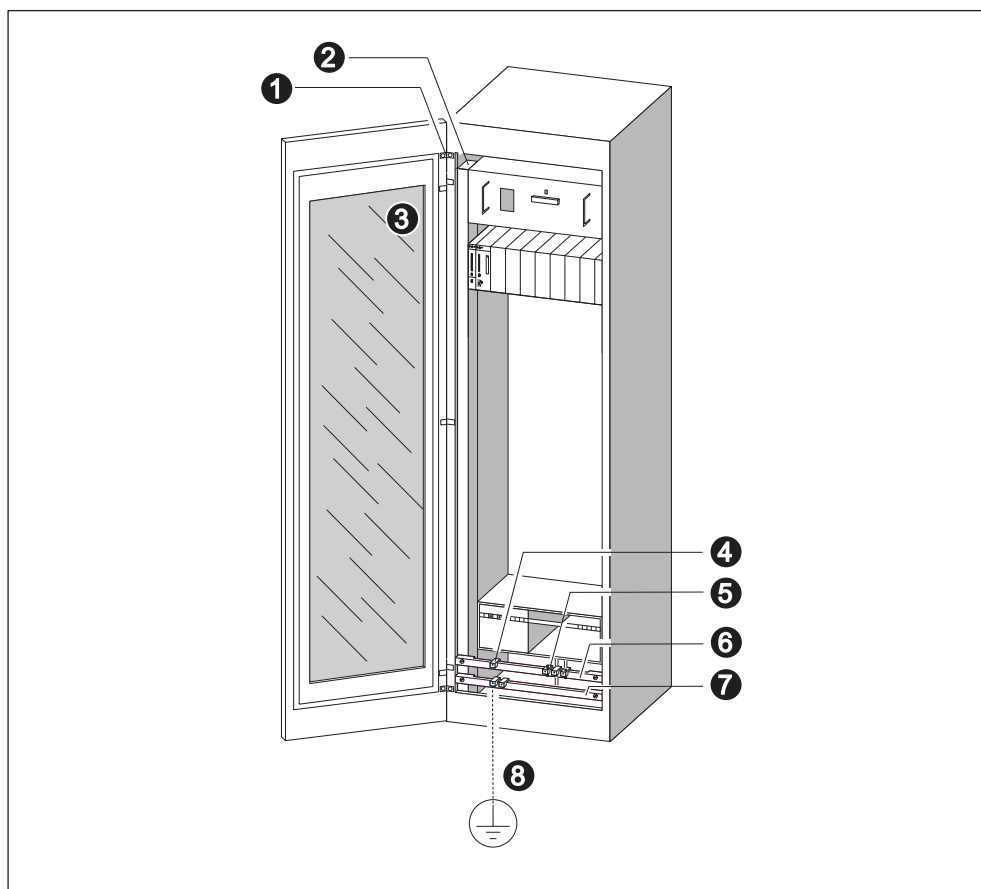

Figure 12-2 Example of an EMC compatible cabinet installation

## Key to example 1

The numbers in the following list refer to the numbers in the figure above.

Table 12-6 Key to example 1

No	Description	Explanation
1	Ground straps	If no large-surface metal-to-metal connections are available, you must either interconnect inactive metal parts (e.g. cabinet doors or mounting plates) or bond them to chassis ground using ground straps. Use short ground straps with a large surface.
2	Supporting bars	Interconnect the supporting bars on a large area to the cabinet walls (metal-to-metal connection).
3	Mounting the rail	The mounting bar and rack must be interconnected with large-area metal-to-metal connections.
4	Signal cables	Connect the shielding of signal cables on a large area of the protective conductor/additional shielding busbar and fasten them with cable clamps.
5	Cable clamp	The cable clamp must cover a large area of the shielding braid and ensure good contact.
6	Shielding busbar	Interconnect the shielding busbar on a large surface with the supporting bars (metal-to-metal connection). The cable shielding is terminated on the busbar.
7	Protective conductor busbar	Interconnect the protective conductor busbar on a large surface with the supporting bars (metal-to-metal connection). Interconnect the protective conductor busbar and the protective ground system, using a separate cable (minimum cross-section 10 mm <sup>2</sup> ).
8	Cable to the protective ground system (equipotential ground)	Interconnect the cable on a large area with the protective ground system (equipotential ground).

## Example 2: EMC compatible wall mounting

When operating your S7 in a low-noise environment that conform with permitted ambient conditions (see Appendix *Ambient conditions*), you can also mount your S7 in frames or to the wall.

Interference coupling must be diverted to large metal surfaces. Therefore, always mount standard profile/shielding/protective conductor rails on metal parts of the construction. Steel sheet panels reference potential surfaces have been found especially suitable for wall-mounting.

Provide a shielding busbar for connecting your cable shielding. This shielding busbar can also be used as protective ground bar.

**Note the following points on framewall-mounting:**

- When mounting on varnished or anodized metal parts, use special contact washers or remove the insulating layers.
- Provide a large-surface and low-impedance metal-to-metal connection for fastening the shielding/protective ground bar.
- Always touch-protect live mains conductors.

The figure below shows an example of EMC compatible wall-mounting of an S7.

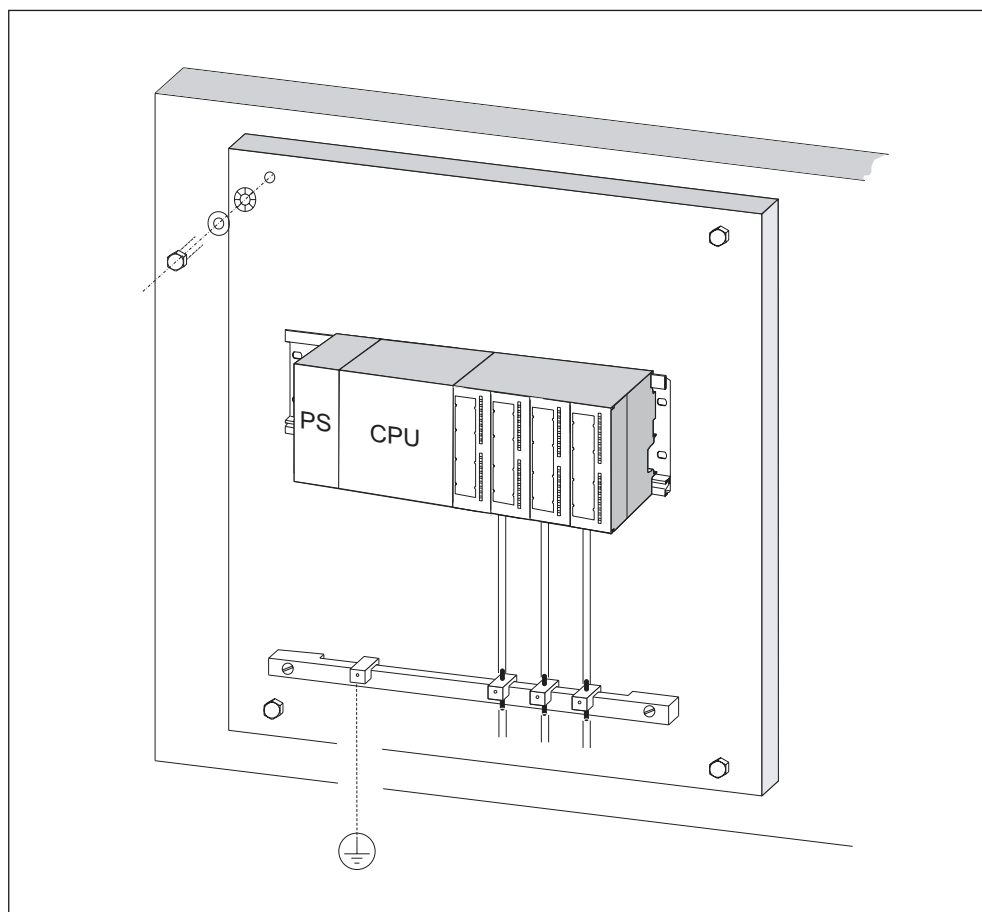

Figure 12-3 Example of EMC compatible wall-mounting

## 12.2.5 Shielding of Cables

### Purpose of the shielding

A cable is shielded to attenuate the effects of magnetic, electrical and electromagnetic interference on the cable.

### Operating principle

Interference currents on cable shielding is diverted to ground conductive interconnection between the shielding and the cabinet. To avoid interference as a result of these currents, it is imperative to provide a low-impedance connection to the protective conductor.

### Suitable cables

Whenever possible, use cables equipped with a shielding braid. Shielding density should be at least 80%. Avoid cables with film shielding, because the film can be easily damaged by tensile or pressure stress, thus reducing its shielding effect.

### Handling of the shielding

Note the following points on handling the shielding:

- Always use metal clamps to mount shielding braid. The clamps must contact a large area of the shielding and provide appropriate contact force.
- Directly behind the cabinet's cable entry, terminate the shielding on a shielding bus. Then, route the cable to the module; however, do not connect the shielding once again to ground in this place.
- In installations outside of cabinets (e.g. for wall-mounting) you can also terminate the shielding on a cable duct.

The figure below shows some options for mounting shielded cables, using cable clamps.

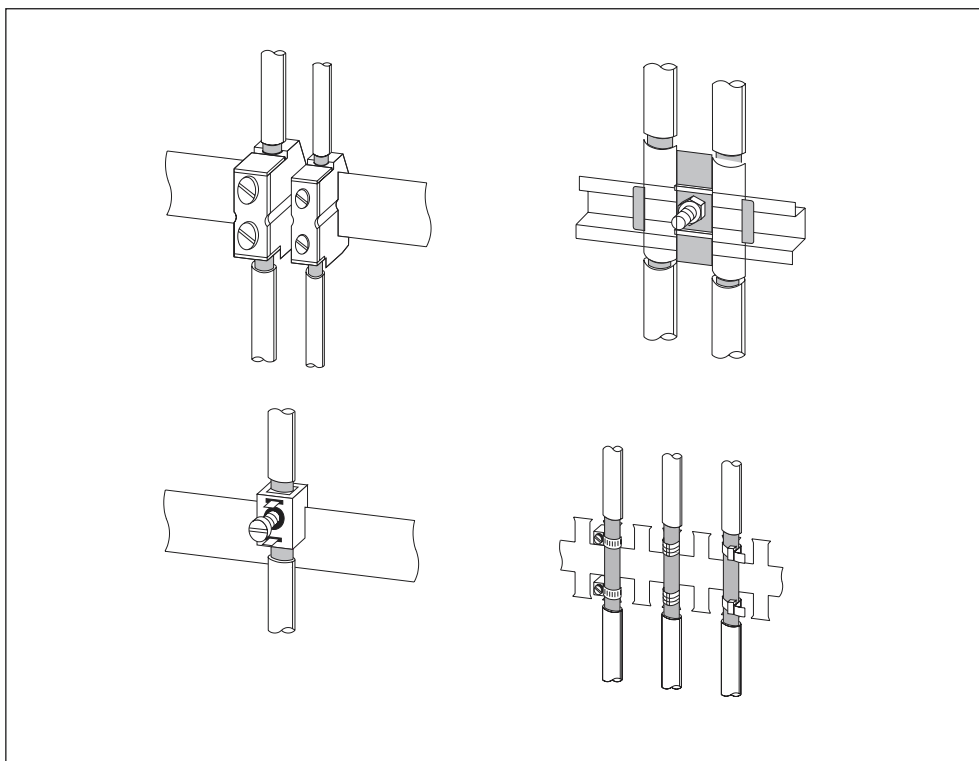

Figure 12-4 Mounting cable shielding

## 12.2.6 Equipotential bonding

### Potential differences

Potential differences can occur between separate system elements. This can result in high equipotential currents, e.g. if the cable shielding is terminated at both ends and grounded to different system components.

The cause of potential difference can be differences in the power supplies.



### Warning

Cable shielding is not suitable for equipotential bonding. Always use the prescribed cables (e.g. with a cross-section of 16 mm<sup>2</sup>). When installing MPI/DP networks, provide a sufficient conductor cross-section. Otherwise, interface hardware might get damaged or even be destroyed.

## Equipotential bonding conductor

To reduce potential differences and ensure proper functioning of your electronic equipment, you must install equipotential bonding conductors.

Note the following points on the use of equipotential bonding conductors:

- The lower the impedance of an equipotential bonding conductor, the more effective is equipotential bonding.
- When shielded signal cables interconnect two system components and the shielding is connected on both ends to ground/protective conductors, the impedance of the additional equipotential bonding conductor must not exceed 10% of the shielding impedance.
- Determine the cross-section of your equipotential bonding conductor on the basis of the maximum equalizing current that will flow through it. The equipotential bonding conductor cross-section that has proven best in practice is  $16 \text{ mm}^2$ .
- Always use equipotential bonding conductors made of copper or galvanized steel. Always connect the cables on a large surface to the equipotential busbar/protective conductor and protect it against corrosion.
- Route your equipotential bonding conductor to minimize the area between the equipotential bonding conductor and signal lines as far as possible (see the figure below).

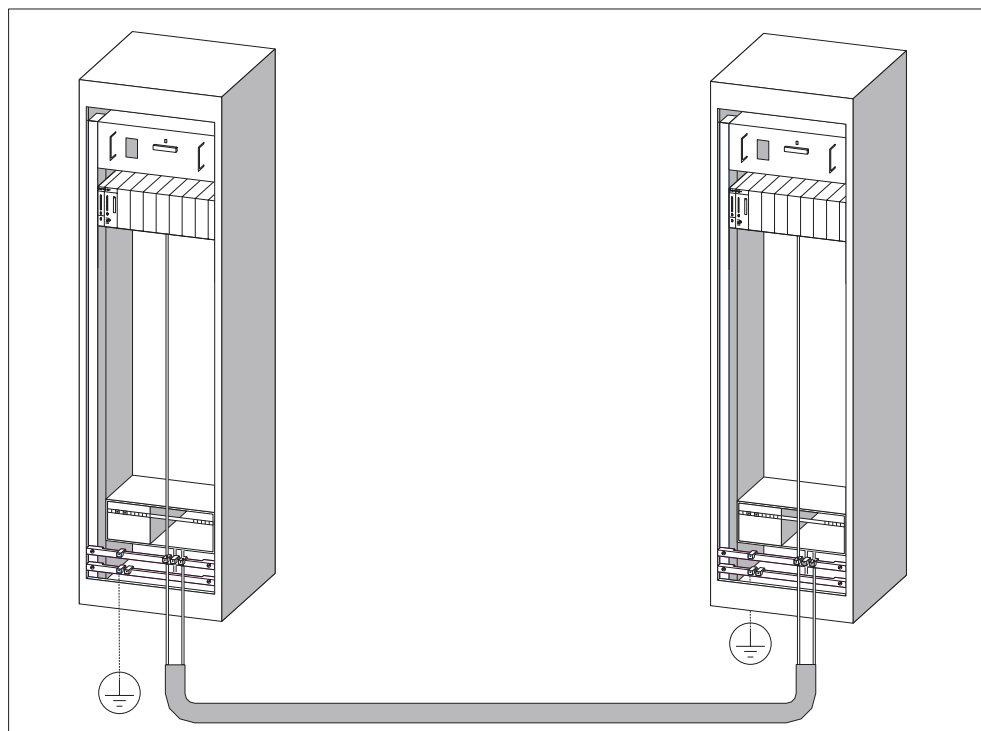

Figure 12-5 Equipotential bonding

## 12.2.7 Cable Routing inside Buildings

### Introduction

Inside buildings (inside and outside cabinets), clearances must be maintained between groups of different cables to achieve the necessary electromagnetic compatibility (EMC). The table contains information on the general rules governing clearances to enable you to choose the right cables.

### How to read the table

To find out how to run two cables of different types, proceed as follows:

1. Look up the type of the first cable in column 1 (Cables for ...).
2. Look up the type of the second cable in the corresponding field in column 2 (and cables for ...).
3. Note the applicable directives in column 3 (Run ...).

Table 12-7 Routing cables inside buildings

Cables for ...	and cables for ...	Run ...
<ul style="list-style-type: none"> <li>• Bus signals, shielded (PROFIBUS)</li> <li>• Data signals, shielded (programming devices, operator panels, printers, counter inputs, etc.)</li> <li>• Analog signals, shielded</li> <li>• DC voltage (<math>\leq 60</math> V), unshielded</li> <li>• Process signals (<math>\leq 25</math> V), shielded</li> <li>• AC voltage (<math>\leq 25</math> V), unshielded</li> <li>• Monitors (coaxial cable)</li> </ul>	<ul style="list-style-type: none"> <li>• Bus signals, shielded (PROFIBUS)</li> <li>• Data signals, shielded (programming devices, operator panels, printers, counter inputs, etc.)</li> <li>• Analog signals, shielded</li> <li>• DC voltage (<math>\leq 60</math> V), unshielded</li> <li>• Process signals (<math>\leq 25</math> V), shielded</li> <li>• AC voltage (<math>\leq 25</math> V), unshielded</li> <li>• Monitors (coaxial cable)</li> </ul>	In common bundles or cable ducts
	<ul style="list-style-type: none"> <li>• DC voltage (<math>&gt; 60</math> V and <math>\leq 400</math> V), unshielded</li> <li>• AC voltage (<math>&gt; 25</math> V and <math>\leq 400</math> V), unshielded</li> </ul>	In separate bundles or cable ducts (no minimum clearance necessary)
	<ul style="list-style-type: none"> <li>• DC and AC voltage (<math>&gt; 400</math> V), unshielded</li> </ul>	<p><b>inside cabinets:</b></p> <p>In separate bundles or cable ducts (no minimum clearance necessary)</p> <p><b>outside cabinets:</b></p> <p>On separate cable racks with a clearance of at least 10 cm</p>



Cables for ...	and cables for ...	Run ...
<ul style="list-style-type: none"> <li>• DC voltage (&gt; 60 V and ≤ 400 V), unshielded</li> <li>• AC voltage (&gt; 25 V and ≤ 400 V), unshielded</li> </ul>	<ul style="list-style-type: none"> <li>• Bus signals, shielded (PROFIBUS)</li> <li>• Data signals, shielded (programming devices, operator panels, printers, counter inputs, etc.)</li> <li>• Analog signals, shielded</li> <li>• DC voltage (≤ 60 V), unshielded</li> <li>• Process signals (≤ 25 V), shielded</li> <li>• AC voltage (≤ 25 V), unshielded</li> <li>• Monitors (coaxial cable)</li> </ul>	In separate bundles or cable ducts (no minimum clearance necessary)
	<ul style="list-style-type: none"> <li>• DC voltage (&gt; 60 V and ≤ 400 V), unshielded</li> <li>• AC voltage (&gt; 25 V and ≤ 400 V), unshielded</li> </ul>	In common bundles or cable ducts
	<ul style="list-style-type: none"> <li>• DC and AC voltage (&gt; 400 V), unshielded</li> </ul>	<p><b>inside cabinets:</b> In separate bundles or cable ducts (no minimum clearance necessary)</p> <p><b>outside cabinets:</b> On separate cable racks with a clearance of at least 10 cm</p>
DC and AC voltage (> 400 V), unshielded	<ul style="list-style-type: none"> <li>• Bus signals, shielded (PROFIBUS)</li> <li>• Data signals, shielded (programming devices, operator panels, printers, counter inputs, etc.)</li> <li>• Analog signals, shielded</li> <li>• DC voltage (≤ 60 V), unshielded</li> <li>• Process signals (≤ 25 V), shielded</li> <li>• AC voltage (≤ 25 V), unshielded</li> <li>• Monitors (coaxial cable)</li> </ul>	<p><b>inside cabinets:</b> In separate bundles or cable ducts (no minimum clearance necessary)</p> <p><b>outside cabinets:</b> On separate cable racks with a clearance of at least 10 cm</p>
	<ul style="list-style-type: none"> <li>• DC and AC voltage (&gt; 400 V), unshielded</li> </ul>	In common bundles or cable ducts
ETHERNET	ETHERNET	In common bundles or cable ducts
	Others	In separate bundles or cable ducts with a clearance of at least 50 cm

## **12.2.8 Outdoor cable routing**

### **Rules for EMC compatible cable routing**

The same EMC compatibility rules apply both for indoor and outdoor routing of cables. The following also applies:

- Running cables on metal cable trays.
- Electrical connection of the joints of cable trays/ducts.
- Ground the cable carriers.
- If necessary, provide adequate equipotential bonding between connected devices.
- Take the necessary (internal and external) lightning protection and grounding measures in as far as they are applicable to your particular application.

### **Rules for lightning protection outside buildings**

Run your cables either:

- in metal conduits grounded at both ends, or
- in concrete cable ducts with continuous end-to-end armoring.

### **Overvoltage protection equipment**

An individual appraisal of the entire plant is necessary before any lightning protection measures are taken.

### **Additional information on lightning protection ...**

can be found in the Lightning and surge voltage protection section.

## 12.3 Lightning and Surge Voltage Protection

### 12.3.1 In the following sections ...

we show you solutions for the protection of your S7-300 against damage as a result of surge voltage.

#### Overview

Failures are very often the result of surge voltage caused by:

- Atmospheric discharge or
- Electrostatic discharge.

We will begin by showing you what the theory of surge protection is based on: the lightning protection zones concept.

At the end of this section, you will find rules for the transition points between individual lightning protection zones.

---

#### Note

This section can only provide information on the protection of a PLC against surge voltage.

However, complete surge protection is guaranteed only if the whole surrounding building is designed to provide protection against overvoltage. This applies especially to constructional measures for the building at the planning stage. If you wish to obtain detailed information on surge protection, we therefore recommend you contact your Siemens partner or a company specialized in lightning protection.

---

### 12.3.2 Lightning Protection Zone Concept

#### Principally of the Lightning protection zone concept to IEC 61312-1/DIN VDE 0185 T103

The principle of the lightning protection zone concept states that the volume to be protected against overvoltage, for example, a manufacturing hall, is subdivided into lightning protection zones in accordance with EMC directives (see Figure ).

The specific lightning protection zones are formed by the following measures:

Lightning protection of the building exterior (field side)	Lightning protection zone 0
Shielding <ul style="list-style-type: none"> <li>• Buildings</li> <li>• Rooms and/or</li> <li>• Devices</li> </ul>	Lightning protection zone 1 Lightning protection zone 2 Lightning protection zone 3

### Effects of the Lightning Strike

Direct lightning strikes occur in lightning protection zone 0. Lightning strike generates high-energy electromagnetic fields which can be reduced or eliminated from one lightning protection zone to the next by suitable lightning protection elements/measures.

### Overvoltage

In lightning protection zones 1 and higher, a lightning strike might additionally cause overvoltage as a result of switching operations, coupling etc.

### Block diagram of the lightning protection zones

The figure below shows a block diagram of the lightning protection zone concept for a detached building.

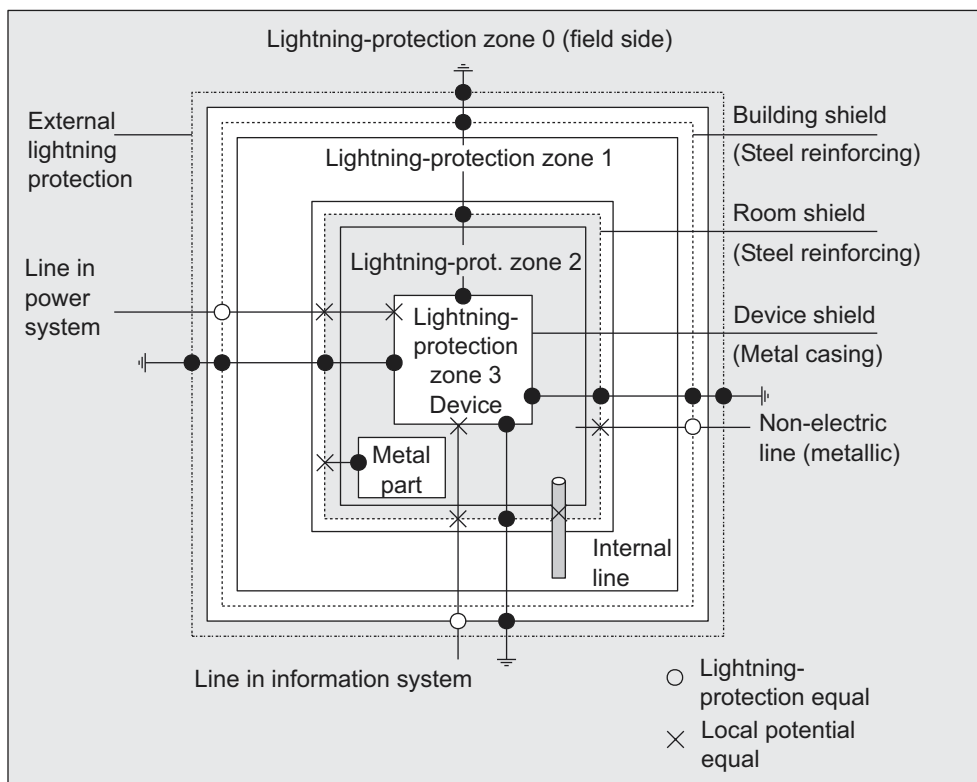

Figure 12-6 Lightning protection zones of a building

## Principle of the transition points between lightning protection zones

At the transition points between lightning protection zones, you must take measures to prevent surges being conducted downstream.

The principle of the lightning protection zone concept also specifies that all cables which are capable of carrying lightning current (!) and installed at the transition points of lightning protection zones must be included in the equipotential bonding system.

Conductors and cables capable of carrying lightning current are:

- Metal pipes (e.g. water, gas and heat)
- Power cables (for example, mains voltage, 24 V supply)
- Data cables (for example, bus cable).

### 12.3.3 Rules for the Transition Point between Lightning Protection Zones 0 <-> 1

#### Rules for transition point 0 <-> 1 (Lightning protection equipotential bonding)

The following measures are suitable for lightning protection equipotential bonding at the transition between lightning protection zones 0 <-> 1:

- Use grounded, spiraled, current-conducting metal straps or metal braiding as a cable shield at both ends, for example, NYCY or A2Y(K)Y.
- Install cables in one of the following media:
  - in continuous metal pipes that are grounded at both ends, or
  - in continuously armored concrete ducts or
  - on closed metal cable trays grounded at both ends.
  - Use fiber optic cables instead of metal conductors.

## Additional Measures

If you cannot take measures as described above, you must install a high-voltage protection for your system between the 0 <-> 1 transition points with a lightning conductor. The table below contains the components you can use for high-voltage protection of your plant.

Table 12-8 High-voltage protection of cables with surge voltage protection components

Con sec. no.	Cables for ...	... equip transition point 0 <-> 1 with:		Order No.
1	3-phase TN-C system	1 x	DEHNbloc/3 lightning conductor, phase L1/L2/L3 to PEN	900 110* 5SD7 031
	3-phase TN-S system	1 x	DEHNbloc/3 lightning conductor, phase L1/L2/L3 to PE	900 110* 5SD7 031
		1 x	DEHNbloc/1 lightning conductor, N to PE	900 111* 5SD7 032
	3-phase TT system	1 x	DEHNbloc/3 lightning conductor, phase L1/L2/L3 to N	900 110* 5SD7 031
		1 x	DEHNgap B/n N-PE lightning conductor, N to PE	900 130*
	AC TN-S system	2 x	DEHNbloc/1 lightning conductor, phase L1 +N to PE	900 111* 5SD7 032
	AC TN-C system	1 x	DEHNbloc/1 lightning conductor, phase L to PEN	900 111* 5SD7 032
	AC TT system	1 x	DEHNbloc/1 lightning conductor, phase to N	900 111* 5SD7 032
1 x		DEHNgap B/n N-PE lightning conductor, N to PE	900 130*	
2	24 VDC Power Supply	1 x	Blitzductor VT Lightning conductor, type A D 24 V -	918 402*
3	MPI bus cable, RS485, RS232 (V.24)	1 x	Blitzductor CT lightning conductor, type B	919 506* and 919 510*
4	Inputs/outputs of digital modules 24 V		DEHNrail 24 FML	909 104*
5	24 VDC power supply module	1 x	Blitzductor VT lightning conductor, type AD 24 V -	918 402* 900 111* 5SD7 032
6	Inputs/outputs of digital modules and 120/230 VAC power supply	2 x	DEHNbloc/1 lightning conductor	900 111* 5SD7 032
7	Inputs/outputs of analog modules up to 12 V +/-	1 x	Blitzductor CT lightning conductor, type B	919 506* and 919 510*

\* You can order these components directly from:

DEHN + SÖHNE  
GmbH + Co. KG  
Elektrotechnische Fabrik  
Hans-Dehn-Str. 1  
D-92318 Neumarkt

### 12.3.4 Rules for the Transition Points between Lightning Protection Zones 1 <-> 2 and Higher

#### Rules for transition points 1 <-> 2 and higher (local equipotential bonding)

The following measures must be taken on all transition points 1 <-> 2 and higher:

- Set up local equipotential bonding at each subsequent lightning protection zone transition.
- Include all lines (also metal conduits, for example) in the local equipotential bonding of all subsequent lightning protection zone transition points.
- Include all metal installations located within the lightning protection zone in the local equipotential bonding (for example, metal part within lightning protection zone 2 at transition 1 <-> 2).

#### Additional Measures

We recommend fine-wire fusing for following elements:

- All 1 <-> 2 and greater lightning protection zone transitions
- All cables that run within a lightning protection zone and are longer than 100 m

#### Lightning protection element for the 24 VDC power supply module.

Always use the Blitzductor VT, type AD 24 V SIMATIC for the 24 VDC power supply module of the S7-300. All other surge protection components do not meet the required tolerance range of 20.4 V to 28.8 V of the S7-300 power supply.

#### Lightning Conductor for Signal Modules

You can use standard surge protection components for the digital I/O modules. However, please note that these only permit a maximum of 26.8 V for a rated voltage of 24 VDC. If the tolerance of your 24 VDC power supply is higher, use surge protection components with 30 VDC rating.

You can also use Blitzductor VT, type AD 24 V. Note that input current can increase if negative input voltages are generated.

## Low-voltage protection elements for 1<-> 2

For the transition points between lightning protection zones 1 <-> 2 we recommend the surge protection components listed in the table below. This low-voltage protection must be used in S7-300 for CE compliance.

Table 12-9 Surge voltage protection components for lightning protection zones 1 <-> 2

Con sec. no.	Cables for ...	... equip transition point 1 <-> 2 with:		Order No.
1	3-phase TN-C system	3 x	DEHNguard 275 surge arresters	900 600* 5SD7 030
	3-phase TN-S system	4 x	DEHNguard 275 surge arresters	900 600* 5SD7 030
	3-phase TT system	3 x	DEHNBloc/275 surge arrester, phase L1/L2/L3 to N	900 600* 5SD7 030
		1 x	DEHNgap C N-PE surge arrester, N to PE	900 131*
	AC TN-S system	2 x	DEHNguard 275 surge arresters	900 600* 5SD7 030
	AC TN-C system	1 x	DEHNguard 275 surge arresters	900 600* 5SD7 030
	AC TT system	1 x	DEHNguard 275 surge arrester, phase L to N	900 600* 5SD7 030
1 x		DEHNgap C, N-PE surge arrester, N to PE	900 131*	
2	24 VDC Power Supply	1 x	Blitzductor VT, type AD 24 V -	918 402*
3	Bus cable			
	<ul style="list-style-type: none"> <li>• MPI, RS485</li> </ul>		<ul style="list-style-type: none"> <li>• Blitzductor CT surge arrester, type MD/HF</li> </ul>	919 506* and 919 570*
	<ul style="list-style-type: none"> <li>• RS232 (V.24)</li> </ul>	1 x	<ul style="list-style-type: none"> <li>• per conductor pair Surge arrester Blitzductor CT type ME 15 V</li> </ul>	919 506* and 919 522*
4	Inputs of digital modules DC 24 V	1 x	Low-voltage surge arrester, type FDK 2 60 V	919 993*
5	Outputs of digital modules 24 V	1 x	Low-voltage surge arrester	919 991*
6	Inputs/outputs of digital modules	2 x	Surge arrester	
	<ul style="list-style-type: none"> <li>• 120 VAC</li> </ul>		<ul style="list-style-type: none"> <li>• DEHNguard 150</li> </ul>	900 603*
	<ul style="list-style-type: none"> <li>• 230 VAC</li> </ul>		<ul style="list-style-type: none"> <li>• DEHNguard 275</li> </ul>	900 600*
7	Inputs of analog modules up to 12 V +/-	1 x	Blitzductor CT surge arrester, type MD 12 V	919 506* and 919 541*

\* You can order these components directly from:

DEHN + SÖHNE  
GmbH + Co. KG  
Elektrotechnische Fabrik  
Hans-Dehn-Str. 1  
D-92318 Neumarkt



### Low-voltage protection elements for 2<-> 3

For the transition points between lightning protection zones 2 <-> 3 we recommend the surge protection components listed in the table below. This low-voltage protection must be used in S7-300 for CE compliance.

Table 12-10 Surge voltage protection components for lightning protection zones 2 <-> 3

Con sec. no.	Cables for ...	... equip transition point 2 <-> 3 with:		Order No.
1	3-phase TN-C system	3 x	DEHNguard 275 surge arresters	900 600* 5SD7 030
	3-phase TN-S system	4 x	DEHNguard 275 surge arresters	900 600* 5SD7 030
	3-phase TT system	3 x	DEHNbloc/275 surge arrester, phase L1/L2/L3 to N	900 600* 5SD7 030
		1 x	DEHNgap C, N-PE surge arrester, N to PE	900 131*
	AC TN-S system	2 x	DEHNguard 275 surge arresters	900 600* 5SD7 030
	AC TN-C system	1 x	DEHNguard 275 surge arresters	900 600* 5SD7 030
	AC TT system	1 x	DEHNguard 275 surge arrester, phase L to N	900 600* 5SD7 030
1 x		DEHNgap C, N-PE surge arrester, N to PE	900 131*	
2	24 VDC Power Supply	1 x	Blitzductor VT, type AD 24 V -	918 402*
3	Bus cable			
	<ul style="list-style-type: none"> <li>• MPI, RS485</li> </ul>		<ul style="list-style-type: none"> <li>• Blitzductor CT surge arrester, type MD/HF</li> </ul>	919 506* and 919 570*
	<ul style="list-style-type: none"> <li>• RS232 (V.24)</li> </ul>	1 x	<ul style="list-style-type: none"> <li>• per conductor pair low-voltage surge protection FDK 2 12 V</li> </ul>	919 995*
4	Inputs of digital modules			
	<ul style="list-style-type: none"> <li>• 24V DC</li> </ul>	1 x	Low voltage protection , type FDK 2 60 V, on insulated rail	919 993*
		2 x	Surge arrester	
	<ul style="list-style-type: none"> <li>• 120 VAC</li> <li>• 230 VAC</li> </ul>		<ul style="list-style-type: none"> <li>• DEHNrail 120 FML</li> <li>• DEHNrail 230 FML</li> </ul>	901 101* 901 100*
5	Outputs of digital modules 24 V	1 x	Low-voltage protection FDK 2 D 5 24	919 991*
6	Outputs of analog modules up to 12 V +/-	1 x	Low-voltage protection , type FDK 2 12 V, on insulated rail connected with M- of the power supply for the modules.	919 995*

\* You can order these components directly from:

DEHN + SÖHNE  
GmbH + Co. KG  
Elektrotechnische Fabrik  
Hans-Dehn-Str. 1  
D-92318 Neumarkt

### 12.3.5 Sample of a Surge Protection Circuit for Networked S7-300 PLCs

#### Sample circuit

The sample in the figure below shows you how install an effective surge protection for 2 networked S7-300 PLCs:

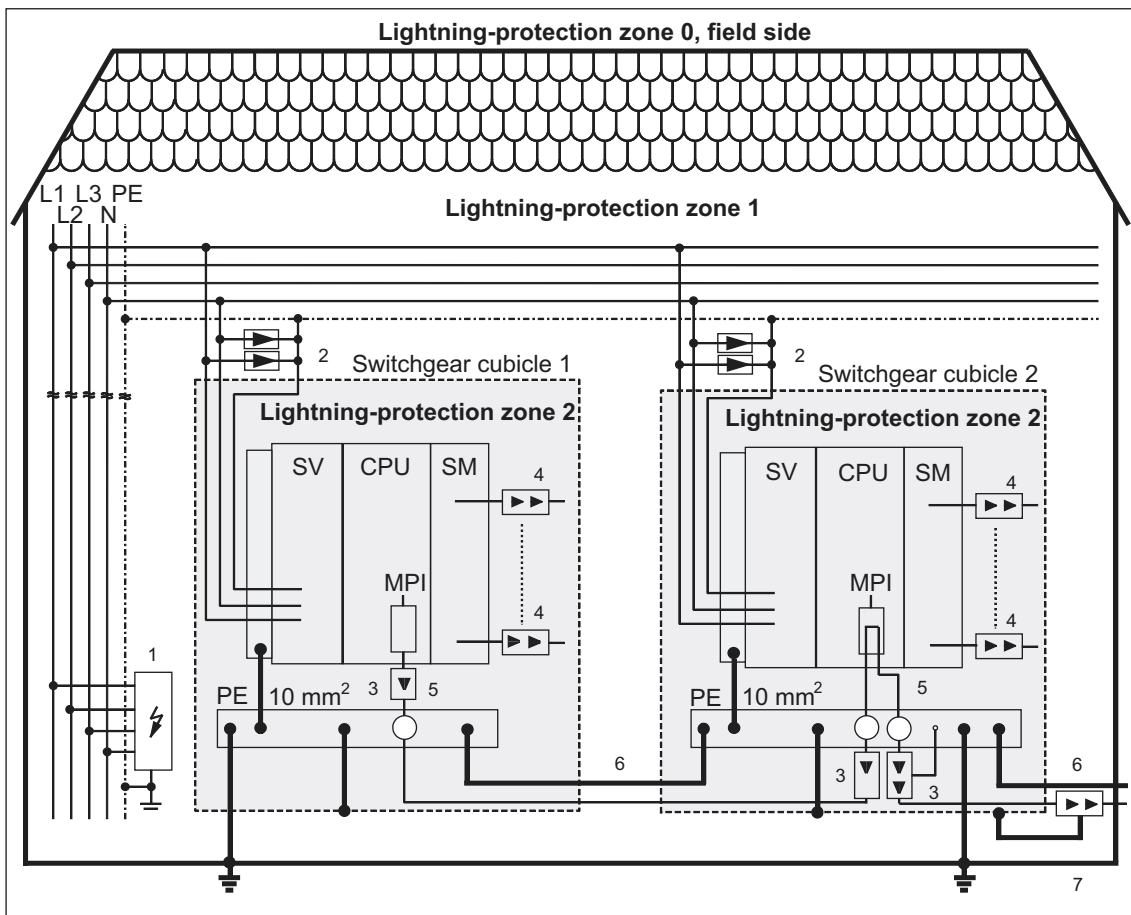

Figure 12-7 Sample circuit for networked S7-300 PLCs

## Components in previous figure 1-2

The table below explains consecutive numbers in the figure above:

Table 12-11 Example of a lightning-protected structure (key to figure above)

Consec. no. from figure above	Components	Description
1	lightning arrester, depending on the mains system, e.g. TN-S system: 1 piece DEHNbloc/3 , Order No.: 900 110* and 1 piece DEHNbloc/1 , Order No.: 900 111*	High-voltage protection against direct lightning strike and surge voltage as of transition 0 <-> 1
2	surge arresters, 2 pieces DEHNguard 275; Order No.: 900 600*	High-voltage surge protection at transition 1 <-> 2
3	Surge arrester, Blitzductor CT type MD/HF ; Order No.: 919 506* and 919 570*	Low-voltage surge protection for RS485 interfaces at transition 1 <-> 2
4	Digital input modules: FDK 2 D 60 V; Order No.: 919 993*  Digital output modules: FDK 2 D 5, 24 V; Order No.: 919 991*  Analog modules: MD 12 V Blitzductor CT; Order No.: 919 506 and 919 541	Low-voltage surge protection, signal modules I/O at transition 1 <-> 2
5	Bus cable shielding mounting device with EMC spring clamp on the basic unit of Blitzductor CT; Order No.: 919 508*	Discharge of interference current
6	Cable for equipotential bonding: 16 sq. mm	Standardization of reference potentials
7	Blitzductor CT, Type B for building transitions; Order No.: 919 506* and 919 510*	High-voltage surge protection for RS485 interfaces at transition 0 <-> 1

\* You can order these components directly from:

DEHN + SÖHNE  
GmbH + Co. KG  
Elektrotechnische Fabrik  
Hans-Dehn-Str.

### 12.3.6 1 How to Protect Digital Output Modules against Inductive Surge Voltage

#### Inductive surge voltage

Overvoltage occurs when inductive devices are switched off. Examples are relay coils and contactors.

#### Integrated surge arrester

S7-300 digital output modules are equipped with an integrated surge arrester.

#### Additional overvoltage protection

Inductive devices require additional surge arresters only in following cases:

- If SIMATIC output circuits can be switched off by additionally installed contacts (e.g. relay contacts).
- If the inductive loads are not controlled by SIMATIC modules

Note: Request information on relevant surge protection rating from the supplier of inductive devices.

#### Example:

The figures illustrates an output circuit requiring additional overvoltage protectors.

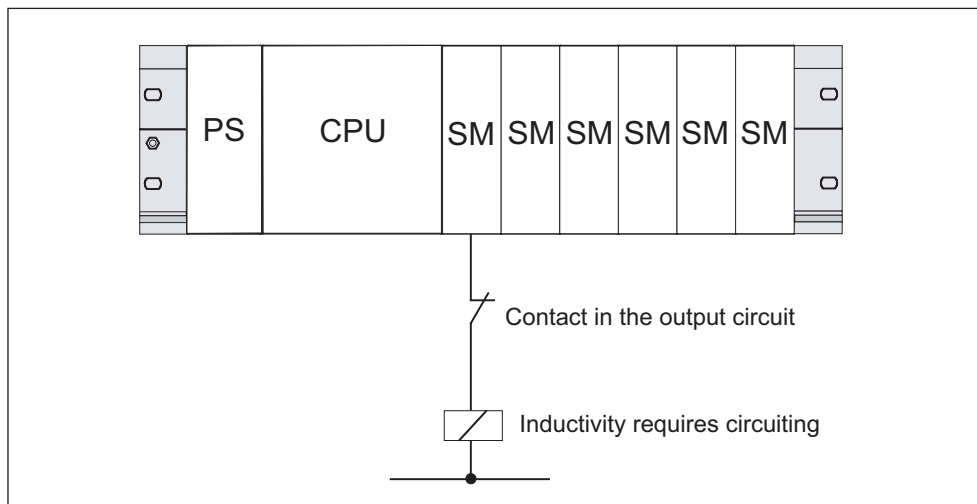

Figure 12-8 EMERGENCY-OFF relay contact in the output circuit

Refer also to the rest of the information in this section.

### Circuit for coils operated with DC voltage

The figure below shows DC-operated coils equipped with diode or Zener diode circuit.

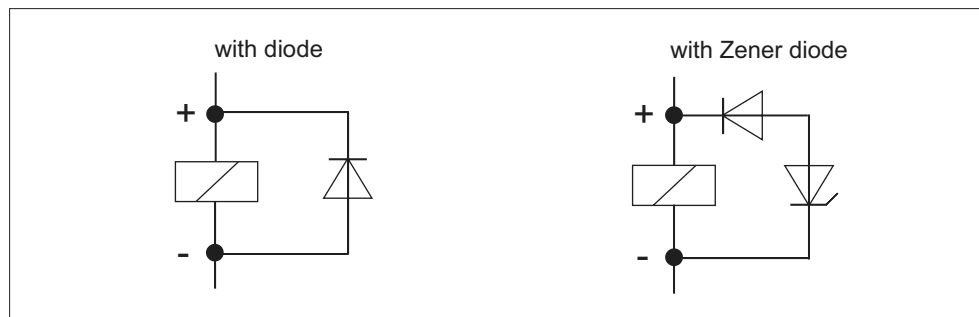

Figure 12-9 Circuit for coils operated with DC voltage

Diode/Zener diode circuits have the following characteristics:

- Opening surge voltage can be totally avoided.  
The Zener diode has a higher switch-off voltage capacity.
- High switch-off delay (6 to 9 times higher than without protective circuit).  
The Zener diode switches off faster than a diode circuit.

### Circuit for coils operated with AC voltage

The figure shows coils operated with AC voltage and varistor or RC circuit.

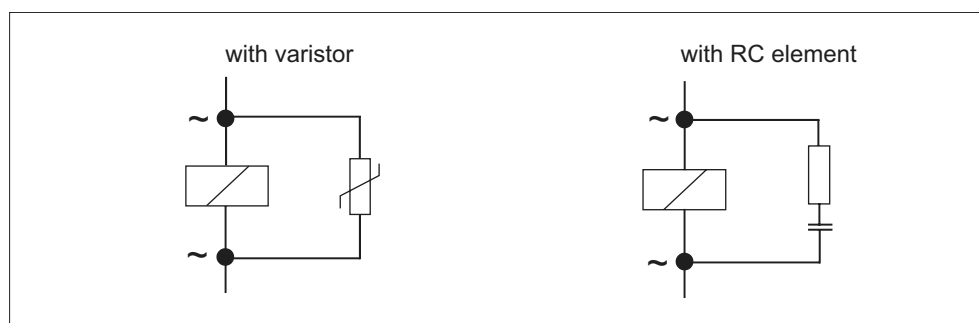

Figure 12-10 Circuit for coils operated with AC voltage

The characteristics of varistor circuits are:

- The amplitude of the opening surge is limited rather than attenuated.
- The surge rise-ratio remains the same
- Short off-delay.

The characteristics of RC circuits are:

- Amplitude and steepness of the opening surge are reduced.
- Short off-delay.

## 12.4 Safety of electronic control equipment

### Introduction

The notes below apply independent of the type or manufacturer of the electronic control.

### Reliability

Maximum reliability of SIMATIC devices and components is achieved by implementing extensive and cost-effective measures during development and manufacture:

This includes the following:

- Use of high-quality components;
- Worst-case design of all circuits;
- Systematic and computer-aided testing of all components;
- Burn-in of all large-scale integrated circuits (e.g. processors, memory, etc.);
- Measures preventing static charge when handling MOS ICs;
- Visual checks at different stages of manufacture;
- Continuous heat-run test at elevated ambient temperature over a period of several days;
- Careful computer-controlled final testing;
- Statistical evaluation of all returned systems and components to enable the immediate initiation of suitable corrective measures;
- Monitoring of major control components, using on-line tests (watchdog for the CPU, etc.).

These measures are referred to in safety technology as basic measures. They prevent or rectify a large proportion of possible faults.

### Risks

In all cases where the occurrence of failures can result in material damage or injury to persons, special measures must be taken to enhance the safety of the installation - and therefore also of the situation. System-specific and special regulations exist for such applications. They must be observed on installing the control system (e.g. VDE 0116 for burner control systems).

For electronic control equipment with a safety function, the measures that have to be taken to prevent or rectify faults are based on the risks involved in the installation. As of a certain degree of hazard the basic measures mentioned above are no longer sufficient. That is, additional measures (e.g. redundant configurations, tests, checksums etc.) must be implemented and certified for the control equipment (DIN VDE 0801). The prototype of the fail-safe PLC S5-95F was tested by TÜV (German Institute for Technological Surveillance), BIA and G EM III; several certificates have been granted. Thus, it is suitable in the same way as the previously tested fail-safe PLC S5-115F to control and monitor safety-relevant system areas.

## Splitting the group into safety-relevant areas and areas which are not safety relevant

Most plants contain equipment performing safety-relevant operations (e.g. EMERGENCY-OFF switch, protective gates, two-hand controls). To avoid the need to examine the entire controller from the aspect of safety, **the controller is usually divided into an area that is safety-relevant and an area that is not safety-relevant**. In the non-safety-related area, no special demands are placed on the safety of the control equipment because any failure in the electronics will have no effect on the safety of the installation. In the safety-relevant area, however, it is only allowed to operate controllers or circuits compliant with corresponding regulations.

The following divisions are common in practical situations:

- For control equipment with few safety-related functions (e.g. machine controls)

The conventional PLC is responsible for machine control, whereas safety-related functions are implemented with a fail-safe mini PLC (e.g. S5-95F).

- For controllers with balanced areas (e.g. chemical installations, cable cars)

The non-secure area is implemented with a conventional PLC, while the secure area requires a tested, fail-safe controller (S7-300F, S7-400F, S7-400FH, S5-115F or several S5-95Fs).

The entire installation is implemented with a fail-safe control system.

- For control equipment with mainly safety-relevant functions (e.g. burner control systems)

The entire control system is implemented with fail-safe technology.

## Important Information

The instructions in the operating manual **MUST** be followed, even if the electronic control equipment has been configured for maximum design safety - e.g. with a multi-channel structure. Incorrect handling can render measures intended to prevent dangerous faults ineffective, or generate additional sources of danger.





## **Accumulator**

The → CPU uses the accumulator registers as intermediate memory for load, transfer, comparison, calculation and conversion operations.

## **Address**

An address represents the ID for a specific address or address range. Example: Input I12.1; Memory bit word MW25; Data block DB3.

## **Analog Module**

Analog modules convert process values (e.g. temperature) into digital values, so that they can be processed by the central processing unit, or convert digital values into analog manipulated variables.

## **Backplane Bus**

The backplane bus is a serial data bus. It supplies power to the modules and is also used by the modules to communicate with each other. Bus connectors interconnect the modules.

## **back-up Memory**

The back-up memory provides a back-up of memory areas for the → CPU without a back-up battery. It backs up a configurable number of timers, counters, memory bits, data bytes and retentive timers, counters, memory bits and data bytes).

## **Bus**

A bus is a communication medium connecting several nodes. Data can be transferred via serial or parallel circuits, that is, via electrical conductors or fiber optic.

## **Bus segment**

A bus segment is a self-contained section of a serial bus system. Bus segments are interconnected using repeaters.

### Chassis ground

Chassis ground is the totality of all the interconnected passive parts of a piece of equipment on which dangerous fault-voltage cannot occur.

### Clock memory bits

Memory bit which can be used to generate clock pulses in the user program (1 byte per memory bit).

---

#### Note

Note in the case of S7-300 CPUs that the clock memory byte is not overwritten in the user program.

---

### Code Block

A SIMATIC S7 code block contains part of the **STEP 7** user program. (In contrast: a → Data Block (DB) only contains data.)

### Communication processor

Communication processors are modules for point-to-point and bus communication.

### Compress

The programming device online function "Compress" is used to align all valid blocks contiguously in the RAM of the CPU at the start of the user memory. This eliminates all gaps which arose when blocks were deleted or modified.

### Configuration

Assignment of modules to racks/slots and (e.g. for signal modules) addresses.

### Consistent data

Data whose contents are related and which should not be separated are known as consistent data.

For example, the values of analog modules must always be handled consistently, that is the value of an analog module must not be corrupted by reading it out at two different times.

### Counters

Counters are part of CPU --> system memory. The content of "Counter cells" can be modified by **STEP 7** instructions (e.g. up/down count).

**CP**

--> Communication processor

**CPU**

Central processing unit of the S7 programmable controller with open and closed-loop control systems, memory, operating system and interface for programming device.

**CPU operating system**

The CPU OS organizes all functions and processes of the CPU which are not associated to a specific control task.

**Cycle Time**

The term cycle time describes the time required by a → CPU to run through a → user program on

**Data block**

Data blocks (DB) are data areas in the user program which contain user data. Global data blocks can be accessed by all code blocks while instance data blocks are assigned to a specific FB call.

**Data, static**

Static data is data which can only be used within a function block. The data is saved in an instance data block belonging to the function block. The data stored in the instance data block is retained until the next function block call.

**Data, temporary**

Temporary data is local data of a block that is stored in the L stack during block execution and no longer available after execution.

**Delay Interrupt**

→ Interrupt, Delay

**Diagnostic buffer**

The diagnostic buffer is a buffered memory area in the CPU in which diagnostic events are stored in the order of their occurrence.

### **Diagnostic Interrupt**

Modules capable of diagnostics operations report detected system errors to the  
→ CPU via diagnostic interrupts.

### **Diagnostics**

→ System Diagnostics

### **DP master**

A → master which behaves in accordance with EN 50170, Part 3 is known as a DP master.

### **DP slave**

A → slave operated on PROFIBUS with PROFIBUS-DP protocol and in accordance with EN 50170, Part 3 is referred to as DP slave.

### **DPV1**

The designation DPV1 means the extended functions of the acyclical services (to include new interrupts, for example) provided by the DP protocol. The DPV1 functionality has been incorporated into IEC 61158/EN 50170, volume 2, PROFIBUS.

### **Electrically isolated**

The reference potential of the control and on-load power circuits for isolated I/Os is galvanically separated; e.g. by optocouplers, relay contact or transformer. Input/output circuits can be connected to a common potential.

### **Equipotential bonding**

Electrical connection (equipotential bonding conductor) which gives the bodies of electrical equipment and external conducting bodies the same or approximately the same potential, in order to prevent disturbing or dangerous voltages from being generated between these bodies.

### **Error display**

One of the possible responses of the operating system to a → runtime error is to display the error. The other possible responses are: → error response in the user program, CPU STOP.

**Error handling via OB**

When the operating system detects a specific error (e.g. access error with **STEP 7**), it calls a dedicated organization block (Error OB) that determines subsequent CPU response.

**Error response**

Response to a → runtime error. The operating system can respond in the following ways: transition of the PLC to STOP mode, call of an organization block in which the user can program an error response or display.

**External power supply**

Power supply for the signal and function modules and the I/O connected to them.

**FB**

→ Function Block

**FC**

→ Function

**Flash EPROM**

FEPROMs are the same as electrically erasable EEPROMS in that they can retain data in the event of a power failure, but they can be erased much more quickly (FEPROM = Flash Erasable Programmable Read Only Memory). They are used on → Memory Cards.

**Floating potential**

No galvanic connection to ground.

**FORCE**

The Force function is used to assign fixed values to certain variables from a user program or CPU (including I/Os).

In this context, please note the limitations listed in the *Overview of the test functions* section in the chapter entitled *Test functions, diagnostics and troubleshooting* in the *S7-300 Installation* manual

**Function**

According to IEC 1131-3 a function is a → code block that contains no → statical data. A function allows parameters to be passed in the user program. Functions are therefore suitable for programming frequently occurring complex functions, e.g. calculations.

### Function block

According to IEC 1131-3, a function block is a → code block that contains → static data. An FB allows parameters to be passed in the user program. Function blocks are therefore suitable for programming complex functions, e.g. closed-loop controls, mode selections, which are repeated frequently.

### Functional grounding

Grounding which has the sole purpose of safeguarding the intended function of electrical equipment. With functional grounding you short-circuit interference voltage which would otherwise have an unacceptable impact on equipment.

### GD circuit

A GD circle encompasses a number of CPUs which exchange data by means of global data communication and which are used as follows:

- One CPU broadcasts a GD packet to the other CPUs.
- One CPU sends and receives a GD packet from another CPU.

A GD circuit is identified by a GD circuit number.

### GD Element

A GD element is generated by assigning shared → global data. It is identified by a unique global data ID in the global data table.

### GD packet

A GD packet can consist of one or more GD objects which are transmitted together in a frame.

### Global data

Global data can be addressed by any → code block (FC, FB, OB). Individually, these are markers M, inputs I, outputs Q, timers, counters, and data blocks DB. Global data can be accessed with either absolute or symbolic access.

### Global data communication

Global data communication is a procedure used to transfer → global data between CPUs (without CFBs).

### Ground

The conductive earth whose electrical potential can be set equal to zero at any point.

Ground potential can be different to zero in the area of grounding electrodes. The term "reference ground" is frequently used to describe this situation.

**Ground (to)**

To ground means to connect an electrically conducting component to the grounding electrode (one or more conducting components which have a very good contact with the earth) across a grounding system.

**GSD file (device master file)**

The device master file (GSD file) stores all slave specific properties. The GSD file format is specified in EN 50170, Volume 2, PROFIBUS.

**Instance data block**

A DB is automatically generated and assigned to every function block in the **STEP 7** user program. The values of the input, output and in/out parameters are stored in the instance data block, together with local block data.

**Interface, multipoint**

→ MPI

**Interrupt**

The CPU's → operating system knows 10 different priority classes for controlling user program execution. These priority classes include interrupts, such as process interrupts. When an interrupt is triggered, the operating system automatically calls an assigned OB. In this OB the user can program the desired response (for example in an FB).

**Interrupt, Delay**

The delay interrupt belongs to one of the priority classes when processing programs in SIMATIC S7. It is started on expiration of a time generated in the user program. A corresponding organization block is then executed.

**Interrupt, diagnostic**

→ Diagnostic interrupt

**Interrupt, Process**

→ Process interrupt

**Interrupt, status**

A status interrupt can be generated by a DPV1 slave and causes OB55 to be called on the DPV1 master. For detailed information on OB55, see the *Reference Manual "System software for S7-300/400: System and Standard Functions"*

### **Interrupt, time-of-day**

The time-of-day interrupt belongs to one of the priority classes in SIMATIC S7 program processing. It is generated depending on a specific date (or daily) and time-of-day (e.g. 9:50 or hourly, or every minute). A corresponding organization block is then executed.

### **Interrupt, update**

An update interrupt can be generated by a DPV1 slave and causes OB 56 to be called on the DPV1 master. For detailed information on OB 56, see the *Reference Manual "System software for S7-300/400: System and Standard Functions"*

### **Interrupt, vendor-specific**

A vendor-specific interrupt can be generated by a DPV1 slave. It causes OB57 to be called on the DPV1 master.

Detailed information on OB 57 can be found in the *Reference Manual "System Software for S7-300/400: System and Standard Functions"*

### **Interrupt, watchdog**

A watchdog interrupt is generated periodically by the CPU in a configurable time pattern. A corresponding → organization block is then executed.

### **Load memory**

Load memory is part of the CPU. It contains objects generated by the programming device. It is implemented either as a plug-in Memory Card or permanently integrated memory.

### **Local data**

→ Data, temporary

### **Main memory**

Work memory is a RAM memory in the → CPU accessed by the processor during user program execution.

### **Master**

Masters in possession of the → Token can send/request data to/from other nodes (= active node).



**Memory bits**

Memory bits are part of the CPU's → system memory. They store intermediate results of calculations. They can be accessed in bit, byte, word or doubleword units.

**Memory Card (MC)**

Memory Cards are memory media for CPUs and CPs. They are implemented in the form of → RAM or → FEPRM. An MC differs from an → Micro Memory Card only in its dimensions (MC is approximately the size of a credit card).

**Micro Memory Card (MMC)**

Micro Memory Cards are memory media for CPUs and CPs. Its smaller dimensions form the only difference compared to the → Memory Card.

**Module Parameters**

Module parameters are values which can be used to control the response of the module. A distinction is made between static and dynamic module parameters.

**MPI**

This interface is capable of multipoint communication (MPI). It forms part of the SIMATIC S7 PG interface. It enables multiple-node operation (PGs, text-based displays, OPs) on one or several PLCs. Each node is identified by a unique address (MPI address).

**MPI address**

→ MPI

**Nesting depth**

One block can be called from another by means of a block call. Nesting depth is defined as the number of simultaneously called → code blocks.

**Non-isolated**

The reference potential of the control and on-load power circuits for non-isolated I/Os is electrically interconnected.

**OB**

Organization Blocks

## OB priority

The CPU → operating system distinguishes between different priority classes, e.g. cyclic program execution, program execution controlled by process interrupt. Each priority class is assigned → organization blocks (OB) in which the S7 user can program a response. The OBs have different standard priorities which determine the order in which they are executed or interrupted in the event that they are activated simultaneously.

## Operating mode

SIMATIC S7 PLC operating modes are: STOP, → START-UP, RUN.

## Organization Blocks

Organization blocks (OBs) form the interface between CPU operating system and the user program. The processing sequence of the user program is defined in the organization blocks.

## Parameters

1. Variable of a **STEP 7** code block
2. Variable for declaring module response (one or several per module). All modules have a suitable basic factory setting which can be customized in **STEP 7**. There are → static parameters and → dynamic parameters

## Parameters, dynamic

Unlike static parameters, dynamic parameters of modules can be changed during operation by calling an SFC in the user program, for example limit values of an analog signal input module.

## Parameters, static

Unlike dynamic parameters, static parameters of modules cannot be changed by the user program. You can only modify these parameters by editing your configuration in **STEP 7**, e.g. modification of input delay parameters of a digital signal input module.

## PG

→ Programming device

## PLC

An automation system in the context of SIMATIC S7 → is a programmable logic controller.

**PLC**

→ Programmable controller

**Priority class**

The S7 CPU operating system provides up to 26 priority classes (or "Program execution levels"). Specific OBs are assigned to these classes. The priority classes determine which OBs interrupt other OBs. If a priority class includes several OBs, they do not interrupt each other, but are executed sequentially.

**Process Image**

The process image is part of CPU → system memory. At the start of cyclic program execution, the signal states at the input modules are written to the process image of the inputs. At the end of cyclic program execution, the signal status of the process image of the outputs is transferred to the output modules.

**Process interrupt**

A process interrupt is triggered by interrupt-triggering modules as a result of a specific event in the process. The process interrupt is reported to the CPU. The assigned → organization block is then processed, according to interrupt priority.

**Product version**

The product version identifies differences between products which have the same order number. The product version is incremented when forward-compatible functions are enhanced, after production-related modifications (use of new parts/components) and for bug fixes.

**PROFIBUS DP**

The PLC distributes controls for digital, analog and intelligent modules as well as a wide range of field devices to EN 50170, part 3, for example, drives or valve blocks, to processes at external locations - even across distances exceeding 23 km.

The modules and field devices are connected to the programmable controller via the PROFIBUS-DP fieldbus and addressed in the same way as centralized I/Os.

**Programming device**

Programming devices are essentially personal computers which are compact, portable and suitable for industrial applications. They are equipped with special hardware and software for SIMATIC PLCs.

### **Programmable controller**

Programmable controllers (PLCs) are electronic controllers whose function is saved as a program in the control unit. The configuration and wiring of the unit are therefore independent of the function of the control system. The PLC has a computer structure; it consists of the → CPU (Central Processing Unit) with memories, I/O modules and internal bus system. The I/Os and the programming language are oriented to control engineering needs.

### **RAM**

RAM (Random Access Memory) is a semiconductor read/write memory.

### **Reference ground**

→ Ground

### **Reference potential**

Potential with reference to which the voltages of participating circuits are observed and/or measured.

### **Retentivity**

A memory area is retentive if its contents are retained even after a power failure and a change from STOP to RUN. The non-retentive area of memory markers, timers and counters is reset following a power failure and a transition from the STOP mode to the RUN mode.

The following can be made retentive:

- flag bits
- S7 timers
- S7 counters
- Data areas

### **Restart**

On CPU startup (e.g. after is switched from STOP to RUN mode via selector switch or with POWER ON), OB100 (restart) is initially executed, prior to cyclic program execution (OB1). On restart, the input process image is read in and the **STEP 7** user program is executed, starting at the first instruction in OB 1.

### **Runtime error**

Errors occurred in the PLC (that is, not in the process itself) during user program execution.

**Scan rate**

The reduction rate determines the send/receive frequency for → GD packets on the basis of the CPU cycle.

**SFB**

→ System function block

**SFC**

→ System function

**Segment**

→ Bus Segment

**Signal module**

Signal modules (SM) form the interface between the process and the PLC. There are digital and analog I/O modules (input/output module, digital or analog).  
(input/output module, analog)

**Slave**

A slave may only exchange data with the → Master on request.

**START-UP**

A STARTUP routine is executed at the transition from STOP to RUN mode. Can be triggered by the → mode selector switch or after power on, or by an operator action on the programming device. An S7–300 performs → a restart.

**STEP 7**

Programming language for developing user programs for SIMATIC S7 PLCs.

**Substitute value**

Substitute values are configurable values which output modules transfer to the process when the CPU switches to STOP mode.

In the event of an input access error, a substitute value can be written to the accumulator instead of the input value which could not be read (SFC 44).

### **System Diagnostics**

System diagnostics refers to the detection, evaluation and signaling of errors which occur within the PLC, for example, program errors or module errors. System errors can be displayed with LED indicators or in **STEP 7**.

### **System function**

A system function (SFC) is a → function integrated in the operating system of the CPU that can be called, as required, in the STEP 7 user program.

### **System Functions Block**

A System Function Block (SFB) is a → function block integrated in the CPU operating system. If required, it can be called in the STEP 7 user program.

### **System memory**

The system memory (RAM) is integrated on the central processing unit. System memory contains the address areas (e.g. timers, counters, memory bits) and the data areas required internally by the → operating system (e.g. buffers for communication).

### **System state list**

The system status list contains data describing the current status of an S7-300. You can always use this list to obtain an overview of:

- The S7-300 configuration
- The current CPU configuration and the configurable signal modules
- Current status and processes in the CPU and configurable signal modules.

### **Terminating resistor**

A terminating resistor is used to terminate data links in order to prevent reflections.

### **Timer**

→ Timer

### **Timers**

Timers are part of CPU → system memory. The content of “timer cells” is automatically updated by the operating system, asynchronously to the user program. **STEP 7** instructions are used to define the exact function of the timer cells (for example on-delay) and initiate their execution (e.g. start).

**Time-of-day interrupt**

→ Interrupt, Time-of-day

**Token**

Bus access rights

**Transmission rate**

Data transfer rate (in bps)

**User Program**

The SIMATIC system distinguishes between the → CPU operating system and user programs. The latter are created with → **STEP 7** programming software, using optional programming languages (LAD and STL). User programs are stored in code blocks. data is stored in data blocks.

**User memory**

User memory contains → code and → data blocks of the user program. The user memory can be integrated in the CPU or can be provided on plug-in memory cards or memory modules. However, user programs are always executed from → CPU main memory.

**Varistor**

voltage-dependent resistor

**Watchdog Interrupt**

→ Interrupt, Watchdog





# Index

## A

- accessories
  - wiring 7-1
- Accessories 6-2
- Accumulator 13-1
- Actuator/sensor interface 5-33
- Address 13-1
- addresses
  - analog modules 8-5
  - integrated I/O of CPUs 8-6
- Addresses
  - Digital modules 8-3
- addressing
  - slotbased 8-1
  - User-defined 8-3
- Addressing
  - slot-based 8-1
  - user-defined 8-1
- Analog Module 13-1
- analog modules
  - addresses 8-5
- arrangement
  - the modules 5-7
- asynchronous error 11-4

## B

- Backplane Bus 13-1
- back-up
  - inserting 9-6
  - operating system 10-2
- back-up battery
  - disposal 10-10
  - handling rules 10-10
  - storing 10-10
- Backup battery
  - replacing 10-9
- back-up memory 13-1
- Basic knowledge required 1-1
- Bus 13-1
  - Backplane 13-1
- Bus cables
  - installation rules 5-40
- bus connector
  - connecting the bus cable 7-17
  - connecting to module 7-18
  - removing 7-18
- Bus connector 5-40
  - connecting the bus cable 7-17
  - setting the terminating resistor 7-18

- bus connectors
  - plug 6-8
- Bus segment 13-1
- Bus termination 5-49
- BUSF
  - LED 11-10
- BUSF1
  - LED 11-10
- BUSF2
  - LED 11-10

## C

- cabinet
  - Selecting and dimensioning 5-12
- Cabinet
  - dimensions 5-13
  - power loss dissipated 5-15
  - types 5-14
- cable lengths
  - longer 5-43
  - PROFIBUS subnet 5-43
- Cable lengths
  - maximum 5-41
  - MPI subnet 5-42
  - stub cables 5-43
- Cable routing inside buildings 12-14
- Cable shielding 12-11
  - ground 5-26
- cables
  - preparing 7-9
- Central unit 5-2
- Chassis ground 13-2
- Clearances 5-6
- Code Block 13-2
- cold restart
  - with key switch 9-15
- cold start 9-15
- commissioning
  - CPU 31x-2 DP as DP master 9-24
  - CPU 31xC-2 DP as DP master 9-24
  - PROFIBUS DP 9-23
  - Recommended procedure with the hardware 9-2
  - Response to errors 9-3
  - software requirements 9-1
  - using the software 9-3
- Commissioning
  - checklist 9-4
  - CPU 31x-2 DP as DP slave 9-27
  - CPU 31xC-2 DP as DP slave 9-27

- Compress 13-2
- Configuration 13-2
- connecting
  - PG 9-8
  - sensors and actors 7-8
- Connecting
  - spring terminals 7-8
- connecting actors 7-8
- connecting cables
  - for interface modules 5-9
- connecting sensors 7-8
- Connection comb 7-6
- Consistent data 8-7, 13-2
- controlling
  - of variables 11-1
- controlling and monitoring variables
  - Controlling outputs in CPU STOP mode 9-22
- Counters 13-2
- CPU
  - operating system 13-3
  - wiring 7-7
- CPU 313C-2 DP
  - commissioning as DP master 9-24
  - commissioning as DP-Slave 9-28
- CPU 314C-2 DP
  - commissioning as DP master 9-24
  - commissioning as DP slave 9-28
- CPU 315-2 DP
  - commissioning as DP master 9-24
  - commissioning as DP slave 9-28
- CPU 316-2 DP
  - commissioning as DP master 9-24
  - commissioning as DP slave 9-28
- CPU 318-2 DP
  - cold restart 9-15
  - commissioning as DP master 9-24
  - commissioning as DP slave 9-28
- Cycle time 13-3
- D**
- data
  - static 13-3
- Data
  - consistent 13-2
  - temporary 13-3
- Data block 13-3
- default addressing 8-1
- Delay Interrupt 13-7
- Device-related diagnostics 11-27
- Diagnostic addresses 11-18
- Diagnostic buffer 11-5, 13-3
- Diagnostic Interrupt 13-4
- diagnostics
  - as DP-Slave 11-15
  - configured address area 11-25
  - diagnostics
    - with LEDs 11-7
- Diagnostics
  - device-related 11-27
  - System 13-14
  - with "hardware diagnostics" 11-6
  - with system functions 11-5
- Diagnostics
  - as DP-Master 11-12
- Digital modules
  - Addresses 8-3
- digital output module
  - replacement fuses 10-11
  - replacing fuses 10-12
- Dimensions
  - of modules 5-4
- Direct data exchange 9-33
- DP master 13-4
  - interrupts 11-21
- DP slave 13-4
- DPV1 13-4
- E**
- Electrically isolated 13-4
- EMC
  - definition 12-3
- EMC correct grounding 12-7
- EMC error-free installation 12-7
- EMC grounded installation, example 12-8
- Equipotential bonding 13-4
- Equipotential bonding - lightning protection 12-19
- Equipotential bonding conductor 5-26
- error
  - asynchronous 11-4
  - synchronous 11-4
- Error display 13-4
- error displays
  - DP-compliant CPUs 11-10
- error handling 11-4
- Error response 13-5
- error-free operation of a S7-300 12-1
- Event recognition 11-14, 11-19
- Expansion module 5-2
- F**
- Floating potential 13-5
- Force 13-5
- forcing 11-2
- front connector
  - preparing 7-9
  - wiring 7-3, 7-10
- Front connector
  - encoding 7-12
- front connector coding
  - remove from front connector 10-7

- front connector coding pin
    - remove from module 10-6
  - Full assembly 5-11
  - Function
    - FC 13-5
  - Function block
    - FB 13-6
  - Functional grounding 13-6
  - Further Support 1-4
- G**
- GD circuit 13-6
  - GD element 13-6
  - GD packet 13-6
  - Global data 13-6
  - Ground 13-6, 13-7
  - ground conductor
    - fixing the ground conductor 6-4
  - Grounding concept 5-22
  - GSD file (device master file) 13-7
- H**
- Highest MPI address 5-35
  - Highest PROFIBUS DP address 5-35
- I**
- Inscription labels 6-2
  - installation
    - Arranging modules 5-7
    - horizontal 5-3
    - vertical 5-3
  - Installation
    - grounded reference potential 5-19
    - in cabinets 5-12
    - ungrounded reference potential 5-20
  - Installing
    - the module 10-7
    - the modules 6-8
  - Installing EMC plants 12-3
  - Instance data block 13-7
  - interface modules
    - connecting cables 5-9
  - interfaces
    - MPI interface 5-37
    - Which devices can I connect to which interface? 5-38
  - Interfaces
    - PROFIBUS DP interface 5-38
  - intermediate memory 9-29
  - Internet 1-6
  - interrupt
    - on the DP master 11-21
    - Process 13-11
    - Update interrupt 13-8
  - Interrupt 13-7
    - Delay 13-7
    - diagnostic 13-4
    - status interrupt 13-7
    - time-of-day 13-8
    - vendor-specific interrupt 13-8
    - watchdog- 13-8
  - Interrupt, time-of-day 13-8
  - Interrupt, watchdog 13-8
- K**
- key switch
    - cold restart with 9-15
- L**
- labeling strips
    - assignment to modules 7-13
    - inserting 7-13
  - LED 11-10
  - Lightning protection equipotential bonding 12-19
  - Lightning protection zone concept 12-17
  - Load
    - from PS 307 5-31
  - Load circuits
    - ground 5-26
  - Load current
    - determining 5-30
  - load memory 13-8
  - Load voltage
    - connecting the reference potential of the load voltage 5-27
  - Local data 13-8
  - Local equipotential bonding 12-21
- M**
- Main memory 13-8
  - Mains voltage selector switch 7-5
  - Material
    - necessary 6-3
  - memory
    - System 13-14
    - User 13-15
  - Memory
    - back-up 13-1
    - Load 13-8
    - main 13-8
  - Memory bits 13-9
  - memory card
    - inserting 9-7
    - replacing 9-7
  - memory reset
    - MPI parameter 9-16
  - Memory reset
    - with mode selector 9-14

- Mode selector
    - memory reset with 9-14
  - module
    - arrangement 5-10
    - installation 6-8
    - Installing 10-7
    - removing 10-5
    - replacing 10-4
  - Module
    - dimensions 5-4
    - labeling 7-13
    - start addresses 8-1
  - module diagnostics 11-25
  - Module Parameters 13-9
  - module replacement
    - controlling 10-4
  - modules
    - arrangement 5-7
  - Modules
    - isolated 5-22
    - non-isolated 5-22
  - Monitor and control variable
    - Setting the trigger points 9-20
  - monitor and control variables
    - controlling variables 9-20
  - monitoring
    - of variables 11-1
  - monitoring and controlling variables
    - Establishing a connection to the CPU 9-21
    - Opening the VAT 9-21
    - Saving the VAT 9-21
  - Monitoring and controlling variables
    - monitoring variables 9-19
  - Mountable shielding terminals 5-5
  - MPI 13-9
    - maximum baud rate 5-34
    - maximum possible number of nodes 5-34
  - MPI Subnet 5-32
  - MPI address
    - default 5-35
    - highest 5-35
    - Recommendations 5-36
    - rules 5-35
  - MPI interface 5-37
  - MPI subnet
    - Example 5-44
    - maximum distances 5-45
    - Segment 5-42
    - terminating resistor 5-49
  - Nesting depth 13-9
  - Noise
    - electromagnetic 12-3
  - Non-isolated 13-9
- O**
- OB 13-10
  - OB priority 13-10
  - Open components 6-1
  - Operating mode 13-10
  - operating system
    - back-up 10-2
  - Operating system
    - CPU 13-3
    - updating 10-3
  - Organization Blocks 13-10
  - Outdoor routing of cables 12-16
- P**
- Parameters 13-10
    - Module 13-9
  - PG
    - access across network boundaries 5-48
    - connecting 9-8
    - ungrounded configuration 9-11
    - via stub cable to subnet 9-10
  - Potential differences 5-26, 12-12
  - power on
    - requirements 9-12
  - Power supply
    - grounded 5-17
  - Power supply module
    - wiring 7-6
  - Power supply module
    - selecting mains voltage 7-5
  - power up
    - initial 9-12
  - priority
    - OB 13-10
  - Priority class 13-11
  - Process Image 13-11
  - process interrupt 13-11
  - Product version 13-11
  - PROFIBUS bus cable 5-39
  - PROFIBUS address
    - Recommendation 5-36
  - PROFIBUS bus cable
    - properties 5-39
  - PROFIBUS DP 13-11
    - commissioning 9-23
    - Direct data exchange 9-33
    - maximum baud rate 5-34
    - maximum possible number of nodes 5-34
  - PROFIBUS DP address
    - highest 5-35
    - rules 5-35
  - PROFIBUS DP addresses
    - default 5-35
  - PROFIBUS DP interface 5-38
  - PROFIBUS DP subnet 5-32

- PROFIBUS subnet
  - cable lengths 5-43
  - Example 5-46
- PROFIBUS Terminator 5-49
- Protect digital output modules from inductive surge 12-26
- protective conductor
  - connecting to the rail 7-4
- Protective ground
  - measures 5-25
- Protective measures
  - for overall system 5-18
- Purpose of this documentation 1-1
- R**
- rail
  - ground conductor 6-4
  - preparing 6-4
- Rail
  - connecting the protective conductor 7-4
  - mounting hole dimensions 6-5
- rails
  - fixing screws 6-5
  - versions 6-3
- Rails
  - length 5-4
- rechargeable battery
  - handling rules 10-10
  - inserting 9-6
- Rechargeable battery
  - replacing 10-9
- Reference potential
  - grounded 5-19
  - ungrounded 5-20
- Repeater
  - RS485 5-41
- replacing
  - module 10-4
- replacing
  - fuses 10-12
- Replacing
  - backup battery 10-9
  - rechargeable battery 10-9
- Replacing a module
  - behavior of S7-300 10-8
- replacing fuses
  - digital output module 10-12
- Restart 13-12
- Retentivity 13-12
- Routing 5-48
- Routing a potential difference cable 12-12
- RS485
  - bus connector 5-40
- RS485 repeater 5-41
- Rules and regulations for error-free operation 12-1
- Runtime error 13-12
- S**
- S7-300
  - initial power up 9-12
- Scan rate 13-13
- Scope of the Manual 1-1
- Segment 5-34
  - in the MPI subnet 5-42
  - in the PROFIBUS subnet 5-43
- Service 1-6
- SF
  - LED, evaluation 11-8
- Shielding cables 12-11
- Shielding contact element 5-5, 7-14
  - mounting 7-14
- Shielding terminal
  - laying cables 7-15
- Signal module 13-13
- SIMATIC Manager 9-17
  - start 9-17
- SINEC L2-DP 13-11
- single-step mode 11-1
- Slave Diagnostic
  - read 11-15
- slave diagnostics
  - read, example 11-17
  - structure 11-22
- slot number
  - assign 6-9
  - insert 6-10
- Slot number label 6-2
- Slot-based addressing 8-1
- Start-up 13-13
  - CPU 31x-2 DP as DP master 9-25
  - CPU 31x-2 DP as DP slave 9-28
  - CPU 31xC-2 DP as DP master 9-25
  - CPU 31xC-2 DP as DP slave 9-28
- Station status 11-23
- Status display
  - DP-compliant CPUs 11-10
- Status interrupt 13-7
- strain relief 7-10
- Stub cables
  - length 5-43
- Subnets 5-32
- Substitute value 13-13
- Support 1-6
  - surge protection, example 12-24
  - synchronous error 11-4
- System Diagnostics 13-14
- System function
  - SFC 13-14
- System Function Block
  - SFB 13-14
- System memory 13-14

## T

- terminating resistor
  - MPI subnet 5-49
- Terminating resistor 13-14
  - setting on the bus connector 7-18
- Timers 13-14
- tool
  - necessary 6-3
- Training Center 1-4

## U

- Ungrounded configuration
  - connecting a PG 9-11
- uninstalling
  - the modules 10-5
- update interrupt 13-8
- Updating
  - operating system 10-3
- User memory 13-15
- User Program 13-15
- User-defined addressing 8-1, 8-3

## V

- variable monitoring or control
  - create variable table 9-18
- variables
  - controlling 11-1
  - force 11-2
  - monitoring 11-1
- Vendor ID 11-24
- Vendor-specific interrupt 13-8
- Voltage
  - selecting mains voltage 7-5

## W

- wiring
  - accessories required 7-1
  - front connector 7-10
  - front connectors 7-3
  - PS and CPU 7-6
- Wiring
  - PS and CPU 7-2
  - required tools and materials 7-2
  - rules 7-2