

# SIEMENS

## RUGGEDCOM WIN7025

### Installation Guide

#### Preface

---

#### Introduction

---

1

#### Installing the Base Station

---

2

#### Device Management

---

3

#### Technical Specifications

---

4

#### Certification

---

5

Copyright © 2019 Siemens Canada Ltd

All rights reserved. Dissemination or reproduction of this document, or evaluation and communication of its contents, is not authorized except where expressly permitted. Violations are liable for damages. All rights reserved, particularly for the purposes of patent application or trademark registration.

This document contains proprietary information, which is protected by copyright. All rights are reserved. No part of this document may be photocopied, reproduced or translated to another language without the prior written consent of Siemens Canada Ltd.

## » Disclaimer Of Liability

Siemens has verified the contents of this document against the hardware and/or software described. However, deviations between the product and the documentation may exist.

Siemens shall not be liable for any errors or omissions contained herein or for consequential damages in connection with the furnishing, performance, or use of this material.

The information given in this document is reviewed regularly and any necessary corrections will be included in subsequent editions. We appreciate any suggested improvements. We reserve the right to make technical improvements without notice.

## » Registered Trademarks

RUGGEDCOM™ and ROS™ are trademarks of Siemens Canada Ltd.

Other designations in this manual might be trademarks whose use by third parties for their own purposes would infringe the rights of the owner.

## » Security Information

Siemens provides products and solutions with industrial security functions that support the secure operation of plants, machines, equipment and/or networks. They are important components in a holistic industrial security concept. With this in mind, Siemens' products and solutions undergo continuous development. Siemens recommends strongly that you regularly check for product updates.

For the secure operation of Siemens products and solutions, it is necessary to take suitable preventive action (e.g. cell protection concept) and integrate each component into a holistic, state-of-the-art industrial security concept. Third-party products that may be in use should also be considered. For more information about industrial security, visit <https://www.siemens.com/industrialsecurity>.

To stay informed about product updates as they occur, sign up for a product-specific newsletter. For more information, visit <https://support.automation.siemens.com>.

## » Warranty

Siemens warrants this product for a period of five (5) years from the date of purchase, conditional upon the return to factory for maintenance during the warranty term. This product contains no user-serviceable parts. Attempted service by unauthorized personnel shall render all warranties null and void. The warranties set forth in this article are exclusive and are in lieu of all other warranties, performance guarantees and conditions whether written or oral, statutory, express or implied (including all warranties and conditions of merchantability and fitness for a particular purpose, and all warranties and conditions arising from course of dealing or usage or trade). Correction of nonconformities in the manner and for the period of time provided above shall constitute the Seller's sole liability and the Customer's exclusive remedy for defective or nonconforming goods or services whether claims of the Customer are based in contract (including fundamental breach), in tort (including negligence and strict liability) or otherwise.

For warranty details, visit <https://www.siemens.com/ruggedcom> or contact a Siemens customer service representative.

## » Contacting Siemens

### Address

Siemens Canada Ltd  
Industry Sector  
300 Applewood Crescent  
Concord, Ontario  
Canada, L4K 5C7

### Telephone

Toll-free: 1 888 264 0006  
Tel: +1 905 856 5288  
Fax: +1 905 856 1995

### E-mail

[ruggedcom.info.i-ia@siemens.com](mailto:ruggedcom.info.i-ia@siemens.com)

### Web

<https://www.siemens.com/ruggedcom>

# Table of Contents

Preface .....	v
Alerts .....	v
Related Documents .....	vi
Training .....	vi
Customer Support .....	vi
Chapter 1	
Introduction .....	1
1.1 Feature Highlights .....	2
1.2 Description .....	3
1.3 Required Tools and Materials .....	4
1.4 Decommissioning and Disposal .....	4
Chapter 2	
Installing the Base Station .....	7
2.1 General Procedure .....	8
2.2 Unpacking the Base Station .....	9
2.3 Site Preparation and Precautions .....	10
2.4 Installing the Base Station in Hazardous Locations .....	11
2.5 Mounting the Base Station .....	12
2.5.1 Mounting the Base Station to a Wall or Tower .....	12
2.5.2 Mounting the Base Station to a Pole .....	13
2.5.3 Assembling the Base Station and Mounting Bracket .....	14
2.6 Installing Antennas .....	15
2.6.1 Installing the GPS Antenna .....	16
2.6.2 Installing an RF Antenna .....	17
2.7 Grounding the Base Station .....	18
2.8 Connecting Power and Data .....	20
2.8.1 Connecting a PEC Type Base Station .....	21
2.8.2 Connecting an SFA Type Base Station .....	21
2.8.3 Connecting an SFD Type Base Station .....	22
2.8.4 Installing the Hazardous Location Kit .....	24
2.9 Weatherproofing the Base Station .....	25
2.9.1 Securing the Sealing Screw .....	26
2.9.2 Weatherproofing a Cable .....	26

---

2.9.3 Applying Cold Shrink Tubing .....	27
2.9.4 Applying Self-Amalgamating Tape .....	27
Chapter 3	
<b>Device Management .....</b>	<b>29</b>
3.1 Connecting to the Base Station .....	29
3.2 Configuring the Base Station .....	30
Chapter 4	
<b>Technical Specifications .....</b>	<b>31</b>
4.1 Power Supply Specifications .....	31
4.2 Radio and Modem Specifications .....	31
4.3 Operating Environment .....	32
4.4 Mechanical Specifications .....	32
4.5 Dimension Drawings .....	32
Chapter 5	
<b>Certification .....</b>	<b>35</b>
5.1 Approvals .....	35
5.1.1 MET Laboratories .....	35
5.1.2 CSA .....	36
5.1.3 European Union (EU) .....	36
5.1.4 TÜV Rheinland .....	37
5.1.5 FCC .....	38
5.1.6 Other Approvals .....	38
5.1.7 RoHS .....	38
5.2 EMC and Environmental Type Tests .....	39

# Preface

This guide describes the RUGGEDCOM WIN7025 base station. It describes the major features of the device, installation, commissioning and important technical specifications.

It is intended for use by network technical support personnel who are responsible for the installation, commissioning and maintenance of the base station. It is also recommended for use by network and system planners, system programmers, and line technicians.



## IMPORTANT!

*While this guide does address some safety precautions, it is expected that installation personnel are trained in safe installation practices. Personnel unfamiliar with safe installation procedures, WiMAX technologies, or service procedures should not rely on this guide for comprehensive guidance.*

## CONTENTS

- [“Alerts”](#)
- [“Related Documents”](#)
- [“Training”](#)
- [“Customer Support”](#)

# Alerts

The following types of alerts are used when necessary to highlight important information.



## DANGER!

*DANGER alerts describe imminently hazardous situations that, if not avoided, will result in death or serious injury.*



## WARNING!

*WARNING alerts describe hazardous situations that, if not avoided, may result in serious injury and/or equipment damage.*



## CAUTION!

*CAUTION alerts describe hazardous situations that, if not avoided, may result in equipment damage.*



## IMPORTANT!

*IMPORTANT alerts provide important information that should be known before performing a procedure or step, or using a feature.*

**NOTE**

*NOTE alerts provide additional information, such as facts, tips and details.*

## Related Documents

Other documents that may be of interest include:

- [RUGGEDCOM WIN User Guide](https://support.industry.siemens.com/cs/ww/en/view/109737450) [https://support.industry.siemens.com/cs/ww/en/view/109737450]
- [RUGGEDCOM WIN1212 Installation Guide](https://support.industry.siemens.com/cs/ww/en/view/109738770) [https://support.industry.siemens.com/cs/ww/en/view/109738770]

## Training

Siemens offers a wide range of educational services ranging from in-house training of standard courses on networking, Ethernet switches and routers, to on-site customized courses tailored to the customer's needs, experience and application.

Siemens' Educational Services team thrives on providing our customers with the essential practical skills to make sure users have the right knowledge and expertise to understand the various technologies associated with critical communications network infrastructure technologies.

Siemens' unique mix of IT/Telecommunications expertise combined with domain knowledge in the utility, transportation and industrial markets, allows Siemens to provide training specific to the customer's application.

For more information about training services and course availability, visit <https://www.siemens.com/ruggedcom> or contact a Siemens Sales representative.

## Customer Support

Customer support is available 24 hours, 7 days a week for all Siemens customers. For technical support or general information, contact Siemens Customer Support through any of the following methods:

**Online**

Visit <http://www.siemens.com/automation/support-request> to submit a Support Request (SR) or check on the status of an existing SR.

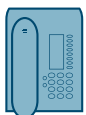
**Telephone**

Call a local hotline center to submit a Support Request (SR). To locate a local hotline center, visit <http://www.automation.siemens.com/mcms/aspa-db/en/automation-technology/Pages/default.aspx>.

**Mobile App**

Install the Industry Online Support app by Siemens AG on any Android, Apple iOS or Windows mobile device and be able to:

- Access Siemens' extensive library of support documentation, including FAQs and manuals
- Submit SRs or check on the status of an existing SR
- Contact a local Siemens representative from Sales, Technical Support, Training, etc.

- Ask questions or share knowledge with fellow Siemens customers and the support community





# 1 Introduction

The RUGGEDCOM WIN7025 base station is a member of the RUGGEDCOM family, a line of mobile WiMAX broadband wireless access systems based on the IEEE 802.16e mobile WiMAX standard. These systems are designed for robustness and simplicity, offering feature-rich services with low deployment and operation costs, for unmatched operator competitiveness and fast return on investment.

The RUGGEDCOM WIN7025 is a cost-effective solution for wireless access services, designed for point-to-multipoint broadband wireless access applications in varying conditions and locations. It is a one-sector base station.

The base station communicates with fixed and mobile subscriber units according to defined service criteria and customer Service Level Agreements (SLAs). The base station also connects to the service provider backbone, supporting end-to-end Quality of Service (QoS) requirements.

The RUGGEDCOM WIN7025 is available in three versions:

- PEC – Power-over-Ethernet (PoE) Copper Interface, DC Power Supply
- SFA – Single Mode Fiber Optic Interface, AC Power Supply
- SFD – Single Mode Fiber Optic Interface, DC Power Supply

Primary benefits offered by the RUGGEDCOM WIN7025 include:

- **Ecosystem Compatibility**  
Compatible with any RUGGEDCOM WIN product or IEEE 802.16e standard compliant WiMAX network equipment.
- **Flexible Configurations**  
Single cable power and Ethernet or Fiber Optic interface.
- **Rated for Harsh Environments**  
IEEE 1613, IEC 61850-3, Class 1 Div 2/ATEX Zone 2, MIL-STD 810F, 509.4 - salt fog.
- **Long Range**  
Transmit and receive diversity combined with high power for improved reach and NLOS (Non-Line-Of-Sight) performance.
- **High Bandwidth**  
RUGGEDCOM WIN has two built-in radios operating on the same frequency simultaneously (MIMO or Multiple Input Multiple Output) to increase bandwidth (up to 40 Mbps) and spectral efficiency.
- **Lowest Frequency Use**  
Leverages OFDMA (Orthogonal Frequency-Division Multiple Access) and built-in GPS (Global Positioning System) to enable users to deploy an entire network on a single frequency channel.
- **Usage Models**  
Designed to support long range connections to fixed, portable and mobile end points, supporting vehicular speed seamless mobility and backhaul mode.
- **Rugged Form Factor**  
All-outdoor, rugged and small form factor allows for flexible deployment options. RUGGEDCOM products are designed for use in harsh environments such as those found in electrical power substations, oil refineries, military applications, roadside traffic control cabinets and metals and minerals processing.

- **Flexible Deployment**

The RUGGEDCOM WIN7025 is a full outdoor base station, designed for easy installation and mounting on poles, street lamps, towers or walls. The WIN7025 can be equipped with copper or fiber network interfaces for flexible integration into the operator's backbone.

- **Remote Monitoring and Configuration with RUGGEDCOM NMS**

RUGGEDCOM NMS is Siemens's Network Management System software for the discovery, monitoring and management of RUGGEDCOM products and other IP enabled devices on a network. This highly configurable, full-featured product records and reports on the availability and performance of network components and services. Device, network and service failures are quickly detected and reported to reduce downtime.

RUGGEDCOM NMS is especially suited for remotely monitoring and configuring RUGGEDCOM routers, switches, serial servers and WiMAX wireless network equipment. For more information, contact a Siemens Sales representative.

## CONTENTS

- [Section 1.1, "Feature Highlights"](#)
- [Section 1.2, "Description"](#)
- [Section 1.3, "Required Tools and Materials"](#)
- [Section 1.4, "Decommissioning and Disposal"](#)

### Section 1.1

## Feature Highlights

The RUGGEDCOM WIN7025 provides the full base station functionality necessary for serving a single sector:

### General

- All-outdoor, single-box base station solution
- Mobile WiMAX compliance based on IEEE 802.16e standard and WiMAX Forum Wave2 (MIMO) certification
- Backbone Ethernet connectivity via a 10/100Base-T network interface
- Fixed and mobile subscriber unit support
- 3.5 MHz, 5 MHz, 7 MHz and 10 MHz channel bandwidth support
- MIMO (2x2) support
- Various Radio Frequency (RF) options, including 1.x, 2.x and 3.x GHz band support

### Antennas

- 2 x N-Type Antennas
- Supports integrated, external sector or omni-directional antennas
- Built-in GPS

### Network Interfaces

- 10/100Base-T Half/Full Duplex IEEE 802.3 CSMA/CD
- ASN-GW Compatibility WiMAX Forum R6, Profile C
- Compatible with Cisco and WiChorus ASN-GW
- Fiber Optic (Optional)

### Power Supply

- 85 to 265 VAC
- Power requirement: 48 VDC
- 37 to 60 VDC (customer supplied for SFD version)

### Hazardous Location Certification

- Class I, Division 2
- ATEX Zone 2

## Section 1.2

# Description

The RUGGEDCOM WIN7025 features various types of ports for connecting antennas and data adapters, and for interfacing with the device. Options are based on the base station type.

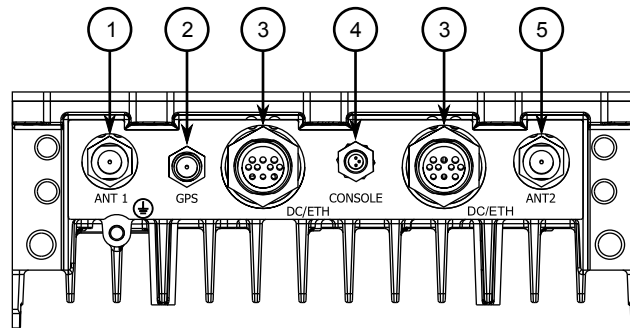

**Figure 1: RUGGEDCOM WIN7025 Communication Ports for PEC Model**

1. ANT1 Port 2. GPS Port 3. DC/ETH Port 4. RS232 Serial Console Port 5. ANT2 Port

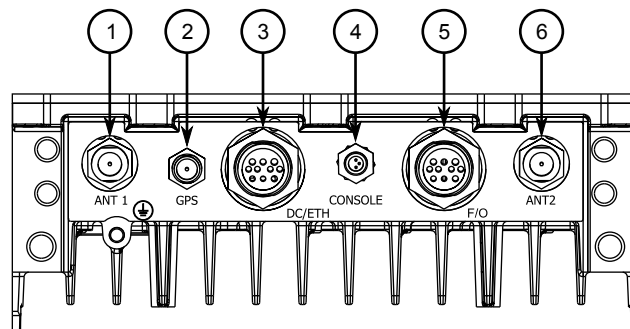

**Figure 2: RUGGEDCOM WIN7025 Communication Ports for SFA and SFD Models**

1. ANT1 Port 2. GPS Port 3. DC/ETH Port 4. RS232 Serial Console Port 5. F/O Port 6. ANT2 Port

### RS-232 Serial Console Port

A 3-pin serial console port for interfacing directly with the base station and accessing low-level management functions. For more information about this port, refer to the *RUGGEDCOM WIN Base Station User Guide*.

**CAUTION!**

Security hazard - risk of unauthorized access and/or exploitation. Restrict access to the serial console port to authorized personnel only.

<b>ANT1 and ANT2 Ports</b>	N-type female ports for connecting RF (Radio Frequency) antennas. Use only RG-6 or RG-9 coaxial cables.
<b>GPS Port</b>	A TNC female port for connecting the GPS antenna.
<b>DC/ETH Ports</b>	A Power-over-Ethernet (PoE) port for supplying power to the base station and connecting it to the network.
<b>F/O Port</b>	<b>For SFA and SFD models only..</b> An LC (Lucent Connector) port for connecting to the network via a 1000Base-LX fiber optic Ethernet cable.

## Section 1.3

## Required Tools and Materials

The following tools and materials are required to install the RUGGEDCOM WIN7025:

**Kits**

- Class I, Division 2 Kit (P/N MKIT0109) – For hazardous locations only

**Tools**

- Wrench or socket set
- Phillips screwdriver
- Drill with an 8 mm (5/16 in) drill bit

**Sprays**

- Cleaner and de-greaser
- SCC3 conformal coating
- Corrosion protection

**Greases**

- Marine grease (for marine applications only)

**Tapes**

- POE cold shrink (maximum 49.2 mm or 1.9 in inner diameter before shrinking) or self-amalgamating tape
- UV-resistant vinyl tape
- Electrical insulation putty

**Mounting Hardware (Wall/Tower Only)**

- Four 8 mm (5/16 in) screws
- Four 8 mm (5/16 in) flat washers
- Four 8 mm (5/16 in) spring washers
- Wall anchors (if necessary)

## Section 1.4

## Decommissioning and Disposal

Proper decommissioning and disposal of this device is important to prevent malicious users from obtaining proprietary information and to protect the environment.

### » Decommissioning

This device may include sensitive, proprietary data. Before taking the device out of service, either permanently or for maintenance by a third-party, make sure it has been fully decommissioned.

For more information, refer to the associated *User Guide*.

## » **Recycling and Disposal**

For environmentally friendly recycling and disposal of this device and related accessories, contact a facility certified to dispose of waste electrical and electronic equipment. Recycling and disposal must be done in accordance with local regulations.



# 2 Installing the Base Station

This chapter describes how to install the base station, including mounting the device, connecting power, and connecting the device to the network.



## DANGER!

*Electrocution hazard – risk of death or serious injury. When the base station is installed in an outdoor location, all indoor components (e.g. Ethernet and power supply) should be connected through a lightning protector.*

*Lightning protection protects people and equipment located indoors from lightning that may strike the base station or its outdoor cables. Therefore, install the lightning protector indoors, as close as possible to the point where the cables enter the building. The lightning protector can also be installed outdoors as long as the cables that lead indoors are well protected from lightning between the protector and the building entrance.*



## WARNING!

*Safety hazard – risk of serious personal injury and/or damage to equipment. Installing the RUGGEDCOM WIN7025 can pose a serious safety hazard. Be sure to take precautions to avoid the following:*

- *Exposure to high voltage lines during installation*
- *Falling when working at heights or with ladders*
- *Injuries from dropping tools*
- *Contact with AC wiring (power system connection)*



## IMPORTANT!

*Only certified personnel should be permitted to install equipment.*



## IMPORTANT!

*This product contains no user-serviceable parts. Attempted service by unauthorized personnel shall render all warranties null and void.*

*Changes or modifications not expressly approved by Siemens Canada Ltd could invalidate specifications, test results, and agency approvals, and void the user's authority to operate the equipment.*



## IMPORTANT!

*This product should be installed in a **restricted access location** where access can only be gained by authorized personnel who have been informed of the restrictions and any precautions that must be taken. Access must only be possible through the use of a tool, lock and key, or other means of security, and controlled by the authority responsible for the location.*



**IMPORTANT!**

Install equipment in accordance with the electrical code relevant to the country of installation, such as:

- the National Electrical Code (NEC), ANSI/NFPA 70
- the Canadian Electrical Code (CEC), Part 1, CSA C22.1
- the National Electrical Safety Code IEEE C2 (when applicable)

Unless marked or otherwise identified, the Standard for the Protection of Electronic Computer/Data Processing Equipment, ANSI/NFPA 75, also applies.



**IMPORTANT!**

Outdoor exposed communication lines longer than 40 m (140 ft) must be considered as TNV-1 circuits. The installer must make sure the power supply and network ports are designed for full compliance with the standards for TNV-1 telecommunication networks.



**IMPORTANT!**

The warranty is void if the base station is assembled without waterproof sealing or if the sealing is removed from the connections.

**CONTENTS**

- [Section 2.1, "General Procedure"](#)
- [Section 2.2, "Unpacking the Base Station"](#)
- [Section 2.3, "Site Preparation and Precautions"](#)
- [Section 2.4, "Installing the Base Station in Hazardous Locations"](#)
- [Section 2.5, "Mounting the Base Station"](#)
- [Section 2.6, "Installing Antennas"](#)
- [Section 2.7, "Grounding the Base Station"](#)
- [Section 2.8, "Connecting Power and Data"](#)
- [Section 2.9, "Weatherproofing the Base Station"](#)

Section 2.1

## General Procedure

The general procedure for installing the base station is as follows:



**IMPORTANT!**

The user is responsible for the operating environment of the device, including maintaining the integrity of all protective conductor connections and checking equipment ratings. Make sure to review all operating and installation instructions before commissioning or performing maintenance on the device.



**IMPORTANT!**

Before installing the base station in a Class I, Division 2 hazardous location, make sure to review the conditions for safe use. For more information, refer to [Section 2.4, "Installing the Base Station in Hazardous Locations"](#).



1. Review the relevant certification information for any regulatory requirements. For more information, refer to [Section 5.1, "Approvals"](#).
2. Select an appropriate site and perform a site survey. For more information, refer to [Section 2.3, "Site Preparation and Precautions"](#).
3. Unpack and inspect the base station components. For more information, refer to [Section 2.2, "Unpacking the Base Station"](#).
4. Mount the base station to a pole, wall or tower. For more information, refer to [Section 2.5, "Mounting the Base Station"](#).
5. Install and connect the antenna(s). For more information, refer to [Section 2.6, "Installing Antennas"](#).
6. For Class I, Division 2 hazardous locations only, connect a RUGGEDCOM WIN1212. For more information, refer to [Section 2.8.4, "Installing the Hazardous Location Kit"](#).
7. Make sure the base station is grounded. For more information, refer to [Section 2.7, "Grounding the Base Station"](#).
8. Connect the base station to a power source and the network. For more information, refer to [Section 2.8, "Connecting Power and Data"](#).
9. Seal all cable connections. For more information, refer to [Section 2.9, "Weatherproofing the Base Station"](#).
10. Configure the base station. For more information, refer to [Section 3.2, "Configuring the Base Station"](#).

## Section 2.2

## Unpacking the Base Station

The following items are included in the RUGGEDCOM WIN7025 package:

Item	Quantity
RUGGEDCOM WIN7025 Base Station	1
Pole/wall/tower mounting kit	1
DB9 Female to 3-Pin Male RS232 Cable, 2 m (6.6 ft)	1
GPS antenna	1
Power supply for PEC (copper) and SFA (optical) configurations	1
coaxial cable, 900 mm (35.4 in) long	1
Radio Frequency (RF) antenna cables, CAT-5, 1.5 m (4.9 ft) long	2

When unpacking the base station, do the following:

1. Inspect the package for damage before opening it.
2. Visually inspect each item in the package for any physical damage.
3. Verify all items are included.

**IMPORTANT!**

*If any item is missing or damaged, contact Siemens for assistance.*

Section 2.3

## Site Preparation and Precautions

Before installing the base station and or antenna(s), it is important to plan the the complete installation and make sure the appropriate safe guards are in place.

### » Site Selection

Consider the following recommendations when selecting an appropriate site for the base station and antenna(s):

- Mount the antenna(s) at the highest point possible. Reception will increase according to the height of the antenna(s).
- Mount the antenna(s) in a place with as few obstructions as possible between the antenna(s) and the planned service area.
- To avoid interference, mount the antenna(s) and base station as far as possible from other antenna(s) and base stations.
- Keep the cable from the base station to the antenna(s) as short as possible and mount the antenna(s) as close as possible to the base station. Using a cable longer than 2 m (6.6 ft) will result in greater loss and more interference, as the cable will act as an antenna itself.
- Do not point the antenna(s) directly at populated areas.
- Locate the antenna(s) at least 3.6 m (11.8 ft) from people and public areas.
- Make sure the antenna(s) and base station are easily accessible for maintenance purposes.
- Mount the GPS antenna in a position where the whole sky is visible to the antenna. If the base station is mounted on a wall and the GPS antenna is mounted on top of the base station, only half of the sky will be visible to the antenna. This may not be enough for proper operation.
- Conduct a site survey to best position the base station and antenna(s) in relation to other base stations, antennas and subscriber units in the area. The site survey should also take into consideration the overall safety of the selected site

### » Site Survey

Most wireless networks include many subscriber/base stations installed in various locations in an overlapping radio-cell pattern. It is important to position each base station in an optimal location considering the assignment of its radio channels. Therefore, a site survey becomes an essential first step before physically deploying the base station.

The site survey should include details important to the planning of the base station deployment in each specific site, including potential mounting points for the device and antennas, as well as the routing options for data, power and antenna cables.

For safety, always consult with the local power utility as well. It is important to select a site that not only offers maximum coverage, but is also safe for installers to work in.

### » Safety Precautions

When installing the base station or an antenna, make sure to adhere to the following safety precautions:

- Always install the base station with the help of a partner.
- Always use the most appropriate mounting method for the site and the equipment being installed. For assistance, contact a Siemens representative.

- Always assume an overhead line can cause serious injury or death. Note that electric power lines and phone lines look alike.
- Always wear the appropriate Personal Protective Equipment (PPE) for the task, including but not limited to rubber boots, rubber gloves, hard hat, harness and lanyard, etc.
- Always use a ladder made of a non-conductive material, such as wood or fiberglass. Do not use a metal ladder.
- Always work under favorable conditions. Do not work on wet or windy days.
- If the base station or antenna begins to drop, step away immediately and allow it to fall. The base station, cables, metal guy wires and pole (in the case of pole mount installations) are all excellent conductors. Any contact between these components and an electrical power line will complete an electrical path through the base station/antenna and the installer.
- If any part of the base station or an antenna comes in contact with an electrical power line, contact the local power utility. Do not attempt to touch or remove the component.

## Section 2.4

## Installing the Base Station in Hazardous Locations

The RUGGEDCOM WIN7025 is designed to comply with the safety standards for Class I, Division 2, Zone 2 hazardous locations where concentrations of flammable gases, vapors or liquids may be present, as opposed to normal operating environments.

### » Special Conditions for Safe Use

Installation and use of the device in a hazardous location must meet the following special conditions for safe use:

- Substitution of components may impair suitability for Class I, Division 2
- Do not disconnect equipment unless power has been switched off or the area is known to be non-hazardous
- Use only a Lambda DPP240-48-1 Power Supply in conjunction with the device

**NOTE**

*For further details of the device's compliance with Class I, Division 2, Zone 2 standards, refer to [Section 5.1, "Approvals"](#).*

### » Sample Hazardous Location Label

The following is an example of the RUGGEDCOM WIN7025 hazardous location label:

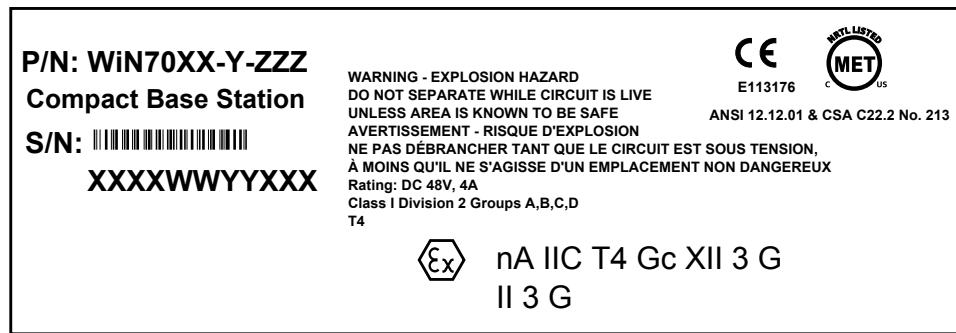

Figure 3: Compliance Label (Example)

## Section 2.5

# Mounting the Base Station

The base station is designed to be mounted to a wall, pole or tower.



### DANGER!

*Electrocution hazard – risk of death or serious injury. Make sure the distance between the base station and nearby power lines meets the minimum requirements established by local standards.*



### CAUTION!

*Crushing hazard – risk of death, serious personal injury and/or equipment damage. Make sure the wall, pole or tower can support the weight of the base station. For more information, refer to [Section 4.4](#), “Mechanical Specifications”.*



### NOTE

*For detailed dimensions of the base station, refer to [Section 4.5](#), “Dimension Drawings”.*

## CONTENTS

- [Section 2.5.1, “Mounting the Base Station to a Wall or Tower”](#)
- [Section 2.5.2, “Mounting the Base Station to a Pole”](#)
- [Section 2.5.3, “Assembling the Base Station and Mounting Bracket”](#)

## Section 2.5.1

# Mounting the Base Station to a Wall or Tower

Mount the base station to any wall or tower capable of supporting its weight. An outer wall on a roof or other high location to avoid interference from other buildings or trees is preferred.

To mount the base station to a wall or tower, do the following:

1. Liberally apply an anti-corrosion spray to all galvanized steel components, including mounting brackets, washers and screws.
2. Select a mounting location on the wall.
3. Lift the mounting bracket assembly using the lifting lugs and align it with the selected mounting location on the wall/tower.
4. Mark the location of the mounting holes on the wall/tower.
5. Remove the mounting bracket from the wall/tower.
6. Using a 8 mm (5/16 in) drill bit suitable for the building material, drill holes at the marked locations.
7. Insert a 8 mm (5/16 in) wall anchor into each mounting hole.
8. Attach the base station to the mounting bracket. For more information, refer to [Section 2.5.3, "Assembling the Base Station and Mounting Bracket"](#).
9. Lift the base station and mounting bracket assembly using the lifting lugs and align it with the selected mounting location on the wall/tower.

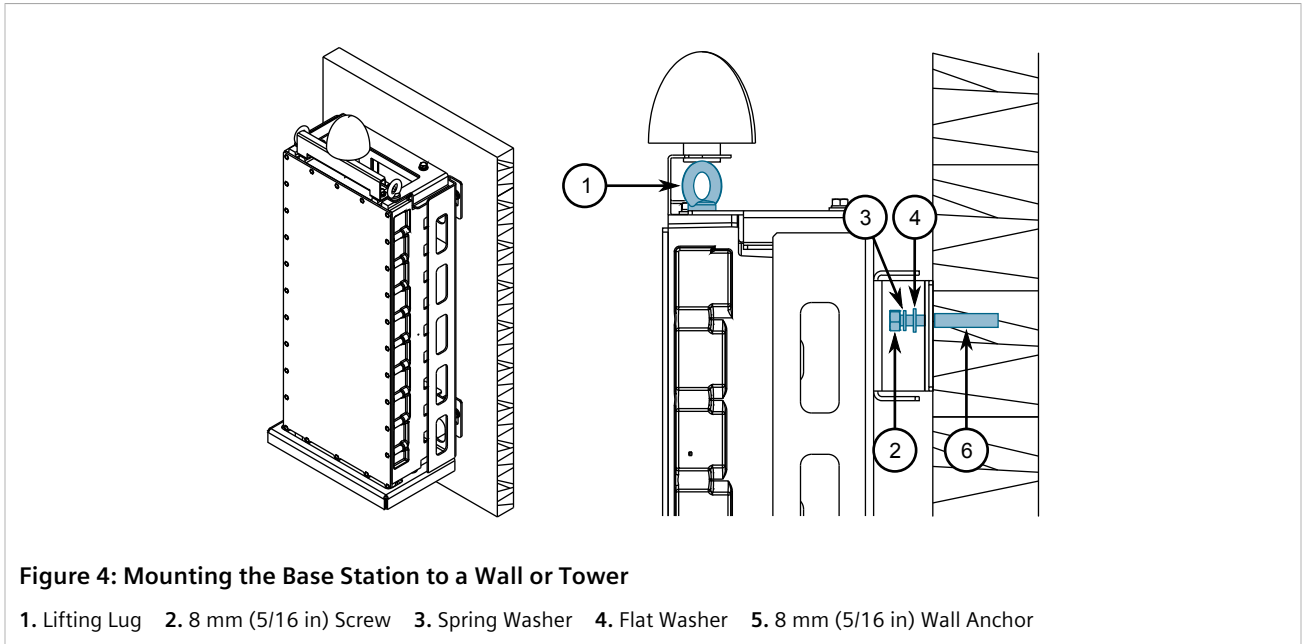

10. Secure the mounting bracket to the wall/tower using the appropriate 8 mm (5/16 in) screws, spring washers and flat washers.
11. Liberally apply an anti-corrosion spray to all exposed screw threads.

### Section 2.5.2

## Mounting the Base Station to a Pole

The base station can be attached to any pole (or pipe) with a 44.45 to 254 mm (1.75 to 10 in) diameter.

To mount the base station to a pole, do the following:

1. Attach the base station to the mounting bracket. For more information, refer to [Section 2.5.3, "Assembling the Base Station and Mounting Bracket"](#).

2. Liberally apply an anti-corrosion spray to all galvanized steel components, including mounting brackets, nuts, washers and screws.
3. Select a mounting location on the pole.
4. Lift the base station and mounting bracket assembly and align it with the selected mounting location on the pole.

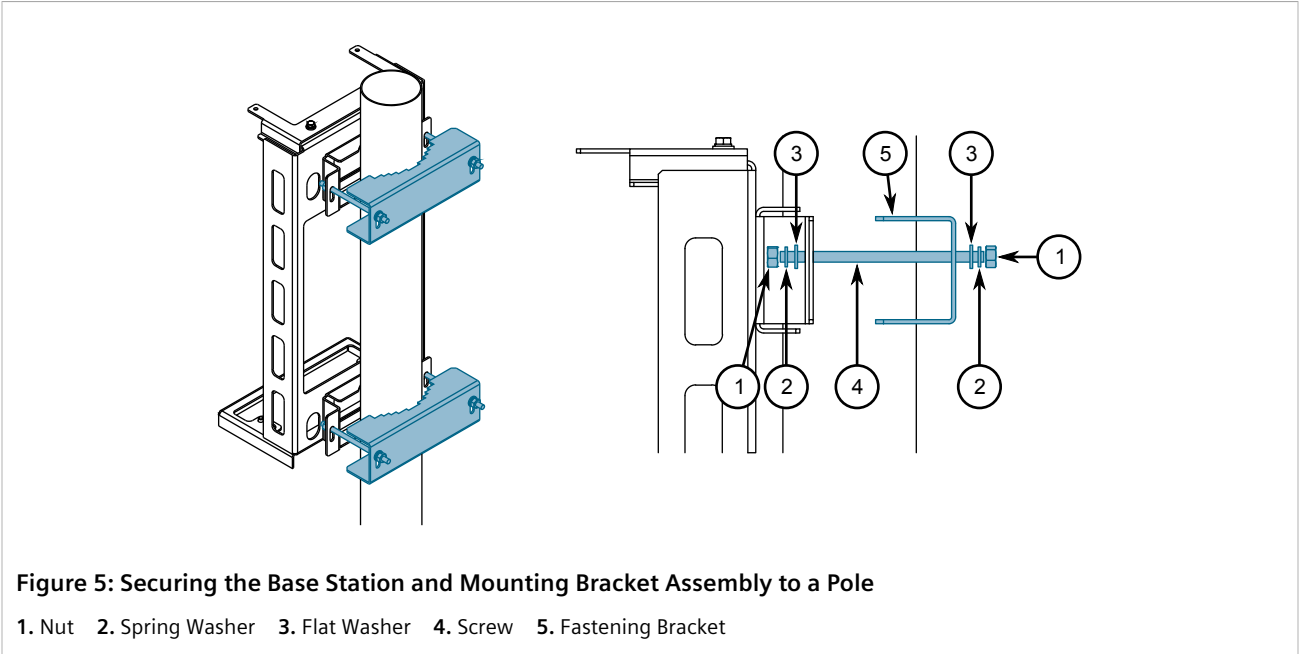

**Figure 5: Securing the Base Station and Mounting Bracket Assembly to a Pole**

1. Nut 2. Spring Washer 3. Flat Washer 4. Screw 5. Fastening Bracket

5. Secure the fastening brackets on the opposite side of the pole to the mounting bracket using the supplied nuts, spring washers, flat washers, and 7.9 × 152 mm (5/16 × 6 in) screws.
6. Liberally apply an anti-corrosion spray to all exposed screw threads.

### Section 2.5.3

## Assembling the Base Station and Mounting Bracket

To assemble the base station and mounting bracket together, do the following:

1. Make sure the mounting bracket is standing on its base.
2. If assembled, remove the top plate from the mounting bracket.
3. Lift the base station by its eye bolts and fit it into the mounting bracket.

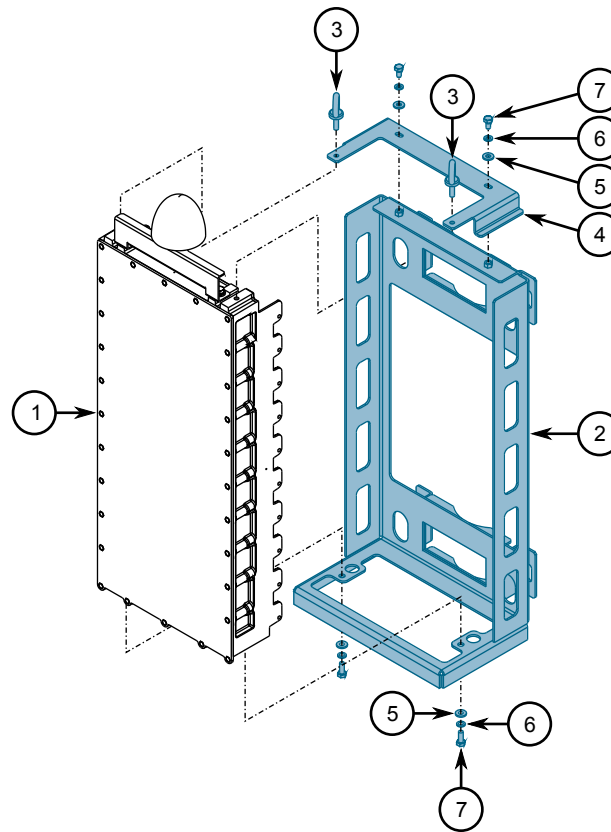

**Figure 6: Base Station and Mounting Bracket Assembly**

1. Base Station 2. Mounting Bracket 3. Eye Bolt 4. Top Plate 5. Flat Washer 6. Spring Washer 7. Screw

4. Temporarily remove the eye bolts.
5. Secure the top plate to the mounting bracket using the screws, spring washers and flat washers removed previously.
6. Install the eye bolts previously removed, securing the top plate to the base station.
7. Secure the bottom of the base station to the mounting bracket using the supplied flat washers, spring washers, and 7.9 × 13 mm (5/16 × 1/2 in) screws.
8. Torque all screws to 8.9 N·m (6.6 lbf-ft).

## Section 2.6

# Installing Antennas

The base station supports external omni-directional and directional Global Positioning System (GPS) or Radio Frequency (RF) antennas.

When selecting the ideal location for an antenna, consider the following recommendations:

- Mount the antenna at the highest possible point to improve reception.

- Select an area where there are few obstacles between the antenna and the planned coverage area or zone. A minimum of 55% of the sky must be visible to the antenna.
- Make sure the antenna is installed at a distance from other antennas or devices that may cause interference.
- Make sure the antenna is accessible for maintenance.

#### CONTENTS

- [Section 2.6.1, "Installing the GPS Antenna"](#)
- [Section 2.6.2, "Installing an RF Antenna"](#)

#### Section 2.6.1

## Installing the GPS Antenna

The RUGGEDCOM WIN7025 base station is shipped with an omni-directional GPS antenna that is mounted to the top of the chassis.



#### CAUTION!

*Interference hazard – risk of frequency disruption. The cable used to connect the GPS antenna to the base station must not exceed 22 m (72 ft) in length, otherwise it may act as an antenna itself and generate interference. Only use the coaxial cable provided with the base station.*

To install the GPS antenna, do the following:

1. Secure the GPS mounting bracket to the base station using the supplied hardware (i.e. screws, spring washers and flat washers).

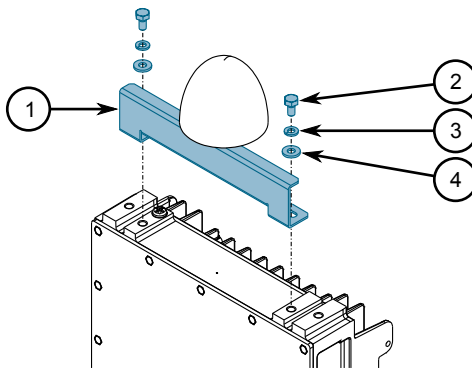

**Figure 7: GPS Antenna Assembly**

1. Mounting Bracket 2. Screw 3. Spring Washer 4. Flat Washer

2. Connect the supplied coaxial cable between the antenna and the **GPS** port on the base station.
3. Connect the grounding lug from the antenna to the common ground connection on the base station.



Section 2.6.2

## Installing an RF Antenna

The RUGGEDCOM WIN7025 base station supports two (primary and secondary) external omni-directional or directional Radio Frequency (RF) antennas.



**WARNING!**

*Radiation hazard – risk of Radio Frequency (RF) exposure. This base station is compliant with the requirements set forth in CFR 47, section 1.1307, addressing Radio Frequency (RF) exposure from radio frequency base stations, as defined in FCC OET Bulletin 65 [[http://transition.fcc.gov/Bureaus/Engineering\\_Technology/Documents/bulletins/oet65/oet65.pdf](http://transition.fcc.gov/Bureaus/Engineering_Technology/Documents/bulletins/oet65/oet65.pdf)]. The emitted radiation should be as little as possible. To achieve minimum RF exposure, install the base station when it is configured not to transmit and set it to operational mode remotely, rather than having a technician enable transmission on-site. For maintenance of the base station, or other operations which require RF exposure, the exposure should be minimized in time and according to the regulations set by the FCC or the regulations relevant to the country of installation.*



**IMPORTANT!**

*The antenna installation must be as per Article 810 of the NEC. Of particular note is the requirement that the grounding conductor not be less than 10 AWG (Cu). The scheme should be either:*

- *in accordance with UL 96 and 96A Lightning Protection Components and Installation Requirements for Lightning Protection Systems*
- *tested in accordance with UL 50 and UL 497*



**IMPORTANT!**

*A Radio Frequency (RF) site survey is recommended prior to any installation to help determine the best location for the antenna(s). For assistance, contact a Siemens Sales representative.*

To install an RF antenna, do the following:

1. Mount the antenna to a pole or wall in an area that provides good signal coverage and is away from any signal noise emanating from other communications equipment. Make sure 55% of the sky at minimum is visible to the antenna.
2. Using one of the supplied CAT-5 cables, connect the antenna to the supplied lightning protector.

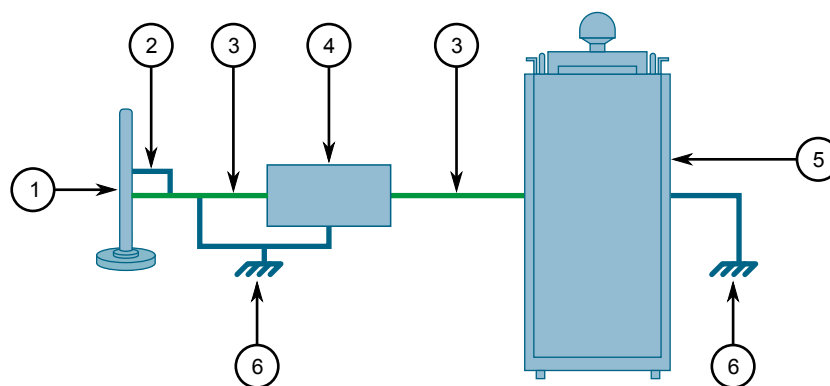

**Figure 8: Antenna and Lightning Protector Assembly**

1. Antenna 2. Ground Wire 3. CAT-5 Cable 4. Lightning Protector 5. Base Station 6. Drain Wire

3. Using the supplied CAT-5 cables, connect the lightning protector to the base station.
  - For the primary antenna, connect to the **ANT1** port
  - For the secondary antenna, connect to the **ANT2** port

Make sure the cable connector is torqued to 1.35 N·m (11.9 lbf-in) at the base station end.
4. Make sure the antenna is properly grounded according to local standards.

Section 2.7

## Grounding the Base Station

The base station is considered to be connected to a centralized DC power system. Therefore, the power cable should be grounded.

The base station should be permanently connected to ground/Earth with a 16 AWG cable or less..

The following illustrates the methods of power grounding, as defined by the UL 60950-1 standard and according to UL 60950-22 requirements.



**NOTE**

*When the base station is connected to a centralized DC power system, the + side of the power supply should be grounded.*

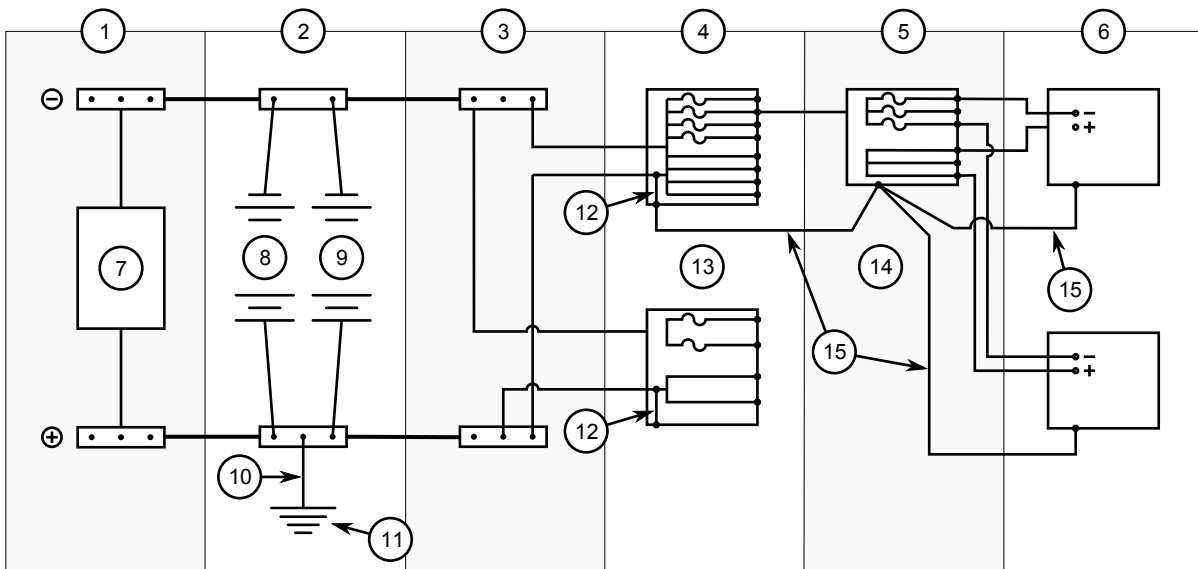

**Figure 9: Typical Centralized DC Power System, Plant and Distribution Source-Grounded DC Power System**

1. Charge Bus 2. Batteries 3. Discharge Bus 4. Primary Distribution 5. Secondary Distribution 6. DC Powered Equipment 7. Charge/ Rectifier 8. Battery Bank #1 9. Battery Bank #2 10. Grounding Electrode Conductor 11. Grounding Electrode 12. Main Bonding Jumper 13. Primary Powerboard 14. Secondary Powerboard 15. Equipment Grounding Conductor

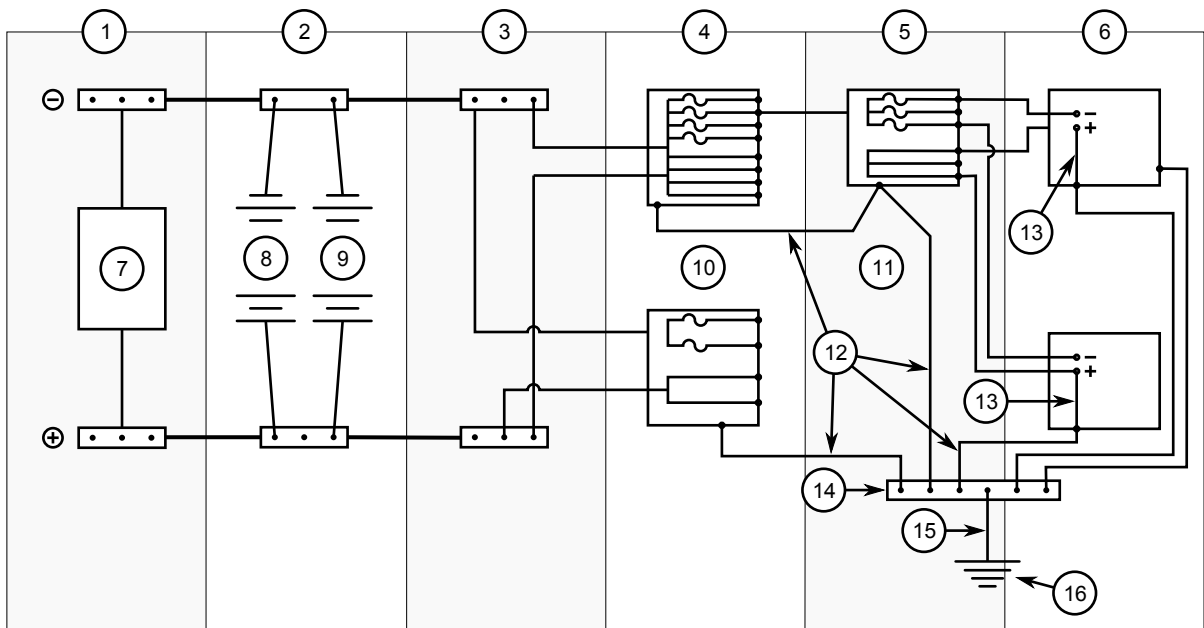

**Figure 10: Typical Centralized DC Power System, Plant and Distribution DC Power System Grounded at the Equipment Location**

1. Charge Bus 2. Batteries 3. Discharge Bus 4. Primary Distribution 5. Secondary Distribution 6. DC Powered Equipment 7. Charge/Rectifier 8. Battery Bank #1 9. Battery Bank #2 10. Primary Powerboard 11. Secondary Powerboard 12. Equipment Grounding Conductor 13. Main Bonding Jumper 14. Grounding Terminal Bar or Bus 15. Grounding Electrode Conductor 16. Grounding Electrode



**DANGER!**

*Electrocution hazard – risk of death or serious injury. The system must be properly grounded to protect against power surges and accumulated static electricity. It is the installer’s responsibility to install this base station in accordance with the local electrical codes.*

To ground the base station, do the following:

1. Assemble the ground connection as shown:

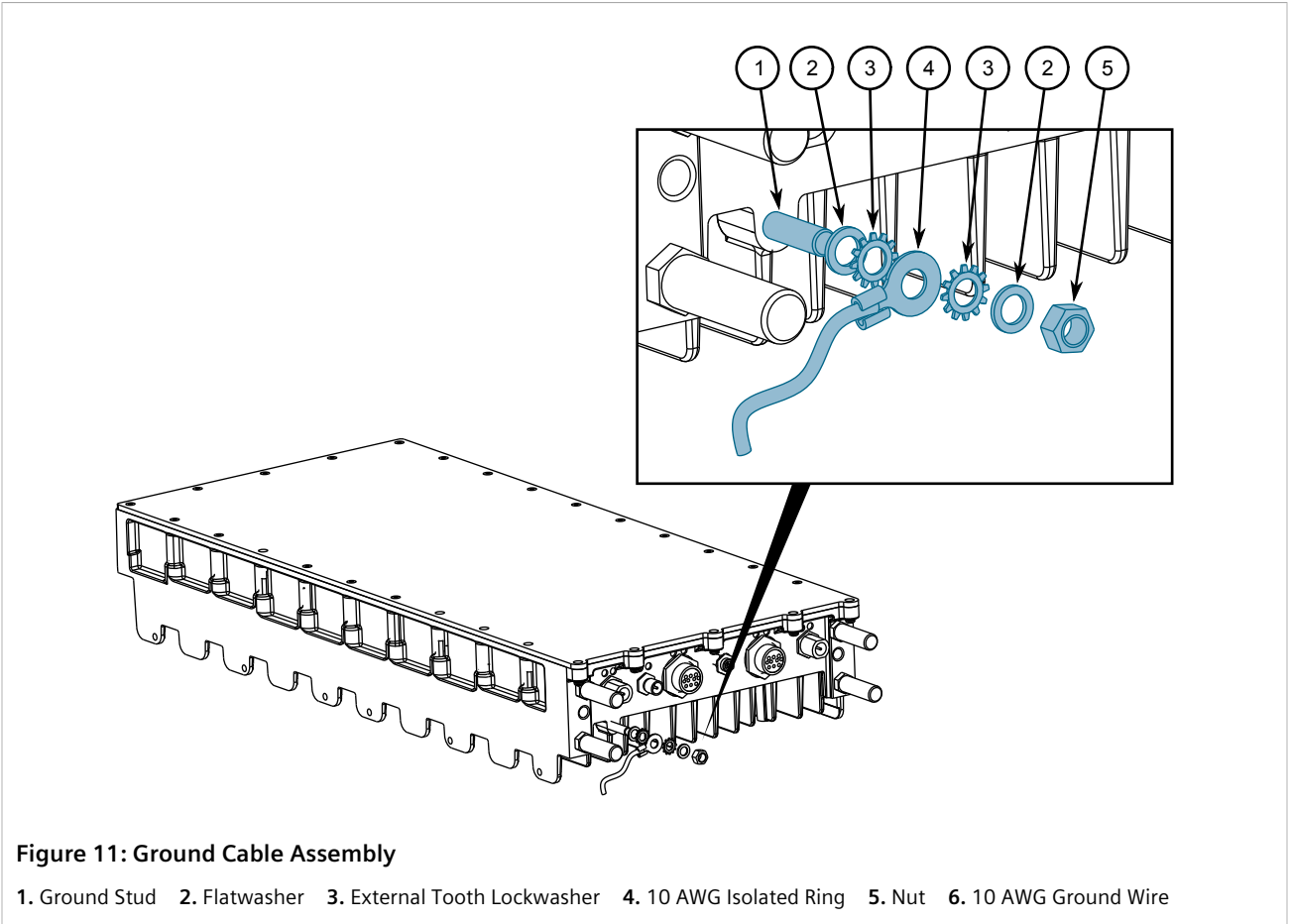

Figure 11: Ground Cable Assembly

1. Ground Stud 2. Flatwasher 3. External Tooth Lockwasher 4. 10 AWG Isolated Ring 5. Nut 6. 10 AWG Ground Wire

2. Using a 6 mm (1/4 in) square drive socket, torque the nut to 8.5 N·m (75 lbf-in).

## Section 2.8

# Connecting Power and Data

This section describes how to supply power to the base station and connect it to the network.

The RUGGEDCOM WIN7025 can be ordered with one of the following power connection options:

- PEC
- SFA
- SFD



### CAUTION!

*Crushing hazard – risk of damage to cables. Route all power supply cables so that people cannot walk on them or place objects on or against them.*

### CONTENTS

- [Section 2.8.1, "Connecting a PEC Type Base Station"](#)
- [Section 2.8.2, "Connecting an SFA Type Base Station"](#)

- [Section 2.8.3, "Connecting an SFD Type Base Station"](#)
- [Section 2.8.4, "Installing the Hazardous Location Kit"](#)

Section 2.8.1

## Connecting a PEC Type Base Station

To connect a PEC (copper) type base station to a power system and the network, do the following:

1. Connect the supplied Power-over-Ethernet (PoE) cable between the **DC/ETH** port on the base station and the **DC/ETH** port on the supplied power system.

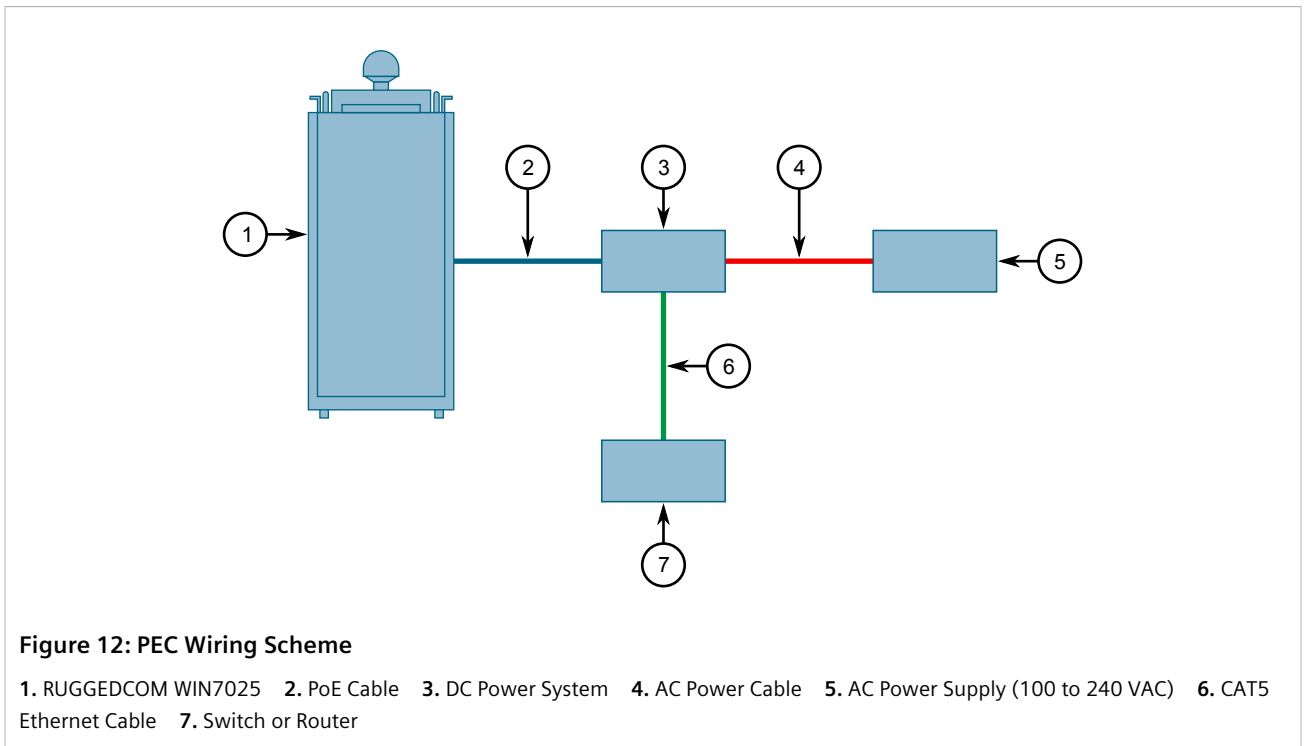

2. Tighten the base station end of the PoE cable to 4 N·m (35.4 lbf-in).
3. Connect a copper Ethernet cable between the 10/100Base-T copper Ethernet port on the power system and a 10/100Base-T copper Ethernet port on a switch or router.

Section 2.8.2

## Connecting an SFA Type Base Station

To connect an SFA (optical) type base station to a power source and the network, do the following:

1. Connect the supplied Power-over-Ethernet (PoE) cable between the **DC/ETH** port on the base station and the **DC/ETH** port on the supplied power system.

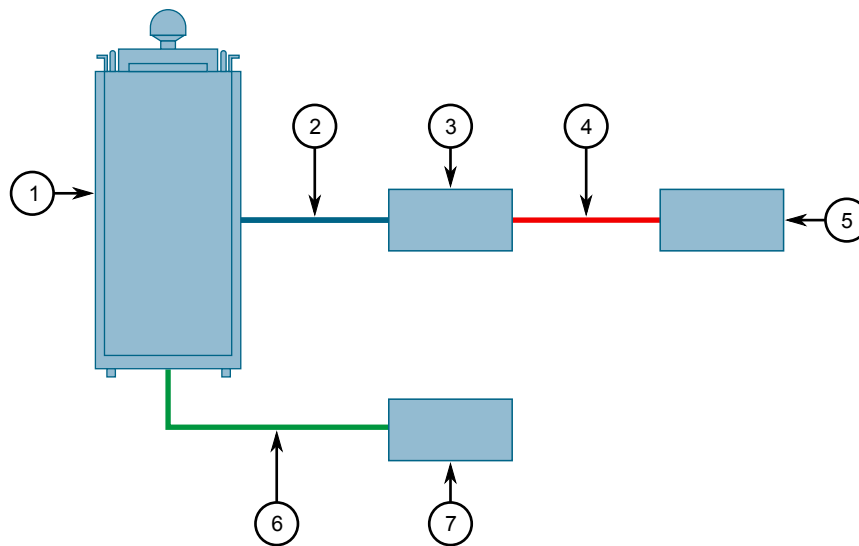

**Figure 13: SFA Wiring Scheme**

1. RUGGEDCOM WIN7025 2. PoE Cable 3. DC Power System 4. AC Power Cable 5. AC Power Supply (100 to 240 VAC) 6. Fiber Optic Ethernet Cable 7. Switch/Router

2. Tighten the base station end of the PoE cable to 4 N·m (35.4 lbf-in).
3. Connect a fiber optic Ethernet cable between the **F/O** port on the base station and a 1000Base-LX fiber optic port on a switch or router.
4. Torque the base station end of the fiber optic Ethernet cable to 4 N·m (35.4 lbf-in).

### Section 2.8.3

## Connecting an SFD Type Base Station

The operator is required to provide an external DC power system for SFD type base stations. The chosen power system must comply with the requirements for a Class II (or double insulated) electrical appliance and be safety-certified according to national codes. Further requirements include:

<b>Maximum Output Current</b>	5 A
<b>Maximum Output Voltage</b>	60 VDC
<b>Minimum Output Voltage</b>	42 VDC

To connect an SFD type base station to the operator's DC power system and network, do the following:

1. Connect the metal connector of the supplied power cable to the power system.
2. Connect the wires at the open end of the cable to the power system.

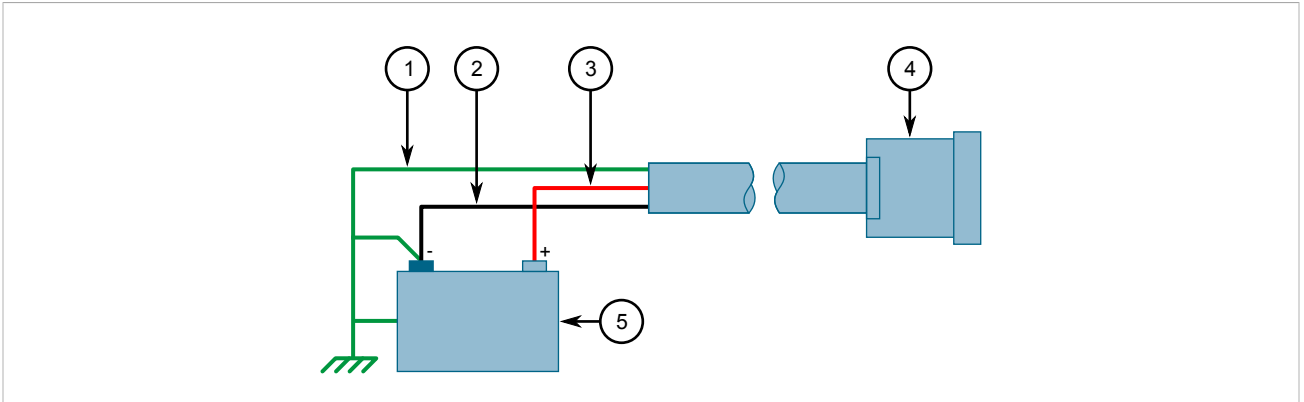

**Figure 14: +48 V Wiring Configuration**

1. Ground Wire (Connects to Connector Chassis) 2. -48 V 3. + 48 V (Hot) 4. Connector 5. 48 V Battery/Power Supply

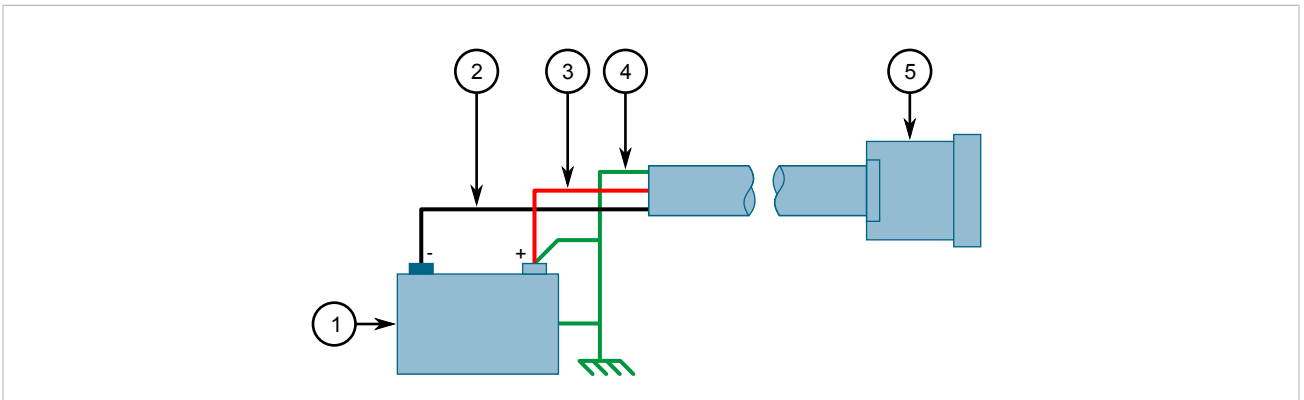

**Figure 15: -48 V Wiring Configuration**

1. 48 V Battery/Power Supply 2. -48 V (Hot) 3. + 48 V 4. Ground Wire (Connects to Connector Chassis) 5. Connector

3. Connect a fiber optic Ethernet cable between the **F/O** port on the base station and a 1000Base-LX fiber optic port on a switch or router.

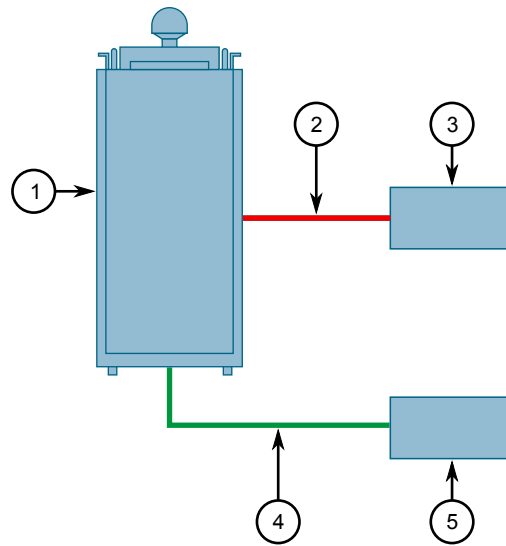

**Figure 16: SFD Wiring Scheme**

1. RUGGEDCOM WIN7025 2. PoE Cable 3. DC Power Cable 4. DC Power System 5. Fiber Optic Ethernet Cable 6. Switch or Router

4. Torque the base station end of the fiber optic Ethernet cable to 4 N·m (35.4 lbf-in).

#### Section 2.8.4

## Installing the Hazardous Location Kit

An approved surge suppression unit is required when the base station is installed in a hazardous location. The RUGGEDCOM WIN7025 is certified for installation in Class I, Division 2 Groups A, B, C and D hazardous locations when installed using the Class I, Division 2 kit (P/N MKIT0109). The Class I, Division 2 kit contains the following items:

- Power supply unit
- WIN1212 surge suppression unit
- DC power cable

To install the base station in a hazardous location, do the following:

1. Connect the DC power cable between the power supply unit and the RUGGEDCOM WIN1212 surge suppression unit.

Connect the DC power cable between the power supply unit and the PoE injector.



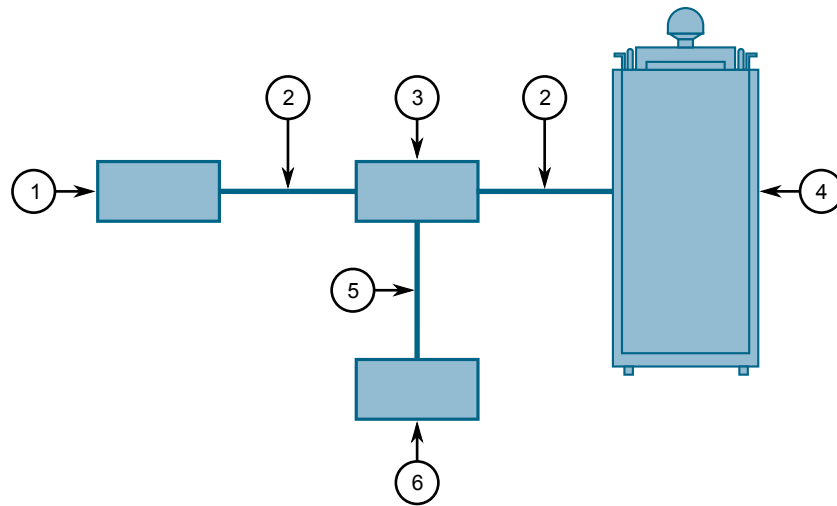

**Figure 17: Connecting the Base Station in a Hazardous Location**

1. Ethernet Switch 2. CAT-5e Cable 3. RUGGEDCOM WIN1212 Surge Suppression Unit 4. Base Station 5. DC Power Cable  
6. Power Supply Unit

2. Connect the RUGGEDCOM WIN1212 surge suppression unit to the **DC/ETH** port on the base station.
3. Connect a CAT-5e cable between the Ethernet switch and the RUGGEDCOM WIN1212 surge suppression unit.



**IMPORTANT!**

*The AC power cable must meet the following specifications:*

- Consist of 3 wires
- Minimum 18 AWG
- Less than 4.5 m (14.7 ft) long
- Safety certified according to national rules

4. Connect the DC power cable to the power supply unit.

Section 2.9

## Weatherproofing the Base Station

This section describes how to protect the base station from the ingress of harmful moisture, dirt and debris that can lead to the premature failure of the device.



**IMPORTANT!**

*The warranty is void if the base station is not properly weatherproofed.*

**CONTENTS**

- [Section 2.9.1, "Securing the Sealing Screw"](#)
- [Section 2.9.2, "Weatherproofing a Cable"](#)

- [Section 2.9.3, “Applying Cold Shrink Tubing”](#)
- [Section 2.9.4, “Applying Self-Amalgamating Tape”](#)

Section 2.9.1

## Securing the Sealing Screw

Always make sure the sealing screw on the top of the base station is secure. The loosening or removal of this screw could cause harmful debris and/or moisture to enter the base station.

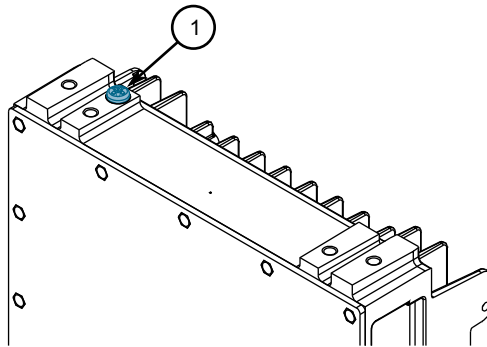

**Figure 18: Base Station with GPS Antenna Assembly Removed**

1. Sealing Screw

Section 2.9.2

## Weatherproofing a Cable

Most outdoor base station, antenna and cable problems are caused by coaxial cable connections loosened by vibration, allowing moisture to penetrate the connector interface. Siemens strongly recommends weatherproofing *all* outdoor cable connections to prevent the ingress of water and help secure connections.

Since PoE cables also carry DC current, the need for proper weatherproofing cannot be overstated.

Use cold shrink tubing or self-amalgamating tape, as well as UV-resistant tape and electrical insulation putty to seal connections.



**IMPORTANT!**

*The method of weatherproofing described in this section must be completed on **all** external connections. If surge arrestors are used, all associated connections and arrestors must be completely wrapped with splicing tape or self-amalgamating tape.*

To weatherproof a cable, do the following:



**IMPORTANT!**

*PVC tape, silicon sealant and glue are not recommended for weatherproofing, as these materials are difficult to apply accurately and are difficult to remove.*

1. Spray the cable end and connector with a cleaner and de-greaser, making sure to remove any excess with a clean lint-free cloth.

2. Spray the cable end and connector with SCC3 conformal coating and allow them to dry fully (approximately 3 to 5 minutes depending on the ambient temperature).
3. Apply cold shrink or self-amalgamating tape to the connector end. For information about how to apply these types of seals, refer to [Section 2.9.3, "Applying Cold Shrink Tubing"](#) or [Section 2.9.4, "Applying Self-Amalgamating Tape"](#).
4. Apply two layers of UV-resistant vinyl tape to the cable ends.
5. Apply electrical insulation putty around the very end of the cable to form a seal between it and the base station.
6. If the base station is installed in a marine environment (e.g. wind farm substation, coastal tower, or marine vessel) apply a coating of marine grease to all galvanized steel components, including mounting brackets, nuts, washers and screws. This is in addition to the anti-corrosion spray applied during the mounting process.

**IMPORTANT!**

*Should a cable need to be replaced, make sure all surfaces are thoroughly cleaned with a cleaner and de-greaser spray before connecting the new cable. No residue from the previous weatherproofing materials should be evident on the connector or the base station chassis.*

## Section 2.9.3

## Applying Cold Shrink Tubing

To apply cold shrink tubing to a cable end, do the following:

1. Disconnect the cable and slide the tube over the connector end.
2. Reconnect the cable and slide the tube up to meet the base station chassis.
3. Hold the tube against the base station chassis and start rotating it clockwise while gently pulling out the core. Stop rotating once the front end of the cold shrink has begun to form around the cable end.
4. Continue to remove the core in a counter-clockwise direction until it is completely removed.

## Section 2.9.4

## Applying Self-Amalgamating Tape

To apply self-amalgamating (or self-fusing) tape to a cable end, do the following:

**IMPORTANT!**

*When applying self-amalgamating tape, make sure to stretch it to 2/3 of its original width to form a tight seal.*

1. Cut a strip of self-amalgamating tape approximately 50 cm (19.7 in) long.
2. Apply one end of the tape to the cable end and tightly wrap it around the cable once fully, making sure the tape overlaps.
3. Tightly wrap the remainder of the tape down the cable, making sure the tape overlaps with each pass.
4. Repeat the previous steps to apply a second layer of tape.



# 3 Device Management

This section describes how to connect to and manage the base station.

## CONTENTS

- [Section 3.1, "Connecting to the Base Station"](#)
- [Section 3.2, "Configuring the Base Station"](#)

### Section 3.1

## Connecting to the Base Station

The following describes the various methods for accessing the RUGGEDCOM WIN console and Web interfaces on the base station. For more detailed instructions, refer to the *RUGGEDCOM WIN User Guide* for the base station.

### » Accessing Boot-Time Control and CLI

To access the boot-time control and RUGGEDCOM WIN CLI, connect a PC or terminal directly to the serial console port.



#### IMPORTANT!

*The serial console port is intended to be used only as temporary connections during initial configuration or troubleshooting.*



#### CAUTION!

*Environmental hazard – risk of damage due to the ingress of water, dirt or debris. The serial console port is protected by a cover from the ingress of harmful water, dirt or debris. Make sure this cover is securely attached when the port is not in use.*

The serial console port is a proprietary 3-pin RS232 female connector. The following is the pin-out for the connector:



#### NOTE

*A custom console cable is provided with the base station.*

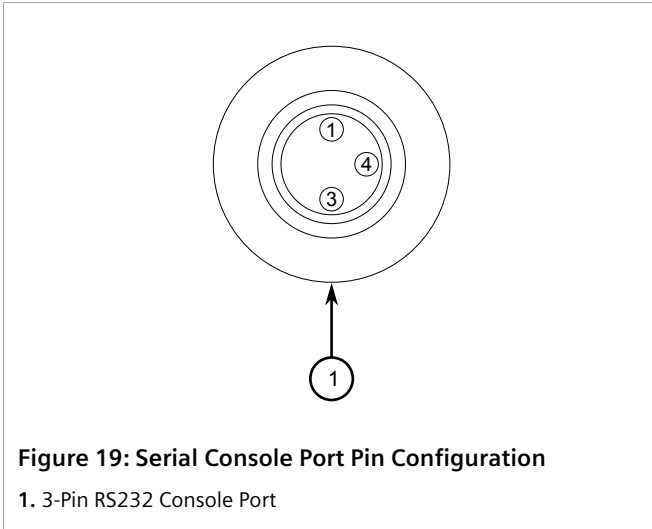

Pin	Name
1	Transmit
3	Receive
4	Ground

For information about how to connect to the device via the serial console port, refer to the *RUGGEDCOM WIN User Guide* for the RUGGEDCOM WIN7025.

## » Accessing the Web Interface

To access the Web interface for RUGGEDCOM WIN, do the following:

1. Connect a PC to the switch/router that is on the same network as the base station.
2. Open a browser and access the base station via its IP address. The factory default IP address is 192.168.100.100/24.

### Section 3.2

## Configuring the Base Station

Once the base station is installed and connected to the network, it must be configured. The RUGGEDCOM WIN7025 features a Web-based User Interface (UI) for all configuration management. For more information about configuring the base station, refer to the *RUGGEDCOM WIN Base Station User Guide* associated with the installed software release.

# 4 Technical Specifications

This section provides important technical specifications related to the device.

## CONTENTS

- [Section 4.1, "Power Supply Specifications"](#)
- [Section 4.2, "Radio and Modem Specifications"](#)
- [Section 4.3, "Operating Environment"](#)
- [Section 4.4, "Mechanical Specifications"](#)
- [Section 4.5, "Dimension Drawings"](#)

### Section 4.1

## Power Supply Specifications

Power Input	Maximum Consumption
85 to 265 VAC	120 W
37 to 60 VDC	

### Section 4.2

## Radio and Modem Specifications

<b>Operating Frequency</b>	2496 to 2690 MHz
<b>Wireless Communication Standard</b>	IEEE 802.16-2005 (16e OFDMA)
<b>Operating Mode</b>	Time-Division Duplexing (TDD)
<b>Channel Bandwidths</b>	3.5 MHz 5 MHz 7 MHz 10 MHz
<b>Frequency Resolution</b>	250 kHz
<b>Antenna Type</b>	Integrated, external sector, or omni-directional
<b>Number of Antennas</b>	2

Type of Ports for External Antenna(s)	N-Connect female, 50 Ω
Output Power (Average)	2 x 36 dBm
Size of Fast Fourier Transform (FFT) Channels	1024/512FFT
Type of Modulation	QPSK, 16-QAM, 64-QAM
Type of Error Compensation	FEC Convolution Code, Turbo Code
Dynamic Range (Receiver)	-60 to 100 dBm
Dynamic Range (Transmitter)	21 to 36 dBm

Section 4.3

## Operating Environment

The RUGGEDCOM WIN7025 can operate under the following environmental conditions:

Ambient Operating Temperature <sup>a</sup>	-40 to 65 °C (-40 to 149 °F)
Ambient Storage Temperature	-40 to 65 °C (-40 to 149 °F)
Ambient Relative Humidity <sup>b</sup>	5% to 95%
Maximum Altitude	2000 m (6562 ft)

<sup>a</sup> Measured from a 30 cm (12 in) radius surrounding the center of the enclosure

<sup>b</sup> Non-condensing

Section 4.4

## Mechanical Specifications

Weight (Base Station)	15 kg (33 lbs)
Weight (Mounting Bracket)	6.5 kg (14 lbs)
Ingress Protection	IP67
Chassis Material	Aluminum

Section 4.5

## Dimension Drawings



**NOTE**

All dimensions are in millimeters, unless otherwise stated.



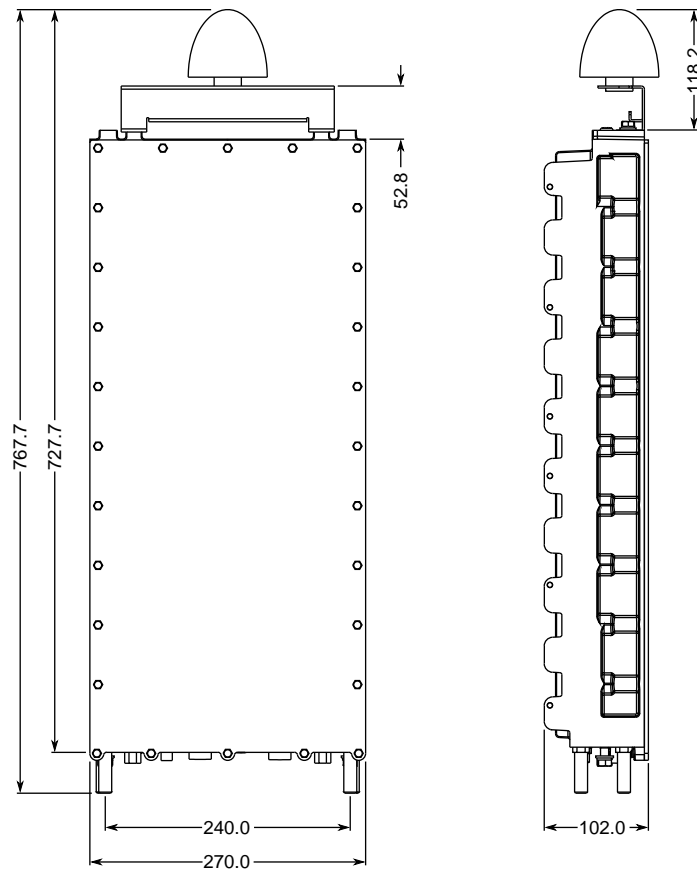

Figure 20: RUGGEDCOM WIN7025 Dimensions without Mounting Bracket

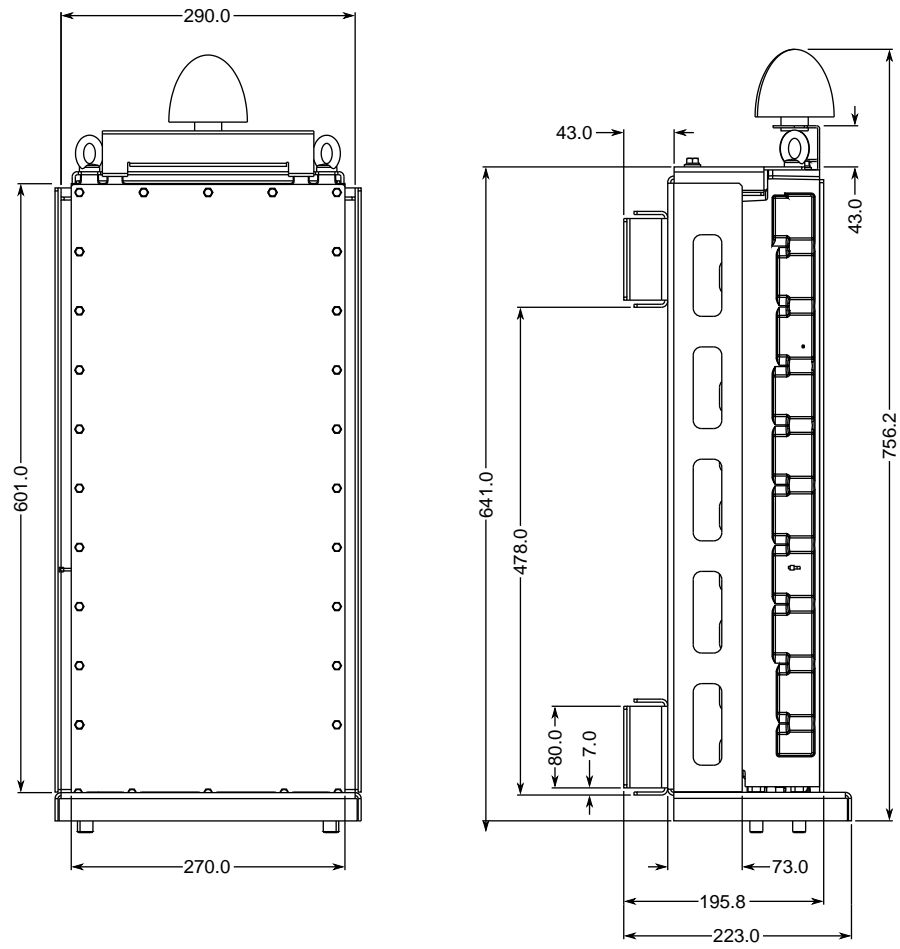

Figure 21: RUGGEDCOM WIN7025 Dimensions with Mounting Bracket

# 5 Certification

The RUGGEDCOM WIN7025 base station has been thoroughly tested to guarantee its conformance with recognized standards and has received approval from recognized regulatory agencies.

## CONTENTS

- [Section 5.1, "Approvals"](#)
- [Section 5.2, "EMC and Environmental Type Tests"](#)

### Section 5.1

## Approvals

The following details the approvals issued for the RUGGEDCOM WIN7025.

## CONTENTS

- [Section 5.1.1, "MET Laboratories"](#)
- [Section 5.1.2, "CSA"](#)
- [Section 5.1.3, "European Union \(EU\)"](#)
- [Section 5.1.4, "TÜV Rheinland"](#)
- [Section 5.1.5, "FCC"](#)
- [Section 5.1.6, "Other Approvals"](#)
- [Section 5.1.7, "RoHS"](#)

### Section 5.1.1

## MET Laboratories

This base station meets the requirements of the following standards:

- **ANSI/ISA 12.12.01, CSA C22.2 No. 213**  
Nonincendive Electrical Equipment for Use in Class I and II, Division 2 and Class III, Divisions 1 and 2 Hazardous (Classified) Locations
- **EN 60079-0:2009**  
Explosive Atmospheres – Equipment – General Requirements
- **EN 60079-15:2010**  
Explosive Atmospheres – Equipment Protection By Type of Protection "N"

The base station is marked with an MET classified mark that indicates compliance with both Canadian and U.S. requirements.



It is specifically approved for use in hazardous locations defined as:

- Class I, Division 2, Groups A, B, C, D T4
- Ex nA nC IIC T4 Gc X II 3G

Notices specific to MET Laboratories:



**WARNING!**

**EXPLOSION HAZARD**

- *Substitution of components may impair suitability for Class I, Division 2*
- *Do not disconnect equipment unless power has been switched off or the area is known to be non-hazardous*

**AVERTISSEMENT !**

**RISQUE D'EXPLOSION**

- *La substitution de composants peut rendre ce matériel inacceptable pour les emplacements de Classe I, Division 2*
- *Avant de déconnecter l'équipement, couper le courant ou s'assurer que l'emplacement est désigné non dangereux*

Section 5.1.2

## CSA

This base station meets the requirements of the following Canadian Standards Association (CSA) standards:

- **CAN/CSA-C22.2 No. 60950-1-07+A1:2011+A2:2014**  
Information Technology Equipment – Safety – Part 1: General Requirements (Bi-National Standard, with UL 60950-1)
- **CAN/CSA-C22.2 No. 60950-22-07+G11:2012**  
Information Technology Equipment – Safety – Part 22: Equipment to be Installed Outdoors (Bi-National standard, with UL 60950-22)

Section 5.1.3

## European Union (EU)

This device is declared by Siemens Canada Ltd to comply with essential requirements and other relevant provisions of the following EU directives:

- **EN 55022**  
Information Technology Equipment – Radio disturbance characteristics – Limits and methods of measurement
- **IEC/EN 60950-1**  
Information Technology Equipment – Safety – Part 1: General Requirements

- **EN 60950-22**  
Information Technology Equipment – Safety – Part 22: Equipment to be Installed Outdoors
- **EN 61850-3**  
Communication Networks and Systems for Power Utility Automation – Part 3: General Requirements
- **EN 301 489-1 (v1.8.1)**  
Electromagnetic Compatibility and Radio Spectrum Matters (ERM) – ElectroMagnetic Compatibility (EMC) Standard for Radio Equipment and Services – Part 1: Common Technical Requirements
- **EN 301 489-4 (v1.3.1)**  
Electromagnetic Compatibility and Radio Spectrum Matters (ERM) – Electromagnetic Compatibility (EMC) Standard for Radio Equipment and Services – Part 4: Specific Conditions for Fixed Radio Links, Broadband Data Transmission System Base Stations, Ancillary Equipment and Services
- **EN 302 544-1 (v1.1.2)**  
Broadband Data Transmission Systems operating in the 2500 MHz to 2690 MHz frequency band – Part 1: TDD Base Stations – Harmonized EN covering the essential requirements of article 3.2 of the R&TTE Directive

The device is marked with a CE marking and can be used throughout the European community.



A copy of the CE Declaration of Conformity is available from Siemens Canada Ltd. For contact information, refer to [“Contacting Siemens”](#).

#### Section 5.1.4

## TÜV Rheinland

This base station is certified by TÜV Rheinland to meet the requirements of the following standards:

- **UL 60950-1:2007 R10.14**  
Information Technology Equipment – Safety – Part 1: General Requirements
- **UL 60950-22:2007 R12.11**  
Information Technology Equipment – Safety – Part 22: Equipment to be Installed Outdoors

The base station is marked with a TÜV Rheinland marking and can be used throughout the European community.



A copy of the TÜV Rheinland Declaration of Conformity is available from Siemens Canada Ltd. For contact information, refer to [“Contacting Siemens”](#).

Section 5.1.5

## FCC

This device has been tested and found to comply with the limits for a Class A digital device, pursuant to Part 15 Subpart B of the FCC Rules. These limits are designed to provide reasonable protection against harmful interference when the equipment is operated in a commercial environment.

This device generates, uses and can radiate radio frequency energy and, if not installed and used in accordance with the instruction manual, may cause harmful interference to radio communications. Operation of this equipment in a residential area is likely to cause harmful interference in which case users will be required to correct the interference at their own expense.

This device further complies with Title 47 of the Code of Federal Regulations (CFR) Part 15 Subpart B and Part 27.



### **IMPORTANT!**

*Changes or modifications not expressly approved by the party responsible for compliance could void the user's authority to operate this device.*

Section 5.1.6

## Other Approvals

This device meets the requirements of the following additional standards:

- **IEEE 1613**  
IEEE Standard Environmental and Testing Requirements for Communications Networking Devices in Electric Power Substations
- **IEC 61850-3**  
General Requirements
- **IEC 870-2-2**  
Telecontrol Equipment and Systems – Part 2: Operating Conditions – Section 2: Environmental Conditions (Climatic, Mechanical and Other Non-Electrical Influences)
- **MIL-STD-810F**  
Department of Defense Test Method Standard for Environmental Engineering Considerations and Laboratory Tests – Method 509.4 (Salt Fog)

Section 5.1.7

## RoHS

This device is declared by Siemens Canada Ltd to meet the requirements of the following RoHS (Restriction of Hazardous Substances) directives for the restricted use of certain hazardous substances in electrical and electronic equipment:

- **China RoHS 2**  
Administrative Measure on the Control of Pollution Caused by Electronic Information Products

A copy of the Material Declaration is available online at <https://support.industry.siemens.com/cs/ww/en/view/109738831>.

## Section 5.2

# EMC and Environmental Type Tests

The RUGGEDCOM WIN7025 has passed the following Electromagnetic Compatibility (EMC) and environmental tests.

## » EMC Type Test for IEC 61850-3

Standard	Method	Description	Test Levels
<b>Climatic Environmental Conditions</b>			
IEC 60068-2-1	IEC 61850-3 (5.2)	Low Temperature (Operational)	-40 °C (-40 °F), 16 Hour Dwell
IEC 60068-2-2	IEC 61850-3 (5.2)	High Temperature (Operational)	-65 °C (-149 °F), 16 Hour Dwell
IEC 60068-2-1	IEC 61850-3 (5.2)	Low Temperature (Storage)	-40 °C (-40 °F), 16 Hour Dwell
IEC 60068-2-2	IEC 61850-3 (5.2)	High Temperature (Storage)	-65 °C (-149 °F), 16 Hour Dwell
IEC 60068-2-30	IEEC 61850-3 (5.2)	Humidity (Operational)	95% at 55 °C (131 °F) for 96 Hours
IEC 60068-2-30	IEEC 61850-3 (5.2)	Humidity (Storage)	95% at 55 °C (131 °F) for 96 Hours
<b>Mechanical Environmental Conditions</b>			
IEC 60068-2-27	IEC 61850-3 (5.5)	Shock	30 g (965 ft/s <sup>2</sup> )
IEC 60068-2-6	IEC 61850-3 (5.5)	Vibration	2 g (32 ft/s <sup>2</sup> ), 10-150 Hz per Axis
<b>EMC</b>			
IEC 61000-4-6	IEC 61850-3 (5.7.1.1)	Conducted Immunity	10 Vrms
IEC 61000-4-5	IEC 61850-3 (5.7.1.2)	Surges Immunity	4 kV L-G
IEC 61000-4-12	IEC 61850-3 (5.7.1.3)	Oscillatory Surge	2.5 kV
IEC 61000-4-4	IEC 61850-3 (5.7.1.4)	Electrical Fast Transients Immunity	4 kV
IEC 61000-4-3	IEC 61850-3 (5.7.2)	Radiated Susceptibility Immunity	20 V/m
IEC 61000-4-16	IEC 61850-3 (5.7.3)	Low Frequency Conducted Susceptibility	30 V, 300 V Continues 3 V, 30 V 15 Hz to 150 kHz
IEC 61000-4-8	IEC 61850-3 (5.7.3)	Magnetic Immunity	100 A/m, 1000 A/m (1 sec)
CISPR 22	IEC 61850-3 (5.8)	Radiated Emission	30 MHz to 8 GHz
EN 55022	IEC 61850-3 (5.8)	Conducted Emission	150 kHz to 30 MHz

## » EMC Immunity Type Tests for IEEE 1613

Standard	Method	Description	Test Levels
<b>Climatic Environmental Conditions</b>			
IEC 60068-2-1	IEEE 1613 (4.1.1)	Low Temperature (Operational)	-40 °C (-40 °F), 16 Hour Dwell

Standard	Method	Description	Test Levels
IEC 60068-2-2	IEEE 1613 (4.1.1)	High Temperature (Operational)	-65 °C (-149 °F), 16 Hour Dwell
IEC 60068-2-1	IEEE 1613 (4.1.2)	Low Temperature (Storage)	-40 °C (-40 °F), 16 Hour Dwell
IEC 60068-2-2	IEEE 1613 (4.1.2)	Low Temperature (Storage)	85 °C (185 °F), 16 Hour Dwell
IEC 60068-2-30	IEEE 1613 (4.1.3)	Humidity (Storage)	95% at 55 °C (131 °F) for 96 Hours
<b>Mechanical Environmental Conditions</b>			
	IEEE 1613 (10)	Shock (Drop)	1 m (3.3 ft), 1 Fall per Axis
IEC 60068-2-6	IEEE 1613 (10)	Vibration	2 g (32 ft/s <sup>2</sup> ), 10-150 Hz per Axis
<b>Power Input</b>			
IEC 61000-4-11	IEEE 1613 (5.1)	Voltage Variations	38.4 to 56 V
<b>EMC</b>			
IEC 61000-4-12	IEEE 1613 (7.3.1) IEEE C37.90.1	Oscillatory SWC	2.5 kV
IEC 61000-4-4	IEEE 1613 (7.3.2) IEEE C37.90.1	Fast Transient SWC	4 kV
IEC 61000-4-3	IEEE 1613 (8) IEEE C37.90.2	Radiated Susceptibility Immunity	80 MHz to 1 GHz 20 V/m (unmodulated) 35 V/m (modulated)
IEC 61000-4-2	IEEE 1613 (9) IEEE C37.90.3	ESD	8 kV Contact, 15 kV Air
<b>Insulation</b>			
IEC 60255-5 (6.1.3)	IEEE 1613 (6.3)	HV Impulse	5 kV
IEC 60255-5 (6.1.4)	IEEE 1613 (6.2)	Dielectric	

## » Military Standard Tests

Test	Description	Test Levels
MIL-STD-810F	Salt Fog	Method 509.4