

SIEMENS



Operating Instructions



SIMATIC

Network transitions

PN/J1939 LINK

Edition

12/2018

siemens.com

SIEMENS

SIMATIC

Gateways SIMATIC PN/J1939 LINK



Operating Instructions

<u>Introduction</u>	1
<u>Safety instructions</u>	2
<u>System overview</u>	3
<u>Functions</u>	4
<u>Application planning</u>	5
<u>Mounting/Extending</u>	6
<u>Connecting</u>	7
<u>Commissioning</u>	8
<u>Configuring / programming</u>	9
<u>Diagnostics</u>	10
<u>Maintenance and service</u>	11
<u>Technical specifications</u>	12
<u>Appendix</u>	A

Legal information

Warning notice system

This manual contains notices you have to observe in order to ensure your personal safety, as well as to prevent damage to property. The notices referring to your personal safety are highlighted in the manual by a safety alert symbol, notices referring only to property damage have no safety alert symbol. These notices shown below are graded according to the degree of danger.

 DANGER
indicates that death or severe personal injury will result if proper precautions are not taken.
 WARNING
indicates that death or severe personal injury may result if proper precautions are not taken.
 CAUTION
indicates that minor personal injury can result if proper precautions are not taken.
NOTICE
indicates that property damage can result if proper precautions are not taken.

If more than one degree of danger is present, the warning notice representing the highest degree of danger will be used. A notice warning of injury to persons with a safety alert symbol may also include a warning relating to property damage.

Qualified Personnel

The product/system described in this documentation may be operated only by **personnel qualified** for the specific task in accordance with the relevant documentation, in particular its warning notices and safety instructions. Qualified personnel are those who, based on their training and experience, are capable of identifying risks and avoiding potential hazards when working with these products/systems.

Proper use of Siemens products

Note the following:

 WARNING
Siemens products may only be used for the applications described in the catalog and in the relevant technical documentation. If products and components from other manufacturers are used, these must be recommended or approved by Siemens. Proper transport, storage, installation, assembly, commissioning, operation and maintenance are required to ensure that the products operate safely and without any problems. The permissible ambient conditions must be complied with. The information in the relevant documentation must be observed.

Trademarks

All names identified by ® are registered trademarks of Siemens AG. The remaining trademarks in this publication may be trademarks whose use by third parties for their own purposes could violate the rights of the owner.

Disclaimer of Liability

We have reviewed the contents of this publication to ensure consistency with the hardware and software described. Since variance cannot be precluded entirely, we cannot guarantee full consistency. However, the information in this publication is reviewed regularly and any necessary corrections are included in subsequent editions.

Table of contents

1	Introduction	5
1.1	Preface.....	5
1.2	Documentation guide.....	6
2	Safety instructions	7
2.1	Safety instructions.....	7
2.2	Security information.....	9
2.3	Protective measures for SIMATIC PN/J1939 LINK.....	9
3	System overview	11
3.1	Field of application.....	11
3.2	Features.....	12
3.3	System configuration.....	13
3.4	System requirements.....	14
3.5	Design.....	14
4	Functions	15
4.1	J1939 protocol.....	15
4.2	PGN parameters.....	19
4.3	Cyclic and acyclic data exchange.....	22
4.4	State model.....	23
4.5	Control and status information.....	25
4.6	Response to errors.....	26
5	Application planning	27
5.1	Installation guidelines.....	27
5.2	Installation location.....	28
5.3	Transportation.....	30
5.4	Storage.....	30
5.5	Scope of delivery.....	31
6	Mounting/Extending	33
6.1	Installing the device.....	33
7	Connecting	35
7.1	Safety instructions and guidelines.....	35
7.2	Potential ratios.....	37

7.3	24 V DC power supply	38
7.4	Connecting the functional ground	39
7.5	Connecting PROFINET	40
7.6	Connecting the J1939 bus	41
8	Commissioning	43
8.1	Commissioning PN/J1939 LINK.....	43
9	Configuring / programming.....	45
9.1	Overview	45
9.2	Devices & networks	45
9.3	PN/J1939 LINK assign parameters.....	47
9.4	Insert and configure parameter groups.....	48
9.5	Checking and compiling the configuration	51
10	Diagnostics	53
10.1	Status LEDs	53
10.1.1	Operating state of the PN/J1939 LINK / PROFINET diagnostics	53
10.1.2	Connection status of the Ethernet interfaces	55
10.1.3	Connection status of the J1939 bus	56
10.2	Diagnostic messages to the S7 controller	57
10.2.1	Events that trigger a diagnostic message	57
10.2.2	Diagnostic messages	58
11	Maintenance and service	61
11.1	Firmware update	61
11.2	Replacing PN/J1939 LINK	61
11.3	Recycling and disposal	62
12	Technical specifications	63
12.1	Technical specifications of the PN/J1939 LINK.....	63
12.2	Dimension drawing	67
A	Appendix	69
A.1	Certificates and approvals	69
A.2	Contact address	70
A.3	Licenses	70
A.4	Service & Support	71
A.4.1	Technical Support	71
A.4.2	Siemens Industry Online Support	71
A.4.3	Online catalog and ordering system	71
	Glossary	73
	Index	75

Introduction

1.1 Preface

Purpose of this documentation

These operating instructions contain all information for configuring, installation, commissioning and operation of the PN/J1939 LINK.

These operating instructions are intended for qualified personnel in the following target groups:

- Commissioning engineers
- Operating and service personnel
- System integrator

Knowledge required

The following knowledge is required in order to understand the operating instructions:

- Knowledge of programming a SIMATIC S7 controller
- Knowledge in the application of the TIA configuration environment
- Knowledge of working with the PROFINET fieldbus
- Well-founded knowledge in the SAE J1939 communication protocol
- General knowledge in the field of automation technology
- General knowledge of communication networks

Trademarks

SIMATIC® is a registered trademark of Siemens AG.

History

Edition	Note
12/2018	First edition

Naming conventions

The term "PN/J1939 LINK" or "device" is used in this documentation instead of the full product name "SIMATIC PN/J1939 LINK".

The term "S7 controller", or "S7" for short, is also used for the SIMATIC S7 controller.

1.2 Documentation guide

Below you will find a list of documents which supplement these operating instructions for the PN/J1939 LINK and which are available on the Internet.

Additional documentation

Subject	Documentation	Most important contents
Designing interference-free controllers	Function Manual Designing interference-free controllers (https://support.industry.siemens.com/cs/ww/en/view/59193566)	<ul style="list-style-type: none">• Basics• Electromagnetic compatibility• Lightning protection
PROFINET	SIMATIC PROFINET System Description (https://support.industry.siemens.com/cs/ww/en/view/19292127)	<ul style="list-style-type: none">• Basics• Installation• Functions• Configuration examples

The latest manuals for SIMATIC products are available for download free of charge from the Internet (<https://support.industry.siemens.com/cs/ww/en/ps/man>).

The information system in the TIA Portal also supports you in configuring and programming your automation system as well as the PN/J1939 LINK.

Safety instructions

2.1 Safety instructions

 CAUTION

Observe the safety instructions on the inside front cover of this documentation.

SIMATIC PN/J1939 LINK devices comply with the approvals printed on the rating plate. If you have questions about whether it is permissible to install the device in the planned environment, please contact your service representative.

NOTICE

Alterations to the devices are not permitted.

Failure to observe this requirement shall constitute a revocation of the CE approval and manufacturer's warranty.

Intended use

NOTICE

The PN/J1939 LINK may only be used for the applications specified in the catalog and the associated technical documentation. If the device is used in a manner other than the one specified by Siemens, the protection offered by the device might be impaired.

See also the section "Legal notices" at the beginning of this manual.

Repairs

 WARNING

The device contains no user-serviceable parts.

May cause death or serious injury

Unauthorized opening or improperly performed repairs can cause considerable damage to property and/or danger to users. Contact Siemens Support (<http://support.automation.siemens.com>) in case of error.

Safety information

 WARNING
Connection only over safety extra-low voltage / protective extra-low voltage May cause death or serious injury The device is designed for operation using directly connectable safety extra-low voltage (SELV) with safe electrical separation according to IEC 60950-1 / EN 60950-1 / VDE 0805-1 or IEC 61131-2 / EN 61131-2 / DIN EN 61131-2. To obtain the safe property of low-voltage circuits of the PN/J1939 LINK, the 24 V rated voltage supply and external connections to communication interfaces must be supplied from approved sources that meet requirements set forth by various standards for SELV/PELV voltage-limited sources. Therefore only connect safety extra-low voltages (SELV) with safe electrical separation according to IEC 60950-1 / EN 60950-1 / VDE 0805-1 to the supply voltage connections and the communications interfaces.

Working on the device or on connected components

 WARNING
Risk of electric shock May cause death or serious injury <ul style="list-style-type: none">• Voltages > 60 V DC or 30 V AC may be present in the control cabinet. Therefore appropriate safety precautions must be taken to prevent contact during commissioning and maintenance work.• Before carrying out any work on the device or on connected components, make sure that the installation is in a zero-voltage state.• Use cable types with UL approval for UL-approved systems.

2.2 Security information

Siemens provides products and solutions with industrial security functions that support the secure operation of plants, systems, machines and networks.

In order to protect plants, systems, machines and networks against cyber threats, it is necessary to implement – and continuously maintain – a holistic, state-of-the-art industrial security concept. Siemens' products and solutions only form one element of such a concept.

Customer is responsible to prevent unauthorized access to its plants, systems, machines and networks. Systems, machines and components should only be connected to the enterprise network or the internet if and to the extent necessary and with appropriate security measures (e.g. use of firewalls and network segmentation) in place.

Additionally, Siemens' guidance on appropriate security measures should be taken into account. For more information about industrial security, please visit (<http://www.siemens.com/industrialsecurity>).

Siemens' products and solutions undergo continuous development to make them more secure. Siemens strongly recommends to apply product updates as soon as available and to always use the latest product versions. Use of product versions that are no longer supported, and failure to apply latest updates may increase customer's exposure to cyber threats.

To stay informed about product updates, subscribe to the Siemens Industrial Security RSS Feed under (<http://www.siemens.com/industrialsecurity>).

2.3 Protective measures for SIMATIC PN/J1939 LINK

Protective measures for SIMATIC PN/J1939 LINK

NOTICE
Only authorized personnel are permitted to access the system and carry out modifications.

System overview

3.1 Field of application



Figure 3-1 SIMATIC PN/J1939 LINK

SIMATIC PN/J1939 LINK is a communication gateway and enables the connection of SIMATIC controllers to the J1939 network via PROFINET. This allows information and data to be exchanged between PROFINET and the J1939 network.

3.2 Features

General characteristics of PN/J1939 LINK

- 1 J1939 connector (CAN, 9-pin D-SUB connector)
- 2 PROFINET interfaces (integrated switch) enable PROFINET line operation according to Conformance Class B (CC-B).
- The PN/J1939 LINK can be used in the line, star and tree network topologies.
- PN/J1939 LINK is configured in the TIA Portal via a GSDML file.
- Firmware update via SAT (SIMATIC Automation Tool)

J1939 features

- J1939 protocol with physical layer according to ISO 11898-2 (high-speed CAN)
- Implementation according to SAE J1939/11/14 standard
- Transmission rates of 100 Kbps, 250 Kbps and 500 Kbps are supported by the J1939.
- The maximum permissible cable length of the J1939 network is 40 m (depending on data transmission rate, cable cross-section, number of nodes).
- PN/J1939 LINK represents an Electronic Control Unit (ECU) and contains a Controller Application (CA)
- PN/J1939 LINK supports "Address Claiming" (ACL)
- PN/J1939 LINK supports the definition of user-specific parameter groups (PGN)
- Peer-to-peer and broadcast communication
- Transport protocol BAM (Broadcast Announce Message) and CMDT (Connection Mode Data Transfer) for larger volumes of data
- PN/J1939 LINK can read DM1 diagnostic messages from other connected ECUs
- PN/J1939 LINK can write and read parameter groups from the S7 user program.

Configuration limits of the PN/J1939 LINK

- PN/J1939 LINK can address up to 30 ECUs in the J1939 network
- PN/J1939 LINK can address up to 253 CAs in the J1939 network

Limits specified by PROFINET or the J1939 protocol

The maximum data length that can be exchanged cyclically via PROFINET is 1440 bytes per transmission direction. The values that can be achieved with PN/J1939 LINK in practice are lower and depend on the controller used and the configuration.

The user can send data records acyclically up to a length of 1785 bytes via the S7 program. Proxy modules with configurable data length are available for this purpose (see Cyclic and acyclic data exchange (Page 22)). The maximum length of 1785 bytes is specified by the J1939 protocol.

3.3 System configuration

System configuration

The following figure shows a basic system configuration with a PN/J1939 LINK as a communication gateway between a PROFINET network and a J1939 network.

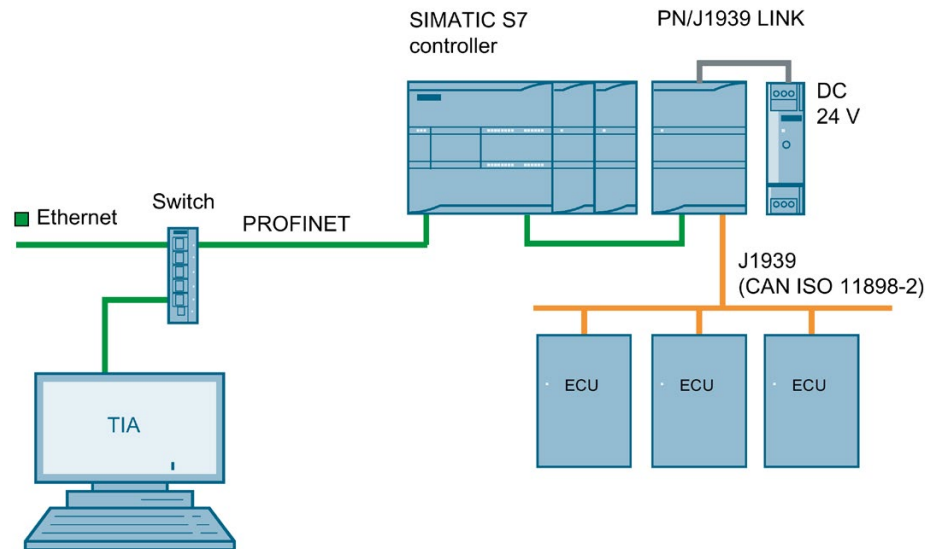

Figure 3-2 System configuration with PN/J1939 LINK

Purpose and function of the system components

PN/J1939 LINK enables PROFINET to be connected to a J1939 network.

Communication of the PN/J1939 LINK with the CPU of the S7 controller takes place exclusively via the PROFINET interface.

From a PROFINET perspective, the PN/J1939 LINK is an IO device according to Conformance Class B (CC-B).

From a J1939 perspective, the PN/J1939 LINK is an Electronic Control Unit (ECU) and contains a Controller Application (CA).

The cyclic data exchange between the PN/J1939 LINK and the connected S7 CPU takes place via an update of the IO image. Acyclic communication takes place by means of the "Read data record" and "Write data record" services.

PN/J1939 LINK is powered either via an external 24 V DC power supply unit or via the 24 V power supply of the SIMATIC S7 system.

The TIA Portal is used for configuring. A corresponding GSDML file is available for this purpose.

3.4 System requirements

System requirements

- PN/J1939 LINK
- Only the following controllers are permissible and are supported:
SIMATIC S7-1200, SIMATIC S7-1500, SIMATIC ET 200SP, SIMATIC OpenController
- 24 V voltage supply
- J1939 bus
- PROFINET bus
- Windows PC (for configuring, commissioning and diagnostics)
- TIA Portal as of V14 SP1
- We recommend a switch for configuring, commissioning and diagnostics.

3.5 Design

PN/J1939 LINK design

Design	
<p>①</p> <p>②</p> <p>③</p> <p>④</p> <p>⑤</p> <p>⑥</p> <p>⑦</p> <p>⑧</p> <p>⑨</p> <p>PN/J1939 LINK design</p>	<p>① 24 V DC connector + functional grounding</p> <p>② Status LEDs device + PROFINET</p> <p>③ MAC address</p> <p>④ Status LEDs Ethernet</p> <p>⑤ Ethernet connector (PROFINET)</p> <p>⑥ J1939 connector</p> <p>⑦ Ethernet connector (PROFINET)</p> <p>⑧ Status LEDs J1939</p> <p>⑨ Rating plate</p>

Functions

4.1 J1939 protocol

Extended CAN format

The J1939 protocol uses the Extended CAN Format CAN 2.0B (29-bit message ID).

The 29-bit message ID consists of the following:

29-bit message ID		
Priority	Parameter Group Number (PGN)	Source Address (SA)
3 Bit	18 Bit	8 Bit

Figure 4-1 29-bit message ID

- Message priority. The priority of a message is used for the bus arbitration. The value 0 has the highest priority.
- Parameter Group Number (PGN)
- Address of the device that transmits the message.

Parameter Group Number (PGN)

A key element of the J1939 protocol is the Parameter Group Number (PGN). The type of a message can be determined or recognized by means of the PGN.

Parameter Group Number (PGN)			
Extended Data Page	Data Page	PDU Format	PDU Specific
1 Bit	1 Bit	8 Bit	8 Bit

Figure 4-2 Parameter Group Number (PGN)

User-specific PGN

Any combination of "PDU Format" and "PDU Specific" parameters is permitted for configuration in the TIA Portal. Requirement: The combination is within the permissible value range and not reserved for special purposes.

Network address (Source Address)

The address space contains 256 possible network addresses.

Address	Meaning
0 to 127	Pre-defined address
128 to 247	Freely available addresses
248 to 253	Pre-defined address
254	Null address
255	Global address (Broadcast)

The address range from 0 to 253 is available for configuring PN/J1939 LINK. See PN/J1939 LINK assign parameters (Page 47).

J1939 device name (Name Field)

The device name is a numeric 64-bit value. The name contains the following information:

- Identification of the device and the device function
- Determines whether the PN/J1939 LINK can select a different network address if it loses "Address Claiming".
- Priority of the device for "Address Claiming"

The device name is composed as follows:

J1939 Name Field	
Arbitrary Address Capable	1-bit
Industry Group	3-bit
Vehicle System Instance	4-bit
Vehicle System	7-bit
Reserved	1-bit
Function	8 bit
Function Instance	5-bit
ECU Instance	3-bit
Manufacturer Code	11-bit
Identity Number	21-bit

These parameters or the corresponding device name are configured in the TIA Portal. See PN/J1939 LINK assign parameters (Page 47).

Address claiming

Addresses for J1939 devices are assigned using the "Address Claiming" procedure. With "Address Claiming", each J1939 device sends its desired network address and its J1939 name with PGN 60928. If no other device is using this address, the preferred address can be used. If the address is already in use, the respective devices compare their names. The name with the lowest numeric value "wins" the conflict and the corresponding device can use the address.

With PN/J1939 LINK, you can configure whether the device is able to change its network address (Arbitrary Address Capable). The parameters are set via the corresponding bit of the device name:

Table 4- 1 Device name - "Arbitrary Address Capable" field (1-bit)

Value	Meaning	Behavior for address claiming
Bit = 0	PN/J1939 LINK cannot change its address.	<p>If another device claims the same address with a higher priority, the PN/J1939 LINK performs the following actions:</p> <ul style="list-style-type: none"> • PN/J1939 LINK sets its address to 254 (Null address). • PN/J1939 LINK sends the diagnostics alarm "Invalid address" to the S7 controller. See Diagnostic messages (Page 58). <p>PN/J1939 LINK can no longer participate in J1939 communication and must be configured with a new J1939 network address.</p>
Bit = 1	PN/J1939 LINK can change its address.	<p>If another device claims the same address with a higher priority, the PN/J1939 LINK performs the following actions:</p> <ul style="list-style-type: none"> • PN/J1939 LINK increments its current address. • PN/J1939 LINK sends the diagnostics alarm "Network address changed" to the S7 controller. See Diagnostic messages (Page 58). <p>PN/J1939 LINK can continue to participate in J1939 communication.</p> <p>After a restart, PN/J1939 LINK uses the "Source Address" configured in the TIA Portal again.</p>

Peer-to-peer and broadcast communications

The J1939 protocol makes it possible to send messages either to all subscribers (broadcast) on the bus or to individual subscribers at specific addresses (peer-to-peer).

Transport protocols

Parameter groups with a maximum data length of 8 bytes can be transmitted within a J1939 data packet.

The following transport protocols are available for the transmission of data volumes larger than 8 bytes.

- BAM (Broadcast Announce Message)
- CMDT (Connection Mode Data Transfer)

BAM messages are sent to all J1939 devices and require no handshaking.

CMDT messages are exchanged peer-to-peer between two J1939 devices. CMDT works with a handshake method for data flow control.

DM messages

J1939 ECUs send DM messages to report their active DTCs (Diagnostic Trouble Codes) and the corresponding lamp status. PN/J1939 LINK can read diagnostic data from the other connected ECUs. The structure of a DM message corresponds to that of a standard PGN. Transmission takes place via a multipackage protocol (BAM).

DM1 messages have a PGN (Parameter Group Number) of 65226 and a cycle of 1 second.

If data lengths of up to 512 bytes are sufficient, standard input modules can be used for the configuration.

For data lengths greater than 512 bytes, configuration takes place via input proxy modules. The maximum data length is 1785 bytes.

If the PGN 65226 is configured in TIA as an input module with a data length of greater than 8 bytes, a corresponding diagnostics alarm is sent to the S7 controller if there is a change of the received DM1 data compared to the previous value.

4.2 PGN parameters

The following table gives an overview of the PGN parameters that can be configured in the TIA Portal via the GSDML file and the meaning of individual parameters. The table also indicates the PGN modules that have the parameters.

Table 4- 2 PGN parameters

Parameter name	Module name	Value range	Description
Extended Data Page	PGN input n bytes PGN output n bytes	Extended 0 ... 1	The "Extended Data Page" and "Data Page" parameter together use 2 bits of the PGN. This means that a maximum of four data pages can be addressed for messages. The PDU format determines whether the message is for a single device or for all devices. PDU format < 240: The message is for a specific device (Peer-to-peer). PDU format ≥ 240: The message is for all devices (Broadcast). The meaning of the field depends on the value in the "PDU format" field. PDU format < 240: The value represents the destination address of the message. PDU format ≥ 240: The value is used as group extension.
Data Page	PGN input proxy PGN output proxy	0 to 1	
PDU Format		0 to 255	
PDU Specific		0 to 255	
CA Source Address	PGN input n bytes PGN input proxy	0 to 255	Control Application Source Address - Network address of the J1939 device

4.2 PGN parameters

Parameter name	Module name	Value range	Description
Priority	PGN output n bytes PGN output proxy	Priority 0 ... 7	Message priority Highest priority: 0
Transmit event		Cyclic	PGN is sent with the time interval set in the "Transmission cycle" parameter. In "Cyclic" mode, standard messages and the Broadcast Announce Message (BAM) can be sent.
		Change of value	PGN is sent when the data value changes. All transport protocols are permitted.
		Remote request	PGN is sent when a request is made from another device in the J1939 network. The request has PGN 59904. Standard messages and CMTD are allowed.
Transport protocol		Standard message	PGN message with up to 8 bytes data length
		Broadcast Announce Message	Fragmented transmission of data with more than 8 bytes without flow control.
		Connection Mode Data Transfer	Fragmented transmission of data with more than 8 bytes with flow control.
Transmission cycle in ms		10 to 5000	Transmission cycle is only valid if "cyclic" is configured as send event.
Reception cycle in ms	PGN input n bytes PGN input proxy	0 to 5000	If a PGN is not received in time, a diagnostics alarm is sent to the S7 controller. The value 0 means that the functionality is disabled.

Parameter name	Module name	Value range	Description
PGN data length	PGN input n bytes PGN output n bytes	8 to 512	<p>PGN modules with specified data lengths from 8 bytes to a maximum of 512 bytes are available.</p> <p>If the value for the PGN data length differs from the maximum module data length, the difference in bytes is truncated from the PGN message.</p> <p>Example: You want to send 20 bytes of data. For this purpose, you select a PGN output module with a predefined size of 32 bytes. You specify 20 bytes as the PGN data length.</p> <p>Only these 20 bytes are transferred via the CAN network. The remaining 12 bytes are truncated.</p>
	PGN input proxy	8 to 1785	Specification of the maximum PGN message length. The corresponding data must be read with the data record index 0x220.
	PGN output proxy		Specification of the maximum PGN message length. The corresponding data must be written with the data record index 0x230.

4.3 Cyclic and acyclic data exchange

Communication paths

The following figure shows the relationships in the communication between S7 controller, PN/J1939 LINK and J1939 bus.

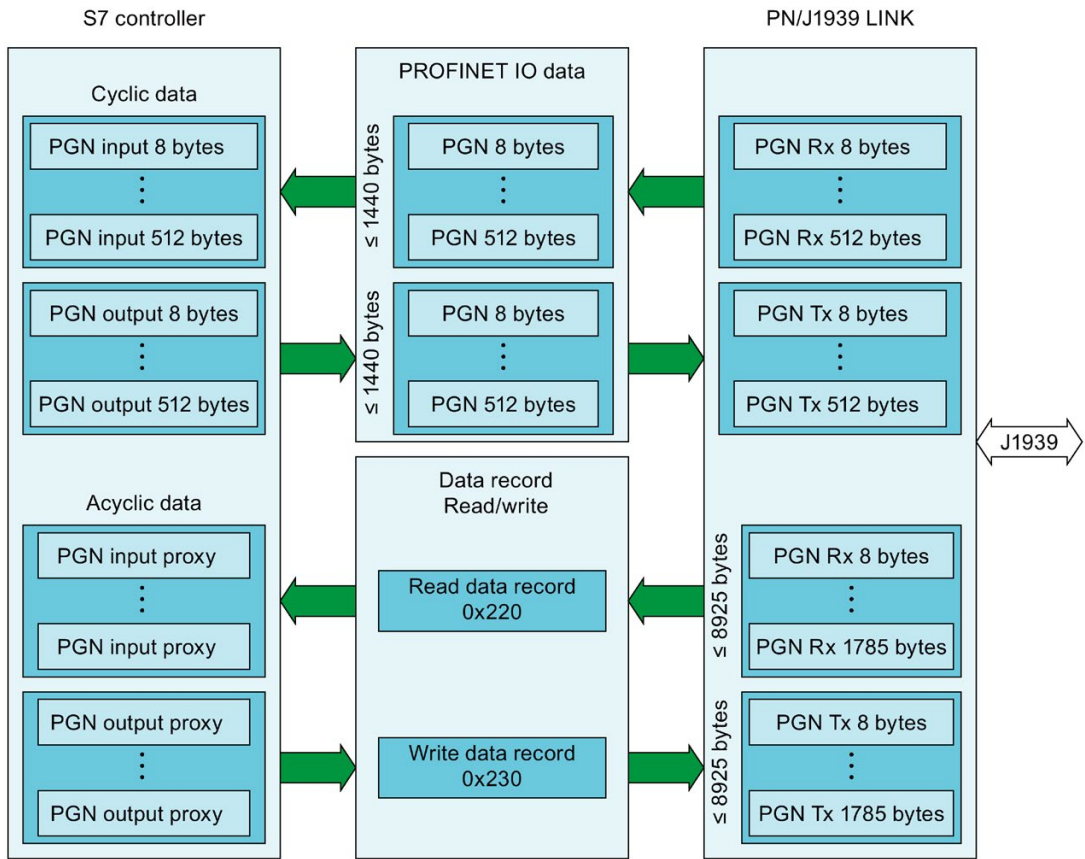

Figure 4-3 Communication paths between S7 controller, PN/J1939 LINK and J1939 bus

Cyclic data exchange: Parameter groups (PGN)

The PGN configured via the GSDML file are transmitted cyclically as PROFINET data between the S7 controller and PN/J1939 LINK. These modules with cyclic data transmission are referred to as PGN modules in the configuration. For information on the possible data length, see section Features (Page 12).

You can find information on configuring the PGN modules in the TIA Portal in the section Configuring / programming (Page 45).

Cyclic data exchange: Control and status information

PN/J1939 LINK and the S7 controller cyclically exchange control and status information.

You can find detailed information on control and status information in the section Control and status information (Page 25).

Acyclic data exchange

The PGN input proxy and PGN output proxy modules are available for acyclic data transmission in the configuration. The configurable data lengths are a minimum of 8 bytes and a maximum of 1785 bytes. The maximum data length of all PGN proxy modules in one transmission direction is 8925 bytes.

With active CAN communication of the PN/J1939 LINK, the proxy modules send or receive parameter groups (PGN) according to the configured parameters.

The proxy modules themselves have no data at their input addresses or output addresses.

PN/J1939 LINK provides two data records for accessing the data, which the S7 user program can access with the acyclic PROFINET IO services RDREC (read data record) and WRREC (write data record).

The data record indices used are

- Read data record: 0x220
- Write data record: 0x230

You can find information on configuring the PGN proxy modules in the TIA Portal in the section Configuring / programming (Page 45).

4.4 State model

PN/J1939 LINK can assume two states: "OFF" and "ON".

"OFF" state

No CAN frames are sent or received in this state. The CAN controller does not participate in the CAN bus communication. It does not send or receive messages or any error frames.

If PN/J1939 LINK is not connected to an S7 controller or if the data from the S7 controller has the "Bad" IO provider status, PN/J1939 LINK assumes the "OFF" state.

"ON" state

In this state, PN/J1939 LINK takes part in CAN bus communication, i.e. it sends and receives CAN telegrams, unless the CAN controller is in "Bus off" state.

Dependence of the status of PN/J1939 LINK on the status of the PROFINET connection and the status of the S7 controller

Event	Reaction
PN/J1939 LINK has never been connected to the S7 controller or has not been configured since startup	PN/J1939 LINK state is "OFF"
S7 controller connected / not yet completely configured	PN/J1939 LINK receives the necessary configuration data from the S7 controller. For the "PGN input modules", the input data is preassigned according to the parameter assignment. PN/J1939 LINK state is "OFF"
S7 controller connected / completely configured / no cyclic PROFINET data exchange or data from the S7 controller has IO provider status "Bad"	PN/J1939 LINK state is "OFF"
Cyclic PROFINET data exchange is active and data from the S7 controller has IO provider status "Good"	PN/J1939 LINK takes the status according to the open loop control bit ("OFF" or "ON"). The control bits are contained in the cyclic data that come from the S7 controller.
S7 controller changes to RUN	PN/J1939 LINK takes the status according to the open loop control bit ("OFF" or "ON"). The control bits are contained in the cyclic data that come from the S7 controller.
Disconnection of the S7 connection (after PN/J1939 LINK has already been configured once by the S7 controller)	PN/J1939 LINK state is "OFF"
Reconfiguration by S7 controller	PN/J1939 LINK receives the necessary configuration data from the S7 controller. For the "PGN input modules", the input data is preassigned according to the parameter assignment. PN/J1939 LINK state is "OFF"

4.5 Control and status information

Controller information

The following control information is cyclically transmitted from the S7 controller to PN/J1939 LINK:

Table 4- 3 Structure of the control information in the PROFINET IO data (from S7 controller to PN/J1939 LINK, 1 byte)

Bit	Meaning	Value		Note
7 to 1	Reserved	0	--	Value must be "0"
0	Control bit	0	No CAN communication	The CAN controller should be in the "OFF" state.
		1	CAN communication active	The CAN controller should be in the "ON" state.

Status information

The following status information is cyclically transmitted from PN/J1939 LINK to the S7 controller:

Table 4- 4 Structure of the status information in the PROFINET IO data (from PN/J1939 LINK to S7 controller, 1 byte)

Bit	Meaning	Possible values		Note
7 to 2	Reserved	--	--	--
1 to 0	State of the CAN controller	0	OFF	When specified accordingly by the S7 controller.
		1	Bus off	Error counter ¹⁾ has exceeded the specified threshold or PN/J1939 LINK takes more than 2 seconds to synchronize to the CAN bus. As a result, the PN/J1939 LINK no longer sends/receives packets.
		2	Error passive	Error counter ¹⁾ has reached the specified threshold. PN/J1939 LINK continues to send / receive packets.
		3	Error active	Error counter ¹⁾ is below a specified threshold. This is the normal state. Everything is okay.

1) The error counters customary in CAN and their associated thresholds are internal functions that are not visible to the user.

Note

For values made up of multiple bits, the first bit is the MSB and the last bit is the LSB.
Example: Bit 1 to 0 = "2" means that bit 0 = "0" and bit 1 = "1".

4.6 Response to errors

Diagnostic resource

The device provides various tools to isolate the cause. These tools are listed below:

Diagnostic resource	Description
LED display	PN/J1939 LINK signals its status with the LEDs on the front of the enclosure. The meaning of the LEDs is described in section Status LEDs (Page 53).
SIMATIC diagnostics	Information on the events that trigger a diagnostics alarm is available in the section Events that trigger a diagnostic message (Page 57). The section Diagnostic messages (Page 58) contains a description of the cause of the error and the possible corrective measures.
Status bit/byte	See section Cyclic and acyclic data exchange (Page 22)

Behavior when communication with S7 controller / J1939 fails

If communication between the PN/J1939 LINK and S7 controller fails, the PN/J1939 LINK changes to the state "not configured". In this state, the PN/J1939 LINK waits for new configuration data from the controller. PN/J1939 LINK cannot be operated in this state.

If communication between PN/J1939 LINK and the CAN network fails, the CAN controller goes into the "Bus off" operating state (see Control and status information (Page 25)). The last PGN data remains available. PN/J1939 LINK remains operable.

Module failure

Module failures are indicated by the status LEDs. If necessary, corresponding diagnostics messages are also output. These can then be taken from the diagnostic buffer of the S7 controller either immediately or during the next start-up.

Note

An Ethernet switch is integrated in the PN/J1939 LINK. This switch is also operational in an error state so that the PROFINET network continues to run.

Application planning

5.1 Installation guidelines

General installation guidelines

The following guidelines must be observed when installing and connecting the PN/J1939 LINK:

- When connecting the PN/J1939 LINK, make sure that you comply with all applicable and legally binding standards. Adhere to the relevant national and regional regulations when installing and operating the device. Check with the local authorities regarding the standards and rules to be followed in your particular case.
- Ensure a zero-voltage state during assembly and connection work.
- Adhere to the installation and wiring guidelines of your automation system and the J1939 system.

Guidelines for the installation of PN/J1939 LINK devices

- PN/J1939 LINK is classified as open equipment according to standards for electrical devices.
- You must install the PN/J1939 LINK in an enclosure, control cabinet or control center.
- Only authorized personnel must have access to the enclosure, control cabinet or control center.
- Installation and operation of the PN/J1939 LINK is only permitted in a dry environment.
- Only one connection to SELV circuits is permitted. Only these offer protection from electric shock in a dry environment.
- The installation must offer the required mechanical protection and environmental protection for open equipment in your specific location category according to the applicable electrical regulations and building code.
- Proper grounding and wiring of the PN/J1939 LINK is important for optimal operation and for sufficient immunity of your system and your application.

5.2 Installation location

Selection of the installation site / mounting position

You can mount the PN/J1939 LINK either on a control panel or on a standard mounting rail:

Permitted mounting positions and permitted ambient temperature

The table below shows the permitted temperature range for the different mounting positions.

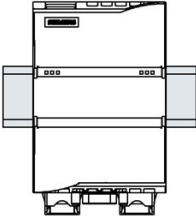
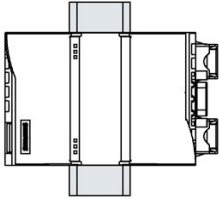
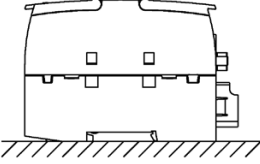
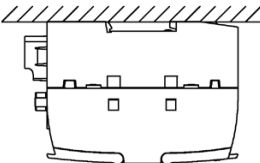
Mounting position		Permitted ambient temperature
Horizontal		-25 ... +60 °C
Vertical		-25 ... +55 °C
Lying		-25 ... +45 °C
Hanging		-25 ... +45 °C

Ensure that condensation is not produced at a relative humidity between 10% and 95%.

Ensure that the atmospheric pressure is between 795 hPa and 1080 hPa. This corresponds to an installation height of -1000 m to +2000 m.

PN/J1939 LINK is designed for natural heat dissipation by convection. Therefore observe sufficient clearances:

- For horizontal mounting position: At least 35 mm above and below the PN/J1939 LINK
- For vertical mounting position: At least 35 mm left and right of PN/J1939 LINK

Provide sufficient space for connection of the supply voltage, Ethernet and J1939 bus.

Also make sure that a depth of at least 25 mm remains clear between the module front and the inside of the enclosure / control panel.

Table 5- 1 Device dimensions

Dimensions of PN/J1939 LINK	
Width	70 mm
Height	111.5 mm (including overhangs)
Depth	75 mm (including overhangs)

You can find the dimension drawing of the PN/J1939 LINK in the section Dimension drawing (Page 67).

NOTICE
Damage due to overheating You must comply with all the instructions regarding the installation site and mounting position. Otherwise the device may malfunction or incur permanent damage as a result of overheating.

Pollution degree

PN/J1939 LINK is designed for Pollution Degree 2. Pollution degree 2 according to the EN 50178 standard is non-conductive contamination in the normal case which can briefly become conductive as a result of condensation when the device is not in operation.

Contamination of conductive parts by dust, moisture and air pollution can lead to operational errors and electrical faults in PN/J1939 LINK.

Degree of protection

The enclosure of the PN/J1939 LINK has IP20 degree of protection according to IEC 60529.

PN/J1939 LINK is classified as "open type" or "open equipment" according to UL 61010-2-201 or IEC 61010-2-201.

If PN/J1939 LINK is located in an area where contamination of conductive parts can occur, PN/J1939 LINK must be protected by an enclosure with the appropriate degree of protection. IP54 is a protection class that is generally used for electronic systems in heavily polluted environments and may be suitable for your application.

Electromagnetic compatibility (EMC) / overvoltage protection

NOTICE

Damage to the device

Inadequately dimensioned overvoltage protection can result in severe damage to the device. Always ensure, therefore, that the overvoltage protection is adequate (see Chapter 24 V DC power supply (Page 38)).

Installation in control cabinet / device connection box

NOTICE

The device is intended for installation in a control cabinet or in a device connection box.

It is important to note that installation in a control cabinet or device connection box is essential for compliance with the UL regulations.

The control cabinet / device connection box must satisfy the regulations regarding fire-protection housing.

Ensure that all cables and leads that protrude externally are equipped with adequate strain relief.

5.3 Transportation

The devices must be transported in a clean and dry state, preferably in their original packaging. The transport temperature must be between -40 °C and +70 °C. Temperature fluctuations greater than 20 K per hour are not permitted.

5.4 Storage

The devices must be stored in clean and dry rooms, preferably in their original packaging. The storage temperature must be between -40 °C and +70 °C.

5.5 Scope of delivery

- PN/J1939 LINK
- 2 securing collars for the Ethernet connections (installed on the device in the delivery state)
- Compact operating instructions
- CD/DVD with license terms

Unpacking and checking the delivery

1. Unpack the device.
2. Check the delivery for completeness.
3. Check the device for transport damage by visual inspection.

NOTICE
Damage to the system
Damaged parts can result in damage to the system. Do not use devices that show evidence of damage!

Mounting/Extending

6.1 Installing the device

PN/J1939 LINK can be mounted on a 35 mm standard mounting rail according to DIN EN 60715 or on a control panel.

Information on the selection of the location of use as well as reliable mounting positions and minimum clearances is available in the section Installation location (Page 28).

Mounting on a standard mounting rail

Proceed as follows:

1. Hook the PN/J1939 LINK onto the mounting rail.
2. Swivel the PN/J1939 LINK backwards until it engages audibly.



Figure 6-1 PN/J1939 LINK standard rail mounting

NOTICE

If the device is not installed on a control panel, the mounting sliders (see figure Control panel mounting item ①) must always be in the default positions set at the factory. Otherwise the mounting sliders may warp if they are exposed to hot and humid ambient conditions for a long time.

Mounting to a control panel

Proceed as follows:

1. Drill holes (M4). The dimensions for the drill holes are available in the figure below.
2. Move the sliders ① to the outside until they latch in place.
3. Fasten the module with a cylinder head screw M4 as well as a spring lock washer and a flat washer.

Note

Do not use a countersunk head screw.

The type of screw required depends on the type of material on which the module is mounted. Fasten the screw with the corresponding torque until the spring lock washer is pressed flat.

Do not fasten the screws with excessive torque.

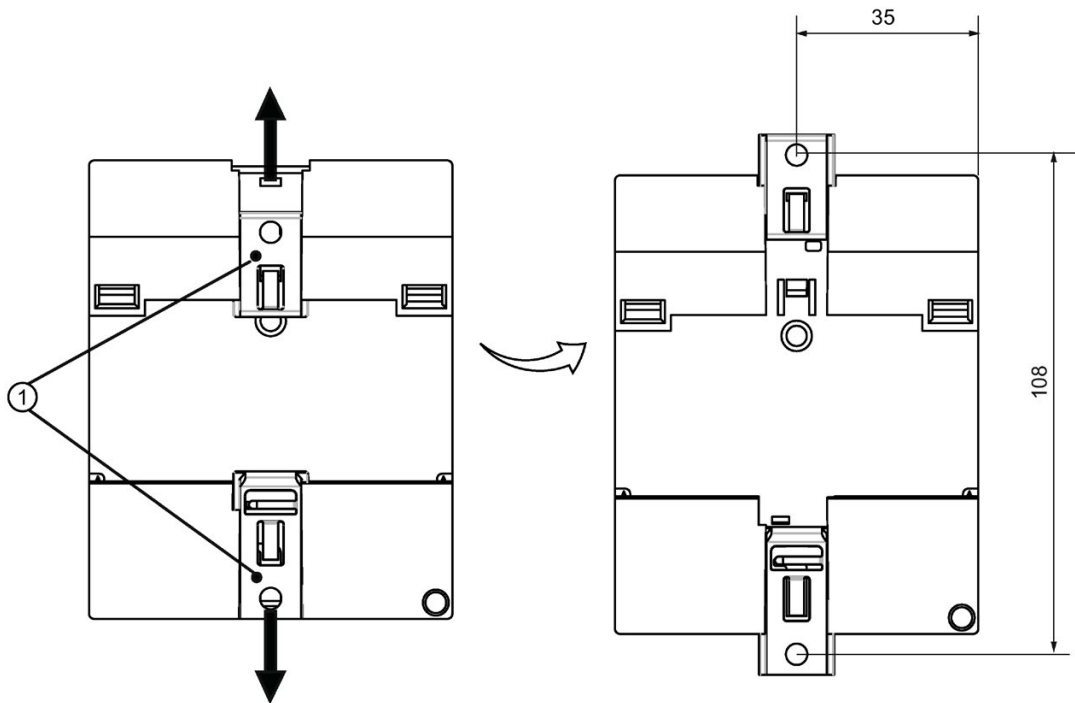



Figure 6-2 Control panel mounting of the PN/J1939 LINK

Connecting

7.1 Safety instructions and guidelines

Safety information

 WARNING
<p>Connection only over safety extra-low voltage / protective extra-low voltage</p> <p>May cause death or serious injury</p> <p>The device is designed for operation using directly connectable safety extra-low voltage (SELV) with safe electrical separation according to IEC 60950-1 / EN 60950-1 / VDE 0805-1 or IEC 61131-2 / EN 61131-2 / DIN EN 61131-2.</p> <p>To obtain the safe property of low-voltage circuits of the PN/J1939 LINK, the 24 V rated voltage supply and external connections to communication interfaces must be supplied from approved sources that meet requirements set forth by various standards for SELV/PELV voltage-limited sources.</p> <p>Therefore only connect safety extra-low voltages (SELV) with safe electrical separation according to IEC 60950-1 / EN 60950-1 / VDE 0805-1 to the supply voltage connections and the communications interfaces.</p>

Working on the device or on connected components

 WARNING
<p>Risk of electric shock</p> <p>May cause death or serious injury</p> <ul style="list-style-type: none"> • Voltages > 60 V DC or 30 V AC are present in the control cabinet. Therefore appropriate safety precautions must be taken to prevent contact during commissioning and maintenance work. • Before working on the PN/J1939 LINK or the connected components, ensure the system is disconnected from the power.

Wiring guidelines

When wiring the PN/J1939 LINK, adhere to the wiring guidelines of your automation system (e.g. SIMATIC S7-1200, SIMATIC S7-1500, SIMATIC ET 200SP).

Also observe the installation instructions and configuration guidelines for routing of the PROFINET cables.

Cable routing and grounding

Note

Electromagnetic interference

Make sure that sufficient potential equalization is implemented in all plants or systems in which the PN/J1939 LINK is installed. E.g. by means of a low-impedance connection to a ground potential.

Note

Strain relief

Ensure that all cables and leads that protrude externally are equipped with adequate strain relief.

Other requirements

NOTICE
Damaged cables <ul style="list-style-type: none">• The cables must be suitably dimensioned to ensure that they cannot be damaged. Make sure that the cables are suitable for the individual application.• Observe the bending radii.
 CAUTION
For system for UL approval: <p>The cables must be specified for an ambient temperature of at least +75 °C.</p>

7.2 Potential ratios

Electrical isolation

Electrical isolation is provided between the following switching components with the PN/J1939 LINK:

- The signals of the PROFINET interfaces are electrically isolated from each other, from the electronics or 24 V supply voltage and from the fieldbus interfaces.
- The J1939/CAN interface is electrically isolated from the power supply.

Shielding

The shields of the PROFINET interface are galvanically connected.

NOTICE

Sufficient interference immunity is only achieved through EMC compliant application of the cable shields of the PROFINET cables to a shield rail.

The shields of the J1939/CAN interface are capacitively decoupled from the shields of the PROFINET interface to prevent compensating currents over the cable shields.

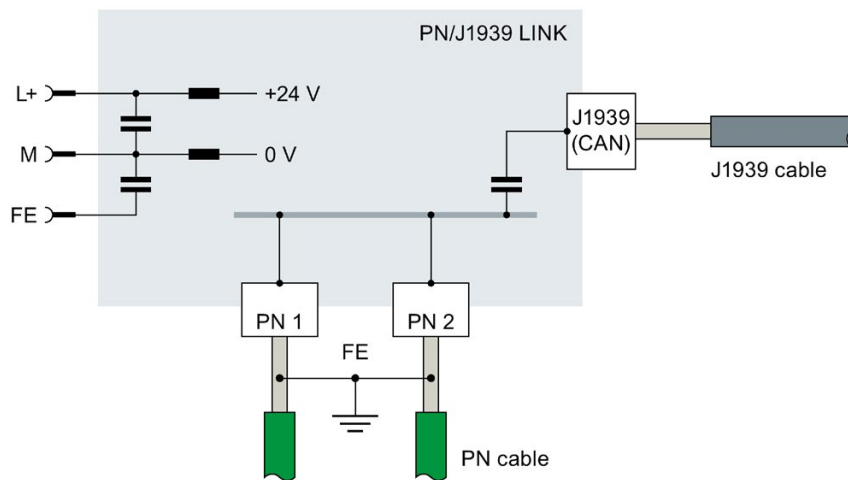

Figure 7-1 Block diagram shielding

7.3 24 V DC power supply

24 V DC power supply

The connection of the external 24 V power supply and the functional earth connection takes place via a 3-pin screw-type terminal. It is located below the top housing cover (see Design (Page 14)).

A suitable power supply is, for example, SIMATIC S7-1200 Power Supply PM1207 (6EP1332-1SH71).



Safety information

 WARNING
<p>Connection only over safety extra-low voltage / protective extra-low voltage</p> <p>May cause death or serious injury</p> <p>The device is designed for operation using directly connectable safety extra-low voltage (SELV) with safe electrical separation according to IEC 60950-1 / EN 60950-1 / VDE 0805-1 or IEC 61131-2 / EN 61131-2 / DIN EN 61131-2.</p> <p>In order to maintain the safe characteristics of the low-voltage circuits of the PN/J1939 LINK, the 24 V rated voltage supply and external connections to communication ports must be supplied from approved sources that meet the requirements of various standards for SELV / PELV voltage-limited sources.</p> <p>Therefore only connect safety extra-low voltages (SELV) with safe electrical separation according to IEC 60950-1 / EN 60950-1 / VDE 0805-1 to the supply voltage connections and the communications interfaces.</p>

Connector pin assignment

The figure below shows the assignment of the terminal for the 24 DC power supply.

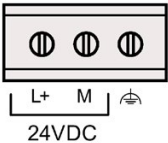
Table 7- 1 Terminal assignment for the 24 DC power supply

	L+	24 V supply for PN/J1939 LINK (+)
	M	24 V supply for PN/J1939 LINK (-)
		Functional ground

Permissible torques for screw terminal:

- Minimum tightening torque: 0.5 Nm
- Maximum tightening torque: 0.6 Nm

External lightning protector

An external lightning protector can be installed in the 24 V DC supply line to protect against powerful pulses on the supply lines:

We recommend the Dehn Blitzductor BXT ML2 BD 180, article number 920 247 (on basis BXT BAS) or an equivalent protection element.

Manufacturer:

DEHN+SOEHNE GmbH+Co.KG, Hans-Dehn-Str.1, Postfach 1640, D-92306 Neumarkt, Germany. The lightning protection module must be installed and used in accordance with the manufacturer's specifications.

7.4 Connecting the functional ground

Connect the ground (e.g. from mounting rail) for discharge of EMI, such as bursts or surges, to the FE terminal (see 24 V DC power supply (Page 38)).

Permissible conductor cross-section:

- 0.5 - 6 mm², AWG 26 - AWG 12

Note

EMC-compliant functional grounding

- Use as short a stranded-wire conductor as possible with a large cross section.
 - Compliance with the technical specifications of the device is only assured with a correct functional ground connection.
-

7.5 Connecting PROFINET

Connecting PROFINET

PROFINET connector	
	<p>Connect Ethernet cable according to PROFINET specification to higher-level controller and / or the next PROFINET node ①.</p> <p>Use a shielded Ethernet cable with shielded connector for the connection.</p> <p>We recommend RJ45 connectors from the Siemens FastConnect system as connectors for the Ethernet cabling.</p> <p>Always apply the shields of the PROFINET Ethernet cable at both ends.</p>

- ① Ethernet connector
- ② Securing collar

Note

In order to increase the mechanical stability, optimized securing collars ② for the two Ethernet connections are attached to the lower part of the PN/J1939 LINK enclosure in the factory state. These securing collars are intended for the Siemens FastConnect connectors.

NOTICE

Make sure you observe the minimum bending radius of the Ethernet cable; otherwise the shield effect of the cable shield may be impaired. There is also the risk that the cable shield breaks.

NOTICE

EMC stability is only guaranteed with shielded PROFINET cables.

⚠ CAUTION

Critical plant state

The Ethernet switch integrated in PN/J1939 LINK is only operational once the PN/J1939 LINK starts up. Restarting the PN/J1939 LINK interrupts the Ethernet switch function.

Existing Ethernet connections via the switch are thus interrupted for the duration of the PN/J1939 LINK startup. This can result in critical plant states.

7.6 Connecting the J1939 bus

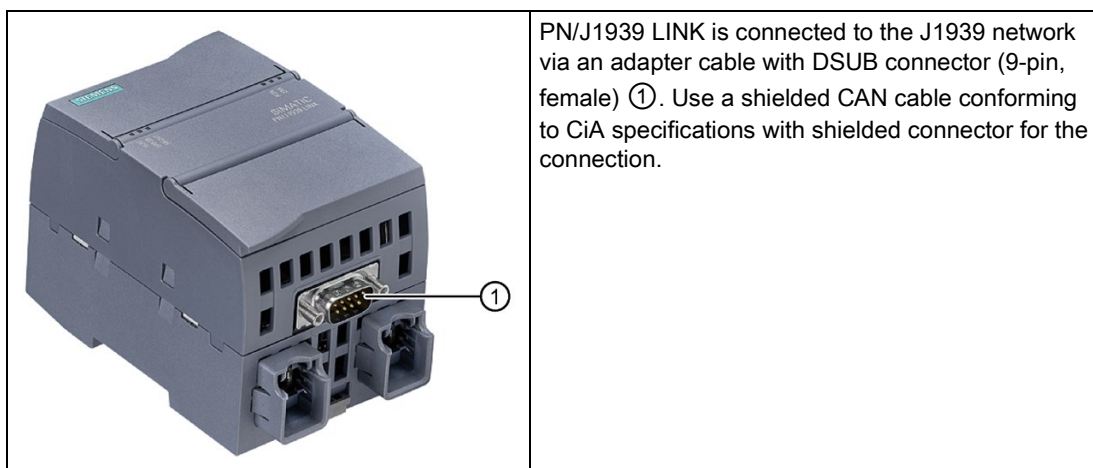

PN/J1939 LINK is connected to the J1939 network via an adapter cable with DSUB connector (9-pin, female) ①. Use a shielded CAN cable conforming to CiA specifications with shielded connector for the connection.

① J1939 connector

The physical data transmission is performed via a CAN interface according to ISO 11898-2 (high-speed).

The following figure shows the assignment of the 9-pin DSUB connector on the PN/J1939 LINK.

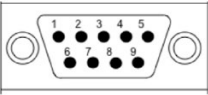
 <p>J1939 connector pin assignment</p>	1	--	Terminating resistor 120 Ω (install jumper from pin 1 to pin 2 for use)
	2	CAN_L	CAN_L bus cable (dominant low)
	3	CAN_GND	CAN Ground
	4	--	Not connected
	5	CAN_SHLD	CAN shield
	6	CAN_GND	CAN Ground
	7	CAN_H	CAN_H bus cable (dominant high)
	8	--	Not connected
	9	--	Not connected

NOTICE

EMC stability is only guaranteed with shielded CAN cables.

Commissioning

8.1 Commissioning PN/J1939 LINK

Prerequisites

- The PN/J1939 LINK is mounted and connected to a SIMATIC S7 CPU via PROFINET.
- The J1939 bus is connected to the PN/J1939 LINK.
- PN/J1939 LINK and all other components are wired and connected.

Basic commissioning procedure

After commissioning of the hardware perform the additional steps required for commissioning in the TIA Portal.

TIA Portal

1. Install the GSDML file. This step integrates the PN/J1939 LINK in the HW catalog (for details, see *Configuring / programming* (Page 45)).
2. Assign a PROFINET device name and an IP address to the PN/J1939 LINK.
3. Create a project
4. Configuration using GSDML file in the TIA Portal (see also *Configuring / programming* (Page 45)).
5. Download project to the S7 CPU
6. Set SIMATIC CPU to "RUN" operating state. The corresponding configuration data is downloaded automatically from the S7 CPU to the PN/J1939 LINK.
7. When the S7 program sets the control bit in the cyclic IO image to "1", the left "RUN" status LED on the PN/J1939 LINK lights up green and signals that the device is in an error-free operating state.

Result

PN/J1939 LINK was successfully commissioned.

Configuring / programming

9.1 Overview

The configuration of PN/J1939 LINK gateway is made in the TIA Portal and essentially consists of the following work procedure:

1. Integrate PN/J1939 LINK from the HW catalog into the project
2. Connect S7 control and PN/J1939 LINK via PROFINET
3. Set the PROFINET-specific parameters.
4. PN/J1939 LINK assign parameters
5. Insert and configure parameter groups
6. Checking and compiling the configuration

The following instructions are intended to show the basic procedure for configuring the PN/J1939 LINK and provide a quick introduction to configuring PN/J1939 LINK.

The description refers to TIA Portal V15.

9.2 Devices & networks

Requirement

Check whether the hardware catalog of the TIA Portal contains PN/J1939 LINK. Otherwise, you have to integrate PN/J1939 LINK by installing a GSDML file.

The GSDML file "GSDML-V2.32-Siemens-PN_J1939_LINK-yyyyymmdd.xml" is available for TIA Portal V15 at "Industry Online Support (<http://www.siemens.com/automation/service&support>)".

The GSDML file is installed in the TIA Portal via "Options > Manage generic description files (GSD)".

Devices & networks

Follow these steps:

1. In the HW catalog ①, select a PN/J1939 LINK corresponding to a concrete article number and double-click on it.

PN/J1939 LINK appears in the "Devices & networks" window.

2. Connect the CPU and PN/J1939 LINK via a PROFINET connection.

CPU and PN/J1939 LINK are linked via a green PN line ② in the "Devices & network" window.

3. Configure the PROFINET interface of the PN/J1939 LINK ③ according to the conditions of your PROFINET network.

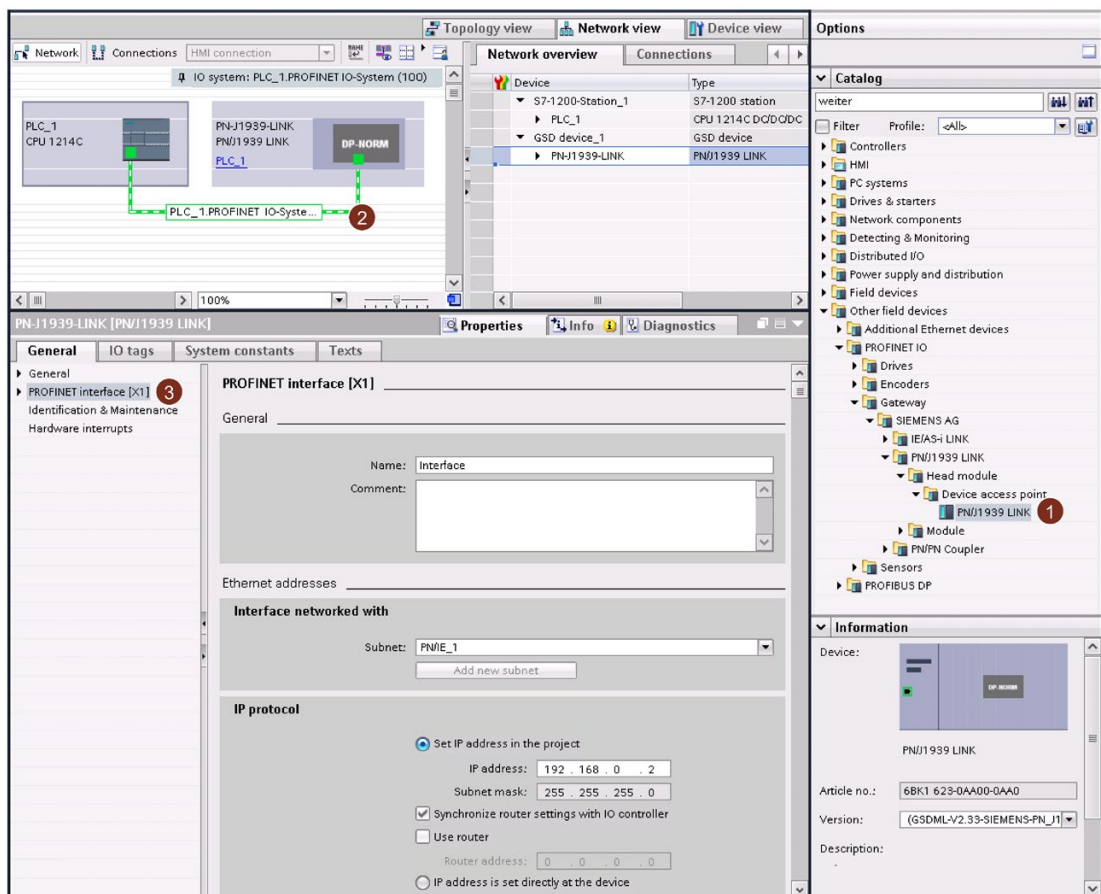

Figure 9-1 Devices & networks

9.3 PN/J1939 LINK assign parameters

You configure module parameters for the created J1939 LINK. The module parameters include:

- Parameters for identifying the PN/J1939 LINK in the J1939 network
- Communication parameters

Module parameters (J1939 device name)

The parameter values entered at ① together form the 64-bit device name of the PN/J1939 LINK. This device name also determines the priority that the device has for "Address Claiming".

You can use the "Arbitrary Address Capable" parameter to specify whether PN/J1939 LINK can change its "Source Address".

You can find additional information on the parameters in the section J1939 protocol (Page 15).

Parameter	
Identity Number:	0
Manufacturer Code:	0
ECU Instance:	0
Function Instance:	0
Function:	0
Vehicle System:	0
Vehicle System Instance:	0
Industry Group:	0
Arbitrary Address Capable:	0
Baud rate:	250 kbps
Source Address:	3

Figure 9-2 Module parameters

Communication parameters

Using the communication parameters ②, you define the data transmission rate between PN/J1939 LINK and J1939 bus and the "Source Address" on the J1939 bus.

Adapting I/O addresses

You can check and set the start and end addresses of the input and output data for J1939 LINK via the "I/O Addresses" page. In addition, the address range can be assigned to an organization block and a process image. I/O addresses are preset by the system.

9.4 Insert and configure parameter groups

Pre-defined modules for parameter groups are available for selection in the HW catalog. The modules differ in the data length, the transmission direction and the type of data exchange via PROFINET.

- Cyclic data exchange:
PGN modules with specified data lengths from 8 bytes to 512 bytes
- Acyclic data exchange:
PGN proxy modules with a configurable data length of 8 bytes to 1785 bytes

Insert parameter group

Follow these steps:

1. Double-click on the desired parameter group ① in the HW catalog.
The selected parameter group is automatically placed as a module in the next free slot ②.
2. Edit the name of the parameter group if needed.

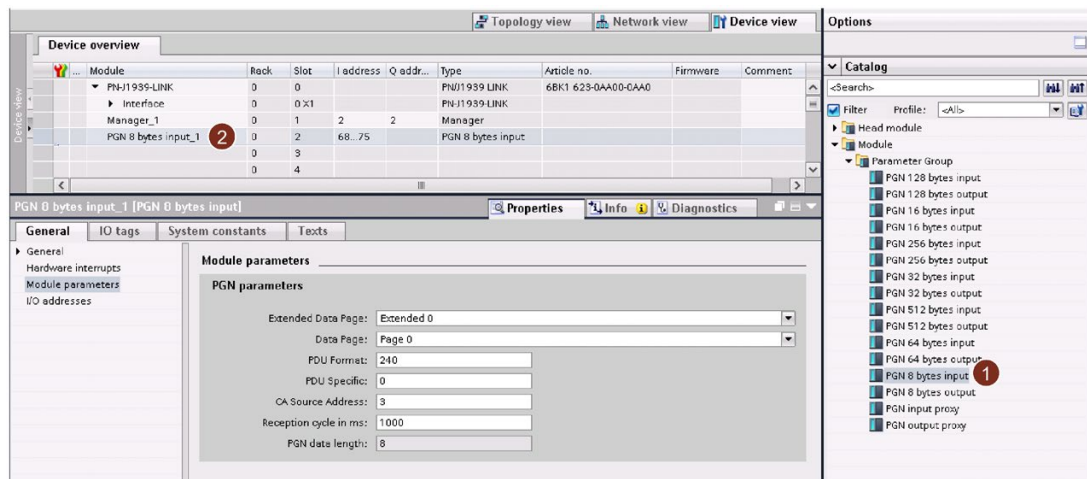
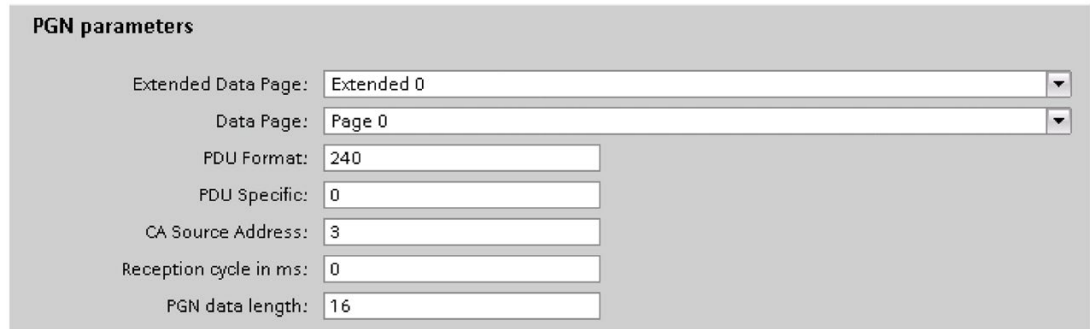

Figure 9-3 Insert parameter group

PGN input modules

Set the PGN parameters according to your requirements. The meaning of the PGN parameters can be found in the section PGN parameters (Page 19).



The screenshot shows a configuration window titled "PGN parameters" for an input module. It contains the following fields:

Extended Data Page:	Extended 0
Data Page:	Page 0
PDU Format:	240
PDU Specific:	0
CA Source Address:	3
Reception cycle in ms:	0
PGN data length:	16

Figure 9-4 PGN input module with a data length of 16 bytes

The received data is available at the input address of the module.

PGN output modules

Set the PGN parameters according to your requirements.

For PGN modules with a data length of 8 bytes, the transmission occurs as a standard message within a CAN data frame. PGN modules from 16 bytes data length are fragmented and transmitted via a transport protocol. If the data length exceeds 16 bytes, also select a suitable transport protocol for the transmission.

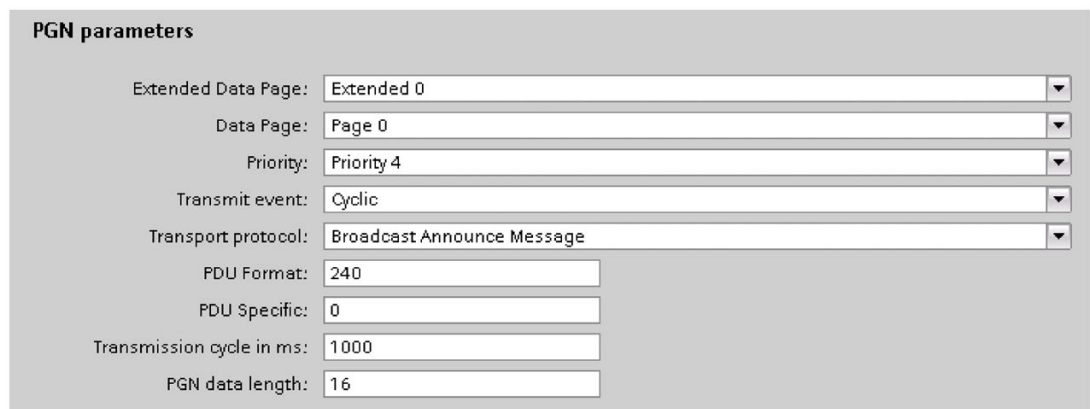

The screenshot shows a configuration window titled "PGN parameters" for an output module. It contains the following fields:

Extended Data Page:	Extended 0
Data Page:	Page 0
Priority:	Priority 4
Transmit event:	Cyclic
Transport protocol:	Broadcast Announce Message
PDU Format:	240
PDU Specific:	0
Transmission cycle in ms:	1000
PGN data length:	16

Figure 9-5 PGN output module with a data length of 16 bytes

The PGN data to be sent must be assigned to the output address of the module. Only the pure user data of the PGN message is sent via the CAN network.

Note

A value for the send cycle is only valid if you have set the "cyclic" send event.

The meaning of the individual PGN parameters can be found in the section PGN parameters (Page 19).

PGN input proxy

If data is to be read acyclically by the S7 controller, select a PGN input proxy.

You can specify a value from 8 bytes to a maximum of 1785 bytes as the PGN data length ①.

The PGN input proxy itself has no data at its input address. The corresponding data is read in the user program via RDREC with the data record index 0x220. You can find detailed information in the section Cyclic and acyclic data exchange (Page 22).

The screenshot shows a configuration window titled "PGN parameters". It contains several input fields and dropdown menus. The "PGN data length" field is highlighted with a red circle and the number 1, indicating it is the focus of the text. The other fields are: Extended Data Page (Extended 0), Data Page (Page 0), PDU Format (240), PDU Specific (0), CA Source Address (150), and Reception cycle in ms (1000).

Figure 9-6 PGN input proxy with a data length of 1785 bytes

PGN output proxy

If data is to be written acyclically by the S7 controller, select a PGN output proxy.

You can specify a value from 8 bytes to a maximum of 1785 bytes for the PGN data length ①.

The PGN output proxy itself has no data at its output address. The corresponding data is written via WRREC with the data record index 0x230. You can find detailed information in the section Cyclic and acyclic data exchange (Page 22).

The screenshot shows a configuration window titled "PGN parameters". It contains several input fields and dropdown menus. The "PGN data length" field is highlighted with a red circle and the number 1, indicating it is the focus of the text. The other fields are: Extended Data Page (Extended 0), Data Page (Page 0), Priority (Priority 4), Transmit event (Cyclic), Transport protocol (Broadcast Announce Message), PDU Format (240), PDU Specific (0), and Transmission cycle in ms (1000).

Figure 9-7 PGN output proxy with a data length of 1785 bytes

9.5 Checking and compiling the configuration

Adapting I/O addresses

If necessary, you must adapt the I/O addresses assigned automatically by the TIA Portal. This is possible, for example, in the "Device overview" window. Here you can also find the I/O addresses used by the slots. The addresses assigned to slot 1, i.e. PN/J1939 LINK (Manager) are particularly important, as this is used to exchange control and status information with the S7 program.

Checking the configuration

You can check the consistency of the configuration by compiling it.

Controlling PN/J1939 LINK via S7 user program

To enable data transfer between the S7 controller and the PN/J1939 LINK, you need to set the control information via the S7 user program accordingly. This control information is cyclically transmitted from the S7 controller to the PN/J1939 LINK. You can find detailed information on this in the section Control and status information (Page 25).

Diagnostics

10.1 Status LEDs

10.1.1 Operating state of the PN/J1939 LINK / PROFINET diagnostics

The LEDs for visualizing the operating states of the PN/J1939 LINK and the PROFINET ports are located on the front of the enclosure.



Figure 10-1 Status LEDs - Operating status of the PN/J1939 LINK / PROFINET diagnostics

Table 10- 1 Behavior of the status LEDs RUN, ERROR, MAINT

RUN LED	ERROR LED	MAINT LED ¹⁾	Operating state	Description
■ On	■ On	■ On	Power-up test / Serious error	<ul style="list-style-type: none"> For approximately 1 second: LED test during startup Longer than 1 second: HW error detected during power-up test or other serious error
□ Off	□ Off	□ Off	System run-up	<ul style="list-style-type: none"> System not completely booted yet but power-up test is complete.
⚡ Flashes	□ Off	□ Off	Not connected to S7 controller	<ul style="list-style-type: none"> No "IO controller" connection established or configuration not yet completed.
■ On	x	□ Off	Connected to S7 controller	<ul style="list-style-type: none"> "IO controller" connection established and configuration completed.
x	⚡ Flashes	□ Off	Error state	<ul style="list-style-type: none"> "IO controller" connection established and configuration completed, but an error occurred: <ul style="list-style-type: none"> Diagnostics alarm to the S7 controller is pending Incorrect configuration by the S7 controller <p>Flashes for at least 3 seconds.</p>
⚡ Flashes	□ Off	□ Off	Firmware update	<ul style="list-style-type: none"> While the firmware is written to the flash memory.
⚡ Flashes	⚡ Flashes	□ Off	LEDs are flashing (triggered by TIA Portal)	<ul style="list-style-type: none"> 3-second intervals For identification of the device

1) The MAINT LED currently has no meaning.

x: LED state is irrelevant

When the PN/J1939 LINK starts up after connecting the power supply, the procedure is as follows:

1. The three LEDs light up briefly for about 1 second and then go dark again.
2. None of the LEDs light up for about 4 seconds.
3. The RUN LED starts flashing.
4. When the startup of the PN/J1939 LINK is successfully complete and the connection to the S7 controller is established, the RUN LED lights up.

10.1.2 Connection status of the Ethernet interfaces

The LEDs for indicating the connection status of the Ethernet interfaces are located under a housing flap.



Figure 10-2 Status LEDs, Ethernet interfaces

Table 10- 2 Behavior of the status LED LINK

LINK	Indicates whether there is a physical connection on the Ethernet level.
■ On	Connection exists
□ Off	No connection exists

Table 10- 3 Behavior of the status LED Rx/Tx

Rx/Tx	Indicates whether a packet is being sent or received
■ On	PN/J1939 LINK is sending or receiving a packet
□ Off	No packet is sent or received

10.1.3 Connection status of the J1939 bus

Connection status J1939 bus

PN/J1939 LINK signals its state with the J1939 bus LEDs on the front of the enclosure.



Figure 10-3 Status LEDs PN/J1939 LINK

Table 10-4 Behavior of the RUN LED

RUN LED	Meaning	Note
<div style="text-align: center;">□</div> Off	PN/J1939 LINK is in the "OFF" state	See State model (Page 23)
<div style="text-align: center;">■</div> On	PN/J1939 LINK is in the "ON" state	

Table 10-5 Behavior of the ERR LED

ERR LED	Meaning	Note
<div style="text-align: center;">□</div> Off	No error on the CAN bus	--
<div style="text-align: center;">⚡</div> Short flashing once	The CAN controller is in the "Error passive" state.	See Control and status information (Page 25)
<div style="text-align: center;">⚡</div> Short flashing twice	"Source Address" is invalid	--
<div style="text-align: center;">■</div> On	The CAN controller is in the "Bus off" state.	See Control and status information (Page 25)

10.2 Diagnostic messages to the S7 controller

10.2.1 Events that trigger a diagnostic message

The following table lists the events that lead to triggering and removal of the diagnostics:

Diagnostics-relevant events

Table 10- 6 Diagnostics-relevant events

Event for triggering	Event for withdrawal
Transition of the CAN controller to "Bus off" state	CAN controller exits the "Bus off" state again.
Transition of the CAN controller to "Error passive" state	CAN controller exits "Error passive" state again
Internal communication error	Diagnostic information was transmitted to the S7 controller via PROFINET
Buffer overflow when sending CAN packets	Diagnostic information was transmitted to the S7 controller via PROFINET
Buffer overflow when receiving CAN packets	Diagnostic information was transmitted to the S7 controller via PROFINET
Null address was set by means of "Address Claiming" procedure	HW configuration with new address was sent
New valid "Source Address" was set by means of "Address Claiming" procedure.	Diagnostic information was transmitted to the S7 controller via PROFINET
Receipt of PGN message with incorrect length	Diagnostic information was transmitted to the S7 controller via PROFINET
Receipt of DM1 message with changed data	Diagnostic information was transmitted to the S7 controller via PROFINET
PGN was not received within the specified time	Diagnostic information was transmitted to the S7 controller via PROFINET

10.2.2 Diagnostic messages

The table below lists the following information:

- Message text assigned to diagnostics
- Causes of errors and possible solutions

Diagnostic messages

Table 10- 7 Diagnostic messages

Module/submodule for which the diagnostic information is signaled	Channel diagnostics error	Cause of error and possible solution
Manager	CAN bus off	CAN messages can no longer be sent or received. Check for errors in the hardware installation (e.g. terminating resistor) or communication settings (e.g. transmission rate).
Manager	CAN error passive	In this state, the device can no longer initiate repetition of defective CAN messages. Check for errors in the hardware installation (e.g. terminating resistor) or communication settings (e.g. transmission rate). The error can also occur if no other devices are connected to the CAN bus.
Manager	CAN Rx buffer overflow	Received CAN messages were lost. Reduce the CAN transmission rate, increase the PROFINET cycle time or reduce the PROFINET IO data to be transmitted.
Manager	CAN Tx buffer overflow	CAN messages to be sent could not be sent and were discarded. This is caused by too much CAN communication traffic or when other problems occurred in the CAN communication ("Bus off" or "Error passive" state). If there is neither "Bus off" nor "Error passive", try reducing the amount of communication traffic or increasing the CAN bit rate.
Manager	Hardware fault detected: - ({1:x})	Hardware faults were detected when switching on the module. The module must be replaced.
Manager	Internal communication error	Received and sent CAN messages might have been lost. Check for communication problems caused by EMI. If these problems can be excluded, there may be a hardware fault and the module must be replaced.
Manager	Invalid address	The configured source address is occupied. The null address was assigned via the "Address Claiming" procedure. Change the source address set in the module parameters.

Module/submodule for which the diagnostic information is signaled	Channel diagnostics error	Cause of error and possible solution
Manager	Source address changed - New address: {{1:d}}	The configured "Source Address" is occupied. A new valid address was set in the "Address Claiming" process. The configured address will be reloaded on device restart. Change the "Source Address" set in the module parameters.
PGN input module	Received PGN message had incorrect length - {{1:d}} bytes	The PGN message was received, but it contains the wrong number of data bytes. Data was partly discarded. Check the PGN parameter assignment.
PGN input module	PGN timeout - {{1:d}}	PGN {1:d} was not received within the specified time. Check the time for the programming PGN Reception cycle.
PGN input module	DM1 data changed - Source Address: {{1:d}}	DM1 message with different data was received from source.
PROFINET interface	Internal software error - {{1:x}}	An internal error was detected and is signaled now, i.e. after the module restart. The error message disappears when you restart the module again.

Maintenance and service

11.1 Firmware update

Procedure

1. Set the S7 CPU to "STOP".
2. Initiate the update of the PN/J1939 LINK in the TIA Portal. Depending on the configuration in the TIA Portal, the PN/J1939 LINK resumes running on its own after a successful update and waits for configuration information from the S7 controller.
3. For operation, set the S7 CPU back to "RUN".

 **CAUTION**

Critical plant state

The Ethernet switch integrated in PN/J1939 LINK is only operational once the PN/J1939 LINK starts up. Restarting the PN/J1939 LINK interrupts the Ethernet switch function.

Existing Ethernet connections via the switch are thus interrupted for the duration of the PN/J1939 LINK startup. This can result in critical plant states.

11.2 Replacing PN/J1939 LINK

Below you will find a description of the basic steps required for replacing the PN/J1939 LINK.

Preparations

Disconnect the S7 setup including PN/J1939 LINK from the power supply.

Replacing the device

Follow these steps:

1. Disconnect the 24 V power supply cables and the functional ground from the screw terminal.
2. Remove PROFINET connector and J1939 connector
3. Disassembling the device from the DIN rail. Proceed in the reverse order to that described in section Installing (Page 33).
4. Installing and connecting the new device

Note

The PROFINET device name and IP address of the new device must match those previously used. Otherwise, the device will not be detected.

Commissioning the device once again

1. Switch on power supply for the S7 configuration and PN/J1939 LINK again.

The configuration data is downloaded automatically from the higher-level S7 CPU. The Step 7 program switches the PN/J1939 LINK to the "ON" state by setting the control bit to "1".

11.3 Recycling and disposal

PN/J1939 LINK is recyclable due to its low-pollutant components.

NOTICE

For environmentally friendly recycling and disposal of your old equipment, contact a certified electronic waste disposal company and dispose of the equipment according to the applicable regulations in your country.

There is no provision for returning the device to Siemens.

For further questions regarding disposal and recycling, please contact your local Siemens contact. You will find the contact details in our database on the Internet at: <http://www.automation.siemens.com/partner>

Technical specifications

12.1 Technical specifications of the PN/J1939 LINK

Technical specifications of PN/J1939 LINK

Article number	6BK1623-0AA00-0AA0
General information	
Product type designation	PN/J1939 LINK
Firmware version	V1.0
<ul style="list-style-type: none"> FW update possible 	Yes
Vendor identification (VendorID)	0x002A
Product function	
<ul style="list-style-type: none"> I&M data 	Yes
<ul style="list-style-type: none"> Isochronous mode 	No
Engineering with	
<ul style="list-style-type: none"> STEP 7 TIA Portal configurable/integrated as of version 	STEP 7 V14 SP1
Installation type/mounting	
Mounting	DIN rail, wall mounting, portrait mounting
Mounting position	Any
Recommended mounting position	Horizontal
Supply voltage	
Type of supply voltage	24 V DC
Rated value (DC)	24 V
permissible range, lower limit (DC)	20.4 V
permissible range, upper limit (DC)	28.8 V
Reverse polarity protection	Yes
Overvoltage protection	Yes
Short-circuit protection	Yes
Mains buffering	
<ul style="list-style-type: none"> Mains/voltage failure stored energy time 	10 ms; PN side
Input current	
Current consumption (rated value)	0.09 A
Current consumption, max.	0.11 A
Power loss	
Power loss, typ.	2.2 W

Article number	6BK1623-0AA00-0AA0
Interfaces	
Interfaces/bus type	2x Ethernet (RJ45), 1x Sub-D (9-pin)
Supports protocol for PROFINET IO	
• automatic detection of transmission rate	No
• Transmission rate, max.	100 Mbit/s
• Number of RJ45 ports	2
• Number of FC (FastConnect) connections	2
PROFINET functions	
• Assignment of the IP address, supported	Yes
• Assignment of the device name, supported	Yes
CAN	
• CAN operating modes	J1939 according to the standard "SAE J1939"
• Transmission rate, min.	100 kbit/s
• Transmission rate, max.	500 kbit/s
• Number of slaves, max.	30
J1939	
• Addressable ECUs, max.	30
• Logical nodes, max.	253
• PDU 1	Yes
• PDU 2	Yes
• DM – data	Yes
• BAM	Yes
• CMDT	Yes
1. Interface	
Interface type	J1939 according to the standard "SAE J1939"
Physics	9-pin sub D socket
Isolated	Yes; 500 V AC or 707 V DC
Interface types	
• Number of ports	1

Article number	6BK1623-0AA00-0AA0
2. Interface	
Interface type	PROFINET
Physics	Ethernet, 2-port switch, 2*RJ45
Isolated	Yes; 1 500 V AC or 2 250 V DC
Interface types	
• Number of ports	2
• integrated switch	Yes
Protocols	
• PROFINET IO Device	Yes
Isochronous mode	
Isochronous operation (application synchronized up to terminal)	No
Interrupts/diagnostics/status information	
Status indicator	Yes
Alarms	Yes
Diagnostics function	Yes
Diagnostics indication LED	
• RUN LED	Yes
• ERROR LED	Yes
• MAINT LED	Yes
• LINK LED	Yes
• RX/TX LED	Yes
Potential separation	
Potential separation exists	Yes
Degree and class of protection	
Degree of protection acc. to EN 60529	IP20
Standards, approvals, certificates	
CE mark	Yes
UL approval	Yes
cULus	Yes
RCM (formerly C-TICK)	Yes
KC approval	Yes
EAC (formerly Gost-R)	Yes
PNO certificate	Yes
RoHS conformity	Yes
Marine approval	
• Germanischer Lloyd (GL)	Yes
• Det Norske Veritas (DNV)	Yes

12.1 Technical specifications of the PN/J1939 LINK

Article number	6BK1623-0AA00-0AA0
Ambient conditions	
Ambient temperature during operation	
• horizontal installation, min.	-25 °C
• horizontal installation, max.	60 °C
• vertical installation, min.	-25 °C
• vertical installation, max.	55 °C
• ceiling installation, min.	-25 °C
• ceiling installation, max.	45 °C
• floor installation, min.	-25 °C
• floor installation, max.	45 °C
Ambient temperature during storage/transportation	
• min.	-40 °C
• max.	85 °C
Relative humidity	
• Operation, max.	95 %
Software	
Runtime software	
Target system	
– ET 200SP	Yes
– Open Controller	Yes
– S7-1200	Yes
– S7-1500	Yes
Dimensions	
Width	70 mm
Height	112 mm
Depth	75 mm
Weights	
Weight, approx.	212 g

12.2 Dimension drawing

Dimension drawings of the PN/J1939 LINK

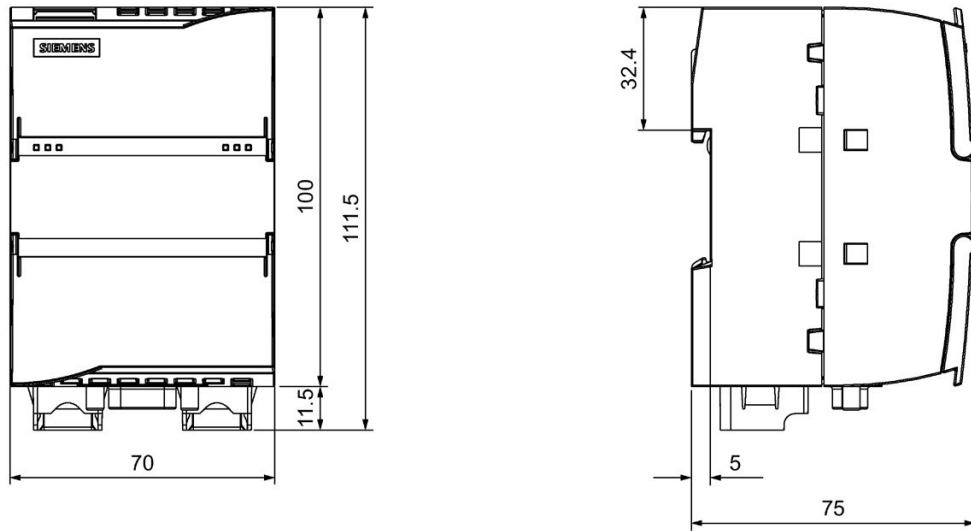

All dimensions in mm

Figure 12-1 Dimension drawing PN/J1939 LINK

Appendix

A.1 Certificates and approvals

Note

Approvals are only valid when marked on the product

The specified approvals apply only when the corresponding mark is printed on the product. You can check which of the following approvals have been granted for your product by the markings on the type plate.

CE marking

SIMATIC PN/J1939 LINK device fulfills the requirements and protection objectives of the following EC directives.

EMC Directive 2014/30/EU

The product is designed for operation in residential and industrial areas.

EMC requirements:

Field of application	Noise emission requirements	Interference immunity requirements
Residential area	EN 61000-6-3	--
Industrial area	EN 61000-6-4	EN 61000-6-2

The product meets these requirements if you adhere to the installation guidelines and safety instructions included in these operating instructions and in the system manual of the S7-1200 automation system during installation and operation.

General approvals

The current approvals for the PN/J1939 LINK are listed in the Siemens Mall.

Declaration of Conformity

The EC Declaration of Conformity is kept available for the responsible authorities in accordance with the above-mentioned EC Directive at the following address:

SIEMENS AG
DF FA SE
BRESLAUER STR. 5
90766 FUERTH
GERMANY

Other applied standards

- IEC 61131-2 / DIN EN 61131-2 Programmable controllers
- IEC 61010-1 / EN 61010-1 Safety requirements for electrical equipment for measurement, control, and laboratory use.

A.2 Contact address

Contact address

SIEMENS AG
DF FA SE
Breslauer Straße 5
90766 FÜRTH
GERMANY

A.3 Licenses

Use of open source software (OSS)

The SIMATIC PN/J1939 LINK product uses open source software in unchanged form or a form we have modified. License conditions and sources that have to be published are included on the CD supplied with the product.

Sources under the GNU General Public License are provided to you free of charge on request. Use the communication channels specified under Technical Support (Page 71) to do this.

A.4 Service & Support

A.4.1 Technical Support

Technical Support

You can contact the Technical Support experts in Germany at the following number:

- Phone: + 49 (0) 911 895 7222
- The contact data for Technical Support in other countries can be found in the Siemens contact database (http://w3.siemens.com/aspa_app/).

A.4.2 Siemens Industry Online Support

Siemens Industry Online Support

You can find various services on the Support homepage (<http://support.automation.siemens.com>) on the Internet.

There you will find the following information, for example:

- The correct documents for you via product-related search functions
- Online support request form
- Your local representative
- A forum for global information exchange by users and specialists.
- Our newsletter containing up-to-date information on your products.

A.4.3 Online catalog and ordering system

Online catalog and ordering system

The online catalog and the online ordering system can be found on the Industry Mall homepage (<https://mall.industry.siemens.com>).

Glossary

ACL (Address Claiming)

Procedure by which a CA claims an address in the network.

AR (Application Relation)

S7 connection for data exchange in PROFINET

BAM (Broadcast Announce Message)

Transport protocol for transmitting the data via broadcast to the bus nodes

CA (Controller Application)

The software of an ECU is called CA (Controller Application). An ECU may contain one or more CAs.

CAN (Controller Area network)

CAN is a serial bus system and belongs to the fieldbus family.

CAN high-speed

Realization of the physical layer according to ISO 11898-2

CiA (CAN in Automation)

International users' and manufacturers' group for the distribution and standardization of CAN

CMDT (Connection Mode Data Transfer)

Protocol for data exchange between two ECUs

ECU (Electronic Control Unit)

Device in the J1939 network, which contains one or more CAs (controller applications).

FE (functional grounding)

Low-impedance connection to ground potential

GSDML (General Station Description Markup Language)

GSDML is a language for describing PROFINET IO field devices. This language is used to create a GSD (General Station Description).

HSP (Hardware Support Package)

The Support Packages enable the configuration of modules that are not included in the hardware catalog of the TIA Portal installation.

J1939

J1939 is a network protocol based on the physical layer of the CAN bus.

OSS (Open Source Software)

Open Source Software (OSS) is software that meets the definition of the Open Source Initiative (OSI), for example, that this software is subject to one of the Open Source Software licenses recognized by OSI.

PGN (Parameter Group Number)

Number used to uniquely identify a parameter group.

PN (PROFINET)

PROFINET (Process Field Network) is the open Industrial Ethernet standard of the PROFIBUS User Organization for automation.

RoHs (Restriction of certain Hazardous Substances)

EU Directive 2011/65/EU restricts the use of certain hazardous substances in electrical and electronic devices.

TIA (Totally Integrated Automation)

The TIA Portal offers complete access to the entire digitalized automation - from digital planning over integrated engineering all the way to transparent operation.

Index

2

24 V DC connector, 14

A

Acyclic communication, 13

Approvals, 69, 69

B

Basic knowledge

Documentation, 5

C

Cable routing, 36

Cables

Requirements, 36

CAN bus

Connecting, 41

CE marking, 69

Commissioning, 43

Hardware, 43

Configuration, 13

Connecting

24 V DC power supply, 38

CAN bus, 41

Functional ground, 39

PROFINET, 40

Connector pin assignment

Terminals for the 24 DC power supply, 38

Contact person for the database, 62

Control panel, 34

Control panel mounting, 33

D

Declaration of Conformity, 70

Delivery

Unpacking, 31

Device

Replacing, 61

Disposal, 62

Documentation

Basic knowledge, 5

History, 5

Purpose, 5

Target group, 5

E

EMC interferences, 39

ERROR LED, 54

Ethernet cable, 40

Ethernet interface, 55

F

FE terminal, 39

Firmware update, 61

Functional ground, 38, 39

G

Gateway, 11, 13

Grounding, 36

H

History

Documentation, 5

I

Installation

- Ambient conditions, 29
- Device dimensions, 29
- Minimum spacing, 29
- Mounting position, 29
- Notes, 29

J

- J1939 connector, 14
- J1939 connector
 - Pin assignment, 41

L

- License conditions, 70

M

- MAINT LED, 54
- Mounting
 - Control panel, 33
 - Standard mounting rail, 33

N

- Notes
 - Installation, 29

O

- Open-source software, 70

P

- PN/J1939 LINK
 - Design, 14
- Power supply, 13, 38
- PROFINET, 13
 - Connecting, 40
- Purpose
 - Documentation, 5

R

- Rating plate, 14
- Recycling, 62
- Requirements
 - Cables, 36
- RUN LED, 54

S

- Safety information
 - General, 7
 - Working on the device, 8, 35
- Scope of delivery, 31
- Securing collar, 40
- Shielding, 37
- SIMATIC
 - Trademark, 5
- Standard mounting rail, 33
- Status LEDs, 14
- Switch, 14
- System components, 13
- System configuration, 13

T

- Target group, 5
 - Documentation, 5
- Technical Support, 71
- TIA Portal, 14
- Trademark
 - SIMATIC!, 5

W

- Wiring guidelines, 35