

SIEMENS

Reyrolle 7SR5
Engineering Guide
Reydisp Manager 2

V02.11

Manual

Preface

Open Source Software

Table of Contents

Reydisp Manager 2 Overview

1

Essential Steps during Engineering

2

Device Tasks

3

Import and Export

4

**NOTE**

For your own safety, observe the warnings and safety instructions contained in this document, if available.

Disclaimer of Liability

Subject to changes and errors. The information given in this document only contains general descriptions and/or performance features which may not always specifically reflect those described, or which may undergo modification in the course of further development of the products. The requested performance features are binding only when they are expressly agreed upon in the concluded contract.

Document version: C53000-G7040-C013-1.00

Edition: 04.2020

Version of the product described: V02.11

Copyright

Copyright © Siemens 2020. All rights reserved.

The disclosure, duplication, distribution and editing of this document, or utilization and communication of the content are not permitted, unless authorized in writing. All rights, including rights created by patent grant or registration of a utility model or a design, are reserved.

Preface

Purpose of the Manual

This manual provides comprehensive information on Reydisp Evolution, getting started with Reydisp Evolution and essential steps during engineering with Reydisp Evolution.

Target Audience

This manual is mainly intended for protection system engineers, commissioning engineers, persons entrusted with the setting, testing and maintenance of automation, selective protection and control equipment, and operational crew in electrical installations and power plants.

Scope

This manual applies to the Reyrolle Reydisp Manager 2 device family.

Further Documentation

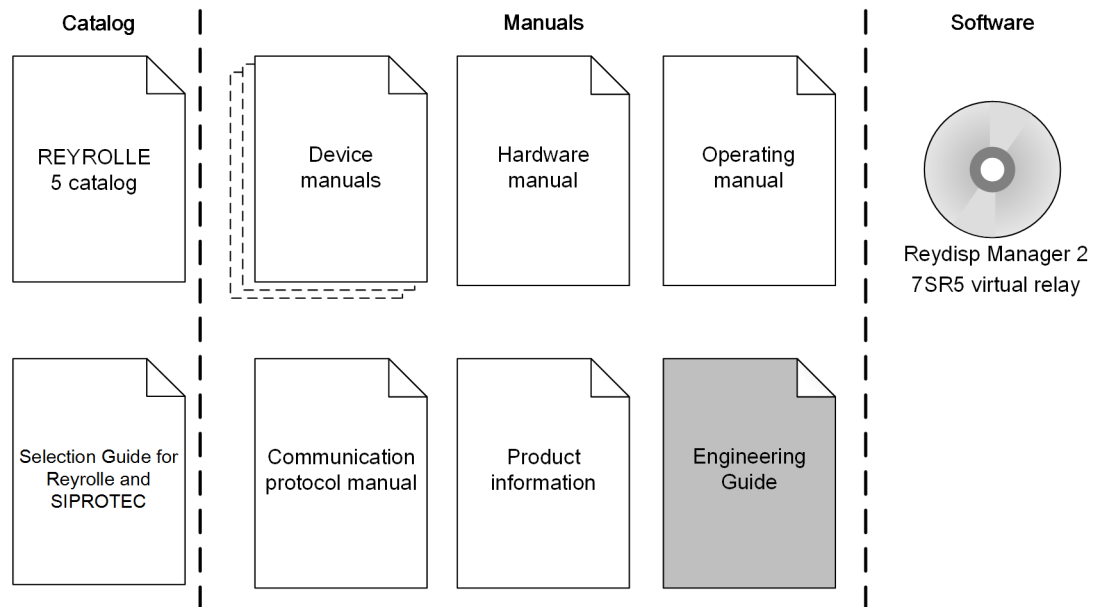

[dw_7SR5_furtherdocumentation_engineeringguide, 1, en_US]

- **Device manuals**
Each device manual describes the functions and applications of a specific Reyrolle Reydisp Manager 2 device. The printed manual for the device has the same informational structure.
- **Hardware manual**
The hardware manual describes the hardware building blocks and device combinations of the Reyrolle Reydisp Manager 2 device family.

- **Operating manual**
The operating manual describes the basic principles and procedures for operating and installing the devices of the Reyrolle Reydisp Manager 2 range.
- **Communication protocol manual**
The communication protocol manual contains a description of the protocols for communication within the Reyrolle Reydisp Manager 2 device family and to higher-level network control centers.
- **Product information**
The product information includes general information about device installation, technical data, limiting values for input and output modules, and conditions when preparing for operation. This document is provided with each Reyrolle Reydisp Manager 2 device.
- **Engineering Guide**
The engineering guide describes the essential steps when engineering with Reydisp Manager 2. In addition, the engineering guide shows you how to load a planned configuration to a Reyrolle Reydisp Manager 2 device and update the functionality of the Reyrolle Reydisp Manager 2 device.
- **Virtual Relay**
The virtual relay allows a user to view, control and manipulate a virtual Reydisp Manager 2 device. The virtual relay is a tool that can facilitate training and understanding of the controls and functions on a Reyrolle Reydisp Manager 2 device.
- **Reyrolle Reydisp Manager 2 catalog**
The Reyrolle Reydisp Manager 2 catalog describes the system features and the devices of Reyrolle Reydisp Manager 2.
- **Selection guide for Reyrolle and SIPROTEC**
The selection guide offers an overview of the device series of the Siemens protection devices, and a device selection table.

Additional Support

For questions about the system, contact your Siemens sales partner.

Customer Support Center

Our Customer Support Center provides a 24-hour service.

Siemens AG
Customer Support Center
Humboldtstrasse 59
90459 Nuremberg
Germany
E-mail: support.energy@siemens.com

Training Courses

Inquiries regarding individual training courses should be addressed to our Training Center:

Siemens AG	Phone: +49 (911) 433-7415
Siemens Power Academy TD	Fax: +49 (911) 433-7929
Humboldtstrasse 59	E-mail: poweracademy@siemens.com
90459 Nuremberg	Internet: www.siemens.com/poweracademy
Germany	

Notes on Safety

This document is not a complete index of all safety measures required for operation of the equipment (module or device). However, it comprises important information that must be followed for personal safety, as well as

to avoid material damage. Information is highlighted and illustrated as follows according to the degree of danger:



DANGER

DANGER means that death or severe injury **will** result if the measures specified are not taken.

- ✧ Comply with all instructions, in order to avoid death or severe injuries.
-



WARNING

WARNING means that death or severe injury **may** result if the measures specified are not taken.

- ✧ Comply with all instructions, in order to avoid death or severe injuries.
-



CAUTION

CAUTION means that medium-severe or slight injuries **can** occur if the specified measures are not taken.

- ✧ Comply with all instructions, in order to avoid moderate or minor injuries.
-

NOTICE

NOTICE means that property damage **can** result if the measures specified are not taken.

- ✧ Comply with all instructions, in order to avoid property damage.
-



NOTE

Important information about the product, product handling or a certain section of the documentation which must be given attention.

Open Source Software

The product contains, among other things, Open Source Software developed by third parties. The Open Source Software used in the product and the license agreements concerning this software can be found in the Readme_OSS. These Open Source Software files are protected by copyright. Your compliance with those license conditions will entitle you to use the Open Source Software as foreseen in the relevant license. In the event of conflicts between Siemens license conditions and the Open Source Software license conditions, the Open Source Software conditions shall prevail with respect to the Open Source Software portions of the software. The Open Source Software is licensed royalty-free. Insofar as the applicable Open Source Software License Conditions provide for it you can order the source code of the Open Source Software from your Siemens sales contact – against payment of the shipping and handling charges – for a period of at least 3 years after purchase of the product. We are liable for the product including the Open Source Software contained in it pursuant to the license conditions applicable to the product. Any liability for the Open Source Software beyond the program flow intended for the product is explicitly excluded. Furthermore any liability for defects resulting from modifications to the Open Source Software by you or third parties is excluded. We do not provide any technical support for the product if it has been modified.

The ReadmeOSS documents for the product can be found here: www.siemens.com/reyrolle

Table of Contents

	Preface	3
	Open Source Software	7
1	Reydisp Manager 2 Overview	11
1.1	What is Reydisp Manager 2?.....	12
1.2	Engineering Philosophy and Terms.....	13
1.3	User Interface.....	17
2	Essential Steps during Engineering	25
2.1	Overview of Engineering Steps.....	26
2.2	Starting Reydisp Manager 2 and Creating a Project.....	28
2.3	Adding a Folder.....	32
2.4	Adding a 7SR5 Device.....	33
2.5	Function Configuration.....	50
2.6	Creating a Logic Diagram.....	53
2.7	Creating a User Display Page.....	63
2.8	Creating User Curves.....	78
2.9	Parameterizing Functions.....	86
2.10	Configuring Communication.....	97
2.11	Device Configuration of Ethernet.....	104
2.12	Device Configuration of Ethernet Timezone.....	108
2.13	Adding an IEC 61850 Station.....	110
3	Device Tasks	113
3.1	Loading Configuration into the Device.....	114
3.2	Change Device Template.....	117
3.3	Install Device Firmware.....	120
3.4	Get Device Data.....	124
3.5	Get Device Configuration.....	129
3.6	Set Device Date and Time.....	137
3.7	Compile IEC 61850 Configuration.....	139
4	Import and Export	141
4.1	Export ICD.....	142
4.2	Import SCD/ICD.....	143
4.3	Export IEC 61850 MICS.....	144
4.4	Export IEC 61850 SNTP.....	146

1 Reydisp Manager 2 Overview

1.1	What is Reydisp Manager 2?	12
1.2	Engineering Philosophy and Terms	13
1.3	User Interface	17

1.1 What is Reydisp Manager 2?

Reydisp Manager 2 is the engineering tool for configuring and operating all 7SR5 devices. The functional scope of Reydisp Manager covers all tasks – from device configuration and device setting to evaluation of fault data.

The user can perform all configuration tasks offline from their PC without the need for a 7SR5 device. All data can be transferred to the device online at a later date – for example, via a direct USB connection or a communication network.

The basic parameter settings can also be viewed and edited from the device fascia.

Reydisp manager 2 is available to download free of charge from the website www.siemens.com/reyrolle.

The Reyrolle 5 device template installer must also be downloaded and installed.

It provides the following features:

- Configure device functionality
- Configure device settings
- Create and edit logic diagrams
- Configure device IEC 61850 interface/time zone
- Create user-definable current/voltage/thermal curves
- Configure serial communication data points and fascia event log
- Edit IEC 61850 Stations using the optional System Configurator with seamless integration with Digi

1.2 Engineering Philosophy and Terms

Offline

The following list provides an overview of the tasks the user can work with, among others, in the **Offline** mode:

- Defining the functional scope of a 7SR5 device
- Setting function parameters
- Defining user curves
- Defining fascia display pages and mimic control
- Project engineering logic
- Defining serial data points and device event log
- Configuring the communication network and setting communication settings
- Displaying saved fault records and evaluating them with suitable viewing software
- Exporting configuration data and printing

Project

Reydisp Manager manages the components of a system and all the data associated with it in relation to the project. The following information is collected under a project:

- Topology information
- Offline configuration of all 7SR5 devices
- Data contained in the offline configuration, for example:
 - Parameter values
 - Communication settings
 - Process data

In other words, the user only has to open 1 project to have access to all data. Conversely, all changes are saved simply by saving or closing the project.

Project Tree

When a project is opened in Reydisp Manager, the project is displayed in a hierarchical structure in the project tree.

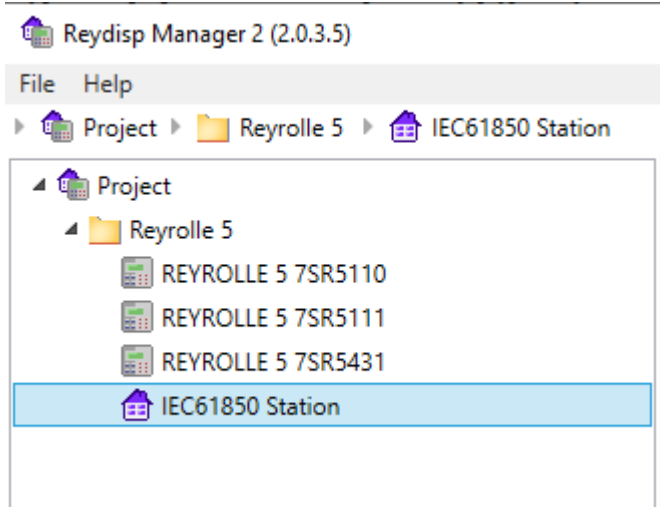

[sc_7SR5_ReydispManager2ProjectTree, 1, --_--]

Figure 1-1 Project Tree with Open Project

The icons and text boxes in the project tree provide access to all of the project data as well as the associated device tasks. Examples of such actions include adding a 7SR5 device or transferring data to the 7SR5 device.

7SR5 Device

The 7SR5 device can be configured from the Reydisp Manager tool. Limited parameter changes can also be made from the device fascia.

Physical Device

Every device has a product code. It specifies the device hardware and the base application software configuration.

The fascia access keys allow parameter changes, input and output mappings, and functions to be enabled/disabled.

Logical Functional Scope and Field of Application

The 7SR5 device provides all the necessary protection functions to address the application requirements ensuring reliability and security of power transmission systems. However, the devices are not simply protection or electronic control units, but can also monitor, measure, log failures and much more.

The application of the 7SR5 device defines the functional scope of the device as well as the connections between functions and hardware.

7SR5 Templates

To edit a 7SR5 device with Reydisp Manager, the user needs an image of the physical device in the project. This image corresponds to the offline configuration of the device. The offline configuration contains all of the data in the physical device.

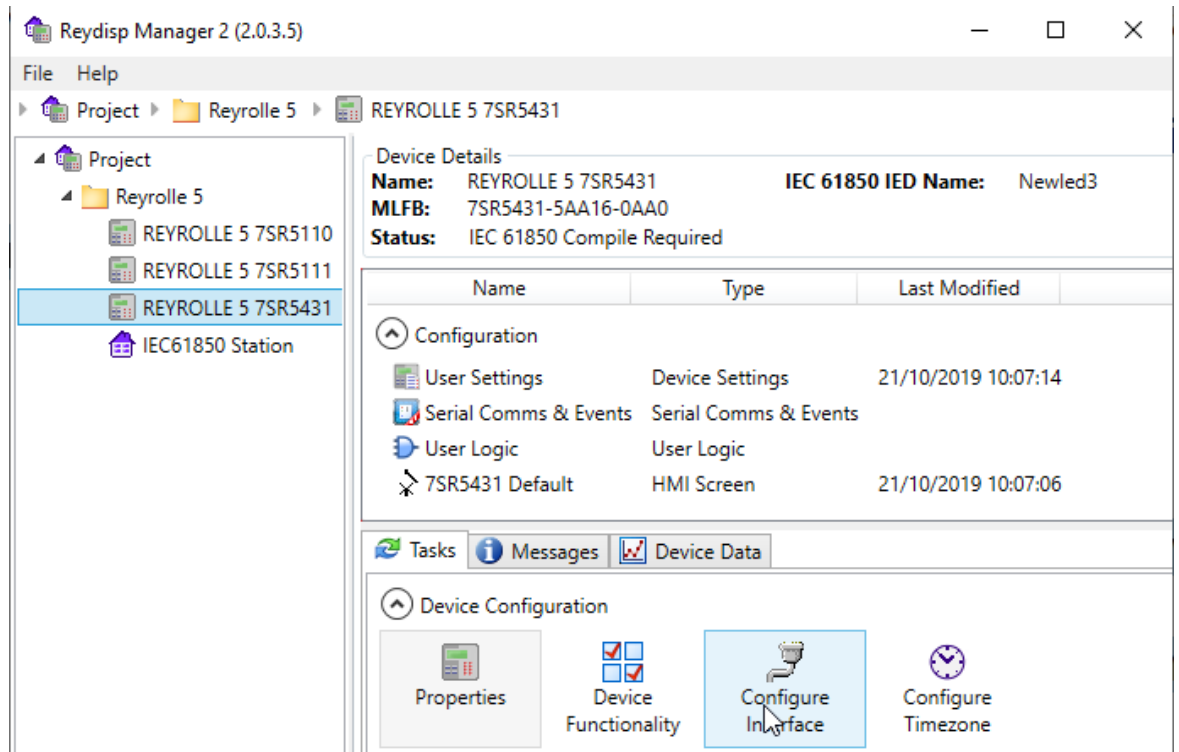

[sc_7SR5_ReydispManager2ProjectTreeEntries, 1, --]

Figure 1-2 Entries in the Project Tree of an Opened Offline Configuration

Product Code

Reyrolle devices have a machine-readable product designation, abbreviated MLFB. The MLFB code designates the hardware specification and the base application functionality.

Application

The application determines the base functional scope and the functionality of the device.

Details on Applications

The product code MLFB designates the hardware platform in the first 4 digits of the MLFB code, with the 5th digit defining the base functionality.

The functionality available to a user is included in the device **Function Template**. Function templates comprise of **Function Groups** (FG) and within each FG there may be a number of **Function Elements** (FE).

7SR5 devices include a number of FG each containing a number of FE.

7SR5 device function groups and elements can be added or removed only by using the Reydisp Manager 2 (RM2) software configurator tool.

FG and FE that have been included from the Reydisp Manager configurator can be enabled/disabled.

The **Default Function Template** is the functionality included in the device when delivered from the factory.

The RM2 settings tool is used to add or remove **Function Groups** and **Function Elements** from the **Default Function Template**. It also allows the customization of the device to assign function elements to specific analogue inputs in the device hardware when applicable. Customization of the **Default Function Template** is typically carried out during the engineering or installation phase of the project, prior to commissioning of the device.

Function Groups and Function Elements

Using the **RDM2 > Tasks > Device Functionality** feature, default RM2 function templates are offered for selection automatically when a new device is created in RM2.

The device is designed to allow all functions and elements visible in the **Device Functionality** feature to be enabled in the device configuration.

1.3 User Interface

Functional Sections of the User Interface

The program structure of Reydisp Manager 2 is designed to optimally support the working steps required during a project.

The user interface is divided into 6 functional sections and a menu bar:

- Menu bar
- Project tree
- Working area
- Device details
- Information workflow, messages, and alerts
- Tasks
- Device data

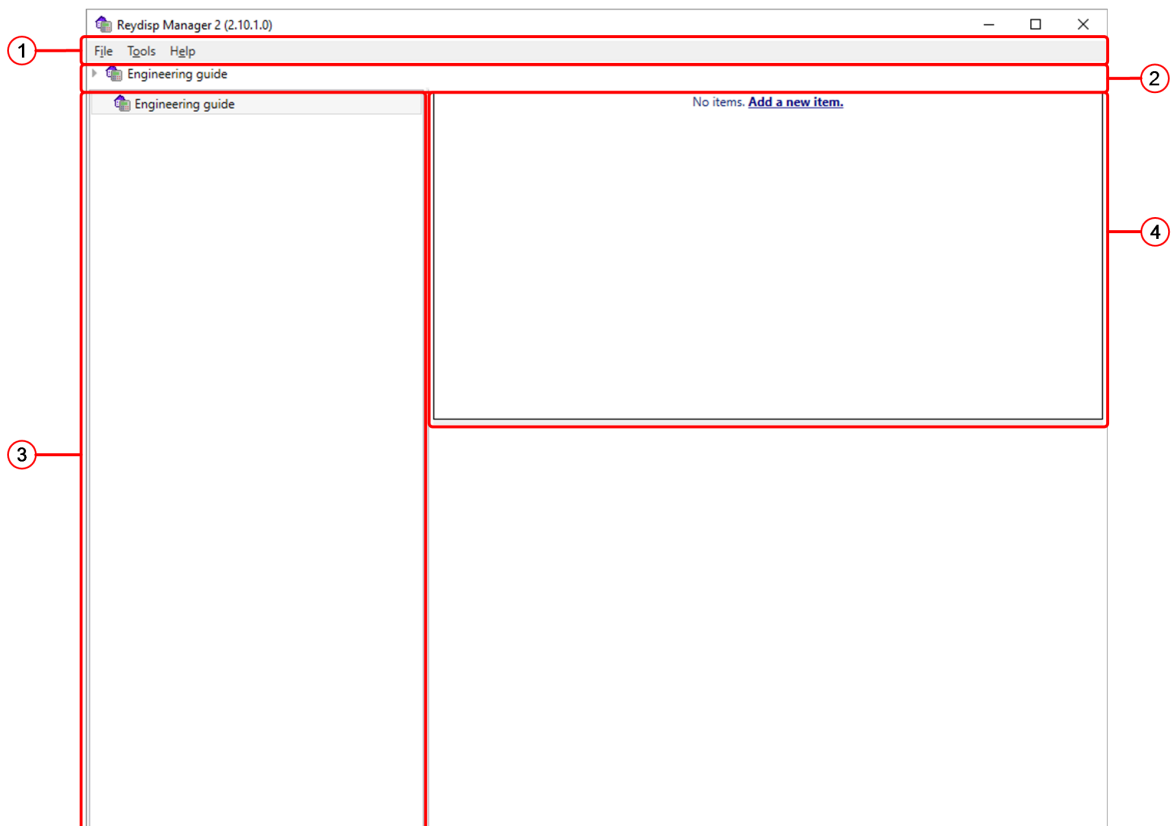

[dw_7SR5_ReydispManager2FunctionOverview, 1, en_US]

Figure 1-3 Reydisp Manager 2 Functional Section Overview

- (1) Menu bar
- (2) Project information
- (3) Project tree
- (4) Working area

Project Tree

The project tree is positioned on the left side of the user interface and is the central element when working with Reydisp Manager 2. The individual device icons and entries gives access to all data and tools. This shows the name of the project, and the folder structure. The folder structure can be changed by dragging folders to move them. The folder names and project name can also be renamed here. The project tree is used to organize a project into logical folders and provides a quick way to navigate between folders.

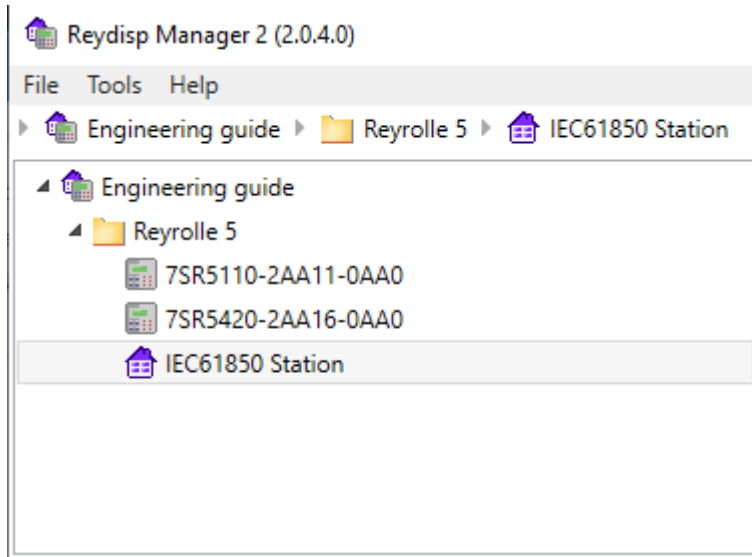

[sc_7SR5_ReydispManager2EntriesInProjectTree, 1, --]

Figure 1-4 Reydisp Manager 2 Entries in the Project Tree

Menu Bar

The menu bar along the upper edge of the user interface contains access to **File** commands, a **Tools**, and a **Help** option.

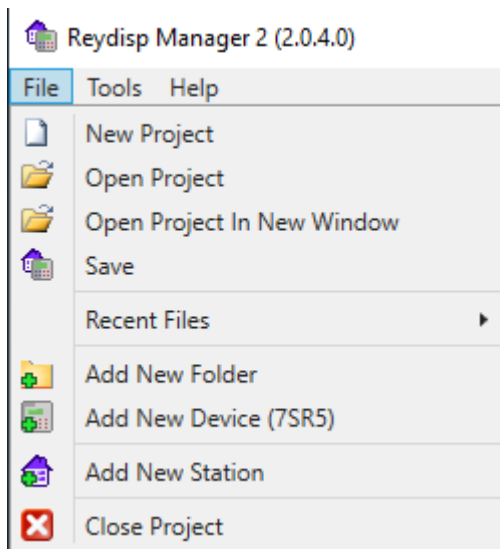

[sc_7SR5_ReydispManager2MenuBar, 1, --]

Figure 1-5 Reydisp Manager 2 Menu Bar

Tools

The tools menu provides an export of a Simple Network Time Protocol (SNTP) time server ICD template file. By selecting the **Export IEC 61850 SNTP** menu the user can save the template SNTP ICD to a suitable file location.

Help

The **About** select advises the version number of Reydisp Manager and provides a link to view details of the Open Source Software information.

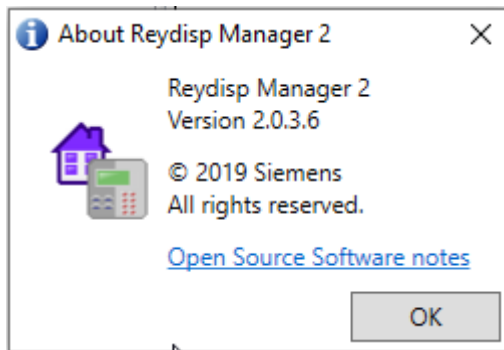

[sc_7SR5_ReydispManager2AboutRM2, 1, --, --]

Figure 1-6 Reydisp Manager 2 About Dialog Box

Working Area

The working area display will show the files or folders contained in the selected item in the tree view.

If a device is selected the display will show details of the device in the top section and contain the user files for device configuration below.

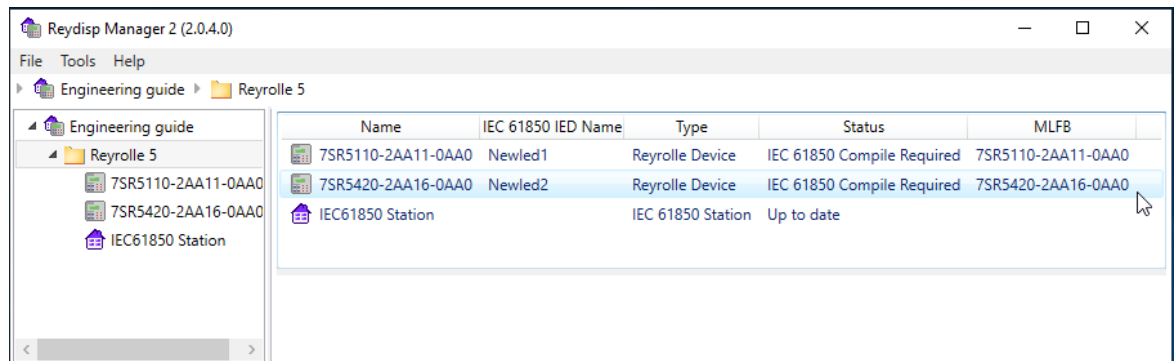

[sc_7SR5_ReydispManager2WorkingArea, 1, --, --]

Figure 1-7 Reydisp Manager 2 Working Area

When a device is selected in the project tree view, the top section displays the device property information. The central area lists the device configurable files and the lower section of the display provides links to the available tasks, messages, and device data for the selected device.

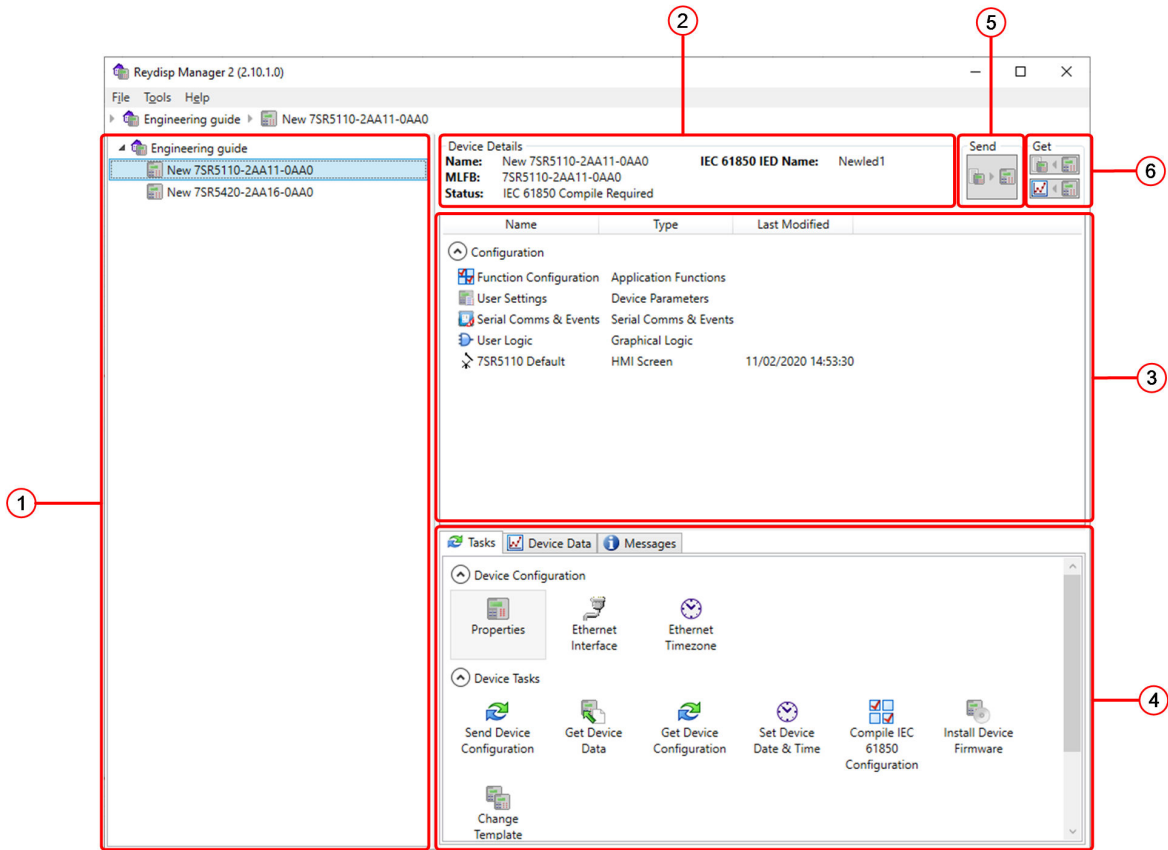

[dw_7SR5_ReydispManager2Tasks, 1, en_US]

Figure 1-8 Reydisp Manager 2 Tasks

- (1) Project tree view
- (2) Device details (Only appears when device is selected in project tree)
- (3) Working area configuration files
- (4) Task area
- (5) Send files to device
- (6) Get files from device

The default configuration includes:

- User setting file
- Logic file
- HMI screen
- Serial comms and events file

In addition a user curve can be added from the **Project Tree > Add Curve** function.

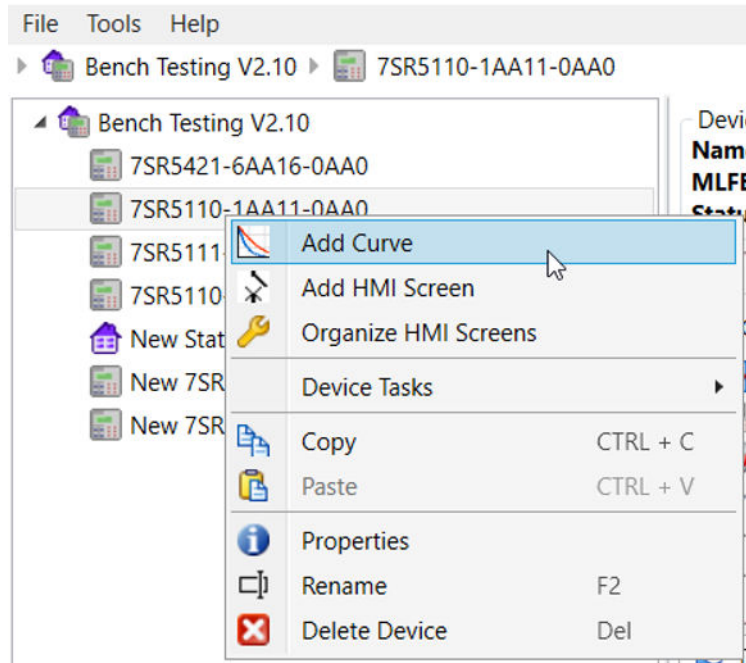

[sc_7SR5_ReydispManager2AddCurve, 2, --]

Figure 1-9 Reydisp Manager 2 Add Curve

The device configuration files are edited using the following tools:

- **Device Functionality** editor for application function files
- **Device Settings** editor for device parameter files
- **Comms Editor** for serial comms and event files
- **Reylogic Express** for graphical logic files
- **ReyMimic Editor** for HMI screen files
- **Curve Editor** for curve files

Copy

The copy selection is for creating an exact copy of a fully configured device. The devices are copied from the **Project Tree > Copy** function.

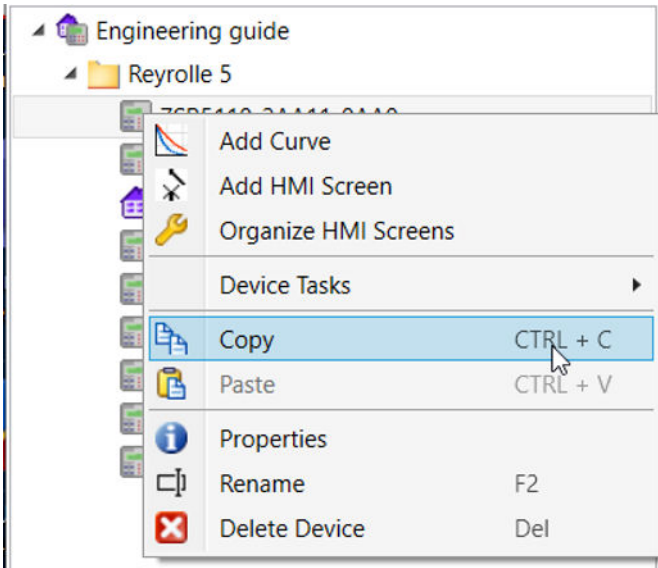

[sc_7SR5_ReydispManager2Copy, 1, --]

Figure 1-10 Reydisp Manager 2 Copy

Paste

Paste is for adding a copy of a fully configured device into the project. The paste is found at the project folder level and devices can be added within a project or copied from another project.

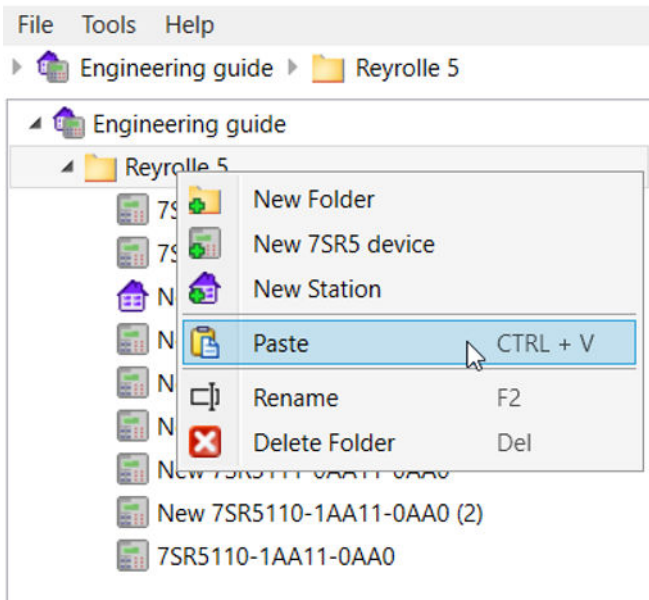

[sc_7SR5_ReydispManager2Paste, 1, --]

Figure 1-11 Reydisp Manager 2 Paste

The new device will be added into the project with a number in brackets if a device in that project already has the same name.

Task Area

The task tab provides the following additional tools for general device configuration:

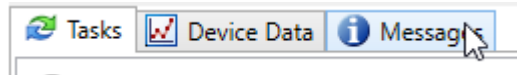

[sc_7SR5_ReydispManager2TasksTab, 1, --_--]

Figure 1-12 Reydisp Manager 2 Task Tab

- Properties – This allows viewing and editing of the device properties including template version, serial number, name, IEC 61850 edition, and IP address.
- Ethernet interface configuration
- Ethernet time zone configuration



NOTE

Some information will only become available after connection to the device.

You can open several tools simultaneously.

The task area also has 2 additional tabs, one for displaying the device data and one displaying the information messages and warnings.

Within the task area are a number of additional features for updating and retrieving information from the device.

- Device Data – Lists the data files when they have been downloaded from the device. They are saved to the PC configuration. Files can also be deleted.
- Messages – Displays the message logs showing actions carried out as well as any user alert messages. The messages can be cleared.

Overview of Editors

This chapter provides an overview of the editors that are needed for the tasks in this manual. This overview also gives a quick idea of the required engineering steps for configuration. An exact description of the editors can be found in the associated descriptions of procedures in this manual.

- **Device Functionality**
This editor is used to modify the application function file, for selecting the protection functions available in the device and which analogue hardware inputs they are associated to.
- **Device Settings**
This editor is used for editing the device parameter file and allows changes to be made to the settings, for example of protection functions. Certain functions, for example, for distance protection or tripping, can be visualized graphically.
- **Comms Editor**
This editor is used for viewing and editing the serial protocol data specific to a device type and configuration. It allows the user to establish which signals will be transmitted and the format of the data transmitted. It also allows the configuration of the event data displayed in the device event log on the fascia.
- **Reylogic Express**
This editor is used for configuring the graphical logic files, and allows the user to configure additional functions for the device. The user can create user logic with predefined gates and device signals.
- **ReyMimic Editor**
This editor is used for generating the HMI screens with a maximum of 5 display pages for use on a 7SR5 device display.
HMI screens can be copied and pasted between device configurations.
- **Curve Editor**
This editor allows the user to create custom curves. The curves are created and saved in the device configuration.
Curves can be copied and pasted between device configurations.

2 Essential Steps during Engineering

2.1	Overview of Engineering Steps	26
2.2	Starting Reydisp Manager 2 and Creating a Project	28
2.3	Adding a Folder	32
2.4	Adding a 7SR5 Device	33
2.5	Function Configuration	50
2.6	Creating a Logic Diagram	53
2.7	Creating a User Display Page	63
2.8	Creating User Curves	78
2.9	Parameterizing Functions	86
2.10	Configuring Communication	97
2.11	Device Configuration of Ethernet	104
2.12	Device Configuration of Ethernet Timezone	108
2.13	Adding an IEC 61850 Station	110

2.1 Overview of Engineering Steps

The first step is to create a new project. The procedure of the subsequent steps however, is not mandated, although the configuration and changes of the Device Functions and Curve Editor may cause changes in the other configuration files.

Siemens recommends the following order which can also be found in this manual:

- Starting Reydisp Manager 2 and creating a project
Whenever you begin engineering, you must first create a new project.
- Creating a project folder
Within the project the user can add folders to assist the file management.
- Adding a 7SR5 device
Each physical device in the system must also be represented in the associated project. A 7SR5 device can be selected by choosing the correct MLFB order code from the create device tool. The user can select the latest firmware version if the device firmware version is not known.
- Adjusting the functional scope
When adding a device to a project, the user will have already selected the basic application when selecting the device template. By doing so, the device is already configured with an application-oriented basic functional scope. The user can change these by adding or deleting function groups and function elements. Function elements can also be assigned to the available analogue inputs from the selected hardware.
- Creating user curves
Time graded elements can be customized with the addition of user defined curves. Depending on the device selected, the option for adding **Current**, **Voltage** and **Thermal** curves is available. The user curves will be included in the device parameters using the name given during the configuration steps. This engineering step is optional. A device also works correctly without additional curves as the default configuration will always contain the IEC and ANSI standard curves.
- Creating user logic
A device can be customized for specific application requirements using the user logic. Self-configured functions can be created using logic symbols and device interface connection points. These can be used for interlocking, control items and indications. The user logic can be used for the mapping of GGIO points and mimic controllable plant items. This engineering step is optional. A device also works correctly without creating any logic.
- Creating display pages
In the default configuration, the display of a 7SR5 device shows the **Primary Current** values. Upto 4 additional display pages can be created for each device. Different device information and selected symbols can be used from a preconfigured library when configuring the display pages. The default display page can also be modified by the user. This engineering step is optional. A device also works correctly without self-created display pages.
- Device configuration parameters
To optimally adapt the device application to suit user requirements, set all protection function parameters for the device, all device configuration, and mappings. This engineering step is essential as the default settings have all elements disabled and do not include any tripping selection.
- Configuring communication
For a device to communicate using the serial protocols these must be set in the device parameters. To ensure compatibility with SCADA the protocol mapping enabled must be configured. This step also allows the selection of events to be displayed in the fascia **Event Log**. This engineering step is optional. A device also works correctly without any user changes.
- Configuring Ethernet communication
For a device to communicate using the Ethernet communication the Ethernet Interface must be configured. This includes the IP address when used as a stand alone device and the Redundancy and SNTP information. This engineering step is optional depending upon the network configuration.

- **Configuring Ethernet time zone**
For a device to communicate using the Ethernet communication the local time zone must be configured with an option to set a summertime switch over time. Note the relay works on local time where the Ethernet connection is on UTC. This engineering step is optional.
- **Adding an IEC 61850 station**
A station is an item that allows multiple IEC 61850 capable devices to be grouped together to allow them to communicate with each other.

2.2 Starting Reydisp Manager 2 and Creating a Project

Starting Reydisp Manager 2

In the **Start** menu under **Reydisp Manager 2**, select the program entry for the current Reydisp Manager 2 version.

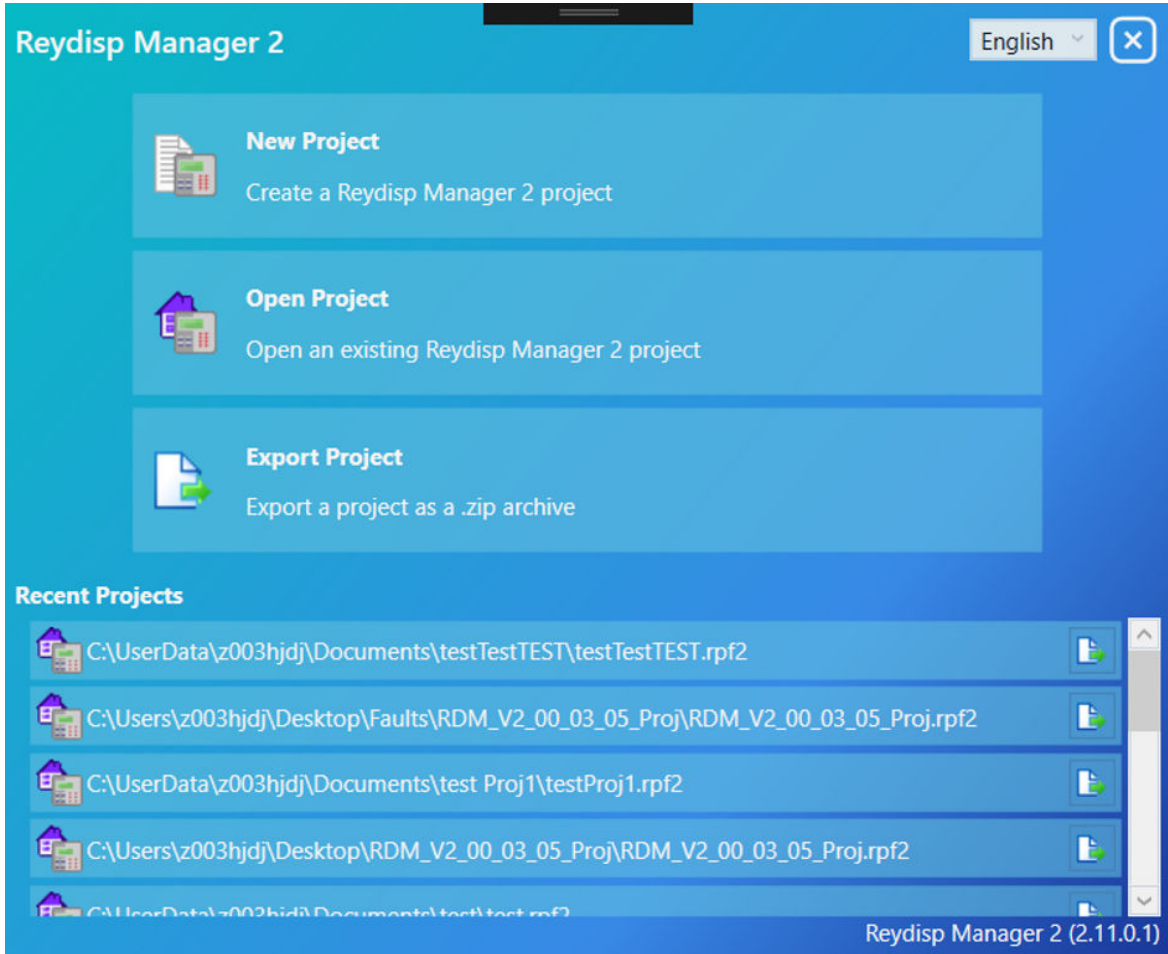

[sc_7SR5_ReydispManager2ProjectScreen, 2, --_]

Figure 2-1 Reydisp Manager 2 Startup Screen

Creating a New Project

Select the **New Project** option.

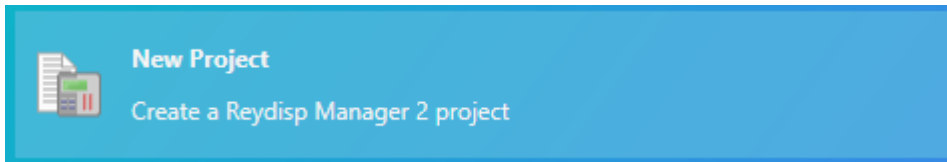

[sc_7SR5_ReydispManager2NewProject, 1, --_]

Figure 2-2 Reydisp Manager 2 New Project

The **Create New Project** dialog opens.

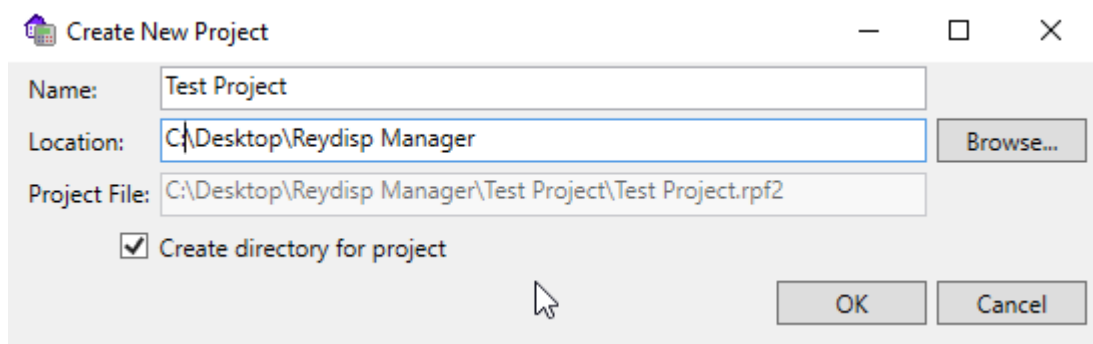

[sc_7SR5_ReydispManager2NewProjectDialog, 1, --]

Figure 2-3 Reydisp Manager 2 New Project Dialog

Enter the desired project name and path or accept the data suggested. A subdirectory is created for the project in the selected location by default. The name is the same as the project name. This can be changed by changing the text in the **Directory** text box. Untick the **Create Directory For Project** check box to save the project file straight to the specified location without creating a subdirectory. Click **OK**.

Open an Existing Project

Select the **Open Project** option.

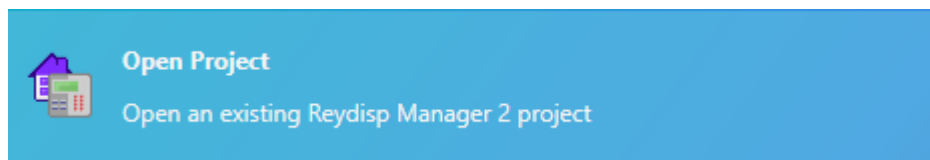

[sc_7SR5_ReydispManager2OpenProject, 1, --]

Figure 2-4 Reydisp Manager 2 Open Project

Alternatively select a recent project from the list.



[sc_7SR5_ReydispManager2RecentProject, 2, --]

Figure 2-5 Reydisp Manager 2 Recent Project

A new project is created and saved in the standard directory for projects. The project is then displayed in the project tree.

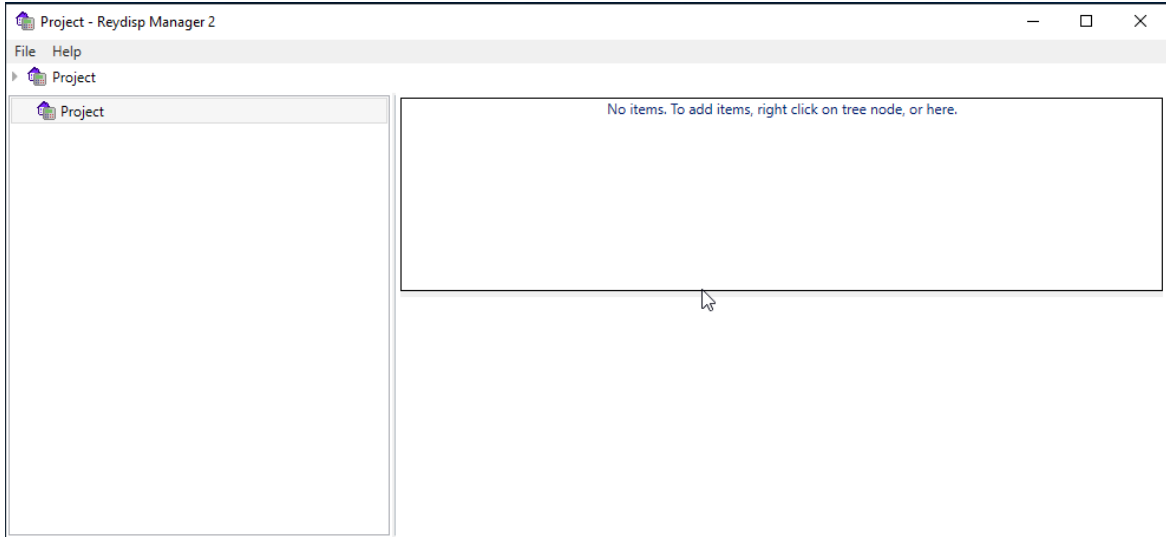

[sc_7SR5_ReydispManager2NewProjectTree, 1, --...]

Figure 2-6 Reydisp Manager 2 Project Tree

Exporting an Existing Project

Select the **Export Project** option.

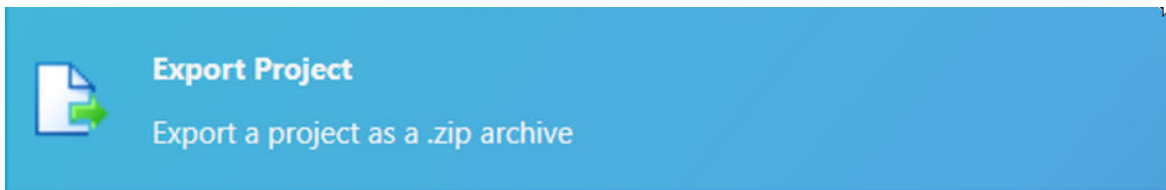

[sc_7SR5_ReydispManager2ExportProject, 1, --...]

Figure 2-7 Reydisp Manager 2 Export Project

The export project feature will add all of the files in the project to a **.zip** file for archiving or transferring to another user.

The recent projects also have a direct export selection option, as shown in the following figure, at the end of the project.

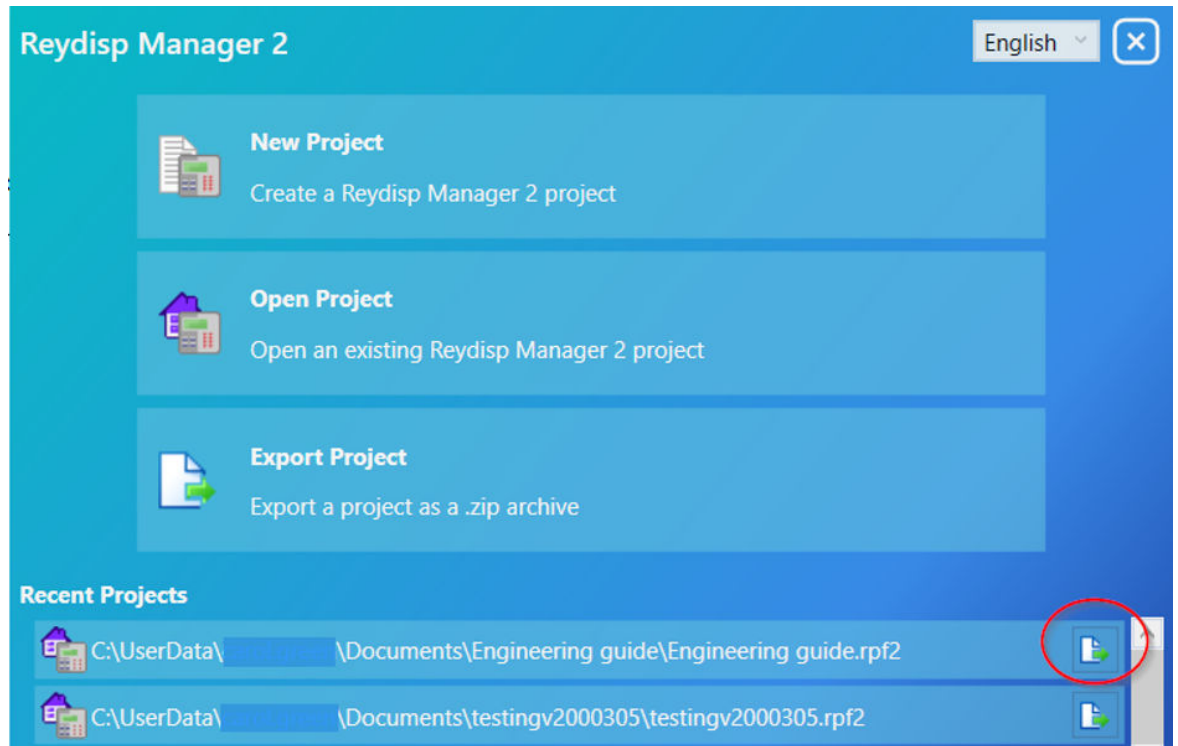

[sc_75R5_ReydispManager2DirectExport, 1, --]

Figure 2-8 Reydisp Manager 2 Direct Export

A **Save As** window is provided to select the name and location where the archive file is to be stored on the PC. When the preferred name and location are entered click **Save**.

2.3 Adding a Folder

Overview

To organize the project more effectively folders can be created which can contain other items, including additional folders.

A **New Folder** can be added to the project by:

- From the menu selecting **File > Add New Folder**
- Right-click on the project and select **New Folder**.

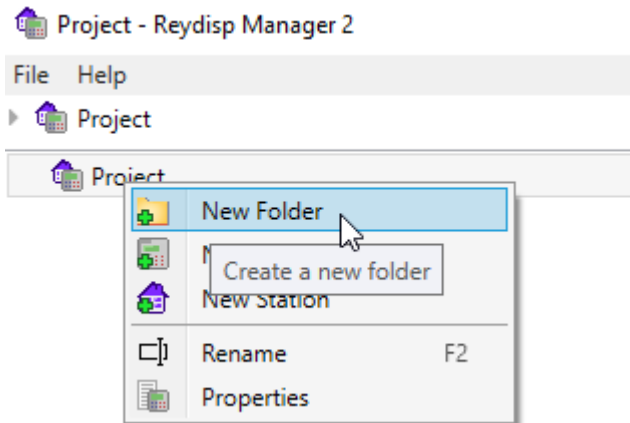

[sc_7SR5_ReydispManager2AddFolder, 1, --,--]

Figure 2-9 Reydisp Manager 2 New Folder

- The folder will be given a default name **New Folder** and will be selected to allow it to be renamed.
- A folder cannot be given the same name as an existing item in the same folder. It's name must be unique.
- Folders may be nested to any required depth.

2.4 Adding a 7SR5 Device

Overview

Inserting a 7SR5 Device into a Project

You can insert a device directly in the project tree with the aid of a valid product code. Everything specified by this product code is created afterwards in Reydisp Manager 2.

The product code can be entered directly into the **Device MLFB** user entry box as a partial code or complete code and the selection will be filtered automatically to assist the selection.

If the device is connected to the PC the product code can be provided from the device using the **From Connected Device** option.

You can also import the connected device into the project.

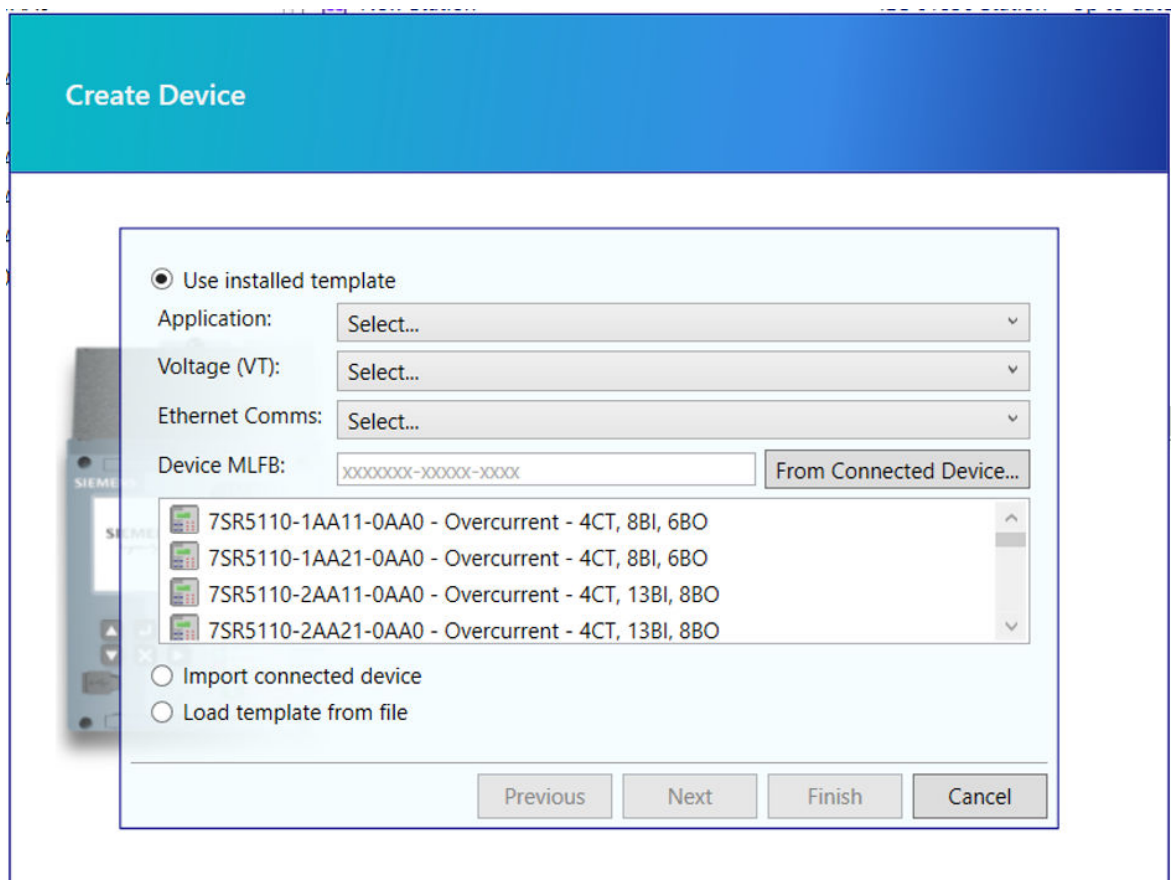

[sc_7SR5_ReydispManager2AddDevice, 1, --, --]

Figure 2-10 Reydisp Manager 2 Adding a Device

Create Device Tool

Using the **Create Device** tool, the basic configurations for new 7SR5 devices can be inserted into the project.

Representations of the Device in the Project

When you insert a device into the project, you can find the device at various locations in the project:

- **Project tree**
When the project is selected in the project tree the overview list of devices are displayed with basic properties and device status.
- **Device view**
When the device is selected in the project tree the **Device** view displays the device details, configuration files, tasks, device data, and Information messages for the selected device.

Inserting a 7SR5 Device with the Product Code

You must know the product code for a physical 7SR5 device to create a 7SR5 device in Reydisp Manager 2. The goal of this chapter is to create the project structure shown in the following figure.

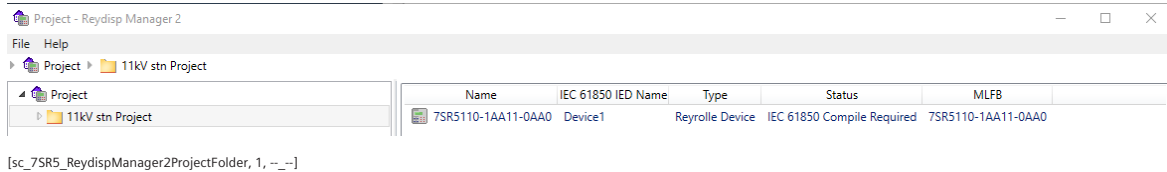

Figure 2-11 Reydisp Manager 2 Project Folder

Overview of the Procedure

Perform the following actions:

- Add the 7SR5 device in the project folder.
- Enter the product code and select an application template firmware version.

Starting the Process

Either from the **File Menu** or by right-clicking on the folder and selecting **New 7SR5 Device** from the **Install** template.

Alternatively the user can load a specific template from a file.

The **New 7SR5 Device** opens the **Create Device** window.

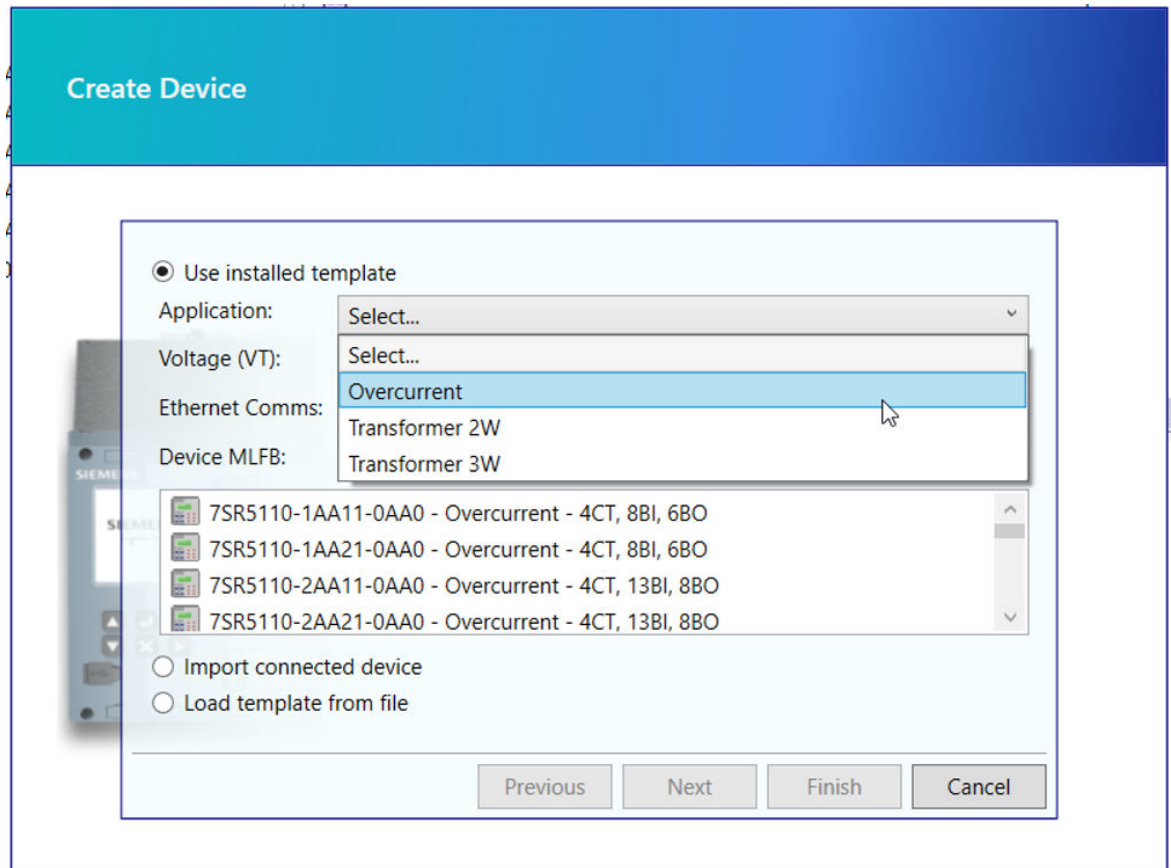

[sc_7SR5_ReydispManager2NewDevice, 2, --...]

Figure 2-12 Reydisp Manager 2 Inserting a New Device

Entering the Product Code and Selecting an Application Template

The tool allows the MLFB order code to be typed directly into the **Filter** input box if it is known, or the device can be selected from the list window using the scroll bar.

If the MLFB order code is not known the drop down selections will reduce the number of device selections according to the filters applied.

The tool provides filter options for the device application, if voltage inputs are required and the ethernet connection type.

Select the product code from the list.

Alternatively enter the following product code in the **Device MLFB**: **7SR5110-1AA11-0AA0**.

Click **Next**.

The product code entered is verified.



NOTE

Entering a partial MLFB will act as a filter on the selection list.

Getting the Product Code from a Connected Device

To add a device to the project which has the same model order code as a connected device, the Device MLFB can be taken from the device and the template identified.

Select the **From Connected Device** option , as shown in *Figure 2-13*.

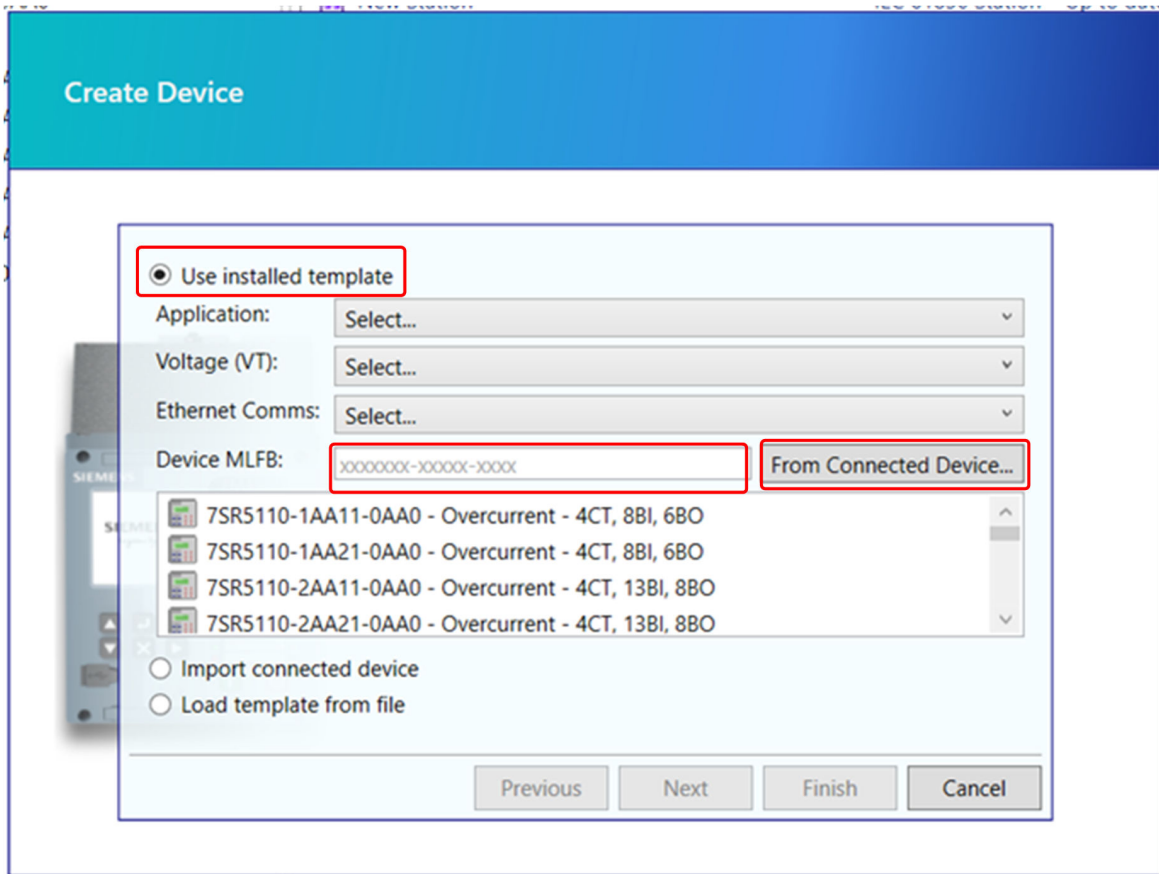

[dw_7SR5_ReydispManager2ConnectedDevice, 1, en_US]

Figure 2-13 Reydisp Manager 2 From Connected Device

Enter the connection method and click **OK**.

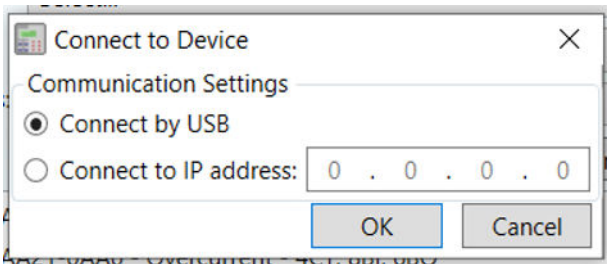

[sc_7SR5_ReydispManager2ConnectionMethod, 1, --]

Figure 2-14 Reydisp Manager 2 Connection Method

The PC will connect to the device and get the MLFB ordering code information.

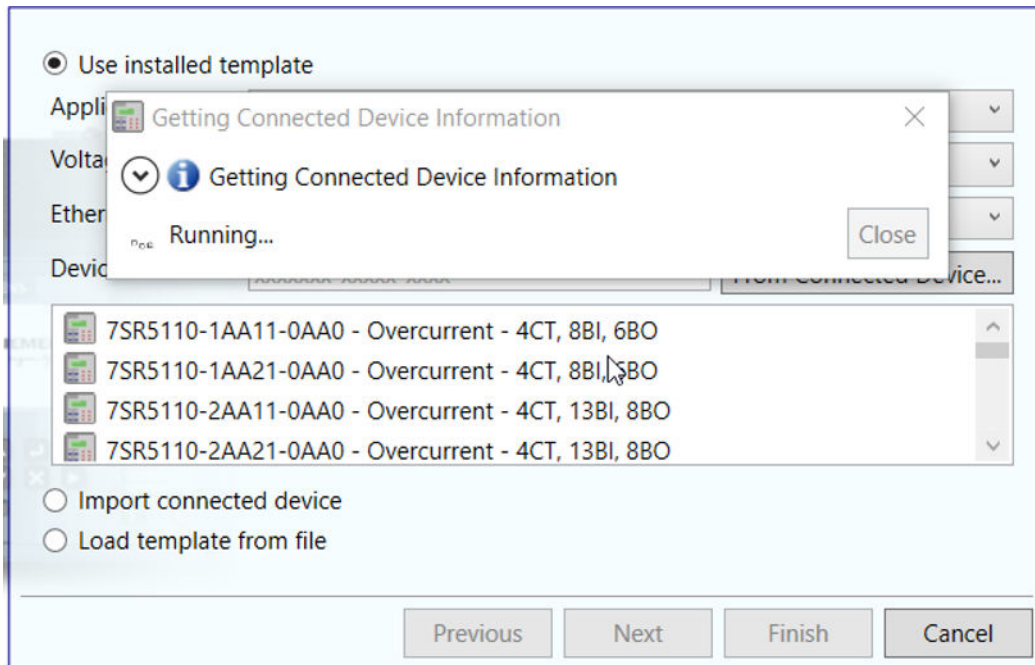

[sc_7SR5_ReyspManager2ConnectingDevice, 1, --_]
Figure 2-15 Reysp Manager 2 Device Connecting



NOTE

If the connection fails a notification similar to the one shown in [Figure 2-16](#) is given.

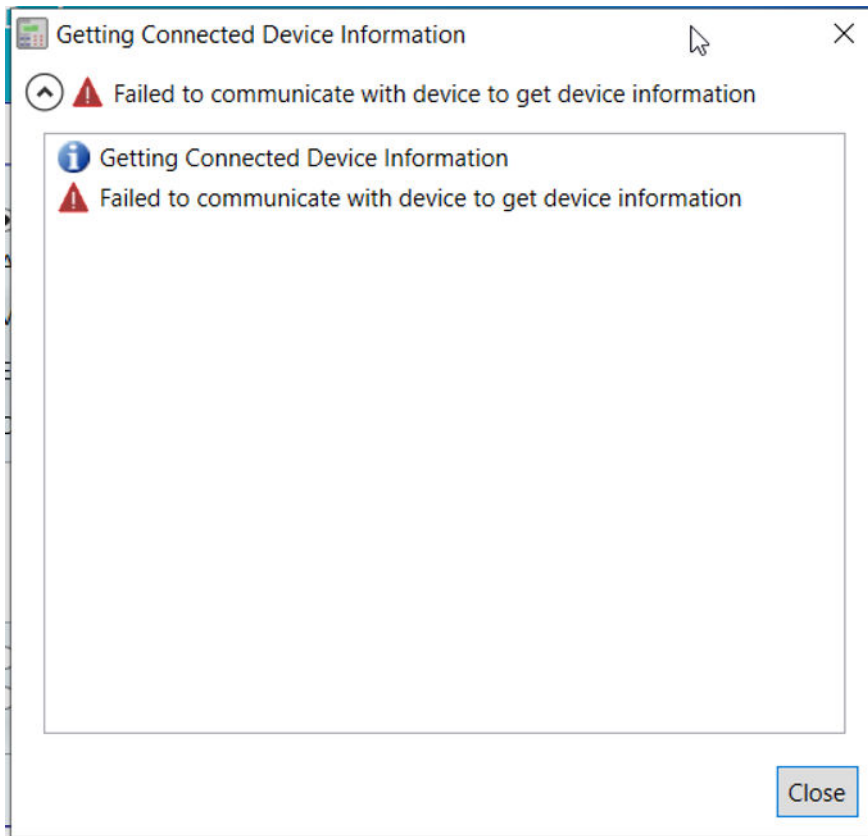

[sc_7SR5_ReydispManager2ConnectionFailed, 1, --, --]

Figure 2-16 Reydisp Manager 2 Connection Failed

The device MLFB will be entered into the **Device MLFB** box and the templates filtered to display the correct device. Select the device from the list.

Click **Next** to continue and proceed as described in this section.

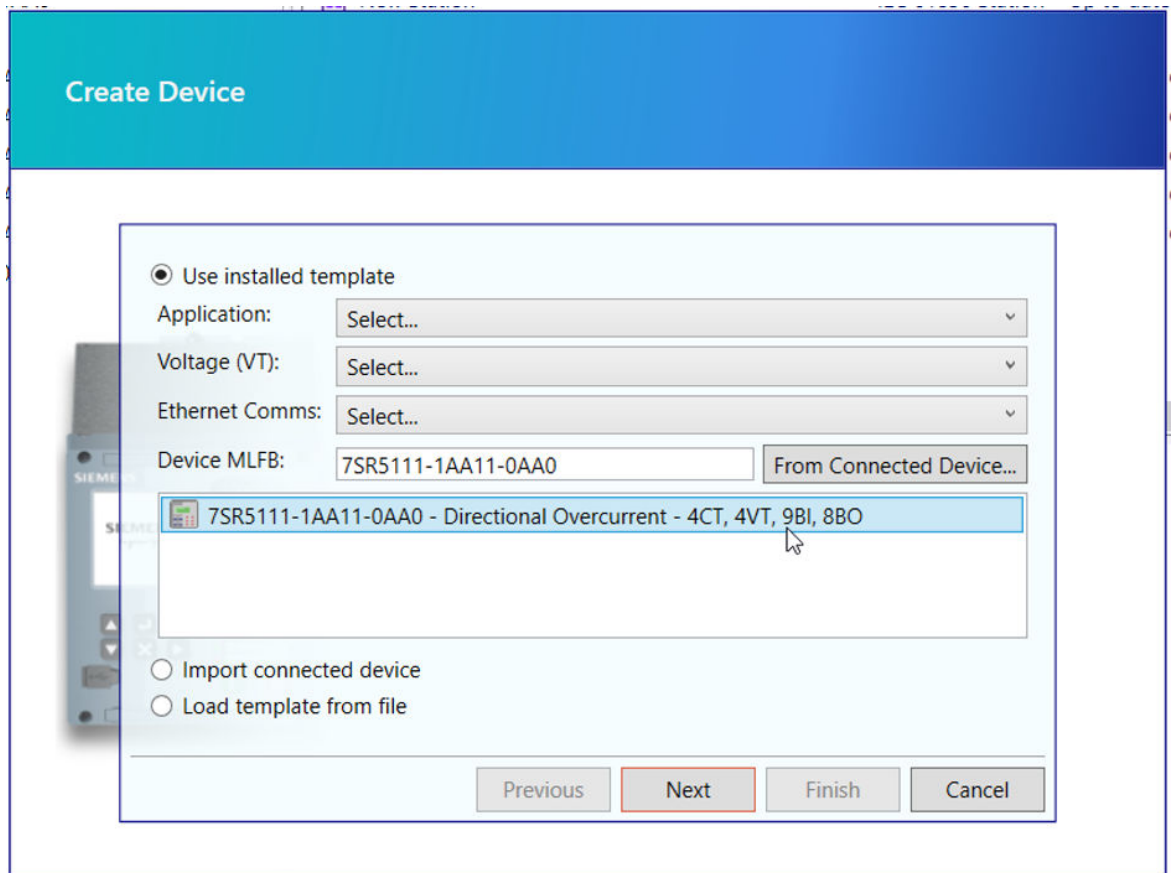

[sc_7SR5_ReydispManager2DeviceSelection, 1, --]

Figure 2-17 Reydisp Manager 2 Device Selection

Importing a Copy of a Connected Device to Add to A Project

Select **Import connected device** and click **Next**.

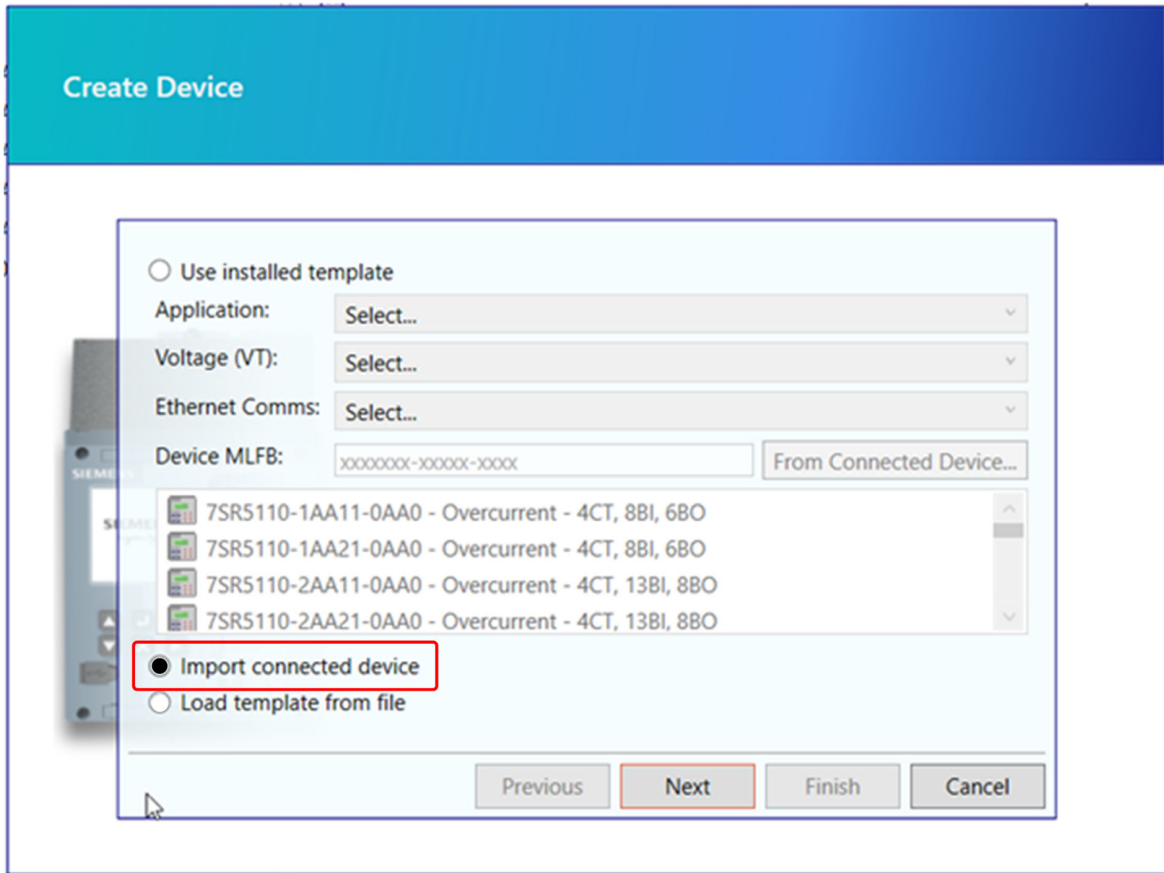

[dw_7SR5_ReydispManager2ImportConnectedDevice, 1, en_US]

Figure 2-18 Reydisp Manager 2 Import Connected Device

Enter the connection method and click **Next**.

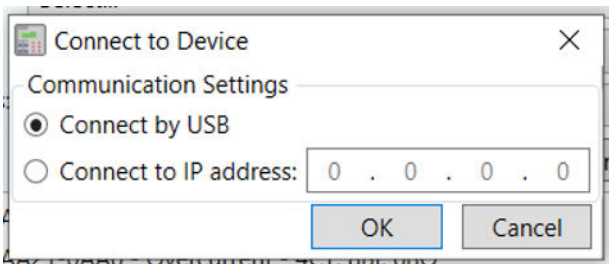

[sc_7SR5_ReydispManager2ConnectionMethod, 1, --]

Figure 2-19 Reydisp Manager 2 Connection Method

The PC will connect to the device and import a copy of the device.



NOTE

Any station association will be lost when the device is imported as a copy in to the project.

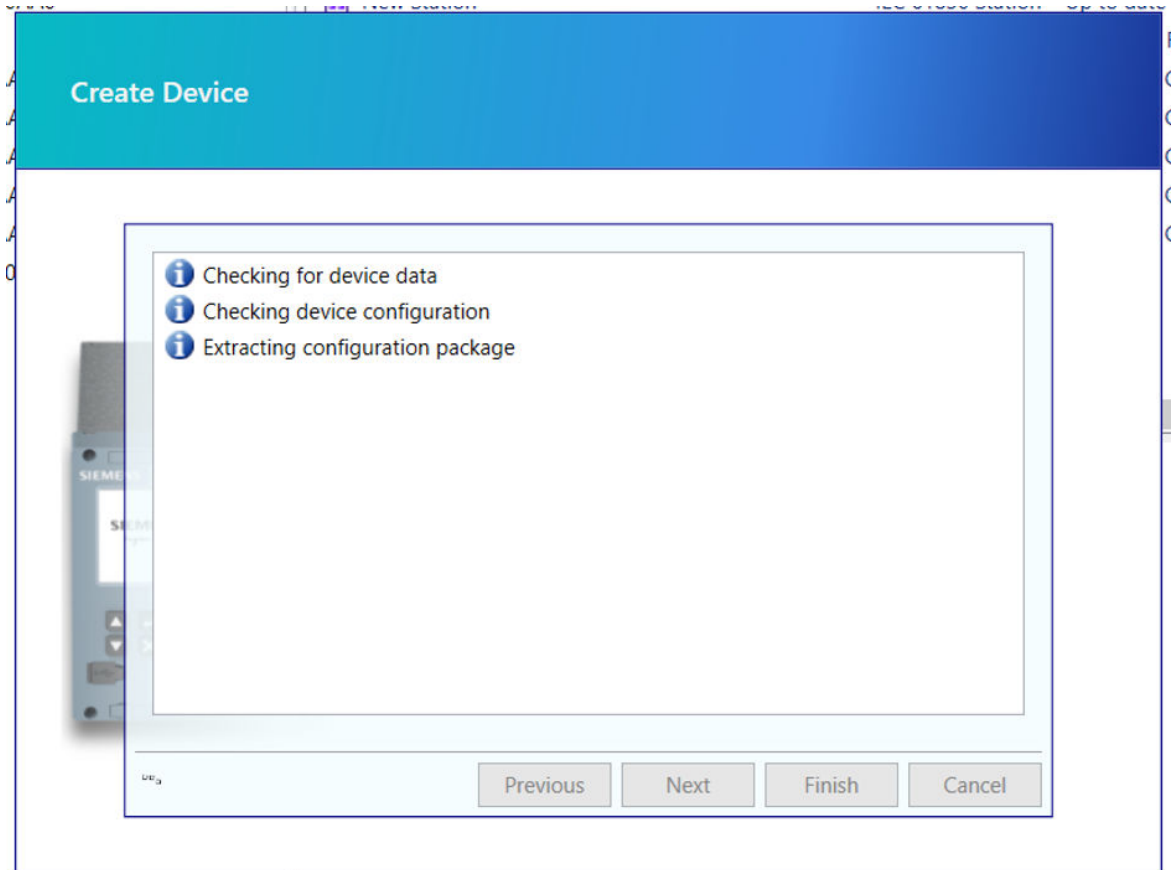

[sc_7SR5_ReydispManager2ImportingCopyofDevice, 1, --,--]

Figure 2-20 Reydisp Manager 2 Importing Copy of Device

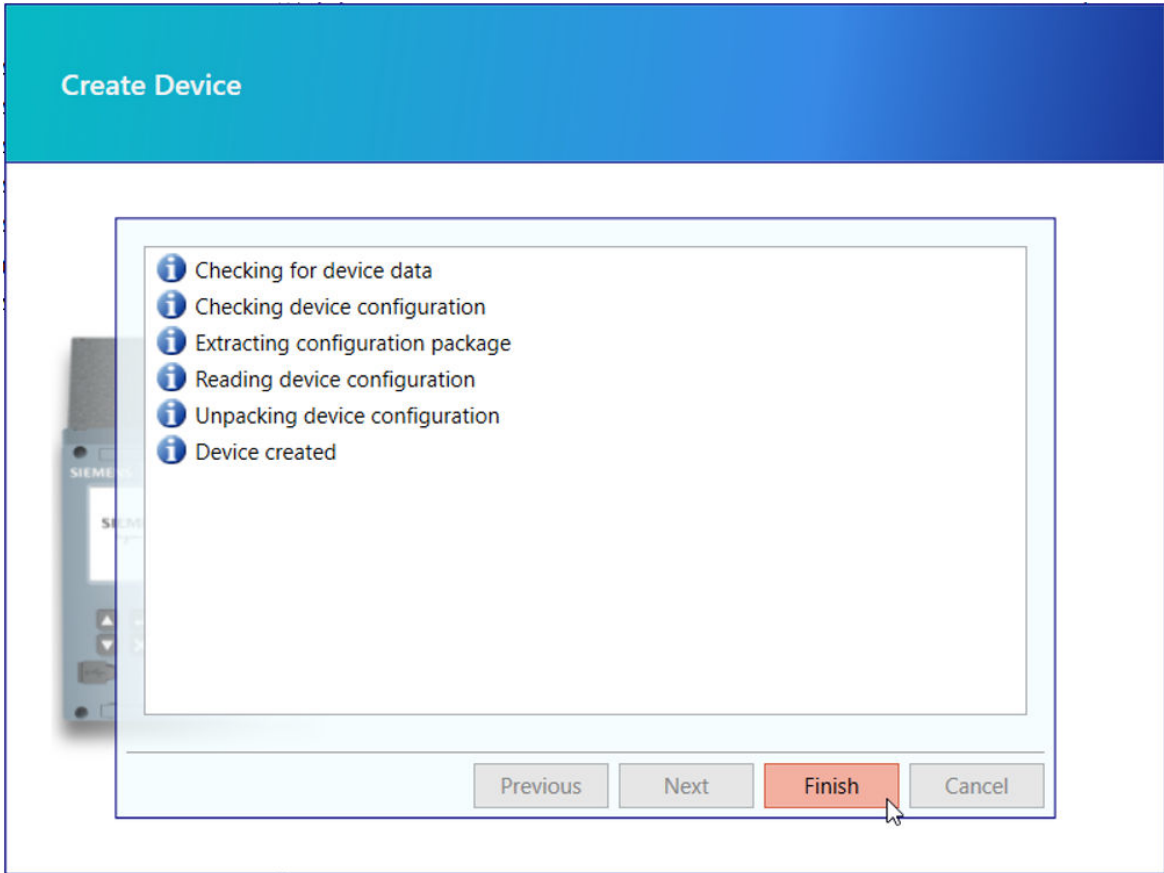

[sc_7SR5_ReydispManager2ImportingCopyofDeviceFinish, 1, --,--]

Figure 2-21 Reydisp Manager 2 Finish Importing Copy of Device

Click **Finish** to complete the import copy and the device will now be shown in the project tree. The device can now be added to the station if required. Refer to [2.13 Adding an IEC 61850 Station](#) for guidance on assigning the device to a station.

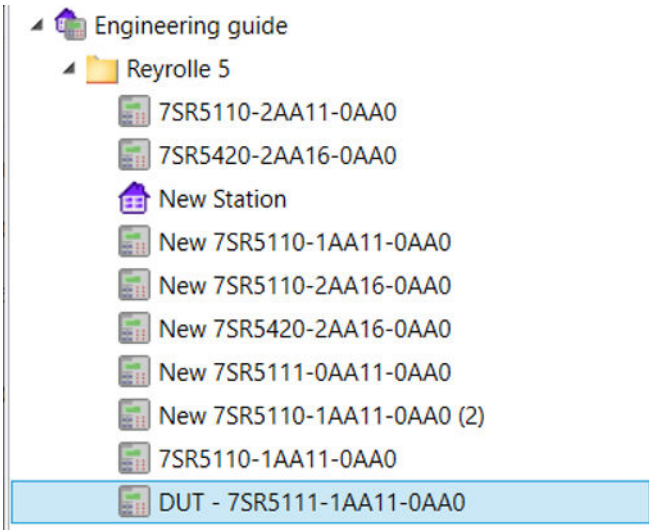

[sc_7SR5_ReydispManager2ImportedDeviceinProjectTree, 1, --,--]

Figure 2-22 Reydisp Manager 2 Imported Device in Project Tree

Selecting An Application Template

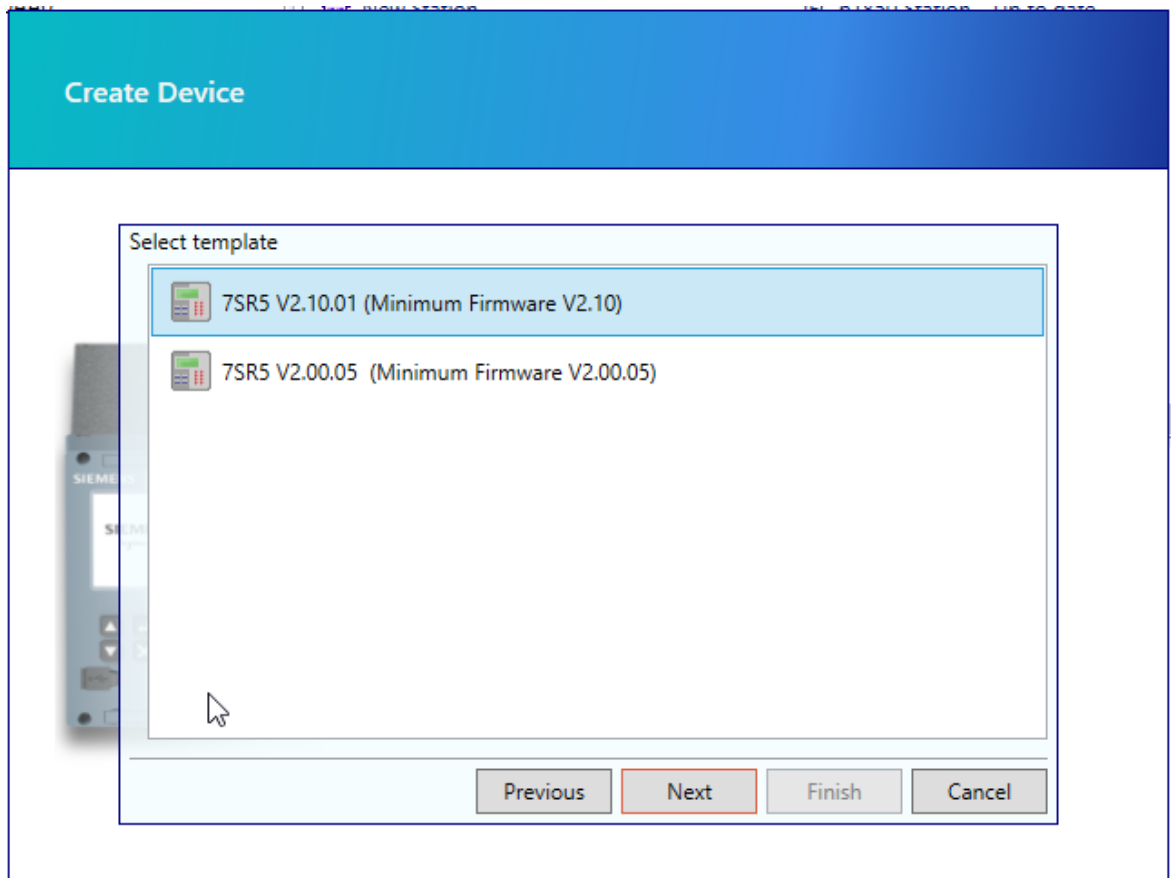

[sc_7SR5_ReydispManager2SelectTemplate, 1, --]

Figure 2-23 Reydisp Manager 2 Selecting a Template

In the **Select template** list box, highlight the application version required of the template. The template version also provides information regarding the minimum device firmware required for that device template. Click **Next**.

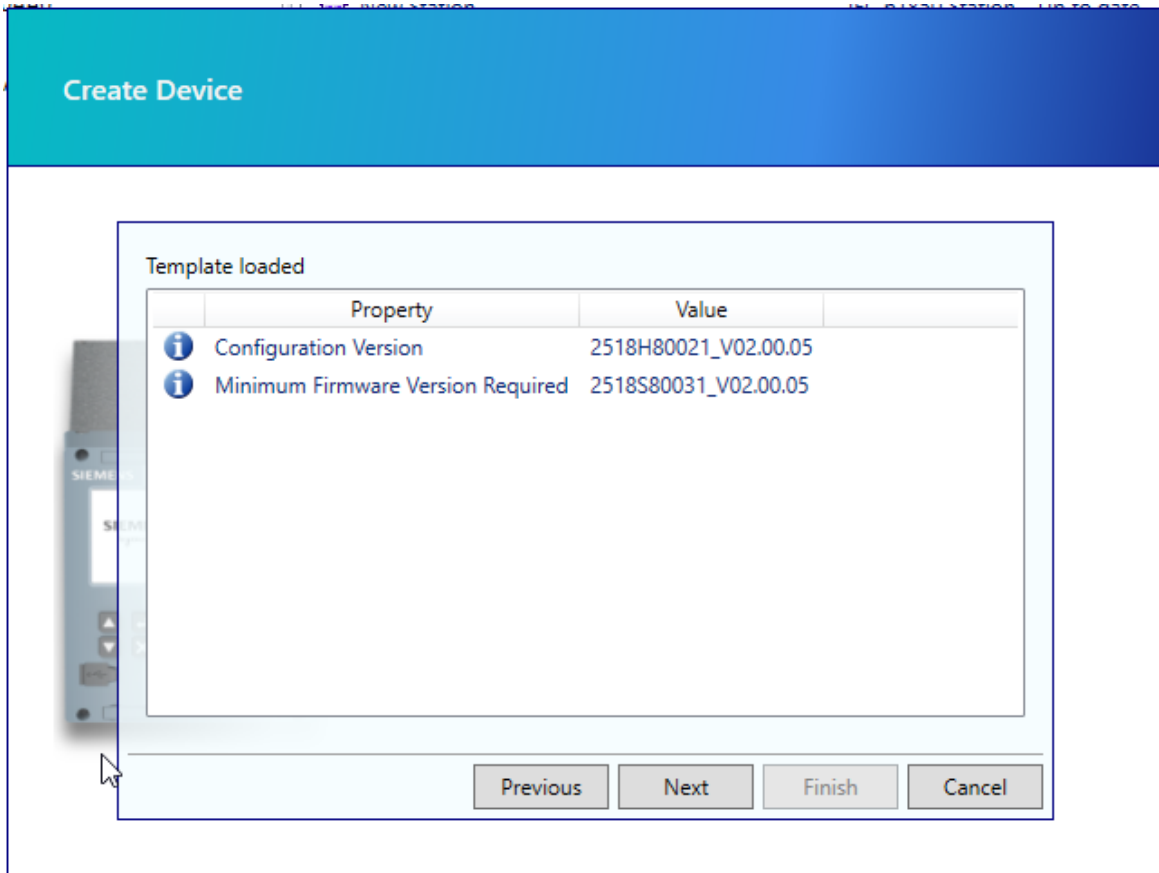

[sc_7SR5_ReydispManager2MinimumFirmware, 1, --]

Figure 2-24 Reydisp Manager 2 Minimum Firmware

After the desired device template is selected the display will now show the user both the configuration version and the minimum firmware version required for the selected template. If correct select **Next** to continue or **Previous** to return to the template version selection.

The user is prompted to enter the **Device Name** in the dialogue box.

Enter a suitable device name and click **Next**.

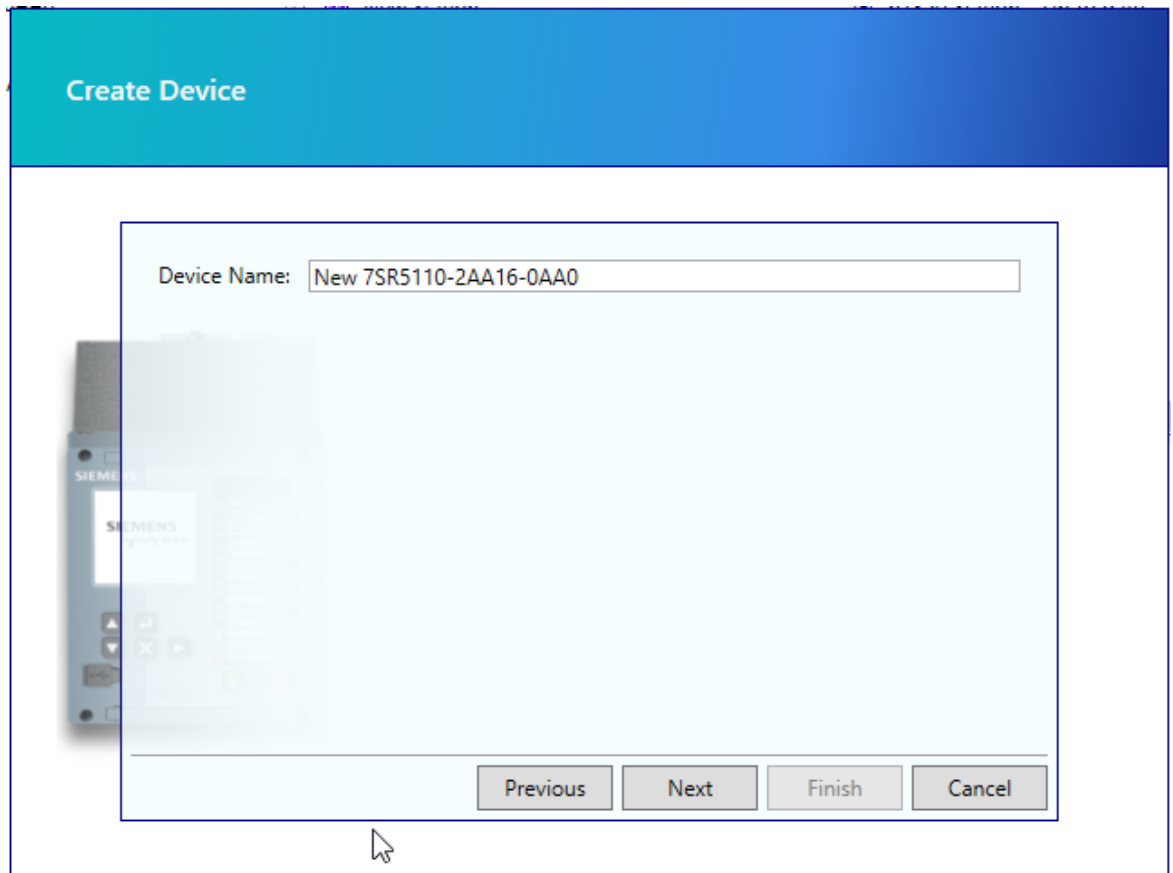

[sc_7SR5_ReydispManager2DeviceName, 1, --_]

Figure 2-25 Reydisp Manager 2 Device Name



NOTE

The device name can be changed after the device is created using the **Rename** feature or in the device properties.

The user is prompted to enter the IEC 61850 IED name in the dialogue box.

Enter a suitable device name and click **Next**.

The IEC 61850 IED name is subject to the following restrictions:

- It may be a maximum of 13 characters.
- It may only contain the characters A-Z, a-z, 0-9 and _.
- It must start with a letter, not a digit or underscore.
- If the device is assigned to a station, an additional rule is imposed: The IED name cannot be the same as another IED name assigned to that station.

Select from the drop down options the IEC 61850 Edition to be used on the device.

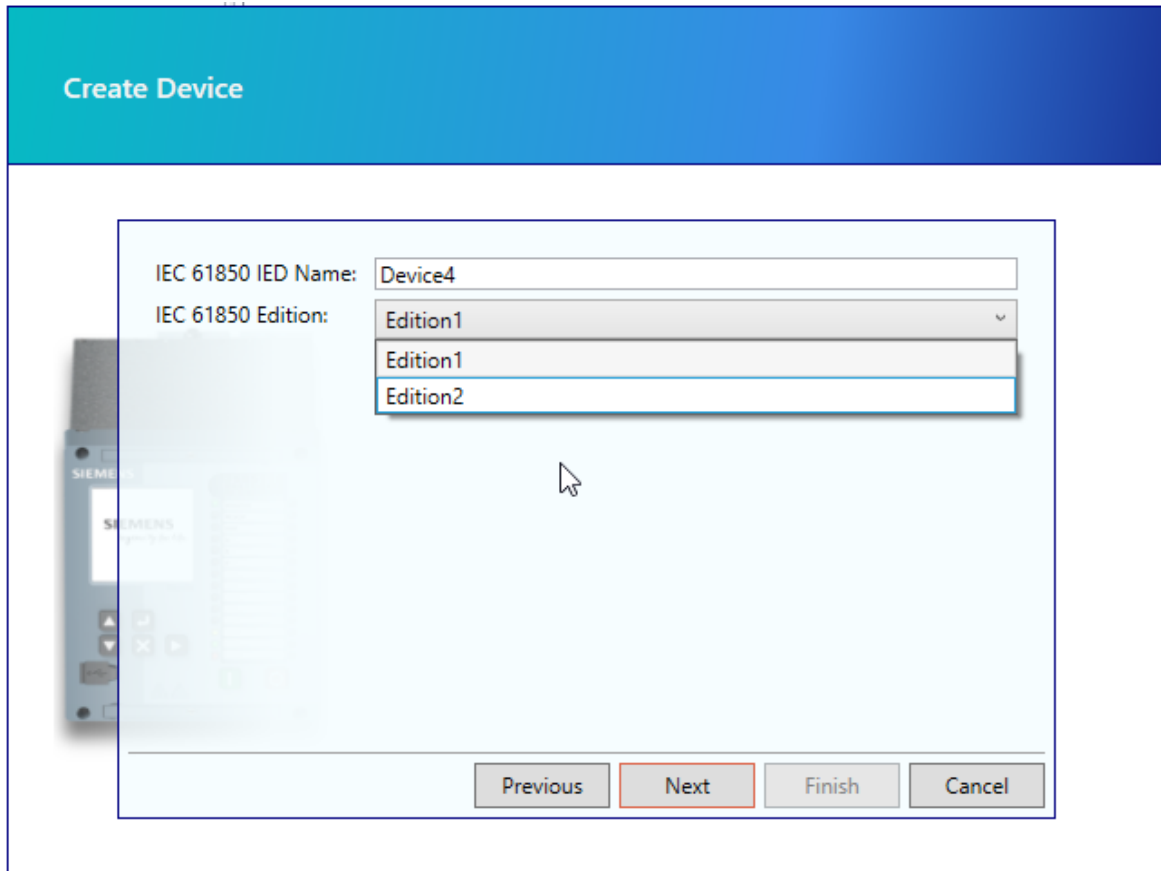

[sc_7SR5_ReydispManager2SelectIECEdition, 1, --_--]

Figure 2-26 Reydisp Manager 2 Selecting IEC 61850 Edition



NOTE

The IEC 61850 IED name and edition number can be changed after the device is created using the device properties.

The **Create Device** tool will proceed to construct the device with a default configuration. Click **Finish** to complete.

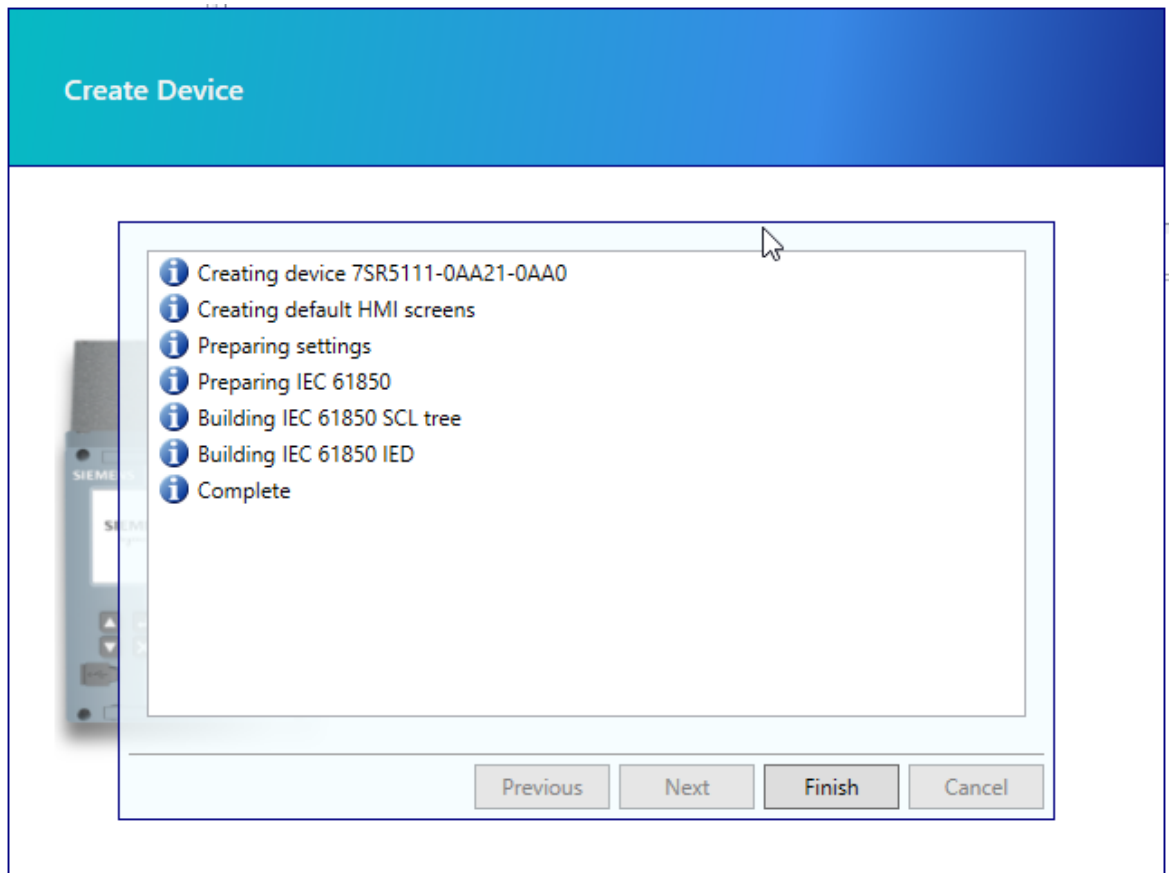

[sc_7SR5_ReydispManager2DeviceConstruction, 1, --_--]

Figure 2-27 Reydisp Manager 2 Device Construction

The project structure will now contain an additional offline configuration for the inserted 7SR5 device with a basic default configuration. The device is now ready for user configuration.

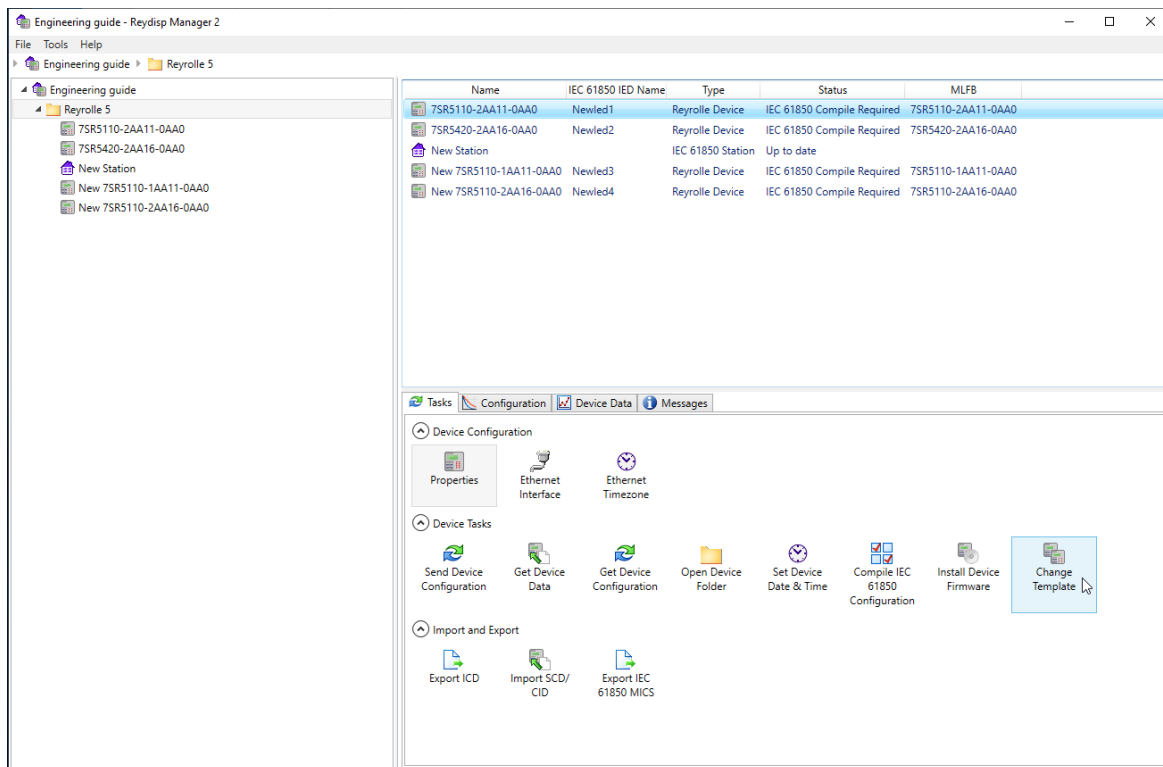

[sc_7SR5_ReydspManager2ProjectStructure, 1, --_--]

Figure 2-28 Reydsp Manager 2 Project Structure

This process should be repeated to add all devices to the project.

Selecting the device will populate the window with the device details, device files, tasks, and device data for the device.

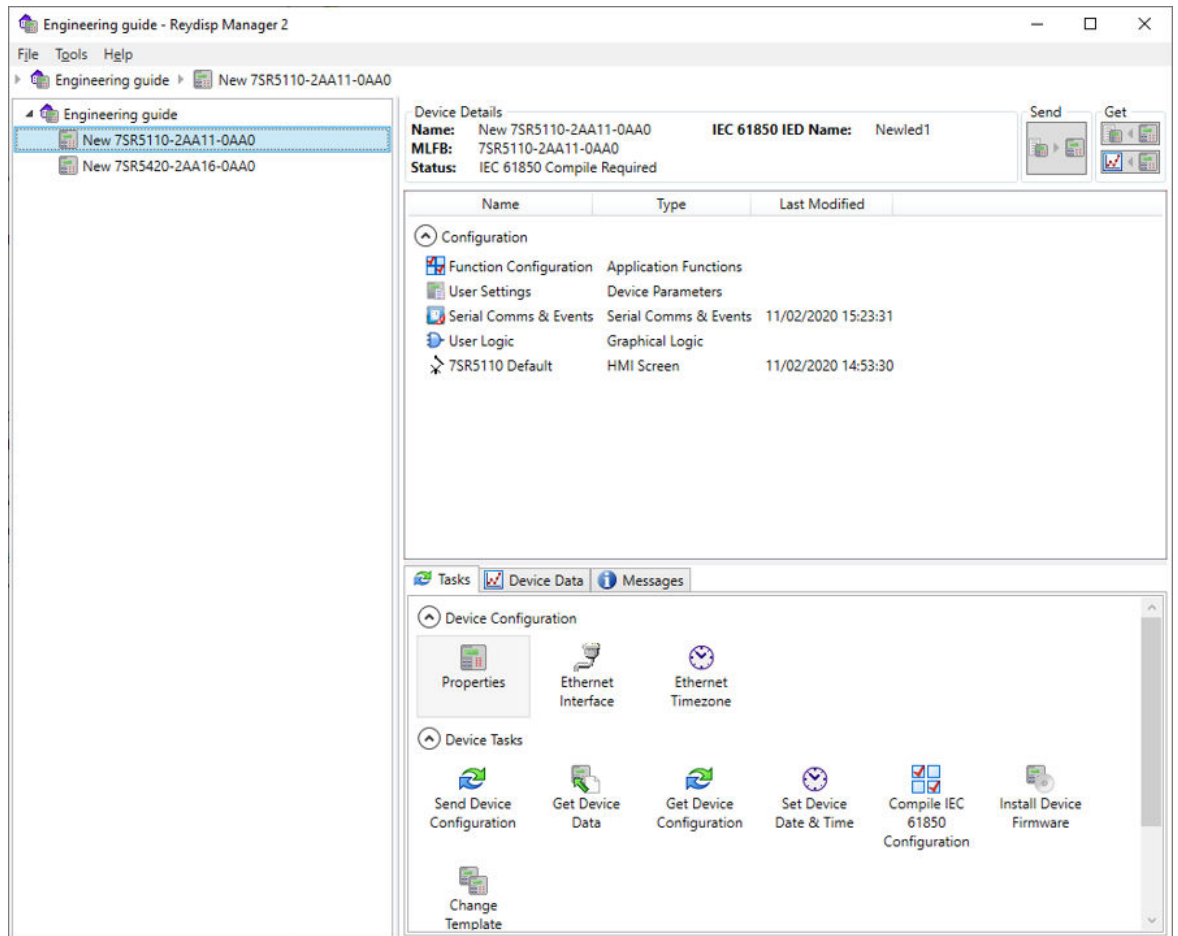

[sc_7SR5_ReydispManager2SelectDevice, 1, --,--]

Figure 2-29 Reydisp Manager 2 Device Details

2.5 Function Configuration

Overview

The protection, control and supervision functions that can be included in the device are dependent on the 7SR5 device type and its hardware configuration. The functionality available to a user is included in the device **Function Template** and can be modified by the user by editing the **Function Configuration** using the **Application Functions** tool in Reydisp Manager 2. In many cases, the selected application template can be used without any change to the functional configuration. In addition, the functional scope of the application, and thus of the 7SR5 device, can be optimized exactly to fit the users specific needs. For many functions, the number of stages can be determined. Thus, the user can adapt the functions exactly to individual protection concepts. Modification of the device **Function Configuration** selection will automatically be reflected in the devices other user files and therefore should be modified first during configuration.

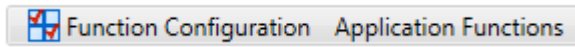

[sc_7SR5_ReydispManager2FunctionConfiguration, 1, --]

Figure 2-30 Reydisp Manager 2 Function Configuration

Function templates comprise **Function Groups** (FG) and within each FG there may be a number of **Function Elements** (FE).

Modifying the Device Application Function Configuration

The default configuration for the device contains a file for the user to customize the functions and elements in the 7SR5 configuration. The default file contains all functions and elements available for the selected device type. Only a subset of the available items are selected to be included in the default configuration.

Goal

The goal of this chapter is to create a functional configuration suitable for the users application in the offline configuration.

Overview of the Procedure

Perform the following actions:

- Open the user **Function Configuration**.
- Modify the **Voltage Input** association with a **Transformer Winding** in the device offline configuration.
- Include/Remove additional function elements in the device offline configuration.
- Modify the analogue inputs which the element is configured to use in the device offline configuration.

Opening the **Function Configuration** will generate the **Device Configuration** file from the **Device Application** template.

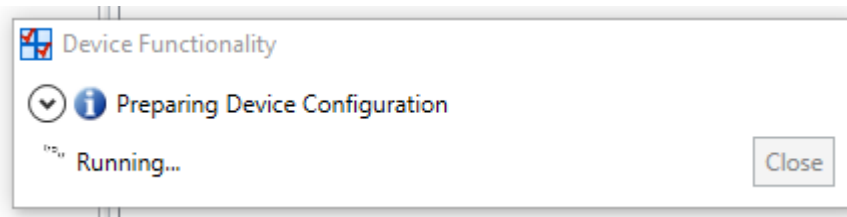

[sc_7SR5_ReydispManager2PreparingDeviceConfiguration, 1, --]

Figure 2-31 Reydisp Manager 2 Preparing Device Configuration

If the device hardware includes voltage inputs that can be associated with different CT configurations the **VT Mapping Option** will be available for selection from a drop down menu. In the following example VT1,VT2,VT3 are selected to operate with **Transformer Winding 1** functions.

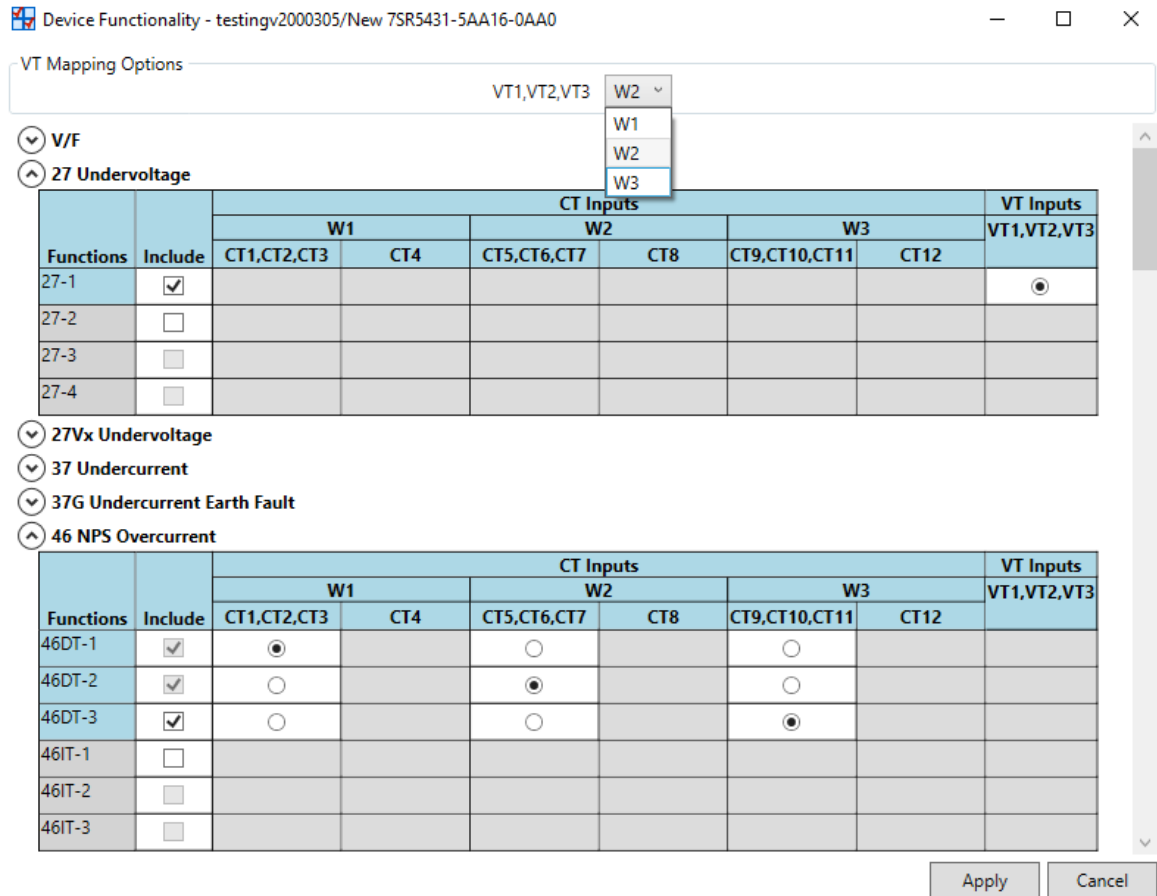

[sc_7SR5_ReydispManager2VTMappingOptions, 1, --]

Figure 2-32 Reydsp Manager 2 VT Mapping Options

The available functions in the template are shown under the function heading and can be expanded or hidden using the button.

Every element available in the function is listed and can be selected to be included in the device configuration by ticking the included option box. The elements must be selected/deselected in numerical order.

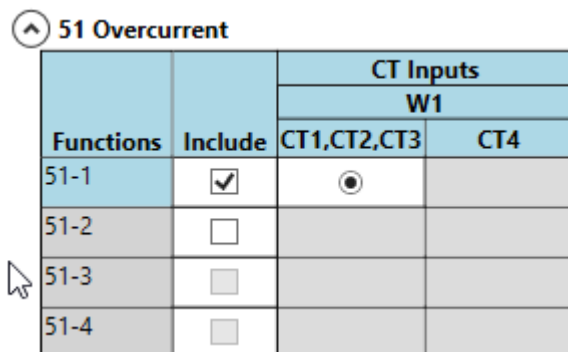

[sc_7SR5_ReydispManager2SelectingFunctionElements, 1, --]

Figure 2-33 Reydsp Manager 2 Selecting Function Elements

If the device has multiple analogue inputs that could be used with the element the user must select the analogue association. This is done by selecting the CT using the option button.

The following example shows the following association:

- 51-1 element is configured to use CT1, CT2, CT3
- 51-2 element is configured to use CT5, CT6, CT7
- 51-3 element is configured to use CT9, CT10, CT11

51 Overcurrent

Functions	Include	CT Inputs						VT Inputs VT1,VT2,VT3
		W1		W2		W3		
		CT1,CT2,CT3	CT4	CT5,CT6,CT7	CT8	CT9,CT10,CT11	CT12	
51-1	<input checked="" type="checkbox"/>	<input checked="" type="radio"/>		<input type="radio"/>		<input type="radio"/>		
51-2	<input checked="" type="checkbox"/>	<input type="radio"/>		<input checked="" type="radio"/>		<input type="radio"/>		
51-3	<input checked="" type="checkbox"/>	<input type="radio"/>		<input type="radio"/>		<input checked="" type="radio"/>		

[sc_7SR5_ReydispManager2ElementConfigurationExample1, 1, --, -]
 Figure 2-34 Reydisp Manager 2 Element Configuration

All elements can be selected to use the same analogue inputs or any combination. The following example shows the following association:

- 51-1 element is configured to use CT5, CT6, CT7
- 51-2 element is configured to use CT9, CT10, CT11
- 51-3 element is configured to use CT9, CT10, CT11

51 Overcurrent

Functions	Include	CT Inputs						VT Inputs VT1,VT2,VT3
		W1		W2		W3		
		CT1,CT2,CT3	CT4	CT5,CT6,CT7	CT8	CT9,CT10,CT11	CT12	
51-1	<input checked="" type="checkbox"/>	<input type="radio"/>		<input checked="" type="radio"/>		<input type="radio"/>		
51-2	<input checked="" type="checkbox"/>	<input type="radio"/>		<input type="radio"/>		<input checked="" type="radio"/>		
51-3	<input checked="" type="checkbox"/>	<input type="radio"/>		<input type="radio"/>		<input checked="" type="radio"/>		

[sc_7SR5_ReydispManager2ElementConfigurationExample2, 1, --, -]
 Figure 2-35 Reydisp Manager 2 Element Configuration

Select the **Apply** button to confirm the configuration and generate the new device configuration.

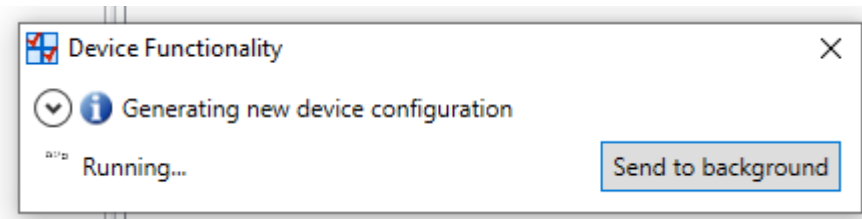

[sc_7SR5_ReydispManager2NewDeviceConfiguration, 1, --, -]
 Figure 2-36 Reydisp Manager 2 New Device Configuration

2.6 Creating a Logic Diagram

Overview

Reylogic Express is a tool to create custom graphical logic diagrams for the device.

Multiple logic diagrams can be created and text labels can be added to annotate diagrams to effectively organize more complex logic schemes.

Reylogic Express is launched by selecting the desired 7SR5 device and clicking **Logic** in the task pane.

These functions take care of, for example, the following tasks:

- Interlockings
- Formation of group indications
- Failure indications
- Interface between device signals and GGIO
- Interface between device signals and user signals for HMI screens





Reylogic Express consists of the following items, shown on the left side of the window:

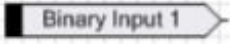
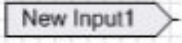

- Logic
Provides standard logic such as AND, OR, XOR, NOT as well as user inputs/outputs, counters and latches.
- Logic Diagrams
A diagram holds the user logic. A scheme can be made up of multiple diagrams.
- Scheme Signals
Shows a list of user outputs available in the current logic scheme from all diagrams.
- Device Signals
Inputs and output signals specific to the selected device.

Logic Symbol Overview

A number of logic symbols can be used within Reylogic Express diagrams.

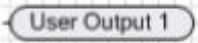
Table 2-1 Reydisp Manager 2 Logic Symbol Overview

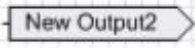
Symbol	Description
	External input
	Internal input
	AND gate
	XOR gate
	Counter
	NOT gate
	External output

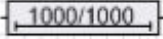
Symbol	Description
	Internal output
	OR gate
	Set/Reset latch
	Pickup/Dropoff timer

Logic Symbol Properties

The properties of logic symbols can be altered by way of the property grid. The property grid is located on the right hand side of Reylogic Express.

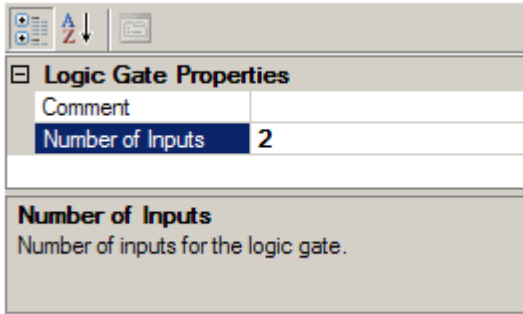

[sc_7SR5_ReydispManager2PropertyGrid, 1, -- --]
 Figure 2-37 Reydisp Manager 2 Property Grid

When a single symbol is selected that symbol's properties will be displayed in the property grid. This allows you to edit property fields for the symbol.

External and Internal Symbols (Inputs/Outputs)

There are 2 types of input/output signal in Reylogic Express, **External** and **Internal**.
 An external symbol is provided by the host device. External inputs are driven by the device and can be used as inputs on your logic diagrams. External outputs are read by the device and are driven by your logic diagrams. They can be used as outputs on your logic diagrams.
 Each device has a list of signals which can be used as either inputs or outputs to your logic scheme.
 All external signals available to a device are shown on the project tree under **Device Signals**. The device signals are ordered into logical groups (type, function, protection elements, etc).

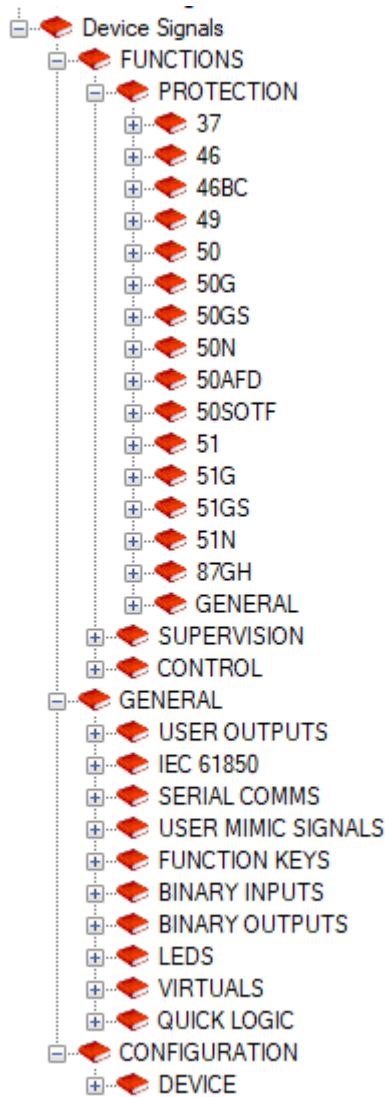

[sc_75R5_ReydispManager2DeviceSignalsProjectTree, 1, --, -]

Figure 2-38 Reydisp Manager 2 Device Signals Project Tree

All other signals in **Reylogic Express** are internal. These signals exist only in your logic scheme and are not visible to the rest of the device.

In [Figure 2-38](#) an external signal from the device function key is made visible to the logic scheme by the use of external input **Function Key 1**. The signal is used to drive an internal signal **My Internal Signal**. The internal signal is then used to drive the user output signal by use of an external output **User Output 1**.

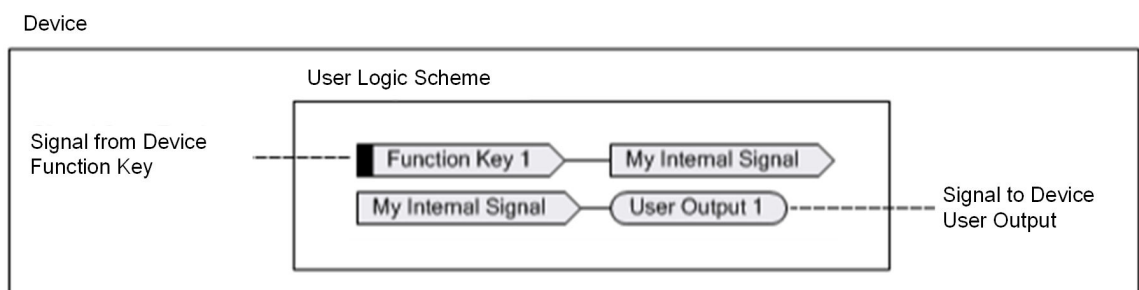

[dw_75R5_ReydispManager2UserLogicScheme, 1, en_US]

Figure 2-39 Reydisp Manager 2 User Logic Scheme

Logic Diagrams

Logic diagrams can be created, deleted, renamed and reordered.
To add a new diagram to the logic scheme the user can either:

- Use the menu **File > New Diagram**
- Use the toolbar icon



[sc_7SR5_ReydispManager2FileNew, 1, --]

Figure 2-40 Reydisp Manager 2 New Diagram Icon

- Use the keyboard shortcut **CTRL + N**
- Use the mouse to right-click on the **Logic Diagrams** section of the project tree. Select **New Diagram** from the menu.

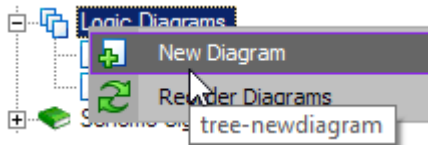

[sc_7SR5_ReydispManager2NewDiagramMenu, 1, --]

Figure 2-41 Reydisp Manager 2 Project Tree New Diagram

A new diagram will appear in the project tree under **Logic Diagrams**. Each new diagram will take a new unique name (**Diagram 1**, **Diagram 2**, etc).

The new diagram page will also be displayed ready for symbols to be added.

Logic diagrams can be removed from the scheme by locating the diagram in the **Logic Diagrams** section of the project tree. Right-click on the diagram to be deleted and in the menu that appears select **Delete Diagram**.

Diagrams can also be reordered.

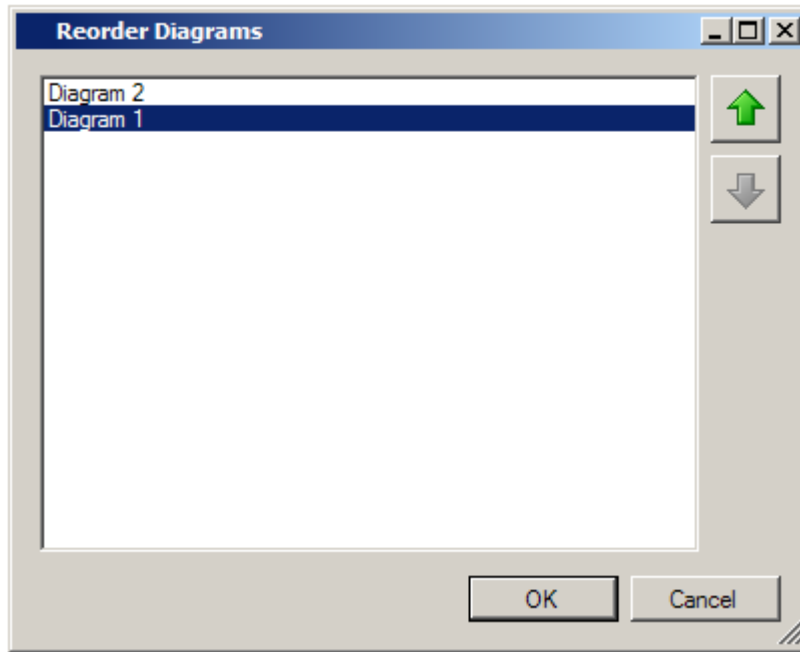

[sc_7SR5_ReydispManager2ReorderDiagrams, 1, --, _]

Figure 2-42 Reydisp Manager 2 Diagram Reordering

Reylogic Express has quick view operations to zoom and pan to sections of your diagrams.

- **Displaying the full Logic Diagram (Zoom Document)**
Zoom and pan the active diagram so that the whole diagram page can be seen in the tab pane. There are multiple ways to achieve this:
 - In the menu click **View** then **Zoom Document** with the mouse.
 - With the keyboard press **CTRL + 9**.
 - Click the **Zoom Document** toolbar item with the mouse.
- **Displaying all Logic (Zoom Diagram)**
Zoom and pan the active diagram so that all visible logic on the diagram is within the view. There are multiple ways to achieve this:
 - In the menu click **View** then **Zoom Diagram** with the mouse.
 - With the keyboard press **CTRL + 8**.
 - Click the **Zoom Diagram** toolbar item with the mouse.
- **Displaying all Selected Logic (Zoom Selection)**
Zoom and pan the active diagram so that all selected logic on the diagram is within the view. There are multiple ways to achieve this:
 - In the menu click **View** then **Zoom Selection** with the mouse.
 - With the keyboard press **CTRL + 7**.
 - Click the **Zoom Selection** toolbar item with the mouse.
- **Panning Logic Diagrams**
Panning the diagram involved moving the view of the logic diagram to suit your display purposes. There are multiple ways to achieve this:
 - Use the horizontal and vertical scrollbars at the bottom and right side of the diagram.
 - Right-click on the diagram and move the mouse. Release the mouse button to stop panning.

- **Zooming In**
View the diagram larger. There are multiple ways to achieve this:
 - In the menu click **View** then **Zoom In** with the mouse. This will zoom around the center of the current view.
 - With the keyboard press **CTRL + +**. This will zoom around the center of the current view.
 - Click the **Zoom In** toolbar item with the mouse.
 - Holding the **CTRL** key on the keyboard and scrolling the mouse wheel upward while the mouse is over the diagram view. This will zoom around the mouse point.
- **Zooming Out**
View the diagram smaller. There are multiple ways to achieve this:
 - In the menu click **View** then **Zoom Out** with the mouse. This will zoom around the center of the current view.
 - With the keyboard press **CTRL + -**. This will zoom around the center of the current view.
 - Click the **Zoom Out** toolbar item with the mouse.
 - Holding the **CTRL** key on the keyboard and scrolling the mouse wheel downward while the mouse is over the diagram view. This will zoom around the mouse point.
- **Resetting Zoom Level**
Resets the zoom level of the diagram view. This puts the diagram to a normal display size. There are multiple ways to achieve this:
 - In the menu click **View** then **Zoom Reset** with the mouse.
 - With the keyboard press **CTRL + 0**.
 - Click the **Reset Zoom** toolbar item with the mouse.

Logic diagrams, when opened for viewing, are displayed in a tabbed interface. The tabbed interface cable is separated into 2 tab panes. This allows the user to view 2 diagrams at the same time. To display a diagram in the second tab pane it must first be visible in the tab pane. To do this the user must right-click on the tab they want to display in the second pane. In the menu that appears select **Swap Pane**.

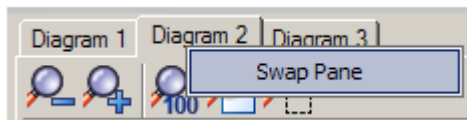

[sc_7SR5_ReydispManager2SwapPaneMenu, 1, --_]

Figure 2-43 Reydisp Manager 2 Swap Pane

The selected tab will now be moved to the second tab pane. Each tab pane can handle multiple diagram tabs. Any diagram can be swapped to either pane.

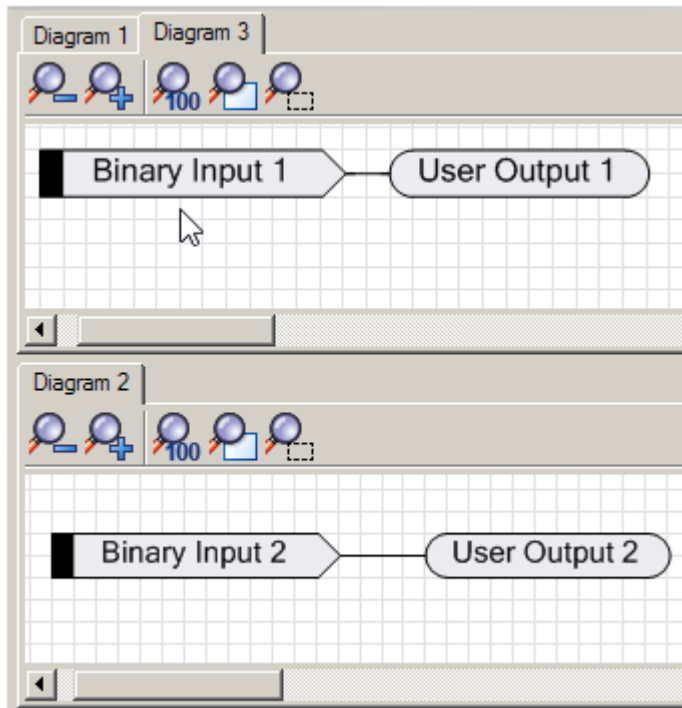

[sc_7SR5_ReydispManager2TwoPanels, 1, --]

Figure 2-44 Reydisp Manager 2 Two Panes

Adding a New Logic Diagram

The default configuration for the device contains a file for the user to add a new logic diagram to the 7SR5 configuration files. The individual logic diagram will depend upon the users application requirements.

Goal

The goal of this chapter is to create a new logic diagram in the offline configuration.

Device Details			
Name:	REYROLLE 5 7SR5431	IEC 61850 IED Name:	Newled3
MLFB:	7SR5431-5AA16-0AA0		
Status:	IEC 61850 Compile Required		
Name	Type	Last Modified	
Configuration			
Function Configuration	Application Functions		
User Settings	Device Parameters	21/10/2019 10:07:14	
Serial Comms & Events	Serial Comms & Events	31/10/2019 13:35:08	
User Logic	Graphical Logic		
7SR5431 Default	HMI Screen	21/10/2019 10:07:06	

[sc_7SR5_ReydispManager2DefaultDeviceConfiguration, 1, --]

Figure 2-45 Reydisp Manager 2 Default Device Configuration

Overview of the Procedure

Perform the following actions:

- Open the **User Logic** graphical logic interface.
- Add a logic diagram to the logic file in the device offline configuration.
- Give the logic diagram a specific name.

Adding a new Logic diagram

In the file configuration view of the 7SR5 device, open the **User Logic**.
The Reylogic Express window will be launched.
Add a new diagram .



[sc_7SR5_ReydispManager2FileNew, 1, --_--]

Figure 2-46 Reydisp Manager 2 New Diagram Icon

A new diagram will be visible in the **Tree**, named **Diagram 1**. Select the diagram and rename.

Adding Logic Symbols and Interconnecting the Items

The new diagram does not contain any logic and an empty space is shown in the working area instead. This chapter describes how to add symbols and device points to the diagram and make connections.

Overview of the Procedure

Perform the following actions:

- Add the required function logic symbols and device connection points.
- Interconnect the symbols and points.

Adding a Symbol or Device Data Signal to the Chart

Use the mouse to locate the required signal or symbol in the project tree.
Use the mouse to click and drag the required signal or symbol from the tree.
While dragging the signal move the mouse over the diagram to place it.
When happy with the placement of the signal release the mouse button.
The external signal will now be placed on the diagram.



NOTE

If the symbol has any properties these will be shown in the right hand side pane.

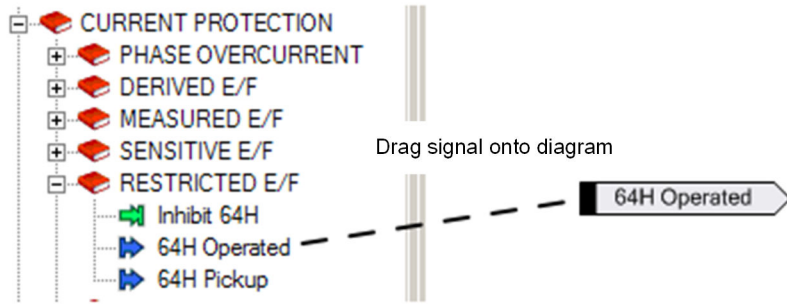

[dw_75R5_ReydispManager2AddingSignal, 1, en_US]
Figure 2-47 Reydisp Manager 2 Adding Signal

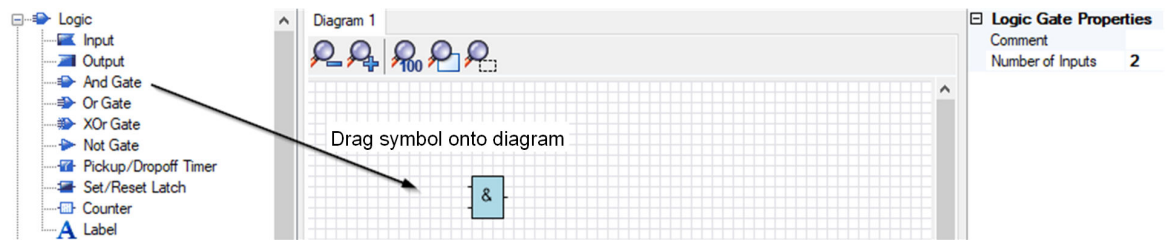

[dw_75R5_ReydispManager2AddingSymbol, 1, en_US]
Figure 2-48 Reydisp Manager 2 Adding Symbol

Interconnecting Function Block with Signals

The connection to the necessary signals is established very simply.

Logic symbols provide a number of connection points which can be used to connect symbols together. Connection points are displayed as protruding from the left/right of symbols. Connection points on the left side of the symbol are that symbol's inputs. Connection points on the right side of the symbol are that symbol's outputs.

A connection can be made between any output connection point and any input connection point which is not already used.

To connect 2 symbols together:

- Move the mouse over a connection point (either connection point which will be used in the new connection).
- Click and hold down the left mouse button.
- Move the mouse across the diagram (toward the second connection point to be used in the new connection). As the mouse is moved a connection indicator will display reminding which connection point is being dragged.

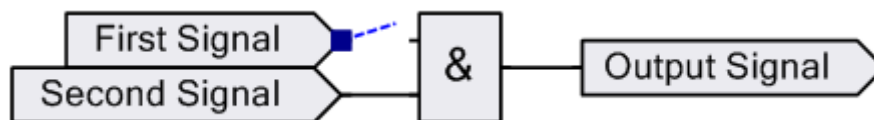

[sc_75R5_ReydispManager2CreatingLogicConnections, 1, --_]
Figure 2-49 Reydisp Manager 2 Connecting Symbols

- Move the mouse over the second connection point to be used in the connection.
- Release the left mouse button to create the connection.

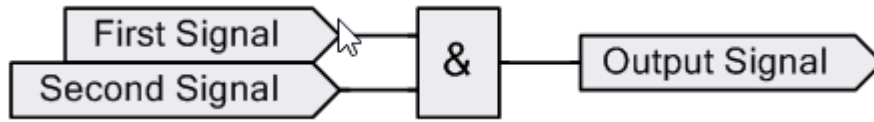

[sc_7SR5_ReydispManager2CreatingLogicComplete, 1, --_--]

Figure 2-50 Reydisp Manager 2 Connected Symbols



NOTE

If the connection made is not valid (for example an attempt has been made to connect 2 output connection points, 2 input connection points or an input connection point already connected to another symbol has been used) then no connection will be made.



NOTE

Signals and symbols can be moved, copied and deleted. Please refer to the Reylogic Express user manual for further information.

Logic Validation Scheme Warnings and Errors

When a graphical logic scheme is closed or saved the diagrams are validated. Reylogic Express may inform you of cases where errors have occurred in your logic scheme. It may also produce warnings to point out bad practices and scheme issues to be aware of.

Warnings and errors are listed in the notification area. Notification entries will specify the problem. If the problem relates to a specific diagram the diagram name will be displayed. If the warning/error relates to a specific symbol the symbol name will be displayed. If a warning or error relates to a specific symbol it is possible to quickly navigate to that symbol by using the left mouse button to double-click on the warning/error line of the notification area.

Description	Diagram	Symbol
Missing connections	Diagram 2	Function Key 1
Invalid Logic Scheme		

[sc_7SR5_ReydispManager2WarningsandErrors, 1, --_--]

Figure 2-51 Logic Validation Scheme Warnings and Errors

2.7 Creating a User Display Page

Overview

The 7SR5 devices are designed with a large graphic display. The 7SR5 device is delivered with a single user HMI configuration displaying the primary metered values applicable to the application option ordered by the MLFB code. The device can be used without any additional user configuration. The display is a 16 by 16 grid with grid lines for positioning the symbols and can be configured for up to 5 user HMI display screens with static, dynamic or controllable graphics.

HMI Screens

Using the ReyMimic Editor, up to 5 different display pages can be configured for each 7SR5 device and loaded into the device. In the device, to switch between the available display pages the right arrow key is used. The display number is shown in the bottom right hand corner of the display. The display pages are ordered in the PC tool with number 1 as the default home page. This default page is shown in the display when the device is first switched on or restarted or if the cancel key is pressed repeatedly from the menus. Display pages are always device-specific. The display pages for a 7SR5 device are thus part of the offline configuration of this device.

HMI screens can be renamed after they are created by right-clicking on the file in the task window and selecting the **Rename HMI Screen**.

Options

When a new display page is added to the offline configuration, this page does not yet contain any elements. Instead, an empty space is shown in the working area of the ReyMimic Editor. In this area, drag and drop is used to insert busbars, disconnectors, circuit-breakers, and other equipment from the symbol library. Text can be added to the graphical representation and connect dynamic graphic elements with process information. In this way, it is possible to visualize the states of equipment items, for example, the position of a circuit-breaker, on the display page. In addition, the control output signals produced from the symbol can be linked when used to control a state change from the display page. The device signal lists are automatically generated in the configuration and in addition to the usual device signals a number of user mimic signals are provided to manage interlocking logic.

Organizing the HMI Screens

The offline configuration allows the user display pages to be arranged in the preferred sequence to be viewed in the device.

Right-click on the device in the tree view and select **Organize HMI Screens**. The screens can be moved up and down the viewing order using the buttons and selecting **Apply**.

Symbol Positioning

All icons for display pages are provided in a standard symbol library which is visible in a tree structure in the left hand pane. The main diagram page is marked with grid lines for positioning the symbols. If an element is inserted from the library, the element symbol is shown as in the library but can be rotated and moved.



[sc_7SR5_ReydispManager2ElementSymbolRotatelcon, 1, --, --]

Figure 2-52 Reydisp Manager 2 Element Symbol Rotation Icon

Display Editor

The ReyMimic Editor tool is used to generate the user screens for a 7SR5 device. The editor consists of a working area and a toolbar for specific actions.

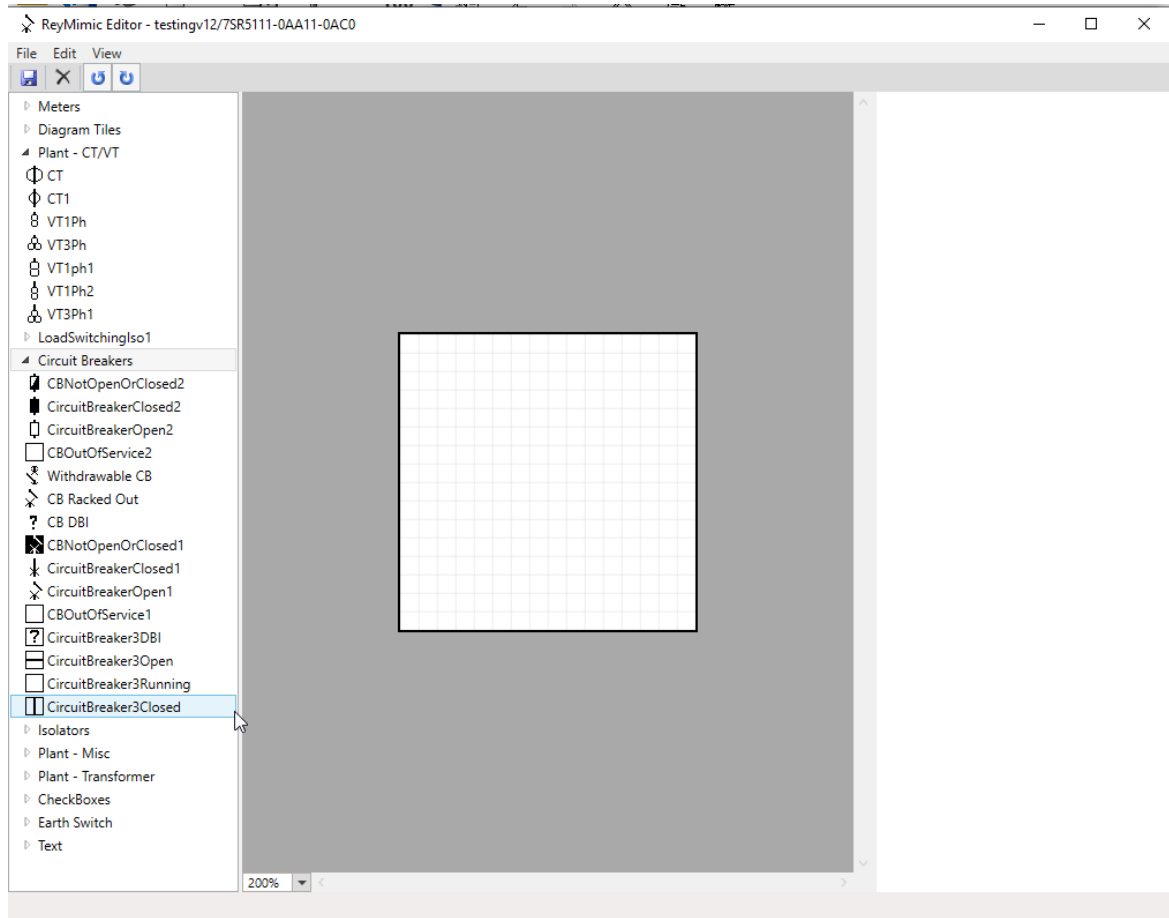

[sc_7SR5_ReydispManager2ReymimicDisplayEditor, 1, --]

Figure 2-53 Reydisp Manager 2 Reymimic Display Editor

Creating a New Display Page

A new display page does not yet contain any elements. An empty space is shown in the working area instead. This chapter describes how to create a feeder on the display page using individual elements selected from the library.

Goal

The goal of this chapter is to create the user screen shown in the following figure.

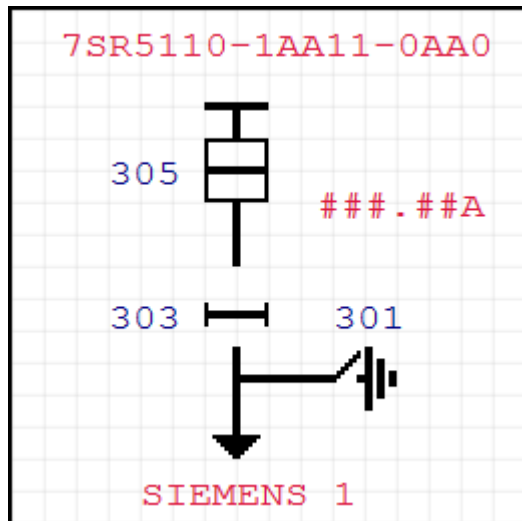

[sc_7SR5_ReydispManager2ExampleUserMimicDisplay, 1, --]

Figure 2-54 Reydisp Manager 2 Example User Mimic Display

The display page contains one or more of each of the following elements:

- Busbar
- Circuit-breaker
- Isolator
- Earth switch
- Meter text
- Static text
- Feeder

Overview of the Procedure

Perform the following actions:

- Add a new display page and rename it.
- Insert a busbar into the display page.
- Insert additional equipment into the display page.
- Connect the individual elements to the device signals.
- Insert the static text into the display page.

Adding a New Display Page and Renaming It

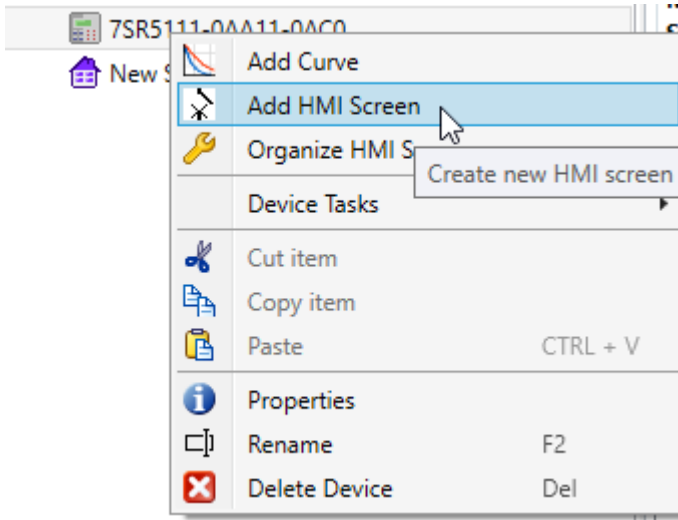

[sc_7SR5_ReydispManager2NewDisplayPageandRename1, 1, --]

Figure 2-55 Reydisp Manager 2 Add HMI Screen

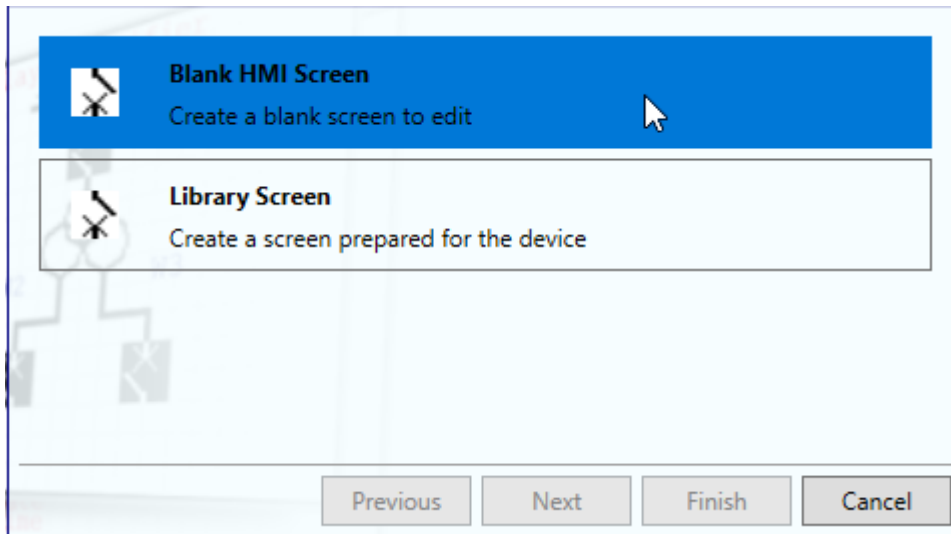

[sc_7SR5_ReydispManager2NewDisplayPageandRename2, 1, --]

Figure 2-56 Reydisp Manager 2 Blank HMI Screen

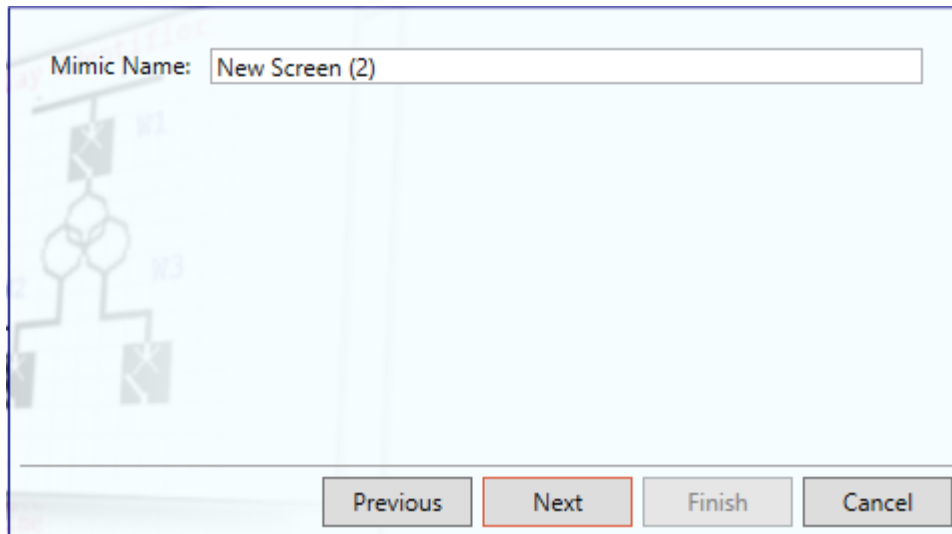

[sc_7SR5_ReydispManager2NewDisplayPageandRename3, 1, --]

Figure 2-57 Reydisp Manager 2 HMI Screen Rename

Up to 5 user HMI display screens can be created for each 7SR5 device.

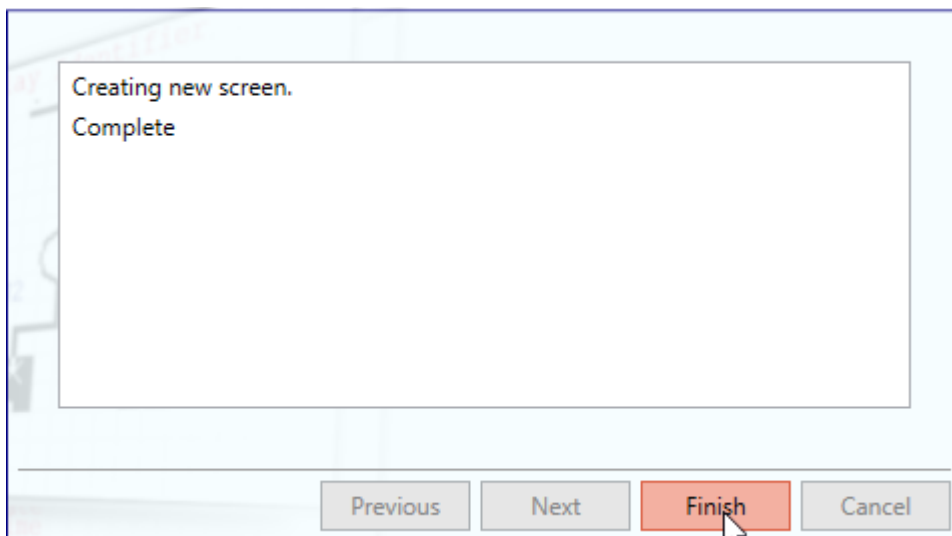

[sc_7SR5_ReydispManager2NewDisplayPageandRename4, 1, --]

Figure 2-58 Reydisp Manager 2 Finish New HMI Screen

In the tree structure of the offline configuration, right-click **Add HMI Screen**. The user can select to use a library screen as a starting screen or a blank screen.

Select a name for the HMI page. On completion the new HMI file is added and shown in the working area.

Open the file by double-clicking.

Click another area of the display page.

Drag and drop elements from the library tree onto the screen page.

Zoom in or out using the drop down menu located at the bottom of the window or holding the control key and using the mouse scroll. Use the rotate symbols to adjust the symbol to the correct orientation.



NOTE

The HMI display file name can be edited at a later date.

Inserting the Busbar

The **Diagram Tiles** folder contains common single line diagram symbols. Select the **Tee** symbol and drag to the desired position on the page. Release the mouse button. The busbar is placed at the selected position within the grid and can be moved or rotated.

Adding Additional Equipment

Insert additional equipment from the library tree into the display page via drag and drop in the same way as the busbar.

Highlight the element **Circuit Breakers** in the open position in the tree. Hold down the right mouse button and drag the element into the working area, positioning it below the busbar.

Release the mouse button. The circuit-breaker is now placed at the insertion position.

Repeat this procedure for the elements, **Isolator** and **Earth Switch**. Position the elements as shown in [Figure 2-54](#).

Rotate the **Earth Switch** by 90° by highlighting the item and selecting the **Rotate** symbol in the menu.



[sc_7SR5_ReydispManager2ElementSymbolRotatelcon, 1, --]

Figure 2-59 Reydisp Manager 2 Element Symbol Rotation Icon

Complete the diagram by selecting suitable items from the **Diagram Tiles** folder. Some tiles will need to be rotated.

The mimic display should now look like the following figure.

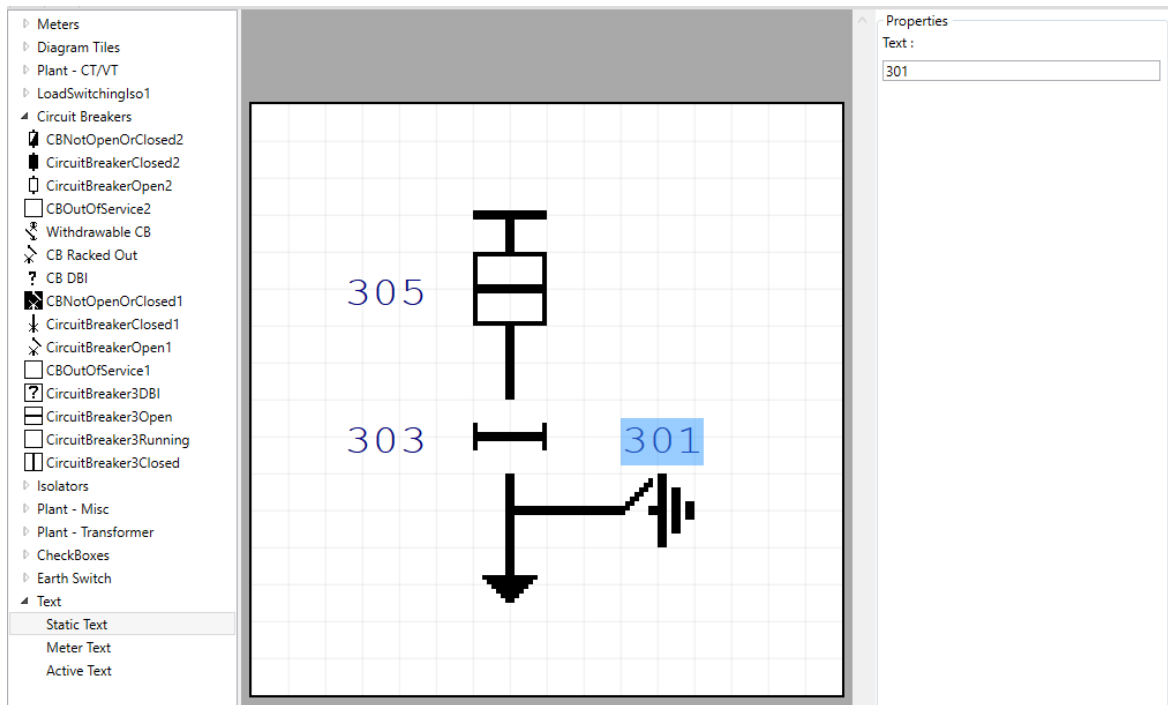

[sc_7SR5_ReydispManager2DisplayPagewithConnectedElements, 1, --]

Figure 2-60 Reydisp Manager 2 Display Page with Connected Elements

Inserting Static Text into the Display Page

A display page can contain static text. Static text is information that you can add to the display page. Insert a static textbox from the library tree into the display page via drag and drop in the same way as the busbar and enter the text information into the **Properties** box on the right hand side of the display.

Expand the **Text** folder and select **Static Text**.

Hold down the right mouse button and drag the static text into the working area, positioning alongside the circuit-breaker.

Enter the required text into the properties.

Repeat for the **Isolator** and **Earth Switch**. The text entered is applied on the display page.

The goal has been achieved.

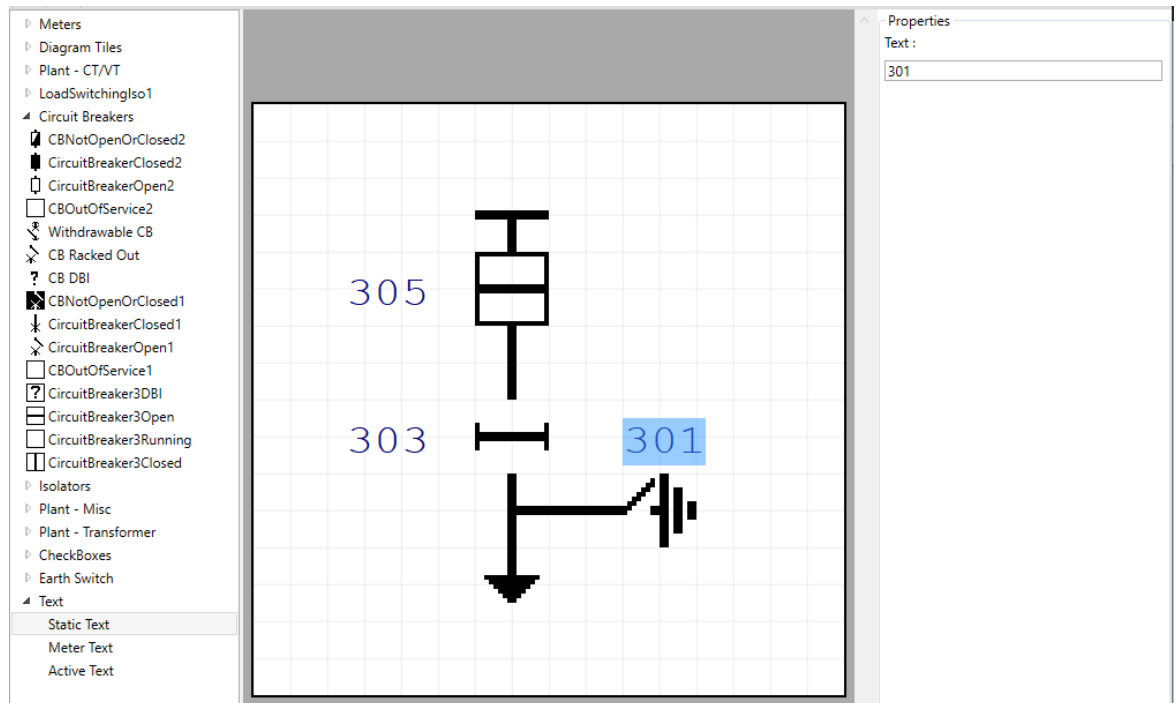

[sc_7SR5_ReydispManager2StaticText, 1, --_--]

Figure 2-61 Reydisp Manager 2 Static Text Added

Inserting Meter Text into the Display Page

A display page can contain meter text. Meter text is information that can be added to the display page to display a dynamic value of measurement, instrumentation and information from the device. Insert a meter textbox from the library tree into the display page via drag and drop in the same way as the static text and select the information to be displayed from the device signal list in the **Properties** box on the right hand side of the display.

Expand the **Text** folder and select **Meter Text**.

Hold down the right mouse button and drag the meter text into the working area, positioning in a free area of the screen.

In the **Properties** area use the drop down to locate the information signal to be displayed, for example **Primary Ib**.

Repeat to display the MLFB order code above the busbar tile. The text entered is applied on the display page.

The goal has been achieved.

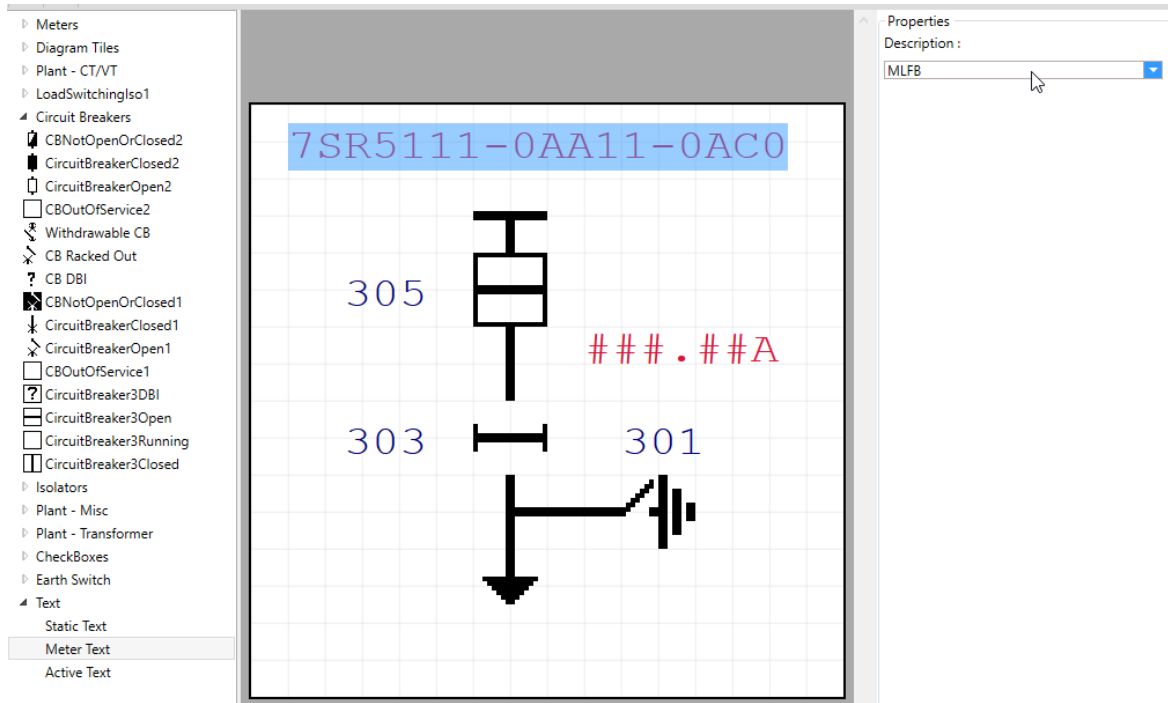

[sc_7SR5_ReydispManager2MeterText, 1, --, -]

Figure 2-62 Reydisp Manager 2 Meter Text Added

Adding Plant Control Signals to the Display Page

Signals can be added to the display page and in this way create a dynamic value display and a dynamic position display.

- **Active Text**

With the dynamic **Active Text** display, device signals can be used to display specific user messages in accordance with the state of the signal, for example, **On** or **Off**.

The **Active Text** element can be connected to be controllable from the fascia and send a command signal out from the device.

Active text only has 2 states for control commands.
- **Dynamic Position display and control**

A graphical element can be connected having multiple states to a device signal. In this way, it is possible to control the states of the graphical element on the display of the 7SR5 device in accordance with the state of the signal.

For example, connect the graphical element for a circuit-breaker to the position signal of the corresponding circuit-breaker. If the circuit-breaker is closed, the display on the unit shows the closed circuit-breaker symbol. If the circuit-breaker is open, the display on the unit shows the open circuit-breaker symbol. This also applies to the intermediate and disturbed position of the circuit-breaker.

Connect the graphical element to be controllable from the fascia and send a command signal out from the device.

Goal

The goal of this chapter is to enable the circuit-breaker symbol to mimic the position of the circuit-breaker and control the circuit-breaker from the device fascia mimic control. Then to add **Active Text** to display and control a plant item without a symbol.

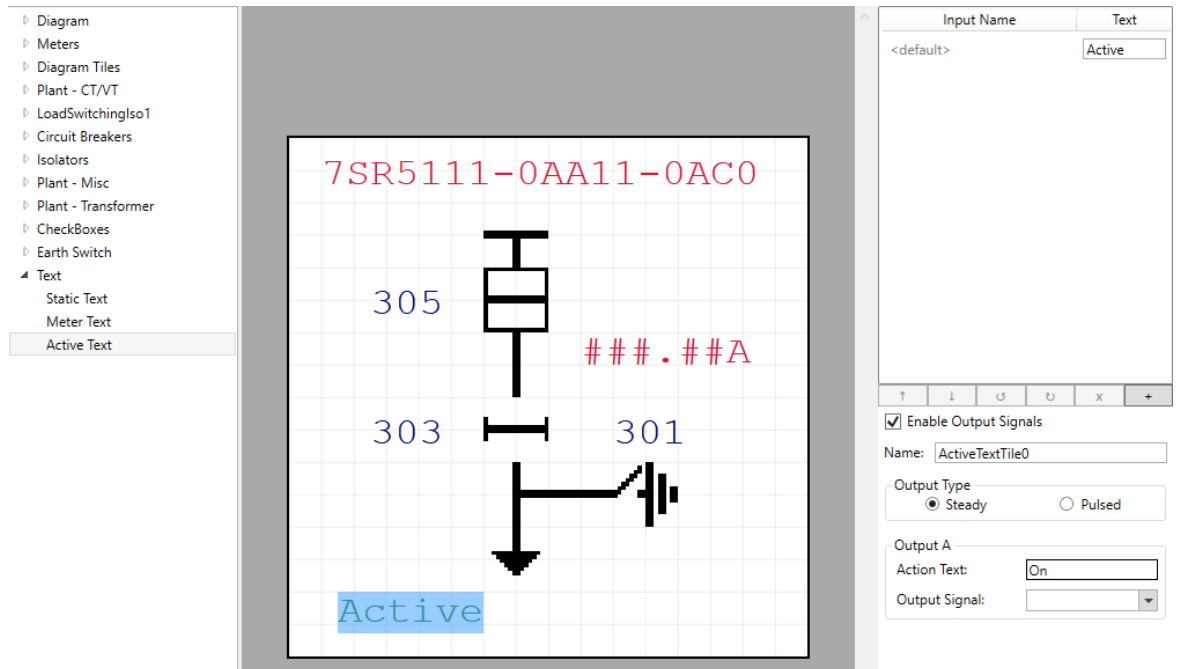

[sc_7SR5_ReydispManager2DisplayPageAddedActiveTextDefault, 1, --_--]

Figure 2-63 Reydisp Manager 2 Display Page with Added Active Text in Default

The display page contains the following items for configuration:

- The plant elements will also have a properties area associated with them.
- The active text is added to the display page with a properties area to the right hand side.

Overview of the Procedure – CB Control

Perform the following actions:

- Select the circuit-breaker symbol already placed on the diagram.
- Insert the alternative plant symbols in the right hand side properties area.
- Add the signals to drive the symbols.
- Enable output signals for control operation.
- Name the controllable device for description in device menus.
- Select the output type of **Steady** or **Pulse** operation of the control output signals.
- Add control output signals.

Opening the Signal Catalog and Selecting the Offline Configuration

With the mimic editor open, highlight the **Circuit-breaker** symbol. The default symbol placed on the diagram will be shown in the right hand area of properties, marked as default. The default symbol is the symbol that will be displayed when the device starts up and if none of the input signals are driving an alternative symbol.

Select the + symbol to add alternative symbols for the circuit-breaker or same device object. For this example 3 additional symbol objects will be added.

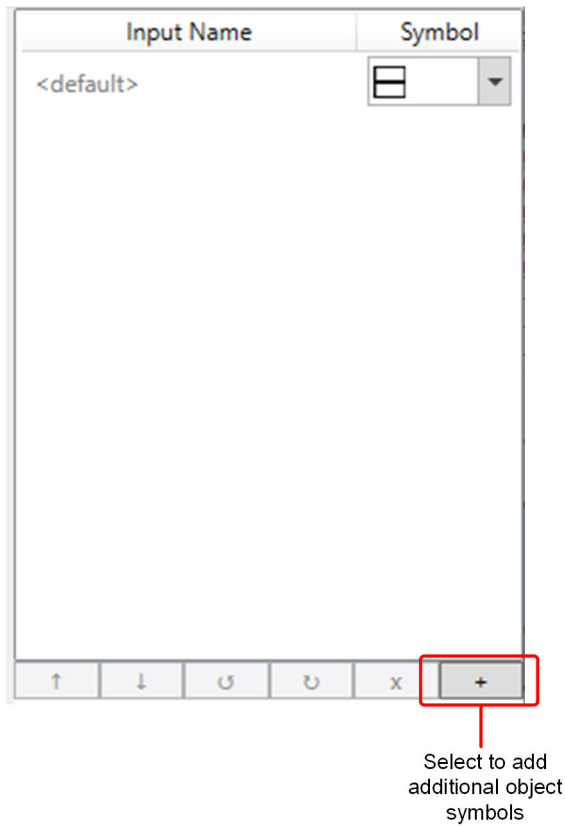

[dw_7SR5_ReyspManager2AddAdditionalSymbolObjects, 1, en_US]

Figure 2-64 Reysp Manager 2 Add Additional Symbol Objects

For each additional object **View a symbol** must be selected from the drop down menu. Alternatively a symbol can be dragged from the symbol tree and dropped into the **Symbol property**.

If the symbol is not in the correct orientation this can be adjusted by highlighting the property line and using the rotate buttons.

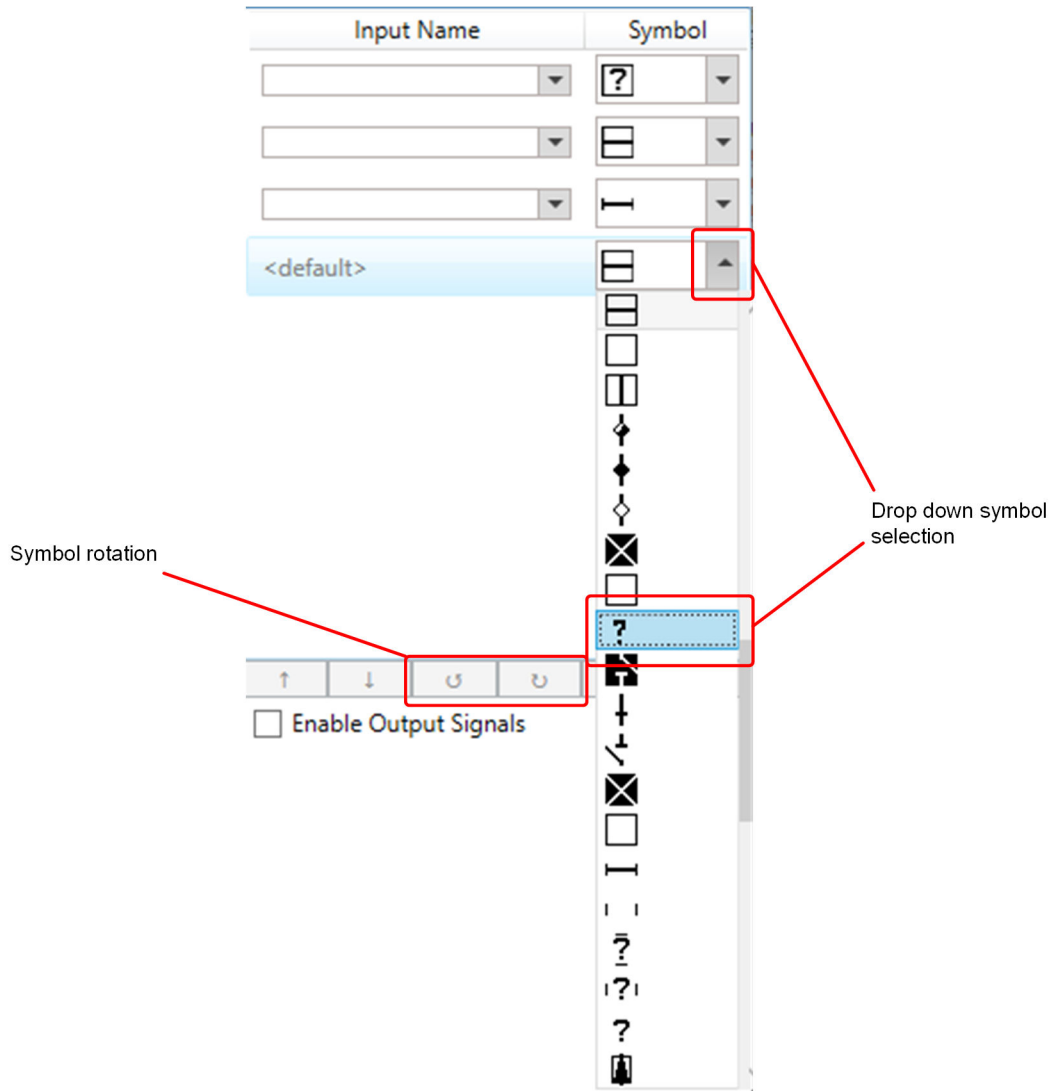

[dw_7SR5_ReydspManager2SymbolRotation, 1, en_US]

Figure 2-65 Reydsp Manager 2 Symbol Rotation

The signal catalog is displayed.

The symbol order of priority can also be changed using the **Up** and **Down** arrows.

In the **Input Name** select the device signal from the drop down list which is to be used to drive the symbol on the HMI screen.

The signals available from the selected offline configuration are created from the devices available signals for configuration and MLFB application template and included functions. The signals are structured hierarchically in different groups. Individual groups can be expanded and closed. To do so, simply click the arrows on the left of the group names as in the library. The signals for the device circuit-breaker can be found in the **Functions** > **Control** > **52** menu

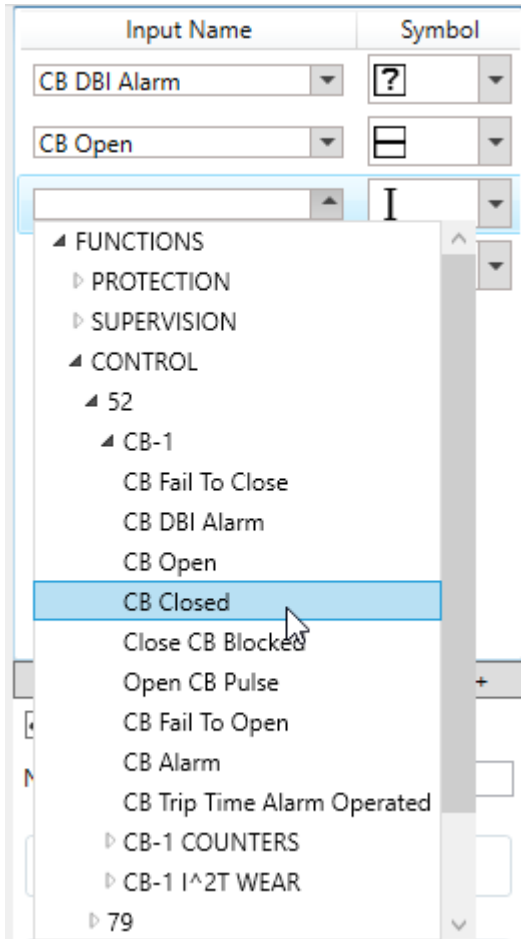

[sc_7SR5_ReydspManager2Circuit-BreakerSignals, 1, --, -]

Figure 2-66 Reydsp Manager 2 Circuit-Breaker Signals

Adding a Signal for Connection to the User Logic Scheme

In the signal list, in addition to the standard device signal the user is provided with some additional signals to allow an easy interface to the user logic.

These additional 10 operation signals are located in the sub menu **General > User Mimic Symbols**.

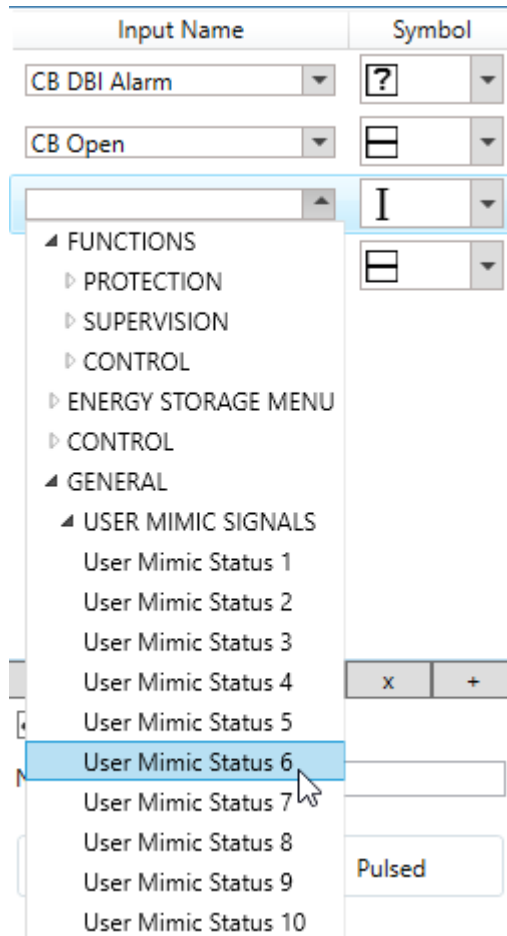

[sc_7SR5_ReysdispManager2UserMimicSymbols, 1, --]

Figure 2-67 Reysdisp Manager 2 User Mimic Signals



NOTE

When configuring **Controllable Plant** items the user must ensure that for safety reasons all interlocking logic is created in the user logic area. Siemens are not responsible for the design, implementation and testing of Interlocking logic.

Connecting an Output Command Signal from the Operation of a Display Item

Under the symbol properties area for the chosen item the **Enable Output Signals** can be selected to allow the item to be a **Controllable Item**. This will enable the option to create output signals when the item state is changed in the fascia control. Multiple Items can be configured to be **Controllable**.

Enter a suitable name for the **Controllable Item**.

When the item changes state from the control menu, select whether the output signal should be a pulse signal or a steady state operation. Siemens recommends that plant is controlled using a pulsed output. A steady state output will generate a signal whenever the item is in a particular condition/position. All graphical elements do not have to be controllable items.

The item will now show a different symbol to represent the input conditions driving the state and will allow the user to control the item and produce the necessary output signals.

The screen should now look as follows.

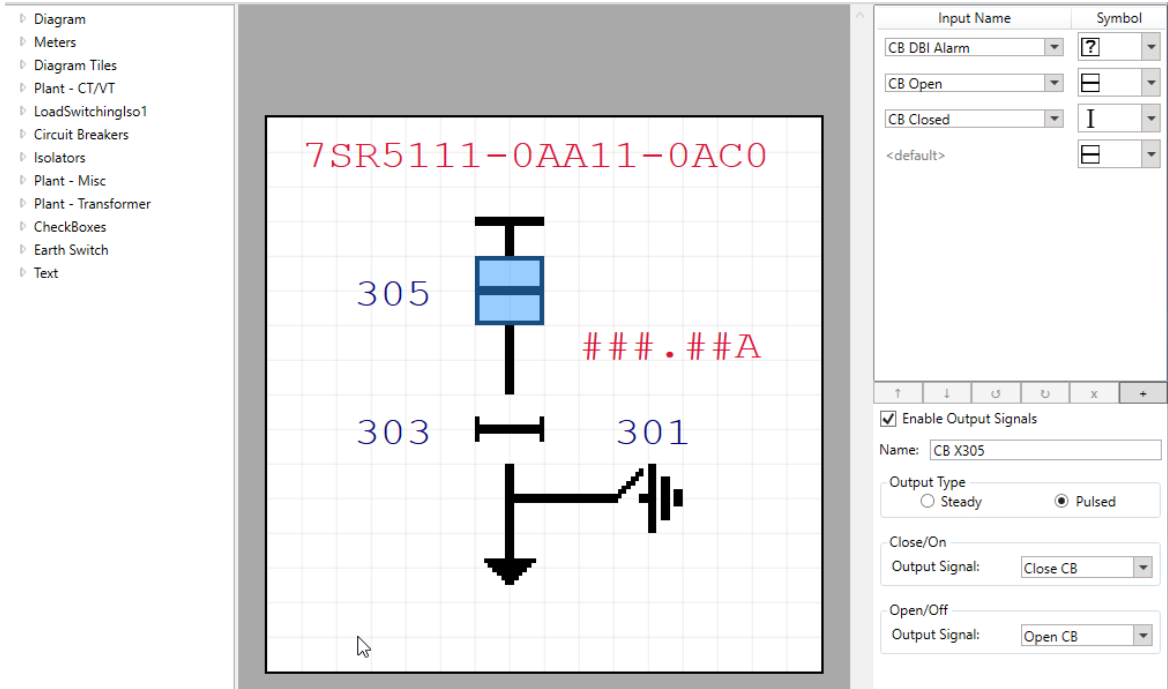

[sc_7SR5_ReydispManager2MimicControlledItem, 1, --_]

Figure 2-68 Reydisp Manager 2 Mimic Controlled Item

The goal has been achieved and if finished, the Mimic Editor can be closed and the file saved.

Overview of the Procedure – Active Text

Perform the following actions in the sample procedure as for the mimic items:

- Insert **Active Text** onto the diagram in the desired location using the drag and drop method.
- Insert the **Text Labels** that should be displayed along with the signals to drive the text.
- Enable output signals for control operation if required.
- Name the controllable device for description in device menus.
- Select the output type of **Steady** or **Pulse** operation of the control output signals.
- Add control output signal from the control operation in the **Output A**.

What is **Output A** – definition required.

All **Active Text** does not have to be controllable.

The screen should now look as follows.

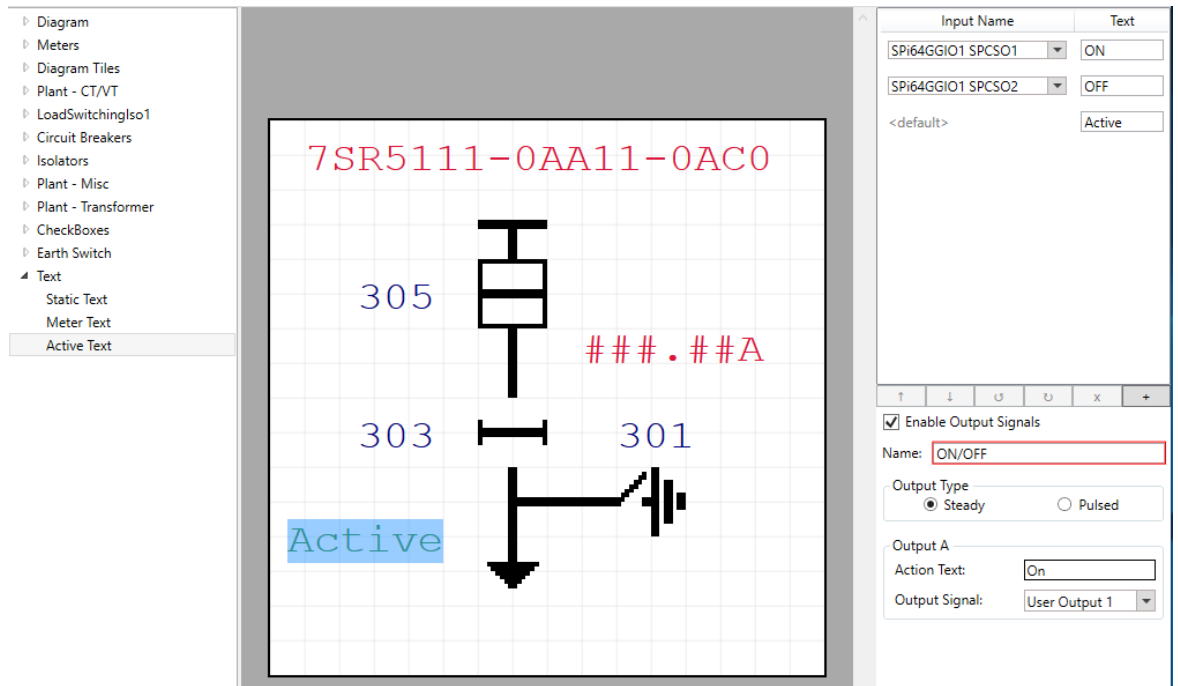

[sc_7SR5_ReydispManager2ActiveText, 1, --,--]

Figure 2-69 Reydisp Manager 2 Mimic Controlled Item with Active Text

The goal has been achieved and if finished, the Mimic Editor can be closed and the file saved.

2.8 Creating User Curves

Overview

The device configuration supports the ability to add custom (User defined) curves to the device. User defined curves are created and added to the device configuration. Once added they will appear as a selectable setting option in the Char parameter list, using the name that is entered when the curve is created, for all elements which are applicable. Both operate and reset curves can be created as required.

The 7SR5 relay will support a maximum of 5 user curves in a device configuration.

The **Curve Editor** tool allows user-definable curves to be created.

To assist in the creation of the user curves, reference curves can be viewed and compared in the tool.

For a more detailed guide on using **Curve Editor**, refer to the **Reyrolle Curve Editor User Manual**. The user manual for the **Curve Editor** can be accessed by opening the **Curve Editor** main window and clicking **Help > User Guide**.

Scope

Curve Files

The following curve types are supported. The curve types available depend on the device template.

Curve Type Curve Extension Description

- Current Curve .I_CRV Current curve, for use with IDMTL current elements.
- Voltage Curve .V_CRV Voltage curve, for use with IDMTL voltage elements.
- Thermal Curve .THERM_CRV Thermal curve, for use with thermal elements.



NOTE

Curve files can be created and then sent to the device on site. However, the device settings must be changed in the **Setting Editor** to set the element to use the user curve characteristic.

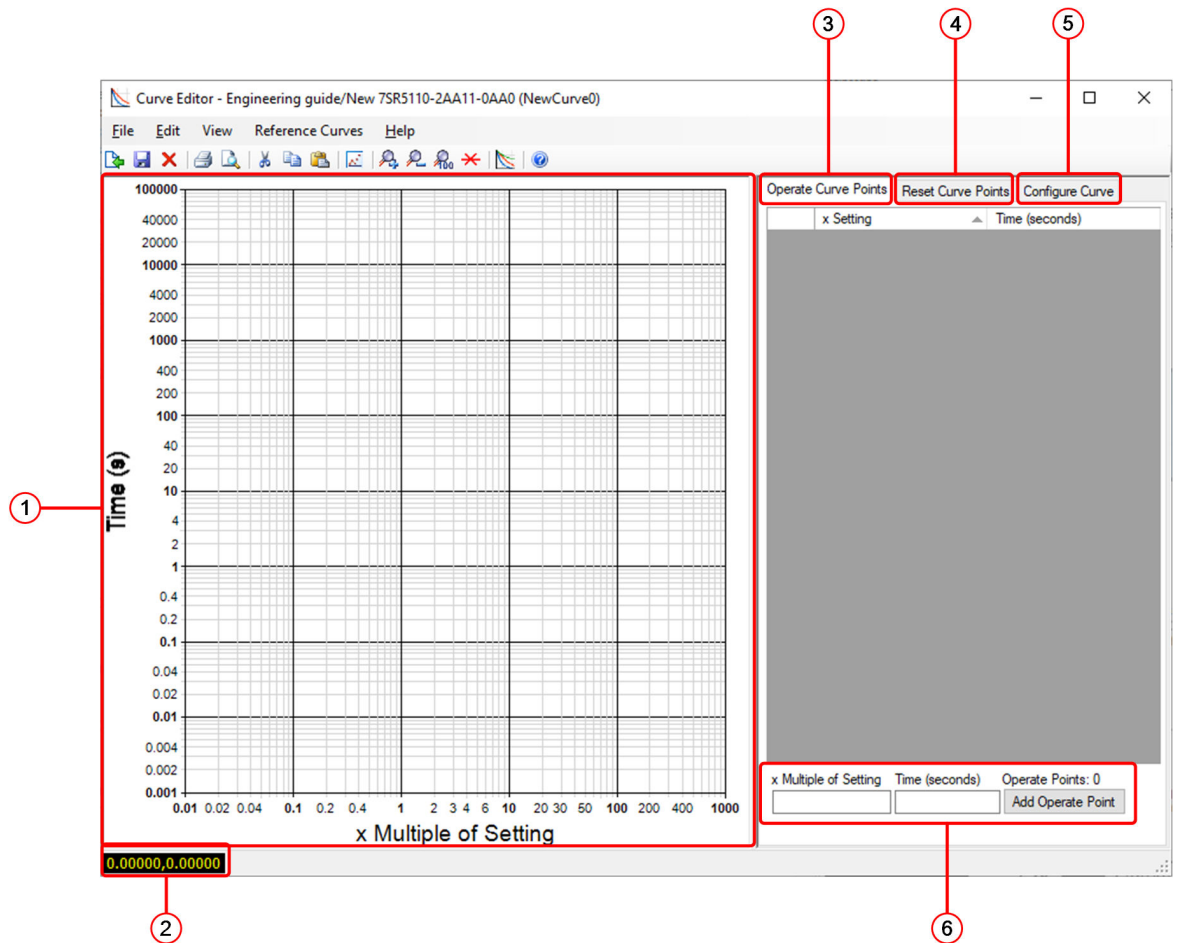

[dw_7SR5_ReydispManager2SettingEditorOverview, 1, en_US]

Figure 2-70 Reydisp Manager 2 Setting Editor Overview

- (1) Graph pane
- (2) Current mouse coordinates
- (3) Operate curve points
- (4) Reset curve points
- (5) Curve parameters
- (6) To add a point, enter x and y values (x is **x Multiple of Setting**, y is **Time (s)**) then click **Add Operate Point**

Overview of the Procedure

Perform the following actions:

- Add a curve to the device configuration from the device in the tree view.
- Enter a name for the curve.
- Select the type of curve – Current, Voltage or Thermal.
- Create a curve from a user defined file, template or equation.

Curve Editor

To add a user curve and subsequently launch the Curve Editor, click on the device in the menu tree and right-click.

Select the **Add Curve**.

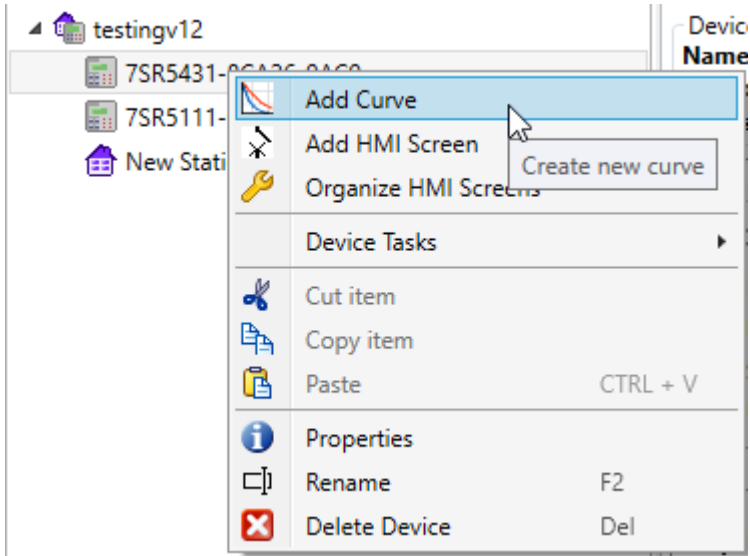

[sc_7SR5_ReydispManager2AddCurve, 1, ...-]
Figure 2-71 Reydisp Manager 2 Add Curve

In the **Create Curve**, give the curve a name. The name given here is the name that will be displayed on the device. Names must be a maximum of 20 characters, consisting of the characters A-Z, a-z, 0-9 and space. The curve cannot be given the same name as an existing curve used on this device.

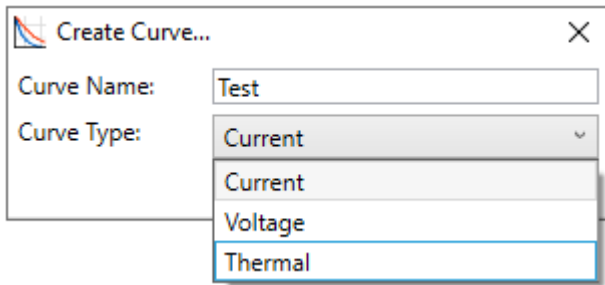

[sc_7SR5_ReydispManager2CreateCurve, 1, ...-]
Figure 2-72 Reydisp Manager 2 Create Curve

Click **Create** to accept.
This brings up the **Reyrolle Curve Editor** main window, as shown in [Figure 2-70](#).
For this example, an existing template will be used rather than applying any grading or manually entering points or equations.
Select **File > Create Curve From**.

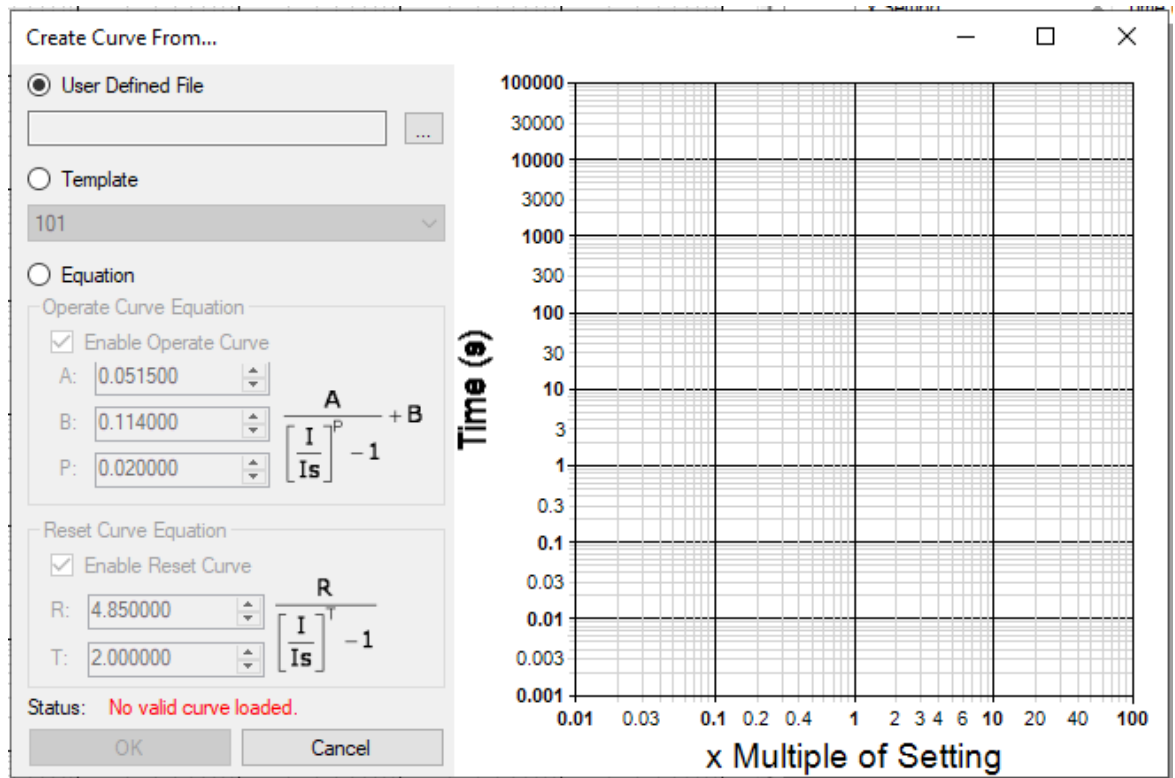

[sc_7SR5_ReydispManager2CreateCurveFrom, 1, --]

Figure 2-73 Reydisp Manager 2 Create Curve From Window

Select the **Template** option and select a suitable curve from the dropdown list.

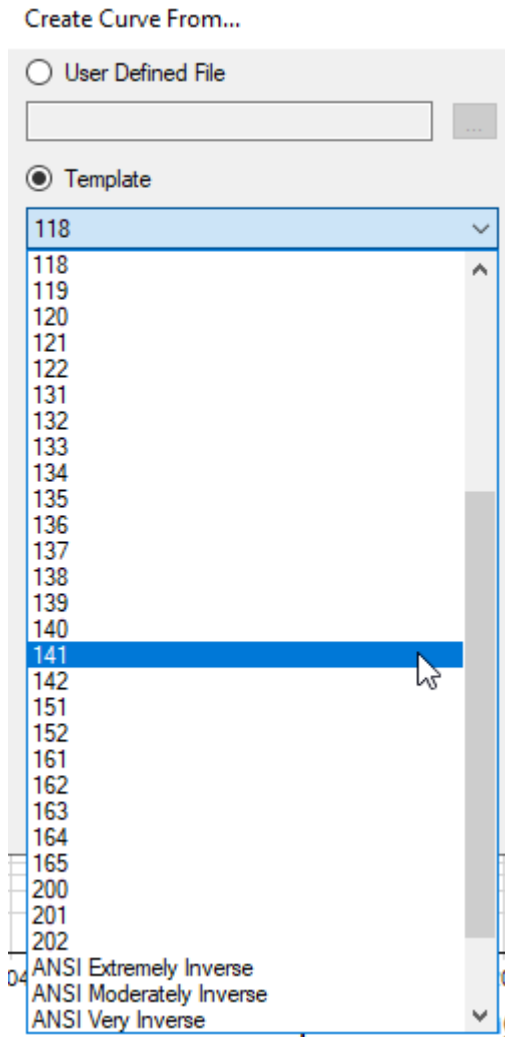

[sc_7SR5_ReydispManager2CreateCurveFromDropdown, 1, --]

Figure 2-74 Reydisp Manager 2 Create Curve From Dropdown List

A curve will appear in the window, once selected press **OK**.
The curve is loaded and the operate curve points displayed.

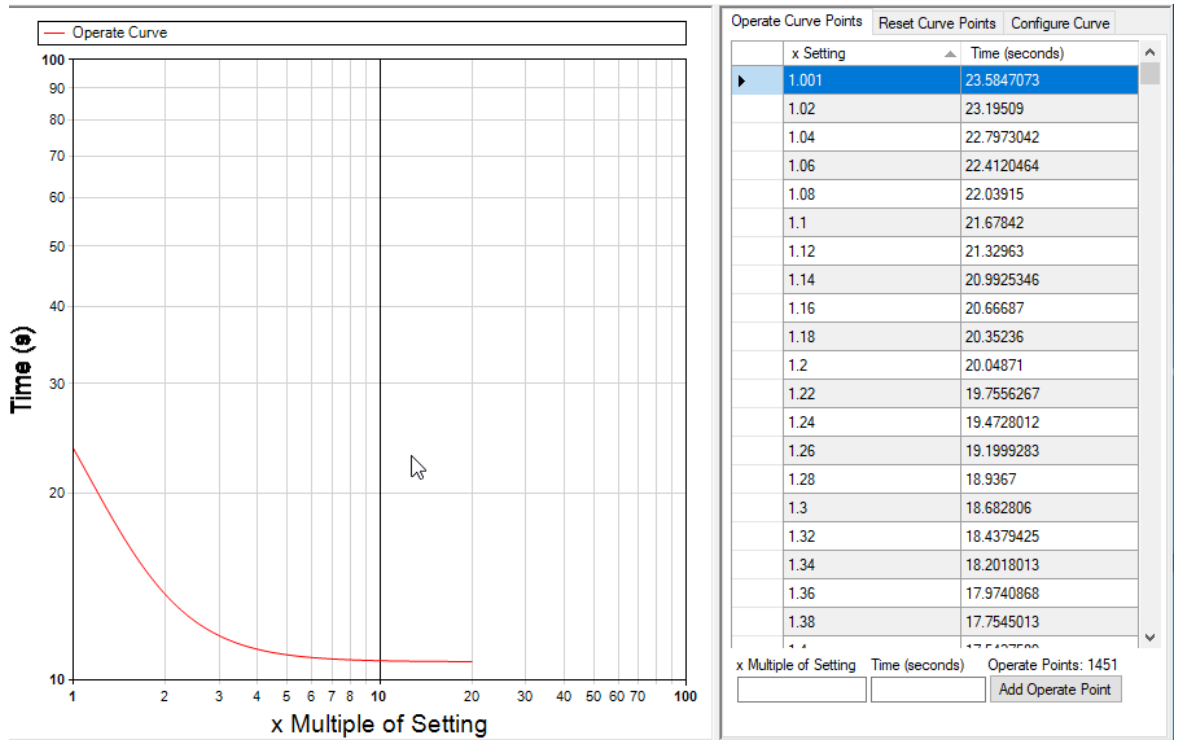

[sc_7SR5_ReydispManager2OperateCurvePoints, 1, --, --]

Figure 2-75 Reydisp Manager 2 Operate Curve Points

The points can be edited and the curve can be configured if required. Please refer to the **Reyrolle Curve Editor User Manual** in the **Curve Editor** tool for further guidance on advanced configurations. Click **X** to close the window and **Yes** to confirm when prompted to save.

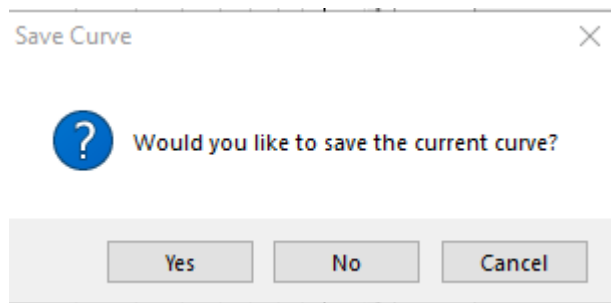

[sc_7SR5_ReydispManager2SaveCurve, 1, --, --]

Figure 2-76 Reydisp Manager 2 Save Curve

The curve **Test** is now visible in the list of configuration files for this device.

Name	Type	Last Modified
Configuration		
Function Configuration	Application Functions	
User Settings	Device Parameters	
Serial Comms & Events	Serial Comms & Events	
User Logic	Graphical Logic	
Test	Curve (Current)	27/11/2019 15:00:16
7SR5431 Default	HMI Screen	16/05/2019 14:35:27
7SR5431 Default (2)	HMI Screen	17/05/2019 08:01:11
New Screen	HMI Screen	21/11/2019 16:05:45

[sc_7SR5_ReydispManager2CurveTest, 1, --]

Figure 2-77 Reydisp Manager 2 Curve Test

Select the curve in the **Setting Editor**.

The curve can be selected in the IDMTL settings. Click **User Settings** to open the **Setting Editor**. For this example, a current curve is used, so 50 Phase Overcurrent element **Char** setting is shown.

W1 51-1

Setting Name	Value
Element	Disabled
Measurement	RMS
Setting	1.00xIn
Char	IEC-NI
Time Mult (IEC/ANSI)	DTL
Delay (DTL)	IEC-VI
Min Operate Time	IEC-EI
Follower DTL	IEC-LTI
Reset	ANSI-MI
81HB2 Inhibit	ANSI-VI
	ANSI-EI
	Test

[sc_7SR5_ReydispManager2CharSetting, 1, --]

Figure 2-78 Reydisp Manager 2 Char Setting

File Management

The curve can be saved on the PC using the **Save As** feature for use in another device. The user defined file selection should be used when creating the file in the device. Browse to the saved file and use the pre configured curve.

Right-click on the curve file will also give the option to:

- Open the curve for editing
- Delete the file from the device
- Copy the file for use in a different device within the project.
- Rename the curve

To paste a curve into the device, a right-click on the device or in the configuration working area will allow a **Paste** option.

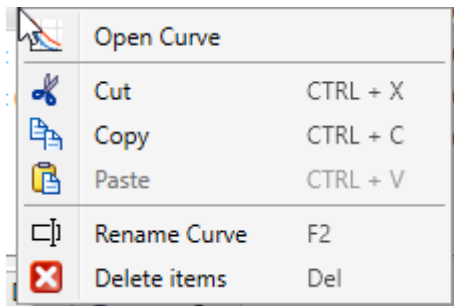

[sc_7SR5_ReydispManager2PasteCurve, 1, --]

Figure 2-79 Reydisp Manager 2 Paste Curve

2.9 Parameterizing Functions

Overview

The parameters for all protection functions are preset to default values. These values can be adapted to the real circumstances and requirements. Function groups and function elements that have been included can be **Enabled** or **Disabled** using Reydisp or from the device fascia:

- Protection and automation function elements
- Supervision function elements
- Control function elements

From the device fascia the protection, supervision and control function groups are enabled and disabled in the **Settings > Functions > Function Config** menu.

Function element parameter changes can be entered from the device fascia or from Reydisp Manager. These can be for the **Function Groups (FG)** or **Function Elements (FE)** i.e. the **Settings > Function** menus. Function groups and elements can be added or removed only by using the Reydisp software configurator tool.

In addition to the protection functions, the **Settings** folder contains other functions and parameters, for example, for input/output mapping or fault recording in the **Setting > Configuration**.

Scope

All protection functions whose parameters and values are part of the offline configuration of a 7SR5 device and are contained in the **Settings** folder. The protection functions are sorted by function groups.

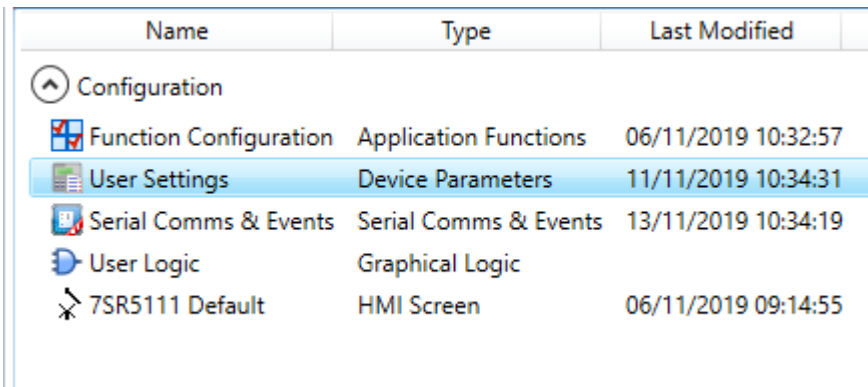

Name	Type	Last Modified
Configuration		
Function Configuration	Application Functions	06/11/2019 10:32:57
User Settings	Device Parameters	11/11/2019 10:34:31
Serial Comms & Events	Serial Comms & Events	13/11/2019 10:34:19
User Logic	Graphical Logic	
7SR5111 Default	HMI Screen	06/11/2019 09:14:55

[sc_7SR5_ReydispManager2UserSettingsFile, 1, --]

Figure 2-80 Reydisp Manager 2 Project Tree showing User Settings File



NOTE

Some parameter setting changes from the fascia will cause the device to restart.

Settings Groups

Different operating cases can require different function settings. To save and use the protection function settings for different operating cases, use settings groups. In a settings group, the parameters can be set specifically for an operating case.

7SR5 devices support 4 independent settings groups and are provided for each function -Group number (Gn) 1 to 4.

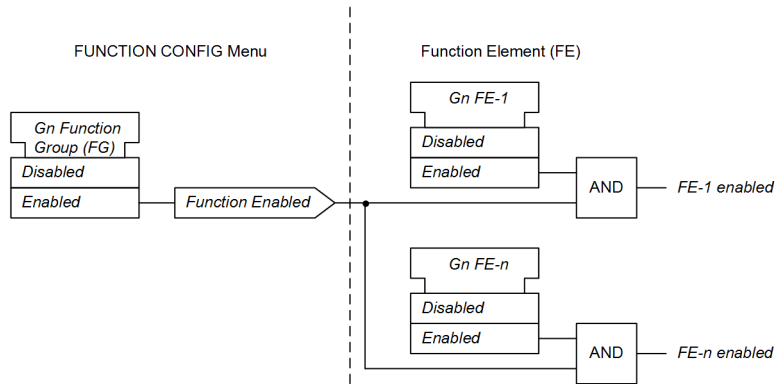

[lo_7SR5_FunctionConfigurationlogicdiagram, 1, en_US]

Figure 2-81 Reydisp Manager 2 Function Configuration Logic Diagram

Settings Editing

With the **Settings Editor**, the settings of parameters are processed, for example, of protection functions or of the data storage. The parameter settings are represented in one of the following ways:

- Drop down menu selection (pc tool)
- Scroll menu selection (fascia)
- Bit String (fascia)
- Text entry
- Matrix view (pc tool)

Selecting the Appropriate Mode for Fascia Setting

From the fascia you can enter and display parameter values as primary values, secondary values, or as default. They are shown as **xNom**. The decision concerning the mode depends on user preference.

- Multiple of Nominal Current (**xNom**)
- Primary values
- Secondary values

In Reydisp Manager the parameters are set using **xNom** (xI_n or I_{rated}).

Parameter Setting from Fascia

Parameters can be divided into 3 different categories:

- Text parameter
Text parameters can accept defined characters.
- Scroll parameter
Scroll parameters are predefined selections of values or operations, for example 0.20 or Enabled.
- Bit String
Parameters are defined by selecting a 1 in a bit location. The selections are made in 8 position selections. In the following example BI4 is set to 50SOFT.





50SOFT ___ 1 _____ BI 4

Using the fascia keys navigate to the required parameter.

When the required parameter is located press the **Enter** key to allow editing of the setting.

When editing a parameter from the fascia the **Setting ID** will be required if active.

Table 2-2 Fascia Pushbuttons

	Menu navigation and settings increase
	Menu navigation and settings decrease
	Enter key, used to initiate and accept settings changes
	Cancel key, used to cancel settings changes and/or move up the menu structure by one level per press
	Menu navigation. Binary output reset from home screen (3 second delay)

Overview of the Procedure

Perform the following actions:

- From the fascia navigate to the **Setting** menu.
- Change the values of the parameters.

Editing a Parameter from the Fascia

From the **Home HMI** screen use the **Down Arrow** to enter the **Main Menu** screen. The **Settings Option** should be highlighted. If not, use the Up/Down keys to navigate to it. Press the **Right Arrow** to enter the **Settings** menu.



NOTE

Siemens recommend only the **Functions** parameters are adjusted from the fascia as many parameters in the **Configuration** menu may require a device restart when changed.

The display now shows the sub menus **Configuration** and **Functions**. Names of all available function groups are listed.



[sc_7SR5_ReydspManager2ViewEditGroup, 1, --]

Figure 2-82 Reydsp Manager 2 View/Edit Group



NOTE

The **Active Setting** group and **View/Edit** group are displayed on the top of the HMI. Please ensure you are viewing/editing the correct group before proceeding. The **View/Edit** group can be changed from the **Configuration > Device** menu on the fascia. If the setting is not group dependent and common to all groups the **View/Edit** information is not applicable and therefore not seen.

Use the **Down Arrow** to highlight the **Function** menu and the **Right Arrow** to enter the menu.

Navigate using the **Down Arrow** and **Right Arrow** to the desired parameter.

Press the **Enter** key to edit the parameter setting. If a **Setting ID** is active the user must enter this before editing a setting. The lock symbol in the top right hand corner will indicate if the settings are locked and ID is required.

The HMI will display the parameter name with the **New Value** flashing and the current/existing value displayed below. Use the **Up/Down** or a combination of **Right Arrow** and **Up/Down** keys to adjust the setting. When the desired setting is visible press the **Enter** key to confirm. The new parameter setting will now be active in the device.



[sc_75R5_ReydispManager2NewValue, 1, --, --]

Figure 2-83 Reydisp Manager 2 New Parameter Setting



NOTE

At any time if the **x** key is pressed it will cancel the operation or move one level up the menu tree structure.

A scroll bar on the right hand side of the display indicates the users position within the menu.



NOTE

If the setting dependencies are enabled, only the parameters of enabled functions will be visible for viewing and editing on the HMI screen.

Parameter Setting from PC Tool

Parameters can be divided into 5 different categories:

- Text parameter
Text parameters can take accept defined characters.

- Drop down parameter selection
Parameters are predefined selections of values or operations in a drop down list, for example 0.20 or **Enabled**.
 - Matrix
Parameters are defined in a matrix with the function listed down the left hand side, the parameter across the top and the mapping selection in a grid matrix.
 - Bit String Selection
Parameters where multiple value selections can be made.
 - Set Value
Parameter where the value is entered by typing a value between a specific range, for example CT Ratio Secondary.

Overview of the Procedure

Perform the following actions:

- From Reydisp Manager open the **Setting Editor** tool.
- Change the values of the parameters.

Opening a Setting File in the Settings Editor

From the device menu select the user setting file with device parameters. Double click to open.

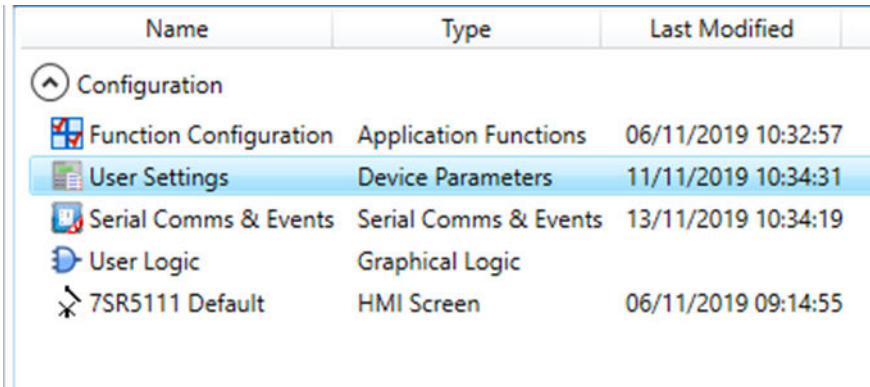

Name	Type	Last Modified
Configuration		
Function Configuration	Application Functions	06/11/2019 10:32:57
User Settings	Device Parameters	11/11/2019 10:34:31
Serial Comms & Events	Serial Comms & Events	13/11/2019 10:34:19
User Logic	Graphical Logic	
7SR5111 Default	HMI Screen	06/11/2019 09:14:55

[sc_7SR5_ReydispManager2UserSettingsDeviceParameters, 1, --]

Figure 2-84 Reydisp Manager 2 User Settings with Device Parameters

The **Setting Editor** will open with the setting tree visible.



NOTE

The setting tree in the PC tool is in the same format as on the device fascia.

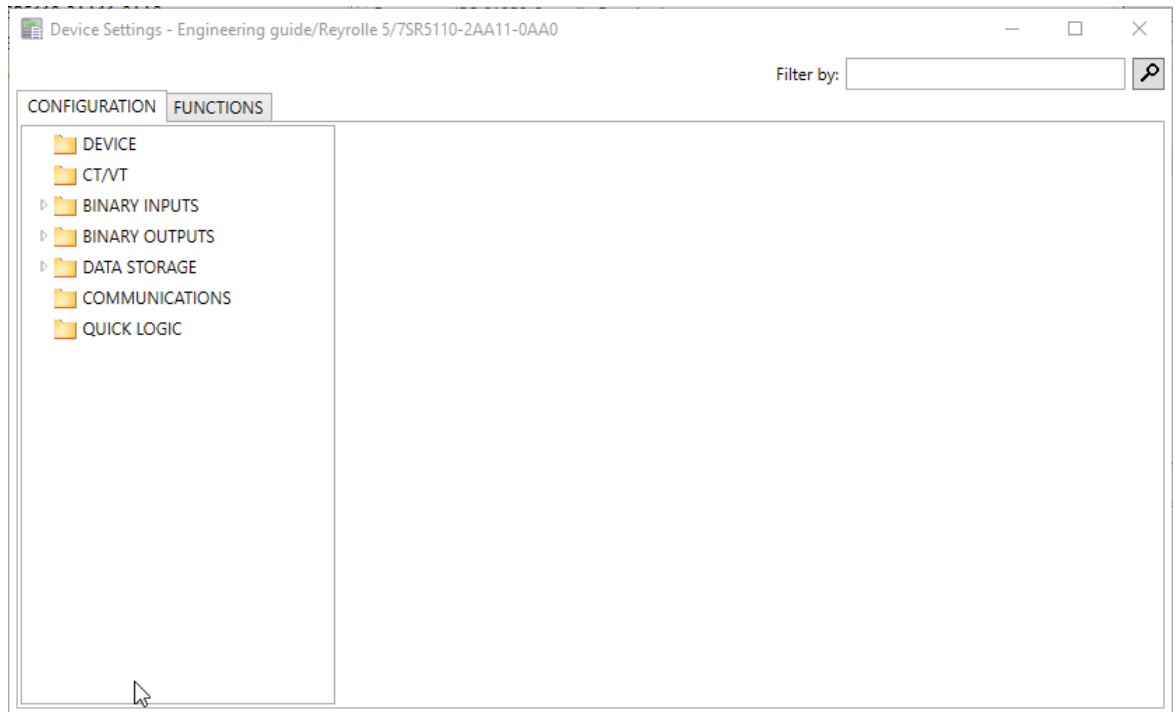

[sc_7SR5_ReydispManager2SettingEditor, 1, --, --]

Figure 2-85 Reydisp Manager 2 Setting Editor

The display now shows 2 tabs, one for **Configuration** and one for **Functions** with their sub folders in the setting tree and any parameters and setting value in the right hand pane.

If a parameter setting is common to the device it will not have a setting group associated with it and will be shown with no group, as shown in the following figure.

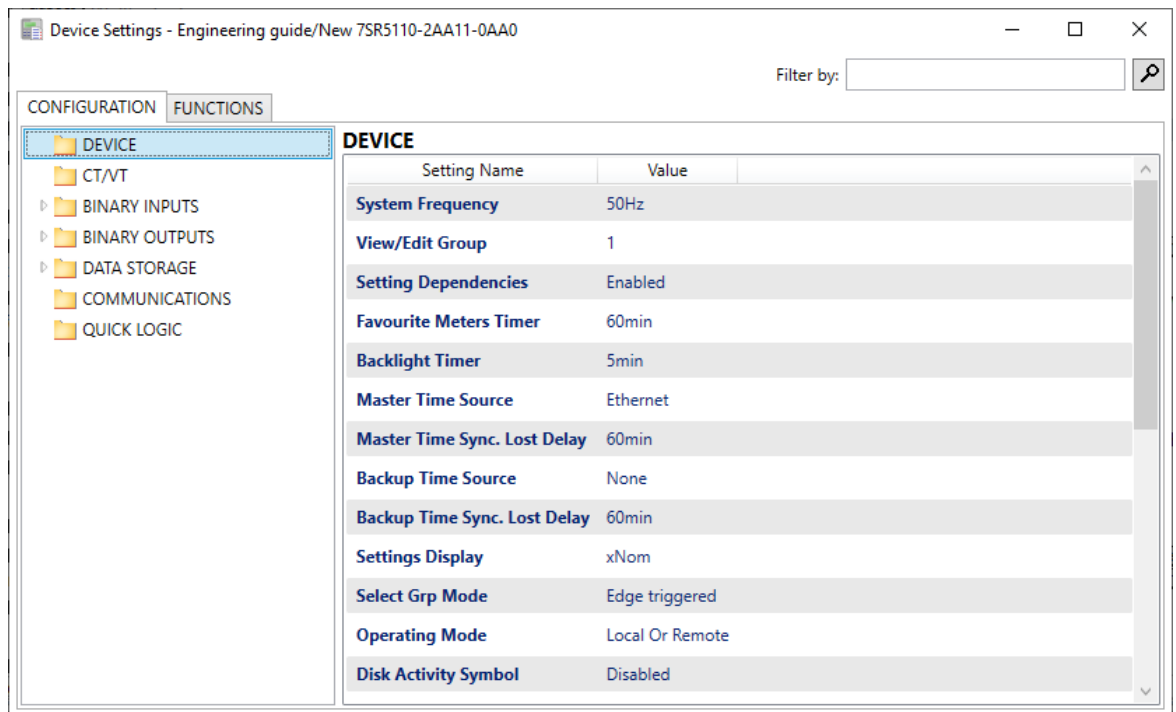

[sc_7SR5_ReydispManager2CommonSetting, 1, --, --]

Figure 2-86 Reydisp Manager 2 Common Setting

If a parameter setting is specific to a group the display will have a tab for viewing each group and also a tab to view all group values together.
 The scroll bar on the right hand side of the window provides navigation to the entire menu list.

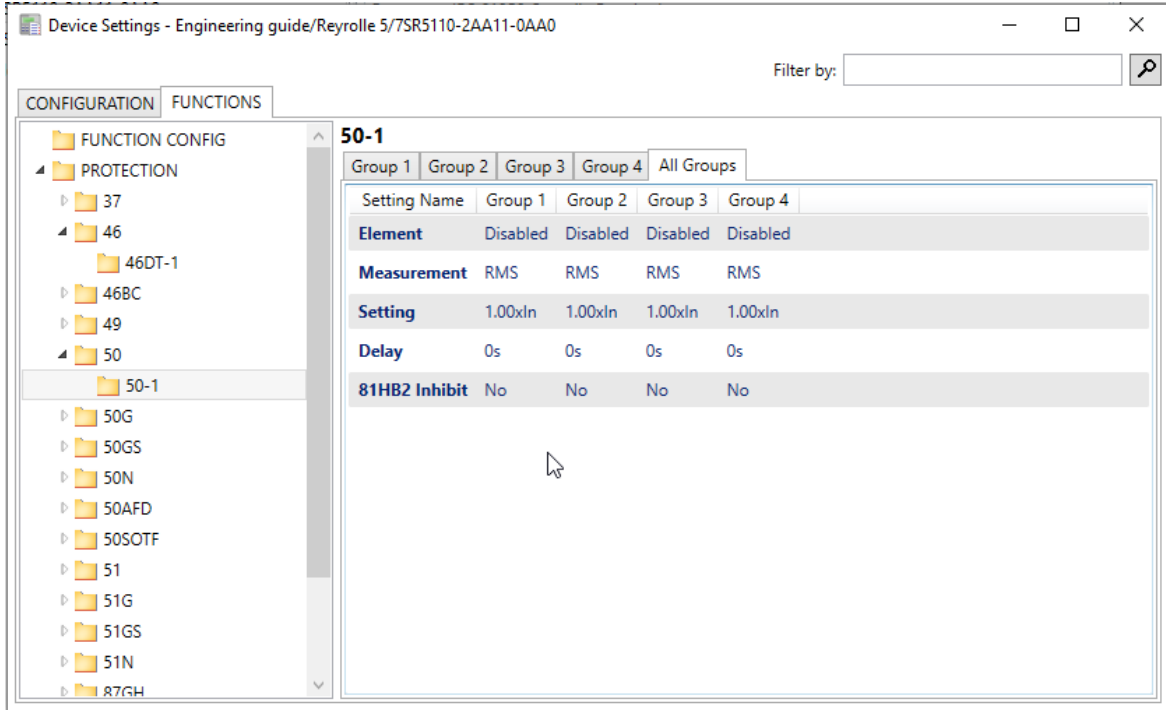

[sc_7SR5_ReydispManager2SpecificSetting, 1, --]
 Figure 2-87 Reydisp Manager 2 Specific Setting

The matrix view allows the display to be filtered to reduce the number of signals in the display. The mapping filters give the user the option to show all signals or only to show the mapped signals.
 Additional filters are also provided in the matrix view to filter the input or output type, to show or hide signals when they are mapped, and to simplify the view.
 The user can choose to view all parameter settings for a particular element or function by using the **Filter by** option. In the following example the filter has been applied to the **Output Matrix** for all parameters containing 37.

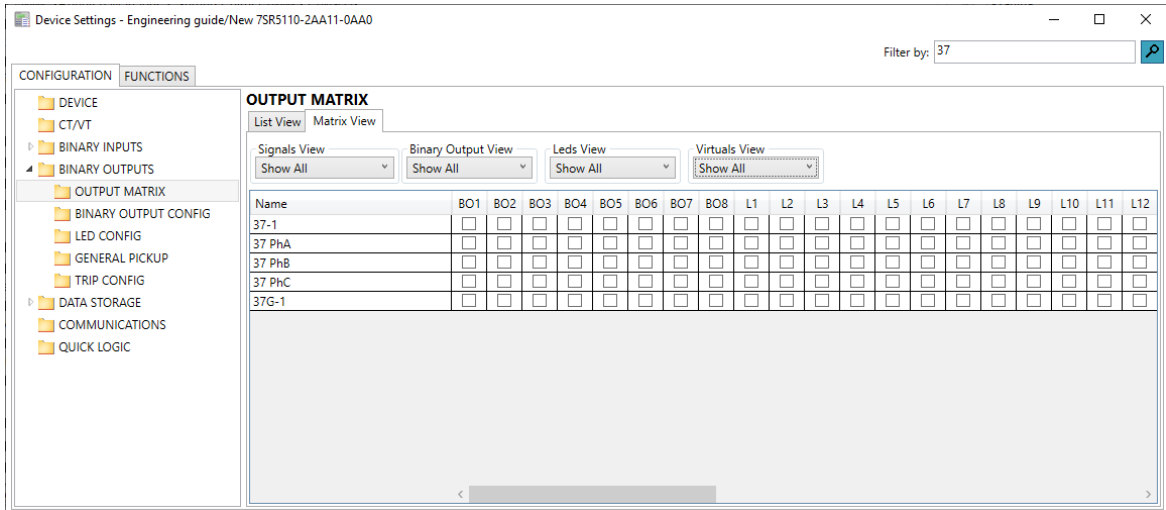

[sc_7SR5_ReydispManager2OutputMatrixFilter, 1, --]
 Figure 2-88 Reydisp Manager 2 Output Matrix Filter

Changing a Parameter Setting

Click the **Settings** tab to make it active.

Click the folder in the tree to locate the required parameter.

Click the setting name to activate the setting value. The method for changing the setting will vary upon the different setting type.

Drop Down Parameter

Select the value to expand and view the value options in the drop down menu.

In the device configuration tab the **Binary Inputs > Input Matrix** have both a list view tab and matrix view.

The parameters shown in the matrix view are a duplication of the setting in the setting tree view and a change made in either view will be automatically reflected in the other view.

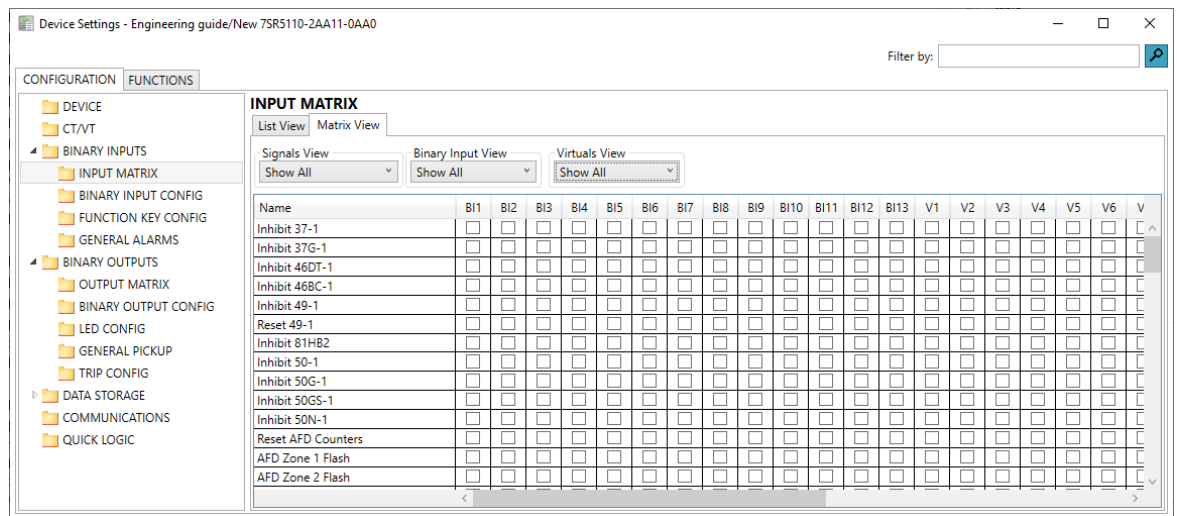

[sc_7SR5_ReydispManager2InputMatrix, 1, --, -]

Figure 2-89 Reydisp Manager 2 Input Matrix View

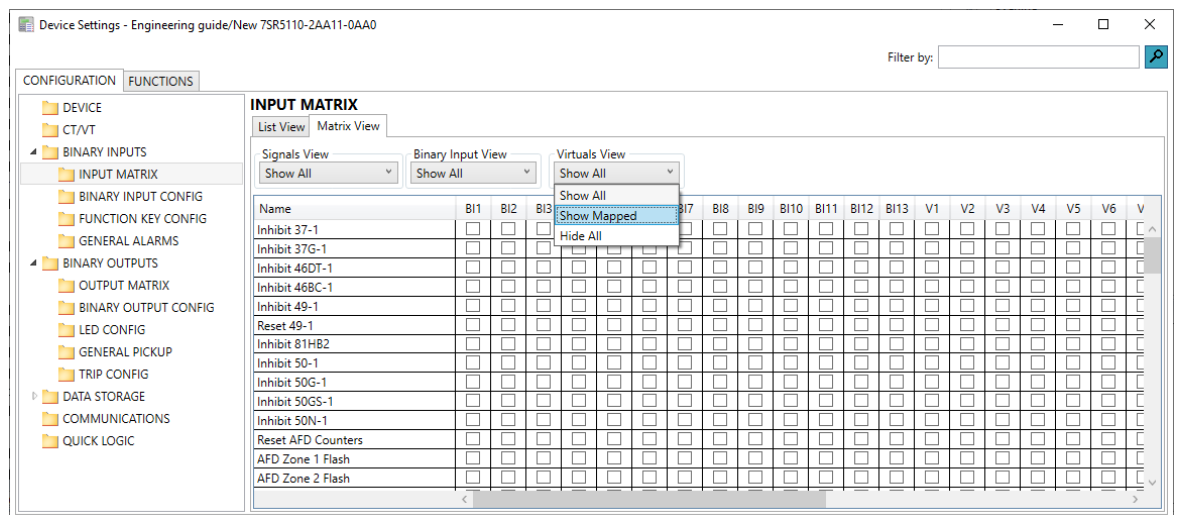

[sc_7SR5_ReydispManager2InputMatrixVirtualsView, 1, --, -]

Figure 2-90 Reydisp Manager 2 Virtuals View

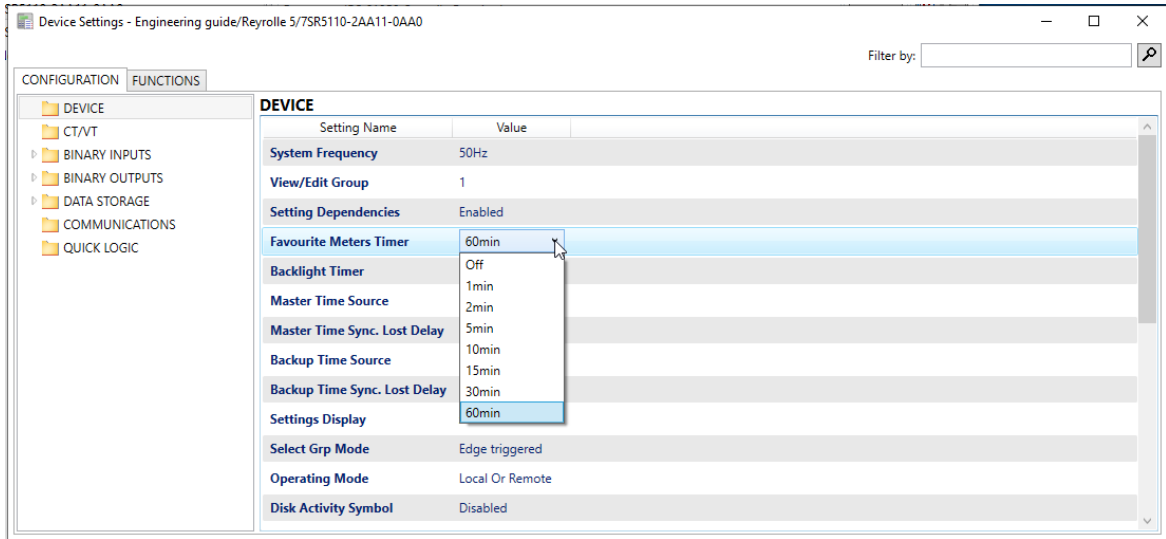

[sc_7SR5_ReydispManager2SettingsDropDownMenu, 1, --,--]

Figure 2-91 Reydisp Manager 2 Settings Drop Down Menu

Select the desired value to appear as the setting value.
Text parameter

For a text setting, for example, **Relay Identifier** or **User Alarm** the text editor will be displayed. Type the text required then press **Enter**.

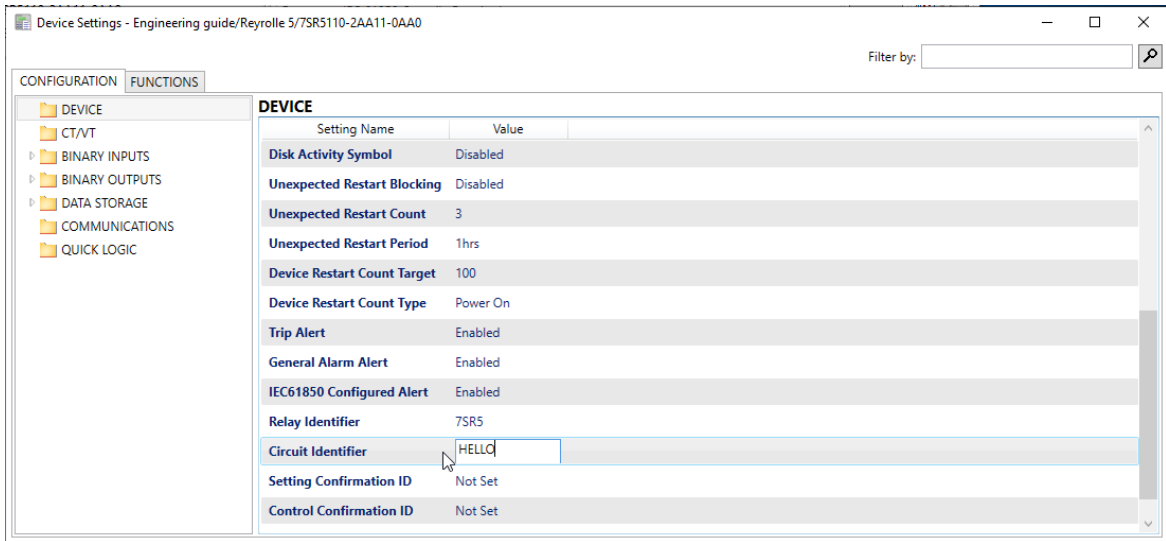

[sc_7SR5_ReydispManager2TextSetting, 1, --,--]

Figure 2-92 Reydisp Manager 2 Text Setting



NOTE

Only valid characters will be accepted and a red ! warning symbol will be shown if an invalid character is entered.

The HMI will display the parameter name with the new value flashing and the current/existing value displayed below. Use the up/down or a combination of right arrow and up/down keys to adjust the setting.

When the desired setting is visible press the **Enter** key to confirm. The new parameter setting will now be active in the device.

Set Value parameter

For a set value setting, for example, **CT Ratio Secondary** value, a symbol with 3 dots will be shown alongside the value.

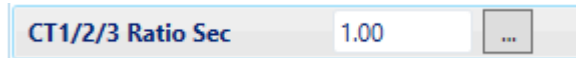

[sc_7SR5_ReydispManager23DotIcon, 1, --]

Figure 2-93 Reydisp Manager 2 Icon with 3 Dots

Click on the box to open a window displaying the current value with the value range display to the right hand side.

Enter the chosen value into the edit box and click **Confirm**. If a value or character outside of the predefined range is entered an error message will be displayed.

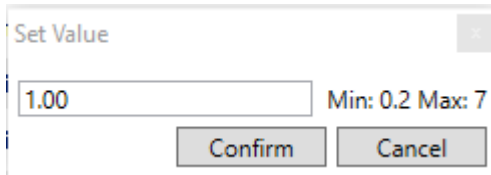

[sc_7SR5_ReydispManager2SetValueDialog, 1, --]

Figure 2-94 Reydisp Manager 2 Set Value Dialog

Bit String Selection

For bit selection, the setting appears as a drop down menu. Opening the drop down menu lists the bit-wise selection where multiple values can be selected.

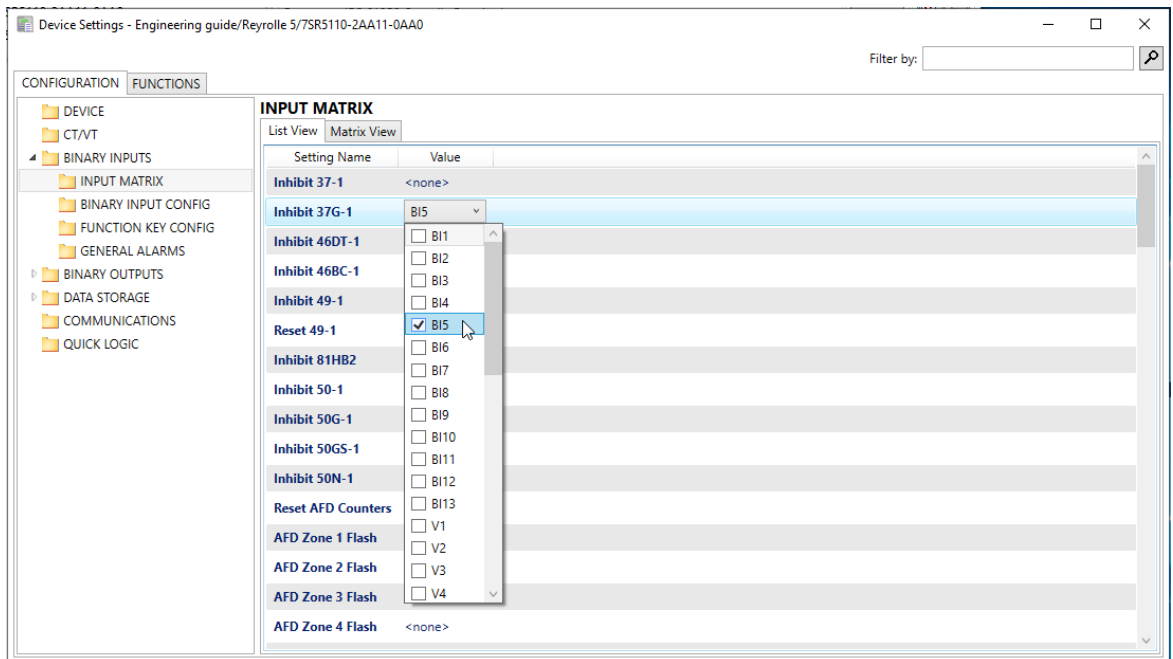

[sc_7SR5_ReydispManager2BitSelection, 1, --]

Figure 2-95 Reydisp Manager 2 Bit Selection

Matrix Editor

To use the matrix editor click the appropriate tab to make it active. A subset of settings is listed in the left pane and the controlled object across in rows. Click on the line/row to be edited to activate it, the row will be highlighted. Click the object to make the selection and the selection will be marked. The following screenshot shows part of a matrix. In it LED (L) 4 will operate by Phase A Trip, L5 by Phase B Trip and L6 by Phase C Trip.

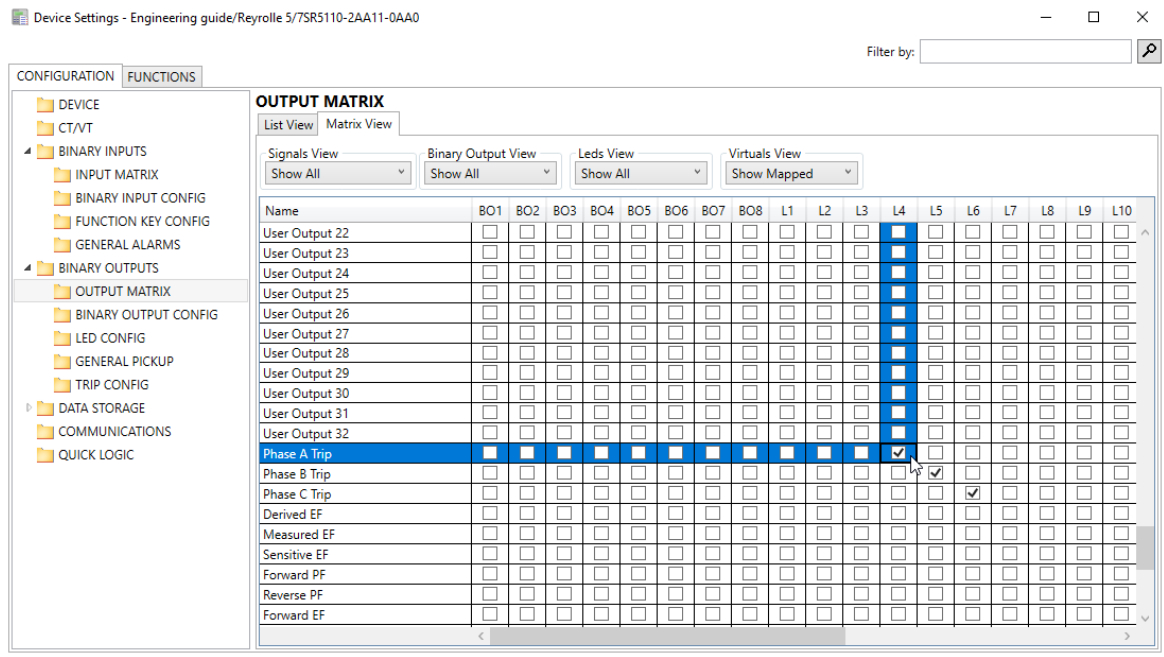

[sc_7SR5_ReydispManager2MatrixEditor, 1, --, --]

Figure 2-96 Reydisp Manager 2 Matrix Editor



NOTE

If the setting dependencies are **Enabled**, only the parameters of enabled functions will be visible for viewing and editing on the HMI screen.

2.10 Configuring Communication

Overview

The device provides 1 front USB communication interface (Com2) on the fascia and 1 RS485 (Com1) on the rear along with 2 Ethernet ports on the rear. The Ethernet ports can be ordered for connection with Electrical RJ45 or Optical LC access. The access to the communication settings for the USB port is available from the front menu structure via the keypad setting menu **Communications** or through the parameter configuration PC software.

Communication interface

- **Com2-USB**
The Com2-USB port is used for configuring the device with Reydisp software and allows the updating of firmware. The Com2-USB port has the IP address 192.168.2.1.
- **Com1-RS485 (Terminal Reference X1)**
The Com1-RS485 port can be used for DNP3.0, IEC 60870-5-103 or Modbus RTU communications to a substation SCADA, integrated control system, or engineer remote access.
The port can be independently mapped to the DNP3.0, IEC 60870-5-103 or Modbus RTU protocol or switched off in the device configuration.
- **Com-Ethernet**
2 electrical (RJ45) ports (Channel 1/Terminal Reference X2 and Channel 2/Terminal Reference X3) or 2 optical (LC) ethernet ports (Channel 1/Terminal Reference X4 and Channel 2/Terminal Reference X5).
The Ethernet ports can be used for IEC 61850 communications to a substation SCADA, integrated control system, or engineer remote access using Reydisp configuration software.

The goal of this chapter is to select and configure the following connections and adaption of protocols:

- Configure RS485 port
- Adapt **Fascia Event Log**
- Protocol DNP3
- Protocol MODBUS RTU
- Protocol IEC 60870-5-103

The device configuration communication mapping can be printed using the **Export Report** function by right clicking on the **Serial Comms & Events** file.

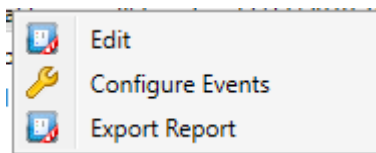

[sc_7SR5_ReydispManager2ExportReportMenu, 1, --...]

Figure 2-97 Reydisp Manager 2 Export Report

Selecting and Configuring Serial Protocols on RS485

With a 7SR5 device, a rear RS485 (Com1) communication module is always provided for connection with a serial communication protocol. The port has a number of parameters that must be set and in addition Reydisp Manager – **Serial Comms and Events** is used to configure the communication protocol.

Overview of the Procedure

Perform the following actions:

- Open the **Device view** and select the **Device Parameters**.
- Configure comm1 in the **Configuration > Communications** menu and save.
- Configure the 2 Ethernet interfaces for DNP3.

Parameter: **COM1-RS485 Protocol**

- Select the protocol used on the Com 1-RS485 interface port designated X1 on the rear of the device as required.

Parameter: **COM1-RS485 Station Address**

- Select a unique address number to identify the device within the relevant range of the selected protocol.

Parameter: **COM1-RS485 Baud Rate**

- Select the baud rate. This is the rate at which the data is transferred via the RS485 serial for connection.

Parameter: **COM1-RS485 Parity**

- Select if a parity bit is added to the binary string to ensure the total number of bits is even or odd and is used for error detection.

Parameter: **COM1-RS485 Mode**

- Select the operating mode of the RS485 port and is used in conjunction with the device operating mode. Some actions are restricted on the port depending upon the ports mode and device operating mode.

If DNP3.0 protocol is to be used some additional parameters are provided.

Parameter: **DNP3 Unsolicited Events**

- Select if the DNP3 protocol should support unsolicited events in the users application.

Parameter: **DNP3 Destination Address**

- Default Setting: 0
 If unsolicited events are to be sent a destination address for the master must be set.

Parameter: **DNP3 Application Timeout**

- Default Setting: 10
 Configure the response time in seconds of the DNP3 application layer confirmation.

Settings Menu

Configuration > Data Storage		
Parameter	Range	Default Setting
COM1-RS485 Protocol	ASCII, IEC 60870-5-103, MODBUS-RTU, DNP3, Off	Off
COM1-RS485 Station address	0 to 254 for IEC 60870-5-103 1 to 247 for Modbus RTU 0 to 65534 for DNP3	0
COM1-RS485 Baud rate	75, 110, 150, 300, 600, 1200, 2400, 4800, 9600, 19200, 38400, 57600, 115200, 230400	19200
COM1-RS485 Parity	NONE, ODD, EVEN	EVEN
COM1-RS485 Mode	Local, Remote, Local or Remote	Remote
USB Mode	Local, Remote, Local or Remote	Local
Ethernet Mode	Local, Remote, Local or Remote	Remote
DNP3 Unsolicited events	Disabled, Enabled	Disabled

Configuration > Data Storage		
Parameter	Range	Default Setting
DNP3 Destination address	0 to 65534	0
DNP3 Application timeout	5 to 300 s	10 s

Configuring the Fascia Event Log

Overview of the Procedure

Perform the following actions:

- Display communication mapping in the **Comms Editor**.
- Adapt required data
- Save as part of device configuration

Displaying Communication Mapping

In the project tree, open the folder for the offline configuration of a 7SR5 device.

In this folder, double-click **Serial Comms & Events**.

Right-click and select **Configure Events** option.

Adapting Communication Mapping for the Serial Protocol

To simplify project engineering, the device is provided with default communication mapping for the DNP3 protocol. As a consequence, routings for signals and settings are defined automatically for mapping parameters. These routings can be adapted for specific requirements. Communication mappings are oriented to the specific device model and configuration. For this reason, the communication mapping in the project structure is always saved in the offline configuration of a device.

The communication mapping of a device can be edited using the **Serial Comms & Events** feature. A comprehensive user guide is provided within the software tool for further support.

Overview of the Procedure

Perform the following actions:

- Display communication mapping in the **Comms Editor**.
- Adapt required data
- Save as part of device configuration

Displaying Communication Mapping

In the project tree, open the folder for the offline configuration of a 7SR5 device.

In this folder, double-click **Serial Comms & Events**.

The **Comms Editor** tool opens and displays the communication mapping of the device.

From the tabs on the right hand side of the window select the protocol that requires adaptation.

Within the protocols the signals are shown according to data type with a page tab along the top.

The protocol and data type will determine the configurable options which can be edited and the options for alternative selections.

Any protocols not available in the device template will be greyed out.

The following image shows DNP3 and data type binary output selected.

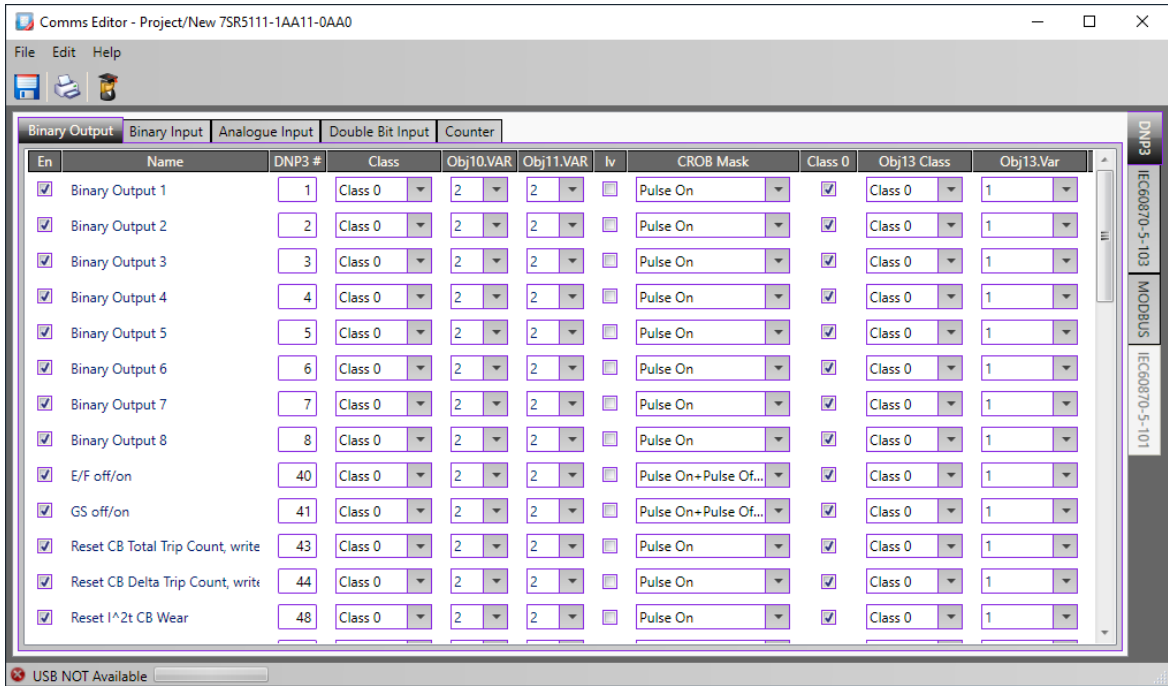

[sc_7SR5_ReydispManager2DNP3BinaryOutput, 1, --,--]

Figure 2-98 Reydisp Manager 2 DNP3 with Binary Output Selected

The adaption of the data point properties is done according to type enable/disable with a tick selection.

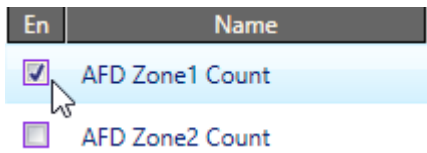

[sc_7SR5_ReydispManager2DataPointPropertiesTick, 1, --,--]

Figure 2-99 Reydisp Manager 2 Data Point Properties

Then entering a valid value.

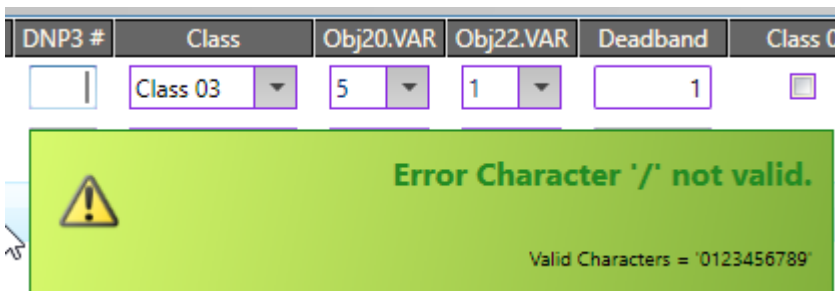

[sc_7SR5_ReydispManager2DNP3ValidValue, 1, --,--]

Figure 2-100 Reydisp Manager 2 Enter Valid Value

Selecting from the provided drop down list.

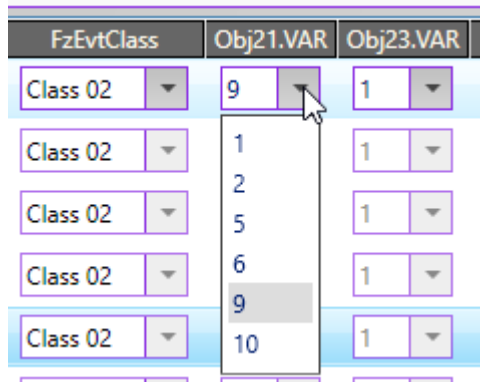

[sc_7SR5_ReydspManager2DNP3DropDownList, 1, --_]

Figure 2-101 Reydsp Manager 2 Value Selection from Dropdown List

Context Menus

Context menus are provided when the user right-clicks on an editor page. A context menu is provided for each protocol. When using the context menus all items selected in the list will be set to the chosen value if applicable. Multiple items are selected using the standard selection method of clicking the mouse while holding down the **Shift** or **Control** keys. This provides a quick method of setting multiple points to the same value.

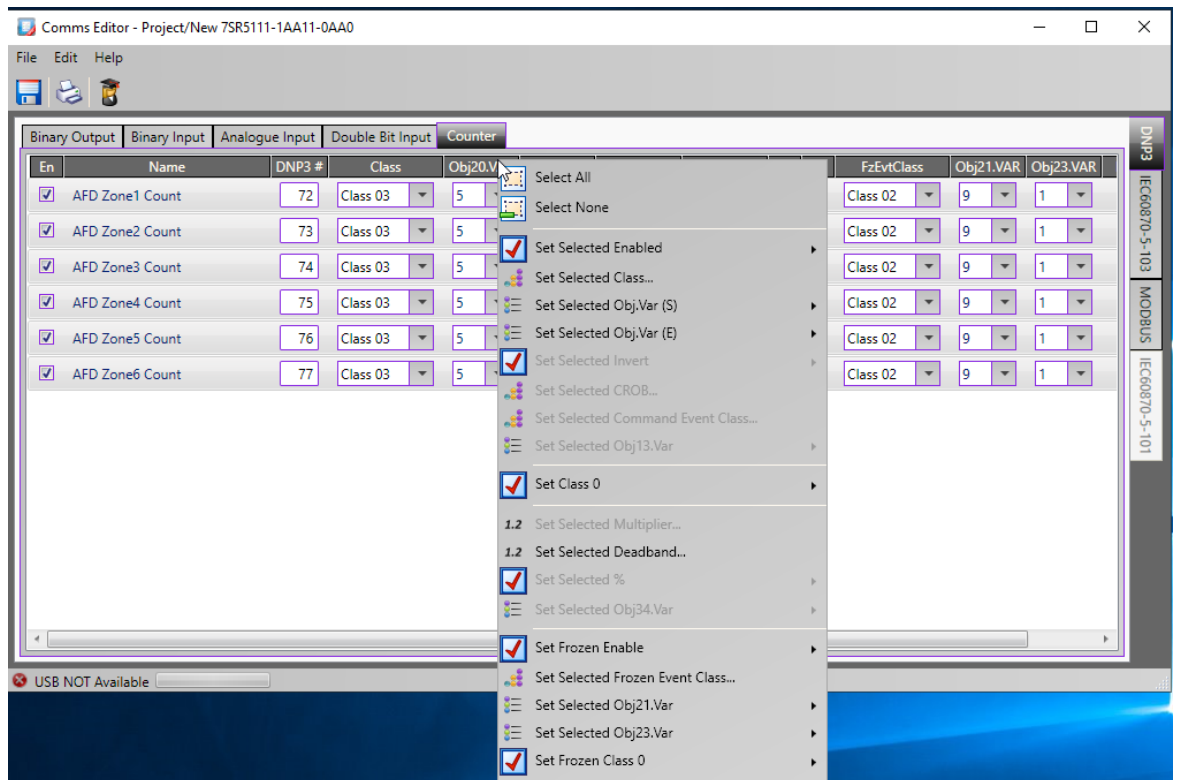

[sc_7SR5_ReydspManager2ContextMenu, 1, --_]

Figure 2-102 Reydsp Manager 2 Context Menu

In addition to the standard adaptations some protocols may have advanced settings that may be configurable. These can be found by going to the **Edit > Advanced Settings** option as shown in the following figure.

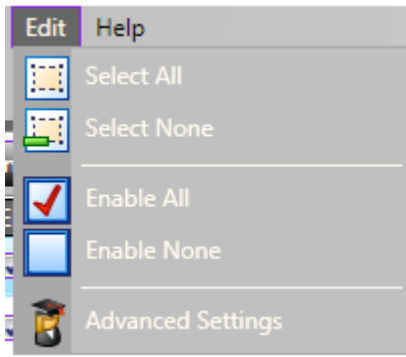

[sc_7SR5_ReydispManager2AdvancedSettingsMenu, 1, --]

Figure 2-103 Reydisp Manager 2 Advanced Settings

The advance setting configuration parameters will appear for editing.

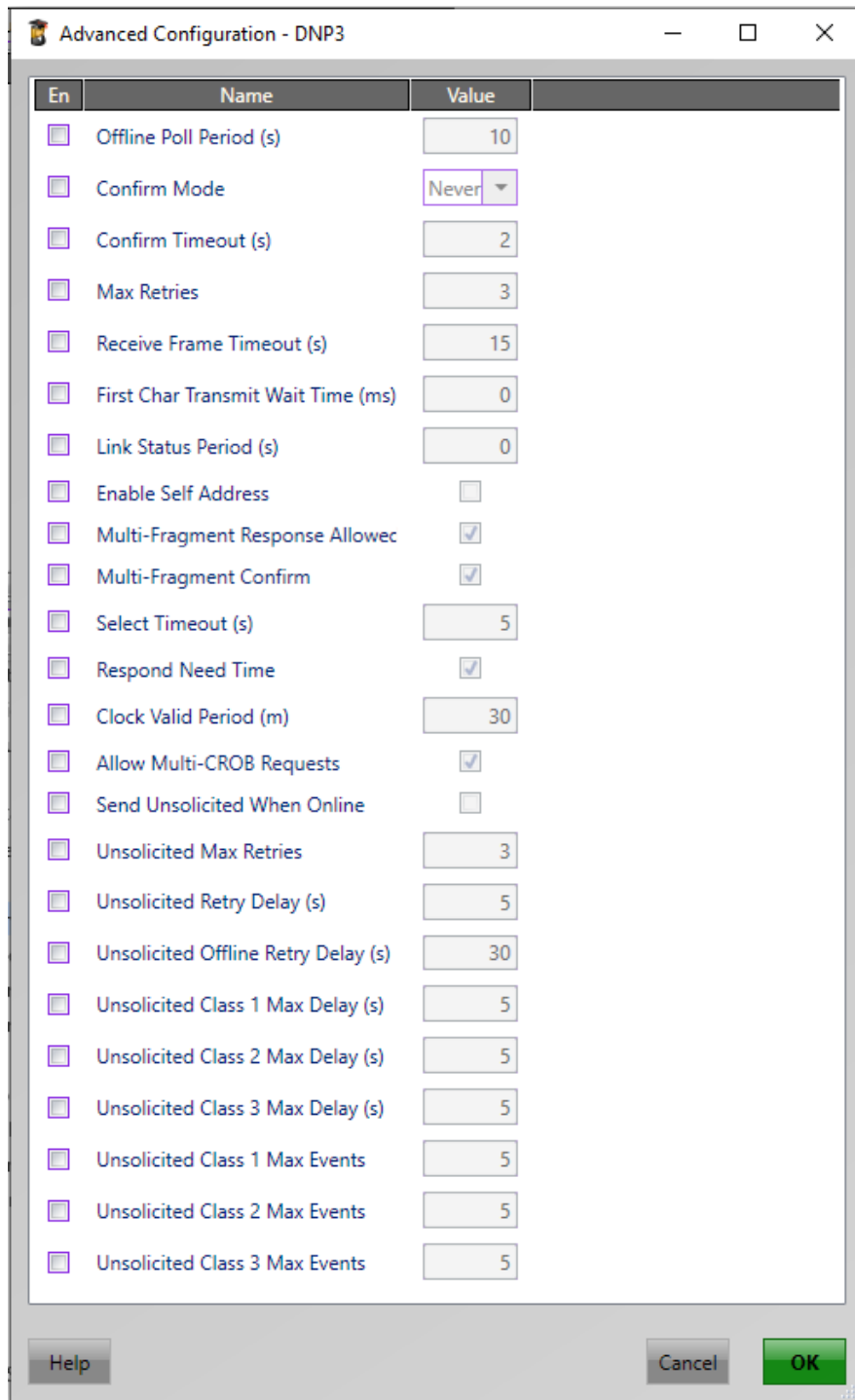

[sc_7SR5_ReydispManager2AdvancedConfiguration, 1, --_--]

Figure 2-104 Reydisp Manager 2 Advanced Configuration for Communication Protocol DNP3.0

2.11 Device Configuration of Ethernet

Overview

The Ethernet interface is used to configure the IEC 61850 interface. The Ethernet communication interface is available in both electrical and optical versions. Both types are provided with an integrated switch functionality. This makes it possible to integrate the devices into common network structures together with third-party components.

IP Address Tab

This tab allows the IP address of the device to be configured. The IP address, subnet mask and gateway address all need to be set for the device to communicate on the network. These values will vary depending on the network. The values shown here are an example only.

If a device is assigned to a station, then the device IP address is set by the station and the ability to configure it from the **IP Address** tab is disabled to avoid conflicting IP addresses.

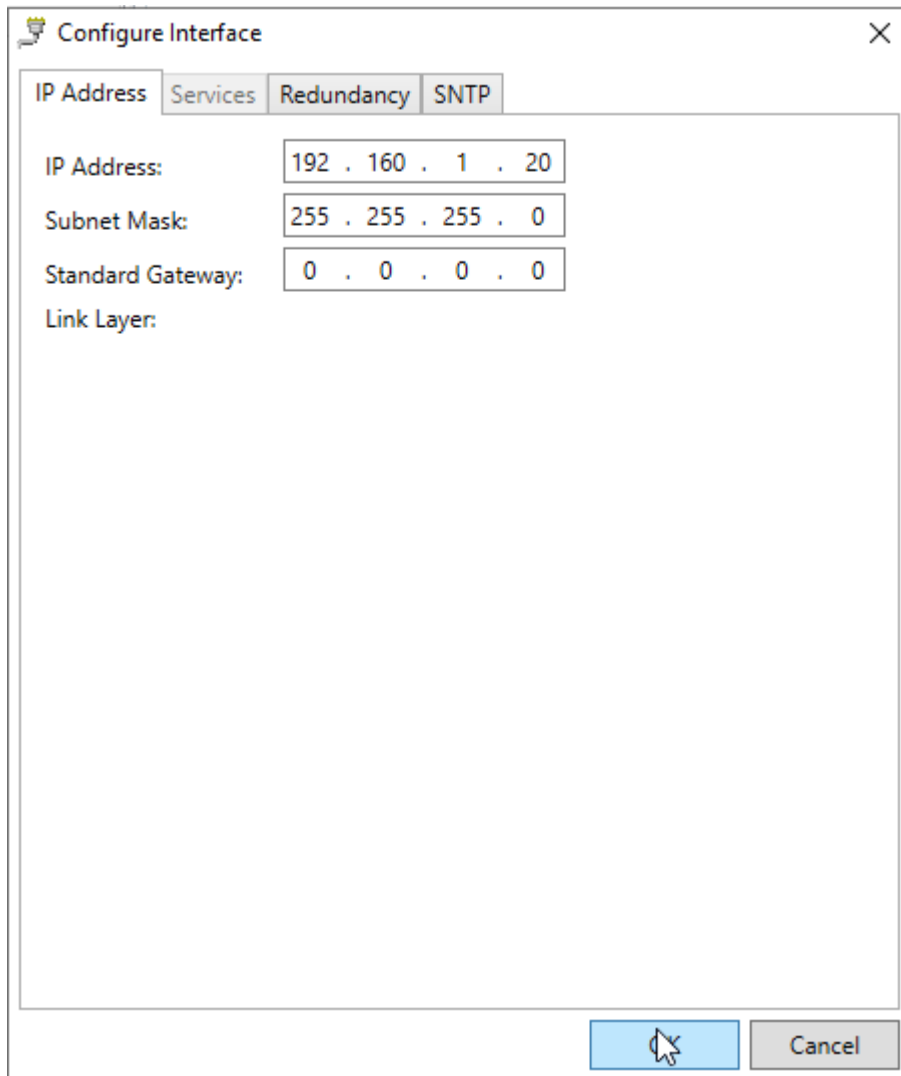

[sc_7SR5_ReydispManager2IPAddressTab, 1, --_]

Figure 2-105 Reydisp Manager 2 IP Address Tab

Services Tab

This tab has no user configuration.

SNMP (Simple Network Management Protocol): SNMP is enabled.
The MIB files for browsing to the device are available from the web site.

Redundancy Tab

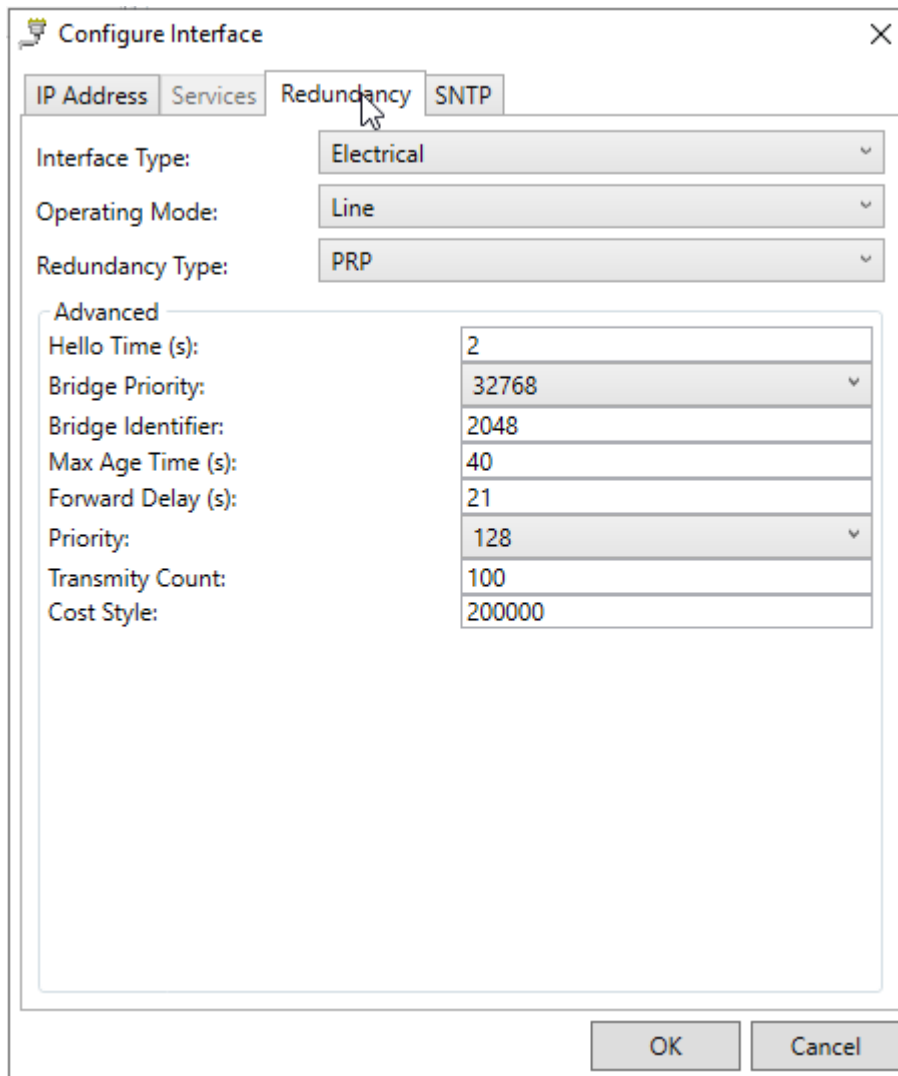

[sc_7SR5_ReydispManager2RedundancyTab, 1, --]

Figure 2-106 Reydisp Manager 2 Redundancy Tab

Interface Type: By default, all IEC 61850 Reyrolle devices are set to use **IEC 61850 Electrical RJ45**. If a fibre optic interface is present, this should be changed to **IEC 61850 Fibre**. To do this, select **IEC 61850 Fibre** from the **Interface Type** drop down menu.

Operating Mode: The modules have 2 interfaces which are designed for either electrical or optical inter-facing. The interfaces on the devices can be used in different operating modes. Select between **Line** mode or **Switch** mode. The default is **Line** mode. (All further options are only enabled if the operating mode is set to **Switch**). When set to **Line** mode, if the active link, i.e. the link transmitting data between the device and the external switch, is broken, the interruption is detected and signaled by the link mentioned previously. When an interruption is detected, switch to the second channel is performed immediately so that data exchange can continue almost without interruption. The interruption signal is then transmitted via the standby channel.

Redundancy Type: When the **Operating Mode** is set to **Switch**, redundancy options are available to select. This can show **RSTP**, **OSM**, **PRP**, and **HSR** depending on the interface type.

- **PRP-Structure**

The PRP structure (Parallel Redundancy Protocol according to IEC 62439-3:2012) provides communication over 2 independent networks (LAN A and LAN B) simultaneously. Both networks may under no circumstances be connected to one another. Siemens recommends building both networks identically. Connect LAN A with channel 1 and LAN B with channel 2. In case of an interrupted network communication the device switches seamlessly.
- **Operating Mode RSTP**

RSTP stands for Rapid Spanning Tree Protocol. This is a standard network redundancy protocol. When this option is selected, the advanced options are enabled. In this all operating devices are arranged in a ring. One or more external switches must be integrated into this ring for the output of data, e.g. for display or for transmission into a different network.

If the ring which includes the devices and the switch is broken, the ring becomes a line, and the functionality is maintained almost without interruption. If the ring is broken in a second place, the structure cannot handle the resulting double error any more, and one part of the line will be disconnected. This means that only single errors resulting from a broken ring can be handled.
- **HSR Structure**

The devices are arranged in rings in the HSR structure (High-availability Seamless Redundancy according to IEC 62439-3:2012) . The procedure does not have parameters of its own. A seamless switchover will take place if an interruption in communication occurs in a network. All components in HSR rings must support HSR. If not connecting to HSR-enabled devices, use special switches that support HSR.
- **OSM**

OSM is a Siemens legacy redundancy protocol. It is only available for optical EN100 modules.

SNTP Tab

The Simple Network Time Protocol tab is completed when SNTP timer servers are required for a project where the devices are not associated with an IEC 61850 station and the time server properties must be added manually in the configuration. If the devices are part of an IEC 61850 station the option is greyed out in the device configuration as the SNTP server is part of the system configuration.

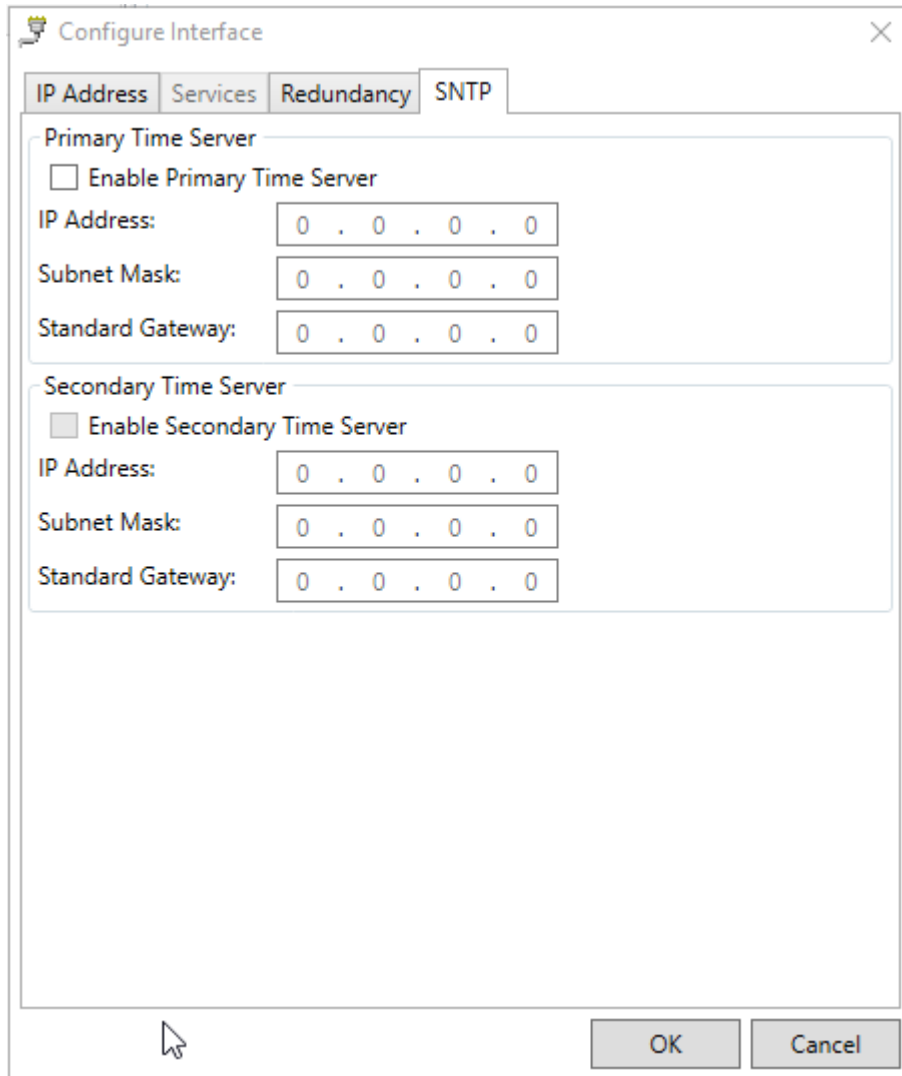

[sc_7SR5_ReydispManager2SNTPTab, 1, --_--]

Figure 2-107 Reydisp Manager 2 SNTP Tab

2.12 Device Configuration of Ethernet Timezone

Overview

The device operational time is set in local time. The **Ethernet Timezone** feature allows the timezone to be set for the device Ethernet port and allows the daylight saving times to be set. This is only applicable for Ethernet communication.

By default, the relay is set to GMT, with no daylight saving offset specified

Configuring the Ethernet Timezone

To set the Ethernet timezone in the device configuration the user must select the following icon.

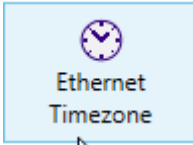

[sc_7SR5_ReydispManager2EthernetTimezoneIcon, 1, --, --]

Figure 2-108 Reydisp Manager 2 Ethernet Timezone Icon

The **Edit Timezone** dialogue window will appear for editing as required by the system application.

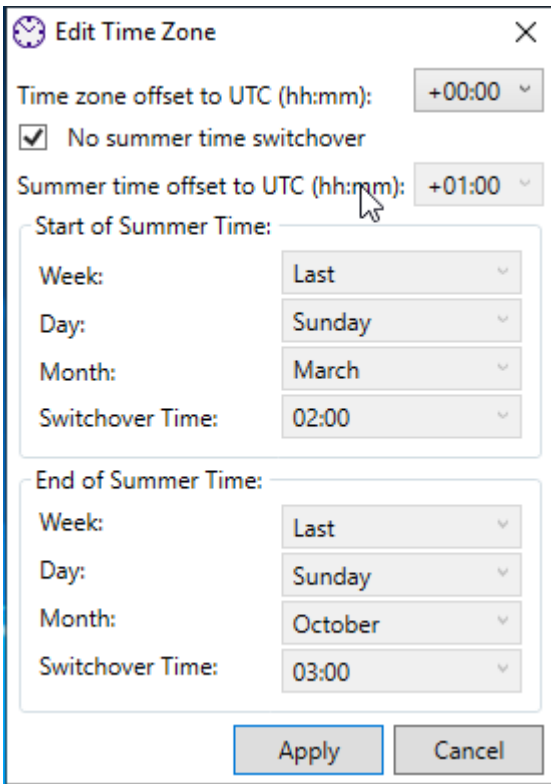

[sc_7SR5_ReydispManager2EditTimeZone, 1, --, --]

Figure 2-109 Reydisp Manager 2 Edit Timezone Properties

- | | |
|---------------------------|--|
| Time zone offset to UTC | This should be set to the offset to UTC. |
| No summer time switchover | Selecting this results in the time remaining the same throughout the year. If this is ticked, the options below it relating to summer time are disabled. |
| Summer time offset to GMT | This should be set to the offset to GMT for summer time. |
| Start of Summer Time | The time daylight savings start. |
| End of Summer Time | The time daylight savings ends. |

Clicking **Apply** will apply the new timezone to the device in the project.

2.13 Adding an IEC 61850 Station

Overview

A station is an item that allows multiple IEC 61850 capable devices to be grouped together. Devices in the same station can then be configured to communicate with each other.

Creating a New Station

To create a new station select the project folder and right-click to select the **Create new 61850 station**.

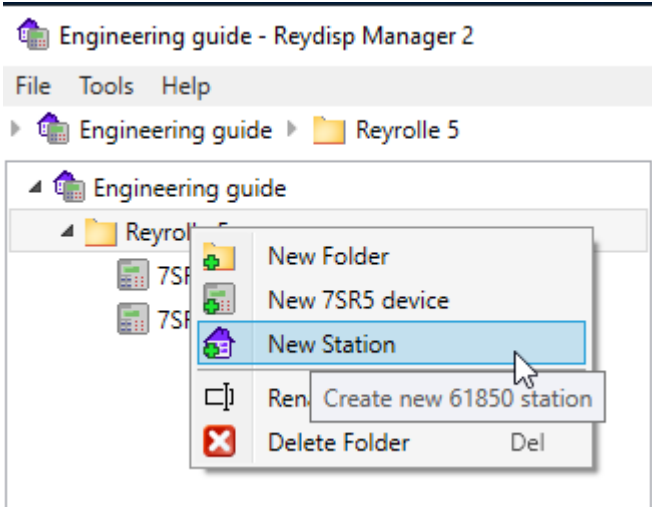

[sc_7SR5_ReydispManager2NewStation, 1, --]

Figure 2-110 Reydisp Manager 2 Create New Station

A new station is created and added to the project. By default, it is called "New Station" and will be listed in the project tree.

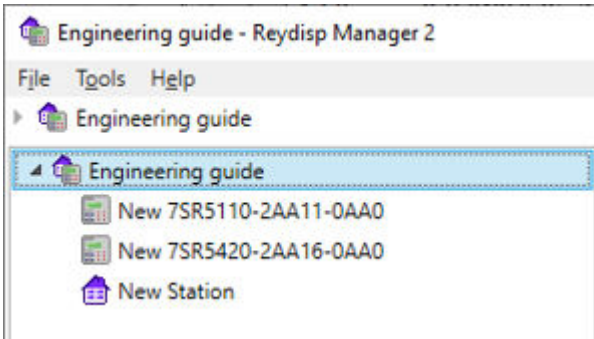

[sc_7SR5_ReydispManager2NewStationProjectTree, 1, --]

Figure 2-111 Reydisp Manager 2 New Station in Project Tree

The station can be given a unique name by right-clicking on the station and selecting to rename. Enter a name into the dialog box and select **Apply**.

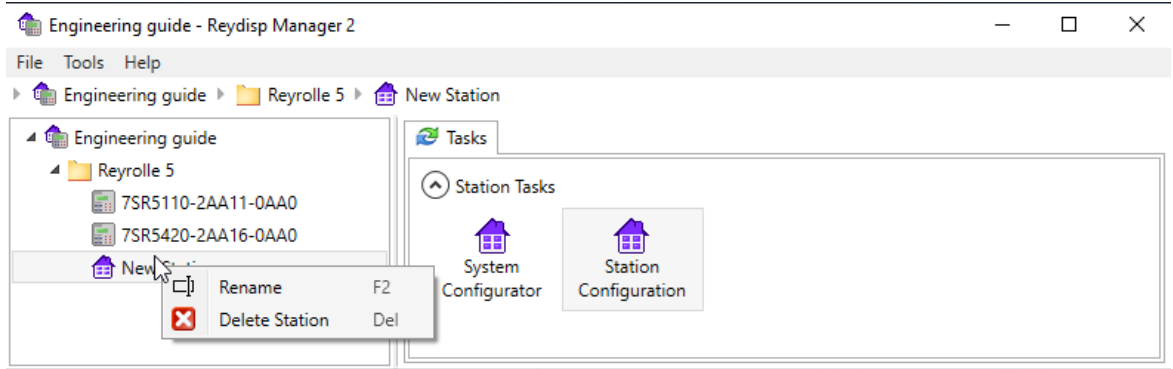

[sc_7SR5_ReydispManager2StationRename, 1, --]

Figure 2-112 Reydisp Manager 2 Station Rename

This new station has no devices assigned to it. The next step is assigning devices to it. Select the station in the project tree and the working area of the display will show the **Station Configuration** icon and if the additional Digi system configurator tool is installed, as shown in the below example, the **System Configurator** icon will also be visible.

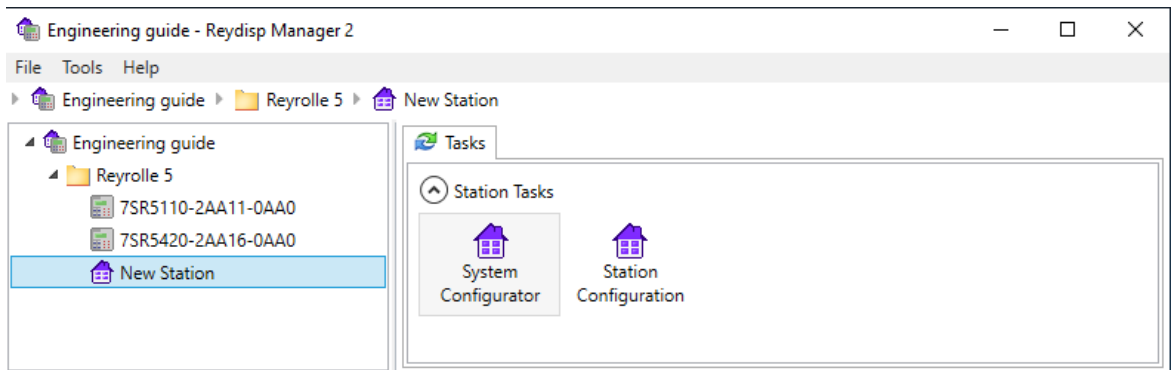

[sc_7SR5_ReydispManager2StationSelected, 1, --]

Figure 2-113 Reydisp Manager 2 Station Selected

Devices are assigned to the station by selecting the **Station Configuration** icon, where a window will display both the devices that are not associated with this station and those already associated.

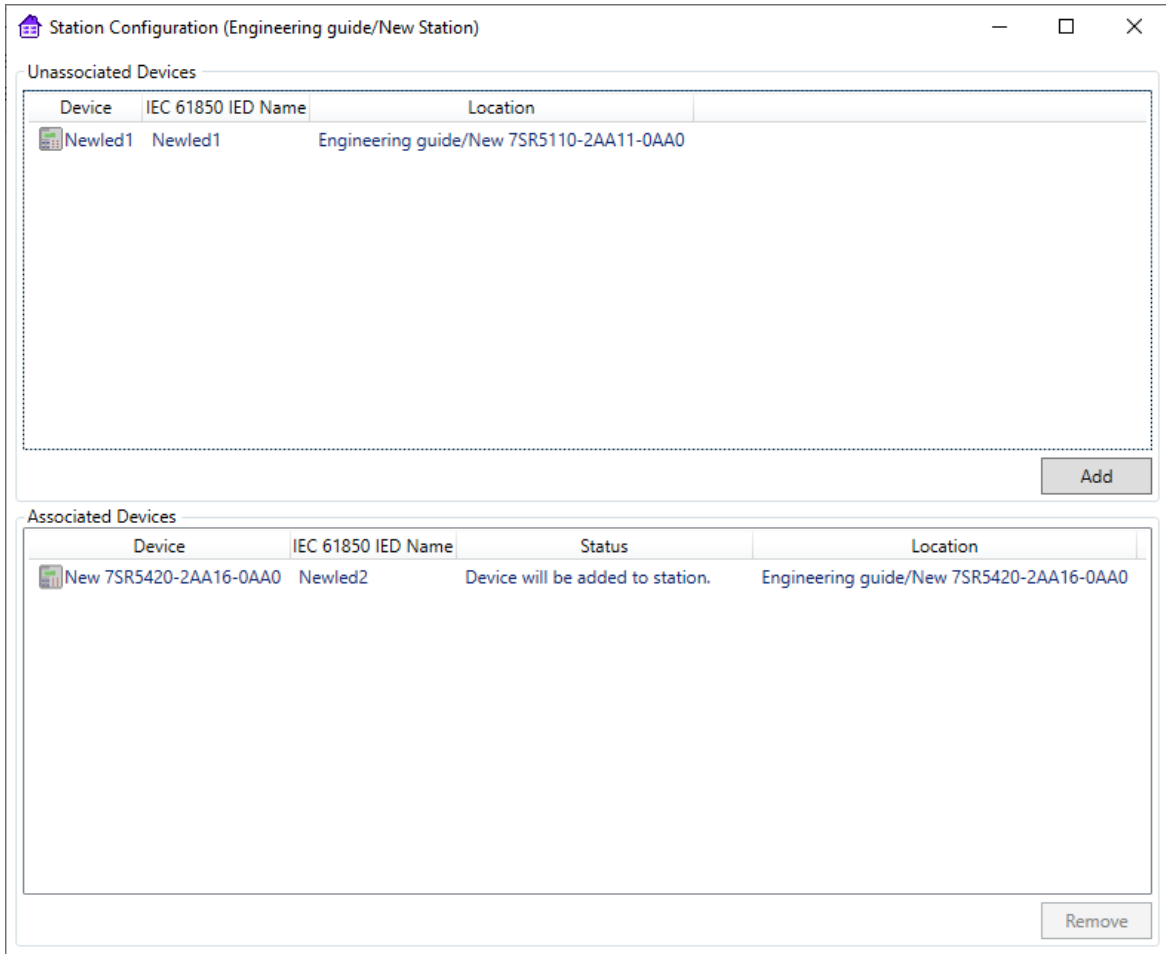

[sc_7SR5_ReydispManager2AssigningDevicesToStation, 1, --]

Figure 2-114 Reydisp Manager 2 Assigning Devices

All unassigned devices in the project are shown in the **Unassigned Devices** list. Select any devices to add to the station and click **Add**. The devices are added to the **Assigned Devices** list and will be added to the station.

The following restrictions apply when adding devices to a station:

- Each device can only be assigned to a single station.
- Each device assigned to the station must have a unique IED name.
- Device assignment cannot be changed if the **System Configurator** is open for the station.

To remove a device from the station, select the required device and click the **Remove** button. The device will be removed and shown in the **Unassigned Devices** list.

The following restrictions apply when removing devices from a station:

- Device assignment cannot be changed if the **System Configurator** is open for the station.

3 Device Tasks

3.1	Loading Configuration into the Device	114
3.2	Change Device Template	117
3.3	Install Device Firmware	120
3.4	Get Device Data	124
3.5	Get Device Configuration	129
3.6	Set Device Date and Time	137
3.7	Compile IEC 61850 Configuration	139

3.1 Loading Configuration into the Device

Overview

If the offline configuration of a device has been completely edited, the user can transmit this to the physical device. To do this, the Reydisp Manager 2 PC and the 7SR5 device must be physically connected via a communication line to the front USB port for the first configuration.

Connection Facilities

There are 2 ways to connect the Reydisp Manager 2 PC to a 7SR5 device:

- Via USB
- Via rear Ethernet port using IP address

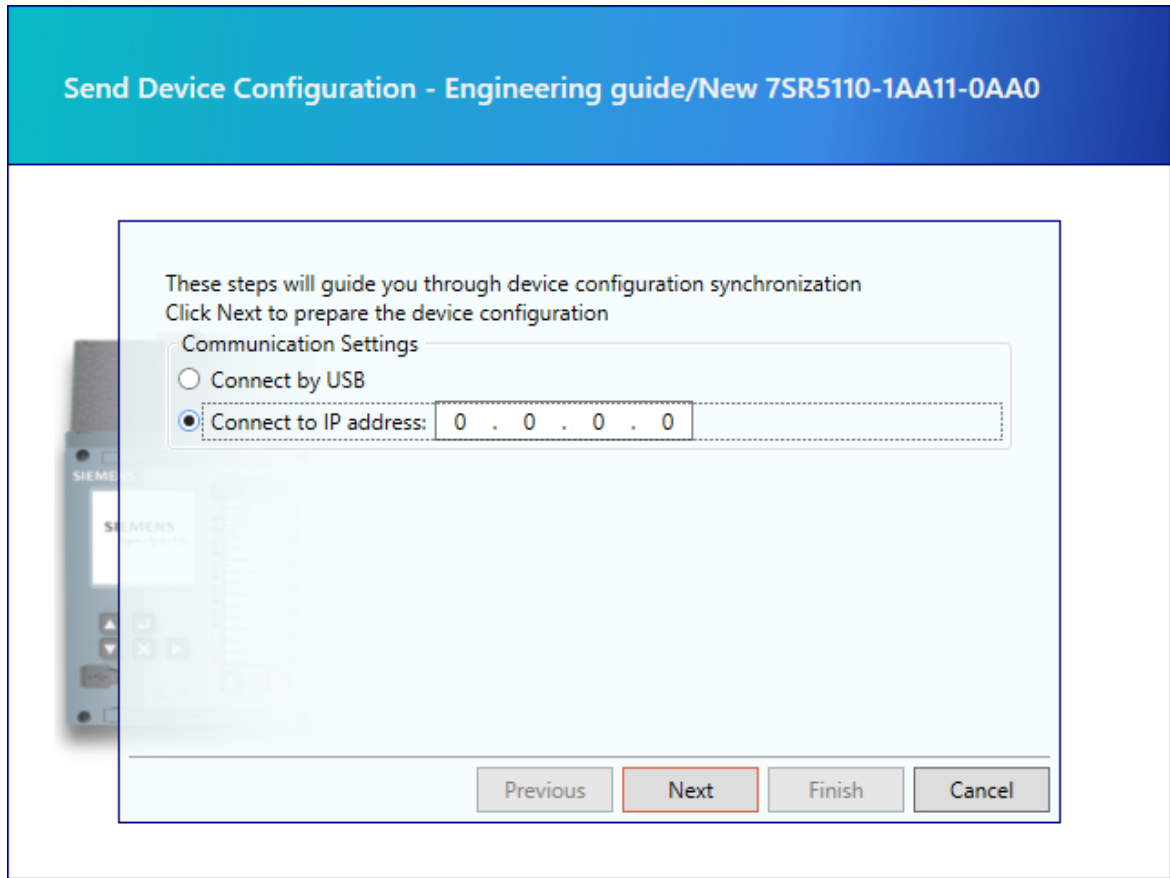

[sc_7SR5_ReydispManager2ConnectionOptions, 1, --,--]

Figure 3-1 Reydisp Manager 2 Connection Options

Confirmation IDs and Connection Password

Confirmation IDs are used for protection against unintentional and unauthorized operation from the fascia and will not be required for a configuration change. If a connection or maintenance password is activated, it must be entered before the relevant action is enabled by the device. For this purpose, the password is encrypted and transmitted to the device, where it is checked.

**NOTE**

The front USB port has a fixed IP address of 192.168.2.1 which is preconfigured in Reydisp Manager for USB connection.

Requirements

The following requirements must be met for the steps described in further chapters:

- **Product code**
An offline configuration can only be transmitted to a device which uses the same product code as the 7SR5 device.
- **Connection password**
The connection and maintenance passwords are not active when the device leaves the factory or is returned to the factory condition. If a connection password has been activated it will be required to allow a configuration to be sent to the 7SR5 device. The passwords can be reset, from the device, to not active using the **Reset Passwords** feature. This can be done using the default reset password **0000**. If the **Setting ID Confirmation ID** is active this must be known to reset the passwords.
- **Physical connection**
The Reydisp Manager 2 PC must be connected to the front USB port of the 7SR5 device. It is then not necessary for communication connection parameters to be configured. If using a USB hub, then it may not be possible to establish a communication connection between the Reydisp Manager 2 PC and the 7SR5 device.

Transmitting the Configuration to a 7SR5 Device for the First Time

When the device is delivered from the factory it will display a message intermittently on the fascia advising the device is not configured. Changing any parameter setting from the fascia or sending a device configuration file will remove this message. A message advising the IEC 61850 is not configured can only be removed if a configuration setting is sent to the device. Before commissioning a device, you must as a minimum parameterize the device from the fascia. It is recommended that the device is fully configured from the Reydisp Manager 2 PC software. In Reydisp Manager 2, initialization with a configuration associates the offline configuration with the 7SR5 device. For this, the 7SR5 device transmits its serial number, which is then entered in the corresponding offline configuration.

Goal

The goal of this chapter is to create a 7SR5 device that is initialized with the offline configuration and is ready for operation.

Sending Configuration

In the project tree, select the device of the offline configuration in question and in the device tasks select the **Load Device Configuration**.



[sc_7SR5_ReydispManager2DeviceTasks, 1, --, --]

Figure 3-2 Reydisp Manager 2 Load Device Configuration Icon

Click **Load Configuration** in device in the context menu and if the connection is made the **Load Device Configuration** wizard will open.

Enter **Next** to proceed.

If the connection password is active the **Enter Password** dialog opens.

Enter the password.

Click **OK**.

The **Enter Password** dialog is closed.

Click **Yes** to confirm.

Initialization starts. Several indications inform the user about each status. Upon completion of initialization or in case of failed initialization, a status dialog opens.

Click **Finish**.

The status dialog closes. After initializing, the 7SR5 device is restarted.

Transmitting a Configuration to 7SR5 Device in Service



NOTE

For any device configuration changes the offline file must be sent to the device. If this is required, device data may be lost or become invalid due to configuration changes. The device data must therefore be retrieved from the device prior to sending a new configuration.



NOTE

The date and time of the device clock will not be lost.

Sending Configuration

The device data must be first retrieved from the device as described in [3.4 Get Device Data](#).

The configuration can now be sent to the device.

3.2 Change Device Template

Overview

When the device template is selected at the start of the engineering process, for example for directional over-current protection, an application template is loaded. With this, the maximum functional scope of the 7SR5 device must be defined with a specific hardware and firmware configuration. In some situations it may be necessary to change the configured device to a different firmware configuration by changing the template to add additional functions available in a new device template.

It is often quicker to adapt an existing device than to start with a new device and configure it.

Changing a Device Application Configuration Template

This chapter describes how to change the device template.

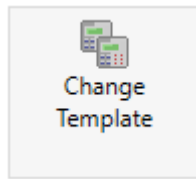

[sc_7SR5_ReydispManager2ChangeDeviceTemplateIcon, 1, --,--]

Figure 3-3 Reydisp Manager 2 Change Template Icon

All necessary application templates must be installed for Reydisp Manager 2 to access or be available on the PC to be directly pointed to using the **Load Template from File** option.

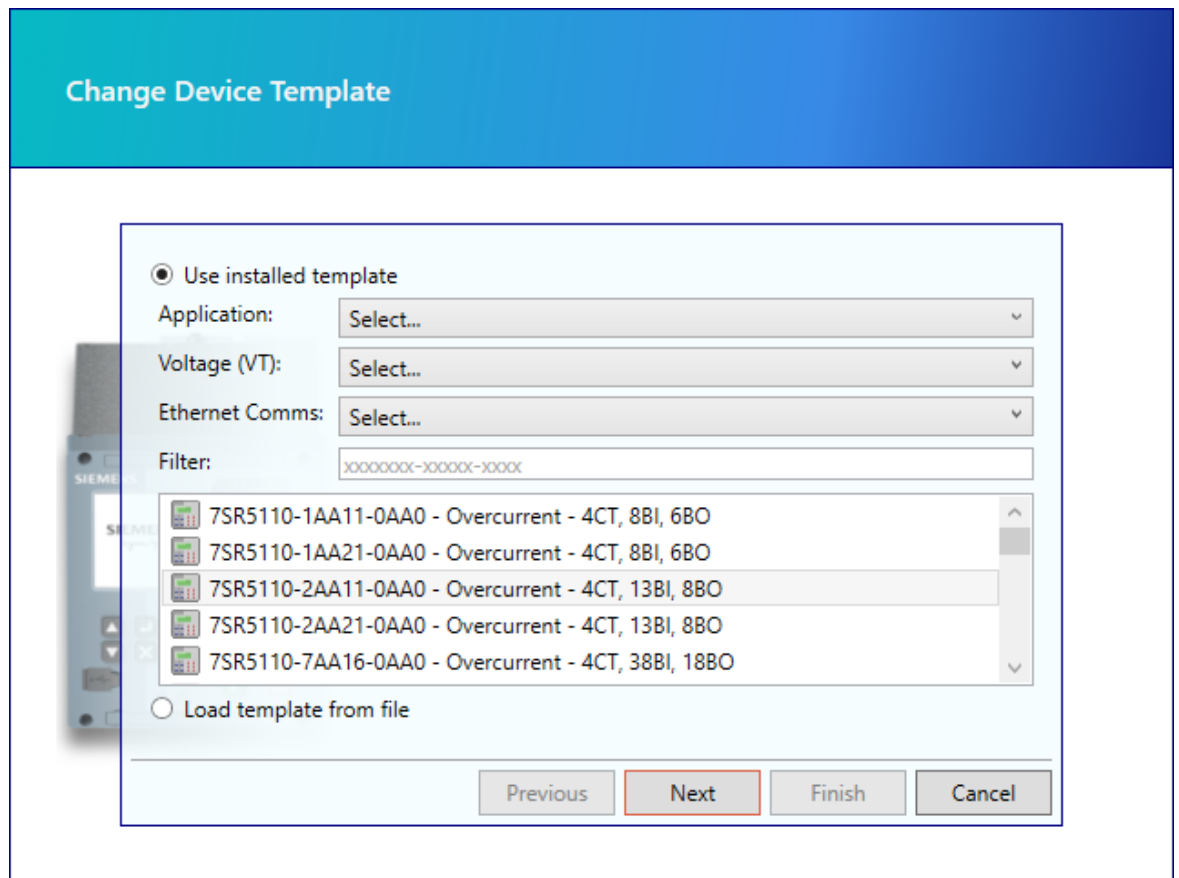

[sc_7SR5_ReydispManager2SelectingDeviceTemplate, 1, --,--]

Figure 3-4 Reydisp Manager 2 Selecting Device Template

Select the MLFB of the device template that the device should be changed to.
Select the **Minimum Firmware** for the template and click **Next**.
Check the version number of the template and firmware are as required and click **Next**.
Select **Finish** and the new template will be imported and device changed.

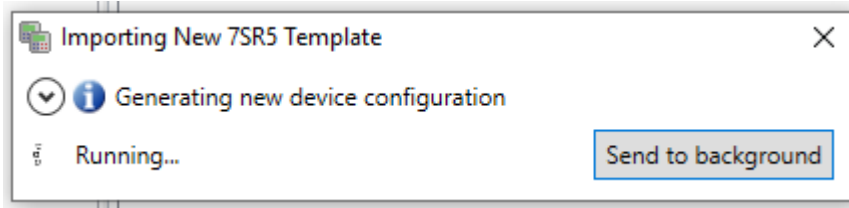

[sc_7SR5_ReydispManager2ImportingDeviceTemplate, 1, --, --]

Figure 3-5 Reydisp Manager 2 Importing Template

During the import, any user information warnings of compatibility issues between the original template and new template will be displayed. These messages are also logged in the **Information messages** tab for the device.

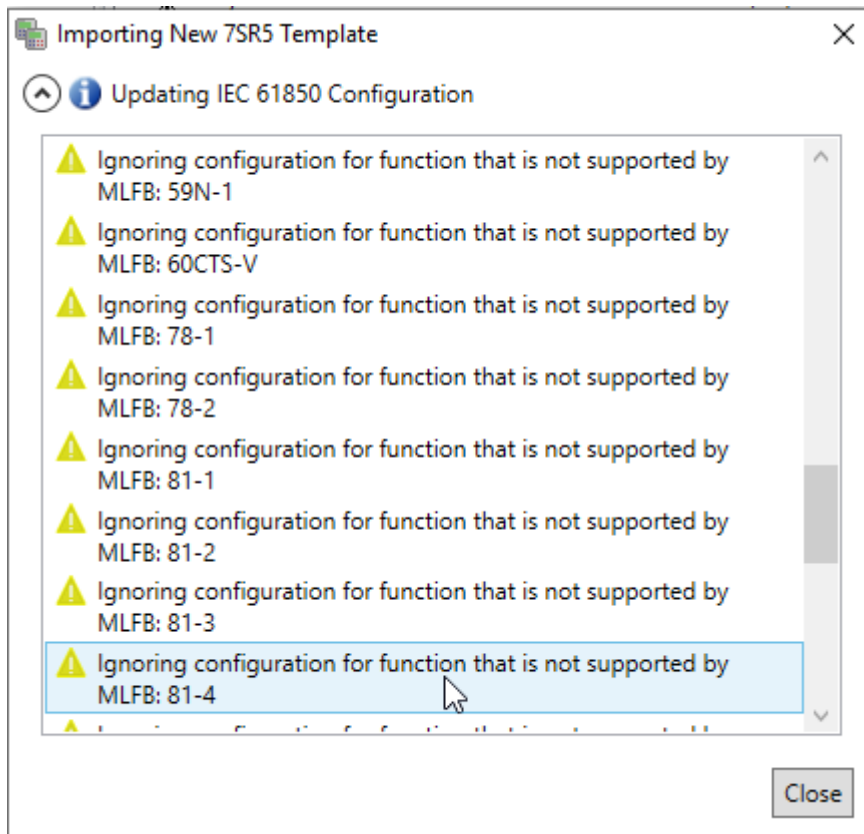

[sc_7SR5_ReydispManager2ImportingDeviceTemplateUpdatingIEC, 1, --, --]

Figure 3-6 Reydisp Manager 2 Updating IEC 61850 Configuration

On completion the MLFB and template version can be checked by viewing the **Device Properties General** tab in the **Device configuration** section of the **Tasks** area for the device.

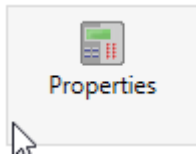

[sc_7SR5_ReydispManager2Properties, 1, --]

Figure 3-7 Reydisp Manager 2 Properties Icon

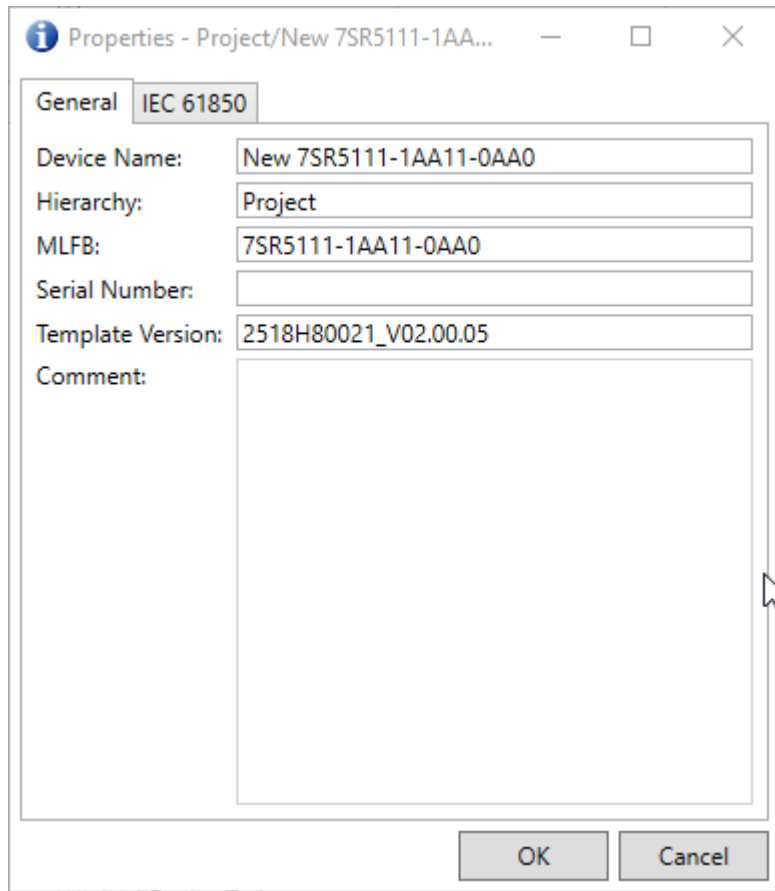

[sc_7SR5_ReydispManager2DeviceGeneralProperties, 1, --]

Figure 3-8 Reydisp Manager 2 Device General Properties

All user configured data will be transferred to the offline device configuration where compatible.

3.3 Install Device Firmware

Overview

When ordering a device, the hardware and certain functional characteristics are selected with the latest released firmware for the chosen model.

Device Firmware Version

The firmware can be viewed in the device on the fascia in **Device Information**:

- > **Firmware Version** – Device firmware
- > **Comms FW Version** – Communication and security firmware
- > **Config Version** – Default configuration scripts

Functional Characteristics

The base application functional specification is fixed by the order code but the functional characteristics may vary with firmware changes. The firmware can be updated in a 7SR5 device to match the firmware in the Reydisp Manager template using the device task function.

For firmware upgrades the install package should be downloaded from the website. A self extracting package is provided which will provide Reydisp Manager Templates. This allows the installation of Reydisp Manager 2 templates including firmware.

The firmware upgrade package will include an update to the firmware and configuration files.

In addition to the firmware upgrades, security update patches may be required throughout the life of the device if vulnerabilities are identified. Such security patch firmware will be released independently from the firmware and will update the Comms Firmware only.

The security updates will be available to download from the website.



NOTE

Siemens advise that the latest security firmware is always installed.

Installing the New Firmware Templates to Reydisp Manager

Reydisp Manager 2 must be installed on the PC to ensure the correct USB drivers are installed.

Clicking the self extracting .exe file will load the files into the Reydisp Manger templates location.

For a new device follow the instructions in [2.2 Starting Reydisp Manager 2 and Creating a Project](#) and [2.4 Adding a 7SR5 Device](#). When selecting the template in [Figure 2-23](#), select the version for this upgrade.

If the device is already existing within a project, the instructions procedure in [3.2 Change Device Template](#) must be followed to upgrade the device to the new firmware template.

Firmware upgrade procedure

The device should be out of service and disconnected from the power system.

Any configuration and data stored in the device will be lost during a firmware upload.

Loading Device Firmware to the 7SR5 Device

The device must be connected to the PC via the front USB port.

The PC will connect to the device and proceed to transfer the firmware package to the device.

Double-click the **Install Device Firmware** in the selected device task area.

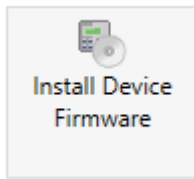

[sc_7SR5_ReydispManager2InstallDeviceFirmware, 1, --]

Figure 3-9 Reydisp Manager 2 Install Device Firmware Icon



NOTE

If the maintenance password is active a prompt window will request that it is entered before continuing.

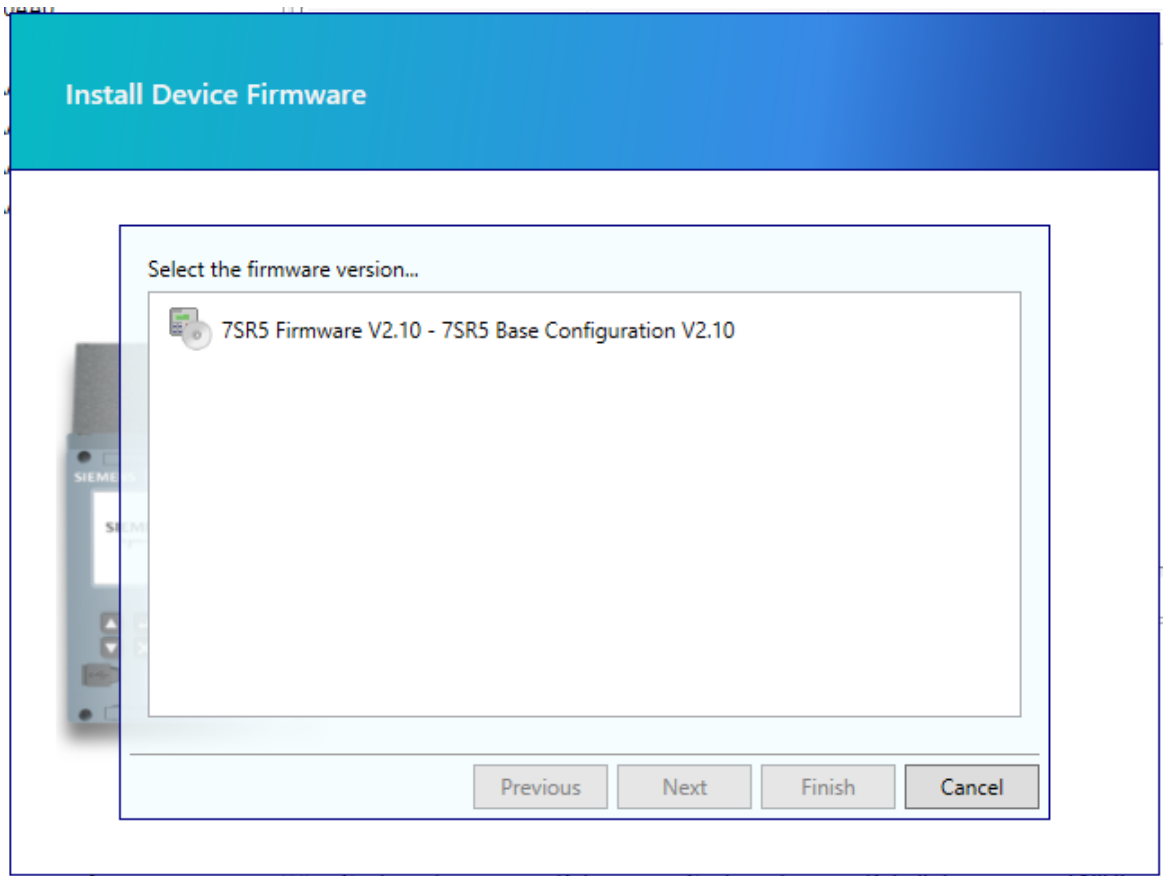

[sc_7SR5_ReydispManager2FirmwareVersion, 1, --]

Figure 3-10 Reydisp Manager 2 Firmware Version

Confirm the firmware is the correct version by selection and click **Next** to continue.

A loader window will be visible for a short duration during the connection.

On completion of the transfer the window will notify the user the upload from the PC to the device is complete and the **Finish** option must be selected.

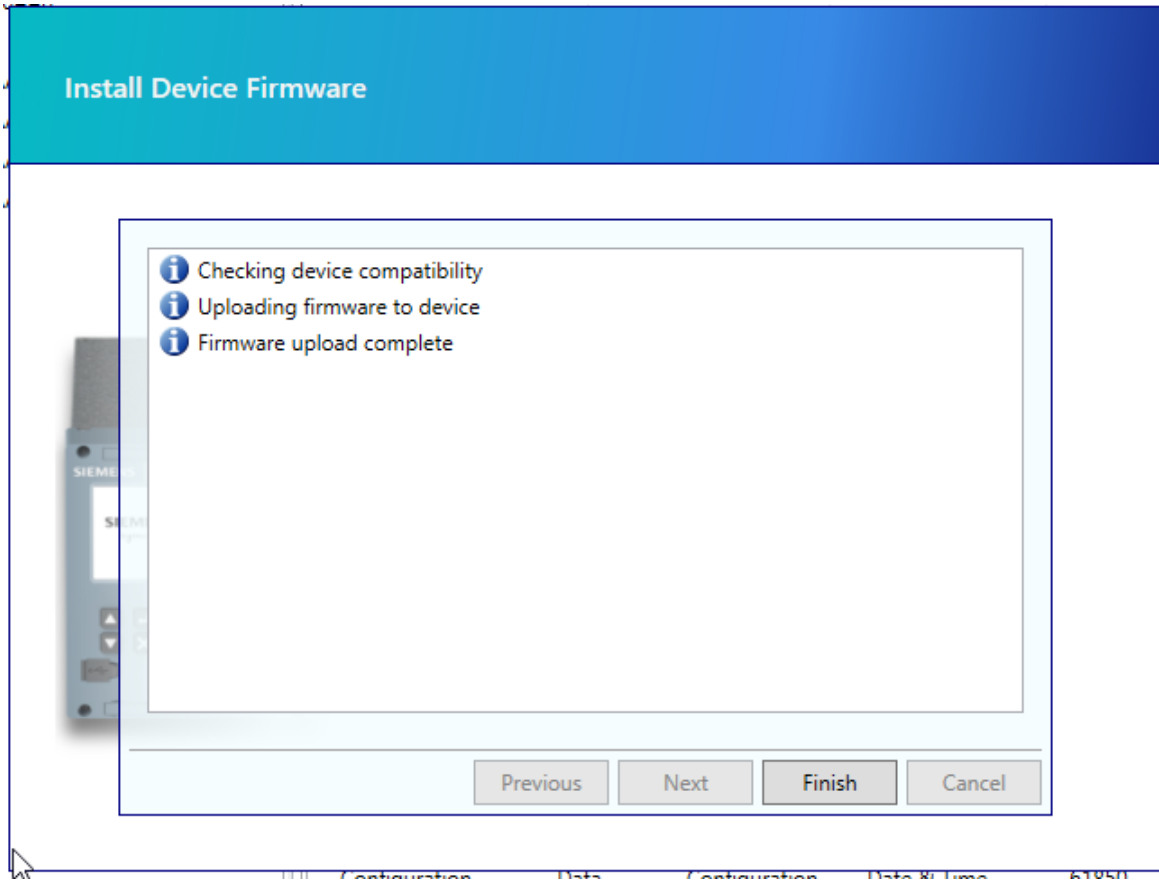

[sc_7SR5_ReydispManager2FirmwareUploadComplete, 1, ...]

Figure 3-11 Reydisp Manager 2 Firmware Upload Complete

During the upgrade process the device fascia will display file transfer information and the device will restart on completion.

All user configuration files and data storage will be erased and the settings defaulted. Press **Enter** on the device to confirm acknowledgement. The device will display the **Device not configured** message on the display after a short duration.

The firmware version can be viewed in the device on the fascia in **Device Information** for confirmation.

Loading a Security Update Comms Firmware to the 7SR5 Device

Download the security patch to the PC.

The device should be out of service and disconnected from the power system.

Browse to the device homepage of the device via a direct connection to the USB port or over an ethernet connection to one of the rear ethernet ports of the device.

For the device front USB port use <https://192.168.2.1/upload> to navigate directly and proceed to the page.

For the rear ethernet port, it must be configured and the IP address used.

Use the **Choose file** option to navigate to the security patch **.pck** file downloaded from the website and select **Update**.



NOTE

If the maintenance password is active a prompt window will request that it is entered before continuing.

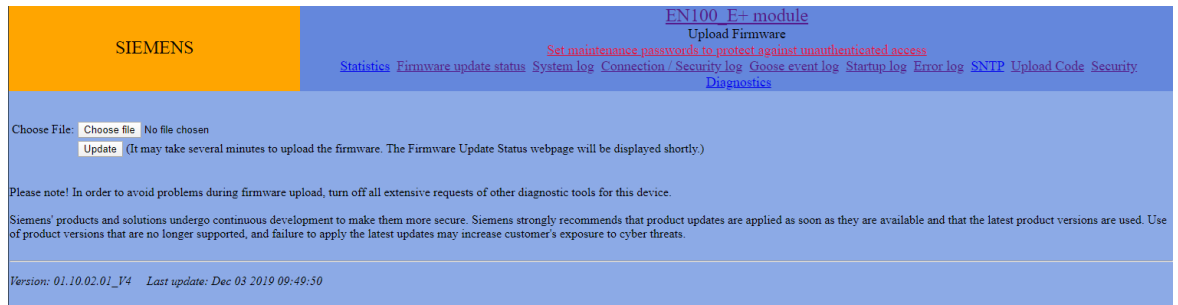

[sc_7SR5_ReydispManager2SecurityUpdate, 1, --]

Figure 3-12 Reydisp Manager 2 Security Update

When the update is complete the device will restart.



NOTE

The user configuration files and data storage files will not be erased during a security patch update.

3.4 Get Device Data

Overview

The device stores data that can be viewed and analyzed on the PC.

The following data files can be retrieved from the device using Reydisp Manager 2:

- Waveform records storage
- Fault records storage
- Event log

When retrieved from the device the files will be associated with the device in the project and stored on the PC using the time and date of the file as the default name.

Get Device Data

The device data can be retrieved from the device using **Device Task > Get Device Data** when connected to the fascia USB port.



NOTE

Any passwords configured in the device may be required to access the data.



[sc_7SR5_ReydispManager2GetDeviceDataIcon, 1, --]

Figure 3-13 Reydisp Manager 2 Get Device Data Icon



NOTE

An error message will be provided if the data can not be retrieved for any reason.



NOTE

The **Get Data** will check for all file types and if none are available will complete the action successfully.

An error message is not given if there are no files available but the device was checked successfully.

Alternatively an icon is located on the right hand side of the device details which can be selected to get the device data for that particular device.



[sc_7SR5_ReydispManager2GetLogsandRecords, 1, --]

Figure 3-14 Reydisp Manager 2 Get Logs and Records

A connection window is provided to select between the default USB connection method and connecting via the rear Ethernet port using the IP address of the device.

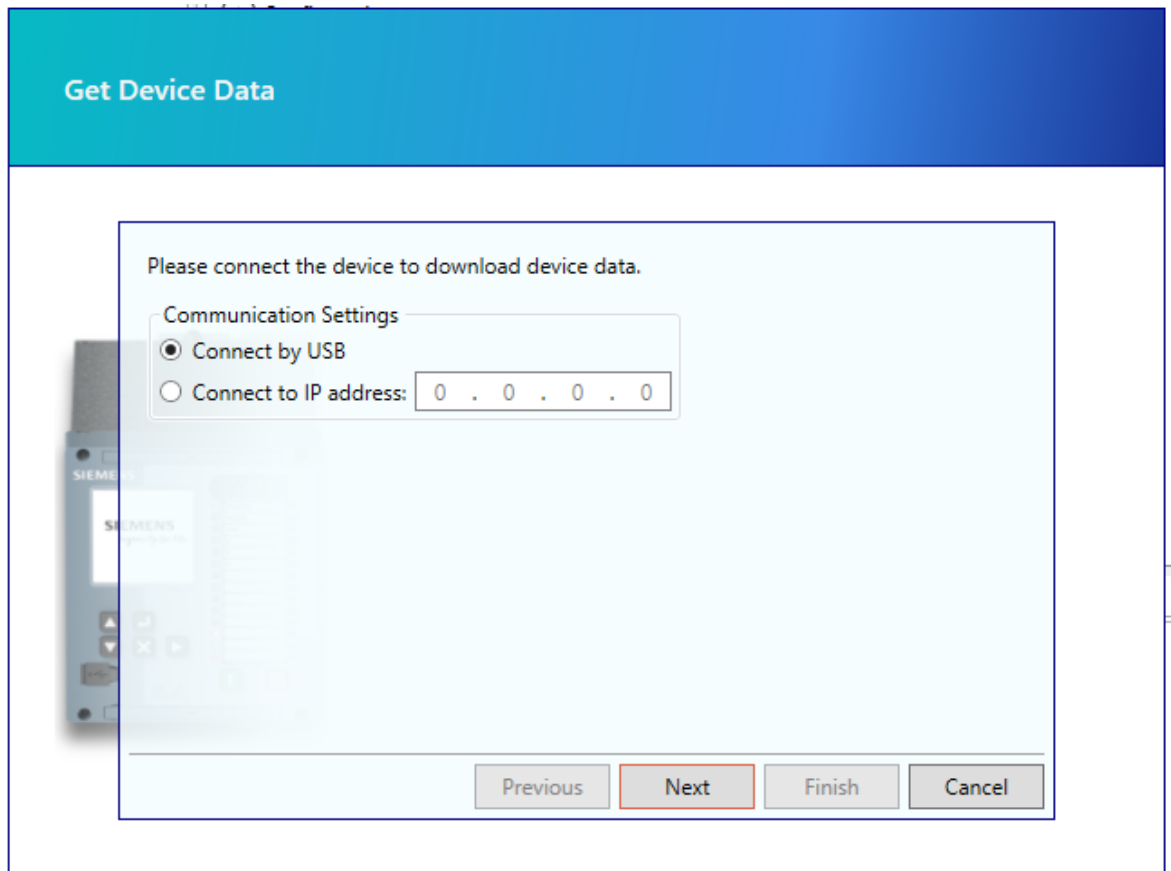

[sc_7SR5_ReydispManager2ConnectByUSB, 1, --_]

Figure 3-15 Reydisp Manager 2 Communication Settings

- Waveform Records

Any available waveform records will be retrieved from the device from both the buffer storage and the archived memory. The files will be stored under the **Device Data** tab using the waveform time and date as the default file name and also the last modified information.

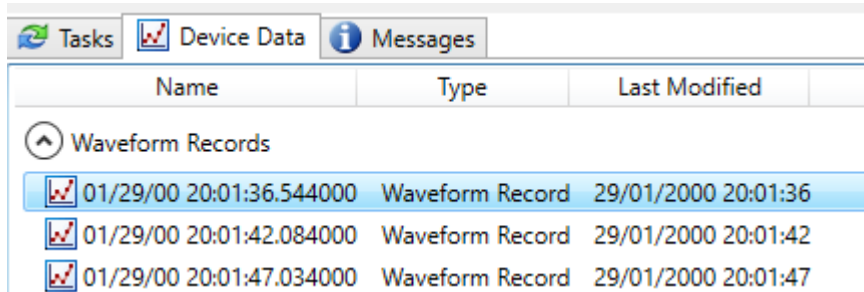

[sc_7SR5_ReydispManager2DeviceDataWaveformRecords, 1, --, --]
Figure 3-16 Reydisp Manager 2 Waveform Records

The file name can be changed by the user by a right-click of the mouse on the waveform record and entering the preferred name followed by **Apply**.

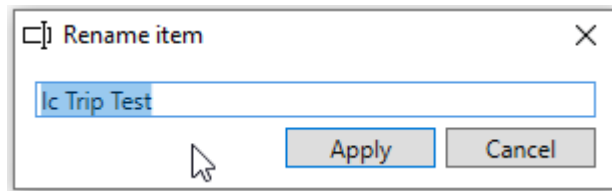

[sc_7SR5_ReydispManager2WaveformRecordRename, 1, --, --]
Figure 3-17 Reydisp Manager 2 Waveform Record Rename

The maximum quantity associated with the device will only be restricted by the PC memory capacity. The file can be exported and saved to a Reyrolle waveform record format, **.rdf2** by right-clicking on the waveform record file in the device data window.

- **Device Event Records**
When the device data is retrieved from the device a new **Event log** is created on the PC containing the last recorded events in the device since the **Event log** was last reset. The same events may be visible in multiple event logs. The files will be stored under the **Device Data** tab using the time and date when the **Event log** was created as the default file name and also the last modified information.

Name	Type	Last Modified
Waveform Records		
Device Event Logs		
Event Log	Device Event Log	01/01/2000 00:09:00
Event Log	Device Event Log	01/01/2000 00:14:49

[sc_7SR5_ReydispManager2DeviceDataEventLogs, 1, --_--]

Figure 3-18 Reydisp Manager 2 Event Logs

The file name can be changed by the user by a right-click of the mouse on the event log, selecting the **Rename Event Log** and entering the preferred name followed by **Apply**.

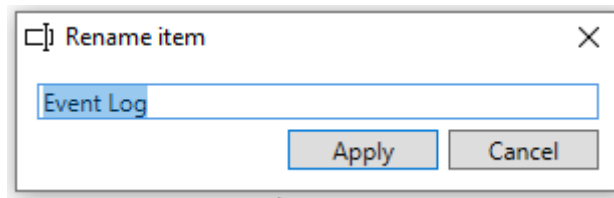

[sc_7SR5_ReydispManager2DeviceDataEventLogsRename, 1, --_--]

Figure 3-19 Reydisp Manager 2 Event Log Rename



NOTE

Event records will be reset when a new device configuration is sent to the device or the firmware is reinstalled.

The event log can be exported by a right-click of the mouse on the event log file. The file is exported as a **.txt** file.

When viewing the event log file the order of the events can be sorted by the timestamp by clicking the timestamp heading which will switch between the earliest date and latest date at the top of the list.

- **Fault Record Logs**
Any available fault logs will be retrieved from the device.
The files will be stored under the **Device Data** tab using the device fault logs time and date as the default file name and also the last modified information.

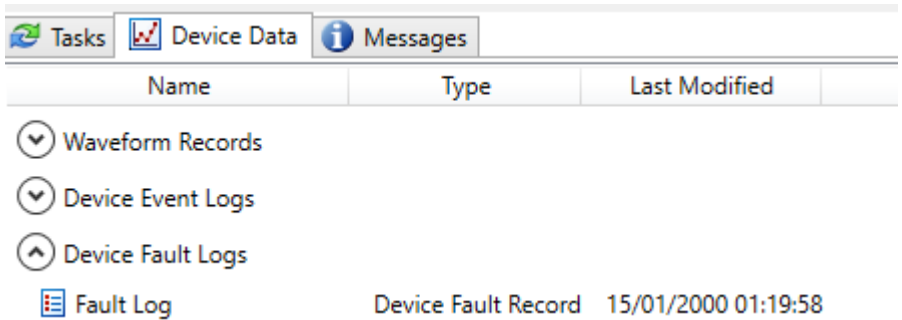

[sc_7SR5_ReydispManager2DeviceDataFaultLogs, 1, --]

Figure 3-20 Reydisp Manager 2 Fault Logs

The file name can be changed by the user by a right-click of the mouse on the **Fault log**, selecting the **Rename Fault Log** and entering the preferred name followed by **Apply**.

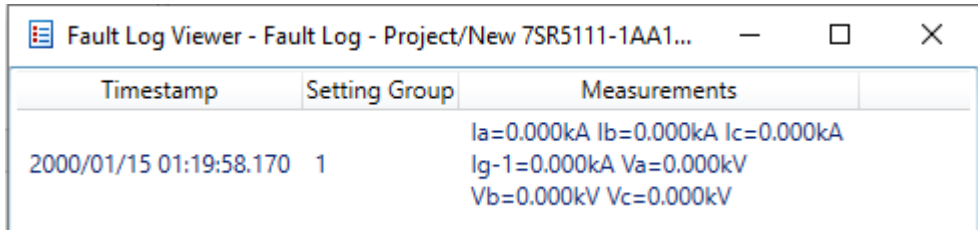

[sc_7SR5_ReydispManager2DeviceDataFaultLogData, 1, --]

Figure 3-21 Reydisp Manager 2 Fault Log Data

The **Fault log** displays the time and date when the fault was stored, with the active setting group and measured values in the device at the time of the fault.

The faults can be sorted by date by clicking the timestamp heading.

3.5 Get Device Configuration

Overview

The device configuration held within the device can be extracted and stored in the device project. The device must be included within the project. The **Get Device Configuration** function will extract the following user files and import them into the project automatically:

- Function configuration
- Serial Comms & Events
- User logic
- HMI screens
- User curves
- Ethernet Interface parameters
- Ethernet time zone

The file information in the project will be updated with the date and time from the extracted files.

The properties of the device will also be updated with the serial number of the connected device.

As the user settings within the device parameter file can be edited from the device fascia, these values will be compared with those held already within the project and the user prompted to agree or ignore the imported values.

Get Device Configuration

The complete user configuration files can be extracted by selecting the specific device and using the **Get Device Configuration** icon in the device tasks working area for that device.

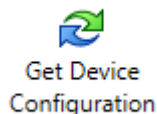

[sc_7SR5_ReydispManager2GetDeviceConfiguration, 1, --]

Figure 3-22 Reydisp Manager 2 Get Device Configuration Icon

Alternatively an icon is located on the right hand side of the device data for that particular device.



[sc_7SR5_ReydispManager2GetDeviceConfigurationOption2, 1, --]

Figure 3-23 Reydisp Manager 2 Get Device Configuration Icon Alternative

Double clicking on one of the available icons will open a connection window, the default connection is a direct connection from the PC to the front USB port.

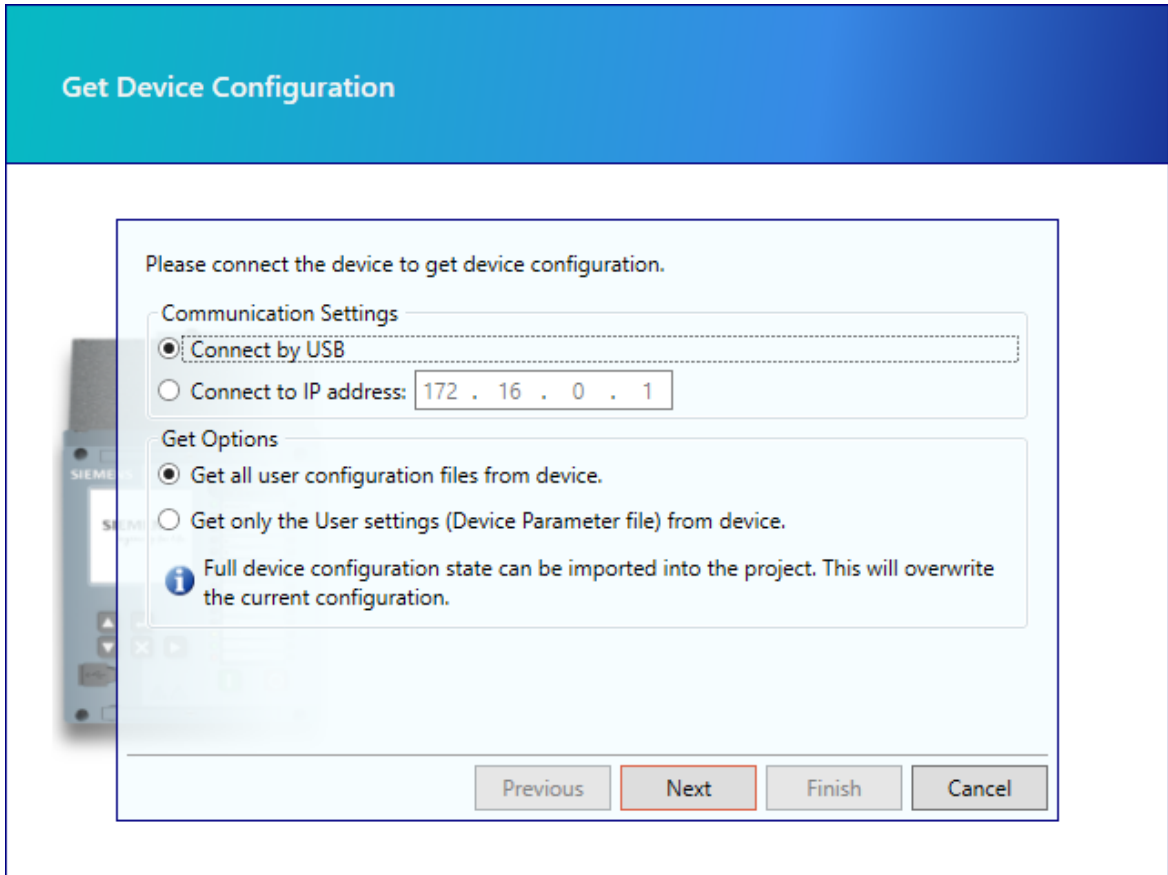

[sc_7SR5_ReydispManager2ConnectionWindow, 1, --]

Figure 3-24 Reydisp Manager 2 Connection Window

At this stage the user must also select between getting the complete device configuration, which will update all of the user configuration files in this device in the project or to only extract the user settings contained in the device parameter file.



NOTE

Both options allow the user to confirm any differences between the user setting values before overwriting the files in Reydisp Manager.

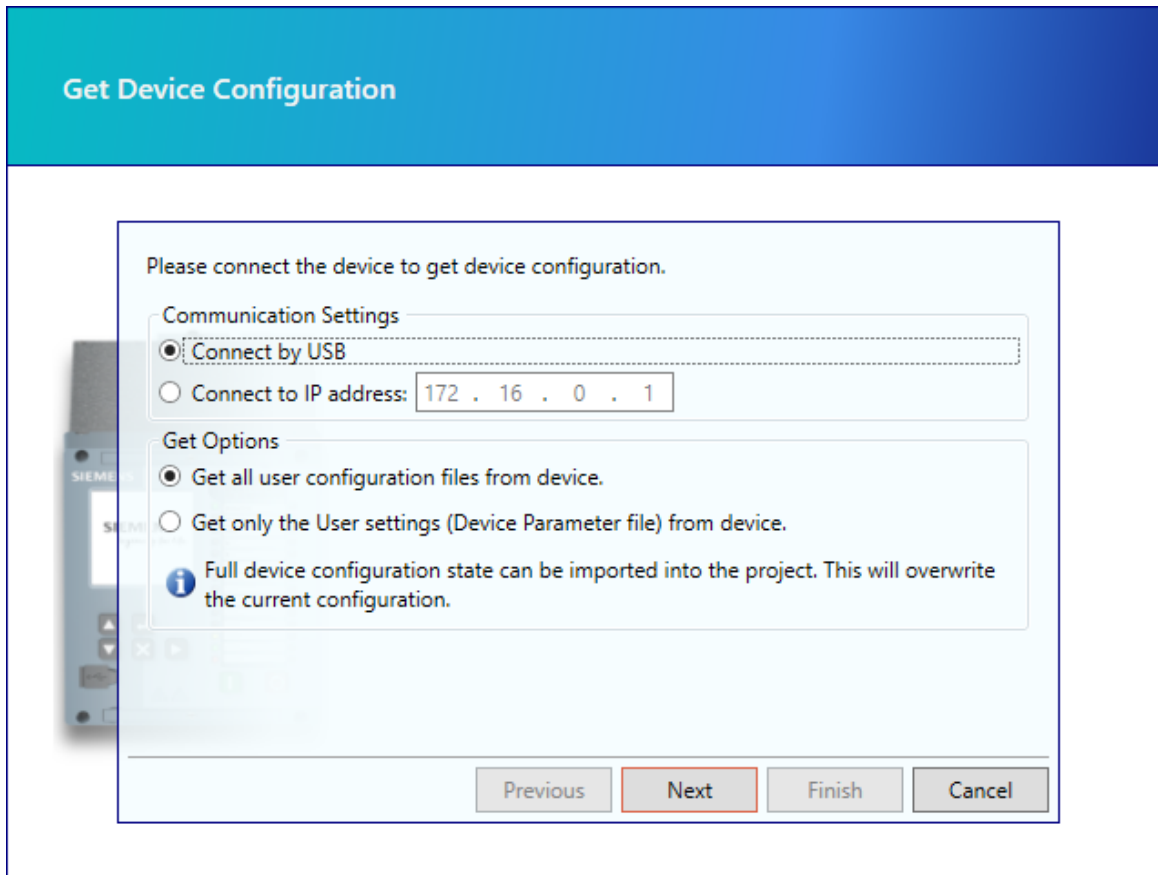

[sc_7SR5_ReydispManager2ConnectionWindow, 1, --]

Figure 3-25 Reydisp Manager 2 Get All User Configuration Files

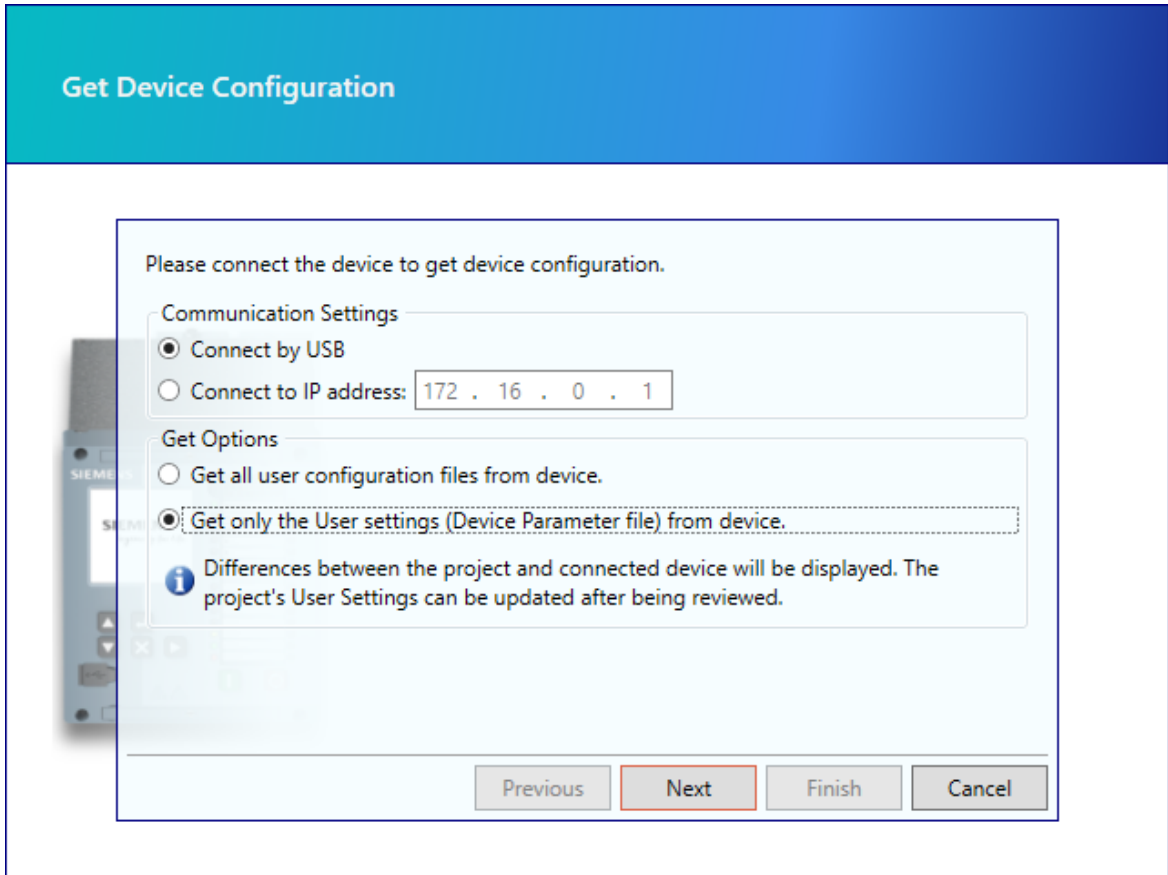

[sc_7SR5_ReydispManager2OnlyUserSettings, 1, --]

Figure 3-26 Reydisp Manager 2 Get Only User Settings

All files that are changed in the project will have the last modified information updated to reflect the date when that file was last changed.



NOTE

If the last modified timestamp on the file in the device was earlier than the one on the PC the timestamp will show the earlier timestamp and not the timestamp of the upload from the device.

The connection will first confirm that the device you are connected to is the correct device associated with this project and report any incompatibility with an information or error message and stop the download process.

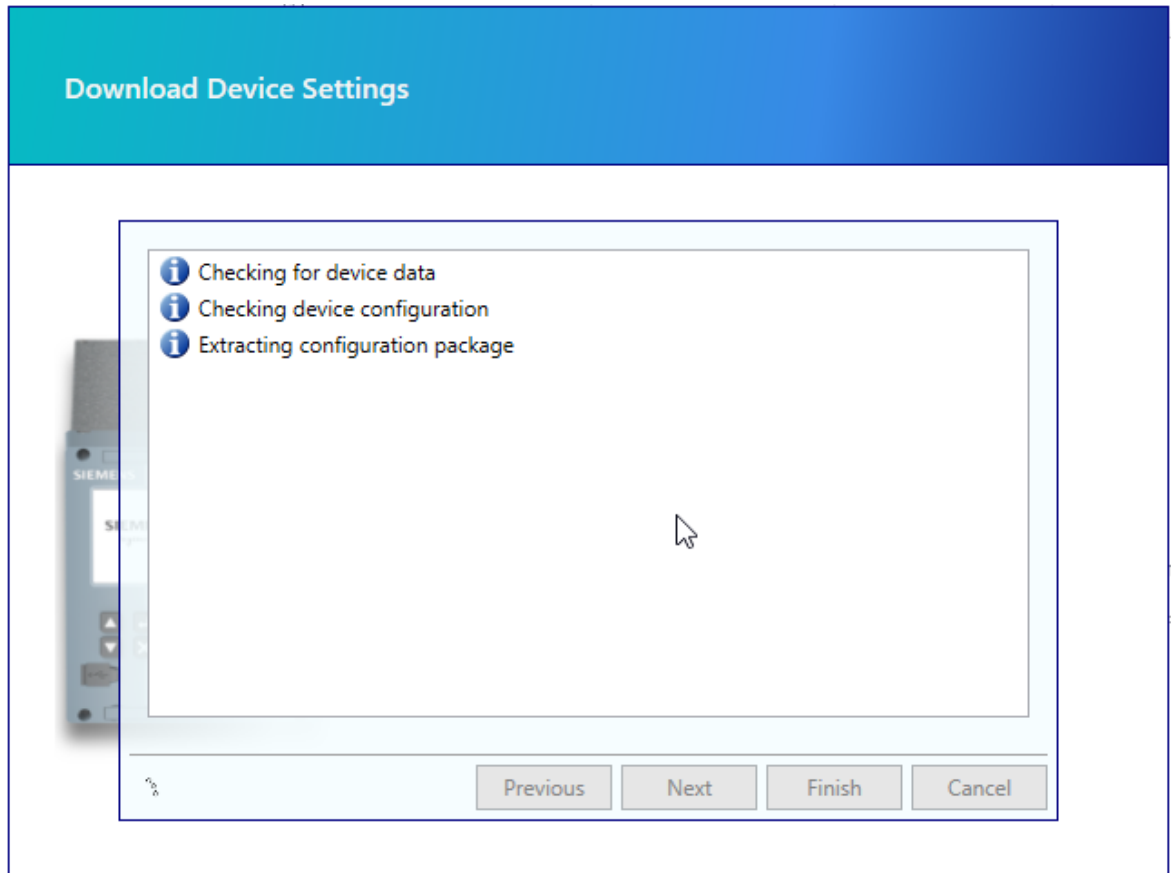

[sc_7SR5_ReydspManager2CheckingDevice, 1, --]

Figure 3-27 Reydsp Manager 2 Checking Device

Failure messages will be displayed in the window, an example of this is shown in [Figure 3-28](#).

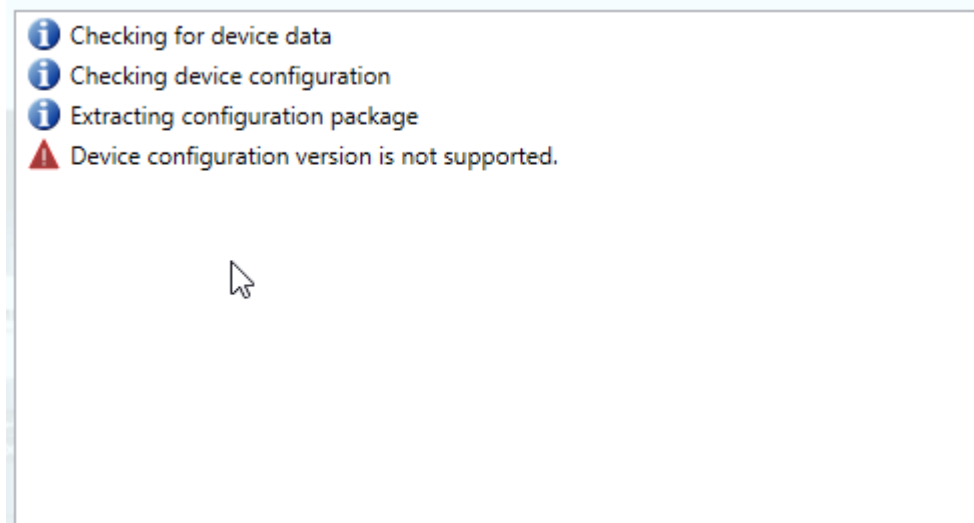

[sc_7SR5_ReydspManager2FailureMessage, 1, --]

Figure 3-28 Reydsp Manager 2 Example Failure Message

If the option for getting the device setting values only has been selected, even if the devices are not of the same type, a warning message is given and the task will continue. The setting values will still be imported for comparison and use.

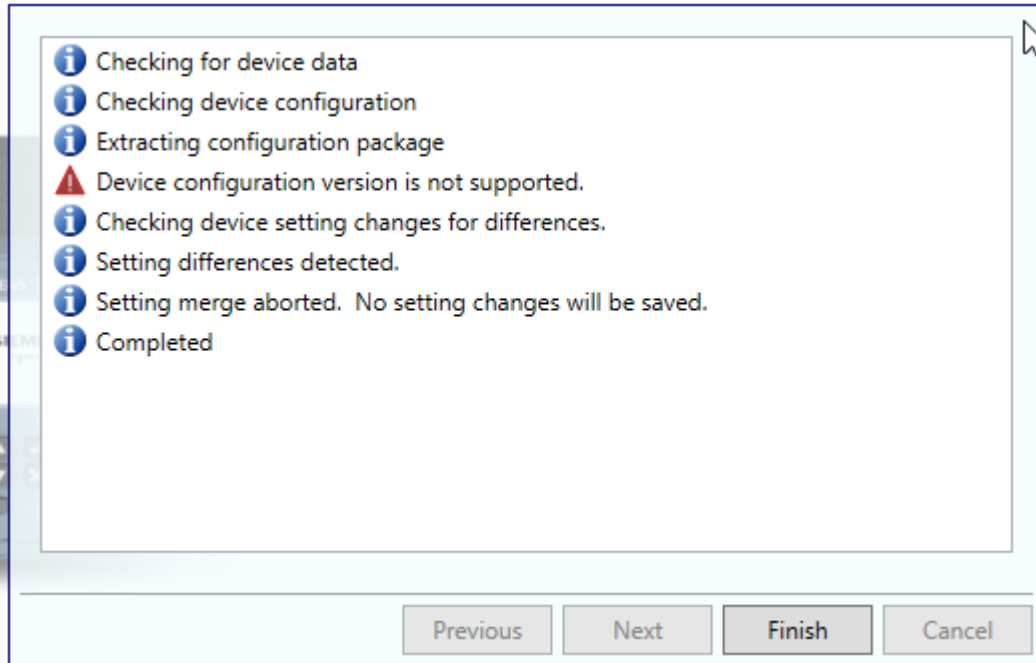

[sc_7SR5_ReydspManager2CheckingComplete, 1, --_]

Figure 3-29 Reydsp Manager 2 Check Complete

On completion of a complete device import the user is prompted with the time and date of the last configuration update on the device and must confirm if they wish to proceed and overwrite the configuration on the PC or keep the existing PC files and stop the import.

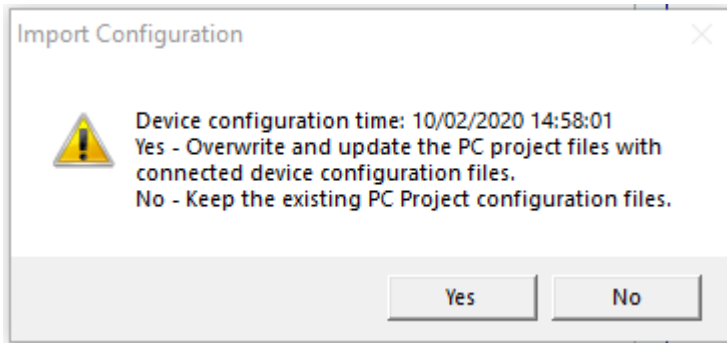

[sc_7SR5_ReydspManager2ImportConfiguration, 1, --_]

Figure 3-30 Reydsp Manager 2 Import Configuration

Any differences between the setting values in the parameter file on the connected device and the values in the file contained in the PC project will be listed in the **Merge Settings** window. The view can be changed to only show the values with differences by selecting the option **Show differences only**.

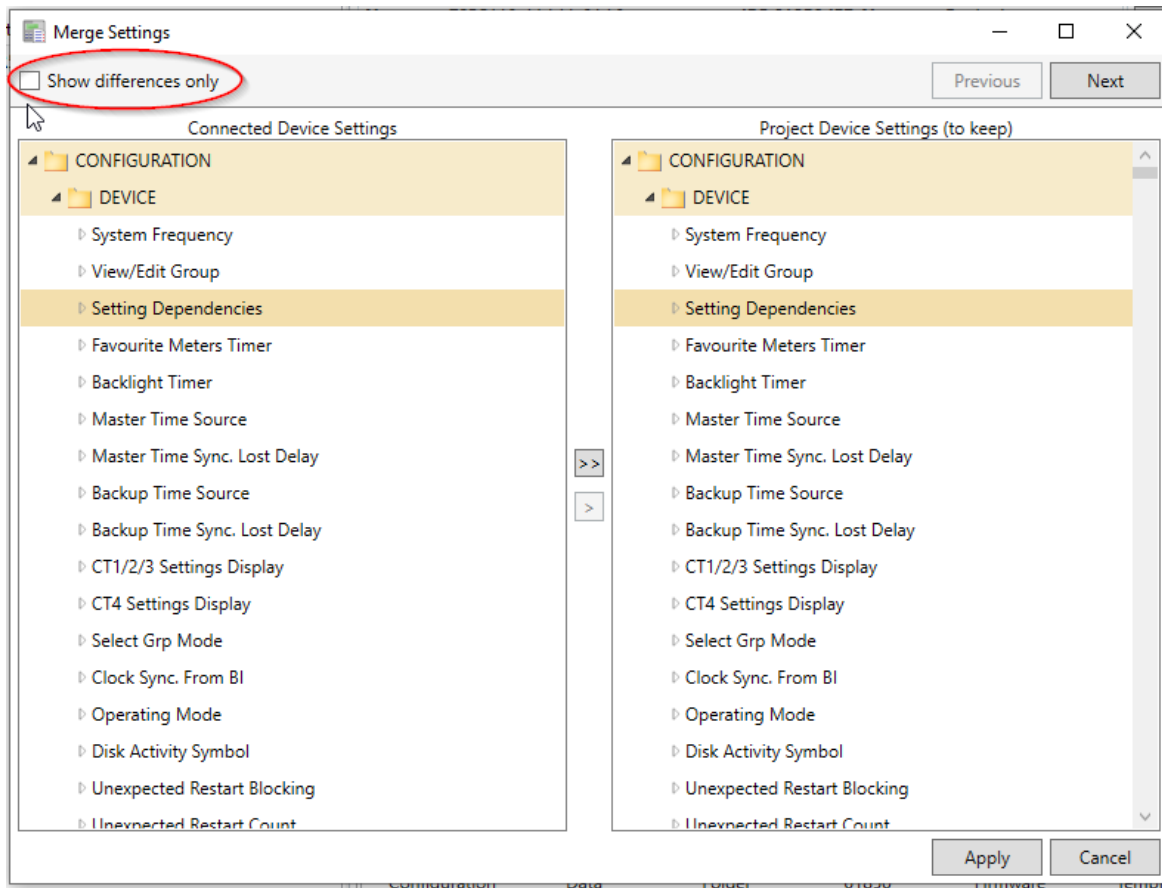

[sc_7SR5_ReydispManager2ShowDifferencesOnly, 1, --, -]

Figure 3-31 Reydisp Manager 2 Show Differences Only

Using the **Next** button the user can cycle through the differences. The user can choose to keep the setting in the PC project file or transfer the setting from the connected device to update the project file by using the arrow key.

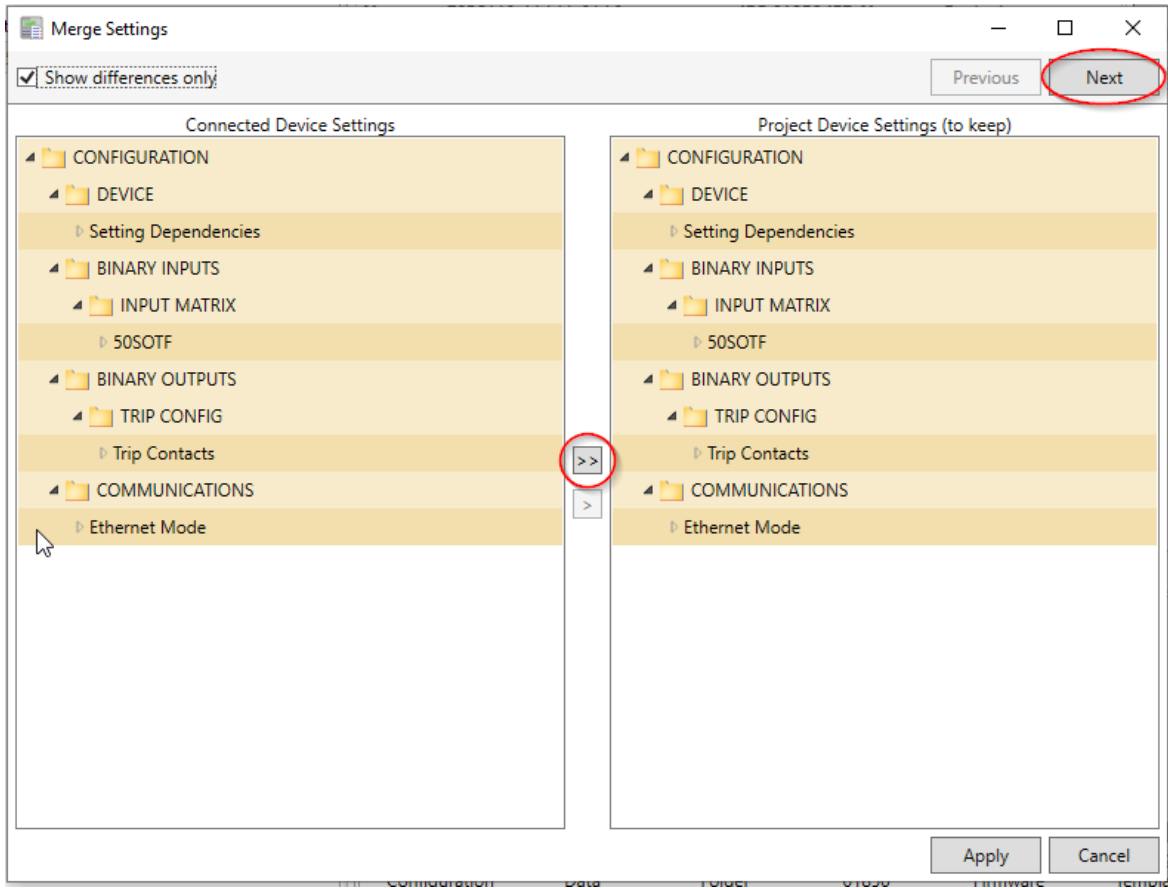

[sc_7SR5_ReydispManager2UpdatingProjectFile, 1, --, --]

Figure 3-32 Reydisp Manager 2 Updating Project File

3.6 Set Device Date and Time

Overview

The device date and time can be set on the device fascia using the menu keys or from the **Set Device Date and Time** function within the device tasks. This can be useful during test and commissioning when the substation clock is not available or connected to the system as it will provide a useful time stamp on the data records in the device.

Set Device Date and Time

The device task operations for each device includes the option to **Set Device Date & Time**.



[sc_7SR5_ReydispManager2SetDeviceDateandTime, 1, --, --]

Figure 3-33 Reydisp Manager 2 Set Device Date and Time Icon

Double clicking the icon opens a time setting window to select the preferred source of the time to be sent to the device. The default option is to use the time from the PC as the source but an option is also available to manually enter a preferred time and date.

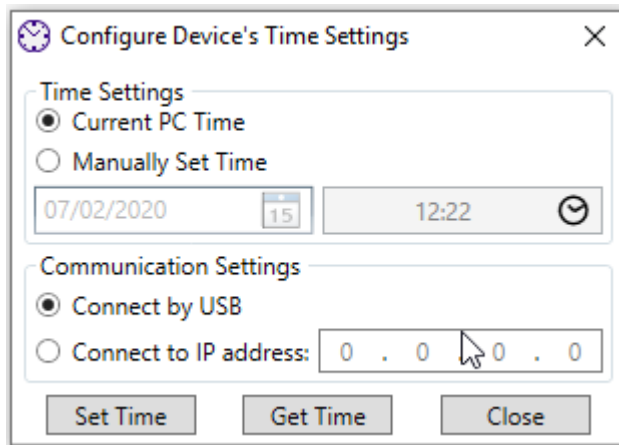

[sc_7SR5_ReydispManager2TimeSettings, 1, --, --]

Figure 3-34 Reydisp Manager 2 Configure Device's Time Settings

The window also includes the connection options available, with the default connection selected as a direct connection from the PC to the front USB port and an option to select an IP address for ethernet connection.

The **Set Time** button is clicked to send the time and date to the device.

The **Get Time** button will retrieve the time and date from the device to confirm the time is correct, the time retrieved from the device will be shown in the **Time Settings** area of the window.



NOTE

If the connection password is active this must be entered to proceed with this action.

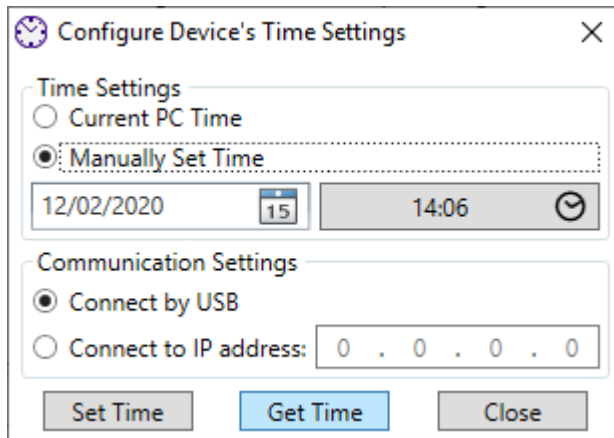

[sc_7SR5_ReydispManager2GetTime, 1, --, --]

Figure 3-35 Reydisp Manager 2 Get Time

3.7 Compile IEC 61850 Configuration

When the **System Configurator** is closed, the IEC 61850 configuration of each 7SR5 device assigned to that station is recompiled. This can take a while if a large number of devices is assigned to a single station. The IEC 61850 configuration will always be updated automatically before any attempt is made to synchronize the device and can be manually recompiled by clicking **Update Station** from the task pane.

If something has changed that affects the IEC 61850 configuration, the IEC 61850 configuration will require updating.

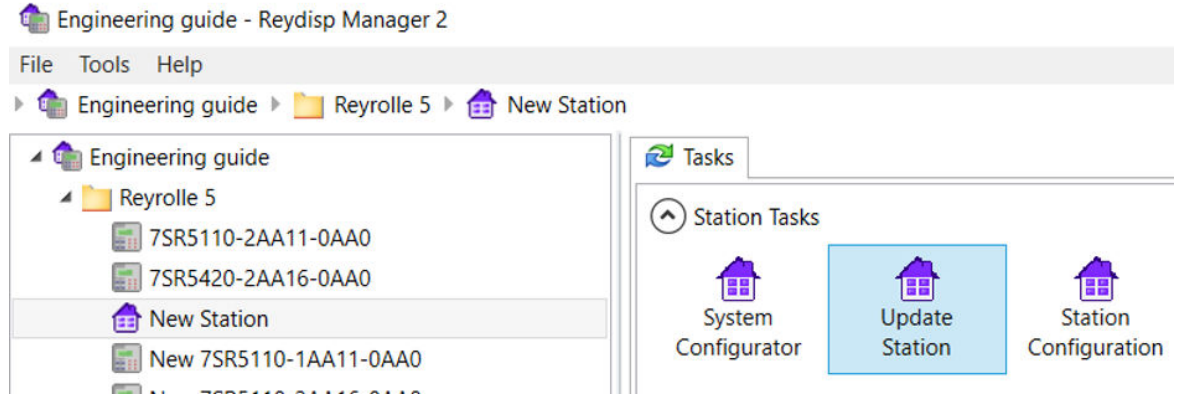

Figure 3-36 Reysdisp Manager 2 Update Station

4 Import and Export

4.1	Export ICD	142
4.2	Import SCD/ICD	143
4.3	Export IEC 61850 MICS	144
4.4	Export IEC 61850 SNTP	146

4.1 Export ICD

A device ICD file can be exported for use in another vendor's IEC 61850 configuration tool. To do this the user must select the device to export in the project and click **Export ICD** from the task pane. The exported ICD file will contain the IED name.

An ICD file can be exported from the device template prior to configuration but it is recommended as a minimum the **Function Configuration** is checked prior to the export.

A window will pop up to select the location the file should be saved to and what it should be called.

4.2 Import SCD/ICD

Overview

A single 7SR5 device may be configured externally for IEC 61850 communications by a tool which produces a CID (Configured ICD File) or an SCD file. A CID file is an SCD file but only contains information relevant to a single device instead of every device in the station.

A CID file can be exported from the **System Configurator**.

Assigning a station to a single device is called a **Local Station**. A local station is only ever assigned to a single device therefore it does not show up in the project as a station because its assignments cannot be changed.

The SCD/CID import is used in the following scenario:

Another vendor's tool is used to configure a station. The tool imports the 7SR5 device ICD and configures the station to use the 7SR5 device. In this scenario, we need the station configuration to also be applied to the 7SR5 device in Reydisp Manager so both the vendor's tool and Reydisp Manager are using the same device configurations to enable the devices to communicate over the network.

The following is a likely scenario:

1. A project is created in Reydisp Manager and a 7SR5 device is added. The ICD for this device is exported.
2. Another vendor's tool is used to configure the station (SCD file). To configure the station, the tool needs to import the 7SR5 device before it can configure it.
3. The ICD is added to the station, and the station is configured, including IP configuration and GOOSE mappings.
4. The SCD (or CID) is exported from the vendor's tool.
5. The CID/SCD file is imported to the device in Reydisp Manager. This creates a local station using the configuration information in the CID/SCD file. Its IP address has been set and any GOOSE messages have been setup. The configuration can now be sent to the device and it will be fully configured for IEC 61850 communications with the other devices in the station.
6. If a CID file is used, which only has a single device, the IED name of the device will be changed to match the IED name in the CID file.
7. If an SCD file is used, the IED name of the device must match up with the IED name of the device in the SCD file.
8. If the device is already assigned to a local station, performing a CID/SCD import will replace the local station with a new local station.
9. If the device is already assigned to another station, the import cannot be performed. Remove the device from the station first and try the import again.

Importing SCD/CID File

In order to create a new device in Reydisp Manager the user must change the configuration - logic, settings, IEC 61850 interface or time zone as required. The user must:

- Update the device name and IED name as required
- Select the device and select **Import SCD/CID** from the task pane
- Import the ICD into the vendor's tool
- Add it to the SCD and configure the device IP settings, GOOSE messages etc. (In this example, we have 3 devices from other vendors plus 1 7SR5 device in the SCD).
- Export the SCD from the vendor's tool
- Create a station in Reydisp Manager
- Select the station and click **Import SCD** from the task pane

4.3 Export IEC 61850 MICS

Overview

The **Export IEC 61850 MICS** feature provides the user with the **Model Implementation Conformance Statement** directly from device configuration to provide an exact statement in accordance to the users particular configuration.

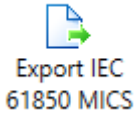

[sc_7SR5_ReydispManager2ExportIEC61850MICS, 1, --_]
Figure 4-1 Export IEC 61850 MICS Icon

The feature will generate the MICS file and request the user to save either an RTP or HTML file using a preferred name and location.

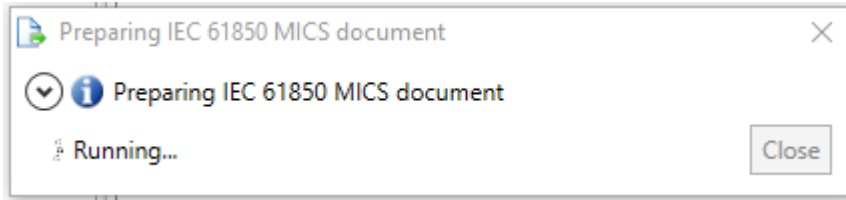

[sc_7SR5_ReydispManager2PreparingIEC61850MICS, 1, --_]
Figure 4-2 Exporting IEC 61850 MICS Message

An example of the HTML file is shown in [Figure 4-3](#). This format provides the user with a structured document with hyperlinks to the various sections.

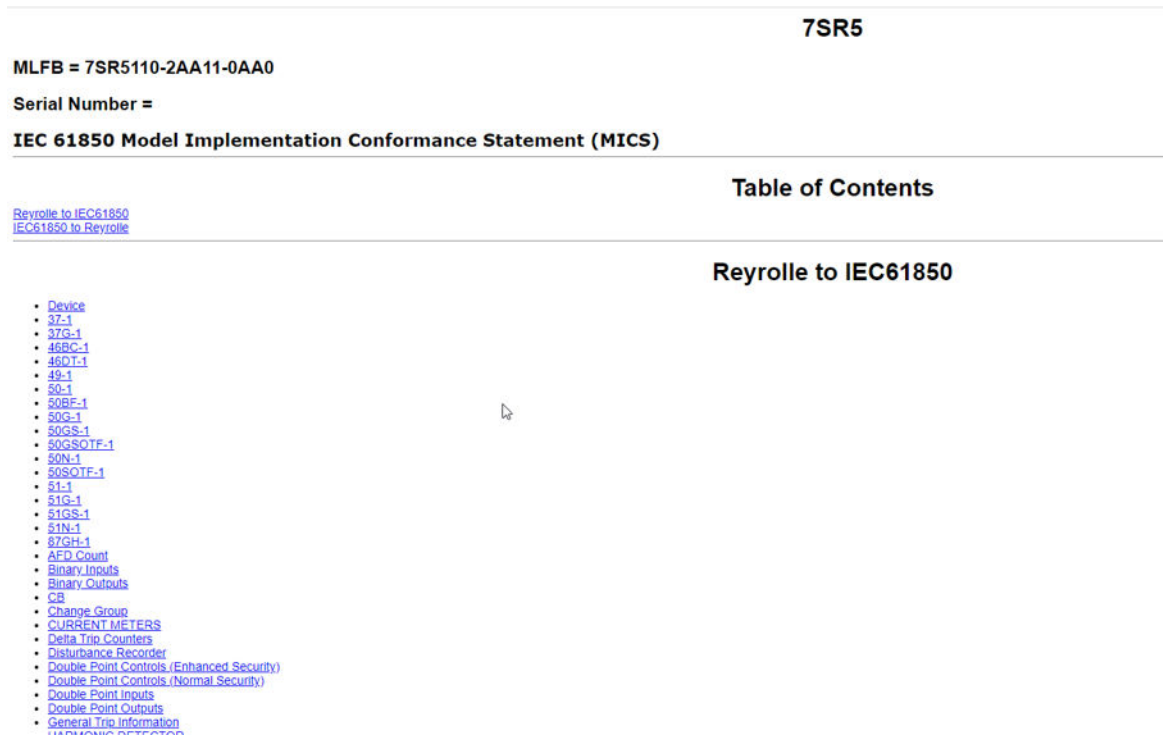

[sc_7SR5_ReydispManager2HTMLFile, 1, --_]
Figure 4-3 Reydisp Manager 2 Example HTML File

Reyrolle to IEC61850

Device

LED Reset

DOI	DA Group
CTRL.LLN0.LEDRs	stVal

Local Mode

DOI	DA Group
PROT.CntDelGGIO1.Loc	stVal
CTRL.DPDOesGGIO1.Loc	stVal
CTRL.DPDOesGGIO2.Loc	stVal
CTRL.DPDOesGGIO3.Loc	stVal
CTRL.DPDOesGGIO4.Loc	stVal
CTRL.DPDOsGGIO1.Loc	stVal
CTRL.DPDOsGGIO2.Loc	stVal
CTRL.DPDOsGGIO3.Loc	stVal
CTRL.DPDOsGGIO4.Loc	stVal
CTRL.DPSBesGAPC1.Loc	stVal
CTRL.DPSBesGAPC2.Loc	stVal
CTRL.DPSBesGAPC3.Loc	stVal
CTRL.DPSBesGAPC4.Loc	stVal
CTRL.LLN0.Loc	stVal
CTRL.Q0CSW11.Loc	stVal
CTRL.Q0XCBR1.Loc	stVal
CTRL.SPDOesGGIO1.Loc	stVal
CTRL.SPDOesGGIO2.Loc	stVal
CTRL.SPDOesGGIO3.Loc	stVal
CTRL.SPDOesGGIO4.Loc	stVal
CTRL.SPDOsGGIO1.Loc	stVal
CTRL.SPDOsGGIO2.Loc	stVal
CTRL.SPDOsGGIO3.Loc	stVal
CTRL.SPDOsGGIO4.Loc	stVal
CTRL.SPSBesGAPC1.Loc	stVal
CTRL.SPSBesGAPC2.Loc	stVal
CTRL.SPSBesGAPC3.Loc	stVal
CTRL.SPSBesGAPC4.Loc	stVal

[sc_7SR5_ReydispManager2MICS, 1, --,--]

Figure 4-4 Reydisp Manager 2 Example Detailed HTML File

4.4 Export IEC 61850 SNTP

A Simple Network Time Protocol (SNTP) is a time server that other devices can synchronize their clock time with.

A SNTP server is usually added to the project via the **System Configuration** tool and is outside of the scope of Reydisp Manager 2.

To export a template SNTP ICD file the **Tools** menu provides an **Export IEC 61850 SNTP** option which in turn provides a **save as** feature for saving to a specific location and naming the file.