

# SIEMENS



Motion Control Drives

## SIMATIC MICRO-DRIVE

Drive system for safety extra low-voltage

Catalog  
D 34

Edition  
August  
2021

[siemens.com/micro-drive](https://www.siemens.com/micro-drive)

## Related catalogs

<p><b>Motion Control Drives</b> D 31.1 SINAMICS Inverters for Single-Axis Drives Built-In Units</p> <p>E86060-K5531-A111-A1-7600</p>		<p><b>Industrial Controls</b> IC 10 SIRIUS</p> <p>PDF (E86060-K1010-A101-B2-7600)</p>	
<p><b>Motion Control Drives</b> D 31.2 SINAMICS Inverters for Single-Axis Drives Distributed Inverters</p> <p>E86060-K5531-A121-A1-7600</p>		<p><b>Industrial Controls</b> IC 10 AO SIRIUS Classic</p> <p>PDF (E86060-K1010-A191-A5-7600)</p>	
<p><b>Motion Control Drives</b> D 31.5 SINAMICS Converters for Single-Axis Drives SINAMICS G120X infrastructure converters for HVAC/Water/Wastewater</p> <p>PDF (E86060-K5531-A151-A3-7600)</p>		<p><b>Low-Voltage Power Distribution and Electrical Installation Technology</b> LV 10 SENTRON • SIVACON • ALPHA Protection, Switching, Measuring and Monitoring Devices, Switchboards and Distribution Systems</p> <p>PDF (E86060-K8280-A101-B2-7600)</p>	
<p><b>Motion Control Drives</b> D 32 SINAMICS S210 Servo Drive System</p> <p>PDF (E86060-K5532-A101-A6-7600)</p>		<p><b>SIMATIC</b> ST 70 Products for Totally Integrated Automation</p> <p>PDF (E86060-K4670-A101-B8-7600)</p>	
<p><b>SINAMICS S120</b> D 21.3 Chassis Format Converter Units Chassis-2 Format Converter Units Cabinet Modules, Cabinet Modules-2 <b>SINAMICS S150</b> Converter Cabinet Units E86060-K5521-A131-A7-7600</p>		<p><b>SIMATIC</b> ST 70 N Products for Totally Integrated Automation</p> <p>PDF (E86060-K4670-A151-B1-7600)</p>	
<p><b>Motion Control Drives</b> D 21.4 SINAMICS S120 and SIMOTICS</p> <p>E86060-K5521-A141-A1-7600</p>		<p><b>SIMATIC HMI / PC-based Automation</b> ST 80/ST PC Human Machine Interface Systems PC-based Automation</p> <p>PDF (E86060-K4680-A101-C8-7600)</p>	
<p><b>SIMOTICS S-1FG1</b> D 41 <b>Servo geared motors</b> Helical, Parallel shaft, Bevel and Helical worm geared motors</p> <p>PDF (E86060-K5541-A101-A5-7600)</p>		<p><b>Industrial Communication</b> IK PI SIMATIC NET</p> <p>E86060-K6710-A101-B8-7600</p>	
<p><b>SIMOTICS GP, SD, XP, DP</b> D 81.1 <b>Low-Voltage Motors</b> Type series 1FP1, 1LE1, 1LE5, 1MB1, 1MB5, 1PC1 Frame sizes 63 to 450 Power range 0.09 to 1000 kW PDF (E86060-K5581-A111-B4-7600)</p>		<p><b>Industry Mall</b> Information and Ordering Platform on the Internet:</p> <p><a href="http://www.siemens.com/industrymall">www.siemens.com/industrymall</a></p>	
<p><b>SIMOGEAR</b> D 50.1 <b>Geared Motors</b> Helical, parallel shaft, bevel, helical worm and worm geared motors</p> <p>E86060-K5250-A111-A6-7600</p>			

The Siemens logo is displayed in a white rectangular box. The background of the entire page is a blue-toned collage of industrial and digital imagery, including a SIMATIC drive unit, binary code (0s and 1s), and technical diagrams.

## SIMATIC MICRO-DRIVE

Drive system for  
safety extra low-voltage  
Motion Control Drives

Catalog D 34 · August 2021

Dear Customer,

We are pleased to present you with the new edition of Catalog D 34 · August 2021. The catalog provides a comprehensive overview of the new SIMATIC MICRO-DRIVE drive system for safety extra low-voltage.

SIMATIC MICRO-DRIVE is an extremely versatile, system-integrated and safety-related drive system which covers a wide range of applications in the protective extra-low voltage range. The system comprises the SIMATIC MICRO-DRIVE PDC Drives (ProfiDriveControl) and SIMATIC MICRO-DRIVE TM Drives – the new drive controller modules for SIMATIC ET 200SP – as well as flexibly applicable motors and plug-in cables.

Suitable control systems from the SIMATIC portfolio from Siemens optimally round off the motion control functions of this future-proof solution.

The products listed in this catalog are also included in the Industry Mall. Please contact your local Siemens office for additional information.

Up-to-date information about SIMATIC MICRO-DRIVE is available on the internet at:

[www.siemens.com/micro-drive](http://www.siemens.com/micro-drive)

You can access our Industry Mall on the internet at

[www.siemens.com/industrymall](http://www.siemens.com/industrymall)

Your personal contact will be glad to receive your suggestions and recommendations for improvement.

You can find your contact in our contact person database at

[www.siemens.com/automation-contact](http://www.siemens.com/automation-contact)

We hope that you will enjoy using Catalog D 34 · August 2021 as a selection and ordering reference document and wish you every success with our products and solutions.

With kind regards,

A handwritten signature in blue ink, appearing to read 'Frank Golüke', is positioned above the typed name.

Frank Golüke  
Vice President  
General Motion Control  
Siemens AG, Digital Industries, Motion Control



# SIMATIC MICRO-DRIVE

Drive system for safety extra low-voltage

## Motion Control Drives

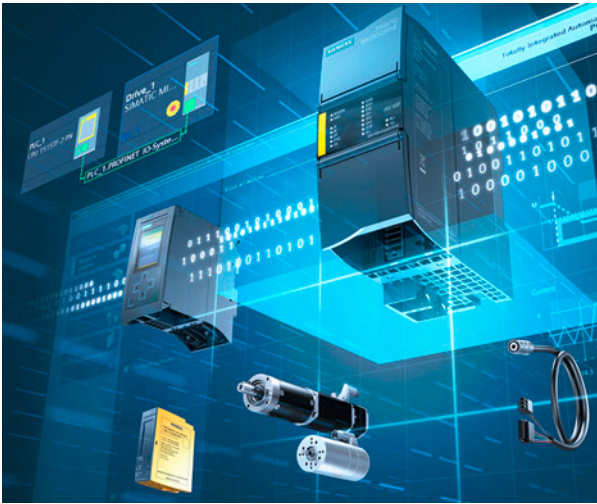

### Catalog D 34 · August 2021

Supersedes:  
Catalog D 34 · December 2020

Refer to the Industry Mall for current updates of  
this catalog:  
[www.siemens.com/industrymall](http://www.siemens.com/industrymall)

Please contact your local Siemens branch.

© Siemens 2021

## System overview

1

## SIMATIC MICRO-DRIVE drive system

2

## Appendix

3



The products and systems described in this catalog are manufactured/distributed under application of a certified quality management system in accordance with EN ISO 9001 (Certified Registration No. 001323 QM15). The certificate is recognized by all IQNet countries.

# Digital Enterprise

## The building blocks that ensure everything works together perfectly in the digital enterprise

Digitalization is already changing all areas of life and existing business models. It is placing greater pressure on industry while at the same time creating new business opportunities. Today, thanks to scalable solutions from Siemens, companies can already become a digital enterprise and ensure their competitiveness.



### Industry faces tremendous challenges



#### Reduce time-to-market

Today manufacturers have to bring products to market at an ever-increasing pace despite the growing complexity of these products. In the past, a major manufacturer would push aside a small one, but now it is a fast manufacturer that overtakes a slow one.



#### Boost flexibility

Consumers want customized products, but at a price they would pay for a mass-produced item. That only works if production is more flexible than ever before.



#### Improve quality

To ensure a high level of quality while meeting legal requirements, companies have to establish closed quality loops and enable the traceability of products.

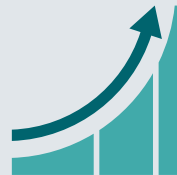

#### Boost efficiency

Today the product itself needs to be sustainable and environmentally friendly, while energy efficiency in production has become a competitive advantage.



#### Increase security

Increasing networking escalates the threat to production facilities of cyberattacks. Today more than ever, companies need suitable security measures.



### The digital enterprise has already become a reality

To fully benefit from all the advantages of digitalization, companies first have to achieve complete consistency of their data. Fully digitally integrated business processes, including those of suppliers, can help to create a digital representation of the entire value chain. This requires

- the integration of industrial software and automation,
- expansion of the communication networks,
- security in automation,
- and the use of business-specific industrial services.

### MindSphere

#### The cloud-based open IoT operating system from Siemens

With MindSphere, Siemens offers a cost-effective and scalable cloud platform as a service (PaaS) for the development of applications. The platform, designed as an open operating system for the Internet of Things, makes it possible to improve the efficiency of plants by collecting and analyzing large volumes of production data.

### Totally Integrated Automation (TIA) Where digitalization becomes reality

Totally Integrated Automation (TIA) ensures the seamless transition from the virtual to the real world. It already encompasses all the necessary conditions for transforming the benefits of digitalization into true added value. The data that will form the digital twin for actual production is generated from a common base.

#### Digital Plant

Learn more about the digital enterprise for the process industry  
[www.siemens.com/digitalplant](http://www.siemens.com/digitalplant)

#### Digital Enterprise Suite

Learn more about the digital enterprise for the discrete industry  
[www.siemens.com/digital-enterprise-suite](http://www.siemens.com/digital-enterprise-suite)

# Integrated Drive Systems

Faster on the market and in the black with Integrated Drive Systems

Integrated Drive Systems are Siemens' trendsetting answer to the high degree of complexity that characterizes drive and automation technology today. The world's only true one-stop solution for entire drive systems is characterized in particular by its threefold integration: Horizontal, vertical, and lifecycle integration ensure that every drive system component fits seamlessly into the whole system, into any automation environment, and even into the entire lifecycle of a plant.

The outcome is an optimal workflow – from engineering all the way to service that entails more productivity, increased efficiency, and better availability. That's how Integrated Drive Systems reduce time to market and time to profit.

## Horizontal integration

**Integrated drive portfolio:** The core elements of a fully integrated drive portfolio are frequency converters, motors, couplings, and gear units. At Siemens, they're all available from a single source. Perfectly integrated, perfectly interacting. For all power and performance classes. As standard solutions or fully customized. No other player in the market can offer a comparable portfolio. Moreover, all Siemens drive components are perfectly matched, so they are optimally interacting.

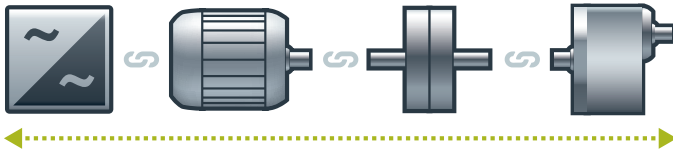

You can boost the availability of your application or plant to up to

**99%\***

\*e.g., conveyor application

## Vertical integration

Thanks to **vertical integration**, the complete drive train is seamlessly integrated in the entire automation environment – an important prerequisite for production with maximum value added. Integrated Drive Systems are part of Totally Integrated Automation (TIA), which means that they are perfectly embedded into the system architecture of the entire industrial production process. This enables optimal processes through maximum communication and control.

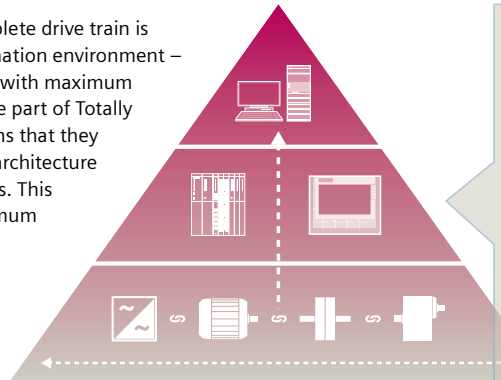

With TIA Portal you can cut your engineering time by up to

**30%**

## Lifecycle integration

**Lifecycle integration** adds the factor of time: Software and service are available for the entire lifecycle of an Integrated Drive System. That way, important optimization potential for maximum productivity, increased efficiency, and highest availability can be leveraged throughout the system's lifecycle – from planning, design, and engineering to operation, maintenance, and all the way even to modernization.

With Integrated Drive Systems, assets become important success factors. They ensure shorter time to market, maximum productivity and efficiency in operation, and shorter time to profit.

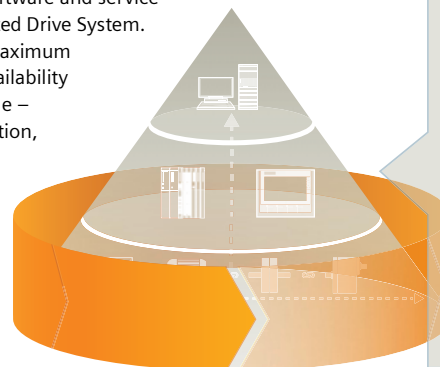

With Integrated Drive Systems you can reduce your maintenance costs by up to

**15%**



## System overview



1/2 **System overview**

1/6 **Safety Integrated**

1/10 **Communication**

1/10 PROFINET

1/13 PROFIdrive

# SIMATIC MICRO-DRIVE drive system

## System overview

### System overview

1

#### Overview



SIMATIC MICRO-DRIVE drive system, PDC Drives, PDC100, PDC100F, PDC600, PDC600F, PDC1000 V1 variants



Drive controller modules for ET200SP  
SIMATIC MICRO-DRIVE F-TM StepDrive ST, ServoDrive HF and  
ServoDrive ST

#### **First-class drive system in the protective extra-low voltage range**

The requirements for motion control tasks in automation are ever increasing and are becoming more and more multi-faceted and complex. Digitalization is bringing about new solution approaches, regardless of the industry or application.

#### **Fit for digitalization with SIMATIC MICRO-DRIVE**

The SIMATIC MICRO-DRIVE drive system allows you to make a perfect entry into the world of digitalization. Thanks to Totally Integrated Automation (TIA), converters and motors are completely integrated into the Siemens automation environment and can be easily selected using the TIA Selection Tool and configured using the TIA Portal. A wide range of tools for the complete machine building cycle ensures efficient engineering and fast commissioning. Machine data is made available through MindSphere, the cloud-based, open IoT operating system from Siemens.

#### **Well designed, flexible and fit for the future**

SIMATIC MICRO-DRIVE is an extremely versatile, seamless and safety-oriented drive system that covers a wide range of applications in the protective extra-low voltage range.

It comprises the SIMATIC MICRO-DRIVE PDC Drives and TM Drives, as well as versatile EC motors and plug-in cables. The right controllers from the SIMATIC portfolio from Siemens optimally round out the motion control functions of this future-proof solution.

The F-TM StepDrive ST completes the portfolio within the range of controlling stepper motors.

In combination with EC Motors and stepper motors up to 280 W the F-TM ServoDrive HF allows positioning and speed control in very confined spaces. The triple overload capability and the support of BiSS-C Multiturn encoders extend the scope of applications.

#### **Can be combined with motors and plug-in cables from selected Siemens Product Partners**

To ensure that all of the requirements in drive technology are met in the best way possible, the SIMATIC MICRO-DRIVE drive system is compatible with individual and supplementary motors (Dunkermotoren, ebm-papst) and plug-in cables (Harting, KnorrTec) from well-established Siemens Product Partners. This allows an optimal combination of suitable products from proven product partners for the individual application.

#### **Strong in classic and innovative applications**

SIMATIC MICRO-DRIVE is the ideal drive in numerous application areas. The system stands out when executing positioning tasks in production and manufacturing as well as in innovative application domains. Examples include drives for storage and retrieval machine shuttles and high bay racking systems, driverless transport systems as well as medical applications such as safely and reliably moving MRT examination tables and automatically aligning ceiling-mounted devices in radiographic applications.

### Overview

#### For all applications

##### Moving

Energy-efficient and rugged solutions for basic conveyor technology with roller or chain conveyors, for hoisting gear and elevators – as well as for storage and retrieval machines – and always with Safety Integrated on board.

##### Processing

Ideal solution for continuous processes with simple speed and torque accuracy, for example with extruders, centrifuges, agitators in all types of production machines – motion control, isochronous communication (only for SIMATIC MICRO-DRIVE PDC Drives) and Safety Integrated.

##### Positioning

SIMATIC MICRO-DRIVE is the solution for 24/48 V DC applications: The positioning of individual axes and even the coordinated interpolation of several axes – such as in complex robotic applications – can be achieved easily.

#### **Simple commissioning of SIMATIC MICRO-DRIVE PDC Drives through One Button Tuning and TIA Portal (V15 SP1 or higher)**

Commissioning and engineering are possible with TIA Portal (V15 SP1 or higher). The tool for configuration, commissioning and diagnostics has been optimized with regard to the consistent utilization of the TIA Portal advantages – one shared work environment for PLC, HMI and drives.

For more information, see the Engineering tools section.

#### **Safety Integrated**

The integrated safety functions provide highly effective, application-oriented protection for personnel and machinery (terms as defined in IEC 61800-5-2).

The following Safety Integrated functions are included (not all of the functions are included in all of the drive controllers):

- Safe Torque Off (STO) <sup>1)</sup>
- Safe Stop 1 (SS1, only for failsafe variants, e.g. PDC100F)
- Safely-Limited Speed (SLS, only for failsafe variants, e.g. PDC100F)
- New function: Safely-Limited Torque (SLT, only for failsafe variants)  
Monitoring of motor current and torque during operation by means of safely-limited torque
- Safe Speed Monitor (SSM, only for failsafe variants, e.g. PDC100F)

The Safety Integrated functions are fully integrated into the drive system (only for failsafe variants, e.g. PDC100F).

The Safety Integrated functions are implemented electronically and therefore require no additional installation effort or space in the control cabinet. Furthermore, the costs are considerably lower than for externally implemented monitoring functions.

The Safety Integrated functions can be easily put into operation via the TIA Portal (V15 SP1 or higher) and activation through a SIMATIC controller via PROFIsafe.

#### **Perfect combination with SIMATIC S7-1500, SIMATIC S7-1500 T-CPU, SIMATIC ET 200SP Open Controller via PROFINET or SIMATIC ET 200SP**

Communication with the higher-level control takes place via PROFINET. For optimal interaction between the controller and the SIMATIC MICRO-DRIVE drive system, SIMATIC S7-1200, SIMATIC S7-1500, SIMATIC S7-1500 T-CPU, SIMATIC ET 200SP Open Controller can be used as the control system.

The SIMATIC MICRO-DRIVE PDC Drives features an integrated PROFINET IRT communication interface with a communication cycle of up to 1 ms for connecting to a control system.

Standardized protocols for linking to a higher-level control with RT and IRT are supported – the PROFIdrive profile for positioning mode and the PROFIsafe profile for safety-oriented communication. Functions such as Shared Device, ring redundancy, and PROFInergy are also possible.

All from a single source: Through the use of Motion Control functionalities in the controller, the combination of converter and SIMATIC S7 automation system or a controller allows ideally harmonized engineering. As a result, commissioning times are shortened.

Technology objects and Motion Control blocks of the higher-level controller provide numerous possibilities of motion, such as continuous operation, positioning, synchronous operation, coordinated motion of multiple axes, cam disks, or interpolation.

Siemens offers tested SIMATIC PLC/HMI application examples for connection of the drive system to a SIMATIC control system:

[www.siemens.com/sinamics-applications](http://www.siemens.com/sinamics-applications)

Further information on the SIMATIC S7-1500, SIMATIC S7-1500 T-CPU controllers and SIMATIC ET 200SP Open Controller is available in the ST 70 Catalog and on the internet at

[www.siemens.com/simatic-s7-1500](http://www.siemens.com/simatic-s7-1500)

<sup>1)</sup> Does not apply for PDC1000 V1.

# SIMATIC MICRO-DRIVE drive system

## System overview

### System overview

1

#### Overview

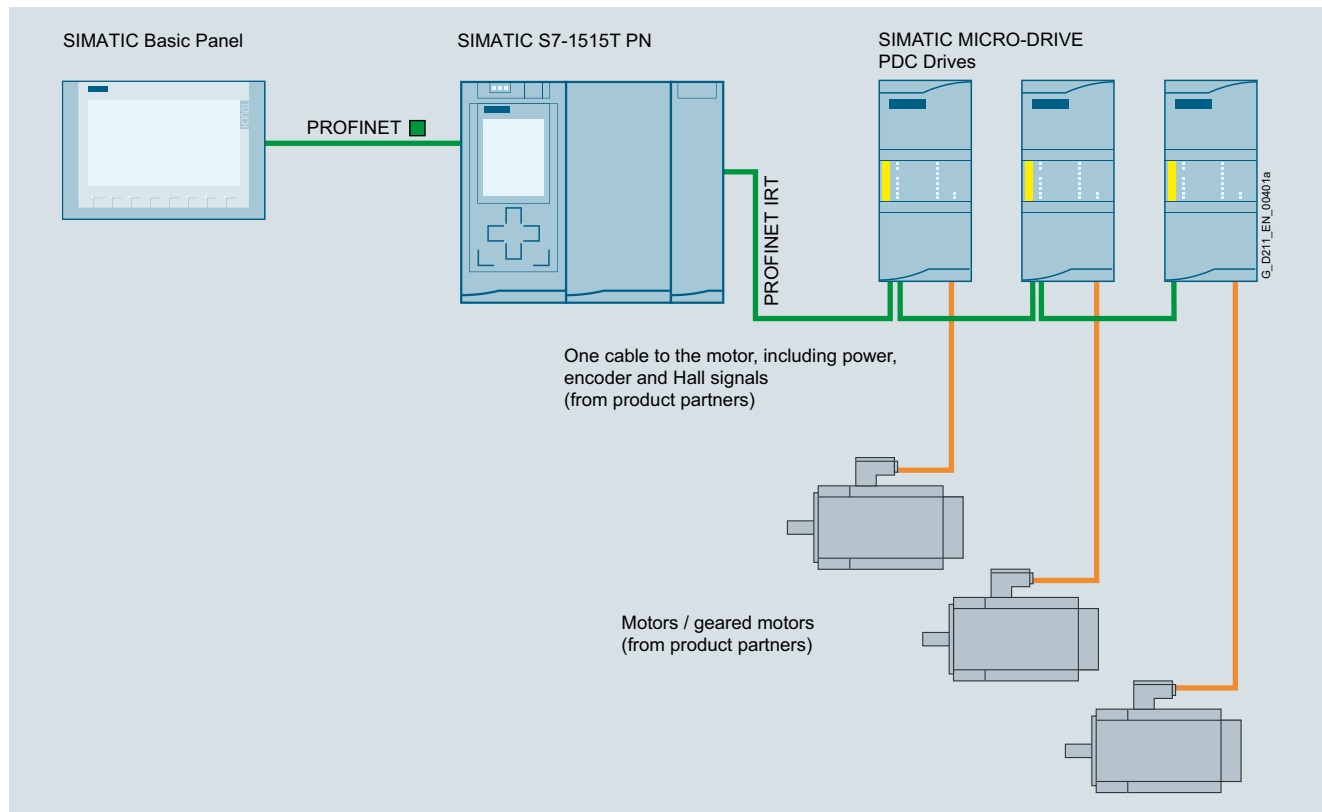

Example: communication via PROFINET with SIMATIC MICRO-DRIVE PDC Drives

## Overview

1

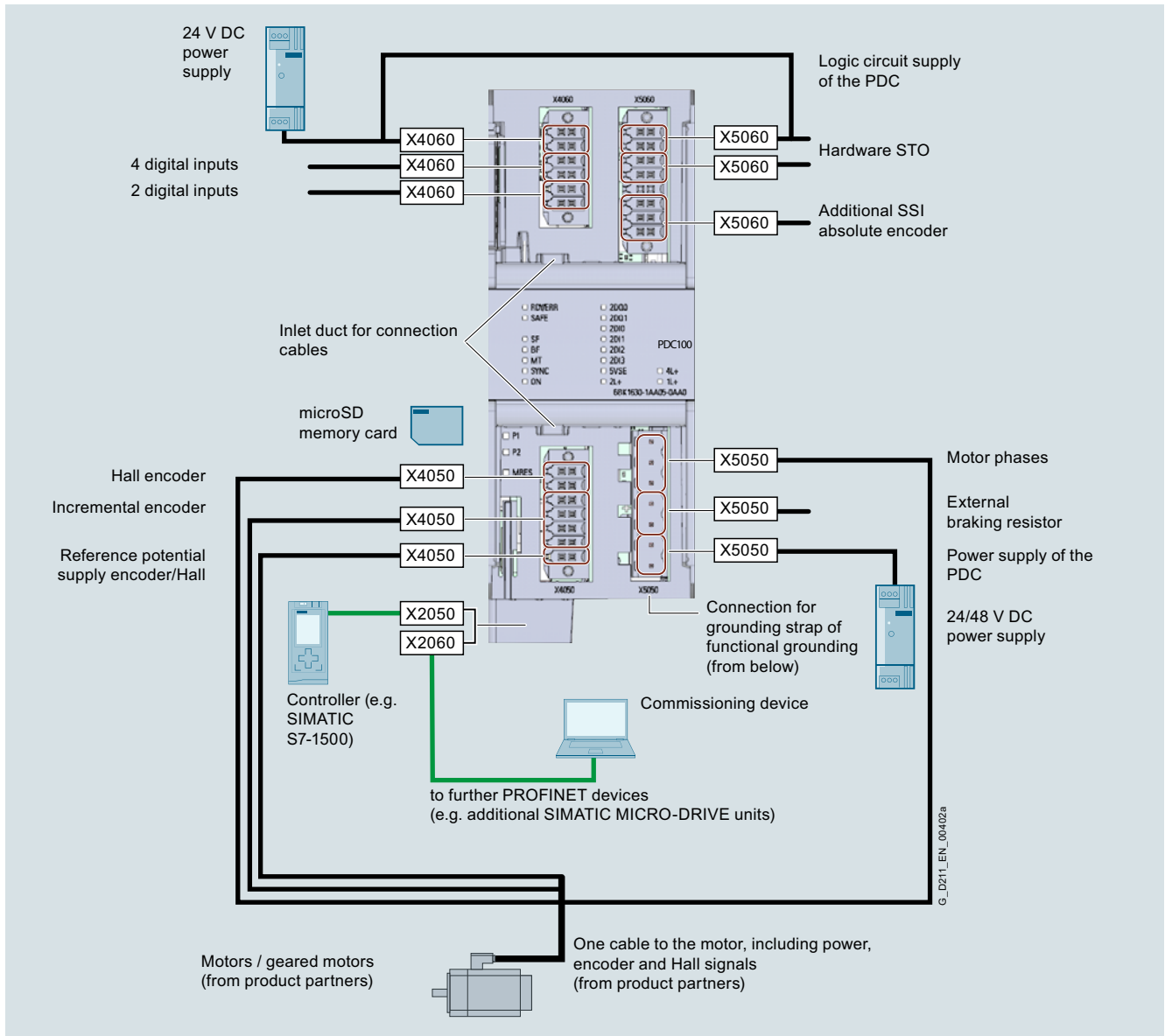

Connection example: SIMATIC MICRO-DRIVE drive system, PDC Drives, PDC100 variant

**Can be used worldwide**

In addition to the usual approvals, the UL approval for the North American market has also been requested for the SIMATIC MICRO-DRIVE drive system. Thus, the SIMATIC MICRO-DRIVE drive system is available for worldwide use.

**Further information**

Detailed information on the SIMATIC MICRO-DRIVE drive system, including the latest technical documentation (brochures, tutorials, dimensional drawings, certificates, equipment manuals and operating instructions), is available on the internet at:

[www.siemens.com/micro-drive](http://www.siemens.com/micro-drive)

and also via the TIA Selection Tool:

[www.siemens.com/tia-selection-tool](http://www.siemens.com/tia-selection-tool)

# SIMATIC MICRO-DRIVE drive system

## System overview

### Safety Integrated

1

#### Overview



#### Legal framework

Machine manufacturers and manufacturing plants must ensure that their machines or plants cannot cause danger due to malfunctions in addition to the general risks of electric shock, heat or radiation.

In Europe, for example, compliance with the Machinery Directive 2006/42/EC is legally stipulated by the EU Directive on Safety and Health at Work. In order to ensure compliance with this directive, it is recommended that the corresponding harmonized European standards are applied. This triggers the "assumption of conformity" and gives manufacturers and operators the legal security in terms of compliance with both national regulations and EU directives. The machine manufacturer uses the CE marking to document the compliance with all relevant directives and regulations in the free movement of goods.

#### Safety-related standards

Functional safety is specified in various standards. For example, EN ISO 12100 specifies standards pertaining to machine safety (risk assessment and risk reduction). IEC 61508 specifies basic requirements for electronic and programmable safety-related systems. EN 62061 (only applicable for electrical and electronic control systems) and EN ISO 13849-1, which has replaced EN 954-1, define the functional and safety-related requirements of safety-oriented control systems.

The above-mentioned standards define different safety requirements that the machine has to satisfy in accordance with the risk, frequency of a dangerous situation, probability of occurrence and the opportunities for recognizing impending danger.

- EN ISO 13849-1: Performance Level PL a ... e; Category B, 1 ... 4
- EN 62061: Safety Integrity Level SIL 1 ... 3

#### Trend toward integrated safety systems

The trend toward greater complexity and higher modularity of machines has seen a shift in safety functions away from the classical central safety functions (for example, shutdown of the complete machine using a main disconnecting means) and into the machine control system and the drives. This is often accompanied by a significant increase in productivity because the equipping times are shortened. Depending on the type of machine, it may even be possible to continue manufacturing other parts while equipping is in progress.

Integrated safety functions act much faster than those of a conventional design. The safety of a machine is increased further with Safety Integrated. Furthermore, thanks to the faster method of operation, safety measures controlled by integrated safety systems are perceived as less of a hindrance by the machine operator, therefore significantly reducing the motivation to consciously bypass safety functions.

#### Function

The safety functions integrated in SIMATIC MICRO-DRIVE are described below.

#### Safety functions integrated in the SIMATIC MICRO-DRIVE drives (integrated in the failsafe variants, e.g. PDC100F)

The large number of safety functions integrated in the SIMATIC MICRO-DRIVE drive system in combination with the sensors and safety control required for the safety function contribute to the implementation of highly effective, practical personnel and machine protection.

They comply with the requirements of the following safety categories:

- PL d and Category 3 according to EN ISO 13849-1
- SIL 2 according to IEC 61508 and IEC 61800-5-2

The Safety Integrated functions are generally certified by independent institutes. You can obtain the corresponding test certificates and manufacturer's declarations from your Siemens contacts.

The integrated safety functions that are currently available are described below. Their functional safety satisfies the requirements defined in the international standard IEC 61800-5-2 for variable-speed drive systems.

The safety functions integrated into the SIMATIC MICRO-DRIVE drive system can be roughly divided into two categories:

- **Functions for safely stopping a drive**
  - Safe Torque Off (STO)
  - Safe Stop 1 (SS1)
- **Functions for safely monitoring the motion of a drive**
  - Safely-Limited Speed (SLS)
  - Safely-Limited Torque (SLT<sup>1)</sup>)
  - Safe Speed Monitor (SSM)

<sup>1)</sup> Only for PDC100F.

## Function

### Safe Torque Off (STO)

The STO function is the most common and basic drive-integrated safety function. It ensures that no torque-generating energy can continue to affect a motor and prevents unintentional start-ups.

#### Effect

This function is a mechanism that prevents the drive from restarting unexpectedly, in accordance with EN 60204-1, Section 5.4. The STO function suppresses the drive pulses (corresponds to Stop Category 0 according to EN 60204-1). The drive is reliably torque-free. This state is monitored internally in the drive.

#### Application

STO has the immediate effect that the drive cannot supply any torque-generating energy. STO can be used wherever the drive will naturally reach a standstill due to load torque or friction in a sufficiently short time or when "coasting down" of the drive will not have any relevance for safety.

STO makes it possible for persons to work safely when the protective door is open (restart interlock) and is used on machines/installations with moving axes, e.g. on handling or conveyor systems.

#### Customer benefits

Some of the advantages of the Safety Integrated Function STO over conventional safety technology with electromechanical switchgear include the elimination of separate components as well as of the work that would be required to wire and service them, i.e. no wearing parts as a result of the electronic shutdown. Because of the fast electronic switching times, the function provides a shorter reaction time than the conventional solution comprising electromechanical components. When STO is triggered, the converter remains connected to the network and can be fully diagnosed.

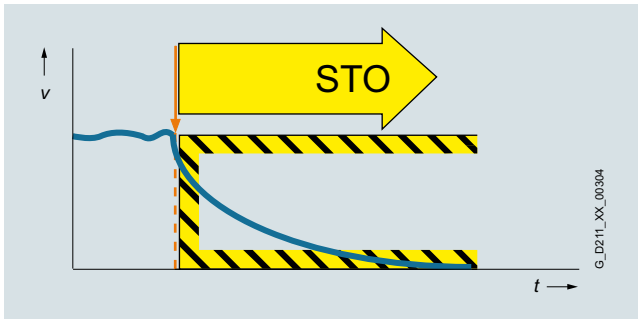

### Safe Stop 1 (SS1)

The SS1 function causes a motor to stop rapidly and safely and switches the motor to torque-free mode after coming to a standstill by activating STO.

#### Effect

The SS1 function can safely stop the drive in accordance with EN 60204-1, Stop Category 1. When the SS1 function is selected, the drive brakes autonomously along a quick stop ramp and automatically activates the Safe Torque Off functions when the set safe delay time has expired.

#### Application

The SS1 function is used when, in the event of a safety-relevant incident, the drive must stop as quickly as possible with a subsequent transition into the STO state (e.g. EMERGENCY STOP). It is thus used to bring large centrifugal masses to a stop as quickly as possible for the safety of the operating personnel, or to brake motors at high speeds as quickly as possible. Examples of typical applications are saws, grinding machine spindles, centrifuges, winders and storage and retrieval machines.

#### Customer benefits

The targeted stopping of a drive by means of SS1 reduces the risk of danger, increases the productivity of a machine, and allows the safety clearances in a machine to be reduced. The principle is to bring the drive actively to a standstill, compared with just using the STO function. Complex mechanical brakes that are susceptible to wear are not normally required to brake the motor.

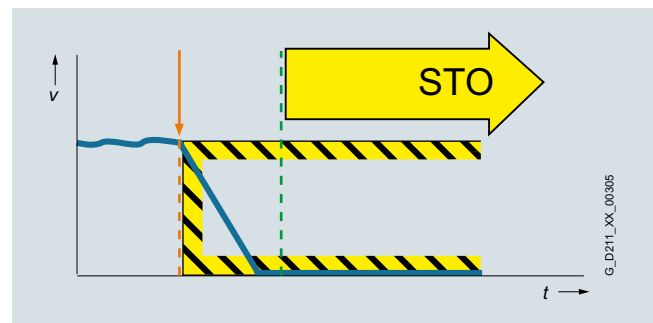

# SIMATIC MICRO-DRIVE drive system

## System overview

### Safety Integrated

1

#### Function

##### **Safely-Limited Speed (SLS)**

The SLS function monitors the drive to ensure that it does not exceed a preset speed or velocity limit.

##### Effect

The SLS function monitors the drive against a parameterized speed limit. Four different limit values can be selected. The speed setpoint is not influenced independently. After SLS has been selected, the higher-level control must bring the drive down below the selected speed limit within a parameterizable time. If the speed limit is exceeded, a customizable drive-integrated fault reaction occurs.

The SLS limit stage 1 can be multiplied by a factor that is transferred in 16-bit resolution via PROFIsafe. This allows an almost unlimited number of limits to be specified.

##### Application

The SLS function is used if people are in the danger zone of a machine and their safety can only be guaranteed by reduced speed. Typical application cases include those in which an operator must enter the danger zone of the machine for the purposes of maintenance or setting up, such as a winder in which the material is manually threaded by the operator. To prevent injury to the operator, the roller may only spin at a safely reduced speed. SLS is often also used as part of a two-stage safety concept. While a person is in a less critical zone, the SLS function is activated, and the drives are only stopped in a smaller area with higher potential risk. SLS can be used not only for operator protection, but also for machinery protection, e.g. if a maximum speed must not be exceeded.

##### Customer benefits

The SLS function can contribute to a significant reduction in downtime, or greatly simplify or even accelerate setup. The overall effect achieved is a higher availability of the machine. Moreover, external components such as speed monitors can be omitted.

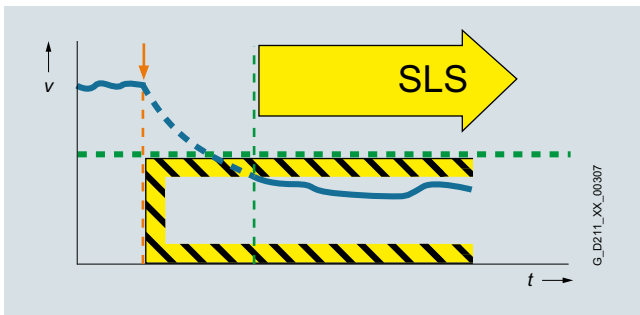

##### **Safely-Limited Torque (SLT)**

The SLT function monitors the current/torque of a motor.

##### Effect

The SLT function allows the torque to be reduced within a defined period of time. If the torque exceeds the SLT monitoring limit, the drive responds with a "Safe Stop". The stop responses STO or SS1 can be specified via parameters.

##### Application

In the simplest case, this function is used for force limiting when opening and closing a protective door on a machine.

##### Customer benefits

The SLT function avoids the use of external hardware for measuring and limiting the force and the associated wiring effort.

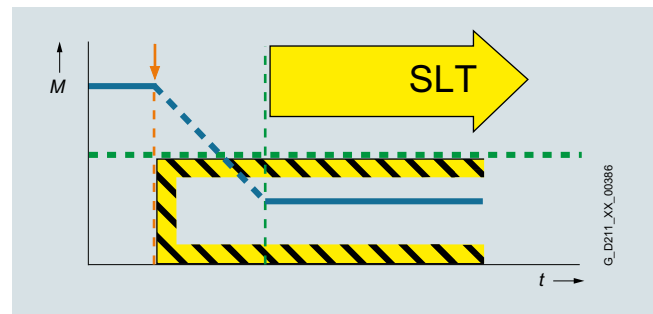



## Function

### Safe Speed Monitor (SSM)

The SSM function warns when a drive is working below an adjustable speed limit. As long as it remains below the threshold, the function issues a safety-related signal.

#### Effect

If a speed value drops below a parameterized limit, a safety-related signal is generated. This can, for example, be processed in a safety controller to respond to the event by programming, depending on the situation.

#### Application

With the SSM function, in the simplest case, a safety door can be unlocked if the speed drops below a non-critical level. Another typical example is that of a centrifuge that may be filled only when it is operating below a configured speed limit.

#### Customer benefits

Unlike SLS, there is no drive-integrated fault reaction when the speed limit is exceeded. The safe feedback can be evaluated in a safety control unit, allowing the user to respond appropriately to the situation.

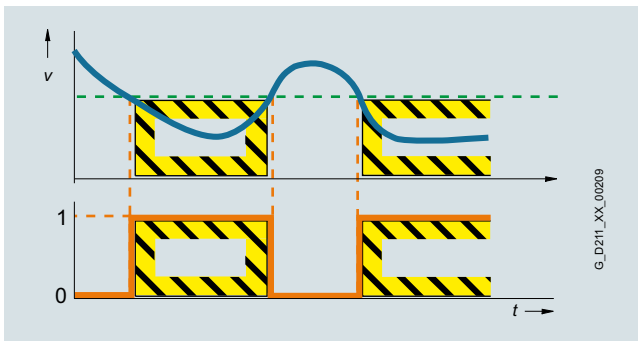

### Activation of the Safety Integrated Functions

The STO safety function for SIMATIC MICRO-DRIVE can be activated via terminals, e.g. for use of a conventional safety circuit.

For standalone safety solutions for small to medium sized applications, it is frequently sufficient that the various sensing components are directly hardwired to the drive.

For integrated safety solutions, the safety-relevant sequences are generally processed and coordinated in the fail-safe SIMATIC controller. In this case, the system components communicate via the PROFINET fieldbus. The safety functions are controlled via the safe PROFIsafe communication protocol.

The SIMATIC MICRO-DRIVE drives can be easily integrated into the plant or system topology.

### PROFIsafe (only for the failsafe variants, e.g. PDC100F)

SIMATIC MICRO-DRIVE drives support the PROFIsafe profile based on PROFINET.

PROFIsafe is an open communications standard that supports standard and safety-related communication over the same communication path (wired or wireless). A second, separate bus system is therefore not necessary. The telegrams that are sent are continually monitored to ensure safety-relevant communication.

Possible errors such as telegrams that have been lost, repeated or received in the incorrect sequence are avoided. This is done by consecutively numbering the telegrams in a safety-relevant fashion, monitoring their reception within a defined time and transferring an ID for transmitter and receiver of a telegram. A CRC (cyclic redundancy check) data security mechanism is also used.

### The operating principle of Safety Integrated

#### Two independent switch-off signal paths

Two independent switch-off signal paths are available. All switch-off signal paths are low active. This ensures that the system is always switched to a safe state if a component fails or in the event of cable breakage. If a fault is discovered in the switch-off signal paths, the STO or SS1 function (depending on parameter settings) is activated and a system restart inhibited.

#### Two-channel monitoring structure

All the main hardware and software functions for Safety Integrated are implemented in two independent monitoring channels (e.g. switch-off signal paths, data management, data comparison). A cyclic crosswise comparison of the safety-relevant data in the two monitoring channels is carried out.

The monitoring functions in each monitoring channel work on the principle that a defined state must prevail before each action is carried out and a specific acknowledgement must be made after each action. If these expectations of a monitoring channel are not fulfilled, the drive coasts to a standstill (two channel) and an appropriate message is output.

### Safe actual value sensing with encoder

The safe actual value sensing is based on the redundant evaluation of the differential incremental tracks A/B that supply HTL/TTL and the three Hall-effect sensors integrated in the motor.

All EC motors of the Siemens Product Partners with IQ encoder and Hall-effect sensors can be used for all of the safety functions of the SIMATIC MICRO-DRIVE drive system.

# SIMATIC MICRO-DRIVE drive system

## System overview

### Communication

1

#### Overview

##### Communication overview

The properties and special application areas of the different bus systems for SIMATIC MICRO-DRIVE are described briefly below.

Protocol	SIMATIC MICRO-DRIVE PDC100, PDC600, PDC1000 V1	SIMATIC MICRO-DRIVE PDC100F, PDC600F	SIMATIC MICRO-DRIVE TM Drives
<b>PROFINET</b>	✓	✓	✓
- PROFINET RT	✓	✓	✓
- PROFINET IRT isochronous	✓	✓	–
- PROFINET Shared Device	✓	✓	–
- PROFINET media redundancy MRP (surge-prone)	✓	✓	–
- PROFI-safe	–	✓	–
- PROFIdrive application class 1	✓	✓	✓
- PROFIdrive application class 4	✓	✓	–

### Communication > PROFINET

#### Overview



##### PROFINET – the Ethernet standard for automation

PROFINET is the world's leading Industrial Ethernet standard for automation with more than 40 million nodes installed worldwide.

PROFINET makes companies more successful, because it speeds up processes and raises both productivity and plant availability.

#### Your advantages at a glance

##### Flexibility

Tailor-made plant concepts

- ▶ Industrial Wireless LAN
- ▶ Safety
- ▶ Flexible topologies
- ▶ Open standard
- ▶ Web tools
- ▶ Expandability

##### Efficiency

Optimal use of resources

- ▶ One cable for everything
- ▶ Device/network diagnostics
- ▶ Energy efficiency
- ▶ Simple wiring
- ▶ Fast device replacement
- ▶ Ruggedness/stability

##### Performance

Increased productivity

- ▶ Speed
- ▶ High precision
- ▶ Large quantity structures
- ▶ High transmission rate
- ▶ Redundancy
- ▶ Fast start-up

G\_IK10\_XX\_10304

### Overview

#### Flexibility

Short response times and optimized processes are the basic requirements for competitiveness in global markets because the product lifecycles are becoming shorter and shorter.

PROFINET ensures maximum flexibility in plant structures and production processes, and it enables you to implement innovative machine and plant concepts. For example, mobile devices can also be integrated at locations that are difficult to access.

#### Flexible topologies

In addition to the linear structure characterized by the established fieldbuses, PROFINET also enables the use of star, tree and ring structures. This is made possible by switching technology via active network components, such as Industrial Ethernet switches and media converters, or by integrating switch functionality into the field devices. This results in increased flexibility in the planning of machines and plants, as well as savings in cabling.

The PROFINET network can be installed without any specialist knowledge at all and meets all requirements that are relevant to the industrial environment. The "PROFINET Installations Guidelines" assist manufacturers and users with network planning, installation and commissioning. Symmetrical copper cables or RFI-resistant fiber-optic cables are used, depending on the application. Devices from different manufacturers are easily connected via standardized and rugged plug-in connectors (up to IP65/IP67 degree of protection).

By integrating switch functionality into the devices, linear topologies can be created that are directly oriented toward an existing machine or plant structure. This reduces cabling overhead and cuts down on components such as external switches.

#### IWLAN

PROFINET also supports wireless communication with Industrial Wireless LAN, thus opening up new fields of application. For example, technologies subject to wear, such as trailing cables, can be replaced and automated guided vehicle systems and mobile operator panels can be used.

#### Safety

The PROFIsafe safety profile, which has been tried and tested with PROFIBUS and which permits the transmission of standard and safety-related data on a single bus cable, can also be used with PROFINET. No special network components are necessary for fail-safe communication, which means that standard switches and standard network transitions can continue to be used without any restrictions. In addition, fail-safe communication is equally possible via Industrial Wireless LAN (IWLAN).

#### Open standard

PROFINET, the open multi-vendor standard (IEC 61158/IEC 61784), is supported by PROFIBUS and PROFINET International (PI). It stands for maximum transparency, open IT communication, network security and simultaneous real-time communication.

Thanks to its openness, PROFINET provides the basis for a standardized automation network in the plant, to which all other machines and devices can be connected. Even the integration of existing plant components, for example using PROFIBUS, presents no problems due to the use of network transitions.

#### Use of web tools

Thanks to the unrestricted support of TCP/IP, PROFINET permits the use of standard web services such as web servers. Irrespective of the tool used, information from the automation level can be accessed from virtually any location using a commercially available internet browser. This considerably simplifies commissioning and diagnostics. Users can then decide for themselves how much openness to the IT world they want to allow for their machine or plant. This means that PROFINET can be used simply as an isolated plant network or connected via appropriate security modules, such as the SCALANCE S modules, to the office network or the internet. In this way, new remote maintenance concepts or the high-speed exchange of production data become possible.

#### Expandability

On the one hand, PROFINET facilitates the integration of existing systems and networks without any great effort. In this way, PROFINET safeguards investments in existing plant components that communicate via PROFIBUS and other fieldbuses such as AS-Interface. On the other hand, additional PROFINET nodes can be added at any time. By using additional network components, network infrastructures can be expanded using cabling or wireless methods – even while the plant is operating.

#### Efficiency

Greater global competition means that companies must use their resources economically and efficiently. This applies in particular to production. This is where PROFINET ensures greater efficiency. Simple engineering guarantees fast commissioning, while reliable devices ensure a high level of plant availability. Comprehensive diagnostic and maintenance concepts help to reduce plant downtimes and keep maintenance costs to a minimum.

#### One cable for everything

PROFINET permits simultaneous fieldbus communication with isochronous mode and standard IT communication (TCP/IP) on one cable. This real-time communication for the transmission of user/process data and diagnostic data takes place on a single cable. Specific profile communication (PROFIsafe and PROFIdrive) can be integrated without any additional cabling. This solution offers a wide scope of functions at a low level of complexity.

#### Device and network diagnostics

By retaining the tried and tested PROFIBUS device model, the same diagnostics information is available with PROFINET. In addition, module-specific and channel-specific data can also be read out from the devices during device diagnosis, enabling faults to be located quickly and easily. Apart from the availability of device information, the reliability of network operation has top priority in the network management.

In existing networks the Simple Network Management Protocol (SNMP) has established itself as the de facto standard for the maintenance and monitoring of the network components and their functions. PROFINET uses this standard and gives users the opportunity to maintain their networks with tools that are familiar to them, such as the SINEMA Server network management software.

For easier maintenance of PROFINET devices, both on-site and remotely via a secure VPN connection, application-specific websites can be set up on the web server of the field devices using the familiar HTML standard.

# SIMATIC MICRO-DRIVE drive system

## System overview

### Communication > PROFINET

1

#### Overview

##### Simple wiring

Particularly stringent demands are made on the installation of cables in the industrial environment. In addition, there is a requirement to set up industry-standard networks in the shortest possible time without any special knowledge.

With FastConnect, Siemens offers a high-speed installation system that meets all of these requirements. FastConnect is the standard-compliant, industry-standard cabling system consisting of cables, connectors and assembly tools for PROFINET networks. The time required for connecting terminals is minimized by the simple installation method using just a single tool, while installation errors are prevented by the practical color-coding. Both copper cables and glass fiber optic cables can be easily assembled on site in this way.

##### Fast device replacement

PROFINET devices are identified by means of a name assigned during configuration. When replacing a defective device, a new device can be recognized from its topology information by the IO controller and a new name can be assigned to it automatically. This means that no engineering tool is necessary for the replacement of equipment.

This mechanism can even be used for the initial commissioning of a complete system. This speeds up commissioning, particularly in the case of series machines.

##### Ruggedness

An automation network must be able to withstand most external sources of interference. The use of Switched Ethernet prevents faults in one section of the network from affecting the entire plant network. For areas that are particularly prone to radio frequency interference (RFI), PROFINET allows the use of fiber optic cables.

##### **Performance**

Productivity and product quality determine the level of success in the market. Precise motion control, dynamic drives, high-speed controllers and the deterministic synchronization of devices are therefore key factors in achieving superior production. They facilitate high production rates and optimum product quality at the same time.

##### Speed and precision

Fast motion control applications demand precise and deterministic exchange of data. This is implemented by means of drive controllers using isochronous real time (IRT).

With IRT and isochronous mode, PROFINET permits fast and deterministic communication. This synchronizes the various cycles of a system (input, network, CPU processing and output), even in the case of parallel TCP/IP traffic. The short cycle times of PROFINET make it possible to raise the productivity of machines and plants and to guarantee the product quality and high level of precision.

The standardized PROFIdrive profile permits vendor-independent communication between CPUs and drives.

##### Large quantity structures

The use of PROFINET makes it possible to overcome the existing restrictions regarding the scope of machines and systems that can be implemented. In one network, several different controllers can interact with their assigned field devices. The number of field devices per PROFINET network is virtually unlimited – the entire range of IP addresses is available.

##### High data rate

By using 100 Mbit/s in full duplex mode, PROFINET achieves a significantly higher data rate than previous fieldbuses. This means that other plant data can be transmitted over TCP/IP without any problems, in addition to the process data. PROFINET therefore meets the combined industrial demands for simultaneously transmitting high-speed IO data and large volumes of data for additional sections of the application. Even the transmission of large volumes of data, such as that from cameras, has no adverse effect on the speed and precision of the IO data transmission, thanks to PROFINET mechanisms.

##### Media redundancy

A higher plant availability can be achieved with a redundant installation (ring topology). The media redundancy can be implemented not only with the aid of external switches, but also by means of integrated PROFINET interfaces. Using the media redundancy protocol (MRP), reconfiguration times of 200 ms can be achieved. If the communication is interrupted in just one part of the ring installation this means that a plant standstill is prevented and any necessary maintenance or repair work can be performed without any time pressure.

For motion control applications, PROFINET with IRT in ring topologies offers extended media redundancy for planned duplication (MRPD) which operates in a bumpless mode without any reconfiguration time. If communication is interrupted (e.g. a cable break) the process can continue operating without interruption.

#### Benefits

- PROFINET is the open Industrial Ethernet standard for automation
- PROFINET is based on Industrial Ethernet
- PROFINET uses TCP/IP and IT standards
- PROFINET is real-time Ethernet
- PROFINET enables seamless integration of fieldbus systems
- PROFINET supports fail-safe communication via PROFIsafe and also via IWLAN

### Overview



#### **PROFIdrive – the standardized drive interface for PROFINET and PROFIBUS**

PROFIdrive defines the device behavior and technique to access internal device data for electric drives connected to PROFINET and PROFIBUS – from basic frequency converters up to high-performance servo controllers.

It describes in detail the practical use of communication functions – slave-to-slave communication, equidistance and clock cycle synchronization (isochronous mode) in drive applications. In addition, it specifies all device characteristics which influence interfaces connected to a controller over PROFINET or PROFIBUS. This also includes the state machine (sequence control), the encoder interface, scaling of values, definition of standard telegrams, access to drive parameters etc.

The PROFIdrive profile supports both central as well as distributed motion control concepts.

#### **What are profiles?**

For devices and systems used in automation technology, profiles define properties and modes of behavior. This allows manufacturers and users to define common standards. Devices and systems that comply with such a cross-manufacturer profile, are interoperable on a fieldbus and, to a certain degree, can be interchanged.

#### **Are there different types of profiles?**

A distinction is made between what are known as application profiles (general or specific) and system profiles:

- Application profiles (also device profiles) predominantly refer to devices (e.g. drives) and include an agreed selection regarding bus communication as well as specific device applications.
- System profiles describe classes of systems, including master functionality, program interfaces and integration resources.

#### **Is PROFIdrive fit for the future?**

PROFIdrive has been specified by the PROFIBUS and PROFINET International (PI) user organization, and is specified as a standard that is fit for the future through standard IEC 61800-7.

#### **The basic philosophy: Keep it simple**

The PROFIdrive profile tries to keep the drive interface as simple as possible and free from technology functions. As a result, referencing models as well as the functionality and performance of the PROFINET/PROFIBUS master have either no or only little influence on the drive interface.

### **One drive profile – different application classes**

The integration of drives into automation solutions depends very strongly on the particular drive application. In order to be able to address the complete, huge bandwidth of drive applications – from basic frequency converters up to synchronized multi-axis systems with a high dynamic performance – using just one profile, PROFIdrive defines six application classes, to which most drive applications can be assigned:

- Class 1 – standard drives (pumps, fans, agitators, etc.)
- Class 2 – standard drives with technological functions
- Class 3 – positioning drives
- Class 4 – motion control drives with central, higher-level motion control intelligence and the patented "Dynamic Servo Control" positioning concept
- Class 5 – motion control drives with central, higher-level motion control intelligence and position setpoint interface
- Class 6 – motion control drives with distributed motion control intelligence integrated in the drives

### **Design**

#### **The device model of PROFIdrive**

PROFIdrive defines a device model comprising function modules, which interoperate inside the device and which reflect the intelligence of the drive system. These modules have objects assigned to them which are described in the profile and are defined with respect to their functions. The overall functionality of a drive is therefore described through the sum of its parameters.

In contrast to other drive profiles, PROFIdrive defines only the access mechanisms to the parameters as well as a subset of profile parameters (approx. 30) such as the fault buffer, drive control and device identification.

All other parameters are vendor-specific which gives drive manufacturers great flexibility with respect to implementing control functions. The elements of a parameter are accessed acyclically over data records.

As a communication protocol, PROFIdrive uses DP-V0, DP-V1, and the DP-V2 expansions for PROFIBUS including the functions "Slave-to-Slave Communication" and "Isochronous Operation", or PROFINET IO with real-time classes RT and IRT.

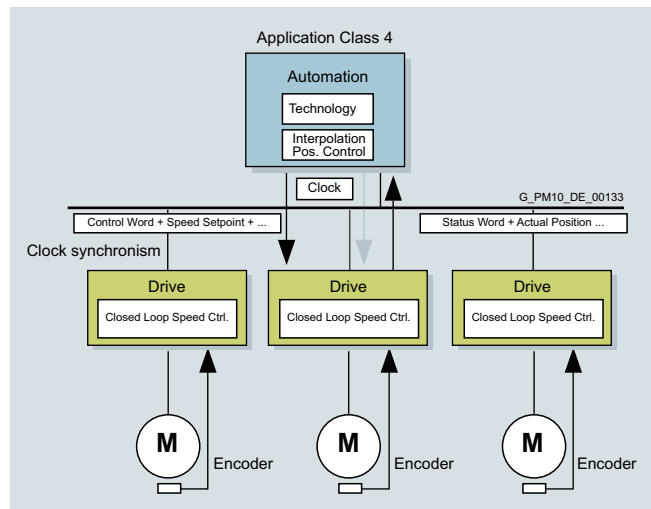

# SIMATIC MICRO-DRIVE drive system

## Notes

1

# SIMATIC MICRO-DRIVE drive system

# 2



<b>2/2</b>	<b>PDC Drives</b>
<b>2/8</b>	<b>TM Drives</b>
2/8	F-TM ServoDrive HF
2/11	F-TM ServoDrive ST
2/14	F-TM StepDrive ST
<b>2/17</b>	<b>Motors/gear units and connection systems from Siemens Product Partners</b>
2/19	ebm-papst motors/gear units
2/23	Dunkermotoren motors/gear units
2/26	KnorrTec connection systems
2/30	Harting connection systems
<b>2/33</b>	<b>Selection and engineering tools</b>
<b>2/34</b>	<b>Services and documentation</b>
2/34	SITRAIN – Digital Industry Academy
2/35	SIMATIC MICRO-DRIVE training case
2/35	SIMATIC F-TM ServoDrive ST Starter Kit
2/36	SIMATIC MICRO-DRIVE documentation

# SIMATIC MICRO-DRIVE drive system

## PDC Drives

### Overview



PDC Drives, PDC100F variant

- SIMATIC MICRO-DRIVE PDC Drives (ProfiDriveControl)
- Available in the variants: Standard (PDCxxx), Failsafe (PDCxxxF)

Variant	Power	Device width
<b>Standard</b>		
PDC100	100 W	50 mm
PDC600	600 W	90 mm
PDC1000 V1	1000 W	90 mm
<b>Failsafe</b>		
PDC100F	100 W	50 mm
PDC600F	600 W	90 mm

### Function

#### Basic functions (for standard PDC for all PDC Drives)

- PROFIdrive profile via PROFINET
- Hardware STO
- Digital inputs and outputs
- PDC100 and PDC100F with integrated braking chopper
- PROFINET line-capable (2 × PROFINET ports)
- PROFINET Shared Device
- TTL/HTL Hall signals

#### In addition to standard PDC for PDCxxxF variants

- Extended Safety drive functions STO, SS1, SLT <sup>1)</sup>, SLS <sup>2)</sup> and SSM <sup>2)</sup> via PROFIsafe

### Selection and ordering data

#### **SIMATIC MICRO-DRIVE PDC Drives (ProfiDriveControl)**

Variant	Article No.
<b>Standard</b>	
• PDC100 Power 100 W	<b>6BK1630-1AA10-0AA0</b>
• PDC600; Power 600 W	<b>6BK1630-1AA60-0AA0</b>
• PDC1000 V1; Power 1000 W	<b>6BK1630-1BA00-0AA0</b>
<b>Failsafe with Extended Safety drive functions</b>	
• PDC100F; Power 100 W	<b>6BK1630-2AA10-0AA0</b>
• PDC600F; Power 600 W	<b>6BK1630-2AA60-0AA0</b>

<sup>1)</sup> Only for PDC100F.

<sup>2)</sup> Extended requirements for the motor and encoder system must be observed. The certified Motor Product Partners comply with these requirements.



**Technical specifications**

Article number	<b>6BK1630-1AA10-0AA0</b> SIMATIC MICRO-DRIVE PDC100 boxed	<b>6BK1630-2AA10-0AA0</b> SIMATIC MICRO-DRIVE PDC100F boxed
<b>General information</b>		
Product type designation	DC and EC motor controller	DC and EC motor controller
Product description	Control of DC and EC motors	Control of DC and EC motors
Mean time between failures (MTBF)	100 000 h	100 000 h
<b>Product function</b>		
• Isochronous mode	Yes	Yes
• Four-quadrant operation	Yes	Yes
• Speed control with encoder	Yes	Yes
• Speed control without encoder	No	No
• Safety Functions	Yes; STO	Yes; STO, SS1, SLT, SLS, SSM
<b>Protection function</b>		
• Undervoltage protection	Yes	Yes
• Overvoltage protection	Yes	Yes
• Overload protection	Yes	Yes
• Ground-fault protection	Yes	Yes
• Short-circuit protection	Yes	Yes
<b>Engineering with</b>		
• STEP 7 TIA Portal configurable/ integrated from version	V14 SP1	V14 SP1
<b>Installation type/mounting</b>		
Mounting type	35 mm rail, screw mounting	35 mm rail, screw mounting
Type of ventilation	Convection cooling	Convection cooling
<b>Supply voltage</b>		
Design of the power supply	DC	DC
Rated value (DC)	24 V	24 V
<b>Supply voltage of the motor</b>		
• Type of motor voltage	24 ... 48 V DC, SELV / PELV	24 ... 48 V DC, SELV / PELV
• permissible range, lower limit (DC)	19.2 V	19.2 V
• supply voltage / of the motor / at DC / rated value / maximum	50.4 V	50.4 V
<b>Output current</b>		
Current output (rated value)	1.56 A	1.56 A
Output current, max.	2.3 A	2.3 A
<b>Digital inputs</b>		
Number of digital inputs	4	4
Number of safety inputs	1; For STO, antivalent (2-pin) - 24 V DC	1; For STO, antivalent (2-pin) - 24 V DC
Input characteristic according to IEC 61131	Permissible DC leakage current (0 signal) to 2 mA	Permissible DC leakage current (0 signal) to 2 mA
<b>Digital outputs</b>		
Type of digital output	Source output (PNP, current-sourcing)	Source output (PNP, current-sourcing)
Number of digital outputs	2	2
Number of safety outputs	0	0
<b>Encoder</b>		
<b>Connectable encoders</b>		
• Incremental encoder (symmetrical)	Yes; Up to 200 kHz	Yes; Up to 200 kHz
• Incremental encoder (asymmetrical)	Yes	Yes
• Absolute encoder (SSI)	Yes; 350 kHz	Yes; 350 kHz
<b>Interfaces</b>		
Number of industrial Ethernet interfaces	0	0
Number of PROFINET interfaces	2	2

# SIMATIC MICRO-DRIVE drive system

## PDC Drives

### Technical specifications

Article number	<b>6BK1630-1AA10-0AA0</b> SIMATIC MICRO-DRIVE PDC100 boxed	<b>6BK1630-2AA10-0AA0</b> SIMATIC MICRO-DRIVE PDC100F boxed
<b>Degree and class of protection</b>		
IP degree of protection	IP20	IP20
<b>Standards, approvals, certificates</b>		
CE mark	Yes	Yes
CSA approval	No	No
cULus	Yes	Yes
RCM (formerly C-TICK)	Yes	Yes
KC approval	Yes	Yes
EAC (formerly Gost-R)	Yes	Yes
China RoHS compliance	Yes	Yes
reference designation according to IEC 81346-2 (2009)	T	T
<b>Highest safety class achievable in safety mode</b>		
• Performance level according to ISO 13849-1	d	d
• SIL acc. to IEC 61508	SIL 2	SIL 2
<b>Ambient conditions</b>		
<b>Ambient temperature during operation</b>		
• min.	-20 °C	-20 °C
• max.	60 °C	60 °C
• horizontal installation, max.	40 °C	40 °C
<b>Ambient temperature during storage/transportation</b>		
• Storage, min.	-20 °C	-20 °C
• Storage, max.	80 °C	80 °C
<b>Relative humidity</b>		
• Operation, max.	95 %; no condensation	95 %; no condensation
• Storage, max.	95 %; no condensation	95 %; no condensation
<b>Vibrations</b>		
• Vibration resistance during operation acc. to IEC 60068-2-6	5 ... 8.5 Hz / 3.5 mm, 8.5 ... 150 Hz / 1 g; for wall mounting: 9 ... 29 Hz / 1.5 mm, 29 ... 200 Hz / 5 g	5 ... 8.5 Hz / 3.5 mm, 8.5 ... 150 Hz / 1 g; for wall mounting: 9 ... 29 Hz / 1.5 mm, 29 ... 200 Hz / 5 g
• Vibration resistance during storage acc. to IEC 60068-2-6	5 ... 9 Hz / 3.5 mm, 9 ... 500 Hz / 1 g	5 ... 9 Hz / 3.5 mm, 9 ... 500 Hz / 1 g
<b>Shock testing</b>		
• Shock resistance during operation acc. to IEC 60068-2-27	15 g / 11 ms; for wall mounting: 10 g / 30 ms, 25 g / 6 ms	15 g / 11 ms; for wall mounting: 10 g / 30 ms, 25 g / 6 ms
<b>Cables</b>		
Cable length for motor, shielded, max.	10 m	10 m
<b>Dimensions</b>		
Width	50 mm	50 mm
Height	125 mm; 136 mm with protective collar for PN connector	125 mm; 136 mm with protective collar for PN connector
Depth	120 mm	120 mm
<b>Weights</b>		
Weight, approx.	350 g	350 g
<b>Other</b>		
Brake design	Holding brake	Holding brake
Braking chopper	Yes; Onboard, expandable	Yes; Onboard, expandable
Note:	Maximum 30 J per braking process, maximum 30 J per minute	Maximum 30 J per braking process, maximum 30 J per minute

**Technical specifications**

Article number	<b>6BK1630-1AA60-0AA0</b> SIMATIC MICRO-DRIVE PDC600 boxed	<b>6BK1630-2AA60-0AA0</b> SIMATIC MICRO-DRIVE PDC600F boxed
<b>General information</b>		
Product type designation	EC motor controller	EC motor controller
Product description	Control of EC motors	Control of EC motors
Mean time between failures (MTBF)	100 000 h	100 000 h
<b>Product function</b>		
• Isochronous mode	Yes	Yes
• Four-quadrant operation	Yes	Yes
• Speed control with encoder	Yes	Yes
• Speed control without encoder	No	No
• Safety Functions	Yes; STO	Yes; STO, SS1, SLS, SSM
<b>Protection function</b>		
• Undervoltage protection	Yes	Yes
• Overvoltage protection	Yes	Yes
• Overload protection	Yes	Yes
• Ground-fault protection	Yes	Yes
• Short-circuit protection	Yes	Yes
<b>Engineering with</b>		
• STEP 7 TIA Portal configurable/ integrated from version	V14 SP1	V14 SP1
<b>Installation type/mounting</b>		
Mounting type	35 mm rail, screw mounting	35 mm rail, screw mounting
Type of ventilation	Convection cooling	Convection cooling
<b>Supply voltage</b>		
Design of the power supply	DC	DC
Rated value (DC)	24 V	24 V
<b>Supply voltage of the motor</b>		
• Type of motor voltage	24 ... 48 V DC, SELV / PELV	24 ... 48 V DC, SELV / PELV
• permissible range, lower limit (DC)	16.8 V	16.8 V
• supply voltage / of the motor / at DC / rated value / maximum	52.8 V	52.8 V
<b>Output current</b>		
Current output (rated value)	11 A	11 A
Output current, max.	22 A	22 A
Output frequency	500 Hz	500 Hz
<b>Digital inputs</b>		
Number of digital inputs	4	4
Number of safety inputs	1; For STO, antivalent (2-pin) - 24 V DC	1; For STO, antivalent (2-pin) - 24 V DC
<b>Digital outputs</b>		
Type of digital output	Source output (PNP, current-sourcing)	Source output (PNP, current-sourcing)
Number of digital outputs	2	2
Number of safety outputs	0	0
<b>Encoder</b>		
<b>Connectable encoders</b>		
• Incremental encoder (symmetrical)	Yes; Up to 200 kHz	Yes; Up to 200 kHz
• Incremental encoder (asymmetrical)	Yes	Yes
• Absolute encoder (SSI)	Yes; 350 kHz	Yes; 350 kHz
<b>Interfaces</b>		
Number of industrial Ethernet interfaces	0	0
Number of PROFINET interfaces	2	2

# SIMATIC MICRO-DRIVE drive system

## PDC Drives

### Technical specifications

Article number	<b>6BK1630-1AA60-0AA0</b>	<b>6BK1630-2AA60-0AA0</b>
	SIMATIC MICRO-DRIVE PDC600 boxed	SIMATIC MICRO-DRIVE PDC600F boxed
<b>Degree and class of protection</b>		
IP degree of protection	IP20	IP20
<b>Standards, approvals, certificates</b>		
CE mark	Yes	Yes
CSA approval	No	No
cULus	Yes	Yes
RCM (formerly C-TICK)	Yes	Yes
KC approval	Yes	Yes
EAC (formerly Gost-R)	Yes	Yes
China RoHS compliance	Yes	Yes
<b>Highest safety class achievable in safety mode</b>		
• Performance level according to ISO 13849-1	d	d
• SIL acc. to IEC 61508	SIL 2	SIL 2
<b>Ambient conditions</b>		
<b>Ambient temperature during operation</b>		
• min.	-20 °C	-20 °C
• max.	60 °C	60 °C
<b>Ambient temperature during storage/transportation</b>		
• Storage, min.	-20 °C	-20 °C
• Storage, max.	80 °C	80 °C
<b>Relative humidity</b>		
• Operation, max.	95 %; no condensation	95 %
• Storage, max.	95 %; no condensation	95 %
<b>Vibrations</b>		
• Vibration resistance during operation acc. to IEC 60068-2-6	5 ... 8.5 Hz / 3.5 mm, 8.5 ... 150 Hz / 1 g; for wall mounting: 9 ... 29 Hz / 1.5 mm, 29 ... 200 Hz / 5 g	5 ... 8.5 Hz / 3.5 mm, 8.5 ... 150 Hz / 1 g; for wall mounting: 9 ... 29 Hz / 1.5 mm, 29 ... 200 Hz / 5 g
• Vibration resistance during storage acc. to IEC 60068-2-6	5 ... 8.5 Hz / 3.5 mm, 8.5 ... 500 Hz / 1 g	5 ... 8.5 Hz / 3.5 mm, 8.5 ... 500 Hz / 1 g
<b>Shock testing</b>		
• Shock resistance during operation acc. to IEC 60068-2-27	15 g / 11 ms; for wall mounting: 5 g / 30 ms, 15 g / 11 ms	15 g / 11 ms; for wall mounting: 5 g / 30 ms, 15 g / 11 ms
<b>Cables</b>		
Cable length for motor, shielded, max.	10 m	10 m
<b>Dimensions</b>		
Width	90 mm	90 mm
Height	125 mm; 136 mm with protective collar for PN connector	125 mm; 136 mm with protective collar for PN connector
Depth	120 mm	120 mm
<b>Weights</b>		
Weight, approx.	0.65 kg	0.65 kg
<b>Other</b>		
Braking chopper	Yes; External resistance	Yes; External resistance

### Technical specifications

Article number	<b>6BK1630-1BA00-0AA0</b> SIMATIC MICRO-DRIVE PDC1000-V1 boxed
<b>General information</b>	
Product type designation	EC motor controller
Product description	Control of EC motors
Mean time between failures (MTBF)	100 000 h
<b>Product function</b>	
• Isochronous mode	Yes
• Four-quadrant operation	Yes
• Speed control with encoder	Yes
• Speed control without encoder	No
• Safety Functions	No
<b>Protection function</b>	
• Undervoltage protection	Yes
• Overvoltage protection	Yes
• Overload protection	Yes
• Short-circuit protection	Yes
<b>Engineering with</b>	
• STEP 7 TIA Portal configurable/ integrated from version	V15 SP1
<b>Installation type/mounting</b>	
Mounting type	35 millimeter rail and mounting plate screw connection
Type of ventilation	Convection cooling
<b>Supply voltage</b>	
Design of the power supply	DC
Rated value (DC)	24 V
<b>Supply voltage of the motor</b>	
• Type of motor voltage	24 ... 48 V DC, SELV / PELV
• permissible range, lower limit (DC)	16.8 V
• supply voltage / of the motor / at DC / rated value / maximum	52.8 V
<b>Output current</b>	
Current output (rated value)	17.3 A
Output current, max.	34.6 A
Output frequency	500 Hz
<b>Digital inputs</b>	
Number of digital inputs	5
Number of safety inputs	0
<b>Digital outputs</b>	
Number of digital outputs	2; 24 V DC, 1 A
Number of safety outputs	0
<b>Encoder</b>	
<b>Connectable encoders</b>	
• Incremental encoder (symmetrical)	Yes; Up to 200 kHz
• Absolute encoder (SSI)	Yes; With SSI interface
<b>Interfaces</b>	
Number of industrial Ethernet interfaces	0
Number of PROFINET interfaces	2
<b>Degree and class of protection</b>	
IP degree of protection	IP20
<b>Standards, approvals, certifi- cates</b>	
CE mark	Yes
CSA approval	No
UL approval	No

Article number	<b>6BK1630-1BA00-0AA0</b> SIMATIC MICRO-DRIVE PDC1000-V1 boxed
cULus	No
FM approval	No
RCM (formerly C-TICK)	No
KC approval	No
EAC (formerly Gost-R)	Yes
China RoHS compliance	No
reference designation according to IEC 81346-2 (2009)	T
<b>Ambient conditions</b>	
<b>Ambient temperature during operation</b>	
• min.	-20 °C
• max.	60 °C
<b>Ambient temperature during storage/transportation</b>	
• Storage, min.	-20 °C
• Storage, max.	80 °C
<b>Relative humidity</b>	
• Operation, max.	90 %; no condensation
• Storage, max.	95 %; no condensation
<b>Vibrations</b>	
• Vibration resistance during operation acc. to IEC 60068-2-6	5 ... 8.5 Hz / 3.5 mm, 8.5 ... 150 Hz / 1 g; for wall mounting: 9 ... 29 Hz / 1.5 mm, 29 ... 200 Hz / 5 g
• Vibration resistance during storage acc. to IEC 60068-2-6	5 ... 9 Hz / 3.5 mm, 9 ... 500 Hz / 1 g
<b>Shock testing</b>	
• Shock resistance during operation acc. to IEC 60068-2-27	15 g / 11 ms; for wall mounting: 10 g / 30 ms, 25 g / 6 ms
<b>Cables</b>	
Cable length for motor, shielded, max.	10 m
<b>Connection method</b>	
Type of connection	Plug-in terminal
<b>Dimensions</b>	
Width	90 mm
Height	125 mm; 136 mm with protective col- lar for PN connector
Depth	120 mm
<b>Weights</b>	
Weight, approx.	0.65 kg
<b>Other</b>	
Brake design	Holding brake
Braking chopper	Yes; External resistance

### Accessories

#### Shielding bracket set

For good EMC shielding on the PDC Drives

- For supporting the plug-in cable/cable shields
- Available in widths of 50 mm, 70 mm und 90 mm

Description	Article No.
<b>Shielding bracket set</b>	
For supporting the plug-in cable/cable shields	
• Width 50 mm	<b>6BK1638-0XA50-0AA0</b>
• Width 70 mm	<b>6BK1638-0XA70-0AA0</b>
• Width 90 mm	<b>6BK1638-0XA80-0AA0</b>

# SIMATIC MICRO-DRIVE drive system

## TM Drives

### F-TM ServoDrive HF

#### Overview



SIMATIC MICRO-DRIVE F-TM ServoDrive HF with Base Unit

In combination with EC Motors and stepper motors up to 280 W the new ET 200SP technology module F-TM ServoDrive HF allows positioning and speed control in very confined spaces. The triple overload capability and the support of BiSS-C multi-turn encoders extend the scope of applications of the TM Drive family.

Engineering in the TIA Portal stands for consistency in a single tool. This facilitates drive dimensioning, commissioning and servicing.

The new drive system consists of:

- The F-TM ServoDrive HF as a new member of the SIMATIC MICRO-DRIVE family,
- The BaseUnit (U0),
- Motors with gearbox for flexible use and
- Connecting cables.

Further information on the distributed I/O system SIMATIC ET 200SP is available in the ST 70 Catalog and on the internet at [www.siemens.com/et200sp](http://www.siemens.com/et200sp)

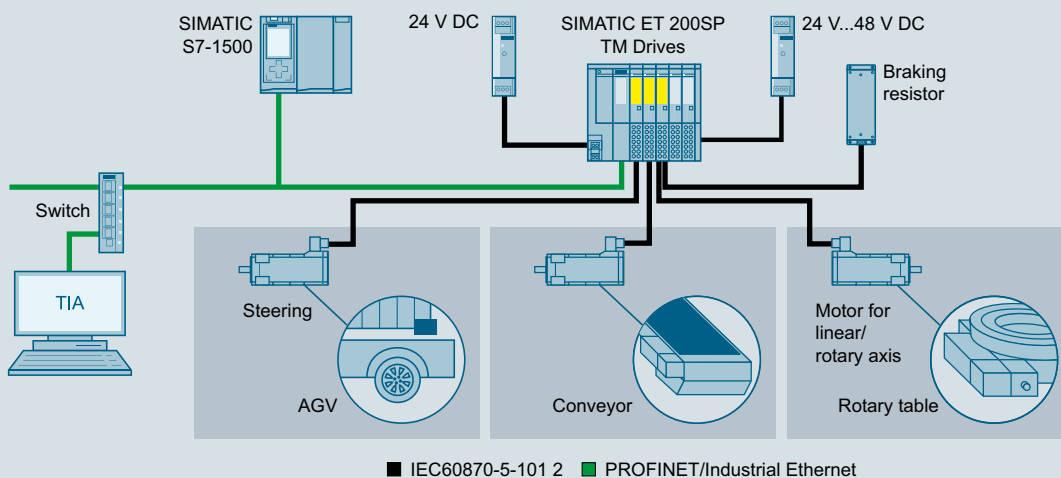

G\_STT0\_XX\_03278

Application example TM Drives

#### Characteristics

- PROFIdrive profile via PROFINET
- Hardware-STO (SIL3)
- Triple overload
- Digital input
- Integrated braking chopper
- Encoder connection for
  - IQ encoders
  - Incremental encoders
  - BiSS-C encoders

Variant	Power	Peak power	Device width
High Feature	280 W	840 W	20 mm

More information:  
[www.siemens.com/micro-drive](http://www.siemens.com/micro-drive)

#### Selection and ordering data

F-TM ServoDrive HF for SIMATIC MICRO-DRIVE	
Variant	Article No.
<ul style="list-style-type: none"> <li>• High Feature V1; 24 ... 48 V, 5 A with hardware STO and integrated braking chopper</li> </ul>	<b>6BK1136-6AB00-0CU0</b>

### Technical specifications

Article number	<b>6BK1136-6AB00-0CU0</b> F-TM ServoDrive HF
<b>General information</b>	
Product type designation	F-TM ServoDrive HF
Product description	control of EC and stepper motors
<b>Product function</b>	
• I&M data	Yes
• Isochronous mode	No
• Four-quadrant operation	Yes
• Speed control with encoder	Yes
• Speed control without encoder	Yes; for stepper motors
• Safety Functions	Yes; Drive controller with hardwired STO
<b>Protection function</b>	
• Undervoltage protection	Yes
• Overvoltage protection	Yes
• Overload protection	Yes
• Ground-fault protection	No
• Short-circuit protection	Yes
<b>Installation type/mounting</b>	
Type of ventilation	Convection cooling
<b>Supply voltage</b>	
Design of the power supply	24 ... 48 V DC, SELV / PELV
<b>Output voltage</b>	
Rated value, min.	24 V
Rated value, max.	48 V
<b>Output current</b>	
Current output (rated value)	5 A
Output current, max.	15 A
Output frequency	599 Hz
<b>Encoder supply</b>	
Number of outputs	1
<b>Digital inputs</b>	
Number of digital inputs	1; input for message signal
Number of safety inputs	1; For STO, antivalent (2-pin) - 24 V DC
<b>Encoder</b>	
<b>Connectable encoders</b>	
• Incremental encoder (symmetrical)	Yes; up to 500 Hz per channel
• Absolute encoder (SSI)	Yes; BiSS-C
• BiSS-C encoder	Yes
<b>Interrupts/diagnostics/status information</b>	
<b>Alarms</b>	
• Diagnostic alarm	Yes
• Hardware interrupt	No
<b>Diagnoses</b>	
• Monitoring the supply voltage	Yes
• Wire-break	Yes
• Short-circuit	Yes
• Telegram error at SSI encoder	Yes; BiSS-C
• Group error	Yes
<b>Diagnostics indication LED</b>	
• RUN LED	Yes
• ERROR LED	Yes

Article number	<b>6BK1136-6AB00-0CU0</b> F-TM ServoDrive HF
<b>Integrated Functions</b>	
<b>Position detection</b>	
• Incremental acquisition	Yes
• Absolute acquisition	Yes
<b>Potential separation</b>	
<b>Potential separation channels</b>	
• between the channels and back-plane bus	Yes
<b>Degree and class of protection</b>	
IP degree of protection	IP20
<b>Standards, approvals, certificates</b>	
CE mark	Yes
cULus	available soon
RCM (formerly C-TICK)	available soon
KC approval	available soon
EAC (formerly Gost-R)	available soon
China RoHS compliance	Yes
Standard for EMC according to EN 61800-3	Yes
Standard for drive acc. to EN 61800-5-1	Yes
Standard for drive acc. to EN 61800-5-2	Yes
<b>Highest safety class achievable in safety mode</b>	
• Performance level according to ISO 13849-1	Category 3, performance level d, according to EN ISO 13849-1:2015
• SIL acc. to IEC 61508	3
<b>Ambient conditions</b>	
<b>Ambient temperature during operation</b>	
• horizontal installation, min.	-30 °C; No condensation, splash water, icing, salt spray or oil mist permitted.
• horizontal installation, max.	60 °C; No condensation, splash water, icing, salt spray or oil mist permitted. Note the derating data!
• vertical installation, min.	-30 °C; No condensation, splash water, icing, salt spray or oil mist permitted.
• vertical installation, max.	50 °C; No condensation, splash water, icing, salt spray or oil mist permitted. Note the derating data!
<b>Ambient temperature during storage/transportation</b>	
• Storage, min.	-30 °C
• Storage, max.	70 °C
<b>Altitude during operation relating to sea level</b>	
• Installation altitude above sea level, max.	3 000 m

**SIMATIC MICRO-DRIVE drive system**

TM Drives

**F-TM ServoDrive HF****Technical specifications**

Article number	<b>6BK1136-6AB00-0CU0</b> F-TM ServoDrive HF
<b>Cables</b>	
Cable length for motor, shielded, max.	10 m
<b>Dimensions</b>	
Width	20 mm
Height	73 mm
Depth	58 mm
<b>Weights</b>	
Weight, approx.	55 g
<b>Other</b>	
Brake design	holding brake control via the process image
Braking chopper	Yes

**Accessories**

Description	Article No.
<b>ET 200SP BaseUnit type U0</b>	
• For constructing a new potential group (white)	<b>6ES7193-6BP00-0DU0</b>
• For continuing an existing potential group (gray)	<b>6ES7193-6BP00-0BU0</b>
<b>Shield connection for ET 200SP</b>	<b>6ES7193-6SC00-1AM0</b>
Includes 5 shield connections	

2



### Overview



SIMATIC MICRO-DRIVE FM-ServoDrive ST

In combination with EC motors, the new ET 200SP technology module F-TM ServoDrive ST allows positioning and speed control of EC motors up to 280 W in very confined spaces.

Engineering in the TIA Portal stands for consistency in a single tool. This facilitates drive dimensioning, commissioning and servicing.

The new drive system consists of

- The F-TM ServoDrive ST as a new member of the SIMATIC MICRO-DRIVE family
- The BaseUnit (U0)
- Motors with gearbox for flexible use and
- Connecting cables.

Further information on the distributed I/O system SIMATIC ET 200SP is available in the ST 70 Catalog and on the internet at [www.siemens.com/et200sp](http://www.siemens.com/et200sp)

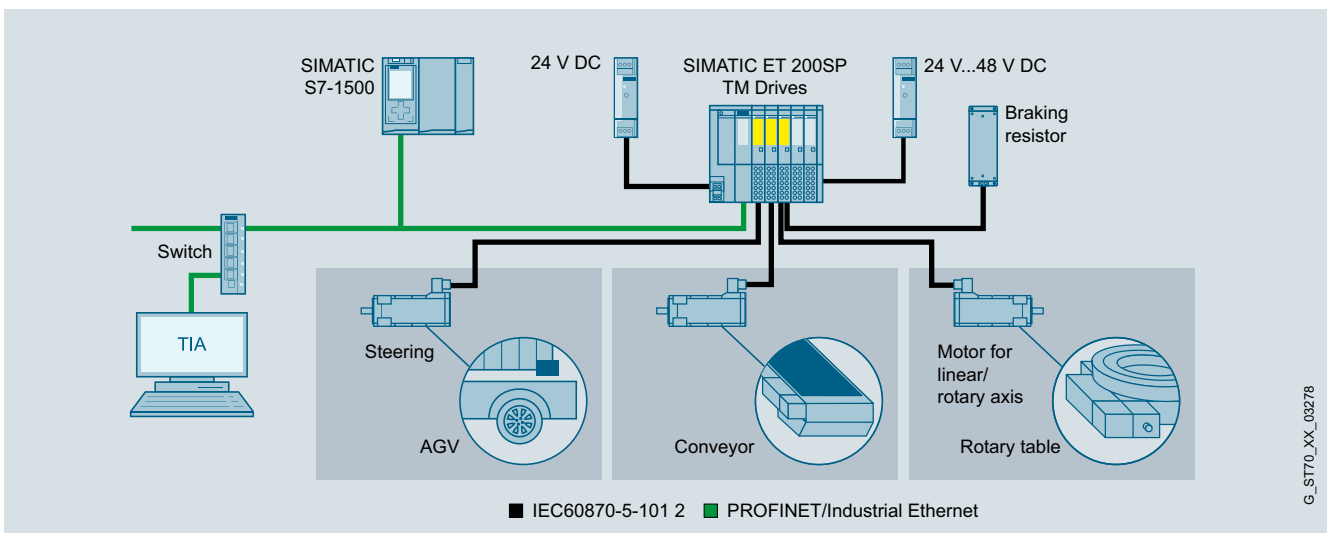

G\_ST70\_XX\_03278

Application example TM Drives

#### Characteristics

- PROFIdrive profile via PROFINET
- Hardware STO
- Digital input
- Integrated braking chopper
- Encoder connection for
  - IQ encoders
  - Incremental encoders

Variant	Power	Device width
Standard	280 W	20 mm

More information:

[www.siemens.com/micro-drive](http://www.siemens.com/micro-drive)

#### Selection and ordering data

##### F-TM ServoDrive ST for SIMATIC MICRO-DRIVE

Variant	Article No.
<ul style="list-style-type: none"> <li>• Standard V1; 24 ... 48 V, 5 A with hardware STO and integrated braking chopper</li> </ul>	<b>6BK1136-6AB00-0BU0</b>

# SIMATIC MICRO-DRIVE drive system

## TM Drives

### F-TM ServoDrive ST

#### Technical specifications

Article number	<b>6BK1136-6AB00-0BU0</b> F-TM ServoDrive ST
<b>General information</b>	
Product type designation	F-TM ServoDrive HF
Product description	Control of EC motors
<b>Product function</b>	
• I&M data	Yes
• Isochronous mode	No
• Four-quadrant operation	Yes
• Speed control with encoder	Yes
• Speed control without encoder	No
• Safety Functions	Yes; Drive controller with hardwired STO
<b>Protection function</b>	
• Undervoltage protection	Yes
• Overvoltage protection	Yes
• Overload protection	Yes
• Ground-fault protection	No
• Short-circuit protection	Yes
<b>Installation type/mounting</b>	
Type of ventilation	Convection cooling
<b>Supply voltage</b>	
Design of the power supply	24 ... 48 V DC, SELV / PELV
<b>Output voltage</b>	
Rated value, min.	24 V
Rated value, max.	48 V
<b>Output current</b>	
Current output (rated value)	5 A
Output current, max.	10 A
Output frequency	599 Hz
<b>Encoder supply</b>	
Number of outputs	1
<b>Digital inputs</b>	
Number of digital inputs	1; input for message signal
Number of safety inputs	1; For STO, antivalent (2-pin) - 24 V DC
<b>Encoder</b>	
<b>Connectable encoders</b>	
• Incremental encoder (symmetrical)	Yes; up to 500 Hz per channel
<b>Interrupts/diagnostics/status information</b>	
<b>Alarms</b>	
• Diagnostic alarm	Yes
• Hardware interrupt	No
<b>Diagnoses</b>	
• Monitoring the supply voltage	Yes
• Wire-break	Yes
• Short-circuit	Yes
• Group error	Yes
<b>Diagnostics indication LED</b>	
• RUN LED	Yes
• ERROR LED	Yes
<b>Integrated Functions</b>	
<b>Position detection</b>	
• Incremental acquisition	Yes

Article number	<b>6BK1136-6AB00-0BU0</b> F-TM ServoDrive ST
<b>Potential separation</b>	
<b>Potential separation channels</b>	
• between the channels and back-plane bus	Yes
<b>Degree and class of protection</b>	
IP degree of protection	IP20
<b>Standards, approvals, certificates</b>	
CE mark	Yes
cULus	Yes
RCM (formerly C-TICK)	Yes
KC approval	Yes
EAC (formerly Gost-R)	Yes
China RoHS compliance	Yes
Standard for EMC according to EN 61800-3	Yes, according to second environment Category C2 acc. EN 61800-3
Standard for drive acc. to EN 61800-5-1	Yes
Standard for drive acc. to EN 61800-5-2	Yes
<b>Highest safety class achievable in safety mode</b>	
• Performance level according to ISO 13849-1	Category 3, performance level d, according to EN ISO 13849-1:2015
• SIL acc. to IEC 61508	2
<b>Ambient conditions</b>	
<b>Ambient temperature during operation</b>	
• horizontal installation, min.	-30 °C; No condensation, splash water, icing, salt spray or oil mist permitted.
• horizontal installation, max.	60 °C; No condensation, splash water, icing, salt spray or oil mist permitted. Note the derating data!
• vertical installation, min.	-30 °C; No condensation, splash water, icing, salt spray or oil mist permitted.
• vertical installation, max.	50 °C; No condensation, splash water, icing, salt spray or oil mist permitted. Note the derating data!
<b>Ambient temperature during storage/transportation</b>	
• Storage, min.	-30 °C
• Storage, max.	70 °C
<b>Altitude during operation relating to sea level</b>	
• Installation altitude above sea level, max.	3 000 m
<b>Cables</b>	
Cable length for motor, shielded, max.	10 m
<b>Dimensions</b>	
Width	20 mm
Height	73 mm
Depth	58 mm
<b>Weights</b>	
Weight, approx.	55 g
<b>Other</b>	
Brake design	holding brake control via the process image
Braking chopper	Yes

## Accessories

Description	Article No.
<b>SIMATIC F-TM ServoDrive ST Starter Kit</b> Scope of supply: <ul style="list-style-type: none"> <li>• SIMATIC MICRO-DRIVE F-TM ServoDrive ST</li> <li>• SIMATIC ET 200SP PROFINET IM 155-6PN ST Interface Module</li> <li>• SIMATIC ET 200SP BaseUnit type U0</li> <li>• All-in-one plug-in cable CSD_LAiO2, length 1.5 m</li> <li>• ebm-papst motor ECI42.20 24 V</li> </ul>	<b>6BK1637-6AB00-0BU0</b>
<b>ET 200SP BaseUnit type U0</b> <ul style="list-style-type: none"> <li>• For constructing a new potential group (white)</li> </ul>	<b>6ES7193-6BP00-0DU0</b>
<ul style="list-style-type: none"> <li>• For continuing an existing potential group (gray)</li> </ul>	<b>6ES7193-6BP00-0BU0</b>
<b>Shield connection for ET 200SP</b> Includes 5 shield connections	<b>6ES7193-6SC00-1AM0</b>

# SIMATIC MICRO-DRIVE drive system

TM Drives

## F-TM StepDrive ST

### Overview



The new ET 200SP technology module F-TM StepDrive ST allows positioning and speed control of stepper motors up to 10 A peak current in very confined spaces.

Engineering in the TIA Portal stands for consistency in a single tool. This facilitates drive dimensioning, commissioning and servicing.

The new drive system consists of

- The F-TM StepDrive ST as a new member of the SIMATIC MICRO-DRIVE family
- The BaseUnit (U0)

Further information on the distributed I/O system SIMATIC ET 200SP is available in the ST 70 Catalog and on the internet at [www.siemens.com/et200sp](http://www.siemens.com/et200sp)

SIMATIC MICRO-DRIVE F-TM StepDrive ST

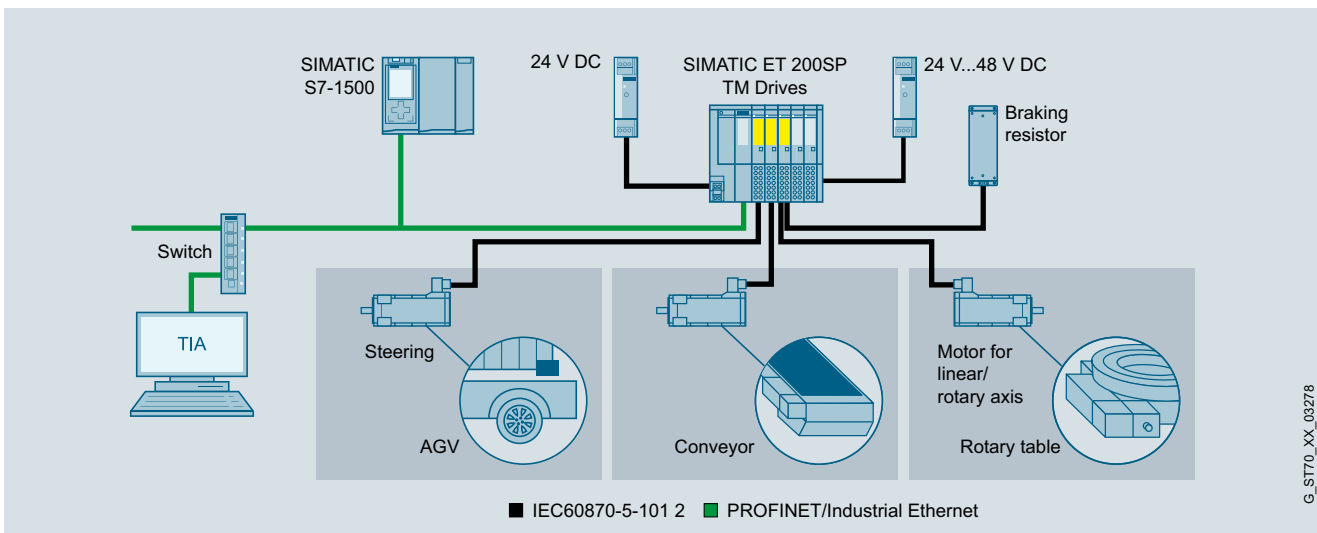

Application example TM Drives

#### Characteristics

- Bipolar stepper motors
- PROFIdrive profile via PROFINET
- Hardware STO (SIL3)
- Digital input
- Encoderless operation
- Encoder connection for
  - Incremental encoders

Variant	Power	Device width
Standard	280 W	20 mm

More information:  
[www.siemens.com/micro-drive](http://www.siemens.com/micro-drive)

### Selection and ordering data

F-TM StepDrive ST for SIMATIC MICRO-DRIVE	
Variant	Article No
• Standard V1; 24 ... 48 V, 5 A with hardware STO	<b>6BK1136-6SB00-0BU0</b>

G\_ST70\_XX\_03278

## Technical specifications

Article number	<b>6BK1136-6SB00-0BU0</b> F-TM StepDrive ST
<b>General information</b>	
Product type designation	F-TM StepDrive ST
Product description	control of stepper motors
<b>Product function</b>	
• I&M data	Yes
• Isochronous mode	No
• Four-quadrant operation	Yes
• Speed control with encoder	No
• Speed control without encoder	No
• Safety Functions	Yes; Drive controller with hardwired STO
<b>Protection function</b>	
• Undervoltage protection	Yes
• Overvoltage protection	Yes
• Overload protection	Yes
• Ground-fault protection	No
• Short-circuit protection	Yes
<b>Installation type/mounting</b>	
Type of ventilation	Convection cooling
<b>Supply voltage</b>	
Design of the power supply	24 ... 48 V DC, SELV / PELV
<b>Output voltage</b>	
Rated value, min.	24 V
Rated value, max.	48 V
<b>Output current</b>	
Current output (rated value)	5 A
Output current, max.	10 A
Output frequency	1 000 Hz
<b>Encoder supply</b>	
Number of outputs	1
<b>5 V encoder supply</b>	
• 5 V	Yes
• Short-circuit protection	Yes
• Output current, max.	150 mA
<b>Digital inputs</b>	
Number of digital inputs	1; input for message signal
Number of safety inputs	1; For STO, antivalent (2-pin) - 24 V DC
<b>Encoder</b>	
<b>Connectable encoders</b>	
• Incremental encoder (symmetrical)	Yes; up to 500 Hz per channel
<b>Interrupts/diagnostics/status information</b>	
<b>Alarms</b>	
• Diagnostic alarm	Yes
• Hardware interrupt	No
<b>Diagnoses</b>	
• Monitoring the supply voltage	Yes
• Wire-break	Yes
• Short-circuit	Yes
• Group error	Yes

Article number	<b>6BK1136-6SB00-0BU0</b> F-TM StepDrive ST
<b>Diagnostics indication LED</b>	
• RUN LED	Yes
• ERROR LED	Yes
<b>Integrated Functions</b>	
<b>Position detection</b>	
• Incremental acquisition	Yes
• Absolute acquisition	No
<b>Potential separation</b>	
<b>Potential separation channels</b>	
• between the channels and back-plane bus	Yes
<b>Degree and class of protection</b>	
IP degree of protection	IP20
<b>Standards, approvals, certificates</b>	
CE mark	Yes
cULus	Available soon
RCM (formerly C-TICK)	Available soon
KC approval	Available soon
EAC (formerly Gost-R)	Available soon
China RoHS compliance	Yes
Standard for EMC according to EN 61800-3	Yes, according to second environment Category C2 acc. EN 61800-3
Standard for drive acc. to EN 61800-5-1	Yes
Standard for drive acc. to EN 61800-5-2	Yes
<b>Highest safety class achievable in safety mode</b>	
• Performance level according to ISO 13849-1	Category 3, performance level d, according to EN ISO 13849-1:2015
• SIL acc. to IEC 61508	SIL 3 according to DIN EN 61800-5-2:2017
<b>Ambient conditions</b>	
Pollution degree during storage and transport	2
<b>Ambient temperature during operation</b>	
• horizontal installation, min.	-30 °C; No condensation, splash water, icing, salt spray or oil mist permitted.
• horizontal installation, max.	60 °C; No condensation, splash water, icing, salt spray or oil mist permitted. Note the derating data!
• vertical installation, min.	-30 °C; No condensation, splash water, icing, salt spray or oil mist permitted.
• vertical installation, max.	50 °C; No condensation, splash water, icing, salt spray or oil mist permitted. Note the derating data!
<b>Ambient temperature during storage/transportation</b>	
• Storage, min.	-40 °C
• Storage, max.	70 °C
<b>Altitude during operation relating to sea level</b>	
• Installation altitude above sea level, max.	3 000 m

**SIMATIC MICRO-DRIVE drive system**

TM Drives

**F-TM StepDrive ST****Technical specifications**

Article number	<b>6BK1136-6SB00-0BU0</b> F-TM StepDrive ST
<b>Cables</b>	
Cable length for motor, shielded, max.	10 m
<b>Dimensions</b>	
Width	20 mm
Height	73 mm
Depth	58 mm
<b>Weights</b>	
Weight, approx.	55 g
<b>Other</b>	
Brake design	holding brake control via the process image
Braking chopper	No

**Accessories**

Description	Article No.
<b>ET 200SP BaseUnit type U0</b>	
• For constructing a new potential group (white)	<b>6ES7193-6BP00-0DU0</b>
• For continuing an existing potential group (gray)	<b>6ES7193-6BP00-0BU0</b>
<b>Shield connection for ET 200SP</b>	<b>6ES7193-6SC00-1AM0</b>
Includes 5 shield connections	

2

**SIMATIC MICRO-DRIVE drive system**

Motors/gear units and connection systems from Siemens Product Partners

**Overview****Motors/gear units and connection systems from Siemens Product Partners**Note

Siemens Product Partners are third-party companies outside of Siemens AG and its associated companies. Information and descriptions of products from the Siemens Product Partners are non-binding and are the responsibility of the Siemens Product Partner. These products are independently manufactured by the respective, responsible Siemens Product Partner and are sold and delivered by said partner according to its business and delivery terms.

Insofar as it is not compulsory by law, Siemens assumes no liability or warranty for these products or for the connection to these products of the Siemens Product Partners. Please also note the information on the exclusion of liability/use of hyperlinks (see More information).

**Motors/gear units**

Motor from ebm-papst and motor from Dunkermotoren

- Fully compatible motors and geared motors for SIMATIC MICRO-DRIVE
- From the portfolios of the Siemens Product Partners<sup>1)</sup> Dunkermotoren and ebm-papst
- Various combinations are available with the following components:
  - Motor
  - Planetary gearbox
  - Hall-effect sensors
  - Encoder (incremental encoder)
  - Optionally with holding brake
- Individual motor-gearbox combinations for the quick configuration during the bidding phase (not for series purchasing) can be ordered via the Siemens Industry Mall
- Complete sets can be ordered via the web shops of the Siemens Product Partners:
  - <https://www.dunkermotoren.com/simatic-micro-drive>

<https://idt-config.ebmpapst.com/simatic-micro-drive>

Delivery time of preferred types

Preferred types are components from Siemens Product Partners that will be shipped within 5 work days. The shipping time must be added to the delivery time. Availability of the individual components is a prerequisite.

**Connection system**

KnorrTec plug-in cable for SIMATIC MICRO-DRIVE

- Fully compatible plug-in cables for SIMATIC MICRO-DRIVE
- From the portfolios of the Siemens Product Partners<sup>1)</sup> HARTING and KnorrTec
- Pre-assembled at both ends
- Different versions available for different requirements
- Individual cable lengths for the quick configuration during the bidding phase (not for series purchasing) can be ordered via the Siemens Industry Mall
- Complete sets can be ordered via the web shops of the Siemens Product Partners:
  - [www.harting.com/US/en/solutions/siemens-product-partner-simatic-micro-drive](http://www.harting.com/US/en/solutions/siemens-product-partner-simatic-micro-drive)

[www.knorrtec.de/eshop.php?seourl=simatic\\_micro-drive.html&s\\_language=english](http://www.knorrtec.de/eshop.php?seourl=simatic_micro-drive.html&s_language=english)

<sup>1)</sup> Information on the Siemens Product Partners:  
[www.siemens.com/productpartner](http://www.siemens.com/productpartner)

## SIMATIC MICRO-DRIVE drive system

Motors/gear units and connection systems from Siemens Product Partners

### Overview

#### PPP plug-in cables for SIMATIC MICRO-DRIVE as of V1.0

In the following you will find an overview of all the plug-in cables that are required between the PDC Drives and the motors or geared motors:

#### Plug-in cables for motors from ebm-papst

Motor size	Motor power W	Motor connector Size	Drive controller		
			PDC100/ PDC100F	PDC600/ PDC600F/ PDC1000 V1	F-TM ServoDrive ST F-TM ServoDrive HF
<b>For 48 V DC</b>					
PDC connector			Weidmüller, small	Phoenix, large	
ECI42.20	46	M12	LAI02	LAI020	CSD_LAI02
ECI42.40	92	M12	LAI02	LAI020	CSD_LAI02
ECI63.20	150	M12	LAI02	LAI020	CSD_LAI02
ECI63.40	280	M12	LAI02	LAI020	CSD_LAI02
ECI63.60	370	M12	LAI02	LAI020	CSD_LAI02
ECI80.40	503	M23	-	LPMo3	-
ECI80.60	754	M23	-	LPMo3	-
Plug-in encoder cable			-	LPEn2	-
Plug-in brake cable			LPBr2	LPBr2	LPBr2

#### Plug-in cables for Dunkermotoren motors

Motor size	Motor power W	Motor connector Size	Drive controller		
			PDC100/ PDC100F	PDC600/ PDC600F/ PDC1000 V1	F-TM ServoDrive ST F-TM ServoDrive HF
<b>For 40 V DC</b>					
PDC connector			Weidmüller, small	Phoenix, large	
BG45x30	90	M16	LAI01	LAI010	CSD_LAI01
BG65Sx50	186	M16	LAI01	LAI010	CSD_LAI01
BG75x50	400	M17	-	LPMo1	-
<b>For 48 V DC</b>					
BG95x40	717	M23	-	LPMo3	-
BG95x80	1109	M23	-	LPMo3	-
Plug-in encoder cable			-	LPEn1	-
Plug-in brake cable			LPBr1	LPBr1	LPBr1

#### Legend

LAI0x = all-in-one connecting cable, single-cable system (all signals in one plug-in cable, motor phases, Hall-effect sensor, incremental encoders, power supplies)

LPMox = plug-in motor cable

LPEnx = plug-in encoder cable

LPBrx = plug-in brake cable

### More information

#### Note

##### Exclusion of liability/use of hyperlinks

Siemens has composed this description with great care. However, it is not possible for Siemens to perform a check of the completeness, correctness and up-to-datedness of the data provided by Siemens Product Partners. Therefore, it cannot be ruled out that individual data may be incorrect, incomplete, or not up-to-date. Siemens does not assume any liability in this case, nor for the usability of the data or of the product for the user, unless the liability is compulsory by law.

This document contains addresses of third-party web pages. Siemens accepts no responsibility for the contents of these web sites, nor does Siemens adopt these web sites and their contents as its own, as Siemens cannot check the information presented there and is also not responsible for the content and information provided on them. The user uses these web sites at his own risk.

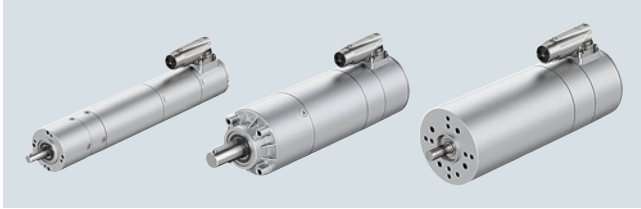

**Overview**

ebm-papst motors ECI-42.40-K1-PP42.2, ECI-63.20-K1-PP63.1, ECI-63.60-K1 for SIMATIC MICRO-DRIVE

- Motors for SIMATIC MICRO-DRIVE from the Siemens Product Partner [ebm-papst](#)
- Motors with 24 V or 48 V supply voltage
- With and without mounted planetary gearbox and mounted IQ encoder (single-turn)
- Hall-effect sensors
- Optionally with holding brake
- Degree of protection IP54 (motors without gearbox) or degree of protection IP50 (motors with gearbox)

The TIA Selection Tool can be used for the technical dimensioning of the drive axis. This allows users to specify the motion and load conditions. The dimensioning tool provides recommendations for the various possible motor-gearbox combinations and the usable PDC Drives with power specification.

All technical data of the drive combinations can be found on the SIMATIC MICRO-DRIVE web pages of the Siemens Product Partners.

For ebm-papst:

<https://idt-config.ebmpapst.com/simatic-micro-drive>

**Selection and ordering data****Motors for SIMATIC MICRO-DRIVE from the Siemens Product Partner [ebm-papst](#)**

Motors with article numbers including the prefix "EBM:" can be ordered directly from Siemens for quick configuration during the bidding phase.

Motors with article numbers without the prefix "EBM:" can be ordered directly from the Product Partner.

**Without brake**

Type of gear unit	Gear unit reduction ratio	Preferred type	Product partner article no. Article No.	Preferred type	Product partner article no. Article No.
<b>Can be used with all PDC and F-TM ServoDrive ST/HF drive controllers</b>					
			<b>Motor ECI42.20 24 V DC</b>		<b>Motor ECI42.20 48 V DC</b>
PerformaxPlus 42.1	5		SGE4220BK1PP42100560		SGE4220DK1PP42100560
PerformaxPlus 42.1	9	✓	SGE4220BK1PP42100960 EBM:SGE4220BK1PP42100960		SGE4220DK1PP42100960
PerformaxPlus 42.2	30		SGE4220BK1PP42203060		SGE4220DK1PP42203060
PerformaxPlus 42.2	54	✓	SGE4220BK1PP42205460 EBM:SGE4220BK1PP42205460		SGE4220DK1PP42205460
without gear unit	-	✓	SSE4220BK1xxxxxxxx60 EBM:SSE4220BK1xxxxxxxx60		SSE4220DK1xxxxxxxx60
<b>Can be used with all PDC and F-TM ServoDrive ST/HF drive controllers</b>					
			<b>Motor ECI42.40 24 V DC</b>		<b>Motor ECI42.40 48 V DC</b>
PerformaxPlus 42.1	5		SGE4240BK1PP42100560	✓	SGE4240DK1PP42100560 EBM:SGE4240DK1PP42100560
PerformaxPlus 42.1	9		SGE4240BK1PP42100960		SGE4240DK1PP42100960
PerformaxPlus 42.2	30		SGE4240BK1PP42203060	✓	SGE4240DK1PP42203060 EBM:SGE4240DK1PP42203060
PerformaxPlus 42.2	54		SGE4240BK1PP42205460		SGE4240DK1PP42205460
without gear unit	-		SSE4240BK1xxxxxxxx60		SSE4240DK1xxxxxxxx60

## SIMATIC MICRO-DRIVE drive system

Motors/gear units and connection systems from Siemens Product Partners

### ebm-papst motors/gear units

#### Selection and ordering data

##### Without brake

Type of gear unit	Gear unit reduction ratio	Preferred type	Product partner article no. Article No.	Preferred type	Product partner article no. Article No.
-------------------	---------------------------	----------------	---	----------------	---

##### Can be used with all PDC and F-TM ServoDrive ST/HF drive controllers

Type of gear unit	Gear unit reduction ratio	Preferred type	Product partner article no. Article No.	Preferred type	Product partner article no. Article No.
			Motor ECI63.20 24 V DC		Motor ECI63.20 48 V DC
PerformaxPlus 63.1	5		SGE6320BK1PP63100560		SGE6320DK1PP63100560
PerformaxPlus 63.1	9		SGE6320BK1PP63100960		SGE6320DK1PP63100960
PerformaxPlus 63.2	30	✓	SGE6320BK1PP63203060 EBM:SGE6320BK1PP63203060		SGE6320DK1PP63203060
PerformaxPlus 63.2	54		SGE6320BK1PP63205460		SGE6320DK1PP63205460
without gear unit	-		SSE6320BK1xxxxxxxx60		SSE6320DK1xxxxxxxx60

##### Can be used with all PDC and F-TM ServoDrive ST/HF drive controllers

Type of gear unit	Gear unit reduction ratio	Preferred type	Product partner article no. Article No.	Preferred type	Product partner article no. Article No.
			Motor ECI63.40 24 V DC		Motor ECI63.40 48 V DC
PerformaxPlus 63.1	5		SGE6340BK1PP63100560		SGE6340DK1PP63100560
PerformaxPlus 63.1	9		SGE6340BK1PP63100960	✓	SGE6340DK1PP63100960 EBM:SGE6340DK1PP63100960
PerformaxPlus 63.2	30		SGE6340BK1PP63203060		SGE6340DK1PP63203060
PerformaxPlus 63.2	54		SGE6340BK1PP63205460		SGE6340DK1PP63205460
without gear unit	-		SSE6340BK1xxxxxxxx60		SSE6340DK1xxxxxxxx60

##### Can be used with all PDC and F-TM ServoDrive ST/HF drive controllers

Type of gear unit	Gear unit reduction ratio	Preferred type	Product partner article no. Article No.	Preferred type	Product partner article no. Article No.
			Motor ECI63.60 24 V DC		Motor ECI63.60 48 V DC
PerformaxPlus 63.1	5	-	-		SGE6360DK1PP63100560
PerformaxPlus 63.1	9	-	-		SGE6360DK1PP63100960
PerformaxPlus 63.2	30	-	-		SGE6360DK1PP63203060
PerformaxPlus 63.2	54	-	-		SGE6360DK1PP63205460
without gear unit	-	-	-		SSE6360DK1xxxxxxxx60

##### Can be used with PDC600/PDC600F drive controller and PDC1000 V1 drive controller

Type of gear unit	Gear unit reduction ratio	Preferred type	Product partner article no. Article No.	Preferred type	Product partner article no. Article No.
			Motor ECI80.40 24 V DC		Motor ECI80.40 48 V DC
PE 80.1	5	-	-		SGE8040DK1PE80100560
PE 80.1	8	-	-		SGE8040DK1PE80100860
PE 80.2	25	-	-		SGE8040DK1PE80202560
PE 80.2	40	-	-		SGE8040DK1PE80204060
without gear unit	-	-	-		SSE8040DK1xxxxxxxx60

##### Can be used with PDC600/PDC600F drive controller and PDC1000 V1 drive controller

Type of gear unit	Gear unit reduction ratio	Preferred type	Product partner article no. Article No.	Preferred type	Product partner article no. Article No.
			Motor ECI80.60 24 V DC		Motor ECI80.60 48 V DC
PE 80.1	5	-	-		SGE8060DK1PE80100560
PE 80.1	8	-	-		SGE8060DK1PE80100860
PE 80.2	25	-	-	✓	SGE8060DK1PE80202560 EBM:SGE8060DK1PE80202560
PE 80.2	40	-	-		SGE8060DK1PE80204060
without gear unit	-	-	-	✓	SSE8060DK1xxxxxxxx60 EBM:SSE8060DK1xxxxxxxx60

## Selection and ordering data

**With brake**

Type of gear unit	Gear unit reduction ratio	Preferred type	Product partner article no. Article No.	Preferred type	Product partner article no. Article No.
-------------------	---------------------------	----------------	--	----------------	--

**Can be used with all PDC and F-TM ServoDrive ST/HF drive controllers**

			Motor ECI42.20 24 V DC			Motor ECI42.20 48 V DC
PerformaxPlus 42.1	5	✓	SGE4220BK1PP42100561 EBM:SGE4220BK1PP42100561			SGE4220DK1PP42100561
PerformaxPlus 42.1	9		SGE4220BK1PP42100961			SGE4220DK1PP42100961
PerformaxPlus 42.2	30	✓	SGE4220BK1PP42203061 EBM:SGE4220BK1PP42203061			SGE4220DK1PP42203061
PerformaxPlus 42.2	54		SGE4220BK1PP42205461			SGE4220DK1PP42205461
without gear unit	-		SSE4220BK1xxxxxxxx61			SSE4220DK1xxxxxxxx61

**Can be used with all PDC and F-TM ServoDrive ST/HF drive controllers**

			Motor ECI42.40 24 V DC			Motor ECI42.40 48 V DC
PerformaxPlus 42.1	5		SGE4240BK1PP42100561			SGE4240DK1PP42100561
PerformaxPlus 42.1	9		SGE4240BK1PP42100961		✓	SGE4240DK1PP42100961 EBM:SGE4240DK1PP42100961
PerformaxPlus 42.2	30		SGE4240BK1PP42203061			SGE4240DK1PP42203061
PerformaxPlus 42.2	54		SGE4240BK1PP42205461			SGE4240DK1PP42205461
without gear unit	-		SSE4240BK1xxxxxxxx61		✓	SSE4240DK1xxxxxxxx61 EBM:SSE4240DK1xxxxxxxx61

**Can be used with all PDC and F-TM ServoDrive ST/HF drive controllers**

			Motor ECI63.20 24 V DC			Motor ECI63.20 48 V DC
PerformaxPlus 63.1	5		SGE6320BK1PP63100561			SGE6320DK1PP63100561
PerformaxPlus 63.1	9		SGE6320BK1PP63100961			SGE6320DK1PP63100961
PerformaxPlus 63.2	30		SGE6320BK1PP63203061			SGE6320DK1PP63203061
PerformaxPlus 63.2	54		SGE6320BK1PP63205461			SGE6320DK1PP63205461
without gear unit	-		SSE6320BK1xxxxxxxx61			SSE6320DK1xxxxxxxx61

**Can be used with all PDC and F-TM ServoDrive ST/HF drive controllers**

			Motor ECI63.40 24 V DC			Motor ECI63.40 48 V DC
PerformaxPlus 63.1	5		SGE6340BK1PP63100561			SGE6340DK1PP63100561
PerformaxPlus 63.1	9	✓	SGE6340BK1PP63100961 EBM:SGE6340BK1PP63100961			SGE6340DK1PP63100961
PerformaxPlus 63.2	30		SGE6340BK1PP63203061			SGE6340DK1PP63203061
PerformaxPlus 63.2	54		SGE6340BK1PP63205461		✓	SGE6340DK1PP63205461 EBM:SGE6340DK1PP63205461
without gear unit	-		SSE6340BK1xxxxxxxx61			SSE6340DK1xxxxxxxx61

**Can be used with all PDC and F-TM ServoDrive ST/HF drive controllers**

			Motor ECI63.60 24 V DC			Motor ECI63.60 48 V DC
PerformaxPlus 63.1	5		-			SGE6360DK1PP63100561
PerformaxPlus 63.1	9		-		✓	SGE6360DK1PP63100961 EBM:SGE6360DK1PP63100961
PerformaxPlus 63.2	30		-		✓	SGE6360DK1PP63203061 EBM:SGE6360DK1PP63203061
PerformaxPlus 63.2	54		-			SGE6360DK1PP63205461
without gear unit	-		-			SSE6360DK1xxxxxxxx61

**SIMATIC MICRO-DRIVE drive system**

Motors/gear units and connection systems from Siemens Product Partners

**ebm-papst motors/gear units****Selection and ordering data****With brake**

Type of gear unit	Gear unit reduction ratio	Preferred type	Product partner article no. Article No.	Preferred type	Product partner article no. Article No.
<b>Can be used with PDC600/PDC600F drive controller and PDC1000 V1 drive controller</b>					
			<b>Motor EC180.40 24 V DC</b>		<b>Motor EC180.40 48 V DC</b>
PE 80.1	5	-	-		SGE8040DK1PE80100561
PE 80.1	8	-	-	✓	SGE8040DK1PE80100861 EBM:SGE8040DK1PE80100861
PE 80.2	25	-	-		SGE8040DK1PE80202561
PE 80.2	40	-	-	✓	SGE8040DK1PE80204061 EBM:SGE8040DK1PE80204061
without gear unit	-	-	-		SSE8040DK1xxxxxxx61
<b>Can be used with PDC600/PDC600F drive controller and PDC1000 V1 drive controller</b>					
			<b>Motor EC180.60 24 V DC</b>		<b>Motor EC180.60 48 V DC</b>
PE 80.1	5	-	-		SGE8060DK1PE80100561
PE 80.1	8	-	-	✓	SGE8060DK1PE80100861 EBM:SGE8060DK1PE80100861
PE 80.2	25	-	-		SGE8060DK1PE80202561
PE 80.2	40	-	-	✓	SGE8060DK1PE80204061 EBM:SGE8060DK1PE80204061
without gear unit	-	-	-		SSE8060DK1xxxxxxx61

**SIMATIC MICRO-DRIVE drive system**

Motors/gear units and connection systems from Siemens Product Partners

Dunkermotoren motors/gear units

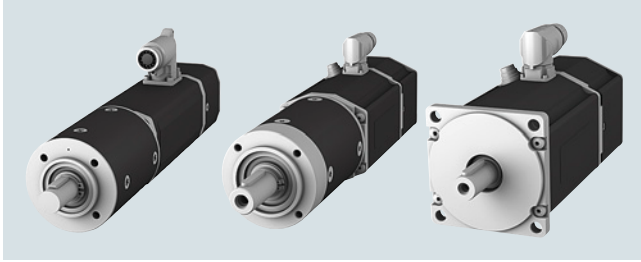
**Overview**

Dunkermotoren motors BG45x30, BG65Sx50, BG95x40 without gear unit for SIMATIC MICRO-DRIVE

- Motors for SIMATIC MICRO-DRIVE from the Siemens Product Partner Dunkermotoren
- Motors with 24 V or 40 V/48 V supply voltage
- With mounted planetary gearbox and mounted IQ encoder (single-turn absolute encoder)
- Hall-effect sensors
- Optionally with holding brake
- Degree of protection IP65 (motors and gearboxes)

The TIA Selection Tool can be used for the technical dimensioning of the drive axis. This allows users to specify the motion and load conditions. The dimensioning tool provides recommendations for the various possible motor-gearbox combinations and the usable PDC Drives with power specification.

All technical data of the drive combinations can be found on the SIMATIC MICRO-DRIVE web pages of the Siemens Product Partners.

For Dunkermotoren:

[www.dunkermotoren.com/simatic-micro-drive](http://www.dunkermotoren.com/simatic-micro-drive)

## SIMATIC MICRO-DRIVE drive system

Motors/gear units and connection systems from Siemens Product Partners

### Dunkermotoren motors/gear units

#### Selection and ordering data

##### Motors for SIMATIC MICRO-DRIVE from the Siemens Product Partner Dunkermotoren

Motors with article numbers including the prefix "DUN:" can be ordered directly from Siemens for quick configuration during the bidding phase.

Motors with article numbers without the prefix "DUN:" can be ordered directly from the Product Partner.

#### Without brake

Type of gear unit	Gear unit reduction ratio	Preferred type	Product partner article no. Article No.	Preferred type	Product partner article no. Article No.
-------------------	---------------------------	----------------	---	----------------	---

##### Can be used with all PDC and F-TM ServoDrive ST/HF drive controllers

			Motor BG45x30 Voltage 24 V DC		Motor BG45x30 Voltage 40 V DC
PLG52	6.25		96545.02600		96545.02800
PLG52	20.25		96545.02601		96545.02801
PLG52	126.56		96545.02602		96545.02802
Without gear unit	-	✓	96545.02699 DUN:9654502699		96545.02899

##### Can be used with all PDC and F-TM ServoDrive ST/HF drive controllers

			Motor BG65Sx50 Voltage 24 V DC		Motor BG65Sx50 Voltage 40 V DC
PLG63	4.00		96566.02610		96566.02810
PLG63	7.00		96566.02611		96566.02811
PLG63	16.80		96566.02612		96566.02812
PLG63	35.00		96566.02613		96566.02813
PLG63	100.00		96566.02614		96566.02814
PLG63	175.00		96566.02615		96566.02815
Without gear unit	-		96566.02699		96566.02899

##### Can be used with PDC600/PDC600F drive controller and PDC1000 V1 drive controller

			Motor BG75x50 Voltage 24 V DC		Motor BG75x50 Voltage 40 V DC
PLG75	4.00		-		96575.02620
PLG75	7.00		-		96575.02621
PLG75	16.80		-		96575.02622
PLG75	35.00		-		96575.02623
PLG75	100.00		-		96575.02624
PLG75	175.00		-		96575.02625
Without gear unit	-		-		96575.02699

##### Can be used with PDC600/PDC600F drive controller and PDC1000 V1 drive controller

			Motor BG95x40 Voltage 24 V DC		Motor BG95x40 Voltage 48 V DC
PLG95	4.00		-		96595.02630
PLG95	16.80		-		96595.02631
Without gear unit	-		-		96595.02699

##### Can be used with PDC600/PDC600F drive controller and PDC1000 V1 drive controller

			Motor BG95x80 Voltage 24 V DC		Motor BG95x80 Voltage 48 V DC
PLG95	4.00		-		96595.03030
PLG95	16.80		-		96595.03031
Without gear unit	-		-		96595.03099

## SIMATIC MICRO-DRIVE drive system

Motors/gear units and connection systems from Siemens Product Partners

### Dunkermotoren motors/gear units

#### Selection and ordering data

##### With brake

Type of gear unit	Gear unit reduction ratio	Preferred type	Product partner article no. Article No.	Preferred type	Product partner article no. Article No.
<b>Can be used with all PDC and F-TM ServoDrive ST/HF drive controllers</b>					
			<b>Motor BG45x30 With brake E38 Voltage 24 V DC</b>		<b>Motor BG45x30 With brake E38 Voltage 40 V DC</b>
PLG52	6.25	✓	96545.02700 DUN:9654502700		96545.02900
PLG52	20.25		96545.02701	✓	96545.02901 DUN:9654502901
PLG52	126.56	✓	96545.02702 DUN:9654502702		96545.02902
Without gear unit	-		96545.02799	✓	96545.02999 DUN:9654502999
<b>Can be used with all PDC and F-TM ServoDrive ST/HF drive controllers</b>					
			<b>Motor BG65Sx50 With brake E90 Voltage 24 V DC</b>		<b>Motor BG65Sx50 With brake E90 Voltage 40 V DC</b>
PLG63	4.00		96566.02710		96566.02910
PLG63	7.00		96566.02711	✓	96566.02911 DUN:9656602911
PLG63	16.80		96566.02712		96566.02912
PLG63	35.00		96566.02713		96566.02913
PLG63	100.00		96566.02714	✓	96566.02914 DUN:9656602914
PLG63	175.00		96566.02715		96566.02915
Without gear unit	-		96566.02799		96566.02999
<b>Can be used with PDC600/PDC600F drive controller and PDC1000 V1 drive controller</b>					
			<b>Motor BG75x50 With brake E100 Voltage 24 V DC</b>		<b>Motor BG75x50 With brake E100 Voltage 40 V DC</b>
PLG75	4.00		-		96575.02720
PLG75	7.00		-		96575.02721
PLG75	16.80		-		96575.02722
PLG75	35.00		-	✓	96575.02723 DUN:9657502723
PLG75	100.00		-		96575.02724
PLG75	175.00		-		96575.02725
Without gear unit	-		-		96575.02799
<b>Can be used with PDC600/PDC600F drive controller and PDC1000 V1 drive controller</b>					
			<b>Motor BG95x40 With brake E600 Voltage 24 V DC</b>		<b>Motor BG95x40 With brake E600 Voltage 48 V DC</b>
PLG95	4.00		-		96595.02730
PLG95	16.80		-	✓	96595.02731 DUN:9659502731
Without gear unit	-		-		96595.02799
<b>Can be used with PDC600/PDC600F drive controller and PDC1000 V1 drive controller</b>					
			<b>Motor BG95x80 With brake E600 Voltage 24 V DC</b>		<b>Motor BG95x80 With brake E600 Voltage 48 V DC</b>
PLG95	4.00		-		96595.03130
PLG95	16.80		-		96595.03131
Without gear unit	-		-		96595.03199

## SIMATIC MICRO-DRIVE drive system

Motors/gear units and connection systems from Siemens Product Partners

### KnorrTec connection systems

#### Overview

- KnorrTec plug-in cables for SIMATIC MICRO-DRIVE
- Can be used for drives of the Siemens Product Partners Dunkermotoren and ebm-papst
- Versions for simple industrial applications:
  - Silicone-free
  - Flame resistance according to IEC 60332 (20 s)
  - Temperature range -30 ... +80 °C (not moving) or -5 ... +80 °C (moving)
- Designs for demanding industrial applications:
  - Highly flexible – suitable for cable carriers
  - Oil-resistant according to EN 60811-404
  - UL/CSA-listed components
  - Halogen-free
  - Silicone-free
  - UV-resistant
  - Generally good chemical resistance
  - Hydrolysis and microbe-resistant
  - Flame resistance according to UL758/1581 (horizontal + FT2) and EN 60332-2-2 (20 s)
  - Temperature range -45 ... +80 °C (not moving) or -25 ... +80 °C (moving)

#### Selection and ordering data

##### Plug-in cables for PDC Drives or TM Drives and Dunkermotoren motors

Plug-in cables with article numbers including the prefix "ZKT:" can be ordered directly from Siemens for quick configuration during the bidding phase.

Plug-in cables with article numbers without the prefix "ZKT:" can be ordered directly from the Product Partner.

Designation of the plug-in cable	Length m	For simple industrial applications		For demanding industrial applications in UL-listed materials		in UL-certified production	
		Preferred type	Product partner article no. Article No.	Preferred type	Product partner article no. Article No.	Preferred type	Product partner article no. Article No.
<b>For connecting PDC100/PDC100F drive controllers and Dunkermotoren motors BG45x30 and BG65Sx50</b>							
LAI01 All-in-one plug-in cable	0.5		70051000000050		70051020000050		70051070000050
	1.5		70051000000150		70051020000150		70051070000150
	3.0		70051000000300	✓	70051020000300 ZKT:70051020000300		70051070000300
	5.0		70051000000500		70051020000500		70051070000500
	10.0		70051000001000	✓	70051020001000 ZKT:70051020001000		70051070001000
	Any, max. 10.0		70051000000000		70051020000000		70051070000000
	<b>For connecting PDC600/PDC600F drive controllers and PDC1000 V1 drive controllers and Dunkermotoren motors BG45x30 and BG65Sx50</b>						
LAI010 All-in-one plug-in cable	0.5	-			70051920000050		70051970000050
	1.5	-			70051920000150		70051970000150
	3.0	-		✓	70051920000300 ZKT:70051920000300		70051970000300
	5.0	-			70051920000500		70051970000500
	10.0	-		✓	70051920001000 ZKT:70051920001000		70051970001000
	Any, max. 10.0	-			70051920000000		70051970000000
	<b>For connecting F-TM ServoDrive ST/HF and Dunkermotoren motors BG45x30 and BG65Sx50</b>						
CSD_LAI01 All-in-one plug-in cable	0.5	-			70056020000050		70056070000050
	1.5	-		✓	70056020000150 ZKT:70056020000150		70056070000150
	3.0	-			70056020000300		70056070000300
	5.0	-		✓	70056020000500 ZKT:70056020000500		70056070000500
	10.0	-			70056020001000		70056070001000
	Any, max. 10.0	-			70056020000000		70056070000000



## Selection and ordering data

Designation of the plug-in cable	Length m	For simple industrial applications		For demanding industrial applications in UL-listed materials		in UL-certified production	
		Preferred type	Product partner article no. Article No.	Preferred type	Product partner article no. Article No.	Preferred type	Product partner article no. Article No.
<b>For connecting PDC600/PDC600F drive controllers and PDC1000 V1 drive controllers and Dunkermotoren motors BG75x50</b>							
LPMo1 Plug-in motor cable	0.5		70051100000050		70051120000050		70051170000050
	1.5		70051100000150		70051120000150		70051170000150
	3.0		70051100000300	✓	70051120000300 ZKT:70051120000300		70051170000300
	5.0		70051100000500		70051120000500		70051170000500
	10.0		70051100001000	✓	70051120001000 ZKT:70051120001000		70051170001000
	Any, max. 10.0		70051100000000		70051120000000		70051170000000
	<b>For connecting PDC600/PDC600F drive controllers and PDC1000 V1 drive controllers and Dunkermotoren motors BG95x40 and BG95x80</b>						
LPMo3 Plug-in motor cable	0.5		70051800000050		70051820000050		70051870000050
	1.5		70051800000150		70051820000150		70051870000150
	3.0		70051800000300	✓	70051820000300 ZKT:70051820000300		70051870000300
	5.0		70051800000500		70051820000500		70051870000500
	10.0		70051800001000	✓	70051820001000 ZKT:70051820001000		70051870001000
	Any, max. 10.0		70051800000000		70051820000000		70051870000000
	<b>For connecting PDC600/PDC600F drive controllers and PDC1000 V1 drive controllers and Dunkermotoren motors BG75x50, BG95x40 and BG95x80</b>						
LPE n1 Plug-in encoder cable	0.5		70051200000050		70051220000050		70051270000050
	1.5		70051200000150		70051220000150		70051270000150
	3.0		70051200000300	✓	70051220000300 ZKT:70051220000300		70051270000300
	5.0		70051200000500		70051220000500		70051270000500
	10.0		70051200001000	✓	70051220001000 ZKT:70051220001000		70051270001000
	Any, max. 10.0		70051200000000		70051220000000		70051270000000
	<b>For connecting PDC100/PDC100F drive controllers, PDC600/PDC600F drive controllers and PDC1000 V1 drive controllers and all motors from Dunkermotoren</b>						
LPBr1 Plug-in brake cable	0.5		70051300000050		70051320000050		70051370000050
	1.5		70051300000150		70051320000150		70051370000150
	3.0		70051300000300	✓	70051320000300 ZKT:70051320000300		70051370000300
	5.0		70051300000500		70051320000500		70051370000500
	10.0		70051300001000	✓	70051320001000 ZKT:70051320001000		70051370001000
	Any, max. 10.0		70051300000000		70051320000000		70051370000000

## SIMATIC MICRO-DRIVE drive system

Motors/gear units and connection systems from Siemens Product Partners

### KnorrTec connection systems

#### Selection and ordering data

##### Plug-in cables for PDC Drives or TM Drives and motors from ebm-papst

Plug-in cables with article numbers including the prefix "ZKT:" can be ordered directly from Siemens for quick configuration during the bidding phase.

Plug-in cables with article numbers without the prefix "ZKT:" can be ordered directly from the Product Partner.

Designation of the plug-in cable	Length m	For simple industrial applications		For demanding industrial applications in UL-listed materials			
		Preferred type	Product partner article no. Article No.	Preferred type	Product partner article no. Article No.	Preferred type	Product partner article no. Article No.
<b>For connecting PDC100/PDC100F drive controllers and ebm-papst motors ECI42.20, ECI42.40, ECI63.20, ECI63.40 and ECI63.60</b>							
LAI02 All-in-one plug-in cable	0.5		7005140000050		7005142000050		7005147000050
	1.5		7005140000150		7005142000150		7005147000150
	3.0		7005140000300	✓	7005142000300 ZKT:70051420000300		7005147000300
	5.0		7005140000500		7005142000500		7005147000500
	10.0		70051400001000	✓	70051420001000 ZKT:70051420001000		70051470001000
	Any, max. 10.0		70051400000000		70051420000000		70051470000000
<b>For connecting PDC600/PDC600F drive controllers and PDC1000 V1 drive controllers and ebm-papst motors ECI42.20, ECI42.40, ECI63.20, ECI63.40 and ECI63.60</b>							
LAI020 All-in-one plug-in cable	0.5	-			7005152000050		7005157000050
	1.5	-			7005152000150		7005157000150
	3.0	-		✓	7005152000300 ZKT:70051520000300		7005157000300
	5.0	-			7005152000500		7005157000500
	10.0	-		✓	70051520001000 ZKT:70051520001000		70051570001000
	Any, max. 10.0	-			70051520000000		70051570000000
<b>For connecting F-TM ServoDrive ST/HF and ebm-papst motors ECI42.20, ECI42.40, ECI63.20, ECI63.40 and ECI63.60</b>							
CSD_LAI02 All-in-one plug-in cable	0.5	-			7005642000050		7005647000050
	1.5	-		✓	7005642000150 ZKT:70056420000150		7005647000150
	3.0	-			7005642000300		7005647000300
	5.0	-		✓	7005642000500 ZKT:70056420000500		7005647000500
	10.0	-			70056420001000		70056470001000
	Any, max. 10.0	-			70056420000000		70056470000000
<b>For connecting PDC600/PDC600F drive controllers and PDC1000 V1 drive controllers and ebm-papst motors ECI80.40 and ECI80.60</b>							
LPMo3 Plug-in motor cable	0.5		7005180000050		7005182000050		7005187000050
	1.5		7005180000150		7005182000150		7005187000150
	3.0		7005180000300	✓	7005182000300 ZKT:70051820000300		7005187000300
	5.0		7005180000500		7005182000500		7005187000500
	10.0		70051800001000	✓	70051820001000 ZKT:70051820001000		70051870001000
	Any, max. 10.0		70051800000000		70051820000000		70051870000000

**Selection and ordering data**

Designation of the plug-in cable	Length m	For simple industrial applications		For demanding industrial applications in UL-listed materials		in UL-certified production	
		Preferred type	Product partner article no. Article No.	Preferred type	Product partner article no. Article No.	Preferred type	Product partner article no. Article No.
<b>For connecting PDC600/PDC600F drive controllers and PDC1000 V1 drive controllers and ebm-papst motors ECI80.40 and ECI80.60</b>							
LPEn2 Plug-in encoder cable	0.5		70051600000050		70051620000050		70051670000050
	1.5		70051600000150		70051620000150		70051670000150
	3.0		70051600000300	✓	70051620000300 ZKT:70051620000300		70051670000300
	5.0		70051600000500		70051620000500		70051670000500
	10.0		70051600001000	✓	70051620001000 ZKT:70051620001000		70051670001000
	Any, max. 10.0		70051600000000		70051620000000		70051670000000
	<b>For connecting PDC100/PDC100F drive controllers, PDC600/PDC600F drive controllers and PDC1000 V1 drive controllers and all motors from ebm-papst</b>						
LPBr2 Plug-in brake cable	0.5		70051700000050		70051720000050		70051770000050
	1.5		70051700000150		70051720000150		70051770000150
	3.0		70051700000300	✓	70051720000300 ZKT:70051720000300		70051770000300
	5.0		70051700000500		70051720000500		70051770000500
	10.0		70051700001000	✓	70051720001000 ZKT:70051720001000		70051770001000
	Any, max. 10.0		70051700000000		70051720000000		70051770000000

## SIMATIC MICRO-DRIVE drive system

Motors/gear units and connection systems from Siemens Product Partners

### Harting connection systems

#### Overview

- HARTING plug-in cables for SIMATIC MICRO-DRIVE
- Can be used for drives of the Siemens Product Partners Dunkermotoren and ebm-papst
- Versions for simple industrial applications:
  - Silicone-free, virtually oil-resistant
  - Flame resistance according to IEC 60332-1 (20 s)
  - Temperature range -30 ... +80 °C (not moving) or -5 ... +80 °C (moving)
- Designs for demanding industrial applications:
  - Highly flexible – suitable for cable carriers
  - Oil-resistant according to EN 60811-404
  - UL/CSA-certified
  - Halogen-free
  - Silicone-free
  - UV-resistant
  - Generally good chemical resistance
  - Hydrolysis and microbe-resistant
  - Flame resistance according to UL758/1581 (horizontal + FT2) and EN 60332-2-2 (20 s)
  - Temperature range -40 ... +80 °C (not moving) or -25 ... +80 °C (moving)

#### Selection and ordering data

##### Plug-in cables for PDC Drives or TM Drives and Dunkermotoren motors

Designation of the plug-in cable	Length m	Preferred type	For simple industrial applications	For demanding industrial applications in UL-certified production
			Product partner article no.	Product partner article no.
<b>For connecting PDC100/PDC100F drive controllers and Dunkermotoren motors BG45x30 and BG65Sx50</b>				
LAI01 All-in-one plug-in cable	0.5		6172010050	6172020050
	1.5		6172010150	6172020150
	3.0		6172010300	6172020300
	5.0		6172010500	6172020500
	10.0		6172011000	6172021000
	Any, max. 10.0		617201xxxx	617202xxxx
<b>For connecting PDC600/PDC600F drive controllers and PDC1000 V1 drive controllers and Dunkermotoren motors BG45x30 and BG65Sx50</b>				
LAI010 All-in-one plug-in cable	0.5		-	6172240050
	1.5		-	6172240150
	3.0		-	6172240300
	5.0		-	6172240500
	10.0		-	6172241000
	Any, max. 10.0		-	on request
<b>For connecting F-TM ServoDrive ST/HF and Dunkermotoren motors BG45x30 and BG65Sx50</b>				
CSD-LAI01 All-in-one plug-in cable	0.5		6172500050	6172510050
	1.5		6172500150	6172510150
	3.0		6172500300	6172510300
	5.0		6172500500	6172510500
	10.0		6172501000	6172511000
	Any, max. 10.0		on request	on request
<b>For connecting PDC600/PDC600F drive controllers and PDC1000 V1 drive controllers and Dunkermotoren motors BG75x50</b>				
LPMo1 Plug-in motor cable	0.5		6172030050	6172040050
	1.5		6172030150	6172040150
	3.0		6172030300	6172040300
	5.0		6172030500	6172040500
	10.0		6172031000	6172041000
	Any, max. 10.0		617203xxxx	617204xxxx

**SIMATIC MICRO-DRIVE drive system**

Motors/gear units and connection systems from Siemens Product Partners

Harting connection systems

**Selection and ordering data**

Designation of the plug-in cable	Length m	Preferred type	For simple industrial applications	For demanding industrial applications in UL-certified production
			Product partner article no.	Product partner article no.
<b>For connecting PDC600/PDC600F drive controllers and PDC1000 V1 drive controllers and Dunkermotoren motors BG95x40 and BG95x80</b>				
LPMo3 Plug-in motor cable	0.5		6172090050	6172100050
	1.5		6172090150	6172100150
	3.0		6172090300	6172100300
	5.0		6172090500	6172100500
	10.0		6172091000	6172101000
	Any, max. 10.0		617209xxxx	617210xxxx
<b>For connecting PDC600/PDC600F drive controllers and PDC1000 V1 drive controllers and Dunkermotoren motors BG75x50, BG95x40 and BG95x80</b>				
LPEn1 Plug-in encoder cable	0.5		6172050050	6172060050
	1.5		6172050150	6172060150
	3.0		6172050300	6172060300
	5.0		6172050500	6172060500
	10.0		6172051000	6172061000
	Any, max. 10.0		617205xxxx	617206xxxx
<b>For connecting PDC100/PDC100F drive controllers, PDC600/PDC600F drive controllers and PDC1000 V1 drive controllers and all motors from Dunkermotoren</b>				
LPBr1 Plug-in brake cable	0.5		6172070050	6172080050
	1.5		6172070150	6172080150
	3.0		6172070300	6172080300
	5.0		6172070500	6172080500
	10.0		6172071000	6172081000
	Any, max. 10.0		617207xxxx	617208xxxx

## SIMATIC MICRO-DRIVE drive system

Motors/gear units and connection systems from Siemens Product Partners

### Harthing connection systems

#### Selection and ordering data

##### Plug-in cables for PDC Drives or TM Drives and motors from ebm-papst

Designation of the plug-in cable	Length m	Preferred type	For simple industrial applications	For demanding industrial applications
			Product partner article no.	Product partner article no.
<b>For connecting PDC100/PDC100F drive controllers and ebm-papst motors ECI42.20, ECI42.40, ECI63.20, ECI63.40 and ECI63.60</b>				
LAIQ2 All-in-one plug-in cable	0.5		6172110050	6172120050
	1.5		6172110150	6172120150
	3.0		6172110300	6172120300
	5.0		6172110500	6172120500
	10.0		6172111000	6172121000
	Any, max. 10.0		617211xxxx	617212xxxx
<b>For connecting PDC600/PDC600F drive controllers and PDC1000 V1 drive controllers and ebm-papst motors ECI42.20, ECI42.40, ECI63.20, ECI63.40 and ECI63.60</b>				
LAIQ20 All-in-one plug-in cable	0.5		-	6172260050
	1.5		-	6172260150
	3.0		-	6172260300
	5.0		-	6172260500
	10.0		-	6172261000
	Any, max. 10.0		-	on request
<b>For connecting F-TM ServoDrive ST/HF and ebm-papst motors ECI42.20, ECI42.40, ECI63.20, ECI63.40 and ECI63.60</b>				
CSD_LAIQ2 All-in-one plug-in cable	0.5		6172520050	6172530050
	1.5		6172520150	6172530150
	3.0		6172520300	6172530300
	5.0		6172520500	6172530500
	10.0		6172521000	6172531000
	Any, max. 10.0		on request	on request
<b>For connecting PDC600/PDC600F drive controllers and PDC1000 V1 drive controllers and ebm-papst motors ECI80.40 and ECI80.60</b>				
LPEn2 Plug-in encoder cable	0.5		6172150050	6172160050
	1.5		6172150150	6172160150
	3.0		6172150300	6172160300
	5.0		6172150500	6172160500
	10.0		6172151000	6172161000
	Any, max. 10.0		617215xxxx	617216xxxx
<b>For connecting PDC100/PDC100F drive controllers, PDC600/PDC600F drive controllers and PDC1000 V1 drive controllers and all motors from ebm-papst</b>				
LPBr2 Plug-in brake cable	0.5		6172170050	6172180050
	1.5		6172170150	6172180150
	3.0		6172170300	6172180300
	5.0		6172170500	6172180500
	10.0		6172171000	6172181000
	Any, max. 10.0		617217xxxx	617218xxxx

### Overview

The TIA Selection Tool is available for selecting the individual drive components. Drive dimensioning can also be carried out there with program support, comparable to the SIZER engineering tool.

You can find information about the TIA Selection Tool at: [www.siemens.com/tst](http://www.siemens.com/tst)

Currently, these functions are only available in the offline version: [www.siemens.com/tia-selection-tool-standalone](http://www.siemens.com/tia-selection-tool-standalone)

### Functions in the TIA Selection Tool

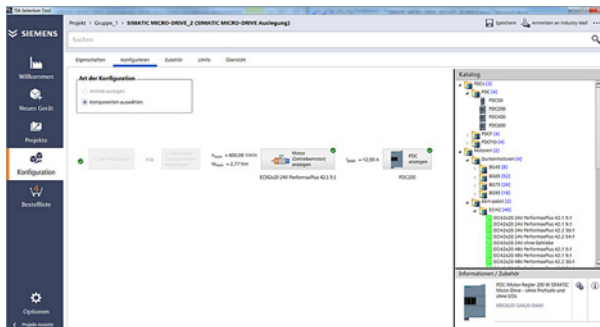

Component selection – Axis overview of the selected components

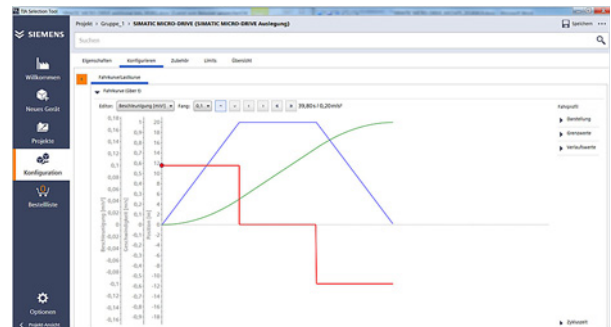

Dimensioning – Traversing profile editor with graphical and tabular input

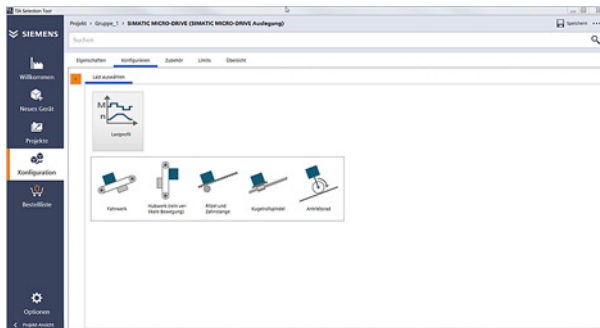

Dimensioning – Selection of the application

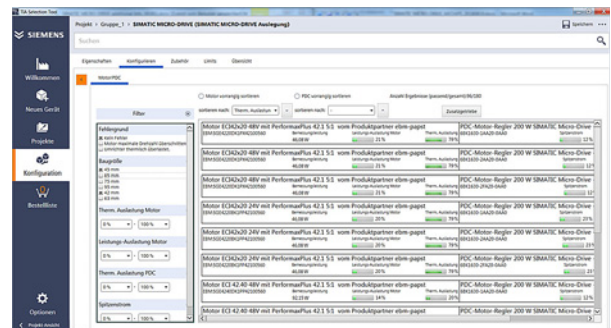

Dimensioning – Selection and filtering of the right combination of motor and PDC Drives

## SIMATIC MICRO-DRIVE drive system

Services and documentation

SITRAIN – Digital Industry Academy

2



### Time for learning

Today's demands on our knowledge are every bit as diverse and dynamic as our profession itself. We keep learning more and longer – for our work, for our career and for ourselves. Advancing digitalization entails new topics and is also changing the way we absorb and process knowledge. SITRAIN – Digital Industry Academy offers the right source of knowledge here, which we can use anytime in just the way we need it. The time for learning is now.

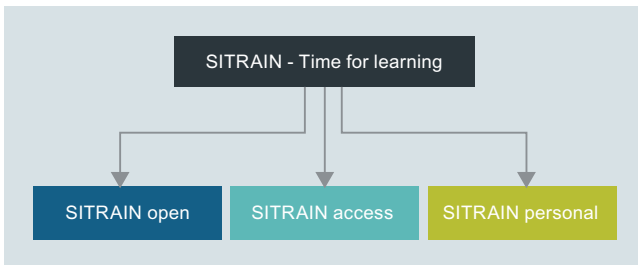

### Knowledge for every need

With its three areas – SITRAIN open, SITRAIN access and SITRAIN personal – SITRAIN offers you an all-encompassing range of options for an ongoing expansion of your knowledge and skills, suited for every type of learner. And SITRAIN uses advancing digitalization to continuously expand content and offer new training methods.



### SITRAIN – Digital Industry Academy Customer Support Germany

Tel.: +49 911 895-7575

Email: [sitrain.digital.industry.academy.de@siemens.com](mailto:sitrain.digital.industry.academy.de@siemens.com)

### Knowledge you can always find

SITRAIN open bundles useful information, worthwhile data and up-to-date expert knowledge about Siemens products for industry. Search it anytime, find anything – and always the right stuff.

### Knowledge that gets you ahead

SITRAIN access is learning in the digital age. It offers you individualized ways to build your knowledge and access to exclusive digital training courses. Take advantage of sustainable learning success with a wide range of learning methods. Improve your skills – whether working in groups with others, or by yourself. Whenever, wherever and however you need to.

### Knowledge you can experience

We all want to learn from the best. And SITRAIN personal's training courses let you benefit from our well-practiced trainers' expert knowledge, along with direct access to our training equipment. That's the best way to convey knowledge – whether at your company or in our training classrooms.

### **SITRAIN – Digital Industry Academy**

[www.siemens.com/sitrain](http://www.siemens.com/sitrain)

- SITRAIN open:  
[www.siemens.com/sitrain-open](http://www.siemens.com/sitrain-open)
- SITRAIN access:  
[www.siemens.com/sitrain-access](http://www.siemens.com/sitrain-access)
- SITRAIN personal:  
[www.siemens.com/sitrain-personal](http://www.siemens.com/sitrain-personal)



## SIMATIC MICRO-DRIVE drive system

### Services and documentation

#### SIMATIC MICRO-DRIVE training case

#### Overview



SIMATIC MICRO-DRIVE, training case, advanced version with F-TM ServoDrive ST

The SIMATIC MICRO-DRIVE training case is a convincing demonstration system thanks to its compact design.

It is suitable for direct customer presentations as well as for tests in technical departments. It enables the functions of SIMATIC MICRO-DRIVE to be demonstrated and tested quickly and easily.

The SIMATIC MICRO-DRIVE training case contains the following components:

- F-TM ServoDrive ST
- PDC Drives, PDC100F variant
- ebm-papst ECI42.20 motor, with angle disc, without gear unit, without brake
- KnorrTec cable
- 4 buttons for digital inputs and 2 LED lamps for digital outputs for PDC100F
- Prepared for S7-1500 PLC.

The SIMATIC MICRO-DRIVE training case is supplied in the form of a stackable Tanos Systainer case.

#### Technical specifications

<b>SIMATIC MICRO-DRIVE training case</b>	<b>6AG1067-2AA00-0AE0</b>
<b>Supply voltage</b>	110 ... 220 V AC
<b>Dimensions</b>	
• Width	210 mm
• Height	270 mm
• Depth	380 mm
<b>Weight, approx.</b>	11 kg

#### Selection and ordering data

SIMATIC MICRO-DRIVE training case	
Variant	Article No.
<b>SIMATIC MICRO-DRIVE training case</b> including PDC Drives, PDC100F variant and F-TM ServoDrive ST bundle	<b>6AG1067-2AA00-0AE0</b>

#### SIMATIC F-TM ServoDrive Starter Kit

#### Overview

The SIMATIC F-TM ServoDrive ST Starter Kit with Article No. 6BK1637-6AB00-0BU0 includes

- SIMATIC MICRO-DRIVE F-TM ServoDrive ST
- SIMATIC ET 200SP PROFINET IM 155-6PN ST Interface Module
- SIMATIC ET 200SP BaseUnit type U0
- All-in-one plug-in cable CSD\_LAiO2, length 1.5 m
- ebm-papst motor ECI42.20 24 V

#### Selection and ordering data

Description	Article No.
<b>SIMATIC F-TM ServoDrive ST Starter Kit</b>	<b>6BK1637-6AB00-0BU0</b>
Scope of supply:	
• SIMATIC MICRO-DRIVE F-TM ServoDrive ST	
• SIMATIC ET 200SP PROFINET IM 155-6PN ST Interface Module	
• SIMATIC ET 200SP BaseUnit type U0	
• All-in-one plug-in cable CSD_LAiO2, length 1.5 m	
• ebm-papst motor ECI42.20 24 V	

## SIMATIC MICRO-DRIVE drive system

Services and documentation

### SIMATIC MICRO-DRIVE documentation

---

#### Overview

The operating instructions for SIMATIC MICRO-DRIVE are available free of charge on the internet at:

[www.siemens.com/micro-drive/documentation](http://www.siemens.com/micro-drive/documentation)

Detailed information on the SIMATIC MICRO-DRIVE drive system, including the latest technical documentation (brochures, tutorials, dimensional drawings, certificates, equipment manuals and operating instructions), is available on the internet at:

[www.siemens.com/micro-drive](http://www.siemens.com/micro-drive)

and also via the TIA Selection Tool:

[www.siemens.com/tia-selection-tool](http://www.siemens.com/tia-selection-tool)

## Appendix



<b>3/2</b>	<b>Partner</b>
<b>3/3</b>	<b>Industry Services</b>
3/4	Industry Services – Portfolio overview
3/6	Online Support
<b>3/7</b>	<b>Conditions of sale and delivery</b>

## Appendix

### Partner

#### Partner at Siemens

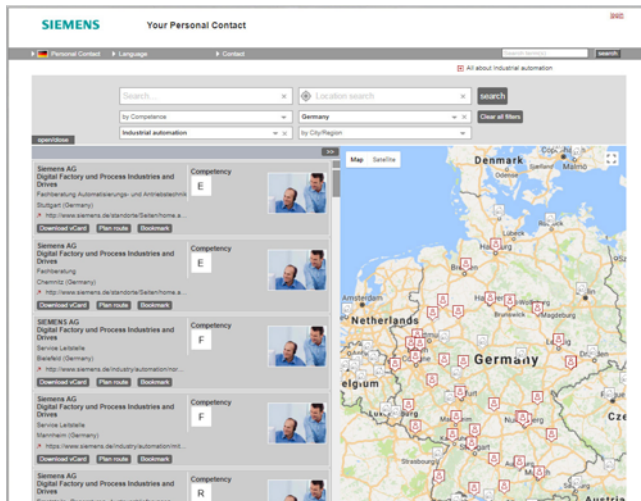

At your service locally, around the globe for consulting, sales, training, service, support, spare parts on the entire portfolio of Digital Industries.

Your partner can be found in our Personal Contacts Database at: [www.siemens.com/automation-contact](http://www.siemens.com/automation-contact)

You start by selecting

- the required competence,
- products and branches,
- a country and a city

or by a

- location search or free text search.

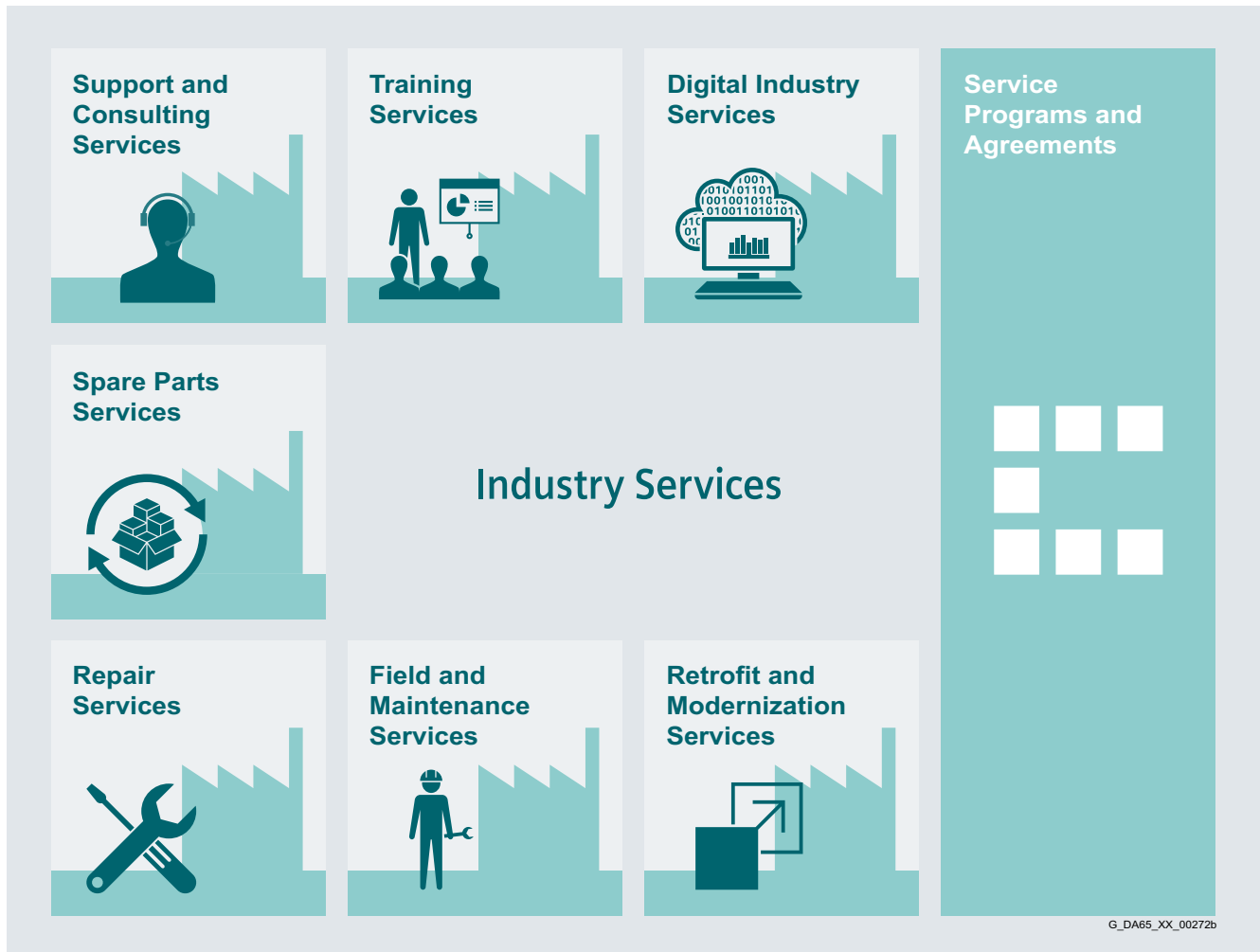
**Overview**

3

**Keep your business running and shaping your digital future – with Industry Services**

Optimizing the productivity of your equipment and operations can be a challenge, especially with constantly changing market conditions. Working with our service experts makes it easier. We understand your industry's unique processes and provide the services needed so that you can better achieve your business goals.

You can count on us to maximize your uptime and minimize your downtime, increasing your operations' productivity and reliability. When your operations have to be changed quickly to meet a new demand or business opportunity, our services give you the flexibility to adapt. Of course, we take care that your production is protected against cyber threats. We assist in keeping your operations as energy and resource efficient as possible and reducing your total cost of ownership. As a trendsetter, we ensure that you can capitalize on the opportunities of digitalization and by applying data analytics to enhance decision making: You can be sure that your plant reaches its full potential and retains this over the longer lifespan.

You can rely on our highly dedicated team of engineers, technicians and specialists to deliver the services you need – safely, professionally and in compliance with all regulations. We are there for you, where you need us, when you need us.

[www.siemens.com/industryservices](http://www.siemens.com/industryservices)

## Appendix

### Industry Services

#### Industry Services – Portfolio overview

##### Overview

#### Digital Industry Services



Digital Industry Services make your industrial processes transparent to gain improvements in productivity, asset availability, and energy efficiency.

Production data is generated, filtered and translated with intelligent analytics to enhance decision-making.

This is done whilst taking data security into consideration and with continuous protection against cyber-attack threats.

[www.siemens.com/global/en/products/services/industry/digital-industry-services.html](http://www.siemens.com/global/en/products/services/industry/digital-industry-services.html)

#### Support and Consulting Services



**Industry Online Support** site for comprehensive information, application examples, FAQs and support requests.

**Technical and Engineering Support** for advice and answers for all inquiries about functionality, handling, and fault clearance. The Service Card as prepaid support for value added services such as Priority Call Back or Extended Support offers the clear advantage of quick and easy purchasing.

**Information & Consulting Services**, e.g. SIMATIC System Audit; clarity about the state and service capability of your automation system or Lifecycle Information Services; transparency on the lifecycle of the products in your plants.

<https://support.industry.siemens.com/cs/ww/en/sc/2235>

#### Training Services

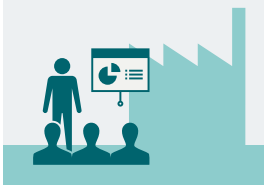

From the basics and advanced to specialist skills, SITRAIN courses provide expertise right from the manufacturer – and encompass the entire spectrum of Siemens products and systems for the industry.

Worldwide, SITRAIN courses are available wherever you need a training course in more than 170 locations in over 60 countries.

<https://support.industry.siemens.com/cs/ww/en/sc/2226>

#### Spare Parts Services



Spare Parts Services are available worldwide for smooth and fast supply of spare parts – and thus optimal plant availability. Genuine spare parts are available for up to ten years. Logistic experts take care of procurement, transport, custom clearance, storage and order management. Reliable logistics processes ensure that components reach their destination as needed.

Since not all spare parts can be kept in stock at all times, Siemens offers a preventive measure for spare parts provisioning on the customer's premises with optimized **Spare Parts Packages** for individual products, custom-assembled drive components and entire integrated drive trains – including risk consulting.

**Asset Optimization Services** help you design a strategy for parts supply where your investment and carrying costs are reduced and the risk of obsolescence is avoided.

<https://support.industry.siemens.com/cs/ww/en/sc/2110>

#### Overview (continued)

##### Repair Services



Repair Services are offered on-site and in regional repair centers for fast restoration of faulty devices' functionality.

Also available are extended repair services, which include additional diagnostic and repair measures, as well as emergency services.

<https://support.industry.siemens.com/cs/ww/en/sc/2154>

##### Retrofit and Modernization Services



Provide a cost-effective solution for the expansion of entire plants, optimization of systems or upgrading existing products to the latest technology and software, e.g. migration services for automation systems.

Service experts support projects from planning through commissioning and, if desired over the entire extended lifespan, e.g. Retrofit for Integrated Drive Systems for an extended lifetime of your machines and plants.

<https://support.industry.siemens.com/cs/ww/en/sc/2286>

##### Field and Maintenance Services

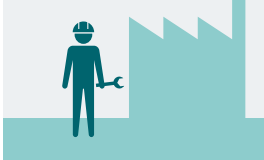

Siemens specialists are available globally to provide expert field and maintenance services, including commissioning, functional testing, preventive maintenance and fault clearance. All services can be included in customized service agreements with defined reaction times or fixed maintenance intervals.

<https://support.industry.siemens.com/cs/ww/en/sc/2265>

##### Service Programs and Agreements



A technical Service Program or Agreement enables you to easily bundle a wide range of services into a single annual or multi-year agreement.

You pick the services you need to match your unique requirements or fill gaps in your organization's maintenance capabilities.

Programs and agreements can be customized as KPI-based and/or performance-based contracts.

<https://support.industry.siemens.com/cs/ww/en/sc/2275>

# Appendix

## Industry Services

### Online Support

#### Overview

Online Support – fast, intuitive, whenever you want, wherever you need

Web

[www.siemens.com/online-support](http://www.siemens.com/online-support)

App



Scan the QR code for information on our Online Support app.



#### FAQ / Application examples

Information about industrial products, programming and configuration as well as application examples



#### Technical information

Videos, documentation, manuals, updates, product notes, compatibility tool, certificates, planning data such as dimensional drawings, product data, 3D models



#### Forum

Exchange information and experience with other users and experts

## Online Support for Siemens Industry Products

Siemens Industry and Online Support with some 1.7 million visitors per month is one of the most popular web services provided by Siemens. It is the central access point for comprehensive technical know-how about products, systems and services for automation and drives applications as well as for process industries.

In connection with the challenges and opportunities related to digitalization you can look forward to continued support with innovative offerings.



### 1. General Provisions

By using this catalog you can purchase products (hardware, software and services) described therein from Siemens Aktiengesellschaft subject to the following Terms and Conditions of Sale and Delivery (hereinafter referred to as "T&C"). Please note that the scope, the quality and the conditions for supplies and services, including software products, by any Siemens entity having a registered office outside Germany, shall be subject exclusively to the General Terms and Conditions of the respective Siemens entity. The following T&C apply exclusively for orders placed with Siemens Aktiengesellschaft, Germany.

#### 1.1 For customers with a seat or registered office in European Union

For customers with a seat or registered office in European Union, the following terms and conditions apply subordinate to T&C:

- for products, which include specific terms and conditions in the description text, these specific terms and conditions shall apply and subordinate thereto,
- for stand-alone software products and software products forming a part of a product or project, the "General License Conditions for Software Products for Automation and Drives for Customers with a Seat or registered Office in Germany"<sup>1)</sup> and/or
- for consulting services the "Allgemeine Geschäftsbedingungen für Beratungsleistungen der Division DF – Deutschland" (available only in German) and/or
- for other services, the „Supplementary Terms and Conditions for Services ("BL")"<sup>1)</sup> and/or
- for other supplies the "General Conditions for the Supply of Products and Services of the Electrical and Electronics Industry"<sup>1)</sup>.

In case such supplies should contain Open Source Software, the conditions of which shall prevail over the "General Conditions for the Supply of Products and Services of the Electrical and Electronics Industry"<sup>1)</sup>, a notice will be contained in the scope of delivery in which the applicable conditions for Open Source Software are specified. This shall apply mutatis mutandis for notices referring to other third party software components.

#### 1.2 For customers with a seat or registered office outside European Union

For customers with a seat or registered office outside European Union, the following terms and conditions apply subordinate to T&C:

- for products, which include specific terms and conditions in the description text, these specific terms and conditions shall apply and subordinate thereto,
- for consulting services the "Standard Terms and Conditions for Consulting Services of the Division DF for Customers with a Seat or Registered Office Outside of Germany"<sup>1)</sup> and/or
- for other services the "International Terms & Conditions for Services"<sup>1)</sup> supplemented by "Software Licensing Conditions"<sup>1)</sup> and/or
- for other supplies of hard- and software the "International Terms & Conditions for Products"<sup>1)</sup> supplemented by "Software Licensing Conditions"<sup>1)</sup>

#### 1.3 For customers with master or framework agreement

To the extent our supplies and/or services offered are covered by an existing master or framework agreement, the terms and conditions of that agreement shall apply instead of T&C.

### 2. Prices

The prices are in € (Euro) ex point of delivery, exclusive of packaging.

The sales tax (value added tax) is not included in the prices. It shall be charged separately at the respective rate according to the applicable statutory legal regulations.

Prices are subject to change without prior notice. We will charge the prices valid at the time of delivery.

To compensate for variations in the price of raw materials (e.g. silver, copper, aluminum, lead, gold, dysprosium and neodym), surcharges are calculated on a daily basis using the so-called metal factor for products containing these raw materials.

A surcharge for the respective raw material is calculated as a supplement to the price of a product if the basic official price of the raw material in question is exceeded.

The metal factor of a product indicates the basic official price (for those raw materials concerned) as of which the surcharges on the price of the product are applied, and with what method of calculation.

An exact explanation of the metal factor can be downloaded at:

[https://mall.industry.siemens.com/legal/ww/en/terms\\_of\\_trade\\_en.pdf](https://mall.industry.siemens.com/legal/ww/en/terms_of_trade_en.pdf)

To calculate the surcharge (except in the cases of dysprosium and neodym), the official price from the day prior to that on which the order was received or the release order was effected is used.

To calculate the surcharge applicable to dysprosium and neodym ("rare earths"), the corresponding three-month basic average price in the quarter prior to that in which the order was received or the release order was effected is used with a one-month buffer (details on the calculation can be found in the explanation of the metal factor).

### 3. Additional Terms and Conditions

The dimensions are in mm. In Germany, according to the German law on units in measuring technology, data in inches apply only to devices for export.

Illustrations are not binding.

Insofar as there are no remarks on the individual pages of this catalog – especially with regard to data, dimensions and weights given – these are subject to change without prior notice.

<sup>1)</sup> The text of the Terms and Conditions of Siemens AG can be downloaded at  
[https://mall.industry.siemens.com/legal/ww/en/terms\\_of\\_trade\\_en.pdf](https://mall.industry.siemens.com/legal/ww/en/terms_of_trade_en.pdf)

## Appendix

### Conditions of sale and delivery

#### 4. Export Regulations

We shall not be obligated to fulfill any agreement if such fulfillment is prevented by any impediments arising out of national or international foreign trade or customs requirements or any embargoes and/or other sanctions.

Export may be subject to license. We shall indicate in the delivery details whether licenses are required under German, European and US export lists.

Our products are controlled by the U.S. Government (when labeled with "ECCN" unequal "N") and authorized for export only to the country of ultimate destination for use by the ultimate consignee or end-user(s) herein identified. They may not be resold, transferred, or otherwise disposed of, to any other country or to any person other than the authorized ultimate consignee or end-user(s), either in their original form or after being incorporated into other items, without first obtaining approval from the U.S. Government or as otherwise authorized by U.S. law and regulations. Products labeled with "AL" unequal "N" are subject to European / national export authorization.

The export indications can be viewed in advance in the description of the respective goods on the Industry Mall, our online catalog system. Only the export labels "AL" and "ECCN" indicated on order confirmations, delivery notes and invoices are authoritative.

Products without label, with label "AL:N" / "ECCN:N", or label "AL:9X9999" / "ECCN: 9X9999" may require authorization from responsible authorities depending on the final end-use, or the destination.

If you transfer goods (hardware and/or software and/or technology as well as corresponding documentation, regardless of the mode of provision) delivered by us or works and services (including all kinds of technical support) performed by us to a third party worldwide, you shall comply with all applicable national and international (re-)export control regulations. In any event of such transfer of goods, works and services you shall comply with the (re-) export control regulations of the Federal Republic of Germany, of the European Union and of the United States of America.

Prior to any transfer of goods, works and services provided by us to a third party you shall in particular check and guarantee by appropriate measures that

- there will be no infringement of an embargo imposed by the European Union, by the United States of America and/ or by the United Nations by such transfer, by brokering of contracts concerning those goods, works and services or by provision of other economic resources in connection with those goods, works and services, also considering the limitations of domestic business and prohibitions of by-passing those embargoes;
- such goods, works and services are not intended for use in connection with armaments, nuclear technology or weapons, if and to the extent such use is subject to prohibition or authorization, unless required authorization is provided;
- the regulations of all applicable Sanctioned Party Lists of the European Union and the United States of America concerning the trading with entities, persons and organizations listed therein are considered.

If required to enable authorities or us to conduct export control checks, you, upon request by us, shall promptly provide us with all information pertaining to the particular end customer, the particular destination and the particular intended use of goods, works and services provided by us, as well as any export control restrictions existing.

You acknowledge that under the EU embargo regulations against Iran, Syria and Russia respectively the sale of certain listed goods and related services is subject to authorization by the competent export control authorities of the European Union. If (i) the goods or services ordered by you are destined for Iran, Syria or Russia, and (ii) the contract for our supplies and/or services is subject to prior authorization of the competent export control authorities of the European Union, the contract between you and us shall come into force in this respect only upon granting of such authorization.

The products listed in this catalog may be subject to European/German and/or US export regulations. Any export requiring approval is therefore subject to authorization by the relevant authorities.

Errors excepted and subject to change without prior notice.

## Selection and ordering at Siemens Industry Mall, downloading and ordering catalogs

### Easy product selection and ordering: Industry Mall

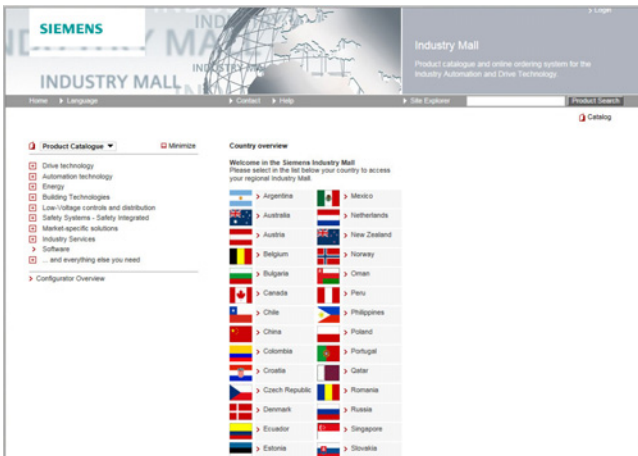

### Industry Mall

The Industry Mall is a Siemens AG Internet ordering platform. It provides you with online access to a comprehensive product spectrum that is presented in an informative, well-organized way.

Powerful search functions help you select the required products, while configurators enable you to configure complex product and system components quickly and easily. CAX data are also available for you to use.

Data transfer allows the entire procedure, from selection through ordering to tracking and tracing, to be carried out online. Availability checks, individual customer discounting, and quotation preparation are also possible.

[www.siemens.com/industrymall](http://www.siemens.com/industrymall)

### Downloading catalogs

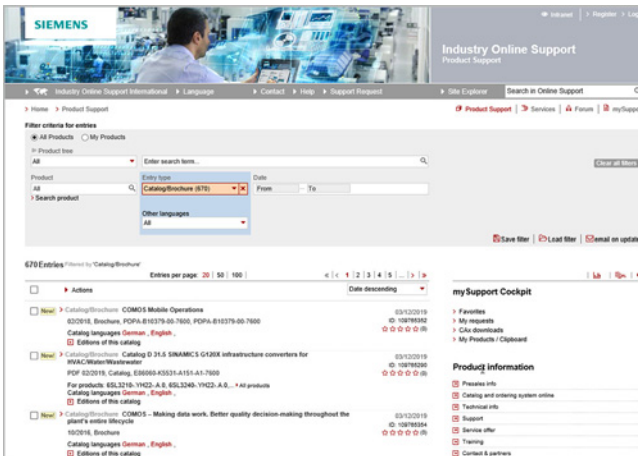

### Siemens Industry Online Support

You can download catalogs and brochures in PDF format from Siemens Industry Online Support without having to register.

The filter box makes it possible to perform targeted searches.

[www.siemens.com/industry-catalogs](http://www.siemens.com/industry-catalogs)

### Ordering printed catalogs



Please contact your local Siemens branch if you are interested in ordering printed catalogs.

Addresses can be found at

[www.siemens.com/automation-contact](http://www.siemens.com/automation-contact)

## Get more information

SIMATIC MICRO-DRIVE drive system:

[www.siemens.com/micro-drive](http://www.siemens.com/micro-drive)

Motion Control Systems and Solutions for production machine and machine tool equipment:

[www.siemens.com/motioncontrol](http://www.siemens.com/motioncontrol)

Local partners worldwide:

[www.siemens.com/automation-contact](http://www.siemens.com/automation-contact)

Published by  
Siemens AG

Digital Industries  
Motion Control  
Postfach 31 80  
91050 Erlangen, Germany

PDF (E86060-K5534-A101-A2-7600)  
V6.MKKATA.DFA.100  
KG 0821 64 En  
Produced in Germany  
© Siemens 2021

Subject to changes and errors. The information given in this document only contains general descriptions and/or performance features which may not always specifically reflect those described, or which may undergo modification in the course of further development of the products. The requested performance features are binding only when they are expressly agreed upon in the concluded contract.

All product designations may be trademarks or other rights of Siemens AG, its affiliated companies or other companies whose use by third parties for their own purposes could violate the rights of the respective owner.

## Security information

Siemens provides products and solutions with industrial security functions that support the secure operation of plants, systems, machines and networks.

In order to protect plants, systems, machines and networks against cyber threats, it is necessary to implement – and continuously maintain – a holistic, state-of-the-art industrial security concept. Siemens' products and solutions constitute one element of such a concept.

Customers are responsible for preventing unauthorized access to their plants, systems, machines and networks. Such systems, machines and components should only be connected to an enterprise network or the internet if and to the extent such a connection is necessary and only when appropriate security measures (e.g. firewalls and/or network segmentation) are in place.

For additional information on industrial security measures that may be implemented, please visit

<https://www.siemens.com/industrialsecurity>

Siemens' products and solutions undergo continuous development to make them more secure. Siemens strongly recommends that product updates are applied as soon as they are available and that the latest product versions are used. Use of product versions that are no longer supported, and failure to apply the latest updates may increase customer's exposure to cyber threats.

To stay informed about product updates, subscribe to the Siemens Industrial Security RSS Feed under

<https://www.siemens.com/industrialsecurity>