

SIEMENS



Continuous gas analysis

Gas analyzer for measuring IR-absorbing gases,
oxygen and hydrogen sulfide

ULTRAMAT 23

Manual

Edition

03/2016

Answers for industry.

Continuous gas analysis

Gas analyzer for measuring IR- absorbing gases, oxygen, and hydrogen sulfide ULTRAMAT 23

Manual

7MB2335, 7MB2337, 7MB2338
7MB2355, 7MB2357, 7MB2358

<u>Introduction</u>	1
<u>Safety instructions</u>	2
<u>Description</u>	3
<u>installation</u>	4
<u>Connecting</u>	5
<u>Commissioning</u>	6
<u>Operation</u>	7
<u>Functions</u>	8
<u>Application note</u>	9
<u>Service and maintenance</u>	10
<u>Error and system messages</u>	11
<u>Taking out of operation and disposal</u>	12
<u>Spare parts/accessories</u>	13
<u>Appendix</u>	A
<u>ESD directives</u>	B
<u>List of abbreviations</u>	C

Legal information

Warning notice system

This manual contains notices you have to observe in order to ensure your personal safety, as well as to prevent damage to property. The notices referring to your personal safety are highlighted in the manual by a safety alert symbol, notices referring only to property damage have no safety alert symbol. These notices shown below are graded according to the degree of danger.

DANGER

indicates that death or severe personal injury **will** result if proper precautions are not taken.

WARNING

indicates that death or severe personal injury **may** result if proper precautions are not taken.

CAUTION

indicates that minor personal injury can result if proper precautions are not taken.

NOTICE

indicates that property damage can result if proper precautions are not taken.

If more than one degree of danger is present, the warning notice representing the highest degree of danger will be used. A notice warning of injury to persons with a safety alert symbol may also include a warning relating to property damage.

Qualified Personnel

The product/system described in this documentation may be operated only by **personnel qualified** for the specific task in accordance with the relevant documentation, in particular its warning notices and safety instructions. Qualified personnel are those who, based on their training and experience, are capable of identifying risks and avoiding potential hazards when working with these products/systems.

Proper use of Siemens products

Note the following:

WARNING

Siemens products may only be used for the applications described in the catalog and in the relevant technical documentation. If products and components from other manufacturers are used, these must be recommended or approved by Siemens. Proper transport, storage, installation, assembly, commissioning, operation and maintenance are required to ensure that the products operate safely and without any problems. The permissible ambient conditions must be complied with. The information in the relevant documentation must be observed.

Trademarks

All names identified by ® are registered trademarks of Siemens AG. The remaining trademarks in this publication may be trademarks whose use by third parties for their own purposes could violate the rights of the owner.

Disclaimer of Liability

We have reviewed the contents of this publication to ensure consistency with the hardware and software described. Since variance cannot be precluded entirely, we cannot guarantee full consistency. However, the information in this publication is reviewed regularly and any necessary corrections are included in subsequent editions.

Table of contents

1	Introduction	11
1.1	Information for our customers.....	11
1.2	Product versions.....	11
1.3	General information.....	12
1.4	Special information and warnings.....	12
1.5	Proper use.....	12
1.6	Qualified Personnel.....	13
1.7	Warranty conditions.....	14
1.8	Delivery information.....	14
1.9	Standards and regulations.....	14
1.10	Conformity with European directives.....	14
2	Safety instructions	15
2.1	Analyzers in biogas plants.....	17
2.2	Analyzers in hazardous areas.....	17
3	Description	19
3.1	Area of application.....	19
3.2	Design.....	22
3.3	Function.....	26
3.4	Technical specifications.....	31
3.4.1	General technical data.....	31
3.4.2	Parts in gas path wetted by sample gas.....	34
3.4.3	Infrared detector.....	35
3.4.4	Electrochemical oxygen sensor.....	38
3.4.5	Paramagnetic oxygen sensor.....	39
3.4.6	Hydrogen sulfide sensor.....	42
3.5	Wiring diagrams.....	43
3.5.1	Gas flow diagram.....	43
3.5.2	Gas connections.....	51
3.5.3	Connection diagrams.....	52
3.5.4	Pin assignments.....	54
3.6	Dimensional drawings.....	56
3.7	Communication.....	57
3.7.1	PROFIBUS DP/PA.....	57
3.7.2	General information.....	59
3.7.3	ELAN interface.....	60
3.7.4	SIPROM GA.....	61

3.7.4.1	SIPROM GA functions	61
3.7.4.2	Upgrading options	62
4	installation.....	63
5	Connecting	67
5.1	Safety instructions.....	67
5.1.1	Condensation in the device.....	67
5.1.2	Laws and directives	67
5.1.3	Operation in hazardous areas.....	67
5.1.4	Electrical circuit breaker in accordance with IEC 60947-1	68
5.1.5	Dangerous contact voltage	68
5.1.6	Missing PE/ground connection	68
5.1.7	Power supply cable for bench-top unit.....	69
5.1.8	Analyzers in hazardous areas.....	69
5.1.9	Analyzers in biogas plants	70
5.1.10	Wetted parts unsuitable for the process medium	70
5.1.11	Variant with specially cleaned gas path (Cleaned for O ₂)	71
5.2	Gas connections and internal gas path	71
5.2.1	Gas connections	71
5.2.2	Gas preparation	72
5.3	Electrical connection	73
5.3.1	Connection of the signal lines	73
5.3.2	Power connection.....	74
6	Commissioning	77
6.1	General information	77
6.2	Safety instructions.....	77
6.2.1	Dangerous contact voltage	77
6.2.2	Loss of degree of protection	78
6.2.3	Commissioning and operation with error message.....	78
6.2.4	For use in hazardous areas	78
6.2.4.1	Analyzers in hazardous areas.....	78
6.2.5	Use in biogas plants.....	80
6.2.5.1	Safety information	80
6.3	Preparation for commissioning	81
6.3.1	Leaks in the gas paths	81
6.3.2	Gas preparation	81
6.3.3	Device interfaces.....	81
6.4	Commissioning.....	82
6.4.1	Commissioning.....	82
6.4.2	AUTOCAL	82
6.4.3	Initial calibration	83
6.5	System setup with several analyzers in parallel	84
7	Operation.....	89
7.1	General information	89
7.2	User prompting.....	90
7.3	Display and control panel.....	91

7.3.1	Display and operator panel.....	91
7.3.2	User interface.....	93
7.3.3	Key assignments.....	94
7.4	Operating modes	94
7.4.1	Warm-up phase	95
7.4.2	Measuring mode	96
7.4.3	Input mode	96
7.4.3.1	Code levels	97
7.4.3.2	Key operations step by step	98
7.4.3.3	The ESC key	101
7.4.3.4	The CAL key	101
7.4.3.5	The PUMP key.....	102
8	Functions.....	103
8.1	Diagnostics	103
8.1.1	Diagnostics: Status	104
8.1.1.1	Analyzer status: Status: Logbook/faults.....	104
8.1.1.2	Analyzer status: Status: Maintenance request	105
8.1.1.3	Analyzer status: Status: AUTOCAL deviation	105
8.1.1.4	Analyzer status: Status: O2 sensor status.....	106
8.1.1.5	Analyzer status: Status: H2S sensor status.....	106
8.1.2	Diagnostics: Diagnostics values	107
8.1.2.1	Analyzer status: Diagnostics values: IR.....	107
8.1.2.2	Analyzer status: Diagnostics values: (Electrochemical) O2 sensor	108
8.1.2.3	Analyzer status: Diagnostics values: (Paramagnetic) O2 sensor.....	108
8.1.2.4	Analyzer status: Diagnostics values: H2S sensor	109
8.1.2.5	Diagnostics: Diagnostics values: Pressure sensor.....	109
8.1.2.6	Analyzer status: Diagnostics values: Other diagnostics values	109
8.1.3	Analyzer status: Factory settings hardware.....	110
8.1.4	Analyzer status: Factory settings software	110
8.2	Calibration.....	111
8.2.1	Calibration.....	111
8.2.2	Calibration: Infrared measuring range	112
8.2.2.1	Calibration: Infrared measuring range: Set span gas values.....	113
8.2.2.2	Calibration: Infrared measuring range: Start with Range MR 1/2.....	113
8.2.3	Calibration: Electrochemical oxygen measuring range	114
8.2.3.1	Calibration: O2 measuring range: Sensor inst. date.....	114
8.2.3.2	Calibration: O2 measuring range: Calibrating the O2 zero point.....	115
8.2.3.3	Calibration: O2 measuring range: Calibrate measuring range	115
8.2.4	Calibration: Paramagnetic oxygen sensor	116
8.2.4.1	Calibration: O2 paramagnetic: Calibrating the zero point.....	117
8.2.4.2	Calibration: O2 paramagnetic: Calibrating the measuring range	117
8.2.5	Calibration: H2S sensor.....	118
8.2.5.1	Calibration: H2S sensor: Defining the installation	119
8.2.5.2	Calibration: H2S sensor: Calibrating the zero point.....	119
8.2.5.3	Calibration: H2S sensor: Calibrating the measuring range	119
8.2.5.4	Calibration: H2S sensor: Enter TC parameters	120
8.2.6	Calibration: Pressure sensor	121
8.2.7	Calibration: AUTOCAL/drift values	122
8.2.7.1	Calibration: AUTOCAL/drift values: Drift values	122
8.2.7.2	Calibration: AUTOCAL/drift values: Cycle time	123

8.2.7.3	Calibration: AUTOCAL/drift values: Purge time	123
8.3	Parameter	124
8.3.1	Parameter: Measuring ranges	125
8.3.1.1	Parameters: Measuring ranges: Switch ranges	125
8.3.1.2	Parameters: Measuring ranges: Setting measuring ranges	126
8.3.1.3	Parameters: Measuring ranges: Hysteresis	127
8.3.2	Parameters: Limits	128
8.3.3	Parameters: Limits: H2S sensor protection	129
8.3.4	Parameters: Time constants	129
8.3.5	Parameter: Pump/LCD contrast	130
8.3.5.1	Parameters: Pump/LCD contrast: Pump	130
8.3.5.2	Parameters: Pump/LCD contrast: LCD contrast	131
8.4	Configuration	132
8.4.1	Configuration: Inputs/outputs/pump	134
8.4.1.1	Configuration: Inputs/outputs/pump: Analog outputs	134
8.4.1.2	Configuration: Inputs/outputs/pump: Assign relays	138
8.4.1.3	Configuration: Inputs/outputs/pump: Binary/sync inputs	141
8.4.1.4	Configuration: Inputs/outputs/pump: Pump at CAL/MEAS	142
8.4.2	Configuration: Special functions	142
8.4.2.1	Configuration: Special functions: Changing the codes/language	143
8.4.2.2	Configuration: Special functions: AUTOCAL deviation	144
8.4.2.3	Configuration: Special functions: ELAN/PROFIBUS/external interference	144
8.4.2.4	Configuration: Special functions: Factory data/reset/units	149
8.4.3	Configuration: Device test	151
8.4.3.1	Configuration: Device test: RAM monitor	151
8.4.3.2	Configuration: Device test: Display/keys/flow	152
8.4.3.3	Configuration: Device test: Inputs/outputs	152
8.4.3.4	Configuration: Device test: Chopper/IR source	154
8.4.4	Configuration: Factory configuration	155
8.5	Automatically executed functions	155
8.5.1	Probe protection and purging function	155
8.5.2	Probe protection function	156
8.5.3	Probe purging function	158
9	Application note	161
9.1	H2S sensor with 'small' measuring range	161
10	Service and maintenance	165
10.1	Safety instructions	165
10.1.1	General safety instructions	165
10.1.2	Safety information for analyzers used in hazardous areas	166
10.2	Maintenance work	167
10.2.1	Cleaning the device	167
10.2.2	Maintenance of the gas path	168
10.2.3	Replacing spare parts	168
10.2.4	Replacing fuses	168
10.2.5	Replacing the fine safety filter	169
10.2.6	Maintenance work on the bench-top unit	170
10.2.6.1	Emptying the condensation trap	170
10.2.6.2	Replacing the coarse filter	170

10.2.7	Replacing the electrochemical oxygen sensor	171
10.2.8	Replacing the hydrogen sulfide sensor.....	172
10.2.9	Replacing the paramagnetic oxygen sensor	176
11	Error and system messages.....	177
11.1	Maintenance requests.....	177
11.2	Faults	178
12	Taking out of operation and disposal.....	181
12.1	Repair or changing of location	181
12.2	Scrapping the analyzer	182
13	Spare parts/accessories.....	185
13.1	Information for ordering spare parts	185
13.2	Gas path	187
13.3	Electronics	190
13.4	Pump.....	192
13.5	IR analyzer units	193
13.5.1	Overview	193
13.5.2	Analyzer unit 7MB2335-, 7MB2355-.....	197
13.5.3	Analyzer unit 7MB2337-, 7MB2357-.....	201
13.5.4	Analyzer unit 1 7MB2338-, 7MB2358-.....	205
13.5.4.1	.AA.-, -.AK.-, -.AB.-, -.AC.- for CO/NO	205
13.5.4.2	.AD.- for CO/NO.....	207
13.5.4.3	.DC.- for CO2/NO.....	209
13.5.4.4	.BA., .BD., .CB.- for CO/CO2 and CO2/CH4	211
13.5.4.5	.BB., .CA.- for CO/CO2 and CO2/CH4	213
13.5.4.6	.BJ., .BK., .BL.- for CO2/CO	216
13.5.5	Analyzer unit 7MB2338-, 7MB2358- third component.....	219
13.6	Sensors.....	221
13.7	Comparison of spare part Order Nos. U23 and U23 analyzer version -B06 'Cleaned for O2'.....	222
A	Appendix.....	225
A.1	Service and support.....	225
A.2	Approvals	225
A.3	Pressure conversion table	225
A.4	Returned delivery.....	226
A.4.1	Return address	227
A.4.2	Error Description	227
A.4.3	Decontamination declaration	228
B	ESD directives	231
B.1	ESD guidelines	231
C	List of abbreviations	233
C.1	List of abbreviations	233

Index239

Introduction

1.1 Information for our customers

Before beginning work with this device, please read this manual! It contains important information and data whose observation ensures proper device function and saves you servicing costs. The manual will help you to operate the device more easily and efficiently, allowing you to achieve reliable results.

1.2 Product versions

The ULTRAMAT 23 gas analyzer is suitable for a wide variety of measurements and is therefore available in different versions. The data on the label, among others, indicates which device version you have.

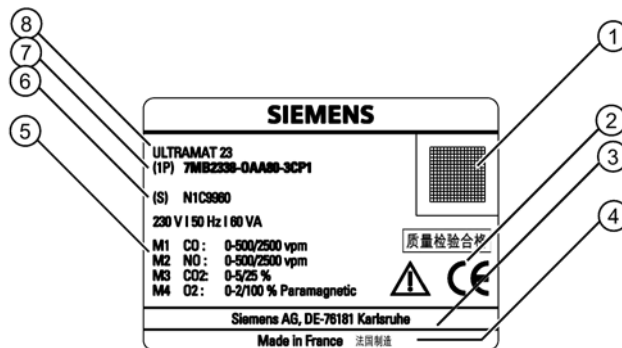

- 1 Data matrix code
- 2 CE conformity symbol
- 3 Name and address of manufacturer
- 4 Designation of origin
- 5 Measuring range(s)
- 6 Serial number
- 7 Order No. (MLFB number) of the device
- 8 Device name

Figure 1-1 ULTRAMAT 23 label (example)

1.3 General information

This device left the factory in a safe and proper condition and has been tested. In order to maintain this condition and to ensure safe operation of this product, it should only be used in the manner described by the manufacturer. Furthermore, proper transportation, storage, installation, operation and maintenance of the device are vital for ensuring correct and safe operation.

This manual contains the information required for the intended use of the described product.

It is addressed to technically qualified personnel who are specially trained or who have the relevant knowledge of automation technology (measuring and control systems).

Knowledge and technically correct implementation of the safety notes and warnings contained in this manual are required for safe installation and commissioning, as well as for safety during the operation and maintenance of the described product. Only qualified personnel have the required professional knowledge for correctly interpreting the generally valid safety notes and warnings in this manual in each specific case and to act accordingly.

This manual is an inherent part of the scope of delivery, despite the fact that it can be ordered separately for logistic reasons.

Due to the variety of technical details, it is not possible to consider every single detail for all versions of the described product and for every conceivable case in the set-up, operation, maintenance and use in systems. For further information, or in the case of problems which are not covered in enough detail in this document, please request the required information from your local or responsible Siemens regional office.

Note

In particular, before using the device for new research and development applications, we recommend that you first contact us to discuss the application in question.

1.4 Special information and warnings

This manual provides you with information on using, installing, operating, and maintaining the device.

Pay particular attention to all special information and warnings. Information of this type is set apart from the rest of the text and is marked with the corresponding pictograms. This information provides you with useful tips and helps avoid maloperations.

1.5 Proper use

Proper use within the context of this manual, means that the product may be used only for the applications described in the catalog or the technical description, and only in combination with the equipment, components and devices of other manufacturers recommended or permitted by Siemens.

The product described in this manual has been developed manufactured, tested and documented in compliance with relevant safety standards. When the handling rules

described for the configuration, installation, proper operation and maintenance, as well as the safety guidelines are adhered to, therefore, there is normally no risk to the health of persons or in respect to damage to property.

This device was designed to ensure safe isolation of the primary and secondary circuits. Low voltages that are connected must therefore also be generated with safe isolation.

 WARNING**Dangerous contact voltage**

After removing the housing or protection against direct contact or after opening the system cabinet, certain parts of this device/system will be exposed that can carry hazardous voltage. Therefore, only appropriately qualified persons are permitted to perform work within this device. These persons must be thoroughly familiar with all sources of danger and service activities in accordance with these operating instructions.

Note**Observe the environmental conditions for the rack unit and bench-top unit**

Make sure that the environmental conditions listed in the technical specifications (Page 31) are observed.

- During operation
- In the event of maintenance

Note**Environmental conditions for bench-top unit in accordance with IEC 61010-1-2010**

In accordance with IEC 61010-1-2010, the bench-top unit may only be used indoors.

1.6 Qualified Personnel

Qualified personnel are people who are familiar with the installation, mounting, commissioning, and operation of the product. These people have the following qualifications:

- They are authorized, trained or instructed in operating and maintaining devices and systems according to the safety regulations for electrical circuits, high pressures and aggressive as well as hazardous media.
- For explosion-proof devices: they are authorized, trained, or instructed in carrying out work on electrical circuits for hazardous systems.
- They are trained or instructed in maintenance and use of appropriate safety equipment according to the safety regulations.

1.7 Warranty conditions

We expressly point out that the product quality is exclusively and conclusively described in the sales contract. The content of this product documentation is neither a part of a previous or existing agreement, promise or legal relationship, nor is it intended to modify these. All obligations on the part of Siemens AG are contained in the respective sales contract, which also contains the complete and solely applicable liability provisions. The provisions defined in the sales contract for the responsibility for defects are neither extended nor limited by the remarks in this document.

1.8 Delivery information

The respective scope of delivery is listed on the shipping documents in accordance with the valid sales contract. These are enclosed with the delivery.

When opening the packaging, please observe the corresponding information on the packaging material. Check the delivery for completeness and undamaged condition. In particular, the Order No. on the labels, if present, must be compared with the ordering data.

If possible, please keep the packaging material since you can reuse it for return deliveries if necessary.

1.9 Standards and regulations

As far as possible, the harmonized European standards were the basis for the specification and production of this device. If no harmonized European standards have been applied, the standards and regulations for the Federal Republic of Germany are valid.

When this product is used beyond the scope of these standards and regulations, the valid standards and regulations of the country of the operating company apply.

1.10 Conformity with European directives

The CE mark on the device is a sign of conformity with the following European directives:

Electromagnetic compatibility EMC	DIRECTIVE 2014/30/EU OF THE EUROPEAN PARLIAMENT AND OF THE COUNCIL on the harmonisation of the laws of the Member States relating to electromagnetic compatibility.
Low voltage directive LVD	DIRECTIVE 2014/35/EU OF THE EUROPEAN PARLIAMENT AND OF THE COUNCIL on the harmonisation of the laws of Member States relating to the making available on the market of electrical equipment designed for use within certain voltage limits.
ATEX	DIRECTIVE 2014/34/EU OF THE EUROPEAN PARLIAMENT AND OF THE COUNCIL on the harmonisation of the laws of the Member States relating to equipment and protective systems intended for use in potentially explosive atmospheres.

The directives applied can be found in the EU declaration of conformity for the associated device.

Security information

Siemens provides products and solutions with industrial security functions that support the secure operation of plants, solutions, machines, equipment and/or networks. They are important components in a holistic industrial security concept. The products and solutions from Siemens undergo continuous development with this factor in mind. Siemens strongly recommends that you regularly check for product updates.

For the safe operation of products and solutions from Siemens, it is necessary to take suitable protective measures (e.g. cell protection concept) and to integrate each component into an overall IT security concept which corresponds to state-of-the-art IT technology. Third-party products that may be in use should also be considered. For more information about industrial security, visit <http://www.siemens.com/industrialsecurity> (<http://www.siemens.com/industrialsecurity>).

To stay informed about product updates as they occur, sign up for a product-specific newsletter. For further information, see

<http://support.automation.siemens.com> (<http://support.automation.siemens.com>).

WARNING

Improper use

A device in the standard version must never be used in hazardous areas.

Explosive gas mixtures (e.g. flammable gases together with air or oxygen in a potentially explosive ratio) must not be measured with this analyzer.

WARNING

Improper device modifications

Danger to personnel, system and environment can result from modifications to the device, particularly in hazardous areas.

- Only carry out modifications that are described in the instructions for the device. Failure to observe this requirement cancels the manufacturer's warranty and the product approvals.

Note

Manipulation on the device

The physical access to the device allows illegal manipulations on the device.

- Ensure that the device is located in a protected area to which only authorized persons have access.
 - If no settings need be carried out, lock the device.
-



WARNING

Toxic and/or corrosive gases

When measuring toxic or corrosive gases, it could occur that sample gas accumulates in the analyzer because of leaks in the gas path.

To prevent the danger of poisoning or damage to parts of the analyzer, the analyzer or the system must be purged with inert gas (e.g. nitrogen). The gas displaced by purging must be collected using appropriate equipment and disposed of environmentally-friendly via an exhaust line.

2.1 Analyzers in biogas plants

DANGER

Danger of poisoning

This device is designed to measure hydrogen sulfide and dihydrogen sulfide, (H₂S)!

Hydrogen sulfide is highly toxic even in small concentrations! The odor threshold for hydrogen sulfide is very low at 0.02 vpm (20 vpb), but higher concentrations result in numbing of the olfactory receptors in the nose so that the odor is no longer perceived. Persons exposed to this gas in concentrations up to 100 vpm for several hours exhibit symptoms of poisoning such as fatigue, headaches, lack of appetite, lack of concentration, irritation of the mucous membranes of eyes and respiratory tract, and throat irritations.

Inhalation of H₂S concentrations of 500 vpm longer than 30 minutes can cause fatal poisoning. Concentrations above 1 000 vpm cause death within a few minutes, concentrations above 5 000 vpm cause death within a few seconds!

When using this device in plant where there may be high concentrations of H₂S and you therefore need to take following continual precautions to prevent the effects of poisoning:

- Connect the gas outlet of the analyzer to a gas exhaust unit so that no gas can escape into the environment!
- Before you begin maintenance on the analyzer, make sure that the H₂S concentration in the analyzer is close to 0 vpm. Before beginning work, always flush the gas path of the analyzer and the gas sampler with ambient air or nitrogen for a duration of about 10 minutes .
- Check for leaks in the analyzer at regular intervals!

DANGER

Danger of explosion

This device is used in biogas plants, among other places. When it is used in biogas plants, you should expect that the sample gas will contain methane, which forms explosive mixtures with oxygen or air in certain concentrations. These conditions are possible with certain operating states of the plant.

2.2 Analyzers in hazardous areas

WARNING

Unsuitable device for the hazardous area

Danger of explosion.

- Only use equipment that is approved for use in the intended hazardous area and labelled accordingly.

Description

3.1 Area of application

Overview

Up to 4 gas components can be measured continuously and simultaneously with the ULTRAMAT 23 gas analyzer. The analyzer has an infrared detector for infrared-sensitive gases such as CO, N₂O or CH₄, and can be optionally fitted with up to two further electrochemical sensors for O₂ and H₂S as well as a paramagnetic O₂ sensor. The following combinations are thus possible:

Table 3- 1 Possible combinations of ULTRAMAT 23

	Electrochemical O ₂ sensor	Paramagnetic O ₂ sensor	H ₂ S sensor
1 IR component + 1 IR component +	x --	-- x	x --
2 IR components + 2 IR components +	x --	-- x	x --
3 IR components + 3 IR components +	x --	-- x	-- --
4 IR components +	--	--	--

Legend:

Use of sensor is possible: x

Use of sensor is not possible: --

These combinations are available for a 19" rack unit with hoses gas paths. The following deviations apply to other analyzer versions:

- Only IR components are available for 19" rack units with piped gas paths
- H₂S sensors and O₂ sensors are available for bench-top units



Figure 3-1 Front view of ULTRAMAT 23 for measurement of CO, NO, and O₂ (example of rack unit)

Areas of application

- Optimization of small firing systems
- Monitoring of exhaust gas concentration from firing systems with all types of fuel (oil, gas and coal) as well as operational measurements with thermal incineration plants
- Room air monitoring
- Monitoring of air in fruit stores, greenhouses, fermenting cellars and warehouses
- Monitoring of process control functions
- Atmosphere monitoring during heat treatment of steel

Areas of application with hydrogen sulfide sensor:

- Biogas plants
 - Monitoring of fermenters for generating biogas (input and pure sides)
 - Monitoring of gas-driven motors (power generation)
 - Monitoring of feeding of biogas into the commercial gas network
- Sewage plants
- Drinking water treatment

Areas of application with paramagnetic oxygen sensor

- Flue gas analysis
- Inerting plants
- Room air monitoring
- Medical engineering

Further applications:

- Environmental protection
- Chemical plants
- Cement industry

Special versions

- The ULTRAMAT 23 with 2 IR components without pump is also available with two separate gas paths. This allows the measurement of two measuring points as used e.g. for the NO_x measurement before and after the NO_x converter.
- The ULTRAMAT 23 gas analyzer can be used in emission measuring systems and for process and safety monitoring.
- For measurement of CO, NO, SO₂ and O₂ according to 13th BImSchV and TA Luft, TÜV-approved versions of the ULTRAMAT 23 are available.
- The analyzers of the 7MB2355, 7MB2357 and 7MB2358 series are suitability-tested in accordance with EN 15267 (emission measurements).
- The current certificates and approvals can be found on the Internet at: Approvals and certificates (<https://support.industry.siemens.com/cs/de/en/ps/17728>)
- Version with faster response time:
There is no connection between the two condensation traps, so that the complete sample gas flow passes through the detector (only 1/3 of the flow in the normal version of the analyzers), i.e. the response time is 2/3 faster. The functions of all other components remain unchanged.
- Version with chopper section purging:
This version consumes approx. 100 ml/min of purging gas; you must set an inlet pressure of 300 kPa (3 bar).
- Variant with specially cleaned gas path: This variant is envisaged for the applications requiring 'Cleaned for O₂ service'.

Benefits

- AUTOCAL can be carried out with ambient air (dependent on the measured component) and is therefore highly cost effective because calibration gases and accessories are not required
- High selectivity thanks to multi-layer detectors, low cross-sensitivity to water vapor
- Sample chambers can be cleaned (dependent on the version), resulting in cost savings through reuse following contamination
- Menu-assisted operation in plain text, thus high operational safety
- Service information and logbook, cost savings through preventive maintenance and help for service and maintenance personnel
- Increased safety through coded operator levels, thus protection against unauthorized access or clumsy working

- Open interface architecture (ELAN (RS485), PROFIBUS-DP/PA), thus simplified process integration
- Communication software. SIMATIC PDM and SIPROM GA.
- Remote operation and control (via SIPROM GA and PROFIBUS).

Special benefits when used in biogas plants

- Continuous measurement of all 4 important components, including H₂S
- Long service life of the H₂S sensor even at increased concentrations; no diluting or backflushing necessary

3.2 Design

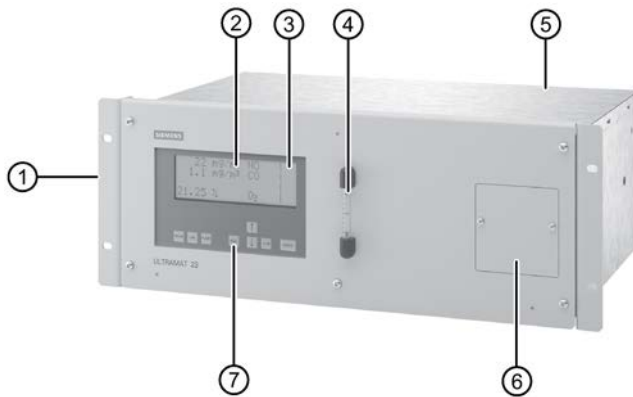

- ① Available as bench-top or rack unit.
- ② 80-digit display panel (4 lines with 20 characters each).
- ③ Dust-tight and washable membrane keyboard.
- ④ Flowmeter for monitoring the sample gas flow.
- ⑤ Gas and electrical connections at the rear.
- ⑥ O₂ sensor (option) can be removed from the front after taking off the cover.
- ⑦ Control and function keys for operation.

Figure 3-2 Design of ULTRAMAT 23 as 19" rack unit

The ULTRAMAT 23 is also available as a bench-top unit. This version differs from the rack unit shown here as follows:

- Closed housing without mounting frame.
- 2 handles on the sides.
- 4 rubber feet for setting up.
- The bench-top unit is not available with Ex approval.

Enclosure

- Bench-top unit or
- 19" rack unit with 4 HU for installation in
 - Hinged frame
 - Cabinets
- Flow indicator for sample gas on front plate (not with piped gas paths)
- Integrated sample gas pump with bench-top unit, available as option for rack unit (not with piped gas paths)
- Gas connections for sample gas inlet and outlet as well as zero gas possible with pipe diameter 6 mm or ¼"
- Gas and electrical connections at the rear.

Display and operator panel

- Operation based on NAMUR recommendation.
- Simple, fast parameterization and commissioning of analyzer.
- Large backlit LCD for measured values.
- Menu-prompted input functions for parameterization, configuration, test functions, calibration.
- Washable membrane keyboard.
- User help in plain text.
- User software available in 6 languages.

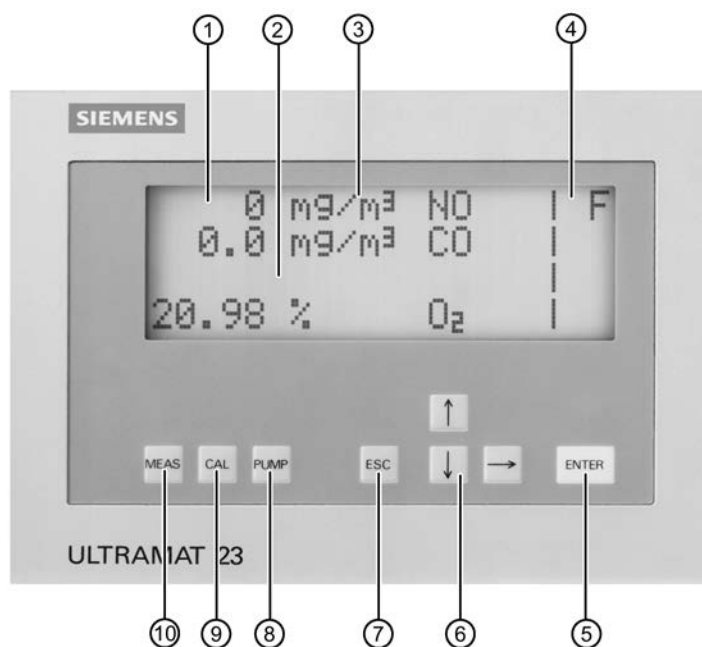

- ① One line per component for measured value, dimension and ID.
- ② LED-backlit display; contrast adjustable using menu.
- ③ Freely-selectable dimension (ppm, vpm, mg/m³, %).
- ④ Two columns are reserved for status displays.
- ⑤ ENTER key for calling the main menu or saving the input values.
- ⑥ ↑ ↓ → keys for menu control and for incrementing/decrementing numerical values.
- ⑦ Scrolling back in menu or cancellation of an input.
- ⑧ Switching on and off of internal pump, pumping capacity adjustable using menu.
- ⑨ Key for starting AUTOCAL.
- ⑩ Immediate return to measuring mode.

Figure 3-3 Operator panel of the ULTRAMAT 23

Note**Energy saving**

The display brightness is reduced after approx. 30 minutes without an operation. This serves for energy saving and has no influence on the other properties of the device.

The display becomes bright again when you continue with operation.

Inputs and outputs

- Three binary inputs for switching the sample gas pump on and off, triggering of AUTOCAL, and synchronization of several devices.
- Eight freely-configurable relay outputs for faults, maintenance requests, maintenance switches, limits, measuring range identifications, and external solenoid valves.
- Analog outputs for each component electrically isolated from analyzer ground.
- Optional: 8 additional relay outputs.
- Optional: 8 additional binary inputs.

Communication

ELAN (RS485) present in basic unit.

Options:

- RS485/USB converter
- RS485/RS232 converter
- RS485/Ethernet converter
- Incorporation in networks via PROFIBUS DP/PA interface (via option board)
- SIPROM GA software as servicing and maintenance tool

3.3 Function

Several independent measuring principles which work selectively may be present in the ULTRAMAT 23. These are described below.

Infrared measurement

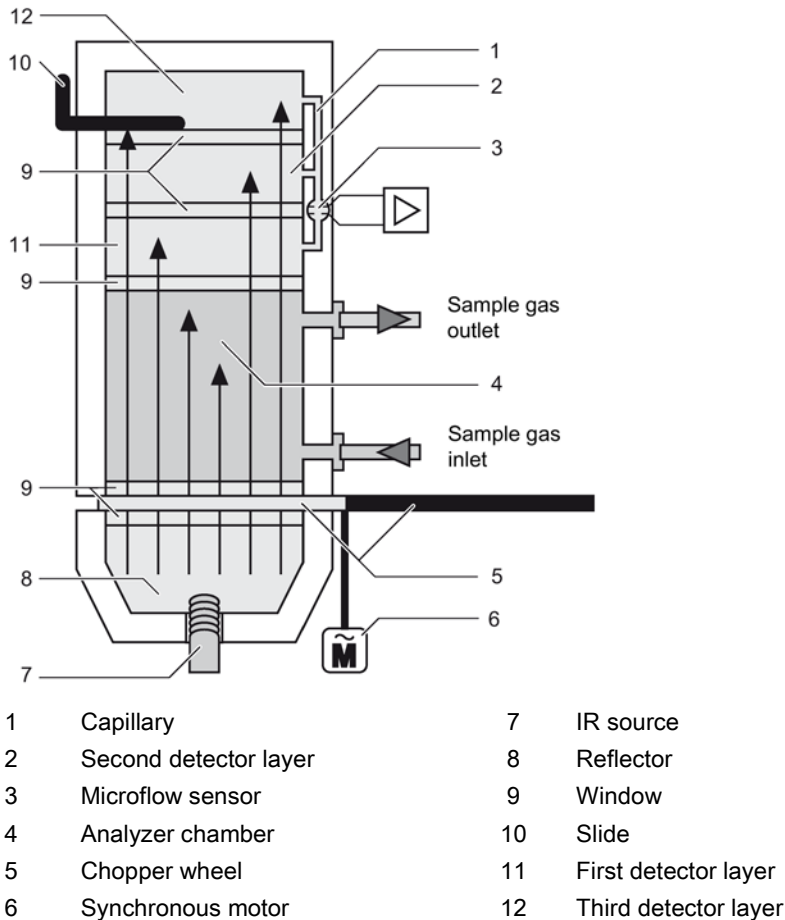

Figure 3-4 Operating principle of infrared measurement

This measuring principle is based on the molecule-specific absorption of bands of infrared radiation, which in turn is based on the "single-beam procedure".

A radiation source (7) operating at 600 °C (1111 °F) emits infrared radiation, which is then modulated by a chopper (5) at 8 1/3 Hz.

The infrared radiation passes through the analyzer chamber (4), into which sample gas is flowing, and its intensity is weakened as a function of the concentration of the measured component.

The receiver chamber (detector) - set up as a two- or three-layer detector - is filled with the component to be measured. The first detector layer (11) primarily absorbs energy from the central sections of the sample gas IR bands. Energy from the peripheral sections of the bands is absorbed by the second (2) and third (12) detector layers. The microflow sensor

generates a pneumatic connection between the upper layer and the lower layers. Negative feedback from the upper and lower layers leads to an overall narrowing of the spectral sensitivity band. The volume of the third layer and, therefore, the absorption of the bands, can be varied using a slide (10), thereby increasing the selectivity of each individual measurement.

The rotating chopper (5) generates a pulsating flow in the receiver chamber that the microflow sensor (3) converts into an electrical signal. The microflow sensor consists of two nickel-plated grids heated to approximately 120 °C (248 °F), which, along with two supplementary resistors, form a Wheatstone bridge. The pulsating flow together with the dense arrangement of the nickel grids causes a change in resistance. This leads to an offset in the bridge which is proportional to the concentration of sample gas.

Note

Contamination of the analyzer chambers

The sample gases must be fed into the analyzers free of dust. Condensation should also be prevented in the analyzer chambers. Therefore, the use of gas modified for the measuring task is necessary in most application cases.

Furthermore, the ambient air of the sensor must not have large concentrations of the components to be measured.

Electrochemical oxygen measurement

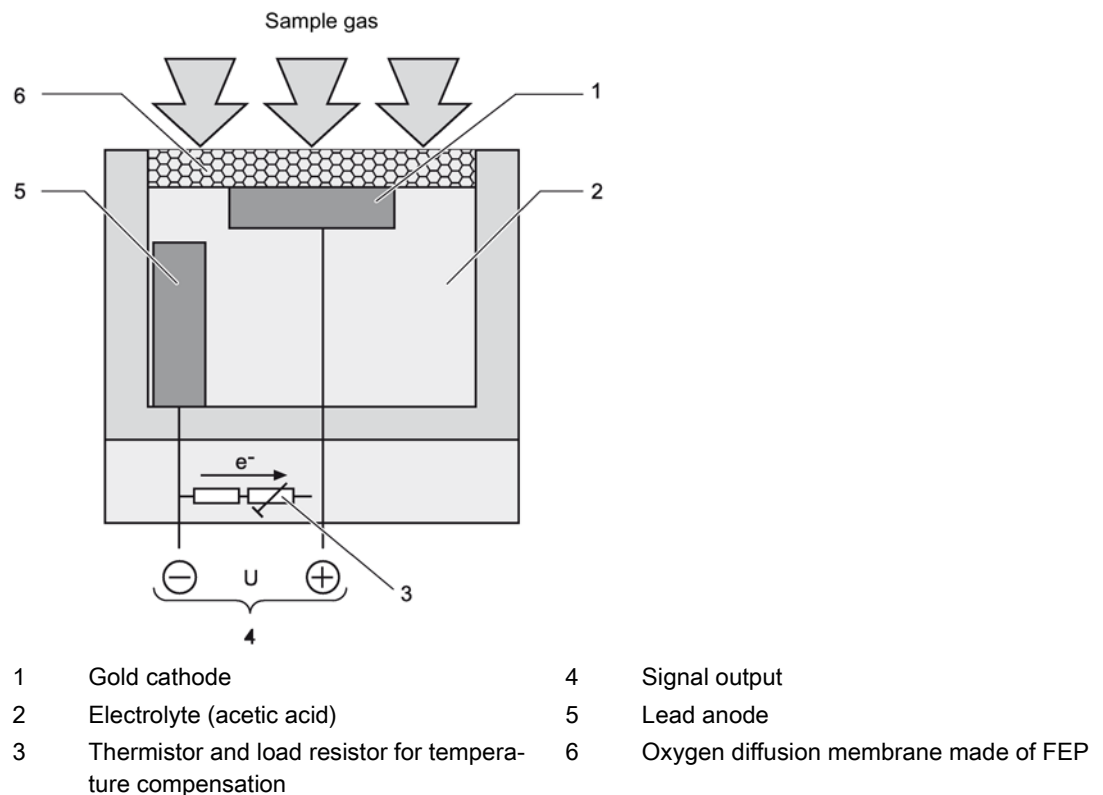

Figure 3-5 Operating principle of the electrochemical O₂ sensor

This oxygen sensor operates according to the principle of a fuel cell. The oxygen is converted at the boundary layer between the cathode and electrolyte. An electron emission current flows between the lead anode and cathode and via a resistor, where a measured voltage is present. This measured voltage is proportional to the concentration of oxygen in the sample gas.

The acidic electrolyte used is less influenced by interference influences (particularly CO₂, CO, H₂, and CH₄) than other sensor types.

Paramagnetic oxygen measurement

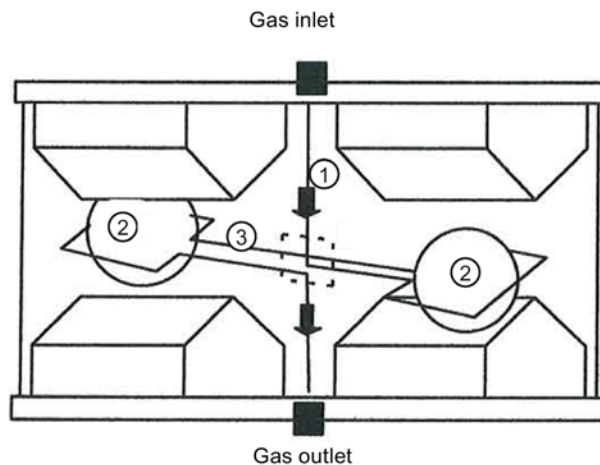

Figure 3-6 Operating principle of the paramagnetic O₂ sensor

In contrast to other gases, oxygen is highly paramagnetic. This property is used as the basis for this method of measurement.

Two permanent magnets generate an inhomogeneous magnetic field in the measuring cell. If oxygen molecules flow into the measuring cell (1), they are drawn into the magnetic field. This results in the two diamagnetic hollow spheres (2) being displaced out of the magnetic field. This rotary motion is recorded optically, and serves as the input variable for control of a compensation flow. This generates a torque opposite to the rotary motion around the two hollow spheres by means of a wire loop (3). The compensation current is proportional to the concentration of oxygen.

The calibration point is calibrated using the AUTOCAL function by connecting oxygen (analogous to calibration of the electrochemical O₂ sensor). In order to comply with the technical data, the zero point of the paramagnetic measuring cell must be calibrated with nitrogen weekly in the case of all measuring ranges < 5% or every two months in the case of all larger measuring ranges.

Electrochemical hydrogen sulfide measurement

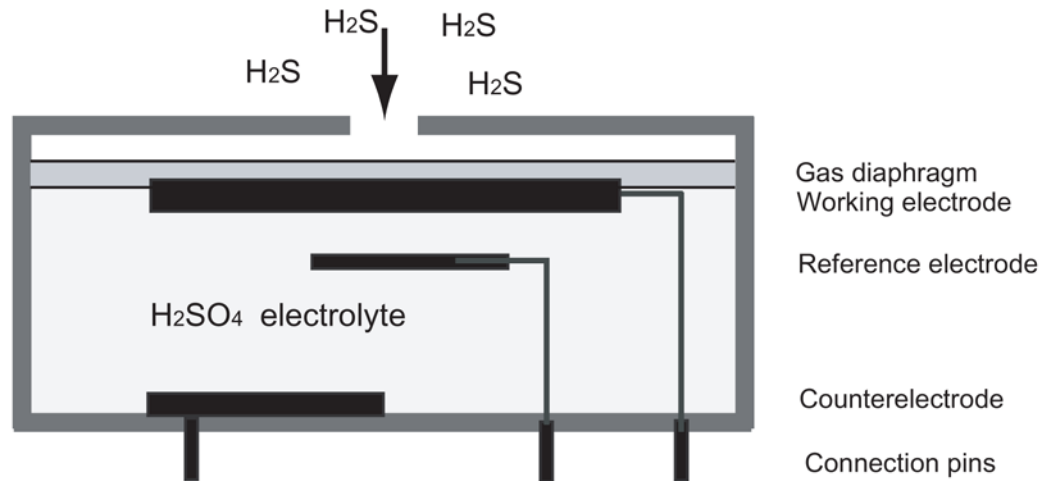

Figure 3-7 Operating principle of H_2S sensor

The hydrogen sulfide (H_2S) enters through the diffusion barrier (gas diaphragm) into the sensor and is oxidized at the working electrode. A reaction in the form of a reduction of atmospheric oxygen takes place on the counter electrode. The transfer of electrons can be tapped on the connector pins as a current which is directly proportional to the gas concentration.

The zero point is automatically recalibrated by the AUTOCAL function when connecting e.g. nitrogen or air.

Automatic calibration of IR components with air (AUTOCAL)

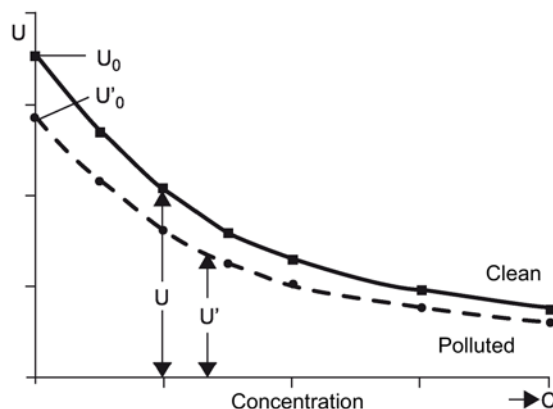

Figure 3-8 Calibration

The ULTRAMAT 23 can be calibrated using, for example, ambient air. During this process (between 1 and 24 hours (adjustable), 0 = no AUTOCAL), the analyzer chamber is purged with air. The detector then generates the largest signal U_0 (no pre-absorption in the analyzer chamber). This signal is used as the reference signal for zero point calibration. The signal U_0 also serves as the initial value for calculating the full-scale value.

As the concentration of the measured component increases, so too does absorption in the analyzer chamber. As a result of this preabsorption, the detectable radiation energy in the detector decreases, and thus also the signal voltage. For the single-beam procedure of the ULTRAMAT 23, the mathematical relationship between the concentration of the measured component and the measured voltage can be approximately expressed as the following exponential function:

$U = U_0 \cdot e^{-kc}$ with the following parameters:

- c Concentration
- k Unit-specific constant
- U_0 Basic signal with zero gas (sample gas without measured component)
- U Detector signal

Changes in the radiation power, contamination of the analyzer chamber, or aging of the detector components have the same effect on both U_0 and U, and result in the following:

$$U' = U'_0 \cdot e^{-kc}$$

Apart from being dependent on concentration c, the measured voltage thus changes continuously as the IR source ages, or with persistent contamination.

Each AUTOCAL thus tracks the total characteristic according to the currently valid value, thereby also compensating temperature and pressure influences.

The influences of contamination and aging, as mentioned above, will have a negligible influence on the measurement as long as U' remains within a certain tolerance range monitored by the unit. The tolerance range between two or more AUTOCAL procedures can be individually parameterized on the ULTRAMAT 23 and a warning output in the event of deviations. A fault message is output when the value falls below the original factory setting of $U_0 < 50\% U$. In most cases, this is due to the analyzer chamber being contaminated.

The units can be set to automatically calibrate the zero point every 1 to 24 hours, using ambient air or nitrogen. The calibration point for the IR-sensitive components is calculated mathematically from the newly determined U'_0 and the device-specific parameters stored as default values. It is recommendable to check the calibration point once a year using a calibration gas. For details on TÜV measurements, see Table "Calibration intervals (TÜV versions)" in section Infrared detector (Page 35).

If an electrochemical O₂ sensor is installed, it is recommendable to use air for the AUTOCAL. In addition to calibration of the zero point of the IR-sensitive components, automatic calibration of the calibration point of the electrochemical O₂ sensor is carried out simultaneously. The characteristic of the O₂ sensor is sufficiently stable following the single-point calibration such that the zero point of the electrochemical O₂ sensor need only be checked once a year by connecting nitrogen.

3.4 Technical specifications

3.4.1 General technical data

General information	
Measured components	Maximum of 4, comprising up to three infrared-sensitive gases as well as oxygen and/or hydrogen sulfide (H ₂ S is not available with 3 infrared-sensitive gases)
Measuring ranges	2 per component
Characteristics	Linearized
Operator panel	LCD with LED backlighting and contrast control, 80 characters (4 lines à 20 characters); function keys
Operating position	Front panel vertical
Shocks / maximum vibration	No shocks; maximum vibration 5 m/s ²
Software release of TÜV version (7MB235x)	3.00.07
Enclosure	
Weight	Approx. 10 kg (22 lbs.) The weight varies according to the ordered variant.
Degree of protection	IP40 in accordance with EN 60529 for the versions 7MB235x (TÜV) IP20 in accordance with EN 60529 for the versions 7MB233x (standard)

Description

3.4 Technical specifications

Electrical characteristics

EMC interference immunity (with safety extra-low voltage (SELV) with safe isolation)	In accordance with standard requirements of NAMUR NE21 or EN 61326-1
Power supply	100 V AC, +10%/-15%, 50 Hz, 120 V AC, +10%/-15%, 50 Hz, 200 V AC, +10%/-15%, 50 Hz, 230 V AC, +10%/-15%, 50 Hz, 100 V AC, +10%/-15%, 60 Hz, 120 V AC, +10%/-15%, 60 Hz, 230 V AC, +10%/-15%, 60 Hz
Power consumption	Approx. 60 VA depending on ordered version

Electrical inputs and outputs

Analog outputs	1 analog current output per component, 0/2/4/NAMUR ... 20 mA, floating, max. load 750 Ω
Relay outputs	8, with changeover contacts, freely selectable, e.g. for fault, loading capacity 24 V AC/DC/1 A, floating, non-sparking
Binary inputs	3, dimensioned for 24 V, floating <ul style="list-style-type: none">• Pump• AUTOCAL• Synchronization
Serial interface	ELAN (RS485), PROFIBUS-PA/DP as option
AUTOCAL function	Automatic calibration with ambient air or nitrogen (depending on measured component), adjustable cycle time from 0 (1) ... 24 hours
Options	Add-on electronics, with 8 additional digital inputs and 8 additional relay outputs, for e.g. triggering of automatic calibration, PROFIBUS PA/DP

Climatic conditions

Permissible ambient temperature	
<ul style="list-style-type: none">• During operation• During transportation and storage	See specific technical specifications for IR detector/sensors (Infrared detector (Page 35)) See specific technical specifications for IR detector/sensors (Infrared detector (Page 35))
Permissible ambient humidity	< 90% RH (relative humidity) during transportation and storage (Delivery information (Page 14))
Permissible ambient pressure	See specific technical specifications for IR detector/sensors (Infrared detector (Page 35))
Maximum operating altitude	2000 m above sea level
Pollution degree	2

Gas inlet conditions

Sample gas pressure

- Without pump Unpressurized (< 1200 hPa (17.4 psi) absolute)
 - With pump Unpressurized suction mode, set in factory with 2 m (6 1/2 ft) hose at sample gas outlet; full-scale value calibration necessary under different venting conditions
-

Sample gas flow 72 ... 120 l/h (1.2 .. 2 l/min)

Sample gas temperature 0 ... 50 °C (32 ... 122 °F)

Sample gas humidity < 90 % RH (relative humidity), non-condensing

Note

Since measuring ranges can be changed, all accuracy data applies to the ranges specified on the label!

3.4.2 Parts in gas path wetted by sample gas

Gas path	19" rack unit	Bench-top unit	
With hoses	Condensation trap at gas inlet	--	PA6 (polyamide)
	Condensation trap	--	PE (polyethylene)
	Gas connections 6 mm	PA6 (polyamide)	PA6 (polyamide)
	Gas connections ¼"	Stainless steel 1.4571	Stainless steel 1.4571
	Hose	FKM	FKM
	Pressure switch	PTFE + PA6 (polyamide)	PTFE + PA6 (polyamide)
	Flowmeter	Borosilicate glass/steel 1.4878	Borosilicate glass/steel 1.4878
	Elbows/T-pieces	PA6	PA6
	Internal pump (optional)	PVDF/PTFE/FKM/HD-PE/ stainless steel 1.4571	PVDF/PTFE/FPM/HD-PE/ stainless steel 1.4571
	Solenoid valve	FPM70/PA6/ stainless steel 1.4310/1.4305	FPM70/PA6/ stainless steel 1.4310/1.4305
	Safety condensation trap	PA66/NBR/PA6	PA66/NBR/PA6
	Analyzer chamber		
	• Body	Aluminum	Aluminum
• Lining	Aluminum	Aluminum	
• Nozzle	Stainless steel 1.4571	Stainless steel 1.4571	
• Window	CaF ₂	CaF ₂	
• Adhesive	Epoxy resin	Epoxy resin	
• O-ring	FKM	FKM	
Piped (only possible without pump)	Gas connections 6 mm / ¼"	Stainless steel 1.4571	
	Pipes	Stainless steel 1.4571	
Analyzer chamber			
• Body	Aluminum	Aluminum	Aluminum
• Lining	Aluminum	Aluminum	Aluminum
• Nozzle	Stainless steel 1.4571	Stainless steel 1.4571	Stainless steel 1.4571
• Window	CaF ₂	CaF ₂	CaF ₂
• Adhesive	Epoxy resin-based adhesive	Epoxy resin-based adhesive	Epoxy resin-based adhesive
• O-ring	FKM	FKM	FKM

 **WARNING**
Operation of analyzers in hazardous areas

For safe operation of the analyzer in hazardous areas, it is essential to observe the information and conditions referred to in "Information pursuant to ATEX for use in hazardous areas" (Order No.: A5E37888334)

3.4.3 Infrared detector

General information	
Measuring ranges	See ordering data
Chopper section purging	
<ul style="list-style-type: none"> Inlet pressure Purging gas consumption 	Approx. 3000 hPa (43.5 psi) absolute Approx. 100 ml/min
Time response	
Warm-up period	Approx. 30 minutes at room temperature. The measured values are invalid for the first 30 minutes following switch-on. The maximum accuracy is achieved after approx. 2 hours
Response time (T_{90} time)	Dependent on length of analyzer chamber, sample gas feed line and parameterizable attenuation
Damping (electronic time constant)	0 ... 99,9 s, adjustable
Measuring response	
Output signal noise	< ± 1 % of the current measuring range (see label)
Display resolution	Depends on the selected measuring range
Output signal resolution	< 0.1% of output signal span
Linearity error	In largest possible measuring range: < ± 1 % of full-scale value In smallest possible measuring range: < 2 % of full-scale value
Repeatability	$\leq \pm 1$ % of current measuring range
Climatic conditions	
Permissible ambient temperature	
<ul style="list-style-type: none"> During operation During transportation and storage 	+5 ... +45 °C (41 ... 113 °F) -20 ... +60 °C (-4 ... 140 °F)
Permissible ambient humidity	< 90% RH (relative humidity) during transportation and storage
Permissible ambient pressure	600 ... 1200 hPa absolute
Maximum operating altitude	2000 m above sea level

Description

3.4 Technical specifications

Influencing variables

Drift	
• With AUTOCAL	Negligible
• Without AUTOCAL	< 2 % of smallest measuring range/week
Temperature	max. 2 % of smallest possible measuring range according to label per 10 K with an AUTOCAL cycle time of 6 h
Air pressure	< 0.2 % of measuring range per 1 % change in pressure
Power supply	< 0.1 % of output signal span with a variation of ± 10 %
Line frequency	± 2 % of full-scale value with a frequency variation of ± 5 %

Deviations with measuring range 0 ... 200 mg/m³ SO₂

(analyzer versions 7MB2335-xNBxx-xAAx, 7MB2337-xNBxx, 7MB2337-xxxx-xNBx, 7MB2338-xxxx-xNBx)

Availability	Max. 95 %
AUTOCAL cycle time	Max. 6 h
Temperature variations	Max. 1 °C (1.8 °F) The device must not be operated in an area subject to drafts. This is especially valid for the rear panel with large cooling element.
Other	This measuring range has not been suitability-tested.

Deviations with measuring range 0 ... 100 mg/m³ SO₂

(analyzer versions 7MB2335-xNTxx-xAAx, 7MB2337-xNTxx-xxxx, 7MB2337-xxxx-xNTx, 7MB2338-xxxx-xNTx)

Delayed display (T ₉₀ time)	Depending on the external gas conditioning. Note: SO ₂ is highly soluble in water
Output signal resolution	≤ 0.1 mg/m ³
Linearity error	≤ 2 mg/m ³ (2% of smallest measuring range)
Drift	
• With constant ambient conditions	≤ 0.33 mg/m ³ per hour after a running-in period of 200 hours
• After temperature jump	Not defined
Temperature influence	≤ 8 mg/m ³ per 10 K deviation; additional drift after temperature jump
Influence of auxiliary power	≤ 0.4 mg/m ³ with a change of ± 10 %
Influence of line frequency	≤ 8 mg/m ³ with a change of ± 5 %
Cross-sensitivities	Refer to following table
Availability	Max. 95 %
AUTOCAL cycle time	Max. 3 h
Temperature variations	Max. 1 °C (1.8 °F) The device must be operated at a constant ambient temperature. The device must not be operated in an area subject to drafts. This is especially valid for the rear panel with large cooling element.
Other	This measuring range has not been suitability-tested.

Cross-sensitivities of measuring range 0 ... 100 mg/m³ SO₂**(analyzer versions 7MB2335-xNTxx-xAAx, 7MB2337-xNTxx-xxxx, 7MB2337-xxxx-xNTx, 7MB2338-xxxx-xNTx)**

The cross-sensitivities have been optimized. Typical results are:

Measured component	mg/m ³ SO ₂ at zero point	mg/m ³ SO ₂ at reference point
O ₂ - 3 vol %	SO ₂ 2.4	- 1.2
O ₂ - 21 vol %	1.2	- 1.7
CO - 300 mg/m ³	- 3.5	- 0.4
CO ₂ - 15 vol %	- 0.8	- 0.6
CH ₄ - 50 mg/m ³	2.8	4.0
N ₂ O - 100 mg/m ³	- 1.2	- 0.3
NO - 300 mg/m ³	- 1.3	1.9
NO ₂ - 30 mg/m ³	- 1.2	- 1.8
NH ₃ - 20 mg/m ³	- 0.3	1.1
HCl - 200 mg/m ³	- 7.5	4.9
Water vapor at dew point 4 °C (39 °F)	1.5 mg/m ³ per 1 °C (1.8 °F) variation in dew point	

Table 3- 2 Calibration interval for device series 7MB235x (TÜV versions of the 7MB233x series; as of February 2016)

Component	Smallest measuring range (TÜV versions)	Calibration interval	Remarks
CO	0 ... 150 mg/m ³	5 months	13th/27th BImSchV
CO	0 ... 250 mg/m ³	12 months	13th/27th BImSchV
NO	0 ... 100 mg/m ³	5 months	13th/27th BImSchV
NO	0 ... 250 mg/m ³	12 months	13th/27th BImSchV
SO ₂	0 ... 400 mg/m ³	12 months	13th/27th BImSchV
N ₂ O	0 ... 500 ppm		Kyoto protocol
N ₂ O	0 ... 50 mg/m ³	6 months	30th BImSchV

Maintenance interval for device series 7MB235x: See the current certificate in accordance with EN 15267.**Note****Device series 7MB235x**

- The table version is as of February 2016
- The specified maintenance intervals refer to the Set CEM CERT systems.
- Also refer to the current certificates in accordance with EN 15267.
- The current certificates can always be found on the Internet at: Approvals and certificates (<https://support.industry.siemens.com/cs/de/en/ps/17728>)

3.4.4 Electrochemical oxygen sensor

General	
Measuring ranges	0 ... 5% to 0 ... 25% O ₂ , parameterizable
Associated gases	The oxygen sensor must not be used if the associated gas contains the following components: <ul style="list-style-type: none"> • Chlorine or fluorine compounds • Heavy metals • Aerosols • Mercaptans • Alkaline components (e.g. NH₃ in % range)
Service life	Approx. 2 years with 21% O ₂
Time response	
Response time (T ₉₀ time)	Dependent on dead time and parameterizable damping, <30 s with sample gas flow of approx. 1.2 l/min
Measuring response	
Output signal noise	< 0.5% of the full-scale value
Display resolution	< 0.2% of the full-scale value
Output signal resolution	< 0.2% of the output signal span
Reproducibility	≤ 0.05% O ₂
Climatic conditions	
Permissible ambient temperature	
• During operation	+5 ... +45 °C (41 ... 113 °F)
• During transportation and storage	-20 ... +60 °C (-4 ... 140 °F)
Permissible ambient humidity	< 90% RH (relative humidity) during transportation and storage
Permissible ambient pressure	600 ... 1200 hPa absolute
Maximum operating altitude	2000 m above sea level

Influencing variables

Oxygen content	In the case of occasional operation < 1% O ₂ , the measuring accuracy below 1% O ₂ is limited. An improvement in the measuring accuracy at concentrations <1% O ₂ is possible under the following conditions: <ul style="list-style-type: none"> • Permanent measurement of concentrations <1% • No mixed operation with occasionally high concentrations and occasionally low concentrations (brief high concentrations e.g. by means of an AUTOCAL with air at intervals of at least 3 hours are permissible)
Typical combustion exhaust gases	Influence: < 0.05% O ₂
Humidity	H ₂ O dew point ≥ 2 °C (36 °F); the oxygen sensor must not be used with dry sample gases (no condensation)
Drift	
<ul style="list-style-type: none"> • With AUTOCAL • Without AUTOCAL 	Negligible 1% O ₂ /year in air, typical
Temperature	<0.5% O ₂ per 20 K, relating to a measured value at 20 °C (68 °F)
Air pressure	< 0.2% of measured value per 1% pressure change

3.4.5 Paramagnetic oxygen sensor**General information**

Measuring ranges	2 per component Min. 0 ... 2 vol % O ₂ (limited accuracy) 0 ... 100 vol % O ₂
Permissible ambient pressure	700 ... 1 200 hPa absolute
Permissible operating temperature	5 ... 45 °C (41 ... 113 °F)

Measuring response

Response time (T ₉₀ time)	<60 s
Output signal noise	< 1% of smallest measuring range
Reproducibility	≤ 1% of smallest measuring range

Description

3.4 Technical specifications

Climatic conditions

Permissible ambient temperature	
• During operation	+5 ... +45 °C (41 ... 113 °F)
• During transportation and storage	-20 ... +60 °C (-4 ... 140 °F)
Permissible ambient humidity	< 90% RH (relative humidity) during transportation and storage
Permissible ambient pressure	600 ... 1200 hPa absolute
Maximum operating altitude	2000 m above sea level

Influencing variables

Cross-inferences (interfering gases)	See table of cross-sensitivities
Zero drift (vol % O ₂)	Measuring range 2%: max. 0.1% with weekly zero adjustment Measuring range 5%: max. 0.1% with weekly zero adjustment Measuring range 25% or greater: max. 0.5% with monthly zero adjustment
Temperature error (vol % O ₂)	<2% /10 K referred to measuring range 5% <5% /10 K referred to measuring range 2%
Humidity error (vol % O ₂) for N ₂ with 90% relative humidity after 30 min	<0.6% at 50 °C (122 °F)
Air pressure	< 0.2% of measured value per 1% pressure change

Cross-sensitivities

All values in this table refer to a zero calibration with nitrogen and a full-scale calibration with 100 vol. % oxygen. The deviations apply to 100 vol. % of the associated gas, and must be considered proportionally for the zero calibration.

Gas	Formula	Deviation at 20 °C	Deviation at 50 °C
Acetyl aldehyde	C ₂ H ₄ O	- 0.31	- 0.34
Acetone	C ₃ H ₆ O	- 0.63	- 0.69
Acetylene, ethine	C ₂ H ₂	- 0.26	- 0.28
Ammonia	NH ₃	- 0.17	- 0.19
Argon	Ar	- 0.23	- 0.25
Benzene	C ₆ H ₆	- 1.24	- 1.34
Bromine	Br ₂	- 1.78	- 1.97
Butadiene	C ₄ H ₆	- 0.85	- 0.93
n-butane	C ₄ H ₁₀	- 1.10	- 1.22
Iso-butylene	C ₄ H ₈	- 0.94	- 1.06
Chlorine	Cl ₂	- 0.83	- 0.91
Diacetylene	C ₄ H ₂	- 1.09	- 1.20
Dinitrogen monoxide	N ₂ O	- 0.20	- 0.22
Ethane	C ₂ H ₆	- 0.43	- 0.47
Ethyl benzene	C ₈ H ₁₀	- 1.89	- 2.08
Ethylene, ethene	C ₂ H ₄	- 0.20	- 0.22
Ethylene glycol	C ₂ H ₆ O ₂	- 0.78	- 0.88
Ethylene oxide	C ₂ H ₄ O	- 0.54	- 0.60

Cross-sensitivities

All values in this table refer to a zero calibration with nitrogen and a full-scale calibration with 100 vol. % oxygen. The deviations apply to 100 vol. % of the associated gas, and must be considered proportionally for the zero calibration.

Gas	Formula	Deviation at 20 °C	Deviation at 50 °C
Furane	C ₄ H ₄ O	- 0.90	- 0.99
Helium	He	+ 0.29	+ 0.32
n-hexane	C ₆ H ₁₄	- 1.78	- 1.97
Hydrogen chloride, hydrochloric acid	HCl	- 0.31	- 0.34
Hydrogen fluoride, hydrofluoric acid	HF	+ 0.12	+ 0.14
Carbon dioxide	CO ₂	- 0.27	- 0.29
Carbon monoxide	CO	- 0.06	- 0.07
Krypton	Kr	- 0.49	- 0.54
Methane	CH ₄	- 0.16	- 0.17
Methanol	CH ₄ O	- 0.27	- 0.31
Methylene chloride	CH ₂ Cl ₂	- 1.00	- 1.10
Monosilane, silane	SiH ₄	- 0.24	- 0.27
Neon	Ne	+ 0.16	+ 0.17
n-octane	C ₈ H ₁₈	- 2.45	- 2.70
Phenol	C ₆ H ₆ O	- 1.40	- 1.54
Propane	C ₃ H ₈	- 0.77	- 0.85
Propylene, propene	C ₃ H ₆	- 0.57	- 0.62
Propylene chloride	C ₃ H ₇ Cl	- 1.42	- 1.44
Propylene oxide	C ₃ H ₆ O	- 0.90	- 1.00
Oxygen	O ₂	+ 100.00	+ 100.00
Sulfur dioxide	SO ₂	- 0.18	- 0.20
Sulfur hexafluoride	SF ₆	- 0.98	- 1.05
Hydrogen sulfide	H ₂ S	- 0.41	- 0.43
Nitrogen	N ₂	0.00	0.00
Nitrogen dioxide	NO ₂	+ 5.00	+ 16.00
Nitrogen monoxide	NO	+ 42.70	+ 43.00
Styrene	C ₈ H ₈	- 1.63	- 1.80
Toluene	C ₇ H ₈	- 1.57	- 1.73
Vinyl chloride	C ₂ H ₃ Cl	-0.68	- 0.74
Vinyl fluoride	C ₂ H ₃ F	- 0.49	- 0.54
Water (vapor)	H ₂ O	- 0.03	- 0.03
Hydrogen	H ₂	+ 0.23	+ 0.26
Xenon	Xe	- 0.95	- 1.02

3.4.6 Hydrogen sulfide sensor

H₂S sensor for measuring range from 5 to 50 vpm H₂S

General information	
Measuring ranges	
• Smallest measuring range	0 ... 5 vpm
• Largest measuring range	0 ... 50 vpm
Service life of the sensor	Approx. 12 months
Operation mode	Continuous measurement between 0 and 12.5 vpm Discontinuous measurement between 12.5 and 50 vpm
AUTOCAL	Cyclic adjustment (see H ₂ S sensor with 'small' measuring range (Page 161))

Climatic conditions	
Permissible ambient temperature	
• During operation	+5 ... +40 °C (41 ... 104 °F)
• During transportation and storage	-10 ... +55 °C (14 ... 131 °F)
Permissible ambient pressure	750 ... 1200 hPa absolute
Maximum operating altitude	2000 m above sea level

Influencing variables	
Associated gases	The hydrogen sulfide sensor cannot be used if the associated gas contains the following components: <ul style="list-style-type: none">• Compounds containing chlorine• Compounds containing fluorine• Heavy metals• Aerosols• Alkaline components (e.g. NH₃ >5 mg/m³)
Cross-interference (interfering gases)	1360 vpm SO ₂ result in a cross-interference of <20 vpm H ₂ S, 180 vpm NO result in a cross-interference of <150 vpm H ₂ S, no cross-interference of CH ₄ , CO ₂ and H ₂ (1000 vpm)
Drift	< 1% per month
Temperature	< 3%/10 K referred to full-scale value
Air pressure	< 0.2 % of measured value per 1% pressure change

Note
Measuring ranges
The exact specification of the largest and smallest H₂S ranges can be found on the label!

3.5 Wiring diagrams

3.5.1 Gas flow diagram

Legend for the gas flow diagrams

- 1 Inlet for sample gas/calibration gas
- 2 Gas outlet
- 3 Inlet for AUTOCAL/zero gas or
inlet for sample gas/calibration gas (channel 2)
- 4 Gas outlet (channel 2)
- 5 Enclosure purging
- 6 Inlet of atmospheric pressure sensor
- 7 Inlet of chopper compartment flushing
- 8 Condensation trap with filter
- 9 Fine safety filter*
- 10 Solenoid valve
- 11 Sample gas pump
- 12 Pressure switch
- 13 Flow indicator
- 14 IR analyzer unit
- 15 Safety condensation trap
- 16 Oxygen sensor (electrochemical)
- 17 Atmospheric pressure sensor
- 18 Hydrogen sulfide sensor
- 19 Oxygen sensor (paramagnetic)

The variant with specially cleaned gas path (Cleaned for O₂) -B06) does not contain a fine safety filter in the sample gas path.

Description

3.5 Wiring diagrams

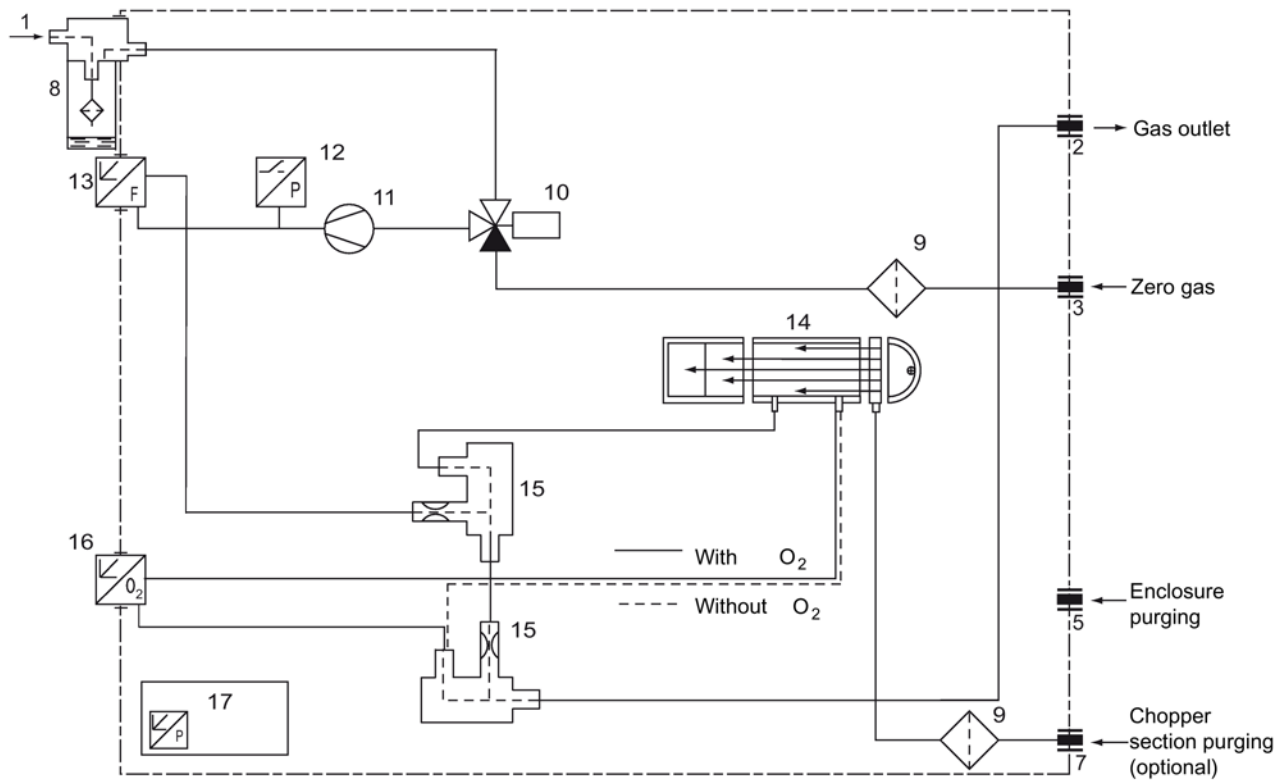

Figure 3-9 ULTRAMAT 23, bench-top unit with internal sample gas pump, condensation trap and fine safety filter on front plate; optional oxygen measurement

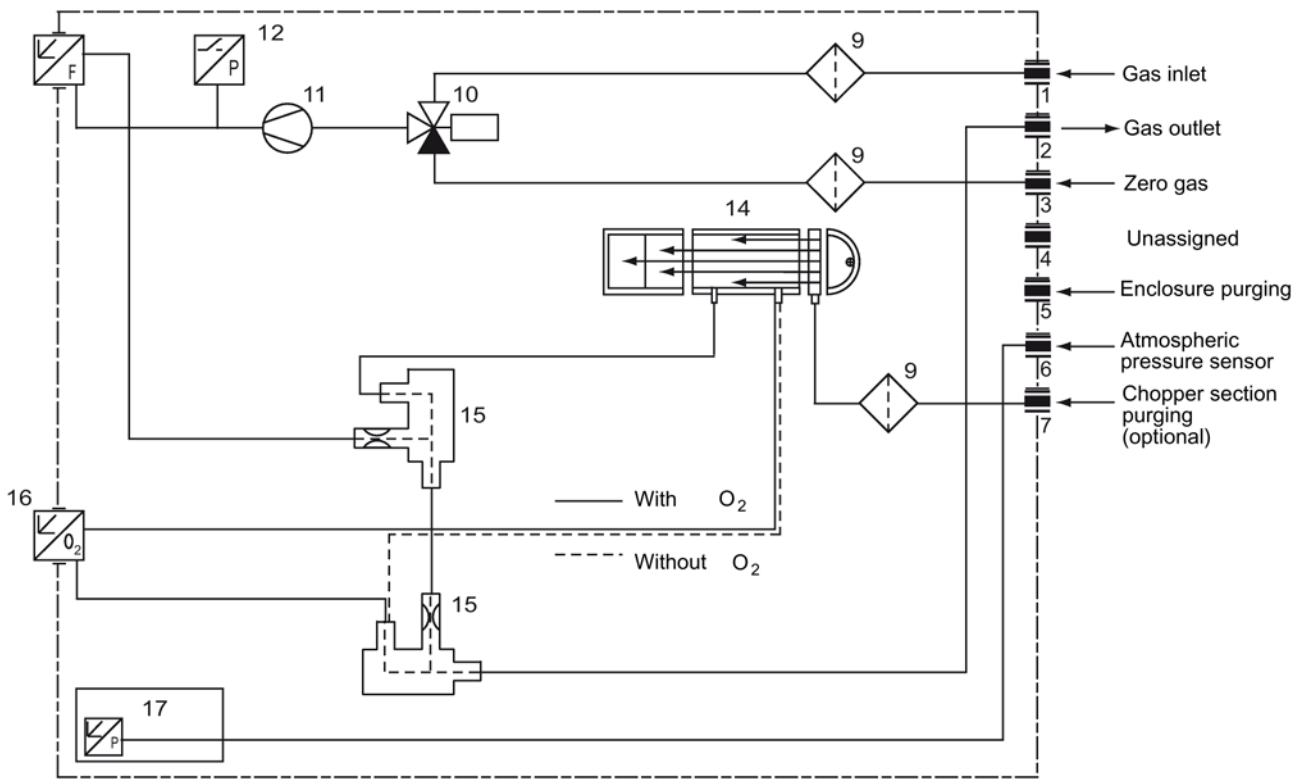

Figure 3-10 ULTRAMAT 23, 19" rack unit enclosure with internal sample gas pump; optional oxygen measurement

Description

3.5 Wiring diagrams

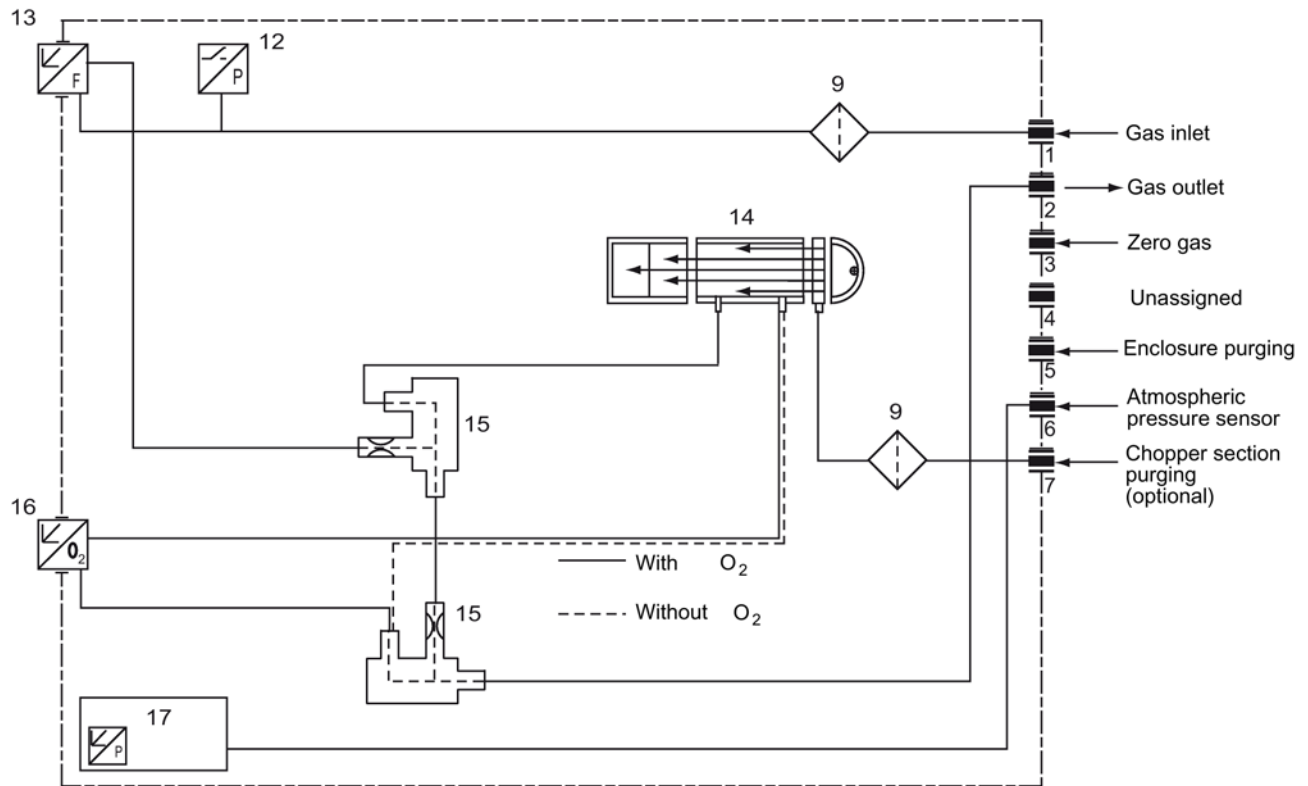

Figure 3-11 ULTRAMAT 23, 19" rack unit enclosure without internal sample gas pump; optional oxygen measurement

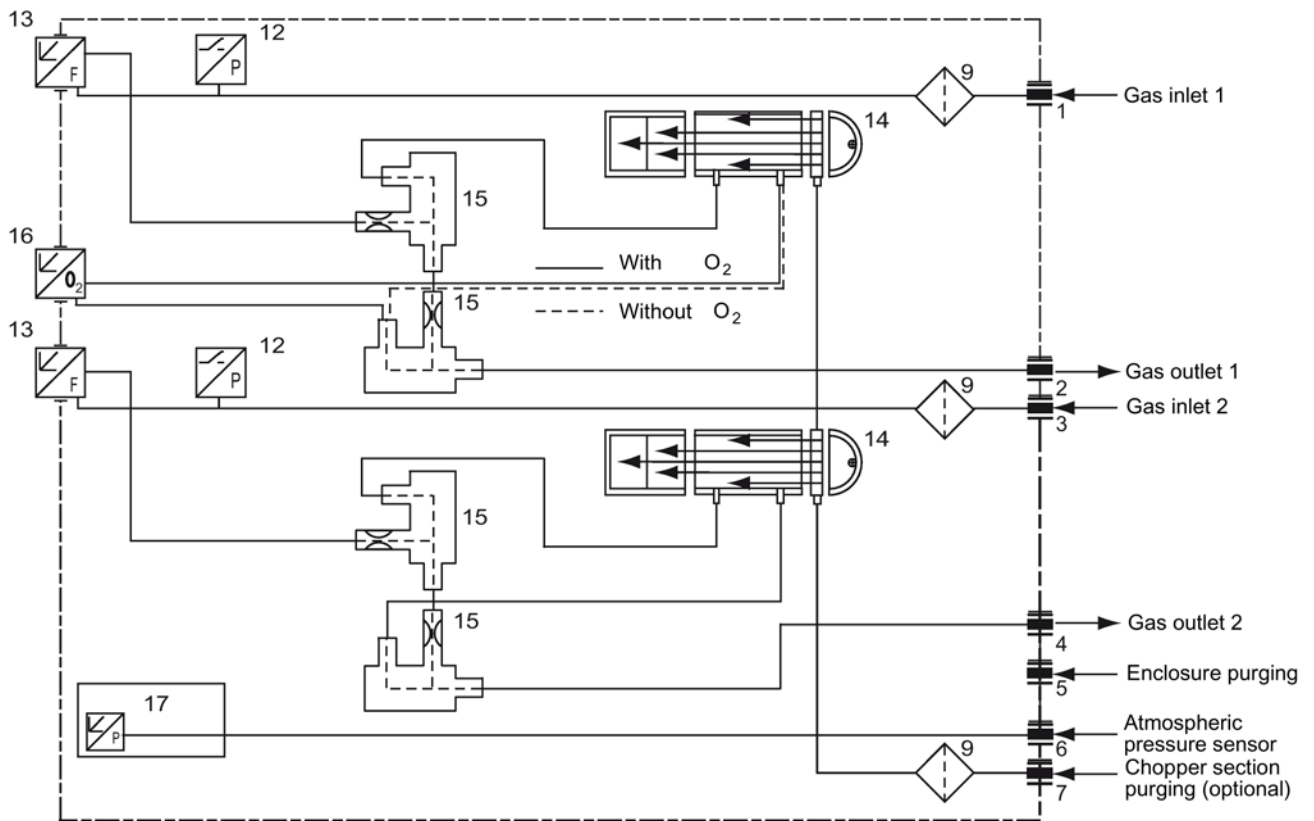

Figure 3-12 ULTRAMAT 23, 19" rack unit enclosure without internal sample gas pump; with separate gas path for further IR components; optional oxygen measurement

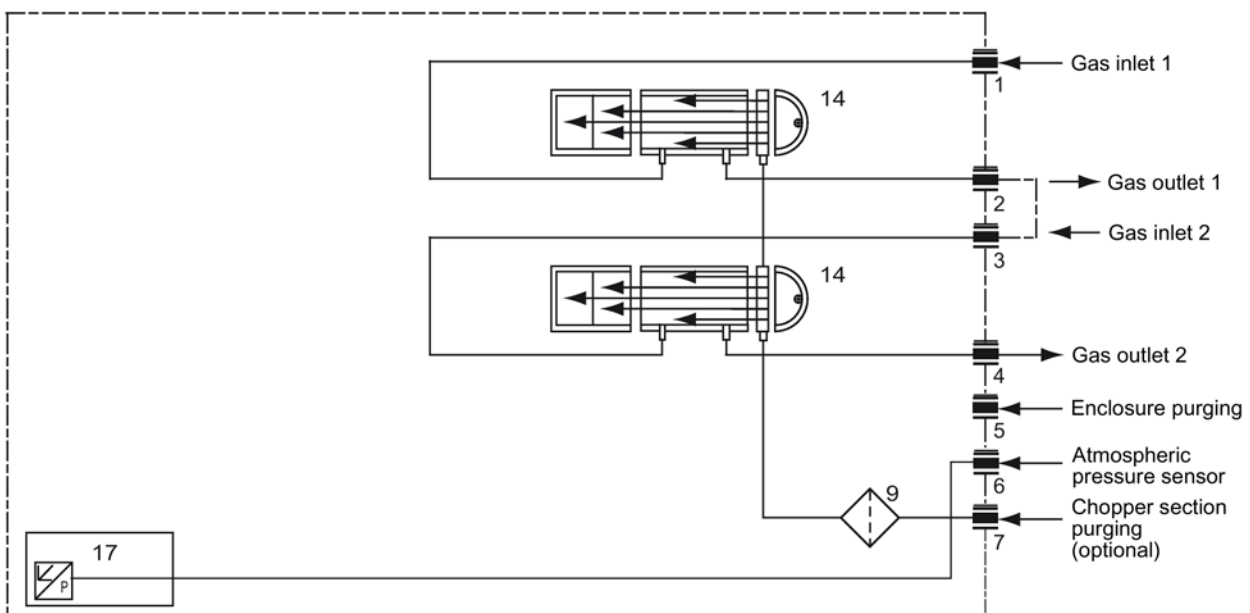

Figure 3-13 ULTRAMAT 23, 19" rack unit enclosure without internal sample gas pump; sample gas path as pipes without safety filter or safety condensation trap; optional separate gas path

Description

3.5 Wiring diagrams

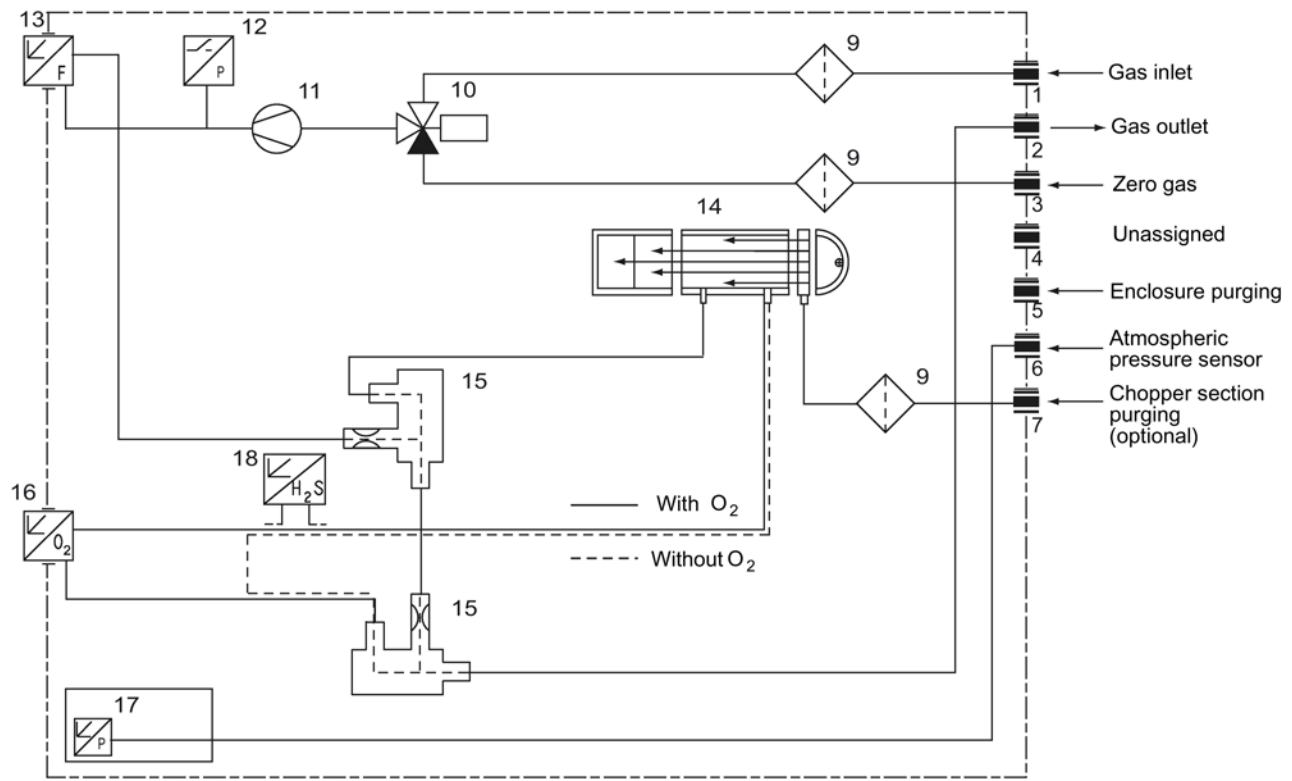

Figure 3-14 ULTRAMAT 23, 19" rack unit enclosure with internal sample gas pump and hydrogen sulfide sensor

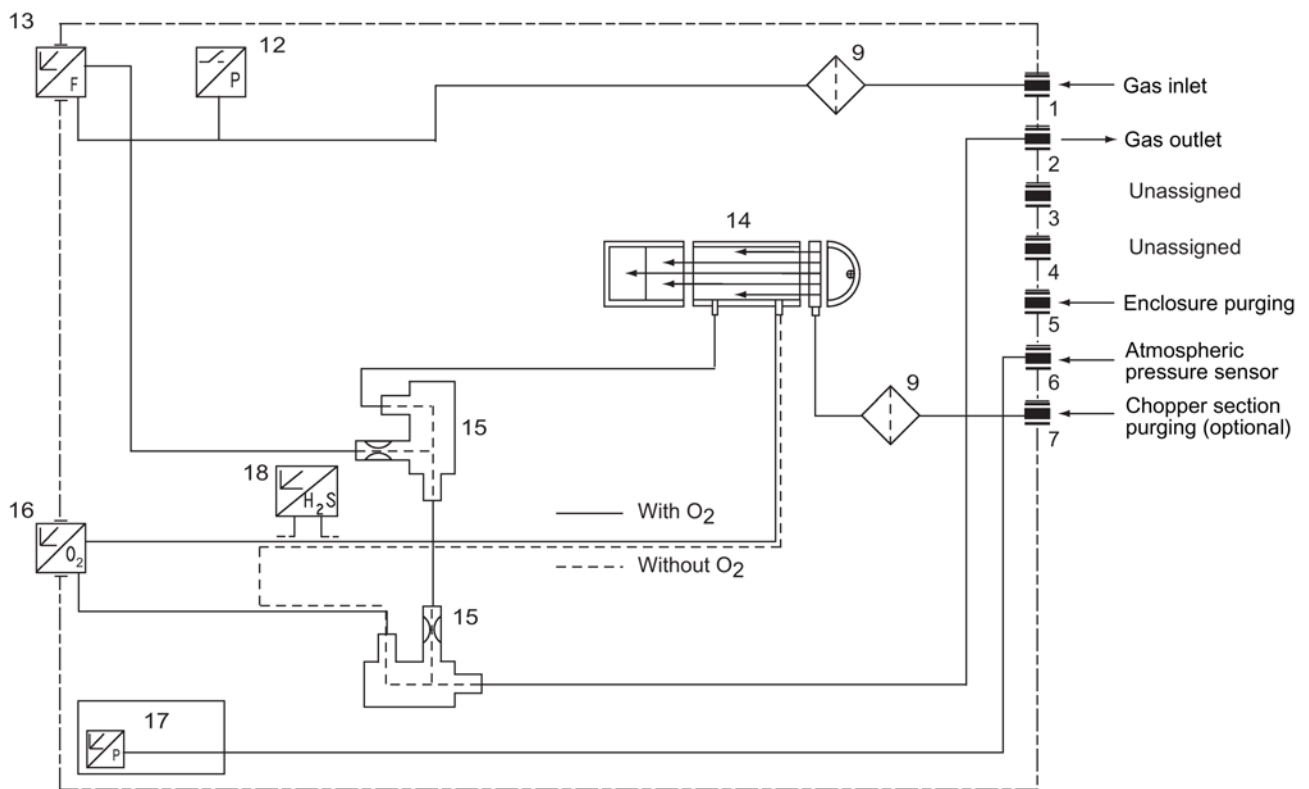

Figure 3-15 ULTRAMAT 23, 19" rack unit enclosure with hydrogen sulfide sensor without internal sample gas pump

Description

3.5 Wiring diagrams

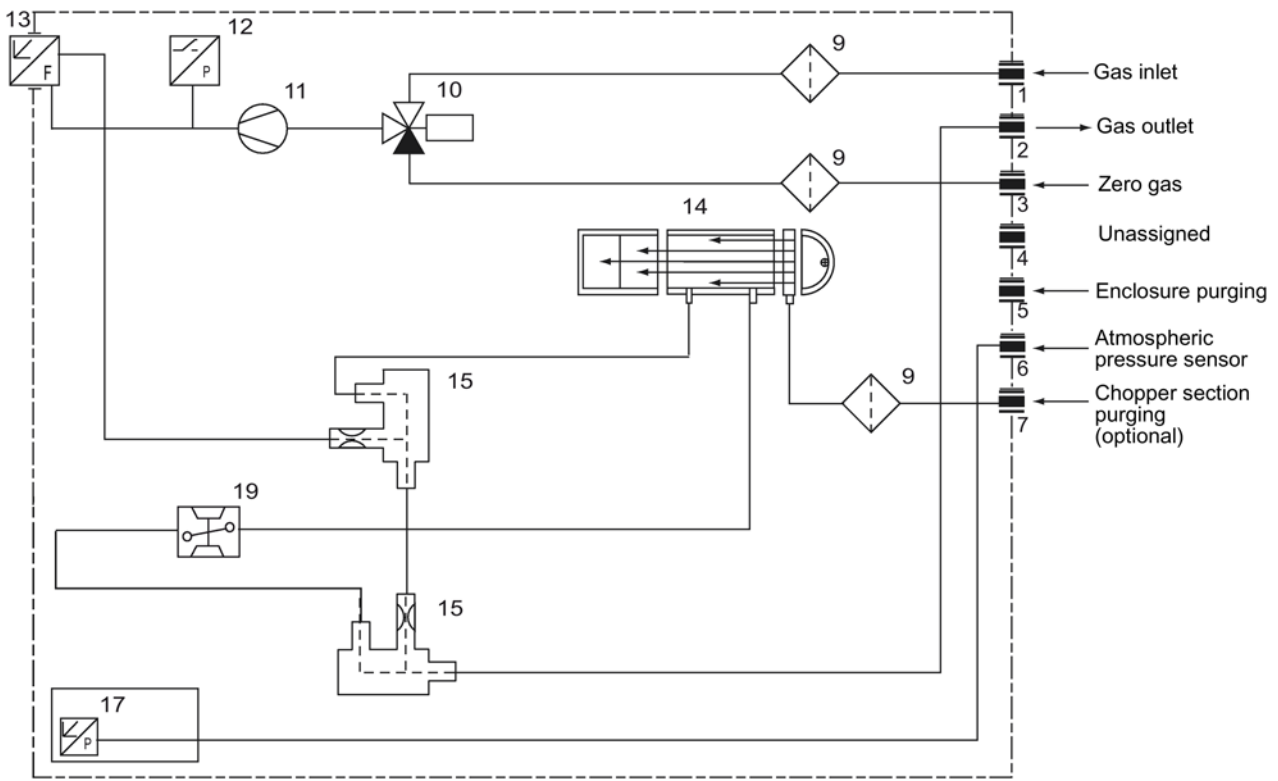

Figure 3-16 ULTRAMAT 23, 19" rack unit enclosure with internal sample gas pump and paramagnetic oxygen sensor

3.5.2 Gas connections

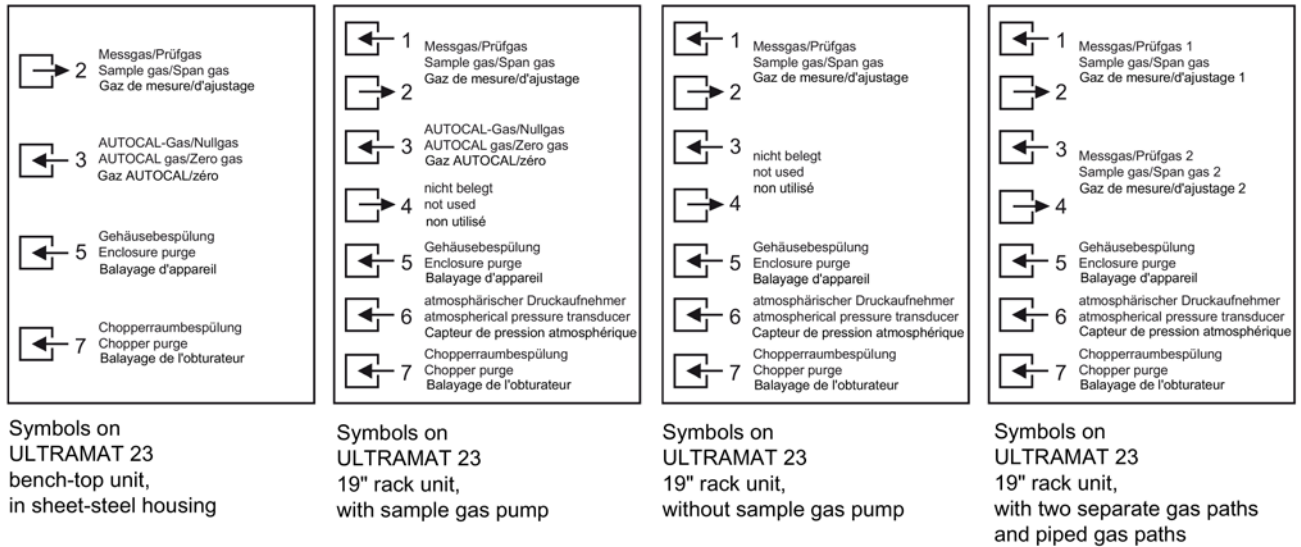
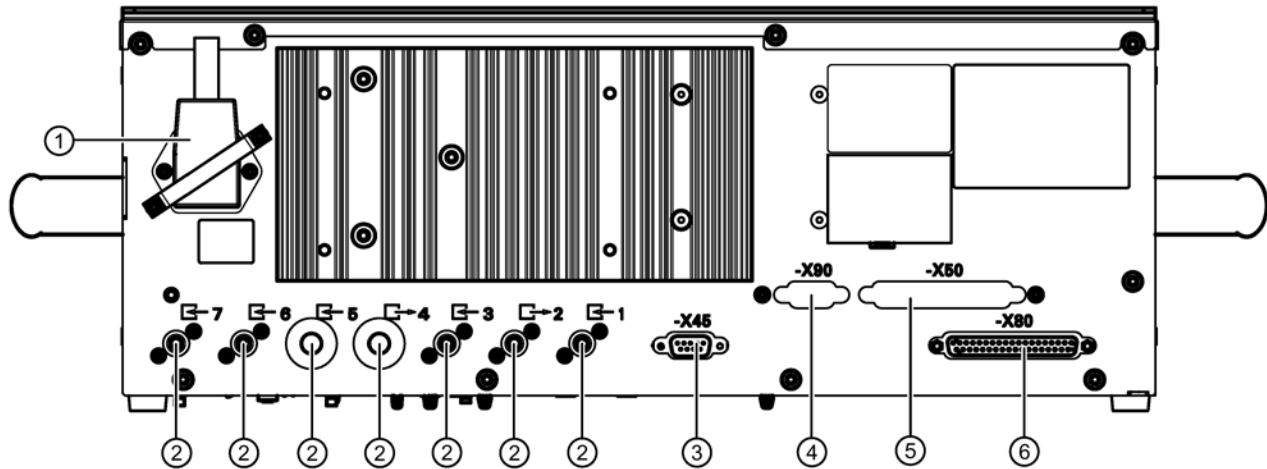

Figure 3-17 Gas connections of ULTRAMAT 23 versions

The positions of the connections on the devices are shown in the connection diagrams in section Connection diagrams (Page 52).

3.5.3 Connection diagrams

Bench-top unit



- ① Power connector
- ② Gas connections: 6 mm nozzles; see section Gas connections (Page 51)
- ③ -X45: ELAN (RS485) 9-pin connector
- ④ -X90: 9-pin interface connector (option board with PROFIBUS-DP/PA)
- ⑤ -X50: 37-pin connector: Option board; binary inputs/relay outputs
- ⑥ -X80: 37-pin connector: Analog and digital inputs and outputs

Figure 3-18 Connections of bench-top unit

19" rack unit

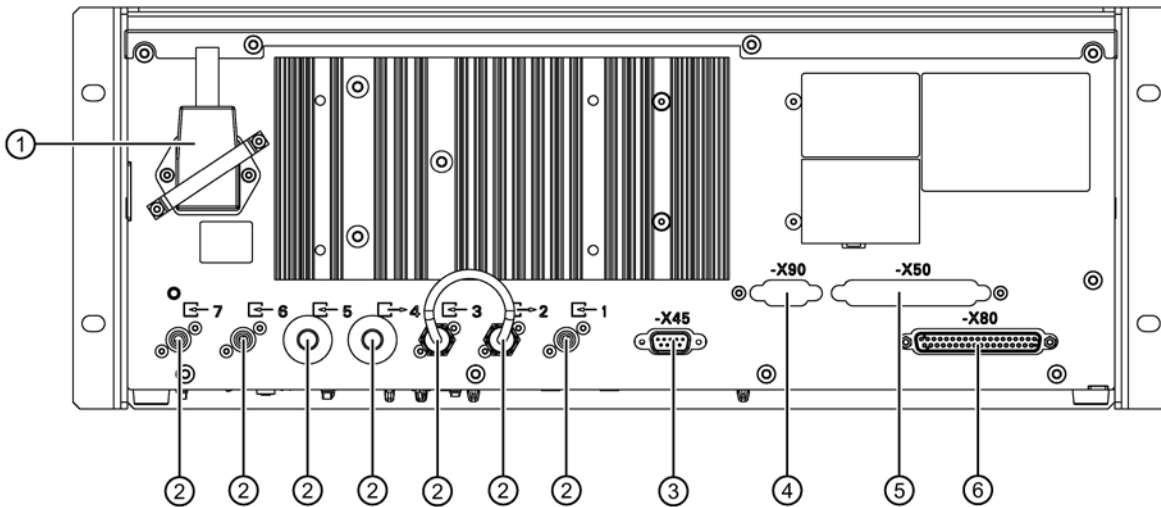

- ① Auxiliary power and fine fuse
- ② Gas connections: 6 mm nozzles; see section Gas connections (Page 51)
- ③ -X45: ELAN (RS485) 9-pin connector
- ④ -X90: 9-pin interface connector (option board with PROFIBUS-DP/PA)
- ⑤ -X50: 37-pin connector: Option board; binary inputs/relay outputs
- ⑥ -X80: 37-pin connector: Analog and digital inputs and outputs

When installing in a cabinet, mount analyzer on support rails or telescopic rails

Figure 3-19 Connections of rack device

3.5.4 Pin assignments

Pin assignments of the motherboard

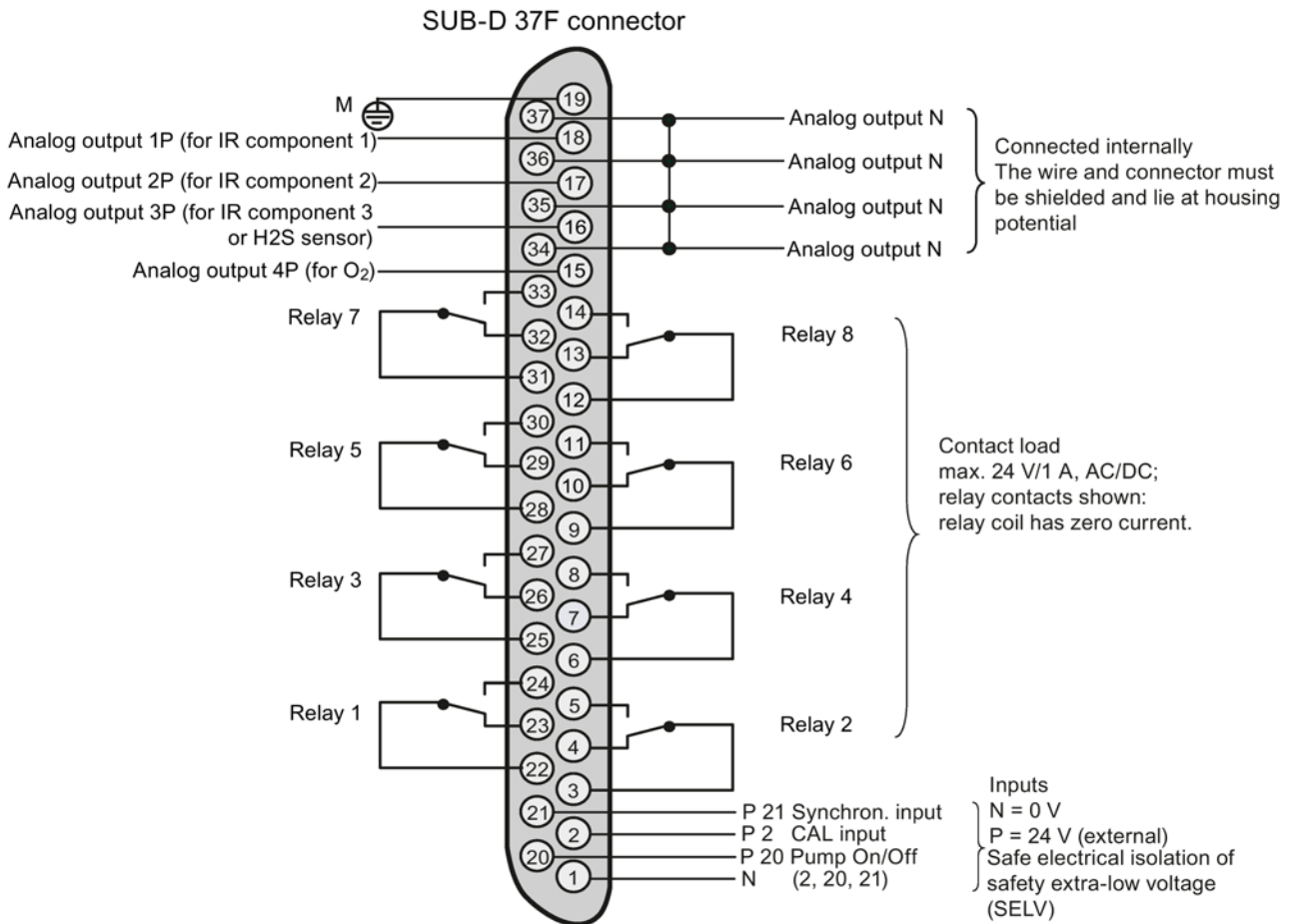
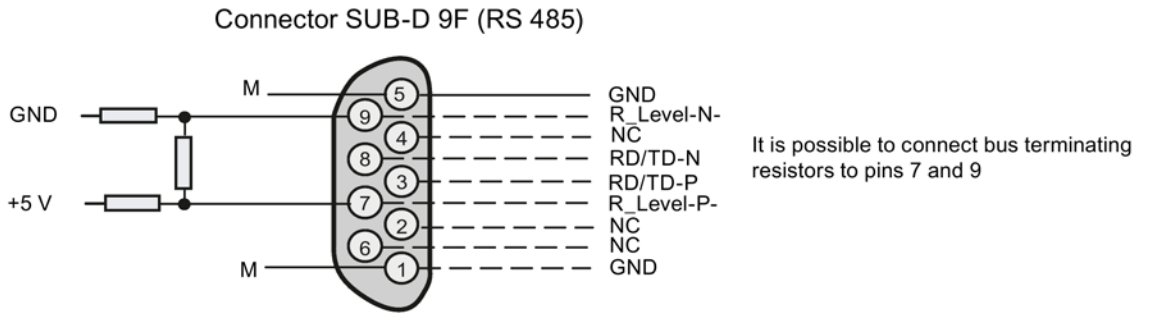

Note:
The wire and connector must be shielded and lie at housing potential

Figure 3-20 ULTRAMAT 23 motherboard

3.6 Dimensional drawings

Rack unit

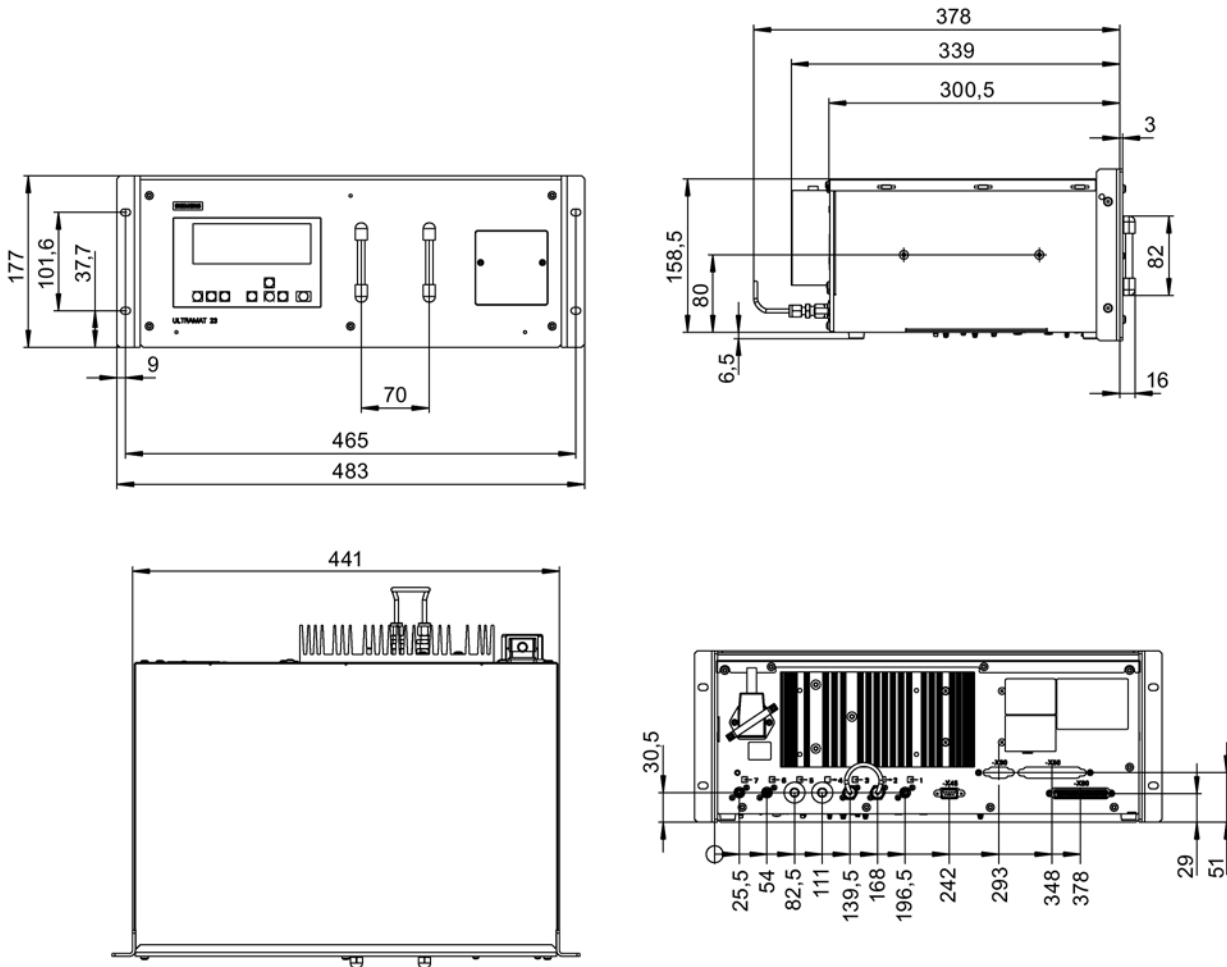

Gas connections: Pipe nozzle diameter 6 mm or 1/4"

Important: When installing in a bench-top enclosure or cabinet, only mount analyzer on support rails.

Figure 3-22 Dimensional drawings of rack unit

Bench-top unit

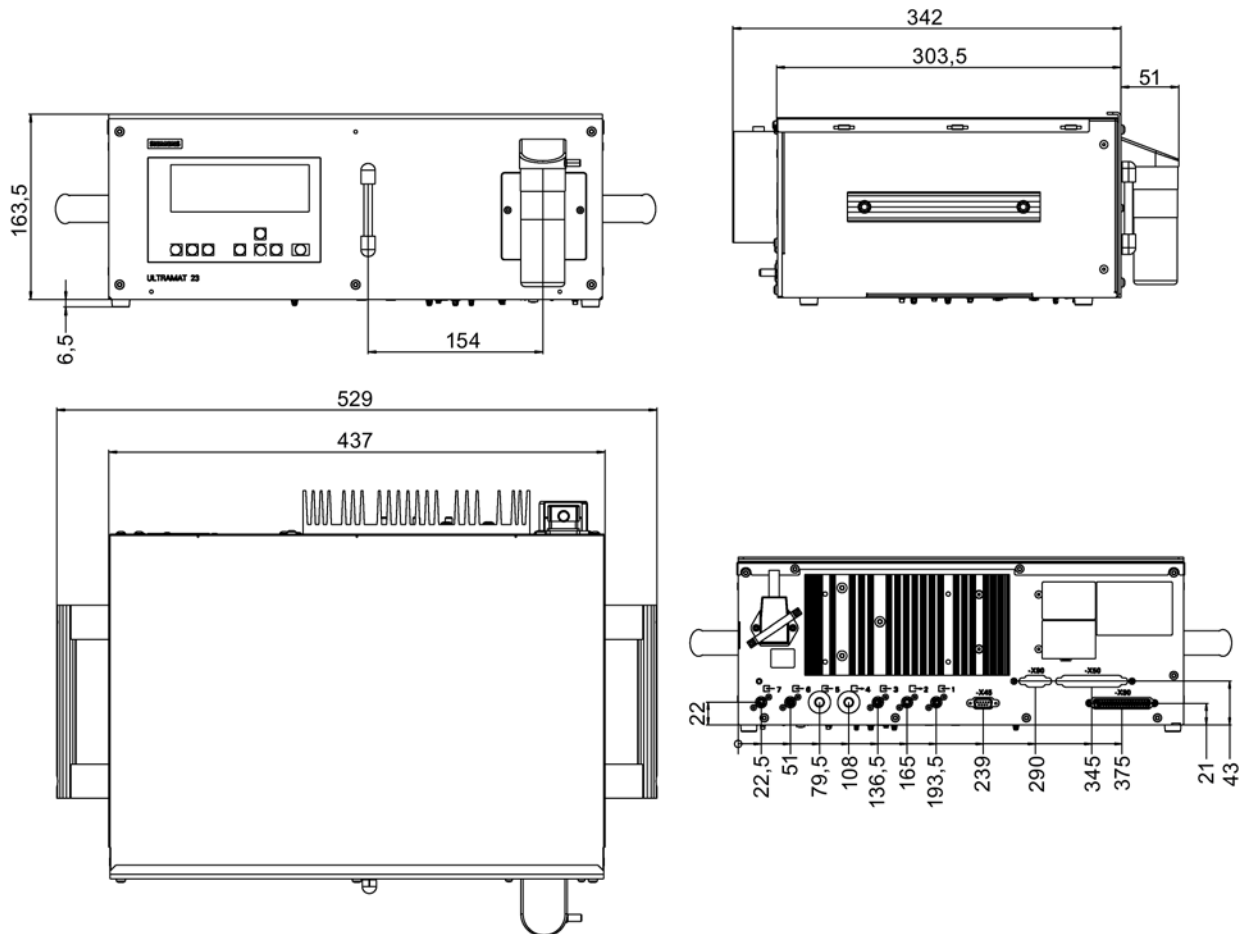

Gas connections: Pipe nozzle diameter 6 mm or 1/4"

Figure 3-23 Dimensional drawings of bench-top unit

3.7 Communication

3.7.1 PROFIBUS DP/PA

PROFIBUS DP/PA is the leading fieldbus on the market. All Siemens gas analyzers with an optional – also retrofittable – plug-in card are Profibus-compatible and comply with the binding "Device profile for analyzers" defined by the PNO (PROFIBUS International). Central access to the system analyzers is possible with the SIMATIC PDM software tool.

"Fieldbus" is the name of a digital communication system with which distributed field devices of a system are linked to each other over a single cable and are simultaneously connected to programmable controllers or a process control system.

The PROFIBUS-DP version is widespread in factory automation due to its high transmission speed per device, while PROFIBUS-PA takes the required properties of process engineering into account, such as use in hazardous areas.

The benefit is the considerable savings potential in all areas of the system, covering project planning and commissioning, operation and maintenance, up to subsequent system extensions.

Operation of the gas analyzers from a control system or a separate PC is possible with the SIMATIC PDM software tool (Process Device Manager). This software executes under Windows XP/Windows 2000 as well as Windows 7 and can also be integrated in the SIMATIC PCS 7 process control system. With this, the integration of the devices in the system as well as the complex parameter structure of the analyzers can be clearly illustrated. Operating becomes simply a matter of "clicking".

PROFIBUS International (PNO) is an independent institution and represents the interests of many manufacturers and users. This organization offers services such as consulting, training and device certification, and understands its primary job as the further development, standardization and promotion of PROFIBUS technology. The binding functionality definition for a device class in the form of a profile is the condition for standardized device behavior from various manufacturers, the so-called interoperability. The binding profile for analyzers was defined at the end of 1999. With this, the interaction of all PROFIBUS-compatible devices of a system is guaranteed.

In this profile, the functionalities of the analyzers are defined in a block model: for example, the physical block describes the measuring procedure, analyzer and manufacturer name, serial number and the operating state (operation, maintenance). Different functional blocks contain the execution of certain functions, such as measured value and alarm processing. The transducer blocks describe the function of the actual measuring process, as well as its control, e.g. the pre-processing of a measured value, correction of cross-interferences, characteristics, measuring ranges, as well as switching and control processes. The data transmission between the bus participants is defined in protocols.

A distinction is made between cyclic and acyclic services. Time-critical data, such as measured values and status, are transmitted with cyclic services. The acyclic services allow device parameters to be queried or changed during operation.

All gas analyzers of Series 6 (ULTRAMAT 6, OXYMAT 6/61/64, CALOMAT 6/62 and FIDAMAT 6 as well as ULTRAMAT 23) are PROFIBUS-compatible with an optional plug-in card, which can also be retrofitted.

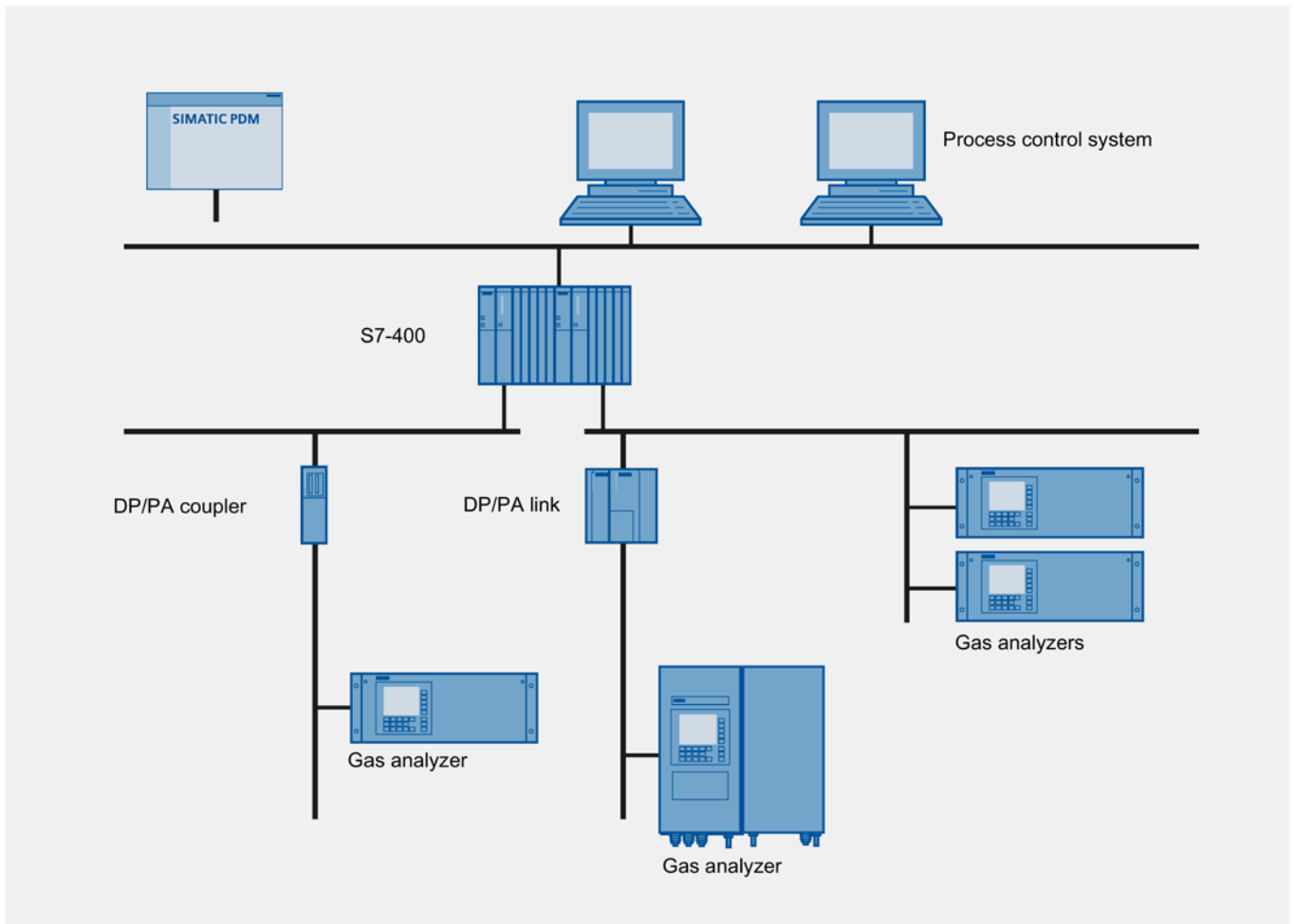

Figure 3-24 Typical structure of a PROFIBUS system

3.7.2 General information

All gas analyzers of series 6 as well as the ULTRAMAT 23 offer the following communication facilities:

- ELAN interface (RS485)
- SIPROM GA
- PROFIBUS DP/PA
- Generic communications interface (only ULTRAMAT 6E, OXYMAT/ULTRAMAT 6E, OXYMAT 61, OXYMAT 6).

3.7.3 ELAN interface

ELAN interface

ELAN is a standard integrated serial interface (RS 485) which allows communication with several analyzers. You can network up to 12 analyzers.

The functional principle of the ELAN interface is shown in the following figure:

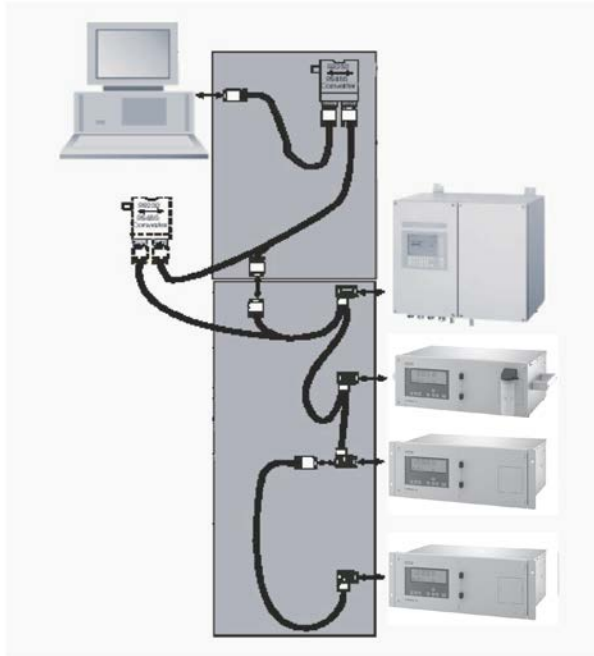

- 1 Computer
- 2 RS485 to RS232/USB/Ethernet converter with connecting cable
- 3 RS485 bus connector with jumper
- 4 Analyzer
- 5 RS485 cable
- 6 RS485 bus connector
- 7 RS485 network
- 8 9-pin Sub-D plug
- 9 Optional: RS485 repeater

Figure 3-25 Typical structure of an ELAN network (RS485)

Interface parameters

Parameter	Value
Level	RS485
Baud rate	9600
Data bits	8
Stop bit	1
Start bit	1
Parity	None
No information feedback	

Ordering information	Article No.
Interface description	C79000-B5200-C176
Converter RS485-RS232 including SIPROM GA	C79451-Z1589-U1
RS485/Ethernet converter	A5E00852383
RS485/USB converter	A5E00852382
SIMATIC cable / bus line	6XV1 830-0EH10
SIMATIC bus connector	6ES7 972-0BB11-0XA0
9-pin Sub-D plug	6ES7 972-0BB11-0XA0
Repeater	6ES7 972-0AA01-0XA0

Further information can be found in the ELAN interface description:

Article numbers:

- C79000-B5200-C176 German
- C79000-B5274-C176 English

3.7.4 SIPROM GA

3.7.4.1 SIPROM GA functions

SIPROM GA is a software tool especially for service and maintenance tasks. All analyzer functions, whether as a single device or several linked together, can be remotely operated and monitored this way.

Functions:

- Display and storage of device data
- Remote operation of device functions
- Parameter and configuration settings
- Comprehensive diagnostics information
- Remote calibration

- Online help
- Cyclic storage of measured values
- Status on hard disk and export to commercially available user programs
- Download of new software
- Drift values according to QAL 3, DIN EN 14181

Hardware requirements:

- PC/laptop Pentium 133 MHz, RAM 32 MB, CD-ROM drive
- At least 35 MB free disk space
- VGA graphics card supported by Windows
- Printer supported by Windows
- Vacant COM port for direct coupling to ELAN RS485 network
- For connection of the Ethernet/485 interface converter, a standard network of 10 Mbit or 100 Mbit (RJ 45 connection) with TCP/IP is necessary.
- In the case of an RS485 network, the distance should not exceed 500 m. If this distance is exceeded, a repeater must be used.

Software requirements:

- Windows 98
- Windows 2000
- Windows XP
- Windows Vista
- Windows 7

The SIPROM GA software is available on the Internet and can be downloaded from the following address: SIPROM GA download

(<http://support.automation.siemens.com/WW/llisapi.dll?aktprim=0&lang=en&referer=%2fWW%2f&func=cslib.csinfo&siteid=csius&groupid=4000002&extranet=standard&viewreg=WW&nodeid=10806991&objaction=csopen>)

3.7.4.2 Upgrading options

It is possible to upgrade the device firmware of older gas analyzers using the SIPROM GA software. Details can be found in the following table.

Firmware upgrades for older analyzers	Article No.
ULTRAMAT 23 (prior to SW version 2.06) (all languages)	C79451-A3494-S501

installation

Make sure when mounting the analyzer that the environment is as free as possible of the gas components to be measured!

In order to achieve the highest possible measuring quality, also observe the following information concerning the location for mounting an analyzer!

 WARNING**Insufficient ventilation**

The device may overheat or start burning in the case of insufficient ventilation.

- Ensure sufficient ventilation between the devices when installing in control cabinets. The heat sinks at the rear must remain free for air circulation.
- Make sure during operation that the permissible ambient temperature range is always observed (see Technical specifications (Page 31)).

NOTICE**Incorrect mounting**

The device can be damaged, destroyed, or its functionality impaired through improper mounting.

- Before installing ensure there is no visible damage to the device.
- Make sure that process connectors are clean, and suitable gaskets and glands are used.
- Mount the device using suitable tools. Refer to the information in Technical specifications (Page 31) for installation torque requirements.

 CAUTION**Strong vibrations**

Strong vibrations could loosen connections or damage sensors, resulting in free passage of the sample gas into the environment.

Even weaker vibrations influence the result!

The analyzer must therefore only be used at a location which is free of vibration.

Please observe the data in the Technical specifications. (Page 31)

 **CAUTION**

Direct sunlight

Device damage.

The device can overheat or materials become brittle due to UV exposure.

- Protect the device from direct sunlight.
- Make sure that the maximum permissible ambient temperature is not exceeded. Refer to the information in Technical specifications (Page 31).

Note

Installation in cabinets

The dead weight of the analyzer could result in deformation of the frame when only secured at the front.

- Therefore place the analyzer on support rails when mounting in control cabinets!
-

 **DANGER**

Explosion hazard

If a flammable or ignitable atmosphere exists, plugs must never be disconnected or lamps/fuses replaced when the analyzer is supplied with power.

ATEX Zone 2

The following applies to devices (special versions) which are operated according to ATEX in Ex zone 2:

 **DANGER**

Explosion hazard

The ULTRAMAT 23 gas analyzers for use in Ex zone 2 must be installed in a lockable enclosure. This enclosure must comply with the requirements of EN 60079-15 and must be designed for all ambient conditions which can occur during operation. This enclosure only be opened using a tool (e.g. a key).

The maximum ambient temperature is 50 °C.

Suitable measures must additionally be applied to ensure that

- the generation of potentially explosive gas mixtures inside the analyzer does not exceed the level of Zone 2
- interferences cannot lead to a deviation of more than 40% from the rated voltage.

Note

In the case of device versions for use in Ex zone 2, it is also essential to observe the 'ATEX compact operating instructions for rack units of Series 6' (A5E37888334)!

Connecting

5.1 Safety instructions

5.1.1 Condensation in the device

NOTICE**Condensation in the device**

Damage to device through formation of condensation if the temperature difference between transportation or storage and the mounting location exceeds 20 °C (36 °F).

- Before taking the device into operation let the device adapt for several hours in the new environment.

5.1.2 Laws and directives

Observe the test certification, provisions and laws applicable in your country during connection, assembly and operation. These include, for example:

- National Electrical Code (NEC - NFPA 70) (USA)
- Canadian Electrical Code (CEC) (Canada)

Further provisions for hazardous area applications are for example:

- IEC 60079-14 (international)
- EN 60079-14 (EC)

5.1.3 Operation in hazardous areas

 WARNING**Operation of analyzers in hazardous areas**

For safe operation of the analyzer in hazardous areas, it is essential to observe the information and conditions referred to in "Information pursuant to ATEX for use in hazardous areas" (Order No.: A5E37888334)

5.1.4 Electrical circuit breaker in accordance with IEC 60947-1

Note

Electrical circuit breaker in accordance with IEC 60947-1 and IEC 60947-3

In accordance with IEC 60947-1 "Standard for low-voltage switchgear and controlgear" and IEC 60947-3 "Switches, disconnectors, fuses" you require an electrical circuit breaker for the device.

We recommend commercially available automatic circuit breakers.

5.1.5 Dangerous contact voltage

 **WARNING**

Dangerous contact voltage

Danger of electric shock in case of incorrect connection.

- For the electrical connection specifications, refer to the information in Electrical connection (Page 73).
- At the mounting location of the device observe the applicable directives and laws for installation of electrical power installations with rated voltages below 1000 V.

5.1.6 Missing PE/ground connection

 **WARNING**

Missing PE/ground connection

Danger of electric shock.

Depending on the device version, connect the power supply as follows:

- **Power plug:** Ensure that the used socket has a PE/ground conductor connection. Check that the PE/ground conductor connection of the socket and power plug match each other.
- **Connecting terminals:** Connect the terminals according to the terminal connection diagram. First connect the PE/ground conductor.

5.1.7 Power supply cable for bench-top unit

Note

Disconnecting means

The power supply cable also serves as the disconnecting means.

Make sure that the cable is

- clearly recognizable
- easy to reach.

The cable length must not exceed 3 m.

5.1.8 Analyzers in hazardous areas

DANGER

Explosion hazard

If a flammable or ignitable atmosphere exists, plugs must never be disconnected or lamps/fuses replaced when the analyzer is supplied with power.

ATEX Zone 2

The following applies to devices (special versions) which are operated according to ATEX in Ex zone 2:

DANGER

Explosion hazard

The ULTRAMAT 23 gas analyzers for use in Ex zone 2 must be installed in a lockable enclosure. This enclosure must comply with the requirements of EN 60079-15 and must be designed for all ambient conditions which can occur during operation. This enclosure only be opened using a tool (e.g. a key).

The maximum ambient temperature is 50 °C.

Suitable measures must additionally be applied to ensure that

- the generation of potentially explosive gas mixtures inside the analyzer does not exceed the level of Zone 2
- interferences cannot lead to a deviation of more than 40% from the rated voltage.

Note

In the case of device versions for use in Ex zone 2, it is also essential to observe the 'ATEX compact operating instructions for rack units of Series 6' (A5E37888334)!

5.1.9 Analyzers in biogas plants

 DANGER
Explosion hazard
This device is used in biogas plants, among other places. When it is used in biogas plants, you should expect that the sample gas will contain methane, which forms explosive mixtures with oxygen or air in certain concentrations. These conditions are possible with certain operating states of the plant.

5.1.10 Wetted parts unsuitable for the process medium

 WARNING
Wetted parts unsuitable for the process media
Danger of injury or damage to device.
Hot, toxic and corrosive media could be released if the process medium is unsuitable for the wetted parts.
<ul style="list-style-type: none">• Ensure that the material of the device parts wetted by the process medium is suitable for the medium. Refer to the information in Technical specifications (Page 31).

5.1.11 Variant with specially cleaned gas path (Cleaned for O₂)

In the version with the order suffix -B06 (Cleaned for O₂), all parts wetted by the sample gas are cleaned and absolutely grease-free.

 CAUTION
Ignition hazard
Because of the danger of ignition, all parts coming into contact with oxygen must be clean. This means they must be free of loose parts or parts which could become loose during operation and of foreign particles, especially oil, grease and solvents.
Observe the following when working on analyzers with specially cleaned gas path:
<ul style="list-style-type: none">• No clothing which is contaminated by oil or grease may be worn.• The installation site must be clean and dust-free.• Only parts which are packed and marked accordingly may be assembled.• Always wash your hands before commencing work.• The cleaned parts must only be handled on the surfaces which do not come into contact with the sample gas.• New filters, new connecting hoses, and oil-free mixing equipment must always be used to check the analyzer function.

5.2 Gas connections and internal gas path

5.2.1 Gas connections

Sample gas line

A pipe with a outer diameter of 6 mm or 1/4" is present as the gas connection. The materials used in the gas path must be suitable for the respective measurement.

If you wish to exit the sample gas into a collective exhaust line, observe the following points:

- The exhaust line must be free of rapid changes in pressure. If this is not possible, either a separate exhaust line must be installed, or a damping vessel with a capacity > >1 l must be installed between the analyzer and the exhaust line.
- The exhaust gas line must always be routed with a falling gradient away from the device since moisture can condense in it.

Path for AUTOCAL/zero gas

The gases for the AUTOCAL calibration must be sucked in via a fine filter. The amount of the measured gas component must be negligibly small in the AUTOCAL gas (zero gas). In particular when carrying out an AUTOCAL for CO₂ ranges <1%, the air must be routed via a CO₂ absorber (e.g. soda lime).

Path for chopper section purging

With CO₂ ranges < 0.1%, the chopper section is purged with clean nitrogen or CO₂-free synthetic air at an inlet pressure of 300 ... 350 kPa (43 ... 51 psi).

Path for pressure sensor

The internal atmospheric pressure sensor is routed via a hose to connection 6. It is therefore possible to connect the pressure sensor (e.g. when using analyzer cabinets or houses) such that it is guaranteed that only changes in atmospheric pressure are recorded.

5.2.2 Gas preparation

The sample gas must be sufficiently conditioned to prevent contamination of the parts through which it flows. The ULTRAMAT 23 is usually preceded by the following elements:

- Gas sampling device with filter
- Sample gas cooler
- Analysis filter (approx. 1-2 µm)
- External gas suction pump (with sample gas lines >20 m/65 1/2 ft)

Note

In the analyzer version with the sample gas path as pipes, there is no safety filter and no condensation trap in the internal gas path.

- Therefore correct gas preparation must always be ensured.
 - Depending on the composition of the sample gas, additional equipment may be necessary such as e.g.
 - A washbottle
 - Additional filters
 - Pressure reducer.
-

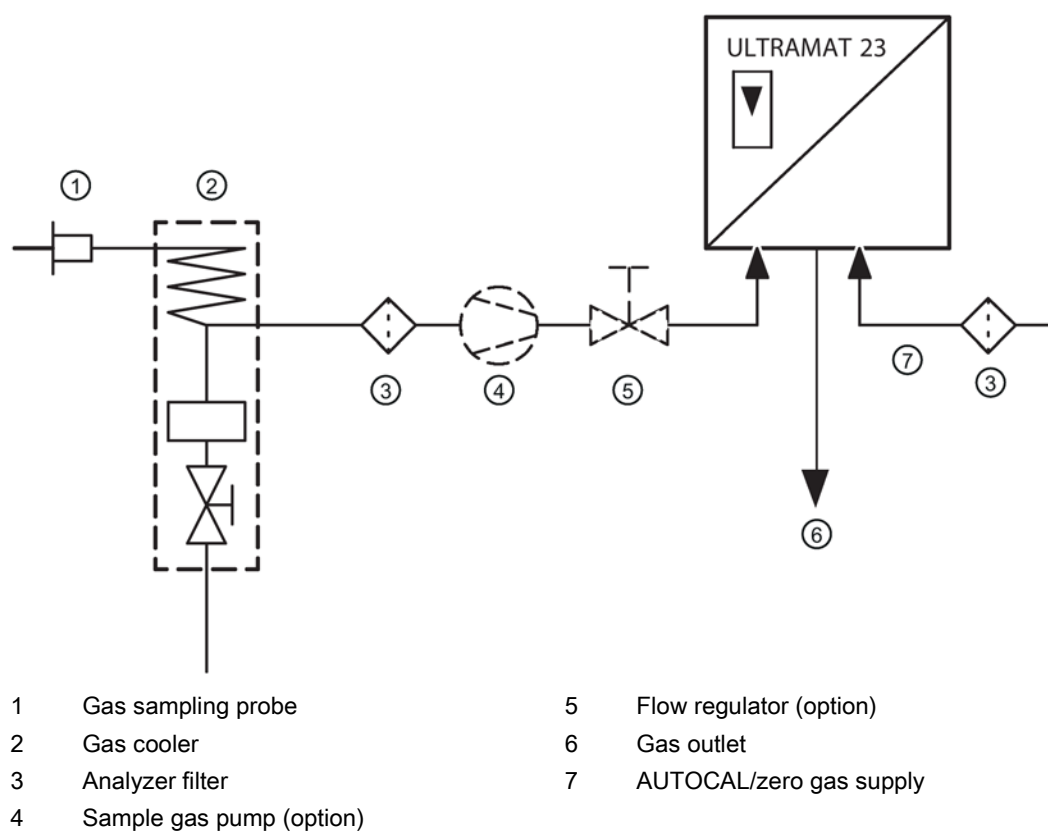

Figure 5-1 Gas conditioning in the ULTRAMAT 23

5.3 Electrical connection

5.3.1 Connection of the signal lines

NOTICE

Incorrect power supply

The 24 V/1 A power supply must be a power-limited safety extra-low voltage with safe electrical isolation (SELV).

Only connect the signal lines to devices which also have reliable electric isolation from their power supply.

- The connection lines to the relay outputs, binary inputs, and analog outputs must be shielded.
- The analog outputs are floating, but have a common negative pole.
- As a measure to suppress sparking across the relay contacts (e.g. limit relays), RC elements must be connected as shown in the following figure. Note that the RC element results in a drop-out delay for an inductive component (e.g. solenoid valve). The RC element should be sized according to the following rule of thumb:
 - $R = R_L/2$; $C = 4L/R^2_L$,
where $R = 100 \Omega$ and $C = 200 \text{ nF}$ are sufficient.
 - You must use a non-polarized capacitor for the RC element.

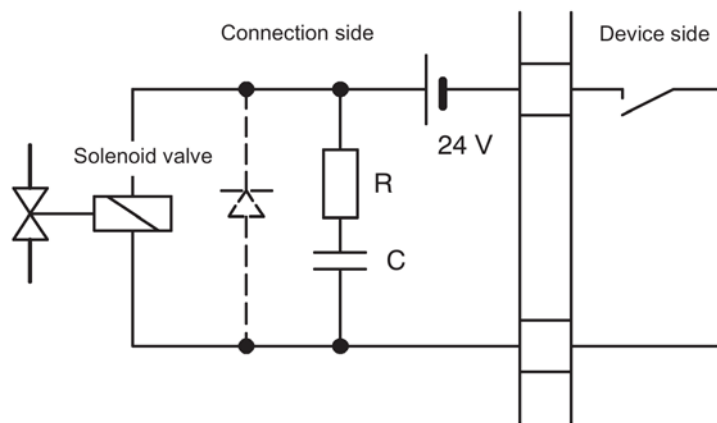

Figure 5-2 Measure to suppress sparks on a relay contact

When operated with direct current, a spark suppression diode can be installed instead of the RC element.

Connect the signal lines to the Sub-D plugs at the rear of the device.

Refer to the ELAN interface description (Order No. C79000-B5200-C176 German, C79000-B5276-C176 English) for details on the interface cable.

5.3.2 Power connection

<p>NOTICE</p> <p>Incorrect power supply</p> <p>Check before connecting that the existing supply voltage corresponds to that specified on the label of the device.</p> <p>Install the power line separately from the signal lines.</p>

A power supply cable or an appliance plug is enclosed with the device, and must only be connected by qualified personnel (see Qualified Personnel (Page 13)). The cable is connected to the appliance socket at the rear of the device. At the power supply end, the cable is inserted into a mains socket.

19" rack unit

A flexible cable suitable for power supply cords must be connected to the appliance plug. The cross-section of each conductor must be at least 1 mm². The cross-section of the PE conductor must not be smaller than that of the L and N conductors. The cable must be suitable for a temperature of at least 70 °C (158 °F) and must be approved for the country of use or the location.

A readily accessible facility for mains disconnection must be provided in the immediate vicinity of the analyzer.

Bench-top unit

A power supply cable must be used which is approved for the country of use or the location. The minimum cross-section of each conductor must be at least 0.75 mm² as long as the maximum length of the cable does not exceed 2 m (6 1/2 ft). Longer cables require larger conductor cross-sections than 0.75 mm². The cable must at least be suitable for a temperature of 70 °C (158 °F).

When positioning the analyzer, make sure that the power connector at the rear is accessible at all times.

Note

Disconnecting means

The power supply cable also serves as the disconnecting means.

Make sure that the cable is

- clearly recognizable
- easy to reach.

The cable length must not exceed 3 m.

Electrical circuit breaker in accordance with IEC 60947-1 and IEC 60947-3

In accordance with IEC 60947-1 "Standard for low-voltage switchgear and controlgear" and IEC 60947-3 "Switches, disconnectors, fuses" you require an electrical circuit breaker for the device.

We recommend commercially available automatic circuit breakers.

Ex analyzers

The following applies to all devices in the hazardous area:

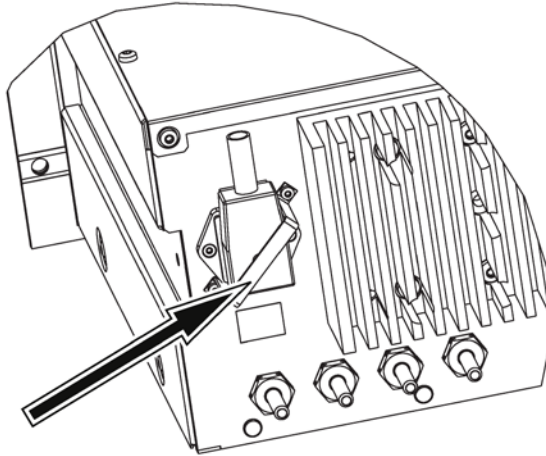

Analyzers envisaged for use in hazardous areas in accordance with CSA Class I Div. 2 must be provided with a safety bracket which protects the power connector from being unintentionally disconnected (see arrow in above picture). This bracket is enclosed loose with the analyzer and must be attached before switching on.

Commissioning

6.1 General information

The analyzer has been parameterized and calibrated prior to delivery. However, a large number of parameters can be subsequently adapted to specific requirements using menu-based functions.

The following sections provide you with information on the display and operator panel as well as the operating modes. You will learn how to scan analyzer statuses, how to calibrate the analyzer, and how you can enter or modify parameters.

The input sequences are described using the maximum configuration. If your analyzer has a different configuration (different measured components, number of infrared ranges, no oxygen measuring cell, no pump, no serial interface etc.), the explanations can be applied accordingly.

The used numbers must be considered as examples. They therefore probably differ from the values displayed on your analyzer. The corresponding line remains empty if components are not present in your analyzer.

If analyzers are installed in closed analysis cabinets, opening the cabinet door may result in brief drifting of the measured values. This is a result of the temperature exchange which then takes place.

6.2 Safety instructions

6.2.1 Dangerous contact voltage

 WARNING
<p>Dangerous contact voltage</p> <p>Danger of injury through dangerous contact voltage when the device is open or not completely closed.</p> <p>The degree of protection specified on the nameplate or in Technical specifications (Page 31) is no longer guaranteed if the device is open or not properly closed.</p> <ul style="list-style-type: none"> • Make sure that the device is securely closed.

6.2.2 Loss of degree of protection

 CAUTION
Loss of type of protection Damage to device if the enclosure is open or not properly closed. The type of protection specified on the nameplate or in Technical specifications (Page 31) is no longer guaranteed. <ul style="list-style-type: none">• Make sure that the device is securely closed.

6.2.3 Commissioning and operation with error message

 WARNING
Commissioning and operation with pending error If an error message appears, correct operation in the process is no longer guaranteed. <ul style="list-style-type: none">• Check the gravity of the error.• Correct the error.• If the error still exists:<ul style="list-style-type: none">– Take the device out of operation.– Prevent renewed commissioning.

6.2.4 For use in hazardous areas

6.2.4.1 Analyzers in hazardous areas

 DANGER
Explosion hazard If a flammable or ignitable atmosphere exists, plugs must never be disconnected or lamps/fuses replaced when the analyzer is supplied with power.

CSA Class I Div. 2 and ATEX Zone 2

The following safety and warning information applies to analyzers (special versions) which are operated in accordance with CSA Class I Div. 2 (hazardous locations) and ATEX Zone 2:

 WARNING
Potentially explosive atmosphere
Do not open, service or repair in an area in which a potentially explosive atmosphere may be present.

ATEX Zone 2

The following applies to devices (special versions) which are operated according to ATEX in Ex zone 2:

 DANGER
Explosion hazard
The ULTRAMAT 23 gas analyzers for use in Ex zone 2 must be installed in an appropriate enclosure. This enclosure must comply with the requirements of EN 60079-15 and must be designed for all ambient conditions which can occur during operation.
The maximum ambient temperature is 50 °C.
Suitable measures must additionally be applied to ensure that
<ul style="list-style-type: none">• the generation of potentially explosive gas mixtures inside the analyzer does not exceed the level of Zone 2• interferences cannot lead to a deviation of more than 40% from the rated voltage.

Note

In the case of device versions for use in Ex zone 2, it is also essential to observe the 'ATEX compact operating instructions for rack units of Series 6' (A5E37888334)!

6.2.5 Use in biogas plants

6.2.5.1 Safety information

 **DANGER**

Danger of poisoning

This device is designed to measure hydrogen sulfide and dihydrogen sulfide, H₂S!

Hydrogen sulfide is highly toxic even in small concentrations! The odor threshold for hydrogen sulfide is very low at 0.02 vpm (20 vpb), but higher concentrations result in numbing of the olfactory receptors in the nose so that the odor is no longer perceived. Persons exposed to this gas in concentrations up to 100 vpm for several hours exhibit symptoms of poisoning such as fatigue, headaches, lack of appetite, lack of concentration, irritation of the mucous membranes of eyes and respiratory tract, and throat irritations.

Inhalation of H₂S concentrations of 500 vpm longer than 30 minutes can cause fatal poisoning. Concentrations above 1 000 vpm cause death within a few minutes, concentrations above 5 000 vpm cause death within a few seconds!

When using this device in plant where there may be high concentrations of H₂S and you therefore need to take following continual precautions to prevent the effects of poisoning:

- Connect the gas outlet of the analyzer to a gas exhaust unit so that no gas can escape into the environment!
- Before you begin maintenance on the analyzer, make sure that the H₂S concentration in the analyzer is close to 0 vpm. Before beginning work, always flush the gas path of the analyzer and the gas sampler with ambient air or nitrogen for a duration of about 10 minutes .
- Check for leaks in the analyzer at regular intervals!

 **DANGER**

Danger of explosion

This device is used in biogas plants, among other places. When it is used in biogas plants, you should expect that the sample gas will contain methane, which forms explosive mixtures with oxygen or air in certain concentrations. These conditions are possible with certain operating states of the plant.

6.3 Preparation for commissioning

6.3.1 Leaks in the gas paths

Checking for leaks is most easily performed by connecting a U-tube manometer to the sample gas inlet. You can check for leaks as follows:

1. Block the sample gas outlet
2. Create an overpressure of around 150 hPa (rel.) at the sample gas inlet.
3. Wait for about 60 seconds for the temperature of the incoming gas to be compensated.
4. Read the pressure on the manometer and note it
5. Wait a further 15 minutes and note the pressure again after this period.
6. Compare the two pressure values.

The sample gas path is sufficiently tight when the pressure has changed by no more than 2 hPa (2 mbar) over 15 minutes.

For analyzers with H₂S sensors:

The sample gas path is sufficiently tight when the pressure has changed by no more than 5 hPa (5 mbar) over 15 minutes.

NOTICE
Damage to the analyzer chambers
If you apply a pressure above the maximum value, the bonding of the analyzer chamber windows could be broken. Discharge of sample gas is possible.
Please observe the pressure data in the section Technical specifications (Page 31).

6.3.2 Gas preparation

Make all gas preparation elements upstream of the analyzer (gas sampling devices, gas cooling devices, condensation vessels, filters, and any connected controllers, recorders or indicators) ready for operation. Refer to the associated operating instructions.

6.3.3 Device interfaces

Check that all device interfaces (see Communication (Page 57)) are properly assigned and configured.

6.4 Commissioning

6.4.1 Commissioning

Once all preparatory work for commissioning has been completed, go through the following checklist:

- The analyzer is set to the correct operating voltage
- All gas preparation elements are connected and ready for operation, and have been checked for leaks
- All required connections to and from the analyzer have been established

Following successful checking, connect the analyzer to the power supply and switch it on. Wait for the warm-up phase to elapse (see Warm-up phase (Page 95)).

6.4.2 AUTOCAL

The analyzer carries out an automatic calibration with the connected medium during the warm-up phase following switching-on. This AUTOCAL adjusts the zero point and sensitivity of the IR channels. If an O₂ sensor is present, its sensitivity is additionally calibrated using the ambient air (20.95% O₂).

Note

Analyzers with H₂S sensor

The hydrogen sulfide sensor is **not** calibrated during the course of this first AUTOCAL. The zero point of the H₂S sensor is only calibrated starting from the second AUTOCAL of the analyzer.

Note

Analyzers without electrochemical O₂ sensor

In the case of analyzers without an electrochemical O₂ sensor, the AUTOCAL can be carried out with nitrogen, but in the case of analyzers with an electrochemical O₂ sensor, it is essential to use air. The correct medium is selected depending on the used configuration (gas connections) and cannot be parameterized using the software.

Note

Analyzers with paramagnetic O₂ sensor

In the case of analyzers with a paramagnetic O₂ sensor, the input menu can be used to select whether the AUTOCAL is to be carried out with air or N₂, and thus whether the sensitivity (20.95 % O₂) or the zero point of the sensor is calibrated.

Note

Analyzers with small CO₂ measuring ranges

In the case of analyzers with small CO₂ measuring ranges, it is necessary to connect the chopper section purging. This can be carried out with nitrogen or synthetic air with an inlet pressure of 300 ... 350 kPa (3 ... 3.5 bar). The purging equipment must be connected at least 30 min before switching on in order to guarantee good purging of the analyzer unit.

You can manually trigger an AUTOCAL during operation by pressing the CAL key or also activate an AUTOCAL via the binary input or the communication interface. The analyzer can also execute an AUTOCAL cyclically, i.e. at regular intervals.

Duration

The duration of the AUTOCAL depends on various factors. It is

- Approx. 12 minutes for analyzers with H₂S sensor
- Approx. 3 minutes for analyzers with O₂S sensor
- Approx. 2 minutes for analyzers which only measure IR components

This is made up as follows:

- Twice the set purge time (see Calibration: AUTOCAL/drift values: Purge time (Page 123))
- Duration of the internal electronic adjustment (corresponds to two and a half times the time constant T₉₀ within (see Parameters: Time constants (Page 129)).

Note

An AUTOCAL is carried out twice during the warm-up phase; the first time approx. 5 min after switching on, and the second time after approx. 30 min.

6.4.3 Initial calibration

Initial calibration with calibration gas

Following installation of the analyzer, we recommend a calibration using calibration gas (see Calibration (Page 111)). The calibration should be carried out with a gas containing a sufficient concentration of the measured component (between 70 and 100% of the full-scale value in nitrogen or synthetic air).

Note

The calibration gas is connected via the sample gas path.

6.5 System setup with several analyzers in parallel

The analyzer must have been in operation for at least 30 minutes before commencing with measurements since a good stability of the analyzer unit is only guaranteed after this time (99% value).

Make sure that the gas flow is between 1.2 and 2.0 l/min.

Any noise which may occur can be suppressed by adjusting various time constants (see Parameters: Time constants (Page 129)).

The calibration should be repeated every six to twelve months depending on the ambient conditions.

6.5 System setup with several analyzers in parallel

Example 1

Both analyzers with internal pump and solenoid valve switching between sample gas and zero gas for AUTOCAL

The cyclic AUTOCAL of the master device triggers an AUTOCAL in parallel for the slave device via its digital output SYNC and the digital input SYNC of the slave device.

The simultaneous connection between the digital output SYNC of the slave device and the digital input SYNC of the master device guarantees that zero gas is always passed simultaneously through both analyzers.

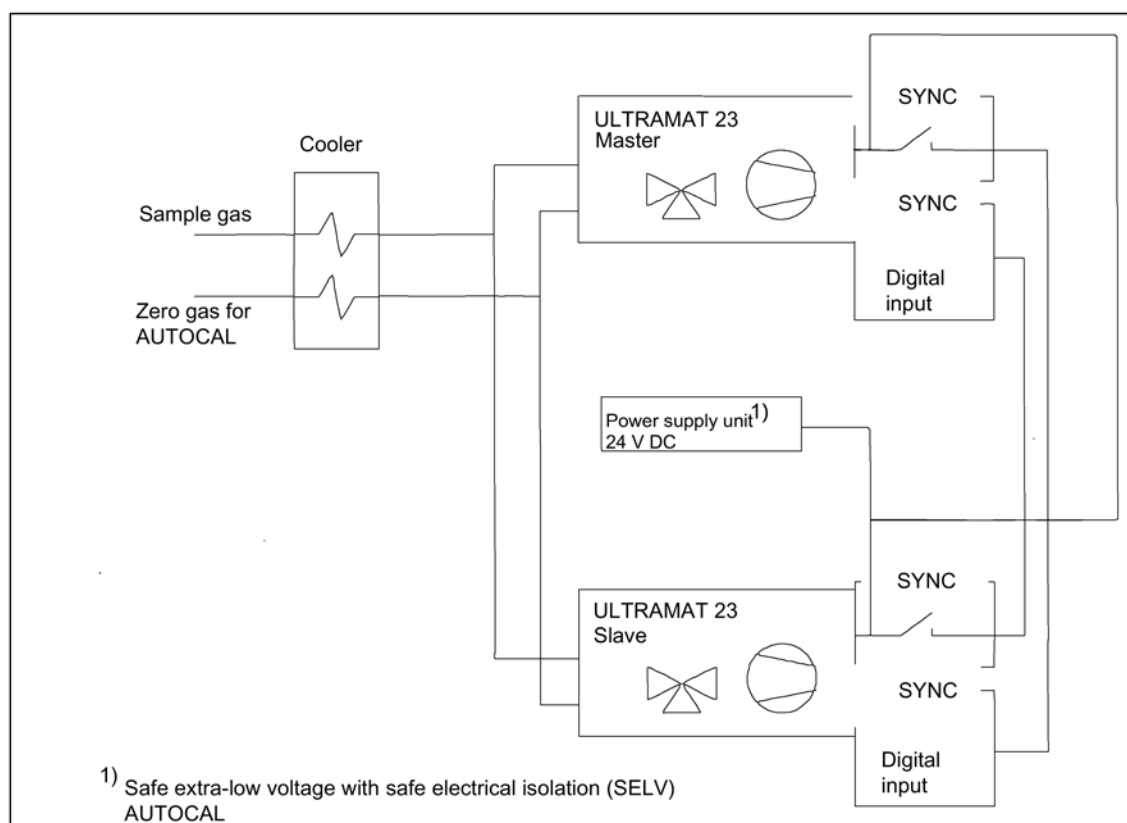

Figure 6-1 Parallel connection, example with internal pump and solenoid valve switching

Parameter assignments

The two analyzers must be parameterized as follows:

Master:

- Enter the AUTOCAL cycle time, e.g.: 6 hours (see Calibration: AUTOCAL/drift values: Cycle time (Page 123)).
- Assign the "Sync." function to a relay (see Calibration: AUTOCAL/drift values: Cycle time (Page 123)).
- Assign the "Only CAL contact" function to the digital input SYNC (see Configuration: Inputs/outputs/pump: Binary/sync inputs (Page 141)).

Slave:

- Set the AUTOCAL cycle time to "0" to prevent a cyclic AUTOCAL from being triggered (see Calibration: AUTOCAL/drift values: Cycle time (Page 123)).
- Assign the "Sync." function to a relay (see Configuration: Inputs/outputs/pump: Assign relays (Page 138)).
- Assign the "AUTOCAL" function to the digital input SYNC (see Configuration: Inputs/outputs/pump: Binary/sync inputs (Page 141)).

Example 2

Both analyzers without internal pump and without solenoid valve switching between sample gas and zero gas for AUTOCAL

Via a digital output, the master controls a solenoid valve for switching between sample gas and zero gas for the AUTOCAL.

The cyclic AUTOCAL of the master device triggers an AUTOCAL in parallel for the slave device via its digital output SYNC and the digital input SYNC of the slave device.

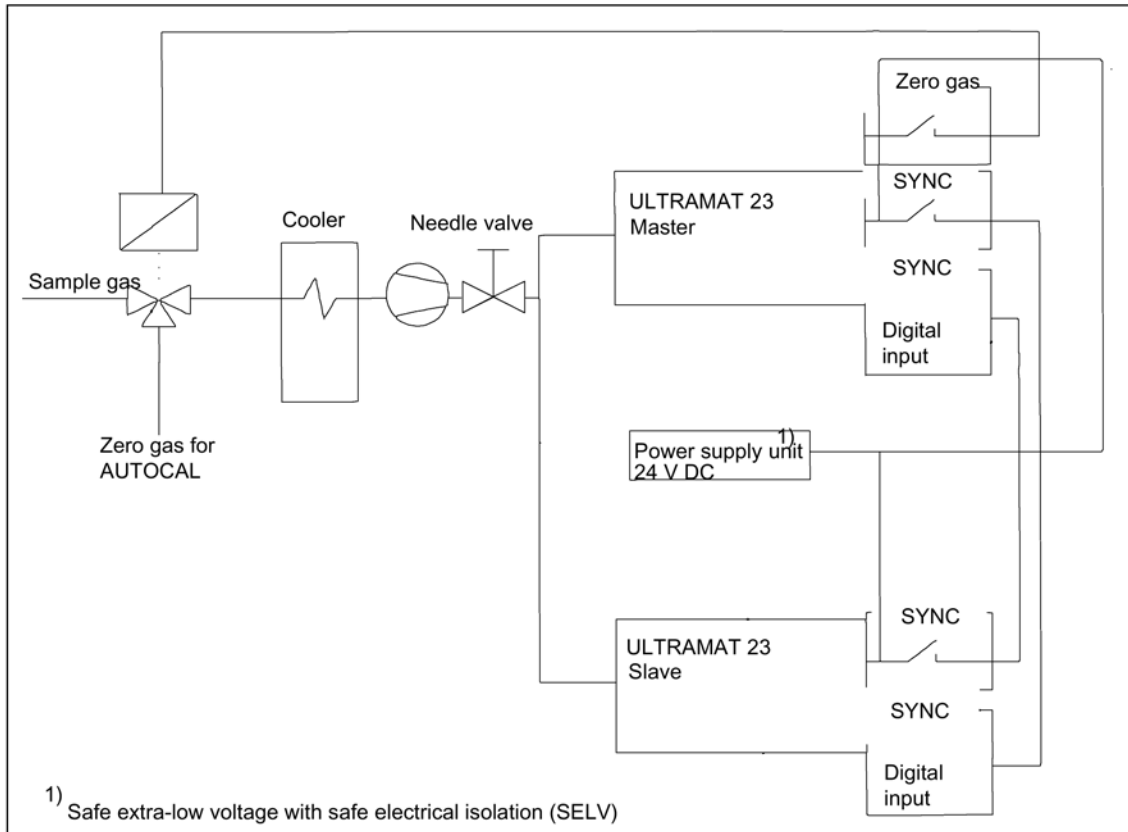

Figure 6-2 Parallel connection without internal pump and solenoid valve switching

Parameter assignments

Master:

- Enter the AUTOCAL cycle time, e.g.: 6 hours (see Calibration: AUTOCAL/drift values: Cycle time (Page 123)).
- Assign the "Sync." function to a relay (see Configuration: Inputs/outputs/pump: Assign relays (Page 138)).
- Assign the "Zero gas" function to a relay (see Configuration: Inputs/outputs/pump: Assign relays (Page 138)).
- Assign the "Only CAL contact" function to the digital input SYNC (see Configuration: Inputs/outputs/pump: Binary/sync inputs (Page 141)).

Slave:

- Set the AUTOCAL cycle time to "0" to prevent a cyclic AUTOCAL from being triggered (see Calibration: AUTOCAL/drift values: Cycle time (Page 123)).
- Assign the "Sync." function to a relay (see Configuration: Inputs/outputs/pump: Assign relays (Page 138)).
- Assign the "AUTOCAL" function to the digital input SYNC (see Configuration: Inputs/outputs/pump: Binary/sync inputs (Page 141)).

Operation

7.1 General information

The analyzer has been parameterized and calibrated prior to delivery. However, a large number of parameters can be subsequently adapted to specific requirements using menu-based functions.

The following sections provide you with information on the display and operator panel as well as the operating modes. You will learn how to scan analyzer statuses, how to calibrate the analyzer, and how you can enter or modify parameters.

The input sequences are described using the maximum configuration. If your analyzer has a different configuration (different measured components, number of infrared ranges, no oxygen measuring cell, no pump, no serial interface etc.), the explanations can be applied accordingly.

The used numbers must be considered as examples. They therefore probably differ from the values displayed on your analyzer. The corresponding line remains empty if components are not present in your analyzer.

If analyzers are installed in closed analysis cabinets, opening the cabinet door may result in brief drifting of the measured values. This is a result of the temperature exchange which then takes place.

CSA Class I Div. 2 and ATEX Zone 2

 WARNING
Potentially explosive atmosphere
The analyzer keys must not be pressed if a potentially explosive atmosphere may be present.
If operation using the keyboard is necessary, a hot work permit is absolutely essential.

7.2 User prompting

In the next sections, operation of the ULTRAMAT 23 is explained according to the following scheme:

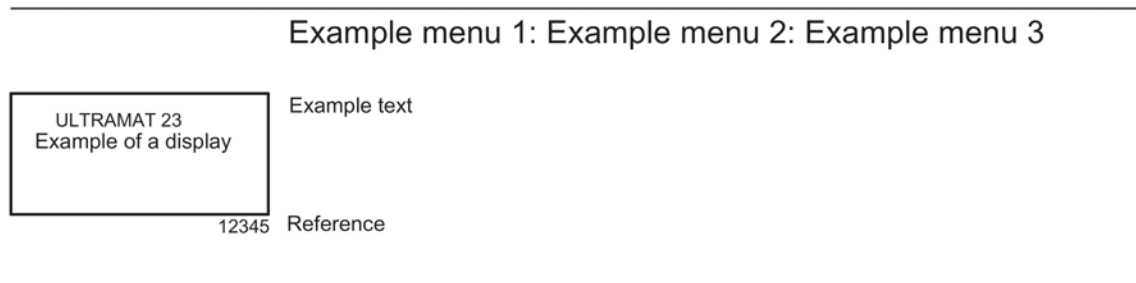

Figure 7-1 User prompting

The heading of the respective section indicates the complete menu path, starting from the main menu, on which the shown display can be reached (see section Display and control panel (Page 91)). The various menu levels are separated from one another by colons.

The display, as it appears on the analyzer, is shown to the left of the text. The accompanying text explains the display, including inputs and instructions if necessary, e.g.:

- You can start the function using the **<ENTER>** key.
- You can terminate the function using the **<ESC>** key.

You can recognize the position of the cursor in the display in these instructions in that the corresponding character is printed in bold type and underlined (in this display: **Example**).

The number on the right below the display, (12345 in this case) is used as a cross-reference to the summaries of all menus and dialogs which precede sections Diagnostics (Page 103) to Configuration (Page 132) in order to facilitate the locating of the described display in these overviews. A reference may be made that the respective function is protected by a code level (see section Code levels (Page 97)) or is specific to a component. In the case of functions specific to a component, you must enter the measured components (up to four) for which you wish to call the respective function.

7.3 Display and control panel

7.3.1 Display and operator panel

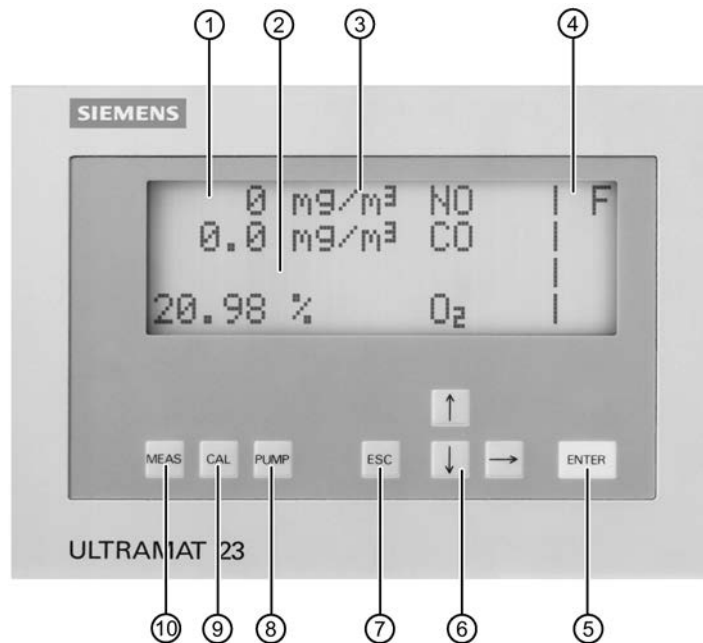

- ① One line per component for measured value, dimension and ID
- ② LED-backlit display; contrast adjustable using menu
- ③ Freely-selectable dimension (ppm, vpm, mg/m³, %)
- ④ Two columns are reserved for status displays
- ⑤ ENTER key for calling the main menu or saving the input values
- ⑥ ↑ ↓ → keys for menu control and for incrementing/decrementing numerical values
- ⑦ Scrolling back in menu or cancellation of an input
- ⑧ Switching on and off of internal pump, pumping capacity adjustable using menu
- ⑨ Key for starting AUTOCAL
- ⑩ Immediate return to measuring mode

Figure 7-2 Operator panel

Note

Energy saving

The display brightness is reduced after approx. 30 minutes without an operation. This serves for energy saving and has no influence on the other properties of the device.

The display becomes bright again when you continue with operation.

7.3 Display and control panel

The display is a backlit liquid crystal display with four lines with 20 characters each (5 x 8-dot matrix) and is covered by a foil. One line is reserved for each measured component in the display. The line displays from left to right: measured value, dimension, and name of component. The last two positions of each line are reserved for displaying certain analyzer statuses. The meanings of these characters depend on the set language. The meanings are as follows:

Description	German	English	French	Spanish	Italian	Polish
Maintenance request (display lights up permanently)	A	M	D	P	R	S
Fault present (display lights up permanently)	S	F	F	A	E	U
Limit violated (display lights up permanently)	G	L	L	L	S	O
Fault logged which is no longer present * (display lights up permanently)	!	!	!	!	!	!
Remote control (display lights up permanently)	R	R	R	R	F	Z
Function control (analyzer uncoded): <ul style="list-style-type: none"> • Access via RS485 serial interface • AUTOCAL or warm-up phase running (display flashes)	F	C	C	F	C	C
Pump running (display lights up permanently) or flow fault (display flashes)	P	P	P	B	P	P
Analyzer uncoded (display flashes)	U	U	U	D	N	K
* In the case of analyzers with an H ₂ S probe, the following statuses can be displayed at the position for the fault which is no longer present						
Protection function of H ₂ S probe running (display lights up permanently)	H	H	H	H	H	H
Protection function of H ₂ S probe running, H ₂ S measured value is invalid (display flashes)	V	V	V	V	V	V

7.3.2 User interface

The ULTRAMAT 23 has a menu-based user interface. The menu structures can always be represented as follows:

MAIN MENU → Submenu 1 → Submenu 2 → Submenu 3 → Submenu 4. The following Fig. shows a diagram of the basic configuration of the user interface.

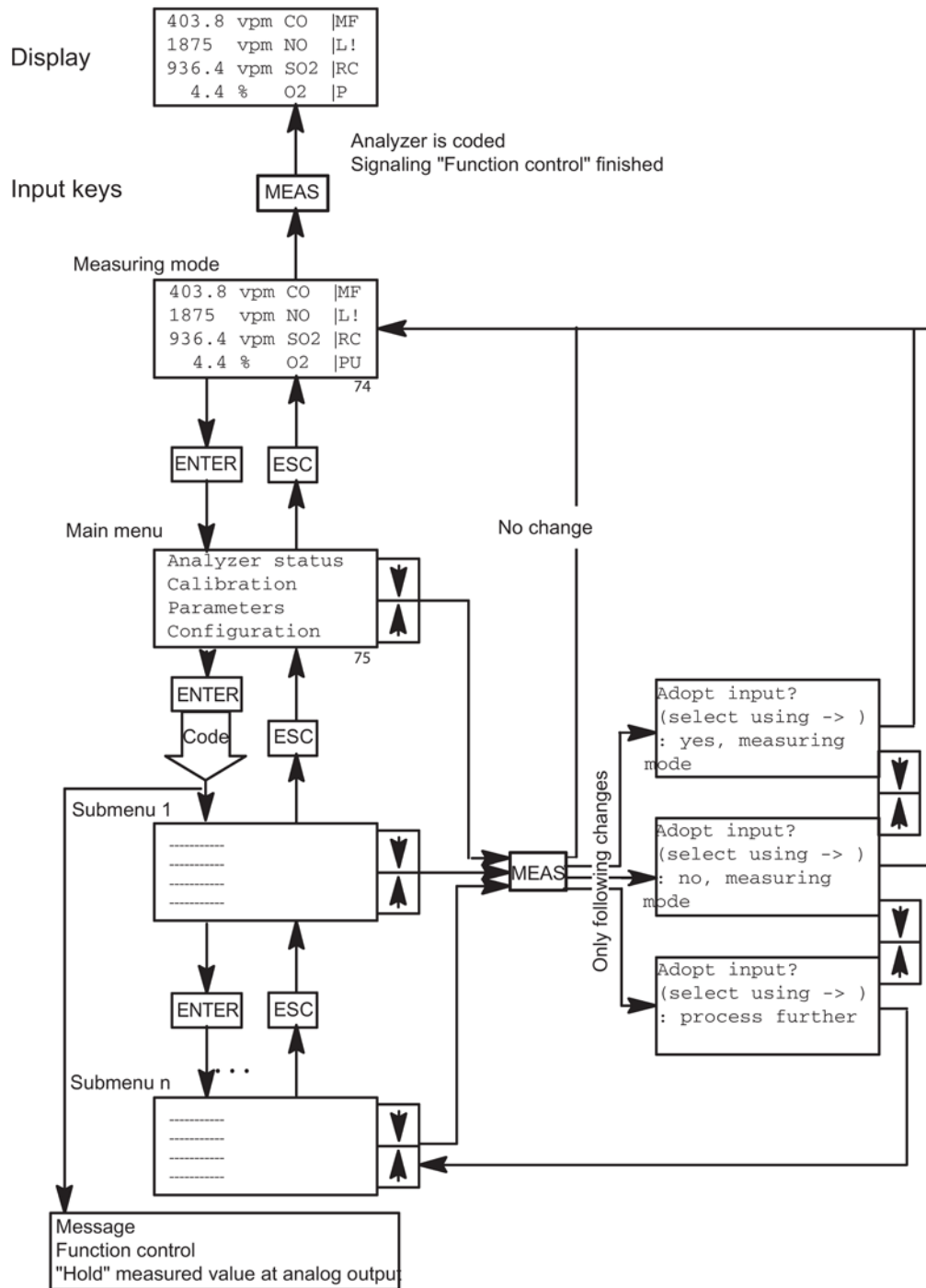

Figure 7-3 Menu structure of the ULTRAMAT 23

7.3.3 Key assignments

Eight keys are available for operating the ULTRAMAT 23. These keys have the following meanings:

No.	Designation	Description	Function
1*	MEAS	Measure	Measure; abort input operations; leave input mode (from any menu level); switch from input mode to measuring mode and code analyzer again
2	CAL	AUTOCAL	Automatic calibration: activation of calibration with ambient air or nitrogen
3*	PUMP	Pump	Switch internal sample gas pump on/off
4	ESC	Escape	In input mode: return by one menu level or cancel current input or cancel calibration*
5	↑	Up arrow	Increase selected digit; select previous menu item
6	↓	Down arrow	Reduce selected digit; select next menu item
7	→	Right arrow	Move input cursor by one position to right (cyclic, i.e. the cursor is set to the left edge when the right edge has been reached)
8	ENTER	Enter	In measuring mode: switch over to input mode; in input mode: import entered parameters or call a menu item

* The input is suppressed if certain conditions are fulfilled.
A corresponding message is then output briefly on the display.

You can use the arrow keys to modify numerical values by increasing or decreasing the digit at which the cursor is located. The digits are modified continuously, i.e. 0 follows again after digit 9. You can also decrement to 9, 8... following digit 0. The analyzer outputs the value FFF... if incorrect numbers are entered.

Use of the <MEAS>, <ESC>, and <ENTER> keys is described using examples in section Key operations step by step (Page 98). Use of the <CAL> key is described in section The CAL key (Page 101), use of the <PUMP> key in section The PUMP key (Page 102).

7.4 Operating modes

During operation, the analyzer is always in one of following operating modes:

- In the **warm-up phase** (see section Warm-up phase (Page 95))
- In **measuring mode** (see section Measuring mode (Page 96))
- In **input mode** (see section Input mode (Page 96))

7.4.1 Warm-up phase

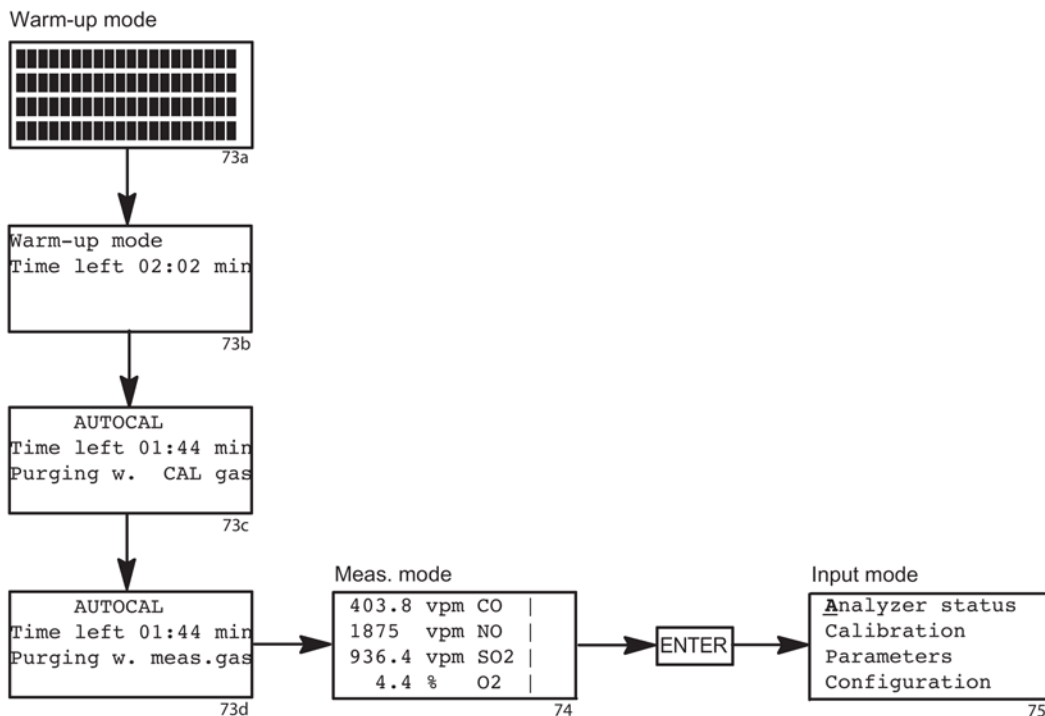
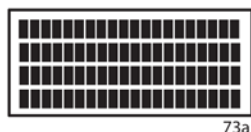
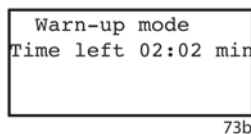

Figure 7-4 Warm-up phase, measuring mode, and input mode



Immediately following switching-on, the ULTRAMAT 23 tests the display elements. During this test, all elements light up simultaneously for approx. five seconds.



The adjacent display subsequently appears with the remaining warm-up period which is counted down in seconds to 00:00 (minutes:seconds).

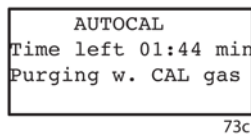

The analyzer initially carries out an AUTOCAL during the warm-up phase. The flow of AUTOCAL gas (nitrogen or air) is displayed in the bottom line, and the remaining time is shown in the line above this. This calibration cannot be interrupted.

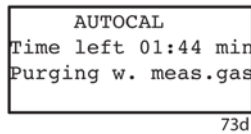

Following the calibration, the analyzer switches to purging with sample gas. At the end of the purging phase, the analyzer switches to measuring mode; however, full measuring accuracy is only reached after approx. 30 min if a further AUTOCAL has been automatically carried out by the analyzer. The warm-up phase is then finished.

7.4.2 Measuring mode

403.8	vpm	CO		
1875	vpm	NO		
936.4	vpm	SO2		
4.4	%	O2		P

74

The measured components are output on the display together with their values and the units in mg/m³, vpm or volume percent. With a change in the analyzer status, the corresponding letter appears in the last two columns ("P" in the example; see also Display and control panel (Page 91)). The analyzer remains in measuring mode until an AUTOCAL (automatic, remote-controlled or manual) is carried out or until you manually switch the analyzer to input mode.

If analyzers are installed in closed analysis cabinets, opening the cabinet door may result in brief drifting of the measured values. This is a result of the temperature exchange which then takes place.

If "*****" is displayed in measuring mode without a fault being present, this means:

- Concentration in sample gas more than 5% higher than the largest measuring range
- Signal saturation resulting from excessively high sample gas concentrations

*****	vpm	CO		
1875	vpm	NO		
936.4	vpm	SO2		
4.4	%	O2		P

74a

7.4.3 Input mode

In input mode, you can view instrument parameters or calibrate and parameterize the analyzer.

CAUTION
Unauthorized operation
The analyzer must only be calibrated and/or parameterized by trained specialists with adherence to these operating instructions.

Analyzer status
Calibration
Parameters
Configuration

75

Once you have selected input mode, the first menu to appear is the main menu which displays four menu items. You can use these to select the individual input functions of the ULTRAMAT 23:

Analyzer status

With these functions you can call submenus which provide information on the analyzer status, e.g. entries in the logbook, diagnostics data, and factory data (see Diagnostics (Page 103) for menu structure).

Calibration

With these functions you can calibrate the zero and sensitivity of the analyzer using calibration gas (see Calibration (Page 111) for menu structure).

Parameters

With these functions you can match the analyzer functions to your specific application, e.g. by entering limits, measuring ranges, and time constants (see Parameter (Page 124) for menu structure).

Configuration

With these functions you can define the assignments of the analyzer interfaces etc., e.g. the assignments of relays and current outputs (see Configuration (Page 132) for menu structure).

7.4.3.1 Code levels

The ULTRAMAT 23 is provided with two code levels to protect against unauthorized or unintentional inputs. As soon as you call a function protected by a code for the first time, you will be requested to enter the three-digit code.

With the introduction of firmware version 2.15.06, you can now use letters and special characters for the code in addition to numbers.

Note

You should change the factory-set codes once you have become acquainted with operation of the ULTRAMAT 23 (see section Configuration: Special functions: Changing the codes/language (Page 143)).

The lowest code level (level 1) is factory-set to "111", and the higher level (level 2) to "222". The following are protected by code level 1:

- The dialogs "Logbook/faults" and "Maintenance requests" in the menu "Analyzer status", submenu "Status",
- the menu "Calibration" ,
and
- the menu "Parameters".

The following is protected by code level 2:

- The menu "Configuration".

Note

If the analyzer requests that you enter code level 1, you can enter the code for level 2 instead to release this level. Level 1 is then enabled simultaneously. Level 1 is automatically enabled as soon as the higher code level 2 has been enabled.

Following input of a code, inputs are possible until the analyzer is recoded.

Note

In order to code the analyzer again when the input procedures have been finished (to protect against unauthorized and unintentional interventions), press the **<MEAS>** key in measuring mode.

7.4.3.2 Key operations step by step

This section describes operation of the analyzer with the keys of the operator panel using an example.

```
403.8 vpm CO |
1875 vpm NO |
936.4 vpm SO2 |
4.4 % O2 |
```

ENTER

```
Analyzer status
Calibration
Parameters
Configuration
```



```
Analyzer status
Calibration
Parameters
Configuration
```

ENTER

```
Level 1 required
Please enter code
: 000
```

```
Level 1 required
Please enter code
: 111
```

```
Measuring ranges
Limit values
Time constants
Pump/LCD contrast
```

ENTER

The analyzer is in measuring mode (see section Measuring mode (Page 96)).

Change from measuring mode to input mode by pressing the <ENTER> key.

You first access the main menu. A cursor flashes on the character "A" at the left edge of the first line.

- You can set the cursor to the start of each line using the <↑> and <↓> keys. Cursor movements are cyclic, i.e. if you move above the top edge of the display, the cursor appears again in the bottom line, and vice versa.
- Call the respective menu item by pressing the <ENTER> key.

The cursor is located at "P" when you have pressed the <↓> key twice.

Now call the "Parameters" submenu by pressing the <ENTER> key.

The adjacent display appears in which you will be requested to enter the code number for code level 1.

- You can change the value of the code digit to which the cursor is pointing using the <↑> and <↓> keys.
- Move to the next position of the code number using the <→> key. This function is also cyclic, and the cursor appears at the first position again when you move it beyond the last position.
- Close the code input by pressing the < ENTER> key.

The initial display of the "Parameters" submenu appears.

Press the <ENTER> again to call the "Measuring ranges" submenu.

```
Select component
: NO 1
```

```
Select component
: CO 3
```

```
ENTER
```

```
Switch ranges CO
Change ranges CO
Hysteresis CO
```

```
Switch ranges CO
Actual range :1
MR 1:0. 250 mg/m3
MR 2:0. 1250 mg/m3
```

```
ESC
```

```
MEAS
```

```
Accept input?
(select using -> )
: Back to the menu
```

```
Accept input?
(select using -> )
: Yes, meas. mode
```

```
Accept input?
(select using -> )
: NO, meas. mode
```

Now select components 1 to 4 for which the subsequently set ranges are to apply. Up to four components can be present.

If your analyzer is configured accordingly, you can select another component by pressing one of the <↑> or <↓> keys. In this example, this is component 3.

Press the <ENTER> key. The analyzer switches one level lower and now offers functions applicable to the selected measuring range.

The adjacent display appears with the functions selectable for this range (MR). You can select these by pressing the <↑> or <↓> key, and branch to the selected function by pressing the <ENTER> key.

In this example, the adjacent display appears following selection of the function "Switch ranges CO".

The first line contains the heading, the second line the parameter and its value to be changed; the cursor is positioned in this line. Only supplementary information is present in lines 3 and 4.

To switch over the measuring range, proceed as follows:

- Press the <ENTER> key.
The cursor jumps to the measuring range number which you can change using one of the <↑> and <↓> keys.
- The range definition is imported when you press the <ENTER> key again, and you return to the start of the line.

You cannot carry out any further settings here. To do so, you must leave the menu display again. This is possible:

- By pressing the <ESC> key. You then return by one step in the menu sequence
- by pressing the <MEAS> key. You then have the following possibilities:
 - To process the previous menu item further using <ENTER>
 - or return to measuring mode using <↑> or <→> and subsequently <ENTER>, where all modifications are imported which you have made since the last decoding operation,
 - or return to measuring mode using <↓> and <ENTER> without importing the modifications..

```
Accept input?
(select using -> )
: Back to the menu
```

Once you have carried out the above sequence on the analyzer, you are already acquainted with the important points for operation of the ULTRAMAT 23.

7.4.3.3 The ESC key

You can trigger two different functions by pressing the <ESC> key:

- Firstly, you can cancel a commenced procedure, e.g.:
 - The input of a number
 - A calibration procedure with calibration gas
 - Any function if a fault occurs, e.g. if the flow of sample gas to the analyzer is missing.
- Secondly, you can use the <ESC> key to move to the next higher level in menu structure ("scroll back"). This procedure is the opposite to selection of a submenu using the <ENTER> key ("scroll forwards"). If you repeatedly press the <ESC> key, you return back to the main menu step-by-step. If you press the <ESC> key again in the main menu, the analyzer switches over from input to measuring mode. All inputs are imported at the same time. However, you will not be asked to confirm the inputs.

An example will clarify this:

```
403.8 vpm CO |
1875 vpm NO |
936.4 vpm SO2 |
4.4 % O2 | U
```

The analyzer is in measuring mode and is uncoded.

```
Analyzer status
Calibration
Parameters
Configuration
```

Switch from measuring mode to input mode using <ENTER>, select the menu item "Parameters" using the <↑> or <↓> key, and press <ENTER> to confirm.

```
Measuring ranges
Limit values
Time constants
Pump/LCD contrast
```

In this manner, you enter the first submenu.

Now press <ESC> and then <ENTER> again. You have returned by one level and then moved forwards by one level again; you are therefore in the same menu again.

```
403.8 vpm CO |
1875 vpm NO |
936.4 vpm SO2 |
4.4 % O2 | U
```

Press the <ESC> key twice, you are back in measuring mode again.

7.4.3.4 The CAL key

If the analyzer is in measuring mode, pressing the <CAL> key triggers a single, automatic calibration with ambient air or nitrogen (AUTOCAL).

The **<CAL>** key cannot be used during the warm-up phase.

If the flow is too low during a zero calibration triggered by pressing the key, the analyzer remains in this status until either the flow is sufficient or the zero calibration is aborted by pressing the **<ESC>** key.

In addition to the **<CAL>** key, an AUTOCAL can also be triggered via the binary input. The binary input has priority over the key.

7.4.3.5 The PUMP key

If the analyzer is equipped with an internal sample gas pump, this can be switched on and off using the **<PUMP>** key. If the pump is switched off while the analyzer is in input mode, it is also switched on again by pressing the **<MEAS>** key if parameterized accordingly (see Configuration: Inputs/outputs/pump: Pump at CAL/MEAS (Page 142)).

In addition to use of the **<PUMP>** key, the pump can also be switched on and off via the binary input. The binary input has priority over the key.

Functions

8.1 Diagnostics

In this function group you can view all analyzer data. The menu sequence in the following Fig. shows all submenus which can be accessed from the "Analyzer status" menu. The arrows lead by one menu item to the next lower menu level which is called by this menu item.

This display applies to an analyzer without H₂S probe and without paramagnetic O₂ probe. The differences when using analyzers with one of these probes are described in section Diagnostics: Diagnostics values (Page 107).

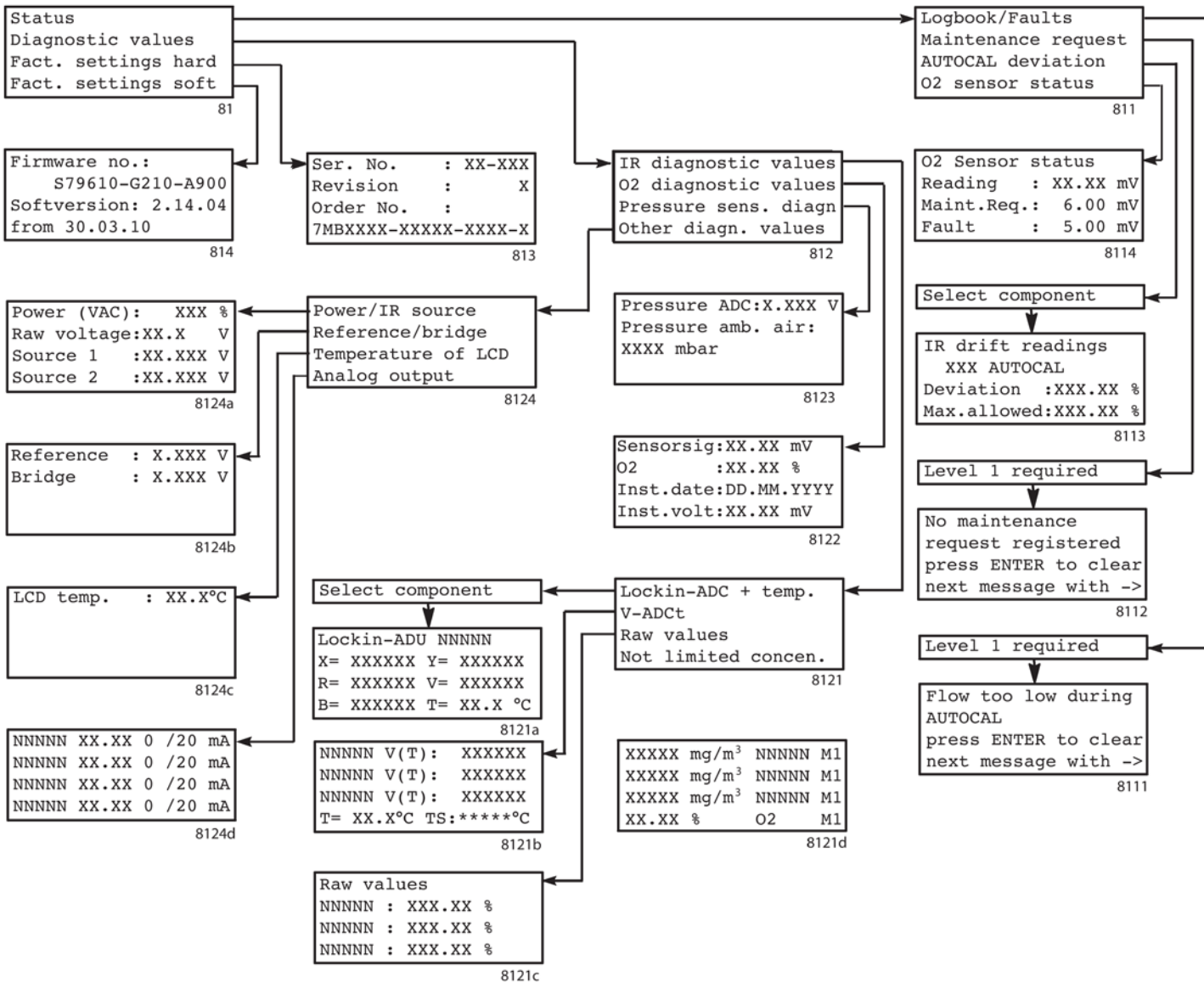

8.1.1 Diagnostics: Status

```
Logbook/faults
Maintenance request
AUTOCAL deviation
O2 sensor status
```

811

In this menu you can call all status messages of the ULTRAMAT 23 via further submenu items.

In this example, the status of the O₂ sensor is shown in the last line. If the analyzer is equipped with software for operating an H₂S sensor, the text 'Probe status' is shown in the last line with the following options:

- Only H₂S sensor:
The analyzer calls this function directly.
- H₂S and O₂ sensors:
You will be requested to select the associated sensor.

8.1.1.1 Analyzer status: Status: Logbook/faults

```
Mains voltage
beyond tolerance
Press ENTER to clear
Next message with ->
```

8111

This dialog displays the contents of a logbook. This contains all recorded faults. Each type of fault only appears once in the logbook and is output in alphanumeric text (an overview of the possible faults can be found in section Faults (Page 178)).

Viewing the logbook is protected by code level 1.

Following access to the logbook you can:

- Display all recorded faults in succession using the <-> key
- Delete the currently displayed fault message using the <ENTER> key.
If further faults are present, these appear in succession. You should delete all fault messages whose causes have been eliminated.

Note

By deleting the fault message you do not eliminate the cause of the fault (see section Faults (Page 178)).

A corresponding text is output when all stored faults have been displayed. Terminate display of the logbook using the <-> key.

Note

If the analyzer is in measuring mode, you can recognize the occurrence of a fault in that an "F" appears at the right edge. A "!" at the right edge signals that a fault has been logged which is no longer present.

8.1.1.2 Analyzer status: Status: Maintenance request

```
AUTOCAL drift  
beyond tolerance  
Press ENTER to clear  
Next message with ->
```

8112

This dialog indicates the logged maintenance requests. A maintenance request is set if the values of certain parameters have reached defined limits, but the analyzer is still able to measure (e.g. AUTOCAL deviation or O₂ sensor status; see also section Analyzer status: Status: O₂ sensor status (Page 106)). A corresponding message is output in alphanumeric text.

Access is protected by code level 1.

Following access to the maintenance request list you can:

- Display all recorded faults in succession using the <-> key
- Delete the currently displayed fault message using the <ENTER> key. If present, the next maintenance request is then displayed. You should delete all maintenance requests whose causes have been eliminated.

Note

If the analyzer is in measuring mode, you can recognize the occurrence of a maintenance request in that an "M" appears at the right edge.

8.1.1.3 Analyzer status: Status: AUTOCAL deviation

```
IR drift readings  
1 AUTOCAL  
Deviation : 2.22 %  
Max. allowed: 6.00 %
```

8113

This dialog indicates the deviation in setpoint between several AUTOCAL procedures. The parameters have the following meanings:

- The text in the two top lines provides information on the number of AUTOCAL procedures which have been carried out since the reference value for AUTOCAL was last set (see section Configuration: Special functions: AUTOCAL deviation (Page 144)).
- **Deviation** is the measured deviation of the actual value from the reference value, displayed in % of the set measuring range (with autoranging, range 1 is assumed). This deviation must not be above the set maximum value.
- **Max. allowed** is the maximum permissible value for the deviation. Refer to section Configuration: Special functions: AUTOCAL deviation (Page 144) for setting the maximum value.

This function is specific to the component.

8.1.1.4 Analyzer status: Status: O2 sensor status

O2 sensor status	
Reading:	11.11 mV
Maint. req:	6.00 mV
Fault:	5.00 mV

8114

The probe voltage of the O₂ sensor is reduced during use due to its aging process. Therefore the probe voltage is measured with each AUTOCAL. A warning (maintenance request) is output if the value drops below 6.0 mV. The oxygen sensor should therefore be replaced when this value is reached. An exact measurement is no longer possible if the probe voltage falls below the minimum value of 5.0 mV (fault message "Sensitivity of O₂ sensor too low").

- The reading (actual value) is the probe voltage measured on the sensor during the last AUTOCAL.
- The warning (maintenance request) and fault are the two minimum values where a maintenance request or fault message is output when fallen below.

8.1.1.5 Analyzer status: Status: H2S sensor status

H2S sensor status	
Reading:	747.00 nA
Maint. req :	373.50 nA
Fault:	298.80 nA

8114

The H₂S sensor ages with increasing operating time, thereby steadily decreasing its sensitivity. If a value below the minimum value for a warning is determined during calibration of the sensitivity, the service life of the sensor has almost been reached (maintenance request). If the sensitivity drops further below the value for a fault, the fault message "Sensitivity of H₂S sensor too low" is output. The sensor must then be replaced.

- The reading (actual value) is the sensor sensitivity measured during the last sensitivity calibration.
- The warning (maintenance request) and fault are the two minimum values where a maintenance request or fault message is output when fallen below.

8.1.2 Diagnostics: Diagnostics values

```
IR diagnostic values
O2 diagnostic values
Pressure sens. diagn
Other diagn. values
```

812

The diagnostics values provide important information for troubleshooting and adjustments. You can select the four displayed function groups in this menu.

```
IR diagnostic values
Sensor diagn. values
Pressure sens. diagn
Other diagn. values
```

812

If the analyzer contains software for H₂S measurement, the adjacent display appears. The following versions are possible following selection of the 'Probe diagnostic values' parameter in the 2nd line:

- Only H₂S sensor: Following selection of this item, a branch is made to the diagnostics values of the H₂S sensor (section Analyzer status: Diagnostics values: H₂S sensor (Page 109)).
- H₂S and O₂ sensors: A query is made for the component, and a branch then made to the called sensor.

8.1.2.1 Analyzer status: Diagnostics values: IR

```
Lockin-ADU + temp.
V-ADUt
Raw values
Not limited concen.
```

8121

In this submenu you can call the diagnostics values of the infrared measuring ranges. These are:

```
Lockin-ADU SO2
X= 408399 Y= 103444
R= 444912 V= 444872
B= 100116 T= 41.0°C
```

8121a

- **ADU** are voltage and signal values of the analog-to-digital converter prior to temperature compensation. These values are specific to the component.

```
NO V(T): 440206
CO V(T): 505577
SO2 V(T): 494135
T: 42.2°C TS:
```

8121b

- **V-ADUt** are voltage and signal values of the analog-to-digital converter following temperature compensation. **T** in the bottom line corresponds to the temperature of the analyzer unit, **TS** the temperature of the IR source (empty field = function not yet implemented, "*****" = no measured value present).

Raw values		
NO	:	1.99 %
CO	:	0.27 %
SO2	:	5.08 %

8121c

18 mg/m ³	NO	M1
2 mg/m ³	CO	M1
11 mg/m ³	SO2	M1
20.77 %	O2	M2

8121d

- **Raw values** are the measured values in % of the full-scale value (= 100 %).
- **Not limited concen.** are the measured values as they are also displayed in measuring mode. You can approximately display the concentrations here even with an upward or downward violation of the largest range. Negative values are also displayed (live zero). The current measuring range is output on this display in the last two columns.

8.1.2.2 Analyzer status: Diagnostics values: (Electrochemical) O2 sensor

Sensorsig	:	11.11 mV
O2	:	20.77 %
Date:		30.11.2012
Inst.volt.:		12.10 mV

8122

This dialog displays the diagnostics values of the electrochemical oxygen sensor (option). Meaning:

- **Sensorsig** is the current pressure-compensated voltage of the O₂ sensor in mV
- **O₂** is the current oxygen value. Negative values are also possible here
- **Inst. date** is the installation date of the O₂ sensor (see section Calibration: O2 measuring range: Sensor inst. date (Page 114))
- **Inst.volt** is the pressure-compensated voltage of the O₂ sensor when it was installed.

8.1.2.3 Analyzer status: Diagnostics values: (Paramagnetic) O2 sensor

Sensorsig.:		1339 mV
O2	:	20.77 %

8122

This dialog displays the diagnostics values of the paramagnetic oxygen sensor (option). Meaning:

- **Sensorsig** is the current voltage of the O₂ sensor in mV
- **O₂** is the current oxygen value. Negative values are also possible here

8.1.2.4 Analyzer status: Diagnostics values: H2S sensor

```
Sensorsig.: 884 nA  
H2S       : 0.78 vpm  
Inst.Date: 30.11.2012  
Inst.Curr.: 500 nA
```

8122

This dialog displays the diagnostics values of the optional H₂S sensor. Meaning:

- **Sensorsig.** is the actual current of the H₂S sensor in nA
- **H₂S** is the current H₂S measured value in vpm. Negative values are also possible here.
- **Inst. date** is the installation date of the H₂S sensor (see section Calibration: H₂S sensor: Defining the installation (Page 119))
- **Inst. cur** is the pressure-compensated current per vpm H₂S of the sensor when it was installed.

8.1.2.5 Diagnostics: Diagnostics values: Pressure sensor

```
Pressure ADC:X.XXX V  
Pressure amb. air:  
XXXX mbar
```

8123

This dialog displays the diagnostics values of the pressure sensor (see section Calibration: Pressure sensor (Page 121)). The displayed values have the following meaning:

- **ADC pressure** is the actual voltage of the pressure sensor measured at the output of the A/D converter.
- **Air pressure** is the actual atmospheric pressure in mbar.

8.1.2.6 Analyzer status: Diagnostics values: Other diagnostics values

```
Power/IR Source  
Reference/Bridge  
Temperature of LCD  
Analog output
```

8124

This menu is used to call further diagnostics functions. You can call the following values:

```
Power (VAC): 101 %  
Raw voltage: 30.0 V  
Source 1   : 7.541 V  
Source 2   :15.023 V
```

8124a

- **Power/IR source**
 - **Power:** Data on the supply voltage in % of the nominal value of the respective supply voltage (e.g.: 100% corresponds to 230 V or 120 V).
 - **Raw voltage:** This is the raw voltage following the rectification
 - **Source 1, Source 2:** Data on the IR source voltage(s), in Volt. An empty value indicates that the corresponding source does not exist.

```
Reference : 2.229 V
Bridge    : 3.379 V
```

8124b

```
LCD Temp. : 33.9°C
```

8124c

```
NO      3.11 4 /20mA
CO      4.25 4 /20mA
SO2     4.04 4 /20mA
O2      20.02 4 /20 mA
```

8124d

- **Reference/bridge**
 - **Reference:** The reference voltage for the electronics of the analyzer.
 - **Bridge:** The supply voltage to the measuring bridge.

- **LCD temp.**
The temperature which determines the display contrast. Setting of the LCD contrast is described in section Parameter: Pump/LCD contrast (Page 130).

- **Analog output**
The actual value of the output current is displayed in mA for each of the measured components (the dimension is not shown for space reasons) as well as the start-of-scale value (either 0, 2 or 4 mA) and the full-scale value (20 mA) of the output current range. Refer to section Configuration: Inputs/outputs/pump: Analog outputs (Page 134) for adjustment of the start-of-scale values.

8.1.3 Analyzer status: Factory settings hardware

```
Ser. No. : IK-001
Revision : 2
Order No. :
7MB2335-1ADE3-A001-X
```

813

Factory settings are parameters which are already set on delivery such as

- Serial No.
- Revision
- Order No.

The hardware configuration and release version can be read here.

8.1.4 Analyzer status: Factory settings software

```
Firmware No. :
S79610-G210-A900
Softversion: 2.14.04
from 30.03.10 3.0
```

814

Factory settings are parameters which are already set on delivery such as

- Software/firmware release version

The software release version can be read here.

8.2 Calibration

8.2.1 Calibration

In this function group you can use one or more calibration gases to calibrate the IR channels of the ULTRAMAT 23 and to readjust the zero point and sensitivity. In addition, you can calibrate the oxygen sensor and the pressure sensor and also define the AUTOCAL parameters. The Fig. shown below indicates the menu sequence for an analyzer without H₂S sensor. The menu displays and their functions are described in the following sections.

The calibration functions can only be addressed if you have enabled code level 1.

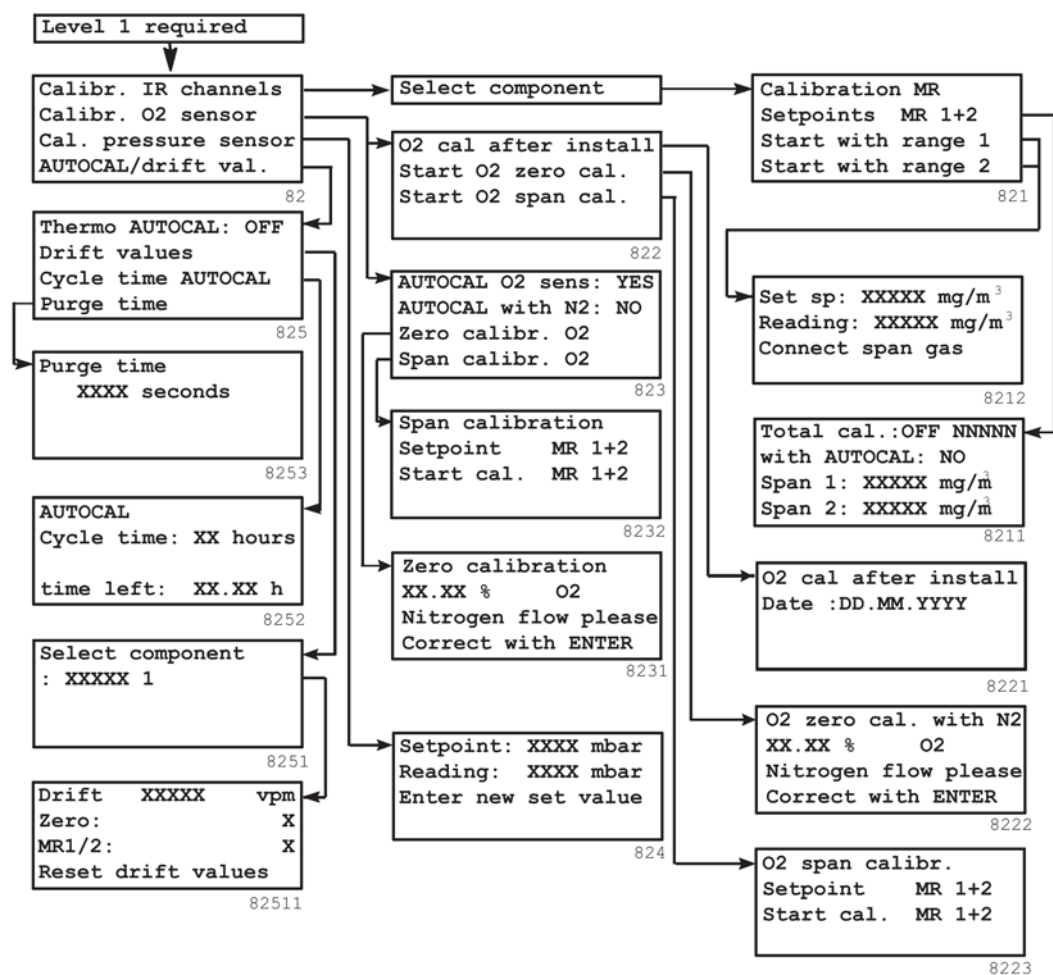

H₂S sensor

If the analyzer is fitted with an H₂S sensor, the input menu for the calibration functions is changed. The following overview shows the menu sequence for the calibration functions of the H₂S sensor. The calibration functions of the H₂S sensor are described in section Calibration: H₂S sensor (Page 118).

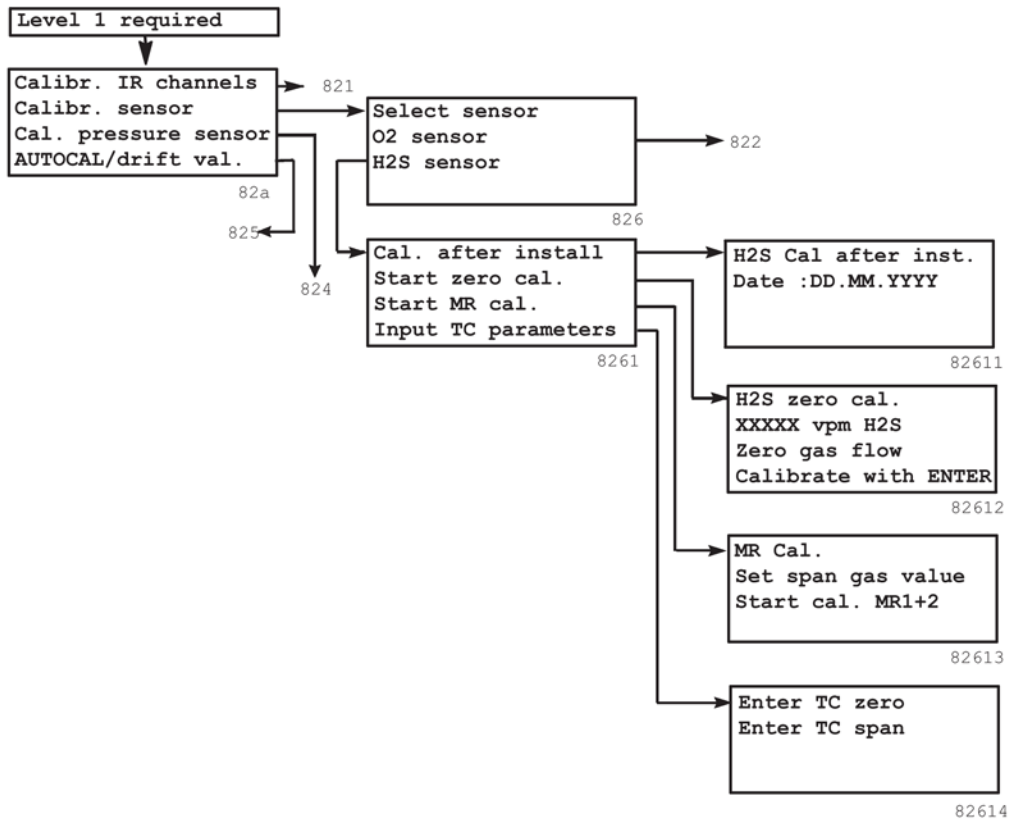

8.2.2 Calibration: Infrared measuring range

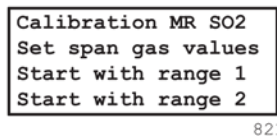

In this menu you can:

- In line 2:
 - Set the setpoints of the calibration gases for the individual ranges
 - Select a total or single calibration
- In lines 3 and 4: Start a calibration procedure.

This function is specific to the component.

8.2.2.1 Calibration: Infrared measuring range: Set span gas values

```
Total cal.:OFF SO2
vorher AUTOCAL: NEIN
MB1 : 386 mg/m3
MB2 : 1920 mg/m3
```

8211

```
Total cal.:OFF SO2
with AUTOCAL: NO
Span 1 : 12 %
Span 2 : 12 %
```

8211a

The parameters have the following meanings:

- **Total cal.:** In the first line of this dialog, you can select either a total or single calibration.
 - **ON** means that one range is calibrated and that this calibration is used for the other ranges (total calibration).
 - **OFF** means that each range is calibrated separately (single calibration, e.g. with different calibration gases).
- **With AUTOCAL:** You can define here whether you wish to carry out an AUTOCAL prior to the calibration procedure (**YES** or **NO**). An AUTOCAL is not necessary if it has already been carried out shortly before the calibration procedure, e.g. a calibration procedure has taken place directly previously.
- **Span1, Span2:** Here you can enter the setpoints for the individual measuring ranges. These are usually the concentrations of the measured components in the respective calibration gas. They should be set to a value which is between 70% and 100% of the full-scale value. If **Total cal.: ON** has been selected, the analyzer automatically uses the setpoint of range 2 for range 1. With **Total cal.: OFF** any input is possible between the start-of-scale and full-scale values of the respective range.

8.2.2.2 Calibration: Infrared measuring range: Start with Range MR 1/2

```
Set span: 386 mg/m3
Reading: 1 mg/m3
Connect span gas
```

8212

```
Set span: 386 mg/m3
Reading: 1 mg/m3
If the reading is
stable, press ENTER
```

8212a

The analyzer interrupts the current measurement if you call one of these two dialogs. If the parameter '**With AUTOCAL**'

- was set to **OFF**, the analyzer expects an immediate flow of calibration gas;
- if the value is set to **ON**, an AUTOCAL is carried out prior to the flow of gas.

The values of the setpoint and actual-value calibrations are displayed in the first two lines.

If the analyzer recognizes a flow of calibration gas, the display changes as shown. If the measured value in the second line remains constant for more than approx. 10 s or does not change significantly, press the **<ENTER>** key.

```
Set span: 386 mg/m3
Reading: 380 mg/m3
Calibration o.k.
Press ESC to return
```

8212b

The analyzer then compares the setpoint and actual value (measured value) of the calibration. If the deviation between the values is within the tolerance, the adjacent message 'o.k.' is output.

```
Set span: 386 mg/m3
Reading: 121 mg/m3
Tolerance not o.k.
Press ESC to return
```

8212c

If the actual value deviates by more than approx. 20% from the setpoint determined in the factory, the message 'not o.k.' appears instead (no calibration possible).

By pressing the <ESC> key you can exit the calibration procedure.

8.2.3 Calibration: Electrochemical oxygen measuring range

```
O2 cal after install
Start O2 zero cal.
Start O2 span cal.
```

822

In this menu you can call the following functions for the electrochemical oxygen sensor in order to:

- Enter the installation date of the electrochemical O₂ sensor
- Recalibrate the zero point of the electrochemical O₂ sensor
- Recalibrate the measuring range of the electrochemical O₂ sensor

8.2.3.1 Calibration: O₂ measuring range: Sensor inst. date

```
O2 cal after install
Date: 30.11.2012
```

8221

You must enter the date every time a new sensor is installed. The entered date is checked for plausibility. A calibration (AUTOCAL) with ambient air is subsequently carried out.

A check is also carried out during this procedure that the probe voltage is greater than 9 mV. If this is not the case, a fault message "Probe voltage too low" is output.

8.2.3.2 Calibration: O2 measuring range: Calibrating the O2 zero point

```
O2 zero cal. with N2
0.18 % O2
Nitrogen flow please
Correct with ENTER
```

8222

You can use this function to re-adjust the zero point of the H₂S sensor with nitrogen. Connect nitrogen to the sensor and commence the calibration with <ENTER>.

```
O2 zero cal. with N2
1.25 % O2
>1% => default value
Press ESC to return
```

8222a

Following calling of the correction function, the current oxygen value is displayed in the second line. If the displayed value does not deviate by more than 1% from the set value, it is used as the new zero point.

If the deviation is greater than 1% (as is the case in the example on the left, see third line), a fixed default value is used instead.

Note

The gas exchange takes place very slowly with low oxygen concentrations. In such cases we recommend flow periods of approx. 30 minutes before you use the current value.

8.2.3.3 Calibration: O2 measuring range: Calibrate measuring range

You can calibrate the sensitivity of the electrochemical O₂ sensor using this function.

```
O2 span calibr.
Setpoint MR 1+2
Start cal. MR 1+2
```

8223

The adjacent menu display appears when you select the function.

Start the calibration procedure by positioning the cursor to the 3rd line and pressing the <ENTER> key.

```
Set sp.: 1.25 %
Reading: 0.11 %
Connect span gas
```

82231

The analyzer interrupts the current measurement when the calibration procedure is selected and expects a flow of calibration gas.

The entered setpoint is displayed in the first line and the actually measured value in the second line.

```
Set sp.: 1.25 %
Reading: 0.11 %
If the reading is
stable, press ENTER
```

82231a

If the analyzer recognizes a flow of calibration gas, the display changes as shown. If the measured value in the second line remains constant for more than approx. 10 s or does not change significantly, press the <ENTER> key.

```
Set sp.: 1.25 %
Reading: 1.21 %
Calibration o.k.
Press ESC to return
```

82231b

The analyzer then compares the setpoint and actual value (measured value) of the calibration. If the deviation between the values is within the tolerance, the adjacent message 'o.k.' is output.

```
Set sp.: 1.25 %
Reading: 3.21 %
Calibration not o.k.
Press ESC to return
```

82231c

If the actual value deviates by more than approx. 20% from the setpoint determined in the factory, the message 'not o.k.' appears instead (no calibration possible). The causes of this message can include:

- Incorrectly entered setpoint
- Calibration gas concentration does not agree with entered value
- The flow of calibration gas is insufficient

By pressing the <ESC> key you can exit the calibration procedure.

8.2.4 Calibration: Paramagnetic oxygen sensor

```
AUTOCAL O2 sens: YES
AUTOCAL with N2: NO
Start cal. O2 zero
Start cal. O2 span
```

823

In this menu you can call the following functions for the paramagnetic oxygen sensor:

- "AUTOCAL O2 sens."
 - YES (factory setting): The zero point or sensitivity of the paramagnetic oxygen sensor is set with each AUTOCAL. Selection of zero point or sensitivity is carried out using the parameter in the 2nd line 'AUTOCAL with N2'.
 - NO: No calibration of the paramagnetic oxygen sensor during an AUTOCAL.
- "AUTOCAL with N2"
 - YES: The AUTOCAL is carried out with nitrogen, where the zero point of the sensor is calibrated.
 - NO: (factory setting) No calibration of the paramagnetic oxygen sensor during an AUTOCAL
- "Calib. O2 zero point"

This function is used to calibrate the zero point of the paramagnetic sensor
- "Calib. O2 range"

This function is used to calibrate the full-scale value or sensitivity of the paramagnetic sensor and to set the setpoint.

8.2.4.1 Calibration: O2 paramagnetic: Calibrating the zero point

You can calibrate the zero point of the paramagnetic oxygen sensor using this function. You must use nitrogen as the zero gas.

```
Zero calibration
0.18 % O2
Nitrogen flow please
Correct with ENTER
```

8231

If the adjacent display appears, start the flow of nitrogen and wait until the displayed value has stabilized. Subsequently begin the calibration by pressing the <ENTER> key.

Calibration of the zero point must be carried out regularly to guarantee the accuracy of the paramagnetic oxygen sensor. Information on the achievable accuracy and the calibration cycles can be found in section Technical specifications (Page 31).

8.2.4.2 Calibration: O2 paramagnetic: Calibrating the measuring range

You can calibrate the sensitivity of the paramagnetic oxygen sensor and set the setpoint using this function.

Calibrating the sensitivity

```
Set sp.: 1.25 %
Reading: 0.11 %
Connect span gas
```

82321

If the adjacent display appears, perform the full-scale calibration as follows:

1. Connect the sample gas inlet to the calibration gas
2. Inject calibration gas with a flow rate of 1 ... 1.2 l/min
3. Position the cursor at the beginning of the 3rd line (Start calibration) and press the <ENTER> key.
Once the intended flow rate has been reached, the message 'Correction with ENTER' appears in the 4th line of the display.
4. Wait until the displayed measured value has stabilized.
5. Start the calibration by pressing the <ENTER> key.
6. To exit the menu, press the <ESC> key.

The measuring range of the paramagnetic oxygen sensor is calibrated as standard with ambient air during each AUTOCAL. However, individual calibration with a freely selectable setpoint between 2% and 100% O₂ is also possible.

Note

If an individual calibration has been carried out using calibration gas, the next AUTOCAL overwrites this calibration. The AUTOCAL must be deactivated if this is not required. To do this:

1. Navigate to the input menu (823) and
 2. set the "Autocal O2 sens." parameter there to the value 'NO'.
-

Adjust setpoint

You can use this function to adjust the setpoint of the calibration gas for calibration of the measuring range.

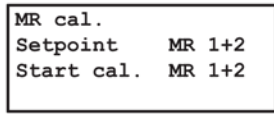

8232

If the adjacent display appears, adjust the setpoint as follows:
Position the cursor at the beginning of the 2nd line (Setpoint) and press the <ENTER> key.

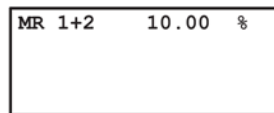

82613a

The adjacent display appears.

- Now enter the desired setpoint using the arrow keys, and then press the <ENTER> key.
- Exit the menu by pressing the <ESC> key.

8.2.5 Calibration: H2S sensor

You first need to select the H₂S sensor in order to adjust it. To do this, navigate in the operator menu as follows:

Calibration -> Please enter code -> Calibrate sensor -> Select sensor -> H₂S sensor.

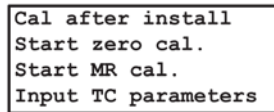

8261

The adjacent display appears.

You can now adjust the H₂S sensor as described in the following sections. The following sequence must be observed when calibrating the sensor:

1. Enter correction factors for temperature compensation of zero point
2. Enter correction factors for temperature compensation of sensitivity
3. Calibrate zero point of the H₂S sensor
4. Calibrate measuring range of the H₂S sensor
5. Enter installation date.

Steps 1, 2 and 5 are only carried out following installation of a new sensor.

The deflection signal of the sensor is subject to drift. This drift can only be detected through regular checking and corrected as necessary. This involves using a calibration gas with a defined concentration of hydrogen sulfide. We recommend monthly calibration with a calibration gas to keep potential measurement uncertainty within strict limits: The hydrogen sulfide concentration of this calibration gas should correspond to the concentration of the sample gas, having a concentration of at least 10% of the largest full-scale value.

8.2.5.1 Calibration: H2S sensor: Defining the installation

You have to re-enter the date of installation after installing a new sensor.

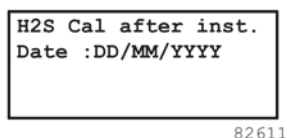

The adjacent display appears when you select the 'Installation date' menu item:

Now you can enter the date of installation in the form: 'DD.MM.YYYY'.

Note

Prior to entering the installation date, you must perform a zero point and measuring range calibration of the H₂S sensor, otherwise the new date will not be accepted.

8.2.5.2 Calibration: H2S sensor: Calibrating the zero point

You can use this function to re-adjust the zero point of the H₂S sensor. As the zero gas you can use:

- Nitrogen
or
- air free of H₂S.

To do this, navigate as follows: Calibration -> Please enter code -> Calibrate probe -> Choose component -> H₂S -> Calibrate zero.

The adjacent display appears.

In the case of analyzers with an internal sample gas pump, selecting this function switches from the sample gas inlet (inlet 1) to the zero gas inlet (inlet 3).

Calibrate the zero point as follows:

- Connect zero gas to the analyzer and observe the display.
- Wait until the displayed value has stabilized.
- Commence with correction of the zero point by pressing the <ENTER> key.
- Exit the calibration by pressing the <ESC> key.

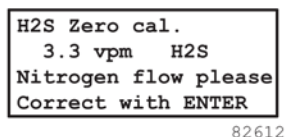

The message "Tolerance not o.k." appears if an error occurs during the calibration.

8.2.5.3 Calibration: H2S sensor: Calibrating the measuring range

You can enter the setpoint and calibrate the sensitivity of the sensor using this function.

Navigate as follows to select this function: Calibration -> Please enter code -> Calibrate sensor -> Select component -> H₂S -> Calibrate MR.

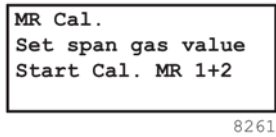

82613

The adjacent display appears.

Proceed as follows to enter the setpoint:

1. Position the cursor on the 2nd line of the display (**Setpoint MR 1+2**)
2. Press the <ENTER> key

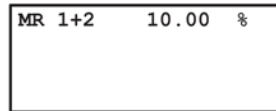

82613a

The adjacent display appears. You can now enter the setpoint of the calibration gas:

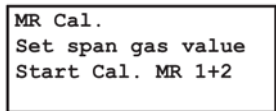

82613

Calibrate the sensitivity as follows:

1. Position the cursor on the 3rd line of the display (Start cal. MR 1+2).
2. Press the <ENTER> key.

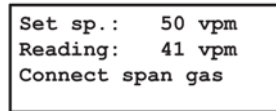

82613b

The adjacent display appears. Now carry out the following steps for the sensitivity calibration:

1. Connect the sample gas inlet to the calibration gas.
2. Inject calibration gas to the sensor with a flow rate of 1.2 ... 2.0 l/min.
3. Wait until the measured value has stabilized.
4. Then press the <ENTER> key.
5. Exit the calibration by pressing the <ESC> key.

The message "Tolerance not o.k." appears if an error occurs during the calibration.

8.2.5.4 Calibration: H₂S sensor: Enter TC parameters

You use this function to enter the temperature compensation parameters for calibration of the zero point and sensitivity. You can read these parameters from the sensor.

To do this, navigate as follows: Calibration -> Please enter code -> Calibrate probe -> Choose component -> H₂S -> Calibrate TC parameters. The following screen appears:

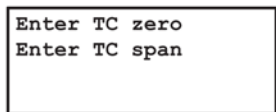

82614

Temperature compensation (TC) of zero point

```
A: -3.0817e+1  
B: +2.2517e+0  
C: -1.1050e-1  
D: +2.8011e-3
```

82614a

To do this, proceed as follows:

1. Position the cursor on the first line
2. Then press the <ENTER> key.

The adjacent display appears.

You can now view the factors of the temperature compensation parameters for the zero point, and change them if necessary.

Temperature compensation of sensitivity

```
Enter TC zero  
Enter TC span
```

82614

Proceed as follows for this (from menu display 'Enter TC parameters'):

1. Position the cursor on the second line.
2. Then press the <ENTER> key.

The adjacent display appears.

```
A: +4.2117e+0  
B: -2.8547e-1  
C: +5.5451e-3  
D: -2.0077e-5
```

82614b

You can now view the factors of the TC parameters for the sensitivity, and change them if necessary.

8.2.6 Calibration: Pressure sensor

```
Setpoint: 1017 mbar  
Reading : 999 mbar  
Enter new set value
```

824

In the first line of this menu display, you can re-enter the setpoint of the pressure sensor.

To do this, measure a reference value, e.g. using an accurate barometer, and change the setpoint in the first line if necessary.

8.2.7 Calibration: AUTOCAL/drift values

```
Thermo AUTOCAL: OFF
Drift values
Cycle time AUTOCAL
Purge time
```

825

It is possible to change the following parameters in this dialog:

- Thermo-AUTOCAL
 - **OFF**: An automatic AUTOCAL only takes place when the cycle time has expired (see there).
 - **ON**: An automatic AUTOCAL only takes place when the cycle time has expired. In addition, an automatic AUTOCAL is triggered if the operating temperature has changed by more than 8 °C compared to that measured during the last AUTOCAL. This AUTOCAL it started with a delay of 280 minutes.
 - Drift values
 - Cycle time
 - Purge time
- These three parameters are described separately.

8.2.7.1 Calibration: AUTOCAL/drift values: Drift values

This function is used to display the drift values of the zero point and sensitivity, and to change them if necessary. The drift values are the total of the deviations in measured values for the zero and sensitivity calibrations. This parameter is specific to the component.

```
Select component
: SO2 1
```

8251

This menu display appears following selection of the drift values and allows selection of the desired component.

You can switch between the individual components by pressing an arrow key. You can select the displayed component using the <ENTER> key.

```
Drift SO2 515 vpm
Zero: 0
MR1/2: 0
Reset drift values
```

82511

You can now view the drift values and reset them if necessary. To do this, position the cursor on the 4th line (reset) of the display and press the <ENTER> key.

8.2.7.2 Calibration: AUTOCAL/drift values: Cycle time

Use this function to set or change the cycle time. This is the time between two AUTOCAL procedures triggered automatically by the analyzer.

```
AUTOCAL
Cycle time: 24 hours
Time left: 11.11 h
```

8252

Valid cycle times are from 0 to 24 hours. A cyclic AUTOCAL is not carried out if 0 hours is set.

The cycle time must not be more than 6 h if the analyzer is used in German systems subject to TA Luft and 13.BImSchV. The fourth line indicates when the next AUTOCAL will take place.

If the flow during a cyclic zero adjustment is too low, this adjustment is aborted and a fault is displayed. This procedure is entered in the logbook.

8.2.7.3 Calibration: AUTOCAL/drift values: Purge time

Use this function to set or change the purge time. This is the duration of flow with sample gas during an AUTOCAL procedure.

```
Purge time
240 seconds
```

8253

Following calling of the purge time you can set or change the purge time in the second line of the menu display. Valid purge times are:

- 60 to 600 seconds for analyzers with oxygen sensor
- 300 to 600 seconds for analyzers with hydrogen sulfide sensor
- 0 to 600 seconds for all other analyzer versions.

There are minimum purge times depending on the measured component, and shorter times should not be used.

8.3 Parameter

In this function group you can change various analyzer parameters. These modifications can only be made within the limits which have been preset for your analyzer. The analyzer checks parameter changes for plausibility and rejects them if applicable. The following figure shows the menu sequence of this function group. The display elements are described in section Input mode (Page 96).

Access to the "Parameters" menu is protected by code level 1.

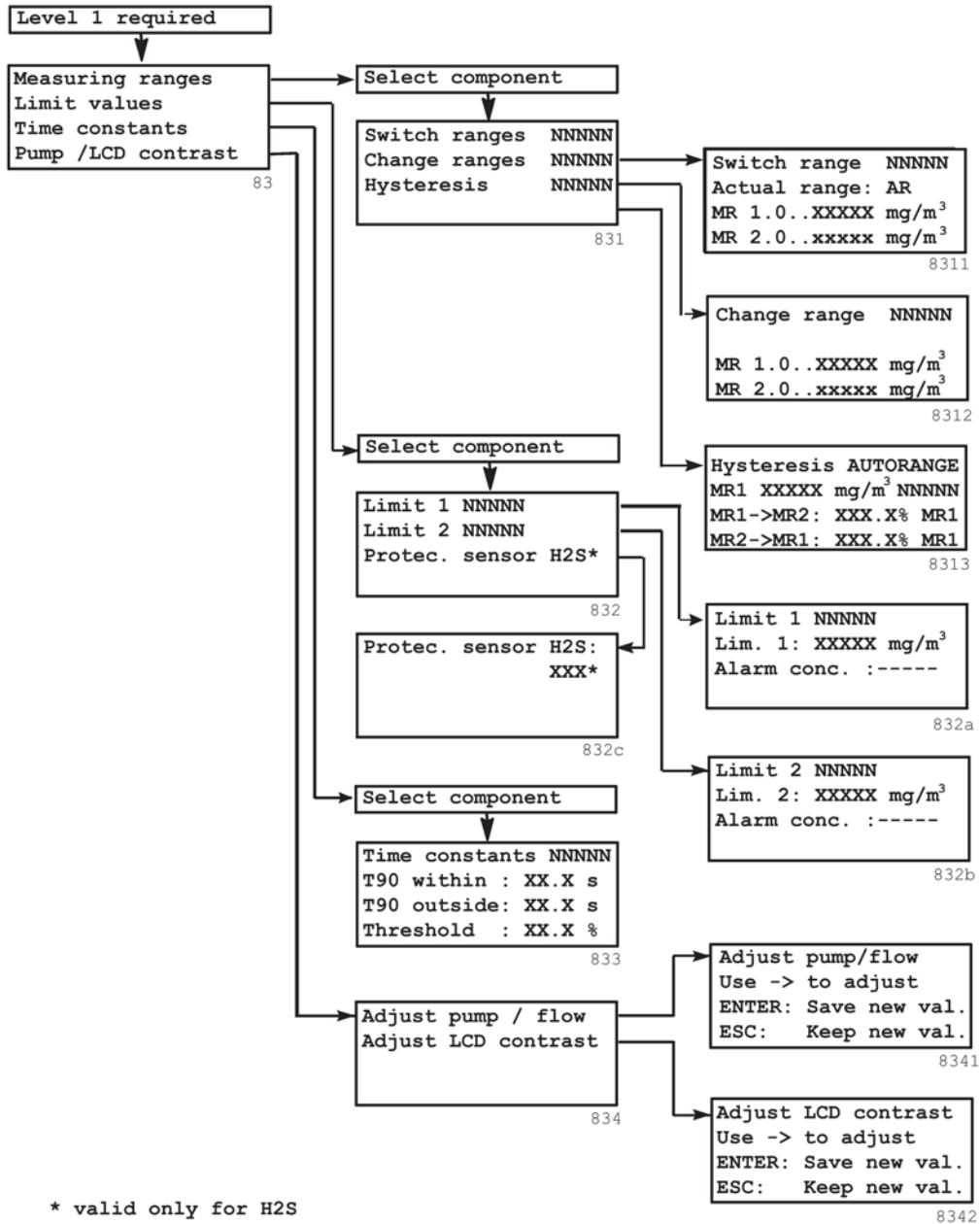

8.3.1 Parameter: Measuring ranges

```
Switch ranges  SO2
Change ranges SO2
Hysteresis    SO2
```

831

In this menu you can:

- Permit or cancel the switching over between measuring ranges
- Set the full-scale values
- Define a hysteresis.

Note

Please note that the range parameters only refer to the measuring ranges at the analog outputs (see section Configuration: Inputs/outputs/pump: Analog outputs (Page 134)). The display always shows the complete, physically possible range.

8.3.1.1 Parameters: Measuring ranges: Switch ranges

```
Switch range  SO2
Actual range:  1
MR 1.0...400 mg/m3
MR 2.0...2000 mg/m3
```

8311

In the second line of this dialog you can set the measuring range 1 or 2 or permit autoranging (automatic switching over between these two ranges).

The '**Actual range**' parameter can have the following values:

- **1:**
The analyzer is set to the smaller range (MR 1).
- **2:**
The analyzer is set to the larger range (MR 2).
- **1/2:**
The analyzer is set to the larger range (MR 2). The start-of-scale value of the analog output corresponds in this case to the full-scale value of the smaller range (MR 1), the full-scale value of the analog output corresponds to that of the larger range (MR 2).
The result is that the analog output of the analyzer has a range with zero offset (e.g. 90 ... 100%).
- **AR:**
The analyzer switches over automatically from one range to the other (AR = autoranging). Setting of the switchover criteria is described in section Parameters: Measuring ranges: Hysteresis (Page 127).

8.3.1.2 Parameters: Measuring ranges: Setting measuring ranges

Change range SO2
MR 1.0...400 mg/m ³
MR 2.0...2000 mg/m ³

8312

The full-scale values of the measuring ranges can be set in the third and fourth lines of this dialog. They must lie within the factory settings, i.e. if an analyzer is factory-set for a total range from 0 to 2000 mg/m³, modifications are only possible within this range. The following definitions also apply:

- The smaller MR must not be greater than the higher MR.
- The following input limits apply to the ranges:
 - Lower limit: 0.01 times the smaller MR according to factory setting (label)
 - Upper limit: 1.1 times the higher MR according to factory setting (label)

In the example:

- Smallest MR 1: 0 to 4 mg/m³
- Highest MR 2: 4 to 2200 mg/m³

8.3.1.3 Parameters: Measuring ranges: Hysteresis

```
Hysteresis AUTORANGE
MR1  400 mg/m3 SO2
MR1->MR2: 100.0% MR1
MR2->MR1:  90.0% MR1
```

8313

In the third and fourth lines of this dialog, you can set the value at which the analyzer switches from one range to the other. The values are specified in % of the full-scale value of range 1 (MR1) (see section Parameters: Measuring ranges: Setting measuring ranges (Page 126)).

Note

The hysteresis is only active if the "**Actual range**" parameter has been set to the value "**AR**" (autoranging) in the dialog "**Switch ranges**" (Parameters: Measuring ranges: Switch ranges (Page 125)).

The two switchover points should be as far apart as possible, and the switchover point from MR1 to MR2 must be greater than that from MR2 to MR1.

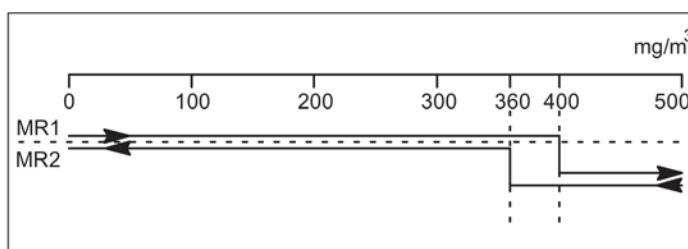

The following conditions have been assumed in the display:

- Your analyzer has two ranges:
 - MR1 from 0 to 400 mg/m³
 - MR2 from 0 to 2000 mg/m³.
- The hystereses are defined as:
 - MR1->MR2 at 100%
 - MR2->MR1 at 90%.

This means:

- If your analyzer is working in the smaller range (MR1), it switches over to the larger range (MR2) when a value greater than 400 mg/m³ SO₂ is measured
- If your analyzer is working in the larger range (MR2), it switches over to the smaller range (MR1) when a value less than 360 mg/m³ SO₂ is measured (=90% of 400 mg/m³).

8.3.2 Parameters: Limits

```
Limit 1 SO2  
Limit 2 SO2
```

832

Two limits are assigned to each component, and can be set using this menu. A relay is triggered when the limits are violated (see section Configuration: Inputs/outputs/pump: Assign relays (Page 138)). Limit 1 is the lower limit, Limit 2 the upper limit.

Note

A set limit only triggers a relay contact if a relay has previously been assigned to the corresponding limit signal (see section Configuration: Inputs/outputs/pump: Assign relays (Page 138)). The limits are not updated:

- During the first warm-up phase
- During an AUTOCAL
- During the message: Function control and analog output at 'Hold measured value' (see section Configuration: Inputs/outputs/pump: Analog outputs (Page 134))

```
Limit 1 SO2  
Lim. 1: 2000 mg/m3  
Meldung bei :-----
```

832a

If you have selected "Limit 1" or "Limit 2", a menu display appears in which you can enter the lower or upper limit for each component. You can define the value in the second line, and the condition under which a contact is triggered in the third (Alarm at conc.):

- **High:** with upward violation
- **Low:** with downward violation
- -----: no signal.

8.3.3 Parameters: Limits: H2S sensor protection

```
Limit 1 H2S
Limit 2 H2S
Protec. sensor H2S
```

832

If 'H₂S' is selected as the component in the higher-level menu display, the 'H₂S sensor protection' function is selected in addition to the limits. The 'Limit' function is described in section Parameters: Limits (Page 128).

```
Protec. sensor H2S :
                    ON
```

832c

In the 3rd line you can select the 'H₂S sensor protection' function.

The adjacent menu display appears when you select the function in which you can switch the 'H₂S sensor protection' function on and off.

Hydrogen sulfide (H₂S) is a corrosive gas, especially in wet condition and in combination with other gases. This function prevents damage occurring to the H₂S sensor from high concentrations of H₂S. This function is enabled by default (**ON**). Execution of this function is described in section Probe protection function (Page 156).

8.3.4 Parameters: Time constants

```
Time constants SO2
T90 within : 12.0 s
T90 outside: 3.5 s
Threshold : 3.0 %
```

833

You can use this function to set various time constants to suppress noise in the measured signal. During processing of the measured signals, these time constants reduce the noise by delaying the signal. The time constant "**T₉₀ within**" is effective within an adjustable interval whose threshold values are defined as a percentage of the smallest measuring range. The time constant dampens small changes in signal (e.g. noise), but becomes immediately ineffective if a fast change in signal exceeds a threshold. If the threshold is exceeded, the signal is dampened by the time constant "**T₉₀ outside**" until it falls below the threshold value again. "**T₉₀ within**" then becomes effective again.

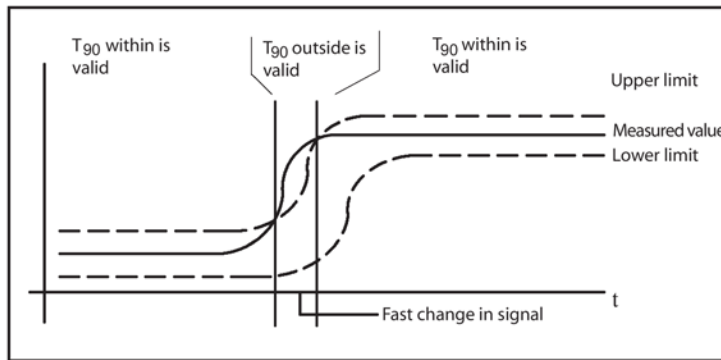
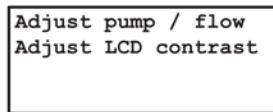

Figure 8-1 Time constants

The following values are possible for the time constants:

- T_{90} within: 0.1 to 99.9 (s)
- T_{90} outside: 0.1 to 99.9 (s)
- Threshold (data in %): 0 ... 100% of smallest range

8.3.5 Parameter: Pump/LCD contrast



834

You can use this menu to select two dialogs via which the pump capacity and the contrast of the LCD can be changed.

8.3.5.1 Parameters: Pump/LCD contrast: Pump

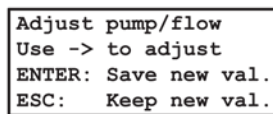

8341

In this menu you can:

- Increase the pump capacity using the <=> or <↑> key
- Decrease the pump capacity using the <↓> key
- Store the set pump capacity using the <ENTER> key
- Cancel the input using the <ESC> key.

Changes to the pump capacity are shown on the flowmeter and directly in the menu display by the message "o.k." or "not o.k."

8.3.5.2 Parameters: Pump/LCD contrast: LCD contrast

```
LCD contrast
Use -> to adjust
ENTER: Save new val.
ESC:  Keep new val.
```

8342

In this menu you can:

- Increase the contrast using the <→> or <↑> key. This darkens the characters.
- Decrease the contrast using the <↓> key. This brightens the characters.
- Store the set contrast using the <ENTER> key
- Cancel the input using the <ESC> key.

Note

Simultaneous pressing of the three keys <↑> , <↓> and <→> sets an average contrast again.

8.4 Configuration

With this function group you can assign relays and inputs/outputs and use special functions and test functions. The following figure shows the associated menu sequence, further menu sequences are shown under '842' and '843'. An explanation of the display elements can be found in section Input mode (Page 96).

Access to the "Configuration" menu is protected by code level 2.

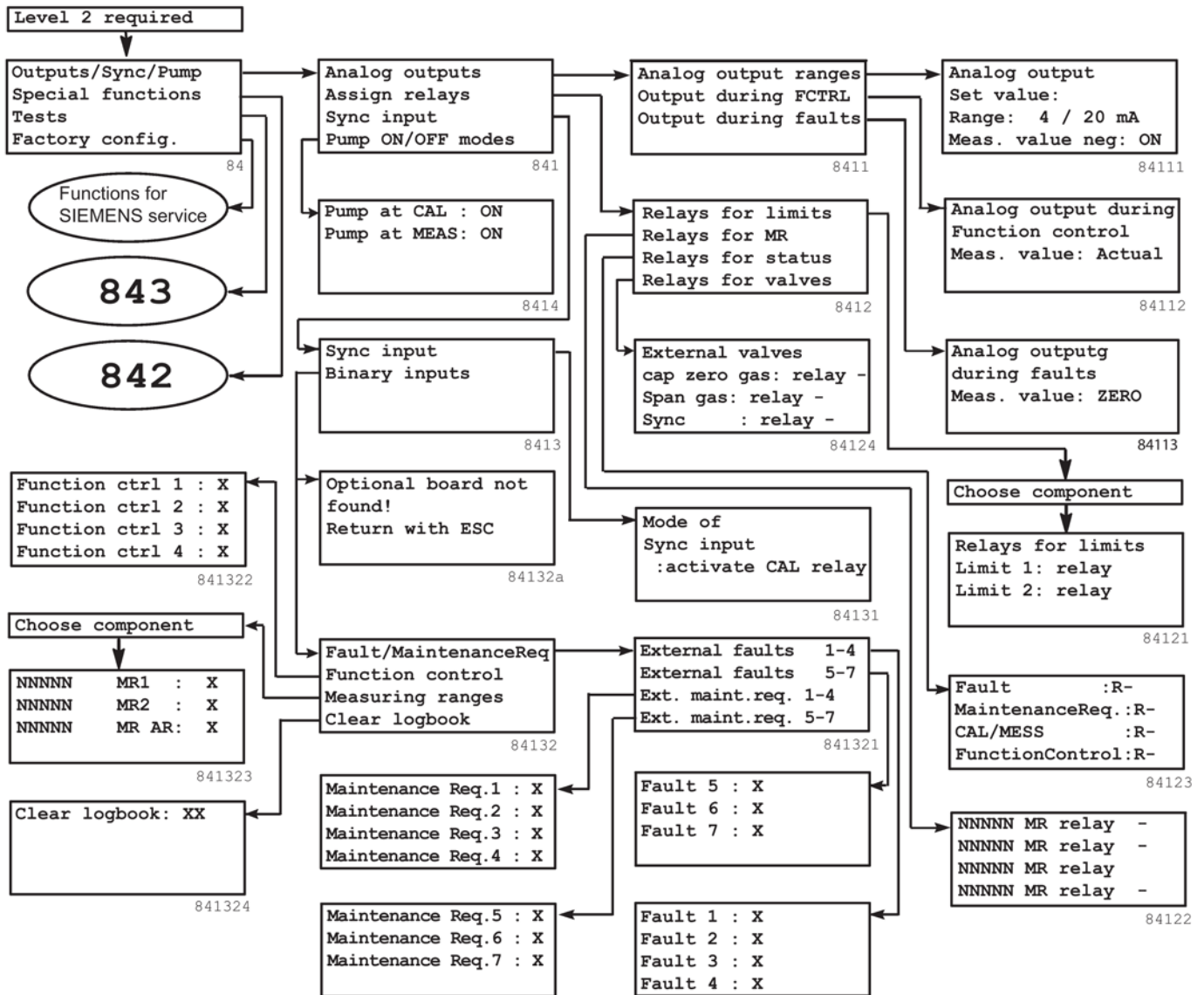

The special functions (menu display 842) are described in section Configuration: Special functions (Page 142), the analyzer tests (menu display 843) in section Configuration: Device test (Page 151).

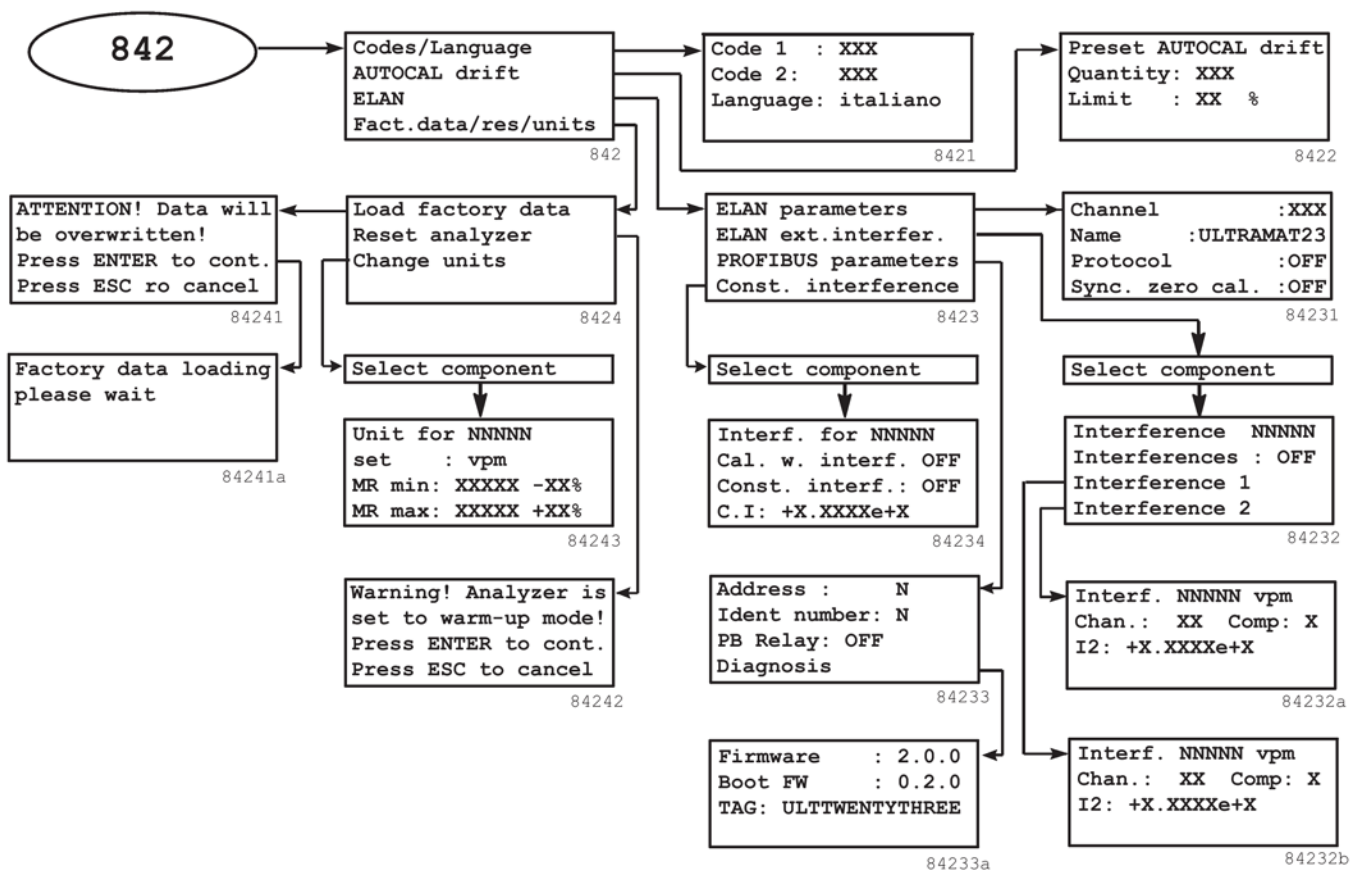

Figure 8-2 Overview of configuration of special functions

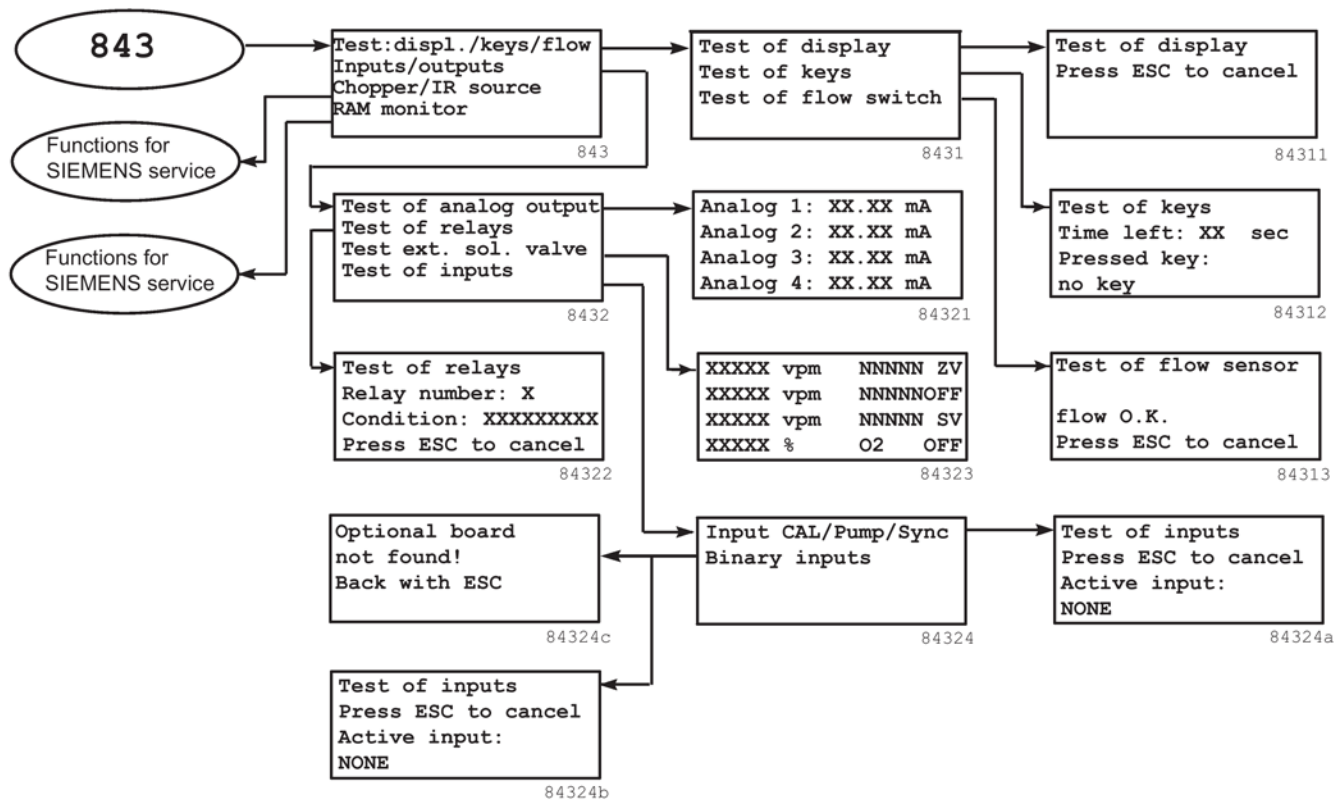

Figure 8-3 Overview of configuration of analyzer tests

8.4.1 Configuration: Inputs/outputs/pump

```

    Analog outputs
    Assign relays
    Sync input
    Pump ON/OFF modes
  
```

841

You can use this menu to assign certain functions to the following elements:

- Relays
- Inputs and outputs

Furthermore, the following settings can be made using this menu:

- Synchronization of several analyzers
- Pump response with AUTOCAL and in measuring mode

8.4.1.1 Configuration: Inputs/outputs/pump: Analog outputs

```

    Analog output ranges
    Output during FCTRL
    Output during faults
  
```

8411

You can use this menu to parameterize the analog outputs. This input always refers equally to all components.

Analog output 0/2/4/NAM mA (start-of-scale value of analog output)

```

Analog output
Set value:
Range: 4 / 20 mA
Meas value neg: ON
    
```

84111

You can set the following start-of-scale values for the analog current range in the 3rd line:

- 0 mA
- 2 mA
- 4 mA
- NAMUR

You can switch suppression of negative measured values on or off in the 4th line. The "ON" option is preset, and means that negative measured values can also be output. With a setting of 2 or 4 mA as the lower limit, values below this down to 0 mA can therefore be output, i.e. negative measured values can be displayed (live zero).

```

Analog output
Set value :
Range: 4 / 20 mA
Meas. value neg: OFF
    
```

84111a

If the output of negative measured values is switched off ("OFF" position), the current output is limited to the start-of-scale value.

If 2 or 4 mA is set as the lower limit, the output is now indeed limited to 2 or 4 mA. In the adjacent display, the start-of-scale value of the analog current range is set to 4 mA.

The following tables represent the correlation between analog current outputs and measuring range limits.

Table 8- 1 Start-of-scale value of the analog current output

Selectable	Analog current (neg. MV on)	Analog current (neg. MV off)
0 - 20 mA	0 mA	0 mA
2 - 20 mA	2 mA	2 mA
4 - 20 mA	4 mA	4 mA
NAMUR - 20 mA	4 mA	4 mA

Table 8- 2 Start-of-scale value of the analog output current for downward limiting of measured value

Selectable	Analog current (neg. MV on)	Analog current (neg. MV off)
0 - 20 mA	0.0 mA	0.0 mA
2 - 20 mA	0.0 mA	2.0 mA
4 - 20 mA	0.0 mA	4.0 mA
NAMUR - 20 mA	3.8 mA	4.0 mA

Table 8- 3 Full-scale value of the analog output current for upward limiting of measured value

Selectable	Analog current (neg. MV on)	Analog current (neg. MV off)
0 - 20 mA	21.0 mA	21.0 mA
2 - 20 mA	21.0 mA ¹⁾	21.0 mA ¹⁾
4 - 20 mA	21.0 mA ¹⁾	21.0 mA ¹⁾
NAMUR - 20 mA	20.5 mA	20.5 mA

¹⁾ If measuring range 2 is set to the maximum possible value, the limiting value of range 2 ... 20 mA is at 20.9 mA and of range 4 ... 20 mA at 20.8 mA.

Analog output during FCTRL (analog output during function control)

Note

If a fault is present on the analyzer, only the values of the setting "Output during faults" apply. Simultaneous occurrence of values of the setting "Output during FCTRL" are ignored in this case.

```

Analog output during
function control
Meas. value: actual
    
```

84112

The status "FCTRL" (function control) is set

- During an AUTOCAL procedure
- During the warm-up phase
- During a calibration procedure
- During remote control via the communication interface
- In the uncoded state:

Output of the following measured values is possible here:

- **Hold:** The value measured directly prior to commencement of a function control is output unchanged. This also applies to the limits which are output (see section Parameters: Limits (Page 128)).
- **Actual:** The measured value is continuously updated.

- **Zero:**
See following table:

Selectable	Analog current
0 - 20 mA	0 mA
2 - 20 mA	2 mA
4 - 20 mA	4 mA
NAMUR - 20 mA	3 mA

- **21 mA:**
see following table:

Selectable	Analog current
0 - 20 mA	21.0 mA
2 - 20 mA	21.0 mA
4 - 20 mA	21.0 mA
NAMUR - 20 mA	21.5 mA

Analog output during fault

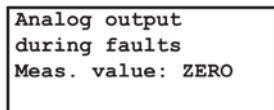

84113

Here, you can define the type of measured value output during a fault.

Output of the following measured values is possible here:

- **Hold:** The value measured directly prior to commencement of a fault is output unchanged. This also applies to the limits which are output (see section Parameters: Limits (Page 128)).
- **Actual:** The measured value is continuously updated.

- **Zero:**
See following table:

Selectable	Analog current
0 - 20 mA	0 mA
2 - 20 mA	2 mA
4 - 20 mA	4 mA
NAMUR - 20 mA	3 mA

- **21 mA:**
see following table:

Selectable	Analog current
0 - 20 mA	21.0 mA
2 - 20 mA	21.0 mA
4 - 20 mA	21.0 mA
NAMUR - 20 mA	21.5 mA

8.4.1.2 Configuration: Inputs/outputs/pump: Assign relays

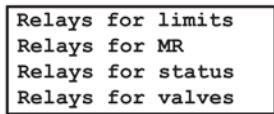

8412

You can use this menu to assign different functions to up to eight relays which are installed in the analyzer, such as signals or functions of external solenoid valves. If an option module is present in the analyzer, eight additional relays, i. e. a total of 16 relays, can be assigned corresponding functions.

Each function may only be assigned once, i.e. to one single relay. The analyzer outputs an error message if you attempt a second assignment for a relay. A relay to which a function has not been assigned is shown on the display by a dash.

The following table shows an overview of the possible relay assignments.

Table 8- 4 Overview of relay assignments

Function	Relay de-energized	Relay energized	Signaling
Limit	Limit has been triggered		Limit (see section Parameters: Limits (Page 128))
Measuring range	Range 2	Range 1	-
Status messages			
Fault	Fault present		
Maintenance request	Maintenance request		
CAL/MEAS	Measure	AUTOCAL	AUTOCAL
Function control	Function control present		During warm-up phase (approx. 30 min), AUTOCAL, uncoded
External solenoid valves			
Zero gas	Zero gas flowing		Ext. solenoid valve open
Calibration gas (sample gas inlet)		Calibration gas flowing	Ext. solenoid valve open
Sync.		Synchronization signal is output	AUTOCAL only "Zero gas flow" and adjustment not during sample gas purging phase

The pin assignments of the relays in the de-energized state are described in section Pin assignments (Page 54).

The functions which can be assigned to the relays have the following meanings:

```
Limits SO2
Limit 1 Relay 1
Limit 2 Relay 2
```

84121

```
NO MR relay 3
CO MR relay -
SO2 MR relay 4
O2 MR relay -
```

84122

Limit messages

The upper and lower limits can be defined as events for triggering relays. Select the desired relay(s) in the second and third lines of this menu.

This function is specific to the component.

Relays for MR

A relay for range switchover can be assigned to each component. This guarantees reliable assignment of the analog output signal to the currently active range, especially with autoranging (see section Parameter: Measuring ranges (Page 125)).

```
Fault :R-  
Maintenance req.:R5  
CAL/MEAS :R6  
FunctionControl:R-
```

84123

Status messages

You can use this menu to apply the signaling of various operating states of the analyzer as an event for relay control (R in the display means Relay).

The following signals are possible:

- **Fault:**
Occurrence of a fault and output of a fault message
- **Maintenance request:**
Occurrence of maintenance request (assigned to relay 5 in Fig.)
- **CAL/MEAS:**
Switching over from measuring mode to AUTOCAL (applied to relay 6 in Fig.)
- **Service switch:**
Occurrence of a function control.

```
External valves  
zero gas : relay -  
span gas : relay 7  
Sync : relay 8
```

84124

In this menu you can trigger external solenoid valves via relay contacts:

- **Zero gas:**
The zero gas supply which is triggered with AUTOCAL
- **Span gas:**
The calibration gas supply (assigned to relay 7 in Fig.)
- **Sync:**
Synchronization of an AUTOCAL with other devices within a system (assigned to relay 8 in Fig.; see section System setup with several analyzers in parallel (Page 84)).

8.4.1.3 Configuration: Inputs/outputs/pump: Binary/sync inputs

```
Sync input
Binary inputs
```

8413

```
Mode of
Sync input
:activate CAL only
```

84131

```
Optional board not
found!
Return with ESC
```

84132a
84324c

```
Fault/MaintenanceReq
Function control
Measuring ranges
Clear logbook
```

84132

You can use this dialog to set the response of the synchronization input and the binary inputs. Select one of the adjacent options:

Sync input

You can use this dialog to set the response of the synchronization input. This function allows an AUTOCAL procedure to be triggered simultaneously for several analyzers within a system. You can select between the following settings in the third line (see also section System setup with several analyzers in parallel (Page 84)):

- **AUTOCAL:**
The analyzer carries out an AUTOCAL and activates its sync output up to the end of the electronic adjustment. If the flow becomes too low during a zero adjustment triggered via the sync input, this zero adjustment is aborted, and an error status set. This aborted zero adjustment is entered in the logbook.
- **Activate CAL relay (set in Fig.):**
The analyzer enters the CAL status, but does not carry out an AUTOCAL. The analyzer waits until the Sync input becomes inactive. It then enters the status 'Purge sample gas' and subsequently selects measuring mode.

Binary inputs

You can use this dialog to freely configure 8 floating binary inputs ["0" = 0 V (0...4.5 V); "1" = 24 V (13...33 V)] in analyzers with an add-on board. The pin assignments of the 37-contact plug are described in section Pin assignments (Page 54). No inputs are preset on delivery.

The adjacent error message occurs if an attempt is made to call this function for a device without add-on board.

The adjacent display appears if an add-on board is present. You can then assign the following functions to the eight binary inputs in a submenu:

- Seven different messages for faults/maintenance requests
- Four different messages for function control
- Switch ranges
- Delete the logbook.

The functions are shown in the following table:

Table 8- 5 Overview of binary inputs

Function	Control with		Effect
	0 V	24 V	
- (vacant)			
External fault 1 ... 7		x	e.g. signaling of a fault in gas conditioning (cooler, flow, condensation trap, ...)
External maintenance request 1 ... 7		x	e.g. signaling of a maintenance request in gas conditioning (filter, flow, ...)
Function control 1 ... 4		x	e.g. signaling of maintenance
Measuring range 1,2		x	The corresponding range is selected (autoranging OFF)
Autorange		x	Autoranging is switched on
Delete logbook		x	Delete all fault and maintenance request entries

8.4.1.4 Configuration: Inputs/outputs/pump: Pump at CAL/MEAS

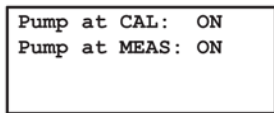

8414

You can use this menu to define the response of the pump. The following parameters and values are possible:

- **Pump at CAL:**
Pump switched **ON** or **OFF** during an AUTOCAL
- **Pump at MEAS:**
Pump switched **ON** or **OFF** during measuring mode.

8.4.2 Configuration: Special functions

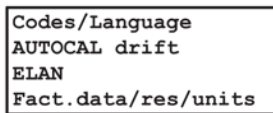

842

Following selection of the special functions, the adjacent menu is displayed with the following options:

- Change codes
- Change language
- Setting of AUTOCAL tolerances
- Parameterization of interfaces
- Change physical units in which the measured values are output
- Changing the factory settings

8.4.2.1 Configuration: Special functions: Changing the codes/language

```
Code 1 : 111
Code 2 : 222
Language: italiano
```

8421

In the first two lines of this dialog, you can change the codes of the two code levels 1 and 2 (see also section Code levels (Page 97)).

The factory settings for the two code levels are:

- Code level 1: **111**
- Code level 2: **222**

You can also reduce the number of code levels by assigning the same code to both levels.

With the introduction of firmware version 2.15.06, you can now use letters and special characters for the code in addition to numbers. With all older firmware versions, you could only enter numbers.

The modified codes are effective immediately. You should therefore make a note of the changed codes and keep this at a safe place.

In third line of this dialog you can change the language of the input dialogs. The analyzer is designed for the following languages:

- German
- English
- Spanish
- French
- Italian
- Polish

A change is immediately effective when you leave this dialog.

8.4.2.2 Configuration: Special functions: AUTOCAL deviation

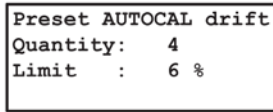

8422

You can use this dialog to define the conditions under which a drift from the value of an AUTOCAL procedure triggers a maintenance request. The adjustable parameters are:

- **Quantity:**
The number of AUTOCAL procedures up to setting of a new reference value (in this example: 4),
- **Limit:**
The largest possible value in % of the set measuring range. In the case of autoranging, range 1 is assumed with max. 99% of the full-scale value. The deviation from the last AUTOCAL must not exceed this value (in this example: 6%, see also section (Page 122)), otherwise a maintenance request is triggered.

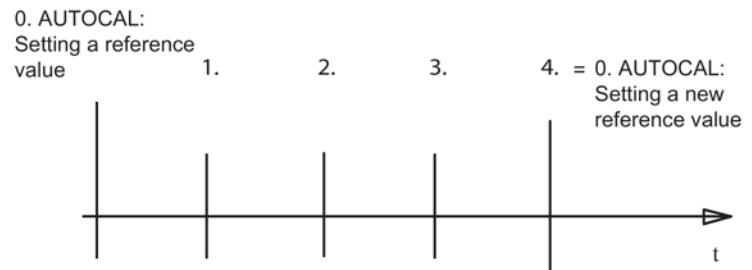

Number of AUTOCAL procedures until a reference is set again (set number: 4)

The previous deviation is still displayed with the 4th AUTOCAL; at the same time the value of the 4th AUTOCAL is used as the new reference value.

If a maintenance request 'AUTOCAL deviation too large' is acknowledged, the values are reset during the next AUTOCAL, and counting commences at 1 again.

8.4.2.3 Configuration: Special functions: ELAN/PROFIBUS/external interference

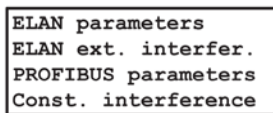

8423

You can use this dialog to configure the analyzer for use in an ELAN or PROFIBUS network.

The adjacent menu display appears when you select the function from the higher-level menu.

Configuration: Special functions: ELAN/PROFIBUS/external interference: ELAN parameters

```
Channel      : 1
Name : ULTTWENTYTHREE
Protocol     : OFF
Sync.zero cal. : OFF
```

84231

You can use this dialog to set the parameters for an ELAN network. These are:

- **Channel**
You must set the channel addresses for the analyzers present in an ELAN network. Addresses from 1 to 12 can be set, where each address may only be used once.
- **Name**
You can set an analyzer name here. During communication with ELAN, it can be used for the plain text identification of the analyzers. An analyzer name may have up to 10 alphanumeric characters.
- **Protocol (ON/OFF)**
The automatic transmission of measured values can be switched on/off. With 'ON', the analyzer sends a measured value frame cyclically every 500 ms.
Note
To avoid considerably hindering communication within an ELAN network, this function should only be set to 'ON' when required (e.g. with correction of cross-interference).
- **Sync. zero cal. (ON/OFF)**
This function is not yet available. Therefore only 'OFF' is the currently valid value.

Note

For further details on operation of the analyzer in an ELAN network, please refer to the ELAN interface description (C79000-B5274-C176 German/English).

Configuration: Special functions: ELAN/PROFIBUS/external interference: ELAN external interference

```
Interference CO2
Interferences : OFF
Interference 1
Interference 2
```

84232

This function can be used for a correction calculation by measuring the influence of an interfering gas by means of another analyzer connected in the ELAN network.

The parameterization of two analyzers for correction of cross-interference is demonstrated using the following example. Analyzer 1 delivers the measured values, analyzer 2 uses these values for a correction calculation.

Note

Neither analyzer is capable of measurements during the AUTOCAL. Therefore it may be necessary to evaluate signals for the function control.

Example of correction of cross-interference of CO₂ on CO with 6 vpm CO at 25% CO₂ via ELAN

1. Connect two analyzers to the ELAN interface using a cable.
(see ELAN interface description (C79000-B5274-C176 Section 2))
2. Select a component using the ELAN menu (8423)

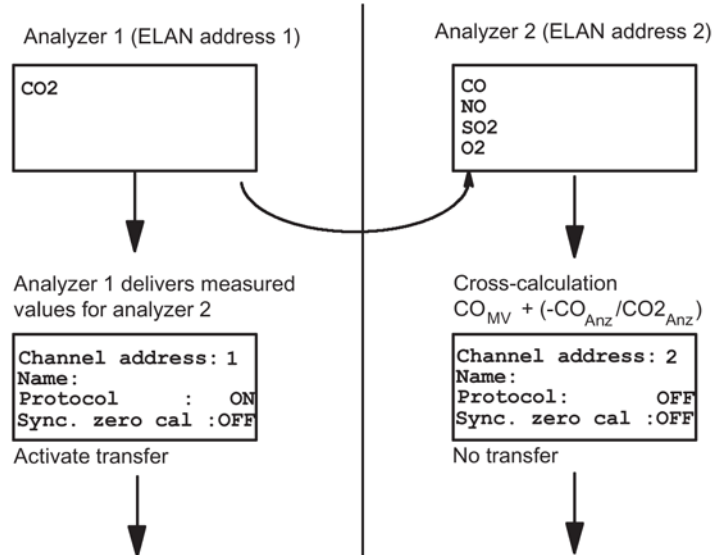

3. ELAN -> Ext. cross-interferences -> Select component



4. Cross-interference 1 or 2

Interf. CO	vpm
Channel: 1	Comp: 1
I1: -2.4000e-1	NR
32.54 %	CO2

Meaning of the parameters:

Channel 1 = analyzer with address 1 in the ELAN network
 Component 1 = component 1 of the analyzer addressed under 'Channel'
 -2.4000e-1 = cross-interference of CO2 on CO is 6 vpm CO with 25% CO2 => correction is - 6 / 25
 32.54% CO2 = measured values sent over ELAN from analyzer 1 component 1 for calculation of correction of cross-interference of CO

Configuration: Special functions: ELAN/PROFIBUS/external interference: PROFIBUS parameters

```

Address      : 126
Ident number : 1
PB Relay    : OFF
Diagnosis
    
```

84233

```

Firmware     : 2.0.0
Boot FW      : 0.2.0
TAG: ULTRAMATDREIUND
    
```

84233a

You can use this function to set the following PROFIBUS parameters:

- **Address**
This function can be used to set a PROFIBUS station address to all numerical values between 0 and 126.
- **Ident number**
This parameter is used to set the configuration response of the device. The values 0, 1 and 3 can be set as valid parameters. They have the following meanings:
 - **0:**
Only the 'Profile ID number' is positively acknowledged
 - **1:**
Only the device-specific 'ID number' is positively acknowledged.

Note:
In order to work with the provided GSD and DD, the '**ID number**' parameter must have the value 1.

 - **3:**
Only the 'Profile ID number' for multi-variable devices (complex analyzers) is positively acknowledged.
- **PB relay**
You can use this function to enable the 8 relays of the add-on card for control via PROFIBUS. To allow activation, none of these relays must already be occupied by a device-internal function.
Note:
The function 'PB relay' is only possible as of PROFIBUS card firmware version 2.0.0 (shown as Firmware in the figure).
- **Diagnosis**
If the 'Diagnosis' parameter is selected, the 'Firmware' display appears with, for example, the following parameters:
 - **Firmware**
The firmware version is displayed here
 - **Boot FW**
The version of the boot firmware is displayed here
 - **TAG**
The name assigned to this analyzer in the network (or the first 16 characters).

Configuration: Special functions: ELAN/PROFIBUS/external interference: Cross-interference

```
Interf. for CO2 vpm
Cal. w. interf. OFF
Const. interf. OFF
C.I: +0.0000e+0
```

84234

The adjacent menu display appears when you select this parameter. You can use this function to:

- Switch the correction of cross-interference on or off for the duration of the calibration. To do this, you must select the 2nd line and switch the parameter on or off there.
 - **OFF** (factory setting) means that the correction of cross-interference is switched off during the calibration.
 - **ON** means that the corrections of cross-interference remain active during the calibrations. It is thus possible to use gas combinations as calibration gases.
- Switch the correction of a constant cross-interference on or off. To do this, you must select the 3rd line and switch the parameter on or off there. If the constant cross-interference is switched **ON**, the measured value of the selected component is corrected with the entered value by adding.

8.4.2.4 Configuration: Special functions: Factory data/reset/units

Configuration: Special functions: Factory data/reset/units

```
Load factory data
Reset analyzer
Change units
```

8424

You can use this menu to select a number of items with which e.g. inappropriate configurations and analyzer settings can be cancelled:

The adjacent menu display appears when you select the function from the higher-level menu.

Configuration: Special functions: Factory data/reset/units: Load factory data

```
ATTENTION! Data will
be overwritten!
Press ENTER to cont.
Press ESC to cancel
```

84241

In this menu you can reestablish the original parameters present when the analyzer was delivered.

Note:

All modifications (parameters and configuration) which you have made since then are deleted.

The adjacent display appears when you select this function. You define the further sequence by pressing either the **<ENTER>** or **<ESC>** key.

When you select this function, the adjacent display appears for the duration of the load procedure.

```
Factory data loading
please wait
```

84241a

Configuration: Special functions: Factory data/reset/units: Reset

```
Warning! Analyzer is  
set to warm-up mode!  
Press ENTER to cont.  
Press ESC to cancel
```

84242

You can use this function to restart the analyzer.. When you select this function, you will be warned (see adjacent display) that the analyzer initially runs through a warm-up phase following the restart and is thus unavailable for measurements for a certain time.

The <ENTER> key initiates the restart with the warm-up phase. Triggering of the restart can be prevented here using the <ESC> key.

Configuration: Special functions: Factory data/reset/units: Change units

```
Unit for SO2  
set:   mg/m3  
MR min: 400 - 10%  
MR max: 2000 + 10%
```

84243a

In the second line of this menu display, you can change the factory-set units of the measured components.

After changing the unit, the display of the 'MB min' and 'MB max' parameters is adapted accordingly.

This dialog is specific to the component.

```
Unit for SO2  
set   : vpm  
MR min: 148 - 3%  
MR max: 757 + 3%
```

84243a

Note

The full-scale values may assume unusual values as a result of the component-specific conversion factors. Subsequent adaptations can be carried out as described in section Parameters: Measuring ranges: Setting measuring ranges (Page 126). In addition, you should also check these parameters following this change:

- Setpoints of the calibration gases (section Calibration: Infrared measuring range: Set span gas values (Page 113))
 - Settings for the limits (section Parameters: Limits (Page 128)).
-

8.4.3 Configuration: Device test

8.4.3.1 Configuration: Device test: RAM monitor

Servicing engineers can use this function to view the contents of certain memory areas.

NOTICE
Device failure Incorrect execution of this function may make the analyzer permanently incapable of measuring! Therefore this function must only be carried out by qualified servicing personnel.

```
Test: displ/keys/flow
Inputs/outputs
Chopper/IR source
RAM monitor
```

843

Following selection of the special functions, the adjacent menu is displayed with options for the following device tests:

- Menu display
- Keys
- Flow switch
- Inputs and outputs
- Various internal components
Testing of chopper, IR source, and RAM monitor can only be carried out by servicing personnel.

8.4.3.2 Configuration: Device test: Display/keys/flow

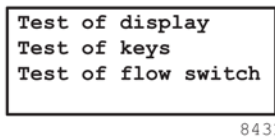

You can select the following three tests in this menu.

- **Test of display**
 In this test, all characters in the character set of this analyzer are output in succession at every position of the display. The display remains empty if characters are output which cannot be displayed. This is a cyclic test, i.e. once the complete character set has been processed, it starts from the beginning again. The test is repeated continuously until terminated by pressing the <ESC> key.
 A corresponding message will inform you of this before the test is started.
- **Test of keys**
 This test takes 30 s, and the time remaining up to the end of the test is output on the display. During this time you can press all input keys in succession. The analyzer normally recognizes that a key has been pressed and indicates this. This test cannot be prematurely cancelled.
- **Test of flow switch**
 This indicates whether the sample gas flow is correct or not. Depending on the type of gas supply, it may be necessary to switch on the pump using the <PUMP> key.

8.4.3.3 Configuration: Device test: Inputs/outputs

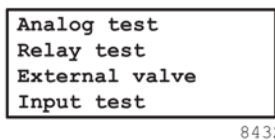

In this menu you can call the tests of the electric inputs and outputs of the analyzer. You require the following equipment to carry out these tests:

- Ammeter
- Ohmmeter
- Power supply (24 V DC)
- Test plugs

Configuration: Device test: Inputs/outputs: Test analog outputs

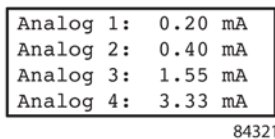

The analyzer has four analog outputs and an output current range of 0/2/4 ... 20 mA. You can test these by setting any value of the output current between 0 and 20 mA in this menu display.

To test these outputs, connect an ammeter to the corresponding analog outputs on plug X80 and measure the output current. The pin assignments of plug X80 are described in section Pin assignments (Page 54).

Configuration: Device test: Inputs/outputs: Test of relays

Test of relays
Relay number 1
Condition: not act
Press ESC to cancel

84322

You can use this function to test the status of the relays controlled by this analyzer.

First enter the relay to be tested in this dialog. The analyzer can control up to eight relays, or up to 16 relays with an add-on board, whose contacts you can test. Connect an ohmmeter to the corresponding relay outputs on the plug.

You can process the following parameters:

- **Relay number:**
One of the relays 1 to 8 (relays 1 to 16 in the case of analyzers with add-on board)
- **Condition:**
The current state of the selected relay (active or inactive; inactive in the Fig.).

The pin assignments of plug X80 (motherboard) und X50 (add-on board) are described in section Pin assignments (Page 54).

You can exit the test by pressing the <ESC> key.

Configuration: Device test: Inputs/outputs: Test external solenoid valve

130 mg/m ³ NO	ZV
89 mg/m ³ CO	OFF
249 mg/m ³ SO ₂	SV
20.77 % O ₂	OFF

84323

You can use this function to trigger external solenoid valves for the zero and calibration gas supplies via the relay contacts.

Use the arrow keys <↑> and <↓> to select the zero gas valve (ZV) in the first line or the calibration (span) gas valve (SV) in the third line, and call the selected valve using the <ENTER> key.

Switch the previously assigned relay using any arrow key in the second or fourth line (the value on the right edge of the line toggles between **OFF** and **ON**). The currently measured values are output in the menu displayed during the test.

Configuration: Device test: Inputs/outputs: Test of inputs

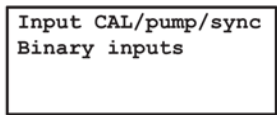

84324

You can use this function to test the status of the analyzer inputs. You can test the following inputs:

- CAL, pump, SYNC (on the motherboard)
- Binary inputs (on add-on board)

After calling this dialog, apply a voltage of 24 V DC to one of the three inputs to be tested. The result is displayed in the fourth line (here: "No active input").

The pin assignments of plug X80 (motherboard) und X50 (add-on board) are described in section Pin assignments (Page 54).

Result of the CAL, pump, SYNC inputs test

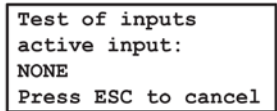

84324a

Result of the binary inputs test

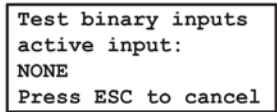

84324b

The adjacent error message occurs if an attempt is made to call this function for a device without add-on board.

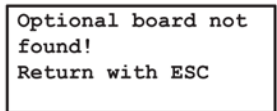

84132a
84324c

8.4.3.4 Configuration: Device test: Chopper/IR source

You can use this function to switch the chopper and IR source off for test purposes.

NOTICE
Device failure Incorrect execution of this function may make the analyzer permanently incapable of measuring! Therefore this function must only be carried out by qualified servicing personnel.

Note

The analyzer is not ready for measurements for a certain period if the IR source or chopper has been switched off. To reestablish the measuring capability, you must therefore provide a sufficiently long warm-up phase depending on the switch-off period, e.g. by restarting the analyzer.

8.4.4 Configuration: Factory configuration

Overview

```
Factory configur.!  
Enter special code  
      : 0000
```

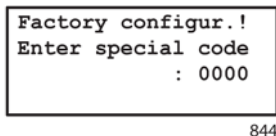
A screenshot of a terminal window with a black border. The text inside is white and reads: "Factory configur.!", "Enter special code", and ": 0000".

844

These are factory settings made especially for your analyzer. Since incorrect modifications to these parameters may permanently influence the functions of your analyzer, access to these functions is only possible by specially trained and authorized servicing engineers using a special access code.

8.5 Automatically executed functions

8.5.1 Probe protection and purging function

A protection and purging function is implemented by means of software since H₂S concentrations above the specified continuous concentration impair the functionality and service life of the H₂S probes.

In addition, a purging function is implemented for the 50 ppm H₂S probe in order to allow an intermittent measurement above the permissible continuous concentration.

These functions are executed automatically when certain operating states occur.

8.5.2 Probe protection function

Definition of probe protection function

A value 1.1 times the specified range can be considered as the maximum continuous concentration. Although a measurement above such a concentration is still correct, the probe is damaged by longer exposure. The maximum continuous concentration remains constant even when changing the measuring range.

The protection function is also implemented with the 50 vpm probe for compatibility reasons even though its maximum continuous concentration is 12.5 vpm. The protection function is executed above this value.

Execution of this function is the same for all probes. The function test is set during execution of the protection function in order to signal that the displayed value is incorrect.

How the protection function works

The protection function is triggered if the continuous measured value of H₂S is greater than the maximum continuous concentration (110 % of full-scale value) in measuring mode for a period of 3 seconds.

The following occurs when the protection function starts:

- The H₂S measured value display is set to "*****"
- An "H" (H₂S protection function running) is displayed in the measurement screen at the right edge where the test letter "!" appears (fault no longer pending has been logged).
- The zero gas valve is opened
- The "Function control" status is set.

As long as the protection function is active, the zero gas valve remains open during the zero gas purge time. The device then switches to purging of the sample gas path with sample gas. This process is repeated if the maximum continuous concentration is exceeded within the sample gas purge time.

This process is repeated up to 6 times. If after the 6th repeat the sample gas concentration is still too high, the zero gas valve remains permanently open and the fault 28 "H₂S probe protection" is entered in the logbook.

If the maximum continuous concentration is not exceeded again, the protection state is terminated and the H₂S measured value is displayed again. Furthermore, the function control and the test letter "H" are deleted.

Return to measuring mode

An active protection function can be interrupted as follows:

- Automatic: Prior to completion of the 6th repeat, the measured value in the sample gas purge time remains permanently below the maximum continuous concentration.
- Set the protection function to 'OFF' by changing the parameter in the limit display or via ELAN
- Start a different state such as calibrate, AUTOCAL, etc.
- Acknowledgment of the fault "H₂S probe protection" in the logbook

Sequence parameter

The zero gas purge time is twice the AUTOCAL purge time. The sample gas purge time is equal to the AUTOCAL purge time. The AUTOCAL purge time is an adjustable parameter whose setting is described in section Calibration: AUTOCAL/drift values: Purge time (Page 123).

The protection function can be enabled and disabled using the menu item '**H₂S probe protection**' (see section Parameters: Limits: H₂S sensor protection (Page 129)). The function is ON with the factory setting.

The device remains in measuring mode while the protection function is running. You can read out via ELAN or PROFIBUS whether the protection function of the analyzer is being processed, and in which step.

The following illustration show how the protection function runs over time:

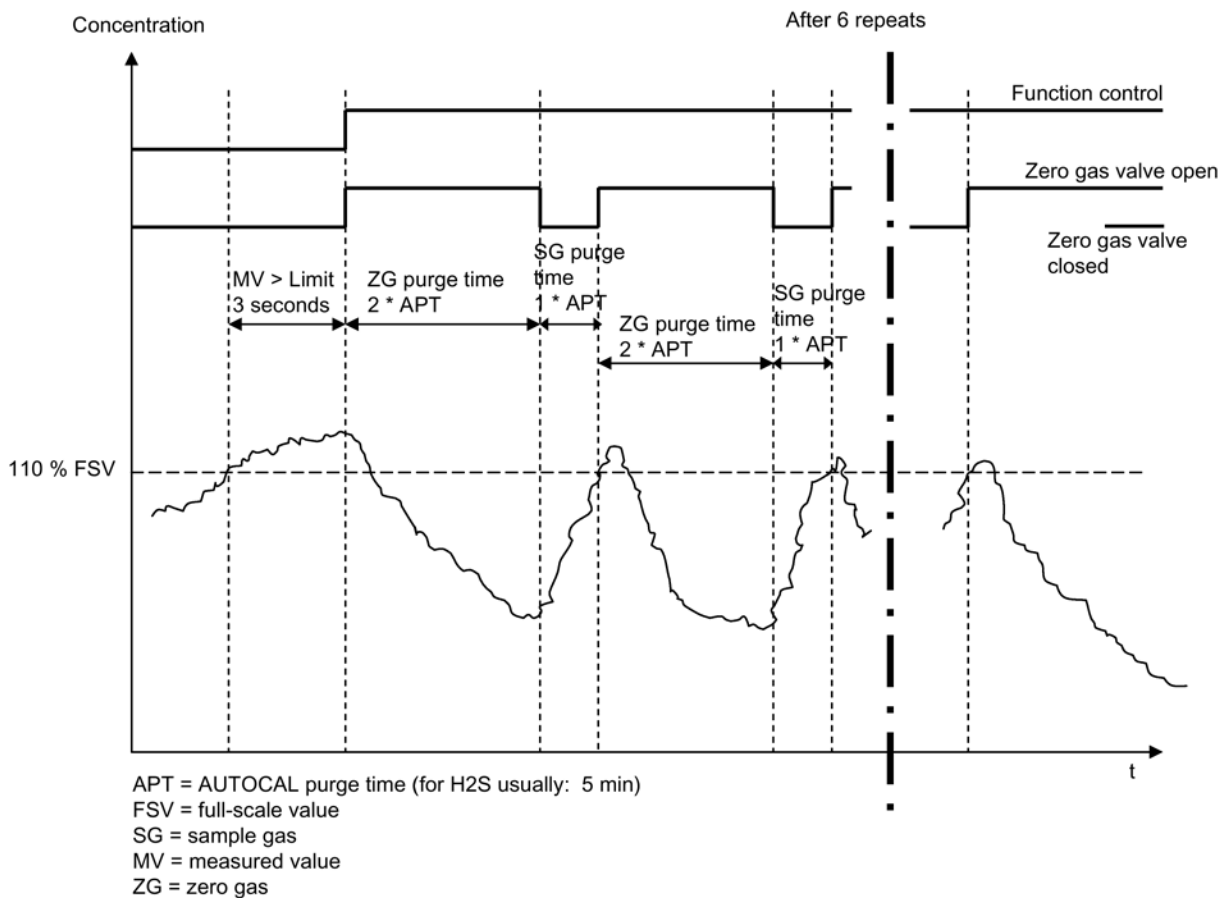

Figure 8-4 The H₂S protection function over time

8.5.3 Probe purging function

Hydrogen sulfide measurement: Purging function of 50 vpm probe

Hydrogen sulfide (H₂S) is a corrosive gas, especially in wet condition and in combination with other gases. A selectable protection function has been implemented (see section Probe protection function (Page 156)) since H₂S concentrations above the permissible continuous concentration impair the functionality and service life of the H₂S probes. A purging function has additionally been integrated for the 50 vpm probe, enabling a discontinuous measurement above its permissible continuous concentration.

The permissible continuous concentration is 12.5 vpm. Although a measurement above such a concentration is still correct, the probe is damaged after a certain period. This period can be set in accordance with the experience gained using the sensor between 10 und 20 minutes using the AUTOCAL purge time (the purging duration corresponds to twice the AUTOCAL purge time). For this reason measurements above a concentration of 12.5 vpm must be carried out discontinuously and alternately with purging gas. The probe can be used for a measurement again following a purging time of equal duration with air.

The function test is set during execution of the purging function in order to signal that the displayed value is incorrect.

How the purging function works

The purging function is triggered if the continuous measured value of H₂S is greater than the permissible continuous concentration (12.5 vpm) in measuring mode for a period equal to the duration of the zero gas purge time.

Following triggering of the purging function:

- The last measured values of all components are 'frozen' if the 'Analog outputs with FCTRL' parameter has been set to 'Hold', or the current measured values are still displayed for all other settings.
- A "V" (H₂S purging function running) is displayed flashing in the measurement screen at the right edge where the test letter "!" appears (fault logged, no longer pending).
- The zero gas valve is opened.
- The "Function control" status is set.

As long as the purging function is active, the zero gas valve remains open during the zero gas purge time. The device then switches to the sample gas path. The status 'Function control (FCTRL)' remains set and the test letter "V" flashes during the zero gas purge time and the subsequent pre-purging phase. This signals that the displayed measured values are incorrect. The status 'Function control' and the test letter are deleted following the pre-purging phase, and the current measured values displayed again. Monitoring of the H₂S threshold for the permissible continuous concentration is already re-activated during the pre-purging phase.

Return to measuring mode

An active purging function can be exited or interrupted if:

- The H₂S measured value remains permanently below the threshold for the permissible continuous concentration during the pre-purging phase
- The probe protection function is triggered
- A different device status is started such as calibration, AUTOCAL, etc.

Sequence parameter

The zero gas purge time is twice the AUTOCAL purge time. The pre-purging phase is equal to the AUTOCAL purge time. The AUTOCAL purge time is an adjustable parameter whose setting is described in section Calibration: AUTOCAL/drift values: Purge time (Page 123).

The device remains in measuring mode while the protection function is running. You can read out via ELAN or PROFIBUS whether the protection function of the analyzer is being processed, and in which step.

The following illustration shows how the purging function runs over time:

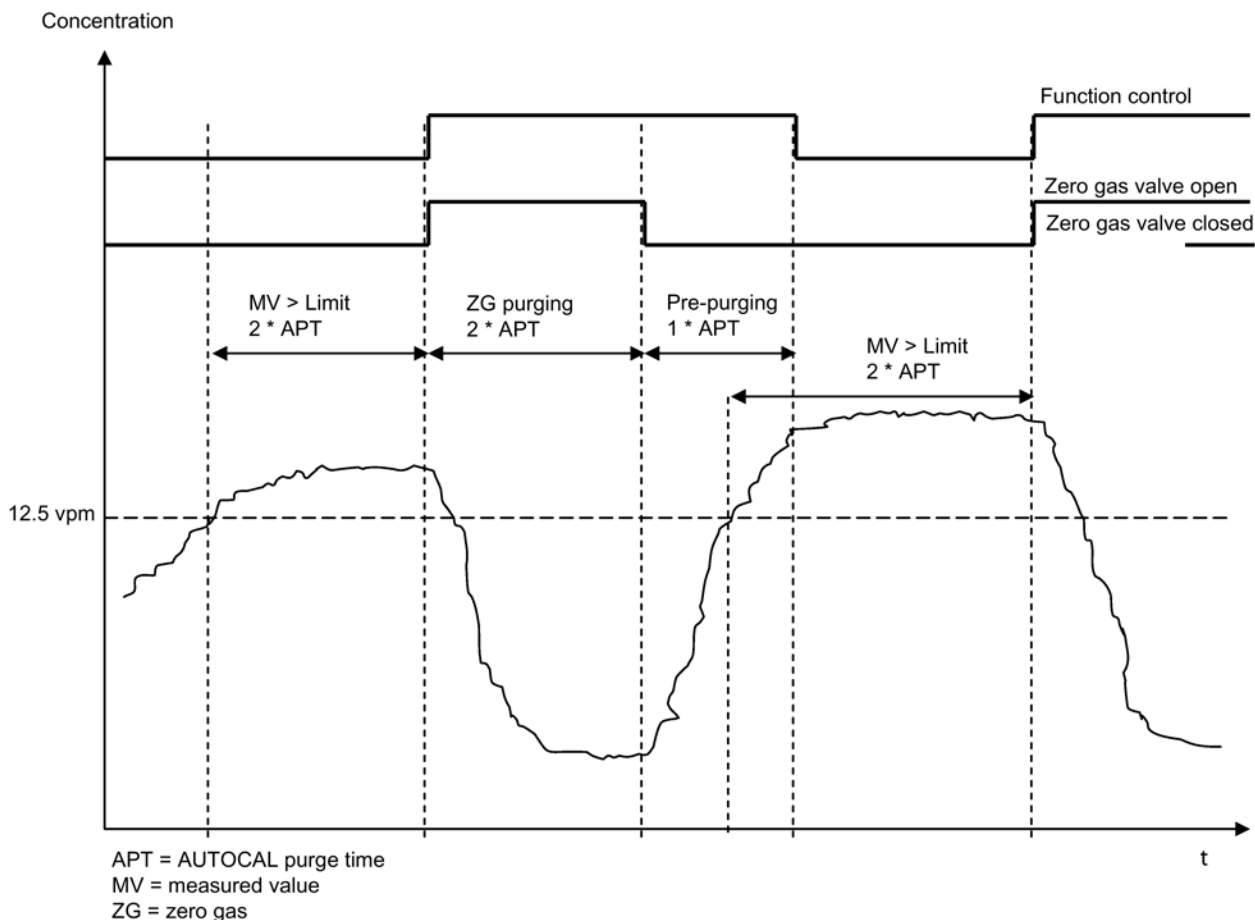

Figure 8-5 The H₂S purging function over time

Application note

9.1 H₂S sensor with 'small' measuring range

This section reflects the experiences gained with operation of a sensor for a measuring range of 5/50 vpm H₂S.

Packaging

The transport packaging is not gas-tight. To prevent drying-out of the sensor and the possibility of malfunctions, the sensor may only be stored for a period up to 3 months.

Storage and transport

Storage at an excessively high humidity (tropics, several months) results in swelling of the electrolyte which could damage the electrolyte vessel.

As a rule of thumb: The sensor can be used for 12 months following manufacture and storage.

Battery

The ULTRAMAT 23 must be operated continuously since the H₂S sensor has its own battery whose voltage is retained through operation of the ULTRAMAT 23.

With the analyzer switched off, the power supply to the sensor is from its own battery. The resulting discharging of the battery impairs the sensor functionality and results in zero and span drifts as well as increased signal noise. This malfunction may last for 2 days or longer.

Materials used in the sample gas path

As a result of its polarity and good solubility in water, H₂S accumulates on various materials. These adsorption and desorption effects lead to increases in the response times. Therefore, the inlet piping for the sample gas should be made of PTFE. Other materials should only be used for short gas lines.

Ambient temperature

The influence of ambient temperature on the sensor is 3%/10 °C, referred to the full-scale value; this corresponds to 1.5 vpm/10 °C.

Sample switchover between raw gas / pure gas

The sensor only functions correctly if the values at the measuring point do not greatly differ from one another. We cannot recommend switching over between measuring points on the raw gas side (high H₂S concentration) and the pure gas side (low H₂S concentration), since the difference between the H₂S concentrations of the two gas flows is too large for a reliable measurement.

Pressure influence

Abrupt changes in pressure must be avoided. Although the sensor compensates pressure variations within approx. 20 seconds, it cannot handle pressure surges which may occur when switching over between samples.

Flow

The sample gas should flow continuously and at a constant rate, also during an AUTOCAL. While an AUTOCAL is being carried out, the sample gas flow must be diverted by means of appropriate valve switching.

Reason: H₂S is highly soluble in water and accumulates in the condensate. This accumulation increases as the sample gas pressure increases. This effect can result in significant delays in the response time.

Gas moisture

The calibration gas must have the same moisture as the sample gas.

If the sensor is used with a very dry gas for a longer period, e.g. when feeding biogas into the natural gas network, it is necessary to carry out an AUTOCAL with ambient air every 60 minutes. The dew point of the air should be in the range of approx. 9 °C ... 12 °C (48 °F ... 54 °F). The AUTOCAL purge time should be at least 5 minutes. This prevents premature drying-out of the sensor.

H₂ influence

The internal design of the 5/50 ppm sensor means that it is immune to the influence of H₂.

NH₃ influence

Loading of 300 vpm NH₃ results in destruction of the H₂S sensor within 2 to 3 days.

AUTOCAL / zero

An AUTOCAL of the zero point should be carried out every 60 minutes. On the one hand, this is used to protect the sensor, but it also compensates the influence of temperature variations during the day.

Calibration of the measured value drift

The deflection signal of the sensor is subject to drift. This drift can be detected only through regular review and corrected as needed. This involves using a calibration gas with a defined concentration of hydrogen sulfide.

To keep potential measurement uncertainty within strict limits, we recommend a monthly calibration with a calibration gas with a concentration of 50 vpm H₂S.

Service and maintenance

10.1 Safety instructions

10.1.1 General safety instructions

 CAUTION**Dangerous voltage at open device**

Danger of electric shock when the enclosure is opened or enclosure parts are removed.

- Before you open the enclosure or remove enclosure parts, de-energize the device.
- If maintenance measures in an energized state are necessary, observe the particular precautionary measures. Have maintenance work carried out by qualified personnel.

 WARNING**Hot, toxic or corrosive process media**

Danger of injury during maintenance work.

When working on the process connection, hot, toxic or corrosive process media could be released.

- As long as the device is under pressure, do not loosen process connections and do not remove any parts that are pressurized.
- Before opening or removing the device ensure that process media cannot be released.

 WARNING**Impermissible repair and maintenance of the device**

- Repair and maintenance must be carried out by Siemens authorized personnel only.

 CAUTION
Electrostatic discharges The electronic components and modules fitted in this device can be destroyed by electrostatic discharging. Comprehensive measures (such as the wearing of protective clothing by the maintenance personnel) must therefore be made to prevent electrostatic discharging wherever they are manufactured, tested, transported and installed.

10.1.2 Safety information for analyzers used in hazardous areas

 WARNING
Impermissible repair and maintenance of the device <ul style="list-style-type: none">• Repair and maintenance must be carried out by Siemens authorized personnel only.

 WARNING
Electrostatic charge Danger of explosion in hazardous areas if electrostatic charges develop, for example, when cleaning plastic surfaces with a dry cloth. <ul style="list-style-type: none">• Prevent electrostatic charging in hazardous areas.

 WARNING
Maintenance during continued operation in a hazardous area There is a danger of explosion when carrying out repairs and maintenance on the device in a hazardous area. <ul style="list-style-type: none">• Isolate the device from power.- or -• Ensure that the atmosphere is explosion-free (hot work permit).

 WARNING**Impermissible accessories and spare parts**

Danger of explosion in areas subject to explosion hazard.

- Only use original accessories or original spare parts.
- Observe all relevant installation and safety instructions described in the instructions for the device or enclosed with the accessory or spare part.

 WARNING**Improper connection after maintenance**

Danger of explosion in areas subject to explosion hazard.

- Connect the device correctly after maintenance.
- Close the device after maintenance work.

Refer to Connecting (Page 67).

10.2 Maintenance work

 WARNING**Dangerous materials**

Switch off the supply of sample gas before commencing maintenance work, and purge the gas paths with air or nitrogen!

During maintenance work, protect yourself against contact with toxic or corrosive condensate. Wear appropriate protective gear.

10.2.1 Cleaning the device

Cleaning the surface

Only use a moist cloth to clean the display.

The front panels and doors are washable. Use a sponge or cloth soaked in water containing washing-up liquid.

The surface in the display area must only be cleaned using gentle pressure to prevent damage to the foil.

Cleaning the interior

After opening the device, you can blow out the interior carefully with a compressed air gun, if necessary.

10.2.2 Maintenance of the gas path

Depending on the corrosivity of the sample gas, check the state of the gas path at regular intervals.

Servicing may be necessary.

10.2.3 Replacing spare parts

CAUTION

Incorrect fitting of replacement parts

Special work is required when replacing parts, especially on the analyzer unit, which can only be carried out at CSC Haguenau or by qualified, specially trained personnel.

Incorrect interventions can result in a reduction in measuring accuracy or malfunctioning of the analyzer.

To maintain the measuring accuracy of the ULTRAMAT 23, it may be necessary to carry out a temperature compensation following the replacement of certain parts. Parts to which this statement apply are identified in the spare parts list (see (Page 185)) by "***".

This particularly applies if brief temperature fluctuations > 5 °C (9 °F) occur at the installation location. This temperature dependence will not occur if you use an "AUTOCAL" cyclic zero point adjustment of e.g. 3 hours.

We recommend having temperature compensation performed at CSC Haguenau.

10.2.4 Replacing fuses

DANGER

Explosion hazard

If a flammable or ignitable atmosphere exists, plugs must never be disconnected or lamps/fuses replaced when the analyzer is supplied with power.

- Make sure when replacing fuses that an explosive atmosphere is not present (fire permit)!

To replace the fuses, proceed as follows:

1. Remove the fuse holder above the appliance plug.
Use a small screwdriver to do this.
2. Remove the blown fuse from the holder.
3. Insert a new fuse.
4. Insert the fuse holder into the compartment again.

Note

Only fuses of the type printed on the rear of the analyzer may be used (see also section Electronics (Page 190)).

10.2.5 Replacing the fine safety filter

To replace the filter, proceed as follows:

- Unscrew the four screws of the top housing cover, and remove the cover to the rear.
- Determine the contaminated filter according to its type (see Gas path (Page 187)).
- Remove the hoses from the filter.
- Remove the old filter.
The filter must be disposed of as residual waste.
- Insert the new filter.
When installing the filter, make sure that the arrow on the filter points in the gas flow direction.
- Push the cover back onto the housing and screw tight.

10.2.6 Maintenance work on the bench-top unit

10.2.6.1 Emptying the condensation trap

Proceed as follows:

1. Switch off the pump by pressing the **<PUMP>** key.
2. Disconnect the analyzer from the power supply.
3. Loosen the condensation trap on the front of the analyzer by tilting it slightly, and pull downwards carefully.
4. Empty the trap and dispose of the condensate according to the composition of the sample gas.
5. Push the condensation trap on again from below.

 **CAUTION**

Condensate in the analyzer

If condensate is spilled onto the analyzer during this process, it can penetrate into the analyzer through gaps in the housing.
Such an analyzer is not suitable for measurements, and therefore must not be used any longer!

10.2.6.2 Replacing the coarse filter

Proceed as follows for this:

1. Switch off the pump by pressing the **<PUMP>** key.
2. Loosen the condensation trap on the front of the analyzer as described in section Emptying the condensation trap (Page 170).
3. Remove the contaminated filter.
4. Insert the new filter.
5. Push the condensation trap on again from below.

10.2.7 Replacing the electrochemical oxygen sensor



WARNING

Danger of chemical burns

The O₂S sensor contains acetic acid, which leads to burns on unprotected skin. When replacing the sensor, its enclosure must not be damaged.

If contact with the acid occurs despite great care being taken, rinse the affected skin immediately with plenty of water!

Also note that an exhausted or faulty O₂ sensor is hazardous waste and must be packed and disposed of accordingly!

To replace the sensor, proceed as follows:

1. Unscrew the two screws of the front cover and remove the cover.
2. Unlock the plug of the sensor connection, and remove.
3. Unscrew the O₂ sensor out of its holder.
4. Remove the gasket of the O₂ sensor.

The exhausted O₂ sensor must be disposed of as electronic waste with the code number 160215 "Dangerous component removed from used equipment". It must therefore be disposed of correctly and in an environmentally-friendly manner by a local waste disposal company.

5. Insert the new gasket.
6. Screw in the new O₂ sensor and tighten hand-tight.
7. Reconnect the plug.
8. Enter the date of installation of the new sensor in the menu item "O₂ cal. after install" as described in section Calibration: O₂ measuring range: Sensor inst. date (Page 114).
9. Calibrate the zero point of the new sensor as described in section Calibration: O₂ measuring range: Calibrating the O₂ zero point (Page 115).

10.2.8 Replacing the hydrogen sulfide sensor

 DANGER
Danger of poisoning
The replacement of the sensor module represents interference in the gas path. The sample gas circulating therein may contain toxic components that lead to death in certain concentrations.
To ensure that the sample gas path is free of toxic material when replacing the sensor module, the gas path must be flushed with ambient air or nitrogen for a period of about 10 minutes before performing the task.

 WARNING
Danger of electric shock
The device will be open when the sensor is being replaced. This means present dangerous contact voltage will be present, which can lead to electric shock.
For this reason, the sensor module may only be replaced when power is off.

 WARNING
Danger of chemical burns
The H ₂ S sensor contains sulfuric acid, which leads to burns on unprotected skin. Therefore do not use any tools when replacing the sensor module which could damage the sensor due to sharp edges or squeezing.
If contact with the acid occurs nevertheless, rinse the affected skin immediately with plenty of water!

NOTICE
Improper disposal
The exhausted or faulty H ₂ sensor is hazardous waste and must be packed and disposed of accordingly!
The exhausted H ₂ S sensor is electronic waste with the code number 160215, that is, a "dangerous component removed from used devices". It must therefore be disposed of correctly and in an environmentally-friendly manner by a local waste disposal company.
Environmental damage may occur if this stipulation is not followed. The polluter is also threatened with criminal action!

Note

The H₂S sensor only has a limited service life depending on the operating mode and is therefore excluded from the analyzer guarantee.

Proceed as follows to remove the old sensor:

1. Flush the gas path for about 10 minutes with zero gas (AUTOCAL)
2. When sample gas is no longer present in the gas path, disconnect the analyzer from the supply voltage.
3. Open the unit by removing the four bolts on the cover.

4. Remove the connector from the H₂S sensor (arrow).
5. Unscrew the H₂S sensor out of the holder.

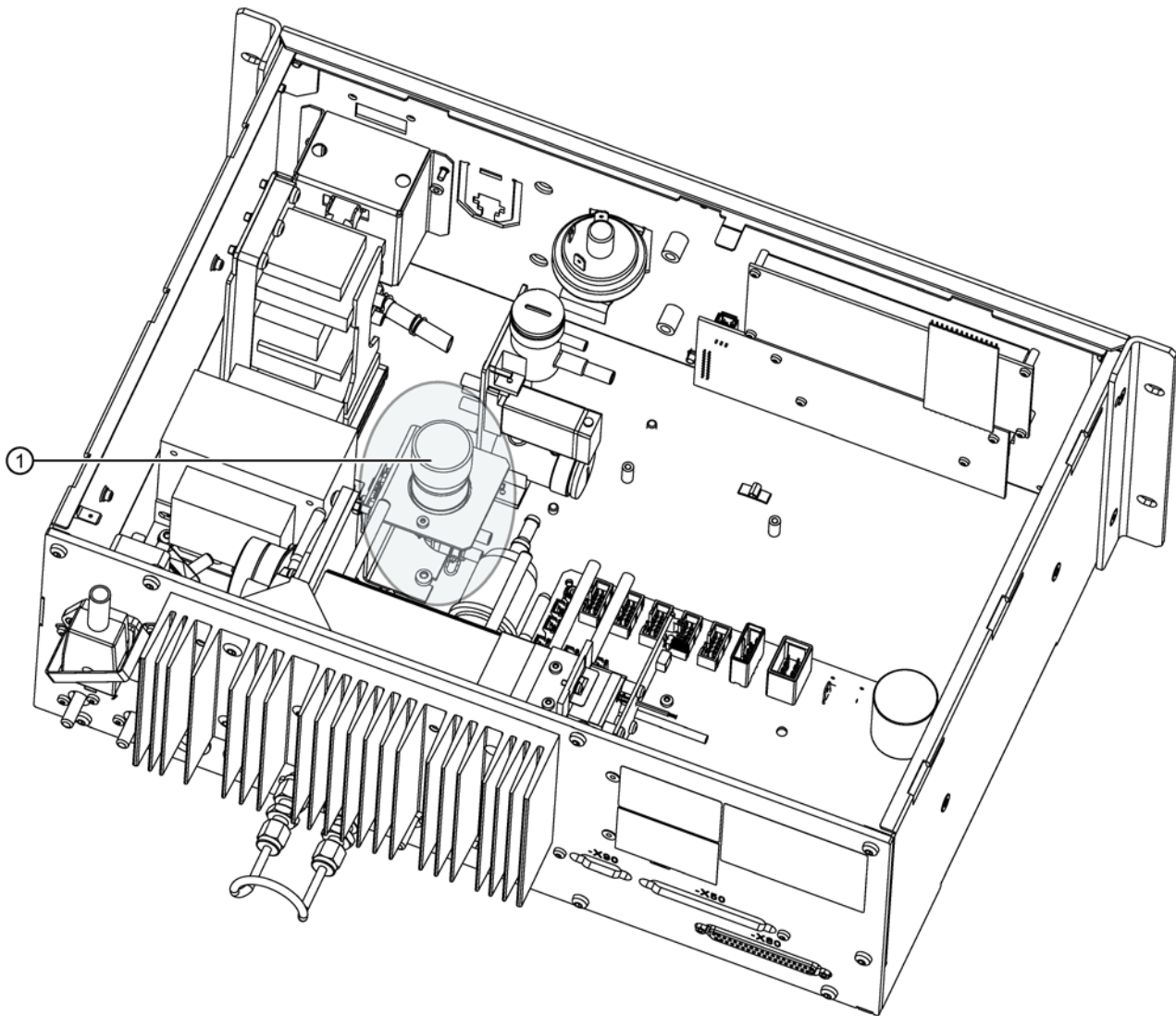

Figure 10-1 Position of the H₂S sensor in the analyzer ① (in shaded area)

Proceed as follows to install the new sensor:

1. Tighten the new H₂S sensor by hand in the holder up to the mechanical limit (shaded)

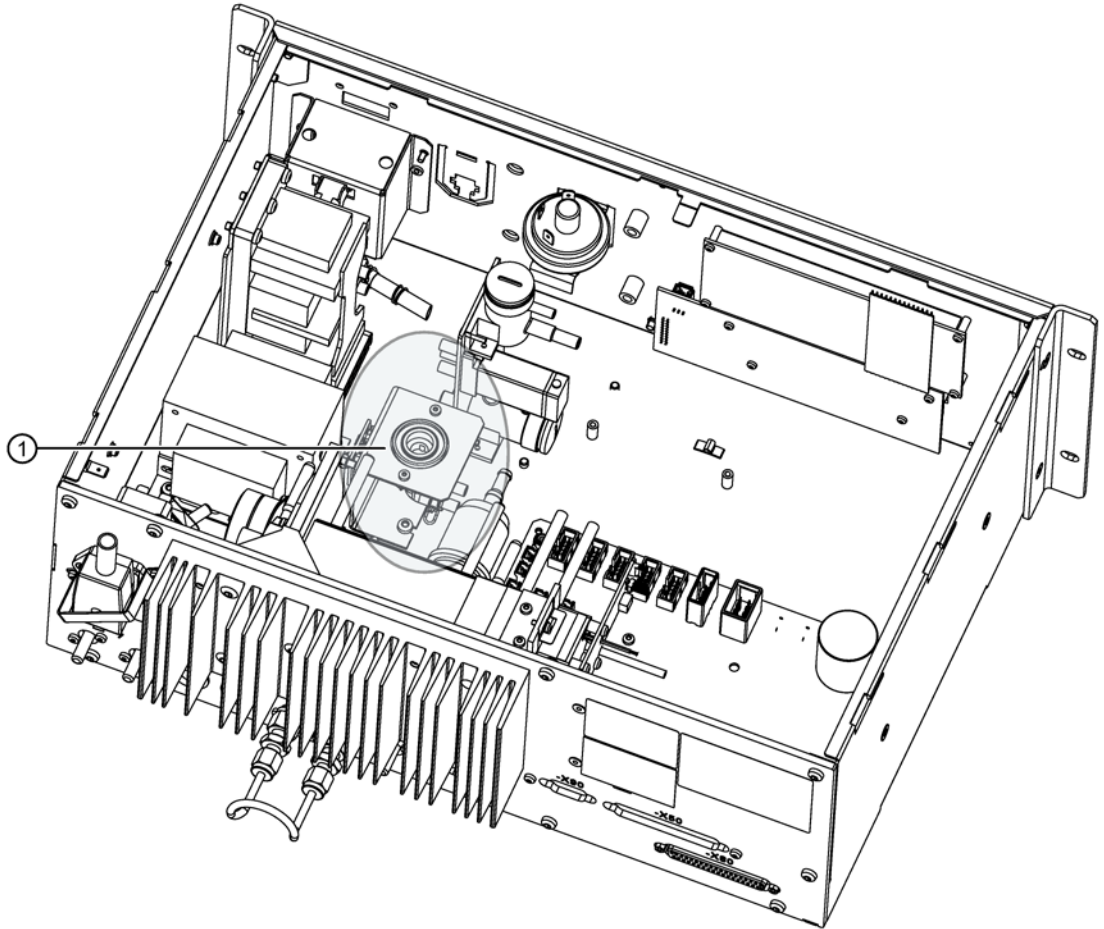

Figure 10-2 Sensor holder ① (shaded)

2. Plug the cable with the connector onto the sensor.
3. Close the analyzer by screwing tight the cover.
4. Switch the analyzer on and wait for the warming-up phase.
5. Check for leaks in the device
This is described in section Leaks in the gas paths (Page 81)
6. Calibrate the H₂S sensor as described in section Calibration: H₂S sensor (Page 118)
7. Enter the installation date with the menu command "H₂S Installation date".

The analyzer is then ready for use again.

10.2.9 Replacing the paramagnetic oxygen sensor

The sensor may only be replaced by specially trained personnel. We therefore recommend that you return the analyzer to the factory in order to replace the sensor. If replacement is carried out on site nevertheless, you must expect limitations in the measuring accuracy.

Details for returning devices can be found in section Returned delivery (Page 226).

Error and system messages

The analyzer can detect and display various fault statuses. These fault statuses are divided into maintenance requests and faults.

11.1 Maintenance requests

Maintenance requests are references to certain changes in the analyzer which - at the time of occurrence - have no influence on the analyzer measurements. However, remedial measures are recommended to guarantee that measurements remain possible.

If the analyzer is in measuring mode, you can recognize the occurrence of a maintenance request in that an "M" appears at the right edge of the measurement screen.

```
AUTOCAL drift
beyond tolerance
Press ENTER to clear
Next message with ->
8112
```

Maintenance requests are logged and can be called in input mode using the menu path "Analyzer status - Status - Maintenance requests" (see section Analyzer status: Status: Maintenance request (Page 105)). The corresponding message texts are stored. You can delete the messages by pressing the <ENTER> key. However, they appear again if the cause has not been eliminated.

The analyzer outputs a maintenance request in the following cases:

- **Message "AUTOCAL drift beyond tolerance"**
The zero drift of a component is too large during the AUTOCAL procedure. The AUTOCAL parameters can be entered as described in section Calibration: AUTOCAL/drift values (Page 122). Using the conditions defined for the AUTOCAL deviation (see section Configuration: Special functions: AUTOCAL deviation (Page 144)), the actual deviation may deviate from the maximum permissible value. In such cases it may be meaningful to set a shorter interval between two AUTOCAL procedures. If this does not improve the situation, contact the servicing department.
- **Message "O₂ sensor"**
The measured voltage of the O₂ sensor has dropped as a result of aging, but is still within the permissible range. This means that it is not necessary to replace the O₂ sensor immediately, but this will soon be exhausted. This would be the correct time to order a new O₂ sensor.
- **Message "Temperature beyond tolerance"**
The contrast control is no longer guaranteed if the LCD temperature is outside the permissible tolerance. It may then be difficult to read the display, or it could remain dark in the worst case. If this fault occurs because of an excessively high ambient temperature, provide sufficient ventilation or air conditioning. If the fault still occurs, contact the servicing department.
- **Message "H₂S sensor status"**
If this message occurs, the measuring reserve of the H₂S sensor is almost used up. We recommend that you then replace the sensor. If the measuring reserve of the H₂S sensor

11.2 Faults

is used up completely, the fault message "Measured value channel 3 beyond tolerance" is displayed. A measurement is no longer possible.

- External maintenance requests
These are signaled via the binary inputs. The analyzer must be equipped with an add-on board for this.

11.2 Faults

Fault messages are references to certain changes in the analyzer which influence its ability to measure correctly. In such cases remedial measures are required.

If the analyzer is in measuring mode, you can recognize the occurrence of a fault in that an "F" appears at the right edge of the measurement screen.

```
Mains voltage
beyond tolerance
Press ENTER to clear
Next message with ->
```

8111

Faults are logged and can be called in input mode using the menu path "Analyzer status - Status - Logbook/faults" (see section Diagnostics: Diagnostics values (Page 107)). The corresponding message texts are stored as alphanumeric text in the logbook. You can delete the messages by pressing the <ENTER> key. However, they appear again if the cause has not been eliminated.

The following table provides a summary of fault messages, their causes, and measures to eliminate the faults.

If nothing is specified for a fault message in the 'Remedy' column, you must contact the servicing department when this message occurs.

Message	Possible causes	Remedy
Measured value channel 1 beyond tolerance Measured value display: *****	Analyzer unit of first component is faulty	
Measured value channel 2 beyond tolerance Measured value display: *****	Analyzer unit of second component is faulty	
Measured value channel 3 beyond tolerance Measured value display: *****	Analyzer unit of third component is faulty	
Measured value channel 3 (H ₂ S sensor) beyond tolerance Measured value display: *****	Sensor faulty	Replace the H ₂ S sensor as described in section Replacing the hydrogen sulfide sensor (Page 172)
Measured value O ₂ beyond tolerance Measured value display: *****	Electrochemical O ₂ sensor faulty or no longer usable as result of aging	Replace the electrochemical O ₂ sensor as described in section Replacing the electrochemical oxygen sensor (Page 171).
Supply voltage beyond tolerance	Supply voltage varies	Correct such that the supply voltage remains stable within the tolerance values permissible for the analyzer.
	Power supply unit on motherboard faulty	
Temperature of analyzer beyond tolerance	Ambient temperature too high or too low	Provide sufficient ventilation or air conditioning.

Message	Possible causes	Remedy
Pressure of ambient air beyond tolerance	Pressure sensor faulty	
Flow too low during measuring	Sample gas path blocked or leaky	Clean or replace the blocked parts (hose, filter etc.). If the problem is still present: Inform the service department
	Pump not running	Start the pump as described in section Configuration: Inputs/outputs/pump (Page 134)
	Pump capacity too low	Increase the pump capacity as described in section Parameters: Pump/LCD contrast: Pump (Page 130)
	Pump faulty	Pump must be replaced. Inform the service department
No data for temperature compensation	Temperature compensation not completed successfully	
	New components have been loaded	
	EEPROM has been initialized	Download the factory data as described in section Configuration: Special functions: Factory data/reset/units: Load factory data (Page 149)
Flow too low during AUTO CAL	Sample gas path blocked or leaky	Clean or replace the blocked parts (hose, filter etc.). If the problem is still present: Inform the service department
	Pump not running	Start the pump as described in section Configuration: Inputs/outputs/pump: Pump at CAL/MEAS (Page 142)
	Pump capacity too low	Increase the pump capacity as described in section Parameters: Pump/LCD contrast: Pump (Page 130)
	Pump faulty	Pump must be replaced. Inform the service department
Concentration of O ₂ too low Measured value display: *****	O ₂ sensor faulty or no longer usable as result of aging	Replace the O ₂ sensor as described in section Replacing the electrochemical oxygen sensor (Page 171)
	O ₂ sensor zero not calibrated	Calibrate the zero point of the O ₂ sensor as described in section Calibration: Electrochemical oxygen measuring range (Page 114)
Fault at analog output	Output component could not be initialized when switching on	
	Limits were violated when calibrating the analog section	
General fault of all IR channels Measured value display: *****	Chopper faulty	
Fault of addresses for IR channels	Plug-in jumper on detector for detection of components not OK	
	The cable of the detector has no contact	Check that the plug is correctly connected to the detector (the plug must latch in twice).

11.2 Faults

Message	Possible causes	Remedy
	Cable of detector faulty	
AUTOCAL drift beyond tolerance	Detector contaminated	
	Receiver chamber faulty	
	IR source power too low	
EEPROM error	Checksum not OK	
	Read character does not correspond to written character	
Channel 1 not calibrated	Calibration of full-scale value / sag missing	
Channel 2 not calibrated	Calibration of full-scale value / sag missing	
Channel 3 not calibrated	Calibration of full-scale value / sag missing	
Voltage for IR source beyond tolerance	IR source not OK	
	Motherboard faulty	
Bridge supply voltage outside tolerance	Channel amplifier faulty	
	Motherboard faulty	
Half-bridge voltage outside tolerance	Channel amplifier faulty	
	Motherboard faulty	
Lockin error	Channel amplifier faulty	
	Motherboard faulty	
Sensitivity of O ₂ sensor too low	O ₂ sensor faulty or no longer usable as result of aging	Replace the O ₂ sensor as described in section Replacing the electrochemical oxygen sensor (Page 171)
External ADC error	Electronics faulty	
External fault	Signaling of an external fault (system-specific)	Check the connected devices for faults as described in section Configuration: Inputs/outputs/pump: Binary/sync inputs (Page 141).
H ₂ S protection function	Sample gas concentration too high	Check sample gas, see also section Probe protection function (Page 156)
Zero point of the H ₂ S sensor beyond tolerances	Purge time too short for calibration	Repeat calibration
Sensitivity of H ₂ S sensor too low	Sensor exhausted	Replace sensor

Taking out of operation and disposal

The ULTRAMAT 23 may be taken out of operation for the following reasons:

- Repair
- New location of use
- Scrapping

12.1 Repair or changing of location

If the ULTRAMAT 23 is shut down for repair or for changing the location of use, proceed as follows:

Rack unit

1. Make sure that gas is no longer flowing through the analyzer. If external pumps are present, switch all of them off.
2. Purge the sample gas path with air or nitrogen.
3. Switch the analyzer off.
4. Disconnect the power plug.
5. Disconnect all hose connections from the rear of the analyzer.
With pipe versions, unscrew all pipes.

Bench-top unit

1. Make sure that gas is no longer flowing through the analyzer. If external pumps are present, switch all of them off.
2. Purge the sample gas path with air or nitrogen.
3. Switch the analyzer off.
4. Disconnect the power plug.
5. Empty the condensation trap (see section Emptying the condensation trap (Page 170)).
6. Disconnect the supply hose from the condensation trap.
7. Disconnect all hose connections from the rear of the analyzer.

12.2 Scrapping the analyzer

If the ULTRAMAT 23 is to be scrapped, take it of operation as follows:

Rack unit

1. Make sure that gas is no longer flowing through the analyzer. If external pumps are present, switch all of them off.
2. Purge the sample gas path with air or nitrogen.
3. Switch the analyzer off.
4. Disconnect the power plug.
5. Disconnect all hose connections from the rear of the analyzer.
With pipe versions, unscrew all pipes.
6. In the case of analyzers with an electrochemical oxygen sensor, remove this from the analyzer (see section Replacing the electrochemical oxygen sensor (Page 171)).
7. In the case of analyzers with a hydrogen sulfide sensor, remove this from the analyzer (see section Replacing the hydrogen sulfide sensor (Page 172)).

Bench-top unit

1. Make sure that gas is no longer flowing through the analyzer. If external pumps are present, switch all of them off.
2. Purge the sample gas path with air or nitrogen.
3. Switch the analyzer off.
4. Disconnect the power plug.
5. Empty the condensation trap (see section Emptying the condensation trap (Page 170)).
6. Disconnect the supply hose from the condensation trap.
7. Disconnect all hose connections from the rear of the analyzer.

Product disposal

The analyzer to be disposed of as electronic waste with the code number 160213 is a 'product containing dangerous components'. It must therefore be disposed of correctly and in an environmentally-friendly manner by a local waste disposal company.

Disposal of the electrochemical oxygen sensor

The exhausted or faulty O₂ sensor is hazardous waste and must be packed and disposed of accordingly!

The exhausted O₂ sensor is electronic waste with the code number 160215, that is, a 'dangerous component removed from used devices'. It must therefore be disposed of correctly and in an environmentally-friendly manner by a local waste disposal company.

 WARNING**Danger of chemical burns**

The O₂S sensor contains acetic acid, which leads to burns on unprotected skin. Therefore do not use any tools when replacing the sensor module which could damage the sensor due to sharp edges or squeezing.

If contact with the acid occurs nevertheless, rinse the affected skin immediately with plenty of water!

Disposal of hydrogen sulfide sensor

The exhausted or faulty H₂ sensor is hazardous waste and must be packed and disposed of accordingly!

The exhausted H₂S sensor is electronic waste with the code number 160215, that is, a "dangerous component removed from used devices". It must therefore be disposed of correctly and in an environmentally-friendly manner by a local waste disposal company.

 WARNING**Danger of chemical burns**

The H₂S sensor contains sulfuric acid, which leads to burns on unprotected skin. Therefore do not use any tools when replacing the sensor module which could damage the sensor due to sharp edges or squeezing.

If contact with the acid occurs nevertheless, rinse the affected skin immediately with plenty of water!

Spare parts/accessories

This spare parts list corresponds to the technical status at the time of printing.

Note

Improper repair work

Repairs noted with a * in this section must only be repaired in the service center because a temperature compensation for the device has to be subsequently executed.

Depending on the replaced component, it may also be necessary to carry out additional adjustment work (e.g. basic electronic adjustment, checking of cross-sensitivities).

13.1 Information for ordering spare parts

The order for spare parts must contain the following information:

- Quantity
- Designation
- Order No.
- Device name, MLFB, and serial number of the gas analyzer to which the spare part belongs.

Ordering address

Siemens AG
CSC (Centre Service Client)
1, chemin de la Sandlach
F-67506 Haguenau/France
Tel.: +33 3 6906 5555
Fax: +33 3 6906 6688

Ordering example:

1 oxygen sensor
C79451-A3458-B55
for ULTRAMAT 23, Type (MLFB) 7MB2337-2AF10-3PH0, serial number N1-D2-111

The spare parts lists of this analyzer are structured according to:

- Gas path
- Electronics unit
- Pump
- Analyzer unit

The following parts of this section contain various drawings showing the position of the spare parts in the analyzer. The parts with numbers are available as spare parts, and are described in the corresponding spare parts tables.

13.2 Gas path

The parts with numbers are available as spare parts. They are described in the corresponding table.

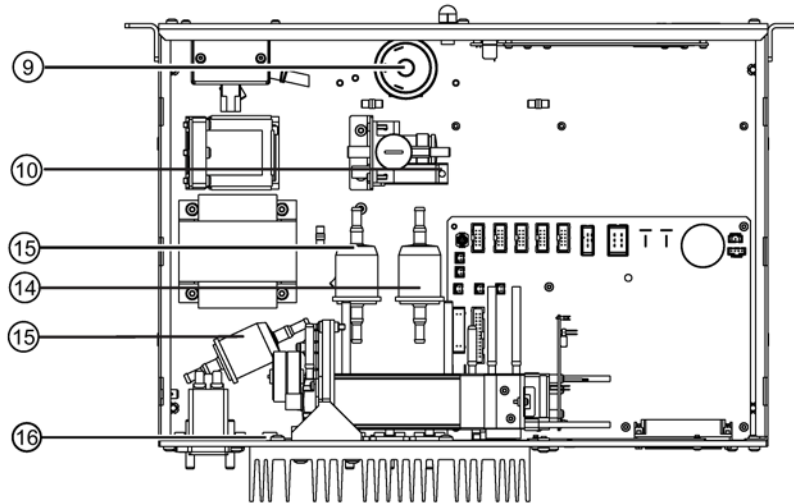

Figure 13-1 19" rack unit

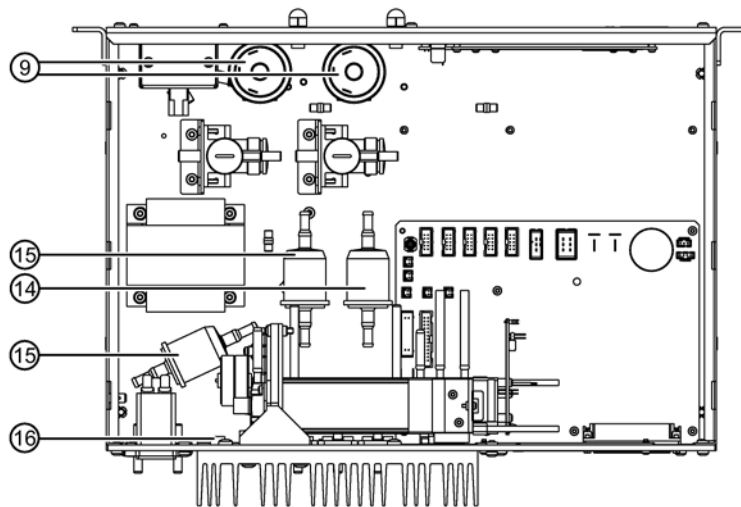

Figure 13-2 19" rack unit with separate gas paths

13.2 Gas path

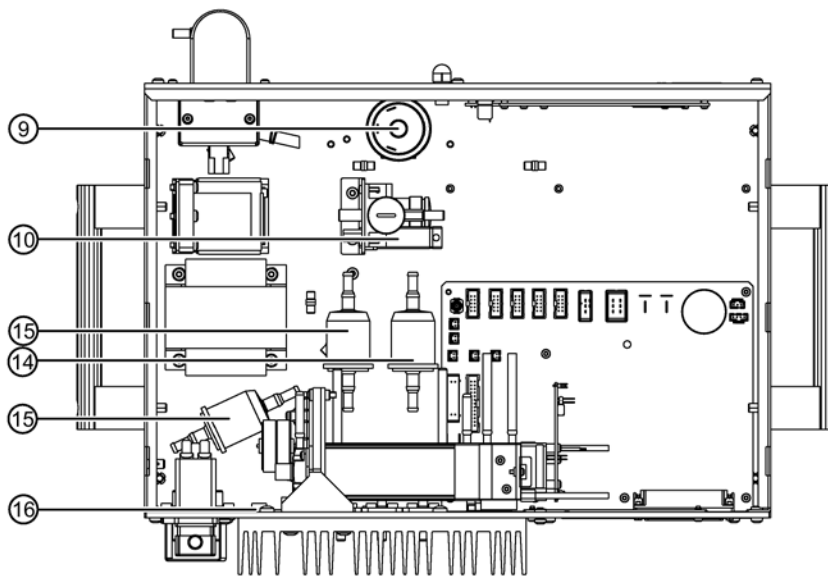

Figure 13-3 Bench-top unit

Part No.	Designation	Order No.	Remarks
9	Pressure switch	C79302-Z1210-A2	
9	Pressure switch	A5E37371678	Variant -B06 'Cleaned for O ₂ '
10	Solenoid valve	A5E35105570	
10	Solenoid valve	C79451-A3494-B33	Variant -B06 'Cleaned for O ₂ '
14	Safety filter for sample gas	C79127-Z400-A1	
15	Safety filter for zero gas/chopper purging	C79127-Z400-A1	
16	Connecting socket	A5E36448145	
16	Connecting socket	A5E36448926	Variant -B06 'Cleaned for O ₂ '

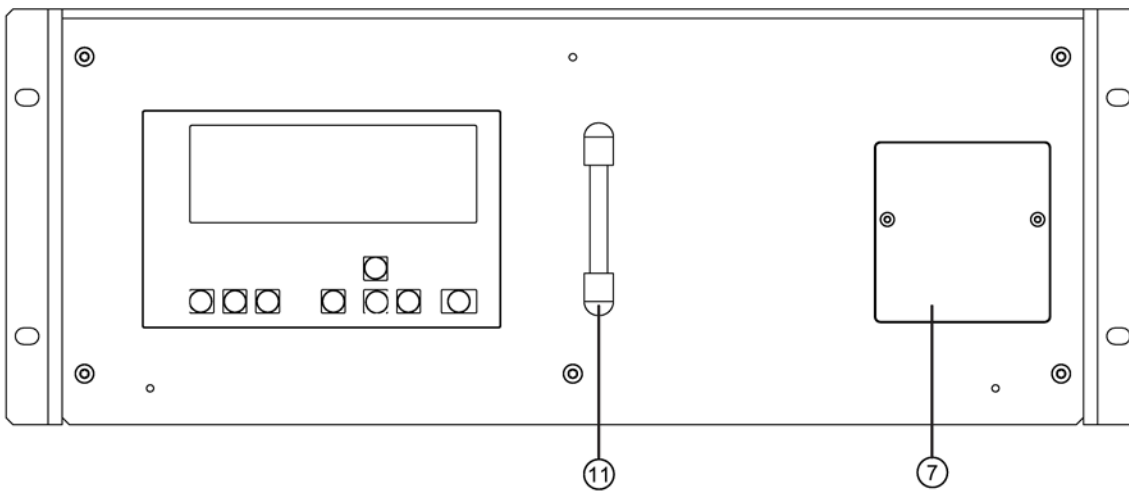

Figure 13-4 Gas path elements at front, 19" rack unit

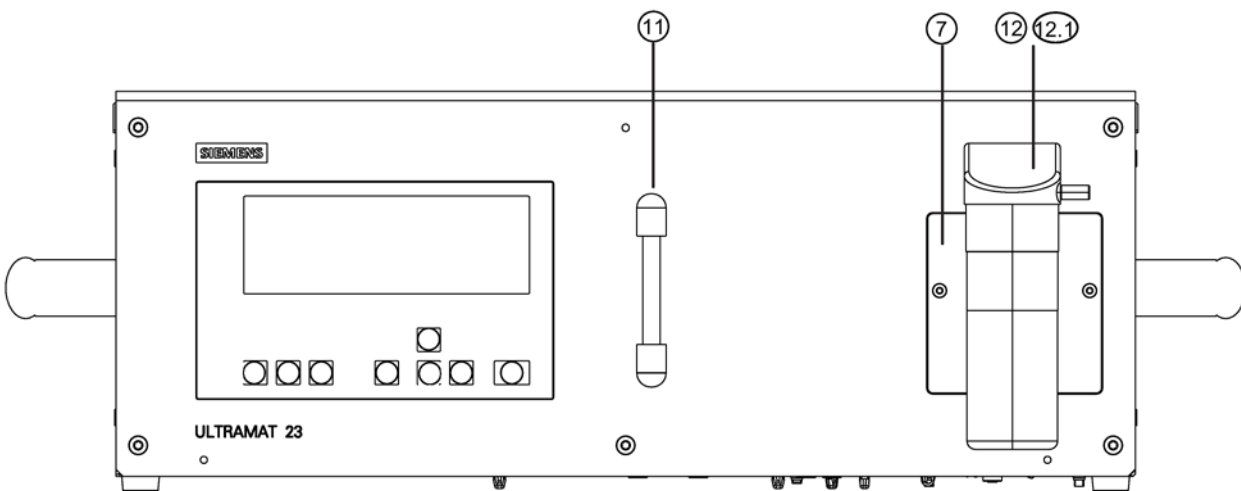

Figure 13-5 Gas path elements at front, bench-top unit

Part No.	Designation	Order No.	Remarks
7	Electrochemical oxygen sensor	C79451--A3458--B55	
7	Electrochemical oxygen sensor	A5E35951900	Variant -B06 'Cleaned for O ₂ '
11	Flowmeter	C79402--Z560--T1	With mounting bracket
11	Flowmeter	A5E35980458	With mounting bracket, only variant -B06 'Cleaned for O ₂ '
12	Condensation trap	C79451--A3008--B43	With mounting bracket
12.1	Filter	C79451--A3008--B60	In the condensation trap, package size: 3 units

13.3 Electronics

Positions of the replaceable electronics modules in example of rack unit

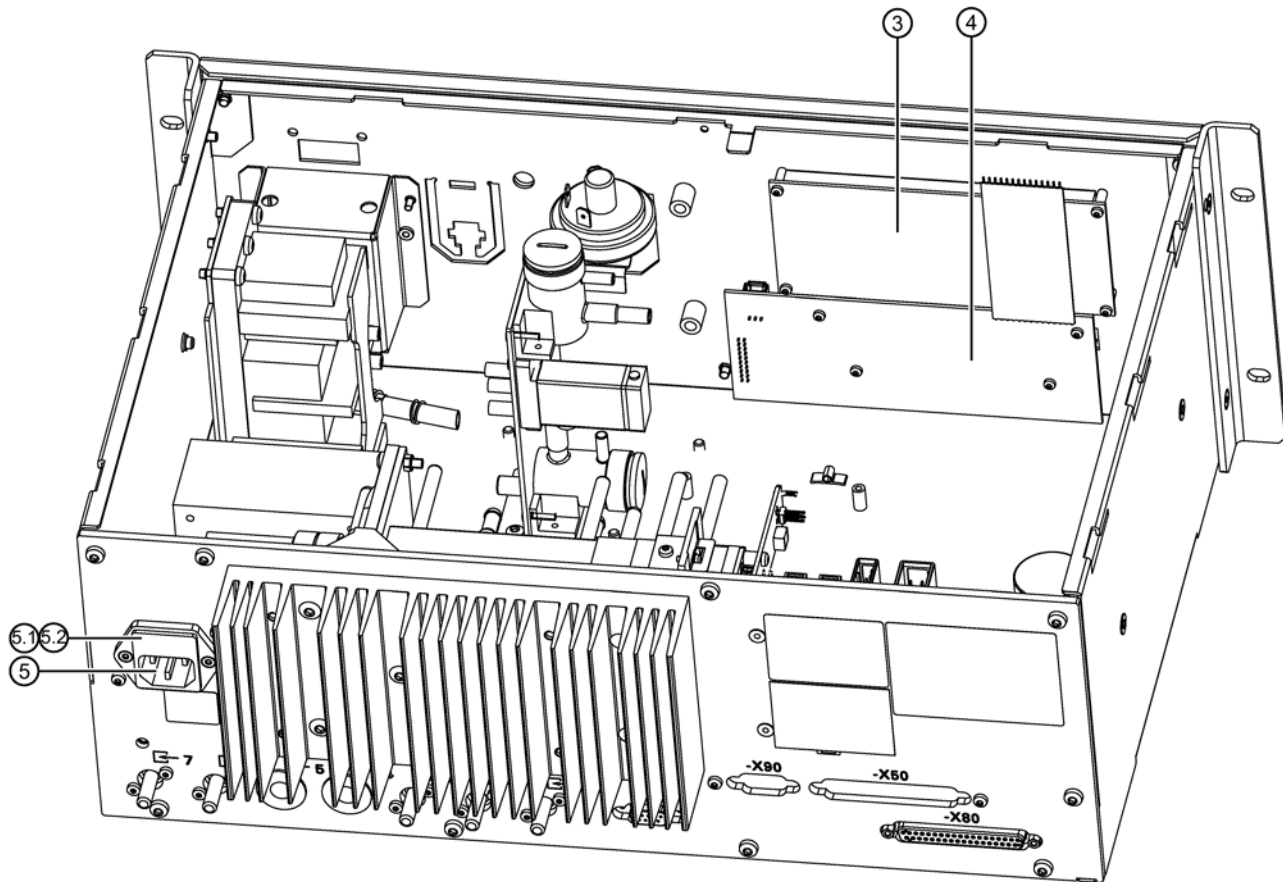

Figure 13-6 Rack unit

Part No.	Designation	Order No.	Remarks
3	LCD module	C79451--A3494--B16	
4	Keypad	C79451--A3492--B605	
5	Plug filter	W75041--E5602--K2	
5.1	Fuse	W79054--L1010--T630	200 V/230 V AC; T 630 mA/L 250 V see inscription on rear of device
5.2	Fuse	W79054--L1011--T125	100 V/120 V AC; T 1.25 A/L 250 V see inscription on rear of device
	Set of connectors (accessory)	A5E33941970	Appliance plug, Sub-D connector
	Set of screwdrivers (accessory)	A5E34821625	

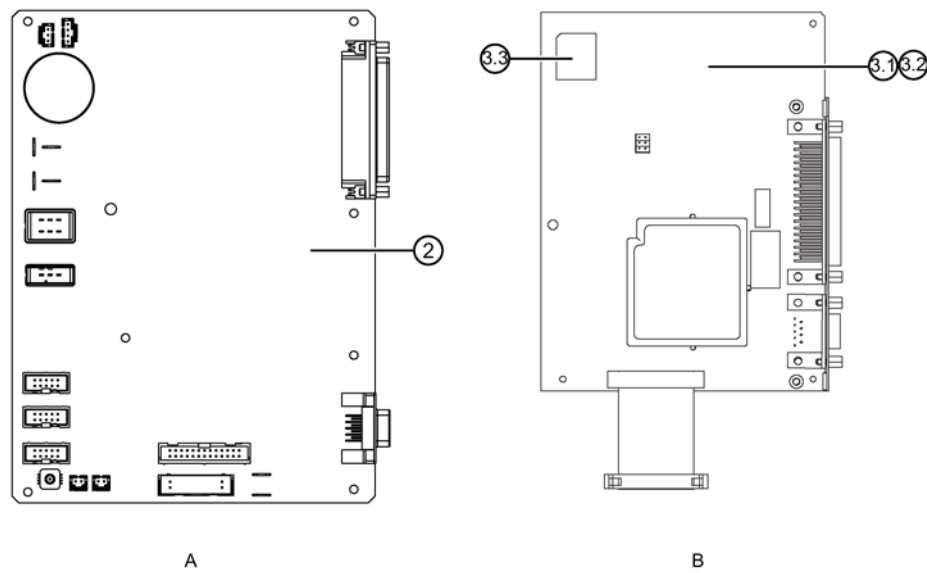

Figure 13-7 Motherboard (A) and option board (B)

Part No.	Designation	Order No.	Remarks
2 *)	Motherboard	A5E37100242	Motherboard with firmware
3.1	Add-on board DP	A5E00057159	PROFIBUS DP
3.2	Add-on board PA	A5E00056834	PROFIBUS PA
3.3	Firmware (PROFIBUS)	A5E00057164	

*) Following replacement of this part, special work is required which can only be carried out by qualified personnel trained for this task, for example temperature compensation, basic electronic adjustment etc.

As a result of an update in the device firmware, please contact the responsible service engineer.

13.4 Pump

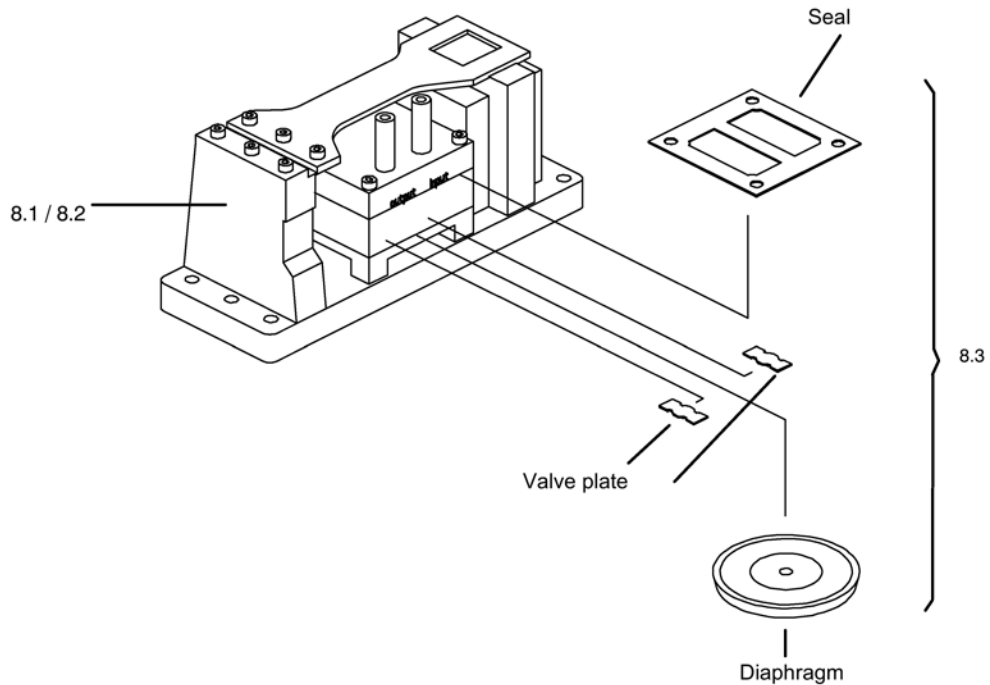

Figure 13-8 Pump

Part No.	Designation	Order No.	Remarks
8.1	Sample gas pump	C79451--A3494--B10	50 Hz
8.1	Sample gas pump	A5E35980470	50 Hz; for variant -B06 'Cleaned for O ₂ '
8.2	Sample gas pump	C79451--A3494--B11	60 Hz
8.2	Sample gas pump	A5E35980528	60 Hz; for variant -B06 'Cleaned for O ₂ '
8.3	Sealing set	C79402--Z666--E20	For sample gas pumps 8.1 and 8.2
8.3	Sealing set	A5E35980531	For sample gas pumps 8.1 and 8.2; variant -B06 'Cleaned for O ₂ '

13.5 IR analyzer units

13.5.1 Overview

13.5 IR analyzer units

Measured component	Measuring range		Measured component				Chopper C79451-A3468-	Plate with threaded bolts and windows C79451-A3468-	Opt. filter	Analyzer chamber 1		Gas filter 1 C79451-	Receiver chamber 1		
	Min.	Max.	Item Order No.	Item Order No. Measuring range new*	Item Order No. Measuring range old*	IR source C79451-A3468-B206				Length (mm)	C79451-A3468-		Type	C79451-A3468-	
CO	50 vpm	250 vpm	A	D	S	✓	B515/B516	B513/B514	-	180	B231	A3458-B500	2-layer HC	B525	
	100 vpm	500 vpm	A	E	A	✓		B513/B514	-	180	B231			B525	
	150 mg/m ³	750 mg/m ³	A	U	N	✓		B513/B514	-	180	B231			B525	
	150 vpm	750 vpm	A	F	-	✓		B513/B514	-	180	B231			B525	
	200 vpm	1000 vpm	A	G	C	✓		B513/B514	-	180	B231			B525	
	500 vpm	2500 vpm	A	H	D	✓		B513/B514	-	180	B231			B525	
	50 vpm	2500 vpm	A	X	T	✓		B513/B514	-	180	B231			B525	
	1000 vpm	5000 vpm	A	J	E	✓		B513/B514	-	90	B232			B525	
	2000 vpm	10000 vpm	A	K	F	✓		B513/B514	-	60	B233			B525	
	0,5 %	2,5 %	A	L	G	✓		B513/B514	-	20	B234			B525	
	1 %	5 %	A	M	H	✓		B513/B514	-	6	B235			B525	
	2 %	10 %	A	N	J	✓		B513/B514	-	2	B236			B525	
	5 %	25 %	A	P	K	✓		B513/B514	-	6	B235			B528	
	10 %	50 %	A	Q	L	✓		B513/B514	-	2	B236			B528	
20 %	100 %	A	R	M	✓	B513/B514	-	2	B236	B528					
CO ₂	50 vpm	250 vpm	C	D	-	✓	B515/B516 Purged	B513/B514	-	180	B231	A3468-B541	2-layer HC	B536	
	200 vpm	1000 vpm	C	G	-	✓		B513/B514	-	180	B231			B536	
	500 vpm	2500 vpm	C	H	-	✓		B513/B514	-	90	B232			B536	
	1000 vpm	5000 vpm	C	J	-	✓		B513/B514	-	20	B234			B536	
	2000 vpm	10000 vpm	C	K	F	✓		B513/B514	-	90	B232			B526	
	0,5 %	2,5 %	C	L	G	✓		B513/B514	-	60	B233			B526	
	1 %	5 %	C	M	H	✓		B513/B514	-	20	B234			B526	
	2 %	10 %	C	N	J	✓		B513/B514	-	20	B234			B526	
	5 %	25 %	C	P	K	✓		B513/B514	-	6	B235			B526	
	10 %	50 %	C	Q	L	✓		B513/B514	-	2	B236			B526	
20 %	100 %	C	R	M	✓	B513/B516	-	2	B236	B526					
NO	100 mg/m ³	750 mg/m ³	P	T	-	✓	B515/B516	B513/B514	C75285-Z1491-C5	180	B231	-	3-layer	Channel 1: B520 Channel 2: B522	
	100 vpm	500 vpm	P	E	-	✓		B513/B514		180	B231				-
	200 vpm	1000 vpm	P	G	C	✓		B513/B514		180	B231				-
	250 mg/m ³	1250 mg/m ³	P	V	P	✓		B513/B514		180	B231				-
	400 mg/m ³	2000 mg/m ³	P	W	Q	✓		B513/B514		180	B231				-
	500 vpm	2500 vpm	P	H	D	✓		B513/B514		180	B231				-
	1000 vpm	5000 vpm	P	J	E	✓		B513/B514		90	B232				-
SO ₂	150 vpm	750 vpm	N	F	B	✓	B515/B516	B513/B514	C75285-Z1302-A4	180	B231	A3458-B508	3-layer	Channel 1: B521 Channel 2: B523	
	200 mg/m ³	1000 mg/m ³	N	-	-	✓		B513/B514		?	B231				-
	400 mg/m ³	2000 mg/m ³	N	W	Q	✓		B513/B514		180	B231				-
	200 vpm	1000 vpm	N	G	C	✓		B513/B514		180	B231				-
	500 vpm	2500 vpm	N	H	D	✓		B513/B514		180	B231				-
	1000 vpm	5000 vpm	N	J	E	✓		B513/B514		60	B233				-
	2000 vpm	10000 vpm	N	K	F	✓		B513/B514		20	B234				-
	0,5 %	2,5 %	N	L	G	✓		B513/B514		20	B234				-
CH ₄	100 vpm	500 vpm	D	E	-	✓	B515/B516	B513/B514	-	180	B231	A3468-B542	2-layer HC	B527	
	500 vpm	2500 vpm	D	H	D	✓		B513/B514		180	B231			-	
	0,5 %	2,5 %	D	L	G	✓		B513/B514		20	B234			-	
	2 %	10 %	D	N	J	✓		B513/B514		6	B235			-	
	5 %	25 %	D	P	K	✓		B513/B514		2	B236			-	
	20 %	100 %	D	R	M	✓		B513/B514		2	B236			-	
N ₂ O	50 mg/m ³	500 mg/m ³	S	S	-	✓	B516	B514	-	180	B231	-	2-layer HC	B581	
	100 vpm	500 vpm	S	E	-	✓	B515/B516	B513/B514		90	B232			-	
	500 vpm	5000 vpm	S	Y	-	✓	B516	B514		6	B235			A3468-B543	B581

* Measuring range old: Up to 05/00



* Measuring range new: From 05/00



Measured component	Measuring range		Item Order No. Measured component	Item Order No. Measuring range new*	Item Order No. Measuring range old*	IR source C79451-A3468-B206	Chopper C79451-A3468-	Plate with threaded bolts and windows C79451-A3468-	Opt. filter	Analyzer chamber 1		Receiver chamber 1		
	Min.	Max.								Length (mm)	C79451-A3468-	Gas filter 1 C79451-	Type	C79451-A3468-
R22	500 vpm	2500 vpm	U	H	D	✓	B515/B516	B513/B514	-	180	B231	-	2-layer HC	B535
C ₂ H ₄	2000 vpm	10000 vpm	F	K	F	✓		B513/B514	C79285-Z1491-C2	180	B231	-	2-layer HC	B537
C ₆ H ₁₄	2000 vpm	10000 vpm	M	K	-	✓		B513/B514	A5E00069310	20	B234	A3468-B553	2-layer without mirror	B538
SF ₆	500 vpm	2500 vpm	V	H	-	✓		B513/B514	C79451-A3182-C161	90	B232	-	2-layer HC	B539
CO ₂ /CO	5 %/100 vpm	25 %/500 vpm		BJ	-	✓	B516	B514	-	6	B235	-	Irradiated	B531
	5 %/75 mg/m ³	25 %/750 mg/m ³		BL	-	✓			-	6	B235	-		B531
	10 %/0,5 %	50 %/2,5 %		BK	-	✓			-	2	B236	-		B531
CO ₂ /CH ₄	5 %/1 %	25 %/5 %	CA	1B	✓	-			6	B235	-	B531		
	5 %/2 %	25 %/10 %	CB	2B	✓	-			6	B235	-	B531		
CO ₂ /NO	5 %/500 vpm	25 %/2500 vpm	DC	-	✓	-			6	B235	-	B531		
CO/CO ₂	10 %/0,5 %	50 %/2,5 %	BB	8A	✓	-			2	B236	-	B532		
	10 %/10 %	50 %/50 %	BA	6A	✓	-			2	B236	-	B532		
	20 %/20 %	100 %/100 %	BD	-	✓	-			2	B236	-	B532		
CO/NO	250/400 mg/m ³	1250/2000 mg/m ³	AK	1A	✓	-			180	B231	A3458-B500	B530		
	500/500 vpm	2500/2500 vpm	AA	2A	✓	-			180	B231		B530		
	2000/1000 vpm	10000/10000 vpm	AB	3A	✓	-			60	B233		B530		
	1000/1000 vpm	5000/5000 vpm	AC	-	✓	-	90	B232	B530					
	1 %/1000 vpm	5 %/5000 vpm	AD	-	✓	-	6	B235	B530					

* Messbereich alt: bis 05/00



* Messbereich neu: ab 05/00



Measured component	Measuring range		Item Order No. Measuring range new*	Item Order No. Measuring range old*	Opt. filter With holder	Analyzer chamber 2		Gas filter 2	Opt. filter C79451-A3458-	Type	Receiver chamber 2 C79451-A3468-
	Min.	Max.				Length (mm)	C79451-A3468-				
CO ₂ /CO	5 %/100 vpm	25 %/500 vpm	BJ	-	-	180	B231	A3458-B500	-	2-layer HC	B525
	5 %/75 mg/m ³	25 %/750 mg/m ³	BL	-	-	180	B231	A3458-B500	-	2-layer HC	B525
	10 %/0,5 %	50 %/2,5 %	BK	-	-	20	B234	A3458-B500	-	2-layer HC	B528
CO ₂ /CH ₄	5 %/1 %	25 %/5 %	CA	1B	-	6	B235	-	-	2-layer HC	B527
	5 %/2 %	25 %/10 %	CB	2B	-	-	-	-	-	-	-
CO ₂ /NO	5 %/500 vpm	25 %/2500 vpm	DC	-	A5E00502911	180	B231	-	-	3-layer	B 520 channel 1
CO/CO ₂	10 %/0,5 %	50 %/2,5 %	BB	8A	-	20	B234	-	-	2-layer HC	B526
	10 %/10 %	50 %/50 %	BA	6A	-	-	-	-	-	-	-
	20 %/20 %	100 %/100 %	BD	-	-	-	-	-	-	-	-
CO/NO	250/400 mg/m ³	1250/2000 mg/m ³	AK	1A	-	-	-	-	B103	3-layer	B520 channel 1
	500/500 vpm	2500/2500 vpm	AA	2A	-	-	-	-	B103	3-layer	B520 channel 1
	2000/1000 vpm	10000/10000 vpm	AB	3A	-	-	-	-	B103	3-layer	B520 channel 1
	1000/1000 vpm	5000/5000 vpm	AC	-	-	-	-	-	B103	3-layer	B520 channel 1
	1 %/1000 vpm	5 %/5000 vpm	AD	-	-	60	B233	A3468-B542	B103	3-layer	B520 channel 1

Spare parts/accessories

13.5 IR analyzer units

7MB235x

Measured component	Measuring range mg/m		Item Order No. Measured component	Item Order No. Measuring range	IR source C79451-A3468-B206	Chopper C79451-A3468-	Plate with threaded bolts and windows C79451-A3468-	Opt. filter C75285-Z1491-	Analyzer chamber 1		Receiver chamber 1		Opt. filter 2 C79451-A3458-	Receiver chamber 2	
	Min.	Max.							Length (mm)	C79451-A3468-	Gas filter 1 C79451-A3458-B500	Type		Order No.	Type
CO	200	1250	A		✓	B516		C4	180	B231	✓	2-layer sel.	A5E34729715 A5E34729727 (channel 1), A5E34778179 (channel 2)	-	
NO	150	750			✓		C5								
	250	1250			✓		C5								
	400	2000			✓		C5								
SO2	200	1000			✓		C5								
CO/NO	250/400	1250/2000			✓	B516	B514	--	✓		2-layer sel.	A5E33463532	B103	3-layer	B520 channel 1

13.5.2 Analyzer unit 7MB2335-, 7MB2355-

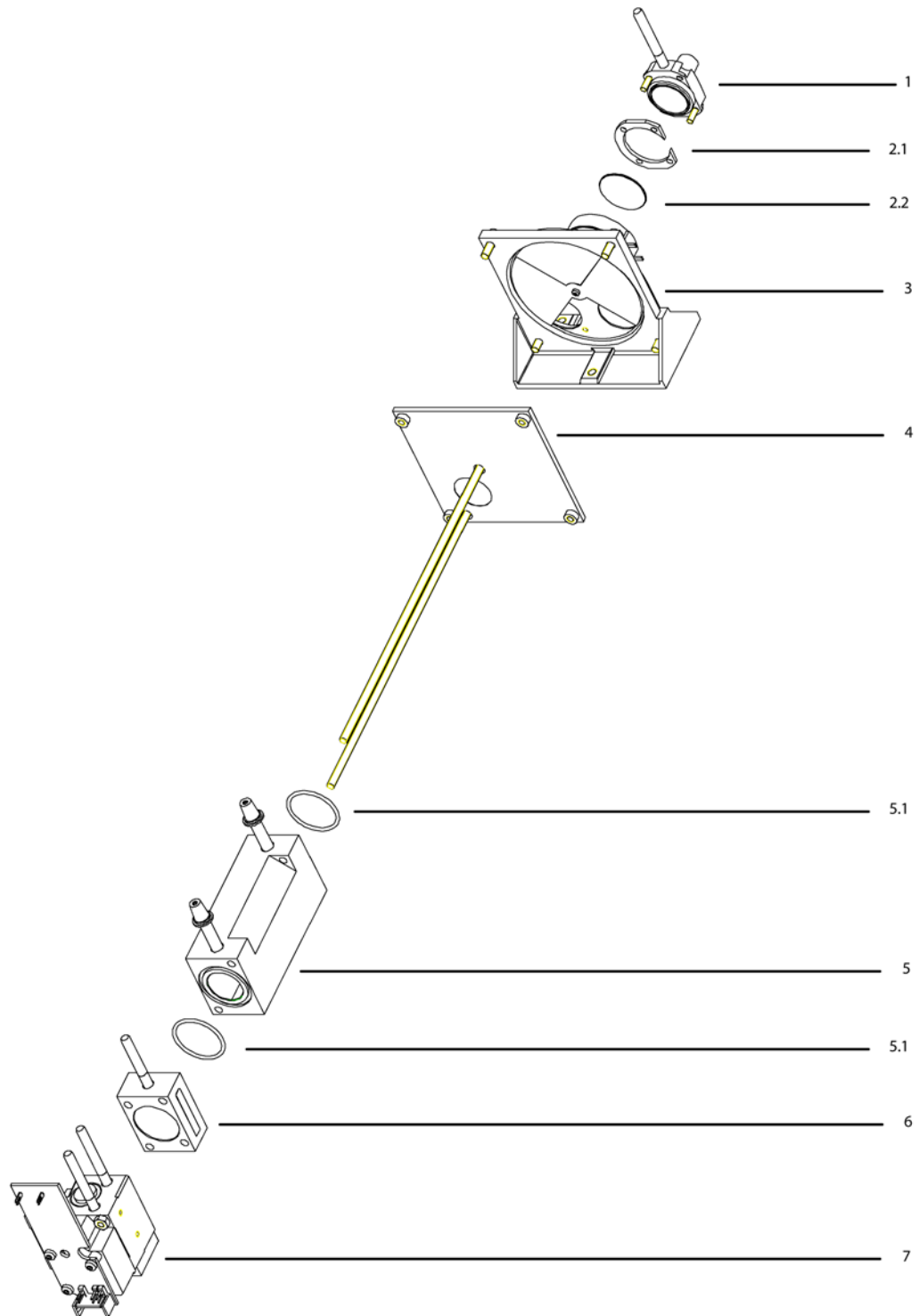

Figure 13-9 Analyzer unit 7MB2335-, 7MB2355-

13.5 IR analyzer units

Part No.	Designation	Order No.	Remarks
1 *)	IR source	C79451-A3468-B206	
2.1	Spacer	C79451-A3468-C20	
2.2	Optical filter	C79285-Z1491-C5	For NO **)
2.2	Optical filter	C79285-Z1302-A4	For SO ₂ **)
2.2	Optical filter	C75285-Z1491-C2	For C ₂ H ₄
2.2	Optical filter	A5E00069310	For C ₆ H ₁₄
2.2	Optical filter	C79451-A3182-C161	For SF ₆
2.2	Optical filter	C75285-Z1491-C4	For CO, MLFB 7MB2355
2.2	Optical filter	A5E36461324	
2.2	Optical filter with filter support	A5E36367217	
3 *)	Chopper	C79451-A3468-B515	
3 *)	Chopper	A5E35980538	Only variant -B06 'Cleaned for O ₂ '
4	Plate with threaded bolts and windows	C79451-A3468-B513	
4	Plate with threaded bolts and windows	A5E35980542	Only variant -B06 'Cleaned for O ₂ '
5.1	O-ring	C71121-Z100-A99	
5.1	O-ring	A5E35980590	Only variant -B06 'Cleaned for O ₂ '
5	Analyzer chamber with O-ring	C79451-A3468-B231	180 mm
5	Analyzer chamber with O-ring	A5E35982142	180 mm; only variant -B06 'Cleaned for O ₂ '
5	Analyzer chamber with O-ring	C79451-A3468-B232	90 mm
5	Analyzer chamber with O-ring	A5E35982156	90 mm; only variant -B06 'Cleaned for O ₂ '
5	Analyzer chamber with O-ring	C79451-A3468-B233	60 mm
5	Analyzer chamber with O-ring	A5E35982163	60 mm; only variant -B06 'Cleaned for O ₂ '
5	Analyzer chamber with O-ring	C79451-A3468-B234	20 mm
5	Analyzer chamber with O-ring	A5E35982170	20 mm; only variant -B06 'Cleaned for O ₂ '
5	Analyzer chamber	C79451-A3468-B235	6 mm
5	Analyzer chamber	A5E35982178	6 mm; only variant -B06 'Cleaned for O ₂ '
5	Analyzer chamber	C79451-A3468-B236	2 mm

Part No.	Designation	Order No.	Remarks
5	Analyzer chamber	A5E35982182	2 mm; only variant -B06 'Cleaned for O ₂ '
6	Gas filter	C79451-A3458-B500	For CO
6	Gas filter	A5E35983013	For CO; only variant -B06 'Cleaned for O ₂ '
6	Gas filter	C79451-A3458-B508	For SO ₂
6	Gas filter	A5E35983026	For SO ₂ ; only variant -B06 'Cleaned for O ₂ '
6	Gas filter	C79451-A3468-B541	For CO ₂ ; smallest MR <5%
6	Gas filter	A5E35983032	For CO ₂ ; smallest MR <5%; only variant -B06 'Cleaned for O ₂ '
6	Gas filter	C79451-A3468-B542	For CH ₄ ; smallest MR <2%
6	Gas filter	A5E35983036	For CH ₄ ; smallest MR <2%; only variant -B06 'Cleaned for O ₂ '
6	Gas filter	C79451-A3468-B553	For C ₆ H ₁₄
6	Gas filter	A5E35983044	For C ₆ H ₁₄ ; only variant -B06 'Cleaned for O ₂ '
7 *)	Receiver chamber	C79451-A3468-B525	For CO; smallest MR <5%
7 *)	Receiver chamber	A5E35983110	For CO; smallest MR <5%; only variant -B06 'Cleaned for O ₂ '
7 *)	Receiver chamber	C79451-A3468-B528	For CO; smallest MR ≥5%
7 *)	Receiver chamber	A5E35983122	For CO; smallest MR ≥5%; only variant -B06 'Cleaned for O ₂ '
7 *)	Receiver chamber	A5E34729715	For CO, MLFB 7MB2355
7 *)	Receiver chamber	C79451-A3468-B536	For CO ₂ ; smallest MR <1000 vpm
7 *)	Receiver chamber	A5E35983141	For CO ₂ ; smallest MR <1000 vpm; only variant -B06 'Cleaned for O ₂ '
7 *)	Receiver chamber	C79451-A3468-B526	For CO ₂ ; smallest MR ≥1000 vpm
7 *)	Receiver chamber	A5E35983146	For CO ₂ ; smallest MR ≥1000 vpm; only variant -B06 'Cleaned for O ₂ '
7 *)	Receiver chamber	C79451-A3468-B527	For CH ₄ ; smallest MR <20%
7 *)	Receiver chamber	A5E35983151	For CH ₄ ; smallest MR <20%; only variant -B06 'Cleaned for O ₂ '
7 *)	Receiver chamber	C79451-A3468-B529	For CH ₄ ; smallest MR ≥20%
7 *)	Receiver chamber	A5E35983152	For CH ₄ ; smallest MR ≥20%; only variant -B06 'Cleaned for O ₂ '
7 *)	Receiver chamber	C79451-A3468-B537	For C ₂ H ₄
7 *)	Receiver chamber	A5E35983172	For C ₂ H ₄ ; only variant -B06 'Cleaned for O ₂ '

13.5 IR analyzer units

Part No.	Designation	Order No.	Remarks
7 *)	Receiver chamber	C79451-A3468-B520	For NO
7 *)	Receiver chamber	A5E35983178	For NO; only variant -B06 'Cleaned for O ₂ '
7 *)	Receiver chamber	A5E34729727	For NO, MLFB 7MB2355
7 *)	Receiver chamber	C79451-A3468-B521	For SO ₂
7 *)	Receiver chamber	A5E35983183	For SO ₂ ; only variant -B06 'Cleaned for O ₂ '
7 *)	Receiver chamber	C79451-A3468-B581	For N ₂ O
7 *)	Receiver chamber	A5E35983192	For N ₂ O; only variant -B06 'Cleaned for O ₂ '
7 *)	Receiver chamber	C79451-A3468-B539	For SF ₆
7 *)	Receiver chamber	A5E35983196	For SF ₆ ; only variant -B06 'Cleaned for O ₂ '
7 *)	Receiver chamber	C79451-A3468-B538	For C ₆ H ₁₄
7 *)	Receiver chamber	A5E35983203	For C ₆ H ₁₄ ; only variant -B06 'Cleaned for O ₂ '

*) Following replacement of this part, special work is required which can only be carried out by qualified personnel trained for this task, for example temperature compensation, basic electronic adjustment etc.

**) Following replacement of this part, the water vapor cross-sensitivity must be checked.

13.5.3 Analyzer unit 7MB2337-, 7MB2357-

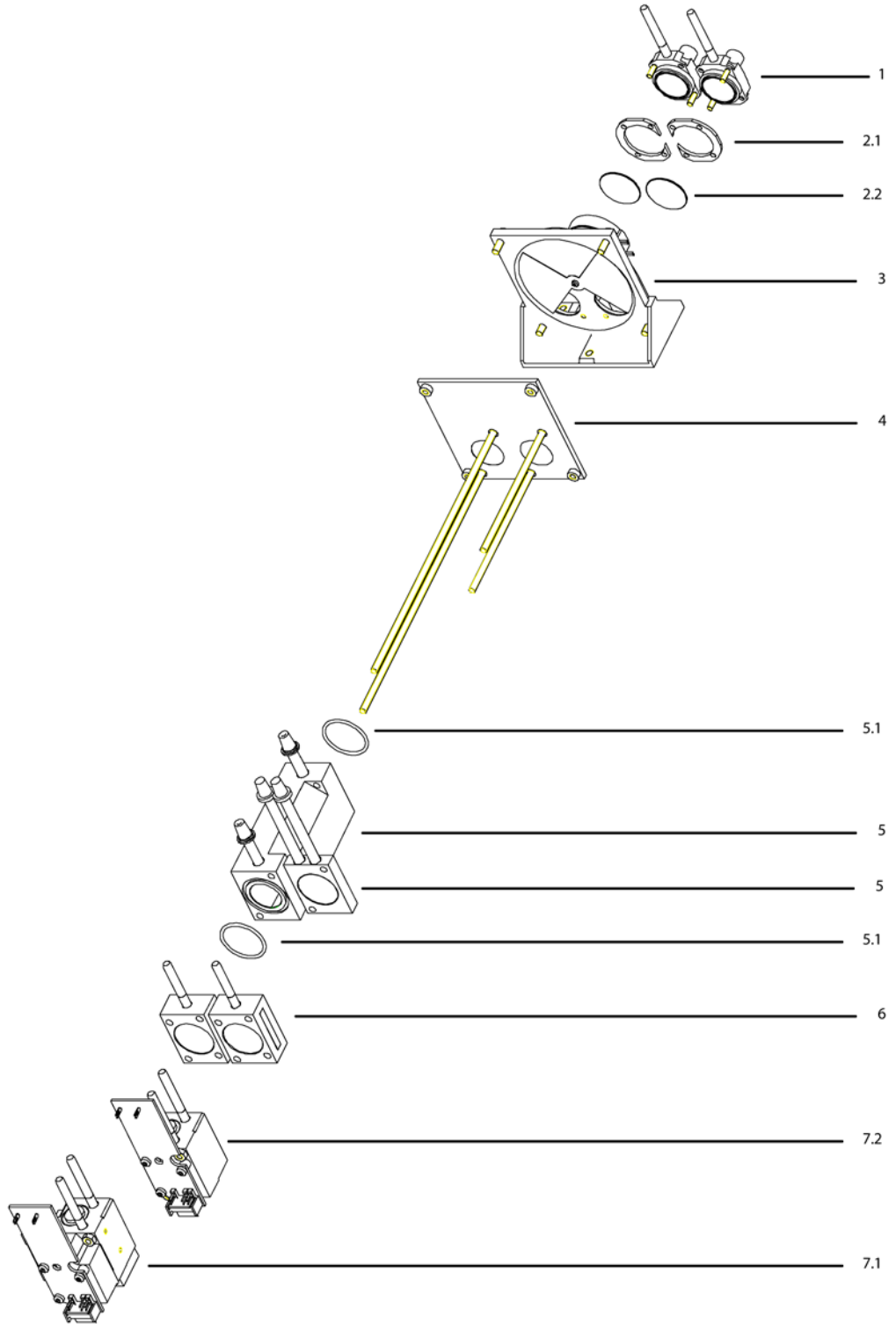

Figure 13-10 Analyzer unit 7MB2337-, 7MB2357-

13.5 IR analyzer units

Part No.	Designation	Order No.	Remarks
1 *)	IR source	C79451-A3468-B206	
2.1	Spacer	C79451-A3468-C20	
2.2	Optical filter	C75285-Z1491-C5	For NO **)
2.2	Optical filter	C79285-Z1302-A4	For SO ₂ **)
2.2	Optical filter	C79285-Z1491-C2	For C ₂ H ₄
2.2	Optical filter	A5E00069310	For C ₆ H ₁₄
2.2	Optical filter	C79451-A3182-C161	For SF ₆
2.2	Optical filter	C75285-Z1491-C4	For CO, MLFB 7MB2357
3 *)	Chopper	C79451-A3468-B516	
3 *)	Chopper	A5E35984159	Only variant -B06 'Cleaned for O ₂ '
4	Plate with threaded bolts and windows	C79451-A3468-B514	
4	Plate with threaded bolts and windows	A5E35984162	Only variant -B06 'Cleaned for O ₂ '
5.1	O-ring	C71121-Z100-A99	
5.1	O-ring	A5E35980590	Only variant -B06 'Cleaned for O ₂ '
5	Analyzer chamber with O-ring	C79451-A3468-B231	180 mm
5	Analyzer chamber with O-ring	A5E35982142	180 mm; only variant -B06 'Cleaned for O ₂ '
5	Analyzer chamber with O-ring	C79451-A3468-B232	90 mm
5	Analyzer chamber with O-ring	A5E35982156	90 mm; only variant -B06 'Cleaned for O ₂ '
5	Analyzer chamber with O-ring	C79451-A3468-B233	60 mm
5	Analyzer chamber with O-ring	A5E35982163	60 mm; only variant -B06 'Cleaned for O ₂ '
5	Analyzer chamber with O-ring	C79451-A3468-B234	20 mm
5	Analyzer chamber with O-ring	A5E35982170	20 mm; only variant -B06 'Cleaned for O ₂ '
5	Analyzer chamber	C79451-A3468-B235	6 mm
5	Analyzer chamber	A5E35982178	6 mm; only variant -B06 'Cleaned for O ₂ '
5	Analyzer chamber	C79451-A3468-B236	2 mm
5	Analyzer chamber	A5E35982182	2 mm; only variant -B06 'Cleaned for O ₂ '
6	Gas filter	C79451-A3458-B508	For SO ₂
6	Gas filter	A5E35983026	For SO ₂ ; only variant -B06 'Cleaned for O ₂ '

Part No.	Designation	Order No.	Remarks
6	Gas filter	C79451-A3468-B541	For CO ₂ ; smallest MR <5%
6	Gas filter	A5E35983032	For CO ₂ ; smallest MR <5%; only variant -B06 'Cleaned for O ₂ '
6	Gas filter	C79451-A3468-B542	For CH ₄ ; smallest MR <2%
6	Gas filter	A5E35983036	For CH ₄ ; smallest MR <2%; only variant -B06 'Cleaned for O ₂ '
6	Gas filter	C79451-A3468-B553	For C ₆ H ₁₄ , N ₂ O 500/5000 vpm
6	Gas filter	A5E35983044	For C ₆ H ₁₄ , N ₂ O 500/5000 vpm; only variant -B06 'Cleaned for O ₂ '
7.1/7.2 *)	Receiver chamber	C79451-A3468-B525	For CO; smallest MR <5%
7.1/7.2 *)	Receiver chamber	A5E35983110	For CO; smallest MR <5%; only variant -B06 'Cleaned for O ₂ '
7.1/7.2 *)	Receiver chamber	C79451-A3468-B528	For CO; smallest MR ≥5%
7.1/7.2 *)	Receiver chamber	A5E35983122	For CO; smallest MR ≥5%; only variant -B06 'Cleaned for O ₂ '
7.1/7.2 *)	Receiver chamber	A5E34729715	For CO, MLFB 7MB2357
7.1/7.2 *)	Receiver chamber	C79451-A3468-B536	For CO ₂ ; smallest MR <1000 vpm
7.1/7.2 *)	Receiver chamber	A5E35983141	For CO ₂ ; smallest MR <1000 vpm; only variant -B06 'Cleaned for O ₂ '
7.1/7.2 *)	Receiver chamber	C79451-A3468-B526	For CO ₂ ; smallest MR ≥1000 vpm
7.1/7.2 *)	Receiver chamber	A5E35983146	For CO ₂ ; smallest MR ≥1000 vpm; only variant -B06 'Cleaned for O ₂ '
7.1/7.2 *)	Receiver chamber	C79451-A3468-B527	For CH ₄ ; smallest MR <20%
7.1/7.2 *)	Receiver chamber	A5E35983151	For CH ₄ ; smallest MR <20%; only variant -B06 'Cleaned for O ₂ '
7.1/7.2 *)	Receiver chamber	C79451-A3468-B529	For CH ₄ ; smallest MR ≥20%
7.1/7.2 *)	Receiver chamber	A5E35983152	For CH ₄ ; smallest MR ≥20%; only variant -B06 'Cleaned for O ₂ '
7.1/7.2 *)	Receiver chamber	C79451-A3468-B537	For C ₂ H ₄
7.1/7.2 *)	Receiver chamber	A5E35983172	For C ₂ H ₄ ; only variant -B06 'Cleaned for O ₂ '
7.1 *)	Receiver chamber	C79451-A3468-B520	For NO (channel 1)
7.1 *)	Receiver chamber	A5E35983178	For NO (channel 1); only variant -B06 'Cleaned for O ₂ '
7.1 *)	Receiver chamber	A5E34729727	For NO (channel 1), MLFB 7MB2357
7.2 *)	Receiver chamber	C79451-A3468-B522	For NO (channel 2)

13.5 IR analyzer units

Part No.	Designation	Order No.	Remarks
7.2 *)	Receiver chamber	A5E35984186	For NO (channel 2); only variant -B06 'Cleaned for O ₂ '
7.2 *)	Receiver chamber	A5E34778179	For NO (channel 2), MLFB 7MB2357
7.1 *)	Receiver chamber	C79451-A3468- B521	For SO ₂ (channel 1)
7.1 *)	Receiver chamber	A5E35983183	For SO ₂ (channel 1); only variant -B06 'Cleaned for O ₂ '
7.1 *)	Receiver chamber	C79451-A3468- B523	For SO ₂ (channel 2)
7.1 *)	Receiver chamber	A5E35984197	For SO ₂ (channel 2); only variant -B06 'Cleaned for O ₂ '
7 *)	Receiver chamber	C79451-A3468- B581	For N ₂ O
7 *)	Receiver chamber	A5E35983192	For N ₂ O; only variant -B06 'Cleaned for O ₂ '
7 *)	Receiver chamber	C79451-A3468- B539	For SF ₆
7 *)	Receiver chamber	A5E35983196	For SF ₆ ; only variant -B06 'Cleaned for O ₂ '
7 *)	Receiver chamber	C79451-A3468- B538	For C ₆ H ₁₄
7 *)	Receiver chamber	A5E35983203	For C ₆ H ₁₄ ; only variant -B06 'Cleaned for O ₂ '

*) Following replacement of this part, special work is required which can only be carried out by qualified personnel trained for this task, for example temperature compensation, basic electronic adjustment etc.

**) Following replacement of this part, the water vapor cross-sensitivity must be checked.

13.5.4 Analyzer unit 1 7MB2338-, 7MB2358-

13.5.4.1 .AA.-, -.AK.-, -.AB.-, -.AC.- for CO/NO

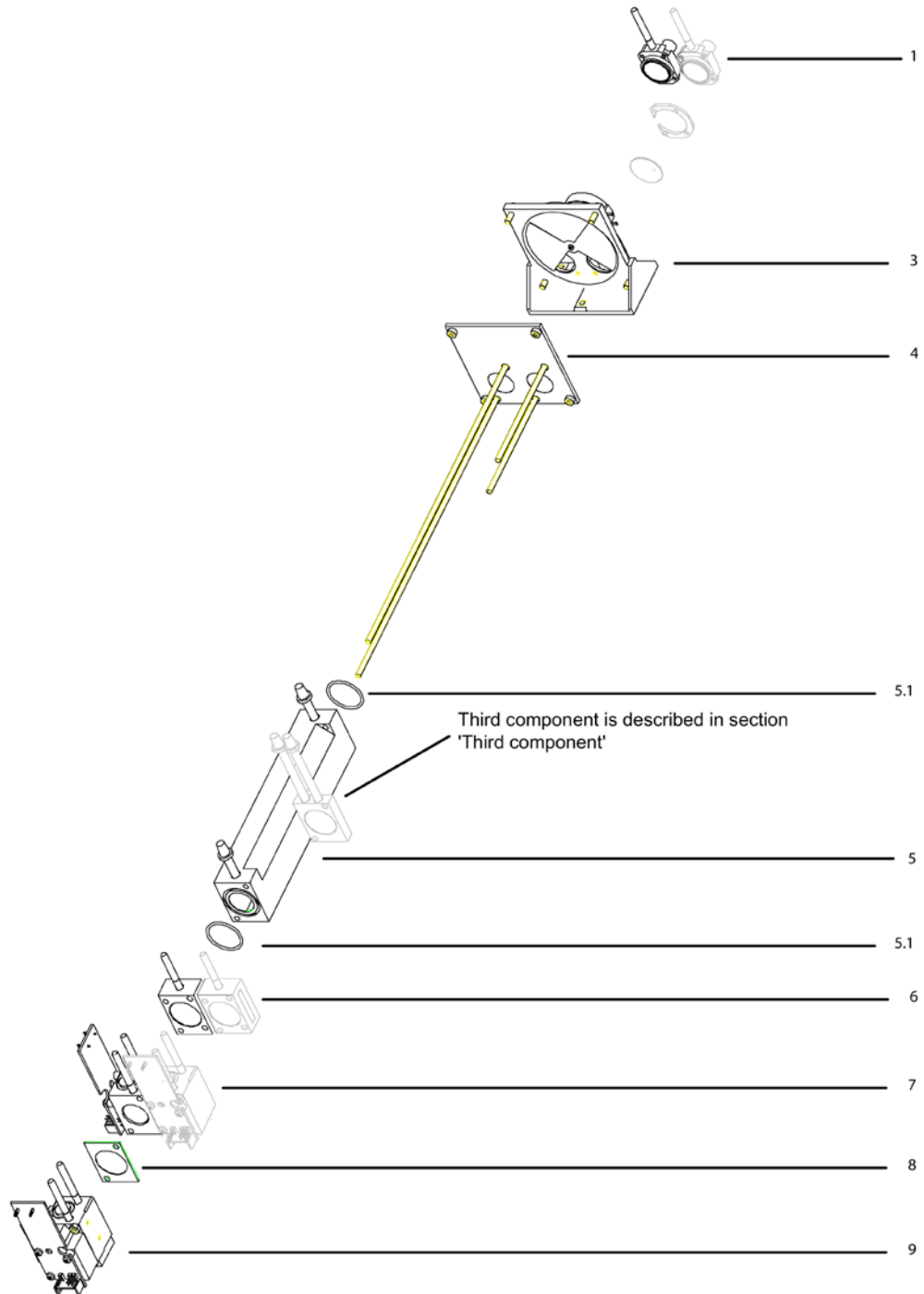

Figure 13-11 Analyzer unit 7MB2338-, 7MB2358-.AA.-, -.AK.-, -.AB.-, -.AC.-, configuration for CO/NO

13.5 IR analyzer units

Part No.	Designation	Order No.	Remarks
1 *)	IR source	C79451-A3468-B206	
3 *)	Chopper	C79451-A3468-B516	
3 *)	Chopper	A5E35984159	Only variant -B06 'Cleaned for O ₂ '
4	Plate with threaded bolts and windows	C79451-A3468-B514	
4	Plate with threaded bolts and windows	CA5E35984162	Only variant -B06 'Cleaned for O ₂ '
5.1	O-ring	C71121-Z100-A99	
5.1	O-ring	A5E35980590	Only variant -B06 'Cleaned for O ₂ '
5	Analyzer chamber with O-ring	C79451-A3468-B231	Analyzer chamber -.AA., -.AK.,; 180 mm
5	Analyzer chamber with O-ring	A5E35982142	Analyzer chamber -.AA., -.AK.,; 180 mm; only variant -B06 'Cleaned for O ₂ '
5	Analyzer chamber with O-ring	C79451-A3468-B232	Analyzer chamber -.AC.,; 90 mm
5	Analyzer chamber with O-ring	A5E35982156	Analyzer chamber -.AC.,; 90 mm; only variant -B06 'Cleaned for O ₂ '
5	Analyzer chamber with O-ring	C79451-A3468-B233	Analyzer chamber -.AB.,; 60 mm
5	Analyzer chamber with O-ring	A5E35982163	Analyzer chamber -.AB.,; 60 mm; only variant -B06 'Cleaned for O ₂ '
6	Gas filter	C79451-A3458-B500	For CO
6	Gas filter	A5E35983013	For CO; only variant -B06 'Cleaned for O ₂ '
7 *)	Receiver chamber	C79451-A3468-B530	For CO
7 *)	Receiver chamber	A5E35984307	For CO; only variant -B06 'Cleaned for O ₂ '
7 *)	Receiver chamber	A5E33463532	For CO, MLFB 7MB2358
8	Optical filter	C79451-A3458-B103	For NO **)
9 *)	Receiver chamber	C79451-A3468-B520	For NO (channel 1)
9 *)	Receiver chamber	A5E35983178	For NO (channel 1); only variant -B06 'Cleaned for O ₂ '

*) Following replacement of this part, special work is required which can only be carried out by qualified personnel trained for this task, for example temperature compensation, basic electronic adjustment etc.

**) Following replacement of this part, the water vapor cross-sensitivity must be checked.

13.5.4.2 .AD..- for CO/NO

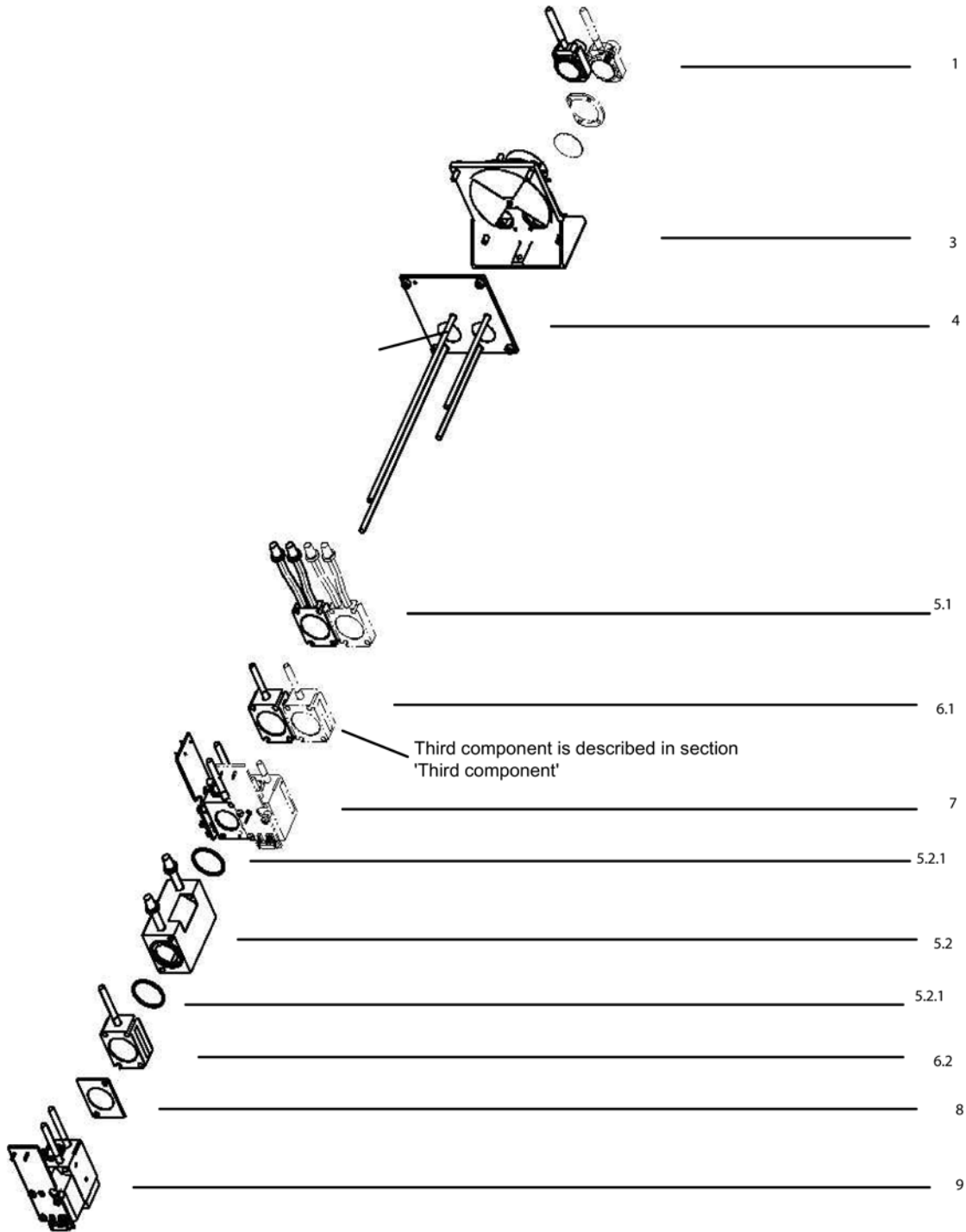

Figure 13-12 Analyzer unit 7MB2338-, 7MB2358.AD..., configuration for CO/NO

13.5 IR analyzer units

Part No.	Designation	Order No.	Remarks
1 *)	IR source	C79451-A3468-B206	
3 *)	Chopper	C79451-A3468-B516	
3 *)	Chopper	A5E35984159	Only variant -B06 'Cleaned for O ₂ '
4	Plate with threaded bolts and windows	C79451-A3468-B514	
4	Plate with threaded bolts and windows	CA5E35984162	Only variant -B06 'Cleaned for O ₂ '
5.1	Analyzer chamber	C79451-A3468-B235	Analyzer chamber 6 mm
5.1	Analyzer chamber	A5E35982178	Analyzer chamber 6 mm; only variant -B06 'Cleaned for O ₂ '
6.1	Gas filter	C79451-A3458-B500	For CO
6.1	Gas filter	A5E35983013	For CO; only variant -B06 'Cleaned for O ₂ '
7 *)	Receiver chamber	C79451-A3468-B530	For CO
7 *)	Receiver chamber	A35984307	For CO; only variant -B06 'Cleaned for O ₂ '
5.2	Analyzer chamber with O-ring	C79451-A3468-B233	Analyzer chamber 60 mm
5.2	Analyzer chamber with O-ring	A5E35982163	Analyzer chamber 60 mm; only variant -B06 'Cleaned for O ₂ '
5.2.1	O-ring	C71121-Z100-A99	
5.2.1	O-ring	A5E35980590	Only variant -B06 'Cleaned for O ₂ '
6.2	Gas filter	C79451-A3468-B542	For NO
6.2	Gas filter	A5E35983036	For NO; only variant -B06 'Cleaned for O ₂ '
8	Optical filter	C79451-A3458-B103	For NO **)
9 *)	Receiver chamber	C79451-A3468-B520	For NO (channel 1)
9 *)	Receiver chamber	A5E35983178	For NO (channel 1); only variant -B06 'Cleaned for O ₂ '

*) Following replacement of this part, special work is required which can only be carried out by qualified personnel trained for this task, for example temperature compensation, basic electronic adjustment etc.

***) Following replacement of this part, the water vapor cross-sensitivity must be checked.

13.5.4.3 .DC.- for CO₂/NO

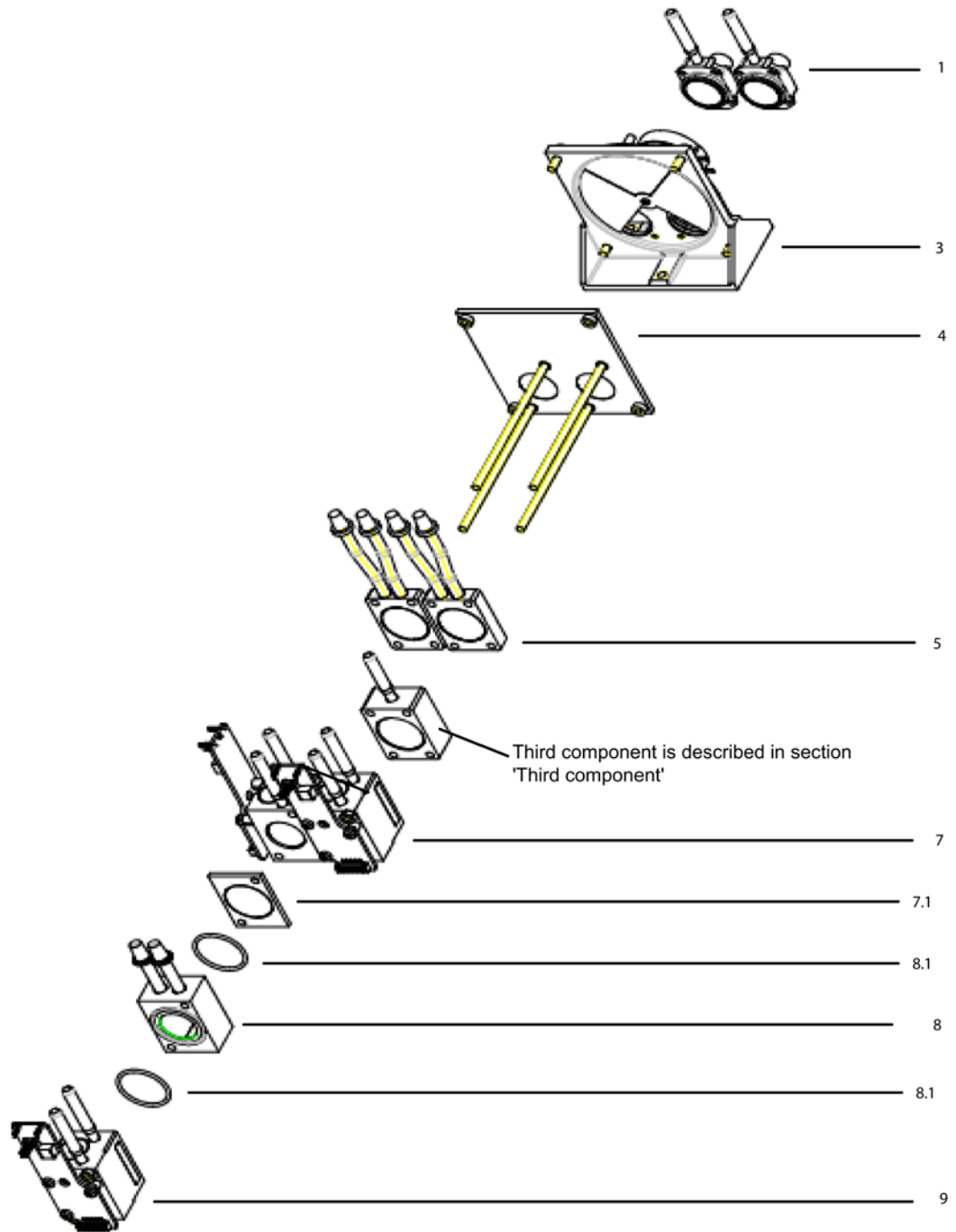

Figure 13-13 Analyzer unit 7MB2338-, 7MB2358-.DC..., configuration for CO₂/NO

13.5 IR analyzer units

Part No.	Designation	Order No.	Remarks
1 *)	IR source	C79451-A3468-B206	
3 *)	Chopper	C79451-A3468-B516	
3 *)	Chopper	A5E35984159	Only variant -B06 'Cleaned for O ₂ '
4	Plate with threaded bolts and windows	C79451-A3468-B514	
4	Plate with threaded bolts and windows	CA5E35984162	Only variant -B06 'Cleaned for O ₂ '
5	Analyzer chamber	C79451-A3468--B235	Analyzer chamber 6 mm
5	Analyzer chamber	A5E35982178	Analyzer chamber 6 mm; only variant -B06 'Cleaned for O ₂ '
7 *)	Receiver chamber	C79451-A3468-B531	For CO ₂
7 *)	Receiver chamber	A5E35984315	For CO ₂ ; only variant -B06 'Cleaned for O ₂ '
7.1	Optical filter with filter support	A5E00502911	
7.1	Optical filter with filter support	A5E35984319	Only variant -B06 'Cleaned for O ₂ '
8	Analyzer chamber with O-ring	C79451-A3468-B231	Analyzer chamber 180 mm
8	Analyzer chamber with O-ring	A5E35982142	Analyzer chamber 180 mm; only variant -B06 'Cleaned for O ₂ '
8.1	O-ring	C71121-Z100-A99	
8.1	O-ring	A5E35980590	Only variant -B06 'Cleaned for O ₂ '
9 *)	Receiver chamber	C79451-A3468-B520	For NO (channel 1)
9 *)	Receiver chamber	A5E35983178	For NO (channel 1); only variant -B06 'Cleaned for O ₂ '

*) Following replacement of this part, special work is required which can only be carried out by qualified personnel trained for this task, for example temperature compensation, basic electronic adjustment etc.

13.5.4.4 .BA., .BD., .CB.- for CO/CO₂ and CO₂/CH₄

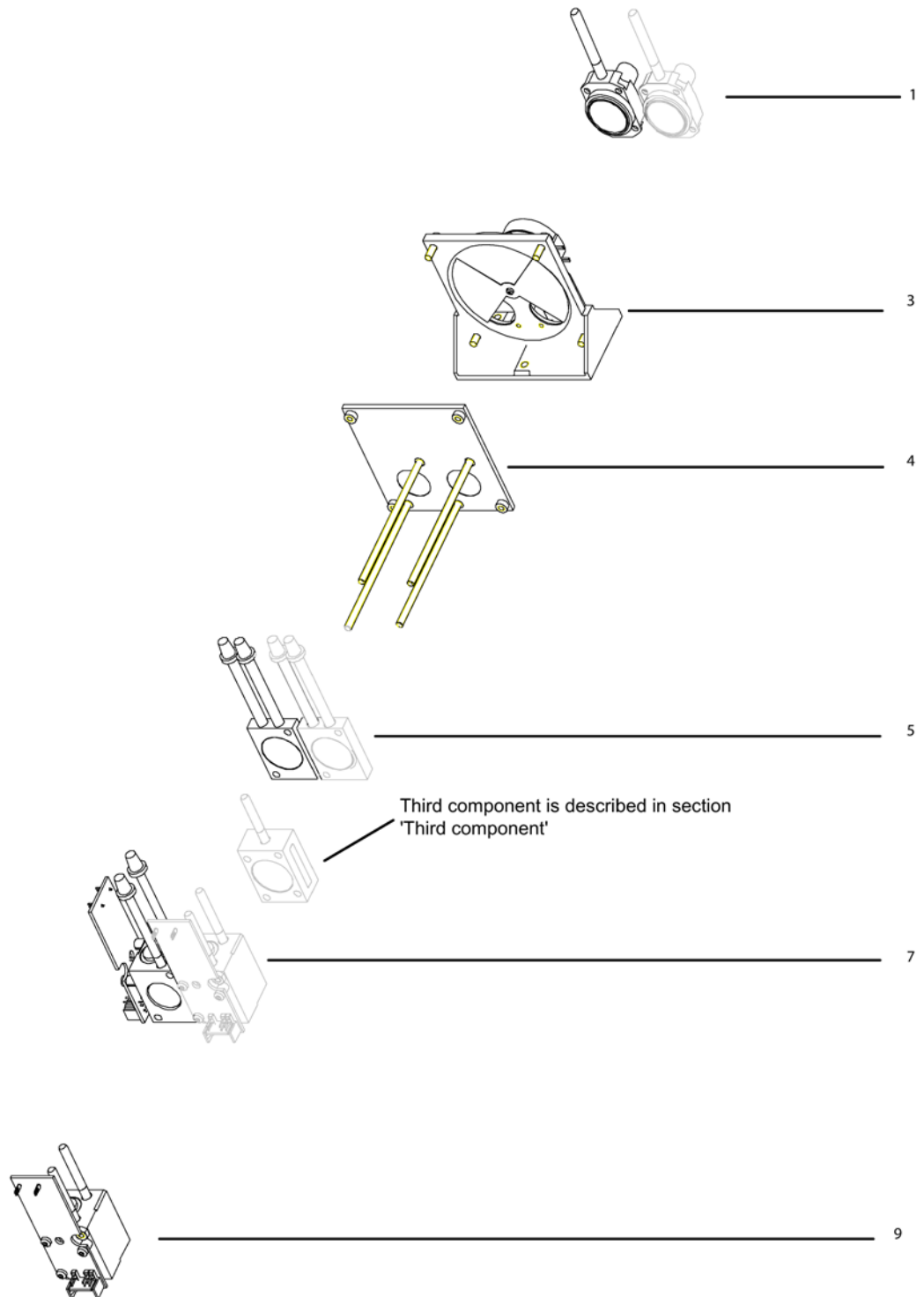

Figure 13-14 Analyzer unit 7MB2338-, 7MB2358-.BA., -.BD.-, -.CB.-, analyzer unit 1 CO/CO₂ and CO₂/CH₄

7MB2338-, 7MB2358-.BA..-, -.BD..-, -.CB..-

Part No.	Designation	Order No.	Remarks
1 *)	IR source	C79451-A3468-B206	
3 *)	Chopper	C79451-A3468-B516	
3 *)	Chopper	A5E35984159	Only variant -B06 'Cleaned for O ₂ '
4	Plate with threaded bolts and windows	C79451-A3468-B514	
4	Plate with threaded bolts and windows	CA5E35984162	Only variant -B06 'Cleaned for O ₂ '

7MB2338-, 7MB2358-.BA..-, -.BD..-

Part No.	Designation	Order No.	Remarks
5	Analyzer chamber	C79451-A3468-B236	Analyzer chamber 2 mm
5	Analyzer chamber	A5E35982182	Analyzer chamber 2 mm; only variant -B06 'Cleaned for O ₂ '
7 *)	Receiver chamber	C79451-A3468-B532	For CO
7 *)	Receiver chamber	A5E35984327	For CO; only variant -B06 'Cleaned for O ₂ '
9 *)	Receiver chamber	C79451-A3468-B526	For CO ₂
9 *)	Receiver chamber	A5E35983146	For CO ₂ ; only variant -B06 'Cleaned for O ₂ '

7MB2338-, 7MB2358-.CB..-

Part No.	Designation	Order No.	Remarks
5	Analyzer chamber	C79451-A3468-B235	Analyzer chamber 6 mm
5	Analyzer chamber	A5E35982178	6 mm; only variant -B06 'Cleaned for O ₂ '
7 *)	Receiver chamber	C79451-A3468-B531	For CO ₂
7 *)	Receiver chamber	A5E35984315	For CO ₂ ; only variant -B06 'Cleaned for O ₂ '
9 *)	Receiver chamber	C79451-A3468-B527	For CH ₄
9 *)	Receiver chamber	A5E35983151	For CH ₄ ; only variant -B06 'Cleaned for O ₂ '

*) Following replacement of this part, special work is required which can only be carried out by qualified personnel trained for this task, for example temperature compensation, basic electronic adjustment etc.

13.5.4.5 .BB.., .CA..- for CO/CO2 and CO2/CH4

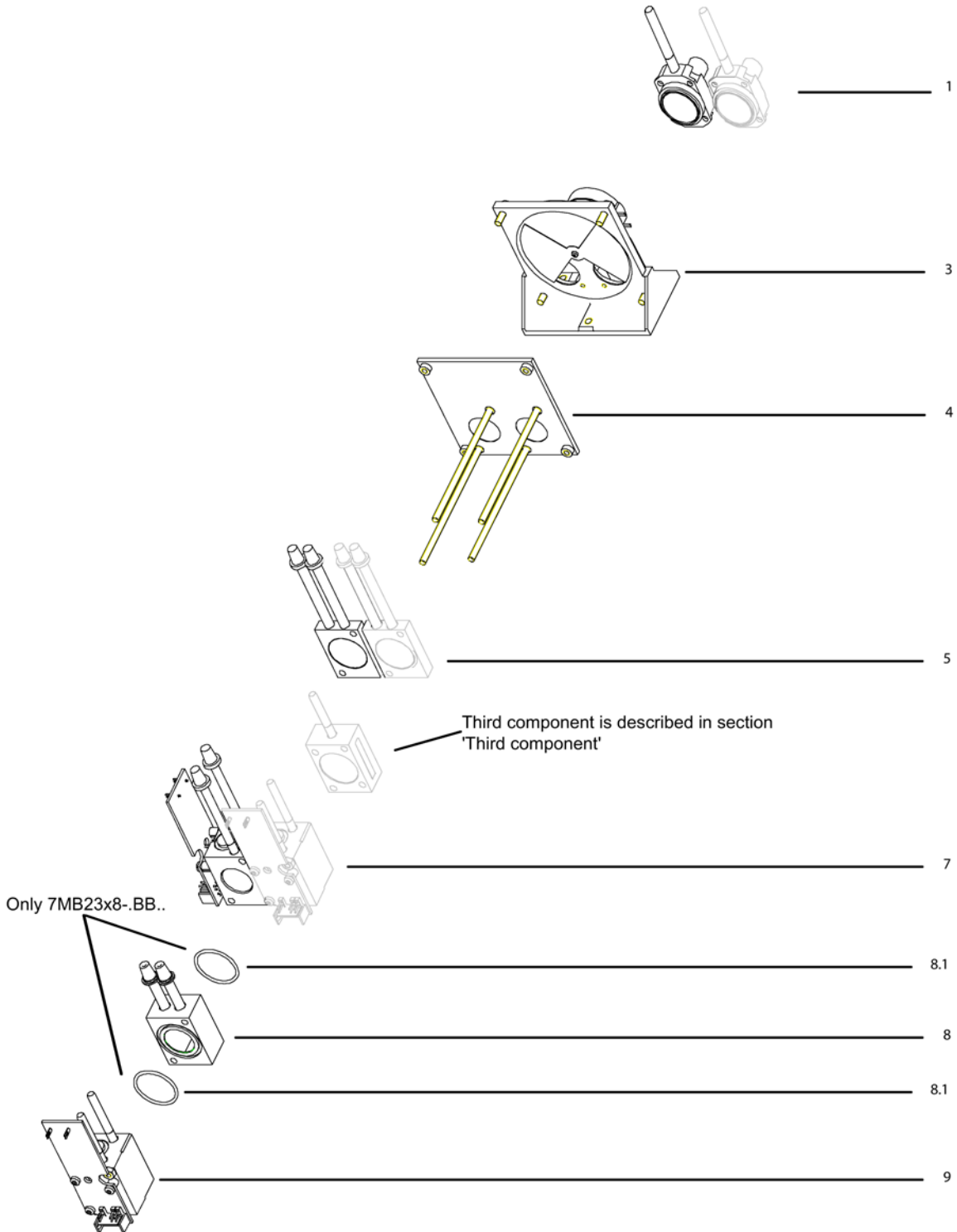

Figure 13-15 Analyzer unit 7MB2338-, 7MB2358-.BB..-, .CA..-

7MB2338-, 7MB2358-.BB..-, -.CA..-

Part No.	Designation	Order No.	Remarks
1 *)	IR source	C79451-A3468-B206	
3 *)	Chopper	C79451-A3468-B516	
3 *)	Chopper	A5E35984159	Only variant -B06 'Cleaned for O ₂ '
4	Plate with threaded bolts and windows	C79451-A3468-B514	
4	Plate with threaded bolts and windows	CA5E35984162	Only variant -B06 'Cleaned for O ₂ '

7MB2338-, 7MB2358-.BB..-

Part No.	Designation	Order No.	Remarks
5	Analyzer chamber	C79451--A3468-B236	Analyzer chamber 2 mm
5	Analyzer chamber	A5E35982182	Analyzer chamber 2 mm; only variant -B06 'Cleaned for O ₂ '
7 *)	Receiver chamber	C79451-A3468-B532	For CO
7 *)	Receiver chamber	A5E35984327	For CO; only variant -B06 'Cleaned for O ₂ '
8.1	O-ring	C71121-Z100-A99	
8.1	O-ring	A5E35980590	Only variant -B06 'Cleaned for O ₂ '
8	Analyzer chamber	C79451-A3468-B234	Analyzer chamber 20 mm
8	Analyzer chamber	A5E35982170	Analyzer chamber 20 mm; only variant -B06 'Cleaned for O ₂ '
9 *)	Receiver chamber	C79451-A3468-B526	For CO ₂
9 *)	Receiver chamber	A5E35983146	For CO ₂ ; only variant -B06 'Cleaned for O ₂ '

7MB2338, 7MB2358-.CA..-

Part No.	Designation	Order No.	Remarks
5	Analyzer chamber	C79451-A3468-B235	Analyzer chamber 6 mm
5	Analyzer chamber	A5E35982178	Analyzer chamber 6 mm; only variant -B06 'Cleaned for O ₂ '
7 *)	Receiver chamber	C79451-A3468-B531	For CO ₂
7 *)	Receiver chamber	A5E35984315	For CO ₂ ; only variant -B06 'Cleaned for O ₂ '

Part No.	Designation	Order No.	Remarks
8	Analyzer chamber	C79451-A3468-B235	Analyzer chamber 6 mm
8	Analyzer chamber	A5E35982178	Analyzer chamber 6 mm; only variant -B06 'Cleaned for O ₂ '
9 *)	Receiver chamber	C79451-A3468-B527	For CH ₄
9 *)	Receiver chamber	A5E35983151	For CH ₄ ; only variant -B06 'Cleaned for O ₂ '

*) Following replacement of this part, special work is required which can only be carried out by qualified personnel trained for this task, for example temperature compensation, basic electronic adjustment etc.

13.5.4.6 .BJ., .BK., .BL.- for CO₂/CO

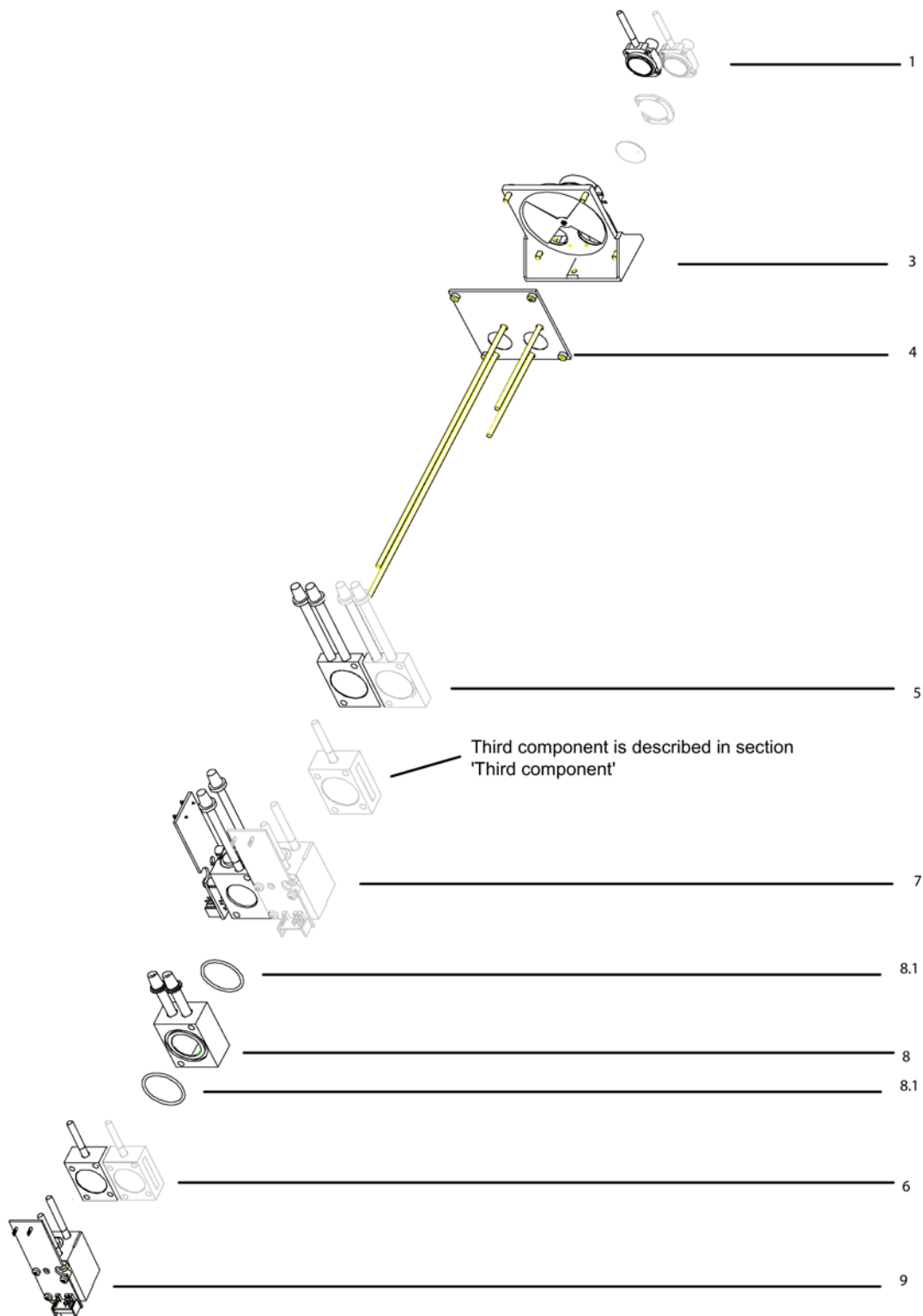

Figure 13-16 Analyzer unit 7MB2338-, 7MB2358-.BJ.-, -.BK.-, -.BL.-, analyzer unit 1 for CO₂/CO

7MB2338-, 7MB2358-.BJ.-, -.BK.-, -.BL.- for CO₂/CO

Part No.	Designation	Order No.	Remarks
1 *)	IR source	C79451--A3468-B206	
3 *)	Chopper	C79451-A3468-B516	
3 *)	Chopper	A5E35984159	Only variant -B06 'Cleaned for O ₂ '
4	Plate with threaded bolts and windows	C79451-A3468-B514	
4	Plate with threaded bolts and windows	CA5E35984162	Only variant -B06 'Cleaned for O ₂ '

7MB2338-, 7MB2358-.BK.-

Part No.	Designation	Order No.	Remarks
5	Analyzer chamber	C79451-A3468-B236	Analyzer chamber 2 mm
5	Analyzer chamber	A5E35982182	Analyzer chamber 2 mm; only variant -B06 'Cleaned for O ₂ '
7 *)	Receiver chamber	C79451-A3468-B531	For CO ₂
7 *)	Receiver chamber	A5E35984315	For CO ₂ ; only variant -B06 'Cleaned for O ₂ '
8.1	O-ring	C71121-Z100-A99	
8.1	O-ring	A5E35980590	Only variant -B06 'Cleaned for O ₂ '
8	Analyzer chamber with O-ring	C79451-A3468-B234	Analyzer chamber 20 mm
8	Analyzer chamber with O-ring	A5E35982170	Analyzer chamber 20 mm; only variant -B06 'Cleaned for O ₂ '
6	Gas filter	C79451-A3458-B500	For CO
6	Gas filter	A5E35983013	For CO; only variant -B06 'Cleaned for O ₂ '
9 *)	Receiver chamber	C79451-A3468-B528	For CO
9 *)	Receiver chamber	A5E35983122	For CO; only variant -B06 'Cleaned for O ₂ '

7MB2338, 7MB2358-.BJ.-, -.BL.-

Part No.	Designation	Order No.	Remarks
5	Analyzer chamber	C79451-A3468-B235	Analyzer chamber 6 mm
5	Analyzer chamber	A5E35982178	6 mm; only variant -B06 'Cleaned for O ₂ '

13.5 IR analyzer units

Part No.	Designation	Order No.	Remarks
7 *)	Receiver chamber	C79451-A3468-B531	For CO ₂
7 *)	Receiver chamber	A5E35984315	For CO ₂ ; only variant -B06 'Cleaned for O ₂ '
8.1	O-ring	C71121-Z100-A99	
8.1	O-ring	A5E35980590	Only variant -B06 'Cleaned for O ₂ '
8	Analyzer chamber with O-ring	C79451-A3468-B231	Analyzer chamber 180 mm
8	Analyzer chamber with O-ring	A5E35982142	180 mm; only variant -B06 'Cleaned for O ₂ '
6	Gas filter	C79451-A3458-B500	For CO
6	Gas filter	A5E35983013	For CO; only variant -B06 'Cleaned for O ₂ '
9 *)	Receiver chamber	C79451-A3468-B525	For CO
9 *)	Receiver chamber	A5E35983110	For CO; only variant -B06 'Cleaned for O ₂ '

*) Following replacement of this part, special work is required which can only be carried out by qualified personnel trained for this task, for example temperature compensation, basic electronic adjustment etc.

13.5.5 Analyzer unit 7MB2338-, 7MB2358- third component

The parts shown in light gray in the following diagram are examples of component 1.

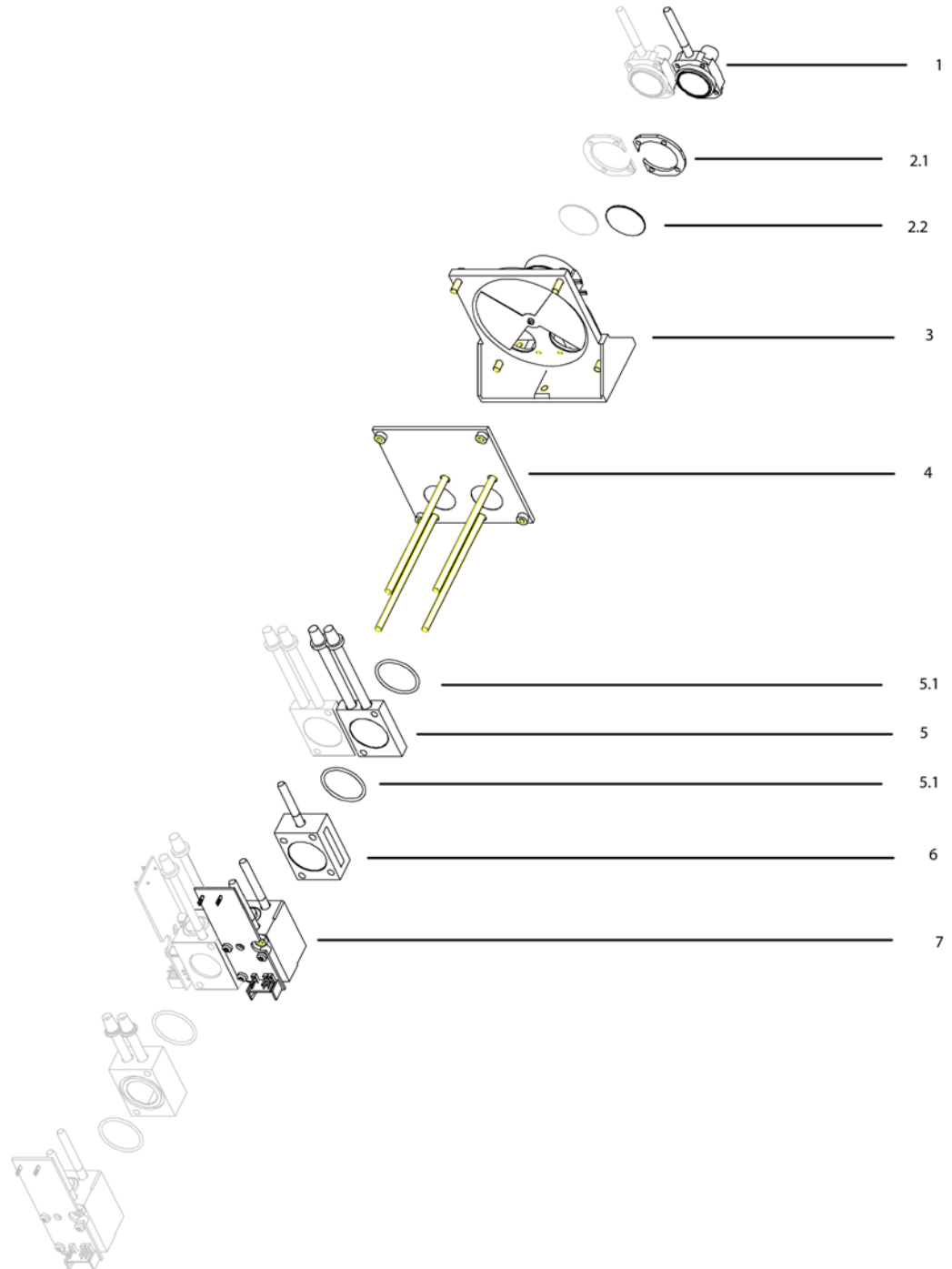

Figure 13-17 Analyzer unit 7MB2338-, 7MB2358-, analyzer unit 2 (third component)

13.5 IR analyzer units

Part No.	Designation	Order No.	Remarks
1 *)	IR source	C79451--A3468--B206	
2.1	Spacer	C79451--A3468--C20	
2.2	Optical filter	C75285--Z1491--C5	For NO **)
2.2	Optical filter	C79285--Z1302--A4	For SO ₂ **)
2.2	Optical filter	C79285--Z1491--C2	For C ₂ H ₄
2.2	Optical filter	A5E00069310	For C ₆ H ₁₄
2.2	Optical filter	C79451--A3182--C161	For SF ₆
3 *)	Chopper	C79451--A3468--B516	
4	Plate with threaded bolts and windows	C79451--A3468--B514	
5.1	O-ring	C71121--Z100--A99	
5	Analyzer chamber with O-ring	C79451--A3468--B231	180 mm
5	Analyzer chamber with O-ring	C79451--A3468--B232	90 mm
5	Analyzer chamber with O-ring	C79451--A3468--B233	60 mm
5	Analyzer chamber with O-ring	C79451--A3468--B234	20 mm
5	Analyzer chamber	C79451--A3468--B235	6 mm
5	Analyzer chamber	C79451--A3468--B236	2 mm
6	Gas filter	C79451--A3458--B500	For CO
6	Gas filter	C79451--A3458--B508	For SO ₂
6	Gas filter	C79451--A3468--B541	For CO ₂ ; smallest MR <5%
6	Gas filter	C79451--A3468--B542	For CH ₄ ; smallest MR <2%
6	Gas filter	C79451--A3468--B553	For C ₆ H ₁₄ , N ₂ O 500/5000 vpm
7.1/7.2 *)	Receiver chamber	C79451--A3468--B525	For CO; smallest MR <5%
7.1/7.2 *)	Receiver chamber	C79451--A3468--B528	For CO; smallest MR ≥5%
7.1/7.2 *)	Receiver chamber	C79451--A3468--B536	For CO ₂ ; smallest MR <1000 vpm
7.1/7.2 *)	Receiver chamber	C79451--A3468--B526	For CO ₂ ; smallest MR ≥1000 vpm
7.1/7.2 *)	Receiver chamber	C79451--A3468--B527	For CH ₄ ; smallest MR <20%
7.1/7.2 *)	Receiver chamber	C79451--A3468--B529	For CH ₄ ; smallest MR ≥20%
7.1/7.2 *)	Receiver chamber	C79451--A3468--B537	For C ₂ H ₄
7.2 *)	Receiver chamber	C79451--A3468--B522	For NO (channel 2)
7.1 *)	Receiver chamber	C79451--A3468--B523	For SO ₂ (channel 2)
7 *)	Receiver chamber	C79451--A3468--B581	For N ₂ O
7 *)	Receiver chamber	C79451--A3468--B539	For SF ₆
7 *)	Receiver chamber	C79451--A3468--B538	For C ₆ H ₁₄

*) Following replacement of this part, special work is required which can only be carried out by qualified personnel trained for this task, for example temperature compensation, basic electronic adjustment etc.

**) Following replacement of this part, the water vapor cross-sensitivity must be checked.

13.6 Sensors

Table 13- 1 Hydrogen sulfide sensors

Part No.	Designation	Order No.	Remarks
-	H ₂ S sensor	A5E03858060	Measuring range 0 ... 50 ppm
-	H ₂ S sensor	A5E35984634	Measuring range 0 ... 50 ppm; for variant -B06 'Cleaned for O ₂ '

Table 13- 2 Paramagnetic oxygen sensor

Part No.	Designation	Order No.	Remarks
-	Paramagnetic oxygen sensor	A5E03347537	
-	Paramagnetic oxygen sensor	A5E35984641	For variant -B06 'Cleaned for O ₂ '
-	Preamplifier board	A5E03347540	

Table 13- 3 Electrochemical oxygen sensor

Part No.	Designation	Order No.	Remarks
-	Electrochemical oxygen sensor	C79451--A3458--B55	
-	Electrochemical oxygen sensor	A5E35951900	For variant -B06 'Cleaned for O ₂ '

13.7 Comparison of spare part Order Nos. U23 and U23 analyzer version -B06 'Cleaned for O2'

The following table shows a comparison between all spare parts for the variant -B06 (Cleaned for O2) and the corresponding parts in the other variants.

Part No. (Section)	Designation	Order no. -B06 'Cleaned for O ₂ '	Order no. for all other variants
9 (13.2)	Pressure switch	A5E37371678	C79302-Z1210-A2
11 (13.2)	Flowmeter	A5E35980458	C79402-Z560-T1
16 (13.2)	Connecting socket	A5E36448926	A5E36448145
8.1 (13.4)	Sample gas pump 50 Hz	A5E35980470	C79451-A3494-B10
8.2 (13.4)	Sample gas pump 60 Hz	A5E35980528	C79451-A3494-B11
8.3 (13.4)	Sealing set	A5E35980531	C79402-Z666-E20
3 (13.5.n)	Chopper	A5E35980538	C79451-A3468-B515
3 (13.5.n)	Chopper	A5E35984159	C79451-A3468-B516
4 (13.5.n)	Plate with threaded bolts and windows	A5E35980542	C79451-A3468-B513
4 (13.5.n)	Plate with threaded bolts and windows	A5E35984162	C79451-A3468-B514
	Optical filter with filter support	A5E35984319	A5E00502911
5.1 (13.5.n) 8.1 (13.5.n)	O-ring	A5E35980590	C71121-Z100-A99
5/8 (13.5.n)	Analyzer chamber with O-ring 180 mm	A5E35982142	C79451-A3468-B231
5/8 (13.5.n)	Analyzer chamber with O-ring 90 mm	A5E35982156	C79451-A3468-B232
5/8 (13.5.n)	Analyzer chamber with O-ring 60 mm	A5E35982163	C79451-A3468-B233
5/8 (13.5.n)	Analyzer chamber with O-ring 20 mm	A5E35982170	C79451-A3468-B234
5/8 (13.5.n)	Analyzer chamber with O-ring 6 mm	A5E35982178	C79451-A3468-B235
5/8 (13.5.n)	Analyzer chamber with O-ring 2 mm	A5E35982182	C79451-A3468-B236
6 (13.5.n)	Gas filter	A5E35983013	C79451-A3468-B500
6 (13.5.n)	Gas filter	A5E35983026	C79451-A3468-B508
6 (13.5.n)	Gas filter	A5E35983032	C79451-A3468-B541
6 (13.5.n)	Gas filter	A5E35983036	C79451-A3468-B542
6 (13.5.n)	Gas filter	A5E35983044	C79451-A3468-B553

13.7 Comparison of spare part Order Nos. U23 and U23 analyzer version -B06 'Cleaned for O₂'

Part No. (Section)	Designation	Order no. -B06 'Cleaned for O ₂ '	Order no. for all other variants
7/9 (13.5.n)	Receiver chamber	A5E35983178	C79451-A3468-B520
7/9 (13.5.n)	Receiver chamber	A5E35983183	C79451-A3468-B521
7/9 (13.5.n)	Receiver chamber	A5E35984186	C79451-A3468-B522
7/9 (13.5.n)	Receiver chamber	A5E35984197	C79451-A3468-B523
7/9 (13.5.n)	Receiver chamber	A5E35983110	C79451-A3468-B525
7/9 (13.5.n)	Receiver chamber	A5E35983146	C79451-A3468-B526
7/9 (13.5.n)	Receiver chamber	A5E35983151	C79451-A3468-B527
7/9 (13.5.n)	Receiver chamber	A5E35983122	C79451-A3468-B528
7/9 (13.5.n)	Receiver chamber	A5E35983152	C79451-A3468-B529
7/9 (13.5.n)	Receiver chamber	A5E35984307	C79451-A3468-B530
7/9 (13.5.n)	Receiver chamber	A5E35984315	C79451-A3468-B531
7/9 (13.5.n)	Receiver chamber	A5E35984327	C79451-A3468-B532
7/9 (13.5.n)	Receiver chamber	A5E35983141	C79451-A3468-B536
7/9 (13.5.n)	Receiver chamber	A5E35983172	C79451-A3468-B537
7/9 (13.5.n)	Receiver chamber	A5E35983203	C79451-A3468-B538
7/9 (13.5.n)	Receiver chamber	A5E35983196	C79451-A3468-B539
7/9 (13.5.n)	Receiver chamber	A5E35983192	C79451-A3468-B581
-	H ₂ S sensor, measuring range 0 ... 50 ppm	A5E35984634	A5E03858060
-	Paramagnetic oxygen sensor	A5E35984641	A5E03347537
-	Electrochemical oxygen sensor	A5E35951900	C79451-A3458-B55

Appendix

A.1 Service and support

Technical support is available on the Internet at: Services & Support
<http://www.siemens.com/automation/service&support>

Your regional Siemens representative can be found here: Contact partner
<http://www.automation.siemens.com/mcms/aspa-db/en/automation-technology/Pages/default.aspx//XmlEditor.InternalXmlClipboard:2b8c9950-1d49-ffc1-5ad9-f7f0b769b59f>

A.2 Approvals

CE	EN 61000-6-2, EN 61000-6-4 (replaces EN 50081-2)
ATEX	Zone 2 II 3G Ex ec ic nC IIC T4 Gc
IECEX	Ex ec ic nC IIC T4 Gc
Class/Div	Class I, Div. 2, Gps ABCD, T4 Class I, Zone 2 Ex nA ic nC II T4Gc
Suitability tests	13. BlmSchV TA Luft QAL 1 EN 15267 (MLFB 7MB235x)

A.3 Pressure conversion table

hPa	kPa	MPa	mbar	bar	psi
1	0.1	0.0001	1	0.001	0.0145
10	1	0.001	10	0.01	0.145
69	6.9	0.0069	69	0.069	1
1000	100	0,1	1000	1	14.49
10000	1000	1	10000	10	144.93

A.4 Returned delivery

Note

Return delivery of contaminated device components

Device components which have come into contact with radioactive gases or substances, or have been exposed to radioactive or high-energy radiation, may no longer be returned.

The owner of the device must ensure in such cases that the contaminated device components are disposed of correctly in accordance with the local directives at the location of use.

The gas analyzer or replacement parts should be returned in their original packaging. If the original packaging is no longer available, we recommend that you wrap the device in plastic foil and pack it with shock-absorbing material (wood shavings, cellular rubber, or similar material) in a sufficiently large box. If you use wood shavings, the stuffed layer on each side should be at least 15 cm thick.

For overseas shipping, shrink-wrap the devices in an additional PE foil which is at least 0.2 mm thick, with a desiccant (e.g. silica gel) enclosed. For this type of shipping, you must also line the inside of the transport container with a double layer of tar paper.

If you return your device for repair, enclose the filled-in decontamination declaration as well as the filled-in fault description. In the case of guarantee claim, please enclose your guarantee card.

Decontamination declaration

With this declaration you confirm "that the device/spare part has been thoroughly cleaned, is free of residues, and that the device/spare part represents no danger for mankind and environment."

If the returned device/spare part has come into contact with poisonous, corrosive, flammable or polluting substances, you must thoroughly rinse, clean and neutralize the device/spare part before returning it, in order to ensure that all hollow areas are free of hazardous substances. Check the item after it has been cleaned.

SIEMENS will return devices or spare parts to you at your expense if a decontamination declaration is not included.

SIEMENS will only service returned products or spare parts if this decontamination declaration is enclosed which confirms that the products or spare parts have been correctly decontaminated and are therefore safe to handle. The decontamination declaration must be visibly attached to the outside of the packaging in a firmly secured transparent document bag.

You can find an empty decontamination declaration form in section Decontamination declaration (Page 228).

A.4.1 Return address

For quick identification and elimination of causes of error, we ask you to return the devices. The return address responsible for your location can be found here:

Return address (<http://www.automation.siemens.com/mcms/aspa-db/en/automation-technology/Pages/default.aspx>)

A.4.2 Error Description

Customer name	
Administrator	
Delivery address	
Phone/ Fax/ E-mail:	
Return delivery address (if not the same address as above)	
Device name	
MLFB No.	
Serial number	
Description of returned part	
Fault indication	
Process data at measuring point	
Operating temperature	
Operating pressure	
Composition of sample gas	
Operating duration/ operating date	
Confirmation	It is confirmed that the returned part has not come into contact with highly toxic or radioactive gases or substances, or been exposed to radioactive or high-energy radiation.
Company, department	
Last name, first name	
Location:	
Date:	Signature:

Software update () yes () no

A.4.3 Decontamination declaration

To protect our employers, equipment and the environment it must be guaranteed that the returned device is completely free of residues of the measured medium.

Therefore we check that a decontamination declaration has been provided before we unpack the device.

Please attach a transparent plastic envelope to the outside of the packaging with the completely filled-in and signed decontamination declaration as well as the shipping documents.

SIEMENS

PD PA AP

Dekontaminations-Erklärung

SIEMENS wird nur solche Produkte oder Ersatzteile reparieren oder an diesen Service durchführen, deren Verpackung mit einer vollständig ausgefüllten und unterzeichneten Dekontaminierungserklärung versehen ist, die bestätigt, dass durch den Umgang mit den Produkten oder Ersatzteilen keine Gefahr für die Mitarbeiter oder die Umwelt verbunden ist.

Bitte die Dekontaminations-Erklärung inklusive Versandpapieren in einer Klarsichthülle **außen an die Verpackung** gut befestigt anbringen.

**Zollabfertigung:
bitte nicht entfernen!**

Das beiliegende Gerät/Ersatzteil:

Produkt/Ersatzteil Name:

Produkt/Ersatzteil Nr. oder MLFB:

Serial Nr.:

Produkt wurde als SIL (Safety Integrity Level) in einem Safety Instrument System benutzt
ja nein

Produkt/Ersatzteil wurde in/mit dem folgendem Medium betrieben:

Dieser Messtoff ist:

harmlos giftig brennbar ätzend wassergefährdend

sonstiges (bitte spezifizieren)

Wir haben:

alle Hohlräume des Gerätes auf Freiheit von diesen Stoffen geprüft/

alle Hohlräume des Gerätes gespült und neutralisiert

Wir bestätigen, dass das Gerät/Ersatzteil sorgfältig gereinigt wurde und frei von Rückständen ist.

Von dem Gerät/Ersatzteil geht keine Gefahr für Mensch und Umwelt aus.

Firma:

Adresse:

Abteilung:

Name:

Tel.-Nr.:

Fax Nr.:

Name:

Datum: Unterschrift:

Firmenstempel

Bitte außen an der Verpackung anbringen

SIEMENS

PD PA AP

Declaration of Decontamination

SIEMENS will only service returned products or spare parts if they are accompanied by this Declaration of Decontamination confirming that the products or spare parts have been properly decontaminated and are safe to handle.

The Declaration of Decontamination must be displayed **outside of the packing** in a well fastened clear document pouch.

**Customs:
please do not remove!**

The enclosed product/spare part:

Product/spare part name:

Product/spare part Nr. or MLFB:

Serial Nr.:

Product/spare part used as a SIL (Safety Integrity Level) in a Safety Instrument System
yes no

Product/spare part operated with liquid/medium:

medium/liquid is:

- harmless toxic flammable corrosive harmful
- other (please specify)

We have:

- checked that all cavities in the product/spare are free from such substances
- flushed out and neutralized all cavities in the device

We hereby certify that the returned products/spare parts have been carefully cleaned and are free from any residues.

They are therefore not harmful to health and environment.

Company: Address:

Department: Name:

Tel. No.: Fax No.:

Name:

Date: Signature:

company stamp

Please attach outside the packaging

B

ESD directives

B.1 ESD guidelines

Definition of ESD

All electronic modules are equipped with large-scale integrated ICs or components. Due to their design, these electronic elements are highly sensitive to overvoltage, and thus to any electrostatic discharge.

The electrostatic sensitive components/modules are commonly referred to as ESD devices. This is also the international abbreviation for such devices.

ESD modules are identified by the following symbol:



NOTICE

ESD devices can be destroyed by voltages well below the threshold of human perception. These static voltages develop when you touch a component or electrical connection of a device without having drained the static charges present on your body. The electrostatic discharge current may lead to latent failure of a module, that is, this damage may not be significant immediately, but in operation may cause malfunction.

Electrostatic charging

Anyone who is not connected to the electrical potential of their surroundings can be electrostatically charged.

The figure below shows the maximum electrostatic voltage which may build up on a person coming into contact with the materials indicated. These values correspond to IEC 801-2 specifications.

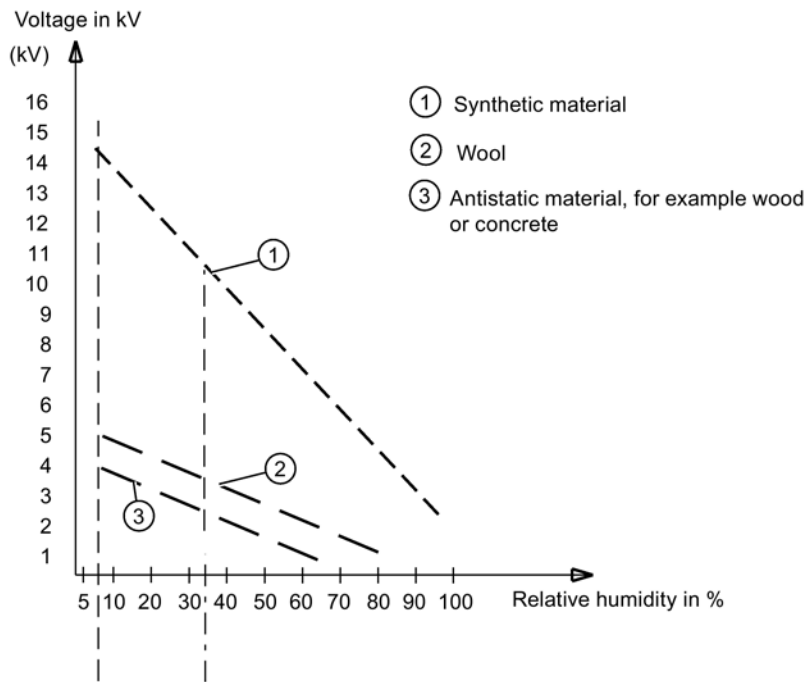

Figure B-1 Electrostatic voltages on an operator

Basic protective measures against electrostatic discharge

- Ensure good equipotential bonding:
When handling electrostatic sensitive devices, ensure that your body, the workplace and packaging are grounded. This prevents electrostatic charge.
- Avoid direct contact:
As a general rule, only touch electrostatic sensitive devices when this is unavoidable (e.g. during maintenance work). Handle the modules without touching any chip pins or PCB traces. In this way, the discharged energy can not affect the sensitive devices.

Discharge your body before you start taking any measurements on a module. Do so by touching grounded metallic parts. Always use grounded measuring instruments.

List of abbreviations

C.1 List of abbreviations

Table C- 1

Abbreviation/symbol	Description
<	Smaller than
>	Greater than
=	Equal to
≤	Smaller than or equal to
≥	Greater than or equal to
≐	corresponds to
≈	Approximately
±	Plus/minus
%	percent; 100th part of whole
vol. %	Volume percent
"	1 inch ≐ 25.4 mm)
°C	Degrees centigrade (1 °C ≐ 1.8 °F)
°F	Degrees Fahrenheit (1 °F ≐ 0.555 °C)
A	A mpere
sec.	Section
AC	A lternate C urrent
ADC	A nalog to D igital C onverter
Ar	A rgon, a noble gas
AR	A utoranging
ATEX	A tmosphère e xplosible (French for explosive atmosphere)
AUTOCAL	Automatic calibration function, derived from A UTOMATIC C ALIBRATION
Bit	b inary digit
BImSchV	B undesimmissionsschutzverordnung (Federal German Emission Protection Directive)
ca.	approx.
CaF ₂	CaF ₂ = calcium fluoride
CD	C ompact D isk, a storage medium
CE	C ommunauté E uropéenne (French for European Community)
CH ₄	CH ₄ = methane
C ₂ H ₄	C ₂ H ₄ = ethene, ethylene
C ₆ H ₁₄	C ₆ H ₁₄ = hexane
CO	CO = carbon monoxide
CS ₂	CO ₂ = carbon dioxide

List of abbreviations

C.1 List of abbreviations

Abbreviation/symbol	Description
COM	common
CSA	Canadian Standards Association , a technical testing organization
DC	Direct Current
DD	Device Description
i.e.	In other words
DIN	Deutsches Institut für Normung e. V. (German standards association)
Div.	Division
DP	Distributed Periphery , a PROFIBUS component
D-Sub	D-shaped Subminiature connector
EEPROM	Electrically Erasable Programmable Read Only Memory
EC	European Community
EU	European Union
ELAN	Economic Local Area Network , a data network
EMC	Electro Magnetic Compatibility
EN	Europäische Norm (European standard)
EPDM	Ethylene Propylene Diene Monomer , a plastic
ESD	Electrostatic Discharge
Serial No.	Serial Number
ft	foot , measure of length; 1 ft \approx 30.48 cm
FKM	Fluorinated rubber , a plastics group
FPM	Fluorinated Polymer rubber , a plastic, tradename e.g. Viton
GND	Ground
GSD	Generic Station Description
H ₂	H ₂ = hydrogen
H ₂ S	H ₂ S = hydrogen sulfide
H ₂ SO ₄	H ₂ SO ₄ = sulfuric acid
H ₂ O	H ₂ O = water
HC	Hydrocarbons
HD-PE	Polyethylene of high density (HD = High density)
He	Helium
HU	Height Unit
hPa	hectopascal
Hz	Hertz
IEC	International Electrotechnical Commission
IEEE	Institute of Electrical and Electronics Engineers
OK	OK
IP	Internal Protection
IR	Infrared
ISO	International Standards Organization (from Greek: " isos "; in English "equal")
kg	Kilogram
kPa	Kilopascal
l	Liter

Abbreviation/symbol	Description
L	Live wire
lb, lbs.	pound(s), 1 lb. \triangleq 435.6 g
LCD	L iquid C rystal D isplay
LED	L ight E mitting D iode
m	M eter
m ³	Cubic meter
max.	M aximum
MR	M easuring R ange
MB = Mbit	10 ⁶ bit
mbar	M illibar, 1 mbar \triangleq 1 hPa
mg	M illigram
MHz	M egahertz
min	M inute(s)
MLFB	Machine-readable Order No. (German M aschinenlesbare F abrikate B ezeichnung)
mm	M illimeter
mm ²	Square millimeter
MPa	M egapascal
mA	M illiampere
mV	M illivolt
MV	Solenoid valve
MV	M easured V alue
N	N eutral (conductor)
N ₂	N ₂ = nitrogen
N ₂ O	N ₂ O = dinitrogen monoxide, common name laughing gas
nA	N anoampere
NAMUR	N ormen A rbeitsgemeinschaft für M ess- und R egeltechnik in der chemischen Industrie (standardization body for instrumentation and control technology in the chemical industry)
NBR	N itrile B utadiene R ubber, a plastic, common name e.g. Buna
NC	N ot C onnected
neg.	n egative
nF	N anofarad
NFPA	N ational F ire P rotection A ssociation, a non-profit fire protection organization in the USA
NH ₃	NH ₃ = ammonia
NO	NO = nitrogen monoxide
NO _x	Name for total nitrogen oxides
No.	N umber
O ₂	O ₂ = oxygen
or similar	or similar
PA	P rocess A alytics
PA	P olyamide, a plastic

Abbreviation/symbol	Description
PC	P ersonal C omputer, a stationary single-user computer
PCS	P rocess C ontrol S ystem
PDM	P rocess D evice M anager, software for operating devices
PE	P oly e thylene, a plastic
PE	P rotective E arth (conductor)
PI	P RO F IBUS I nternational
ppm	p arts p er m illion ($\triangleq 10^{-6}$)
PROFIBUS	P rocess F ield B us
psi	p ounds per s quare i nch; 1 psi \approx 69 hPa
PTB	P hysikalisch- T echnische B undesanstalt (German technical inspectorate)
PTFE	P oly t etra f luoro e thylene, a plastic, tradename e.g. Teflon
PVDF	P oly v inylidene f luoride, a plastic, tradename e.g. Kynar
QAL	Q uality A ssurance L evel
R22	Common name for chlorodifluoromethane, CHClF ₂
RAM	R andom A ccess M emory
rel.	r elative
RH	R elative H umidity
ROM	R ead O nly M emory
RS	R ecommended S tandard
RS 232	(also EIA-232) Identifies an interface standard for a sequential, serial data transmission
RS 485	(also EIA-485) Identifies an interface standard for a differential, serial data transmission
s	S econd(s)
s.	Refer to
SELV	S afety E xtra L ow V oltage
SF ₆	SF ₆ = sulfur hexafluoride
SIPROM GA	S iemens P rocess M aintenance for G as A nalyzers
SO ₂	SO ₂ = sulfur dioxide
SW	S oftware
t	t ime
T	T emperature
TA Luft	T echnical I nstructions on A ir Q uality C ontrol (Germany)
TCP/IP	T ransmission C ontrol P rotocol/ I nternet P rotocol; a reference model for Internet communication
TÜV	T echnischer Ü berwachungs v erein, German Technical Inspectorate
U	Symbol for electric voltage
LEL	L ower E xplosion L imit
USB	U niversal S erial B us
UV	U ltraviolet
V	V olt
V.	V ersion
VA	V olt a mpere

Abbreviation/symbol	Description
VDE	V erband d er E lektrotechnik, E lektronik und I nformationstechnik (German Association for Electrical, Electronic and Information Technologies)
VGA	V ideo G raphics A rray, a graphics card standard
vpb	v olume p arts p er b illion ($\triangleq 10^{-9}$ of a volume)
vpm	v olume parts p er m illion ($\triangleq 10^{-6}$ of a volume)
e.g.	F or e xample
μm	Micrometer
Ω	Ohm

Index

1

13th BImSchV, 225
17th BImSchV, 225

A

Access code, 97, 143
Add-on board
 Pin assignments, 55
Analog output
 Configuration, 135
 Device test, 152
 Fault, 137
 Function control, 136
 Start-of-scale value, 135
Analyzers for operation in hazardous areas
 Safety instructions, 79
Approvals, 225
Area of application, 19
Areas of application, 20
ATEX, 79, 225
AUTOCAL
 Commissioning, 82
 Deviation, 105, 144
 Warm-up phase, 82
AUTOCAL deviation, 105

B

Bench-top unit
 Connection diagrams, 52, 52
 Dimensions, 57
 Disposal, 182
 Gas flow diagram, 44
 Maintenance work, 170
 Power connection, 75
Binary inputs, 141
Biogas measurement
 Safety instructions, 17, 80

C

CAL, 101

Calibration
 Electrochemical oxygen sensor, 114
 H₂S sensor, 118
 IR measuring ranges, 112
 Paramagnetic oxygen sensor, 117
 Pressure sensor, 121
Calibration functions, 111
Certificates, 67
Change units, 150
Chopper section purging, 72
Class/Div, 225
Cleaning, 167
 Device, 167
 Enclosure, 167
Coarse filter, 170
Code, 97
Code level, 97, 143
Commissioning
 Checklist, 82
 Initial calibration, 83
 Preparations, 81
Communication interface
 ELAN, 60
 PROFIBUS-DP/PA, 57
 SIPROM GA, 61
Configuration, 132
 Access code, 143
 Assign relays, 138
 AUTOCAL deviation, 144
 Binary inputs, 141
 Change units, 150
 Cross-interference, 149
 Device test: Analog outputs,
 ELAN, (Correction of cross-interference)
 ELAN parameters, 145
 Factory configuration, 155
 Inputs, outputs, (Analog outputs)
 Load factory data, 149
 Operating language, 143
 PROFIBUS parameters, 148
 Reset, 150
 Sync input, 141
Connection
 Bench-top unit, 52
 Pin assignments, 54
 Rack unit, 53
Connection diagrams, 52
Correct usage, (See improper device modifications)

Correction of cross-interference, 145
 ELAN, 145
CSA, 76, 79

D

Decontamination declaration, 226, 228
Delivery, 14
Design, 22
Device test
 Analog outputs, 152
 Chopper, 154
 Display, 152
 Flow switch, 152
 Inputs, 152
 IR source, 154
 Keyboard, 152
 Outputs, 152
 RAM monitor, 151
 Test of display, 152
Diagnostics functions, 103
Diagnostics values, 107
 ADC, 107
 Bridge voltage, 110
 Display temperature, 110
 Electrochemical oxygen sensor, 108
 Factory data, 110
 H₂S sensor, 109
 IR measured values, 108
 IR measuring ranges, 107
 IR raw values, 108
 Output current, 110
 Paramagnetic oxygen sensor, 108
 Reference voltage, 110
 Source voltage, 109
 Supply voltage, 109
 V-ADUt, 107, 107
Dimensions, 56
Display, 24, 24, 92, 92
Display field, 92
 Contrast, 131
Disposal, 226
 Bench-top unit, 182
 Electrochemical oxygen sensor, 182
 H₂S sensor, 183
 Rack unit, 182

E

ELAN
 Correction of cross-interference, 145

 Interface, 60
 Operating principle, 60
 Parameters, 145
Electrical connections
 Power connection, 74
 Signal connections, 73
Electrochemical oxygen measurement
 Disposal of sensor, 182
 Measuring ranges, 38
 Operating principle, 27
 Replacing the sensor, 171
 Technical specifications, 38
Electrochemical oxygen sensor
 Calibration, 114
 Diagnostics values, 108
 Disposal, 182
 Replacing, 171
 Spare part, 221
Enclosure
 Cleaning, 167
Error messages, 177
 Fault, 178
ESC, 101
ESD guidelines, 231
Ex area
 Connecting, 79
 CSA Class I Div. 2, (Safety bracket)
External solenoid valves, 140

F

Factory configuration, 155
Factory data
 Diagnostics values, 110
Fault, 104, 178
 Analog output, 137
 Display, 92
Fine safety filter, 169
Function
 H₂S sensor protection, 156
 Purging function for H₂S sensor, 158
Function control
 Analog output, 136
 Display, 92
Functions
 Calibration functions, 111
 Configuration of binary inputs, 141
 Configuration of sync input, 141
 Diagnostics functions, 103

G

- Gas connections, 51, 71
- Gas cooler, 72
- Gas flow diagram, 43
- Gas inlets, 51
- Gas outlets, 51
- Gas path
 - Leak test, 81
 - Used materials, 34
- Gas preparation, 72, 81
- Gas pump, 72
- Gas sampling device, 72, 81
- Guidelines
 - ESD guidelines, 231

H

- H2S measurement
 - Safety instructions, 17, 80
- H2S sensor
 - Calibration, 118
 - Calibration functions, 112
 - Diagnostics values, 109
 - Disposal, 183
 - Location, 173
 - Probe protection, 129, 156
 - Protection function, 156
 - Purging function, 158
 - Replacing, 173
 - Sensor protection limits, 129
 - Spare part, 221
- H2S sensor status, 106
- Hazardous area
 - Laws and directives, 67
- Hydrogen sulfide measurement
 - Areas of application, 20
 - Disposal of sensor, 183
 - Measuring ranges, 42
 - Operating principle, 29
 - Probe protection, 156
 - Probe protection function, 92
 - Purging function, 158
 - Replacing the sensor, 173
 - Safety instructions, 17, 80
 - Technical specifications, 42
- Hydrogen sulfide sensor, (H2S sensor)
- Hysteresis, 127

I

- IECEEx, 225

- Improper device modifications, 15
- Infrared detector, 35
 - Technical specifications, 35
- Infrared measurement
 - Automatic calibration, 29
 - Operating principle, 26
- inlets
 - Gas, 51
- Inlets
 - Gas, 72
- Input keys, 94
 - Arrow keys, 94
 - CAL, 94, 101
 - ENTER, 94
 - ESC, 94, 101
 - MEAS, 94
 - PUMP, 94, 102, 170, 170
- Input menu, 93
- Input mode, 96
- Input sequence, 99
- Inputs, 25
 - SYNC, 84
 - Technical specifications, 32
- Interface
 - RS485, 60
- IR detector, 26
- IR measuring ranges
 - Calibration, 112
 - Diagnostics values, 107

K

- Key operations, 99
- Keys
 - CAL, 101
 - ESC, 101
 - PUMP, 102, 152

L

- Label, 11
- Language, 143
- Leak test, 81
- Limit messages, 139
- Limit violated
 - Display, 92
- Limits, 128
- List of abbreviations, 233
- Load factory data, 149
- Location, 63
- Logbook, 104

M

- Maintenance request, 105, 177
 - Display, 92
 - Display status, 105
- Maintenance work, 167
 - Bench-top unit, 170
- Master/slave operation, 84
- Measuring mode, 96, 96
- Measuring ranges
 - Electrochemical oxygen measurement, 38
 - Hydrogen sulfide measurement, 42
 - Hysteresis, 127
 - Paramagnetic oxygen measurement, 39
 - Possible combinations, 19
 - Setting, 126
 - Switching, 125
- Messages, 177
 - Maintenance request, 177
- Microflow sensor, 27
- Mounting, 63
 - Requirements, 63
 - Safety instructions, 63

N

- Noise suppression, 129

O

- O₂ sensor, (See oxygen sensor (electrochemical or paramagnetic))
- O₂ sensor status, 106
- Operating language, 143
- Operating modes, 94
- Operating principle, 26
 - ELAN interface, 60
 - PROFIBUS, 58
- Operation, 77, 89
 - Menu structure, 93
- Operator panel, 24, 92
- outlets
 - Gas, 51
- Output current
 - Diagnostics values, 110
- Outputs, 25
 - SYNC, 84
 - Technical specifications, 32

P

- Paramagnetic oxygen measurement
 - Areas of application, 20
 - Cross-sensitivities, 40
 - Operating principle, 28
 - Replacing the sensor, 176
 - Technical specifications, 39
- Paramagnetic oxygen sensor
 - Calibration, 117
 - Diagnostics values, 108
 - Replacing, 176
 - Spare part, 221
- Parameters, 124
 - Contrast, 131
 - H₂S sensor protection, 157
 - Limits, 128
 - Measuring ranges, 125
 - Pump capacity, 130
 - Purging function for H₂S sensor, 159
 - Time constants, 129
- Pin assignments, 54
 - Motherboard, 54
- Power connection, 75
- Pressure sensor, 72
 - Calibration, 121
- PROFIBUS
 - Parameters, 148
- PROFIBUS-DP/PA, 57
- Proper use, 12
- PUMP, 102, 152
- Pump capacity, 130
- Pump key, 102

Q

- Qualified personnel, 13

R

- Rack unit
 - Connection diagrams, 53
 - Dimensions, 56
- Receiver chamber, 26
- Relays
 - Configure, 138
- Relays for MR, 139
- Repair, 181, 226
- Replacing
 - Coarse filter, 170
 - Electrochemical oxygen sensor, 171
 - Fine safety filter, 169

- H2S sensor, 173
- Paramagnetic oxygen sensor, 176
- Spare parts, 168
- Reset, 150
- Returned delivery, 226
 - Decontamination declaration, 228
- RS485, 60

S

- Safety bracket, 76
- Safety extra-low voltage, 73
- Safety instructions
 - Analyzers in biogas plants, 17, 80
 - Biogas plants, 70
 - Connecting, 79
 - Ex analyzers, 79
 - General information, 15
 - Maintenance and servicing, 166
 - Mounting, 63
 - Signal connections, 73
- Sample gas
 - Conditioning, 72
 - Line, 72
- Sensors
 - Possible combinations, 19
- Service, 225
- Setting
 - Access code, 143
 - AUTOCAL deviation, 144
 - Contrast, 131
 - ELAN parameters, 145
 - Operating language, 143
 - PROFIBUS parameters, 148
 - Pump capacity, 130
- Shutting down, 181
- SIPROM GA, 61
 - Upgrades, 62
- Spare parts, 168
 - Electronics, 190
 - Gas path, 187
 - IR analyzer units, 193
 - Pump, 192
 - Sensors, 221
- Spare parts list, 185
- Status, 104
 - AUTOCAL deviation, 105
 - H2S sensor status, 106
 - Logbook/fault, 104
 - Maintenance request, 105
 - O2 sensor status, 106
- Status display, 92

- Status messages, 140
- Suitability tests, 225
- SYNC input, 84
- SYNC output, 84

T

- T90 time, (Time constants)
- TA Luft
 - EN 15267, 225
- Technical specifications, 31
 - Electrochemical oxygen measurement, 38
 - General information, 31
 - Hydrogen sulfide measurement, 42
 - Infrared detector, 35
 - Paramagnetic oxygen measurement, 39
- Technical support, 225
- Temperature compensation, 168
- Test certificates, 67
- Time constants, 129
- TÜV versions, 37

U

- User interface, 92, 93
- User prompting, 90

W

- Warm restart, 150
- Warm-up phase, 82, 95
 - AUTOCAL, 82
- Warranty, 14, 14

Z

- Zero gas
 - Line, 72

Get more information:

www.siemens.com/processanalytics

Siemens AG
Process Industries and Drives
Process Automation
Analytical Products
76181 Karlsruhe
Germany

Subject to change without prior notice
A5E37100388-003
© Siemens AG 2016



A5E37100388



A5E37100388

www.siemens.com/automation