

Overview



SITRANS LR260 is a 2-wire 25 GHz pulse radar level transmitter for continuous monitoring of solids and liquids in storage vessels including extreme levels of dust and high temperatures, to a range of 30 m (98.4 ft).

Benefits

- Graphical local user interface (LUI) makes operation simple with plug-and-play setup using the intuitive Quick Start Wizard
- LUI displays echo profiles for diagnostic support
- 25 GHz high frequency allows for small horn antennas mounted easily in nozzles
- Communication using HART or PROFIBUS PA
- Process Intelligence signal processing for improved measurement reliability and Auto False-Echo Suppression of fixed obstructions
- Programming using infrared Intrinsically Safe handheld programmer or SIMATIC PDM

Application

SITRANS LR260 includes a graphical local user interface (LUI) that improves setup and operation using an intuitive Quick Start Wizard, and echo profile displays for diagnostic support. Startup is easy using the Quick Start wizard with a few parameters required for basic operation.

SITRANS LR260's unique design allows safe and simple programming using the Intrinsically Safe handheld programmer without having to open the instrument's lid.

SITRANS LR260 measures virtually any solids material to a range of 30 m (98.4 ft).

- Key Applications: cement powder, plastic powder/pellets, grain, flour, coal, solids and liquids bulk storage vessels, and other applications

Configuration

Mounting on a nozzle

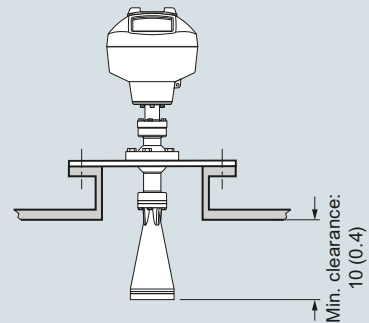

Installation

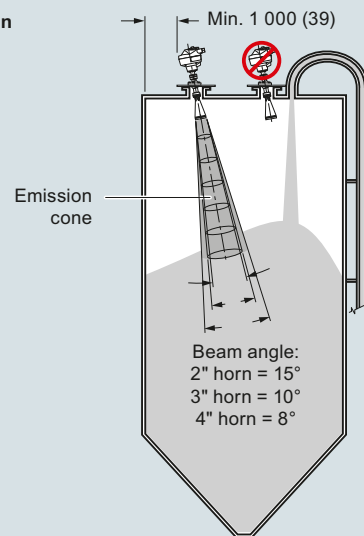

Positioning with easy Aimer

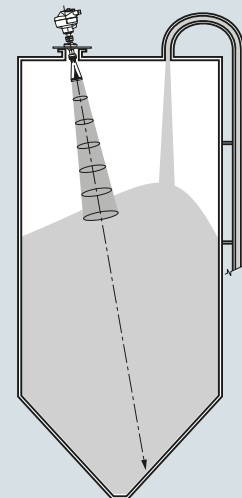

SITRANS LR260 installation, dimensions in mm (inch)

Level Measurement

Continuous level measurement
Radar transmitters

SITRANS LR260

Technical specifications

Mode of operation

Measuring principle	Pulse radar level measurement
Frequency	K-band (25.0 GHz)
Minimum detectable distance	0.05 m (2 inch) from end of horn
Maximum measuring range ¹⁾	
Solids	<ul style="list-style-type: none"> • 2" horn: 10 m (32.8 ft) • 3" horn: 20 m (65.6 ft) • 4" horn: 30 m (98.4 ft)
Liquids	<ul style="list-style-type: none"> • 2" horn: 20 m (65.6 ft) • 3" horn: 30 m (98.4 ft) • 4" horn: 30 m (98.4 ft)

Output - HART

Power	4 ... 20 mA (± 0.02 mA accuracy)
Fail signal	Nominal 24 V DC (max. 30 V DC)
Load	3.6 mA ... 23 mA; or last value 230 ... 600 Ω

Output - PROFIBUS PA

- Per IEC 61158-2
- 15.0 mA
- Profile version 3.01, Class B

Performance (according to reference conditions IEC60770-1)

Maximum measured error (including hysteresis and non-repeatability)	<ul style="list-style-type: none"> • 25 mm (1 inch) from minimum detectable distance to 300 mm (11.8 inch) • Remainder of range = 6 mm (0.23 inch) or 0.05 % of spa (whichever is greater)
---	--

Rated operating conditions

Installation conditions	
Location	Indoor/outdoor
Ambient conditions (enclosure)	
• Ambient temperature	-40 ... +80 °C (-40 ... +176 °F)
• Installation category	I
• Pollution degree	4

Medium conditions

Dielectric constant ϵ_r	$\epsilon_r > 1.6$, antenna and application dependent
Process temperature	-40 ... +200 °C (-40 ... +392 °F)
Process pressure	<ul style="list-style-type: none"> • 0.5 bar g (7.25 psi g) maximum • 3 bar g (43.5 psi g) optional with 80 °C (176 °F) temperature max

Design

Enclosure	
• Construction	Aluminum, polyester powder-coated
• Conduit entry	2 x M20 x 1.5 or 2 x 1/2" NPT
Degree of protection	Type 4X/NEMA 4X, Type 6/ NEMA 6, IP67, IP68
Weight	< 8.14 kg (17.9 lb) including 4" flange and standard Easy Aimer with 4" horn antenna
Display (local)	Graphic LCD, with bar graph representing level
Flange and horn (easy aimer model)	
• Material	304 stainless steel
• Horn antenna	2" horn 3" horn 4" horn
Process connections	
• Universal flanges ²⁾	2 inch/50 mm, 3 inch/80 mm, 4 inch/100 mm, 6 inch/150 mm
Mechanical (Threaded Connection model)	
• Threaded connection	2" NPT (ASME B1.20.1), R (BSPT, EN 10226-1), or G (BSPP, EN ISO 228-1) 316L/1.4404 or 316L/1.4435 stainless steel PTFE emitter
• Materials	
Certificates and approvals	
General	CSA _{US/C} , CE, FM
Radio	Europe (RED), FCC, Industry Canada, RCM
Hazardous	CSA/FM Class II, Div. 1, Groups E, F, G, Class III ATEX II 1D, 1/2D, 2D Ex ta IIIC T100 °C Da IECEX/ATEX II 1 GD Ex ia IIC T4 Ga, Ex ta IIIC T100 °C Da CSA/FM Class I, II, III, Div. 1, Groups A, B, C, D, E, F, G SABS ARP0108 Ex ia IIC T4 Ga
Programming	
Intrinsically Safe Siemens handheld programmer	Infrared receiver
• Approvals for handheld programmer	IS model: ATEX II 1GD Ex ia IIC T4 GaEx iaD 20 T135 °C Ta = -20 ... +50 °C CSA/FM Class I, II, and III, Div. 1, Groups A, B, C, D, E, F, G, T6 Ta = 50 °C
Handheld communicator	HART communicator 375
PC	SIMATIC PDM
Display (local)	Graphic local user interface including quick start wizard and echo profile displays

¹⁾ From sensor reference point

²⁾ Universal flange mates with EN 1092-1 (PN 16)/ASME B16.5 (150 lb)/JIS 2220 (10K) bolt hole pattern

Selection and Ordering data	Article No.	Selection and Ordering data	Order code
<p>SITRANS LR260 2-wire, 25 GHz pulse radar level transmitter for continuous monitoring of solids to a range of 30 m (98.4 ft).</p> <p>Order handheld programmer separately Click on the Article No. for the online configuration in the PIA Life Cycle Portal.</p> <p>Process connection Universal flat faced flange fits ANSI/DIN/JIS flanges, Easy Aimer with integral (Easy Aimer ball) 2 inch/50 mm 3 inch/80 mm 4 inch/100 mm 6 inch/150 mm Threaded connection 2" NPT (ASME B1.20.1) (tapered thread)¹⁾²⁾⁵⁾ R 2" [(BSPT), EN 10226-1] (tapered thread)¹⁾²⁾⁵⁾ G 2" [(BSPT), EN ISO 228-1] (parallel thread)¹⁾²⁾⁵⁾ For custom process connections, contact a local sales person. For more information, please visit http://www.usa.siemens.com/level.</p> <p>Antenna 2" Horn antenna, fits 50 mm or 2" nozzles¹⁾ 2" Horn antenna with 100 mm extension¹⁾ 2" Horn antenna with 200 mm extension¹⁾ 2" Horn antenna with 500 mm extension¹⁾²⁾ 2" Horn antenna with 1 000 mm extension¹⁾²⁾ 3" Horn antenna, fits 80 mm or 3" nozzles³⁾ 3" Horn antenna with 100 mm extension³⁾ 3" Horn antenna with 200 mm extension³⁾ 3" Horn antenna with 500 mm extension²⁾³⁾ 3" Horn antenna with 1 000 mm extension²⁾³⁾ 4" Horn antenna, fits 100 mm or 4" nozzles 4" Horn antenna with 100 mm extension 4" Horn antenna with 200 mm extension 4" Horn antenna with 500 mm extension²⁾ 4" Horn antenna with 1 000 mm extension²⁾ For custom antennas, contact a local sales person. For more information, please visit http://www.usa.siemens.com/level.</p> <p>Purge (self cleaning) connection No purge connection Purge connection</p> <p>Output/communication 4 ... 20 mA, HART PROFIBUS PA</p> <p>Cable inlet 2 x M20 x 1.5 2 x 1/2" NPT Note: Polymeric cable glands will be provided with M20 devices.</p> <p>Approvals General purpose, CSA_{US/C}, FM, Industry Canada, FCC, CE, RED, RCM CSA/FM Class II, Div. 1, Groups E, F, G, Class III, Industry Canada, FCC, RCM ATEX II 1D, 1/2D, 2D Ex ta IIIC T100 °C Da, CE, RED, RCM, INMETRO Non-incendive, CSA/FM Class I, Div. 2, Groups A, B, C, D, Industry Canada, FCC, RCM Intrinsically safe, IECEx/ATEX II 1 GD Ex ia IIC T4 Ga, Ex ta IIIC T100 °C Da, RED, RCM Intrinsically safe, CSA/FM Class I, II, III, Div. 1, Groups A, B, C, D, E, F, G, Industry Canada, FCC, RCM Intrinsically safe, South Africa ARP0108 Ex ia IIC T4 Ga</p> <p>Pressure rating Rating per Pressure/Temperature curves in manual⁶⁾ 0.5 bar g (7.25 psi g) maximum</p>	<p>7ML5427-0000</p> <p>A B C D E F G Z</p> <p>A B C D E F G H J K L M N P Q Z</p> <p>0 1</p> <p>0 1</p> <p>A B</p> <p>A B C D E F G</p> <p>0 1</p>	<p>Further designs Please add "-Z" to Article No. and specify Order code(s). Stainless steel tag [69 x 50 mm (2.71 x 1.97 inch)]: Measuring-point number/identification (max. 27 characters); specify in plain text Manufacturer's test certificate: M to DIN 55350, Part 18 and to ISO 9000 Material inspection Certificate Type 3.1 per EN 10204⁴⁾</p> <p>Operating Instructions All literature is available to download for free, in a range of languages, at http://www.siemens.com/processinstrumentation/documentation</p> <p>Accessories One metallic cable gland M20 x 1.5, rated -40 ... +80 °C (-40 ... +176 °F), HART One metallic cable gland M20 x 1.5, rated -40 ... +80 °C (-40 ... +176 °F), PROFIBUS PA Handheld programmer, Infrared, Intrinsically Safe Dust cap, PTFE, for 2 inch/50 mm horn Dust cap, PTFE, for 3 inch/75 mm horn Dust cap, PTFE, for 4 inch/100 mm horn HART modem/USB (for use with a PC and SIMATIC PDM) SITRANS RD100, loop powered display - see Chapter 7 SITRANS RD200, universal input display with Modbus conversion - see Chapter 7 SITRANS RD300, dual line display with totalizer and linearization curve and Modbus conversion - see Chapter 7 SITRANS RD500 web, universal remote monitoring solution for instrumentation - see Chapter 7 For applicable back up point level switch - see point level measurement section Note: Products shipped with plastic cable gland, rated to -20 °C. If -40 °C rating required, then metallic cable gland is recommended.</p> <p>1) Maximum measurement range 10 m (32.8 ft) solids or 20 m (65.6 ft) liquids 2) Available with Purge option 0 only 3) Maximum measurement range 20 m (65.6 ft) solids or 30 m (98.4 ft) liquids 4) Available with Pressure option 0 only 5) Available with Antenna options A, B, F, G, L, and M only 6) Available with Pressure option 0 only</p>	<p>Y15 C11 C12</p> <p>Article No. 7ML1930-1AP 7ML1930-1AQ 7ML1930-1BK 7ML1930-1DE 7ML1930-1BL 7ML1930-1BM 7MF4997-1DB 7ML5741-... 7ML5740-... 7ML5744-... 7ML5750-...</p>

Level Measurement

Continuous level measurement

Radar transmitters

SITRANS LR260

Characteristic curves

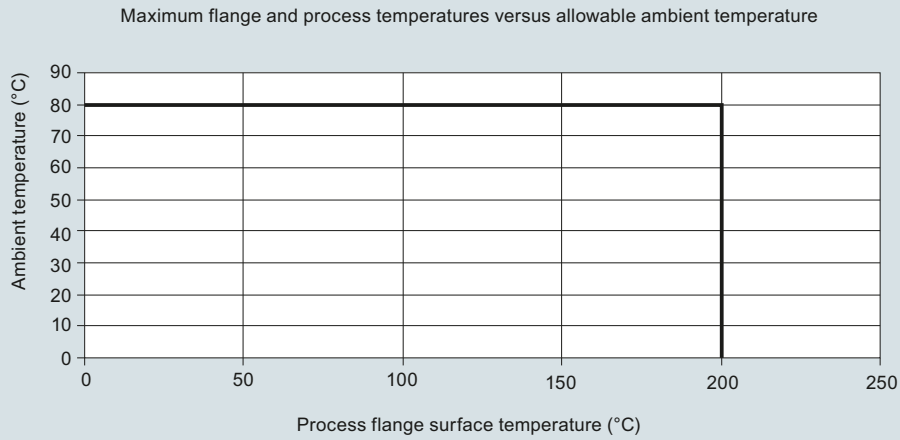

SITRANS LR260 ambient/process flange surface temperature curve

Dimensional drawings

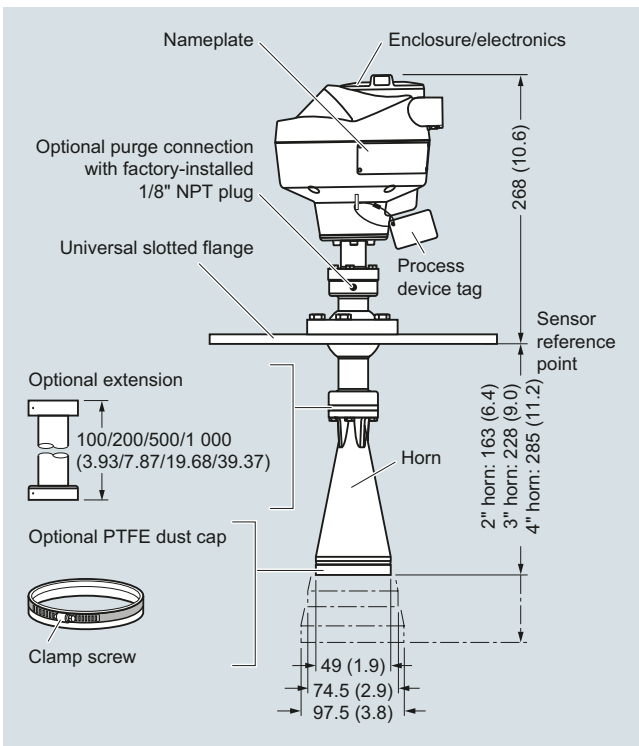

SITRANS LR260, dimensions in mm (inch)

SITRANS LR260

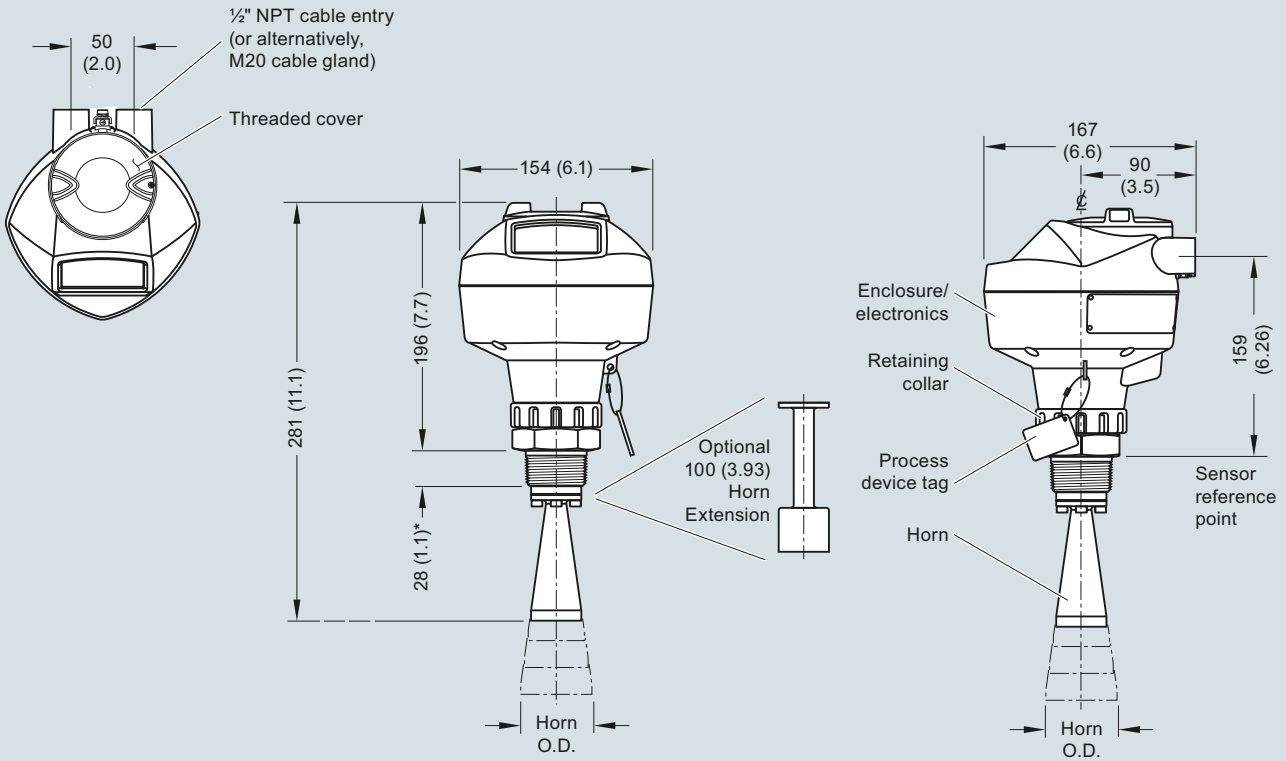

Antenna Type	Antenna O.D.	Height to sensor reference point			Beam angle	Measurement range
		1-1/2" threaded connection	2" threaded connection	3" threaded connection		
2" horn	47.8 (1.88)	N/A	166 (6.55)	180 (7.09)	15 degrees	20 m (65.6 ft)
3" horn	74.8 (2.94)	N/A	199 (7.85)	213 (8.39)	10 degrees	30 m (98.4 ft)
4" horn	94.8 (3.73)	N/A	254 (10)	268 (10.55)	8 degrees	30 m (98.4 ft)

SITRANS LR260, dimensions in mm (inch)

Level Measurement

Continuous level measurement
Radar transmitters

SITRANS LR260

Circuit diagrams

4

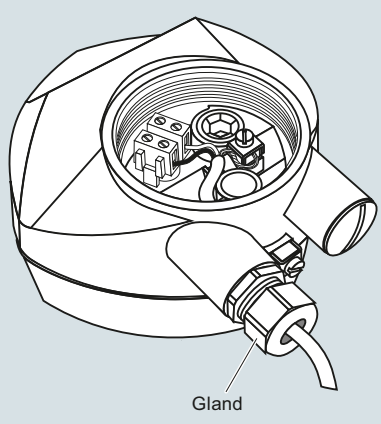

Gland

Connect the wires to the terminals as shown: the polarity is identified on the terminal block.

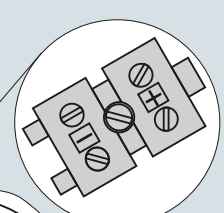
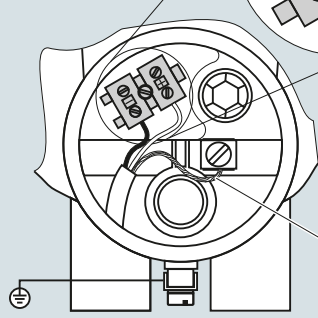
Shield for HART and PROFIBUS PA intrinsically safe versions only.

Hand programmer

SIEMENS

1	2	3	4
5	6	7	8
9	0	.	↵
C	⏪	⏩	⏴
←	↑	↓	→

Part number:
7ML1930-1BK

Notes:

1. DC terminal shall be supplied from a source providing electrical isolation between the input and output, to meet the applicable safety requirements of IEC 61010-1.
2. All field wiring must have insulation suitable for rated input voltages.
3. Use shielded twisted pair cable (14 ... 22 AWG) for HART version.
4. Separate cables and conduit may be required to conform to standard instrumentation wiring practices or electrical codes.

SITRANS LR260 connections