

Application Description • 08/2015

Controlling a Fan (ebm-papst) via Modbus RTU

SIMATIC S7-1200

Warranty and Liability

Note

The Application Examples are not binding and do not claim to be complete regarding the circuits shown, equipping and any eventuality. The Application Examples do not represent customer-specific solutions. They are only intended to provide support for typical applications. You are responsible for ensuring that the described products are used correctly. These application examples do not relieve you of the responsibility to use safe practices in application, installation, operation and maintenance. When using these Application Examples, you recognize that we cannot be made liable for any damage/claims beyond the liability clause described. We reserve the right to make changes to these Application Examples at any time without prior notice.

If there are any deviations between the recommendations provided in these application examples and other Siemens publications – e.g. Catalogs – the contents of the other documents have priority.

We do not accept any liability for the information contained in this document.

Any claims against us – based on whatever legal reason – resulting from the use of the examples, information, programs, engineering and performance data etc., described in this Application Example shall be excluded. Such an exclusion shall not apply in the case of mandatory liability, e.g. under the German Product Liability Act (“Produkthaftungsgesetz”), in case of intent, gross negligence, or injury of life, body or health, guarantee for the quality of a product, fraudulent concealment of a deficiency or breach of a condition which goes to the root of the contract (“wesentliche Vertragspflichten”). The damages for a breach of a substantial contractual obligation are, however, limited to the foreseeable damage, typical for the type of contract, except in the event of intent or gross negligence or injury to life, body or health. The above provisions do not imply a change of the burden of proof to your detriment.

Any form of duplication or distribution of these Application Examples or excerpts hereof is prohibited without the expressed consent of the Siemens AG.

Security information

Siemens provides products and solutions with industrial security functions that support the secure operation of plants, solutions, machines, equipment and/or networks. They are important components in a holistic industrial security concept. With this in mind, Siemens' products and solutions undergo continuous development. Siemens recommends strongly that you regularly check for product updates.

For the secure operation of Siemens products and solutions, it is necessary to take suitable preventive action (e.g. cell protection concept) and integrate each component into a holistic, state-of-the-art industrial security concept. Third-party products that may be in use should also be considered. For more information about industrial security, visit <http://www.siemens.com/industrialsecurity>.

To stay informed about product updates as they occur, sign up for a product-specific newsletter. For more information, visit <https://support.industry.siemens.com>.

Table of Contents

Warranty and Liability	2
1 Task.....	5
1.1 Overview.....	5
2 Solution.....	6
2.1 Solution overview	6
2.2 Description of the core functions	7
2.3 Hardware and software components	9
2.3.1 Validity	9
2.3.2 Used components	9
3 Function Mechanisms	11
3.1 General overview	11
3.2 Register	12
3.2.1 Holding register	12
3.2.2 Input register	13
3.3 PLC data types.....	14
3.3.1 "typeProductionData"	14
3.3.2 "typeRead".....	14
3.3.3 "typeData".....	14
3.3.4 "typeWrite".....	15
3.3.5 "typeCyclic".....	15
3.3.6 "typeManual"	15
3.3.7 "typeHMI".....	16
3.4 FB "EbmPapst".....	17
3.5 FC "ReadWrite"	21
3.5.1 Function mechanisms	23
3.5.2 Sequential call of FC "ReadWrite".....	25
4 Installation and Startup.....	27
4.1 Installation of the hardware	27
4.2 Network connections	28
4.2.1 Setting the PG/PC interface	29
4.3 Configuration instructions.....	29
4.3.1 Adjusting the device configuration	29
4.3.2 Downloading the controller project part.....	30
4.4 HMI project part.....	31
4.4.1 Configuring the HMI	31
Downloading the HMI project part into the KTP900 Basic	32
Starting the PC runtime	33
5 Operation of the Application	34
5.1 Overview (start screen)	34
5.2 Recurrent display elements.....	36
5.2.1 Cyclically retrieved values (input registers).....	36
5.2.2 Writing to the holding registers.....	36
Default settings to operate the application	37
5.2.3 Status evaluation	38
5.3 Trend view	39
5.4 All parameters	40
5.5 Alarm buffer.....	41
5.6 System diagnostics	42
5.7 Settings.....	43
5.7.1 System time/PLC.....	43
System time.....	43

Table of Contents

	PLC	44
	FB "EbmPapst"	44
5.7.2	Brightness	44
5.7.3	User display.....	45
5.7.4	System.....	45
6	Related Literature	46
7	Contact.....	47
8	History.....	47

1 Task

1.1 Overview

Introduction

ebm-papst offers fans with an integrated RS485 interface that can be controlled via the Modbus RTU protocol.

These fans (here at the example of “VarioDrive C”) are to be connected to a SIMATIC PLC, monitored and controlled.

Overview of the automation task

The figure below provides an overview of the automation task.

Figure 1-1

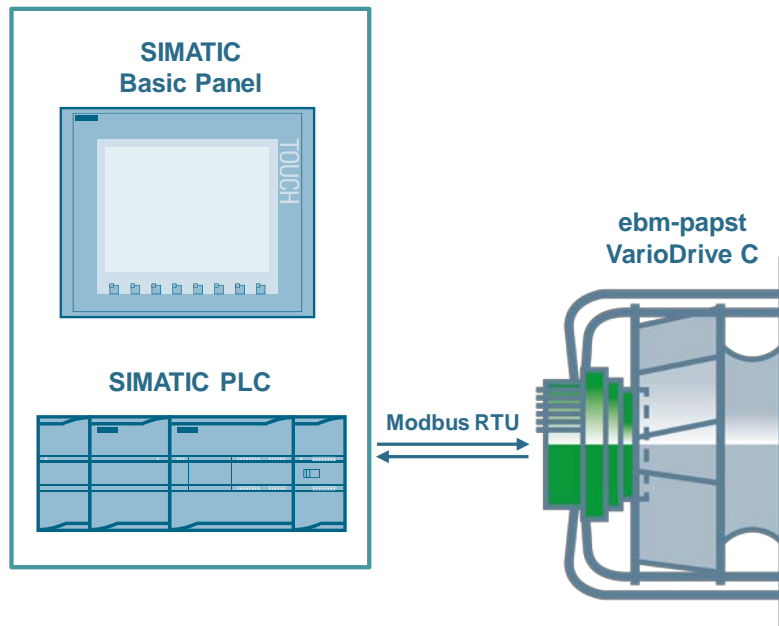

Description of the automation task

The application has to satisfy the following requirements:

- Communication between the SIMATIC PLC and the ebm-papst fan (reading and writing the parameters) via Modbus RTU.
- Operation and monitoring of the motor parameters via HMI

2 Solution

2.1 Solution overview

Display

The following figure shows the most important components of the solution:

Figure 2-1

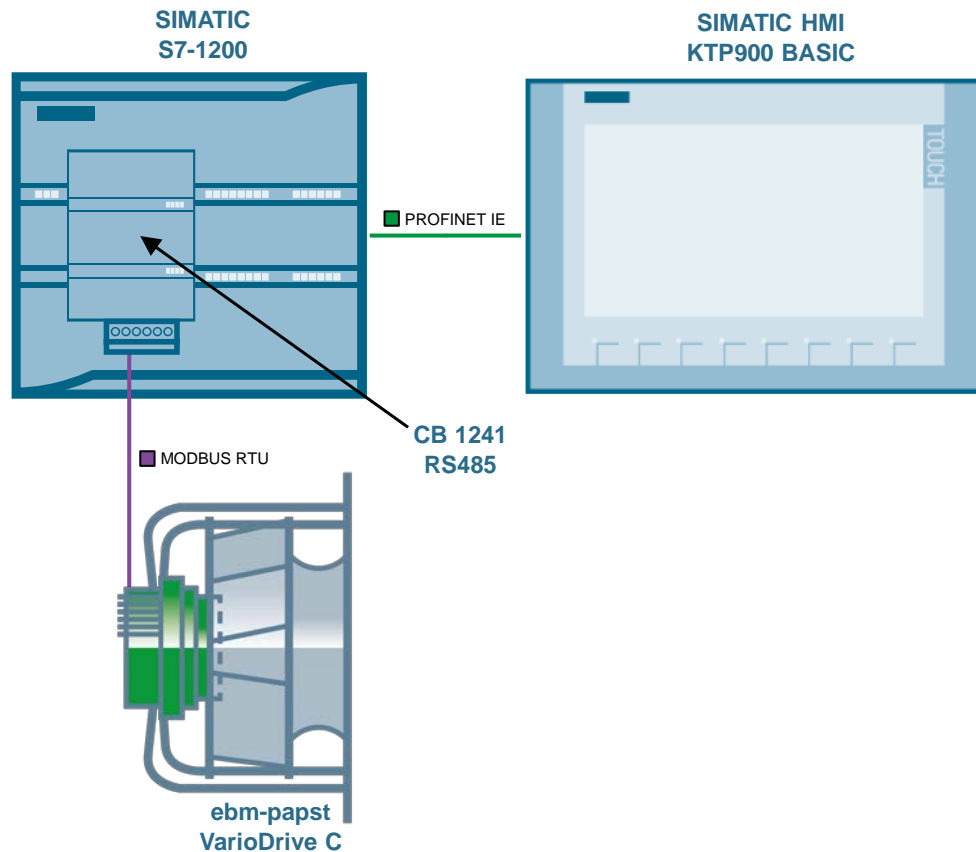

Setup

A SIMATIC S7-1200 CPU with firmware V4.1.1 is used as the controller. It exchanges the motor data with the ebm-papst fan using the serial communication board CB 1241 RS485 via the Modbus RTU data protocol.

To operate and monitor the motor data, a SIMATIC HMI KTP900 BASIC (or its simulation in the TIA Portal) is used.

Configuration was performed with STEP 7 V13 SP1.

NOTE

Instead of the CB 1241 RS485 the CM 1241 RS422/485 with 9-pin D-sub connector (6ES7241-1CH32-0XB0) may be used alternatively ([3](#)).

However, the CB 1241 RS485 is better suited for direct wiring of the fan (without D-sub connector).

2.2 Description of the core functions

The application's core functionality is the operation of the ebm-papst fan using the HMI.

Overview and description of the HMI

Figure 2-2

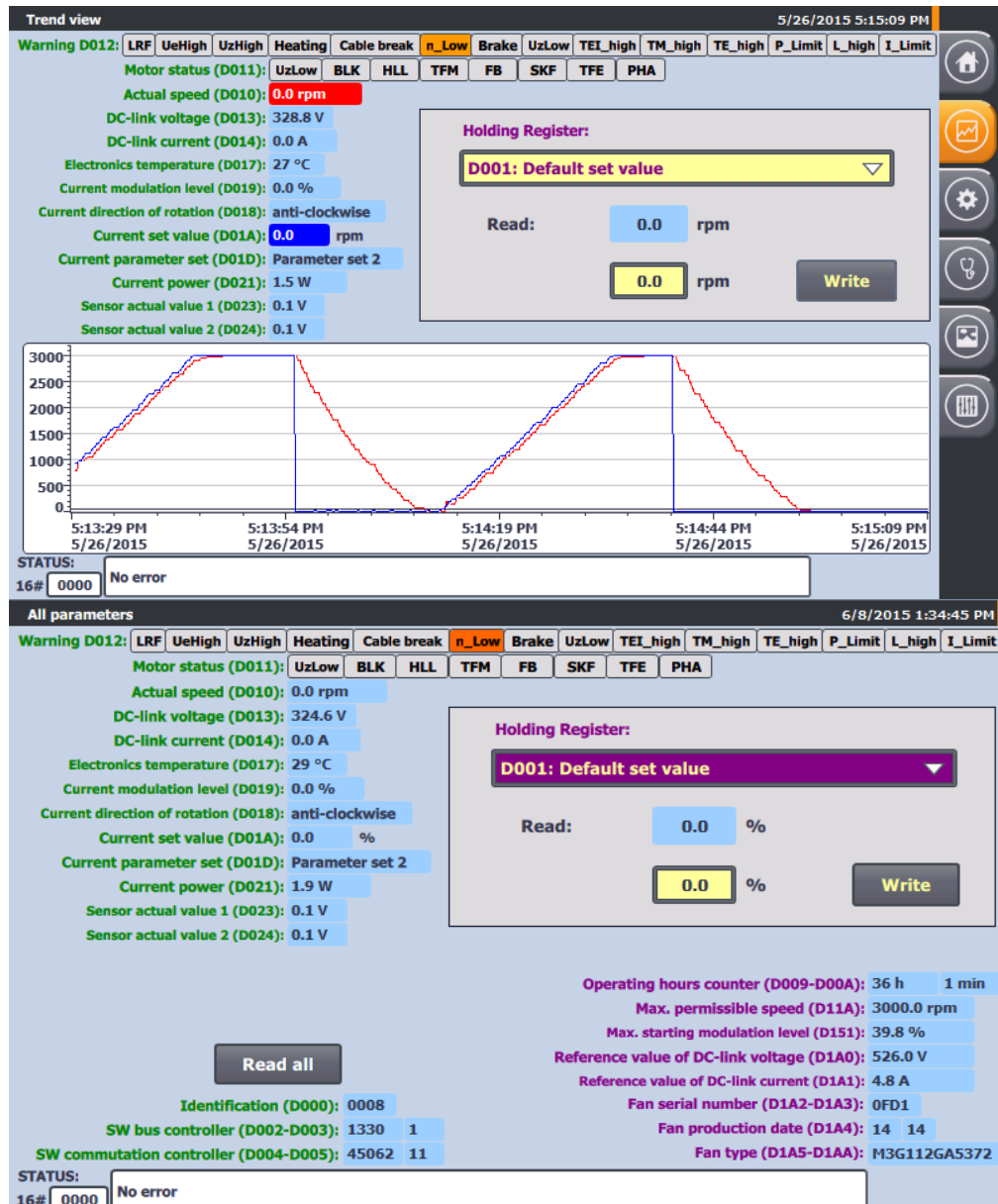

The application can be operated using the following 2 displays:

- Trend view (speed curve with editing the key parameters)
- All parameters (monitoring and editing the most common parameters)

Chapter 5 gives a more detailed description of how to operate the user interface.

Advantages

In addition to the cyclic reading of the most important input registers of the ebm-papst fan, the application allows you to edit the most common holding registers and to read fan-specific (non-writable) parameters upon request.

This application offers you the following advantages:

- Input and output of the parameters with the correct unit and meaning through the KTP900 Basic PN operator panel
- Cyclic reading of the key input registers
- Curve progress of actual and set speed values
- Automatic reading of the most common holding registers after selection and subsequent editing
- Collective reading of device-specific input registers and non-writable holding registers upon request
- Access to all registers via the control program

Delimitation

This application establishes the direct communication between the S7-1200 and a VarioDrive C by means of Modbus RTU.

The selected registers are converted to the correct unit according to their meaning in line with the MODBUS parameter specification for “ebm-papst series 84 / 112 / 150 / 200” V5.00 and output.

To safely operate your ebm-papst fan, you have to familiarize yourself with this specification.

This specification does not provide a detailed description of the parameters.

Using this application you can also access other registers from the control program (in addition to the ones selected in chapter [3.2](#)). However, the conversion into the correct unit is not implemented for these registers.

NOTE

The MODBUS parameter specification for “ebm-papst series 84 / 112 / 150 / 200” V5.00 is provided by ebm-papst when purchasing a fan/motor of this series and upon request (see chapter [7](#)).

Required knowledge

Basic knowledge and experience with the following subjects are required for this application:

- SIMATIC S7-1200 controller family
- TIA Portal engineering interface
- MODBUS-RTU communication protocol

2.3 Hardware and software components

2.3.1 Validity

This application example is valid for

- STEP 7 from V13 SP1 (TIA Portal)
- SIMATIC S7-1200 for firmware V4.1.1 and higher

2.3.2 Used components

The application was generated with the following components:

Hardware components

Table 2-1

Component	Qty	Article number	Note
POWER SUPPLY S7-1200 PM1207	1	6EP1332-1SH71	
COMPACT SWITCH MODULE CSM 1277	1	6GK7277-1AA10-0AA0	
CPU 1214C, DC/DC/RELAY, 6DI/4DO/2AI	1	6ES7214-1HG40-0XB0	Firmware V4.1.1 (\6)
COMMUNICATION BOARD CB 1241, RS485	1	6ES7241-1CH30-1XB0	Alternatively, you can use the COMMUNICATION MODULE CM 1241, RS422/485 with 9-PIN D-SUB CONNECTOR (6ES7241-1CH32-0XB0) (\3)
SIMATIC HMI KTP900 BASIC	1	6AV2123-2JB03-0AX0	Optional (can also be simulated in WinCC Basic V13 SP1)
Ethernet cable TP CORD RJ45/RJ45 2M	3	6XV1870-3QH20	
Standard rail	1	6ES5 710-8MA11	35 mm
Motor "VarioDrive C"	1	Type: M3G112-GA53-72	Manufacturer: ebm-papst (\10 and \11)

Standard software components

Table 2-2

Component	Qty	Article number	Note
SIMATIC STEP 7 BASIC V13 SP1	1	6ES7822-0AA03-0YA5	<ul style="list-style-type: none"> • Includes WinCC Basic V13 SP1; • With update 2 (\5)
SIMATIC STEP 7 BASIC UPGRADE V13 SP1	1	6ES7822-0AA03-0YE5	(optional) only to upgrade STEP 7 Basic V11 or V12

2 Solution

2.3 Hardware and software components

Sample files and projects

The following list includes all files and projects that are used in this example.

Table 2-3

Component	Note
109476801_S7-1200_ebmpapst_CODE_v1d0.zip	This zip file contains the STEP 7 project.
109476801_S7-1200_ebmpapst_DOKU_v1d0_en.pdf	This document.

3 Function Mechanisms

3.1 General overview

Figure 3-1 shows the time sequence of the block calls in the control part of the application project.

Figure 3-1

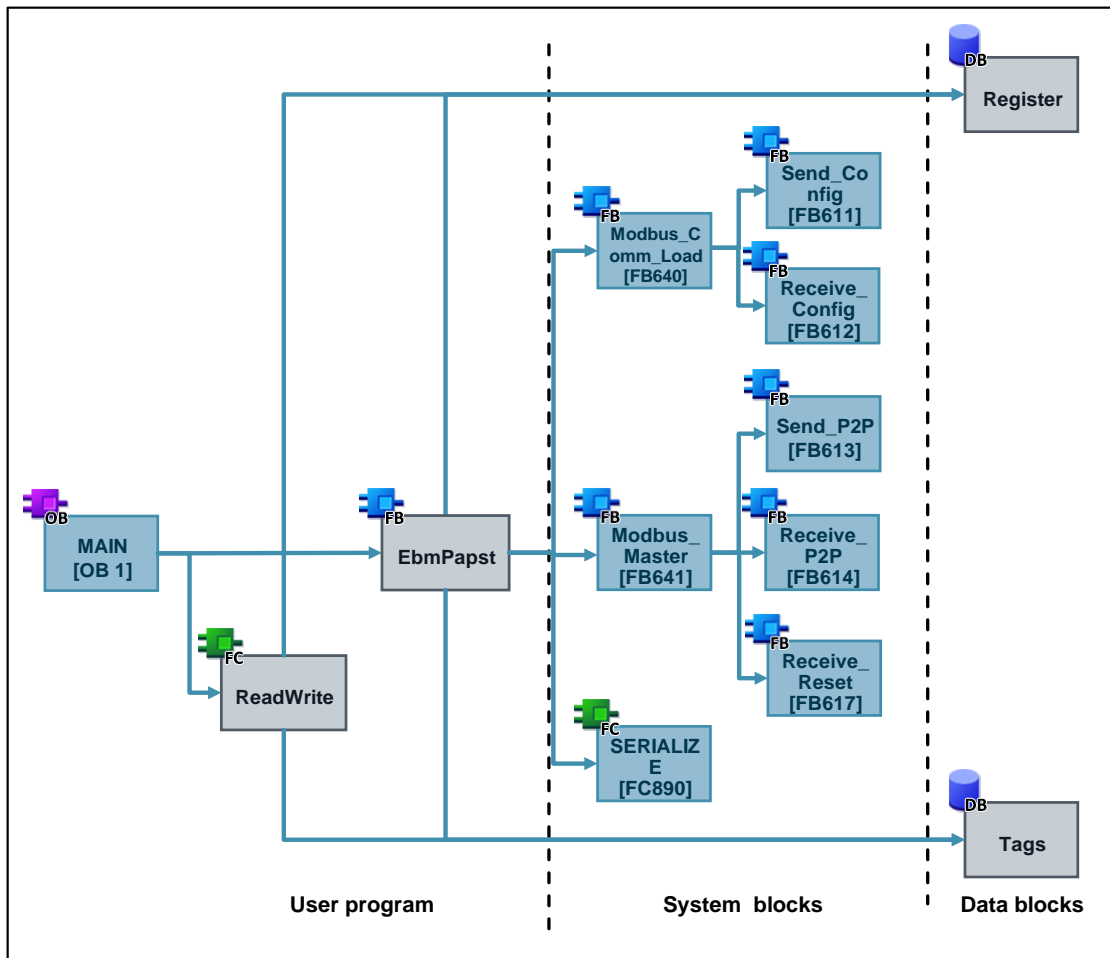

The core functionality includes the function block “EbmPapst”. This block is called in the cyclic organization block “Main”. The interfaces of FB “EbmPapst” are fed from the data blocks

- “Register” (this DB contains the register structure and the order of the data to be read) and
- “Tags” (this DB contains the variables to parameterize and operator the FB “EbmPapst”).

The following system blocks are called in the FB “EbmPapst”:

- “Modbus_Comm_Load” [FB640] to initialize the Modbus RTU communication

3.2 Register

- “Modbus_Master” [FB641] for data exchange of the S7-1200 as the master with the ebm-papst fan as the slave
- “SERIALIZE” [FB890] to convert words into an array of bytes and subsequent output as a string

The actual values of the function blocks are stored as a multi-instance in the instance data block of the FB “EbmPapst”.

The FC “ReadWrite” serves to access additional registers which are not listed in the following chapter. It is called in the cyclic organization block “Main”. It has an interface to the FB “EbmPapst” and is fed by the data blocks “Register” and “Tags”.

3.2 Register

3.2.1 Holding register

This application allows you to access the following holding registers through the HMI:

Table 3-1

Address		Length	Designation	Write	Reset required	Password required
hex.	dec.					
D000	53248	1	Reset	X	-	-
D001	53249	1	Default set value	X	-	-
D002	53250	3	Password	X	-	-
D005	53253	1	Control default setting	X	-	X
D009	53257	1	Operating hours counter	-	-	-
D00A	53258	1	Operating minutes counter	-	-	-
D100	53504	1	Fan address	X	X	-
D101	53505	1	Set value source	X	X	-
D102	53506	1	Preferred running direction	X	-	-
D103	53507	1	Save set value	X	X	-
D104	53508	1	Source parameter set	X	X	-
D105	53509	1	Internal parameter set	X	-	-
D106	53510	1	Control mode (parameter set 1)	X	X	-
D107	53511	1	Control mode (parameter set 2)	X	X	-
D112	53522	1	Motor stop enable (parameter set 1)	X	X	-
D113	53523	1	Motor stop enable (parameter set 2)	X	X	-
D114	53524	1	Set value (parameter set 1)	-	-	-
D115	53525	1	Set value (parameter set 2)	-	-	-
D119	53529	1	Maximum speed	X	X	X
D11A	53530	1	Max. permissible speed	-	-	-
D11F	53535	1	Ramp-up time	X	X	-
D120	53536	1	Ramp-down time	X	X	-
D145	53573	1	Ceiling speed for speed monitoring	X	X	X
D148	53576	1	Source direction of rotation	X	X	-
D149	53577	1	Transfer rate	X	X	X
D14A	53578	1	Parity configuration	X	X	X

3 Function Mechanisms

3.2 Register

Address		Length	Designation	Write	Reset required	Password required
hex.	dec.					
D150	53584	1	Shedding function	X	X	X
D151	53585	1	Max. starting modulation level	-	-	-
D152	53586	1	Number of start attempts	X	X	X
D153	53587	1	Relay drop-out delay	X	X	-
D15B	53595	1	Emergency operation running direction	X	X	X
D15C	53596	1	Emergency operation function on/off	X	X	X
D15D	53597	1	Set value for emergency operation	X	X	X
D15E	53598	1	Emergency operation time lag	X	X	X
D1A0	53664	1	Reference value of DC-link voltage	-	-	-
D1A1	53665	1	Reference value of DC-link current	-	-	-
D1A2	53666	2	Fan serial number	-	-	-
D1A4	53668	1	Fan production date	-	-	-
D1A5	53669	6	Fan type	-	-	-

3.2.2 Input register

This application allows you to read the following input registers through the HMI:

Table 3-2

Address		Designation
hex.	dec.	
D000	53248	Identification
D002	53250	Software name of bus controller
D003	53251	Software version of bus controller
D004	53252	Software name of commutation controller
D005	53253	Software version of commutation controller
D010	53264	Actual speed
D011	53265	Motor status
D012	53266	Warning
D013	53267	DC-link voltage
D014	53268	DC-link current
D017	53271	Electronics temperature
D018	53272	Current direction of rotation
D019	53273	Current modulation level
D01A	53274	Current set value
D01D	53277	Current parameter set
D021	53281	Current power
D023	53283	Sensor actual value 1
D024	53284	Sensor actual value 2

3.3 PLC data types

3.3.1 “typeProductionData”

The PLC data type “typeProductionData” includes the fan's manufacturing data.

Table 3-3

Name	Data type	Description
serialNumber	String[4]	Fan serial number (consecutive number)
productionDate	“typeProductionDate”	PLC data type with the fan's production date (year/week)
fanType	String[12]	Fan type (designation)

3.3.2 “typeRead”

The PLC data type “typeRead” includes the placeholder to read registers.

Table 3-4

Name	Data type	Description
req	Bool	Request to read a register
data	“typeData”	PLC data type with the read parameters
uint	Uint	Read data value

3.3.3 “typeData”

The PLC data type “typeData” includes the parameters for reading and writing to the registers.

Table 3-5

Name	Data type	Description
mode	USInt	Mode selection: Defines the type of request [read (0 for holding registers; 104 for input registers) or write(1)]
addr	UDInt	Start address in the slave: Defines the start address of the data to access: <ul style="list-style-type: none"> 453249 through 453675 (16#D000 through 16#D1AA) for reading (mode = 0) and writing holding registers (mode = 1) 53248 through 53286 (16#D000 through 16#D026) for reading input registers (mode = 104)
len	Uint	Data length: Defines the number of words which this request should access (max. 9 words possible due to slave).

3.3.4 “typeWrite”

The PLC data type “typeWrite” includes the placeholder to read registers.

Table 3-6

Name	Data type	Description
req	Bool	Request to write to registers
data	“typeData”	PLC data type with the write parameters
uint	Array[0..2] of UInt	Data values to write in the “UInt” data format
minUInt	UInt	Lower input limit value for the HMI input field for the “UInt” data format
maxUInt	UInt	Upper input limit value for the HMI input field for the “UInt” data format
real	Real	Data value to write in the “Real” data format
maxReal	Real	Upper input limit value for the HMI input field for the “Real” data format

3.3.5 “typeCyclic”

The PLC data type “typeCyclic” includes the order of the data to be exchanged.

Table 3-7

Name	Data type	Description
last	Int	Last field element to be edited
data	Array[0..9] of “typeData”	Order of the data to exchange

3.3.6 “typeManual”

The PLC data type “typeManual” contains the information for exchanging data between the FB “EbmPapst” and the FC “ReadWrite”.

Table 3-8

Name	Data type	Description
step	USInt	Step counter for FC “ReadWrite”
req	Bool	Request of manual access via FC “ReadWrite”
data	“typeData”	Contains the information which data to read
dataPtr	Array[0..8] of UInt	Data buffer with the values to read or write
busy	Bool	FC “ReadWrite” is being edited
done	Bool	FC “ReadWrite” was completed without errors (active for one cycle)
error	Bool	FC “ReadWrite” was completed with errors (active for one cycle)
errorStatus	Word	Status evaluation (error code) of FC “ReadWrite”

3.3.7 “typeHMI”

The PLC data type “typeHMI” contains information about the visibility display in the HMI.

Table 3-9

Name	Data type	Description
unit	“typeUnit”	Includes information about the correct representation of the setpoint unit (“1/min” or “%”)
writelInvisible	Bool	Hides the write request
readAllBusy	Bool	Is TRUE for as long as the “Read all registers” job is executed

3.4 FB "EbmPapst"

This function block was especially developed for serial communication with fans from ebm-papst via the Modbus RTU data protocol (based on the MODBUS parameter specification for "ebm-papst series 84 / 112 / 150 / 200" V5.00).

It is called in the cyclic organization block "Main".

Figure 3-2

Network 1: Modbus RTU communication with fan (ebm-papst)

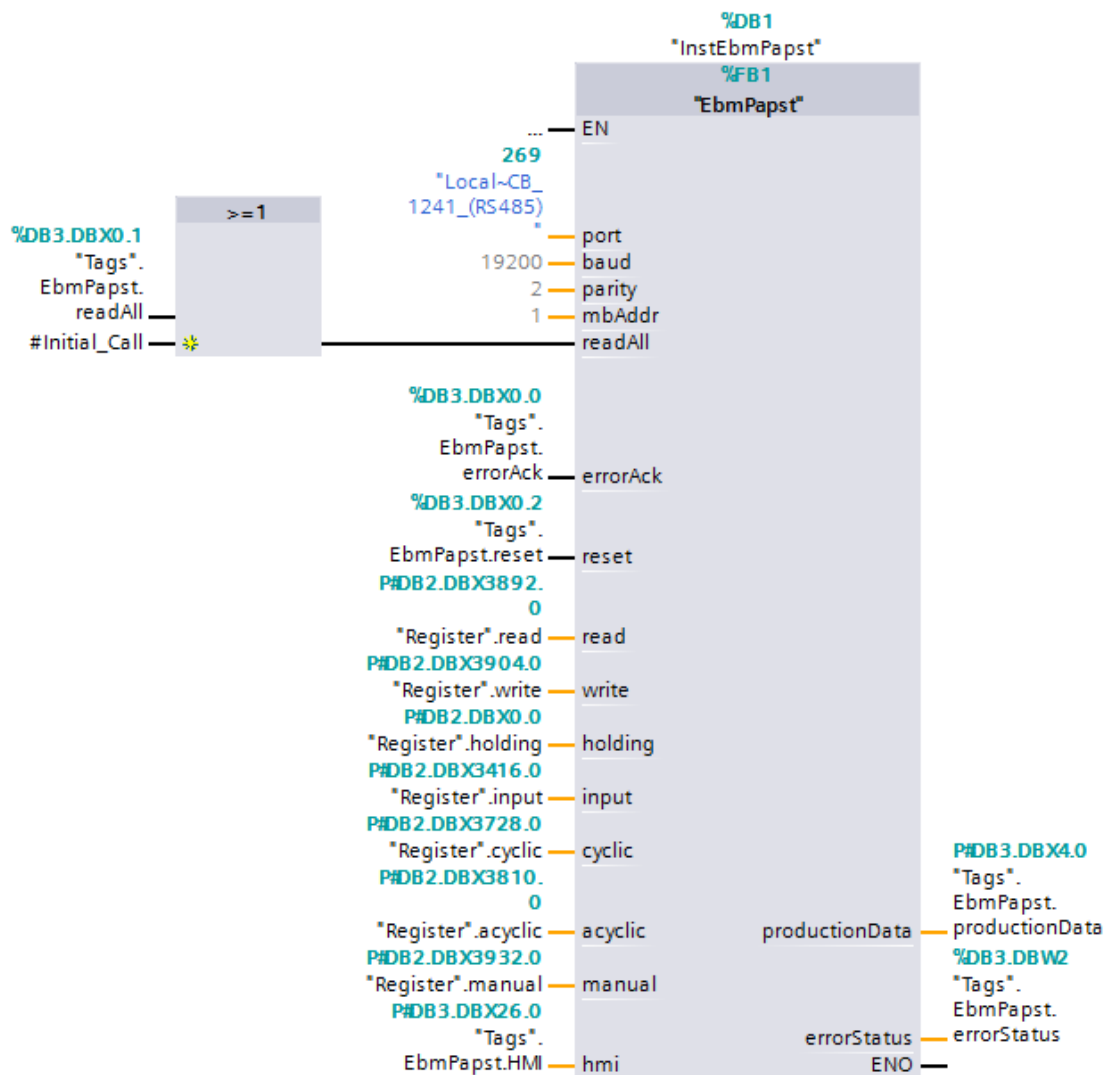

© Siemens AG 2015. All rights reserved.

Table 3-10

	Name	Data type	Description
Input	port	PORT	Hardware ID of the RS485 CB or CM used
	baud	UDInt	Baud rate (default: 19200 bit/s)
	parity	UInt	Parity (default: 2 = even)
	mbAddr	UInt	Modbus address of the slave (default: 1)

3 Function Mechanisms

3.4 FB "EbmPapst"

	Name	Data type	Description
	readAll	Bool	Request to read all predefined registers (in the project OR operation from HMI variable "Tags.EbmPapst.readAll" and initial pass of OB1 "Inital_Call")
	errorAck	Bool	Acknowledgment of the pending error message ("status")
	reset	Bool	Reset, restart block
Output	productionData	"typeProductionData"	Fan production data
	errorStatus	Word	Status evaluation (error code)
InOut	read	"typeRead"	PLC data type to read a register
	write	"typeWrite"	PLC data type to write holding registers
	holding	Array[53248..53674] of "typeRegister"	Memory buffer of holding registers (16#D000 through 16#D1AA)
	input	Array[53248..53286] of "typeRegister"	Memory buffer of input registers (16#D000 through 16#D026)
	cyclic	"typeCyclic"	PLC data type with the order of the data to be exchanged cyclically
	acyclic	"typeCyclic"	PLC data type with the order of the data to be exchanged acyclically
	manual	"typeManual"	PLC data type to exchange data with the FC "ReadWrite"
	hmi	"typeHMI"	PLC data type with display information for the HMI

The FB "EbmPapst" includes the calls of the system blocks "Modbus_Comm_Load" and "Modbus_Master".

The "Modbus_Master" only allows blocks to be handed to the parameter "DATA_PTR" in which the attribute property "optimized block access" is not enabled. No block of this application (FB or DB) has the property "optimized block access". This prevents cycle time increases due to recopying optimized DBs in non-optimized DBs.

NOTE

For a more detailed description of the communication instructions "Modbus_Comm_Load" and "Modbus_Master", see the STEP 7 V13 SP1 online help or the chapter ["Modbus RTU"](#) in the S7-1200 system manual (8).

3 Function Mechanisms

3.4 FB “EbmPapst”

The FB “EbmPapst” reads the most important input registers of the ebm-papst fans in cyclic intervals of approximately 500 ms. Additionally, you can retrieve and write to predefined holding registers in connection with the configured HMI (see chapter 3.2).

The FC “ReadWrite” enables you to access further registers in the control program part (see chapter 3.5).

Program workflow

Figure 3-3 shows the schematic structure of the FB “EbmPapst”.

Figure 3-3

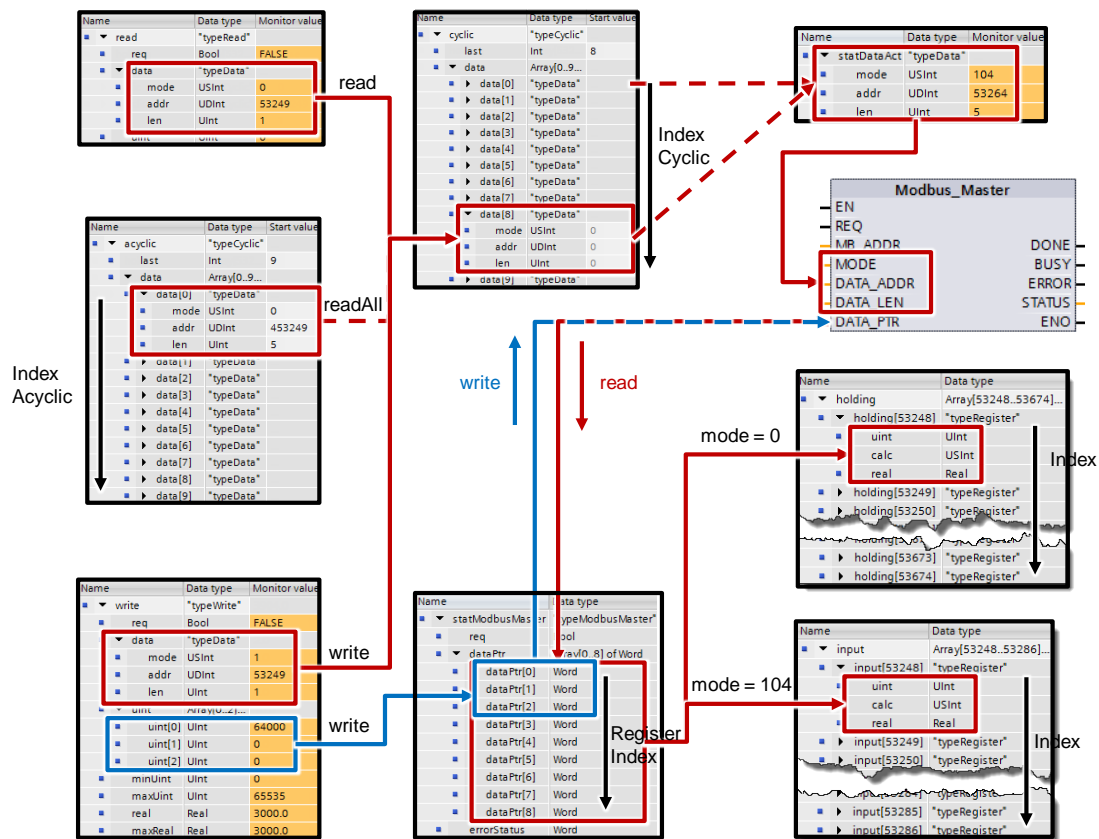

The sequence for reading the input registers is processed cyclically as a function of the running index “IndexCyclic”. The information (access mode “mode”, register address “addr” and register length “len”) are provided as start values in the interface parameter “cyclic” in the field 0 to 7.

The following is written into the last field (“cyclic.last”) via the HMI depending on the request (“read”, “readAll” or “write”):

- the holding register to read (provided in the interface parameter “read”)
- the sequence for reading the acyclic registers as a function of the running index “IndexAcyclic” (provided in the interface parameter “acyclic”)
- the holding register to write to (provided in the interface parameter “write”)

The field (“cyclic.last”) is only processed if the data length “len” is greater than zero.

3.4 FB "EbmPapst"

Based on the running index "IndexCyclic", the information is transferred to the static placeholder "statDataAct" and handed to the communication block "Modbus_Master".

The system block "Modbus_Master" provides the interface for exchanging data with the ebm-papst fan via Modbus RTU.

The 9-word field "dataPtr" in the static parameter "statModbusMaster" functions as a data buffer for the read values/the values to write. It is limited to 9 words due to the permitted maximum telegram length of the fan.

With read access, the read data are successively ("RegisterIndex") written into the corresponding register file ("Index") depending on the access mode:

- Interface parameter "holding" for the holding registers ("mode" = 0)
- Interface parameter "input" for the input registers ("mode" = 104)

If necessary, the read value ("uint") is subsequently converted into the corresponding floating point value ("real") depending on the calculation instruction ("calc").

With write access ("write.req"), the entered floating point value ("real") is converted into the corresponding data value in the format "Uint" if necessary and subsequently transmitted into the data buffer "dataPtr" of the Modbus_Master and executed for the holding register to write based on the calculation instruction ("calc").

As the only exception, the holding register "Password" to write to has a length of 3 words (see [Table 3-1](#)). Here, the first and additionally the two following field elements are transmitted ("dataPtr [0..2] = uint [0..2]").

3.5 FC "ReadWrite"

This function gives individual access to all registers of the ebm-papst fans. To operate the block, you have to be familiar with the MODBUS parameter specification for "ebm-papst series 4 / 112 / 150 / 200" V5.00. The FC "ReadWrite" is only functional in connection with the FB "EbmPapst".

It is called in the cyclic organization block "Main".

Figure 3-4

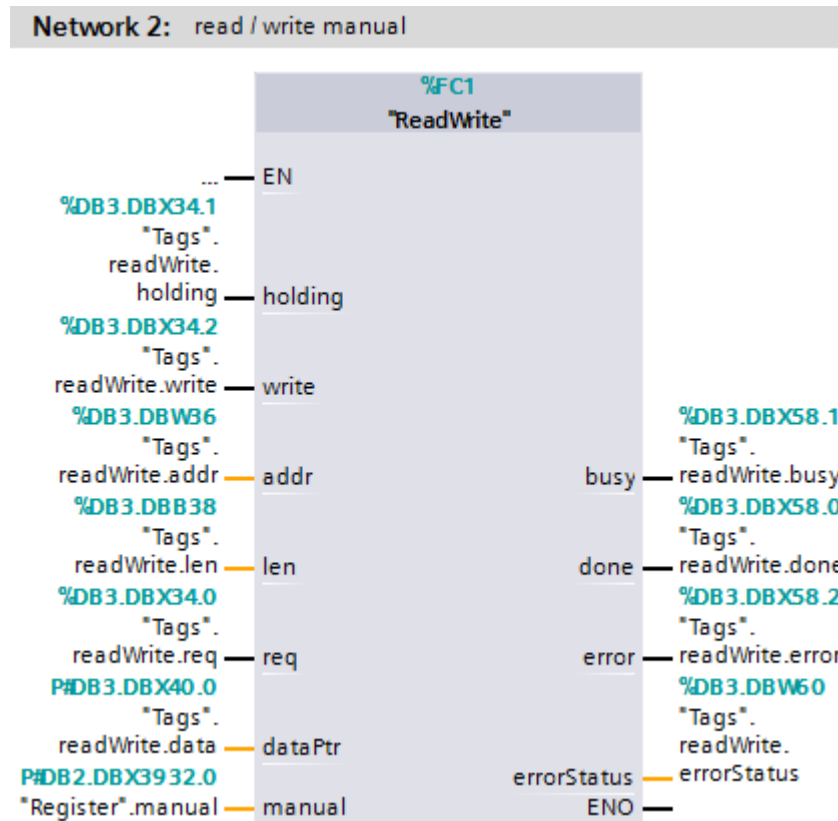

Table 3-11

	Name	Data type	Description
Input	holding	Bool	Register type (false = input register; true = holding register)
	write	Bool	Only relevant for holding registers (false = read; true = write)
	addr	UInt	Start address in the slave: Defines the start address of the data to access: <ul style="list-style-type: none"> 53248 through 53286 (16#D000 through 16#D026) for input registers (holding = false) 53248 through 53674 (16#D000 through 16#D1AA) for holding registers (holding = true)
	len	USInt	Data length: Defines the number of words which this request shall access (a maximum of 9 words is possible due to the slave)
Output	busy	Bool	FC "ReadWrite" is being edited
	done	Bool	FC "ReadWrite" was completed without errors (active for one cycle)
	error	Bool	FC "ReadWrite" was completed with errors (active for one cycle)
	errorStatus	Word	Status evaluation (error code) of FC "ReadWrite"
InOut	req	Bool	Request of manual access via FC "ReadWrite" (is reset after completion)
	dataPtr	Array[0..8] of UInt	Data buffer with the values to be read or written
	manual	"typeManual"	PLC data type to exchange data with the FB "EbmPapst"

The FC "ReadWrite" was made to resemble the instruction "Modbus_Master" and places the manual register access to the last position of the data transfer of FB "EbmPapst" that is to be processed cyclically.

Execution of the FC "ReadWrite" may hence be delayed by max. 500 ms.

NOTE

For a more detailed description of the communication instructions "Modbus_Comm_Load" and "Modbus_Master", see the STEP 7 V13 SP1 online help or the chapter "[Modbus RTU](#)" in the S7-1200 system manual ([8](#)).

The FB "EbmPapst" reads the most important input registers of the ebm-papst fans in cyclic intervals of approximately 400 ms. Additionally, you can retrieve and write to predefined holding registers in connection with the configured HMI (see chapter [3.2](#)).

The FC "ReadWrite" enables you to access further registers in the control program part.

3.5.1 Function mechanisms

The function mechanism is demonstrated at the example of "reading the 6 holding registers starting from address 16#D108" in [Figure 3-5](#).

Figure 3-5

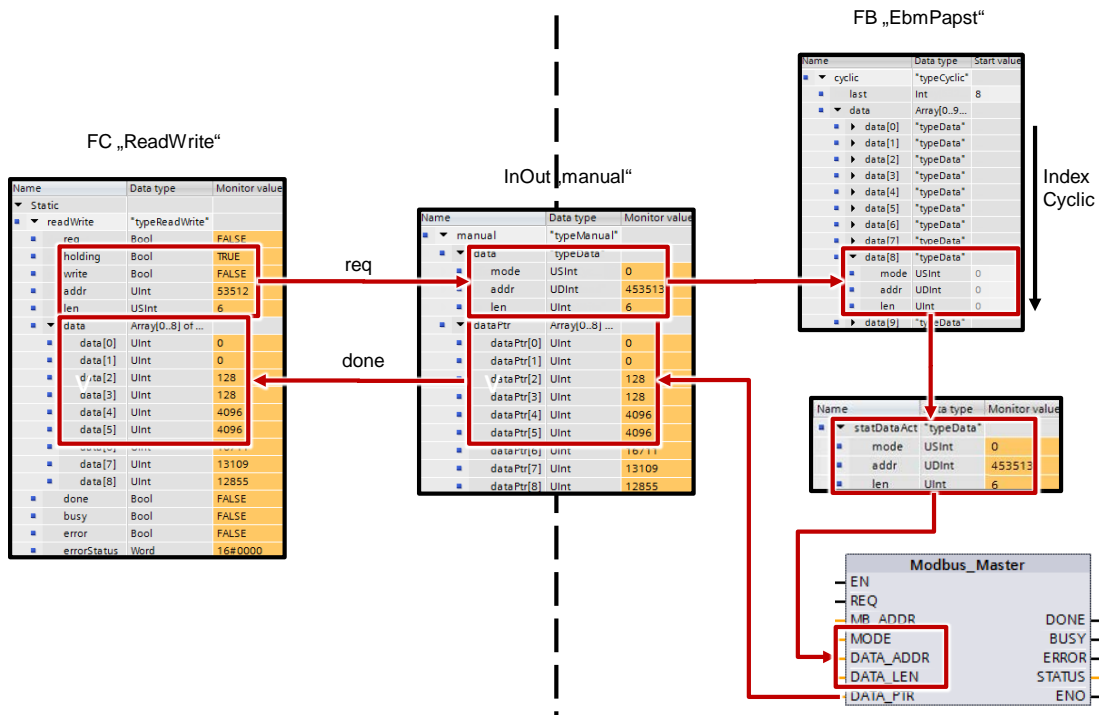

The task is transmitted to the FC "ReadWrite" via the following input parameters:

- "holding" = "TRUE" (register type: holding register)
- "write" = "FALSE" (access type: read)
- "addr" = 53512 (corresponds to 16#D108)
- "len" = 6 (6 words are to be read)

The FC "ReadWrite" converts this information for the request "req" into the parameter in the PLC data type "typeData" which the instruction "Modbus_Master" understands:

- "mode" = 0 (corresponds to: "read holding register")
- "addr" = 453513 (= holding register offset 400001 + x)
- "len" = 6 (6 words are to be read)

This data type is transferred "manually" to the FB "EbmPapst" by means of the input/output data and written into the last field ("cyclic.last") of the data transfer jobs ("cyclic") to be processed cyclically.

If the running index "IndexCyclic" equals "cyclic.last", the information is transmitted to the static placeholder "statDataAct" and handed to the communication block "Modbus_Master".

3.5 FC "ReadWrite"

The system block "Modbus_Master" receives the read data and writes it into the data buffer "dataPtr" in the input/output data "manual" and transmits it to the FC "ReadWrite" in case of successful transmission "done".

The output "done" is only active for one cycle and resets the request bit "req".

Only the data to be transmitted is valid respectively (defined by the data length "len"). Before the FC "ReadWrite" is called again, the data has to be processed or it will be overwritten.

The read registers ("holding" or "input") are also written to the correct field in the DB "Register".

Besides the example "Reading holding registers" already described you can also read input registers or write to holding registers.

If errors occur, the output bit "error" is set for one cycle.

The status "errorStatus" delivers the corresponding error code (remains pending).

NOTE For a detailed list of the error codes for the "Modbus_Master" instruction, refer to the online help of the TIA Portal using F1.

You can check the function of the FC "ReadWrite" using the watch table "ReadWrite":

Figure 3-6

Name	...	Display format	Monitor value	Modify value	
Tags.readWrite.req	...	Bool	<input type="checkbox"/> FALSE	TRUE	<input checked="" type="checkbox"/>
Tags.readWrite.holding	...	Bool	<input checked="" type="checkbox"/> TRUE	TRUE	<input checked="" type="checkbox"/>
Tags.readWrite.write	...	Bool	<input type="checkbox"/> FALSE		<input type="checkbox"/>
Tags.readWrite.addr	...	Hex	16#D108	16#D108	<input checked="" type="checkbox"/>
Tags.readWrite.len	...	DEC	6	6	<input checked="" type="checkbox"/>
dataPtr					<input type="checkbox"/>
Tags.readWrite.data[0]	...	DEC	0	1	<input type="checkbox"/>
Tags.readWrite.data[1]	...	DEC	0		<input type="checkbox"/>
Tags.readWrite.data[2]	...	DEC	128		<input type="checkbox"/>
Tags.readWrite.data[3]	...	DEC	128		<input type="checkbox"/>
Tags.readWrite.data[4]	...	DEC	4096		<input type="checkbox"/>
Tags.readWrite.data[5]	...	DEC	4096		<input type="checkbox"/>
Tags.readWrite.data[6]	...	DEC	16711		<input type="checkbox"/>
Tags.readWrite.data[7]	...	DEC	13109		<input type="checkbox"/>
Tags.readWrite.data[8]	...	DEC	12855		<input type="checkbox"/>
output					<input type="checkbox"/>
Tags.readWrite.busy	...	Bool	<input type="checkbox"/> FALSE		<input type="checkbox"/>
Tags.readWrite.done	...	Bool	<input type="checkbox"/> FALSE		<input type="checkbox"/>
Tags.readWrite.error	...	Bool	<input type="checkbox"/> FALSE		<input type="checkbox"/>
Tags.readWrite.errorStatus	...	Hex	16#0000		<input type="checkbox"/>

3.5.2 Sequential call of FC "ReadWrite"

To execute several register accesses successively, the parameters have to be handed to the FC "ReadWrite" in the form of a sequencer.

In the OB "Main" this is presented in networks 4 through 7.

Description of the task

The following actions are to be performed successively:

1. Reading input register 16#D015
2. Reading holding registers 16#D108 through 16#D10D (see chapter [3.5.1](#))
3. Writing the value 1 to holding register 16#D105 ("internal parameter set") (corresponds to: parameter set 2)

[Figure 3-8](#) shows the program sequence.

The sequencer is started in network 4. The step is displayed in white font. The jobs are processed in the networks 5 through 7. A job consists of the parameter handover and the subsequent action in case of the ready message ("done"). Subsequently, the program continues with the next step.

The steps are called in the reverse order of the networks. This is necessary to prevent "sliding through" the steps.

You can check the function of the sequencer using the watch table "ReadWrite":

Figure 3-7

Name	...	Display format	Monitor value	Modify value
Register				
Tags.start	...	Bool	<input type="checkbox"/> FALSE	TRUE
Tags.readInput	...	DEC	28	
Register.input[53269].uint	...	DEC	28	
Tags.readholding[0]	...	DEC	0	
Tags.readholding[1]	...	DEC	0	
Tags.readholding[2]	...	DEC	128	
Tags.readholding[3]	...	DEC	128	
Tags.readholding[4]	...	DEC	4096	
Tags.readholding[5]	...	DEC	4096	
Register.holding[53512].uint	...	DEC	0	
Register.holding[53513].uint	...	DEC	0	
Register.holding[53514].uint	...	DEC	128	
Register.holding[53515].uint	...	DEC	128	
Register.holding[53516].uint	...	DEC	4096	
Register.holding[53517].uint	...	DEC	4096	

Successful writing to holding register 16#D105 is accomplished by reading the register again or using [Cyclically retrieved values \(input registers\)](#):

Current parameter set (D01D): Parameter set 2

Figure 3-8

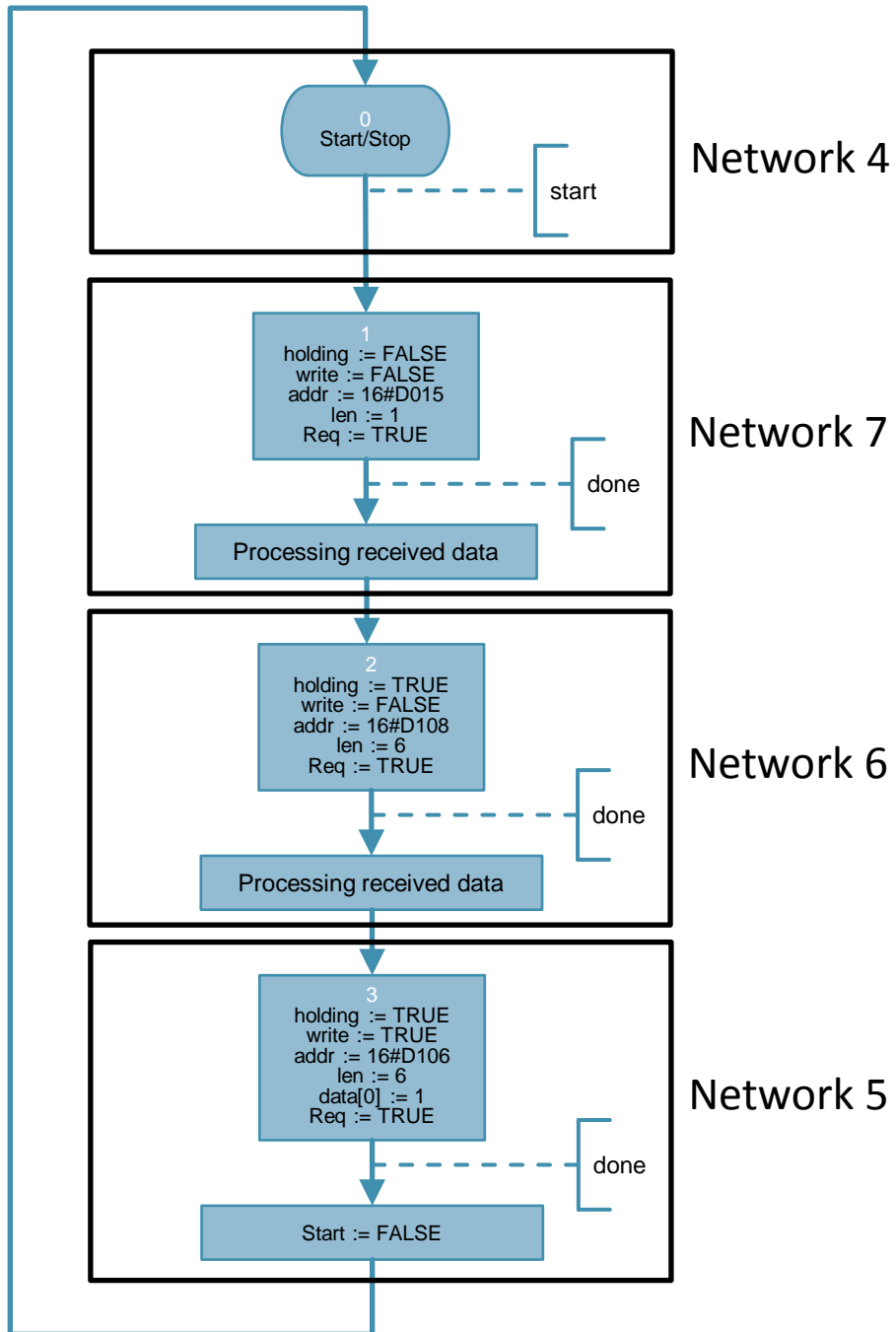

4 Installation and Startup

The application was set up using a CPU 1214C and a 1241 RS485 communication board. If you are using a different CPU, please follow the instructions in chapter [4.3.1](#).

Instead of the CB 1241 RS485 communication board you can also use the CM 1241 RS422/485 communication module to communicate with the ebm-papst fan (here: "VarioDrive C") ([3](#)).

4.1 Installation of the hardware

The figure below shows the hardware configuration of the application:

Figure 4-1

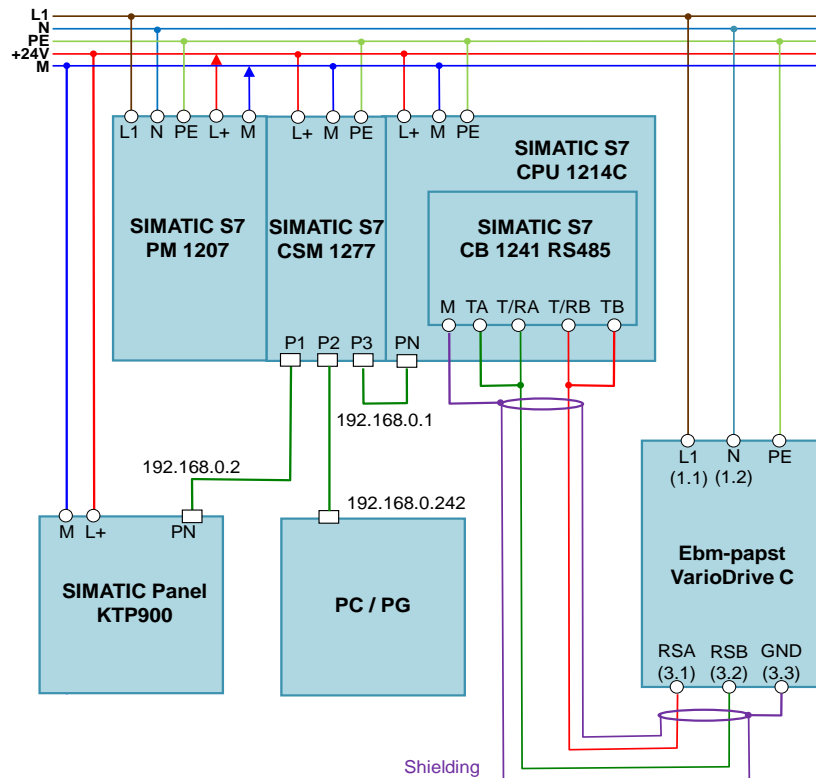

© Siemens AG 2015. All rights reserved.

Table 4-1

No.	Action	Remarks
1.	Install all required S7-1200 components on a top hat rail.	See Table 2-1
2.	Wire and connect all required components as described. Pay special attention to the crossed communication link between CB 1241 RS485 and fan (T/RA – RSB and T/RB – RSA).	See S7-1200 manual (8) Chapter A "Technical Data" and #operating instructions for ebm-papst motor (11)

4 Installation and Startup

4.2 Network connections

No.	Action	Remarks
3.	Finally, connect the VarioDrive C and the SIMATIC PM 1207 power supply to the AC power system (230 V).	

4.2 Network connections

To configure the controller and the HMI, the LAN network card of the programming unit needs a static IP address.

The configuration of the LAN connection is described in the following.

Table 4-2

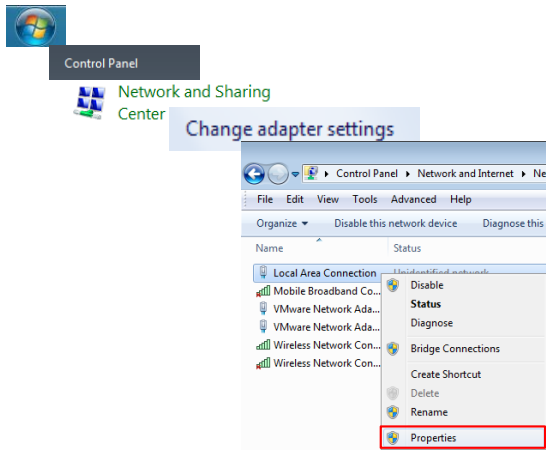
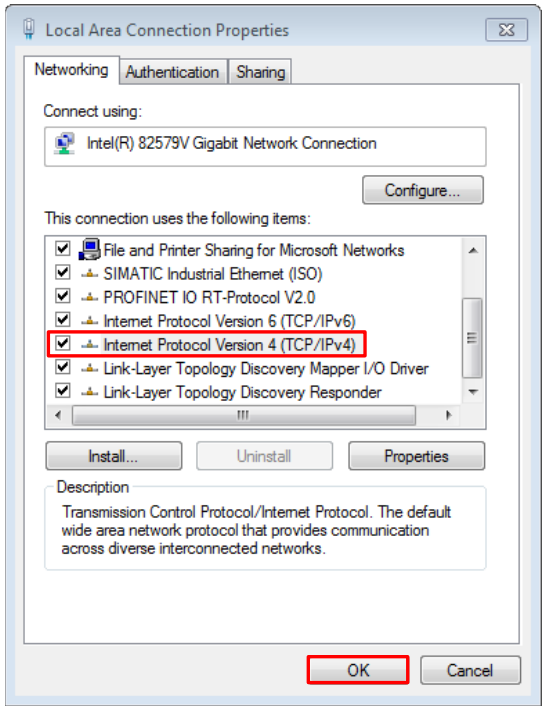
No.	Action	Remarks
1.	<p>Click “Start > Control Panel > Network and Sharing Center > Change adapter settings” to open the network connections.</p> <ul style="list-style-type: none"> Select your network connection. Right-click to open the properties. 	
2.	Select the option “Internet Protocol Version 4 (TCP/IPv4)” and open its properties.	

4 Installation and Startup

4.3 Configuration instructions

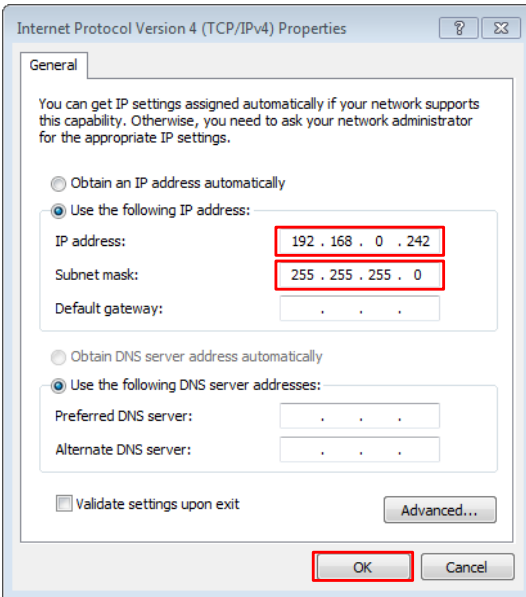
No.	Action	Remarks
3.	<ul style="list-style-type: none"> Choose "Use the following IP address". Select an IP address in the CPU's subnet mask. Confirm the settings with "OK" and "Close". 	

4.2.1 Setting the PG/PC interface

Table 4-3

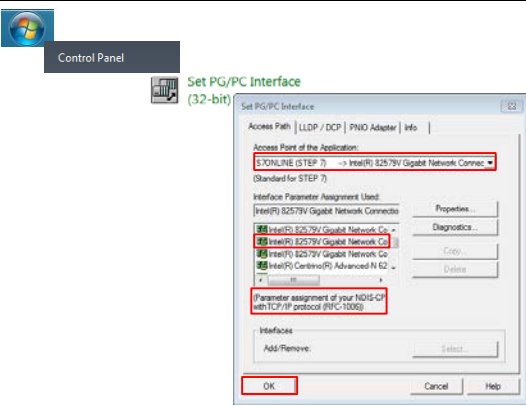
No.	Action	Remarks
1.	<p>Open the PG/PC interface settings via "Start > Control Panel" to set the correct access path for STEP 7 V13.</p> <ul style="list-style-type: none"> Select "S7ONLINE (STEP 7)" as the application's access point. Select your network card with "(Parameter assignment of your NDIS CP with TCP/IP protocol (RFC-1006))" as the interface parameterization used. Confirm the settings with "OK". 	

4.3 Configuration instructions

4.3.1 Adjusting the device configuration

Table 4-4

No.	Action	Remarks
1.	<p>Network the S7-1200 controller with your programming unit. Assign the IP addresses specified in Figure 4-1 for this purpose.</p>	<p>Configuring the CPU for communication: S7-1200 manual (\8) → Chapter 6.8</p>

4 Installation and Startup

4.3 Configuration instructions

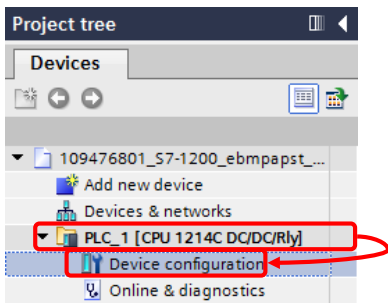
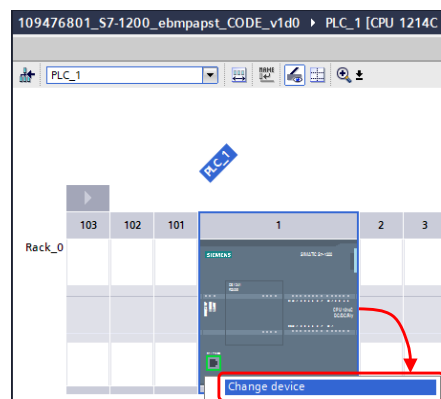
No.	Action	Remarks
2.	Use STEP 7 V13 SP1 to open the project file (ap13).	See Table 2-3
3.	Open the device configuration of the controller "PLC_1".	
4.	If necessary, adjust the CPU configured in the project to the real CPU by selecting the configured CPU and clicking the right mouse button to choose "Change device..." (S7-1200 manual (\8)→ chapter 6.5).	

4.3.2 Downloading the controller project part

Table 4-5

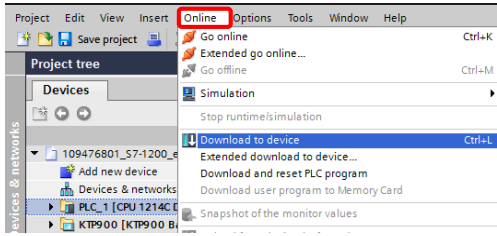

No.	Action	Remarks
1.	Save the project if you have changed CPUs. Select the program folder of the S7-1200 and transfer the program into the controller by clicking the "Download to device" option. Select the option "Stop all" in the "Load preview" under "Stop modules". Select the option "Start all" in the "Load results" under "Start modules" and complete the loading process.	 <p>See S7-1200 manual (\8)→ chapter 15.2</p>

4.4 HMI project part

4.4.1 Configuring the HMI

When using the KTP900 Basic as operator panel, the project-specific IP address (see [Figure 4-1](#)) has to be set.

Table 4-6

No.	Action	Remarks
1.	<ul style="list-style-type: none"> Connect the KTP900 Basic to the power supply voltage. Access the settings by clicking the "Settings" button in the "Start Center". 	
2.	<ul style="list-style-type: none"> Next open the settings of the network interface by clicking the "Network interface" button. 	

4 Installation and Startup

4.4 HMI project part

No.	Action	Remarks
3.	<ul style="list-style-type: none"> Disable the option "DHCP". Enter the network setting from Figure 4-1 for the HMI: <ul style="list-style-type: none"> IP address: 192.168.0.2 Subnet mask = 255.255.255.0 "Default gateway" is irrelevant. Select "Auto negotiation" in the Ethernet parameters to automatically determine the speed transmission. 	

Downloading the HMI project part into the KTP900 Basic

Connect your PG/PC to the HMI either directly or using the CSM1277 switch.

Table 4-7

No.	Action	Remarks
1.	<ul style="list-style-type: none"> Select the operator panel folder "HMI_1 [KTP900 Basic PN]". Click the "Download to device" button to download the HMI project part into the KTP900 Basic. 	
2.	<ul style="list-style-type: none"> When the "Extended download to device" window opens, select "PN/IE" as the type of the PG/PC interface. Select the network card you are using as the PG/PC interface. 	

4 Installation and Startup

4.4 HMI project part

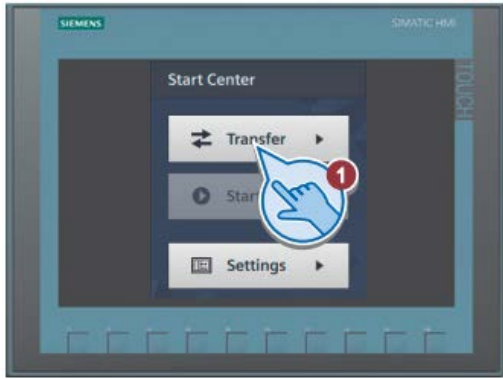
No.	Action	Remarks
3.	<ul style="list-style-type: none"> If necessary, activate the option "Overwrite all". Click the "Load" button. 	
4.	<ul style="list-style-type: none"> Depending on the operator panel settings, you may have to trigger the transfer by clicking the "Transfer" button in the Start Center of the KTP900 Basic. 	

Starting the PC runtime

If you want to use the PG/PC as the operator panel, start the PC runtime as follows:

Table 4-8

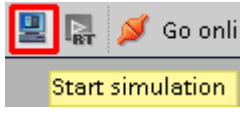
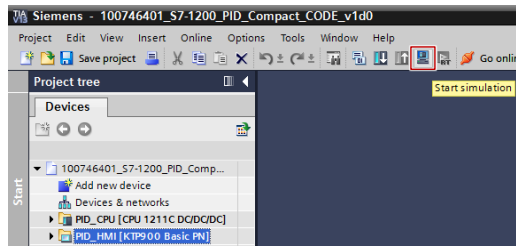
No.	Action	Remarks
1.	<ul style="list-style-type: none"> Select the operator panel folder "PID_HMI [KTP900 Basic PN]". Click the "Start simulation" button. 	

5 Operation of the Application

Overview and description of the HMI

Figure 5-1



The user interface consists of 6 menus:

- Overview (start display)
- Trend view
- All parameters
- Alarm buffer
- System diagnostics
- Settings

5.1 Overview (start screen)

The overview provides information about the current topic.





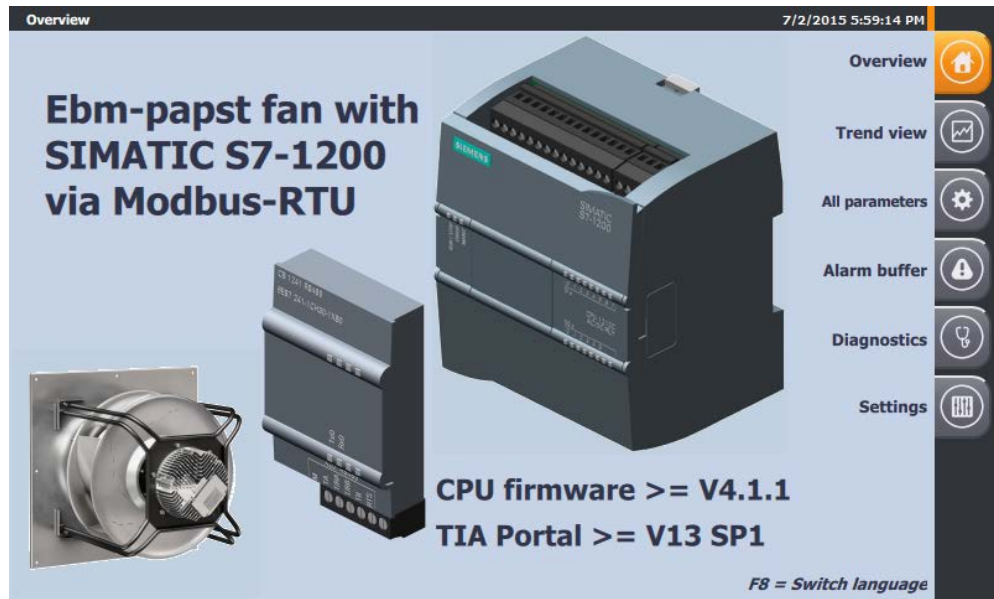

It presents the connection of a fan from ebm-papst to the SIMATIC S7-1200 product family using Modbus-RTU. The integrated system functions "Modbus_Comm_Load" and "Modbus_Master" are available in the SIMATIC S7-1200 controller from CPU firmware V4.1.1 in connection with STEP 7 (TIA Portal) from version V13 SP1 ([\3](#)).

Additionally, operation of the right menu bar is explained.

This bar is available on each display.

Figure 5-2



-  takes you to the “Overview” (the picture above).
 -  takes you to the “Trend view” ([Figure 5-6](#)).
 -  takes you to the “All parameters” overview ([Figure 5-8](#)).
 -  takes you to the “Alarm buffer” display ([Figure 5-10](#)).
 -  takes you to the “System diagnostics” display ([Figure 5-11](#)).
 -  takes you to the “Settings” display ([Figure 5-12](#)).
 - The F8 key can be used to switch between German and English.
- The currently selected menu is highlighted by the orange background of the icon,

e.g.  (for the overview) and in the title in header (left): **Overview**.

In the right section of the header you can see the current date and time:

9/19/2014 1:15:40 PM

The header is also visible in all displays.

5.2 Recurrent display elements

The following subchapters describe the recurrent display elements available both in the “Trend view” display and in the “All parameters” display:

5.2.1 Cyclically retrieved values (input registers)

The upper part of the display shows the most important input registers (in green) which are read cyclically.

These values are available both in the “Trend view” display and in the “All parameters” display (with the difference that the “Actual speed” and the “Current set value” have the same background color as the lines in the “Trend view”).

Figure 5-3

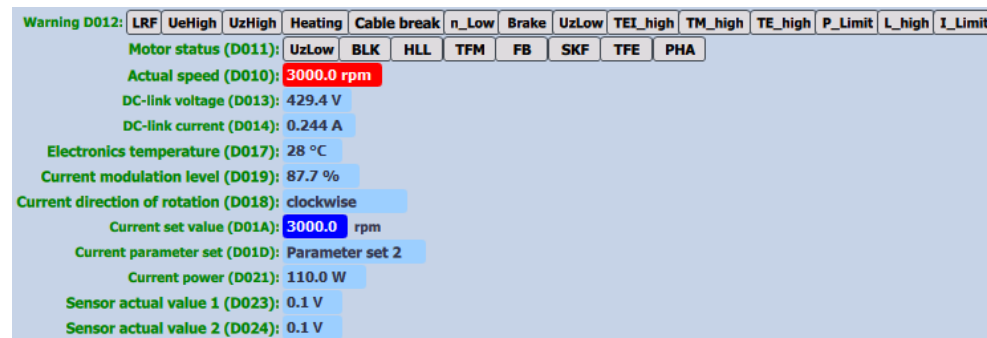

All registers are displayed numerically or as text.

The statuses for “Motor status (D011)” and “Warnings” (D012) are displayed in color.



These messages are also listed in the alarm buffer in text form (chapter 5.5).

Additionally, the motor statuses are also displayed globally as current alarm states in the lower section:



This display has to be closed using (before operation of the HMI using the touch function is possible again).

5.2.2 Writing to the holding registers

The holding registers (purple font) are written according to the selection of the corresponding register in the drop-down menu.

Depending on the selected display, you can access all writable registers from [Table 3-1](#) in the “All parameters” display and only the following registers in the “Trend view” display:

- D001: Default set value
- D102: Preferred running direction
- D105: Internal parameter set

Figure 5-4

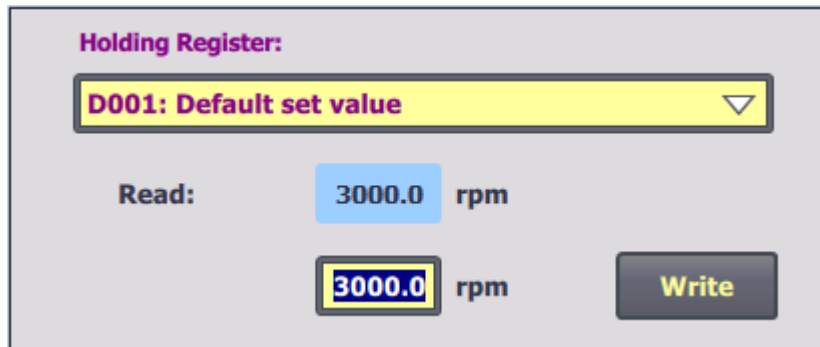

If the register to be written changes, it will be read automatically (blue background) and the read value is taken over from the input/output field (yellow background) to be written. You can now edit the value within the specified limits and transfer the value to the fan using the “Write” button.

Subsequently, the selected register is automatically read again.

If the transfer has been successful, the read value corresponds to the written value.

Certain holding registers (see [Table 3-1](#)) are first written to the fan's EEPROM and in order to be transferred to the RAM, they require the “Param.” function to be executed in the “Reset” (D000) holding register. These parameters have the edit

value field displayed with an orange background: 1

If the register access requires authorization of a password (see [Table 3-1](#)) that has not been transferred yet, error code 16#8388 (“Error in the response of the slave to write request”) occurs in the status evaluation.

Default settings to operate the application

Starting from the factory settings of the interface parameter settings,

Table 5-1

Address	Designation	Value
D100	Fan address	1
D149	Transfer rate	19200 bit/sec
D14A	Parity configuration	8E1

the following default settings of the holding registers have to be made for the application to run smoothly:

Table 5-2

Address	Designation	Value
D101	Set value source	RS485
D104	Source parameter set	“Internal parameter set”
D148	Source direction of rotation	“Preferred running direction”

5.2 Recurrent display elements

All 3 parameter defaults are written to the fan's EEPROM. To be applied, the values have to be copied into the RAM. This is accomplished by executing (write) the "Param." function in the "Reset" (D000) holding register.

NOTE You can restore the factory settings using the "Control default setting" (D005) holding register by executing the function "W -> D". For this purpose, you need a 12-digit hexadecimal password which you have to write into the "Password" (D002) holding register first. This password is available from ebm-papst.

5.2.3 Status evaluation

At the bottom edge of the display, you see a status display of the data exchange with the fan.

Figure 5-5

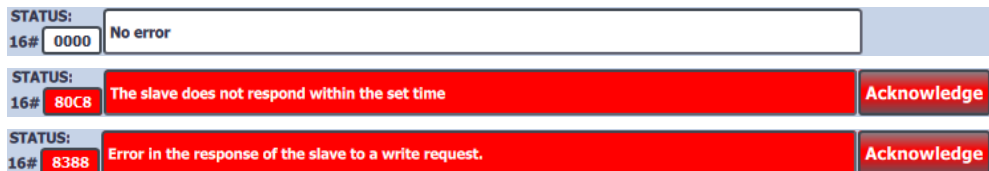

During error-free operation, the status is marked with hexadecimal code 16#0000 ("No error").

When errors occur, the error code in connection with the plain text output provides information about the error that has occurred.

The following table lists the most frequent errors:

Table 5-3

Code	Text	Cause
16#80C8	The slave does not respond within the set time	Disturbed connection to the fan (e.g. missing voltage supply of fan)
16#8388	Error in the response of the slave to a write request	Missing password authorization to write the selected holding register

NOTE Further conditional codes are provided in the chapter "[Modus RTU Instructions](#)" in the S7-1200 system manual ([18](#)).

Errors that occur remain pending. The error display is only reset after the error has been acknowledged using the **Acknowledge** button (provided that the error no longer applies).

5.3 Trend view

The “Trend view” display shows the progress over a period of 100 seconds

- of the current set value **Current set value (D01A): 0.0 rpm / 0.0 %**
- of the actual speed **Actual speed (D010): 0.0 rpm**

Figure 5-6

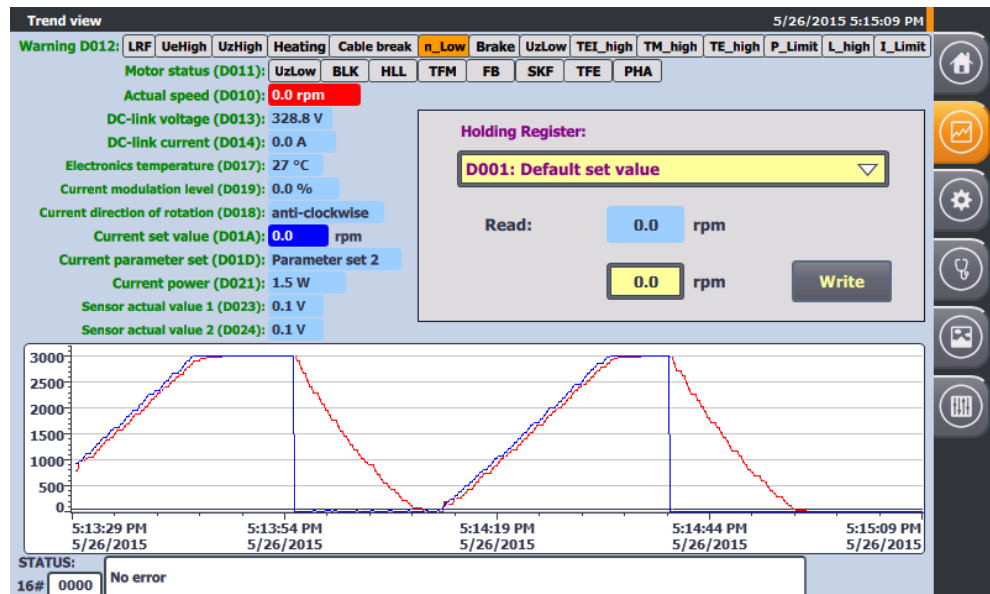

Depending on which operating mode is set (holding register D106/D107), the current set value is displayed in the unit “1/min” for speed control and in “%” for control.

Accordingly, the display of the curve will vary. In the operating mode “speed control”, the reference scale for set and actual values is located on the left. In the operating mode “control”, the reference scale for the set value is located left (in “%”) and the reference scale for the actual value right (in “1/min”).

Figure 5-7

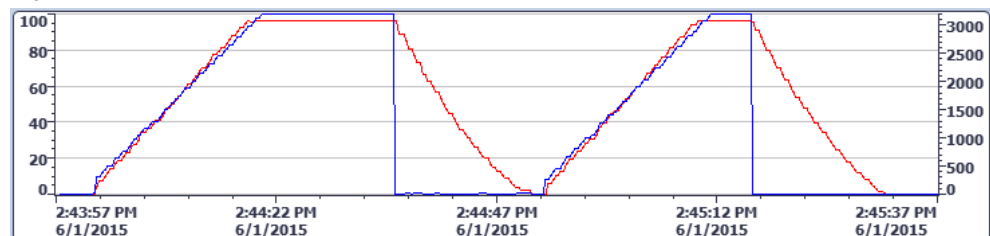

5.4 All parameters

The “All parameters” display gives access to the recurrent display elements (chapter 5.2) and also to all registers (see chapter 3.2).

Figure 5-8

The screenshot shows the 'All parameters' interface with a top navigation bar containing tabs: Warning D012, LRF, UeHigh, UzHigh, Heating, Cable break, n_Low (selected), Brake, UzLow, TEI_high, TM_high, TE_high, P_Limit, L_high, I_Limit. Below the tabs, a list of parameters is displayed with their values and units. A 'Holding Register' dialog is open for D001, showing a dropdown menu with 'Default set value', a 'Read' field with '0.0 %', and a 'Write' field with '0.0 %' and a 'Write' button. At the bottom, a 'Read all' button is visible, and a 'STATUS' section shows '16# 0000 No error'.

Parameter	Value	Unit
Motor status (D011)	UzLow	
Actual speed (D010)	0.0	rpm
DC-link voltage (D013)	324.6	V
DC-link current (D014)	0.0	A
Electronics temperature (D017)	29	°C
Current modulation level (D019)	0.0	%
Current direction of rotation (D018)	anti-clockwise	
Current set value (D01A)	0.0	%
Current parameter set (D01D)	Parameter set 2	
Current power (D021)	1.9	W
Sensor actual value 1 (D023)	0.1	V
Sensor actual value 2 (D024)	0.1	V
Operating hours counter (D009-D00A)	36 h	1 min
Max. permissible speed (D11A)	3000.0	rpm
Max. starting modulation level (D151)	39.8	%
Reference value of DC-link voltage (D1A0)	526.0	V
Reference value of DC-link current (D1A1)	4.8	A
Fan serial number (D1A2-D1A3)	0FD1	
Fan production date (D1A4)	14	14
Fan type (D1A5-D1AA)	M3G112GA5372	
Identification (D000)	0008	
SW bus controller (D002-D003)	1330	1
SW commutation controller (D004-D005)	45062	11

The drop-down menu in the dialog for writing to the holding registers provides access to all writable holding registers (see Table 3-1).

Additionally, you can read all other non-writable registers (blue background) using the **Read all** button:

- Device-specific input registers (green font)
- Non-writable holding registers (purple font)

Figure 5-9

The screenshot shows the 'All parameters' interface with a 'Read all' button highlighted. The parameters are displayed in a grid format, with some values highlighted in blue background. The 'Read all' button is positioned over the 'Identification (D000)' parameter.

Parameter	Value	Unit
Operating hours counter (D009-D00A)	36 h	1 min
Max. permissible speed (D11A)	3000.0	rpm
Max. starting modulation level (D151)	39.8	%
Reference value of DC-link voltage (D1A0)	526.0	V
Reference value of DC-link current (D1A1)	4.8	A
Fan serial number (D1A2-D1A3)	0FD1	
Fan production date (D1A4)	14	14
Fan type (D1A5-D1AA)	M3G112GA5372	
Identification (D000)	0008	
SW bus controller (D002-D003)	1330	1
SW commutation controller (D004-D005)	45062	11

While all other parameters are being read, the **Read all** button disappears.

Reading of the other parameters is a snapshot.

For an update, the action has to be repeated (for example for the operating hours counter: holding register D009 / D00A).

5.5 Alarm buffer

NOTE In order to control the fan via Modbus RTU without any problems, certain holding registers need to have the corresponding default settings (see chapter [5.2.2](#)).

5.5 Alarm buffer

This display lists the following alarm messages including time stamp and status in text form as alarm buffer:

- System alarms (marked by a prefixed “\$”)
- Motor status (input register D011 – marked by a prefixed “!” – red background)
- Warnings (input register D012 – orange background)

Both the incoming event (status “I”) and the outgoing event (status “IO”) are recorded.

Figure 5-10

Time	Date	Status	Text
! 6:07:01 PM	7/2/2015	IO	PHA: Phase failure (3-phase devices) or mains undervoltage (1-phase devices)
! 6:07:01 PM	7/2/2015	I	PHA: Phase failure (3-phase devices) or mains undervoltage (1-phase devices)
6:03:55 PM	7/2/2015	I	n_Low: Actual speed is less than limit speed for running monitor
6:03:32 PM	7/2/2015	IO	n_Low: Actual speed is less than limit speed for running monitor
4:56:25 PM	7/2/2015	I	n_Low: Actual speed is less than limit speed for running monitor
\$ 4:56:25 PM	7/2/2015	I	Connection established: HMI_Connection_1, Station 192.168.0.1, Rack 0, Slot 1.
\$ 4:56:23 PM	7/2/2015	I	Change to operating mode 'online'.
\$ 4:56:23 PM	7/2/2015	I	Project modified: Alarms cannot be restored from the persistent alarm buffer.

NOTE For more information about the input registers D011 (motor status) and D012 (warning), see chapter [5.2.1](#) and the MODBUS parameter specification for “ebm-papst series 84 / 112 / 150 / 200” V5.00 (see chapter 7).

5.6 System diagnostics

The “System diagnostics” display shows the system diagnostics buffer of the S7-1200 controller.

Figure 5-11

System diagnostics			
5/29/2015 4:36:22 PM			
Diagnostic overview \ Diagnostic buffer view			
No.	Date	Time	Event
1	5/29/2015	11:04:28 AM	Follow-on operating mode change - CPU changes from STARTUP to RUN mode
2	5/29/2015	11:04:27 AM	Follow-on operating mode change - CPU changes from STOP to STARTUP mode
3	5/29/2015	11:04:27 AM	New startup information - Current CPU operating mode: STOP
4	5/29/2015	11:04:27 AM	Follow-on operating mode change - CPU changes from STOP (initialization) to STOP mode
5	5/29/2015	11:04:24 AM	Power on - CPU changes from NO POWER to STOP (initialization) mode
6	5/28/2015	6:07:30 PM	Power off - CPU changes from RUN to NO POWER mode
7	5/28/2015	1:25:22 PM	Follow-on operating mode change - CPU changes from STARTUP to RUN mode
8	5/28/2015	1:25:21 PM	Follow-on operating mode change - CPU changes from STOP to STARTUP mode
9	5/28/2015	1:25:21 PM	New startup information - Current CPU operating mode: STOP
10	5/28/2015	1:25:21 PM	Follow-on operating mode change - CPU changes from STOP (initialization) to STOP mode
11	5/28/2015	1:25:18 PM	Power on - CPU changes from NO POWER to STOP (initialization) mode
12	5/28/2015	1:24:45 PM	Power off - CPU changes from RUN to NO POWER mode
13	5/28/2015	11:13:28 AM	Follow-on operating mode change - CPU changes from STARTUP to RUN mode

5.7 Settings

The settings menu contains the dialogs:

- System time / PLC
- Brightness
- User view
- System

Figure 5-12

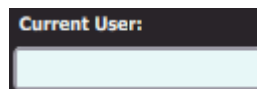
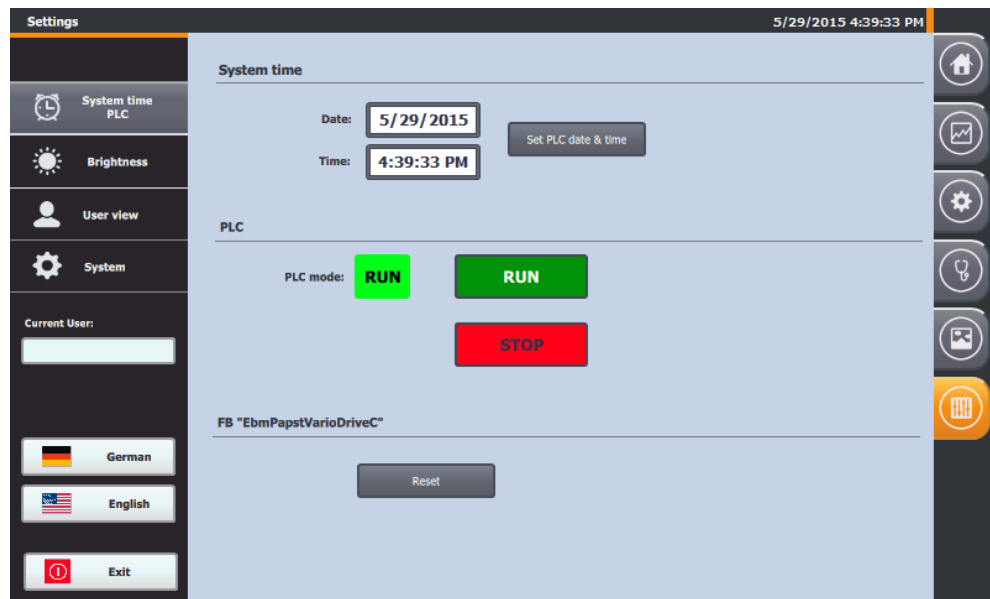

When a user logs on, the name is displayed:

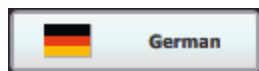

Click to select “German” as the display language.

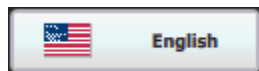

Click to select “English” as the display language.

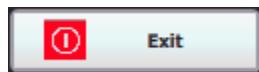

Click to exit the HMI runtime.

5.7.1 System time/PLC

System time

The application has a time synchronization between PLC and HMI.

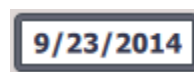

allows you to edit the date and

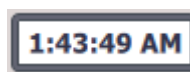

to edit the time.

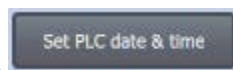

Click to apply the settings and adjust the CPU system time.

5.7 Settings

PLC



shows the current PLC mode.



Click to switch the PLC to "RUN" mode.



Click to switch the PLC to "STOP" mode.

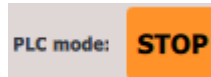

In the PLC mode, the header and side bar alternately flash orange:



FB "EbmPapst"

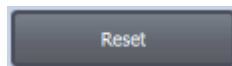

Click the button to reset the sequencer of the function block "EbmPapst".

5.7.2 Brightness

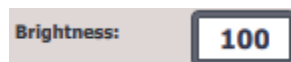

allows you to regulate the brightness in percent (setting range: 30 to 100%) of the operator panel (only possible when using a real HMI).

5.7.3 User display

When a user logs on, the details (user, password, group and logoff time) are displayed here. No authorization was assigned for the application. Therefore, no user logon is necessary.

Figure 5-13

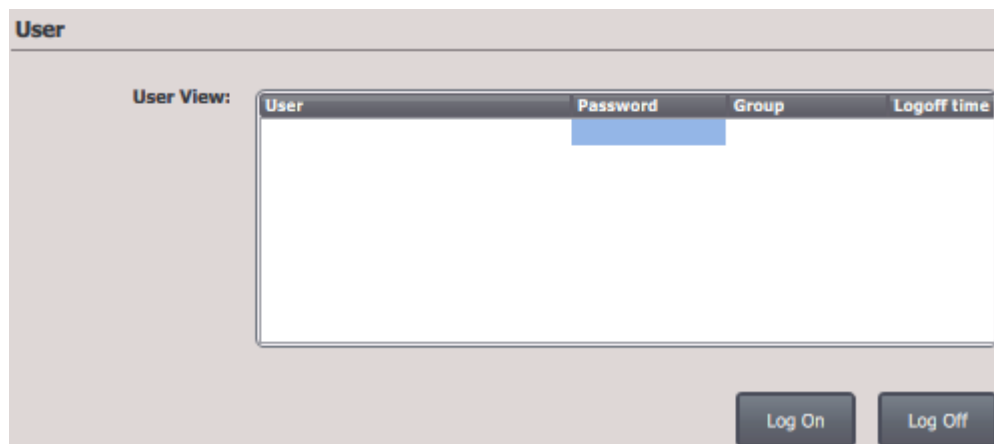

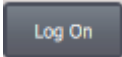
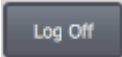
Click  to log on and  to log off.

5.7.4 System

Click  to temporarily disable the touch panel in order to clean it (only possible when using a real HMI).

6 Related Literature

Table 6-1

	Topic	Title / Link
\1\	Siemens Industry Online Support	http://support.industry.siemens.com
\2\	Download page of this entry	https://support.industry.siemens.com/cs/ww/en/view/109476801
\3\	How can you read input words in the address range from 9999 to 65535 with the SIMATIC S7-1200 via Modbus RTU?	https://support.industry.siemens.com/cs/ww/en/view/109474481
\4\	Service Pack 1 for SIMATIC STEP 7 V13 incl. PLCSIM (TIA Portal)	https://support.industry.siemens.com/cs/ww/en/view/105825934
\5\	Updates for STEP 7 V13 SP1 and WinCC V13 SP1	https://support.industry.siemens.com/cs/ww/en/view/109311724
\6\	Firmware updates for SIMATIC S7-1200 CPUs	https://support.industry.siemens.com/cs/ww/en/ps/13685/dl
\7\	Firmware update V2.1.0 for CM 1241	https://support.industry.siemens.com/cs/ww/en/view/108819199
\8\	Manual: SIMATIC S7 S7-1200 Programmable controller	https://support.industry.siemens.com/cs/ww/en/view/107623221
\9\	Manual: STEP 7 Basic V13 SP1	https://support.industry.siemens.com/cs/ww/en/view/109054417
\10\	Ebm-papst website	http://www.ebmpapst.com/en/index.php
\11\	Operating instructions M3G112GA5271	img.ebmpapst.com/products/manuals/M3G112GA5271-BA-ENG.pdf

7 Contact

If you have questions regarding compatible fans (e.g.

- MODBUS parameter specification for “ebm-papst series 84 / 112 / 150 / 200” V5.00 or
- passwords required to write protected holding registers),

please contact:

ebm-papst Mulfingen GmbH & Co. KG

Bachmühle 2

D - 74673 Mulfingen

Telephone: +49 7938 81-0

mailto: info1@de.ebmpapst.com

8 History

Table 8-1

Version	Date	Modifications
V1.0	08/2015	First version