

# SIEMENS

## SIMATIC NET

### Industrial Ethernet switches SCALANCE XB-000



#### Operating Instructions

<u>Introduction</u>	<b>1</b>
<u>Network topologies</u>	<b>2</b>
<u>Description of the device</u>	<b>3</b>
<u>Mounting</u>	<b>4</b>
<u>Connecting up</u>	<b>5</b>
<u>Maintenance and troubleshooting</u>	<b>6</b>
<u>Technical specifications</u>	<b>7</b>
<u>Approvals</u>	<b>8</b>
<u>Dimension drawings</u>	<b>9</b>

## Legal information

### Warning notice system

This manual contains notices you have to observe in order to ensure your personal safety, as well as to prevent damage to property. The notices referring to your personal safety are highlighted in the manual by a safety alert symbol, notices referring only to property damage have no safety alert symbol. These notices shown below are graded according to the degree of danger.

 <b>DANGER</b>
indicates that death or severe personal injury <b>will</b> result if proper precautions are not taken.
 <b>WARNING</b>
indicates that death or severe personal injury <b>may</b> result if proper precautions are not taken.
 <b>CAUTION</b>
indicates that minor personal injury can result if proper precautions are not taken.
<b>NOTICE</b>
indicates that property damage can result if proper precautions are not taken.

If more than one degree of danger is present, the warning notice representing the highest degree of danger will be used. A notice warning of injury to persons with a safety alert symbol may also include a warning relating to property damage.

### Qualified Personnel

The product/system described in this documentation may be operated only by **personnel qualified** for the specific task in accordance with the relevant documentation, in particular its warning notices and safety instructions. Qualified personnel are those who, based on their training and experience, are capable of identifying risks and avoiding potential hazards when working with these products/systems.

### Proper use of Siemens products

Note the following:

 <b>WARNING</b>
Siemens products may only be used for the applications described in the catalog and in the relevant technical documentation. If products and components from other manufacturers are used, these must be recommended or approved by Siemens. Proper transport, storage, installation, assembly, commissioning, operation and maintenance are required to ensure that the products operate safely and without any problems. The permissible ambient conditions must be complied with. The information in the relevant documentation must be observed.

### Trademarks

All names identified by ® are registered trademarks of Siemens AG. The remaining trademarks in this publication may be trademarks whose use by third parties for their own purposes could violate the rights of the owner.

### Disclaimer of Liability

We have reviewed the contents of this publication to ensure consistency with the hardware and software described. Since variance cannot be precluded entirely, we cannot guarantee full consistency. However, the information in this publication is reviewed regularly and any necessary corrections are included in subsequent editions.

# Table of contents

<b>1</b>	<b>Introduction</b> .....	<b>5</b>
1.1	On the Operating Instructions.....	5
1.2	On the product.....	7
<b>2</b>	<b>Network topologies</b> .....	<b>11</b>
<b>3</b>	<b>Description of the device</b> .....	<b>13</b>
3.1	SCALANCE XB-000 overview.....	13
3.2	Product characteristics.....	15
3.2.1	SCALANCE XB004-1.....	15
3.2.2	SCALANCE XB004-2.....	16
3.2.3	SCALANCE XB004-1LD.....	17
3.2.4	SCALANCE XB005.....	18
3.2.5	SCALANCE XB008.....	19
3.2.6	SCALANCE XB004-1G.....	20
3.2.7	SCALANCE XB004-1LDG.....	21
3.2.8	SCALANCE XB005G.....	22
3.2.9	SCALANCE XB008G.....	23
3.3	TP ports (twisted pair).....	24
3.3.1	Pin assignment.....	24
3.3.2	Functions.....	25
3.3.3	Insulation between the TP ports.....	26
3.4	FO port (fiber optic).....	28
3.4.1	SCALANCE XB004-1.....	28
3.4.2	SCALANCE XB004-2.....	29
3.4.3	SCALANCE XB004-1LD.....	30
3.4.4	SCALANCE XB004-1G.....	31
3.4.5	SCALANCE XB004-1LDG.....	32
3.5	LEDs.....	33
<b>4</b>	<b>Mounting</b> .....	<b>35</b>
4.1	Safety notices for installation.....	35
4.2	Types of installation.....	36
4.3	Fixing onto standard mounting rails.....	37
4.4	Wall mounting.....	39
<b>5</b>	<b>Connecting up</b> .....	<b>41</b>
5.1	Power supply.....	41
5.1.1	Power supply 24 VAC.....	41
5.1.2	Power supply 24 VDC.....	42

5.2	Grounding .....	43
5.3	Twisted pair cable .....	44
5.4	IE FC RJ-45 Plug 180 .....	44
<b>6</b>	<b>Maintenance and troubleshooting.....</b>	<b>47</b>
6.1	Possible sources of problems and how to deal with them.....	47
<b>7</b>	<b>Technical specifications .....</b>	<b>49</b>
7.1	SCALANCE XB004-1.....	49
7.2	SCALANCE XB004-2.....	52
7.3	SCALANCE XB004-1LD .....	54
7.4	SCALANCE XB005.....	57
7.5	SCALANCE XB008.....	59
7.6	SCALANCE XB004-1G.....	61
7.7	SCALANCE XB004-1LDG .....	63
7.8	SCALANCE XB005G .....	65
7.9	SCALANCE XB008G .....	67
<b>8</b>	<b>Approvals .....</b>	<b>69</b>
<b>9</b>	<b>Dimension drawings.....</b>	<b>73</b>
	<b>Index .....</b>	<b>75</b>

# Introduction

## 1.1 On the Operating Instructions

### Purpose of the Operating Instructions

These Operating Instructions support you when commissioning networks with the Industrial Ethernet switches of the SCALANCE XB-000 product line.

### Validity of the Operating Instructions

These operating instructions are valid for the following devices:

Device	Article number
XB004-1	6GK5 004-1BD00-1AB2
XB004-2	6GK5 004-2BD00-1AB2
XB004-1LD	6GK5 004-1BF00-1AB2
XB005	6GK5 005-0BA00-1AB2
XB008	6GK5 008-0BA00-1AB2
XB004-1G	6GK5 004-1GL00-1AB2
XB004-1LDG	6GK5 004-1GM00-1AB2
XB005G	6GK5 005-0GA00-1AB2
XB008G	6GK5 008-0GA00-1AB2

### Further documentation

The "SIMATIC NET Industrial Ethernet Twisted Pair and Fiber Optic Networks" manual contains additional information on other SIMATIC NET products that you can operate along with the IE switches of the SCALANCE XB-000 product line in an Industrial Ethernet network.

You can order the manual "SIMATIC NET Industrial Twisted Pair and Fiber Optic Networks", release 05/2001, using the following order numbers:

6GK1970-1BA10-0AA0 German  
 6GK1970-1BA10-0AA1 English  
 6GK1970-1BA10-0AA2 French  
 6GK1970-1BA10-0AA4 Italian

You will also find this network manual on the Internet pages of Service & Support under the following entry ID: 1172207 (<http://support.automation.siemens.com/WW/view/en/1172207>).

You will find further information in the "System Manual Industrial Ethernet" in the Manual Collection.

You will find further information on the SCALANCE system on the Internet at [www.siemens.com/scalance](http://www.siemens.com/scalance) ([www.siemens.com/scalance](http://www.siemens.com/scalance)).

## Audience

These Operating Instructions are intended for persons who commission networks with the IE switches of the SCALANCE XB-000 product line.

## SIMATIC NET glossary

Explanations of many of the specialist terms used in this documentation can be found in the SIMATIC NET glossary.

You will find the SIMATIC NET glossary here:

- SIMATIC NET Manual Collection or product DVD  
The DVD ships with certain SIMATIC NET products.
- On the Internet under the following address:  
50305045 (<http://support.automation.siemens.com/WW/view/en/50305045>)

## Security information

Siemens provides products and solutions with industrial security functions that support the secure operation of plants, solutions, machines, equipment and/or networks. They are important components in a holistic industrial security concept. With this in mind, Siemens' products and solutions undergo continuous development. Siemens recommends strongly that you regularly check for product updates.

For the secure operation of Siemens products and solutions, it is necessary to take suitable preventive action (e.g. cell protection concept) and integrate each component into a holistic, state-of-the-art industrial security concept. Third-party products that may be in use should also be considered. For more information about industrial security, visit <http://www.siemens.com/industrialsecurity>.

To stay informed about product updates as they occur, sign up for a product-specific newsletter. For more information, visit <http://support.automation.siemens.com>.

## 1.2 On the product

### What is possible?

The IE switches of the SCALANCE XB-000 product line allow the cost-effective installation of Industrial Ethernet bus and star structures with switching functionality.

With the following IE switches, there are also electrical/optical media transitions:

- SCALANCE XB004-1
- SCALANCE XB004-2
- SCALANCE XB004-1LD
- SCALANCE XB004-1G
- SCALANCE XB004-1LDG

---

#### Note

It is not possible to use IE switches of the SCALANCE XB-000 product line in a redundant ring because they do not support redundancy.

---

#### Note

If devices are supplied over long 24 V power supply lines or networks, measures are necessary to prevent interference by strong electromagnetic pulses on the supply lines. These can result, for example, due to lightning or switching of large inductive loads.

One of the tests used to attest the immunity of these devices to electromagnetic interference is the "surge immunity test" according to EN 61000-4-5. This test requires overvoltage protection for the power supply lines. A suitable device is, for example, the Dehn Blitzductor BVT AVD 24 V type no. 918 422 or a comparable protective element. For AC operation, for example the blitzductor BVT ALD 60 Art. no. 918409 or a comparable protective element is suitable.

Manufacturer:

DEHN+SÖHNE GmbH+Co.KG Hans Dehn Str.1 Postfach 1640 D-92306 Neumarkt,  
Germany

---

### Components of the product

The following components are supplied with a SCALANCE XB-000:

- IE switch SCALANCE XB-000
- 3-pin terminal block (power supply)
- Product information

## Accessories

Component	Length	Packaging unit	Order number	Suitable for XB-000 Fast Ethernet	Suitable for XB-000G Gigabit Ethernet
IE TP Cord RJ-45/RJ-45, CAT 6, TP cable 4x2, fitted with 2 RJ-45 plugs	0.5 m	1	6XV1870-3QE50	+	+
IE TP Cord RJ-45/RJ-45, CAT 6, TP cable 4x2, fitted with 2 RJ-45 plugs	1 m	1	6XV1870-3QH10	+	+
IE TP Cord RJ-45/RJ-45, CAT 6, TP cable 4x2, fitted with 2 RJ-45 plugs	2 m	1	6XV1870-3QH20	+	+
IE TP Cord RJ-45/RJ-45, CAT 6, TP cable 4x2, fitted with 2 RJ-45 plugs	6 m	1	6XV1870-3QH60	+	+
IE TP Cord RJ-45/RJ-45, CAT 6, TP cable 4x2, fitted with 2 RJ-45 plugs	10 m	1	6XV1870-3QN10	+	+
IE FC Stripping Tool	-	1	6GK1901-1GA00	+	+
IE FC blade cassettes (5 mm)	-	1	6GK1901-1GB01	+	+
IE FC TP standard cable GP 2x2	-	1	6XV1840-2AH10	+	-
IE FC TP standard cable GP 4x2	-	1	6XV1878-2A	(+)	+
IE FC TP trailing cable	-	1	6XV1840-3AH10	+	-
IE FC TP marine cable	-	1	6XV1840-4AH10	+	-
IE FC TP trailing cable GP	-	1	6XV1870-2D	+	-
IE FC TP flexible cable GP 2x2	-	1	6XV1870-2B	+	-
IE FC TP flexible cable GP 4x2	-	1	6XV1878-2B	(+)	+
IE FC TP FRNC cable GP	-	1	6XV1871-2F	+	-
IE FC TP festoon cable GP	-	1	6XV1871-2S	+	-
IE FC TP food cable	-	1	6XV1871-2L	+	-
IE TP torsion cable	-	1	6XV1870-2F	+	-
FO standard cable 50/125, fitted with 2x2 SC connectors, pulling aid	80 m	1	6XV1873-6AN80	+	+
FO standard cable 50/125, fitted with 2x2 SC connectors, pulling aid	100 m	1	6XV1873-6AT10	+	+
FO standard cable 50/125, fitted with 2x2 SC connectors, pulling aid	150 m	1	6XV1873-6AT15	+	+
FO standard cable 50/125, fitted with 2x2 SC connectors, pulling aid	200 m	1	6XV1873-6AT20	+	+
FO standard cable 50/125, fitted with 2x2 SC connectors, pulling aid	300 m	1	6XV1873-6AT30	+	+
FO standard cable GP (50/125)	-	1	6XV1873-2A	+	+
FO trailing cable (50/125)	-	1	6XV1873-2C	+	+
FO trailing cable GP (50/125)	-	1	6XV1873-2D	+	+
FO ground cable (50/125)	-	1	6XV1873-2G	+	+

Component	Length	Packaging unit	Order number	Suitable for XB-000 Fast Ethernet	Suitable for XB-000G Gigabit Ethernet
FO FRNC cable (50/125)	-	1	6XV1873-2B	+	+
IE FC RJ-45 Plug 180 2x2	-	1	6GK1901-1BB10-2AA0	+	-
IE FC RJ-45 Plug 4x2	-	1	6GK1901-1BB11-2AA0	(+)	+
IE FC RJ-45 Plug 180 2x2	-	10	6GK1901-1BB10-2AB0	+	-
IE FC RJ-45 Plug 4x2	-	10	6GK1901-1BB11-2AB0	(+)	+
IE FC RJ-45 Plug 180 2x2	-	50	6GK1901-1BB10-2AE0	+	-
IE FC RJ-45 Plug 4x2	-	50	6GK1901-1BB11-2AE0	(+)	+

### Note

For the devices with Fast Ethernet, you can use cables and connectors with 2x2 lines. The use of 4x2 lines is also possible but not absolutely necessary. These products are indicated by (+).

## Unpacking and checking

<p> <b>WARNING</b></p> <p><b>Do not use any parts that show evidence of damage</b></p> <p>If you use damaged parts, there is no guarantee that the device will function according to the specification.</p> <p>If you use damaged parts, this can lead to the following problems:</p> <ul style="list-style-type: none"> <li>• Injury to persons</li> <li>• Loss of the approvals</li> <li>• Violation of the EMC regulations</li> <li>• Damage to the device and other components</li> </ul> <p>Use only undamaged parts.</p>
---

1. Make sure that the package is complete.
2. Check all the parts for transport damage.

## Electrostatic discharge



### NOTICE

#### Electrostatic sensitive devices (ESD)

Electronic modules contain electrostatic sensitive components

These components can easily be destroyed if handled incorrectly.

Note the following instructions to avoid damage.

- Touch electronic modules only when you absolutely need to work on them.
- If electronic modules need to be touched, the body of the person involved must first be electrostatically discharged and grounded.
- Do not bring electronic modules in contact with electrically isolating materials such as plastic film, isolating table top pads or clothing made of synthetic fibers.
- Place the modules only on conductive surfaces.
- Pack, store and transport electronic modules and components only in conductive packaging such as metalized plastic or metal containers, conductive foam or household aluminum foil.

## Network topologies

Switching technology allows extensive networks to be set up with numerous nodes and simplifies network expansion.

### Which topologies can be implemented?

Using the IE switches of the SCALANCE XB-000 product line, you can implement star topologies.

---

#### Note

Keep to the maximum permitted cable lengths of the devices you are using. You will find the permitted cable lengths in the section "Technical specifications (Page 49)".

---

### Star topology

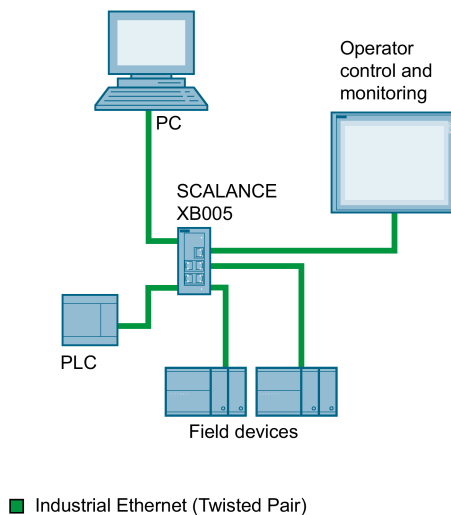

Figure 2-1 Example of an electrical star topology with SCALANCE XB005

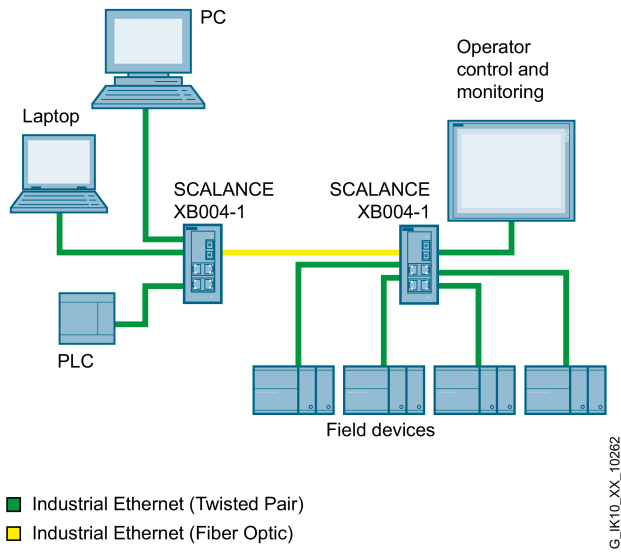

Figure 2-2 Example of an electrical/optical star topology with SCALANCE XB004-1

## Description of the device

### 3.1 SCALANCE XB-000 overview

Table 3- 1 Overview of the product characteristics

	XB004-1	XB004-2	XB004-1LD	XB005	XB008	XB004-1G	XB004-1LDG	XB005G	XB008G
SIMATIC environment	+	+	+	+	+	+	+	+	+
Diagnostics LED	+	+	+	+	+	+	+	+	+
24 VDC	+	+	+	+	+	+	+	+	+
24 VAC	+ <sup>1)</sup>	-	+ <sup>1)</sup>	+ <sup>1)</sup>	-	-	-	-	-
2 x 24 VDC	-	-	-	-	-	-	-	-	-
Signaling contact + on-site operation	-	-	-	-	-	-	-	-	-
Diagnostics: Web, SNMP, PROFINET	-	-	-	-	-	-	-	-	-
C-PLUG	-	-	-	-	-	-	-	-	-
Ring redundancy with RM	-	-	-	-	-	-	-	-	-
Passive ring redundancy	-	-	-	-	-	-	-	-	-
Standby redundancy	-	-	-	-	-	-	-	-	-
IRT capability	-	-	-	-	-	-	-	-	-
Fast learning	-	-	-	-	-	-	-	-	-
Passive listening	-	-	-	-	-	-	-	-	-
Log table	-	-	-	-	-	-	-	-	-
SNTP + SICLOCK	-	-	-	-	-	-	-	-	-
Cut Through	-	-	-	-	-	-	-	-	-

<sup>1)</sup>Note the Hardware version (Page 49).

3.1 SCALANCE XB-000 overview

Table 3-2 Overview of the connection options

	XB004-1	XB004-2	XB004-1LD	XB005	XB008	XB004-1G	XB004-1LDG	XB005G	XB008G
TP (RJ-45) Fast Ethernet 10 / 100 Mbps	4	4	4	5	8	-	-	-	-
Fiber multimode (SC) Fast Ethernet 100 Mbps	1	2	0	-	-	-	-	-	-
Single-mode fiber (SC) Fast Ethernet 100 Mbps	0	0	1	-	-	-	-	-	-
TP (RJ-45) Gigabit Ethernet 10 / 100 / 1000 Mbps	-	-	-	-	-	4	4	5	8
Fiber multimode (SC) Gigabit Ethernet 1000 Mbps	-	-	-	-	-	1	0	-	-
Fiber single mode (SC) Gigabit Ethernet 1000 Mbps	-	-	-	-	-	0	1	-	-

## 3.2 Product characteristics

### 3.2.1 SCALANCE XB004-1

#### Possible attachments

The SCALANCE XB004-1 has four RJ-45 jacks and an SC socket for the connection of end devices or other network segments.



Figure 3-1 SCALANCE XB004-1

### 3.2.2 SCALANCE XB004-2

#### Possible attachments

The SCALANCE XB004-2 has four RJ-45 jacks and two SC sockets for the connection of end devices or other network segments.



Figure 3-2 SCALANCE XB004-2

### 3.2.3 SCALANCE XB004-1LD

#### Possible attachments

The SCALANCE XB004-1LD has four RJ-45 jacks and an SC socket for the connection of end devices or other network segments.



Figure 3-3 SCALANCE XB004-1LD

### 3.2.4 SCALANCE XB005

#### Possible connections

The SCALANCE XB005 has five RJ-45 jacks for connection of end devices or other network segments.



Figure 3-4 SCALANCE XB005

### 3.2.5 SCALANCE XB008

#### Possible connections

The SCALANCE XB008 has eight RJ-45 jacks for the connection of end devices or other network segments.



Figure 3-5 SCALANCE XB008

### 3.2.6 SCALANCE XB004-1G

#### Possible attachments

The SCALANCE XB004-1G has four RJ-45 jacks capable of Gigabit and an SC socket for the connection of end devices or other network segments.



Figure 3-6 SCALANCE XB004-1G

### 3.2.7 SCALANCE XB004-1LDG

#### Possible attachments

The SCALANCE XB004-1LDG has four RJ-45 jacks capable of Gigabit and an SC socket for the connection of end devices or other network segments.



Figure 3-7 SCALANCE XB004-1LDG

### 3.2.8 SCALANCE XB005G

#### Possible attachments

The SCALANCE XB005G has five RJ-45 jacks capable of Gigabit for connection of end devices or other network segments.



Figure 3-8 SCALANCE XB005G

### 3.2.9 SCALANCE XB008G

#### Possible attachments

The SCALANCE XB008G has eight RJ-45 jacks capable of Gigabit for the connection of end devices or other network segments.

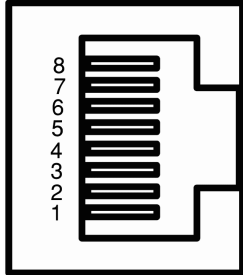

Figure 3-9 SCALANCE XB008G

### 3.3 TP ports (twisted pair)

#### 3.3.1 Pin assignment

With IE switches of the SCALANCE XB-000 product line, the twisted-pair ports are designed as RJ-45 jacks with MDI-X pin assignment (Medium Dependent Interface Autocrossover) of a network component.



Pin number	Assignment for SCALANCE XB-000	Assignment for SCALANCE XB-000G
Pin 8	n. c.	D4-
Pin 7	n. c.	D4+
Pin 6	TD-	D2-
Pin 5	n. c.	D3-
Pin 4	n. c.	D3+
Pin 3	TD+	D2+
Pin 2	RD-	D1-
Pin 1	RD+	D1+

---

#### Note

TP cords or TP-XP cords with a maximum length of 10 m can be connected to the TP port with the RJ-45 jack.

With the IE FC cables and IE FC RJ-45 plug 180, an overall cable length of a maximum of 100 m is permitted between two devices depending on the cable type.

---

### 3.3.2 Functions

#### Autonegotiation

With the autonegotiation mechanism, repeaters and end devices can automatically determine the transmission speed and the transmission mode of the partner port. This makes it possible to configure different devices automatically.

Two components connected to a link segment can exchange information about the data transfer and can adapt their settings to each other. The mode with the highest possible speed is set.

---

#### **Note**

Devices not supporting autonegotiation must be set to 1000 Mbps/ half duplex, 100 Mbps/ half duplex or 10 Mbps half duplex.

---

#### **Note**

The IE switches of the SCALANCE XB-000 product line are plug-and-play devices that require no settings during commissioning.

---

#### Auto polarity exchange

If the pair of receiving cables is connected incorrectly (RD+ and RD- interchanged), the polarity is adapted automatically.

#### MDI / MDI-X autocrossover function

With the MPI/MDI-X autocrossover function, the send and receive contacts of an Ethernet port are assigned automatically. The assignment depends on the cable with which the communications partner is connected. This means that it does not matter whether the port is connected using a patch cable or crossover cable. This prevents malfunctions resulting from mismatching send and receive lines. This makes installation much easier for the user.

The IE switches of the SCALANCE XB-000 product line all support the MDI/MDIX autocrossover function.

---

#### **Note**

Please note that the direct connection of two ports on the IE switch or accidental connection over several IE switches causes an illegal loop. Such a loop can lead to network overload and network failures.

---

### 3.3.3 Insulation between the TP ports

The insulation between the TP ports is based on the number of TP ports.

The SCALANCE XB004-1 group includes the following devices:

- SCALANCE XB004-1
- SCALANCE XB004-1LD
- SCALANCE XB004-1G
- SCALANCE XB004-1LDG

The SCALANCEXB004-2 group includes the following devices:

- SCALANCE XB004-2

The SCALANCE XB005 group includes the following devices:

- SCALANCE XB005
- SCALANCE XB005G

The SCALANCE XB008 group includes the following devices:

- SCALANCE XB008
- SCALANCE XB008G

#### SCALANCE XB004-1

There are two TP port groups:

Group1: P1 and P4

Group2: P2 and P5

Between ports of different port groups, an insulation voltage of 1.5 kV is adhered to (corresponds to IEEEE802.3, Chapter 33.4.1.1, Environment B), e.g. between P1 and P2.

The requirements for Environment A are met between ports of the same group, e.g. between P1 and P4.

#### SCALANCE XB004-2

There are two TP port groups:

Group1: P2 and P5

Group2: P3 and P6

Between ports of different port groups, an insulation voltage of 1.5 kV is adhered to (corresponds to IEEEE802.3, Chapter 33.4.1.1, Environment B), e.g. between P2 and P3.

The requirements for Environment A are met between ports of the same group, e.g. between P2 and P5.

## **SCALANCE XB005**

There are three TP port groups:

Group1: P1 and P4

Group2: P2 and P5

Group3: P3

Between ports of different port groups, an insulation voltage of 1.5 kV is adhered to (corresponds to IEEEE802.3, Chapter 33.4.1.1, Environment B), e.g. between P1 and P2.

The requirements for Environment A are met between ports of the same group, e.g. between P2 and P5.

## **SCALANCE XB008**

There are four TP port groups:

Group1: P1 and P5

Group2: P2 and P6

Group3: P3 and P7

Group4: P4 and P8

Between ports of different port groups, an insulation voltage of 1.5 kV is adhered to (corresponds to IEEEE802.3, Chapter 33.4.1.1, Environment B), e.g. between P2 and P4.

The requirements for Environment A are met between ports of the same group, e.g. between P1 and P5.

### 3.4 FO port (fiber optic)

<b>NOTICE</b>
<b>Failure of the data traffic due to contamination of optical plug-in connections</b>
Optical sockets and plugs are sensitive to contamination of the end face. Contamination can lead to the failure of the optical transmission network.
Close unused optical sockets and plugs as well as pluggable transceivers and slots with the supplied protective caps.
Remove the protective caps only immediately before you use the plug-in connection.

#### 3.4.1 SCALANCE XB004-1

##### Transmission rate

The transmission rate of the optical Fast Ethernet port is 100 Mbps.

##### Transmission mode

The transmission mode for 100Base-FX is specified in the IEEE 802.3 standard.

Since the full duplex mode and the transmission rate cannot be modified for optical transmission, autonegotiation cannot be used.

##### Transmission medium

Data transmission is over multimode fiber-optic cable (FOC). The wavelength is 1310 nm. The FO cables are compatible with multimode FO cables with 1300 nm.

Multimode fiber-optic cables are used with a core of 50 or 62.5 µm; the light source is an LED.

The outer diameter of the FOC is 125 µm.

##### Range

The maximum transmission range (segment length) with a signal attenuation of the fiber-optic cable of ≤ 1 dB/km at 1310 nm is:

- with 62.5/125 µm fiber multimode SIMATIC NET cable: 4 km
- with 50.0/125 µm fiber multimode SIMATIC NET cable: 5 km

## **Connectors**

The cables are connected to SC sockets.

### **3.4.2 SCALANCE XB004-2**

#### **Transmission rate**

The transmission speed of the optical Fast Ethernet ports is 100 Mbps.

#### **Transmission mode**

The transmission mode for 100Base-FX is specified in the IEEE 802.3 standard.

Since the full duplex mode and the transmission rate cannot be modified for optical transmission, autonegotiation cannot be used.

#### **Transmission medium**

Data transmission is over multimode fiber-optic cable (FOC). The wavelength is 1310 nm. The FO cables are compatible with multimode FO cables with 1300 nm.

Multimode fiber-optic cables are used with a core of 50 or 62.5  $\mu\text{m}$ ; the light source is an LED.

The outer diameter of the FOC is 125  $\mu\text{m}$ .

#### **Range**

The maximum transmission range (segment length) with a signal attenuation of the fiber-optic cable of  $\leq 1$  dB/km at 1310 nm is:

- with 62.5/125  $\mu\text{m}$  fiber multimode SIMATIC NET cable: 4 km
- with 50.0/125  $\mu\text{m}$  fiber multimode SIMATIC NET cable: 5 km

## **Connectors**

The cables are connected to SC sockets.

### 3.4.3 SCALANCE XB004-1LD

#### Transmission rate

The transmission rate of the optical Fast Ethernet port is 100 Mbps.

#### Transmission mode

The transmission mode for 100Base-LX is specified in the IEEE 802.3 standard.

Since the full duplex mode and the transmission rate cannot be modified for optical transmission, autonegotiation cannot be used.

#### Transmission medium

Data transmission is over single-mode fiber-optic cable (FO cable). The transceiver wavelength is 1310 nm. The FO cables are compatible with single-mode FO cables with 1300 nm.

Single-mode fiber-optic cable with a core diameter of 10 µm is used. The outer diameter of the FOC is 125 µm.

#### Sender

The light source is an "eye safe" class 1 laser with a wavelength of 1310 nm.



#### Range

The maximum transmission range (segment length) is 26 km for a signal attenuation of the fiber-optic cable of ≤ 0.5 dB/km.

#### Connectors

The cables are connected to SC sockets.

### 3.4.4 SCALANCE XB004-1G

#### Transmission rate

The transmission rate of the optical Fast Ethernet port is 1000 Mbps.

#### Transmission mode

The transmission mode for 1000Base-SX is specified in the IEEE 802.3z standard.

Since the full duplex mode and the transmission rate cannot be modified for optical transmission, autonegotiation cannot be used.

#### Transmission medium

Data transmission is over multimode fiber-optic cable (FOC). The wavelength is 850 nm.

Multimode fiber-optic cable with a core diameter of 50  $\mu\text{m}$  is used. Fiber-optic cables with a core diameter of 62.5  $\mu\text{m}$  are not recommended for 1000Base-SX because this reduces the maximum segment length drastically.

The outer diameter of the FOC is 125  $\mu\text{m}$ .

#### Sender

The light source is an "eye safe" class 1 laser with a wavelength of 850 nm (EN60825-1).

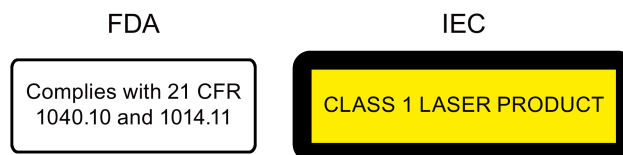

#### Range

Depending on the fiber-optic cable used, the maximum transmission range (segment length) is 750 m when using SIMATIC NET fiber-optic multimode cable with SC duplex connectors or 550 m when using a standard multimode FO cable.

#### Connectors

The cables are connected to SC sockets.

### 3.4.5 SCALANCE XB004-1LDG

#### Transmission rate

The transmission rate of the optical Fast Ethernet port is 1000 Mbps.

#### Transmission mode

The transmission mode for 1000Base-LH is specified in the IEEE 802.3z standard.

Since the full duplex mode and the transmission rate cannot be modified for optical transmission, autonegotiation cannot be used.

#### Transmission medium

Data transmission is over single-mode fiber-optic cable (FO cable). The transceiver wavelength is 1310 nm. The FO cables are compatible with single-mode FO cables with 1300 nm.

Single-mode fiber-optic cable with a core diameter of 10 µm is used. The outer diameter of the FOC is 125 µm.

#### Sender

The light source is an "eye safe" class 1 laser with a wavelength of 1310 nm.

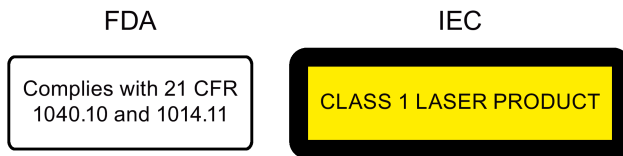

#### Range

The maximum transmission range (segment length) is 10 km for a signal attenuation of the fiber-optic cable of ≤ 0.5 dB/km.

#### Connectors

The cables are connected to SC sockets.

## 3.5 LEDs

### Power LED 'L' (green LED)

The power LED shows the status of the power supply.

LED color	LED status	Meaning
Green	Lit	Power supply is connected
-	Off	Power supply is not connected or the applied voltage is too low. Refer also to the section "Possible sources of errors and eliminating errors (Page 47)"

### Port LED 'P' (green LED)

The port LEDs indicate the status of the ports. The port LEDs are located directly on the port.

LED color	LED status	Meaning
Green	Lit	Link exists, no data reception at port
Green	Flashing	Link exists, data reception at port
Green	Flashing / flash on and off in sequence	Test phase during power on

*3.5 LEDs*

# Mounting

## 4.1 Safety notices for installation

### Safety notices

When installing the device, keep to the safety notices listed below.

 **WARNING**

If the cable or conduit entry point exceeds 70 °C or the branching point of conductors exceeds 80 °C, special precautions must be taken. If the equipment is operated in an air ambient in excess of 50 °C to 60 °C, only use cables with admitted maximum operating temperature of at least 80 °C.

 **WARNING**

If the device is installed in a cabinet, the inner temperature of the cabinet corresponds to the ambient temperature of the device.

### Safety notices on use in hazardous areas

#### General safety notices relating to protection against explosion

 **WARNING**

The device is suitable only for operation in the interior.

 **WARNING**

The device may only be operated in an environment with pollution degree 1 or 2 (see IEC 60664-1).

 **WARNING**

When used in hazardous environments corresponding to Class I, Division 2 or Class I, Zone 2, the device must be installed in a cabinet or a suitable enclosure.

## 4.2 Types of installation

The devices can be installed in the following ways:

- Installation on a 35 mm DIN rail
- Wall mounting



### WARNING

If a device is operated in an ambient temperature of more than 50 °C to 60 °C, the temperature of the device housing may be higher than 70 °C. The device must therefore be installed so that it is only accessible to service personnel or users that are aware of the reason for restricted access and the required safety measures at an ambient temperature higher than 60 °C.

### Installation clearance

Keep to the minimum clearances so that the convection ventilation of the device is not blocked.

- Below at least 10 cm
- Above at least 10 cm

### See also

SIMATIC NET Industrial Ethernet TP and Fiber Optic Networks  
(<http://support.automation.siemens.com/WW/view/en/8763736>)

## 4.3 Fixing onto standard mounting rails

### Mounting

To install the device on a 35 mm DIN rail, follow the steps below:

1. Place the housing guide of the device on the top edge of the DIN rail.
2. Push the device down against rail until it locks in place.

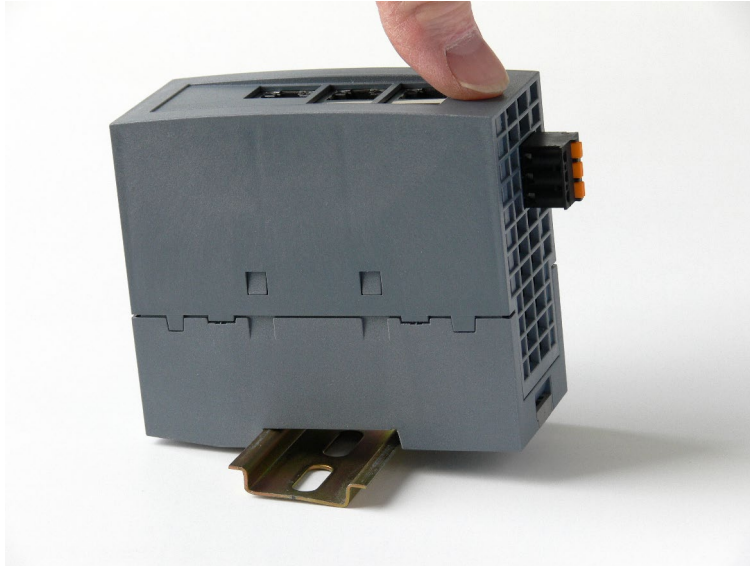

Figure 4-1 Installation on a 35 mm DIN rail

3. Fit the connectors for the power supply. See also section "Power supply (Page 41)"
4. Insert the terminal block into the sockets on the device.

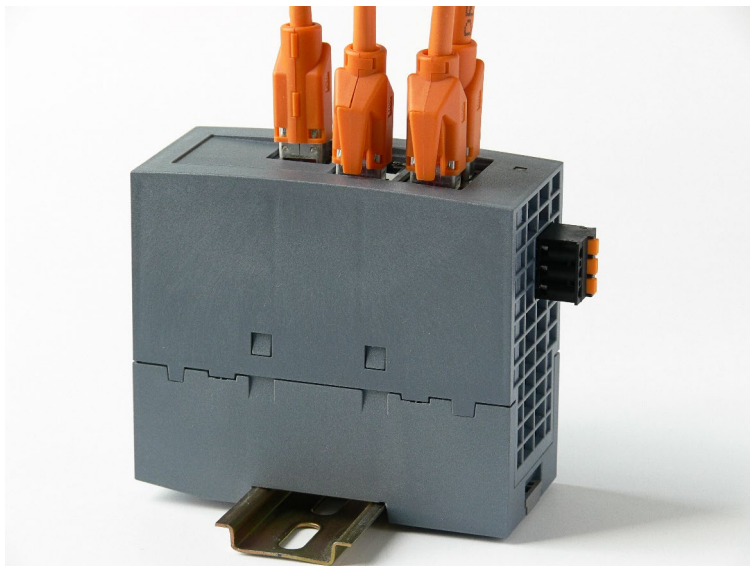

Figure 4-2 SCALANCE XB-000 mounted on the 35 mm DIN rail

## Removal

To remove the device from the DIN rail, follow the steps below:

1. Disconnect all connected cables.
2. Pull out the terminal block for the power supply.
3. Lever the catch on the underside of the device approximately 5 mm out using a screwdriver
4. Pull the lower part of the device away from the DIN rail.

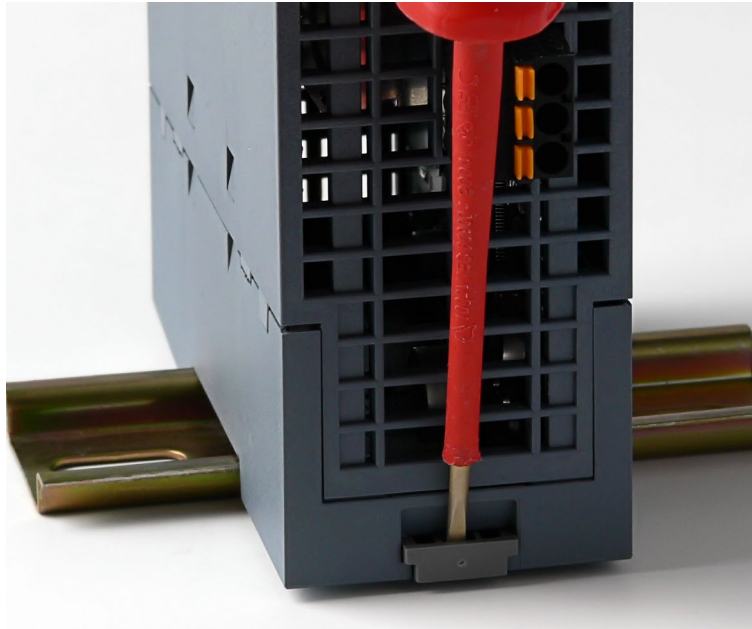

Figure 4-3 Removal from a 35 mm DIN rail

## 4.4 Wall mounting

To mount the device on a wall, you require the following:

- 2 wall plugs, 6 mm in diameter and 30 mm long
- 2 washers
- 2 screws 3.5 mm in diameter and 35 mm long

To mount the device on a wall, follow the steps below:

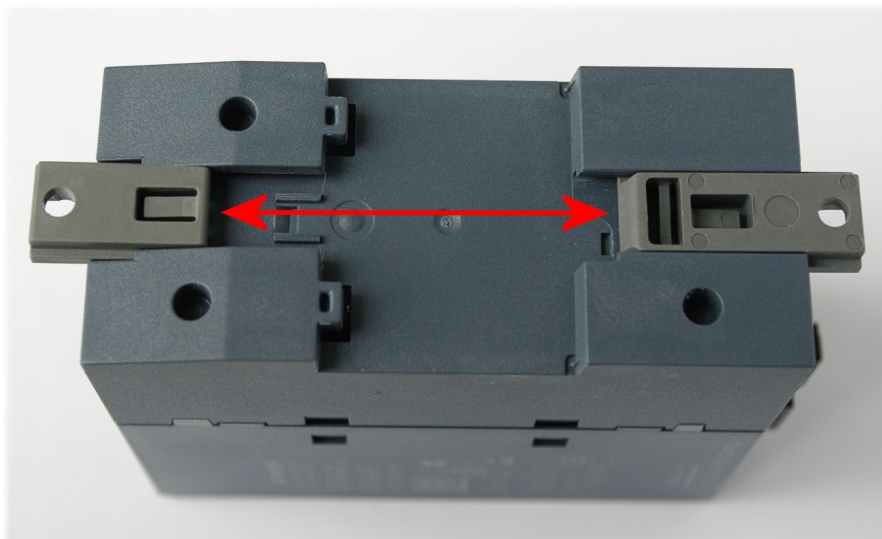

Figure 4-4 Preparation for wall mounting

1. Push out the two catches on the rear of the device.
2. Prepare the drill holes for wall mounting. For the precise dimensions, refer to the section "Dimension drawings (Page 73)".
3. Fit the connectors for the power supply. See also section "Power supply (Page 41)".
4. Insert the terminal block into the socket on the device.
5. Screw the device to the wall.



Figure 4-5 Wall mounting of the SCALANCE XB-000

---

**Note**

The wall mounting must be capable of supporting at least four times the weight of the device.

---

## Connecting up

### 5.1 Power supply

The power supply is connected via a plug-in terminal block with three terminals on the underside of the SCALANCE XB-000. The functional ground can be connected to the grounded DIN rail. It does not need to be connected for problem-free operation. The power supply is non-floating.

---

#### Note

The device can be disconnected from the power supply with the terminal block.

---

#### 5.1.1 Power supply 24 VAC

You can operate the following devices as of a certain hardware version (Page 49) with a 24 VAC power supply

- XB004-1
- XB004-1LD
- XB005

The following figure shows the position of the power supply and the assignment of the terminal block.

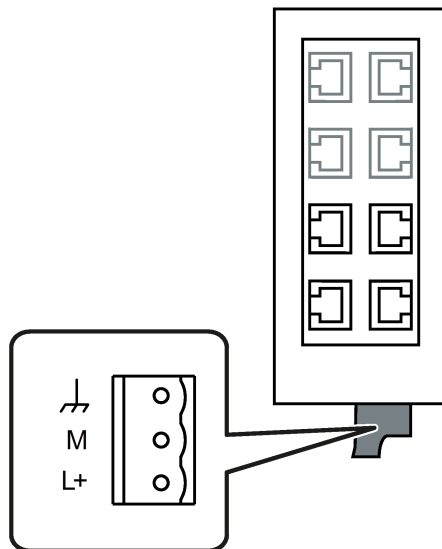

Pin number	Assignment
Pin 1	Functional ground
Pin 2	M (24 VAC, 50/60 Hz)
Pin 3	L+ (24 VAC, 50/60 Hz)

<b>⚠ WARNING</b>
<b>Incorrect power supply</b>
The power supply unit for supplying the devices must comply with NEC Class 2 (voltage range 19.2 - 28.8 V, current requirements 350 mA).
Do not operate the devices with AC voltages higher than 28.8 VAC.

### 5.1.2 Power supply 24 VDC

You can operate the following devices with a 24 VDC power supply

- XB004-1
- XB004-2
- XB004-1LD
- XB005
- XB008
- XB004-1G
- XB004-1LDG
- XB005G
- XB008G

The following figure shows the position of the power supply and the assignment of the terminal block.

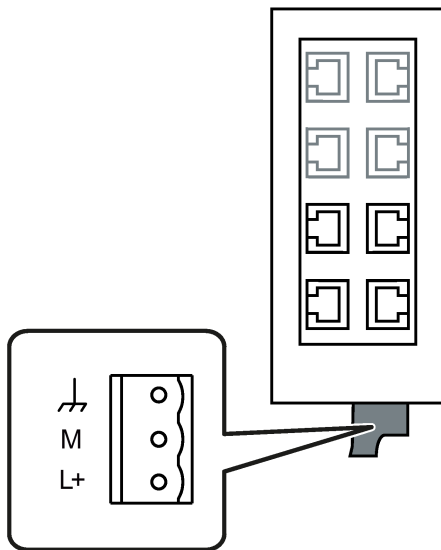

Pin number	Assignment
Pin 1	Functional ground
Pin 2	M (chassis ground)
Pin 3	L+ (24 VDC)

 **WARNING**

**Incorrect power supply**

The power supply unit for supplying the devices must comply with NEC Class 2 (voltage range 19.2 - 28.8 V, current requirements 350 mA).

Do not operate the devices with DC voltages higher than 28.8 VDC.

Do not operate the device with an AC voltage:

- XB008
- XB004-1G
- XB004-1LDG
- XB005G
- XB008G

 **WARNING**

The equipment is designed for operation with Safety Extra-Low Voltage (SELV) by a Limited Power Source (LPS).

This means that only SELV / LPS complying with IEC 60950-1 / EN 60950-1 / VDE 0805-1 must be connected to the power supply terminals. The power supply unit for the equipment power supply must comply with NEC Class 2, as described by the National Electrical Code (r) (ANSI / NFPA 70).

If the equipment is connected to a redundant power supply (two separate power supplies), both must meet these requirements.

## 5.2 Grounding

A functional grounding can be established by connecting a cable from terminal 1 to the DIN rail, , for example. Such a cable should be kept as short as possible. Grounding is, however, not necessary for operation.

## 5.3 Twisted pair cable

### Recommendation

- Cable quality at least CAT 5
- Standard cables and IE FC RJ-45 Plug 180 connectors that can be assembled in the field for connection to the LAN over greater distances.
- To connect the device over a short distance, preassembled cables e.g. TP Cord RJ-45 0.5m

## 5.4 IE FC RJ-45 Plug 180

The rugged node connectors are designed for industry with PROFINET-compliant connectors and provide additional strain and bending relief with a locking mechanism on the casing.

### Fitting the IE FC RJ45 Plug 180 to the IE FC Standard Cable

You will find the notes on installation in the instructions that ship with the IE FC RJ45 Plug 180.

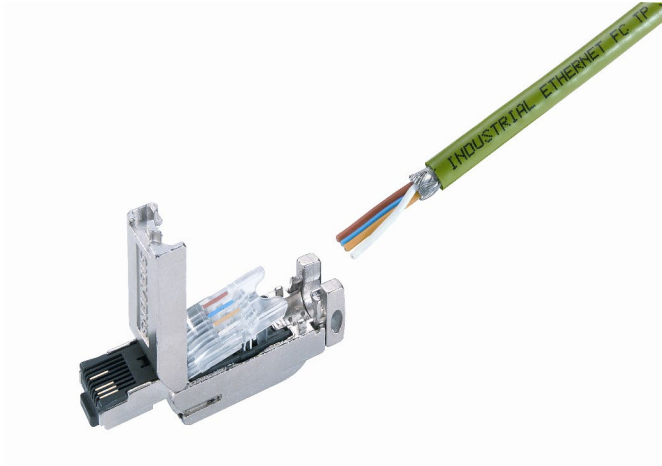

Figure 5-1 IE FC 45 Plug 180

### Plugging in the IE FC RJ45 Plug 180

Plug the IE FC RJ45 Plug 180 into the twisted-pair port of the device until it locks in place.



Figure 5-2 Plugging in the IE FC RJ45 Plug 180

When using Ethernet cables with IE FastConnect RJ-45 plugs on devices without securing collars, the cables must be supported on a cable guide close to the device.

### Pulling the IE FC RJ45 Plug 180

Press on the locking lever of the IE FC RJ45 Plug 180 gently to remove the plug.

If there is not enough space to release the lock with your hand, you can also use a 2.5 mm screwdriver. You can then remove the IE FC RJ45 Plug 180 from the RJ-45 jack.



## Maintenance and troubleshooting

### 6.1 Possible sources of problems and how to deal with them

#### Fuses

The IE switches of the SCALANCE XB-000 product line have a resettable fuse / PTC. If the fuse triggers (all LEDs are off despite correctly applied power supply), the device should be disconnected from the power supply for approximately 30 minutes before turning it on again.

#### LED display when voltage is too low

If the power supply is too low, then the internal power supply will switch off causing the Power LED and all port LEDs to go off. The functionality of the SCALANCE XB-000 is no longer available. A power supply of at least 19.2 V is necessary for correct operation.

#### Device defective

If a fault develops, please send the device to your SIEMENS service center for repair. Repairs on-site are not possible.



# Technical specifications

## 7.1 SCALANCE XB004-1

Table 7- 1 Technical specifications of the SCALANCE XB004-1

<b>Technical specifications</b>		
<b>Order number</b>		
SCALANCE XB004-1	6GK5 004-1BD00-1AB2	
<b>Attachment to Industrial Ethernet</b>		
Quantity	4	
Design	RJ-45 jacks with MDI-X pinning	
Properties	Half / full duplex	
Transmission rate	10/100 Mbps	
<b>Optical connectors</b>		
Quantity	1	
Design	SC socket	
Properties	Full duplex acc. to 100Base-FX	
Transmission rate	100 Mbps	
<b>Permitted cable lengths (Industrial Ethernet)</b>	<b>Alternative combinations per length range</b>	
0 to 55 m	<ul style="list-style-type: none"> <li>Max. 55 m IE TP Torsion Cable with IE FC RJ45 Plug 180</li> <li>Max. 45 m IE TP Torsion Cable with IE FC RJ45 + 10 m TP Cord via IE FC RJ45 Outlet</li> </ul>	
0 to 85 m	<ul style="list-style-type: none"> <li>Max. 85 m IE FC TP Marine/Trailing Cable with IE FC RJ45 Plug 180</li> <li>Max. 75 m IE FC TP Marine/Trailing Cable + 10 m TP Cord via IE FC RJ45 Outlet</li> </ul>	
0 to 100 m	<ul style="list-style-type: none"> <li>Max. 100 m IE FC TP Standard Cable with IE FC RJ45 Plug 180</li> <li>Max. 90 m IE FC TP Standard Cable + 10 m TP Cord via IE FC RJ45 Outlet</li> </ul>	
<b>Optical parameters</b>		
Cable type	Multimode glass FO cable, cable cross sections 62.5/125 µm and 50/125 µm	
Permitted cable length (glass FO cable)	Cable cross-section	Permitted cable length
	<ul style="list-style-type: none"> <li>62.5/125 µm</li> </ul>	<ul style="list-style-type: none"> <li>0 to 4,000 m</li> </ul>
	<ul style="list-style-type: none"> <li>50/125 µm</li> </ul>	<ul style="list-style-type: none"> <li>0 to 5,000 m</li> </ul>

## Technical specifications

### 7.1 SCALANCE XB004-1

#### Technical specifications

##### Electrical data

Power supply	Rated voltage	24 VAC, 50/60 Hz <sup>1)</sup>
		24 VDC
	Voltage range	19.2 to 28.8 VAC/VDC Safety Extra Low Voltage (SELV)
	Design	3-terminal plug-in block
Current consumption	Typically, 24 VAC	230 mA
	Typically 24 VDC	105 mA
Effective power loss	Typically, 24 VAC	5.5 VA
	Typically 24 VDC	2.5 W
Overvoltage protection at input		PTC resettable fuse (0.5 A / 60 V)

##### Permitted ambient conditions

Ambient temperature	During operation	-10 °C to +60 °C
	During storage	-40 °C to +80 °C
	During transportation	-40 °C to +80 °C
Relative humidity	During operation	≤ 95 % no condensation
Operating altitude	During operation	≤ 2,000 m above sea level at max. 56 °C ambient temperature
		≤ 3,000 m above sea level at max. 50 °C ambient temperature

##### Design, dimensions and weight

Immunity	EN 61000-6-2
Emission	EN 61000-6-4
Degree of protection	IP20
MTBF (EN/IEC 61709; 40 °C)	157 years
Housing material	Polycarbonate (plastic)
Weight	165 g
Dimensions (W x H x D)	45 x 100 x 87 mm
Installation options	• Mounting on a DIN rail
	• Wall mounting

## Technical specifications

### Switching properties

Aging time	300 seconds / 45 seconds <sup>1)</sup>
Max. number of learnable MAC addresses	1024
Response to LLDP frames	Blocking
Response to spanning tree BPDU frames	Forwarding
CoS acc. to IEEE 802.1Q	Yes
QoS priority queues	2 / 4 <sup>1)</sup>
IEEE 802.1Q tags (VLAN ID, priority) transparent forwarding	Yes

<sup>1)</sup> as of hardware version 4

### Note

The number of IE switches of the SCALANCE XB-000 product line connected in a line influences the frame delay.

When a frame passes through IE switches of the SCALANCE XB-000 product line, it is delayed by the store and forward function of the switch

- with a 64 byte frame length by approx. 10 microseconds (at 100 Mbps)
- with a 1500 byte frame length by approx. 130 microseconds (at 100 Mbps)

This means the more devices of the SCALANCE XB-000 product line that the frame passes through, the longer the frame propagation time.

### Hardware version

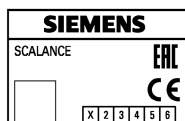

You will find the hardware version of your device on the type plate. On the type plate, the hardware version is printed as a placeholder "X".

Example: X 2 3 4 5 6

In this case, "X" would be the placeholder for hardware version 1.

## 7.2 SCALANCE XB004-2

Table 7- 2 Technical specifications of the SCALANCE XB004-2

<b>Technical specifications</b>		
<b>Order number</b>		
SCALANCE XB004-2		
<b>Attachment to Industrial Ethernet</b>		
Quantity	4	
Design	RJ-45 jacks with MDI-X pinning	
Properties	Half / full duplex	
Transmission rate	10/100 Mbps	
<b>Optical connectors</b>		
Quantity	2	
Design	SC socket	
Properties	Full duplex acc. to 100Base-FX	
Transmission rate	100 Mbps	
<b>Permitted cable lengths (Industrial Ethernet)</b>	<b>Alternative combinations per length range</b>	
0 to 55 m	<ul style="list-style-type: none"> <li>Max. 55 m IE TP Torsion Cable with IE FC RJ45 Plug 180</li> <li>Max. 45 m IE TP Torsion Cable with IE FC RJ45 + 10 m TP Cord via IE FC RJ45 Outlet</li> </ul>	
0 to 85 m	<ul style="list-style-type: none"> <li>Max. 85 m IE FC TP Marine/Trailing Cable with IE FC RJ45 Plug 180</li> <li>Max. 75 m IE FC TP Marine/Trailing Cable + 10 m TP Cord via IE FC RJ45 Outlet</li> </ul>	
0 to 100 m	<ul style="list-style-type: none"> <li>Max. 100 m IE FC TP Standard Cable with IE FC RJ45 Plug 180</li> <li>Max. 90 m IE FC TP Standard Cable + 10 m TP Cord via IE FC RJ45 Outlet</li> </ul>	
<b>Optical parameters</b>		
Cable type	Multimode glass FO cable, cable cross sections 62.5/125 µm and 50/125 µm	
Permitted cable length (glass FO cable)	<b>Cable cross-section</b>	<b>Permitted cable length</b>
	<ul style="list-style-type: none"> <li>62.5/125 µm</li> <li>50/125 µm</li> </ul>	<ul style="list-style-type: none"> <li>0 to 4,000 m</li> <li>0 to 5,000 m</li> </ul>
<b>Electrical data</b>		
Power supply	Rated voltage	24 VDC
	Voltage range	19.2 to 28.8 VDC Safety Extra Low Voltage (SELV)
	Design	3-terminal plug-in block
Current consumption	Typically 24 VDC	165 mA
Effective power loss	Typically 24 VDC	4 W
Overvoltage protection at input	PTC resettable fuse (0.5 A / 60 V)	

<b>Technical specifications</b>		
<b>Permitted ambient conditions</b>		
Ambient temperature	During operation	-10 °C to +60 °C
	During storage	-40 °C to +80 °C
	During transportation	-40 °C to +80 °C
Relative humidity	During operation	≤ 95 % no condensation
Operating altitude	During operation	≤ 2,000 m above sea level at max. 56 °C ambient temperature
		≤ 3,000 m above sea level at max. 50 °C ambient temperature
<b>Design, dimensions and weight</b>		
Immunity	EN 61000-6-2	
Emission	EN 61000-6-4	
Degree of protection	IP20	
MTBF (EN/IEC 61709; 40 °C)	115 years	
Housing material	Polycarbonate (plastic)	
Weight	205 g	
Dimensions (W x H x D)	45 x 100 x 87 mm	
Installation options	<ul style="list-style-type: none"> <li>• Mounting on a DIN rail</li> <li>• Wall mounting</li> </ul>	
<b>Switching properties</b>		
Aging time	45 seconds	
Max. number of learnable MAC addresses	1024	
Response to LLDP frames	Blocking	
Response to spanning tree BPDU frames	Forwarding	
CoS acc. to IEEE 802.1Q	Yes	
QoS priority queues	4	
IEEE 802.1Q tags (VLAN ID, priority) transparent forwarding	Yes	

**Note**

The number of IE switches of the SCALANCE XB-000 product line connected in a line influences the frame delay.

When a frame passes through IE switches of the SCALANCE XB-000 product line, it is delayed by the store and forward function of the switch

- with a 64 byte frame length by approx. 10 microseconds (at 100 Mbps)
- with a 1500 byte frame length by approx. 130 microseconds (at 100 Mbps)

This means the more devices of the SCALANCE XB-000 product line that the frame passes through, the longer the frame propagation time.

## 7.3 SCALANCE XB004-1LD

Table 7- 3 Technical specifications of the SCALANCE XB004-1LD

<b>Technical specifications</b>	
<b>Order number</b>	
SCALANCE XB004-1LD	6GK5 004-1BF00-1AB2
<b>Attachment to Industrial Ethernet</b>	
Quantity	4
Design	RJ-45 jacks with MDI-X pinning
Properties	Half / full duplex
Transmission rate	10/100 Mbps
<b>Optical connectors</b>	
Quantity	1
Design	SC sockets
Properties	Full duplex acc. to 100Base-LX
Transmission rate	100 Mbps
<b>Permitted cable lengths (Industrial Ethernet)</b>	<b>Alternative combinations per length range</b>
0 to 55 m	<ul style="list-style-type: none"> <li>Max. 55 m IE TP Torsion Cable with IE FC RJ45 Plug 180</li> <li>Max. 45 m IE TP Torsion Cable with IE FC RJ45 + 10 m TP Cord via IE FC RJ45 Outlet</li> </ul>
0 to 85 m	<ul style="list-style-type: none"> <li>Max. 85 m IE FC TP Marine/Trailing Cable with IE FC RJ45 Plug 180</li> <li>Max. 75 m IE FC TP Marine/Trailing Cable + 10 m TP Cord via IE FC RJ45 Outlet</li> </ul>
0 to 100 m	<ul style="list-style-type: none"> <li>Max. 100 m IE FC TP Standard Cable with IE FC RJ45 Plug 180</li> <li>Max. 90 m IE FC TP Standard Cable + 10 m TP Cord via IE FC RJ45 Outlet</li> </ul>
<b>Optical parameters</b>	
Cable type	Single mode glass FO cable
Cable cross-section	10/125 µm
Permitted cable length	0 to 26,000 m
Attenuation	≤ 0.5 dB/km at 1310 nm 13 dB max. permitted FO cable attenuation with 2 dB link power margin

---

**Technical specifications**

---

**Electrical data**

---

Power supply	Rated voltage	24 VAC, 50/60 Hz <sup>1)</sup>
		24 VDC
	Voltage range	19.2 to 28.8 VAC/VDC Safety Extra Low Voltage (SELV)
	Design	3-terminal plug-in block
Current consumption	Typically, 24 VAC	210 mA
	Typically 24 VDC	95 mA
Effective power loss	Typically, 24 VAC	5.1 VA
	Typically 24 VDC	2.3 W
Overvoltage protection at input		PTC resettable fuse (0.5 A / 60 V)

**Permitted ambient conditions**

---

Ambient temperature	During operation	-10 °C to +60 °C
	During storage	-40 °C to +80 °C
	During transportation	-40 °C to +80 °C
Relative humidity	During operation	≤ 95 % no condensation
Operating altitude	During operation	≤ 2,000 m above sea level at max. 56 °C ambient temperature
		≤ 3,000 m above sea level at max. 50 °C ambient temperature

**Design, dimensions and weight**

---

Immunity	EN 61000-6-2
Emission	EN 61000-6-4
Degree of protection	IP20
MTBF (EN/IEC 61709; 40 °C)	176 years
Housing material	Polycarbonate (plastic)
Weight	165 g
Dimensions (W x H x D)	45 x 100 x 87 mm
Installation options	<ul style="list-style-type: none"> <li>• Mounting on a DIN rail</li> <li>• Wall mounting</li> </ul>

---

**Technical specifications**

**Switching properties**

Aging time	300 seconds / 45 seconds <sup>1)</sup>
Max. number of learnable MAC addresses	1024
Response to LLDP frames	Blocking
Response to spanning tree BPDU frames	Forwarding
CoS acc. to IEEE 802.1Q	Yes
QoS priority queues	2 / 4 <sup>1)</sup>
IEEE 802.1Q tags (VLAN ID, priority) transparent forwarding	Yes

<sup>1)</sup> as of hardware version 4

**Note**

The number of IE switches of the SCALANCE XB-000 product line connected in a line influences the frame delay.

When a frame passes through IE switches of the SCALANCE XB-000 product line, it is delayed by the store and forward function of the switch

- with a 64 byte frame length by approx. 10 microseconds (at 100 Mbps)
- with a 1500 byte frame length by approx. 130 microseconds (at 100 Mbps)

This means the more devices of the SCALANCE XB-000 product line that the frame passes through, the longer the frame propagation time.

**Hardware version**

You will find the hardware version of your device on the type plate. On the type plate, the hardware version is printed as a placeholder "X".

Example: X 2 3 4 5 6

In this case, "X" would be the placeholder for hardware version 1.

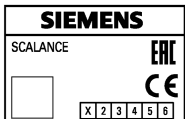

## 7.4 SCALANCE XB005

Table 7- 4 Technical specifications of the SCALANCE XB005

<b>Technical specifications</b>		
<b>Order number</b>		
SCALANCE XB005	6GK5 005-0BA00-1AB2	
<b>Attachment to Industrial Ethernet</b>		
Quantity	5	
Design	RJ-45 jacks with MDI-X pinning	
Properties	Half / full duplex	
Transmission rate	10/100 Mbps	
<b>Permitted cable lengths (Industrial Ethernet)</b>	<b>Alternative combinations per length range</b>	
0 to 55 m	<ul style="list-style-type: none"> <li>• Max. 55 m IE TP Torsion Cable with IE FC RJ45 Plug 180</li> <li>• Max. 45 m IE TP Torsion Cable with IE FC RJ45 + 10 m TP Cord via IE FC RJ45 Outlet</li> </ul>	
0 to 85 m	<ul style="list-style-type: none"> <li>• Max. 85 m IE FC TP Marine/Trailing Cable with IE FC RJ45 Plug 180</li> <li>• Max. 75 m IE FC TP Marine/Trailing Cable + 10 m TP Cord via IE FC RJ45 Outlet</li> </ul>	
0 to 100 m	<ul style="list-style-type: none"> <li>• Max. 100 m IE FC TP Standard Cable with IE FC RJ45 Plug 180</li> <li>• Max. 90 m IE FC TP Standard Cable + 10 m TP Cord via IE FC RJ45 Outlet</li> </ul>	
<b>Electrical data</b>		
Power supply	Rated voltage	24 VAC, 50/60 Hz <sup>1)</sup> 24 VDC
	Voltage range	19.2 to 28.8 VAC/VDC Safety Extra Low Voltage (SELV)
	Design	3-terminal plug-in block
Current consumption	Typically, 24 VAC	150 mA
	Typically 24 VDC	65 mA
Effective power loss	Typically, 24 VAC	3.6 VA
	Typically 24 VDC	1.6 W
Overvoltage protection at input	PTC resettable fuse (0.5 A / 60 V)	
<b>Permitted ambient conditions</b>		
Ambient temperature	During operation	-10 °C to +60 °C
	During storage	-40 °C to +80 °C
	During transportation	-40 °C to +80 °C
Relative humidity	During operation	≤ 95 % no condensation
Operating altitude	During operation	≤ 2,000 m above sea level at max. 56 °C ambient temperature
		≤ 3,000 m above sea level at max. 50 °C ambient temperature

Technical specifications	
Design, dimensions and weight	
Immunity	EN 61000-6-2
Emission	EN 61000-6-4
Degree of protection	IP20
MTBF (EN/IEC 61709; 40 °C)	195 years
Housing material	Polycarbonate (plastic)
Weight	165 g
Dimensions (W x H x D)	45 x 100 x 87 mm
Installation options	<ul style="list-style-type: none"> <li>• Mounting on a DIN rail</li> <li>• Wall mounting</li> </ul>
Switching properties	
Aging time	300 seconds / 45 seconds <sup>1)</sup>
Max. number of learnable MAC addresses	1024
Response to LLDP frames	Blocking
Response to spanning tree BPDU frames	Forwarding
CoS acc. to IEEE 802.1Q	Yes
QoS priority queues	2 / 4 <sup>1)</sup>
IEEE 802.1Q tags (VLAN ID, priority)	Yes
transparent forwarding	

<sup>1)</sup> as of hardware version 5

**Note**

The number of IE switches of the SCALANCE XB-000 product line connected in a line influences the frame delay.

When a frame passes through IE switches of the SCALANCE XB-000 product line, it is delayed by the store and forward function of the switch

- with a 64 byte frame length by approx. 10 microseconds (at 100 Mbps)
- with a 1500 byte frame length by approx. 130 microseconds (at 100 Mbps)

This means the more devices of the SCALANCE XB-000 product line that the frame passes through, the longer the frame propagation time.

**Hardware version**

You will find the hardware version of your device on the type plate. On the type plate, the hardware version is printed as a placeholder "X".

Example: X 2 3 4 5 6

In this case, "X" would be the placeholder for hardware version 1.

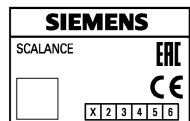

## 7.5 SCALANCE XB008

Table 7- 5 Technical specifications of the SCALANCE XB008

<b>Technical specifications</b>		
<b>Order number</b>		
SCALANCE XB008	6GK5 008-0BA00-1AB2	
<b>Attachment to Industrial Ethernet</b>		
Quantity	8	
Design	RJ-45 jacks with MDI-X pinning	
Properties	Half / full duplex	
Transmission rate	10/100 Mbps	
<b>Permitted cable lengths (Industrial Ethernet)</b>	<b>Alternative combinations per length range</b>	
0 to 55 m	<ul style="list-style-type: none"> <li>• Max. 55 m IE TP Torsion Cable with IE FC RJ45 Plug 180</li> <li>• Max. 45 m IE TP Torsion Cable with IE FC RJ45 + 10 m TP Cord via IE FC RJ45 Outlet</li> </ul>	
0 to 85 m	<ul style="list-style-type: none"> <li>• Max. 85 m IE FC TP Marine/Trailing Cable with IE FC RJ45 Plug 180</li> <li>• Max. 75 m IE FC TP Marine/Trailing Cable + 10 m TP Cord via IE FC RJ45 Outlet</li> </ul>	
0 to 100 m	<ul style="list-style-type: none"> <li>• Max. 100 m IE FC TP Standard Cable with IE FC RJ45 Plug 180</li> <li>• Max. 90 m IE FC TP Standard Cable + 10 m TP Cord via IE FC RJ45 Outlet</li> </ul>	
<b>Electrical data</b>		
Power supply	Rated voltage	24 VDC
	Voltage range	19.2 to 28.8 VDC Safe Extra Low Voltage (SELV)
	Design	3-terminal plug-in block
Current consumption	Typical	150 mA
Power loss at 24 VDC	Typical	3.40 W
Overvoltage protection at input	PTC resettable fuse (0.6 A / 60 V)	
<b>Permitted ambient conditions</b>		
Ambient temperature	During operation	-10 °C to +60 °C
	During storage	-40 °C to +80 °C
	During transportation	-40 °C to +80 °C
Relative humidity	During operation	≤ 95 % no condensation
Operating altitude	During operation	≤ 2,000 m above sea level at max. 56 °C ambient temperature
		≤ 3,000 m above sea level at max. 50 °C ambient temperature

---

**Technical specifications**

**Design, dimensions and weight**

Immunity	EN 61000-6-2
Emission	EN 61000-6-4
Degree of protection	IP20
MTBF (EN/IEC 61709; 40 °C)	214 years
Housing material	Polycarbonate (plastic)
Weight	180 g
Dimensions (W x H x D)	45 x 100 x 87 mm
Installation options	<ul style="list-style-type: none"><li>• Mounting on a DIN rail</li><li>• Wall mounting</li></ul>

**Switching properties**

Aging time	300 seconds
Max. number of learnable MAC addresses	1024
Response to LLDP frames	Blocking
Response to spanning tree BPDU frames	Forwarding
CoS acc. to IEEE 802.1Q	Yes
QoS priority queues	2
IEEE 802.1Q tags (VLAN ID, priority) transparent forwarding	Yes

---

**Note**

The number of IE switches of the SCALANCE XB-000 product line connected in a line influences the frame delay.

When a frame passes through IE switches of the SCALANCE XB-000 product line, it is delayed by the store and forward function of the switch

- with a 64 byte frame length by approx. 10 microseconds (at 100 Mbps)
- with a 1500 byte frame length by approx. 130 microseconds (at 100 Mbps)

This means the more devices of the SCALANCE XB-000 product line that the frame passes through, the longer the frame propagation time.

---

## 7.6 SCALANCE XB004-1G

Table 7- 6 Technical specifications of the SCALANCE XB004-1G

<b>Technical specifications</b>		
<b>Order number</b>		
SCALANCE XB004-1G	6GK5 004-1GL00-1AB2	
<b>Attachment to Industrial Ethernet</b>		
Quantity	4	
Design	RJ-45 jacks with MDI-X pinning	
Properties	Half / full duplex	
Transmission rate	10 / 100 / 1000 Mbps	
<b>Optical connectors</b>		
Quantity	1	
Design	SC socket	
Properties	Full duplex acc. to 1000Base-SX	
Transmission rate	1000 Mbps	
<b>Permitted cable lengths (Industrial Ethernet)</b>	<b>Alternative combinations per length range</b>	
0 to 55 m	<ul style="list-style-type: none"> <li>Max. 55 m IE TP Torsion Cable 4x2 with IE FC RJ45 Plug 180 4x2</li> <li>Max. 45 m IE TP Torsion Cable 4x2 with IE FC RJ45 + 10 m TP Cord 4x2 via IE FC RJ45 Outlet</li> </ul>	
0 to 85 m	<ul style="list-style-type: none"> <li>Max. 85 m IE FC TP Marine/Trailing Cable 4x2 with IE FC RJ45 Plug 180 4x2</li> <li>Max. 75 m IE FC TP Marine/Trailing Cable 4x2 + 10 m TP Cord 4x2 via IE FC RJ45 Outlet</li> </ul>	
0 to 100 m	<ul style="list-style-type: none"> <li>Max. 100 m IE FC TP Standard Cable 4x2 with IE FC RJ45 Plug 180 4x2</li> <li>Max. 90 m IE FC TP Standard Cable 4x2 + 10 m TP Cord 4x2 via IE FC RJ45 Outlet</li> </ul>	
<b>Optical parameters</b>		
Cable type	Multimode glass FO cable	
Cable cross-section	50/125 µm	
Permitted cable length	0 to 750 m	
<b>Electrical data</b>		
Power supply	Rated voltage	24 VDC
	Voltage range	19.2 to 28.8 VDC Safe Extra Low Voltage (SELV)
	Design	3-terminal plug-in block
Current consumption	Typical	650 mA
Power loss at 24 VDC	Typical	15.6 W
Overvoltage protection at input	PTC resettable fuse (1.0 A / 60 V)	

**Technical specifications**

**Permitted ambient conditions**

Ambient temperature	During operation	-10 °C to +60 °C
	During storage	-40 °C to +80 °C
	During transportation	-40 °C to +80 °C
Relative humidity	During operation	≤ 95 % no condensation
Operating altitude	During operation	≤ 2,000 m above sea level at max. 56 °C ambient temperature
		≤ 3,000 m above sea level at max. 50 °C ambient temperature

**Design, dimensions and weight**

Immunity	EN 61000-6-2
Emission	EN 61000-6-4
Degree of protection	IP20
MTBF (EN/IEC 61709; 40 °C)	146 years
Housing material	Polycarbonate (plastic)
Weight	210 g
Dimensions (W x H x D)	45 x 100 x 87 mm
Installation options	<ul style="list-style-type: none"> <li>• Mounting on a DIN rail</li> <li>• Wall mounting</li> </ul>

**Switching properties**

Aging time	300 seconds
Max. number of learnable MAC addresses	8192
Response to LLDP frames	Blocking
Response to spanning tree BPDU frames	Forwarding
CoS acc. to IEEE 802.1Q	Yes
QoS priority queues	4
IEEE 802.1Q tags (VLAN ID, priority) transparent forwarding	Yes

**Note**

The number of IE switches of the SCALANCE XB-000 product line connected in a line influences the frame delay.

When a frame passes through IE switches of the SCALANCE XB-000 product line, it is delayed by the store and forward function of the switch

- with a 64 byte frame length by approx. 10 microseconds (at 100 Mbps)
- with a 1500 byte frame length by approx. 130 microseconds (at 100 Mbps)

This means the more devices of the SCALANCE XB-000 product line that the frame passes through, the longer the frame propagation time.

## 7.7 SCALANCE XB004-1LDG

Table 7- 7 Technical specifications of the SCALANCE XB004-1LDG

<b>Technical specifications</b>		
<b>Order number</b>		
SCALANCE XB004-1LDG	6GK5 004-1GM00-1AB2	
<b>Attachment to Industrial Ethernet</b>		
Quantity	4	
Design	RJ-45 jacks with MDI-X pinning	
Properties	Half / full duplex	
Transmission rate	10 / 100 / 1000 Mbps	
<b>Optical connectors</b>		
Quantity	1	
Design	SC sockets	
Properties	Full duplex acc. to 1000Base-LH	
Transmission rate	1000 Mbps	
<b>Permitted cable lengths (Industrial Ethernet)</b>	<b>Alternative combinations per length range</b>	
0 to 55 m	<ul style="list-style-type: none"> <li>• Max. 55 m IE TP Torsion Cable 4x2 with IE FC RJ45 Plug 180 4x2</li> <li>• Max. 45 m IE TP Torsion Cable 4x2 with IE FC RJ45 + 10 m TP Cord 4x2 via IE FC RJ45 Outlet</li> </ul>	
0 to 85 m	<ul style="list-style-type: none"> <li>• Max. 85 m IE FC TP Marine/Trailing Cable 4x2 with IE FC RJ45 Plug 180 4x2</li> <li>• Max. 75 m IE FC TP Marine/Trailing Cable 4x2 + 10 m TP Cord 4x2 via IE FC RJ45 Outlet</li> </ul>	
0 to 100 m	<ul style="list-style-type: none"> <li>• Max. 100 m IE FC TP Standard Cable 4x2 with IE FC RJ45 Plug 180 4x2</li> <li>• Max. 90 m IE FC TP Standard Cable 4x2 + 10 m TP Cord 4x2 via IE FC RJ45 Outlet</li> </ul>	
<b>Optical parameters</b>		
Cable type	Single mode glass FO cable	
Cable cross-section	10/125 $\mu\text{m}$	
Permitted cable length	0 to 10,000 m	
Attenuation	$\leq 0.5$ dB/km at 1310 nm 13 dB max. permitted FO cable attenuation with 2 dB link power margin	
<b>Electrical data</b>		
Power supply	Rated voltage	24 VDC
	Voltage range	19.2 to 28.8 VDC Safe Extra Low Voltage (SELV)
	Design	3-terminal plug-in block
Current consumption	Typical	650 mA
Power loss at 24 VDC	Typical	15.6 W
Overvoltage protection at input	PTC resettable fuse (1.0 A / 60 V)	

**Technical specifications**

**Permitted ambient conditions**

Ambient temperature	During operation	-10 °C to +60 °C
	During storage	-40 °C to +80 °C
	During transportation	-40 °C to +80 °C
Relative humidity	During operation	≤ 95 % no condensation
Operating altitude	During operation	≤ 2,000 m above sea level at max. 56 °C ambient temperature
		≤ 3,000 m above sea level at max. 50 °C ambient temperature

**Design, dimensions and weight**

Immunity	EN 61000-6-2
Emission	EN 61000-6-4
Degree of protection	IP20
MTBF (EN/IEC 61709; 40 °C)	146 years
Housing material	Polycarbonate (plastic)
Weight	210 g
Dimensions (W x H x D)	45 x 100 x 87 mm
Installation options	<ul style="list-style-type: none"> <li>• Mounting on a DIN rail</li> <li>• Wall mounting</li> </ul>

**Switching properties**

Aging time	300 seconds
Max. number of learnable MAC addresses	8192
Response to LLDP frames	Blocking
Response to spanning tree BPDU frames	Forwarding
CoS acc. to IEEE 802.1Q	Yes
QoS priority queues	4
IEEE 802.1Q tags (VLAN ID, priority) transparent forwarding	Yes

**Note**

The number of IE switches of the SCALANCE XB-000 product line connected in a line influences the frame delay.

When a frame passes through IE switches of the SCALANCE XB-000 product line, it is delayed by the store and forward function of the switch

- with a 64 byte frame length by approx. 10 microseconds (at 100 Mbps)
- with a 1500 byte frame length by approx. 130 microseconds (at 100 Mbps)

This means the more devices of the SCALANCE XB-000 product line that the frame passes through, the longer the frame propagation time.

## 7.8 SCALANCE XB005G

Table 7- 8 Technical specifications of the SCALANCE XB005G

<b>Technical specifications</b>		
<b>Order number</b>		
SCALANCE XB005G	6GK5 005-0GA00-1AB2	
<b>Attachment to Industrial Ethernet</b>		
Quantity	5	
Design	RJ-45 jacks with MDI-X pinning	
Properties	Half / full duplex	
Transmission rate	10 / 100 / 1000 Mbps	
<b>Permitted cable lengths (Industrial Ethernet)</b>	<b>Alternative combinations per length range</b>	
0 to 55 m	<ul style="list-style-type: none"> <li>Max. 55 m IE TP Torsion Cable 4x2 with IE FC RJ45 Plug 180 4x2</li> <li>Max. 45 m IE TP Torsion Cable 4x2 with IE FC RJ45 + 10 m TP Cord 4x2 via IE FC RJ45 Outlet</li> </ul>	
0 to 85 m	<ul style="list-style-type: none"> <li>Max. 85 m IE FC TP Marine/Trailing Cable 4x2 with IE FC RJ45 Plug 180 4x2</li> <li>Max. 75 m IE FC TP Marine/Trailing Cable 4x2 + 10 m TP Cord 4x2 via IE FC RJ45 Outlet</li> </ul>	
0 to 100 m	<ul style="list-style-type: none"> <li>Max. 100 m IE FC TP Standard Cable 4x2 with IE FC RJ45 Plug 180 4x2</li> <li>Max. 90 m IE FC TP Standard Cable 4x2 + 10 m TP Cord 4x2 via IE FC RJ45 Outlet</li> </ul>	
<b>Electrical data</b>		
Power supply	Rated voltage	24 VDC
	Voltage range	19.2 to 28.8 VDC Safe Extra Low Voltage (SELV)
	Design	3-terminal plug-in block
Current consumption	Typical	550 mA
Power loss at 24 VDC	Typical	13.2 W
Overvoltage protection at input	PTC resettable fuse (1.0 A / 60 V)	
<b>Permitted ambient conditions</b>		
Ambient temperature	During operation	-10 °C to +60 °C
	During storage	-40 °C to +80 °C
	During transportation	-40 °C to +80 °C
Relative humidity	During operation	≤ 95 % no condensation
Operating altitude	During operation	≤ 2,000 m above sea level at max. 56 °C ambient temperature
		≤ 3,000 m above sea level at max. 50 °C ambient temperature
<b>Design, dimensions and weight</b>		
Immunity	EN 61000-6-2	
Emission	EN 61000-6-4	

---

**Technical specifications**

Degree of protection	IP20
MTBF (EN/IEC 61709; 40 °C)	168 years
Housing material	Polycarbonate (plastic)
Weight	220 g
Dimensions (W x H x D)	45 x 100 x 87 mm
Installation options	<ul style="list-style-type: none"><li>• Mounting on a DIN rail</li><li>• Wall mounting</li></ul>

---

**Switching properties**

Aging time	300 seconds
Max. number of learnable MAC addresses	8192
Response to LLDP frames	Blocking
Response to spanning tree BPDU frames	Forwarding
CoS acc. to IEEE 802.1Q	Yes
QoS priority queues	4
IEEE 802.1Q tags (VLAN ID, priority) transparent forwarding	Yes

---

**Note**

The number of IE switches of the SCALANCE XB-000 product line connected in a line influences the frame delay.

When a frame passes through IE switches of the SCALANCE XB-000 product line, it is delayed by the store and forward function of the switch

- with a 64 byte frame length by approx. 10 microseconds (at 100 Mbps)
- with a 1500 byte frame length by approx. 130 microseconds (at 100 Mbps)

This means the more devices of the SCALANCE XB-000 product line that the frame passes through, the longer the frame propagation time.

---

## 7.9 SCALANCE XB008G

Table 7- 9 Technical specifications of the XB008G

<b>Technical specifications</b>		
<b>Order number</b>		
SCALANCE XB008G	6GK5 008-0GA00-1AB2	
<b>Attachment to Industrial Ethernet</b>		
Quantity	8	
Design	RJ-45 jacks with MDI-X pinning	
Properties	Half / full duplex	
Transmission rate	10 / 100 / 1000 Mbps	
<b>Permitted cable lengths (Industrial Ethernet)</b>	<b>Alternative combinations per length range</b>	
0 to 55 m	<ul style="list-style-type: none"> <li>• Max. 55 m IE TP Torsion Cable 4x2 with IE FC RJ45 Plug 180 4x2</li> <li>• Max. 45 m IE TP Torsion Cable 4x2 with IE FC RJ45 + 10 m TP Cord 4x2 via IE FC RJ45 Outlet</li> </ul>	
0 to 85 m	<ul style="list-style-type: none"> <li>• Max. 85 m IE FC TP Marine/Trailing Cable 4x2 with IE FC RJ45 Plug 180 4x2</li> <li>• Max. 75 m IE FC TP Marine/Trailing Cable 4x2 + 10 m TP Cord 4x2 via IE FC RJ45 Outlet</li> </ul>	
0 to 100 m	<ul style="list-style-type: none"> <li>• Max. 100 m IE FC TP Standard Cable 4x2 with IE FC RJ45 Plug 180 4x2</li> <li>• Max. 90 m IE FC TP Standard Cable 4x2 + 10 m TP Cord 4x2 via IE FC RJ45 Outlet</li> </ul>	
<b>Electrical data</b>		
Power supply	Rated voltage	24 VDC
	Voltage range	19.2 to 28.8 VDC Safe Extra Low Voltage (SELV)
	Design	3-terminal plug-in block
Current consumption	Typical	650 mA
Power loss at 24 VDC	Typical	15.6 W
Overvoltage protection at input	PTC resettable fuse (1.0 A / 60 V)	
<b>Permitted ambient conditions</b>		
Ambient temperature	During operation	-10 °C to +60 °C
	During storage	-40 °C to +80 °C
	During transportation	-40 °C to +80 °C
Relative humidity	During operation	≤ 95 % no condensation
Operating altitude	During operation	≤ 2,000 m above sea level at max. 56 °C ambient temperature
		≤ 3,000 m above sea level at max. 50 °C ambient temperature

---

**Technical specifications**

**Design, dimensions and weight**

Immunity	EN 61000-6-2
Emission	EN 61000-6-4
Degree of protection	IP20
MTBF (EN/IEC 61709; 40 °C)	138 years
Housing material	Polycarbonate (plastic)
Weight	260 g
Dimensions (W x H x D)	45 x 100 x 87 mm
Installation options	<ul style="list-style-type: none"><li>• Mounting on a DIN rail</li><li>• Wall mounting</li></ul>

**Switching properties**

Aging time	300 seconds
Max. number of learnable MAC addresses	8192
Response to LLDP frames	Blocking
Response to spanning tree BPDU frames	Forwarding
CoS acc. to IEEE 802.1Q	Yes
QoS priority queues	4
IEEE 802.1Q tags (VLAN ID, priority) transparent forwarding	Yes

---

**Note**

The number of IE switches of the SCALANCE XB-000 product line connected in a line influences the frame delay.

When a frame passes through IE switches of the SCALANCE XB-000 product line, it is delayed by the store and forward function of the switch

- with a 64 byte frame length by approx. 10 microseconds (at 100 Mbps)
- with a 1500 byte frame length by approx. 130 microseconds (at 100 Mbps)

This means the more devices of the SCALANCE XB-000 product line that the frame passes through, the longer the frame propagation time.

---

# Approvals

The SIMATIC NET products described in these Operating Instructions have the approvals listed below.

---

**Note****Issued approvals on the type plate of the device**

The specified approvals apply only when the corresponding mark is printed on the product. You can check which of the following approvals have been granted for your product by the markings on the type plate.

---

**Note the installation guidelines**

The devices meet the requirements if you keep to the installation instructions and safety-related notices as described here and in the manual "SIMATIC NET Industrial Ethernet Twisted Pair and Fiber Optic Networks (<http://support.automation.siemens.com/WW/view/en/8763736>)" when installing and operating the device.

**Notes for the Manufacturers of Machines**

The devices are not machines in the sense of the EC Machinery Directive. There is therefore no declaration of conformity relating to the EC Machinery Directive 2006/42/EC for these devices.

If the devices are part of the equipment of a machine, they must be included in the declaration of conformity procedure by the manufacturer of the machine.

**EU declaration of conformity**

You will find EC declaration of conformity for these products on the Internet pages of Siemens Industry Online Support (<http://support.automation.siemens.com/WW/view/en/33118389/134200>).

## ATEX (explosion protection directive)

 <b>WARNING</b>
<p>When using SIMATIC NET products in hazardous area zone 2, make absolutely sure that the associated conditions in the following document are adhered to:</p> <p>"SIMATIC NET Product Information Use of subassemblies/modules in a Zone 2 Hazardous Area".</p> <p>You will find this document</p> <ul style="list-style-type: none"><li>• on the data medium that ships with some devices.</li><li>• on the Internet pages of Siemens Industry Online Support (<a href="http://support.automation.siemens.com/WW/view/en">http://support.automation.siemens.com/WW/view/en</a>).</li></ul> <p>Enter the document identification number C234 as the search term.</p>

SIMATIC NET products meet the requirements of the EC directive:94/9/EC "Equipment and Protective Devices for Use in Potentially Explosive Atmospheres".

ATEX classification:

II 3 G Ex nA IIC T4 Gc

KEMA 07ATEX0145 X

The products meet the requirements of the following standards:

- EN 60079-15 (electrical apparatus for potentially explosive atmospheres; Type of protection "n")
- EN 60079-0 (Explosive atmospheres - Part 0: Equipment - General requirements)

You will find the current versions of the standards in the currently valid ATEX certificates.

## IECEX

The SIMATIC NET products meet the requirements of explosion protection according to IECEX.

IECEX classification:

Ex nA IIC T4 Gc

DEK 14.0025X

The products meet the requirements of the following standards:

- IEC 60079-15 (Explosive atmospheres - Part 15: Equipment protection by type of protection "n")
- IEC 60079-0 (Explosive atmospheres - Part 0: Equipment - General requirements)

You will find the current versions of the standards in the currently valid IECEX certificates.

**FM**

The product meets the requirements of the standards:

- Factory Mutual Approval Standard Class Number 3611
- FM Hazardous (Classified) Location Electrical Equipment:  
Non Incendive / Class I / Division 2 / Groups A,B,C,D / T4 and  
Non Incendive / Class I / Zone 2 / Group IIC / T4

Ta: -10 to 60 °C

**cULus approval for industrial control equipment**

cULus Listed IND. CONT. EQ.

Underwriters Laboratories Inc. complying with

- UL 61010-2-201
- CAN/CSA-IEC 61010-2-201

Report no. E85972

**cULus Approval for Information Technology Equipment**

cULus Listed I. T. E.

Underwriters Laboratories Inc. complying with

- UL 60950-1 (Information Technology Equipment)
- CSA C22.2 No. 60950-1-03

Report no. E115352

**cULus for Hazardous Locations**

ANSI/ISA 12.12.01-2007, CSA C22.2 No. 213-M1987

CL. 1, Div. 2 GP. A.B.C.D T..

CL. 1, Zone 2, GP, IIC, T..

CL. 1, Zone 2, AEx nC IIC T..

(T.. = For detailed information on the temperature class, refer to the type plate)

**RCM**

The product meets the requirements of the AS/NZS 2064 standard (Class A).

**Marking for the customs union**

EAC (Eurasian Conformity)

Customs union of Russia, Belarus and Kazakhstan

Declaration of the conformity according to the technical regulations of the customs union (TR CU)

**KC (Korean Standard)**

The products meet the requirements of the "Korean Standard".

**Mechanical stability (in operation)**

Device	DIN EN 60068-2-6 vibration	DIN EN 60068-2-6 vibration ship building	DIN EN 60068-2-27 shock
	5 - 8.51 Hz: 7.0 mm <sup>PP</sup> 8.51 - 150 Hz: 10 m/s <sup>2</sup> 1 oct/min, 20 sweeps	2 - 13.2 Hz: 2.0 mm <sup>PP</sup> 13.2 - 100 Hz: 7 m/s <sup>2</sup> 2 min/oct, 1 sweep	150 m/s <sup>2</sup> , 11 ms duration 6 shocks per axis
XB004-1	•	•	•
XB004-2	•	•	•
XB004-1LD	•	•	•
XB005	•	•	•
XB008	•	•	•

Device	DIN EN 60068-2-6 vibration	DIN EN 60068-2-6 vibration	DIN EN 60068-2-6 vibration ship building	DIN EN 60068-2-27 shock	DIN EN 60068-2-29 permanent shock
	5 - 8.51 Hz: 7.0 mm <sup>PP</sup> 8.51 - 150 Hz: 10 m/s <sup>2</sup> 1 oct/min, 20 sweeps	5 - 8.51 Hz: 7.0 mm <sup>PP</sup> 8.51 - 500 Hz: 10 m/s <sup>2</sup> 1 oct/min, 20 sweeps	2 - 13.2 Hz: 2.0 mm <sup>PP</sup> 13.2 - 100 Hz: 7 m/s <sup>2</sup> 2 min/oct, 1 sweep	150 m/s <sup>2</sup> , 11 ms duration 6 shocks per axis	250 m/s <sup>2</sup> , 6 ms duration 1000 shocks per axis
XB004-1G	•	•	•	•	•
XB004-1LD G	•	•	•	•	•
XB005G	•	•	•	•	•
XB008G	•	•	•	•	•

# Dimension drawings

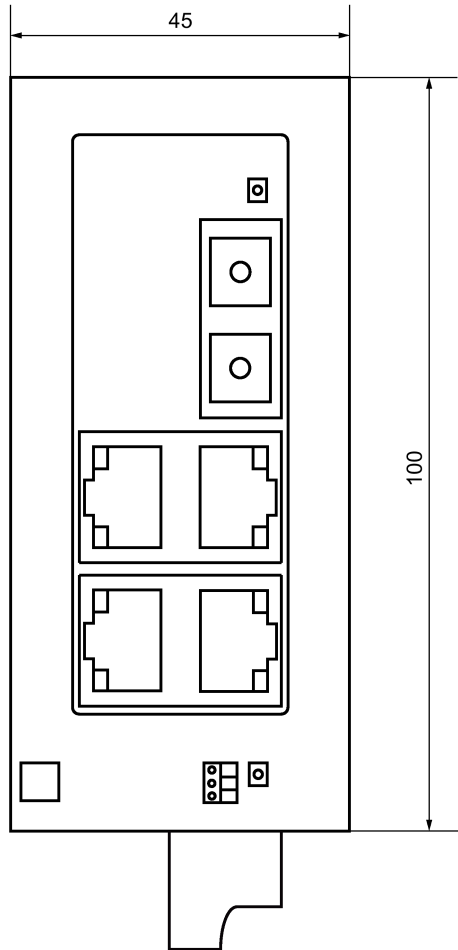

Figure 9-1 Dimension drawing, front view (example: SCALANCE XB004-1)

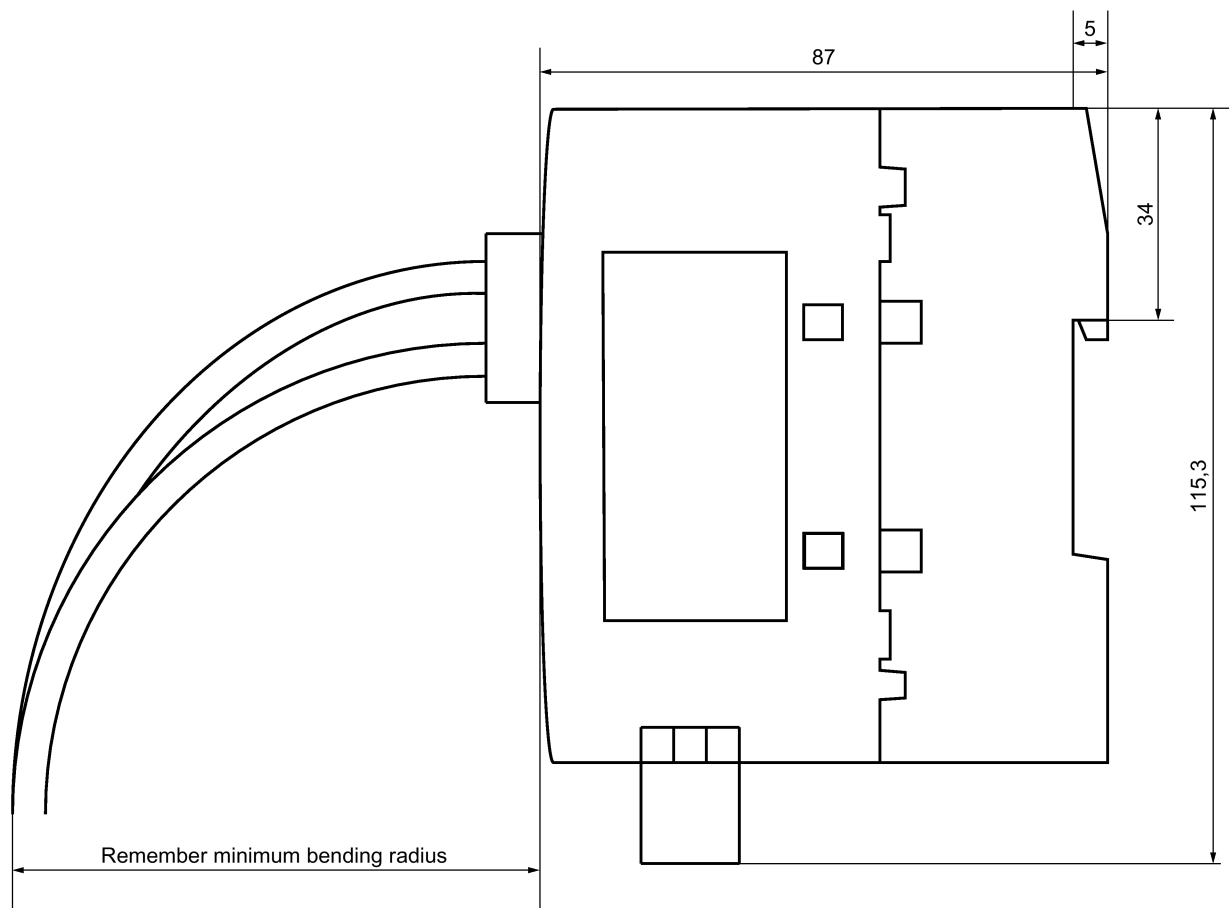

Figure 9-2 Dimension drawing, side view (example: SCALANCE XB004-1)

---

**Note**

The minimum bending radius of the optical and electrical signal cables used must not be fallen below.

---

Example:

SIMATIC NET FO standard cable - bending radius  $\geq 70$  mm

# Index

## A

- Accessories, 8
- Approvals, 69
- Article numbers, 5
- Attachment to Industrial Ethernet, 49, 52, 54, 57, 59, 61, 63, 65, 67
- Auto polarity exchange, 25
- Autonegotiation, 25

## C

- CE mark, 69
- Class 1 laser, 30, 31, 32
- Components of the product, 7

## D

- defective, 47
- Design, dimensions and weight, 50, 53, 55, 58, 60, 62, 64, 65, 68
- Dimension drawing, 73
  - Bending radius, 74
  - From above, 73
  - Side view, 74

## E

- Electrical data, 50, 52, 55, 57, 59, 61, 63, 65, 67
- Electrical/optical star topology, 12
- Error
  - LED display when voltage is too low, 47
- ESD directives, 10

## F

- FO port, 28, 29
  - SCALANCE XB004-1, 28
  - SCALANCE XB004-1G, 31
  - SCALANCE XB004-1LD, 30
  - SCALANCE XB004-1LDG, 32
  - SCALANCE XB004-2, 29
- Further documentation, 5

## G

- Glossary, 6
- Grounding, 43

## I

- IE FC RJ-45 Plug 180, 44
  - Mounting, 44
  - Plugging in, 45
  - Pulling, 45
- Insulation between the TP ports, 26
  - SCALANCE XB004-1, 26
  - SCALANCE XB004-2, 26
  - SCALANCE XB005, 27
  - SCALANCE XB008, 27

## L

- LED display, 47
  - Port LEDs, 33
  - Power LED, 33

## M

- MDI / MDIX autocrossover function, 25
- Mounting, 36
  - Installation on a DIN rail, 37
  - Types of installation, 36
  - Wall mounting, 39

## N

- Network topology, 11
  - Star topology, 11

## O

- Optical connectors, 49, 52, 54, 61, 63
- Optical parameters, 49, 52, 54, 61, 63
- Order numbers, 49, 52, 54, 57, 59, 61, 63, 65, 67

**P**

Permitted ambient conditions, 50, 53, 55, 57, 59, 62, 64, 65, 67  
Permitted cable lengths, 49, 52, 54, 57, 59, 61, 63, 65, 67  
Pin assignment, 24  
Possible attachments  
    SCALANCE XB004-1, 15  
    SCALANCE XB004-1G, 20  
    SCALANCE XB004-1LD, 17  
    SCALANCE XB004-1LDG, 21  
    SCALANCE XB004-2, 16  
    SCALANCE XB005G, 22  
    SCALANCE XB008G, 23  
Possible connections  
    SCALANCE XB005, 18  
    SCALANCE XB008, 19  
Product characteristics, 13

**R**

Reduced voltage, 47

**S**

Safety notices  
    for installation, 35  
    Use in hazardous areas, 35  
SCALANCE XB004-1  
    Attachment to Industrial Ethernet, 49  
    Design, dimensions and weight, 50  
    Electrical data, 50  
    Frame delay time, 51  
    Optical connectors, 49  
    Optical parameters, 49  
    Order numbers, 49  
    Permitted ambient conditions, 50  
    Permitted cable lengths, 49  
    Switching properties, 51  
SCALANCE XB004-1G  
    Attachment to Industrial Ethernet, 61  
    Design, dimensions and weight, 62  
    Electrical data, 61  
    Frame delay time, 62  
    Optical connectors, 61  
    Optical parameters, 61  
    Order numbers, 61  
    Permitted ambient conditions, 62  
    Permitted cable lengths, 61  
    Switching properties, 62

SCALANCE XB004-1LD  
    Attachment to Industrial Ethernet, 54  
    Design, dimensions and weight, 55  
    Electrical data, 55  
    Frame delay time, 56  
    Optical connectors, 54  
    Optical parameters, 54  
    Order numbers, 54  
    Permitted ambient conditions, 55  
    Permitted cable lengths, 54  
    Switching properties, 56  
SCALANCE XB004-1LDG  
    Attachment to Industrial Ethernet, 63  
    Design, dimensions and weight, 64  
    Electrical data, 63  
    Frame delay time, 64  
    Optical connectors, 63  
    Optical parameters, 63  
    Order numbers, 63  
    Permitted ambient conditions, 64  
    Permitted cable lengths, 63  
    Switching properties, 64  
SCALANCE XB004-2  
    Attachment to Industrial Ethernet, 52  
    Design, dimensions and weight, 53  
    Electrical data, 52  
    Frame delay time, 53  
    Optical connectors, 52  
    Optical parameters, 52  
    Order numbers, 52  
    Permitted ambient conditions, 53  
    Permitted cable lengths, 52  
    Switching properties, 53  
SCALANCE XB005  
    Attachment to Industrial Ethernet, 57  
    Design, dimensions and weight, 58  
    Electrical data, 57  
    Frame delay time, 58  
    Order numbers, 57  
    Permitted ambient conditions, 57  
    Permitted cable lengths, 57  
    Switching properties, 58  
SCALANCE XB005G  
    Attachment to Industrial Ethernet, 65  
    Design, dimensions and weight, 65  
    Electrical data, 65  
    Frame delay time, 66  
    Order numbers, 65  
    Permitted ambient conditions, 65  
    Permitted cable lengths, 65  
    Switching properties, 66

**SCALANCE XB008**

- Attachment to Industrial Ethernet, 59
- Design, dimensions and weight, 60
- Electrical data, 59
- Frame delay time, 60
- Order numbers, 59
- Permitted ambient conditions, 59
- Permitted cable lengths, 59
- Switching properties, 60

**SCALANCE XB008G**

- Attachment to Industrial Ethernet, 67
- Design, dimensions and weight, 68
- Electrical data, 67
- Frame delay time, 68
- Order numbers, 67
- Permitted ambient conditions, 67
- Permitted cable lengths, 67
- Switching properties, 68

**SIMATIC NET glossary, 6**

Switching properties, 51, 53, 56, 58, 60, 62, 64, 66, 68

**T****Technical**

specifications, 49, 52, 54, 57, 59, 61, 63, 65, 67

- SCALANCE XB004-1, 49
- SCALANCE XB004-1G, 61
- SCALANCE XB004-1LD, 54
- SCALANCE XB004-1LDG, 63
- SCALANCE XB004-2, 52
- SCALANCE XB005, 57
- SCALANCE XB005G, 65
- SCALANCE XB008, 59
- SCALANCE XB008G, 67

Twisted pair cable, 44

