

Flow Measurement

SITRANS FP (differential pressure flow measurement)

SITRANS FP230/FPS200 primary elements (ISO 5167)

Overview

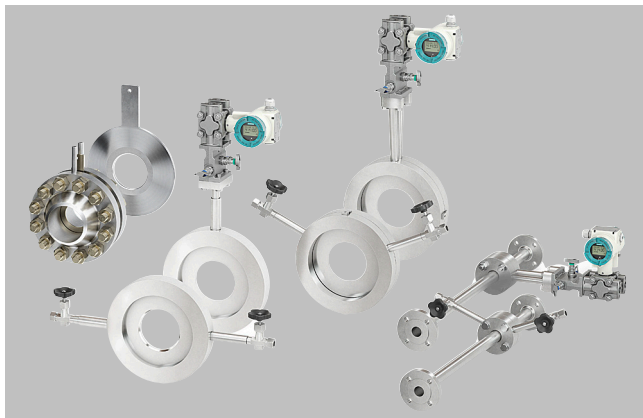

Primary differential pressure devices are standardized mechanical flow sensors, often also referred to as differential pressure transducers. The primary differential pressure devices are calculated and manufactured according to DIN EN ISO 5167.

Through constriction of the line diameter in the pressure device, the flow rate creates a differential pressure that is converted with the help of a differential pressure transmitter into a proportional current signal or flow value. The assignment of differential pressure to flow is created by a calculation of the primary differential pressure device.

Primary differential pressure devices are suitable for single-phase media such as gas, steam and liquids without solid components.

Benefits

- Suitable for universal use across the globe and widely accepted in all industries
- Very robust and can be used in a wide range of nominal diameters
- Suitable for high temperature and pressure ranges
- Low uncertainty of measurement
- No wet calibration required as they use an internationally standardized flow rate measurement procedure
- Differential pressure transmitter can be used over a long distance from the measuring location
- Differential pressure method is well known and has a large installed base
- SITRANS P differential pressure transmitter is easy to parameterize again if process data change. They are adapted by recalculating and assigning new parameters to the transmitter or, in case of an orifice plate with annular chamber, by using a new orifice plate

Application

- Technical gases
- Compressed air
- Fresh and combustion air
- Steam/Heat quantities
- Heat transfer fluids
- Water

Design

Basics: Orifices for flow measurement

Orifice plates are usually differentiated by their type of installation, type of differential pressure tapping and the shape of the orifice.

The characteristic differential pressure is created by the orifice bore which is the defined circular opening. It is usually of square edged concentric type according to ISO 5167-2 positioned in the middle of the pipe.

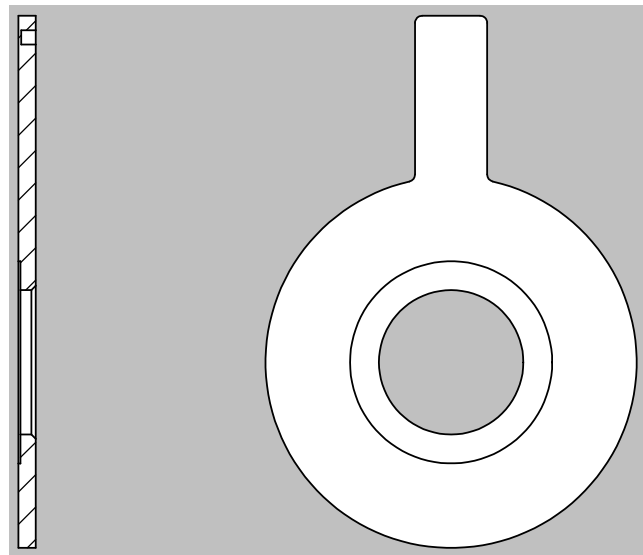

The main features are a sharp edge, a cylindrical bore of a certain length and a conical bevel tapering to the rear. Alternatively, the relevant standards provide for deviating designs, which are used for applications with highly viscous (e.g. quarter-circle nozzles) or contaminated media (e.g. segment orifices).

The standard design is permitted by the standard for an inner diameter of the pipe between 50 mm and 1000 mm. For pipes with smaller inside diameters, standards such as ISO 15377-TR or ASME MFC-14M which go beyond these standards must be taken into account. Orifice plates for pipes with small inside diameters are usually designed as meter tubes.

In order to reduce the uncertainties of these meter tubes, the devices can be calibrated on a flow test bench if required on request.

Types of differential pressure tapings

The differential pressure can be tapped in different ways:

Corner tapping

Directly in front of and behind the orifice plate an opening is placed in the corner of a carrier ring to measure upstream and downstream pressure. Both pressure signals are routed through these openings to the outside.

Corner tapping with annular chamber

The orifice plate is held by an annular chamber. Upstream and downstream pressure are measured through an annular gap opening between carrier ring and orifice plate. Both pressure signals are averaged over the entire circumference and routed outside.

Flange tapping

The orifice plate is held between two so-called orifice flanges. Upstream and downstream pressure signals are measured through flange taps which are drilled into the flanges.

Design (continued)Tapping with distance D, D/2

The orifice plate is held between regular flanges. Upstream and downstream pressure signals are measured through taps in the pipe with distance of D (upstream) and D/2 (downstream) to the orifice plate.

Designs

- Standard orifice plate with corner pressure tapplings (7ME171)
- Standard orifice plate with annular chamber (7ME172)
- Orifice meter run (7ME173)
- Orifice plate (7ME174)
- Orifice plate with orifice flanges (7ME175)

Mounting arrangements

For more information on installation position and piping, please see the Operating Instructions "SITRANS FPS200" on SIOS.

Integration

The orifice plate is installed between two flanges in the pipeline. Using condensation pots (for steam) and initial shut-off valves, the differential pressure of the high-pressure side and low-pressure side is directed through differential pressure lines to a manifold and to the differential pressure transmitter. For fluids with pressure and temperature fluctuations it makes sense to take an additional measurement of the pressure and temperature in order to correct the flow signal of the transmitter in a subsequent correction computer.

Selection of mounting point

The flow measuring regulations DIN EN ISO 5167 not only consider the design of primary differential pressure devices, but also assume that their installation is in accordance with the standard so that the specified tolerances can be retained. The required inlet and outlet pipe sections according to ISO 5167 can be found in the calculation protocol of the respective orifice plate. Configuration of the pipeline should allow for standardized installation (required inlet and outlet pipe section). Particular attention must be paid to ensure that the primary device can be fitted in a sufficiently long straight section of pipe. Bends, valves and similar should be fitted sufficiently far upstream of the primary device to prevent them having a detrimental effect. Primary devices with a large diameter ratio are particularly sensitive to interferences.

Design of measuring point

The design of the measuring point depends on the medium and on the spatial conditions. The designs for gas and water only differ with regard to the position of the tapping sockets (see section "Tapping sockets"); condensation pots are provided for steam applications.

Orifice meter runs

On lines with small nominal diameters (DN 10 to DN 50) the measurements are influenced by the wall roughness and diameter tolerances of the pipes, more than measurements with larger nominal diameters. These influences are counteracted by using orifice meter runs with fitted inlet and outlet pipe sections made of precision pipes. For exact measurements with orifice meter runs, the flow coefficient C can be determined by means of calibration.

Technical specifications

SITRANS FP230/FPS200	
General design	
Working principle	Differential pressure orifice meter (other ISO 5167 primary elements on request)
Media	<ul style="list-style-type: none"> • Steam (saturated, superheated) • Gas (dry, up to 100% water saturated) • Liquids (water, non-conductive liquids, oil, etc.)
Transmitter installation	<ul style="list-style-type: none"> • Compact mount with differential pressure transmitter (acc. to IEC 61518) • Remote mounted differential pressure transmitter
Bidirectional flow	On request
Design	According to ISO 5167-2 (2003); for orifice plates smaller than 50 mm inner diameter according to ISO/TR 15377 or ASME MFC-14M:2003
Accuracy	
Uncertainty at design flow (of Sensor Coefficient of Discharge)	Typically in the range of 0.5 ... 1.2% (depends on application and final design)
Measurement range	Typically between up to 1:5 ... 1:10 (real measurement range depends on transmitter performance and non-linearity of coefficient of discharge)
Operating conditions	
Pressure	Max. PN 100 or Class 600 (higher pressure ratings on request)
Temperature	According to EN 1092-1 or ASME B16.5 (exact maximum temperature depends on sensor design)
Pressure loss	30 ... 80% of differential pressure
Installation conditions	
Straight inlet diameter	Will be calculated by sizing tool (depends on β -coefficient, typically in the range of 16 ... 44 x inner diameter behind 90° elbow, can be reduced with 0.5% added uncertainty)
Straight outlet diameter	Will be calculated by sizing tool (depends on β -coefficient, typically in the range of 6 ... 8 x inner diameter, can be reduced with 0.5% added uncertainty) Note: For detailed calculation of recommended installation pipe length please refer to sizing tool or manual
Design	
Material orifice plate	Standard: <ul style="list-style-type: none"> • Stainless steel 1.4404/AISI 316L • Carbon steel (other materials on request)
Material orifice flanges / orifice holder	<ul style="list-style-type: none"> • Stainless steel 1.4404/AISI 316L • Carbon steel (other materials on request)
Pipe diameter	<ul style="list-style-type: none"> • DIN: DN 10 ... 600 • ASME: 3/8" ... 24" (other sizes on request)
Process connection	Orifice meter runs: Flanges EN 1092-1 B1 or ASME B16.5 RF All other designs: Suitable for installation between flanges EN 1092-1 B1 or ASME B16.5 RF (other process connections on request)
Length	Orifice with carrier ring and pressure tapplings: 40 mm (65 mm for compact steam applications) Orifice plate with annular chamber: 65 mm Orifice meter run: depends on pipe diameter (see below) Single piece orifice for orifice flanges (with or without orifice flanges): depends on pipe diameter (see below)

Flow Measurement

SITRANS FP (differential pressure flow measurement)

SITRANS FP230/FPS200 primary elements (ISO 5167)

Technical specifications (continued)

SITRANS FP230/FPS200

Approvals

• Hazardous area	(see differential pressure transmitter)
• Enclosure rating	(see differential pressure transmitter)
• Operational safety	(see differential pressure transmitter)

Accessories

Z-Options for cable glands, plugs, labeling, approvals, blanking plugs, flanges seals, device settings, etc. according to SITRANS P320

Options

Further versions that are available on request:

- Other types of primary differential pressure device: nozzles, venturi nozzles, classic venturi tubes etc.
- Other nominal diameters and nominal pressures to EN, ASME and other standards
- Other lengths, special lengths
- Other materials
- Sealing face with recess or groove
- Flushing rings
- Other tapping sockets, multiple tappings
- Material acceptance test certificates or cold water pressure tests

More information

For more information please see the Installation Instructions and the Instruction Manuals SITRANS P on SIOS.

Application



SITRANS FP230 compact design



SITRANS FPS200 remote design

Compact orifice plate with integrated pressure tapings in carbon or stainless steel for flow measurement of gas, steam and liquid.

Flow Measurement

SITRANS FP (differential pressure flow measurement)

SITRANS FP230/FPS200 primary elements (ISO 5167) / Standard orifice plate with corner pressure tapplings

Design

Standard orifice plates with integral tapplings are manufactured from a single body and are therefore particularly inexpensive. The pressure tapping takes place at two points and is integrated into the carrier ring. Differential pressure connection can be compact and remote. The instruments are easy to handle and offer good accuracy with reasonable inlet and outlet runs. They are installed between regular flanges.

Nominal size

- EN: DN 50 ... 500
- ASME: 2 ... 20 inch

Nominal pressure

- EN: PN 6 ... 100
- ASME: class 150 ... 600

Differential pressure tapping

- Corner tapping: Measurement of differential pressure at 2 points in the corner of the carrier ring

Sealing face

- According to EN 1092-1: flat (for flanges type B1 and B2)
- According to ASME B16.5: flat (for flanges RF and SF)

Material

- Orifice: Carbon steel / orifice edge: ER307
- Orifice: 316L/1.4404 / orifice edge: 316L/1.4404

Connection length

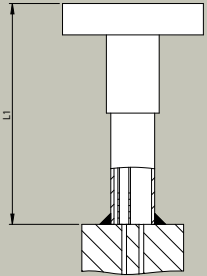
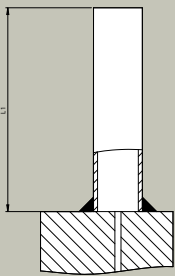
Connection length	
<p>Compact mount for gas and liquids</p> 	<ul style="list-style-type: none"> • L1 = 130 mm • Max. isolation = 110 mm
<p>Remote mount for gas and liquids</p> 	<ul style="list-style-type: none"> • L1 = 100 mm • Max. isolation = 80 mm

Design (continued)

Connection length

Compact mount for steam

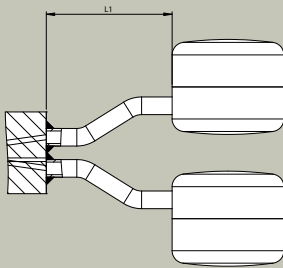

- L1 = 150 mm
- Max. isolation = 110 mm

Remote mount for steam

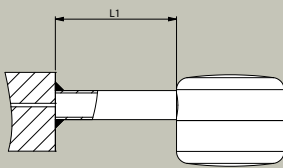

- L1 = 150 mm
- Max. isolation = 140 mm

Tapping sockets

Gases and liquids

Remote design

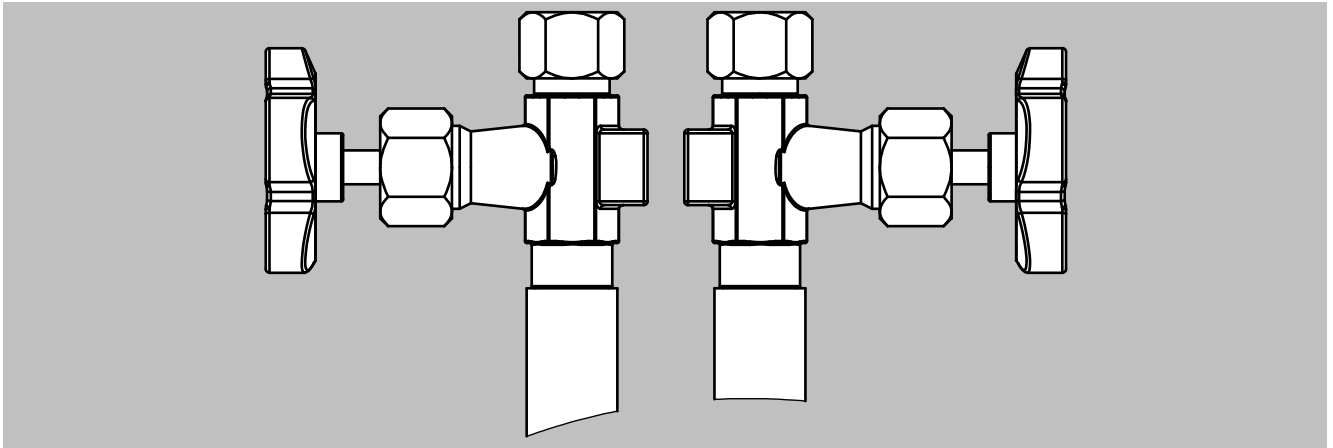

For single body standard orifice plates in remote design, the angle α between the pressure tapplings depends on the pressure rating and the nominal diameter of the flanges.

Flow Measurement

SITRANS FP (differential pressure flow measurement)

SITRANS FP230/FPS200 primary elements (ISO 5167) / Standard orifice plate with corner pressure tapings

Design (continued)

Compact design

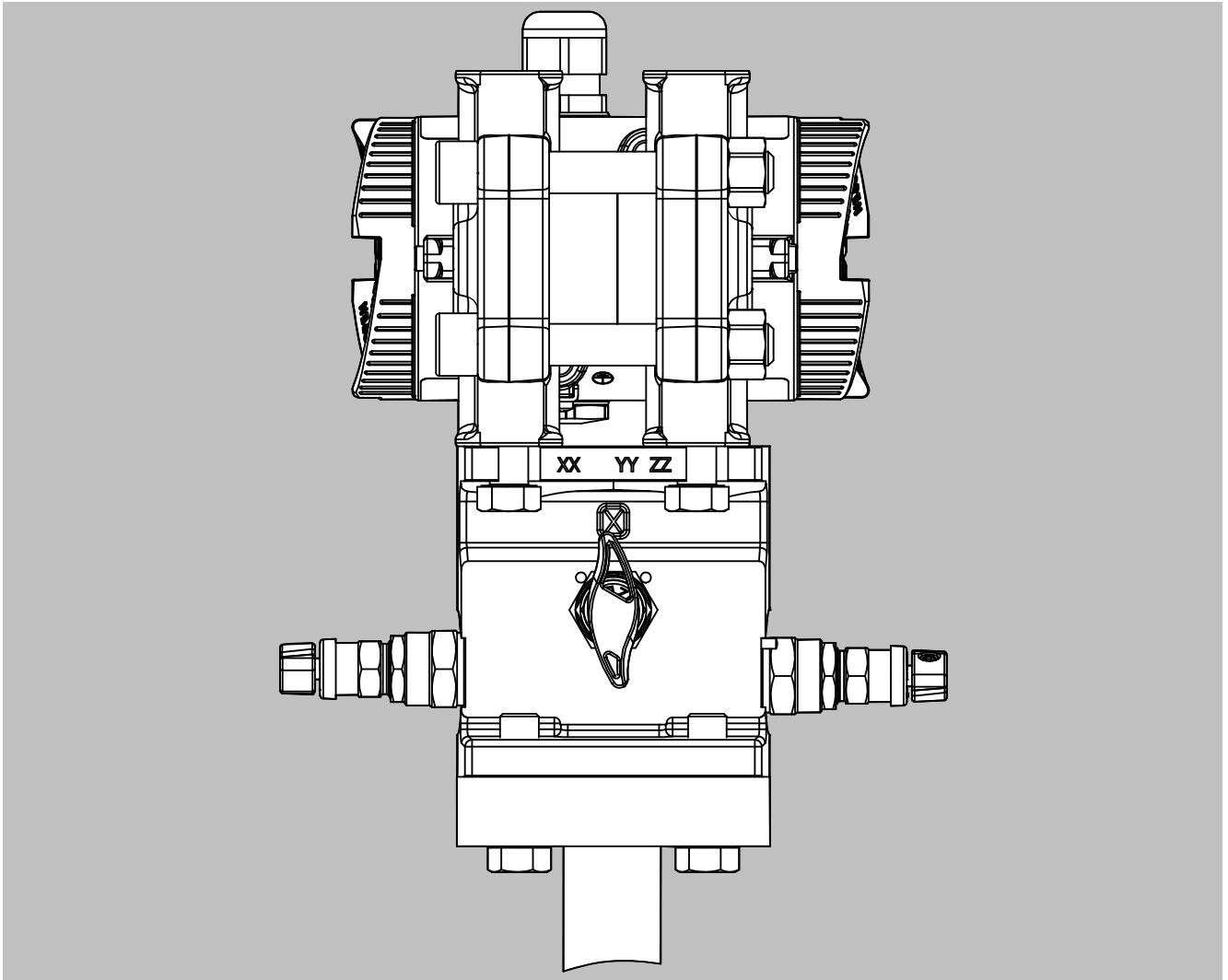

For single body standard orifice plates in compact design, a so-called flange plate is used. The manifold and the differential pressure transmitter are mounted on this flange plate.

Design (continued)

Tap position/angle in horizontal pipe

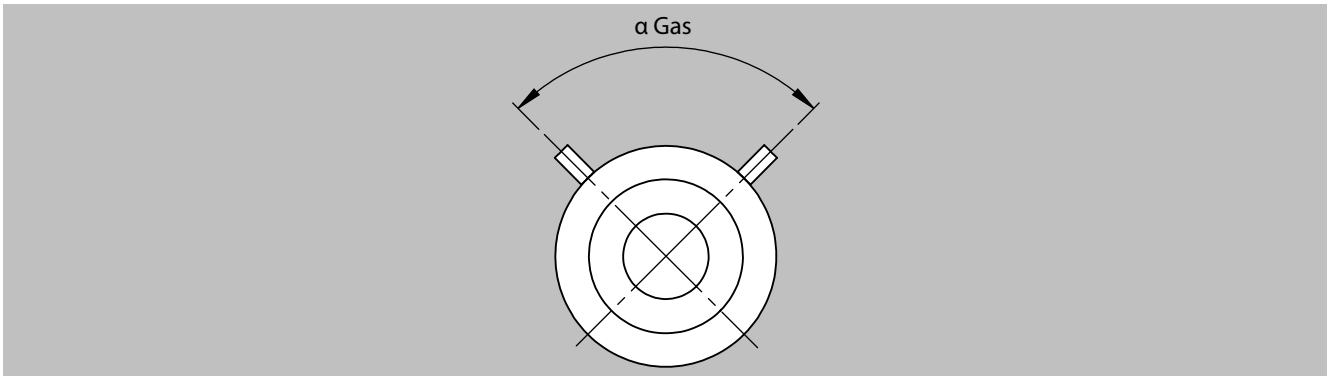

Tap position/angle in horizontal pipe (gas)

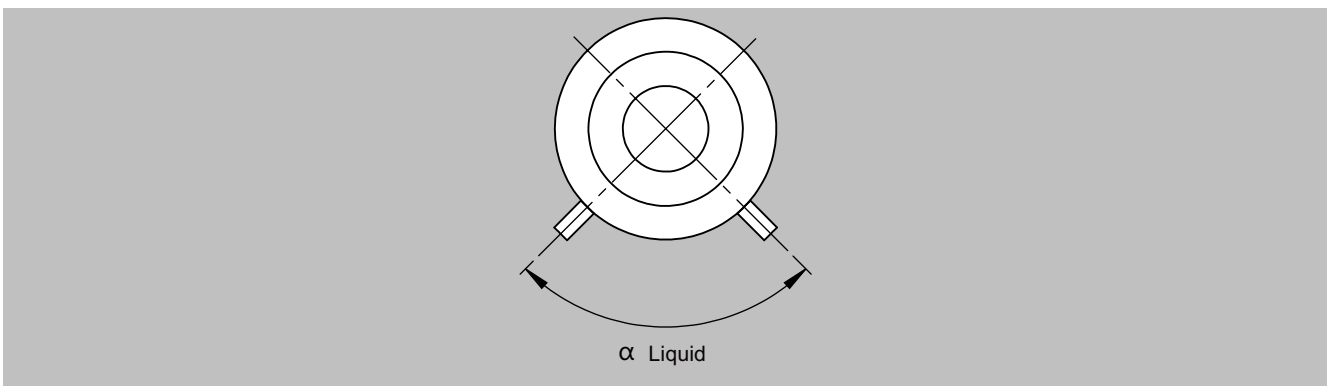

Tap position/angle in horizontal pipe (liquid)

Remote design for gases and liquids for DIN flange

Nominal size	DIN flange						
	PN 6	PN 10	PN 16	PN 25	PN 40	PN 64	PN 100
DN 50	135	135	135	135	135	135	135
DN 65	135	135	135 ^{*)}	90	90	90	90
DN 80	135	90	90	90	90	90	90
DN 100	135	90	90	90	90	90	90
DN 125	90	90	90	90	90	90	90
DN 150	90	90	90	90	90	90	60
DN 175	90	90	90	60	60	60	60
DN 200	90	90	60	60	60	60	60
DN 250	60	60	60	60	60	60	60
DN 300	60	60	60	45	45	45	45
DN 350	60	45	45	45	45	45	45
DN 400	45	45	45	45	45	45	45
DN 450	45	36	36	36	-	-	-
DN 500	36	36	36	36	36	36	36

^{*)} Fitting for DN 65 PN 16 flange with 4 holes. If design for flange with 8 holes is required, please add a comment to the corresponding project within the sizing tool.

Flow Measurement

SITRANS FP (differential pressure flow measurement)

SITRANS FP230/FPS200 primary elements (ISO 5167) / Standard orifice plate with corner pressure tapings

Design (continued)

Remote design for gases and liquids for ANSI flange

Nominal size	ANSI flange		
	Class 150	Class 300	Class 600
2"	135	90	90
2,5"	135	90	90
3"	135	90	90
4"	90	90	90
5"	90	90	90
6"	90	60	60
8"	90	60	60
10"	60	45	45
12"	60	45	36
14"	60	36	36
16"	45	36	36
18"	45	30	36
20"	36	30	30

Wet gases

Remote design

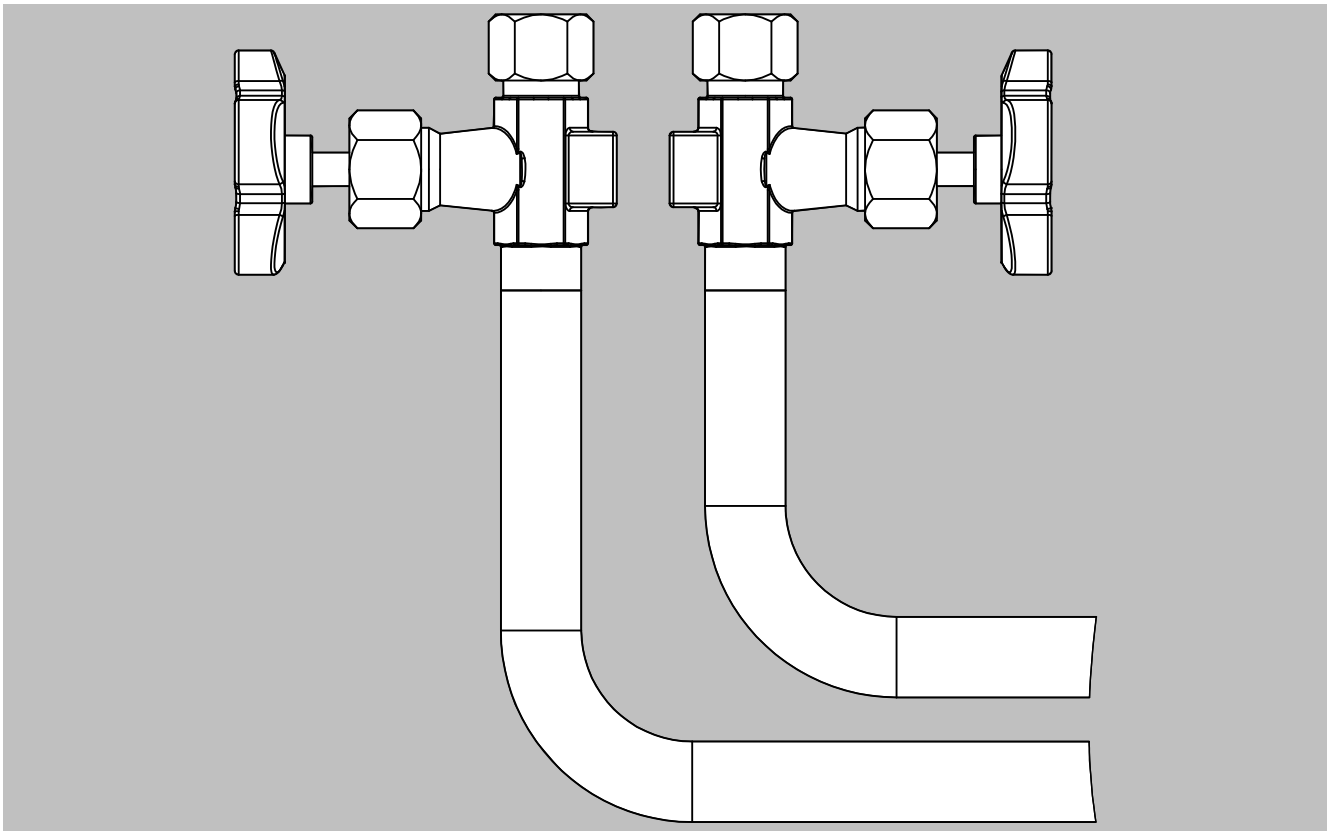

For single body standard orifice plates in remote design for wet gases, nozzles bent at right angles with welded-on valves are used. This design is only necessary for vertical pipes. For horizontal pipes, the design for gases and liquids can be selected because the nozzles point up as listed in the table above.

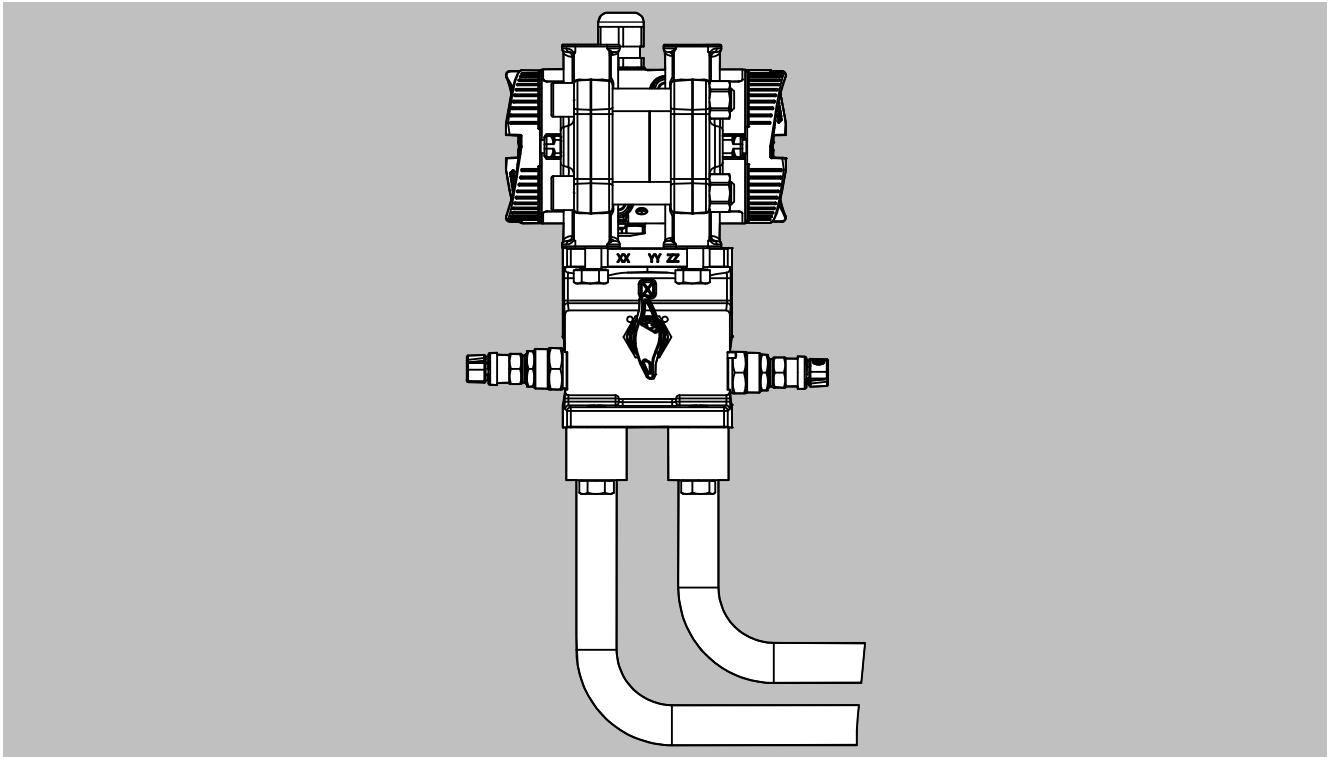
Design (continued)Compact design

For single body standard orifice plates in compact design for wet gases, nozzles bent at right angles with oval flanges are used. The manifold and the differential pressure transmitter are mounted on these oval flanges. This design is only necessary for vertical pipes. For horizontal pipes, the design for gases and liquids can be selected because the flange plate with manifold and transmitter always points up.

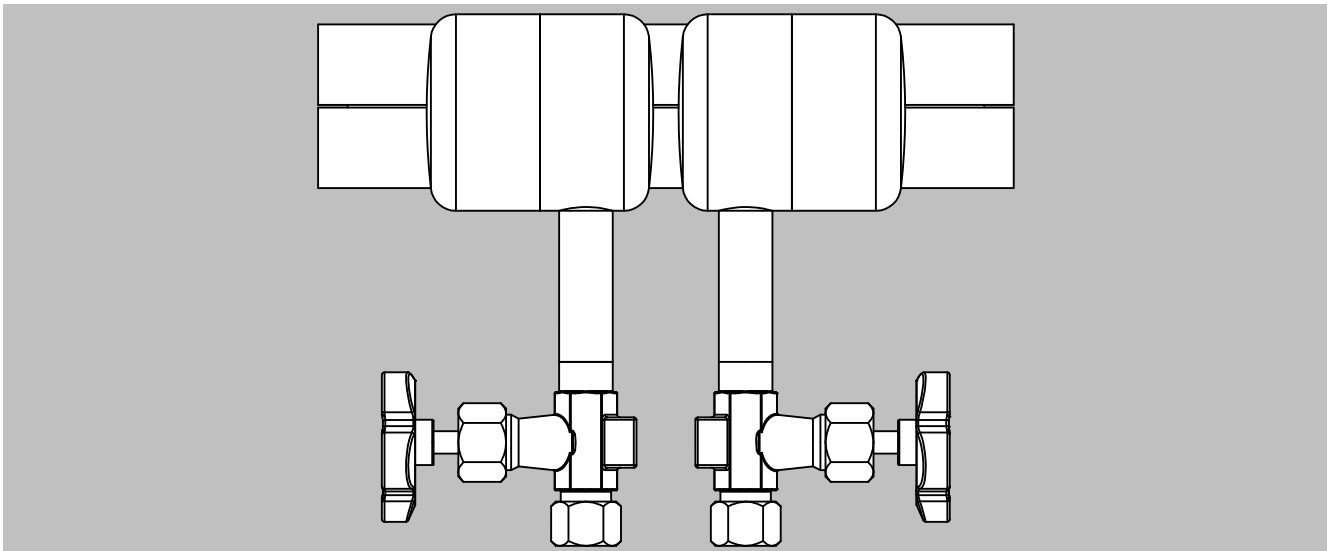
SteamRemote design

For single body standard orifice plates in remote design for steam, the condensate vessels with shut-off valves are welded at an angle of 180°.

Flow Measurement

SITRANS FP (differential pressure flow measurement)

SITRANS FP230/FPS200 primary elements (ISO 5167) / Standard orifice plate with corner pressure tapings

Design (continued)

Compact remote

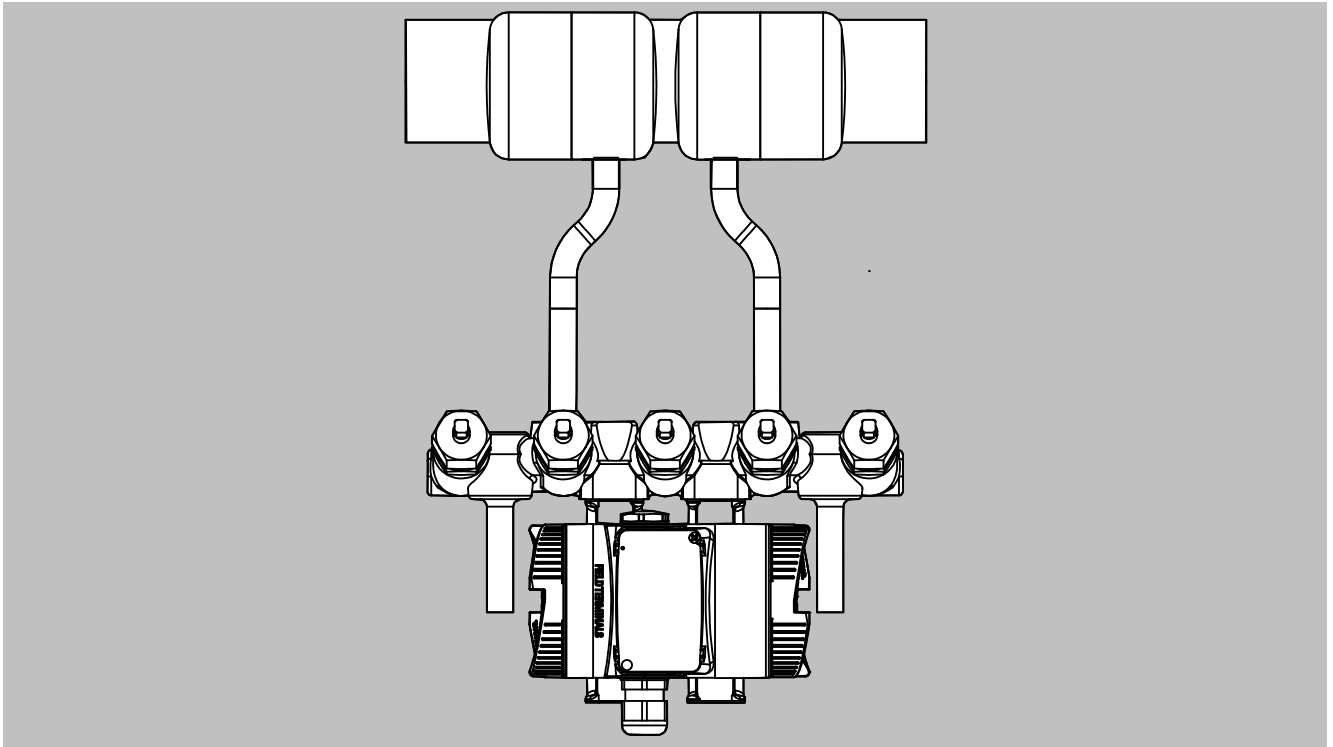

For single body standard orifice plates in compact design for steam, the condensate vessels and the manifold are welded-on one side. The orifice has a width of 65 mm in this case (deviating from the standard).

SITRANS FP230/FPS200 primary elements (ISO 5167) / Standard orifice plate with corner pressure tapings

Selection and ordering data

SITRANS FP230/FPS200 standard orifice plate with corner pressure tapings	Article No. 7ME171 ● - ● ● ● ● 0 - ● ● ● ●
Click on the Article No. for the online configuration in the PIA Life Cycle Portal.	
Communication	
HART (4 ... 20 mA)	0
PROFIBUS PA	1
FOUNDATION Fieldbus	2
Without transmitter	8
Nominal size	
DN 50 (2")	1 D
DN 65 (2½")	1 E
DN 80 (3")	1 F
DN 100 (4")	2 G
DN 125 (5")	2 H
DN 150 (6")	2 J
DN 200 (8")	2 K
DN 250 (10")	2 L
DN 300 (12")	2 M
DN 350 (14")	2 N
DN 400 (16")	2 P
DN 450 (18")	2 Q
DN 500 (20")	2 R
Nominal pressure	
Flange EN 1092-1 type B1 PN 6	A
Flange EN 1092-1 type B1 PN 10	B
Flange EN 1092-1 type B1 PN 16	C
Flange EN 1092-1 type B1 PN 25	D
Flange EN 1092-1 type B1 PN 40	E
Flange EN 1092-1 type B1 PN 64	F
Flange EN 1092-1 type B1 PN 100	G
Flange ASME B16.5 Class 150	Q
Flange ASME B16.5 Class 300	R
Flange ASME B16.5 Class 600	S
Wetted parts material	
Orifice: Carbon steel / orifice edge: ER307	0
Orifice: 316L/1.4404 / orifice edge: 316L/1.4404	1
System design	
Compact design for dry gases (horizontal and vertical pipes)	0
Compact design for liquids	1
Compact design for wet gases (only vertical pipes)	2
Compact design for steam	3
Remote design for dry gases	4
Remote design for liquids	5
Remote design for wet gases	6
Remote design for steam	7
Type of protection of pressure transmitter	
No Ex / without pressure transmitter	A
Intrinsic safety	B
Explosion proof	C
Intrinsic safety, Explosion proof	D
Dust ignition proof zone 21/22 (DIP), increased safety zone 2	L
Dust ignition proof zone 20/21/22 (DIP), increased safety zone 2	M
Intrinsic safety, Explosion proof, Dust ignition proof zone 21/22 (DIP), increased safety zone 2	S
Intrinsic safety, Explosion proof, Dust ignition proof zone 21/22 (DIP), increased safety zone 2, class division	T
Electrical connections/cable entries of pressure transmitter	
Without pressure transmitter	A
2 × M20 × 1.5	F
2 × 1/2-14 NPT	M
Local operation/display of pressure transmitter	
Without display (closed lid) / without pressure transmitter	0
With display (closed lid)	1

Flow Measurement

SITRANS FP (differential pressure flow measurement)

SITRANS FP230/FPS200 primary elements (ISO 5167) / Standard orifice plate with corner pressure tapings

Selection and ordering data (continued)

SITRANS FP230/FPS200 standard orifice plate with corner pressure tapings		Article No.
With display (lid with glass window)		7ME171 ● - ● ● ● ● 0 - ● ● ● ●
		2

	Order code
Further designs*	
Please add "-Z" to Article No. and specify Order code(s) and plain text.	
Certificates of primary element incl. manifolds	
Inspection certificate of the primary element (EN 10204-3.1) - material of pressure-containing and wetted parts	C52
Factory certificate of the primary element (EN 10204-2.2) - wetted parts (MR 0175-2015)	C54
Dimensional record of the primary element	C55
Inspection certificate (DIN EN 571-1) - dye penetration test of weldings	C56
Hydrostatic pressure test of the primary element (EN 13480-5) of weldings	C58
Dimensional drawing 1:1 DWG of the primary element	C59
Maximum measuring span of pressure transmitter	
20 mbar (8.037 inH ₂ O)	I01
60 mbar (24.11 inH ₂ O)	I02
250 mbar (100.5 inH ₂ O)	I03
600 mbar (241.1 inH ₂ O)	I04
1600 mbar (643 inH ₂ O)	I05
Shut-off valves	
With mounted shut-off valves DN8 made of carbon steel, up to 300 °C with tube fitting 12 mm	T50
With mounted shut-off valves DN8 made of stainless steel, up to 300 °C with tube fitting 12 mm	T51
With mounted shut-off valves DN8 made of carbon steel, up to 300 °C and condensate vessel made of carbon steel with tube fitting 12 mm	T56
With mounted shut-off valves DN8 made of stainless steel, and condensate vessel made of stainless steel with tube fitting 12 mm	T57
Valve manifolds for mounting on primary element	
With mounted manifold (3-fold) made of stainless steel, PTFE sealings, cadmium-plated steel screws	U40
With mounted manifold (3-fold) made of stainless steel, PTFE sealings, stainless steel screws	U41
With mounted manifold (5-fold) made of stainless steel, PTFE sealings, cadmium-plated steel screws	U42
With mounted manifold (5-fold) made of stainless steel, PTFE sealings, stainless steel screws	U43
With mounted manifold (5-fold) made of carbon steel, up to 300 °C cadmium-plated steel screws and condensate vessel made of carbon steel	U46
With enclosed manifold (3-fold) made of stainless steel, PTFE sealings, cadmium-plated steel screws with tube fitting 12 mm	U50
With enclosed manifold (3-fold) made of stainless steel, PTFE sealings, stainless steel screws with tube fitting 12 mm	U51
With enclosed manifold (5-fold) made of stainless steel, PTFE sealings, cadmium-plated steel screws with tube fitting 12 mm	U52

Selection and ordering data (continued)

	Order code
With enclosed manifold (5-fold) made of stainless steel, PTFE sealings, stainless steel screws with tube fitting 12 mm	U53
With enclosed manifold (5-fold) made of carbon steel, up to 300 °C cadmium-plated steel screws with tube fitting 12 mm	U56
Application data	
ID number of the primary element according to sizing tool	Y40

* For further options, please refer to SITRANS P320.

Scope of delivery

- Orifice with pressure tapping in carrier ring
- Condensation pots for steam applications
- Shut-off valves for remote design (options T5x selected in PIA)
- Manifold for compact/remote design (options U4x, U5x selected in PIA) incl. mounting brackets

Flow Measurement

SITRANS FP (differential pressure flow measurement)

SITRANS FP230/FPS200 primary elements (ISO 5167) / Standard orifice plate with corner pressure tapings

Dimensional drawings

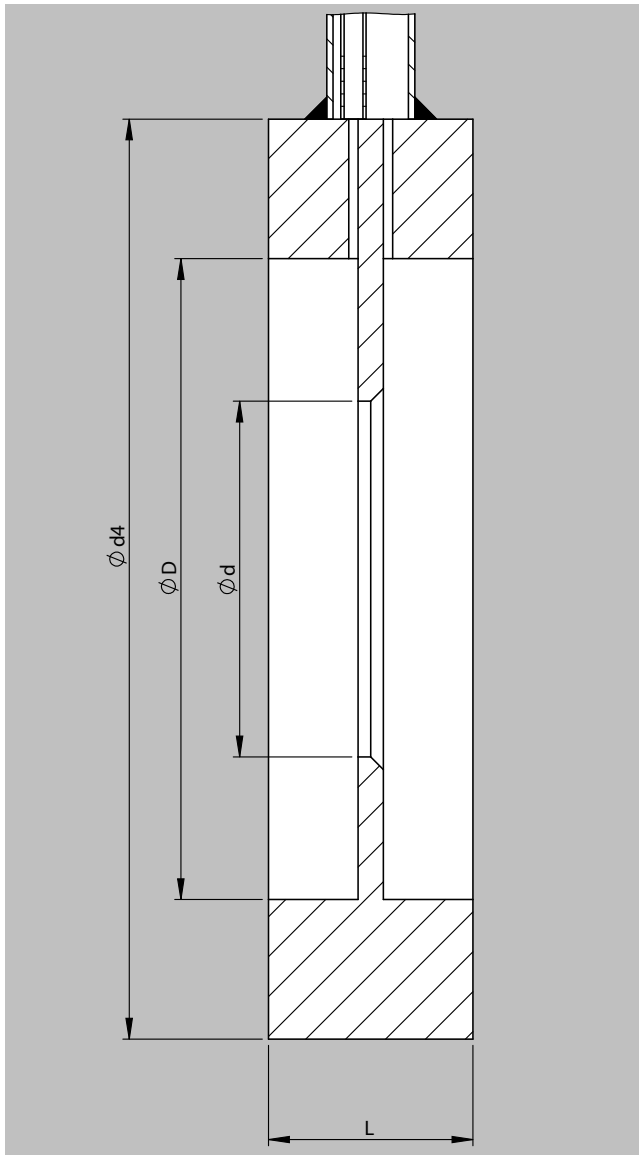

L: Overall length 40 mm (65 mm for compact steam applications)

d: According to sizing calculation

D: According to inner diameter of pipe (sizing tool)

d4: See table below

Nominal size	Outer diameter d4 / Sealing face: flat						
	PN 6	PN 10	PN 16	PN 25	PN 40	PN 63	PN 100
DN 50	96	107	107	107	107	113	119
DN 65	116	127	127	127	127	138	144
DN 80	132	142	142	142	142	148	154
DN 100	152	162	162	168	168	174	180
DN 125	182	192	192	194	194	210	217
DN 150	207	218	218	224	224	247	257
DN 200	262	273	273	284	290	309	324
DN 250	317	328	329	340	352	364	391
DN 300	373	378	384	400	417	424	458
DN 350	423	438	444	457	474	486	512

Flow Measurement

SITRANS FP (differential pressure flow measurement)

SITRANS FP230/FPS200 primary elements (ISO 5167) / Standard orifice plate with corner pressure tapings

Dimensional drawings (continued)

Nominal size	Outer diameter d4 / Sealing face: flat						
	PN 6	PN 10	PN 16	PN 25	PN 40	PN 63	PN 100
DN 400	473	489	495	514	546	543	-
DN 500	578	594	617	624	628	-	-

Nominal size	Outer diameter d4 / Sealing face: flat		
	Class 150	Class 300	Class 600
2"	105	111	111
2,5"	124	130	130
3"	137	149	149
4"	175	181	194
5"	197	216	241
6"	222	251	267
8"	279	308	321
10"	340	362	400
12"	410	422	457
14"	451	486	492
16"	514	540	565
20"	549	597	613

Flow Measurement

SITRANS FP (differential pressure flow measurement)

SITRANS FP230/FPS200 primary elements (ISO 5167) / Standard orifice plate with annular chamber

Application



SITRANS FP230 compact design



SITRANS FPS200 remote design

Orifice plate with annular chamber pressure tapping in carbon or stainless steel for flow measurement of gas, steam and liquid.

Design

Annular chamber orifice plates consist of two rings pressed together, between which the orifice plate is clamped. The pressure is measured upstream and downstream through an annular chamber. The accuracy is comparable to that of the standard orifice plate.

Orifice plates with annular chamber tapplings consist of a two-piece carrier ring with annular chamber and integral tapplings and an inserted orifice plate. Pressure before and after the orifice is averaged through the annular chamber. Tapping connections are integrated into each part of the carrier ring. Differential pressure connection can be compact and remote. The instruments are easy to handle and offer good accuracy with reasonable inlet and outlet runs. They are installed between regular flanges. The orifice can be disassembled to replace the inserted orifice plate.

Nominal sizes

- EN: DN 50 ... 600
- ASME: 2 ... 24 inch

Nominal pressure

- EN: PN 6 ... 64 (for steam applications maximum of PN 16 is recommended)
- ASME: class 150 ... 600 (for steam applications maximum of class 150 is recommended)

Pressure tapping

- Annular chamber: Corner tapping through annular chamber

Connection length

- Suitable for gases and liquids for a maximum of approx. 80 mm pipe insulation
- Suitable for steam for a maximum of approx. 140 mm pipe insulation

Sealing face

- According to EN 1092-1: flat (for flanges type B1 and B2)
- According to ASME B16.5: flat (for flanges RF and SF)

Material

- Carrier ring: Carbon steel / orifice plate: 316L/1.4404
- Carrier ring: 316L/1.4404 / orifice plate: 316L/1.4404

Gaskets

- Gas and liquids: Klingersil C4400
- Steam: Graphite with stainless steel inlay

Tapping sockets

Gases and liquids

Remote design

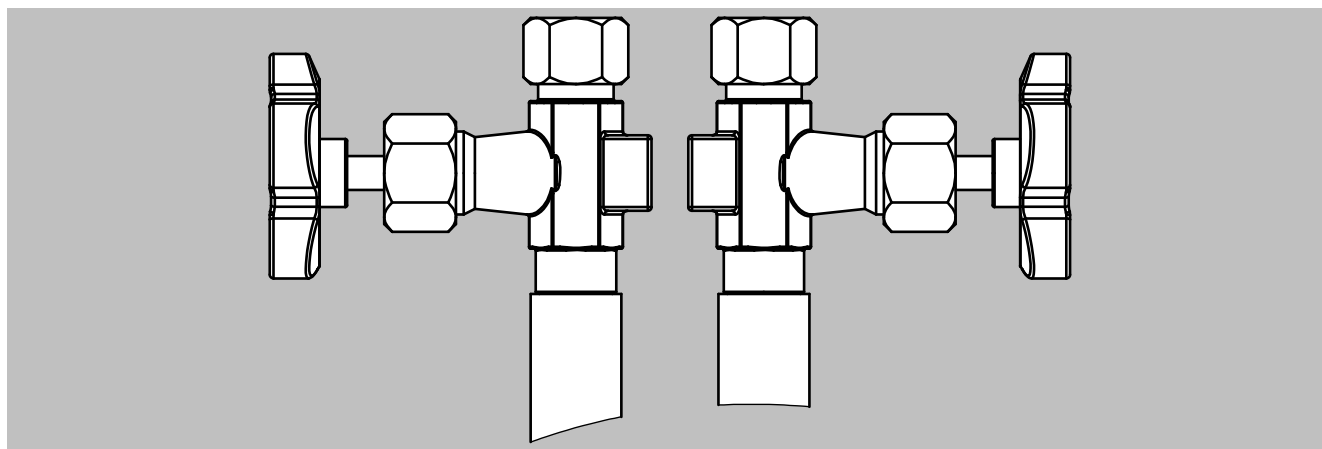

For annular chamber orifice plates in remote design, the angle α between the pressure tap depends on the pressure rating and the nominal size of the flanges.

Flow Measurement

SITRANS FP (differential pressure flow measurement)

SITRANS FP230/FPS200 primary elements (ISO 5167) / Standard orifice plate with annular chamber

Design (continued)

Compact design

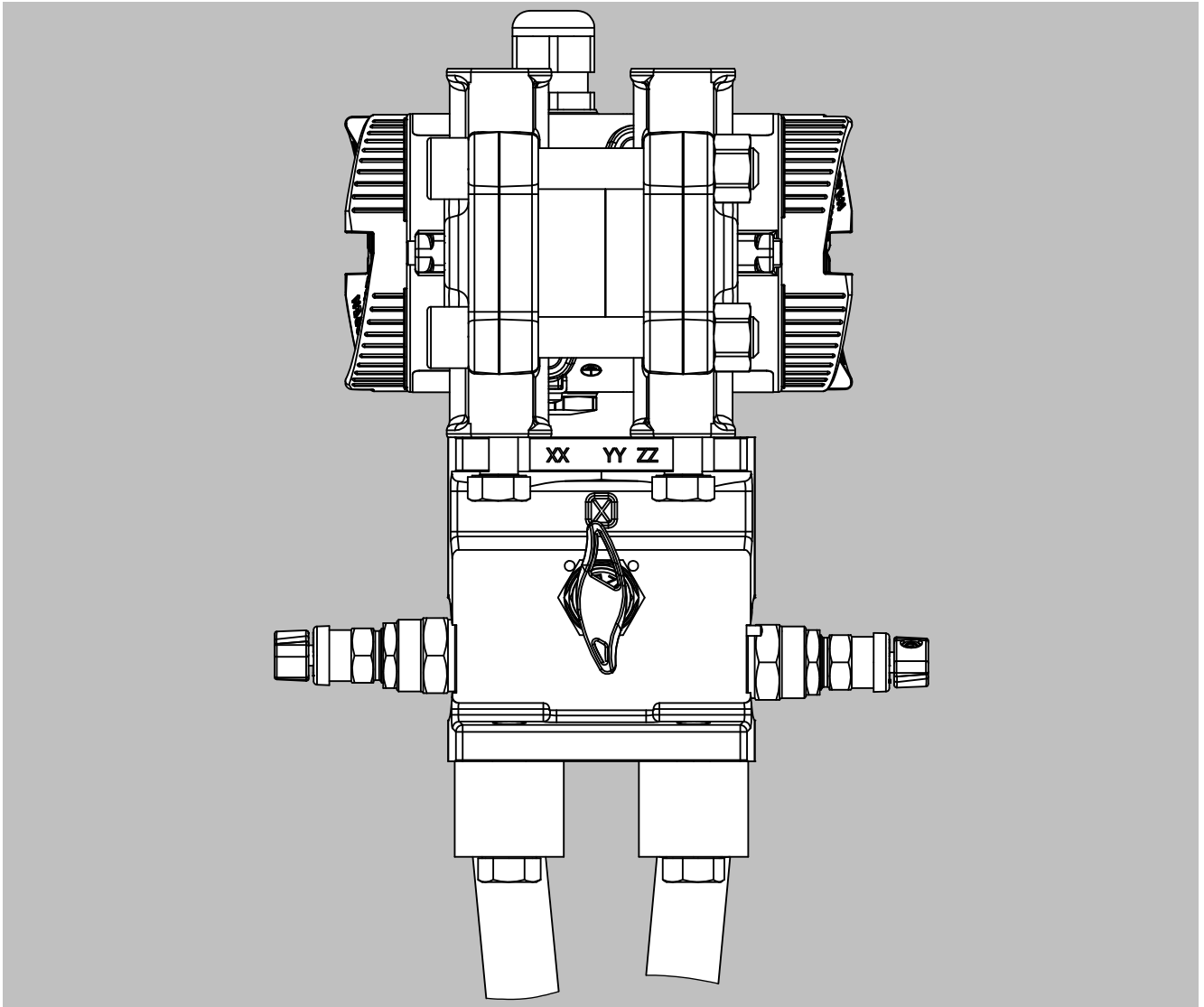

For annular chamber orifice plates in compact design, so-called oval flanges are used. The manifold and the differential pressure transmitter are mounted on these oval flanges.

Design (continued)

Tap position/angle in horizontal pipe

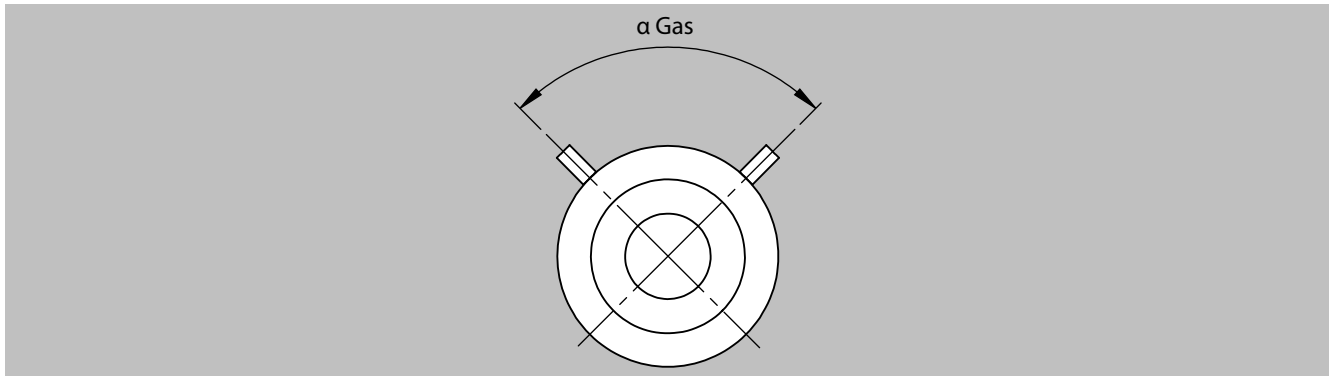

Tap position/angle in horizontal pipe (gas)

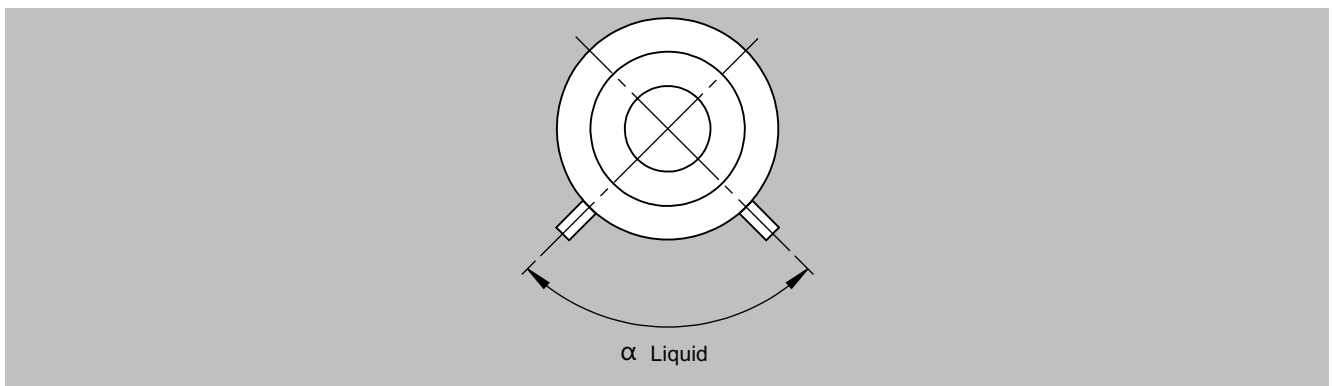

Tap position/angle in horizontal pipe (liquid)

Nominal size	DIN flange					
	PN 6	PN 10	PN 16	PN 25	PN 40	PN 64
DN 50	135	135	135	135	135	135
DN 65	135	135	135 ^{*)}	90	90	90
DN 80	135	90	90	90	90	90
DN 100	135	90	90	90	90	90
DN 125	90	90	90	90	90	90
DN 150	90	90	90	90	90	90
DN 175	90	90	90	60	60	60
DN 200	90	90	60	60	60	60
DN 250	60	60	60	60	60	60
DN 300	60	60	60	45	45	45
DN 350	60	45	45	45	45	45
DN 400	45	45	45	45	45	45
DN 450	45	36	36	36	-	-
DN 500	36	36	36	36	36	36

^{*)} Fitting for DN 65 PN 16 flange with 4 holes. If design for flange with 8 holes is required, please add a comment to the corresponding project within the sizing tool.

Flow Measurement

SITRANS FP (differential pressure flow measurement)

SITRANS FP230/FPS200 primary elements (ISO 5167) / Standard orifice plate with annular chamber

Design (continued)

Nominal size	ANSI flange		
	Class 150	Class 300	Class 600
2"	135	90	90
2,5"	135	90	90
3"	135	90	90
4"	90	90	90
5"	90	90	90
6"	90	60	60
8"	90	60	60
10"	60	45	45
12"	60	45	36
14"	60	36	36
16"	45	36	36
18"	45	30	36
20"	36	30	30
22"	36	30	30
24"	36	30	30

Wet gases

Remote design

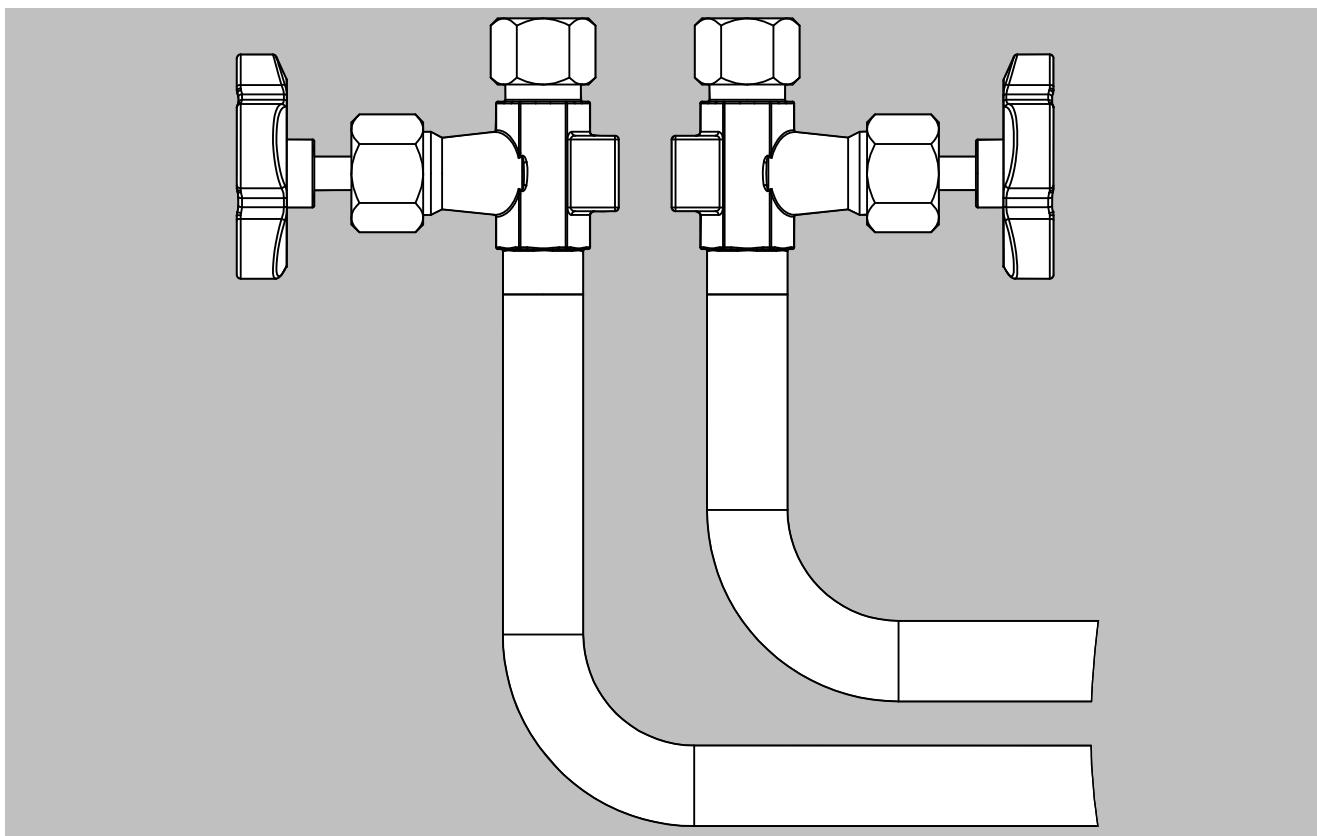

For annular chamber orifice plates in remote design for wet gases, nozzles bent at right angles with welded-on valves are used. This design is only necessary **for vertical pipes**. For horizontal pipes, the design for gases and liquids can be selected because the nozzles point up as listed in the table above.

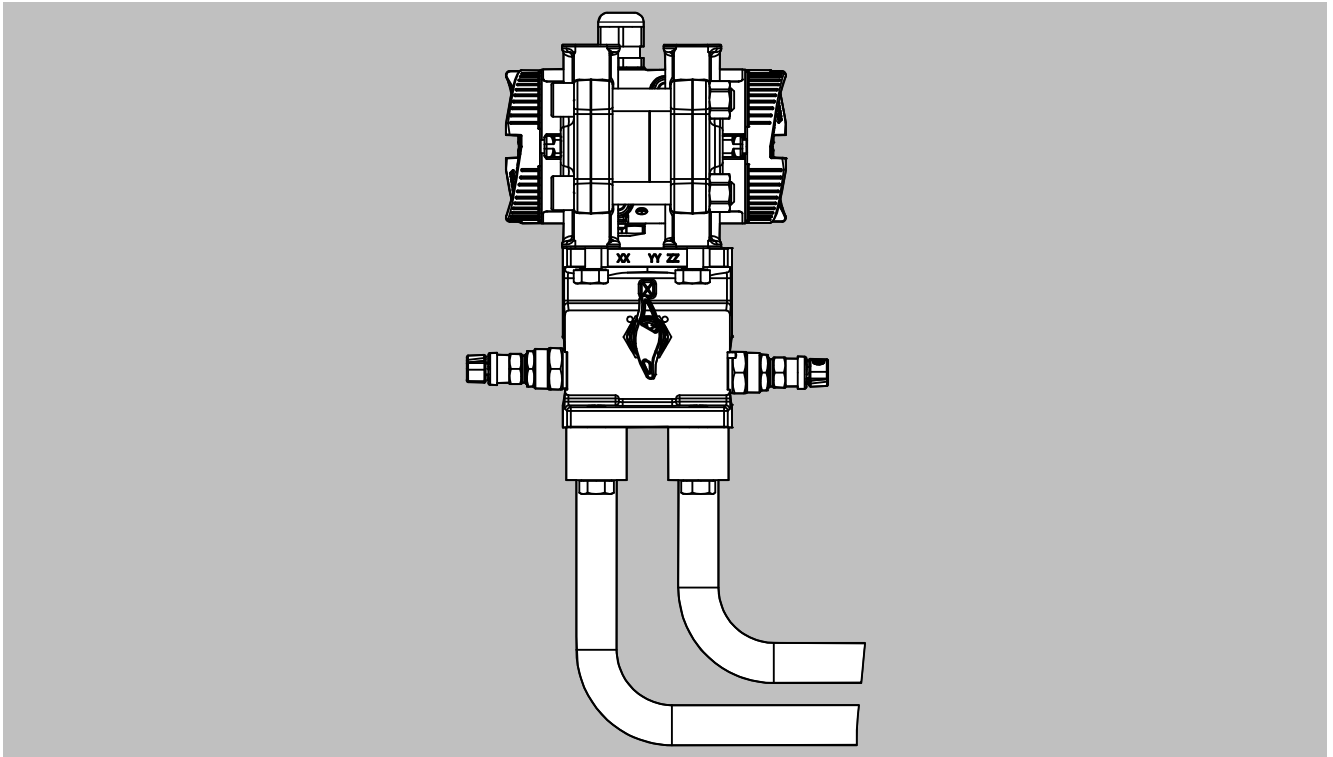
Design (continued)Compact design

For annular chamber orifice plates in compact design for wet gases, nozzles bent at right angles with oval flanges are used. The manifold and the differential pressure transmitter are mounted on these oval flanges. This design is only necessary **for vertical pipes**. For horizontal pipes, the design for gases and liquids can be selected because the flange plate with manifold and transmitter always points up.

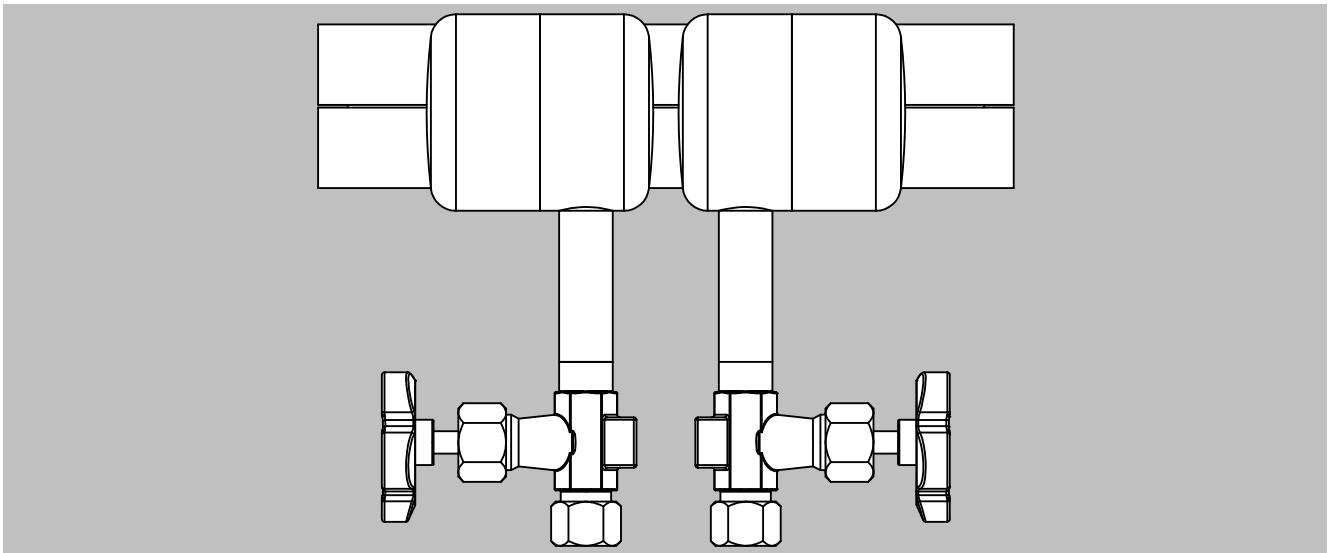
SteamRemote design

For annular chamber orifice plates in remote design for steam, the condensate vessels with shut-off valves are mounted at an angle of 0°.

Flow Measurement

SITRANS FP (differential pressure flow measurement)

SITRANS FP230/FPS200 primary elements (ISO 5167) / Standard orifice plate with annular chamber

Design (continued)

Compact design

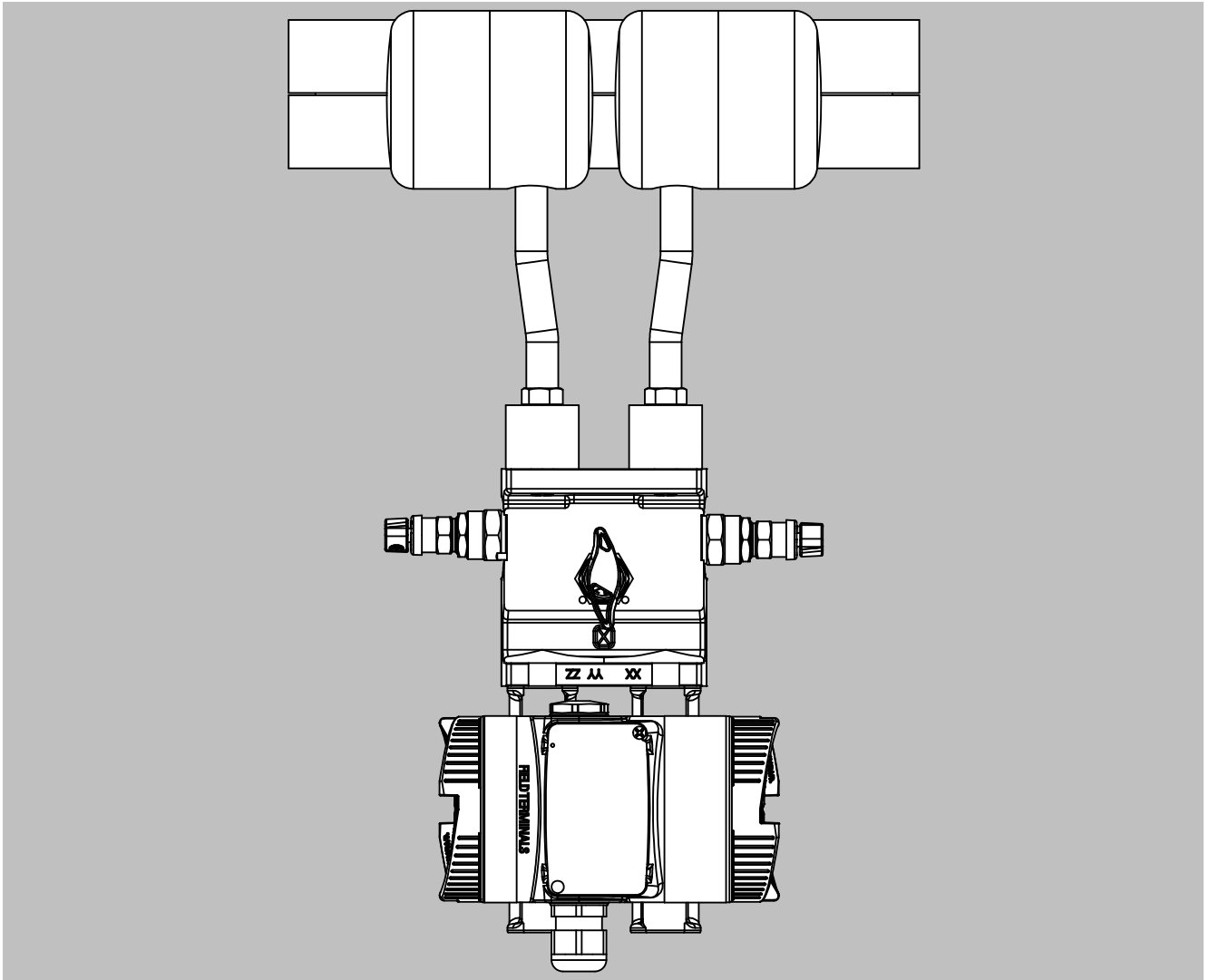

For annular chamber orifice plates in compact design for steam, the condensate vessels are mounted on one side. The manifold and the differential pressure transmitter are mounted to the condensate vessels using oval flanges. The condensate vessels are equipped with filling nozzles, which means a 3-way manifold can be used.

Selection and ordering data

SITRANS FP230/FPS200 standard orifice plate with annular chamber		Article No.	
		7ME172	● - ● ● ● ● 0 - ● ● ● ●
Click on the Article No. for the online configuration in the PIA Life Cycle Portal.			
Communication			
HART (4 ... 20 mA)		0	
PROFIBUS PA		1	
FOUNDATION Fieldbus		2	
Without transmitter		8	
Nominal size			
DN 50 (2")		1	D
DN 65 (2½")		1	E
DN 80 (3")		1	F
DN 100 (4")		2	G
DN 125 (5")		2	H
DN 150 (6")		2	J
DN 200 (8")		2	K
DN 250 (10")		2	L
DN 300 (12")		2	M
DN 350 (14")		2	N
DN 400 (16")		2	P
DN 450 (18")		2	Q
DN 500 (20")		2	R
DN 600 (24")		2	S
Nominal pressure			
Flange EN 1092-1 type B1 PN 6			A
Flange EN 1092-1 type B1 PN 10			B
Flange EN 1092-1 type B1 PN 16			C
Flange EN 1092-1 type B1 PN 25			D
Flange EN 1092-1 type B1 PN 40			E
Flange EN 1092-1 type B1 PN 64			F
Flange ASME B16.5 Class 150			Q
Flange ASME B16.5 Class 300			R
Flange ASME B16.5 Class 600			S
Wetted part materials			
Carrier ring: Carbon steel / orifice plate: 316L/1.4404			2
Carrier ring: 316L/1.4404 / orifice plate: 316L/1.4404			3
System design			
Compact design for dry gases (horizontal and vertical pipes)			0
Compact design for liquids			1
Compact design for wet gases (only vertical pipes)			2
Compact design for steam			3
Remote design for dry gases			4
Remote design for liquids			5
Remote design for wet gases			6
Remote design for steam			7
Type of protection of pressure transmitter			
No Ex / without pressure transmitter			A
Intrinsic safety			B
Explosion proof			C
Intrinsic safety, Explosion proof			D
Dust ignition proof zone 21/22 (DIP), increased safety zone 2			L
Dust ignition proof zone 20/21/22 (DIP), increased safety zone 2			M
Intrinsic safety, Explosion proof, Dust ignition proof zone 21/22 (DIP), increased safety zone 2			S
Intrinsic safety, Explosion proof, Dust ignition proof zone 21/22 (DIP), increased safety zone 2, class division			T
Electrical connections/cable entries of pressure transmitter			
Without pressure transmitter			A
2 × M20 × 1.5			F
2 × 1/2-14 NPT			M
Local operation/display of pressure transmitter			
Without display (closed lid) / without pressure transmitter			0
With display (closed lid)			1

Flow Measurement

SITRANS FP (differential pressure flow measurement)

SITRANS FP230/FPS200 primary elements (ISO 5167) / Standard orifice plate with annular chamber

Selection and ordering data (continued)

SITRANS FP230/FPS200 standard orifice plate with annular chamber	Article No. 7ME172 ● - ● ● ● ● 0 - ● ● ● ●
With display (lid with glass window)	

	Order code
Further designs*	
Please add "-Z" to Article No. and specify Order code(s) and plain text.	
Certificates of primary element incl. manifolds	
Inspection certificate of the primary element (EN 10204-3.1) - material of pressure-containing and wetted parts	C52
Factory certificate of the primary element (EN 10204-2.2) - wetted parts (MR 0175-2015)	C54
Dimensional record of the primary element	C55
Inspection certificate (DIN EN 571-1) - dye penetration test of weldings	C56
Hydrostatic pressure test of the primary element (EN 13480-5) of weldings	C58
Dimensional drawing 1:1 DWG of the primary element	C59
Maximum measuring span of pressure transmitter	
20 mbar (8.037 inH ₂ O)	I01
60 mbar (24.11 inH ₂ O)	I02
250 mbar (100.5 inH ₂ O)	I03
600 mbar (241.1 inH ₂ O)	I04
1600 mbar (643 inH ₂ O)	I05
Shut-off valves	
With mounted shut-off valves DN8 made of carbon steel, up to 300 °C with tube fitting 12 mm	T50
With mounted shut-off valves DN8 made of stainless steel, up to 300 °C with tube fitting 12 mm	T51
With mounted shut-off valves DN8 made of carbon steel, up to 300 °C and condensate vessel made of carbon steel with tube fitting 12 mm	T56
With mounted shut-off valves DN8 made of stainless steel, and condensate vessel made of stainless steel with tube fitting 12 mm	T57
Valve manifolds for mounting on primary element	
With mounted manifold (3-fold) made of stainless steel, PTFE sealings, cadmium-plated steel screws	U40
With mounted manifold (3-fold) made of stainless steel, PTFE sealings, stainless steel screws	U41
With mounted manifold (5-fold) made of stainless steel, PTFE sealings, cadmium-plated steel screws	U42
With mounted manifold (5-fold) made of stainless steel, PTFE sealings, stainless steel screws	U43
With mounted manifold (5-fold) made of carbon steel, up to 300 °C cadmium-plated steel screws and condensate vessel made of carbon steel	U46
With mounted manifold (3-fold) made of stainless steel, PTFE sealings, stainless steel screws and condensation vessels incl. filling union 1/2" NPT made of stainless steel	U47
With enclosed manifold (3-fold) made of stainless steel, PTFE sealings, cadmium-plated steel screws with tube fitting 12 mm	U50
With enclosed manifold (3-fold) made of stainless steel, PTFE sealings, stainless steel screws with tube fitting 12 mm	U51

Selection and ordering data (continued)

	Order code
With enclosed manifold (5-fold) made of stainless steel, PTFE sealings, cadmium-plated steel screws with tube fitting 12 mm	U52
With enclosed manifold (5-fold) made of stainless steel, PTFE sealings, stainless steel screws with tube fitting 12 mm	U53
With enclosed manifold (5-fold) made of carbon steel, up to 300 °C cadmium-plated steel screws with tube fitting 12 mm	U56
Application data	
ID number of the primary element according to sizing tool	Y40

* For further options, please refer to SITRANS P320.

Scope of delivery

- Annular chamber consisting of two pieces, each with integrated pressure tapping
- Orifice plate mounted in annular chamber
- Gasket for annular chamber
- Condensation pots for steam applications
- Shut-off valves for remote design (options T5x selected in PIA)
- Manifold for compact/remote design (options U4x, U5x selected in PIA) incl. mounting brackets

Flow Measurement

SITRANS FP (differential pressure flow measurement)

SITRANS FP230/FPS200 primary elements (ISO 5167) / Standard orifice plate with annular chamber

Dimensional drawings

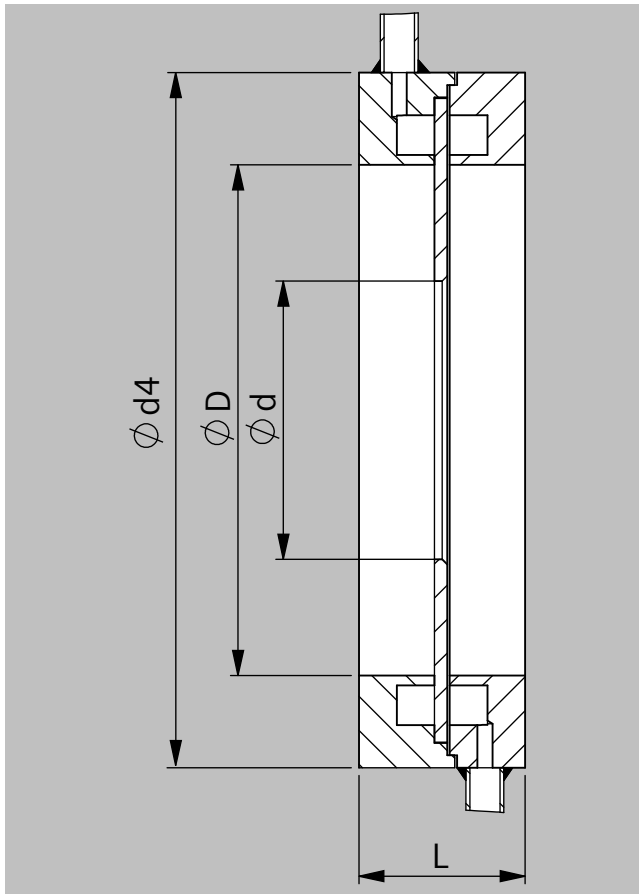

L: Overall length 65 mm

d: According to sizing calculation

D: According to inner diameter of pipe (sizing tool)

d4: See table below

Nominal size	Outer diameter d4 / Sealing face: flat						
	PN 6	PN 10	PN 16	PN 25	PN 40	PN 63	PN 100
DN 50	96	107	107	107	107	113	119
DN 65	116	127	127	127	127	138	144
DN 80	132	142	142	142	142	148	154
DN 100	152	162	162	168	168	174	180
DN 125	182	192	192	194	194	210	217
DN 150	207	218	218	224	224	247	257
DN 200	262	273	273	284	290	309	324
DN 250	317	328	329	340	352	364	391
DN 300	373	378	384	400	417	424	458
DN 350	423	438	444	457	474	486	512
DN 400	473	489	495	514	546	543	-
DN 500	578	594	617	624	628	-	-

Nominal size	Outer diameter d4 / Sealing face: flat		
	Class 150	Class 300	Class 600
2"	105	111	111
2,5"	124	130	130
3"	137	149	149
4"	175	181	194

Dimensional drawings (continued)

Nominal size	Outer diameter d4 / Sealing face: flat		
	Class 150	Class 300	Class 600
5"	197	216	241
6"	222	251	267
8"	279	308	321
10"	340	362	400
12"	410	422	457
14"	451	486	492
16"	514	540	565
20"	549	597	613

Flow Measurement

SITRANS FP (differential pressure flow measurement)

SITRANS FP230/FPS200 primary elements (ISO 5167) / Orifice meter run

Application



SITRANS FP230 compact design



SITRANS FPS200 remote design

Orifice meter run with flanges ends in carbon or stainless steel for flow measurement of gas, steam and liquid.

Design

Orifice meter runs for small diameter pipes come with partial straight inlet and outlet pipe runs with flanged ends. The pipes are connected to an annular chamber where the orifice plate is mounted. The annular chamber consists of a two-piece carrier ring with annular chamber and integral tapings and an inserted orifice plate.

Pressure before and after the orifice is averaged through the annular chamber. Tapping connections are integrated into each part of the carrier ring. Differential pressure connection can be compact and remote. The instruments are easy to install in the pipe system. Additional straight pipe length may be required before and after the orifice meter run. The orifice can be disassembled to replace the inserted orifice plate.

Nominal sizes

- EN: DN 10 ... 50
- ASME: 3/8 ... 2 inch

Nominal pressure

- EN: PN 6 ... 64
- ASME: class 150 ... 600

Pressure tapping

- Annular chamber: Corner tapping through annular chamber

Connection length

- Suitable for gases for a maximum of approx. 80 mm pipe insulation
- Suitable for steam for a maximum of approx. 140 mm pipe insulation

Sealing face

- According to EN 1092-1: flat (for flanges type B1 and B2)
- According to ASME B16.5: flat (for flanges RF and SF)

Material

- Pipe/Flanges: Carbon steel / orifice plate: 316L/1.4404
- Pipe/Flanges: 316L/1.4404 / orifice plate: 316L/1.4404

Gaskets

- Gas and liquids: Klingersil C4400
- Steam: Graphite with stainless steel inlay

Tapping sockets

Gases and liquids

Remote design

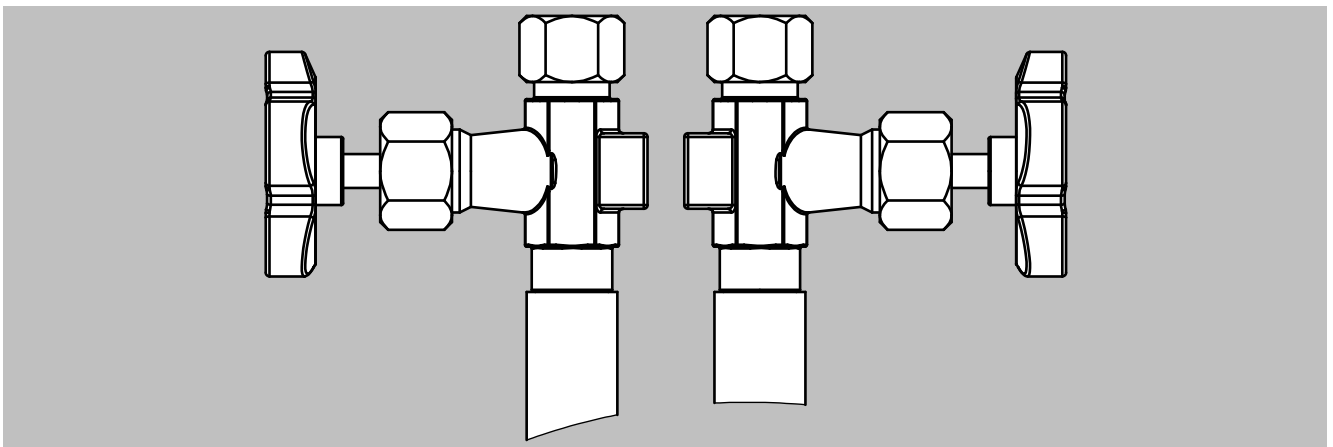

For metering pipes in remote design, the angle α between the pressure taps is 135°.

Flow Measurement

SITRANS FP (differential pressure flow measurement)

SITRANS FP230/FPS200 primary elements (ISO 5167) / Orifice meter run

Design (continued)

Compact design

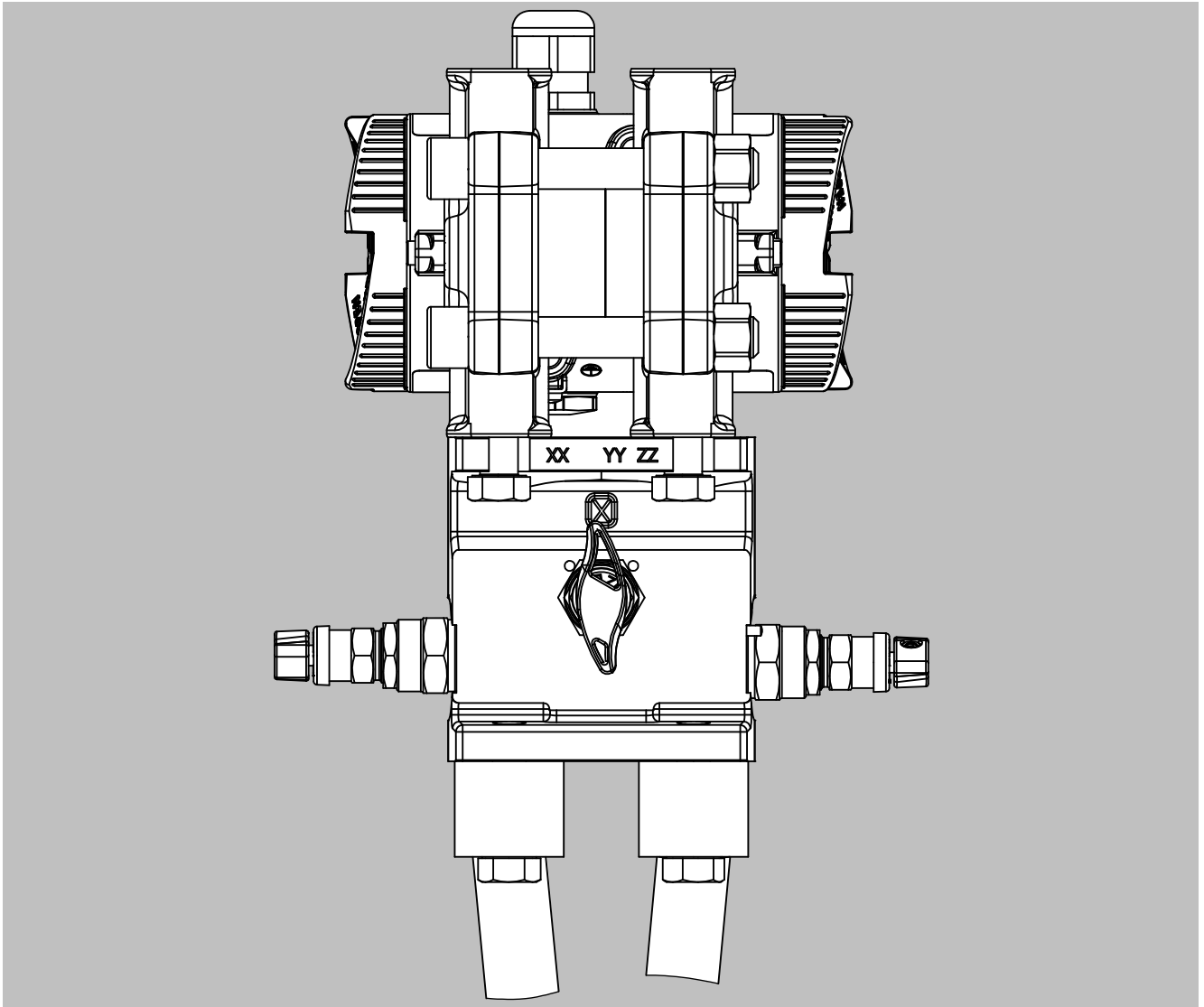

For metering pipes in compact design, so-called oval flanges are used. The manifold and the differential pressure transmitter are mounted on these oval flanges.

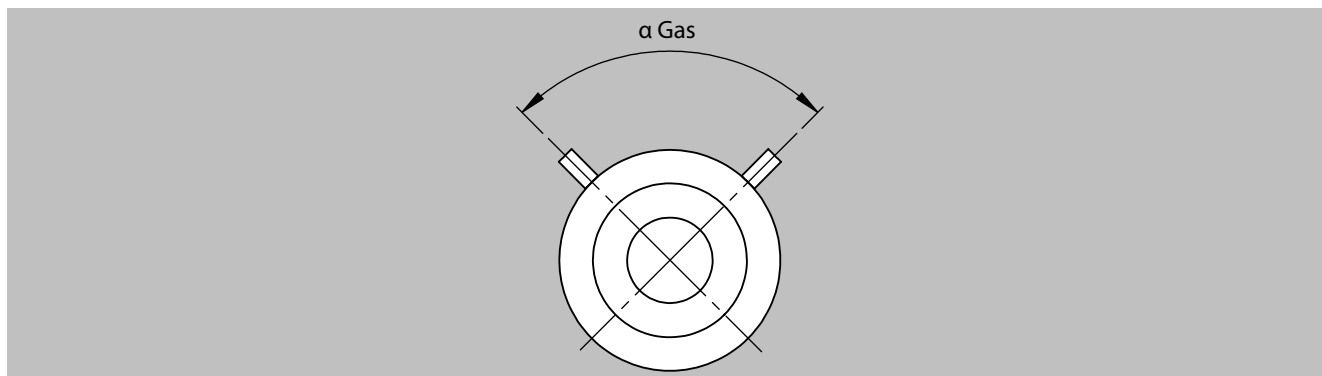
Design (continued)Tap position/angle in horizontal pipe

Tap position/angle in horizontal pipe (gas)

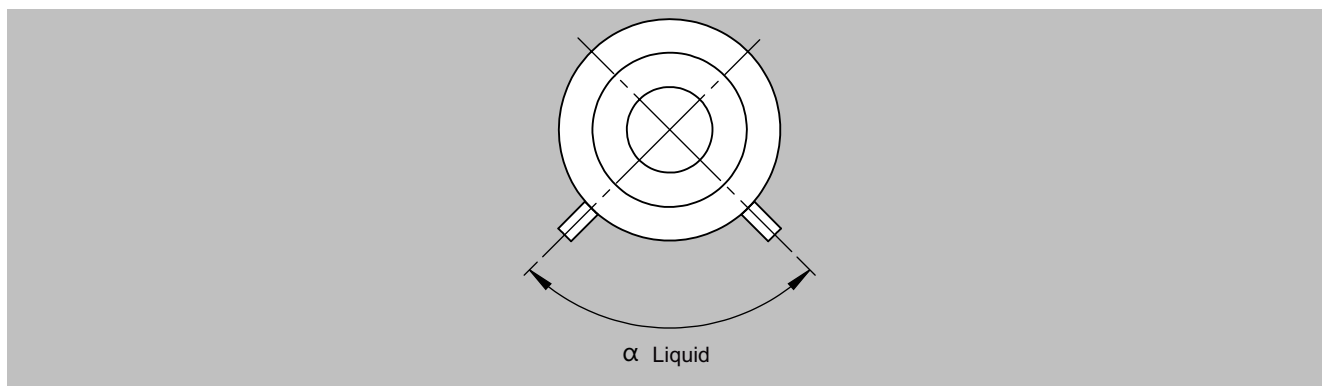

Tap position/angle in horizontal pipe (liquid)

Flow Measurement

SITRANS FP (differential pressure flow measurement)

SITRANS FP230/FPS200 primary elements (ISO 5167) / Orifice meter run

Design (continued)

Wet gases

Remote design

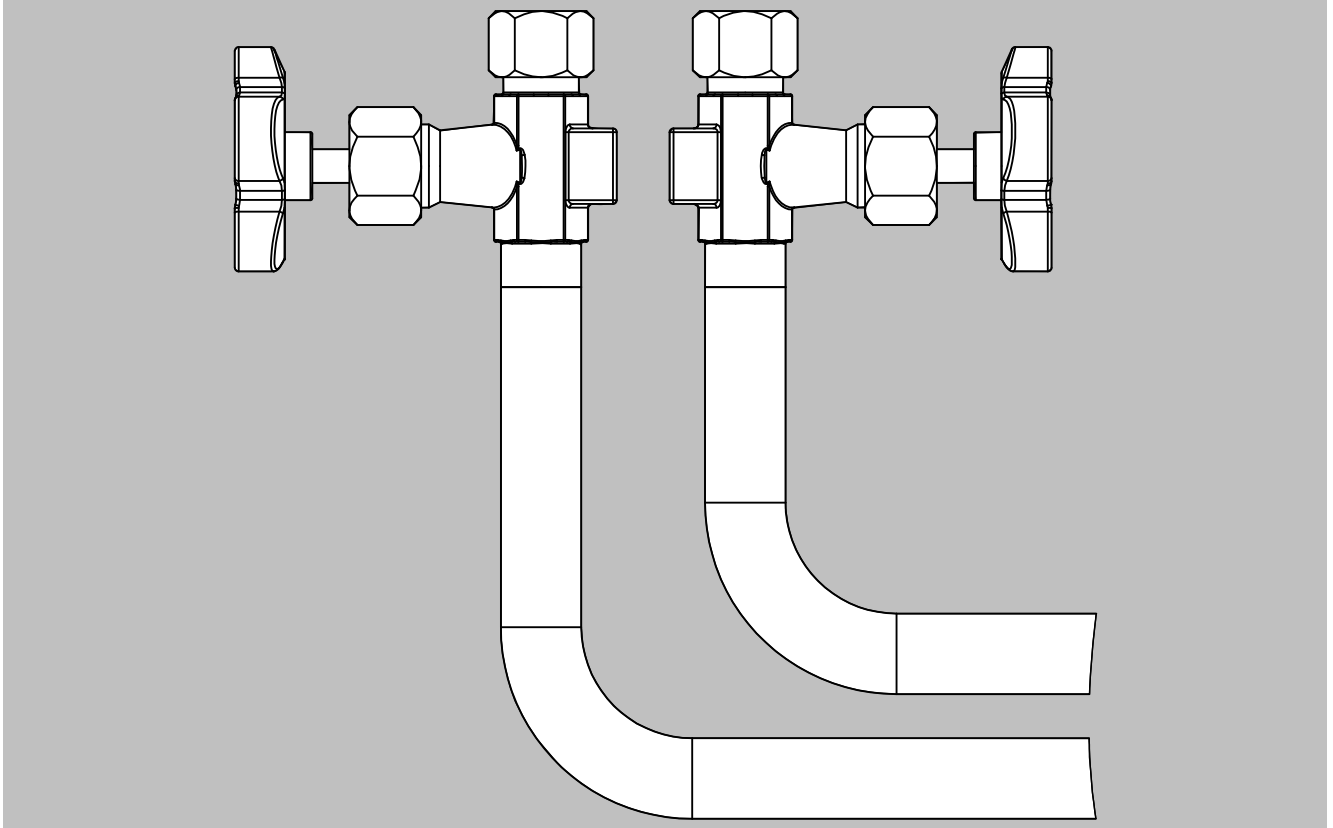

For metering pipes in remote design for wet gases, nozzles bent at right angles with welded-on valves are used. This design is only necessary for vertical pipes. For horizontal pipes, the design for gases and liquids can be selected because the nozzles point up as listed in the table above.

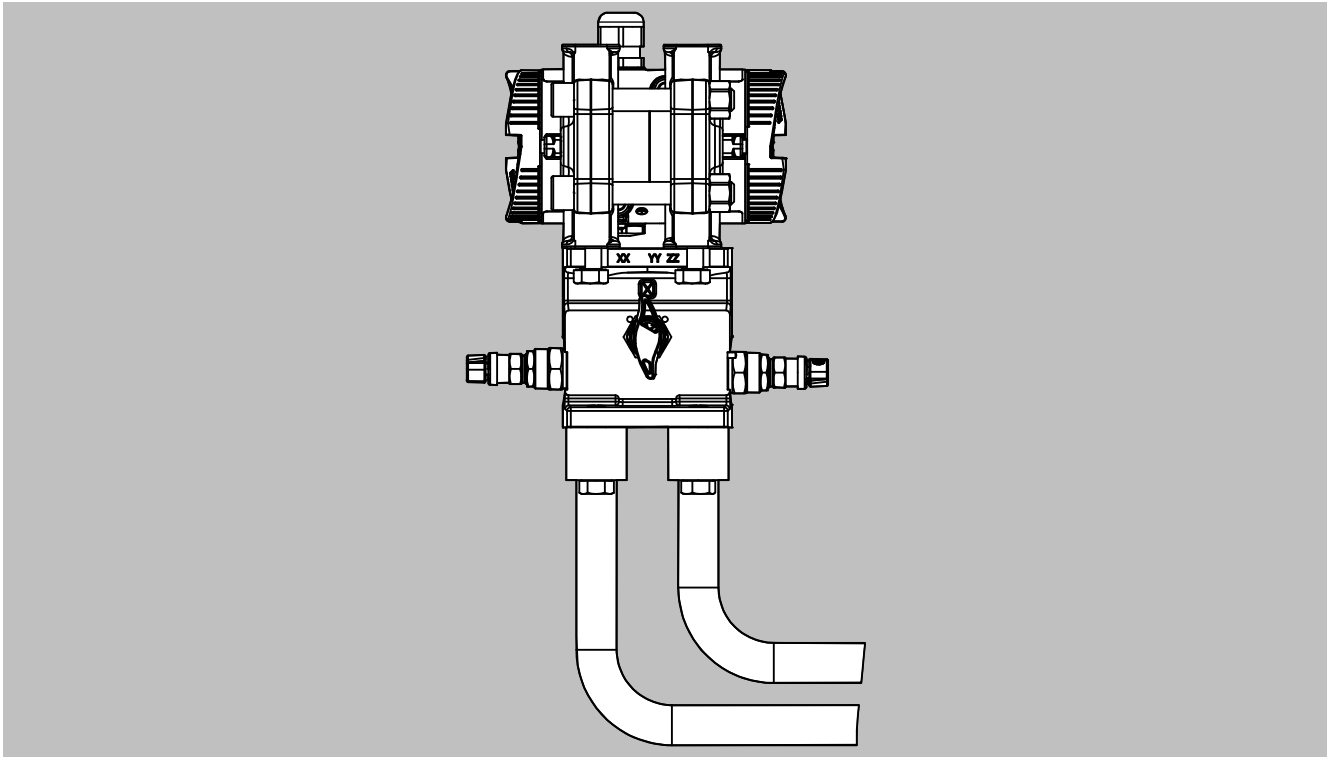
Design (continued)Compact design

For metering pipes in compact design for wet gases, nozzles bent at right angles with oval flanges are used. The manifold and the differential pressure transmitter are mounted on these oval flanges. This design is only necessary for vertical pipes. For horizontal pipes, the design for gases and liquids can be selected because the flange plate with manifold and transmitter always points up.

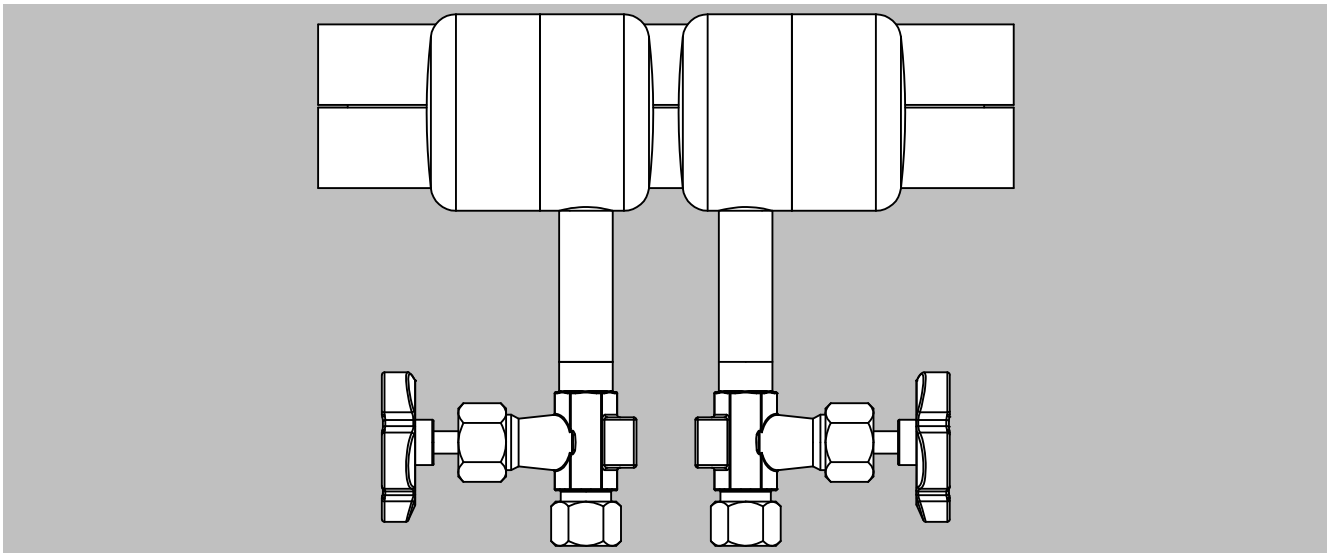
SteamRemote design

For metering pipes in remote design for steam, the condensate vessels with shut-off valves are mounted at an angle of 180°.

Flow Measurement

SITRANS FP (differential pressure flow measurement)

SITRANS FP230/FPS200 primary elements (ISO 5167) / Orifice meter run

Design (continued)

Compact design

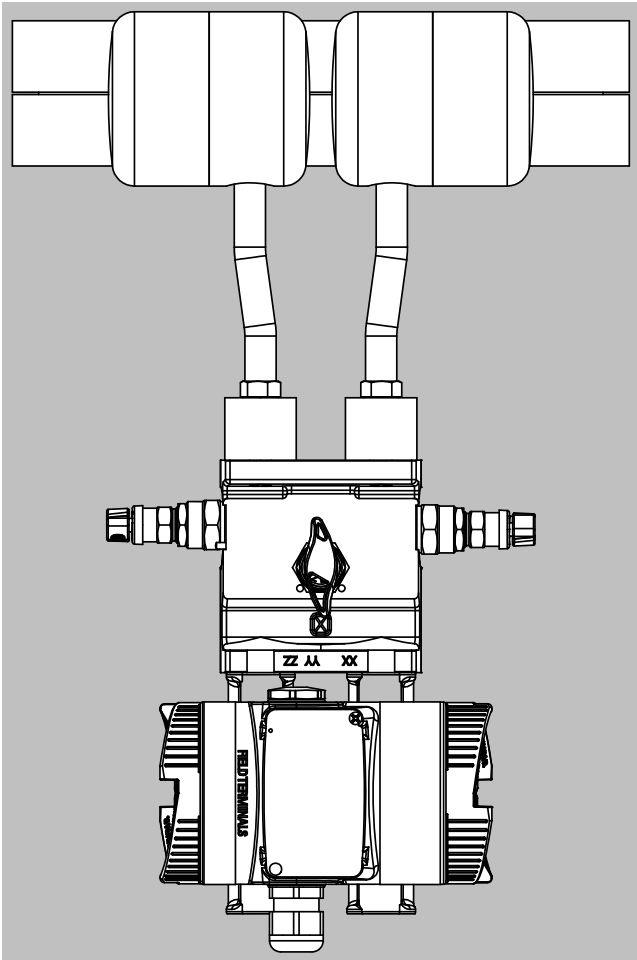

For metering pipes in compact design for steam, the condensate vessels are mounted on one side. The manifold and the differential pressure transmitter are mounted to the condensate vessels using oval flanges. The condensate vessels are equipped with filling nozzles, which means a 3-way manifold can be used.

Flow Measurement

SITRANS FP (differential pressure flow measurement)

SITRANS FP230/FPS200 primary elements (ISO 5167) / Orifice meter run

Selection and ordering data

	Article No.
SITRANS FP230/FPS200 orifice meter run	7ME173 ● - ● ● ● ● 0 - ● ● ● ●
Click on the Article No. for the online configuration in the PIA Life Cycle Portal.	
Communication	
HART (4 ... 20 mA)	0
PROFIBUS PA	1
FOUNDATION Fieldbus	2
Without transmitter	8
Nominal size	
DN 10 (3/8")	0 A
DN 15 (1/2")	0 B
DN 20 (3/4")	0 C
DN 25 (1")	0 D
DN 32 (1 1/4")	0 E
DN 40 (1 1/2")	1 C
DN 50 (2")	1 D
Nominal pressure	
Flange EN 1092-1 type B1 PN 6	A
Flange EN 1092-1 type B1 PN 10	B
Flange EN 1092-1 type B1 PN 16	C
Flange EN 1092-1 type B1 PN 25	D
Flange EN 1092-1 type B1 PN 40	E
Flange EN 1092-1 type B1 PN 64	F
Flange ASME B16.5 Class 150	Q
Flange ASME B16.5 Class 300	R
Flange ASME B16.5 Class 600	S
Wetted parts material	
Pipe/Flanges: Carbon steel / orifice plate: 316L/1.4404	4
Pipe/Flanges: 316L/1.4404 / orifice plate: 316L/1.4404	5
System design	
Compact design for dry gases (horizontal and vertical pipes)	0
Compact design for liquids	1
Compact design for wet gases (only vertical pipes)	2
Compact design for steam	3
Remote design for dry gases	4
Remote design for liquids	5
Remote design for wet gases	6
Remote design for steam	7
Type of protection of pressure transmitter	
No Ex / without pressure transmitter	A
Intrinsic safety	B
Explosion proof	C
Intrinsic safety, Explosion proof	D
Dust ignition proof zone 21/22 (DIP), increased safety zone 2	L
Dust ignition proof zone 20/21/22 (DIP), increased safety zone 2	M
Intrinsic safety, Explosion proof, Dust ignition proof zone 21/22 (DIP), increased safety zone 2	S
Intrinsic safety, Explosion proof, Dust ignition proof zone 21/22 (DIP), increased safety zone 2, class division	T
Electrical connections/cable entries of pressure transmitter	
Without pressure transmitter	A
2 × M20 × 1.5	F
2 × 1/2-14 NPT	M
Local operation/display of pressure transmitter	
Without display (closed lid) / without pressure transmitter	0
With display (closed lid)	1
With display (lid with glass window)	2

Flow Measurement

SITRANS FP (differential pressure flow measurement)

SITRANS FP230/FPS200 primary elements (ISO 5167) / Orifice meter run

Selection and ordering data (continued)

	Order code
Further designs*	
Please add "-Z" to Article No. and specify Order code(s) and plain text.	
Certificates of primary element incl. manifolds	
Inspection certificate of the primary element (EN 10204-3.1) - material of pressure-containing and wetted parts	C52
Factory certificate of the primary element (EN 10204-2.2) - wetted parts (MR 0175-2015)	C54
Dimensional record of the primary element	C55
Inspection certificate (DIN EN 571-1) - dye penetration test of weldings	C56
Hydrostatic pressure test of the primary element (EN 13480-5) of weldings	C58
Dimensional drawing 1:1 DWG of the primary element	C59
Maximum measuring span of pressure transmitter	
20 mbar (8.037 inH ₂ O)	I01
60 mbar (24.11 inH ₂ O)	I02
250 mbar (100.5 inH ₂ O)	I03
600 mbar (241.1 inH ₂ O)	I04
1600 mbar (643 inH ₂ O)	I05
Shut-off valves	
With mounted shut-off valves DN8 made of carbon steel, up to 300 °C with tube fitting 12 mm	T50
With mounted shut-off valves DN8 made of stainless steel, up to 300 °C with tube fitting 12 mm	T51
With mounted shut-off valves DN8 made of carbon steel, up to 300 °C and condensate vessel made of carbon steel with tube fitting 12 mm	T56
With mounted shut-off valves DN8 made of stainless steel, and condensate vessel made of stainless steel with tube fitting 12 mm	T57
Valve manifolds for mounting on primary element	
With mounted manifold (3-fold) made of stainless steel, PTFE sealings, cadmium-plated steel screws	U40
With mounted manifold (3-fold) made of stainless steel, PTFE sealings, stainless steel screws	U41
With mounted manifold (5-fold) made of stainless steel, PTFE sealings, cadmium-plated steel screws	U42
With mounted manifold (5-fold) made of stainless steel, PTFE sealings, stainless steel screws	U43
With mounted manifold (5-fold) made of carbon steel, up to 300 °C cadmium-plated steel screws and condensate vessel made of carbon steel	U46
With mounted manifold (3-fold) made of stainless steel, PTFE sealings, stainless steel screws and condensation vessels incl. filling union 1/2" NPT made of stainless steel	U47
With enclosed manifold (3-fold) made of stainless steel, PTFE sealings, cadmium-plated steel screws with tube fitting 12 mm	U50
With enclosed manifold (3-fold) made of stainless steel, PTFE sealings, stainless steel screws with tube fitting 12 mm	U51
With enclosed manifold (5-fold) made of stainless steel, PTFE sealings, cadmium-plated steel screws with tube fitting 12 mm	U52
With enclosed manifold (5-fold) made of stainless steel, PTFE sealings, stainless steel screws with tube fitting 12 mm	U53
With enclosed manifold (5-fold) made of carbon steel, up to 300 °C cadmium-plated steel screws with tube fitting 12 mm	U56

Selection and ordering data (continued)

	Order code
Application data	
ID number of the primary element according to sizing tool	Y40

* For further options, please refer to SITRANS P320.

Scope of delivery

- Orifice meter run consisting of 2 parts, each with flanged ends, pipe, and annular chamber with integrated pressure tapping
- Orifice plate mounted in annular chamber
- Gasket for annular chamber
- Screws and nuts for annular chamber
- Condensation pots for steam applications
- Shut-off valves for remote design (options T5x selected in PIA)
- Manifold for compact/remote design (options U4x, U5x selected in PIA) incl. mounting brackets

Flow Measurement

SITRANS FP (differential pressure flow measurement)

SITRANS FP230/FPS200 primary elements (ISO 5167) / Orifice meter run

Dimensional drawings

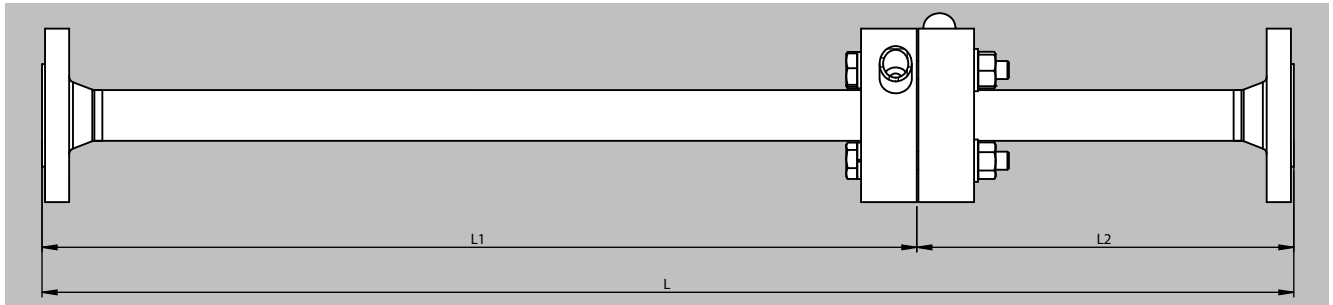

Overall length

Nominal size	DN 10 3/8"	DN 15 1/2"	DN 20 3/4"	DN 25 1"	DN 32 1 1/4"	DN 40 1 1/2"	DN 50 2"
L	400	550	700	900	1100	1300	1500
L1	230	380	500	650	800	1000	1200
L2	170	170	200	250	300	300	300

Pipe dimensions

Carbon steel							
Nominal size	PN 16	PN 40	PN 63	Nominal size	Class 150	Class 300	Class 600
DN 10	21.3 × 6.3	21.3 × 6,3	21.3 × 6,3	3/8"	21.3 × 7.47 ¹⁾	21.3 × 7.47 ¹⁾	21.3 × 7.47 ¹⁾
DN 15	21.3 × 2.6	21.3 × 2.6	21.3 × 2.6	1/2"	21.3 × 3.73	21.3 × 3.73	21.3 × 3.73
DN 20	26.9 × 2.6	26.9 × 2.6	26.9 × 2.6	3/4"	26.7 × 2.87	26.7 × 2.87	26,7 × 2.87
DN 25	33.7 × 2.6	33,7 × 2.6	33,7 × 2.6	1"	33.4 × 3.38	33.4 × 3.38	33.4 × 3.38
DN 32	42.4 × 2.6	42.4 × 2.6	n/a	1 1/4"	42.2 × 3.56	42.2 × 3.56	42.2 × 3.56
DN 40	48.3 × 2.6	48.3 × 2.6	48.3 × 2.9	1 1/2"	48.3 × 3.68	48.3 × 3.68	48.3 × 3.68
DN 50	60.3 × 2.9	60.3 × 2.9	60.3 × 3.6	2"	60.3 × 3.91	60.3 × 3.91	60.3 × 3.91

Stainless steel							
Nominal size	PN 16	PN 40	PN 63	Nominal size	Class 150	Class 300	Class 600
DN 10	21.3 × 7.47	21.3 × 7.47	21.3 × 7.47	3/8"	21.3 × 2.77 ¹⁾	21.3 × 2.77 ¹⁾	21.3 × 2.77 ¹⁾
DN 15	21.3 × 2.77	21.3 × 2.77	21.3 × 3.73	1/2"	21.3 × 2.77	21.3 × 2.77	21.3 × 2.77
DN 20	26.7 × 2.87	26.7 × 2.87	26.7 × 3.91	3/4"	26.7 × 2.87	26.7 × 2.87	26.7 × 2.87
DN 25	33.4 × 3.38	33.4 × 3.38	33.4 × 3.38	1"	33.4 × 3.38	33.4 × 3.38	33.4 × 3.38
DN 32	42.2 × 3.56	42.2 × 3.56	n/a	1 1/4"	42.2 × 3.56	42.2 × 3.56	42.2 × 3.56
DN 40	48.3 × 2.77	48.3 × 2.77	48.3 × 3.68	1 1/2"	48.3 × 3.68	48.3 × 3.68	48.3 × 3.68
DN 50	60.3 × 3.91	60.3 × 3.91	60.3 × 3.91	2"	60.3 × 3.91	60.3 × 3.91	60.3 × 3.91

¹⁾ Orifice meter runs with 3/8" diameter will be built with 1/2" flanges.

Application



SITRANS FPS200 remote design

Orifice plate for installation between flanges in stainless steel for flow measurement of gas, steam and liquid.

Design

Orifice plates for the installation with flange tappings consist of the orifice plate with a welded-on marking and grip plate. The plates have no pressure tappings and are therefore normally mounted between measuring flanges containing the pressure tappings.

Pressure tapping

- Not included

Sealing face

- According to EN 1092-1: flat (for flanges type B1 and B2)
- According to ASME B16.5: flat (for flanges RF and SF)

Material

- 316L/1.4404

Flow Measurement

SITRANS FP (differential pressure flow measurement)

SITRANS FP230/FPS200 primary elements (ISO 5167) / Orifice plate

Selection and ordering data

SITRANS FP230/FPS200 orifice plate		Article No.
		7ME174 ● - ● ● ● ● 0 - ● ● ● ●
Click on the Article No. for the online configuration in the PIA Life Cycle Portal.		
Communication		
HART (4 ... 20 mA)		0
PROFIBUS PA		1
FOUNDATION Fieldbus		2
Without transmitter		8
Nominal size		
DN 50 (2")		1 D
DN 65 (2½")		1 E
DN 80 (3")		1 F
DN 100 (4")		2 G
DN 125 (5")		2 H
DN 150 (6")		2 J
DN 200 (8")		2 K
DN 250 (10")		2 L
DN 300 (12")		2 M
DN 350 (14")		2 N
DN 400 (16")		2 P
DN 450 (18")		2 Q
DN 500 (20")		2 R
DN 600 (24")		2 S
Nominal pressure		
Flange EN 1092-1 type B1 PN 6		A
Flange EN 1092-1 type B1 PN 10		B
Flange EN 1092-1 type B1 PN 16		C
Flange EN 1092-1 type B1 PN 25		D
Flange EN 1092-1 type B1 PN 40		E
Flange EN 1092-1 type B1 PN 64		F
Flange EN 1092-1 type B1 PN 100		G
Flange ASME B16.5 Class 150		Q
Flange ASME B16.5 Class 300		R
Flange ASME B16.5 Class 600		S
Wetted parts material		
Orifice plate: 316L/1.4404		6
System design		
Without connection for pressure lines		8
Type of protection of pressure transmitter		
No Ex / without pressure transmitter		A
Intrinsic safety		B
Explosion proof		C
Intrinsic safety, Explosion proof		D
Dust ignition proof zone 21/22 (DIP), increased safety zone 2		L
Dust ignition proof zone 20/21/22 (DIP), increased safety zone 2		M
Intrinsic safety, Explosion proof, Dust ignition proof zone 21/22 (DIP), increased safety zone 2		S
Intrinsic safety, Explosion proof, Dust ignition proof zone 21/22 (DIP), increased safety zone 2, class division		T
Electrical connections/cable entries of pressure transmitter		
Without pressure transmitter		A
2 × M20 × 1.5		F
2 × 1/2-14 NPT		M
Local operation/display of pressure transmitter		
Without display (closed lid) / without pressure transmitter		0
With display (closed lid)		1
With display (lid with glass window)		2

Selection and ordering data (continued)

	Order code
Further designs*	
Please add "-Z" to Article No. and specify Order code(s) and plain text.	
Certificates of primary element incl. manifolds	
Inspection certificate of the primary element (EN 10204-3.1) - material of pressure-containing and wetted parts	C52
Factory certificate of the primary element (EN 10204-2.2) - wetted parts (MR 0175-2015)	C54
Dimensional record of the primary element	C55
Dimensional drawing 1:1 DWG of the primary element	C59
Maximum measuring span of pressure transmitter	
20 mbar (8.037 inH ₂ O)	I01
60 mbar (24.11 inH ₂ O)	I02
250 mbar (100.5 inH ₂ O)	I03
600 mbar (241.1 inH ₂ O)	I04
1600 mbar (643 inH ₂ O)	I05
Valve manifolds for mounting on primary element	
With enclosed manifold (3-fold) made of stainless steel, PTFE sealings, cadmium-plated steel screws with tube fitting 12 mm	U50
With enclosed manifold (3-fold) made of stainless steel, PTFE sealings, stainless steel screws with tube fitting 12 mm	U51
With enclosed manifold (5-fold) made of stainless steel, PTFE sealings, cadmium-plated steel screws with tube fitting 12 mm	U52
With enclosed manifold (5-fold) made of stainless steel, PTFE sealings, stainless steel screws with tube fitting 12 mm	U53
Application data	
ID number of the primary element according to sizing tool	Y40

* For further options, please refer to SITRANS P320.

Scope of delivery

- Orifice plate
- Manifold for compact/remote design (options U4x, U5x selected in PIA) incl. mounting brackets

Flow Measurement

SITRANS FP (differential pressure flow measurement)

SITRANS FP230/FPS200 primary elements (ISO 5167) / Orifice plate

Dimensional drawings

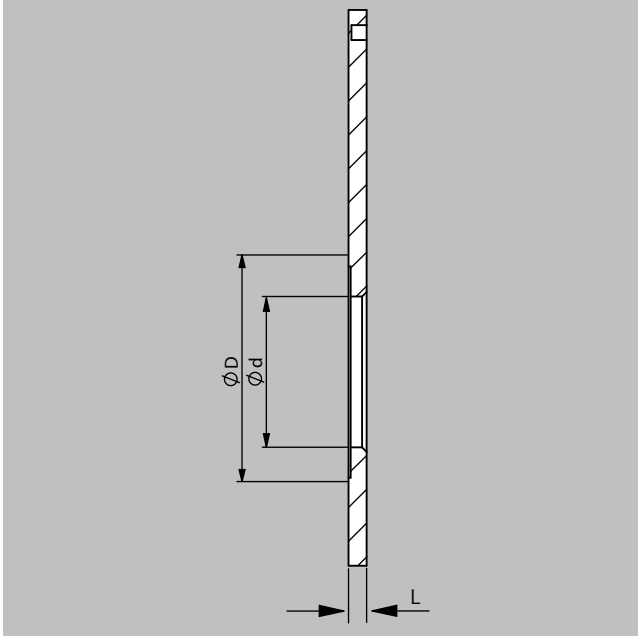

L: Overall length

d: According to sizing calculation

D: According to inner diameter of pipe (sizing tool)

Nominal size of orifice plate

DIN/EN

DN	Nominal size, up to														
	50	65	80	100	125	150	175	200	250	300	350	400	450	500	600
mm	3	3	4	4	4	4	4	4	4	4	4	4	4	6	6

ASME

DN	Nominal size, up to															
	2"	2,5"	3"	4"	5"	6"	7"	8"	10"	12"	14"	16"	18"	20"	22"	24"
mm	3	3	3	3	3	3	6	6	6	6	6	10	10	10	12	12

*) Not standardized in DIN standard.

Up to DN 50 adjusted for general practice. Nominal width designed for a differential pressure of up to 1000 mbar.

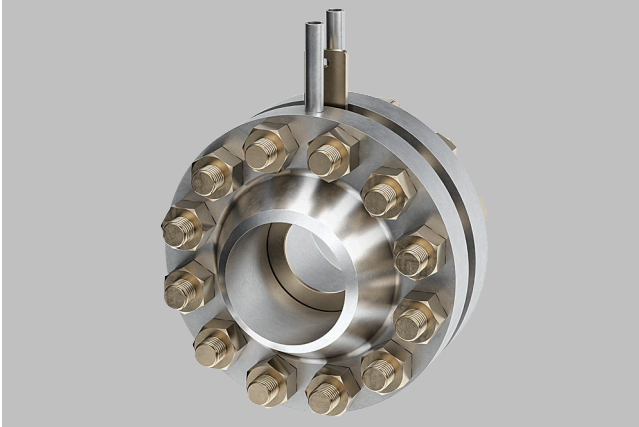
Application

SITRANS FPS200 remote design

Orifice flange pair according to ASME B16.36 with orifice plate in carbon steel (flanges) or stainless steel for flow measurement of gas and liquid.

Design

The orifice plate is mounted between traditional orifice flanges according to ASME B16.36. The orifice flanges are manufactured with integral pressure tappings. System design is always remote. The orifice plate can be exchanged. The flanges have to be welded into the pipe.

- Design of orifice plate, see Orifice plates

Differential pressure tapping

- In the flange: Differential pressure tapping in special measuring flanges with integrated connectors in the flange, always remote

Tapping sockets

- 0°

Connection length

- For gases and liquids suitable for up to approx. 80 mm pipe insulation

Sealing face

- According to ASME B16.5: flat

Materials

- Flange carbon steel, plate 316L
- Flange and plate 316L

Gaskets

- Spiral graphite

Flow Measurement

SITRANS FP (differential pressure flow measurement)

SITRANS FP230/FPS200 primary elements (ISO 5167) / Orifice plate with orifice flanges (ASME B16.36)

Selection and ordering data

SITRANS FP230/FPS200 orifice plate with orifice flanges		Article No. 7ME175 ● - ● ● ● ● 0 - ● ● ● ●	
Click on the Article No. for the online configuration in the PIA Life Cycle Portal.			
Communication			
HART (4 ... 20 mA)		0	
PROFIBUS PA		1	
FOUNDATION Fieldbus		2	
Without transmitter		8	
Nominal size			
DN 50 (2")		1	D
DN 65 (2½")		1	E
DN 80 (3")		1	F
DN 100 (4")		2	G
DN 125 (5")		2	H
DN 150 (6")		2	J
DN 200 (8")		2	K
DN 250 (10")		2	L
DN 300 (12")		2	M
DN 350 (14")		2	N
DN 400 (16")		2	P
DN 450 (18")		2	Q
DN 500 (20")		2	R
DN 600 (24")		2	S
Nominal pressure			
Flange ASME B16.5 Class 300			R
Flange ASME B16.5 Class 600			S
Wetted parts material			
Flanges: Carbon steel / orifice plate: 316L/1.4404			7
Flanges: 316L/1.4404 / orifice plate: 316L/1.4404			8
System design			
Remote design for dry gases			4
Remote design for liquids			5
Remote design for wet gases			6
Type of protection of pressure transmitter			
No Ex / without pressure transmitter			A
Intrinsic safety			B
Explosion proof			C
Intrinsic safety, Explosion proof			D
Dust ignition proof zone 21/22 (DIP), increased safety zone 2			L
Dust ignition proof zone 20/21/22 (DIP), increased safety zone 2			M
Intrinsic safety, Explosion proof, Dust ignition proof zone 21/22 (DIP), increased safety zone 2			S
Intrinsic safety, Explosion proof, Dust ignition proof zone 21/22 (DIP), increased safety zone 2, class division			T
Electrical connections/cable entries of pressure transmitter			
Without pressure transmitter			A
2 × M20 × 1.5			F
2 × 1/2-14 NPT			M
Local operation/display of pressure transmitter			
Without display (closed lid) / without pressure transmitter			0
With display (closed lid)			1
With display (lid with glass window)			2

Order code	
Further designs*	
Please add "-Z" to Article No. and specify Order code(s) and plain text.	
Certificates of primary element incl. manifolds	
Inspection certificate of the primary element (EN 10204-3.1) - material of pressure-containing and wetted parts	C52
Factory certificate of the primary element (EN 10204-2.2) - wetted parts (MR 0175-2015)	C54

Selection and ordering data (continued)

	Order code
Dimensional record of the primary element	C55
Dimensional drawing 1:1 DWG of the primary element	C59
Maximum measuring span of pressure transmitter	
20 mbar (8.037 inH ₂ O)	I01
60 mbar (24.11 inH ₂ O)	I02
250 mbar (100.5 inH ₂ O)	I03
600 mbar (241.1 inH ₂ O)	I04
1600 mbar (643 inH ₂ O)	I05
Shut-off valves	
With mounted shut-off valves DN8 made of carbon steel, up to 300 °C with tube fitting 12 mm	T50
With mounted shut-off valves DN8 made of stainless steel, up to 300 °C with tube fitting 12 mm	T51
Valve manifolds for mounting on primary element	
With enclosed manifold (3-fold) made of stainless steel, PTFE sealings, cadmium-plated steel screws with tube fitting 12 mm	U50
With enclosed manifold (3-fold) made of stainless steel, PTFE sealings, stainless steel screws with tube fitting 12 mm	U51
With enclosed manifold (5-fold) made of stainless steel, PTFE sealings, cadmium-plated steel screws with tube fitting 12 mm	U52
With enclosed manifold (5-fold) made of stainless steel, PTFE sealings, stainless steel screws with tube fitting 12 mm	U53
Application data	
ID number of the primary element according to sizing tool	Y40

* For further options, please refer to SITRANS P320.

Scope of delivery

- Orifice plate
- Orifice flanges according to ASME B16.36 with pressure tapings
- 2× Gaskets for orifice flanges
- Screws and nuts
- Shut-off valves for remote design (options T5x selected in PIA)
- Manifold for compact/remote design (options U4x, U5x selected in PIA) incl. mounting brackets

Flow Measurement

SITRANS FP (differential pressure flow measurement)

SITRANS FP230/FPS200 primary elements (ISO 5167) / Orifice plate with orifice flanges (ASME B16.36)

Dimensional drawings

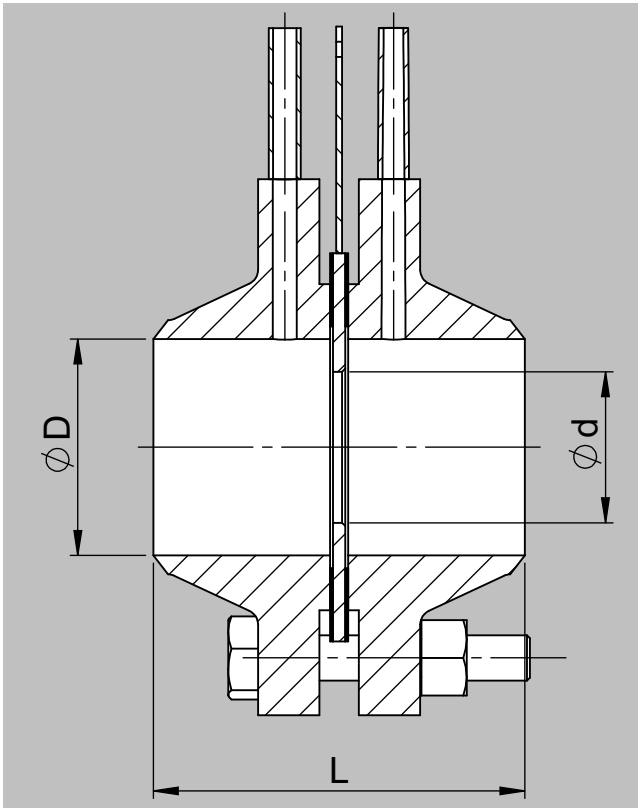

L: Overall length

d: According to sizing calculation

D: According to inner diameter of pipe (sizing tool)

Overall length

DN/Inch	PN/lbs	L	Hex nut bolt	Bolts (pcs.)	Gasket
24	600	433.10	1 7/8	24	2.0
20	600	407.70	1 5/8	24	2.0
18	600	395.00	1 5/8	20	2.0
16	600	382.30	1 1/2	20	2.0
14	600	352.90	1 3/8	20	2.0
12	600	333.60	1 1/4	20	2.0
10	600	327.50	1 1/4	16	2.0
8	600	286.40	1 1/8	12	2.0
6	600	254.40	1	12	2.0
4	600	222.90	7/8	8	2.0
3	600	184.80	3/4	8	2.0
2½	600	184.80	3/4	8	2.0
2	600	178.70	5/8	8	2.0
24	300	350.30	1 1/2	24	2.0
20	300	338.10	1 1/4	24	2.0
18	300	331.50	1 1/4	24	2.0
16	300	306.10	1 1/4	20	2.0
14	300	295.50	1 1/8	20	2.0
12	300	270.10	1 1/8	16	2.0
10	300	244.70	1	16	2.0
8	300	229.50	7/8	12	2.0

Dimensional drawings (continued)

DN/Inch	PN/lbs	L	Hex nut bolt	Bolts (pcs.)	Gasket
6	300	207.16	3/4	12	2.0
4	300	190.90	3/4	8	2.0
3	300	184.80	3/4	8	2.0
2½	300	184.80	3/4	8	2.0
2	300	178.70	5/8	4	2.0

Nominal size of orifice plate

DIN/EN

DN	Nominal size, up to														
	50	65	80	100	125	150	175	200	250	300	350	400	450	500	600
mm	3	3	4	4	4	4	4	4	4	4	4	4	4	6	6

ASME

DN	Nominal size, up to															
	2"	2.5"	3"	4"	5"	6"	7"	8"	10"	12"	14"	16"	18"	20"	22"	24"
mm	3	3	3	3	3	3	6	6	6	6	6	10	10	10	12	12

Nominal size designed for a differential pressure of up to 1000 mbar.

The specified dimensions are approximate dimensions, exact dimensions depend on the gasket used.