

Short Documentation • 11/2014

SINAMICS V: Speed Control of a V20 with S7-1200 (TIA Portal) via MODBUS RTU, with HMI

SINAMICS V20, SIMATIC S7-1200

Warranty and liability

Note

The Application Examples are not binding and do not claim to be complete regarding the circuits shown, equipping and any eventuality. The Application Examples do not represent customer-specific solutions. They are only intended to provide support for typical applications. You are responsible for ensuring that the described products are used correctly. These application examples do not relieve you of the responsibility to use safe practices in application, installation, operation and maintenance. When using these Application Examples, you recognize that we cannot be made liable for any damage/claims beyond the liability clause described. We reserve the right to make changes to these Application Examples at any time without prior notice.

If there are any deviations between the recommendations provided in these application examples and other Siemens publications – e.g. Catalogs – the contents of the other documents have priority.

We do not accept any liability for the information contained in this document.

Any claims against us – based on whatever legal reason – resulting from the use of the examples, information, programs, engineering and performance data etc., described in this Application Example shall be excluded. Such an exclusion shall not apply in the case of mandatory liability, e.g. under the German Product Liability Act (“Produkthaftungsgesetz”), in case of intent, gross negligence, or injury of life, body or health, guarantee for the quality of a product, fraudulent concealment of a deficiency or breach of a condition which goes to the root of the contract (“wesentliche Vertragspflichten”). The damages for a breach of a substantial contractual obligation are, however, limited to the foreseeable damage, typical for the type of contract, except in the event of intent or gross negligence or injury to life, body or health. The above provisions do not imply a change of the burden of proof to your detriment.

Any form of duplication or distribution of these Application Examples or excerpts hereof is prohibited without the expressed consent of Siemens Industry Sector.

Security information

Siemens provides products and solutions with industrial security functions that support the secure operation of plants, solutions, machines, equipment and/or networks. They are important components in a holistic industrial security concept. With this in mind, Siemens' products and solutions undergo continuous development. Siemens recommends strongly that you regularly check for product updates.

For the secure operation of Siemens products and solutions, it is necessary to take suitable preventive action (e.g. cell protection concept) and integrate each component into a holistic, state-of-the-art industrial security concept. Third-party products that may be in use should also be considered. For more information about industrial security, visit <http://www.siemens.com/industrialsecurity>.

To stay informed about product updates as they occur, sign up for a product-specific newsletter. For more information, visit <http://support.automation.siemens.com>.

Table of contents

	Warranty and liability	2
1	Overview	4
	1.1 Content.....	4
	1.2 Requirements.....	5
	Hardware components.....	5
	Control software.....	5
	Bus wiring.....	6
2	Program Structure	7
3	V20_Modbus [FB1] Function Block	8
	3.1 Parameters.....	8
	3.2 Status diagram.....	11
4	Expansion to Several Drives	12
	4.1 Expansion to up to 247 drives per port.....	12
	4.2 Expansion to up to 4 ports.....	12
5	Literature	13
6	History	13

1 Overview

1.1 Content

The present short documentation describes a block that you can use for the connection of a SINAMICS V20 to a SIMATIC S7-1200 via the Modbus protocol in STEP 7 in the TIA portal.

This short documentation largely does not use explanations. It explains the block parameters and shows the main steps for the integration of the blocks in your own projects.

Table 1-1: Block functions

Block	Function	Explanation
V20_Modbus (FB1)	Cyclic write/read access to process data. Up to 32 ¹ drives are supported at one port.	Control of the SINAMICS V20 via the STW1 control word
		Specified setpoint speed value (HSW)
		Condition monitoring of the SINAMICS V20 via the ZSW1 status word
	Acyclic write/read access to all data of a SINAMICS V20 that is provided via a Modbus register. Up to 32 drives ¹ are supported at one port.	Reading of the actual speed value (HIW)
		A mapping table in the SINAMICS V20 manual V7 , chap. 6.2 lists the data that can be exchanged via the bus. It is process data as well as a selection of parameters. A broadcast transmission of all drives on the bus is also possible.

¹ With repeaters expandable to 247 drives.

1.2 Requirements

Hardware components

Table 1-2: Hardware components

Component	MLFB	Firmware	
SIMATIC S7-1200	6ES721...	V2.2.0 and higher	
CM 1241 (RS422/485)	optional 6ES7241-1CH32-0XB0	V2.0 and higher	
CM 1241 (RS485)		6ES7241-1CH30-0XB0	V1.0 and higher
CB 1241 (RS485)		6ES7241-1CH30-1XB0	V1.0 and higher
SINAMICS V20	6SL3210-5B...	V3.5 and higher	

Control software

STEP 7 BASIC

Libraries are available for TIA Portal V11, V12 and V13. The blocks have been tested in the following combination:

Table 1-3: test combination

TIA Portal	USS library version	CPU firmware version
V13	V1.1	V4.0
V12	V1.1	V3.0
V11	V1.1	V2.2

Ensure always to use the last service pack / update with the corresponding portal version.

1 Overview

1.2 Requirements

Bus wiring

Figure 1-1: Wiring example Modbus

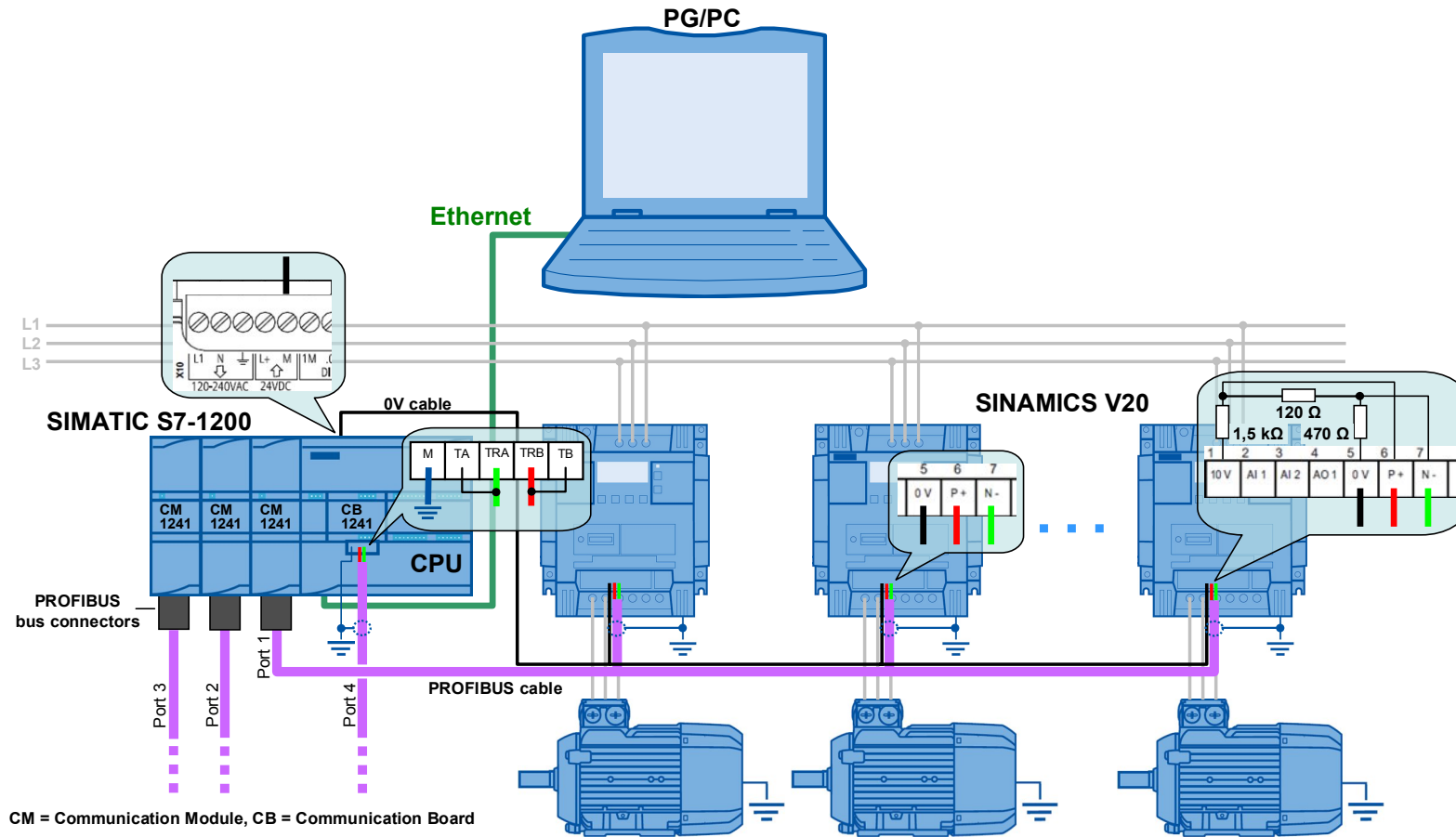

Terminate the bus on the side of the controller with 120Ω, as long as you don't use a PROFIBUS plug with the CM1241.

2 Program Structure

Figure 2-1: Program structure

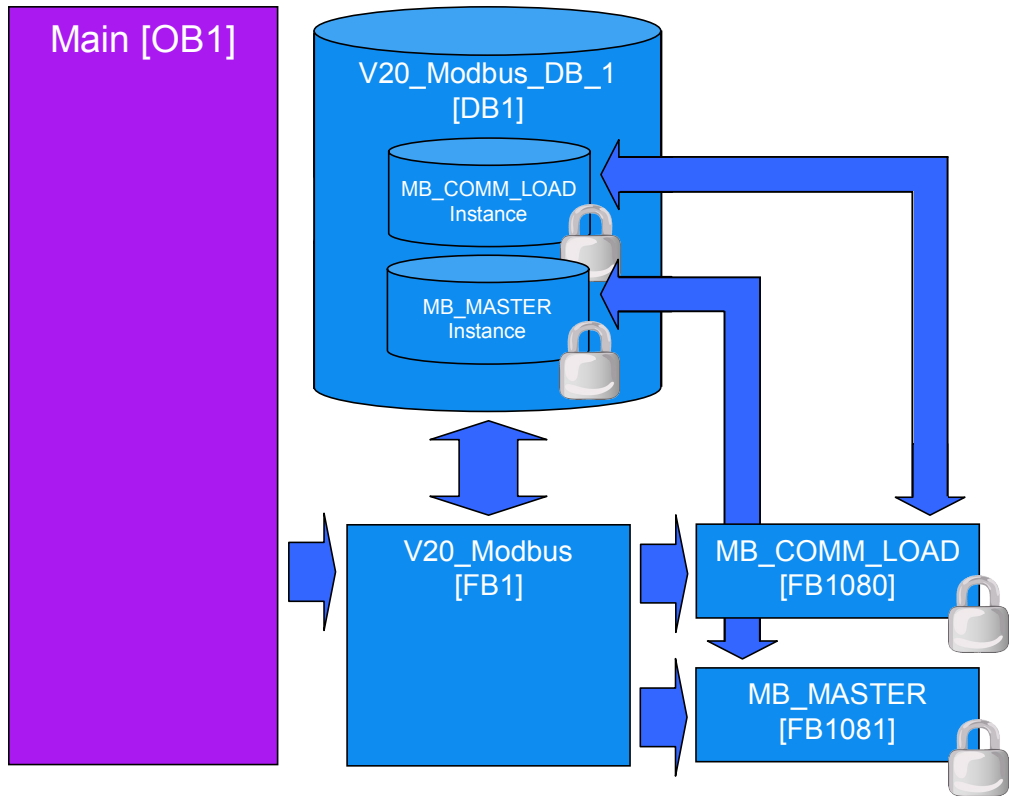

In the screen above, the Modbus system blocks marked with a padlock, are created by STEP 7 itself when calling the instructions with the same name in the V20_Modbus [FB1] FB.

3 V20_Modbus [FB1] Function Block

3.1 Parameters

Table 3-1: Parameter of V20_Modbus [FB1]

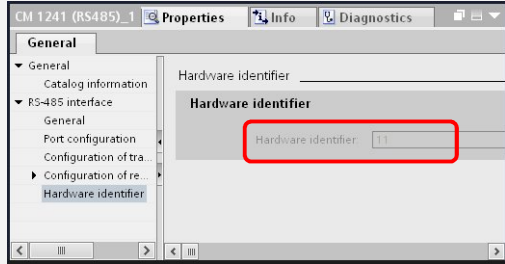
Name	IN / OUT	Type	Explanation
P2010	IN	USInt	Baud rate The coding is identical with that of the V20 parameter P2010 (values: 6...12). See 17 .
HW_ID	IN	PORT	Hardware identifier of the communication module (board) You can find the value in the device configuration in the properties of the communication module. 
RESP_TO	IN	UInt	Timeout of reply Time in milliseconds for which the MB_MASTER system FB waits for the reply by the slave. If the slave does not reply within this time, "MB_MASTER" repeats the request or finishes it with an error, provided the indicated number of repeats ² has been sent. 5 ms to 65535 ms (default value = 1000 ms).
NUMBER_OF_DRIVES	IN	USInt	Number of drives Number of SINAMICS V20 that are connected to the respective port (1...32). With repeaters, the number can be increased to up to 247.
DRIVE_ADDR	IN	USInt	Current drive address Address of the drive that you want to monitor, control or configure.
SPEED_SCALING	IN	Real	Reference frequency Enter the motor frequency in Hz. Internally it is standardized to 16384. With this scaling HSW and HIW are transferred via the Modbus register.

² The number of request repetitions is stored in the RETRIES variable in the "Static" data segment of the instance data of the MB_COMM_LOAD and can be changed by you if required.

3 V20_Modbus [FB1] Function Block

3.1 Parameters

Name	IN / OUT	Type	Explanation
CYCLIC_PROCESSING	IN	Bool	Cyclic PZD transfer on/off false = switched off (no transfer by STW, HSW, ZSW, HIW; only acyclic register transfer) true = switched on
RW_REGISTER_IN. START FUNCTION REG_NUMBER DATA_LEN	IN	Struct Bool USInt UDInt UInt	acyclic register transfer (IN) Start of the operation with positive edge 0 = read 1 = write 2 = read&write Register number (see mapping table in 17 , chap. 6.2) Number of registers (words) to be read/written
ZSW	OUT	Word	Status word ZSW1 of the SINAMICS V20 with the DRIVE_ADDR address
HIW	OUT	Real	Main actual value HIW [Hz] of the SINAMICS V20 with the DRIVE_ADDR address
RW_REGISTER_OUT. DONE BUSY	OUT	Struct Bool Bool	acyclic register transfer (OUT) Done message (pending at cycle 1); The action specified in RW_REGISTER_IN.FUNCTION has been fully completed. A register value read into the PLC by SINAMICS V20 can be removed or further processed. A register value written in the SINAMICS V20 will have an effect there. = True, as long as the action specified in RW_REGISTER_IN.FUNCTION is enabled.
ERROR	OUT	Bool	Communication error True = An error has occurred in the Modbus communication. The bit is pending for 1 cycle.
ERROR_INFO. drive_number step STATUS	OUT	Struct USInt USInt Word	extended error information ³ Number of the drive at which the communication error occurred. Step within the sequencer of the V20_Modbus [FB1] at which the communication error occurred. Error status information of the blocks MB_COMM_LOAD or MB_MASTER (see Online help or 13 , chap. 12.5.3).

³ Always only the error information of the error that occurred last in the instance DB is saved. A new error – signaled by the ERROR bit – overwrites the previous error information.

3 V20_Modbus [FB1] Function Block

3.1 Parameters

Name	IN / OUT	Type	Explanation
STW	IN / OUT	Word	Control word STW1 of the SINAMICS V20 with the DRIVE_ADDR address. The control word is not only continuously transferred to the drive but is also continuously read back.
HSW	IN / OUT	Real	Setpoint value HSW of the SINAMICS V20 with the DRIVE_ADDR address. The setpoint is not only continuously transferred to the drive but is also continuously read back.
DATA_PTR_IN	IN / OUT	Variant	Write pointer Pointer to the data to be written (data source) into the SINAMICS V20 for the acyclic register transfer.
DATA_PTR_OUT	IN / OUT	Variant	Read pointer Pointer to the data to be read for the acyclic register transfer from the SINAMICS V20 to the S7-1200 (data destination).

Tip:

Transfer only one word at a time for the acyclic register transfer (RW_REGISTER_IN.DATA_LEN =1). This makes it possible to symbolically provide the formal parameters DATA_PTR_IN or DATA_PTR_OUT with the variable name of the data word that corresponds to the register to be transferred to the S7-1200. Flexible, symbolic access to field elements and also to loop processing is possible, since this data word can also be an array element with an index which in turn can be indicated symbolically.

Example: Pointer addressing options

Addressing absolute
(no indexing possible)



Addressing symbolic
(indexing possible)

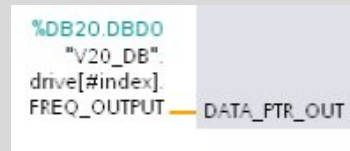

3.2 Status diagram

Figure 3-1: Status diagram

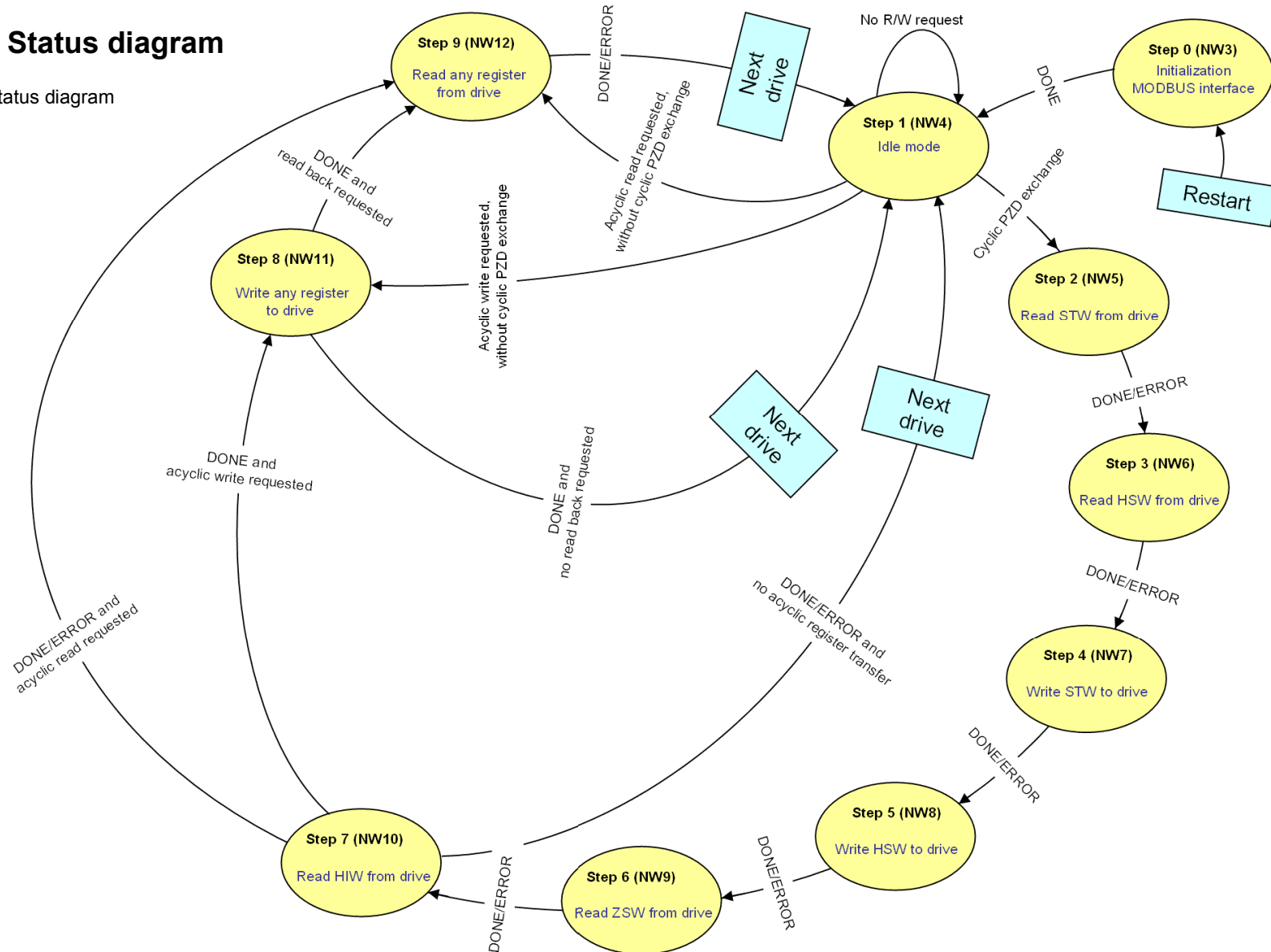

Copyright © Siemens AG 2014 All rights reserved

4 Expansion to Several Drives

4.1 Expansion to up to 247 drives per port

Regarding Modbus and the address space, up to 247 drives can be operated by one port when using repeaters. For more than 32 drives you have to expand the "Drive" array in the "Static" data segment of the interface of the V20_Modbus_DB_1 FB to the desired number of drives.

Figure 4-1: Expanding array in FB V20_Modbus

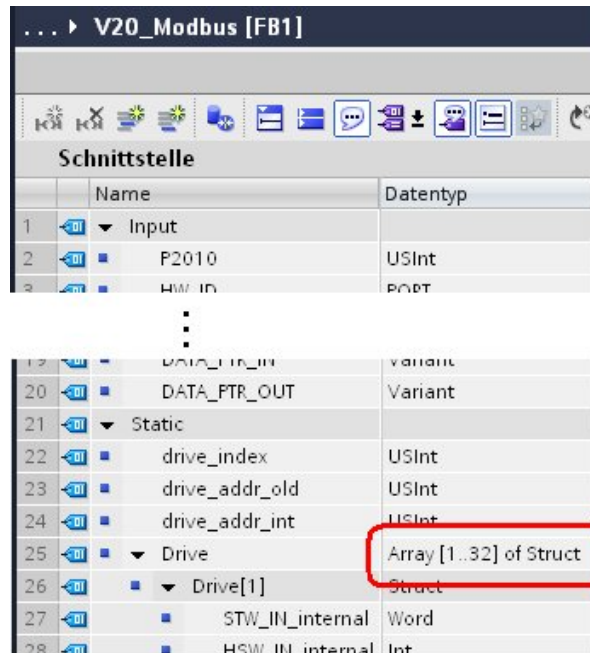

4.2 Expansion to up to 4 ports

You can provide the CPU with a maximum of three communication modules and one communication board. In the TIA portal the following steps have to be executed to create a new instance:

Table 4-1: Port expansion

	Instruction
1.	Supplement the device configuration by the additional communication module/board
2.	Call the V20_Modbus FB for a second time in your user program. Name the respective instance DB which is newly created by STEP7, e.g. V20_Modbus_DB_2.
3.	Configure the new block call according to your requirements. Specify the hardware identifier for the newly added communication module at the HW_ID IN parameter. You can find it in its device configuration.
4.	Now expand your user program regarding the new port.

5 Literature

The following list is by no means complete and only provides a selection of appropriate sources.

Table 5-1: Literature

	Topic	Title / link
\1\	Siemens Industry Online Support	http://support.automation.siemens.com
\2\	Download page of this entry	http://support.automation.siemens.com/WW/view/en/63696870
\3\	STEP7 SIMATIC S7-1200	SIMATIC S7-1200 Automation System - System Manual http://support.automation.siemens.com/WW/view/en/91696622
\4\		Update of the S7-1200 system manual http://support.automation.siemens.com/WW/view/en/89851659
\5\		Updates for STEP 7 V13 and WinCC V13 http://support.automation.siemens.com/WW/view/en/90466591
\6\	MODBUS-RTU	How do you establish a MODBUS-RTU communication with STEP 7 (TIA Portal) for the SIMATIC S7-1200? http://support.automation.siemens.com/WW/view/en/47755811
\7\	SINAMICS V20	SINAMICS V20 Inverter - Operating Instructions http://support.automation.siemens.com/WW/view/en/104426056

6 History

Table 6-1: History

Version	Date	Revisions
V1.0	11/2012	First issue
V1.1	07/2013	Extended to TIA V12
V1.2	11/2014	Extended to TIA V13