

SIEMENS

SITRANS F

Electromagnetic flowmeters SITRANS FM MAG 3100

Operating Instructions

<u>Introduction</u>	1
<u>Safety notes</u>	2
<u>Description</u>	3
<u>Installing/Mounting</u>	4
<u>Connecting</u>	5
<u>Service and maintenance</u>	6
<u>Troubleshooting/FAQs</u>	7
<u>Dimension drawings</u>	8
<u>Technical specifications</u>	9
<u>Product documentation and support</u>	A

Sensors
7ME6340
7ME6310
7ME6320

Legal information

Warning notice system

This manual contains notices you have to observe in order to ensure your personal safety, as well as to prevent damage to property. The notices referring to your personal safety are highlighted in the manual by a safety alert symbol, notices referring only to property damage have no safety alert symbol. These notices shown below are graded according to the degree of danger.

 DANGER
indicates that death or severe personal injury will result if proper precautions are not taken.

 WARNING
indicates that death or severe personal injury may result if proper precautions are not taken.

 CAUTION
indicates that minor personal injury can result if proper precautions are not taken.

NOTICE
indicates that property damage can result if proper precautions are not taken.

If more than one degree of danger is present, the warning notice representing the highest degree of danger will be used. A notice warning of injury to persons with a safety alert symbol may also include a warning relating to property damage.

Qualified Personnel

The product/system described in this documentation may be operated only by **personnel qualified** for the specific task in accordance with the relevant documentation, in particular its warning notices and safety instructions. Qualified personnel are those who, based on their training and experience, are capable of identifying risks and avoiding potential hazards when working with these products/systems.

Proper use of Siemens products

Note the following:

 WARNING
Siemens products may only be used for the applications described in the catalog and in the relevant technical documentation. If products and components from other manufacturers are used, these must be recommended or approved by Siemens. Proper transport, storage, installation, assembly, commissioning, operation and maintenance are required to ensure that the products operate safely and without any problems. The permissible ambient conditions must be complied with. The information in the relevant documentation must be observed.

Trademarks

All names identified by ® are registered trademarks of Siemens AG. The remaining trademarks in this publication may be trademarks whose use by third parties for their own purposes could violate the rights of the owner.

Disclaimer of Liability

We have reviewed the contents of this publication to ensure consistency with the hardware and software described. Since variance cannot be precluded entirely, we cannot guarantee full consistency. However, the information in this publication is reviewed regularly and any necessary corrections are included in subsequent editions.

Table of contents

1	Introduction	5
1.1	Purpose of this documentation	5
1.2	Document history	5
1.3	Checking the consignment.....	6
1.4	Items supplied	6
1.5	Designated use	6
1.6	Security information	6
1.7	Transportation and storage	7
1.8	Notes on warranty	7
2	Safety notes	9
2.1	Precondition for use.....	9
2.2	Warning symbols on the device	9
2.3	Laws and directives	9
2.4	Installation in hazardous locations.....	14
3	Description	19
3.1	System components.....	19
3.2	Design	20
3.3	Theory of operation	22
4	Installing/Mounting	23
4.1	Determining a location.....	23
4.2	Orienting the sensor	26
4.3	Mounting	28
4.3.1	Installing the sensor.....	31
4.3.2	Torque values	33
4.4	Potential equalization.....	39
4.5	Installation with grounding rings.....	41
5	Connecting	43
5.1	General safety requirements	43
5.2	Remote installation	45
5.3	Installation check.....	48
5.4	Potting	49

6	Service and maintenance	51
6.1	Maintenance.....	51
6.2	Recalibration.....	51
6.3	Transportation and storage	52
6.4	Repair.....	52
6.5	Ordering of spare parts	52
7	Troubleshooting/FAQs	55
7.1	Sensor check	55
7.2	Fluctuating process values	56
8	Dimension drawings	59
8.1	Dimensions and weight.....	59
9	Technical specifications	73
9.1	Cable data	79
9.2	Pressure / temperature range	80
9.3	Process fluid conductivity	81
9.4	Liner selection	82
9.5	Electrode selection.....	82
A	Product documentation and support	85
A.1	Product documentation	85
A.2	Technical support.....	86
	Glossary	87
	Index	89

Introduction

1.1 Purpose of this documentation

These instructions contain all information required to commission and use the device. Read the instructions carefully prior to installation and commissioning. In order to use the device correctly, first review its principle of operation.

The instructions are aimed at persons mechanically installing the device, connecting it electronically, configuring the parameters and commissioning it, as well as service and maintenance engineers.

1.2 Document history

The contents of these instructions are regularly reviewed and corrections are included in subsequent editions. We welcome all suggestions for improvement.

The following table shows the most important changes in the documentation compared to each previous edition.

Edition	Remarks
12/2021	Update to include new DN32 variant and Class 600 flanges: <ul style="list-style-type: none"> • Updated PED table • Updated process connection table • Updated dimensions and weights table • Updated coil resistance table
09/2021	Updated nameplate Updated safety notes Updated remote installation Updated technical specifications Updated coil resistance table Updated torque values
09/2012	Updated temperature specifications Updated coil resistance table
12/2011	General update Updated ATEX approval
06/2010	First edition The Operating Instruction replaces: <ul style="list-style-type: none"> • MAG 3100 part of SITRANS F M HANDBOOK • MAG 3100 part of SITRANS F M MAG 6000 I Ex d Operating Instructions • MAG 3100 part of SITRANS F M MAG 6000 19" & Safety Barrier Operating Instructions • MAG 3100 Instructions • MAG 3100 with PTFE and PFA liners Instructions

1.3 Checking the consignment

1. Check the packaging and the delivered items for visible damages.
2. Report any claims for damages immediately to the shipping company.
3. Retain damaged parts for clarification.
4. Check the scope of delivery by comparing your order to the shipping documents for correctness and completeness.

⚠ WARNING
Using a damaged or incomplete device
Risk of explosion in hazardous areas.
<ul style="list-style-type: none">• Do not use damaged or incomplete devices.

1.4 Items supplied

- SITRANS F M MAG 3100
- Calibration report
- Siemens Process Instrumentation documentation disk containing certificates, and manuals
- Safety note

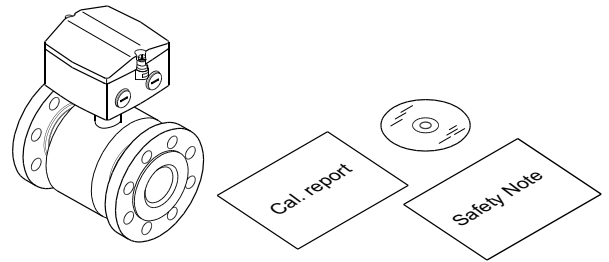

1.5 Designated use

Use the device in accordance with the information on the nameplate and in the Technical specifications (Page 73).

NOTICE
Use in a domestic environment
This Class A Group 1 equipment is intended for use in industrial areas.
In a domestic environment this device may cause radio interference.

1.6 Security information

Siemens provides products and solutions with industrial security functions that support the secure operation of plants, systems, machines and networks.

In order to protect plants, systems, machines and networks against cyber threats, it is necessary to implement – and continuously maintain – a holistic, state-of-the-art industrial security concept. Siemens' products and solutions constitute one element of such a concept.

Customers are responsible for preventing unauthorized access to their plants, systems, machines and networks. Such systems, machines and components should only be connected to an enterprise network or the internet if and to the extent such a connection is necessary and only when appropriate security measures (e.g. firewalls and/or network segmentation) are in place.

For additional information on industrial security measures that may be implemented, please visit

<https://www.siemens.com/industrialsecurity>.

Siemens' products and solutions undergo continuous development to make them more secure. Siemens strongly recommends that product updates are applied as soon as they are available and that the latest product versions are used. Use of product versions that are no longer supported, and failure to apply the latest updates may increase customer's exposure to cyber threats.

To stay informed about product updates, subscribe to the Siemens Industrial Security RSS Feed under

<https://www.siemens.com/industrialsecurity>.

1.7 Transportation and storage

To guarantee sufficient protection during transport and storage, observe the following:

- Keep the original packaging for subsequent transportation.
- Devices/replacement parts should be returned in their original packaging.
- If the original packaging is no longer available, ensure that all shipments are properly packaged to provide sufficient protection during transport. Siemens cannot assume liability for any costs associated with transportation damages.

NOTICE

Insufficient protection during storage

The packaging only provides limited protection against moisture and infiltration.

- Provide additional packaging as necessary.

Special conditions for storage and transportation of the device are listed in Technical specifications (Page 73).

1.8 Notes on warranty

The contents of this manual shall not become part of or modify any prior or existing agreement, commitment or legal relationship. The sales contract contains all obligations on the part of Siemens as well as the complete and solely applicable warranty conditions. Any statements regarding device versions described in the manual do not create new warranties or modify the existing warranty.

The content reflects the technical status at the time of publishing. Siemens reserves the right to make technical changes in the course of further development.

Safety notes

2.1 Precondition for use

This device left the factory in good working condition. In order to maintain this status and to ensure safe operation of the device, observe these instructions and all the specifications relevant to safety.

Observe the information and symbols on the device. Do not remove any information or symbols from the device. Always keep the information and symbols in a completely legible state.

2.2 Warning symbols on the device

Symbol	Explanation
	Consult operating instructions

2.3 Laws and directives

General requirements

Installation of the equipment must comply with national regulations.

Instrument safety standards

The device has been tested at the factory, based on the safety requirements. In order to maintain this condition over the expected life of the device the requirements described in these Operating Instructions must be observed.

NOTICE
<p>Material compatibility</p> <p>Siemens Flow Instruments can provide assistance with the selection of wetted sensor parts. However, the full responsibility for the selection rests with the customer and Siemens Flow Instruments can take no responsibility for any failure due to material incompatibility.</p>

Conformity with European directives

The CE marking on the device symbolizes the conformity with the following European directives:

Electromagnetic compatibility EMC 2004/108/EC	Directive of the European Parliament and of the Council on the approximation of the laws of the Member States relating to electromagnetic compatibility and repealing Directive 89/336/EEC.
Low voltage directive LVD 2006/95/EC	Directive of the European Parliament and of the Council on the harmonisation of the laws of Member States relating to electrical equipment designed for use within certain voltage limits.
Pressure equipment directive PED 97/23/EC	Directive of the European Parliament and of the Council on the approximation of the laws of the Member States concerning pressure equipment.

- EMC Directive 2004/108/EC
- Low Voltage Directive (LVD) 2006/95/EC
- Pressure Equipment Directive (PED/DGRL) 93/23/EC
- ATEX Directive 94/9/EC
- MID Directive 2004/22/EC

Compliance with PED directive

"Pressure Equipment Directive" (PED) is mandatory for all pressure equipment sold within the EU and EFTA.

Siemens Flow Instruments products comply with PED as stated in the following table.

Table 2-1 MAG 3100 (7ME631) PED Compliance for fluids under 100 °C (PED classification: liquids) EN 1092 and B16.5 flanges

Flange mm	EN 1092						B16.5			
	PN 6	PN 10	PN 16	PN25	PN 40	PN 63	PN 100	Class 150	Class 300	Class 600
15	N/A	N/A	N/A	N/A	SEP	N/A	N/A	SEP	SEP	N/A
25	N/A	N/A	N/A	N/A	SEP	N/A	SEP	SEP	SEP	SEP
32	N/A	N/A	N/A	N/A	SEP	N/A	PED (II)	SEP	SEP	PED (II)
40	N/A	N/A	N/A	N/A	SEP	N/A	PED (II)	SEP	PED (II)	PED (II)
50	N/A	N/A	N/A	N/A	SEP	PED (II)	PED (II)	SEP	PED (II)	PED (II)
65	SEP	N/A	SEP	N/A	PED (II)	PED (II)	PED (II)	SEP	PED (II)	PED (II)
80	SEP	N/A	SEP	N/A	PED (II)	PED (II)	PED (II)	SEP	PED (II)	PED (II)
100	SEP	N/A	SEP	N/A	PED (II)	PED (II)	PED (II)	SEP	PED (II)	PED (II)
125	SEP	N/A	SEP	N/A	PED (II)	PED (II)	PED (II)	PED (II)	PED (II)	PED (II)
150	SEP	N/A	PED (II)	N/A	PED (II)	PED (II)	PED (II)	PED (II)	PED (II)	PED (II)
200	SEP	SEP	PED (II)	PED (II)	PED (II)	PED (II)	PED (II)	PED (II)	PED (II)	PED (II)
250	SEP	PED (I)	PED (II)	PED (II)	PED (II)	PED (II)	PED (II)	PED (II)	PED (II)	PED (II)
300	SEP	PED (I)	PED (II)	PED (II)	PED (II)	PED (II)	PED (II)	PED (II)	PED (II)	PED (II)
350	PED (I)	PED (I)	PED (II)	PED (II)	PED (II)	N/A	N/A	PED (II)	PED (II)	PED (II)
400	PED (I)	PED (I)	PED (II)	PED (II)	PED (II)	N/A	N/A	PED (II)	PED (II)	PED (II)

Flange mm	EN 1092						B16.5			
	PN 6	PN 10	PN 16	PN25	PN 40	PN 63	PN 100	Class 150	Class 300	Class 600
450	PED (I)	PED (I)	PED (II)	PED (II)	PED (II)	N/A	N/A	PED (II)	PED (II)	N/A
500	PED (I)	PED (I)	PED (II)	PED (II)	PED (II)	N/A	N/A	PED (II)	PED (II)	N/A
600	PED (I)	PED (I)	PED (II)	PED (II)	PED (II)	N/A	N/A	PED (II)	PED (II)	N/A
700	PED (I)	PED (I)	PED* (II)	N/A	N/A	N/A	N/A	N/A	N/A	N/A
750	N/A	N/A	N/A	N/A	N/A	N/A	N/A	N/A	N/A	N/A
800	PED (I)	PED (I)	PED* (II)	N/A	N/A	N/A	N/A	N/A	N/A	N/A
900	PED (I)	PED (I)	PED* (II)	N/A	N/A	N/A	N/A	N/A	N/A	N/A
1000	PED (I)	PED (I)	PED* (II)	N/A	N/A	N/A	N/A	N/A	N/A	N/A
1050	N/A	N/A	N/A	N/A	N/A	N/A	N/A	N/A	N/A	N/A
1100	N/A	N/A	N/A	N/A	N/A	N/A	N/A	N/A	N/A	N/A
1200	PED (I)	PED (I)	PED* (II)	N/A	N/A	N/A	N/A	N/A	N/A	N/A
1300	PED (I)	PED (I)	PED* (II)	N/A	N/A	N/A	N/A	N/A	N/A	N/A
1400	PED (I)	PED (I)	PED* (II)	N/A	N/A	N/A	N/A	N/A	N/A	N/A
1500	PED (I)	PED (I)	PED* (II)	N/A	N/A	N/A	N/A	N/A	N/A	N/A
1600	PED (I)	PED (I)	PED* (II)	N/A	N/A	N/A	N/A	N/A	N/A	N/A
1700	PED (I)	PED (I)	PED* (II)	N/A	N/A	N/A	N/A	N/A	N/A	N/A
1800	PED (I)	PED (I)	PED* (II)	N/A	N/A	N/A	N/A	N/A	N/A	N/A
1900	PED (I)	PED (I)	PED* (II)	N/A	N/A	N/A	N/A	N/A	N/A	N/A
2000	PED (I)	PED (I)	PED* (II)	N/A	N/A	N/A	N/A	N/A	N/A	N/A

Table 2-2 MAG 3100 (7ME631) PED Compliance for fluids under 100 °C (PED classification: liquids) JIS2220, AS2129, AS4087, AWWA C207 flanges

Flange mm	JIS2220		AS2129		AS4087		AWWA C207
	10K / E	20K	Table E	class16 (AS16)	class21 (AS21)	class35 (AS35)	Class D
15	SEP	SEP	SEP	N/A	N/A	N/A	N/A
25	SEP	SEP	SEP	N/A	N/A	N/A	N/A
32	SEP	SEP	SEP	N/A	N/A	N/A	N/A
40	SEP	SEP	SEP	N/A	N/A	N/A	N/A
50	SEP	SEP	SEP	SEP	SEP	SEP	N/A
65	SEP	PED (II)	SEP	SEP	SEP	SEP	N/A
80	SEP	PED (II)	SEP	SEP	SEP	SEP	N/A
100	SEP	PED (II)	SEP	SEP	SEP	SEP	N/A
125	SEP	PED (II)	SEP	N/A	N/A	N/A	N/A
150	PED (II)	PED (II)	PED (II)	SEP	SEP	SEP	N/A
200	PED (II)	PED (II)	PED (II)	SEP	SEP	SEP	N/A
250	PED (II)	PED (II)	PED (II)	SEP	PED (I)	PED (I)	N/A
300	PED (II)	PED (II)	PED (II)	SEP	PED (I)	PED (I)	N/A
350	PED (II)	PED (II)	PED (II)	PED (I)	PED (I)	PED (I)	N/A

Safety notes

2.3 Laws and directives

Flange mm	JIS2220		AS2129	AS4087			AWWA C207
	10K / E	20K	Table E	class16 (AS16)	class21 (AS21)	class35 (AS35)	Class D
400	PED (II)	PED (II)	PED (II)	PED (I)	PED (I)	PED (I)	N/A
450	PED (II)	PED (II)	PED (II)	PED (I)	PED (I)	PED (I)	N/A
500	PED (II)	PED (II)	PED (II)	PED (I)	PED (I)	PED (I)	N/A
600	PED (II)	PED (II)	PED (II)	PED (I)	PED (I)	PED (I)	N/A
700	N/A	N/A	PED (II)	PED (I)	N/A	N/A	PED (I)
750	N/A	N/A	PED (II)	N/A	N/A	N/A	PED (I)
800	N/A	N/A	PED (II)	PED (I)	N/A	N/A	PED (I)
900	N/A	N/A	PED (II)	PED (I)	N/A	N/A	PED (I)
1000	N/A	N/A	PED (II)	PED (I)	N/A	N/A	PED (I)
1050	N/A	N/A	N/A	N/A	N/A	N/A	PED (I)
1100	N/A	N/A	N/A	N/A	N/A	N/A	PED (I)
1200	N/A	N/A	PED (II)	PED (I)	N/A	N/A	PED (I)
1300	N/A	N/A	N/A	N/A	N/A	N/A	PED (I)
1400	N/A	N/A	N/A	N/A	N/A	N/A	PED (I)
1500	N/A	N/A	N/A	N/A	N/A	N/A	PED (I)
1600	N/A	N/A	N/A	N/A	N/A	N/A	PED (I)
1700	N/A	N/A	N/A	N/A	N/A	N/A	PED (I)
1800	N/A	N/A	N/A	N/A	N/A	N/A	PED (I)
1900	N/A	N/A	N/A	N/A	N/A	N/A	PED (I)
2000	N/A	N/A	N/A	N/A	N/A	N/A	PED (I)

Table 2-3 MAG 3100 HT (7ME632) PED Compliance for fluids over 100 °C (PED classification: gas)

Flange mm	EN 1092				B16.5		AS2129
	PN 10	PN 16	PN25	PN 40	Class 150	Class 300	Table E
15	N/A	N/A	N/A	SEP	SEP	SEP	SEP
25	N/A	N/A	N/A	SEP	SEP	SEP	SEP
32	N/A	N/A	N/A	PED (II)	PED (I)	PED (II)	PED (I)
40	N/A	N/A	N/A	PED (II)	PED (I)	PED (II)	PED (I)
50	N/A	N/A	N/A	PED (II)	PED (I)	PED (II)	PED (I)
65	N/A	PED (II)	N/A	PED (II)	PED (II)	PED (II)	PED (I)
80	N/A	PED (II)	N/A	PED (II)	PED (II)	PED (II)	PED (II)
100	N/A	PED (II)	N/A	PED (II)	PED (II)	PED (II)	PED (II)
125	N/A	PED (II)	N/A	PED (III)	PED (II)	PED (III)	PED (II)
150	N/A	PED (II)	N/A	PED (III)	PED (II)	PED (III)	PED (II)
200	PED (II)	PED (II)	PED (III)	PED (III)	PED (III)	PED (III)	PED (II)
250	PED (II)	PED (III)	PED (III)	PED (III)	PED (III)	PED (III)	PED (II)
300	PED (II)	PED (III)	PED (III)	PED (III)	PED (III)	PED (III)	PED (III)

Table 2-4 MAG 3100 P (7ME634) PED Compliance for fluids over 100 °C (PED classification: gas)

Flange mm	EN 1092			B16.5
	PN 10	PN 16	PN 40	Class 150
15	N/A	N/A	SEP	SEP
25	N/A	N/A	SEP	SEP
32	N/A	N/A	PED (II)	PED (I)
40	N/A	N/A	PED (II)	PED (I)
50	N/A	N/A	PED (II)	PED (I)
65	N/A	PED (II)	N/A	PED (II)
80	N/A	PED (II)	N/A	PED (II)
100	N/A	PED (II)	N/A	PED (II)
125	N/A	PED (II)	N/A	PED (II)
150	N/A	PED (II)	N/A	PED (II)
200	PED (II)	PED (II)	N/A	PED (III)
250	PED (II)	PED (III)	N/A	PED (III)
300	PED (II)	PED (III)	N/A	PED (III)

Table 2-5 PED table key

SEP	Product covered by PED under category SEP (Sound Engineering Practice)
PED	Product covered by PED under category I to III as fully PED-conforming
PED*	Product sold with or without PED certification (only pressure test not done, example water transport industry)
N/A	Size/pressure not available in the size range

**CAUTION**

All products sold outside of EU and EFTA are excluded from the Pressure Equipment directive, also products sold into certain market sectors are excluded. These include

1. Meters used in networks for the supply, distribution and discharge of water.
2. Meters used in pipelines for the conveyance of any fluid from offshore to onshore.
3. Meters used in the extraction of petroleum or gas, including christmas tree and manifold equipment.
4. Any meter mounted on a ship or mobile offshore platform.

2.4 Installation in hazardous locations

⚠ DANGER

Unsuitable device for the hazardous area

Risk of explosion.

- Only use equipment that is approved for use in the intended hazardous area and labelled accordingly.

⚠ DANGER

Non-flammable media only

Risk of explosion.

Ensure that there is no explosive or flammable gas inside the pipe during process or maintenance.

Hazardous area approvals

The device is approved for use in hazardous area and has the following approvals:

MAG 3100 Ex DN 350-2000:

- Ex e ia IIC T3-T6 Gb Ex tD A21 IP67 T*°C (* pipe temperature +5 K) (remote mounted)
- Ex d e [ia] ia IIC T3-T6 Gb Ex tD A21 IP67 T**°C (** pipe temperature +5 K, but not less than 85°C) (compact mounted)

MAG 3100 Ex DN 15-300:

- Ex de ia IIC T3-T6 Gb Ex tD A21 IP67 T*°C (* pipe temperature +13 K) (remote mounted)
- Ex de* [ia] [ib] ia ib* IIC T3-T6 Gb Ex tD A21 IP67 T**°C (** pipe temperature +13 K, but not less than 85°C) (compact mounted)

* The "e" and "ib" markings on the compact version are only applicable if the "Ex e" supply/data terminal chamber option is used.

Intrinsically safe data

Table 2-6 Intrinsically safe data for MAG 3100 Ex remote mounted

Electrode circuit "ia" (Terminal 82,83)	
Ui	30 V
Li	2 μH
li	50 mA
Pi	0.5 W
Ci	50 nF

Coil circuit "Ex e" (Terminal 85,86)	
Ui	30 V (70 V peak)
Ii	130 mA

Note**Compact mounted versions**

For intrinsically safe data for MAG 3100 Ex compact mounted with MAG 6000 I Ex d, refer to the Operating Instructions of MAG 6000 I or to certificate number Sira 11ATEX2124X, available here: Certificates (<http://www.siemens.com/processinstrumentation/certificates>).

 WARNING
With intrinsically safe circuits
If a non-conforming supply unit is used, the "fail-safe" type of protection will no longer be effective and the approval certification will be invalid.
With intrinsically safe circuits, use only certified meters appropriate for the transmitter.

Temperature specifications for Ex use

Table 2-7 Temperature classifications for MAG 3100 Ex (remote or compact with MAG 6000 I)

Maximum process fluid temperature [°C]	Temperature class	Ambient temperature [°C]
75	T6 (85 °C)	-25 to +60
90	T5 (100 °C)	-25 to +60
125	T4 (135 °C)	-25 to +60
180 (Remote configuration)	T3 (200 °C)	-25 to +60
150 (Compact configuration)	T3 (200 °C)	-25 to +50

For dust protection, the surface temperature is equal to the process fluid temperature plus 5 °C.





Special conditions for safe use

It is required that:

- Electrical connections are in accordance with national requirements.
- Appropriate cable connectors are used for the output circuits:
 - Intrinsically safe: blue
 - Non-intrinsically safe: black
- Minimum 4 mm² cable is to be used for potential equalization
- Cable glands for coil circuit must be Ex e approved (increased safety) and fit the application by being approved for the cable used as regards size and temperature.

2.4 Installation in hazardous locations

- Sensor insulation thickness is max. 100mm (only insulated sensors).
- IEC/EN 61241-14 and 61241-17 are considered for installation in areas with combustible dust.

 DANGER
Risk of explosion Do NOT open the device while energized; otherwise there is a risk of explosion.
 WARNING
Explosive gas or dust The terminal box shall not be opened when an explosive gas or dust atmosphere may be present.
 WARNING
Potential equalization In operation, the output is earthed through the conductive medium being measured and therefore potential equalization is necessary throughout the hazardous area. The apparatus housing shall be connected to the potential equalizing conductor in the hazardous area.
 WARNING
External connections to Ex e terminals The external connections to the Ex 'e' Terminals of the Remote version shall comply with the following: <ul style="list-style-type: none">• The wire conductors shall have a cross-sectional area between 0.5 mm² and 2.5 mm².• No more than one single or multiple strand wire conductor shall normally be connected to each of the terminals. If multiple conductors are required, these shall be joined in a suitable manner, for example two conductors into a single insulated crimped boot lace ferrule.• The insulation on the wire conductors shall extend to within 1 mm of the metal of the terminal throat.• The terminal screws shall be tightened down with a torque between 0.5 Nm and 0.7 Nm.• The terminals shall never be exposed to temperatures outside of the range -50°C to +130°C; in addition, they shall only be installed and wired with cable in an ambient temperature of -10 to +80°C. Furthermore, in the event of there being a process temperatures of +180°C in conjunction with an upper ambient temperature of +50°C the terminal strips should not be installed or wired with cable.

 WARNING**Laying of cables**

Cable for use in zone 1 and 2 or 21 and 22 must satisfy the requirements for having a proof voltage < AC 500 V applied between the conductor/ground, conductor/shield and shield/ground.

Connect the devices that are operated in hazardous areas as per the stipulations applicable in the country of operation, for example for Ex "d" and "nA", permanent cables must be laid.

2.4 Installation in hazardous locations

Description

The main applications of the SITRANS F M electromagnetic flow sensors can be found in the following fields:

- Process industry
- Chemical industry
- Steel industry
- Mining
- Utility
- Power generation & distribution
- Oil & gas / HPI
- Water & waste water
- Pulp & paper

3.1 System components

The SITRANS FM flowmeter system includes:

- Transmitter (types: SITRANS FM MAG 5000/6000 or MAG 6000 I)
- Sensor (types: SITRANS FM MAG 1100/1100 F, MAG 3100/3100 P or MAG 5100 W)
- Communication module (optional) (types: HART, PROFIBUS PA/DP, MODBUS RTU RS 485, Foundation Fieldbus H1, Devicenet)
- SENSORPROM memory unit

Communication solutions

The SITRANS FM range of add-on modules, presently including HART, Foundation Fieldbus, MODBUS RTU RS 485, PROFIBUS PA / DP and Devicenet, are all applicable with the SITRANS FM MAG 6000 transmitter.

3.2 Design

SITRANS F M MAG 3100 is available in a wide range of sizes (DN 15 to DN 2000 (1/2" to 78")) and pressure ratings (PN 6 to PN 100 / ANSI Class 150 / 300 / 600, AS 2129 / AS 4087 - on request up to 690 bar (10 000 psi)). The fully welded construction provides a ruggedness that suits the toughest applications and environments.



Sensor housing and flanges are designed in carbon steel (ASTM A 105) and terminal box in fibre glass reinforced polyamide or optionally in stainless steel (AISI 316). Measuring pipe is made of stainless steel (AISI 304) while liners and electrodes are available in various material, which makes the sensor highly resistant to a wide range of chemicals.

The present range of liner types includes:

- PTFE
- PFA
- Soft rubber
- EPDM
- Linatex
- Ebonite Hard Rubber

Electrodes are available in:

- Hastelloy C276 or C22
- AISI 316Ti (1.4571)
- Platinum / Iridium
- Titanium
- Tantalum

The sensors carry a wide range of approvals, see Technical data (Page 73).

Inspection

1. Check for mechanical damage due to possible improper handling during shipment. All claims for damage are to be made promptly to the shipper.
2. Make sure the scope of delivery, and the information on the nameplate corresponds to the ordering information.

MAG 3100 sensor identification nameplate

SIEMENS
SITRANS F M MAG 3100

⑤	Order No.: 7ME63XX-XXXX-XXXX	MAWP (PS) at 20°C: XXbar/XXXpsi	⑥
④	Serial No.: 7ME63X XXXXXHX	MAWP (PS) at 20°C: XXbar/XXXpsi	
③	Size: XXXX	Lining: XXXX	TM max.: XXXC/XXXpsi
	Tube: AISI XXX/X.XXXX	TM min.: XXbar/XXX°F	⑦
②	Electrodes: XXXX/XXXX	Process connection: -XX°C/-X°F	
	Cal factor: X.XXXXXXX	Year of Manufacture: XXXX XXX	⑧
①	Fluid group: PED/x1	Rating: PNXX	Input 60V max. 0.125A max. 20 XXI

Siemens A/S, Flow Instruments 6430 Nordborg, Denmark
Made in France

- ① Fluid group
- ② Calibration factor
- ③ Size and liner type
- ④ Serial Number
- ⑤ Order Number
- ⑥ Maximum allowable pressure
- ⑦ Media temperature
- ⑧ Year of Manufacture
- ⑨ Power supply

Figure 3-1 Example of product nameplate

MAG 3100 sensor specification nameplate

SIEMENS
SITRANS F M MAG 3100

Ex ia Terminals: Ui = 30V; Li = 50mA;
Pi = 0.5W; Ci = 50nF; Li = 2µH

CE 0539 Ex II 2 (1) GD

WARNING - DO NOT OPEN WHEN
NON-INTRINSICALLY SAFE
CIRCUITS ARE ENERGIZED

Ex d e ia IIC T3-T6 Gb
Ex tD A21 IP67 T* °C
(* pipe temperature +13K)
Sira 07ATEX1182X

Siemens A/S, Flow Instruments 6400 Soenderborg, Denmark
Made in France

- ① Intrinsically safe data
- ② Ex approval type
- ③ Ex approval reference

Figure 3-2 Example of specification nameplate

3.3 Theory of operation

The flow measuring principle is based on Faraday's law of electromagnetic induction.

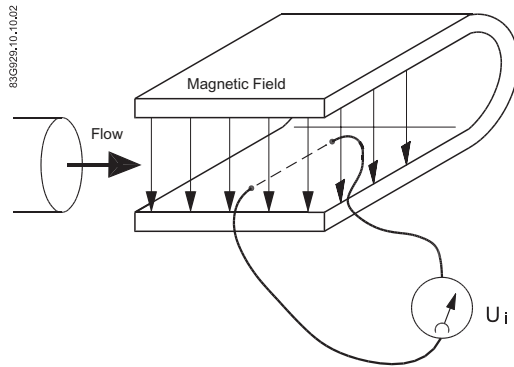

U_i = When an electrical conductor of length L is moved at velocity v , perpendicular to the lines of flux through a magnetic field of strength B , the voltage U_i is induced at the ends of the conductor

$$U_i = L \times B \times v$$

- U_i = Induced voltage
- L = Conductor length = Inner pipe diameter = k_1
- B = Magnetic field strength = k_2
- v = Velocity of conductor (media)
- $k = k_1 \times k_2$

$U_i = k \times v$, the electrode signal is directly proportional to the fluid velocity

Operating principle

The coil current module generates a pulsating magnetizing current that drives the coils in the sensor. The current is permanently monitored and corrected. Errors or cable faults are registered by the self-monitoring circuit.

The input circuit amplifies the flow-proportional induced voltage signal from the electrodes. The input impedance is extremely high: $>10^{14} \Omega$ which allows flow measurements on fluids with conductivities as low as $5 \mu\text{S/cm}$. Measuring errors due to cable capacitance are eliminated due to active cable screening.

The digital signal processor converts the analog flow signal to a digital signal and suppresses electrode noise through a digital filter. Inaccuracies in the transmitter as a result of long-term drift and temperature drift are monitored and continuously compensated for via the self-monitoring circuit. The analog to digital conversion takes place in an ultra low noise ASIC with 23 bit signal resolution. This has eliminated the need for range switching. The dynamic range of the transmitter is therefore unsurpassed with a turn down ratio of minimum 3000:1.

Installing/Mounting

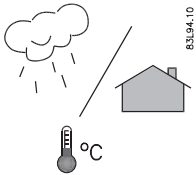

SITRANS F flowmeters with minimum IP65/NEMA 4 enclosure rating are suitable for indoor and outdoor installations.

- Make sure that pressure and temperature specifications indicated on the device nameplate / label will not be exceeded.

! WARNING

Installation in hazardous location

Special requirements apply to the location and interconnection of sensor and transmitter. See Installation in hazardous locations (Page 14)

! WARNING

High pressure hazard

In applications with working pressures/media that can be dangerous to people, surroundings, equipment or others in case of pipe fracture, we recommend that special precautions such as special placement, shielding or installation of a pressure guard or a safety valve are taken when the flowmeter is mounted.

4.1 Determining a location

Note

The sensor must always be completely filled with liquid.

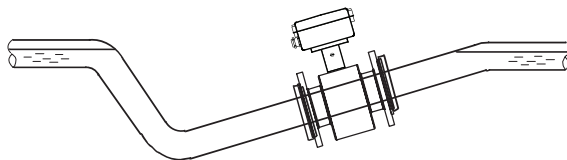

Figure 4-1 Correct installation with filled pipes

4.1 Determining a location

- Avoid the following installations
 - Installation at the highest point in the pipe system
 - Installation in vertical pipes with free outlet

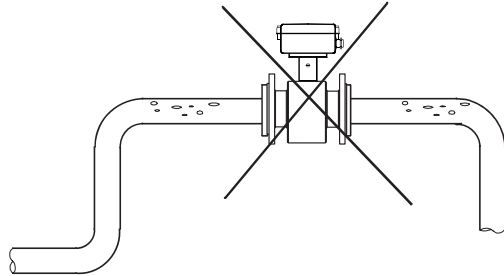

Figure 4-2 Wrong installation at high point

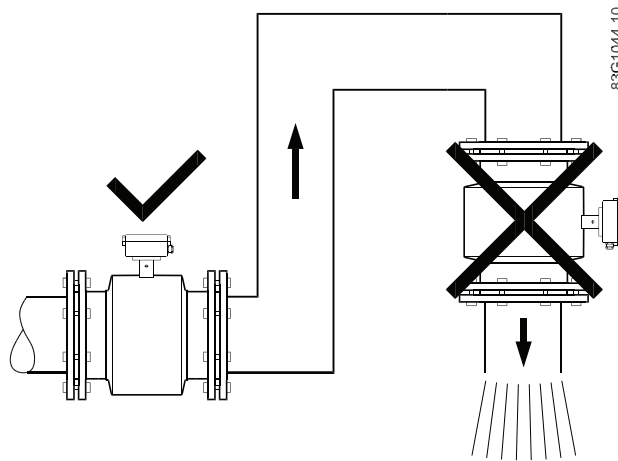

Figure 4-3 Correct installation at low point before outlet

Vibrations

In installations with strong vibrations remote installation of the transmitter is recommended. Alternatively mitigate vibrations by installing pipe support in close proximity to the flowmeter.

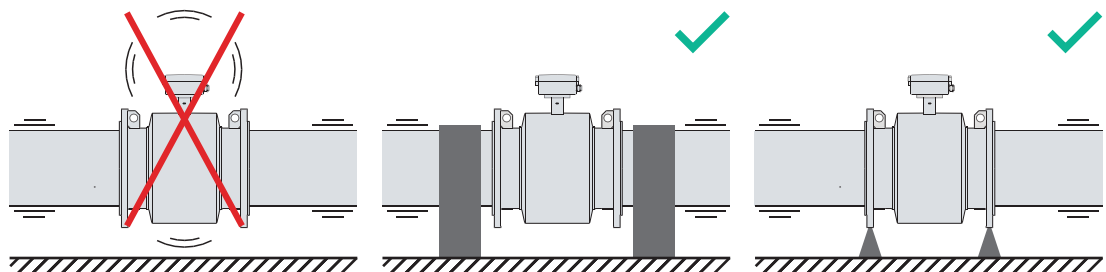
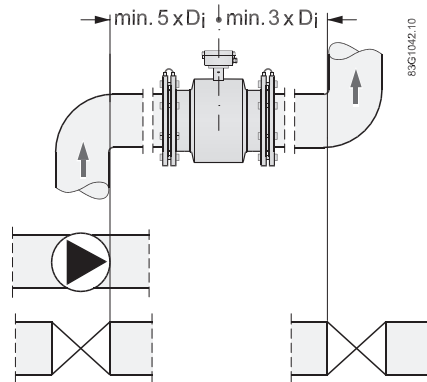

Figure 4-4 Avoid vibrations

Inlet and outlet conditions

To achieve accurate flow measurement it is essential to have straight lengths of inlet and outlet pipes and a certain distance to pumps and valves.

It is also important to centre the flowmeter in relation to pipe flanges and gaskets.



Installation in large pipes

The flowmeter can be installed between two reducers (for example DIN 28545). At $\alpha \leq 8^\circ$ the following pressure drop curves apply. The curves are applicable to water.

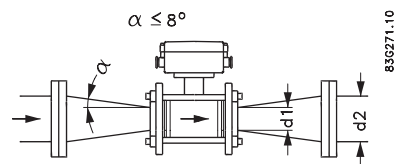

4.2 Orienting the sensor

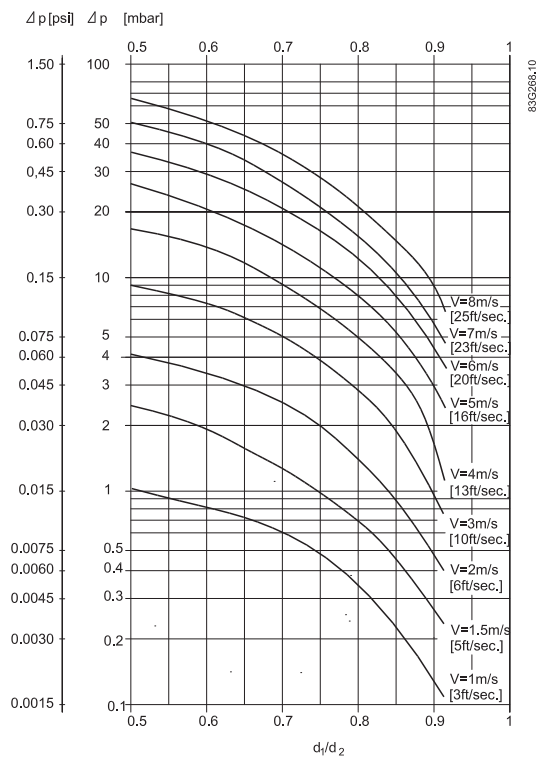

Example:

A flow of 3 m/s (v) in a sensor with a diameter reduction from DN 100 to DN 80 ($d_1/d_2 = 0.8$) gives a pressure drop of 2.9 mbar.

4.2 Orienting the sensor

Flow direction

The calibrated flow direction is marked by the arrow on the sensor. Flow in this direction is indicated as positive by default. The accuracy of the sensor does not change with reverse flow.

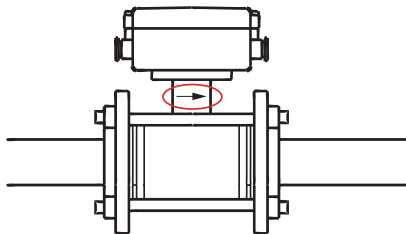

Figure 4-5 Flow direction indicator

Orientation

The sensor operates in all orientations, but Siemens has the following recommendations:

- Vertical installation with an upwards flow

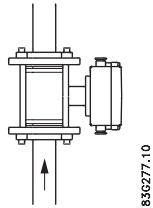

Figure 4-6 Vertical orientation, upwards flow

NOTICE

Abrasive liquids / liquids containing solid particles

A vertical installation minimizes wear and deposits in the sensor

Note

Gas/air bubbles in the liquid

A vertical installation minimizes any negative effect of gas/air bubbles in the liquid

- Horizontal installation, terminal box upwards or downwards

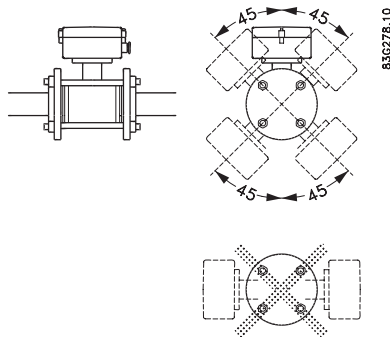

Figure 4-7 Horizontal installation, various terminal box positions

NOTICE

Do NOT mount the sensor with the terminal box sideways

This will position the electrodes at the top where there is possibility for air bubbles and at the bottom where there is possibility for mud, sludge, sand etc.

Note

Empty pipe detection

For applications with empty pipe detection, the sensor can be tilted 45°, as shown above.

4.3 Mounting

Installation conditions

The following points must be observed during installation:

- Install the sensor in rigid pipelines in order to support the weight of the meter.
- The device must be installed without mechanical tension (torsion, bending).
- Install flange devices with plane parallel counter-flanges and only use appropriate gaskets.
- Use proper gaskets made from a material that is compatible with the measuring medium and measuring medium temperature.
- Gaskets must not extend into the flow area, since possible turbulence could influence the accuracy of the device.
- The piping may not exert any inadmissible forces or torques on the device.
- Make sure that the temperature limits are not scaled up during operation of the device.
- Vacuum shocks in the piping should be avoided to prevent damage to the liners (PTFE liner). Vacuum shocks can destroy the device.
- Do not remove the blind plugs in the cable glands until you are ready to install the electrical cable
- If earthing rings are used, use standard flange gaskets on both sides of the ring.

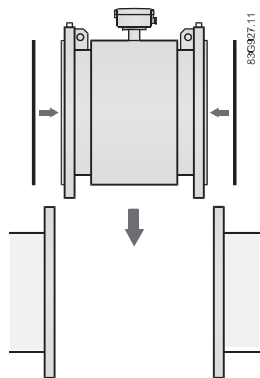

Figure 4-8 Correct installation with gaskets

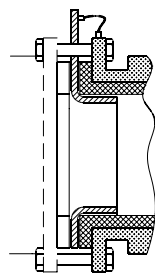

Figure 4-9 Inlet protection

Transporting

WARNING

Lifting the sensor

Do **NOT** lift the sensor by the terminal box. Do **NOT** use a forklift. If available lift the sensor by the lifting eyes fitted to the device. Otherwise lift the sensor by the process connections.

CAUTION

Flange devices \leq DN 300

- Use carrying straps to transport devices with flange sizes smaller than DN 300.
- Wrap the carrying straps around both process connections when lifting the device.
- Chains should not be used, since these may damage the enclosure.

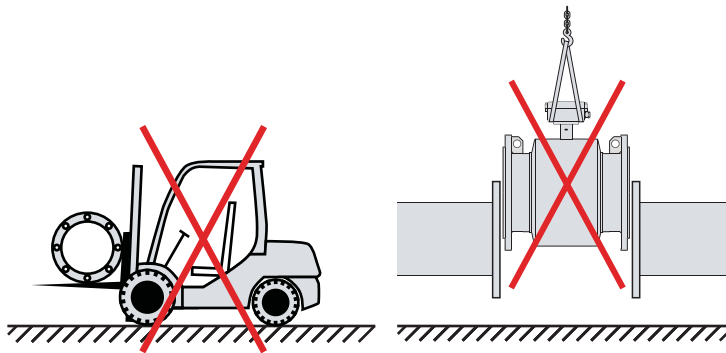

Figure 4-10 Incorrect transportation

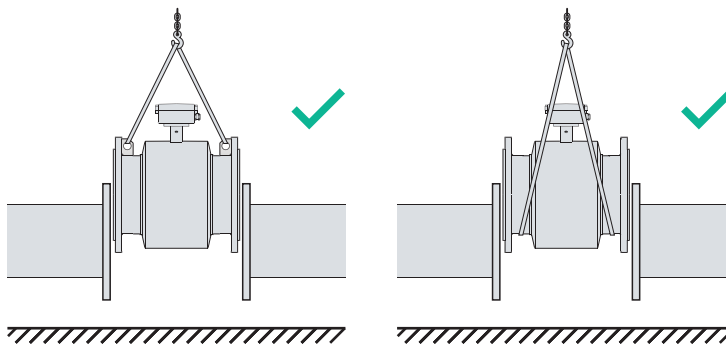

Figure 4-11 Correct transportation

Removing the liner protectors

NOTICE

Sensors with PTFE or PFA liners only

The following information is only relevant for sensor types with PTFE or PFA liners.

Sensors with PTFE liner

At delivery, the sensor is mounted with wooden blanks to hold the liner in place during transportation and storage. Do not remove the blanks until you are ready for installation. After only a few hours without the blanks, the liner creeps back towards its original shape. As a result, the installation is more difficult to carry out.

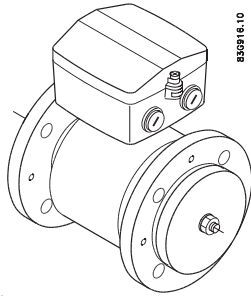

Figure 4-12 Sensor with wooden blanks

Remove the blanks immediately before mounting the sensor

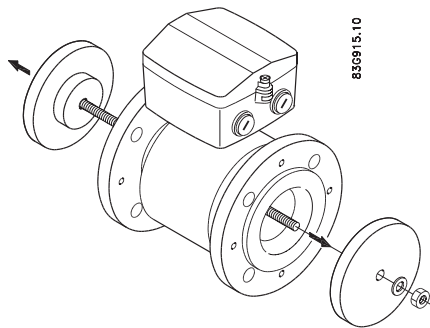

Figure 4-13 Removing wooden blanks

Sensors with PFA liner

NOTICE

Sharp objects can damage the liner

Do not use sharp objects to remove the blanks as this can damage the liner.

At delivery, the sensor is mounted with blanks to protect the liner during transportation and storage.

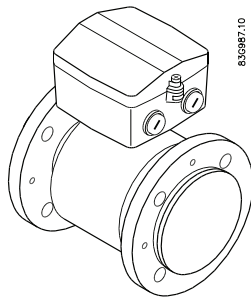

Figure 4-14 Sensor with blanks

Remove the blanks immediately before mounting the sensor

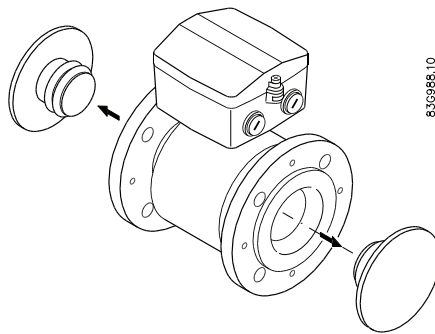

Figure 4-15 Removing blanks

See also

Installing the sensor (Page 31)

4.3.1 Installing the sensor

Before you start

- Consider the installation conditions as described under Determining a location (Page 23).
- Read the safety notes (Page 23).

Gaskets

NOTICE
Devices with a PTFE or PFA liner
Devices with a PTFE or PFA liner do not require additional gaskets.

NOTICE

Gaskets shall not protrude

Ensure the gaskets fit concentrically. Otherwise the flow profile can get distorted.

NOTICE

Devices with hard rubber or soft rubber liner

- Devices with a hard or soft rubber liner always require additional gaskets.
- Siemens recommends using gaskets made from rubber or rubber-like sealing materials.
- Do not scale up the tightening torques to fit your gasket selection. See Torque values (Page 33).

Procedure

Fasten screws according to the torques values below

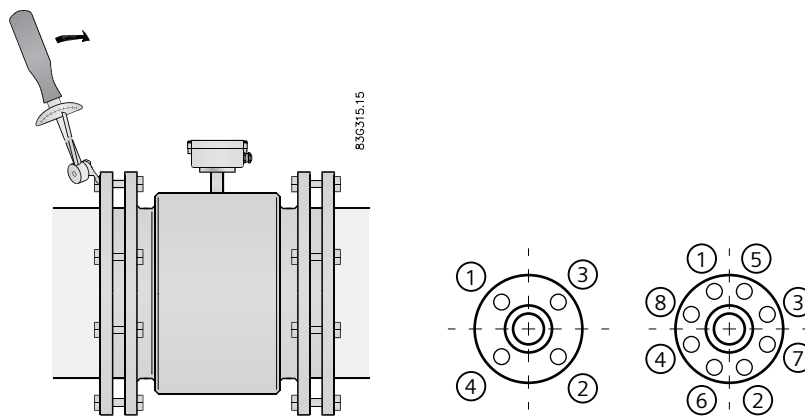

Mounting

Torque sequence

1. Remove the liner protectors, if present. Mounting (Page 28).
2. Position the sensor plane parallel and centered between the pipes.
3. Install gaskets between mating surfaces according to recommendations.
4. Consider the torque values and use appropriate bolts.
5. Tighten the bolts crosswise as shown in the torque sequence. Increase the torque gradually:
 - Tighten the bolts to 50 % of maximum torque.
 - Tighten the bolts to 80 % of maximum torque.
 - Tighten the bolts to maximum torque, but do **NOT** exceed.

4.3.2 Torque values

Torque calculations



CAUTION

Overtightened bolts

Leakage/damage to flowmeter or piping may arise if bolts are overtightened.

All values are theoretical and are calculated on the assumption that:

- All bolts are new and material selection is according to EN 1515-1 table 2.
- Gasket material not exceeding 75 shore A is used between the flowmeter and mating flanges.
- All bolts are galvanized and adequately lubricated.
- Flanges are made of carbon steel.
- Flowmeter and mating flanges are correctly aligned.

Torque values

Note

Conversion to F/Lbs

To convert the torque values from Nm to F/Lbs multiply by 0.74.

Table 4-1 Minimum and maximum torques for EN 1092-1 PN 6 to PN 16 in Nm

Nominal size		EN 1092-1											
		PN 6				PN 10				PN 16			
Liner		PFA, PTFE, Ebonite		Soft rubber, EPDM, Linatex		PFA, PTFE, Ebonite		Soft rubber, EPDM, Linatex		PFA, PTFE, Ebonite		Soft rubber, EPDM, Linatex	
		mm	inch	Min	Max	Min	Max	Min	Max	Min	Max	Min	Max
15	½	-	-	-	-	-	-	-	-	-	-	-	-
25	1	-	-	-	-	-	-	-	-	-	-	-	-
32	1¼	-	-	-	-	-	-	-	-	-	-	-	-
40	1½	-	-	-	-	-	-	-	-	-	-	-	-
50	2	-	-	-	-	-	-	-	-	-	-	-	-
65	2½	3.9	4	3.2	4	-	-	-	-	8.5	9	6.9	7
80	3	6.9	7	5.7	6	-	-	-	-	10.8	11	8.8	9
100	4	10.3	11	8.7	9	-	-	-	-	13.8	14	11.6	12
125	5	6.4	7	5.5	6	-	-	-	-	19.2	20	16.5	17
150	6	8.1	9	7.2	8	-	-	-	-	29.8	31	26.1	27

4.3 Mounting

Nominal size		EN 1092-1											
		PN 6				PN 10				PN 16			
Liner		PFA, PTFE, Ebonite		Soft rubber, EPDM, Linatex		PFA, PTFE, Ebonite		Soft rubber, EPDM, Linatex		PFA, PTFE, Ebonite		Soft rubber, EPDM, Linatex	
mm	inch	Min	Max	Min	Max	Min	Max	Min	Max	Min	Max	Min	Max
200	8	13.0	14	11.7	12	29.3	31	26.2	27	31.2	33	27.9	29
250	10	12.5	13	11.4	12	27.4	29	24.9	26	52.4	55	47.7	50
300	12	21.0	22	19.5	20	36.2	38	33.3	35	72.6	76	66.5	70
350	14	27.3	29	25.1	26	36.9	39	33.7	35	73.5	77	67.0	70
400	16	25.5	27	23.7	25	55.0	58	50.7	53	102.6	108	94.3	99
450	18	31.7	33	29.6	31	53.2	56	49.4	52	102.9	108	95.1	100
500	20	30.3	32	28.5	30	64.0	67	59.8	63	140.7	148	130.6	137
600	24	49.7	52	47.1	49	97.8	103	92.3	97	214.7	225	200.6	211
700	28	55.4	58	52.5	55	111.3	117	104.9	110	213.5	224	201.0	211
750	30	-	-	-	-	-	-	-	-	-	-	-	-
800	32	79.9	84	76.2	80	158.0	166	149.8	157	298.1	313	282.3	296
900	36	98.6	104	94.5	99	166.3	175	158.4	166	313.7	329	298.8	314
1000	40	102.2	107	98.4	103	219.8	231	210.1	221	419.6	441	400.6	421
1050	42	-	-	-	-	-	-	-	-	-	-	-	-
1100	44	-	-	-	-	-	-	-	-	-	-	-	-
1200	48	143.0	150	138.1	145	301.0	316	289.1	304	599.7	630	575.4	604
1400	54	187.5	197	181.5	191	382.8	402	369.2	388	702.1	737	676.9	711
1500	59	212.1	223	206.3	217	437.8	460	424.0	445	-	-	-	-
1600	66	215.7	226	209.4	220	521.6	548	503.8	529	951.2	999	917.5	963
1800	72	270.2	284	263.0	276	586.3	616	568.1	596	1069.0	1122	1035.8	1088
2000	78	326.6	343	318.4	334	657.5	690	638.3	670	1284.4	1349	1246.9	1309
2200	87	363.9	382	-	-	832.4	874	-	-	1423.3	1494	1386.9	1456

Table 4-2 Minimum and maximum torques for EN 1092-1 PN 40 to PN 63 in Nm

Nominal size		EN 1092-1											
		PN 25				PN 40				PN 63			
Liner		PFA, PTFE, Ebonite		Soft rubber, EPDM, Linatex		PFA, PTFE, Ebonite		Soft rubber, EPDM, Linatex		PFA, PTFE, Ebonite		Soft rubber, EPDM, Linatex	
mm	inch	Min	Max	Min	Max	Min	Max	Min	Max	Min	Max	Min	Max
15	½	-	-	-	-	4.7	5	-	-	-	-	-	-
25	1	-	-	-	-	10.7	11	8.0	9	-	-	-	-
32	1¼	-	-	-	-	18.2	19	13.8	14	-	-	-	-
40	1½	-	-	-	-	22.9	24	17.6	19	-	-	-	-
50	2	-	-	-	-	30.3	32	23.9	25	60.2	63	46.5	49
65	2½	-	-	-	-	21.3	22	17.2	18	42.4	45	33.5	35
80	3	-	-	-	-	26.9	28	22.0	23	53.6	56	43.0	45
100	4	-	-	-	-	45.2	47	38.0	40	86.5	91	71.3	75
125	5	-	-	-	-	77.8	82	59.9	63	128.7	135	108.4	114

Nominal size		EN 1092-1											
		PN 25				PN 40				PN 63			
Liner		PFA, PTFE, Ebonite		Soft rubber, EPDM, Linatex		PFA, PTFE, Ebonite		Soft rubber, EPDM, Linatex		PFA, PTFE, Ebonite		Soft rubber, EPDM, Linatex	
mm	inch	Min	Max	Min	Max	Min	Max	Min	Max	Min	Max	Min	Max
150	6	-	-	-	-	94.8	99	82.6	87	190.4	200	163.0	171
200	8	63.2	66	56.1	59	120.0	126	106.1	111	232.3	244	202.4	212
250	10	101.7	107	91.8	96	193.5	203	173.7	182	336.5	353	296.9	312
300	12	105.3	111	95.7	101	203.5	214	184.1	193	352.7	370	314.8	331
350	14	152.6	160	138.6	146	284.5	299	257.4	270	-	-	-	-
400	16	207.4	218	189.9	199	410.4	431	373.4	392	-	-	-	-
450	18	198.9	209	183.5	193	355.4	373	327.5	344	-	-	-	-
500	20	243.3	255	225.4	237	459.8	483	426.1	447	-	-	-	-
600	24	362.1	380	338.6	356	753.0	791	702.2	737	-	-	-	-
700	28	-	-	-	-	-	-	-	-	-	-	-	-
750	30	-	-	-	-	-	-	-	-	-	-	-	-
800	32	-	-	-	-	-	-	-	-	-	-	-	-
900	36	-	-	-	-	-	-	-	-	-	-	-	-
1000	40	-	-	-	-	-	-	-	-	-	-	-	-
1050	42	-	-	-	-	-	-	-	-	-	-	-	-
1100	44	-	-	-	-	-	-	-	-	-	-	-	-
1200	48	-	-	-	-	-	-	-	-	-	-	-	-
1400	54	-	-	-	-	-	-	-	-	-	-	-	-
1500	59	-	-	-	-	-	-	-	-	-	-	-	-
1600	66	-	-	-	-	-	-	-	-	-	-	-	-
1800	72	-	-	-	-	-	-	-	-	-	-	-	-
2000	78	-	-	-	-	-	-	-	-	-	-	-	-
2200	87	-	-	-	-	-	-	-	-	-	-	-	-

Table 4-3 Minimum and maximum torques for EN 1092-1 PN 100 and AS 2129 in Nm

Nominal size		EN 1092-1				AS 2129			
		PN 100				Table E			
Liner		PFA, PTFE, Ebonite		Soft rubber, EPDM, Linatex		PFA, PTFE, Ebonite		Soft rubber, EPDM, Linatex	
mm	inch	Min	Max	Min	Max	Min	Max	Min	Max
15	½	-	-	-	-	1.8	2	-	-
25	1	35.3	37	25.8	27	3.2	4	2.4	3
32	1¼	57.3	60	42.5	45	3.6	4	2.7	3
40	1½	72.3	76	54.5	57	4.8	5	3.7	4
50	2	114.8	121	88.1	93	8.2	9	6.5	7
65	2½	80.5	85	63.6	67	10.5	11	8.6	9
80	3	101.8	107	81.7	86	14.6	15	12.1	13
100	4	155.3	163	127.2	134	11.4	12	9.7	10

4.3 Mounting

Nominal size		EN 1092-1				AS 2129			
		PN 100				Table E			
Liner		PFA, PTFE, Ebonite		Soft rubber, EPDM, Linatex		PFA, PTFE, Ebonite		Soft rubber, EPDM, Linatex	
mm	inch	Min	Max	Min	Max	Min	Max	Min	Max
125	5	229.2	241	191.8	201	16.4	17	14.1	15
150	6	202.9	213	172.4	181	24.8	26	21.8	23
200	8	370.7	389	321.0	337	39.7	42	35.5	37
250	10	586.6	616	516.2	542	40.4	42	36.6	38
300	12	665.6	699	590.0	620	62.0	65	57.0	60
350	14	-	-	-	-	85.7	90	78.1	82
400	16	-	-	-	-	105.9	111	97.4	102
450	18	-	-	-	-	100.9	106	93.1	98
500	20	-	-	-	-	122.2	128	113.4	119
600	24	-	-	-	-	210.9	221	197.4	207
700	28	-	-	-	-	211.0	222	199.6	210
750	30	-	-	-	-	277.4	291	261.6	275
800	32	-	-	-	-	313.4	329	296.4	311
900	36	-	-	-	-	323.2	339	306.9	322
1000	40	-	-	-	-	406.9	427	389.5	409
1050	42	-	-	-	-	-	-	-	-
1100	44	-	-	-	-	-	-	-	-
1200	48	-	-	-	-	444.2	466	426.3	448
1400	54	-	-	-	-	-	-	-	-
1500	59	-	-	-	-	-	-	-	-
1600	66	-	-	-	-	-	-	-	-
1800	72	-	-	-	-	-	-	-	-
2000	78	-	-	-	-	-	-	-	-
2200	87	-	-	-	-	-	-	-	-

Table 4-4 Minimum and maximum torques for ANSI B16.5 in Nm

Nominal size		ANSI B16.5											
		Class 150				Class 300				Class 600			
Liner		PFA, PTFE, Ebonite		Soft rubber, EPDM, Linatex		PFA, PTFE, Ebonite		Soft rubber, EPDM, Linatex		PFA, PTFE, Ebonite		Soft rubber, EPDM, Linatex	
mm	inch	Min	Max	Min	Max	Min	Max	Min	Max	Min	Max	Min	Max
15	½	1.5	2	-	-	3.9	4	-	-	-	-	-	-
25	1	3.1	4	2.5	3	10.0	11	8.0	9	21.0	22	15.6	16
32	1¼	5.0	6	3.9	4	15.9	17	12.5	13	32.9	35	24.4	26
40	1½	6.6	7	5.2	6	24.7	26	19.4	20	50.6	53	38.2	40
50	2	12.7	13	10.0	11	16.5	17	13.1	14	33.7	35	25.9	27
65	2½	16.0	17	13.1	14	24.5	26	20.1	21	50.2	53	39.8	42
80	3	23.5	25	19.3	20	36.0	38	29.7	31	73.2	77	58.9	62

Nominal size		ANSI B16.5											
		Class 150				Class 300				Class 600			
Liner		PFA, PTFE, Ebonite		Soft rubber, EPDM, Linatex		PFA, PTFE, Ebonite		Soft rubber, EPDM, Linatex		PFA, PTFE, Ebonite		Soft rubber, EPDM, Linatex	
mm	inch	Min	Max	Min	Max	Min	Max	Min	Max	Min	Max	Min	Max
100	4	17.6	19	14.9	16	54.1	57	45.6	48	124.2	130	101.8	107
125	5	28.5	30	24.5	26	74.2	78	63.9	67	193.7	203	162.2	170
150	6	38.0	40	33.2	35	66.0	69	57.6	61	172.4	181	146.5	154
200	8	58.1	61	51.9	54	113.5	119	101.2	106	296.1	311	257.6	270
250	10	61.7	65	56.0	59	137.3	144	124.6	131	346.8	364	306.9	322
300	12	84.8	89	77.6	81	211.9	222	194.0	204	381.4	400	340.1	357
350	14	112.6	118	103.7	109	197.9	208	182.2	191	491.1	516	440.6	463
400	16	108.8	114	100.8	106	280.4	294	259.8	273	683.1	717	618.4	649
450	18	157.1	165	145.9	153	300.4	315	279.0	293	942.8	990	857.0	900
500	20	149.9	157	140.1	147	358.3	376	334.8	352	936.2	983	857.0	900
600	24	229.9	241	216.4	227	596.3	626	561.3	589	1478.5	1552	1365.7	1434
700	28	-	-	-	-	-	-	-	-	-	-	-	-
750	30	-	-	-	-	-	-	-	-	-	-	-	-
800	32	-	-	-	-	-	-	-	-	-	-	-	-
900	36	-	-	-	-	-	-	-	-	-	-	-	-
1000	40	-	-	-	-	-	-	-	-	-	-	-	-
1050	42	-	-	-	-	-	-	-	-	-	-	-	-
1100	44	-	-	-	-	-	-	-	-	-	-	-	-
1200	48	-	-	-	-	-	-	-	-	-	-	-	-
1400	54	-	-	-	-	-	-	-	-	-	-	-	-
1500	59	-	-	-	-	-	-	-	-	-	-	-	-
1600	66	-	-	-	-	-	-	-	-	-	-	-	-
1800	72	-	-	-	-	-	-	-	-	-	-	-	-
2000	78	-	-	-	-	-	-	-	-	-	-	-	-
2200	87	-	-	-	-	-	-	-	-	-	-	-	-

Table 4-5 Minimum and maximum torques for AS 4087

Nominal size		AS 4087											
		PN 16				PN 21				PN 35			
Liner		PFA, PTFE, Ebonite		Soft rubber, EPDM, Linatex		PFA, PTFE, Ebonite		Soft rubber, EPDM, Linatex		PFA, PTFE, Ebonite		Soft rubber, EPDM, Linatex	
mm	inch	Min	Max	Min	Max	Min	Max	Min	Max	Min	Max	Min	Max
15	½	-	-	-	-	-	-	-	-	-	-	-	-
25	1	-	-	-	-	-	-	-	-	-	-	-	-
32	1¼	-	-	-	-	-	-	-	-	-	-	-	-
40	1½	-	-	-	-	-	-	-	-	-	-	-	-
50	2	9.4	10	7.5	8	16.2	17	12.8	13	27.0	28	21.3	22
65	2½	12.0	13	9.8	10	11.2	12	9.0	10	18.6	20	15.0	16

4.3 Mounting

Nominal size		AS 4087											
		PN 16				PN 21				PN 35			
Liner		PFA, PTFE, Ebonite		Soft rubber, EPDM, Linatex		PFA, PTFE, Ebonite		Soft rubber, EPDM, Linatex		PFA, PTFE, Ebonite		Soft rubber, EPDM, Linatex	
mm	inch	Min	Max	Min	Max	Min	Max	Min	Max	Min	Max	Min	Max
80	3	16.7	17	13.8	15	14.8	16	12.1	13	24.6	26	20.1	21
100	4	26.1	27	22.1	23	20.3	21	17.0	18	33.8	36	28.4	30
125	5	-	-	-	-	-	-	-	-	-	-	-	-
150	6	23.7	25	20.8	22	31.6	33	27.4	29	52.7	55	45.6	48
200	8	37.7	40	33.6	35	50.7	53	44.6	47	64.0	67	57.5	60
250	10	69.3	73	62.8	66	82.9	87	74.3	78	107.5	113	98.5	103
300	12	60.7	64	55.6	58	83.3	88	75.5	79	108.1	113	100.2	105
350	14	98.0	103	89.3	94	119.8	126	108.6	114	164.3	173	150.9	158
400	16	121.0	127	111.4	117	120.2	126	109.8	115	174.0	183	160.4	168
450	18	153.7	161	141.9	149	163.3	171	150.1	158	234.8	247	218.1	229
500	20	139.7	147	129.6	136	167.1	175	154.2	162	245.0	257	228.0	239
600	24	218.0	229	203.9	214	244.6	257	227.9	239	361.8	380	340.0	357
700	28	217.9	229	206.0	216	-	-	-	-	-	-	-	-
750	30	-	-	-	-	-	-	-	-	-	-	-	-
800	32	358.2	376	338.8	356	-	-	-	-	-	-	-	-
900	36	369.4	388	350.8	368	-	-	-	-	-	-	-	-
1000	40	427.2	449	408.5	429	-	-	-	-	-	-	-	-
1050	42	-	-	-	-	-	-	-	-	-	-	-	-
1100	44	-	-	-	-	-	-	-	-	-	-	-	-
1200	48	465.9	489	446.7	469	-	-	-	-	-	-	-	-
1400	54	-	-	-	-	-	-	-	-	-	-	-	-
1500	59	-	-	-	-	-	-	-	-	-	-	-	-
1600	66	-	-	-	-	-	-	-	-	-	-	-	-
1800	72	-	-	-	-	-	-	-	-	-	-	-	-
2000	78	-	-	-	-	-	-	-	-	-	-	-	-
2200	87	-	-	-	-	-	-	-	-	-	-	-	-

Table 4-6 Minimum and maximum torques for JIS B2220 and AWWA C-207 in Nm

Nominal size		JIS B2220								AWWA C-207			
		10K				20K				Class D			
Liner		PFA, PTFE, Ebonite		Soft rubber, EPDM, Linatex		PFA, PTFE, Ebonite		Soft rubber, EPDM, Linatex		PFA, PTFE, Ebonite		Soft rubber, EPDM, Linatex	
mm	inch	Min	Max	Min	Max	Min	Max	Min	Max	Min	Max	Min	Max
15	½	2.2	3	-	-	5.2	6	-	-	-	-	-	-
25	1	4.7	5	3.5	4	11.5	12	8.6	9	-	-	-	-
32	1¼	6.0	7	4.6	5	14.7	15	11.1	12	-	-	-	-
40	1½	6.8	7	5.2	6	16.5	17	12.7	13	-	-	-	-
50	2	9.4	10	7.4	8	11.4	12	9.0	10	-	-	-	-

Nominal size		JIS B2220								AWWA C-207			
		10K				20K				Class D			
Liner		PFA, PTFE, Ebonite		Soft rubber, EPDM, Linatex		PFA, PTFE, Ebonite		Soft rubber, EPDM, Linatex		PFA, PTFE, Ebonite		Soft rubber, EPDM, Linatex	
mm	inch	Min	Max	Min	Max	Min	Max	Min	Max	Min	Max	Min	Max
65	2½	13.4	14	10.9	11	16.3	17	13.2	14	-	-	-	-
80	3	7.8	8	6.4	7	26.0	27	21.3	22	-	-	-	-
100	4	11.0	12	9.3	10	37.4	39	31.5	33	-	-	-	-
125	5	19.5	20	16.8	18	60.3	63	51.6	54	-	-	-	-
150	6	26.1	27	22.9	24	32.5	34	28.2	30	-	-	-	-
200	8	26.0	27	23.3	25	45.4	48	40.4	42	-	-	-	-
250	10	43.3	45	39.3	41	77.1	81	69.2	73	-	-	-	-
300	12	41.2	43	38.1	40	74.8	79	68.1	71	-	-	-	-
350	14	52.0	55	47.9	50	116.4	122	106.0	111	-	-	-	-
400	16	74.6	78	69.0	72	146.2	154	134.3	141	-	-	-	-
450	18	73.9	78	68.7	72	149.2	157	137.5	144	-	-	-	-
500	20	89.6	94	83.7	88	179.0	188	165.9	174	-	-	-	-
600	24	129.4	136	121.9	128	241.4	253	225.7	237	-	-	-	-
700	28	-	-	-	-	-	-	-	-	124.1	130	116.9	123
750	30	-	-	-	-	-	-	-	-	139.4	146	131.7	138
800	32	-	-	-	-	-	-	-	-	188.4	198	178.3	187
900	36	-	-	-	-	-	-	-	-	204.2	214	194.1	204
1000	40	-	-	-	-	-	-	-	-	222.8	234	212.3	223
1050	42	-	-	-	-	-	-	-	-	246.8	259	233.7	245
1100	44	-	-	-	-	-	-	-	-	241.4	254	230.7	242
1200	48	-	-	-	-	-	-	-	-	257.7	271	246.8	259
1400	54	-	-	-	-	-	-	-	-	373.4	392	360.8	379
1500	59	-	-	-	-	-	-	-	-	388.6	408	374.0	393
1600	66	-	-	-	-	-	-	-	-	471.5	495	452.6	475
1800	72	-	-	-	-	-	-	-	-	480.8	505	464.1	487
2000	78	-	-	-	-	-	-	-	-	592.6	622	575.3	604
2200	87	-	-	-	-	-	-	-	-	802.5	843	-	-

4.4 Potential equalization

To obtain optimum results from the measuring system, the sensor must have the same electrical potential as the liquid being measured.

This is achieved by means of built-in grounding electrodes.

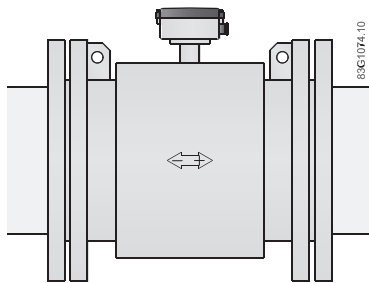

Figure 4-16 Potential equalization with earthing electrodes

Cathodic protected piping

Special attention must be paid to systems with cathodic protection.

⚠ WARNING

Use in hazardous area!

Cathodic protection is not allowed in hazardous areas

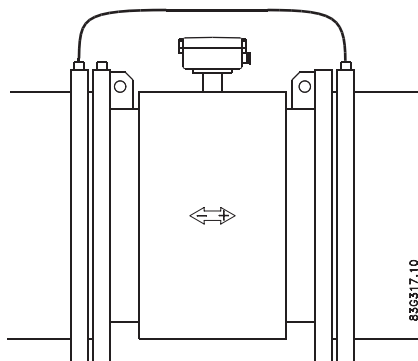

Figure 4-17 Cathodic protection

- Isolate the sensor from cathodic protected pipes using insulated bolts.
- Use bypass cable between the mating flanges

Note

Remote mounted sensor versions

If the above is not acceptable, remote mounted sensors can alternatively be connected as follows:

- Connect coil current cable shield at sensor end via a 1.5 μ F condensator
- Make sure that electrode cable shield is not connected at both ends

4.5 Installation with grounding rings

NOTICE

Only sensors with PTFE or PFA liners without grounding electrodes

Installation with grounding rings is only relevant for sensors with PTFE or PFA liners

- Mount grounding rings where necessary on non-conductive pipes.

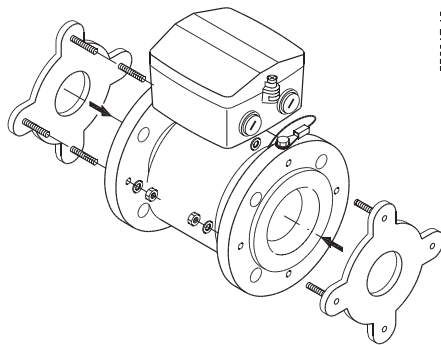

Installation with grounding rings on sensors with PTFE liner

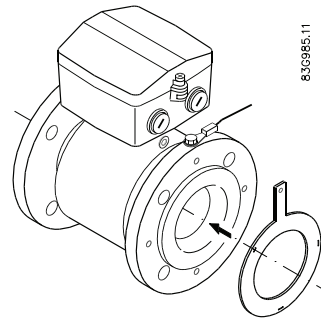

Installation with flat grounding rings on sensors with PFA liner

Note

Potential equalization

For potential equalization one grounding ring is sufficient.

By unidirectional flow it is recommended to mount the grounding ring on the inlet side.

- Connect the grounding rings to the sensor with the enclosed grounding straps.

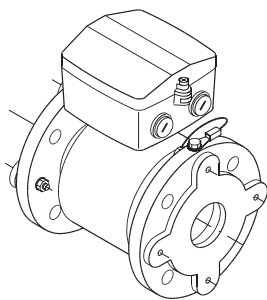

Groundingstrap connection on type E grounding rings

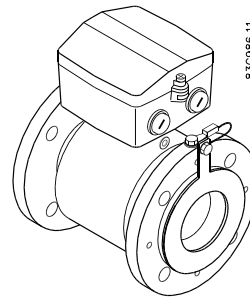

Grounding strap connection on flat grounding rings

Note

Abrasive liquids

In special cases the grounding rings can work as inlet protection.

NOTICE

High temperature sensors

High temperature sensors are delivered with two factory mounted grounding rings. No further action need to be taken for potential equalisation.

Connecting

The following contains a short description of how to connect a remote mounted sensor to transmitter types:

- SITRANS F M MAG 5000 / 6000 (standard versions)
- SITRANS F M MAG 6000 19" with Safety barrier
- SITRANS F M MAG 6000 I Ex de

For more information, for example about wiring of power supply and outputs, refer to the operating instructions for the respective transmitters.

Before connecting

- Check that the serial numbers on the sensor and the SENSORPROM® unit are identical.

5.1 General safety requirements

<p> WARNING</p> <p>The pertinent regulations must be observed for electrical installation.</p> <ul style="list-style-type: none"> • Never install the device with the mains voltage switched on! • Danger of electric shock! • The electrodes and magnetic current line may only be connected when the device is not connected to the power supply. • If the housing is under voltage (power supply), the cover may be unscrewed by qualified personnel only.
--

<p> WARNING</p> <p>Mains supply from building installation Class II</p> <p>A switch or circuit breaker (max. 15 A) must be installed in close proximity to the equipment and within easy reach of the operator. It must be marked as the disconnecting device for the equipment.</p>

Note

Hazardous area applications

Special requirements apply to the location and interconnection of sensor and transmitter. See Installation in hazardous locations (Page 14).

5.1 General safety requirements

 WARNING
Terminal box Before opening the terminal box check that: <ul style="list-style-type: none">• No explosion hazard exists• All connection leads are potential free

 WARNING
Grounding The mains protective earth wire must be connected to the PE terminal in accordance with the diagram (class 1 power supply)
Mechanical counters When mounting a mechanical counter to terminals 57 and 58 (active output), a 1000 µF capacitor must be connected to terminals 56 and 58. Capacitor + is connected to terminal 56 and capacitor - to terminal 58.
Output cables If long cables are used in electrically noisy environments, it is recommended to use screened cables.
Electrode cables Dotted connections are only to be made when using special electrode cables.

 WARNING
National requirements Observe country-specific installation directives for field wiring.

Cable specifications

- Only use cables with at least the same degree of protection as the sensor to install the sensor.
- The line length from the cable gland to the terminals must be kept as short as possible. Line loops in the terminal box must be avoided.
- To guarantee the IP67 degree of protection, use cables with the required specifications.

 WARNING
Protective conductor terminal The required cable is min. AGW16 or 1.5 mm ² Cu.

 WARNING
Wire insulation For field wiring installation: Ensure that the national requirements of the country in which the flowmeters are installed is met.

See also

Cable data (Page 79)

5.2 Remote installation

Note

Remote installation only

The following applies to remote installation of MAG 5000 / 6000 or MAG 6000 I.

1. Unscrew and remove terminal box lid.

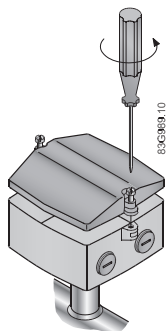

2. Mount the two terminal blocks as shown and insert electrode cable plug ① (terminals 82, 0 and 83) and coil cable plug ② (terminals 85 and 86).
 Terminals electrode cable: 82, 0 and 83
 Terminals special electrode cable: 84, 83, 0, 82 and 81
 Terminals coil cable: 85; 86

Note

Special electrode cable

Special electrode cable must be connected to terminals 84, 83, 0, 82 and 81.

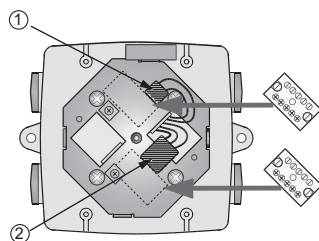
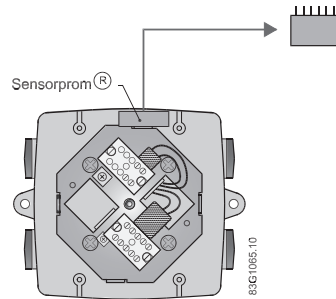

Figure 5-1 Terminal box without blocks

3. Remove SENSORPROM® unit from sensor and mount it on connection plate in transmitter, see relevant transmitter operating instructions.



4. Fit the 1/2" NPT or M20 cable glands for supply and output cables.

5. Fit and connect electrode and coil cables as shown below.

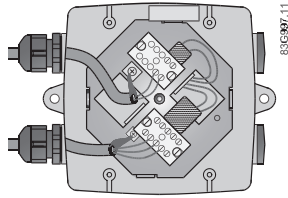

Power supply
Transmitter

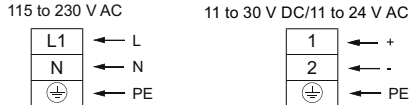

Outputs

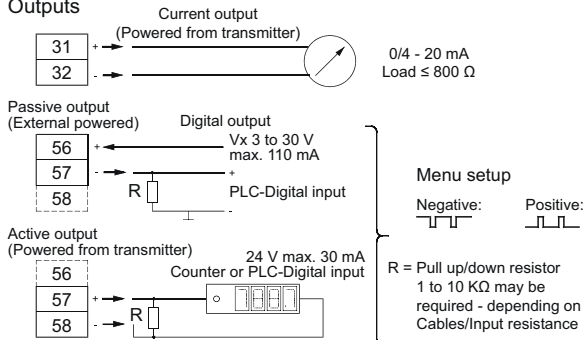

Relay output

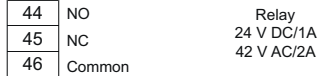

Digital input

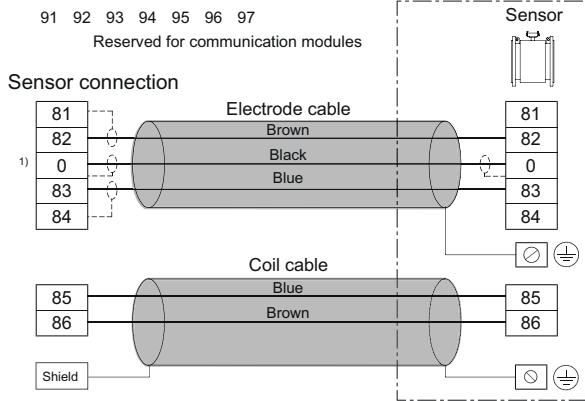
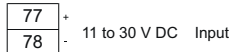

1) Note:
Special cable with individual wire shields (shown as dotted lines) are only required when using empty pipe function or long cables.

⚠ CAUTION
Unscreened cable ends Keep unscreened cable ends as short as possible.
⚠ CAUTION
Prevent interference Separate electrode and coil cables to prevent interference.
⚠ WARNING
Use in hazardous area Connect mains protective earth to the PE terminal in accordance with the above diagram in order to obtain potential equalization.

6. Tighten cable glands well to obtain optimum sealing. The cable entry gasket must obtain firm contact with the cable.

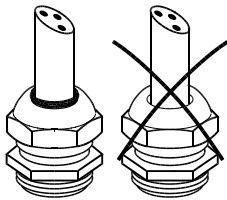

7. Remount terminal box lid.

Note

Tightening torque

Tighten the bolts with 0.5 Nm.

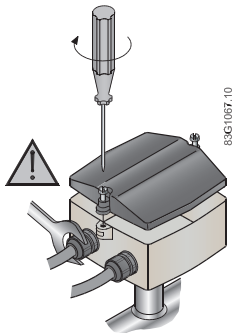

5.3 Installation check

The meter is now ready to go into normal operation - for commissioning and setting of parameters refer to the relevant transmitter manual.

Before commissioning it must be checked that:

- The device has been installed and connected in accordance with the guidelines provided previous in this chapter and in Installing/Mounting (Page 23).

5.4 Potting

If sensor is buried or permanently submerged, terminal box must be encapsulated with silicon dielectric gel (non-toxic, transparent and self-healing gel).

NOTICE

Electrical connections

Do **not** pot meter before electrical connections have been made.

- Mix the two components of the potting kit well and pour into terminal box.
- Let cure for approximately 24 hours at approximately 25°C (77°F). Curing time increases by 100% per -10°C (-18°F).

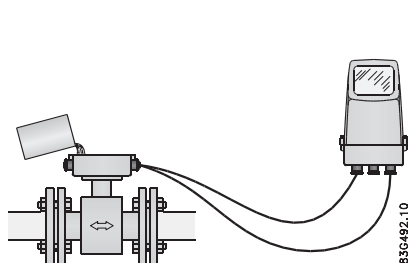

Horizontal orientation

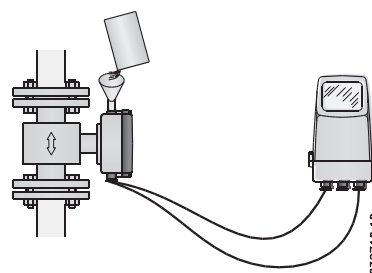

Vertical orientation

Note

Gel can be penetrated with test instruments or be removed in case of cable replacement.

Service and maintenance

6.1 Maintenance

The device is maintenance-free. However, a periodic inspection according to pertinent directives and regulations must be carried out.

An inspection can include check of:

- Ambient conditions
- Seal integrity of the process connections, cable entries, and cover screws
- Reliability of power supply, lightning protection, and grounds

NOTICE
Repair and service must be carried out by Siemens authorized personnel only.

Note

Siemens defines flow sensors as non-repairable products.

6.2 Recalibration

Siemens Process Instrumentation offers to recalibrate the sensor. The following calibration types are offered as standard:

- Standard matched pair calibration
- Customer-specified calibration
- Accredited Siemens ISO/IEC 17025 calibration

Note

For recalibration the SENSORPROM unit must always be returned with the sensor.

6.3 Transportation and storage

To guarantee sufficient protection during transport and storage, observe the following:

- Keep the original packaging for subsequent transportation.
- Devices/replacement parts should be returned in their original packaging.
- If the original packaging is no longer available, ensure that all shipments are properly packaged to provide sufficient protection during transport. Siemens cannot assume liability for any costs associated with transportation damages.

 CAUTION
Insufficient protection during storage
The packaging only provides limited protection against moisture and infiltration.
<ul style="list-style-type: none">• Provide additional packaging as necessary.

Special conditions for storage and transportation of the device are listed in Technical data (Page 73).

6.4 Repair

 WARNING
Impermissible repair of explosion protected devices
Risk of explosion in hazardous areas
<ul style="list-style-type: none">• Repair must be carried out by Siemens authorized personnel only.

 WARNING
Impermissible accessories and spare parts
Risk of explosion in areas subject to explosion hazard.
<ul style="list-style-type: none">• Only use original accessories or original spare parts.• Observe all relevant installation and safety instructions described in the instructions for the device or enclosed with the accessory or spare part.

6.5 Ordering of spare parts

Condition

- You have a Siemens Industry Mall account.

Procedure

1. Open the Process instrumentation catalog (<https://www.siemens.com/processinstrumentation/catalogs>).
2. Select the desired language.
3. To find spare parts for your device, do one of the following:
 - Enter the complete order number of your device (e.g. 7ME4633-4KA51-8DC3-Z A05+B11+E06+F11) into the "Product number" field and click "Go".
 - Enter the serial number of your device (e.g. N1KXXXXXXX) in the "Serial number" field and click "Go".
 - If you do not know the product or serial number, search for your device under "Product family".
4. Navigate to the "Spare parts" tab.
You see the list of spare parts available for your device.

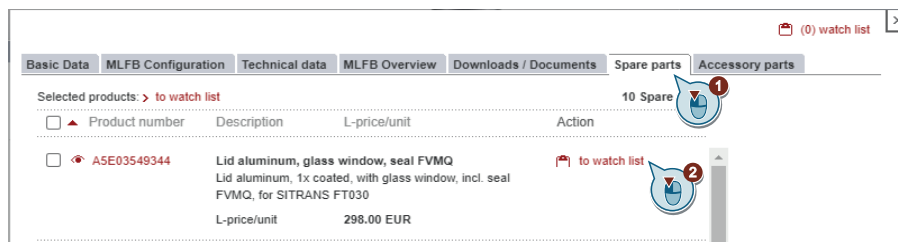

5. Select a spare part and add it to your watch list.
The watch list opens.
6. Click "Add to cart of Industry Mall".

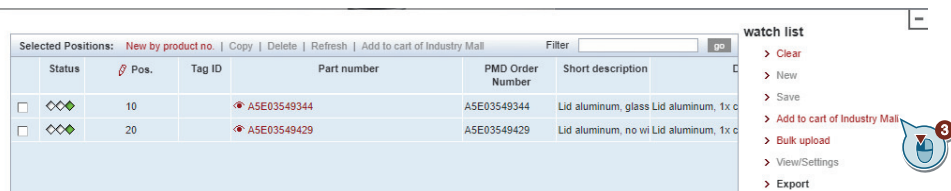

The Siemens Industry Mall opens and you can order your spare part.

To return a product to Siemens, see Returns to Siemens (www.siemens.com/returns-to-siemens).

Contact your Siemens representative to clarify if a product is repairable, and how to return it. They can also help with quick repair processing, a repair cost estimate, or a repair report/cause of failure report.

NOTICE

Decontamination

The product may have to be decontaminated before it is returned. Your Siemens contact person will let you know for which products this is required.

Troubleshooting/FAQs

7.1 Sensor check

Requirement

To check the SITRANS FM sensors the following test instruments will be required:

- Digital Meter/Multimeter
- Megger
- (Moving Coil Meter)

Sensor check

Remove the transmitter from the sensor or remote position before making the following checks.

Coil resistance check

- Measure the coil resistance between connection numbers 85 and 86 using a digital meter. Resistance should be within range stated in Coil resistance table (Page 59).

A low reading may indicate moisture within the coil housing or shorted coil turns.

A high reading would indicate an open circuit coil.

Note

In case of deviation from nominal coil values, the sensor is damaged and must be replaced

Coil insulation check

 WARNING
Potential hazard!
Only carry out a coil insulation check in non-hazardous area!

- Megger between connection number 85 and the sensor body. The resistance should be above 20 MΩ.

A low megger reading would indicate the coil insulation is breaking down. This is normally due to fluid ingress into the coil housing.

Sensors with an insulation resistance down to 1 MΩ may still work satisfactorily but this is not guaranteed.

7.2 Fluctuating process values

Electrode resistance check

- Measure the electrode resistance between connections 82 and 0 with a moving coil meter. With a sensor full of fluid the resistance should be between 5 K Ω and 50 K Ω . If the sensor is empty the resistance will be infinite.
- Repeat the resistance measurements between connections 83 and 0. The results should be the same.

If the resistance is low there may be a short on the electrodes or wiring (in the case of a remote mounted transmitter). Alternatively there may be water ingress or moisture in the terminal box.

If the resistance is high and the pipe is completely full of fluid check the following:

1. Fluid is electrically conductive.
2. Electrodes are not coated with grease or any deposit.
3. Electrode circuit is not open.
4. Remote mounted transmitter has a 3 core cable with an overall shield continuously from sensor to transmitter, including junction boxes and terminal rails inside panels.
5. Shield is connected to 0 or to earth terminal (PE) on sensor.

Note

Sensors removed from line

For sensors removed from line with dry bore, use megger between terminal 82 and compression plate, and 83 and compression plate to show any water ingress behind electrodes or within enclosure.

7.2 Fluctuating process values

Question

Why do the displayed process values fluctuate when the electrode cable is moved?

Answer

There are several causes of the fluctuating process values:

- Deposits on electrodes
 - Clean the electrodes.
- Defect electrode cable
 - Replace the cable
- Incorrect cable connection
 - Connect the electrode cable (82, 83, 0 and shield) according to the instructions in Connecting (Page 43)

Note

Vibrating environments

It is recommended to use special low noise cables for sensor sizes DN 2 and DN 3 installed in vibrating environments.

Dimension drawings

8.1 Dimensions and weight

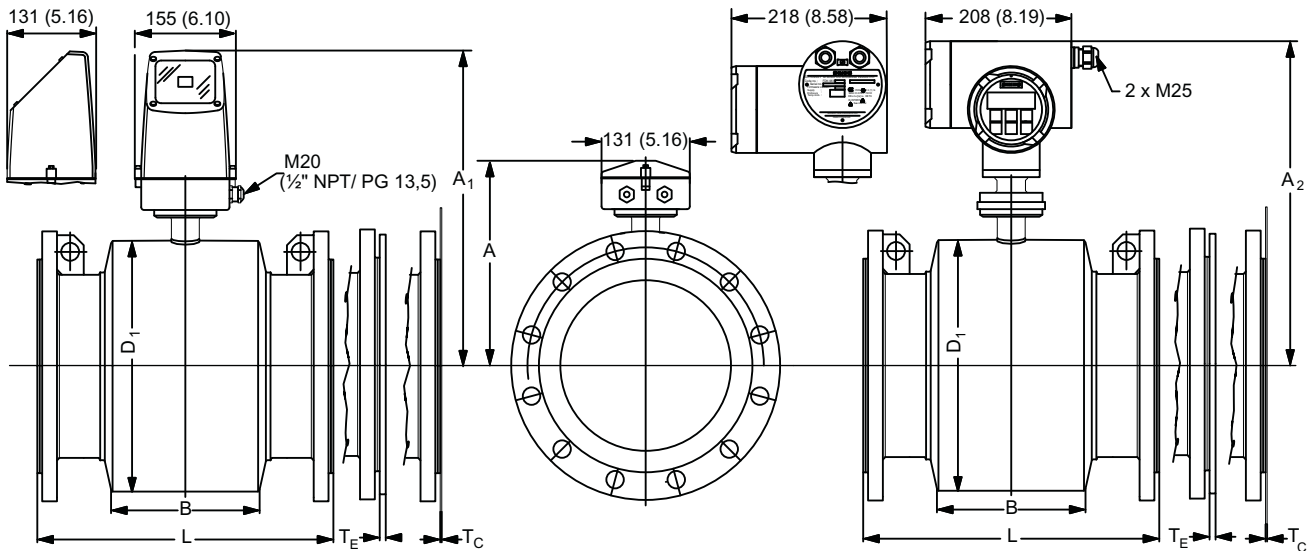

Table 8-1 Dimensions

Nominal size		A ¹⁾		A ₁ /A ₂ ⁸⁾		B		D ₁	
mm	inch	mm	inch	mm	inch	mm	inch	mm	inch
15	½	187	7.4	341/338	13.4	59	2.4	104	4.1
25	1	187	7.4	341/338	13.4	59	2.4	104	4.1
32	1¼	193	7.6	346/336	13.6	86	3.4	114	4.5
40	1½	197	7.8	351/348	13.7	82	3.3	124	4.9
50	2	205	8.1	359/356	14.1	72	2.9	139	5.5
65	2½	212	8.3	366/363	14.3	72	2.9	154	6.1
80	3	222	8.7	376/373	14.7	72	2.9	174	6.9
100	4	242	9.5	396/393	15.5	85	3.4	214	8.5
125	5	255	10.0	409/406	16	85	3.4	239	9.5
150	6	276	10.9	430/427	16.9	85	5.4	282	11.1
200	8	304	12.0	458/455	18	137	5.4	338	13.4
250	10	332	13.1	486/483	19.1	157	6.2	393	15.5
300	12	357	14.1	511/508	20.0	157	6.2	444	17.5
350	14	362	14.3	516/513	20.2	270	10.7	451	17.8
400	16	387	15.2	541/538	21.2	270	10.7	502	19.8
450	18	418	16.5	572/569	22.4	310	12.2	563	22.2
500	20	443	17.4	597/594	23.4	350	13.8	614	24.2
600	24	494	19.4	648/645	25.4	320	12.6	715	28.2

Dimension drawings

8.1 Dimensions and weight

Nominal size		A ¹⁾		A ₁ /A ₂ ⁸⁾		B		D ₁	
mm	inch	mm	inch	mm	inch	mm	inch	mm	inch
700	28	544	21.4	698/695	27.4	450	17.8	816	32.2
750	30	571	22.5	725/722	28.5	556	21.9	869	34.3
800	32	606	23.9	760/757	30.0	560	22.1	927	36.5
900	36	653	25.7	807/804	31.7	630	24.9	1032	40.7
1000	40	704	27.7	858/855	35.7	670	26.4	1136	44.8
1050	42	704	27.7	858/855	35.7	670	26.4	1136	44.8
1100	44	755	29.7	904/901	35.7	770	30.4	1238	48.8
1200	48	810	31.9	964/961	37.9	792	31.2	1348	53.1
1400	54	925	36.4	1079/1076	42.4	1000	39.4	1574	66.0
1500	60	972	38.2	1126/1123	44.3	1020	40.2	1672	65.9
1600	66	1025	40.4	1179/1176	46.3	1130	44.5	1774	75.4
1800	72	1123	44.2	1277/1274	50.2	1250	49.3	1974	77.8
2000	78	1223	48.1	1377/1374	55.0	1375	54.2	2174	85.6

¹⁾:14.5 mm shorter with AISI terminal box (Ex and high temperature version)

Table 8-2 Built-in lengths

Nominal size		L ²⁾											
		EN 1092-1-201											
		PN 6 / PN 10		PN 16 / PN 16 non-PED		PN 25		PN 40		PN 63		PN 100	
mm	inch	mm	inch	mm	inch	mm	inch	mm	inch	mm	inch	mm	inch
15	1	-	-	-	-	-	-	200	7.9	-	-	-	-
25	1	-	-	-	-	-	-	200	7.9	-	-	260	10.3
32	1¼	-	-	-	-	-	-	200	7.9	-	-	280	11.1
40	1½	-	-	-	-	-	-	200	7.9	-	-	280	11.1
50	2	-	-	-	-	-	-	200	7.9	276	10.9	300	11.9
65	2½	200	7.9	200 / -	7.9 / -	-	-	200	7.9	320	12.6	350	13.8
80	3	200	7.9	200 / -	7.9 / -	-	-	272	10.8	323	12.8	340	13.4
100	4	250	9.8	250 / -	9.8 / -	-	-	250	9.9	380	15.0	400	-
125	5	250	9.8	250 / -	9.8 / -	-	-	250	9.9	420	16.6	450	-
150	6	300	11.8	300 / -	11.8 / -	-	-	300	11.9	415	16.4	450	-
200	8	350	13.8	350 / -	13.8 / -	350	13.8	350	13.8	480	18.9	530	-
250	10	450	17.7	450 / -	17.7 / -	450	17.7	450	17.8	550	-	620	-
300	12	500	19.7	500 / -	19.7 / -	500	19.7	500	19.7	600	-	680	-
350	14	550	21.7	550 / -	21.7 / -	550	21.7	550	21.7	-	-	-	-
400	16	600	23.6	600 / -	23.6 / -	600	23.6	600	23.7	-	-	-	-
450	18	600	23.6	600 / -	23.6 / -	600	23.6	600	23.7	-	-	-	-

Nominal size		L ²⁾											
		EN 1092-1-201											
		PN 6 / PN 10		PN 16 / PN 16 non-PED		PN 25		PN 40		PN 63		PN 100	
mm	inch	mm	inch	mm	inch	mm	inch	mm	inch	mm	inch	mm	inch
500	20	600	23.6	600 / -	23.6 / -	625		680	26.8	-	-	-	-
600	24	600	23.6	600 / -	23.6 / -	750	30	800	31.5	-	-	-	-
700	28	700	27.6	875 / 700	31.5 / 27.6	800	31.5	-	-	-	-	-	-
750	30	-	-	-	-	-	-	-	-	-	-	-	-
800	32	800	31.5	1000 / 800	39.4 / 31.5	900	35.4	-	-	-	-	-	-
900	36	900	35.4	1125 / 900	49.2 / 35.4	1000	39.4	-	-	-	-	-	-
1000	40	1000	39.4	1250 / 1000	49.2 / 39.4	1100	43.4	-	-	-	-	-	-
1050	42	-	-	-	-	-	-	-	-	-	-	-	-
1100	44	-	-	-	-	-	-	-	-	-	-	-	-
1200	48	1200	47.2	1500 / 1200	59.1 / 47.2	1300	51.2	-	-	-	-	-	-
1400	54	1400	55.1	- / 1400	- / 55.1	-	-	-	-	-	-	-	-
1500	60	1500	59.1	- / 1500	- / 59.1	-	-	-	-	-	-	-	-
1600	66	1600	63.0	- / 1600	- / 63.0	-	-	-	-	-	-	-	-
1800	72	1800	70.9	- / 1800	- / 70.9	-	-	-	-	-	-	-	-
2000	78	2000	78.7	- / 2000	- / 78.7	-	-	-	-	-	-	-	-

2): When earthing flanges are used, the thickness of the earthing flange must be added to the built-in length

Table 8-3 Built-in lengths

Nominal size		L ³⁾											
		ANSI 16.5 Class 150		ANSI 16.5 Class 300		AS 2129 E AS 4087 PN 16, 21, 35		AWWA C-207 Class D		JIS K10		JIS K20	
		mm	inch	mm	inch	mm	inch	mm	inch	mm	inch	mm	inch
15	1	200	7.9	200	7.9	200	7.9	-	-	200	7.9	200	7.9
25	1	200	7.9	200	7.9	200	7.9	-	-	200	7.9	200	7.9
32	1¼	200	7.9	200	7.9	200	7.9	-	-	200	7.9	240	9.5
40	1½	200	7.9	200	7.9	200	7.9	-	-	200	7.9	240	9.5
50	2	200	7.9	200	7.9	200	7.9	-	-	200	7.9	240	9.5
65	2½	200	7.9	272	10.8	200	7.9	-	-	200	7.9	272	10.7
80	3	272	10.8	272	10.8	200 ⁴⁾	7.9	-	-	200 ⁸⁾	7.9	272 ⁸⁾	10.7

8.1 Dimensions and weight

Nominal size		L ³											
		ANSI 16.5 Class 150		ANSI 16.5 Class 300		AS 2129 E AS 4087 PN 16, 21, 35		AWWA C-207 Class D		JIS K10		JIS K20	
mm	inch	mm	inch	mm	inch	mm	inch	mm	inch	mm	inch	mm	inch
100	4	250	9.9	310	12.2	250	9.9	-	-	250	9.9	310	12.2
125	5	250	9.9	335	13.1	250	9.9	-	-	250	9.9	335	13.2
150	6	300	11.8	300	11.9	300	11.9	-	-	300	11.9	300	11.9
200	8	350	13.8	350	13.8	350	13.8	-	-	350	13.8	350	13.8
250	10	450	17.7	450	17.8	450	17.8	-	-	450	17.8	450	17.8
300	12	500	19.7	500	19.7	500	19.7	-	-	500	19.7	500	19.7
350	14	550	21.7	550	21.7	550	21.7	-	-	550	21.7	550	21.7
400	16	600	23.7	600	23.7	600	23.7	-	-	600	23.7	600	23.7
450	18	600	23.7	640	23.7	600	23.7	-	-	600	23.7	640	25.2
500	20	600	23.7	730	28.7	600 ⁵⁾	23.7	-	-	600	23.7	680	26.8
600	24	600	23.7	860	33.8	600 ⁶⁾	23.7	-	-	600	23.7	800	31.5
700	28	700	31.5	-	-	700 ⁷⁾	27.6	700	27.6	-	-	-	-
750	30	950	37.4	-	-	750 ⁷⁾	29.6	750	29.6	-	-	-	-
800	32	900	35.5	-	-	800 ⁷⁾	31.5	800	31.5	-	-	-	-
900	36	1100	43.4	-	-	900 ⁷⁾	35.5	900	35.5	-	-	-	-
1000	40	1100	43.4	-	-	1000 ⁷⁾	39.4	1000	39.4	-	-	-	-
1050	42	-	-	-	-	-	-	1000	39.4	-	-	-	-
1100	44	-	-	-	-	-	-	1100	43.4	-	-	-	-
1200	48	1400	55.2	-	-	1200 ⁷⁾	47.3	1200	47.3	-	-	-	-
1400	54	-	-	-	-	-	-	1400	55.2	-	-	-	-
1500	60	-	-	-	-	-	-	1500	59.1	-	-	-	-
1600	66	-	-	-	-	-	-	1600	63.0	-	-	-	-
1800	72	-	-	-	-	-	-	1800	70.9	-	-	-	-
2000	78	-	-	-	-	-	-	2000	78.8	-	-	-	-

³⁾: When earthing flanges are used, the thickness of the earthing flange must be added to the built-in length

⁴⁾: PN 35 DN 80 = 272 mm (not according to ISO 13359)

⁵⁾: PN 35 DN 500 = 680 mm

⁶⁾: PN 35 DN 600 = 750 mm

⁷⁾: Not AS 4087 PN 21 or PN 35

Table 8-4 Grounding rings

Nominal size		T _c ³⁾		T _e ³⁾		T _F ³⁾		Wgt. ⁴⁾	
mm	inch	mm	inch	mm	inch	mm	inch	kg	lbs
15	1	--	0.1	6	0.3	2	0.1	4	9
25	1	1.2	0.1	6	0.3	2	0.1	5	11
32	1¼	1.2	0.1	6	0.3	2	0.1	7	15

Nominal size		T _C ³⁾		T _E ³⁾		T _F ³⁾		Wgt. ⁴⁾	
mm	inch	mm	inch	mm	inch	mm	inch	kg	lbs
40	1½	1.2	0.1	6	0.3	2	0.1	8	17
50	2	1.2	0.1	6	0.3	2	0.1	9	20
65	2½	1.2	0.1	6	0.3	2	0.1	11	24
80	3	1.2	0.1	6	0.3	2	0.1	12	26
100	4	1.2	0.1	6	0.3	2	0.1	16	35
125	5	1.2	0.1	6	0.3	2	0.1	19	42
150	6	1.2	0.1	6	0.3	2	0.1	27	60
200	8	1.2	0.1	8	0.3	2	0.1	40	88
250	10	1.2	0.1	8	0.4	2	0.1	60	132
300	12	1.6	0.1	8	0.4	2	0.1	80	176
350	14	1.6	0.1	8	0.4	-	-	110	242
400	16	1.6	0.1	10	0.4	-	-	125	275
450	18	1.6	0.1	10	0.4	-	-	175	385
500	20	1.6	0.1	10	0.4	-	-	200	440
600	24	1.6	0.1	10	0.4	-	-	287	633
700	28	2.0	0.1	-	-	-	-	330	728
750	30	2.0	0.1	-	-	-	-	360	794
800	32	2.0	0.1	-	-	-	-	450	992
900	36	2.0	0.1	-	-	-	-	530	1168
1000	40	2.0	0.1	-	-	-	-	660	1455
1050	42	2.0	0.1	-	-	-	-	660	1455
1100	44	2.0	0.1	-	-	-	-	1140	2513
1200	48	2.0	0.1	-	-	-	-	1180	2601
1400	54	2.0	0.1	-	-	-	-	1600	3528
1500	60	3.0	0.1	-	-	-	-	2460	5423
1600	66	3.0	0.1	-	-	-	-	2525	5566
1800	72	3.0	0.1	-	-	-	-	2930	6460
2000	78	3.0	0.1	-	-	-	-	3665	8080

³⁾: T_C = Type C grounding ring

T_E = Type E grounding ring (included and factory-mounted on high-temperature 180 °C PTFE sensor)

T_F = Flat type grounding rings

⁴⁾: Weights are approx. (for PN 16) without transmitter

Dimension drawings

8.1 Dimensions and weight

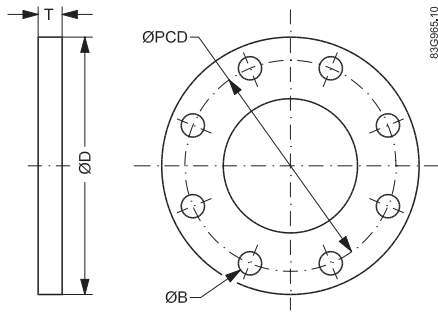

Figure 8-1 Flange mating dimensions

Table 8-5 Flange mating dimensions (metric) for 7ME6520

DN mm	Dimensions (mm)				Bolting	
	D	PCD	T	B	Holes	Bolts
PN10						
200	340	295	24	22	8	M20
250	395	350	26	22	12	M20
300	445	400	26	22	12	M20
350	505	460	30	22	16	M20
400	565	515	32	26	16	M24
450	615	565	36	26	20	M24
500	670	620	38	26	20	M24
600	780	725	42	30	20	M27
700	895	840	35	30	24	M27
800	1015	950	38	33	24	M30
900	1115	1050	38	33	28	M30
1000	1230	1160	44	36	28	M33
1200	1455	1380	55	39	32	M36
PN16						
50	165	125	20	18	4	M16
65	185	145	20	18	8	M16
80	200	160	20	18	8	M16
100	220	180	22	18	8	M16
125	250	210	22	18	8	M16
150	285	240	24	22	8	M20
200	340	295	26	22	12	M20
250	405	355	30	26	12	M24
300	460	410	36	26	12	M24
350	520	470	37	26	16	M24
400	580	525	41	30	16	M27
450	640	585	46	30	20	M27
500	715	650	50	33	20	M30
600	840	770	56	36	20	M33
700	910	840	40	36	24	M33

DN	Dimensions (mm)				Bolting	
	mm	D	PCD	T	B	Holes
800	1025	950	41	39	24	M36
900	1125	1050	48	39	28	M36
1000	1255	1170	59	42	28	M39
1200	1485	1390	78	48	32	M45
PN40						
15	95	65	14	14	4	M12
25	115	85	16	14	4	M16
40	150	110	18	18	4	M16
150 lb						
15	89	60	12	16	4	M12
25	108	79	16	16	4	M12
40	127	98	19	16	4	M12
50	150	121	21	19	4	M16
65	180	140	24	19	4	M16
80	190	152	26	19	4	M16
100	230	191	27	19	8	M16
125	255	216	28	22	8	M20
150	279	241	31	22	8	M20
200	343	298	34	22	8	M20
250	406	362	38	25	12	M24
300	483	432	42	25	12	M24
350	535	476	35	29	12	M27
400	595	540	37	29	16	M27
450	635	578	40	32	16	M30
500	700	635	43	32	20	M30
600	815	749	48	35	20	M33
AWWA						
700	927	864	33	35	28	M33
750	984	914	35	35	28	M33
800	1060	978	38	41	28	M39
900	1168	1086	41	41	32	M39
1000	1289	1200	41	41	36	M39
1050	1346	1257	45	41	36	M39
1100	1403	1315	45	41	40	M39
1200	1511	1422	48	41	44	M39
AS 4087 PN16						
50	150	114	20	18	4	M16
65	165	127	20	18	4	M16
80	185	146	20	18	4	M16
100	215	178	20	18	4	M16
150	280	235	23	18	8	M16
200	335	292	24	18	8	M16

Dimension drawings

8.1 Dimensions and weight

DN	Dimensions (mm)				Bolting	
mm	D	PCD	T	B	Holes	Bolts
250	405	356	30	22	8	M20
300	455	406	33	22	12	M20
350	525	470	30	26	12	M24
400	580	521	30	26	12	M24
450	640	584	30	26	12	M24
500	705	641	38	26	16	M24
600	825	756	48	30	16	M27
700	910	845	56	30	20	M27
800	1060	984	56	36	20	M33
900	1175	1092	66	36	24	M33
1000	1255	1175	66	36	24	M33
1200	1490	1410	76	36	32	M33
K10						
15	95	70	12	15	4	M12
25	125	90	16	19	4	M16
40	140	105	18	19	4	M16
50	155	120	20	19	4	M16
65	175	140	20	19	4	M16
80	185	150	20	19	8	M16
100	210	175	20	19	8	M16
125	250	210	22	23	8	M20
150	280	240	22	23	8	M20
200	330	290	22	23	12	M20
250	400	355	24	25	12	M22
300	445	400	24	25	16	M22
350	490	445	26	25	16	M22
400	560	510	28	27	16	M24
450	620	565	30	27	20	M24
500	675	620	30	27	20	M24
600	795	730	32	33	24	M30

Table 8-6 Flange mating dimensions (metric) for 7ME6580

DN	Dimensions (mm)				Bolting	
mm	D	PCD	T	B	Holes	Bolts
PN6						
1400	1630	1560	56	36	36	M33
1500	1730	1660	80	36	36	M33
1600	1830	1760	63	36	40	M33
1800	2045	1970	69	39	44	M36

DN	Dimensions (mm)				Bolting	
	mm	D	PCD	T	B	Holes
2000	2265	2180	74	42	48	M39
PN10						
200	340	295	24	22	8	M20
250	395	350	26	22	12	M20
300	445	400	26	22	12	M20
350	505	460	30	22	16	M20
400	565	515	32	26	16	M24
450	615	565	36	26	20	M24
500	670	620	38	26	20	M24
600	780	725	42	30	20	M27
700	895	840	35	30	24	M27
800	1015	950	38	33	24	M30
900	1115	1050	38	33	28	M30
1000	1230	1160	44	36	28	M33
1200	1455	1380	55	39	32	M36
1400	1675	1590	65	42	36	M39
1500	1785	1700	105	42	36	M39
1600	1915	1820	75	48	40	M45
1800	2115	2020	85	48	44	M45
2000	2325	2230	90	48	48	M45
PN16						
65	185	145	20	18	8	M16
80	200	160	20	18	8	M16
100	220	180	22	18	8	M16
125	250	210	22	18	8	M16
150	285	240	24	22	8	M20
200	340	295	26	22	12	M20
250	405	355	29	26	12	M24
300	460	410	32	26	12	M24
350	520	470	37	26	16	M24
400	580	525	41	30	16	M27
450	640	585	46	30	20	M27
500	715	650	50	33	20	M30
600	840	770	56	36	20	M33
700 (WN)	910	840	40	36	24	M33
800	1025	950	41	39	24	M36
900	1125	1050	48	39	28	M36
1000	1255	1170	59	42	28	M39
1200	1485	1390	78	48	32	M45
1400	1685	1590	84	48	36	M45
1500	1820	1710	130	56	36	M52
1600	1930	1820	102	56	40	M52

Dimension drawings

8.1 Dimensions and weight

DN mm	Dimensions (mm)				Bolting	
	D	PCD	T	B	Holes	Bolts
1800	2130	2020	110	56	44	M52
2000	2345	2230	124	62	48	M56
PN40						
25	115	85	16	14	4	M12
40	150	110	18	18	4	M16
50	165	125	20	18	4	M16
150 lb						
25	110	79	16	16	4	M12
40	125	98	20	16	4	M12
50	150	121	21	19	4	M16
65	180	140	24	19	4	M16
80	190	152	26	19	4	M16
100	230	191	26	19	8	M16
125	255	216	26	22	8	M20
150	280	241	27	22	8	M20
200	345	299	31	22	8	M20
250	405	362	32	25	12	M24
300	485	432	34	25	12	M24
350	535	476	37	29	12	M27
400	595	540	37	29	16	M27
450	635	578	42	32	16	M30
500	700	635	45	32	20	M30
600	815	749	50	35	20	M33
AWWA						
700	927	864	33	35	28	M33
750	984	914	35	35	28	M33
800	1061	978	38	41	28	M39
900	1168	1086	41	41	32	M39
1000	1289	1200	41	41	36	M39
1050	1346	1257	45	41	36	M39
1100	1403	1316	45	41	40	M39
1200	1511	1422	48	41	44	M39
1400	1683	1594	54	48	44	M45
1500	1854	1759	57	48	52	M45
1600	2032	1930	64	48	52	M45
1800	2197	2096	67	48	60	M45
2000	2362	2261	70	54	64	M52
AS 4087 PN16						
50	150	114	11	18	4	M16
65	165	127	11	18	4	M16
80	185	146	11	18	4	M16
100	215	178	13	18	4	M16

DN	Dimensions (mm)				Bolting	
	mm	D	PCD	T	B	Holes
150	280	235	13	18	8	M16
200	335	292	19	18	8	M16
250	405	356	19	22	8	M20
300	455	406	23	22	12	M20
350	525	470	30	26	12	M24
400	580	521	30	26	12	M24
450	640	584	30	26	12	M24
500	705	641	38	26	16	M24
600	825	756	48	30	16	M27
700	910	845	56	30	20	M27
800	1060	984	56	36	20	M33
900	1175	1092	66	36	24	M33
1000	1255	1175	66	36	24	M33
1200	1490	1410	76	36	32	M33
K10						
25	125	90	14	19	4	M16
40	140	105	16	19	4	M16
50	155	120	16	19	4	M16
65	175	140	18	19	4	M16
80	185	150	18	19	8	M16
100	210	175	18	19	8	M16
125	250	210	20	23	8	M20
150	280	240	22	23	8	M20
200	330	290	22	23	12	M20
250	400	355	24	25	12,	M22
300	445	400	24	25	16	M22
350	490	445	26	25	16	M22
400	560	510	28	27	16	M24
450	620	565	30	27	20	M24
500	675	620	30	27	20	M24
600	795	730	32	33	24	M30

Dimension-dependent factory settings

Table 8-7 50 Hz version

DN		Qmax			Unit	Volume/ pulse	Pulse unit	Totalizer unit
mm	Inch	Fac. set- tings	Min.	Max.				
15	½	2000	159	6361	l/h	1		
25	1	5000	441	17671	l/h	10		

Dimension drawings

8.1 Dimensions and weight

DN		Qmax			Unit	Volume/ pulse	Pulse unit	Totalizer unit
mm	Inch	Fac. set- tings	Min.	Max.				
32	1¼	8270	724	28953	l/h	10	l	l
40	1½	12	1.1	45	m³/h	10	l	l
50	2	20	1.7	70	m³/h	10	l	l
65	2½	30	2.9	119	m³/h	100	l	l
80	3	50	4.5	180	m³/h	100	l	l
100	4	120	7	282	m³/h	100	l	l
125	5	180	11	441	m³/h	100	l	m³
150	6	250	15.9	636	m³/h	100	l	m³
200	8	400	28.2	1130	m³/h	1	m³	m³
250	10	700	44.1	1767	m³/h	1	m³	m³
300	12	1000	63.6	2544	m³/h	1	m³	m³
350	14	1200	86.5	3463	m³/h	1	m³	m³
400	16	1800	113	4523	m³/h	1	m³	m³
450	18	2000	143.1	5725	m³/h	1	m³	m³
500	20	3000	176.7	7068	m³/h	1	m³	m³
600	24	4000	254.4	10178	m³/h	10	m³	m³
700	28	5000	346.3	13854	m³/h	10	m³	m³
750	30	6000	397.6	15904	m³/h	10	m³	m³
800	32	7000	452.3	18095	m³/h	10	m³	m³
900	36	9000	572.5	22902	m³/h	10	m³	m³
1000	40	12000	706.8	28274	m³/h	10	m³	m³
1050	42	12000	706.8	28274	m³/h	10	m³	m³
1100	44	14000	855.2	34211	m³/h	10	m³	m³
1200	48	15000	1017.8	40715	m³/h	10	m³	m³
1400	54	25000	1385.4	55417	m³/h	10	m³	m³
1500	60	30000	1590.4	63617	m³/h	10	m³	m³
1600	66	35000	1809.5	72382	m³/h	10	m³	m³
1800	72	40000	2290.2	91608	m³/h	10	m³	m³
2000	78	45000	2827.4	113097	m³/h	10	m³	m³

Table 8-8 60 Hz version

DN		Qmax			Unit	Volume/ pulse	Pulse unit	Totalizer unit
mm	Inch	Fac. set- tings	Min.	Max.				
15	½	8.8	0.7	28.0	US GPM	1	US G	US G
25	1	22	1.9	77.8	US GPM	1	US G	US G
32	1¼	36.4	3.2	127.5	US GPM	1	US G	US G
40	1½	52	4.9	199.1	US GPM	1	US G	US G
50	2	88	7.7	311.2	US GPM	1	US G	US G
65	2½	132	13.1	525.9	US GPM	1	US G	US G

DN		Qmax			Unit	Volume/ pulse	Pulse unit	Totalizer unit
mm	Inch	Fac. set- tings	Min.	Max.				
80	3	220	19.9	796.7	US GPM	1	US G	US MG
100	4	528	31.1	1244.8	US GPM	1	US G	US MG
125	5	793	48.6	1945.1	US GPM	1	US G	US MG
150	6	1101	70	2800.9	US GPM	1	US G	US MG
200	8	1761	124.4	4979.5	US GPM	1	US G	US MG
250	10	3082	194.5	7780.5	US GPM	1	US G	US MG
300	12	4402	280	11203.9	US GPM	1	US G	US MG
350	14	5283	381.2	15249.7	US GPM	1	US G	US MG
400	16	7925	497.9	19918.1	US GPM	1	US G	US MG
450	18	8806	630.2	25208.8	US GPM	1	US G	US MG
500	20	13209	778	31122	US GPM	1	US G	US MG
600	24	17611	1120.3	44815.7	US GPM	10	US G	US MG
700	28	19812	1524.9	60999.1	US GPM	10	US G	US MG
750	30	22014	1750.6	70024.5	US GPM	10	US G	US MG
800	32	30820	1991.8	79672.4	US GPM	10	US G	US MG
900	36	39626	2522.8	100835.3	US GPM	10	US G	US MG
1000	40	52834	3112.2	124488.1	US GPM	10	US G	US MG
1050	42	52834	3431.2	137248.1	US GPM	10	US G	US MG
1100	44	61640	3765.7	150630.6	US GPM	10	US G	US MG
1200	48	66043	4481	179262.9	US GPM	10	US G	US MG
1400	54	110072	6099.9	243993.7	US GPM	1000	US G	US MG
1500	60	132086	7002.4	280098.3	US GPM	1000	US G	US MG
1600	66	154100	7967.2	318689.6	US GPM	1000	US G	US MG
1800	72	176115	10083.5	403341.5	US GPM	1000	US G	US MG
2000	78	198129	12448.8	497952.5	US GPM	1000	US G	US MG

Table 8-9 Coil resistance [Ω]

		MAG 3100 / MAG 3100 HT /MAG 3100 P	
DN	Inch	Resistance	Tolerance
15	½"	100	-25/+60
25	1"	100	-25/+60
32	1¼"	100	-25/+60
40	1½"	100	-25/+60
50	2"	100	-25/+60
65	2½"	100	-25/+60
80	3"	100	-25/+60
100	4"	100	-25/+60
125	5"	100	-25/+60
150	6"	100	-25/+60
200	8"	100	-25/+60

Dimension drawings

8.1 Dimensions and weight

		MAG 3100 / MAG 3100 HT /MAG 3100 P	
250	10"	100	-25/+60
300	12"	100	-25/+60
400	16"	100	-25/+60
450	18"	100	-25/+60
500	20"	100	-25/+60
600	24"	100	-25/+60
700	28"	100	-25/+60
800	32"	100	-25/+60
900	36"	100	-25/+60
1000	40"	100	-25/+60
1100	44"	100	-25/+60
1200	48"	100	-25/+60
1400	54"	100	-25/+60
1500	60"	100	-25/+60
1600	66"	100	-25/+60
1800	72"	100	-25/+60
2000	78"	100	-25/+60

Technical specifications

Table 9-1

Version	MAG 3100 P	MAG 3100	MAG 3100 HT
Product characteristic	Process and chemical (Short lead time)	Flexible product program	Process temperature above 150 °C (300 °F)
Nominal size	DN 15 to DN 300 (½" to 12")	DN 15 to DN 2000 (½" to 78")	DN 15 to DN 300 (½" to 12")
Measuring principle	Electromagnetic induction		
Excitation frequency (Mains supply: 50 Hz/60 Hz)	<ul style="list-style-type: none"> • DN 15 to 65 (½" to 2½"): 12.5 Hz/15 Hz • DN 80 to 150 (3" to 6"): 6.25 Hz/7.5 Hz • DN 200 to 300 (8" to 12"): 3.125 Hz/3.75 Hz 	<ul style="list-style-type: none"> • DN 15 to 65 (½" to 2½"): 12.5 Hz/15 Hz • DN 80 to 150 (3" to 6"): 6.25 Hz/7.5 Hz • DN 200 to 1200 (8" to 48"): 3.125 Hz/3.75 Hz • DN 1400 to 2000 (54" to 78"): 1.5625 Hz/1.875 Hz 	<ul style="list-style-type: none"> • DN 15 to 65 (½" to 2½"): 12.5 Hz/15 Hz • DN 80 to 150 (3" to 6"): 6.25 Hz/7.5 Hz • DN 200 to 300 (8" to 12"): 3.125 Hz/3.75 Hz
Enclosure rating	IP67 (EN/IEC 60529) / NEMA 4X/ 6, 1 mH ₂ O for 30 min Option: IP68 (EN/IEC 60529) / NEMA 6P, 10 mH ₂ O cont. (not for Ex)	IP67 (EN/IEC 60529) / NEMA 4X/ 6, 1 mH ₂ O for 30 min Option: IP68 (EN/IEC 60529) / NEMA 6P, 10 mH ₂ O cont. (not for Ex)	IP67 (EN/IEC 60529) / NEMA 4X/ 6, 1 mH ₂ O for 30 min Option: IP68 (EN/IEC 60529) / NEMA 6P, 10 mH ₂ O cont. (not for Ex)
Test pressure	1.5 x PN (where applicable)	1.5 x PN (where applicable)	1.5 x PN (where applicable)
Pressure drop at 3 m/s	-	As straight pipe	-
EMC	According to 2004/108/EC		

Table 9-2 Process connections

Version	MAG 3100 P	MAG 3100	MAG 3100 HT
EN 1092-1, raised face (EN 1092-1, DIN 2501 & BS 4504 have the same mating dimensions)	<ul style="list-style-type: none"> DN 15 to 50 (½" to 2"): PN 40 (580 psi) DN 65 to 300 (2½" to 12"): PN 16 (232 psi) DN 200 to 300 (8" to 12"): PN 10 (145 psi) 	<ul style="list-style-type: none"> DN 65 to 2000 (2½" to 78"): PN 6 (87 psi) DN 200 to 2000 (8" to 78"): PN 10 (145 psi) DN 65 to 2000 (2½" to 78"): PN 16 (232 psi) DN 200 to 600 (8" to 24"): PN 25 (362 psi) DN 15 to 600 (½" to 24"): PN 40 (580 psi) DN 50 to 300 (2" to 12"): PN 63 (913 psi) DN 25 to 300 (1" to 12"): PN 100 (1450 psi) 	<ul style="list-style-type: none"> DN 15 to 300 (½" to 12"): PN 40 (580 psi) DN 65 to 300 (2½" to 12"): PN 16 (232 psi) DN 200 to 300 (8" to 12"): PN 10 (145 psi) DN 200 to 300 (8" to 12"): PN 25 (362 psi)
ANSI B16.5 (~BS 1560), raised face	<ul style="list-style-type: none"> ½" to 12": Class 150 (20 bar (290 psi)) 	<ul style="list-style-type: none"> ½" to 24": Class 150 (20 bar (290 psi)) ½" to 24": Class 300 (50 bar (725 psi)) 1" to 24": Class 600 (100 bar (1450 psi)) 	<ul style="list-style-type: none"> ½" to 12": Class 150 (20 bar (290 psi)) ½" to 12": Class 300 (50 bar (725 psi))
AWWA C-207, flat face	-	28" to 78": Class D (10 bar)	-
AS 2129, raised face	-	½" to 48": Table E	½" to 12": Table E
AS 4087, raised face	-	<ul style="list-style-type: none"> PN 16 (DN 50 to 1200, 16 bar (232 psi)) PN 21 (DN 50 to 600, 21 bar (304 psi)) PN 35 (DN 50 to 600, 35 bar (508 psi)) 	-
JIS B 2220:2004	-	<ul style="list-style-type: none"> K10 (½" to 24") K20 (½" to 24") 	-
Other flanges and pressure ratings	-	On request	On request

Table 9-3 Rated operating conditions (Ambient temperatures)¹

Version	MAG 3100 P	MAG 3100	MAG 3100 HT
Sensor	-40 to +100 °C (-40 to +212 °F)	-40 to +100 °C (-40 to +212 °F)	-40 to +100 °C (-40 to +212 °F)
Ex Sensor	-20 to +60 °C (-4 to +140 °F)	-20 to +60 °C (-4 to +140 °F)	For media temperature up to 150 °C (302 °F): <ul style="list-style-type: none"> -20 to +60 °C (-4 to +140 °F) For media temperature 150 to 180 °C (302 to 356 °F): <ul style="list-style-type: none"> -20 to +50 °C (-4 to +122 °F)
With compact transmitter			
MAG 5000/6000, MAG 6000 I MAG 6000 I Ex de	-20 to +60 °C (-4 to +140 °F)	-20 to +60 °C (-4 to +140 °F)	-20 to +60 °C (-4 to +140 °F)

¹ Conditions also dependent on liner characteristics

 Table 9-4 Operating pressure [abs.bar]¹

Version	MAG 3100 P	MAG 3100	MAG 3100 HT
PTFE Teflon	<ul style="list-style-type: none"> DN 15 to 300 (½" to 12"): 0.3 to 40 bar (4 to 580 psi) 	<ul style="list-style-type: none"> DN ≤ 300 (≤ 12"): 0.3 to 50 bar (4 to 725 psi) 350 ≤ DN ≤ 600 (14" ≤ DN ≤ 24"): 0.3 to 40 bar (4 to 580 psi) 	<ul style="list-style-type: none"> DN 15 to 300 (½" to 12") (130/180 °C (266/356 °F)): 0.3/0.6 to 50 bar (4/8 to 725 psi) 180 °C (356 °F) PTFE has factory-mounted grounding stainless steel rings type E and stainless steel terminal box
PFA	DN 15 to 150 (½" to 6"): Vacuum 0.02 to 50 bar (0.29 to 725 psi)	DN 15 to 150 (½" to 6"): Vacuum 0.02 to 50 bar (0.29 to 725 psi)	DN 15 to 150 (½" to 6"): Vacuum 0.02 to 50 bar (0.29 to 725 psi)
Soft rubber		0.01 to 100 bar (0.15 to 1450 psi)	
EPDM		0.01 to 40 bar (0.15 to 580 psi)	
Linatex®		0.01 to 40 bar (0.15 to 580 psi)	
Ebonite		0.01 to 100 bar (0.15 to 1450 psi)	

¹ Maximum operating pressure decreases with increasing operating temperature and with stainless steel flanges

Table 9-5 Mechanical load/Vibration

Version	MAG 3100 P	MAG 3100	MAG 3100 HT
Description	18 to 1000 Hz random in x, y, z, directions for 2 hours according to EN 60068-2-36		
Sensor	3.17 grms		

Technical specifications

Version	MAG 3100 P	MAG 3100	MAG 3100 HT
Sensor with compact MAG 5000/6000 transmitter mounted		3.17 grms	
Sensor with MAG 6000 II/6000 I Ex transmitter mounted		1.14 grms	

Table 9-6 Media temperature

Version	MAG 3100 P	MAG 3100	MAG 3100 HT
PTFE Teflon	-20 to +130 °C (-4 to +266 °F)	-20 to +100 °C (-4 to +212 °F)	<ul style="list-style-type: none"> -20 to +130 °C (-4 to +266 °F) -20 to +180 °C (-4 to +356 °F) <p>Factory mounted grounding rings type E and SS terminal box. Can only be used with remote transmitter.</p>
PFA	-20 to +150 °C (-4 to +302 °F)	-20 to +100 °C (-4 to +212 °F)	-20 to +150 °C (-4 to +302 °F)
Soft rubber		0 to +70 °C (32 to 158 °F)	
EPDM		-10 to +70 °C (14 to 158 °F)	
Linatex®		-40 to +70 °C (-40 to +158 °F) For temperatures below -20 °C (-4 °F) AISI 304 or 316 flanges must be used	
Ebonite		0 to 95 °C (32 to 203 °F)	

Table 9-7 Design

Version	MAG 3100 P	MAG 3100	MAG 3100 HT
Weight	See dimensional drawings		
Flange and housing material	<ul style="list-style-type: none"> Carbon steel ASTM A 105, with corrosion resistant two component epoxy coating (min. 150 µm) 	<ul style="list-style-type: none"> Carbon steel ASTM A 105, with corrosion resistant two component epoxy coating (min. 150 µm) AISI 304 (1.4301) flanges and carbon steel housing, with corrosion resistant two component epoxy coating (min. 150 µm) AISI 316L (1.4404) flanges and housing, polished 	<ul style="list-style-type: none"> Carbon steel ASTM A 105, with corrosion resistant two component epoxy coating (min. 150 µm) AISI 304 (1.4301) flanges and carbon steel housing, with corrosion resistant two component epoxy coating (min. 150 µm) AISI 316L (1.4404) flanges and housing, polished
Measuring pipe material	AISI 304 (1.4301)		

Version	MAG 3100 P	MAG 3100	MAG 3100 HT
Electrode material	<ul style="list-style-type: none"> Hastelloy C276 (PFA: Hastelloy C22) 	<ul style="list-style-type: none"> AISI 316Ti (1.4571) Hastelloy C276 (PFA: Hastelloy C22) Platinum/Iridium, Titanium Tantalum 	<ul style="list-style-type: none"> AISI 316Ti (1.4571) Hastelloy C276 (PFA: Hastelloy C22) Platinum/Iridium, Titanium Tantalum
Grounding Electrode material	<ul style="list-style-type: none"> PTFE: Hastelloy PFA: Hastelloy 	Material as measuring electrodes Exceptions - see ordering data	No grounding electrodes
Terminal box (remote version only)	<ul style="list-style-type: none"> Standard fibre glass reinforced polyamide Stainless steel AISI 316 (1.4436) 	<ul style="list-style-type: none"> Standard fibre glass reinforced polyamide Stainless steel AISI 316 (1.4436) 	Stainless steel AISI 316 (1.4436)
Cable entries			
Remote installation	<ul style="list-style-type: none"> 2 x M20 2 x 1/2" NPT 	<ul style="list-style-type: none"> 2 x M20 2 x 1/2" NPT 	<ul style="list-style-type: none"> 2 x M20 2 x 1/2" NPT
Compact installation	MAG 5000/MAG 6000: <ul style="list-style-type: none"> 4 x M20 4 x 1/2" NPT MAG 6000 I: <ul style="list-style-type: none"> 2 x M20 (for supply/output) 2 x 1/2" NPT MAG 6000 I Ex de: <ul style="list-style-type: none"> 2 x M20 (for supply/output) 2 x 1/2" NPT 	MAG 5000/MAG 6000: <ul style="list-style-type: none"> 4 x M20 4 x 1/2" NPT MAG 6000 I: <ul style="list-style-type: none"> 2 x M20 (for supply/output) 2 x 1/2" NPT MAG 6000 I Ex de: <ul style="list-style-type: none"> 2 x M20 (for supply/output) 2 x 1/2" NPT 	-

Table 9-8 Certificates and approvals



Version	MAG 3100 P	MAG 3100	MAG 3100 HT
Calibration Standard production calibration, calibration report shipped with sensor	Zero-point, 2 x 25 % and 2 x 90 %	Zero-point, 2 x 25 % and 2 x 90 %	Zero-point, 2 x 25 % and 2 x 90 %
Conforms to	PED (All EN1092-1 flanges conforms to PED – 97/23/EC ¹⁾ CRN	PED (All EN1092-1 flanges conforms to PED - 97/23/EC ¹⁾ CRN	PED (All EN1092-1 flanges conforms to PED - 97/23/EC ¹⁾ CRN
Material certificate EN 10204 3.1	On request	On request	On request

Version	MAG 3100 P	MAG 3100	MAG 3100 HT
Ex approvals	<p>Ex sensor DN 15 to 300:</p> <ul style="list-style-type: none"> • ATEX 2GD Ex de ia IIC T3 - T6 • IEC Ex de e ia IIC T3 - T6 • FM Class 1 Div 1 (only compact mounted) • FM Class 1 Zone 1 • CSA Class 1 Zone 1 <p>Standard sensors:</p> <ul style="list-style-type: none"> • FM Class 1 Div 2 • CSA Class 1, Div 2 	<p>Ex sensor DN 15 to 300:</p> <ul style="list-style-type: none"> • ATEX 2GD Ex de ia IIC T3 - T6 • IEC Ex e ia IIC T3 - T6 • FM Class 1 Div 1 (only compact mounted) • FM Class 1 Zone 1 • CSA Class 1 Zone 1 <p>DN 350 to 2000:</p> <ul style="list-style-type: none"> • Ex e ia IIC T4 - T6 • FM Class 1 zone 1 • CSA Class 1 zone 1 • IEC Ex de ia IIC T3-T6 • Ex tD A21 IP67 <p>Standard sensors:</p> <ul style="list-style-type: none"> • FM Class 1 Div 2 • CSA Class 1, Div 2 	<p>Ex sensor DN 15 to 300:</p> <ul style="list-style-type: none"> • ATEX 2GD Ex de ia IIC T3 - T6 • IEC Ex de ia IIC T3-T6 • FM Class 1 zone 1 • CSA Class 1 zone 1 <p>Standard sensors:</p> <ul style="list-style-type: none"> • FM Class 1 Div 2 • CSA Class 1, Div 2
Drinking water approvals		<p>EPDM lining:</p> <ul style="list-style-type: none"> • WRAS (WRc, BS6920 cold water, GB) • NSF/ANSI Standard 61 (Cold water, US) • ACS listed (F) • DVGW W270 (D) • Belgaqua (B) • MCERTS (GB) (EPDM or PTFE lining with AISI 316 or Hastelloy electrodes) 	
Custody transfer (CT) (≤ DN 2000) (only with MAG 5000/6000 CT)		<p>Cold water pattern approval:</p> <ul style="list-style-type: none"> • OIML R 49 (Denmark) <p>Cold water pattern approval:</p> <ul style="list-style-type: none"> • PTB (Germany) <p>Other media than water</p> <ul style="list-style-type: none"> • OIML R 117 (Denmark) 	

1) For sizes larger than 600 mm (24") in PN 16 PED conformity is available as a cost-added option. The basic unit will carry the LVD (Low Voltage Directive) and EMC approval.

9.1 Cable data

Description

Cable for standard electrode or coil	
Electrode cable, double shielded	
Cable kit with standard coil cable and electrode cable double shielded (also available as low noise cable for MAG 1100 sensor)	

Standard applications

Table 9-9 Technical data, standard application cables

		Coil cable	Standard electrode cable
Basic data	No. of conductors	2	3
	Min. sqr. area	0.5 mm ²	0.2 mm ²
	Shield	Yes	Yes
	Max. capacitance	N/A	350 pF/m
Max. cable loop resistance	Media temperature:		
	< 100 °C (212 °F)	40 Ω	N/A
	> 200 °C (392 °F)	6 Ω	N/A
Cable glands on sensor and transmitter	M20x1.5 gland - Cable ø 5 to 13 mm (0.20 to 0.51 inches)		
	½ NPT gland - cable ø 5 to 9 mm (0.20 to 0.35 inches)		

Special applications, for example low conductivity or electrical noise

Table 9-10 Technical data, special application cables

		Coil cable	Special electrode cable
Basic data	No. of conductors	3	3
	Sqr. area	1.5 mm ²	0.25 mm ²
	Shield	Yes	Double
	Color code	Brown, blue, black	Brown, blue, black
	Outside color	Grey	Grey
	Ext. diameter	7.8 mm	8.1 mm
	Conductor	Flexible CU	Flexible CU
	Isolation material	PVC	PVC
Ambient temperature	Flexible installation	-5 to +70°C (23 to 158°F)	-5 to +70°C (23 to 158°F)
	Non-flexible installation	-30 to +70°C (-22 to 158°F)	-30 to +70°C (-22 to 158°F)

9.2 Pressure / temperature range

Cable parameter	Coil cable		Special electrode cable
	Capacity	161.50 pF/m	N/A
Inductance	0.583 μH/m	N/A	
L/R	43.83 μH/Ω	N/A	

9.2 Pressure / temperature range

The following diagrams and tables show the maximum allowable working pressure at various working temperatures. For maximum allowable working pressure (MAWP) at 20 °C and at maximum working temperature, see the nameplate on the device.

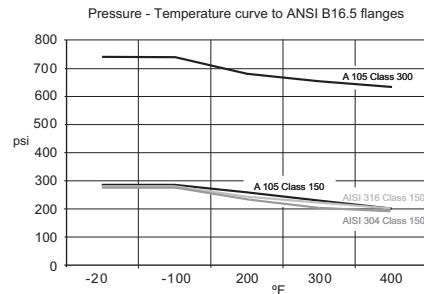
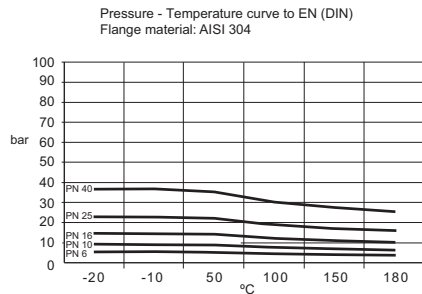
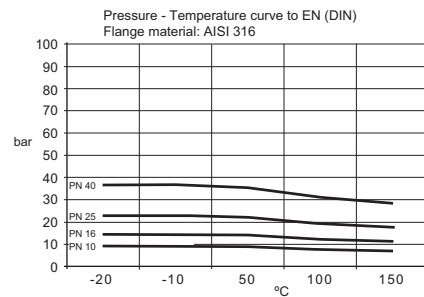
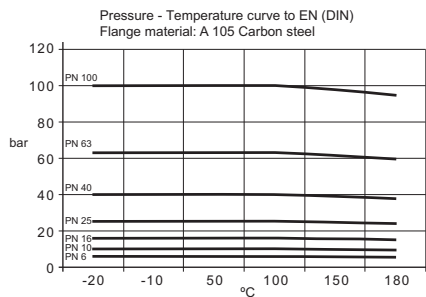

Table 9-11 Metric measures (pressure in bar) - Sizes 25 mm, 40 mm and >300 mm

Flange specifications	Flange rating	Temperature (°C)			
		-5	10	50	90
EN 1092-1	PN 10	10.0	10.0	9.7	9.4
	PN 16	16.0	16.0	15.5	15.1
	PN 40	40.0	40.0	38.7	37.7
ANSI B16.5	150 lb	19.7	19.7	19.3	18.0
AWWA C-207	Class D	10.3	10.3	10.3	10.3

Table 9-12 Imperial measures (pressure in psi) - Sizes 1", 1½" and >12"

Flange specifications	Flange rating	Temperature (°F)			
		23	50	120	200
EN 1092-1	PN 10	145	145	141	136
	PN 16	232	232	225	219
	PN 40	580	580	561	547
ANSI B16.5	150 lb	286	286	280	261
AWWA C-207	Class D	150	150	150	150

9.3 Process fluid conductivity

Compact installation

Liquids with an electrical conductivity $\geq 5 \mu\text{S/cm}$.

Remote installation

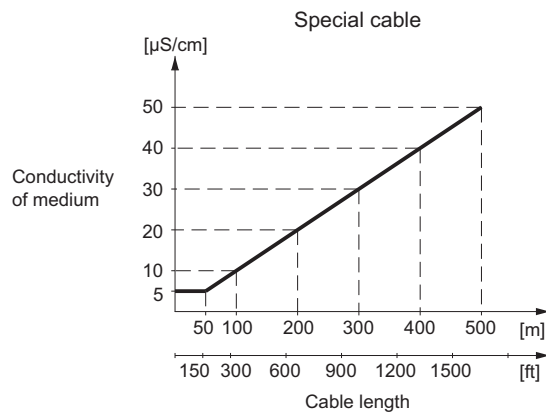
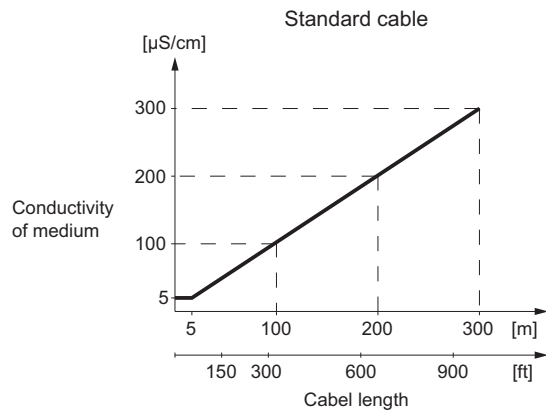

<p>⚠ WARNING</p> <p>Empty pipe detection</p> <p>The installation has to fulfill the following limitations for usage of the empty pipe detection function:</p> <ul style="list-style-type: none"> • media conductivity $\geq 20 \mu\text{S/cm}$ • length of cable at remote installation ≤ 50 (150 ft) • special shield cable must be used <p>Note for MAG 1100 sizes DN 2 and DN 3:</p> <ul style="list-style-type: none"> • empty pipe detection is not available • media conductivity $\geq 30 \mu\text{S/cm}$ <p>Note for MAG 5000/6000 CT (FW 3.03):</p> <ul style="list-style-type: none"> • empty pipe detection is not available

9.4 Liner selection

Table 9-13

Liner	Applications
EPDM	Drinking Water, Low abrasive media, Food & Beverage
Ebonite	Drinking Water, Wastewater, Fine low abrasive media
PTFE	Drinking Water, Wastewater, Chemicals, Food & Beverage, Pulp & Paper
PFA	Drinking Water, Wastewater, Chemicals, Food & Beverage, Pulp & Paper
Linatex	Abrasive media
Soft rubber	Drinking Water, Wastewater, Abrasive media, Chemicals

9.5 Electrode selection

Table 9-14

Electrodes	Applications	Chemical Resistance
Stainless Steel	Drinking Water, Wastewater, Chemicals, Food & Beverage, Pulp & Paper	Reducing acids, Oxidizing acids, Organic acids, Alkalis, Diluted salts
Hastelloy C22	Drinking Water, Wastewater, Abrasive Liquids, Chemicals, Food & Beverage, Pulp & Paper	Reducing acids, Oxidizing acids, Organic acids, Alkalis, Diluted salts
Hastelloy C267	Drinking Water, Wastewater, Abrasive Liquids, Chemicals, Food & Beverage, Pulp & Paper	Reducing acids, Oxidizing acids, Organic acids, Alkalis, Diluted salts

Electrodes	Applications	Chemical Resistance
Titanium	Drinking Water, Wastewater, Chemicals, Food & Beverage, Pulp & Paper	Reducing acids, Oxidizing acids, Organic acids, Alkalis, Diluted salts
Tantalum	Drinking Water, Wastewater, Chemicals, Food & Beverage, Pulp & Paper	Reducing acids, Oxidizing acids, Organic acids, Alkalis, Diluted salts
Platinum	Drinking Water, Wastewater, Chemicals, Food & Beverage, Pulp & Paper	Reducing acids, Oxidizing acids, Organic acids, Alkalis, Diluted salts

Product documentation and support

A.1 Product documentation

Process instrumentation product documentation is available in the following formats:

- Certificates (<http://www.siemens.com/processinstrumentation/certificates>)
- Downloads (firmware, EDDs, software) (<http://www.siemens.com/processinstrumentation/downloads>)
- Catalog and catalog sheets (<http://www.siemens.com/processinstrumentation/catalogs>)
- Manuals (<http://www.siemens.com/processinstrumentation/documentation>)
You have the option to show, open, save, or configure the manual.
 - "Display": Open the manual in HTML5 format
 - "Configure": Register and configure the documentation specific to your plant
 - "Download": Open or save the manual in PDF format
 - "Download as html5, only PC": Open or save the manual in the HTML5 view on your PC

You can also find manuals with the Mobile app at Industry Online Support (<https://support.industry.siemens.com/cs/ww/en/sc/2067>). Download the app to your mobile device and scan the device QR code.

Product documentation by serial number

Using the PIA Life Cycle Portal, you can access the serial number-specific product information including technical specifications, spare parts, calibration data, or factory certificates.

Entering a serial number

1. Open the PIA Life Cycle Portal (<https://www.pia-portal.automation.siemens.com>).
2. Select the desired language.
3. Enter the serial number of your device. The product documentation relevant for your device is displayed and can be downloaded.

To display factory certificates, if available, log in to the PIA Life Cycle Portal using your login or register.

Scanning a QR code

1. Scan the QR code on your device with a mobile device.
2. Click "PIA Portal".

To display factory certificates, if available, log in to the PIA Life Cycle Portal using your login or register.

A.2 Technical support

Technical support

If this documentation does not completely answer your technical questions, you can enter a Support Request (<http://www.siemens.com/automation/support-request>).

For help creating a support request, view this video here (www.siemens.com/opensr).

Additional information on our technical support can be found at Technical Support (<http://www.siemens.com/automation/csi/service>).

Service & support on the Internet

In addition to our technical support, Siemens offers comprehensive online services at Service & Support (<http://www.siemens.com/automation/serviceandsupport>).

Contact

If you have further questions about the device, contact your local Siemens representative at Personal Contact (<http://www.automation.siemens.com/partner>).

To find the contact for your product, go to "all products and branches" and select "Products & Services > Industrial automation > Process instrumentation".

Contact address for business unit:

Siemens AG
Digital Industries
Process Automation
Östliche Rheinbrückenstr. 50
76187 Karlsruhe, Germany

Glossary

ASIC

Application-Specific Integrated Circuit is an integrated circuit (IC) customized for a particular use, rather than intended for general-purpose use.

EMC

Electromagnetic compatibility (EMC) is the branch of electrical sciences which studies the unintentional generation, propagation and reception of electromagnetic energy with reference to the unwanted effects (Electromagnetic Interference, or EMI) that such energy may induce. The goal of EMC is the correct operation, in the same electromagnetic environment, of different equipment which use electromagnetic phenomena, and the avoidance of any interference effects.

HART

HART Communication is a bi-directional industrial field communication protocol used to communicate between intelligent field instruments and host systems. HART is the global standard for smart process instrumentation and the majority of smart field devices installed in plants worldwide are HART-enabled. HART technology is easy to use and very reliable

IP

An IP (Ingress Protection) number is used to specify the environmental protection of enclosures around electronic equipment. These ratings are determined by specific tests. The IP number is composed of two numbers, the first referring to the protection against solid objects and the second against liquids. The higher the number, the better the protection. For example, in IP67 the first Number (6) means that the device is totally protected against dust, and the second (7) that it is protected against the effect of immersion between 15cm and 1m

MODBUS

MODBUS is a serial communications protocol intended for use with programmable logic controllers (PLCs). MODBUS allows for communication between many devices connected to the same network, for example a system that measures temperature and humidity and communicates the results to a computer. MODBUS is often used to connect a supervisory computer with a remote terminal unit (RTU) in supervisory control and data acquisition systems.

NAMUR

Normenarbeitsgemeinschaft für Meß- und Regeltechnik in der Chemischen Industrie (NAMUR). NAMUR is a group representing the interests of the chemical industry which create standards for instrumentation and electrical devices used in industrial plants.

PED

The Pressure Equipment Directive (97/23/EC) is the legislative framework on European level for equipment subject to a pressure hazard. It was adopted by the European Parliament and the European Council in May 1997 and has been obligatory throughout the European Union since May 2002.

PROFIBUS

PROFIBUS (Process Field Bus) is a vendor-independent, open bus system standardized in the German DIN 19 245. It is a standard for field bus communication in automation technology and should not be confused with the PROFINET standard for industrial Ethernet. PROFIBUS-PA (Process Automation) is one of three PROFIBUS variants that are compatible with each other. PROFIBUS-DP (Decentralized Periphery)

SENSORPROM

All sensor related settings/data saved on an EPROM. SENSORPROM technology automatically configures the transmitter at start up providing calibration data, pipe size, sensor type, and output settings. The SENSORPROM automatically stores values or settings changed by users, and automatically re-programs any new transmitter without loss of accuracy.

Turndown ratio

'Turndown ratio' is a flow measurement term indicating the range a specific flow meter, or meter type, is able to measure with acceptable accuracy. It is also known as rangeability. If a gas flow to be measured is expected to vary between 100,000 m³ per day and 1,000,000 m³ per day, the specific application has a turndown ratio of at 10:1. Therefore the meter requires a turndown ratio of at least 10:1.

USM

USM II is a Communication Platform. The Siemens USM II concept enables fitting of add-on bus modules without loss of functionality:

1. All modules can be fitted as true "plug & play"
2. Module and transmitter are automatically configured through the SENSORPROM

Index

A

- Abrasive liquids, 27, 42
- Add-on modules, (See Communication module)
- Ambient temperature
 - Hazardous area, 15
- Ambient temperatures, 75
- Applications, 19

C

- Cable specifications, 44, 79
- Catalog
 - catalog sheets, 85
- Cathodic protection, 40
- Certificates, 85
- Certificates and approvals, 77
- Coil insulation check, 55
- Coil resistance check, 55
- Communication modules, 19
- Compliance, 9
- Customer Support, (Refer to Technical support)

D

- Design, 20, 76
- Device
 - Identification, 21
 - Inspection, 20
- Dimensions, 59
- Document history, 5
- Downloads, 85

E

- Electrical connection
 - Cable specifications, 44
 - In hazardous area, 43
 - Remote installations, 45
 - Safety instructions, 43
- Electrode
 - Material, 20, 82
- Electrode resistance check, 56
- Empty pipe detection, 27

F

- Factory settings
 - Dimension dependent, 69
- FAQ
 - Fluctuating process values, 56
- Flange mating dimensions, 64

G

- Gas / Air bubbles, 27
- grounding rings, 41

H

- Hazardous area
 - Approvals, 14
 - Electrical connection, 43
 - Special conditions, 15
 - Temperature specifications, 15
- Horizontal Pipes, 27
- Hotline, (Refer to Support request)

I

- Inlet / outlet conditions, 25
- Installation
 - Horizontal Pipes, 27
 - in U-tube, 23
 - Indoor/outdoor, 23
 - Large pipes, 25
 - Location in system, 23
 - Pipes with free outlet, 24
 - Remote, 45
 - Safety instructions, 23
 - Vertical pipes, 27
- Intrinsically safe data, 14
- Items supplied, 6

L

- Laws and directives, 9
- Liner
 - Material, 20, 82
 - Protectors, 29

M

Mains supply, 43
Maintenance, 51
Manuals, 85
Material compatibility, 9
Measurement principle, 22
Mechanical load, 75

O

Operating pressure, 75

P

Potential equalization, 40
Potting, 49
Pressure
 Compliance with Pressure Equipment Directive, 10
 In relation to temperature, 80
 Safety instructions, 23
Process connections, 74
Process fluid
 Conductivity, 81
 Temperature, 76
Product label, 21
Protective conductor terminal, 44
Protective earth, 44

R

Recalibration, 51
Repair, 51
Return procedure, 53

S

Safety
 Instrument safety standards, 9
 Sensor installation, 23
Safety instructions
 Electrical connection, 43
Scope of delivery, 6
Sensor check, 55
Sensor orientation, 27
Service, 51, 86
Service and support
 Internet, 86

Specification label, 21
Support, 86
Support request, 86
Symbols, (Refer to warning symbols)
System components, 19

T

Technical data, 73
Technical support, 86
 partner, 86
 personal contact, 86
Temperature
 Ambient, 75
 In relation to pressure, 80
 Process fluid, 76
 Use in hazardous area, 15
Theory of operation, 22

V

Vertical Pipes, 27
Vibrations, 24, 75

W

Warning symbols, 9
Warranty, 7
Wire insulation, 44
Wiring, (See Electrical connection)