

Overview



The SITRANS DA400 acoustic diagnostic unit acoustically measures the structure-borne noise

- In the version for pump monitoring; on oscillating displacement pumps
- In the version for material flow monitoring; on pipes, conveying equipment or channels.

It comprises an electric diagnostic unit and up to four acoustic sensors.

Benefits

Benefits when pump monitoring

- Increased availability of the system through:
 - Advanced maintenance planning thanks to early recognition of defective components
 - Reduced downtimes (no fault locating necessary)
 - Increased maintenance intervals
 - Greater pump reliability
- Prevention of expensive consequential damage
- Increased safety of critical applications
- Early recognition of a reduction in power
- Increased productivity

Benefits when material flow monitoring

- Detection of insufficient or excessive inflow of material in a liquid or gas flow
- Detection of blockages or clogging
- Reduction of down times
- Increased product quality
- Increased availability
- Guaranteed operational safety
- Increased productivity

Application

In the version for pump monitoring, the SITRANS DA400 allows continuous, simultaneous and independent monitoring of up to four flow control valves in a pump for leaks. In addition, another four inputs are available for monitoring standard signals (e.g. diaphragm and temperature monitoring). This means that the condition of an oscillating displacement pump is monitored in every phase of its operation.

The SITRANS DA400 is used in all industries where an oscillating displacement pump is used.

The version for material flow monitoring monitors the material flow in liquids or gases that is usually as a result of impact or friction, e.g. against the pipe or channel wall.

Function

Product features

Continuous and independent status monitoring:

- Of the flow control valves, for leaks
- Of the membranes, for material fatigue
- Of the temperature loading of the hydraulic oil
- Of flowing bulk solids in pipes, conveying equipment or channels

Communication of the status to superordinate control systems:

- Via digital outputs
- Digitally, via PROFIBUS DP

Simple to operate and parameterize:

- Locally, via digital display and keys
- PROFIBUS DP

Mode of operation

Principle of measurement

Leaks in the flow control valves of oscillating displacement pumps are flows in which cavitation occurs. This results in sound waves that are transmitted to the valve housing, where they are recorded by the structure-borne sound sensor in the SITRANS DA400 on the outside.

The SITRANS DA400 utilizes the fact that with both an open valve and a closed intact valve, no cavitation occurs and the measured sound level thus corresponds to the operating noise of the pump. By contrast, with a closed defective valve cavitation does occur, which can be identified by a period increase in the sound level (see figures). The measured value from the SITRANS DA400 corresponds exactly to this increase in the sound level.

In the version for material flow monitoring, SITRANS DA400 continuously detects high-frequency acoustic oscillations by means of structure-born noise sensors.

These oscillations are created by:

- Friction and impact of bulk solids in:
 - pipes, raceways or channels
 - chutes
 - conveyors
- Friction and impact of mechanical parts
- Bursting of bubbles
- Cavitation
- Turbulence in gas and liquid flows

The following shows an example of signal levels at an oscillating displacement pump

Process Protection

Acoustic sensors

SITRANS DA400 Acoustic diagnostic unit

Function (continued)

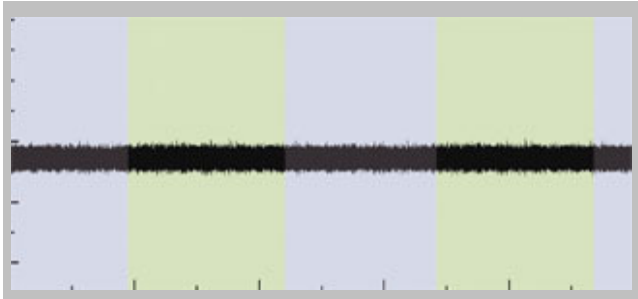

Signal from structure-borne sound sensor with intact valve

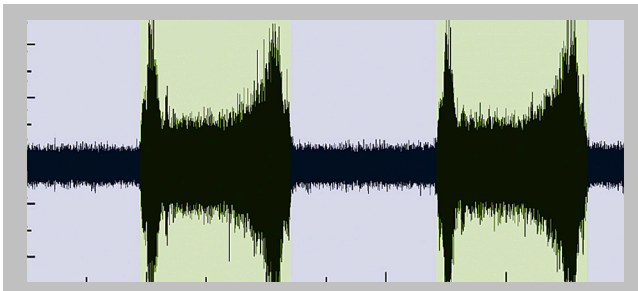

Signal from structure-borne sound sensor with defective valve

Sensor operation

The structure-borne sound sensor works on the piezoelectric principle. The structure-borne sound is injected into the sensor via the sensor base (mounting surface) and inside it is converted into an electrical voltage by a piezo-ceramic element. This is amplified in the sensor and transmitted via the cable.

The sensor frequency range lies in the ultrasonic range (> 20 kHz). The sensor is non-directional, i.e. the angle at which the sound wave impacts on the sensor base is not important.

Selection and ordering data

SITRANS DA400 Acoustic diagnostic unit Monitors material flow in pipes, leakage in valves or oscillating pumps with up to 4 independent acoustic sensors.	Article No. 7MJ2400- ● A A 0 ●				
Click on the Article No. for the online configuration in the PIA Life Cycle Portal.					
Communication					
• PROFIBUS DP		1			
Application software					
For continuous condition monitoring of positive displacement pumps					1
For material flow monitoring in pipes, raceways and conveyors					2

SITRANS DA400 Acoustic diagnostic unit Monitors material flow in pipes, leakage in valves or oscillating pumps with up to 4 independent acoustic sensors.	Article No. 7MJ2000- 1 A ● 0 0				
Click on the Article No. for the online configuration in the PIA Life Cycle Portal.					
Cable (incl. pin and allen screw M6)					
20 m				B	
40 m				C	
100 m				F	

Technical specifications

SITRANS DA400	
Input	
Acoustic channels	4
• Cycle time	10 ms
Universal inputs	4
• Cycle time	80 ms
• Low pass filter time	1 s
Universal analog current input	
• Load	< 105 Ω
• Resolution	0.1 %
• Accuracy	0.5 %
• Fault signal	> 21 mA or < 3.6 mA (at 4 ... 20 mA)
• Alarm monitoring hysteresis	0.5 %
• Static destruction limit	40 mA, 4 V
Universal input 24 V digital signal	
• Input resistance	> 19 kΩ
• Signal level Low	< 4.5 V or open
• Signal level High	> 7 V
• Hysteresis	> 1 V
• Static destruction limit	± 40 V
8.2 V source for NAMUR signal (DIN EN 60947-5-6)	
• Open circuit voltage	8.2 V ± 0.3 V, short-circuit proof
• Input resistance	< 950 Ω
• Static destruction limit for incorrect wiring	+20 V/-10 V
Output	
Digital outputs	6
• Semiconductor relay	Individually isolated, short circuit-proof
• Switching voltage	24 V AC/36 V DC, any polarity
• Destruction limit	35 V AC, 50 V DC
• Max. switching current	100 mA
Conditions of use	
Installation conditions	Vertical wall mounting, cables fed in from below
Climatic class	Class 4K4 according to EN 60721-3-4
Permissible ambient temperature	-20 ... +60 °C (-4 ... +140 °F)
Storage temperature	-20 ... +60 °C (-4 ... 140 °F)
Mechanical load	Class 4M3 according to EN 60721-3-4
Degree of protection to EN 60529	IP65
Electromagnetic Compatibility	
• Emitted interference and interference immunity	To EN 61326 and NAMUR NE 21
Usage limits for water	
• Delivery side	≥ 10 bar a
• Number of strokes	Min. 4 min ⁻¹ , max. 10 ... 500 min ⁻¹
Design	
Weight (without options)	Approx. 2.5 kg
Dimensions (W x H x D) in mm (inch)	172 x 320 x 80 (6.8 x 12.6 x 3.2)
Enclosure material	Polycarbonate
Electrical connection via screw terminals	<ul style="list-style-type: none"> Rigid 2.5 mm (0.984 inch) Flexible 1.5 mm (0.59 inch) Flexible with connector sleeves 1.5 mm (0.59 inch)
Cable inlet via plastic cable joints	<ul style="list-style-type: none"> 2 x Pg 13.5 5 x Pg 11

Technical specifications (continued)

SITRANS DA400	
Power supply	
Rated voltage	24 V DC
Operating range	19 ... 36 V DC
Current consumption	< 100 mA
Communication	
PROFIBUS DP	RS 485, switchable terminating resistor
Protocol	Cyclic with Master C1 and acyclic with Master C2
PC parameterization software	SIMATIC PDM (not included in the scope of delivery)
Sensor for SITRANS DA400	
Setup	<ul style="list-style-type: none"> Piezoceramic sensor with pre-amplifier Encapsulated electronics 4-wire cable with anti-kink sleeve
Conditions of use	
Permissible ambient temperature	-40 ... +110 °C (-40 ... +230 °F)
Degree of protection to EN 60529	P66/IP68
Mechanical load	Class 4M7 according to EN 60721-3-4
Climatic class	Class 4K4 according to EN 60721-3-4
Design	
Housing material	Stainless steel 1.4571 (316Ti SST)
Cable	Ends with wire protectors and cable shoe for connection to the SITRANS DA400
Weight	125 g (0.276 lb)
Dimensions (W x H x D) in mm (inch)	26 x 29 x 40 (1.02 x 1.14 x 1.57)
Power Supply	Power fed from device

Dimensional drawings

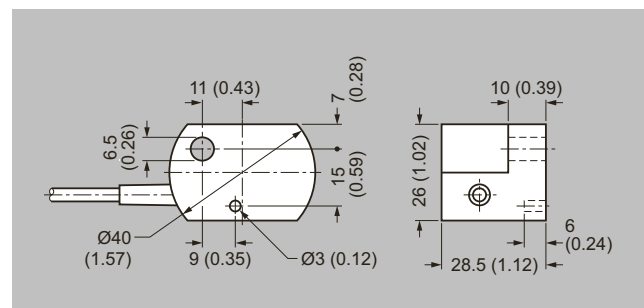

Sensor for SITRANS DA400, dimensions in mm (inch)

Process Protection

Acoustic sensors

SITRANS DA400 Acoustic diagnostic unit

Dimensional drawings (continued)

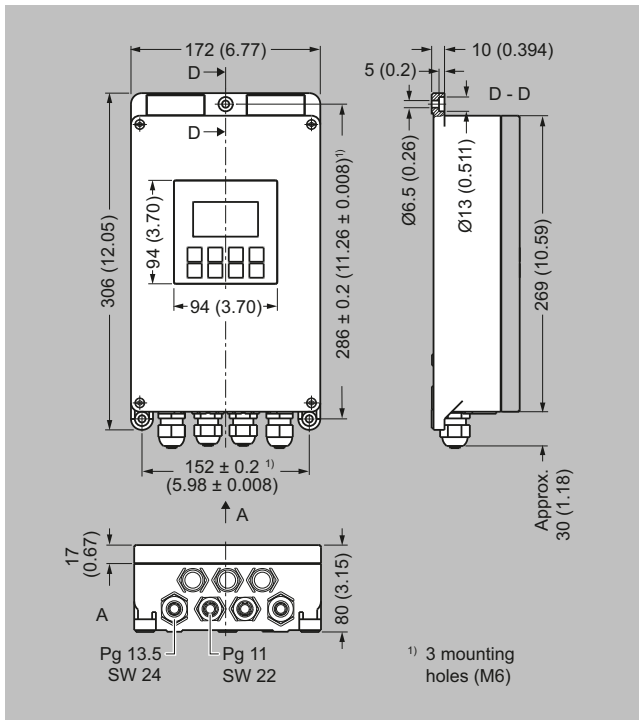

SITRANS DA400, dimensions in mm (inch)

Circuit diagrams

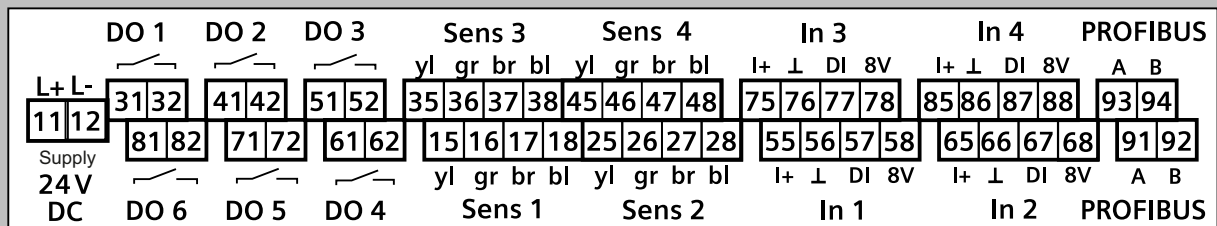

L+/L- Power supply
DO Digital output
Sens Sensor

In Input
yl Yellow
gr Green
br Brown
bl Black
I+ Analog current input +

⊥ Ground
DI Digital input
A Signal A (green) with PROFIBUS DP
B Signal B (red) with PROFIBUS DP

SITRANS DA400, terminal assignment