

Distributed Use of a Safety Laser Scanner on a SIMATIC F-CPU, with Monitoring Case Switching Using an F-CPU

SIMATIC Safety Integrated for Factory Automation

[Application Description](#) • March 2012

Applications & Tools

Answers for industry.

SIEMENS

Siemens Industry Online Support

This document is taken from Siemens Industry Online Support. The following link takes you directly to the download page of this document:

<http://support.automation.siemens.com/WW/view/en/58804919>

Caution

The functions and solutions described in this entry predominantly confine themselves to the realization of the automation task. Please also take into account that corresponding protective measures have to be taken in the context of Industrial Security when connecting your equipment to other parts of the plant, the enterprise network or the Internet. For more information, please refer to Entry ID 50203404.

<http://support.automation.siemens.com/WW/view/en/50203404>.

If you have any questions concerning this document please e-mail us to the following address:

<mailto:online-support.industry@siemens.com>

Please also actively use our technical forum from Siemens Industry Online Support regarding this subject. Share your questions, suggestions or problems and discuss them with our strong forum community:

<http://www.siemens.com/forum-applications>

SIEMENS

SIMATIC

Safety Laser Scanner with Monitoring Case Switching Using F-CPU

Problem

1

Solution

2

SICK S3000 PROFINET IO
Basics

3

Functional Mechanisms

4

Configuration of the
SIMATIC Components

5

Configuration of the
SICK Laser Scanner

6

Installation and
Commissioning

7

Operation of the
Application Example

8

Evaluation according to
IEC 62061 and
ISO 13849-1

9

Safety Function

10

Glossary

11

References

12

History

13

Warranty and Liability

Note

The application examples are not binding and do not claim to be complete regarding the circuits shown, equipping and any eventuality. The application examples do not represent customer-specific solutions. They are only intended to provide support for typical applications. You are responsible for ensuring that the described products are correctly used. These application examples do not relieve you of the responsibility of safely and professionally using, installing, operating and servicing equipment. When using these application examples, you recognize that Siemens cannot be made liable for any damage/claims beyond the liability clause described. We reserve the right to make changes to these application examples at any time without prior notice. If there are any deviations between the recommendations provided in these application examples and other Siemens publications – e.g. Catalogs – then the contents of the other documents have priority.

We do not accept any liability for the information contained in this document.

Any claims against us – based on whatever legal reason – resulting from the use of the examples, information, programs, engineering and performance data etc. described in this application example shall be excluded. Such an exclusion shall not apply in the case of mandatory liability, e.g. under the German Product Liability Act (“Produkthaftungsgesetz”), in case of intent, gross negligence, or injury of life, body or health, guarantee for the quality of a product, fraudulent concealment of a deficiency or breach of a condition which goes to the root of the contract (“wesentliche Vertragspflichten”). However, claims arising from a breach of a condition which goes to the root of the contract shall be limited to the foreseeable damage which is intrinsic to the contract, unless caused by intent or gross negligence or based on mandatory liability for injury of life, body or health. The above provisions do not imply a change in the burden of proof to your detriment.

It is not permissible to transfer or copy these application examples or excerpts of them without first having prior authorization from Siemens Industry Sector in writing.

Table of Contents

	Warranty and Liability	4
1	Problem	7
	1.1 Starting point	7
	1.2 Problem	7
2	Solution.....	8
	2.1 Overview	8
	2.1.1 Core components	8
	2.1.2 Core functionality.....	9
	2.2 Hardware and software components used.....	10
	2.2.1 Hardware components	10
	2.2.2 Software components.....	11
	2.2.3 Downloads for the application example	11
	2.3 Advantages	12
	2.4 Required knowledge.....	12
3	SICK S3000 PROFINET IO Basics	13
	3.1 Field of application	13
	3.2 Principle of operation.....	13
	3.3 Field set and monitoring case	14
	3.4 Communication via PROFINET	16
4	Functional Mechanisms	17
	4.1 Functionality of the application example	17
	4.1.1 Overview	17
	4.1.2 Start machine	17
	4.1.3 Stop machine	19
	4.1.4 Time relationships	20
	4.1.5 Monitoring case switching	21
	4.1.6 Reintegration of F-I/O.....	22
	4.2 Code description (STEP 7 project).....	23
	4.2.1 User program structure	23
	4.2.2 Function circuit diagram	24
	4.2.3 Program block: Start_Stop_Machine	25
	4.2.4 Program block: On_Off_Machine.....	26
	4.2.5 Interaction of Start_Stop_Machine / On_Off_Machine	27
	4.2.6 Program block: Safety.....	28
	4.2.7 Program block: Monitoring_Case_Switching	29
	4.2.8 Program block: Reintegration.....	31
5	Configuration of the SIMATIC Components	32
	5.1 Preliminary remark	32
	5.2 Requirements	32
	5.3 Device configuration.....	33
	5.3.1 PROFINET network.....	33
	5.3.2 PLC_1	34
	5.3.3 S3000	35
	5.3.4 F-CPU.....	36
	5.3.5 F-DI.....	37
	5.3.6 F-DO.....	40
	5.4 Safety Administration	42
6	Configuration of the SICK Laser Scanner	43
	6.1 Preliminary remark	43
	6.2 Requirements	43

Table of Contents

6.3	PROFIsafe address	45
6.4	Inputs	46
6.5	Field sets	47
6.6	Monitoring cases	48
6.7	Restart	48
7	Installation and Commissioning	49
7.1	Overview of the steps	49
7.2	Loading the downloads to the PG/PC	49
7.2.1	Code for the F-CPU	49
7.2.2	Configuration file for the laser scanner	49
7.3	Installing the hardware	50
7.3.1	Installation	50
7.3.2	Overview of the configuration	51
7.3.3	DI wiring	52
7.3.4	F-DI wiring	53
7.3.5	F-DO wiring	54
7.4	Setting the F-CPU to the initial state	55
7.5	Setting the laser scanner to the initial state	57
7.6	Downloading the code to the F-CPU	58
7.7	IP address and device name for the laser scanner	59
7.8	Downloading the configuration file to the laser scanner	60
8	Operation of the Application Example	61
8.1	Creating the initial state of the setup	61
8.2	Operating monitoring case 1	62
8.3	Setting monitoring case 2	62
8.4	Operating monitoring case 2	63
8.5	Error when switching the monitoring case	63
8.6	Watch and force table	64
8.7	PLC tags	65
8.8	Indications on the laser scanner	67
9	Evaluation according to IEC 62061 and ISO 13849	68
9.1	Information on the standards	68
9.2	Safety function	68
10	Safety Function	69
10.1	Mapping of the safety function	69
10.2	Assessment of Detect	70
10.2.1	Evaluation according to IEC 62061	70
10.2.2	Evaluation according to ISO 13849-1	70
10.3	Assessment of Evaluate	71
10.3.1	Evaluation according to IEC 62061	71
10.3.2	Evaluation according to ISO 13849-1	71
10.4	Assessment of React	71
11	Glossary	72
12	References	73
13	History	74

1 Problem

1.1 Starting point

An assembly cell with a robot has two workstations (station 1 and station 2) that can alternately be freely accessed by an operator:

- Case 1: While the robot works at station 1, the operator can load or unload at station 2.
- Case 2: While the the robot works at station 2, the operator can load or unload at station 1.

During operation, the situation changes due to the movement of the robot: The hazardous area becomes the working area and vice versa.

The diagrammatic representation below shows the two cases in the assembly cell (top view).

Figure 1-1

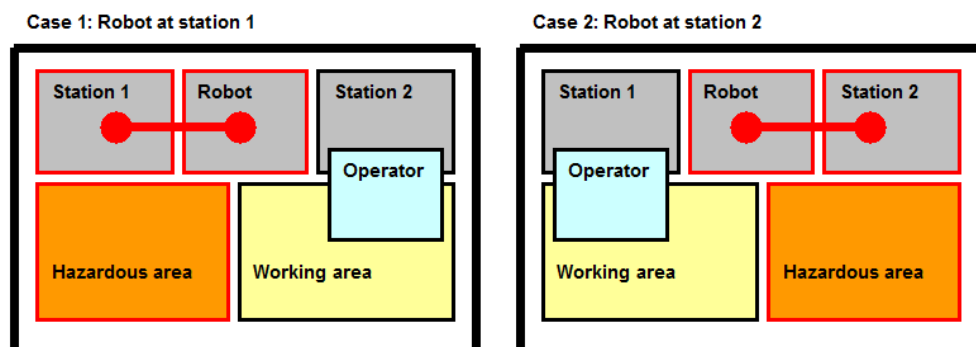

1.2 Problem

To monitor this assembly cell, a SICK safety laser scanner is to be used in conjunction with a fail-safe SIMATIC S7-CPU (F-CPU).

Figure 1-2

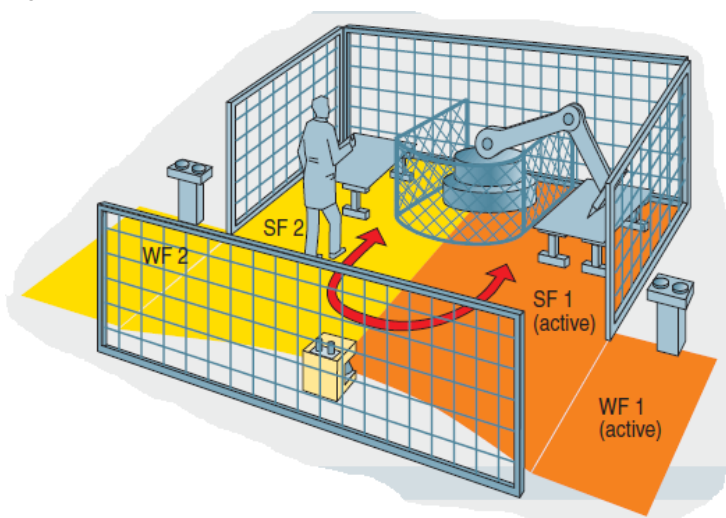

2 Solution

2.1 Overview

2.1.1 Core components

A SICK safety laser scanner is operated on a fail-safe SIMATIC controller via PROFINET.

The following figure schematically shows the most important components of the application example:

- F-CPU (IO controller) with central I/O (DI, F-DI, F-DO)
- Safety laser scanner (IO device), connected via PROFINET on a distributed basis

Figure 2-1

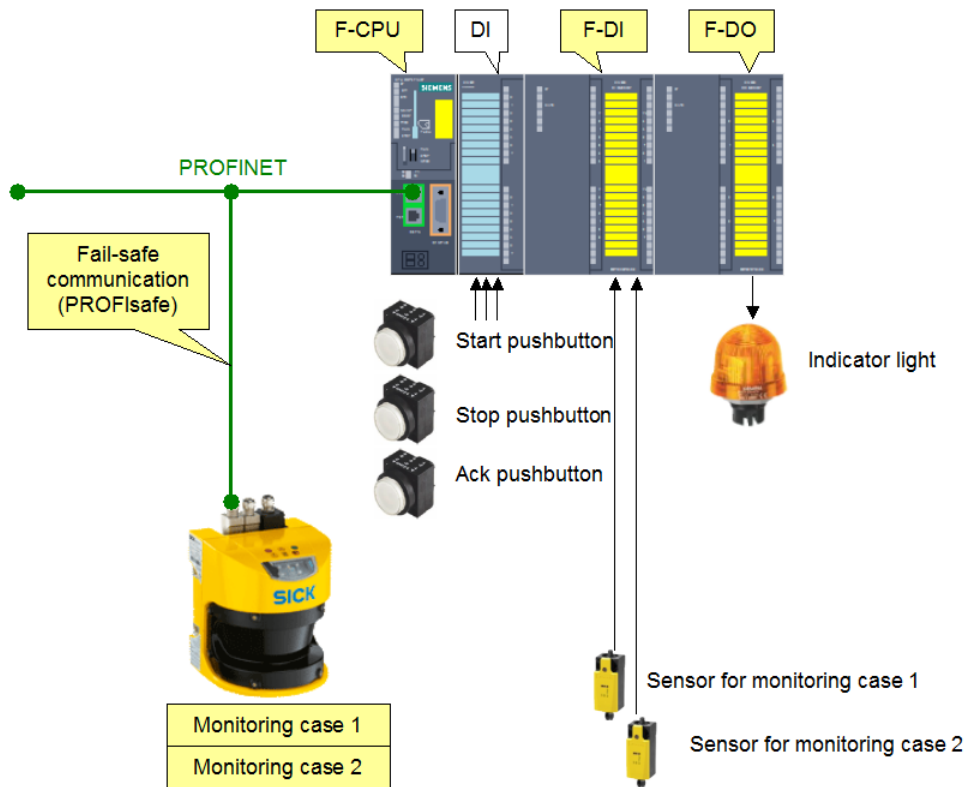

2.1.2 Core functionality

The following functions are implemented in the application example:

- Switching a machine (*1)
- Monitoring changing hazardous areas:
 - Stop of the machine when the active protective field is violated
 - Switching between two monitoring cases (*2)
- Reintegration of passivated F-I/O (*3)

In the safety laser scanner, two field sets are configured for the two monitoring cases:

- Field set 1: Protective field 1 (SF1) and warning field 1 (WF1)
- Field set 2: Protective field 2 (SF2) and warning field 2 (WF2)

(*1): The machine is simulated with an indicator light.

(*2): The application example is prepared for four monitoring cases.

(*3): F-DI, F-DO, safety laser scanner

2.2 Hardware and software components used

The application example was created with the following components.

2.2.1 Hardware components

Manufactured by Siemens

Table 2-1

Component	Type	Qty.	Order no.
DIN rail	Length: 585 mm	1	6ES7390-1AF85-0AA0
Power supply	PS307 24V/5A	1	6ES7307-1EA01-0AA0
Fail-safe S7-CPU	CPU 315F-2PN/DP	1	6ES7315-2FJ14-0AB0
SIMATIC Micro Memory Card	2 MB	1	6ES7953-8LL20-0AA0
Digital input module (DI)	SM 321; DI 16 x 24 VDC	1	6ES7321-1BH02-0AA0
Fail-safe digital input module (F-DI)	SM 326; DI 24 x 24 VDC	1	6ES7326-1BK02-0AB0
Fail-safe digital output module (F-DO)	SM 326; DO 8 x 24 VDC/2 A PM	1	6ES7326-2BF41-0AB0
Front connector for DI	20-pin	1	6ES7392-1BJ00-0AA0
Front connector for F-DI, F-DO	40-pin	2	6ES7392-1BM00-0AA0
Sensor for monitoring case 1, 2 (NC)	SIRIUS mechanical position switch / safety position switch	2	3SE5 / 3SF1
Pushbutton for start, acknowledgement (NO)	SIRIUS pushbutton, indicator light	2	3SB2, 3SB3, 3SF5
Pushbutton for stop (NC)	SIRIUS pushbutton, indicator light	1	3SB2, 3SB3, 3SF5
Indicator light	SIRIUS pushbutton, indicator light	1	3SB2, 3SB3, 3SF5

Manufactured by SICK

Table 2-2

Component	Type	Qty.	Part no.
SICK S3000 PROFINET IO safety laser scanner	Type: S3000-M Advanced Device type: S30A-6111CP	1	1045652
Plug connector with cable for S3000 PROFINET IO	Device type: Sx1A-B0201L	1	2049575
Connecting cable to connect the configuration port to the serial interface of the PC	---	1	6021195

2.2.2 Software components

Siemens software components

Table 2-3

Component	Type	Order no.	Note
STEP 7 Professional V11	SP1, Update 2	6ES7822-1A.01-..	---
STEP 7 Safety Advanced V11	---	6ES7833-1FA11-0YA5	---

SICK software components

Table 2-4

Component	Type	Order no.	Note
Configuration & Diagnostic Software (CDS)	CDS V3.6.6	---	Supplied with the laser scanner, can alternatively be downloaded at /1/

2.2.3 Downloads for the application example

The table contains all downloads of the application example ([/2/](#)).

Table 2-5

Download	File name	Contents
Documentation	58804919_LASER_DOKU_V10_en.pdf	Description for the application example
Code	58804919_LASER_CODE_V10.zip	STEP 7 project
Configuration file	58804919_LASER_CONF_V10.zip	Configuration for the SICK safety laser scanner

2.3 Advantages

SIMATIC Safety Integrated for Factory Automation

In SIMATIC, standard applications and safety-related applications can be implemented with a single system (hardware and software):

This has the following advantages:

- One controller for both applications
- Uniform engineering for both applications
- One bus system for communication for both applications
- Uniform, centrally accessible diagnostics for both applications
- Easy connection of the safety program to the standard user program

SICK S3000 PROFINET IO laser scanner ([/1/](#))

The laser scanner allows flexible protection of hazardous areas:

- Ideal cost-effective, customized solution for direct integration into bus systems
- Communicates all I/O signals directly with the network or the higher level control, including detailed diagnosis
- Up to 8 protective/warning fields
- 3 scanning range variants, each with 4 or 8 protective fields
- Instructive acyclic diagnosis messages
- Simple process image
- Future-oriented and extendable

Examples of fields of application:

- Protection of machines with changing protection areas
- Entry/exit systems
- Hazardous area protection in robot cells and production systems

2.4 Required knowledge

The application example shows the principle of how a laser scanner can be operated on an F-CPU. It does not describe details. Therefore, basic knowledge of the following topics is required:

- Software for SIMATIC controllers:
 - STEP 7 V11 ([/22/](#))
 - STEP 7 Safety Advanced V11 ([/9/](#))
- SIMATIC S7 modular controllers: S7-300 ([/3/](#), [/16/](#))
- Industrial communication: PROFINET ([/20/](#))
- Safety laser scanners: SICK S3000 PROFINET IO ([/1/](#))

3 SICK S3000 PROFINET IO Basics

The application example focuses on the use of a safety laser scanner for SIMATIC Safety Integrated for Factory Automation.

A safety laser scanner from SICK is used as an example.

This chapter describes the basics of the SICK S3000 PROFINET IO safety laser scanner ([1](#)).

3.1 Field of application

The S3000 PROFINET IO safety laser scanner is used for personnel and plant protection. The laser scanner allows monitoring of hazardous areas on machines or vehicles.

Examples of applications:

- Protection of machines with changing hazardous areas
- Hazardous area protection in robot cells and production systems

3.2 Principle of operation

The S3000 is an optical sensor that scans its surroundings in two dimensions using infrared laser beams. The S3000 works on the principle of time of flight measurement. The figure below shows the principle of operation.

Figure 3-1

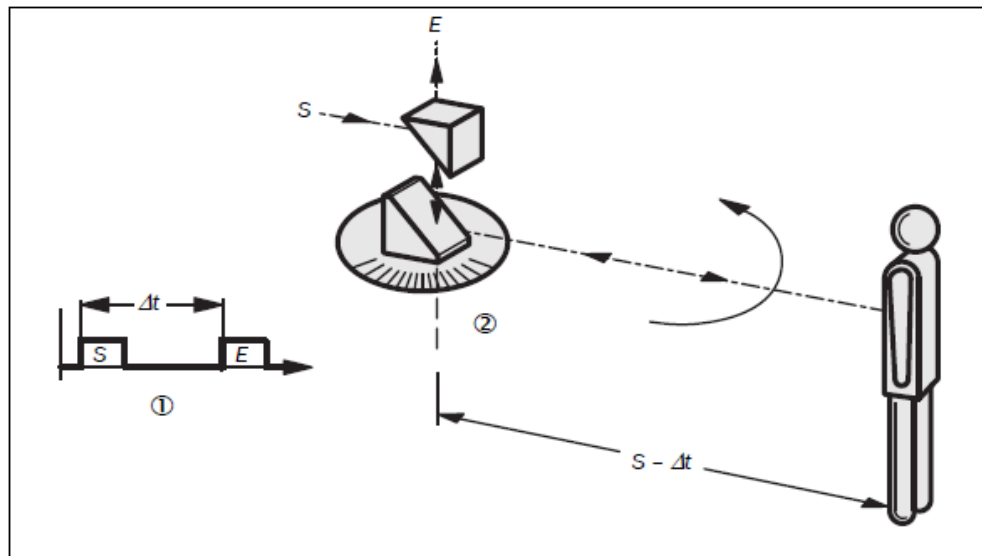

The S3000 sends out very short light pulses (S). At the same time, an “electronic stopwatch” is started. When the light is incident on an object, it is reflected and received by the safety laser scanner (E). From the time between sending and receiving (Δt), the S3000 calculates the distance to the object.

In the S3000, there is also a mirror rotating at a constant speed that deflects the light pulses so that they cover an arc of 190° (Figure 3-2). By determining the angle of rotation of the mirror, the S3000 determines the direction of the object.

From the measured distance and the direction of the object, the safety laser scanner determines the exact position of the object.

Figure 3-2

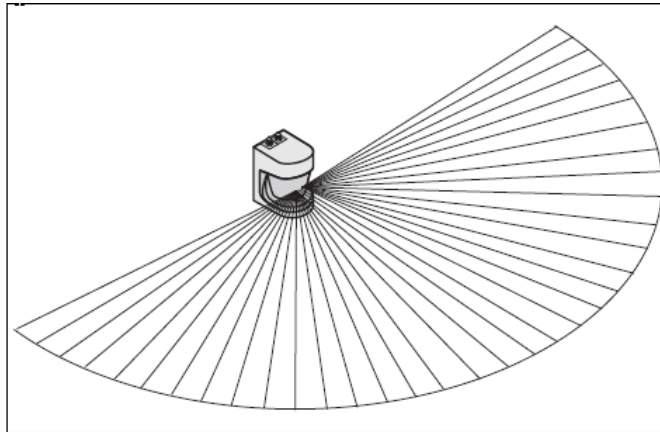

3.3 Field set and monitoring case

Protective field and warning field

The protective field (Figure 3-3, (1)) secures the hazardous area on a machine or vehicle. As soon as the safety laser scanner detects an object in the protective field, the S3000 switches the OSSD signal output (*1) to the off status ("0" signal) and thus initiates the shutdown of the machine or stop of the vehicle.

The warning field (Figure 3-3, ((2)) can be defined so that the safety laser scanner detects an object before the actual hazardous area and, for example, triggers a warning signal.

Figure 3-3

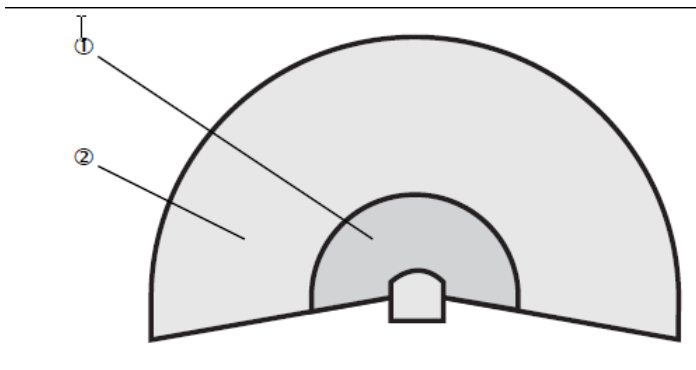

(*1):

OSSD (output signal switching device): Signal output of the protective device that is used to stop the dangerous movement.

Field set

Protective field and warning field form a pair, the so-called field set. With the aid of the Configuration & Diagnostic Software (CDS, [/8/](#)), these field sets are configured and transferred to the S3000. Up to eight field sets can be defined and saved in the S3000 PROFINET IO.

Monitoring case

With the S3000 safety laser scanner, you can define different monitoring cases to match the protective fields and warning fields to the situation on the machine. This allows situation-specific monitoring of changing hazardous areas, for example during the different production phases of a machine.

When configuring using the Configuration & Diagnostic Software (CDS, [/8/](#)), a monitoring case x is assigned a field set y (protective field y, warning field y).

Example

Figure 3-4 shows an example of hazardous area protection with two areas to be monitored. Two monitoring cases are defined in the robot cell shown in this figure:

- Monitoring case 1: Warning field 1 (WF1) and protective field 1 (SF1)
- Monitoring case 2: Warning field 2 (WF2) and protective field 2 (SF2)

Depending on where the robot is located in the robot cell, the respective monitoring case is active:

- The robot is located on the left: Monitoring case 2 is active
- The robot is located on the right: Monitoring case 1 is active

Figure 3-4

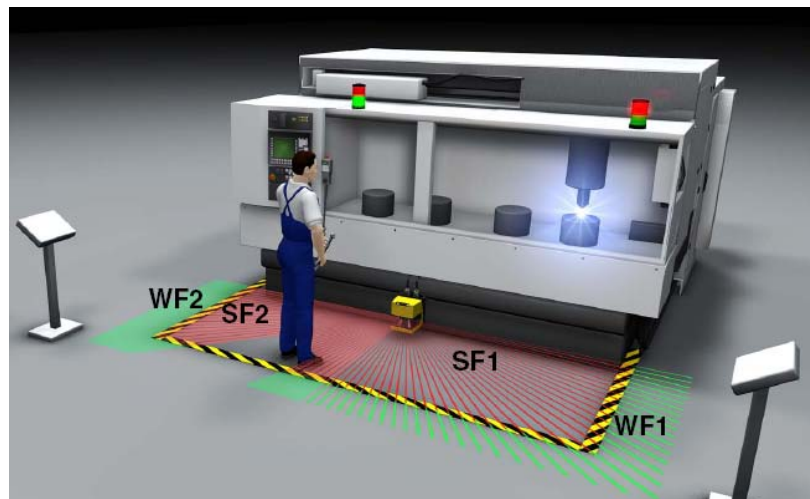

In the figure, the robot is located on the right of the robot cell, i.e. monitoring case 1 is active. This means:

- When the operator enters protective field 1, the robot will stop.
- The operator may enter protective field 2 and warning field 2.

3.4 Communication via PROFINET

The S3000 PROFINET IO is operated as an IO device on PROFINET. All input signals and output signals of the laser scanner are exchanged with the IO controller via the PROFINET interface.

Secure communication

Safety-related components and standard components can be operated together on PROFINET. This is enabled by PROFINsafe, an extension of PROFINET.

PROFINsafe defines how safety-related IO devices (e.g., a SICK safety laser scanner) securely communicate with safety-related IO controllers (e.g., a SIMATIC F-CPU) via a network.

Process image of the SIMATIC F-CPU

F-CPU and safety laser scanner cyclically exchange signals via the process image.

Figure 3-5

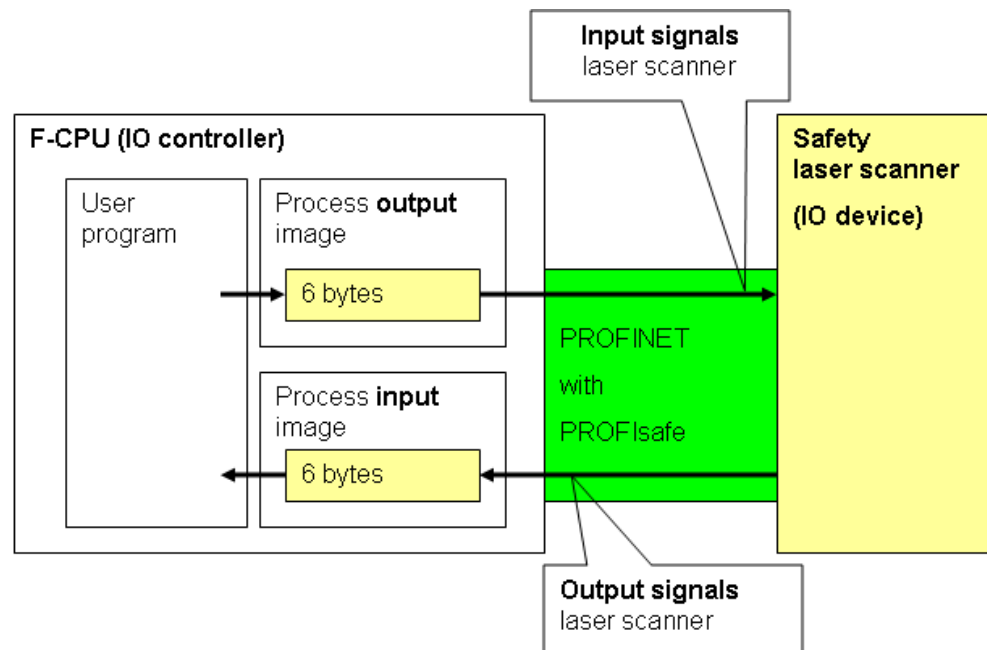

Examples of input signals of the laser scanner (F-CPU outputs):

- Number of the monitoring case
- Reset protective field
- Initialize

Examples of output signals of the laser scanner (F-CPU inputs):

- Protective field unoccupied
- Warning field unoccupied
- Contamination

4 Functional Mechanisms

4.1 Functionality of the application example

4.1.1 Overview

The following functions are implemented in the application example:

- Switching a machine (*1)
- Monitoring changing hazardous areas:
 - Stop of the machine when the active protective field is violated
 - Switching between two monitoring cases (*2)
- Reintegration of passivated F-I/O (*3)

In the safety laser scanner, two field sets are configured for the two monitoring cases:

- Field set 1: Protective field 1 (SF1) and warning field 1 (WF1)
- Field set 2: Protective field 2 (SF2) and warning field 2 (WF2)

(*1): The machine is simulated with an indicator light.

(*2): The application example is prepared for four monitoring cases.

(*3): F-DI, F-DO, safety laser scanner

4.1.2 Start machine

The start of the machine depends on how the machine was previously stopped.

The following events cause the machine to stop:

- Stop pushbutton
- Error:
 - Protective field violation
 - Passivation (F-DI, F-DO, laser scanner)
 - Error when switching the monitoring case

Start after: Stop pushbutton

The machine will only be started again when (AND):

- Start pushbutton pressed
- No error has occurred

See Figure 4-1.

Start after: Protective field violation

The machine will only be started again when (AND):

- Protective field not violated
- Acknowledgement pushbutton pressed, then start pushbutton pressed
- No error has occurred

Figure 4-1

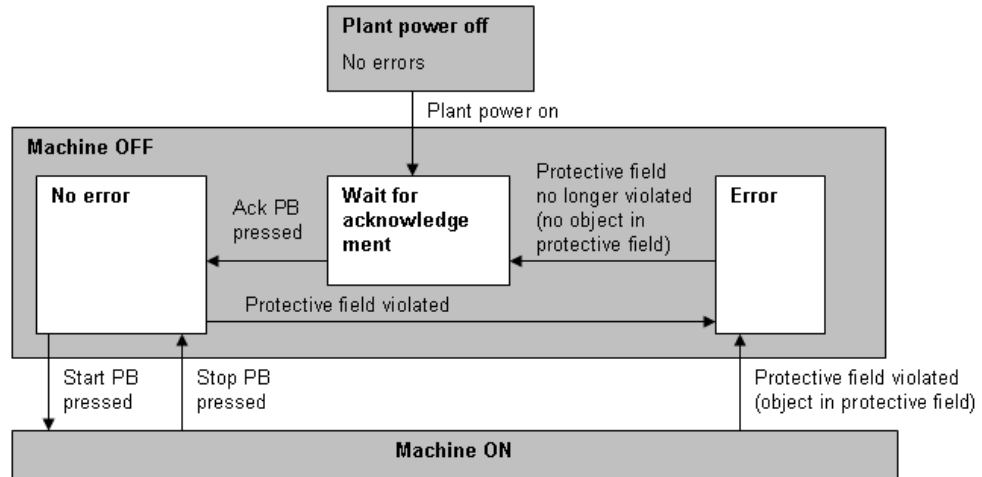

Start after: Passivation of F-DO

The machine will only be started again when (AND):

- Error of the F-DO eliminated
- Positive edge at the "Ack_Passivation" flag
- No error has occurred

Figure 4-2

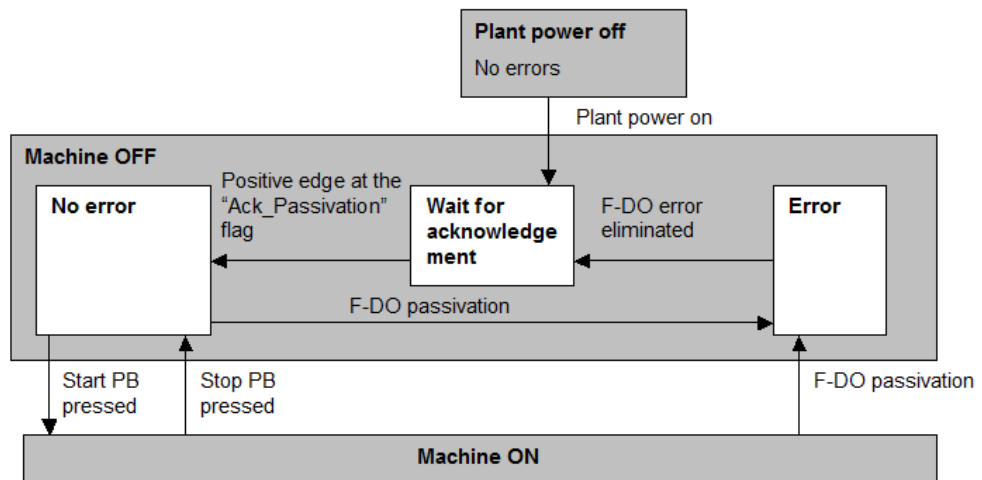

Start after:**Passivation of F-DI or laser scanner, error when switching the monitoring case**

The machine will only be started again when (AND):

- Power off, then power on
- Acknowledgement pushbutton pressed, then start pushbutton pressed
- No error has occurred

Figure 4-3

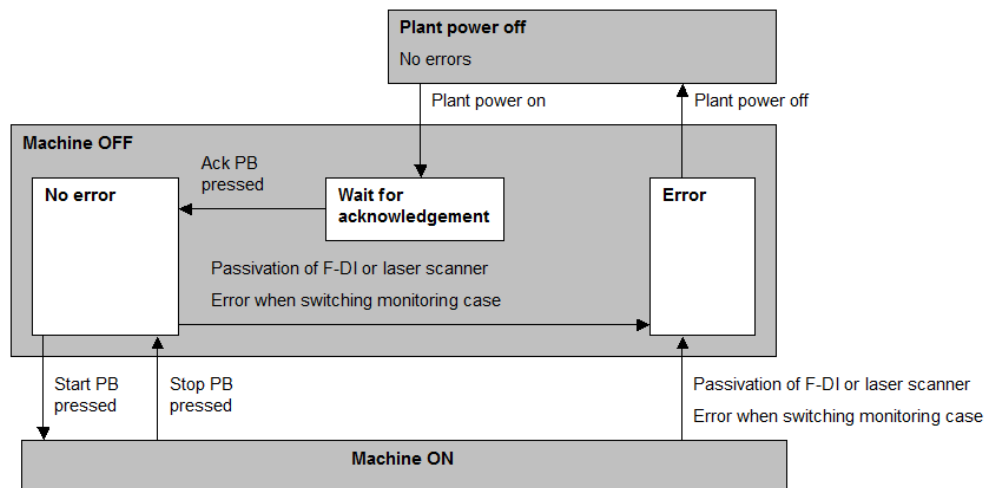
**4.1.3 Stop machine**

The machine will be stopped when (OR):

- Stop pushbutton pressed
- Error (*1) has occurred

(*1):

The following errors can occur:

- Violation of the protective field
- Passivation (F-DI, F-DO, laser scanner)
- Error when switching the monitoring case

4.1.4 Time relationships

The figure below shows the time relationships:

- Start and stop of the machine using pushbuttons
- Stop due to a violation of the active protective field
- Start when the active protective field is unoccupied again and acknowledgement has been made.

Explanation of the signals shown in Figure 4-4.

Table 4-1

Signal	Hardware	Explanations
START	Start pushbutton	Positive edge: Start the machine
STOP	Stop pushbutton	"0" Signal: Stop the machine
ACK	Acknowledgement pushbutton	Positive edge: Acknowledgement
OSSD	Laser scanner	"0" Signal: Protective field violation
ACTUATOR	Machine (indicator light)	---

Time characteristic of the signals:

Figure 4-4

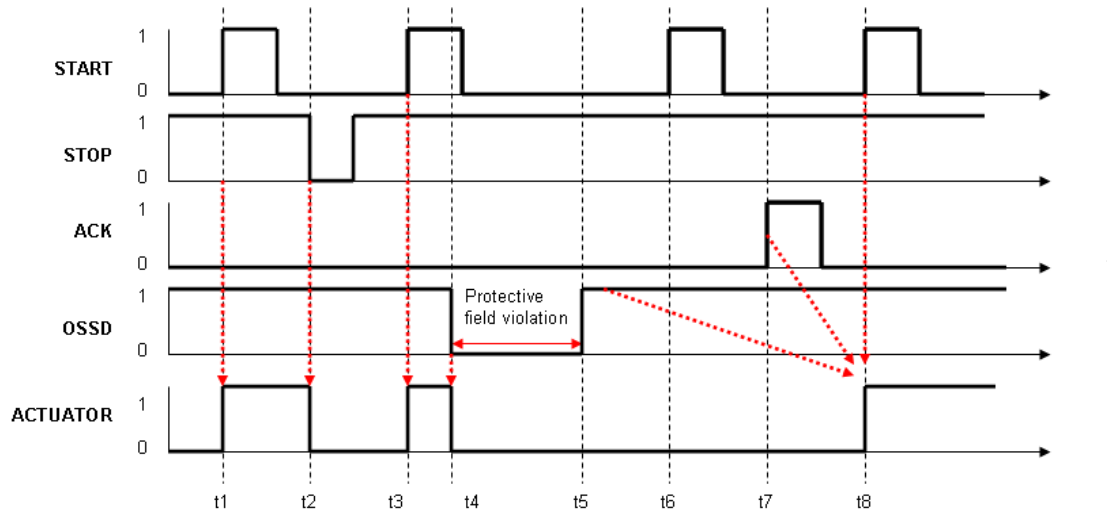

Explanation of the above times tx:

Time	Explanations
t1	Start the machine
t2	Stop the machine
t3	Start the machine
t4	Violation of the active protective field: Stop the machine
t5	Protective field free again
t6	Machine cannot be started due to missing acknowledgement
t7	Acknowledgement
t8	Start the machine

4.1.5 Monitoring case switching

Monitoring cases

Two monitoring cases are implemented in the application example. The monitoring cases are selected using two sensors (e.g., position switches):

- Sensor 1 has “0”, sensor 2 has “1”: Monitoring case 1 is selected
- Sensor 1 has “1”, sensor 2 has “0”: Monitoring case 2 is selected

Note: The application example can be extended to four monitoring cases. For this purpose, preparations were made in the code. To extend the application example, basically perform the following steps:

- Connect additional sensors for case switching (connection to F-DI)
- Configure additional monitoring cases and field sets (with CDS [/8/](#))

Monitoring the case switching

Switching from monitoring case 1 to monitoring case 2 means:

- Sensor 1 changes from “0” to “1”
- Within the switching time, sensor 2 changes from “1” to “0”

The maximum permissible time (switching time) for switching between two monitoring cases is monitored by the F-CPU. The permissible switching time depends on the specific application. Therefore, the switching time can be parameterized in the application example.

Figure 4-5 shows the correlations for four sensors and switching from monitoring case 1 to monitoring case 2.

Figure 4-5

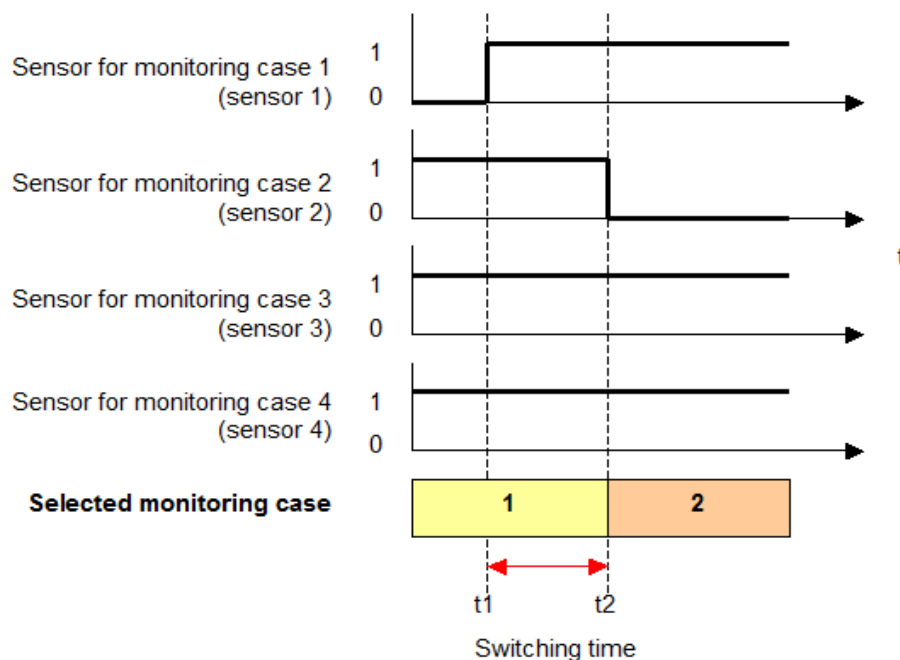

4.1.6 Reintegration of F-I/O

If an error occurs in a component of the F-I/O, this results in the passivation of this component. Once the error has been eliminated, the passivated component must be reintegrated.

In the application example, reintegration is implemented in different ways:

- F-DI and laser scanner: Reintegration without operator intervention
- F-DO: Reintegration with operator intervention
(generation of a positive edge at the Ack_Passivation flag)

4.2 Code description (STEP 7 project)

4.2.1 User program structure

Preliminary remark

The code contains the user program (STEP 7 project) for the F-CPU.

The user program consists of:

- Standard user program
- Safety program

Overview

Standard user program:

Figure 4-6

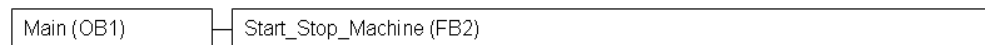

Safety program:

Figure 4-7

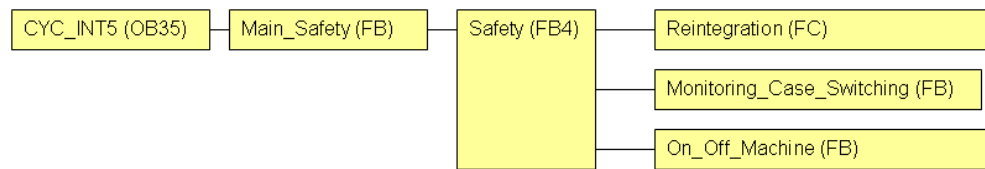

Program blocks of the standard user program

Table 4-2

Program block	Function
Start_Stop_Machine	Request to start or stop the machine

Program blocks of the safety program

Table 4-3

Program block	Function
Safety	Call of the following blocks: <ul style="list-style-type: none"> • Reintegration • Monitoring_Case_Switching • On_Off_Machine
Reintegration	Reintegration of passivated F-I/O
Monitoring_Case_Switching	Monitoring case switching
On_Off_Machine	Switching the machine (indicator light) on or off

Password for the safety program

A password for the safety program is not used in the code of the application example.

4.2.2 Function circuit diagram

The figure shows the following correlations:

- Hardware / user program
- Standard user program / safety program

Figure 4-8

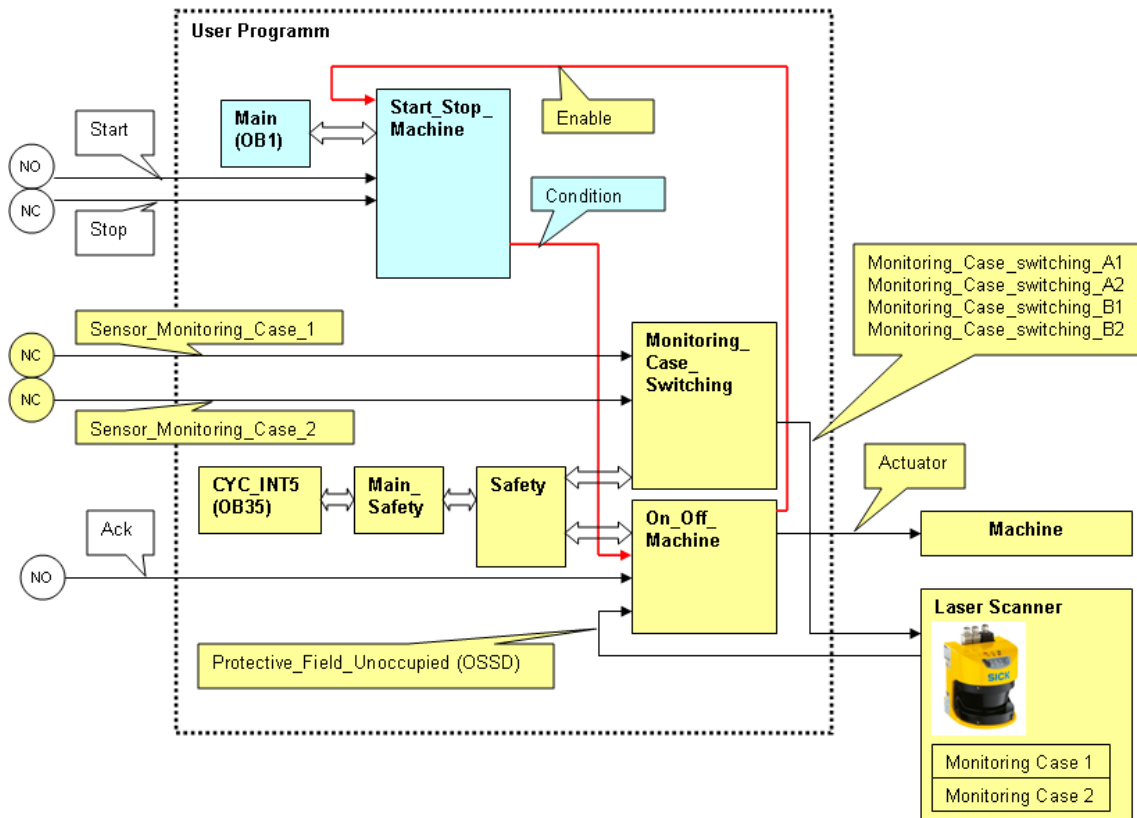

Explanations

NO: Pushbutton (NO)

NC: Pushbutton (NC)

Contents of the legends in the figure: Variables of the user program

4.2.3 Program block: Start_Stop_Machine

Program

Standard user program

Function

The block generates a request to start or stop the machine. The request is evaluated in the safety program.

The block evaluates:

- Start pushbutton
- Stop pushbutton
- "Enable" signal from the safety program (On_Off_Machine)

The block provides to the safety program (On_Off_Machine):

- "Condition" signal

Parameters of the function block

Figure 4-9

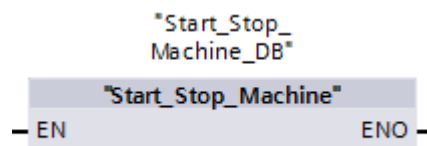

Table 4-4

Parameter	Declaration	Type	Description
---	---	---	---

Implementation

Description: See chapter 4.2.5.

It describes the interaction of the following two program blocks:

- Start_Stop_Machine
- On_Off_Machine

4.2.4 Program block: On_Off_Machine

Program

Safety program

Function

The block implements the start or stop of the machine.

The block evaluates:

- Acknowledgement pushbutton
- “Flag_Condition” signal from the standard user program (Start_Stop_Machine)
- “OSSD” signal from the laser scanner

The block provides to the standard user program:

- “Enable” signal

Parameters of the function block

Figure 4-10

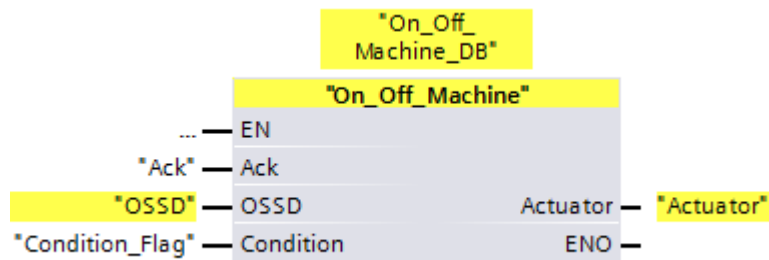

Table 4-5

Parameter	Declaration	Type	Description
Ack	IN	Bool	Signal from the acknowledgement pushbutton
OSSD	IN	Bool	Safety-related signal from the laser scanner. “0” signal: Active protective field violated
Condition (*1)	IN	Bool	The signal is generated in the standard user program. “0” signal: Prevents the machine from starting.
Actuator	OUT	Bool	Signal to the machine (indicator light)

(*1):

“Condition” must be transferred to the safety program via a flag (“Condition_Flag”).

Implementation

Description: See chapter 4.2.5.

It describes the interaction of the following two program blocks:

- Start_Stop_Machine
- On_Off_Machine

4.2.5 Interaction of Start_Stop_Machine / On_Off_Machine

The figure shows the interaction of the following two blocks:

- Start_Stop_Machine
- On_Off_Machine

Description of functionality:

- See chapter 4.1.2 and 4.1.3.

Figure 4-11

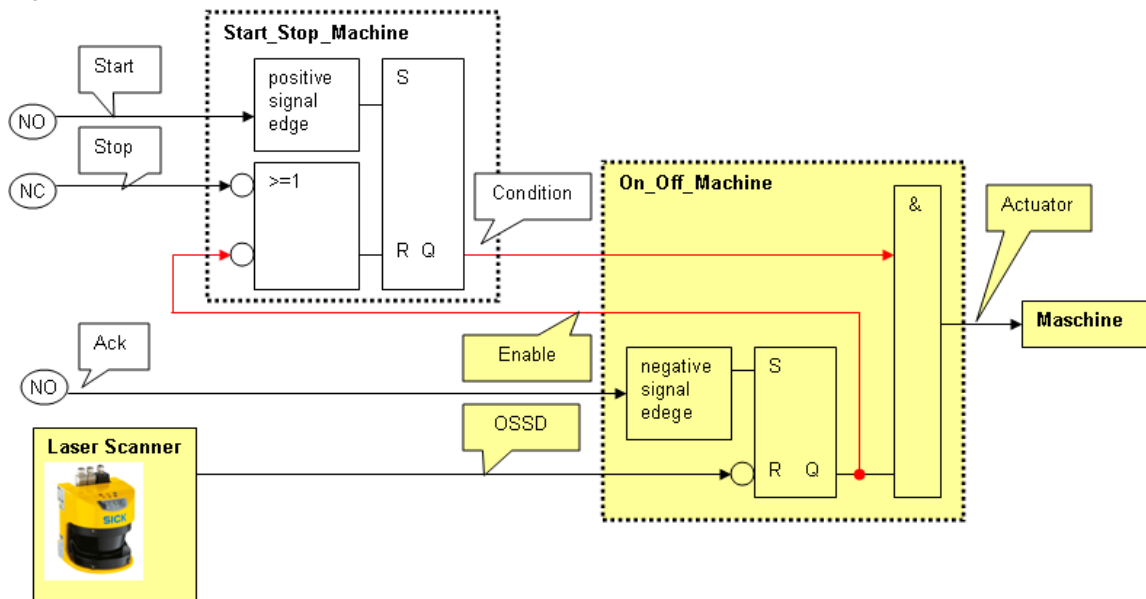

Copyright © Siemens AG 2012 All rights reserved

Explanations of the figure

For the flipflop (SR), reset (R) has priority.

Meaning of the variables:

Table 4-6

Variable	Explanation
Start	Positive edge: Request to start the machine
Stop	"0" signal: Stop of the machine
Ack	Negative edge: The machine can be started again
Enable	"0" signal: Prevents the machine from starting "1" signal: The machine can be started
OSSD	"0" signal: Stop of the machine
Condition (*1)	"0" signal: Prevents the machine from starting
Actuator	"1" signal: Signal to the machine (indicator light)

(*1):

"Condition" must be transferred to the safety program via a flag ("Condition_Flag").

4.2.6 Program block: Safety

Program

Safety program

Function

The program block calls the following blocks:

- Reintegration (chapter 4.2.8)
- Monitoring_Case_Switching (chapter 4.2.7)
- On_Off_Machine (chapter 4.2.4)

Parameters of the function block

Figure 4-12

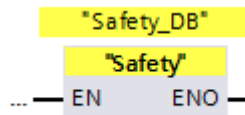

Table 4-7

Parameter	Declaration	Type	Description
---	---	---	---

4.2.7 Program block: Monitoring_Case_Switching

Program

Safety program

Function

Monitoring case switching

This block implements monitoring case switching of max. four monitoring cases.

For this purpose, the F-CPU reads in the status of max. 4 sensors, derives the monitoring case number from this information and writes the respective control signals (A1, A2, B1, B2) to the laser scanner. The laser scanner activates the field set that is allocated to the monitoring case number.

One sensor (NC) is allocated to each monitoring case:

- Monitoring case 1: Sensor 1
- Monitoring case 2: Sensor 2
- Monitoring case 3: Sensor 3
- Monitoring case 4: Sensor 4

Monitoring case x is selected when the following applies (AND):

- The sensor for monitoring case x is active ("0" signal)
- All other sensors are not active ("1" signal)

Switching time monitoring

The time that is required to switch between two monitoring cases (switching time) is monitored. The switching time can be parameterized on the block.

The following conditions are monitored:

- After switching a sensor from "0" to "1", another sensor must switch from "1" to "0" within the monitoring time.
- After switching, exactly one of the following cases must be present:
 - Sensor 1 has "0" signal and all other sensors have "1" signal
 - Sensor 2 has "0" signal and all other sensors have "1" signal
 - Sensor 3 has "0" signal and all other sensors have "1" signal
 - Sensor 4 has "0" signal and all other sensors have "1" signal

If the above conditions are not met, an error has occurred.

Response in the event of an error

The control signals (from the F-CPU to the laser scanner) for switching the monitoring cases (A1, A2, B1, B2) are deleted ("0").

In the laser scanner, the deletion of the control signals ("0") causes the following actions:

- Reset of the OSSD bit (signal from the laser scanner to the F-CPU):
This causes the stop of the machine via the F-CPU.
- Error display on the laser scanner:
"Incorrect operation of the control inputs" (see chapter 8.8).

Implementation in the application example

Two monitoring cases are implemented in the application example. The code is prepared for max. 4 monitoring cases. To use additional monitoring cases, perform the following steps:

- Configure the additional field sets and allocate the monitoring cases using the CDS (/8/)
- Interconnect the additional sensors for the monitoring cases at the call interface of the program block

Parameters of the function block

Figure 4-13

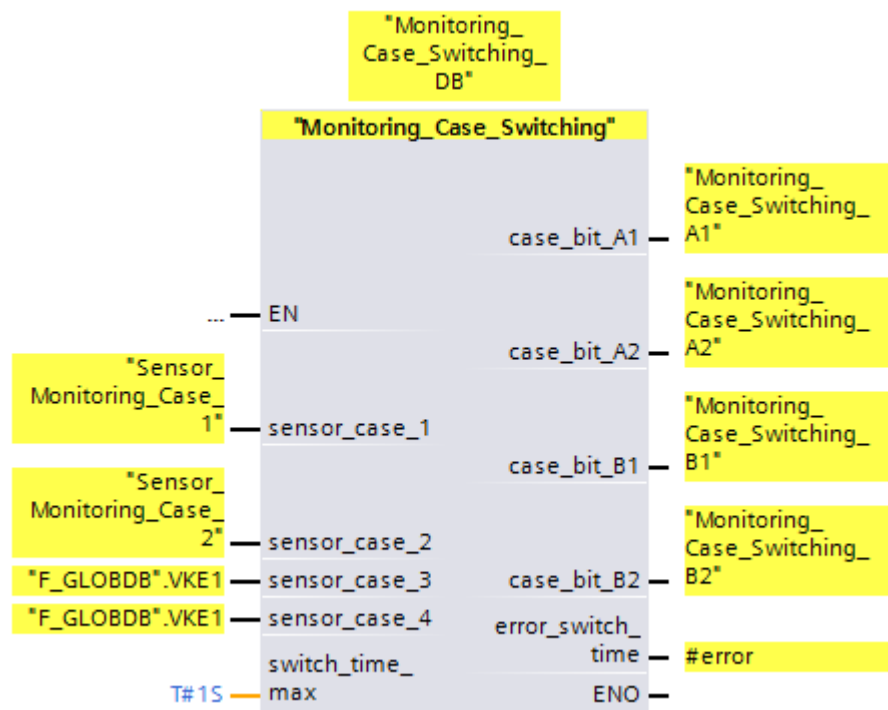

Table 4-8

Parameter	Declaration	Type	Description
sensor_case_1	IN	Bool	Sensor for monitoring case 1 (*1)
sensor_case_2	IN	Bool	Sensor for monitoring case 2 (*1)
sensor_case_3	IN	Bool	Sensor for monitoring case 3 (*1)
sensor_case_4	IN	Bool	Sensor for monitoring case 4 (*1)
switch_time_max	IN	Time	Maximum permissible switching time
case_bit_A1	OUT	Bool	Control signals for switching the monitoring cases: Monitoring case number (*2)
case_bit_A2	OUT	Bool	
case_bit_B1	OUT	Bool	
case_bit_B2	OUT	Bool	
error_switch_time	OUT	Bool	Error when monitoring the switching time

(*1): Non-existent sensors must be interconnected with a "1" signal.

(*2): The following table shows the allocation:

Table 4-9

Sensor for monitoring case				Control signals from F-CPU to laser scanner				Monitoring case
sensor_case_1	sensor_case_2	sensor_case_3	sensor_case_4	case_bit_B2	case_bit_B1	case_bit_A2	case_bit_A1	
0	1	1	1	0	1	0	1	1
1	0	1	1	0	1	1	0	2
1	1	0	1	1	0	0	1	3
1	1	1	0	1	0	1	0	4

4.2.8 Program block: Reintegration

Program

Safety program

Function

Components of the F-I/O (F-DI, F-DO, laser scanner) can passivate.

Examples of events that cause passivation:

- Wire break on the F-DO
- Missing power supply on the F-DI
- No communication between laser scanner and F-CPU

The block reintegrates passivated components. Reintegration is implemented differently in the code:

- Reintegration without operator intervention
 - F-DI
 - Laser scanner
- Reintegration with operator intervention (*1)
 - F-DO

(*1): After passivation, a positive edge must be generated at a flag bit (Ack_Passivation) (chapter 8.6).

Parameters of the function block

Figure 4-14

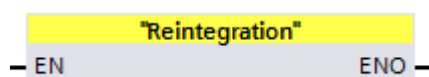

Table 4-10

Parameter	Declaration	Type	Description
---	---	---	---

5 Configuration of the SIMATIC Components

5.1 Preliminary remark

This chapter describes the most important settings that were made in the application example for the SIMATIC components:

- Settings in the Device Configuration of STEP 7
- Settings in the Safety Administration of STEP 7

Note

It is not necessary to make the settings in the application example, they are already included in the code. This chapter is for information only.

5.2 Requirements

The SICK safety laser scanner must be integrated into the STEP 7 hardware catalog. The laser scanner comes with a CD-ROM that includes the device master file (GSDML file). New IO devices installed via GSDML files can be found in "Other field devices" in the hardware catalog.

Figure 5-1

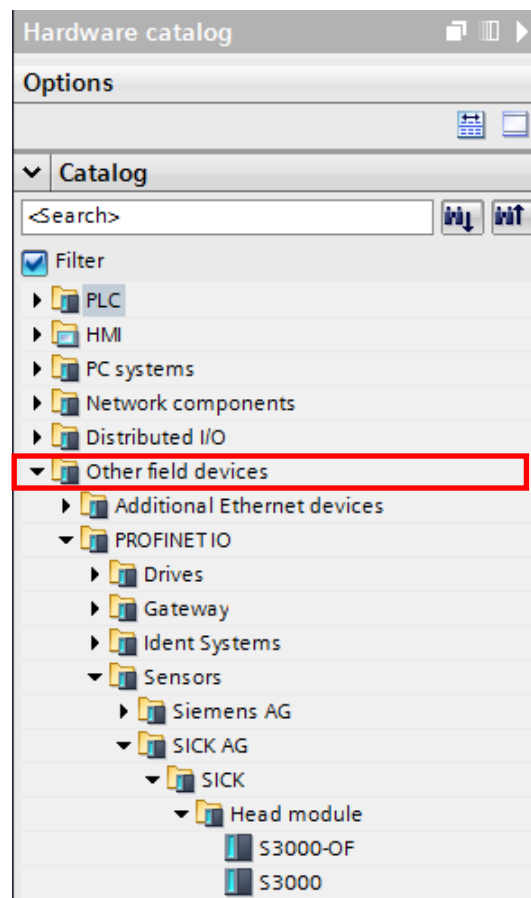

5.3 Device configuration

Open the Device configuration as follows:

- Start the TIA Portal
- Open the project view
- Open the “laser_scanner_03” project
- In the project tree:
Open “PLC_1 (CPU 315-F-2 PN/DP)” device > Open the Device configuration

5.3.1 PROFINET network

Actions in the Device configuration:

- In the workspace: Open the Network view
- In the Inspector window: Open the Network overview

Result:

Figure 5-2

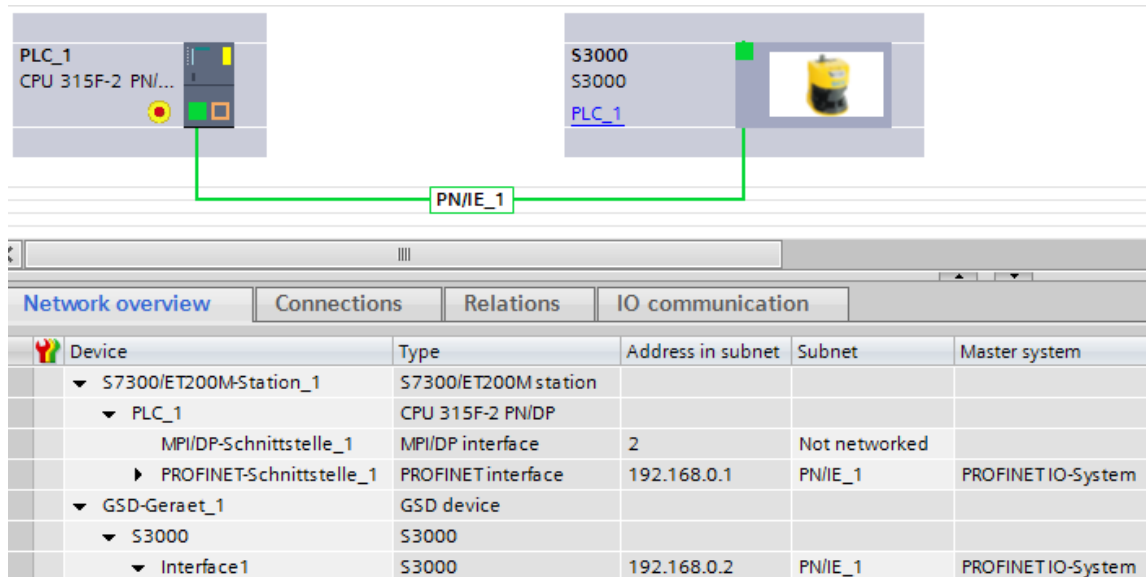

5.3.2 PLC_1

Actions in the Device configuration:

- In the workspace: Open the device view > Select “PLC_1”

Result:

Figure 5-3

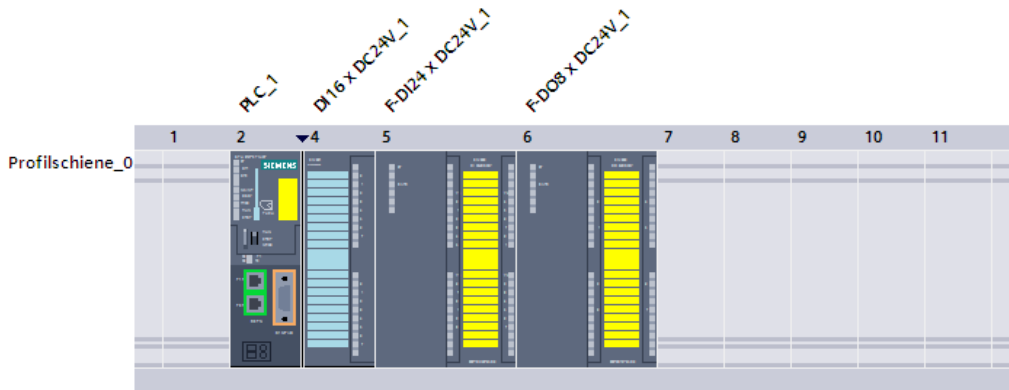

Device overview								
Module	Rack	Slot	I address	Q address	Type	Order no.	Firmware	
▼ PLC_1	0	1						
MPI/DP-Schnittstelle_1	0	2 X1	2047*		MPI/DP interface	6ES7 315-2FJ14-0AB0	V3.2	
▶ PROFINET-Schnittstelle_1	0	2 X2	2046*		PROFINET interface			
	0	3						
DI16 x DC24V_1	0	4	0...1		DI16 x 24VDC	6ES7 321-1BH02-0AA0		
F-DI24 x DC24V_1	0	5	2...11	2...5	F-DI24 x DC24V	6ES7 326-1BK02-0AB0		
F-DO8 x DC24V_1	0	6	12...16	12...16	F-DO8 x DC24V	6ES7 326-2BF41-0AB0		

5.3.3 S3000

Actions in the Device configuration:

- In the workspace:
 - Open the device view > Select "S3000"
 - In the device overview: Select "S3000 In/Out_1"
- In the Inspector window:
 - Select the "Properties" tab > Select "PROFIsafe"

Result:

Figure 5-4

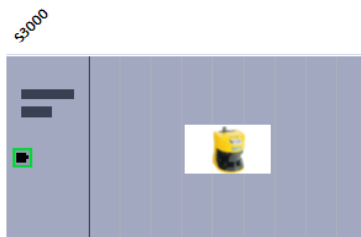

Module	Rack	Slot	I address	Q address	Type	Order no.	Firmware	Comment
S3000	0	0	2042*		S3000		1.2.0	
Interface1	0	0 X1	2041*		S3000			
S3000 In/Out_1	0	1	17...26	17...26	S3000 In/Out			

Properties
S3000 In/Out_1

General

PROFIsafe

I/O addresses

PROFIsafe

F_SIL: SIL2

F_CRC_Length: 3-Byte-CRC

F_Block_ID: 0

F_Par_Version: 1

F_Source_Add: 1

F_Dest_Add: 2

F_Par_CRC_WithoutAddresses: 3813

Manual setting of F_WD_Time

The PROFIsafe address (F_Dest_Add) of the laser scanner is read out here.

CDS (/8/) is used to enter the value in the configuration file of the laser scanner (chapter 6.3).

5.3.4 F-CPU

Actions in the Device configuration:

- In the workspace:
 - Open the device view > Select “PLC_1”
- In the Inspector window:
 - Select the “Properties” tab
 - Select “Fail-safe” (see result 1)
 - Select “F-parameter” (see result 2)

Result 1:

Figure 5-5

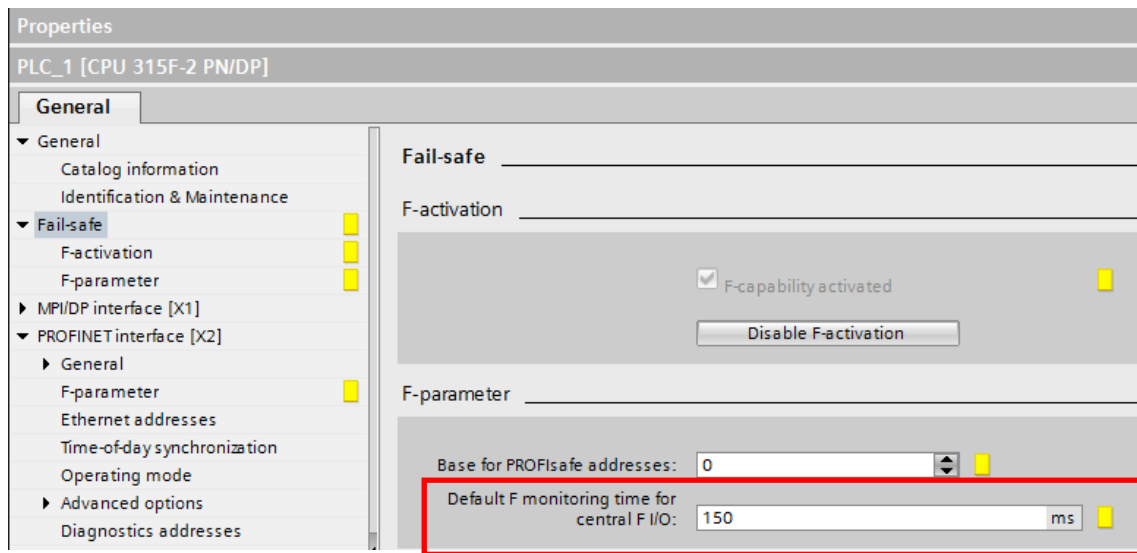

F-monitoring time for central F-I/O: 150 ms (Default)

Result 2:

Figure 5-6

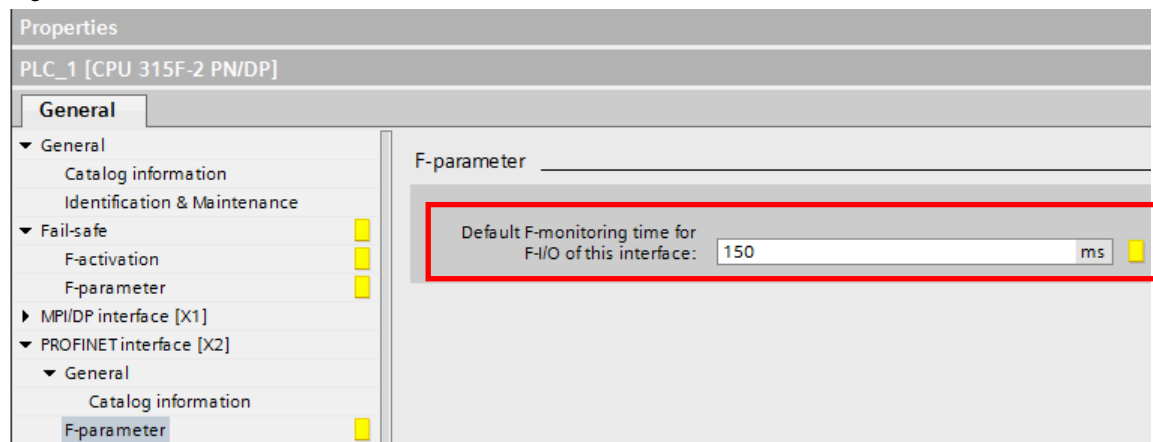

F-monitoring time for F-I/O of this interface: 150 ms (Default)

5.3.5 F-DI

Actions in the Device configuration:

In the workspace:

- Open the device view > Select “F-DI24 xDC24V_1”

In the Inspector window:

- Select the “Properties” tab
- Select “F-parameter” (see result 1)
- “DI parameter” > “Supply group 1Vs/3Vs” (see result 2)
- “DI parameter” > “Supply group 2Vs/4Vs” (see result 3)

Result 1:

Figure 5-7

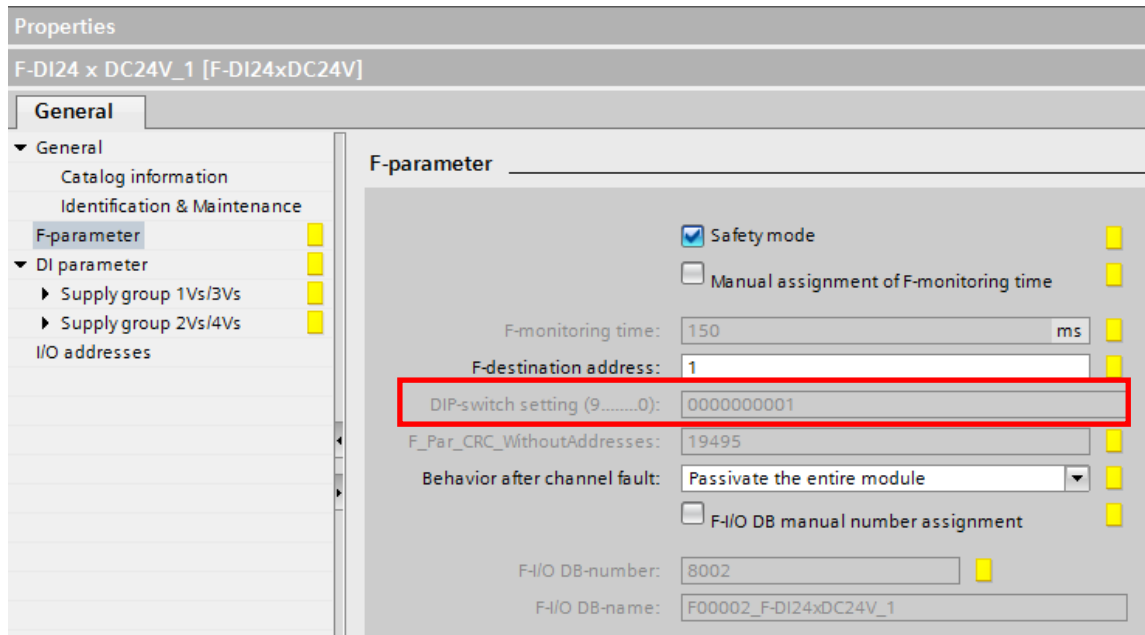

On the F-DI, the F-destination address is set on the DIP switch.

Result 2:

Figure 5-8

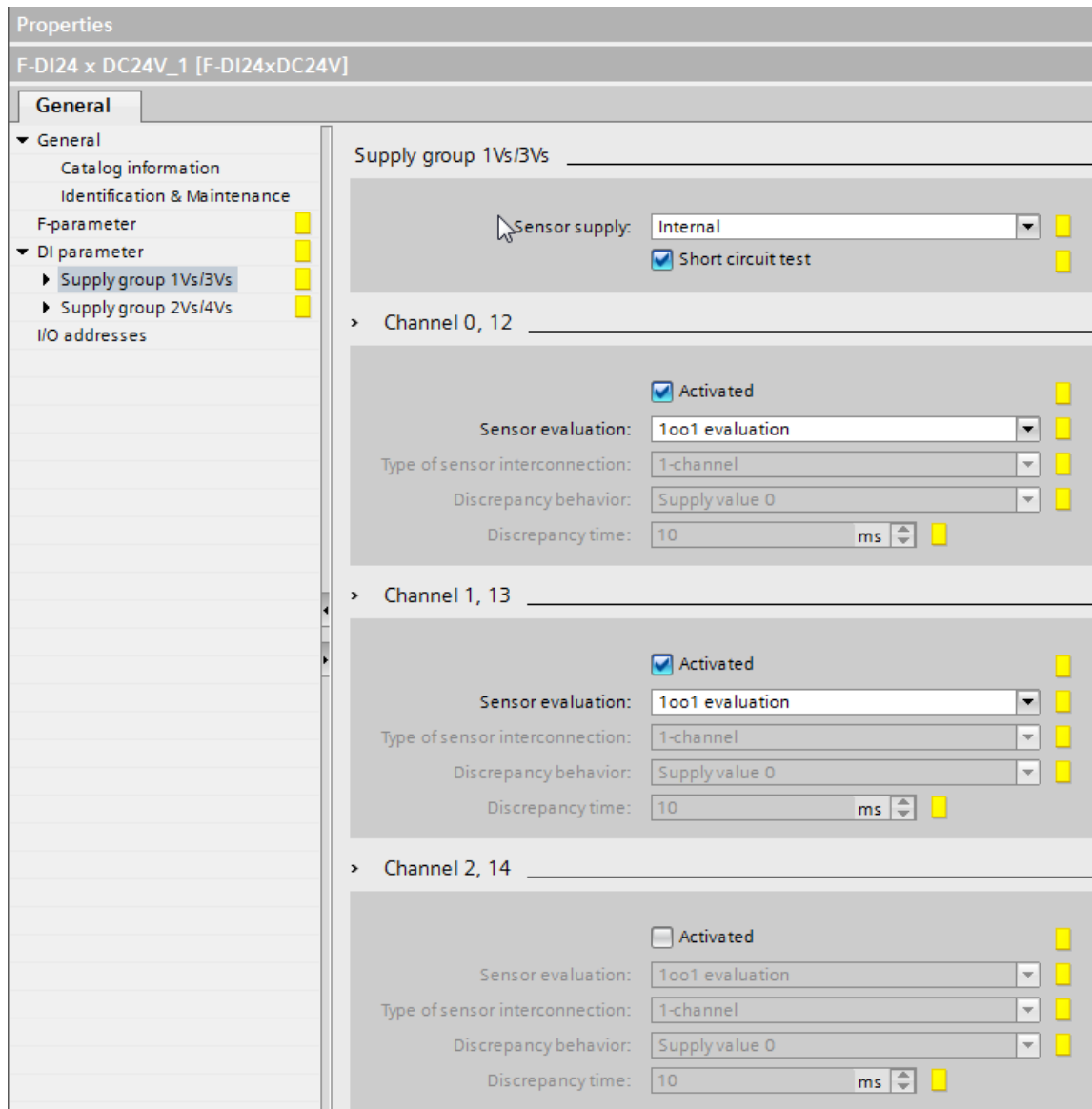

Settings:

- Internal sensor supply / short circuit test activated
- Channel 0,12: 1001 evaluation
- Channel 1,13: 1001 evaluation
- All other channels: Not activated

Channel assignment:

- Channel 0: Sensor for monitoring case 1
- Channel 1: Sensor for monitoring case 2

Result 3:

Figure 5-9

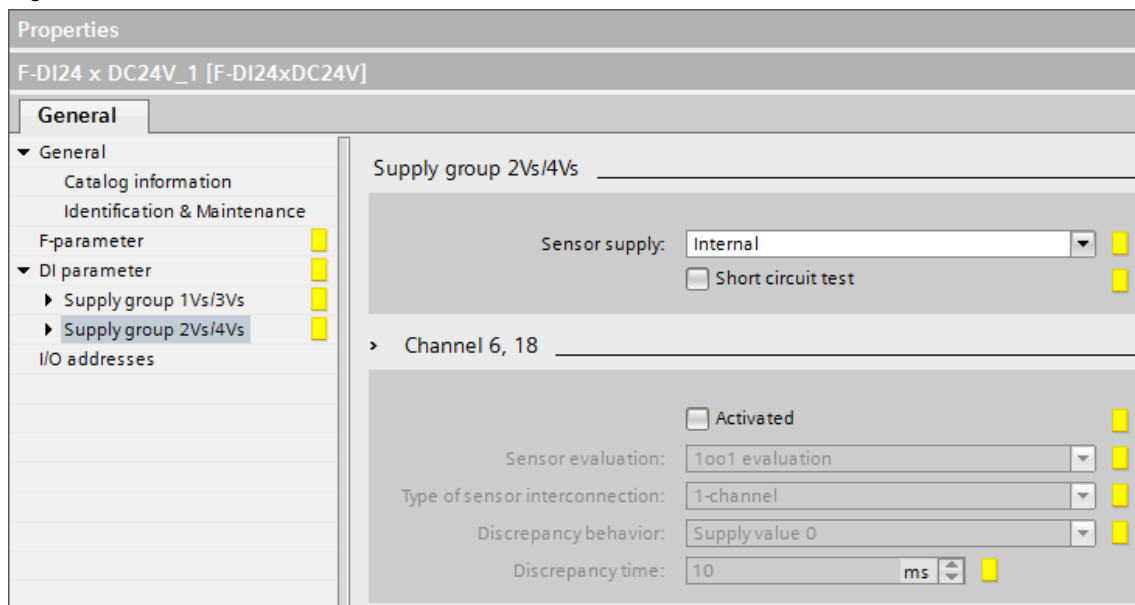

Settings:

- Internal sensor supply / short circuit test not activated
- All channels: Not activated

5.3.6 F-DO

Actions in the Device configuration:

In the workspace:

- Open the device view > Select “F-DO8 xDC24V_1”

In the Inspector window:

- Select the “Properties” tab
- Select “F-parameter” (see result 1)
- Select “DO parameter” (see result 2)

Result 1:

Figure 5-10

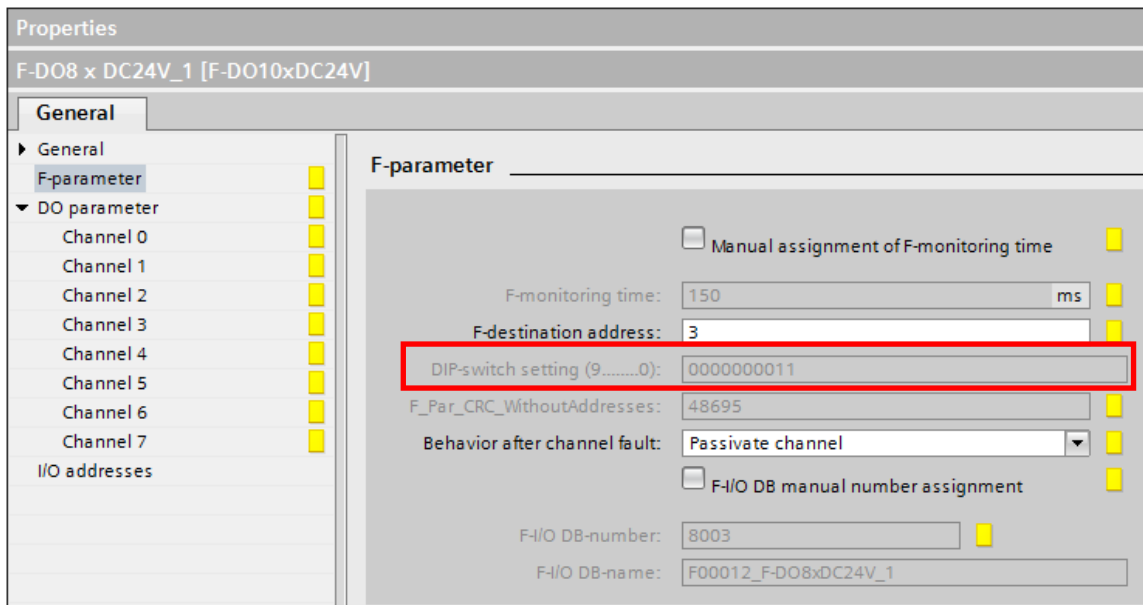

On the F-DO, the F-destination address is set on the DIP switch.

Result 2:

Figure 5-11

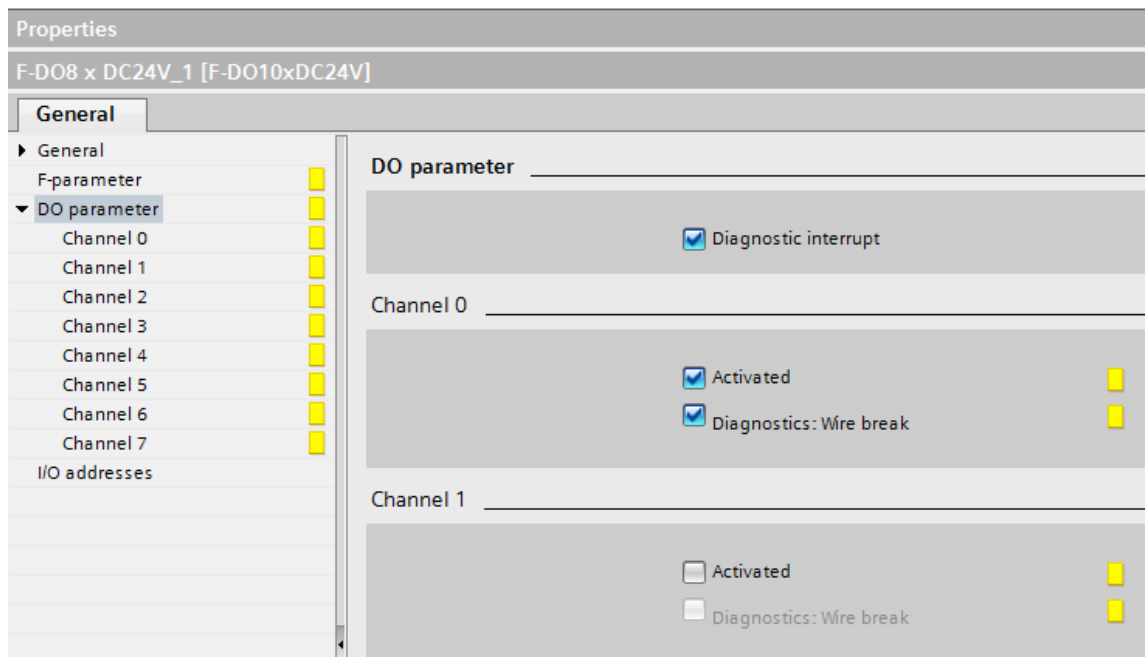

Settings:

- Channel 0: Activated
- All other channels: Not activated

Channel assignment:

- Channel 0: Machine (indicator light)

5.4 Safety Administration

Open the Safety Administration as follows:

- Start the TIA Portal
- Open the project view
- Open the “laser_scanner_03” project
- In the project tree:
 - Open the “PLC_1 (CPU 315-F-2 PN/DP)” device
 - Open the Safety Administration
- In the workspace, select “F-runtime groups”

Result:

Figure 5-12

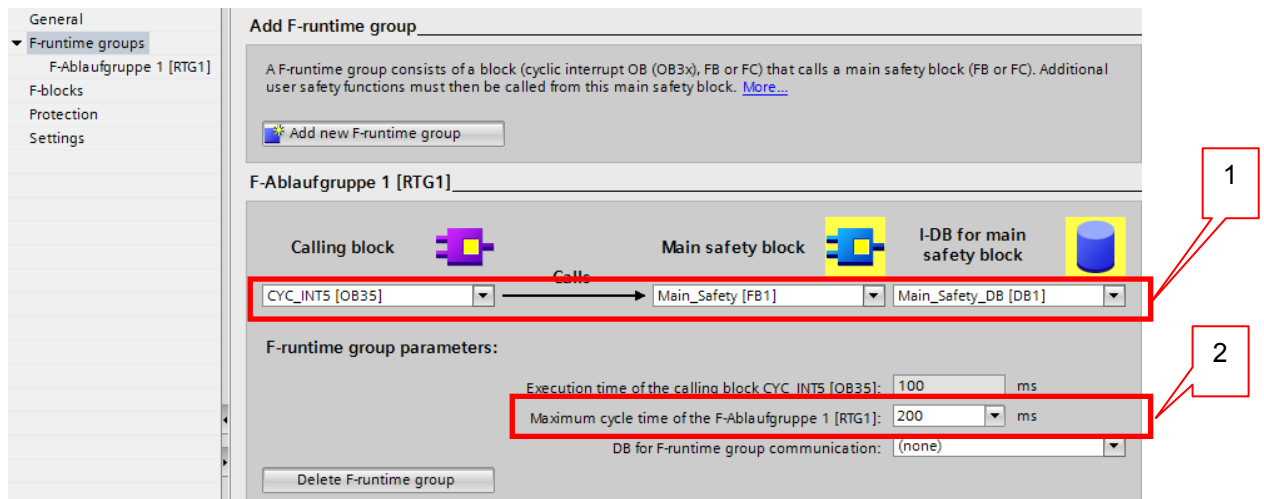

(1): Define the F-runtime group

(2): Set the monitoring time for the F-runtime group

6 Configuration of the SICK Laser Scanner

6.1 Preliminary remark

This chapter describes the most important settings that were made in the application example for the SICK safety laser scanner:

- Settings with the Configuration & Diagnostic Software (CDS, [/8/](#))

Note

It is not necessary to make the settings in the application example, they are already included in the configuration file. This chapter is for information only.

6.2 Requirements

For the requirements, see [/1/](#), [/8/](#).

Configuration & Diagnostic Software (CDS)

For the configuration, the laser scanner must be connected to the PG/PC. The CDS must be installed on the PG/PC.

The CDS can be used to configure all available parameters of the S3000 and define the field geometries of the protective fields and warning fields.

The result of the configuration is stored in a configuration file (name.skp). The configuration file is downloaded to the laser scanner.

Configuration of the laser scanner

For the application example, the configuration was performed via the local serial interface of the laser scanner.

Figure 6-1

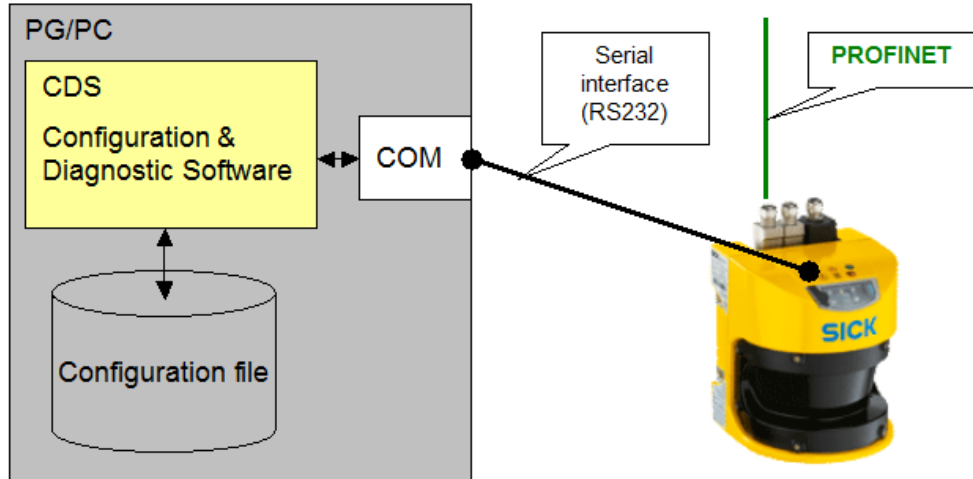
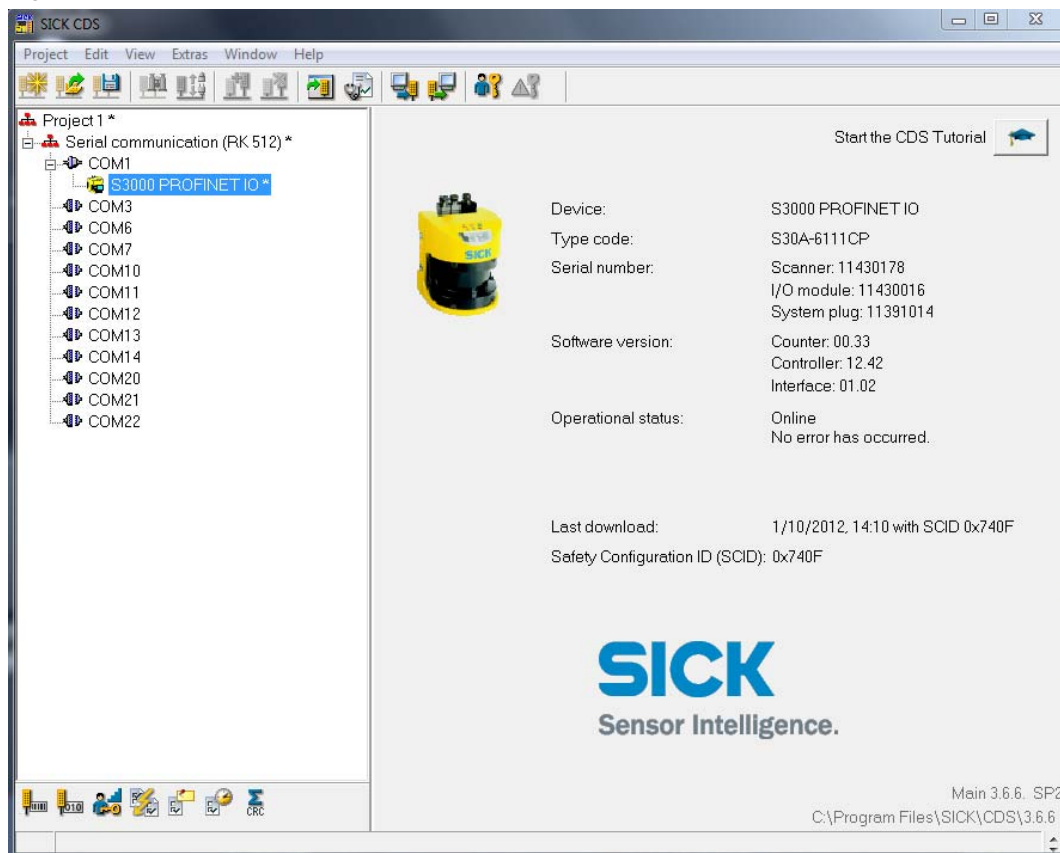

Figure 6-2 shows an example of the user interface of the Configuration & Diagnostic Software (CDS).

Figure 6-2



6.3 PROFIsafe address

To ensure that the laser scanner can be operated as a PROFIsafe node, it must have its own PROFIsafe address. The PROFIsafe address of the laser scanner was taken from STEP 7 (chapter 5.3.3) and entered in the CDS.

Figure 6-3

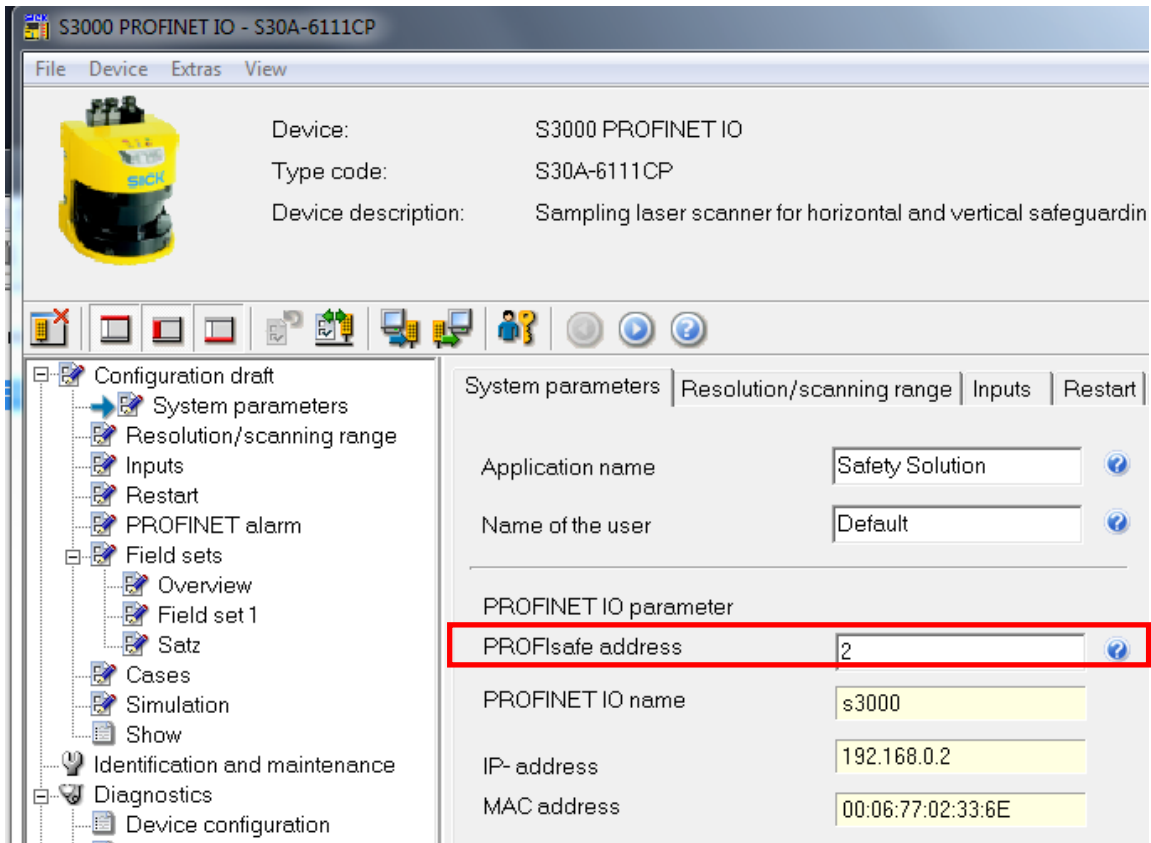

6.4 Inputs

Two monitoring cases are implemented in the application example, four monitoring cases are prepared. Therefore, the “Input A-B” case is configured.

Figure 6-4

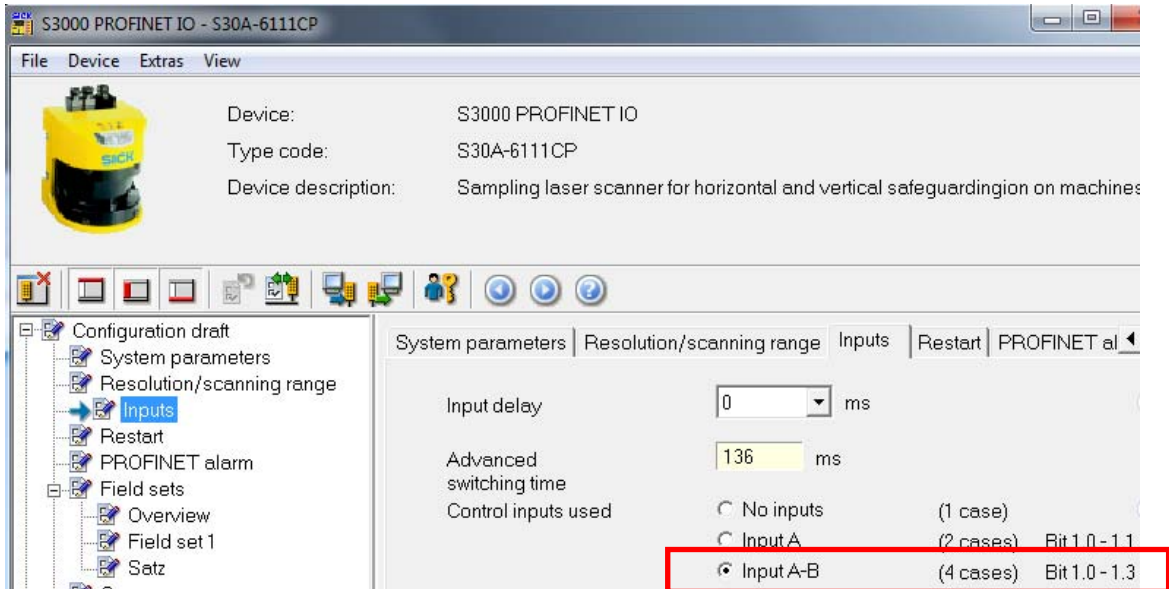

6.5 Field sets

Two field sets are configured:

- Field set 1 (protective field 1, warning field 1)
- Field set 2 (protective field 2, warning field 2)

Figure 6-5

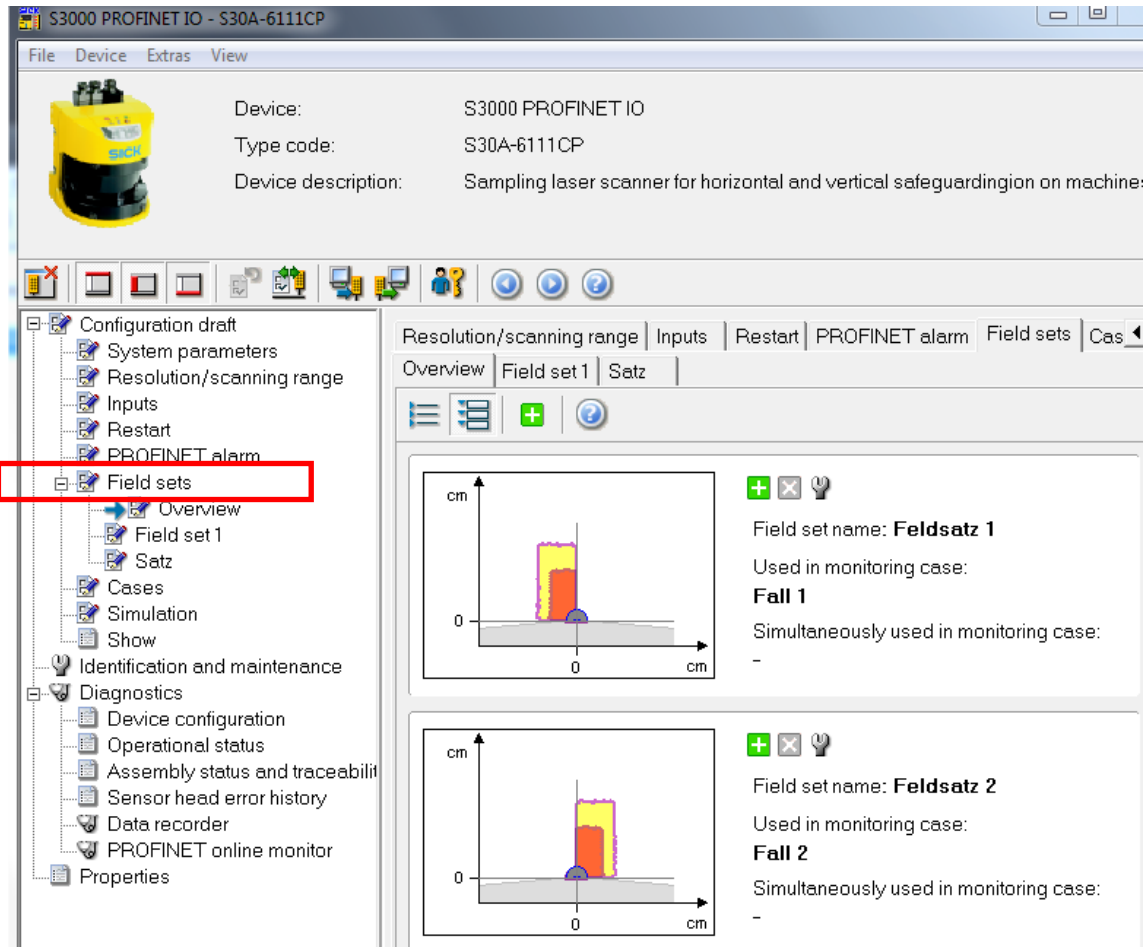

6.6 Monitoring cases

Two monitoring cases are configured:

- Monitoring case 1 with field set 1
- Monitoring case 2 with field set 2

Figure 6-6

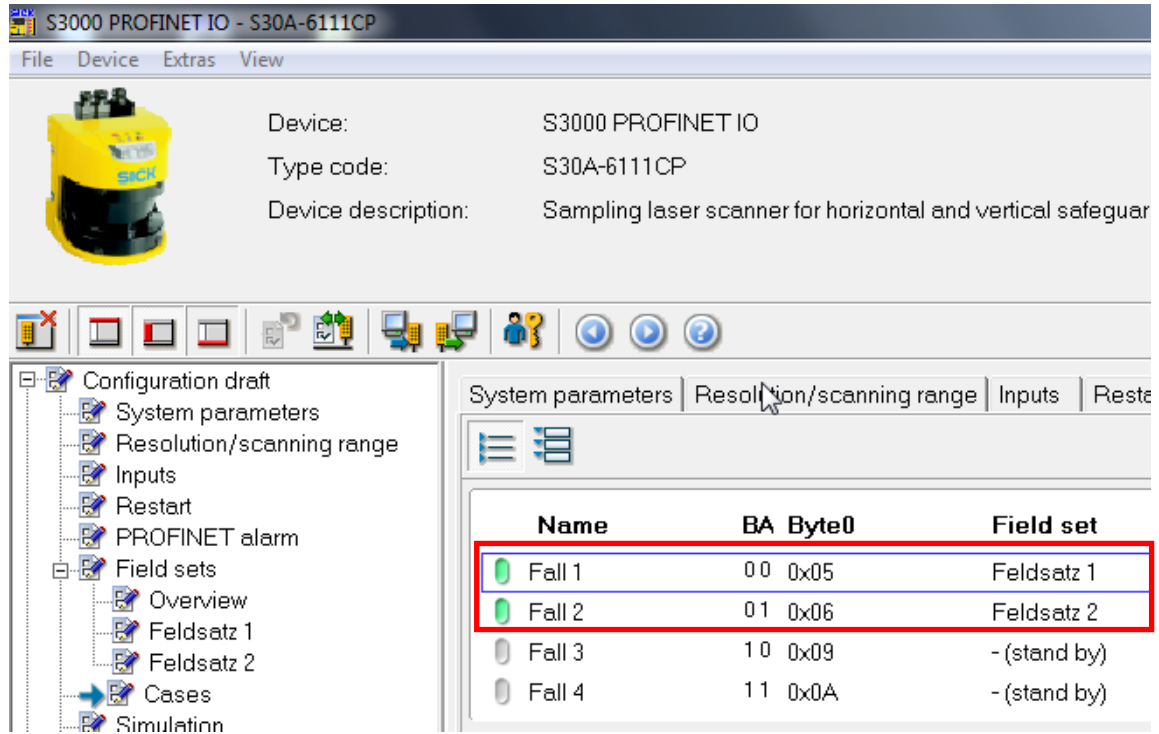

Copyright © Siemens AG 2012 All rights reserved

6.7 Restart

The “without restart interlock” case is configured.

In the code (STEP 7 project), a restart interlock is implemented in the user program of the F-CPU.

7 Installation and Commissioning

7.1 Overview of the steps

The following steps are necessary to install the application example:

- Load the downloads to the PG/PC:
 - Code (STEP 7 project) for the F-CPU
 - Configuration file for the laser scanner
- Install the hardware:
 - SIMATIC components
 - SICK safety laser scanner
- Create a defined initial state:
 - F-CPU
 - Laser scanner
- Download the code to the F-CPU
- For the laser scanner: Assign the IP address and device name
- Download the configuration file to the laser scanner

The following chapters describe the steps.

7.2 Loading the downloads to the PG/PC

The downloads for the application example are listed in chapter 2.2.3.

7.2.1 Code for the F-CPU

To install the code (STEP 7 project) on the PG/PC, the following actions are necessary:

- Download the “58804919_LASER_CODE_V10.zip” code to any directory on the PG/PC.
- Unzip the file.

7.2.2 Configuration file for the laser scanner

To install the configuration file on the PG/PC, the following actions are necessary:

- Download the “58804919_LASER_CONF_V10.zip” configuration file to any directory on the PG/PC.
- Unzip the file.

7.3 Installing the hardware

For the necessary hardware components, please refer to chapter 2.2.1.

NOTICE Follow the installation guidelines for PROFINET ([/4/](#)), SICK laser scanner ([/1/](#)) and SIMATIC S7-300 ([/3/](#), [/16/](#)). Refer to the relevant manuals.

7.3.1 Installation

The table shows the procedure to install the hardware.

Table 7-1

No.	Hardware	Action
1.	F-CPU and MMC	Delete the SIMATIC Micro Memory Card (MMC) for the F-CPU and insert the MMC into the F-CPU.
2.	F-DI	Set the PROFIsafe address on the DIP switch (*1)
3.	F-DO	Set the PROFIsafe address on the DIP switch (*1)
4.	S7-300 mounting rail	Mount the following devices on the mounting rail: PS, F-CPU, DI, F-DI, F-DO
5.	DI	Wire the 3 pushbuttons
6.	F-DI	Wire the 2 sensors
7.	F-DO	Wire the indicator light
8.	PROFINET cable	Connect: <ul style="list-style-type: none"> F-CPU to laser scanner F-CPU to PG/PC.
9.	Power supply (PS)	Complete all necessary connections: <ul style="list-style-type: none"> For the SIMATIC components For the laser scanner

(*1):

The PROFIsafe addresses are automatically assigned when configuring the fail-safe signal modules in STEP 7:

- F-DI: See chapter 5.3.5
- F-DO: See chapter 5.3.6

7.3.2 Overview of the configuration

The figure schematically shows the configuration of the application example.

Figure 7-1

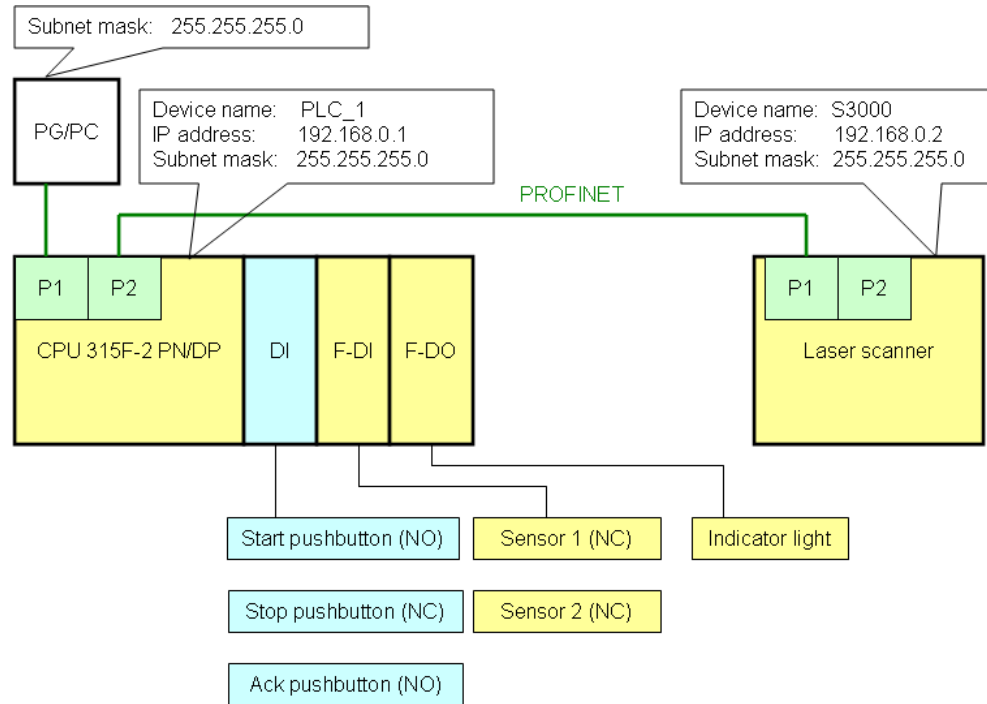

7.3.3 DI wiring

The figure schematically shows the wiring.

Figure 7-2

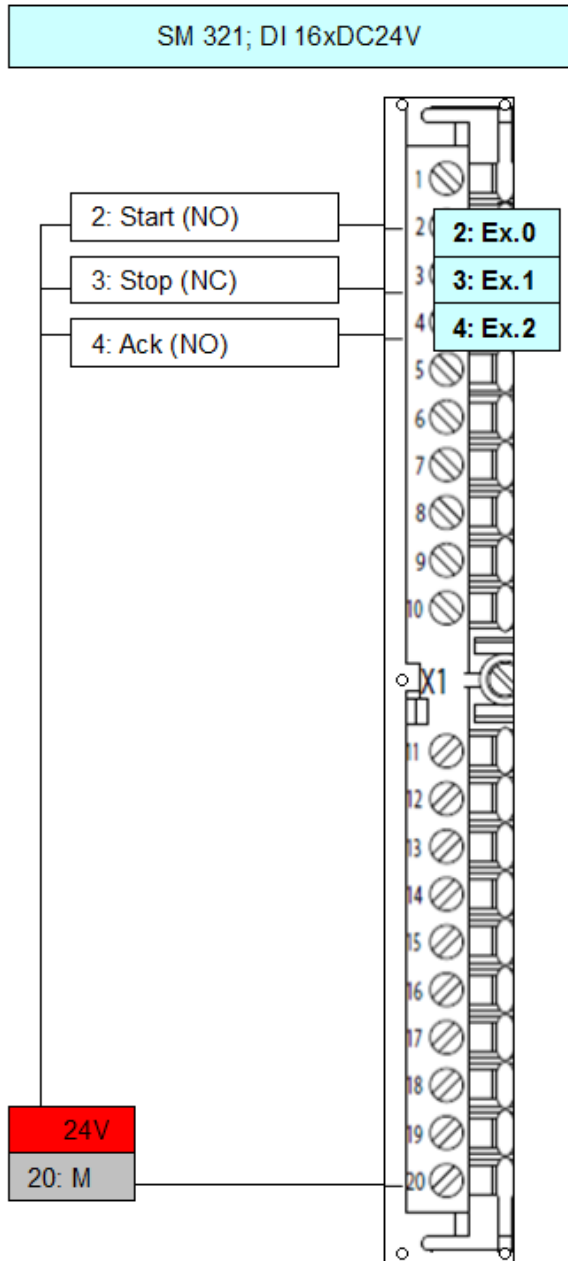

7.3.4 F-DI wiring

The figure schematically shows the wiring.

Figure 7-3

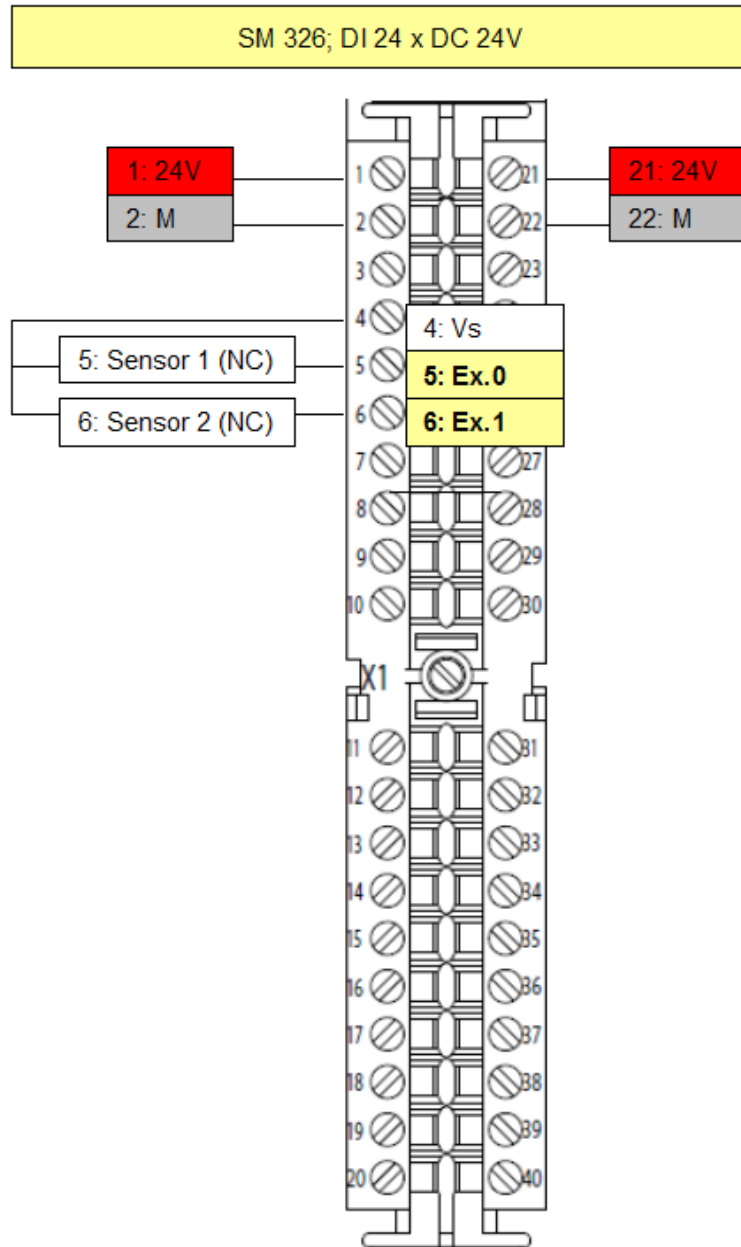

7.3.5 F-DO wiring

The figure schematically shows the wiring.

Figure 7-4

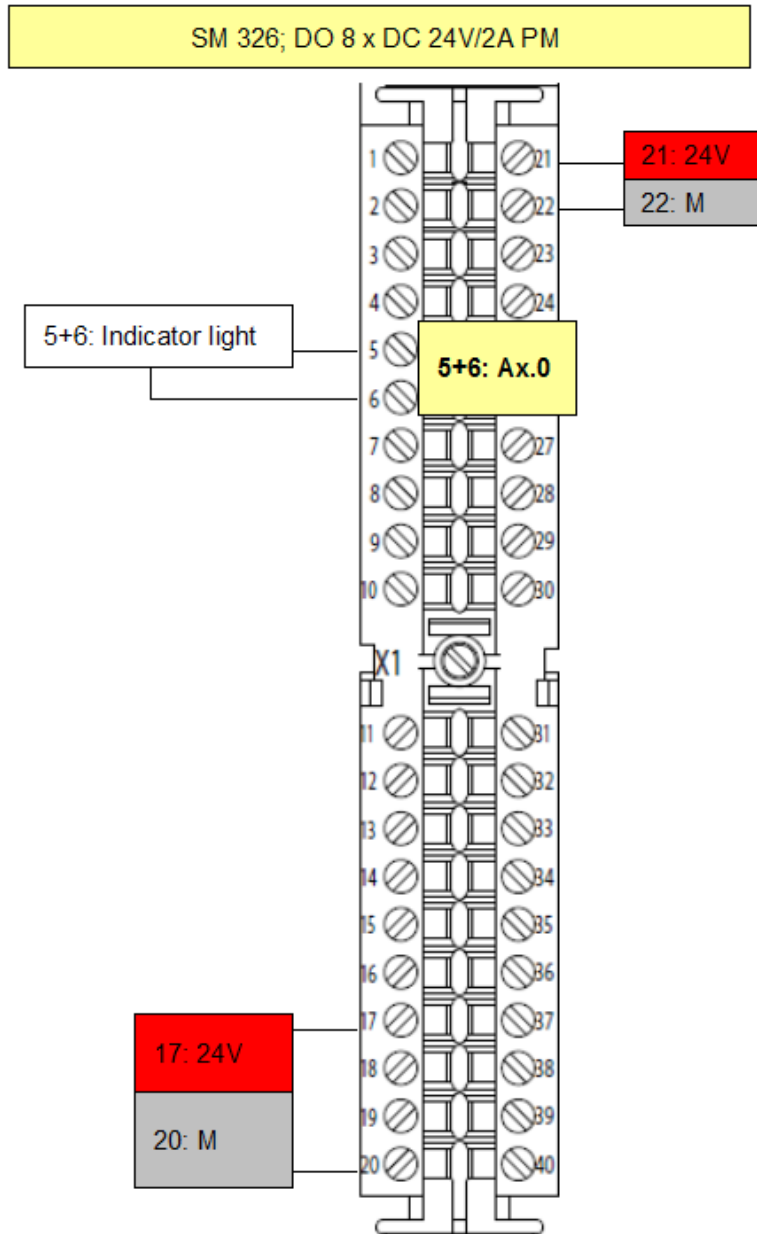

7.4 Setting the F-CPU to the initial state

Initial state means:

- F-CPU has the factory setting
- SIMATIC Micro Memory Card (MMC) is empty (deleted)

Prerequisite:

- PG/PC is connected to F-CPU via Ethernet
- STEP 7 V11 is installed on PG/PC

Restore the F-CPU to factory setting

Prerequisite:

- No MMC is inserted in the F-CPU.
- The F-CPU is in STOP mode (mode selector in position STOP)

Procedure:

- Select in the project tree the F-CPU
- Select in the toolbar the "Go online" button
- Open the online and diagnostics view of the F-CPU
- Select: "Functions" > "Reset to factory settings"
- Select the "Reset" button

Result:

- RAM, internal load memory and all operand areas have been deleted.
- All parameters have been reset to their default values.
- The diagnostic buffer and the time has been deleted.
- The IP address and the PROFINET device name has been deleted.

Display in "Accessible Nodes" for the F-CPU:

Table 7-2

Device	Device type	Type	Address	MAC address
Accessible device	S7-300	ISO	---	00-1B-1B-17-4C-3D (example)

Delete the MMC

Procedure:

- Insert the MMC into the programming device
- In the project tree:
 - Select: "SIMATIC Card Reader" > "Internal prommer"
 - Select "Micro Memory Card"
- In the Project menu, select:
"SIMATIC Card Reader" >
"Format memory card"

Insert the empty MMC

Prerequisite:

- The F-CPU is in STOP mode (mode selector in position STOP)

Procedure:

- Switch off the power supply of the F-CPU
- Insert the MMC into the F-CPU
- Switch on the power supply of the F-CPU

7.5 Setting the laser scanner to the initial state

Initial state means:

- Laser scanner has no settings for PROFINET

Prerequisite:

- PG/PC is connected to the laser scanner via the serial interface
- CDS (Configuration & Diagnostic Software) is installed on the PG/PC

Procedure:

- Call the CDS
- Select COM1 and right-click:
 - Select "Identify"
 - Select the "Continue" button
- Answer the question "Do you want to read the current device configuration?" with "Yes"
- Select the "S3000 PROFINET IO" device and right-click:
 - Select "Open device window"
- In the tree, select "Identification and maintenance"
 - Delete the following values:
PROFINET IO name, IP address, subnet, gateway
 - Select the "Transfer" button
- In the "Change user group" window:
 - In "Password", edit: SICKSAFE
 - Select the "Log on" button
- Select the "Continue" button
- Close the CDS, without saving the current project

Result:

- The PROFINET settings have been deleted
- Laser scanner display:
 - LED: STOP (red)
 - Segment: P

Display in "Accessible Nodes" in STEP 7:

Table 7-3

Device	Device type	Type	Address	MAC address
Accessible device	SICK-S3000PROFI-safe	ISO	-	00-06-77-02-33-6E (example)

7.6 Downloading the code to the F-CPU

Prerequisite:

- Initial state of the F-CPU (chapter 7.4)
- On the PG/PC an interface is installed, which is physically connected to the F-CPU

Procedure:

- Start the TIA Portal
- Open the Project view
- Open the “laser_scanner_03” project
- In the project tree
 - Select: “PLC_1(CPU 315F-2 PN/DP)”
 - Right-click and select:
“Download to device” >
“Software (all blocks)”
- In the “Extended download to device” window:
 - Activate the
“Show all accessible devices” option
 - In the “Accessible devices in target subnet” table,
select the “S7-300” row
 - Select the “Load” button
- In the “Load preview” window:
Select the “Load” button
- In the “Load results” window:
Select the “Finish” button
- Switch the F-CPU to RUN (mode selector in position STOP)

Result:

- LED RUN: On (green)
- LED SF: On (red)
- LED BF2: Flashing (red)

7.7 IP address and device name for the laser scanner

Prerequisite

Initial state of the laser scanner (chapter 7.5).

Procedure

Open the Device configuration:

- Start the TIA Portal
- Open the Project view
- Open the “laser_scanner_03” project
- In the project tree:
 - Open the following device: “PLC_1(CPU 315F-2 PN/DP)”
 - Open the Device configuration

Actions in the Device configuration:

- In the workspace, select: “Network view”
- Select “Subnet PN/IE_1”
- Right-click
- Select “Assign device name”

Actions in the “Assign PROFINET device name” window:

- Select the “Accessible devices in the network“ button
- In the “PROFINET device name” drop-down list, select “s3000”
- In the table, select the “SICK-S3000PROFIsafe” row
- Select the “Assign name” button
- Select the “Accessible devices in the network“ button

Result

Display in “Accessible devices in the network”:

Table 7-4

IP address	MAC address	Type	Name	Status
192.168.0.1	00-1B-1B-17-C-3D (example)	S7-300	plc_1	ok
192.168.0.2	00-06-77-02-33-6E (example)	SICK-S3000PROFIsafe	s3000	ok

Notifications on the F-CPU:

- LED RUN: On (green)

7.8 Downloading the configuration file to the laser scanner

Prerequisite:

- PG/PC is connected to laser scanner via serial interface (chapter 6.2).
- either monitoring case 1 or monitoring case 2 is set by the two sensors for monitoring case switching

Procedure:

- Open the CDS
- Open the "S3000_01.skp" configuration file
- Select COM1 and right-click:
 - Select "Connect"
- Select the "S3000 PROFINET IO" device and right-click:
 - Select: "Configuration draft" > "Transfer"
- In the "Change user group" window:
 - Enter the password "SICKSAFE"
 - Select the "Log on" button
- Select the "Release" button
- Close the CDS

Result:

- Laser scanner starts operating, the display (chapter 8.8) shows:
 - LED: Green
 - Segment: Flashing red dot
- F-CPU: All LEDs are green

8 Operation of the Application Example

Prerequisite:

- Hardware and software have been installed as described in chapter 7.

The chapter describes the following actions:

- Creating the initial state of the setup
- Operating monitoring case 1
- Setting monitoring case 2
- Operating monitoring case 2
- Error when switching the monitoring case

8.1 Creating the initial state of the setup

Set monitoring case 1:

- Switch the F-CPU to RUN
- Switch off the power supplies for F-CPU, signal modules and laser scanner (state: power off)
- Activate sensor 1 ("0" signal), deactivate sensor 2 ("1" signal)
- Switch on the power supplies for F-CPU, signal modules and laser scanner (state: power on)

Monitoring area of the laser scanner:

- No object in the monitoring area

Result:

- Indicator light is off
- Laser scanner with active monitoring case 1 (field set 1)

8.2 Operating monitoring case 1

Table 8-1

No.	Action	Explanation	Indicator light		Laser scanner
			Response	State	Display (*1)
1	Press the acknowledgement pushbutton	Acknowledgement necessary after power on	---	Off	No error
2	Press the start pushbutton	---	Off > On	On	No error
3	Press the stop pushbutton	---	On > Off	Off	No error
4	Press the start pushbutton	---	Off > On	On	No error
5	Set object in warning field 2	Non-active monitoring case	---	On	No error
6	Set object in protective field 2	Non-active monitoring case	---	On	No error
7	Set object in warning field 1	Active monitoring case	---	On	Warning field violated
8	Set object in protective field 1	Active monitoring case	On > Off	Off	Protective field violated
9	Press the start pushbutton	---	---	Off	Protective field violated
10	Remove object from field set 1	Restart interlock	---	Off	No error
11	Press the start pushbutton	Restart interlock	---	Off	No error
12	Press the acknowledgement pushbutton	---	---	Off	No error
13	Press the start pushbutton	---	Off > On	On	No error

(*1): See chapter 8.8.

8.3 Setting monitoring case 2

Table 8-2

No.	Action	Explanation	Indicator light		Laser scanner
			Response	State	Display (*1)
14	Switch from monitoring case 1: Sensor 1 = "0" Sensor 2 = "1" ... to monitoring case 2: Sensor 1 = "1" Sensor 2 = "0"	Switching must be performed within the time parameterized in the "Monitoring_Case_Switching" block (switching time).	---	On	No error

(*1): See chapter 8.8.

8.4 Operating monitoring case 2

Table 8-3

No.	Action	Explanation	Indicator light		Laser scanner
			Response	State	Display (*1)
15	Set object in warning field 1	Non-active monitoring case	---	On	No error
16	Set object in protective field 1	Non-active monitoring case	---	On	No error
17	Set object in warning field 2	Active monitoring case	---	On	Warning field violated
18	Set object in protective field 2	Active monitoring case	On > Off	Off	Protective field violated
19	Press the start pushbutton		---	Off	Protective field violated
20	Remove object from field set 2	Restart interlock	---	Off	No error
21	Press the start pushbutton	Restart interlock	---	Off	No error
22	Press the acknowledgement pushbutton		---	Off	No error
23	Press the start pushbutton		Off > On	On	No error

(*1): See chapter 8.8.

8.5 Error when switching the monitoring case

No.	Action	Explanation	Indicator light		Laser scanner
			Response	State	Display (*1)
24	Sensor 1: Unchanged "1" Sensor 2: From "0" to "1"	Non-permissible switching state of the sensors	On > Off	Off	Incorrect operation of the control inputs
25	Press the start pushbutton		---	Off	Incorrect operation of the control inputs
26	Press the acknowledgement pushbutton		---	Off	Incorrect operation of the control inputs
27	Press the start pushbutton		---	Off	Incorrect operation of the control inputs
28	Sensor 1: Unchanged "1" Sensor 2: From "1" to "0"		---	Off	Incorrect operation of the control inputs
29	Power off		---	---	---
30	Power on		---	Off	No error
31	Press the acknowledgement pushbutton	Acknowledgement necessary after power on	---	Off	No error

(*1): See chapter 8.8.

8.6 Watch and force table

The “Watch_Table_1” table can be used to

- display if a component of the F-I/O is passivated (laser scanner, F-DI, F-DO)
- reintegrate the passivated F-DO: Positive edge at “Ack_Passivation” (Modify variable)

Open the table as follows:

- Open the Project tree
- Open “PLC_1 (CPU 315F-2 PN/DP)”
- Open “Watch and force tables”
- Open the “Watch_Table_1” table
- Select “Go online”
- Select “Monitor all”

Result:

Figure 8-1

	i	Name	Address	Display format	Monitor value	Modify value
1		*F00017_SICK_S3000*.QBAD	%DB8004.DBX2.1	Bool	<input type="checkbox"/> FALSE	
2		*F00002_F-DI24xDC24V_1*.QBAD	%DB8002.DBX2.1	Bool	<input type="checkbox"/> FALSE	
3		*F00012_F-DO8xDC24V_1*.QBAD	%DB8003.DBX2.1	Bool	<input type="checkbox"/> FALSE	
4		*Ack_Passivation*	%M0.1	Bool	<input type="checkbox"/> FALSE	
5		*Actuator*	%Q12.0	Bool	<input type="checkbox"/> FALSE	

8.7 PLC tags

The tables in the “PLC tags” folder can be used for testing. The following two tables are available for the application example:

- CPU
- Laser_Scanner

“CPU” table

Open the tables as follows:

- Open the Project tree
- Open “PLC_1 (CPU 315F-2 PN/DP)”
- Open “PLC tags”
- Open the “CPU” table
- Select “Go online”
- Select “Monitor all”

Result:

Figure 8-2

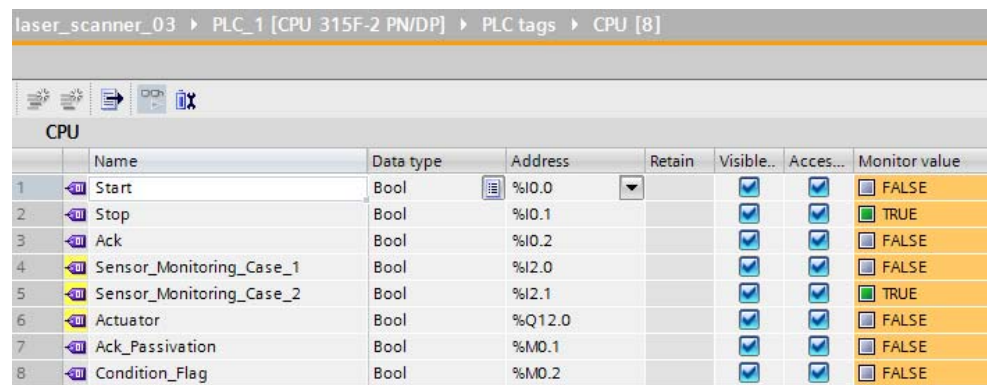

	Name	Data type	Address	Retain	Visible..	Acces...	Monitor value
1	Start	Bool	%I0.0		<input checked="" type="checkbox"/>	<input checked="" type="checkbox"/>	FALSE
2	Stop	Bool	%I0.1		<input checked="" type="checkbox"/>	<input checked="" type="checkbox"/>	TRUE
3	Ack	Bool	%I0.2		<input checked="" type="checkbox"/>	<input checked="" type="checkbox"/>	FALSE
4	Sensor_Monitoring_Case_1	Bool	%I2.0		<input checked="" type="checkbox"/>	<input checked="" type="checkbox"/>	FALSE
5	Sensor_Monitoring_Case_2	Bool	%I2.1		<input checked="" type="checkbox"/>	<input checked="" type="checkbox"/>	TRUE
6	Actuator	Bool	%Q12.0		<input checked="" type="checkbox"/>	<input checked="" type="checkbox"/>	FALSE
7	Ack_Passivation	Bool	%M0.1		<input checked="" type="checkbox"/>	<input checked="" type="checkbox"/>	FALSE
8	Condition_Flag	Bool	%M0.2		<input checked="" type="checkbox"/>	<input checked="" type="checkbox"/>	FALSE

“Laser_Scanner” table

Open the tables as follows:

- Open the Project tree
- Open “PLC_1 (CPU 315F-2 PN/DP)”
- Open “PLC tags”
- Open the “Laser_Scanner” table
- Select “Go online”
- Select “Monitor all”

Result:



Figure 8-3

laser_scanner_03 ▸ PLC_1 [CPU 315F-2 PN/DP] ▸ PLC tags ▸ Laser_Scanner [18]							
Laser_Scanner							
	Name	Data type	Address	Retain	Visible..	Acces...	Monitor value
1	OSSD	Bool	%I17.0		<input checked="" type="checkbox"/>	<input checked="" type="checkbox"/>	<input checked="" type="checkbox"/> TRUE
2	Warning_Field_Unoccupied	Bool	%I17.1		<input checked="" type="checkbox"/>	<input checked="" type="checkbox"/>	<input checked="" type="checkbox"/> TRUE
3	Contamination	Bool	%I18.0		<input checked="" type="checkbox"/>	<input checked="" type="checkbox"/>	<input type="checkbox"/> FALSE
4	Monitoring_Case_Valid	Bool	%I18.1		<input checked="" type="checkbox"/>	<input checked="" type="checkbox"/>	<input checked="" type="checkbox"/> TRUE
5	Monitoring_Case_Number_Bit0	Bool	%I18.2		<input checked="" type="checkbox"/>	<input checked="" type="checkbox"/>	<input type="checkbox"/> FALSE
6	Monitoring_Case_Number_Bit1	Bool	%I18.3		<input checked="" type="checkbox"/>	<input checked="" type="checkbox"/>	<input type="checkbox"/> FALSE
7	Simultaneous_Protective_Field_Un...	Bool	%I17.2		<input checked="" type="checkbox"/>	<input checked="" type="checkbox"/>	<input type="checkbox"/> FALSE
8	Simultaneous_Warning_Field_Uno...	Bool	%I17.3		<input checked="" type="checkbox"/>	<input checked="" type="checkbox"/>	<input type="checkbox"/> FALSE
9	Reset_Required_Protective_Field	Bool	%I17.4		<input checked="" type="checkbox"/>	<input checked="" type="checkbox"/>	<input type="checkbox"/> FALSE
10	Reset_Required_Simultaneous_Prot	Bool	%I17.6		<input checked="" type="checkbox"/>	<input checked="" type="checkbox"/>	<input type="checkbox"/> FALSE
11	Monitoring_Case_Switching_A1	Bool	%Q17.0		<input checked="" type="checkbox"/>	<input checked="" type="checkbox"/>	<input checked="" type="checkbox"/> TRUE
12	Monitoring_Case_Switching_A2	Bool	%Q17.1		<input checked="" type="checkbox"/>	<input checked="" type="checkbox"/>	<input type="checkbox"/> FALSE
13	Monitoring_Case_Switching_B1	Bool	%Q17.2		<input checked="" type="checkbox"/>	<input checked="" type="checkbox"/>	<input checked="" type="checkbox"/> TRUE
14	Monitoring_Case_Switching_B2	Bool	%Q17.3		<input checked="" type="checkbox"/>	<input checked="" type="checkbox"/>	<input type="checkbox"/> FALSE
15	Reset_Protective_Field	Bool	%Q18.0		<input checked="" type="checkbox"/>	<input checked="" type="checkbox"/>	<input type="checkbox"/> FALSE
16	Reset_Simultaneous_Protective_Fie	Bool	%Q18.2		<input checked="" type="checkbox"/>	<input checked="" type="checkbox"/>	<input type="checkbox"/> FALSE
17	Stand_By	Bool	%Q18.4		<input checked="" type="checkbox"/>	<input checked="" type="checkbox"/>	<input type="checkbox"/> FALSE
18	Initialising	Bool	%Q18.5		<input checked="" type="checkbox"/>	<input checked="" type="checkbox"/>	<input type="checkbox"/> FALSE

8.8 Indications on the laser scanner

The display of the laser scanner shows the laser scanner states. The following table shows examples of indications on the laser scanner ([/1/](#)).

Table 8-4

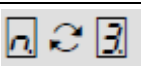
State	Laser scanner display		Explanations
	LED	Segment	
No error	Green: On		---
Warning field violated	Green: On Yellow: On		Object in the warning field
Protective field violated	Green: On Yellow: On		Object in the protective field
Incorrect operation of the control inputs	Green: On		Incorrect operation of the control inputs for switching the monitoring cases

9 Evaluation according to IEC 62061 and ISO 13849

9.1 Information on the standards

Overview

For an overview of IEC 62061, please refer to the following Safety Functional Example:

Practical Application of IEC 62061 Illustrated Using an Application Example with SIMATIC S7 Distributed Safety ([/11/](#))

For an overview of ISO 13849-1, please refer to the following book:

Funktionale Sicherheit von Maschinen und Anlagen.

Umsetzung der europäischen Maschinenrichtlinie in der Praxis ([/12/](#)).

Calculations

Support for the calculations is provided by:

Safety Evaluation Tool (SET) ([/15/](#))

9.2 Safety function

The following considerations are based on the following safety function (example):

“When the active protective field is violated, the machine must be stopped.”

The application example does not consider the entire safety function:

Table 9-1

Tasks of a safety function		
Detect	Evaluate	React
Is considered	Is considered	Is <u>not</u> considered

In the following, the above-listed tasks of a safety function are evaluated according to the two standards EN 62061 and EN ISO 13849-1.

10 Safety Function

Chapter 9.2 describes the safety function.

This chapter considers only parts of the safety function:

- Detect via SICK safety laser scanner
- Evaluate with SIMATIC F-PLC

Therefore, the safety function is not evaluated in the application example.

10.1 Mapping of the safety function

The figure below shows the mapping of the safety function to the hardware of the application example.

Figure 10-1

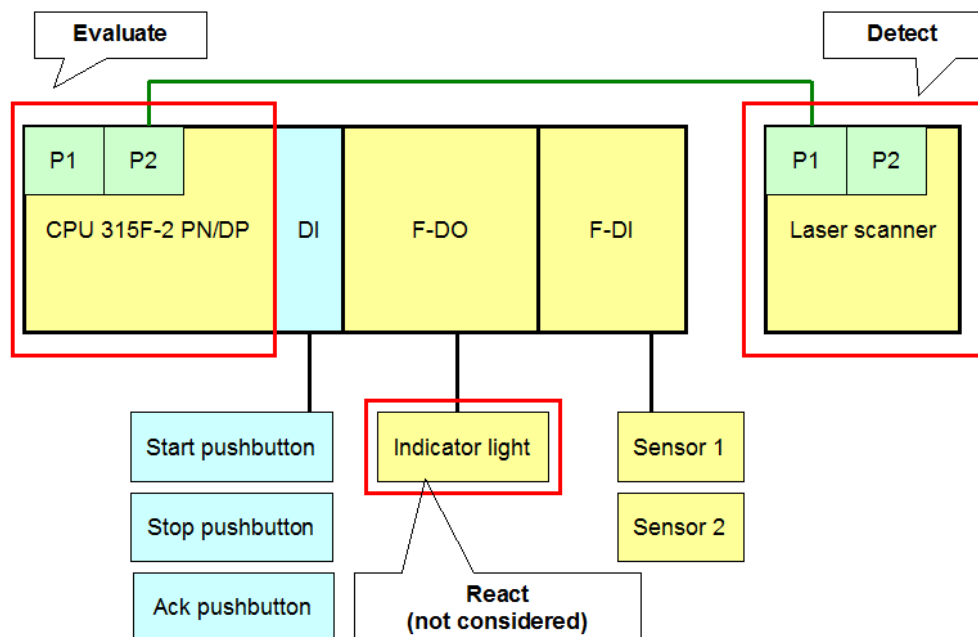

10.2 Assessment of Detect

Component involved:
SICK safety laser scanner

10.2.1 Evaluation according to IEC 62061

Result:
Table 10-1

Result		Reason
SILCL	2	Specified by the manufacturer, SICK AG
PFH _D	$76.7 * 10^{-9}$	

10.2.2 Evaluation according to ISO 13849-1

Result:
Table 10-2

Result		Reason
PL	d	Specified by the manufacturer, SICK AG
Average probability of a dangerous failure per hour	$76.7 * 10^{-9}$	

10.3 Assessment of Evaluate

Components involved:

SIMATIC Safety Integrated / safety-related SIMATIC controllers

10.3.1 Evaluation according to IEC 62061

Result:

Table 10-3

Result		Reason
SILCL	3	Specified by the manufacturer, SIEMENS AG
PFH _D	$2 * 10^{-9}$	The values for the calculation can be found in the following table.

Values to calculate the PFH_D:

Table 10-4

Parameter	Component	Value	Definition
PFH _D (F-CPU)	CPU 315F-2 PN/DP	$1 * 10^{-9}$	Siemens AG
P _{TE} (F-communication)	Fail-safe communication PROFIsafe: F-CPU and laser scanner	$1 * 10^{-9}$	

10.3.2 Evaluation according to ISO 13849-1

Result:

Table 10-5

Result		Reason
PL	e	Derived from the evaluation according to IEC 62061.
Average probability of a dangerous failure per hour	$2 * 10^{-9}$	

10.4 Assessment of React

In the application example, switching off is only used for test purposes and therefore not assessed at this point.

If safety-related switching off is to be performed, special arrangements must be made for diagnostics (for example, read back) when switching via contactors.

An application example exists that deals with read back ([/7/](#)). An assessment is made in this application example.

11 Glossary

Table 11-1

Abbreviation / term in the document	Meaning
"1" signal	Signal has the TRUE logic state
CDS	Tool to configure and diagnose the SICK S3000 safety laser scanner: Configuration & Diagnostic Software
ESPE	Electro-sensitive protective equipment
Field set x	Field set x consists of protective field x and warning field x. Field set x can be allocated to monitoring case y.
MMC	SIMATIC Micro Memory Card
OSSD	Output signal switching device: Signal output of the protective device that is used to stop the dangerous movement.
PG/PC	Programming device / personal computer
Power off	The power supply for F-CPU, signal modules and laser scanner is switched off.
Power on	The power supply for F-CPU, signal modules and laser scanner is switched on.
PROFIsafe address	Each fail-safe component has its own PROFIsafe address. Safety mode requires that the PROFIsafe address be configured in the hardware configuration and set on the component. Depending on the component, this is done via the DIP switch or configuration.
User program	User program = safety program + standard user program The term "safety program" refers to the fail-safe part of the user program and is used instead of "fail-safe user program", "F-program", etc. For differentiation purposes, the non-safety-related part of the user program is referred to as the "standard user program".

12 References

Notes with reference (/x/) in the document:

Table 12-1

	Topic	Link / source
/1/	SICK S3000 Safety Laser Scanner Operating Instructions	www.sick.com
	SICK S3000 PROFINET IO and S3000 PROFINET IO-OF Safety Laser Scanner Addendum Operating Instructions	
/2/	Reference to the document	http://support.automation.siemens.com/WW/view/en/58804919
/3/	SIMATIC S7-300, CPU 31xC and CPU 31x: Installation / Operating Instructions	http://support.automation.siemens.com/WW/view/en/13008499
/4/	PROFINET / System Manual	http://support.automation.siemens.com/WW/view/en/19292127
/7/	Integration of the Readback Signal in an Application of Category 4 according to EN 954-1: 1996 (with evaluation according to EN 62061 and EN ISO 13849-1: 2006)	http://support.automation.siemens.com/WW/view/en/21331098
/8/	SICK / Help on configuration S3000/S300/S200 Configuration & Diagnostic Software	CD-ROM for CDS
/9/	SIMATIC Industrial Software SIMATIC Safety – Configuring and Programming	http://support.automation.siemens.com/WW/view/en/54110126
/11/	Practical Application of IEC 62061 Illustrated Using an Application Example with SIMATIC S7 Distributed Safety	http://support.automation.siemens.com/WW/view/en/23996473
/12/	Funktionale Sicherheit von Maschinen und Anlagen. Umsetzung der europäischen Ma- schinenrichtlinie in der Praxis.	ISBN-13: 978-3-89578-281-7, ISBN-10: 3-89578-281-5
/15/	Safety Evaluation Tool	http://www.industry.siemens.com/topics/global/en/safety-integrated/machine-safety/safety-evaluation-tool/Pages/Default.aspx
/16/	SIMATIC / Automation System S7-300 ET 200M Distributed I/O Device Fail-safe signal modules Installation and Operating Manual	http://support.automation.siemens.com/WW/view/en/19026151
/18/	System Description: Safety Engineering in SIMATIC S7	http://support.automation.siemens.com/WW/view/en/12490443
/20/	PROFINET with STEP 7 V11 Function Manual	http://support.automation.siemens.com/WW/view/en/49948856
/21/	SIMATIC Safety Getting Started	http://support.automation.siemens.com/WW/view/en/49972838
/22/	STEP 7 Professional V11.0 SP2	http://support.automation.siemens.com/WW/view/en/57185407

Notes without reference (/x/) in the document:

Table 12-2

Topic	Link / source
Siemens Industry Online Support	http://support.automation.siemens.com

13 History

Version	Date	Modification
V1.0	03/2012	First edition