

SIEMENS

SIMATIC

S7-300

SM331; AI 8 x 12 Bit Getting Started part 3: Thermocouples

Getting Started

Preface	1
Prerequisites	2
Task	3
Mechanical setup of the example station	4
Electrical connection of the example station	5
Configuration of the SIMATIC Manager	6
Testing the user program	7
Diagnostic interrupt	8
Hardware interrupt	9
Appendix	A

Safety Guidelines

This manual contains notices you have to observe in order to ensure your personal safety, as well as to prevent damage to property. The notices referring to your personal safety are highlighted in the manual by a safety alert symbol, notices referring only to property damage have no safety alert symbol. These notices shown below are graded according to the degree of danger.



Danger

indicates that death or severe personal injury **will** result if proper precautions are not taken.



Warning

indicates that death or severe personal injury **may** result if proper precautions are not taken.



Caution

with a safety alert symbol, indicates that minor personal injury can result if proper precautions are not taken.

Caution

without a safety alert symbol, indicates that property damage can result if proper precautions are not taken.

Notice

indicates that an unintended result or situation can occur if the corresponding information is not taken into account.

If more than one degree of danger is present, the warning notice representing the highest degree of danger will be used. A notice warning of injury to persons with a safety alert symbol may also include a warning relating to property damage.

Qualified Personnel

The device/system may only be set up and used in conjunction with this documentation. Commissioning and operation of a device/system may only be performed by **qualified personnel**. Within the context of the safety notes in this documentation qualified persons are defined as persons who are authorized to commission, ground and label devices, systems and circuits in accordance with established safety practices and standards.

Prescribed Usage

Note the following:



Warning

This device may only be used for the applications described in the catalog or the technical description and only in connection with devices or components from other manufacturers which have been approved or recommended by Siemens. Correct, reliable operation of the product requires proper transport, storage, positioning and assembly as well as careful operation and maintenance.

Trademarks

All names identified by ® are registered trademarks of the Siemens AG. The remaining trademarks in this publication may be trademarks whose use by third parties for their own purposes could violate the rights of the owner.

Disclaimer of Liability

We have reviewed the contents of this publication to ensure consistency with the hardware and software described. Since variance cannot be precluded entirely, we cannot guarantee full consistency. However, the information in this publication is reviewed regularly and any necessary corrections are included in subsequent editions.

Table of contents

1	Preface	1-1
1.1	General information	1-1
2	Prerequisites	2-1
2.1	Basics.....	2-1
3	Task	3-1
3.1	Example of an application.....	3-1
4	Mechanical setup of the example station	4-1
4.1	Mounting the example station	4-1
4.2	Mounting of analog module components.....	4-3
4.2.1	General	4-3
4.2.2	Components of the SM331	4-4
4.2.3	Features of the analog modules	4-5
4.2.4	Measuring range modules	4-6
4.2.5	Mounting the SM331 module.....	4-8
5	Electrical connection of the example station	5-1
5.1	General	5-1
5.2	Wiring the power supply module and the CPU	5-2
5.3	Connection variations of the analog module.....	5-4
5.3.1	General	5-4
5.3.2	Shielded wires for analog signals	5-4
5.3.3	Connection diagram of thermocouples with internal reference junction.....	5-5
5.3.4	Connection diagram of an analog module with internal reference junction.....	5-6
5.3.5	Wiring of the analog module with internal reference junction	5-7
5.3.6	Connection diagram of thermocouples with external reference junction.....	5-8
5.3.7	Connection diagram of an analog module with external reference junction.....	5-9
5.3.8	Wiring of the analog module with external reference junction	5-11
5.3.9	Wiring of the external reference junction	5-12
5.3.10	Check the wiring	5-14
6	Configuration of the SIMATIC Manager	6-1
6.1	Creating a new STEP7 project.....	6-1
6.1.1	Create a new project.....	6-1
6.1.2	CPU selection	6-3
6.1.3	Defining the basic user program.....	6-4
6.1.4	Assigning the project name.....	6-5
6.1.5	Result S7 project is created.....	6-6

6.2	Hardware configuration	6-7
6.2.1	Creating the hardware configuration	6-7
6.2.2	Adding SIMATIC components	6-8
6.2.3	Parameterization of the analog module of the example station	6-10
6.2.4	Explanation of the settings of the SM331	6-13
6.2.5	Power up test	6-14
6.3	STEP 7 user program	6-18
6.3.1	Tasks of the user program	6-18
6.3.2	Creating a user program	6-19
7	Testing the user program.....	7-1
7.1	Downloading the system data and user program	7-1
7.2	Visualization of the sensor values.....	7-3
7.3	Analog-value representation of the thermocouple	7-7
8	Diagnostic interrupt.....	8-1
8.1	Reading diagnostic information from a PG	8-1
8.2	General diagnostics	8-3
8.3	Channel dependent diagnostic messages	8-4
9	Hardware interrupt.....	9-1
9.1	Hardware interrupt	9-1
A	Appendix.....	A-1
A.1	Source code of the user program	A-1
	Index.....	Index-1

Preface

1.1 General information

Purpose of the Getting Started

The Getting Started gives you a complete overview of the commissioning of the SM331 analog module (6ES7331-7KF02-0AB0). It assists you in the installation and configuration of the hardware of a thermocouple and the configuration of the analog module with SIMATIC S7 Manager.

The intended readership of the Getting Started is a novice with only basic experience in the configuration, commissioning and servicing of automation systems.

What to expect

The procedures, from mounting the module to storing analog values in the STEP7 user program, are explained step-by-step and in detail based on an example. In the following sections you will be introduced to:

- Problem analysis
- Mechanical setup of the example station
- Electrical connection of the example station
- Configuration of the SIMATIC Manager
- Creating a small user program with STEP7 which stores the read analog values in a data block
- Triggering and interpreting diagnostic and hardware interrupts

Prerequisites

2.1 Basics

Basic knowledge

No special knowledge of the field of automation technology is required in order to understand the Getting Started guide. As the configuration of the analog module is done with the STEP7 software, proficiency in STEP7 would be advantageous.

Further information on STEP7 can be found in the electronic manuals that are supplied with STEP7.

You will also need to know how to use computers or PC-like equipment (such as programming devices) under Windows 95/98/2000/NT or XP.

Required hardware and software

The scope of delivery of the analog module consists of 2 parts:

- SM331 modules
- Front connector for easy connection of the power supply and the data connections

Analog module components

Quantity	Item	Order no.
1	SM 331, ISOLATED 8 AI, ALARM DIAGNOSTICS	6ES7331-7KF02-0AB0
1	20-pin FRONT CONNECTOR with spring contacts Alternatively: 20-pin FRONT CONNECTOR with screw contacts	6ES7392-1BJ00-0AA0 66ES7392-1AJ00-0AA0
1	SIMATIC S7 SHIELD CONNECTING ELEMENT	6ES7390-5AA00-0AA0
2	SIMATIC S7, TERMINAL ELEMENT F. 1 CABLE W. 4 TO 13 MM DIA.	6ES7390-5CA00-0AA0

The general SIMATIC components required for the example are as follows:

SIMATIC components of the example station

Quantity	Item	Order no.
1	PS 307 Power Supply AC 120/230V, DC 24V, 5A (incl. power supply bridge circuit)	6ES7307-1EA00-0AA0
1	CPU 315-2 DP	6ES7315-2AG10-0AB0
1	MICRO MEMORY CARD, NFLASH, 128 KB	6ES7953-8LG00-0AA0
1	SIMATIC S7-300, RAIL L=530MM	6ES7390-1AF30-0AA0
1	Programming device (PD) with MPI interface and MPI cable PC with suitable interface card	depending on the configuration

Installed software STEP7:

Quantity	Item	Order no.
1	STEP7 Software version 5.2 or later, installed on the programming device.	6ES7810-4CC06-0YX0

You can use the following thermocouples for the acquisition of analog signals:

Quantity	Item	Order no.
2	Thermocouple type J	depends on the manufacturer
2	Thermocouple type K	depends on the manufacturer
1	Siemens compensating box (type J – 24 V DC)	M72166-B4200

Note

This "Getting Started" describes only the application of the thermocouples. If you wish to use other transducers, you will need to wire and configure the SM331 differently.

Separate Getting Starteds are available for 4 - 20 mA current transducers, voltage transducers and the resistance thermometer PT100 standard, which can be connected to the SM331.

Furthermore, the following tools and materials are necessary:

General tools and materials

Quantity	Item	Order no.
various	M6-bolts and nuts (Length depending on the mounting position)	commonly available
1	Screwdriver with 3.5 mm blade	commonly available
1	Screwdriver with 4.5 mm blade	commonly available
1	Side cutter and cable stripper	commonly available
1	Crimp tool	commonly available
X m	Wire for grounding the mounting rail with 10 mm ² cross-section, ring terminal with 6.5 mm hole, length appropriate for local requirements.	commonly available
X m	Flexible wire with 1mm ² diameter with fitting wire end sleeves, form A in 3 different colors – blue, red and green	commonly available
X m	3-wire power cord (AC 230/120V) with protective contact socket, length according to local conditions.	commonly available
1	Calibration device (measuring instrument for commissioning, that can measure and supply current)	depends on the manufacturer

Task

3.1 Example of an application

Overview

The Getting Started leads you successfully through a sample application, in which you will install the following thermocouples:

- Two thermocouples with type J and type K, which are directly installed on the analog module SM331 (using the internal reference junction)
- Two equal thermocouples of type J, which are connected through an intermediate terminal (compensation point with external compensating box)

You will activate failure diagnostics and hardware interrupts. You have the analog input module SM331, AI8x12 Bit (order number 6ES7 331-7KF02-0AB0) available.

The module can process up to 8 analog inputs and trigger hardware and diagnostic interrupts. For each module, different measurement types can be set (e.g., current or voltage measurement, PT 100, thermocouple).

The following mounting options are described in the sample task:

- The thermocouples are installed close enough to the analog module and, therefore, the wires can be connected directly to the module.
- The connection location of the thermocouples is further away from the analog module. In this case, the compensation wire is replaced by copper wires through a connection point. A compensating box has to be installed in the close vicinity of the connection point.

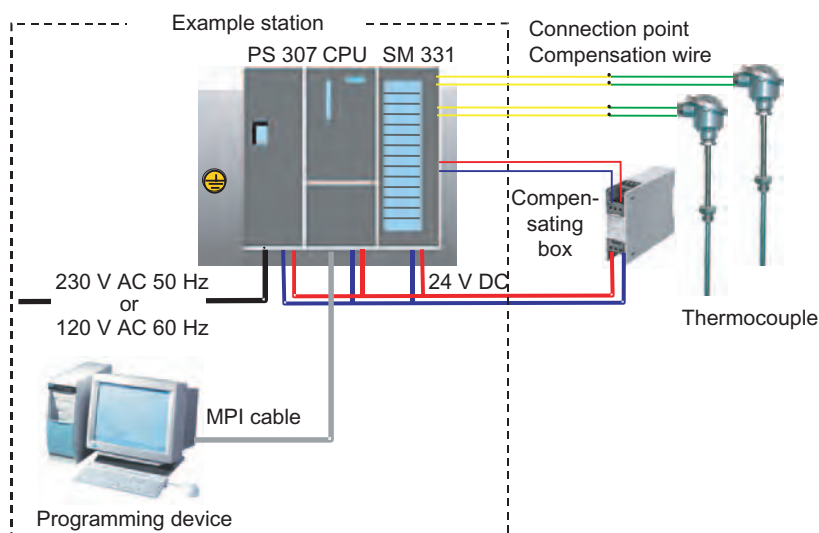

Figure 3-1 Components of the example station

In the following sections you will be introduced to:

- Mechanical setup of the example station
 - General mounting instructions for S7-300 modules
 - Configuration of the SM331 for the two selected measurement transducer types
- Electrical connection of the example station
 - Wiring the power supply module and the CPU
 - Wiring of the analog module
 - Standard pin layout of the voltage transducer and resistance thermometer
- Configuration of the SIMATIC Manager
 - Using the project wizard
 - Completing the automatically generated hardware configuration
 - Integrating the supplied user program source
- Testing the user program
 - Interpreting the read values
 - Converting the measured values into readable analog values
- Utilizing the diagnostic capabilities of the SM331 module
 - Triggering a diagnostic interrupt
 - Evaluating the diagnostics:
- Application of hardware interrupts
 - Configuration of hardware interrupts
 - Configuration and analysis of hardware interrupts

See also

General (Page 5-1)

Create a new project (Page 6-1)

Downloading the system data and user program (Page 7-1)

Reading diagnostic information from a PG (Page 8-1)

Hardware interrupt (Page 9-1)

Mechanical setup of the example station

4.1 Mounting the example station

Structure of the explanations

The setup of the example station is divided into two steps. First, the setup of the power supply and the CPU is explained. After becoming acquainted with the analog module SM331, the mounting of it is described.

Prerequisites





Before you can use analog input module SM331, you need a basic setup of general SIMATIC S7-300 components.

The order of the mounting takes place from left to right:

- Power supply PS307
- CPU 315-2 DP
- Analog module SM331

4.1 Mounting the example station

Procedure

Step	Graphic	Description
1		<p>Screw on the mounting rail (screw size: M6) so that at least 40 mm space remains above and below the rail.</p> <p>When mounting it on a grounded steel panel or on a grounded device mounting panel made of steel sheet, make sure you have a low impedance connection between the mounting rail and the mounting surface.</p> <p>Connect the rail to the protective conductor. An M6 screw is provided for this purpose on the rail.</p>
2		<p>Mounting the power supply:</p> <ul style="list-style-type: none"> • Hang the power supply on to the top end of the rail • • • • • • • Screw it tight to the rail underneath.
3		<p>Connect the bus connector (delivered with the SM331) to the left connector on the back of the CPU</p>
4		<p>Mounting the CPU:</p> <ul style="list-style-type: none"> • Hang the CPU on to the top end of the rail • Push it all the way left to the power supply • Push it down • Screw it tight to the rail underneath

4.2 Mounting of analog module components

4.2.1 General

Overview

The measuring range modules should be plugged in accordingly before the mounting of SM331.

In this section, you will learn about:

- The components you need
- The properties of the analog input module
- What a measuring range module is and how it is configured
- Mounting a configured module

4.2.2 Components of the SM331

Overview

A functional analog module consists of the following components:

- Module SM331 (in our example 6ES7331-7KF02-0AB0)
- 20-pin front connector There are two different types of front connectors:
 - With spring contacts (order number 6ES7392-1BJ00-0AA0)
 - With screw contacts (order number 6ES7392-1AJ00-0AA0)

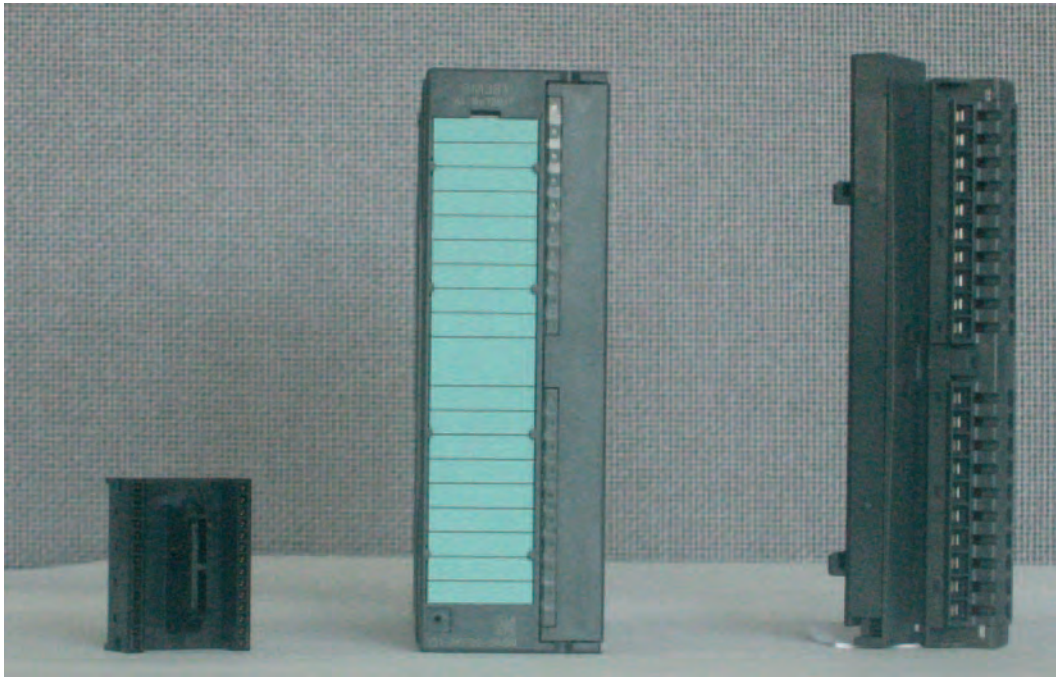

Figure 4-1 Components of the SM331

The scope of delivery of SM331

Components
Analog module SM331
Labeling strips
Bus connectors
2 cable ties (not in the picture) to tie the external wiring

4.2.3 Features of the analog modules

Features

The module is a universal analog module applicable to the most commonly used applications.

The desired measuring mode should be set up directly on the module with the measuring range modules.

- 8 inputs in 4 channel groups (each group with two inputs of same type)
- Measurement resolution adjustable for each channel group
- User defined measuring mode per channel group:
 - Voltage
 - Current
 - Resistance-type sensor
 - Temperature
- Programmable diagnostic interrupt
- Two channels with limit alarms (only channel 0 and channel 2 are configurable)
- Electrically isolated against backplane bus
- Electrically isolated against load voltage (exception: at least one module is set to position D)

Alternatively applicable SM331; AI 8 x TC (only for thermocouples)

If you install thermocouples solely, you can also use the analog module SM331; AI 8 x TC with the order number 6ES7331-7PF10-0AB0. Notes on connecting this device can be found in the *"S7-300 Automation System, Module data"* reference manual.

4.2.4 Measuring range modules

Connection

Module SM331 has 4 measuring range modules on it side (one measuring range module per channel group). You can set the measuring range modules to 4 different positions (A, B, C, or D). The position enables you to specify the transducer to be connected to the respective channel group.

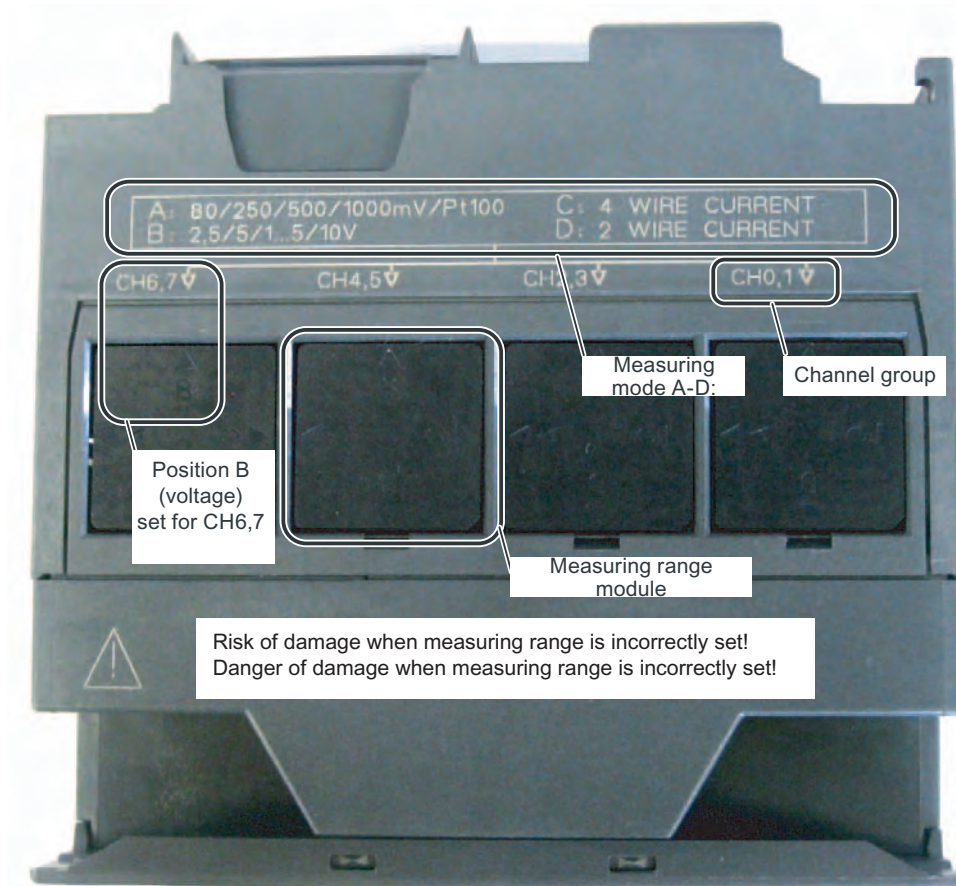



Figure 4-2 Measuring range modules with default setting B (Voltage)

Possible positions of the measuring range modules

Position	Type of measurement
A	Thermocouple/resistance measurement
B	Voltage (factory setting)
C	Current (4-wire transducer)
D	Current (2-wire transducer)

In our sample task we use the channel groups CH0, 1 and CH2, 3 in the measurement mode "Thermocouple". Verify that the measuring range modules are set to position A. If needed, adjust the desired position as described in the table below.

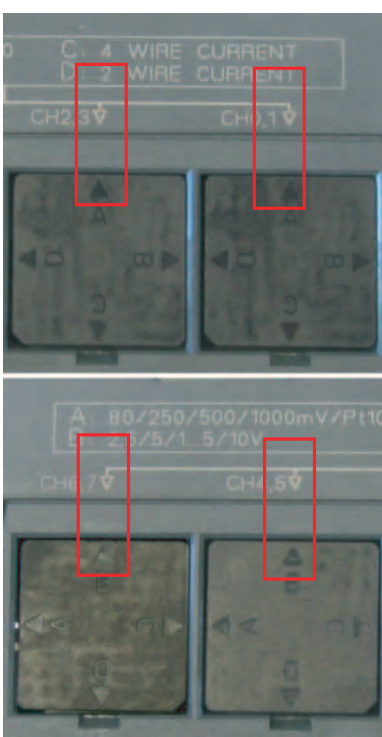

Positioning of the measuring range modules

Step	Graphic	Description
1		<p>With a screwdriver, pull out the two measuring range modules.</p>
2		<p>Turn the measuring range modules to the desired position.</p>
3		<p>Plug the measuring range modules back into the module.</p> <p>In our example, the module should have the following positions:</p> <p>CH0,1: A CH2,3: A CH4,5: B CH6,7: B</p>

4.2.5 Mounting the SM331 module

Procedure

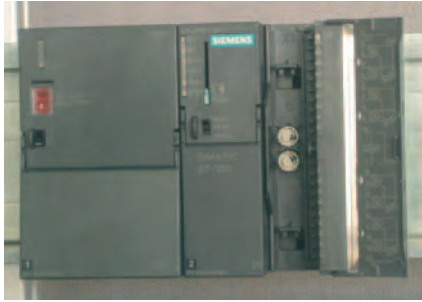
After you have prepared the analog module accordingly, mount it to the rail as well.

Step	Graphic	Description
1		Mounting the SM331: <ul style="list-style-type: none">• Hang the SM311 to the top end of the rail• Push it all the way to the left up to the CPU• Push it down• Screw it tight to the rail underneath
2		Mounting the front connector: <ul style="list-style-type: none">• Press the upper release button of the front connector.• Insert the front connector into the module until it snaps in

The example station is now mechanically mounted.

Electrical connection of the example station

5.1 General

Overview

This chapter describes how the various parts of the example station are electrically wired from the power supply to the analog module.



Warning

You might get an electrical shock if the power supply PS307 is turned on or the power cord is connected to the line.

Always switch off power before you start wiring the S7-300.

5.2 Wiring the power supply module and the CPU



Overview



Figure 5-1 Wiring the power supply module and the CPU

The example station requires a power supply. The wiring is done as follows:

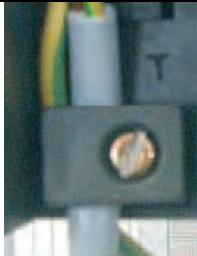
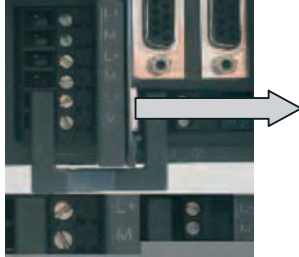
Wiring the Power Supply and the CPU

Step	Graphic	Description
1		Open the front panel covers of the power supply module and CPU.
2		Unscrew the cable grip on the power supply.
3		Remove the insulation from the power cord, attach the cable end sleeves (for stranded wires) and connect it to the power supply.
4		Screw the strain-relief assembly tight.
5		Insert two connecting cables between the power supply and the CPU and tighten them. Do not modify the grounding switch, as the SM331 is already set up to be isolated. Information about the CPU's grounding switch: <ul style="list-style-type: none"> • Pressed: Electrically isolated (as-delivered state) • Pulled: Isolated
6		Check that the line voltage selector switch is set to the correct line voltage. Mains voltage The default line voltage setting for the power supply module is 230 VAC. To label a front connector, follow the steps outlined below: Remove the protective cap with a screwdriver, set the switch to the required line voltage and replace the protective cap.

5.3 Connection variations of the analog module

5.3.1 General

Overview

For the connection of thermocouples the wiring of the analog module SM331 differs only through the selection of:

- Usage of the internal reference junction
- Usage of an external reference junction

In the following chapters you will be led through the two types of connection with internal and external reference junction.

5.3.2 Shielded wires for analog signals

Wires

You should use shielded and twisted-pair wires for analog signals. This reduces the effect of interference. You should ground the shield of the analog wires at both ends of the wire.

If there are differences in potential between the ends of the wires, equipotential current may flow across the shield, which could disturb the analog signals. In this case, you should either ground the shield at only one end or install an appropriate compensation wire.

Usage of the internal and external reference junction

Property	Usage of an internal reference junction	Usage of an external reference junction
Wiring with thermocouples of the same type	A maximum of 8 thermocouples is possible.	A maximum of 8 thermocouples is possible.
Wiring with a combination of different thermocouple types	For each channel group 2 thermocouples of the same type can be installed. This means that: A total of 8 thermocouples with maximum 4 different types can be installed.	A combination of different thermocouples is not possible. All channels of the module refer to the same reference junction. Therefore, a maximum of 8 thermocouples of the same type can be installed.
Usable connection wires	Direct connection of the thermocouples Connection through compensation wires	Long copper wires are possible. Connection of the thermocouples directly at the reference junction.

5.3.3 Connection diagram of thermocouples with internal reference junction

Overview

The following figure shows analog module SM331 with thermocouples connected via a compensation wire and internal reference junction.

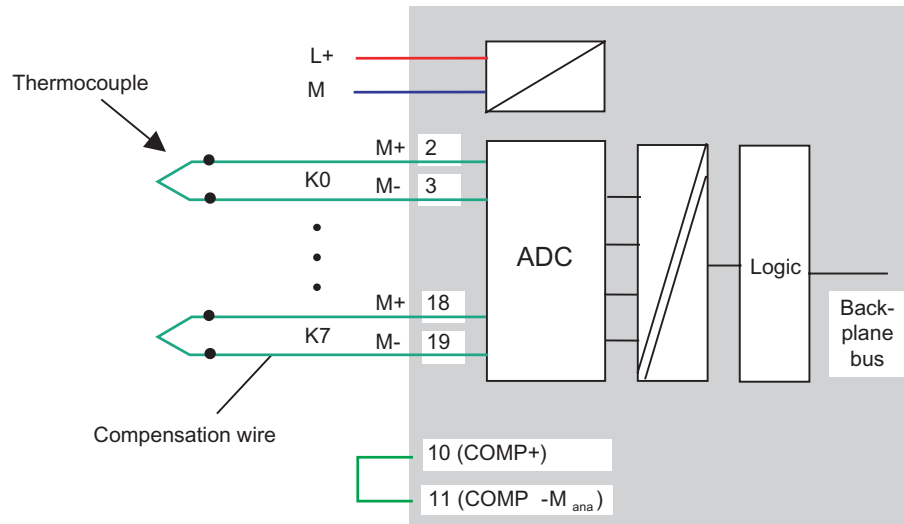

Figure 5-2 Connection diagram: Usage of the internal reference junction

The compensation wire always has to be the same material (alloy) as the thermocouple itself.

On a channel group, only thermocouples of the same type can be installed.

5.3.4 Connection diagram of an analog module with internal reference junction

Overview

The wiring of the analog module consists of the following tasks:

- Connecting the power supply (red cable)
- Connecting the compensation wires for the thermocouples
- Short-circuiting the reference junction
- Connecting to ground and short-circuiting the other unused channels (blue cables)

Details of the wiring are explained in the next chapter.

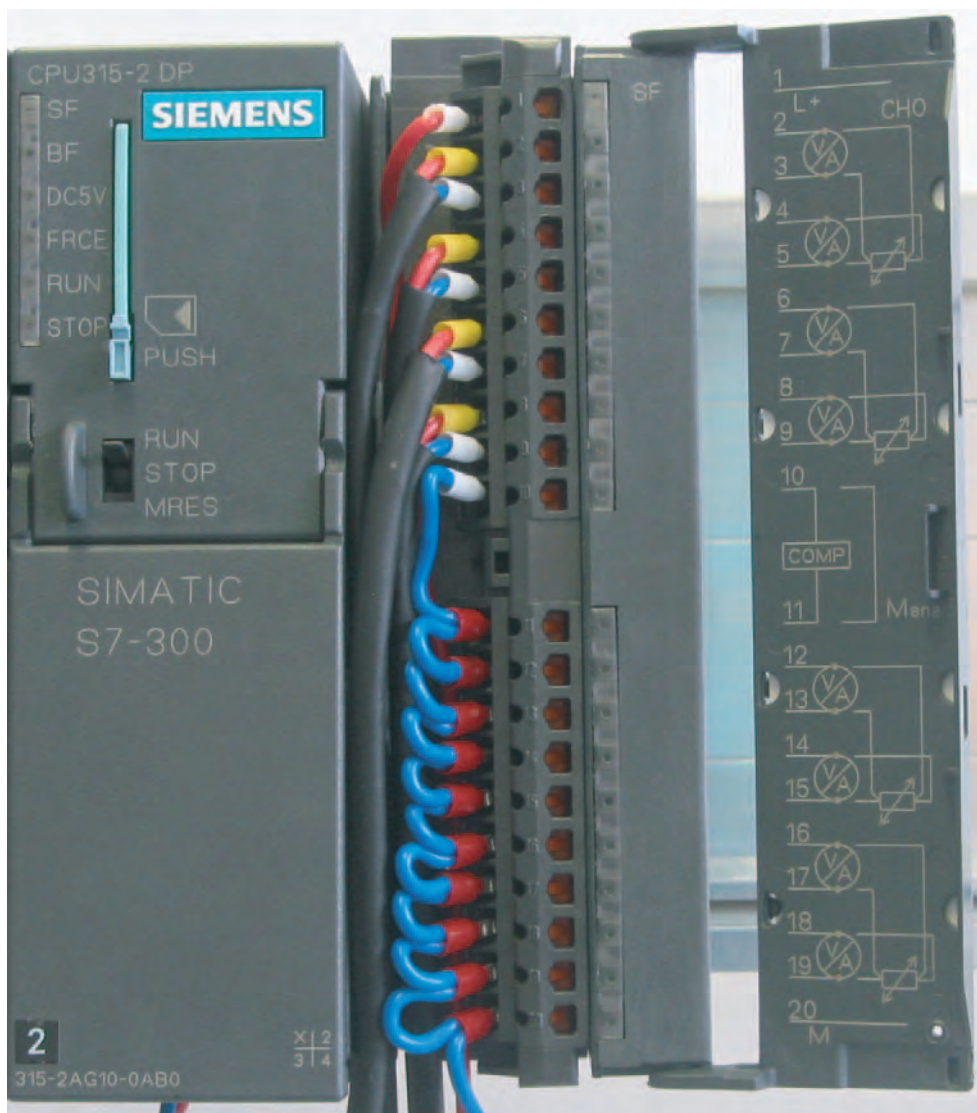





Figure 5-3 SM331 Front connector wiring

5.3.5 Wiring of the analog module with internal reference junction

Procedure

Wire the thermocouples either directly to the inputs of the module, or indirectly via compensation wires. The following table describes the wiring step-by-step:

SM331 Front connector wiring

Step	Graphic	wiring	Comments
1		Open the front door of the SM331	The connection diagram is printed on the front flap.
2		Remove 6 mm of the insulation from the ends of the wires that go into the front connector. Attach cable end sleeves to these ends.	
3		Wire the front connector as follows: Terminal 1: L+	power supply of the module
4		Terminal 2: M+ First thermocouple type J Terminal 3: M- First thermocouple type J Terminal 4: M+ Second thermocouple type J Terminal 5: M- Second thermocouple type J Terminal 6: M+ First thermocouple type K Terminal 7: M- First thermocouple type K Terminal 8: M+ Second thermocouple type K Terminal 9: M- Second thermocouple type K	Standard wiring for thermocouples with internal reference junctions. If you swap M+ and M-, the measurement values obtained will be incorrect and will not correspond to the real temperature!
5		Terminal 10: (Comp+) and Terminal 11: (Comp-)	Thermocouples that are connected directly or via compensation wires do not need an external reference junction. The external reference junction is short-circuited via the bridge.
6		Short-circuit terminal 11: (M _{ana}) and terminal 12 to 19 and connect with terminal 20: M.	Unused channel groups should be short-circuited with M _{ana} (Comp-) and M in order to achieve a maximum interference resistance. Note: Terminal 11 M _{ana} is called Comp- when used with an external cold junction.

5.3.6 Connection diagram of thermocouples with external reference junction

Overview

The diagram illustrates the analog module SM331 with connection

- Of thermocouples over a connection point for compensation wire
- Of an external reference junction

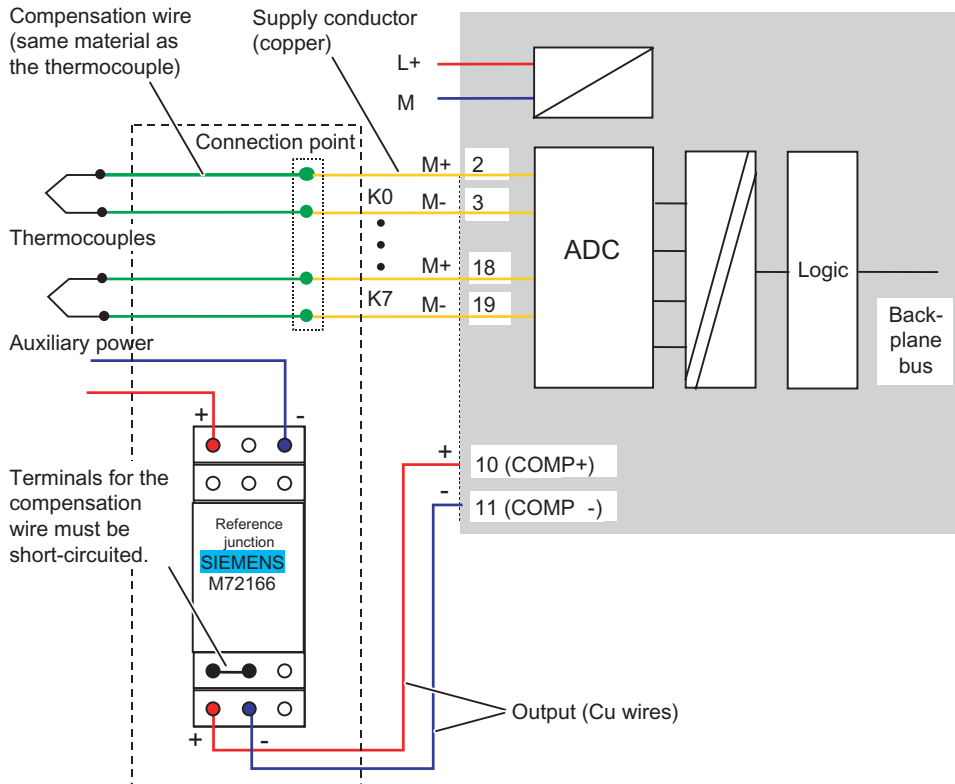

Figure 5-4 Wiring: Thermocouple with external reference junction

In the case of external compensation, the temperature of the reference junction for the thermocouple is acquired by means of a compensating box.

The compensating box contains a bridge circuit that is adjusted for a certain reference temperature (compensating temperature).

The thermocouple-compensation-wire should be connected in the immediate vicinity of the compensating box. Only then can you guarantee that the surrounding temperature of the connection point of the thermocouple and the compensating box is the same.

5.3.7 Connection diagram of an analog module with external reference junction

Overview

The wiring of the analog module consists of the following tasks:

- Connecting the power supply (red cable)
- Connecting the compensation wires for the thermocouples
- Connecting the reference junction
- Connecting to ground and short-circuiting the other unused channels (blue cables)

Details of the wiring are explained in the relevant chapter.

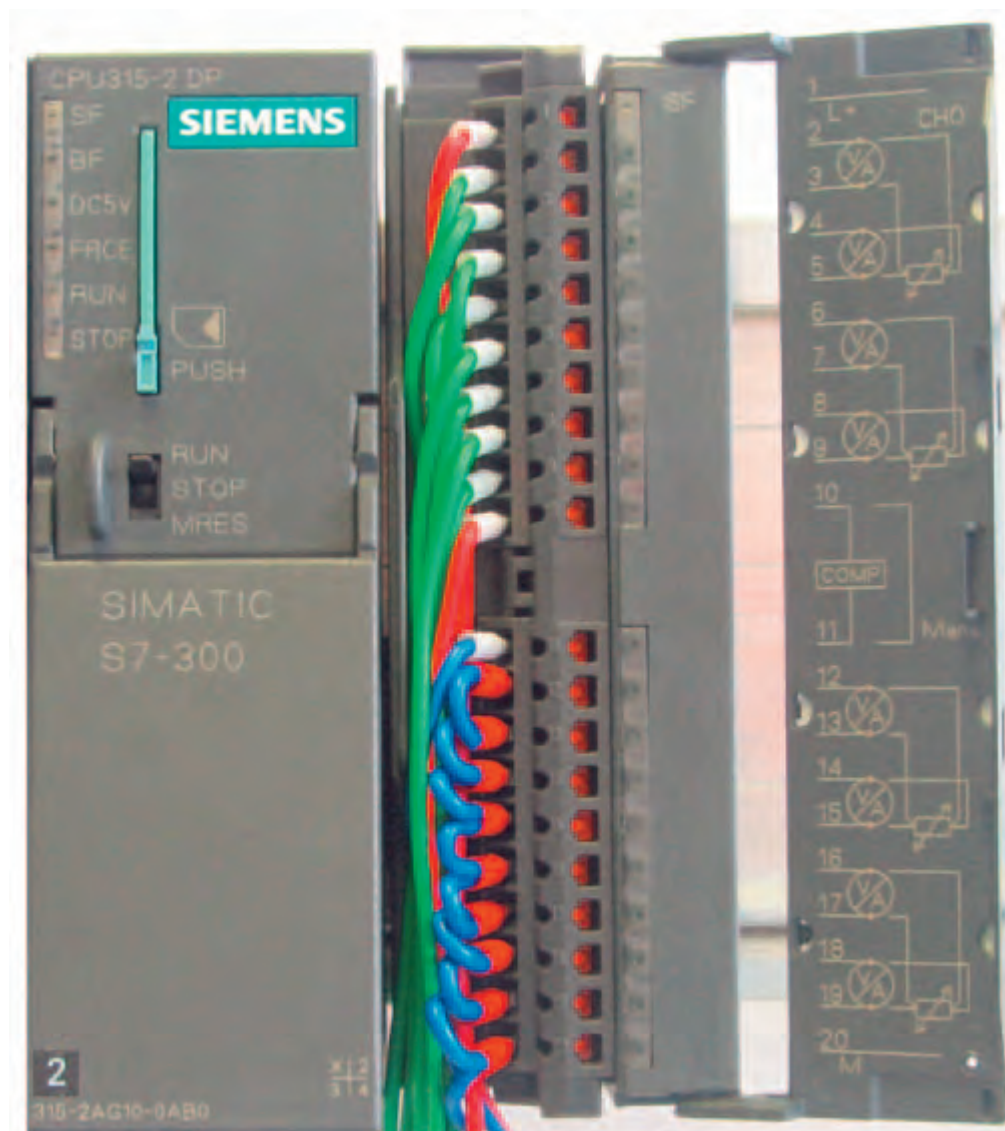

Figure 5-5 SM331 Front connector wiring

See also



Wiring of the analog module with external reference junction (Page 5-11)

5.3.8 Wiring of the analog module with external reference junction

Procedure

Install the thermocouple over a compensation point. From this terminal on, copper wires are used all the way to the inputs of module SM331. The required wiring tasks are explained below step-by-step:

SM331 Front connector wiring

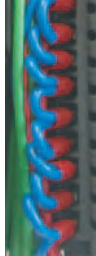
Step	Graphic	wiring	Comments
1		Open the front door of the SM331	The connection diagram is printed on the front flap
2		Remove 6 mm of the insulation from the ends of the wires that go into the front connector. Attach cable end sleeves to these ends.	
3		Wire the front connector as follows: Terminal 1: L+	L+ from the power supply of the module
4		Terminal 2: M+ First thermocouple type J Terminal 3: M- First thermocouple type J Terminal 4: M+ Second thermocouple type J Terminal 5: M- Second thermocouple type J Terminal 6: M+ Third thermocouple type J Terminal 7: M- Third thermocouple type J Terminal 8: M+ Fourth thermocouple type J Terminal 9: M- Fourth thermocouple type J	Standard wiring for thermocouples with external reference junctions. If you swap M+ and M-, the measurement values obtained will be incorrect and will not correspond to the real temperature!
5		Connect terminal 10: (Comp+) and terminal 11: (Comp-) with the compensating box.	For the wiring of the compensating box, see the relevant chapter
6		Short-circuit terminals 12 to 19 and connect with terminal 20. Terminal 20: M	Unused channel groups should be short-circuited with M in order to achieve a maximum interference resistance. M from the power supply of the module

5.3.9 Wiring of the external reference junction

Procedure

In our example we use a Siemens compensating box for thermocouple type J (MLFB M72166-B4200) with 24 V DC as auxiliary power. The compensating box should be mounted in the direct vicinity of the connection point.

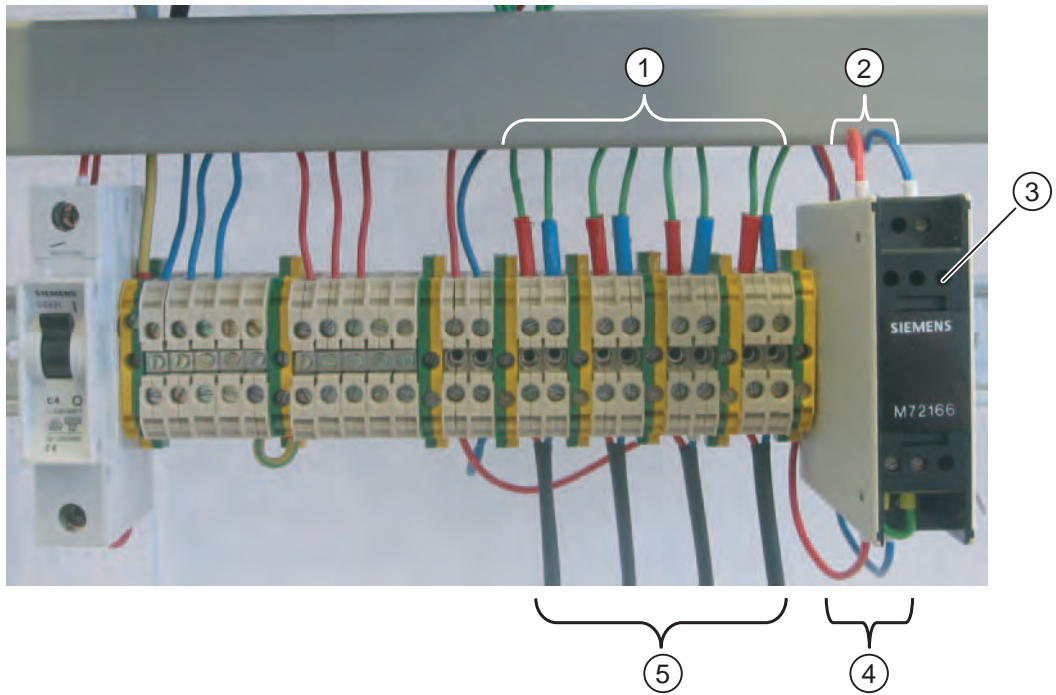



Figure 5-6 Connection point

- (1) Copper wires to module SM331
- (2) Auxiliary power 24 V DC
- (3) Compensating box
- (4) Connection of the reference junction
- (5) Compensation wires of thermocouple

Wiring of the compensating box

Graphic	wiring	Comments
	<p>Wire the compensating box as follows:</p> <p>Terminal 1: M Auxiliary power 24 V DC</p> <p>Terminal 3: L+ Auxiliary power 24 V DC</p> <p>Short-circuit terminals 11 and 12 (green cable).</p> <p>Connect terminal 8 with terminal 11 (Comp-) of the SM331.</p> <p>Connect terminal 9 with terminal 10 (Comp+) of the SM331.</p>	<p>The reference temperature of 0°C that is required by SM331 is reached by short-circuiting terminals 11 and 12.</p>

5.3.10 Check the wiring

Introduction

If you want to test the wiring, you may now switch the power supply on.
Do not forget to set the CPU to STOP (see the red circle).

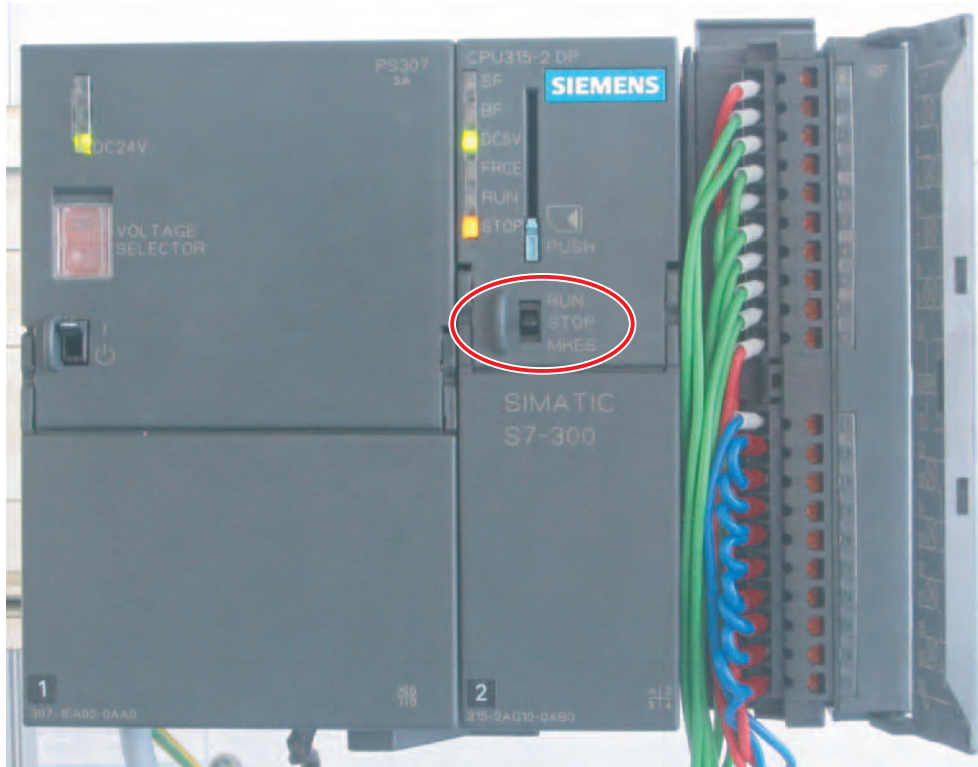

Figure 5-7 Successful wiring, CPU in position STOP

If a red LED is lit, then there is an error in the wiring. Verify your wiring.

Configuration of the SIMATIC Manager

6.1 Creating a new STEP7 project

6.1.1 Create a new project

Overview

In this chapter you will be guided through the following tasks:

- Creating a new STEP7 project
- Parameterization of the hardware configuration

Wizard "New Project..."

Use STEP7 V5.2 or later for configuring the new CPU 315-2 DP.

Start SIMATIC Manager by clicking the "SIMATIC Manager" icon on your Windows Desktop and create a new project with the STEP7 "New Project" wizard.

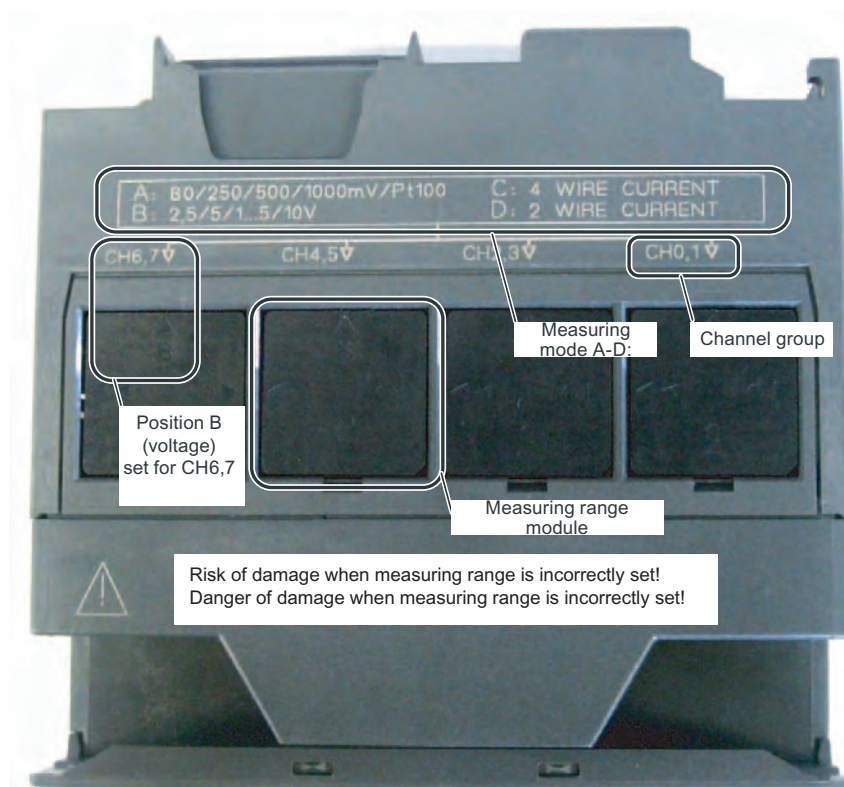

Figure 6-1 Starting the "New Project..." wizard

A project wizard introduction window appears. The wizard guides you through the procedure for creating a new project.

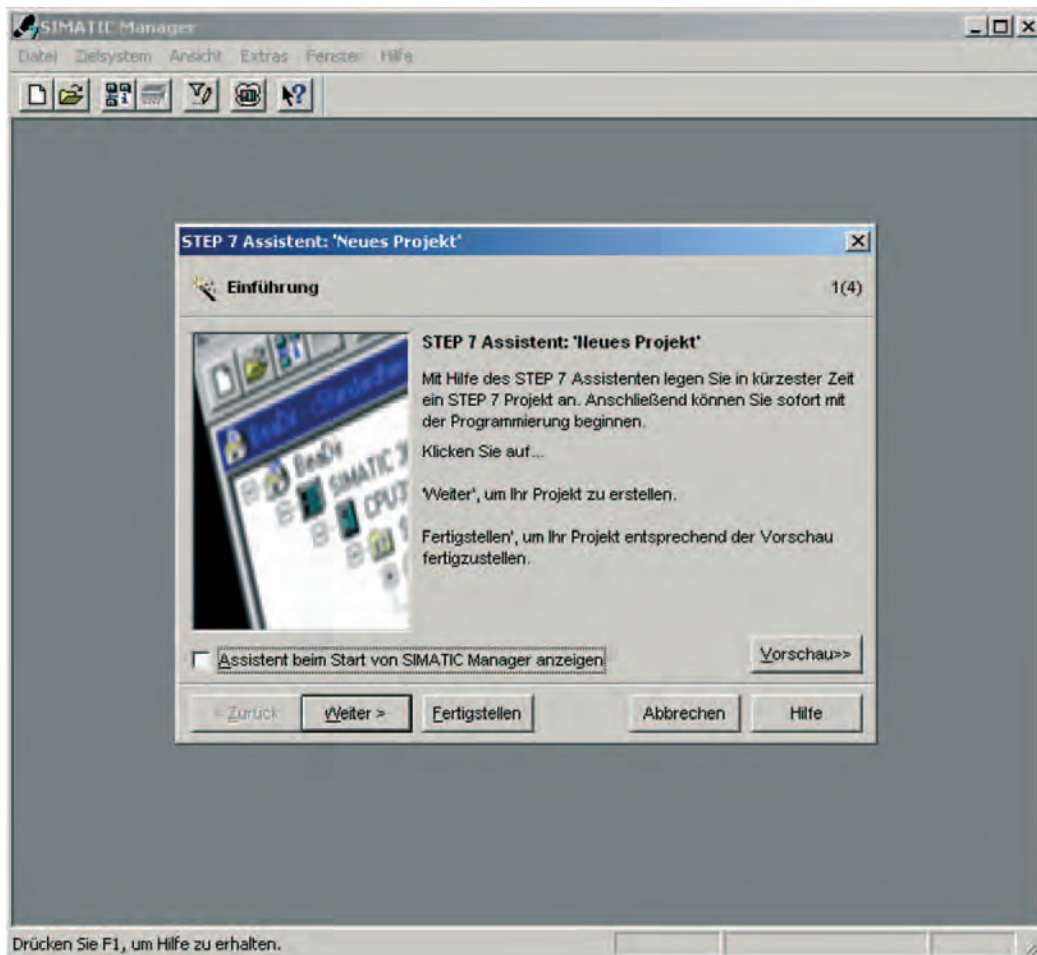

Figure 6-2 Wizard "New Project", start

The following must be specified during the creation procedure:

- The CPU type
- The basic user program
- The organization blocks
- Project name

Click "Next."

6.1.2 CPU selection

Procedure

Choose the CPU 315-2DP for the example project. (You can also use our example for a different CPU. Select the appropriate CPU in this case.)

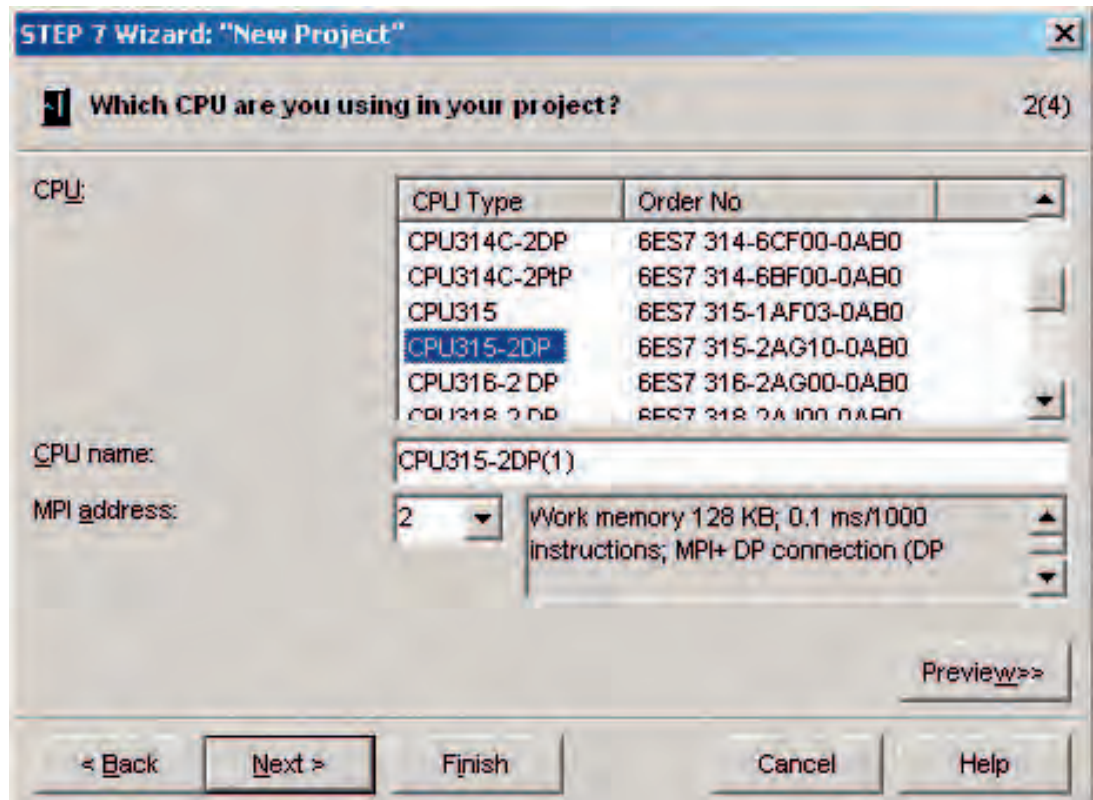

Figure 6-3 "New Project" wizard: Selecting a CPU

Click "Next".

6.1.3 Defining the basic user program

Procedure

Choose the SIMATIC language STL and select the following organization blocks (OBs):

- OB1 cyclically executed block
- OB40 hardware interrupt
- OB82 diagnostic interrupt

OB1 is required in every project and is called cyclically.

OB40 is called when a hardware interrupt occurs.

OB 82 is called when a diagnostic interrupt occurs.

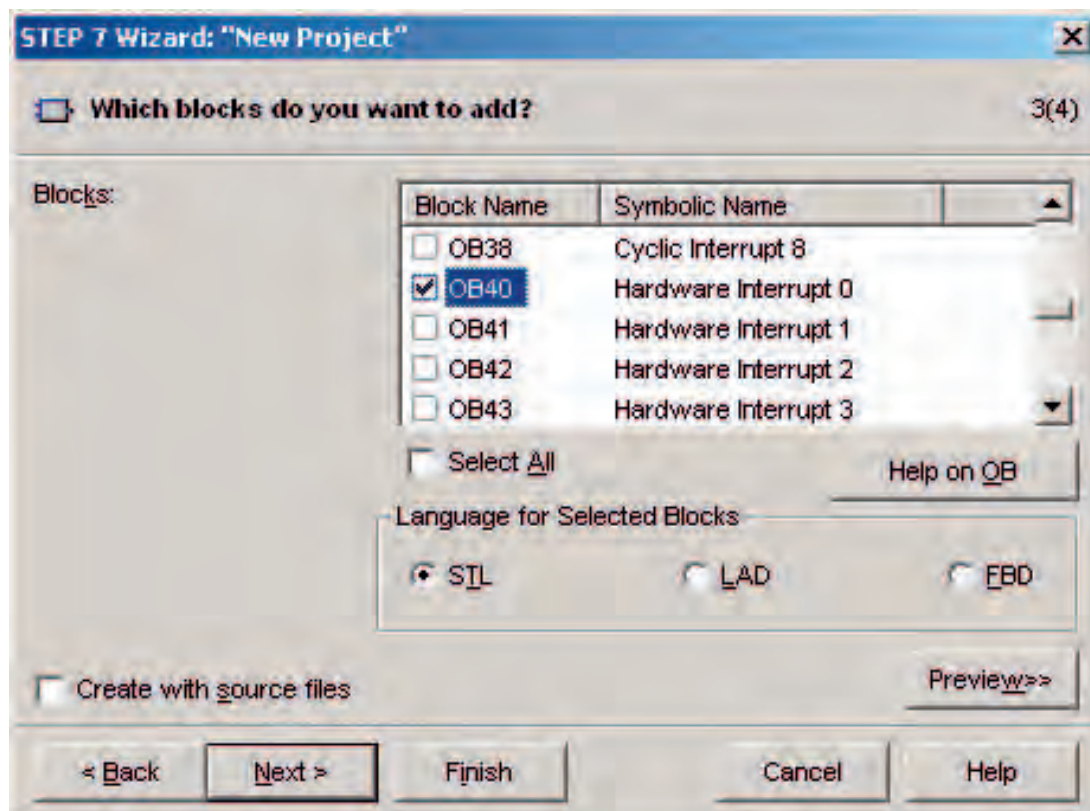

Figure 6-4 From part 1, "New Project" wizard: Inserting organization blocks

Click "Next."

6.1.4 Assigning the project name

Procedure

Select the "Project name" text box and overwrite the name it contains with "Getting Started S7 SM331".

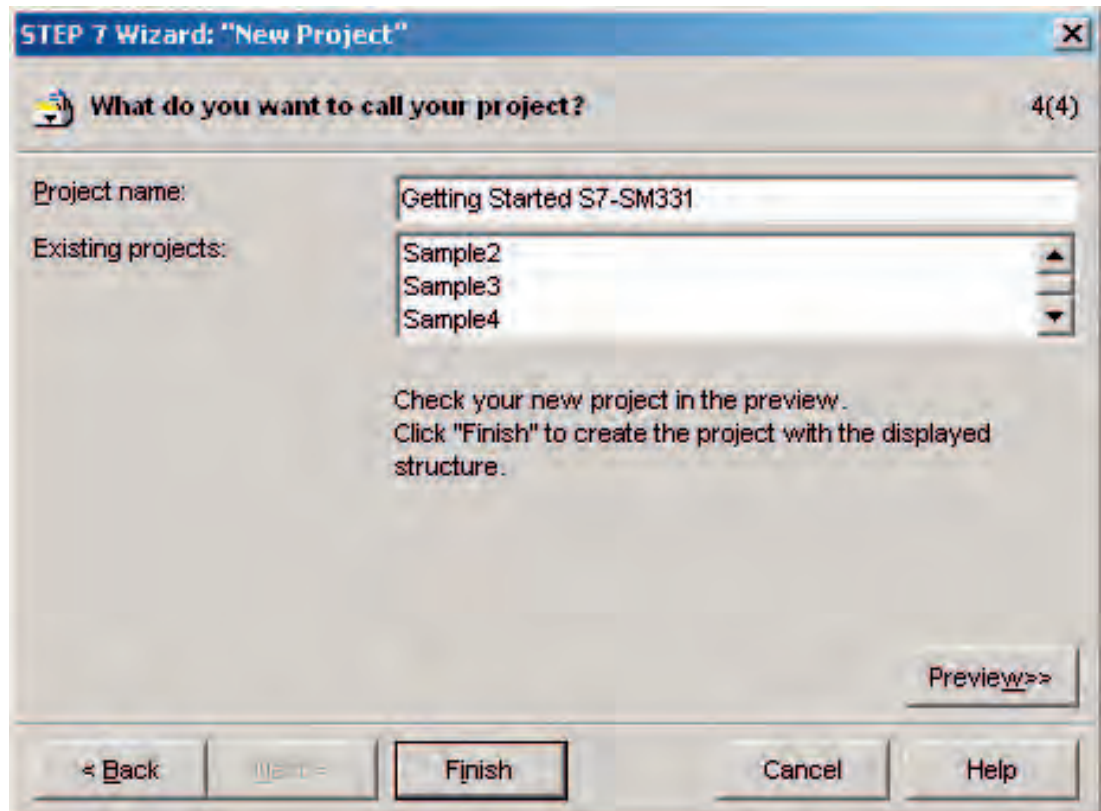

Figure 6-5 From part 1, "New Project" wizard: Naming the project

Click "Finish". The basic STEP7 project is created automatically.

6.1.5 Result S7 project is created

Result

The wizard has created the project "Getting Started S7-SM331". You can see the inserted organization blocks in the right window.

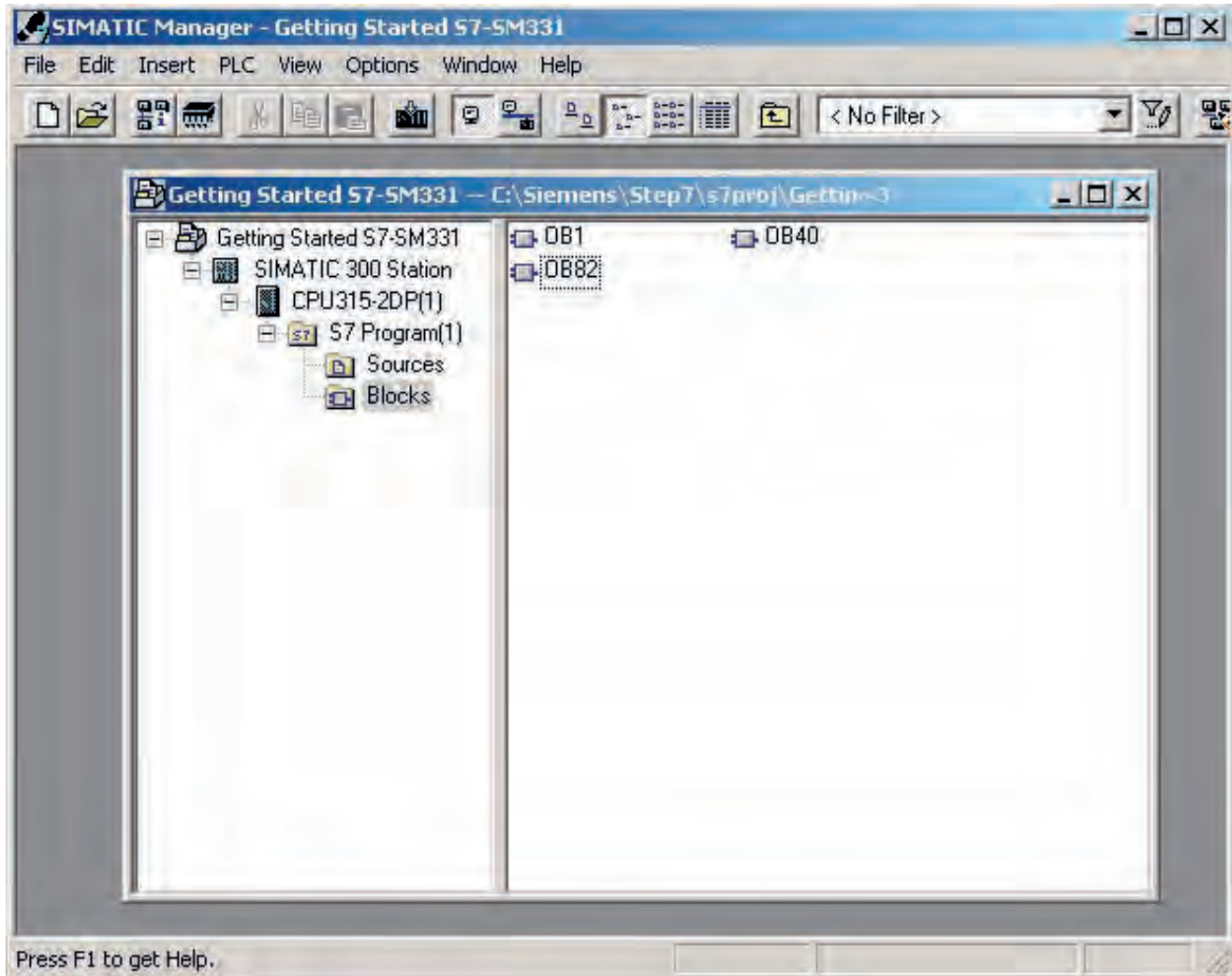

Figure 6-6 "New Project" wizard results

6.2 Hardware configuration

6.2.1 Creating the hardware configuration

Overview

The STEP7 wizard has created a basic S7 project. You also need a complete hardware configuration in order to create the system data for the CPU.

Procedure

You can create the hardware configuration of the example station with SIMATIC Manager. . .
To do this, select the folder "SIMATIC 300 Station" in the left window. Start the hardware configuration by double-clicking the folder "Hardware" in the right window. . .

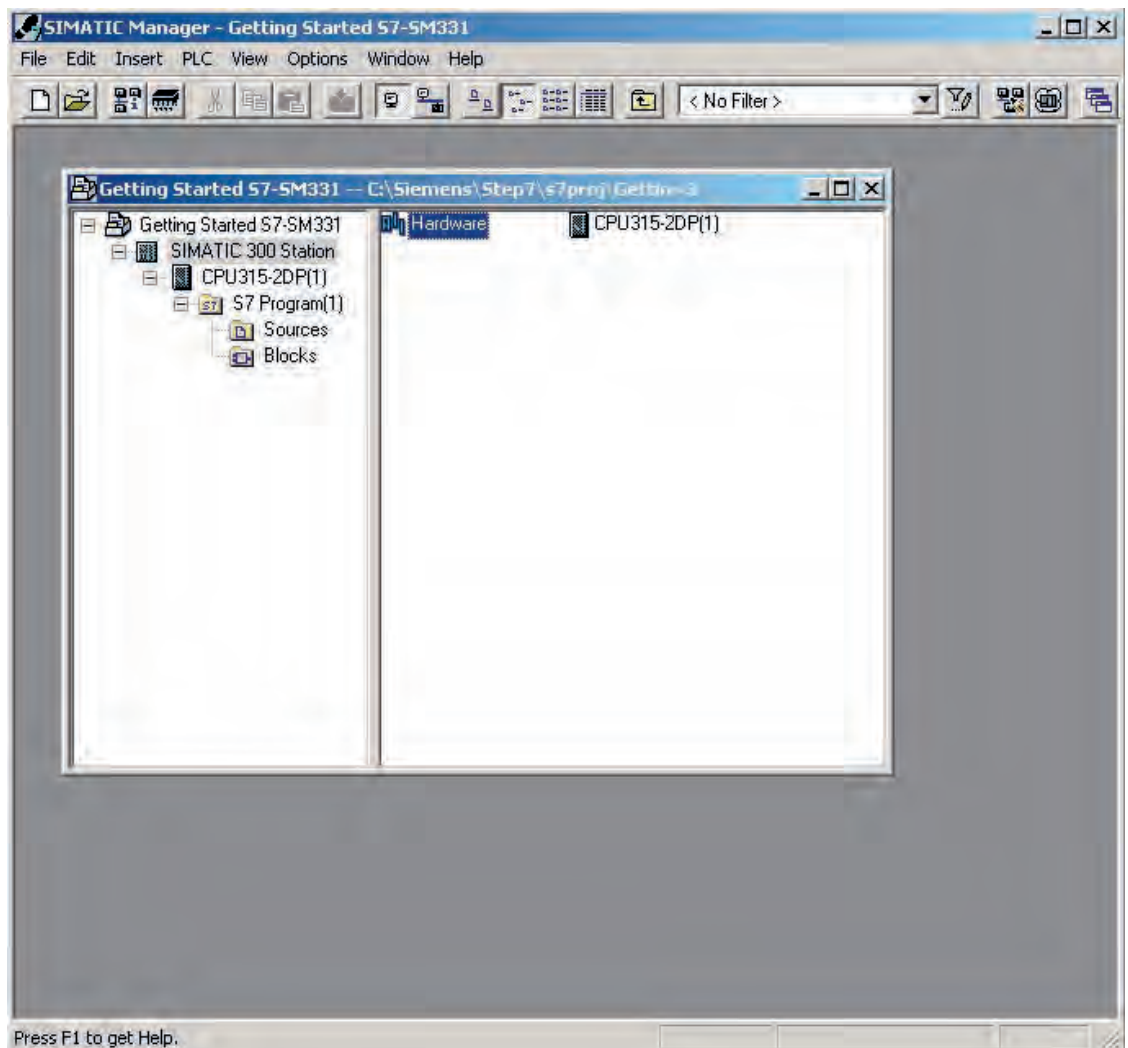

Figure 6-7 Opening the hardware configuration

6.2.2 Adding SIMATIC components

Procedure

First select a power supply module from the hardware catalog.

If the hardware catalog is not visible, open it with the shortcut key Ctrl+K or by clicking the catalog icon (blue arrow).

In the hardware catalog you can browse through the folder SIMATIC 300 to the folder PS-300.

Select the PS307 5A and drag it into slot 1 (see red arrow).

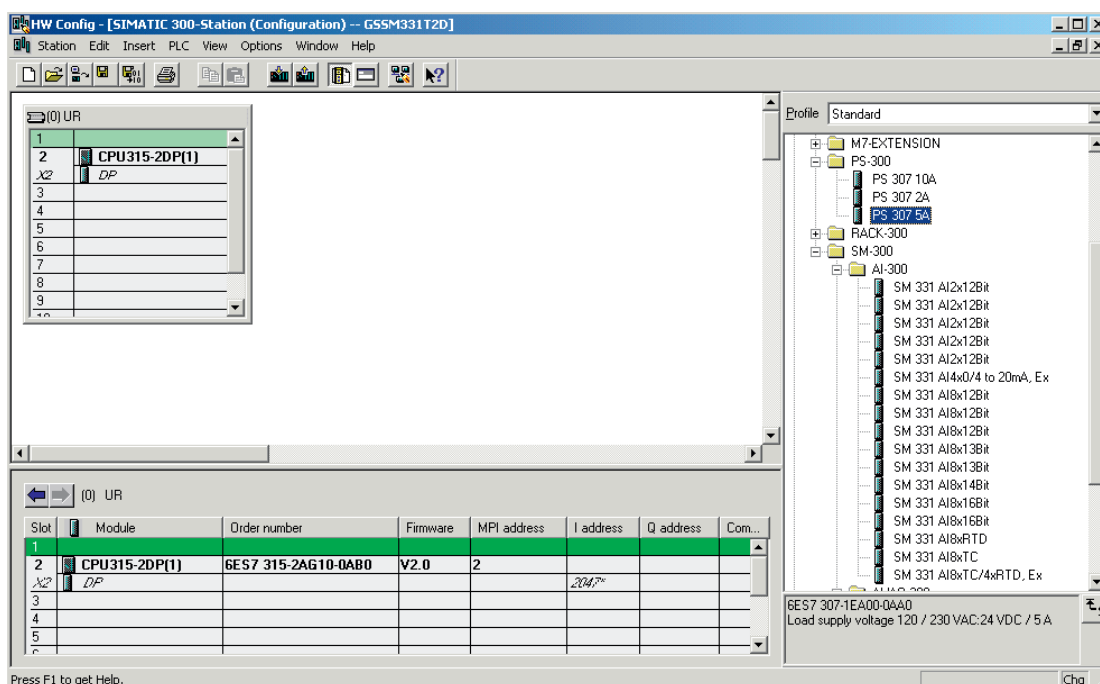

Figure 6-8 Hardware configuration: Basic configuration

Result: PS 307 5A appears in the configuration of your rack.

Inserting an analog module

There are many SM331 analog modules. For this project we use an SM331, AI8x12 bit with the order number 6ES7 331-7KF02-0AB0.

The order number is displayed at the bottom of the hardware catalog (see blue arrow).

Select the SM331 AI8x12bit from the right window and drag it onto the first free field in slot 4 (see red arrow) in the configuration table.

You have inserted all the modules into the hardware configuration table. In the next step, you configure the modules. SIMATIC Manager inserts the analog module with its default settings. You can modify the parameters to change the sensor types, diagnostics and interrupt capabilities.

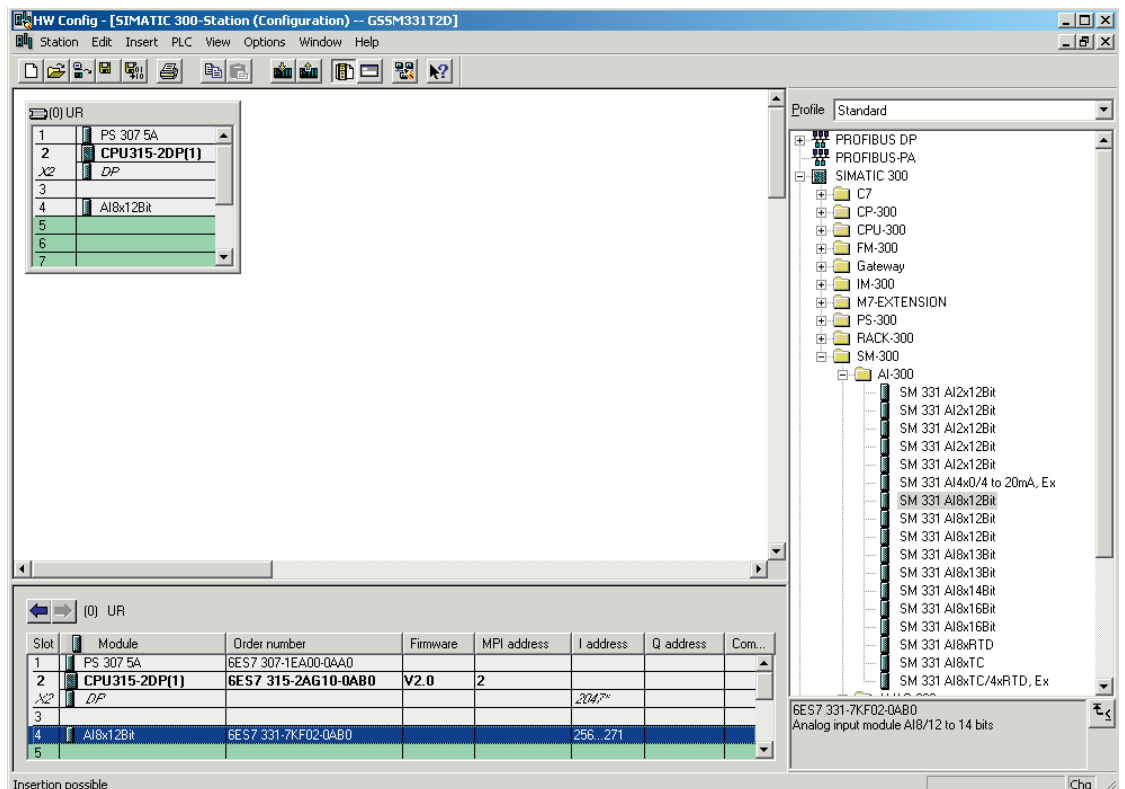

Figure 6-9 Hardware configuration: SM331 insert

6.2.3 Parameterization of the analog module of the example station

Overview

You can modify the parameters to change the sensor types, diagnostics and interrupt capabilities.

To open the parameterization, double-click the analog module in the configuration table. The Properties view of the SM331 opens.

Overview of the functionalities with internal compensation

The table shows the parameters that have to be set with internal compensation.

SM331 functionalities of the example station with internal compensation

Functionalities	Description	Remark
Process reactions	Diagnostics – enabled Hardware interrupt when limit exceeded - enabled	
Encoder 1	Thermocouple type J	Channel group (input) 0 - 1
Encoder 2	Thermocouple type J	Channel group (input) 0 - 1
Encoder 3	Thermocouple type K	Channel group (input) 2 -3
Encoder 4	Thermocouple type K	Channel group (input) 2 -3

Parameterization of the SM331 with internal compensation

If you want to parameterize the SM331 for internal compensation, please set the module as follows:

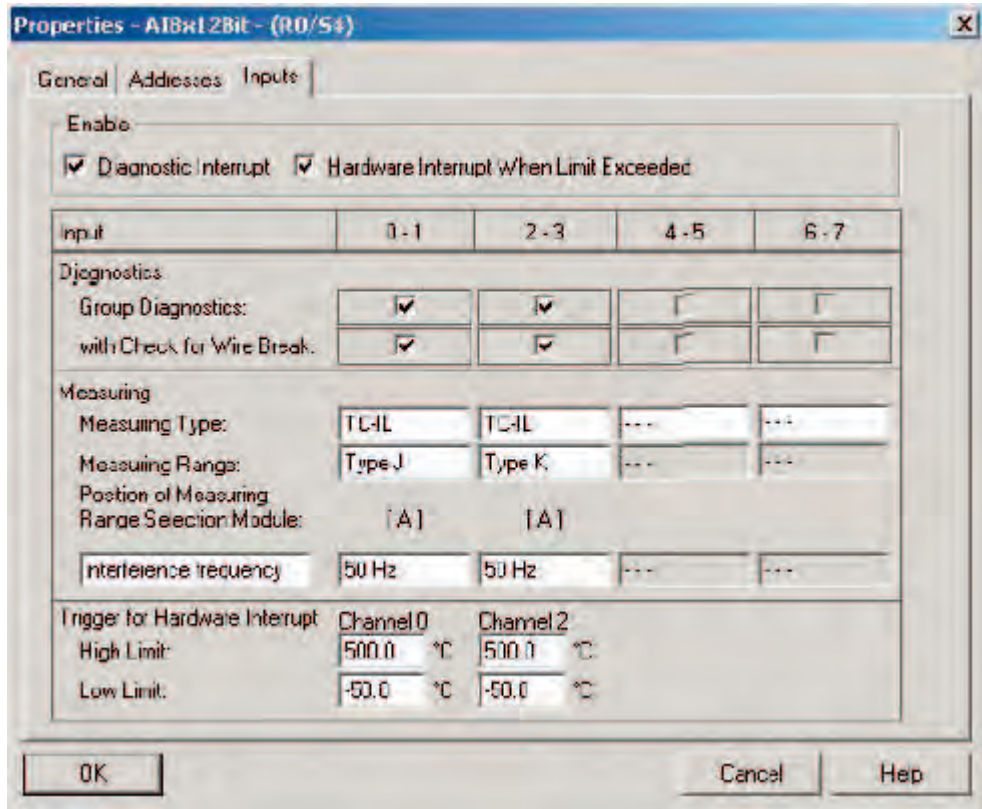

Figure 6-10 SM331: Parameterization of thermocouple with internal reference junction

Overview of the functionalities with external compensation

The table shows the parameters that you have to set with internal compensation.

SM331 functionalities of the example station with external compensation

Functionalities	Description	Remark
Process reactions	Diagnostics – enabled Hardware interrupt when limit exceeded - enabled	
Encoder 1	Thermocouple type J	Channel group (input) 0 - 1
Encoder 2	Thermocouple type J	Channel group (input) 0 - 1
Encoder 3	Thermocouple type J	Channel group (input) 2 -3
Encoder 4	Thermocouple type J	Channel group (input) 2 -3

Parameter window with external compensation

If you want to use a compensating box, please set the module as follows:

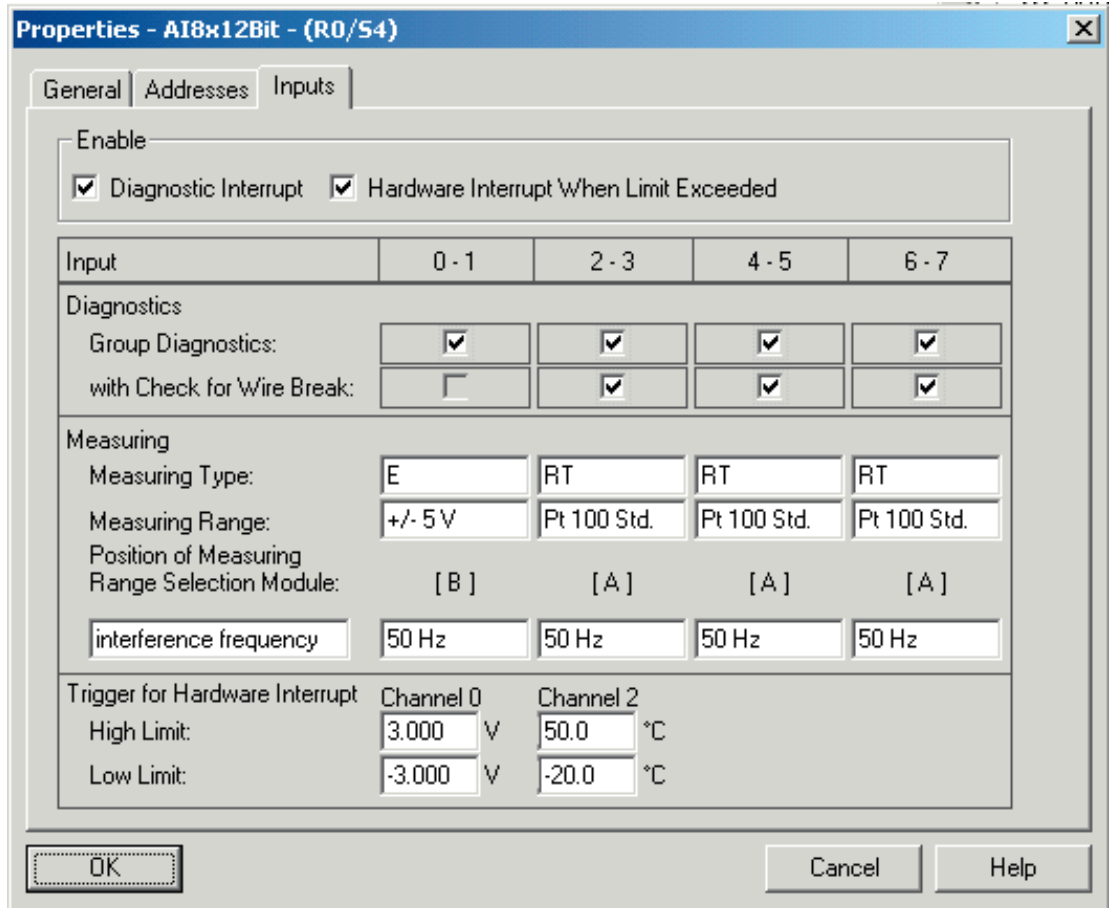

Figure 6-11 SM331: Parameterization of thermocouple with external reference junction

6.2.4 Explanation of the settings of the SM331

Attitudes

The SM331 setting options are explained below.

Diagnostic interrupt

When the diagnostic interrupt is activated, the diagnostic OB82 is called if the grounding or the power supply is lacking.

Hardware interrupt when limit exceeded

If the parameter "Hardware interrupt when limit exceeded" is activated, hardware interrupt OB40 is called when the set limit values are exceeded or undershot.

Only the channels (inputs) 0 and 2 have hardware-interrupt capabilities. No other inputs can trigger hardware interrupts.

The limit values can be set in the same window under "Trigger for Hardware Interrupt".

Group diagnostics

If Group diagnostics is selected, channel-specific diagnostic messages are activated. When a diagnostic event occurs, OB82 is called.

Wire break monitoring

When wire break monitoring is activated, wire breaks will be diagnosed. OB82 is called.

Type of measurement

TC-IL: Thermocouple with internal reference junction

TC-EL: Thermocouple with external reference junction

Measurement range

Specification of the thermocouple type

Position of the Coding Key

The required setting of the measuring range module is displayed.

Interference frequency (Interference frequency suppression)

The interference frequency is set to your local power line frequency.

Finish the hardware configuration

Close the window with the configuration.

Compile and save the project with the command "Station > Save and Compile" (Ctrl+S).

This completes your hardware configuration for the project.

See also

Channel dependent diagnostic messages (Page 8-4)





Measuring range modules (Page 4-6)

6.2.5 Power up test

Procedure

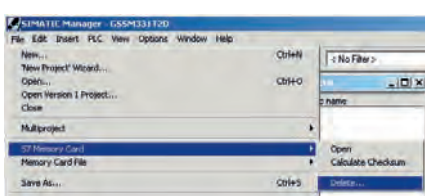
For testing, do a power up test and download the system data.

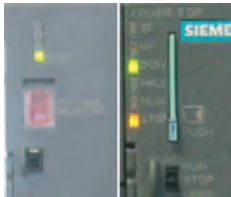
Powering-up

Steps	Graphic	Description
1		Eraser your Micro Memory Card with a Power PG or a PC with external programming device: : In SIMATIC Manager click "File -> S7 Memory Card > Delete ...". The MCC will be deleted.
2		Switch off the power supply to the CPU. Insert the MMC into the CPU. Switch on the power supply.
3		Set the CPU from "RUN" mode to "STOP" mode.
4		Switch the power supply on again. If the STOP LED blinks, the CPU requests a reset. . Acknowledge this by turning the mode switch to MRES for a moment.
5		Connect the CPU to the PG with an MPI cable. . To do this, connect the MPI cable with the CPU's MPI port. Connect the other end to the PG interface of your programming device.

Downloading hardware configuration

Download the hardware configuration into the CPU with HW Config.

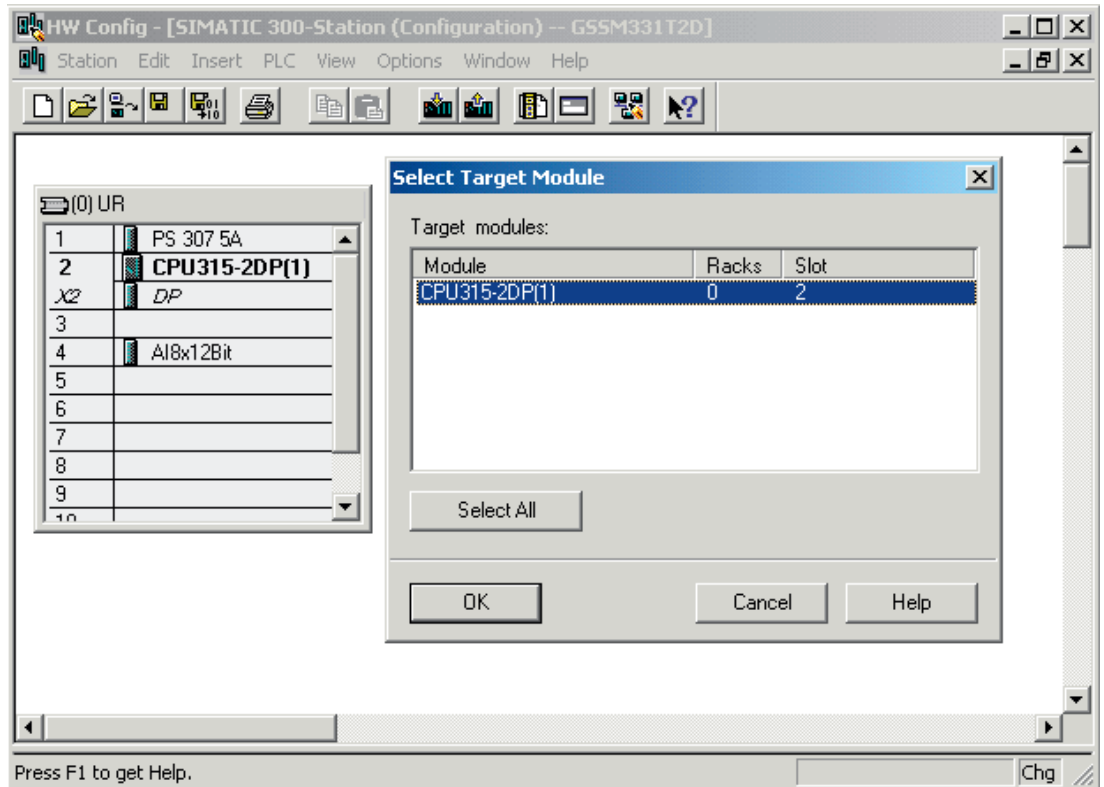

Figure 6-12 Downloading the CPU hardware configuration (1)

Click the "Load to module" icon (shown in the red circle).
When the dialog window "Select target module" appears, click OK.

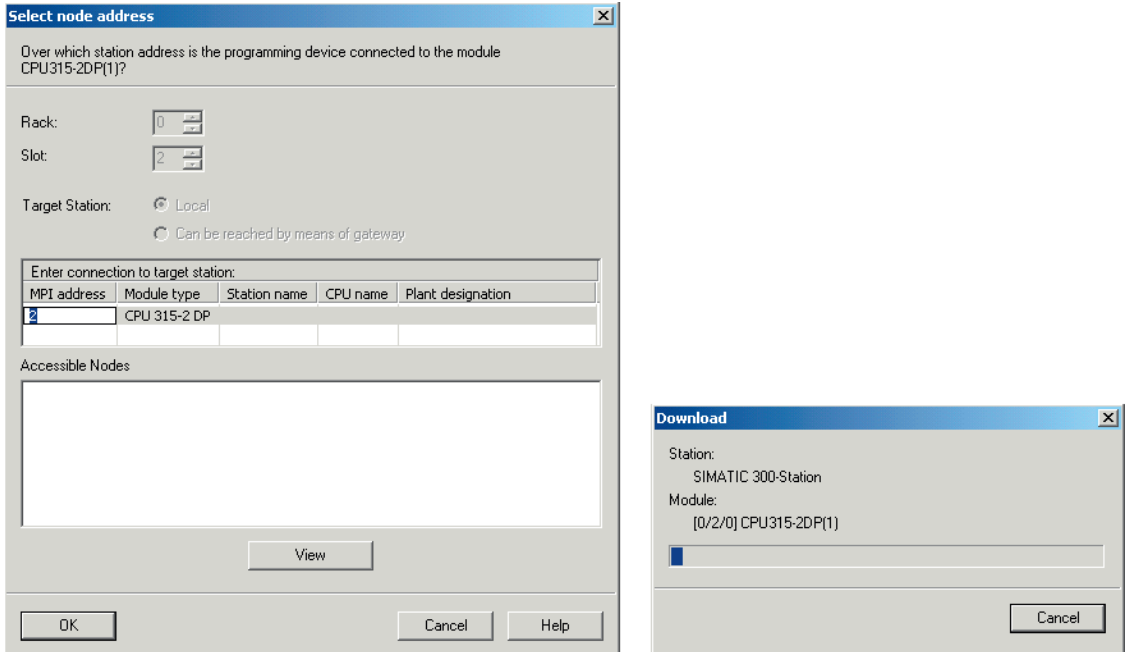

Figure 6-13 Downloading the CPU hardware configuration (2)

The dialog window "Select target address" is shown. Click "OK." The system data will now be transferred to the CPU.

Starting the CPU

Switch the CPU to RUN.

If the hardware configuration was undertaken correctly, two green LEDs (RUN and DC5V) should be lit on the CPU.

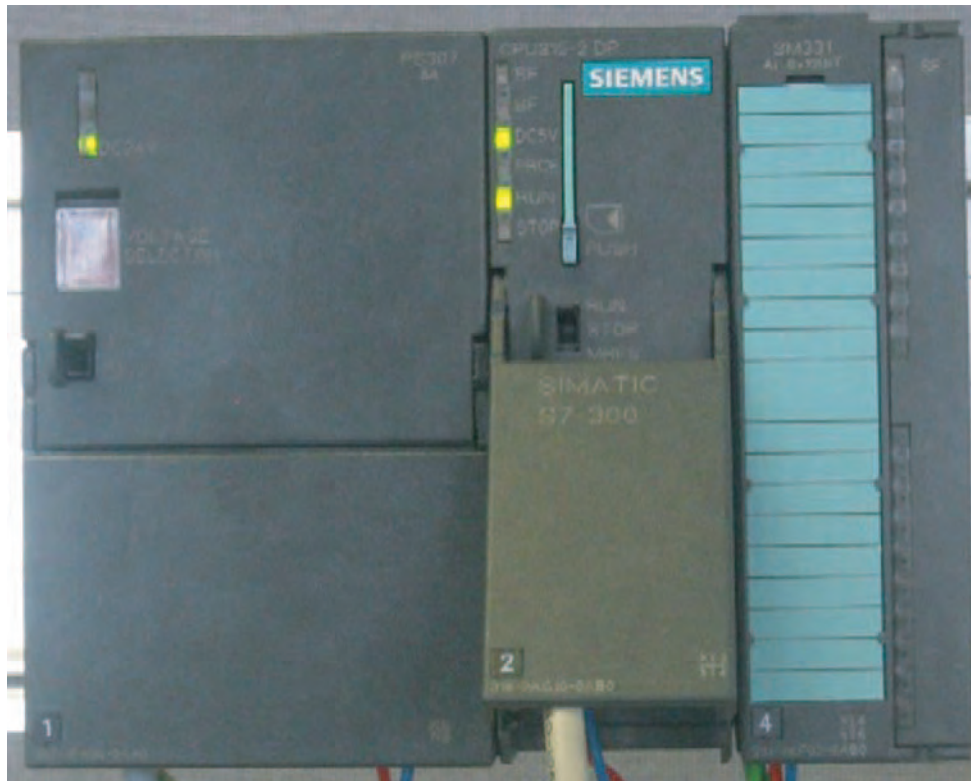

Figure 6-14 CPU in error-free state

If the RUN LED light is not lit, then there is an error.

In order to locate the error, read the diagnostic buffer with a PG. Possible causes of error:

- The wiring has been done incorrectly
- The coding device has been plugged in incorrectly
- You have entered the parameters of the SM331 incorrectly.

6.3 STEP 7 user program

6.3.1 Tasks of the user program

Overview

The example user program

- Stores the sensor values in a data block and
- Saves the status information of the hardware interrupts in a marker word.

The status information is acknowledged by means of a bit. Furthermore, the channel values (values of the input words) are stored in another data block.

The following tasks have to be performed in the user program:

1. Cyclical storage of the analog input values in a data block (DB1)
2. Cyclical conversion of the sensor values into floating point values (FC1) and storage in a data block (DB2)
3. Acknowledgement of the hardware interrupt status when the acknowledge marker (M200.0) is TRUE
4. Saving of the status in a marker word (MW100) when a hardware interrupt occurs

Structure of the user program

Call type	Responsible organization block	Task to be programmed	Used block or marker
Cyclic execution	OB1	Save analog input values	DB1
		Convert and store the sensor values	FC1, DB2
		Acknowledge hardware interrupt	M200.0
Execution triggered by hardware interrupt	OB40	Save status	MW100
Execution triggered by diagnostic interrupt	OB82	Has to be implemented because a module with diagnostic capabilities is used.	---

Diagnostic interrupt OB82

In the STEP7 program, OB82 is used for modules with diagnostic capabilities.

If the module detects a failure (incoming and outgoing events), the module sends a request to the CPU for diagnostics. The operating system then calls OB 82.

In our example, we use OB82 to prevent the CPU from changing to STOP mode. You can program reactions to diagnostic interrupts in OB82.

6.3.2 Creating a user program

Procedure

There are two ways to create a user program:

- If you know how to program STEP7 SCL, then you can create and program the necessary blocks and the function blocks in the Blocks folder of STEP7.
- You can insert the user program from an SCL source into the project. In this “Getting started” we describe this method.

Creating a user program in STEP7 requires three steps:

1. Downloading the source file directly from the HTML page
2. Importing a source file
3. Compiling the source

Downloading the source file

You can download the source file directly from the HTML page from which you loaded this “Getting Started”. Click "Info" and the download window will be opened.

- Note the name of the source file.
- Save the source file to your hard drive.

Importing a source file

You can import the source file into SIMATIC Manager as follows:

1. Right-click the folder "Sources".
2. Select "Insert New Object > External Source..."

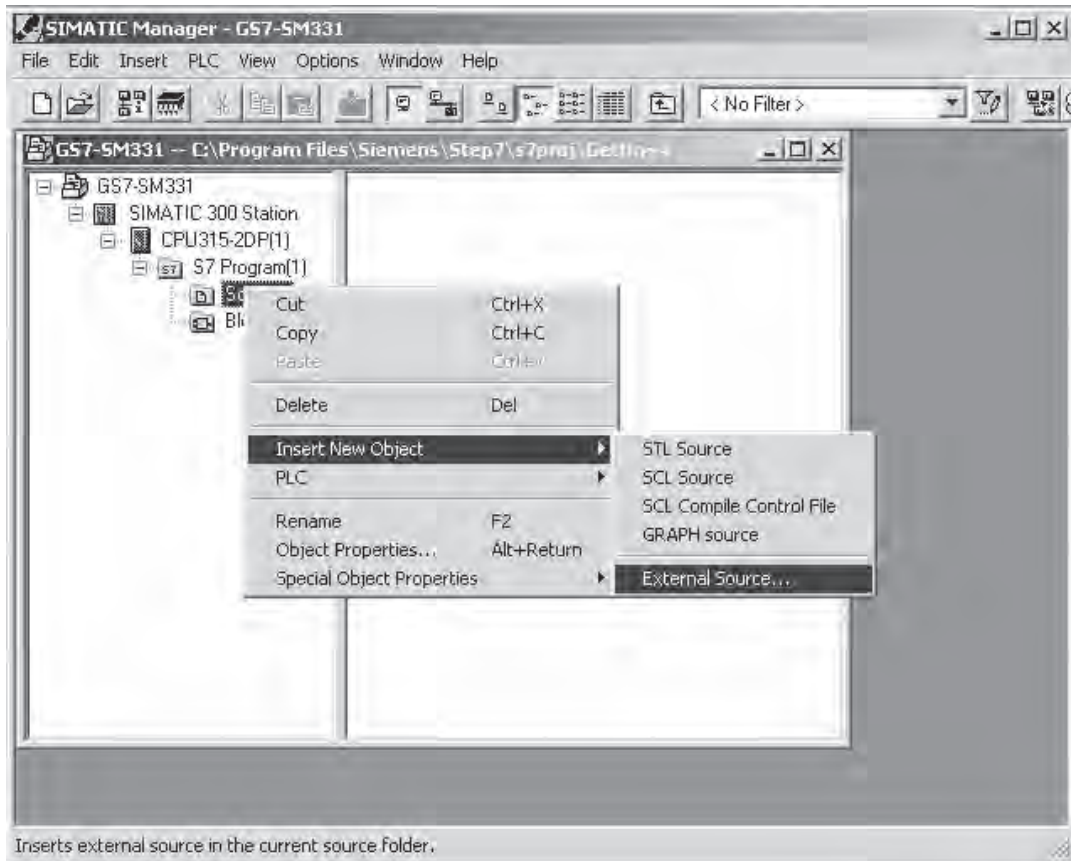

Figure 6-15 Importing an external source

In the "Insert external source" dialog, browse for the source file GSSM331T1DE.AWL, which you have already downloaded and saved on your hard disk.

Select the source file GSSM331T1DE.AWL (red arrow).

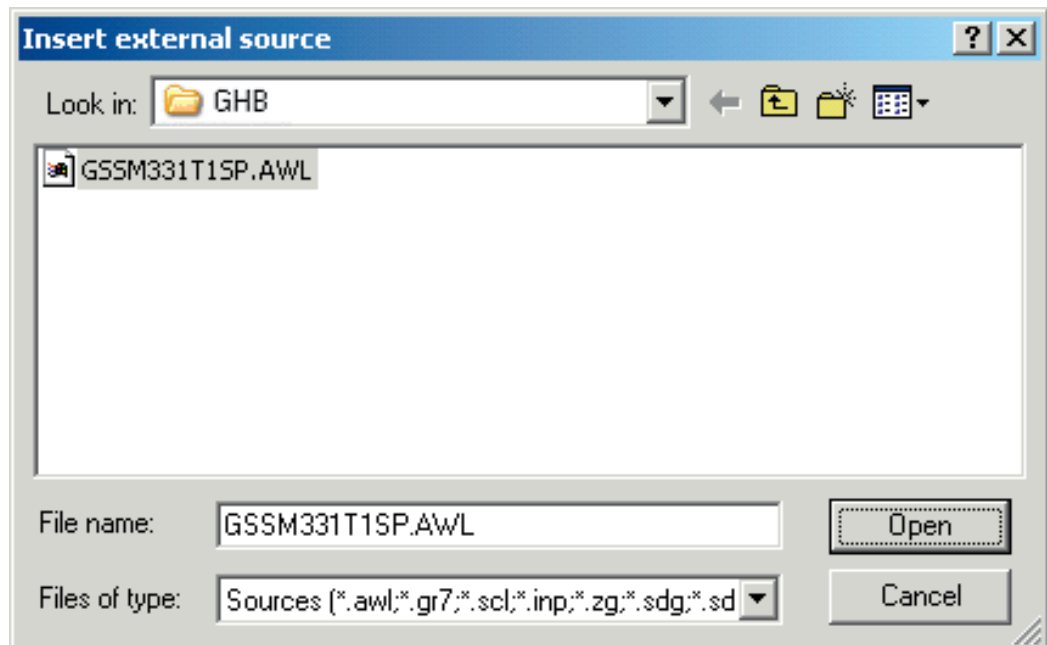

Figure 6-16 Importing an external source

Click "Open".

SIMATIC Manager has opened the source file. In the right window you can see the source file inserted.

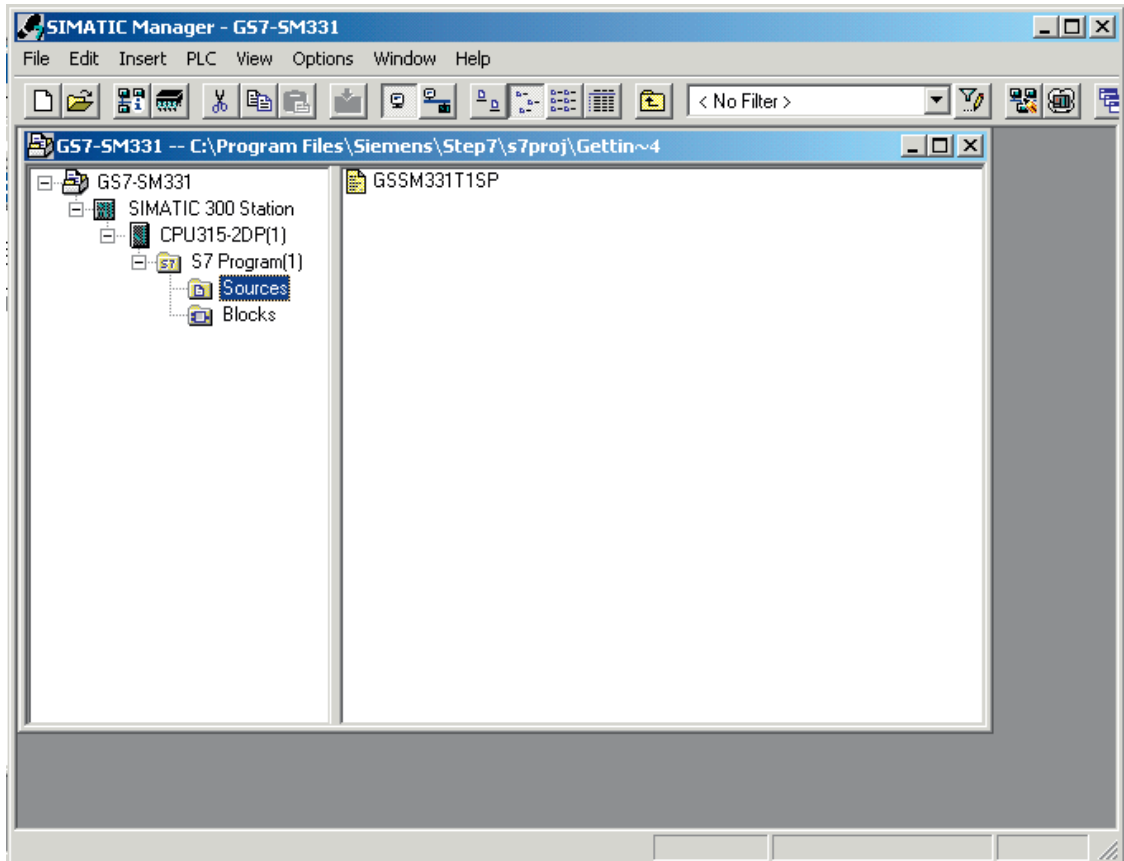

Figure 6-17 Compiling the source code

Compiling the source code

In order to create an executable STEP7 program, the STL source has to be compiled.

Double-click the source file GSSM331T1DE in the Sources folder. The source code editor opens.

In the window of the source code editor you can view the source code.

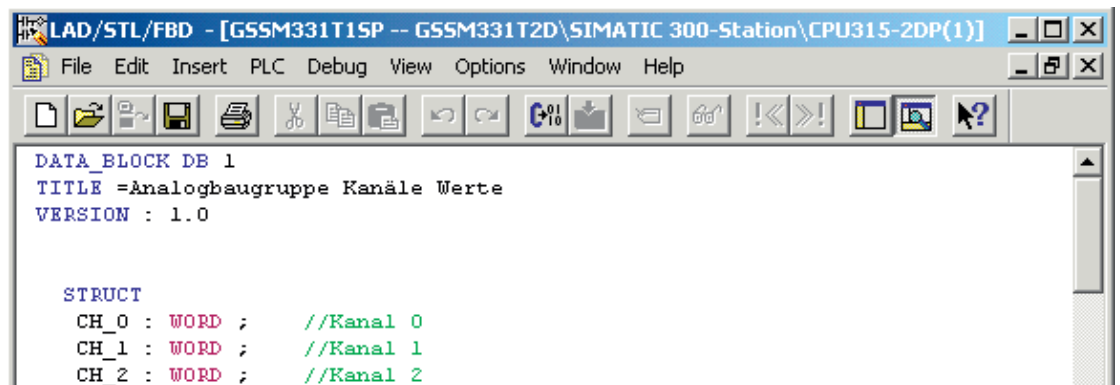

The screenshot shows a window titled "LAD/STL/FBD - [GSSM331T1SP -- GSSM331T2D\SIMATIC 300-Station\CPU315-2DP(1)]". The menu bar includes File, Edit, Insert, PLC, Debug, View, Options, Window, and Help. The toolbar contains various icons for file operations and editing. The main text area displays the following code:

```
DATA_BLOCK DB 1
TITLE =Analogbaugruppe Kanäle Werte
VERSION : 1.0

STRUCT
  CH_0 : WORD ; //Kanal 0
  CH_1 : WORD ; //Kanal 1
  CH_2 : WORD ; //Kanal 2
```

Figure 6-18 Source code editor

After the source code is loaded, start the compilation.

Press the shortcut key Ctrl+K or select "File > Compile". The compilation starts immediately.

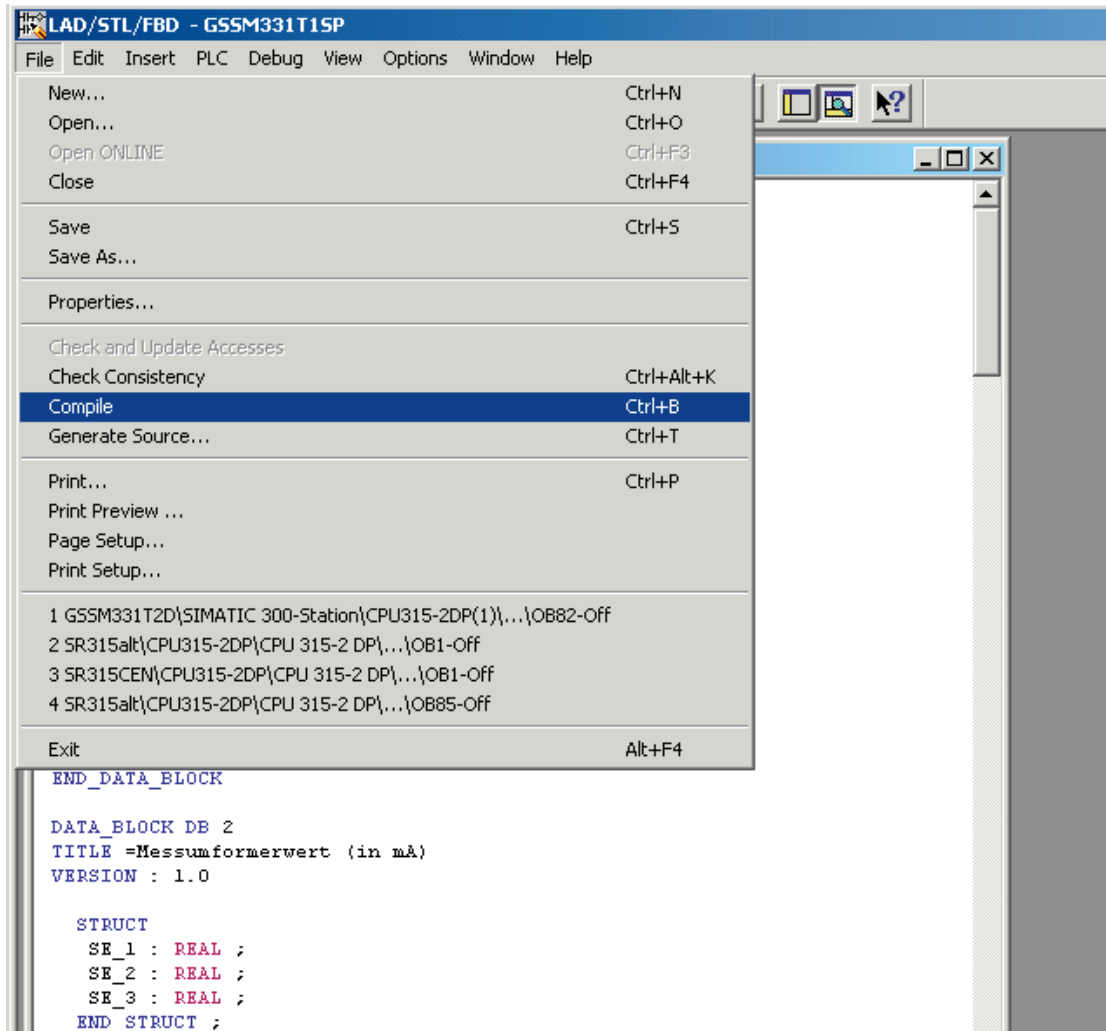

Figure 6-19 Compiling STL source

In case of warning or error messages, check the source code.

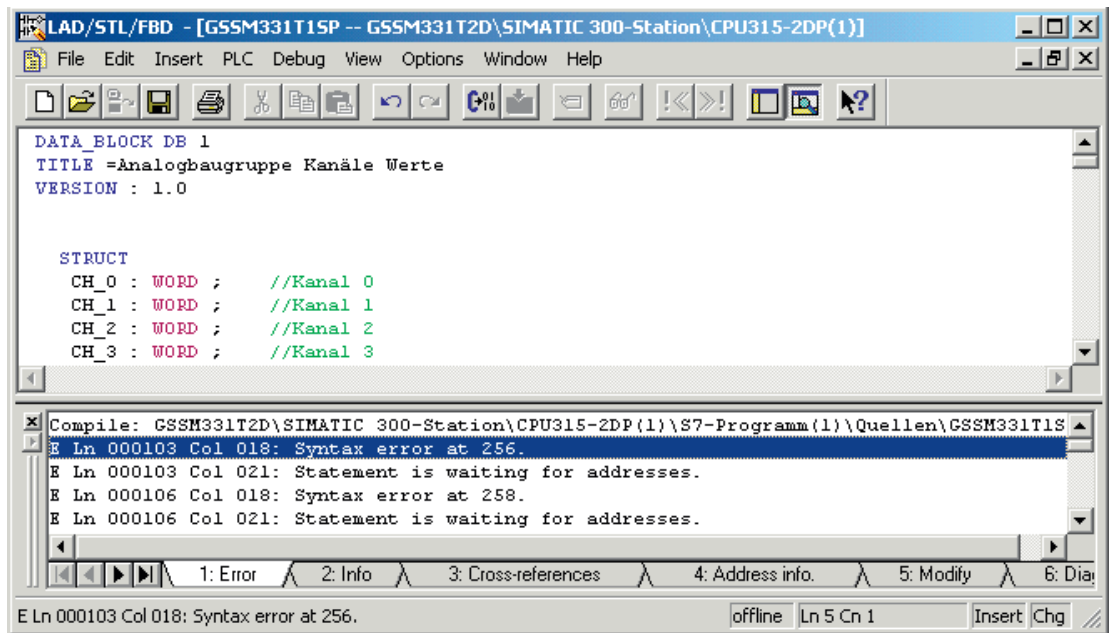

Figure 6-20 Source code editor, messages after compilation

Close the source editor.

After compiling the STL source without errors the following blocks should appear in the Blocks folder:

OB1, OB40, OB82, FC1, DB1 and DB2

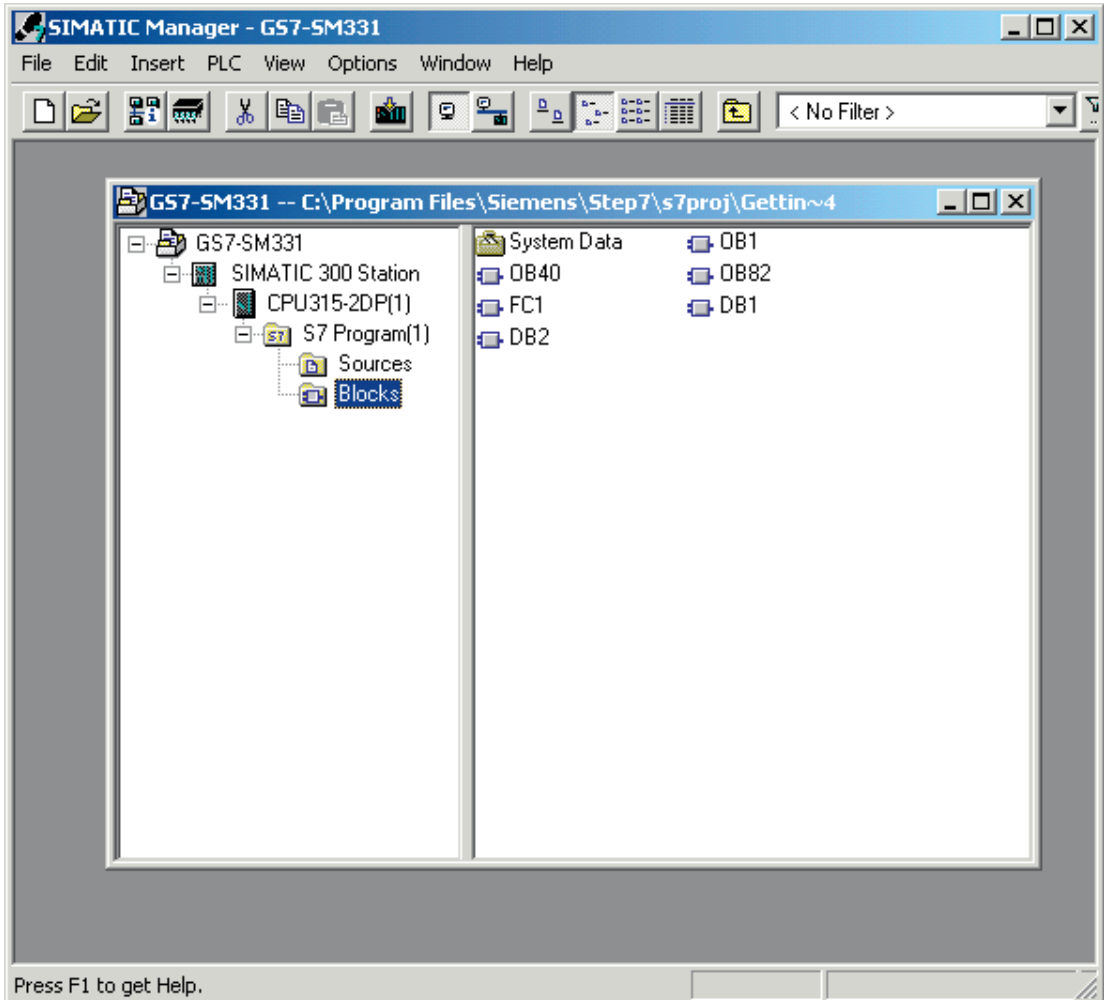

Figure 6-21 Generated blocks

Testing the user program

7.1 Downloading the system data and user program

Procedure

The hardware and software are now ready. The next step is to download the system data and the user program into the automation system. To do this, proceed as follows:

Downloading the system data and user program

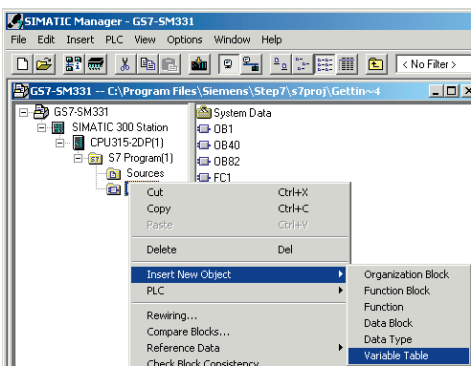
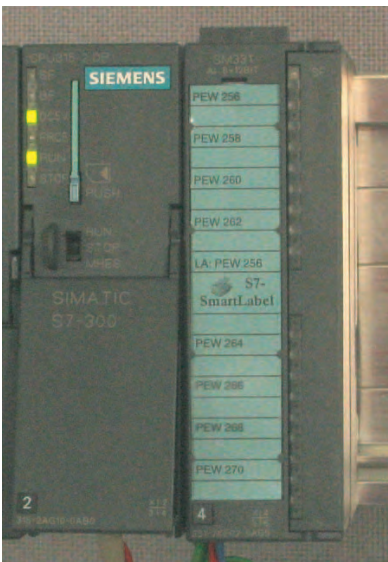
Step	Graphic	Description
1		<p>Using the SIMATIC Manager, download the user program and the system data (containing the hardware configuration) into the CPU.</p>
2		<p>Follow the instructions displayed on the screen.</p> <p>If all sensors are properly connected, the CPU and the SM331 do not display an error light.</p> <p>The status of the CPU is displayed by the green "RUN" light.</p>

Smart Label

The labeling strips for the modules were created with Siemens S7 Smart Label (order no: 2XV9 450-1SL01-0YX0).

A labeling strip in its actual size:

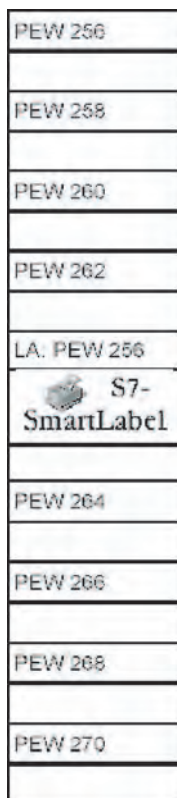

Figure 7-1 S7-SmartLabel labeling strip for the example

7.2 Visualization of the sensor values

Procedure

In order to visualize the sensor values, insert a variable table as follows into the project. To do this, select from the context menu of the Blocks folder: :

"Insert New Object > Variable Table"

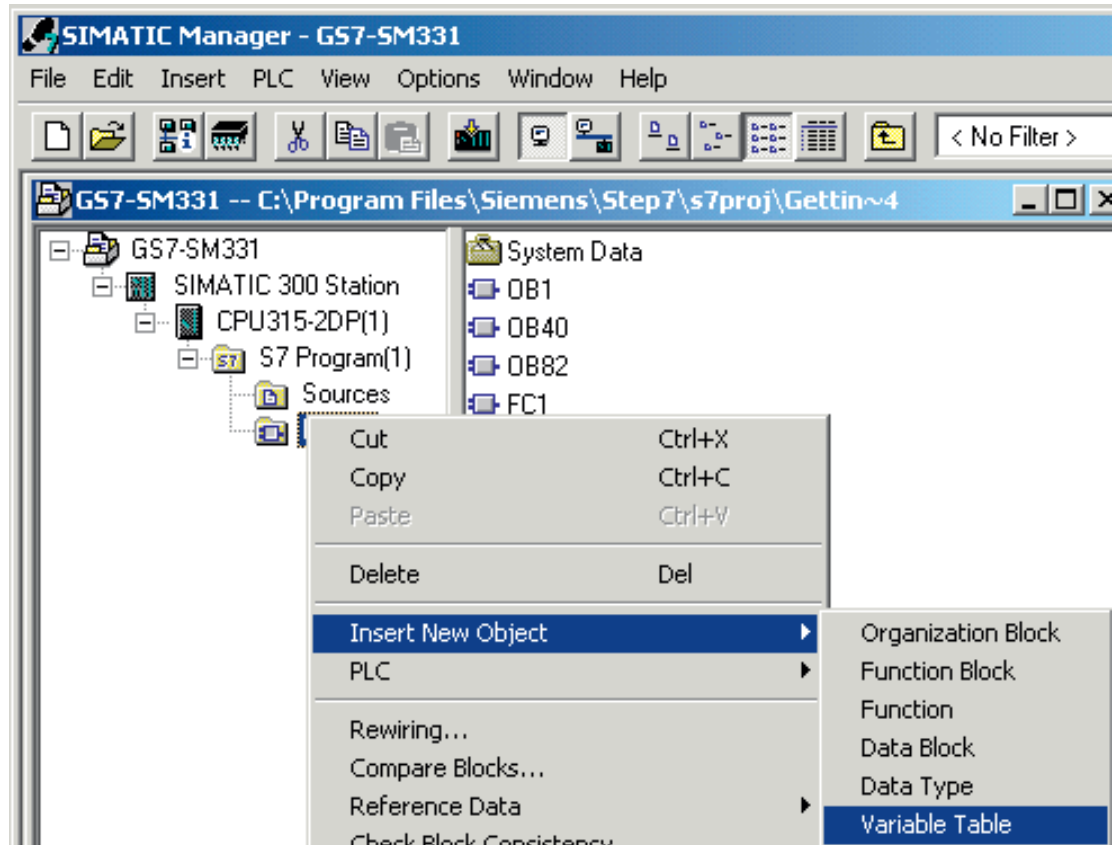

Figure 7-2 Insert Variable Table

Complete the new variable table as follows:

	Address	Symbol	Display format	Status value	Modify value
1	// Channel values				
2	DB1.DBW 0		HEX		
3	DB1.DBW 2		HEX		
4	DB1.DBW 4		HEX		
5	DB1.DBW 6		HEX		
6	DB1.DBW 8		HEX		
7	DB1.DBW 10		HEX		
8	DB1.DBW 12		HEX		
9	DB1.DBW 14		HEX		
10					
11	// Analog values				
12	DB2.DBD 0		FLOATING_POINT		
13	DB2.DBD 4		FLOATING_POINT		
14	DB2.DBD 8		FLOATING_POINT		
15	DB2.DBD 12		FLOATING_POINT		
16	// Process control status				
17	M 200.0		BOOL		
18	MW 100		BIN		
19					

Figure 7-3 Control_Display variable table

- (1) In this area you can monitor the channel values
- (2) In this area you can monitor and control the status signals.
- (3) In this area you can see the analog values

Monitoring values

In order to monitor values, open the online view of the controller by clicking the eye glasses symbol. Now you can monitor the values in the data blocks and markers.

	Address	Symbol	Display format	Status value	Modify
1	// Channel values				
2	DB1.DBW 0		HEX	W#16#0000	
3	DB1.DBW 2		HEX	W#16#0000	
4	DB1.DBW 4		HEX	W#16#009C	
5	DB1.DBW 6		HEX	W#16#7FFF	
6	DB1.DBW 8		HEX	W#16#0114	
7	DB1.DBW 10		HEX	W#16#7FFF	
8	DB1.DBW 12		HEX	W#16#01AF	
9	DB1.DBW 14		HEX	W#16#7FFF	
10					
11	// Analog values				
12	DB2.DBD 0		FLOATING_POINT	0.0	
13	DB2.DBD 4		FLOATING_POINT	15.6	
14	DB2.DBD 8		FLOATING_POINT	27.6	
15	DB2.DBD 12		FLOATING_POINT	43.1	
16	// Process control status				
17	M 200.0		BOOL	false	
18	MW 100		BIN	2#0000_0000_0000_0000	
19					

GSSM331T2D\SIMATIC 300-Station\...\S7-Programm(1) RUN

Figure 7-4 Online view of the variable table

Controlling values

To control the process acknowledgement, enter the desired value ("TRUE" or "FALSE", depending on whether you want to activate or deactivate acknowledgement) into the column "Control Value" and click the icon with the two arrows:

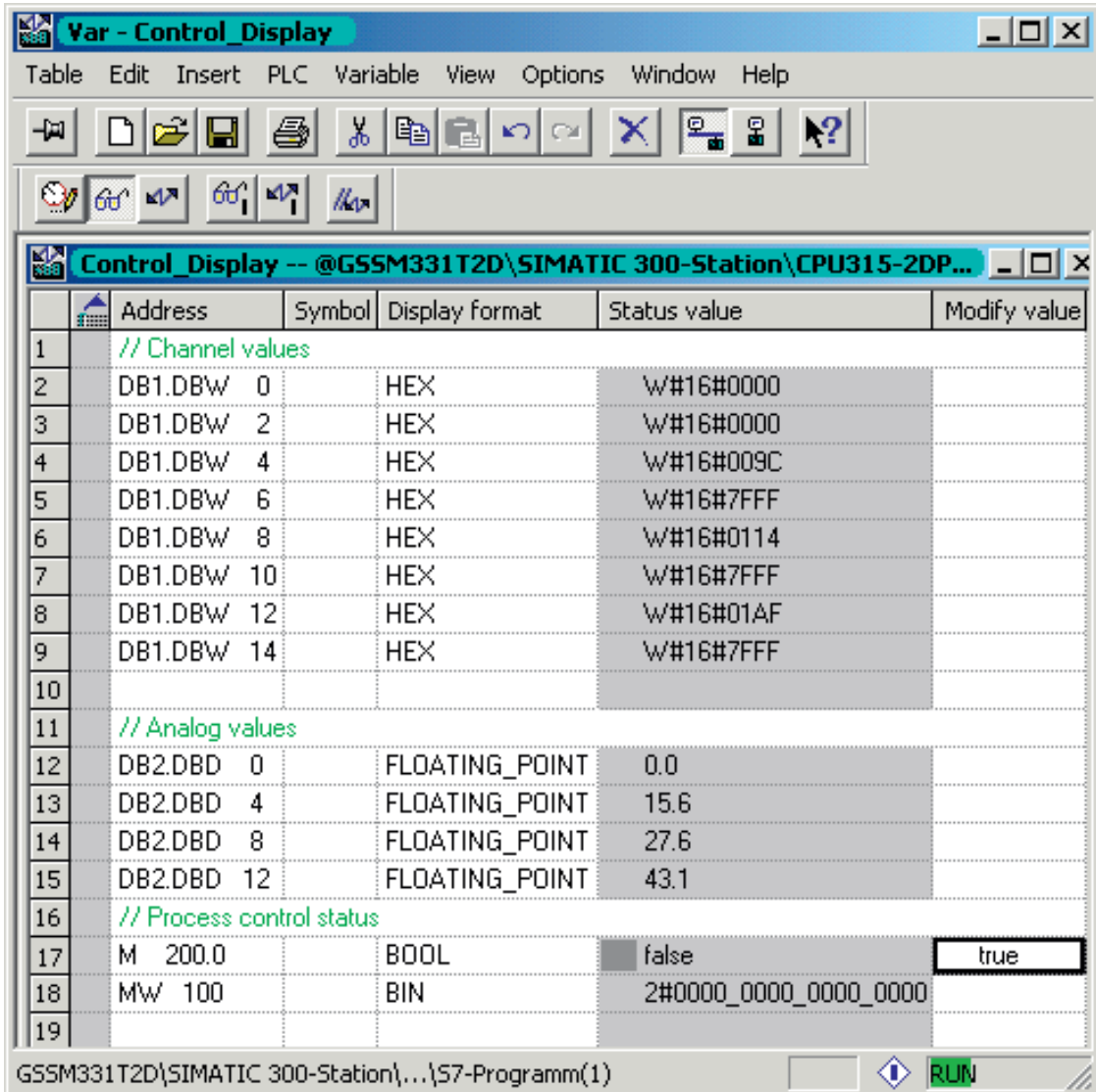

Figure 7-5 Controlling tags

Peculiarity in monitoring the values

While monitoring the values you will surely notice that the channel values are different from the analog values. The reason for this is that the analog module only supports the binary format "Word" (16 bits). Therefore, the values of the analog module have to be converted.

7.3 Analog-value representation of the thermocouple

Overview

Analog input modules convert the analog process signal into a digital format (16-bit word). If you want to display the analog process values, then the digital values of the module should be converted to decimal values.

In our example program, the process values are shown in the readable format °F. The conversion of the digital values into decimal values is realized in the programmed function FC1.

In the following tables you will find information on the temperature range and digital values (display in hexadecimal) of the thermocouple that are created by the module:

- Type E
- Type J
- Type K
- Type L

Representation of Analog Values for Thermocouples Type E

Analog-value representation		Temperature	Scope	Remark
32767	7FFF	> 2,192.00°F	Overflow	From hex value 16#2E01 on, the sensor value is above the configured measurement value range and is no longer valid.
12000	2E00	2,192.00°F	Overload range	This range corresponds to a tolerance band before the overflow range is reached. Within this range the resolution is not optimal though.
...		
10001	2711	1,832.18°F		
10000	2710	1,832.00°F	Rated range	The nominal range is the normal range for recording measurement values. This range guarantees optimal resolution.
...		
...		
-2700	F574	-454.00°F	Underflow	If the wiring is wrong (e.g., swapped wires or open circuited inputs) or a sensor error occurs in a negative range (e.g., wrong thermocouple type), the analog module will report an underflow for values lower than 16#F0C4 and the output will be 16#8000.
< -2700	<F574	< -454.00°F		

Representation of Analog Values for Thermocouples Type J

Decimal	Hexadecimal	Temperature	Scope	Remark
32767	7FFF	> 2,642.00°F	Overflow	From hex value 16#38A5 on, the sensor value is above the configured measurement value range and is no longer valid.
14500	38A4	2,642.00°F	Overload range	This range corresponds to a tolerance band before the overflow range is reached. Within this range the resolution is not optimal though.
...		
12010	2EEA	2,193.80°F		
12000	2EE0	2,192.00°F	Rated range	The nominal range is the normal range for recording measurement values. This range guarantees optimal resolution.
...		
...		
-2100	F7CC	-346.00°F		
< -210	<F7CC	< -346.00°F	Underflow	If the wiring is wrong (e.g., swapped wires or open circuited inputs) or a sensor error occurs in a negative range (e.g., wrong thermocouple type), the analog module will report an underflow for values lower than 16#F31C and the output will be 16#8000.

Representation of Analog Values for Thermocouple Type K

Decimal	Hexadecimal	Temperature	Scope	Remark
32767	7FFF	> 2,951.60°F	Overflow	From hex value 16#3F5D on, the sensor value is above the configured measurement value range and is no longer valid.
16220	3F5C	2,642.00°F	Overload range	This range corresponds to a tolerance band before the overflow range is reached. Within this range the resolution is not optimal though.
...		
13730	35A2	2,503.40°F		
13720	3598	2,501.60°F	Rated range	The nominal range is the normal range for recording measurement values. This range guarantees optimal resolution.
...		
...		
-2700	F574	-454.00 °F		
< -2700	<F574	< -454.00 °F	Underflow	If the wiring is wrong (e.g., swapped wires or open circuited inputs) or a sensor error occurs in a negative range (e.g., wrong thermocouple type), the analog module will report an underflow for values lower than 16#F0C4 and the output will be 16#8000.

Representation of Analog Values for Thermocouple Type L

Decimal	Hexadecimal	Temperature	range	Remark
32767	7FFF	> 2,102.00°F	Overflow	From hex value 16#2CED on, the sensor value is above the configured measurement value range and is no longer valid.
11500	2CEC	2,102.00°F	Overload range	This range corresponds to a tolerance band before the overflow range is reached. Within this range the resolution is not optimal though.
...		
9010	2332	1,653.80°F		
9000	2328	1,652.00°F	Rated range	The nominal range is the normal range for recording measurement values. This range guarantees optimal resolution.
...		
...		
-2000	F830	-328.00 °F	Underflow	If the wiring is wrong (e.g., swapped wires or open circuited inputs) or a sensor error occurs in a negative range (e.g., wrong thermocouple type), the analog module will report an underflow for values lower than 16#F380 and the output will be 16#8000.
< -2000	<F830	< -328.00°F		

Diagnostic interrupt

8.1 Reading diagnostic information from a PG

Overview

Diagnostic interrupts enable the user program to react to hardware errors.
 Modules must have diagnostic capabilities in order to generate diagnostic interrupts.
 In OB82 you program the reaction to diagnostic interrupts.

Diagnostic-interrupt display

The analog input module SM331 AI8x12bit has diagnostic capabilities.
 Diagnostic interrupts that occur are signaled by the red "SF" LED on the SM331 and on the CPU.
 Generation of a hardware error

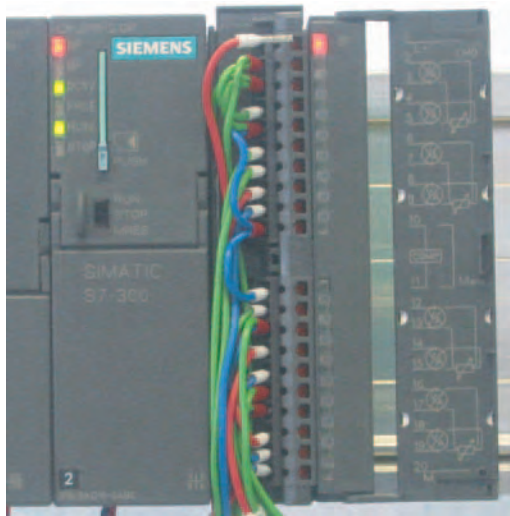
Graphic	Description
	<p>Release the power supply wire from terminal 1. Result: A diagnostic interrupt has been triggered.</p>

The cause of the error can be determined "online" by requesting the hardware status.

In order to determine the state of module "online", proceed as follows.

1. Select the SM331 in the hardware configuration.
2. Click the menu item "PLC > Module Information..." in order to perform a hardware diagnosis.

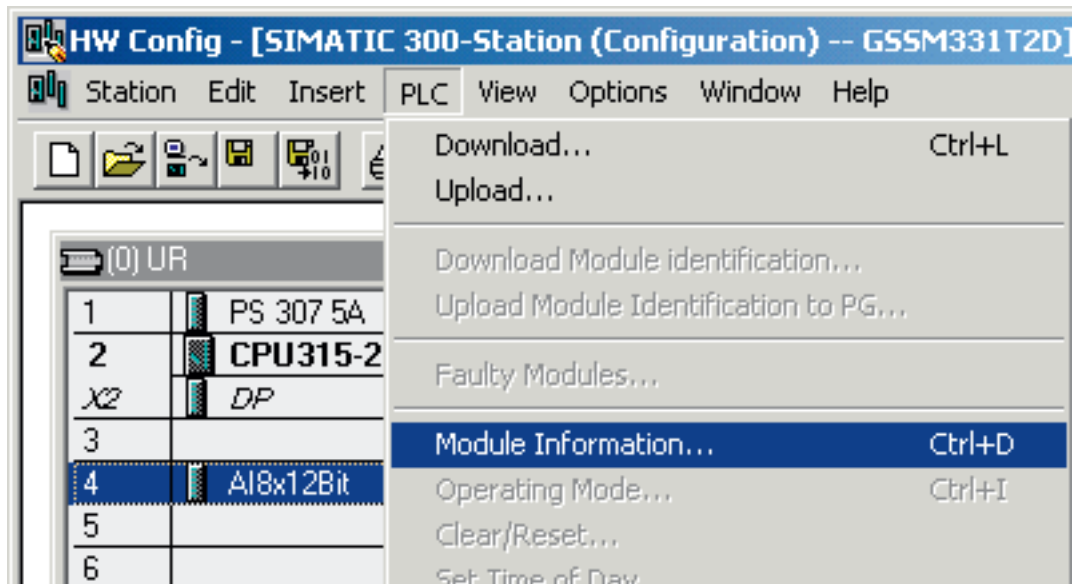

Figure 8-1 Module status

8.2 General diagnostics

Diagnostic interrupt tab

On the Diagnostic Interrupt tab you will find information for the reported error.

The interrupts are not channel dependent and apply to the entire module.

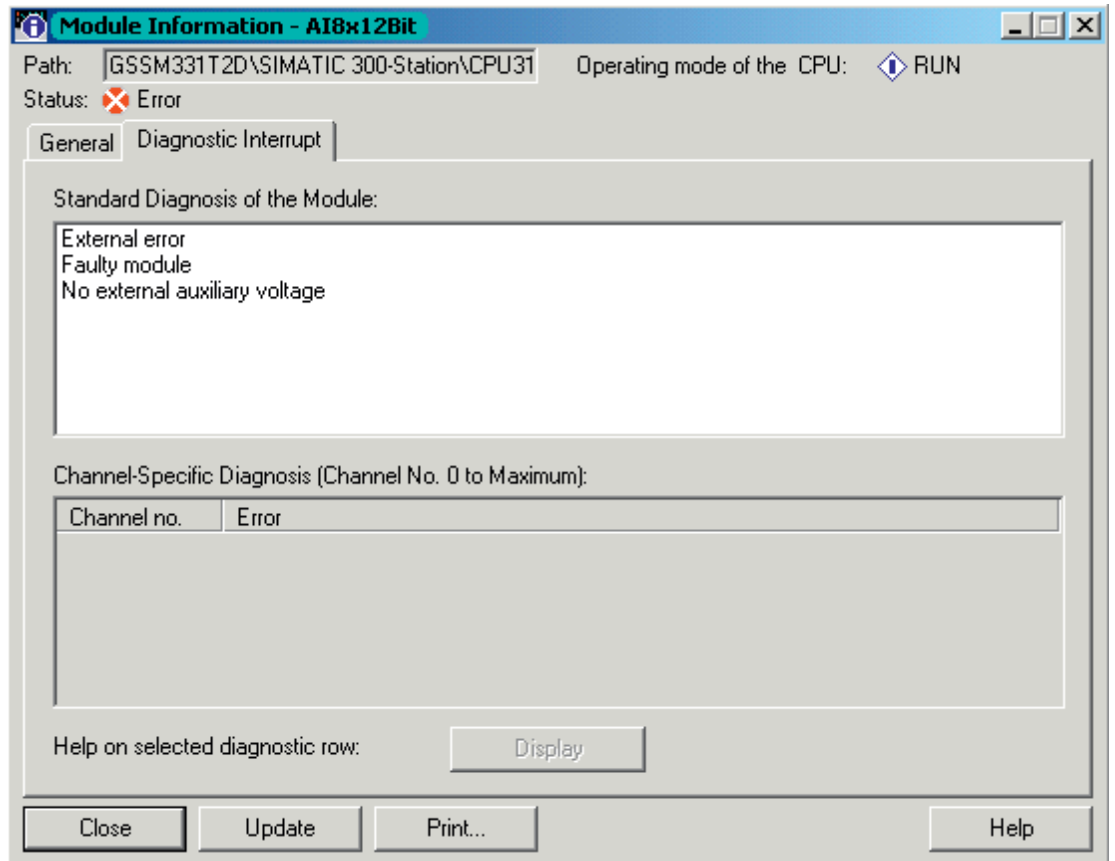

Figure 8-2 Diagnostics for SM331

8.3 Channel dependent diagnostic messages

Channel dependent diagnostic messages

There are five channel dependent diagnostic messages:

- Configuration/programming error
- Common mode error
- Wire break
- Underflow
- Overflow

Note

Here we show you only the channel specific diagnostics for the measuring modes 2 or 4-wire current transducers. Other measuring modes are similar and are not described here.

Configuration/programming error

The position of the measuring range modules does not match the measuring mode set in the hardware configuration.

Common mode error

The voltage difference U_{cm} between the inputs (M-) and the common voltage potential of the measuring circuit (M_{ana}) is too high.

In our example, this error cannot occur because M_{ana} is connected to M for a 2-wire transducer.

Wire break

For all thermocouple types you can detect a wire break in the diagnostics.

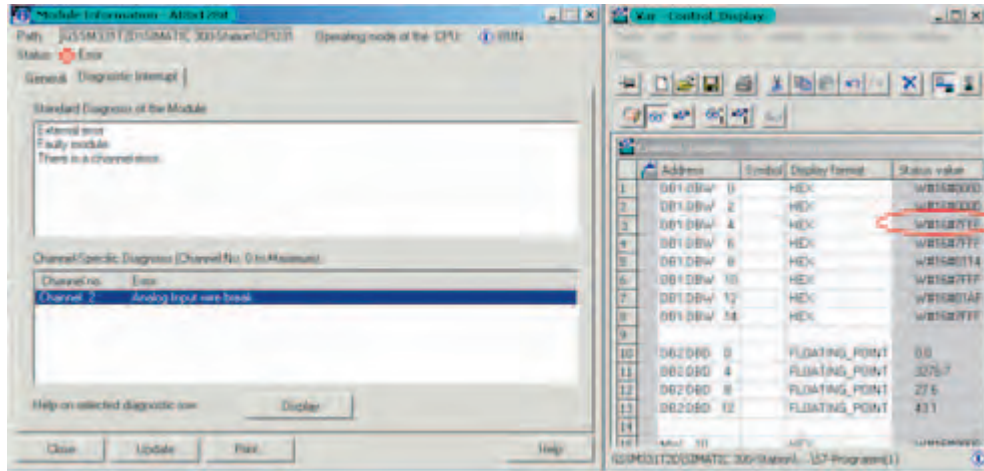

Figure 8-3 Left: Diagnostic message with wire break/Right: Variable table

The analog-value representation shows an overflow (HEX 7FFF).

Underflow

The thermocouples can trigger the diagnostic message "Analog input measuring range/low limit undershot".

If you install the wrong thermocouple type you can also create an underflow.

In our example, we have simulated a thermocouple type E with a thermocouple simulator (to -454.00°F). At -454.01°F we get an underflow of the measuring range.

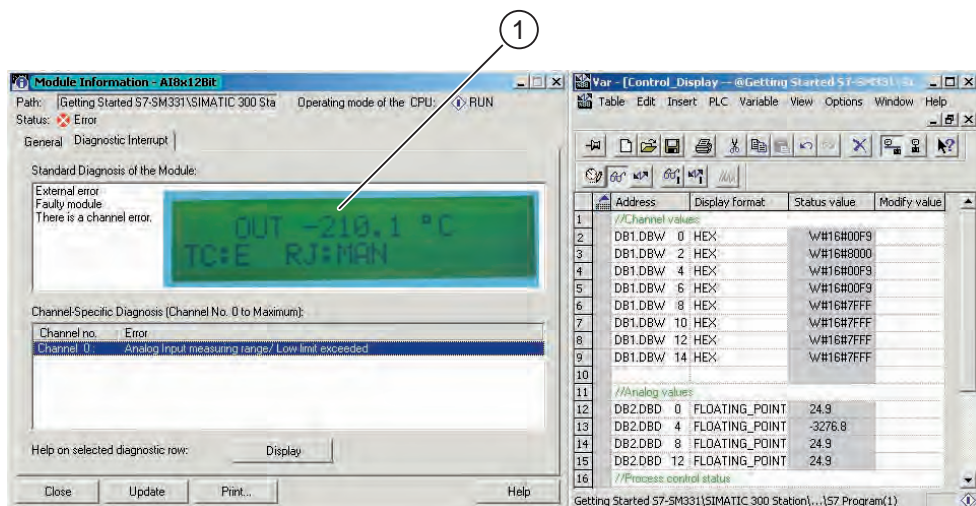

Figure 8-4 Left: Diagnostic message with underflow/Right: Variable table

(1) Display -454.01°F at the thermocouple simulator

Overflow

The thermocouples can trigger the diagnostic message "Analog input measuring range/high limit exceeded".

In our example, we have simulated a thermocouple type B with a thermocouple simulator (to +3,092.00°F). At 2642.01°F we get an overflow of the measuring range.

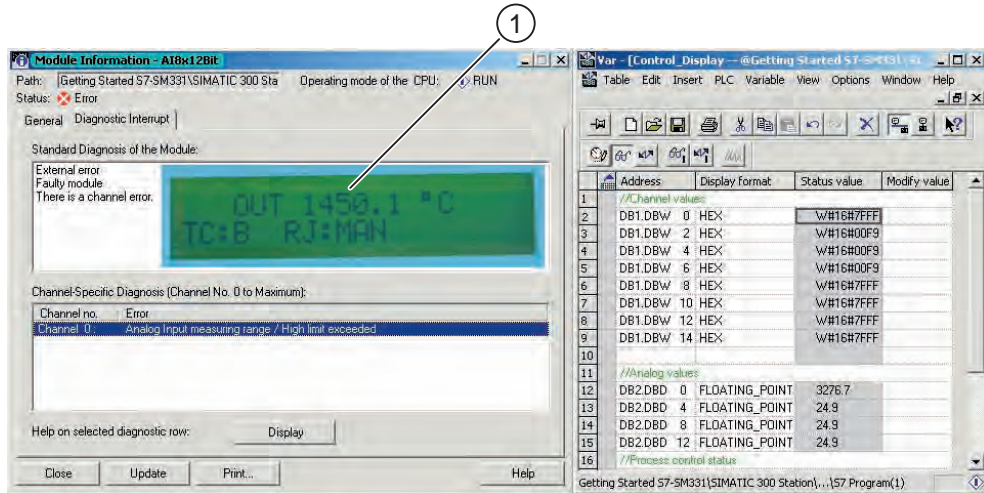

Figure 8-5 Left: Diagnostic message with overflow/Right: Variable table

- (1) Display 2642.01°F at the thermocouple simulator

Hardware interrupt

9.1 Hardware interrupt

Overview

A special feature of the SM331 AI8x12bit is its capability to also trigger hardware interrupts. Two channels (0 and 2) can be correspondingly configured.

The limits of the hardware interrupts must be specified for the thermocouples in °C (not in °F or K).

Properties of the hardware interrupt trigger

In order to trigger a hardware interrupt, the limit values have to be within the nominal values of the measuring mode.

Example

Let us assume that you are using a thermocouple type J with a nominal range of -210.0°C and 1450.0°C. When you enter the low limit of -250°C, the setting is accepted by the system but the hardware interrupt is not triggered because the diagnostic interrupt (underflow of the nominal range) is always triggered first.

In our example, channel 0 (thermocouple type J) is configured with the following limits:

- Lower limit value -50 °C
- Upper limit value +500 °C

If these values exceed or fall below the nominal range, hardware interrupt OB40 will be triggered.

Hardware interrupt OB40

Hardware interrupts generally trigger alarm organization blocks in the CPU. In our example, OB40 is called.

In the STEP7 program, OB40 is used for hardware interrupts. Depending on the CPU, more hardware interrupts can be configured.

If a hardware interrupt occurs, OB40 is called. In the user program of OB40 you can program the reaction of the automation system to hardware interrupts.

In the example user program, OB40 reads the cause of the hardware interrupt. This can be found in the temporary variable structure OB40_POINT_ADDR (local bytes 8 to 11).

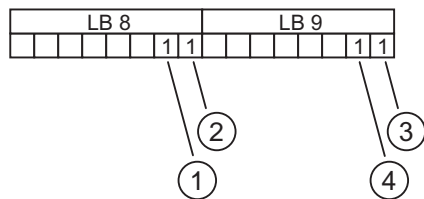

Figure 9-1 OB40 start information: Which event has violated limits and triggered a hardware interrupt

- (1) Violation of the low limit at channel 0
- (2) Violation of the low limit at channel 1
- (3) Violation of the high limit at channel 0
- (4) Violation of the high limit at channel 1

In the example, OB40 only transfers the LB8 and LB9 local data variables into a marker word (MW100). The marker word is monitored in the existing variable table.

You can acknowledge the marker word in OB1 by setting marker bit M200.0 or by setting it to "TRUE" in the variable table.

Simulation of a hardware interrupt

When you heat a thermocouple type J with a lighter, in the variable table in MW100 you will get the binary value 0000 0001 0000 0000. That means the OB40 was called and channel 0 had an overflow of the high limit >500°C.

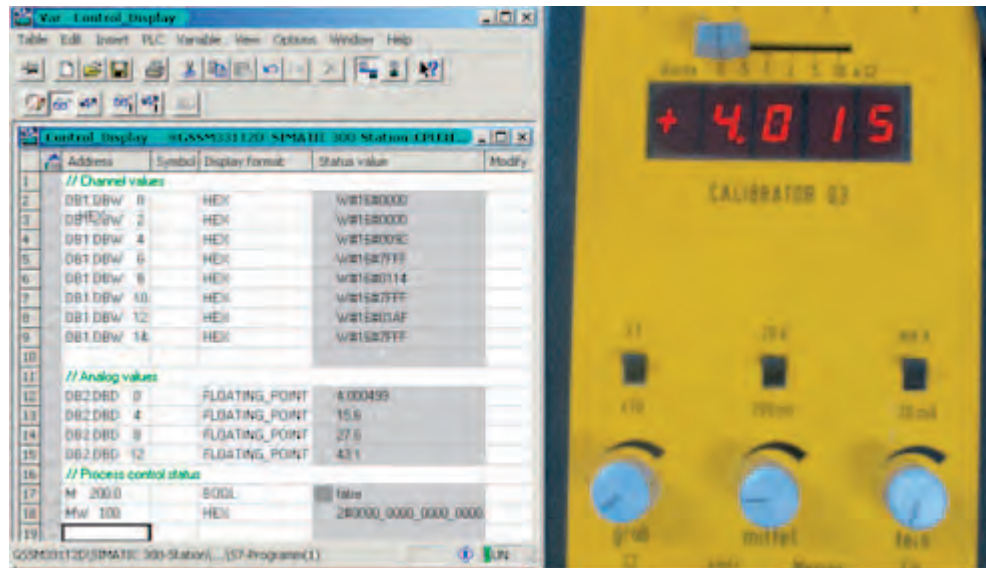

Figure 9-2 Process interrupt: Low limit undershot at channel 0

Appendix

A.1 Source code of the user program

Overview

This chapter provides a quick overview of the functions associated with the example station's user program. A flowchart shows the general program structure and in the STL source code you will find the complete program in detail.

You can download the STL source code file for your own application directly from the HTML page from which you loaded this "Getting Started".

Flowchart

The red text corresponds to the source code in the user program.

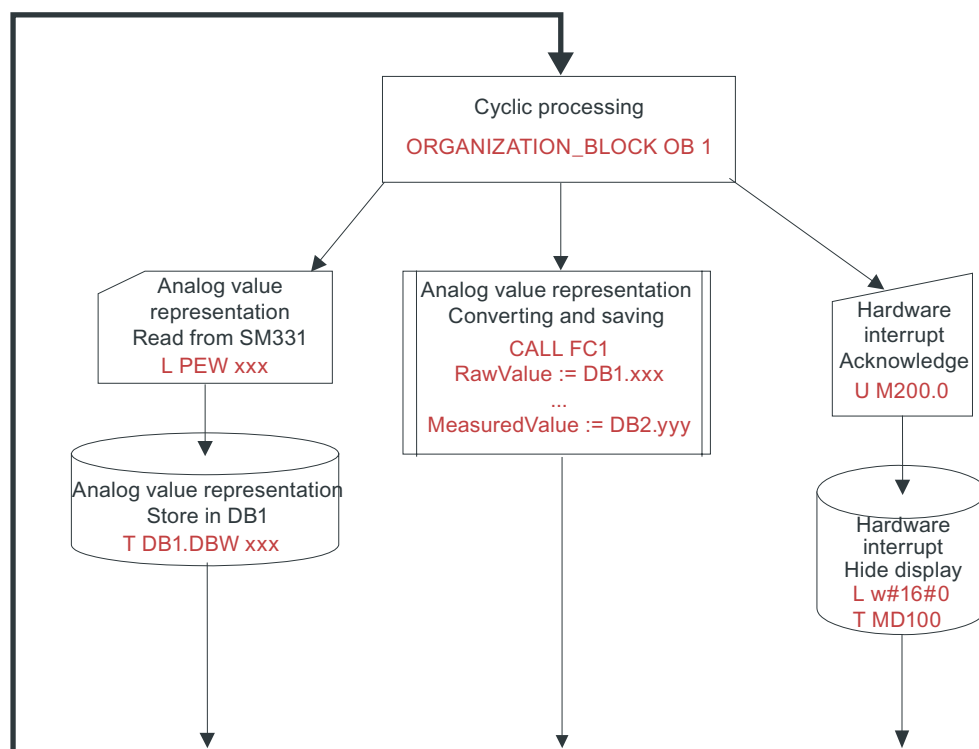

Figure A-1 OB1 flowchart

Variable description

Variables	Description
DB1.DBW 0	Channel 0 Display of analog value
DB1.DBW 2	Channel 1 Display of analog value
DB1.DBW 4	Channel 2 Display of analog value
DB1.DBW 6	Channel 3 Display of analog value
DB1.DBW 8	Channel 4 Display of analog value
DB1.DBW 10	Channel 5 Display of analog value
DB1.DBW 12	Channel 6 Display of analog value
DB1.DBW 14	Channel 7 Display of analog value
DB2.DBD 0	Thermocouple (°C)
DB2.DBD 4	Thermocouple (°C)
DB2.DBD 8	Thermocouple (°C)
DB2.DBD 12	Thermocouple (°C)
M200.0	Acknowledge hardware interrupt
MW 100	Status hardware interrupt

STL source code

```
DATA_BLOCK DB 1
TITLE =
VERSION : 0.1
```

```
STRUCT
    CH_0 : INT;           //Channel 0
    CH_1 : INT;           //Channel 1
    CH_2 : INT;           //Channel 2
    CH_3 : INT;           //Channel 3
    CH_4 : INT;           //Channel 4
    CH_5 : INT;           //Channel 5
    CH_6 : INT;           //Channel 6
    CH_7 : INT;           //Channel 7
END_STRUCT ;
BEGIN
    CH_0 := 0;
    CH_1 := 0;
    CH_2 := 0;
    CH_3 := 0;
    CH_4 := 0;
    CH_5 := 0;
    CH_6 := 0;
    CH_7 := 0;
END_DATA_BLOCK
```

```

DATA_BLOCK DB 2
TITLE =
VERSION : 0.1

STRUCT
    SE_1 : REAL ;      // Temperature
    SE_2 : REAL ;      // Temperature
    SE_3 : REAL ;      // Not used
    SE_4 : REAL ;      // Not used
END_STRUCT ;

BEGIN
    SE_1 := 0.000000e+000;
    SE_2 := 0.000000e+000;
    SE_3 := 0.000000e+000;
    SE_4 := 0.000000e+000;
END_DATA_BLOCK

FUNCTION FC 1 : VOID
TITLE =
VERSION : 0.1

VAR_INPUT
    RawValue : INT;
    Factor : REAL ;
    Offset : REAL ;
    OverFlow : INT;
    OverRange : INT;
    UnderRange : INT;
    UnderFlow : INT;
END_VAR
VAR_OUTPUT
    MeasuredValue : REAL ;
    Status: WORD ;
END_VAR
VAR_TEMP
    TInt : INT;
    TDoubleInt : DINT ;
    TFactor : REAL ;
    TOffset : REAL ;
    TFactor1 : DINT ;
    TFactor2 : REAL ;
END_VAR
BEGIN
NETWORK
TITLE = Conversion
    L      #RawValue;
    ITD    ;
    DTR    ;
    L      #Factor;

```

Appendix

A.1 Source code of the user program

```
*R      ;  
L      #Offset;  
+R     ;  
M      #MeasuredValue;
```

NETWORK

TITLE =Analog-value representation monitoring

```
L      W#16#0;  
M      #Status;  
  
L      #RawValue;  
L      #OverFlow;  
>=I   ;  
JC     m_of;  
  
L      #RawValue;  
L      #OverRange;  
>=I   ;  
JC     m_or;  
  
L      #RawValue;  
L      #UnderFlow;  
<=I   ;  
JC     m_uf;  
  
L      #RawValue;  
L      #UnderRange;  
<=I   ;  
JC     m_ur;  
  
JL     end;
```

```
m_of:  L      W#16#800;  
       M      #Status;  
       JL     end;
```

```
m_or:  L      W#16#400;  
       M      #Status;  
       JL     end;
```

```
m_uf:  L      W#16#200;  
       M      #Status;  
       JL     end;
```

```

m_ur:          L          W#16#100;
               M          #Status;
               JL         end;

end:           NOP       0;

END_FUNCTION

ORGANIZATION_BLOCK OB 1
TITLE = "Main Program Sweep (Cycle)"
VERSION : 0.1

VAR_TEMP

    OB1_EV_CLASS : BYTE ;           //Bits 0-3 = 1 (Coming event), Bits 4-7 = 1 (Event
    OB1_SCAN_1   : BYTE ;           //1 (Cold restart scan 1 of OB 1), 3 (Scan 2-n of
    OB1_PRIORITY : BYTE ;           //Priority of OB Execution
    OB1_OB_NUMBR : BYTE ;           //1 (Organization block 1, OB1)
    OB1_RESERVED_1 : BYTE ;        //Reserved for system
    OB1_RESERVED_2 : BYTE ;        //Reserved for system
    OB1_PREV_CYCLE : INT;           //Cycle time of previous OB1 scan (milliseconds)
    OB1_MIN_CYCLE : INT;           //Minimum cycle time of OB1 (milliseconds)
    OB1_MAX_CYCLE : INT;           //Minimum cycle time of OB1 (milliseconds)
    OB1_DATE_TIME : DATE_AND_TIME ; //Date and time OB1 started

END_VAR
BEGIN
NETWORK
TITLE =Transfer channel values to data block DB 1
// Channel 0 -> Data block
    L          PEW 256;
    M          DB1.DBW      0;

// Channel 1 -> Data block
    L          PEW 258;
    M          DB1.DBW      2;

// Channel 2 -> Data block
    L          PEW 260;
    M          DB1.DBW      4;

// Channel 3 -> Data block
    L          PEW 262;

```

Appendix

A.1 Source code of the user program

```

        M          DB1.DBW          6;

// Channel 4 -> Data block
    L          PEW 264;
        M          DB1.DBW          8;

// Channel 5 -> Data block
    L          PEW 266;
        M          DB1.DBW         10;

// Channel 6 -> Data block
    L          PEW 268;
        M          DB1.DBW         12;

// Channel 7 -> Data block
    L          PEW 270;
        M          DB1.DBW         14;

NETWORK
TITLE =Conversion of analog-value representation -> Measurement value
// Channel 1 : Thermocouple type J
    CALL FC      1(
                RawValue          := DB1.DBW          0,
                Factor             := 1.000000e-001,
                Offset             := 0.000000e+000,
                OverFlow           := 14501,
                OverRange          := 12010,
                UnderRange         := -2101,
                UnderFlow          := -2101,
                MeasuredValue      := DB2.DBW          0,
                Status             := MW              10);

// Channel 2 : Thermocouple type J

    CALL FC      1 (
                RawValue          := DB1.DBW          2,
                Factor             := 1.000000e-001,
                Offset             := 0.000000e+000,
                OverFlow           := 14501,
                OverRange          := 12010,
                UnderRange         := -2101,
                UnderFlow          := -2101,
                MeasuredValue      := DB2.DBW          4,
                Status             := MW              20);

// Channel 3 : Thermocouple type K
```



```

CALL FC      1 (
              RawValue      := DB1.DBW 4,
              Factor        := 1.000000e-001,
              Offset        := 0.000000e+000,
              OverFlow      := 16221,
              OverRange     := 13730,
              UnderRange    := -2701,
              UnderFlow     := -2701,
              MeasuredValue  := DB2.DBD 8,
              Status        := MW 30);

// Channel 4 : Thermocouple type K

CALL FC      1 (
              RawValue      := DB1.DBW 6,
              Factor        := 1.000000e-001,
              Offset        := 0.000000e+000,
              OverFlow      := 16221,
              OverRange     := 13730,
              UnderRange    := -2701,
              UnderFlow     := -2701,
              MeasuredValue  := DB2.DBD 12,
              Status        := MW 40);

NETWORK
TITLE =Acknowledge hardware interrupt
      U      M      200.0;
      EP     M      200.1;
      SPBN   m001;
      L      0;
      M      FD     100;
      M      FW     104;
      M      FW     106;
      R      M      200.0;
m001:  NOP      0;

END_ORGANIZATION_BLOCK

ORGANIZATION_BLOCK OB 40
TITLE = "Hardware Interrupt"
VERSION : 0.1

VAR_TEMP
  OB40_EV_CLASS : BYTE ; //Bits 0-3 = 1 (Coming event), Bits 4-7 = 1 (Event
                          class 1)
  OB40_STRT_INF : BYTE ; //16#41 (OB 40 has started)
  OB40_PRIORITY : BYTE ; //Priority of OB Execution

```

Appendix

A.1 Source code of the user program

```
OB40_OB_NUMBR : BYTE ;           //40 (Organization block 40, OB40)
    OB40_RESERVED_1 : BYTE ;     //Reserved for system
OB40_IO_FLAG : BYTE ;           //16#54 (input module), 16#55 (output module)
OB40_MDL_ADDR : WORD ;         //Base address of module initiating interrupt
OB40_POINT_ADDR : DWORD ;      //Interrupt status of the module
OB40_DATE_TIME : DATE_AND_TIME ; //Date and time OB40 started
END_VAR
BEGIN
NETWORK
TITLE =
    L  #OB40_IO_FLAG;           //OB40_IO_FLAG       : 16#54=Input module
    M  MB      104;            //                : 16#55=Output module
    L  #OB40_MDL_ADDR;         //OB40_MDL_ADDR    : Base address of
    M  FW      106;            //                : module initiating interrupt
    L  #OB40_POINT_ADDR;      //OB40_POINT_ADDR  : LB8 = Exceeding
    M  FD      100;            //                : high limit
    NO 0;                     //OB40_POINT_ADDR  : LB9 = Underflow of
    P
    NO 0;                     //                : low limit
    P

END_ORGANIZATION_BLOCK

ORGANIZATION_BLOCK OB 82
TITLE = "I/O Point Fault"
VERSION : 0.1

VAR_TEMP
    OB82_EV_CLASS : BYTE ;     //16#39, Event class 3, Entering event state,
                                //Internal fault event
    OB82_FLT_ID : BYTE ;       //16#XX, Fault identification code
    OB82_PRIORITY : BYTE ;     //Priority of OB Execution
    OB82_OB_NUMBR : BYTE ;     //82 (Organization block 82, OB82)
    OB82_RESERVED_1 : BYTE ;   //Reserved for system
    OB82_IO_FLAG : BYTE ;     //Input (01010100), Output (01010101)
    OB82_MDL_ADDR : WORD ;     //Base address of module with fault
    OB82_MDL_DEFECT : BOOL;    //Module defective
    OB82_INT_FAULT : BOOL;    //Internal fault
    OB82_EXT_FAULT : BOOL;    //External fault
    OB82_PNT_INFO : BOOL;     //Point information
    OB82_EXT_VOLTAGE : BOOL;   //External voltage low
    OB82_FLD_CONNCTR : BOOL;   //Field wiring connector missing
    OB82_NO_CONFIG : BOOL;    //Module has no configuration data
    OB82_CONFIG_ERR : BOOL;   //Module has configuration error
    OB82_MDL_TYPE : BYTE ;    //Type of module
    OB82_SUB_MDL_ERR : BOOL;   //Sub-Module is missing or has error
    OB82_COMM_FAULT : BOOL;   //Communication fault
    OB82_MDL_STOP : BOOL;     //Module is stopped
    OB82_WTCH_DOG_FLT : BOOL; //Watch dog timer stopped module
```

```
OB82_INT_PS_FLT : BOOL;           //Internal power supply fault
OB82_PRIM_BATT_FLT : BOOL;        //Primary battery is in fault
OB82_BCKUP_BATT_FLT : BOOL;       //Backup battery is in fault
OB82_RESERVED_2 : BOOL;          //Reserved for system
OB82_RACK_FLT : BOOL;            //Rack fault, only for bus interface module
OB82_PROC_FLT : BOOL;           //Processor fault
OB82_EPROM_FLT : BOOL;          //EPROM fault
OB82_RAM_FLT : BOOL;            //RAM fault
OB82_ADU_FLT : BOOL;            //ADC fault
OB82_FUSE_FLT : BOOL;           //Fuse fault
OB82_HW_INTR_FLT : BOOL;        //Hardware interrupt input in fault
OB82_RESERVED_3 : BOOL;          //Reserved for system
OB82_DATE_TIME : DATE_AND_TIME ; //Date and time OB82 started

END_VAR
BEGIN
END_ORGANIZATION_BLOCK
```

See also

Creating a user program (Page 6-19)

Index

A

- Add
 - SIMATIC components, 6-8
- Adding SIMATIC components, 6-8
- Analog module
 - Connection variations, 5-4
- Analog module
 - Features, 4-5
 - The required hardware and software, 2-1
- Analog module
 - Inserting, 6-9
- Analog module
 - parameter assignment, 6-10
- Analog module with external reference junction
 - Connection diagram, 5-9
 - wiring, 5-11
- Analog module with internal reference junction
 - Connection diagram, 5-6
 - wiring, 5-7
- Analog value representation
 - for thermocouple type E, 7-7
 - for thermocouple type J, 7-8
 - for thermocouple type K, 7-8
 - for thermocouple type L, 7-9
 - of the thermocouple, 7-7
- Assembling
 - CPU, 4-2
 - Example station, 4-1
 - Front connectors, 4-8
 - Power Supply, 4-2
 - SM331 module, 4-8
- Assigning
 - Project name, 6-5
- Assigning parameters
 - Analog module, 6-10
- Attitudes
 - test, 6-14

B

- Bus connectors
 - Insert, 4-2

C

- Calling
 - Hardware configuration, 6-7
- check
 - wiring, 5-14
- Check
 - Mains voltage, 5-3
- Common mode error, 8-4
- Components
 - SM331, 4-4
- Components of the product
 - SM331 modules, 4-4
- configuration
 - CPU 315-2 DP, 6-1
- Configuration
 - opening, 6-10
 - with internal compensation, 6-11
- Configuration language
 - STL, 6-4
- Configuration/programming error, 8-4
- configuring
 - Hardware configuration, 6-7
 - with SIMATIC Manager, 6-1
- Connecting
 - CPU with programming device, 6-14
- Connection diagram
 - Analog module with external reference junction, 5-9
 - Analog module with internal reference junction, 5-6
 - Thermocouples with external reference junction, 5-8
 - Thermocouples with internal reference junction, 5-5
- Connection variations
 - Analog module, 5-4
- Converting
 - digital values to analog values, 7-7
- CPU
 - CPU with programming device, 6-14
 - Installing, 4-2
 - Selecting, 6-3
 - start, 6-17
 - Wiring the power supply, 5-2
- CPU 315-2 DP
 - configuration, 6-1
- CPU memory reset, 6-14

Creating

- STEP 7 project, 6-1
- User Program, 6-19

D

Defining

- Defining the basic user program, 6-4

Defining the basic user program

- Defining, 6-4

Deleting

- Micro Memory Card, 6-14

Diagnostic information

- read from a PG, 8-1

Diagnostic interrupt, 6-13

- OB82, 6-18

Diagnostics message

- channel dependent, 8-4
- general, 8-3

Digital value

- convert to analog value, 7-7

Display

- Sensor values, 7-3

Download

- Download system data and user program into the automation system, 7-1
- Source file, 6-19

Downloading system data and user program

- Downloading to automation system, 7-1

E

Electric connection

- Example station, 5-1

Error display, 8-3

Example station

- Electrical connection, 5-1
- Installing, 4-1

F

Features

- Analog module, 4-5
- Hardware interrupt trigger, 9-1

Fill out

- Variable table, 7-3

Flowchart, A-1

Front connectors

- Installing, 4-8

Functionalities

- with external compensation, 6-11
- with internal compensation, 6-10

G

Group diagnostics, 6-13

H

Hardware and software

- for analog modules, 2-1

Hardware catalog

- opening, 6-8

Hardware configuration

- Calling, 6-7
- configuration, 6-7
- load, 6-15

Hardware interrupt

- Simulation, 9-3

Hardware interrupt, 9-1

Hardware interrupt =B40, 9-2

Hardware interrupt trigger

- Features, 9-1

Hardware interrupt when limit exceeded, 6-13

I

Importing

- Source file, 6-20

Insert

- Bus connectors, 4-2

Inserting

- Analog module, 6-9

Interference frequency, 6-13

Interference frequency suppression, 6-13

L

Labeling strips for modules, 7-2

LED

- red, 5-14

load

- Hardware configuration, 6-15

Load power supply

- Selecting, 6-8

M

- Mains voltage
 - Check, 5-3
 - modify, 5-3
- Measurement range, 6-13
- Measuring range modules, 4-6
 - Positioning, 4-7
 - Positions, 4-6
- Micro Memory Card
 - Deleting, 6-14
- Modify
 - Mains voltage, 5-3
- Monitoring
 - Values, 7-5
- Mounting rail
 - screw, 4-2

O

- OB82
 - Diagnostic interrupt, 6-18
- Open
 - Configuration, 6-10
 - Hardware catalog, 6-8
- Organizational blocks
 - Selecting, 6-4
- Overflow, 8-6

P

- Parameter window
 - with internal compensation, 6-12
- Position of the Coding Key, 6-13
- Positioning
 - Measuring range modules, 4-7
- Positions
 - Measuring range modules, 4-6
- Power Supply
 - Installing, 4-2
 - screw, 4-2
 - Wiring the CPU, 5-2
- Powering-up, 6-14
- Process Acknowledgement, 7-6
- Project name
 - Assigning, 6-5

R

- Read out
 - Read diagnostic information from a PG, 8-1

- Reference junction, external
 - Wiring, 5-12

S

- screw
 - Mounting rail, 4-2
 - Power Supply, 4-2
- Selecting
 - CPU, 6-3
 - Load power supply, 6-8
 - Organizational blocks, 6-4
 - Target addresses, 6-16
- Sensor values
 - window, 7-3
- SIMATIC Manager, 6-1
 - Hardware configuration, 6-7
 - start, 6-1
- Simulation
 - Hardware interrupt, 9-3
- SM331
 - Components, 4-4
- SM331 Front connector
 - Wiring, 5-7, 5-11
- SM331 module
 - Installing, 4-8
- SM331 modules
 - Components of the product, 4-4
- Smart Label, 7-2
- source code
 - compiling, 6-23
 - Variable description, A-2
- Source code
 - User Program, A-2
- Source file
 - Block Version, 6-20
 - Download, 6-19
- start
 - CPU, 6-17
 - SIMATIC Manager, 6-1
- STEP 7 project
 - Creating, 6-1
- STEP7 user program, 6-18
 - Tasks, 6-18
- STL, 6-4
- STL source code, A-2
- Structure
 - User Program, 6-18

T

- Target addresses
 - Selecting, 6-16
- test
 - wiring, 5-14
- Test
 - Attitudes, 6-14
 - User Program, 7-1
- Thermocouples
 - Analog value representation, 7-7
- Thermocouples with external reference junction
 - Connection diagram, 5-8
- Thermocouples with internal reference junction
 - Connection diagram, 5-5
- Translating
 - source code, 6-23
- Type of measurement, 6-13

U

- Underflow, 8-5
- User Program
 - Creating, 6-19
 - source code, A-2
 - Structure, 6-18
 - test, 7-1

V

- Values
 - Monitor, 7-5
- Variable description, A-2
 - source code, A-2
- Variable table
 - Fill out, 7-3

W

- window
 - Errors, 8-3
- Wire break, 8-5
- Wire break monitoring, 6-13
- Wires, shielded
 - For analog signals, 5-4
- wiring
 - Analog module with external reference junction, 5-11
 - Analog module with internal reference junction, 5-7
- wiring
 - test, 5-14
- Wiring
 - Power supply and CPU, 5-2
 - Reference junction, external, 5-12
 - SM331 Front connector, 5-7, 5-11
- Wizard "New Project...", 6-1