

SIEMENS

SIMATIC

Process Control System PCS 7 Advanced Process Library (V9.0 SP1)

Function Manual

Security information	1
Basics of APL	2
Operator control blocks	3
Monitoring blocks	4
Controller blocks	5
Dosing blocks	6
Motor and valve blocks	7
Interlock blocks	8
Message blocks	9
Counter blocks	10
Timers	11
Mathematical blocks	12
Analog logic blocks	13
Digital logic blocks	14
Generator blocks	15
Channel blocks	16
Conversion blocks	17
Maintenance blocks	18
System blocks	19
Communication blocks	20
Process tag types (insertible templates)	21
Definitions	22

Legal information

Warning notice system

This manual contains notices you have to observe in order to ensure your personal safety, as well as to prevent damage to property. The notices referring to your personal safety are highlighted in the manual by a safety alert symbol, notices referring only to property damage have no safety alert symbol. These notices shown below are graded according to the degree of danger.

⚠ DANGER
indicates that death or severe personal injury will result if proper precautions are not taken.

⚠ WARNING
indicates that death or severe personal injury may result if proper precautions are not taken.

⚠ CAUTION
indicates that minor personal injury can result if proper precautions are not taken.

NOTICE
indicates that property damage can result if proper precautions are not taken.

If more than one degree of danger is present, the warning notice representing the highest degree of danger will be used. A notice warning of injury to persons with a safety alert symbol may also include a warning relating to property damage.

Qualified Personnel

The product/system described in this documentation may be operated only by **personnel qualified** for the specific task in accordance with the relevant documentation, in particular its warning notices and safety instructions. Qualified personnel are those who, based on their training and experience, are capable of identifying risks and avoiding potential hazards when working with these products/systems.

Proper use of Siemens products

Note the following:

⚠ WARNING
Siemens products may only be used for the applications described in the catalog and in the relevant technical documentation. If products and components from other manufacturers are used, these must be recommended or approved by Siemens. Proper transport, storage, installation, assembly, commissioning, operation and maintenance are required to ensure that the products operate safely and without any problems. The permissible ambient conditions must be complied with. The information in the relevant documentation must be observed.

Trademarks

All names identified by ® are registered trademarks of Siemens AG. The remaining trademarks in this publication may be trademarks whose use by third parties for their own purposes could violate the rights of the owner.

Disclaimer of Liability

We have reviewed the contents of this publication to ensure consistency with the hardware and software described. Since variance cannot be precluded entirely, we cannot guarantee full consistency. However, the information in this publication is reviewed regularly and any necessary corrections are included in subsequent editions.

Table of contents

1	Security information.....	39
2	Basics of APL.....	41
2.1	Functions of the blocks.....	41
2.1.1	General information.....	41
2.1.1.1	User-configured message classes.....	41
2.1.1.2	Forcing operating modes.....	41
2.1.1.3	Resetting the block in case of interlocks or errors.....	43
2.1.1.4	Neutral position for motors, valves and controllers.....	48
2.1.1.5	Specifying warning times for control functions at motors and valves.....	51
2.1.1.6	Output signal as a static signal or pulse signal.....	51
2.1.1.7	Recording the first signal for interlock blocks.....	52
2.1.1.8	Outputting a signal for start readiness.....	53
2.1.1.9	Simulating signals.....	58
2.1.1.10	Dead band.....	61
2.1.1.11	Request for maintenance release.....	62
2.1.1.12	Release for maintenance.....	64
2.1.1.13	SIMATIC BATCH functionality.....	67
2.1.1.14	Flutter suppression for channel blocks.....	67
2.1.1.15	Startup characteristics over Trigger block.....	69
2.1.2	Operating modes of the blocks.....	69
2.1.2.1	Overview of the modes.....	69
2.1.2.2	On.....	71
2.1.2.3	Out of service.....	71
2.1.2.4	Manual and automatic mode for control blocks.....	72
2.1.2.5	Manual and automatic mode for motors, valves and dosers.....	75
2.1.2.6	Program mode for controllers.....	78
2.1.2.7	Local mode.....	79
2.1.2.8	State graph of the operating modes.....	83
2.1.3	Monitoring functions.....	85
2.1.3.1	Monitoring functions in the Advanced Process Library.....	85
2.1.3.2	Group display for limit monitoring, CSF and ExtMsgx.....	85
2.1.3.3	Limit monitoring.....	86
2.1.3.4	Feedbacks.....	97
2.1.3.5	Motor protection function.....	99
2.1.4	Interlocking functions.....	99
2.1.4.1	Interlocks.....	99
2.1.4.2	Disabling interlocks.....	103
2.1.4.3	Influence of the signal status on the interlock.....	104
2.1.4.4	Forming the group status for interlock information.....	105
2.1.4.5	Rapid stop for motors.....	107
2.1.4.6	Bypassing signals.....	107
2.1.5	Form signal status.....	108
2.1.5.1	Forming and outputting signal status for blocks.....	108
2.1.5.2	Forming and outputting the signal status for technologic blocks.....	109
2.1.5.3	Forming and outputting the signal status of digital logic blocks.....	111

2.1.5.4	Forming and outputting the signal status of analog logic blocks.....	112
2.1.5.5	Forming and outputting the signal status of redundancy blocks.....	112
2.1.5.6	Forming and outputting the signal status for blocks with configurable status prioritization....	114
2.1.5.7	Forming and outputting the signal status for interlock blocks.....	116
2.1.5.8	Forming and outputting the signal status for mathematical blocks.....	118
2.1.5.9	Forming and outputting the signal status for PCS 7 channel blocks.....	119
2.1.5.10	Forming and outputting the signal status for channel blocks for field devices.....	119
2.1.6	Error handling.....	120
2.1.6.1	Error handling.....	120
2.1.6.2	Outputting group errors.....	122
2.1.7	Ramp function.....	123
2.1.7.1	Using setpoint ramp.....	123
2.1.7.2	Gradient limit of the setpoint.....	124
2.1.7.3	Using a manipulated variable ramp.....	125
2.1.7.4	Gradient limiting of the manipulated variable.....	126
2.1.8	Internal/external setting.....	127
2.1.8.1	Applying the dynamically activated dead band during the PV settling time.....	127
2.1.8.2	Setpoint specification - internal/external.....	128
2.1.8.3	Manipulated variable specification - internal/external.....	129
2.1.9	Configurable response using the Feature I/O.....	131
2.1.9.1	Configurable functions using the Feature I/O.....	131
2.1.9.2	Stopping dosing at a flow alarm.....	137
2.1.9.3	Failure handling.....	138
2.1.9.4	Set startup characteristics.....	138
2.1.9.5	Applying the dynamically activated dead band during the PV settling time.....	141
2.1.9.6	Evaluation of signal status.....	142
2.1.9.7	Evaluation of the signal status of the interlock signals.....	142
2.1.9.8	Automatic post dosing for underdosing in automatic mode.....	143
2.1.9.9	Block as summing unit or integrator.....	143
2.1.9.10	Switching operator controls for external setpoint to visible.....	144
2.1.9.11	Limit output Out.....	144
2.1.9.12	Activating calculation of the flow rate for dosing by scale.....	144
2.1.9.13	Condition monitoring information at MOD_Blocks.....	145
2.1.9.14	Condition monitoring information at the channel blocks.....	145
2.1.9.15	Disabling operating points.....	145
2.1.9.16	Enabling direct changeover between forward and reverse.....	146
2.1.9.17	Specifying the dosing type.....	146
2.1.9.18	Flow setpoints in percent.....	146
2.1.9.19	Specifying the influence of the signal status on the dosing process.....	147
2.1.9.20	Unit for the rate of change.....	147
2.1.9.21	Reading messages.....	147
2.1.9.22	Setting the scaling for the process values.....	148
2.1.9.23	Outputting a de-energized value for block-external simulation.....	148
2.1.9.24	Switch to substitute value.....	149
2.1.9.25	Substitute value switch in the event of an error.....	149
2.1.9.26	Output substitute value if raw value is invalid.....	149
2.1.9.27	Activating recording of the first signal.....	150
2.1.9.28	External control deviation.....	151
2.1.9.29	Activating error state for external process control error CSF	151
2.1.9.30	Frequency converter with separate device feed.....	151
2.1.9.31	Separate evaluation for excluded and simulated interlock signals.....	152
2.1.9.32	Use an internal or external setpoint for the absolute fine dosing quantity.....	153

2.1.9.33	Activating the run time of feedback signals.....	153
2.1.9.34	Outputting last valid value if raw value is invalid.....	154
2.1.9.35	Use the last value following a complete download as the current value during startup of the block.....	154
2.1.9.36	Activate LowCutOff.....	155
2.1.9.37	Selecting values associated with messages.....	156
2.1.9.38	Reporting with BATCH parameters.....	156
2.1.9.39	Motor feedback is not available.....	157
2.1.9.40	Display only input values that are interconnected in the faceplate.....	157
2.1.9.41	Activate OS_Perm bits.....	157
2.1.9.42	Disabling opening and closing.....	158
2.1.9.43	Enabling local operator authorization.....	158
2.1.9.44	Enable configuration of the dribbling quantity.....	159
2.1.9.45	Enabling program mode.....	159
2.1.9.46	Update acknowledgment and error status of the message call.....	160
2.1.9.47	Control zone with frozen I component	160
2.1.9.48	Control zone with specified I component	160
2.1.9.49	Resetting the commands for changing the mode.....	161
2.1.9.50	Enabling resetting of commands for the control settings.....	161
2.1.9.51	Resetting the dosing quantity when dosing starts.....	162
2.1.9.52	Process value with separate scale range.....	162
2.1.9.53	Resetting via input signals in the event of interlocking (Protection) or errors.....	163
2.1.9.54	Set reset depending on the operating mode or the LiOp parameter.....	163
2.1.9.55	Activating reset of protection / error in manual mode.....	165
2.1.9.56	Reset even with locked state.....	165
2.1.9.57	Neutral position manipulated variable takes effect at startup.....	166
2.1.9.58	Neutral position manipulated variable takes effect with "out of service" operating mode	166
2.1.9.59	Setting switch or button mode.....	167
2.1.9.60	Specifying switching mode.....	168
2.1.9.61	Creep rate is always detected in the dosing quantity.....	168
2.1.9.62	Enabling rapid stop via faceplate.....	168
2.1.9.63	Position feedback signals are active.....	169
2.1.9.64	Separate monitoring time for stopping the motor.....	169
2.1.9.65	Separate interlock for each direction or position.....	170
2.1.9.66	Separate delay times for each alarm.....	170
2.1.9.67	Signaling limit violation.....	170
2.1.9.68	Alarm setpoint difference.....	171
2.1.9.69	Setpoint specification with separate display area and custom unit.....	171
2.1.9.70	Control via auxiliary valve.....	172
2.1.9.71	Enabling bumpless change to the proportional gain, derivative time and amplification of the differentiator.....	172
2.1.9.72	Enable bumpless switchover to "Automatic" mode for operator only.....	172
2.1.9.73	Disabling bumpless switchover to automatic mode for controllers.....	173
2.1.9.74	Enabling bumpless switchover to automatic mode for valves, motors, and dosers.....	173
2.1.9.75	Summing characteristics continuous or triggered.....	174
2.1.9.76	Suppression of all messages.....	174
2.1.9.77	Output invalid raw value.....	174
2.1.9.78	Transmission of status information of devices.....	175
2.1.9.79	Control priority in the event of an invalid input command.....	175
2.1.9.80	Sealing the valve.....	176
2.1.9.81	First-in detection response to deactivation.....	176
2.1.9.82	Reaction of the switching points in the "Out of service" operating mode.....	176

2.1.9.83	Reaction to the out of service mode.....	177
2.1.9.84	Exiting local mode.....	177
2.1.9.85	Interlock display with LocalSetting 2 or 4.....	178
2.1.9.86	Vibrate after torque monitoring.....	178
2.1.9.87	With acknowledge overdosage.....	179
2.1.9.88	Ramp rate calculation.....	179
2.1.9.89	SP following PV in open loop has no priority over SP_Ext and SP limits.....	179
2.1.9.90	With accelerated return of the integral action from the manipulated variable limit.....	180
2.1.9.91	External/internal selection specification.....	180
2.1.9.92	Setting switch or button mode for local commands.....	181
2.1.9.93	Gradient limitation with time duration.....	182
2.1.9.94	Analog input 1 is reserved for the operator.....	183
2.1.9.95	Operator can change the setpoint via faceplate also in the "Local" mode.....	183
2.1.9.96	Define the setpoint after stop and start of the motor.....	184
2.1.9.97	Retain last output value in case of bad input signal status.....	184
2.1.9.98	Forcing operating modes in the "Local" mode.....	184
2.1.9.99	Motor stop in end position depends only on the corresponding feedback signal.....	185
2.1.9.100	Substitution value is active if the block is in bypass.....	185
2.1.9.101	Enable external message.....	185
2.1.9.102	Considering bad quality of automatic commands or external values.....	186
2.1.9.103	Disable calculation of impulse control in LocalSetting 2 and 4.....	186
2.1.9.104	Inverter enable.....	187
2.1.9.105	Scale dosing can be started only if StandStill = 1.....	187
2.1.9.106	Delete history of MV and DV moves during restart.....	187
2.1.9.107	Status output calculation.....	188
2.1.9.108	Suppress MsgLock and "Out of service" mode for a connected message block.....	188
2.1.9.109	Variants of CPI calculation.....	188
2.1.9.110	Scalable measuring range.....	189
2.1.9.111	2 decimal points (scalable measuring range).....	189
2.1.9.112	3 decimal points (scalable measuring range).....	190
2.1.10	Functions for controllers.....	190
2.1.10.1	Delay alarm for control deviation at setpoint step changes.....	190
2.1.10.2	Inverting control direction.....	192
2.1.10.3	Error signal generation and dead band.....	192
2.1.10.4	Using control zones.....	194
2.1.10.5	Setpoint limiting for external setpoints.....	196
2.1.10.6	Tracking setpoint in manual mode.....	196
2.1.10.7	Tracking and limiting a manipulated variable.....	196
2.1.10.8	Feedforwarding and limiting disturbance variables.....	197
2.1.10.9	Structure segmentation at controllers.....	198
2.1.11	Messaging.....	199
2.1.11.1	Area of application of the alarm delays.....	199
2.1.11.2	One time value for all limits.....	199
2.1.11.3	One time value per limit pair.....	200
2.1.11.4	Two time values per limit pair.....	201
2.1.11.5	Two time values for each individual limit.....	202
2.1.11.6	Generating instance-specific messages.....	204
2.1.11.7	Suppressing messages using the MsgLock parameter.....	205
2.1.11.8	Time stamp.....	205
2.1.11.9	Connection of the time-stamped messages from EventTs or Event16Ts.....	207
2.1.12	Settings for operator control and monitoring.....	207
2.1.12.1	Display and operator input area for process values and setpoints.....	207

2.1.12.2	Opening additional faceplates.....	208
2.1.12.3	Labeling of buttons and text.....	209
2.1.12.4	Displaying auxiliary values.....	211
2.1.12.5	Selecting a unit of measure.....	212
2.2	Functions of the block icons.....	230
2.2.1	Block icon structure.....	230
2.2.2	Configuring the block icons.....	237
2.2.3	Operation via the block icon.....	239
2.2.4	Block icons for PID and FM controller	239
2.2.5	Block icon for interlock blocks.....	241
2.2.6	Block icons for SFC.....	243
2.2.7	Adding block icons to static picture components.....	245
2.2.8	Format specification for the analog value display.....	246
2.3	Functions of the faceplates.....	248
2.3.1	Structure of the faceplate.....	248
2.3.2	Operator control permissions.....	254
2.3.3	Display of delay times.....	256
2.3.4	Switching operating states and operating modes.....	257
2.3.5	Changing values.....	259
2.3.6	FM controllers standard view (analog)	261
2.3.7	FM controllers standard view (pulse controller).....	265
2.3.8	FM controllers standard view (step controller with position feedback).....	269
2.3.9	FM controllers standard view (step controller without position feedback)	273
2.3.10	Interlock blocks standard view.....	276
2.3.11	Parameter view of PID controllers.....	281
2.3.12	Parameter view of FM controllers.....	284
2.3.13	Parameter view for motors and valves.....	286
2.3.14	Limit view of FM controllers.....	288
2.3.15	Limit view of PID controllers.....	291
2.3.16	Limit view of motors.....	294
2.3.17	Preview of FM controllers.....	297
2.3.18	Preview of interlock blocks.....	299
2.3.19	Ramp view.....	300
2.3.20	Alarm view.....	302
2.3.21	Batch view.....	302
2.3.22	Memo view.....	304
2.3.23	Trend view.....	305
2.3.24	APL Operator Trend Control (AOTC).....	307
2.3.25	Limit operation and display in the faceplate.....	319
2.3.26	Central color management.....	320
2.4	PCS 7 measuring point browser.....	341
2.4.1	Overview of the "PCS 7 measuring point browser" window.....	341
3	Operator control blocks.....	345
3.1	Comparison of large & small blocks.....	345
3.1.1	OpAnL compared to OpAnS.....	345
3.2	OpAnL - Check and output analog signals (large).....	347
3.2.1	Description of OpAnL.....	347
3.2.2	OpAnL modes.....	348
3.2.3	OpAnL functions.....	349

3.2.4	OpAnL error handling.....	352
3.2.5	OpAnL messaging.....	352
3.2.6	OpAnL I/Os.....	354
3.2.7	OpAnL block diagram.....	359
3.2.8	Operator control and monitoring.....	360
3.2.8.1	OpAnL views.....	360
3.2.8.2	OpAnL standard view.....	360
3.2.8.3	OpAnL parameter view.....	363
3.2.8.4	OpAnL trend view.....	363
3.2.8.5	OpAnL preview.....	365
3.2.8.6	Block icon for OpAnL.....	366
3.3	OpAnS - Check and output analog signals (small).....	368
3.3.1	Description of OpAnS.....	368
3.3.2	OpAnS modes.....	369
3.3.3	OpAnS functions.....	370
3.3.4	OpAnS error handling.....	372
3.3.5	OpAnS messaging.....	373
3.3.6	OpAnS I/Os.....	373
3.3.7	OpAnS block diagram.....	376
3.3.8	Operator control and monitoring.....	376
3.3.8.1	OpAnS views.....	376
3.3.8.2	OpAnS standard view.....	377
3.3.8.3	OpAnS parameter view.....	378
3.3.8.4	OpAnS preview.....	379
3.3.8.5	OpAnS block icon.....	380
3.4	OpDi01 - Manipulating a digital value (2 pushbuttons).....	382
3.4.1	Description of OpDi01.....	382
3.4.2	OpDi01 modes.....	383
3.4.3	OpDi01 functions.....	384
3.4.4	OpDi01 error handling.....	386
3.4.5	OpDi01 messaging.....	387
3.4.6	OpDi01 I/Os.....	387
3.4.7	OpDi01 block diagram.....	390
3.4.8	Operator control and monitoring.....	390
3.4.8.1	OpDi01 views.....	390
3.4.8.2	OpDi01 standard view.....	391
3.4.8.3	OpDi01 preview.....	392
3.4.8.4	Block icon for OpDi01.....	394
3.5	OpDi03 - Manipulating a digital value (3 pushbuttons).....	396
3.5.1	Description of OpDi03.....	396
3.5.2	OpDi03 modes.....	397
3.5.3	OpDi03 functions.....	398
3.5.4	OpDi03 error handling.....	401
3.5.5	OpDi03 messaging.....	402
3.5.6	OpDi03 I/Os.....	402
3.5.7	OpDi03 block diagram.....	405
3.5.8	Operator control and monitoring.....	406
3.5.8.1	OpDi03 view.....	406
3.5.8.2	OpDi03 standard view.....	406
3.5.8.3	OpDi03 preview.....	408
3.5.8.4	Block icon for OpDi03.....	409

3.6	OpStations - Configuration of the local operator authorization.....	411
3.6.1	Description of OpStations.....	411
3.6.2	OpStations operating modes.....	413
3.6.3	OpStations functions.....	414
3.6.4	OpStations error handling.....	415
3.6.5	OpStations messaging.....	415
3.6.6	OpStations I/Os.....	416
3.6.7	OpStations block diagram.....	418
3.6.8	Operator control and monitoring.....	419
3.6.8.1	OpStations views.....	419
3.6.8.2	OpStations standard view.....	420
3.6.8.3	Block icon of OpStations.....	422
3.7	OpTrig - Manipulating a digital value (1 pushbutton).....	423
3.7.1	Description of OpTrig.....	423
3.7.2	OpTrig modes.....	424
3.7.3	OpTrig functions.....	424
3.7.4	OpTrig error handling.....	426
3.7.5	OpTrig messaging.....	427
3.7.6	OpTrig I/Os.....	427
3.7.7	OpTrig block diagram.....	429
3.7.8	Operator control and monitoring.....	430
3.7.8.1	OpTrig views.....	430
3.7.8.2	OpTrig standard view.....	430
3.7.8.3	OpTrig preview.....	431
3.7.8.4	Block icon for OpTrig.....	432
4	Monitoring blocks.....	435
4.1	Comparison of large & small blocks.....	435
4.1.1	MonAnL compared to MonAnS.....	435
4.1.2	MonDiL compared to MonDiS.....	437
4.2	AV - Displaying and monitoring additional value.....	439
4.2.1	Description of AV.....	439
4.2.2	AV modes.....	440
4.2.3	AV functions.....	441
4.2.4	AV error handling.....	443
4.2.5	AV messaging.....	443
4.2.6	AV I/Os.....	445
4.2.7	AV block diagram.....	448
4.3	MonAnL - Monitoring of an analog process tag (Large).....	449
4.3.1	Description of MonAnL.....	449
4.3.2	MonAnL modes.....	452
4.3.3	MonAnL functions.....	452
4.3.4	MonAnL error handling.....	459
4.3.5	MonAnL messaging.....	460
4.3.6	MonAnL I/Os.....	462
4.3.7	MonAnL block diagram.....	470
4.3.8	Operator control and monitoring.....	470
4.3.8.1	MonAnL views.....	470
4.3.8.2	MonAnL standard view.....	471
4.3.8.3	MonAnL limit view.....	474

4.3.8.4	MonAnL parameter view.....	476
4.3.8.5	MonAnL preview.....	477
4.3.8.6	Block icon for MonAnL	478
4.4	MonAnS - Monitoring of an analog process tag (Small).....	480
4.4.1	Description of MonAnS.....	480
4.4.2	MonAnS operating modes.....	482
4.4.3	MonAnS functions.....	482
4.4.4	MonAnS error handling.....	485
4.4.5	MonAnS messaging.....	486
4.4.6	MonAnS I/Os.....	488
4.4.7	MonAnS block diagram.....	491
4.4.8	Operator control and monitoring.....	492
4.4.8.1	MonAnS views.....	492
4.4.8.2	MonAnS standard view.....	492
4.4.8.3	MonAnS limit view.....	494
4.4.8.4	MonAnS parameter view.....	495
4.4.8.5	MonAnS preview.....	496
4.4.8.6	Block icon for MonAnS.....	497
4.5	MonDiL - Monitoring of a digital process tag (Large).....	499
4.5.1	Description of MonDiL.....	499
4.5.2	MonDiL modes.....	502
4.5.3	MonDiL functions.....	503
4.5.4	MonDiL error handling.....	508
4.5.5	MonDiL messaging.....	509
4.5.6	MonDiL I/Os.....	510
4.5.7	MonDiL block diagram.....	515
4.5.8	Operator control and monitoring.....	515
4.5.8.1	MonDiL views.....	515
4.5.8.2	MonDiL standard view.....	516
4.5.8.3	MonDiL parameter view.....	518
4.5.8.4	MonDiL preview.....	519
4.5.8.5	Block icon for MonDiL.....	520
4.6	MonDiS - Monitoring of a digital process tag (Small).....	523
4.6.1	Description of MonDiS.....	523
4.6.2	MonDiS operating modes.....	526
4.6.3	MonDiS functions.....	527
4.6.4	MonDiS error handling.....	530
4.6.5	MonDiS messaging.....	531
4.6.6	MonDiS I/Os.....	532
4.6.7	MonDiS block diagram.....	535
4.6.8	Operator control and monitoring.....	535
4.6.8.1	MonDiS views.....	535
4.6.8.2	MonDiS standard view.....	536
4.6.8.3	MonDiS parameter view.....	537
4.6.8.4	MonDiS preview.....	538
4.6.8.5	Block icon for MonDiS.....	539
4.7	MonDi08 - Monitoring 8 digital process tags.....	542
4.7.1	Description of MonDi08.....	542
4.7.2	MonDi08 modes.....	544
4.7.3	MonDi08 functions.....	545

4.7.4	MonDi08 error handling.....	547
4.7.5	MonDi08 messaging.....	548
4.7.6	MonDi08 I/Os.....	550
4.7.7	MonDi08 block diagram.....	554
4.7.8	Operator control and monitoring.....	554
4.7.8.1	MonDi08 views.....	554
4.7.8.2	MonDi08 standard view.....	555
4.7.8.3	MonDi08 parameter view.....	557
4.7.8.4	MonDi08 preview.....	558
4.7.8.5	Block icon for MonDi08.....	559
5	Controller blocks.....	561
5.1	Comparison of large & small blocks.....	561
5.1.1	PIDConL compared to PIDConS.....	561
5.2	ConPerMon - Monitoring of the control performance of control loops.....	565
5.2.1	Description of ConPerMon.....	565
5.2.2	ConPerMon modes.....	569
5.2.3	ConPerMon functions.....	569
5.2.4	ConPerMon error handling.....	581
5.2.5	ConPerMon messaging.....	581
5.2.6	ConPerMon I/Os.....	583
5.2.7	ConPerMon block diagram.....	589
5.2.8	Operator control and monitoring.....	590
5.2.8.1	ConPerMon views.....	590
5.2.8.2	ConPerMon standard view.....	590
5.2.8.3	ConPerMon limit view.....	592
5.2.8.4	ConPerMon parameter view.....	593
5.2.8.5	ConPerMon preview.....	594
5.2.8.6	ConPerMon setpoint view.....	595
5.2.8.7	Block icon for ConPerMon.....	597
5.3	FmCont - Interface to module FM 355.....	599
5.3.1	Description of FmCont.....	599
5.3.2	FmCont modes.....	603
5.3.3	FmCont functions.....	604
5.3.4	FmCont error handling.....	614
5.3.5	FmCont messaging.....	616
5.3.6	FmCont I/Os.....	619
5.3.7	FmCont block diagram.....	634
5.3.8	Operator control and monitoring.....	636
5.3.8.1	FmCont views.....	636
5.4	FmTemp - Interface to temperature controller modules FM 355-2.....	637
5.4.1	Description of FmTemp.....	637
5.4.2	FmTemp modes.....	641
5.4.3	FmTemp functions.....	642
5.4.4	FmTemp error handling.....	654
5.4.5	FmTemp messaging.....	655
5.4.6	FmTemp I/Os.....	658
5.4.7	FmTemp block diagram.....	675
5.4.8	Operator control and monitoring.....	677
5.4.8.1	FmTemp views.....	677

5.5	GainSched - Adapting parameter values for a PID controller.....	678
5.5.1	Description of GainSched.....	678
5.5.2	GainSched modes.....	680
5.5.3	GainSched functions.....	681
5.5.4	GainSched error handling.....	682
5.5.5	GainSched messaging.....	682
5.5.6	GainSched I/Os.....	683
5.5.7	GainSched block diagram.....	685
5.5.8	Operator control and monitoring.....	686
5.5.8.1	GainSched views.....	686
5.5.8.2	GainSched standard view.....	686
5.5.8.3	GainSched parameter view.....	687
5.5.8.4	GainSched preview.....	688
5.6	ModPreCon - Model predictive controller.....	689
5.6.1	Description of ModPreCon.....	689
5.6.2	ModPreCon modes.....	694
5.6.3	ModPreCon functions.....	695
5.6.4	ModPreCon error handling.....	708
5.6.5	ModPreCon messaging.....	709
5.6.6	ModPreCon I/Os.....	709
5.6.7	ModPreCon block diagram.....	720
5.6.8	Operator control and monitoring.....	721
5.6.8.1	ModPreCon views.....	721
5.6.8.2	ModPreCon standard view.....	722
5.6.8.3	ModPreCon parameter view.....	726
5.6.8.4	ModPreCon parameter view channel 1 to 4.....	728
5.6.8.5	ModPreCon preview.....	729
5.6.8.6	ModPreCon trend view.....	731
5.6.8.7	Block icon for ModPreCon.....	732
5.7	PIDConL - Continuous PID controller (Large).....	735
5.7.1	Description of PIDConL.....	735
5.7.2	PIDConL modes.....	740
5.7.3	PIDConL functions.....	741
5.7.4	PIDConL error handling.....	752
5.7.5	PIDConL messaging.....	753
5.7.6	PIDConL I/Os.....	756
5.7.7	PIDConL block diagram.....	773
5.7.8	Operator control and monitoring.....	775
5.7.8.1	PIDConL views.....	775
5.7.8.2	PIDConL, PIDConS and PIDConR standard views.....	776
5.7.8.3	PIDConL, PIDConS and PIDConR previews.....	781
5.8	PIDConS - Continuous PID controller (Small).....	784
5.8.1	Description of PIDConS.....	784
5.8.2	PIDConS modes.....	787
5.8.3	PIDConS functions.....	788
5.8.4	PIDConS error handling.....	794
5.8.5	PIDConS messaging.....	795
5.8.6	PIDConS I/Os.....	797
5.8.7	PIDConS block diagram.....	804
5.8.8	Operator control and monitoring.....	806

5.8.8.1	PIDConS views.....	806
5.9	PIDConR - Continuous PID controller with external reset.....	807
5.9.1	Description of PIDConR.....	807
5.9.2	PIDConR modes.....	813
5.9.3	PIDConR functions.....	815
5.9.4	PIDConR error handling.....	829
5.9.5	PIDConR messaging	830
5.9.6	PIDConR I/Os.....	833
5.9.7	PIDConR block diagram.....	850
5.9.8	Operator control and monitoring.....	850
5.9.8.1	PIDConR views.....	850
5.10	PIDStepL - Step controller.....	851
5.10.1	Description of PIDStepL.....	851
5.10.2	PIDStepL modes.....	855
5.10.3	PIDStepL functions.....	856
5.10.4	PIDStepL error handling.....	867
5.10.5	PIDStepL messaging.....	868
5.10.6	PIDStepL I/Os.....	871
5.10.7	PIDStepL block diagram.....	886
5.10.8	Operator control and monitoring.....	891
5.10.8.1	PIDStepL views.....	891
5.10.8.2	PIDStepL standard view without position feedback.....	892
5.10.8.3	PIDStepL standard view with position feedback.....	895
5.10.8.4	PIDStepL preview.....	899
5.11	Ratio - Ratio controlling.....	902
5.11.1	Description of Ratio.....	902
5.11.2	Ratio modes.....	904
5.11.3	Ratio functions.....	904
5.11.4	Ratio error handling.....	907
5.11.5	Ratio messaging.....	908
5.11.6	Ratio I/Os.....	908
5.11.7	Ratio block diagram.....	912
5.11.8	Operator control and monitoring.....	913
5.11.8.1	Ratio views.....	913
5.11.8.2	Ratio standard view.....	913
5.11.8.3	Ratio parameter view.....	916
5.11.8.4	Ratio preview.....	917
5.11.8.5	Block icon for Ratio.....	918
5.12	SplRange - Signal splitter.....	921
5.12.1	Description of SplRange.....	921
5.12.2	SplRange modes.....	922
5.12.3	SplRange functions.....	923
5.12.4	SplRange error handling.....	926
5.12.5	SplRange messaging.....	926
5.12.6	SplRange I/Os.....	927
5.12.7	SplRange block diagram.....	928
5.13	AutoExcitation - Process trigger for predictive controller.....	929
5.13.1	Description of AutoExcitation.....	929
5.13.2	AutoExcitation modes.....	931
5.13.3	AutoExcitation functions.....	931

5.13.4	AutoExcitation error handling.....	932
5.13.5	AutoExcitation messaging.....	932
5.13.6	AutoExcitation I/Os.....	932
5.13.7	AutoExcitation block diagram.....	933
5.14	LPOptim - Optimization after traversing the linear programming.....	934
5.14.1	Description of LPOptim.....	934
5.14.2	LPOptim modes.....	935
5.14.3	LPOptim functions.....	935
5.14.4	LPOptim error handling.....	935
5.14.5	LPOptim messaging.....	935
5.14.6	LPOptim I/Os.....	936
5.14.7	LPOptim block diagram.....	938
5.15	MPC10x10 - Large predictive controller	939
5.15.1	Description of MPC10x10.....	939
5.15.2	MPC10x10 modes.....	946
5.15.3	MPC10x10 functions.....	947
5.15.4	MPC10x10 error handling.....	957
5.15.5	MPC10x10 messaging.....	958
5.15.6	MPC10x10 I/Os.....	959
5.15.7	MPC10x10 block diagram.....	964
5.15.8	Operator control and monitoring.....	965
5.15.8.1	MPC10x10 views.....	965
5.15.8.2	MPC10x10 standard view.....	965
5.15.8.3	MPC10x10 parameter view.....	971
5.15.8.4	MPC10x10 CV parameter view.....	973
5.15.8.5	MPC10x10 MV parameter view.....	974
5.15.8.6	MPC10x10 preview.....	975
5.15.8.7	MPC10x10 trend view.....	977
5.15.8.8	Block icon for MPC10x10	978
5.16	KalFilt - State observer.....	980
5.16.1	Description of KalFilt.....	980
5.16.2	KalFilt modes.....	986
5.16.3	KalFilt functions.....	987
5.16.4	KalFilt error handling.....	988
5.16.5	KalFilt I/Os.....	990
5.16.6	KalFilt messaging.....	994
5.16.7	KalFilt block diagram.....	994
5.16.8	Operator control and monitoring.....	995
5.16.8.1	KalFilt views.....	995
5.16.8.2	KalFilt standard view.....	995
5.16.8.3	KalFilt parameter view.....	999
5.16.8.4	KalFilt parameter view 2.....	1000
5.16.8.5	KalFilt preview.....	1001
5.16.8.6	KalFilt measurements view.....	1002
5.16.8.7	KalFilt trend view.....	1003
5.16.8.8	Block icon for KalFilt	1004
6	Dosing blocks.....	1005
6.1	DoseL - Dosing device.....	1005
6.1.1	Description of DoseL.....	1005
6.1.2	DoseL modes.....	1009

6.1.3	DoseL functions.....	1011
6.1.4	DoseL error handling.....	1025
6.1.5	DoseL messaging.....	1028
6.1.6	DoseL I/Os.....	1031
6.1.7	DoseL block diagram.....	1045
6.1.8	Operator control and monitoring.....	1046
6.1.8.1	DoseL views.....	1046
6.1.8.2	DoseL standard view.....	1047
6.1.8.3	DoseL limit view.....	1051
6.1.8.4	DoseL parameter view.....	1053
6.1.8.5	DoseL flow setpoint view.....	1055
6.1.8.6	DoseL quantity setpoint view.....	1058
6.1.8.7	DoseL preview.....	1060
6.1.8.8	Block icon for DoseL.....	1062
7	Motor and valve blocks.....	1065
7.1	Comparison of large & small blocks.....	1065
7.1.1	MotL compared to MotS.....	1065
7.1.2	VlvL compared to VlvS.....	1068
7.1.3	ShrdResL compared to ShrdResS.....	1071
7.2	MotL - Motor (Large).....	1073
7.2.1	Description of MotL.....	1073
7.2.2	MotL modes.....	1077
7.2.3	MotL functions.....	1078
7.2.4	MotL error handling.....	1085
7.2.5	MotL messaging.....	1086
7.2.6	MotL I/Os.....	1088
7.2.7	MotL block diagram.....	1096
7.2.8	Operator control and monitoring.....	1097
7.2.8.1	MotL views.....	1097
7.2.8.2	MotL standard view.....	1097
7.2.8.3	MotL preview.....	1101
7.2.8.4	Block icon for MotL.....	1104
7.3	MotS - Motor (Small).....	1107
7.3.1	Description of MotS.....	1107
7.3.2	MotS modes.....	1109
7.3.3	MotS functions.....	1111
7.3.4	MotS error handling.....	1115
7.3.5	MotS messaging.....	1116
7.3.6	MotS I/Os.....	1118
7.3.7	MotS block diagram.....	1123
7.3.8	Operator control and monitoring.....	1123
7.3.8.1	MotS views.....	1123
7.3.8.2	MotS standard view.....	1124
7.3.8.3	MotS preview.....	1127
7.3.8.4	Block icon for MotS.....	1128
7.4	MotRevL - Reversible motor	1131
7.4.1	Description of MotRevL.....	1131
7.4.2	MotRevL modes.....	1135
7.4.3	MotRevL functions.....	1137
7.4.4	MotRevL error handling.....	1144

7.4.5	MotRevL messaging.....	1146
7.4.6	MotRevL I/Os.....	1148
7.4.7	MotRevL block diagram.....	1157
7.4.8	Operator control and monitoring.....	1158
7.4.8.1	MotRevL views.....	1158
7.4.8.2	MotRevL standard view.....	1159
7.4.8.3	MotRevL preview.....	1163
7.4.8.4	Block icon for MotRevL.....	1168
7.5	MotSpdCL - Controllable reversible motor.....	1171
7.5.1	Description of MotSpdCL.....	1171
7.5.2	MotSpdCL modes.....	1176
7.5.3	MotSpdCL functions.....	1177
7.5.4	MotSpdCL error handling.....	1189
7.5.5	MotSpdCL messaging.....	1192
7.5.6	MotSpdCL I/Os.....	1194
7.5.7	MotSpdCL block diagram.....	1207
7.5.8	Operator control and monitoring.....	1207
7.5.8.1	MotSpdCL views.....	1207
7.5.8.2	MotSpdCL standard view.....	1208
7.5.8.3	MotSpdCL preview.....	1214
7.5.8.4	MotSpdCL limit view for readback values.....	1217
7.5.8.5	MotSpdCL parameter view.....	1219
7.5.8.6	MotSpdCL trend view.....	1221
7.5.8.7	Block icon for MotSpdCL.....	1222
7.6	MotSpdL - Two-speed motor.....	1225
7.6.1	Description of MotSpdL.....	1225
7.6.2	MotSpdL modes.....	1229
7.6.3	MotSpdL functions.....	1230
7.6.4	MotSpdL error handling.....	1238
7.6.5	MotSpdL messaging.....	1240
7.6.6	MotSpdL I/Os.....	1241
7.6.7	MotSpdL block diagram.....	1250
7.6.8	Operator control and monitoring.....	1251
7.6.8.1	MotSpdL views.....	1251
7.6.8.2	MotSpdL standard view.....	1251
7.6.8.3	MotSpdL preview.....	1255
7.6.8.4	Block icon for MotSpdL.....	1258
7.7	ShrdResL - Multiplexer for shared resources (Large).....	1261
7.7.1	Description of ShrdResL.....	1261
7.7.2	ShrdResL modes.....	1264
7.7.3	ShrdResL functions.....	1265
7.7.4	ShrdResL error handling.....	1271
7.7.5	ShrdResL messaging.....	1271
7.7.6	ShrdResL I/Os.....	1272
7.7.7	ShrdResL block diagram.....	1277
7.7.8	Operator control and monitoring.....	1277
7.7.8.1	ShrdResL views.....	1277
7.7.8.2	ShrdResL standard view.....	1278
7.7.8.3	ShrdResL general preview.....	1280
7.7.8.4	ShrdResL preview.....	1280
7.7.8.5	ShrdResL parameter view.....	1281

7.7.8.6	Block icon for ShrdResL.....	1282
7.8	ShrdResS - Multiplexer for shared resources (Small).....	1284
7.8.1	Description for ShrdResS.....	1284
7.8.2	ShrdResS modes.....	1286
7.8.3	ShrdResS functions.....	1287
7.8.4	ShrdResS error handling.....	1290
7.8.5	ShrdResS messaging.....	1290
7.8.6	ShrdResS I/Os.....	1291
7.8.7	ShrdResS block diagram.....	1299
7.8.8	Operator control and monitoring.....	1300
7.8.8.1	ShrdResS views.....	1300
7.8.8.2	ShrdResS standard view.....	1300
7.8.8.3	ShrdResS preview.....	1302
7.8.8.4	Block icon for ShrdResS	1303
7.9	Vlv2WayL - Two-way valve	1305
7.9.1	Description of Vlv2WayL.....	1305
7.9.2	Vlv2WayL modes.....	1309
7.9.3	Vlv2WayL functions.....	1310
7.9.4	Vlv2WayL error handling.....	1318
7.9.5	Vlv2WayL messaging.....	1320
7.9.6	Vlv2WayL I/Os.....	1321
7.9.7	Vlv2WayL block diagram.....	1332
7.9.8	Operator control and monitoring.....	1332
7.9.8.1	Vlv2WayL views.....	1332
7.9.8.2	Vlv2WayL standard view.....	1333
7.9.8.3	Vlv2WayL parameter view.....	1336
7.9.8.4	Vlv2WayL preview.....	1338
7.9.8.5	Block icon for Vlv2WayL.....	1343
7.10	VlvL - Valve (Large).....	1346
7.10.1	Description of VlvL.....	1346
7.10.2	VlvL modes.....	1349
7.10.3	VlvL functions.....	1350
7.10.4	VlvL error handling.....	1356
7.10.5	VlvL messaging.....	1358
7.10.6	VlvL I/Os.....	1359
7.10.7	VlvL block diagram.....	1366
7.10.8	Operator control and monitoring.....	1367
7.10.8.1	VlvL views.....	1367
7.10.8.2	VlvL standard view.....	1367
7.10.8.3	VlvL preview.....	1371
7.10.8.4	VlvL block icon.....	1374
7.11	VlvS - Valve (small).....	1377
7.11.1	Description of VlvS.....	1377
7.11.2	VlvS modes.....	1379
7.11.3	VlvS functions.....	1381
7.11.4	VlvS error handling.....	1385
7.11.5	VlvS reporting.....	1386
7.11.6	VlvS I/Os.....	1388
7.11.7	VlvS block diagram.....	1393
7.11.8	Operator control and monitoring.....	1393

7.11.8.1	VlvS views.....	1393
7.11.8.2	VlvS standard view.....	1394
7.11.8.3	VlvS preview.....	1397
7.11.8.4	VlvS block icon.....	1399
7.12	VlvMotL - Motor valve.....	1401
7.12.1	Description of VlvMotL.....	1401
7.12.2	VlvMotL modes.....	1406
7.12.3	VlvMotL functions.....	1407
7.12.4	VlvMotL error handling.....	1418
7.12.5	VlvMotL messaging.....	1420
7.12.6	VlvMotL I/Os.....	1421
7.12.7	VlvMotL block diagram.....	1432
7.12.8	Operator control and monitoring.....	1433
7.12.8.1	VlvMotL views.....	1433
7.12.8.2	VlvMotL standard view.....	1433
7.12.8.3	VlvMotL parameter view.....	1437
7.12.8.4	VlvMotL preview.....	1440
7.12.8.5	Block icon for VlvMotL.....	1444
7.13	VlvAnL - Control valve.....	1448
7.13.1	Description of VlvAnL.....	1448
7.13.2	VlvAnL modes.....	1452
7.13.3	VlvAnL functions.....	1454
7.13.4	VlvAnL error handling.....	1467
7.13.5	VlvAnL messaging.....	1469
7.13.6	VlvAnL I/Os.....	1470
7.13.7	VlvAnL block diagram.....	1483
7.13.8	Operator control and monitoring.....	1484
7.13.8.1	VlvAnL views.....	1484
7.13.8.2	VlvAnL standard view with auxiliary valve.....	1485
7.13.8.3	VlvAnL standard view without auxiliary valve.....	1490
7.13.8.4	VlvAnL limit view.....	1494
7.13.8.5	VlvAnL preview.....	1497
7.13.8.6	VlvAnL parameter view.....	1501
7.13.8.7	Block icon for VlvAnL.....	1503
7.14	VlvPosL - Valve positioner.....	1506
7.14.1	Description of VlvPosL.....	1506
7.14.2	VlvPosL modes.....	1511
7.14.3	VlvPosL functions.....	1513
7.14.4	VlvPosL error handling.....	1528
7.14.5	VlvPosL messaging.....	1531
7.14.6	VlvPosL I/Os.....	1533
7.14.7	VlvPosL block diagram.....	1546
7.14.8	Operator control and monitoring.....	1547
7.14.8.1	VlvPosL views.....	1547
7.14.8.2	VlvPosL standard view.....	1548
7.14.8.3	VlvPosL limit view.....	1553
7.14.8.4	VlvPosL parameter view.....	1555
7.14.8.5	VlvPosL preview.....	1559
7.14.8.6	Block icon for VlvPosL.....	1564

8	Interlock blocks.....	1567
8.1	Intlk02 - Interlock display with 2 input signals.....	1567
8.1.1	Description of Intlk02.....	1567
8.1.2	Intlk02 modes.....	1570
8.1.3	Intlk02 functions.....	1570
8.1.4	Intlk02 error handling.....	1573
8.1.5	Intlk02 messaging.....	1574
8.1.6	Intlk02 I/Os.....	1574
8.1.7	Intlk02 block diagram.....	1578
8.1.8	Operator control and monitoring.....	1578
8.1.8.1	Interlock block views.....	1578
8.2	Intlk04 - Interlock display with 4 input signals.....	1579
8.2.1	Description of Intlk04.....	1579
8.2.2	Intlk04 modes.....	1582
8.2.3	Intlk04 functions.....	1582
8.2.4	Intlk04 error handling.....	1586
8.2.5	Intlk04 messaging.....	1587
8.2.6	Intlk04 I/Os.....	1587
8.2.7	Intlk04 block diagram.....	1591
8.2.8	Operator control and monitoring.....	1591
8.2.8.1	Interlock block views.....	1591
8.3	Intlk08 - Interlock display with 8 input signals.....	1592
8.3.1	Description of Intlk08.....	1592
8.3.2	Intlk08 modes.....	1595
8.3.3	Intlk08 functions.....	1596
8.3.4	Intlk08 error handling.....	1600
8.3.5	Intlk08 messaging.....	1601
8.3.6	Intlk08 I/Os.....	1601
8.3.7	Intlk08 block diagram.....	1606
8.3.8	Operator control and monitoring.....	1606
8.3.8.1	Interlock block views.....	1606
8.4	Intlk16 - Interlock display with 16 input signals.....	1607
8.4.1	Description of Intlk16.....	1607
8.4.2	Intlk16 modes.....	1612
8.4.3	Intlk16 functions.....	1612
8.4.4	Intlk16 error handling.....	1616
8.4.5	Intlk16 messaging.....	1617
8.4.6	Intlk16 I/Os.....	1617
8.4.7	Intlk16 block diagram.....	1625
8.4.8	Operator control and monitoring.....	1625
8.4.8.1	Interlock block views.....	1625
8.5	FirstIn - Transform output Intlck FirstIn for message associated value.....	1626
8.5.1	Description of FirstIn.....	1626
8.5.2	FirstIn modes.....	1627
8.5.3	FirstIn functions.....	1628
8.5.4	FirstIn error handling.....	1628
8.5.5	FirstIn messaging.....	1629
8.5.6	FirstIn I/Os.....	1629
8.5.7	FirstIn block diagram.....	1630

9	Message blocks.....	1631
9.1	Event - Creating messages.....	1631
9.1.1	Description of Event.....	1631
9.1.2	Event modes.....	1634
9.1.3	Event functions.....	1634
9.1.4	Event error handling.....	1636
9.1.5	Event messaging.....	1637
9.1.6	Event I/Os.....	1639
9.1.7	Event block diagram.....	1643
9.2	EventNck - Generating messages without acknowledgment.....	1644
9.2.1	Description of EventNck.....	1644
9.2.2	EventNck modes.....	1646
9.2.3	EventNck functions.....	1647
9.2.4	EventNck error handling.....	1649
9.2.5	EventNck messaging.....	1650
9.2.6	EventNck I/Os.....	1651
9.2.7	EventNck block diagram.....	1655
9.3	EventTs - Creating messages with time stamp.....	1656
9.3.1	Description of EventTs.....	1656
9.3.2	EventTs modes.....	1659
9.3.3	EventTs functions.....	1660
9.3.4	EventTs error handling.....	1662
9.3.5	EventTs messaging.....	1663
9.3.6	EventTs I/Os.....	1666
9.3.7	EventTs block diagram.....	1670
9.4	Event16Ts - Creating 16 messages with time stamp.....	1671
9.4.1	Description of Event16Ts.....	1671
9.4.2	Event16Ts operating modes.....	1676
9.4.3	Event16Ts functions.....	1676
9.4.4	Event16Ts error handling.....	1679
9.4.5	Event16Ts messages.....	1679
9.4.6	Event16Ts I/Os.....	1685
9.4.7	Event16Ts block diagram.....	1687
10	Counter blocks.....	1689
10.1	CountScL - Counter with up and down counting direction.....	1689
10.1.1	Description of CountScL.....	1689
10.1.2	CountScL modes.....	1693
10.1.3	CountScL functions.....	1694
10.1.4	CountScL error handling.....	1697
10.1.5	CountScL messaging.....	1698
10.1.6	CountScL I/Os.....	1699
10.1.7	CountScL block diagram.....	1702
10.1.8	Operator control and monitoring.....	1703
10.1.8.1	CountScL views.....	1703
10.1.8.2	CountScL standard view.....	1704
10.1.8.3	CountScL limit view.....	1706
10.1.8.4	CountScL parameter view.....	1707
10.1.8.5	CountScL preview.....	1708
10.1.8.6	Block icon for CountScL.....	1709

10.2	CountOh - Determining runtime.....	1711
10.2.1	Description of CountOh.....	1711
10.2.2	CountOh modes.....	1715
10.2.3	CountOh functions.....	1715
10.2.4	CountOh error handling.....	1720
10.2.5	CountOh messaging	1720
10.2.6	CountOh I/Os.....	1722
10.2.7	CountOh block diagram.....	1726
10.2.8	Operator control and monitoring.....	1727
10.2.8.1	CountOh views.....	1727
10.2.8.2	CountOh standard view.....	1728
10.2.8.3	CountOh limit view.....	1730
10.2.8.4	CountOh parameter view.....	1731
10.2.8.5	CountOh preview.....	1732
10.2.8.6	Block icon for CountOh.....	1733
10.3	TotalL - Additive counter with upward or downward counting direction (totalizer).....	1735
10.3.1	Description of TotalL.....	1735
10.3.2	TotalL operating modes.....	1744
10.3.3	TotalL functions.....	1745
10.3.4	TotalL error handling.....	1749
10.3.5	TotalL messaging.....	1750
10.3.6	TotalL I/Os.....	1752
10.3.7	TotalL block diagram.....	1757
10.3.8	Operator control and monitoring.....	1758
10.3.8.1	TotalL views.....	1758
10.3.8.2	TotalL standard view.....	1758
10.3.8.3	TotalL limit view.....	1761
10.3.8.4	TotalL parameter view.....	1763
10.3.8.5	TotalL preview.....	1765
10.3.8.6	TotalL block icon.....	1766
10.4	CntOhSc - Runtime determination and counters with counting direction "up".....	1768
10.4.1	Description of CntOhSc.....	1768
10.4.2	CntOhSc operating modes.....	1770
10.4.3	CntOhSc functions.....	1770
10.4.4	CntOhSc error handling.....	1772
10.4.5	CntOhSc messaging.....	1773
10.4.6	CntOhSc I/Os.....	1773
10.4.7	CntOhSc block diagram.....	1776
10.4.8	Operator control and monitoring.....	1776
10.4.8.1	CntOhSc views.....	1776
10.4.8.2	CntOhSc standard view.....	1777
10.4.8.3	CntOhSc limit view.....	1779
10.4.8.4	CntOhSc preview.....	1780
10.4.8.5	Block icon for CntOhSc.....	1781
11	Timers.....	1783
11.1	TimerP - Time delays signal forwarding / pulse generator.....	1783
11.1.1	Description of TimerP.....	1783
11.1.2	TimerP modes.....	1784
11.1.3	TimerP functions.....	1784
11.1.4	TimerP error handling.....	1787

11.1.5	TimerP messaging.....	1788
11.1.6	TimerP I/Os.....	1788
11.1.7	TimerP block diagram.....	1790
11.2	TimeTrig - Calculations with the date formats DT and TIME	1791
11.2.1	Description of TimeTrig.....	1791
11.2.2	TimeTrig modes.....	1793
11.2.3	TimeTrig functions.....	1793
11.2.4	TimeTrig error handling.....	1797
11.2.5	TimeTrig messaging.....	1798
11.2.6	TimeTrig I/Os.....	1798
11.2.7	TimeTrig block diagram.....	1802
11.2.8	Operator control and monitoring.....	1802
11.2.8.1	TimeTrig views.....	1802
11.2.8.2	TimeTrig standard view.....	1803
11.2.8.3	TimeTrig parameter view.....	1805
11.2.8.4	TimeTrig preview.....	1807
11.2.8.5	Block icon for TimeTrig.....	1808
12	Mathematical blocks.....	1811
12.1	AbsR - Absolute value of a real value.....	1811
12.1.1	Description of AbsR.....	1811
12.1.2	AbsR modes.....	1812
12.1.3	AbsR functions.....	1812
12.1.4	AbsR error handling.....	1812
12.1.5	AbsR messaging.....	1812
12.1.6	AbsR I/Os.....	1812
12.1.7	AbsR block diagram.....	1813
12.2	Add04 - Adder with 4 values.....	1814
12.2.1	Description of Add04.....	1814
12.2.2	Add04 modes.....	1815
12.2.3	Add04 functions.....	1815
12.2.4	Add04 error handling.....	1816
12.2.5	Add04 messaging.....	1816
12.2.6	Add04 I/Os.....	1817
12.2.7	Add04 block diagram.....	1818
12.3	Add08 - Adder with 8 values.....	1819
12.3.1	Description of Add08.....	1819
12.3.2	Add08 modes.....	1820
12.3.3	Add08 functions.....	1820
12.3.4	Add08 error handling.....	1821
12.3.5	Add08 messaging.....	1821
12.3.6	Add08 I/Os.....	1822
12.3.7	Add08 block diagram.....	1823
12.4	Average - Mean value calculation.....	1824
12.4.1	Description of Average.....	1824
12.4.2	Average modes.....	1825
12.4.3	Average functions.....	1826
12.4.4	Average error handling.....	1826
12.4.5	Average messaging.....	1827
12.4.6	Average I/Os.....	1828

12.4.7	Average block diagram.....	1829
12.5	DeadTime - Delayed signal output.....	1830
12.5.1	Description of DeadTime.....	1830
12.5.2	DeadTime modes.....	1832
12.5.3	DeadTime functions.....	1832
12.5.4	DeadTime error handling.....	1833
12.5.5	DeadTime messaging.....	1834
12.5.6	DeadTime I/Os.....	1835
12.5.7	DeadTime block diagram.....	1836
12.6	Derivative - Obtaining a derivative.....	1837
12.6.1	Description of Derivative.....	1837
12.6.2	Derivative modes.....	1839
12.6.3	Derivative functions.....	1840
12.6.4	Derivative error handling.....	1841
12.6.5	Derivative messaging.....	1841
12.6.6	Derivative I/Os.....	1842
12.6.7	Derivative block diagram.....	1843
12.7	Div02 - Division of two values.....	1844
12.7.1	Description of Div02.....	1844
12.7.2	Div02 modes.....	1845
12.7.3	Div02 functions.....	1845
12.7.4	Div02 error handling.....	1846
12.7.5	Div02 messaging.....	1847
12.7.6	Div02 I/Os.....	1847
12.7.7	Div02 block diagram.....	1848
12.8	FlowCorr - Flow correction.....	1849
12.8.1	Description of FlowCorr.....	1849
12.8.2	FlowCorr modes.....	1851
12.8.3	FlowCorr functions.....	1852
12.8.4	FlowCorr error handling.....	1853
12.8.5	FlowCorr messaging.....	1854
12.8.6	FlowCorr I/Os.....	1854
12.8.7	FlowCorr block diagram.....	1856
12.9	Integral - Generating a time integral.....	1857
12.9.1	Description of Integral.....	1857
12.9.2	Integral modes.....	1858
12.9.3	Integral functions.....	1859
12.9.4	Integral error handling.....	1861
12.9.5	Integral messaging.....	1862
12.9.6	Integral I/Os.....	1862
12.9.7	Integral block diagram.....	1863
12.10	Lag - Low-pass filter.....	1865
12.10.1	Description of Lag.....	1865
12.10.2	Lag modes.....	1867
12.10.3	Lag functions.....	1867
12.10.4	Lag error handling.....	1868
12.10.5	Lag messaging.....	1869
12.10.6	Lag I/Os.....	1870
12.10.7	Lag block diagram.....	1871

12.11	MeanTime - Averaging.....	1872
12.11.1	Description of MeanTime.....	1872
12.11.2	MeanTime modes.....	1873
12.11.3	MeanTime functions.....	1873
12.11.4	MeanTime error handling.....	1876
12.11.5	MeanTime messaging.....	1876
12.11.6	MeanTime I/Os.....	1877
12.11.7	MeanTime block diagram.....	1878
12.12	Mul04 - Multiplier with 4 values.....	1879
12.12.1	Description of Mul04.....	1879
12.12.2	Mul04 modes.....	1881
12.12.3	Mul04 functions.....	1881
12.12.4	Mul04 error handling.....	1882
12.12.5	Mul04 messaging.....	1882
12.12.6	Mul04 I/Os.....	1883
12.12.7	Mul04 block diagram.....	1884
12.13	Mul08 - Multiplier with 8 values.....	1885
12.13.1	Description of Mul08.....	1885
12.13.2	Mul08 modes.....	1886
12.13.3	Mul08 functions.....	1886
12.13.4	Mul08 error handling.....	1887
12.13.5	Mul08 messaging.....	1888
12.13.6	Mul08 I/Os.....	1888
12.13.7	Mul08 block diagram.....	1889
12.14	Polygon - Converting the first signal (non-linear)	1891
12.14.1	Description of Polygon.....	1891
12.14.2	Polygon modes.....	1894
12.14.3	Polygon functions.....	1894
12.14.4	Polygon error handling.....	1895
12.14.5	Polygon messaging.....	1896
12.14.6	Polygon I/Os.....	1897
12.14.7	Polygon block diagram.....	1900
12.15	Smooth - Low pass filter.....	1901
12.15.1	Description of Smooth	1901
12.15.2	Smooth modes.....	1902
12.15.3	Smooth functions.....	1902
12.15.4	Smooth error handling.....	1903
12.15.5	Smooth messaging.....	1904
12.15.6	Smooth I/Os.....	1905
12.15.7	Smooth block diagram.....	1906
12.16	SqrRoot - Derive the root of a value.....	1907
12.16.1	Description of SqrRoot.....	1907
12.16.2	SqrRoot modes.....	1908
12.16.3	SqrRoot functions.....	1908
12.16.4	SqrRoot error handling.....	1909
12.16.5	SqrRoot messaging.....	1909
12.16.6	SqrRoot I/Os.....	1910
12.16.7	SqrRoot block diagram.....	1911
12.17	Sub02 - Subtracting two values.....	1912

12.17.1	Description of Sub02.....	1912
12.17.2	Sub02 modes.....	1913
12.17.3	Sub02 functions.....	1913
12.17.4	Sub02 error handling.....	1914
12.17.5	Sub02 messaging.....	1914
12.17.6	Sub02 I/Os.....	1915
12.17.7	Sub02 block diagram.....	1916
13	Analog logic blocks.....	1917
13.1	CompAn02 - Comparison of two analog values.....	1917
13.1.1	Description of CompAn02.....	1917
13.1.2	CompAn02 modes.....	1918
13.1.3	CompAn02 functions.....	1918
13.1.4	CompAn02 error handling.....	1919
13.1.5	CompAn02 messaging.....	1920
13.1.6	CompAn02 I/Os.....	1920
13.1.7	CompAn02 block diagram.....	1921
13.2	Limit - Limiting an analog value.....	1922
13.2.1	Description of Limit.....	1922
13.2.2	Limit modes.....	1924
13.2.3	Limit functions.....	1924
13.2.4	Limit error handling.....	1925
13.2.5	Limit messaging.....	1926
13.2.6	Limit I/Os.....	1926
13.2.7	Limit block diagram.....	1927
13.3	MuxAn03 - Selection of an analog value to increase availability / safety.....	1928
13.3.1	Description of MuxAn03.....	1928
13.3.2	MuxAn03 modes.....	1929
13.3.3	MuxAn03 functions.....	1929
13.3.4	MuxAn03 error handling.....	1932
13.3.5	MuxAn03 messaging.....	1933
13.3.6	MuxAn03 I/Os.....	1933
13.3.7	MuxAn03 block diagram.....	1935
13.4	MuxAn08 - Selection of an analog value to increase availability / safety.....	1936
13.4.1	Description of MuxAn08.....	1936
13.4.2	MuxAn08 modes.....	1936
13.4.3	MuxAn08 functions.....	1937
13.4.4	MuxAn08 error handling.....	1939
13.4.5	MuxAn08 messaging.....	1939
13.4.6	MuxAn08 I/Os.....	1939
13.4.7	MuxAn08 block diagram.....	1941
13.5	RateLim - Signal ramp.....	1942
13.5.1	Description of RateLim.....	1942
13.5.2	RateLim modes.....	1943
13.5.3	RateLim functions.....	1943
13.5.4	RateLim error handling.....	1946
13.5.5	RateLim messaging.....	1946
13.5.6	RateLim I/Os.....	1947
13.5.7	RateLim block diagram.....	1949
13.6	RedAn02 - 1 out of 2 selection for redundant analog values.....	1950

13.6.1	Description of RedAn02.....	1950
13.6.2	RedAn02 modes.....	1951
13.6.3	RedAn02 functions.....	1951
13.6.4	RedAn02 error handling.....	1952
13.6.5	RedAn02 messaging.....	1952
13.6.6	RedAn02 I/Os.....	1953
13.6.7	RedAn02 block diagram.....	1954
13.7	SelA02In - Output of two analog values.....	1955
13.7.1	Description of SelA02In.....	1955
13.7.2	SelA02In modes.....	1956
13.7.3	SelA02In functions.....	1956
13.7.4	SelA02In error handling.....	1957
13.7.5	SelA02In messaging.....	1958
13.7.6	SelA02In I/Os.....	1958
13.7.7	SelA02In block diagram.....	1959
13.8	SelA16In - Output of 16 analog values.....	1960
13.8.1	Description of SelA16In.....	1960
13.8.2	SelA16In modes.....	1961
13.8.3	SelA16In functions.....	1962
13.8.4	SelA16In error handling.....	1965
13.8.5	SelA16In messaging.....	1965
13.8.6	SelA16In I/Os.....	1966
13.8.7	SelA16In block diagram.....	1970
13.8.8	Operator control and monitoring.....	1970
13.8.8.1	SelA16In views.....	1970
13.8.8.2	SelA16In standard view.....	1971
13.8.8.3	SelA16In preview.....	1973
13.8.8.4	Block icon for SelA16In.....	1974
14	Digital logic blocks.....	1977
14.1	And04 - Forming an AND signal from 4 binary input signals.....	1977
14.1.1	Description of And04.....	1977
14.1.2	And04 modes.....	1978
14.1.3	And04 functions.....	1978
14.1.4	And04 error handling.....	1979
14.1.5	And04 messaging.....	1979
14.1.6	And04 I/Os.....	1980
14.1.7	And04 block diagram.....	1981
14.2	And08 - Forming an AND signal from 8 binary input signals.....	1982
14.2.1	Description of And08.....	1982
14.2.2	And08 modes.....	1983
14.2.3	And08 functions.....	1983
14.2.4	And08 error handling.....	1983
14.2.5	And08 messaging.....	1984
14.2.6	And08 I/Os.....	1984
14.2.7	And08 block diagram.....	1986
14.3	FlipFlop - preparation of a bistable flip-flop.....	1987
14.3.1	Description of FlipFlop.....	1987
14.3.2	FlipFlop modes.....	1988
14.3.3	FlipFlop functions.....	1989

14.3.4	FlipFlop error handling.....	1990
14.3.5	FlipFlop messaging.....	1991
14.3.6	FlipFlop I/Os.....	1991
14.3.7	FlipFlop block diagram.....	1992
14.4	Or04 - Forming an OR signal from 4 binary input signals.....	1993
14.4.1	Description of Or04.....	1993
14.4.2	Or04 modes.....	1994
14.4.3	Or04 functions.....	1995
14.4.4	Or04 error handling.....	1995
14.4.5	Or04 messaging.....	1996
14.4.6	Or04 I/Os.....	1996
14.4.7	Or04 block diagram.....	1997
14.5	Or08 - Forming an OR signal from 8 binary input signals.....	1998
14.5.1	Description of Or08.....	1998
14.5.2	Or08 modes.....	1999
14.5.3	Or08 functions.....	1999
14.5.4	Or08 error handling.....	2000
14.5.5	Or08 messaging.....	2000
14.5.6	Or08 I/Os.....	2001
14.5.7	Or08 block diagram.....	2002
14.6	Not01 - Inversion of an input signal.....	2003
14.6.1	Description of Not01.....	2003
14.6.2	Not01 modes.....	2004
14.6.3	Not01 functions.....	2004
14.6.4	Not01 error handling.....	2004
14.6.5	Not01 messaging.....	2005
14.6.6	Not01 I/Os.....	2005
14.6.7	Not01 block diagram.....	2006
14.7	RedDi02 - 1 out of 2 selection for redundant digital values.....	2007
14.7.1	Description of RedDi02.....	2007
14.7.2	RedDi02 modes.....	2008
14.7.3	RedDi02 functions.....	2008
14.7.4	RedDi02 error handling.....	2009
14.7.5	RedDi02 messaging.....	2009
14.7.6	RedDi02 I/Os.....	2010
14.7.7	RedDi02 block diagram.....	2011
14.8	SelD02In - Output of one of two digital signals.....	2012
14.8.1	Description of SelD02In.....	2012
14.8.2	SelD02In modes.....	2013
14.8.3	SelD02In functions.....	2013
14.8.4	SelD02In error handling.....	2014
14.8.5	SelD02In messaging.....	2014
14.8.6	SelD02In I/Os.....	2015
14.8.7	SelD02In block diagram.....	2016
14.9	StrctCom - Structure composer for 32-bit structures.....	2017
14.9.1	Description of StrctCom.....	2017
14.9.2	StrctCom modes.....	2018
14.9.3	StrctCom functions.....	2018
14.9.4	StrctCom error handling.....	2019

14.9.5	StrctCom messaging.....	2019
14.9.6	StrctCom I/Os.....	2019
14.9.7	StrctCom block diagram.....	2020
14.10	StrctDeC - Structure decomposer for 32-bit structures.....	2022
14.10.1	Description of StrctDeC.....	2022
14.10.2	StrctDeC modes.....	2023
14.10.3	StrctDeC functions.....	2023
14.10.4	StrctDeC error handling.....	2024
14.10.5	StrctDeC messaging.....	2024
14.10.6	StrctDeC I/Os.....	2024
14.10.7	StrctDeC block diagram.....	2025
14.11	Trigger - Detection of rising and falling edges.....	2027
14.11.1	Description of Trigger.....	2027
14.11.2	Trigger modes.....	2028
14.11.3	Trigger functions.....	2029
14.11.4	Trigger error handling.....	2029
14.11.5	Trigger messaging.....	2030
14.11.6	Trigger I/Os.....	2030
14.11.7	Trigger block diagram.....	2031
14.12	XOr04 - EXCLUSIVE OR logic operation.....	2032
14.12.1	Description of XOr04.....	2032
14.12.2	XOr04 modes.....	2033
14.12.3	XOr04 functions.....	2033
14.12.4	XOr04 error handling.....	2034
14.12.5	XOr04 messaging.....	2034
14.12.6	XOr04 I/Os.....	2035
14.12.7	XOr04 block diagram.....	2036
15	Generator blocks.....	2037
15.1	NoiseGen - Generating signal noise.....	2037
15.1.1	Description of NoiseGen.....	2037
15.1.2	NoiseGen I/Os.....	2038
16	Channel blocks.....	2039
16.1	Information on using channel blocks.....	2039
16.2	FbAnIn - Analog input channel block for field devices.....	2041
16.2.1	Description of FbAnIn.....	2041
16.2.2	FbAnIn modes.....	2043
16.2.3	FbAnIn functions.....	2043
16.2.4	FbAnIn error handling.....	2045
16.2.5	FbAnIn messaging.....	2046
16.2.6	FbAnIn I/Os.....	2047
16.2.7	FbAnIn block diagram.....	2049
16.3	FbAnOu - Analog output channel block for field devices.....	2050
16.3.1	Description of FbAnOu.....	2050
16.3.2	FbAnOu modes.....	2052
16.3.3	FbAnOu functions.....	2052
16.3.4	FbAnOu error handling.....	2054
16.3.5	FbAnOu messaging.....	2054
16.3.6	FbAnOu I/Os.....	2055

16.3.7	FbAnOu block diagram.....	2059
16.4	FbDiIn - Digital input channel block for field devices.....	2060
16.4.1	Description of FbDiIn.....	2060
16.4.2	FbDiIn modes.....	2061
16.4.3	FbDiIn functions.....	2062
16.4.4	FbDiIn error handling.....	2064
16.4.5	FbDiIn messaging.....	2064
16.4.6	FbDiIn I/Os.....	2065
16.4.7	FbDiIn block diagram.....	2068
16.5	FbDiOu - Digital output channel block for field devices.....	2069
16.5.1	Description of FbDiOu.....	2069
16.5.2	FbDiOu modes.....	2071
16.5.3	FbDiOu functions.....	2071
16.5.4	FbDiOu error handling.....	2072
16.5.5	FbDiOu messaging.....	2073
16.5.6	FbDiOu I/Os.....	2074
16.5.7	FbDiOu block diagram.....	2078
16.6	FbDrive - Channel block for compact drives.....	2079
16.6.1	Description of FbDrive.....	2079
16.6.2	FbDrive modes.....	2080
16.6.3	FbDrive functions.....	2080
16.6.4	FbDrive error handling.....	2082
16.6.5	FbDrive messaging.....	2082
16.6.6	FbDrive status word.....	2082
16.6.7	FbDrive I/Os.....	2083
16.6.8	FbDrive block diagram.....	2089
16.7	FbEnMe - Channel block for ET 200SP Energy Meter.....	2090
16.7.1	Description of FbEnMe.....	2090
16.7.2	FbEnMe modes.....	2091
16.7.3	FbEnMe functions.....	2091
16.7.4	FbEnMe error handling.....	2093
16.7.5	FbEnMe messaging.....	2093
16.7.6	FbEnMe I/Os.....	2094
16.7.7	FbEnMe block diagram.....	2100
16.8	FbSwtMMS - Channel block for MM starter.....	2101
16.8.1	Description of FbSwtMMS.....	2101
16.8.2	FbSwtMMS modes.....	2102
16.8.3	FbSwtMMS functions.....	2102
16.8.4	FbSwtMMS error handling.....	2103
16.8.5	FbSwtMMS messaging.....	2104
16.8.6	FbSwtMMS status word.....	2104
16.8.7	FbSwtMMS I/Os.....	2105
16.8.8	FbSwtMMS block diagram.....	2109
16.9	Pcs7AnIn - Analog input channel block.....	2110
16.9.1	Description of Pcs7AnIn.....	2110
16.9.2	Pcs7AnIn modes.....	2112
16.9.3	Pcs7AnIn functions.....	2113
16.9.4	Pcs7AnIn error handling.....	2117
16.9.5	Pcs7AnIn messaging.....	2118

16.9.6	Pcs7AnIn I/Os.....	2118
16.9.7	Pcs7AnIn block diagram.....	2121
16.10	Pcs7AnOu - Analog output channel block.....	2122
16.10.1	Description of Pcs7AnOu.....	2122
16.10.2	Pcs7AnOu modes.....	2125
16.10.3	Pcs7AnOu functions.....	2125
16.10.4	Pcs7AnOu error handling.....	2127
16.10.5	Pcs7AnOu messaging.....	2128
16.10.6	Pcs7AnOu I/Os.....	2128
16.10.7	Pcs7AnOu block diagram.....	2131
16.11	FbAnTot - Analog totalizer channel block for field devices.....	2132
16.11.1	Description of FbAnTot.....	2132
16.11.2	FbAnTot modes.....	2133
16.11.3	FbAnTot functions.....	2133
16.11.4	FbAnTot error handling.....	2135
16.11.5	FbAnTot messaging.....	2135
16.11.6	FbAnTot I/Os.....	2135
16.11.7	FbAnTot block diagram.....	2138
16.12	Pcs7DiIn - Digital input channel block.....	2139
16.12.1	Description of Pcs7DiIn.....	2139
16.12.2	Pcs7DiIn modes.....	2141
16.12.3	Pcs7DiIn functions.....	2142
16.12.4	Pcs7DiIn error handling.....	2143
16.12.5	Pcs7DiIn messaging.....	2144
16.12.6	Pcs7DiIn I/Os.....	2144
16.12.7	Pcs7DiIn block diagram.....	2146
16.13	Pcs7DiIT - Digital input channel block with time stamp.....	2147
16.13.1	Description of Pcs7DiIT.....	2147
16.13.2	Pcs7DiIT modes.....	2149
16.13.3	Pcs7DiIT functions.....	2149
16.13.4	Pcs7DiIT error handling.....	2151
16.13.5	Pcs7DiIT messaging.....	2152
16.13.6	Pcs7DiIT I/Os.....	2152
16.13.7	Pcs7DiIT block diagram.....	2155
16.14	Pcs7DiOu - Digital output channel block.....	2156
16.14.1	Description of Pcs7DiOu.....	2156
16.14.2	Pcs7DiOu modes.....	2158
16.14.3	Pcs7DiOu functions.....	2158
16.14.4	Pcs7DiOu error handling.....	2159
16.14.5	Pcs7DiOu messaging.....	2160
16.14.6	Pcs7DiOu I/Os.....	2160
16.14.7	Pcs7DiOu block diagram.....	2162
16.15	Pcs7Cnt1 - Controlling and reading FM 350 modules.....	2164
16.15.1	Description of Pcs7Cnt1.....	2164
16.15.2	Pcs7Cnt1 modes.....	2166
16.15.3	Pcs7Cnt1 functions.....	2166
16.15.4	Pcs7Cnt1 error handling.....	2168
16.15.5	Pcs7Cnt1 messaging.....	2169
16.15.6	Pcs7Cnt1 I/Os.....	2169

16.15.7	Pcs7Cnt1 block diagram.....	2173
16.16	Pcs7Cnt2 - Control and read an 8-DI_NAMUR module of the ET 200iSP.....	2174
16.16.1	Description of Pcs7Cnt2.....	2174
16.16.2	Pcs7Cnt2 modes.....	2177
16.16.3	Pcs7Cnt2 functions.....	2177
16.16.4	Pcs7Cnt2 error handling.....	2179
16.16.5	Pcs7Cnt2 messaging.....	2180
16.16.6	Pcs7Cnt2 I/Os.....	2180
16.16.7	Pcs7Cnt2 block diagram.....	2182
16.17	Pcs7Cnt3 - Control and read the 1 COUNT 24V/100kHz module for count mode.....	2183
16.17.1	Description of Pcs7Cnt3.....	2183
16.17.2	Pcs7Cnt3 modes.....	2185
16.17.3	Pcs7Cnt3 functions.....	2185
16.17.4	Pcs7Cnt3 error handling.....	2186
16.17.5	Pcs7Cnt3 messaging.....	2187
16.17.6	Pcs7Cnt3 I/Os.....	2187
16.17.7	Pcs7Cnt3 block diagram.....	2191
16.18	Pcs7HaAI - HART variable channel block for AI-HART modules.....	2192
16.18.1	Description of Pcs7HaAI.....	2192
16.18.2	Pcs7HaAI modes.....	2193
16.18.3	Pcs7HaAI functions.....	2193
16.18.4	Pcs7HaAI error handling.....	2194
16.18.5	Pcs7HaAI messaging.....	2194
16.18.6	Pcs7HaAI I/Os.....	2195
16.18.7	Pcs7HaAI block diagram.....	2197
16.19	Pcs7HaAO - HART variable channel block for AO-HART modules.....	2199
16.19.1	Description of Pcs7HaAO.....	2199
16.19.2	Pcs7HaAO modes.....	2200
16.19.3	Pcs7HaAO functions.....	2200
16.19.4	Pcs7HaAO error handling.....	2201
16.19.5	Pcs7HaAO messaging.....	2201
16.19.6	Pcs7HaAO I/Os.....	2202
16.19.7	Pcs7HaAO block diagram.....	2204
16.20	Annex for channel blocks.....	2206
16.20.1	Mode Settings for SM Modules.....	2206
16.20.2	Mode settings for field devices.....	2217
17	Conversion blocks.....	2219
17.1	StrgToBy - String in byte structure (Struct of Byte).....	2219
17.1.1	Description of StrgToBy.....	2219
17.1.2	StrgToBy modes.....	2220
17.1.3	StrgToBy functions.....	2220
17.1.4	StrgToBy error handling.....	2221
17.1.5	StrgToBy messaging.....	2221
17.1.6	StrgToBy I/Os.....	2221
17.1.7	StrgToBy block diagram.....	2222
17.2	StruAnIn - Separating an analog structured variable.....	2223
17.2.1	Description of StruAnIn.....	2223
17.2.2	StruAnIn modes.....	2224

17.2.3	StruAnIn functions.....	2224
17.2.4	StruAnIn error handling.....	2224
17.2.5	StruAnIn messaging.....	2225
17.2.6	StruAnIn I/Os.....	2225
17.2.7	StruAnIn block diagram.....	2226
17.3	StruAnOu - Creating an analog structured variable.....	2227
17.3.1	Description of StruAnOu.....	2227
17.3.2	StruAnOu modes.....	2228
17.3.3	StruAnOu functions.....	2228
17.3.4	StruAnOu error handling.....	2228
17.3.5	StruAnOu messaging.....	2229
17.3.6	StruAnOu I/Os.....	2229
17.3.7	StruAnOu block diagram.....	2230
17.4	StruDIn - Separating a digital structured variable.....	2231
17.4.1	Description of StruDIn.....	2231
17.4.2	StruDIn modes.....	2232
17.4.3	StruDIn functions.....	2232
17.4.4	StruDIn error handling.....	2232
17.4.5	StruDIn messaging.....	2233
17.4.6	StruDIn I/Os.....	2233
17.4.7	StruDIn block diagram.....	2234
17.5	StruDIOu - Creating a digital structured variable.....	2235
17.5.1	Description of StruDIOu.....	2235
17.5.2	StruDIOu modes.....	2236
17.5.3	StruDIOu functions.....	2236
17.5.4	StruDIOu error handling.....	2236
17.5.5	StruDIOu messaging.....	2237
17.5.6	StruDIOu I/Os.....	2237
17.5.7	StruDIOu block diagram.....	2238
17.6	StruScIn - Separating a display area into two variables.....	2239
17.6.1	Description of StruScIn.....	2239
17.6.2	StruScIn modes.....	2240
17.6.3	StruScIn functions.....	2240
17.6.4	StruScIn error handling.....	2240
17.6.5	StruScIn messaging.....	2241
17.6.6	StruScIn I/Os.....	2241
17.6.7	StruScIn block diagram.....	2242
17.7	StruScOu - Merging two variables into a display area.....	2243
17.7.1	Description of StruScOu.....	2243
17.7.2	StruScOu modes.....	2244
17.7.3	StruScOu functions.....	2244
17.7.4	StruScOu error handling.....	2244
17.7.5	StruScOu messaging.....	2245
17.7.6	StruScOu I/Os.....	2245
17.7.7	StruScOu block diagram.....	2246
17.8	STIn - Separating the signal status into individual binary displays.....	2247
17.8.1	Description of STIn.....	2247
17.8.2	STIn modes.....	2248
17.8.3	STIn functions.....	2248

17.8.4	STIn error handling.....	2248
17.8.5	STIn messaging.....	2249
17.8.6	STIn I/Os.....	2249
17.8.7	STIn block diagram.....	2250
17.9	STOu - Merging individual binary signals into a signal status.....	2251
17.9.1	Description of STOu.....	2251
17.9.2	STOu modes.....	2252
17.9.3	STOu functions.....	2252
17.9.4	STOu error handling.....	2252
17.9.5	STOu messaging.....	2253
17.9.6	STOu I/Os.....	2253
17.9.7	STOu block diagram.....	2254
17.10	MSTIn - Separating the maintenance status into individual status displays.....	2255
17.10.1	Description of MSTIn.....	2255
17.10.2	MSTIn modes.....	2256
17.10.3	MSTIn functions.....	2256
17.10.4	MSTIn error handling.....	2256
17.10.5	MSTIn messaging.....	2257
17.10.6	MSTIn I/Os.....	2257
17.10.7	MSTIn block diagram.....	2258
17.11	MSTOu - Merging individual status displays into a maintenance status.....	2259
17.11.1	Description of MSTOu.....	2259
17.11.2	MSTOu modes.....	2260
17.11.3	MSTOu functions.....	2260
17.11.4	MSTOu error handling.....	2260
17.11.5	MSTOu messaging.....	2261
17.11.6	MSTOu I/Os.....	2261
17.11.7	MSTOu block diagram.....	2262
17.12	RealToDw - Converting REAL to DWORD.....	2263
17.12.1	Description of RealToDw.....	2263
17.12.2	RealToDw modes.....	2264
17.12.3	RealToDw functions.....	2264
17.12.4	RealToDw error handling.....	2264
17.12.5	RealToDw messaging.....	2264
17.12.6	RealToDw I/Os.....	2265
17.12.7	RealToDw block diagram.....	2265
17.13	StateMap - Conversion of other signal states into APL signal states	2266
17.13.1	Description of StateMap.....	2266
17.13.2	StateMap modes.....	2267
17.13.3	StateMap functions.....	2267
17.13.4	StateMap error handling.....	2267
17.13.5	StateMap messaging.....	2267
17.13.6	StateMap I/Os.....	2267
17.13.7	StateMap block diagram.....	2268
18	Maintenance blocks.....	2269
18.1	MuxMST - Determination of the worst maintenance status.....	2269
18.1.1	Description of MuxMST.....	2269
18.1.2	MuxMST modes.....	2270
18.1.3	MuxMST functions.....	2270

18.1.4	MuxMST error handling	2271
18.1.5	MuxMST messaging.....	2271
18.1.6	MuxMST I/Os.....	2272
18.1.7	MuxMST block diagram.....	2272
18.2	MuxST- Determination of the worst signal status.....	2274
18.2.1	Description of MuxST.....	2274
18.2.2	MuxST modes.....	2275
18.2.3	MuxST functions.....	2275
18.2.4	MuxST error handling.....	2276
18.2.5	MuxST messaging.....	2276
18.2.6	MuxST I/Os.....	2277
18.2.7	MuxST block diagram.....	2278
18.3	STRep - Status display of block groups.....	2279
18.3.1	Description of STRep.....	2279
18.3.2	STRep modes.....	2279
18.3.3	STRep functions.....	2280
18.3.4	STRep error handling.....	2280
18.3.5	STRep messaging.....	2280
18.3.6	STRep I/Os.....	2280
18.3.7	STRep block diagram.....	2281
18.4	AssetM - Process variable monitoring for violation of limits.....	2282
18.4.1	Description of AssetM.....	2282
18.4.2	AssetM modes.....	2285
18.4.3	AssetM functions.....	2285
18.4.4	AssetM error handling.....	2286
18.4.5	AssetM messages.....	2286
18.4.6	AssetM I/Os.....	2287
18.4.7	AssetM block diagram.....	2289
19	System blocks.....	2291
19.1	AddInt64 - Addition of two 64-bit integer variables.....	2291
19.1.1	Description of AddInt64.....	2291
19.2	AddR64 - Addition of two 64-bit REAL variables.....	2292
19.2.1	Description of AddR64.....	2292
19.3	DiToInt64 - Converting from DINT to Int64.....	2293
19.3.1	Description of DiToInt64.....	2293
19.4	Int64ToDi - Converting from Int64 to DINT.....	2294
19.4.1	Description of Int64ToDi.....	2294
19.5	MemR256 - Increasing the number of internal previous values.....	2295
19.5.1	Description of MemR256.....	2295
19.6	NegInt64 - Negation of an Int64 variable.....	2296
19.6.1	Description of NegInt64.....	2296
19.7	NegR64 - Negation of a Real64 variable.....	2297
19.7.1	Description of NegR64.....	2297
19.8	PIDCoefR - Calculation of coefficients	2298
19.8.1	Description of PIDCoefR.....	2298
19.9	R64ToReal - Converting Real64 to REAL	2299

19.9.1	Description of R64ToReal.....	2299
19.10	RealToR64 - Converting REAL to Real64.....	2300
19.10.1	Description of RealToR64.....	2300
19.11	SelST16 - Output of the best or worst signal status.....	2301
19.11.1	Description of SelST16.....	2301
19.12	ShLeInt64 - Left shift of an Int64 variable.....	2302
19.12.1	Description of ShLeInt64.....	2302
19.13	ShRiInt64 - Right shift of an Int64 variable.....	2303
19.13.1	Description of ShRiInt64.....	2303
19.14	PIDKernR - Calculation of the manipulated variable.....	2304
19.14.1	Description of PIDKernR.....	2304
20	Communication blocks.....	2305
20.1	Snd_DigVal - Send Boolean values including quality code (Snd_DigVal).....	2305
20.1.1	Description of Snd_DigVal.....	2305
20.1.2	Snd_DigVal modes.....	2306
20.1.3	Snd_DigVal functions.....	2306
20.1.4	Snd_DigVal error handling.....	2307
20.1.5	Snd_DigVal messages.....	2307
20.1.6	Snd_DigVal I/Os.....	2307
20.1.7	Snd_DigVal block diagram.....	2307
20.2	Rcv_DigVal - Receive Boolean values including quality code (Rcv_DigVal).....	2308
20.2.1	Description of Rcv_DigVal.....	2308
20.2.2	Rcv_DigVal modes.....	2309
20.2.3	Rcv_DigVal functions.....	2310
20.2.4	Rcv_DigVal error handling.....	2310
20.2.5	Rcv_DigVal messages.....	2310
20.2.6	Rcv_DigVal I/Os.....	2310
20.2.7	Rcv_DigVal block diagram.....	2311
20.3	Snd_AnaVal - Send analog values including quality code (SND_AnaVal).....	2312
20.3.1	Description of Snd_AnaVal.....	2312
20.3.2	Snd_AnaVal modes.....	2313
20.3.3	Snd_AnaVal functions.....	2313
20.3.4	Snd_AnaVal error handling.....	2313
20.3.5	Snd_AnaVal messages.....	2314
20.3.6	Snd_AnaVal I/Os.....	2314
20.3.7	Snd_AnaVal block diagram.....	2314
20.4	Rcv_AnaVal - Receive analog values including quality code (Rcv_AnaVal).....	2315
20.4.1	Description of Rcv_AnaVal.....	2315
20.4.2	Rcv_AnaVal modes.....	2316
20.4.3	Rcv_AnaVal functions.....	2316
20.4.4	Rcv_AnaVal error handling.....	2316
20.4.5	Rcv_AnaVal messages.....	2317
20.4.6	Rcv_AnaVal I/Os.....	2317
20.4.7	Rcv_AnaVal block diagram.....	2318
21	Process tag types (insertible templates).....	2319
21.1	Introduction to process tag types.....	2319

21.2	PID controller (PIDControl_Lean).....	2322
21.3	PID controller for PA/FF devices (PIDControl_Lean_Fb).....	2323
21.4	PID controller with safety logic and control loop monitoring (PIDConL_ConPerMon).....	2324
21.5	PIDConR with safety logic and control loop monitoring (PIDConR_ConPerMon).....	2325
21.6	PID controller with safety logic and manipulated variable ramp (PIDConR_MV_Ramp) . . .	2326
21.7	PID - control with operating-point-oriented parameter control (GainScheduling).....	2327
21.8	PID controller with dynamic feedforward control (FwdDisturbCompensat).....	2329
21.9	PID controller with Smith predictor (SmithPredictorControl).....	2332
21.10	Step controller with direct access to the actuator and without position feedback (StepControlDirect).....	2333
21.11	Step controller with assigned actuator block and position feedback (StepControlActor) . . .	2334
21.12	Split-range controller with control loop monitoring through ConPerMon (SplitrangeControl).....	2335
21.13	Split-Range control (SplitRangeControl_Lean).....	2337
21.14	Ratio control with control loop monitoring through ConPerMon (RatioControl).....	2338
21.15	Ratio control (RatioControl_Lean).....	2340
21.16	Ratio control with PIDConR (RatioR).....	2341
21.17	Cascade control with control loop monitoring through ConPerMon (CascadeControl).....	2342
21.18	Cascade control (CascadeControl_Lean).....	2344
21.19	Cascade control with PIDConR (CascadeR).....	2345
21.20	Cascade control with PIDStepL (CascadeStepControl).....	2346
21.21	Source chart for GainSched function block (gain scheduling).....	2347
21.22	Override control.....	2348
21.23	Override control with PIDConR (OverrideR).....	2350
21.24	Model-based predictive control (ModPreCon).....	2351
21.25	Monitoring of a digital process tag (DigitalMonitoring).....	2353
21.26	Monitoring a digital process tag for PA/FF devices (DigitalMonitoring_Fb).....	2354
21.27	Monitoring eight digital process tags (Digital8Monitoring).....	2355
21.28	Monitoring an analog process tag (AnalogMonitoring).....	2356
21.29	Monitoring of an analog process tag for PA/FF devices (AnalogMonitoring_Fb).....	2357
21.30	Dosing (Dose_Lean).....	2358
21.31	Dosing with PA/FF devices (Dose_Lean_Fb).....	2359
21.32	Motor (Motor_Lean).....	2360
21.33	Motor with PROFIdrive Drive Profile telegram 1 and 20 (Namur).....	2361
21.34	Two-speed motor (Motor2Speed).....	2362

21.35	Reversing motor (MotorReversible).....	2363
21.36	Reversible motor with controllable speed (MotorSpeedControlled).....	2364
21.37	Motor with an additional analog value and time-stamped signals (Motor_AV_EventTs)....	2365
21.38	Motor according to the profile for low voltage switchgear devices with profile 1 of the MM_Starter.....	2366
21.39	Valve (Valve_Lean).....	2367
21.40	Two-way valve (Valve2Way).....	2368
21.41	Motor valve (ValveMotor).....	2369
21.42	Control valve (VlvAnL)	2370
21.43	Control valve for PA/FF devices (ValveAnalog_Fb).....	2371
21.44	Example project APL_Example_xx.....	2372
21.44.1	Introduction to the PCS 7 example project for Advanced Process Control.....	2372
21.44.2	Process simulation including noise generator (ProcSimC; ProcSimS).....	2373
21.44.3	Cascade control of temperature by using the heat flow (CascadeSim).....	2375
21.44.4	Control loop monitoring for simulation with colored noise (ConPerMonSim).....	2377
21.44.5	Feedforward control to compensate a measurable disturbance variable (DisturbCompSim).....	2377
21.44.6	Operating point-oriented adaptation of parameters (gain scheduling) for non-linear processes (GainSchedSim).....	2378
21.44.7	Override control on a pipeline (OverrideSim).....	2379
21.44.8	Smith predictor for a dead time system (SmithPredictorSim).....	2379
21.44.9	Filtering of noisy measured values in a control loop (SigSmoothSim).....	2380
21.44.10	Predictive control of a 2x2 multi-variable controlled system (ModPreConSim).....	2381
21.44.11	Predictive control of a non-linear process (ModPreConNonLinSim).....	2381
22	Definitions.....	2383
22.1	Batch process.....	2383
22.2	Approximation.....	2384
22.3	Prediction horizon.....	2385
22.4	Trajectory.....	2386
22.5	Maverick.....	2387
22.6	Ergodic process.....	2388
22.7	Conti process.....	2389
22.8	Multivariable controller.....	2390
22.9	non-phase minimum.....	2391
	Index.....	2393

Security information

Siemens provides products and solutions with industrial security functions that support the secure operation of plants, systems, machines, and networks.

In order to protect plants, systems, machines and networks against cyber threats, it is necessary to implement – and continuously maintain – a holistic, state-of-the-art industrial security concept. Siemens' products and solutions constitute one element of such a concept.

Customers are responsible for preventing unauthorized access to their plants, systems, machines and networks. Such systems, machines and components should only be connected to an enterprise network or the internet if and to the extent such a connection is necessary and only when appropriate security measures (e.g. firewalls and/or network segmentation) are in place.

For additional information on industrial security measures that may be implemented, please visit:

<https://www.siemens.com/industrialsecurity>

Siemens' products and solutions undergo continuous development to make them more secure. Siemens strongly recommends that product updates are applied as soon as they are available and that the latest product versions are used. Use of product versions that are no longer supported, and failure to apply the latest updates may increase customer's exposure to cyber threats.

To stay informed about product updates, subscribe to the Siemens Industrial Security RSS Feed under

<https://www.siemens.com/industrialsecurity>.

Basics of APL

2.1 Functions of the blocks

2.1.1 General information

2.1.1.1 User-configured message classes

User-configured message classes

The message classes Alarm, Warning and Tolerance, the corresponding abbreviations in symbols and colors, and the terms used in this documentation are not valid for user-configured message classes.

These terms and colors depend on the project-specific setting. The user-configured messages classes are only supported for block symbols as of V8.

2.1.1.2 Forcing operating modes

Forcing operating modes

The "forcing of operating modes" function lets you set the function block into a different operating mode using interconnectable input parameters, regardless of the currently active control. This can, for example, be:

- Forces tracking for closed-loop controllers and control valves
- Enabling and disabling at motors
- Opening and closing of valves

It is only possible to force operating modes with "Large" blocks in the following operating modes:

- Manual mode
- Automatic mode
- Local mode (only if `Feature2.Bit8 = 1`)

Forcing operating modes has the highest priority over all three operating modes.

Note

It is not possible to force operating modes in local mode.

Forcing operating modes at closed-loop controllers

In control engineering, this procedure is also known as forced tracking of values. Refer to the Tracking and limiting a manipulated variable (Page 196) section for more on this.

Forcing operating modes at motors and valves

The input parameter `xxxxForce = 1` (for example `OpenForce` and `CloseForce` at a valve) is used for forced controlling of the function block and thus an intervention in the function of the block, irrespective of currently active controls, interlock conditions and monitoring errors. If the input parameters are inconsistent (for example `OpenForce = 1` and `CloseForce = 1` at valves), an error number (Page 120) is output at the parameter `ErrorNum` and the control remains unchanged.

Note

If you have set the parameters for the advance warning time `WarnTiMan` and the idle time `IdleTime` to values higher than 0, the control will only take effect once the set times have elapsed.

Note

With block `VlvAnl`, the warning time is ignored in tracking `MV_TrkOn = 1` and in forced tracking `MV_ForOn`.

The Enabling direct changeover between forward and reverse (Page 146) feature bit has no effect when forcing the operating modes of the `MotRevL` and `MotSpdCL` blocks. Direct switchover between forward and reverse is always possible.

Display in the faceplate and in the block icon

If an operating mode is forced, this is displayed in the block icon and in the standard view of the faceplate:

Block icon: In the block icon, the display for motors, valves and dosers involves the use of a red F and a crossed-out padlock.

There is no display for closed-loop controllers.

Faceplate: An information text on the forced operating mode is displayed in the standard view of the faceplate, for example, "Forced stop" for motors. This is also indicated by a crossed-out padlock:



Messaging

No messages are assigned to the forcing of operating modes. However, if you want to have corresponding messages, you can use the freely interconnectable input parameters to generate the messages. Refer also to the Generating instance-specific messages (Page 204) section for more on this.

2.1.1.3 Resetting the block in case of interlocks or errors

Resetting the block

The block must be reset when an interlock has been set via the `Protect` input ("Protection"), Trip ("Protection") or an error has occurred ("Runtime" or "Control", external error `FaultExt` or `CSF` with Feature Bit 18).

Note

"Small" blocks do not feature protection (`Protect`).

The `RdyToReset` output signals when a reset can be carried out via the `RstLi` input parameter or the automatic commands.

There are different ways to reset the block:

- Reset by interconnection (input `RstLi`).
- Reset by the operator using a button in the faceplate (input `RstOp`).
- Reset with a 0-1 edge transition in the corresponding automatic or local signal (except with motor protection). Refer to the following sections for more information.

Note

The reset via input `RstLi` or `RstOp` does not depend on the selected operating mode.

The operator must have the appropriate authorization to use the reset function in the faceplate (`OS_Perm`). After a reset, the output parameter `P_Rst` is set for a cycle.

Resetting monitoring errors and interlocks in manual and automatic mode

You can influence the reaction using the following `Feature Bits`:

- `Feature Bit 9`: Resetting via input signals in the event of interlocking (Protection) or errors (Page 163)
- `Feature Bit 30`: Set reset depending on the operating mode or the `LiOp` parameter (Page 163)
- `Feature Bit 31`: Activating reset of protection / error in manual mode (Page 165)

Note

The following applies for valves:

With `MonSafePos = 0`, no reset is required; the valve can be moved in spite of the response fault.

Resetting monitoring errors, external errors and interlocks in local mode

The monitoring error can occur in local mode if you have set 1, 3 or 5 for the input parameter `LocalSetting` (see Local mode (Page 79)). When `LocalSetting` is set to 2 or 4, a monitoring error can only occur when a rapid stop is triggered.

The following applies with `LocalSetting` 1 or 3:

The monitoring error, the external error and the interlocks cannot be reset when the control and feedback signals do not match.

- When the control and feedback signals match, the monitoring error, external error and the interlocks are reset by stopping (`StopLocal = 1`) the drive.
- With `Vlv2WayL` in the `MonSafePos = 1` setting, a monitoring error is reset by `Pos0Local = 1`.
- With `VlvL`, `VlvMotL` in the `MonSafePos = 1` setting, a monitoring error is reset with the local command, which moves the valve to the neutral position.
- With `Vlv2WayL`, `VlvMotL` and `VlvL` in the `MonSafePos = 0` setting, no reset of the monitoring error is required. The currently pending control is in effect.
- With `Vlv2WayL`, `VlvL` and `VlvMotL`, an external error is reset with the local command, which moves the valve to the neutral position
- With `DoseL`, you must acknowledge the protection (`Protect`) and flow alarms with a positive edge at the "CancelLocal" or "PauseLocal" output parameter.

The following applies with `LocalSetting` 2, 4 or 5:

No reset required.

Resetting motor protection (Trip) in local mode

In local mode, the "Motor protection" display is reset in the faceplate and not using the Reset button available there. The display disappears as soon as `Trip = 1`, the activation signals and feedback match and a command for stopping the drive has been issued.

Note

A motor protection signal (Trip parameter) with signal status 16#00 or 16#28 is used to activate motor protection. This is indicated by "Motor protection" in the standard view of the faceplates.

Resetting monitoring errors, external errors and interlocks using the "Forcing operating states" function

With "Forcing operating states", monitoring errors, external errors, interlocks or the motor protection function are reset under the following conditions and a reset pulse is output at the `P_Rst` output:

- The block is in an operating mode in which a reset is necessary and
- a monitoring error, an external error, a "Protection" interlock or the motor protection function is ready to be reset. This can be seen in the faceplate with the reset button or with the Request 0/1 indicator in the faceplate. When `Feature Bit 19 = 1`, the block is ready to reset as soon as the protection (`Protect = 0`) or motor protection (`Trip = 0`) interlock is set, whereby enabled motor protection prevents the motor from starting.

See also the following chapter: Forcing operating modes (Page 41).

Tabular overview for resetting for interlocks and errors

	Permit	Interlock	Protect
Meaning	Activation enable ("Permission")	Interlock without reset ("Interlock")	Interlock with reset ("Protection")
Description	The activation enable (input <code>Permit = 1</code>) makes it possible to leave the neutral position of the block in response to operator input or a command from the program (CFC/SFC). The activation enable has no effect if the block is not in the neutral position.	A pending interlock condition brings the block to the neutral position (input <code>Intlock = 0</code>).	A pending interlock condition brings the block to the neutral position (input <code>Protect = 0</code>).
Mode: Automatic	Takes effect if block is in the neutral position. After the interlock condition has gone, the currently pending control function becomes active again.	After the interlock condition has gone, the currently pending control function becomes active again.	Feature Bit 9 and 30 = 0: Reset via faceplate or <code>RstLi = 1</code> Feature Bit 9 = 1 and 30 = 0: Reset via faceplate or <code>RstLi = 1</code> or a 0-1 edge transition in the control Feature Bit 9 = 0 and 30 = 1: Reset via <code>RstLi = 1</code> Feature Bit 9 and 30 = 1: Reset via <code>RstLi = 1</code> or a 0-1 edge transition in the control = 1 or 0-1 edge transition in the control

2.1 Functions of the blocks

	Permit	Interlock	Protect
Mode: Local	Takes effect if block is in the neutral position. After the interlock condition has gone, the currently pending control function becomes active again.	After the interlock condition has gone, the currently pending control function becomes active again.	The following applies with <code>LocalSetting = 1</code> or <code>3</code> : Generally: When the control and feedback signals match, reset via <code>StopLocal = 1</code> . Vlv2WayL, VlvMotL und VlvL: Reset via local command, which moves the valve into the neutral position. DoseL: Reset via a positive edge at "CancelLocal" or "PauseLocal". The following applies with <code>LocalSetting = 2,4</code> or <code>5</code> : No reset required
Mode: Manual	Takes effect if block is in the neutral position. It is possible to leave the neutral position with an operation in the faceplate.	The faceplate can be operated again after the interlock condition has gone.	Feature Bit 30 and 31 = 0: Resetting not necessary Feature Bit 30 = 1 and 31 = 0: Resetting not necessary Feature Bit 30 = 0 and 31 = 1: Reset via faceplate or <code>RstLi = 1</code> Feature Bit 30 and 31 = 1: Reset via faceplate

	Trip	Error	Rapid stop
Meaning	Motor protection	Monitoring errors and external errors	Rapid stop
Description	The motor protection function is used to switch off the motor when there is a heat overload (input <code>Trip = 0</code>).	<ul style="list-style-type: none"> Monitoring the startup and stop characteristics for motors or the runtime of valves Monitoring the operation of motors or the maintenance of the position of valves External error <code>FaultExt</code>: Block goes to error state without a message being output. External control system fault <code>CSF</code> with set <code>Feature Bit 18</code>: block reports an external control system fault and goes to error state. 	A rapid stop stops the drive immediately.

	Trip	Error	Rapid stop
Mode: Automatic	<p>Feature Bit 9 and 30 = 0: Reset via faceplate or $RstLi = 1$</p> <p>Feature Bit 9 = 1 and 30 = 0: Reset via faceplate or $RstLi = 1$ or a 0-1 edge transition in the control</p> <p>Feature Bit 9 = 0 and 30 = 1: Reset via $RstLi = 1$</p> <p>Feature Bit 9 and 30 = 1: Reset via $RstLi = 1$ or a 0-1 edge transition in the control = 1 or 0-1 edge transition in the control</p>		<p>Feature Bit 9 = 0: Reset via faceplate or $RstLi = 1$</p> <p>Feature Bit 9 = 1: Reset via faceplate or $RstLi = 1$ or a 0-1 edge transition in the control</p>
Mode: Local	<p>The following applies with $LocalSetting = 1$ or 3:</p> <p>When the control and feedback signals of the drive match, reset via $StopLocal = 1$.</p> <p>The following applies with $LocalSetting = 2, 4$ or 5:</p> <p>No reset required.</p>	<p>The following applies with $LocalSetting = 1$ or 3:</p> <ul style="list-style-type: none"> • When the control and feedback signals of the drive match, reset via $StopLocal = 1$. • With $Vlv2WayL, VlvMotL$ and $VlvL$ <ul style="list-style-type: none"> – Monitoring error with $MonSafePos = 1$: Reset via the local command, which moves the valve into the neutral position. – Monitoring error with $MonSafePos = 0$: No resetting required; the currently pending control function is active. – External error: Reset via the local command, which moves the valve into the neutral position. • With $DoseL$, resetting via a positive edge at "CancelLocal" or "PauseLocal". <p>The following applies with $LocalSetting = 2, 4$ or 5:</p> <p>No reset required.</p>	<p>The rapid stop function is unlocked in the faceplate via the "Reset" button ($RstOp = 1$). In CFC, unlocking is carried out using the input parameter $RstLi = 1$</p>
Mode: Manual	<p>Feature Bit 30 and 31 = 0: Resetting not necessary</p> <p>Feature Bit 30 = 1 and 31 = 0: Resetting not necessary</p> <p>Feature Bit 30 = 0 and 31 = 1: Reset via faceplate or $RstLi = 1$</p> <p>Feature Bit 30 and 31 = 1: Reset via faceplate</p>		<p>The rapid stop function is unlocked in the faceplate via the "Reset" button ($RstOp = 1$). In CFC, unlocking is carried out using the input parameter $RstLi = 1$</p>

2.1.1.4 Neutral position for motors, valves and controllers

Neutral position for motors, valves and controllers

The neutral position always represents the deenergized state.

Neutral position for motors

The neutral position for motors is always the stopped motor.

The neutral position is adopted when:

- The function Monitoring the feedbacks (Page 97) was triggered.
- One of the interlock conditions is active (see Interlocks (Page 99)).
- An external error via `FaultExt` or `CSF` was triggered (see Error handling (Page 120)).
- The Motor protection function (Page 99) was triggered.
- The function Rapid stop for motors (Page 107) was triggered.
- During start-up (see Set startup characteristics (Page 138)).
- The "Out of service" mode is active.
- One of the automatic commands has bad signal status (16#00 or 16#28) and the `Feature2` bit Considering bad quality of automatic commands or external values (Page 186) is set to 1.

Neutral position for valves

There are different forms of the deenergized state for valves:

- Valve is closed in a de-energized state
- Valve is open in a de-energized state
- Valve is stopped in a de-energized state (e.g. motor valve)

The input parameter `SafePos` is used to set these properties of the valve:

- `SafePos` = 0: Valve is closed in a de-energized state
- `SafePos` = 1: Valve is open in a de-energized state
- `SafePos` = 2: Valve is stopped in a de-energized state (e.g. motor valve)

The neutral position is adopted when:

- The function Monitoring the feedbacks (Page 97) was triggered.
- One of the interlock conditions is active (see Interlocks (Page 99)).
- An external error via `FaultExt` or `CSF` was triggered (see Error handling (Page 120)).
- During start-up (see Set startup characteristics (Page 138)).

- The "Out of service" mode is active.
- One of the automatic commands has bad signal status (16#00 or 16#28) and the `Feature2` bit Considering bad quality of automatic commands or external values (Page 186) is set to 1.

Neutral position for the VlvAnL and VlvPosL blocks (actuator)

The possible neutral positions are set by the `SafePos` parameter:

- `SafePos = 0`: Neutral position of the control valve is "Closed" (`MV.Value = MV_LoLim`)
- `SafePos = 1`: Neutral position of the control valve is "Open" (`MV.Value = MV_HiLim`)
- `SafePos = 2`: Neutral position of the control valve is "Stop" (`MV.Value` remains unchanged)

The control valve VlvAnL is brought to the neutral position when the `FbkAuxVCloseOut = 1` auxiliary valve is closed.

The neutral position of the control valve VlvAnL and VlvPosL is adopted when:

- The function Monitoring the feedbacks (Page 97) was triggered.
- One of the interlock conditions is active (see Interlocks (Page 99)).
- An external error via `FaultExt` or `CSF` was triggered (see Error handling (Page 120)).
- During start-up (see Set startup characteristics (Page 138)).
- The "Out of service" mode is active.
- One of the automatic commands has bad signal status (16#00 or 16#28) and the `Feature2` bit Considering bad quality of automatic commands or external values (Page 186) is set to 1.

In case of startup or "Out of service" mode, the valve VlvAnL has additional `Feature` bits for adopting the neutral position:

- During start-up, if the `Feature` bit Set startup characteristics (Page 138) and the `Feature` bit Neutral position manipulated variable takes effect at startup (Page 166) are set.
- In the "Out of service" mode, if the `Feature` bit Neutral position manipulated variable takes effect with "out of service" operating mode (Page 166) is set.

Neutral position for continuous controllers (does not apply to controller modules)

- Only the limits or a special analog value for the manual value are taken into consideration for the neutral position with continuous controllers.
The input parameter `SafePos` is used to specify the neutral position:
 - `SafePos = 0` corresponds to the low limit (`ManLoLim` or `MV_LoLim` for PIDConS)
 - `SafePos = 1` corresponds to the high limit (`ManHiLim` or `MV_HiLim` for PIDConS)
- The input parameters `SafePos` and `SafePos2` are used to determine the neutral position:

2.1 Functions of the blocks

SafePos	SafePos2	Neutral position	Remarks
=0	=0	ManLoLim for PIDConL, PIDConR or MV_LoLim for PIDConS	Low limit for manipulated variable in manual mode
=1	=0	ManHiLim for PIDConL, PIDConR or MV_HiLim for PIDConS	High limit for manipulated variable in manual mode
x	=1	MV_SafePos	Manipulated variable neutral position
x	=2	Last manipulated variable (stop)	Last manipulated variable (stop)

x: Not relevant

The neutral position is adopted:

- The interlock conditions is active (see Interlocks (Page 99) only at PIDConL and PIDConR).

In case of startup or "Out of service" mode, the controller has additional Feature bits for adopting the neutral position:

- During start-up, if the Feature bit Set startup characteristics (Page 138) and the Feature bit Neutral position manipulated variable takes effect at startup (Page 166) are set.
- In the "Out of service" mode, if the Feature bit Neutral position manipulated variable takes effect with "out of service" operating mode (Page 166) is set.

Neutral position for step controllers (does not apply to controller modules)

You can use the input parameter SafePos to determine if the step controller should close, open or stop the valve when it enters the neutral position:

SafePos = 0: close valve

SafePos = 1: open valve

SafePos = 2: stop valve

When the neutral position (fully opened or fully closed) is reached and a limit stop signal (FbkOpened or FbkClosed) is set, the valve is stopped (Stop = 1).

The neutral position is adopted:

- during start-up if the Feature bit Set startup characteristics (Page 138) and the Feature bit Neutral position manipulated variable takes effect at startup (Page 166) are set.
- in the "Out of service" mode if the Feature bit Neutral position manipulated variable takes effect with "out of service" operating mode (Page 166) is set.

Safety control for controllers of the FM 355 or FM 355-2 modules

The controller modules have their own mechanism for feedforwarding a safety value (see Temperature Controller FM 355-2 manual or Controller Module FM 355 manual)

2.1.1.5 Specifying warning times for control functions at motors and valves

Specifying warning times for control functions at motors and valves

This function is only supported by "Large" blocks.

You can generate warning signals when, for example, motors are started or valves are opened. Warning signals can be generated in the following modes:

- Manual mode (input parameter `WarnTiMan`)
- Automatic mode (input parameter `WarnTiAut`)

You specify the warning times in seconds using the input parameters `WarnTiMan` and `WarnTiAut`. If, for example, a motor is started then, this is displayed at the output parameter with `WarnAct = 1`. The motor then starts after the configured warning time has expired and `WarnAct` is reset (`WarnAct = 0`).

A corresponding warning is not output if the warning times (`WarnTiMan` or `WarnTiAut`) are specified with a smaller value than the `SampleTime` parameter.

Note

In this case, the warning time is only active if the block is controlled from the de-energized state.

Disabling warnings

Configure each parameter with 0 seconds to generate no warnings.

2.1.1.6 Output signal as a static signal or pulse signal

Output signal as a static signal or pulse signal

You can output the control signals for motors, valves and dosers as:

- Static signal or as a
- Pulse signal with configurable pulse length.

You can find the signals in the I/O table of the individual blocks.

Note

The pulse signal is available only for the "large" blocks.

Output signal as a static signal

The control settings are made available as a static signal in the blocks in the form of interconnectable output parameters. The `MotRevL` block, for example, provides these as static signals via the alternative output parameters `Fwd`, `Rev` and `Run`.

Output signal as a pulse signal

The control is made available as pulse signals at the blocks using interconnectable output parameters. You specify the pulse length of the output signals in seconds using the input parameter `PulseWidth`. The `MotRevL` block, for example, provides these as pulse signals via the output parameters `P_Fwd`, `P_Rev` and `P_Stop`.

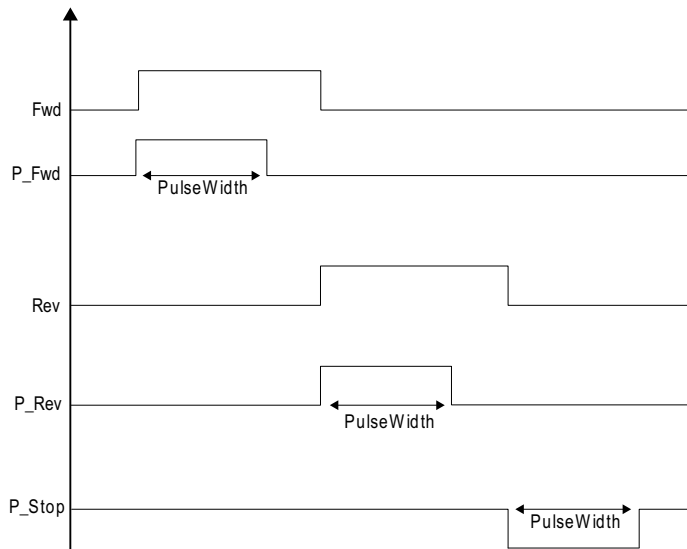

Note

Almost all output parameters for pulse control, for example `P_Fwd`, `P_Rev`, `P_Ctrl`, have a positive effective direction, i.e. a `0→1→0` pulse triggers activation.

The only exception is the `P_Stop` output parameter with a negative effective direction, i.e. a `1→0→1` pulse triggers activation.

2.1.1.7 Recording the first signal for interlock blocks

Recording the first signal

You activate the function described below using the `Feature` bit "Activating recording of the first signal (Page 150)".

The number of the input that caused the last output signal change from 1 to 0 (good state to locked) is displayed for you in bit coding at the `FirstIn` output. The cause may be:

- A signal change at the input or a change in inversion
Example: With an OR logic operation, the single 1 changes to 0. The output then changes from 1 to 0.
- A change to the I/O
Example: Excluding the single 1 then results in an output of 0 with an OR logic operation.

- A change to the signal status
If the signal status of the input, which forms the output value alone and has the value 1, changes from 16#80 to 16#00, the output value changes from 1 to 0.
- `FirstIn` is not changed if the following events occur, despite a change to the output:
 - Change in output value from or to `DefaultOut`

If several signals are at the same time responsible for the change, all responsible inputs are indicated in the faceplate and output in bit coding in the `FirstIn` output. If the input signals change without this causing the signal at the output to change, `FirstIn` does not change.

Inputs which are not interconnected or which are excluded are not taken into account.

You can reset `FirstIn` to 0 if you set the `RstLi` input from 0 to 1 (positive edge) or you can operate the `RstOp` input using the faceplate ("Reset" button).

If at least one bit in `FirstIn` is set, other signal changes are not taken into account.

2.1.1.8 Outputting a signal for start readiness

Outputting a signal for start readiness

The `RdyToStart = 1` output parameter is used to indicate start readiness in automatic mode.

Start readiness is output when the following conditions are met:

- No group error pending (group fault with consideration of feature bit 18 for `CSF` and `MonSafePos` for feedback errors)
- No interlock is active
- No forced operating mode or manipulated variable is active
- No rapid stop is active (only applies to motors or `VlvMotL`)
- The block is in automatic mode (not with controller blocks)
- The waiting time for the restart must have expired (only applies to motors or `VlvMotL`)

The start readiness is shown at the following block groups via the `RdyToStart` output parameter:

- Motors
- Valves
- Dosers
- Software controller
- Hardware controller

Start readiness for motors

The start readiness for motor blocks is formed as follows:

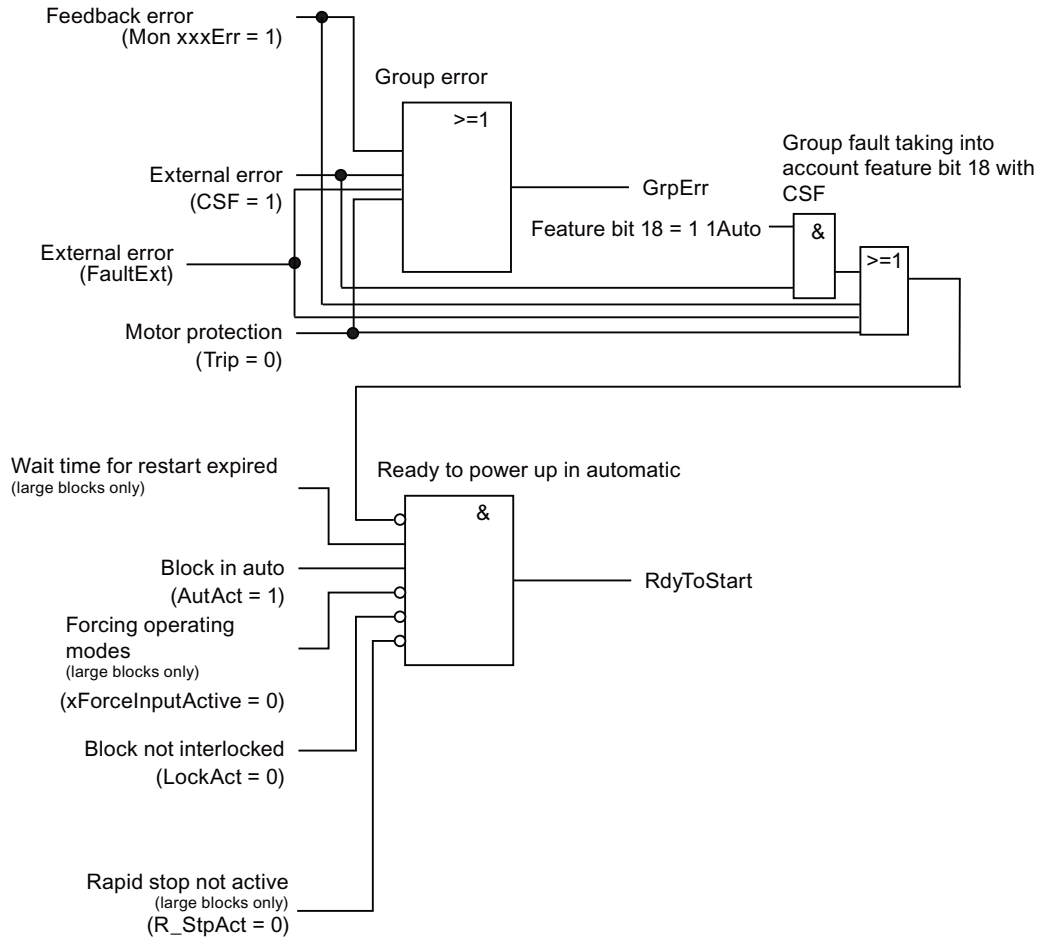

Figure 2-1 Output signal for start readiness for motors

Start readiness for valves

The start readiness for valve blocks is formed as follows:

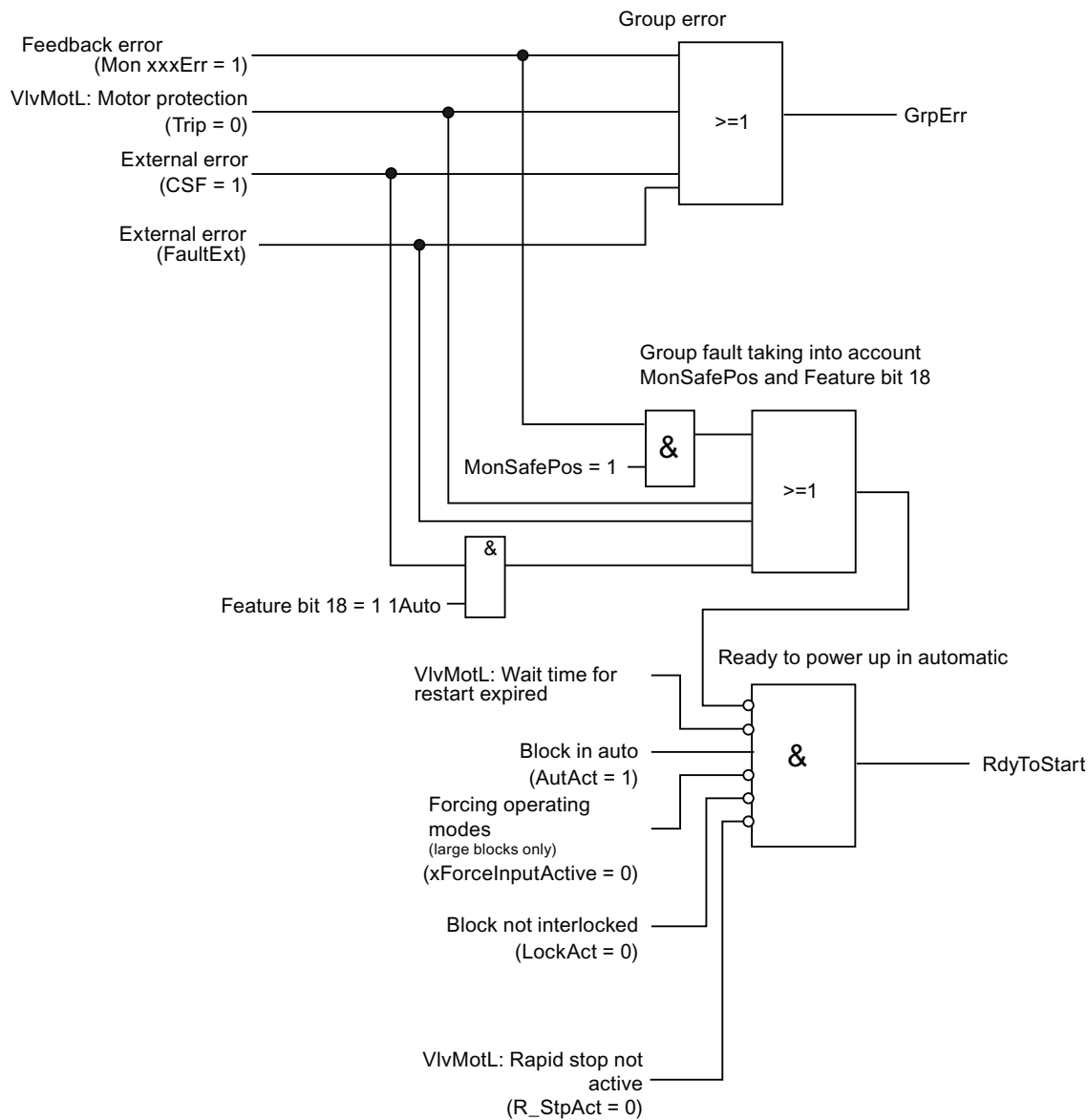

Figure 2-2 Output signal for start readiness for valves

Start readiness for dosers

The start readiness for dosers is formed as follows:

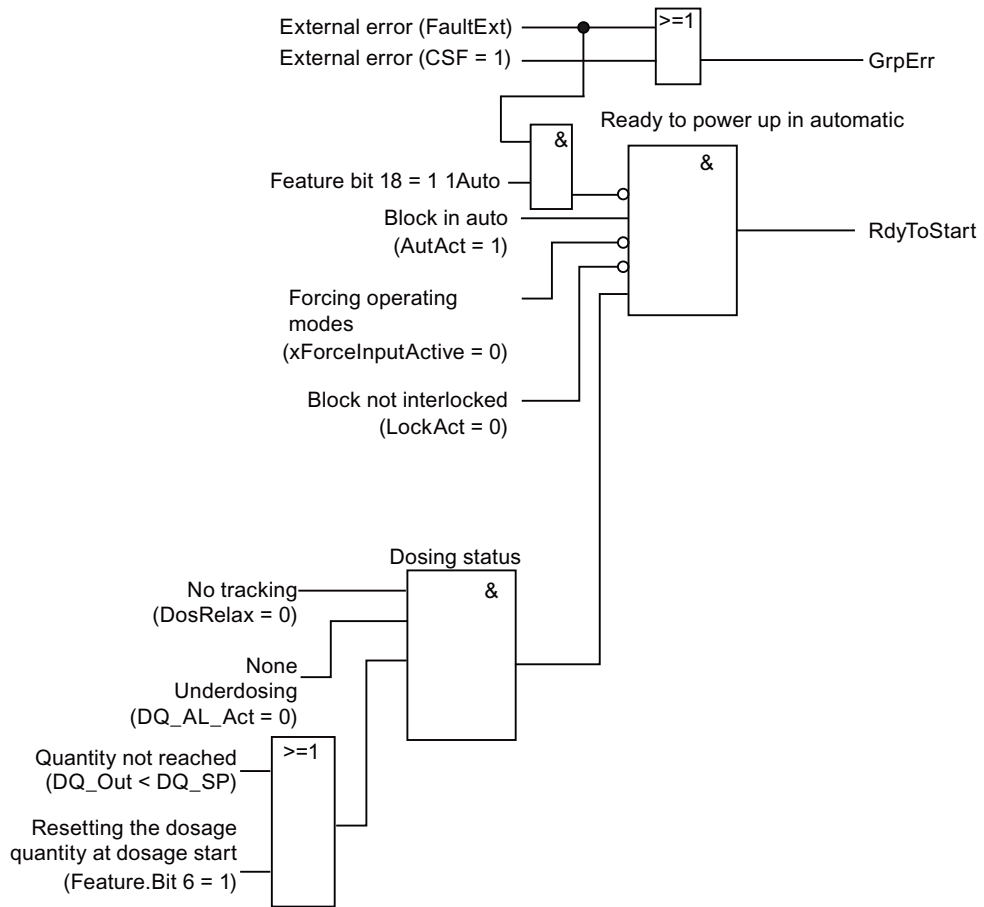

Figure 2-3 Output signal for start readiness for dosers

Start readiness for software controllers

The start readiness for software controllers is formed as follows:

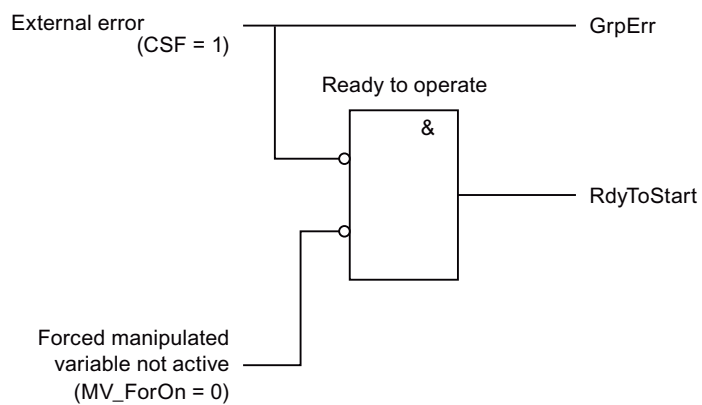

Figure 2-4 Output signal for start readiness for software controllers

Start readiness for hardware controllers

The start readiness for hardware controllers is formed as follows:

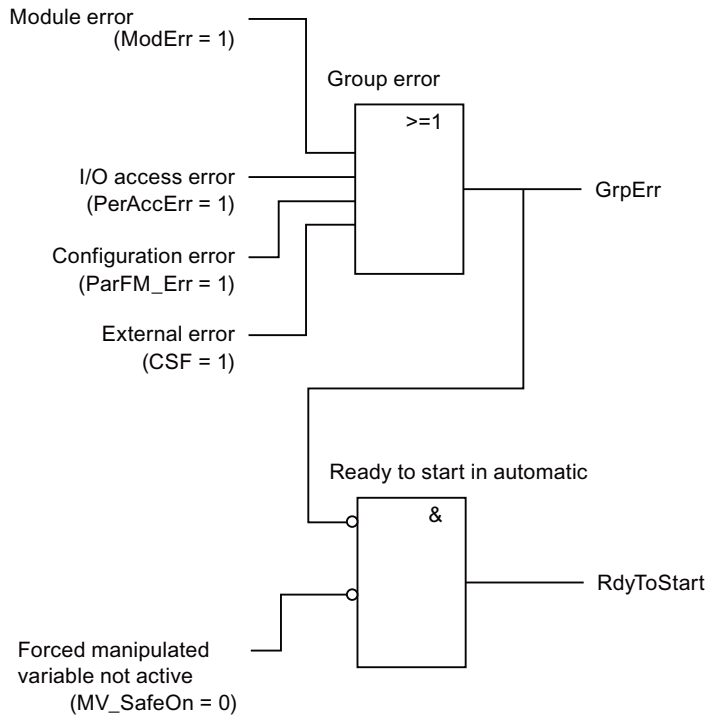

Figure 2-5 Output signal for start readiness for hardware controllers

2.1.1.9 Simulating signals

Simulating signals

Simulation means the manipulation of a signal regardless of the actual source of the signal or logic that generates this signal.

Simulation is carried out either at the field device (externally from the control system) itself or at a block (internally in the control system).

In either case, the associated status in the signal is set to the simulation value (see also Forming and outputting signal status for blocks (Page 108)).

During the simulation, every block is considered in isolation. There are two different forms of simulation here, namely:

- Block-external simulation and
- Block-internal simulation.

Block-external simulation

Block-external simulation is characterized by the fact that:

- The simulation function is not executed in the block itself and
- A signal whose status has the simulation state, for example, a simulation of the signal at another block or directly in the I/O device, is applied at an input parameter.

The block-external simulation has the following effects on the functionality of the block:

- The technological functions are not influenced
- All the process-relevant output signals do not receive the simulation status. In the case of technologic blocks, process-related output signals are parameters that actively affect the process, e.g. "Start" for block MotL.
- In the case of blocks with operator control or monitoring functions (for example faceplates), these signals are identified in the faceplate with the status for the simulation as follows:



- Blocks with one or more input parameters for signals with "Generate status from individual status" receive a group status in accordance with the priority table. This group status is displayed in the status bar of the block icon and of the faceplate with the simulation status as follows:



- The interlocking functions of the block are not influenced.

Note

For the output channel blocks, you need to specify the exact block response with external simulation using the `Feature` bit Outputting a de-energized value for block-external simulation (Page 148).

Block-internal simulation

Block-internal simulation is characterized by the "simulation" function being run in the block itself.

With operator control and monitoring blocks, all process values that cannot be controlled (e.g. `PV`, `AV`, `In`) can be simulated. This is used primarily as an aid for commissioning and servicing of the system. For example, the control settings of a motor can be simulated and the feedback values corrected without the monitoring functions being active.

For blocks that can be operated and monitored, simulation can take place via the faceplate as well as interconnectable inputs:

- `SimLiOp = 0`: The simulation is activated/deactivated via faceplate (parameter view) at the input `SimOn`.

- `SimLiOp = 1`: The simulation is activated/deactivated via the input `SimOnLi`. The interconnectable simulation values (e.g. `SimPVLi`, `SimAVLi`, `SimInLi`) will become effective in the process. In this case, the input `SimOn` is written back with `SimOnLi`.

The `Feature` bit Activating the run time of feedback signals (Page 153) can be used to delay tracking of the feedback signals for motors and valves (for example, `Fbkxxxx`).

2.1 Functions of the blocks

Simulation can also be carried out for blocks (such as channel blocks) that cannot be controlled and monitored by the operator.

The control is simulated in the CFC by setting parameters directly in the block with the input parameters `SimOn = 1` and `Simxxxx =` for the desired simulation value (e.g. `SimPV`, `SimAV` or `SimIn`).

Note

With channel blocks, ensure that the `Mode` parameter is set correctly during simulation. Otherwise this is displayed on the `Bad = 1` output parameter with a higher-level error.

If the block is not in simulation, the simulation value (`SimPV`, `SimAV` or `SimRbk`) process value (`PV`, `AV` or `Rbk`) is tracked.

Simulation is triggered during runtime in the faceplate's parameter view by clicking on the "Simulation" button.

This simulation is characterized by the fact that:

- The simulation can only be enabled / disabled with the operator authorization level for system authorization.
- The technological functions are not influenced.
- All the process-related output signals receive the "simulation" status. In the case of technologic blocks, process-related output signals are parameters that actively affect the process, e.g. "Start" for block `MotL`.
- In the case of blocks with operator control or monitoring functions (for example faceplates), these signals are identified in the faceplate with the status for the simulation as follows:



- The group status of the block is displayed in the status bar of the block icon and of the faceplate with the simulation status as follows:



- All the process values displayed in the faceplate that cannot be operated-controlled in normal operation (e.g. `PV`).
- When the block control can be manipulated, the readback and feedback values (for example `Rbk`, `FbkSpd1`) are adjusted according to the manipulation of the control.
- Associated values (for example `UserAnal`) cannot be simulated.
- The interlocking functions of the block are activated in accordance with input parameter `ByProt = 0` or deactivated (`ByProt = 1`). This is shown as follows in the faceplate and block icon:

Enabled	
Disabled	

Block-internal simulation for controllers

How block-internal simulation for controllers works ($\text{SimOn} = 1$):

- In manual mode, both the simulated process value SimPV and the simulated repeated manipulated variable SimRbk can be entered in the faceplate as a simulated value.
- When a switchover to automatic mode is performed, the simulated process value SimPV is set so that it is equal to the setpoint SP (= tracking). This means the control deviation is no longer present and the pending manipulated variable (from the bumpless manual-automatic switchover, for example) remains constant. SimRbk can still be controlled.

Note

If you switch a controller block to block-internal simulation during automatic mode and the controller is connected to the actual process on the actuator side, you will open the control loop as a result.

The actuating signals calculated on the basis of the simulated actual value are switched to the process, but the resulting motion in the process is no longer visible in terms of the controller actual value, as a copy of the setpoint is present at this point instead, where it takes the form of a simulated actual value. The process could move away from the setpoint without the controller doing anything to counteract this and without you seeing this happen in the controller faceplate.

Manipulated variable step changes occur during switchover to automatic mode if an error signal was already present before the switchover.

The following applies to program mode:

- Program mode with setpoint specification should be considered the same as automatic mode from a control engineering point of view. Block-internal simulation reacts in the same way as it does in automatic mode: The process value PV is set so that it is equal to the setpoint SP , which in this case is derived from the input parameter AdvCoMV .
- Program mode with manipulated variable specification should be considered the same as manual mode from a control engineering point of view. Block-internal simulation reacts in the same way as it does in manual mode: The simulated process value SimPV can be entered as a simulated value. In this case the manipulated variable MV is derived from the input parameter AdvCoMV .

2.1.1.10 Dead band

Dead band

To suppress values fluctuating around zero, you can set a dead band (Deadband):

$\text{Deadband} = 0$: Dead band is disabled

$\text{Deadband} \neq 0$: Dead band is enabled

With a negative dead band ($\text{Deadband} < 0.0$), calculation is continued internally with this value

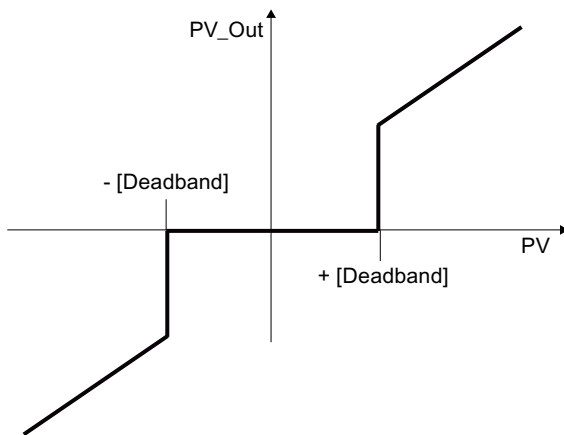

2.1.1.11 Request for maintenance release

Issuing a request for maintenance (MS → APL)

An operator can issue a request for maintenance release from the Maintenance view of the ASSET faceplate ("Status service" → "Release request"). After issuing a maintenance request, the operator can set the maintenance release. This will display the message which the operator has configured. Later, operator can set the Maintenance Release in the technological Block (Page 64). It indicates that the maintenance operator can start the maintenance.

Functional sequence in APL

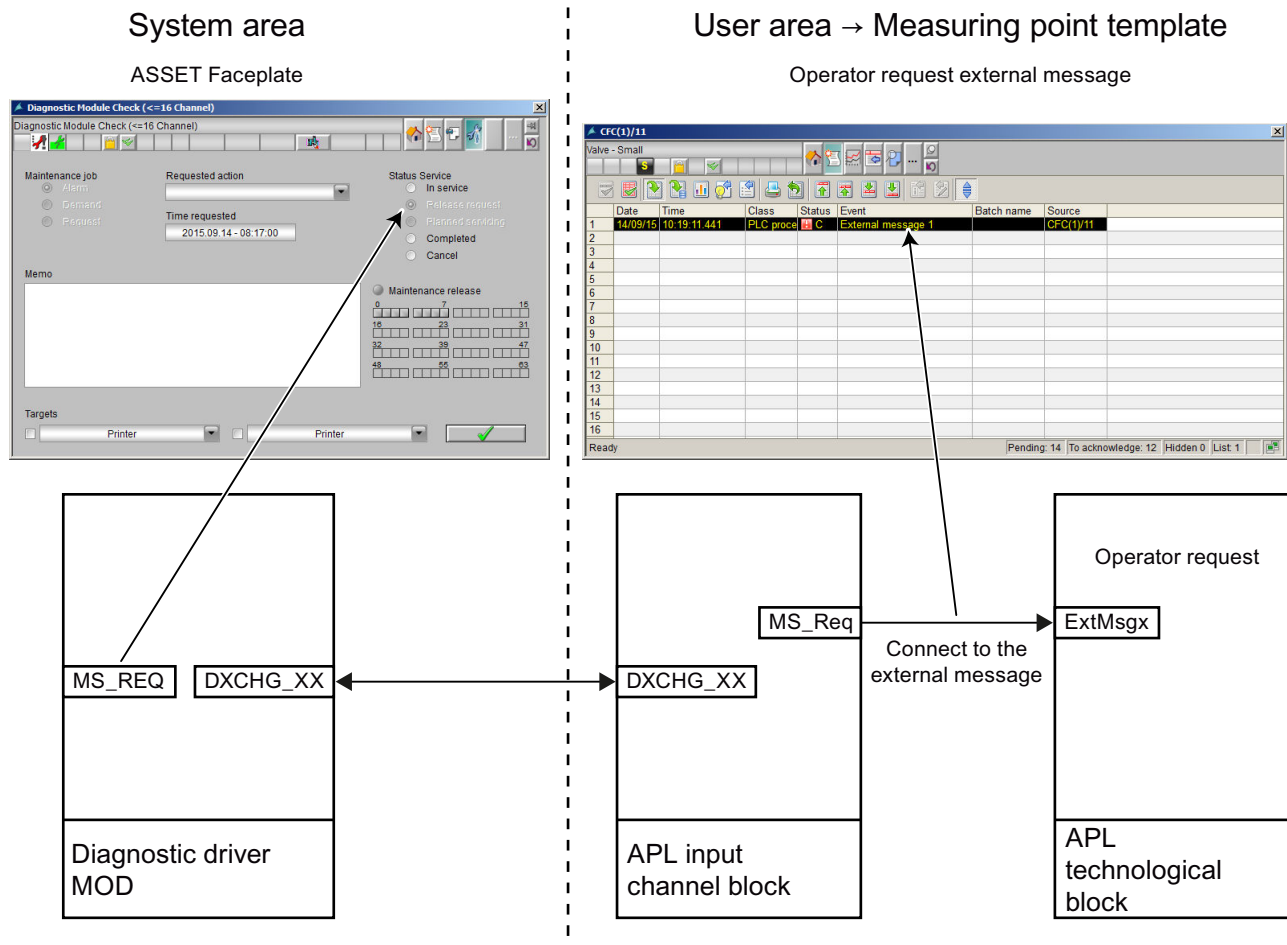

- The output parameter `MS_Req` of the channel block will be set to 1 when an operator issues a maintenance request in Maintenance view of the ASSET faceplate.
- The output parameter `MS_Req` has to be connected to the input parameter `ExtMsgx` of the desired technological block for which the user wants to issue an operator request message.
- The operator has to configure the "Message class" and enter a suitable text in the "Event" field for the operator request message in the "PCS7 Message Configuration" window of the technological block.
- With the configured message and issued maintenance release, the maintenance operator can start the maintenance.
- The operator request message stays active until the user changes to "In service" or "Cancel" mode in the Maintenance view of ASSET faceplate.
- Once the maintenance is done, the operator can change the mode to "Completed". This will deactivate the "In service" mode (`OosAct = 0`).

2.1.1.12 Release for maintenance

Issuing a release for maintenance

The release for maintenance serves as information about a process tag at which maintenance, service or calibration should be carried out. You can use the signal for release for maintenance to transfer the information about the enabling of a process tag from the OS to a Maintenance Station.

Note

The block must be in either "Manual," "On" or "Out of service" mode to set the release for maintenance.

You set the release for maintenance (operator control permission "System control" required) in the parameter view using the input parameter `MS_RelOp = 1`. A release for maintenance is then made available via the interconnectable output parameter `MS_Release = 1` for further processing. In order to make this information of the Maintenance Station available, you have to interconnect the output parameter `MS_Release` of the technologic block with the input parameter `MS_Release` of the corresponding channel block.

The issuing of a release for maintenance does not have any influence on the function of the block. An operation message is generated.

Use of the state "In progress" on the Maintenance Station

The status "In progress" is implemented on the Maintenance Station for a process tag or a field device using the channel blocks and the interconnectable output parameter `OosAct = 1`. You can interconnect the output parameter `OosAct` of the channel block with the input parameter `OosLi` of a technologic block.

Use the `Feature` bit `Reaction` to the out of service mode (Page 177) to specify, in case the input parameter is `OosLi = 1`, if:

- there is a switchover to the "out of service" mode and the symbol for the "In progress" (see table) status is displayed. You can change to manual mode at any time.
- Only the "In progress" display (see table) in the block icon and in the faceplate of the assigned technologic block is made.

Display	Meaning
	In progress

Function sequence in the APL

- The OS operator issues the release for maintenance (`MS_RelOp = 1`) in the technologic block's parameter view.
- The technologic block then sets the `MS_Release = 1` output parameter.
- The channel block's `MS_Rel` input is now also 1.

- The channel block signals the release for maintenance to the diagnostics block via the DXCHG parameter.
- The release for maintenance is only signaled to the Maintenance Station once all 0 bits of the parameter DXCHG_XX are set on the diagnostics block.

2.1 Functions of the blocks

- The channel block determines the "in progress" state of the Maintenance Station using the MS input parameter and makes this information available at the OosAct output parameter.
- On the technologic block, the "working" state is displayed at input parameter OosLi and forwarded for display to the faceplate.

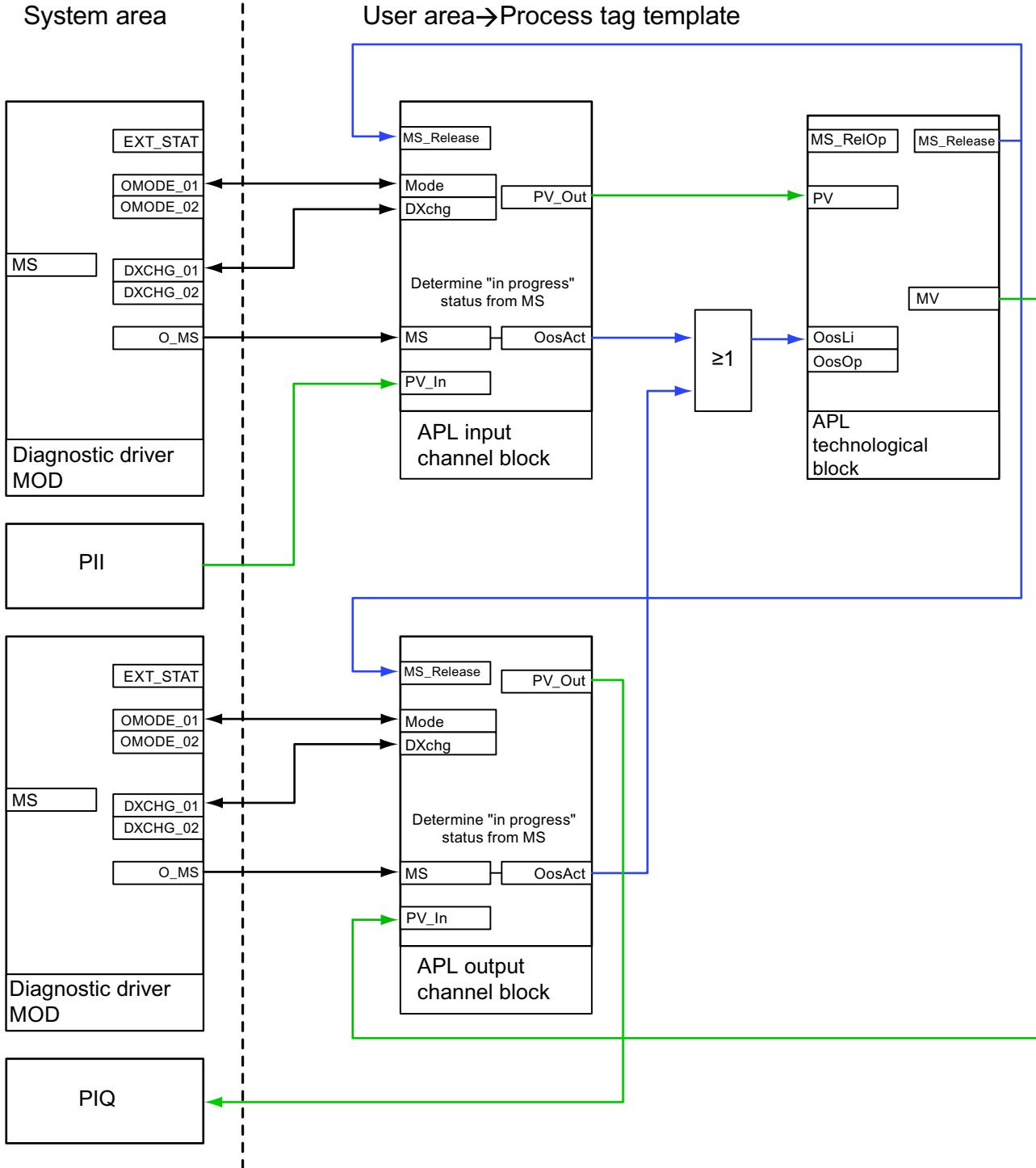

Figure 2-6 Release for maintenance

Key to diagram:

PII	Process image of inputs
PIQ	Process image of outputs
Black lines	Automatic system connections
Green lines	Process value connections made by the planner
Blue lines	Connections for release for maintenance made by the planner

Note

For additional information on the topic of maintenance please refer to PCS 7 OS process management.

2.1.1.13 SIMATIC BATCH functionality**SIMATIC BATCH functionality**

Some blocks have an interface to SIMATIC BATCH. You use them when you connect `BatchEn`, `BatchID`, `BatchName`, `StepNo` and `Occupied I/Os` to the corresponding SIMATIC BATCH blocks. A new `BatchName` becomes effective if the `BatchID` is changed. Refer to the SIMATIC BATCH documentation.

Please refer to the descriptions of the individual blocks for information about whether a block supports the SIMATIC BATCH functionality.

2.1.1.14 Flutter suppression for channel blocks**Flutter suppression**

The time-controlled "Flutter suppression" function is used to delay the outgoing of a message by a configurable period.

Flutter suppression is used for

- OB82 events - diagnostic messages
- OB83 events - fault

used.

The flutter time is entered at the channel block at the `FlutTmIn` parameter. The high byte of the `DataXchg` parameter of the channel blocks contains the flutter time.

Flutter suppression comes into effect when `FlutEN = 1` and `FlutTmIn > 0` is set at the channel block.

There is only one flutter message per module. The delay times and fault messages are channel-specific. The fault messages are extended by at least the delay time. Flutter occurs when the status of fault messages changes from "Outgoing" back to "Incoming" within the delay time.

The last fluttering channel and its set delay time deactivates the flutter message.

2.1 Functions of the blocks

The following channel blocks have this function:

FbAnIn - Analog input channel block for field devices (Page 2041)

FbAnTot - Analog totalizer channel block for field devices (Page 2132)

FbAnOu - Analog output channel block for field devices (Page 2050)

FbDiIn - Digital input channel block for field devices (Page 2060)

FbDiOu - Digital output channel block for field devices (Page 2069)

Pcs7AnIn - Analog input channel block (Page 2110)

Pcs7AnOu - Analog output channel block (Page 2122)

Pcs7DiIn - Digital input channel block (Page 2139)

Pcs7DiIT - Digital input channel block with time stamp (Page 2147)

Pcs7DiOu - Digital output channel block (Page 2156)

Pcs7Cnt1 - Controlling and reading FM 350 modules (Page 2164)

Pcs7Cnt2 - Control and read an 8-DI_NAMUR module of the ET 200iSP (Page 2174)

Pcs7Cnt3 - Control and read the 1 COUNT 24V/100kHz module for count mode (Page 2183)

2.1.1.15 Startup characteristics over Trigger block

Startup characteristics over Trigger block

With the function block Trigger, you can influence the startup characteristics of the blocks Limit, TimerP, FlipFlop, and Trigger. Connect the output parameter `InitOut` of the Trigger block with the input parameter `Init` of the block Limit, TimerP, or FlipFlop to initialize these blocks. In the second cycle of OB30 to OB38, the output parameter `InitOut` of the Trigger block will be reset after a startup.

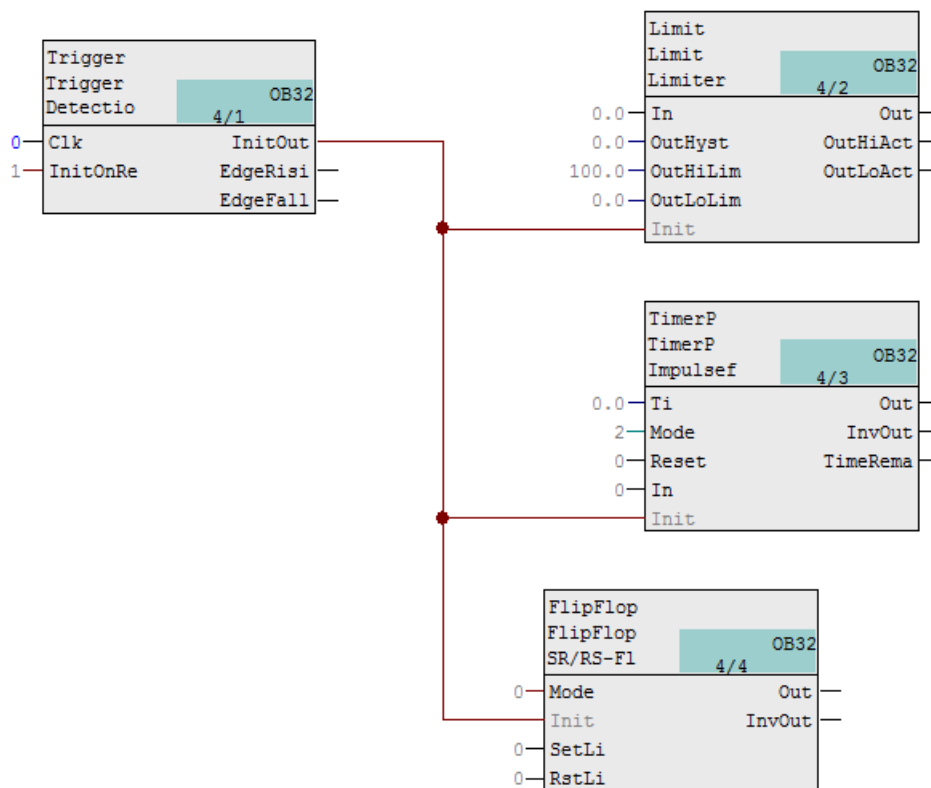

2.1.2 Operating modes of the blocks

2.1.2.1 Overview of the modes

Overview of the individual modes

The available operating modes are assigned to the block families:

- Motors, valves and dosers
- Controllers
- Blocks without "Manual" and "Automatic" modes

2.1 Functions of the blocks

You can find an overview below. Click on one of the operating modes to go directly to the relevant detailed description.

You can find a state graph for the operating modes (Page 83) at the end of this section.

Operating modes for motors, valves and dosers

The following operating modes are available:

1. Local mode (Page 79)
2. Automatic mode (Page 75)
3. Manual mode (Page 75)
4. Out of service (Page 71)

The mode with the lowest number in the list above has the highest priority. "Manual" and "Automatic" modes have the same priority. General information on the individual modes is available in the following sections. The sections also include block-specific information, for example, non-standard parameter assignment. Refer to the description and function of the relevant blocks.

Operating modes for controllers

The following operating modes are available:

1. Automatic mode (Page 72)
2. Manual mode (Page 72)
3. Program mode for controllers (Page 78)
4. Out of service (Page 71)

The mode with the lowest number has highest priority. "Manual" and "Automatic" modes have the same priority. General information on the individual modes is available in the following sections. The sections also include block-specific information, for example, non-standard parameter assignment. Refer to the description and function of the relevant blocks.

Operating modes for blocks without "Manual" and "Automatic" operation

The following operating modes are available:

1. On (Page 71)
2. Out of service (Page 71)

The mode with the lowest number has highest priority. General information on the individual modes is available in the following sections. The sections also include block-specific information, for example, non-standard parameter assignment. Refer to the description and function of the relevant blocks.

Note

Note that the operating modes are realized differently in the individual block families.

2.1.2.2 On

"On" operating mode

The "On" operating mode tells you that the block algorithm is being processed (output parameter `OnAct = 1`). This operating mode is only available for blocks that have faceplates but not the following operating modes:

- Manual mode or
- Automatic mode or
- Local mode

The "On" mode can only be activated via a control on the faceplate (input parameter `OnOp = 1`). The block must be in the "Out of service" operating mode for this to be possible.

2.1.2.3 Out of service

Using the "out of service" operating mode

The "Out of service" operating mode is available to all blocks that have an operating mode switchover and a direct connection to the process (with a connection to a process tag, for example).

The "Out of service" operating mode is intended for purposes of maintenance and servicing (replacing the device, for example). All of the block's functions are disabled. No incoming or outgoing messages are generated. The only function still possible is an operating mode switchover.

All outputs for motors and valves are set to the neutral position in this operating mode.

The timer for the function "Restart disable after the shutoff of motor (Page 1407)" is reset in this mode.

Note

Notes on `VlvMotL` and `VlvPosL`

If the neutral position of `VlvMotL` is "Closed" or "Open", the corresponding control outputs "Closed" or "Open" are set. The control outputs are reset after reaching the neutral position or with an active torque signal. The "Seal valve" function (`Feature` bit 8) is a component.

Note

Note on `VlvMotL`

If the timer of the "Restart disable after the shutoff of motor (Page 1407)" function is running and the block is not in the neutral position, it is not possible to switch to "Out of service" mode.

For controllers, the neutral position manipulated variable (high or low manual limit of the manipulated variable) is only used if the `Feature` bit Neutral position manipulated variable takes effect at startup (Page 166) is active. Otherwise the manipulated variable remains at the latest value like all the other output parameters.

2.1 Functions of the blocks

See also the section Neutral position for motors, valves and controllers (Page 48) for more on this.

The last value available is output permanently for all other blocks.

Requirement for the "out of service" mode

Prerequisite for switching to this operating mode is that the block is in "Manual mode" or "On" mode.

Activating the "Out of service" operating mode using the faceplate

The "Out of service" operating mode can only be switched on by using the faceplate when it is in the default block view (OosOp = 1 parameter) and even then, only if ModLiOp = 0.

To switch the operating mode using the faceplate, refer to the descriptions relating to the standard view of the individual blocks.

Switching on the Out of service operating mode by using the interconnection

The "Out of service" operating mode is switched on by using the configurable parameter OosLi = 1. This is only possible if the block is in manual mode or "On" mode and the Feature bit Reaction to the out of service mode (Page 177) was set to 1.

Regardless of operating mode, the parameter view of the faceplate will always display the status of the parameter OosLi =1 with the symbol for the status "In progress" (see table) next to the Maintenance enable button.

Display	Meaning
	In progress

See also the section Release for maintenance (Page 64) for more on this.

Exiting the "Out of service" operating mode

From this operating mode, a block can only be switched by an operator action at the faceplate into the following operating modes:

- "On"
- "Manual mode"

2.1.2.4 Manual and automatic mode for control blocks

"Manual" and "Automatic" modes for controller blocks

In "manual mode", the control settings for the device are made manually by the operator. The operator decides how to change the block's manipulated variable (output signal). The manipulated variable can be analog or binary.

In "automatic mode", the control settings for the controller are made automatically as calculated by the block algorithm.

Changing between operating modes

The switchover between manual and automatic modes takes place as shown in the following schematic:

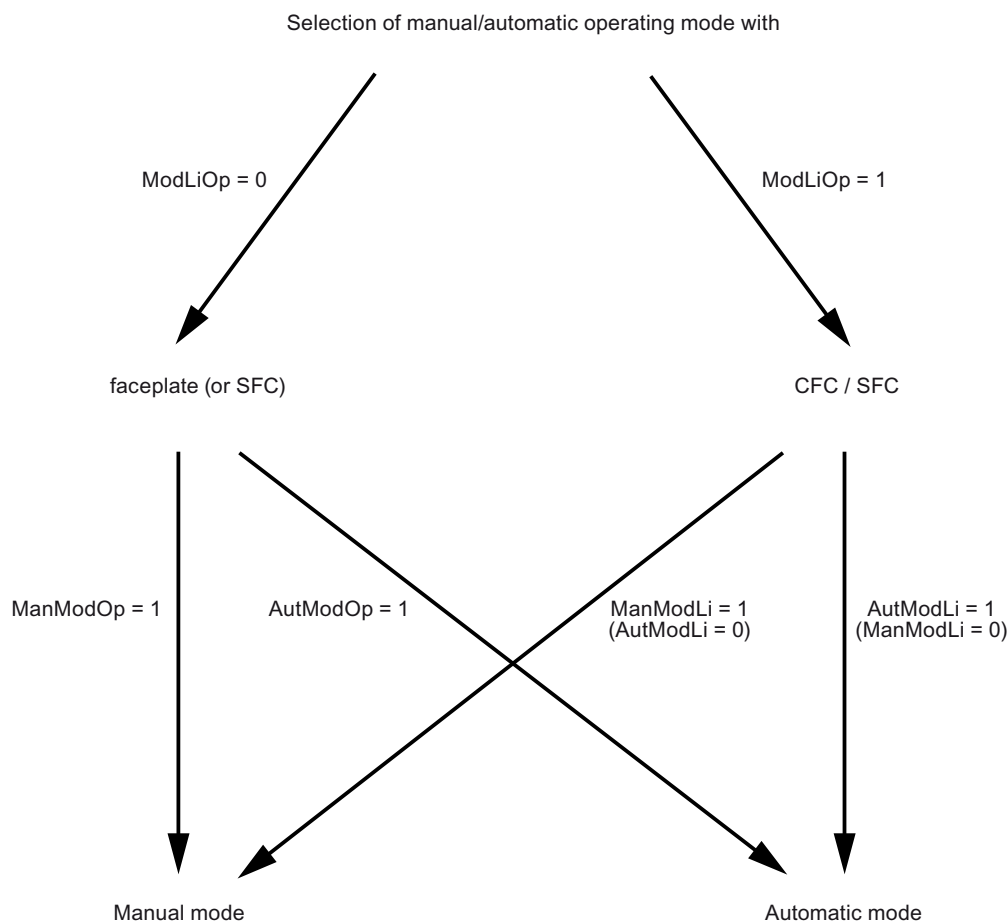

Switchover initiated in the faceplate ($\text{ModLiOp} = 0$): The switchover between operating modes is carried out in the standard view of the faceplate. In the function block, the parameters ManModOp for "manual mode" and AutModOp for "automatic mode" are used.

If both signals ($\text{ManModOp} = 1$, $\text{AutModOp} = 1$) are set, $\text{ManModOp} = 1$ has priority.

Switchover per interconnection (CFC or SFC instance) ($\text{ModLiOp} = 1$): The switchover between the operating modes is carried out with an interconnection on the function block. The parameters ManModLi for "manual mode" and AutModLi for "automatic mode" are used in pushbutton operation. In switching mode (requirement: Feature Bit 4 = 1, see Setting switch or button mode (Page 167)) connection AutModLi is used exclusively.

If both signals ($\text{ManModLi} = 1$, $\text{AutModLi} = 1$) are set, $\text{ManModLi} = 1$ has priority.

Note

You can access the variable parameters AutModOp and ManModOp from a normal SFC (in contrast to the instance of an SFC type). The SFC can thus change the operating mode without revoking the access rights of the operator (i.e. without setting $\text{ModLiOp} = 1$).

Switchover from automatic mode to manual mode

When changing over from "automatic mode" to "manual mode", the last valid control settings (**Manipulated Value MV**) for the controller set in "automatic mode" remain valid until you change the control settings manually.

Switchover from automatic mode to manual mode

The switchover from manual to automatic mode can take place with or without the internal setpoint tracking the process value. You specify this behavior on the SP_TrkPV I/O, which can also be operated from the faceplate in the parameter view (Option "SP = PV"). For the blocks PIDConL and PIDStepL you can also change the behavior for the switchover via the parameter Feature bit Disabling bumpless switchover to automatic mode for controllers (Page 173):

- **Switchover with internal setpoint tracking process variable** ($\text{SP_TrkPV} = 1$) means that in "Manual" mode the setpoint (SP) tracks the process value (PV) (bumpless switchover). After switching back to "Automatic" mode, the manipulated variable remains constant until the setpoint value (SP) is changed or the process value (PV) changes.
- **Switchover without internal setpoint tracking process variable** ($\text{SP_TrkPV} = 0$) means that the block immediately recalculates the value of the manipulated variable based on the setpoint and process value (PV) when the mode is changed. The Feature parameter is used to choose between the two variants:
 - **Switchover without P step** (standard setting, $\text{Feature bit} = 0$):
During switchover, the I action of the controller is set in such a way that the switchover is carried out without a P step (virtually bumpless referring to the manipulated variable). A control deviation is only regulated via the I action.
 - **Switchover with P step** ($\text{Feature bit} = 1$):
During switchover, the I action of the controller is set in such a way that the switchover is carried out with a P step (not bumpless referring to the manipulated variable). A control deviation is regulated via the P and the I action.

Note

Points to note about switchovers with a P step change:

- The P action must be active for the setting "Switchover with P step" ($\text{PropSel} = 1$)
 - If the P action is in the feedback ($\text{PropFacSP} = 0$), the "Switchover with P step" setting has no effect.
 - If the switchover function with the internal setpoint tracking the process variable is active ($\text{SP_TrkPV} = 1$), the "Switchover with P step" setting has no effect.
-

Reaction of signals when operating mode is changed

Using the `Feature` bit Resetting the commands for changing the mode (Page 161), you can choose whether the block automatically resets the signal for changing the operating mode.

Switch on program mode

A few controller blocks allow you to operate in program mode. Refer to the relevant sections for the controller blocks to learn whether a control block allows program mode.

Also refer to the section Program mode for controllers (Page 78) for information on program mode.

2.1.2.5 Manual and automatic mode for motors, valves and dosers

Manual and automatic mode for motors, valves and dosers

In "manual mode", the control settings for the device are made manually by the operator. The operator decides how to change the block's manipulated variable (output signal). The manipulated variable can be analog or binary in accordance with the function block.

In "automatic mode", the control settings for the device are made by the block algorithm via interconnected inputs or inputs controlled by SFC.

Changing between operating modes

The switchover between "manual and automatic mode" takes place as shown in the following schematic:

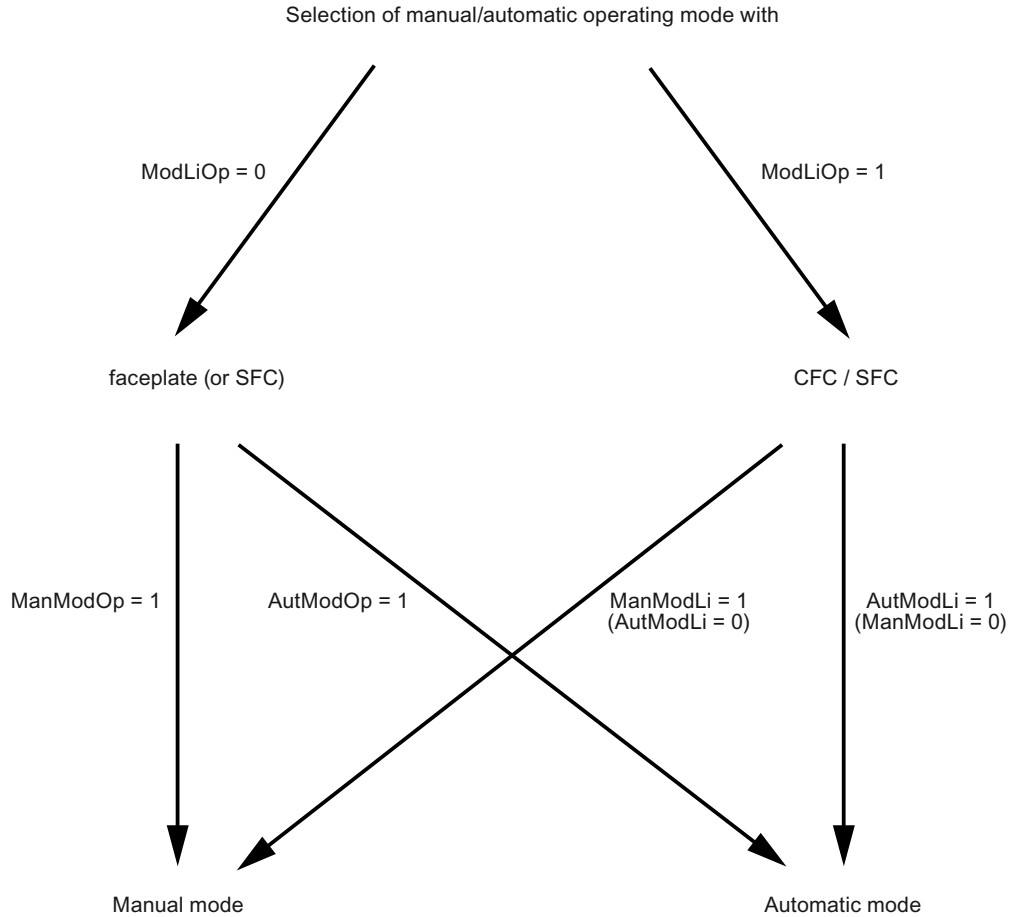

Note

The two selections (manual and automatic) cannot both be set to "1" in switching mode.

Switchover using faceplates ($ModLiOp = 0$): The switchover between operating modes is carried out in the standard view of the faceplate. In the function block, the parameters `ManModOp` for "manual mode" and `AutModOp` for "automatic mode" are used.

Switchover per interconnection (CFC or SFC instance) ($ModLiOp = 1$): The switchover between the operating modes is carried out with an interconnection on the function block. The parameters `ManModLi` for "manual mode" and `AutModLi` for "automatic mode" are used in

pushbutton operation. In switching mode (requirement: `Feature Bit 4 = 1`, see Setting switch or button mode (Page 167)) connection `AutModLi` is used exclusively.

Note

The `Feature Bit 4` is available only for the "large" blocks.

Note

You can access the variable parameters `AutModOp` and `ManModOp` from a normal SFC (in contrast to the instance of an SFC type). The SFC can thus change the operating mode without revoking the access rights of the operator (i.e. without setting `ModLiOp = 1`).

Switchover from automatic mode to manual mode

When changing over from "automatic mode" to "manual mode", the last valid control settings for the block set in "automatic mode" remain valid until you change the control settings manually.

Note

For `VlvAnL`, the bumplessness of the switchover depends on the parameter `MV_TrkExt`.

Switchover from manual to automatic mode

You can set the following options for changing over from "manual mode" to "automatic mode" using the `Feature` bit Bumpless switchover to automatic mode (Page 173). Refer to the I/O descriptions for the relevant block.

- A switchover from manual to automatic mode is possible at any time (standard setting, `Feature` bit = 0). The control settings for the automatic mode become effective immediately.
- Switchover from manual to automatic mode is only possible if the control settings for the manual and automatic modes match (Bumpless switchover), (`Feature` bit = 1). An error message is output if they do not match. In this case, you will need to adapt the control settings in "manual mode" to the control settings in "automatic mode".

Note

The "Bumpless switchover to automatic mode" function is supported only by "large" blocks.

Reaction of signals when operating mode is changed

Using the `Feature` bit Resetting the commands for changing the mode (Page 161), you can choose whether the block automatically resets the signal for changing the operating mode.

Resetting the commands for the control settings

With the `Feature` bit Enabling resetting of commands for the control settings (Page 161), you select how the block handles commands for the control settings (for example motor on) via the interconnected input parameters.

2.1.2.6 Program mode for controllers

Program mode for controllers - interface for higher-level control functions

The interface for primary controller functions (external Advanced Control software package) provides primary controller functions, which run on an external PC as an OPC client, the option of using the control from the controller function block and specifying the setpoint or manipulated variable from a remote location. This procedure is called program mode.

You can use the feature bit Enabling program mode (Page 159) to specify whether or not the controller block is intended for program mode.

Program mode requires an enable signal (input parameter `AdvCoEn = 1`) from a central control block. If this enable signal goes from 1 to 0, for example, due to errors in the OPC communication, the controller block switches to manual mode if it is in program mode with manipulated variable specification or to automatic mode if it is in program mode with setpoint specification.

You activate program mode in the standard view of the controller faceplate. In addition to switching from manual to automatic mode, you are also given the option of using program mode as the operating mode. You exit program mode by operator input or by switching back into manual or automatic mode.

A 0-1 edge transition of the interconnectable input parameter `AdvCoMstrOn` activates program mode depending on the conditions described below. You can use this to put an entire group of downstream controller blocks into program mode at the same time from a central control block. Both the input parameter `AdvCoOn` and the interconnectable input parameter `AdvCoMstrOn` can be used at the same time, since the parameter `AdvCoMstrOn` only reacts to edges of the binary signal.

Program mode is deactivated with a 1 - 0 edge transition.

Note

The output parameters `ManAct` or `AutAct` display the mode to which the controller changes with a 1 - 0 edge transition.

The output parameter `AdvCoRdy = 1` indicates if the PID controller is ready to switch to program mode. At a central control block, you can use an AND operation for all `AdvCoRdy` signals of the downstream controllers to enable central switchover.

The output parameter `AdvCoAct = 1` indicates if the block is in program mode.

Selecting the type of program mode

There are two types of program mode:

- Program mode driven by setpoint (in automatic mode only)
- Program mode driven by manipulated variable (in manual mode only, not for step controllers without position feedback)

Program mode with setpoint: If you set the input parameter `AdvCoModSP = 1`, the analog value provided by the OPC client (`AdvCoMV`) is used as an external setpoint for the controller. The controller and faceplate otherwise react as they do with automatic mode and an external setpoint. Refer to section Setpoint specification - internal/external (Page 128) for more about this.

Requirements for program mode with setpoint:

- `AdvCoModSP = 1`,
- `AdvCoEn = 1`,
- Controller is preferably in manual mode, but it may also be in automatic mode
- The setpoint can be set to internal as well as external.

Program mode with manipulated variable: If you set the input parameter `AdvCoModSP = 0`, the analog value provided by the OPC client (`AdvCoMV`) is used as an external manipulated variable for the controller. The algorithm of the PID controller is bypassed. The controller and faceplate otherwise react as they do with tracking (`MV_TrkOn = 1`). Refer to section Tracking and limiting a manipulated variable (Page 196) for more about this.

Requirements for program mode with manipulated variable:

- `AdvCoModSP = 0`,
- `AdvCoEn = 1`,
- Controller is preferably in manual mode, but it can also be in automatic mode.
- The setpoint can be set to internal as well as external.

Note

Program mode with manipulated variable is not available for step controllers without position feedback (available in `PIDStepL`, `FmCont` and `FmTemp`). `ErrorNum = 50` is output on the controller block and the controller cannot switch into program mode (`AdvCoAct=0`).

2.1.2.7 Local mode

Areas of application for local mode

This operating mode is used for motors, valves and dosing units. The control settings are made directly or via a control station that is located "locally". In addition, you can set different control strategies with the parameter `LocalSetting`.

With `LocalSetting = 0`, you prevent a change to "local mode".

Note

Differences between "Large" and "Small" blocks

The operating mode described here is valid for "Large" blocks. For "Small" blocks, `LocalSetting` can be configured only on a limited basis. For more information, refer to the respective description for the operating modes of the blocks.

Changing to local mode

Changing to local mode is only possible from the manual and automatic operating modes. The change to this mode is initiated by:

- An operation on the faceplate (input parameter `LocalOp = 1`, valid if `LocalSetting = 3` or `LocalSetting = 4` and `ModLiOp = 0`) or
- The interconnected input parameter (`LocalLi = 1`, valid if `LocalSetting = 1` or `LocalSetting = 2`).

Exiting local mode

You leave local mode using:

- An operation on the faceplate (`LocalSetting = 3` or `LocalSetting = 4` and `ModLiOp = 0`) or
- the interconnected input parameter (`LocalSetting = 1` or `LocalSetting = 2`).
In order to exit local mode via the interconnected input parameter, you can configure various reactions using a `Feature` bit `Exiting local mode` (Page 177).

Operator input in "local mode" using a faceplate

You are not permitted to functionally operate the block in local mode. You can only use the faceplate to exit local mode if you have also activated "local mode" using the faceplate. The rules you specified for exiting "local mode" apply here.

Input in "local mode" via interconnected inputs

In "local mode", the way the block functions is influenced via interconnected input parameters according to the settings of the `LocalSetting` parameter. You have the following options:

- `LocalSetting = 1` and `LocalSetting = 3`
 - The control settings for the block are adjusted (tracking) via an interconnected input parameter. The interconnected input parameter includes the control signal for the local operator station on the system.
 - The runtime monitoring of the block is effective in accordance with your configuration.
 - The interlocking functions of the block are activated in accordance with input parameter `ByProt = 0` or deactivated (`ByProt = 1`).

Note

The block `VlvAnL` does not support `LocalSetting = 1/3`.

- `LocalSetting = 2` and `LocalSetting = 4`
 - The control settings for the block are made based on internal adjustment of the feedback value.
 - Runtime monitoring of the block is active only with rapid stop, external fault, motor protection, and if both feedback signals are set (discrepancy).
An exception is `VlvMotL`:

Note

`VlvMotL`

The motor and valve feedback signals are monitored if the motor feedback signals exist and are connected with `FbkOpening` and `FbkClosing` (`Feature bit 12 = 0`). The motor feedback signals are only monitored in the end positions of the valve and in discrepancy. For example, if the valve is in end position `FbkOpen = 1` and the motor feedback `FbkOpening = 1` is pending, an error message is generated upon expiration of the monitoring time. If there are no motor feedback signals (`Feature bit 12 = 1`), monitoring of the valve and motor feedback signals does not take place.

`VlvAnL`: The auxiliary valve is controlled via internal tracking of the feedback signals `FbkAuxVCloseOut` and `FbkAuxVOpenOut`. The control of the main valve via the feedback value `Rbk` is not affected by this.

The texts for labeling the command buttons in the faceplates of the motor and valve blocks can now be assigned for each specific instance.

The configuration of the texts is performed with the "Text 1" property of the respective control inputs of the motor and valve blocks in the CFC.

If no instance-specific text is configured, the previous default texts are used and displayed in the faceplate.

The following table shows the assignment of the command buttons to the corresponding block input:

The interlock functions of the block are deactivated.

Overview of behavior in local mode

LocalSetting =	0	1	2	3	4	5 (VlvS only)
Switch on operating mode	Cannot be set	CFC/SFC	CFC/SFC	Faceplate	Faceplate	CFC
Changing the operating mode: Local mode/to manual mode only (Feature = 0)	-	CFC/SFC	CFC/SFC	-	-	CFC/SFC
Changing the operating mode: Local mode/previous mode (Feature = 1)	-	CFC/SFC	CFC/SFC	-	-	CFC/SFC
Operating in the faceplate	-	Only rapid stop and resetting of rapid stop	Only rapid stop and resetting of rapid stop (only for "Large" blocks)	Only switching of operating mode, rapid stop, internal/external set-point switch-over and resetting of rapid stop	Only switching of operating mode, rapid stop, and resetting of rapid stop	-
Executing local commands	-	Yes	No	Yes	No	No
Reaction of the block	-	Monitoring the feedbacks	Tracking of feedback, monitoring feedback during rapid stop, external errors, motor protection or discrepancy	Monitoring the feedbacks	Tracking of feedback, monitoring feedback during rapid stop, external errors, motor protection or discrepancy	Monitoring the feedbacks
Interlock activated	-	Yes: (ByProt = 0) No: (ByProt = 1)	only at output LockAct with Feature Bit 27 = 1 and ByProt = 0	Yes: (ByProt = 0) No: (ByProt = 1)	only at output LockAct with Feature Bit 27 = 1 and ByProt = 0	only at output LockAct with Feature Bit 27 = 1 and ByProt = 0

2.1.2.8 State graph of the operating modes

State graph of the operating modes

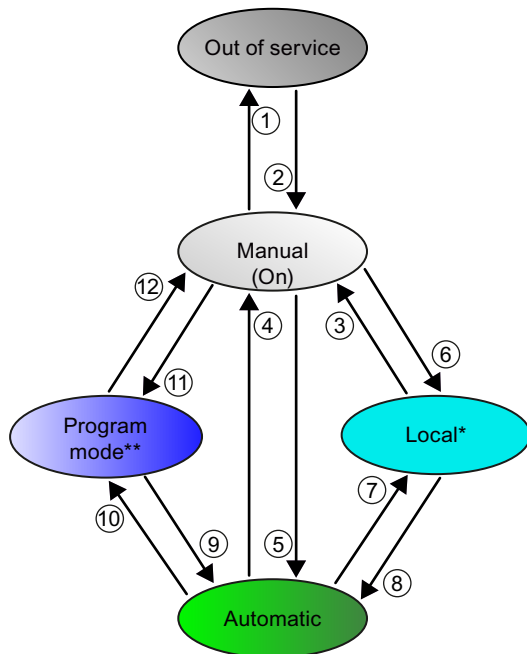

Figure 2-7 State graph of the operating modes

* This operating mode is used for motors, valves, and dosing units.

** This operating mode is used for controllers only.

Number in graphic (top)	Condition for status change
(1)	Manual (on) → Out of service <ul style="list-style-type: none"> • Via faceplate (OosOp = 1) if ModLiOp = 0 or • Via edge transition 0 → 1 of OosLi if Feature bit Reaction to the out of service mode (Page 177)= 1
(2)	Out of service → Manual (on) <ul style="list-style-type: none"> • Via faceplate (ManModOp = 1)
(3)	Local mode → Manual <ul style="list-style-type: none"> • Via faceplate (ManModOp = 1) if ModLiOp = 0 and LocalSetting = 3 or LocalSetting = 4 or • Via LocalLi = 0 if LocalSetting = 1, LocalSetting = 2 or LocalSetting = 5. See section Exiting local mode (Page 177) for more conditions.

2.1 Functions of the blocks

Number in graphic (top)	Condition for status change
(4)	<p>Automatic → Manual</p> <ul style="list-style-type: none"> • Via faceplate (ManModOp = 1) if ModLiOp = 0 or • Via ManModLi = 1 if ModLiOp = 1 and Feature bit Setting switch or button mode (Page 167)= 0 or • Via AutModLi = 0 if ModLiOp = 1 and Feature bit Setting switch or button mode (Page 167)= 1
(5)	<p>Manual → Automatic</p> <ul style="list-style-type: none"> • Via faceplate (AutModOp = 1) if ModLiOp = 0 or • Via AutModLi = 1 if ModLiOp = 1
(6)	<p>Manual → Local mode</p> <ul style="list-style-type: none"> • Via faceplate (LocalOp = 1) if ModLiOp = 0 and LocalSetting = 3 or LocalSetting = 4 or • Via LocalLi = 1 if LocalSetting = 1, LocalSetting = 2 or LocalSetting = 5
(7)	<p>Automatic → Local mode</p> <ul style="list-style-type: none"> • Via faceplate (LocalOp = 1) if ModLiOp = 0 and LocalSetting = 3 or LocalSetting = 4 or • Via LocalLi = 1 if LocalSetting = 1, LocalSetting = 2 or LocalSetting = 5
(8)	<p>Local mode → Automatic</p> <ul style="list-style-type: none"> • Via faceplate (AutModOp = 1) if ModLiOp = 0 and LocalSetting = 3 or LocalSetting = 4 or • Via LocalLi = 0 if LocalSetting = 1, LocalSetting = 2 or LocalSetting = 5. See section Exiting local mode (Page 177) for more conditions.
(9)	<p>Program mode → Automatic</p> <ul style="list-style-type: none"> • Via faceplate (AutModOp = 1) if ModLiOp = 0 or • Via AutModLi = 1 if ModLiOp = 1 or • Via edge transition 1 → 0 of AdvCoMstrOn if automatic is set before program mode.
(10)	<p>Automatic → Program mode</p> <p>Requirement for switchover in program mode: AdvCoEn = 1</p> <ul style="list-style-type: none"> • Via faceplate (AdvCoOn= 1) if ModLiOp = 0 or • Via AdvCoMstrOn = 1
(11)	<p>Manual → Program mode</p> <p>Requirement for switchover from manual to program mode: AdvCoEn = 1 and AdvCoModSP = 0</p> <ul style="list-style-type: none"> • Via faceplate (AdvCoOn= 1) if ModLiOp = 0 or • Via AdvCoMstrOn = 1
(12)	<p>Program mode → Manual</p> <ul style="list-style-type: none"> • Via faceplate (ManModOp = 1) if ModLiOp = 0 or • Edge transition 1 → 0 of AdvCoMstrOn if manual is set before program mode.

2.1.3 Monitoring functions

2.1.3.1 Monitoring functions in the Advanced Process Library

Monitoring functions in the Advanced Process Library

This and the following chapters encompass the standard monitoring functions in the Advanced Process Library. The monitoring functions include:

- Limit value monitoring
- Feedback monitoring
- Motor protection

Some of the configured time values (e.g. `MonTiStatic`, `MonTiDynamic`) are limited at the low end to the sampling time by the block algorithm and written back to the block input. "Reset Program" (after a "Download Entire Program" for example) writes the parameter values changed in this way to the offline data storage system.

For further and detailed information, refer to the following chapters. For the block-specific monitoring functions, also refer to the description of the particular block.

2.1.3.2 Group display for limit monitoring, CSF and ExtMsgx

Group display for limit monitoring, CSF and ExtMsgx

The `SumMsgAct` output parameter assembles the following signals of a block and makes them available to you:

- Limit monitoring of the process value
- Limit monitoring of the count value
- Limit monitoring of the feedback
- Limit monitoring of setpoint difference, manipulated variable difference and error signal
- External control system fault (CSF)
- Freely selectable messages `ExtMsg1..4`

Note

The signal status of the individual signals is not taken into consideration for forming the group error.

2.1.3.3 Limit monitoring

Limit monitoring of the process value

You can monitor the process value to the following high and low alarm, warning and tolerance limits:

- PV_AH_Lim: Limit for high alarm
- PV_AL_Lim: Limit for low alarm
- PV_WH_Lim: Limit for high warning
- PV_WL_Lim: Limit for low warning
- PV_TH_Lim: Limit for the high tolerance
- PV_TL_Lim: Limit for the low tolerance

Note

The message classes Alarm, Warning and Tolerance are not valid for user-configured message classes. Please take into consideration the validity of terms for user-configured message classes (Page 41).

Note

Special note for "Small" blocks

"Small" blocks provide only the monitoring for alarms and warnings.

Result of the limit monitoring

The result of limit monitoring is made available at the interconnectable output parameters:

- PV_AH_Act = 1:: Limit for high alarm reached or exceeded
- PV_AL_Act = 1:: Limit for low alarm reached or undershot
- PV_WH_Act = 1:: Limit for high warning reached or exceeded
- PV_WL_Act = 1:: Limit for low warning reached or undershot
- PV_TH_Act = 1:: Limit for high tolerance reached or exceeded
- PV_TL_Act = 1:: Limit for low tolerance reached or undershot

made available (see figure). The SumMsgAct = 1 output parameter is also set when at least one limit value is reached or violated.

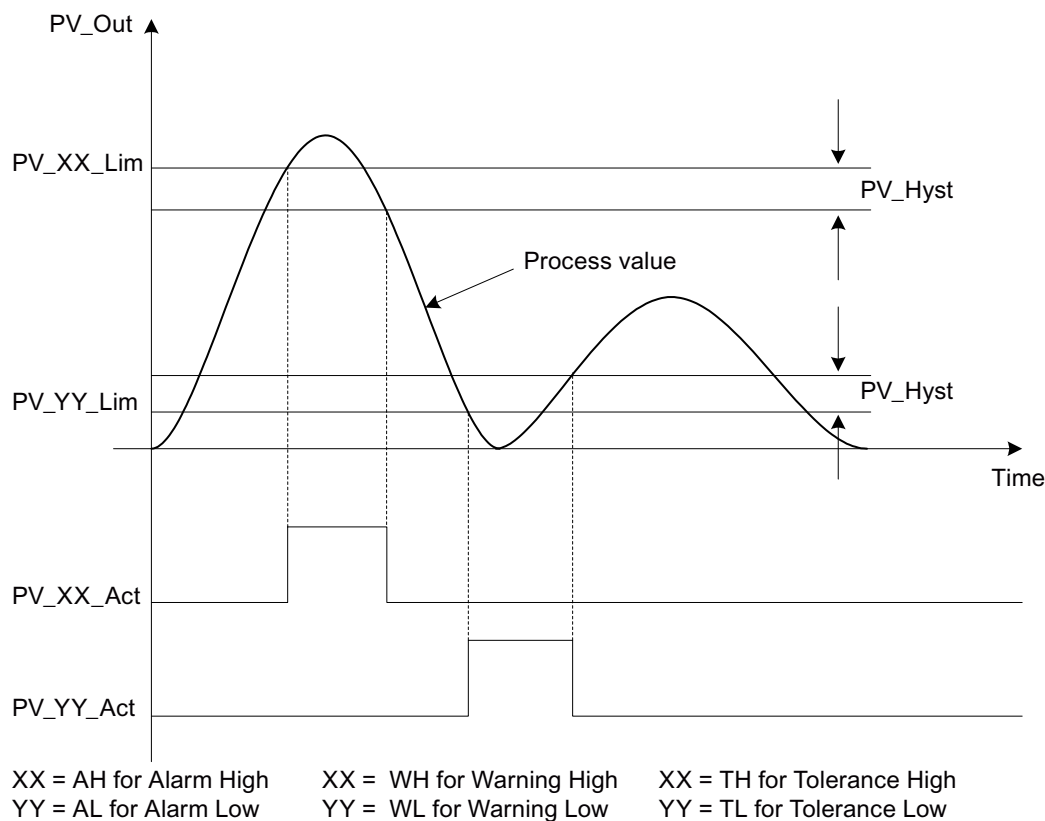

You can use [Feature Bit 29 Signaling limit violation](#) (Page 170) to determine whether the output parameter triggers limit monitoring with the value "0" or "1".

You can use [Feature Bit 28 Disabling operating points](#) (Page 145) to disable limit monitoring when message suppression is enabled (`MsgLock = 1`).

Activating limit monitoring

Monitoring is always enabled using the input parameters:

- `PV_AH_En = 1`: Monitoring of the high alarm limits
- `PV_AL_En = 1`: Monitoring of the low alarm limits
- `PV_WH_En = 1`: Monitoring of the high warning limits
- `PV_WL_En = 1`: Monitoring of the low warning limits
- `PV_TH_En = 1`: Monitoring of the high tolerance limits
- `PV_TL_En = 1`: Monitoring of the low tolerance limits

Predefinition: When the block is installed, monitoring of the tolerance limits is disabled, meaning that the parameters are configured with 0. To activate monitoring, assign 1 to these parameters.

All other monitoring functions are enabled.

Message suppression

	Symbol for message suppression
---	--------------------------------

The corresponding message is suppressed using the parameters:

- PV_AH_MsgEn = 0: Alarm (high) messages are suppressed
- PV_AL_MsgEn = 0: Alarm (low) messages are suppressed
- PV_WH_MsgEn = 0: Warning (high) messages are suppressed
- PV_WL_MsgEn = 0: Warning (low) messages are suppressed
- PV_TH_MsgEn = 0: Tolerance (high) messages are suppressed
- PV_TL_MsgEn = 0: Tolerance (low) messages are suppressed

The output of messages is not suppressed when the block is installed (all xx_MsgEn parameters are preset to 1). Messages can only be output if limit monitoring of the additional analog value has been enabled.

Hysteresis

You can specify a hysteresis (PV_Hyst) for the limits, for example, to suppress signal flutter. Refer to the Limit monitoring with hysteresis (Page 97) chapter for more on this.

Alarm delays

You can set alarm delays for incoming and outgoing alarms, warnings and tolerances. Refer to the Area of application of the alarm delays (Page 199) chapter for more on this.

Operating in the faceplate

You can also change the limits and the hysteresis using the faceplate. Refer to the Limit operation and display in the faceplate (Page 319) chapter for more on this.

See also

Two time values per limit pair (Page 201)

Two time values for each individual limit (Page 202)

User-configured message classes (Page 41)

Limit monitoring of the count value

You can monitor the count value to the following high and low alarm, warning and tolerance limits:

- OutAH_Lim: Limit for high alarm
- OutAL_Lim: Limit for low alarm
- OutWH_Lim: Limit for high warning
- OutWL_Lim: Limit for low warning
- OutTH_Lim: Limit for the high tolerance
- OutTL_Lim: Limit for the low tolerance

Note

The message classes Alarm, Warning and Tolerance are not valid for user-configured message classes. Please take into consideration the validity of terms for user-configured message classes (Page 41).

Note

Monitoring the limits

The limits monitored depend on the direction of counting:

- In Mode 1 (summing up or integrating), the high limits are monitored:
 - OutAH_Lim
 - OutWH_Lim
 - OutTH_Lim
 - In Mode 2 (summing down or integrating), the low limits are monitored:
 - OutAL_Lim
 - OutWL_Lim
 - OutTL_Lim
-

Example for limit monitoring with a counter

Monitoring of the high limit is performed only if the counter is running in "up" direction.

If you count "up" but with negative values, for example, from 100 down, you need to adjust the high limit accordingly (for example, the high limit could be -15).

This behavior applies to the blocks CountScL, CountOh and TotalL.

Result of the limit monitoring

The result of limit monitoring is made available at the interconnectable output parameters:

- OutAH_Act = 1:: Limit for high alarm reached or exceeded
- OutAL_Act = 1:: Limit for low alarm reached or undershot
- OutWH_Act = 1:: Limit for high warning reached or exceeded
- OutWL_Act = 1:: Limit for low warning reached or undershot

2.1 Functions of the blocks

- `OutTH_Act = 1`:: Limit for high tolerance reached or exceeded
- `OutTL_Act = 1`:: Limit for low tolerance reached or undershot

made available (see figure). The `SumMsgAct = 1` output parameter is also set when at least one limit value is reached or violated.

You can use `Feature Bit 29 Signaling limit violation` (Page 170) to determine whether the output parameter triggers limit monitoring with the value "0" or "1".

You can use `Feature Bit 28 Disabling operating points` (Page 145) to disable limit monitoring when message suppression is enabled (`MsgLock = 1`).

Activating limit monitoring

Monitoring is always enabled using the input parameters:

- `OutAH_En = 1`: Monitoring of the high alarm limits
- `OutAL_En = 1`: Monitoring of the low alarm limits
- `OutWH_En = 1`: Monitoring of the high warning limits
- `OutWL_En = 1`: Monitoring of the low warning limits
- `OutTH_En = 1`: Monitoring of the high tolerance limits
- `OutTL_En = 1`: Monitoring of the low tolerance limits

Predefinition: When the block is installed, monitoring of the tolerance limits is disabled, meaning that the parameters are configured with 0. To activate monitoring, assign 1 to these parameters.

All other monitoring functions are enabled.

Message suppression

The corresponding message is suppressed using the parameters:

- `OutAH_MsgEn = 0`: Alarm (high) messages are suppressed
- `OutAL_MsgEn = 0`: Alarm (low) messages are suppressed
- `OutWH_MsgEn = 0`: Warning (high) messages are suppressed
- `OutWL_MsgEn = 0`: Warning (low) messages are suppressed
- `OutTH_MsgEn = 0`: Tolerance (high) messages are suppressed
- `OutTL_MsgEn = 0`: Tolerance (low) messages are suppressed

The output of messages is not suppressed when the block is installed (all `xx_MsgEn` parameters are preset to 1). Messages can only be output if limit monitoring of the additional analog value has been enabled.

Operating in the faceplate

You can also change the limits using the faceplate. Refer to the Limit operation and display in the faceplate (Page 319) chapter for more on this.

See also

User-configured message classes (Page 41)

Limit monitoring of an additional analog value**Limit monitoring of an additional analog value**

Limit monitoring is performed for an additional analog value on the basis of the AV block, see Description of AV (Page 439) chapter.

You can monitor an additional analog value to the following high and low limits for alarms warnings and tolerances at the technologic block:

- AV_AH_Lim: Limit for high alarm
- AV_AL_Lim: Limit for low alarm
- AV_WH_Lim: Limit for high warning
- AV_WL_Lim: Limit for low warning
- AV_TH_Lim: Limit for the high tolerance
- AV_TL_Lim: Limit for the low tolerance

Note

The message classes Alarm, Warning and Tolerance are not valid for user-configured message classes. Please take into consideration the validity of terms for user-configured message classes (Page 41).

Note

The AV block and the technologic block must be built into the same cyclic interrupt OB.

Result of the limit monitoring

The result of limit monitoring is made available at the interconnectable output parameters of the AV block:

- AV_AH_Act = 1:: Limit for high alarm reached or exceeded
 - AV_AL_Act = 1:: Limit for low alarm reached or undershot
 - AV_WH_Act = 1:: Limit for high warning reached or exceeded
 - AV_WL_Act = 1:: Limit for low warning reached or undershot
 - AV_TH_Act = 1:: Limit for high tolerance reached or exceeded
 - AV_TL_Act = 1:: Limit for low tolerance reached or undershot
- made available (see figure).

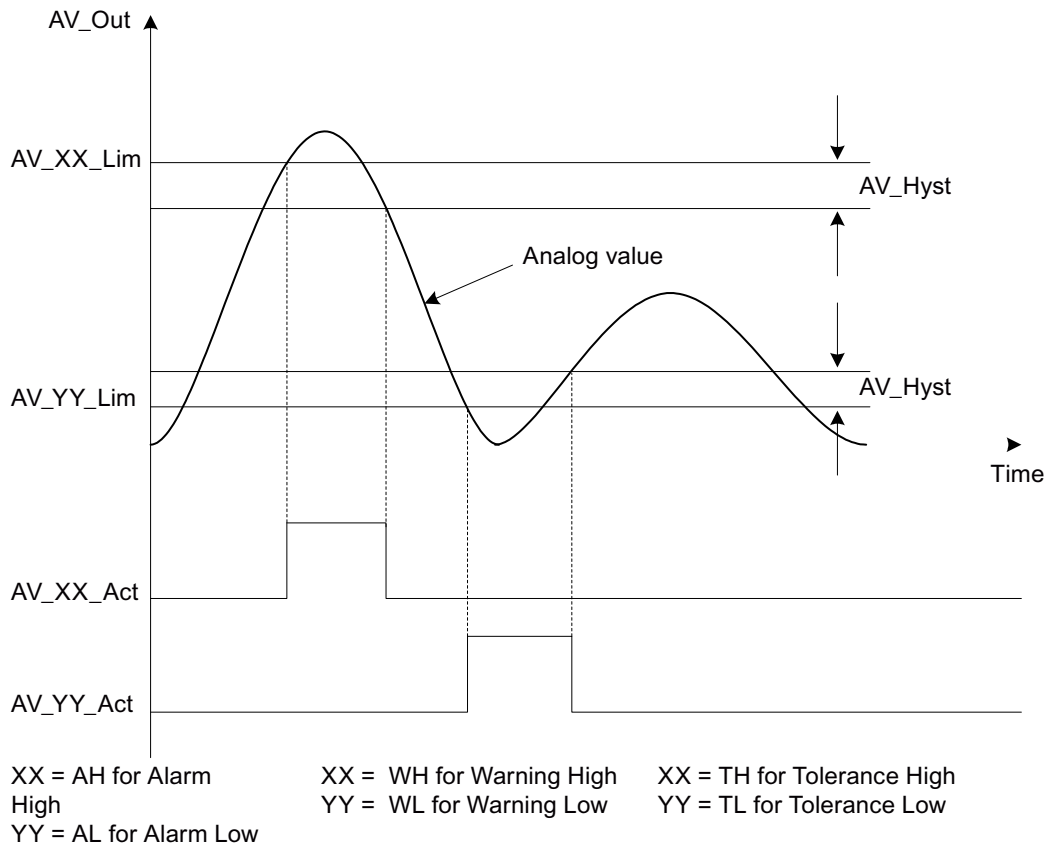

You can use **Feature Bit 29 Signaling limit violation** (Page 170) to determine whether the output parameter triggers limit monitoring with the value "0" or "1".

You can use **Feature Bit 28 Disabling operating points** (Page 145) to disable limit monitoring when message suppression is enabled (`MsgLock = 1`).

Activating limit monitoring

Monitoring is always enabled using the input parameters of the AV block:

- `AV_AH_En = 1`: Monitoring of the high alarm limits
- `AV_AL_En = 1`: Monitoring of the low alarm limits
- `AV_WH_En = 1`: Monitoring of the high warning limits
- `AV_WL_En = 1`: Monitoring of the low warning limits
- `AV_TH_En = 1`: Monitoring of the high tolerance limits
- `AV_TL_En = 1`: Monitoring of the low tolerance limits

Predefinition: When the block is installed, monitoring of the tolerance limits is disabled, meaning that the parameters are configured with 0. To activate monitoring, assign 1 to these parameters.

All other monitoring functions are enabled.

Message suppression

The corresponding message is suppressed at the block AV using the parameters:

- AV_AH_MsgEn = 0: Alarm (high) messages are suppressed
- AV_AL_MsgEn = 0: Alarm (low) messages are suppressed
- AV_WH_MsgEn = 0: Warning (high) messages are suppressed
- AV_WL_MsgEn = 0: Warning (low) messages are suppressed
- AV_TH_MsgEn = 0: Tolerance (high) messages are suppressed
- AV_TL_MsgEn = 0: Tolerance (low) messages are suppressed

The output of messages is not suppressed when the block is installed (all `xx_MsgEn` parameters are preset to 1). Messages can only be output if limit monitoring of the additional analog value has been enabled.

Hysteresis

You can specify a hysteresis (`AV_Hyst`) at the technologic block for the limits, for example, to suppress signal flutter. Refer to the Limit monitoring with hysteresis (Page 97) chapter for more on this.

Alarm delays

You can set alarm delays for incoming and outgoing alarms, warnings and tolerances. Refer to the Area of application of the alarm delays (Page 199) chapter for more on this.

Operating in the faceplate

You can also change the limits and the hysteresis using the faceplate. Refer to the Limit operation and display in the faceplate (Page 319) chapter for more on this.

See also

User-configured message classes (Page 41)

Limit monitoring of the feedback

Limit monitoring of position feedback

The position feedback of the manipulated variable can be monitored for the following high and low warning limits:

- `RbkWH_Lim`: Limit for high warning
- `RbkWL_Lim`: Limit for low warning

Note

The message classes Alarm, Warning and Tolerance are not valid for user-configured message classes. Please take into consideration the validity of terms for user-configured message classes (Page 41).

Result of limit monitoring of the position feedback

The result of limit monitoring of the position feedback is made available at the interconnectable output parameters:

- `RbkWH_Act = 1`: High limit reached or exceeded
- `RbkWL_Act = 1`: Low limit reached or undershot

made available. The `SumMsgAct = 1` output parameter is also set when at least one limit value is reached or violated.

When the limits are reached or exceeded, messages that can be suppressed are output.

You can use `Feature Bit 29 Signaling limit violation` (Page 170) to determine whether the output parameter triggers limit monitoring with the value "0" or "1".

You can use `Feature Bit 28 Disabling operating points` (Page 145) to disable limit monitoring when message suppression is enabled (`MsgLock = 1`).

Activating limit monitoring

Monitoring is always enabled using the input parameters:

- `RbkWH_En = 0`: Monitoring of the high warning limit is disabled
- `RbkWL_En = 0`: Monitoring of the low warning limit is disabled

Predefinition: When the block is installed, monitoring is enabled (default is 1).

Message suppression

The corresponding message is suppressed using the parameters:

- `RbkWH_MsgEn = 0`: Messages from the high limit monitoring are suppressed
- `RbkWL_MsgEn = 0`: Messages from the low limit monitoring are suppressed

The output of messages is not suppressed when the block is installed (for example, `RbkWH_MsgEn = 1`). Messages can only be output if limit monitoring of the position feedback has been enabled.

Hysteresis

You can specify a hysteresis (`RbkHyst`) for the limits, for example, to suppress signal flutter. Refer also to chapter Limit monitoring with hysteresis (Page 97) for more on this.

Alarm delays (only for the PIDConR and MotSpdCL blocks)

You can set alarm delays for incoming and outgoing warnings. Refer to the Area of application of the alarm delays (Page 199) chapter for more on this.

Operating in the faceplate

You can also change the limits and the hysteresis using the faceplate. Refer to the Limit operation and display in the faceplate (Page 319) chapter for more on this.

See also

User-configured message classes (Page 41)

Limit monitoring of setpoint, manipulated variable and control deviation

Limit monitoring of setpoint, manipulated variable and error signal

The setpoint, manipulated variable and error signal can be monitored for the following high and low alarm limits:

- `ER_AH_Lim`: Limit for high alarm
- `ER_AL_Lim`: Limit for low alarm

Note

The message classes Alarm, Warning and Tolerance are not valid for user-configured message classes. Please take into consideration the validity of terms for user-configured message classes (Page 41).

Result of the limit monitoring

The result of limit monitoring is made available at the interconnectable output parameters:

- `ER_AH_Act = 1`: High limit violated (reached or exceeded)
- `ER_AL_Act = 1`: Low limit (reached or undershot)

made available. The `SumMsgAct = 1` output parameter is also set when at least one limit value is reached or violated.

When the limits are reached or exceeded, messages that can be suppressed are output.

You can use `Feature Bit 29 Signaling limit violation` (Page 170) to determine whether the output parameter triggers limit monitoring with the value "0" or "1".

You can use `Feature Bit 28 Disabling operating points` (Page 145) to disable limit monitoring when message suppression is enabled (`MsgLock = 1`).

Activating limit monitoring

Alarm monitoring is enabled using the input parameters:

- `ER_AH_En = 1`: Monitoring of the high alarm limit
- `ER_AL_En = 1`: Monitoring of the low alarm limit

Predefinition: When the block is installed, monitoring is disabled.

Message suppression

The corresponding message is suppressed using the parameters:

- `ER_AH_MsgEn = 0`: Messages from the high limit monitoring are suppressed
- `ER_AL_MsgEn = 0`: Messages from the low limit monitoring are suppressed

The output of messages is not suppressed when the block is installed (for example, `ER_AH_MsgEn = 1`). Messages can only be output if limit monitoring has been enabled.

Note

With the `MotSpdCL` block, messages are only output if you have enabled `Feature Bit 5 (Alarm setpoint difference)` (Page 171)).

Hysteresis

You can specify a hysteresis (`ER_Hyst`) for these limits, for example, in order to suppress signal flutter. Refer also to chapter `Limit monitoring with hysteresis` (Page 97) for more on this.

Alarm delays

You can set alarm delays for incoming and outgoing alarms. Refer to the `Area of application of the alarm delays` (Page 199) chapter for more on this.

Operating in the faceplate

You can also influence the limits and the hysteresis by means of the faceplate. Refer to the `Limit operation and display in the faceplate` (Page 319) chapter for more on this.

See also

User-configured message classes (Page 41)

Limit monitoring with hysteresis

Limit monitoring with hysteresis

You can additionally define a hysteresis for all limit monitoring functions (parameter `xxx_Hyst`, `xxx` can, for example, be `PV` for the process value). You use the hysteresis, for example, to suppress signal flutter.

Enter the hysteresis as a physical variable at the block and faceplate (if you have the appropriate operator control permissions (WinCC)).

For the WinCC operator control permissions, refer to the help on WinCC.

2.1.3.4 Feedbacks

Monitoring the feedbacks

Feedback monitoring

You can use the following monitoring functions:

- Monitoring the start-up and stop characteristics for motors or the runtime of valves
- Monitoring the operation of motors or the maintenance of the position of valves
- Disabling feedback

This monitoring function is enabled via the `Monitor = 1` input.

Static and dynamic errors are reset by disabling the monitoring (`Monitor = 0`). If you reactivate monitoring during the plant runtime, only dynamic monitoring (`MonTiDynamic`) will be performed.

Monitoring the start-up and stop characteristics for motors or the runtime of valves

Monitoring of the startup characteristics is implemented using the parameter `MonTiDynamic`. The monitoring time specifies the period within which the feedback value, for example, `FbkStart` with motors, must be available in response to a control signal. If this is not the case, the text "Control error" is displayed in the standard view of the faceplate. An error message is generated at the same time. The block then goes to its neutral position. In the case of motors, this is always the stop state. With other blocks, this is a neutral position you have specified (`SafePos` parameter). The block signals this at the corresponding output parameter of the error message with 1, for example, with `MonDynErr = 1` for motors.

With the motors `MotL`, `MotRevL`, `MotSpdL`, `MotSpdCL` and the motor valve `VlvMotL`, the `Feature` bit 13 can be set to use a separate monitoring time `MonTiDyStop` for the stop behavior. The monitoring time for the stop behavior is displayed at the `MonDynStopErr` output.

Parameters are set in seconds.

Note

In manual mode, you can control all valves (including the motor valve) despite the `MonSafePos = 1` setting and with "End position error" even without reaching the neutral position.

Monitoring the operation of motors or the maintenance of the position of valves

The following applies for "Large" blocks: Monitoring of the operation or the maintenance of the position of valves is implemented using the parameter `MonTiStatic`. The monitoring time specifies the period in which the feedback value can change its value briefly without an error message being output. An example would be a running motor with the feedback via the input parameter `FbkStart`. This parameter should be static in accordance with the control function. However, its value can change within the monitoring time. If the change in the `FbkStart` parameter takes longer than the monitoring time, the text "End position error" is displayed in the standard view of the faceplate. An error message is generated at the same time. The block then goes to its neutral position. In the case of motors, this is always the stop state. With other blocks, this is an neutral position you have specified (`SafePos` parameter). The block signals this at the corresponding output parameter of the error message with 1, for example, with `MonStaErr = 1` for motors.

Parameters are set in seconds.

Note

Please note that $\text{MonTiDynamic} \geq \text{MonTiStatic}$ and $\text{MonTiDynamic} \geq \text{SampleTime}$ have to be configured. If something is set outside these limits, the block always returns the respective limit at the input.

If `SampleTime` changes, `MonTiDynamic` may be tracked to the new value for `SampleTime`. `MonTiStatic` is tracked if `MonTiDynamic < MonTiStatic` changes. With `MonTiStatic = 0`, each feedback change without change of the control immediately results in a runtime error.

The following applies for "Small" blocks: These blocks operate like "Large" blocks; however, the monitoring time is set to 0 within the block and cannot be changed. Any change is displayed immediately at the output parameter `MonStaErr` with 1.

Disabling feedback for valves

You can also disable feedback completely. Please refer to section Disabling feedback for valves (Page 99) for further information.

Note

This function is only supported by "Large" blocks.

Resetting the block in case of interlocks or errors

In the event of an interlock or error, the block has to be reset. Refer to the Resetting the block in case of interlocks or errors (Page 43) section for more on this.

Disabling feedback for valves

Disabling monitoring of feedback for valves

This function is only supported by "Large" blocks.

If you operate a block without feedback, use the parameter `NoFbkOpen = 1` bzw. `NoFbkClose = 1`. This means, for example, that you do not have any feedbacks for the opened state of the valve. Monitoring is thus disabled for this feedback. The feedback at the block is adjusted according to the control signal.

2.1.3.5 Motor protection function

Motor protection function

The motor protection function is used to turn off the motor if there is thermal overload (`Trip = 0`, interconnectable input parameter).

If the motor is turned off by the motor protection function, a message (process control message) is generated. This is indicated in the faceplate by the "Motor protection" text. You can influence the reset using a various `Feature` bits. Refer to the Resetting the block in case of interlocks or errors (Page 43) section for more on this.

You can find more information in Section Influence of the signal status on the interlock (Page 104).

2.1.4 Interlocking functions

2.1.4.1 Interlocks

Interlocks at blocks

A maximum of three types of interlock can be used depending on the block. Three separate inputs named `Intlock`, `Protect` and `Permit` are available for these functions. The blocks `MotRevL`, `VlvMotL`, and `VlvPosL` with `Feature2.Bit16 = 1` (see section Separate interlock for each direction or position (Page 170)) have inputs for interlock functionality with direction:

MotRevL (Feature2.Bit16 = 1)	VlvMotL, VlvPosL (Feature2.Bit16 = 1)
Permit: Enable forward	Permit: Enable open
PermRev: Enable reverse	PermCls: Enable close
Intlock: Interlock forward	Intlock: Interlock open

MotRevL (Feature2.Bit16 = 1)	VlvMotL, VlvPosL (Feature2.Bit16 = 1)
IntlRev: Interlock reverse	IntlCls: Interlock close
Protect: Protection forward	Protect: Protection open
ProtRev: Protection reverse	ProtCls: Protection close

Note

Interlocks for "small" blocks and controller blocks

Ensure that "small" blocks and controller blocks PIDConL and PIDConR have only the `Intlock` parameter. The other two interlocks are not included in these block variants.

The following interlock types exist:

All blocks with the interlock function and MotRevL with Feature 2 bit 16 = 0

- **Activation enable ("Permission"):** The activation enable (input `Permit/PermRev/PermCls = 1`) makes it possible to leave the neutral position of the block in response to operator input or a command from the program (CFC/SFC). The activation enable has no effect if the block is not in the neutral position. See also the section Neutral position for motors, valves and controllers (Page 48) for information on the neutral position.
- **Interlock without reset ("Interlock"):** An active interlock condition brings the block to the neutral position (input `Intlock/IntlRev/IntlCls = 0`). After the interlock condition has gone, the currently active control function becomes active again in automatic or local mode. In manual mode the faceplate can be operated again after the interlock condition has gone.
- **Interlock with reset ("Protection"):** An active interlock condition brings the block to the neutral position (input `Protect/ProtRev/ProtCls`). After the interlock conditions are cleared, the operator or an activation sequence must perform a reset to once again enable activation of the control according to the input parameters.
You can influence the reset using a various `Feature` bits. Refer to the Resetting the block in case of interlocks or errors (Page 43) section for more on this.

Only MotRevL with Feature 2 bit 16 = 1

- **Activation enable forward ("Enable forward"):** The activation enable (input `Permit = 1`) makes it possible to leave the neutral position of the block in the forward direction in response to operator input or a command from the program (CFC/SFC). The activation enable has no effect if the block is not in the neutral position. See also the section Neutral position for motors, valves and controllers (Page 48) for information on the neutral position.
- **Activation enable reverse ("Enable reverse"):** The activation enable (input `PermRev = 1`) makes it possible to leave the neutral position of the block in the reverse direction in response to operator input or a command from the program (CFC/SFC). The activation enable has no effect if the block is not in the neutral position. See also the section Neutral position for motors, valves and controllers (Page 48) for information on the neutral position.
- **Interlock forward without reset ("Interlock forward"):** A pending forward interlock condition only puts the block in the neutral position when the motor is running in this direction (input `Intlock = 0`). Once the forward interlock condition is cleared, the currently active forward control function becomes active again in automatic or local mode. In manual mode, the faceplate can be operated forward again.

- **Interlock reverse without reset ("Interlock reverse"):** A pending reverse interlock condition only puts the block in the neutral position when the motor is running in this direction (input `IntlRev = 0`). Once the reverse interlock condition is cleared, the currently active reverse control function becomes active again in automatic or local mode. In manual mode, the faceplate can be operated reverse again.
- **Interlock forward with reset ("Protection forward"):** A pending forward interlock condition only puts the block in the neutral position when the motor is running in this direction (input `Protect = 0`). Once the interlock conditions are cleared, the operator or an activation sequence must perform a reset to once again enable activation of the forward control according to the input parameters. You can influence the reset using a various `Feature` bits. Refer to the Resetting the block in case of interlocks or errors (Page 43) section for more on this.
- **Interlock reverse with reset ("Protection reverse"):** A pending reverse interlock condition only puts the block in the neutral position when the motor is running in this direction (input `ProtRev = 0`). Once the interlock conditions are cleared, the operator or an activation sequence must perform a reset to once again enable activation of the reverse control according to the input parameters. You can influence the reset using a various `Feature` bits. Refer to the Resetting the block in case of interlocks or errors (Page 43) section for more on this.

Display of the interlock in the faceplate and in the block icon

The interlock state is visualized in the faceplate and in the block icon by a status display (padlock) as follows:

- Open padlock: No interlock pending
- Closed padlock: One or more interlocks are pending
- No padlock: Individual interlocks are not active
 - `Perm_En = 0` or `Permit.ST = 16#FF`:
The input parameter `Permit` has no effect, the button in the faceplate is invisible.
 - `PermRevEn/PermClsEn = 0` or `PermRev.ST/PermCls.ST = 16#FF` or `Feature2.Bit16 = 0`:
The input parameter `PermRev/PermCls` has no effect, the button in the faceplate is invisible.
 - `Prot_En = 0` or `Protect.ST = 16#FF`:
The input parameter `Protect` has no effect, the button in the faceplate is invisible.
 - `ProtRevEn/ProtClsEn = 0` or `ProtRev.ST/ProtCls.ST = 16#FF` or `Feature2.Bit16 = 0`:
The input parameter `ProtRev/ProtCls` has no effect, the button in the faceplate is invisible.
 - `Intl_En = 0` or `Intlock.ST = 16#FF`:
The input parameter `Intlock` has no effect, the button in the faceplate is invisible
 - `IntlRevEn/IntlClsEn = 0` or `IntlRev.ST/IntlRev.ST = 16#FF` or `Feature2.Bit16 = 0`:
The input parameter has no effect, the button in the faceplate is invisible.

The block icon indicates the prioritized group status according to the active operating state. See also the section Forming the group status for interlock information (Page 105) for more on this.

The faceplate visualizes the state of each interlock type separately.

The padlock is not shown in the block icon if all parameters for enabling the button are set to 0 or all parameters have the signal status 16#FF.

Note

Motors and valves are not put into the neutral position if one of the interlock inputs is active (for example `Intlock = 0`) and the corresponding signal status is 16#FF (`Intlock.ST = 16#FF`).

Influence of the signal status on the interlock

See also the section Influence of the signal status on the interlock (Page 104) for more on this.

Outputting "Interlock active" using the `LockAct` parameter

If an interlock is set at the parameter:

- `Intlock`
- `Permit`
- `Protect`
- `Int1Rev/Int1Cls` (only for blocks with directional interlock and `Feature2.Bit16 = 1`)
- `PermRev/PermCls` (only for blocks with directional interlock and `Feature2.Bit16 = 1`)
- `ProtRev/ProtCls` (only for blocks with directional interlock and `Feature2.Bit16 = 1`)
- `Trip` (only for motors and motor valves),

the `LockAct` parameter is set automatically to active (=1). The parameter `LockAct` is set to 0 if the interlock is no longer present and those interlocks which require acknowledgement have been acknowledged.

You can bypass the interlock using `ByProt = 1` in local mode and during simulation. This also makes `LockAct = 0`.

Note

The `LockAct` parameter is not set despite a pending interlock, if a value in the block is forced. See also the section Forcing operating modes (Page 41) for more on this.

Messaging

No messages are assigned to the interlock types. However, if you want to have a message when an interlock condition is violated, you can use the freely interconnectable input parameters to generate the messages. See also the section Generating instance-specific messages (Page 204) for more on this.

2.1.4.2 Disabling interlocks

Disabling individual interlocks

You can disable the block interlocks that are implemented using the input parameters `Intlock`, `Protect` and `Permit`.

If you want to disable the block interlock, you have to set the following parameters:

- `Perm_En = 0` or `Permit.ST = 16#FF`:
The input parameter `Permit` has no effect.
- `PermRevEn/PermClsEn = 0` or `PermRev.ST/PermCls.ST = 16#FF` or `Feature2.Bit16 = 0`:
The input parameter `PermRev/PermCls` has no effect.
- `Prot_En = 0` or `Protect.ST = 16#FF`:
The input parameter `Protect` has no effect.
- `ProtRevEn/ProtClsEn = 0` or `ProtRev.ST/ProtCls.ST = 16#FF` or `Feature2.Bit16 = 0`:
The input parameter `ProtRev/ProtCls` has no effect.
- `Intl_En = 0` or `Intlock.ST = 16#FF`:
The input parameter `Intlock` has no effect.
- `IntlRevEn/IntlClsEn = 0` or `IntlRev.ST/IntlCls.ST = 16#FF` or `Feature2.Bit16 = 0`:
The input parameter `IntlRev/IntlCls` has no effect.

Note

"Small" blocks have only the `Intlock` parameter

With "Small" blocks, you can only assign parameters to "Interlock without reset" (input parameter `Intlock` or for the deactivation of the interlock for the input parameter `Intl_En`).

Disabling of all the interlocks (only for local operation and for simulation)

You can use the input parameter `ByProt = 1` to disable all the interlocks, irrespective of the parameter assignment of the individual interlock, in local mode as well as for the "simulation" function.

2.1.4.3 Influence of the signal status on the interlock

Influence of the signal status on the interlock

There are three ways in which the signal status affects the interlocks:

- Simulation signal status
- Signal status "Bad, device related" (value `16#00`) or "Bad, process related" (value `16#28`)
- Signal status \neq "Simulation" and "Bad, device related"

"Simulation" signal status

An interlock signal is displayed differently depending on the "Separate evaluation for excluded and simulated interlock signals (Page 152)" function and the status of the interlock (see "Forming the group status for interlock information (Page 105)").

Signal status "Bad, device related" (value 16#00) or "Bad, process related" (value 16#28)

An interlock signal with this status is always processed as an active interlock signal in the block and displayed with the following icons in the faceplate:



for 16#00 or



for 16#28 and



A motor protection signal (`Trip` parameter) with signal status 16#00 or 16#28 is used to activate motor protection. This is indicated by "Motor protection" in the standard view of the faceplates.

A torque-monitoring signal (`TorqueOpen`, `TorqueClose` parameters) with signal status 16#00 or 16#28 is used to activate torque monitoring for motor valve `VlvMotL`.

Signal status ≠ "Simulation" as well as "Bad, device related" and "Bad, process related"

Only signal states "Simulation", "Bad, device related" and "Bad, process related" have an effect on the processing in the block; all others are only displayed with their relevant icon in the faceplate.

2.1.4.4 Forming the group status for interlock information

Forming the group status for interlock information

A group status for interlock information is required for:

- Interlock state for:
 - Interlocked
 - Not interlocked
 - Disabled

Group status for the interlock state

All the effective interlock states are combined and displayed in the block icon. The interlock states are displayed with the following prioritization:

1. Function interlocked, shown in the block icon with a closed padlock



2. Function not interlocked, shown in the block icon as an open padlock



3. Function disabled, shown in the block icon as a crossed-out, closed padlock



Overview: Display for the interlock status in faceplate

If the Separate evaluation for excluded and simulated interlock signals (Page 152) function is not enabled (Feature bit =0), the bypass signals in the structures Permission, Protection, and Interlock are not evaluated.

Interlocks are shown in the faceplate as follows:

Parameter: BypProt	Parameter: Perm_En ²⁾ or Prot_En ²⁾ or Intl_En ²⁾	Value: Permission ²⁾ or Protection ²⁾ or Intlock ²⁾	Status: Permission ²⁾ or Protection ²⁾ or Intlock ²⁾	Button	Icon	Icon
x	x	X	16#FF	-	-	-
x	0	x	x	-	-	-
0	1	1	16#00	Visible		
0	1	1	16#28	Visible		
0	1	0	16#60	Visible		
0	1	1	16#60	Visible		
0	1	0	≠ 16#FF	Visible		Status based on priority
0	1	1	≠ (16#FF, 16#60, 16#00, 16#28)	Visible		Status based on priority
1 (for local mode and simulation only)	1	x	≠ 16#FF	Visible		Status based on priority

2.1 Functions of the blocks

Comments on table:



- X: The value is irrelevant for the display of the icon.
- ²⁾: Blocks with directional interlock and `Feature2.Bit16 = 1`: "Perm_En", "Intl_En", "Prot_En", "Enable", "Interlock" and "Protection" also include the direction

Note

If values are forced in the block, this is indicated in the block icon by a crossed-out, closed padlock.

If the Separate evaluation for excluded and simulated interlock signals (Page 152) function is enabled (Feature bit =1), the bypass signals in the structures Permission, Protection, and Interlock are evaluated. The bypass signals can be read from the upstream interlock block at the output Bypass.

Excluded interlock signals are shown in the faceplate as follows:

Parameter: Perm_En ²⁾ or Prot_En ²⁾ or Intl_En ²⁾	Status: Permission ²⁾ or Protection ²⁾ or Intlock ²⁾	Bypass: Permission ²⁾ or Protection ²⁾ or Intlock ²⁾	Button	Icon
x	16#FF	x	-	-
0	x	x	-	-
1	≠ 16#FF	0	Visible	 1)
1	≠ 16#FF	1	Visible	 1)

Comments on table:

- X: The value is irrelevant for the display of the icon.
- 1): Icon corresponding to the status of the interlock signal (for 16#80 no icon)
- ²⁾: Blocks with directional interlock and `Feature2.Bit16 = 1`: "Perm_En", "Intl_En", "Prot_En", "Enable", "Interlock" and "Protection" also include the direction

2.1.4.5 Rapid stop for motors

Rapid stop for motors

Rapid stop has the highest priority in all operating modes (manual and automatic mode as well as local mode) and operating states (such as the forcing of states). It is activated via the faceplate. This depends on the setting at the `Feature` bit Enabling rapid stop via faceplate (Page 168).

Note

"Small" blocks do not feature rapid stop.

The "rapid stop" function is supported only by "Large" blocks.

You issue the command for rapid stop state using the `RapidStp = 1` input parameter.

When you click on the "Rapid Stop" button in the faceplate, the drive stops immediately, shown as follows in the faceplate:

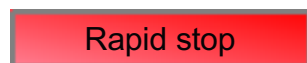

The $R_StpAct = 1$ output parameter is set to implement the rapid stop function for local mode. You need to interconnect this parameter with the corresponding channel block and in the I/O to realize the rapid stop function in the hardware.

Rapid stop is unlocked for all operating modes using the "Reset" button in the faceplate ($RstOp = 1$); in CFC it is unlocked using the $RstLi = 1$ input parameter. In automatic mode, the unlocking can also be performed via a 0-1 edge transition in the control if the $Feature$ is $Bit9 = 1$.

Rapid stop can be selected even with the motor in stop state. In this case, the motor start is prevented.

2.1.4.6 Bypassing signals

Bypassing signals

With this function, you can flag a block as bypassed. If the bypass function is active, the output parameter $BypassAct$ will be set from the block. With a connection from $BypassAct$ to an input parameter $BypLixx$ of an interlock block, you can bypass the corresponding input of the interlock block.

If the block is set to bypass, the bypass information bit of the process output and the limit switch points listed in the following table are set. If you connect one of this listed parameter with bypass information bit to an interlock input Inx , you can use the bypass information bit to switch the interlock signal in bypass. For this in the interlock block the corresponding bypass enable bit $BypEn.Inx$ and the $Feature$ Bit2 Separate evaluation for excluded and simulated interlock signals (Page 152) have to set.

Additionally, you can define over the $Feature$ bit Substitution value is active if the block is in bypass (Page 185) if the block shall use the process value or a substitution value in case of an active bypass.

Block	Process value/signal	Process value/signal	Parameter with bypass information bits
MonAnL	PV_Out	BypPV	PV_Out, PV_AH_Act, PV_WH_Act, PV_TH_Act, PV_AL_Act, PV_WL_Act, PV_TL_Act, GradHUpAct, GradHDnAct, GradLAct
PIDConL, PID-ConR, and PID-StepL	PV_Out	BypPV	PV_Out, PV_AH_Act, PV_WH_Act, PV_TH_Act, PV_AL_Act, PV_WL_Act, PV_TL_Act, ER_AH_Act, ER_AL_Act
MonDiL	Out	BypIn	Out
TotalL	Out	BypOut	Out, OutAH_Act, OutWH_Act, OutTH_Act, OutAL_Act, OutWL_Act, OutTL_Act

With the parameter `BypLiOp`, you can decide whether the switching on/off will be done by the input parameters which are connected in CFC or by the faceplate from an operator.

- `BypLiOp = 0`: In the "Parameter view", the operator can switch on/off the bypass function over the parameter `BypPVOp` or `RstBypOp`. If `BypLock = 1`, you cannot make any change to the parameters `BypPVOp` or `ResBypOp`. The button for switching the bypass functionality on/off in the "Parameter view" is deactivated.
- `BypLiOp = 1`: With a connection of the parameter `BypPVLi` or `RstBypLi`, the bypass function will be switched on/off.

2.1.5 Form signal status

2.1.5.1 Forming and outputting signal status for blocks

General information on forming and outputting the signal status

The process values of the function blocks are generated and transferred along with a signal status as a structured variable. This contains a statement about the signal quality. The function blocks determine the appropriate signal status for their process outputs depending on the signal status of the process inputs, which are involved in calculating the process outputs. If multiple process inputs are involved in calculating a process output, the signal status is formed according to prioritization defined by function block groups. The highest priority is the signal status with the value 0.

The blocks are grouped into the following function block groups:

- Technologic blocks (Page 109)
- Digital logic blocks (Page 111)
- Analog logic blocks (Page 112)
- Redundancy blocks (Page 112)
- Blocks with configurable status prioritization (Page 114)
- Interlock blocks (Page 116)
- Mathematical blocks (Page 118)
- PCS 7 channel blocks (Page 119)
- Channel blocks for field devices (Page 119)

All blocks of a group use the same priority specifications and form the signal status of the process outputs based on them.

Note

The status / quality of control inputs for logic functions and parameters have no influence on the status / quality of process values and logic functions of the blocks.

The status / quality of process values inherit the results of mathematic and logic functions, which are directly related to the process value.

The status/quality of process values immediately inherit the results of monitoring and limiting functions directly related to the process value.







2.1.5.2 Forming and outputting the signal status for technologic blocks

Forming the signal status for technology blocks

For more general information on forming the status signal, refer to the section: Forming and outputting signal status for blocks (Page 108).

In technology blocks, a group status is formed from the input parameters (see description of the relevant blocks) according to the priority table below (highest priority is 0). This group status is displayed in the status bar of the faceplate and of the block icon.

The group status is set to 16#68 (Uncertain, device related) with an undefined signal status at a control input, which is involved in the formation of the group status.

Signal status icon	Priority	Value	Meaning
	0	16#60	Manipulated value (for example, substitute value, simulation, last valid value)
	1	16#00	Bad, device related
	2	16#28	Bad, process related
	3	16#68	Uncertain, device related
	4	16#78	Uncertain, process related
	5	16#A4	Maintenance request
	6	16#80	Good

Interconnectable output parameters for limits (for example, `PV_AH_Act`) that can be influenced directly by an interconnectable input parameter (for example, `PV`) inherit the status from the associated output parameter (for example, `PV_Out`).

If an output parameter for limits is influenced directly by several interconnectable input parameters (limit monitoring), it receives the status of the input parameter with the highest priority (see overview above). Thus, for example, the control deviation is formed from the setpoint (SP) and the process value (PV). The output parameter for limits `ER_AH_Act`, for example, which signals an active violation of the high limit for the error signal, has a signal status based on the group status formed from the process value and setpoint (ER).

Evaluation of the signal status in case of interlocks in technology blocks

The signal states of the interconnectable input parameters of the interlocking and protective signals are treated exactly like process values with the following exceptions:

- The signal status is displayed in the faceplate at the buttons for calling the series-connected interlocking blocks.
- If the input signal has "Simulation" status and the input signal is therefore inactive (for example, `Protect = 1`), the input signal in this case is interpreted as a bypassed signal and is displayed by the icon for bypassing:



- If the input signal has "Simulation" status and the input signal is therefore inactive (for example, `Protect = 0`), the input signal in this case is interpreted as a simulated signal and is displayed by the icon for simulation:



- If the input signal has the "Bad, device related" or "Bad, process related" signal status, this is evaluated as an active input signal, regardless of its value, i.e. safety interlock signal (`Protect = 1`) that is inactive due to its value, triggers a safety interlock when its status is "Bad, device related" or "Bad, process related".

Display of the signal status in the faceplate and block icon for technology blocks

The signal status is displayed for each individual input parameter in the faceplate next to the process values or the interlock buttons. The group status is displayed in the block icon and in the group display of the faceplate.

Note







The interlocks and additional values are not included in the formation of the group status.

2.1.5.3 Forming and outputting the signal status of digital logic blocks

Forming the signal status of digital logic blocks

For more general information on forming the status signal, refer to the section: Forming and outputting signal status for blocks (Page 108).

The status for the result of the output is formed within digital logic blocks from all input parameters, according to the following priority table (highest priority is 0)

Signal status icon	Priority	Value	Meaning
	0	16#00	Bad, device related
	1	16#28	Bad, process related
	2	16#60	Manipulated value (for example, substitute value, simulation, last valid value)
	3	16#68	Uncertain, device related
	4	16#78	Uncertain, process related
	5	16#A4	Maintenance request
	6	16#80	Good

The group status is set to 16#68 (uncertain, device-related), with an undefined signal status at a control input that is involved in forming the group status.

A signal status 16#FF at a control input is not used for the calculation of the group status. If all relevant control inputs are 16#FF, the group status is 16#80.

If only one process input is decisive for calculating the output value, the status of the process input is transferred to the status of the output.

Special notes for the Andxx blocks

- If the output value is 1, it has the signal status with the highest priority of all input signals.
- If the output value is 0, it has the signal status with the lowest priority of all input signals, which have a value of 0.

Special notes for the Orxx blocks

- If the output value is 1, it has the signal status with the lowest priority of all input signals, which have a value of 1.
- If the output value is 0, it has the signal status with the highest priority of all input signals.

Special notes for the Xor04 block

The worst signal status of all input parameters is always selected and output with the `Out` output parameter.

2.1.5.4 Forming and outputting the signal status of analog logic blocks







Forming the signal status of analog logic blocks

For more general information on forming the status signal, refer to the section: Forming and outputting signal status for blocks (Page 108).

The signal status of the Out output value within the block is taken directly from the In_x input value.

Special notes for the CompAn02 block

This block evaluates the signal status of the two input parameters In_1 and In_2 as shown in the following table.



Signal status icon	Priority	Value	Meaning
	0	16#60	Manipulated value (for example, substitute value, simulation, last valid value)
	1	16#00	Bad, device related
	2	16#28	Bad, process related
	3	16#68	Uncertain, device related
	4	16#78	Uncertain, process related
	5	16#A4	Maintenance request
	6	16#80	Good





2.1.5.5 Forming and outputting the signal status of redundancy blocks

Forming the signal status of redundancy blocks RedAn02 and RedDi02

For more general information on forming the status signal, refer to the section: Forming and outputting signal status for blocks (Page 108).

The signal status is evaluated according to the following priority:

Signal status icon	Priority	Value	Meaning
	0	16#60	Manipulated value (for example, substitute value, simulation, last valid value)
	1	16#80	Good

Signal status icon	Priority	Value	Meaning
	2	16#A4	Maintenance request
	3	16#78	Uncertain, process related
	4	16#68	Uncertain, device related
	5	16#28	Bad, process related
	6	16#00	Bad, device related

The output value is generated based on the signal status of the process value with the above table of priorities. In addition, the output parameters `SimAct`, `Uncertain`, and `LossRed` are still set according to the signal status.

In1 .ST	In2 .ST	Out .ST	Out .Value	SimAct .Value	Uncertain .Value	LossRed .Value
16#80	16#80	16#80	In1	0	0	0
16#80	16#60	16#60	In2	1	1	0
16#80	16#A4	16#80	In1	0	1	0
16#80	16#78	16#80	In1	0	1	0
16#80	16#68	16#80	In1	0	1	0
16#80	16#28	16#68	In1	0	1	1
16#80	16#00	16#68	In1	0	1	1
16#60	16#80	16#60	In1	1	1	0
16#60	16#60	16#60	In1	1	1	0
16#60	16#A4	16#60	In1	1	1	0
16#60	16#78	16#60	In1	1	1	0
16#60	16#68	16#60	In1	1	1	0
16#60	16#28	16#60	In1	1	1	1
16#60	16#00	16#60	In1	1	1	1
16#A4	16#80	16#80	In2	0	1	0
16#A4	16#60	16#60	In2	1	1	0
16#A4	16#A4	16#A4	In1	0	1	0
16#A4	16#78	16#A4	In1	0	1	0
16#A4	16#68	16#A4	In1	0	1	0
16#A4	16#28	16#68	In1	0	1	1
16#A4	16#00	16#68	In1	0	1	1
16#78	16#80	16#80	In2	0	1	0
16#78	16#60	16#60	In2	1	1	0
16#78	16#A4	16#A4	In2	0	1	0
16#78	16#78	16#78	In1	0	1	0
16#78	16#68	16#78	In1	0	1	0

2.1 Functions of the blocks

















In1 . ST	In2 . ST	Out . ST	Out . Value	SimAct . Value	Uncertain . Value	LossRed . Value
16#78	16#28	16#68	In1	0	1	1
16#78	16#00	16#68	In1	0	1	1
16#68	16#80	16#80	In2	0	1	0
16#68	16#60	16#60	In2	1	1	0
16#68	16#A4	16#A4	In2	0	1	0
16#68	16#78	16#78	In2	0	1	0
16#68	16#68	16#68	In1	0	1	0
16#68	16#28	16#68	In1	0	1	1
16#68	16#00	16#68	In1	0	1	1
16#28	16#80	16#68	In2	0	1	1
16#28	16#60	16#60	In2	1	1	1
16#28	16#A4	16#68	In2	0	1	1
16#28	16#78	16#68	In2	0	1	1
16#28	16#68	16#68	In2	0	1	1
16#28	16#28	16#28	In1	0	1	1
16#28	16#00	16#28	In1	0	1	1
16#00	16#80	16#68	In2	0	1	1
16#00	16#60	16#60	In2	1	1	1
16#00	16#A4	16#68	In2	0	1	1
16#00	16#78	16#68	In2	0	1	1
16#00	16#68	16#68	In2	0	1	1
16#00	16#28	16#28	In2	0	1	1
16#00	16#00	16#00	In1	0	1	1









































2.1.5.6 Forming and outputting the signal status for blocks with configurable status prioritization

Forming the signal status for blocks with configurable status priority

For more general information on forming the status signal, refer to the section: Forming and outputting signal status for blocks (Page 108).

The SelPrio parameter is used for this block to define the priority setting for linking the individual states. You have the option between the following specifications:

Priority	SelPrio = 0	SelPrio = 1	SelPrio = 2	SelPrio = 3	SelPrio = 4	SelPrio = 5	SelPrio = 6	SelPrio = 7
0	 16#60	 16#80	 16#A4	 16#80	 16#A4	 16#60	 16#80	 16#60
1	 16#00	 16#00	 16#00	 16#A4	 16#80	 16#80	 16#A4	 16#80

Priority	SelPrio = 0	SelPrio = 1	SelPrio = 2	SelPrio = 3	SelPrio = 4	SelPrio = 5	SelPrio = 6	SelPrio = 7
2	 16#28	 16#28	 16#28	 16#60	 16#60	 16#A4	 16#78	 16#A4
3	 16#68	 16#68	 16#68	 16#00	 16#00	 16#00	 16#68	 16#78
4	 16#78	 16#78	 16#78	 16#28	 16#28	 16#28	 16#28	 16#68
5	 16#A4	 16#60	 16#60	 16#68	 16#68	 16#68	 16#00	 16#28
6	 16#80	 16#A4	 16#80	 16#78	 16#78	 16#78	 16#60	 16#00

Special notes for the MuxAn03 block

The status priority for this block, which is used by the block to process the status of the PV1 ... PV3 process value inputs, can be set with the SelPrio parameter.

Note

The parameter SelPrio can take a value from 0 to 7. SelPrio = 6 is set by default.

If you enter a value greater than 7, the setting for 7 is used. If you enter a value lower than 0, the setting for 0 is used.

For information on evaluating the status of the process value inputs, refer to the section MuxAn03 functions (Page 1929).







2.1.5.7 Forming and outputting the signal status for interlock blocks

Forming the signal status for interlock blocks

For more general information on forming the status signal, refer to the section: Forming and outputting signal status for blocks (Page 108).

2.1 Functions of the blocks

The block determines the signal status of the output signal, based on the signal status of the input values from the configured logical operation according to the following table (highest priority is 0):

Signal status icon	Priority	Value	Meaning
	0	16#00	Bad, device related
	1	16#28	Bad, process related
	2	16#60	Manipulated value (for example, substitute value, simulation, last valid value)
	3	16#68	Uncertain, device related
	4	16#78	Uncertain, process related
	5	16#A4	Maintenance request
No icon	6	16#80	Good
No icon	-	16#FF	Input is not connected

General rules

- If a given input causes a signal change at the output, the signal status of the input with the highest priority (worst signal status) is set at the output, since each input can influence the output:
 - Logical AND operation (logic = 1):
If the output value is 1, it has the signal status with the highest priority of all interconnected input signals.
 - Logical OR operation (logic = 0):
If the output value is 0, it has the signal status with the highest priority of all interconnected input signals.
- If several inputs have the same priority and the output therefore cannot be changed, the signal status of the input with the lowest priority (highest signal status) is set at the output, since the output is uniquely determined by the signal with the best signal status:
 - Logical AND operation (logic = 1):
If the output value is 0, it has the signal status with the lowest priority of all interconnected input signals, which have a value of 0.

Note

With feature bit 23 = 1 (evaluation signal status), input signals with a bad signal status (16#28 or 16#00) are processed with the value 0, regardless of their actual value

- Logical OR operation (logic = 0):
If the output value is 1, it has the signal status with the lowest priority of all interconnected input signals, which have a value of 1.
- If no inputs are interconnected, the signal status of the output is set to simulation (16#60).

Display of the signal status in the faceplate and block icon for interlocking blocks

The signal status is displayed for each individual parameter (except for the analog values) in the faceplate next to the process values.

If you bypass a signal, it is displayed in the faceplate of the interlocking block next to the button for excluding, as well as in the block icon as follows.



Note

If an excluded interlock signal can become switchover-relevant, the status of the output Out.ST is set to simulation 16#60, as long as it is not forced by other interlock inputs to Bad, device-related 16#00 or Bad, process-related 16#28.

An excluded interlock input has no influence on the status when the Separate evaluation for excluded and simulated interlock signals (Page 152) function is enabled.

The currently valid status for the output signal is also displayed in the faceplate.

2.1.5.8 Forming and outputting the signal status for mathematical blocks

Forming the signal status for mathematical blocks

For more general information on forming the status signal, refer to the section: Forming and outputting signal status for blocks (Page 108).

The status for the result of the output is formed within mathematical blocks from all process inputs involved in the calculation, according to the following table (highest priority is 0)

Signal status icon	Priority	Value	Meaning
	0	16#00	Bad, device related
	1	16#28	Bad, process related
	2	16#60	Manipulated value (for example, substitute value, simulation, last valid value)
	3	16#68	Uncertain, device related
	4	16#78	Uncertain, process related
	5	16#A4	Maintenance request
	6	16#80	Good

2.1 Functions of the blocks

The group status is set to 16#68 (uncertain, device-related), with an undefined signal status at a control input that is involved in forming the group status.

A 16#FF signal status at a control input is not used for the calculation of the group status. If all relevant control inputs are 16#FF, the group status in the search for the worst group status is 16#80 and 16#00 in the search for the best group status.

If only one process input is decisive for calculating the output value, the status of the process input is transferred to the status of the output.

Note

Special notes for the Integral mathematical block

Due to its application area (time integral, I-component for the configuration of a controller), the Integral block generates the signal status like the technological blocks.

Special notes for the mathematical blocks Addxx, Mulxx, Div02 and Sub02





If the result of the mathematic operation is a floating-point number that cannot be displayed, the result of the status is set to 16#28. Floating-point numbers that cannot be displayed are labeled in the CFC with #+Inf (+ infinite), #-Inf (- infinite) or with #NaN (not a number).

2.1.5.9 Forming and outputting the signal status for PCS 7 channel blocks

Forming the signal status for PCS7 channel blocks

For more general information on forming the status signal, refer to the section: Forming and outputting signal status for blocks (Page 108).

The signal status for PCS7 channel blocks can assume the following values:







Signal status icon	Value	Meaning
	16#80	Good
	16#78	Uncertain, process related: Limitation of input parameter PV_In is active (analog output channel blocks only)
	16#60	Manipulated value (for example, substitute value, simulation, last valid value)
	16#00	Bad, device related (value not valid)

2.1.5.10 Forming and outputting the signal status for channel blocks for field devices

Forming the signal status for channel blocks (field devices)

For more general information on forming the status signal, refer to the section: Forming and outputting signal status for blocks (Page 108).

The signal status of channel blocks for field devices can assume the following values:

Signal status icon	Value	Meaning
	16#80	Good
	16#78	Uncertain, process related
	16#68	Uncertain, device related
	16#60	Manipulated value (for example, substitute value, simulation, last valid value)
	16#28	Bad, process related
	16#00	Bad, device related (value not valid)
	16#A4	Maintenance required, maintenance demanded

2.1.6 Error handling

2.1.6.1 Error handling

Error handling

The channel and technologic blocks feature error handling routines. A distinction must be made between the following areas:

- Error numbers
- External process control error (CSF)
- Process-specific errors
- Invalid signal states
- Mode switchover error
- Errors in channel blocks

Error numbers

Most blocks have an output parameter `ErrorNum` that can be used to output internal error states of the block as error numbers.

With some blocks, input parameters are checked for permissible values. They are therefore only used to prevent the output value from remaining invalid when the input value is once again in the valid range. If an invalid value is detected, and the corresponding output value is held at the last displayed value instead of an invalid value being displayed. If blocks do not have this check, an invalid value can appear at the output. However, a valid value is displayed again at the output as soon as the input values of the block have changed correspondingly.

Any value set over an interconnection or as a result of a parameter assignment that is outside the range of values (e.g. "Not a Number") is not processed by the block algorithm. The last valid value is processed instead.

In addition to the errors stated above, a limit violation is also signaled for example. Each error number is assigned to a specific error.

If there is more than one error, all error numbers have the same priority. The routine always displays the error number of the error most recently detected in a block cycle.

External process control error (CSF)

An external process control error always lies outside the process - it exists in the form of device or other hardware faults. If, for example, a run-time error occurs at a valve, there is an error or fault in the pneumatic system.

A process control error is output if an external error is set at the input `CSF`. You can enable this output function, for example, by interconnecting output `Bad` of the channel block with input `CSF` of the technologic block.

The error message "\$\$BlockComment\$\$ External error occurred" is output at `CSF = 1`.

This state is visualized in the group display by an "S" character in the faceplate overview and in the block icon.

With motor, valve and dosing blocks, there is also the possibility that the block switches to error processing. `Feature` bit 18 Activating error state for external process control error `CSF` (Page 151) must be set for this. The device goes into error processing and moves the drive to the neutral position or switches the dosing operation to off for a doser. If the dosing operation is already finished, it remains in the completed state. Resetting the error is described in Resetting the block in case of interlocks or errors (Page 43).

External error (FaultExt)

The `FaultExt` input can be used to pass an external error without the generation of a message. The device goes into error processing and moves the drive to the neutral position or switches the dosing operation to off for a doser. If the dosing operation is already finished, it remains in the completed state. Separate messages can be generated by interconnecting the external error to `ExtMsgx` messages that can be freely selected. Resetting the error is described in Resetting the block in case of interlocks or errors (Page 43).

Process-specific errors

Process-specific errors can have the following causes:

- Runtime monitoring: If the feedback signals do not match the control settings after a selected time has expired, a process-related error is output.
- Feedback monitoring: Refer to the Monitoring the feedbacks (Page 97) section for more on this.

If the block algorithm detects a monitoring error while monitoring is enabled, the corresponding output parameter is set to 1 in the block. The "\$\$BlockComment\$\$ Feedback error xxx" error message is also output, where xxx, for example, stands for the valve.

This state is visualized in the group display by an "S" character in the faceplate overview and in the block icon.

The block must be reset after the monitoring error was cleared and if automatic mode is set.

Invalid input signals

This error is output if inconsistencies are detected between associated I/Os. The close and open commands cannot be output simultaneously to the valve, for example.

If the block algorithm detects an invalid combination of input signals, an error number (`ErrorNum`) is output that depends on the block type.

In the case of motors, valves and batches, the faceplates' standard view will additionally output the text "invalid signal".

Mode switchover error

This error is reported if you change the mode of the block from:

- Manual to automatic mode or
- Local mode to automatic mode

and the previous and target state are **inconsistent** (bumpless switchover). You can only change the block mode if the subsequent state corresponds with the previous state.

Bumpless switchover can be activated / deactivated using the `Feature` connection on the Enabling bumpless switchover to automatic mode for valves, motors, and dosers (Page 173) or Disabling bumpless switchover to automatic mode for controllers (Page 173) bit.

Bumpless switchover from local to automatic mode is undertaken using the `LocalSetting` parameter, as described in section Local mode (Page 79).

In the standard view of the faceplate, the text "Changeover error" is displayed in the event of an unwanted switchover with bumps.

The block retains local mode if the operator changes the mode from local to automatic and the error mentioned above occurs. The block changes to manual mode if the mode is changed from local to automatic over interconnected inputs and the error mentioned above occurs.

Errors in channel blocks

The following errors may be displayed by the channel blocks:

- Channel error
- Device or module fault
- Higher-level error
- Invalid measuring range

2.1.6.2 Outputting group errors

Outputting group errors

The `GrpErr` output parameter assembles the faults of a block and makes them available to you. A group error is compiled from the following error information:

- Feedback errors (static or dynamic feedback monitoring)
- External error (CSF and `FaultExt`)
- Motor protection (only for motors)
- Module errors (only for hardware controllers)
- I/O access errors (only for hardware controllers)
- Parameter assignment errors (only for hardware controllers)

For information on how the signal is formed for the group error at the `GrpErr` output parameter, refer to the corresponding block descriptions in the "Functions" chapter.

Note

The signal status of the individual signals is not taken into consideration for forming the group error. The outputs therefore always have the status, `16#80`.

2.1.7 Ramp function

2.1.7.1 Using setpoint ramp

Using setpoint ramp

Starting at the current internal setpoint, the setpoint can be set to a target setpoint value over a ramp-shaped function. In the faceplate, you can start the function in ramp view ($SP_RmpOn = 1$).

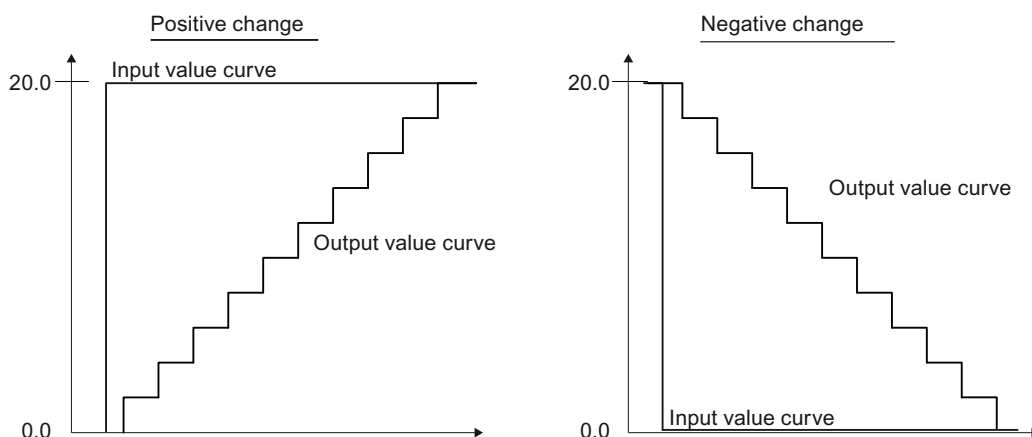

Use the $SP_RmpModTime$ input parameter or the ramp view of the faceplate to specify whether the setpoint ramp is defined by time or by gradients:

- If you select time ($SP_RmpModTime = 1$): The ramp of the setpoint is calculated automatically by the block so that after the ramp has started ($SP_RmpOn = 1$), the setpoint will reach the target setpoint ($SP_RmpTarget$) after the selected time ($SP_RmpTime$).
- If you select ramp ($SP_RmpModTime = 0$): The inclination of the ramp matches the selected rates of change $SP_UpRaLim$ (positive) or $SP_DnRaLim$ (negative).

Once the setpoint has reached the target setpoint, the function is terminated automatically ($SP_RmpOn = 0$). The ramp trip can be prematurely aborted in the faceplate by setting $SP_RmpOn = 0$.

Requirements for using a setpoint ramp

Block	Manipulated variable	Gradient limit	Operating mode
Controller	Internal	Off	Automatic
OpAnL	Internal	Off	
MotSpdCL	Internal	Off	

If the requirements are not fulfilled during the ramp trip, the ramp trip is automatically canceled.

Note

Special note for the MotSpdCL block

In the case of an interlock, a monitoring error, motor protection or rapid stop, the motor is switched off and the internal ramp setpoint is reset to the starting setpoint of the ramp trip.

2.1.7.2 Gradient limit of the setpoint

Gradient limit of the setpoint

The gradient limit is activated via the `SP_RateOn = 1` input parameter.

The values are set at the `SP_UpRaLim` and `SP_DnRaLim` parameters depending on the `TimeFactor`.

- `TimeFactor = 0`: Unit of the gradient limiting is Unit/Second
- `TimeFactor = 1`: Unit of the gradient limiting is Unit/Minute
- `TimeFactor = 2`: Unit of the gradient limiting is Unit/Hour
- `SP_UpRaLim` sets the gradient high limit
- `SP_DnRaLim` sets the gradient low limit

Note

Parameters `SP_UpRaLim` and `SP_DnRaLim` are always evaluated according to their magnitude.

With the `Feature Bit Gradient limitation with time duration` (Page 182), you can also use the parameters `SP_RmpModTime` and `SP_RmpTime` in the gradient limit function. If this `Feature Bit = 1` and `SP_RmpModTime = 1` is parameterized, the ramp rate is calculated with a change of setpoint such that the new value of the setpoint will reach after the time of `SP_RmpTime`.

External setpoint

If the external setpoint (`SP_ExtAct.Value = 1`) is switched on, the linkable values `SP_LiUpRaLim`, `SP_LiDnRaLim`, `SP_LiRmpTime`, of `SP_UpRaLim`, `SP_DnRaLim`, `SP_RmpTime` respectively will be used. The values will be active only if they are connected (`SP_LiX.ST <> 16#FF`).

Displaying active limitation

A gradient limit is indicated at the following output parameters:

- `SP_UpRaAct = 1`: Gradient has a high limit
- `SP_DnRaAct = 1`: Gradient has a low limit

2.1.7.3 Using a manipulated variable ramp

Using a manipulated variable ramp

Starting at the current internal manipulated variable, the manipulated variable can be brought to a target value in the form of a ramp. In the faceplate, you can start the function in ramp view ($MV_RmpOn = 1$).

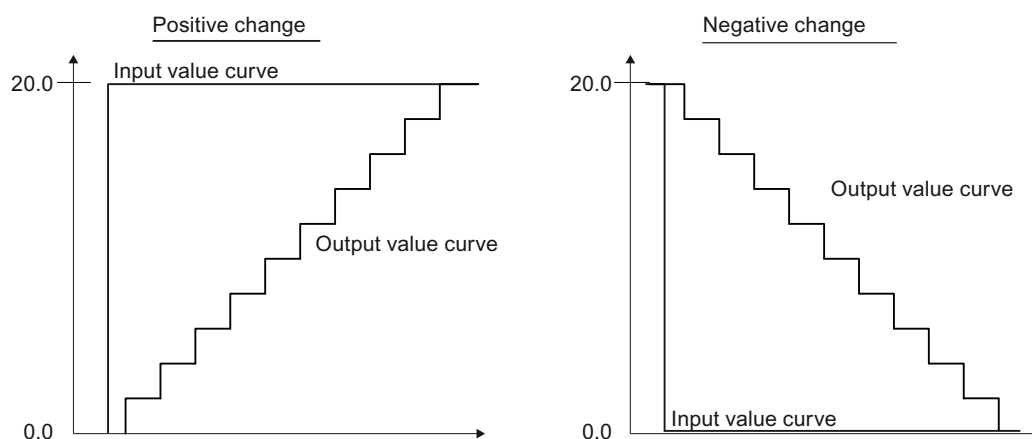

Use the $MV_RmpModTime$ input parameter or the ramp view of the faceplate to specify whether the manipulated variable ramp is defined by time or by gradients:

- If you select time ($MV_RmpModTime = 1$): The gradients of the manipulated variable are calculated automatically by the block so that after the ramp has started ($MV_RmpOn = 1$), the manipulated variable will reach the target value ($MV_RmpTarget$) after the configured time ($MV_RmpTime$).
- Specification with gradients ($MV_RmpModTime = 0$): The ramp slope matches the configured rates of change $MV_UpRaLim$ (positive) or $MV_DnRaLim$ (negative).

Once the manipulated variable has reached the target value, the function is terminated automatically ($MV_RmpOn = 0$). The ramp trend can be prematurely aborted in the faceplate by setting $MV_RmpOn = 0$.

Requirements for using a manipulated value ramp:

Block	Manipulated variable	Gradient limit	Operating mode
VlvAnL without auxiliary valve	Internal	Off	Manual
VlvAnL with auxiliary valve	Internal	Off	

If the requirements are not fulfilled during the ramp trip, the ramp trip is automatically canceled.

2.1.7.4 Gradient limiting of the manipulated variable

Gradient limiting of the manipulated variable

The gradient limit is activated via the `MV_RateOn = 1` input parameter.

The values are set at the `MV_UpRaLim` and `MV_DnRaLim` parameters depending on the `TimeFactor`.

- `TimeFactor = 0`: Unit of the gradient limiting is Unit/Second
- `TimeFactor = 1`: Unit of the gradient limiting is Unit/Minute
- `TimeFactor = 2`: Unit of the gradient limiting is Unit/Hour
- `MV_UpRaLim` sets the gradient high limit
- `MV_DnRaLim` sets the gradient low limit

Note

Parameters `MV_UpRaLim` and `MV_DnRaLim` are always evaluated according to their magnitude.

With the `Feature Bit Gradient limitation with time duration` (Page 182), you can also use the parameters `MV_RmpModTime` and `MV_RmpTime` in the gradient limit function. If this `Feature Bit = 1` and `MV_RmpModTime = 1` is parameterized, the ramp rate is calculated with a change of manipulated variable such that the new value of the manipulated variable will reach after the time of `MV_RmpTime`.

External manipulated variable

If the external manipulated variable (`MV_ExtAct.Value = 1`) is switched on, the linkable values `MV_LiUpRaLim`, `MV_LiDnRaLim`, `MV_LiRmpTime`, of `MV_UpRaLim`, `MV_DnRaLim`, `MV_RmpTime` respectively will be used. The values will be active only if they are connected (`MV_LiX.ST <> 16#FF`).

Displaying active limitation

A gradient limit is indicated at the following output parameters:

- `MV_UpRaAct = 1`: Gradient has an high limit
- `MV_DnRaAct = 1`: Gradient has a low limit

2.1.8 Internal/external setting

2.1.8.1 Applying the dynamically activated dead band during the PV settling time

Feature bit

Number of the `Feature` bit: 30.

Dynamic deactivation of the dead band by the `PV` settling time

You can use this `Feature` bit to improve the `PV` settling time in the range of the dead band.

The deadband is deactivated until the `PV` settles more in the center than at the edges of the dead band. The probability that the controlled variable is within the dead zone time is increased, and further control actions are no longer necessary. This leads to reduced wear and less energy consumption.

Bit = 0: Dead band width is constant

Bit = 1: The dead band is deactivated for the `PV` settling time. When the `PV` settling time is over, the dead zone gets the value of the `DeadBand` parameter.

2.1.8.2 Setpoint specification - internal/external

Setpoint specification internal & external

Some blocks have a function that allows setpoints to be specified. This specification is carried out either by means of a CFC/SFC program or by means of the faceplate (operator). With doser blocks and frequency converters, the operator can specify the internal setpoint value (SP_Int) or a higher-level open-loop control will specify an external setpoint value (SP_Ext). In principle, the blocks operate according to the same scheme:

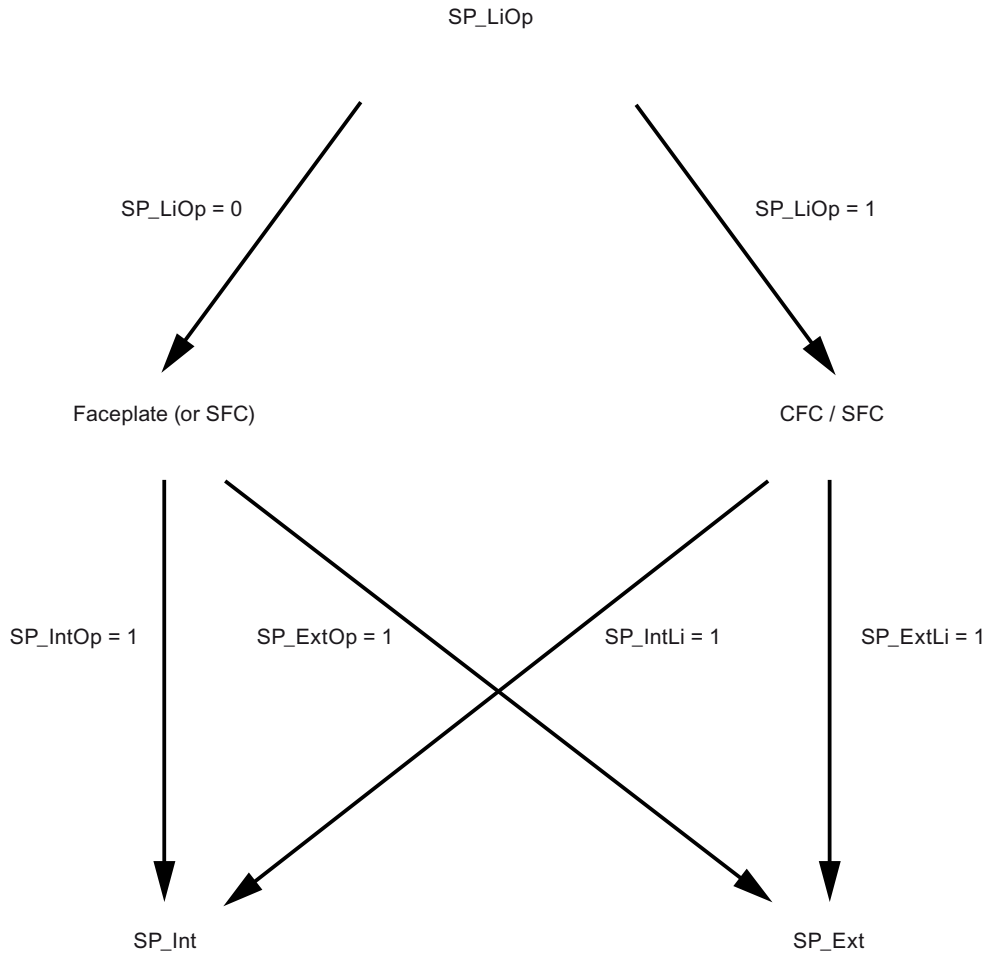

First you define whether the setpoint specification is to be carried out by means of a CFC/SFC program or by means of the faceplate. In the next step you specify whether the internal or the external setpoint is to be used.

Setpoint specification by means of faceplate or interconnection

With the `SP_LiOp` parameter, you define whether the setpoint will be set by a CFC/SFC program or using the faceplate.

- Parameterize `SP_LiOp` with 0 so that the setpoint specification is carried out by means of the faceplate.
- Parameterize `SP_LiOp` with 1 so that the setpoint specification is carried out by means of a CFC / SFC program.

Setpoint specification internal & external

You have to set the corresponding parameters depending on how the setpoint specification is to be carried out.

If the setpoint is set in the faceplate (`SP_LiOp = 0`), you have to set the parameter:

- `SP_IntOp = 1` in order to achieve an internal setpoint specification by means of the faceplate.
- `SP_ExtOp = 1` to have an external setpoint set in the faceplate.

If both signals are set, `SP_IntOp = 1` has priority.

If the setpoint is set by a CFC / SFC program (`SP_LiOp = 1`), you have to set the parameter:

1. `SP_IntLi = 1` to have an internal setpoint set by a CFC / SFC program.
2. `SP_ExtLi = 1` in order to achieve an external setpoint specification by means of a CFC / SFC program.

Note

For `PIDConL`, `PIDStepL`, `FmCont`, `FmTemp`: If both signals are set, `SP_IntLi = 1` has priority.

Bumpless switchover from external to internal setpoint

The parameter `SP_TrkExt = 1` is used so that the internal setpoint tracks the external setpoint to achieve a Bumpless switchover from the external to the internal setpoint. This allows unwanted jumps at the output parameter to be avoided.

2.1.8.3 Manipulated variable specification - internal/external

Manipulated variable specification internal and external

The `VlvAnl` block provides a function for specifying manipulated variables. This specification is carried out either using a CFC/SFC program or using a faceplate (operator).

If an auxiliary valve is used for operation, it is possible to switch between internal and external in the both manual and automatic mode.

If no auxiliary valve is used for operation, the external manipulated variable is used for automatic mode and the internal manipulated variable is used for manual mode. It is not possible to switch between internal and external.

Note

If no auxiliary valve is used and either the "Open" or "Close" command is active, a new manipulated variable (internal or external) only takes effect after the change. In automatic mode, the manipulated variable is ignored as long as the "Open" or "Close" command is pending.

Manipulated variable specification using a faceplate or interconnection

You can use the `MV_LiOp` parameter to determine if the manipulated variable should be set by a CFC/SFC program or via the faceplate.

- Set `MV_LiOp` to 0 for manipulated variable specification to be performed with the faceplate.
- Set `MV_LiOp` to 1 for manipulated variable specification to be performed by a CFC/SFC program.

Manipulated variable specification internal and external

You need to set the corresponding parameters depending on the selected method for manipulated variable specification.

If the manipulated variable is to specified via the faceplate `MV_LiOp = 0`, you have to set the parameter:

- `MV_IntOp = 1` in order to achieve internal manipulated variable specification via the faceplate.
- `MV_ExtOp = 1` in order to achieve external manipulated variable specification via the faceplate.

If both signals are set, the most recently active state is retained.

If the manipulated variable is set by a CFC/SFC program (`MV_LiOp = 1`), you have to set the parameter:

- `MV_IntLi = 1` to have an internal manipulated variable set by a CFC/SFC program.
- `MV_ExtLi = 1` in order to achieve an external manipulated variable specification by a CFC/SFC program.

If both signals are set, `MV_IntLi = 1` has priority.

Note

It is only possible to switch between internal and external when operating with a auxiliary valve.

Bumpless switchover of the manipulated variable from external to internal

The parameter `SP_TrkExt = 1` is used so that the internal setpoint tracks the external setpoint to achieve a Bumpless switchover from the external to the internal setpoint. This allows unwanted jumps at the output parameter to be avoided.

Forming the manipulated variable externally

With external manipulated variable specification, the manipulated variable is restricted to the `MV_HiLim` and `MV_LoLim` limits and sent to the `MV_ExtOut` output.

2.1.9 Configurable response using the Feature I/O

2.1.9.1 Configurable functions using the Feature I/O

Configurable functions using the Feature I/O

Some blocks have an input called `Feature`. This input can be used to influence the way in which the block works.

The `Feature` bits are assigned in the following order:

Bit number	Meaning	Block
0	Set startup characteristics (Page 138)	AV, Average, CountOh, CountScL, DeadTime, Derivative, DoseL, FmCont, FmTemp, Integral, Lag, MeanTime, ModPreCon, MonAnL, MonAnS, MonDi08, MonDiL, MonDiS, MotL, MotS, MotRevL, MotSpdCL, MotSpdL, OpAnL, Pcs7AnOu, Pcs7DiOu, PIDConL, PIDConR, PIDStepL, RateLim, Ratio, ShrdResS, TotalL, Vlv2WayL, VlvAnL, VlvMotL, VlvL, VlvS
1	Reaction to the out of service mode (Page 177)	ConPerMon, CountOh, CountScL, DoseL, Event, EventNck, EventTs, FmCont, ModPreCont, MonAnL, MonAnS, MonDi08, MonDiL, MonDiS, MotL, MotS, MotRevL, MotRevSpdL, OpAnL, OpDi01, OpDi03, OpTrig, PIDConL, PIDConR, PIDStepL, Ratio, SeIA16In, TotalL, Vlv2Way, VlvAnL, VlvL, VlvS, VlvMotL

2.1 Functions of the blocks

Bit number	Meaning	Block
2	Resetting the commands for changing the mode (Page 161)	DoseL, FmCont, FmTemp, Mod-PreCon, MotL, MotS, MotRevL, MotSpdCL, MotSpdL, PID-ConL, PIDConR, PIDStepL, Viv2WayL, VivAnL, VivL, VivS, VivMotL, SelA16In
	Separate evaluation for excluded and simulated interlock signals (Page 152)	Intlk02, Intlk04, Intlk08, Intlk16, OpDi01, OpDi03
3	Enabling resetting of commands for the control settings (Page 161)	DoseL, MotL, MotS, MotRevL, MptSpdCL, MotSpdL, Viv2WayL, VivAnL, VivL, Viv-MotL
	Control priority in the event of an invalid input command (Page 175)	VivS
4	Setting switch or button mode (Page 167)	DoseL, FMCont, FMTemp, Mod-PreCon, MotL, MotRevL, MotSpdCL, MotSpdL, PID-ConL, PIDStepL, Viv2WayL, VivAnL, VivL, VivMotL, SelA16In
	Setting switch or button mode for local commands (Page 181)	MotL, MotRevL, MotSpdCL, MotSpdL, VivL, Viv2WayL, VivMotL, VivPosL
5	Specifying the dosing type (Page 146)	DoseL
	Control via auxiliary valve (Page 172)	VivAnL
	Alarm setpoint difference (Page 171)	MotSpdCL
	Specifying switching mode (Page 168)	MotSpdL
	Use the last value following a complete download as the current value during startup of the block (Page 154)	Totall
	Display only input values that are interconnected in the faceplate (Page 157)	SelA16In
	Activate OS_Perm bits (Page 157)	Intlk02, Intlk04, Intlk08, Intlk16
	Limit output Out (Page 144)	Polygon
	Setting the scaling for the process values (Page 148)	FbDrive
	Activate LowCutOff (Page 155)	Pcs7AnIn
	Evaluation of the signal status of the interlock signals (Page 142)	OpDi01, OpDi03
		DoseL, MotL, MotRevL, MotS, MotSpdCL, MotSpdL, Viv2WayL, VivAnL, VivL, VivS, VivMotL
	Retain last output value in case of bad input signal status (Page 184)	MeanTime

Bit number	Meaning	Block
6	Resetting the dosing quantity when dosing starts (Page 162)	DoseL
	Block as summing unit or integrator (Page 143)	TotalL
	Disabling opening and closing (Page 158)	VlvAnL
	Substitute value switch in the event of an error (Page 149)	Polygon
	Failure handling (Page 138)	FbDrive
	Vibrate after torque monitoring (Page 178)	VlvPosL
	Ramp rate calculation (Page 179)	PIDConL, PIDConR, PIDStepL, MotSpdCL, OpAnL, FMTemp, FMCont
	External/internal selection specification (Page 180)	SelA16In
	Operator can change the setpoint via faceplate also in the "Local" mode (Page 183)	MotSpdCL
	Scalable measuring range (Page 189)	Pcs7AnIn
7	Enabling direct changeover between forward and reverse (Page 146)	MotRevL, MotSpdCL
	Summing characteristics continuous or triggered (Page 174)	TotalL
	Activating calculation of the flow rate for dosing by scale (Page 144)	DoseL
	Ramp rate calculation (Page 179)	VlvAnL
	Analog input 1 is reserved for the operator (Page 183)	SelA16In
	Define the setpoint after stop and start of the motor (Page 184)	MotSpdCL
	2 decimal points (scalable measuring range) (Page 189)	Pcs7AnIn
8	Unit for the rate of change (Page 147)	RateLim
	Sealing the valve (Page 176)	DoseL
	Reporting with BATCH parameters (Page 156)	Event, EventTS
	Sealing the valve (Page 176)	VlvMotL
	Switch to substitute value (Page 149)	FlowCorr
	Separate delay times for each alarm (Page 170)	MonAnL, PIDConL, PIDConR
	Forcing operating modes in the "Local" mode (Page 184)	MotL, MotRevL, MotSpdCL, MotSpdL, VlvL, Vlv2WayL, VlvMotL, VlvPosL, DoseL
	Inverter enable (Page 187)	MotSpdCL
	Delete history of MV and DV moves during restart (Page 187)	ModPreCon, MPC10x10
	Status output calculation (Page 188)	Integral
	Variants of CPI calculation (Page 188)	ConPerMon
	3 decimal points (scalable measuring range) (Page 190)	Pcs7AnIn
9	Resetting via input signals in the event of interlocking (Protection) or errors (Page 163)	DoseL, MotL, MotS, MotRevL, MotSpdCL, MotSpdL, Vlv2WayL, VlvAnL, VlvL, VlvS, VlvMotL
	Substitution value is active if the block is in bypass (Page 185)	MonAnL, MonDiL, PIDConL, PIDConR, PIDStepL, TotalL
	Enable external message (Page 185)	EventTs, Event16Ts

2.1 Functions of the blocks

Bit number	Meaning	Block
10	Exiting local mode (Page 177)	DoseL, MotL, MotS, MotRevL, MotSpdCL, MotSpdL, Vlv2WayL, VlvAnL, VlvL, VlvS, VlvMotL
	Condition monitoring information at MOD_Blocks (Page 145)	FbAnIn, FbAnOu, FbDiIn, FbDiOu, FbAnTot, Pcs7AnIn, Pcs7AnOu, Pcs7DiIn, Pcs7DiOu, Pcs7Cnt1, Pcs7Cnt2, Pcs7Cnt3, FmCont, FmTemp
	Condition monitoring information at the channel blocks (Page 145)	FbAnIn, FbAnOu, FbAnTot, FbDiIn, FbDiOu, FbDrive, FbEnMe, FbSwtMMS, Pcs7AnIn, Pcs7AnOu, Pcs7Cnt1, Pcs7Cnt2, Pcs7Cnt3, Pcs7DiIn, Pcs7DiIT, Pcs7DiOu, FmCont, FmTemp
	Considering bad quality of automatic commands or external values (Page 186)	MotL, MotS, MotRevL, MotSpdCL, MotSpdL, Vlv2WayL, VlvL, VlvS, VlvMotL, VlvPosL, VlvAnL, DoseL, OpAnL, OpAnS, OpDi01, OpDi03, OpTrig
11	Stopping dosing at a flow alarm (Page 137)	DoseL
	Activating the run time of feedback signals (Page 153)	MotL, MotS, MotRevL, MotSpdL, MotSpdCL, VlvL, Vlv2WayL, VlvMotL, VlvAnL
	Gradient limitation with time duration (Page 182)	PIDConL, PIDConR, PIDStepL
	Suppress MsgLock and "Out of service" mode for a connected message block (Page 188)	DoseL, FmCont, FmTemp, PIDConL, PIDConR, PIDStepL, MonDi08, MonAnL, MonDiL, MotL, MotSpdCL, MotRevL, MotSpdL, VlvL, VlvMotL, Vlv2WayL, VlvAnL, VlvPosL
12	Automatic post dosing for underdosing in automatic mode (Page 143)	DoseL
	Control zone with specified I component (Page 160)	PIDConL
	Motor feedback is not available (Page 157)	VlvMotL
	Position feedback signals are active (Page 169)	Vlv2WayL
	Gradient limitation with time duration (Page 182)	MotSpdCL, VlvAnL, OpAnL
13	Creep rate is always detected in the dosing quantity (Page 168)	DoseL
	Control zone with frozen I component (Page 160)	PIDConL
	Separate monitoring time for stopping the motor (Page 169)	MotL, MotRevL, MotSpdCL, MotSpdL, VlvMotL
14	Enabling rapid stop via faceplate (Page 168)	MotL, MotRevL, MotSpdCL, MotSpdL, VlvMotL
	External control deviation (Page 151)	PIDConL
	Scale dosing can be started only if StandStill = 1 (Page 187)	DoseL

Bit number	Meaning	Block
15	Neutral position manipulated variable takes effect with "out of service" operating mode (Page 166)	ModPreCon, PIDConL, PIDConR, PIDStepL, VlvAnL
	Frequency converter with separate device feed (Page 151)	MotSpdL
	Frequency converter with separate device feed (Page 151)	DoseL
	Motor stop in end position depends only on the corresponding feedback signal (Page 185)	VlvMotL
16	Neutral position manipulated variable takes effect at startup (Page 166)	ModPreCon, PIDConL, PIDConR, PIDStepL, VlvAnL
	Process value with separate scale range (Page 162)	OpAnL
	Setpoint specification with own scale and unit of the parameter (Page 171)	MotSpdCL
	Separate interlock for each direction or position (Page 170)	MotRevL
17	Enabling bumpless switchover to automatic mode for valves, motors, and dosers (Page 173)	DoseL, MotL, MotRevL, MotSpdCL, MotSpdL, Vlv2WayL, VlvAnL, VlvL, VlvMotL
	With accelerated return of the integral action from the manipulated variable limit (Page 180)	PIDConR
18	Disabling bumpless switchover to automatic mode for controllers (Page 173)	PIDConL, PIDConR, PIDStepL
	Activating error state for external process control error CSF (Page 151)	DoseL, MotL, MotS, MotRevL, MotSpdCL, MotSpdL, Vlv2WayL, VlvAnL, VlvL, VlvS, VlvMotL
19	Enabling program mode (Page 159)	PIDConR
	Reset even with locked state (Page 165)	MotL, MotS, MotRevL, MotSpdCL, MotSpdL, VlvMotL
20	Enabling bumpless change to the proportional gain, derivative time and amplification of the differentiator (Page 172)	PIDConR
	Disable calculation of impulse control in LocalSetting 2 and 4 (Page 186)	MotL, MotRevL, MotSpdCL, MotSpdL, VlvL, VlvMotL, VlvPosL, Vlv2WayL
21	Enable bumpless switchover to "Automatic" mode for operator only (Page 172)	MotL, MotRevL, MotSpdCL, MotSpdL, VlvMotL, VlvL, Vlv2WayV, VlvAnL, DoseL
	Switching operator controls for external setpoint to visible (Page 144)	PIDConR
	First-in detection response to deactivation (Page 176)	Intlk02, Intlk04, Intlk08, Intlk16
22	Update acknowledgment and error status of the message call (Page 160)	AssetM, AV, ConPerMon, CountOh, CounnScL, DoseL, Event, EventTs, FmCont, FmTemp, MonAnL, MonDi08, MonDiL, MotL, MotRevL, MotSpdCL, MotSpdL, OpAnL, PIDConL, PIDConR, PIDStepL, TotalL, Vlv2WayL, VlvAnL, VlvL, VlvMotL

2.1 Functions of the blocks

Bit number	Meaning	Block
23	Evaluation of signal status (Page 142)	Intlk02, Intlk04, Intlk08, Intlk16
	Specifying the influence of the signal status on the dosing process (Page 147)	DoseL
	SP following PV in open loop has no priority over SP_Ext and SP limits (Page 179)	PIDConL, PIDConR, PIDConS, PIDStepL, FmTemp, FmCont
24	Enabling local operator authorization (Page 158)	ConPerMon, CountOh, CountScL, DoseL, FmCont, FmTemp, GainSched, Intlk02, Intlk04, Intlk08, Intlk16, ModPreCon, MonAnL, MonAnS, MonDi08, MonDiL, MonDiS, MotL, MotS, MotRevL, MotSpdCL, MotSpdL, OpAnL, OpDi01, OpDi03, OpTrig, PIDConL, PIDConR, PIDStepL, Ratio, SeIA16In, TotalL, Vlv2WayL, VlvAnL, VlvL, VlvS, VlvMotL, KalFilt
	With acknowledge overdosage (Page 179)	DoseL
25	Suppression of all messages (Page 174)	ConPerMon, DoseL, FmCont, FmTemp, MonAnL, MonAnS, MonDiL, MonDiS, MotL, MotS, MotRevL, MotSpdCL, MotSpdL, PIDConL, PIDConR, PIDStepL, Vlv2WayL, VlvAnL, VlvL, VlvS, VlvMotL
26	Reaction of the switching points in the "Out of service" operating mode (Page 176)	ConPerMon, FmCont, FmTemp, PIDConL, PIDConR, PIDStepL, AV, MotL, MotRevL, MotSpdL, VlvMotL, MotSpdCL, VlvAnL, DoseL, CountOh, CountScL, TotalL, MonAnL, MonAnS, CntOhSc, PIDConS
27	Selecting values associated with messages (Page 156)	Event, EventNck, EventTs
	Interlock display with LocalSetting 2 or 4 (Page 178)	MotL, MotS, MotRevL, MotSpdCL, MotSpdL, Vlv2WayL, VlvAnL, VlvL, VlvS, VlvMotL
	Enable configuration of the dribbling quantity (Page 159)	DoseL
28	Output invalid raw value (Page 174)	Pcs7AnIn, Pcs7DiIn, Pcs7DiIT
	Disabling operating points (Page 145)	AssetM, AV, ConPerMon, CountOh, CountScL, DoseL, FmCont, MonAnL, PIDConL, PIDStepL, VlvAnL, FmTemp, PIDConR, MotL, MotRevL, MotSpdCL, MotSpdL, TotalL, VlvMotL
	Reading messages (Page 147)	FbDrive

Bit number	Meaning	Block
29	Output substitute value if raw value is invalid (Page 149)	FbAnIn, FbDiIn, Pcs7AnIn, Pcs7DiIn, Pcs7DiIT
	Signaling limit violation (Page 170)	AV, ConPerMon, CountOh, CountScL, DoseL, FmCont, FmTemp, MonAnL, MotL, MotRevL, MotSpdCL, MotSpdL, PIDConL, PIDConR, PIDStepL, TotalL, VlvAnL, VlvMotL
	Transmission of status information of devices (Page 175)	FbDrive, FbSwtMMS
30	Outputting last valid value if raw value is invalid (Page 154)	FbAnIn, FbDiIn, Pcs7AnIn, Pcs7DiIn, Pcs7DiIT
	Outputting a de-energized value for block-external simulation (Page 148)	FbAnOu, FbDiOu, Pcs7AnOu, Pcs7DiOu, FbDrive, FbSwtMMS
	Set reset depending on the operating mode or the LiOp parameter (Page 163)	DoseL, MotL, MotS, MotRevL, MotSpdL, MotspdCL, VlvL, VlvS, VlvMotL, VlvAnL, Vlv2WayL, CountScL, CountOh, CntOhSc; TotalL
	Applying the dynamically activated dead band during the PV settling time (Page 141)	PIDConL, PIDConR
31	Activating recording of the first signal (Page 150)	Intlk02, Intlk04, Intlk08, Intlk16
	Activating reset of protection / error in manual mode (Page 165)	DoseL, MotL, MotS, MotRevL, MotSpdL, MotspdCL, VlvL, VlvS, VlvMotL, VlvAnL, Vlv2WayL

See also

Flow setpoints in percent (Page 146)

Use an internal or external setpoint for the absolute fine dosing quantity (Page 153)

Polygon functions (Page 1894)

2.1.9.2 Stopping dosing at a flow alarm

Feature bit

Number of the Feature bit: 11

Stopping dosing at a flow alarm

You can use this feature bit to enable stopping dosing at a flow alarm.

The default setting is 0.

Bit = 0: Disabled, dosing is not stopped when a flow alarm occurs

Bit = 1: Enabled, dosing is stopped when a flow alarm occurs

2.1.9.3 Failure handling

Feature bit

Number of the Feature Bit: 6

Failure handling

Use this Feature bit to configure "Failure handling" in the case of device failure.

The default setting is 0.

Bit = 0: Commands `Local` and `Ackn` only active

Bit = 1: All commands active

See also

Configurable functions using the Feature I/O (Page 131)

2.1.9.4 Set startup characteristics

Feature bit

Number of the Feature bit: 0

Set startup characteristics

With this Feature bit, you set the startup characteristics of the function blocks, for example, for:

- Motors, valves and controllers
- Channel blocks
- Monitoring blocks, e.g. `MonAnL` and `MonDiL`.
- Mathematical and analog logic blocks
- The `OpAnL`, `OpAnS`, `OpDi01`, and `OpDi03` block
- The `TimeTrg` block
- Counter blocks
- The `Average` block
- The `TimeTrig` block
- The `Trigger` block

The default setting is 0.

Note

This `Feature` bit has no function in the "Out of service" operating mode. The process tag remains in the "Out of service" operating mode after a warm restart of the CPU.

Note

The message classes Alarm, Warning and Tolerance are not valid for user-configured message classes. Please take into consideration the validity of terms for user-configured message classes (Page 41).

Note

With a Run-Stop-Run transition of the CPU and internally pending messages, non-stuck-through messages with time stamps and auxiliary values beginning with `RunUpCycle` occur for blocks with the startup characteristic `Feature bit = 0` after expiration of the `RunUpCycle` counter in the following cases:

- Alarm, warning or tolerance messages from the operating points (motor, valve, dosing, controller and analog monitoring blocks)
- Feedback errors (motor and valve blocks)
- Output signals of digital process tags (MonDiL, MonDi08)
- Flutter limits violated (MonDiL)

The restart routines of the blocks reset the following outputs in OB100:

- Operating point outputs `xx_AH_Act`, `xx_AL_Act`, `xx_WH_Act`, `xx_WL_Act`, `xx_TH_Act`, `xx_TL_Act` or `GradHUpAct`, `GradHDnAct`, `GradLAct`
- Feedback error outputs `MonDynErr` and `MonStaErr`
- Output binary signals `Out`, `Out1` . . . `8` for MonDiL or MonDi08
- Flutter suppression `FlutAct` for MonDiL

This causes an outgoing message when initializing Alarm8_P in OB100 and an incoming message after expiration of the `RunUpCycle` counter on the cyclic interrupt level.

Note

During a complete download with AS stop, the blocks (with `Feature.Bit0 = 1`) cannot resume operation in their previous mode and control when restarted.

Set startup characteristics for motors, valves and controllers

Bit = 0: Starting the block in manual mode and in neutral position. With controllers, the setpoint is set to (`SP_Int`) internally. See also the section Neutral position for motors, valves and controllers (Page 48) for more on this.

The controller blocks PIDConL, PIDConS, PIDConR, PIDStepL, ModPreCon, MPC10x10, and the valve block VlvAnL have the additional `Feature` bit 16, Neutral position manipulated variable takes effect at startup (Page 166), which specifies whether the neutral position is approached

Bit = 1: Starting the block with the last stored values, in other words in the last operating mode set (manual, automatic or local mode) and at the last valid position.

Note

Special note following complete download to the CPU

Following a complete download to the CPU, the motor protection signal `Trip` is evaluated during the initial run as good (=1).

When a motor protection signal is pending, this causes a non-struck-through message with time stamp and auxiliary values beginning with `RunUpCycle` after the complete download and after expiration of the `RunUpCycle` counter.

Startup characteristics for the ShrdResS block

Bit = 0: The output command interface is reset to 0.

Bit = 1: The block leaves the output command interface unchanged.

Defining the startup characteristics for channel blocks

Bit = 0: The channel block uses either the process value `PV_In` or the value of `SimPV_In` as the startup value, depending on the setting of the input parameter `SimOn` (`PV_In = PV_Out` or `SimPV_In = PV_Out`).

Bit = 1: The channel block uses the value `StartVal` as the startup value (`StartVal = PV_Out`).

Defining the startup characteristics for monitoring blocks

Bit = 0: The most recently stored values are reset on startup.

Bit = 1: The most recently used value at the output parameter `Out` is output on startup.

Defining the startup characteristics for mathematical, analog logic blocks

Bit = 0: The `Out` output parameter is reset to 0 on startup.

Bit = 1: The most recently saved value is output at the `Out` output parameter on startup.

Defining startup characteristics for the OpAnL/OpAnS blocks

Bit = 0: The internal setpoint is used for startup.

Bit = 1: The most recently saved value is output at the `Out` output parameter on startup.

Defining startup characteristics for the OpDi01/OpDi03 blocks

Bit = 0: The output parameters `Out` or `Out1...Out3` will be reset on startup.

Bit = 1: The most recently used value at the output parameter `Out` or `Out1...Out3` is outputted on startup.

Defining the startup characteristics for counter blocks

Bit = 0: On startup, the counter is stopped and reset to the value specified in the input parameter.

Bit = 1: On startup, counting continues with the most recently stored value.

Input parameters for the startup characteristics of the counter blocks:

- Block CountOh: Input parameter `PresetTime`
- Block CountScL: Input parameter `PresetVal`
- Block TotalL: Input parameter `PresetVal`

Messages can be suppressed for a short time after startup. You can set the number of cycles using the input parameter `RunUpCyc`.

Note

Advanced configuration of the startup characteristics for the counter blocks

Note that you can further affect the startup characteristics via the `Feature Bit 5` as a function of this `Feature Bits 0`. Refer to the section: Use the last value following a complete download as the current value during startup of the block (Page 154).

Defining startup characteristics for the Average block

Bit = 0: At startup, averaging begins with the value that is currently at the input parameter (`Out = In`, `NumCycles = 1`).

Bit = 1: When starting-up, the last `Out` and `NumCycles` values saved are used as the last value for averaging (`Out ≠ In`).

Defining startup characteristics for the TimeTrig block

Bit 0 =0: Periodic trigger and single trigger can be shut off. The trigger pulse `Trigger` is reset.

Bit 0 =1: The activation of the periodic trigger and single trigger as well as the single trigger point are retained.

The `InPerTrigOn`, `InSglTrigOn` and `InSglTrigDT` inputs are applied for this. If you want to use the reset for a complete download, you must read back the marked parameters in addition to the operated and monitored parameters before a complete download.

See also

User-configured message classes (Page 41)

2.1.9.5 Applying the dynamically activated dead band during the PV settling time

Feature bit

Number of the `Feature bit`: 30.

Dynamic deactivation of the dead band by the PV settling time

You can use this `Feature` bit to improve the `PV` settling time in the range of the dead band.

The deadband is deactivated until the `PV` settles more in the center than at the edges of the dead band. The probability that the controlled variable is within the dead zone time is increased, and further control actions are no longer necessary. This leads to reduced wear and less energy consumption.

Bit = 0: Dead band width is constant

Bit = 1: The dead band is deactivated for the `PV` settling time. When the `PV` settling time is over, the dead zone gets the value of the `DeadBand` parameter.

2.1.9.6 Evaluation of signal status

Feature bit

Number of the `Feature` bit: 23

Evaluation of signal status

You can use the `Feature` bit to specify if the signal status of the inputs is to be checked for the values `16#00` or `16#28`. The signal status of the inputs itself remains unchanged here.

The default setting is 0.

Bit = 0: No evaluation of the signal status for `16#00` or `16#28`.

Bit = 1: the signal status is determined, an input with `ST = 16#00` or `16#28` is forwarded with value = 0. The "Negate signal" function at the input of the block has no influence on the reaction in this case.

2.1.9.7 Evaluation of the signal status of the interlock signals

`Feature` / `Feature2` bit

Number of the `Feature` / `Feature2` bit: 5

Family

Family: Operate number of the `Feature` bit: 5

Family: Control, drives, dosage number of the `Feature2` bit: 5

Evaluation of the signal status of the interlock signals

You can use the `Feature` / `Feature2` bit to specify if the signal status of the interlock inputs is to be checked for the values `16#00` or `16#28`. The signal status of the inputs itself remains unchanged here.

The default setting is 0.

Bit = 0: the signal status is determined, an input with $ST = 16\#00$ or $16\#28$ is forwarded with value = 0.

Bit = 1: No evaluation of the signal status for $16\#00$ or $16\#28$.

2.1.9.8 Automatic post dosing for underdosing in automatic mode

Feature bit

Number of the `Feature bit`: 12

Automatic post dosing for underdosing in automatic mode

Use this `Feature bit` to enable automatic post dosing for underdosing in automatic mode.

The default setting is 0.

Bit = 0: Disabled, no automatic post dosing is started for underdosing in automatic mode.

Bit = 1: Enabled, automatic post dosing is started for underdosing in automatic mode.

2.1.9.9 Block as summing unit or integrator

Feature bit

Number of the `Feature bit`: 6

Specifying the summing unit or integrator function mode

You can define the summing response of the block via this `Feature bit`.

The default setting is 0.

Bit = 0: The block operates as a summing unit.

Bit = 1: The block operates as an integrator.

Note

Special note for the summing unit

Note that the characteristics of the block as a summing unit (`Feature Bit 6 = 0`) can be further affected via the `Feature Bit 7`.

Refer to the section: [Summing characteristics continuous or triggered \(Page 174\)](#).

2.1.9.10 Switching operator controls for external setpoint to visible

Feature bit

Number of the Feature bit: 21

Switching operator controls for external setpoint to visible

Use this Feature bit to switch all operator controls for the external setpoint to visible in the faceplates for the OS operator. This is always required when the external setpoint should actually be used, for example, for slave controllers in cascade and ration controlling.

The default setting is 0, which keeps the faceplate as clear as possible for simple applications.

Bit = 0: The operator controls for the external setpoint are **not visible** in the faceplate.

Bit = 1: The operator controls for the external setpoint are **visible** in the faceplate.

2.1.9.11 Limit output Out

Feature bit

Number of the Feature Bit: 5

Limit output Out

Use this Feature bit to define the limit for the output Out.

The default setting is 0.

Bit = 0: Beyond the end interpolation points, the Out output is extrapolated based on the first two or last two interpolation points.

Bit = 1: The Out output is limited to the first and last interpolation point.

See also

Configurable functions using the Feature I/O (Page 131)

2.1.9.12 Activating calculation of the flow rate for dosing by scale

Feature bit

Number of the Feature bit: 7

Calculation of the flow rate for dosing by scale

Use this Feature bit to activate calculation of the flow rate for dosing by scale.

The default setting is 0.

Bit = 0: Deactivated

Bit = 1: Calculation activated.

The flow is determined by the change to the dosing quantity per second.

2.1.9.13 Condition monitoring information at MOD_Blocks

Feature bit

Number of the `Feature` bit: 10

Bit = 0: Not forwarded

Bit = 1: forwarded

2.1.9.14 Condition monitoring information at the channel blocks

Feature bit

Number of the `Feature` bit: 10

Transferring condition monitoring information to the Maintenance Station

With this `Feature` bit, the data which is entered at the parameters `MS_Ext` and `TextRef` will be transferred to the corresponding driver block and the same data will be displayed on the asset faceplate of the Maintenance Station. For more information, refer to the *Maintenance Handbook*.

The default setting is 0.

Bit = 0: Data will not be transferred.

Bit = 1: Data will be transferred.

2.1.9.15 Disabling operating points

Feature bit

Number of the `Feature` bit: 28

Disabling operating points

You can use this `Feature` bit to determine if the operating point function of a limit for disabling the message (`MsgLock = 1`) should also be disabled.

The default setting is 0.

Bit = 0: Operating point is not suppressed

Bit = 1: Operating point is suppressed

2.1.9.16 Enabling direct changeover between forward and reverse

Feature bit

Number of the `Feature` bit: 7

Direct changeover between forward and reverse

With this `Feature` bit, you can enable direct reversal of the direction of motors.

The default setting is 0.

Bit = 0: Direct reversal of the direction is disabled.

You can only change the direction of the motor by first stopping and starting the motor again in the required direction. The motor can only be started again after the time set in the `IdleTime` parameter has elapsed.

Bit = 1: Direct changeover is enabled.

You can reverse the motor direction directly. The motor block reverses the direction automatically. The motor is stopped and is started in the other direction when the time set in the `IdleTime` parameter has elapsed.

2.1.9.17 Specifying the dosing type

Feature bit

Number of the `Feature` bit: 5

Specifying the dosing type

You can specify the dosing type to be used for the block using this `Feature` bit.

The default setting is 0.

Bit = 0: Flow

Bit = 1: Scales

2.1.9.18 Flow setpoints in percent

Feature bit

Number of the `Feature` bit: 15

Flow setpoints in percent

You can use this `Feature` bit to specify if the doser block should display the flow setpoints in the faceplate as percentages.

The default setting is 0.

Bit = 0: Deactivated. The display of the flow setpoints is made in the unit specified with the `PV_Unit` parameter.

Bit = 1: Activated: The display of the flow setpoints is made in the unit %.

2.1.9.19 Specifying the influence of the signal status on the dosing process

Feature bit

Number of the `Feature` bit: 23

Specifying the influence of the signal status on the dosing process

You can use this `Feature` bit to specify how the doser should react dependent on the signal status.

The default setting is 0.

Bit = 0: Dosing process does not stop with bad signal status of the process value `PV`.

Bit = 1: Dosing process stops with bad signal status of the process values `PV`. The doser is also set to the "Off" state (see state diagram: DoseL functions (Page 1011)).

See also the following section:

- Forming and outputting signal status for blocks (Page 108)

2.1.9.20 Unit for the rate of change

Feature bit

Number of the `Feature` bit: 8

Specifying the unit for the rate of change

You can use this `Feature` bit to specify the unit for the rate of change:

The default setting is 0.

Bit = 0: unit for the rate of change in the unit of measurement to or from the field device

Bit = 1: unit for the rate of change as a percentage to or from the field device

2.1.9.21 Reading messages

Feature bit

Number of the `Feature` bit: 28

Use of the input data

You can use this `Feature` bit to specify the format for reading messages.

Default setting is 0

Bit = 0: Messages are read as PV freely configurable

Bit = 1: Messages are read as `MsgNamur`

Note

This feature bit is only used when "Message frame type 20" and the "PZD 6" parameter are active.

2.1.9.22 Setting the scaling for the process values

Feature Bit

Number of the Feature Bit: 5

Calculation for the outputs `CurrentLi`, `Power1Li`, `Power2Li`, `FreeLi`

Feature Bit 5 defines whether the `PZDInXScale` is used for the calculation for the other process values.

Bit = 0: `xxxx.Value := (PZDIn*(100/16384.0));`

Bit = 1: `xxxx.Value := (PZDIn*((PZDInXScale.HIGH- PZDInXScale.LOW)/16384.0))+ PZDInXScale.LOW;`

2.1.9.23 Outputting a de-energized value for block-external simulation

Feature bit

Number of the Feature bit: 30

Outputting a de-energized value for block-external simulation

Use this `Feature` bit for channel blocks to specify which value is to be output during the block-external simulation (Simulating signals (Page 58)).

The default setting is 1.

Bit = 0: If process value input has the status `16#60`, the output value will be set to the input value.

Bit = 1: If process value input has the status `16#60`, the output value will be set to "0".

2.1.9.24 Switch to substitute value

Feature bit

Number of the `Feature` bit: 8

Switch to substitute value

You can use this `Feature` bit to specify whether a substitute value should be applied or the last valid value should be retained when certain conditions occur.

The default setting is 0.

Bit = 0: Retain last valid value

Bit = 1: Apply the substitute value

See also

Output invalid raw value (Page 174)

Outputting last valid value if raw value is invalid (Page 154)

2.1.9.25 Substitute value switch in the event of an error

Feature bit

Number of the `Feature` bit: 6

Substitute value switch in the event of an error

You can specify the substitute value activation at errors using this `Feature` bit.

The default setting is 0.

Bit = 0: No substitute value switch

Bit = 1: The substitute value `SubV_In` is output at `Out` for `ErrorNum` ≠

See also

Configurable functions using the `Feature` I/O (Page 131)

2.1.9.26 Output substitute value if raw value is invalid

Feature bit

Number of the `Feature` bit: 29

Output substitute value if raw value is invalid

Use this `Feature` bit to activate output of the substitute value (input parameter `SubsPV_In`) for channel blocks if there is an invalid raw value or the device is in the initialization phase (input parameter `PV_ST 16#4C..4F`).

The default setting is 0.

Bit = 0: If there is an invalid raw value or the device is in the initialization phase, the substitute value is not output.

Bit = 1: If there is an invalid raw value or the device is in the initialization phase, the substitute value is output. The signal status of the output value is set to "Manipulated value (for example, substitute value, simulation, last valid value).

If there is an invalid raw value or the device is in the initialization phase, the output parameter `Bad = 1` is set automatically.

Prioritizing the `Feature` bits for channel blocks:

You need to assign parameters for three `Feature` bits for the response to an invalid raw value for the channel blocks.

If more than one of these `Feature` bits are set (=1), the following priority applies:

- Output invalid raw value (Page 174) (`Feature` bit 28 = highest priority)
- Output substitute value if raw value is invalid (`Feature` bit 29)
- Outputting last valid value if raw value is invalid (Page 154) (`Feature` bit 30 = lowest priority)

The raw value is output if none of the `Feature` bits 28, 29 or 30 is set.

2.1.9.27 Activating recording of the first signal

Feature Bit

Number of the `Feature` bit: 31

Activating recording of the first signal

Use this `Feature` bit to activate recording of the first signal with interlock blocks. Please also refer to the section Recording the first signal for interlock blocks (Page 52).

Default setting is 0

Bit = 0: Recording of the first signal is deactivated.

Bit = 1: Recording of the first signal is activated.

2.1.9.28 External control deviation

Feature bit

Number of the `Feature` bit: 14

External control deviation

You can use this `Feature` bit to specify whether the external control deviation is to be activated.

The default setting is 0.

Bit = 0: The external control deviation is deactivated, the internal control deviation is active.

Bit = 1: The external control deviation is activated.

2.1.9.29 Activating error state for external process control error CSF

Feature bit

Number of the `Feature` bit: 18

Activating error state for external process control error CSF

You can use this `Feature` bit to specify whether the block should switch to the error state at an external process control error CSF =1.

The default setting is 0.

Bit = 0 : Block does not go to error state with process control error CSF = 1.

Bit = 1: Activated: Block goes to error state with process control error CSF = 1.

2.1.9.30 Frequency converter with separate device feed

Feature bit

Number of the `Feature` bit: 15

Frequency converter with separate device feed

You can use this `Feature` bit to specify if a frequency converter with a separate device feed or the inverter enable should be used.

The default setting is 0.

Bit = 0: Motor without device feed or without inverter enable

Bit = 1: Frequency converter with separate device feed or with inverter enable

2.1.9.31 Separate evaluation for excluded and simulated interlock signals

Feature bit

Number of the `Feature2` bit: 2

Separate evaluation for excluded and simulated interlock signals

You can use this `Feature` bit to set the reaction of the block to an interlock signal of an interlock block that is excluded or simulated.

The default setting is 0

Bit = 0: Switch-relevant excluded and simulated interlock signals are processed with the status 16#60 and are displayed as simulated or excluded, depending on the interlock status.

Bit = 1: Excluded and simulated interlock signals are evaluated separately. All excluded interlock signals in a sequence of interlock blocks are displayed as excluded. Switch-relevant simulated interlock signals are processed with the status 16#60 and displayed as simulated.

Note

If the `Feature` Bit is enabled, the signal cannot be inverted via CFC during interconnections at the inputs, as, otherwise, the bypass display would not update.

The interlocking inputs of the following blocks are affected:

- **Intlk02, Intlk04, Intlk08, Intlk16:** `In01, In02, ...`
- **Dosel, MotL, MotSpdL, MotSpdCL, VivL, Viv2WayL, VivAnL:** `Permit, Interlock, Protect`
- **MotRevL:** `Permit, Interlock, Protect, PermRev, IntlRev, ProtRev`
- **VivMotL, VivPosL:** `Permit, Interlock, Protect, PermCls, IntlCls, ProtCls`
- **MotS, VivS, OpDi01, OpDi03, PIDConL, PIDConR:** `Interlock`

The inversion of the interlocking signals occurs via the `InvIn01, InvIn02, ...` inputs on the interlocking blocks.

See also

OpDi01 functions (Page 384)

OpDi03 functions (Page 398)

Intlk02 functions (Page 1570)

Intlk04 functions (Page 1582)

Intlk16 functions (Page 1612)

Intlk08 functions (Page 1596)

MotL functions (Page 1078)

MotS functions (Page 1111)

MotRevL functions (Page 1137)

MotSpdL functions (Page 1230)
Vlv2WayL functions (Page 1310)
VlvL functions (Page 1350)
VlvMotL functions (Page 1407)
VlvAnL functions (Page 1454)
MotSpdCL functions (Page 1177)
VlvS functions (Page 1381)
DoseL functions (Page 1011)
Influence of the signal status on the interlock (Page 103)
Forming the group status for interlock information (Page 104)
Forming and outputting the signal status for interlock blocks (Page 115)

2.1.9.32 Use an internal or external setpoint for the absolute fine dosing quantity

Feature Bit

Number of the `Feature` bit: 8

Use an internal and external setpoint for the absolute fine dosing quantity

Use this `Feature` bit to determine whether the doser processes the internal and external setpoint for the fine dosing quantity in an absolute manner and is displayed or operated in an absolute manner in the faceplate.

The default setting is 0.

Bit = 0: Deactivated. The internal and external I/Os as well as the display and operation of the fine dosing quantity setpoint are processed in the % unit.

Bit = 1: Activated: The internal and external I/Os as well as the display and operation of the fine dosing quantity setpoint are processed in the unit that was set using the parameter `DQ_Unit`.

2.1.9.33 Activating the run time of feedback signals

Feature Bit

Number of the `Feature` bit: 11

Activating the run time of feedback signals

Use this `Feature` bit to activate the run time of feedback signals.

The default setting is 0.

Bit = 0: Deactivated: Tracking of feedback for simulation immediately after the trigger signal.

Bit = 1: Activated: Tracking of feedback for simulation after the trigger signal and expiration of the monitoring time (`MonTiDynamic`). The feedback signals are generated after expiration of the monitoring time.

2.1.9.34 Outputting last valid value if raw value is invalid

Feature bit

Number of the `Feature` bit: 30

Outputting last valid value if raw value is invalid

Use this `Feature` bit to activate output of the last valid value for channel blocks if there is an invalid raw value or the device is in the initialization phase (input parameter `PV_ST = 16#4C..4F`).

The default setting is 0.

Bit = 0: If there is an invalid raw value or the device is in the initialization phase, the last valid value is not output.

Bit = 1: If there is an invalid raw value or the device is in the initialization phase, the last valid value is output. The signal status of the output value is set to local "Manipulated value (for example, substitute value, simulation, last valid value).

If there is an invalid raw value or the device is in the initialization phase, the output parameter `Bad = 1` is set.

Prioritizing the `Feature` bits for channel blocks:

You need to assign parameters for three `Feature` bits for the response to an invalid raw value for the channel blocks.

If more than one of these `Feature` bits are set (=1), the following priority applies:

- Output invalid raw value (Page 174) (`Feature` bit 28 = highest priority)
- Output substitute value if raw value is invalid (Page 149)(`Feature` bit 29)
- Output the last valid value if raw value is invalid (`Feature` bit 30, lowest priority)

The raw value is output of none of the `Feature` bits 28, 29 or 30 is set.

2.1.9.35 Use the last value following a complete download as the current value during startup of the block

Feature bit

Number of the `Feature` bit: 5

Use the last value during startup of the block after a complete download of the CPU

You can use this `Feature` bit to define the startup characteristics of the block as a function of the `Feature` bit 0.

This feature bit is used on the following parameters:

- `Block TotalL`: `OldOut`, `OldCntOut`
- `Block CountScL`: `OldOut`
- `Block CountOh`: `OldDays`, `OldHours`, `OldMinutes`, `OldSeconds`

For the settings on `Feature` bit 0, refer to the section: `Set startup characteristics` (Page 138).

Note

If you want to use this function, you must read back the marked parameters in addition to the operated and monitored parameters before a complete download.

The default setting is 0.

Bit = 0: Define the startup characteristics as a function of `Feature` bit 0:

- `Feature` bit 0 = 0: The block is set to the default value (input parameter `Preset`) during startup.
- `Feature` bit 0 = 1: On startup, counting continues with the most recently stored value.

Bit = 1: During startup of the block after a complete download, the last value (`Oldxxx`) is used as the current value regardless of `Feature` bit 0 (`Set startup characteristics` (Page 138)).

2.1.9.36 Activate LowCutOff

Feature bit

Number of the `Feature` bit: 5

Activate LowCutOff

You use this `Feature` bit to activate the use of `LowCutOff` bits.

The default setting is 0.

Bit = 0: Low signal cut-off - OFF (default)

Bit = 1: Low signal cut-off - ON

2.1.9.37 Selecting values associated with messages

Feature Bit

Number of the `Feature` bit: 27

Selecting values associated with messages

Use this `Feature` bit to select which values associated with messages are to be output.

The default setting is 0.

Bit = 0: The signal status of the binary input is output as the value associated with messages.

Bit = 1: The associated analog value is output as the value associated with messages.

2.1.9.38 Reporting with BATCH parameters

Feature bit

Number of the `Feature` bit: 8

Reporting with BATCH parameters

You can use this `Feature` bit to specify whether the block transfers the BATCH parameters

- `BatchID`: Batch ID
- `BatchName`: Batch name
- `StepNo`: Batch step number

Are transferred as associated values to the OS during messaging.

The default setting is 0.

Bit = 0: The block does not transfer any BATCH parameters to the OS.

Bit = 1: The block transfers BATCH parameters to the OS.

Note

Information about the setting "Bit = 1:

The Event block can no longer transfer the `In8.ST` or `AV8.Value` as an associated value.

The EventTS block can no longer transfer the signal status of the signal `In7` and `In8` or `InTS7` and `InTS8` as an associated value.

You will find more information in the following chapters:

- Event messaging (Page 1637)
- EventTs messaging (Page 1663)

2.1.9.39 Motor feedback is not available

Feature bit

Number of the `Feature` bit: 12

Motor feedback is not available

You can use this `Feature` bit to specify whether or not motor feedback should be available. The default setting is 0.

Bit = 0: Motor feedback is available.

Bit = 1: Motor feedback is not available. The motor feedback is derived from the control signals internally in the block; this disables the monitoring of the motor feedback.

2.1.9.40 Display only input values that are interconnected in the faceplate

Feature bit

Number of the `Feature` bit: 5

Display only input values that are interconnected in the faceplate

You can use this feature bit to specify whether only interconnected input values `In01` to `In16` (status not equal to `16#FF`) should be displayed in the faceplate.

The default setting is 0.

Bit = 0: Display all input values.

Bit = 1: Display only interconnected input values (status not equal to `16#FF`) and in case inputs are not connected, the faceplate size should shrink to the last connected input.

2.1.9.41 Activate OS_Perm bits

Feature bit

Number of the `Feature` bit: 5

Display only input values that are interconnected in the faceplate

You use this `Feature` bit to activate the use of additional `OS_Perm` bits in the faceplate.

The default setting is 0.

Bit = 0: `OS_Perm` bits XXX inactive

Bit = 1: `OS_Perm` bits XXX active

With XXX:

Block	OS_Perm bit X
Intlk02	16-17
Intlk04	16-19
Intlk08	16-23
Intlk16	16-31

OS_Perm bit 16	OS_Perm bit 0	OS_Perm bit 1	Operation exclu- sion "Set" In01	Operation exclu- sion "Reset" In01
0	0	0	No	No
0	0	1	No	Yes
0	1	0	Yes	No
0	1	1	Yes	Yes
1	X	X	Yes	Yes

2.1.9.42 Disabling opening and closing

Feature bit

Number of the Feature bit: 6

Disabling the Open and Close commands

Only applicable when no auxiliary valve is used (bit 5 = 0)

Bit = 0: Open and Close commands affect control valve

Bit = 1: Disable the Open and Close commands

2.1.9.43 Enabling local operator authorization

Feature bit

Number of the Feature bit: 24

Enabling local operator authorization

You can use this Feature bit to enable local permission for a technologic block.

The default setting is 0.

Bit = 0: Disabled

Bit = 1: Enabled

For information on this operator permission, refer to the section Operator control permissions (Page 254).

2.1.9.44 Enable configuration of the dribbling quantity

Feature bit

Number of the Feature bit: 27

Enable configuration of the dribbling quantity

With this Feature bit, you can enable configuration of the dribbling quantity during dosing.

The default setting is 0.

Bit = 0: Disabled, the dribbling quantity can only be configured in the "End" state or with the automatic determination of the dribbling quantity (`DribbCor = 1`).

Bit = 1: Enabled, the dribbling quantity can always be configured, but not in the "Dribbling" state. The automatic determination of the dribbling quantity must be switched off (`DribbCor = 0`).

2.1.9.45 Enabling program mode

Feature bit

Number of the Feature bit: 19

Enabling program mode

You can use this Feature bit to specify whether or not the controller block should be used for program mode.

Default setting is 0.

Bit = 0: The block is not intended for program mode.

Bit = 1: The block can be used for program mode. The operator control elements required for this are then visible in the faceplate.

Note

This Feature bit only applies to the PIDConR block.

What is the program mode?

Program mode provides primary controller functions (external Advanced Control software package), which run on an external PC as an OPC client, the option of using the control from the controller function block and specifying the setpoint or manipulated variable from a remote location.

2.1.9.46 Update acknowledgment and error status of the message call

Feature bit

Number of the `Feature` bit: 22

Update acknowledgment and error status of the message call

You can use the `Feature` bit to determine if the acknowledgment and error status of the message call at the block output should be updated.

The default setting is 0.

- **Bit = 0:** The `MsgErr`, `MsgStat` and `MsgAckn` block outputs are set to the default settings and not updated. The block will run faster with this setting.
- **Bit = 1:** The `MsgErr`, `MsgStat` and `MsgAckn` block outputs are updated based on the feedback of the lower level message blocks. The lower level message blocks are called every other cycle as long as an acknowledgment is expected or error information is pending.

2.1.9.47 Control zone with frozen I component

Feature bit

Number of the `Feature` bit: 13

Freezing the I component for control with control zone

You can use this `Feature` bit to specify how the controller should react to control zone operation. The I component must be enabled for this `TI <> 0`.

The default setting is 0.

Bit = 0: The I component is set in such a way that the manipulated variable reacts bumplessly when the error signal reoccurs in the control zone.

Bit = 1: If the error signal is outside the control zone, the I component is frozen internally. When it enters the control zone, the controller starts with the value of the I component that was in effect when it left the control zone.

The reaction depends on additional `Feature` bits and controller settings. See also the following section:

- Using control zones (Page 194)

2.1.9.48 Control zone with specified I component

Feature bit

Number of the `Feature` bit: 12

Specifying I component for control with control zone

You can use this `Feature` bit to specify how the controller should react to control zone operation. The I component must be enabled for this `TI <> 0`.

The default setting is 0.

Bit = 0: The I component is set in such a way that the manipulated variable reacts bumplessly when the error signal reoccurs in the control zone.

Bit = 1: If the error signal is outside the control zone, the I component is set internally as follows:

- `I_Part := MV_Offset`.

The reaction depends on additional `Feature` bits and controller settings. See also the following section:

Using control zones (Page 194)

2.1.9.49 Resetting the commands for changing the mode

Feature Bit

Number of the `Feature` bit: 2

Resetting the commands for changing the mode

Using this `Feature` bit, you define how the block handles the incoming control commands:

- `SP_IntLi` and `SP_ExtLi` for controllers
- `AutModLi` and `ManModLi` for controllers, drives, and dosage block
- `SaPo_Ext` for `KalFilt` block
- `OffLi`, `UpLi`, and `DnLi` for `TotalL` block

The default setting is 0.

Bit = 0: The control commands are not reset by the block. If there are two pending control commands for changing mode, the mode is not changed. In this case, the note text "Invalid command" is displayed in the faceplate.

Bit = 1: The control commands are reset by the block. This, for example, ensures that if a control command is sent from the SFC, the command is reset automatically after a step is exited.

2.1.9.50 Enabling resetting of commands for the control settings

Feature bit

Number of the `Feature` bit: 3

Enabling resetting of commands for the control settings

With this `Feature` bit, you select how the block handles commands for the control settings (for example motor on) via the interconnected input parameters.

The default setting is 0.

Bit = 0: The control commands are not reset by the block. If there are two commands relating to the control settings at the same time, the status of the control settings is retained. In this case, the "Invalid signal" message is displayed in the standard view of the faceplate.

Bit = 1: The control commands are reset by the block. This, for example, ensures that if a control command is sent from the SFC, the command is reset automatically after a step is exited.

2.1.9.51 Resetting the dosing quantity when dosing starts

Feature bit

Number of the `Feature` bit: 6

Resetting the dosing quantity when dosing starts

Use this feature bit to enable resetting the dosing quantity when dosing starts.

The default setting is 0.

Bit = 0: Disabled, the dosing quantity is not reset when dosing starts

Bit = 1: Enabled, the dosing quantity is reset when dosing starts.

2.1.9.52 Process value with separate scale range

Feature bit

Number of the `Feature` bit: 16

Process value with separate scale range

You can use this `Feature` bit to assign a separate scale range to the process value. The default setting is 0.

Bit = 0: Apply scale range from `SP`.

Bit = 1: `PV` has a separate scale range.

See also

Neutral position for motors, valves and controllers (Page 48)

Neutral position manipulated variable takes effect at startup (Page 166)

Use the last value following a complete download as the current value during startup of the block (Page 154)

2.1.9.53 Resetting via input signals in the event of interlocking (Protection) or errors

Feature Bit

Number of the `Feature` bit: 9

Resetting the block in the event of interlocking (only Protection: Input parameter `Protect`) or errors via input signals

With this `Feature` bit, you define how automatic control is to be re-enabled after an active interlock.

The default setting is 0.

Bit = 0: After an interlock (only Protection: Input parameter `Protect`) or errors, the system can only be restarted using a reset command. Reset is initiated either by operator input in the faceplate or via the interconnectable input parameter (`RstLi = 1`) in the block. Thereafter, the currently pending command takes effect in automatic mode.

Bit = 1: It is also possible to reset with a 0-1 edge change in the control signal in automatic mode.

2.1.9.54 Set reset depending on the operating mode or the LiOp parameter

Feature Bit

Number of the `Feature Bit`: 30

Set reset depending on the operating mode (motor, valve and dosing blocks)

When the "Protection" interlock, feedback error ("Status error", "Control error") or "Motor protection" signal is present again, use this `Feature` bit to specify if a reset can be made depending on the mode only by the operator in manual mode or only by the automatic I/Os in automatic mode.

Resetting to manual mode is enabled with `Feature Bit 31` (Activating reset of protection / error in manual mode (Page 165)). Also refer to the Resetting the block in case of interlocks or errors (Page 43) chapter.

The default setting is 0.

Bit = 0: Reset does not depend on the operating mode

Bit = 1: In manual mode, manual reset by the operator is only possible if Feature Bit 31 is set, otherwise no reset is required in manual mode.

In automatic mode, reset can only be made with automatic I/Os, regardless of Feature Bit 31. This is performed either with a 0-1 edge transition at the RstLi input or, when Feature Bit 9 is set, with a 0-1 edge transition at the automatic inputs, for example OpenAut, CloseAut.

Note

Rapid stop is unlocked for all operating modes using the "Reset" button in the faceplate (RstOp = 1); in CFC it is unlocked using the RstLi = 1 input parameter.

Note

The local operating mode does not depend on this Feature Bit and has a separate reset mechanism.

Resetting the dosing mode depending on the operating mode (dosing blocks)

You can also use this feature bit to set whether or not the reset of the dosing quantity is dependent on the operating mode.

The default setting is 0.

Bit = 0: Reset does not depend on the operating mode

Bit = 1: In manual mode, only a manual reset by the operator is possible at the input RstDQ_Op. In automatic mode, a reset is only possible by a 0-1 edge transition at the input RstDQ_Li.

Note

The operating mode Local is independent of this feature bit. The dosing quantity can be reset by the operator at the input RstDQ_Op or via a 0-1 edge transition at the input RstDQ_Li.

Set reset depending on the LiOp parameter (counter blocks)

You can use this Feature Bit to determine whether the setting or resetting to a default value should be made dependent on the LiOp parameter.

The default setting is 0.

Bit = 0: Setting or resetting to a default value does not depend on the LiOp parameter.

Bit = 1: Setting or resetting to a default value depends on the LiOp parameter.

LiOp = 0: Setting or resetting to a default value can only be made via the faceplate or at the parameter for the faceplate.

LiOp = 1: Setting or resetting to a default value can only be made at the parameter for interconnections.

2.1.9.55 Activating reset of protection / error in manual mode

Feature bit

Number of the Feature bit: 31

Activating reset of protection / error in manual mode

Use this Feature bit to specify whether a reset is necessary once the "Protection" interlock signal, feedback errors ("Runtime error", "Control deviation"), or "Motor protection" are present again. See also the following section: Resetting the block in case of interlocks or errors (Page 43).

The default setting is 0.

Bit = 0: No reset required in manual mode.

Bit = 1: Reset required in manual mode. The reset is performed using the "Reset" button ($RstOp = 1$) or, in CFC, using the input parameter $RstLi$.

Note

Rapid stop is unlocked for all operating modes using the "Reset" button in the faceplate ($RstOp = 1$); in CFC it is unlocked using the $RstLi = 1$ input parameter.

Note

The local operating mode has a separate reset mechanism.

2.1.9.56 Reset even with locked state

Feature Bit

Number of the Feature bit: 19

Reset even with locked state

With this Feature bit, you specify if it is possible to perform a reset with an active "Protection" or "Motor protection" type interlock. This can be used, for example, to reset hardware interlocks.

The default setting is 0.

Bit = 0: No reset is possible with a "Protection" type interlock or with active motor protection.

Bit = 1: Reset is possible with a "Protection" type interlock or with active motor protection.

2.1.9.57 Neutral position manipulated variable takes effect at startup

Feature Bit

Number of the `Feature` bit: 16

Neutral position manipulated variable takes effect at startup

You can use this `Feature` bit to specify if the block should go to the neutral position at startup.

Default setting is 0

Bit = 0: The block does not go to the neutral position at startup

With control valve `VlvAnL`, the main valve is closed and the auxiliary valve (if configured) opened.

Bit = 1: The block goes to the neutral position at startup

With control valve `VlvAnL`, the main valve and auxiliary valve (if configured) go to the neutral position.

You can find more information in Section Neutral position for motors, valves and controllers (Page 48).

Note:

`Feature` bit 16 is only effective when `Feature` bit 0 = 0.

2.1.9.58 Neutral position manipulated variable takes effect with "out of service" operating mode

Feature Bit

Number of the `Feature` bit: 15

Neutral position manipulated variable takes effect with "out of service" operating mode

You can use this `Feature` bit to specify if the block should go to the neutral position when it transitions to the "Out of service" operating mode.

Default position is "0".

Bit = 0: The block does not go to the neutral position at the transition to the "out of service" operating mode.

Bit = 1: The block goes to the neutral position at the transition to the "out of service" operating mode.

Refer to the Neutral position for motors, valves and controllers (Page 48) section for more information.

2.1.9.59 Setting switch or button mode

Feature bit

Number of the `Feature` bit: 4

Setting switch or button mode (input signal as pulse signal or as static signal)

You can use this `Feature` bit to determine whether a separate interconnectable 1-active control input has to be used for every automatic command of the block or two automatic commands are assigned to a control input.

The `Feature` bit affects the following control inputs:

- starting and stopping a motor
- Opening and closing a valve
- switching modes (parameters `AutModLi` and `ManModLi`)
- Setpoint specification internal and external (parameters `SP_ExtLi` and `SP_IntLi`)

is given in the form of a pulse (pushbutton operation) or a static signal (switching mode).

You can find the commands for controlling the block in the relevant section on block operating modes. They are always the parameters that are used for the automatic operation of a block.

Bit = 0: Button mode: Each automatic command is assigned to a control input. This has a latching reaction and is 1-active.

Example with a motor `MotRevL`: In this case, use the interconnectable input parameters.

- `FwdAut = 1` for the command "Start forward"
- `RevAut = 1` for the command "Start backwards"
- `StopAut = 1` for the stop command and
- `AutModLi = 1` for setting "Automatic" operating mode
- `ManModLi = 1` for setting "Manual" operating mode

Bit = 1: Switching mode: two static automatic commands are assigned to a control input.

Example with a motor `MotRevL`: In this case, use the interconnectable input parameters.

- `FwdAut = 1` for the command "Start forward"
- `RevAut = 1` for the command "Start backwards" and
- `FwdAut = 0` and `RevAut = 0` for the stop command
- `AutModLi = 1` for setting "Automatic" operating mode
- `AutModLi = 0` for setting "Manual" operating mode

The `StopAut` and `ManModLi` control inputs are irrelevant in this case.

2.1.9.60 Specifying switching mode

Feature Bit

Number of the `Feature` bit: 5

Specifying switching mode

Use this `Feature` bit to specify switching mode for the motor block.

The default setting is 0.

Bit = 0: Switching mode "On over speed 1" with the `SwOverTi > 0` parameter

Bit = 1: Switching mode "Off over speed 1" with the `SwOverTi > 0` parameter

Note

This `Feature` bit is only used with the `SwOverTi > 0` parameter. Refer also to the `MotSpdL` functions (Page 1230) section for more on this.

2.1.9.61 Creep rate is always detected in the dosing quantity

Feature Bit

Number of the `Feature` bit: 13

Enable: Creep rate is always detected in the dosing quantity

Use the `Feature` bit to specify the response for detecting the creep rate in the dosing quantity.

The default setting is 0.

Bit = 0: Disabled, the creep rate is only detected in the dosing quantity over the limit `CR_AH_Lim` (high alarm for creep rate). With `CR_AH_En = 0`, the creep rate has no effect on the dosing quantity calculation.

Bit = 1: Enabled, the creep rate is always detected in the dosing quantity.

Note

Creep rate is the flow in the states "End", "Off", and "Pause".

2.1.9.62 Enabling rapid stop via faceplate

Feature bit

Number of the `Feature` bit: 14

Enabling rapid stop via faceplate

You can use the `Feature` bit "Enable rapid stop via faceplate" to specify if the OS operator can use rapid stop for the block via the standard view of the faceplate.

The default setting is 0.

Bit = 0: The "Rapid stop" button is not visible in the faceplate.

Bit = 1: The OS operator can use the button for rapid stop.

2.1.9.63 Position feedback signals are active

Feature bit

Number of the `Feature` bit: 12

Position feedback signals are active

You can use this `Feature` bit to activate the position feedback signals (`FbkP1` and `FbkP2`) and deactivate the separate valve feedback signals (`FbkV0`, `FbkV1` and `FbkV2`). In the trend view and preview, the position feedback signals and control signals `Pos0Out`, `Pos1Out`, `Pos2Out` are used for display.

Default: 0

Bit = 0: The valve feedback signals `FbkV0`, `FbkV1`, `FbkV2` are active. The position feedback signals `FbkP1`, `FbkP2` are deactivated.

Bit = 1: The position feedback signals `FbkP1`, `FbkP2` are activate. The valve feedback signals `FbkV0`, `FbkV1`, `FbkV2` are deactivated.

Note

`SafeV0`, `SafeV1`, `SafeV2` and `DefPos1`, `DefPos2` are only used for configuring the icon displays in the OS.

2.1.9.64 Separate monitoring time for stopping the motor

Feature bit

Number of the `Feature` bit: 13

Separate monitoring time for stopping the motor

You can use this `Feature` bit to activate a separate monitoring time for stopping the motor.

The default setting is 0.

bit = 0: A monitoring time for starting and stopping the motor

Bit = 1: Separate monitoring time for stopping the motor

2.1.9.65 Separate interlock for each direction or position

Feature bit

Number of the `Feature2` bit: 16

Separate interlock for each direction or position

You can use this `Feature` bit to enable the use of the "Separate interlock for each direction or position" function.

Default setting is 0

Bit = 0: One interlock for each direction or position.

Bit = 1: Separate interlock for each direction or position.

2.1.9.66 Separate delay times for each alarm

Feature bit

Number of the `Feature` bit: 8

Separate delay times for each alarm

You can use this `Feature` bit to activate the alarm delay type Two time values for each individual limit (Page 202).

The default setting is 0.

Bit = 0: The alarm delay type Two time values for each individual limit (Page 202) is deactivated.

Bit = 1: The alarm delay type Two time values for each individual limit (Page 202) is activated.

See also

User-configured message classes (Page 41)

Two time values per limit pair (Page 201)

2.1.9.67 Signaling limit violation

Feature bit

Number of the `Feature` bit: 29

Signaling limit violation

With this `Feature` bit, you specify how limit violation should be sent to the respective limit outputs.

The default setting is 0.

Bit = 0: Output value of the limit output = 1 (1 active)

Bit = 1: Output value of the limit output = 0 (0 active)

Note

To learn about the parameters with which you can influence this behavior, refer to the description of the connections for the respective blocks.

2.1.9.68 Alarm setpoint difference

Feature bit

Number of the `Feature` bit: 5

Setpoint difference should be alarmed

Use this `Feature` bit to activate alarming when a setpoint difference occurs.

The default setting is 0.

Bit = 0: Disabled: The message for the `ExtMsg2` and `ExtMsg3` parameters are output.

Bit = 1: Enabled: The messages for the `ER_H_Lim` or `ER_L_Lim` parameter are output instead of the message parameters `ExtMsg2` and `ExtMsg3`.

2.1.9.69 Setpoint specification with separate display area and custom unit

Feature bit

Number of the `Feature` bit: 16

Setpoint specification with separate display area and custom unit

You can use this `Feature` bit to specify the display area and the unit of the setpoint specification.

The default setting is 0.

Bit = 0: Setpoint specification and readback value have the same display area (`RbkOpScale`, `RbkUnit`)

Bit = 1: The setpoint specification has a separate display area and a custom unit (`SP_OpScale`, `SP_Unit`)

2.1.9.70 Control via auxiliary valve

Feature Bit

Number of the `Feature` bit: 5

Control via a auxiliary valve

You can use this `Feature` bit to specify if control should be performed by a auxiliary valve.

The default setting is 0.

Bit = 0: Control without auxiliary valve / no auxiliary valve present

Bit = 1: Control via auxiliary valve

2.1.9.71 Enabling bumpless change to the proportional gain, derivative time and amplification of the differentiator

Feature Bit

Number of the `Feature` bit: 20

Enabling bumpless change to the proportional gain, derivative time and amplification of the differentiator

Use this `Feature` bit to enable bumpless change to proportional gain `Gain`, derivative action time `TD` and gain of the differentiator in automatic mode.

The default setting is 0.

Bit = 0: The bumpless switchover is deactivated.

Bit = 1: The bumpless switchover is activated.

2.1.9.72 Enable bumpless switchover to "Automatic" mode for operator only

Feature bit

Number of the `Feature` bit: 21

Enable bumpless switchover to automatic mode for operator only

You can use this `Feature` bit to specify whether bumpless switchover to automatic mode for valves, motors and dosing unit should be enabled only if switching via the faceplate is in effect, or whether switching using interconnectable inputs `AutModLi` and `ManModLi` (`ModLiOp` = 1) is also possible.

The default setting is 0

Bit = 0: The function "Bumpless switchover to automatic mode for valves, motors and dosers" works when switching via the faceplate and switching using interconnectable inputs `AutModLi` and `ManModLi` (`ModLiOp = 1`).

Bit = 1: The "Bumpless switchover in automatic mode for valves, motors and dosers" function only works for switching via the faceplate. Bumping switchover can be activated via the inputs `AutModLi` and `ManModLi` (`ModLiOp = 1`).

2.1.9.73 Disabling bumpless switchover to automatic mode for controllers

Feature Bit

Number of the `Feature` bit: 18

Changeover with or without P step change when the internal setpoint is not in tracking mode

Use this `Feature` bit to specify if a changeover should occur with or without a P step change when the internal setpoint (`SP_TrkPv = 0`) does not track the process value.

The default setting is 0.

Bit = 0: Changeover without P step change (bumpless)

Bit = 1: Changeover with P step change (not bumpless)

For more detailed information, refer to the description of Manual and automatic mode for control blocks (Page 72).

2.1.9.74 Enabling bumpless switchover to automatic mode for valves, motors, and dosers

Feature bit

Number of the `Feature` bit: 17

Bumpless switchover

You can use this `Feature` bit to enable the bumpless switchover from local/manual mode to automatic mode.

Default setting is 0

Bit = 0: Bumpless switchover is disabled. You can switch from local/manual mode to automatic mode at any time.

Bit = 1: Bumpless switchover from local/manual mode to automatic mode is enabled. A switchover from local/manual mode to automatic mode is only possible if the control settings of the local/manual mode and automatic modes match. If switchover occurs at a different point in time, this is indicated in the faceplate with the text "Switchover error".

Refer to the Manual and automatic mode for motors, valves and dosers (Page 75) section for more on this.

2.1 Functions of the blocks

A second feature bit is used to specify if bumpless switchover to automatic mode is only possible via the faceplate or if switching is also possible via the interconnectable parameters `AutModLi` and `ManModLi` (`ModLiOp = 1`).

Refer to the section `Enable bumpless switchover to "Automatic" mode for operator only` (Page 172).

2.1.9.75 Summing characteristics continuous or triggered

Feature bit

Number of the `Feature` bit: 7

Define summing characteristics

You can use this `Feature` bit to define the summing characteristics of the block as a function of the `Feature` bit 6 = 0. If you have set the `Feature` bit 6 = 1, this `Feature` bit has no function.

The default setting is 0.

Bit = 0: Triggered summing characteristics.

Bit = 1: Continuous summing characteristics.

2.1.9.76 Suppression of all messages

Feature Bit

Number of the `Feature` bit: 25

Suppression of all messages

You can use this `Feature` bit to determine whether all messages of the block are to be suppressed.

Bit = 0: Process messages are suppressed.

Bit = 1: All messages are suppressed.

2.1.9.77 Output invalid raw value

Feature bit

Number of the `Feature` bit: 28

Output invalid raw value

Use this `Feature` bit to activate output of the invalid raw value for channel blocks.

Default setting is 1

Bit = 0: The invalid raw value is not output. Either the substitute value (`Feature bit Output substitute value if raw value is invalid` (Page 149)) or the last valid value (`Feature bit Outputting last valid value if raw value is invalid` (Page 154)) is output.

Bit = 1: The invalid raw value is output. The signal status of the output value is set to "Bad, device related" or "Bad, process related".

If there is no valid raw value the output parameter `Bad = 1` is set automatically.

Prioritizing the `Feature` bits for channel blocks:

You need to assign parameters for three `Feature` bits for the response to an invalid raw value for the channel blocks.

If more than one of these `Feature` bits are set (=1), the following priority applies:

- Output invalid raw value (`Feature bit 28 = highest priority`)
- Output substitute value if raw value is invalid (Page 149)(`Feature bit 29`)
- Outputting last valid value if raw value is invalid (Page 154) (`Feature bit 30 = lowest priority`)

The raw value is output if none of the `Feature` bits 28, 29 or 30 is set.

2.1.9.78 Transmission of status information of devices

Feature bit

Number of the `Feature` bit: 29

Transmission of status information of devices

You can use this `Feature` bit to specify if status information of the device should be transferred to the upstream diagnostics block.

The default setting is 1.

Bit = 0: No transfer of status information.

Bit = 1: Transfer status information of the device to the upstream diagnostics block.

2.1.9.79 Control priority in the event of an invalid input command

Feature2 Bit

Number of the `Feature2` bit: 3

Control priority in the event of an invalid input command

You can use this function to define the control priority in the event of an invalid input command.

Default setting: 0

Bit = 0: In the event of an invalid input command, the control output is retained.

Bit = 1: In the event of an invalid input command, the control output switches to the "neutral position".

2.1.9.80 Sealing the valve

Feature Bit

Number of the `Feature` bit: 8

Sealing the valve

You can use this `Feature` to enable the valve sealing function. The torque shutoff is then also evaluated when the valve is closed.

The default setting is 0.

Bit = 0: "Seal valve" function is disabled.

Bit = 1: "Seal valve" function is enabled.

2.1.9.81 First-in detection response to deactivation

Feature Bit

Number of the `Feature` Bit: 21

First-in detection response to deactivation

You can use this `Feature` Bit to define the first-in detection response of the interlock blocks depending on the `FirstInEn = 0` input parameter.

The default setting is 0.

- **Bit = 0:** When first-in detection is deactivated via `FirstInEn = 0`, the output parameter `FirstIn` is reset.
- **Bit = 1:** When first-in detection is deactivated via `FirstInEn = 0`, the output parameter `FirstIn` is maintained. When first-in detection is activated for the first time by an edge change of `FirstInEn 0->1`, the output parameter `FirstIn` is reset.

2.1.9.82 Reaction of the switching points in the "Out of service" operating mode

Feature Bit

Number of the `Feature` bit: 26

Reaction of the switching points in the "Out of service" operating mode

You can use this `Feature` bit to specify the reaction of the switching points to the "Out of service" operating mode.

The default setting is 0.

Bit = 0: Last state of the switching points before switching to the "Out of service" operating mode is retained.

Bit = 1: The state of the switching points is reset to "Good".

2.1.9.83 Reaction to the out of service mode

Feature bit

Number of the `Feature` bit: 1

Reaction to the out of service mode

You can use this `Feature` bit to define the reaction of the technologic block based on the interconnectable input parameter `OosLi = 1`.

The default setting is 0.

- **Bit = 0:** The symbol for the "In progress" status (see below) appears in the block icon and in the faceplate of the assigned technologic block. A 0-1 edge transition at the input parameter `OosLi` has no further influence on the reaction of the technological block; the previous status is retained. No switch to the "Out of service" mode is performed.
- **Bit = 1:** The mode switches to "Out of service" assuming that the block is "On" or "Manual" mode. If this is not the case, the mode does not change. The symbol for the "In progress" (see below) status also appears in the block icon and in the faceplate of the assigned technologic block regardless of the mode change. No message is output to indicate whether or not the mode change took place.

The status display for "In progress" appears as follows:



A 1-0 edge transition at the input parameter `OosLi` has no influence on the reaction of the technologic block, the previous status is retained.

See also the section Release for maintenance (Page 64) for more on this.

2.1.9.84 Exiting local mode

Feature bit

Number of the `Feature` bit: 10

Reaction to exiting local mode

Use this `Feature` bit to define how "Local mode" is be exited with `LocalSetting = 1` or `LocalSetting = 2` and if the mode is not specified by `AutModLi` or `ManModLi`.

2.1 Functions of the blocks

Default setting is 0

Bit = 0: Exiting local mode in manual mode (bumpless because the control signals are continuously adjusted).

Bit = 1: When local mode is exited, the mode changes back to the last mode that was active prior to local mode (not bumpless).

For more detailed information, refer to the description of Local mode (Page 79).

2.1.9.85 Interlock display with LocalSetting 2 or 4

Feature bit

Number of the Feature bit: 27

Interlock display with LocalSetting 2 or 4

Use this Feature bit to specify the display of interlocks with LocalSetting 2 or 4 at the faceplate and at the faceplate output LockAct .

The default setting is 0

Bit = 0: LocalSetting 2and4 crossed out locks are displayed in the standard view. LockAct is not set with interlock.

Bit = 1: LocalSetting 2and4 locks are displayed in the standard view according to the interlock. LockAct is set according to interlock. This setting is used for hardware interlock.

Note

A decreasing motor protection (Trip.Value=0) is displayed at the output parameter LockAct , regardless of the Feature bit setting.

This feature bit is also applicable for the LocalSetting 5 in VlvS where LocalSetting 4 is not available

2.1.9.86 Vibrate after torque monitoring

Feature2 bit

Number of the Feature2 bit: 6

Vibrate after torque monitoring

You can use this Feature2 bit to determine whether vibration should be started after a torque monitoring error TorqOpen or TorqClose.

The default setting is 0.

Bit = 0: No vibration.

Bit = 1: Vibration is started after a torque monitoring error.

2.1.9.87 With acknowledge overdosage

Feature2 bit

Number of the `Feature2` bit: 24

With acknowledge overdosage

You can use this `Feature2` bit to change the acknowledgment behavior of overdosage and underdosage.

The default setting is 0.

Bit = 0: After an overdosage is identified, the block changes directly to the "End" state.

Bit = 1: After an overdosage is identified, the block changes and continues to be in the "Off" state. An acknowledgment is necessary to change the dosing state to "End". In the standard view, status display shows the state "Ack Dos End".

2.1.9.88 Ramp rate calculation

Feature bit

Number of the `Feature` bit: 6 (7 for `VlvAnL`)

Define ramp rate

You can use this `Feature` bit to define the ramp rate calculation based on the actual start point and the actual ramp target value.

The default setting is 0.

Bit = 0: New ramp rate will not be calculated after a change in the ramp target value.

Bit = 1: Ramp rate is calculated with the actual start point and the actual ramp target value.

2.1.9.89 SP following PV in open loop has no priority over `SP_Ext` and `SP` limits

Feature bit

Number of the `Feature` bit: 23

SP following PV in open loop has no priority over `SP_Ext` and `SP` limits

You can use this `Feature` bit to specify whether the setpoint follows the process value in "manual mode" with tracking (`SP_TrkPV = 1`). You can specify this function in case of setpoint is external or limited.

2.1 Functions of the blocks

The default setting is 0.

Bit = 0: Setpoint follows process value ($SP = PV$) irrespective of whether setpoint is external or limited.

Bit = 1: If the setpoint is external, setpoint follows the external setpoint ($SP = SP_{Ext}$) and will be limited to the external limits ($SP_{ExHiLim}$ and $SP_{ExLoLim}$). If the setpoint is internal, setpoint follows the process value ($SP = PV$) and will be limited to the internal limits ($SP_{InHiLim}$ and $SP_{InLoLim}$).

2.1.9.90 With accelerated return of the integral action from the manipulated variable limit

Feature bit

Number of the `Feature` bit: 17

With accelerated return of the integral action from the manipulated variable limit

When switching to the automatic mode (manually, by tracking, forced tracking, or program mode with manipulated variable specification) or when the controller is initialized by the `InitPid` input, the integral action (reset) is moved to preserve bumpless operation in case of an impending control deviation. The greater the control deviation and the controller gain, the greater is this shift. The result may be that the integral action is set far outside the manipulated variable limits. If the control deviation decreases after switching to the automatic mode, it may happen that in controllers with large `TI` values, the manipulated variable stays within the limit for a longer duration.

You can use this `Feature` bit to accelerate the return of the integral action from the limit. In case of a pending control deviation, the integral action is moved only in the direction of the control range to the extent that the manipulated variable can remove itself quickly and bumplessly from the manipulated variable limits (MV_{HiLim}/MV_{LoLim}).

The default setting is 0.

Bit = 0: Without accelerated return of the integral action.

Bit = 1: With accelerated return of the integral action when the integral action and the manipulated variable are outside or at the manipulated variable limits.

Note

In regular control mode, the integral action cannot move outside the manipulated variable limits because the manipulated variable is limited first and then fed back to the reset memory (see also anti-windup in `PIDConR` functions (Page 815)).

2.1.9.91 External/internal selection specification

Feature bit

Number of the `Feature` bit: 6

External/internal selection specification

You can use this `Feature` bit to switch from the faceplate between internal and external selection of the inputs `In01` to `In10` (`SelInt` or `SelExt`).

The default setting is 0.

- **Bit = 0:**

<code>LiOp = 0</code>	Selection of <code>In01</code> to <code>In16</code> is internal; <code>SelInt</code> is active and can be used via faceplate.
<code>LiOp = 1</code>	Selection of <code>In01</code> to <code>In16</code> is external; <code>SelExt</code> is active and can be used via interconnection.

- **Bit = 1:**

<code>LiOp = 0</code>	With the input parameter <code>SelIntOp</code> or <code>SelExtOp</code> , you can change the selection between internal (<code>SelInt</code>) and external (<code>SelExt</code>) via faceplate.
<code>LiOp = 1</code>	With the input parameter <code>SelIntLi</code> or <code>SelExtLi</code> , you can change the selection between internal (<code>SelInt</code>) and external (<code>SelExt</code>) via interconnection.

2.1.9.92 Setting switch or button mode for local commands

Feature2 bit

Number of the `Feature2` bit: 4

Setting switch or button mode for local commands (input signal as pulse signal or as static signal)

You can use this `Feature2` bit to determine whether a separate interconnectable 1-active control input has to be used for every local command of the block or two local commands are assigned to a control input.

The `Feature2` bit affects the following control inputs for local mode in the form of a pulse (pushbutton operation) or a static signal (switching mode):

- Starting and stopping a motor
- Opening and closing a valve

You can find the commands for controlling the block in the relevant section on block operating modes. They are always the parameters that are used for the local operation of a block.

Bit = 0: Button mode: Each local command is assigned to a control input. This has a latching reaction and is 1-active.

1. Example with a motor `MotRevL`: In this case, use the interconnectable input parameters.

- `FwdLocal = 1` for the command "Start forward"
- `RevLocal = 1` for the command "Start backwards"
- `StopLocal = 1` for the stop command

Bit = 1: Switching mode: two static local commands are assigned to a control input.

2. Example with a motor MotRevL: In this case, use the interconnectable input parameters.

- `FwdLocal = 1` for the command "Start forward"
- `RevLocal = 1` for the command "Start backwards"
- `FwdLocal = 0` and `RevLocal = 0` for the stop command

The `StopLocal` control input is irrelevant in this case.

3. Example with motor MotSpdL: In this case, use the interconnectable input parameters.

- `Spd1Local = 1` for the command Motor to run with Speed1
- `Spd2Local = 1` for the command Motor to run with Speed2
- `Spd1Local = 0` and `Spd2Local = 0` for the stop Command

4. Example with motor MotSpdCL: In this case, use the interconnectable input parameters.

- `FwdLocal = 1` for the command "Start forward"
- `RevLocal = 1` for the command "Start backwards"
- `FwdLocal = 0` and `RevLocal = 0` for the stop command

5. Example with VlvPosL: In this case, use the interconnectable input parameters.

- `OpenLocal = 1`, Command for Valve to "Open"
- `CloseLocal = 1`, Command for Valve to "Close"
- `OpenLocal = 0` and `CloseLocal = 0` for the stop command

6. Example with Vlv2WayL: In this case, use the interconnectable input parameters.

- `Pos1Local = 1`, Command for Valve1 to "Open"
- `Pos2Local = 1`, Command for Valve2 to "Open"
- `Pos1Local = 0` and `Pos2Local = 0`, Command for "Position 0" (neutral position),

7. Example with VlvL

- `OpenLocal = 1`, Command for Valve to "Open"
- `OpenLocal = 0`, Command for Valve to "Close"

With `Feature2.Bit4 = 1`, two static local commands are assigned to a control input.

2.1.9.93 Gradient limitation with time duration

Feature bit

Number of the `Feature` bit:

- 11 for `PIDConL`, `PIDConR`, and `PIDStepL`
- 12 for `MotSpdCL`, `VlvAnL`, and `OpAnL`

Gradient limitation with time duration

You can use this `Feature` bit to ramp up or ramp down the setpoint `SP` respectively `MV` as a function of time duration. With this `Feature` bit, the gradient limitation function can also work with the time duration.

The default setting is 0.

Bit = 0: Gradient limitation works only with the gradient values: `SP/MV_UpRaLim`, `SP/MV_DnRaLim`

Bit = 1: Gradient limitation also works with the time duration with the following parameters: `SP/MV_RmpModTime`, `SP/MV_RmpTime`.

2.1.9.94 Analog input 1 is reserved for the operator

Feature bit

Number of the `Feature` bit: 7

Analog input 1 is reserved for the operator

You can use this `Feature` bit to reserve the analog input 1 (`In01`) for the operator.

The default setting is 0.

Bit = 0: Operator cannot use the analog input 1 (`In01`).

Bit = 1: Operator can change the value of analog input 1 (`In01`) if the input is not connected and `OS_Perm.Bit22` is set to 1.

2.1.9.95 Operator can change the setpoint via faceplate also in the "Local" mode

Feature2 bit

Number of the `Feature2` bit: 6

Operator can change the setpoint via faceplate also in the "Local" mode

You can use this `Feature2` bit to enable the input of a setpoint for the operator in the "Local" mode.

The default setting is 0.

Bit = 0: Operator cannot change the setpoint in the "Local" mode.

Bit = 1: Operator can change the setpoint via faceplate in the "Local" mode.

2.1.9.96 Define the setpoint after stop and start of the motor

Feature2 bit

Number of the `Feature2` bit: 7

Define the setpoint after stop and start of the motor

You can use this `Feature2` bit to define the setpoint after stop and start of the motor.

The default setting is 0.

Bit = 0: The setpoint is retained after the motor is stopped.

Bit = 1: After the motor is stopped, the setpoint will be set to `SP_Off`. If the motor is started and the setpoint is in internal mode, the setpoint will be set to the low limitation `SP_LoLim`. Up to this value, the internal setpoint can be changed. In case the setpoint is external after the start of the motor, the setpoint will be changed directly to the external setpoint. The low limitation will be limited downwards to `SP_Off` and will be written back if the limitation is reached.

2.1.9.97 Retain last output value in case of bad input signal status

Feature bit

Number of the `Feature` bit: 5

Retain last output value in case of bad input signal status

You can use this `Feature` bit to specify that the block holds its output value if the input signal status is bad (16#00 or 16#28).

The default setting is 0.

Bit = 0: Default state of the block.

Bit = 1: Retain last output value in case of bad input signal status.

2.1.9.98 Forcing operating modes in the "Local" mode

Feature2 bit

Number of the `Feature2` bit: 8

Forcing operating modes in the "Local" mode

You can use this `Feature2` bit to specify whether forcing operating modes is possible in the "Local" mode.

The default setting is 0.

Bit = 0: In the "Local" mode, forcing operating modes is not possible.

Bit = 1: In the "Local" mode, forcing operating modes is possible.

2.1.9.99 Motor stop in end position depends only on the corresponding feedback signal

Feature bit

Number of the `Feature` bit: 15

Motor stop in end position depends only on the corresponding feedback signal

With this `Feature` bit, you can specify whether the motor stop in end position depends only on the corresponding feedback signal or on both feedback signals.

The default setting is 0.

Bit = 0: Motor stop in end position depends on two feedback signals (`FbkOpen` and `FbkClose`). For example, motor stop in the end position "Open" depends on both feedback signals "Opened" and "Closed". In this case, `FbkOpen = 1` and `FbkClose = 0` are parameterized such that the drive output control of the motor "Open" is reset.

Bit = 1: Motor stop in end position depends only on the corresponding feedback signal. For example, motor stop in the end position "Open" depends only on the feedback signal "Opened". In this case, only `FbkOpen = 1` is parameterized such that the drive output control of the motor "Open" is reset.

2.1.9.100 Substitution value is active if the block is in bypass

Feature bit

Number of the `Feature` bit: 9

Substitution value is active if the block is in bypass

You can use this `Feature` bit to specify whether the block uses the process value or a substitution value in case of an active bypass.

The default setting is 0.

Bit = 0: Block will use the process value (`PV/In/Out`).

Bit = 1: Block will use the substitution value (`BypPV/BypIn/BypOut`).

2.1.9.101 Enable external message

Feature bit

Number of the `Feature` bit: 9

Enable external message

You can use this `Feature` bit to specify if you want to use the quality code of `Inx/InTSx` or the external values `ExtValxx` as the associated value.

The default setting is 0.

Bit = 0: Use quality code of `Inx` or `InTSx` as the associated value.

Bit = 1: Use external values `ExtValxx` as the associated value.

2.1.9.102 Considering bad quality of automatic commands or external values

Feature/Feature2 bit

Number of the `Feature/Feature2` bit: 10

Considering bad quality of automatic commands or external values

You can use this `Feature/Feature2` bit to consider the bad signal status (16#00 or 16#28) in the parameter for the automatic commands or external values to move the block into the neutral position.

The default setting is 0.

Bit = 0: A bad signal status will not be considered.

Bit = 1: A bad signal status (16#00 or 16#28) in the automatic commands or external values will be considered from the block. The block goes to a defined neutral position.

2.1.9.103 Disable calculation of impulse control in LocalSetting 2 and 4

Feature bit

Number of the `Feature` bit: 20

Disable calculation of impulse control in LocalSetting 2 and 4

You can use this `Feature` bit to disable the tracking of feedback signals in the "Local" mode setting 2 and 4.

The default setting is 0.

Bit = 0: Calculation of impulse controls in `LocalSetting 2` and `4`.

Bit = 1: Disable calculation of Impulse controls in `LocalSetting 2` and `4`.

2.1.9.104 Inverter enable

Feature bit

Number of the `Feature` bit: 8

Inverter enable

You can use this `Feature` bit to specify whether, after the activation of `Feature` bit 15 (`Feature.Bit15 = 1`), a frequency converter with a separate device infeed is to be used or the inverter enable.

The default setting is 0.

Bit = 0: Frequency converter with separate device infeed

Bit = 1: Inverter enable

2.1.9.105 Scale dosing can be started only if `StandStill = 1`

Feature bit

Number of the `Feature` bit: 14

Scale dosing can be started only if `StandStill = 1`

You can use this `Feature` bit to specify the start of scale dosing.

The default setting is 0.

Bit = 0: Start scale dosing independent of standstill.

Bit = 1: Start scale dosing only with `StandStill = 1`

2.1.9.106 Delete history of MV and DV moves during restart

Feature bit

Number of the `Feature` bit: 8

Delete history of MV and DV moves during restart

You can use this `Feature` bit to determine whether the history of MV and DV moves will be deleted after CPU restart or block restart.

The default setting is 0.

Bit = 0: The history of MV and DV will be deleted only after CPU restart if OB100 is running.

Bit = 1: The history of MV and DV will be deleted after CPU restart and also after a block restart (`Restart = 1`), if user DBs/FCs will be loaded in controller.

2.1.9.107 Status output calculation

Feature bit

Number of the `Feature` bit: 8

Status output calculation

You can use this `Feature` bit to define how the block calculates the status of output `Out`.

Bit = 0: The Status output is calculated with actual status input `In.ST` and the last status output `Out.ST`. The block makes a worst status calculation like technological blocks over the whole integration. With function "Tracking values" (`OutTrkOn = 1`) the status is reset to `OutTrk.ST`.

Bit = 1: The Status output is equal to status input (`Out.ST = In.ST`).

2.1.9.108 Suppress `MsgLock` and "Out of service" mode for a connected message block

Feature/Feature2 bit

Number of the `Feature2` bit: 11

Suppress `MsgLock` and "Out of service" mode for a connected message block

With this `Feature/Feature2` bit, you can suppress the message lock with the parameter `MsgLock` and the switchover to the "Out of service" mode for a connected message block (`EventTs`, `Event16Ts`). Only the connected block over the parameter `EventTsIn` is concerned. This allows generating messages also in the case of `MsgLock = 1` or during a switchover to the "Out of Service" mode in the main block. For example, if the main block goes to the "Out of service" mode, the switchover can be messaged over a connection from the main block output `OosAct` to an input `Inx` of `EventTs/Event16Ts`.

The default setting is 0.

Bit = 0: No suppression.

Bit = 1: A message lock with the parameter `MsgLock` and a switchover to the "Out of service" mode are suppressed for connected message block over `EventTsIn`.

2.1.9.109 Variants of CPI calculation

Feature bit

Number of the `Feature` bit: 8

Variants of CPI calculation

With this `Feature` bit, you can choose between the two variants of CPI calculation.

The default setting is 0.

Bit = 0: Approximate calculation with reduced computing power consumption.

Bit = 1: More precise calculation corresponding to mathematical definition of variance.

Note

If you change the variant of calculation, the limits `CPI_AL_Lim` and `CPI_WL_Lim` may have to be adapted.

2.1.9.110 Scalable measuring range

Feature bit

Number of the `Feature` bit: 6

Scalable measuring range

With this `Feature` bit, the scalable measuring range is activated. This `Feature` bit is used by the driver generator according to the information from the HW Config / STEP 7 attribute and therefore this `Feature` bit is set by the driver wizard.

The default setting is 0.

Bit = 0: Scalable measuring range is not active.

Bit = 1: Scalable measuring range is active.

2.1.9.111 2 decimal points (scalable measuring range)

Feature bit

Number of the `Feature` bit: 7

2 decimal points (scalable measuring range)

With this `Feature` bit, the measuring range resolution is set to 2 decimal points. This `Feature` bit is used by the driver generator according to the information from the HW Config / STEP 7 attribute and therefore this `Feature` bit is set by the driver wizard.

The default setting is 0.

Bit = 0: Measuring range resolution is not set to 2 decimal points.

Bit = 1: Measuring range resolution is set to 2 decimal points.

2.1.9.112 3 decimal points (scalable measuring range)

Feature bit

Number of the Feature bit: 8

3 decimal points (scalable measuring range)

With this Feature bit, the measuring range resolution is set to 3 decimal points. This Feature bit is used by the driver generator according to the information from the HW Config / STEP 7 attribute and therefore this Feature bit is set by the driver wizard.

The default setting is 0.

Bit = 0: Measuring range resolution is not set to 3 decimal points.

Bit = 1: Measuring range resolution is set to 3 decimal points.

2.1.10 Functions for controllers

2.1.10.1 Delay alarm for control deviation at setpoint step changes

Alarm delay for blocks with the function "Delay alarm for control deviation at setpoint step changes"

This type of alarm delay is used when temporary violations of set alarm thresholds of the control deviation are to be suppressed at setpoint step changes. The alarm delay is parameterized at the following inputs:

Parameter for the delay time	Explanation
ER_AH_DFac	Delay factor at positive setpoint step changes for incoming alarms at the control deviation monitoring ER_AH_Lim
ER_AL_DFac	Delay factor at negative setpoint step changes for incoming alarms at the control deviation monitoring ER_AL_Lim

The effective delay time is calculated from the delay factor and the setpoint difference:

- Positive setpoint step change: $ER_A_DCOut = \text{Maximum}$
The maximum is formed from the parameters ER_A_DC as well as $ER_AH_DFac \cdot \text{Setpoint difference}$
- Negative setpoint step change: Maximum
The maximum is formed from the parameters ER_A_DC as well as $-1 \cdot ER_AL_DFac \cdot \text{Setpoint difference}$

The effective delay time is specified at the output parameter:

Parameter	Explanation
ER_A_DCOut	Effective delay time at setpoint step changes for incoming alarms during control deviation monitoring

Before a setpoint change, the effective delay time amounts to
 $ER_A_DCOut = ER_A_DC$.

For a setpoint step change, the effective delay time increases depending on the factors ER_AH_DFac as well as ER_AL_DFac .

When the control loop has settled again, meaning that
 $(ER_AL_Lim + ER_Hyst) \leq ER \leq (ER_AH_Lim - ER_Hyst)$
 and that the delay time for outgoing alarms (ER_A_DG) has expired, the output is reset again to
 ER_A_DC : $ER_A_DCOut = ER_A_DC$

Activating the alarm delay

The alarm delay factors have a default value of 0, meaning that the function is deactivated. Specify a delay factor > 0 in order to use the function.

Pending alarms

Pending alarms are output at the output parameters ER_AL_Act and ER_AH_Act .

Calculation of the output parameter ER_A_DCOut

ER_A_DC is assigned by default to the output before a setpoint change.

$$ER_A_DCOut = ER_A_DC$$

In the case of a setpoint change in the positive direction during automatic mode, the output is calculated as follows:

$$ER_A_DCOut = \text{Maximum}(ER_A_DC, ER_AH_DFac * \text{Setpoint difference})$$

In the case of a setpoint change in the negative direction during automatic mode, the output is calculated as follows:

$$ER_A_DCOut = \text{Maximum}(ER_A_DC, -1 * ER_AL_DFac * \text{Setpoint difference})$$

When the control circuit has stabilized again, meaning $(ER_AL_Lim + ER_Hyst) \leq ER \leq (ER_AH_Lim - ER_Hyst)$, and the delay time for outgoing alarms ER_A_DG has expired, the output is reset again to ER_A_DC : $ER_A_DCOut = ER_A_DC$.

Activating and deactivating the function

The function is deactivated (default) when $ER_AH_DFac = 0.0$ and $ER_AL_DFac = 0.0$.

2.1.10.2 Inverting control direction

Inverting control direction

For some processes (for example cooling processes), negative control gain is necessary. This is achieved by the inverting the control direction by means of the input parameter `NegGain = 1`. The gain is always entered positively at the input parameter `Gain`. If there is an inversion, this is indicated at the output parameter `GainEff` by a negative number.

2.1.10.3 Error signal generation and dead band

Error signal generation and dead band

The signal error is formed from the effective setpoint `SP` and the process value `PV` ($ER = SP - PV_{Out}$) (PIDConR $ER = PV_{Out} - SP$) and is available at the `ER` output.

In the case of activated error signal generation (only at block PIDConL, Feature bit 14), `ER` is formed by `ER_Ext`.

To suppress disturbances in the steady state, you can assign a dead band (`Deadband`):

- `Deadband = 0`: Dead band is disabled
- `Deadband ≠ 0`: Dead band is enabled

With a negative dead band (`Deadband < 0.0`), calculation is continued internally with this value

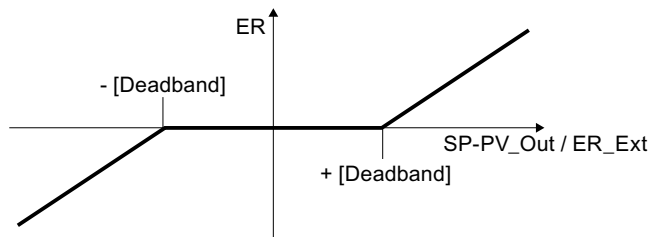

A dead zone in the controller can help reduce the movements of the actuator and thus reduce the energy consumption and wear of the actuator. This applies especially to mechanical actuators, such as valves and pumps. The dead zone may also required in order to avoid small, stable, continuous oscillations (working movement), which are caused by the quantization of the control actions in the control loop.

Note

Calming the control signals via dead band is only possible when no structure splitting is active, i.e. when `PropFacSP = 1` and `DiffToFbk = 0`. Controller actions in the feedback branch directly process the measured actual value instead of the control deviation and are therefore not affected by the dead band.

- Remaining control deviations smaller than the dead band are ignored by the controller, i.e. it does nothing even it can. Therefore, steady states of the actual value can occur, the average time of which significantly differs from the setpoint.
- When such steady states occur at the edges of the dead zone, it must be expected that even the smallest problems will cause control intervention (i.e. actuator energy consumption).
- Large dead zones have a negative effect on the control response of the control loop for setpoint changes. This is because the controller "stops work", for example, in the rising phase of a positive step response when entering the dead band. This can lead to creeping settling time, or cause the controller to be activated again when the actual value exceeds the high limit of the dead band in the form of an overshoot.
- After a fault event that leads to exiting the dead band, the controller brings the actual value back only to the edge of the dead band, which has the above-mentioned disadvantages.

By setting `Feature` bit 30, you can activate dynamic adjustment of the dead band. This allows you to benefit from the advantages of a dead band without having to tolerate the above-mentioned disadvantages.

When large control deviations occur (i.e. the dead band is exited), it is temporarily deactivate until the controller returns the actual value to the proximity of the setpoint. The controller also demonstrates control response for setpoint changes without a dead band in this way.

There is then a wait until it can be assumed that the process has settled on operating point. Only then is the dead band activated again. When it is reactivated, the manipulated variable is set to the mean of a sliding time window. This ensures that the actual value to be controlled settles more in the middle of the dead band than at the edges. This avoids unnecessary shifting of the mean value of the controlled variable from the setpoint, and thus poor stationary control performance. The probability that the controlled variable is within the dead zone time is increased, and further control actions are no longer necessary. This leads to reduced wear and less energy consumption.

Configuration and commissioning

- Use a process tag type that contains the `ConPerMon` function block for monitoring the control performance in addition to the controller.
- Check whether the additional interconnections between the monitoring block and controller are available:
 - `PIDConL.MV_Mean:= ConPerMon.MV_Mean`
 - `PIDConL.SettliTime:= ConPerMon.SettliDeadBand`
- Put the controller into operation as usual with the PID Tuner, and then initialize the `ConPerMon` block.
- Perform a setpoint step with activated control performance monitoring and without dead band (`PIDConL.DeadBand:=0`). Various characteristics of the step response can be determined by the `ConPerMon` block in this way. Check if the determined settling time at the `ConPerMon.SettliTime` output parameter appears plausible.
- Specify the width of the dead band at the `PIDConL.DeadBand` input parameter.
- Check the actuating signal signal in the steady state of the control loop. Has the desired calming of the signal form been achieved?

- Activate `Feature` bit 30.
- Check the control response of the control loop. If the control loop has not sufficiently settled as expected near the center of the dead band after a setpoint change, it may help to increase the value of the `PIDConL.SettliTime` input parameter.

Notes on selecting the width of the dead band

The width of the dead band primarily depends on the desired precision of the control, in other words, after the maximum, permanent, control deviations permissible by process engineering and after the change of the manipulated variable based on a minimum possible change of the manipulated variable (caused, for example, by a switching actuator). With regard to the minimization of control interventions, the following adjustment rules help to select the dead band wide enough that unavoidable variances of the control variables due to measurement noise or quantization noise do not lead to permanent control movements:

- Assuming a normal distribution of the statistical control variables around the setpoint, two to three times the standard deviation of the actual value in the steady state is used as the width of the dead band. This information can be obtained from the control loop monitoring block: `PIDConL.DeadBand := (2...3)*ConPerMon.RefStdDev`.
- If working movements in the control loop are systematically caused by the manipulated variable quantization, for example, due to a pulse width modulation with a defined minimum pulse duration and pulse period, a step controller with defined minimum step size or an electro-pneumatic positioner, the width of the dead band depends on the manipulated variable quantization multiplied by the process gain.

Example: A control signal resolution of 5% for temperature regulation with the process gain $1.5^{\circ}\text{C}/\%$ means that only temperatures in a grid of 5%, $1.5^{\circ}\text{C}/\% = 7.5^{\circ}\text{C}$ can be reached exactly. The dead band must then be selected wide enough so that at least one grid point falls within the dead band in which the process can remain in a steady-state, i.e. `DeadBand > 3.8^{\circ}\text{C}` in this case.

2.1.10.4 Using control zones

Using control zones

The control zone function is mainly used for temperature processes in which the time lag is small compared to the recovery time (no more than a tenth of the recovery time). This is typically the case when the temperature controller accesses the actuator directly (e.g. heating, steam valve), and typically not the case with master controllers of cascade interconnections (e.g. control of the internal temperature of a reactor via the shell temperature).

The control zone can result in large overshoots in processes with an excessively large time lag.

During commissioning with the PCS 7 PID-Tuner, you can check whether the process order is smaller than 2 and the process type "VZ2 model" is displayed. An initial approach for dimensioning the control zone: `ConZone = MV_HiLim/Gain`.

If `ConZone > 0`, the controller works with a control zone; if `ConZone <= 0`, the "control zone" function is deactivated. With a negative control zone, an error ID is output at the

ErrorNum parameter. When the control zone is enabled, the controller operates according to the following algorithm:

- If the process value *PV* exceeds the setpoint *SP* by more than *ConZone*, the value *MV_LoLim* is output as the manipulated variable (controlled mode, in order to return to the control zone as fast as possible).
- If the process value *PV* falls below the setpoint *SP* by more than *ConZone*, *MV_HiLim* is output (controlled mode).
- (Only possible with *PIDConL*, not with *FmTemp*) In controlled mode of the control zone and when the I component is enabled ($TI <> 0$), the I component can be set in a variety of ways when the control zone is entered, depending on three *Feature* bits:

Feature bit 12	Feature bit 13	Feature bit 18	Response
0	0	0	$I_Part := MV.Value - P_Part - FFwd$; The controller operates bumplessly when entering automatic control mode. (This corresponds to the reaction up to V8.0)
0	0	1	$I_Part := MV.Value - FFwd$; A P jump of the manipulated variable occurs when entering automatic control mode (use only in exceptional cases)
1	x	x	$I_Part := MV_Offset.Value$; The controller starts with the default value <i>MV_Offset</i> as I component when entering automatic control mode
0	1	x	I component is frozen. When it enters the control zone, the controller starts with the value of the I component that was in effect when it left the control zone. This can be useful for continuous processes, where it can be assumed that the controller is at the same operating point as it was when it left the control zone, nearly in a steady state.

x = any

The I component is always set to *MV_Offset* when the I component is disabled ($TI=0$). I.e.: The control zone operates with the specified $I_Part := MV_Offset$ with P or PD controlling.

Freezing of the I component with *IntHoldPos* or *IntHoldNeg* has no effect during controlled mode due to the control zone.

- If the process value *PV* stays within the control zone (*ConZone*), the manipulated variable assumes the value of the PID algorithm (automatic closed-loop mode).

Note

The change from controlled closed-loop mode to automatic closed-loop mode is based on a hysteresis of 20% of the control zone. Make sure that the control zone has an adequate width before you manually activate the control zone. An insufficient width of the control zone leads to oscillation of the manipulated variable and of the process value.

Advantages of the control zone:

Once the control zone is entered, the manipulated variable is quickly reduced by the applied D component. The control zone is therefore only useful if the derivative component is activated. Without the derivative component, only the reducing proportional component would reduce the manipulated variable to any significant degree. The control zone speeds up settling without overshoot or undershoot if the value of the output minimum or maximum manipulated variable is a long way from the stationary manipulated variable required for the new operating point.

2.1.10.5 Setpoint limiting for external setpoints

Setpoint limiting for external setpoints

With this function you can limit the external setpoint to a range by means of the parameters `SP_ExHiLim` (high limit) and `SP_ExLoLim` (low limit). If the setpoint lies outside the range defined by you, it is limited to the valid range.

If the external setpoint lies on or above the limit `SP_ExHiLim`, this is displayed at the output `SP_ExHiAct = 1`.

If the external setpoint lies on or below the limit of `SP_ExLoLim`, this is displayed at the output `SP_ExLoAct = 1`.

The external setpoint limits can be tracked internally via the interconnection of the output parameters `SP_InHiOut` or `SP_InLoOut` following `SP_ExHiLim` or `SP_ExLoLim`. You can control the two limit pairs from the faceplate.

2.1.10.6 Tracking setpoint in manual mode

Tracking setpoint in manual mode

To allow a bumpless transfer to automatic mode, the setpoint tracks the process value. When tracking, (`SP_TrkPV = 1`) the internal setpoint `SP_Int` is tracked to the process value `PV`.

Additional information on setpoint tracking is available in Manual and automatic mode for control blocks (Page 72).

2.1.10.7 Tracking and limiting a manipulated variable

Manipulated variable tracking

You adjust the manipulated value (tracking) in order to implement a Bumpless switchover of controllers. A typical use case is cascade control: If the assigned secondary controller is no longer in automatic mode with external setpoint, the primary controller must track it.

To adjust the manipulated variable (tracking), you have to set the parameter `MV_TrkOn = 1`. Now the manipulated variable is taken from the interconnected tracking value `MV_Trk` and passed to the output `MV`. The `MV` output is limited to the `MV_HiLim` and `MV_LoLim` parameters.

Manual mode takes priority over tracking to allow a plant operator to set the controller to manual mode using the faceplate even when tracking the manipulated variable and therefore continue to normal operation.

The text "Tracking" is also displayed in the standard view of the faceplate.

Activating forced tracking mode for the manipulated variable

Forced tracking is used to set the controller output of a higher-level controller to a value that can be specified.

You can use forced tracking, for example, to implement a centralized emergency stop in the plant. This can be put into effect regardless of the operating mode the controller is currently in.

To force adjustment of the manipulated variable (tracking), you have to set the parameter `MV_ForOn = 1`. Now the manipulated variable is taken from the interconnected tracking value `MV_Forced` and passed to the output `MV`.

With forced tracking, it is not possible to limit the manipulated variable, nor can the plant operator change to manual mode in the faceplate. The text "Forced tracking" is also displayed in the standard view of the faceplate.

Note

This function is not available for the `FmCont`, `FmTemp`, and `ModPreCon` blocks.

Limiting the value of a manipulated variable in automatic mode

In automatic mode, the manipulated variable is set to its automatic manipulated variable limits as specified by the input parameters `MV_HiLim` and `MV_LoLim` and output at the output parameter `MV`. Reaching the limit is then displayed at the output parameter `MV_HiAct = 1` for the high limit and `MV_LoAct = 1` for the low limit.

Interconnecting the output parameter `ManHiOut` or `ManLoOut` to `MV_HiLim` or `MV_LoLim` allows the automatic manipulated variable limits to tracked to manual manipulated variable limits. You can keep both limit pairs in synch and control the manual manipulated variable limits in the faceplate.

Limiting the value of a manipulated variable in manual mode

In manual mode, the manipulated variable is set to its manual manipulated variable limits as specified by the input parameters `ManHiLim` and `ManLoLim` and output at the output parameter `MV`.

See also

Forcing operating modes (Page 41)

2.1.10.8 Feedforward and limiting disturbance variables

Feedforward control and limitation

The feedforward control is used in order to compensate measurable disturbance variables, such as temperature or pressure, that can have an effect on the process. In automatic mode, the disturbance variable is added to the result of the PID algorithm.

The disturbance variable is connected to the `FFwd` Parameter. It is limited to the `FFwdHiLim` and `FFwdLoLim` limits. If the disturbance variable is outside or at the limits, this is indicated by the `FFwdHiAct = 1` or `FFwdLoAct = 1` output parameters.

2.1.10.9 Structure segmentation at controllers

Structure segmentation at controllers

In order to avoid jumps at the manipulated value (controller output) during setpoint changes, proportional and derivative actions can be switched into the feedback path. I.e.: The proportional action (proportionally) and the derivative action are then only influenced by the process value.

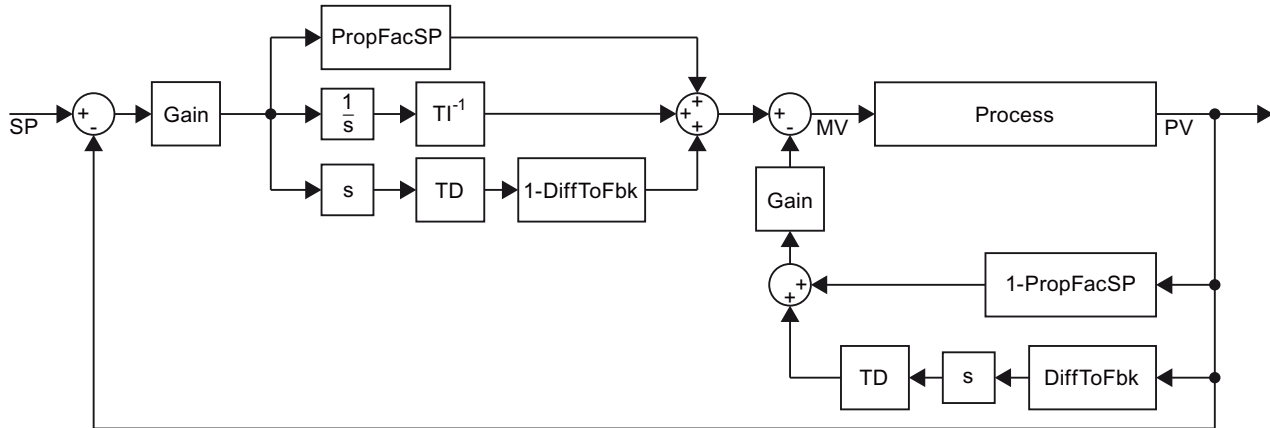

Switching proportional action into the feedback path

A proportion of the P action can be placed in the feedback using the `PropFacSP` parameter. Setpoint jumps then only affect the proportional action proportionally.

`PropFacSP = 0`: Proportional action is completely in the feedback path. Setpoint jumps do not affect the proportional action.

`PropFacSP = 1`: Proportional action is not in the feedback path. Proportional action is affected by setpoint and process variable (default setting).

Switching derivative action into the feedback path

The parameter `DiffToFbk` can be used to switch the D action into the feedback path. Setpoint jumps then no longer affect the derivative action directly.

`DiffToFbk = 0`: Derivative action is not in the feedback path. Derivative action is affected by setpoint and process variable (default setting).

`DiffToFbk = 1`: Derivative action is in the feedback path. Setpoint jumps do not affect the derivative action.

Implementation of the structure segmentation

The implementation of the structure segmentation differs from the figure shown above such that changing `PropFacSP` does not change `MV`. Control behavior corresponds to the figure.

2.1.11 Messaging

2.1.11.1 Area of application of the alarm delays

Area of application

A sensible area of application for setting alarm delays can, for example, be a motor. When it is started, an elevated starting current can occur and this could be reported depending on the configured limit. Since this usually settles down to a value below the set limit, the alarm would not make sense. In this case, the alarm delay that is intended to bridge the duration of the active alarm is used.

Note

Alarms that are really wanted are, naturally, also delayed when an alarm delay is used. Therefore select the delay period prudently!

Alarm delays in the Advanced Process Library

There are three block types with a different application of the alarm delay for:

- One time value for all limits (Page 199)
- One time value per limit pair (Page 200)
- Two time values per limit pair (Page 201)
- Two time values for each individual limit (Page 202)

Note

An alarm delay is displayed with the following symbol in the limit view and in the faceplate overview:



2.1.11.2 One time value for all limits

Blocks with one time value for the alarm delay

This form of alarm delay is used for blocks without a unit designation in the name, for example, ConPerMon.

The alarm delay is used when brief violations of the set alarm thresholds are to be suppressed. The duration of the time delay is parameterized at the input `AlmDelay`. Parameter assignment is always carried out in seconds.

Activating the alarm delay

The alarm delay is disabled by default (`AlmDelay = 0`). To use the function, set a delay time [s] with the `AlmDelay` parameter.

2.1.11.3 One time value per limit pair

Blocks with one time value for the alarm delay per limit pair

The alarm delay is used when brief violations of the set alarm thresholds are to be suppressed.

Note

The message classes Alarm, Warning and Tolerance are not valid for user-configured message classes. Please take into consideration the validity of terms for user-configured message classes (Page 41).

The alarm delay is configured at the following inputs:

Parameter for the delay time	Explanation
XXX_A_DC	Delay time for incoming events of the class <ul style="list-style-type: none"> Alarm <code>XXX_Alarm_DelayComing</code> XXX: Value to be monitored
XXX_W_DC	Delay time for incoming events of the class <ul style="list-style-type: none"> Warning <code>XXX_Warning_DelayComing</code> XXX: Value to be monitored

Activating the alarm delay

By default, the alarm delay is disabled for each limit, meaning that each individual parameter has 0 [s] pre-assigned.

To use the function, set a delay time [s] for each parameter.

Pending alarms

Pending alarms, warnings, or tolerances are output at the corresponding output parameters:

- `XXX_AH_Act = 1`: Alarm limit (high) reached or violated
- `XXX_AL_Act = 1`: Alarm limit (low) reached or violated
- `XXX_WH_Act = 1`: Warning limit (high) reached or violated
- `XXX_WL_Act = 1`: Warning limit (low) reached or violated

If a message is active at one of these outputs, this is indicated by a 1.

See also

User-configured message classes (Page 41)

2.1.11.4 Two time values per limit pair**Blocks with two time values for the alarm delay per limit pair**

The alarm delay is used when brief violations of the set alarm thresholds are to be suppressed.

Note

The message classes Alarm, Warning and Tolerance are not valid for user-configured message classes. Please take into consideration the validity of terms for user-configured message classes (Page 41).

The alarm delay is configured at the following inputs:

Parameter for the delay time	Explanation
XXX_A_DC	Delay time for incoming events of the class <ul style="list-style-type: none"> Alarm XXX_Alarm_DelayComing XXX: Value to be monitored
XXX_A_DG	Delay time for outgoing events of the class <ul style="list-style-type: none"> Alarm XXX_Alarm_DelayGoing XXX: Value to be monitored
XXX_W_DC	Delay time for incoming events of the class <ul style="list-style-type: none"> Warning XXX_Warning_DelayComing XXX: Value to be monitored
XXX_W_DG	Delay time for outgoing events of the class <ul style="list-style-type: none"> Warning XXX_Warning_DelayGoing XXX: Value to be monitored
XXX_T_DC	Delay time for incoming events of the class <ul style="list-style-type: none"> Tolerance XXX_Tolerance_DelayComing XXX: Value to be monitored
XXX_T_DG	Delay time for outgoing events of the class <ul style="list-style-type: none"> Tolerance XXX_Tolerance_DelayGoing XXX: Value to be monitored

2.1 Functions of the blocks

Activating the alarm delay

By default, the alarm delay is disabled for each individual pair, meaning that each individual parameter has 0 [s] pre-assigned.

To use the function, set a delay time [s] for each parameter.

Pending alarms

Pending alarms, warnings, or tolerances are output at the corresponding output parameters:

- XXX_AH_Act = 1: Alarm limit (high) reached or violated
- XXX_AL_Act = 1: Alarm limit (low) reached or violated
- XXX_WH_Act = 1: Warning limit (high) reached or violated
- XXX_WL_Act = 1: Warning limit (low) reached or violated
- XXX_TH_Act = 1: Tolerance limit (high) reached or violated
- XXX_TL_Act = 1: Tolerance limit (low) reached or violated

If a message is active at one of these outputs, this is indicated by a 1.

See also

User-configured message classes (Page 41)

2.1.11.5 Two time values for each individual limit

Alarm delay for blocks with two time values for each individual limit

This form of alarm delay is used for the blocks PIDConL, PIDConR, and MonAnL.

Note

The message classes Alarm, Warning and Tolerance are not valid for user-configured message classes. Please take into consideration the validity of terms for user-configured message classes (Page 41).

The alarm delay is used when brief violations of the set alarm thresholds are to be suppressed. The alarm delay is configured at the following inputs:

Parameter for the delay time	Explanation
XX_AH_DC	Delay time for incoming events of the class <ul style="list-style-type: none"> Alarm (for high limit) XX_AlarmHigh_DelayComing XX: Value to be monitored
XX_AH_DG	Delay time for outgoing events of the class <ul style="list-style-type: none"> Alarm (for high limit) XX_AlarmHigh_DelayGoing XX: Value to be monitored
XX_AL_DC ¹⁾	Delay time for incoming events of the class <ul style="list-style-type: none"> Alarm (for low limit) XX_AlarmLow_DelayComing XX: Value to be monitored
XX_AL_DG ¹⁾	Delay time for outgoing events of the class <ul style="list-style-type: none"> Alarm (for low limit) XX_AlarmLow_DelayGoing XX: Value to be monitored
XX_WH_DC	Delay time for incoming events of the class <ul style="list-style-type: none"> Warning (for high limit) XX_WarningHigh_DelayComing XX: Value to be monitored
XX_WH_DG	Delay time for outgoing events of the class <ul style="list-style-type: none"> Warning (for high limit) XX_WarningHigh_DelayGoing XX: Value to be monitored
XX_WL_DC ¹⁾	Delay time for incoming events of the class <ul style="list-style-type: none"> Warning (for low limit) XX_WarningLow_DelayComing XX: Value to be monitored
XX_WL_DG ¹⁾	Delay time for outgoing events of the class <ul style="list-style-type: none"> Warning (for low limit) XX_WarningLow_DelayGoing XX: Value to be monitored
XX_TH_DC	Delay time for incoming events of the class <ul style="list-style-type: none"> Tolerance (for high limit) XX_ToleranceHigh_DelayComing XX: Value to be monitored
XX_TH_DG	Delay time for outgoing events of the class <ul style="list-style-type: none"> Tolerance (for high limit) XX_ToleranceHigh_DelayGoing XX: Value to be monitored

Parameter for the delay time	Explanation
XX_TL_DC ¹⁾	Delay time for incoming events of the class <ul style="list-style-type: none"> • Tolerance (for low limit) XX_ToleranceLow_DelayComing XX: Value to be monitored
XX_TL_DG ¹⁾	Delay time for outgoing events of the class <ul style="list-style-type: none"> • Tolerance (for low limit) XX_ToleranceLow_DelayGoing XX: Value to be monitored

¹⁾ In the "MonAnL" block, the inputs for a low delay time do not have the separate "L" letters (e.g. XX_AL_DC: the input name is XX_A_DC).

Activating the alarm delay

By default, the alarm delay is disabled for each individual limit, meaning that each individual parameter has 0 [s] pre-assigned.

To use the function, set a delay time [s] for each parameter.

Pending alarms

Pending alarms, warnings, or tolerances are output at the corresponding output parameters:

- XX_AL_Act = 1: Alarm limit (low) reached or violated
- XX_AH_Act = 1: Alarm limit (high) reached or violated
- XX_WL_Act = 1: Warning limit (low) reached or violated
- XX_WH_Act = 1: Warning limit (high) reached or violated
- XX_TL_Act = 1: Tolerance limit (low) reached or violated
- XX_TH_Act = 1: Tolerance limit (high) reached or violated

If a message is active at one of these outputs, this is indicated by a 1.

See also

User-configured message classes (Page 41)

Separate delay times for each alarm (Page 170)

2.1.11.6 Generating instance-specific messages

Generating instance-specific messages

You can generate instance-specific messages for a binary signal of every block.

The number of interconnectable input parameters that can be used freely varies with relation to the blocks. The X in the parameter name designates the position.

You can specify the following messages for these instance-specific messages:

- Message class
- Priority of the message
- Message text
- Message auxiliary value
- Acknowledge behavior

Additional information is available in the descriptions of the message functionality of the individual blocks and in the PCS 7 Configuration Manual Operator Station under "How to configure the user-specific messages".

See also

Time stamp (Page 205)

2.1.11.7 Suppressing messages using the `MsgLock` parameter

The `MsgLock = 1` parameter is used to selectively suppress the following messages depending on `Feature` bit 25:

- All messages at the block

or

- All messages at the block, except for process control messages (for example, `CSF`, motor protection, feedback error) and external messages.

Messages already queued received the "outgoing" status with `MsgLock = 1`.

You can find additional information on `Feature` bit 25 in the section `Suppression of all messages` (Page 174)

Note

With the block `OpAnL`, this function is independent of `Feature` bit 25.

2.1.11.8 Time stamp

Time stamp

The time stamp is the assignment of time information to the status change of a binary process signal. The status change of the signal is signaled together with the time information.

Use the `EventTS` block to report time stamped signals.

For more information on time stamping and how to configure it, please refer to the "PCS 7 - High-Precision Time Stamping Function Manual".

Areas of application

Areas of application of the time stamp are for example:

- Accurately-timed detection of problems in process-related equipment. The time stamp enables you to explicitly identify signals that indicate the cause of the failure of a process unit.
- Analysis of system-wide interrelationships
- Detection and reporting of the sequence of time-critical signal changes

Forming the time information

The time information is generated by one of the following methods and is specified at the block by means of the input parameter `TimeStampOn`:

- `TimeStampOn = 0`: Use time stamp of the CPU (default)
- `TimeStampOn = 1`: Use time stamp of the I/O

Time stamping in the EventTS block

Connect the binary output parameter of another block (e.g. `Pcs7DiIn`) with a message input `Inx` ($x = 1 \dots 8$) of the `EventTS` block.

When the `EventTS` block recognizes a change in the signal state at this message input, it uses the current time of the CPU as the time stamp. Only the signal changes that are slower than the cycle time of the block can be detected.

High-precision time stamp in the process I/O

You have configured the hardware of your system for high-precision time stamping as explained in the "PCS 7 - High-Precision Time Stamping Function Manual". The signal changes are recognized in the I/O devices and the time stamp assigned to them. This data is available at the output parameter `TS_Out` of the `Pcs7DiIT` block.

The high-precision time stamp is independent of the cycle time of the blocks. The actual time resolution for two different status changes depends on your plant configuration and the hardware you are using.

Interconnect the output parameter `TS_Out` of `Pcs7DiIT` with a message input `InTSx` ($x = 1 \dots 8$) of the `EventTS` block.

Error handling

The system block `ImDrvTs` recognizes when the time stamp function in the I/O devices is defective and forwards this information to the `Pcs7DiIT` block. This then forms the time stamp using the current CPU time and sets the signal status of `TS_Out` output parameter to "Bad, due to device". The `EventTS` block then uses the current time of the CPU as the time stamp. You can find additional information in the "PCS 7 - High-Precision Time Stamping Function Manual".

2.1.11.9 Connection of the time-stamped messages from EventTs or Event16Ts

If the output parameter `EventTsOut` of the block `EventTs` or `Event16Ts` is connected to the input parameter `EventTsIn` or `EventTs2In` of another block, the time-stamped messages of the block `EventTs` or `Event16Ts` will be displayed at the connected block. The following functionalities or parameters of the block are transferred to the connected message blocks:

- Maintenance release status (`MS_Release`)
- Operating mode "Out of service" (depends on `Feature2.Bit11`)
- Message lock with the parameter `MsgLock` (depends on `Feature2.Bit11`)
- Batch parameters (`BatchEn`, `Occupied`, `BatchID`, `BatchName`, and `StepNo`)

With `Feature2.Bit11 Suppress MsgLock` and "Out of service" mode for a connected message block (Page 188), you can suppress the change to the "Out of service" mode and the message lock over `MsgLock`.

2.1.12 Settings for operator control and monitoring

2.1.12.1 Display and operator input area for process values and setpoints

Display and operator input area for process values and setpoints

You specify the upper and lower area limits in the faceplate using interconnectable input parameters for the following:

- Display areas (bar display)
- Operator input area (for example setpoint and manipulated value)
- Input area for the limit values
 - Up to 7 numbers (including a decimal separator and a minus sign) are possible in the faceplates

The interconnectable input parameter is a structured variable that contains two analog values. Refer to the descriptions of the individual blocks for the relevant input parameters.

Using a structured variable for scaling

There are three possibilities with which you can influence the contents of the structured variables, namely with:

- The corresponding channel function block, for example, the `FbAnIn` block
- A conversion block, for example, the `StruScIn` block
- Direct parameter assignment at the block input

Additional information on data types is available in the documentation of CFC and STEP 7.

2.1.12.2 Opening additional faceplates

Opening additional faceplates

You can open standard views of other faceplates from various faceplate views. Here, you have the following options:

- Two buttons that you can assign freely and that are used to call faceplates of other blocks.
- Two predefined buttons for calling faceplates with a fixed assignment to the controller blocks.
- Buttons predefined for interlock functions

Note**"Small" blocks**

With "Small" blocks, you can call up only one faceplate from the standard view.

Freely assignable buttons

From the standard view and from the preview, you can use a button to open the standard view of a block that can be selected freely. In order to use this function, in the CFC you need to interconnect the `SelfFp1` input parameter for the button in the standard view or `SelfFp2` for the button in the preview to any given output parameter of the block whose faceplate is to be opened. This makes the buttons in the faceplates visible.

Note

You can only configure the button in the standard view (`SelfFp1`) with interlock blocks. There are no buttons with the `GainSched` block.

Button label

You can change the button labels in the "OS additional text" attribute to `"SelfFp1"/"SelfFp2"`.

Note

There is also an alternative solution for labeling the buttons:

- Open the process picture in WinCC GraphicsDesigner.
- Open the object properties of the block icon.
- Under Configurations, assign the desired text to the attribute `UserButtonText1` or `UserButtonText2`.

The main difference between this solution and the first solution is that the labels are only specified when the faceplate above the block icon is opened. This solution is therefore outdated.

Predefined buttons for controller blocks

You can open the standard view for the following blocks from a controller standard view or parameter view (for example PIDConL):

- ConPerMon (can be called from the standard view)
 - To do this, you need to interconnect the output parameter `CPI` of the ConPerMon block to the input parameter `CPI_In` of the controller block.
- GainSched (can be called from the parameter view)
 - To do this, you need to interconnect the output parameter `Link2Gain` of the GainSched block to the input parameter `Gain` of the controller block.

The labels of the buttons cannot be changed here.

Predefined buttons for interlocks

You can open the following interlock blocks from the standard view of the technology blocks:

- Activation enable
- Interlock without reset (interlock)
- Interlock with reset (protection)

The buttons intended for this are visible when the relevant input parameter (`Permit`, `Intlock` or `Protect`) is interconnected to an interlock block.

You can open the standard view for the following faceplates from the standard view of the interlock blocks:

- The blocks interconnected to the input values.
- The block interconnected to the output value.

The buttons intended for this are visible when the input parameters (for example `In01`) or the `Out` output parameter of the interlock block is interconnected to a block that has a faceplate.

Note

Interconnection of the `Out` output parameter to multiple blocks is not permitted. The reason for this is that a direct relationship must be established between the button in the faceplate and the faceplate to be opened by it.

2.1.12.3 Labeling of buttons and text

Labeling of buttons and text

You can change the text of buttons (such as start/stop) for each specific instance. For binary OpDiXX faceplates, you can also change the static text for the "x command" for each specific instance.

2.1 Functions of the blocks

To do this, you need to specify how the buttons are labeled yourself using the attributes "Text0" and "Text1" in the object properties of the block. These texts are displayed in the standard view and preview of the faceplate.

Block type	Command button	Block I/O for parameter assignment "Text 1"
FmCont	Open Close Stop	OpenOp CloseOp StopOp
FmTemp	Open Close Stop	OpenOp CloseOp StopOp
MonDiL	Process value	Out
MonDiS	Process value	Out
MotL	Start Stop Rapid stop	StartMan StopMan RapidStp
MotRevL	Start - -> Start < - - Stop Rapid stop	FwdMan RevMan StopMan RapidStp
MotS	Start Stop	StartMan StopMan
MotSpdCL	Start -> Start < - Stop Rapid stop	FwdMan RevMan StopMan RapidStp
MotSpdL	Start > Start >> Stop Rapid stop	Spd1Man Spd2Man StopMan RapidStp
PIDConL	Automatic Manual Program Out of service External Internal	AutModOp ManModOp AdvCoOn OosOp SP_ExtOp SP_IntOp
PIDConR	Automatic Manual Program Out of service External Internal	AutModOp ManModOp AdvCoOn OosOp SP_ExtOp SP_IntOp

Block type	Command button	Block I/O for parameter assignment "Text 1"
PIDStepL	Open Close Stop	OpenOp CloseOp StopOp
VivAnl	Open Close	OpenOp CloseOp
VivL	Open Close	OpenMan CloseMan
Viv2WayL	Pos0 Pos1 Pos2	Pos0Man Pos1Man Pos2Man
VivMotL	Open Close Stop Rapid stop	OpenMan CloseMan StopMan RapidStp
VivPosL	Open Close Stop Rapid stop	OpenMan CloseMan StopMan RapidStp
VivS	Open Close	OpenMan CloseMan

The default text is shown if no text is configured.

If the text is longer than can be displayed with the default font size, the font size is automatically reduced until the text is fully shown. The smallest font size is 7 point.

Refer to the function description of the faceplate to learn which parameters are affected by this function.

2.1.12.4 Displaying auxiliary values

Displaying auxiliary values

Up to two auxiliary values can be displayed in the standard view of some faceplates. This feature can be used, for example, with motors to indicate the motor current and winding temperature.

To do so interconnect the value that you want to have displayed with the input parameters `UserAna1` or `UserAna2`.

In the object properties (I/Os > Identifier) of the block in CFC, you can specify the text to be displayed for these parameters in the standard view of the faceplate.

2.1.12.5 Selecting a unit of measure

Coded unit of measure

The parameter `XXX_Unit` is used to specify the unit of measure for the corresponding input parameter (`XXX` stands for a specific parameter, for example, `PV_Unit`). Entry is carried out in the form of a code. Exactly one unit of measure is assigned to each code and is displayed on the faceplate.

You can interconnect the `XXX_Unit` input parameter of a technologic block with the `XXXUnit` output parameter of an analog input channel block. At the analog input channel block, enter the unit of measure at the `XXXUnit` input parameter (`XXX` stands for a specific parameter, for example `PV_InUnit`, `PVOutUnit`).

If the parameter value of `XXX_Unit` is out of range (that is, the value is not defined), the faceplate displays "!undef.!" in the place of unit.

Note

Special notes for channel blocks `PCS7AnIn`, `PCS7AnOu`, `FbAnIn` and `FbAnOu`

You can use the `S7_enum` attribute to display the unit in plain text in the CFC editor for these blocks.

Note

In block icons, the update/refresh time of the units is 1 h. If the unit is changed from CFC, the new unit will be visible in the block icon after 1 hour or if the process picture is reloaded. In faceplates, the update/refresh time of the units is 5 seconds, so the new unit will be visible after 5 s.

Customer-specific units

It is possible to use units which differ from the IEC 611582 standard. You can define your own units in the range 1 to 199 in an XML file.

The name of the XML should be `APLCustomerUnits.xml` and should be placed in the project path in the folder "GraCS" on both server and client.

Below is an example to describe the content of the XML file `APLCustomerUnits.xml`:

```
<?xml version="1.0" encoding="utf-8"?>
<UserDefinedUnits>                                <!-- Root node start -->
  <!-- Define the first unit for different languages -->
  <Unit id="1">                                     <!-- first node with unit ID 1 start -->
    <Name lcid="1031">German1</Name>                <!-- unit value (e.g. German1) in German -->
    <Name lcid="1033">English1</Name>               <!-- unit value (e.g. English1) in English -->
    <Name lcid="1034">Spanish1</Name>               <!-- unit value (e.g. Spanish1) in Spanish -->
    <Name lcid="1036">French1</Name>                <!-- unit value (e.g. French1) in French -->
    <Name lcid="1040">Italian1</Name>               <!-- unit value (e.g. Italian1) in Italian -->
    <Name lcid="1041">Japanese1</Name>              <!-- unit value (e.g. Japanese1) in Japanese -->
    <Name lcid="2052">Chinese1</Name>               <!-- unit value (e.g. Chinese1) in Chinese -->
```



```

</Unit>                                <!-- first node with unit ID 1 end -->
<!-- Define the second unit for different languages -->
<Unit id="2">
  <Name lcid="1031">German2</Name>      <!-- lcid="1031" is for German -->
  <Name lcid="1033">English2</Name>     <!-- lcid="1033" is for English -->
  <Name lcid="1034">Spanish2</Name>     <!-- lcid="1034" is for Spanish -->
  <Name lcid="1036">French2</Name>      <!-- lcid="1036" is for French -->
  <Name lcid="1040">Italian2</Name>     <!-- lcid="1040" is for Italian -->
  <Name lcid="1041">Japanese2</Name>    <!-- lcid="1041" is for Japanese -->
  <Name lcid="2052">Chinese2</Name>    <!-- lcid="2052" is for Chinese -->
</Unit>
<!-- similarly define other units up to unit id = 199-->
</UserDefinedUnits>                    <!-- Root node end -->

```

The "Unit id" value should be given to `XXX_Unit` parameter in the function blocks.

Note

The XML is read-only once when WinCC runtime is activated. If any changes are done in the XML later, you must deactivate, close, and activate the WinCC runtime again to reflect the changes.

Using the unit of measure with controllers for the ConPerMon block

For controller blocks, the current unit of measure is output via output parameter `XX_UnitOut`. If you use the ConPerMon block, you must switch this output parameter with the corresponding input parameter `XXX_Unit` on the ConPerMon block.

Using the S7_unit attribute

If you set the `xxx_Unit` parameter to 0, the entry is displayed by the `S7_Unit` attribute in the faceplate and in the block symbol.

Overview of the units of measure

The units of measure are listed in the following tables:

List of the most commonly used units of measure in accordance with IEC 61158

Note

Due to space constraints on the system, not all units referred to can be displayed in totality. The display of the measurement units is left-aligned. If you want to abbreviate the unit of measurement, use the function **Customer-specific units**.

2.1 Functions of the blocks

Value	Display	Description
1000	K	Kelvin
1001	°C	Degrees Celsius
1002	°F	Degrees Fahrenheit
1005	°	Degree
1006	'	Minute
1007	"	Second
1010	m	Meter
1013	mm	Millimeter
1018	ft	Foot
1023	m ²	Square meter
1038	L	Liter
1041	hl	Hectoliter
1054	s	Second
1058	min	Minute
1059	h	Hour
1060	d	Day
1061	m/s	Meters per second
1077	Hz	Hertz
1081	kHz	Kilohertz
1082	1/s	Per second
1083	1/min	Per minute
1088	kg	Kilogram
1092	t	Metric ton
1100	g/cm ³	Grams per cubic centimeter
1105	g/L	Grams per liter
1120	N	Newton
1123	mN	Millinewton
1130	Pa	Pascal
1133	kPa	Kilopascal
1137	bar	Bar
1138	mbar	Millibar
1149	mmH ₂ O	Millimeters of water ¹
1175	W·h	Watt hour
1179	kW·h	Kilowatt hour
1181	kcal _{th}	Kilocalories ¹
1190	kW	Kilowatt
1209	A	Ampere
1211	mA	Milliampere
1221	A·h	Ampere hour
1240	V	Volt
1349	m ³ /h	Cubic meters per hour
1353	L/h	Liters per hour

Value	Display	Description
1384	mol	Mol
1422	pH	pH value

List of all units of measure in accordance with IEC 61158

Value	Display	Description
1000	K	Kelvin
1001	°C	Degrees Celsius
1002	°F	Degrees Fahrenheit
1003	°R	Degree Rankine
1004	rad	Radian
1005	°	Degree
1006	'	Minute
1007	"	Second
1008	gon	Gon
1009	r	Revolution
1010	m	Meter
1011	km	Kilometer
1012	cm	Centimeter
1013	mm	Millimeter
1014	µm	Micrometer
1015	nm	Nanometer
1016	pm	Picometer
1017	Å	Angstrom ²
1018	ft	Foot
1019	in	Inch
1020	yd	Yard
1021	mile	Mile
1022	nautical mile	Nautical mile
1023	m ²	Square meter
1024	km ²	Square kilometer
1025	cm ²	Square centimeter
1026	dm ²	Square decimeter
1027	mm ²	Square millimeter
1028	a	Are
1029	ha	Hectare
1030	in ²	Square inch
1031	ft ²	Square foot
1032	yd ²	Square yard
1033	mile ²	Square mile
1034	m ³	Cubic meter
1035	dm ³	Cubic decimeter

2.1 Functions of the blocks

Value	Display	Description
1036	cm ³	Cubic centimeter
1037	mm ³	Cubic millimeter
1038	L	Liter
1039	cl	Centiliter
1040	ml	Milliliter
1041	hl	Hectoliter
1042	in ³	Cubic inch
1043	ft ³	Cubic foot
1044	yd ³	Cubic yard
1045	mile ³	Cubic mile
1046	pint	Pint
1047	quart	Quart
1048	gal	US gallon
1049	ImpGal	Imperial gallon
1050	bushel	Bushel
1051	bbbl	Barrel = 42 gallons
1052	bbbl(liq)	Liquid barrel = 31.5 gallons
1053	ft ³ std.	Standard cubic foot
1054	s	Second
1055	ks	Kilosecond
1056	ms	Millisecond
1057	μs	Microsecond
1058	min	Minute
1059	h	Hour
1060	d	Day
1061	m/s	Meters per second
1062	mm/s	Millimeters per second
1063	m/h	Meters per hour
1064	km/h	Kilometers per hour
1065	knot	Knot
1066	in/s	Inches per second
1067	ft/s	Feet per second
1068	yd/s	Yards per second
1069	in/min	Inches per minute
1070	ft/min	Feet per minute
1071	yd/min	Yards per minute
1072	in/h	Inches per hour
1073	ft/h	Feet per hour
1074	yd/h	Yards per hour
1075	mi/h	Miles per hour
1076	m/s ²	Meter/second squared
1077	Hz	Hertz
1078	THz	Terahertz

Value	Display	Description
1079	GHz	Gigahertz
1080	MHz	Megahertz
1081	kHz	Kilohertz
1082	1/s	Per second
1083	1/min	Per minute
1084	r/s	Revolutions per second
1085	rpm	Revolutions per minute
1086	rad/s	Radians per second
1087	1/s ²	Per second squared
1088	kg	Kilogram
1089	g	Gram
1090	mg	Milligram
1091	Mg	Megagram
1092	t	Metric ton
1093	oz	Ounce
1094	lb	Pound
1095	STon	US ton (short ton)
1096	LTon	British ton (long ton)
1097	kg/m ³	Kilograms per cubic meter
1098	Mg/dm ³	Megagrams per cubic meter
1099	kg/dm ³	Kilograms per cubic decimeter
1100	g/cm ³	Grams per cubic centimeter
1101	g/m ³	Grams per cubic meter
1102	t/m ³	Metric tons per cubic meter
1103	kg/L	Kilogram per liter
1104	g/ml	Grams per milliliter
1105	g/L	Grams per liter
1106	lb/in ³	Pounds per cubic inch
1107	lb/ft ³	Pounds per cubic foot
1108	lb/gal	Pounds per US gallon
1109	STon/yd ³	US tons per cubic yard
1110	°Twad	Degree Twaddell
1111	°Baum (hv)	Degree Baumé (heavy)
1112	°Baum (lt)	Degree Baumé (light)
1113	°API	Degrees API
1114	SGU	Specific gravity units
1115	kg/m	Kilograms per meter
1116	mg/m	Milligrams per meter
1117	tex	Tex
1118	kg·m ²	Kilograms per square meter
1119	kg·m/s	Kilograms per meter per second
1120	N	Newton
1121	MN	Meganewton

2.1 Functions of the blocks

Value	Display	Description
1122	kN	Kilonewton
1123	mN	Millinewton
1124	μ N	Micronewton
1125	kg·m ² /s	Kilograms per square meter per second
1126	N·m	Newton meter
1127	MN·m	Meganewton meter
1128	kN·m	Kilonewton meter
1129	mN·m	Millinewton meter
1130	Pa	Pascal
1131	GPa	Gigapascal
1132	MPa	Megapascal
1133	kPa	Kilopascal
1134	mPa	Millipascal
1135	μ Pa	Micropascal
1136	hPa	Hectopascal
1137	bar	Bar
1138	mbar	Millibar
1139	torr	Torr
1140	atm	Atmosphere
1141	psi	Pounds per square inch
1142	psia	Pounds per square inch (absolute)
1143	psig	Pounds per square inch (gauge)
1144	g/cm ²	Grams per square centimeter
1145	kg/cm ²	Kilograms per square centimeter
1146	inH ₂ O	Inches of water
1147	inH ₂ O (4°C)	Inches of water at 4 degrees Celsius
1148	inH ₂ O (68°F)	Inches of water at 68 degrees Fahrenheit
1149	mmH ₂ O	Millimeters of water ¹
1150	mmH ₂ O (4°C)	Millimeters of water at 4 degrees Celsius ¹
1151	mmH ₂ O (68°F)	Millimeters of water at 68 degrees Fahrenheit ¹
1152	ftH ₂ O	Feet of water ¹
1153	ftH ₂ O (4°C)	Feet of water at 4 degrees Celsius ¹
1154	ftH ₂ O (68°F)	Feet of water at 68 degrees Fahrenheit ¹
1155	inHg	Inches of mercury
1156	inHg (0°C)	Inches of mercury at 0 degrees Celsius
1157	mmHg	Millimeters of mercury

Value	Display	Description
1158	mmHg (0°C)	Millimeters of mercury at 0 degrees Celsius
1159	Pa·s	Pascal second
1160	m ² /s	Square meters per second
1161	P	Poise
1162	cP	Centipoise
1163	St	Stokes
1164	cSt	Centistokes
1165	N/m	Newtons per meter
1166	mN/m	Millinewtons per meter
1167	J	Joule
1168	EJ	Exajoule
1169	PJ	Petajoule
1170	TJ	Terajoule
1171	GJ	Gigajoule
1172	MJ	Megajoule
1173	kJ	Kilojoule
1174	mJ	Millijoule
1175	W·h	Watt hour
1176	TW·h	Terawatt hour
1177	GW·h	Gigawatt hour
1178	MW·h	Megawatt hour
1179	kW·h	Kilowatt hour
1180	cal _{th}	Calorie (thermo chemical) ¹
1181	kcal _{th}	Kilocalorie (thermo chemical) ¹
1182	Mcal _{th}	Megacalorie (thermo chemical) ¹
1183	Btu _{th}	British thermal unit ¹
1184	datherm	Decatherm
1185	ft·lbf	Foot pound
1186	W	Watt
1187	TW	Terawatt
1188	GW	Gigawatt
1189	MW	Megawatt
1190	kW	Kilowatt
1191	mW	Milliwatt
1192	μW	Microwatt
1193	nW	Nanowatt
1194	pW	Picowatt
1195	Mcal _{th} /h	Megacalorie per hour ¹
1196	MJ/h	Megajoule per hour
1197	Btu _{th} /h	British thermal units per hour ¹
1198	hp	Horsepower
1199	W/(m·K)	Watts per meter kelvin

2.1 Functions of the blocks

Value	Display	Description
1200	W/(m ² ·K)	Watts per (square meter kelvin)
1201	m ² ·K/W	Square meters kelvin per Watt
1202	J/K	Joules per kelvin
1203	kJ/K	Kilojoules per kelvin
1204	J/(kg·K)	Joules per (kilogram kelvin)
1205	kJ/(kg·K)	Kilojoules per (kilogram kelvin)
1206	J/kg	Joules per kilogram
1207	MJ/kg	Megajoules per kilogram
1208	kJ/kg	Kilojoules per kilogramm
1209	A	Ampere
1210	kA	Kiloampere
1211	mA	Milliampere
1212	μA	Microampere
1213	nA	Nanoampere
1214	pA	Picoampere
1215	C	Coulomb
1216	MC	Megacoulomb
1217	kC	Kilocoulomb
1218	μC	Microcoulomb
1219	nC	Nanocoulomb
1220	pC	Picocoulomb
1221	A·h	Ampere hour
1222	C/m ³	Coulombs per cubic meter
1223	C/mm ³	Coulombs per cubic millimeter
1224	C/cm ³	Coulombs per cubic centimeter
1225	kC/m ³	Kilocoulombs per cubic meter
1226	mC/m ³	Millicoulombs per cubic meter
1227	μC/m ³	Microcoulombs per cubic meter
1228	C/m ²	Coulombs per square meter
1229	C/mm ²	Coulombs per square millimeter
1230	C/cm ²	Coulombs per square centimeter
1231	kC/m ²	Kilocoulombs per square meter
1232	mC/m ²	Millicoulombs per square meter
1233	μC/m ²	Microcoulombs per square meter
1234	V/m	Volts per meter
1235	MV/m	Megavolts per meter
1236	kV/m	Kilovolts per meter
1237	V/cm	Volts per centimeter
1238	mV/m	Millivolts per meter
1239	μV/m	Microvolts per meter
1240	V	Volt
1241	MV	Megavolt
1242	kV	Kilovolt

Value	Display	Description
1243	mV	Millivolt
1244	μ V	Microvolt
1245	F	Farad
1246	mF	Millifarad
1247	μ F	Microfarad
1248	nF	Nanofarad
1249	pF	Picofarad
1250	F/m	Farad per meter
1251	μ F/m	Microfarad per meter
1252	nF/m	Nanofarad per meter
1253	pF/m	Picofarad per meter
1254	C·m	Coulomb meter
1255	A/m ²	Amperes per square meter
1256	MA/m ²	Megaamperes per square meter
1257	A/cm ²	Amperes per square centimeter
1258	kA/m ²	Kiloamperes per square meter
1259	A/m	Amperes per meter
1260	kA/m	Kiloamperes per meter
1261	A/cm	Amperes per centimeter
1262	T	Tesla
1263	mT	Millitesla
1264	μ T	Microtesla
1265	nT	Nanotesla
1266	Wb	Weber
1267	mWb	Milliweber
1268	Wb/m	Webers per meter
1269	kWb/m	Kilowebers per meter
1270	H	Henry
1271	mH	Millihenry
1272	μ H	Microhenry
1273	nH	Nanohenry
1274	pH	Picohenry
1275	H/m	Henries per meter
1276	μ H/m	Microhenries per meter
1277	nH/m	Nanohenries per meter
1278	A·m ²	Ampere square meters
1279	N·m ² /A	Newton meter squared per ampere
1280	Wb·m	Weber meter
1281	Ω	Ohm ¹
1282	G Ω	Gigaohm ¹
1283	M Ω	Megaohm ¹
1284	k Ω	Kiloohm ¹
1285	m Ω	Milliohm ¹

2.1 Functions of the blocks

Value	Display	Description
1286	$\mu\Omega$	Microohm ¹
1287	S	Siemens
1288	kS	Kilosiemens
1289	mS	Millisiemens
1290	μ S	Microsiemens
1291	$\Omega \cdot m$	Ohms times meters ¹
1292	$G\Omega \cdot m$	Gigaohms times meters ¹
1293	$M\Omega \cdot m$	Megaohms times meters ¹
1294	$k\Omega \cdot m$	Kiloohms times meters ¹
1295	$\Omega \cdot cm$	Ohms times centimeters ¹
1296	$m\Omega \cdot m$	Milliohms times meters ¹
1297	$\mu\Omega \cdot m$	Microohms times meters ¹
1298	$n\Omega \cdot m$	Nanoohms times meters ¹
1299	S/m	Siemens per meter
1300	MS/m	Megasiemens per meter
1301	kS/m	Kilosiemens per meter
1302	mS/cm	Millisiemens per centimeter
1303	μ S/mm	Microsiemens per millimeter
1304	1/H	Per henry
1305	sr	Steradian
1306	W/sr	Watts per steradian
1307	$W/(sr \cdot m^2)$	Watts per (steradian square meter)
1308	$W/(m^2)$	Watts per square meter
1309	lm	Lumen
1310	lm·s	Lumen second
1311	lm·h	Lumen hour
1312	lm/m ²	Lumens per square meter
1313	lm/W	Lumens per watt
1314	lx	Lux
1315	lx·s	Lux second
1316	cd	Candela
1317	cd/m ²	Candela per square meter
1318	g/s	Grams per second
1319	g/min	Grams per minute
1320	g/h	Grams per hour
1321	g/d	Grams per day
1322	kg/s	Kilograms per second
1323	kg/min	Kilograms per minute
1324	kg/h	Kilograms per hour
1325	kg/d	Kilograms per day
1326	t/s	Metric tons per second
1327	t/min	Metric tons per minute
1328	t/h	Metric tons per hour

Value	Display	Description
1329	t/d	Metric tons per day
1330	lb/s	Pounds per second
1331	lb/min	Pounds per minute
1332	lb/h	Pounds per hour
1333	lb/d	Pounds per day
1334	STon/s	US tons per second
1335	STon/min	US tons per minute
1336	STon/h	US tons per hour
1337	STon/d	US tons per day
1338	LTon/s	British tons per second
1339	LTon/min	British tons per minute
1340	LTon/h	British tons per hour
1341	LTon/d	British tons per day
1342	%	Percent
1343	% sol/wt	Percentage solids per weight unit
1344	% sol/vol	Percentage solids per volume unit
1345	% stm qual	Percentage steam quality
1346	°Plato	Degree plato
1347	m ³ /s	Cubic meters per second
1348	m ³ /min	Cubic meters per minute
1349	m ³ /h	Cubic meters per hour
1350	m ³ /d	Cubic meters per day
1351	L/s	Liters per second
1352	L/min	Liters per minute
1353	L/h	Liters per hour
1354	L/d	Liters per day
1355	ML/d	Megaliters per day
1356	ft ³ /s	Cubic feet per second
1357	ft ³ /m	Cubic feet per minute
1358	ft ³ /h	Cubic feet per hour
1359	ft ³ /d	Cubic feet per day
1360	ft ³ /min std	Standard cubic feet per minute
1361	ft ³ /h std	Standard cubic feet per hour
1362	gal/s	US gallons per second
1363	gal/min	US gallons per minute
1364	gal/h	US gallons per hour
1365	gal/d	US gallons per day
1366	Mgal/d	Mega US gallons per day
1367	ImpGal/s	Imperial gallons per second
1368	ImpGal/min	Imperial gallons per minute
1369	ImpGal/h	Imperial gallons per hour
1370	ImpGal/d	Imperial gallons per day
1371	bbl/s	Barrels per second

2.1 Functions of the blocks

Value	Display	Description
1372	bbl/min	Barrels per minute
1373	bbl/h	Barrels per hour
1374	bbl/d	Barrels per day
1375	W/m ²	Watts per square meter
1376	mW/m ²	Milliwatts per square meter
1377	μW/m ²	Microwatts per square meter
1378	pW/m ²	Picowatts per square meter
1379	Pa·s/m ³	Pascal seconds per cubic meter
1380	N·s/m	Newton seconds per meter
1381	Pa·s/m	Pascal seconds per meter
1382	B	Bel
1383	dB	Decibel
1384	mol	Mol
1385	kmol	Kilomole
1386	mmol	Millimole
1387	μmol	Micromole
1388	kg/mol	Kilograms per mole
1389	g/mol	Grams per mole
1390	m ³ /mol	Cubic meters per mole
1391	dm ³ /mol	Cubic decimeters per mole
1392	cm ³ /mol	Cubic centimeters per mole
1393	L/mol	Liters per mole
1394	J/mol	Joules per mole
1395	kJ/mol	Kilojoules per mole
1396	J/(mol·K)	Joules per mole kelvin
1397	mol/m ³	Moles per cubic meter
1398	mol/dm ³	Moles per cubic decimeter
1399	mol/L	Moles per liter
1400	mol/kg	Moles per kilogram
1401	mmol/kg	Millimoles per kilogram
1402	Bq	Becquerel
1403	MBq	Megabecquerel
1404	kBq	Kilobecquerel
1405	Bq/kg	Becquerels per kilogram
1406	kBq/kg	Kilobecquerels per kilogram
1407	MBq/kg	Megabecquerels per kilogram
1408	Gy	Gray
1409	mGy	Milligray
1410	rd	Rad
1411	Sv	Sievert
1412	mSv	Millisievert
1413	rem	Rem
1414	C/kg	Coulombs per kilogram

Value	Display	Description
1415	mC/kg	Millicoulombs per kilogram
1416	R	Röntgen
1417	1/Jm ³	Density of magnetic energy
1418	e/Vm ³	
1419	m ³ /C	Cubic meters per coulomb
1420	V/K	Volts per kelvin
1421	mV/K	Millivolts per kelvin
1422	pH	pH value
1423	ppm	Parts per million
1424	ppb	Parts per billion
1425	ppth	Parts per trillion
1426	°Brix	Degrees Brix
1427	°Ball	Degrees Balling
1428	proof/vol	Proof per volume
1429	proof/mass	Proof per mass
1430	lb/ImpGal	Pounds per Imperial gallon
1431	kcal _{th} /s	Kilocalories per second ¹
1432	kcal _{th} /min	Kilocalories per minute ¹
1433	kcal _{th} /h	Kilocalories per hour ¹
1434	kcal _{th} /d	Kilocalories per day ¹
1435	Mcal _{th} /s	Megacalories per second ¹
1436	Mcal _{th} /min	Megacalories per minute ¹
1437	Mcal _{th} /d	Megacalories per day ¹
1438	kJ/s	Kilojoules per second
1439	kJ/min	Kilojoules per minute
1440	kJ/h	Kilojoule per hour
1441	kJ/d	Kilojoules per day
1442	MJ/s	Megajoules per second
1443	MJ/min	Megajoules per minute
1444	MJ/d	Megajoules per day
1445	Btu _{th} /s	British thermal units per second ¹
1446	Btu _{th} /min	British thermal units per minute ¹
1447	Btu _{th} /d	British thermal units per day ¹
1448	μgal/s	Micro US gallons per second
1449	mgal/s	Milli US gallons per second
1450	kgal/s	Kilo US gallons per second
1451	Mgal/s	Mega US gallons per second
1452	μgal/min	Micro US gallons per minute
1453	mgal/min	Milli US gallons per minute
1454	kgal/min	Kilo US gallons per minute
1455	Mgal/min	Mega US gallons per minute
1456	μgal/h	Micro US gallons per hour
1457	mgal/h	Milli US gallons per hour

2.1 Functions of the blocks

Value	Display	Description
1458	kgal/h	Kilo US gallons per hour
1459	Mgal/h	Mega US gallons per hour
1460	µgal/d	Micro US gallons per day
1461	mgal/d	Milli US gallons per day
1462	kgal/d	Kilo US gallons per day
1463	µImpGal/s	Micro Imperial gallons per second
1464	mImpGal/s	Milli Imperial gallons per second
1465	kImpGal/s	Kilo Imperial gallons per second
1466	MImpGal/s	Mega Imperial gallons per second
1467	µImpGal/min	Micro Imperial gallons per minute
1468	mImpGal/min	Milli Imperial gallons per minute
1469	kImpGal/min	Kilo Imperial gallons per minute
1470	MImpGal/min	Mega Imperial gallons per minute
1471	µImpGal/h	Micro Imperial gallons per hour
1472	mImpGal/h	Milli Imperial gallons per hour
1473	kImpGal/h	Kilo Imperial gallons per hour
1474	MImpGal/h	Mega Imperial gallons per hour
1475	µImpgal/d	Micro Imperial gallons per day
1476	mImpgal/d	Milli Imperial gallons per day
1477	kImpgal/d	Kilo Imperial gallons per day
1478	MImpgal/d	Mega Imperial gallons per day
1479	µbbl/s	Microbarrels per second
1480	mbbl/s	Millibarrels per second
1481	kbbl/s	Kilobarrels per second
1482	Mbbl/s	Megabarrels per second
1483	µbbl/min	Microbarrels per minute
1484	mbbl/min	Millibarrels per minute
1485	kbbl/min	Kilobarrels per minute
1486	Mbbl/min	Megabarrels per minute
1487	µbbl/h	Microbarrels per hour
1488	mbbl/h	Millibarrels per hour
1489	kbbl/h	Kilobarrels per hour
1490	Mbbl/h	Megabarrels per hour
1491	µbbl/d	Microbarrels per day
1492	mbbl/d	Millibarrels per day
1493	kbbl/d	Kilobarrels per day
1494	Mbbl/d	Megabarrels per day
1495	µm ³ /s	Cubic micrometers per second
1496	mm ³ /s	Cubic millimeters per second
1497	km ³ /s	Cubic kilometers per second
1498	Mm ³ /s	Cubic megameters per second
1499	µm ³ /min	Cubic micrometers per minute
1500	mm ³ /min	Cubic millimeters per minute

Value	Display	Description
1501	km ³ /min	Cubic kilometers per minute
1502	mm ³ /min	Cubic megameters per minute
1503	μm ³ /h	Cubic micrometers per minute
1504	mm ³ /h	Cubic millimeters per minute
1505	km ³ /h	Cubic kilometers per minute
1506	Mm ³ /h	Cubic megameters per minute
1507	μm ³ /d	Cubic micrometers per day
1508	mm ³ /d	Cubic millimeters per day
1509	km ³ /d	Cubic kilometers per day
1510	Mm ³ /d	Cubic megameters per day
1511	cm ³ /s	Cubic centimeters per second
1512	cm ³ /min	Cubic centimeters per minute
1513	cm ³ /h	Cubic centimeters per hour
1514	cm ³ /d	Cubic centimeters per day
1515	kcal _{th} /kg	Kilocalories per kilogram ¹
1516	Btu _{th} /lb	British thermal units per pound ¹
1517	kL	Kiloliter
1518	kL/min	Kiloliters per minute
1519	kL/h	Kiloliters per hour
1520	kL/d	Kiloliters per day
1551	S/cm	Siemens per centimeter
1552	μS/cm	Microsiemens per centimeter
1553	mS/m	Millisiemens per meter
1554	μS/m	Microsiemens per meter
1555	MΩ · cm	Megaohm centimeter ¹
1556	kΩ · cm	Kiloohm centimeter ¹
1557	Weight%	Weight percent
1558	mg/L	Milligram per liter
1559	μg/L	Microgram per liter
1560	%Sat	-
1561	vpm	-
1562	%vol	Volume percent
1563	ml/min	Milliliters per minute
1564	mg/dm ³	Milligrams per cubic centimeter
1565	mg/L	Milligram per liter
1566	mg/m ³	Milligrams per cubic meter
1567	ct	Carat (jewels) = 200.0·10 ⁻⁶ kg
1568	lb (tr)	Pound (troy or apothecary) = 0.3732417216 kg
1569	oz (tr)	Ounce (troy or apothecary) = 1/12 lb (tr)
1570	fl oz (U.S.)	Ounce (U.S. fluid) = (1/128) gal
1571	cm ³	Cubic centimeter = 10 ⁻⁶ m ³

2.1 Functions of the blocks

Value	Display	Description
1572	af	acre foot = 43560 ft ³
1573	m ³ normal	Cubic meter
1574	L normal	Liter
1575	m ³ std.	Standard cubic meter
1576	L std.	Standard liter
1577	ml/s	Milliliters per second
1578	ml/h	Milliliters per hour
1579	ml/d	Milliliters per day
1580	af/s	Acre foot per second
1581	af/min	Acre foot per minute
1582	af/h	Acre foot per hour
1583	af/d	Acre foot per day
1584	fl oz (U.S.)/s	Ounces per second
1585	fl oz (U.S.) /min	Ounces per minute
1586	fl oz (U.S.)/h	Ounces per hour
1587	fl oz (U.S.)/d	Ounces per day
1588	m ³ /s normal	Standard cubic meters per second
1589	m ³ /min normal	Standard cubic meters per minute
1590	m ³ /h normal	Standard cubic meters per hour
1591	m ³ /d normal	Standard cubic meters per day
1592	L/s normal	Standard liters per second
1593	L/min normal	Standard liters per minute
1594	L/h normal	Standard liters per hour
1595	L/d normal	Standard liters per second
1596	m ³ /s std.	Standard cubic meters per second
1597	m ³ /min std.	Standard cubic meters per minute
1598	m ³ /h std.	Standard cubic meters per hour
1599	m ³ /d std.	Standard cubic meters per day
1600	L/s std.	Standard liters per second
1601	L/min std.	Standard liters per minute
1602	L/h std.	Standard liters per hour
1603	L/d std.	Standard liters per day
1604	ft ³ /s std.	Standard cubic feet per second
1605	ft ³ /d std.	Standard cubic feet per day
1606	oz/s	Ounces per second
1607	oz/min	Ounces per minute
1608	oz/h	Ounces per hour
1609	oz/d	Ounces per day
1610	Paa	Pascal (absolute)
1611	Pag	Pascal (gauge)
1612	GPaa	Gigapasacal (absolute)
1613	GPag	Gigapascal (gauge)
1614	MPaa	Megapascal (absolute)

Value	Display	Description
1615	MPag	Megapascal (gauge)
1616	kPaa	Kilopascal (absolute)
1617	kPag	Kilopascal (gauge)
1618	mPaa	Millipascal (absolute)
1619	mPag	Millipascal (gauge)
1620	μPaa	Micropascal (absolute)
1621	μPag	Micropascal (gauge)
1622	hPaa	Hectopascal (absolute)
1623	hPag	Hectopascal (gauge)
1624	gf/cm ² a	
1625	gf/cm ² g	
1626	kgf/cm ² a	
1627	kgf/cm ² g	
1628	SD4°C	Standard density at 4°C
1629	SD15°C	Standard density at 15°C
1630	SD20°C	Standard density at 20°C
1631	PS	Metric horsepower
1632	ppt	Parts per trillion = 10 ¹²
1633	hl/s	Hectoliters per second
1634	hl/min	Hectoliters per minute
1635	hl/h	Hectoliters per hour
1636	hl/d	Hectoliters per day
1637	bbl (liq)/s	Barrels (US liquid) per second
1638	bbl (liq)/min	Barrels (US liquid) per minute
1639	bbl (liq)/h	Barrels (US liquid) per hour
1640	bbl (liq)/d	Barrels (US liquid) per day
1641	bbl (fed)	Barrel (U.S. federal) = 31 gallons
1642	bbl (fed)/s	Barrels (US federal) per second
1643	bbl (fed)/min	Barrels (US federal) per minute
1644	bbl (fed)/h	Barrels (US federal) per hour
1645	bbl (fed)/d	Barrels (US federal) per day
1998	Unknown unit	To be used when the unit of measure is not known during configuration
1999	Special	Special units

¹ A notation different to the PA profile must be used in order to represent this unit in conformity with the system.

² "m2" is used instead of "m3" in the Chinese and Japanese documentation.



2.2 Functions of the block icons

2.2.1 Block icon structure

Block icon structure

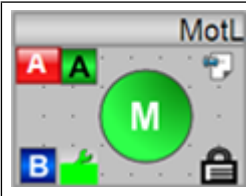
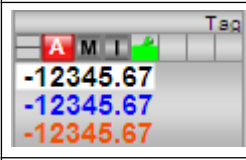
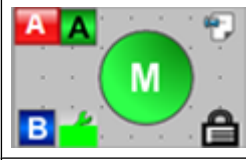

The new block icons are located in the template "@PCS7TypicalsAPL8.pdl" and "@TemplateAPL8.PDL".

There are two types of block icons (V8.0), those with a display of the instance-specific name and those without:

	<p>Block icon of MotL with instance-specific name</p>
	<p>Block icon of PIDConL with instance-specific name</p>
	<p>Block icon of MotL without instance-specific name The toolbar only shows the information that is actually available.</p>
	<p>Block icon of PIDConL without instance-specific name The toolbar only shows the information that is actually available.</p>

The old block icons are located in the template "PCS7TypicalsAPL7.pdl" and "@TemplateAPL7.PDL".

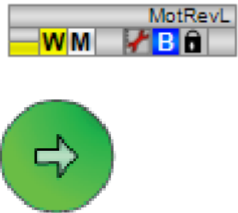
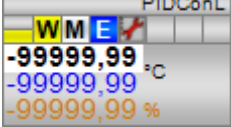
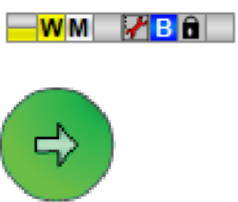
There are two types of block icons (V7.1), those with a display of the instance-specific name and those without:

	<p>Block icon of MotRevL with instance-specific name</p>
	<p>Block icon of PIDConL with instance-specific name</p>
	<p>Block icon of MotRevL without instance-specific name The toolbar only shows the information that is actually available.</p>
	<p>Block icon of PIDConL without instance-specific name The toolbar only shows the information that is actually available.</p>

You can select one of these block icons. See section Configuring the block icons (Page 237) for more information.

A block icon has several display areas:

- CPU stop
- Instance-specific name
- Icon for the block
- Analog value display
- Status bar for the block status

Displaying CPU stop

With a CPU stop, boxes are unavailable and a yellow warning triangle is displayed in the group display for blocks with messaging.

Instance-specific name

The name of the associated block is shown in the instance-specific name, for example for the PIDConL block:



You can change this name in the object properties of the instance block.

There are block icons with or without display of the instance-specific name. Refer to the individual block descriptions to learn about them.

You can reach the visible display for blocks without display of the instance-specific name in two different ways:

- **Displaying individual instance-specific names:** Click on the block icon while holding down the Shift key: The name remains visible as long as the process picture is displayed.
- **Displaying all instance-specific names at once:** All instance-specific names can be made visible in a process picture at once by clicking a button. To do this, copy this button into the process picture of the chart from the @PCS7TypicalsAPLV7.PDL/ @PCS7TypicalsAPLV8.PDL or insert this button in the "Key area" of WinCC. If you insert it into the key area, read the manual section "PCS 7 OS Process Control " > "Layout of the User Interface".
The instance-specific names are hidden once more by clicking the button again.

Icon for the block

Block icons for technologic blocks have their own operable symbols (for example, for the MotRevL block) and represent a status display of the block.



This symbol can be positioned at various locations, 0°, 90°, 180° and 270°. Refer to the Configuring the block icons (Page 237) section for more on this. You can change the operating mode of the block by right-clicking on the status display. Refer to the Operation via the block icon (Page 239) section for more on this.

Note

Block icons for motors and valves are available in various mounting positions and forms of representation. However, a general state icon is always displayed in the faceplates that does not consider the mounting position and form of representation in the block icons.

Analog value display

For block icons with analog value displays (for example, for the PIDConL block), there are basic settings that differ depending of the associated unit of measure:



Refer to the Configuring the block icons (Page 237) section for more on this.

These analog values can be controlled according to the Operator control permissions (Page 254). See also the section Operation via the block icon (Page 239) for more on this.

As of V8.0 block icons, when the actual values are displayed with limit monitoring in the analog value displays, the background and font colors for an alarm, warning or tolerance correspond to the message colors.

Note

As of V8.0 block icons, when the actual values are displayed with limit monitoring in the analog value displays, the background and font colors for an alarm, warning or tolerance, control system fault or control system fault correspond to the message colors.

If the analog value display shows *****, the display field is too small for the parameterized format specification. In this case, adapt the format specification AnalogValueFormatx in the block icon APL_BLOCK_ICON.

For specification of the format, refer to Format specification for the analog value display (Page 246).

Status bar for the block status

The status bar of the block icon provides an overview of the overall status of the block (see figure below).







The arrangement of icons in the following tables is prioritized from high to low.

The following elements can be displayed:

Alarms, warnings, tolerances, and messages

Refer to the Monitoring functions in the Advanced Process Library (Page 85) section for more on this.

Icon	Meaning
	No messages are output.
	A fault has occurred.
	An alarm is triggered.
	An alarm for the high alarm limit is triggered.
	An alarm for the low alarm limit is triggered.
	An warning is triggered.
	A warning for the high warning limit is triggered.
	A warning for the low warning limit is triggered.

Icon	Meaning
	A tolerance violation has occurred.
	A tolerance violation for the high tolerance limit has been triggered.
	A tolerance violation for the low tolerance limit has been triggered.
	The block has an operator prompt.
	There is a process status determination.

Note







The message classes Alarm, Warning and Tolerance are not valid for user-configured message classes. Please take into consideration the validity of terms for user-configured message classes (Page 41).

Note

For user-configured message classes, the symbols for high/low alarm, warning and tolerance limits are displayed only for limit violations which are triggered within the APL blocks with the colors of the user-configured message classes.

Operating modes

Refer to the Overview of the modes (Page 69) section for more on this.



Icon	Meaning
	The block is in automatic mode.
	The block is in the "On" operating mode.
	The block is in manual mode.
	A program is running.
	The block is in local mode.
	The block is in the "Out of service" operating mode. In this operating mode, no other symbols are displayed and no values are shown in the analog value display except for: - Display for an active message in the memo view - Display for the maintenance enable

Note

No symbol is displayed for the "On" operating mode (no green "O" displayed) if the block only has the operating modes "On" and "Out of service".







Internal or external setpoint

Refer to the section Setpoint specification - internal/external (Page 128).

Icon	Meaning
	Setting the setpoint internally
	External setpoint specification
	SP/MV ramp active



Signal status

Refer to the Forming and outputting signal status for blocks (Page 108) section for more on this.

Icon	Meaning
	The block is in simulation.
	Signal status is "Bad, device related".
	Signal status is "Bad, process related".
	Signal status is "Uncertain, device related".
	Signal status is "Uncertain, process related".
	A maintenance request is pending.
	Block is released for maintenance





Tracking and forcing of values and bypasses

See sections Forcing operating modes (Page 41), Interlocks (Page 99) and Manual and automatic mode for control blocks (Page 72).

Icon	Meaning
	At least one value has been forced
	Value is tracked
	There is a bypass of an interlock or a bypass condition of an upstream Intlock FB or tag bypass is active.

Interlocks

Refer to the Interlocks (Page 99) section for more on this.

Icon	Meaning
	Block is not interlocked.
	Block is interlocked.
	Bypass protection.
	Rapid stop is commanded.

Memo display

Icon	Meaning
	A message is available in the memo view.

Customer-specific icons

In the block icons, the icons can be replaced with customer-specific icons. A subdirectory must therefore be created in the OS project directory "GraCS" and the customer-specific icons must be inserted there with the same name as before. The name of the subdirectory must be adapted in the block icon in the "**Directory for pictures**" property ("Configurations" group). The icons in the subdirectory are not changed by the OS project editor or a new version of APL faceplates.

Note

- The "Directory for pictures" property is an instance-specific property. This means that the adaptations of block icons already configured in the process pictures are not changed by an update of the block icons in the process picture.
 - We recommend that you adapt this property in the process picture and not in the "@PCS7TypicalsAPLVx.PDL" or "@TemplateAPLVx.PDL" pictures. The "@" pictures are system pictures and are replaced by the new version of APL faceplates. Customer changes will be lost.
 - In the WinCC Graphics Designer, the PCS 7 "Export Objects" wizard can be used to generate a list of adaptations of instance-specific properties in the block icons. The "Directory for pictures" property can be changed in the exported list and collectively transferred back into the block icons with the PCS 7 "Import Objects" wizard.
 - It is possible to use several subdirectories. This can be useful to create different variants of block icons in the process pictures.
-

See also

Motor protection function (Page 99)

Forming the group status for interlock information (Page 104)

User-configured message classes (Page 41)

2.2.2 Configuring the block icons

Configuring the block icons

There are two ways to configure your block icons:

- Automatically
- Manually

The new block icons are located in the template "@PCS7TypicalsAPL8.pdl" and "@TemplateAPL8.PDL".

The old block icons are located in the template "PCS7TypicalsAPL7.pdl" and "@TemplateAPL7.PDL".

If you still want to continue using the V7.1 block icons in the project, you need to delete the V8.0 template or remove the "@" and deselect the update for the V8 template in the OS project editor on the basic data tab.

The block icons V7.1 are to remain in status V7.1 and be set to care and maintenance. New blocks are not to be integrated any longer.

Automatic configuration of block icons

There is a variety of block icons, which you can select for a block. You select a block icon by entering the number of the block icon in the field "OCM possible" > "Create block icon" in the object properties of the block instance:

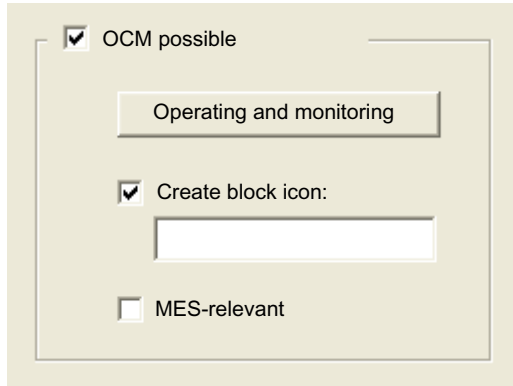

You can find the names (numerical entry) of the respective block icons in the description for the blocks (Operator Control and Monitoring section).

If you do not enter a number for a block icon, the number 1 is always used for the block icon. The template for automatically generated block icons is @PCS7TypicalsAPLV7.PDL/ @PCS7TypicalsAPLV8.PDL.

Additional information

- Manual *Process Control System PCS 7; Engineering System*

Manual configuration of block icons

You can configure block icons manually by copying them from the @TemplateAPLV7.PDL/ @TemplateAPLV8.PDL template and inserting them into plant pictures.

The connection to the process tag is established with the "Connect faceplate with process tag" Wizard, see WinCC Information System, section "Making Process Pictures Dynamic" and "Standard Dynamics".

You can find information on exporting/importing and updating these objects in the WinCC Information System, section "Graphic Object Update Wizard". Use the "TemplateControlAPL.cfg" configuration file for these wizards.

Note

The procedure for changing the tooltip text of the block icons is described in the *APL Style Guide*. Otherwise, this property may not be changed.

2.2.3 Operation via the block icon

Operation via the block icon

The block icon can be used to operate elements directly if a relevant operator control permission (`OS_Perm`) is available. This operator control permission can be configured in the engineering system (ES).

The operation is performed by right-clicking on the element involved. The operable elements in the block icon include:

- Switching the operating mode
- Internal and external setpoint specification
- Changing the process value, setpoint and manipulated variable
- Changing the operating state

The operation is then performed in the same way as in the faceplate. Refer to the section Switching operating states and operating modes (Page 257) as well as Changing values (Page 259).





2.2.4 Block icons for PID and FM controller

Block icons for PID and FM controller

A variety of block icons are available with the following functions:



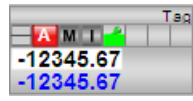
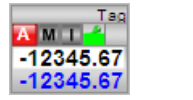

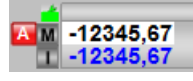
- Process tag type
- Limits (high/low)
- Violation of alarm, warning, and tolerance limits (tolerance limits not with PIDConS) as well as control system faults
- Operating modes
- Internal and external setpoint specification
- Signal status, release for maintenance
- Memo display
- Process value (black, with and without decimal places, with and without color change at limit violations)
- Setpoint (blue, with decimal places)
- Feedback value (red, with decimal points), not available for types 3 and 4
With FmCont and FmTemp as a step controller without feedback, there is no feedback value
- only `PIDStepL`: Position feedback value (green, with decimal points), not available for types 3 and 4
- Interlock without reset (only for PIDConR and PIDConL)

The block icons from template @TemplateAPLV8.PDL:

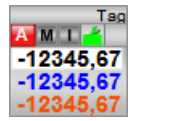
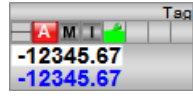
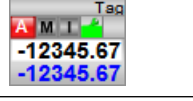
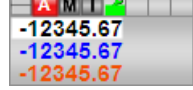
Icons	Selection of the block icon in the CFC	Special features
	1	
	2	
	3	
	4	
	5	Block icon in the full display
	6	Block icon in the full display

The block icons from template @TemplateAPLV7.PDL:

Icons	Selection of the block icon in CFC	Special features
	1	Block icon in the full display
	2	
	3	
	4	
	5	

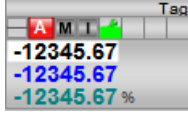
Icons	Selection of the block icon in CFC	Special features
	6	
	7	
	8	
	-	Block icon in "Out of service" mode (example with type 1 block icon)
Special case for PIDStepL:		
	-	In the case of the PIDStepL block only, the green value shows the position feedback (only visible if WithRbk = 1 has been assigned parameters). With operation by means of the block icon, however, the manipulated variable is operated.

Additional information on the block icon and the control options in the block icon is available in the following sections:

- Configuring the block icons (Page 237)
- Block icon structure (Page 230)
- Operation via the block icon (Page 239)







2.2.5 Block icon for interlock blocks

Properties of the block icon for interlock blocks Intlk02, Intlk04, Intlk08, Intlk16

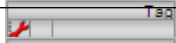











A variety of block icons are available with the following functions:

- Signal status
- Memo display
- Output signal

The block icons from template @TemplateAPLV8.PDL:

Icons	Selection of the block icon in CFC	Block icon for
	1	Intlk02
	1	Intlk04
	1	Intlk08
	1	Intlk16
	2	Intlk02
	2	Intlk04
	2	Intlk08
	2	Intlk16

The block icons from template @TemplateAPLV7.PDL:

Icons	Selection of the block icon in CFC	Block icon for
	1	Intlk02
	1	Intlk04
	1	Intlk08
	1	Intlk16
	2	Intlk02
	2	Intlk04
	2	Intlk08
	2	Intlk16
	3	Intlk02
	3	Intlk04
	3	Intlk08
	3	Intlk16

Block icons (mini) without display of instance-specific names

These icons only show the output signal. They take the form of a small rectangle.

Display of the output signal

The display can show the following states for the output signal (priority from high to low):

- Gray: No inputs interconnected at the interlock block, the block is not used
- Blue: The output signal is 1, at least one input signal is bypassed. There is no gray state.
- Yellow: The signal status is 16#60; the output signal is simulated. There are no gray and blue states.
- Red: The output signal is 0; there is an interlock. There are no gray, blue, and yellow states.
- Green: The output signal is 1; the block is in the good state. There are no gray, blue, yellow, and red states.

Additional information on the block icon is available in the following chapters:

- Configuring the block icons (Page 237)
- Block icon structure (Page 230)
- Operation via the block icon (Page 239)





2.2.6 Block icons for SFC

Block icons for SFC

A variety of SFC block icons are available with the following functions:

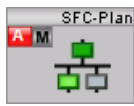

- Alarm indicator
- Current active mode indicator ("Manual" or "Automatic" mode)
- Operator request icon
- Indicator for SFC operating status

The block icons from template @PCS7TypicalsAPLV8.PDL:

















Block icons	Type 2	Type 3
SFC-Type		
SFC-Plan		

The following icons are displayed in the SFC block icon:



1. Mode indicators:

Icon	Bit number	Tag name	Description
	7	.SFC_STATE	The block is in "Automatic" mode.
	7	.SFC_STATE	The block is in "Manual" mode.

2. Status indicators:

Icon	Bit number				Tag name	Description
	0	1	2	3		
	0	0	0	0	.SFC_STATE	IDLE
	0	0	0	1	.SFC_STATE	RUN
	0	0	1	0	.SFC_STATE	COMPLETED
	0	0	1	1	.SFC_STATE	HELD
	0	1	0	0	.SFC_STATE	ABORTED
	0	1	0	1	.SFC_STATE	STARTING
	0	1	1	0	.SFC_STATE	COMPLETING
	0	1	1	1	.SFC_STATE	ERROR_COMPLETING
	1	0	0	0	.SFC_STATE	HOLDING
	1	0	0	1	.SFC_STATE	RESUMING
	1	0	1	0	.SFC_STATE	ERROR
	1	0	1	1	.SFC_STATE	HELD_ERROR
	1	1	0	0	.SFC_STATE	RESU_ERROR
	1	1	0	1	.SFC_STATE	ABORTING
	1	1	1	0	.SFC_STATE	STOPPING
	1	1	1	1	.SFC_STATE	STOPPED

3. Acquired status indicators (for SFC type only):

Icon	Bit number	Tag name	Description
	14	.VSTATUS	EM-SFC is acquired by a superordinated equipment phase (EPH)
	15	.VSTATUS	Acquiring of at least one subordinated equipment module (EM) failed

See also

Block icon structure (Page 230)

Configuring the block icons (Page 237)

Operation via the block icon (Page 239)

2.2.7 Adding block icons to static picture components**Static picture component for the block icons**

The block icons for drives and valves contain no static picture components. However, you can add static picture components to the block icons by copying them from the @TemplateAPLV8.PDL/@TemplateAPLV7.PDL template and placing them over the block icons.

The following static picture components are available:

- Static picture components for motor blocks:



ISO 7000-0134
DIN 30600-0695



ISO 7000-0135
DIN 30600-0708



ISO 7000-0137
DIN 30600-0715

- Static picture components for valve blocks:

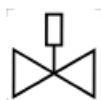

DIN 30600-2232



DIN 30600-2230



ISO 7000-1630
DIN 30600-2231



DIN 30600-2283



DIN 30600-2228



DIN 30600-2233

Note

The static picture components for the valves are visible here above the valve icon.

Note that all the block icons of the APL are located on layer 0 of the process picture. Layer 1 is intended for the static picture component. This ensures that the static picture component is always over the block icon. If you have changed this layer of the block icon, the static picture component should always be placed in a higher layer.

2.2.8 Format specification for the analog value display

The format specification for the analog value display can parameterize centrally in the block icon at the attribute Configurations > AnalogValueFormat1...AnalogValueFormat5. If the attribute is empty, the format specification will be taken directly from the faceplate PDL file.

The parameterization in the block icon takes effect in the standard view, limit view, and the block icon. The following table shows the analog values for which format specification can be parametrized in the block icon:

Blocks	AnalogValue-Format1	AnalogValue-Format2	AnalogValue-Format3	AnalogValue-Format4	AnalogValue-Format5
	Standard view, Limit view	Standard view, Limit view	Standard view, Limit view	Standard view	Limit view for motors
MotL			UserAna1	UserAna2	AV values
MotRevL			UserAna1	UserAna2	AV values
MotSpdL			UserAna1	UserAna2	AV values
MotSpdCL	Rbk values ER values	SP values	UserAna1	UserAna2	AV values
VivL			UserAna1	UserAna2	-
VivMotL			UserAna1	UserAna2	AV values
VivPosL	Rbk values MV value		UserAna1	UserAna2	AV values
VivAnL	Rbk values MV value		UserAna1	UserAna2	-
Viv2WayL			UserAna1	UserAna2	-
DoseL	PV values	SP values	UserAna1	UserAna2	-
MonAnL	PV values		UserAna1	UserAna2	-
MonAnS	PV values				-
OpAnL	PV values	SP values			-
OpAnS	PV values	SP values			-
PIDConL	PV values	SP values	MV values Rbk values		-
PIDConS	PV values	SP values	MV values Rbk values		-
PIDConR	PV values	SP values	MV values Rbk values		-
PIDStepL	PV values	SP values	MV values Rbk values		-

Blocks	AnalogValueFormat1...AnalogValueFormat4	AnalogValueFormat5...AnalogValueFormat8	AnalogValueFormat9
ModPreCon	CV1...CV4, SP1...SP4 values	MV5...MV8 values	DV values

Blocks	AnalogValueFormat1...AnalogValueFormat10	AnalogValueFormat11...AnalogValueFormat20	AnalogValueFormat21...AnalogValueFormat24
MPC10x10	CV1...CV10, SP1...SP10 values	MV1...MV10 values	DV1...DV5 values

Note

If the analog value display shows *****, the display field is too small for the parameterized format specification. In this case, adapt the format specification AnalogValueFormatx in the block icon APL_BLOCK_ICON.

2.3 Functions of the faceplates

2.3.1 Structure of the faceplate

General functions of the faceplates

This section provides general information that applies to all faceplates.

Recommended screen resolution

The faceplates are shown in full on the screen with a resolution of 1280 x 1024. The full-screen mode (press the F11 key) must also be activated on the Web client.

Scaling the faceplates

You can scale the faceplates from 50% to 200%. The value to scale is given in the internal variable "@APLFaceplateScaleFactor" which is of type unsigned 32-bit value. The default value of the scale is 100. You can scale the faceplates from 101% to 200% by providing a value in the range of 101 to 200 in the internal variable. Similarly, you can scale down the faceplates from 50% to 99% by providing a value in the range of 50 to 99. The reference for calculation is default size of the faceplates which is 100%. This means if the value given is 150, the faceplates will be scaled to 150% of the default size. Similarly, if the value given is 90, the faceplate will be scaled down to 90% of the default size.

Note

You must reopen the faceplate after changing the scale value. Already opened faceplate will not be scaled if the scale value is changed.

Displaying CPU stop

With a CPU stop, boxes are unavailable or hidden and a yellow warning triangle is displayed in the group display for blocks with messaging. No operations are possible.

Opening the faceplate

Click on the block icon in WinCC to open the faceplate with the standard view; in this example this is the standard view of PIDConL:

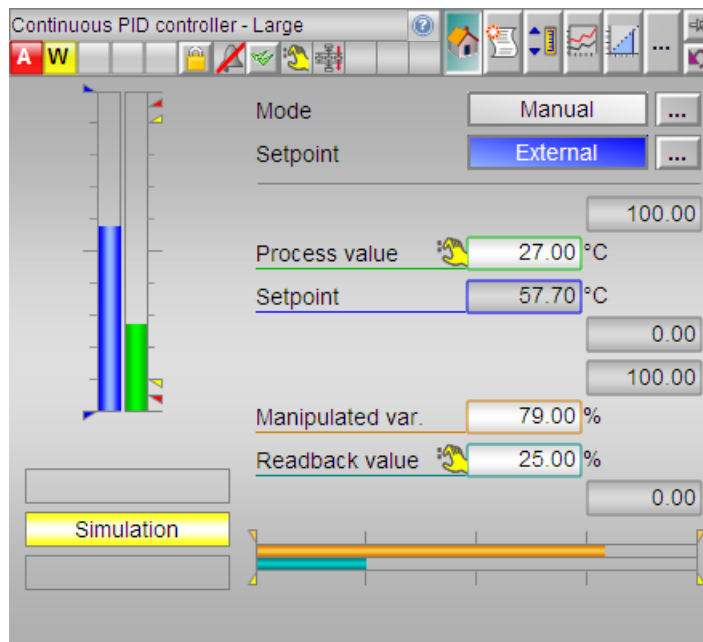

Note

Some of the illustrations of the faceplate views and block icons in the help for the PCS 7 Advanced Process Library are examples or offline representations. The representations on runtime may vary.

The views differ depending on the block functions. All blocks that have faceplates provide a status bar where you can see the most important information relating to the block status. There are additional functions available that are described in the next sections.

Note

Display elements of block inputs with 16#FF as their status default, are only shown when their block inputs are interconnected (status ≠ FF). Exception: The values for Gain, TI and TD are always displayed for controller blocks.

Displays and operator controls

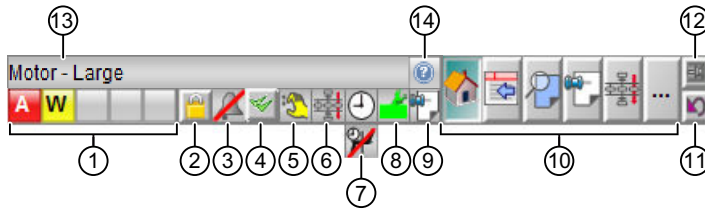

The faceplate provides the following display and operator controls:

- (1) Group display
- (2) Lock alarms
- (3) Suppress messages / alarm delays with the icon 
- (4) Acknowledge alarms
- (5) Worst signal status
- (6) Batch display
- (7) At least one delay time effective at the block
- (8) Maintenance request and release
- (9) Memo display
- (10) Open views of the block
- (11) Back to block icon
- (12) Pin faceplate
- (13) Instance name of the block
- (14) Help button

(1) Group display

The group display shows the information that is transferred from ALARM_8P of the block instance to WinCC.

- Alarms
- Warnings
- Tolerances
- Faults
- Operator prompts
- Process messages

Note

The message classes Alarm, Warning and Tolerance are not valid for user-configured message classes. For user-configured message classes, message types depend on the project-specific setting. Please take into consideration the validity of terms for user-configured message classes (Page 41).

(2) Lock/unlock alarms

You can use this button to lock or unlock block alarms.

The alarms are displayed again in the group view when you unlock the block's alarms. The block instance then resumes sending new alarms. Alarms generated in the locked phase are displayed when you enable the alarm function.

The operator authorization level for this button is set in the internal variable `@LockMessageAuthLevel`. This variable is set by the OS project editor.

For reasons of optimization, the operator authorization level set in `@LockMessageAuthLevel` also has to exist at an `OperationLevelx` of the block icon of the process tag (for example higher process control). Otherwise, operator control of the button "Disable messages" is not possible.

You can hide this button from specific users / user groups using the permissions in PCS 7-OS. Refer to the PCS 7-OS help system.

Note

Since as of V8.1 the disabling of block alarms must be confirmed via the PCS 7 system dialog, the operator can also enter a reason for the disabling in this dialog.

The inputs are always confirmed with "OK", even in 2 step operation.

(3) Suppress messages

Message suppression indicates whether or not the "Suppress process messages" function in the AS block is activated with the `MsgLock` parameter. If message suppression is activated, all messages in this block instance – except for process control messages – are suppressed.

(4) Acknowledge alarms

You can acknowledge all alarms from the block instance using this button.

You can hide this button from specific users / user groups using the permissions in PCS 7-OS. Refer to the *Process Control System PCS 7; OS Process Control* documentation for more on this.



(5) Display for worst signal status

This display shows the worst signal status currently present. You will find more detailed information in section Forming and outputting signal status for blocks (Page 108).

(6) Batch display

The batch display shows whether or not the block instance is in use by SIMATIC BATCH. You will find more detailed information in section SIMATIC BATCH functionality (Page 67).

(7) At least one delay time effective at the block

	This display shows you the active delay time. You will find more detailed information in section Display of delay times (Page 256).
	The "dead band" function is temporarily deactivated.

(8) Maintenance request and release

This display shows you if a maintenance request or release has been made for this block. You will find more detailed information in section Release for maintenance (Page 64).









(9) Memo display







This display shows you if a message has been left in the memo view for you. You will find more detailed information in section Memo view (Page 304).

(10) Open views of a block

You can use this field to open the various views of a block. Refer to the block description to learn of the available views. Left clicking shows the view in the same window. Right clicking opens a new window.

You can select from the following typical views here:

Icon	Identifier
	Standard view
	Message view
	Limit view (several limit views within a block are possible)
	Trend view
	Ramp view
	Parameter view (several parameter views within a block are possible)
	Preview
	Memo view

Icon	Identifier
	Batch view
	Setpoint view
	Parameter view 1 (continues to parameter view 4, see line below)
	Parameter view 4
	Quantity view
	Flow view
	Views (additional views within a block are possible)

Note

The buttons are unavailable when views cannot be selected.

(11) Back to block icon

Use this button to return to the block icon in the process image of the corresponding faceplate. You can use this function, for example, when you have pinned a block **(12)** and the process picture has changed in the meantime.

(12) Pin faceplate

You can pin the faceplate on top of the user interface using this button. This allows you to change to another picture or area without closing the faceplate.

Note

You can learn about additional operator controls in the descriptions of the individual blocks.

(13) Instance name of the block

This area displays the instance specific name of the block.

(14) Help button

Click this button to open the *APL Operator Guide* online help of the corresponding view of the faceplate.

2.3.2 Operator control permissions

Operator control permissions for blocks

The following conditions have an effect on operator control permissions:

- User management in the PCS 7 OS
- Local operating permission using the OpStations block
- Dependencies on operating modes in blocks
- Permissions via parameter assignment / interconnection of blocks
- Permissions via the OS_Perm input parameter at the block itself

User management in the PCS 7 OS

The following operator authorization levels from user management are used in the APL:

- Process control (for example, manual/automatic mode switchover, changing setpoints and manipulated variables).
With this operator control permission, operations can be performed in the standard view of all blocks and input can be made in the ramp and memo views. The "Out of service" operating mode cannot be used with process controlling.
- Higher process controls (for example, changing limits, controller parameters and monitoring times).
With this operator control permission, all operations in all views of all blocks are possible, including the operations for "Out of service" operating mode. Exception: The operations listed under "Highest process controlling".
- Highest process controls (simulate process values and release process tag for maintenance).
With this operator control permission, simulation can be switched on and off in the parameter view and the process tag for maintenance work can be released.
- Extended operation 1
Free project-specific operator authorization
- Extended operation 2
Free project-specific operator authorization

Note

Exceptions to the uses described above are listed in the descriptions of the individual views.

Each operation is assigned with an operator authorization level in the faceplates. This fixed assignment can be changed for each instance at the "operator authorization level" property of an I/O in the AS block (for example, SP_Int with PIDConL). The following assignment applies:

Operator authorization level in the user management	Value "Operator authorization level" property
Process controls	1
Higher process controls	2

Operator authorization level in the user management	Value "Operator authorization level" property
Highest process controls	3
Extended operation 1	4
Extended operation 2	5

Note

- The free three assignments in the upper table can be changed in the block icon at the properties "OperationLevel1_backup", "OperationLevel2_backup" and "OperationLevel3_backup". Any operator authorization level from the user management can be assigned the values 1 to 3. This type of instance-specific configuration is still available only for reasons of downward compatibility and should no longer be used in new projects.
- The controls for the message system (e.g. acknowledge messages) and trend display (e.g. export) are fixed across the system and cannot be changed via the AS block. The "Lock messages" control can be changed system-wide via the internal variable "@LockMessageAuthLevel" with the value of the operator authorization level from the user management (for example, value "6" for "Higher process controls").

Local operating permission using the OpStations block

Local operating permission is an upstream operator control permission which is determined before the operator control permissions for user management and the release of the block, and is realized via the OpStations (Page 411) block.

If local operating permission is missing, operation of a block instance on an OS is usually blocked. Otherwise, when local operating permission is allowed, the operator control permission is normally determined through user management and the block.

Local operating permission can be set for each specific instance; in other words, block instances can be enabled or disabled for use on an operator station independently of one another.

You can find additional information for the use of local operating permission in the section Description of OpStations (Page 411).

Dependencies on operating modes in blocks

You can execute various functions depending on the block mode. These permissions are stored in the block algorithm and are determined dynamically in online mode.

Permissions via parameter assignment / interconnection of blocks

The block is either controlled by the operator or by the controller, depending on parameter settings or on the interconnection. An example for this is the switchover from manual to automatic mode by a higher-level controller or by the operator. These permissions are stored in the block algorithm and are determined dynamically in online mode.

Permissions via the OS_Perm input parameter at the block itself

Controllable blocks have the OS_Perm input parameter which allows you to implement individual operator control strategies by setting the operator control permissions. A pressure relief valve, for example, can only be opened by the master control system. The operator may only close the valve. These authorizations are defined during configuration. These operator control permissions are displayed in the preview view of the faceplate. For information about setting the individual operator control permissions (OS_Perm) refer to the description of the functions of the individual blocks.

The relevant operator controls are enabled if the operator has suitable permissions. The block algorithm processes the input data.

Note

If you interconnect a parameter that is also listed in OS_Perm as a parameter, you have to reset the corresponding OS_Perm bit.

See also

Enabling local operator authorization (Page 158)

2.3.3 Display of delay times

Display of delay times

As soon as the immediate command output is delayed due to an active delay time at the "Large" blocks of the "Drives" family, this fact is signaled by a bit in the status word and a display in the faceplate.

These times include:

- Pre-warning time
- On/Off delays
- Restart inhibit

2.3.4 Switching operating states and operating modes

Requirements

You can change the operating state, operating mode and other parameters if needed in faceplates if you have the corresponding operator control permission (OS_Perm). This operator control permission can be configured in the engineering system (ES).

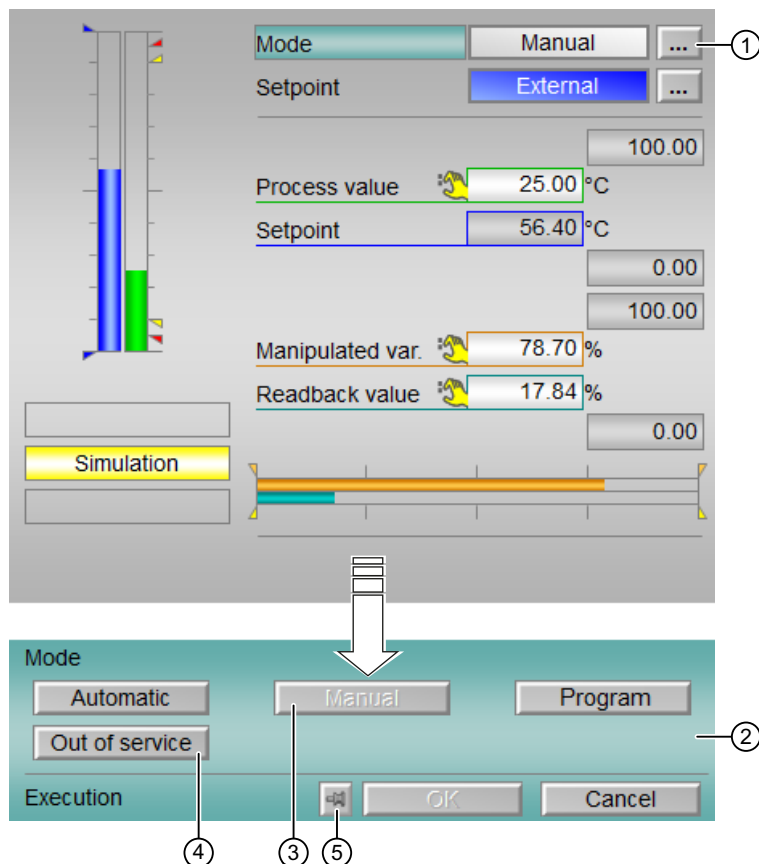

(1) The mouse cursor changes when you place it over the following button:



The mouse pointer now looks as follows:



When you click on the button with the mouse pointer, the bottom of the faceplate expands. You now see the field for changing the operating mode, for example.

(2) Field for changing the operating mode, operating state etc. This example describes changing the operating mode.

If the indicators for the operating state is currently located in this field and you have configured text for specific instances, this text is also shown. You can find more information about this in the section Labeling of buttons and text (Page 209).

(3) The text on this button is gray. You cannot select this operating mode due to the following reasons:

- This operator control permission for this operating mode cannot be configured in the engineering system (ES).

or

- The operating mode is already selected at this time.

or

- Due to the technology, you cannot switch from the operating mode currently set and the desired operating mode.

(4) The text on this button is black. You can switch to this operating mode.

How to change the operating mode (using the PIDConL block in standard view as an example)

1. Click one of the selectable buttons in the operating mode field.
2. Confirm your selection by clicking "OK".
3. If you do not want to apply your selection, click "Cancel".

After clicking the "OK" or "Cancel" button, the faceplate is reduced again to its original form.

(5) Multiple operation

If the operating window is not to close after the confirmation of a command, it can be "attached". The following button is located below the operating window for this purpose:



Operating window is closed after the value is applied



Operating window remains open after the value is applied

2.3.5 Changing values

Requirements

You can change the values in faceplates and in the block icons if you have the corresponding operator authorization (OS_Perm). This operator permission can be configured in the engineering system (ES). The following example shows how values are changed via the faceplate.

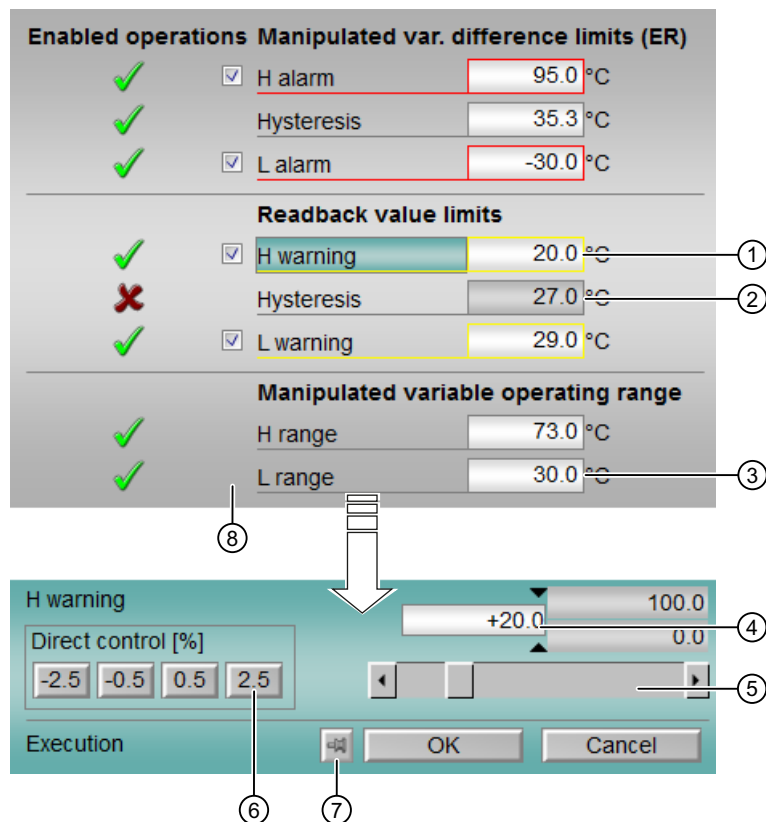

(1) The background color of the input box is white. You can change the value. The mouse pointer changes when you place it over the input box:



(2) The background color of the input box is gray. You cannot change the value.

(3) If you click on the input box, the bottom of the faceplate expands. You now see the field for changing values.

How to change values in faceplates

You have three options for changing values:

- "Direct control": Click on a button such as "2.5" in the box (6). The value is immediately changed and applied. It is no longer necessary to confirm this value.
- Changing values using the slide control (5): move the slide control until the desired value is shown in the box. Then confirm the value using the Enter key or by clicking "OK". Read the section "Setting the multiple step operation".
- Change the values in the input box (4): Click the input box and enter the new value. If the new values are outside the limits, they are rejected and the old values are retained. Then confirm the value using the Enter key and clicking "OK". Read the section "Setting the multiple step operation".

Setting the multiple step operation

You can use the internal @APLCommandExecutionSteps tag in the Tag Management of the WinCC Explorer to specify if values are to be changed in two or three steps.

Follow the steps outlined below:

1. Double-click on the internal @APLCommandExecutionSteps tag
2. Change the start value to 2 or 3 in the Limits/Reporting tab.
Start value = 2: It is no longer necessary to confirm the value in the faceplate by clicking "OK"; values are applied immediately.
Start value = 3: Each value change in the faceplate (with the exception of those for direct control) needs to be confirmed with "OK".

Changing the values for "Direct control"

Specify the percentage values for the two inner keys for direct control with the DirectOperationValue property at the block icon. The outer two keys are automatically determined with DirectOperationValue times the factor 5.

If DirectOperationValue is not an integer but the values in the faceplate are integers, then DirectOperationValue is rounded up to the next integer.

If the rounded value is 0, 1 is used for DirectOperationValue.

The default value for DirectOperationValue is 0.5. With integer format, the "+/-1%" results for the inner keys and "+/-5%" for the outer keys.

(7) Multiple operation

If the operating window is not to close after the confirmation of a command, it can be "attached". The following button is located below the operating window for this purpose:



Operating window is closed after the value is applied



Operating window remains open after the value is applied

(8) Suppress messages

You can enable / disable messages by setting the check mark.

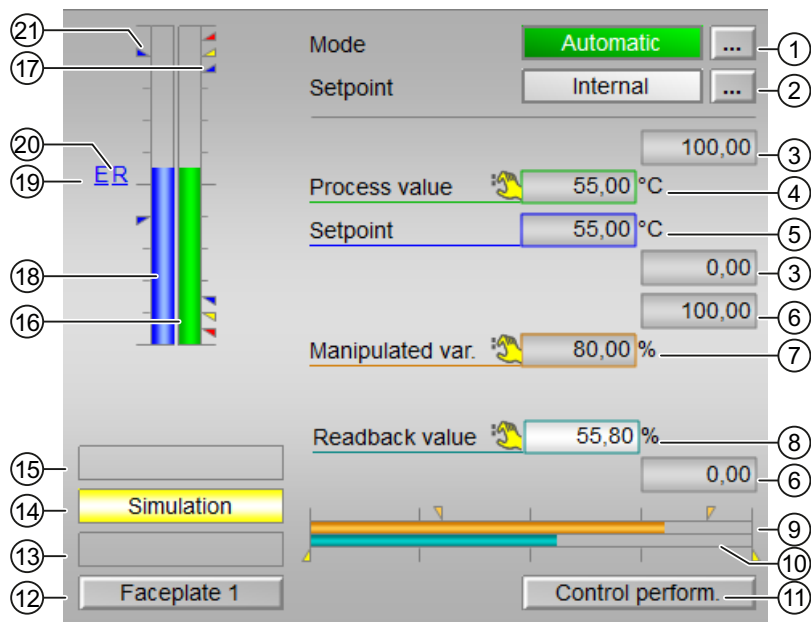
2.3.6 FM controllers standard view (analog)**Standard view (analog) of FM controllers****(1) Display and switch the operating mode**

This area provides information on the currently valid operating mode. The following operating modes can be shown here:

- Manual mode (Page 72)
- Automatic mode (Page 72)
- Program mode for controllers (Page 78)
- Out of service (Page 71)

Refer to chapter Switching operating states and operating modes (Page 257) for information on switching the operating mode.

(2) Display and switch the setpoint specification

This area shows how to specify the setpoint. The setpoint can be specified as follows:

- By the application ("External", CFC/SFC)
- By the user directly in the faceplate ("Internal").

Refer to the Switching operating states and operating modes (Page 257) chapter for information on switching the setpoint specification.

For more information on the setpoint specification, refer to the Setpoint specification - internal/external (Page 128) chapter.

If text is configure for these commands, it is displayed as additional text and as button labels for command selection. You can find more information about this in chapter Labeling of buttons and text (Page 209)

(3) High and low scale range for the process value

These values provide information on the display range ($PV_OpScale$) for the bar graph of the process value. The scale range is defined in the Engineering System.

(4) Display of the process value including signal status

This area provides information on the current process value (PV) with the corresponding signal status.

(5) Display and change the setpoint including signal status

This area provides information on the current setpoint (SP) with the corresponding signal status.

Refer to the Changing values (Page 259) chapter for information on changing the setpoint. The setpoint specification (2) also needs to be set to "Internal" for this block.

(6) High and low scale range for the setpoint

This area is already set and cannot be changed.

(7) Display and change the manipulated variable including signal status

This area shows the current "Manipulated variable" (MV) with the corresponding signal status.

Refer to chapter Changing values (Page 259) for information on changing the manipulated variable. You can only make a change in manual mode.

(8) Display of the position feedback including signal status

This display is only visible when the corresponding block input is connected.

This area provides information on the current readback value of the manipulated variable with the corresponding signal status. This display is only available when the readback value in the box is interconnected to the Rbk input parameter.

(9) Bar graph for the "Manipulated variable"

This area shows the current "Manipulated variable" in the form of a bar graph ($MV_OpScale$). The visible area in the bar graph depends on the configuration in the Engineering System (ES).

(10) Bar graph for position feedback

This display is only visible when the corresponding block input is connected.

This area shows the current position feedback in the form of a bar graph. The visible area in the bar graph depends on the configuration in the Engineering System (ES).

(11) Navigation button for switching to the standard view of the ConPerMon block

Use this navigation button to reach the standard view of the ConPerMon block. The visibility of this navigation button depends on the configuration in the Engineering System (ES).

Refer also to chapter Opening additional faceplates (Page 208) for more on this.

(12) Navigation button for switching to the standard view of any faceplate

Use this navigation button to reach the standard view of a block configured in the Engineering System. The visibility of this navigation button depends on the configuration in the Engineering System (ES).

Refer also to chapter Opening additional faceplates (Page 208) for more on this.

(13) Display area for block states

This area provides additional information on the operating state of the block:

- "Maintenance"

Additional information on this is available in chapter Release for maintenance (Page 64) Display area for block states.

(14) Display area for block states

This area provides additional information on the operating state of the block:

- "Simulation"

You can find additional information on this in chapter Simulating signals (Page 58).

(15) Display area for block states

This area provides additional information on the operating state of the block (from high to low according to priority):

- "Fuzzy Optim." (FmCont only)
- "Tracking FB"
- "Tracking FM"
- "Safety mode FM"
- "Fuzzy control" (FmCont only)

(16) Limit display

These colored triangles indicate the configured limits in the respective bar graph:

- Red: Alarm
- Yellow: Warning
- Blue: Tolerance

Note

The symbols displayed are not valid for user-configured message classes. Please take into consideration the validity of terms for User-configured message classes (Page 41).

(17) Bar graph for the "Process value"

This area shows the current "Process value" in the form of a bar graph. The visible area in the bar graph depends on the configuration in the Engineering System (ES).

(18) Bar graph for the "Setpoint"

This area shows the current "Setpoint" in the form of a bar graph. The visible area in the bar graph depends on the configuration in the Engineering System (ES).

(19) Display of external setpoint

This display [E] is only visible when you have selected "Internal" setpoint specification. It shows the external setpoint that would apply if you were to change the setpoint specification to "external".

(20) Display for the target setpoint of the setpoint ramp

This display [R] shows the target setpoint and is only visible if you have enabled ramp generation in the Ramp view (Page 300).

(21) Limit display for the setpoint

These triangles show the `SP_HiLim` and `SP_LoLim` setpoint limits configured in the ES.

2.3.7 FM controllers standard view (pulse controller)

Standard view (pulse) of FM controllers

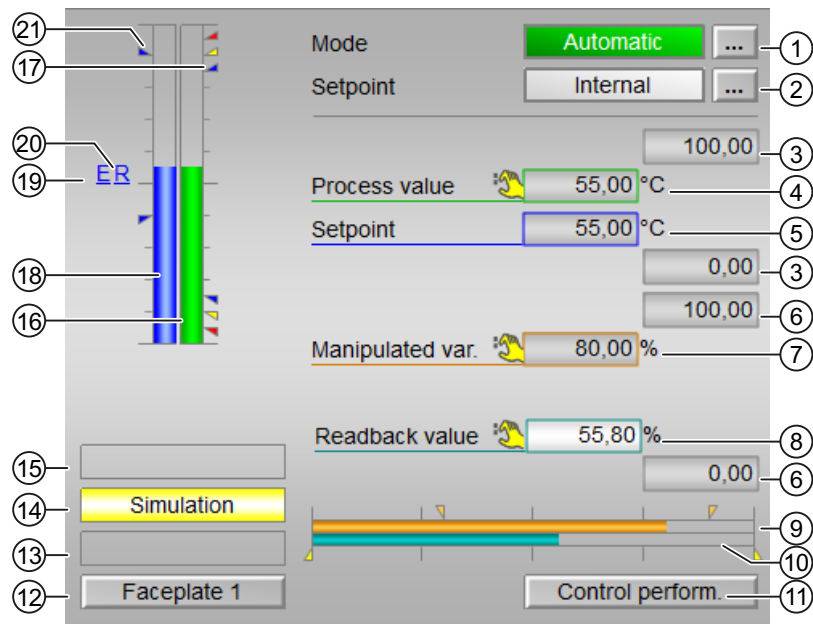

(1) Display and switch the operating mode

This area provides information on the currently valid operating mode. The following operating modes can be shown here:

- Manual mode (Page 72)
- Automatic mode (Page 72)
- Program mode for controllers (Page 78)
- Out of service (Page 71)

Refer to chapter Switching operating states and operating modes (Page 257) for information on switching the operating mode.

(2) Display and switch the setpoint specification

This area shows how to specify the setpoint. The setpoint can be specified as follows:

- By the application ("External", CFC/SFC)
- By the user directly in the faceplate ("Internal").

Refer to the Switching operating states and operating modes (Page 257) chapter for information on switching the setpoint specification.

For more information on the setpoint specification, refer to the Setpoint specification - internal/external (Page 128) chapter.

(3) High and low scale range for the process value

These values provide information on the display range (*PV_OpScale*) for the bar graph of the process value. The scale range is defined in the Engineering System.

(4) Display of the process value including signal status

This area provides information on the current process value (*PV*) with the corresponding signal status.

(5) Display and change the setpoint including signal status

This area provides information on the current setpoint (*SP*) with the corresponding signal status. Refer to the Changing values (Page 259) chapter for information on changing the setpoint. The setpoint specification **(2)** also needs to be set to "Internal" for this block.

(6) High and low scale range for the setpoint

This area is already set and cannot be changed.

(7) Display and change the manipulated variable including signal status

This area shows the current "Manipulated variable" (*MV*) with the corresponding signal status. Refer to chapter Changing values (Page 259) for information on changing the manipulated variable. You can only make a change in manual mode.

(8) Display of the position feedback including signal status

This display is only visible when the corresponding block input is interconnected. This area shows the current feedback of the manipulated variable with the corresponding signal status. This display is only available when the readback value in the box is interconnected to the *Rbk* input parameter.

(9) Bar graph for the "Manipulated variable"

This area shows the current "Manipulated variable" in the form of a bar graph (*MV_OpScale*). The visible area in the bar graph depends on the configuration in the Engineering System (ES).

(10) Bar graph for position feedback

This display is only visible when the corresponding block input is interconnected. This area shows the current position feedback in the form of a bar graph. The visible area in the bar graph depends on the configuration in the Engineering System (ES).

(11) Button for switching to the standard view of the ConPerMon block

Use this button for the standard view of the ConPerMon block. The visibility of this button depends on the configuration in the Engineering System (ES).

Refer also to chapter Opening additional faceplates (Page 208) for more on this.

(12) Button for switching to the standard view of any faceplate

Use this button for the standard view of a block configured in the engineering system. The visibility of this button depends on the configuration in the Engineering System (ES).

Refer also to chapter Opening additional faceplates (Page 208) for more on this.

(13) Display area for block states

This area provides additional information on the operating state of the block:

- "Maintenance"

Additional information on this is available in chapter Release for maintenance (Page 64) Display area for block states.

(14) Display area for block states

This area provides additional information on the operating state of the block:

- "Simulation"

You can find additional information on this in section Simulating signals (Page 58).

(15) Display area for block states

This area provides additional information on the operating state of the block (from high to low according to priority):

- "Fuzzy Optim." (FmCont only)
- "Tracking FB"
- "Tracking FM"
- "Safety mode FM"
- "Fuzzy control" (FmCont only)

(16) Bar graph for the "Process value"

This area shows the current "Process value" in the form of a bar graph. The visible area in the bar graph depends on the configuration in the Engineering System (ES).

(17) Limit display

These colored triangles indicate the configured limits in the respective bar graph:

- Red: Alarm
- Yellow: Warning
- Blue: Tolerance

Note

The symbols displayed are not valid for user-configured message classes. Please take into consideration the validity of terms for User-configured message classes (Page 41).

(18) Bar graph for the "Setpoint"

This area shows the current "Setpoint" in the form of a bar graph. The visible area in the bar graph depends on the configuration in the Engineering System (ES).

(19) Display of external setpoint

This display [E] is only visible when you have selected "Internal" setpoint specification. It shows the external setpoint that would apply if you were to change the setpoint specification to "external".

(20) Display for the target setpoint of the setpoint ramp

This display [R] shows the target setpoint and is only visible if you have enabled ramp generation in the Ramp view (Page 300).

(21) Limit display for the setpoint

These triangles show the `SP_HiLim` and `SP_LoLim` setpoint limits configured in the ES.

See also

Labeling of buttons and text (Page 209)

2.3.8 FM controllers standard view (step controller with position feedback)

Standard view with position feedback of FM controllers

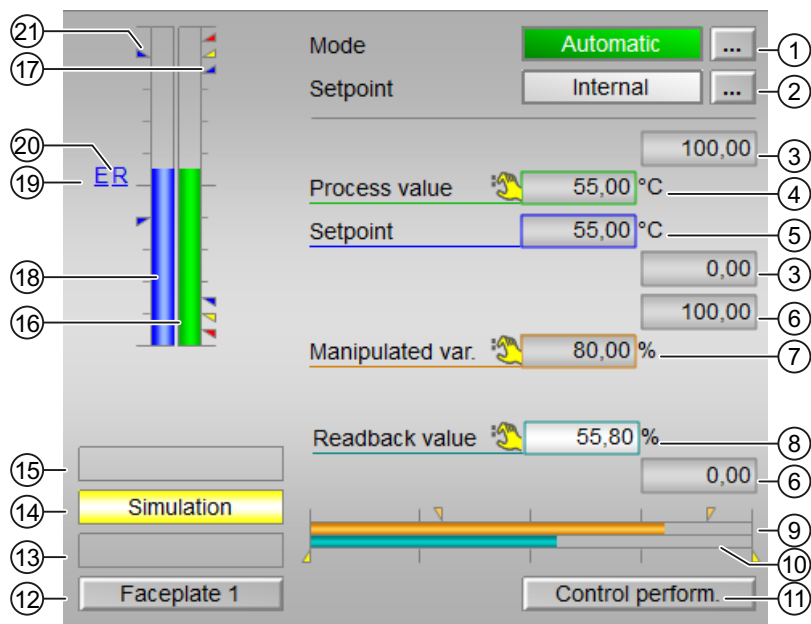

(1) Display and switch the operating mode

This area provides information on the currently valid operating mode. The following operating modes can be shown here:

- Manual mode (Page 72)
- Automatic mode (Page 72)
- Program mode for controllers (Page 78)
- Out of service (Page 71)

Refer to chapter Switching operating states and operating modes (Page 257) for information on switching the operating mode.

(2) Display and switch the setpoint specification

This area shows how to specify the setpoint. The setpoint can be specified as follows:

- By the application ("External", CFC/SFC)
- By the user directly in the faceplate ("Internal").

Refer to the Switching operating states and operating modes (Page 257) chapter for information on switching the setpoint specification.

For more information on the setpoint specification, refer to the Setpoint specification - internal/external (Page 128) chapter.

(3) High and low scale range for the process value

These values provide information on the display range (*PV_OpScale*) for the bar graph of the process value. The scale range is defined in the Engineering System.

(4) Display of the process value including signal status

This area provides information on the current process value (*PV*) with the corresponding signal status.

(5) Display and change the setpoint including signal status

This area provides information on the current setpoint (*SP*) with the corresponding signal status. Refer to the Changing values (Page 259) chapter for information on changing the setpoint. The setpoint specification (2) also needs to be set to "Internal" for this block.

(6) High and low scale range for the setpoint

This area is already set and cannot be changed.

(7) Display and change the manipulated variable including signal status

This area shows the current "Manipulated variable" (*MV*) with the corresponding signal status. Refer to chapter Changing values (Page 259) for information on changing the manipulated variable. You can only make a change in manual mode.

(8) Display of the position feedback including signal status

This display is only visible when the corresponding block input is interconnected. This area shows the current feedback of the manipulated variable with the corresponding signal status. This display is only available when the readback value in the box is interconnected to the *Rbk* input parameter.

(9) Bar graph for the "Manipulated variable"

This area shows the current "Manipulated variable" in the form of a bar graph (*MV_OpScale*). The visible area in the bar graph depends on the configuration in the Engineering System (ES).

(10) Bar graph for position feedback

This display is only visible when the corresponding block input is interconnected. This area shows the current position feedback in the form of a bar graph. The visible area in the bar graph depends on the configuration in the Engineering System (ES).

(11) Button for switching to the standard view of the ConPerMon block

Use this button for the standard view of the ConPerMon block. The visibility of this button depends on the configuration in the Engineering System (ES).

Refer also to chapter Opening additional faceplates (Page 208) for more on this.

(12) Button for switching to the standard view of any faceplate

Use this button for the standard view of a block configured in the Engineering System. The visibility of this button depends on the configuration in the Engineering System (ES).

Refer also to chapter Opening additional faceplates (Page 208) for more on this.

(13) Display area for block states

This area provides additional information on the operating state of the block:

- "Maintenance"

Additional information on this is available in chapter Release for maintenance (Page 64) Display area for block states.

(14) Display area for block states

This area provides additional information on the operating state of the block:

- "Simulation"

You can find additional information on this in section Simulating signals (Page 58).

(15) Display area for block states

This area provides additional information on the operating state of the block (from high to low according to priority):

- "Fuzzy Optim." (FmCont only)
- "Tracking FB"
- "Tracking FM"
- "Safety mode FM"
- "Fuzzy control" (FmCont only)

(16) Bar graph for the "Process value"

This area shows the current "Process value" in the form of a bar graph. The visible area in the bar graph depends on the configuration in the Engineering System (ES).

(17) Limit display

These colored triangles indicate the configured limits in the respective bar graph:

- Red: Alarm
- Yellow: Warning
- Blue: Tolerance

Note

The symbols displayed are not valid for user-configured message classes. Please take into consideration the validity of terms for User-configured message classes (Page 41).

(18) Bar graph for the "Setpoint"

This area shows the current "Setpoint" in the form of a bar graph. The visible area in the bar graph depends on the configuration in the Engineering System (ES).

(19) Display of external setpoint

This display [E] is only visible when you have selected "Internal" setpoint specification. It shows the external setpoint that would apply if you were to change the setpoint specification to "external".

(20) Display for the target setpoint of the setpoint ramp

This display [R] shows the target setpoint and is only visible if you have enabled ramp generation in the Ramp view (Page 300).

(21) Limit display for the setpoint

These triangles show the `SP_HiLim` and `SP_LoLim` setpoint limits configured in the ES.

See also

Labeling of buttons and text (Page 209)

2.3.9 FM controllers standard view (step controller without position feedback)

Standard view without position feedback of FM controllers

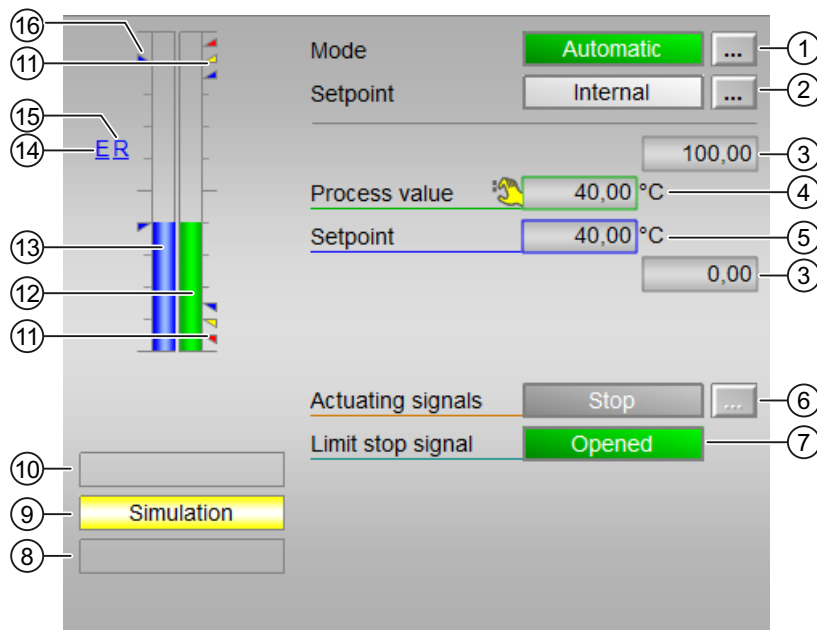

(1) Display and switch the operating mode

This area provides information on the currently valid operating mode. The following operating modes can be shown here:

- Manual mode (Page 72)
- Automatic mode (Page 72)
- Program mode for controllers (Page 78)
- Out of service (Page 71)

Refer to chapter Switching operating states and operating modes (Page 257) for information on switching the operating mode.

(2) Display and switch the setpoint specification

This area shows how to specify the setpoint. The setpoint can be specified as follows:

- By the application ("External", CFC/SFC)
- By the user directly in the faceplate ("Internal").

Refer to the Switching operating states and operating modes (Page 257) chapter for information on switching the setpoint specification.

For more information on the setpoint specification, refer to the Setpoint specification - internal/external (Page 128) chapter.

(3) High and low scale range for the process value

These values provide information on the display range (`PV_OpScale`) for the bar graph of the process value. The scale range is defined in the Engineering System.

(4) Display of the process value including signal status

This area provides information on the current process value (`PV`) with the corresponding signal status.

(5) Display and change the setpoint including signal status

This area provides information on the current setpoint (`SP`) with the corresponding signal status.

Refer to the Changing values (Page 259) chapter for information on changing the setpoint. The setpoint specification (2) also needs to be set to "Internal" for this block.

(6) Operating and displaying the actuating signal

This area shows the current feedback of the actuating signal.

- "Open"
- "Stop"
- "Close"

The button is shown next to the display in manual mode. You can influence the actuating signal here. Refer to the Switching operating states and operating modes (Page 257) chapter for more on this.

If text is configured for these commands, it is displayed as status text and as button labels for command selection. You can find more information about this in section Labeling of buttons and text (Page 209)

(7) Display of the limit stop value including signal status

This area shows the limit stop signal with the corresponding signal status.

- "Open"
- "Closed"

If text is configured for these commands, it is displayed as status text and as button labels for command selection. You can find more information about this in section Labeling of buttons and text (Page 209)

(8) Display area for block states

This area provides additional information on the operating state of the block:

- "Maintenance"

Additional information on this is available in chapter Release for maintenance (Page 64) Display area for block states.

(9) Display area for block states

This area provides additional information on the operating state of the block:

- "Simulation"

You can find additional information on this in section Simulating signals (Page 58).

(10) Display area for block states

This area provides additional information on the operating state of the block (from high to low according to priority):

- "Fuzzy Optim." (FmCont only)
- "Tracking FB"
- "Tracking FM"
- "Safety mode FM"
- "Fuzzy control" (FmCont only)

(11) Limit display

These colored triangles indicate the configured limits in the respective bar graph:

- Red: Alarm
- Yellow: Warning
- Blue: Tolerance

Note

The symbols displayed are not valid for user-configured message classes. Please take into consideration the validity of terms for User-configured message classes (Page 41).

(12) Bar graph for the "Process value"

This area shows the current "Process value" in the form of a bar graph. The visible area in the bar graph depends on the configuration in the Engineering System (ES).

(13) Bar graph for the "Setpoint"

This area shows the current "Setpoint" in the form of a bar graph. The visible area in the bar graph depends on the configuration in the Engineering System (ES).

(14) Display of external setpoint

This display [E] is only visible when you have selected "Internal" setpoint specification. It shows the external setpoint that would apply if you were to change the setpoint specification to "external".

(15) Display for the target setpoint of the setpoint ramp

This display [R] shows the target setpoint and is only visible if you have enabled ramp generation in the Ramp view (Page 300).

(16) Limit display for the setpoint

These triangles show the SP_HiLim and SP_LoLim setpoint limits configured in the ES.

See also

Opening additional faceplates (Page 208)

2.3.10 Interlock blocks standard view

Interlock blocks standard view Intlk02, Intlk04, Intlk08, Intlk16

The number of the displayed input values depends on the interlock block you have selected. The operation and functions are identical for all interlock blocks and do not depend on the number of input values.

The **Intlk16** interlock block has two additional buttons for switching between the input values 1 to 8 and 9 to 16.

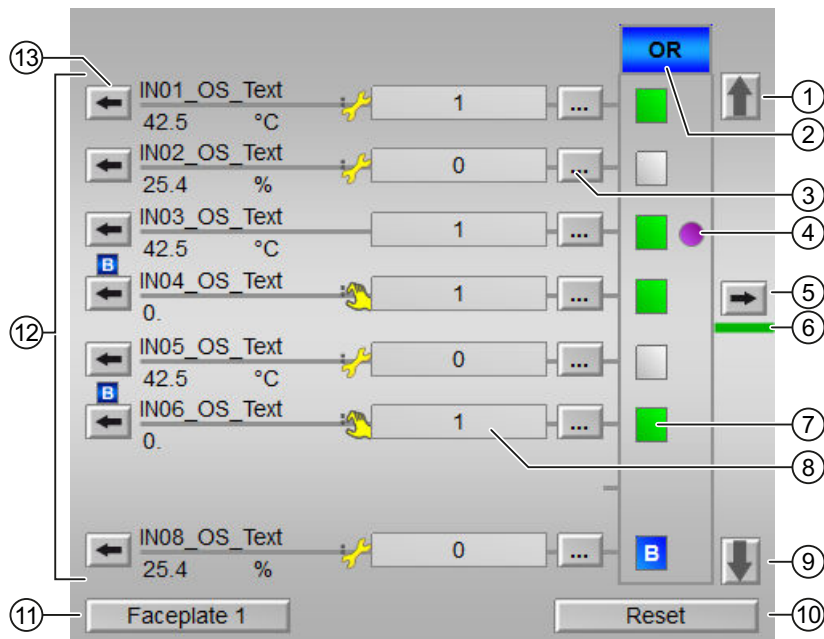

(1), (9) Switching between the input values 1 to 8 and 9 to 16 (for Intlk16 only)

The buttons (1) or (9) are displayed depending on the view you are in. These buttons are only available for the **Intlk16** block.

The **Intlk16** block provides two views:

- When you are in the first view, the input values 1 to 8 are available in the area (12). The button (9) is displayed. You switch to the second view by clicking on the button (9).
- When you are in the second view, the input values 9 to 16 are available in the area (12). The button (1) is displayed. You switch back to the first view by clicking on the button (1).

(2) Status of the output signal of the interlock block

This area (2) shows the status of the output signal of the interlock block (priority from high to low). You can configure the logic in the engineering system (ES).

Color of the field	Logic	
	AND	OR
Gray	Block is not used (only for display in the faceplate, interlock logic still enabled), set using the <code>NotUsed = 1</code> parameter	
Blue	Excluded (bypass)	
Yellow	Simulated	
Red	Interlocked	
Green	Not interlocked	

(3) Exclude input values

You can use the button (3) to exclude input values from processing. Depending on the previous settings, you can "Set" or "Reset" this property.

If the input value has been excluded, the following symbol appears in the field (8):



For more information on the operation, refer to the section Switching operating states and operating modes (Page 257).

Note

This function can only be executed in the faceplate with "high-level operating permission".

Note

Operator permissions via OS_Perm do not depend on the Feature bit 5 setting. You can find additional information in section Activate OS_Perm bits (Page 157)

(4) "First in" status display

The following symbol is displayed next to an input value, if this input value has caused the last output signal change from 1 to 0 (good state to locked):



You can reset the first-in (initial) signal with the button (10).

Note

This function can only be executed in the faceplate with "process control" operating permission.

You can find additional information on this in the section Recording the first signal for interlock blocks (Page 52).

For more information on the operation, refer to the section Switching operating states and operating modes (Page 257).

(5) Open faceplate of the output value

When you press the button (5), you can open the faceplate associated with the output value. The function of this button depends on the configuration in the engineering system (ES). See also the section Opening additional faceplates (Page 208) for more on this.

(6) Status of the block output

The line color indicates the status of the block output:

Color of the line	Output status
Green	Output is enabled
White	Output is disabled

(7) Display the status for further processing

The symbol shows the status for further processing of the input values:

Icon	Further processing
	The input value is processed further with value 1.
	The input value is processed further with value 0.
	The input value is excluded from further processing.

(8) Display of input values (BOOL) with signal status (in front of the field)

These fields show the interlock information associated with the analog value (13) with a signal status:

- 1 = "Good" state
- 0 = "Locked"

Changing the display

You can change the displays for 0 and 1 in the CFC in the object properties of the Interlock block:

- Navigate to the I/Os (object properties).
- Change the default for the input parameters (In_{xx}) in the Text 0 and Text 1 columns to what you later want to see in runtime.

(9) Switching input values

Read point (1) for this.

(10) "Reset" the settings for further processing

When you press the button (10), you can "Reset" all input values:

- "Reset exclusions": the exclusions of the input values are reset.
- "Reset first-in": First-in detection / status display (4) is reset.

You can find additional information on this in the section Recording the first signal for interlock blocks (Page 52).

(11) Navigation button for switching to the standard view of any faceplate

Use this navigation button to open the standard view of a block configured in the engineering system. The visibility of this navigation button depends on the configuration in the engineering system (ES).

You can find additional information on this in the section Opening additional faceplates (Page 208).

(12) Displaying analog input values

The interconnected analog input values (AV_{xx}) are displayed in this area. Set a unit of measure (AV_{xx_Unit} as shown in the picture with [Unit]) for each input in the engineering system (ES).

Changing the display

You can change the displays in the CFC in the object properties of the Interlock block:

- Navigate to the I/Os (object properties).
- In the "OS additional text" column, change the default setting for the input parameter (IN_{xx}) to what you want to see during runtime later.

- In the "Identifier" column, change the default setting for the input parameter (AV_{xx}) to what you want to see during runtime later.
- The text is used as a label and is therefore always displayed, in other words, it is independent of the signal status of the corresponding AV_{xxx} input.
- The font size is reduced during the runtime if the input text length is greater than the label width.

Note

If a text is added to the "OS additional text" field of the input parameter (IN_{xx}), this text will be displayed even if the "Identifier" text field of the input parameter (AV_{xx}) is not empty. If the "OS additional text" field of the input parameter (IN_{xx}) is empty, the "Identifier" text of the input parameter (AV_{xx}) is displayed.

The number of input values may vary depending on the selected interlock block:

- **Intlk02:** the input values 1 and 2 are available.
- **Intlk04:** the input values 1 to 4 are available.
- **Intlk08:** the input values 1 to 8 are available.
- **Intlk16:** the input values 1 to 8 are available. The input values 9 to 16 become available by pressing the button (9). You can find additional information on this topic in the description for (1) and (9).

(13) Open faceplate of the input value

When you press the button (13), you can open the faceplate associated with each input value. The function of this button depends on the configuration in the engineering system (ES). See also the section Opening additional faceplates (Page 208) for more on this.

The connected block is in bypass if the following small bypass symbol is displayed over the arrow symbol:



This display can be used only if `Feature2.Bit2` Separate evaluation for excluded and simulated interlock signals (Page 152) is active. If additionally the input `BypEn.Inx = 1`, this interlock input will be set in bypass.

2.3.11 Parameter view of PID controllers

Parameter view of PID controllers

Enabled operations Settings	
✓	PID optimization <input type="checkbox"/>
✓	SP := PV in manual mode <input type="checkbox"/>
✓	SP := SP external <input checked="" type="checkbox"/>
Parameters	
✓	Gain <input type="text" value="0."/>
✓	P in feedback path <input type="text" value="1."/>
✓	Integral time <input type="text" value="100."/> s
✓	Derivative time TD <input type="text" value="0."/> s
✓	Derivative gain <input type="text" value="5."/>
✓	D in feedback path <input type="checkbox"/>
✓	Dead band <input type="text" value="0.00"/> °C
✓	Control zone <input type="text" value="0.00"/> °C
Delay factor	
✓	ER H alarm <input type="text" value="0"/>
✓	ER L alarm <input type="text" value="0"/>
Service	
✓	Bypass <input type="button" value="On"/> ...
✓	Simulation <input type="button" value="Off"/> ...
✓	Release for maint. <input type="button" value="Yes"/> ...
	<input type="button" value="Gain scheduler"/>

(1) "Enabled operation"

This area shows all operations for which special operator permissions are assigned. They depend on the configuration in the engineering system (ES) that applies to this block.

Icons for enabled operation:

- **Green check mark:** the OS operator can control this parameter
- **Gray check mark:** the OS operator cannot control this parameter at this time due to the process
- **Red cross:** the OS operator cannot control this parameter due to the configured AS operator permissions (OS_Perm or OS1Perm).

(2) "Settings"

You can activate the following functions for the controller in this area:

- "PID optimization": activate controller optimization
- "SP := PV in manual mode": Bumpless switchover from manual mode to automatic mode
- "SP := SP external": Bumpless switchover of the setpoint for setpoint switchover from "external" to "internal". The internal setpoint is tracked to the external one.
 - With the PIDConR block, this area is only visible if you have set the `Feature` bit Switching operator controls for external setpoint to visible (Page 144) to 1.

(3) "Parameters"

In this area, you change parameters and therefore influence the controller. Refer to the Changing values (Page 259) section for more on this.

You can influence the following parameters:

- "Gain": Proportional gain
- "P in feedback path" : Proportional action to the feedback path (0 to 1), 0 = Proportional action is completely in the feedback path (only with PIDConL, PIDConR, and PIDStepL)
- "Integral time": Integral action time in [s]
- "Derivative time TD": Derivative action time in [s]
- "Derivative gain": Gain of the derivative action
- "D in feedback path": Derivative action is moved to the feedback path (only with PIDConL, PIDConR, and PIDStepL)
- "Dead band": Width of dead band
 Dead band is temporarily disabled
- "Control zone": Width of the control zone (only with PIDConL block)
- "Motor actuating time": Motor actuating time [s] (for PIDStepL block only)
- "Minimum pulse duration": Minimum pulse duration [s] (for PIDStepL block only)
- "Minimum break duration": Minimum break duration [s] (for PIDStepL block only)

(4) "Delay factor" (only for PIDConL and PIDConR)

In this area, you can change the following parameters:

- "ER H alarm": Delay factor at the positive setpoint step changes for incoming alarms at the control deviation monitoring `ER_AH_Lim`.
- "ER L alarm": Delay factor at the negative setpoint step changes for incoming alarms at the control deviation monitoring `ER_AL_Lim`.

(5) "Service"

You can select the following functions in this area:

- "Bypass" (only with PIDConL, PIDConR, and PIDStepL)
- "Simulation"
- "Release for maintenance" (with display for a maintenance request)

Refer to the Switching operating states and operating modes (Page 257) section for more on this.

You can find information on this area in the section:

- Bypassing signals (Page 107) (for PIDConL, PIDConR, and PIDStepL)
- Simulating signals (Page 58)
- Release for maintenance (Page 64)

(6) Navigation button for the GainSched block

You can use this navigation button to reach the GainSched block configured in the engineering system. The visibility of this navigation button depends on the configuration in the engineering system (ES).

You can find additional information on this in the section Opening additional faceplates (Page 208).

2.3.12 Parameter view of FM controllers

Parameter view of FM controllers

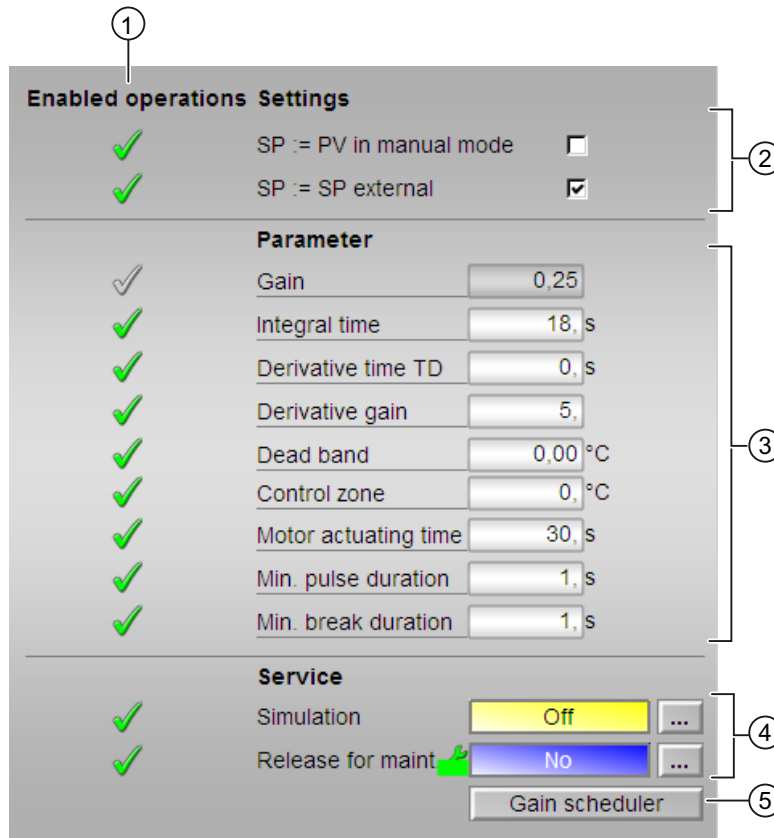

(1) "Enabled operations"

This area shows all operations for which special operator control permissions are assigned. They depend on the configuration in the engineering system (ES) that applies to this block.

Symbols for enabled operations:

- **Green check mark:** the OS operator can control this parameter
- **Gray check mark:** the OS operator cannot control this parameter at this time due to the process
- **Red cross:** the OS operator cannot control this parameter due to the configured AS operator control permissions (OS_Perm or OS1Perm).

(2) "Settings"

You can activate the following functions for the controller in this area:

- "SP := PV in manual mode": Bumpless switchover from manual mode to automatic mode
- "SP := SP external": Bumpless switchover of the setpoint for setpoint switchover from "external" to "internal" The internal setpoint is tracked to the external one.

(3) "Parameters"

In this area, you change parameters and therefore influence the controller. Refer to the Changing values (Page 259) section for more on this.

You can influence the following parameters:

- "Gain": Proportional gain
- "Integral time" Integral action time in [s]
- "Derivative time TD": Derivative action time in [s]
- "Derivative gain": Gain of the derivative action
- "Dead band": Width of dead band
- "Control zone": Width of the control zone (for block FmTemp only)
- "Motor actuating time": Motor actuating time [s]
- "Minimum pulse duration": Minimum pulse duration [s]
- "Minimum break duration": Minimum break duration [s]

(4) "Service"

You can activate the following functions in this area:

- "Simulation"
- "Release for maintenance" (with display for a maintenance request)

Refer to the Switching operating states and operating modes (Page 257) section for more on this.

You can find information on this area in the section:

- Simulating signals (Page 58)
- Release for maintenance (Page 64)

(5) Navigation button for the GainSched block

You can use this navigation button to reach the GainSched block configured in the engineering system. The visibility of this navigation button depends on the configuration in the engineering system (ES).

You can find additional information on this in the Opening additional faceplates (Page 208) section.

2.3.13 Parameter view for motors and valves

Parameter view for motors and valves

The following parameter view applies to the following bocks:

- MotL - Motor (Large) (Page 1073)
- MotRevL - Reversible motor (Page 1131)
- MotS - Motor (Small) (Page 1107)
- MotSpdL - Two-speed motor (Page 1225)
- VlvL - Valve (Large) (Page 1346)
- MotS - Motor (Small) (Page 1107)

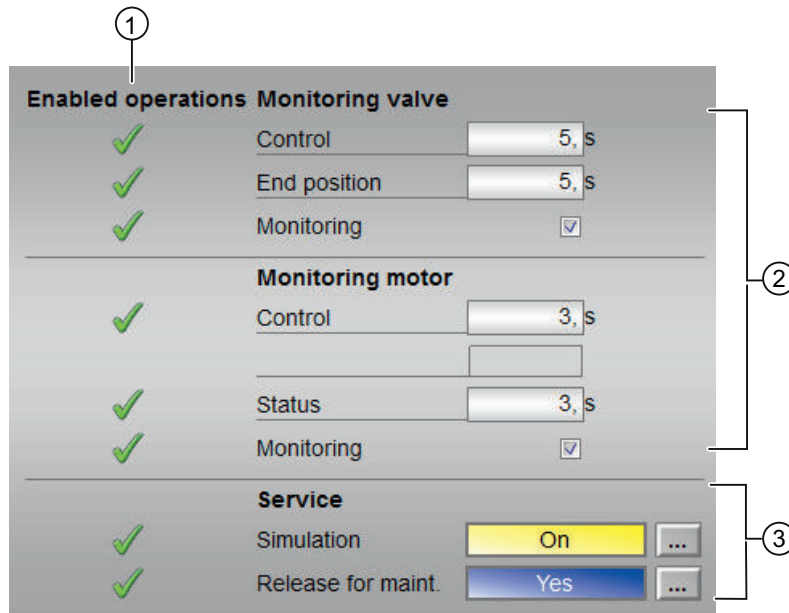

Parameter view for MotL, MotRevL, MotSpdL and MotSpdCL with Feature bit 13 = 0.

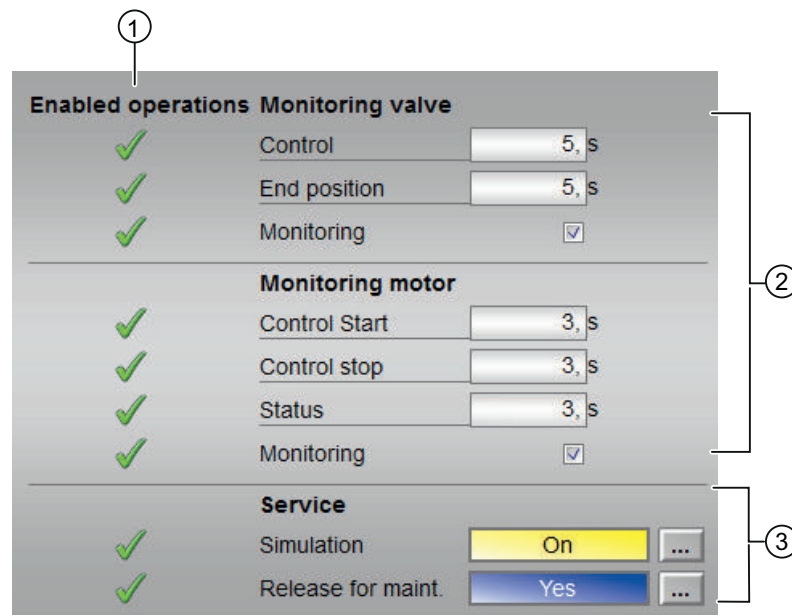

Parameter view for MotL, MotRevL, MotSpdL and MotSpdCL with Feature bit 13 = 1.

(1) "Enabled operation"

This area shows all operations for which special operator permissions are assigned. They depend on the configuration in the engineering system (ES) that applies to this block.

Icons for enabled operation:

- **Green check mark:** the OS operator can control this parameter
- **Gray check mark:** the OS operator cannot control this parameter at this time due to the process
- **Red cross:** the OS operator cannot control this parameter due to the configured AS operator permissions (OS_Perm or OS1Perm).

(2) "Monitoring"

In this area, you change parameters and therefore influence the motor. Refer to the Changing values (Page 259) section for more on this.

You can influence the following parameters:

- "Control": Monitoring time during startup and shutdown of the motor (dynamic)
- "Control stop": Monitoring time during shutdown of the motor (dynamic) only for MotL, MotRevL, MotSpdL and MotSpdCL with Feature bit 13 = 1
- "Control start": Monitoring time during startup of the motor (dynamic) only for MotL, MotRevL, MotSpdL and MotSpdCL with Feature bit 13 = 1
- "End position": Monitoring time during permanent operation of the motor (static)
- "Status": Monitoring time during permanent operation of the motor (static)
The state is not displayed for small blocks.

Enabling "Monitoring"

You can enable monitoring by selecting the check box (☑)

You can find additional information on this in the section Monitoring the feedbacks (Page 97).

(3) "Service"

You can select the following functions in this area:

- "Simulation"
- "Release for maintenance" (with display for a maintenance request)

Refer to the Switching operating states and operating modes (Page 257) section for more on this.

You can find information on this area in the section:

- Simulating signals (Page 58)
- Release for maintenance (Page 64)

See also

VlvS - Valve (small) (Page 1377)

2.3.14 Limit view of FM controllers

Limit view of FM controllers

Several values are set in this view by default:

- Process value limits
- Error signal limits
- Readback value limits
- Setpoint operation range

The toolbars of the faceplate and the block icon indicate when the limits are reached or violated.

Note

The symbols displayed are not valid for user-configured message classes. Take into consideration the validity of terms for User-configured message classes (Page 41)

Enabled operations

Process value limits (PV)

- H alarm 95,00 °C
- H warning 90,00 °C
- Hysteresis 1,00 °C
- L warning 10,00 °C
- L alarm 5,00 °C

Control deviation limits (ER)

- H alarm 100,00 °C
- Hysteresis 1,00 °C
- L alarm -100,00 °C

Readback value limits

- H warning 100,00 %
- Hysteresis 1,00 %
- L warning 0,00 %

Setpoint operating range (SP)

- H range 100,00 °C
- L range 0,00 °C

Manipulated variable operating range

- H range 100,00 %
- L range 0,00 %

(1) "Enabled operation"

This area shows all operations for which special operator permissions are assigned. They depend on the configuration in the engineering system (ES) that applies to this block.

Icons for enabled operation:

- **Green check mark:** the OS operator can control this parameter
- **Gray check mark:** the OS operator cannot control this parameter at this time due to the process
- **Red cross:** the OS operator cannot control this parameter due to the configured AS operator permissions (OS_Perm or OS1Perm)

(2) "Process value limits (PV)"

In this area, you can enter the limits for the process value. Refer to the Changing values (Page 259) section for more on this.

You can change the following limits:

- "H alarm": Alarm high
- "H warning": Warning high
- "H tolerance": Tolerance high
- "Hysteresis"
- "L tolerance": Tolerance low
- "L warning": Warning low
- "L alarm": Alarm low

(3) "Error signal limits (ER)"

In this area, you can enter the limits for the control deviation. Refer to the Changing values (Page 259) section for more on this.

You can change the following limits:

- "H alarm": Alarm high
- "Hysteresis"
- "L alarm": Alarm low

(4) "Readback value limits (RBK)"

In this area, you can enter the limits for the readback value. Refer to the Changing values (Page 259) section for more on this.

You can change the following limits:

- "H warning": Warning high
- "Hysteresis"
- "L warning": Warning low

(5) "Setpoint operation range (SP)"

In this area, you can enter the limits for the setpoint operation range. Refer to the Changing values (Page 259) section for more on this.

You can change the following limits:

- "H range": Range limit high
- "L range": Range limit low

(6) "Manipulated variable operating range"

In this area, you can enter the limits for the manipulated variable operation range. Refer to the Changing values (Page 259) section for more on this.

You can change the following limits:

- "H range": Range limit high
- "L range": Range limit low

(7) "Message suppression/delay"

Message suppression indicates whether or not the suppression of the associated message in the AS block is activated with the `xx_MsgEn` parameter. The output of messages is not suppressed when the block is installed (all `xx_MsgEn` parameters are preset to 1). Messages can only be output if limit monitoring of the additional analog value has been enabled.

Alarm delays are also displayed in this position; for more on this see section Area of application of the alarm delays (Page 199).

(8) Suppressing messages

You can enable / disable messages by setting the check mark.

2.3.15 Limit view of PID controllers

Limit view of PID controllers

Several values are set in this view by default:

- Process value limits
- Error signal limits
- Readback value limits
- Setpoint operation range

The toolbars of the faceplate and the block icon indicate when the limits are reached or violated.

Note

The symbols displayed are not valid for user-configured message classes. Take into consideration the validity of terms for User-configured message classes (Page 41).

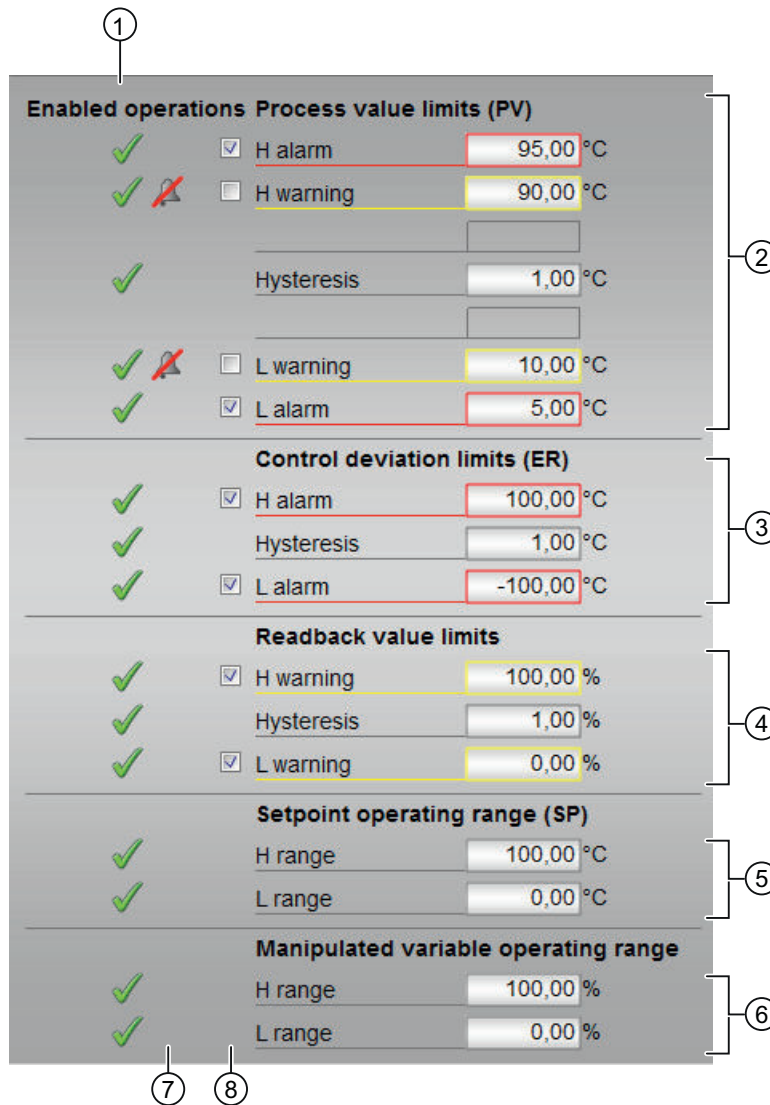

(1) "Enabled operation"

This area shows all operations for which special operator permissions are assigned. They depend on the configuration in the engineering system (ES) that applies to this block.

Icons for enabled operation:

- **Green check mark:** the OS operator can control this parameter
- **Gray check mark:** the OS operator cannot control this parameter at this time due to the process
- **Red cross:** the OS operator cannot control this parameter due to the configured AS operator permissions (OS_Perm or OS1Perm)

(2) "Process value limits (PV)"

In this area, you can enter the limits for the process value. Refer to the Changing values (Page 259) section for more on this.

You can change the following limits:

- "H alarm": Alarm high
- "H warning": Warning high
- "H tolerance": Tolerance high (not with PIDConS)
- "Hysteresis"
- "L tolerance": Tolerance low (not with PIDConS)
- "L warning": Warning low
- "L alarm": Alarm low

(3) "Error signal limits (ER)" (not with PIDConS)

In this area, you can enter the limits for the control deviation. Refer to the Changing values (Page 259) section for more on this.

You can change the following limits:

- "H alarm": Alarm high
- "Hysteresis"
- "L alarm": Alarm low

(4) "Readback value limits (RBK)" (not with PIDConS)

In this area, you can enter the limits for the readback value. Refer to the Changing values (Page 259) section for more on this.

You can change the following limits:

- "H warning": Warning high
- "Hysteresis"
- "L warning": Warning low

(5) Setpoint operation range (SP)

In this area, you can enter the limits for the setpoint operation range. Refer to the Changing values (Page 259) section for more on this.

You can change the following limits:

- "H range": Range limit high
- "L range": Range limit low

(6) Manipulated variable operating range

In this area, you can enter the limits for the manipulated variable operation range. Refer to the Changing values (Page 259) section for more on this.

You can change the following limits:

- "H range": Range limit high
- "L range": Range limit low

(7) "Message suppression / delay"

Message suppression indicates whether or not the suppression of the associated message in the AS block is activated with the `xx_MsgEn` parameter. The output of messages is not suppressed when the block is installed (all `xx_MsgEn` parameters are preset to 1). Messages can only be output if limit monitoring of the additional analog value has been enabled.

Alarm delays are also displayed in this position; for more on this see section Area of application of the alarm delays (Page 199).

(8) Suppress messages

You can enable / disable messages by setting the check mark.

2.3.16 Limit view of motors

Limit view of motors

The limit view of motors is only available when an AV block has been interconnected to the motor.

The toolbars of the faceplate and the block icon indicate when the limits are reached or violated.

Note

The symbols displayed are not valid for user-configured message classes. Take into consideration the validity of terms for User-configured message classes (Page 41).

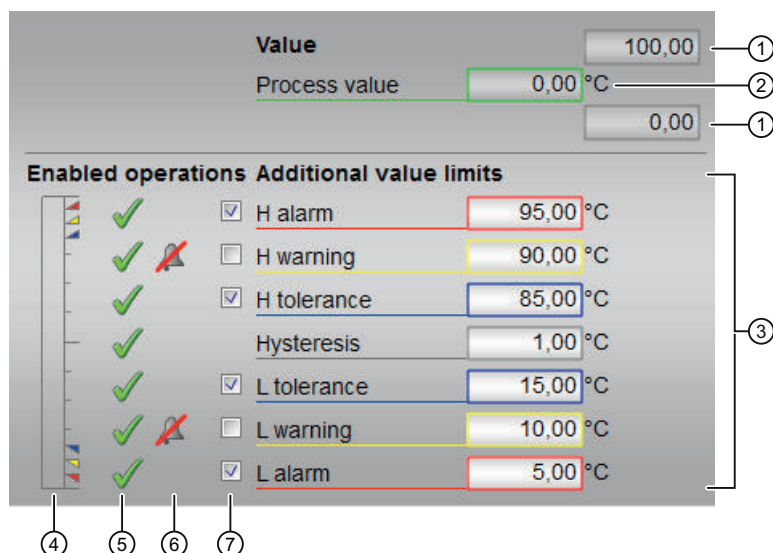

(1) High and low scale range for the additional value

These values provide information on the display range for the bar graph of the additional value. The scale range is defined in the engineering system.

(2) Display of the additional value including signal status

This area shows the current additional value with the corresponding signal status.

(3) "Limits for the additional value"

In this area, you can enter the limits for the additional value. Refer to the Changing values (Page 259) section for more on this.

You can change the following limits:

- "H alarm": Alarm high
- "H warning": Warning high
- "H tolerance": Tolerance high
- Hysteresis
- "L tolerance": Tolerance low
- "L warning": Warning low
- "L alarm": Alarm low

(4) Bar graph for the additional value

This area shows you the current additional value in the form of a bar graph. The visible area in the bar graph depends on the configuration in the engineering system (ES).

(5) "Enabled operation"

This area shows all operations for which special operator permissions are assigned. They depend on the configuration in the engineering system (ES) that applies to this block.

Icons for enabled operation:

- **Green check mark:** the OS operator can control this parameter
- **Gray check mark:** the OS operator cannot control this parameter at this time due to the process
- **Red cross:** the OS operator cannot control this parameter due to the configured AS operator permissions (OS_Perm or OS1Perm)

The colored triangles indicate the specified limits **(3)** for the additional value.

(6) Message suppression / delay

Message suppression indicates whether or not the suppression of the associated message in the AS block is activated with the `xx_MsgEn` parameter. The output of messages is not suppressed when the block is installed (all `xx_MsgEn` parameters are preset to 1). Messages can only be output if limit monitoring of the additional analog value has been enabled.

Alarm delays are also displayed in this position; for more on this see section Area of application of the alarm delays (Page 199).

(7) Suppress messages

You can enable / disable messages by setting the check mark.

2.3.17 Preview of FM controllers

Preview of FM controllers

The preview shows you the parameters that you, as an OS operator, can control in the entire block. You cannot control anything in this view, however.

Process value (PV)	0.00 °C
SP external	0.00 °C
SP internal	43.00 °C
Control deviation	0.00 °C
Program value	0.00 °C
Disturbance	0.00 %
Tracking FM	0
Tracking FB	0
Tracking value	0.00 %
Safety mode	0
Safety value	0.00 %

Enabled operations

<input checked="" type="checkbox"/> Close	<input checked="" type="checkbox"/> Automatic
<input checked="" type="checkbox"/> Open	<input checked="" type="checkbox"/> Manual
<input checked="" type="checkbox"/> Stop	<input checked="" type="checkbox"/> Out of service
<input checked="" type="checkbox"/> SP external	<input checked="" type="checkbox"/> Local oper. permission <input type="button" value="←"/>
<input checked="" type="checkbox"/> SP internal	
<input checked="" type="checkbox"/> SP Change	
<input checked="" type="checkbox"/> Change MV	
<input checked="" type="checkbox"/> Program mode	

Faceplate 1

(1) Preview area

This area shows you a preview for the following values:

- "SP external": currently applicable external setpoint
- "SP internal": currently applicable internal setpoint
- "Control deviation": Current Control deviation
- "Program mode": Specified value for program mode
- "Disturbance variable": additive value for feedforward control
- "Tracking FM": track a manipulated variable in the FM module (value is 1)
- "Tracking FB": Track manipulated variable at the block (value is 1)

- "Tracking value": Effective manipulated variable for "Track manipulated variable at block"
- "Safety mode": safety mode in the FM module (value is 1)
- "Safety value": effective manipulated variable for "Safety mode"

(2) "Enabled operations"

This area shows all operations for which special operator control permissions are assigned. They depend on the configuration in the engineering system (ES) that applies to this block.

Symbols for enabled operations:

- **Green check mark:** the OS operator can control this parameter
- **Gray check mark:** the OS operator cannot control this parameter at this time due to the process
- **Red cross:** the OS operator cannot control this parameter due to the configured AS operator control permissions (`OS_Perm` or `OS1Perm`)

The following enabled operations are shown here:

- "Close": You can select the manipulated variable "Close". If text is configured for this command, it is also displayed in brackets. You can find more information about this in the Section Labeling of buttons and text (Page 209).
- "Open": You can select the manipulated variable "Open". If text is configured for this command, it is also displayed in brackets. You can find more information about this in the Section Labeling of buttons and text (Page 209).
- "Stop": You can select the manipulated variable "Stop". If text is configured for this command, it is also displayed in brackets. You can find more information about this in the Section Labeling of buttons and text (Page 209).
- "SP external": You can feedforward the external setpoint.
- "SP internal": You can feedforward the internal setpoint.
- "Change SP": You can change the setpoint.
- "Change MV": You can change the manipulated variable.
- "Program mode": You can switch to program mode.
- "Automatic": You can switch to automatic mode.
- "Manual": You can switch to manual mode.
- "Out of service": You can switch to "Out of service" operating mode.
- "Local operating permission": Use the ← button to switch to the standard view of the "OpStations" block. Additional information is available in the section Operator control permissions (Page 254).

(3) Navigation button for switching to the standard view of any faceplate

Use this navigation button to reach the standard view of a block configured in the engineering system. The visibility of this navigation button depends on the configuration in the engineering system (ES).

See also the Opening additional faceplates (Page 208) section for more on this.

(4) Process value

This area displays the real process value (PV).

2.3.18 Preview of interlock blocks

Preview of interlock blocks

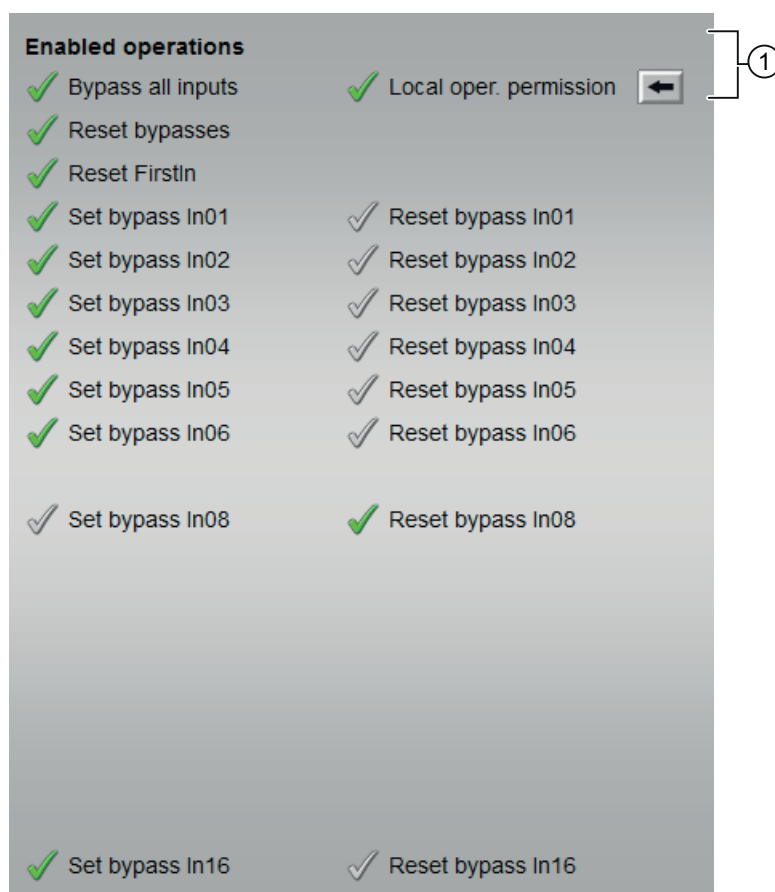

(1) Enabled operations

This area shows all operations for which special operator control permissions are assigned. They depend on the configuration in the engineering system (ES) that applies to this block.

Symbols for enabled operations:

- **Green check mark:** the OS operator can control this parameter
- **Gray check mark:** the OS operator cannot control this parameter at this time due to the process
- **Red cross:** the OS operator cannot control this parameter due to the configured AS operator control permissions (OS_Perm or OS1Perm).

The following enabled operations are shown here:

- "Local operating permission": Use the <-- button to switch to the standard view of the OpStations block. Additional information is available in the section Operator control permissions (Page 254).

2.3.19 Ramp view

Ramp view

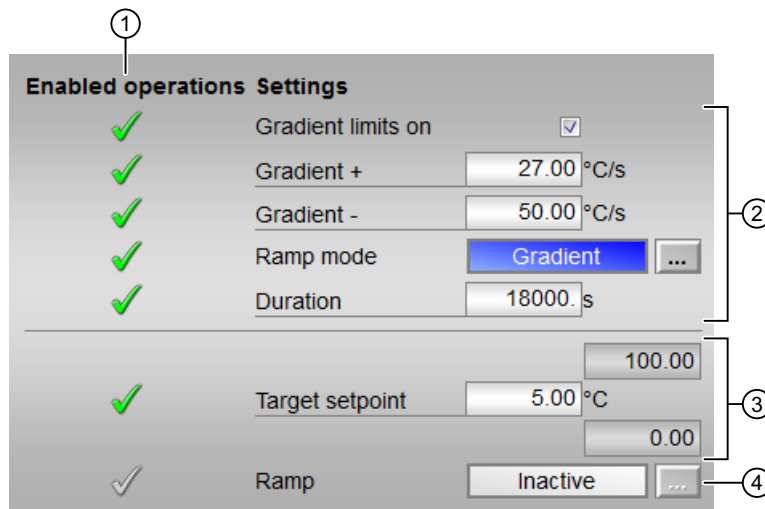

(1) "Enabled operations"

This area shows all operations for which special operator control permissions are assigned. They depend on the configuration in the engineering system (ES) that applies to this block.

Symbols for enabled operations:

- Green check mark: the OS operator can control this parameter
- Gray check mark: the OS operator cannot control this parameter at this time due to the process
- Red cross: the OS operator cannot control this parameter due to the configured AS operator control permissions (OS_Perm or OS1Perm)

(2) Enable "gradient limit"

Use this check box to enable "gradient limit" for the setpoint. "Gradient limit" can be set separately for positive or negative setpoint changes ("Gradient +" or "Gradient -"). Refer to the Changing values (Page 259) section for more on this.

If there is a difference between target setpoint and currently effective setpoint, a blue "G" may be displayed at the bar in standard view of FmCont, FmTemp, PIDConL, PIDConR, PIDStepL, OpAnL and MotSpdCL with parameter assignment of `SP_RateTarget` (target setpoint for gradient limit).

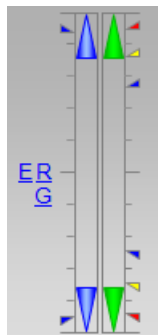

If there is a difference between the target manipulated variable and the currently effective manipulated variable, an orange "G" may be displayed at the bar in the standard view of VlvAnI with parameter assignment of `MV_RateTarget` (target manipulated variable for gradient limit).

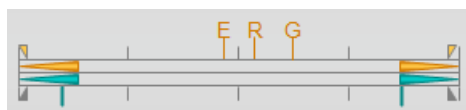

The gradient limitation includes the Ramp function (Page 123). You can set the ramp mode in the following two ways:

- Gradient
- Duration [s]

(3) "Target setpoint"

In this area, you can set the type of ramp function for the setpoint.

You can set the time duration and the target setpoint. Refer to the Changing values (Page 259) section for more on this.

(4) Enable "Ramp"

You can use this control to enable or disable the configured function in the ramp function for the setpoint change.

You can only enable this when the setpoint specification is set to "Internal" in the standard view of the block. The enable is only valid for one setpoint change and is subsequently disabled again.

2.3.20 Alarm view

Message view

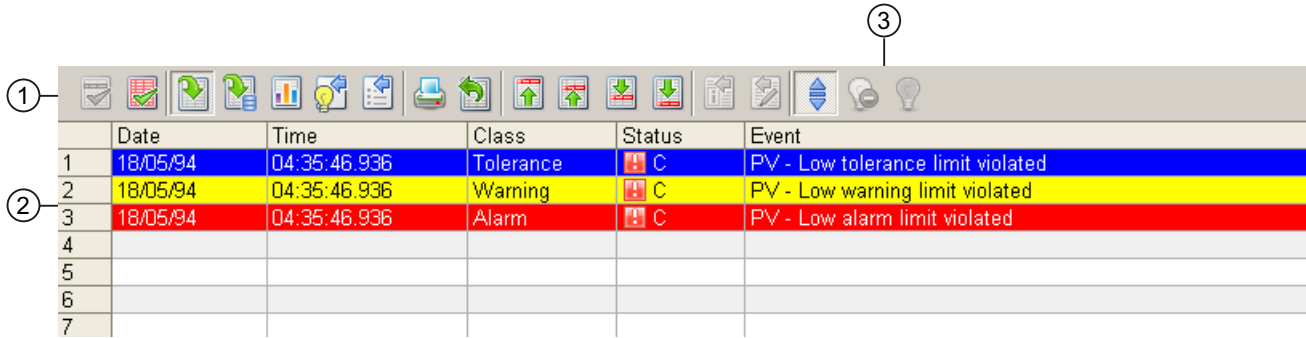

(1) Toolbar

If the short-term archive list is selected, a new button appears in the toolbar:



You can use this button to toggle between the "History" and "Operator messages" views.

You must be registered with the "Higher process control" operating permission in order to export and hide messages.

(2) Display area for alarms

For additional information about the alarm view, refer to the *WinCC Information System* Online Help.

(3) "Hide messages" button

Messages can be displayed and/or hidden with this button. The view of this button changes accordingly:



Show messages



Hide messages



"Higher process controlling" operating permission is required and manual hiding must be active. You can find additional information in the manual "Process Control System PCS 7 Operator Station".

2.3.21 Batch view

Batch view

This area shows a display of the batch that is currently running (Batchview).

You can use the internal tag "@APLBatchEnable" to enable/disable the "Batch" button in the toolbar.

Value of @APLBatchEnable	Operating the "Batch" button in the toolbar	Icon of the "Batch" button in the toolbar
0	Disabled	
1	Enabled	

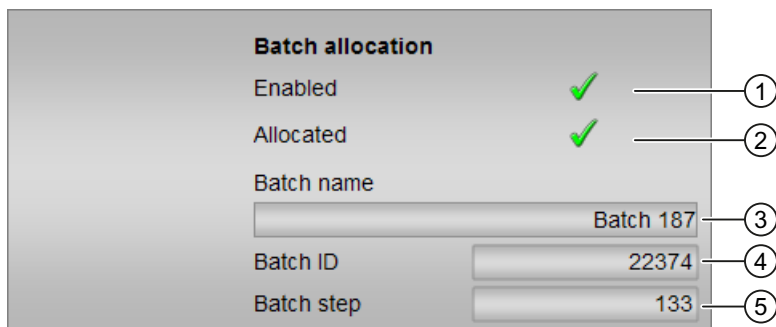

(1) "Enabled"

This area shows you if the block is enabled for operation via SIMATIC BATCH (BatchEn = 1).

(2) "Allocated"

This area shows if the block is currently in use by SIMATIC BATCH (Occupied = 1).

(3) "Batch name"

This area shows the name of the batch that is currently running (Batchname).

(4) "Batch ID"

This area shows the identification number of the batch that is currently running (BatchID).
The batch view is disabled if BatchID = 16#00000000.

(5) "Batch step"

This area shows the step number of the batch that is currently running (StepNo).

2.3.22 Memo view

Memo view

You can leave temporary messages for other OS operators in this view. Messages are entered in the text box, and saved and activated by selecting the check box in the lower right corner of the faceplate.



(1) Text box for notes

(2) Check box for activating the note

The next time the faceplate is opened or there is a process picture change, you can see in the status bar of the block icon and the faceplate that there is a new message for you.

Clearing the check box deletes the indicators in the status bars.

The message is not deleted automatically.

Note

The content of the memo view is cleared when you perform a full compilation and download of the OS.

2.3.23 Trend view

Trend view

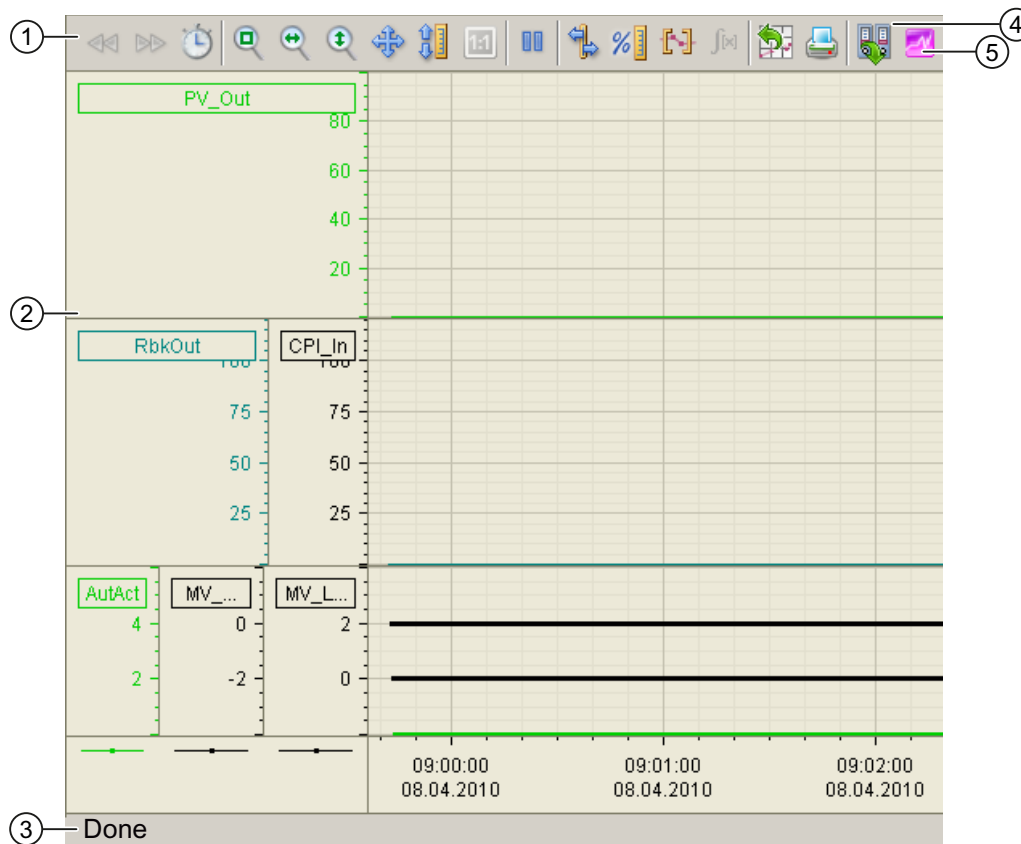

(1) Toolbar

(2) Display area for trends

(3) Status bar

(4) Button for switching between archive tags and online tags. The status bar shows if the trend view is working with online data or archive data.

(5) Button for opening the "Scatter plot" window

The Export button is only visible and operable with the "Higher-level process control" operating permission.

For additional information about the trend view, refer to the *WinCC Information System Online Help*.

Configuration of the trend view

The trend view can be configured so that archive values are displayed immediately after opening. A prerequisite for this is that archive variables exist. Proceed as follows:

- A "1" is attached at the block icon in the "TrendPictureName" property. A semicolon is used as the separator to the name of the trend view.
Example: @pg_apl_trendPID_Statistic.pdl;1

Special considerations for controllers

You can select two different representations for the display area:

1. Detailed display (default setting):

Display area consisting of three coordinate systems:

- Setpoint trend, actual value trend;
- Manipulated variable, control performance index trend;
- Binary trend via automatic/manual, manipulated variable at high or low limit

Open the scatterplot diagram with the user button (number 2) in the toolbar. It shows a coordinate system with the process value on the value axis and the manipulated variable or position feedback on the X axis. A new value pair is entered into the coordinate system with each cycle.

If you want to use the detail display, you need to enter the following in the block icon under Trends in the WinCC Graphics Designer:

TrendPictureName = @pg_apl_trendPID_Statistic.pdl

2. Simple display:

Display area consisting of two coordinate systems:

- Setpoint trend, actual value trend;
- Manipulated variable;

If you want to use the simple display, you need to enter the following in the block icon under Trends in the WinCC Graphics Designer:

TrendPictureName =@pg_apl_trendPID.pdl

Notes on step controllers with position feedback:

If you use a step controller with position feedback as the controller type, you need to enter the following in the block icon under Trends in the WinCC Graphics Designer:

TrendConfiguration5 = *.MV#Value;...

TrendConfiguration6 = .RbkOut#Value;...

The following applies to all other controller types (default setting):

TrendConfiguration5 = .MV#Value;...

TrendConfiguration6 = *.RbkOut#Value;...

2.3.24 APL Operator Trend Control (AOTC)

Opening the AOTC window

Press and hold the Ctrl key and left-click the value on the block icon to open the AOTC window. The first value is added to the Trend Control and the detailed information is displayed in the first row of the overview area.

Adding values to the AOTC window

To add values to the AOTC window, press and hold the Ctrl key and left-click the value on the block icon. The value is added to the Trend Control. You can add up to 8 values in the AOTC window. The following colors are assigned to the trends in the sequence they are added:

1. Black (HTML code 000000)
2. Red (HTML code FF0000)
3. Green (HTML code 00FF00)
4. Blue (HTML code 0000FF)
5. Yellow (HTML code FFFF00)
6. Turkish (HTML code 00FFFF)
7. Pink (HTML code FF00FF)
8. Orange (HTML code FFA100)

If the value is an archived value, the value is displayed from the archive. If the value is not archived, it is displayed as an online value. The default time range for the time axis is 1 minute.

Note

For the Web Navigator, when a new value is added, the Trend Control always displays only the online value. You can switch to display the archived values through the buttons "Monday", "Tuesday", and so on.

For information on adding additional values to the AOTC window, refer to **(10) Adding additional values**.

Adding digital values to the AOTC window

To add digital values to the AOTC window, press and hold the Ctrl key and left-click the value on the block icon. You can add digital values from the following blocks:

Family	Blocks
Drives	MotL, MotRevL, MotSpdCL, MotSpdL, MotS, VlvL, VlvS, Vlv2WayL, VlvAnL, VlvMotL, VlvPosL
Operate	OpDi01, OpTrig, OpDi03
Monitor	MonDiL, MonDiS, MonDi08

Example: If you perform Ctrl key + left-click operation on the MotL block icon, the AOTC window opens showing its current status taken from the parameter `FbkRunOut.Value`. After opening the AOTC window, if you perform Ctrl key + left-click operation on any other block then the parameter corresponding to that block is added to the AOTC window.

For information on adding additional values to the AOTC window, refer to **(10) Adding additional values**.

The AOTC window

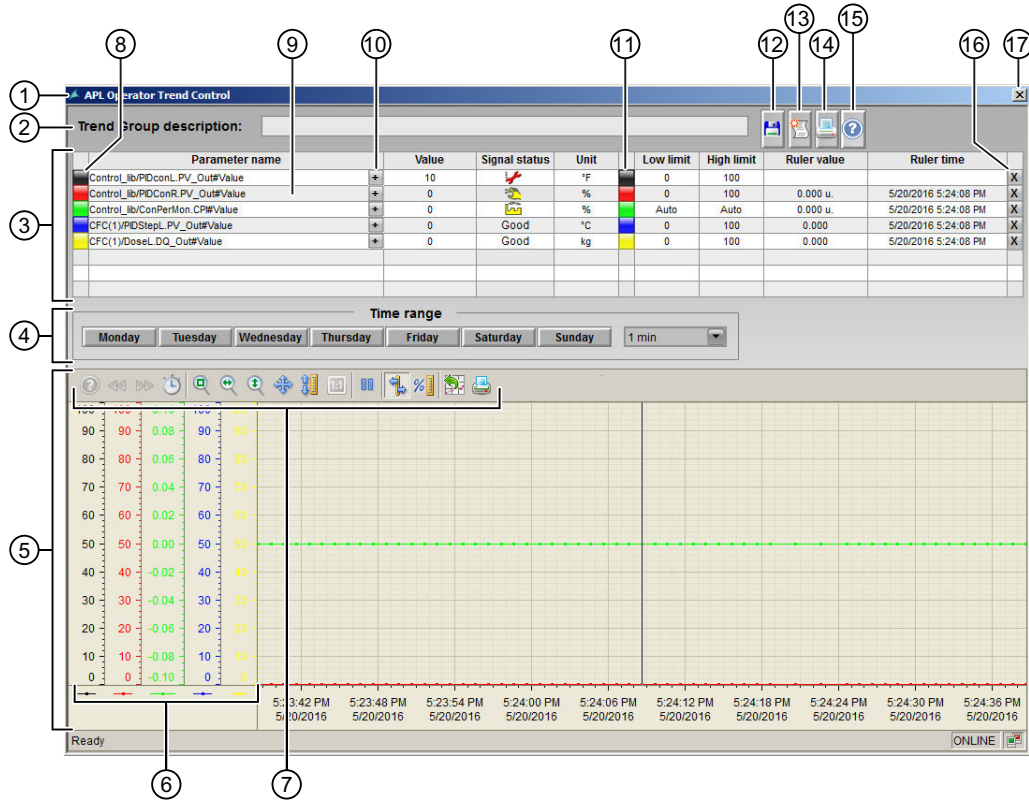

1. Title
2. Trend group description
3. Tag row
4. Time range selection
5. WinCC online trend control
6. Value axis
7. Toolbar of the trend window
8. Enabling/disabling a trend
9. Opening a faceplate
10. Adding additional values
11. Enabling/disabling a value axis

12. Saving a trend group
13. Opening a separate message window
14. Printing screenshot of the AOTC window
15. Help button
16. Deleting a trend
17. Closing the AOTC window

(1) Title

The title displays the name of the AOTC. If the trend group is not saved, the default title "APL Operator Trend Control" is displayed. If a saved trend group is opened, title displays the group name.

(2) Trend group description

This field displays the description of the trend group if it is saved with a description otherwise it is empty.

(3) Tag row

The tag row displays the following information about the trend added.

- Button to enable/disable the trend:
Click this button to enable or disable the trend. For more information, refer to the description of **(8) Enabling/disabling a trend**.
- "Parameter name":
This field displays the name of the trend.
- Button to add additional values:
Click this button to add additional values to the corresponding parameter. For more information, refer to the description of **(10) Adding additional values**.
- "Value":
This field displays the current value of the trend.
- "Signal status":
This field displays the signal status of the trend. The corresponding icon is displayed in case the quality is not good that is the quality code is not 0x80. In case of good quality (quality code 0x80), the text "Good" is displayed.
- "Unit":
This field displays the unit of the trend. Units are calculated only while adding a trend to the AOTC window. If the unit of a trend changes after it has been added to the AOTC window, the new unit will not be updated in the AOTC window. For example, if `PV_Unit` changes, the trend must be removed and added again.
- Button to enable/disable the value axis:
Click this button to enable or disable the value axis. For more information, refer to the description of **(11) Enabling/disabling a value axis**.

- "Low limit":
This field displays the low limit of the trend. The low limit is taken from the tag "XX_OpScale#Low". If the tag is not present, the value is taken automatically by the Trend control and low limit field displays "Auto".
- "High limit":
This field displays the high limit of the trend. The high limit is taken from the tag "XX_OpScale#High". If the tag is not present, the value is taken automatically by the Trend Control and the high limit field displays "Auto".
- "Ruler value":
This field displays the ruler value of the trend where the ruler intersects with the trend in the Trend Control.
- "Ruler time":
This field displays the ruler time of the trend where the ruler intersects with the trend in the Trend Control.
- Button to delete the trend:
Click this button to delete the trend. For more information, refer to the description of **(15) Deleting a trend**.

(4) Time range selection

This area provides the option to select the time range based on the weekdays for the archived view and fixed time frame for the online view.

Press the buttons named "Monday" to "Sunday" to switch to the archive view for that day. For example, if today is Tuesday and the "Tuesday" button is pressed, the archived values from today will be displayed. If the "Sunday" button is pressed, the archived values from last Sunday will be displayed. The time range is 24 hours. If the trend is not archived, no value will be displayed.

Press the "Start/stop" button from the trend toolbar to switch back to the online view.

Use the drop-down list in the time range selection area to change the time range of the time axis. The following preconfigured time ranges are available:

- Hour/minute based
 - 1 min
 - 2 min
 - 5 min
 - 10 min
 - 15 min
 - 30 min
 - 1 h
 - 2 h
 - 3 h
 - 5 h
 - 12 h
 - 24 h

The following figure shows the AOTC window when the time range is selected to "10 min" from the drop-down list in "Time range" section:

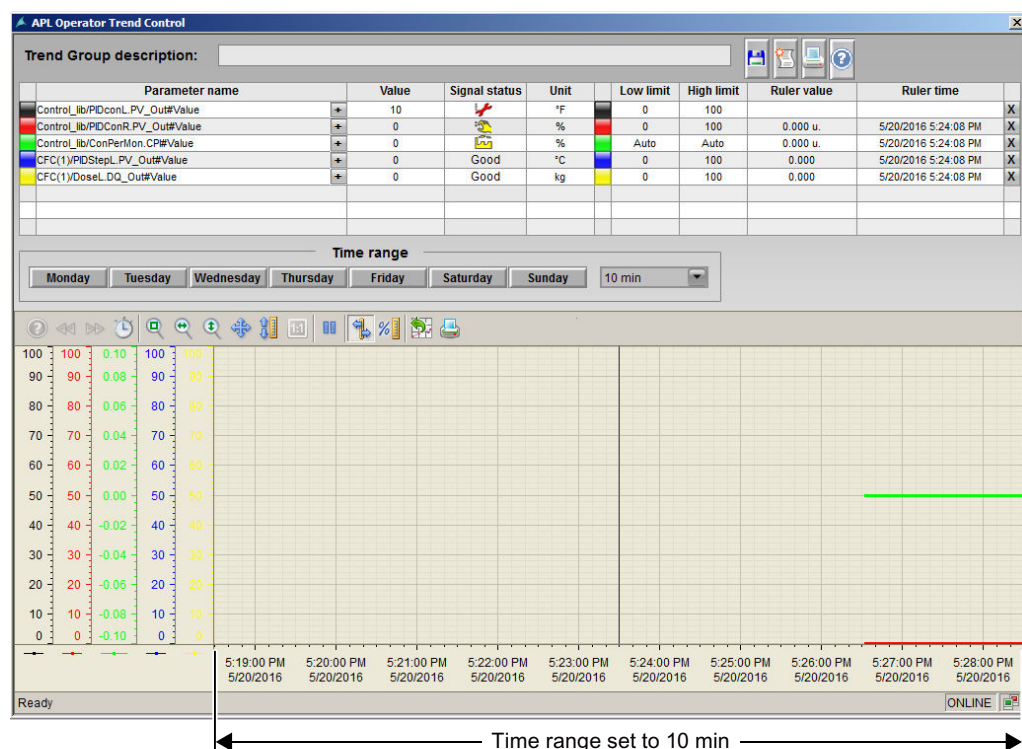

(5) WinCC online trend control

The Trend Control displays the trends added to the AOTC window. Each trend added to the AOTC window will appear in different color.

The following colors have been defined default for the 8 trends:

1. Black
2. Red
3. Green
4. Blue
5. Yellow
6. Turkish
7. Pink
8. Orange

(6) Value axis

Each trend is shown in a separate value axis, therefore there can be maximum of 8 value axis. The value axis appears in the same color as the corresponding trend.

(7) Toolbar of the trend window

Use these button to operate the trend window.

For more information, refer to *WinCC Information System* Online Help.

(8) Enabling/disabling a trend

Press these buttons to disabled or enabled trends.

If a trend is enabled, the corresponding button will be displayed in the same color as the value trend.

If a trend is disabled, the corresponding button will be displayed in Grey color.

By default the trend added to the AOTC is enabled, therefore the corresponding button is visible and appears in the the same color as the value trend.

When the button is pressed the first time, the corresponding trend is hidden from the Trend Control. The color of the button changes to Grey. The corresponding tag row in the overview area is hidden except the "Parameter name".

On pressing the button again, the corresponding trend is visible again in the Trend Control. The color of the button changes to the same color as the value trend. The corresponding row of values is visible again.

(9) Opening a related faceplate

Click the parameter name in the tag row to open the corresponding faceplate.

The screenshot displays the APL Operator Trend Control (AOTC) interface. At the top, a 'Trend Group description:' section contains a table with the following data:

Parameter name	Value	Signal status	Unit	Low limit	High limit	Ruler value	Ruler time
Control_lib/PIDconL_PV_Out#Value	10		°F	0	100		
Control_lib/PIDConR_PV_Out#Value	0		%	0	100	0.000 u.	5/20/2016 5:34:06 PM
Control_lib/ConPerMon_CP#Value	0		%	Auto	Auto	0.000 u.	5/20/2016 5:34:06 PM
CFC(1)/PIDStepL_PV_Out#Value	0	Good	°C	0	100	0.000	5/20/2016 5:34:06 PM
CFC(1)/DoseL_DQ_Out#Value	0	Good	kg	0	100	0.000	5/20/2016 5:34:06 PM

An arrow points from the 'Control_lib/PIDConR_PV_Out#Value' parameter name in the table to the 'Control_lib/PIDConR' faceplate window. The faceplate window shows a 'Continuous PID controller with external reset' in 'Manual' mode. It features a 'Process value' of 0.00%, a 'Setpoint' of 0.00%, and a 'Manipulated var.' of 0.00%. The background shows a trend graph with a green horizontal line at 50 on the y-axis. The x-axis represents time from 5:30:00 PM to 5:39:00 PM on 5/20/2016. The status bar at the bottom indicates 'Ready' and 'ONLINE'.

(10) Adding additional values

This button is used to configure values of a particular function block which is already configured in the parameter list of the AOTC window. This button is visible only for the parameters which are configured in the AOTC window.

Perform the following steps to configure additional values to the AOTC window:

1. Click the [+] button which is available in the right corner of a configured parameter. The "Additional Values" window opens which displays a list of parameters of the corresponding function block.

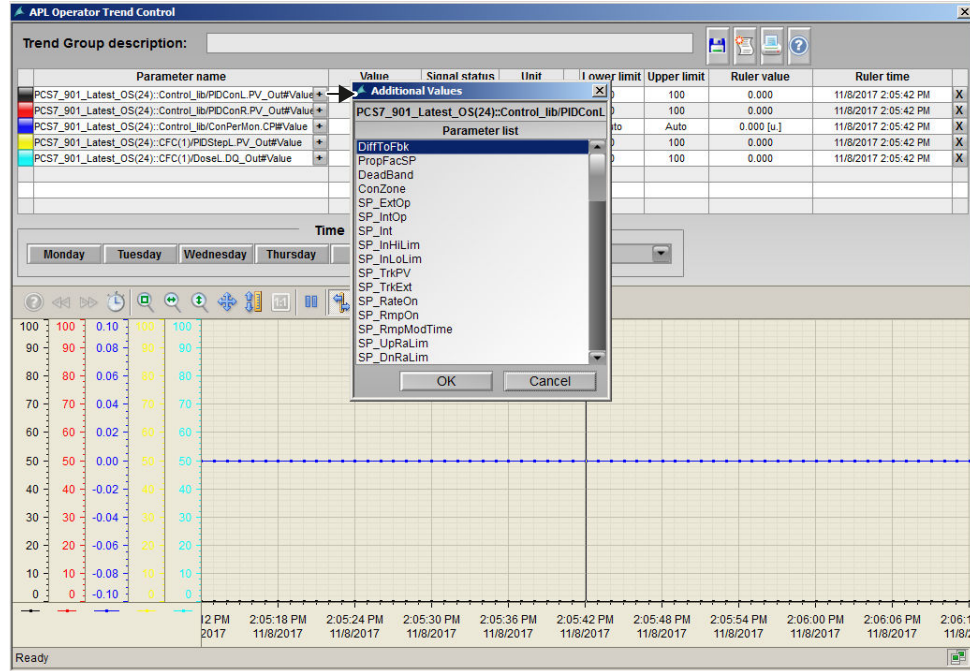

2. Select a value from the list and click OK to configure the selected value in the AOTC window.

Note

- You can select only one value at a time. Multiple selections are disabled.
- Additional value buttons are visible only if the number of trends configured is less than the maximum number of trends allowed (8 values).
- Additional value buttons will be disabled if the configured values in the AOTC reaches its maximum allowed limit.

(11) Enabling/disabling a value axis

Click the button next to the I/O field of the unit to enable or disable the value axis. The value itself will stay in the Trend Control, only the value axis will be hidden from the Trend Control.

2.3 Functions of the faceplates

The AOTC full screen display is used to display configured trend groups on a dedicated screen. The AOTC full screen window has four quadrants which means you can display four different trend groups at a time. This window is termed as "Quad trend window" or "Full screen display".

Perform the following steps to display the trend groups in "Full screen display":

1. Click the AOTC full screen display button at the bottom of the WinCC runtime window.



The AOTC full screen display opens with four empty quadrants and with four buttons at the bottom to select a saved trend group for each quadrant.

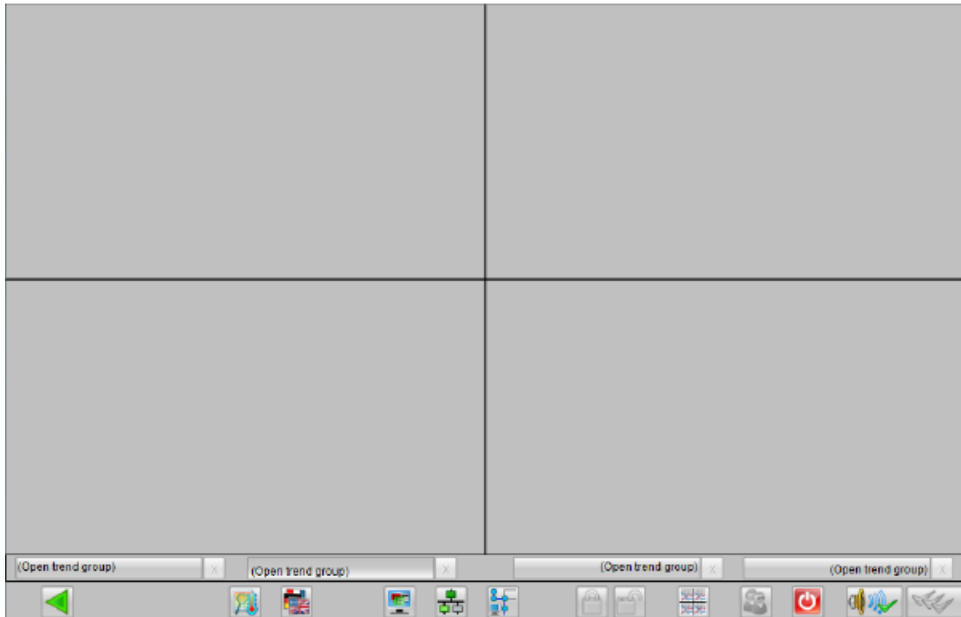

2. Click the "(open trend group)" button at the bottom of the AOTC full screen display for the quadrant in which you want to display a particular trend group. A window opens with a list of saved trend groups.

3. Select a trend group from the list and click "Display" to load the trend group into the corresponding quadrant.
4. Use all four buttons to load four different trend groups into the different quadrants of the full screen display.



(13) Opening a separate message window

Press the "Messages" button to open a new message window which displays the messages for the selected block types corresponding to the trends added in the AOTC window.

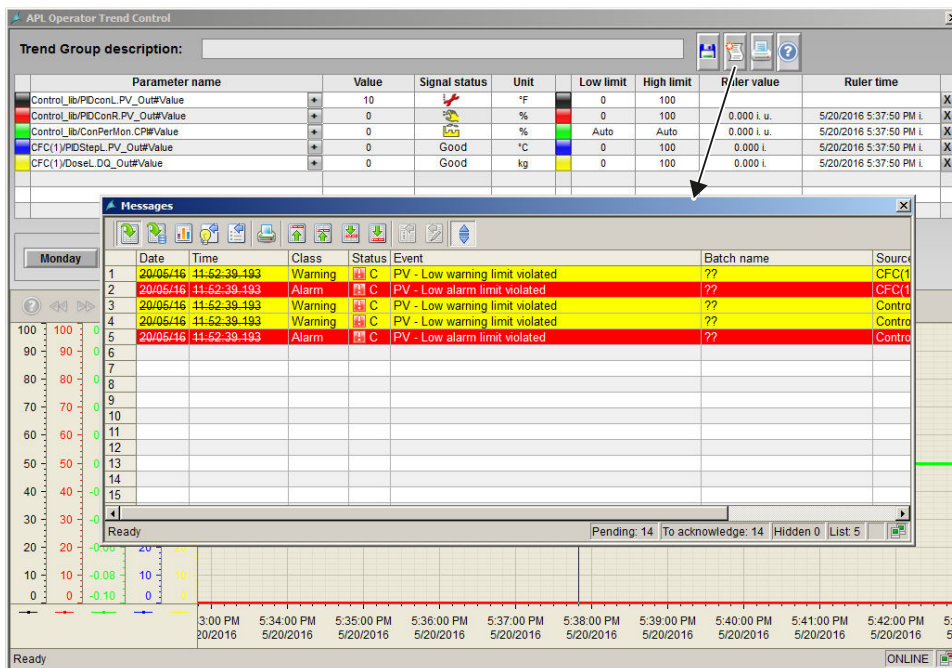

In the online mode, only the actual messages (all active messages, acknowledged and unacknowledged) will be displayed.

If you select a time range displaying values from the archive, the message window will display all the messages within this time range.

Messages only from the enabled trend will be displayed. If a trend is enabled or disabled and the message window is open, the corresponding messages will be displayed or not displayed accordingly. Similarly if a trend is deleted, the corresponding messages will disappear from the messages window.

If two or more trends of the same block type are added to the AOTC window, and one of them is disabled, the corresponding messages will not be removed from message window. All the trends should be disabled or deleted to remove the corresponding messages from the message window.

Only one message window can be opened at a time. If one more AOTC window is opened and you want to display the messages for the values in that window, the already opened message view should be closed and opened again from the specific AOTC window.

(14) Printing screenshot of the AOTC window

Press the "Print" button to print the screenshot of the complete AOTC window. WinCC runtime (also the Web Navigator) should be in full screen mode without scroll bar. As screenshot is taken from the process picture visible in runtime, the AOTC window should be visible completely in the runtime, otherwise the screenshot will show only the visible section of the AOTC faceplate.

(15) Help button

Click this button to open the AOTC chapter in the *APL Operator Guide* online help. You will find detailed information about the AOTC window and its functionalities in this online help.

(16) Deleting a trend

Click the "X" button at the end of the row in the overview area to delete existing values.

The corresponding trend is removed from the Trend Control. In the overview area, the rows below the deleted row are moved up and an empty row is added at the end.

New values are added to the first empty row.

(17) Closing the AOTC window

Click the "Close" button in the title bar to close the AOTC window.

Operator permissions

The operator permissions are similar to the existing online trend function.

The following fields are enabled only if the area authorization is available:

1. Delete buttons to delete trends.
2. Save button to open the pop-up window to save the trend group.
3. Field to enter the trend group name in the pop-up window.
4. Field to enter the trend group description in the pop-up window.
5. Checkbox to select private trend group.
6. The "OK" button to save the trend in the pop-up window.

Note



The functions for example, disable/enable trend, disable/enable value axis, delete trend, open message window, print AOTC screenshot, select private trend group, need no operation area or quitting function. The feature "Save Trend Group" needs an operation area where only 3 step operation is possible. It does not support 2 step operation.

2.3.25 Limit operation and display in the faceplate

Limit operation and display in the faceplate

The limit value view of the faceplate can be used to modify limits and the hysteresis if the corresponding operating permission (higher process controlling) is available. The limits are displayed graphically in the standard view of the faceplate.

If the limits are reached or exceeded, an alarm, warning or tolerance class message is triggered. This is indicated graphically as follows:

Symbol	Meaning
	Alarm
	Warning
	Tolerance

Note

The symbols displayed are not valid for user-configured message classes. For user-configured message classes, the colors and abbreviations depend on the project-specific setting. Please take into consideration the validity of terms for user-configured message classes (Page 41).

See also

User-configured message classes (Page 41)

2.3.26 Central color management

Central color management

As of version 8.1, the colors in the faceplates and block icons can be changed centrally via the central color palette in WinCC. The central color palette is located in the "User interface and design" tab of the project properties.

The following colors cannot be changed via the central color palette:

- The colors (except trend colors) of WinCC Alarm Control, WinCC Online Trend Control, WinCC Ruler Control and WinCC Function Control.
- The window titles can only be changed by editing the Windows designs.
- The colors of check boxes cannot be changed.
- Alarm colors are changed via the PCS 7 message system.
- Trend colors are not automatically changed in the block icons in existing projects, because these properties are changeable instance-specific and not in the update mechanisms for the block icons.

The user can use a color spectrum of 0-199; the APL color spectrum begins with the color index 200.

Description of the APL color index:

Color index for block icons

The following color indexes can be created for block icons.

Color index	Section	Transparency	HTML code (RGB)	Color name	Description	Property(ies) [attribute name]	Type block icons
200	1	0	B6B6B6	Gray	Background: Background color	BackgroundColor	Block icons with analog values
201	1	0	DADADA	Very light gray	Background: Fill pattern color	BackgroundFillColor	Block icons with analog values
202	1	0	B6B6B6	Gray	Tag display: Background color	TagBackColor	All block icons with tag display
203	1	0	DADADA	Very light gray	Tag display: Fill pattern color	TagFillColor	All block icons with tag display
204	1	0	919191	Dark gray	Tag display: Border color	TagBorderColor	All block icons with tag display
205	1	0	000000	Black	Tag display: Font color	TagFontColor	All block icons with tag display
206	1	0	00FFFA	Pure cyan	Tag highlight: Background color	BlockIconHighlight-BackColor	All block icons

Color index	Section	Transparency	HTML code (RGB)	Color name	Description	Property(ies) [attribute name]	Type block icons
207	1	0	5CC2BC	Medium cyan	Tag highlight: Fill pattern color	BlockIconHighlightFillColor	All block icons
208	1	0	FFFFFF	White	Tag highlight: Font color	BlockIconHighlightFontColor	All block icons
209	1	0	B6B6B6	Gray	Display of high limit: Background color	LimitObjectHighBackColor	Block icons with display of the high limit
210	1	0	DADADA	Very light gray	Display of high limit: Fill pattern color	LimitObjectHighFillColor	Block icons with display of the high limit
211	1	0	B6B6B6	Gray	Display of the low limit: Background color	LimitObjectLowBackColor	Block icons with display of the low limit
212	1	0	DADADA	Very light gray	Display of the low limit: Fill pattern color	LimitObjectLowFillColor	Block icons with display of the low limit
213	1	0	B6B6B6	Gray	Empty rectangle: Background color	EmptyRectBackColor ¹	Block icons with status bar
214	1	0	DADADA	Very light gray	Empty rectangle: Fill pattern color	EmptyRectFillColor ¹	Block icons with status bar
215	1	0	808080	Dark gray	Empty rectangle: Border color	EmptyRectBorderColor ¹	Block icons with status bar
216	1	0	FFFFFF	White	Process value: Background color	Value1BackColorValue10BackColor	Block icons with analog value
217	1	0	000000	Black	Process value: Font color	Value1FontColorValue10FontColor	Block icons with analog value
218	1	100	C0C0C0	None (transparent)	Setpoint: Background color	Value2BackColor	Block icons with analog value
219	1	0	0000FF	Pure blue	Setpoint: Font color	Value2FontColor	Block icons with analog value
220	2	100	C0C0C0	None (transparent)	Changed variable: Background color	Value3BackColor	Block icons with analog value
221	2	0	F24F00	Pure orange	Changed variable: Font color	Value3FontColor	Block icons with analog value
222	2	100	C0C0C0	None (transparent)	Read-back value: Background color	Value3BackColor Value4BackColor	Block icons with analog value
223	2	0	008080	Dark cyan	Read-back value: Font color	Value3FontColor Value4FontColor	Block icons with analog value
224	2	100	B6B6B6	None (transparent)	Unit ² , process value/setpoint: Background color	UnitBackColor, Unit1BackColor-Unit4BackColor	Block icons with analog value
225	2	0	494949	Very dark gray	Unit, process value/setpoint: Font color	UnitFontColor, Unit1FontColor-Unit4FontColor	Block icons with analog value

2.3 Functions of the faceplates

Color index	Section	Transparency	HTML code (RGB)	Color name	Description	Property(ies) [attribute name]	Type block icons
226	2	100	B6B6B6	None (transparent)	Unit ² , changed variable: Background color	Unit2BackColor	Block icons with analog value
227	2	0	494949	Very dark gray	Unit, changed variable: Font color	Unit2FontColor	Block icons with analog value
228	2	100	B6B6B6	None (transparent)	Unit ² , read-back value: Background color	Unit1BackColor, Unit2BackColor	Block icons with analog value
229	2	0	494949	Very dark gray	Unit, read-back value: Font color	Unit1FontColor, Unit2FontColor	Block icons with analog value
230	2	0	6D6D6D	Very dark gray	"Not used" state: background color	BackColorOn1	Interlock
231	2	0	919191	Dark gray	"Not used" state: fill pattern color	FillColorOn1	Interlock
232	2	0	0000FF	Pure blue	"Bypassed" state: background color	BackColorOn2	Interlock
233	2	0	00A2E8	Pure blue	"Bypassed" state: fill pattern color	FillColorOn2	Interlock
234	2	0	E4D400	Pure yellow	"Simulation" state: background color	BackColorOn3	Interlock
235	2	0	FFFF00	Pure yellow	"Simulation" state: fill pattern color	FillColorOn3	Interlock
236	2	0	00B500	Bright lime green	"Unlocked" state: background color	BackColorOn4	Interlock
237	2	0	00FF00	Pure lime green	"Unlocked" state: fill pattern color	FillColorOn4	Interlock
238	2	0	E60000	Pure red	"Locked" state: background color	BackColorOn5	Interlock
239	2	0	FF0000	Pure red	"Locked" state: fill pattern color	FillColorOn5	Interlock
240	3	0	00B500	Bright lime green	"On" state: Background color	BackColorOn, OnBackColor	Family counter / MonDi08/ MonDiL-MonDiS (type 1 and 4) / OpDi03 / ShrdResS/ Time-Trig/ TotalL
241	3	0	00FF00	Pure lime green	"On" state: Fill pattern color	FillColorOn, OnFillColor	
242	3	0	00FF00	Pure lime green	"On" state: Background color	Value2BackColor	OpDi01, OpTrig
243	3	0	000000	Black	"On" state: Font color	Value2FontColor	OpDi01, OpTrig
244	3	0	FFFFFF	White	"On" state: Background color	Value2BackColor	MonDiL-MonDiS (types 2, 3 and 5)
245	3	0	000000	Black	"On" state: Font color	Value2FontColor	MonDiL-MonDiS (types 2, 3 and 5)
246	3	0	FFFFFF	White	"On" state: Font color	FontColorOn	MonDiL-MonDiS (type 4)

Color index	Section	Transparency	HTML code (RGB)	Color name	Description	Property(ies) [attribute name]	Type block icons
247	3	0	B6B6B6	Gray	"Off" state: Background color	BackColorOff, BackColorOn	
248	3	0	DADADA	Very light gray	"Off" state: Fill pattern color	FillColorOff, FillColorOn	
249	3	0	DADADA	Very light gray	"Off" state: Background color	BackColorOff	Family counter, MonDi08, Time-Trig
250	3	0	FFFFFF	White	"Off" state: Fill pattern color	FillColorOff	Family counter, MonDi08, Time-Trig
251	3	0	FFFFFF	White	"Off" state: Background color	Value1BackColor	MonDiLMonDiS (types 2, 3 and 5)
252	3	0	000000	Black	"Off" state: Font color	Value1FontColor	MonDiLMonDiS (types 2, 3 and 5)
253	3	0	000000	Black	"Off" state: Font color	FontColorOff	MonDiLMonDiS (type 4)
254	3	0	B6B6B6	Gray	"Not used" state: Background color	BackColorNA	MonDi08
255	3	0	000000	Black	"No operation" state: Font color	ForeColorValue	OpStations
256	3	0	C0C0C0	Light gray	Display of the selected analog value: Background color	Value2BackColor	SelA16In
257	3	0	6D6D6D	Very dark gray	Display of the selected analog value: Font color	Value2FontColor	SelA16In
258	3	0	494949	Very dark gray	ISO/DIN symbols: Line color	BorderColor	

¹ New property

² Note: The pattern in the block icon must be changed to "single color" for the color to take effect.

Color indexes for faceplates

The following color indexes can be created for faceplates.

Color index	Section	Transparency	HTML code (RGB)	Color name	Description	Property(ies) [attribute name]	Types views/ objects
259	3	0	AFAFAF	Gray	View: Background color	BackColor	Views in all faceplates
260	4	0	DEDEDE	Very light gray	View: Fill pattern color	FillColor	Views in all faceplates
261	4	0	62ACAA	Dark cyan	Operating area: Background color	BackColor	Total operating area
262	4	0	AACFCD	Gray cyan	Operating area: Fill pattern color	FillColor	Total operating area

2.3 Functions of the faceplates

Color index	Section	Transparency	HTML code (RGB)	Color name	Description	Property(ies) [attribute name]	Types views/ objects
263	4	0	000000	Black	Title or label of operating area: Font color	ForeColor	All static texts in the operating area
264	4	0	C0C0C0	Light gray	Slider operating area: Background color	BackColor, BackColorTop, BackColorBottom, ButtonColor, HighLimitColor, LowLimitColor	Operating area "@PG_APL_OA_Analogwithlimits100.PDL"
265	4	0	FFFFFF	White	Slider operating area: Border background color	BorderBackColor	Operating area "@PG_APL_OA_Analogwithlimits100.PDL"
266	4	0	000000	Black	Slider operating area: Border color	BorderColor	Operating area "@PG_APL_OA_Analogwithlimits100.PDL"
267	4	0	DADADA	Very light gray	Block comment: Fill pattern color	FillColor	Header in all faceplates
268	4	0	808080	Dark gray	Block comment: Border color	BorderColor	Header in all faceplates
269	4	0	000000	Black	Block comment: Font color	FontColor	Header in all faceplates
270	4	0	B6B6B6	Gray	Empty rectangle overview: Background color	BackColor	Header in all faceplates
271	4	0	DADADA	Very light gray	Empty rectangle overview: Fill pattern color	FillColor	Header in all faceplates
272	4	0	808080	Dark gray	Empty rectangle overview: Border color	BorderColor	Header in all faceplates
273	4	0	C0C0C0	Light gray	Group display overview: Background color	BackColor	Header in all faceplates [1]
274	4	0	C0C0C0	Light gray	Toolbar button: Background color	BackColor	Header in all faceplates
275	4	0	BABABA	Gray	Toolbar button: Fill pattern color	FillColor	Header in all faceplates
276	4	0	808080	Dark gray	Toolbar button: Border color	BorderColor	Header in all faceplates
277	4	0	000000	Black	Toolbar button: Font color	FontColor	Header in all faceplates [2]
278	4	0	C0C0C0	Light gray	Header button[3]: Background color	BackColor	Header in all faceplates
279	4	0	808080	Dark gray	Toolbar button: Border color	BorderColor 8	Header in all faceplates
280	5	0	000000	Black	Title or label in views: Font color	TextFontColor, FontColor, ForeColor, LeftHandTextFontColor[4]	Views with static text and APL objects with type ID=17-20, 22-24, 27, 29, 64, 120, 130

Color index	Section	Transparency	HTML code (RGB)	Color name	Description	Property(ies) [attribute name]	Types views/objects
281	5	0	AFAFAF	Gray	Button in views/operating areas: Background color	BackColor	Views with APL objects with type ID=30-34, 50-52
282	5	0	CECECE	Light gray	Button in views/operating areas: Fill pattern color	FillColor	Views with APL objects with type ID=30-34, 50-52
283	5	0	808080	Dark gray	Button in views/operating areas: Border color	BorderColor	Views with APL objects with type ID=30-34, 50-52
284	5	0	FFFFFF	White	Button in views/operating areas: 3D border color	BorderColorTop	Views with APL objects with type ID=30-34, 50-52
285	5	0	808080	Dark gray	Button in views/operating areas: 3D shadow color	BorderColorBottom	Views with APL objects with type ID=30-34, 50-52
286	5	0	000000	Black	Button in views/operating areas: Font color	ForeColor	Views with APL objects with type ID=30-34, 50-52
287	5	0	DADADA	Very light gray	Analog value enabled in views/operating areas: Background color	EnabledBackColor, BackColor, BackColor_OK	Views with I/O fields (also extended) and APL objects with type ID=20, 22-24, 27, 28-29, 130
288	5	0	FFFFFF	White	Analog value enabled in views/operating areas: Fill pattern color	EnabledFillColor, FillColor, FillColor_OK	Views with I/O fields (also extended) and APL objects with type ID=20, 22-24, 27, 28-29, 130
289	5	0	B6B6B6	Gray	Analog value disabled in views/operating areas: Background color	DisabledBackColor, BackColor, BackColor_OK	Views with I/O fields (also extended) and APL objects with type ID=20, 22-24, 27, 28-29, 91 ¹³ , 92, 130
290	5	0	DADADA	Very light gray	Analog value disabled in views/operating areas: Fill pattern color	DisabledFillColor, FillColor, FillColor_OK	Views with I/O fields (also extended) and APL objects with type ID=20, 22-24, 27, 28-29, 91 ¹³ , 92, 130
291	5	0	000000	Black	Analog value or unit in views/operating areas: Font color	ValueFontColor, ForeColor, ForeColor_OK	Views with I/O fields (also extended) and APL objects with type ID=16, 20, 22-24, 27, 28-29, 91, 130

2.3 Functions of the faceplates

Color index	Section	Transparency	HTML code (RGB)	Color name	Description	Property(ies) [attribute name]	Types views/ objects
292	5	0	00B500	Bright lime green	Analog process value: Border color	LineColor, BorderColor	Views with I/O fields (also extended) and APL objects with type ID=20, 24
293	5	0	0000FF	Pure blue	Analog setpoint: Border color	LineColor, BorderColor	Views with I/O fields (also extended) and APL objects with type ID=20, 28
294	5	0	D27A00	Bright orange	Changed analog variable: Border color	LineColor, BorderColor	Views with I/O fields (also extended) and APL objects with type ID=20, 24, 28
295	5	0	008582	Dark cyan	Analog read-back value: Border color	LineColor, BorderColor	Views with I/O fields (also extended) and APL objects with type ID=20
296	5	0	808080	Dark gray	Analog parameter/ range value: border color	LineColor, BorderColor	Views with I/O fields (also extended) and APL objects with type ID=20, 22-24, 27, 28, 90, 92, 130
297	5	0	000000	Black	Analog limit (no alarm), input value, offset, gradient: border color	LineColor, BorderColor	In "@PG_CntOhSc_Limit.PDL", "@PG_MonAnL_Standard.PDL", "@PG_Ratio_Standard.PDL", "@PG_Total_Standard.PDL" APL objects with type ID=20, 24, 28, 29 and HMISStaticText
298	5	0	808080	Dark gray	Empty analog value displays	BorderColor	Views with APL objects with type ID=21, 25, 26
299	5	0	00B500	Bright lime green	Binary value on: Background color	OnBackColor, State1BackColor	Views with APL objects with type ID=17, 18 ¹³ , 120
300	6	0	00FF00	Pure lime green	Binary value on: Fill pattern color	OnFillColor, State1FillColor	Views with APL objects with type ID=17, 18 ¹³ , 120

Color index	Section	Transparency	HTML code (RGB)	Color name	Description	Property(ies) [attribute name]	Types views/ objects
301	6	0	FFFFFF	White	Binary value on: Font color	OnFontColor, State1FontColor	Views with APL objects with type ID=17,18 ¹³ ,120
302	6	0	FFFFFF	White	Binary value off: Background color	OffBackColor, State2BackColor	Views with APL objects with type ID=17,18 ¹³ ,120
303	6	0	DADADA	Very light gray	Binary value off: Fill pattern color	OffFillColor, State2FillColor	Views with APL objects with type ID=17,18 ¹³ ,120
304	6	0	000000	Black	Binary value off: Font color	OffFontColor, State2FontColor	Views with APL objects with type ID=17,18 ¹³ ,120
305	6	0	808080	Dark gray	Binary value: Border color	BorderColor	Views with APL objects with type ID=17,18 ¹³ ,120
306	6	0	B6B6B6	Gray	Binary value preview: Background color	BackColor	Preview, APL objects with type ID=14
307	6	0	DADADA	Very light gray	Binary value preview: Fill pattern color	FillColor	Preview, APL objects with type ID=14
308	6	0	000000	Black	Binary value preview: Font color	FontColor	Preview, APL objects with type ID=14
309	6	0	808080	Dark gray	Binary value preview: Border color	BorderColor	Preview, APL objects with type ID=14
310	6	0	00B500	Bright lime green	Status display "On" mode: background color	State1BackColor... State7BackColor	Standard view, APL objects with type ID=11
311	6	0	00FF00	Pure lime green	Status display "On" mode: fill pattern color	State1FillColor... State7FillColor	Standard view, APL objects with type ID=11
312	6	0	FFFFFF	White	Status display "On" mode: font color	State1FontColor... State7FontColor	Standard view, APL objects with type ID=11
313	6	0	FFFFFF	White	Status display "Manual" mode: background color	State1BackColor... State7BackColor	Standard view, APL objects with type ID=11
314	6	0	CECECE	Light gray	Status display "Manual" mode: fill pattern color	State1FillColor... State7FillColor	Standard view, APL objects with type ID=11
315	6	0	000000	Black	Status display "Manual" mode: font color	State1FontColor... State7FontColor	Standard view, APL objects with type ID=11
316	6	0	00FF00	Pure lime green	Status display "Automatic" mode: background color	State1BackColor... State7BackColor	Standard view, APL objects with type ID=11

2.3 Functions of the faceplates

Color index	Section	Transparency	HTML code (RGB)	Color name	Description	Property(ies) [attribute name]	Types views/ objects
317	6	0	008500	Dark lime green	Status display "Automatic" mode: fill pattern color	State1FillColor... State7FillColor	Standard view, APL objects with type ID=11
318	6	0	FFFFFF	White	Status display "Automatic" mode: font color	State1FontColor... State7FontColor	Standard view, APL objects with type ID=11
319	6	0	00CECA	Bright cyan	Status display "Local" mode: background color	State1BackColor... State7BackColor	Standard view, APL objects with type ID=11
320	7	0	00FFFA	Pure cyan	Status display "Local" mode: fill pattern color	State1FillColor... State7FillColor	Standard view, APL objects with type ID=11
321	7	0	000000	Black	Status display "Local" mode: font color	State1FontColor... State7FontColor	Standard view, APL objects with type ID=11
322	7	0	0000FF	Pure blue	Status display "Programm MV/SP" mode: background color	State1BackColor... State7BackColor	Standard view, APL objects with type ID=11
323	7	0	98BDFF	Very light blue	Status display "Programm MV/SP" mode: fill pattern color	State1FillColor... State7FillColor	Standard view, APL objects with type ID=11
324	7	0	FFFFFF	White	Status display "Programm MV/SP" mode: font color	State1FontColor... State7FontColor	Standard view, APL objects with type ID=11
325	7	0	919191	Dark gray	Status display "Out of service" mode: background color	State1BackColor... State7BackColor	Standard view, APL objects with type ID=11
326	7	0	CECECE	Light gray	Status display "Out of service" mode: fill pattern color	State1FillColor... State7FillColor	Standard view, APL objects with type ID=11
327	7	0	000000	Black	Status display "Out of service" mode: font color	State1FontColor... State7FontColor	Standard view, APL objects with type ID=11
328	7	0	808080	Dark gray	Status display operating mode: Border color	BorderColor	Standard view, APL objects with type ID=11
329	7	0	FFFFFF	White	Status display control command "Stop"/"Close"/"Off"/"Pause"/"Cancel"/"Requested"/"No": background color	State1BackColor... State7BackColor	Mostly standard/parameter view/preview, APL objects with type ID=10, 11, 15
330	7	0	DADADA	Very light gray	Status display control command "Stop"/"Close"/"Off"/"Pause"/"Cancel"/"Requested"/"No": fill pattern color	State1FillColor... State7FillColor	Mostly standard/parameter view/preview, APL objects with type ID=10, 11, 15

Color index	Section	Transparency	HTML code (RGB)	Color name	Description	Property(ies) [attribute name]	Types views/ objects
331	7	0	000000	Black	Status display control command "Stop"/"Close"/"Off"/"Pause"/"Cancel"/"Requested"/"No": font color	State1FontColor... State7FontColor	Mostly standard/parameter view/preview, APL objects with type ID=10, 11, 15
332	7	0	00B500	Bright lime green	Status display control command "Start"/"Open"/"On"/"Continue"/"Active"/"ready"/"Yes": background color	State1BackColor... State7BackColor	Mostly standard/parameter view/preview, APL objects with type ID=10, 11, 15, 19
333	7	0	00FF00	Pure lime green	Status display control command "Start"/"Open"/"On"/"Continue"/"Active"/"ready"/"Yes": fill pattern color	State1FillColor... State7FillColor	Mostly standard/parameter view/preview, APL objects with type ID=10, 11, 15, 19
334	7	0	FFFFFF	White	Status display control command "Start"/"Open"/"On"/"Continue"/"Active"/"ready"/"Yes": font color	State1FontColor... State7FontColor	Mostly standard/parameter view/preview, APL objects with type ID=10, 11, 15, 19
335	7	0	FF0000	Pure red	Status display control command "Rapid stop": background color	State1BackColor... State7BackColor	Standard view, APL objects with type ID=10, 15
336	7	0	FF8296	Very light red	Status display control command "Rapid stop": fill pattern color	State1FillColor... State7FillColor	Standard view, APL objects with type ID=10, 15
337	7	0	000000	Black	Status display control command "Rapid stop": font color	State1FontColor... State7FontColor	Standard view, APL objects with type ID=10, 15
338	7	0	FFFFFF	White	Status display control command "Internal": background color	State1BackColor... State7BackColor	Standard view, APL objects with type ID=11
339	7	0	CECECE	Light gray	Status display control command "Internal": fill pattern color	State1FillColor... State7FillColor	Standard view, APL objects with type ID=11
340	8	0	000000	Black	Status display control command "Internal": font color	State1FontColor... State7FontColor	Standard view, APL objects with type ID=11
341	8	0	0000FF	Pure blue	Status display control command "External": background color	State1BackColor... State7BackColor	Standard view, APL objects with type ID=10, 11, 15
342	8	0	98BDFF	Very light blue	Status display control command "External": fill pattern color	State1FillColor... State7FillColor	Standard view, APL objects with type ID=10, 11, 15
343	8	0	FFFFFF	White	Status display control command "External": font color	State1FontColor... State7FontColor	Standard view, APL objects with type ID=10, 11, 15

2.3 Functions of the faceplates

Color index	Section	Transparency	HTML code (RGB)	Color name	Description	Property(ies) [attribute name]	Types views/ objects
344	8	0	808080	Dark gray	Status display control command: Border color	BorderColor	Standard view, APL objects with type ID=10, 11, 15
345	8	0	000000	Black	Status display error ("End position error", "Control error", "Invalid Signal", "Changeover error", "Motor protection", "Torque active", "External error", "CPI invalid", "Changeover error", "Fluttering"): Background color	BackColor, State1BackColor... State7BackColor	Standard view, mostly APL objects with type ID=12
346	8	0	919191	Dark gray	Status display error ("End position error", "Control error", "Invalid Signal", "Changeover error", "Motor protection", "Torque active", "External error", "CPI invalid", "Changeover error", "Fluttering"): Fill pattern color	FillColor, State1FillColor... State7FillColor	Standard view, mostly APL objects with type ID=12
347	8	0	FFFF00	Pure yellow	Status display error ("End position error", "Control error", "Invalid Signal", "Changeover error", "Motor protection", "Torque active", "External error", "CPI invalid", "Changeover error", "Fluttering"): Font color	FontColor, State1FontColor... State7FontColor	Standard view, mostly APL objects with type ID=12
348	8	0	919191	Dark gray	Status display AS block state ("Forced", "Request 0/1", "Tracking", "Optimizing", "Output ..."[5], "Fuzzy...", "Safety mode", "End", "Taring", "Dribbling", "Paused", "Off"[6], "... Trigger", "Disabled", "SP/MV ramp active"): Background color	BackColor, State1BackColor... State7BackColor	Standard view, mostly APL objects with type ID=12, 13

Color index	Section	Transparency	HTML code (RGB)	Color name	Description	Property(ies) [attribute name]	Types views/ objects
349	8	0	DADADA	Very light gray	Status display AS block state ("Forced", "Request 0/1", "Tracking", "Optimizing", "Output ..."[7], "Fuzzy...", "Safety mode", "End", "Taring", "Dribbling", "Paused", "Off"[8], "... Trigger", "Disabled", "SP/MV ramp active"): Fill pattern color	FillColor, State1FillColor... State7FillColor	Standard view, mostly APL objects with type ID=12, 13
350	8	0	000000	Black	Status display AS block state ("Forced", "Request 0/1", "Tracking", "Optimizing", "Output ..."[9], "Fuzzy...", "Safety mode", "End", "Taring", "Dribbling", "Paused", "Off"[10], "... Trigger", "Disabled", "SP/MV ramp active"): Font color	FontColor, State1FontColor... State7FontColor	Standard view, mostly APL objects with type ID=12, 13
351	8	0	FF0000	Pure red	Status display alarm ("Flow", "Underdosed", "Overdosed"): Background color	BackColor, State1BackColor... State7BackColor	Standard view, mostly APL objects with type ID=12, 13
352	8	0	FFFFFF	White	Status display alarm ("Flow", "Underdosed", "Overdosed"): Fill pattern color	FillColor, State1FillColor... State7FillColor	Standard view, mostly APL objects with type ID=12, 13
353	8	0	000000	Black	Status display alarm ("Flow", "Underdosed", "Overdosed"): Font color	FontColor, State1FontColor... State7FontColor	Standard view, mostly APL objects with type ID=12, 13
354	8	0	00B500	Dark lime green	Status display enabled ("On"[11], "Enabled", "... dosing"): Background color	BackColor, State1BackColor... State7BackColor	Standard view, mostly APL objects with type ID=12, 13, 15
355	8	0	00FF00	Pure lime green	Status display enabled ("On"[12], "Enabled", "... dosing"): Fill pattern color	FillColor, State1FillColor... State7FillColor	Standard view, mostly APL objects with type ID=12, 13, 15
356	8	0	FFFFFF	White	Status display enabled ("On"[13], "Enabled", "... dosing"): Font color	FontColor, State1FontColor... State7FontColor	Standard view, mostly APL objects with type ID=12, 13, 15
357	8	0	DADADA	Very light gray	Status display disabled ("Off"[14]): Background color	BackColor, State1BackColor... State7BackColor	Standard view, mostly APL objects with type ID=12, 13, 15

2.3 Functions of the faceplates

Color index	Section	Transparency	HTML code (RGB)	Color name	Description	Property(ies) [attribute name]	Types views/ objects
358	8	0	FFFFFF	White	Status display disabled ("Off"): Fill pattern color	FillColor, State1FillColor... State7FillColor	Standard view, mostly APL objects with type ID=12, 13, 15
359	8	0	000000	Black	Status display disabled ("Off"): Font color	FontColor, State1FontColor... State7FontColor	Standard view, mostly APL objects with type ID=12, 13, 15
360	9	0	FFFA00	Pure yellow	Status display important AS block information ("Simulation", "Process excitation", "Time delay"): Background color	BackColor, State1BackColor... State7BackColor	Standard/parameter view, mostly APL objects with type ID=12, 13
361	9	0	FFFFFF	White	Status display important AS block information ("Simulation", "Process excitation", "Time delay"): Fill pattern color	FillColor, State1FillColor... State7FillColor	Standard/parameter view, mostly APL objects with type ID=12, 13
362	9	0	000000	Black	Status display important AS block information ("Simulation", "Process excitation", "Time delay"): Font color	FontColor, State1FontColor... State7FontColor	Standard/parameter view, mostly APL objects with type ID=12, 13
363	9	0	0000FF	Pure blue	Status display maintenance ("Maintenance"): Background color	BackColor, State1BackColor... State7BackColor	Standard view, mostly APL objects with type ID=12, 13
364	9	0	96BBFF	Very light blue	Status display maintenance ("Maintenance"): Fill pattern color	FillColor, State1FillColor... State7FillColor	Standard view, mostly APL objects with type ID=12, 13
365	9	0	000000	Black	Status display maintenance ("Maintenance"): Font color	FontColor, State1FontColor... State7FontColor	Standard view, mostly APL objects with type ID=12, 13
366	9	0	808080	Dark gray	Status display error, ..., Maintenance: Border color	BorderColor	Standard view / preview, mostly APL objects with type ID=11-13, 15
367	9	0	DADADA	Very light gray	Interlock, display of input values (BOOL): Background color	BackColor	Standard view interlock, APL objects with type ID=100
368	9	0	CECECE	Light gray	Interlock, display of input values (BOOL): Fill pattern color	FillColor	Standard view interlock, APL objects with type ID=100

Color index	Section	Transparency	HTML code (RGB)	Color name	Description	Property(ies) [attribute name]	Types views/ objects
369	9	0	000000	Black	Interlock, display of input values (BOOL): Font color	FontColor	Standard view interlock, APL objects with type ID=100
370	9	0	808080	Dark gray	Interlock, display of input values (BOOL): Border color	BorderColor	Standard view interlock, APL objects with type ID=100
371	9	0	919191	Dark gray	Interlock, display of input values (BOOL): Background color separator	SeparatorBackColor	Standard view interlock, APL objects with type ID=100
372	9	0	00FF00	Pure lime green	Interlock, status "1" for further processing: Background color	SetBackColor	Standard view interlock, APL objects with type ID=101
373	9	0	00B500	Dark lime green	Interlock, status "1" for further processing: Fill pattern color	SetFillColor	Standard view interlock, APL objects with type ID=101
374	9	0	FFFFFF	White	Interlock, status "0" for further processing: Background color	ResetBackColor	Standard view interlock, APL objects with type ID=101
375	9	0	B6B6B6	Gray	Interlock, status "0" for further processing: Fill pattern color	ResetFillColor	Standard view interlock, APL objects with type ID=101
376	9	0	0000FF	Pure blue	Interlock, status "Bypassed" (excluded) for further processing: Background color	BypassBackColor	Standard view interlock, APL objects with type ID=101
377	9	0	00A2E8	Pure blue	Interlock, status "Bypassed" (excluded) for further processing: Fill pattern color	BypassFillColor	Standard view interlock, APL objects with type ID=101
378	9	0	FFFFFF	White	Interlock, status for further processing: Font color	ForeColor	Standard view interlock, APL objects with type ID=101
379	9	0	6D6D6D	Very dark gray	Interlock, status for further processing: Border color	BorderColor	Standard view interlock, APL objects with type ID=101
380	10	0	B6B6B6	Gray	Interlock, "Not used" status of the output signal of the interlock block: Background color	Set5BackColor	Standard view interlock, APL objects with type ID=103

2.3 Functions of the faceplates

Color index	Section	Transparency	HTML code (RGB)	Color name	Description	Property(ies) [attribute name]	Types views/ objects
381	10	0	DADADA	Very light gray	Interlock, "Not used" status of the output signal of the interlock block: Fill pattern color	Set5FillColor	Standard view interlock, APL objects with type ID=103
382	10	0	0000FF	Pure blue	Interlock, "Not used" status of the output signal of the interlock block: Background color	Set4BackColor	Standard view interlock, APL objects with type ID=103
383	10	0	00A2E8	Pure blue	Interlock, "Not used" status of the output signal of the interlock block: Fill pattern color	Set4FillColor	Standard view interlock, APL objects with type ID=103
384	10	0	E4D400	Pure yellow	Interlock, "Simulation" status of the output signal of the interlock block: Background color	Set2BackColor	Standard view interlock, APL objects with type ID=103
385	10	0	FFFF00	Pure yellow	Interlock, "Simulation" status of the output signal of the interlock block: Fill pattern color	Set2FillColor	Standard view interlock, APL objects with type ID=103
386	10	0	00B500	Bright lime green	Interlock, "Unlocked" status of the output signal of the interlock block: Background color	Set1BackColor	Standard view interlock, APL objects with type ID=103
387	10	0	00FF00	Pure lime green	Interlock, "Unlocked" status of the output signal of the interlock block: Fill pattern color	Set1FillColor	Standard view interlock, APL objects with type ID=103
388	10	0	E60000	Pure red	Interlock, "Locked" status of the output signal of the interlock block: Background color	Set3BackColor	Standard view interlock, APL objects with type ID=103
389	10	0	FF0000	Pure red	Interlock, "Locked" status of the output signal of the interlock block: Fill pattern color	Set3FillColor	Standard view interlock, APL objects with type ID=103
390	10	0	000000	Black	Interlock, status of the output signal of the interlock block: Font color	ForeColor	Standard view interlock, APL objects with type ID=103
391	10	0	919191	Dark gray	Interlock, status of the output signal of the interlock block: Border color	BorderColor	Standard view interlock, APL objects with type ID=103
392	10	0	850082	Dark magenta	Interlock, "First signal" status display: Background color	BackColor	Standard view interlock, APL objects with type ID=102

Color index	Section	Transparency	HTML code (RGB)	Color name	Description	Property(ies) [attribute name]	Types views/ objects
393	10	0	CD51FF	Light purple	Interlock, "First signal" status display: Fill pattern color	FillColor	Standard view interlock, APL objects with type ID=102
394	10	0	808080	Dark gray	Interlock, "First signal" status display: Border color	BorderColor	Standard view interlock, APL objects with type ID=102
395	10	0	00B500	Bright lime green	Interlock, "Unlocked" status of the block output: Line color	OnStateColor	Standard view interlock, APL objects with type ID=104
396	10	0	FFFFFF	White	Interlock, "Locked" status of the block output: Line color	OffStateColor	Standard view interlock, APL objects with type ID=104
397	10	0	B6B6B6	Gray	Interlock, block rectangle: Background color	BackgroundColor	Standard view interlock, HMIRectangle
398	10	0	DADADA	Very light gray	Interlock, block rectangle: Fill pattern color	FillPatternColor	Standard view interlock, HMIRectangle
399	10	0	919191	Dark gray	Interlock, block rectangle: Border color	BorderColor	Standard view interlock, HMIRectangle
400	11	0	00B500	Bright lime green	Bar chart, analog process value: Background color	ValueColor	Standard/setpoint view, APL objects with type ID=71
401	11	0	00FF00	Pure lime green	Bar chart, analog process value: Fill pattern color	ValueFillColor	Standard/setpoint view, APL objects with type ID=71
402	11	0	0000FF	Pure blue	Bar chart, analog setpoint: Background color, foreground color	ValueColor, FontColor	Standard/setpoint view, APL objects with type ID=70, 80, 81
403	11	0	98BDFF	Very light blue	Bar chart, analog setpoint: Fill pattern color	ValueFillColor	Standard/setpoint view, APL objects with type ID=70
404	11	0	D27A00	Bright orange	Bar chart, changed analog variable: Background color, foreground color	ValueColor, FontColor	Standard view, APL objects with type ID=72, 82, 83
405	11	0	FFC848	Light orange	Bar chart, changed analog variable: Fill pattern color	ValueFillColor	Standard view, APL objects with type ID=72
406	11	0	008582	Dark cyan	Bar chart, analog read-back value: Background color	ValueColor	Standard view, APL objects with type ID=71, 73

2.3 Functions of the faceplates

Color index	Section	Transparency	HTML code (RGB)	Color name	Description	Property(ies) [attribute name]	Types views/ objects
407	11	0	00CECA	Bright cyan	Bar chart, analog read-back value: Fill pattern color	ValueFillColor	Standard view, APL objects with type ID=71, 73
408	11	0	008582	Dark cyan	Bar chart, predicted value: Background color	ValueColor	Standard view, APL objects with type ID=75
409	11	0	00CECA	Bright cyan	Bar chart, predicted value: Fill pattern color	ValueFillColor	Standard view, APL objects with type ID=75
410	11	0	000000	Black	Bar chart, message gradient value or limit (without alarm): Background color	ValueColor, AlarmColor, WarningColor	Standard view, APL objects with type ID=74 or 71[15]
411	11	0	6D6D6D	Very dark gray	Bar chart, gradient value: Fill pattern color	ValueFillColor	Standard view, APL objects with type ID=74
412	11	0	808080	Dark gray	Bar chart: Border color	BorderColor	Standard/setpoint view, APL objects with type ID=7075
413	11	0	62ACAA	Mostly unsaturated dark cyan	Selection rectangle operation: Background color	BackgroundColor	All views with operation, HMIRectangle object name "rect_selectionBorder"
414	11	0	B1CFCD	Gray cyan	Selection rectangle operation: Fill pattern color	FillColor	All views with operation, HMIRectangle object name "rect_selectionBorder"
415	11	0	808080	Dark gray	Selection rectangle operation: Border color	BorderColor	All views with operation, HMIRectangle object name "rect_selectionBorder"
416	11	0	808080	Dark gray	Dividing line: Border color	BorderColor	All views with dividing line, HMILine

[1] Note: Also types without messages have an empty group display

[2] Note: Only important for the "Next" button

[3] "Lock"/"Acknowledgement"/"Attach"/"Back to process picture" buttons; "Attach" button in the operating area

[4] In the standard view Ratio

[5] Used in type ID = 17, 18, 120

[6] In the standard view DoseL

[7] In the standard view Ratio

[8] In the standard view DoseL

[9] In the standard view Ratio

[10] In the standard view DoseL

[11] In the standard view OpDi01, OpDi03, display the confirmation of the command

[12] In the standard view OpDi01, OpDi03, display the confirmation of the command

[13] Not used, only in @PCS7ElementsAPL.pdl

[14] In the standard view OpDi01, OpDi03, display the confirmation of the command

[15] In @PG_CntOhSc_Standard.PDL

Color indexes for trends

The following color indexes can be created for trends:

Color index	Section	Transparency	HTML code (RGB)	Color name	Description	Property(ies) [attribute name]	Type block icons
417	11	0	00CE00	Bright lime green	Actual value	TrendColor1 - TrendColor12	Trend view
418	11	0	0000FF	Pure blue	Setpoint	TrendColor1 - TrendColor12	Trend view
419	11	0	E69100	Pure orange	Changed variable	TrendColor1 - TrendColor12	Trend view
420	12	0	008582	Dark cyan	Read-back value	TrendColor1 - 1TrendColor12	Trend view
421	12	0	00CE00	Bright lime green	Controller, closed loop	TrendColor8	Trend view controller
422	12	0	000000	Black	Controller, input for control performance index (CPI)	TrendColor7	Trend view controller
423	12	0	000000	Black	Controller, binary message "violated"	TrendColor3, TrendColor4, TrendColor9, TrendColor10	Trend view controller
424	12	0	B100B5	Bright magenta	Controller, control performance index (CPI)	TrendColor1	Trend view ConPerMon
425	12	0	E69100	Pure orange	Ratio, analog input "In"	TrendColor1	Trend view Ratio
426	12	0	00FF00	Pure lime green	Ratio, input for process variable "InPV"	TrendColor2	Trend view Ratio
427	12	0	0000FF	Pure blue	Ratio, process value of the secondary component "SecCompPV"	TrendColor3	Trend view Ratio
428	12	0	B100B5	Bright magenta	Ratio, output "Out"	TrendColor4	Trend view Ratio
429	12	0	FF0000	Pure red	Ratio, current ratio "RatioPV"	TrendColor5	Trend view Ratio

2.3 Functions of the faceplates

Color index	Section	Transparency	HTML code (RGB)	Color name	Description	Property(ies) [attribute name]	Type block icons
430	12	0	6D6D6D	Very dark gray	Ratio, applied ratio (RatioInt or RatioExt) "RatioOut"	TrendColor6	Trend view Ratio
431	12	0	009D00	Dark lime green	Dosing, dosing amount	TrendColor3	Trend view Dosing
432	12	0	FF0000	Pure red	Monitoring, gradient value	TrendColor2	Trend view MonAnL
433	12	0	E69100	Pure orange	Monitoring, output 1	TrendColor1	Trend view MonDi08, MonDiL, MonDiS
434	12	0	00CE00	Bright lime green	Monitoring, output 2	TrendColor2	Trend view MonDi08
435	12	0	0000FF	Pure blue	Monitoring, output 3	TrendColor3	Trend view MonDi08
436	12	0	B100B5	Bright magenta	Monitoring, output 4	TrendColor4	Trend view MonDi08
437	12	0	FF0000	Pure red	Monitoring, output 5	TrendColor5	Trend view MonDi08
438	12	0	494949	Very dark gray	Monitoring, output 6	TrendColor6	Trend view MonDi08
439	12	0	543500	Very dark orange	Monitoring, output 7	TrendColor7	Trend view MonDi08
440	13	0	005400	Very dark lime green	Monitoring, output 8	TrendColor8	Trend view MonDi08
441	13	0	00CE00	Bright lime green	Monitoring, flutter value	TrendColor2	Trend view MonDiL
442	13	0	E69100	Pure orange	Operation, binary output / binary output 1	TrendColor1	Operation, trend view binary
443	13	0	494949	Very dark gray	Operation, binary output 2	TrendColor2	Operation, trend view binary
444	13	0	0000FF	Pure blue	Operation, binary output 3	TrendColor3	Operation, trend view binary
445	13	0	B100B5	Bright magenta	Operation, binary feedback 1	TrendColor4	Operation, trend view binary
446	13	0	FF0000	Pure red	Operation, binary feedback 2	TrendColor5	Operation, trend view binary
447	13	0	00CE00	Bright lime green	Operation, binary feedback / binary feedback 3	TrendColor2, TrendColor6	Operation, trend view binary
448	13	0	0000FF	Pure blue	Actuators, valve control output	TrendColor1 - TrendColor4, TrendColor6	Trend view Valve
449	13	0	000000	Black	Actuators, valve feedback open	TrendColor1	Trend view Valve
450	13	0	6D6D6D	Very dark gray	Actuators, valve feedback close	TrendColor2	Trend view Valve

Color index	Section	Transparency	HTML code (RGB)	Color name	Description	Property(ies) [attribute name]	Type block icons
451	13	0	005400	Very dark lime green	Actuators, valve feedback	TrendColor1, TrendColor3, TrendColor5, TrendColor7	Trend view Viv2WayL
452	13	0	E69100	Pure orange	Actuators, open valve output	TrendColor1	Trend view VivMotL
453	13	0	00CE00	Bright lime green	Actuators, close valve output	TrendColor2	Trend view VivMotL
454	13	0	0000FF	Pure blue	Actuators, valve feedback open	TrendColor3	Trend view VivMotL
455	13	0	B100B5	Bright magenta	Actuators, valve feedback close	TrendColor4	Trend view VivMotL
456	13	0	FF0000	Pure red	Actuators, valve feedback open	TrendColor5	Trend view VivMotL
457	13	0	005400	Very dark lime green	Actuators, valve feedback close	TrendColor6	Trend view VivMotL
458	13	0	E69100	Pure orange	Actuators, motor start output	TrendColor1	Trend view MotL/MotS
459	13	0	00CE00	Bright lime green	Actuators, motor feedback	TrendColor2	Trend view MotL/MotS
460	14	0	E69100	Pure orange	Drives, motor start Speed1 / forward	TrendColor1	Trend view MotSpdL/MotRevL/MotSpdCL
461	14	0	00CE00	Bright lime green	Drives, motor start Speed2 / reverse	TrendColor2	Trend view MotSpdL/MotRevL/MotSpdCL
462	14	0	0000FF	Pure blue	Drives, feedback Speed1 / forward	TrendColor3	Trend view MotSpdL/MotRevL
463	14	0	B100B5	Bright magenta	Drives, feedback Speed2 / reverse	TrendColor4	Trend view MotSpdL/MotRevL
464	14	0	00FFFA	Pure cyan	Drives, feedback forward	TrendColor3	Trend view MotSpdCL
465	14	0	B100B5	Bright magenta	Drives, feedback reverse	TrendColor4	Trend view MotSpdCL
466	14	0	E69100	Pure orange	Count: Output	TrendColor1	Trend view Counter
467	14	0	E69100	Pure orange	Count / time: Unit on	TrendColor1	CountOh / Time-Trig
468	14	0	005400	Very dark lime green	Count / time: Count type	TrendColor7	CountOh / Time-Trig
469	14	0	E69100	Pure orange	Count / time: Count type	TrendColor1	Trend view CntOhSc
470	14	0	00CE00	Bright lime green	Count / time: Unit on	TrendColor2	Trend view CntOhSc
471	14	0	005400	Very dark lime green	Count: Service life	TrendColor7	Trend view CntOhSc

2.3 Functions of the faceplates

Color index	Section	Transparency	HTML code (RGB)	Color name	Description	Property(ies) [attribute name]	Type block icons
472	14	0	6D6D6D	Very dark gray	Count: Count	TrendColor8	Trend view CntOhSc
473	14	0	0000FF	Pure blue	Statusdisplay operation command - Release for Maintenance ("Yes"): background color	State1BackColor	Mostly In Parameter view APL objects with Type-ID=11
474	14	0	FFFFFF	White	Statusdisplay operation command - Release for Maintenance ("Yes"): filling pattern color	State1FillColor	Mostly In Parameter view APL objects with Type-ID=11
475	14	0	FFFFFF	White	Statusdisplay operation command -Release for Maintenance ("Yes"): font color	State1FontColor	Mostly In Parameter view APL objects with Type-ID=11
476	14	0	919191	Dark gray	Statusdisplay ("Not Ready", "None", "No"): background color	State1BackColor... State7BackColor	Mostly In ShrdResS Standard \Preview view APL objects with TypeID=11,19
477	14	0	DADADA	Very light gray	Statusdisplay ("Not Ready", "None", "No"): filling pattern color	State1FillColor... State7FillColor	Mostly In ShrdResS Standard \Preview view APL objects with TypeID=11,19
478	14	0	000000	Black	Statusdisplay ("Not Ready", "None", "No"): font color	State1FontColor... State7FontColor	Mostly In ShrdResS Standard \Preview view APL objects with TypeID=11,19

¹ For example, PIDConL "PV_ToleHi#Value", ".MV_HiAct#Value"

² ModPreCon=@PG_APL_TrendMPC.PDL; MPC10x10=@PG_APL_TrendMPC_L.PDL

Note

If these colors were changed only via the OS project editor, the default values can be assigned again.

2.4 PCS 7 measuring point browser

2.4.1 Overview of the "PCS 7 measuring point browser" window

Overview

The "PCS 7 measuring point browser" window displays all relevant status information of the APL function blocks.

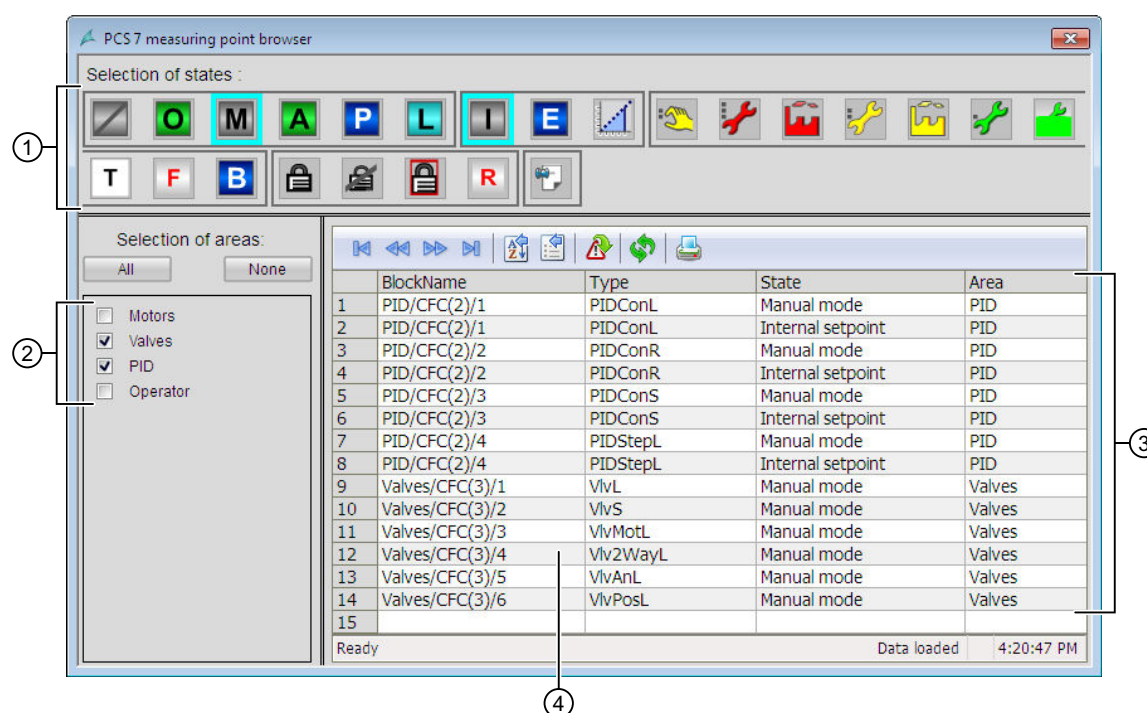





(1) "Selection of states"

This area displays all possible states of APL function blocks. All state icons are shown in their respective status group frames. The group name is displayed in the tooltip when the mouse pointer is hovered in the area between the state icon and the group frame. You can select/deselect one or more states from any status group by clicking the icon. The status information of the selected states is displayed in the status area.

The following states are displayed in this area:

Icon	State	Status group
	Out of service	Operating mode
	On mode	
	Manual mode	
	Automatic mode	
	Program mode	
	Local mode	
	Internal setpoint	Setpoint
	External setpoint	
	Ramp active	
	Manipulated value	Signal status
	Bad, device-related	
	Bad, process-related	
	Uncertain, device-related	
	Uncertain, process-related	
	Maintenance request	
	In progress	
	Tracking	Tracking, Forcing and Bypass
	Forcing	
	Bypass	

Icon	State	Status group
	Interlock active	Interlock
	Interlock disabled	
	Rapid stop	
	Reset request	
	Active memo	Memo

(2) "Selection of areas"

This area displays the top folders of the plant hierarchy. You can select/deselect one or more areas. The status information from the selected areas is displayed in the status area.

(3) Status area

This area shows the list of blocks with their corresponding "Type", "State", and "Area" depending on the "Selection of states" and "Selection of areas".

(4) Opening the faceplate

Double-click a row in the status area to open the corresponding faceplate.

Operator control blocks

3.1 Comparison of large & small blocks

3.1.1 OpAnL compared to OpAnS

Comparison of the OpAnL and OpAnS blocks

The following tables are intended to help you decide which block to use.

Memory and runtime savings of the small block compared to the large block

You save the following resources for each instance:

- Memory space: ~ 60%
- Runtime: ~ 30%

Block operating modes

	OpAnL	OpAnS
On (Page 71)	X	X
Out of service (Page 71)	X	X

Functions of the blocks

	OpAnL	OpAnS
Setpoint specification - internal/external (Page 128)	X	X
Setpoint limiting for external setpoints (Page 196)	X	
Using setpoint ramp (Page 123)	X	
Gradient limit of the setpoint (Page 124)	X	
Forming and outputting the signal status for technologic blocks (Page 109)	X	X
Selecting a unit of measure (Page 212)	X	X
Simulating signals (Page 58)	X	X
Operator control permissions (Page 254)	X	X

3.1 Comparison of large & small blocks

	OpAnL	OpAnS
Display and operator input area for process values and setpoints (Page 207)	X	
Opening additional faceplates (Page 208)	X	X
SIMATIC BATCH functionality (Page 67)	X	X
Generating instance-specific messages (Page 204)	X	
Suppressing messages using the MsgLock parameter (Page 205)	X	
Process value with separate scale range (Page 162)	X	

Configurable functions using the Feature parameter

Bit number	Feature bit function	OpAnL	OpAnS
0	Set startup characteristics (Page 138)	X	X
1	Reaction to the out of service mode (Page 177)	X	X
16	Process value with separate scale range (Page 162)	X	
22	Update acknowledgment and error status of the message call (Page 160)	X	
24	Enabling local operator authorization (Page 158)	X	X
26	Reaction of the switching points in the "Out of service" operating mode (Page 176)	X	X

See also

Manual and automatic mode for control blocks (Page 72)

3.2 OpAnL - Check and output analog signals (large)

3.2.1 Description of OpAnL

Object name (type + number) and family

Type + number: FB 1865

Family: Operate

Area of application for OpAnL

The block is used for the following applications:

- Checking and transferring analog input values

How it works

The block checks incoming, internal (entered in the faceplate) or external (CFC/SFC) analog signals for their limits at the `SP_Int` or `SP_Ext` input and forwards them to the output `SP`, depending on the setting of the `SP_LiOp` input parameter.

Configuration

Use the CFC editor to install the block in a cyclic interrupt OB (OB30 to OB38). The block is also installed automatically in the startup OB (OB100).

Startup characteristics

Use the `Feature Bit Set` startup characteristics (Page 138) to define the startup characteristics of this block.

The messages are suppressed after startup for the number of cycles set at `RunUpCyc`.

Status word allocation for `status1` parameter

For a description of the individual parameters, see the section `OpAnL I/Os` (Page 354).

Status bit	Parameter
0	Occupied
1	BatchEn
2	Not used
3	<code>OosAct.Value</code>
4	<code>OosLi.Value</code>
5	Not used
6	<code>OnAct.Value</code>
7	<code>SP_UpRaAct</code> , <code>SP_DnRaAct</code> limits enabled for gradient mode (<code>SP_RateOn = 1</code>)

3.2 OpAnL - Check and output analog signals (large)

Status bit	Parameter
8	SP_ExtAct.Value
9	SP_LoAct.Value
10	SP_HiAct.Value
11 - 13	Not used
14	SP_RmpOn
15	SP_RmpModTime
16 - 17	Not used
18	Feature Bit 16
19 - 21	Not used
22	1 = SP ramp active
23 - 31	Not used

See also

- OpAnL functions (Page 349)
- OpAnL messaging (Page 352)
- OpAnL block diagram (Page 359)
- OpAnL error handling (Page 352)
- OpAnL modes (Page 348)

3.2.2 OpAnL modes

OpAnL modes

The block can be operated using the following modes:

- On (Page 71)
- Out of service (Page 71)

"On"

General information on the "On" mode is available in the section On (Page 71).

"Out of service"

You can find general information about the "Out of service" mode in the section Out of service (Page 71).

See also

- OpAnL I/Os (Page 354)
- OpAnL messaging (Page 352)

OpAnL error handling (Page 352)

Description of OpAnL (Page 347)

OpAnL functions (Page 349)

OpAnL block diagram (Page 359)

3.2.3 OpAnL functions

Functions of OpAnL

The functions for this block are listed below.

Suppressing messages using the MsgLock parameter

This block provides the standard function Suppressing messages using the MsgLock parameter (Page 205)

Internal or external setpoint selection

This block provides the standard function Setpoint specification - internal/external (Page 128).

Setpoint limitation

Use the `SP_HiLim` and `SP_LoLim` input parameters to limit the setpoint to maximum and minimum limits. If a limit is violated, the setpoint is limited to the limits you have set. If the limits are infringed, the output parameters `SP_HiAct` and `SP_LoAct` display 1.

Using setpoint ramp

This block provides the standard function Using setpoint ramp (Page 123).

Gradient limit of the setpoint

This block provides the standard function Gradient limit of the setpoint (Page 124).

Forming the signal status for blocks

This block provides the standard function Forming and outputting the signal status for technologic blocks (Page 109).

The worst signal status `ST_Worst` for the block is formed from the following parameters:

- `SP_Out.ST`
- `PV_In.ST`
- `SP_Ext.ST` (only if `Feature.Bit10 = 1`)

3.2 OpAnL - Check and output analog signals (large)

The signal status of the SP_Out output parameter is always equivalent to the signal status of input parameter SP_Ext or SP_Int, depending on how the setpoint is specified. If the internal setpoint SP_Int is used, the signal status is always output as 16#80.

In case of Feature.Bit10 = 1, SP_Ext.ST influences ST_Worst independent of setpoint specification.

If an external setpoint is used, the signal status 16#60 (external simulation) is suppressed because the block acts as a sink with external simulation.

Considering bad quality of automatic commands or external values

If the Feature bit Considering bad quality of automatic commands or external values (Page 186) is set to 1 and the parameter SP_Ext has bad signal status (16#00 or 16#28), the block works with the last valid value of SP_Ext in the "On" mode.

Selecting a unit of measure

This block provides the standard function Selecting a unit of measure (Page 212).

Simulating signals

This block provides the standard function Simulating signals (Page 58).

Configurable reactions using the Feature parameter

You can find an overview of all reactions provided by the Feature parameter in the Configurable functions using the Feature I/O (Page 131) . The following functionality is available for this block at the relevant bits:

Bit	Function
0	Set startup characteristics (Page 138)
1	Reaction to the out of service mode (Page 177)
6	Ramp rate calculation (Page 179)
10	Considering bad quality of automatic commands or external values (Page 186)
12	Gradient limitation with time duration (Page 182)
16	Process value with separate scale range (Page 162)
22	Update acknowledgment and error status of the message call (Page 160)
24	Enabling local operator authorization (Page 158)

Operator permissions

This block provides the standard function Operator control permissions (Page 254).

The block has the following permissions for the OS_Perm parameter:

Bit	Function
0	Not used
1	1 = Operator can switch to "On" mode

Bit	Function
2	Not used
3	1 = Operator can switch to "Out of service" mode
4 - 9	Not used
10	1 = Operator can switch to internal
11	1 = Operator can switch to external
12	1 = Operator can enable bumpless switchover
13	1 = Operator can change SP_Int
14	1 = Operator can enable SP_RateOn
15	1 = Operator can change SP_UpRaLim
16	1 = Operator can change SP_DnRaLim
17	1 = Operator can activate the setpoint ramp (SP_RmpOn)
18	1 = Operator can switch between specification of the duration (SP_RmpTime) and gradient (SP_DnRaLim, SP_UpRaLim) for calculating the ramp slope
19	1 = Operator can change the time for the setpoint ramp (SP_RmpTime)
20	1 = Operator can change the target setpoint (SP_RmpTarget)
21 - 31	Not used

Note

If you interconnect a parameter that is also listed in OS_Perm as a parameter, you have to reset the corresponding OS_Perm bit.

Specifying the display area for process and setpoint values as well as operations

The block provides the standard function Display and operator input area for process values and setpoints (Page 207).

Opening additional faceplates

The block provides the standard function Opening additional faceplates (Page 208).

SIMATIC BATCH functionality

The block provides the standard function SIMATIC BATCH functionality (Page 67).

See also

Description of OpAnL (Page 347)

OpAnL messaging (Page 352)

OpAnL I/Os (Page 354)

OpAnL block diagram (Page 359)

OpAnL error handling (Page 352)

OpAnL modes (Page 348)

3.2.4 OpAnL error handling

Error handling of OpAnL

Refer to the section Error handling (Page 119) in the basic instructions.

The following errors can be displayed for this block:

- Error numbers

Overview of error numbers

The `ErrorNum` I/O can be used to output the following error numbers:

Error number	Meaning of the error number
-1	Predefined value when inserting the block; the block is not processed.
0	There is no error.
51	Invalid signal <code>SP_LiOp = 1 and SP_ExtLi = 1 and SP_IntLi = 1</code>

See also

OpAnL block diagram (Page 359)

OpAnL I/Os (Page 354)

OpAnL messaging (Page 352)

OpAnL functions (Page 349)

OpAnL modes (Page 348)

Description of OpAnL (Page 347)

3.2.5 OpAnL messaging

Messaging

The following messages can be generated for this block:

- Process messages

Process messages

Message instance	Message identifier	Message class	Event
MsgEvId	SIG 1	AS process control message - fault	\$\$BlockComment\$\$ External message 1
	SIG 2	AS process control message - fault	\$\$BlockComment\$\$ External message 2
	SIG 3	AS process control message - fault	\$\$BlockComment\$\$ External message 3
	SIG 4	AS process control message - fault	\$\$BlockComment\$\$ External message 4
	SIG 5	Reserved	\$\$BlockComment\$\$ Reserved
	SIG 6	Reserved	\$\$BlockComment\$\$ Reserved
	SIG 7	Reserved	\$\$BlockComment\$\$ Reserved
	SIG 8	Reserved	\$\$BlockComment\$\$ Reserved

Explanation:

\$\$BlockComment\$\$: Content of the instance-specific comment

Associated values for message instance `MsgEvId`

Associated value	Block parameters
1	BatchName
2	StepNo
3	BatchID
4	ExtVa104
5	ExtVa105
6	ExtVa106
7	ExtVa107

The associated values 4 ... 7 are allocated to the parameters ExtVa104 ... ExtVa107 and can be used. Additional information is available in the "Process Control System PCS 7 - Engineering System" manual.

See also

OpAnL error handling (Page 352)

OpAnL modes (Page 348)

OpAnL block diagram (Page 359)

3.2.6 OpAnL I/Os

OpAnL I/Os

Input parameters

Parameter	Description	Type	Default
BatchEn	1 = Enable allocation	BOOL	0
BatchID	Batch ID	DWORD	16#00000000
BatchName	Batch name	S7-String	
EN	1 = Called block will be processed	BOOL	1
ExtMsg1	Binary input for freely selectable message 1	STRUCT <ul style="list-style-type: none"> • Value: BOOL • ST: BYTE 	- <ul style="list-style-type: none"> • 0 • 16#80
ExtMsg2	Binary input for freely selectable message 2	STRUCT <ul style="list-style-type: none"> • Value: BOOL • ST: BYTE 	- <ul style="list-style-type: none"> • 0 • 16#80
ExtMsg3	Binary input for freely selectable message 3	STRUCT <ul style="list-style-type: none"> • Value: BOOL • ST: BYTE 	- <ul style="list-style-type: none"> • 0 • 16#80
ExtMsg4	Binary input for freely selectable message 4	STRUCT <ul style="list-style-type: none"> • Value: BOOL • ST: BYTE 	- <ul style="list-style-type: none"> • 0 • 16#80
ExtVal04	Associated value 4 for messages (MsgEvID1)	ANY	
ExtVal05	Associated value 5 for messages (MsgEvID1)	ANY	
ExtVal06	Associated value 6 for messages (MsgEvID1)	ANY	
ExtVal07	Associated value 7 for messages (MsgEvID1)	ANY	
Feature	I/O for additional functions (Page 349)	STRUCT <ul style="list-style-type: none"> • Bit 0: BOOL • ... • Bit 31: BOOL 	- <ul style="list-style-type: none"> • 0 • 0 • 0
MsgEvId	Message number (assigned automatically)	DWORD	16#00000000
Occupied	1 = Occupied by batch control	BOOL	0
OnOp*	1 = "On" mode via operator	BOOL	0

Parameter	Description	Type	Default
OosLi	1 = "Out of service", via interconnection or SFC (0-1 edge transition)	STRUCT <ul style="list-style-type: none"> Value: BOOL ST: BYTE 	- <ul style="list-style-type: none"> 0 16#80
OosOp*	1 = "Out of service", via OS operator	BOOL	0
OpSt_In	Input parameter for local operating permission, connected with the Out output parameter of the upstream block, OpStations (Page 411)	DWORD	16#00000000
OS_Perm	I/O for operating permissions (Page 349)	STRUCT <ul style="list-style-type: none"> Bit 0: BOOL ... Bit 31: BOOL 	- <ul style="list-style-type: none"> 1 1 1
PV_In	Process value	STRUCT <ul style="list-style-type: none"> Value: REAL ST: BYTE 	- <ul style="list-style-type: none"> 0.0 16#80
PV_Unit	Unit of measure for process value	INT	1001
PV_OpScale*	OS display range for process value	STRUCT <ul style="list-style-type: none"> High: REAL Low: REAL 	- <ul style="list-style-type: none"> 100.0 0.0
RunUpCyc	Number of cycles in startup; messages are suppressed during these cycles	INT	3
SampleTime	Sampling time [s] (assigned automatically)	REAL	0.1
SP_DnRaLim*	Limit (low) for the gradient of the setpoint [Unit/Time unit] Time unit depends on TimeFactor	REAL	100.0
SP_Ext	external setpoint - (to interconnection)	STRUCT <ul style="list-style-type: none"> Value: REAL ST: BYTE 	- <ul style="list-style-type: none"> 0.0 16#80
SP_ExtLi	1 = Select internal setpoint (via interconnection)	STRUCT <ul style="list-style-type: none"> Value: BOOL ST: BYTE 	- <ul style="list-style-type: none"> 0 16#80
SP_ExtOp*	1 = Select external setpoint (via operator)	BOOL	0
SP_HiLim	Limit (high) of setpoint	REAL	100.0

3.2 OpAnL - Check and output analog signals (large)

Parameter	Description	Type	Default
SP_LiDnRaLim	Linkable limit (low) for the gradient of the setpoint [Unit/(Time unit)] Time unit depends on TimeFactor	REAL	100.0
SP_LiRmpTime	Linkable time [Time unit] for gradient limitation in ramp mode duration Time unit depends on TimeFactor	REAL	0.0
SP_LiUpRaLim	Linkable gradient limit (high) for the setpoint [Unit/(Time unit)] Time unit depends on TimeFactor	REAL	100.0
SP_LoLim	Limit (low) of setpoint	REAL	0.0
SP_Int*	Internal setpoint for operation	REAL	0.0
SP_IntLi	1 = Select internal setpoint (via interconnection)	STRUCT • Value: BOOL • ST: BYTE	- • 0 • 16#80
SP_IntOp*	1 = Select internal setpoint (via operator)	BOOL	1
SP_LiOp	Select internal/external setpoint source: 1 = Via interconnection 0 = Via operator	STRUCT • Value: BOOL • ST: BYTE	- • 0 • 16#80
SP_OpScale	OS display range for setpoint	STRUCT • High: REAL • Low: REAL	- 100.0 0.0
SP_RateOn	1 = Activate limitation of setpoint gradients	BOOL	0
SP_RmpModTime	1 = Use time values (SP_RmpTime, SP_LiRmpTime) 0 = Use gradient limits (SP_DnRaLim, SP_LiDnRaLim, SP_UpRaLim, SP_LiUpRaLim)	BOOL	0
SP_RmpOn*	1 = Activate setpoint ramp to target setpoint SP_RmpTarget	BOOL	0
SP_RmpTarget*	Target setpoint for setpoint ramp	REAL	0.0

Parameter	Description	Type	Default
SP_RmpTime*	Time [Time unit] for set-point ramp from current SP up to SP_RmpTarget or time [Time unit] for gradient limitation in ramp mode duration Time unit depends on TimeFactor	REAL	0.0
SP_TrkExt	1 = Bumpless switch-over from external to internal setpoint active	BOOL	0
SP_Unit	Unit of measure for setpoint	INT	1001
SP_UpRaLim*	Gradient limit (high) for the setpoint [Unit/ (Time unit)] Time unit depends on TimeFactor	REAL	100.0
SelFp1	Call a block saved in this parameter as an additional faceplate (Page 208) in the standard view	ANY	-
SelFp2	Call a block saved in this parameter as an additional faceplate (Page 208) in the preview	ANY	-
StepNo	Batch step number	DWORD	16#00000000
TimeFactor	Time unit: 0 = Seconds 1 = Minutes 2 = Hours	INT	0
UserStatus	Freely assignable bits for use in PCS 7 OS	BYTE	16#00

* Values can be written back to these inputs during processing of the block by the block algorithm.

Output parameters

Parameter	Description	Type	Default
ENO	1 = Block algorithm completed without errors	BOOL	0
ErrorNum	Output of current error number. For error numbers that can be output by this block, see OpAnL error handling (Page 352)	INT	-1
MsgAckn	Message acknowledgment status (output ACK_STATE of ALARM_8P)	WORD	16#0000
MsgErr	1 = Message error (output ERROR of ALARM_8P)	BOOL	0
MsgStat	Message status (output STATUS of ALARM_8P)	WORD	16#0000
OnAct	1 = "On" mode enabled	STRUCT <ul style="list-style-type: none"> Value: BOOL ST: BYTE 	- <ul style="list-style-type: none"> 1 16#80
OosAct	1 = Block is "Out of service"	STRUCT <ul style="list-style-type: none"> Value: BOOL ST: BYTE 	- <ul style="list-style-type: none"> 0 16#80
OpSt_Out	Value of the OpSt_In input parameter, for feedforwarding to other blocks. Bit 31 of this parameter is used by Feature Bit 24	DWORD	16#00000000
OS_PermLog	Display of OS_Perm with settings changed by the block algorithm	DWORD	16#FFFFFFFF
OS_PermOut	Display of OS_Perm	DWORD	16#FFFFFFFF
SP_Out	Setpoint used by controller	STRUCT <ul style="list-style-type: none"> Value: REAL ST: BYTE 	- <ul style="list-style-type: none"> 0.0 16#80
SP_DnRaAct	1 = Negative gradient limiting of setpoint is active	STRUCT <ul style="list-style-type: none"> Value: BOOL ST: BYTE 	- <ul style="list-style-type: none"> 0 16#80
SP_ExtAct	1 = External setpoint is active 0 = Internal setpoint is active	STRUCT <ul style="list-style-type: none"> Value: BOOL ST: BYTE 	- <ul style="list-style-type: none"> 0 16#80
SP_HiAct	High limit for SP_Ext or SP_Int reached or exceeded	STRUCT <ul style="list-style-type: none"> Value: BOOL ST: BYTE 	- <ul style="list-style-type: none"> 0 16#80

Parameter	Description	Type	Default
SP_LoAct	Low limit for SP_Ext or SP_Int reached or under-shot	STRUCT <ul style="list-style-type: none"> Value: BOOL ST: BYTE 	- <ul style="list-style-type: none"> 0 16#80
SP_RateTarget	Target setpoint for the gradient limitation	REAL	0.0
SP_UpRaAct	1 = Positive gradient limiting of setpoint is active	STRUCT <ul style="list-style-type: none"> Value: BOOL ST: BYTE 	- <ul style="list-style-type: none"> 0 16#80
SP_RemRT	Remaining ramp time of the setpoint	REAL	0.0
ST_Worst	Worst signal status	BYTE	16#80
Status1	Status word (Page 347)	DWORD	16#00000000

See also

- OpAnL messaging (Page 352)
- OpAnL block diagram (Page 359)
- OpAnL modes (Page 348)

3.2.7 OpAnL block diagram**OpAnL block diagram**

A block diagram is not provided for this block.

See also

- OpAnL I/Os (Page 354)
- OpAnL error handling (Page 352)
- OpAnL functions (Page 349)
- Description of OpAnL (Page 347)
- OpAnL modes (Page 348)
- OpAnL messaging (Page 352)

3.2.8 Operator control and monitoring

3.2.8.1 OpAnL views

Views of the OpAnL block

The block OpAnL provides the following views:

- OpAnL standard view (Page 360)
- Alarm view (Page 302)
- Trend view (Page 305)
- Ramp view (Page 300)
- OpAnL parameter view (Page 363)
- OpAnL preview (Page 365)
- Memo view (Page 304)
- Batch view (Page 302)
- Block icon for OpAnL (Page 366)

Refer to the sections Structure of the faceplate (Page 248) and Block icon structure (Page 230) for general information on the faceplate and block icon.

3.2.8.2 OpAnL standard view

OpAnL standard view

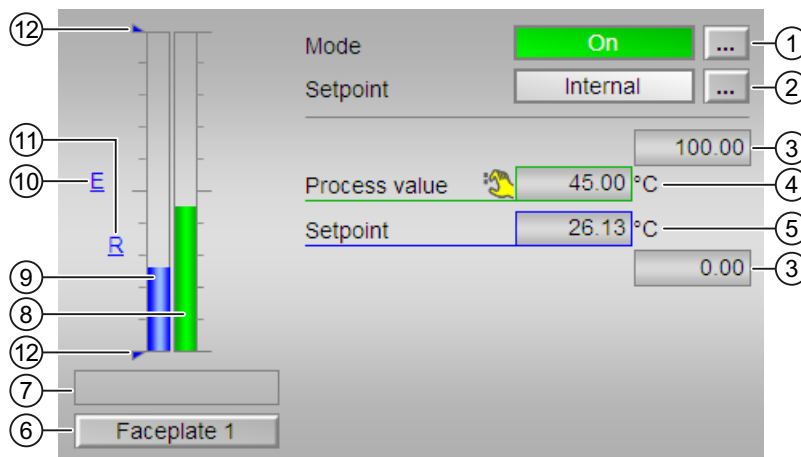

The view is switched depending on the Feature Bit 16 = 1 (process value with separate scale range)

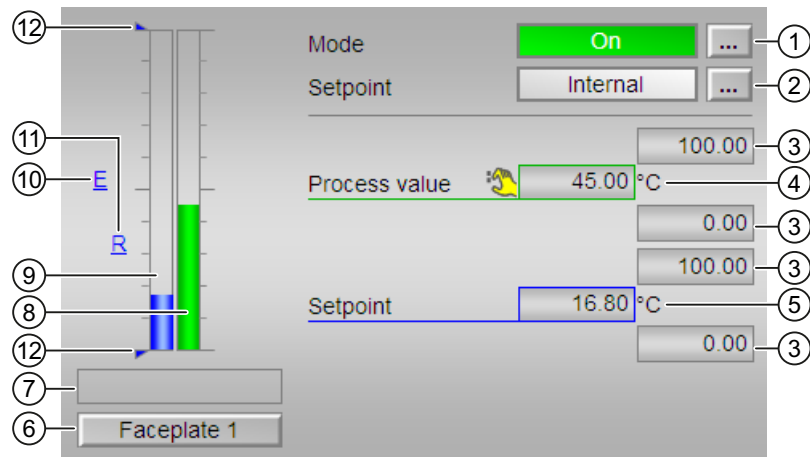

(1) Display and switch the operating mode

This area provides information on the currently valid operating mode. The following operating modes can be shown here:

- On (Page 71)
- Out of service (Page 71)

Refer to chapter Switching operating states and operating modes (Page 257) for information on switching the operating mode.

(2) Display and switch the setpoint specification

This area shows how to specify the setpoint. The setpoint can be specified as follows:

- By the application ("External", CFC/SFC)
- By the user directly in the faceplate ("Internal").

Refer to the Switching operating states and operating modes (Page 257) chapter for information on switching the setpoint specification.

You can find additional information on this in chapter Setpoint specification - internal/external (Page 128).

(3) High and low scale range for the process value and setpoint

These values provide information on the display range for the bar graph of the process value. The scale range is defined in the Engineering System.

(4) Display of the process value including signal status

This area shows the current process value with the corresponding signal status.

(5) Display and change the setpoint including signal status

This area shows the current setpoint with the corresponding signal status.

3.2 OpAnL - Check and output analog signals (large)

Refer to the Changing values (Page 259) chapter for information on changing the setpoint. The setpoint specification also needs to be set to "Internal" for this block.

(6) Navigation button for switching to the standard view of any faceplate

Use this navigation button to reach the standard view of a block configured in the Engineering System (ES). The visibility of this navigation button depends on the configuration in the Engineering System (ES).

Refer also to chapter Opening additional faceplates (Page 208) for more on this.

(7) Display area for block states

This area provides additional information on the operating state of the block:

- "SP ramp active"

(8) Bar graph for the process value

This area shows the current process value in the form of a bar graph. The visible area in the bar graph depends on the configuration in the Engineering System (ES).

(9) Bar graph for the setpoint

This area shows the current setpoint in the form of a bar graph. The visible area in the bar graph depends on the configuration in the Engineering System (ES).

(10) Display of external setpoint

This display [E] is only visible when you have selected "Internal" setpoint specification. It shows the external setpoint that would apply if you were to change the setpoint specification to "external".

(11) Display for the target setpoint of the setpoint ramp

This display [R] shows the target setpoint and is only visible if you have enabled ramp generation in the Ramp view (Page 300).

(12) Displaying the limits

These triangles show the `SP_HiLim` and `SP_LoLim` setpoint limits configured in the Engineering System (ES).

3.2.8.3 OpAnL parameter view

Parameter view of OpAnL

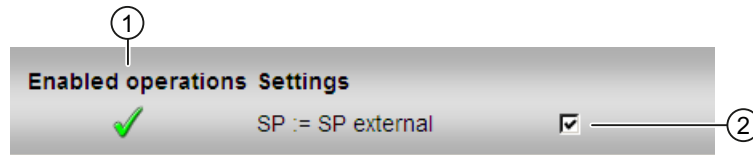

(1) Enabled operations

This area shows all operations for which special operator control permissions are assigned. They depend on the configuration in the engineering system (ES) that applies to this block.

Symbols for enabled operations:

- **Green check mark:** the OS operator can control this parameter
- **Gray check mark:** the OS operator cannot control this parameter at this time due to the process
- **Red cross:** the OS operator cannot control this parameter due to the configured AS operator control permissions (OS_Perm or OS1Perm).

(2) Settings

You can select the following functions in this area:

- "SP := SP external": Bumpless switchover of setpoint from external to internal. The internal setpoint is tracked to the external one.

3.2.8.4 OpAnL trend view

OpAnL trend view

You can find general information in section Trend view (Page 305).

3.2 OpAnL - Check and output analog signals (large)

Depending on feature bit 16 (process value with separate scale range) either one or two value axes are shown in the trend view.

- Process value with separate scale range

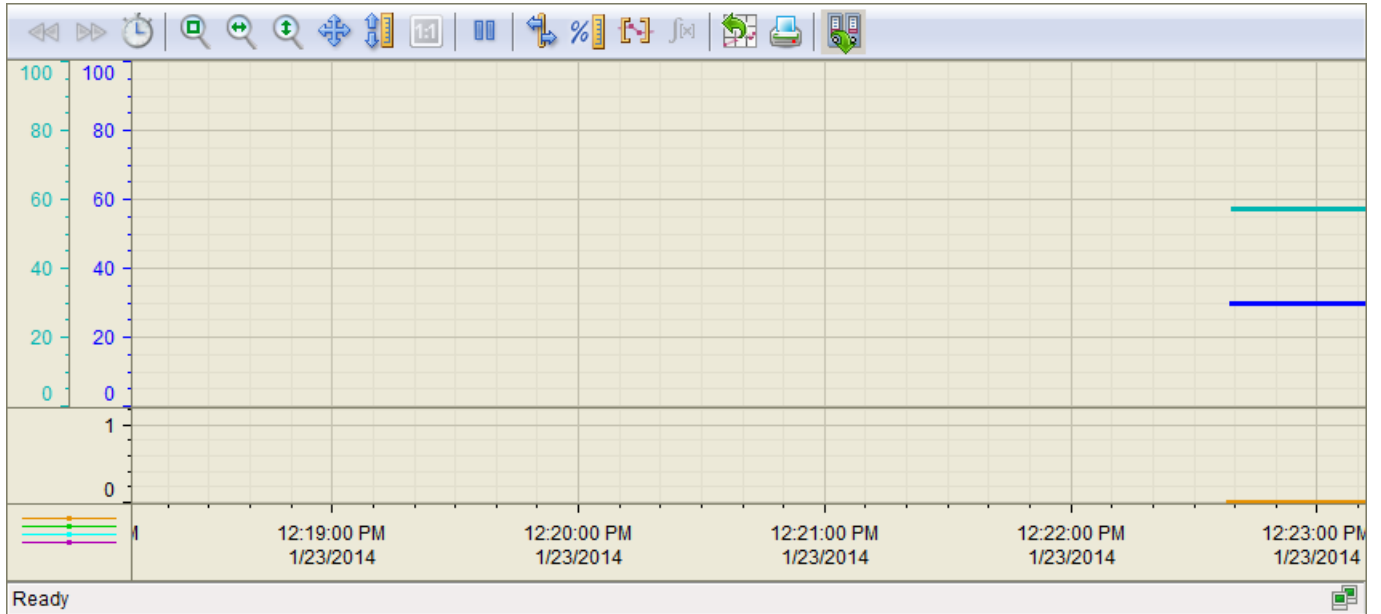

- Process value without separate scale range

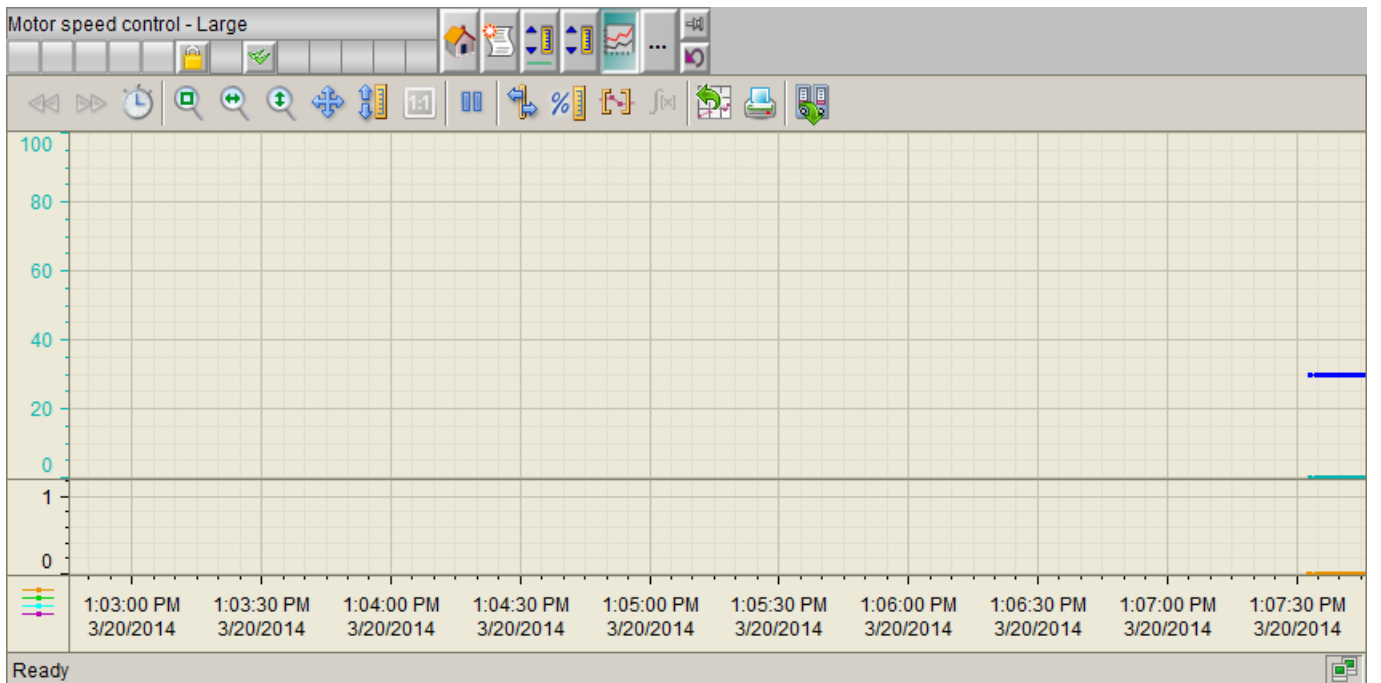

Note

This function only has an effect when `SP_Out` is configured in "TrendConfiguration1" and `PV_In` is configured in "TrendConfiguration2" in the block icon (default).

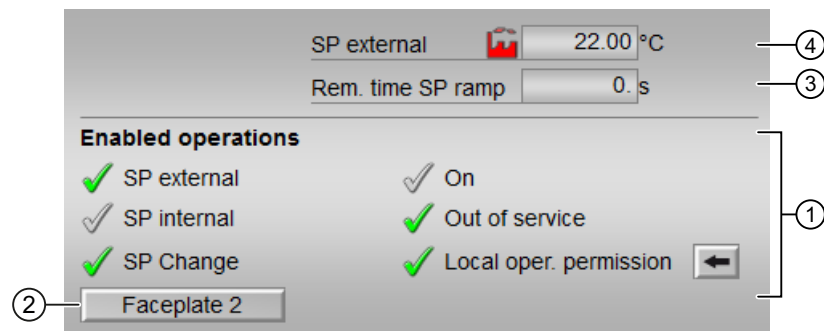
3.2.8.5 OpAnL preview**Preview of OpAnL****(1) Enable operations**

This area shows all operations for which special operator permissions are assigned. They depend on the configuration in the engineering system (ES) that applies to this block.

Icons for enabled operation:

- **Green check mark:** the OS operator can control this parameter
- **Gray check mark:** the OS operator cannot control this parameter at this time due to the process
- **Red cross:** the OS operator cannot control this parameter due to the configured AS operator permissions (`OS_Perm` or `OS1Perm`)

The following enabled operations are shown here:

- "SP external": You can feedforward the external setpoint.
- "SP internal": You can feedforward the internal setpoint.
- "Change SP": You can change the setpoint.
- "On": You can switch to "On" operating mode.
- "Out of service": You can switch to "Out of service" operating mode.
- "Local operator permission": Use the ← button to switch to the standard view of the OpStations block. You can find additional information on this in the section Operator control permissions (Page 254).

(2) Navigation button for switching to the standard view of any faceplate

Use this navigation button to open the standard view of a block configured in the engineering system (ES). The visibility of this navigation button depends on the configuration in the engineering system (ES).

See also the section Opening additional faceplates (Page 208) for more on this.

(3) Remaining time to reach SP ramp

- "Rem. time SP ramp" : Remaining time to reach the ramp target value.

(4) SP external

Currently applicable external setpoint with the corresponding signal status.

3.2.8.6 Block icon for OpAnL

Block icons for OpAnL





A variety of block icons are available with the following functions:

- Process tag type
- Operating modes
- Internal and external setpoint specification
- Signal status, release for maintenance
- Memo display
- Process value (black, with and without decimal places)
- Setpoint (blue, with and without decimal places)

The block icons from template @TemplateAPLV8.PDL:

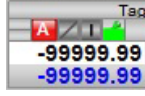
Icons	Selection of the block icon in CFC	Special features
	1	
	2	
	3	
	4	

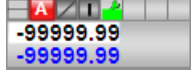
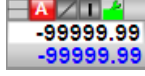
The block icons from template @TemplateAPLV7.PDL:

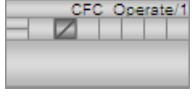
Icons	Selection of the block icon in CFC	Special features
	1	Block icon in the full display
	2	
	3	
	4	
	5	
	6	
	7	
	8	
	-	Block icon in "Out of service" mode (example with type 1 block icon)

Additional information on the block icon and the control options in the block icon is available in the following sections:

- Configuring the block icons (Page 237)
- Block icon structure (Page 230)
- Operation via the block icon (Page 239)

3.3 OpAnS - Check and output analog signals (small)

3.3.1 Description of OpAnS

Object name (type + number) and family

Type + number: FB 1915

Family: Operate

Area of application for OpAnS

The block is used for the following applications:

- Checking and transferring analog input values

How it works

The block forwards incoming, internal (entered in the faceplate) or external (CFC/SFC) analog signals at the `SP_Int` or `SP_Ext` input to the `SP` output, depending on the setting for the `SP_LiOp` input parameter.

Configuration

Use the CFC editor to install the block in a cyclic interrupt OB (OB30 to OB38). The block is also installed automatically in the startup OB (OB100).

Startup characteristics

Use the `Feature Bit Set` startup characteristics (Page 138) to define the startup characteristics of this block.

Status word allocation for `Status1` parameter

For a description of the individual parameters, see the chapter `OpAnS I/Os` (Page 373).

Status bit	Parameter
0	Occupied
1	BatchEn
2	Not used
3	OosAct.Value
4	OosLi.Value
5	Not used
6	OnAct.Value
7	Not used

Status bit	Parameter
8	SP_ExtAct.Value
9 - 31	Not used

See also

OpAnS functions (Page 370)
 OpAnS messaging (Page 373)
 OpAnS block diagram (Page 376)
 OpAnS error handling (Page 372)
 OpAnS modes (Page 369)

3.3.2 OpAnS modes**OpAnS operating modes**

The block can be operated using the following modes:

- On (Page 71)
- Out of service (Page 71)

"On"

General information on the "On" mode is available in the chapter On (Page 71).

"Out of service"

You can find general information about the "Out of service" mode in the chapter Out of service (Page 71).

See also

OpAnS I/Os (Page 373)
 OpAnS messaging (Page 373)
 OpAnS error handling (Page 372)
 Description of OpAnS (Page 368)
 OpAnS functions (Page 370)
 OpAnS block diagram (Page 376)

3.3.3 OpAnS functions

Functions of OpAnS

The functions for this block are listed below.

Internal or external setpoint selection

This block provides the standard function Setpoint specification - internal/external (Page 128).

Forming the signal status for blocks

This block provides the standard function Forming and outputting the signal status for technologic blocks (Page 109).

The worst signal status `ST_Worst` for the block is formed from the following parameters:

- `SP_Out.ST`
- `PV_In.ST`
- `SP_Ext.ST` (only if `Feature.Bit10 = 1`)

The signal status of the `SP_Out` output parameter is always equivalent to the signal status of input parameter `SP_Ext` or `SP_Int`, depending on how the setpoint is specified. If the internal setpoint `SP_Int` is used, the signal status is always output as 16#80.

In case of `Feature.Bit10 = 1`, `SP_Ext.ST` influences `ST_Worst` independent of setpoint specification.

If an external setpoint is used, the signal status 16#60 (external simulation) is suppressed because the block acts as a sink with external simulation.

Considering bad quality of automatic commands or external values

If the `Feature` bit Considering bad quality of automatic commands or external values (Page 186) is set to 1 and the parameter `SP_Ext` has bad signal status (16#00 or 16#28), the block works with the last valid value of `SP_Ext` in the "On" mode.

Selecting a unit of measure

This block provides the standard function Selecting a unit of measure (Page 212).

Simulating signals

This block provides the standard function Simulating signals (Page 58).

Configurable reactions using the Feature parameter

You can find an overview of all reactions provided by the `Feature` parameter in the Configurable functions using the Feature I/O (Page 131) . The following functionality is available for this block at the relevant bits:

Bit	Function
0	Set startup characteristics (Page 138)
1	Reaction to the out of service mode (Page 177)
10	Considering bad quality of automatic commands or external values (Page 186)
24	Enabling local operator authorization (Page 158)

Operator permissions

This block provides the standard function Operator control permissions (Page 254).

The block has the following permissions for the `OS_Perm` parameter:

Bit	Function
0	Not used
1	1 = Operator can switch to "On" mode
2	Not used
3	1 = Operator can switch to "Out of service" mode
4 - 9	Not used
10	1 = Operator can switch to internal
11	1 = Operator can switch to external
12	1 = Operator can enable bumpless switchover
13	1 = Operator can change <code>SP_Int</code>
14 - 31	Not used

Note

If you interconnect a parameter that is also listed in `OS_Perm` as a parameter, you have to reset the corresponding `OS_Perm` bit.

Specifying the display area for process and setpoint values as well as operations

The block provides the standard function Display and operator input area for process values and setpoints (Page 207).

Opening additional faceplates

The block provides the standard function Opening additional faceplates (Page 208).

SIMATIC BATCH functionality

The block provides the standard function SIMATIC BATCH functionality (Page 67).

See also

Description of OpAnS (Page 368)

OpAnS messaging (Page 373)

OpAnS I/Os (Page 373)

OpAnS block diagram (Page 376)

OpAnS error handling (Page 372)

OpAnS modes (Page 369)

Using setpoint ramp (Page 123)

Gradient limit of the setpoint (Page 124)

Update acknowledgment and error status of the message call (Page 160)

3.3.4 OpAnS error handling

Error handling of OpAnS

Refer to the chapter Error handling (Page 119) in the basic instructions.

The following errors can be displayed for this block:

- Error numbers

Overview of error numbers

The `ErrorNum` I/O can be used to output the following error numbers:

Error number	Meaning of the error number
-1	Predefined value when inserting the block; the block is not processed.
0	There is no error.
51	Invalid signal <code>SP_LiOp = 1</code> and <code>SP_ExtLi = 1</code> and <code>SP_IntLi = 1</code>

See also

OpAnS block diagram (Page 376)

OpAnS I/Os (Page 373)

OpAnS messaging (Page 373)

OpAnS functions (Page 370)

OpAnS modes (Page 369)

Description of OpAnS (Page 368)

3.3.5 OpAnS messaging

Messaging

This block does not offer messaging.

See also

OpAnS error handling (Page 372)

OpAnS modes (Page 369)

OpAnS block diagram (Page 376)

3.3.6 OpAnS I/Os

I/Os of OpAnS

Input parameters

Parameter	Description	Type	Default
BatchEn	1 = Enable allocation	BOOL	0
BatchID	Batch ID	DWORD	16#00000000
BatchName	Batch name	S7-String	
EN	1 = Called block will be processed	BOOL	1
Feature	I/O for additional functions (Page 370)	STRUCT <ul style="list-style-type: none"> • Bit 0: BOOL • ... • Bit 31: BOOL 	- <ul style="list-style-type: none"> • 0 • 0 • 0
Occupied	1 = Occupied by batch control	BOOL	0
OnOp*	1 = "On" mode via operator	BOOL	0
OosLi	1 = "Out of service", via interconnection or SFC (0-1 edge transition)	STRUCT <ul style="list-style-type: none"> • Value: BOOL • ST: BYTE 	- <ul style="list-style-type: none"> • 0 • 16#80
OosOp*	1 = "Out of service", via OS operator	BOOL	0

Operator control blocks

3.3 OpAnS - Check and output analog signals (small)

Parameter	Description	Type	Default
OpSt_In	Input parameter for local operating permission, connected with the Out output parameter of the upstream block, OpStations (Page 411)	DWORD	16#00000000
OS_Perm	I/O for operator control permissions (Page 370)	STRUCT <ul style="list-style-type: none"> • Bit 0: BOOL • ... • Bit 31: BOOL 	- <ul style="list-style-type: none"> • 1 • 1 • 1
PV_In	Process value	STRUCT <ul style="list-style-type: none"> • Value: REAL • ST: BYTE 	- <ul style="list-style-type: none"> • 0.0 • 16#80
PV_Unit	Unit of measure for process value	INT	1001
RunUpCyc	Number of cycles in startup; messages are suppressed during these cycles	INT	3
SampleTime	Sampling time [s] (assigned automatically)	REAL	0.1
SP_Ext	external setpoint - (to interconnection)	STRUCT <ul style="list-style-type: none"> • Value: REAL • ST: BYTE 	- <ul style="list-style-type: none"> • 0.0 • 16#80
SP_ExtLi	1 = Select internal setpoint (via interconnection)	STRUCT <ul style="list-style-type: none"> • Value: BOOL • ST: BYTE 	- <ul style="list-style-type: none"> • 0 • 16#80
SP_ExtOp*	1 = Select external setpoint (via operator)	BOOL	0
SP_Int*	Internal setpoint for operation	REAL	0.0
SP_IntLi	1 = Select internal setpoint (via interconnection)	STRUCT <ul style="list-style-type: none"> • Value: BOOL • ST: BYTE 	- <ul style="list-style-type: none"> • 0 • 16#80
SP_IntOp*	1 = Select internal setpoint (via operator)	BOOL	1
SP_LiOp	Select internal/external setpoint source: 1 = Via interconnection 0 = Via operator	STRUCT <ul style="list-style-type: none"> • Value: BOOL • ST: BYTE 	- <ul style="list-style-type: none"> • 0 • 16#80
SP_OpScale	OS display range for setpoint	STRUCT <ul style="list-style-type: none"> • High: REAL • Low: REAL 	- <ul style="list-style-type: none"> 100.0 0.0
SP_TrkExt	1 = Bumpless switchover from external to internal setpoint active	BOOL	0
SP_Unit	Unit of measure for setpoint	INT	1001

Parameter	Description	Type	Default
SelfPl	Call a block saved in this parameter as an additional faceplate (Page 208) in the standard view	ANY	-
StepNo	Batch step number	DWORD	16#00000000
UserStatus	Freely assignable bits for use in PCS 7 OS	BYTE	16#00

* Values can be written back to these inputs during processing of the block by the block algorithm.

Output parameters

Parameter	Description	Type	Default
ENO	1 = Block algorithm completed without errors	BOOL	0
ErrorNum	Output of current error number. For error numbers that can be output by this block, see OpAnS error handling (Page 372)	INT	-1
OnAct	1 = "On" mode enabled	STRUCT <ul style="list-style-type: none"> • Value: BOOL • ST: BYTE 	- <ul style="list-style-type: none"> • 1 • 16#80
OosAct	1 = Block is "Out of service"	STRUCT <ul style="list-style-type: none"> • Value: BOOL • ST: BYTE 	- <ul style="list-style-type: none"> • 0 • 16#80
OpSt_Out	Value of the OpSt_In input parameter, for feedforwarding to other blocks. Bit 31 of this parameter is used by Feature bit 24	DWORD	16#00000000
OS_PermLog	Display of OS_Perm with settings changed by the block algorithm	DWORD	16#FFFFFFFF
OS_PermOut	Display of OS_Perm	DWORD	16#FFFFFFFF
SP_Out	Setpoint used by controller	STRUCT <ul style="list-style-type: none"> • Value: REAL • ST: BYTE 	- <ul style="list-style-type: none"> • 0.0 • 16#80
ST_Worst	Worst signal status	BYTE	16#80
Status1	Status word (Page 368)	DWORD	16#00000000

See also

- OpAnS messaging (Page 373)
- OpAnS block diagram (Page 376)
- OpAnS modes (Page 369)

3.3.7 OpAnS block diagram

OpAnS block diagram

A block diagram is not provided for this block.

See also

- OpAnS I/Os (Page 373)
- OpAnS error handling (Page 372)
- OpAnS functions (Page 370)
- Description of OpAnS (Page 368)
- OpAnS modes (Page 369)
- OpAnS messaging (Page 373)

3.3.8 Operator control and monitoring

3.3.8.1 OpAnS views

Views of the OpAnS block

The block OpAnS provides the following views:

- OpAnS standard view (Page 377)
- Trend view (Page 305)
- OpAnS parameter view (Page 378)
- OpAnS preview (Page 379)
- Memo view (Page 304)
- Batch view (Page 302)
- OpAnS block icon (Page 380)

Refer to the chapters Structure of the faceplate (Page 248) and Block icon structure (Page 230) for general information on the faceplate and block icon.

See also

Ramp view (Page 300)

Alarm view (Page 302)

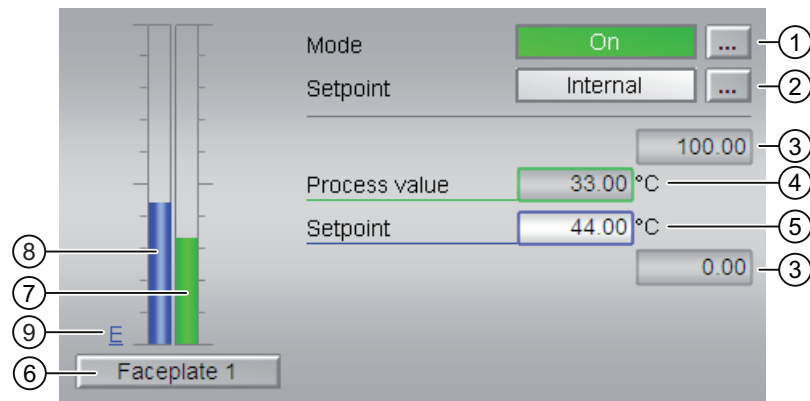
3.3.8.2 OpAnS standard view**OpAnS standard view****(1) Display and switch the operating mode**

This area provides information on the currently valid operating mode. The following operating modes can be shown here:

- On (Page 71)
- Out of service (Page 71)

Refer to chapter Switching operating states and operating modes (Page 257) for information on switching the operating mode.

(2) Display and switch the setpoint specification

This area shows how to specify the setpoint. The setpoint can be specified as follows:

- By the application ("External", CFC/SFC)
- By the user directly in the faceplate ("Internal").

Refer to the Switching operating states and operating modes (Page 257) chapter for information on switching the setpoint specification.

You can find additional information on this in chapter Setpoint specification - internal/external (Page 128).

(3) High and low scale range for the process value

These values provide information on the display range for the bar graph of the process value. The scale range is defined in the Engineering System.

(4) Display of the process value including signal status

This area shows the current process value with the corresponding signal status.

(5) Display and change the setpoint including signal status

This area shows the current setpoint with the corresponding signal status.

Refer to the Changing values (Page 259) chapter for information on changing the setpoint. The setpoint specification also needs to be set to "Internal" for this block.

(6) Navigation button for switching to the standard view of any faceplate

Use this navigation button to reach the standard view of a block configured in the Engineering System (ES). The visibility of this navigation button depends on the configuration in the Engineering System (ES).

Refer also to chapter Opening additional faceplates (Page 208) for more on this.

(7) Bar graph for the process value

This area shows the current process value in the form of a bar graph. The visible area in the bar graph depends on the configuration in the Engineering System (ES).

(8) Bar graph for the setpoint

This area shows the current setpoint in the form of a bar graph. The visible area in the bar graph depends on the configuration in the Engineering System (ES).

(9) Display of external setpoint

This display [E] is only visible when you have selected "Internal" setpoint specification. It shows the external setpoint that would apply if you were to change the setpoint specification to "external".

3.3.8.3 OpAnS parameter view

Parameter view of OpAnS

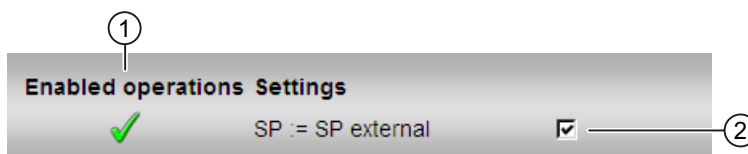

(1) Enabled operations

This area shows all operations for which special operator control permissions are assigned. They depend on the configuration in the engineering system (ES) that applies to this block.

Symbols for enabled operations:

- **Green check mark:** the OS operator can control this parameter
- **Gray check mark:** the OS operator cannot control this parameter at this time due to the process
- **Red cross:** the OS operator cannot control this parameter due to the configured AS operator control permissions (OS_Perms or OS1Perm).

(2) Settings

You can select the following functions in this area:

- "SP := SP external": Bumpless switchover of setpoint from external to internal. The internal setpoint is tracked to the external one.

3.3.8.4 OpAnS preview

Preview of OpAnS

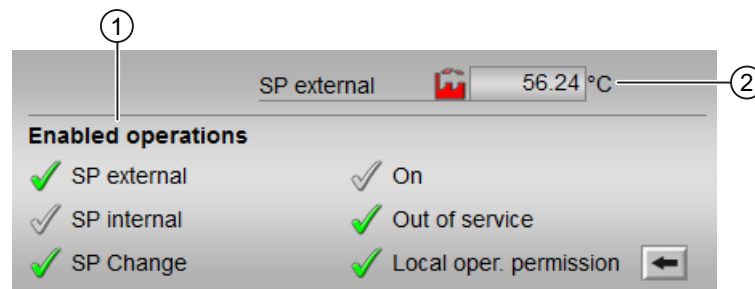

(1) Enabled operations

This area shows all operations for which special operating permissions are assigned. They depend on the configuration in the Engineering System (ES) that applies to this block.

Symbols for enabled operations:

- **Green check mark:** the OS operator can control this parameter
- **Gray check mark:** the OS operator cannot control this parameter at this time due to the process
- **Red cross:** the OS operator cannot control this parameter at all due to the configured AS operating permissions (OS_Perms or OS1Perm)

The following enabled operations are shown here:

- "SP external": You can feedforward the external setpoint.
- "SP internal": You can feedforward the internal setpoint.
- "Change SP": You can change the setpoint.
- "On": You can switch to "On" operating mode.
- "Out of service": You can switch to "Out of service" operating mode.
- "Local operating permission": Use the ← button to switch to the standard view of the OpStations block. You can find additional information on this in chapter Operator control permissions (Page 254).

(2) SP external

Currently applicable external setpoint with the corresponding signal status.

See also

Opening additional faceplates (Page 208)

3.3.8.5 OpAnS block icon

Block icons for OpAnS

A variety of block icons are available with the following functions:

- Process tag type
- Operating modes
- Internal and external setpoint specification
- Signal status, release for maintenance
- Memo display
- Process value (black, with and without decimal places)
- Setpoint (blue, with and without decimal places)

The block icons from template @TemplateAPLV8.PDL:

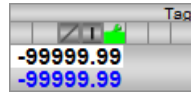
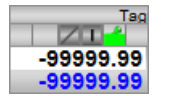
Icons	Selection of the block icon in CFC	Special features
	1	
	2	

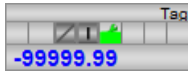
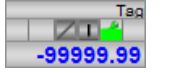
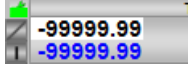
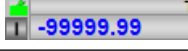
Icons	Selection of the block icon in CFC	Special features
	3	
	4	
	5	Block icon in the full display
	6	Block icon in the full display

Additional information on the block icon and the control options in the block icon is available in the following chapters:

- Configuring the block icons (Page 237)
- Block icon structure (Page 230)
- Operation via the block icon (Page 239)

3.4 OpDi01 - Manipulating a digital value (2 pushbuttons)

3.4.1 Description of OpDi01

Object name (type + number) and family

Type + number: FB 1866

Family: Operate

Area of application for OpDi01

The block is used for the following applications:

- Manipulating a digital value

How it works

A digital value is manipulated by interconnection or via the faceplate.

Configuration

Use the CFC editor to install the block in a cyclic interrupt OB (OB30 to OB38).

Startup characteristics

If `Feature.Bit0 = 0`, the output parameter `Out` will reset to 0.

Status word allocation for `Status1` parameter

You can find a description for each parameter in section OpDi01 I/Os (Page 387).

Status bit	Parameter
0	Occupied
1	BatchEn
2	Not used
3	OosAct.Value
4	OosLi.Value
5	Not used
6	OnAct.Value
7	Out.Value
8	LiOp
9	FbkIn.Value
10 - 13	Not used
14	1 = Invalid signal status

Status bit	Parameter
15	Not used
16	0: Open padlock in the block icon 1: Closed padlock in the block icon
17	Hidden bypass signal in interlock
18	Feature2 bit 2: Separate bypass signal
19 - 22	Not used
23	"Interlock" button is enabled
24 - 25	Not used
26	Bypass information from previous function block
27 - 31	Not used

See also

OpDi01 functions (Page 384)
 OpDi01 messaging (Page 387)
 OpDi01 block diagram (Page 390)
 OpDi01 error handling (Page 386)
 OpDi01 modes (Page 383)

3.4.2 OpDi01 modes**OpDi01 operating modes**

The block can be operated using the following modes:

- On (Page 71)
- Out of service (Page 71)

"On"

General information on the "On" mode is available in the section On (Page 71).

"Out of service"

You can find general information about the "Out of service" mode in the section Out of service (Page 71).

See also

OpDi01 block diagram (Page 390)
 OpDi01 I/Os (Page 387)

3.4 OpDi01 - Manipulating a digital value (2 pushbuttons)

- OpDi01 messaging (Page 387)
- OpDi01 error handling (Page 386)
- OpDi01 functions (Page 384)
- Description of OpDi01 (Page 382)

3.4.3 OpDi01 functions

Functions of OpDi01

The functions for this block are listed below.

Internal or external digital value

Use the `LiOp` input parameter to define whether the digital value is set (0 - 1, parameter `SetOp` or `SetLi`) or is reset (1 - 0, parameter `RstOp` or `RstLi`) via the faceplate or an interconnection.

`LiOp = 0`: Specification of digital value via faceplate (`SetOp` or `RstOp`)

`LiOp = 1`: Specification of digital value via interconnection (`SetLi` or `RstLi`)

Interlocks

Use the `Intl_En = 1` and `Intlock.ST ≠ 16#FF` input parameters to activate the interlock function on this block.

An active interlock condition brings the block to the neutral position (`Intlock.Value = 0` or `Intlock.ST = 16#00` input). Output parameter `Out` is set to 0. When the interlocking condition no longer applies, the digital value currently valid is output again.

Input parameter for feedback value

This block has a `FbkIn` input parameter for displaying a feedback value in the faceplate.

Opening additional faceplates

This block provides the standard function Opening additional faceplates (Page 208).

Changing labels on buttons and text

This block provides the standard function Labeling of buttons and text (Page 209).

Instance-specific text can be configured for the following parameters:

- `Out`
- `SetOp`

- RstOp
- FbkIn

Forming the signal status for blocks

The worst signal status `ST_Worst` for the block is formed from the following parameters:

- `FbkIn.ST`
- `SetLi.ST` (only if `Feature.Bit10 = 1`)
- `RstLi.ST` (only if `Feature.Bit10 = 1`)

Considering bad quality of automatic commands or external values

If the `Feature` bit Considering bad quality of automatic commands or external values (Page 186) is set to 1 and one of the following parameters has bad signal status (16#00 or 16#28), the block goes to the neutral position (`Out = 0`) in the "On" mode:

- `SetLi.ST`
- `RstLi.ST`

Operator permissions

This block provides the standard function Operator control permissions (Page 254).

The block has the following permissions for the `OS_Perm` parameter:

Bit	Function
0	Not used
1	1 = Operator can switch to "On" mode
2	Not used
3	1 = Operator can switch to "Out of service" mode
4	1 = Operator can set the digital value
5	1 = Operator can reset the digital value
6 - 31	Not used

Note

If you interconnect a parameter that is also listed in `OS_Perm` as a parameter, you have to reset the corresponding `OS_Perm` bit.

Configurable reactions using the Feature parameter

You can find an overview of all reactions provided by the Feature parameter in the section Configurable functions using the Feature I/O (Page 131). The following functionality is available for this block at the relevant bits:

Bit	Function
0	Set startup characteristics (Page 138)
1	Reaction to the out of service mode (Page 177)
2	Separate evaluation for excluded and simulated interlock signals (Page 152)
5	Evaluation of the signal status of the interlock signals (Page 142)
10	Considering bad quality of automatic commands or external values (Page 186)
24	Enabling local operator authorization (Page 158)

SIMATIC BATCH functionality

This block provides the standard function SIMATIC BATCH functionality (Page 67).

See also

- Description of OpDi01 (Page 382)
- OpDi01 messaging (Page 387)
- OpDi01 I/Os (Page 387)
- OpDi01 block diagram (Page 390)
- OpDi01 error handling (Page 386)
- OpDi01 modes (Page 383)

3.4.4 OpDi01 error handling

Error handling of OpDi01

Refer to the section Error handling (Page 119) in the basic instructions for the error handling of all blocks.

The following errors can be displayed for this block:

- Error numbers

Overview of error numbers

The `ErrorNum` I/O can be used to output the following error numbers:

Error number	Meaning of the error number
-1	Predefined value when inserting the block; block is not processed
0	There is no error.
51	SetLi = 1 and RstLi = 1 and LiOp = 1

See also

OpDi01 block diagram (Page 390)

OpDi01 I/Os (Page 387)

OpDi01 messaging (Page 387)

OpDi01 functions (Page 384)

OpDi01 modes (Page 383)

Description of OpDi01 (Page 382)

3.4.5 OpDi01 messaging

Messaging

This block does not offer messaging.

See also

Description of OpDi01 (Page 382)

OpDi01 functions (Page 384)

OpDi01 I/Os (Page 387)

OpDi01 block diagram (Page 390)

OpDi01 error handling (Page 386)

OpDi01 modes (Page 383)

3.4.6 OpDi01 I/Os

I/Os of OpDi01

Input parameters

Parameter	Description	Type	Default
BatchEn	1 = Enable allocation	BOOL	0
BatchID	Batch ID	DWORD	16#00000000
BatchName	Batch name	S7-String	
EN	1 = Called block will be processed	BOOL	1
FbkIn	Input for feedback	STRUCT <ul style="list-style-type: none"> • Value: BOOL • ST: BYTE 	- <ul style="list-style-type: none"> • 0 • 16#80
Feature	I/O for additional functions (Page 384)	STRUCT <ul style="list-style-type: none"> • Bit 0: BOOL • ... • Bit 31: BOOL 	- <ul style="list-style-type: none"> • 0 • 0 • 0
Intlock	0 = Interlocking without reset is active; you can operate the block without reset once the interlocking condition has disappeared 1 = Interlock not activated	STRUCT <ul style="list-style-type: none"> • Value: BOOL • ST: BYTE • Bit 1: BOOL (Bypass information bit) 	- <ul style="list-style-type: none"> • 1 • 16#FF • 0
Intl_En	1 = Interlock without reset (interlock, parameter <i>Intlock</i>) can be used	BOOL	1
LiOp	Switchover of operating mode between: 1 = Interconnection 0 = Operator	STRUCT <ul style="list-style-type: none"> • Value: BOOL • ST: BYTE 	- <ul style="list-style-type: none"> • 0 • 16#80
Occupied	1 = Occupied by batch control	BOOL	0
OnOp*	1 = "On" mode via operator	BOOL	0
OosLi	Edge transition (0-1) = "Out of service", via interconnection or SFC	STRUCT <ul style="list-style-type: none"> • Value: BOOL • ST: BYTE 	- <ul style="list-style-type: none"> • 0 • 16#80
OosOp*	1 = "Out of service", via OS operator	BOOL	0
OpSt_In	Input parameter for local operating permission, connected with the <i>Out</i> output parameter of the upstream block, <i>OpStations</i> (Page 411)	DWORD	16#00000000
OS_Perm	I/O for operator control permissions (Page 384)	STRUCT <ul style="list-style-type: none"> • Bit 0: BOOL • ... • Bit 31: BOOL 	- <ul style="list-style-type: none"> • 1 • 1 • 1
RstLi	Reset via interconnection	STRUCT <ul style="list-style-type: none"> • Value: BOOL • ST: BYTE 	- <ul style="list-style-type: none"> • 0 • 16#80
RstOp*	Reset by the operator	BOOL	0

3.4 OpDi01 - Manipulating a digital value (2 pushbuttons)

Parameter	Description	Type	Default
SelFp1	Call a block saved in this parameter as an additional faceplate (Page 208) in the standard view	ANY	-
SelFp2	Call a block saved in this parameter as an additional faceplate (Page 208) in the preview	ANY	-
SetLi	Connected digital input	STRUCT <ul style="list-style-type: none"> Value: BOOL ST: BYTE 	- <ul style="list-style-type: none"> 0 16#80
SetOp*	Digital input for operator	BOOL	0
StepNo	Batch step number	DWORD	16#00000000
UserStatus	Freely assignable bits for use in PCS 7 OS	BYTE	16#00

* Values can be written back to these inputs during processing of the block by the block algorithm.

Output parameters

Parameter	Description	Type	Default
ENO	1 = Block algorithm completed without errors	BOOL	0
ErrorNum	Output of current error number. For error numbers that can be output by this block, see OpDi01 error handling (Page 386)	INT	-1
LockAct	1 = Interlock (Intlock) is active	STRUCT <ul style="list-style-type: none"> Value: BOOL ST: BYTE 	- <ul style="list-style-type: none"> 0 16#80
OnAct	1 = "On" mode enabled	STRUCT <ul style="list-style-type: none"> Value: BOOL ST: BYTE 	- <ul style="list-style-type: none"> 1 16#80
OosAct	1 = Block is "Out of service"	STRUCT <ul style="list-style-type: none"> Value: BOOL ST: BYTE 	- <ul style="list-style-type: none"> 0 16#80
OpSt_Out	Value of the OpSt_In input parameter, for feedforwarding to other blocks. Bit 31 of this parameter is used by Feature bit 24	DWORD	16#00000000
OS_PermLog	Display of OS_Perm with settings changed by the block algorithm	DWORD	16#FFFFFFFF
OS_PermOut	Display of OS_Perm	DWORD	16#FFFFFFFF
Out	Digital output value	STRUCT <ul style="list-style-type: none"> Value: BOOL ST: BYTE 	- <ul style="list-style-type: none"> 0 16#80

3.4 OpDi01 - Manipulating a digital value (2 pushbuttons)

Parameter	Description	Type	Default
ST_Worst	Worst signal status	BYTE	16#80
Status	Status word (Page 382)	DWORD	16#00000000

See also

- OpDi01 messaging (Page 387)
- OpDi01 block diagram (Page 390)
- OpDi01 modes (Page 383)

3.4.7 OpDi01 block diagram

OpDi01 block diagram

A block diagram is not provided for this block.

See also

- OpDi01 I/Os (Page 387)
- OpDi01 messaging (Page 387)
- OpDi01 error handling (Page 386)
- OpDi01 functions (Page 384)
- OpDi01 modes (Page 383)
- Description of OpDi01 (Page 382)

3.4.8 Operator control and monitoring

3.4.8.1 OpDi01 views

Views of the OpDi01 block

The block OpDi01 provides the following views:

- OpDi01 standard view (Page 391)
- Trend view (Page 305)
- OpDi01 preview (Page 392)
- Memo view (Page 304)

- Batch view (Page 302)
- Block icon for OpDi01 (Page 394)

Refer to the sections Structure of the faceplate (Page 248) and Block icon structure (Page 230) for general information on the faceplate and block icon.

3.4.8.2 OpDi01 standard view

OpDi01 standard view

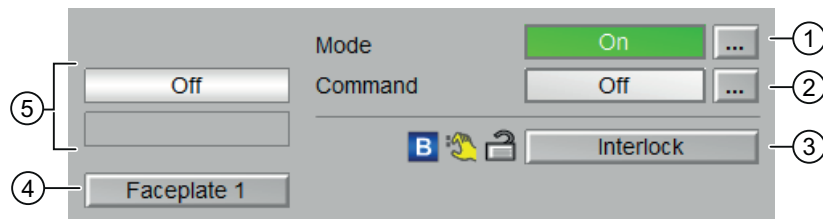

(1) Display and switch the operating mode

This area provides information on the currently valid operating mode. The following operating modes can be shown here:

- On (Page 71)
- Out of service (Page 71)

You can find additional information on this in section Switching operating states and operating modes (Page 257).

(2) Displaying and switching the command

This area shows you the current selection. You can output a continuous signal as follows:

- "On": Continuous signal is output
- "Off"

You can find additional information on this in section Switching operating states and operating modes (Page 257).

You can rename the display text as you please, as described in the section Labeling of buttons and text (Page 209).

Do this with the following parameters:

- Text for "Command": Parameter `SetOp#string_1`
- Text for "On/Off": Parameter `Out#string_0 / Out#string_1`

(3) Operating range for the interlock functions of the block

This display is only visible when the corresponding block input is interconnected.

3.4 OpDi01 - Manipulating a digital value (2 pushbuttons)

You can use this button to control the interlock functions of the block. You can find additional information on this in section OpDi01 functions (Page 384).

- Bypass information (see Forming the group status for interlock information (Page 104)):



(4) Button for switching to the standard view of any faceplate

Use this button for the standard view of a block configured in the engineering system. The visibility of this button depends on the configuration in the engineering system (ES).

You can find additional information on this in section Opening additional faceplates (Page 208).

(5) Displaying the feedback of the command

This area shows you the currently valid command. The following commands can be shown here:

- "On"
- "Off"
- "Invalid signal"

You can rename the display text as you please, as described in the section Labeling of buttons and text (Page 209).

Do this with the following parameter:

- Text for "On/Off": Parameter FbkIn#string_0 / FbkIn#string_1

3.4.8.3 OpDi01 preview

Preview of OpDi01

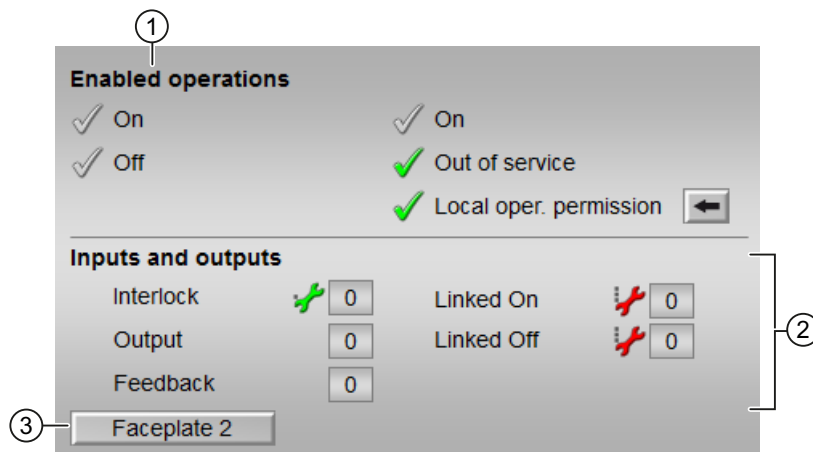

(1) Enabled operations

This area shows all operations for which special operator control permissions are assigned. They depend on the configuration in the engineering system (ES) that applies to this block.

Symbols for enabled operations:

- **Green check mark:** the OS operator can control this parameter
- **Gray check mark:** the OS operator cannot control this parameter at this time due to the process
- **Red cross:** the OS operator cannot control this parameter due to the configured AS operator control permissions (OS_Perm or OS1Perm)

The following enabled operations are shown here:

- "On": You can set the digital value (0 - 1 edge).
You can rename the display text as you please, as described in the section Labeling of buttons and text (Page 209).
Do this with the following parameters:
 - Text for "On": Parameter `.Out#Value#string_1`
- "Off": You can set the digital value (1 - 0 edge).
You can rename the display text as you please, as described in the section Labeling of buttons and text (Page 209).
Do this with the following parameters:
 - Text for "Off": Parameter `.Out#Value#string_0`
- "On": You can switch to "On" operating mode.
- "Out of service": You can switch to "Out of service" operating mode.
- "Local operating permission": Use the ← button to switch to the standard view of the OpStations block. Additional information is available in the section Operator control permissions (Page 254).

(2) Display of current inputs and outputs

This area shows the most important parameters for this block with the current selection:

- "Interlock":
This display is only visible when the corresponding block input is connected.
 - 0 = Interlocking without reset is active; you can operate the block without reset once the interlocking condition has disappeared
 - 1 = "Good" state
- "Output": 1 = Digital output value set
- "Feedback": 1 = Feedback set
- "Linked On": 1 = Linked input on
- "Linked Off": 1 = Linked input off

(3) Navigation button for switching to the standard view of any faceplate

Use this navigation button to reach the standard view of a block configured in the Engineering System (ES). The visibility of this navigation button depends on the configuration in the engineering system (ES).

Refer also to the Opening additional faceplates (Page 208) section for more on this.



3.4.8.4 Block icon for OpDi01

Block icons for OpDi01



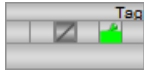

A variety of block icons are available with the following functions:

- Process tag type
- Operating modes
- Signal status, release for maintenance
- Bypass
- Interlocks
- Output signal
- Memo display

The block icons from template @TemplateAPLV8.PDL:

Icons	Selection of the block icon in CFC	Special features
	1	
	2	
	3	Block icon in the full display

The block icons from template @TemplateAPLV7.PDL:

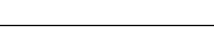
Icons	Selection of the block icon in CFC	Special features
	1	Block icon in the full display
	2	
	3	
	4	
	-	Block icon in "Out of service" mode (example with type 1 block icon)

Additional information on the block icon and the control options in the block icon is available in the following chapters:

- Configuring the block icons (Page 237)
- Block icon structure (Page 230)
- Operation via the block icon (Page 239).

3.5 OpDi03 - Manipulating a digital value (3 pushbuttons)

3.5.1 Description of OpDi03

Object name (type + number) and family

Type + number: FB 1867

Family: Operate

Area of application for OpDi03

The block is used for the following applications:

- Manipulating a digital value (3 pushbuttons)

How it works

A digital value is manipulated at three possible outputs by interconnection or via the faceplate.

If two or three input parameters are set for an interconnection (parameter `SetLix`), the input parameter with the highest index will be set to the corresponding output parameter. For example, if the `SetLi1` and `SetLi2` input parameters are set (= 1), then `Out2` will be set (= 1).

Configuration

Use the CFC editor to install the block in a cyclic interrupt OB (OB30 to OB38).

Startup characteristics

If `Feature.Bit0 = 0`, the output parameters `Out1` to `Out3` will reset to 0.

Status word allocation for `Status1` parameter

You can find a description for each parameter in section OpDi03 I/Os (Page 402).

Status bit	Parameter
0	Occupied
1	BatchEn
2	Not used
3	OosAct.Value
4	OosLi.Value
5	Not used
6	OnAct.Value
7	Out1.Value

Status bit	Parameter
8	Out2.Value
9	Out3.Value
10	LiOp.Value
11	Fbk1In.Value
12	Fbk2In.Value
13	Fbk3In.Value
14	1 = Invalid signal status
15	Not used
16	0: Open padlock in the block icon 1: Closed padlock in the block icon
17	Hidden bypass signal in interlock
18	Feature2 bit 2: Separate bypass signal
19 - 22	Not used
23	"Interlock" button is enabled
24 - 25	Not used
26	Bypass information from previous function block
27 - 31	Not used

See also

- OpDi03 functions (Page 398)
- OpDi03 messaging (Page 402)
- OpDi03 block diagram (Page 405)
- OpDi03 error handling (Page 401)
- OpDi03 modes (Page 397)

3.5.2 OpDi03 modes

OpDi03 operating modes

The block can be operated using the following modes

- On (Page 71)
- Out of service (Page 71)

"On"

You can find general information about the "On" mode in the On (Page 71) section.

"Out of service"

You can find general information about the "Out of service" mode in the section Out of service (Page 71).

See also

OpDi03 block diagram (Page 405)

OpDi03 I/Os (Page 402)

OpDi03 messaging (Page 402)

OpDi03 error handling (Page 401)

OpDi03 functions (Page 398)

Description of OpDi03 (Page 396)

3.5.3 OpDi03 functions

Functions of OpDi03

The functions for this block are listed below.

Internal or external digital value

Use the `LiOp` input parameter to define whether it is through the faceplate or an interconnection using a 1 out of 3 that the selection of the digital value is set (0 - 1) or reset (1 - 0, input parameter `RstOut`).

- `LiOp = 0`: Specification of digital value via faceplate. One of the input parameters `SetOp1`, `SetOp2` or `SetOp3` is now routed to the relevant output `Out1`, `Out2` or `Out3`. For example, if `SetOp2 = 1`, then `Out2 = 1`.
- `LiOp = 1`: Specification of digital value via interconnection. One of the input parameters `SetLi1`, `SetLi2` or `SetLi3` is now routed to the relevant output `Out1`, `Out2` or `Out3`. For example, if `SetLi2 = 1`, then `Out2 = 1`.

The reset (1 - 0) is always undertaken using the `RstOut` input parameter.

Interlocks

Use the `Intl_En = 1` and `Intlock.ST ≠ 16#FF` input parameters to activate the interlock function on this block.

An active interlock condition brings the block to the neutral position (`Intlock.Value = 0` or `Intlock.ST = 16#00` input). Output parameter `Out` is set to 0. When the interlocking condition no longer applies, the digital value currently valid is output again.

Input parameter for feedback value

This block has three input parameters `Fbk1In`, `Fbk2In` and `Fbk3In` for displaying three feedback values in the faceplate.

Resetting all output values

Reset all output parameters (`Out1 ... Out3`) by setting all interconnected input parameters for setting (`SetLi1 ... SetLi3`) or enabled input parameters for setting (`SetOp1 ... SetOp3`) to 0.

A 0 - 1 edge at the `RstOut` parameter then resets the three output parameters `Out1 ... Out3`.

Opening additional faceplates

This block provides the standard function Opening additional faceplates (Page 208).

Changing labels on buttons and text

This block provides the standard function Labeling of buttons and text (Page 209).

Instance-specific text can be configured for the following parameters:

- `OutX`
 - `SetOpX`
 - `FbkXIn`
- $X = (1 \dots 3)$

Forming the signal status for blocks

This block provides the standard function Forming and outputting the signal status for technologic blocks (Page 109).

The worst signal status `ST_Worst` for the block is formed from the following parameters:

- `Fbk1In.ST`
- `Fbk2In.ST`
- `Fbk3In.ST`
- `SetLi1.ST` (only if `Feature.Bit10 = 1`)
- `SetLi2.ST` (only if `Feature.Bit10 = 1`)
- `SetLi3.ST` (only if `Feature.Bit10 = 1`)
- `RstOut.ST` (only if `Feature.Bit10 = 1`)

Considering bad quality of automatic commands or external values

If the `Feature` bit Considering bad quality of automatic commands or external values (Page 186) is set to 1 and one of the following parameters has bad signal status (16#00 or 16#28), the block goes to the neutral position (`Out1 = 0`, `Out2 = 0`, and `Out3 = 0`) in the "On" mode:

- `SetLi1.ST`
- `SetLi2.ST`
- `SetLi3.ST`
- `RstOut.ST`

Operator permissions

This block provides the standard function Operator control permissions (Page 254).

The block has the following permissions for the `OS_Perm` parameter:

Bit	Function
0	Not used
1	1 = Operator can switch to "On" mode
2	Not used
3	1 = Operator can switch to "Out of service" mode
4	1 = Operator can set the digital value <code>SetOp1</code>
5	1 = Operator can set the digital value <code>SetOp2</code>
6	1 = Operator can set the digital value <code>SetOp3</code>
7 - 31	Not used

Note

If you interconnect a parameter that is also listed in `OS_Perm` as a parameter, you have to reset the corresponding `OS_Perm` bit.

Configurable reactions using the `Feature` parameter

You can find an overview of all reactions provided by the `Feature` parameter in the section Configurable functions using the Feature I/O (Page 131). The following functionality is available for this block at the relevant bits:

Bit	Function
0	Set startup characteristics (Page 138)
1	Reaction to the out of service mode (Page 177)
2	Separate evaluation for excluded and simulated interlock signals (Page 152)
5	Evaluation of the signal status of the interlock signals (Page 142)
10	Considering bad quality of automatic commands or external values (Page 186)
24	Enabling local operator authorization (Page 158)

SIMATIC BATCH functionality

This block provides the standard function SIMATIC BATCH functionality (Page 67).

See also

Description of OpDi03 (Page 396)

OpDi03 messaging (Page 402)

OpDi03 I/Os (Page 402)

OpDi03 block diagram (Page 405)

OpDi03 error handling (Page 401)

OpDi03 modes (Page 397)

3.5.4 OpDi03 error handling

Error handling of OpDi03

Refer to the section Error handling (Page 119) in the basic instructions for the error handling of all blocks.

The following errors can be displayed for this block:

- Error numbers

Overview of error numbers

The `ErrorNum` I/O can be used to output the following error numbers:

Error number	Meaning of the error number
-1	Predefined value when inserting the block; block is not processed
0	There is no error.
51	The value 1 is set at two or more inputs ($\text{SetLi1} = 1 \text{ AND } \text{SetLi2} = 1$) or ($\text{SetLi2} = 1 \text{ AND } \text{SetLi3} = 1$) or ($\text{SetLi1} = 1 \text{ AND } \text{SetLi3} = 1$) and $\text{LiOp} = 1$

See also

OpDi03 block diagram (Page 405)

OpDi03 I/Os (Page 402)

OpDi03 messaging (Page 402)

OpDi03 functions (Page 398)

OpDi03 modes (Page 397)

Description of OpDi03 (Page 396)

3.5.5 OpDi03 messaging

Messaging

This block does not offer messaging.

See also

Description of OpDi03 (Page 396)

OpDi03 functions (Page 398)

OpDi03 I/Os (Page 402)

OpDi03 block diagram (Page 405)

OpDi03 error handling (Page 401)

OpDi03 modes (Page 397)

3.5.6 OpDi03 I/Os

I/Os of OpDi03

Input parameters

Parameter	Description	Type	Default
BatchEn	1 = Enable allocation	BOOL	0
BatchID	Batch ID	DWORD	16#00000000
BatchName	Batch name	S7-String	
EN	1 = Called block will be processed	BOOL	1
Fbk1In	Feedback for input In1	STRUCT <ul style="list-style-type: none"> • Value: BOOL • ST: BYTE 	- <ul style="list-style-type: none"> • 0 • 16#80
Fbk2In	Feedback for input In2	STRUCT <ul style="list-style-type: none"> • Value: BOOL • ST: BYTE 	- <ul style="list-style-type: none"> • 0 • 16#80
Fbk3In	Feedback for input In3	STRUCT <ul style="list-style-type: none"> • Value: BOOL • ST: BYTE 	- <ul style="list-style-type: none"> • 0 • 16#80

3.5 OpDi03 - Manipulating a digital value (3 pushbuttons)

Parameter	Description	Type	Default
Feature	I/O for additional functions (Page 398)	STRUCT <ul style="list-style-type: none"> • Bit 0: BOOL • ... • Bit 31: BOOL 	- <ul style="list-style-type: none"> • 0 • 0 • 0
Intlock	0 = Interlocking without reset is active; you can operate the block without reset once the interlocking condition has disappeared 1 = Interlock not activated	STRUCT <ul style="list-style-type: none"> • Value: BOOL • ST: BYTE • Bit 1: BOOL (Bypass information bit) 	- <ul style="list-style-type: none"> • 1 • 16#FF • 0
Intl_En	1 = Interlock without reset (interlock, parameter <i>Intlock</i>) can be used	BOOL	1
LiOp	Switchover of operating mode between: 1 = Interconnection 0 = Operator	STRUCT <ul style="list-style-type: none"> • Value: BOOL • ST: BYTE 	- <ul style="list-style-type: none"> • 0 • 16#80
Occupied	1 = Occupied by batch control	BOOL	0
OnOp*	1 = "On" mode via operator	BOOL	0
OosLi	1 = "Out of service", via interconnection or SFC	STRUCT <ul style="list-style-type: none"> • Value: BOOL • ST: BYTE 	- <ul style="list-style-type: none"> • 0 • 16#80
OosOp*	1 = "Out of service", via OS operator	BOOL	0
OpSt_In	Input parameter for local operating permission, connected with the <i>Out</i> output parameter of the upstream block, <i>OpStations</i> (Page 411)	DWORD	16#00000000
OS_Perm	I/O for operator control permissions (Page 398)	STRUCT <ul style="list-style-type: none"> • Bit 0: BOOL • ... • Bit 31: BOOL 	- <ul style="list-style-type: none"> • 1 • 1 • 1
RstOut	Reset by the operator	STRUCT <ul style="list-style-type: none"> • Value: BOOL • ST: BYTE 	- <ul style="list-style-type: none"> • 0 • 16#80
SelFp1	Call a block saved in this parameter as an additional faceplate (Page 208) in the standard view	ANY	-
SelFp2	Call a block saved in this parameter as an additional faceplate (Page 208) in the preview	ANY	-
SetLil	Connected digital input 1	STRUCT <ul style="list-style-type: none"> • Value: BOOL • ST: BYTE 	- <ul style="list-style-type: none"> • 0 • 16#80

Operator control blocks

3.5 OpDi03 - Manipulating a digital value (3 pushbuttons)

Parameter	Description	Type	Default
SetLi2	Connected digital input 2	STRUCT <ul style="list-style-type: none"> Value: BOOL ST: BYTE 	- <ul style="list-style-type: none"> 0 16#80
SetLi3	Connected digital input 3	STRUCT <ul style="list-style-type: none"> Value: BOOL ST: BYTE 	- <ul style="list-style-type: none"> 0 16#80
SetOp1*	Digital input 1 for operator	BOOL	0
SetOp2*	Digital input 2 for operator	BOOL	0
SetOp3*	Digital input 3 for operator	BOOL	0
StepNo	Batch step number	DWORD	16#00000000
UserStatus	Freely assignable bits for use in PCS 7 OS	BYTE	16#00

* Values can be written back to these inputs during processing of the block by the block algorithm.

Output parameters

Parameter	Description	Type	Default
ENO	1 = Block algorithm completed without errors	BOOL	0
ErrorNum	Output of current error number. For error numbers that can be output by this block, see OpDi03 error handling (Page 401)	INT	-1
LockAct	1 = Interlock (Intlock) is active	STRUCT <ul style="list-style-type: none"> Value: BOOL ST: BYTE 	- <ul style="list-style-type: none"> 0 16#80
OosAct	1 = Block is "Out of service"	STRUCT <ul style="list-style-type: none"> Value: BOOL ST: BYTE 	- <ul style="list-style-type: none"> 0 16#80
OnAct	1 = "On" mode enabled	STRUCT <ul style="list-style-type: none"> Value: BOOL ST: BYTE 	- <ul style="list-style-type: none"> 1 16#80
OpSt_Out	Value of the OpSt_In input parameter, for feedforwarding to other blocks. Bit 31 of this parameter is used by Feature bit 24	DWORD	16#00000000
OS_PermLog	Display of OS_Perm with settings changed by the block algorithm	DWORD	16#FFFFFFFF
OS_PermOut	Display of OS_Perm	DWORD	16#FFFFFFFF
Out1	Digital output value 1	STRUCT <ul style="list-style-type: none"> Value: BOOL ST: BYTE 	- <ul style="list-style-type: none"> 0 16#80

Parameter	Description	Type	Default
Out2	Digital output value 2	STRUCT <ul style="list-style-type: none"> • Value: BOOL • ST: BYTE 	- <ul style="list-style-type: none"> • 0 • 16#80
Out3	Digital output value 3	STRUCT <ul style="list-style-type: none"> • Value: BOOL • ST: BYTE 	- <ul style="list-style-type: none"> • 0 • 16#80
ST_Worst	Worst signal status	BYTE	16#80
Status	Status word (Page 396)	DWORD	16#00000000

See also

OpDi03 messaging (Page 402)
OpDi03 block diagram (Page 405)
OpDi03 modes (Page 397)

3.5.7 OpDi03 block diagram**OpDi03 block diagram**

A block diagram is not provided for this block.

See also

OpDi03 I/Os (Page 402)
OpDi03 messaging (Page 402)
OpDi03 error handling (Page 401)
OpDi03 functions (Page 398)
OpDi03 modes (Page 397)
Description of OpDi03 (Page 396)

3.5.8 Operator control and monitoring

3.5.8.1 OpDi03 view

Views of the OpDi03 block

The block OpDi03 provides the following views:

- OpDi03 standard view (Page 406)
- Trend view (Page 305)
- OpDi03 preview (Page 408)
- Memo view (Page 304)
- Batch view (Page 302)
- Block icon for OpDi03 (Page 409)

Refer to the sections Structure of the faceplate (Page 248) and Block icon structure (Page 230) for general information on the faceplate and block icon.

3.5.8.2 OpDi03 standard view

OpDi03 standard view

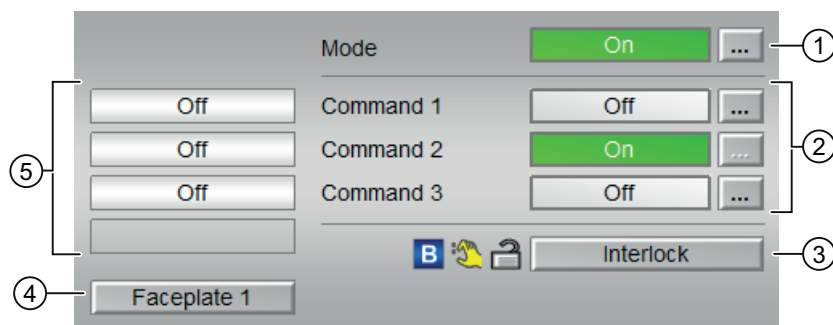

(1) Display and switch the operating mode

This area provides information on the currently valid operating mode. The following operating modes can be shown here:

- On (Page 71)
- Out of service (Page 71)

You can find additional information on this in section Switching operating states and operating modes (Page 257).

(2) Displaying and switching the command 1 to 3

This area shows you the current selection. You can output a continuous signal at the outputs Out1 to Out3 as follows:

- "On": Continuous signal is output
- "Off"

You can find additional information on this in section Switching operating states and operating modes (Page 257).

You can rename the display text as you please, as described in the section Labeling of buttons and text (Page 209).

Do this with the following parameters:

- Text for "Command 1/Command 2/Command 3": Parameter `SetOpX#string_1`, (X = 1 ... 3)
- Text for "On/Off": Parameter `OutX#string_0`, `OutX#string_1`, (X = 1 ... 3)

(3) Operating range for the interlock functions of the block

This display is only visible when the corresponding block input is interconnected.

You can use this button to control the interlock functions of the block. You can find additional information on this in section OpDi03 functions (Page 398).

- Bypass information (see Forming the group status for interlock information (Page 104)):



(4) Button for switching to the standard view of any faceplate

Use this button for the standard view of a block configured in the engineering system. The visibility of this button depends on the configuration in the engineering system (ES).

You can find additional information on this in section Opening additional faceplates (Page 208).

(5) Displaying the feedback of the command 1 to 3

This area shows you the current valid selection from Out1 to Out3.

- "On"
- "Off"
- "Invalid signal"

You can rename the display text as you please, as described in the section Labeling of buttons and text (Page 209).

Do this with the following parameters:

- Text for "On/Off": Parameter `FbkInX#string_1`, `FbkInX#string_0`, (X = 1 ... 3)

3.5.8.3 OpDi03 preview

Preview of OpDi03

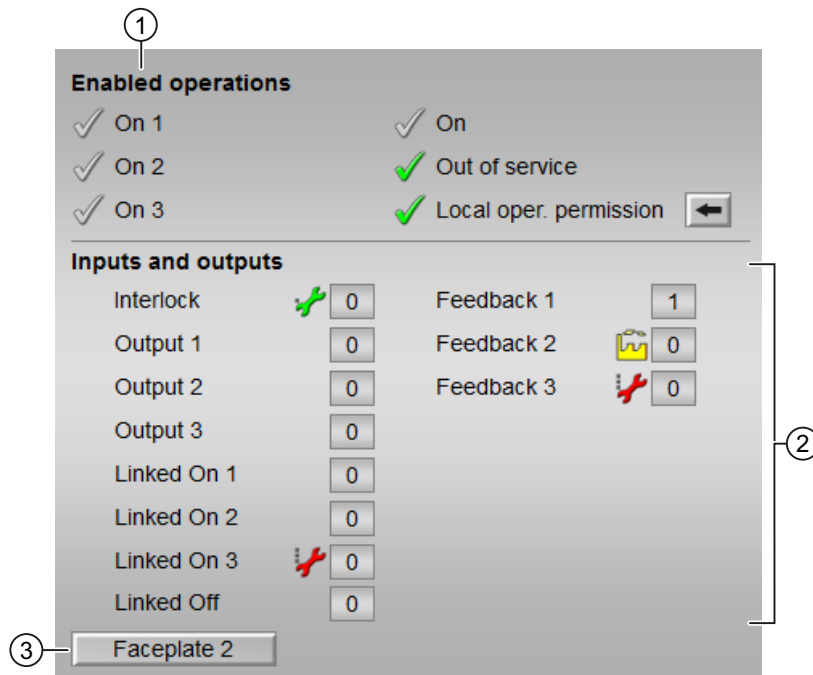

(1) Enabled operations

This area shows all operations for which special operator control permissions are assigned. They depend on the configuration in the engineering system (ES) that applies to this block.

Symbols for enabled operations:

- **Green check mark:** the OS operator can control this parameter
- **Gray check mark:** the OS operator cannot control this parameter at this time due to the process
- **Red cross:** the OS operator cannot control this parameter due to the configured AS operator control permissions (*OS_Perm* or *OS1Perm*)

The following enabled operations are shown here:

- "On 1 to 3": You can now set the digital value (0 - 1 edge).
You can rename the display text as you please, as described in the section Labeling of buttons and text (Page 209).
Do this with the following parameters:
 - Text for "Command X": Parameter *OutX#string_1*, (X = 1 ... 3)
- "On": You can switch to "On" operating mode.

- "Out of service": You can switch to "Out of service" operating mode.
- "Local operating permission": Use the ← button to switch to the standard view of the OpStations block. Additional information is available in the section Operator control permissions (Page 254).

(2) Display of current inputs and outputs

This area shows the most important parameters for this block with the current selection:

- "Interlock":
 - This display is only visible when the corresponding block input is connected.
 - 0 = Interlocking without reset is active; you can operate the block without reset once the interlocking condition has disappeared
 - 1 = "Good" state
- "Output 1 to 3": 1 = Digital output value set
- "Feedback 1 to 3": 1 = Feedback set
- "Linked On 1 to 3": 1 = Linked input on
- "Linked Off": 1 = Linked input off

(3) Navigation button for switching to the standard view of any faceplate

Use this navigation button to reach the standard view of a block configured in the engineering system. The visibility of this navigation button depends on the configuration in the engineering system (ES).

Refer also to the Opening additional faceplates (Page 208) section for more on this.

3.5.8.4 Block icon for OpDi03



Block icons for OpDi03

A variety of block icons are available with the following functions:



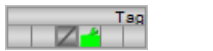

- Process tag type
- Operating modes
- Signal status, release for maintenance
- Bypass
- Interlocks
- Output signal
- Memo display

3.5 OpDi03 - Manipulating a digital value (3 pushbuttons)

The block icons from template @TemplateAPLV8.PDL:

Icons	Selection of the block icon in CFC	Special features
	1	
	2	
	3	Block icon in the full display

The block icons from template @TemplateAPLV7.PDL:

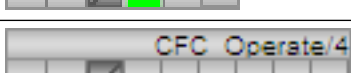
Icons	Selection of the block icon in CFC	Special features
	1	Block icon in the full display
	2	
	3	
	4	
	-	Block icon in "Out of service" mode (example with type 1 block icon)

Additional information on the block icon and the control options in the block icon is available in the following chapters:

- Configuring the block icons (Page 237)
- Block icon structure (Page 230)
- Operation via the block icon (Page 239).

3.6 OpStations - Configuration of the local operator authorization

3.6.1 Description of OpStations

Object name (type + number) and family

Type + number: FB 1901

Family: Operate

Area of application for OpStations

The block is used for the following applications:

- Configuration of the local operatorcontrol permission

How it works

The block converts the enabled operations or locks for up to 16 individual permissions in the bit-coded `Out` output.

Refer also to OpStations block diagram (Page 418).

Configuration

Use the CFC editor to install the block in a cyclic interrupt OB (OB30 to OB38). The OpStations block and the technologic block must be installed into the same cyclic interrupt OB.

Note

Install the blocks in a slower cyclic interrupt OB.

With the default, the local operatorcontrol permission for all block instances on the faceplate is disabled (= 0) and is configured as follows:

1. Assign each operator station a bit-coded ID (1, 2, 4, 8, 16, ...), which you set in the internal APLOpStation variables as a start value. You can set up to 16 different operator stations. The variable is automatically created using the OS project editor and is located in the Split Screen Manager group.

Note

A redundant server pair can only be represented as an operator station, which also affects referenced client or single stations in the engineering station (ES). If a distinguishable operator station is needed, different groups of referenced clients or single stations must be created

2. Place the OpStations block in the chart.

Note

If you use the Opening additional faceplates (Page 208) function in multiple technologic blocks, you need to use one OpStations block for every technologic block. Otherwise, the call of the technologic block from the OpStations block is only possible for a technologic block.

3. Enable the function at the technologic block via `Feature Bit 24`(Enabling local operator authorization (Page 158)).
4. Interconnect the `OpSt_In` input parameter of the technologic block to the `Out` output parameter of the OpStations block.
5. Select the operator stations on which the technologic block will usually be used. You can select several at once. The selection is sent bit-coded to the `Out` output of the OpStations block.
6. Specify a list for the texts for the standard view in the OpStations faceplate in the shared declarations under the name `APLOpStations` in the SIMATIC Manager. Refer also to the section OpStations standard view (Page 420) for more information.

Once these configuration steps are completed, the local operatorcontrol permission is enabled. The enable for a technologic block is made when the bit-by-bit comparison between the `OpSt_Out` parameter and the operator station ID "APLOpStation" does not equal 0.

Note

The local operatorcontrol permission is not visualized in the "Enabled operation" icons of the block I/Os.

Startup characteristics

This block does not have any startup characteristics.

Status word allocation for Status1 parameter

You can find a description for each parameter in section OpStations I/Os (Page 416).

Status bit	Parameter
0	In0
1	In1
2	In2
3	In3
4	In4
5	In5
6	In6
7	In7
8	In8
9	In9
10	In10
11	In11
12	In12
13	In13
14	In14
15	In15
16 - 29	Not used
30	Occupied
31	BatchEn

See also

OpStations operating modes (Page 413)

OpStations functions (Page 414)

OpStations error handling (Page 415)

OpStations messaging (Page 415)

3.6.2 OpStations operating modes**OpStations operating modes**

This block does not have any modes.

See also

Description of OpStations (Page 411)

OpStations functions (Page 414)

OpStations error handling (Page 415)

- OpStations messaging (Page 415)
- OpStations I/Os (Page 416)
- OpStations block diagram (Page 418)

3.6.3 OpStations functions

Functions of OpStations

The functions for this block are listed below.

Operator control permissions

This block provides the standard function Operator control permissions (Page 254).

The block has the following permissions for the OS_Perm parameter:

Bit	Function
0	1 = Operator can enable In0
1	1 = Operator can enable In1
2	1 = Operator can enable In2
3	1 = Operator can enable In3
4	1 = Operator can enable In4
5	1 = Operator can enable In5
6	1 = Operator can enable In6
7	1 = Operator can enable In7
8	1 = Operator can enable In8
9	1 = Operator can enable In9
10	1 = Operator can enable In10
11	1 = Operator can enable In11
12	1 = Operator can enable In12
13	1 = Operator can enable In13
14	1 = Operator can enable In14
15	1 = Operator can enable In15
16 - 31	Not used

Note

If you interconnect a parameter that is also listed in OS_Perm as a parameter, you have to reset the corresponding OS_Perm bit.

SIMATIC BATCH functionality

This block provides the standard function SIMATIC BATCH functionality (Page 67).

See also

- Description of OpStations (Page 411)
- OpStations operating modes (Page 413)
- OpStations error handling (Page 415)
- OpStations messaging (Page 415)
- OpStations I/Os (Page 416)
- OpStations block diagram (Page 418)

3.6.4 OpStations error handling

OpStations error handling

This block does not have any error handling.

See also

- Description of OpStations (Page 411)
- OpStations operating modes (Page 413)
- OpStations functions (Page 414)
- OpStations messaging (Page 415)
- OpStations I/Os (Page 416)
- OpStations block diagram (Page 418)

3.6.5 OpStations messaging

OpStations messaging

This block does not offer messaging.

See also

- Description of OpStations (Page 411)
- OpStations operating modes (Page 413)
- OpStations functions (Page 414)

OpStations error handling (Page 415)

OpStations I/Os (Page 416)

OpStations block diagram (Page 418)

3.6.6 OpStations I/Os

OpStations I/Os

Input parameters

Parameter	Description	Type	Default
BatchEn	1 = Enable allocation	BOOL	0
BatchID	Batch ID	DWORD	16#00000000
BatchName	Batch name	S7-String	
EN	1 = Called block will be processed	BOOL	1
Feature	I/O for additional functions (Page 414)	STRUCT	-
		<ul style="list-style-type: none"> • Bit 0: BOOL • ... • Bit 31: BOOL 	<ul style="list-style-type: none"> • 0 • 0 • 0
In0	1 = Enable for operator station 1	BOOL	0
In1	1 = Enable for operator station 2	BOOL	0
In2	1 = Enable for operator station 3	BOOL	0
In3	1 = Enable for operator station 4	BOOL	0
In4	1 = Enable for operator station 5	BOOL	0
In5	1 = Enable for operator station 6	BOOL	0
In6	1 = Enable for operator station 7	BOOL	0
In7	1 = Enable for operator station 8	BOOL	0
In8	1 = Enable for operator station 9	BOOL	0
In9	1 = Enable for operator station 10	BOOL	0
In10	1 = Enable for operator station 11	BOOL	0
In11	1 = Enable for operator station 12	BOOL	0
In12	1 = Enable for operator station 13	BOOL	0
In13	1 = Enable for operator station 14	BOOL	0
In14	1 = Enable for operator station 15	BOOL	0
In15	1 = Enable for operator station 16	BOOL	0
Occupied	1 = Occupied by batch control	BOOL	0

3.6 OpStations - Configuration of the local operator authorization

Parameter	Description	Type	Default
OS_Perm	I/O for operator control permissions (Page 414)	STRUCT <ul style="list-style-type: none"> • Bit 0: BOOL • ... • Bit 31: BOOL 	- <ul style="list-style-type: none"> • 1 • 1 • 1
StepNo	Batch step number	DWORD	16#00000000
UserStatus	Freely assignable bits for use in PCS 7 OS	BYTE	16#00

Output parameters

Parameter	Description	Type	Default
ENO	1 = Block algorithm completed without errors	BOOL	0
OS_PermLog	Display of OS_Perm with settings changed by the block algorithm	DWORD	16#FFFFFFFF
OS_PermOut	Display of OS_Perm	DWORD	16#FFFFFFFF
Out	Output value: for additional interconnections to the OpSt_In input of a technology block	DWORD	16#00000000
Status	Status word (Page 411)	DWORD	16#00000000

See also

- OpStations operating modes (Page 413)
- OpStations error handling (Page 415)
- OpStations messaging (Page 415)
- OpStations block diagram (Page 418)

3.6.7 OpStations block diagram

OpStations block diagram

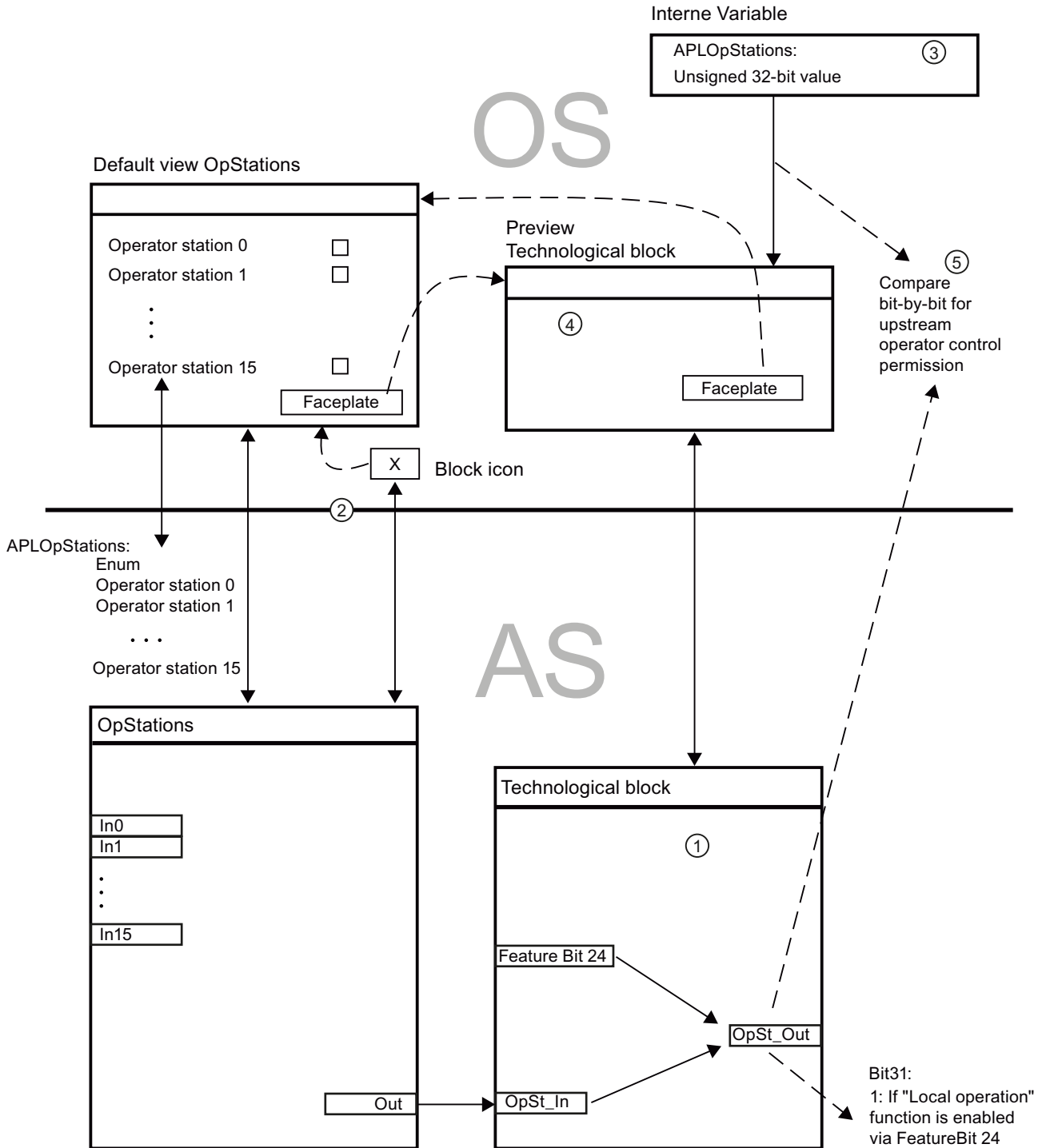

See also

Description of OpStations (Page 411)
OpStations operating modes (Page 413)
OpStations functions (Page 414)
OpStations error handling (Page 415)
OpStations messaging (Page 415)
OpStations I/Os (Page 416)

3.6.8 Operator control and monitoring**3.6.8.1 OpStations views****Views of the OpStations block**

The `OpStations` block provides the following views:

- OpStations standard view (Page 420)
- Memo view (Page 304)
- Block icon of OpStations (Page 422)

Refer to the sections Structure of the faceplate (Page 248) and Block icon structure (Page 230) for general information on the faceplate and block icon.

3.6.8.2 OpStations standard view

OpStations standard view

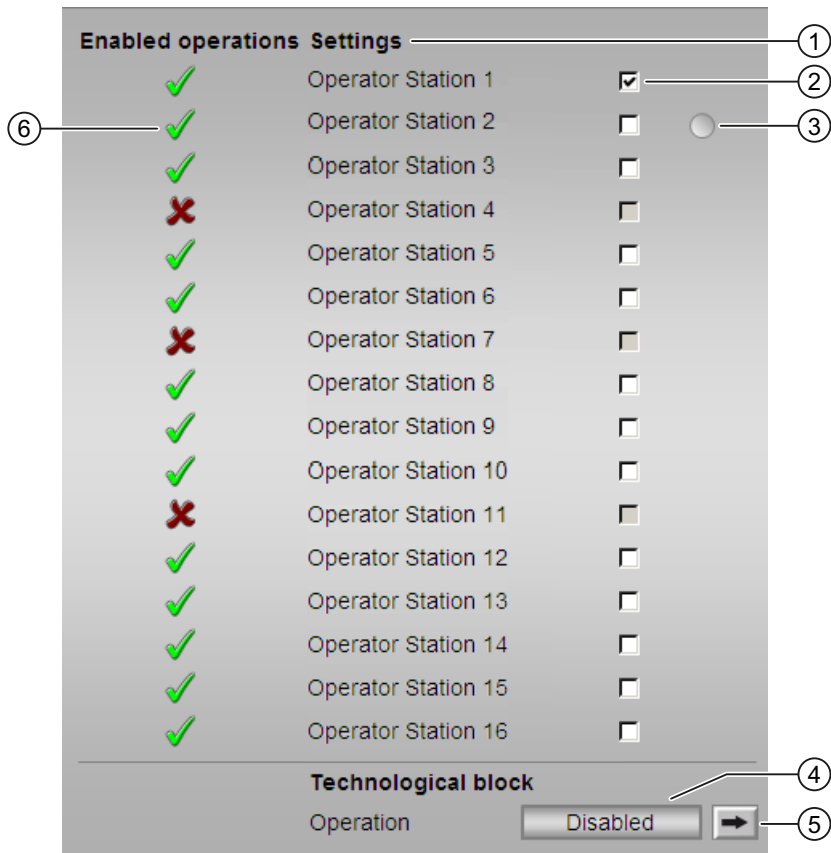

(1) Configurable display text under the settings

You yourself can define the text for operator station 1 to operator station 15 instead of the default text. Follow the steps outlined below:

- Create a list with the name "APLOpStations" in the SIMATIC Manager in the shared declarations. To learn more on this, refer to "How to save shared declarations" in the Process Control System PCS 7 Engineering System Configuration Manual.

Only values from 0 to 15 are permitted, other values will not be saved in the list.

The display names of the values are changed with the names of the operator stations. The display name corresponds to the value 0 of the display for the check box `In0` in the standard view etc.

If the text is not configured, the entire line is not displayed.

(2) Disabling or enabling operation for operator stations

In this area, you can disable the operation for an operator station or enable the operator station for the connected technologic block. In this case, the upper check box corresponds to the `In0` I/O and the lower check box to the `In15` I/O. Operation is only possible with the highest-level operator control permission (same as simulation) .

(3) Display for the current operator station

The value of the current operator station is displayed as a gray dot in the corresponding line.

(4) Display for operability

Display of the operability of the technologic block on the current operator station.

(5) Navigation button for switching to the standard view of the technologic block

Use this navigation button to reach the standard view of the technologic block. The visibility of this navigation button depends on the configuration in the engineering system (ES).

Additional information is available in the section Opening additional faceplates (Page 208).

(6) Enabled operations

This area shows all operations for which special operator control permissions are assigned. They depend on the configuration in the engineering system (ES) that applies to this block.

Symbols for enabled operations:

- **Green check mark:** the OS operator can control this parameter
- **Red cross:** the OS operator cannot control this parameter due to the configured AS operator control permissions (`OS_Perm` or `OS1Perm`).

3.6.8.3 Block icon of OpStations

Block icons for OpStations

A variety of block icons are available with the following functions:

- Opening the faceplate

Icons	Selection of the block icon in CFC	Special features
Without icon	1	Default no block icon
	2	The block icon is transparent, if operation on the operator station is possible

Note

The block icon is the size of a field in the status bar of a technologic block icon and can be used as an add-on to the status bar. The layer of the block icon here should always be higher than the layer of the technologic block icon, otherwise the block icon may be hidden after an update.

3.7 OpTrig - Manipulating a digital value (1 pushbutton)

3.7.1 Description of OpTrig

Object name (type + number) and family

Type + number: FB 1868

Family: Operate

Area of application for OpTrig

The block is used for the following applications:

- Generation of a pulse signal (trigger)

How it works

Operator control block is used to implement single pushbutton control (comparable with RESET pushbutton).

Configuration

Use the CFC editor to install the block in a cyclic interrupt OB (OB30 to OB38).

Startup characteristics

The block does not have any startup characteristics.

Status word allocation for `Status1` parameter

You can find a description for each parameter in section OpTrig I/Os (Page 427).

Status bit	Parameter
0	Occupied
1	BatchEn
2	Not used
3	OosAct.Value
4	OosLi.Value
5	Not used
6	OnAct.Value
7	Out.Value
8	LiOpAct.Value
9	FbkIn.Value
10 - 31	Not used

See also

- OpTrig functions (Page 424)
- OpTrig messaging (Page 427)
- OpTrig block diagram (Page 429)
- OpTrig error handling (Page 426)
- OpTrig modes (Page 424)

3.7.2 OpTrig modes

OpTrig operating modes

The block can be operated using the following modes:

- On (Page 71)
- Out of service (Page 71)

"On"

General information on the "On" mode is available in the section On (Page 71).

"Out of service"

You can find general information about the "Out of service" mode in the section Out of service (Page 71).

See also

- OpTrig block diagram (Page 429)
- OpTrig I/Os (Page 427)
- OpTrig messaging (Page 427)
- OpTrig functions (Page 424)
- OpTrig error handling (Page 426)
- Description of OpTrig (Page 423)

3.7.3 OpTrig functions

Functions of OpTrig

The functions for this block are listed below.

Issuing trigger signal internally or externally

Use the parameter `LiOp` to define whether the trigger signal is to be output by interconnection or by the OS operator:

`LiOp = 0`: Trigger signal by OS operator (input parameter `InOp`)

`LiOp = 1`: Trigger signal via interconnection (input parameter `InLi`)

Input parameter for feedback value

This block has a `FbkIn` input parameter for displaying a feedback value in the faceplate.

Opening additional faceplates

This block provides the standard function Opening additional faceplates (Page 208).

Forming the signal status for blocks

This block provides the standard function Forming and outputting the signal status for technologic blocks (Page 109).

The worst signal status `ST_Worst` for the block is formed from the following parameter:

- `FbkIn.ST`
- `InLi.ST` (only if `Feature.Bit10 = 1`)

Considering bad quality of automatic commands or external values

If the `Feature` bit Considering bad quality of automatic commands or external values (Page 186) is set to 1 and the parameter `InLi.ST` has bad signal status (16#00 or 16#28), the block goes to the neutral position (`Out = 0`) in the "On" mode.

Operator control permissions

This block provides the standard function Operator control permissions (Page 254).

The block has the following permissions for the `OS_Perm` parameter:

Bit	Function
0	Not used
1	1 = Operator can switch to "On" mode
2	Not used
3	1 = Operator can switch to "Out of service" mode
4	1 = Operator can set the input parameter <code>In</code>
5 - 31	Not used

Note

If you interconnect a parameter that is also listed in OS_Perm as a parameter, you have to reset the corresponding OS_Perm bit.

Simulating signals

This block provides the standard function Simulating signals (Page 58).

Configurable reactions using the Feature parameter

You can find an overview of all reactions provided by the Feature parameter in the section Configurable functions using the Feature I/O (Page 131). The following functionality is available for this block at the relevant bits:

Bit	Function
1	Reaction to the out of service mode (Page 177)
10	Considering bad quality of automatic commands or external values (Page 186)
24	Enabling local operator authorization (Page 158)

SIMATIC BATCH functionality

This block provides the standard function SIMATIC BATCH functionality (Page 67).

See also

- Description of OpTrig (Page 423)
- OpTrig messaging (Page 427)
- OpTrig I/Os (Page 427)
- OpTrig block diagram (Page 429)
- OpTrig error handling (Page 426)
- OpTrig modes (Page 424)

3.7.4 OpTrig error handling

OpTrig error handling

The block does not report any errors.

See also

OpTrig block diagram (Page 429)
 OpTrig I/Os (Page 427)
 OpTrig messaging (Page 427)
 OpTrig functions (Page 424)
 OpTrig modes (Page 424)
 Description of OpTrig (Page 423)

3.7.5 OpTrig messaging**Messaging**

This block does not offer messaging.

See also

Description of OpTrig (Page 423)
 OpTrig functions (Page 424)
 OpTrig I/Os (Page 427)
 OpTrig block diagram (Page 429)
 OpTrig error handling (Page 426)
 OpTrig modes (Page 424)

3.7.6 OpTrig I/Os**OpTrig I/Os****Input parameters**

Parameter	Description	Type	Default
BatchEn	1 = Enable allocation	BOOL	0
BatchID	Batch ID	DWORD	16#00000000
BatchName	Batch name	S7-String	
EN	1 = Called block will be processed	BOOL	1

Operator control blocks

3.7 OpTrig - Manipulating a digital value (1 pushbutton)

Parameter	Description	Type	Default
FbkIn	Input for feedback	STRUCT <ul style="list-style-type: none"> Value: BOOL ST: BYTE 	- <ul style="list-style-type: none"> 0 16#80
Feature	I/O for additional functions (Page 424)	STRUCT <ul style="list-style-type: none"> Bit 0: BOOL ... Bit 31: BOOL 	- <ul style="list-style-type: none"> 0 0 0
InLi	Interconnectable binary input	STRUCT <ul style="list-style-type: none"> Value: BOOL ST: BYTE 	- <ul style="list-style-type: none"> 0 16#80
InOp*	Binary input for operator	BOOL	0
LiOp	Switchover of operating mode between: 1 = Interconnection 0 = Operator	STRUCT <ul style="list-style-type: none"> Value: BOOL ST: BYTE 	- <ul style="list-style-type: none"> 0 16#80
Occupied	1 = Occupied by batch control	BOOL	0
OnOp*	1 = "On" mode via operator	BOOL	0
OosLi	1 = "Out of service", via interconnection or SFC	STRUCT <ul style="list-style-type: none"> Value: BOOL ST: BYTE 	- <ul style="list-style-type: none"> 0 16#80
OosOp*	1 = "Out of service", via OS operator	BOOL	0
OpSt_In	Input parameter for local operating permission, connected with the <code>Out</code> output parameter of the upstream block, <code>OpStations</code> (Page 411)	DWORD	16#00000000
OS_Perm	I/O for operator control permissions (Page 424)	STRUCT <ul style="list-style-type: none"> Bit 0: BOOL ... Bit 31: BOOL 	- <ul style="list-style-type: none"> 1 1 1
SelFp1	Call a block saved in this parameter as additional faceplate (Page 208) in standard view	ANY	-
SelFp2	Call a block saved in this parameter as additional faceplate (Page 208) in the preview	ANY	-
StepNo	Batch step number	DWORD	16#00000000
UserStatus	Freely assignable bits for use in PCS 7 OS	BYTE	16#00

* Values can be written back to these inputs during processing of the block by the block algorithm.

Output parameters

Parameter	Description	Type	Default
ENO	1 = Block algorithm completed without errors	BOOL	0
ErrorNum	Reserved	INT	-1
LiOpAct	Operator/interconnection is active	STRUCT <ul style="list-style-type: none"> Value: BOOL ST: BYTE 	- <ul style="list-style-type: none"> 0 16#80
OosAct	1 = Block is "Out of service"	STRUCT <ul style="list-style-type: none"> Value: BOOL ST: BYTE 	- <ul style="list-style-type: none"> 0 16#80
OnAct	1 = "On" mode enabled	STRUCT <ul style="list-style-type: none"> Value: BOOL ST: BYTE 	- <ul style="list-style-type: none"> 1 16#80
OpSt_Out	Value of the OpSt_In input parameter, for feedforwarding to other blocks. Bit 31 of this parameter is used by Feature bit 24	DWORD	16#00000000
OS_PermLog	Display of OS_Perm with settings changed by the block algorithm	DWORD	16#FFFFFFFF
OS_PermOut	Display of OS_Perm	DWORD	16#FFFFFFFF
Out	Output	STRUCT <ul style="list-style-type: none"> Value: BOOL ST: BYTE 	- <ul style="list-style-type: none"> 0 16#80
ST_Worst	Worst signal status	BYTE	16#80
Status	Status word (Page 423)	DWORD	16#00000000

See also

- OpTrig messaging (Page 427)
- OpTrig block diagram (Page 429)
- OpTrig error handling (Page 426)
- OpTrig modes (Page 424)

3.7.7 OpTrig block diagram

OpTrig block diagram

A block diagram is not provided for this block.

See also

- OpTrig I/Os (Page 427)
- OpTrig messaging (Page 427)
- OpTrig functions (Page 424)
- OpTrig error handling (Page 426)
- OpTrig modes (Page 424)
- Description of OpTrig (Page 423)

3.7.8 Operator control and monitoring

3.7.8.1 OpTrig views

Views of the OpTrig block

The block OpTrig provides the following views:

- OpTrig standard view (Page 430)
- OpTrig preview (Page 431)
- Memo view (Page 304)
- Batch view (Page 302)
- Block icon for OpTrig (Page 432)

Refer to the sections Structure of the faceplate (Page 248) and Block icon structure (Page 230) for general information on the faceplate and block icon.

3.7.8.2 OpTrig standard view

OpTrig standard view

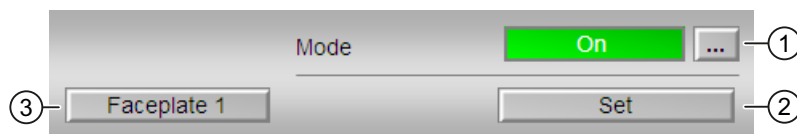

(1) Displaying and switching the operating mode

This area provides information on the currently valid operating mode. The following operating modes can be shown here:

- On (Page 71)
- Out of service (Page 71)

You can find additional information on this in the Switching operating states and operating modes (Page 257) section.

(2) Set

Clicking "Set", outputs a pulse signal with the length of the cycle time at the `Out` output.

(3) Navigation button for switching to the standard view of any faceplate

Use this navigation button to reach the standard view of a block configured in the Engineering System (ES). The visibility of this navigation button depends on the configuration in the engineering system (ES).

You can find additional information on this in the Opening additional faceplates (Page 208) section.

3.7.8.3 OpTrig preview

Preview of OpTrig

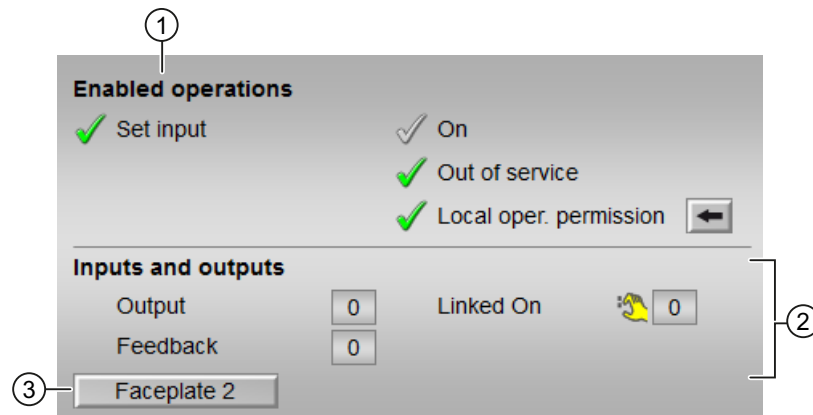

(1) Enabled operations

This area shows all operations for which special operator control permissions are assigned. They depend on the configuration in the engineering system (ES) that applies to this block.

Symbols for enabled operations:

- **Green check mark:** the OS operator can control this parameter.
- **Gray check mark:** the OS operator cannot control this parameter at this time due to the process.
- **Red cross:** the OS operator cannot control this parameter due to the configured AS operator control permissions (`OS_Perm` or `OS1Perm`).

3.7 OpTrig - Manipulating a digital value (1 pushbutton)

The following enabled operations are shown here:

- "Set input": You can set the input.
- "On": You can switch to "On" operating mode.
- "Out of service": You can switch to "Out of service" operating mode.
- "Local operating permission": Use the ← button to switch to the standard view of the OpStations block. Additional information is available in the section Operator control permissions (Page 254).

(2) Display of current inputs and outputs

This area shows the most important parameters for this block with the current selection:

- "Output": 1 = Digital output value set
- "Feedback": 1 = Feedback set
- "Linked On": 1 = Linked input on

(3) Navigation button for switching to the standard view of any faceplate

Use this navigation button to reach the standard view of a block configured in the engineering system. The visibility of this navigation button depends on the configuration in the engineering system (ES).

Refer also to the Opening additional faceplates (Page 208) section for more on this.



3.7.8.4 Block icon for OpTrig

Block icons for OpTrig



A variety of block icons are available with the following functions:

- Process tag type
- Operating modes
- Signal status, release for maintenance
- Memo display

The block icons from template @TemplateAPLV8.PDL:

Icons	Selection of the block icon in CFC	Special features
	1	
	2	Block icon in the full display

The block icons from template @TemplateAPLV7.PDL:

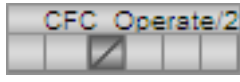
Icons	Selection of the block icon in CFC	Special features
	1	Block icon in the full display
	2	
	-	Block icon in "Out of service" mode (example with type 1 block icon)

Additional information on the block icon and the control options in the block icon is available in the following chapters:

- Configuring the block icons (Page 237)
- Block icon structure (Page 230)
- Operation via the block icon (Page 239)

Monitoring blocks

4.1 Comparison of large & small blocks

4.1.1 MonAnL compared to MonAnS

Comparison of the MonAnL and MonAnS blocks

The following tables are intended to help you decide which block to use.

Memory and runtime savings of the small block compared to the large block

You save the following resources for each instance:

- Memory space: ~ 45%
- Runtime: ~ 30%

Operating modes of the blocks

	MonAnL	MonAnS
On (Page 71)	X	X
Out of service (Page 71)	X	X

Functions of the blocks

	MonAnL	MonAnS
Alarm delays with two time values per limit pair (Page 201)	X	
Alarm delays with one time value per limit pair (Page 200)		X
Limit monitoring (Page 86)	X	X
Suppressing messages using the MsgLock parameter (Page 205)	X	X
Gradient monitoring (Page 452)	X	
Displaying auxiliary values (Page 211)	X	
Forming and outputting the signal status for technologic blocks (Page 109)	X	X

4.1 Comparison of large & small blocks

	MonAnL	MonAnS
Dead band (Page 61)	X	X
Release for maintenance (Page 64)	X	X
Simulating signals (Page 58)	X	X
Selecting a unit of measure (Page 212)	X	X
Operator control permissions (Page 254)	X	X
Generating instance-specific messages (Page 204)	X	X
Display and operator input area for process values and setpoints (Page 207)	X	X
Opening additional faceplates (Page 208)	X	X
Time stamp (Page 1660)	X	
SIMATIC BATCH functionality (Page 67)	X	X
Providing PV limit at the output (Page 452)	x	

Configurable functions using the Feature parameter

Bit number	Feature bit function	MonAnL	MonAnS
0	Set startup characteristics (Page 138)	X	X
1	Reaction to the out of service mode (Page 177)	X	X
22	Update acknowledgment and error status of the message call (Page 160)	X	
24	Enabling local operator authorization (Page 158)	X	X
25	Suppression of all messages (Page 174)	X	X
26	Reaction of the switching points in the "Out of service" operating mode (Page 176)	X	X
28	Disabling operating points (Page 145)	X	
29	Signaling limit violation (Page 170)	X	

4.1.2 MonDiL compared to MonDiS

Comparison of the MonDiL and MonDiS blocks

The following tables are intended to help you decide which block to use.

Memory and runtime savings of the small block compared to the large block

You save the following resources for each instance:

- Memory space: ~ 55%
- Runtime: ~ 12%

Operating modes of the blocks

	MonDiL	MonDiS
On (Page 71)	x	x
Out of service (Page 71)	x	x

Functions of the blocks

	MonDiL	MonDiS
Suppression and reporting of signal flutter (Page 503)	x	
Delaying the on and off function (Page 503)	x	
Delaying the on function (Page 527)		x
Specifying the status display for the block icon (Page 503)	x	x
Displaying auxiliary values (Page 211)	x	
Labeling of buttons and text (Page 209)	x	x
Generating instance-specific messages (Page 204)	x	x
Suppressing messages using the MsgLock parameter (Page 205)	x	x
Forming and outputting the signal status for technologic blocks (Page 109)	x	x
Release for maintenance (Page 64)	x	x
Simulating signals (Page 58)	x	x

Monitoring blocks

4.1 Comparison of large & small blocks

	MonDiL	MonDiS
Operator control permissions (Page 254)	x	x
Opening additional faceplates (Page 208)	x	x
Time stamp (Page 1660)	x	
SIMATIC BATCH functionality (Page 67)	x	x
Group display for limit monitoring, CSF and ExtMsgx (Page 85)	x	x

Configurable functions using the Feature parameter

Bit number	Feature bit function	MonDiL	MonDiS
0	Set startup characteristics (Page 138)	x	x
1	Reaction to the out of service mode (Page 177)	x	x
22	Update acknowledgment and error status of the message call (Page 160)	x	
24	Enabling local operator authorization (Page 158)	x	x
25	Suppression of all messages (Page 174)	x	x

4.2 AV - Displaying and monitoring additional value

4.2.1 Description of AV

Object name (type + number) and family

Type + number: FB 1903

Family: Monitor

Area of application for AV

The block is used for the following applications:

- Monitoring an additional analog value at a technologic block (for example, motor, valve).

How it works

The block must be connected to a channel block and monitors an additional analog value. The messages of the AV block appear in the alarm view of the technologic block connected to it. Monitoring limits are configured and controlled at the technologic block.

Configuration

Use the CFC editor to install the block in a cyclic interrupt OB (OB30 to OB38). The block is also installed automatically in the startup OB (OB100). The AV block and the technologic block must be installed in the same cyclic interrupt OB.

Interconnect the `AV_Tech` output parameter of the AV block to the input parameter `AV` of the technologic block in the CFC.

Note

Interconnection of the block to multiple technologic blocks is not permitted.

For the AV block, the Advanced Process Library contains process tag type templates; these serve as examples by providing various application scenarios for this block.

Examples of process tag types:

- Motor with an additional analog value and time-stamped signals (Motor_AV_EventTs) (Page 2365)

Startup characteristics

Use the `Feature Bit Set` startup characteristics (Page 138) to define the startup characteristics of this block.

The messages are suppressed after startup for the number of cycles set at `RunUpCyc`.

Status word allocation for status1 parameter

You can find a description for each parameter in section AV I/Os (Page 445).

Status bit	Parameter
0	Occupied
1	BatchEn
2	SimOn
3	MsgLock
4	AV_AH_Act.Value
5	AV_WH_Act.Value
6	AV_TH_Act.Value
7	AV_TL_Act.Value
8	AV_WL_Act.Value
9	AV_AL_Act.Value
10	AV_AH_En
11	AV_WH_En
12	AV_TH_En
13	AV_TL_En
14	AV_WL_En
15	AV_AL_En
16	AV_AH_MsgEn
17	AV_WH_MsgEn
18	AV_TH_MsgEn
19	AV_TL_MsgEn
20	AV_WL_MsgEn
21	AV_AL_MsgEn
22 - 31	Not used

See also

- AV modes (Page 440)
- AV functions (Page 441)
- AV error handling (Page 443)
- AV messaging (Page 443)
- AV block diagram (Page 448)

4.2.2 AV modes

AV operating modes

The block does not have any of its own operating modes.

If the interconnected technologic block is set to the "Out of service" operating mode, the AV block is also set to the "Out of service" mode. In this case $AV_Out = AV$.

See also

Description of AV (Page 439)

AV functions (Page 441)

AV error handling (Page 443)

AV messaging (Page 443)

AV I/Os (Page 445)

AV block diagram (Page 448)

4.2.3 AV functions

Functions of AV

The functions for this block are listed below.

Alarm delays with two time values per limit pair

This block includes the standard function alarm delay for Two time values per limit pair (Page 201).

Limit monitoring of an additional analog value

This block provides the standard function Limit monitoring of an additional analog value (Page 91).

Limit monitoring with hysteresis

This block provides the standard function Limit monitoring with hysteresis (Page 97). It is performed via the input parameter AV_Hyst .

Group display SumMsgAct for limit monitoring, CSF and ExtMsgx

The block provides the standard function Group display for limit monitoring, CSF and ExtMsgx (Page 85).

Forming the signal status for blocks

The worst signal status ST_Worst for the block is formed from the following parameter:

- $AV_Out.ST$

Simulating signals

This block provides the standard function Simulating signals (Page 58).

The simulation in the block AV is activated at the technological block (`SimOn = 1`). The simulation value `SimAV` for the block AV is also specified there. If internal simulation of the technological block is switched on, the output `AV_Out` has the value of `SimAV` and the status `16#60`.

Release for maintenance

The release for maintenance in the AV block is activated at the technological block (`MS_Release = 1`).

Selecting a unit of measure

This block provides the standard function Selecting a unit of measure (Page 212).

Generating instance-specific messages

This block provides the standard function Generating instance-specific messages (Page 204).

Configurable reactions using the `Feature` parameter

You can find an overview of all reactions provided by the `Feature` parameter in the Configurable functions using the Feature I/O (Page 131) chapter. The following functionality is available for this block at the relevant bits:

Bit	Function
0	Set startup characteristics (Page 138)
22	Update acknowledgment and error status of the message call (Page 160)
26	Reaction of the switching points in the "Out of service" operating mode (Page 176) (transferred to AV via <code>AV_Tech.Mode.Bit</code>)
29	Signaling limit violation (Page 170) (transferred to AV via <code>AV_Tech.Mode.Bit</code>)

See also

- AV modes (Page 440)
- AV error handling (Page 443)
- AV messaging (Page 443)
- AV I/Os (Page 445)
- AV block diagram (Page 448)
- Description of AV (Page 439)

4.2.4 AV error handling

Error handling of AV

Refer to the section Error handling (Page 119) in the basic instructions for the error handling of all blocks.

The following errors can be displayed for this block:

- Error numbers
- Mode switchover error

Overview of error numbers

The `ErrorNum` I/O can be used to output various error numbers:

Error number	Meaning of the error number
-1	Predefined value when inserting the block; block is not processed
0	There is no error.
30	The value of <code>AV</code> can no longer be displayed in the REAL number field.

Mode switchover error

This error can be output by the block, see the section Error handling (Page 119).

See also

Description of AV (Page 439)

AV modes (Page 440)

AV functions (Page 441)

AV messaging (Page 443)

AV I/Os (Page 445)

AV block diagram (Page 448)

4.2.5 AV messaging

Messaging

The following messages can be generated for this block:

- Process messages

Process messages

Message instance	Message identifier	Message class	Event
MsgEvId1	SIG 1	Alarm - high	\$\$BlockComment\$\$ AV - high alarm limit violated
	SIG 2	Warning - high	\$\$BlockComment\$\$ AV - high warning limit violated
	SIG 3	Tolerance - high	\$\$BlockComment\$\$ AV - high tolerance limit violated
	SIG 4	Tolerance - low	\$\$BlockComment\$\$ AV - low tolerance limit violated
	SIG 5	Warning - low	\$\$BlockComment\$\$ AV - Low warning limit violated
	SIG 6	Alarm - low	\$\$BlockComment\$\$ AV - low alarm limit violated

Explanation

\$\$BlockComment\$\$: Content of the instance-specific comment

Associated values for message instance **MsgEvId1**

Associated value	Block parameters
1	Reserved
2	Reserved
3	Reserved
4	AV_Out
5	ExtVa105
6	ExtVa106
7	ExtVa107
8	Reserved
9	Reserved
10	Reserved

The associated values 5 ... 7 are allocated to the parameters ExtVa105 ... ExtVa107 and can be used. Additional information is available in the "Process Control System PCS 7 - Engineering System" manual.

See also

Description of AV (Page 439)

AV modes (Page 440)

AV functions (Page 441)

AV error handling (Page 443)

AV I/Os (Page 445)

AV block diagram (Page 448)

4.2.6 AV I/Os

I/Os of AV

Input parameters

Parameter	Description	Type	Default
AV	Analog value	STRUCT • Value:REAL • ST:BYTE	- • 0.0 • 16#80
AV_Unit	Unit of measure for the analog value	INT	1001
AV_A_DC*	Delay time for incoming alarms [s]	REAL	0.0
AV_A_DG*	Delay time for outgoing alarms [s]	REAL	0.0
AV_AH_En	1 = Enable high alarm	BOOL	1
AV_AH_MsgEn	1 = Enable high alarm message	BOOL	1
AV_AL_En	1 = Enable low alarm	BOOL	1
AV_AL_MsgEn	1 = Enable low alarm message	BOOL	1
AV_OpScale	Limit for scale in bar graph of faceplate for the analog value	STRUCT • High:REAL • Low:REAL	- • 100.0 • 0.0
AV_T_DC*	Delay time for incoming tolerances [s]	REAL	0.0
AV_T_DG*	Delay time for outgoing tolerances [s]	REAL	0.0
AV_TH_En	1 = Enable high tolerance	BOOL	0
AV_TH_MsgEn	1 = Enable high tolerance message	BOOL	1
AV_TL_En	1 = Enable low tolerance	BOOL	0
AV_TL_MsgEn	1 = Enable low tolerance message	BOOL	1
AV_W_DC*	Delay time for incoming warnings [s]	REAL	0.0
AV_W_DG*	Delay time for outgoing warnings [s]	REAL	0.0
AV_WH_En	1 = Enable high warning	BOOL	1
AV_WH_MsgEn	1 = Enable high warning message	BOOL	1
AV_WL_En	1 = Enable low warning	BOOL	1
AV_WL_MsgEn	1 = Enable low warning message	BOOL	1
EN	1 = Called block will be processed	BOOL	1
ExtVal05	Associated value 5 for messages (MsgEvID1)	ANY	
ExtVal06	Associated value 6 for messages (MsgEvID1)	ANY	

4.2 AV - Displaying and monitoring additional value

Parameter	Description	Type	Default
ExtVal107	Associated value 7 for messages (MsgEvID1)	ANY	
Feature	I/O for additional functions (Page 441)	STRUCT <ul style="list-style-type: none"> • Bit 0: BOOL • ... • Bit 31: BOOL 	- <ul style="list-style-type: none"> • 0 • 0 • 0
MsgEvID1	Message number (assigned automatically)	DWORD	16#00000000
RunUpCyc	Number of cycles in startup; messages are suppressed during these cycles	INT	3
SampleTime	Sampling time [s] (assigned automatically)	REAL	0.1

* Values can be written back to these inputs during processing of the block by the block algorithm.

Output parameters

Parameter	Description	Type	Default
AV_AH_Act	1 = High alarm active. You can change the reaction for this parameter with <code>Feature</code> Bit 28 (Disabling operating points (Page 145)) and with <code>Feature</code> Bit 29 (Signaling limit violation (Page 170)).	STRUCT <ul style="list-style-type: none"> • Value: BOOL • ST: BYTE 	- <ul style="list-style-type: none"> • 0 • 16#80
AV_AL_Act	1 = Low alarm active. You can change the reaction for this parameter with <code>Feature</code> Bit 28 (Disabling operating points (Page 145)) and with <code>Feature</code> Bit 29 (Signaling limit violation (Page 170)).	STRUCT <ul style="list-style-type: none"> • Value: BOOL • ST: BYTE 	- <ul style="list-style-type: none"> • 0 • 16#80
AV_Out	Analog value output	STRUCT <ul style="list-style-type: none"> • Value: REAL • ST: BYTE 	- <ul style="list-style-type: none"> • 0.0 • 16#80
AV_Tech	Output parameter with which the input parameter <code>AV</code> of the technologic block has to be connected. This includes tags which are passed on to the technologic block for additional processing.	STRUCT <ul style="list-style-type: none"> • Value: REAL • ST: BYTE 	- <ul style="list-style-type: none"> • 0.0 • 16#00
AV_TH_Act	1 = High tolerance active. You can change the reaction for this parameter with <code>Feature</code> Bit 28 (Disabling operating points (Page 145)) and with <code>Feature</code> Bit 29 (Signaling limit violation (Page 170)).	STRUCT <ul style="list-style-type: none"> • Value: BOOL • ST: BYTE 	- <ul style="list-style-type: none"> • 0 • 16#80

Parameter	Description	Type	Default
AV_TL_Act	1 = Low tolerance active. You can change the reaction for this parameter with <code>Feature Bit 28</code> (Disabling operating points (Page 145)) and with <code>Feature Bit 29</code> (Signaling limit violation (Page 170)).	STRUCT • Value: BOOL • ST: BYTE	- • 0 • 16#80
AV_WH_Act	1 = High warning active. You can change the reaction for this parameter with <code>Feature Bit 28</code> (Disabling operating points (Page 145)) and with <code>Feature Bit 29</code> (Signaling limit violation (Page 170)).	STRUCT • Value: BOOL • ST: BYTE	- • 0 • 16#80
AV_WL_Act	1 = Low warning active. You can change the reaction for this parameter with <code>Feature Bit 28</code> (Disabling operating points (Page 145)) and with <code>Feature Bit 29</code> (Signaling limit violation (Page 170)).	STRUCT • Value: BOOL • ST: BYTE	- • 0 • 16#80
ENO	1 = Block algorithm completed without errors	BOOL	0
ErrorNum	Output of current error number. For error numbers that can be output by this block, see AV error handling (Page 443)	INT	-1
MS_Release	Release for maintenance: 1 = Release for OS operator	STRUCT • Value: BOOL • ST: BYTE	- • 0 • 16#80
MsgAckn1	Message acknowledgement status 1 (output <code>ACK_STATE</code> of first <code>ALARM_8P</code>)	WORD	16#0000
MsgErr1	Alarm error 1 (output <code>ERROR</code> of first <code>ALARM_8P</code>)	BOOL	0
MsgStat1	Message status 1 (output <code>STATUS</code> of first <code>ALARM_8P</code>)	WORD	16#0000
ST_Worst	Worst signal status	BYTE	16#80
Status1	Status word 1 (Page 439)	DWORD	16#00000000

See also

AV modes (Page 440)

AV messaging (Page 443)

AV block diagram (Page 448)

4.2.7 AV block diagram

AV block diagram

A block diagram is not provided for this block.

See also

Description of AV (Page 439)

AV modes (Page 440)

AV functions (Page 441)

AV error handling (Page 443)

AV messaging (Page 443)

AV I/Os (Page 445)

4.3 MonAnL - Monitoring of an analog process tag (Large)

4.3.1 Description of MonAnL

Object name (type+number) and family

Type + number: FB 1845

Family: Monitor

Area of application for MonAnL

The block is used for the following fields of applications:

- Monitoring an analog process value
- Monitoring of the gradient of an analog process value

Note

This block is also available as a small block. A comparison of the MonAnL and MonAnS blocks is available in the section: MonAnL compared to MonAnS (Page 435)

How it works

The MonAnL block is used to monitor an analog process tag and the corresponding limits. It also monitors the gradient of these signals. The block generates and outputs corresponding messages if limits are violated or if a signal gradient does not meet requirements.

Configuration

Use the CFC editor to install the block in a cyclic interrupt OB (OB30 to OB38). The block is also installed automatically in the startup OB (OB100).

For the MonAnL block, the Advanced Process Library contains templates for process tag types as examples with various application scenarios for this block.

Examples of process tag types:

- Monitoring an analog process tag (AnalogMonitoring) (Page 2356)
- Monitoring of an analog process tag for PA/FF devices (AnalogMonitoring_Fb) (Page 2357)

Startup characteristics

Use the `Feature Bit Set` startup characteristics (Page 138) to define the startup characteristics of this block.

The messages are suppressed after startup for the number of cycles set at `RunUpCyc`.

4.3 MonAnL - Monitoring of an analog process tag (Large)

The output parameters PV_HysOut, PV_AH_Out, PV_WH_Out, PV_TH_Out, PV_AL_Out, PV_WL_Out and PV_TL_Out are written by the corresponding input parameters PV_Hys, PV_AH_Lim, PV_WH_Lim, PV_TH_Lim, PV_AL_Lim, PV_WL_Lim and PV_TL_Lim.

Status word allocation for status1 parameter

You can find a description for each parameter in section MonAnL I/Os (Page 462).

Status bit	Parameter
0	Occupied
1	BatchEn
2	SimOn
3	OosAct.Value
4	OosLi.Value
5	Not used
6	OnAct.Value
7	BypassAct.Value
8	Display of BypassAct.Value in faceplate (display and operator controls) and block icon
9	Not used
10	SimLiOp.Value
11	Delay of the PV_AH_Lim message
12	Delay of the PV_WH_Lim message
13	Delay of the PV_TH_Lim message
14	Delay of the PV_TL_Lim message
15	Delay of the PV_WL_Lim message
16	Delay of the PV_AL_Lim message
17	Collection of message delays
18 - 29	Not used
30	Auxiliary value 1 visible
31	Auxiliary value 2 visible

Status word allocation for status2 parameter

Status bit	Parameter
0	MsgLock
1	PV_AH_Act.Value
2	PV_WH_Act.Value
3	PV_TH_Act.Value
4	PV_TL_Act.Value
5	PV_WL_Act.Value
6	PV_AL_Act.Value
7	PV_AH_En
8	PV_WH_En

4.3 MonAnL - Monitoring of an analog process tag (Large)

Status bit	Parameter
9	PV_TH_En
10	PV_TL_En
11	PV_WL_En
12	PV_AL_En
13	PV_AH_MsgEn
14	PV_WH_MsgEn
15	PV_TH_MsgEn
16	PV_TL_MsgEn
17	PV_WL_MsgEn
18	PV_AL_MsgEn
19	GradHUpAct.Value
20	GradHDnAct.Value
21	GradLAct.Value
22	GradHUpEn
23	GradHDnEn
24	GradLEn
25	GradHUpMsgEn
26	GradHDnMsgEn
27	GradLMsgEn
28	0 = falling measured value 1 = rising measured value
29	Not used
30	Not used
31	MS_RelOp

Status word allocation for status3 parameter

Status bit	Parameter
0	Effective signal 1 of the message block connected via EventTsIn
1	Effective signal 2 of the message block connected via EventTsIn
2	Effective signal 3 of the message block connected via EventTsIn
3	Effective signal 4 of the message block connected via EventTsIn
4	Effective signal 5 of the message block connected via EventTsIn
5	Effective signal 6 of the message block connected via EventTsIn
6	Effective signal 7 of the message block connected via EventTsIn
7	Effective signal 8 of the message block connected via EventTsIn
8 - 23	Effective signal 9..16 of the message block connected via EventTsIn
24 - 31	Not used

See also

- MonAnL functions (Page 452)
- MonAnL messaging (Page 460)
- MonAnL block diagram (Page 470)
- MonAnL error handling (Page 459)
- MonAnL modes (Page 452)

4.3.2 MonAnL modes

MonAnL operating modes

The block can be operated using the following modes:

- On (Page 71)
- Out of service (Page 71)

"On"

You can find general information about the "On" mode in the On (Page 71) section.

"Out of service"

You can find general information about the "Out of service" mode in the Out of service (Page 71) section.

See also

- MonAnL block diagram (Page 470)
- MonAnL I/Os (Page 462)
- MonAnL messaging (Page 460)
- MonAnL error handling (Page 459)
- MonAnL functions (Page 452)
- Description of MonAnL (Page 449)

4.3.3 MonAnL functions

Functions of MonAnL

The functions for this block are listed below.

Alarm delays with two time values

With the Separate delay times for each alarm (Page 170) function (Feature bit 8), separate input parameters can be set for the alarm delay on the high and low limits.

Feature bit **8 = 0**

This block includes the standard function alarm delay for Two time values per limit pair (Page 201).

Feature bit **8 = 1**

This block includes the standard function alarm delay for Two time values for each individual limit (Page 202).

Limit monitoring of the process value

This block provides the standard function Limit monitoring of the process value (Page 86).

Group display SumMsgAct for limit monitoring, CSF and ExtMsgx

The block provides the standard function Group display for limit monitoring, CSF and ExtMsgx (Page 85).

Suppressing messages using the MsgLock parameter

This block provides the standard function Suppressing messages using the MsgLock parameter (Page 205).

Gradient monitoring

The `PV_Grad` gradient is calculated with a delay function, `LagTime`. This setting smoothes the jumps of the PV input value with gradient calculation.

The gradient peak values are output at the output parameters `PV_GradNP` (negative slope) and `PV_GradPP` (positive slope). They are reset as soon as the operator issues the reset command.

The slope of the `PV_Grad` gradient can be monitored for the following limits:

- Limit (high) for positive gradients (`GradHUpLim`)
- Limit (high) for negative gradients (`GradHDnLim`)
- Limit (low) for absolute gradients (`GradLLim`)

The individual monitoring functions are activated at the corresponding "Enable" parameters, e.g. `GradHUpEn` for activating the high gradient limit for positive gradients (`GradHUpLim`).

When the values you have defined are reached or exceeded, this is indicated at the corresponding "Active" output parameters, e.g. with `GradHUpAct = 1` for the limit (high) for positive gradients.

4.3 MonAnL - Monitoring of an analog process tag (Large)

Messages can be output for these alarms. You activate these as follows:

- Message for alarms (high) for positive gradients: $GradHUpMsgEn = 1$
- Message for alarms (high) for negative gradients: $GradHDnMsgEn = 1$
- Message for alarms (low) for absolute gradients: $GradLMsgEn = 1$

Example of generating alarms for gradient monitoring

The following example shows how alarms for gradient monitoring are generated.

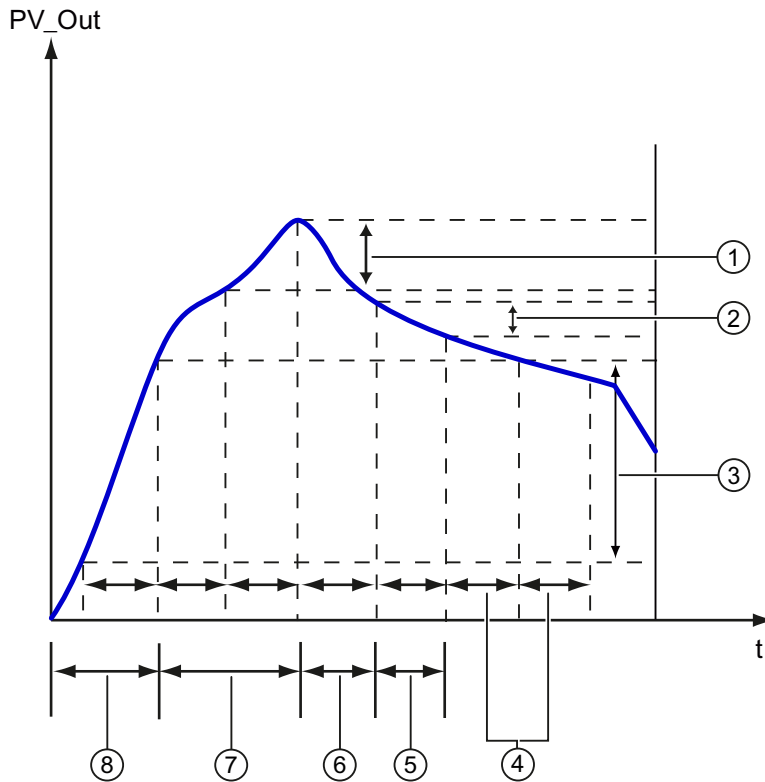

Number	Description
1	Absolute gradient difference $\geq GradHDnLim$
2	Absolute gradient difference $\leq GradLLim$
3	Gradient difference $\geq GradHUpLim$
4	Sampling time (SampleTime)
5	Alarm (low) for absolute gradients
6	Alarm (high) for negative gradients
7	No alarm
8	Alarm (high) for positive gradients

Displaying auxiliary values

This block provides the standard function Displaying auxiliary values (Page 211).

Providing PV limit at the output

The following input parameters are also available at the output for making additional interconnections to other blocks:

• PV_HysOut	:= PV_Hyst
• PV_AH_Out	:= PV_AH_Lim
• PV_WH_Out	:= PV_WH_Lim
• PV_TH_Out	:= PV_TH_Lim
• PV_TL_Out	:= PV_TL_Lim
• PV_WL_Out	:= PV_WL_Lim
• PV_AL_Out	:= PV_AL_Lim

Forming the signal status for blocks

This block provides the standard function Forming and outputting the signal status for technologic blocks (Page 109).

The worst signal status `ST_Worst` for the block is formed from the following parameters:

- `PV_Out.ST`

Dead band

To suppress values that fluctuate around the zero point, this block has the standard function Dead band (Page 61).

Smoothing PV

The block smoothes the input value `PV` using a first order time delay. This delay time can be configured with the parameter `SmoothTi`. The input of `SmoothTi` is limited to 0 to 999999 sec. The block writes back the limits if the input value is outside the limits.

The block works according to the following formula:

$$PV_Out_{(n)} = PV_{(n)} + (PV_Out_{(n-1)} - PV_{(n)}) * e^{(-SampleTime/SmoothTi)}$$

Where:

- `PV_Out` = Output value
- `SmoothTi` = Smooth time
- `SampleTime` = Sampling time
- `PV` = Input value

The formula is valid only if `SmoothTi > 0`. If `SmoothTi = 0`, the input is passed directly to the output. If the input value is outside the REAL range limits, the calculation is stopped. If the input value is inside the range limits again, the calculation is resumed automatically.

4.3 MonAnL - Monitoring of an analog process tag (Large)

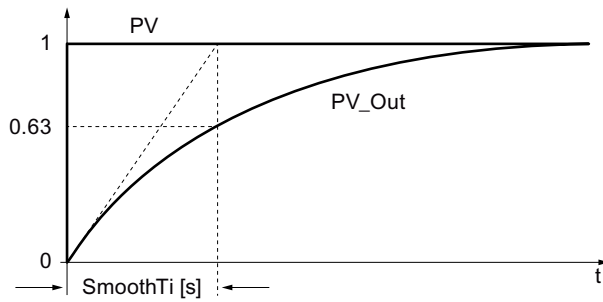

Release for maintenance

This block provides the standard function Release for maintenance (Page 64).

Simulating signals

This block provides the standard function Simulating signals (Page 58).

You can simulate the following values:

- Process value (SimPV, SimPV_Li)

Bypass function

This block provides the standard function Bypassing signals (Page 107).

Selecting a unit of measure

This block provides the standard function Selecting a unit of measure (Page 212).

Configurable reactions using the Feature parameter

You can find an overview of all reactions provided by the Feature parameter in the Configurable functions using the Feature I/O (Page 131) . The following functionality is available for this block at the relevant bits:

Bit	Function
0	Set startup characteristics (Page 138)
1	Reaction to the out of service mode (Page 177)
8	Separate delay times for each alarm (Page 170)
9	Substitution value is active if the block is in bypass (Page 185)
11	Suppress MsgLock and "Out of service" mode for a connected message block (Page 188)
22	Update acknowledgment and error status of the message call (Page 160)
24	Enabling local operator authorization (Page 158)
25	Suppression of all messages (Page 174)
26	Reaction of the switching points in the "Out of service" operating mode (Page 176)
28	Disabling operating points (Page 145)
29	Signaling limit violation (Page 170)

Operator permissions

This block provides the standard function Operator control permissions (Page 254).

The block has the following permissions for the `OS_Perm` parameter:

Bit	Function
0	Not used
1	1 = Operator can switch to "On" mode
2	Not used
3	1 = Operator can switch to "Out of service" mode
4	1 = Operator can activate bypass functionality
5	1 = Operator can deactivate bypass functionality
6	1 = Operator can change the simulation value <code>SimPV</code>
7	1 = Operator can reset the maximum values
8	1 = Operator can activate / deactivate messages via <code>GradHUpMsgEn</code>
9	1 = Operator can activate / deactivate messages via <code>GradHDnMsgEn</code>
10	1 = Operator can activate / deactivate messages via <code>GradLMsgEn</code>
11	1 = Operator can activate the Simulation function
12	1 = Operator can activate the Release for maintenance function
13	1 = Operator can change the limit (PV) for high alarm
14	1 = Operator can change the limit (PV) for high warning
15	1 = Operator can change the limit (PV) for high tolerance
16	1 = Operator can change the limit (PV) for hysteresis
17	1 = Operator can change the limit (PV) for low alarm
18	1 = Operator can change the limit (PV) for low warning
19	1 = Operator can change the limit (PV) for low tolerance
20	1 = Operator can change the value for the high gradient limit for positive slopes (<code>GradHUpLim</code>)
21	1 = Operator can change the value for high gradient limit for negative slopes (<code>GradHDnLim</code>)
22	1 = Operator can change the value for the low gradient limit for positive and negative slopes (<code>GradLLim</code>)
23	1 = Operator can change the dead band parameter <code>DeadBand</code>
24	1 = Operator can activate / deactivate messages via <code>PV_AH_MsgEn</code>
25	1 = Operator can activate / deactivate messages via <code>PV_WH_MsgEn</code>
26	1 = Operator can activate / deactivate messages via <code>PV_TH_MsgEn</code>
27	1 = Operator can activate / deactivate messages via <code>PV_TL_MsgEn</code>
28	1 = Operator can activate / deactivate messages via <code>PV_WL_MsgEn</code>
29	1 = Operator can activate / deactivate messages via <code>PV_AL_MsgEn</code>
30	1 = Operator can enter <code>SmoothTi</code>
31	Reserved

Note

If you interconnect a parameter that is also listed in OS_Perm as a parameter, you have to reset the corresponding OS_Perm bit.

Generating instance-specific messages

This block provides the standard function Generating instance-specific messages (Page 204).

Specifying the display area for process and setpoint values as well as operations

This block provides the standard function Display and operator input area for process values and setpoints (Page 207).

Opening additional faceplates

This block provides the standard function Opening additional faceplates (Page 208).

Connection of the time-stamped messages from EventTs or Event16Ts

This block provides the standard function Connection of the time-stamped messages from EventTs or Event16Ts (Page 207).

SIMATIC BATCH functionality

This block provides the standard function SIMATIC BATCH functionality (Page 67).

See also

- Description of MonAnL (Page 449)
- MonAnL messaging (Page 460)
- MonAnL I/Os (Page 462)
- MonAnL block diagram (Page 470)
- MonAnL error handling (Page 459)
- MonAnL modes (Page 452)
- EventTs functions (Page 1660)
- Error handling (Page 119)
- Sealing the valve (Page 176)

4.3.4 MonAnL error handling

Error handling of MonAnL

Refer to the section Error handling (Page 119) in the basic instructions for the error handling of all blocks.

The following error message can be generated at this block:

- Error numbers
- Control system fault (CSF)

Overview of error numbers

The `ErrorNum` I/O can be used to output various error numbers:

Error number	Meaning of the error number
-1	Predefined value when inserting the block; the block is not executed.
0	There is no error.
11	SmoothTi < 0 or SmoothTi > 999999: Due to the internal limitation to 0 or 999999 by the block, the error number has the value 11 only for one cycle. If SmoothTi is connected and is written in every cycle, the value 11 will be retained.
30	The value of PV can no longer be displayed in the REAL number field.
43	TimeFactor < 0 or TimeFactor > 2

Control system fault (CSF)

An external signal can be activated via the CSF input. If this signal changes to = 1, a control system fault is triggered. Refer to the Error handling (Page 119) section for more on this.

See also

MonAnL block diagram (Page 470)

MonAnL I/Os (Page 462)

MonAnL messaging (Page 460)

MonAnL functions (Page 452)

MonAnL modes (Page 452)

Description of MonAnL (Page 449)

4.3.5 MonAnL messaging

Messaging

The following messages can be generated for this block:

- Process control fault
- Process messages
- Instance-specific messages

Process control fault

You can interconnect an external fault (signal) to input parameter `CSF`. If it changes to `CSF = 1`, a process control fault is triggered (`MsgEvId2`, SIG 2).

Process messages

Message instance	Message identifier	Message class	Event
MsgEvId1	SIG 1	Alarm - high	\$\$BlockComment\$\$ PV - high alarm limit violated
	SIG 2	Warning - high	\$\$BlockComment\$\$ PV - high warning limit violated
	SIG 3	Tolerance - high	\$\$BlockComment\$\$ PV - high tolerance limit violated
	SIG 4	Tolerance - low	\$\$BlockComment\$\$ PV - low tolerance limit violated
	SIG 5	Warning - low	\$\$BlockComment\$\$ PV - low warning limit violated
	SIG 6	Alarm - low	\$\$BlockComment\$\$ PV - low alarm limit violated
	SIG 7	Alarm - high	\$\$BlockComment\$\$ Limit (high) for positive gradients violated
	SIG 8	Alarm - high	\$\$BlockComment\$\$ Limit (high) for negative gradients violated

Explanation:

\$\$BlockComment\$\$: Content of the instance-specific comment

Instance-specific messages

You can use up to three instance-specific messages with this block.

Message instance	Message identifier	Message class	Event
MsgEvId2	SIG 1	Alarm - low	\$\$BlockComment\$\$ Limit (low) for absolute gradients violated
	SIG 2	AS process control message - fault	\$\$BlockComment\$\$ External error has occurred
	SIG 3	AS process control message - fault	\$\$BlockComment\$\$ External message 1
	SIG 4	AS process control message - fault	\$\$BlockComment\$\$ External message 2
	SIG 5	AS process control message - fault	\$\$BlockComment\$\$ External message 3

Explanation:

\$\$BlockComment\$\$: Content of the instance-specific comment

Associated values for message instance `MsgEvId1`

Associated value	Block parameters
1	BatchName
2	StepNo
3	BatchID
4	ExtVa104
5	ExtVa105
6	ExtVa106
7	ExtVa107
8	ExtVa108
9	PV.Value
10	Reserved

The associated values 4 to 9 are allocated to the parameters `ExtVa104...ExtVa108`, `PV.Value` and can be used.

Additional information is available in the "Process Control System PCS 7 - Engineering System" manual.

Associated values for message instance `MsgEvId2`

Associated value	Block parameters
1	BatchName
2	StepNo
3	BatchID
4	ExtVa204

4.3 MonAnL - Monitoring of an analog process tag (Large)

Associated value	Block parameters
5	ExtVa205
6	ExtVa206
7	ExtVa207
8	ExtVa208
9	PV.Value
10	Reserved

The associated values 4 to 9 are allocated to the parameters ExtVa204...ExtVa208, PV.Value and can be used.

Additional information is available in the "Process Control System PCS 7 - Engineering System" manual.

See also

- Description of MonAnL (Page 449)
- MonAnL functions (Page 452)
- MonAnL I/Os (Page 462)
- MonAnL block diagram (Page 470)
- MonAnL error handling (Page 459)
- MonAnL modes (Page 452)

4.3.6 MonAnL I/Os

MonAnL I/Os

Input parameters

Parameter	Description	Type	Default
BatchEn	1 = Enable allocation	BOOL	0
BatchID	Batch ID	DWORD	16#00000000
BatchName	Batch name	S7-String	
BypLiOp	1 = Bypass commands via interconnection	STRUCT <ul style="list-style-type: none"> • Value: BOOL • ST: BYTE 	- <ul style="list-style-type: none"> • 0 • 16#80
BypLock	1 = Bypass activation or deactivation is locked for operator	STRUCT <ul style="list-style-type: none"> • Value: BOOL • ST: BYTE 	- <ul style="list-style-type: none"> • 0 • 16#80
BypPV	Substitution value if block is in bypass	REAL	0.0
BypPVLi	1 = Select bypass PV (via interconnection)	STRUCT <ul style="list-style-type: none"> • Value: BOOL • ST: BYTE 	- <ul style="list-style-type: none"> • 0 • 16#80

4.3 MonAnL - Monitoring of an analog process tag (Large)

Parameter	Description	Type	Default
BypPVOp	1 = Select bypass PV (via operator)	BOOL	0
CSF	1 = External error (control system fault) Error handling (Page 119)	STRUCT <ul style="list-style-type: none"> Value: BOOL ST: BYTE 	- <ul style="list-style-type: none"> 0 16#80
DeadBand	Width of dead band	REAL	0.0
EN	1 = Called block will be processed	BOOL	1
EventTsIn	For interconnecting data between a technology block and the message blocks <code>EventTs</code> , <code>Event16Ts</code> . The <code>EventTsIn</code> input parameter serves to interconnect the <code>EventTsOut</code> output parameter of the <code>EventTs</code> , <code>Event16Ts</code> block. When this interconnection is configured, the messages of the <code>EventTs</code> , <code>Event16Ts</code> block are displayed on the OS in the alarm view of the technology block and can also be acknowledged there.	ANY	
ExtMsg1	Binary input for freely selectable message 1	STRUCT <ul style="list-style-type: none"> Value: BOOL ST: BYTE 	- <ul style="list-style-type: none"> 0 16#80
ExtMsg2	Binary input for freely selectable message 2	STRUCT <ul style="list-style-type: none"> Value: BOOL ST: BYTE 	- <ul style="list-style-type: none"> 0 16#80
ExtMsg3	Binary input for freely selectable message 3	STRUCT <ul style="list-style-type: none"> Value: BOOL ST: BYTE 	- <ul style="list-style-type: none"> 0 16#80
ExtVa104	Associated value 4 for messages (<code>MsgEvID1</code>)	ANY	
ExtVa105	Associated value 5 for messages (<code>MsgEvID1</code>)	ANY	
ExtVa106	Associated value 6 for messages (<code>MsgEvID1</code>)	ANY	
ExtVa107	Associated value 7 for messages (<code>MsgEvID1</code>)	ANY	
ExtVa108	Associated value 8 for messages (<code>MsgEvID1</code>)	ANY	
ExtVa204	Associated value 4 for messages (<code>MsgEvID2</code>)	ANY	
ExtVa205	Associated value 5 for messages (<code>MsgEvID2</code>)	ANY	
ExtVa206	Associated value 6 for messages (<code>MsgEvID2</code>)	ANY	
ExtVa207	Associated value 7 for messages (<code>MsgEvID2</code>)	ANY	
ExtVa208	Associated value 8 for messages (<code>MsgEvID2</code>)	ANY	
Feature	I/O for additional functions (Page 452)	STRUCT <ul style="list-style-type: none"> Bit 0: BOOL ... Bit 31: BOOL 	- <ul style="list-style-type: none"> 0 0 0
GradHUpLim	Gradient monitoring: Limit (high) for positive gradients	REAL	10.0
GradHDnLim	Gradient monitoring: Limit (high) for negative gradients	REAL	10.0

Monitoring blocks

4.3 MonAnL - Monitoring of an analog process tag (Large)

Parameter	Description	Type	Default
GradLLim	Gradient monitoring: Limit (low) for absolute gradients	REAL	1.0
GradHUpEn	1 = Activate gradient monitoring (high) for positive changes	BOOL	1
GradHDnEn	1 = Activate gradient monitoring (high) for negative changes	BOOL	1
GradLEn	1 = Activate gradient monitoring (low)	BOOL	0
GradHUpMsgEn	1 = Activate gradient (high) message for positive changes	BOOL	1
GradHDnMsgEn	1 = Activate gradient (high) message for negative changes	BOOL	1
GradLMsgEn	1 = Activate gradient (low) message	BOOL	1
LagTime	Delay time [s]	REAL	1.0
MS_RelOp*	1 = Release for maintenance by OS operator	BOOL	0
MsgEvId1	Message number (assigned automatically)	DWORD	16#00000000
MsgEvId2	Message number (assigned automatically)	DWORD	16#00000000
MsgLock	1 = Suppress process messages. See also the section Suppressing messages using the MsgLock parameter (Page 205) for more on this.	STRUCT <ul style="list-style-type: none"> Value: BOOL ST: BYTE 	- <ul style="list-style-type: none"> 0 16#80
Occupied	1 = Occupied by batch control	BOOL	0
OnOp*	1 = "On" mode via operator	BOOL	0
OosLi	1 = "Out of service", via interconnection or SFC (0-1 edge transition)	STRUCT <ul style="list-style-type: none"> Value: BOOL ST: BYTE 	- <ul style="list-style-type: none"> 0 16#80
OosOp*	1 = "Out of service", via OS operator	BOOL	0
OpSt_In	Input parameter for local operator authorization, connected with the <code>Out</code> output parameter of the upstream block, <code>OpStations</code> (Page 411)	DWORD	16#00000000
OS_Perm	I/O for operator permissions (Page 452)	STRUCT <ul style="list-style-type: none"> Bit 0: BOOL Bit 10: BOOL Bit 31: BOOL 	- <ul style="list-style-type: none"> 1 1 1
PV*	Process value	STRUCT <ul style="list-style-type: none"> Value: REAL ST: BYTE 	- <ul style="list-style-type: none"> 0.0 16#80
PV_A_DC*	Delay time for incoming <code>PV</code> alarms for overshoot/undershoot or only for undershot process values [s]	REAL	0.0
PV_A_DG*	Delay time for outgoing <code>PV</code> alarms for overshoot/undershoot or only for undershot process values [s]	REAL	0.0
PV_AH_DC*	Delay time for incoming alarms for overshoot process values [s]	REAL	0.0

4.3 MonAnL - Monitoring of an analog process tag (Large)

Parameter	Description	Type	Default
PV_AH_DG*	Delay time for outgoing alarms for overshoot process values [s]	REAL	0.0
PV_AH_En	1 = Enable PV alarm limit (high)	BOOL	1
PV_AH_Lim	Limit PV alarm (high)	REAL	95.0
PV_AH_MsgEn	1 = Enable PV alarm (high) message	BOOL	1
PV_AL_En	1 = Enable PV alarm limit (low)	BOOL	1
PV_AL_Lim	PV alarm limit (low)	REAL	5.0
PV_AL_MsgEn	1 = Enable PV alarm (low) message	BOOL	1
PV_Hyst*	Hysteresis for PV alarm, warning and tolerance limits	REAL	0.0
PV_OpScale	Limit for scale in PV bar graph of faceplate	STRUCT • High: REAL • Low: REAL	- • 100.0 • 0.0
PV_T_DC*	Delay time for incoming PV tolerance messages for overshoot/undershoot or only for undershot process values [s]	REAL	0.0
PV_T_DG*	Delay time for outgoing PV tolerance messages for overshoot/undershoot or only for undershot process values [s]	REAL	0.0
PV_TH_DC*	Delay time for incoming tolerance messages for overshoot process values [s]	REAL	0.0
PV_TH_DG*	Delay time for outgoing tolerance messages for overshoot process values [s]	REAL	0.0
PV_TH_En	1 = Enable PV tolerance limit (high)	BOOL	0
PV_TH_Lim	Limit PV tolerance message (high)	REAL	85.0
PV_TH_MsgEn	1 = Enable message for PV tolerance message (high)	BOOL	1
PV_TL_En	1 = Enable PV tolerance limit (low)	BOOL	0
PV_TL_Lim	Limit PV tolerance message (low)	REAL	15.0
PV_TL_MsgEn	1 = Activate message for PV tolerance message (low)	BOOL	1
PV_Unit	Unit of measure for process value	INT	1001
PV_W_DC*	Delay time for incoming PV warnings for overshoot/undershoot or only for undershot process values [s]	REAL	0.0
PV_W_DG*	Delay time for outgoing PV warnings for overshoot/undershoot or only for undershot process values [s]	REAL	0.0
PV_WH_DC*	Delay time for incoming warnings for overshoot process values [s]	REAL	0.0
PV_WH_DG*	Delay time for outgoing warnings for overshoot process values [s]	REAL	0.0
PV_WH_En	1 = Enable PV warning limit (high)	BOOL	1
PV_WH_Lim	Limit PV warning (high)	REAL	90.0
PV_WH_MsgEn	1 = Enable PV warning (high) message	BOOL	1

Monitoring blocks

4.3 MonAnL - Monitoring of an analog process tag (Large)

Parameter	Description	Type	Default
PV_WL_En	1 = Enable PV warning limit (low)	BOOL	1
PV_WL_Lim	Limit PV warning (low)	REAL	10.0
PV_WL_MsgEn	1 = Enable PV warning (low) message	BOOL	1
RstBypLi	1 = Reset bypass PV (via interconnection)	STRUCT <ul style="list-style-type: none"> • Value: BOOL • ST: BYTE 	- <ul style="list-style-type: none"> • 0 • 16#80
RstBypOp	1 = Reset bypass PV (via operator)	BOOL	0
RstOp*	1 = Operator reset of the gradient's peak values	BOOL	0
RunUpCyc	Number of cycles in startup; messages are suppressed during these cycles	INT	3
SampleTime	Sampling time [s] (assigned automatically)	REAL	0.1
SelFp1	1 = Call a block saved in this parameter as an additional faceplate (Page 208) in the standard view	ANY	-
SelFp2	1 = Call a block saved in this parameter as an additional faceplate (Page 208) in the preview	ANY	-
SimLiOp	Activation/deactivation of the simulation by: 0 = Operator 1 = Interconnection or SFC	STRUCT <ul style="list-style-type: none"> • Value: BOOL • ST: BYTE 	- <ul style="list-style-type: none"> • 0 • 16#80
SimOnLi	1 = Simulation via interconnection or SFC (controlled by SimLiOp = 1)	STRUCT <ul style="list-style-type: none"> • Value: BOOL • ST: BYTE 	- <ul style="list-style-type: none"> • 0 • 16#80
SimOn*	1 = Simulation on	BOOL	0
SimPV*	Process value that is used for SimOn = 1	REAL	0.0
SimPV_Li	Process value that is used for SimOnLi.Value = 1 (SimLiOp.Value = 1)	STRUCT <ul style="list-style-type: none"> • Value: REAL • ST: BYTE 	- <ul style="list-style-type: none"> • 0.0 • 16#80
StepNo	Batch step number	DWORD	16#00000000
SmoothTi*	Smooth time [s] (limited to 0 to 999999)	REAL	0.0
TimeFactor	Time unit: 0 = Seconds 1 = Minutes 2 = Hours	INT	0
UA1unit	Unit of measure for analog auxiliary value 1	INT	0
UA2unit	Unit of measure for analog auxiliary value 2	INT	0
UserAna1	Analog auxiliary value 1	STRUCT <ul style="list-style-type: none"> • Value: REAL • ST: BYTE 	- <ul style="list-style-type: none"> • 0.0 • 16#FF
UserAna2	Analog auxiliary value 2	STRUCT <ul style="list-style-type: none"> • Value: REAL • ST: BYTE 	- <ul style="list-style-type: none"> • 0.0 • 16#FF
UserStatus	Freely assignable bits for use in PCS 7 OS	BYTE	16#00

* Values can be written back to these inputs during processing of the block by the block algorithm.

Output parameters

Parameter	Description	Type	Default
BypassAct	1 = Bypass is activated in this block	STRUCT <ul style="list-style-type: none"> Value: BOOL ST: BYTE 	- <ul style="list-style-type: none"> 0 16#80
ENO	1 = Block algorithm completed without errors	BOOL	0
ErrorNum	Output of pending error number. For error numbers that can be output by this block, see MonAnL error handling (Page 459)	INT	-1
GradHUpAct	1 = Gradient alarm (high) for positive changes. You can change the reaction for this parameter with <i>Feature</i> bit 28 (Disabling operating points (Page 145)) and with <i>Feature</i> bit 29 (Signaling limit violation (Page 170)).	STRUCT <ul style="list-style-type: none"> Value: BOOL ST: BYTE Bit 1: BOOL (Bypass information bit) 	- <ul style="list-style-type: none"> 0 16#80 0
GradHDnAct	1 = Gradient alarm (high) for negative changes. You can change the reaction for this parameter with <i>Feature</i> bit 28 (Disabling operating points (Page 145)) and with <i>Feature</i> bit 29 (Signaling limit violation (Page 170)).	STRUCT <ul style="list-style-type: none"> Value: BOOL ST: BYTE Bit 1: BOOL (Bypass information bit) 	- <ul style="list-style-type: none"> 0 16#80 0
GradLAct	1 = Low gradient alarm. You can change the reaction for this parameter with <i>Feature</i> bit 28 (Disabling operating points (Page 145)) and with <i>Feature</i> bit 29 (Signaling limit violation (Page 170)).	STRUCT <ul style="list-style-type: none"> Value: BOOL ST: BYTE Bit 1: BOOL (Bypass information bit) 	- <ul style="list-style-type: none"> 0 16#80 0
MS_Release	Release for maintenance: 1 = Release for OS operator	STRUCT <ul style="list-style-type: none"> Value: BOOL ST: BYTE 	- <ul style="list-style-type: none"> 0 16#80
MsgAckn1	Message acknowledgement status 1 (output <i>ACK_STATE</i> of first <i>ALARM_8P</i>)	WORD	16#0000
MsgAckn2	Message acknowledgement status 2 (output <i>ACK_STATE</i> of second <i>ALARM_8P</i>)	WORD	16#0000
MsgErr1	1 = Alarm error 1 (output <i>ERROR</i> of the first <i>ALARM_8P</i>)	BOOL	0
MsgErr2	1 = Alarm error 2 (output <i>ERROR</i> of the second <i>ALARM_8P</i>)	BOOL	0
MsgStat1	Message status 1 (output <i>STATUS</i> of first <i>ALARM_8P</i>)	WORD	16#0000

Monitoring blocks

4.3 MonAnL - Monitoring of an analog process tag (Large)

Parameter	Description	Type	Default
MsgStat2	Message status 2 (output STATUS of second ALARM_8P)	WORD	16#0000
OnAct	1 = "On" mode enabled	STRUCT <ul style="list-style-type: none"> Value: BOOL ST: BYTE 	- <ul style="list-style-type: none"> 1 16#80
OosAct	1 = Block is "Out of service"	STRUCT <ul style="list-style-type: none"> Value: BOOL ST: BYTE 	- <ul style="list-style-type: none"> 0 16#80
OpSt_Out	Value of the OpSt_In input parameter, for feed-forwarding to other blocks. Bit 31 of this parameter is used by Feature bit 24	DWORD	16#00000000
OS_PermLog	Display of OS_Perm with settings changed by the block algorithm	DWORD	16#FFFFFFFF
OS_PermOut	Display of OS_Perm	DWORD	16#FFFFFFFF
PV_AH_Act	1 = PV alarm (high) active. You can change the reaction for this parameter with Feature bit 28 (Disabling operating points (Page 145)) and with Feature bit 29 (Signaling limit violation (Page 170)).	STRUCT <ul style="list-style-type: none"> Value: BOOL ST: BYTE Bit 1: BOOL (Bypass information bit) 	- <ul style="list-style-type: none"> 0 16#80 0
PV_AH_Out	PV - alarm limit (high) output	REAL	0.0
PV_AL_Act	1 = PV alarm (low) active. You can change the reaction for this parameter with Feature bit 28 (Disabling operating points (Page 145)) and with Feature bit 29 (Signaling limit violation (Page 170)).	STRUCT <ul style="list-style-type: none"> Value: BOOL ST: BYTE Bit 1: BOOL (Bypass information bit) 	- <ul style="list-style-type: none"> 0 16#80 0
PV_AL_Out	PV - alarm limit (low) output	REAL	0.0
PV_Grad	Gradient value.	STRUCT <ul style="list-style-type: none"> Value: REAL ST: BYTE 	- <ul style="list-style-type: none"> 0.0 16#80
PV_GradPP	Gradient maximum peak value	STRUCT <ul style="list-style-type: none"> Value: REAL ST: BYTE 	- <ul style="list-style-type: none"> 0.0 16#80
PV_GradNP	Gradient minimum peak value	STRUCT <ul style="list-style-type: none"> Value: REAL ST: BYTE 	- <ul style="list-style-type: none"> 0.0 16#80
PV_HysOut	Hysteresis for PV alarm, output	REAL	0.0

4.3 MonAnL - Monitoring of an analog process tag (Large)

Parameter	Description	Type	Default
PV_Out	Output for process value	STRUCT <ul style="list-style-type: none"> Value: REAL ST: BYTE Bit 1: BOOL of internal fill byte (Bypass information bit) 	- <ul style="list-style-type: none"> 0.0 16#80 0
PV_TH_Act	1 = PV tolerance message (high) active. You can change the reaction for this parameter with Feature bit 28 (Disabling operating points (Page 145)) and with Feature bit 29 (Signaling limit violation (Page 170)).	STRUCT <ul style="list-style-type: none"> Value: BOOL ST: BYTE Bit 1: BOOL (Bypass information bit) 	- <ul style="list-style-type: none"> 0 16#80 0
PV_TH_Out	PV tolerance limit (high) output	REAL	0.0
PV_TL_Act	1 = PV tolerance message (low) active. You can change the reaction for this parameter with Feature bit 28 (Disabling operating points (Page 145)) and with Feature bit 29 (Signaling limit violation (Page 170)).	STRUCT <ul style="list-style-type: none"> Value: BOOL ST: BYTE Bit 1: BOOL (Bypass information bit) 	- <ul style="list-style-type: none"> 0 16#80 0
PV_TL_Out	PV tolerance limit (low) output	REAL	0.0
PV_WH_Act	1 = PV warning (high) active. You can change the reaction for this parameter with Feature bit 28 (Disabling operating points (Page 145)) and with Feature bit 29 (Signaling limit violation (Page 170)).	STRUCT <ul style="list-style-type: none"> Value: BOOL ST: BYTE Bit 1: BOOL (Bypass information bit) 	- <ul style="list-style-type: none"> 0 16#80 0
PV_WH_Out	Limit PV warning (high) output	REAL	0.0
PV_WL_Act	1 = PV warning (low) active. You can change the reaction for this parameter with Feature bit 28 (Disabling operating points (Page 145)) and with Feature bit 29 (Signaling limit violation (Page 170)).	STRUCT <ul style="list-style-type: none"> Value: BOOL ST: BYTE Bit 1: BOOL (Bypass information bit) 	- <ul style="list-style-type: none"> 0 16#80 0
PV_WL_Out	Limit PV warning (low) output	REAL	0.0
ST_Worst	Worst signal status	BYTE	16#80
Status1	Status word 1 (Page 449)	DWORD	16#00000000
Status2	Status word 2 (Page 449)	DWORD	16#00000000
Status3	Status word 3 (Page 449)	DWORD	16#00000000
SumMsgAct	1 = Group message is active	STRUCT <ul style="list-style-type: none"> Value: BOOL ST: BYTE 	- <ul style="list-style-type: none"> 0 16#80

4.3 MonAnL - Monitoring of an analog process tag (Large)

See also

- MonAnL messaging (Page 460)
- MonAnL block diagram (Page 470)
- MonAnL modes (Page 452)

4.3.7 MonAnL block diagram

MonAnL block diagram

A block diagram is not provided for this block.

See also

- MonAnL I/Os (Page 462)
- MonAnL messaging (Page 460)
- MonAnL error handling (Page 459)
- MonAnL functions (Page 452)
- MonAnL modes (Page 452)
- Description of MonAnL (Page 449)

4.3.8 Operator control and monitoring

4.3.8.1 MonAnL views

Views of the MonAnL block

The block MonAnL provides the following views:

- MonAnL standard view (Page 471)
- Alarm view (Page 302)
- MonAnL limit view (Page 474)
- Trend view (Page 305)
- MonAnL parameter view (Page 476)
- MonAnL preview (Page 477)
- Memo view (Page 304)
- Batch view (Page 302)
- Block icon for MonAnL (Page 478)

Refer to the sections Structure of the faceplate (Page 248) and Block icon structure (Page 230) for general information on the faceplate and block icon.

4.3.8.2 MonAnL standard view

MonAnL standard view

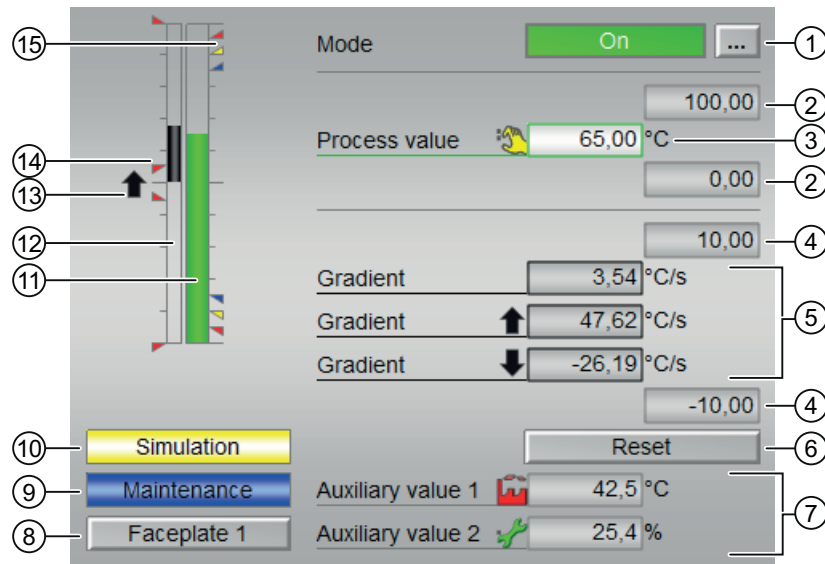

(1) Displaying and switching the operating mode

This area provides information on the currently valid operating mode. The following operating modes can be shown here:

- On (Page 71)
- Out of service (Page 71)

Refer to the Switching operating states and operating modes (Page 257) section for information on switching the operating mode.

(2) High and low scale range for the process value

These values provide information on the display range for the bar graph of the process value. The scale range is defined in the engineering system.

(3) Display of the process value including signal status

This area shows the current process value with the corresponding signal status.

If text is configured for this command, it is displayed as additional text and button label for command selection. Additional information is available in the section Labeling of buttons and text (Page 209).

You can change the text for the process value with the `PV_Out` parameter.

(4) High and low scale range for the gradient value

These values provide information on the display range for the bar graph of the gradient. The scale range corresponds to 10% of the scale range for the process value: For example, once you have specified a process value scale range of 0 to 100, the scale range of the gradient will be automatically set to a value between -10 and 10.

The current gradient value is displayed when one of the following monitoring functions is activated:

- Gradient monitoring for positive changes (`GradHUpEn = 1`)
- Gradient monitoring for negative changes (`GradHDnEn = 1`)
- Gradient monitoring (`GradLEn = 1`)

(5) Display of the gradient

This area shows the current, minimum and maximum gradient value and the rise and fall of the value. This display of the minimum and maximum gradient value functions like a min/max pointer.

The current gradient value is displayed when one of the following monitoring functions is activated:

- Gradient monitoring for positive changes (`GradHUpEn = 1`)
- Gradient monitoring for negative changes (`GradHDnEn = 1`)
- Gradient monitoring (`GradLEn = 1`)

The maximum peak gradient value is displayed when the gradient monitoring is activated for positive changes (`GradHUpEn = 1`)

The minimum peak gradient value is displayed when the gradient monitoring is activated for negative changes (`GradHDnEn = 1`)

(6) Resetting the peak values of the gradient

You can use this button to reset the maximum or minimum peak value of the gradient (`PV_GradPP` and `PV_GradNP` output parameters).

The button is displayed when gradient monitoring is activated for positive (`GradHUpEn = 1`) or negative changes (`GradHDnEn = 1`).

(7) Display of auxiliary values

You can use this area to display two auxiliary values that have been configured in the engineering system. You can find additional information on this in the Displaying auxiliary values (Page 211) section.

(8) Navigation button for switching to the standard view of any faceplate

Use this navigation button to reach the standard view of a block configured in the engineering system. The visibility of this navigation button depends on the configuration in the engineering system (ES).

You can find additional information on this in the Opening additional faceplates (Page 208) section.

(9) Display area for block states

This area provides additional information on the operating state of the block:

- "Maintenance"

(10) Display area for block states

This area provides additional information on the operating state of the block:

- "Simulation"

(11) Bar graph for the "process value"

This area shows the current "Process value" in the form of a bar graph. The visible area in the bar graph depends on the configuration in the engineering system (ES).

(12) Bar graph for the gradient

This area shows the current gradient value in the form of a bar graph. The visible area in the bar graph depends on the configuration in the engineering system (ES).

The bar graph is displayed when gradient monitoring is activated for positive ($\text{GradHUpEn} = 1$) or negative changes ($\text{GradHDnEn} = 1$).

(13) Display of the gradient

This display indicates the movement of the gradient up (\uparrow) or down (\downarrow).

Gradient monitoring is displayed when the gradient value $\text{PV_Grad} \neq 0$ and one of the following monitoring functions is activated:

- Gradient monitoring for positive changes ($\text{GradHUpEn} = 1$)
- Gradient monitoring for negative changes ($\text{GradHDnEn} = 1$)
- Gradient monitoring ($\text{GradLEn} = 1$)

(14) Display of limits in the bar graph

This area shows you the specified limits. Refer to the MonAnL limit view (Page 474) section for more on this.

The display only appears when the bar for the gradients is also displayed.

(15) Limit display

These colored triangles show you the specified limits in the respective bar graph.

4.3.8.3 MonAnL limit view

Limit view of MonAnL

Several values are set in this view by default:

- Process value limits
- Gradient limits

The toolbars of the faceplate and the block icon indicate when the limits are reached or violated.

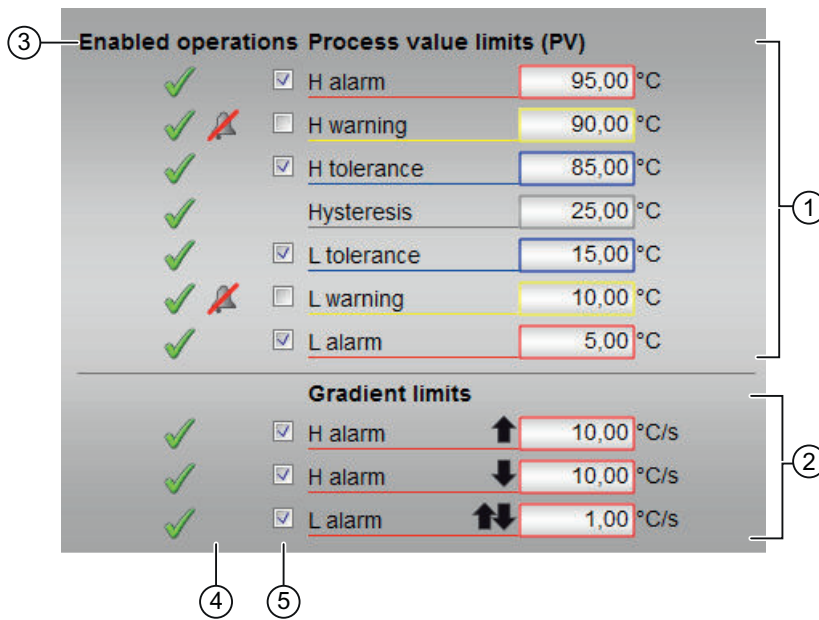

(1) Process value limits

In this area, you can enter the limits for the process value. Refer to the Changing values (Page 259) section for more on this.

You can change the following limits:

- "H alarm": Alarm high
- "H warning": Warning high
- "H tolerance": Tolerance high
- "Hysteresis"
- "L tolerance": Tolerance low
- "L warning": Warning low
- "L alarm": Alarm low

(2) Gradient limits

You can enter the gradient limits in this area. Refer to the Changing values (Page 259) section for more on this.

You can change the following limits:

- "H alarm ↑": Gradient for the high slope for positive changes
- "H alarm ↓": Gradient for the high slope for negative changes
- "L alarm ↑↓": Gradient for the low slope (absolute)

(3) Enabled operation

This area shows all operations for which special operator permissions are assigned. They depend on the configuration in the engineering system (ES) that applies to this block.

Icons for enabled operation:

- **Green check mark:** the OS operator can control this parameter
- **Gray check mark:** the OS operator cannot control this parameter at this time due to the process
- **Red cross:** the OS operator cannot control this parameter due to the configured AS operator permissions (OS_Perm or OS1Perm)

(4) Message suppression / delays

Message suppression indicates whether or not the suppression of the associated message in the AS block is activated with the `xx_MsgEn` parameter. The output of messages is not suppressed when the block is installed (all `xx_MsgEn` parameters are preset to 1). Messages can only be output if limit monitoring of the additional analog value has been enabled.

Alarm delays are also displayed in this position; for more on this see section Area of application for alarm delays (Page 199).

(5) Suppress messages

You can enable / disable messages by setting the check mark.

4.3.8.4 MonAnL parameter view

Parameter view of MonAnL

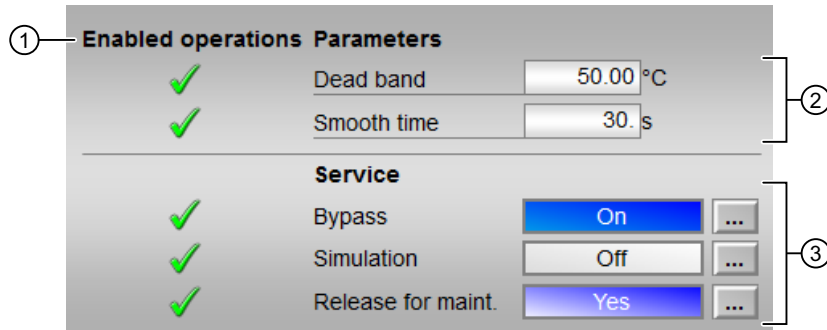

(1) Enabled operations

This area shows all operations for which special operator control permissions are assigned. They depend on the configuration in the engineering system (ES) that applies to this block.

Symbols for enabled operations:

- **Green check mark:** the OS operator can control this parameter
- **Gray check mark:** the OS operator cannot control this parameter at this time due to the process
- **Red cross:** the OS operator cannot control this parameter due to the configured AS operator control permissions (OS_Perm or OS1Perm).

(2) Parameter

You can change the following parameter in this area:

- "Dead band"
- "Smooth time"

You can find more information about this in the section Changing values (Page 259).

(3) Service

You can select the following functions in this area:

- "Bypass"
- "Simulation"
- "Release for maintenance"

Refer to the Switching operating states and operating modes (Page 257) section for more on this.

You can find information on this area in the section:

- Bypassing signals (Page 107)
- Simulating signals (Page 58)
- Release for maintenance (Page 64)

4.3.8.5 MonAnL preview

Preview of MonAnL

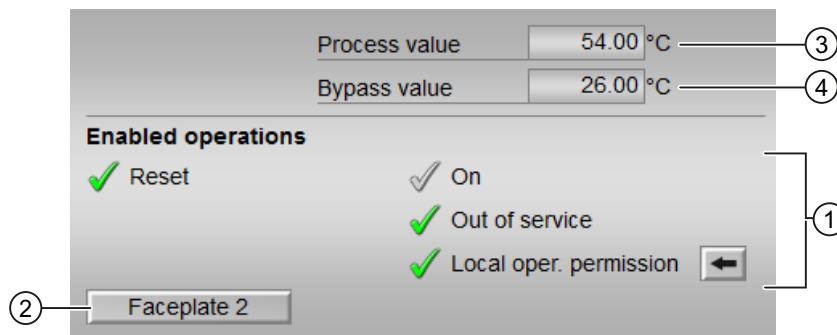

(1) Enable operations

This area shows all operations for which special operator permissions are assigned. They depend on the configuration in the engineering system (ES) that applies to this block.

Icons for enabled operation:

- **Green check mark:** the OS operator can control this parameter
- **Gray check mark:** the OS operator cannot control this parameter at this time due to the process
- **Red cross:** the OS operator cannot control this parameter due to the configured AS operator permissions (OS_Perm or OS1Perm)

The following enabled operations are shown here:

- **Reset:** You can reset the peak value of the gradient.
- **"On":** You can switch to "On" operating mode.
- **"Out of service":** You can switch to "Out of service" operating mode.
- **"Local operator permission":** Use the ← button to switch to the standard view of the OpStations block. You can find additional information on this in the section Operator control permissions (Page 254) .

4.3 MonAnL - Monitoring of an analog process tag (Large)

(2) Navigation button for switching to the standard view of any faceplate

Use this navigation button to open the standard view of a block configured in the engineering system (ES). The visibility of this navigation button depends on the configuration in the engineering system (ES).

You can find additional information on this in the section Opening additional faceplates (Page 208) .

(3) Process value

This area displays the real process value (PV).

(4) Bypass value

This area displays the bypass value (BypPV).

4.3.8.6 Block icon for MonAnL

Block symbols for MonAnL

A variety of block symbols are available with the following functions:

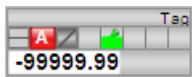
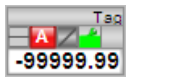
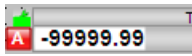
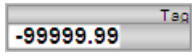

- Process tag type
- Limits (high/low)
- Violation of alarm, warning, and tolerance limits as well as control system faults
- Operating modes
- Signal status, release for maintenance
- Memo display
- Process value

The block symbols from template @TemplateAPLV8.PDL:

Symbols	Selection of the block symbol in CFC	Special features
	1	
	2	
	3	
	4	

4.3 MonAnL - Monitoring of an analog process tag (Large)

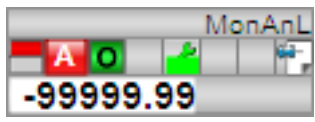
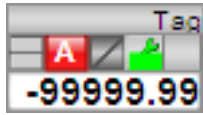
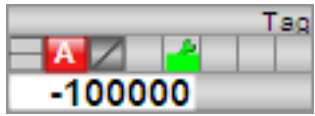
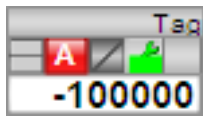
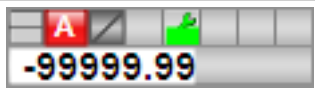
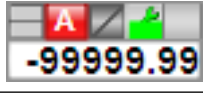
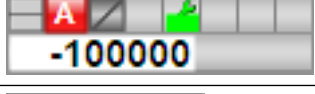
The block symbols from template @TemplateAPLV7.PDL:

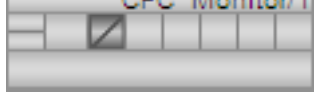
Symbols	Selection of the block symbol in CFC	Special features
	1	Block symbol in the full display
	2	
	3	
	4	
	5	
	6	
	7	
	8	
	-	Block symbol in "Out of service" mode (example with block symbol type 1)

Additional information on the block symbol and the control options in the block symbol is available in the following chapters:

- Configuring the block icons (Page 237)
- Block icon structure (Page 230)
- Operation via the block icon (Page 239).

4.4 MonAnS - Monitoring of an analog process tag (Small)

4.4.1 Description of MonAnS

Object name (type + number)

Type + number: FB 1912

Family: Monitor

Area of application for MonAnS

The block is used for the following fields of application

- Monitoring an analog process value

Note

This block is also available as a large block. A comparison of the MonAnL and MonAnS blocks is available in the section: MonAnL compared to MonAnS (Page 435)

How it works

The MonAnS block is used to monitor an analog process tag and the corresponding limits. The block generates and outputs messages if any violation of limits is detected.

Configuration

Use the CFC editor to install the block in a cyclic interrupt OB (OB30 to OB38). The block is also installed automatically in the startup OB (OB100).

Startup characteristics

Use the `Feature Bit Set` startup characteristics (Page 138) to define the startup characteristics of this block.

The messages are suppressed after startup for the number of cycles set at `RunUpCyc`.

Status word allocation for `Status1` parameter

You can find a description for each parameter in section MonAnS I/Os (Page 488).

Status bit	Parameter
0	Occupied
1	BatchEn
2	SimOn

Status bit	Parameter
3	OosAct.Value
4	OosLi.Value
5	Not used
6	OnAct.Value
7 - 10	Not used
11	Delay of the PV_AH_Lim message
12	Delay of the PV_WH_Lim message
13 - 14	Not used
15	Delay of the PV_WL_Lim message
16	Delay of the PV_AL_Lim message
17	Collection of message delays
18 - 31	Not used

Status word allocation for Status2 parameter

Status bit	Parameter
0	MsgLock
1	PV_AH_Act.Value
2	PV_WH_Act.Value
3 - 4	Not used
5	PV_WL_Act.Value
6	PV_AL_Act.Value
7	PV_AH_En
8	PV_WH_En
9 - 10	Not used
11	PV_WL_En
12	PV_AL_En
13	PV_AH_MsgEn
14	PV_WH_MsgEn
15 - 16	Not used
17	PV_WL_MsgEn
18	PV_AL_MsgEn
19 - 30	Not used
31	MS_RelOp

See also

MonAnS operating modes (Page 482)

MonAnS functions (Page 482)

MonAnS error handling (Page 485)

4.4 MonAnS - Monitoring of an analog process tag (Small)

MonAnS messaging (Page 486)

MonAnS block diagram (Page 491)

4.4.2 MonAnS operating modes

MonAnS operating modes

The block can be operated using the following modes:

- On (Page 71)
- Out of service (Page 71)

"On"

General information on the "On" mode is available in the section On (Page 71).

"Out of service"

You can find general information about the "Out of service" mode in the section Out of service (Page 71).

See also

Description of MonAnS (Page 480)

MonAnS functions (Page 482)

MonAnS error handling (Page 485)

MonAnS messaging (Page 486)

MonAnS I/Os (Page 488)

MonAnS block diagram (Page 491)

4.4.3 MonAnS functions

Functions of MonAnS

The functions for this block are listed below.

Alarm delays with one time value per limit pair

This block includes the standard function alarm delay for One time value per limit pair (Page 200).

Limit monitoring of the process value

This block provides the standard function Limit monitoring of the process value (Page 86).

Suppressing messages using the `MsgLock` parameter

This block provides the standard function Suppressing messages using the `MsgLock` parameter (Page 205).

Group display `SumMsgAct` for limit monitoring, CSF and `ExtMsgx`

The block has the standard function Group display for limit monitoring, CSF and `ExtMsgx` (Page 85).

Forming the signal status for blocks

This block provides the standard function Forming and outputting the signal status for technologic blocks (Page 109).

The worst signal status `ST_Worst` for the block is formed from the following parameters:

- `PV_Out.ST`

Dead band

To suppress values that fluctuate around the zero point, this block has the standard function Dead band (Page 61).

Release for maintenance

This block provides the standard function Release for maintenance (Page 64).

Simulating signals

This block provides the standard function Simulating signals (Page 58).

Selecting a unit of measure

This block provides the standard function Selecting a unit of measure (Page 212).

Configurable reactions using the `Feature` parameter

You can find an overview of all reactions provided by the `Feature` parameter in the Configurable functions using the `Feature` I/O (Page 131) . The following functionality is available for this block at the relevant bits:

Bit	Function
0	Set startup characteristics (Page 138)
1	Reaction to the out of service mode (Page 177)

4.4 MonAnS - Monitoring of an analog process tag (Small)

Bit	Function
24	Enabling local operator authorization (Page 158)
25	Suppression of all messages (Page 174)
26	Reaction of the switching points in the "Out of service" operating mode (Page 176)

Operator permissions

This block provides the standard function Operator control permissions (Page 254).

The block has the following permissions for the OS_Perm parameter:

Bit	Function
0	Not used
1	1 = Operator can switch to "On" mode
2	Not used
3	1 = Operator can switch to "Out of service" mode
4 - 9	Not used
10	1 = Operator can change the simulation value SimPV
11	1 = Operator can activate the Simulation function
12	1 = Operator can activate the Release for maintenance function
13	1 = Operator can change the limit (PV) for high alarm
14	1 = Operator can change the limit (PV) for high warning
15	Not used
16	1 = Operator can change the limit (PV) for hysteresis
17	1 = Operator can change the limit (PV) for low alarm
18	1 = Operator can change the limit (PV) for low warning
19 - 22	Not used
23	1 = Operator can change the dead band parameter DeadBand
24	1 = Operator can activate / deactivate messages via PV_AH_MsgEn
25	1 = Operator can activate / deactivate messages via PV_AL_MsgEn
26 -27	Not used
28	1 = Operator can activate / deactivate messages via PV_WH_MsgEn
29	1 = Operator can activate / deactivate messages via PV_WL_MsgEn
30 - 31	Not used

Note

If you interconnect a parameter that is also listed in OS_Perm as a parameter, you have to reset the corresponding OS_Perm bit.

Generating instance-specific messages

This block provides the standard function Generating instance-specific messages (Page 204).

Specifying the display area for process and setpoint values as well as operations

This block provides the standard function Display and operator input area for process values and setpoints (Page 207).

Opening additional faceplates

This block provides the standard function Opening additional faceplates (Page 208).

SIMATIC BATCH functionality

This block provides the standard function SIMATIC BATCH functionality (Page 67).

See also

- Description of MonAnS (Page 480)
- MonAnS operating modes (Page 482)
- MonAnS error handling (Page 485)
- MonAnS messaging (Page 486)
- MonAnS I/Os (Page 488)
- MonAnS block diagram (Page 491)

4.4.4 MonAnS error handling

Error handling of MonAnS

Refer to the section Error handling (Page 119) in the basic instructions for the error handling of all blocks.

The following error message can be generated at this block:

- Error numbers
- Control system fault (CSF)

Overview of error numbers

The `ErrorNum` I/O can be used to output various error numbers:

Error number	Meaning of the error number
-1	Predefined value when inserting the block; the block is not executed.
0	There is no error.
30	The value of <code>PV</code> can no longer be displayed in the REAL number field.

4.4 MonAnS - Monitoring of an analog process tag (Small)

Control system fault (CSF)

An external signal can be activated via the CSF input. If this signal changes to = 1, a control system fault is triggered. Refer to the Error handling (Page 119) section for more on this.

See also

Description of MonAnS (Page 480)

MonAnS operating modes (Page 482)

MonAnS functions (Page 482)

MonAnS messaging (Page 486)

MonAnS I/Os (Page 488)

MonAnS block diagram (Page 491)

4.4.5 MonAnS messaging

Messaging

The following messages can be generated for this block:

- Process control fault
- Process messages
- Instance-specific messages

Process control fault

You can interconnect an external fault (signal) to input parameter CSF. If it changes to CSF = 1, a process control fault is triggered (MsgEvId1, SIG 5).

Process messages

Message instance	Message identifier	Message class	Event
MsgEvId1	SIG 1	Alarm - high	\$\$BlockComment\$\$ PV - high alarm limit violated
	SIG 2	Warning - high	\$\$BlockComment\$\$ PV - high warning limit violated
	SIG 3	Warning - low	\$\$BlockComment\$\$ PV - low warning limit violated
	SIG 4	Alarm - low	\$\$BlockComment\$\$ PV - low alarm limit violated
	SIG 5	AS process control message - fault	\$\$BlockComment\$\$ External error has occurred

Explanation:

\$\$BlockComment\$\$: Content of the instance-specific comment

Instance-specific messages

You have the option to use two instance-specific messages for this block.

Message instance	Message identifier	Message class	Event
MsgEvId1	SIG 6	AS process control message - fault	\$\$BlockComment\$\$ External message 1
	SIG 7	AS process control message - fault	\$\$BlockComment\$\$ External message 2

Explanation:

\$\$BlockComment\$\$: Content of the instance-specific comment

Associated values for message instance **MsgEvId1**

Associated value	Block parameters
1	BatchName
2	StepNo
3	BatchID
4	ExtVal04
5	ExtVal05
6	Reserved
7	Reserved
8	Reserved
9	Reserved
10	Reserved

4.4 MonAnS - Monitoring of an analog process tag (Small)

The associated values 4 ... 5 are allocated to the parameters ExtVa104 ... ExtVa105 and can be used. Additional information is available in the "Process Control System PCS 7 - Engineering System" manual.

See also

- Description of MonAnS (Page 480)
- MonAnS operating modes (Page 482)
- MonAnS functions (Page 482)
- MonAnS error handling (Page 485)
- MonAnS I/Os (Page 488)
- MonAnS block diagram (Page 491)

4.4.6 MonAnS I/Os

MonAnS I/Os

Input parameters

Parameter	Description	Type	Default
BatchEn	1 = Enable allocation	BOOL	0
BatchID	Batch ID	DWORD	16#00000000
BatchName	Batch name	S7-String	
CSF	1 = External error (control system fault) Error handling (Page 119)	STRUCT <ul style="list-style-type: none"> • Value: BOOL • ST: BYTE 	- <ul style="list-style-type: none"> • 0 • 16#80
DeadBand	Width of dead band	REAL	0.0
EN	1 = Called block will be processed	BOOL	1
ExtMsg1	Binary input for freely selectable message 1	STRUCT <ul style="list-style-type: none"> • Value: BOOL • ST: BYTE 	- <ul style="list-style-type: none"> • 0 • 16#80
ExtMsg2	Binary input for freely selectable message 2	STRUCT <ul style="list-style-type: none"> • Value: BOOL • ST: BYTE 	- <ul style="list-style-type: none"> • 0 • 16#80
ExtVa104	Associated value 4 for messages (MsgEvID1)	ANY	
ExtVa105	Associated value 5 for messages (MsgEvID1)	ANY	
Feature	I/O for additional MonAnS functions (Page 482)	STRUCT <ul style="list-style-type: none"> • Bit 0: BOOL • ... • Bit 31: BOOL 	- <ul style="list-style-type: none"> • 0 • 0 • 0
MS_RelOp*	1 = Release for maintenance by OS operator	BOOL	0

4.4 MonAnS - Monitoring of an analog process tag (Small)

Parameter	Description	Type	Default
MsgEvId1	Message number (assigned automatically)	DWORD	16#00000000
MsgLock	1 = Suppress process messages. See also the section Suppressing messages using the MsgLock parameter (Page 205) for more on this.	STRUCT <ul style="list-style-type: none"> Value: BOOL ST: BYTE 	- <ul style="list-style-type: none"> 0 16#80
Occupied	1 = Occupied by batch control	BOOL	0
OnOp*	1 = "On" mode via operator	BOOL	0
OosLi	1 = "Out of service", via interconnection or SFC (0-1 edge transition)	STRUCT <ul style="list-style-type: none"> Value: BOOL ST: BYTE 	- <ul style="list-style-type: none"> 0 16#80
OosOp*	1 = "Out of service", via OS operator	BOOL	0
OpSt_In	Input parameter for local operator authorization, connected with the Out output parameter of the upstream block, Description of OpStations (Page 411)	DWORD	16#00000000
OS_Perm	I/O for MonAnS functions (Page 482)	STRUCT <ul style="list-style-type: none"> Bit 0: BOOL Bit 10: BOOL Bit 31: BOOL 	- <ul style="list-style-type: none"> 1 1 1
PV*	Process value	STRUCT <ul style="list-style-type: none"> Value: REAL ST: BYTE 	- <ul style="list-style-type: none"> 0.0 16#80
PV_A_DC*	Delay time for incoming PV alarms [s]	REAL	0.0
PV_AH_En	1 = Enable PV alarm limit (high)	BOOL	1
PV_AH_Lim	Limit PV alarm (high)	REAL	95.0
PV_AH_MsgEn	1 = Enable PV alarm (high) message	BOOL	1
PV_AL_En	1 = Enable PV alarm limit (low)	BOOL	1
PV_AL_Lim	PV alarm limit (low)	REAL	5.0
PV_AL_MsgEn	1 = Enable PV alarm (low) message	BOOL	1
PV_Hyst*	Hysteresis for PV alarm, warning and tolerance limits	REAL	0.0
PV_OpScale	Limit for scale in PV bar graph of faceplate	STRUCT <ul style="list-style-type: none"> High: REAL Low: REAL 	- <ul style="list-style-type: none"> 100.0 0.0
PV_Unit	Unit of measure for process value	INT	1001
PV_W_DC*	Delay time for incoming PV warnings [s]	REAL	0.0
PV_WH_En	1 = Enable PV warning limit (high)	BOOL	1
PV_WH_Lim	Limit PV warning (high)	REAL	90.0
PV_WH_MsgEn	1 = Enable PV warning (high) message	BOOL	1
PV_WL_En	1 = Enable PV warning limit (low)	BOOL	1
PV_WL_Lim	Limit PV warning (low)	REAL	10.0
PV_WL_MsgEn	1 = Enable PV warning (low) message	BOOL	1

Monitoring blocks

4.4 MonAnS - Monitoring of an analog process tag (Small)

Parameter	Description	Type	Default
RunUpCyc	Number of cycles in startup; messages are suppressed during these cycles	INT	3
SampleTime	Sampling time [s] (assigned automatically)	REAL	0.1
SelFp1	1 = Call a block saved in this parameter as an Opening additional faceplates (Page 208) in the standard view	ANY	-
SimOn	1 = Simulation on	BOOL	0
SimPV*	Process value used for SimOn = 1	REAL	0.0
StepNo	Batch step number	DWORD	16#00000000
UserStatus	Freely assignable bits for use in PCS 7 OS	BYTE	16#00

* Values can be written back to these inputs during processing of the block by the block algorithm.

Output parameters

Parameter	Description	Type	Default
ENO	1 = Block algorithm completed without errors	BOOL	0
ErrorNum	Output of pending error number. For error numbers that can be output by this block, see MonAnS error handling (Page 485)	INT	-1
MS_Release	Release for maintenance: 1 = Release for OS operator	STRUCT <ul style="list-style-type: none"> Value: BOOL ST: BYTE 	- <ul style="list-style-type: none"> 0 16#80
OnAct	1 = "On" mode enabled	STRUCT <ul style="list-style-type: none"> Value: BOOL ST: BYTE 	- <ul style="list-style-type: none"> 1 16#80
OosAct	1 = Block is "Out of service"	STRUCT <ul style="list-style-type: none"> Value: BOOL ST: BYTE 	- <ul style="list-style-type: none"> 0 16#80
OpSt_Out	Value of the OpSt_In input parameter, for feed-forwarding to other blocks. Bit 31 of this parameter is used by Feature bit 24	DWORD	16#00000000
OS_PermLog	Display of OS_Perm with settings changed by the block algorithm	DWORD	16#FFFFFFFF
OS_PermOut	Display of OS_Perm	DWORD	16#FFFFFFFF
PV_AH_Act	1 = PV alarm (high) active. You can change the reaction for this parameter with Feature bit 28 (Disabling operating points (Page 145)) and with Feature bit 29 (Signaling limit violation (Page 170)).	STRUCT <ul style="list-style-type: none"> Value: BOOL ST: BYTE 	- <ul style="list-style-type: none"> 0 16#80
PV_AL_Act	1 = PV alarm (low) active. You can change the reaction for this parameter with Feature bit 28 (Disabling operating points (Page 145)) and with Feature bit 29 (Signaling limit violation (Page 170)).	STRUCT <ul style="list-style-type: none"> Value: BOOL ST: BYTE 	- <ul style="list-style-type: none"> 0 16#80

Parameter	Description	Type	Default
PV_Out	Output for process value	STRUCT <ul style="list-style-type: none"> Value: REAL ST: BYTE 	- <ul style="list-style-type: none"> 0.0 16#80
PV_WH_Act	1 = PV warning (high) active. You can change the reaction for this parameter with <code>Feature</code> bit 28 (Disabling operating points (Page 145)) and with <code>Feature</code> bit 29 (Signaling limit violation (Page 170)).	STRUCT <ul style="list-style-type: none"> Value: BOOL ST: BYTE 	- <ul style="list-style-type: none"> 0 16#80
PV_WL_Act	1 = PV warning (low) active. You can change the reaction for this parameter with <code>Feature</code> bit 28 (Disabling operating points (Page 145)) and with <code>Feature</code> bit 29 (Signaling limit violation (Page 170)).	STRUCT <ul style="list-style-type: none"> Value: BOOL ST: BYTE 	- <ul style="list-style-type: none"> 0 16#80
ST_Worst	Worst signal status	BYTE	16#80
Status1	Description of MonAnS (Page 480)	DWORD	16#00000000
Status2	Description of MonAnS (Page 480)	DWORD	16#00000000
SumMsgAct	1 = Group message is active	STRUCT <ul style="list-style-type: none"> Value: BOOL ST: BYTE 	- <ul style="list-style-type: none"> 0 16#80

See also

[MonAnS operating modes \(Page 482\)](#)
[MonAnS messaging \(Page 486\)](#)
[MonAnS block diagram \(Page 491\)](#)

4.4.7 MonAnS block diagram**MonAnS block diagram**

A block diagram is not provided for this block.

See also

[Description of MonAnS \(Page 480\)](#)
[MonAnS operating modes \(Page 482\)](#)
[MonAnS functions \(Page 482\)](#)
[MonAnS error handling \(Page 485\)](#)
[MonAnS messaging \(Page 486\)](#)
[MonAnS I/Os \(Page 488\)](#)

4.4.8 Operator control and monitoring

4.4.8.1 MonAnS views

Views of the MonAnS block

The block MonAnS provides the following views:

- MonAnS standard view (Page 492)
- Alarm view (Page 302)
- MonAnS limit view (Page 494)
- Trend view (Page 305)
- MonAnS parameter view (Page 495)
- MonAnS preview (Page 496)
- Memo view (Page 304)
- Batch view (Page 302)
- Block icon for MonAnS (Page 497)

Refer to the sections Structure of the faceplate (Page 248) and Block icon structure (Page 230) for general information on the faceplate and block icon.

4.4.8.2 MonAnS standard view

MonAnS standard view

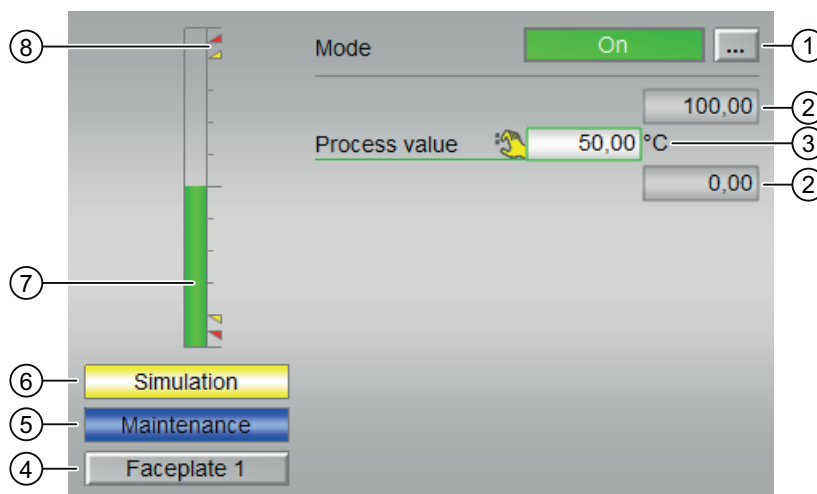

(1) Displaying and switching the operating mode

This area provides information on the currently valid operating mode. The following operating modes can be shown here:

- On (Page 71)
- Out of service (Page 71)

Refer to the Switching operating states and operating modes (Page 257) section for information on switching the operating mode.

(2) High and low scale range for the process value

These values provide information on the display range for the bar graph of the process value. The scale range is defined in the engineering system.

(3) Display of the process value including signal status

This area shows the current process value with the corresponding signal status.

If text is configured for this command, it is displayed as additional text and button label for command selection. You can find more information about this in the section Labeling of buttons and text (Page 209).

You can change the text for the process value with the `PV_Out` parameter.

(4) Navigation button for switching to the standard view of any faceplate

Use this navigation button to reach the standard view of a block configured in the engineering system. The visibility of this navigation button depends on the configuration in the engineering system (ES).

Additional information is available in the section Opening additional faceplates (Page 208).

(5) Display area for block states

This area provides additional information on the operating state of the block:

- "Maintenance"

(6) Display area for block states

This area provides additional information on the operating state of the block:

- "Simulation"

(7) Bar graph for the "process value"

This area shows the current "Process value" in the form of a bar graph. The visible area in the bar graph depends on the configuration in the engineering system (ES).

(8) Limit display

These colored triangles show you the configured limits in the respective bar graph.

See also

Displaying auxiliary values (Page 211)

4.4.8.3 MonAnS limit view

Limit view of MonAnS

You can specify the process value limits in this view:

The toolbars of the faceplate and the block icon indicate when the limits are reached or violated.

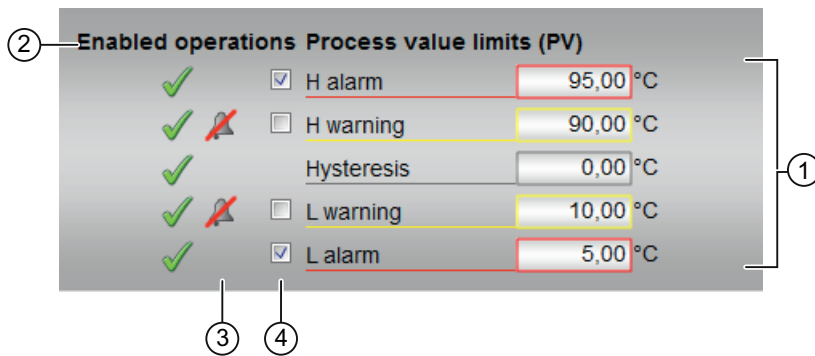

(1) Process value limits

In this area, you can enter the limits for the process value. Refer to the Changing values (Page 259) section for more on this.

You can change the following limits:

- "H alarm": Alarm high
- "H warning": Warning high
- "Hysteresis"
- "L warning": Warning low
- "L alarm": Alarm low

(2) Enabled operation

This area shows all operations for which special operator permissions are assigned. They depend on the configuration in the engineering system (ES) that applies to this block.

Icons for enabled operation:

- **Green check mark:** the OS operator can control this parameter
- **Gray check mark:** the OS operator cannot control this parameter at this time due to the process
- **Red cross:** the OS operator cannot control this parameter due to the configured AS operator permissions (OS_Permission or OS1Perm)

(3) Message suppression / delay

Message suppression indicates whether or not the suppression of the associated message in the AS block is activated with the `xx_MsgEn` parameter. The output of messages is not suppressed when the block is installed (all `xx_MsgEn` parameters are preset to 1). Messages can only be output if limit monitoring of the additional analog value has been enabled.

Alarm delays are also displayed in this position; for more on this see section Area of application for alarm delays (Page 199).

(4) Suppress messages

You can enable / disable messages by setting the check mark.

4.4.8.4 MonAnS parameter view

Parameter view of MonAnS

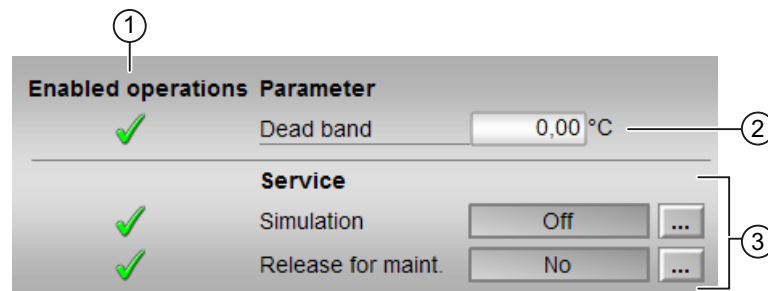

(1) Enabled operations

This area shows all operations for which special operator control permissions are assigned. They depend on the configuration in the engineering system (ES) that applies to this block.

Symbols for enabled operations:

- **Green check mark:** the OS operator can control this parameter
- **Gray check mark:** the OS operator cannot control this parameter at this time due to the process
- **Red cross:** the OS operator cannot control this parameter due to the configured AS operator control permissions (OS_Permission or OS1Perm).

(2)Parameter

You can change parameters in this area. Refer to the section Changing values (Page 259).

You can influence the following parameters:

- "Dead band": Width of dead band

(3)Service

You can select the following functions in this area:

- "Simulation"
- "Release for maintenance"

Refer to the Switching operating states and operating modes (Page 257) section for more on this.

You can find information on this area in the section:

- Simulating signals (Page 58)
- Release for maintenance (Page 64)

4.4.8.5 MonAnS preview

Preview of MonAnS

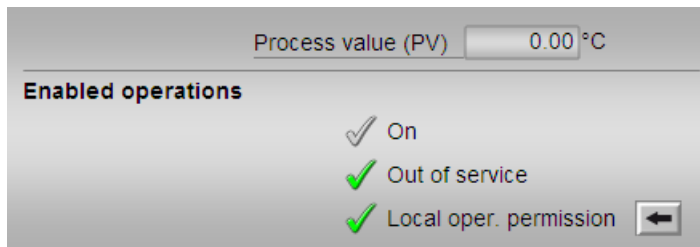

Process value

This area displays the real process value (PV).

Enabled operations

This area shows all operations for which special operator control permissions are assigned. They depend on the configuration in the engineering system (ES) that applies to this block.

Symbols for enabled operations:

- **Green check mark:** the OS operator can control this parameter
- **Gray check mark:** the OS operator cannot control this parameter at this time due to the process
- **Red cross:** the OS operator cannot control this parameter due to the configured AS operator control permissions (OS_Perm or OS1Perm)

The following enabled operations are shown here:

- "On": You can switch to "On" operating mode.
- "Out of service": You can switch to "Out of service" operating mode.
- "Local operating permission": Use the ← button to switch to the standard view of the OpStations block. Additional information is available in the section Operator control permissions (Page 254).

4.4.8.6 Block icon for MonAnS

Block symbols for MonAnS

A variety of block symbols are available with the following functions:

- Process tag type
- Limits (high/low)
- Violation of alarm, warning, and tolerance limits as well as control system faults
- Operating modes
- Signal status, release for maintenance
- Memo display
- Process value

The block symbols from template @TemplateAPLV8.PDL:

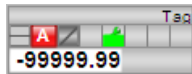
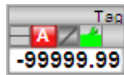
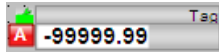
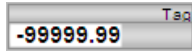
Symbols	Selection of the block symbol in CFC	Special features
	1	
	2	
	3	
	4	

4.4 MonAnS - Monitoring of an analog process tag (Small)

The block symbols from template @TemplateAPLV7.PDL:

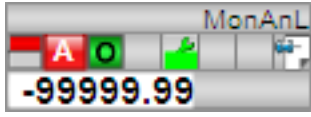
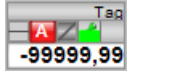
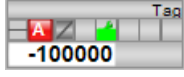
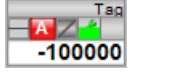
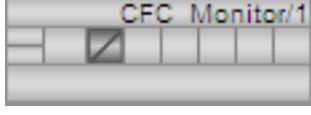
Symbols	Selection of the block symbol in CFC	Special features
	1	Block symbol in the full display
	2	
	3	
	4	
	-	Block symbol in "Out of service" mode (example with type 1 block symbol)

Additional information on the block symbol and the control options in the block symbol is available in the following chapters:

- Configuring the block icons (Page 237)
- Block icon structure (Page 230)
- Operation via the block icon (Page 239).

4.5 MonDiL - Monitoring of a digital process tag (Large)

4.5.1 Description of MonDiL

Object name (type + number) and family

Type + number: FB 1848

Family: Monitor

Area of application for MonDiL

The block is used for the following applications:

- Monitoring a digital process tag

Note

This block is also available as a small block. A comparison of the MonDiL and MonDiS blocks is available in the section: MonDiL compared to MonDiS (Page 437)

How it works

The MonDiL block is used to monitor a digital process tag with flutter suppression. The block reports excess flutter signals which are generated within a defined period.

The digital value to be monitored is interconnected to the `In` input parameter. Every time there is a signal change (1 - 0 or 0 - 1) the configurable timer (`FlutTmIn`) for flutter suppression is started as shown in the figure below.

When the time you have specified expires and no single change occurs, the input signal is written to the `Out` output parameter.

Set the time in the timer (`FlutTmIn`) to 0 seconds; the input signal is written directly to the output.

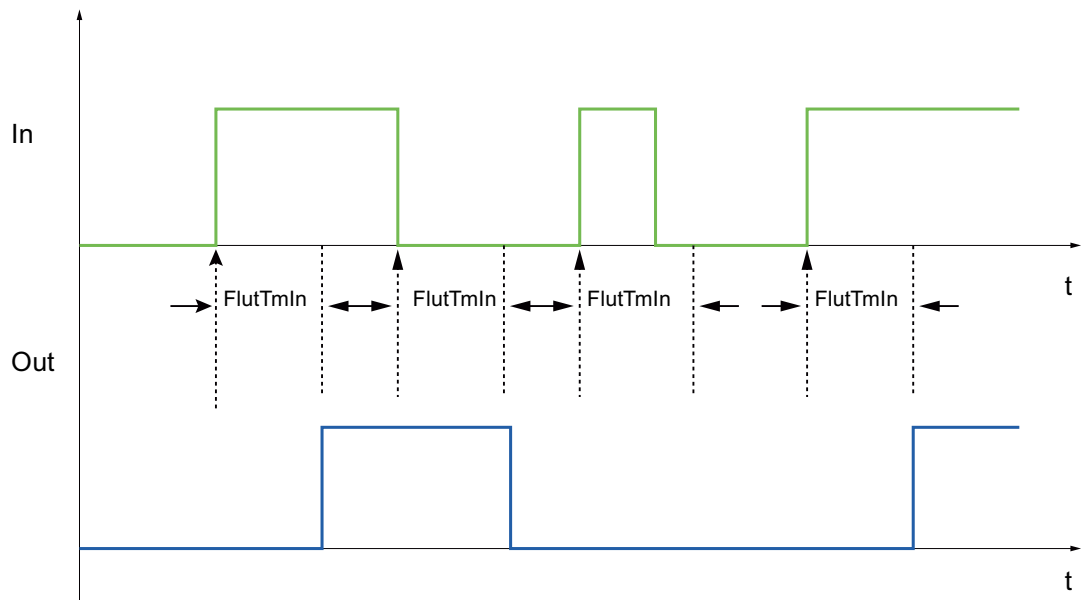

Configuration

Use the CFC editor to install the block in a cyclic interrupt OB (OB30 to OB38). The block is also installed automatically in the startup OB (OB100).

For the MonDiL block, the Advanced Process Library contains templates for process tag types as examples with various application scenarios for this block.

Examples of process tag types:

- Monitoring of a digital process tag (DigitalMonitoring) (Page 2353)
- Monitoring a digital process tag for PA/FF devices (DigitalMonitoring_Fb) (Page 2354)

Startup characteristics

Use the `Feature Bit Set` startup characteristics (Page 138) to define the startup characteristics of this block. The `Out` and `FlutAct` parameters are affected.

The messages are suppressed after startup for the number of cycles set at `RunUpCyc`.

Status word allocation for `Status1` parameter

You can find a description for each parameter in section MonDiL I/Os (Page 510).

Status bit	Parameter
0	Occupied
1	BatchEn
2	SimOn
3	OosAct.Value
4	OosLi.Value
5	BypassAct.Value

Status bit	Parameter
6	OnAct.Value
7	Out.Value
8	AlmMsgEn
9	Display of BypassAct.Value in faceplate (display and operator controls) and block icon
10	SimLiOp.Value
11 - 29	Not used
30	Auxiliary value 1 is visible
31	Auxiliary value 2 is visible

Status word allocation for Status2 parameter

Status bit	Parameter
0	MsgLock.Value
1	FlutAct.Value
2	FlutEn
3	FlutMsgEn
4 - 30	Not used
31	MS_RelOp

Status word allocation for Status3 parameter

Status bit	Parameter
0	Effective signal 1 of the message block connected via EventTsIn
1	Effective signal 2 of the message block connected via EventTsIn
2	Effective signal 3 of the message block connected via EventTsIn
3	Effective signal 4 of the message block connected via EventTsIn
4	Effective signal 5 of the message block connected via EventTsIn
5	Effective signal 6 of the message block connected via EventTsIn
6	Effective signal 7 of the message block connected via EventTsIn
7	Effective signal 8 of the message block connected via EventTsIn
8 - 13	Not used
14	Color = 11 (Background color is derived directly from EventState, without message classes process message and operator prompt), only for block icon type 5
15	Color = 10 (Background color of the message instance MsgEvid1 - Message identifier SIG1)
16-19	Not used
20	Color = 6 (Violet, operator prompt) and Out = 1
21	Not used
22	Color = 5 (Pastel green, process) and Out = 1
23 - 24	Not used
25	Color = 4 (Black, control system) and Out = 1
26	Color = 9 (UCMC 6) and Out = 1

4.5 MonDiL - Monitoring of a digital process tag (Large)

Status bit	Parameter
27	Color = 3 (Blue, tolerance / UCMC 5) and Out = 1
28	Color = 8 (UCMC 4) and Out = 1
29	Color = 2 (Yellow, warning UCMC 3) and Out = 1
30	Color = 7 (UCMC 2) and Out = 1
31	Color = 1 (Red, alarm / UCMC 1) and Out = 1

Explanation:
UCMC = user-configured messages classes

Note

The user-configured message classes 5, 3 and 1 are displayed in the existing status bits 27, 29 and 31.

Status word allocation for Status4 parameter

Status bit	Parameter
0 - 15	Effective signal 9..16 of the message block connected via EventTsIn
16 - 31	Not used

See also

- MonDiL functions (Page 503)
- MonDiL messaging (Page 509)
- MonDiL block diagram (Page 515)
- MonDiL error handling (Page 508)
- MonDiL modes (Page 502)

4.5.2 MonDiL modes

MonDiL operating modes

This block provides the following modes.

- On (Page 71)
- Out of service (Page 71)

"On"

You can find general information about the "On" mode in the On (Page 71) section.

Out of service

You can find general information about the "Out of service" mode in the Out of service (Page 71) section.

See also

MonDiL block diagram (Page 515)

MonDiL I/Os (Page 510)

MonDiL messaging (Page 509)

MonDiL error handling (Page 508)

MonDiL functions (Page 503)

Description of MonDiL (Page 499)

4.5.3 MonDiL functions

Functions of MonDiL

The functions for this block are listed below.

Suppression and reporting of signal flutter

The block is operated as "flutter filter". The block receives digital signals at the `In` input parameter and ideally these do not develop any flutter. The block monitors this if you activate the function via the `FlutEn = 1` input parameter.

Use the `FlutTmIn` input parameter to set how long a continuous signal should last in order to be transferred to the process without flutter.

The preprocessed signal is sent to the process via the `Out` output parameter.

The block can be set up to report signal flutter. To do this, set parameter `FlutMsgEn = 1`. Monitoring starts at the next 0 - 1 - 0 edge transition at the input signal `In`.

Use the `FlutFactor` input parameter to specify the maximum number of signals to be filtered per minute by the block. If this maximum value is exceeded, this is indicated at the output parameter `FlutAct` by a 1. The message (`FlutAct = 0`). is cleared after the maximum value has dropped again by more than half.

Example of the flutter suppression

You can use the `FlutFactor` input parameter to limit flutter signals to 3 per minute.

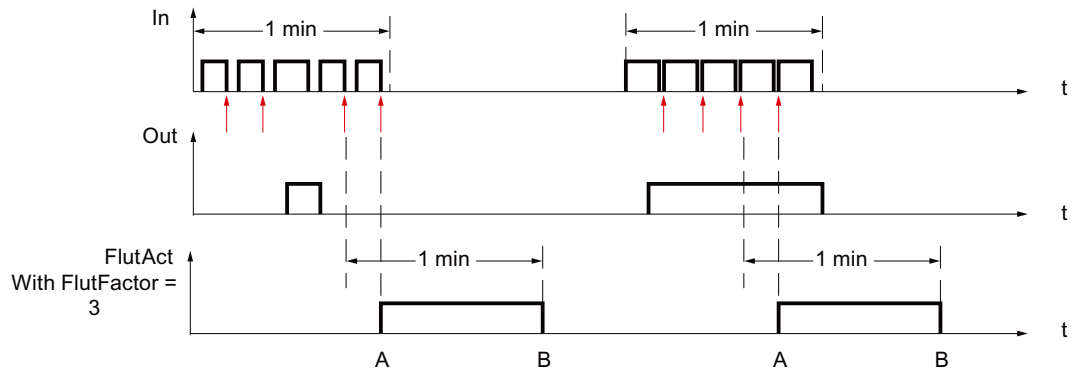

Case A:

Four flutter signals have occurred within a minute. `FlutFactor` is set to three, in other words, a maximum of three flutter signal per minute are allowed, the `FlutAct` output is set to one.

Case B:

Only one flutter signal has occurred within a minute, which corresponds to less than half the `FlutFactor`. The `FlutAct` output is reset.

Delaying the on and off switching functions

You set delay times for setting the output using the input parameter `Out_DC` or `Out_DG`:

- `Out_DC`: delay time [s] for rising edges (0 - 1 edge)
- `Out_DG`: delay time [s] for falling edge (1 - 0 edge)

The `Out` output parameter is after expiration of the delay time.

You disable this function if you set the value of the respective parameter to 0 seconds.

Adapting the color representation in the configured message class

You can set the background color of instance-specific texts for the block icons 3 to 6 and thereby adapt them to the configured message class. This background color is displayed when the output parameter `Out = 1`.

You set the color coding with the `Color` parameter:

Value <code>Color</code>	Color
0	Old reaction
1	Red (alarm)
2	Yellow (warning)
3	Blue (tolerance)
4	Black (control system)
5	Pastel green (process)
6	Violet (operator prompt)

Value Color	Color
7...9	Old reaction
10	Background color of the message instance MsgEvd1 - Message identifier SIG1
11	For block icon type 5 only, background color is derived directly from EventState without message classes process message and operator prompt ¹

¹ This also takes into consideration the CSF input

The following colors are shown for user-configured message classes

Value Color	Color
0	Old reaction
1	User-configured message classes 1
2	User-configured message classes 3
3	User-configured message classes 5
4	Black (control system)
5	Pastel green (process)
6	Violet (operator prompt)
7	User-configured message classes 2
8	User-configured message classes 4
9	User-configured message classes 6
10	Background color of the message instance MsgEvd1 - Message identifier SIG1
11	For block icon type 5 only, background color is derived directly from EventState without message classes process message and operator prompt ¹

¹ This also takes into consideration the CSF input

Displaying auxiliary values

This block provides the standard function Displaying auxiliary values (Page 211).

Changing labels on buttons and text

This block provides the standard function Labeling of buttons and text (Page 209).

You can change the label for "Process value" for this block as you please. The change is made with the `FlutTmIn` parameter.

Generating instance-specific messages

This block provides the standard function Generating instance-specific messages (Page 204).

Group display `SumMsgAct` for limit monitoring, CSF and `ExtMsgx`

The block provides the standard function Group display for limit monitoring, CSF and `ExtMsgx` (Page 85).

Suppressing messages using the `MsgLock` parameter

This block provides the standard function Suppressing messages using the `MsgLock` parameter (Page 205).

Forming the signal status for blocks

This block provides the standard function Forming and outputting the signal status for technologic blocks (Page 109).

The worst signal status `ST_Worst` for the block is formed from the following parameters:

- `In.ST`

Release for maintenance

This block provides the standard function Release for maintenance (Page 64).

Simulating signals

This block provides the standard function Simulating signals (Page 58).

You can simulate the following values:

- `Value (SimIn, SimInLi)`

Bypass function

This block provides the standard function Bypassing signals (Page 107).

Configurable reactions using the `Feature` parameter

You can find an overview of all reactions provided by the `Feature` parameter in the Configurable functions using the `Feature` I/O (Page 131) . The following functionality is available for this block at the relevant bits:

Bit	Function
0	Set startup characteristics (Page 138)
1	Reaction to the out of service mode (Page 177)
9	Substitution value is active if the block is in bypass (Page 185)
11	Suppress <code>MsgLock</code> and "Out of service" mode for a connected message block (Page 188)
22	Update acknowledgment and error status of the message call (Page 160)
24	Enabling local operator authorization (Page 158)
25	Suppression of all messages (Page 174)

Operator permissions

This block provides the standard function Operator control permissions (Page 254).

The block has the following permissions for the OS_Perm parameter:

Bit	Function
0	Not used
1	1 = Operator can switch to "On" mode
2	Not used
3	1 = Operator can switch to "Out of service" mode
4	1 = Operator can change the delay time for rising edges (Out_DC)
5	1 = Operator can change the delay time for falling edges (Out_DG)
6 - 7	Not used
8	1 = Operator can activate bypass functionality
9	1 = Operator can deactivate bypass functionality
10	1 = Operator can change the simulation value SimIn
11	1 = Operator can activate the Simulation function
12	1 = Operator can activate the Release for maintenance function
13	Not used
14	1 = The user can input the duration for flutter suppression.
15	1 = The user can specify the number of flutter signals that should be suppressed.
16 - 31	Not used

Note

If you interconnect a parameter that is also listed in OS_Perm as a parameter, you have to reset the corresponding OS_Perm bit.

Opening additional faceplates

This block provides the standard function Opening additional faceplates (Page 208).

Connection of the time-stamped messages from EventTs or Event16Ts

This block provides the standard function Connection of the time-stamped messages from EventTs or Event16Ts (Page 207).

SIMATIC BATCH functionality

This block provides the standard function SIMATIC BATCH functionality (Page 67).

See also

Description of MonDiL (Page 499)

MonDiL messaging (Page 509)

MonDiL I/Os (Page 510)

MonDiL block diagram (Page 515)

MonDiL error handling (Page 508)

MonDiL modes (Page 502)

EventTs functions (Page 1660)

Reaction of the switching points in the "Out of service" operating mode (Page 176)

User-configured message classes (Page 41)

4.5.4 MonDiL error handling

Error handling of MonDiL

Refer to the section Error handling (Page 119) in the basic instructions for the error handling of all blocks.

The following errors can be displayed for this block:

- Error numbers
- Control system fault (CSF)
- Flutter alarm

Overview of error numbers

The `ErrorNum` I/O can be used to output various error numbers:

Error number	Meaning of the error number
-1	Predefined value when inserting the block; the block is not executed.
0	There is no error.
11	<code>FlutTmIn < 0</code>
16	<code>FlutFactor</code> is -ve or > 100

Control system fault (CSF)

An external signal can be activated via the `CSF` input. If this signal changes to = 1, a control system fault is triggered. Refer to the Error handling (Page 119) section for more on this.

Flutter alarm

An alarm is output at output `FlutAct` with 1 if signal flutter is detected. Refer to the functions of the block > Error handling (Page 119).

See also

MonDiL block diagram (Page 515)

MonDiL I/Os (Page 510)

MonDiL messaging (Page 509)

MonDiL functions (Page 503)

MonDiL modes (Page 502)

Description of MonDiL (Page 499)

4.5.5 MonDiL messaging

Messaging

The following messages can be generated for this block:

- Process control fault
- Process messages
- Instance-specific messages

Process control fault

You can interconnect an external fault (signal) to input parameter `CSF`. If it changes to `CSF = 1`, a process control fault is triggered (`MsgEvId1`, SIG 3).

Process messages

You can use up to four instance-specific messages with this block.

Message instance	Message identifier	Message class	Event
MsgEvId1	SIG 1	Alarm - high	\$\$BlockComment\$\$ Out - Binary value set
	SIG 2	Warning - high	\$\$BlockComment\$\$ Flutter limits violated
	SIG 3	AS process control message - fault	\$\$BlockComment\$\$ External error has occurred
	SIG 4	AS process control message - fault	\$\$BlockComment\$\$ External message 1
	SIG 5	AS process control message - fault	\$\$BlockComment\$\$ External message 2
	SIG 6	AS process control message - fault	\$\$BlockComment\$\$ External message 3

Explanation:

\$\$BlockComment\$\$: Content of the instance-specific comment

Associated values for message instance `MsgEvId1`

Associated value	Block parameters
1	BatchName
2	StepNo
3	BatchID
4	ExtVa104
5	ExtVa105
6	ExtVa106
7	ExtVa107
8	ExtVa108
9	Reserved
10	Reserved

The associated values 4 ... 8 are allocated to the parameters `ExtVa104` ... `ExtVa108` and can be used. Additional information is available in the "Process Control System PCS7 - Engineering System" manual.

See also

- Description of MonDiL (Page 499)
- MonDiL functions (Page 503)
- MonDiL I/Os (Page 510)
- MonDiL block diagram (Page 515)
- MonDiL error handling (Page 508)
- MonDiL modes (Page 502)
- Time stamp (Page 205)

4.5.6 MonDiL I/Os

I/Os of MonDiL

Input parameters

Parameter	Description	Type	Default
<code>AlmMsgEn</code>	1 = Alarms are output	BOOL	1
<code>BatchEn</code>	1 = Enable allocation	BOOL	0
<code>BatchID</code>	Batch ID	DWORD	16#00000000
<code>BatchName</code>	Batch name	S7-String	
<code>BypLiOp</code>	1 = Bypass commands via interconnection	STRUCT	-
		<ul style="list-style-type: none"> • Value: BOOL • ST: BYTE 	<ul style="list-style-type: none"> • 0 • 16#80

4.5 MonDiL - Monitoring of a digital process tag (Large)

Parameter	Description	Type	Default
BypLock	1 = Bypass activation or deactivation is locked for operator	STRUCT <ul style="list-style-type: none"> Value: BOOL ST: BYTE 	- <ul style="list-style-type: none"> 0 16#80
BypIn	Substitution value if block is in bypass	REAL	0.0
BypInLi	1 = Select bypass In (via interconnection)	STRUCT <ul style="list-style-type: none"> Value: BOOL ST: BYTE 	- <ul style="list-style-type: none"> 0 16#80
BypInOp	1 = Select bypass In (via operator)	BOOL	0
CSF	1 = External error (control system fault) Error handling (Page 119)	STRUCT <ul style="list-style-type: none"> Value: BOOL ST: BYTE 	- <ul style="list-style-type: none"> 0 16#80
Color	Display for status display in the block icon: 0 = Default setting 1 = Red (alarm) 2 = Yellow (warning) 3 = Blue (tolerance) 4 = Black (control system message) 5 = Pastel green (process message) 6 = Violet (operator prompt)	BYTE	16#00
EN	1 = Called block will be processed	BOOL	1
EventTsIn	For interconnecting data between a technology block and the message blocks <code>EventTs</code> , <code>Event16Ts</code> . The <code>EventTsIn</code> input parameter serves to interconnect the <code>EventTsOut</code> output parameter of the <code>EventTs</code> , <code>Event16Ts</code> block. When this interconnection is configured, the messages of the <code>EventTs</code> , <code>Event16Ts</code> block are displayed on the OS in the alarm view of the technology block and can also be acknowledged there.	ANY	
ExtMsg1	Binary input for freely selectable message 1	STRUCT <ul style="list-style-type: none"> Value: BOOL ST: BYTE 	- <ul style="list-style-type: none"> 0 16#80
ExtMsg2	Binary input for freely selectable message 2	STRUCT <ul style="list-style-type: none"> Value: BOOL ST: BYTE 	- <ul style="list-style-type: none"> 0 16#80
ExtMsg3	Binary input for freely selectable message 3	STRUCT <ul style="list-style-type: none"> Value: BOOL ST: BYTE 	- <ul style="list-style-type: none"> 0 16#80
ExtVal04	Associated value 4 for messages (<code>MsgEvID1</code>)	ANY	
ExtVal05	Associated value 5 for messages (<code>MsgEvID1</code>)	ANY	
ExtVal06	Associated value 6 for messages (<code>MsgEvID1</code>)	ANY	
ExtVal07	Associated value 7 for messages (<code>MsgEvID1</code>)	ANY	
ExtVal08	Associated value 8 for messages (<code>MsgEvID1</code>)	ANY	

Monitoring blocks

4.5 MonDiL - Monitoring of a digital process tag (Large)

Parameter	Description	Type	Default
Feature	I/O for additional functions (Page 503)	STRUCT <ul style="list-style-type: none"> • Bit 0: BOOL • ... • Bit 31: BOOL 	- <ul style="list-style-type: none"> • 0 • 0 • 0
FlutEn	1 = Flutter suppression on	BOOL	1
FlutFactor	Number of flutter signals that can be suppressed	INT	2
FlutMsgEn	1 = Signal flutter is reported if the period of the signal flutter is < FlutTmIn.	BOOL	1
FlutTmIn	Period during which signal flutter is suppressed.	REAL	0.0
In	Digital input value	STRUCT <ul style="list-style-type: none"> • Value: BOOL • ST: BYTE 	- <ul style="list-style-type: none"> • 0 • 16#80
MS_RelOp*	1 = Release for maintenance by OS operator	BOOL	0
MsgEvId1	Message number (assigned automatically)	DWORD	16#00000000
MsgLock	1 = Suppress process messages. See also the section Suppressing messages using the MsgLock parameter (Page 205) for more on this.	STRUCT <ul style="list-style-type: none"> • Value: BOOL • ST: BYTE 	- <ul style="list-style-type: none"> • 0 • 16#80
Occupied	1 = Occupied by batch control	BOOL	0
OosLi	1 = "Out of service", via interconnection or SFC (0-1 edge transition)	STRUCT <ul style="list-style-type: none"> • Value: BOOL • ST: BYTE 	- <ul style="list-style-type: none"> • 0 • 16#80
OnOp*	1 = "On" mode via operator	BOOL	0
OosOp*	1 = "Out of service", via OS operator	BOOL	0
OpSt_In	Input parameter for local operator authorization, connected with the Out output parameter of the upstream block, OpStations (Page 411)	DWORD	16#00000000
OS_Perm	I/O for operator permissions (Page 503)	STRUCT <ul style="list-style-type: none"> • Bit 0: BOOL • Bit 10: BOOL • Bit 31: BOOL 	- <ul style="list-style-type: none"> • 1 • 1 • 1
Out_DC	Delay time for setting the output parameter Out for rising edges	REAL	0.0
Out_DG	Delay time for setting the output parameter Out for falling edges	REAL	0.0
RstBypLi	1 = Reset bypass In (via interconnection)	STRUCT <ul style="list-style-type: none"> • Value: BOOL • ST: BYTE 	- <ul style="list-style-type: none"> • 0 • 16#80
RstBypOp	1 = Reset bypass In (via operator)	BOOL	0
RunUpCyc	Number of cycles in startup; messages are suppressed during these cycles	INT	3
SampleTime	Sampling time [s] (assigned automatically)	REAL	0.1
SelFp1	1 = Call a block saved in this parameter as an additional faceplate (Page 208) in the standard view	ANY	-

4.5 MonDiL - Monitoring of a digital process tag (Large)

Parameter	Description	Type	Default
SelFp2	1 = Call a block saved in this parameter as an additional faceplate (Page 208) in the preview	ANY	-
SimLiOp	Activation/deactivation of the simulation by: 0 = Operator 1 = Interconnection or SFC	STRUCT • Value: BOOL • ST: BYTE	- • 0 • 16#80
SimOnLi	1 = Simulation via interconnection or SFC (controlled by SimLiOp = 1)	STRUCT • Value: BOOL • ST: BYTE	- • 0 • 16#80
SimOn*	1 = Simulation on	BOOL	0
SimIn*	Value used for SimOn = 1	BOOL	0
SimInLi	Value that is used for SimOnLi.Value = 1 (SimLiOp.Value = 1)	STRUCT • Value: BOOL • ST: BYTE	- • 0 • 16#80
StepNo	Batch step number	DWORD	16#00000000
UserAna1	Analog auxiliary value 1	STRUCT • Value: REAL • ST: BYTE	- • 0.0 • 16#FF
UA1unit	Unit of measure for analog auxiliary value 1	INT	0
UserAna2	Analog auxiliary value 2	STRUCT • Value: REAL • ST: BYTE	- • 0.0 • 16#FF
UA2unit	Unit of measure for analog auxiliary value 2	INT	0
UserStatus	Freely assignable bits for use in PCS 7 OS	BYTE	16#00

* Values can be written back to these inputs during processing of the block by the block algorithm.

Output parameters

Parameter	Description	Type	Default
BypassAct	1 = Bypass is activated in this block	STRUCT • Value: BOOL • ST: BYTE	- • 0 • 16#80
ENO	1 = Block algorithm completed without errors	BOOL	0
ErrorNum	Output of pending error number. For error numbers that can be output by this block, see MonDiL error handling (Page 508)	INT	-1
FlutAct	1 = Suppresses flutter signal	STRUCT • Value: BOOL • ST: BYTE	- • 0 • 16#80
MS_Release	Release for maintenance: 1 = Release for OS operator	STRUCT • Value: BOOL • ST: BYTE	- • 0 • 16#80

Monitoring blocks

4.5 MonDiL - Monitoring of a digital process tag (Large)

Parameter	Description	Type	Default
MsgAckn1	Message acknowledgement status 1 (output ACK_STATE of first ALARM_8P)	WORD	16#0000
MsgErr1	1 = Alarm error 1 (output ERROR of the first ALARM_8P)	BOOL	0
MsgStat1	Message status 1 (output STATUS of first ALARM_8P)	WORD	16#0000
OnAct	1 = "On" mode enabled	STRUCT <ul style="list-style-type: none">• Value: BOOL• ST: BYTE	- <ul style="list-style-type: none">• 1• 16#80
OosAct	1 = Block is "Out of service"	STRUCT <ul style="list-style-type: none">• Value: BOOL• ST: BYTE	- <ul style="list-style-type: none">• 0• 16#80
OpSt_Out	Value of the OpSt_In input parameter, for feed-forwarding to other blocks. Bit 31 of this parameter is used by Feature bit 24	DWORD	16#00000000
OS_PermOut	Display of OS_Perm	DWORD	16#FFFFFFFF
OS_PermLog	Display of OS_Perm with settings changed by the block algorithm	DWORD	16#FFFFFFFF
Out	Output	STRUCT <ul style="list-style-type: none">• Value: BOOL• ST: BYTE• Bit 1: BOOL (Bypass information bit)	- <ul style="list-style-type: none">• 0• 16#80• 0
ST_Worst	Worst signal status	BYTE	16#80
Status1	Status word 1 (Page 499)	DWORD	16#00000000
Status2	Status word 2 (Page 499)	DWORD	16#00000000
Status3	Status word 3 (Page 499)	DWORD	16#00000000
SumMsgAct	1 = Group message is active	STRUCT <ul style="list-style-type: none">• Value: BOOL• ST: BYTE	- <ul style="list-style-type: none">• 0• 16#80

See also

MonDiL messaging (Page 509)

MonDiL block diagram (Page 515)

MonDiL modes (Page 502)

4.5.7 MonDiL block diagram

MonDiL block diagram

A block diagram is not provided for this block.

See also

MonDiL I/Os (Page 510)

MonDiL messaging (Page 509)

MonDiL error handling (Page 508)

MonDiL functions (Page 503)

MonDiL modes (Page 502)

Description of MonDiL (Page 499)

4.5.8 Operator control and monitoring

4.5.8.1 MonDiL views

Views of the MonDiL block

The block MonDiL provides the following views:

- MonDiL standard view (Page 516)
- Alarm view (Page 302)
- Trend view (Page 305)
- MonDiL parameter view (Page 518)
- MonDiL preview (Page 519)
- Memo view (Page 304)
- Batch view (Page 302)
- Block icon for MonDiL (Page 520)

Refer to the sections Structure of the faceplate (Page 248) and Block icon structure (Page 230) for general information on the faceplate and block icon.

4.5.8.2 MonDiL standard view

MonDiL standard view

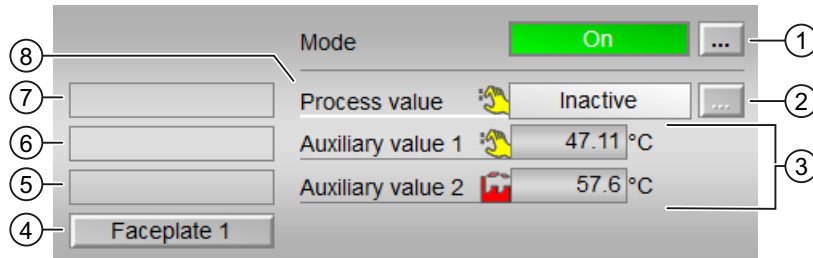

(1) Display and switch the operating mode

This area provides information on the currently valid operating mode. The following operating modes can be shown here:

- On (Page 71)
- Out of service (Page 71)

Refer to chapter Switching operating states and operating modes (Page 257) for information on switching the operating mode.

(2) Display of process value enabled/disabled

This area shows you the status of the individual connected parameters.

The identifier can be changed using Text 0 / Text 1 at the output parameter `Out`.

If the block is in simulation, you can enable or disable the process value. To do this, click on the display to open the operator input area.

If text is configured for these commands, it is displayed as additional text and as button labels for command selection. You can find additional information on this in chapter Labeling of buttons and text (Page 209).

You can change the text for the process value with the `FlutTmIn` parameter.

The background color of the display can be changed using the "Color" parameter; see MonDiL functions (Page 503) under "Adapting the color representation in the configured message class".

(3) Display of auxiliary values

You can use this area to display two auxiliary values that have been configured in the Engineering System. You can find additional information on this in chapter Displaying auxiliary values (Page 211).

(4) Navigation button for switching to the standard view of any faceplate

Use this navigation button to reach the standard view of a block configured in the Engineering System (ES). The visibility of this navigation button depends on the configuration in the Engineering System (ES).

You can find additional information on this in chapter Opening additional faceplates (Page 208).

(5) Display area for block states

This area provides additional information on the operating state of the block:

- "Maintenance"

(6) Display area for block states

This area provides additional information on the operating state of the block:

- "Simulation"

(7) Display area for block states

This area provides additional information on the operating state of the block:

- "Fluttering"

(8) Displaying input values

Changing the display:

Follow these steps to change the displays:

1. In the CFC, right-click the MonDiL block and select "Object Properties" from the context menu.
2. Select "I/Os" tab in the properties window.
3. In the "OS additional text" column, change the default setting for the input parameter (`FlutTmIn`) to what you want to see during runtime later.
4. In the "Identifier" column, change the default setting for the input parameter (`FlutTmIn`) to what you want to see during runtime later.
5. If both "OS additional text" and "Identifier" columns are empty, the default value is displayed in the runtime.
6. The text is used as a label and is therefore always displayed, which means it is independent of the signal status of the corresponding input (`FlutTmInx`).
7. The font size is reduced during the runtime if the input text length is greater than the label width.

Note

If a text is added to the "OS additional text" field of the input parameter (FlutTmIn), this text is displayed even if the "Identifier" text field of the same input parameter is not empty. If the "OS additional text" field of the input parameter (FlutTmIn) is empty, the "Identifier" text of the same input parameter is displayed.

4.5.8.3 MonDiL parameter view

Parameter view of MonDiL

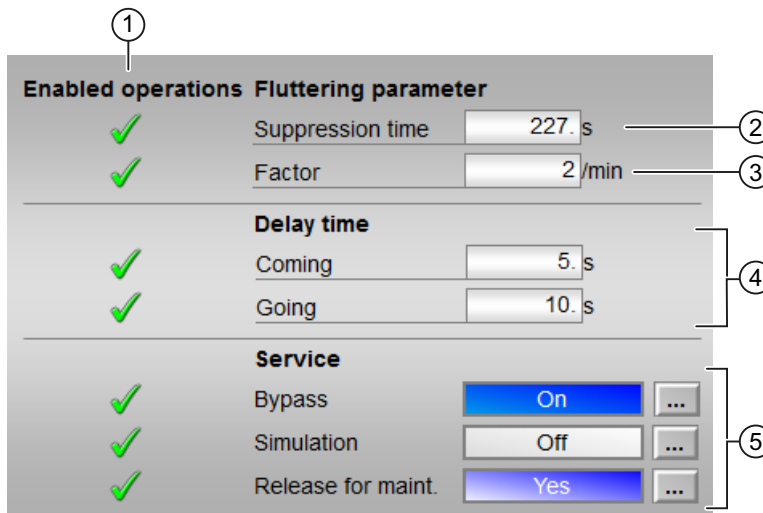

(1) Enabled operations

This area shows all operations for which special operator control permissions are assigned. They depend on the configuration in the engineering system (ES) that applies to this block.

Symbols for enabled operations:

- **Green check mark:** the OS operator can control this parameter
- **Gray check mark:** the OS operator cannot control this parameter at this time due to the process
- **Red cross:** the OS operator cannot control this parameter due to the configured AS operator control permissions (OS_Perm or OS1Perm).

(2) Suppression time

Enter the time period during which signal flutter is suppressed. You can find additional information on this in the Changing values (Page 259) section.

(3) Factor

Enter the number of flutter signals that can be suppressed. You can find additional information on this in the Changing values (Page 259) section.

(4) Delay time

Enter here the delay time by which the output should be set. Enter delay times here for positive ("incoming", 0 - 1 edge) and negative edges ("outgoing", 1 - 0 edge). You can find additional information on this in the Changing values (Page 259) section.

(5) Service

You can select the following functions in this area:

- "Bypass"
- "Simulation"
- "Release for maintenance"

Refer to the Switching operating states and operating modes (Page 257) section for more on this.

You can find information on this area in the section:

- Bypassing signals (Page 107)
- Simulating signals (Page 58)
- Release for maintenance (Page 64)

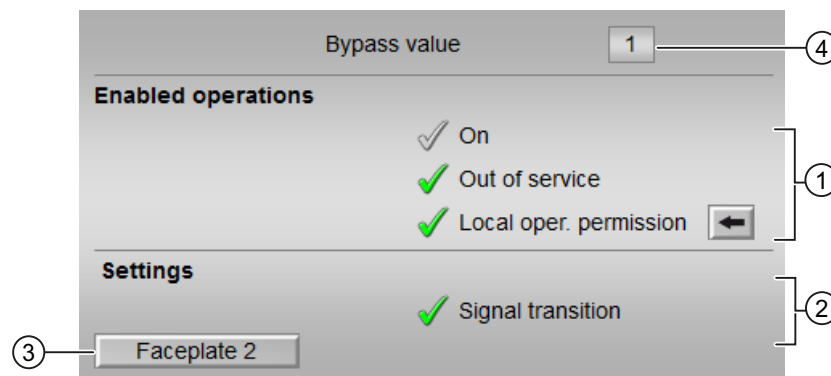
4.5.8.4 MonDiL preview**Preview of MonDiL****(1) Enabled operations**

This area shows all operations for which special operator control permissions are assigned. They depend on the configuration in the engineering system (ES) that applies to this block.

Symbols for enabled operations:

- **Green check mark:** the OS operator can control this parameter
- **Gray check mark:** the OS operator cannot control this parameter at this time due to the process
- **Red cross:** the OS operator cannot control this parameter due to the configured AS operator control permissions (OS_Perm or OS1Perm)

The following enabled operations are shown here:

- "On": You can switch to "On" operating mode.
- "Out of service": You can switch to "Out of service" operating mode.
- "Local operating permission": Use the ← button to switch to the standard view of the OpStations block. Additional information is available in the section Operator control permissions (Page 254).

(2) Settings

- "Signal transition":
 - Activated: A message is generated with a "0 → 1" signal transition at the monitored input.
 - Deactivated: No message is generated.

(3) Navigation button for switching to the standard view of any faceplate

Use this navigation button to reach the standard view of a block configured in the engineering system. The visibility of this navigation button depends on the configuration in the engineering system (ES).

You can find additional information on this in the Opening additional faceplates (Page 208) section.

(4) Bypass value

This area displays the bypass value (BypIn).

4.5.8.5 Block icon for MonDiL

Block icons for MonDiL





A variety of block icons are available with the following functions:

- Process tag type
- Limits (high/low)
- Violation of alarm, warning, and tolerance limits as well as control system faults
- Operating modes
- Signal status, release for maintenance

4.5 MonDiL - Monitoring of a digital process tag (Large)

- Memo display
- Display of the output signal
- Display configured instance-specific text for the process value (only for block icons 3 to 6). The instance-specific text for the process value can be changed using Text 0 / Text 1 at the output parameter `Out`.

The block icons from template @TemplateAPLV8.PDL:







Icons	Selection of the block icon in CFC	Special features
	1	
	2	The text background color for output <code>Out = 1</code> depends on the parameter assignment of the input "Color".
	3	See 2
	4	The text background color for output <code>Out = 1</code> depends on the parameter assignment of the input "Color". Text in block icon can be configured via Text 1 at the <code>Out</code> output parameter, a maximum of two characters are supported.
	5	The text background color for output <code>Out = 1</code> depends on the parameter assignment of the input "Color". For <code>Color = 11</code> , the text background color is directly derived from <code>EventState</code> (but without the message classes process message and operator prompt) which also takes into consideration the CSF input. <code>Color = 11</code> is only supported by type 5.

Note

Text 1 is also used in the standard view of the faceplate in the display process value active/inactive. Long static texts must therefore be displayed on the "Process value" text using the "FlutTmIn" parameter (see MonDiL standard view (Page 516))

4.5 MonDiL - Monitoring of a digital process tag (Large)

The block icons from template @TemplateAPLV7.PDL:

Icons	Selection of the block icon in CFC	Special features
	1	Block icon in the full display
	2	
	3	The text background color for output $Out = 1$ depends on the parameter assignment of the input "Color".
	4	See 3
	5	See 3
	6	See 3
	-	Block icon in "Out of service" mode (example with type 1 block icon)

Additional information on the block icon and the control options in the block icon is available in the following sections:

- Configuring the block icons (Page 237)
- Block icon structure (Page 230)
- Operation via the block icon (Page 239).

4.6 MonDiS - Monitoring of a digital process tag (Small)

4.6.1 Description of MonDiS

Object name (type + number) and family

Type + number: FB 1913

Family: Monitor

Area of application for MonDiS

The block is used for the following applications:

- Monitoring a digital process tag

Note

This block is also available as a large block. A comparison of the MonDiL and MonDiS blocks is available in the section: MonDiL compared to MonDiS (Page 437)

How it works

The MonDiS is used to monitor a digital process tag. The digital value to be monitored is interconnected to the `In` input parameter. The input signal is written directly to the `Out` output parameter.

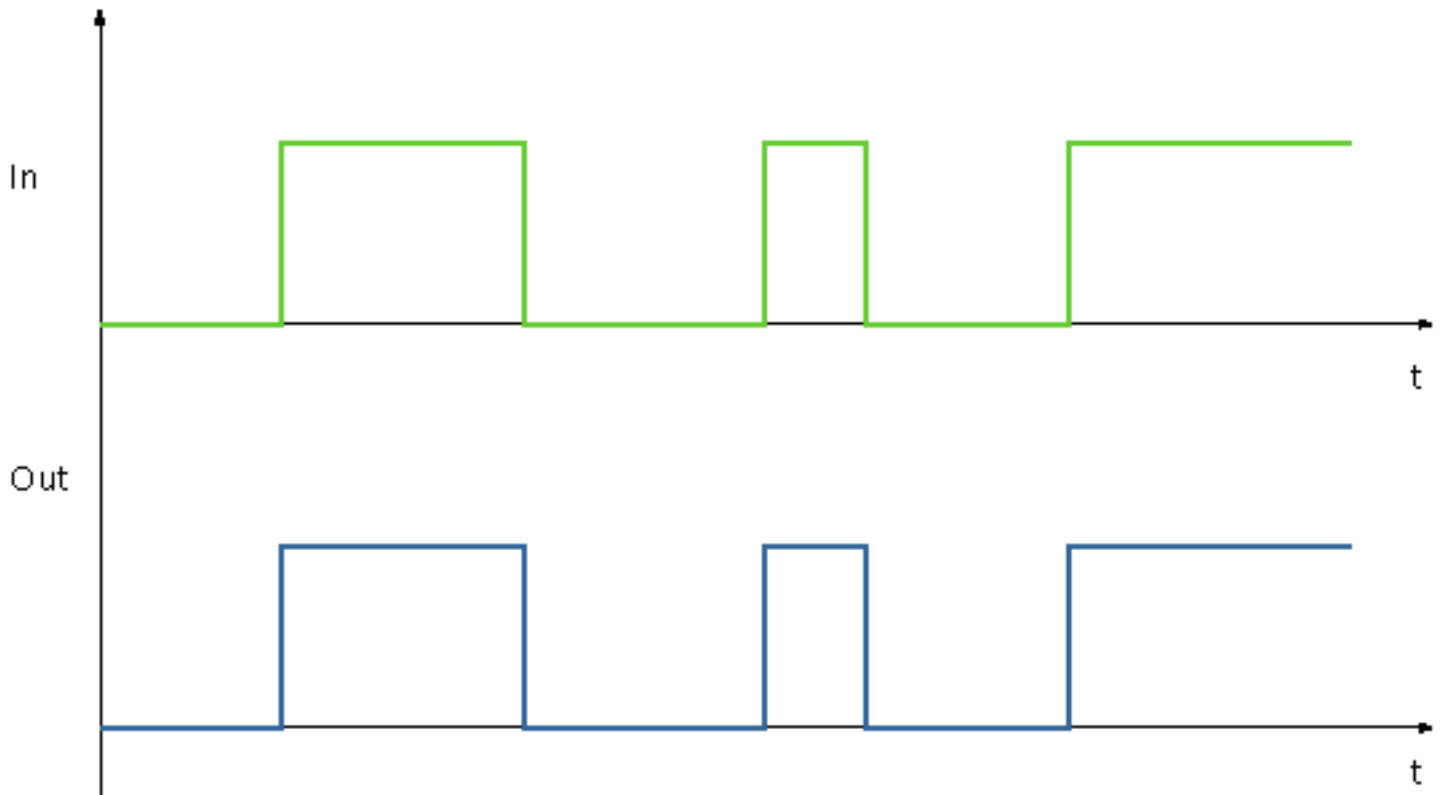

Configuration

Use the CFC editor to install the block in a cyclic interrupt OB (OB30 to OB38). The block is also installed automatically in the startup OB (OB100).

Startup characteristics

Use the `Feature Bit Set` startup characteristics (Page 138) to define the startup characteristics of this block. The `Out` parameter is affected.

The messages are suppressed after startup for the number of cycles set at `RunUpCyc`.

Status word allocation for `Status1` parameter

You can find a description for each parameter in section MonDiS I/Os (Page 532).

Status bit	Parameter
0	Occupied
1	BatchEn

Status bit	Parameter
2	SimOn
3	OosAct.Value
4	OosLi.Value
5	Not used
6	OnAct.Value
7	Out.Value
8	AlmMsgEn
9 - 31	Not used

Status word allocation for Status2 parameter

Status bit	Parameter
0	MsgLock.Value
1 - 30	Not used
31	MS_RelOp

Status word allocation for Status3 parameter

Status bit	Parameter
0 - 13	Not used
14	Color = 11 (Background color is derived directly from EventState, without message classes process message and operator prompt), only for block icon type 5
15	Color = 10 (Background color of the message instance MsgEvid1 - Message identifier SIG1)
16-19	Not used
20	Color = 6 (Violet, operator prompt) and Out = 1
21	Not used
22	Color = 5 (Pastel green, process) and Out = 1
23 - 24	Not used
25	Color = 4 (Black, control system) and Out = 1
26	Color = 9 (UCMC 6) and Out = 1
27	Color = 3 (Blue, tolerance / UCMC 5) and Out = 1
28	Color = 8 (UCMC 4) and Out = 1
29	Color = 2 (Yellow, warning / UCMC 3) and Out = 1
30	Color = 7 (UCMC 2) and Out = 1
31	Color = 1 (Red, alarm / UCMC 1) and Out = 1

Explanation:

UCMC = user-configured messages classes

Note

The user-configured message classes 5, 3 and 1 are displayed in the existing status bits 27, 29 and 31.

See also

- MonDiS operating modes (Page 526)
- MonDiS functions (Page 527)
- MonDiS error handling (Page 530)
- MonDiS messaging (Page 531)
- MonDiS block diagram (Page 535)

4.6.2 MonDiS operating modes

MonDiS operating modes

This block provides the following modes.

- On (Page 71)
- Out of service (Page 71)

"On"

General information on the "On" mode is available in the section On (Page 71).

Out of service

You can find general information about the "Out of service" mode in the section Out of service (Page 71).

See also

- Description of MonDiS (Page 523)
- MonDiS functions (Page 527)
- MonDiS error handling (Page 530)
- MonDiS messaging (Page 531)
- MonDiS I/Os (Page 532)
- MonDiS block diagram (Page 535)

4.6.3 MonDiS functions

Functions of MonDiS

The functions for this block are listed below.

Delaying the on function

You set delay times for setting the output using the input parameter `Out_DC`:

- `Out_DC`: delay time [s] for rising edges (0 - 1 edge)

The `Out` output parameter is after expiration of the delay time.

You disable this function if you set the value of the respective parameter to 0 seconds.

Adapting the color representation in the configured message class

You can set the background color of instance-specific texts for the block icons 2 and 3 and thereby adapt them to the configured message class. This background color is displayed when the output parameter `Out = 1`.

You set the color coding with the `Color` parameter:

Value <code>Color</code>	Color
0	Old reaction
1	Red (alarm)
2	Yellow (warning)
3	Blue (tolerance)
4	Black (control system)
5	Pastel green (process)
6	Violet (operator prompt)
7...9	Old reaction
10	Background color of the configured message class SIG1 ("Out - setting binary output values")
11	For block icon type 5 only, background color is derived directly from <code>EventState</code> without message classes process message and operator prompt ¹

¹ This also takes into consideration the CSF input

The following colors are shown for user-configured message classes

Value <code>Color</code>	Color
0	Old reaction
1	User-configured message classes 1
2	User-configured message classes 3
3	User-configured message classes 5
4	Black (control system)
5	Pastel green (process)
6	Violet (operator prompt)

Value Color	Color
7	User-configured message classes 2
8	User-configured message classes 4
9	User-configured message classes 6
10	Background color of the configured message class SIG1 ("Out - setting binary output values")
11	For block icon type 5 only, background color is derived directly from EventState without message classes process message and operator prompt ¹

¹ This also takes into consideration the CSF input

Changing labels on buttons and text

This block provides the standard function Labeling of buttons and text (Page 209).

You can change the label for "Process value" for this block as you please. The change is made with the `OnOp` parameter.

Generating instance-specific messages

This block provides the standard function Generating instance-specific messages (Page 204).

Group display `SumMsgAct` for limit monitoring, CSF and `ExtMsgx`

The block provides the standard function Group display for limit monitoring, CSF and `ExtMsgx` (Page 85).

Suppressing messages using the `MsgLock` parameter

This block provides the standard function Suppressing messages using the `MsgLock` parameter (Page 205).

Forming the signal status for blocks

This block provides the standard function Forming and outputting the signal status for technologic blocks (Page 109).

The worst signal status `ST_Worst` for the block is formed from the following parameters:

- `In.ST`

Release for maintenance

This block provides the standard function Release for maintenance (Page 64).

Simulating signals

This block provides the standard function Simulating signals (Page 58).

Configurable reactions using the `Feature` parameter

You can find an overview of all reactions provided by the `Feature` parameter in the Configurable functions using the Feature I/O (Page 131) . The following functionality is available for this block at the relevant bits:

Bit	Function
0	Set startup characteristics (Page 138)
1	Reaction to the out of service mode (Page 177)
24	Enabling local operator authorization (Page 158)
25	Suppression of all messages (Page 174)

Operator permissions

This block provides the standard function Operator control permissions (Page 254).

The block has the following permissions for the `OS_Perm` parameter:

Bit	Function
0	Not used
1	1 = Operator can switch to "On" mode
2	Not used
3	1 = Operator can switch to "Out of service" mode
4	1 = Operator can change the delay time for rising edges (<code>Out_DC</code>)
5 - 9	Not used
10	1 = Operator can change the simulation value <code>SimIn</code>
11	1 = Operator can activate the Simulation function
12	1 = Operator can activate the Release for maintenance function
13 - 31	Not used

Note

If you interconnect a parameter that is also listed in `OS_Perm` as a parameter, you have to reset the corresponding `OS_Perm` bit.

Opening additional faceplates

This block provides the standard function Opening additional faceplates (Page 208).

SIMATIC BATCH functionality

This block provides the standard function SIMATIC BATCH functionality (Page 67).

See also

Description of MonDiS (Page 523)

MonDiS operating modes (Page 526)

4.6 MonDiS - Monitoring of a digital process tag (Small)

- MonDiS error handling (Page 530)
- MonDiS messaging (Page 531)
- MonDiS I/Os (Page 532)
- MonDiS block diagram (Page 535)
- User-configured message classes (Page 41)

4.6.4 MonDiS error handling

Error handling of MonDiS

Refer to the section Error handling (Page 119) in the basic instructions for the error handling of all blocks.

The following errors can be displayed for this block:

- Error numbers
- Control system fault (CSF)

Overview of error numbers

The `ErrorNum` I/O can be used to output various error numbers:

Error number	Meaning of the error number
-1	Predefined value when inserting the block; the block is not executed.
0	There is no error.

Control system fault (CSF)

An external signal can be activated via the `CSF` input. If this signal changes to = 1, a control system fault is triggered. Refer to the Error handling (Page 119) section for more on this.

See also

- Description of MonDiS (Page 523)
- MonDiS operating modes (Page 526)
- MonDiS functions (Page 527)
- MonDiS messaging (Page 531)
- MonDiS I/Os (Page 532)
- MonDiS block diagram (Page 535)

4.6.5 MonDiS messaging

Messaging

The following messages can be generated for this block:

- Process control fault
- Process messages
- Instance-specific messages

Process control fault

You can interconnect an external fault (signal) to input parameter `CSF`. If it changes to `CSF = 1`, a process control fault is triggered (`MsgEvId1`, SIG 3).

Process messages

You can use up to four instance-specific messages with this block.

Message instance	Message identifier	Message class	Event
MsgEvId1	SIG 1	Alarm - high	\$\$BlockComment\$\$ Out - Binary value set
	SIG 2	Not used	
	SIG 3	AS process control message - fault	\$\$BlockComment\$\$ External error has occurred
	SIG 4	AS process control message - fault	\$\$BlockComment\$\$ External message 1
	SIG 5	AS process control message - fault	\$\$BlockComment\$\$ External message 2

Explanation:

\$\$BlockComment\$\$: Content of the instance-specific comment

Associated values for message instance `MsgEvId1`

Associated value	Block parameters
1	BatchName
2	StepNo
3	BatchID
4	ExtVal04
5	ExtVal05
6	Reserved
7	Reserved
8	Reserved

4.6 MonDiS - Monitoring of a digital process tag (Small)

Associated value	Block parameters
9	Reserved
10	Reserved

The associated values 4 and 5 are allocated to the parameters `ExtVa104` and `ExtVa105` and can be used. Additional information is available in the "Process Control System PCS 7 - Engineering System" manual.

See also

- Description of MonDiS (Page 523)
- MonDiS operating modes (Page 526)
- MonDiS functions (Page 527)
- MonDiS error handling (Page 530)
- MonDiS block diagram (Page 535)

4.6.6 MonDiS I/Os

I/Os of MonDiS

Input parameters

Parameter	Description	Type	Default
<code>AlmMsgEn</code>	1 = Alarms are output	BOOL	1
<code>BatchEn</code>	1 = Enable allocation	BOOL	0
<code>BatchID</code>	Batch ID	DWORD	16#00000000
<code>BatchName</code>	Batch name	S7-String	
<code>CSF</code>	1 = External error (control system fault) Error handling (Page 530)	STRUCT • Value: BOOL • ST: BYTE	- • 0 • 16#80
<code>Color</code>	Color for status display in the block icon: 0 = Default setting 1 = Red (alarm) 2 = Yellow (warning) 3 = Blue (tolerance) 4 = Black (control system message) 5 = Pastel green (process message) 6 = Violet (operator prompt)	BYTE	16#00
<code>EN</code>	1 = Called block will be processed	BOOL	1
<code>ExtMsg1</code>	Binary input for freely selectable message 1	STRUCT • Value: BOOL • ST: BYTE	- • 0 • 16#80

4.6 MonDiS - Monitoring of a digital process tag (Small)

Parameter	Description	Type	Default
ExtMsg2	Binary input for freely selectable message 2	STRUCT <ul style="list-style-type: none"> Value: BOOL ST: BYTE 	- <ul style="list-style-type: none"> 0 16#80
ExtVal04	Associated value 4 for messages (MsgEvID1)	ANY	
ExtVal05	Associated value 5 for messages (MsgEvID1)	ANY	
Feature	I/O for additional functions (Page 527)	STRUCT <ul style="list-style-type: none"> Bit 0: BOOL ... Bit 31: BOOL 	- <ul style="list-style-type: none"> 0 0 0
In	Digital input value	STRUCT <ul style="list-style-type: none"> Value: BOOL ST: BYTE 	- <ul style="list-style-type: none"> 0 16#80
MS_RelOp*	1 = Release for maintenance by OS operator	BOOL	0
MsgEvID1	Message number (assigned automatically)	DWORD	16#00000000
MsgLock	1 = Suppress process messages. See also the section Suppressing messages using the MsgLock parameter (Page 205) for more on this.	STRUCT <ul style="list-style-type: none"> Value: BOOL ST: BYTE 	- <ul style="list-style-type: none"> 0 16#80
Occupied	1 = Occupied by batch control	BOOL	0
OosLi	1 = "Out of service", via interconnection or SFC (0-1 edge transition)	STRUCT <ul style="list-style-type: none"> Value: BOOL ST: BYTE 	- <ul style="list-style-type: none"> 0 16#80
OnOp*	1 = "On" mode via operator	BOOL	0
OosOp*	1 = "Out of service", via OS operator	BOOL	0
OpSt_In	Input parameter for local operator authorization, connected with the Out output parameter of the upstream block, OpStations (Page 411)	DWORD	16#00000000
OS_Perm	I/O for operator permissions (Page 527)	STRUCT <ul style="list-style-type: none"> Bit 0: BOOL Bit 10: BOOL Bit 31: BOOL 	- <ul style="list-style-type: none"> 1 1 1
Out_DC	Delay time for setting the output parameter Out for rising edges	REAL	0.0
RunUpCyc	Number of cycles in startup; messages are suppressed during these cycles	INT	3
SampleTime	Sampling time [s] (assigned automatically)	REAL	0.1
SelFp1	1 = Call a block saved in this parameter as an additional faceplate (Page 208) in the standard view	ANY	-
SimOn	1 = Simulation on	BOOL	0
SimIn*	Value used for SimOn = 1	BOOL	0
StepNo	Batch step number	DWORD	16#00000000
UserStatus	Freely assignable bits for use in PCS 7 OS	BYTE	16#00

* Values can be written back to these inputs during processing of the block by the block algorithm.

Output parameters

Parameter	Description	Type	Default
ENO	1 = Block algorithm completed without errors	BOOL	0
ErrorNum	Output of pending error number. For error numbers that can be output by this block, see MonDiS error handling (Page 530)	INT	-1
MS_Release	Release for maintenance: 1 = Release for OS operator	STRUCT <ul style="list-style-type: none"> Value: BOOL ST: BYTE 	- <ul style="list-style-type: none"> 0 16#80
OnAct	1 = "On" mode enabled	STRUCT <ul style="list-style-type: none"> Value: BOOL ST: BYTE 	- <ul style="list-style-type: none"> 1 16#80
OosAct	1 = Block is "Out of service"	STRUCT <ul style="list-style-type: none"> Value: BOOL ST: BYTE 	- <ul style="list-style-type: none"> 0 16#80
OpSt_Out	Value of the OpSt_In input parameter, for feed-forwarding to other blocks. Bit 31 of this parameter is used by Feature bit 24	DWORD	16#00000000
OS_PermOut	Display of OS_Perm	DWORD	16#FFFFFFFF
OS_PermLog	Display of OS_Perm with settings changed by the block algorithm	DWORD	16#FFFFFFFF
Out	Output	STRUCT <ul style="list-style-type: none"> Value: BOOL ST: BYTE 	- <ul style="list-style-type: none"> 0 16#80
ST_Worst	Worst signal status	BYTE	16#80
Status1	Status word 1 (Page 523)	DWORD	16#00000000
Status2	Status word 2 (Page 523)	DWORD	16#00000000
Status3	Status word 3 (Page 523)	DWORD	16#00000000
SumMsgAct	1 = Group message is active	STRUCT <ul style="list-style-type: none"> Value: BOOL ST: BYTE 	- <ul style="list-style-type: none"> 0 16#80

See also

MonDiS operating modes (Page 526)

MonDiS block diagram (Page 535)

Error handling (Page 119)

4.6.7 MonDiS block diagram

MonDiS block diagram

A block diagram is not provided for this block.

See also

Description of MonDiS (Page 523)
MonDiS operating modes (Page 526)
MonDiS functions (Page 527)
MonDiS messaging (Page 531)
MonDiS I/Os (Page 532)
MonDiS error handling (Page 530)

4.6.8 Operator control and monitoring

4.6.8.1 MonDiS views

Views of the MonDiS block

The block MonDiS provides the following views:

- MonDiS standard view (Page 536)
- Alarm view (Page 302)
- Trend view (Page 305)
- MonDiS parameter view (Page 537)
- MonDiS preview (Page 538)
- Memo view (Page 304)
- Batch view (Page 302)
- Block icon for MonDiS (Page 539)

Refer to the sections Structure of the faceplate (Page 248) and Block icon structure (Page 230) for general information on the faceplate and block icon.

4.6.8.2 MonDiS standard view

MonDiS standard view

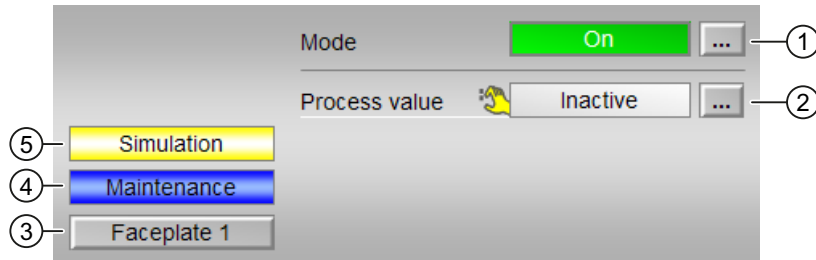

(1) Displaying and switching the operating mode

This area provides information on the currently valid operating mode. The following operating modes can be shown here:

- On (Page 71)
- Out of service (Page 71)

Refer to the Switching operating states and operating modes (Page 257) section for information on switching the operating mode.

(2) Display of process value enabled/disabled

This area shows you the status of the individual connected parameters.

The identifier can be changed using Text 0 / Text 1 at the output parameter `Out`.

If the block is in simulation, you can enable or disable the process value. To do this, click on the display to open the operator input area.

If text is configure for these commands, it is displayed as additional text and as button labels for command selection. Additional information is available in the section Labeling of buttons and text (Page 209).

(3) Navigation button for switching to the standard view of any faceplate

Use this navigation button to reach the standard view of a block configured in the engineering system. The visibility of this navigation button depends on the configuration in the engineering system (ES).

Additional information is available in the section Opening additional faceplates (Page 208).

(4) Display area for block states

This area provides additional information on the operating state of the block:

- "Maintenance"

(5) Display area for block states

This area provides additional information on the operating state of the block:

- "Simulation"

See also

Displaying auxiliary values (Page 211)

4.6.8.3 MonDiS parameter view

Parameter view of MonDiS

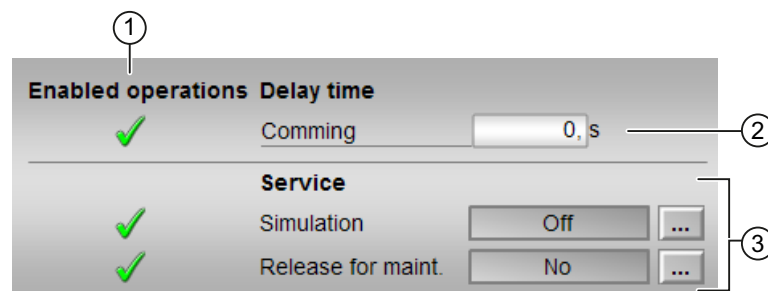

(1) Enabled operations

This area shows all operations for which special operator control permissions are assigned. They depend on the configuration in the engineering system (ES) that applies to this block.

Symbols for enabled operations:

- **Green check mark:** the OS operator can control this parameter
- **Gray check mark:** the OS operator cannot control this parameter at this time due to the process
- **Red cross:** the OS operator cannot control this parameter due to the configured AS operator control permissions (OS_Perm or OS1Perm).

(2) Delay time

Enter here the delay time by which the output should be set. Enter delay times here for positive ("incoming", 0 - 1 edge) edges. Additional information is available in the section Switching operating states and operating modes (Page 257).

(3) Service

You can select the following functions in this area:

- "Simulation"
- "Release for maintenance"

Refer to the Switching operating states and operating modes (Page 257) section for more on this.

You can find information on this area in the section:

- Simulating signals (Page 58)
- Release for maintenance (Page 64)

See also

Changing values (Page 259)

4.6.8.4 MonDiS preview

Preview of MonDiS

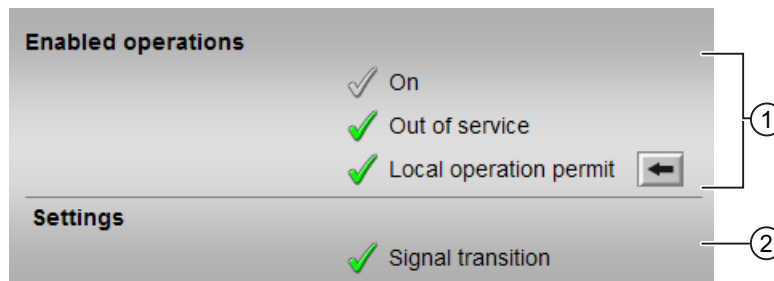

(1) Enabled operations

This area shows all operations for which special operator control permissions are assigned. They depend on the configuration in the engineering system (ES) that applies to this block.

Symbols for enabled operations:

- **Green check mark:** the OS operator can control this parameter
- **Gray check mark:** the OS operator cannot control this parameter at this time due to the process
- **Red cross:** the OS operator cannot control this parameter due to the configured AS operator control permissions (OS_Perm or OS1Perm)

The following enabled operations are shown here:

- "On": You can switch to "On" operating mode.
- "Out of service": You can switch to "Out of service" operating mode.
- "Local operating permission": Use the ← button to switch to the standard view of the OpStations block. Additional information is available in the section Operator control permissions (Page 254).

(2) Settings

- "Signal transition":
 - Activated: A message is generated with a "0 → 1" signal transition at the monitored input.
 - Deactivated: No message is generated.



4.6.8.5 Block icon for MonDiS

Block icons for MonDiS



A variety of block icons are available with the following functions:

- Process tag type
- Limits (high/low)
- Violation of alarm, warning, and tolerance limits as well as control system faults
- Operating modes
- Signal status, release for maintenance
- Memo display
- Display of the output signal
- Display configured instance-specific text for the process value (only for block icons 2 and 3). The instance-specific text for the process value can be changed using Text 0 / Text 1 at the output parameter `Out`.

The block icons from template @TemplateAPLV8.PDL:

Icons	Selection of the block icon in CFC	Special features
	1	
	2	The text background color for output <code>Out = 1</code> depends on the parameter assignment of the input "Color".
	3	See 2





4.6 MonDiS - Monitoring of a digital process tag (Small)

Icons	Selection of the block icon in CFC	Special features
	4	The text background color for output <code>Out = 1</code> depends on the parameter assignment of the input "Color". Text in block icon can be configured via Text 1 at the <code>Out</code> output parameter, a maximum of two characters are supported.
	5	The text background color for output <code>Out = 1</code> depends on the parameter assignment of the input "Color". For <code>Color = 11</code> , the text background color is directly derived from <code>EventState</code> (but without the message classes process message and operator prompt) which also takes into consideration the CSF input. <code>Color = 11</code> is only supported by type 5.

Note

Text 1 is also used in the standard view of the faceplate in the display process value active/inactive. Long static texts must therefore be displayed on the "Process value" text using the "FlutTmIn" parameter (see MonDiS standard view (Page 536))

The block icons from template @TemplateAPLV7.PDL:

Icons	Selection of the block icon in CFC	Special features
	1	
	2	The text background color for output <code>Out = 1</code> depends on the parameter assignment of the input "Color".
	3	See 2
	-	Block icon in "Out of service" mode (example with type 1 block icon)

Additional information on the block icon and the control options in the block icon is available in the following sections:

- Configuring the block icons (Page 237)
- Block icon structure (Page 230)
- Operation via the block icon (Page 239).

4.7 MonDi08 - Monitoring 8 digital process tags

4.7.1 Description of MonDi08

Object name (type + number) and family

Type + number: FB 1847

Family: Monitor

Area of application for MonDi08

The block is used for the following applications:

- Monitoring of up to eight digital process tags

How it works

The MonDi08 block is used to monitor up to eight digital process tags with flutter suppression.

Configuration

Use the CFC editor to install the block in a cyclic interrupt OB (OB30 to OB38). The block is also installed automatically in the startup OB (OB100).

For the MonDi08 block, the Advanced Process Library contains templates for process tag types as examples with various application scenarios for this block.

Examples of process tag types:

- Monitoring eight digital process tags (Digital8Monitoring) (Page 2355)

Startup characteristics

Use the `Feature Bit Set` startup characteristics (Page 138) to define the startup characteristics of this block.

The messages are suppressed after startup for the number of cycles set at `RunUpCyc`.

Status word allocation for `Status1` parameter

You can find a description for each parameter in section MonDi08 I/Os (Page 550).

Status bit	Parameter
0 - 2	Not used
3	<code>OosAct.Value</code>
4	<code>OosLi.Value</code>
5	Not used
6	<code>OnAct.Value</code>

Status bit	Parameter
7	Out1.Value
8	Out2.Value
9	Out3.Value
10	Out4.Value
11	Out5.Value
12	Out6.Value
13	Out7.Value
14	Out8.Value
15 - 19	Not used
20	In1 is used
21	In2 is used
22	In3 is used
23	In4 is used
24	In5 is used
25	In6 is used
26	In7 is used
27	In8 is used
28 - 31	Not used

Status word allocation for status2 parameter

Status bit	Parameter
0	MsgLock.Value
1	Alm1MsgEn
2	Alm2MsgEn
3	Alm3MsgEn
4	Alm4MsgEn
5	Alm5MsgEn
6	Alm6MsgEn
7	Alm7MsgEn
8	Alm8MsgEn
9 - 30	Not used
31	MS_RelOp

Status word allocation for status3 parameter

Status bit	Parameter
0	Effective signal 1 of the message block connected via EventTsIn
1	Effective signal 2 of the message block connected via EventTsIn
2	Effective signal 3 of the message block connected via EventTsIn
3	Effective signal 4 of the message block connected via EventTsIn
4	Effective signal 5 of the message block connected via EventTsIn

Status bit	Parameter
5	Effective signal 6 of the message block connected via <code>EventTsIn</code>
6	Effective signal 7 of the message block connected via <code>EventTsIn</code>
7	Effective signal 8 of the message block connected via <code>EventTsIn</code>
8 - 23	Effective signal 9..16 of the message block connected via <code>EventTsIn</code>
24 - 31	Not used

See also

- MonDi08 messaging (Page 548)
- MonDi08 functions (Page 545)
- MonDi08 block diagram (Page 554)
- MonDi08 error handling (Page 547)
- MonDi08 modes (Page 544)

4.7.2 MonDi08 modes

MonDi08 operating modes

This block provides the following modes.

- On (Page 71)
- Out of service (Page 71)

"On"

You can find general information about the "On" mode in the On (Page 71) section.

Out of service

You can find general information about the "Out of service" mode in the Out of service (Page 71) section.

See also

- MonDi08 block diagram (Page 554)
- MonDi08 I/Os (Page 550)
- MonDi08 messaging (Page 548)
- MonDi08 error handling (Page 547)
- MonDi08 functions (Page 545)
- Description of MonDi08 (Page 542)

4.7.3 MonDi08 functions

Functions of MonDi08

The functions for this block are listed below.

Monitoring and output of digital signals

The block is operated as "flutter filter". The block receives digital signals at the input In_x ($x = 1 \dots 8$) which ideally do not develop any flutter. The block monitors these signals. Use the $FlutTmIn_x$ ($x = 1 \dots 8$) input to determine the duration of a continuous signal in order to transfer it to the process without flutter.

The preprocessed signal is sent to the process via the Out_x ($x = 1 \dots 8$) output.

Suppressing messages using the `MsgLock` parameter

This block provides the standard function Suppressing messages using the `MsgLock` parameter (Page 205).

Forming the signal status for blocks

This block provides the standard function Forming and outputting the signal status for technologic blocks (Page 109).

The worst signal status `ST_Worst` for the block is formed from the following parameters:

- `In1.ST`
- `In2.ST`
- `In3.ST`
- `In4.ST`
- `In5.ST`
- `In6.ST`
- `In7.ST`
- `In8.ST`

Release for maintenance

This block provides the standard function Release for maintenance (Page 64).

Simulating signals

This block provides the standard function Simulating signals (Page 58).

Configurable reactions using the Feature parameter

You can find an overview of all reactions provided by the `Feature` parameter in the Configurable functions using the Feature I/O (Page 131) section. The following functionality is available for this block at the relevant bits:

Bit	Function
0	Set startup characteristics (Page 138)
1	Reaction to the out of service mode (Page 177)
11	Suppress MsgLock and "Out of service" mode for a connected message block (Page 188)
22	Update acknowledgment and error status of the message call (Page 160)
24	Enabling local operator authorization (Page 158)
25	Suppression of all messages (Page 174)

Operator control permissions

This block provides the standard function Operator control permissions (Page 254).

The block has the following permissions for the `OS_Perm` parameter:

Bit	Function
0	Not used
1	1 = Operator can switch to "On" mode
2	Not used
3	1 = Operator can switch to "Out of service" mode
4 - 11	Not used
12	1 = Operator can activate the Release for maintenance function
13	1 = Operator can change the time for flutter suppression at the <code>In1</code> input
14	1 = Operator can change the time for flutter suppression at the <code>In2</code> input
15	1 = Operator can change the time for flutter suppression at the <code>In3</code> input
16	1 = Operator can change the time for flutter suppression at the <code>In4</code> input
17	1 = Operator can change the time for flutter suppression at the <code>In5</code> input
18	1 = Operator can change the time for flutter suppression at the <code>In6</code> input
19	1 = Operator can change the time for flutter suppression at the <code>In7</code> input
20	1 = Operator can change the time for flutter suppression at the <code>In8</code> input
21 - 31	Not used

Note

If you interconnect a parameter that is also listed in `OS_Perm` as a parameter, you have to reset the corresponding `OS_Perm` bit.

Opening additional faceplates

This block provides the standard function Opening additional faceplates (Page 208).

Changing labels on buttons and text

This block provides the standard function Labeling of buttons and text (Page 209).

You can change the label for "Process value" for this block as you please. The change is made with the `FlutXTmIn` parameter.

Connection of the time-stamped messages from EventTs or Event16Ts

This block provides the standard function Connection of the time-stamped messages from EventTs or Event16Ts (Page 207).

SIMATIC BATCH functionality

This block provides the standard function SIMATIC BATCH functionality (Page 67).

See also

MonDi08 messaging (Page 548)
MonDi08 I/Os (Page 550)
Description of MonDi08 (Page 542)
MonDi08 block diagram (Page 554)
MonDi08 error handling (Page 547)
MonDi08 modes (Page 544)
EventTs functions (Page 1660)

4.7.4 MonDi08 error handling

Error handling of MonDi08

Refer to the section Error handling (Page 119) in the basic instructions for the error handling of all blocks.

The following errors can be displayed for this block:

- Error numbers
- Flutter alarm

Overview of error numbers

The `ErrorNum` I/O can be used to output various error numbers:

Error number	Meaning of the error number
-1	Predefined value when inserting the block; the block is not processed.
0	There is no error.
11	Fluttering time < 0

Flutter alarm

An alarm is output at output `FlutAct` with 1 if signal flutter is detected. Refer to the functions of the block > Monitoring and reporting flutter signals (Page 545).

See also

- MonDi08 block diagram (Page 554)
- MonDi08 I/Os (Page 550)
- MonDi08 messaging (Page 548)
- MonDi08 modes (Page 544)
- Description of MonDi08 (Page 542)

4.7.5 MonDi08 messaging

Messaging

The following messages can be generated for this block:

- Process messages
- Instance-specific messages

Process messages

Message instance	Message identifier	Message class	Event
MsgEvId1	SIG 1	Alarm - high	\$\$BlockComment\$\$ Signal change Signal 1 has occurred
	SIG 2	Alarm - high	\$\$BlockComment\$\$ Signal change Signal 2 has occurred
	SIG 3	Alarm - high	\$\$BlockComment\$\$ Signal change Signal 3 has occurred
	SIG 4	Alarm - high	\$\$BlockComment\$\$ Signal change Signal 4 has occurred
	SIG 5	Alarm - high	\$\$BlockComment\$\$ Signal change Signal 5 has occurred
	SIG 6	Alarm - high	\$\$BlockComment\$\$ Signal change Signal 6 has occurred
	SIG 7	Alarm - high	\$\$BlockComment\$\$ Signal change Signal 7 has occurred
	SIG 8	Alarm - high	\$\$BlockComment\$\$ Signal change Signal 8 has occurred

Explanation:

\$\$BlockComment\$\$: Content of the instance-specific comment

Associated values for message instance **MsgEvId1**

Associated value	Block parameters
1	Out1.ST
2	Out2.ST
3	Out3.ST
4	Out4.ST
5	Out5.ST
6	Out6.ST
7	Out7.ST
8	Out8.ST

See also

Description of MonDi08 (Page 542)
 MonDi08 functions (Page 545)
 MonDi08 I/Os (Page 550)
 MonDi08 block diagram (Page 554)
 MonDi08 error handling (Page 547)
 MonDi08 modes (Page 544)
 Time stamp (Page 205)

4.7.6 MonDi08 I/Os

I/Os of MonDi08

Input parameters

Parameter	Description	Type	Default
Alm1MsgEn	1 = Activate error message	BOOL	1
Alm2MsgEn	1 = Activate error message	BOOL	1
Alm3MsgEn	1 = Activate error message	BOOL	1
Alm4MsgEn	1 = Activate error message	BOOL	1
Alm5MsgEn	1 = Activate error message	BOOL	1
Alm6MsgEn	1 = Activate error message	BOOL	1
Alm7MsgEn	1 = Activate error message	BOOL	1
Alm8MsgEn	1 = Activate error message	BOOL	1
BatchEn	1 = Enable allocation	BOOL	0
BatchID	Batch ID	DWORD	16#00000000
BatchName	Batch name	S7-String	
EN	1 = Called block will be processed	BOOL	1
EventTsIn	For interconnecting data between a technology block and the message blocks <code>EventTs</code> , <code>Event16Ts</code> . The <code>EventTsIn</code> input parameter serves to interconnect the <code>EventTsOut</code> output parameter of the <code>EventTs</code> , <code>Event16Ts</code> block. When this interconnection is configured, the messages of the <code>EventTs</code> , <code>Event16Ts</code> block are displayed on the OS in the alarm view of the technology block and can also be acknowledged there.	ANY	
ExtVa104	Associated value 4 for messages (<code>MsgEvID1</code>)	ANY	
ExtVa105	Associated value 5 for messages (<code>MsgEvID1</code>)	ANY	
ExtVa106	Associated value 6 for messages (<code>MsgEvID1</code>)	ANY	
ExtVa107	Associated value 7 for messages (<code>MsgEvID1</code>)	ANY	

4.7 MonDi08 - Monitoring 8 digital process tags

Parameter	Description	Type	Default
ExtVal08	Associated value 8 for messages (MsgEvID1)	ANY	
Feature	I/O for additional functions (Page 545)	STRUCT <ul style="list-style-type: none"> • Bit 0: BOOL • ... • Bit 31: BOOL 	- <ul style="list-style-type: none"> • 0 • 0 • 0
Flut1TmIn	Flutter time [s]	REAL	0.0
Flut2TmIn	Flutter time [s]	REAL	0.0
Flut3TmIn	Flutter time [s]	REAL	0.0
Flut4TmIn	Flutter time [s]	REAL	0.0
Flut5TmIn	Flutter time [s]	REAL	0.0
Flut6TmIn	Flutter time [s]	REAL	0.0
Flut7TmIn	Flutter time [s]	REAL	0.0
Flut8TmIn	Flutter time [s]	REAL	0.0
In1	Binary input In1	STRUCT <ul style="list-style-type: none"> • Value: BOOL • ST: BYTE 	- <ul style="list-style-type: none"> • 0 • 16#FF
In2	Binary input In2	STRUCT <ul style="list-style-type: none"> • Value: BOOL • ST: BYTE 	- <ul style="list-style-type: none"> • 0 • 16#FF
In3	Binary input In3	STRUCT <ul style="list-style-type: none"> • Value: BOOL • ST: BYTE 	- <ul style="list-style-type: none"> • 0 • 16#FF
In4	Binary input In4	STRUCT <ul style="list-style-type: none"> • Value: BOOL • ST: BYTE 	- <ul style="list-style-type: none"> • 0 • 16#FF
In5	Binary input In5	STRUCT <ul style="list-style-type: none"> • Value: BOOL • ST: BYTE 	- <ul style="list-style-type: none"> • 0 • 16#FF
In6	Binary input In6	STRUCT <ul style="list-style-type: none"> • Value: BOOL • ST: BYTE 	- <ul style="list-style-type: none"> • 0 • 16#FF
In7	Binary input In7	STRUCT <ul style="list-style-type: none"> • Value: BOOL • ST: BYTE 	- <ul style="list-style-type: none"> • 0 • 16#FF
In8	Binary input In8	STRUCT <ul style="list-style-type: none"> • Value: BOOL • ST: BYTE 	- <ul style="list-style-type: none"> • 0 • 16#FF
MS_RelOp*	1 = Release for maintenance by OS operator	BOOL	0
MsgEvId1	Message number (assigned automatically)	DWORD	16#00000000

Monitoring blocks

4.7 MonDi08 - Monitoring 8 digital process tags

Parameter	Description	Type	Default
MsgLock	1 = Suppress process messages. See also the section Suppressing messages using the MsgLock parameter (Page 205) for more on this.	STRUCT <ul style="list-style-type: none"> Value: BOOL ST: BYTE 	- <ul style="list-style-type: none"> 0 16#80
Occupied	1 = Occupied by batch control	BOOL	0
OnOp*	1 = "On" mode via operator	BOOL	0
OosLi	1 = "Out of service", via interconnection or SFC (0-1 edge transition)	STRUCT <ul style="list-style-type: none"> Value: BOOL ST: BYTE 	- <ul style="list-style-type: none"> 0 16#80
OosOp*	1 = "Out of service", via OS operator	BOOL	0
OpSt_In	Input parameter for local operator authorization, connected with the Out output parameter of the upstream block, OpStations (Page 411)	DWORD	16#00000000
OS_Perm	I/O for operator permissions (Page 545)	STRUCT <ul style="list-style-type: none"> Bit 0: BOOL ... Bit 31: BOOL 	- <ul style="list-style-type: none"> 1 1 1
RunUpCyc	Number of cycles in startup; messages are suppressed during these cycles	INT	3
SampleTime	Sampling time [s] (assigned automatically)	REAL	0.1
SelFp1	1 = Call a block saved in this parameter as an additional faceplate (Page 208) in the standard view	ANY	-
SelFp2	1 = Call a block saved in this parameter as an additional faceplate (Page 208) in the preview	ANY	-
StepNo	Batch step number	DWORD	16#00000000
UserStatus	Freely assignable bits for use in PCS 7 OS	BYTE	16#00

* Values can be written back to these inputs during processing of the block by the block algorithm.

Output parameters

Parameter	Description	Type	Default
ENO	1 = Block algorithm completed without errors	BOOL	0
ErrorNum	Output of pending error number. For error numbers that can be output by this block, see MonDi08 error handling (Page 547)	INT	-1
MS_Release	Release for maintenance: 1 = Release for OS operator	STRUCT <ul style="list-style-type: none"> Value: BOOL ST: BYTE 	- <ul style="list-style-type: none"> 0 16#80
MsgAckn1	Message acknowledgement status 1 (output ACK_STATE of first ALARM_8P)	WORD	16#0000
MsgErr1	1 = Alarm error 1 (output ERROR of the first ALARM_8P)	BOOL	0

4.7 MonDi08 - Monitoring 8 digital process tags

Parameter	Description	Type	Default
MsgStat1	Message status 1 (output STATUS of first ALARM_8P)	WORD	16#0000
OnAct	1 = "On" mode enabled	STRUCT <ul style="list-style-type: none"> Value: BOOL ST: BYTE 	- <ul style="list-style-type: none"> 1 16#80
OosAct	1 = Block is "Out of service"	STRUCT <ul style="list-style-type: none"> Value: BOOL ST: BYTE 	- <ul style="list-style-type: none"> 0 16#80
OpSt_Out	Value of the OpSt_In input parameter, for feedforwarding to other blocks. Bit 31 of this parameter is used by Feature bit 24	DWORD	16#00000000
OS_PermLog	Display of OS_Perm with settings changed by the block algorithm	DWORD	16#FFFFFFFF
OS_PermOut	Display of OS_Perm	DWORD	16#FFFFFFFF
Out1	Output	STRUCT <ul style="list-style-type: none"> Value: BOOL ST: BYTE 	- <ul style="list-style-type: none"> 0 16#80
Out2	Output	STRUCT <ul style="list-style-type: none"> Value: BOOL ST: BYTE 	- <ul style="list-style-type: none"> 0 16#80
Out3	Output	STRUCT <ul style="list-style-type: none"> Value: BOOL ST: BYTE 	- <ul style="list-style-type: none"> 0 16#80
Out4	Output	STRUCT <ul style="list-style-type: none"> Value: BOOL ST: BYTE 	- <ul style="list-style-type: none"> 0 16#80
Out5	Output	STRUCT <ul style="list-style-type: none"> Value: BOOL ST: BYTE 	- <ul style="list-style-type: none"> 0 16#80
Out6	Output	STRUCT <ul style="list-style-type: none"> Value: BOOL ST: BYTE 	- <ul style="list-style-type: none"> 0 16#80
Out7	Output	STRUCT <ul style="list-style-type: none"> Value: BOOL ST: BYTE 	- <ul style="list-style-type: none"> 0 16#80
Out8	Output	STRUCT <ul style="list-style-type: none"> Value: BOOL ST: BYTE 	- <ul style="list-style-type: none"> 0 16#80
ST_Worst	Worst signal status	BYTE	16#80
Status1	Status word 1 (Page 542)	DWORD	16#00000000
Status2	Status word 2 (Page 542)	DWORD	16#00000000
Status3	Status word 3 (Page 542)	DWORD	16#00000000

See also

- MonDi08 messaging (Page 548)
- MonDi08 block diagram (Page 554)
- MonDi08 modes (Page 544)

4.7.7 MonDi08 block diagram

MonDi08 block diagram

A block diagram is not provided for this block.

See also

- MonDi08 I/Os (Page 550)
- MonDi08 messaging (Page 548)
- MonDi08 error handling (Page 547)
- MonDi08 functions (Page 545)
- MonDi08 modes (Page 544)
- Description of MonDi08 (Page 542)

4.7.8 Operator control and monitoring

4.7.8.1 MonDi08 views

Views of the MonDi08 block

The block MonDi08 provides the following views:

- MonDi08 standard view (Page 555)
- Alarm view (Page 302)
- Trend view (Page 305)
- MonDi08 parameter view (Page 557)
- MonDi08 preview (Page 558)
- Memo view (Page 304)
- Batch view (Page 302)
- Block icon for MonDi08 (Page 559)

Refer to the sections Structure of the faceplate (Page 248) and Block icon structure (Page 230) for general information on the faceplate and block icon.

4.7.8.2 MonDi08 standard view

MonDi08 standard view

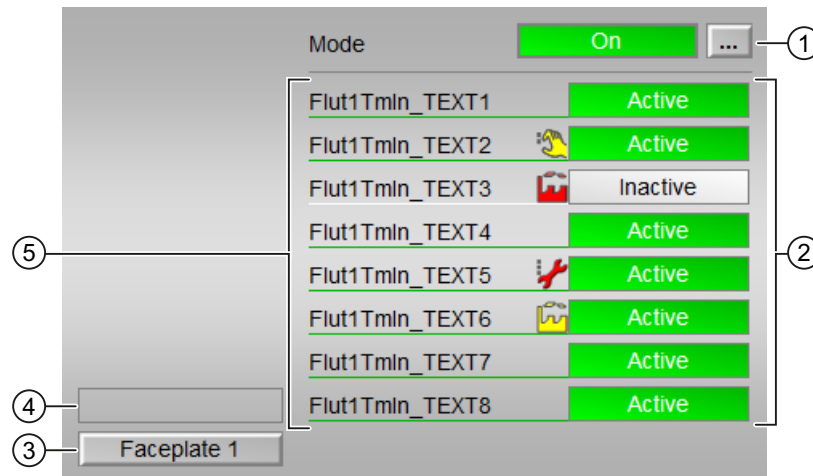

(1) Displaying and switching the operating mode

This area provides information on the currently valid operating mode. The following operating modes can be shown here:

- On (Page 71)
- Out of service (Page 71)

Refer to the Switching operating states and operating modes (Page 257) section for information on switching the operating mode.

(2) Display of the status for each parameter

This display is only visible when the corresponding block input is connected.

This area shows you the status of the individual parameters available.

You can determine the names for the connected parameters using the `S7_String` attribute at the corresponding input parameter. A default text is displayed if you enter nothing here.

You can change the text for value 1 ... 8 with the `FlutXTmIn` parameter.

Additional information is available in the section Labeling of buttons and text (Page 209).

(3) Navigation button for switching to the standard view of any faceplate

Use this navigation button to reach the standard view of a block configured in the engineering system. The visibility of this navigation button depends on the configuration in the engineering system (ES).

You can find additional information on this in the Opening additional faceplates (Page 208) section.

(4) Display area for block states

This area provides additional information on the operating state of the block:

- "Maintenance"

(5) Displaying input values

Changing the display:

Follow these steps to change the displays:

1. In the CFC, right-click the MonDi08 block and select "Object Properties" from the context menu.
2. Select "I/Os" tab in the properties window.
3. In the "OS additional text" column, change the default setting for the input parameter (`FlutXTmIn`, where $x = 1..8$) to what you want to see during runtime later.
4. In the "Identifier" column, change the default setting for the input parameter (`FlutXTmIn`, where $x = 1..8$) to what you want to see during runtime later.
5. If both "OS additional text" and "Identifier" columns are empty, the default value is displayed in the runtime.
6. The text is used as a label and is therefore always displayed, which means it is independent of the signal status of the corresponding input (`FlutXTmIn`, where $x = 1..8$).
7. The font size is reduced during the runtime if the input text length is greater than the label width.

Note

If a text is added to the "OS additional text" field of the input parameter (`FlutXTmIn`, where $x = 1..8$), this text is displayed even if the "Identifier" text field of the same input parameter is not empty. If the "OS additional text" field of the input parameter (`FlutXTmIn`, where $x = 1..8$) is empty, the "Identifier" text of the same input parameter is displayed.

4.7.8.3 MonDi08 parameter view

Parameter view of MonDi08

The screenshot displays the parameter view for MonDi08. It is divided into two main sections. The top section, labeled (1), is titled 'Enabled operations' and 'Fluttering time'. It contains a list of eight values, each with a green checkmark in the 'Enabled operations' column and a numerical value in seconds in the 'Fluttering time' column. The values are: Value 1 (25. s), Value 2 (50. s), Value 3 (44. s), Value 4 (227. s), Value 5 (278. s), Value 6 (427. s), Value 7 (222. s), and Value 8 (0. s). A bracket labeled (2) encompasses this entire list. The bottom section, labeled (3), is titled 'Service' and contains a 'Release for maint.' label, a blue 'Yes' button, and a three-dot menu button.

Enabled operations	Fluttering time
✓	Value 1 25. s
✓	Value 2 50. s
✓	Value 3 44. s
✓	Value 4 227. s
✓	Value 5 278. s
✓	Value 6 427. s
✓	Value 7 222. s
✓	Value 8 0. s

Service
Release for maint. Yes ...

(1) Enabled operations

This area shows all operations for which special operator control permissions are assigned. They depend on the configuration in the engineering system (ES) that applies to this block.

Symbols for enabled operations:

- **Green check mark:** the OS operator can control this parameter
- **Gray check mark:** the OS operator cannot control this parameter at this time due to the process
- **Red cross:** the OS operator cannot control this parameter due to the configured AS operator control permissions (`OS_Perm` or `OS1Perm`).

(2) Area for entering the flutter time

Use this area to set the time period to determine how long a continuous signal should last in order for it to be transferred to the process without flutter.

Refer to the Changing values (Page 259) section for more on this.

You can determine the names for the connected parameters using the `S7_String` attribute at the corresponding input parameter. A default text is displayed if you enter nothing here.

You can change the text for value 1 ... 8 with the `FlutXTmIn` parameter.

Additional information is available in the section Labeling of buttons and text (Page 209).

(3) Service

You can select the following function in this area:

- "Release for maintenance"

Refer to the Switching operating states and operating modes (Page 257) section for more on this.

You can find information on this area in the Release for maintenance (Page 64) section.

4.7.8.4 MonDi08 preview

Preview of MonDi08

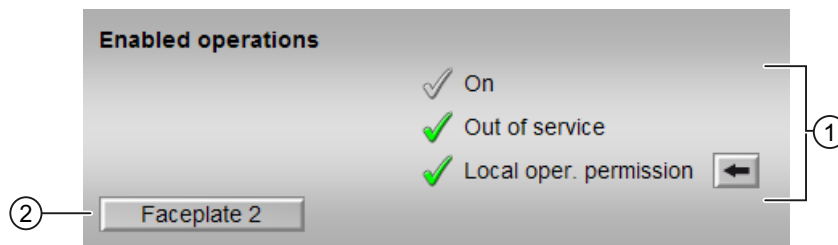

(1) Enabled operations

This area shows all operations for which special operator control permissions are assigned. They depend on the configuration in the engineering system (ES) that applies to this block.

Symbols for enabled operations:

- **Green check mark:** the OS operator can control this parameter
- **Gray check mark:** the OS operator cannot control this parameter at this time due to the process
- **Red cross:** the OS operator cannot control this parameter due to the configured AS operator control permissions (OS_Perm or OS1Perm)

The following enabled operations are shown here:

- "On": You can switch to "On" operating mode.
- "Out of service": You can switch to "Out of service" operating mode.
- "Local operating permission": Use the ← button to switch to the standard view of the OpStations block. Additional information is available in the section Operator control permissions (Page 254).

(2) Navigation button for switching to the standard view of any faceplate

Use this navigation button to reach the standard view of a block configured in the engineering system. The visibility of this navigation button depends on the configuration in the engineering system (ES).

You can find additional information on this in the Opening additional faceplates (Page 208) section.

4.7.8.5 Block icon for MonDi08

Block symbols for MonDi08



A variety of block symbols are available with the following functions:

- Process tag type
- Limits (high/low)
- Violation of alarm, warning, and tolerance limits as well as control system faults
- Operating modes
- Signal status, release for maintenance
- Memo display
- Display of the output signal

The block symbols from template @TemplateAPLV8.PDL:

Symbols	Selection of the block symbol in CFC	Special features
	1	

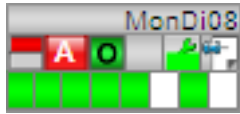
The block symbols from template @TemplateAPLV7.PDL:

Symbols	Selection of the block symbol in CFC	Special features
	1	Block symbol in the full display
	2	
	-	Block symbol in "Out of service" mode (example with type 1 block symbol)

Additional information on the block symbol and the control options in the block symbol is available in the following chapters:

- Configuring the block icons (Page 237)
- Block icon structure (Page 230)
- Operation via the block icon (Page 239).

Controller blocks

5.1 Comparison of large & small blocks

5.1.1 PIDConL compared to PIDConS

Comparison of the PIDConL and PIDConS blocks

The following tables are intended to help you decide which block to use.

Memory and runtime savings of the small block compared to the large block

You save the following resources for each instance:

- Memory space: ~ 45%
- Runtime: ~ 40%

Block operating modes

	PIDConL	PIDConS
Manual mode (Page 72)	X	X
Automatic mode (Page 72)	X	X
Program mode for controllers (Page 78)	X	
Out of service (Page 71)	X	X

Functions of the blocks

	PIDConL	PIDConS
Generating and limiting the manipulated variable	X	X
Tracking and limiting a manipulated variable (Page 196)	X	X
Tracking and limiting a manipulated variable (Page 196)	X	X
Neutral position for motors, valves and controllers (Page 48)	X	X
Outputting group errors (Page 122)	X	X
Outputting a signal for start readiness (Page 53)	X	X

5.1 Comparison of large & small blocks

	PIDConL	PIDConS
"Actuator active" information	X	X
Limit monitoring of the feedback (Page 94)	X	
Setpoint specification - internal/external (Page 128)	X	X
Setpoint limiting for external setpoints (Page 196)	X	X
Gradient limit of the setpoint (Page 124)	X	
Using setpoint ramp (Page 123)	X	
Tracking setpoint in manual mode (Page 196)	X	X
Simulating signals (Page 58)	X	X
Limit monitoring of the process value (Page 86)	X	X
Alarm delays with two time values per limit pair		
Alarm delay with one time value per limit pair	X	X
Error signal generation and dead band (Page 192)	X	X
Delay alarm for control deviation at setpoint step changes (Page 190)	X	
Limit monitoring of error signal	X	
Inverting control direction (Page 192)	X	
Physical standardization of setpoint, manipulated variable and process value	X	
Selecting a unit of measure (Page 212)	X	X
PID algorithm	X	X
Structure segmentation at controllers (Page 198)	X	
Anti-windup (Page 741)	X	X
Feedforwarding and limiting disturbance variables (Page 197)	X	
Using control zones (Page 194)	X	
Forming and outputting the signal status for technologic blocks (Page 109)	X	X
Operator control permissions (Page 254)	X	X
Release for maintenance (Page 64)	X	X
Generating instance-specific messages (Page 204)	X	X

	PIDConL	PIDConS
Suppressing messages using the MsgLock parameter (Page 205)	X	X
Display and operator input area for process values and setpoints (Page 207)	X	X
Opening additional faceplates (Page 208)	X	X
SIMATIC BATCH functionality (Page 67)	X	X
Time stamp	X	
Dead band is temporarily disabled (Page 141)	X	
Labeling of buttons and text (Page 209)	X	
Displaying current control signals from output channel block	X	X
Interlocks (Page 99)	X	
Disabling interlocks (Page 103)	X	

Configurable functions using the Feature parameter

Bit number	Feature bit function	PIDConL	PIDConS
0	Set startup characteristics (Page 138)	X	X
1	Reaction to the out of service mode (Page 177)	X	X
2	Resetting the commands for changing the mode (Page 161)	X	X
4	Setting switch or button mode (Page 167)	X	
12	Control zone with specified I component (Page 160)	X	
13	Control zone with frozen I component (Page 160)	X	
14	External control deviation (Page 151)	X	
15	Neutral position manipulated variable takes effect with "out of service" operating mode (Page 166)	X	X
16	Neutral position manipulated variable takes effect at startup (Page 166)	X	X
18	Disabling bumpless switchover to automatic mode for controllers (Page 173)	X	
22	Update acknowledgment and error status of the message call (Page 160)	X	
24	Enabling local operator authorization (Page 158)	X	X

5.1 Comparison of large & small blocks

Bit number	Feature bit function	PIDConL	PIDConS
25	Suppression of all messages (Page 174)	X	X
26	Reaction of the switching points in the "Out of service" operating mode (Page 176)	X	X
28	Disabling operating points (Page 145)	X	
29	Signaling limit violation (Page 170)	X	
30	Dead band is temporarily disabled (Page 141)	X	

5.2 ConPerMon - Monitoring of the control performance of control loops

5.2.1 Description of ConPerMon

Object name (type + number) and family

Type + number: FB 1805

Family: Control

Area of application for ConPerMon

The block is used for the following applications:

- Permanent monitoring of control performance of control loops for early detection of problems as they develop

The block calculates:

- Stochastic characteristics of the control performance with the process in a steady state
 - Mean value, variance and standard deviation of controlled variable
 - Mean value of the manipulated variable and control deviation
 - Control performance index
 - Estimated steady state process gain
- Deterministic characteristics of the control performance with step changes in the setpoint
 - Response time and settling time and the settling ratio
 - Overshoot absolute and relative to the step height

Other statistical and graphic evaluations of the signals in the control loop over longer, freely selectable periods are available in the faceplate of the ConPerMon block.

In an overview representation of a plant or unit, you can obtain a clear picture of the status of all control loops based on ConPerMon block icons (indicator light function).

The aim is to detect problems as they develop and to focus the attention of the user on the control loops in a plant that are no longer operating correctly.

How it works

The ConPerMon block evaluates the setpoint and process value signals and the manipulated variable of the PID controller in a sliding time window. The mode of the controller is also taken into account.

With the process in a steady state, the detected stochastic characteristics are compared with the reference values obtained during commissioning. If there is a step change in the setpoint, the stochastic characteristics are by definition irrelevant and are temporarily frozen. Instead, the monitoring of the deterministic characteristics is automatically activated.

If the control performance falls below a defined limit a message is generated. This is also the case when a defined limit for overshoot is exceeded when there is a step change in the setpoint.

Configuration

Each PID controller has a ConPerMon block assigned to it that is installed in the same CFC chart and interconnected with the controller. This already takes place with the corresponding process tag types.

You can open the standard view for the ConPerMon block from the standard view of a controller (for example PIDConL). Additional information on this topic is available in the section Opening additional faceplates (Page 208).

After successful commissioning and optimization of the PID controller to be monitored, the ConPerMon block is initialized while the process is in a steady state and it stores the corresponding characteristic values as reference values.

Follow the steps outlined below:

- Change the PID controller you want to monitor to automatic mode and set the setpoint to the typical operating point. This operating status is intended to represent the normal operation of the process; in other words, the entire plant/unit should be running under production conditions. Monitor the process with a trend writer (CFC trend in the Engineering-System or WinCC Online-Trend-Control on the Operator Station) and wait until the process has settled
- To specify the length `TimeWindow` of the sliding time window, monitor the `PV_Variance` block output of the ConPerMonblock in a trend. The time window should be long enough to keep the variance fairly constant in the relevant decimal places. If the selected time window is too short in relation to the time constants in the control loop and the disturbance signal spectrum, the variance will have too much noise and no useful information. If the selected time window is too long, it takes longer before any deterioration of the control performance is detected by the ConPerMon block. It also takes longer following a step change in the setpoint before the monitoring of the stochastic characteristics can be resumed. A good starting value for the `TimeWindow` parameter is 10 times as long as the longest process time constant or 20 times as long as the reset time of the PID controller.
- If the controller
 - is set perfectly,
 - has achieved a steady state,
 - the time window has been defined and filled with values from the steady state,

the ConPerMon block can be initialized. You do this by clicking the "Initialize" button in the parameter view of the ConPerMon faceplate or by setting the `InitRefVar = 1` parameter in the CFC block. This saves the `PV_Variance` parameter in the current time window as a reference value for calculating the control performance in the block along with reference values for manipulated variable and process variable.

The Control Performance Index CPI should now be approximately at 100% and therefore indicate that the control loop is operating correctly. Due to stochastic fluctuations, the CPI can also temporarily exceed the 100% mark. If, however, the CPI drops by a significant amount over a longer period, this indicates deterioration of the control performance.

For more detailed information on interpreting the calculation results of the block, refer to the section ConPerMon functions (Page 569).

Note

If the length of the time window is changed during runtime, the CPI will temporarily deviate considerably from its old value and then gradually settle to the new steady value. It is advisable to reinitialize the ConPerMon block after the CPI value has settled to a constant level.

The ConPerMon faceplate is opened from the faceplate of the assigned PID controller so that the ConPerMon icons do not need to be installed separately in each OS picture. It is, in fact, advisable to group all ConPerMon block icons of a plant or unit in one overview picture at the appropriate hierarchy level.

You can expand this overview picture with the trend display of the control performance of all control loops over a longer time to allow you to recognize gradual deterioration (for example reflecting wear and tear). You can also display a further view of the message archive (WinCC AlarmLogging Control) as a hit list sorted according to the frequency in which they occur. In this list, the control loops that caused the most alarms will be shown at the top.

For the ConPerMon block, the Advanced Process Library contains templates for process tag types as examples with various application scenarios for this block.

Examples of process tag types:

- PID controller with dynamic feedforward control (FwdDisturbCompensat) (Page 2329)
- PID - control with operating-point-oriented parameter control (GainScheduling) (Page 2327)
- PID controller with safety logic and control loop monitoring (PIDConL_ConPerMon) (Page 2324)
- PIDConR with safety logic and control loop monitoring (PIDConR_ConPerMon) (Page 2325)
- Ratio control with control loop monitoring through ConPerMon (RatioControl) (Page 2338)
- Ratio control with PIDConR (RatioR) (Page 2341)
- PID controller with Smith predictor (SmithPredictorControl) (Page 2332)
- Step controller with direct access to the actuator and without position feedback (StepControlDirect) (Page 2333)

Startup characteristics

When the CPU starts up, the block is reinitialized but the stored reference values are retained. The messages are suppressed after startup for the number of cycles set at RunUpCyc.

Status word allocation for status1 parameter

You can find a description for each parameter in section ConPerMon I/Os (Page 583)

Status bit	Parameter
0	Occupied
1	BatchEn
2	Not used
3	OosAct.Value
4	OosLi.Value
5	PID_AutAct.Value
6	OnAct.Value
7 - 14	Not used
15	CPI_Suppress
16 - 31	Not used

Status word allocation for status2 parameter

Status bit	Parameter
0	MsgLock
1	OvsAH_Act.Value
2	OvsWH_Act.Value
3 - 4	Not used
5	CPI_WL_Act.Value
6	CPI_AL_Act.Value
7	OvsAH_En
8	OvsWH_En
9 - 10	Not used
11	CPI_WL_En
12	CPI_AL_En
13	OvsAH_MsgEn
14	OvsWH_MsgEn
15 - 16	Not used
17	CPI_WL_MsgEn
18	CPI_AL_MsgEn
19	Delay of the CPI_WL_Lim message
20	Delay of the CPI_AL_Lim message
21	Collection of message delays
22 - 31	Not used

See also

ConPerMon messaging (Page 581)

ConPerMon block diagram (Page 589)

ConPerMon error handling (Page 581)

ConPerMon modes (Page 569)

5.2.2 ConPerMon modes

ConPerMon operating modes

The block can be operated using the following modes

- On (Page 71)
- Out of service (Page 71)

"On"

You can find general information about the "On" mode in the On (Page 71) section.

"Out of service"

You can find general information about the "Out of service" mode in the Out of service (Page 71) section.

See also

ConPerMon block diagram (Page 589)

ConPerMon I/Os (Page 583)

ConPerMon messaging (Page 581)

ConPerMon error handling (Page 581)

ConPerMon functions (Page 569)

Description of ConPerMon (Page 565)

5.2.3 ConPerMon functions

Functions of ConPerMon

The functions for this block are listed below.

Monitoring of stochastic characteristics of the control performance

The mean value of a variable relating to an ergodic stochastic process (Page 2388) can be determined from a sliding time window with the length $n = \text{TimeWindow} / \text{SampleTime}$, for example, for the controlled variable $y = \text{PV}$:

$$\bar{y} = \frac{1}{n} \sum_{i=1}^n y(i)$$

A recursive formulation of this calculation is included in the MeanTime block that is called by the ConPerMonblock. Most steady-state time series can be considered as being ergodic so that the expected value can be estimated by averaging over a window of finite length.

The mean control deviation is $\text{ER_Mean} = \text{SP} - \text{PV_Mean}$. A mean steady-state control deviation $\neq 0$ at a constant setpoint is an indication of problems in the control loop if the controller has I component. You should then check the following potential causes:

- The actuator does not have sufficient capacity. As a result, the controller's actuating signal constantly approaches its limit. This can be caused by unsuitably dimensioned actuators or may simply be due to wear and tear.
- The manipulated variable demanded by the controller does not take effect in the process, for example because the actuator is defective.

If a steady-state reference operating point (MV_Ref , PV_Ref) is known, this can be used to estimate the current mean steady state gain of a linear process model if it is assumed that only disturbances without mean value have an effect:

$$\text{StatGain} = \frac{\text{PV}_{\text{Mean}} - \text{PV}_{\text{Ref}}}{\text{MV}_{\text{Mean}} - \text{MV}_{\text{Ref}}}$$

Normally the reference operating point is obtained during the initialization of the ConPerMon block. Estimation of the steady state gain is then, however, impossible precisely at this operating point. As an alternative, you can also enter the reference values PV_Ref and MV_Ref manually at the appropriate block inputs. Typical steady-state operating points are often known in advance, for example

- Flow control: $\text{PV} = 0$ for $\text{MV} = 0$, in other words, valve closed,
- Temperature control: $\text{PV} = \text{PV_Ambient}$ for $\text{MV} = 0$, in other words, ambient temperature

If the steady state gain changes gradually as time progresses, this is an indication of wear phenomena in the process, such as deposits on heat exchangers, valves or shutters, failing efficiency of process plant, etc.

If, for example, a temperature regulation circuit is closed by a heat exchanger and a deposit forms on the exchanger surfaces, the heat transfer coefficient, and consequently the process gain, is reduced. Within certain limits, this can be compensated by a closed control loop (so that the controller initially disregards the problem). Although the original control loop dynamics can be restored (to a certain extent) by suitable increase of the controller gain as the pollution increases, it is advisable to eliminate the cause of the problem; in other words, to clean the heat exchanger.

If the estimated steady state gain changes suddenly and temporarily, this tends to point to an external disturbance. This may be a normal occurrence in the operation of the process. If, however, these occurrences become more frequent, it is worth finding out the cause.

Due to the approach, the variance `PV_Variance` as second moment requires the calculation of differences of each current measured value from (constant !) mean value:

- `Feature.Bit8 = 0` (default), approximate calculation with reduced computing power consumption:

$$\sigma_y^2 = \frac{1}{n} \left(\sum_{i=1}^n y^2(i) \right) - \bar{y}^2$$

- `Feature.Bit8 = 1`, more exact calculation corresponding to mathematical definition of variance:

$$\sigma_y^2 = \frac{1}{n-1} \sum_{i=1}^n (y(i) - \bar{y})^2$$

The standard deviation

$$PV_StdDev = \sigma_y = \sqrt{\sigma_y^2}$$

as the square root of the variance is easier to interpret because it has the same physical unit as the measured value.

The control performance index CPI (**C**ontrol **P**erformance **I**ndex) in the unit [%] describes the current variance of the controlled variable relative to a reference variance (benchmark). It is defined as

$$\zeta = \frac{\sigma_{ref}^2}{\sigma_y^2} 100\%$$

The CPI moves in the $0 < \zeta \leq 100\%$ range. If the current variance corresponds to the benchmark, the index reaches the value 100. If, by contrast, the current variance becomes larger, the control performance index decreases accordingly. Ideally, the benchmark is obtained in a defined good state of the control loop and stored when the ConPerMon block is initialized. It does not matter if the CPI temporarily reaches values somewhat higher than 100%. A CPI > 100% only means that the variance of the controlled variable is currently somewhat lower than in the reference state. Other alternatives for determining the benchmark will be explained in a separate .

If you consider the calculated CPI signal to be too strongly affected by noise, you can smooth it using the integrated low pass filter (parameter `CPI_FiltFactor`) with the filter time constant `TimeWindow * CPI_FiltFactor`.

The disadvantage of these stochastic characteristics is that they assume an ergodic (Page 2388) or steady state in the process - at least in a statistical sense. Each step change in the standpoint in a controller is an elementary violation of this requirement and leads temporarily to incorrect statements of the stochastic characteristics, for example variances increasing too much. The basic principle of the combined approach implemented in the ConPerMonblock is to use both stochastic and deterministic characteristics for the control performance and to select the suitable characteristics automatically depending on the operating state.

If a step change in the setpoint is detected in a control loop, the ConPerMon block freezes the CPIvalue and automatically suppresses all messages relating to this. As a user, you can also

force the suppression of the messages manually via the `ManSupprCPI = 1` binary input. This setting is useful to avoid false alarms when known disturbances occur, for example at a load change in a Conti process (Page 2389) or a dosing procedure in a Batch process (Page 2383). In such cases the variance of the controlled variable usually rises momentarily. This should not be interpreted as a worsening of the control performance.

Monitoring of deterministic characteristics of the control performance

Assessment of the control performance based on the response to a step change in the setpoint is relatively simple. In the sense of automatic monitoring, the ConPerMon block is capable of determining the essential characteristics of the control performance directly from the signal changes so that when necessary a message or an alarm can be generated automatically by the system.

The first thing to look for is always the overshoot if it is present and clearly distinct from the noise level. For a positive step response,

$$\text{OverAbso} = \max(\text{PV}) - \text{SP} > 0$$

is output where is for a negative step response (step response down), and negative values

$$\text{OverAbso} = \min(\text{PV}) - \text{SP} < 0$$

are also output. For normalization, the absolute overshoot is related to the height of the step change in the setpoint and is therefore always positive. The relative overshoot (`Overshoot`) as a percentage is a measure of the damping of the control loop. If this is more than 20 or 30%, the loop gain (gain of the controller multiplied by the gain of the control system) is generally too high either because the controller was badly set from the beginning or because the properties of the control system have changed over the course of time. If overshoot is significantly too high, the control loop is generating weakly damped oscillations in the plant. The block sends a message to this effect if the relative overshoot is above a specified limit.

5.2 ConPerMon - Monitoring of the control performance of control loops

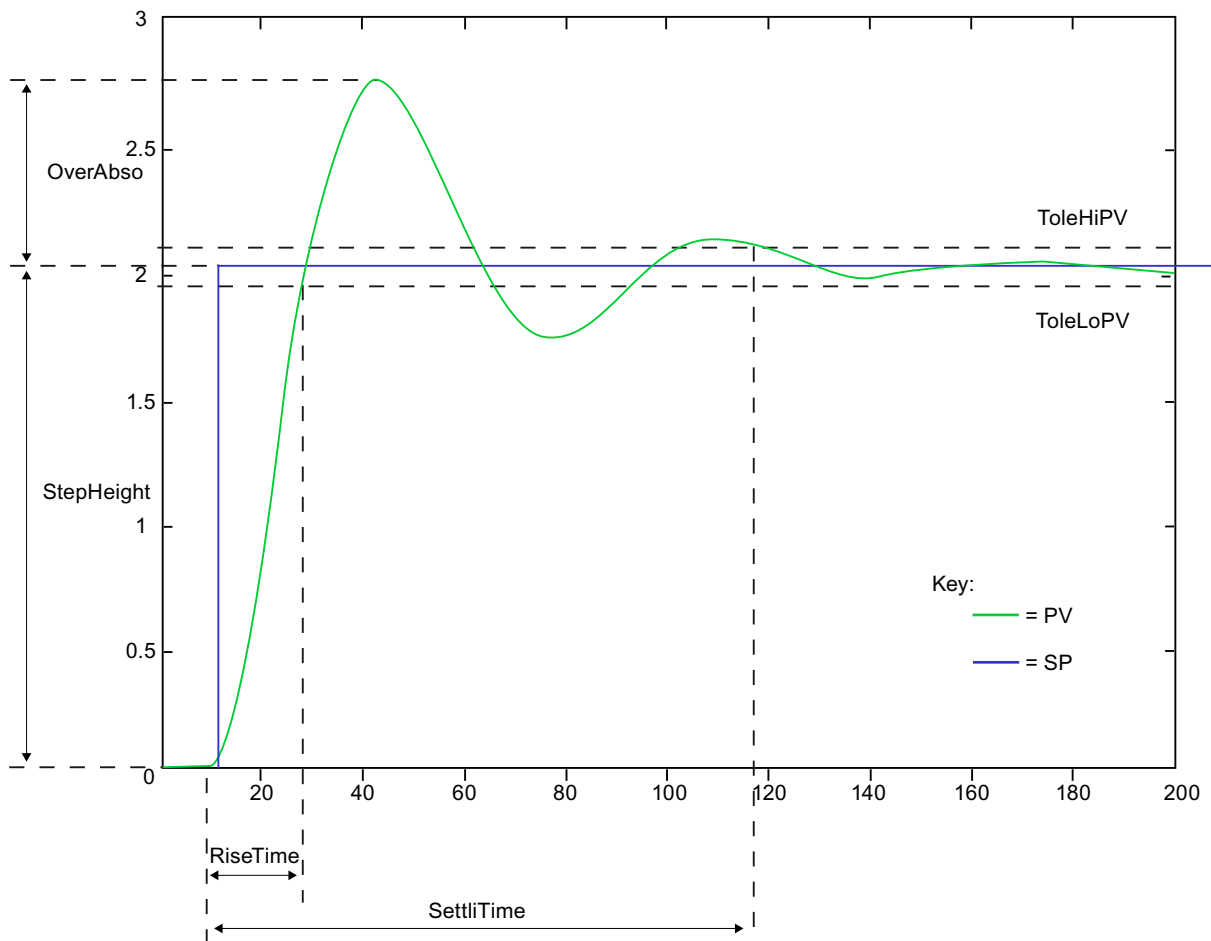

In every control loop, there is a general correlation between overshoot and phase reserve: The higher the overshoot, the lower the phase reserve. If the response of the closed control loop can be described approximately by a 2nd order transfer function

$$g_{cl}(s) = \frac{PV(s)}{SP(s)} = \frac{1}{\frac{1}{\omega_0^2} s^2 + 2 \frac{\delta}{\omega_0} s + 1}$$

the following relationships are known:

- If $\delta \geq 1$, the overshoot is equal to zero and the settling response is asymptotic.
- If $\delta < 1$, overshoot and oscillations occur.

The damping of the closed loop can be determined approximately from the overshoot:

$$\delta = \frac{-\ln\left(\frac{\text{Overshoot}}{100\%}\right)}{\sqrt{\ln^2\left(\frac{\text{Overshoot}}{100\%}\right) + \pi^2}}$$

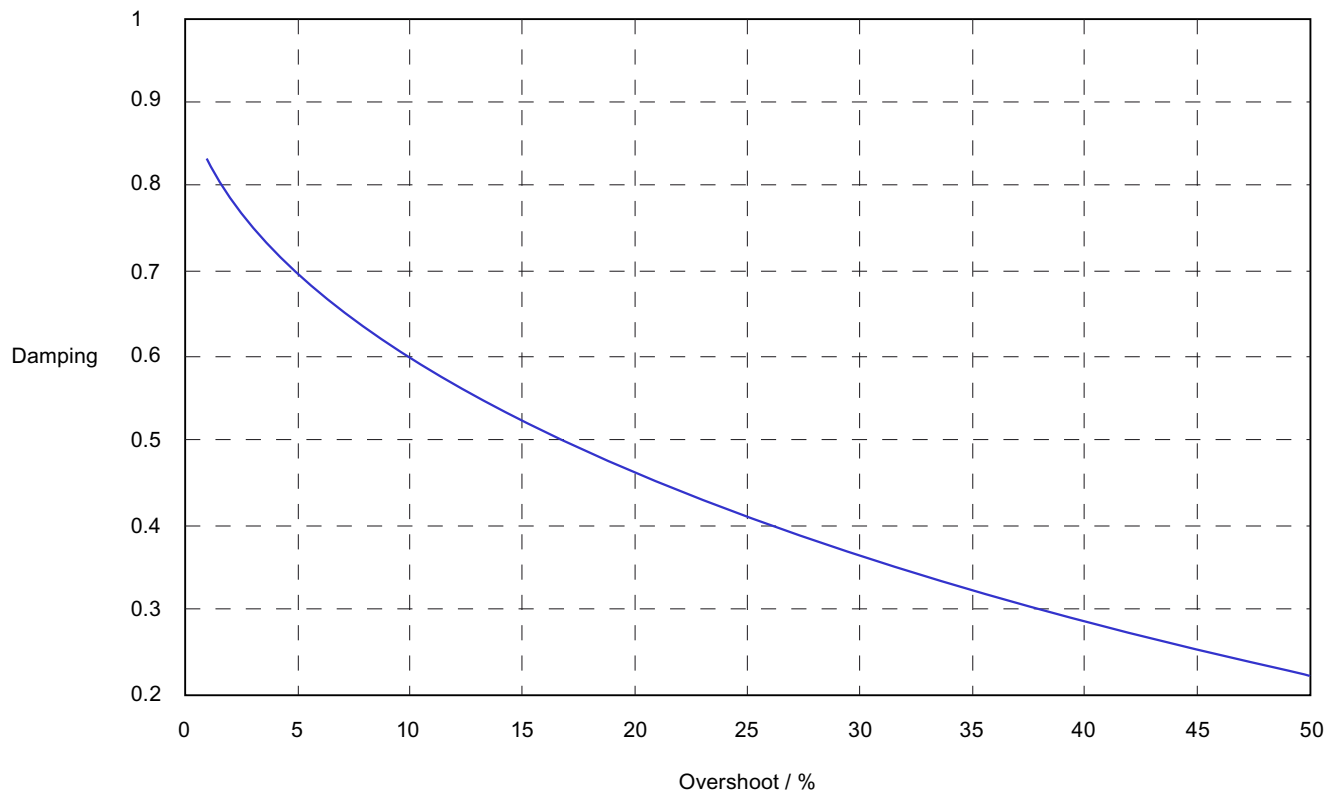

An optimum controller setting typically aims for overshoot between 5 and 25%, which means damping between 0.7 and 0.4.

If overshoot is too high, it is often helpful to reduce the gain of the controller.

While overshoot primarily serves to check controller gain, there is a further characteristic that provides information on the setting of the I component: If the setting of the reset time is unsuitable, the process value will creep towards the new setpoint following a step change in the setpoint. The ratio to the `RiseTime` is relevant, and not the absolute value of the `SettliTime`. If the settling ratio, in other words the quotient of the rise time and settling time, is less than approximately 25%, it can generally be assumed that the reset time of the controller is too slow. To determine the rise time and settling time, a 3σ tolerance band is placed around the setpoint and is also displayed in the faceplate of the ConPerMon block. The absolute values of the settling time and rise time can be assessed in terms of the concrete requirements of the process control for a specific application.

During a step change in the setpoint, larger mathematical variances of the controlled variable are bound to occur compared with the steady state so that generating alarms due to the variance limits being exceeded needs to be suppressed until the settling process has neared completion following the step change in the setpoint. The calculated deterministic characteristics are then output and the stochastic evaluation is reactivated.

Group display SumMsgAct for limit monitoring, CSF and ExtMsgx

The block provides the standard function Group display for limit monitoring, CSF and ExtMsgx (Page 85).

Alternatives for determining the benchmark

During planned commissioning of a plant with integrated ConPerMon, following controller optimization, the ConPerMon block is initialized for every control loop and the calculated variance stored as the benchmark for calculating the CPI.

As an alternative, a benchmark can be set via the `RefVarExt` input parameter by setting the `RefVarExtOn = 1` input parameter. There are various ways of obtaining numeric values for the benchmark:

- Take the lowest variance that was ever measured in this control loop since the initialization of the ConPerMon block. This is displayed at the `PV_VarMin` output parameter. This value is only useful when the control loop has been in a stable and desirable operating state for a longer period of time at least once since the initialization of the ConPerMon block.
- Take the variance of the control loop with a theoretical minimum variance controller as can be obtained based on archived data using another supplier's CPM application. This depends only on the process dead time and the disturbance model. This form of CPI is known as the Harris index and represents a lower barrier that can generally not be reached by a PID controller which is why CPI seldom reaches the value 100% even by well tuned controllers. Low CPI values provide the first indication that the controller settings could be improved. You should, however, bear in mind that the minimum variance is only a theoretically achievable value and that the minimum variance controller has characteristics that are not desired in the real application, for example extremely high manipulated variable amplitudes. With minimum variance-based CPI, therefore, it is not worth making every effort to bring this as close as possible to 100%

Cascade control

In a cascade control, you should only use the ConPerMon block for the primary controller and not for the secondary controller. The ConPerMon block cannot make any useful statements about the control performance of the secondary controller because

- the variance of the process value in the secondary control loop depends directly on the variance of the setpoint that is set as the manipulated variable by the primary controller,
- there are neither operating phases with a constant setpoint nor defined step changes in the setpoint.

Apart from this, from the perspective of process control, the primary control loop is, of course, the one whose control performance should be monitored while the control performance of the secondary loop is of secondary importance. It is nevertheless advisable to set the secondary controller carefully before optimization and monitoring of the primary controller is started because a poor response by the secondary controller cannot be compensated by the primary controller.

For additional information, read about the process tag template Cascade control with control loop monitoring through ConPerMon (CascadeControl) (Page 2342).

Split-range control

The split-range function block contains two separate (static) characteristics for both actuators. Any significant difference between the two actuators in terms of performance (in other words, different steady state gains for heating and cooling) can be compensated by setting different gradients for the characteristics, so that the controller is presented with a linear process response (regardless of the sign) as far as possible. If this does not work, the control performance will differ slightly in the two areas. The initialization of the ConPerMon block should then be performed in the worse area to avoid error alarms.

For additional information, read about the process tag template Split-range controller with control loop monitoring through ConPerMon (SplitrangeControl) (Page 2335).

PID controller with gain scheduler

The aim of gain scheduling is to achieve consistent control performance over the entire operating range. If this does not work perfectly, the initialization of the ConPerMon block should be performed in an operating point with worse control performance to avoid error alarms. We recommend that you expand the alarm limits somewhat at the ConPerMon block: permit lower CPIs and higher overshoot.

For additional information, read about the process tag template PID - control with operating-point-oriented parameter control (GainScheduling) (Page 2327).

Override control

For change-over control, different controllers are active depending on the process state; their control performances differ, of course. We recommend using control loop monitoring only for the primary controller, and to suppress it using the `ManSuprCPI` input parameter if limit controlling is activated.

For additional information, read about the process tag template Override control (Page 2348).

Feedforward control

The task of feedforward control is to avoid or at least to reduce degradation of the control performance caused by a measurable disturbance variable. Control loop monitoring therefore can basically be used as it is used for simple control loop. When the disturbance variable is quiet for a time and then acts up for a brief period, the resulting fluctuations of the control performance cannot be ruled out. The reason behind it is that feedforward control represents a model-based intervention, and a model is never a perfect reflection of reality.

For additional information, read about the process tag template PID controller with dynamic feedforward control (FwdDisturbCompensat) (Page 2329).

Smith predictor

The Smith predictor enables higher control performance than a simple PI controller in control loops with dead time. Control loop monitoring therefore can basically be used as it is used for simple control loop. If the dead time changes during ongoing operation, control performance will most likely go down.

For additional information, read about the process tag template PID controller with Smith predictor (SmithPredictorControl) (Page 2332).

Ratio control

With ratio controlling, the control loop monitoring should only be used in the primary control loop if the setpoints are to be determined for combined components from the actual value of the primary component. In this case, you can expect continuous setpoint changes in the control loops for the combined components - similar to sequential control loop of a cascade. If the setpoints for combined components are to be determined from the setpoint of the primary component, the lower-level control loops can be monitored as well.

For additional information, read about the process tag template Ratio control with control loop monitoring through ConPerMon (RatioControl) (Page 2338).

Multivariable controller

The mathematical concept of the ConPerMon block is intended for monovaryable control loops. If the variance in a control loop is found to be too high, the block cannot determine whether the actual cause is within the control loop or whether influences are being brought in due to interactions from the outside. If, therefore, you notice strong interactions between various control loops in your plant or even use multivariable controllers, the information provided by the ConPerMon block should be treated with caution.

It can nevertheless make sense to equip a multivariable controller such as the ModPreCon block with control loop monitoring to establish whether the control performance achieved during commissioning of the controller is also retained in runtime. In this case, each controller channel of the multivariable controller has a separate ConPerMon block. Several additional logic functions need to be configured upstream from the `ManSuprCPI` input parameter as shown in the corresponding sample project Predictive control of a 2x2 multi-variable controlled system (ModPreConSim) (Page 2381):

- If one or more other channels for the multivariable controller is in a non-steady state (for example, step change in the setpoint) indicated by the `CPI_SupRoot = 1` output parameter, the temporarily increased variance cannot be avoided in this controller channel and should not cause a CPI message.
- If one or more other channels of the multivariable controller have higher variances (poor control performance) indicated by the corresponding output `CPI_WrnAct = 1`, due to the interaction, these variances also cause a higher variance in this controller channel that cannot be avoided and should not lead to a CPI warning. It is possible to find the actual cause of a disturbance in a multivariable system as follows: The channel that first detects higher variances, set the alarm while subsequent alarms in adjacent channels are suppressed.

Note

In the case of multivariables, the estimated steady state gains from the monovaryable observation are irrelevant. By setting the input parameter `StGainValid = 0`, this status is also displayed in the faceplate as "Uncertain, process related".

If a PID controllers is remotely controlled in program mode (Page 78), it should be treated similar to a secondary controller for a cascade connection in regard to control performance monitoring, i.e. monitoring is usually impractical in this case.

If program mode is the typical operating mode of the controller involved, the corresponding ConPerMon block can be completely removed. If the controller involved is often used in automatic mode, however, monitoring can be temporarily disabled during program mode by connecting the output parameter `AdvCoAct` of the PIDConL block to the input parameter `ManSupprCPI` of the ConPerMon block.

Selecting a unit of measure

The block provides the standard function Selecting a unit of measure (Page 212).

Forming the signal status for blocks

The block provides the standard function Forming and outputting the signal status for technologic blocks (Page 109).

The worst signal status for the block is formed from the following parameters:

- `SP_Mon.ST`
- `PV_Mon.ST`
- `MV_Mon.ST`
- `ER_Mean.ST`
- In addition, the ConPerMon block has the following special functions for determining status values:
 - If you use a step controller without position feedback, there is no manipulated variable that you could interconnect with the input parameter `MV_Mon`. Unlike most other input parameters `MV_Mon` does not have the preset signal status "Uncertain, process related" (16#78). If there is no interconnected value, this status is transferred to the calculated output parameters `MV_Mean` and `StatGain`.
 - `StGainValid`: Set this input to 0 if you use a multivariable controller or observe strong interactions between neighboring control loops. This gives the calculated output parameter `StatGain` the signal status "Uncertain, process related". If known disturbances affect your process, for example dosing procedures in a batch process, you can also set this input temporarily using the recipe control.
 - Under normal circumstances the output parameter `StatGain` accepts the worse signal status of `PV_Mon` and `MV_Mon`. Other possible causes of uncertain status for `StatGain` are:
 - the process is currently very close to the reference operating point, or
 - the process is currently in transition, e.g. step change in the setpoint.
 - The signal status of the CPI output parameter is dependent on output parameter `CPI_Suppress`: If `CPI_Suppress = 1`, the control performance index CPI is uncertain. Apart from this, the CPI can also become uncertain in occasional situations when there are numeric problems in the calculation of the variance. Under normal circumstances the CPI signal status is the same as the `PV_Mon` signal status.
 - The signal status of the `OverAbso` output parameter is set to invalid when step changes in the setpoint are evaluated whose step change height is too low in relation to the noise level.

Configurable reactions using the `Feature` parameter

You can find an overview of all reactions provided by the `Feature` parameter in the Configurable functions using the Feature I/O (Page 131) . The following functionality is available for this block at the relevant bits:

Bit	Function
1	Reaction to the out of service mode (Page 177)
8	Variants of CPI calculation (Page 188)
22	Update acknowledgment and error status of the message call (Page 160)
24	Enabling local operator authorization (Page 158)
25	Suppression of all messages (Page 174)
26	Reaction of the switching points in the "Out of service" operating mode (Page 176)
28	Disabling operating points (Page 145)
29	Signaling limit violation (Page 170)

Operator permissions

The block provides the standard function Operator control permissions (Page 254).

The block has the following permissions for the `OS_Perm` parameter:

Bit	Function
0 - 1	Not used
2	1 = Operator can switch to "Out of service" mode
3 - 27	Not used
28	1 = Operator can initialize the block
29	1 = Operator may input a value for the time window, the reference value for the controlled variable and the reference value of the manipulated variable
30	1 = Operator can abort the evaluation of the step response
31	Not used

The block has the following permissions for the `OS1Perm` parameter:

Bit	Function
0	1 = Operator can change the limit (overshoot) for high alarm
1	1 = Operator can change the limit (process value) for the high warning
2	Not used
3	1 = Operator may change a value for the CPI hysteresis.
4	Not used
5	1 = Operator can change the limit (control performance index CPI) for the low warning
6	1 = Operator can change the limit (control performance index CPI) for the low alarm
7	1 = Operator can activate / deactivate messages via <code>CPI_WL_MsgEn</code>
8	1 = Operator can activate / deactivate messages via <code>CPI_AL_MsgEn</code>
9	1 = Operator can activate / deactivate messages via <code>OvsAH_MsgEn</code>
10	1 = Operator can activate / deactivate messages via <code>OvsWH_MsgEn</code>
7 - 31	Not used

Note

If you interconnect a parameter that is also listed in `OS_Perm` as a parameter, you have to reset the corresponding `OS_Perm` bit.

Alarm delays with a time value for all limits

The block provides the standard function One time value for all limits (Page 199).

This function is used only for monitoring the control performance index `CPI`.

Limit operation and display in the faceplate

This block provides the standard function Limit operation and display in the faceplate (Page 319).

Generating instance-specific messages

The block provides the standard function Generating instance-specific messages (Page 204) without the time stamp function in the I/O.

Suppressing messages using the `MsgLock` parameter

This block provides the standard function Suppressing messages using the `MsgLock` parameter (Page 205).

Opening additional faceplates

This block provides the standard function Opening additional faceplates (Page 208).

SIMATIC BATCH functionality

This block provides the standard function SIMATIC BATCH functionality (Page 67).

See also

Description of ConPerMon (Page 565)

ConPerMon messaging (Page 581)

ConPerMon I/Os (Page 583)

ConPerMon block diagram (Page 589)

ConPerMon error handling (Page 581)

ConPerMon modes (Page 569)

5.2.4 ConPerMon error handling

Error handling of ConPerMon

Refer to the section Error handling (Page 119) in the basic instructions for the error handling of all blocks.

The following errors can be displayed for this block:

- Error numbers

Overview of error numbers

The `ErrorNum` I/O can be used to output the following error numbers:

Error number	Meaning of the error number
-1	Predefined value when inserting the block; the block is not processed.
0	There is no error.
2	$\text{SampleTime} < 0.001$
10	$\text{TimeWindow} < 20 \cdot \text{SampleTime}$

See also

ConPerMon block diagram (Page 589)

ConPerMon I/Os (Page 583)

ConPerMon messaging (Page 581)

ConPerMon functions (Page 569)

ConPerMon modes (Page 569)

Description of ConPerMon (Page 565)

5.2.5 ConPerMon messaging

Messaging

If the control performance falls below a defined limit a message is generated. This is also the case when a defined limit for overshoot is exceeded when there is a step change in the setpoint.

If the CPI temporarily falls below the configured warning and alarm limits, it is not necessary to trigger an alarm immediately. The main aim of the control loop monitoring is to signal the need for maintenance or optimization measures in individual control loops. With the alarm delay, you can make sure that an alarm is triggered only after the cause exists for longer than a configured period `AlmDelay`.

5.2 ConPerMon - Monitoring of the control performance of control loops

The following messages can be generated for this block:

- Process messages
- Instance-specific messages

Process messages

Message instance	Message identifier	Message class	Event
MsgEvID	SIG 1	Alarm - high	\$\$BlockComment\$\$ Overshoot - high alarm limit violated
	SIG 2	Warning - high	\$\$BlockComment\$\$ Overshoot - high warning limit violated
	SIG 3	Warning - low	\$\$BlockComment\$\$ CPI - low warning limit violated
	SIG 4	Alarm - low	\$\$BlockComment\$\$ CPI - low alarm limit violated

Explanation:

\$\$BlockComment\$\$: Content of the instance-specific comment

Instance-specific messages

You can use up to three instance-specific messages with this block.

Message instance	Message identifier	Message class	Event
MsgEvID	SIG 5	AS process control message - fault	\$\$BlockComment\$\$ External message 1 Status 16#@5%#@
	SIG 6	AS process control message - fault	\$\$BlockComment\$\$ External message 2 Status 16#@6%#@
	SIG 7	AS process control message - fault	\$\$BlockComment\$\$ External message 3 Status 16#@7%#@

Explanation:

\$\$BlockComment\$\$: Content of the instance-specific comment

Associated values for message instance MsgEvID

Associated value	Block parameters
1	BatchName
2	StepNo

5.2 ConPerMon - Monitoring of the control performance of control loops

Associated value	Block parameters
3	BatchID
4	CPI(control performance index)
5	ExtMsg1.ST
6	ExtMsg2.ST
7	ExtMsg3.ST
8	ExtVa108
9	ExtVa109
10	Reserved

The associated values 8 ... 9 are allocated to the parameters ExtVa108 ... ExtVa109 and can be used. Additional information is available in the "Process Control System PCS 7 - Engineering System" manual.

See also

Description of ConPerMon (Page 565)

ConPerMon functions (Page 569)

ConPerMon I/Os (Page 583)

ConPerMon block diagram (Page 589)

ConPerMon error handling (Page 581)

ConPerMon modes (Page 569)

5.2.6 ConPerMon I/Os

I/Os of ConPerMon

Input parameters

Parameter	Description	Type	Default
AlmDelay	Alarm delay time [s] for monitoring the control performance index CPI 0 = Alarm delay deactivated	REAL	0.0
BatchEn	1 = Enable allocation for batch control	BOOL	0
BatchID	Current batch ID	DWORD	16#00000000
BatchName	Current batch designation	S7-String	
BreakSuppress	1 = Manually cancel suppression of the control performance alarm during a step response	BOOL	0
CPI_AlmHyst	Alarm hysteresis of the control performance index [%]	REAL	5.0
CPI_AL_En	1 = Activate alarm (low) for monitoring of control performance	BOOL	1

Controller blocks

5.2 ConPerMon - Monitoring of the control performance of control loops

Parameter	Description	Type	Default
CPI_AL_Lim	Low alarm limit for control performance [%]	REAL	30.0
CPI_FiltFactor	Low pass filter for CPI, filter time constant = $\text{TimeWindow} \cdot \text{CPI_FiltFactor}$	REAL	10.0
CPI_WL_En	1 = Activate warning (low) for monitoring of control performance	BOOL	1
CPI_WL_Lim	Low warning limit for control performance [%]	REAL	50.0
CPI_AL_MsgEn	1 = Activate alarm message for: Low limit for control performance	BOOL	0
CPI_WL_MsgEn	1 = Activate warning message for: Low limit for control performance	BOOL	0
EN	1 = Called block will be processed	BOOL	1
ExtMsg1	Binary input for freely selectable message 1	STRUCT <ul style="list-style-type: none"> • Value: BOOL • ST: BYTE 	- <ul style="list-style-type: none"> • 0 • 16#80
ExtMsg2	Binary input for freely selectable message 2	STRUCT <ul style="list-style-type: none"> • Value: BOOL • ST: BYTE 	- <ul style="list-style-type: none"> • 0 • 16#80
ExtMsg3	Binary input for freely selectable message 3	STRUCT <ul style="list-style-type: none"> • Value: BOOL • ST: BYTE 	- <ul style="list-style-type: none"> • 0 • 16#80
ExtVa108	Associated value 8 for messages (MsgEvID)	ANY	
ExtVa109	Associated value 9 for messages (MsgEvID)	ANY	
Feature	I/O for additional functions (Page 569)	STRUCT <ul style="list-style-type: none"> • Bit 0: BOOL • ... • Bit 31: BOOL 	- <ul style="list-style-type: none"> • 0 • 0 • 0
InitRefVar	1 = Initialization of the block. The benchmark of the controlled variable variance and the reference values of the controlled variable and manipulated variable are measured in the steady state.	BOOL	0
LoopClosed	1 = Control loop is closed	STRUCT <ul style="list-style-type: none"> • Value: BOOL • ST: BYTE 	- <ul style="list-style-type: none"> • 0 • 16#80
ManSupprCPI	1 = Manual suppression of the CPI calculation and message, e.g. during known disturbances	STRUCT <ul style="list-style-type: none"> • Value: BOOL • ST: BYTE 	- <ul style="list-style-type: none"> • 0 • 16#80

5.2 ConPerMon - Monitoring of the control performance of control loops

Parameter	Description	Type	Default
MsgEvID	Message number (assigned automatically)	DWORD	16#00000000
MsgLock	1 = Suppress process messages. See also the section Suppressing messages using the MsgLock parameter (Page 205) for more on this.	STRUCT <ul style="list-style-type: none"> Value: BOOL ST: BYTE 	- <ul style="list-style-type: none"> 0 16#80
MV_Mon	Manipulated variable of the controller for monitoring	STRUCT <ul style="list-style-type: none"> Value: REAL ST: BYTE 	- <ul style="list-style-type: none"> 1.0 16#78
MV_Ref	Reference value of the manipulated variable	REAL	0.0
MV_Unit	Unit of measure for manipulated variable	INT	1342
Occupied	1 = Occupied by batch control	BOOL	0
OnOp*	1 = "On" mode via operator	BOOL	1
OosLi	1 = Edge transition (0-1) = "Out of service", via interconnection or SFC	STRUCT <ul style="list-style-type: none"> Value: BOOL ST: BYTE 	- <ul style="list-style-type: none"> 0 16#80
OosOp*	1 = "Out of service", via OS operator	BOOL	0
OpSt_In	Input parameter for local operator authorization, connected with the <code>Out</code> output parameter of the upstream block, <code>OpStations</code> (Page 411)	DWORD	16#00000000
OS_Perm	I/O for operator permissions (Page 569)	STRUCT <ul style="list-style-type: none"> Bit 0: BOOL ... Bit 31: BOOL 	- <ul style="list-style-type: none"> 1 1 1
OS1Perm	I/O for operator permissions (Page 569)	STRUCT <ul style="list-style-type: none"> Bit 0: BOOL ... Bit 31: BOOL 	- <ul style="list-style-type: none"> 1 1 1
OvsAH_En	1 = Activate alarm (high) for overshoot	BOOL	1
OvsAH_Lim	Overshoot alarm limit [%]	REAL	25.0
OvsAH_MsgEn	1 = Enable alarm message for overshoot	BOOL	0
OvsWH_En	1 = Activate warning (high) for overshoot	BOOL	1
OvsWH_Lim	Overshoot warning limit [%]	REAL	20.0
OvsWH_MsgEn	1 = Enable warning message for overshoot	BOOL	0
PV_Mon	Controlled variable for monitoring	STRUCT <ul style="list-style-type: none"> Value: REAL ST: BYTE 	- <ul style="list-style-type: none"> 0.0 16#80
PV_Ref	Reference value for controlled variable	REAL	0.0
PV_Unit	Unit of measure for process value	INT	1001

Controller blocks

5.2 ConPerMon - Monitoring of the control performance of control loops

Parameter	Description	Type	Default
RefVarExt	Reference value for PV_Variance in control loop "good" status	REAL	0.0
ReVaExOn	1 = Use the external reference value of RefVarExt	BOOL	0
RefVariance	Variance of controlled variable in control loop "good" status	REAL	100.0
RunUpCyc	Number of start cycles in which messages are suppressed	INT	32000
SampleTime	Sampling time [s] (assigned automatically)	REAL	0.1
SelFp1	1 = Call a block saved in this parameter as an additional faceplate (Page 208) in the standard view	ANY	-
SelFp2	1 = Call a block saved in this parameter as an additional faceplate (Page 208) in the preview	ANY	-
SettlingTimer	Settling time for the adjustment of the dead band	STRUCT <ul style="list-style-type: none"> Value: BOOL ST: BYTE 	- <ul style="list-style-type: none"> 0 16#80
SP_Mon	Setpoint of the corresponding controller for monitoring	STRUCT <ul style="list-style-type: none"> Value: REAL ST: BYTE 	- <ul style="list-style-type: none"> 0.0 16#80
StepNo	Batch step number	DWORD	16#00000000
StGainValid	0 = Output parameter StatGain systematically invalid, e.g. for multi-variable processes	BOOL	1
TimeWindow	Width of the sliding time window [s] for statistical evaluations	REAL	120.0
UserStatus	Freely assignable bits for use in PCS 7 OS	BYTE	16#00

* Values can be written back to these inputs during processing of the block by the block algorithm.

Output parameters

Parameter	Description	Type	Default
CPI	Control performance index	STRUCT <ul style="list-style-type: none"> Value: REAL ST: BYTE 	- <ul style="list-style-type: none"> 0.0 16#80
CPI_AL_Act	1 = Alarm due to control performance is active. You can change the reaction for this parameter with Feature bit 28 (Disabling operating points (Page 145)) and with Feature bit 29 (Signaling limit violation (Page 170)).	STRUCT <ul style="list-style-type: none"> Value: BOOL ST: BYTE 	- <ul style="list-style-type: none"> 0 16#80

5.2 ConPerMon - Monitoring of the control performance of control loops

Parameter	Description	Type	Default
CPI_Suppress	1 = Message for the control performance index is suppressed; retain last valid CPI value	BOOL	1
CPI_SuRoot	1= CPI message suppression was triggered in this control loop	STRUCT <ul style="list-style-type: none"> Value: BOOL ST: BYTE 	- <ul style="list-style-type: none"> 0 16#80
CPI_WL_Act	1 = Warning due to control performance is active. You can change the reaction for this parameter with <code>Feature</code> bit 28 (Disabling operating points (Page 145)) and with <code>Feature</code> bit 29 (Signaling limit violation (Page 170)).	STRUCT <ul style="list-style-type: none"> Value: BOOL ST: BYTE 	- <ul style="list-style-type: none"> 0 16#80
ENO	1 = Block algorithm completed without errors	BOOL	0
ER_Mean	Mean value of the error signal in the time window [PV_Unit]	STRUCT <ul style="list-style-type: none"> Value: REAL ST: BYTE 	- <ul style="list-style-type: none"> 0.0 16#80
ErrorNum	Output of pending error number. For error numbers that can be output by this block, see ConPerMon error handling (Page 581)	INT	-1
MsgAckn	Message acknowledgment status (output <code>ACK_STATE</code> of <code>ALARM_8P</code>)	WORD	16#0000
MsgErr	1 = Message error (output <code>ERROR</code> of <code>ALARM_8P</code>)	BOOL	0
MsgStatus	Message status (output <code>STATUS</code> of <code>ALARM_8P</code>)	WORD	16#0000
MV_Mean	Mean value of the manipulated variable in the time window [MV_Unit]	STRUCT <ul style="list-style-type: none"> Value: REAL ST: BYTE 	- <ul style="list-style-type: none"> 0.0 16#80
O_MS_Ext	Reserved	DWORD	0
OnAct	1 = "On" mode enabled	STRUCT <ul style="list-style-type: none"> Value: BOOL ST: BYTE 	- <ul style="list-style-type: none"> 1 16#80
OosAct	1 = Block is "Out of service"	STRUCT <ul style="list-style-type: none"> Value: BOOL ST: BYTE 	- <ul style="list-style-type: none"> 0 16#80
OpSt_Out	Value of the <code>OpSt_In</code> input parameter, for feedforwarding to other blocks. Bit 31 of this parameter is used by <code>Feature</code> bit 24	DWORD	16#00000000
OS_PermOut	Display of <code>OS_Perm</code>	DWORD	16#FFFFFFFF
OS_PermLog	Display of <code>OS_Perm</code> with settings changed by the block algorithm	DWORD	16#FFFFFFFF
OS1PermOut	Display of <code>OS1Perm</code>	DWORD	16#FFFFFFFF

5.2 ConPerMon - Monitoring of the control performance of control loops

Parameter	Description	Type	Default
OS1PermLog	Display of OS1Perm with settings changed by the block algorithm	DWORD	16#FFFFFFFF
OverAbso	Absolute overshoot of the step response [PV_Unit]	STRUCT <ul style="list-style-type: none"> Value: REAL ST: BYTE 	- <ul style="list-style-type: none"> 0.0 16#80
Overshoot	Relative overshoot of the step response with respect to the step change height [%]	STRUCT <ul style="list-style-type: none"> Value: REAL ST: BYTE 	- <ul style="list-style-type: none"> 0.0 16#80
OvsAH_Act	1 = Alarm due to overshoot is active. You can change the reaction for this parameter with Feature bit 28 (Disabling operating points (Page 145)) and with Feature bit 29 (Signaling limit violation (Page 170)).	STRUCT <ul style="list-style-type: none"> Value: BOOL ST: BYTE 	- <ul style="list-style-type: none"> 0 16#80
OvsWH_Act	1 = Warning due to overshoot is active. You can change the reaction for this parameter with Feature bit 28 (Disabling operating points (Page 145)) and with Feature bit 29 (Signaling limit violation (Page 170)).	STRUCT <ul style="list-style-type: none"> Value: BOOL ST: BYTE 	- <ul style="list-style-type: none"> 0 16#80
PV_Mean	Mean value of the controlled variable in the time window [PV_Unit]	STRUCT <ul style="list-style-type: none"> Value: REAL ST: BYTE 	- <ul style="list-style-type: none"> 0.0 16#80
PV_StdDev	Standard deviation of the controlled variable	STRUCT <ul style="list-style-type: none"> Value: REAL ST: BYTE 	- <ul style="list-style-type: none"> 0.0 16#80
PV_ToleHi	Limit (high) of the 3 σ band around the setpoint	REAL	0.0
PV_ToleLo	Limit (low) of the 3 σ band around the setpoint	REAL	0.0
PV_Variance	Variance of the controlled variable	STRUCT <ul style="list-style-type: none"> Value: REAL ST: BYTE 	- <ul style="list-style-type: none"> 0.0 16#80
PV_VarMin	Minimum observed value of the process variance (slave pointer)	REAL	10000.0
RefStdDev	Standard deviation of controlled variable in control loop "good" status	STRUCT <ul style="list-style-type: none"> Value: REAL ST: BYTE 	- <ul style="list-style-type: none"> 0.0 16#80
RiseTime	Rise time of the step response [s]	REAL	0.0
SettliDeadBand	Settling time for the adjustment of the dead band	STRUCT <ul style="list-style-type: none"> Value: REAL ST: BYTE 	- <ul style="list-style-type: none"> 0.0 16#80
SettlRatio	Ratio = Rise time/settling time · 100%	REAL	0.0
SettliTime	Settling time of the step response [s]	REAL	0.0

5.2 ConPerMon - Monitoring of the control performance of control loops

Parameter	Description	Type	Default
StatGain	Steady-state process gain [PV_Unit / MV_Unit]	STRUCT <ul style="list-style-type: none"> • Value: REAL • ST: BYTE 	- <ul style="list-style-type: none"> • 0.0 • 16#80
ST_Worst	Worst signal status	BYTE	16#80
Status1	Status word 1 (Page 565)	DWORD	16#00000000
Status2	Status word 2 (Page 565)	DWORD	16#00000000
StepPhase	Phase of the step response: 0 = Waiting 1 = Rising 2 = Overshoot 3 = Settled	INT	0

See also

[ConPerMon messaging \(Page 581\)](#)
[ConPerMon block diagram \(Page 589\)](#)
[ConPerMon modes \(Page 569\)](#)

5.2.7 ConPerMon block diagram**ConPerMon block diagram**

A block diagram is not provided for this block.

See also

[ConPerMon I/Os \(Page 583\)](#)
[ConPerMon messaging \(Page 581\)](#)
[ConPerMon error handling \(Page 581\)](#)
[ConPerMon functions \(Page 569\)](#)
[ConPerMon modes \(Page 569\)](#)
[Description of ConPerMon \(Page 565\)](#)

5.2.8 Operator control and monitoring

5.2.8.1 ConPerMon views

Views of the ConPerMon block

The block ConPerMon provides the following views:

- ConPerMon standard view (Page 590)
- Alarm view (Page 302)
- ConPerMon limit view (Page 592)
- Trend view (Page 305)
- ConPerMon parameter view (Page 593)
- ConPerMon preview (Page 594)
- Memo view (Page 304)
- Batch view (Page 302)
- ConPerMon setpoint view (Page 595)
- Block icon for ConPerMon (Page 597)

Refer to the sections Structure of the faceplate (Page 248) and Block icon structure (Page 230) for general information on the faceplate and block icon.

5.2.8.2 ConPerMon standard view

ConPerMon standard view

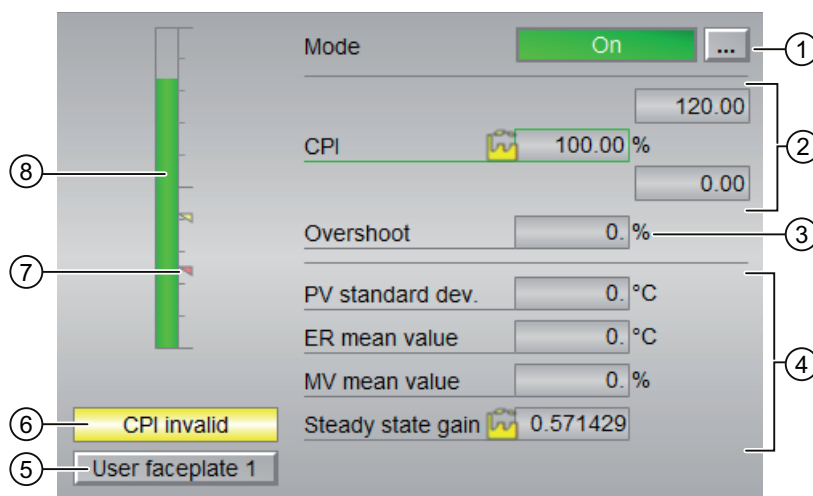

(1) Displaying and switching the operating mode

This area provides information on the currently valid operating mode. The following operating modes can be shown here:

- On (Page 71)
- Out of service (Page 71)

Refer to the Switching operating states and operating modes (Page 257) section for information on switching the operating mode.

(2) Display area for control performance

This area shows the current control performance index.

(3) Display area for the overshoot

This area shows you the relative overshoot based on a step change [%].

(4) Display area for the static evaluation of the current time window (**TimeWindow**)

This area shows you the statistical evaluation of the current time window. The following values are evaluated:

- "PV standard dev.": Standard deviation of the controlled variable
- "ER mean value": Mean value of the control deviation
- "MV mean value": Mean value of the manipulated variable
- "Steady state gain": Steady-state process gain

(5) Navigation button for switching to the standard view of any faceplate

Use this navigation button to reach the standard view of a block configured in the engineering system. The visibility of this navigation button depends on the configuration in the engineering system (ES).

See also the Opening additional faceplates (Page 208) section for more on this.

(6) Display for CPI valid / CPI invalid

This area shows you if the control performance index is valid or invalid:

- "CPI invalid": Control performance is invalid

You set the limits for the control performance index in the limits views, depending on the configuration in the engineering system (ES).

(7) Limit display

These colored triangles show you the configured limits in the respective bar graph.

(8) Bar graph for control performance index

This area shows you the current CPI control performance index in the form of a bar graph. The visible area in the bar graph depends on the configuration in the engineering system (ES).

5.2.8.3 ConPerMon limit view

Limit view of ConPerMon

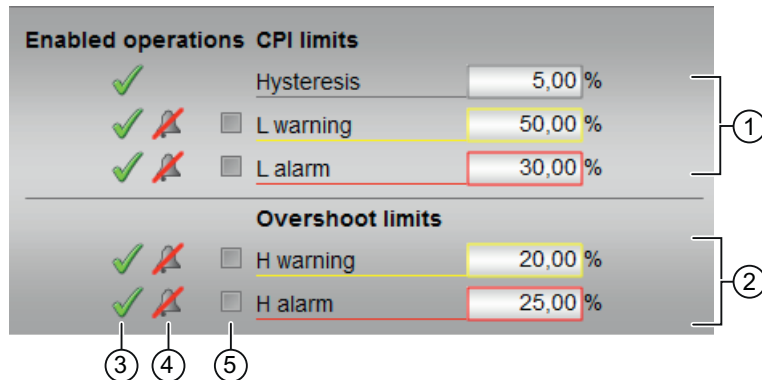

(1) CPI limits

In this area, you can enter the limits for the CPI control performance index. Refer to the Changing values (Page 259) section for more on this.

You can change the following limits:

- "Hysteresis"
- "L warning": Warning low
- "L alarm": Alarm low

(2) Overshoot limits

In this area, you can enter the limits for the overshoot. Refer to the Changing values (Page 259) section for more on this.

You can change the following limits:

- "H warning": Warning high
- "H alarm": Alarm high

(3) Enabled operation

This area shows all operations for which special operator permissions are assigned. They depend on the configuration in the engineering system (ES) that applies to this block.

Icons for enabled operation:

- **Green check mark:** the OS operator can control this parameter
- **Gray check mark:** the OS operator cannot control this parameter at this time due to the process
- **Red cross:** the OS operator cannot control this parameter due to the configured AS operator permissions (OS_Permission or OS1Perm)

(4) "Message suppression/delay"

Message suppression indicates whether or not the suppression of the associated message in the AS block is activated with the `xx_MsgEn` parameter. The output of messages is not suppressed when the block is installed (all `xx_MsgEn` parameters are preset to 1). Messages can only be output if limit monitoring of the additional analog value has been enabled.

Alarm delays are also displayed in this position; for more on this see section Area of application of the alarm delays (Page 199).

(5) Suppress messages

You can enable / disable messages by setting the check mark.

5.2.8.4 ConPerMon parameter view

Parameter view of ConPerMon

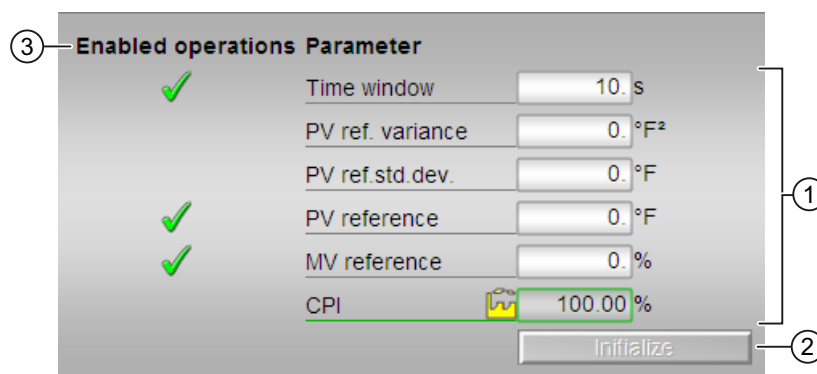

(1) Parameter

In this area, you change parameters and therefore influence the controller. Refer to the Changing values (Page 259) section for more on this.

You can influence the following parameters:

- "Time window": Set the time window here, in which the statical evaluation for the following values is to be performed:
 - Standard deviation of the controlled variable
 - Mean value of the control deviation
 - Mean value of the manipulated variable
 - Steady-state process gain
- "PV reference": Reference value for controlled variable
- "MV reference": Reference value of the manipulated variable

(2) Initialize button

Clicking this button initializes the block. The benchmark of the controlled variable variance and the reference values of the controlled variable and manipulated variable are measured in the steady state.

(3) Enabled operations

This area shows all operations for which special operator control permissions are assigned. They depend on the configuration in the engineering system (ES) that applies to this block.

Symbols for enabled operations:

- **Green check mark:** the OS operator can control this parameter
- **Gray check mark:** the OS operator cannot control this parameter at this time due to the process
- **Red cross:** the OS operator cannot control this parameter due to the configured AS operator control permissions (OS_Perm or OS1Perm)

5.2.8.5 ConPerMon preview

Preview of ConPerMon

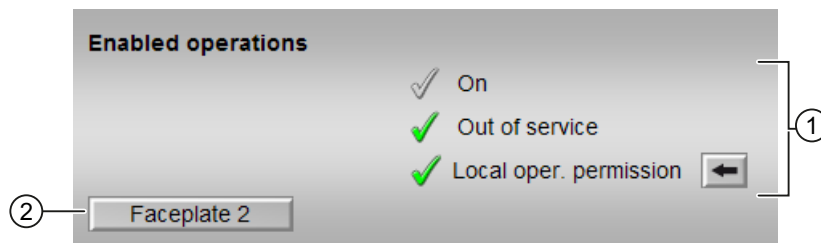

(1) Enabled operations

This area shows all operations for which special operator control permissions are assigned. They depend on the configuration in the engineering system (ES) that applies to this block.

Symbols for enabled operations:

- **Green check mark:** the OS operator can control this parameter
- **Gray check mark:** the OS operator cannot control this parameter at this time due to the process
- **Red cross:** the OS operator cannot control this parameter due to the configured AS operator control permissions (OS_Perm or OS1Perm)

The following enabled operations are shown here:

- "On": You can switch to "On" operating mode.
- "Out of service": You can switch to "Out of service" operating mode.
- "Local operating permission": Use the ← button to switch to the standard view of the OpStations block. You can find more information about this in the section titled: Operator control permissions (Page 254)

(2) Navigation button for switching to the standard view of any faceplate

Use this navigation button to reach the standard view of a block configured in the engineering system. The visibility of this navigation button depends on the configuration in the engineering system (ES).

Additional information is available in the section Opening additional faceplates (Page 208).

5.2.8.6 ConPerMon setpoint view

Setpoint view of ConPerMon

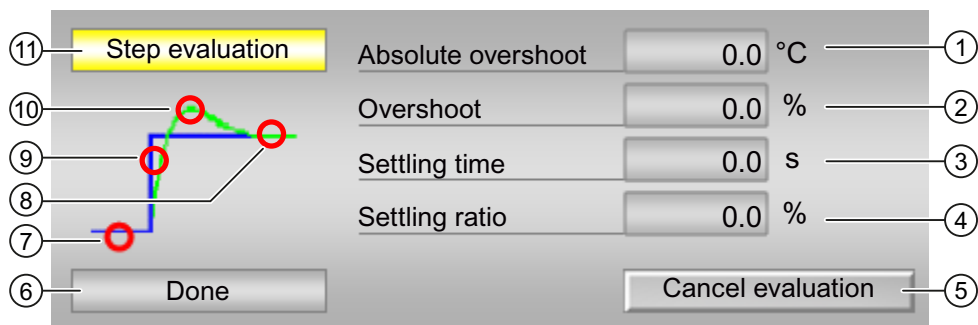

(1) Absolute overshoot

The absolute overshoot is given in the physical unit of the actual value.

(2) Overshoot

Output of the relative overshoot base on a step change.

(3) Settling time

Settling time of the step response in seconds.

(4) Settling time ratio

The settling time ratio is formed from the ramp time by the settling time.

(5) Cancel evaluation button

You can use the button to show the evaluation of the step response.

Note

The "Cancel evaluation" button is operable when **all** of the following conditions are met:

- Operator permission level = 2 (Higher-level process control)
- Parameter `OS_Perm Bit30 = 1` (Operator can abort the evaluation of the step response)

(6), (7), (8), (9) and (10): Status of the step response

The following states are shown here:

- (6) Textual display of the states
- (7) "Idle": steady state
- (8) "Steady-state": i.e. the actual value is located within the tolerance band of the setpoint
- (9) "Rising phase": from the initial state to the first time the setpoint is reached
- (10) "Overshoot"

(11) Display: Evaluation of the step response in progress:

- "Step evaluation"
- "Constant PV"

See also

ConPerMon standard view (Page 590)

ConPerMon limit view (Page 592)

ConPerMon parameter view (Page 593)



5.2.8.7 Block icon for ConPerMon

Block icons for ConPerMon

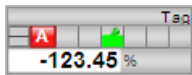
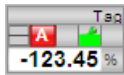

A variety of block icons are available with the following functions:

- Process tag type
- Limits (high/low)
- Violation of alarm, warning, and tolerance limits
- Operating modes
- Signal status, release for maintenance
- Memo display
- Process value (black, with and without decimal places)

The block icons from template @TemplateAPLV8.PDL:

Icons	Selection of the block icon in CFC	Special features
	1	
	2	
	3	Block icon in the full display

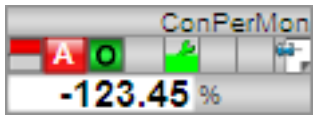
The block icons from template @TemplateAPLV7.PDL:

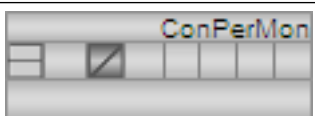
Icons	Selection of the block icon in CFC	Special features
	1	Block icon in the full display
	2	
	-	Block icon in "Out of service" mode (example with type 1 block icon)

Additional information on the block icon and the control options in the block icon is available in the following chapters:

- Configuring the block icons (Page 237)
- Block icon structure (Page 230)
- Operation via the block icon (Page 239)

5.3 FmCont - Interface to module FM 355

5.3.1 Description of FmCont

Object name (type + number) and family

Type + number: FB 1818

Family: Control

Area of application for FmCont

The block is used for the following applications:

- Fixed setpoint control
- Cascade control
- Ratio control
- Split-range control

How it works

Block FmCont is used to interface the FM 355 controller modules.

FmCont can be used for the C (continuous controllers) and S (step and pulse controllers) module types. It contains the algorithms of the setpoint ramp, the setpoint rise limitation, and the limit monitoring of the process value, the control deviation, and the position feedback. Limit monitoring is not used on the module. The control function itself (e.g. PID algorithm) is processed on the module.

You can use the FmCont block to monitor all relevant process values and to change all relevant controller parameters.

Application examples of the FM 355 and detailed descriptions of the associated input and output parameters can be found in the manual for the FM 355 controller module.

Process values such as temperatures, levels and flows can be controlled. However, pressure processes which are not excessively fast are also possible.

Configuration

Use the CFC editor to install the block in a cyclic interrupt OB (OB30 to OB38). The block is also installed automatically in the startup OB (OB100). Set the input parameter `LogAddr` to the module address from HW Config and the input parameter `Channel` to the desired controller channel (1 ... 4).

When the CFC function "Generate module drivers" is used, the following occurs automatically:

- The parameter `CoordNo` is set
- The in/out parameter `Mode` is interconnected to the corresponding `OMODE_XX` output parameter of the MOD block.

5.3 FmCont - Interface to module FM 355

- The parameter FM 355 is set in accordance with the module type C/S
- The in/out parameter EnCoord is interconnected to the output EN_CO_x of the FM_CO block of the Basis Library (x = number of the rack)
- The output parameter EnCoNum is interconnected to the input ENCOx_yy of the FmCont block (x = number of the rack, yy = coordination number).

For the control loop monitoring to work as planned in the trend view of the controller faceplates, the

S7_xarchive:='Value,shortterm;'

attributes in the process tag types for control loops at the controller function block must be set for the following tags:

- Input parameters:
 - CPI_In
- Output parameters
 - MV
 - MV_HiAct
 - MV_LoAct
 - LoopClosed
 - SP
 - PV_Out
 - PV_ToleHi
 - PV_ToleLo

Startup characteristics

Use the Feature startup characteristics (Page 138) to define the startup characteristics of this block.

The messages are suppressed after startup for the number of cycles set at RunUpCyc.

Status word allocation for Status1 parameter

For a description of the individual parameters, see the section I/Os of FmCont (Page 619)

Status bit	Parameter
0	Occupied
1	BatchEn
2	SimOn
3	OosAct.Value
4	OosLi.Value
5	AutAct.Value
6	Not used
7	ManAct.Value

Status bit	Parameter
8	SP_ExtAct.Value
9	MV_SafeOn.Value AND NOT OosAct.Value
10	MV_TrkOn.Value AND NOT (ManAct.Value OR OosAct.Value OR MV_SafeAct.Value)
11	MV.Value > ManLoLim for continuous or pulse controller NOT FbkClosed.Value for step controller with/without position feedback
12	Open.Value
13	Close.Value
14	Stop.Value
15	FbkOpnOut.Value
16	FbkClsOut.Value
17	SimOn AND ManAct
18	MV_SafeOn.Value
19	AdvCoAct.Value
20	1 = Input parameter Rbk is not interconnected (RbkOut.ST = 16#FF)
21	NegGain.Value
22	MV_FmTrkAct.Value AND NOT (OosAct.Value OR MV_SafeAct.Value)
23 - 24	Not used
25	MV_TrkOn.Value
26	MV_FmTrkOn.Value
27	AdvCoModSP
28	1 = Analog controller (FM 355 = 1)
29	1 = Pulse controller (FM 355 = 0 AND StepCon = 0)
30	1 = Step controller with position feedback (FM 355 = 0 AND StepCon = 1 AND WithRbk = 1)
31	1=Step controller without position feedback (FM 355 = 0 AND StepCon = 1 AND WithRbk = 0)

Status word allocation for status2 parameter

Status bit	Parameter
0	MsgLock
1	PV_AH_Act.Value
2	PV_WH_Act.Value
3	PV_TH_Act.Value
4	PV_TL_Act.Value
5	PV_WL_Act.Value
6	PV_AL_Act.Value
7	PV_AH_En
8	PV_WH_En
9	PV_TH_En
10	PV_TL_En
11	PV_WL_En

5.3 FmCont - Interface to module FM 355

Status bit	Parameter
12	PV_AL_En
13	PV_AH_MsgEn
14	PV_WH_MsgEn
15	PV_TH_MsgEn
16	PV_TL_MsgEn
17	PV_WL_MsgEn
18	PV_AL_MsgEn
19	ER_AH_Act.Value
20	ER_AL_Act.Value
21	ER_AH_En
22	ER_AL_En
23	ER_AH_MsgEn
24	ER_AL_MsgEn
25	RbkWH_Act.Value
26	RbkWL_Act.Value
27	RbkWH_En
28	RbkWL_En
29	RbkWH_MsgEn
30	RbkWL_MsgEn
31	MS_RelOp

Status word allocation for Status3 parameter

Status bit	Parameter
0	Effective signal 1 of the message block connected via EventTsIn
1	Effective signal 2 of the message block connected via EventTsIn
2	Effective signal 3 of the message block connected via EventTsIn
3	Effective signal 4 of the message block connected via EventTsIn
4	Effective signal 5 of the message block connected via EventTsIn
5	Effective signal 6 of the message block connected via EventTsIn
6	Effective signal 7 of the message block connected via EventTsIn
7	Effective signal 8 of the message block connected via EventTsIn
8	Delay of the PV_AH_Lim message
9	Delay of the PV_WH_Lim message
10	Delay of the PV_TH_Lim message
11	Delay of the PV_TL_Lim message
12	Delay of the PV_WL_Lim message
13	Delay of the PV_AL_Lim message
14	Delay of the ER_AH_Lim message
15	Delay of the ER_AL_Lim message
16	Collection of message delays
17 - 26	Not used

Status bit	Parameter
27	SP_UpRaAct, SP_DnRaAct limits enabled for gradient mode (SP_RateOn = 1)
28	GrpErr.Value
29	RdyToStart.Value
30	SimLiOp.Value
31	Not used

Status word allocation for status4 parameter

Status bit	Parameter
0 - 7	Effective signal 9..16 of the message block connected via EventTsIn
8 - 31	Not used

See also

- FmCont messaging (Page 616)
- FmCont block diagram (Page 634)
- FmCont modes (Page 603)
- FmCont error handling (Page 614)
- FmCont functions (Page 604)

5.3.2 FmCont modes

FmCont operating modes

The block can be operated using the following modes:

- Automatic mode (Page 72)
- Manual mode (Page 72)
- Program mode for controllers (Page 78)
- Out of service (Page 71)

The next section provides additional block-specific information relating to the general descriptions.

"Automatic mode"

You can find general information on "Automatic mode", switching modes and bumpless switchover in the Manual and automatic mode for control blocks (Page 72) section.

"Manual mode"

You can find general information on "Manual mode", switching modes and bumpless switchover in the Manual and automatic mode for control blocks (Page 72) section.

"Program mode for controllers"

General information on "Program mode for controllers" is available in the section Program mode for controllers (Page 78).

"Out of service"

You can find general information about the "Out of service" mode in the section Out of service (Page 71).

See also

- FmCont block diagram (Page 634)
- FmCont I/Os (Page 619)
- Description of FmCont (Page 599)
- FmCont functions (Page 604)
- FmCont error handling (Page 614)
- FmCont messaging (Page 616)

5.3.3 FmCont functions

Functions of FmCont

The functions for this block are listed below.

Module types

FmCont can be used for the C (continuous controllers) and S (step controllers with and without position feedback and pulse controllers) module types. You can use the following parameters to identify which module type and controller type has been set:

FM 355	StepCon	WithRbk	Module type, controller type
1 or C	-	-	FM 355 C: Continuous controller
0 or S	1	1	FM 355 S: Step controller with position feedback
0 or S	1	0	FM 355 S: Step controller without position feedback
0 or S	0	-	FM 355 S: Pulse controller

You must set input parameter `StepCon` if you want to set the step controller with/without position feedback as the controller type.

Generating manipulated variables for continuous controllers, step controllers with position feedback, or pulse controllers

The manipulated variable *MV* and the actuating signals *Open*, *Close* and *Stop* are generated as follows

MV_Safe-On	MV_FmTrk-On	ManAct	MV_TrkOn	AdvCoAct AND NOT AdvCo-ModSP	MV =	Manipulated variable limit	State	Open, Close, Stop
1	-	-	-	-	MV_Safe	MV_HiLim MV_LoLim	Tracking to safety value	Cont. controller: Open, Close, Stop = 0 Step controller with position feedback: Depending on Rbk and MV, the output signals Open, Close and Stop are generated using the algorithm of a positioner. Pulse controller: Depending on MV, the output signals Open and Close are generated using the algorithm of a pulse controller (Stop = 0).
0	1	-	-	-	Prepared FM analog input	MV_HiLim MV_LoLim	Tracking to an FM analog input	
0	0	1	-	-	Man	ManHiLim ManLoLim	Manual mode, set by the operator	
0	0	0	1	-	MV_Trk	MV_HiLim MV_LoLim	Tracking to block input MV_Trk	
0	0	0	0	1	AdvCoMV	MV_HiLim MV_LoLim	Higher-level program mode	
0	0	0	0	0	P_Part + I_Part + D_Part + FFwd	MV_HiLim MV_LoLim	Automatic mode (PID algorithm)	

Generating actuating signals for step controllers without position feedback (WithRbk = 0)

The manipulated variable signals *Open*, *Close* and *Stop* can be generated as follows:

ManAct	Open, Close, Stop	State
1	The output signals are generated using input signals <i>OpenOp/Li</i> , <i>CloseOp/Li</i> or <i>StopOp/Li</i>	Manual mode, set by the operator
0	The output signals are generated using PID output variables <i>P_Part</i> , <i>I_Part</i> , <i>D_Part</i> and <i>FFwd</i>	Automatic mode (PID algorithm)

Tracking and limiting a manipulated variable (cont. controller, step controller with position feedback and pulse controller)

The block provides the standard function Tracking and limiting a manipulated variable (Page 196).

Neutral position

The controller modules have their own mechanism for feedforwarding a safety value (see manual for Temperature Controller FM 355-2 or manual for Controller Module FM 355).

Group error

This block provides the standard function Outputting group errors (Page 122).

The following parameters are taken into consideration when forming the group error:

- CSF
- ModErr
- ParFM_Err
- PerACCerr

Outputting a signal for start readiness

This block provides the standard function Outputting a signal for start readiness (Page 53).

"Actuator active" information

For continuous and pulse controllers: If the manipulated variable MV is greater than the minimum manual limit $ManLoLim$, this is recognized as actuator active.

For step controllers: If the parameter $FbkClosed = 0$, this is recognized as "Actuator active".

This status can be used to indicate a customized symbol in the process image, for example, and is saved in the status word (see Status word section in Description of FmCont (Page 599)).

Limit monitoring of position feedback (cont. controller, step controller with position feedback and pulse controller)

The block provides the standard function Limit monitoring of the feedback (Page 94).

Group display SumMsgAct for limit monitoring, CSF and ExtMsgx

The block provides the standard function Group display for limit monitoring, CSF and ExtMsgx (Page 85).

External/internal setpoint specification

The block provides the standard function Setpoint specification - internal/external (Page 128).

Setpoint limiting for external setpoints

The block provides the standard function Setpoint limiting for external setpoints (Page 196).

Gradient limit of the setpoint

The block provides the standard function Gradient limit of the setpoint (Page 124).

Using setpoint ramp

The block provides the standard function Using setpoint ramp (Page 123).

Tracking setpoint in manual mode

The block provides the standard function Tracking setpoint in manual mode (Page 196).

Simulating signals

The block provides the standard function Simulating signals (Page 58).

You can simulate the following values:

- Process value (*SimPV*, *SimPV_Li*)
- Position feedback (*SimRbk*, *SimRbkLi*)

Note

The simulated process value *SimPV* only affects alarm processing and not the PID algorithm in the control module.

Limit monitoring of the process value

The block provides the standard function Limit monitoring of the process value (Page 86).

Error signal generation and dead band

The block provides the standard function Error signal generation and dead band (Page 192).

Limit monitoring of error signal

The block provides the standard function Limit monitoring of setpoint, manipulated variable and control deviation (Page 95).

Inverting control direction

The block provides the standard function Inverting control direction (Page 192).

Physical standardization of setpoint, manipulated variable and process value

Controller gain *Gain* is entered either using a physical variable or as standardized value.

- Gain as a physical variable:

The standardized variables retain their default values:

- *NormPV.High* = 100 and *NormPV.Low* = 0
- *NormMV.High* = 100 and *NormMV.Low* = 0

For step controllers with/without position feedback and pulse controllers, the values of *NormMV.High* and *NormMV.Low* are not taken into account. The algorithm uses default values 0 and 100 for internal calculations.

The effective gain is: $\text{GainEff} = \text{Gain}$

- Entering a standardized *Gain* (dimensionless):

Change the standardized variables to the actual range of the process values and manipulated variables.

- Internal and external setpoints; the process value and corresponding parameters are entered according to the physical measuring range of the process value.

Continuous controller, pulse controller:

- The manual value, the tracking value of the manipulated variable, feedforward control and the corresponding parameters are set according to the physical measuring range of the manipulated variable.

Step controller with position feedback:

- The manual parameter, the tracking value of the manipulated variable, feedforward control and the corresponding parameters are entered as a percentage 0 ... 100.

Step controller without position feedback:

- No physical measuring range available.

The effective gain is:

- Step controller with/without position feedback:

$$\text{GainEff} = 100.0 / (\text{NormPV.High} - \text{NormPV.Low}) \cdot \text{Gain}$$

- Continuous controller, pulse controller:

$$\text{GainEff} = (\text{NormMV.High} - \text{NormMV.Low}) / (\text{NormPV.High} - \text{NormPV.Low}) \cdot \text{Gain}$$

Selecting a unit of measure

The block provides the standard function Selecting a unit of measure (Page 212).

PID algorithm

The manipulated variable is generated in automatic mode according to the following algorithm:

$$\text{MV} = \text{GainEff} \cdot (1 + 1 / (\text{TI} \cdot s) + (\text{TD} \cdot s) / (1 + \text{TD} / \text{DiffGain} \cdot s)) \cdot \text{ER}$$

Where: *s* = Complex number

The following step response occurs:

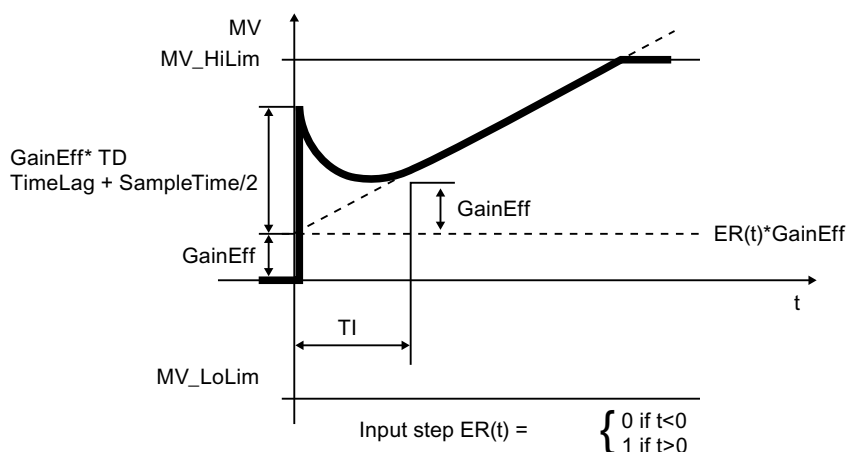
**Note**

This formula describes a standard application where the P, I and D components are activated and the P and D components are not in the feedback circuit ($PropSel = 1$, $TI \neq 0$, $D_InSel = 0$ and $P_FbkSel = 0$).

The D component delay is derived from $TD / DiffGain$.

- The P component can be shut down by $PropSel = 0$.
- The I component can be shut down by $TI = 0$.
- The D component can be shut down by $TD = 0$.

Structure segmentation at controllers

The PID controller algorithm of FM 355 features structure segmentation. It is activated via the P_FbkSel and D_InSel parameters. The precise functionality is described in the FM 355 manual.

Anti-windup

The PID control algorithm of FM 355 has an anti-windup function. The I component is frozen or tracked after the manipulated variable has reached its limits (MV_HiLim or MV_LoLim).

Feedforwarding and limiting disturbance variables

The block provides a function for activating the disturbance variable feedforward. The precise functionality is described in the FM 355 manual.

Forming the signal status for blocks

The block provides the standard function Forming and outputting the signal status for technologic blocks (Page 109).

- Signal status for the setpoint value `SP`:
The signal status of the `SP` output parameter is always equivalent to the signal status of input parameter `SP_Ext` or `SP_Int`, depending on how the setpoint is specified. If the internal setpoint `SP_Int` is used, the signal status is always output as `16#80`.
- Signal status for `PV_Out`, `RbkOut`, `Open`, `Close`, `Stop`:
The signal status is always `16#60` when simulation is activated.
When the `ModErr.Value`, `ChFM_Err`, `ParFM_Err` module error occurs, the signal status of `PV_Out` is always `16#0`. `RbkOut` is always `16#0` for step controllers with position feedback
Otherwise, the following applies:
`PV_Out.ST: 16#80`
Step controller: `RbkOut.ST: = 16#80`
Continuous controller or pulse controller: `RbkOut.ST: = Rbk.ST`
`Open.ST := 16#80;`
`Close.ST := 16#80;`
`Stop.ST := 16#80;`
- Signal status of the error signal `ER`:
The signal status of output parameter `ER` is obtained from the worst signal status of the two output parameters `PV_Out` and `SP` and is output. The signal status `16#60` (external simulation) is suppressed because the block acts as a sink with external simulation.
Signal status for `FbkOpnOut`, `FbkClsOut`:
`FbkOpnOut.ST := FbkOpened.ST;`
`FbkClsOut.ST := FbkClosed.ST;`
- Signal status for the manipulated variable `MV`:
The status signal from the output parameter `MV` is always set to `16#80` in "manual mode" and for step controllers without position feedback.
In "automatic mode", the signal status for continuous controllers or pulse controllers is formed from the following parameters:
`RbkOut.ST`, `FFwdOut.ST`, `STER.ST` With step controllers, the `FbkOpnOut.ST`, `FbkClsOut.ST` parameters are also included. The signal status `16#60` (external simulation) is suppressed because the block acts as a sink with external simulation.
- Worst signal status:
The worst signal status `ST_Worst` for the block is formed from:
 - `PV_Out.ST;`
 - `SP:ST;`
 - `FFwdOut.ST;`
 - `RbkOut.ST;`
 With step controllers (`FM355 = 0`, `StepCon = 1`), the following are also included:
 - `FbkOpnOut.ST;`
 - `FbkClsOut.ST;`

Configurable reactions using the `Feature` parameter

You can find an overview of all reactions provided by the `Feature` parameter in the Configurable functions using the Feature I/O (Page 131) . The following functionality is available for this block at the relevant bits:

Bit	Function
0	Set startup characteristics (Page 138)
1	Reaction to the out of service mode (Page 177)
2	Resetting the commands for changing the mode (Page 161)
4	Setting switch or button mode (Page 167)
6	Ramp rate calculation (Page 179)
10	Condition monitoring information at the channel blocks (Page 145)
22	Update acknowledgment and error status of the message call (Page 160)
23	SP following PV in open loop has no priority over SP_Ext and SP limits (Page 179)
24	Enabling local operator authorization (Page 158)
25	Suppression of all messages (Page 174)
26	Reaction of the switching points in the "Out of service" operating mode (Page 176)
28	Disabling operating points (Page 145)
29	Signaling limit violation (Page 170)

Configurable reactions using the `Feature2` parameter

Bit	Function
11	Suppress <code>MsgLock</code> and "Out of service" mode for a connected message block (Page 188)

Operator permissions

The block provides the standard function Operator control permissions (Page 254).

The block has the following permissions for the `OS_Perm` parameter:

Bit	Function
0	1 = Operator can switch to "automatic mode" <code>AutModOp</code>
1	1 = Operator can switch to "manual mode" <code>ManModOp</code>
2	1 = Operator can switch to "Out of service" mode <code>OosOp</code>
3	1 = Operator can switch to "program mode" <code>AdvCoEn</code>
4	1 = Operator can switch the setpoint to "external" <code>SP_ExtOp</code>
5	1 = Operator can switch the setpoint to "internal" <code>SP_IntOp</code>
6	1 = Operator can change the internal setpoint <code>SP_Int</code>
7	Continuous controllers, pulse controllers or step controllers with position feedback: 1 = Operator can change the manual parameter <code>Man</code> Step controller without position feedback: 1 = Operator can change the manual operation signals <code>OpenOp</code> , <code>StopOp</code> , <code>CloseOp</code>
8	1 = Operator can change operation high limit of the setpoint <code>SP_InHiLim</code>
9	1 = Operator can change operation low limit of the setpoint <code>SP_InLoLim</code>

5.3 FmCont - Interface to module FM 355

Bit	Function
10	1 = Operator can change the operation high limit of the manipulated variable <code>ManHiLim</code>
11	1 = Operator can change the operation low limit of the manipulated variable <code>ManLoLim</code>
12	1 = Operator can enable the setpoint's gradient limitation function <code>SP_RateOn</code>
13	1 = Operator can change the setpoint's high limit for the ramp <code>SP_UpRaLim</code>
14	1 = Operator can change the setpoint's low limit for the ramp <code>SP_DnRaLim</code>
15	1 = Operator can switch between the time value or the value for the ramp <code>SP_RmpModTime</code>
16	1 = Operator can change the ramp time <code>SP_RmpTime</code>
17	1 = Operator can change the target setpoint <code>SP_RmpTarget</code> for the setpoint ramp
18	1 = Operator can enable the setpoint ramp function <code>SP_RmpOn</code>
19	Not used
20	1 = Operator can enable the track setpoint in manual mode function <code>SP_TrkPV</code>
21	1 = Operator can enable the bumpless switchover from external to internal <code>SP_TrkExt</code>
22	1 = Operator can change the gain parameter <code>Gain</code>
23	1 = Operator can change the integral time parameter <code>TI</code>
24	1 = Operator can change the derivative time parameter <code>TD</code>
25	1 = Operator can change the derivative gain parameter <code>DiffGain</code>
26	1 = Operator can change the dead band parameter <code>DeadBand</code>
27	Not used
28	1 = Operator can change the integral time parameter <code>MotorTime</code>
29	1 = Operator can change the integral time parameter <code>PulseTime</code>
30	1 = Operator can change the integral time parameter <code>BreakTime</code>
31	Not used

The block has the following permissions for the `OS1Perm` parameter:

Bit	Function
0	1 = Operator can change the limit (process value) <code>PV_AH_Lim</code> for the high alarm
1	1 = Operator can change the limit (process value) <code>PV_WH_Lim</code> for the high warning
2	1 = Operator can change the limit (process value) <code>PV_TH_Lim</code> for the high tolerance
3	1 = Operator can change the hysteresis (process value) <code>PV_Hyst</code>
4	1 = Operator can change the limit (process value) <code>PV_TL_Lim</code> for the low tolerance
5	1 = Operator can change the limit (process value) <code>PV_WL_Lim</code> for the low warning
6	1 = Operator can change the limit (process value) <code>PV_AL_Lim</code> for the low alarm
7	1 = Operator can change the limit (error signal) <code>ER_AH_Lim</code> for the high alarm
8	1 = Operator can change the hysteresis (error signal) <code>ER_Hyst</code>
9	1 = Operator can change the limit (error signal) <code>ER_AL_Lim</code> for the low alarm
10	1 = Operator can change the limit (position feedback) <code>RbkWH_Lim</code> for the high warning
11	1 = Operator can change the hysteresis (position feedback) <code>RbkHyst</code>
12	1 = Operator can change the limit (position feedback) <code>RbkWL_Lim</code> for the low warning
13	1 = Operator can open the valve
14	1 = Operator can close the valve
15	1 = Operator can stop the valve
16	1 = Operator can activate the Simulation function <code>SimOn</code>

Bit	Function
17	1 = Operator can activate the Release for maintenance function MS_RelOp
18	1 = Operator can activate / deactivate messages via PV_AH_MsgEn
19	1 = Operator can activate / deactivate messages via PV_WH_MsgEn
20	1 = Operator can activate / deactivate messages via PV_TH_MsgEn
21	1 = Operator can activate / deactivate messages via PV_TL_MsgEn
22	1 = Operator can activate / deactivate messages via PV_WL_MsgEn
23	1 = Operator can activate / deactivate messages via PV_AL_MsgEn
24	1 = Operator can activate / deactivate messages via ER_AH_MsgEn
25	1 = Operator can activate / deactivate messages via ER_AL_MsgEn
26	1 = Operator can activate / deactivate messages via RbkWH_MsgEn
27	1 = Operator can activate / deactivate messages via RbkWL_MsgEn
28	1 = Operator can change the simulation value SimPV
29	1 = Operator can change the simulation value SimRbk
30 - 31	Not used

Note

If you interconnect a parameter that is also listed in OS_Perm as a parameter, you have to reset the corresponding OS_Perm bit.

Release for maintenance

The block provides the standard function Release for maintenance (Page 64).

Generating instance-specific messages

The block provides the standard function Generating instance-specific messages (Page 204) without the time stamp function in the I/O.

Suppressing messages using the MsgLock parameter

This block provides the standard function Suppressing messages using the MsgLock parameter (Page 205).

Specifying the display area for process and setpoint values as well as operations

This block provides the standard function Display and operator input area for process values and setpoints (Page 207).

Opening additional faceplates

This block provides the standard function Opening additional faceplates (Page 208).

SIMATIC BATCH functionality

This block provides the standard function SIMATIC BATCH functionality (Page 67).

Button labels

This block provides the standard function Labeling of buttons and text (Page 209)

Instance-specific text can be configured for the following parameters:

- OpenOp
- StopOp
- CloseOp

Connection of the time-stamped messages from EventTs or Event16Ts

This block provides the standard function Connection of the time-stamped messages from EventTs or Event16Ts (Page 207).

See also

- FmCont messaging (Page 616)
- FmCont I/Os (Page 619)
- FmCont block diagram (Page 634)
- FmCont modes (Page 603)
- FmCont error handling (Page 614)
- EventTs functions (Page 1660)

5.3.4 FmCont error handling

Error handling of FmCont

Refer to section Error handling (Page 119) in the basic instructions for the error handling of all blocks.

The following errors can be displayed for this block:

- Error numbers
- Control system fault (CSF)

Overview of error numbers

The `ErrorNum` I/O can be used to output various error numbers:

Error number	Meaning of the error number
-1	Predefined value when inserting the block; the block is not executed
0	There is no error.
30	The value of <code>PV</code> can no longer be displayed in the REAL number field.
31	The value of <code>SP_Ext</code> can no longer be displayed in the REAL number field.
33	The value of <code>MV_Trk</code> can no longer be displayed in the REAL number field.
35	The value of <code>Rbk</code> can no longer be displayed in the REAL number field.
36	The value of <code>MV</code> can no longer be displayed in the REAL number field.
50	The controller cannot be switched to program mode, because program mode with default setpoint (<code>AdvCoModSP = 0</code>) is not possible for step controllers without position feedback (<code>WithRbk = 0</code>).
51	<code>AutModLi = 1 and ManModLi = 1</code> <code>SP_LiOp = 1 and SP_IntLi = 1 and SP_ExtLi = 1</code> <code>OpenLi = 1 and StopLi = 1</code> <code>CloseLi = 1 and StopLi = 1</code> <code>OpenLi = 1 and CloseLi = 1</code>
59	= 1, "Gain is negative"
60	$ TI < SampleTime / 2$
61	$ TD < SampleTime$
62	$DiffGain < 1$ or $DiffGain > 10$
63	$TD / DiffGain < SampleTime / 2$
64	$PropFacSP < 0$ or $PropFacSP > 1$
66	$NormPV_High = NormPV_Low$
67	$MotorTime < SampleTime$
68	$PulseTime < SampleTime$
69	$BreakTime < SampleTime$
70	$Channel < 1$ or $Channel > 4$
71	$(D_InSel < 0$ or $D_InSel > 4)$ and $D_InSel \neq 17$

Control system fault (CSF)

An external signal can be activated via the CSF input. A control system fault is triggered if this signal changes to 1. Refer to the Error handling (Page 119) section for more on this.

See also

FmCont block diagram (Page 634)

FmCont I/Os (Page 619)

Description of FmCont (Page 599)

FmCont modes (Page 603)

FmCont functions (Page 604)

FmCont messaging (Page 616)

Setting switch or button mode (Page 167)

5.3.5 FmCont messaging

Messaging

The following messages can be generated for this block:

- Process control fault
- Process messages
- Instance-specific messages

Process control fault

The following control system error messages can be output:

Message instance	Message identifier	Message class	Event
MsgEvId2	SIG 6	AS process control message - fault	\$\$BlockComment\$\$ External error has occurred

Explanation:

\$\$BlockComment\$\$: Content of the instance-specific comment

You can interconnect an external fault (signal) to input parameter CSF. If it changes to CSF = 1, a process control fault is triggered (MsgEvId2, SIG 6).

Process messages

Message instance	Message identifier	Message class	Event
MsgEvId1	SIG 1	Alarm - high	\$\$BlockComment\$\$ PV - high alarm limit violated
	SIG 2	Warning - high	\$\$BlockComment\$\$ PV - high warning limit violated
	SIG 3	Tolerance - high	\$\$BlockComment\$\$ PV - high tolerance limit violated
	SIG 4	Tolerance - low	\$\$BlockComment\$\$ PV - low tolerance limit violated
	SIG 5	Warning - low	\$\$BlockComment\$\$ PV - low warning limit violated
	SIG 6	Alarm - low	\$\$BlockComment\$\$ PV - low alarm limit violated
	SIG 7	Alarm - high	\$\$BlockComment\$\$ ER - high alarm limit violated
	SIG 8	Alarm - low	\$\$BlockComment\$\$ ER - low alarm limit violated
MsgEvId2	SIG 7	Warning - high	\$\$BlockComment\$\$ Rbk - high warning limit violated
	SIG 8	Warning - low	\$\$BlockComment\$\$ Rbk - low warning limit violated

Explanation:

\$\$BlockComment\$\$: Content of the instance-specific comment

Instance-specific messages

You can use up to four instance-specific messages with this block.

Message instance	Message identifier	Message class	Event
MsgEvId2	SIG 1	AS process control message - fault	\$\$BlockComment\$\$ External message 1 Status 16#@5%x@
	SIG 2	AS process control message - fault	\$\$BlockComment\$\$ External message 2 Status 16#@6%x@
	SIG 3	AS process control message - fault	\$\$BlockComment\$\$ External message 3 Status 16#@7%x@
	SIG 4	AS process control message - fault	\$\$BlockComment\$\$ External message 4 Status 16#@8%x@

Explanation:

\$\$BlockComment\$\$: Content of the instance-specific comment

Associated values for message instance `MsgEvId1`

Associated value	Block parameters
1	BatchName
2	StepNo
3	BatchID
4	Process value PV_Out
5	Control deviation ER
6	ExtVa106
7	ExtVa107
8	Not allocated
9	Not allocated
10	Not allocated

The associated values 6 ... 7 are allocated to the parameters ExtVa106 ... ExtVa107 and can be used. Additional information is available in the "Process Control System PCS 7 - Engineering System" manual.

Associated values for message instance `MsgEvId2`

Associated value	Block parameters
1	BatchName
2	StepNo
3	BatchID
4	Position feedback Rbk
5	Signal status ExtMsg1
6	Signal status ExtMsg2
7	Signal status ExtMsg3
8	Signal status ExtMsg4
9	ExtVa209
10	ExtVa210

The associated values 9 ... 10 are allocated to the parameters ExtVa209 ... ExtVa210 and can be used. Additional information is available in the "Process Control System PCS 7 - Engineering System" manual.

See also

FmCont block diagram (Page 634)

FmCont modes (Page 603)

FmCont error handling (Page 614)

5.3.6 FmCont I/Os

I/Os of FmCont

Input parameters

Parameter	Description	Type	Default
AccMode*	1 = Transfer of operating parameters SubN1_ID, SubN2_ID, RackNo, SlotNo and Channel to internal processing	BOOL	1
AdvCoEn	1 = Enable "program mode" via interconnection	STRUCT <ul style="list-style-type: none"> Value: BOOL ST: BYTE 	- <ul style="list-style-type: none"> 0 16#80
AdvCoModSP	Type of "program mode": 1 = Setpoint specification 0 = Manipulated variable specification	BOOL	1
AdvCoMstrOn	Activate (0-1) or deactivate (1-0) "program mode" via edge transition	STRUCT <ul style="list-style-type: none"> Value: BOOL ST: BYTE 	- <ul style="list-style-type: none"> 0 16#80
AdvCoMV	Specified value from the external program	REAL	0.0
AdvCoOn*	1 = Enable "program mode" via faceplate	BOOL	0
AutModLi*	1 = "Automatic mode" via interconnection or SFC (controlled by ModLiOp = 1)	STRUCT <ul style="list-style-type: none"> Value: BOOL ST: BYTE 	- <ul style="list-style-type: none"> 0 16#80
AutModOp*	1 = "Automatic mode" via operator (controlled by ModLiOp = 0)	BOOL	0
BatchEn	1 = Enable allocation for batch control	BOOL	0
BatchID	Batch ID	DWORD	16#00000000
BatchName	Batch name	S7-String	
BreakTime*	Minimum break duration [s]	REAL	1.0
Channel	Controller channel number (1..4)	INT	1
CloseLi*	1 = Close via interconnection or CFC	STRUCT <ul style="list-style-type: none"> Value: BOOL ST: BYTE 	- <ul style="list-style-type: none"> 0 16#80
CloseOp*	1 = Close via operator	BOOL	0
CoordNo	Coordination number	INT	0
CPI_In	Input for control performance index, which is calculated by the assigned ConPerMon block	STRUCT <ul style="list-style-type: none"> Value: REAL ST: BYTE 	- <ul style="list-style-type: none"> 0.0 16#78
CSF	1 = External error (control system fault) Error handling (Page 119)	STRUCT <ul style="list-style-type: none"> Value: BOOL ST: BYTE 	- <ul style="list-style-type: none"> 0 16#80

Controller blocks

5.3 FmCont - Interface to module FM 355

Parameter	Description	Type	Default
D_InSel*	Input for differentiator: 0 = Error signal 1..4 = Channel 1..4 17 = Actual value to feedback	INT	0
DeadBand*	Width of dead band	REAL	0.0
DiffGain*	Gain of differentiator [1...10] $\text{DiffGain} = \text{TD}/(\text{delay time of D component})$	STRUCT <ul style="list-style-type: none"> Value: REAL ST: BYTE 	- <ul style="list-style-type: none"> 5.0 16#80
EN	1 = Called block will be processed	BOOL	1
ER_A_DC*	Delay for incoming alarms during error signal monitoring	REAL	0.0
ER_A_DG*	Delay for outgoing alarms during error signal monitoring	REAL	0.0
ER_AH_En	1 = Activate alarm (high) for error signal monitoring	BOOL	1
ER_AH_Lim	Alarm limit (high) for error signal monitoring	REAL	100.0
ER_AH_MsgEn	1 = Activate messages for alarm (high) for error signal monitoring	BOOL	1
ER_AL_En	1 = Activate alarm (low) for error signal monitoring	BOOL	1
ER_AL_Lim	Alarm limit (low) for error signal monitoring	REAL	-100.0
ER_AL_MsgEn	1 = Activate messages for alarm (low) for error signal monitoring	BOOL	1
ER_Hyst	Alarm hysteresis for error signal	REAL	1.0
EventTsIn	For interconnecting data between a technology block and the message blocks <code>EventTs</code> , <code>Event16Ts</code> . The <code>EventTsIn</code> input parameter serves to interconnect the <code>EventTsOut</code> output parameter of the <code>EventTs</code> , <code>Event16Ts</code> block. When this interconnection is configured, the messages of the <code>EventTs</code> , <code>Event16Ts</code> block are displayed on the OS in the alarm view of the technology block and can also be acknowledged there.	ANY	
ExtMsg1	Binary input for freely selectable message 1	STRUCT <ul style="list-style-type: none"> Value: BOOL ST: BYTE 	- <ul style="list-style-type: none"> 0 16#80
ExtMsg2	Binary input for freely selectable message 2	STRUCT <ul style="list-style-type: none"> Value: BOOL ST: BYTE 	- <ul style="list-style-type: none"> 0 16#80

Parameter	Description	Type	Default
ExtMsg3	Binary input for freely selectable message 3	STRUCT <ul style="list-style-type: none"> Value: BOOL ST: BYTE 	- <ul style="list-style-type: none"> 0 16#80
ExtMsg4	Binary input for freely selectable message 4	STRUCT <ul style="list-style-type: none"> Value: BOOL ST: BYTE 	- <ul style="list-style-type: none"> 0 16#80
ExtVa106	Associated value 6 for messages (MsgEvID1)	ANY	
ExtVa107	Associated value 7 for messages (MsgEvID1)	ANY	
ExtVa209	Associated value 9 for messages (MsgEvID2)	ANY	
ExtVa210	Associated value 10 for messages (MsgEvID2)	ANY	
FbkClosed	Low limit stop signal of position feedback	STRUCT <ul style="list-style-type: none"> Value: BOOL ST: BYTE 	- <ul style="list-style-type: none"> 0 16#80
FbkOpened	High limit stop signal of position feedback	STRUCT <ul style="list-style-type: none"> Value: BOOL ST: BYTE 	- <ul style="list-style-type: none"> 0 16#80
Feature	I/O for additional functions (Page 604)	STRUCT <ul style="list-style-type: none"> Bit 0: BOOL ... Bit 31: BOOL 	- <ul style="list-style-type: none"> 0 0 0
FM355	Module type: 0: FM 355 S; 1: FM 355 C	BOOL	0
FuzOptOn*	Fuzzy optimization	BOOL	0
Gain*	Proportional gain Gain.ST = 16#FF: Enabled in faceplate	STRUCT <ul style="list-style-type: none"> Value: REAL ST: BYTE 	- <ul style="list-style-type: none"> 1.0 16#FF
LogAddr	Logical address FM 355	INT	0
Man*	Manual specification for the manipulated variable	REAL	0.0
ManHiLim*	Limit (high) for manual parameter <i>Man</i>	REAL	100.0
ManLoLim*	Limit (low) for manual parameter <i>Man</i>	REAL	0.0
ManModLi*	1 = "Manual mode" via interconnection or SFC (controlled by <i>ModLiOp</i> = 1)	STRUCT <ul style="list-style-type: none"> Value: BOOL ST: BYTE 	- <ul style="list-style-type: none"> 0 16#80
ManModOp*	1 = "Manual mode" via OS operator (controlled by <i>ModLiOp</i> = 0)	BOOL	1
Mode	Operating mode	DWORD	16#00000000

Controller blocks

5.3 FmCont - Interface to module FM 355

Parameter	Description	Type	Default
ModLiOp	Operating mode switchover between: 0 = Operator 1 = Interconnection or SFC	STRUCT • Value: BOOL • ST: BYTE	- • 0 • 16#80
MotorTime*	Motor actuating time [s]	REAL	30.0
MS	Maintenance status	DWORD	0
MS_Release	Release for maintenance (interconnected with MS_Release of the technology block)	STRUCT • Value: BOOL • ST: BYTE	- • 0 • 16#80
Ms_Ext	External maintenance status	DWORD	0
MS_RelOp*	1 = Release for maintenance by OS operator	BOOL	0
MsgEvID1	Message number (assigned automatically)	DWORD	16#00000000
MsgEvID2	Message number (assigned automatically)	DWORD	16#00000000
MsgLock	1 = Suppress process messages. See also the section Suppressing messages using the MsgLock parameter (Page 205) for more on this.	STRUCT • Value: BOOL • ST: BYTE	- • 0 • 16#80
MV_FmTrkOn	1 = Manipulated variable tracking in the FM	STRUCT • Value: BOOL • ST: BYTE	- • 0 • 16#80
MV_HiLim*	Limit (high) for manipulated variable MV	STRUCT • Value: REAL • ST: BYTE	- • 100.0 • 16#80
MV_LoLim*	Limit (low) for manipulated variable MV	STRUCT • Value: REAL • ST: BYTE	- • 0.0 • 16#80
MV_OpScale	OS display range for manipulated variable MV	STRUCT • High: REAL • Low: REAL	- • 100.0 • 0.0
MV_Safe*	Neutral position manipulated variable	REAL	0.0
MV_SafeOn	1 = Neutral position manipulated variable MV_Safe at output MV	STRUCT • Value: BOOL • ST: BYTE	- • 0 • 16#80
MV_Trk*	Tracking value for the manipulated variable MV	STRUCT • Value: REAL • ST: BYTE	- • 0.0 • 16#80
MV_TrkOn	1 = Tracking of manipulated variable MV	STRUCT • Value: BOOL • ST: BYTE	- • 0 • 16#80
MV_Unit	Unit of measure for manipulated variable	INT	1342

Parameter	Description	Type	Default
NegGain*	0 = Effective proportional gain $Gain_{Eff}$ is positive 1 = Effective proportional gain $Gain_{Eff}$ is negative	STRUCT <ul style="list-style-type: none"> Value: BOOL ST: BYTE 	- <ul style="list-style-type: none"> 0 16#80
NormMV	Manipulated variable range (MV) for standardizing the proportional gain (GAIN)	STRUCT <ul style="list-style-type: none"> High: REAL Low: REAL 	- <ul style="list-style-type: none"> 100.0 0.0
NormPV	Process value range (PV) for standardizing the proportional gain (GAIN)	STRUCT <ul style="list-style-type: none"> High: REAL Low: REAL 	- <ul style="list-style-type: none"> 100.0 0.0
Occupied	Occupied by batch control	BOOL	0
OosLi	Edge transition (0-1) = "Out of service", via interconnection or SFC	STRUCT <ul style="list-style-type: none"> Value: BOOL ST: BYTE 	- <ul style="list-style-type: none"> 0 16#80
OosOp*	1 = "Out of service", via OS operator	BOOL	0
OP_Sel*	Operation via OP 0 = "Off" (P bus) 1 = "On" (K bus)	BOOL	0
OpenLi*	1 = Open via interconnection or CFC	STRUCT <ul style="list-style-type: none"> Value: BOOL ST: BYTE 	- <ul style="list-style-type: none"> 0 16#80
OpenOp*	1 = Open via operator	BOOL	0
OptimEn	1 = Enable optimization of PID parameters by PID tuner	BOOL	0
OptimOcc	1 = Optimization running	BOOL	0
OpSt_In	Input parameter for local operator authorization, connected with the Out output parameter of the upstream block, OpStations (Page 411)	DWORD	16#00000000
OS_Perm	I/O for operator permissions (Page 604)	STRUCT <ul style="list-style-type: none"> Bit 0: BOOL ... Bit 31: BOOL 	- <ul style="list-style-type: none"> 1 1 1
OS1Perm	I/O for operator permissions (Page 604)	STRUCT <ul style="list-style-type: none"> Bit 0: BOOL Bit 18: BOOL Bit 19: BOOL Bit 31: BOOL 	- <ul style="list-style-type: none"> 1 1 1 1
P_FbkSel*	1 = P component in feedback	BOOL	0
PropSel*	1 = Activate P component	BOOL	1
PulseTime*	Minimum pulse duration [s]	REAL	1.0
PV_A_DC*	Delay time for incoming PV alarms [s]	REAL	0.0
PV_A_DG*	Delay time for outgoing PV alarms [s]	REAL	0.0

Controller blocks

5.3 FmCont - Interface to module FM 355

Parameter	Description	Type	Default
PV_AH_En	1 = Enable PV alarm limit (high)	BOOL	1
PV_AH_Lim	Limit PV alarm (high)	REAL	95.0
PV_AH_MsgEn	1 = Enable PV alarm (high) message	BOOL	1
PV_AL_En	1 = Enable PV alarm limit (low)	BOOL	1
PV_AL_Lim	PV alarm limit (low)	REAL	5.0
PV_AL_MsgEn	1 = Enable PV alarm (low) message	BOOL	1
PV_Hyst	Hysteresis for PV alarm, warning and tolerance limits	REAL	1.0
PV_OpScale	Limit for scale in PV bar graph of face-plate	STRUCT <ul style="list-style-type: none"> • High: REAL • Low: REAL 	- <ul style="list-style-type: none"> • 100.0 • 0.0
PV_T_DC*	Delay time for incoming PV tolerance messages [s]	REAL	0.0
PV_T_DG*	Delay time for outgoing PV tolerance messages [s]	REAL	0.0
PV_TH_En	1 = Enable PV tolerance limit (high)	BOOL	0
PV_TH_Lim	Limit PV tolerance message (high)	REAL	85.0
PV_TH_MsgEn	1 = Enable message for PV tolerance message (high)	BOOL	1
PV_TL_En	1 = Enable PV tolerance limit (low)	BOOL	0
PV_TL_Lim	Limit PV tolerance message (low)	REAL	15.0
PV_TL_MsgEn	1 = Activate message for PV tolerance message (low)	BOOL	1
PV_Unit	Unit of measure for process value	INT	1001
PV_W_DC*	Delay time for incoming PV warnings [s]	REAL	0.0
PV_W_DG*	Delay time for outgoing PV warnings [s]	REAL	0.0
PV_WH_En	1 = Enable PV warning limit (high)	BOOL	1
PV_WH_Lim	Limit PV warning (high)	REAL	90.0
PV_WH_MsgEn	1 = Enable PV warning (high) message	BOOL	1
PV_WL_En	1 = Enable PV warning limit (low)	BOOL	1
PV_WL_Lim	Limit PV warning (low)	REAL	10.0
PV_WL_MsgEn	1 = Enable PV warning (low) message	BOOL	1
RackNo	Rack number	BYTE	16#FF
Rbk*	Position feedback for display on OS	STRUCT <ul style="list-style-type: none"> • Value: REAL • ST: BYTE 	- <ul style="list-style-type: none"> • 0.0 • 16#FF
RbkHyst	Alarm hysteresis for position feedback	REAL	1.0
RbkWH_En	1 = Enable warning (high) for position feedback	BOOL	1
RbkWH_Lim	Limit for position feedback of warning (high)	REAL	100.0
RbkWH_MsgEn	1 = Enable messages for warning (high) for position feedback	BOOL	1

Parameter	Description	Type	Default
RbkWL_En	1 = Enable warning (low) for position feedback	BOOL	1
RbkWL_Lim	Limit for position feedback of warning (low)	REAL	0.0
RbkWL_MsgEn	1 = Enable messages for warning (low) for position feedback	BOOL	1
RefStdDevIn	Reference value of PV standard deviation (sigma) in defined "good" state of control loop	STRUCT <ul style="list-style-type: none"> Value: REAL ST: BYTE 	- <ul style="list-style-type: none"> 0.0 16#78
RunUpCyc	Number of cycles in startup; messages are suppressed during these cycles	INT	3
S_RbkOnPIDTun	Simulation of position feedback on; For PCS 7 PID tuner only	BOOL	0
S_RbkPIDTun	Simulated position feedback	REAL	50.0
SampleTime	Sampling time [s] (assigned automatically)	REAL	0.1
SelfP1	Call a block saved in this parameter as an additional faceplate (Page 208) in the standard view	ANY	-
SelfP2	Call a block saved in this parameter as an additional faceplate (Page 208) in the preview	ANY	-
SimLiOp	Activation/deactivation of the simulation by: 0 = Operator 1 = Interconnection or SFC	STRUCT <ul style="list-style-type: none"> Value: BOOL ST: BYTE 	- <ul style="list-style-type: none"> 0 16#80
SimOnLi	1 = Simulation via interconnection or SFC (controlled by SimLiOp = 1)	STRUCT <ul style="list-style-type: none"> Value: BOOL ST: BYTE 	- <ul style="list-style-type: none"> 0 16#80
SimOn*	1 = Simulation on	BOOL	0
SimPV*	Process value used for SimOn = 1	REAL	0.0
SimPV_Li	Process value that is used for SimOnLi.Value = 1 (SimLiOp.Value = 1)	STRUCT <ul style="list-style-type: none"> Value: REAL ST: BYTE 	- <ul style="list-style-type: none"> 0.0 16#80
SimRbk*	Position feedback used for SimOn = 1	REAL	0.0
SimRbkLi	Position feedback used for SimOnLi.Value = 1 (SimLiOp.Value = 1)	STRUCT <ul style="list-style-type: none"> Value: REAL ST: BYTE 	- <ul style="list-style-type: none"> 0.0 16#80
SlotNo	Slot number	BYTE	16#FF
SP_DnRaLim	Limit (low) for the gradient of the setpoint [SP_Unit/s]	REAL	100.0
SP_ExHiLim*	Limit (high) for external setpoint	STRUCT <ul style="list-style-type: none"> Value: REAL ST: BYTE 	- <ul style="list-style-type: none"> 100.0 16#80

Controller blocks

5.3 FmCont - Interface to module FM 355

Parameter	Description	Type	Default
SP_ExLoLim*	Limit (low) for external setpoint	STRUCT <ul style="list-style-type: none"> Value: REAL ST: BYTE 	- <ul style="list-style-type: none"> 0.0 16#80
SP_Ext*	External setpoint of - (to interconnection)	STRUCT <ul style="list-style-type: none"> Value: REAL ST: BYTE 	- <ul style="list-style-type: none"> 0.0 16#80
SP_ExtLi*	1 = Select external setpoint (via interconnection)	STRUCT <ul style="list-style-type: none"> Value: BOOL ST: BYTE 	- <ul style="list-style-type: none"> 0 16#80
SP_ExtOp*	1 = Select external setpoint (via operator)	BOOL	0
SP_InHiLim*	Limit (high) of internal setpoint	REAL	100.0
SP_InLoLim*	Limit (low) of internal setpoint	REAL	0.0
SP_Int*	Internal setpoint for operation	REAL	0.0
SP_IntLi*	1 = Select internal setpoint (via interconnection)	STRUCT <ul style="list-style-type: none"> Value: BOOL ST: BYTE 	- <ul style="list-style-type: none"> 0 16#80
SP_IntOp*	1 = Select internal setpoint (via operator)	BOOL	0
SP_LiOp	Select setpoint source (internal/external): 1 = Via interconnection 0 = Via operator	STRUCT <ul style="list-style-type: none"> Value: BOOL ST: BYTE 	- <ul style="list-style-type: none"> 0 16#80
SP_RateOn*	1 = Activate limitation of setpoint gradients	BOOL	0
SP_RmpModTime	1 = Use time (SP_RmpTime) for setpoint ramp, 0 = Use gradient	BOOL	0
SP_RmpOn*	1 = Activate setpoint ramp to target setpoint SP_RmpTarget	BOOL	0
SP_RmpTarget*	Target setpoint for setpoint ramp	REAL	0.0
SP_RmpTime*	Time for setpoint ramp [s] from current SP up to SP_RmpTarget	REAL	0.0
SP_TrkExt	1 = Bumpless switchover from external to internal setpoint active	BOOL	1
SP_TrkPV	1 = Setpoint follows PV in "manual mode" and with tracking	BOOL	0
SP_UpRaLim	Gradient limit (high) for the setpoint [SP_Unit/s]	REAL	100.0
StepCon	Controller type in the FM 355 S: 0 = Pulse controller 1 = Step controller	BOOL	0
StepNo	Batch step number	DWORD	16#00000000

Parameter	Description	Type	Default
StopLi*	1 = Stop via interconnection or CFC	STRUCT <ul style="list-style-type: none"> Value: BOOL ST: BYTE 	- <ul style="list-style-type: none"> 0 16#80
StopOp*	1 = Stop via operator	BOOL	0
SubN1_ID	ID of the primary DP master system	BYTE	16#FF
SubN2_ID	ID of the redundant DP master system	BYTE	16#FF
TD*	Derivative time [s] TD.ST = 16#FF: Enabled in faceplate	STRUCT <ul style="list-style-type: none"> Value: REAL ST: BYTE 	- <ul style="list-style-type: none"> 0.0 16#FF
TextRef	Text reference	WORD	0
TI*	Integral time [s] TI.ST = 16#FF: Enabled in faceplate	STRUCT <ul style="list-style-type: none"> Value: REAL ST: BYTE 	- <ul style="list-style-type: none"> 100.0 16#FF
TimeFactor	Time unit: 0 = Seconds 1 = Minutes 2 = Hours	INT	0
UserStatus	Freely assignable bits for use in PCS 7 OS	BYTE	16#00

* Values can be written back to these inputs during processing of the block by the block algorithm.

In/out parameters

Parameter	Description	Type	Default
DataXchg	Internal data exchange channel to the diagnostics block	DWORD	16#00000000
DataXchg1	Internal data exchange channel to the diagnostics block	DWORD	16#00000000
EnCoord	Current coordination number	STRUCT <ul style="list-style-type: none"> CO_ACT : INT 	- <ul style="list-style-type: none"> 0
MS_Xchg	Exchange of the maintenance status	DWORD	16#00000000

Output parameters

Parameter	Description	Type	Default
AdvCoAct	1 = "Program mode" enabled	STRUCT <ul style="list-style-type: none"> Value: BOOL ST: BYTE 	- <ul style="list-style-type: none"> 0 16#80
AdvCoRdy	1 = "Program mode" available	STRUCT <ul style="list-style-type: none"> Value: BOOL ST: BYTE 	- <ul style="list-style-type: none"> 0 16#80

Controller blocks

5.3 FmCont - Interface to module FM 355

Parameter	Description	Type	Default
AutAct	1 = "Automatic mode" enabled	STRUCT <ul style="list-style-type: none"> Value: BOOL ST: BYTE 	- <ul style="list-style-type: none"> 0 16#80
ChFM_Err	1 = Channel error on the module	BOOL	0
Close	Control output: 1 = Closed is active	STRUCT <ul style="list-style-type: none"> Value: BOOL ST: BYTE 	- <ul style="list-style-type: none"> 0 16#80
EnCoNum	Coordination number	BYTE	16#00
ENO	1 = Block algorithm completed without errors	BOOL	0
ER	Error signal	STRUCT <ul style="list-style-type: none"> Value: REAL ST: BYTE 	- <ul style="list-style-type: none"> 0.0 16#80
ER_AH_Act	1 = Alarm limit (high) for control deviation violated. You can change the reaction for this parameter with <i>Feature</i> bit 28 (Disabling operating points (Page 145)) and with <i>Feature</i> bit 29 (Signaling limit violation (Page 170)).	STRUCT <ul style="list-style-type: none"> Value: BOOL ST: BYTE 	- <ul style="list-style-type: none"> 0 16#80
ER_AL_Act	1 = Alarm limit (low) for control deviation violated. You can change the reaction for this parameter with <i>Feature</i> bit 28 (Disabling operating points (Page 145)) and with <i>Feature</i> bit 29 (Signaling limit violation (Page 170)).	STRUCT <ul style="list-style-type: none"> Value: BOOL ST: BYTE 	- <ul style="list-style-type: none"> 0 16#80
ErrorNum	Output of pending error number; for error numbers that can be output by this block, see FmCont error handling (Page 614)	INT	-1
FbkClsOut	1 = Low limit stop of the position feedback reached	STRUCT <ul style="list-style-type: none"> Value: BOOL ST: BYTE 	- <ul style="list-style-type: none"> 0 16#80
FbkOpnOut	1 = High limit stop of the position feedback reached	STRUCT <ul style="list-style-type: none"> Value: BOOL ST: BYTE 	- <ul style="list-style-type: none"> 0 16#80
FFwdOut	Disturbance variable generated in the FM	STRUCT Value: REAL ST: BYTE	- 0.0 16#80
FuzCon	Controller type: 0 = PID controller 1 = Fuzzy controller	BOOL	0
FuzOptAct	1 = Optimization of fuzzy controller active	BOOL	0
FuzSP_PV_Act	Fuzzy controller display: Setpoint < actual value	BOOL	0

Parameter	Description	Type	Default
GainEff	Effective proportional gain depends on NegGain, Gain, NormPV, and NormMV	REAL	1.0
GrpErr	1 = Group error pending	STRUCT <ul style="list-style-type: none"> Value: BOOL ST: BYTE 	- <ul style="list-style-type: none"> 0 16#80
LoopClosed	1 = Control loop closed 0 = Control loop open	STRUCT <ul style="list-style-type: none"> Value: BOOL ST: BYTE 	- <ul style="list-style-type: none"> 0 16#80
ManAct	1 = "Manual mode" enabled	STRUCT <ul style="list-style-type: none"> Value: BOOL ST: BYTE 	- <ul style="list-style-type: none"> 1 16#80
ManARW_Act	1 = Tracking mode or anti-reset windup by secondary controller	STRUCT <ul style="list-style-type: none"> Value: BOOL ST: BYTE 	- <ul style="list-style-type: none"> 0 16#80
ManHiOut	Limit (high) for "manual mode", corresponds to input parameter ManHiLim	STRUCT <ul style="list-style-type: none"> Value: REAL ST: BYTE 	- <ul style="list-style-type: none"> 100.0 16#80
ManLoOut	Limit (low) for "manual mode", corresponds to input parameter ManLoLim	STRUCT <ul style="list-style-type: none"> Value: REAL ST: BYTE 	- <ul style="list-style-type: none"> 0.0 16#80
ModErr	1 = Module error	STRUCT <ul style="list-style-type: none"> Value: BOOL ST: BYTE 	- <ul style="list-style-type: none"> 0 16#80
MS_Dev	Maintenance state	DWORD	16#00000000
MS_Release	Release for maintenance: 1 = Release for OS operator	STRUCT <ul style="list-style-type: none"> Value: BOOL ST: BYTE 	- <ul style="list-style-type: none"> 0 16#80
MS_Req	1 = Maintenance request from the diagnostic area	STRUCT <ul style="list-style-type: none"> Value: BOOL ST: BYTE 	- <ul style="list-style-type: none"> 0 16#80
MsgAckn1	Message acknowledgement status 1 (output ACK_STATE of first ALARM_8P)	WORD	16#0000
MsgAckn2	Message acknowledgement status 2 (output ACK_STATE of second ALARM_8P)	WORD	16#0000
MsgErr1	Alarm error 1 (output ERROR of first ALARM_8P)	BOOL	0
MsgErr2	Alarm error 2 (output ERROR of second ALARM_8P)	BOOL	0
MsgStat1	Message status 1 (output STATUS of first ALARM_8P)	WORD	16#0000
MsgStat2	Message status 2 (output STATUS of second ALARM_8P)	WORD	16#0000

Controller blocks

5.3 FmCont - Interface to module FM 355

Parameter	Description	Type	Default
MV	Manipulated variable	STRUCT <ul style="list-style-type: none"> Value: REAL ST: BYTE 	- <ul style="list-style-type: none"> 0.0 16#80
MV_FmTrkAct	1 = Track manipulated variable in the FM enabled	STRUCT <ul style="list-style-type: none"> Value: BOOL ST: BYTE 	- <ul style="list-style-type: none"> 0 16#80
MV_HiAct	1 = Limit (high) of manipulated variable violated	STRUCT <ul style="list-style-type: none"> Value: BOOL ST: BYTE 	- <ul style="list-style-type: none"> 0 16#80
MV_LoAct	1 = Limit (low) of manipulated variable violated	STRUCT <ul style="list-style-type: none"> Value: BOOL ST: BYTE 	- <ul style="list-style-type: none"> 0 16#80
MV_SafeAct	1 = Neutral position manipulated variable of the FM enabled	STRUCT <ul style="list-style-type: none"> Value: BOOL ST: BYTE 	- <ul style="list-style-type: none"> 0 16#80
MV_SpliA	Manipulated variable A of split-range function	STRUCT <ul style="list-style-type: none"> Value: REAL ST: BYTE 	- <ul style="list-style-type: none"> 0.0 16#80
MV_SpliB	Manipulated variable B of split-range function	STRUCT <ul style="list-style-type: none"> Value: REAL ST: BYTE 	- <ul style="list-style-type: none"> 0.0 16#80
MV_UnitOut	Unit of measure for manipulated variable, for interconnecting to the MV_Unit input parameter of the ConPerMon block	INT	0
MV_Visible	1 = MV display visible Evaluated by block icon	BOOL	0
OosAct	1 = Block is "Out of service"	STRUCT <ul style="list-style-type: none"> Value: BOOL ST: BYTE 	- <ul style="list-style-type: none"> 0 16#80
Open	Control output: 1 = Open is active	STRUCT <ul style="list-style-type: none"> Value: BOOL ST: BYTE 	- <ul style="list-style-type: none"> 0 16#80
OpSt_Out	Value of the OpSt_In input parameter, for feedforwarding to other blocks. Bit 31 of this parameter is used by Feature bit 24	DWORD	16#00000000
OS_PermOut	Display of OS_Perm	DWORD	16#FFFFFFFF
OS_PermLog	Display of OS_Perm with settings changed by the block algorithm	DWORD	16#FFFFFFFF
OS1PermOut	Display of OS_Perm1	DWORD	16#FFFFFFFF
OS1PermLog	Display of OS1Perm with settings changed by the block algorithm	DWORD	16#FFFFFFFF

Parameter	Description	Type	Default
ParFM_Err	1 = Direct parameter-assignment error of the FM or input Channel configured incorrectly	BOOL	0
PerAccErr	1 = I/O access error	BOOL	0
PV	Process value of the module	STRUCT <ul style="list-style-type: none"> Value: REAL ST: BYTE 	- <ul style="list-style-type: none"> 0.0 16#80
PV_AH_Act	1 = PV alarm (high) active. You can change the reaction for this parameter with Feature bit 28 (Disabling operating points (Page 145)) and with Feature bit 29 (Signaling limit violation (Page 170)).	STRUCT <ul style="list-style-type: none"> Value: BOOL ST: BYTE 	- <ul style="list-style-type: none"> 0 16#80
PV_AL_Act	1 = PV alarm (low) active. You can change the reaction for this parameter with Feature bit 28 (Disabling operating points (Page 145)) and with Feature bit 29 (Signaling limit violation (Page 170)).	STRUCT <ul style="list-style-type: none"> Value: BOOL ST: BYTE 	- <ul style="list-style-type: none"> 0 16#80
PV_Out	Output for process value	STRUCT <ul style="list-style-type: none"> Value: REAL ST: BYTE 	- <ul style="list-style-type: none"> 0.0 16#80
PV_TH_Act	1 = PV tolerance message (high) active. You can change the reaction for this parameter with Feature bit 28 (Disabling operating points (Page 145)) and with Feature bit 29 (Signaling limit violation (Page 170)).	STRUCT <ul style="list-style-type: none"> Value: BOOL ST: BYTE 	- <ul style="list-style-type: none"> 0 16#80
PV_TL_Act	1 = PV tolerance message (low) active. You can change the reaction for this parameter with Feature bit 28 (Disabling operating points (Page 145)) and with Feature bit 29 (Signaling limit violation (Page 170)).	STRUCT <ul style="list-style-type: none"> Value: BOOL ST: BYTE 	- <ul style="list-style-type: none"> 0 16#80
PV_ToleHi	Limit (high) of 3-sigma band around the setpoint is calculated when a ConPerMon block is connected	STRUCT <ul style="list-style-type: none"> Value: REAL ST: BYTE 	- <ul style="list-style-type: none"> 0.0 16#80
PV_ToleLo	Limit (low) of 3-sigma band around the setpoint is calculated when a ConPerMon block is connected	STRUCT <ul style="list-style-type: none"> Value: REAL ST: BYTE 	- <ul style="list-style-type: none"> 0.0 16#80
PV_UnitOut	Unit of measure for process value, for interconnecting to the PV_Unit input parameter of the ConPerMon block	INT	0

Parameter	Description	Type	Default
PV_WH_Act	1 = PV warning (high) active. You can change the reaction for this parameter with <code>Feature</code> bit 28 (Disabling operating points (Page 145)) and with <code>Feature</code> bit 29 (Signaling limit violation (Page 170)).	STRUCT • Value: BOOL • ST: BYTE	- • 0 • 16#80
PV_WL_Act	1 = PV warning (low) active. You can change the reaction for this parameter with <code>Feature</code> bit 28 (Disabling operating points (Page 145)) and with <code>Feature</code> bit 29 (Signaling limit violation (Page 170)).	STRUCT • Value: BOOL • ST: BYTE	- • 0 • 16#80
RbkOut	Output for position feedback	STRUCT • Value: REAL • ST: BYTE	- • 0.0 • 16#80
RbkVisible	1 = Rbk display visible Evaluated by block icon	BOOL	0
RbkWH_Act	1 = Warning (high) for position feedback active. You can change the reaction for this parameter with <code>Feature</code> bit 28 (Disabling operating points (Page 145)) and with <code>Feature</code> bit 29 (Signaling limit violation (Page 170)).	STRUCT • Value: BOOL • ST: BYTE	- • 0 • 16#80
RbkWL_Act	1 = Warning (low) for position feedback active. You can change the reaction for this parameter with <code>Feature</code> bit 28 (Disabling operating points (Page 145)) and with <code>Feature</code> bit 29 (Signaling limit violation (Page 170)).	STRUCT • Value: BOOL • ST: BYTE	- • 0 • 16#80
RdyToStart	1 = Active start readiness	STRUCT • Value: BOOL • ST: BYTE	- • 0 • 16#80
RetVal	Return value of <code>WRREC</code> / <code>RDREC</code>	WORD	16#0000
SP	Setpoint used by controller	STRUCT • Value: REAL • ST: BYTE	- • 0.0 • 16#80
SP_DnRaAct	1 = Negative gradient limiting of setpoint is active	STRUCT • Value: BOOL • ST: BYTE	- • 0 • 16#80
SP_ExHiAct	1 = Limit (high) for external setpoint has been reached	STRUCT • Value: BOOL • ST: BYTE	- • 0 • 16#80

Parameter	Description	Type	Default
SP_ExLoAct	1 = Limit (low) for external setpoint has been reached	STRUCT <ul style="list-style-type: none"> Value: BOOL ST: BYTE 	- <ul style="list-style-type: none"> 0 16#80
SP_ExtAct	1 = External setpoint is active 0 = Internal setpoint is active	STRUCT <ul style="list-style-type: none"> Value: BOOL ST: BYTE 	- <ul style="list-style-type: none"> 0 16#80
SP_ExtOut	External setpoint, corresponds to input parameter SP_Ext	STRUCT <ul style="list-style-type: none"> Value: REAL ST: BYTE 	- <ul style="list-style-type: none"> 0.0 16#80
SP_InHiOut	Limit (high) for SP_Int corresponds to input parameter SP_InHiLim	STRUCT <ul style="list-style-type: none"> Value: REAL ST: BYTE 	- <ul style="list-style-type: none"> 100.0 16#80
SP_InLoOut	Limit (low) for SP_Int corresponds to input parameter SP_InLoLim	STRUCT <ul style="list-style-type: none"> Value: REAL ST: BYTE 	- <ul style="list-style-type: none"> 0.0 16#80
SP_RateTarget	Target setpoint for the gradient limitation	REAL	0.0
SP_UpRaAct	Positive gradient limiting of setpoint is active	STRUCT <ul style="list-style-type: none"> Value: BOOL ST: BYTE 	- <ul style="list-style-type: none"> 0 16#80
ST_Worst	Worst signal status	BYTE	16#80
SplitRange	1 = Split-range function has been activated	BOOL	0
Status1	Status word 1 (Page 599)	DWORD	16#00000000
Status2	Status word 2 (Page 599)	DWORD	16#00000000
Status3	Status word 2 (Page 599)	DWORD	16#00000000
Stop	Control output: 1 = Stopped is active	STRUCT <ul style="list-style-type: none"> Value: BOOL ST: BYTE 	- <ul style="list-style-type: none"> 0 16#80
SumMsgAct	1 = Active hardware interrupt	STRUCT <ul style="list-style-type: none"> Value: BOOL ST: BYTE 	- <ul style="list-style-type: none"> 0 16#80
WithRbk	Controller type: 0 = Step controller without position feedback 1 = Step controller with position feedback	BOOL	0

See also

FmCont messaging (Page 616)

FmCont block diagram (Page 634)

FmCont modes (Page 603)

Neutral position for motors, valves and controllers (Page 48)

5.3.7 FmCont block diagram

FmCont block diagram

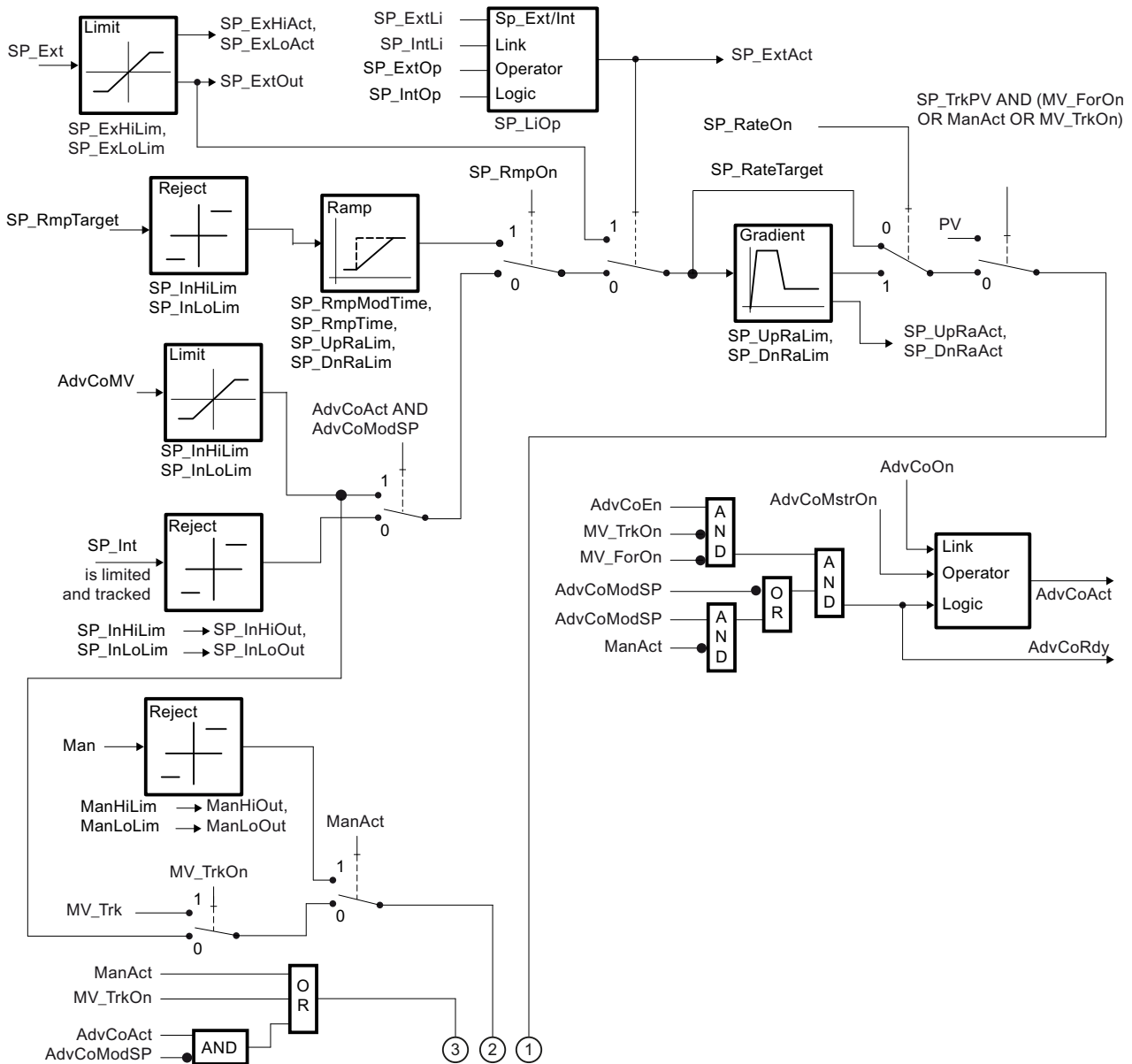

5.3 FmCont - Interface to module FM 355

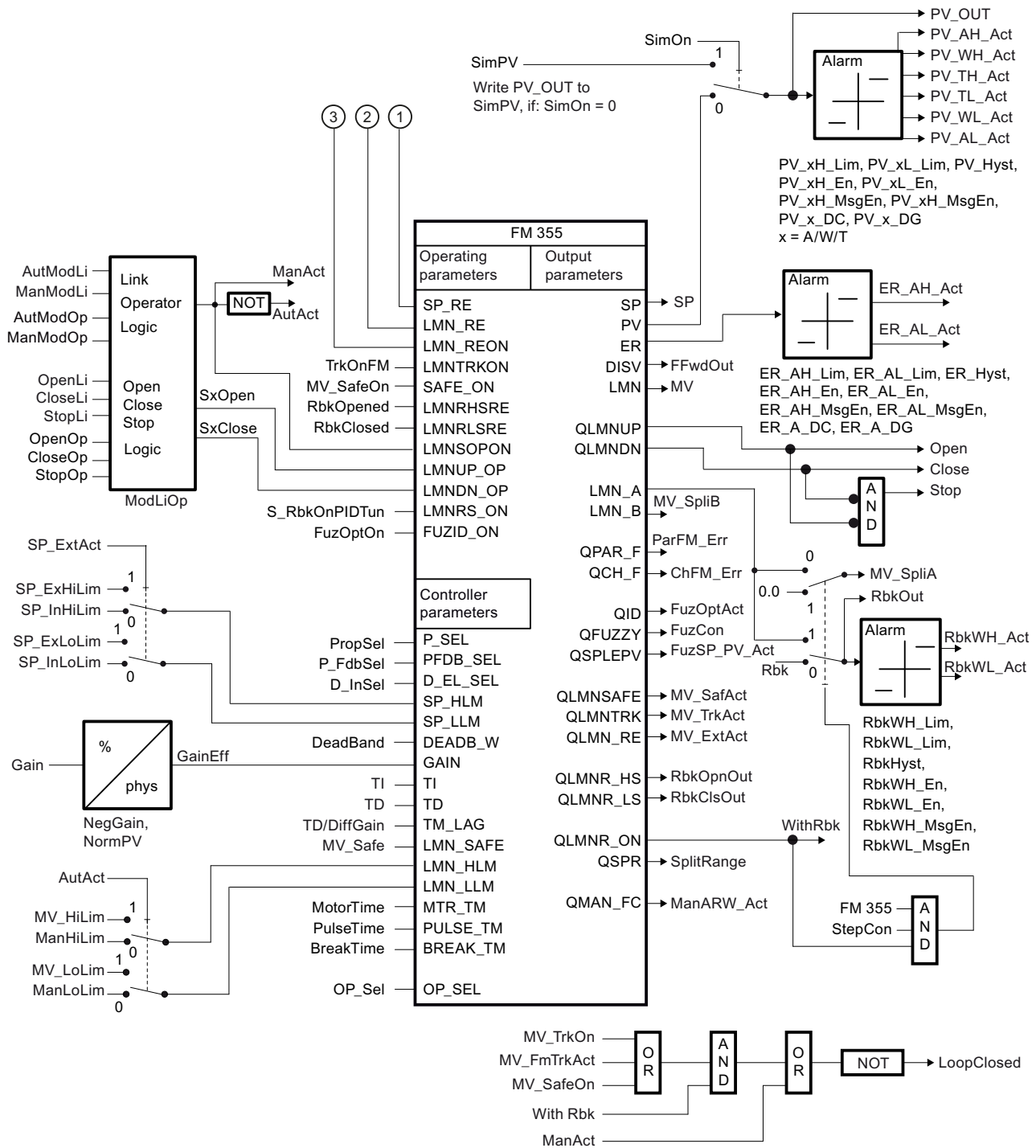

See also

- FmCont I/Os (Page 619)
- FmCont messaging (Page 616)
- FmCont error handling (Page 614)

FmCont functions (Page 604)

FmCont modes (Page 603)

Description of FmCont (Page 599)

5.3.8 Operator control and monitoring

5.3.8.1 FmCont views

Views of the FmCont block

The block FmCont provides the following views:

- FM controllers standard view (analog) (Page 261)
- FM controllers standard view (pulse controller) (Page 265)
- FM controllers standard view (step controller with position feedback) (Page 269)
- FM controllers standard view (step controller without position feedback) (Page 273)
- Alarm view (Page 302)
- Limit view of FM controllers (Page 288)
- Trend view (Page 305)
- Ramp view (Page 300)
- Parameter view of FM controllers (Page 284)
- Preview of FM controllers (Page 297)
- Memo view (Page 304)
- Batch view (Page 302)
- Block icons for PID and FM controller (Page 239)

Refer to the Structure of the faceplate (Page 248) and Block icon structure (Page 230) sections for general information about the faceplate and block icon.

5.4 FmTemp - Interface to temperature controller modules FM 355-2

5.4.1 Description of FmTemp

Object name (type + number) and family

Type + number: FB 1819

Family: Control

Area of application for FmTemp

The block is used for the following applications:

- Fixed setpoint control
- Cascade control
- Ratio control
- Split-range control

How it works

Block FmTemp is used to interface the FM 355-2 temperature controller modules.

FmTemp can be used for the C (continuous controllers) and S (step and pulse controllers) module types. It contains the algorithms of the setpoint ramp, the setpoint rise limitation, and the limit monitoring of the process value, the control deviation, and the position feedback. Limit monitoring is not used on the module.

The control function itself (e.g. PID algorithm) is processed on the module. You can use the FmTemp block to monitor all relevant process values and to change all relevant controller parameters.

Application examples of the FM 355-2 and detailed descriptions of the associated input and output parameters can be found in the manual of the FM 355-2. temperature controller.

It is primarily used for controlling temperature processes, but can also control level and flow processes which are not excessively fast, for example.

Module FM 355-2 features online optimization of the PID parameters. You can set the corresponding parameters for performing online optimization in the CFC chart at block FmTemp .

Configuration

Use the CFC editor to install the block in a cyclic interrupt OB (OB30 to OB38). The block is also installed automatically in the startup OB (OB100). Set the input `LogAddr` to the module address from HW Config and the input `Channel` to the desired controller channel (0 ... 3)..

When the CFC function "Generate module drivers" is used, the following occurs automatically:

- The parameter `CoordNo` is set
- The in/out parameter `Mode` is interconnected to the corresponding `OMODE_xx` output parameter of the MOD block.
- The parameter `FM_355_2` is set in accordance with the module type C/S
- The in/out parameter `EnCoord` is interconnected to the output `EN_CO_x` of the FM_CO block of the Basis Library (x = number of the rack)
- The output `EnCoNum` is interconnected to the input `ENCOx_yy` of the FM_CO block (x = number of the rack, yy = coordination number).

For the control loop monitoring to work as planned in the trend view of the controller faceplates, the

`S7_xarchive:='Value, shortterm;'`

attributes in the process tag types for control loops at the controller function block must be set for the following tags:

- Input parameters:
 - `CPI_In`
- Output parameters
 - `MV`
 - `MV_HiAct`
 - `MV_LoAct`
 - `LoopClosed`
 - `SP`
 - `PV_Out`
 - `PV_ToleHi`
 - `PV_ToleLo`

Startup characteristics

Use the `Feature Set` startup characteristics (Page 138) to define the startup characteristics of this block.

The messages are suppressed after startup for the number of cycles set at `RunUpCyc`.

Status word allocation for `Status1` parameter

You can find a description for each parameter in section FmTemp I/Os (Page 658).

Status bit	Parameter
0	Occupied
1	BatchEn
2	SimOn

5.4 FmTemp - Interface to temperature controller modules FM 355-2

Status bit	Parameter
3	OosAct.Value
4	OosLi.Value
5	AutAct.Value
6	Not used
7	ManAct.Value
8	SP_ExtAct.Value
9	MV_SafeOn.Value
10	MV_TrkOn.Value
11	MV.Value > ManLoLim for continuous or pulse controller NOT FbkClosed.Value for step controller with/without position feedback
12	Open.Value
13	Close.Value
14	Stop.Value
15	FbkOpened.Value
16	FbkClosed.Value
17	SimOn AND ManAct
18	SimOn AND ManAct
19	AdvCoAct
20	1 = Input parameter Rbk is not interconnected (RbkOut.ST = 16#FF)
21	NegGain
22 - 27	Not used
28	1 = Analog controller (FM 355_2 = 1)
29	1 = Pulse controller (FM 355_2 = 0 AND StepCon = 0)
30	1 = Step controller with position feedback (FM 355_2 = 0 AND StepCon = 1 AND WithRbk = 1)
31	1 = Step controller without position feedback (FM 355_2 = 0 AND StepCon = 1 AND WithRbk = 0)

Status word allocation for status2 parameter

Status bit	Parameter
0	MsgLock
1	PV_AH_Act.Value
2	PV_WH_Act.Value
3	PV_TH_Act.Value
4	PV_TL_Act.Value
5	PV_WL_Act.Value
6	PV_AL_Act.Value
7	PV_AH_En
8	PV_WH_En
9	PV_TH_En
10	PV_TL_En

5.4 FmTemp - Interface to temperature controller modules FM 355-2

Status bit	Parameter
11	PV_WL_En
12	PV_AL_En
13	PV_AH_MsgEn
14	PV_WH_MsgEn
15	PV_TH_MsgEn
16	PV_TL_MsgEn
17	PV_WL_MsgEn
18	PV_AL_MsgEn
19	ER_AH_Act.Value
20	ER_AL_Act.Value
21	ER_AH_En
22	ER_AL_En
23	ER_AH_MsgEn
24	ER_AL_MsgEn
25	RbkWH_Act.Value
26	RbkWL_Act.Value
27	RbkWH_En
28	RbkWL_En
29	RbkWH_MsgEn
30	RbkWL_MsgEn
31	MS_RelOp

Status word allocation for Status3 parameter

Status bit	Parameter
0	Effective signal 1 of the message block connected via EventTsIn
1	Effective signal 2 of the message block connected via EventTsIn
2	Effective signal 3 of the message block connected via EventTsIn
3	Effective signal 4 of the message block connected via EventTsIn
4	Effective signal 5 of the message block connected via EventTsIn
5	Effective signal 6 of the message block connected via EventTsIn
6	Effective signal 7 of the message block connected via EventTsIn
7	Effective signal 8 of the message block connected via EventTsIn
8	Delay of the PV_AH_Lim message
9	Delay of the PV_WH_Lim message
10	Delay of the PV_TH_Lim message
11	Delay of the PV_TL_Lim message
12	Delay of the PV_WL_Lim message
13	Delay of the PV_AL_Lim message
14	Delay of the ER_AH_Lim message
15	Delay of the ER_AL_Lim message
16	Collection of message delays

Status bit	Parameter
17 - 26	Not used
27	SP_UpRaAct, SP_DnRaAct limits enabled for gradient mode (SP_RateOn = 1)
28	GrpErr.Value
29	RdyToStart.Value
30	SimLiOp.Value
31	Not used

Status word allocation for Status4 parameter

Status bit	Parameter
0 - 7	Effective signal 9..16 of the message block connected via EventTsIn
8 - 31	Not used

See also

- FmTemp functions (Page 642)
- FmTemp messaging (Page 655)
- FmTemp modes (Page 641)
- FmTemp error handling (Page 654)
- FmTemp block diagram (Page 675)

5.4.2 FmTemp modes

FmTemp operating modes

The block can be operated using the following modes:

- Automatic mode (Page 72)
- Manual mode (Page 72)
- Program mode for controllers (Page 78)
- Out of service (Page 71)

The next section provides additional block-specific information relating to the general descriptions.

"Automatic mode"

You can find general information on "Automatic mode", switching modes and bumpless switchover in the Manual and automatic mode for control blocks (Page 72) section.

"Manual mode"

You can find general information on "Manual mode", switching modes and bumpless switchover in the Manual and automatic mode for control blocks (Page 72) section.

"Program mode for controllers"

General information on "Program mode for controllers" is available in the section Program mode for controllers (Page 78).

"Out of service"

You can find general information about the "Out of service" mode in the section Out of service (Page 71).

See also

- Description of FmTemp (Page 637)
- FmTemp functions (Page 642)
- FmTemp error handling (Page 654)
- FmTemp messaging (Page 655)
- FmTemp I/Os (Page 658)
- FmTemp block diagram (Page 675)

5.4.3 FmTemp functions

Functions of FmTemp

The functions for this block are listed below.

Module types

FmTemp can be used for the C (continuous controllers) and S (step controllers with and without position feedback and pulse controllers) module types. You can use the following parameters to identify which module type and controller type has been set:

FM 355	StepCon	WithRbk	Module type, controller type
1 or C	-	-	FM 355-2 C: Continuous controller
0 or S	1	1	FM 355-2 S: Step controller with position feedback
0 or S	1	0	FM 355-2 S: Step controller without position feedback
0 or S	0	-	FM 355-2 S: Pulse controller

Generating manipulated variables for continuous controllers, step controllers with position feedback, or pulse controllers

The manipulated variable *MV* and the actuating signals *Open*, *Close* and *Stop* are generated as follows:

MV_Safe-On	MV_FMTrk-On	ManAct	MV_TrkOn	AdvCoAct AND NOT AdvCo-ModSP	MV =	Manipulated variable limit	State	Open, Close, Stop
1	-	-	-	-	MV_Safe	MV_HiLim MV_LoLim	Tracking to safety value	Cont. controller: Open, Close, Stop = 0 Step controller with position feedback: Depending on Rbk and MV, the output signals Open, Close and Stop are generated using the algorithm of a positioner. Pulse controller: Depending on MV, the output signals Open and Close are generated using the algorithm of a pulse controller (Stop = 0).
0	1	-	-	-	Prepared FM analog input	MV_HiLim MV_LoLim	Tracking to an FM analog input	
0	0	1	-	-	Man	ManHiLim ManLoLim	Manual mode, set by the operator	
0	0	0	1	-	MV_Trk	MV_HiLim MV_LoLim	Tracking to block input MV_Trk	
0	0	0	0	1	AdvCoMV	MV_HiLim MV_LoLim	Higher-level program mode	
0	0	0	0	0	P_Part + I_Part + D_Part + FFwd	MV_HiLim MV_LoLim	Automatic mode (PID algorithm)	

Generating actuating signals for step controllers without position feedback (WithRbk = 0)

The manipulated variable signals `Open`, `Close` and `Stop` can be generated as follows:

ManAct	Open, Close, Stop	State	ManAct
1	The output signals are generated using input signals <code>OpenOp/Li</code> , <code>CloseOp/Li</code> or <code>StopOp/Li</code>	Manual mode, set by the operator	1
0	The output signals are generated using PID output variables <code>P_Part</code> , <code>I_Part</code> , <code>D_Part</code> and <code>FFwd</code>	Automatic mode (PID algorithm)	0

Tracking and limiting a manipulated variable (cont. controller, step controller with position feedback and pulse controller)

The block provides the standard function Tracking and limiting a manipulated variable (Page 196).

Neutral position

The controller modules have their own mechanism for feedforwarding a safety value (see manual for Temperature Controller FM 355-2).

Group error

This block provides the standard function Outputting group errors (Page 122).

The following parameters are taken into consideration when forming the group error:

- `CSF`
- `ModErr`
- `ParFM_Err`
- `PerAccErr`

Outputting a signal for start readiness

This block provides the standard function Outputting a signal for start readiness (Page 53).

"Actuator active" information

For continuous and pulse controllers: If the manipulated variable `MV` is greater than the minimum manual limit `ManLoLim`, this is recognized as actuator active.

For step controllers: If the parameter `FbkClosed = 0`, this is recognized as "Actuator active".

This status can be used to indicate a customized symbol in the process image, for example, and is saved in the status word (see Status word section in Description of FmTemp (Page 637)).

Limit monitoring of position feedback (cont. controller, step controller with position feedback and pulse controller)

The block provides the standard function Limit monitoring of the feedback (Page 94).

Group display SumMsgAct for limit monitoring, CSF and ExtMsgx

The block provides the standard function Group display for limit monitoring, CSF and ExtMsgx (Page 85).

External/internal setpoint specification

The block provides the standard function Setpoint specification - internal/external (Page 128).

Setpoint limiting for external setpoints

The block provides the standard function Setpoint limiting for external setpoints (Page 196).

Limitation of rate of change of setpoint

The block provides the standard function Gradient limit of the setpoint (Page 124).

Using setpoint ramp

The block provides the standard function Using setpoint ramp (Page 123).

Tracking setpoint in manual mode

The block provides the standard function Tracking setpoint in manual mode (Page 196).

Simulating signals

The block provides the standard function Simulating signals (Page 58).

You can simulate the following values:

- Process value (*SimPV*, *SimPV_Li*)
- Position feedback (*SimRbk*, *SimRbkLi*)

Note

The simulated process value *SimPV* only affects alarm processing and not the PID algorithm in the control module.

Limit monitoring of the process value

The block provides the standard function Limit monitoring of the process value (Page 86).

Error signal generation and dead band

The block provides the standard function Error signal generation and dead band (Page 192).

Limit monitoring of error signal

The block provides the standard function Limit monitoring of setpoint, manipulated variable and control deviation (Page 95).

Inverting control direction

The block provides the standard function Inverting control direction (Page 192).

Physical standardization of setpoint, manipulated variable and process value

Controller gain *Gain* is entered either using a physical variable or as standardized value.

- *Gain* as a physical variable:

The standardized variables retain their default values:

- *NormPV.High* = 100 and *NormPV.Low* = 0
- *NormMV.High* = 100 and *NormMV.Low* = 0

For step controllers with/without position feedback and pulse controllers, the values of *NormMV.High* and *NormMV.Low* are not taken into account. The algorithm uses default values 0 and 100 for internal calculations.

The effective gain is: $GainEff = Gain$

- Entering a standardized *Gain* (dimensionless):

Change the standardized variables to the actual range of the process values and manipulated variables.

- Internal and external setpoints; the process value and corresponding parameters are entered according to the physical measuring range of the process value.

Continuous controller, pulse controller:

- The manual value, the tracking value of the manipulated variable, disturbance variable feedforward and the corresponding parameters are set according to the physical measuring range of the manipulated variable.

Step controller with position feedback:

- The manual parameter, the tracking value of the manipulated variable, disturbance variable feedforward and the corresponding parameters are entered as a percentage 0 ... 100.

Step controller without position feedback:

- No physical measuring range available.

The effective gain is:

- Step controller with/without position feedback:

$$GainEff = 100.0 / (NormPV.High - NormPV.Low) \cdot Gain$$

- Continuous controller, pulse controller:

$$GainEff = (NormMV.High - NormMV.Low) / (NormPV.High - NormPV.Low) \cdot Gain$$

Selecting a unit of measure

The block provides the standard function Selecting a unit of measure (Page 212).

PID algorithm

The manipulated variable is generated in automatic mode according to the following algorithm:

$$MV = \text{GainEff} \cdot (1 + 1 / (\text{TI} \cdot s) + (\text{TD} \cdot s) / (1 + \text{TD} / \text{DiffGain} \cdot s)) \cdot \text{ER}$$

Where: s = Complex number

The following step response occurs:

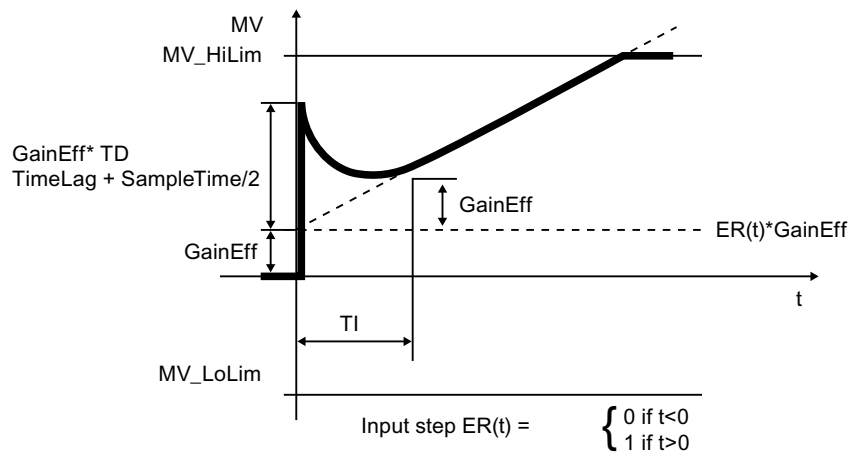

Note

This formula describes a standard application where P, I and D components are activated and the P and D components are not in the feedback circuit ($\text{PropSel} = 1$, $\text{TI} \neq 0$, $\text{D_InSel} = 0$ and $\text{PropFacSP} = 1$).

The D component delay is derived from $\text{TD} / \text{DiffGain}$.

- The P component can be shut down by $\text{PropSel} = 0$.
- The I component can be shut down by $\text{TI} = 0$.
- The D component can be shut down by $\text{TD} = 0$.

Structure segmentation at controllers

The PID controller algorithm of FM 355 features structure segmentation. It is activated via the PropFacSel and D_InSel parameters. The precise functionality is described in the FM 355 manual.

Online optimization of the PID controller parameters

- Optimization sequence
The optimization sequence is as follows:
 - Create a steady state
 - Set `PID_On = 1` (if PID parameters are required)
 - Assign parameters of `TunD_MV / TunC_MVLMN`
 - Set `TunOn = 1` (phase 1, preparing for optimization)
 - Start the optimization using a step change in the setpoint or by setting `TunStart`If you have not made any configuration errors, the controller optimization is now in phase 2 and `StatusH` is 0.
 - When the point of inflection has been reached (`PHASE ≥ 3`) evaluate the diagnostics display at the `StatusH` parameter. Phase 0 is reached in a few cycles for process type I and the optimization is completed in full. For process types II and III, the optimization goes to phase 7 (checking the process type). If `StatusH > 20000`, an estimation error has occurred or the point of inflection has not been reached. In this case, repeat the procedure.
- Result
 - Once optimization is complete, the parameters `PropFacSP, GAIN, TI, TD, DiffGain, ConZone` are updated (both for the module and at FmTemp). Furthermore, the PI or PID parameter sets are saved on the FM 355-2.
 - The precise procedure is described in the FM 355-2 manual of the temperature controller module.
- Permanent backup of optimized controller parameters
 - Save, compile and download the hardware configuration; the optimized controller parameters are now in the system data block (SDB).
 - Transfer the modified parameters to the offline data management of the CFC via Chart > Readback.

Anti-windup

The PID control algorithm of FM 355 has an anti-windup function. The I component is frozen or tracked after the manipulated variable has reached its limits (`MV_HiLim` or `MV_LoLim`).

Feedforwarding and limiting disturbance variables

The block provides a function for activating the disturbance variable feedforward. The precise functionality is described in the FM 355-2 manual.

Control zone

The block provides the standard function Using control zones (Page 194).

Forming the signal status for blocks

The block provides the standard function Forming and outputting the signal status for technologic blocks (Page 109).

- **Signal status for the setpoint value SP:**
The signal status of the SP output parameter is always equivalent to the signal status of input parameter `SP_Ext` or `SP_Int`, depending on how the setpoint is specified. If the internal setpoint `SP_Int` is used, the signal status is always output as `16#80`.
- **Signal status for PV_Out, RbkOut, Open, Close, Stop:**
When the manipulated value (for example, substitute value, simulation, last valid value) is activated, the signal status is always `16#60`.
When the `ModErr.Value`, `ChFM_Err`, `ParFM_Err` module error occurs, the signal status of `PV_Out` is always `16#0`. `RbkOut` is always `16#0` for step controllers with position feedback
Otherwise, the following applies:
`PV_Out.ST: 16#80`
Step controller: `RbkOut.ST: = 16#80`
Continuous controller or pulse controller: `RbkOut.ST: = Rbk.ST`
`Open.ST := 16#80;`
`Close.ST := 16#80;`
`Stop.ST := 16#80;`
- **Signal status of the error signal ER:**
The signal status of output parameter `ER` is obtained from the worst signal status of the two output parameters `PV_Out` and `SP` and is output. The signal status `16#60` (external manipulated value - for example, substitute value, simulation, last valid value) is suppressed because the block acts as a sink with external simulation.
Signal status for `FbkOpnOut`, `FbkClsOut`:
`FbkOpnOut.ST := FbkOpened.ST;`
`FbkClsOut.ST := FbkClosed.ST;`

- Signal status for the manipulated variable `MV`:
 The status signal from the output parameter `MV` is always set to `16#80` in "manual mode" and for step controllers without position feedback.
 In "automatic mode", the signal status for continuous controllers or pulse controllers is formed from the following parameters:
`RbkOut`.`STFFwdOut`.`STER`.`ST`With step controllers, the `FbkOpnOut`.`STFbkClsOut`.`ST`parameters are also included. The signal status `16#60` (external manipulated value - for example, substitute value, simulation, last valid value) is suppressed because the block acts as a sink with an external manipulated value (for example, substitute value, simulation, last valid value).
- Worst signal status:
 The worst signal status `ST_Worst` for the block is formed from:
 - `PV_Out`.`ST`;
 - `SP`:`ST`;
 - `FFwdOut`.`ST`;
 - `RbkOut`.`ST`;
 With step controllers (`FM355-2 = 0`, `StepCon = 1`), the following are also included:
 - `FbkOpnOut`.`ST`;
 - `FbkClsOut`.`ST`;

Configurable reactions using the `Feature` parameter

You can find an overview of all reactions provided by the `Feature` parameter in the Configurable functions using the `Feature` I/O (Page 131) . The following functionality is available for this block at the relevant bits:

Bit	Function
0	Set startup characteristics (Page 138)
1	Reaction to the out of service mode (Page 177)
2	Resetting the commands for changing the mode (Page 161)
4	Setting switch or button mode (Page 167)
6	Ramp rate calculation (Page 179)
10	Condition monitoring information at the channel blocks (Page 145)
22	Update acknowledgment and error status of the message call (Page 160)
23	SP following PV in open loop has no priority over <code>SP_Ext</code> and SP limits (Page 179)
24	Enabling local operator authorization (Page 158)
25	Suppression of all messages (Page 174)
26	Reaction of the switching points in the "Out of service" operating mode (Page 176)
28	Disabling operating points (Page 145)
29	Signaling limit violation (Page 170)

Configurable reactions using the Feature2 parameter

Bit	Function
11	Suppress MsgLock and "Out of service" mode for a connected message block (Page 188)

Operator permissions

The block provides the standard function Operator control permissions (Page 254).

The block has the following permissions for the OS_Perm parameter:

Bit	Function
0	1 = Operator can switch to "automatic mode" AutModOp
1	1 = Operator can switch to "manual mode" ManModOp
2	1 = Operator can switch to "Out of service" mode OosOp
3	1 = Operator can switch to "program mode" AdvCoEn
4	1 = Operator can switch the setpoint to "external" SP_ExtOp
5	1 = Operator can switch the setpoint to "internal" SP_IntOp
6	1 = Operator can change the internal setpoint SP_Int
7	Continuous controllers, pulse controllers or step controllers with position feedback: 1 = Operator can change the manual parameter Man Step controller without position feedback: 1 = Operator can change the manual operation signals OpenOp, StopOp, CloseOp
8	1 = Operator can change operation high limit of the setpoint SP_InHiLim
9	1 = Operator can change operation low limit of the setpoint SP_InLoLim
10	1 = Operator can change the operation high limit of the manipulated variable ManHiLim
11	1 = Operator can change the operation low limit of the manipulated variable ManLoLim
12	1 = Operator can enable the setpoint's gradient limitation function SP_RateOn
13	1 = Operator can change the setpoint's high limit for the ramp SP_UpRaLim
14	1 = Operator can change the setpoint's low limit for the ramp SP_DnRaLim
15	1 = Operator can switch between the time value or the value for the ramp SP_RmpModTime
16	1 = Operator can change the ramp time SP_RmpTime
17	1 = Operator can change the target setpoint SP_RmpTarget for the setpoint ramp
18	1 = Operator can enable the setpoint ramp function SP_RmpOn
19	Not used
20	1 = Operator can enable the track setpoint in manual mode function SP_TrkPV
21	1 = Operator can enable the bumpless switchover from external to internal SP_TrkExt
22	1 = Operator can change the gain parameter Gain
23	1 = Operator can change the integral time parameter TI
24	1 = Operator can change the derivative time parameter TD
25	1 = Operator can change the derivative gain parameter DiffGain
26	1 = Operator can change the dead band parameter DeadBand
27	1 = Operator can change the control zone parameter ConZone
28	1 = Operator can change the integral time parameter MotorTime
29	1 = Operator can change the integral time parameter PulseTime

Bit	Function
30	1 = Operator can change the integral time parameter <code>BreakTime</code>
31	Not used

The block has the following permissions for the `OS1Perm` parameter:

Bit	Function
0	1 = Operator can change the limit (process value) <code>PV_AH_Lim</code> for the high alarm
1	1 = Operator can change the limit (process value) <code>PV_WH_Lim</code> for the high warning
2	1 = Operator can change the limit (process value) <code>PV_TH_Lim</code> for the high tolerance
3	1 = Operator can change the hysteresis (process value) <code>PV_Hyst</code>
4	1 = Operator can change the limit (process value) <code>PV_TL_Lim</code> for the low tolerance
5	1 = Operator can change the limit (process value) <code>PV_WL_Lim</code> for the low warning
6	1 = Operator can change the limit (process value) <code>PV_AL_Lim</code> for the low alarm
7	1 = Operator can change the limit (error signal) <code>ER_AH_Lim</code> for the high alarm
8	1 = Operator can change the hysteresis (error signal) <code>ER_Hyst</code>
9	1 = Operator can change the limit (error signal) <code>ER_AL_Lim</code> for the low alarm
10	1 = Operator can change the limit (position feedback) <code>RbkWH_Lim</code> for the high warning
11	1 = Operator can change the hysteresis (position feedback) <code>RbkHyst</code>
12	1 = Operator can change the limit (position feedback) <code>RbkWL_Lim</code> for the low warning
13	1 = Operator can open the valve
14	1 = Operator can close the valve
15	1 = Operator can stop the valve
16	1 = Operator can activate the Simulation function <code>SimOn</code>
17	1 = Operator can activate the Release for maintenance function <code>MS_RelOp</code>
18	1 = Operator can activate / deactivate messages via <code>PV_AH_MsgEn</code>
19	1 = Operator can activate / deactivate messages via <code>PV_WH_MsgEn</code>
20	1 = Operator can activate / deactivate messages via <code>PV_TH_MsgEn</code>
21	1 = Operator can activate / deactivate messages via <code>PV_TL_MsgEn</code>
22	1 = Operator can activate / deactivate messages via <code>PV_WL_MsgEn</code>
23	1 = Operator can activate / deactivate messages via <code>PV_AL_MsgEn</code>
24	1 = Operator can activate / deactivate messages via <code>ER_AH_MsgEn</code>
25	1 = Operator can activate / deactivate messages via <code>ER_AL_MsgEn</code>
26	1 = Operator can activate / deactivate messages via <code>RbkWH_MsgEn</code>
27	1 = Operator can activate / deactivate messages via <code>RbkWL_MsgEn</code>
28	1 = Operator can change the simulation value <code>SimPV</code>
29	1 = Operator can change the simulation value <code>SimRbk</code>
30 - 31	Not used

Note

If you interconnect a parameter that is also listed in `OS_Perm` as a parameter, you have to reset the corresponding `OS_Perm` bit.

Release for maintenance

The block provides the standard function Release for maintenance (Page 64).

Generating instance-specific messages

The block provides the standard function Generating instance-specific messages (Page 204) without the time stamp function in the I/O.

Suppressing messages using the `MsgLock` parameter

This block provides the standard function Suppressing messages using the `MsgLock` parameter (Page 205).

Specifying the display area for process and setpoint values as well as operations

This block provides the standard function Display and operator input area for process values and setpoints (Page 207).

Opening additional faceplates

This block provides the standard function Opening additional faceplates (Page 208).

SIMATIC BATCH functionality

This block provides the standard function SIMATIC BATCH functionality (Page 67).

Button labels

This block provides the standard function Labeling of buttons and text (Page 209)

Instance-specific text can be configured for the following parameters:

- `OpenOp`
- `StopOp`
- `CloseOp`

Connection of the time-stamped messages from `EventTs` or `Event16Ts`

This block provides the standard function Connection of the time-stamped messages from `EventTs` or `Event16Ts` (Page 207).

See also

FmTemp messaging (Page 655)

FmTemp I/Os (Page 658)

FmTemp modes (Page 641)

FmTemp block diagram (Page 675)

FmTemp error handling (Page 654)

EventTs functions (Page 1660)

5.4.4 FmTemp error handling

Error handling of FmTemp

Refer to section Error handling (Page 119) in the basic instructions for the error handling of all blocks.

The following errors can be displayed for this block:

- Error numbers
- Control system fault (CSF)

Overview of error numbers

The `ErrorNum` output parameter can be used to output the following error numbers:

Error number	Meaning of the error number
-1	Predefined value when inserting the block; the block is not executed
0	There is no error.
30	The value of <code>PV</code> can no longer be displayed in the REAL number field.
31	The value of <code>SP_Ext</code> can no longer be displayed in the REAL number field.
33	The value of <code>MV_Trk</code> can no longer be displayed in the REAL number field.
35	The value of <code>Rbk</code> can no longer be displayed in the REAL number field.
36	The value of <code>MV</code> can no longer be displayed in the REAL number field.
50	The controller cannot be switched to program mode, because program mode with default setpoint (<code>AdvCoModSP = 0</code>) is not possible for step controllers without position feedback (<code>WithRbk = 0</code>).
51	<code>AutModLi = 1 and ManModLi = 1</code> <code>SP_LiOp = 1 and SP_IntLi = 1 and SP_ExtLi = 1</code> <code>OpenLi = 1 and StopLi = 1</code> <code>CloseLi = 1 and StopLi = 1</code> <code>OpenLi = 1 and CloseLi = 1</code>
59	= 1, "Gain is negative"
60	$ TI < SampleTime / 2$
61	$ TD < SampleTime$
62	$DiffGain < 1$ or $DiffGain > 10$
63	$TD / DiffGain < SampleTime / 2$
64	$PropFacSP < 0$ or $PropFacSP > 1$
66	$NormPV_High = NormPV_Low$
67	$MotorTime < SampleTime$

Error number	Meaning of the error number
68	PulseTime < SampleTime
69	BreakTime < SampleTime
70	Channel < 0 or Channel > 3
71	(D_InSel < 0 or D_InSel > 4) and D_InSel ≠ 17
74	ConZone < 0.0 FM 355-2 sets the output ParFM_Err = 1

Control system fault (CSF)

An external signal can be activated via the CSF input. A control system fault is triggered if this signal changes to 1. Refer to the Error handling (Page 119) section for more on this.

See also

Description of FmTemp (Page 637)

FmTemp modes (Page 641)

FmTemp functions (Page 642)

FmTemp messaging (Page 655)

FmTemp I/Os (Page 658)

FmTemp block diagram (Page 675)

Setting switch or button mode (Page 167)

5.4.5 FmTemp messaging

Messaging

The following messages can be generated for this block:

- Process control fault
- Process messages
- Instance-specific messages

Process control fault

The following control system error messages can be output:

Message instance	Message identifier	Message class	Event
MsgEvId2	SIG 6	AS process control message - fault	\$\$BlockComment\$\$ External error has occurred

Explanation:

\$\$BlockComment\$\$: Content of the instance-specific comment

You can interconnect an external fault (signal) to input parameter `CSF`. If it changes to `CSF = 1`, a process control fault is triggered (`MsgEvId2`, SIG 6).

Process messages

Message instance	Message identifier	Message class	Event
MsgEvId1	SIG 1	Alarm - high	\$\$BlockComment\$\$ PV - high alarm limit violated
	SIG 2	Warning - high	\$\$BlockComment\$\$ PV - high warning limit violated
	SIG 3	Tolerance - high	\$\$BlockComment\$\$ PV - high tolerance limit violated
	SIG 4	Tolerance - low	\$\$BlockComment\$\$ PV - low tolerance limit violated
	SIG 5	Warning - low	\$\$BlockComment\$\$ PV - low warning limit violated
	SIG 6	Alarm - low	\$\$BlockComment\$\$ PV - low alarm limit violated
	SIG 7	Alarm - high	\$\$BlockComment\$\$ ER - high alarm limit violated
	SIG 8	Alarm - low	\$\$BlockComment\$\$ ER - low alarm limit violated
MsgEvId2	SIG 7	Warning - high	\$\$BlockComment\$\$ Rbk - high warning limit violated
	SIG 8	Warning - low	\$\$BlockComment\$\$ Rbk - low warning limit violated

Explanation:

\$\$BlockComment\$\$: Content of the instance-specific comment

Instance-specific messages

You can use up to four instance-specific messages with this block.

Message instance	Message identifier	Message class	Event
MsgEvId2	SIG 1	AS process control message - fault	\$\$BlockComment\$\$ External message 1 Status 16#@5%x@
	SIG 2	AS process control message - fault	\$\$BlockComment\$\$ External message 2 Status 16#@6%x@
	SIG 3	AS process control message - fault	\$\$BlockComment\$\$ External message 3 Status 16#@7%x@
	SIG 4	AS process control message - fault	\$\$BlockComment\$\$ External message 4 Status 16#@8%x@

Explanation:

\$\$BlockComment\$\$: Content of the instance-specific comment

Associated values for message instance **MsgEvId1**

Associated value	Block parameters
1	BatchName
2	StepNo
3	BatchID
4	Process value PV_Out
5	Control deviation ER
6	ExtVa106
7	ExtVa107
8	Not allocated
9	Not allocated
10	Not allocated

The associated values 6 ... 7 are allocated to the parameters ExtVa106 ... ExtVa107 and can be used. Additional information is available in the "Process Control System PCS 7 - Engineering System" manual.

Associated values for message instance **MsgEvId2**

Associated value	Block parameters
1	BatchName
2	StepNo
3	BatchID

Associated value	Block parameters
4	Position feedback Rbk
5	Signal status ExtMsg1
6	Signal status ExtMsg2
7	Signal status ExtMsg3
8	Signal status ExtMsg4
9	ExtVa209
10	ExtVa210

The associated values 9 ... 10 are allocated to the parameters ExtVa209 ... ExtVa210 and can be used. Additional information is available in the "Process Control System PCS 7 - Engineering System" manual.

See also

- Description of FmTemp (Page 637)
- FmTemp functions (Page 642)
- FmTemp I/Os (Page 658)
- FmTemp modes (Page 641)
- FmTemp error handling (Page 654)
- FmTemp block diagram (Page 675)

5.4.6 FmTemp I/Os

I/Os of FmTemp

Input parameters

Parameter	Description	Type	Default
AccMode*	1 = Transfer of operating parameters SubN1_ID, SubN2_ID, RackNo, SlotNo and Channel to internal processing	BOOL	1
AdvCoEn	1 = Enable "program mode" via interconnection	STRUCT <ul style="list-style-type: none"> • Value: BOOL • ST: BYTE 	- <ul style="list-style-type: none"> • 0 • 16#80
AdvCoModSP	Type of "program mode": 1 = Setpoint specification 0 = Manipulated variable specification	BOOL	1
AdvCoMstrOn	Activate (0-1) or deactivate (1-0) "program mode" via edge transition	STRUCT <ul style="list-style-type: none"> • Value: BOOL • ST: BYTE 	- <ul style="list-style-type: none"> • 0 • 16#80

5.4 FmTemp - Interface to temperature controller modules FM 355-2

Parameter	Description	Type	Default
AdvCoMV	Specified value from the external program	REAL	0.0
AdvCoOn*	1 = Enable "program mode" via faceplate	BOOL	0
AutModLi*	1 = "Automatic mode" via interconnection or SFC (controlled by ModLiOp = 1)	STRUCT <ul style="list-style-type: none"> • Value: BOOL • ST: BYTE 	- <ul style="list-style-type: none"> • 0 • 16#80
AutModOp*	1 = "Automatic mode" via operator (controlled by ModLiOp = 0)	BOOL	0
BatchEn	1 = Enable allocation for batch control	BOOL	0
BatchID	Batch ID	DWORD	16#00000000
BatchName	Batch name	S7-String	
BreakTime*	Minimum break duration [s]	REAL	1.0
Channel	Controller channel number (0..3)	INT	0
CloseLi*	1 = Close via interconnection or CFC	STRUCT <ul style="list-style-type: none"> • Value: BOOL • ST: BYTE 	- <ul style="list-style-type: none"> • 0 • 16#80
CloseOp*	1 = Close via operator	BOOL	0
ConZone*	Control zone	REAL	0.0
CoordNo	Coordination number	INT	0
CPI_In	Input for control performance index, which is calculated by the assigned ConPerMon block	STRUCT <ul style="list-style-type: none"> • Value: REAL • ST: BYTE 	- <ul style="list-style-type: none"> • 0.0 • 16#78
CSF	1 = External error (control system fault) Error handling (Page 119)	STRUCT <ul style="list-style-type: none"> • Value: BOOL • ST: BYTE 	- <ul style="list-style-type: none"> • 0 • 16#80
D_InSel*	Input for differentiator: 0 = Error signal 1..4 = Channel 0..3 17 = Actual value to feedback	INT	0
DeadBand*	Width of dead band	REAL	0.0
DiffGain*	Gain of differentiator [1..10] $\text{DiffGain} = \text{TD} / (\text{delay time of D component})$	STRUCT <ul style="list-style-type: none"> • Value: REAL • ST: BYTE 	- <ul style="list-style-type: none"> • 5.0 • 16#80
EN	1 = Called block will be processed	BOOL	1
ER_A_DC*	Delay for incoming alarms during error signal monitoring	REAL	0.0
ER_A_DG*	Delay for outgoing alarms during error signal monitoring	REAL	0.0
ER_AH_En	1 = Activate alarm (high) for error signal monitoring	BOOL	1
ER_AH_Lim	Alarm limit (high) for error signal monitoring	REAL	100.0

Controller blocks

5.4 FmTemp - Interface to temperature controller modules FM 355-2

Parameter	Description	Type	Default
ER_AH_MsgEn	1 = Activate messages for alarm (high) for error signal monitoring	BOOL	1
ER_AL_En	1 = Activate alarm (low) for error signal monitoring	BOOL	1
ER_AL_Lim	Alarm limit (low) for error signal monitoring	REAL	-100.0
ER_AL_MsgEn	1 = Activate messages for alarm (low) for error signal monitoring	BOOL	1
ER_Hyst	Alarm hysteresis for error signal	REAL	1.0
EventTsIn	For interconnecting data between a technology block and the message blocks EventTs, Event16Ts. The EventTsIn input parameter serves to interconnect the EventTsOut output parameter of the EventTs, Event16Ts block. When this interconnection is configured, the messages of the EventTs, Event16Ts block are displayed on the OS in the alarm view of the technology block and can also be acknowledged there.	ANY	
ExtMsg1	Binary input for freely selectable message 1	STRUCT • Value: BOOL • ST: BYTE	- • 0 • 16#80
ExtMsg2	Binary input for freely selectable message 2	STRUCT • Value: BOOL • ST: BYTE	- • 0 • 16#80
ExtMsg3	Binary input for freely selectable message 3	STRUCT • Value: BOOL • ST: BYTE	- • 0 • 16#80
ExtMsg4	Binary input for freely selectable message 4	STRUCT • Value: BOOL • ST: BYTE	- • 0 • 16#80
ExtVa106	Associated value 6 for messages (MsgEvID1)	ANY	
ExtVa107	Associated value 7 for messages (MsgEvID1)	ANY	
ExtVa209	Associated value 9 for messages (MsgEvID2)	ANY	
ExtVa210	Associated value 10 for messages (MsgEvID2)	ANY	
FbkClosed	Low limit stop signal of position feedback	STRUCT • Value: BOOL • ST: BYTE	- • 0 • 16#80

5.4 FmTemp - Interface to temperature controller modules FM 355-2

Parameter	Description	Type	Default
FbkOpened	High limit stop signal of position feedback	STRUCT <ul style="list-style-type: none"> Value: BOOL ST: BYTE 	- <ul style="list-style-type: none"> 0 16#80
Feature	I/O for additional functions (Page 642)	STRUCT <ul style="list-style-type: none"> Bit 0: BOOL ... Bit 31: BOOL 	- <ul style="list-style-type: none"> 0 0 0
FM355_2	Module type: 0: FM 355-2 S; 1: FM 355-2 C	BOOL	0
Gain*	Proportional gain Gain.ST = 16#FF: Enabled in faceplate	STRUCT <ul style="list-style-type: none"> Value: REAL ST: BYTE 	- <ul style="list-style-type: none"> 1.0 16#FF
LoadPID*	Load optimized PI/PID parameters	BOOL	0
LogAddr	Logical address FM 355	INT	0
Man*	Manual specification for the manipulated variable	REAL	0.0
ManHiLim*	Limit (high) for manual parameter <i>Man</i>	REAL	100.0
ManLoLim*	Limit (low) for manual parameter <i>Man</i>	REAL	0.0
ManModLi*	1 = "Manual mode" via interconnection or SFC (controlled by <i>ModLiOp</i> = 1)	STRUCT <ul style="list-style-type: none"> Value: BOOL ST: BYTE 	- <ul style="list-style-type: none"> 0 16#80
ManModOp*	1 = "Manual mode" via OS operator (controlled by <i>ModLiOp</i> = 0)	BOOL	1
Mode	Operating mode	DWORD	16#00000000
ModLiOp	Operating mode switchover between: 0 = Operator 1 = Interconnection or SFC	STRUCT <ul style="list-style-type: none"> Value: BOOL ST: BYTE 	- <ul style="list-style-type: none"> 0 16#80
MotorTime*	Motor actuating time [s]	REAL	30.0
MS_RelOp*	1 = Release for maintenance by OS operator	BOOL	0
MS	Maintenance status	DWORD	0
MS_Release	Release for maintenance (interconnected with <i>MS_Release</i> of the technology block)	STRUCT <ul style="list-style-type: none"> Value: BOOL ST: BYTE 	- <ul style="list-style-type: none"> 0 16#80
Ms_Ext	External maintenance status	DWORD	0
MsgEvID1	Message number (assigned automatically)	DWORD	16#00000000
MsgEvID2	Message number (assigned automatically)	DWORD	16#00000000

Parameter	Description	Type	Default
MsgLock	1 = Suppress process messages. See also the section Suppressing messages using the MsgLock parameter (Page 205) for more on this.	STRUCT <ul style="list-style-type: none"> Value: BOOL ST: BYTE 	- <ul style="list-style-type: none"> 0 16#80
MV_FmTrkOn	1 = Manipulated variable tracking in the FM	STRUCT <ul style="list-style-type: none"> Value: BOOL ST: BYTE 	- <ul style="list-style-type: none"> 0 16#80
MV_HiLim*	Limit (high) for manipulated variable MV	STRUCT <ul style="list-style-type: none"> Value: REAL ST: BYTE 	- <ul style="list-style-type: none"> 100.0 16#80
MV_LoLim*	Limit (low) for manipulated variable MV	STRUCT <ul style="list-style-type: none"> Value: REAL ST: BYTE 	- <ul style="list-style-type: none"> 0.0 16#80
MV_OpScale	OS display range for manipulated variable MV	STRUCT <ul style="list-style-type: none"> High: REAL Low: REAL 	- <ul style="list-style-type: none"> 100.0 0.0
MV_Safe*	Neutral position manipulated variable	REAL	0.0
MV_SafeOn	1 = Neutral position manipulated variable MV_Safe at output MV	STRUCT <ul style="list-style-type: none"> Value: BOOL ST: BYTE 	- <ul style="list-style-type: none"> 0 16#80
MV_Trk*	Tracking value for the manipulated variable MV	STRUCT <ul style="list-style-type: none"> Value: REAL ST: BYTE 	- <ul style="list-style-type: none"> 0.0 16#80
MV_TrkOn	1 = Tracking of manipulated variable MV	STRUCT <ul style="list-style-type: none"> Value: BOOL ST: BYTE 	- <ul style="list-style-type: none"> 0 16#80
MV_Unit	Unit of measure for manipulated variable	INT	1342
NegGain*	0 = Effective proportional gain GainEff is positive 1 = Effective proportional gain GainEff is negative	STRUCT <ul style="list-style-type: none"> Value: BOOL ST: BYTE 	- <ul style="list-style-type: none"> 0 16#80
NormMV	Manipulated variable range (MV) for standardizing the proportional gain (GAIN)	STRUCT <ul style="list-style-type: none"> High: REAL Low: REAL 	- <ul style="list-style-type: none"> 100.0 0.0
NormPV	Process value range (PV) for standardizing the proportional gain (GAIN)	STRUCT <ul style="list-style-type: none"> High: REAL Low: REAL 	- <ul style="list-style-type: none"> 100.0 0.0
Occupied	Occupied by batch control	BOOL	0
OosLi	Edge transition (0-1) = "Out of service", via interconnection or SFC	STRUCT <ul style="list-style-type: none"> Value: BOOL ST: BYTE 	- <ul style="list-style-type: none"> 0 16#80
OosOp*	1 = "Out of service", via OS operator	BOOL	0

5.4 FmTemp - Interface to temperature controller modules FM 355-2

Parameter	Description	Type	Default
OpenLi*	1 = Open via interconnection or CFC	STRUCT <ul style="list-style-type: none"> • Value: BOOL • ST: BYTE 	- <ul style="list-style-type: none"> • 0 • 16#80
OpenOp*	1 = Open via operator	BOOL	0
OpSt_In	Input parameter for local operator authorization, connected with the <code>Out</code> output parameter of the upstream block, <code>OpStations</code> (Page 411)	DWORD	16#00000000
OS_Perm	I/O for operator permissions (Page 642)	STRUCT <ul style="list-style-type: none"> • Bit 0: BOOL • ... • Bit 31: BOOL 	- <ul style="list-style-type: none"> • 1 • 1 • 1
OS1Perm	I/O for operator permissions (Page 642)	STRUCT <ul style="list-style-type: none"> • Bit 0: BOOL • Bit 18: BOOL • Bit 19: BOOL • Bit 31: BOOL 	- <ul style="list-style-type: none"> • 1 • 1 • 1 • 1
PID_On*	1 = PID mode on	BOOL	0
PropFacSP*	Applying the P component to the feedback [0..1]. 0 = P component fully in feedback	REAL	1.0
PropSel*	1 = Activate P component	BOOL	1
PulseTime*	Minimum pulse duration [s]	REAL	1.0
PV_A_DC*	Delay time for incoming PV alarms [s]	REAL	0.0
PV_A_DG*	Delay time for outgoing PV alarms [s]	REAL	0.0
PV_AH_En	1 = Enable PV alarm limit (high)	BOOL	1
PV_AH_Lim	Limit PV alarm (high)	REAL	95.0
PV_AH_MsgEn	1 = Enable PV alarm (high) message	BOOL	1
PV_AL_En	1 = Enable PV alarm limit (low)	BOOL	1
PV_AL_Lim	PV alarm limit (low)	REAL	5.0
PV_AL_MsgEn	1 = Enable PV alarm (low) message	BOOL	1
PV_Hyst	Hysteresis for PV alarm, warning and tolerance limits	REAL	1.0
PV_OpScale	Limit for scale in PV bar graph of faceplate	STRUCT <ul style="list-style-type: none"> • High: REAL • Low: REAL 	- <ul style="list-style-type: none"> • 100.0 • 0.0
PV_T_DC*	Delay time for incoming PV tolerance messages [s]	REAL	0.0
PV_T_DG*	Delay time for outgoing PV tolerance messages [s]	REAL	0.0
PV_TH_En	1 = Enable PV tolerance limit (high)	BOOL	0
PV_TH_Lim	Limit PV tolerance message (high)	REAL	85.0

Controller blocks

5.4 FmTemp - Interface to temperature controller modules FM 355-2

Parameter	Description	Type	Default
PV_TH_MsgEn	1 = Enable message for PV tolerance message (high)	BOOL	1
PV_TL_En	1 = Enable PV tolerance limit (low)	BOOL	0
PV_TL_Lim	Limit PV tolerance message (low)	REAL	15.0
PV_TL_MsgEn	1 = Activate message for PV tolerance message (low)	BOOL	1
PV_Unit	Unit of measure for process value	INT	1001
PV_W_DC*	Delay time for incoming PV warnings [s]	REAL	0.0
PV_W_DG*	Delay time for outgoing PV warnings [s]	REAL	0.0
PV_WH_En	1 = Enable PV warning limit (high)	BOOL	1
PV_WH_Lim	Limit PV warning (high)	REAL	90.0
PV_WH_MsgEn	1 = Enable PV warning (high) message	BOOL	1
PV_WL_En	1 = Enable PV warning limit (low)	BOOL	1
PV_WL_Lim	Limit PV warning (low)	REAL	10.0
PV_WL_MsgEn	1 = Enable PV warning (low) message	BOOL	1
RackNo	Rack number	BYTE	16#FF
RatioFac*	Ratio factor	REAL	0.0
Rbk*	Position feedback for display on OS	STRUCT <ul style="list-style-type: none"> • Value: REAL • ST: BYTE 	- <ul style="list-style-type: none"> • 0.0 • 16#FF
RbkHyst	Alarm hysteresis for position feedback	REAL	1.0
RbkWH_En	1 = Enable warning (high) for position feedback	BOOL	1
RbkWH_Lim	Limit for position feedback of warning (high)	REAL	100.0
RbkWH_MsgEn	1 = Enable messages for warning (high) for position feedback	BOOL	1
RbkWL_En	1 = Enable warning (low) for position feedback	BOOL	1
RbkWL_Lim	Limit for position feedback of warning (low)	REAL	0.0
RbkWL_MsgEn	1 = Enable messages for warning (low) for position feedback	BOOL	1
RefStdDevIn	Reference value of PV standard deviation (sigma) in defined "good" state of control loop	STRUCT <ul style="list-style-type: none"> • Value: REAL • ST: BYTE 	- <ul style="list-style-type: none"> • 0.0 • 16#78
RunUpCyc	Number of cycles in startup; messages are suppressed during these cycles	INT	3
SampleTime	Sampling time [s] (assigned automatically)	REAL	0.1
SavePar*	1 = Save PID controller parameters	BOOL	0
SelFp1	Call a block saved in this parameter as an additional faceplate (Page 208) in the standard view	ANY	-

5.4 FmTemp - Interface to temperature controller modules FM 355-2

Parameter	Description	Type	Default
SelFp2	Call a block saved in this parameter as an additional faceplate (Page 208) in the preview	ANY	-
SimLiOp	Activation/deactivation of the simulation by: 0 = Operator 1 = Interconnection or SFC	STRUCT • Value: BOOL • ST: BYTE	- • 0 • 16#80
SimOnLi	1 = Simulation via interconnection or SFC (controlled by SimLiOp = 1)	STRUCT • Value: BOOL • ST: BYTE	- • 0 • 16#80
SimOn*	1 = Simulation on	BOOL	0
SimPV*	Process value used for SimOn = 1	REAL	0.0
SimPV_Li	Process value that is used for SimOnLi.Value = 1 (SimLiOp.Value = 1)	STRUCT • Value: REAL • ST: BYTE	- • 0.0 • 16#80
SimRbk*	Position feedback used for SimOn = 1	REAL	0.0
SimRbkLi	Position feedback used for SimOnLi.Value = 1 (SimLiOp.Value = 1)	STRUCT • Value: REAL • ST: BYTE	- • 0.0 • 16#80
SlotNo	Slot number	BYTE	16#FF
SP_DnRaLim	Limit (low) for the gradient of the setpoint [SP_Unit/s]	REAL	100.0
SP_ExHiLim*	Limit (high) for external setpoint	STRUCT • Value: REAL • ST: BYTE	- • 100.0 • 16#80
SP_ExLoLim*	Limit (low) for external setpoint	STRUCT • Value: REAL • ST: BYTE	- • 0.0 • 16#80
SP_Ext*	External setpoint of - (to interconnection)	STRUCT • Value: REAL • ST: BYTE	- • 0.0 • 16#80
SP_ExtLi*	1 = Select external setpoint (via interconnection)	STRUCT • Value: BOOL • ST: BYTE	- • 0 • 16#80
SP_ExtOp*	1 = Select external setpoint (via operator)	BOOL	0
SP_InHiLim*	Limit (high) of internal setpoint	REAL	100.0
SP_InLoLim*	Limit (low) of internal setpoint	REAL	0.0
SP_Int*	Internal setpoint for operation	REAL	0.0
SP_IntLi*	1 = Select internal setpoint (via interconnection)	STRUCT • Value: BOOL • ST: BYTE	- • 0 • 16#80
SP_IntOp*	1 = Select internal setpoint (via operator)	BOOL	0

Controller blocks

5.4 FmTemp - Interface to temperature controller modules FM 355-2

Parameter	Description	Type	Default
SP_LiOp	Select setpoint source (internal/external): 1 = Via interconnection 0 = Via operator	STRUCT • Value: BOOL • ST: BYTE	- • 0 • 16#80
SP_RateOn*	1 = Activate limitation of setpoint gradients	BOOL	0
SP_RmpModTime	1 = Use time (SP_RmpTime) for setpoint ramp, 0 = Use gradient	BOOL	0
SP_RmpOn*	1 = Activate setpoint ramp to target setpoint SP_RmpTarget	BOOL	0
SP_RmpTarget*	Target setpoint for setpoint ramp	REAL	0.0
SP_RmpTime*	Time for setpoint ramp [s] from current SP up to SP_RmpTarget	REAL	0.0
SP_TrkExt	1 = Bumpless switchover from external to internal setpoint active	BOOL	1
SP_TrkPV	1 = Setpoint follows PV in "manual mode" and with tracking	BOOL	0
SP_UpRaLim	Gradient limit (high) for the setpoint [SP_Unit/s]	REAL	100.0
StepNo	Batch step number	DWORD	16#00000000
StopLi*	1 = Stop via interconnection or CFC	STRUCT • Value: BOOL • ST: BYTE	- • 0 • 16#80
StopOp*	1 = Stop via operator	BOOL	0
SubN1_ID	ID of the primary DP master system	BYTE	16#FF
SubN2_ID	ID of the redundant DP master system	BYTE	16#FF
TD*	Derivative time [s] TD.ST = 16#FF: Enabled in faceplate	STRUCT • Value: REAL • ST: BYTE	- • 0.0 • 16#FF
TextRef	Text reference	WORD	0
TI*	Integral time [s] TI.ST = 16#FF: Enabled in faceplate	STRUCT • Value: REAL • ST: BYTE	- • 100.0 • 16#FF
TimeFactor	Time unit: 0 = Seconds 1 = Minutes 2 = Hours	INT	0
TunC_MV*	Delta manipulated variable for cooling optimization	REAL	-20.0
TunC_Start*	Start cooling optimization	BOOL	0
TunD_MV*	Delta manipulated variable for process trigger	REAL	20.0
TunOn*	Enable controller optimization	BOOL	0

5.4 FmTemp - Interface to temperature controller modules FM 355-2

Parameter	Description	Type	Default
TunStart*	Start controller optimization	BOOL	0
UndoPar*	Undo controller parameter changes	BOOL	0
UserStatus	Freely assignable bits for use in PCS 7 OS	BYTE	16#00

* Values can be written back to these inputs during processing of the block by the block algorithm.

In/out parameters

Parameter	Description	Type	Default
DataXchg	Internal data exchange channel to the diagnostics block	DWORD	16#00000000
DataXchg1	Internal data exchange channel to the diagnostics block	DWORD	16#00000000
EnCoord	Current coordination number	STRUCT <ul style="list-style-type: none"> • CO_ACT : INT 	- <ul style="list-style-type: none"> • 0
MS_Xchg	Exchange of the maintenance status	DWORD	16#00000000

Output parameters

Parameter	Description	Type	Default
AdvCoAct	1 = "Program mode" enabled	STRUCT <ul style="list-style-type: none"> • Value: BOOL • ST: BYTE 	- <ul style="list-style-type: none"> • 0 • 16#80
AdvCoRdy	1 = "Program mode" available	STRUCT <ul style="list-style-type: none"> • Value: BOOL • ST: BYTE 	- <ul style="list-style-type: none"> • 0 • 16#80
AutAct	1 = "Automatic mode" enabled	STRUCT <ul style="list-style-type: none"> • Value: BOOL • ST: BYTE 	- <ul style="list-style-type: none"> • 0 • 16#80
ChFM_Err	1 = Channel error on the module	BOOL	0
Close	Control output: 1 = Closed is active	STRUCT <ul style="list-style-type: none"> • Value: BOOL • ST: BYTE 	- <ul style="list-style-type: none"> • 0 • 16#80
EnCoNum	Coordination number	BYTE	16#00
ENO	1 = Block algorithm completed without errors	BOOL	0
ER	Error signal	STRUCT <ul style="list-style-type: none"> • Value: REAL • ST: BYTE 	- <ul style="list-style-type: none"> • 0.0 • 16#80

5.4 FmTemp - Interface to temperature controller modules FM 355-2

Parameter	Description	Type	Default
ER_AH_Act	1 = Alarm limit (high) for control deviation violated. You can change the reaction for this parameter with <i>Feature</i> bit 28 (Disabling operating points (Page 145)) and with <i>Feature</i> bit 29 (Signaling limit violation (Page 170)).	STRUCT <ul style="list-style-type: none"> Value: BOOL ST: BYTE 	- <ul style="list-style-type: none"> 0 16#80
ER_AL_Act	1 = Alarm limit (low) for control deviation violated. You can change the reaction for this parameter with <i>Feature</i> bit 28 (Disabling operating points (Page 145)) and with <i>Feature</i> bit 29 (Signaling limit violation (Page 170)).	STRUCT <ul style="list-style-type: none"> Value: BOOL ST: BYTE 	- <ul style="list-style-type: none"> 0 16#80
ErrorNum	Output of pending error number, for error numbers that can be output by this block, see FmTemp error handling (Page 654)	INT	-1
FFwdOut	Disturbance variable generated in the FM	STRUCT <ul style="list-style-type: none"> Value: REAL ST: BYTE 	- <ul style="list-style-type: none"> 0.0 16#80
FbkClsOut	1 = Low limit stop of the position feedback reached	STRUCT <ul style="list-style-type: none"> Value: BOOL ST: BYTE 	- <ul style="list-style-type: none"> 0 16#80
FbkOpnOut	1 = High limit stop of the position feedback reached	STRUCT <ul style="list-style-type: none"> Value: BOOL ST: BYTE 	- <ul style="list-style-type: none"> 0 16#80
GainEff	Effective proportional gain depends on <i>NegGain</i> , <i>Gain</i> , <i>NormPV</i> , and <i>NormMV</i>	REAL	1.0
GrpErr	1 = Group error pending	STRUCT <ul style="list-style-type: none"> Value: BOOL ST: BYTE 	- <ul style="list-style-type: none"> 0 16#80
LoopClosed	1 = Control loop closed 0 = Control loop open	STRUCT <ul style="list-style-type: none"> Value: BOOL ST: BYTE 	- <ul style="list-style-type: none"> 0 16#80
ManAct	1 = "Manual mode" enabled	STRUCT <ul style="list-style-type: none"> Value: BOOL ST: BYTE 	- <ul style="list-style-type: none"> 1 16#80

5.4 FmTemp - Interface to temperature controller modules FM 355-2

Parameter	Description	Type	Default
ManARW_Act	1 = Tracking mode or anti-reset windup by secondary controller	STRUCT <ul style="list-style-type: none"> Value: BOOL ST: BYTE 	- <ul style="list-style-type: none"> 0 16#80
ManHiOut	Limit (high) for "manual mode", corresponds to input parameter <code>ManHiLim</code>	STRUCT <ul style="list-style-type: none"> Value: REAL ST: BYTE 	- <ul style="list-style-type: none"> 100.0 16#80
ManLoOut	Limit (low) for "manual mode", corresponds to input parameter <code>ManLoLim</code>	STRUCT <ul style="list-style-type: none"> Value: REAL ST: BYTE 	- <ul style="list-style-type: none"> 0.0 16#80
ModErr	1 = Module error	STRUCT <ul style="list-style-type: none"> Value: BOOL ST: BYTE 	- <ul style="list-style-type: none"> 0 16#80
MS_Dev	Maintenance state	DWORD	16#00000000
MS_Release	Release for maintenance: 1 = Release for OS operator	STRUCT <ul style="list-style-type: none"> Value: BOOL ST: BYTE 	- <ul style="list-style-type: none"> 0 16#80
MS_Req	1 = Maintenance request from the diagnostic area	STRUCT <ul style="list-style-type: none"> Value: BOOL ST: BYTE 	- <ul style="list-style-type: none"> 0 16#80
MS_Xchg	Exchange of the maintenance status	DWORD	0
MsgAckn1	Message acknowledgement status 1 (output <code>ACK_STATE</code> of first <code>ALARM_8P</code>)	WORD	16#0000
MsgAckn2	Message acknowledgement status 2 (output <code>ACK_STATE</code> of second <code>ALARM_8P</code>)	WORD	16#0000
MsgErr1	Alarm error 1 (output <code>ERROR</code> of first <code>ALARM_8P</code>)	BOOL	0
MsgErr2	Alarm error 2 (output <code>ERROR</code> of second <code>ALARM_8P</code>)	BOOL	0
MsgStat1	Message status 1 (output <code>STATUS</code> of first <code>ALARM_8P</code>)	WORD	16#0000
MsgStat2	Message status 2 (output <code>STATUS</code> of second <code>ALARM_8P</code>)	WORD	16#0000
MV	Manipulated variable	STRUCT <ul style="list-style-type: none"> Value: REAL ST: BYTE 	- <ul style="list-style-type: none"> 0.0 16#80
MV_FmTrkAct	1 = Track manipulated variable in the FM enabled	STRUCT <ul style="list-style-type: none"> Value: BOOL ST: BYTE 	- <ul style="list-style-type: none"> 0 16#80

Controller blocks

5.4 FmTemp - Interface to temperature controller modules FM 355-2

Parameter	Description	Type	Default
MV_HiAct	1 = Limit (high) of manipulated variable violated	STRUCT <ul style="list-style-type: none"> Value: BOOL ST: BYTE 	- <ul style="list-style-type: none"> 0 16#80
MV_LoAct	1 = Limit (low) of manipulated variable violated	STRUCT <ul style="list-style-type: none"> Value: BOOL ST: BYTE 	- <ul style="list-style-type: none"> 0 16#80
MV_SafeAct	1 = Neutral position manipulated variable of the FM enabled	STRUCT <ul style="list-style-type: none"> Value: BOOL ST: BYTE 	- <ul style="list-style-type: none"> 0 16#80
MV_SpliA	Manipulated variable A of split-range function	STRUCT <ul style="list-style-type: none"> Value: REAL ST: BYTE 	- <ul style="list-style-type: none"> 0.0 16#80
MV_SpliB	Manipulated variable B of split-range function	STRUCT <ul style="list-style-type: none"> Value: REAL ST: BYTE 	- <ul style="list-style-type: none"> 0.0 16#80
MV_UnitOut	Unit of measure for manipulated variable, for interconnecting to the MV_Unit input parameter of the ConPerMon block	INT	0
MV_Visible	1 = MV display visible Is evaluated by the block icon	BOOL	0
OosAct	1 = Block is "Out of service"	STRUCT <ul style="list-style-type: none"> Value: BOOL ST: BYTE 	- <ul style="list-style-type: none"> 0 16#80
Open	Control output 1 = Open is active	STRUCT <ul style="list-style-type: none"> Value: BOOL ST: BYTE 	- <ul style="list-style-type: none"> 0 16#80
OpSt_Out	Value of the OpSt_In input parameter, for feedforwarding to other blocks. Bit 31 of this parameter is used by Feature bit 24	DWORD	16#00000000
OS_PermLog	Display of OS_Perm with settings changed by the block algorithm	DWORD	16#FFFFFFFF
OS1PermLog	Display of OS1Perm with settings changed by the block algorithm	DWORD	16#FFFFFFFF
OS_PermOut	Display of OS_Perm	DWORD	16#FFFFFFFF
OS1PermOut	Display of OS_Perm1	DWORD	16#FFFFFFFF
ParFM_Err	1 = Direct parameter-assignment error of the FM or input Channel configured incorrectly	BOOL	0

5.4 FmTemp - Interface to temperature controller modules FM 355-2

Parameter	Description	Type	Default
PerAccErr	1 = I/O access error	BOOL	0
Phase	Phase of auto-tuning [0..7]	INT	0
PV	Process value of the module	STRUCT <ul style="list-style-type: none"> Value: REAL ST: BYTE 	- 0.0 16#80
PV_AH_Act	1 = PV alarm (high) active. You can change the reaction for this parameter with Feature bit 28 (Disabling operating points (Page 145)) and with Feature bit 29 (Signaling limit violation (Page 170)).	STRUCT <ul style="list-style-type: none"> Value: BOOL ST: BYTE 	- 0 16#80
PV_AL_Act	1 = PV alarm (low) active. You can change the reaction for this parameter with Feature bit 28 (Disabling operating points (Page 145)) and with Feature bit 29 (Signaling limit violation (Page 170)).	STRUCT <ul style="list-style-type: none"> Value: BOOL ST: BYTE 	- • 0 • 16#80
PV_Out	Output for process value	STRUCT <ul style="list-style-type: none"> Value: REAL ST: BYTE 	- • 0.0 • 16#80
PV_TH_Act	1 = PV tolerance message (high) active. You can change the reaction for this parameter with Feature bit 28 (Disabling operating points (Page 145)) and with Feature bit 29 (Signaling limit violation (Page 170)).	STRUCT <ul style="list-style-type: none"> Value: BOOL ST: BYTE 	- • 0 • 16#80
PV_TL_Act	1 = PV tolerance message (low) active. You can change the reaction for this parameter with Feature bit 28 (Disabling operating points (Page 145)) and with Feature bit 29 (Signaling limit violation (Page 170)).	STRUCT <ul style="list-style-type: none"> Value: BOOL ST: BYTE 	- • 0 • 16#80
PV_ToleHi	Limit (high) of 3-sigma band around the setpoint is calculated when a ConPerMon block is connected	STRUCT <ul style="list-style-type: none"> Value: REAL ST: BYTE 	- • 0.0 • 16#80
PV_ToleLo	Limit (low) of 3-sigma band around the setpoint is calculated when a ConPerMon block is connected	STRUCT <ul style="list-style-type: none"> Value: REAL ST: BYTE 	- • 0.0 • 16#80

Controller blocks

5.4 FmTemp - Interface to temperature controller modules FM 355-2

Parameter	Description	Type	Default
PV_UnitOut	Unit of measure for process value, for interconnecting to the PV_Unit input parameter of the ConPerMon block	INT	0
PV_WH_Act	1 = PV warning (high) active. You can change the reaction for this parameter with Feature bit 28 (Disabling operating points (Page 145)) and with Feature bit 29 (Signaling limit violation (Page 170)).	STRUCT <ul style="list-style-type: none"> Value: BOOL ST: BYTE 	- <ul style="list-style-type: none"> 0 16#80
PV_WL_Act	1 = PV warning (low) active. You can change the reaction for this parameter with Feature bit 28 (Disabling operating points (Page 145)) and with Feature bit 29 (Signaling limit violation (Page 170)).	STRUCT <ul style="list-style-type: none"> Value: BOOL ST: BYTE 	- <ul style="list-style-type: none"> 0 16#80
RbkOut	Output for position feedback	STRUCT <ul style="list-style-type: none"> Value: REAL ST: BYTE 	- <ul style="list-style-type: none"> 0.0 16#80
RbkWH_Act	1 = Warning (high) for position feedback active. You can change the reaction for this parameter with Feature bit 28 (Disabling operating points (Page 145)) and with Feature bit 29 (Signaling limit violation (Page 170)).	STRUCT <ul style="list-style-type: none"> Value: BOOL ST: BYTE 	- <ul style="list-style-type: none"> 0 16#80
RbkWL_Act	1 = Warning (low) for position feedback active. You can change the reaction for this parameter with Feature bit 28 (Disabling operating points (Page 145)) and with Feature bit 29 (Signaling limit violation (Page 170)).	STRUCT <ul style="list-style-type: none"> Value: BOOL ST: BYTE 	- <ul style="list-style-type: none"> 0 16#80
RetVal	Return value of WRREC / RDREC	WORD	16#0000
RbkVisible	1 = Rbk display visible Is evaluated by the block icon	BOOL	0
RdyToStart	1 = Active start readiness	STRUCT <ul style="list-style-type: none"> Value: BOOL ST: BYTE 	- <ul style="list-style-type: none"> 0 16#80

5.4 FmTemp - Interface to temperature controller modules FM 355-2

Parameter	Description	Type	Default
SP	Setpoint used by controller	STRUCT <ul style="list-style-type: none"> Value: REAL ST: BYTE 	- <ul style="list-style-type: none"> 0.0 16#80
SP_DnRaAct	1 = Negative gradient limiting of setpoint is active	STRUCT <ul style="list-style-type: none"> Value: BOOL ST: BYTE 	- <ul style="list-style-type: none"> 0 16#80
SP_ExHiAct	1 = Limit (high) for external setpoint has been reached	STRUCT <ul style="list-style-type: none"> Value: BOOL ST: BYTE 	- <ul style="list-style-type: none"> 0 16#80
SP_ExLoAct	1 = Limit (low) for external setpoint has been reached	STRUCT <ul style="list-style-type: none"> Value: BOOL ST: BYTE 	- <ul style="list-style-type: none"> 0 16#80
SP_ExtAct	1 = External setpoint is active 0 = Internal setpoint is active	STRUCT <ul style="list-style-type: none"> Value: BOOL ST: BYTE 	- <ul style="list-style-type: none"> 0 16#80
SP_ExtOut	External setpoint, corresponds to input parameter SP_Ext	STRUCT <ul style="list-style-type: none"> Value: REAL ST: BYTE 	- <ul style="list-style-type: none"> 0.0 16#80
SP_InHiOut	Limit (high) for SP_Int corresponds to input parameter SP_InHiLim	STRUCT <ul style="list-style-type: none"> Value: REAL ST: BYTE 	- <ul style="list-style-type: none"> 100.0 16#80
SP_InLoOut	Limit (low) for SP_Int corresponds to input parameter SP_InLoLim	STRUCT <ul style="list-style-type: none"> Value: REAL ST: BYTE 	- <ul style="list-style-type: none"> 0.0 16#80
SP_RateTarget	Target setpoint for the gradient limitation	REAL	0.0
SP_UpRaAct	Positive gradient limiting of setpoint is active	STRUCT <ul style="list-style-type: none"> Value: BOOL ST: BYTE 	- <ul style="list-style-type: none"> 0 16#80
SplitRange	1 = Split-range function has been activated	BOOL	0
ST_Worst	Worst signal status	BYTE	16#80
Status1	Status word 1 (Page 637)	DWORD	16#00000000
Status2	Status word 2 (Page 637)	DWORD	16#00000000
Status3	Status word 2 (Page 637)	DWORD	16#00000000
StatusC	Status of cooling optimization	INT	0
StatusD	Status of controller design	INT	0
StatusH	Status of heating optimization	INT	0
StepCon	1 = Step controller	BOOL	0

Controller blocks

5.4 FmTemp - Interface to temperature controller modules FM 355-2

Parameter	Description	Type	Default
Stop	Control output: 1 = Stopped is active	STRUCT <ul style="list-style-type: none">• Value: BOOL• ST: BYTE	- <ul style="list-style-type: none">• 0• 16#80
SumMsgAct	1 = Active hardware interrupt	STRUCT <ul style="list-style-type: none">• Value: BOOL• ST: BYTE	- <ul style="list-style-type: none">• 0• 16#80
TunAct	1 = Optimization running	BOOL	0
WithRbk	Controller type: 0 = Step controller without position feedback 1 = Step controller with position feedback	BOOL	0
ZoneTun	Controller channels grouped in one zone for parallel optimization	WORD	16#0000

See also

FmTemp messaging (Page 655)

FmTemp modes (Page 641)

FmTemp block diagram (Page 675)

5.4.7 FmTemp block diagram

FmTemp block diagram

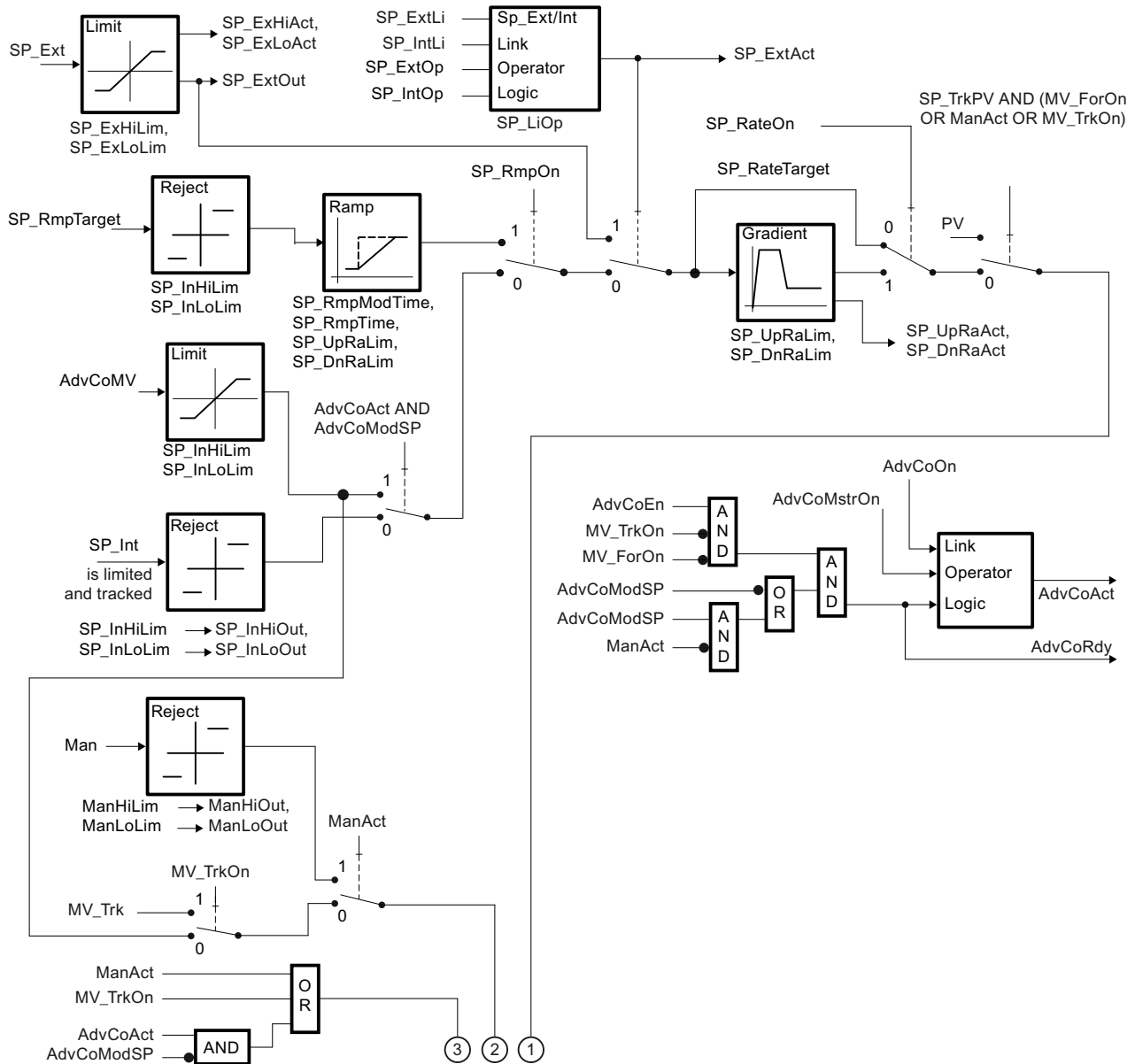

5.4 FmTemp - Interface to temperature controller modules FM 355-2

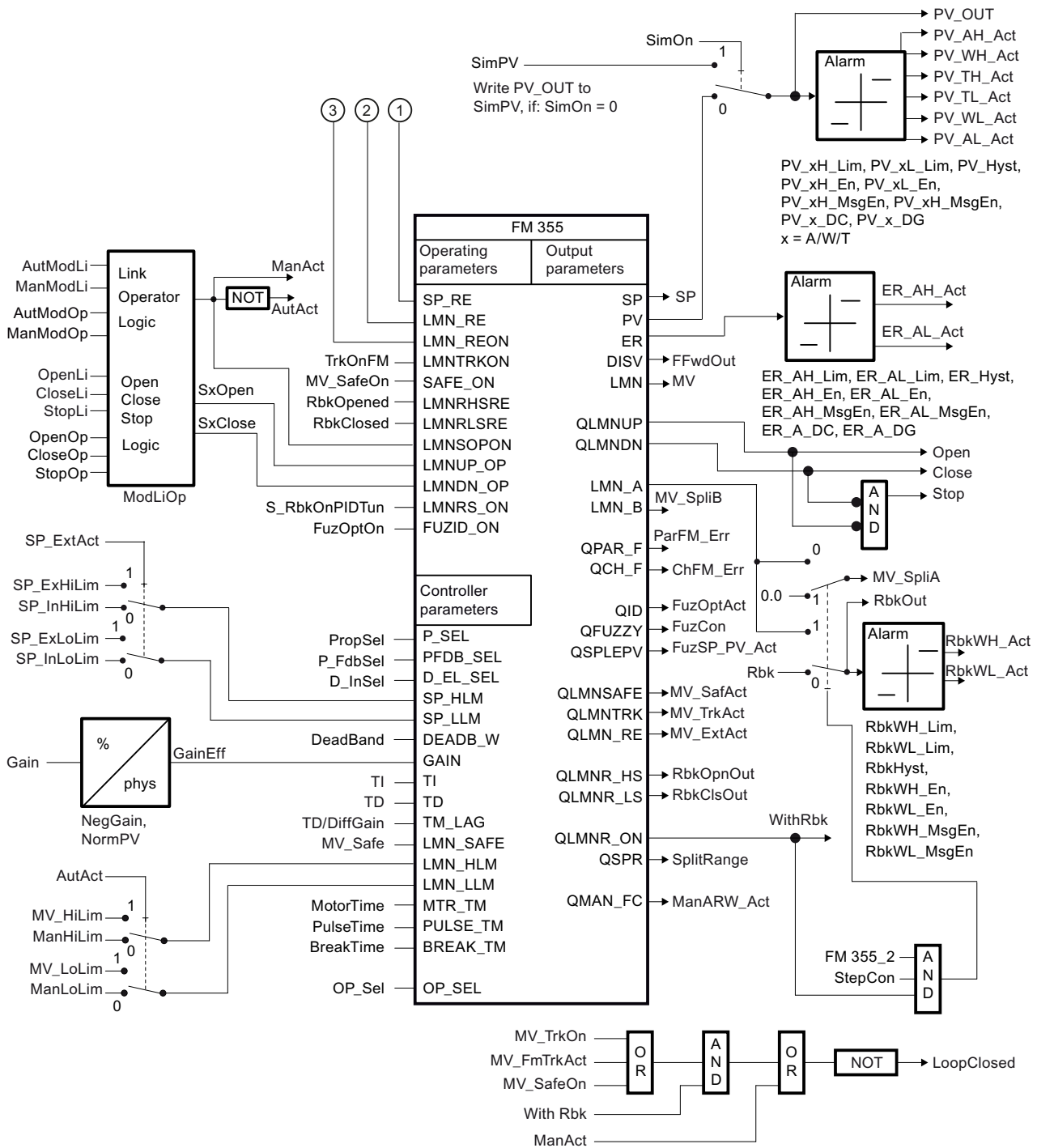

See also

- Description of FmTemp (Page 637)
- FmTemp modes (Page 641)
- FmTemp functions (Page 642)

FmTemp error handling (Page 654)

FmTemp messaging (Page 655)

FmTemp I/Os (Page 658)

5.4.8 Operator control and monitoring

5.4.8.1 FmTemp views

Views of the FmTemp block

The block FmTemp provides the following views:

- FM controllers standard view (analog) (Page 261)
- FM controllers standard view (pulse controller) (Page 265)
- FM controllers standard view (step controller with position feedback) (Page 269)
- FM controllers standard view (step controller without position feedback) (Page 273)
- Alarm view (Page 302)
- Limit view of FM controllers (Page 288)
- Trend view (Page 305)
- Parameter view of FM controllers (Page 284)
- Preview of FM controllers (Page 297)
- Memo view (Page 304)
- Batch view (Page 302)
- Block icons for PID and FM controller (Page 239)

Refer to the Structure of the faceplate (Page 248) and Block icon structure (Page 230) sections for general information about the faceplate and block icon.

5.5 GainSched - Adapting parameter values for a PID controller

5.5.1 Description of GainSched

Object name (type + number) and family

Type + number: FB 1820

Family: Control

Area of application for GainSched

The block is used for the following applications:

- Continuous adaptation of the parameter values of a PID controller to the current operating point of a non-linear process
- Controller gain
- Integral action time
- Derivative action time

How it works

If your process requires different PID controller parameters due to its non-linear response at different operating points, you can store optimum parameter sets for up to three different operating points in the GainSched block in the form of a table ("timetable"). The current operating point is represented by a continuously measurable variable X, typically by the actual value of the controller itself. The block ensures that the suitable optimum parameters $Gain(j)$, $TI(j)$ and $TD(j)$ are made available to the controller for each operating point X(j).

If the process is between two operating points, the parameters are calculated by linear interpolation between the optimum values of the two nearest operating points. This allows a bumpless, continuous adaptation of the controller parameters while the process moves from one operating point to another.

The block should be considered a supplementary function for a PID controller to improve the control performance of the PID controller in non-linear processes. The GainSched faceplate is called from the parameter view of the corresponding PID controller using the "Gain scheduler" button.

In contrast to all other function blocks, the GainSched block is implemented as a CFC chart and is generated with the "Compile chart as block type" function. The source chart "FbGainSchedLim" is supplied with the library so that you have more options open to you:

- You can use the precompiled function block GainSched from the library if the standard functionality is adequate for your needs.
- If you require special additional functions for gain scheduling in your application (for example more than three operating points, additional logic functions for selecting the parameters), you will need to modify the CFC source chart and compile it as a block type with a different FB number.

If the current value of input parameter x is below the lowest value x_1 in the table or above the highest value x_3 , precisely the controller parameters which are specified at the relevant boundary point x_1 or x_3 in the table are output.

Configuration

The GainSched block is placed in the same CFC chart as the assigned controller and interconnected with it as shown in the corresponding template: The output parameters `Link2Gain`, `Link2TI` and `Link2TD` are connected to the inputs `Gain`, `TI` and `TD` of the PID controller. The input x of GainSched is supplied with the measured value for the operating point, typically with the same value as `PV` of the controller.

You can open the standard view for the GainSched block from the parameter view of a controller (for example PIDConL). Additional information on this topic is available in the section [Opening additional faceplates \(Page 208\)](#).

To specify the parameters for gain scheduling, run separate controller optimizations at each of the intended operating points, for example with a tool such as the PID tuner. Use amplitudes as small as possible to excite the process to capture the approximately linear response in the area of the operating point under investigation. The optimum parameter values calculated by the PID tuner are entered in the relevant row belonging to the operating point in the table of the GainSched block. The table is clearly displayed in the standard view of the faceplate. Make sure that the numeric values are also permanently stored in the data management of the engineering system by reading back the numeric values of the parameters from AS to the ES or entering them manually at the inputs of the CFC block.

For the GainSched block, the Advanced Process Library contains a template for process tag types as an example with an application scenario for this block.

Example of process tag types:

- PID - control with operating-point-oriented parameter control (GainScheduling) (Page 2327)

Gain scheduling for batch processes

A typical area of application for gain scheduling is in batch processes that, in contrast to continuous processes, cannot be linearized around a fixed operating point because they need to be moved backwards and forwards between different operating points during the course of the batch. Here, there are three application scenarios:

- The controller parameters depend on a single continuously measurable variable that is representative of the operating point, for example, the reactor temperature. This is the normal use case for the GainSched block: The management of the controller parameters is handled in the block and is independent of batch recipes.
- The controller parameters depend on a continuously measurable variable that is representative of the operating point, but there is also a dependency on the materials used in the reaction. Suitable parameter sets for gain scheduling can then be anchored in the recipe and transferred by SIMATIC BATCH to the GainSched block.

- The controller parameters depend only the current phase of the batch. They can then be written directly from the Batch package to the PID controller and no gain scheduling block is necessary. The disadvantage of this is that there is bump in the controller parameters at the transfer from one phase to the next. The controller should be put into manual mode temporarily at the time of the transfer to avoid a bump in the manipulated variable.
- The recipe only specifies which of the controller parameter sets 1 ... 3 is currently required from the GainSched block. The numerical values of the parameter, however, are not anchored in the recipe. In this case input variable x of the GainSched block can then be used as the number of the required data record and assigned by the recipe instead of being linked with a measurable process variable. In this case, there are only three discrete values for x and the precautions against a change of controller parameters with bump outlined above must be taken because the interpolation abilities of the GainSched block are not used.

In general, it is not necessary to manage the batch parameters (batch number, batch name, etc.) in the GainSched block because the block does not generate any separate messages and there is always a 1-to-1 relationship with a controller block that knows the batch parameters.

Startup characteristics

The block does not have any startup characteristics.

Status word allocation for `Status` parameter

This block does not have the `Status` parameter.

See also

GainSched functions (Page 681)
GainSched messaging (Page 682)
GainSched I/Os (Page 683)
GainSched block diagram (Page 685)
GainSched error handling (Page 682)
GainSched modes (Page 680)

5.5.2 GainSched modes

GainSched modes

The block can be operated using the following modes:

- Automatic mode (Page 72)
- Manual mode (Page 72)

"Automatic mode"

In "automatic mode" (`ManParOn = 0`) the controller parameters are determined through a polygon in accordance with the settings in the "automatic" area of the parameter view.

You can find general information on "Automatic mode", switching modes and Bumpless switchover in the Manual and automatic mode for control blocks (Page 72) section.

"Manual mode"

In "manual mode" (`ManParOn = 1`) the controller parameters correspond to the settings in the "manual" area.

You can find general information on "Manual mode", switching modes and bumpless switchover in the section Manual and automatic mode for control blocks (Page 72).

See also

GainSched block diagram (Page 685)

GainSched I/Os (Page 683)

GainSched messaging (Page 682)

GainSched error handling (Page 682)

GainSched functions (Page 681)

Description of GainSched (Page 678)

5.5.3 GainSched functions**Functions of GainSched**

The functions for this block are listed below.

Configurable reactions using the `Feature` parameter

You can find an overview of all reactions provided by the `Feature` parameter in the Configurable functions using the Feature I/O (Page 131) section. The following functionality is available for this block at the relevant bits:

Bit	Function
24	Enabling local operator authorization (Page 158)

Selecting a unit of measure

This block provides the standard function Selecting a unit of measure (Page 212).

See also

- Description of GainSched (Page 678)
- GainSched messaging (Page 682)
- GainSched I/Os (Page 683)
- GainSched block diagram (Page 685)
- GainSched error handling (Page 682)
- GainSched modes (Page 680)
- GainSched standard view (Page 686)

5.5.4 GainSched error handling

GainSched error handling

The block does not report any errors.

See also

- GainSched block diagram (Page 685)
- GainSched I/Os (Page 683)
- GainSched messaging (Page 682)
- GainSched functions (Page 681)
- GainSched modes (Page 680)
- Description of GainSched (Page 678)

5.5.5 GainSched messaging

Messaging

This block does not offer messaging.

See also

- Description of GainSched (Page 678)
- GainSched functions (Page 681)
- GainSched I/Os (Page 683)
- GainSched block diagram (Page 685)

GainSched error handling (Page 682)

GainSched modes (Page 680)

5.5.6 GainSched I/Os

GainSched I/Os

Input parameters

Parameter	Description	Type	Default
EN	1 = Called block will be processed	BOOL	1
Gain1	PID gain for operating point 1	STRUCT <ul style="list-style-type: none"> Value: REAL ST: BYTE 	- <ul style="list-style-type: none"> 0.0 16#80
Gain2	PID gain for operating point 2	STRUCT <ul style="list-style-type: none"> Value: REAL ST: BYTE 	- <ul style="list-style-type: none"> 0.0 16#80
Gain3	PID gain for operating point 3	STRUCT <ul style="list-style-type: none"> Value: REAL ST: BYTE 	- <ul style="list-style-type: none"> 0.0 16#80
GainOp	PID gain: Input for "manual mode"	STRUCT <ul style="list-style-type: none"> Value: REAL ST: BYTE 	- <ul style="list-style-type: none"> 0.0 16#80
Feature	I/O for additional functions (Page 681)	STRUCT <ul style="list-style-type: none"> Bit 0: BOOL ... Bit 31: BOOL 	- <ul style="list-style-type: none"> 0 0 0
ManParOn	1 = input of PID parameters in "manual mode" 0 = use the planned controller parameters from the table	STRUCT <ul style="list-style-type: none"> Value: BOOL ST: BYTE 	- <ul style="list-style-type: none"> 0 16#80
OpSt_In	Input parameter for local operating permission, connected with the <code>Out</code> output parameter of the upstream block, <code>OpStations</code> (Page 411)	DWORD	16#00000000
TD_Op	PID derivative action time [s]: Manual input for the operator	STRUCT <ul style="list-style-type: none"> Value: REAL ST: BYTE 	- <ul style="list-style-type: none"> 0.0 16#80
TD1	PID derivative action time [s] for operating point 1	STRUCT <ul style="list-style-type: none"> Value: REAL ST: BYTE 	- <ul style="list-style-type: none"> 0.0 16#80

5.5 GainSched - Adapting parameter values for a PID controller

Parameter	Description	Type	Default
TD2	PID derivative action time [s] for operating point 2	STRUCT <ul style="list-style-type: none"> Value: REAL ST: BYTE 	- <ul style="list-style-type: none"> 0.0 16#80
TD3	PID derivative action time [s] for operating point 3	STRUCT <ul style="list-style-type: none"> Value: REAL ST: BYTE 	- <ul style="list-style-type: none"> 0.0 16#80
TI_Op	PID integral action time [s]: Manual input for the operator	STRUCT <ul style="list-style-type: none"> Value: REAL ST: BYTE 	- <ul style="list-style-type: none"> 0.0 16#80
TI1	PID integral action time [s] for operating point 1	STRUCT <ul style="list-style-type: none"> Value: REAL ST: BYTE 	- <ul style="list-style-type: none"> 0.0 16#80
TI2	PID integral action time [s] for operating point 2	STRUCT <ul style="list-style-type: none"> Value: REAL ST: BYTE 	- <ul style="list-style-type: none"> 0.0 16#80
TI3	PID integral action time [s] for operating point 3	STRUCT <ul style="list-style-type: none"> Value: REAL ST: BYTE 	- <ul style="list-style-type: none"> 0.0 16#80
X	Process value that defines the operating point	STRUCT <ul style="list-style-type: none"> Value: REAL ST: BYTE 	- <ul style="list-style-type: none"> 0.0 16#80
X1	Operating point 1 (support point) for x	STRUCT <ul style="list-style-type: none"> Value: REAL ST: BYTE 	- <ul style="list-style-type: none"> 0.0 16#80
X2	Operating point 2 (support point) for x	STRUCT <ul style="list-style-type: none"> Value: REAL ST: BYTE 	- <ul style="list-style-type: none"> 0.0 16#80
X3	Operating point 3 (support point) for x	STRUCT <ul style="list-style-type: none"> Value: REAL ST: BYTE 	- <ul style="list-style-type: none"> 0.0 16#80
X_Unit	Unit of measure for the operating point	INT	1001

Output parameters

Parameter	Description	Type	Default
ENO	1 = Block algorithm completed without errors	BOOL	0
Link2Gain	Calculated controller gain	STRUCT <ul style="list-style-type: none"> Value: REAL ST: BYTE 	- <ul style="list-style-type: none"> 0.0 16#80

5.5 GainSched - Adapting parameter values for a PID controller

Parameter	Description	Type	Default
Link2TD	Calculated integral action time	STRUCT <ul style="list-style-type: none"> Value: REAL ST: BYTE 	- <ul style="list-style-type: none"> 0.0 16#80
Link2TI	Calculated derivative action time	STRUCT <ul style="list-style-type: none"> Value: REAL ST: BYTE 	- <ul style="list-style-type: none"> 0.0 16#80
OpSt_Out	Value of the OpSt_In input parameter, for feedforwarding to other blocks. Bit 31 of this parameter is used by Feature bit 24	DWORD	16#00000000
OS_PermLog	Parameter used to hide operator controls in the faceplate	DWORD	16#00000000

See also

Description of GainSched (Page 678)

GainSched messaging (Page 682)

GainSched block diagram (Page 685)

GainSched modes (Page 680)

5.5.7 GainSched block diagram**GainSched block diagram**

A block diagram is not provided for this block.

See also

GainSched I/Os (Page 683)

GainSched messaging (Page 682)

GainSched error handling (Page 682)

GainSched functions (Page 681)

GainSched modes (Page 680)

Description of GainSched (Page 678)

5.5.8 Operator control and monitoring

5.5.8.1 GainSched views

Views of the GainSched block

The GainSched block provides the following views:

- GainSched standard view (Page 686)
- GainSched parameter view (Page 687)
- GainSched preview (Page 688)
- Memo view (Page 304)

Refer to the sections Structure of the faceplate (Page 248) and Block icon structure (Page 230) for general information on the faceplate and block icon.

5.5.8.2 GainSched standard view

GainSched standard view

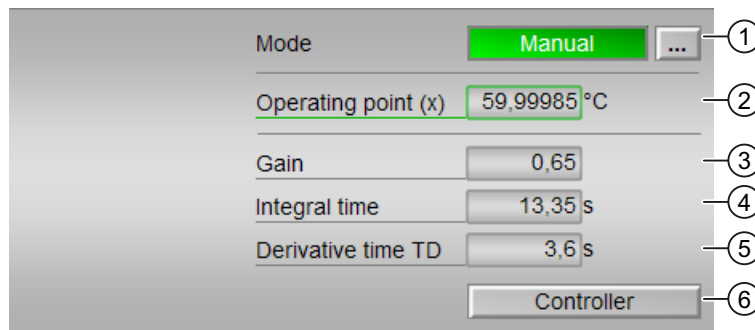

(1) Displaying and switching the operating mode

This area provides information on the currently valid operating mode. The following operating modes can be shown here:

- Manual mode (Page 72)
- Automatic mode (Page 72)

Refer to the Switching operating states and operating modes (Page 257) section for information on switching the operating mode.

In "manual mode", you can specify the values on the OS in the parameter view of this block; they are then output directly via the corresponding output parameters.

In "automatic mode", an interpolation is performed through the interpolation points, which can also be specified in the parameter view.

(2) Displaying the operating point (X)

Currently used operating point.

(3) Displaying the gain

The controller gain currently output at the `Link2Gain` output parameter.

(4) Displaying the integration time τ_I

Integration time currently output at the `Link2TI` output parameter.

(5) Displaying and changing the derivative time τ_D

Derivative time currently output at the `Link2TD` output parameter.

(6) Navigation button to GainSched block

Use this navigation button to reach the standard view of a controller block configured in the engineering system. The visibility of this navigation button depends on the configuration in the engineering system (ES).

Additional information is available in the section *Opening additional faceplates* (Page 208).

5.5.8.3 GainSched parameter view**Parameter view of GainSched**

Manual	WP	Gain	TI s	TD s
		<input type="text" value="1."/>	<input type="text" value="0."/>	<input type="text" value="0."/>
Automatic				
X1		<input type="text" value="5."/>	<input type="text" value="3."/>	<input type="text" value="2."/>
X2		<input type="text" value="3."/>	<input type="text" value="20."/>	<input type="text" value="1."/>
X3		<input type="text" value="4."/>	<input type="text" value="0."/>	<input type="text" value="3."/>

(1) Displaying and changing the values for the controller parameters in "manual mode"

This is where you enter the values for the parameters to be used in "manual mode" at the corresponding output parameters of the block:

- "Gain": Input parameter `GainOp`
- "TI": Integration time, input parameter `TI_Op`
- "TD": Derivative time, input parameter `TD_Op`

Refer to the section titled Changing values (Page 259) for information on changing the values.

(2) Displaying and changing the values for the controller parameters in "automatic mode"

This is where you enter the values for the parameters to be used in "automatic mode" for the interpolation (max. 3 values):

- "X1": Operating point 1, input parameter X1
- "X2": Operating point 2, input parameter X2
- "X3": Operating point 3, input parameter X3
- "Gain": Input parameter Gain1 ... Gain3
- "TI": Integration time, input parameter TI1 ... TI3
- "TD": Derivative time, input parameter TD1 ... TD3

Refer to the section titled Changing values (Page 259) for information on changing the values.

5.5.8.4 GainSched preview

Preview of GainSched

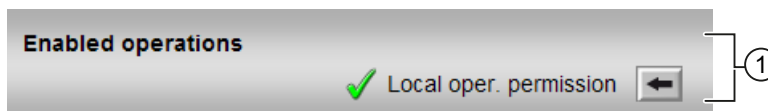

(1) Enabled operations

This area shows all operations for which special operator control permissions are assigned. They depend on the configuration in the engineering system (ES) that applies to this block.

Symbols for enabled operations:

- **Green check mark:** the OS operator can control this parameter
- **Gray check mark:** the OS operator cannot control this parameter at this time due to the process
- **Red cross:** the OS operator cannot control this parameter due to the configured AS operator control permissions (OS_Perm or OS1Perm).

The following enabled operations are shown here:

- "Local operating permission": Use the ← button to switch to the standard view of the OpStations block. Additional information is available in the section Operator control permissions (Page 254).

5.6 ModPreCon - Model predictive controller

5.6.1 Description of ModPreCon

Object name (type + number) and family

Type + number: FB 1843

Family: Control

Area of application for ModPreCon

The block is used in much the same way as a PIDConL block for the following applications:

- Fixed setpoint control
- Cascade control
- Ratio control
- Split-range control

In contrast to the PID controllers, this is a multivariable controller.

Compared to Advanced Process Library V7.1.4, the new version provides the following functional enhancements:

- Integrated static operating point optimization,
- Prediction without control response and display of the prediction of the free motion,
- Automatic process trigger for model identification,
- Verification of the sampling time.

Method of operation and area of application

The block is used for multivariable control (Page 2390) of dynamic processes. It can handle up to four dependent manipulated and controlled variables as well as a measurable disturbance.

In special situations, the ModPreCon block can also be used for particularly difficult dynamic, single-variable controls. It is better than a PID controller, for example, in systems with non-minimum phase (Page 2391) or a strongly oscillating response.

The ModPreCon algorithm only works for stable processes with a step response that settles to a fixed value in a finite time. If the process is unstable in one of the main transfer functions or includes an integrator (level control, for example), the corresponding partial transfer function must be stabilized with a secondary controller.

A simple P controller (proportional component only) is sufficient as a subordinate controller for integrating processes. It is inserted between the manipulated variable output from ModPreCon and the input of the unstable process section, and receives the output of the integrating process section as a manipulated variable. (Unstable data links are stabilized with this approach.)

You can find an explanation of "multivariable controls" and "non-phase-minimum response" in the Help on the Advanced Process Library > Definitions.

Note on the area of application of the controller: Longer run times

Due to the principle on which they work, the runtime for multivariable controllers is significantly longer than that for PID controllers, because the matrix calculations in the algorithm are much more complex. The runtime is also determined by the number of the process and manipulated variables in the control algorithm. This is why the multivariable controller is unsuited for rapid control and is usually used for slow, complex control tasks.

The computation time required on the CPU is compensated for by the fact that very slow sample times of > 20s are used for the typical ModPreCon applications (see Advanced control templates). The ModPreCon is then typically in OB30 and can be interrupted by faster OBs.

Optimization is called within the ModPreCon block in the program section in which OB1 is executed. In cyclic operation (OB3x), this avoids the additional computing time required by the optimizer, the acyclic time, i.e. which is only relevant for changes to the optimizer inputs. The calculation time load caused by the ModPreCon block is hardly more with optimization than it is for ModPreCon without optimization.

Operating principle

The ModPreCon block is a model-based predictive multivariable controller. It uses a mathematical model of the process dynamics including all interactions as part of the controller. This model allows the process response to be predicted over a defined period in the future, also known as the prediction horizon.

Based on this prediction, a performance index

$$J = (\overset{r}{w} - \overset{r}{y})^T \cdot \overset{r}{R} \cdot (\overset{r}{w} - \overset{r}{y}) + \Delta \overset{r}{u}^T \cdot \overset{r}{Q} \Delta \overset{r}{u}$$

is optimized (minimized) where the following applies:

- w contains the time series of the future setpoints,
- y contains the vector of the controlled variables in the future,
- Δu contains the future changes to the manipulated variable.

If you increase the weighting in the Q diagonal matrix, the controller moves its manipulated variables more cautiously resulting in a slower but more robust control response. Using the weighting factors in the R diagonal matrix, you specify the relative significance of the individual controlled variables. A higher weighting (priority) for a controlled variable means that this CV moves more quickly towards the setpoint and remains more accurately at the setpoint in steady state if it is not possible to achieve all setpoints precisely.

The algorithm is a variant of the DMC procedure (**D**ynamic **M**atrix **C**ontrol) in which the optimization problem is solved in the design phase ignoring the constraints. The function block itself contains the analytical solution of the optimization problem. Manipulated variable limitations, both absolute and relating to the gradients, are treated in the algorithm of the function block as hard constraints that must not be violated. This means that precise setpoints or target zones for the controlled variables are taken into account during optimization as well as possible. The target zones for the controlled variables are therefore soft limits, which are

maintained as well as possible although they cannot be guaranteed. Using a reference variable filter for future setpoint settings, the control response of the controller can be fine-tuned during operation.

You can achieve significant improvements in control performance when individual disturbances can be measured, for example variations in throughput. In this case, it is a good idea to take into account a model of the influence of this disturbance on the controlled variables when predicting the controlled variables so that the controller can react preemptively to such disturbances.

Operating point optimization

The integrated static operating point optimization can be used when at least one controlled variable provides certain degrees of freedom. No exact setpoint is specified for such controlled variables. Instead there is a tolerance band, e.g.

SP2OptHiLim...SP2OptLoLim

within which the process value, CV2, must remain. These areas can be defined for any subset of the relevant controlled variables. From an economic perspective, different values within the tolerance range can be more or less favorable. With the help of the optimization function, the optimal economic point can be found within the tolerance range. This is done by defining a target function (performance criterion), which depends on the manipulated variable and controlled variable of the predictive controller. This can be, for example, the economic yield of plant operation per time unit or it may involve specific costs or energy consumption.

Configuration

Use the CFC editor to install the block in a cyclic interrupt OB (OB30 to OB38). The block is also installed automatically in the startup OB (OB100).

After installation in CFC, follow the steps outlined below:

1. Excite the process with the controller in manual mode by applying a series of manipulated variable step changes.
2. Record the measured data with the CFC trend display and export it to an archive file.
3. Select the ModPreCon instance in the CFC. Start the MPC Configurator with the command Edit > MPC Configurator. The working steps process identification, controller design and simulation of the closed control loop are executed in the MPC Configurator. You can find a detailed description of this procedure in the MPC Configurator help. You can find the help with a button in the MPC Configurator or directly under ...\\Program Files (x86)\\SIEMENS\\STEP7\\S7JMPC\\s7jmpctb.chm. (the last letter is the language code).
4. Using the Configurator, create an SCL source code for the user data block (DB). It contains the models and matrices required for a ModPreCon instance.

5. Compile the SCL source code in the engineering system and download it to the AS.
6. Enter the number of the data block at the DB_No input parameter of the ModPreCon block. The values are adopted in the controller by restarting the block using the Restart input parameter.

Note

During controller design in the MPC Configurator, a controller cycle time and an OB sampling time are calculated, displayed, and stored in the user data block. You yourself are responsible for the ModPreCon block being called in the cyclic interrupt level suitable for the OB sampling time. This is checked in the current ModPreCon version during initialization. If the SampleTime parameter of the function block does not match the OB_SampleTime parameter of the user data block, a parameter assignment error (ErrorNum=3) is displayed. For controller cycle times greater than 5 s, specify the ModPreCon block in the OB30 and specify the appropriate cycle time for the OB30 in the hardware configuration of the Simatic CPU. Controller cycle times slower than 20 s cannot be set in the hardware configuration. The block would then be called every 20s and the slower sampling time automatically realized by an internal cycle reduction ratio in the block.

For the ModPreCon block, the Advanced Process Library contains a template for a process tag type as examples and there is an example project (where APL_Example_xx, xx designates the language variant) containing various application cases for this block. Several application cases are simulated in the example project and serve to explain how the block works.

Example of a process tag type:

- Model-based predictive control (you can find additional information on this in the Help on Advanced Process Library > PCS 7 Advanced Process Control Templates > Process tag types > Model-based predictive control (ModPreCon))

Application cases in example project:

- Predictive control of a 2x2 multi-variable controlled system (you can find additional information on this in the Help on Advanced Process Library > PCS 7 Advanced Process Control Templates > Example project APL_Example_xx > Predictive control of a 2x2 multi-variable controlled system)
- Predictive control of a non-linear process (you can find additional information on this in the Help on Advanced Process Library > PCS 7 Advanced Process Control Templates > Example project APL_Example_xx > Predictive control of a non-linear process)

Startup characteristics

When the CPU starts up, the block always starts in manual mode. It is only possible to change to automatic mode when a user data block is loaded and the internal measured value memory in ModPreCon is filled with data.

Use the `Feature Bit Set` startup characteristics (Page 138) to define the startup characteristics of this block.

You can find additional information on the feature bit "Set startup characteristics" in the Help on Advanced Process Library > Basics of APL > Selectable block response > Set startup characteristics.

Status word allocation for status1 parameter

You can find a description for each parameter in section ModPreCon I/Os (Page 709)

Status bit	Parameter
0	Occupied
1	BatchEn
2	SimOn
3	OosAct.Value
4	OosLi.Value
5	AutAct.Value
6	Not used
7	ManAct.Value
8 - 9	Not used
10	MV1TrkOn.Value AND NOT (ManAct.Value OR OosAct.Value)
11	MV2TrkOn.Value AND NOT (ManAct.Value OR OosAct.Value)
12	MV3TrkOn.Value AND NOT (ManAct.Value OR OosAct.Value)
13	MV4TrkOn.Value AND NOT (ManAct.Value OR OosAct.Value)
14	Not used
15	DB_Loaded
16	DV_Model Available
17	OptimAct
18	NOT (OptimAct)
19	SimOn AND ManAct
20	J_Mini
21	NOT(J_Mini)
22	ExciteOn AND ManAct.Value
23-30	Not allocated
31	Feature.Bit31: Display of the predictions in the faceplate

Status word allocation for status2 parameter

Status bit	Parameter
0 - 30	Not used
31	MS_RelOp

See also

[ModPreCon functions \(Page 695\)](#)
[ModPreCon messaging \(Page 709\)](#)
[ModPreCon block diagram \(Page 720\)](#)
[ModPreCon error handling \(Page 708\)](#)
[ModPreCon modes \(Page 694\)](#)

Model-based predictive control (ModPreCon) (Page 2351)

Predictive control of a 2x2 multi-variable controlled system (ModPreConSim) (Page 2381)

Predictive control of a non-linear process (ModPreConNonLinSim) (Page 2381)

5.6.2 ModPreCon modes

Operating modes of ModPreCon

The block can be operated using the following modes:

- Automatic mode (Page 72)
- Manual mode (Page 72)
- Out of service (Page 71)

The next section provides additional block-specific information relating to the general descriptions.

The aforementioned operating modes are valid for the block with all control channels (MV1 ... MV4). Moreover, individual control channels can be tracked; see chapter ModPreCon functions (Page 695) for more information.

"Automatic mode"

You can find general information on "Automatic mode", switching modes and bumpless switchover in the Manual and automatic mode for control blocks (Page 72) section.

Note

In contrast to PID controllers, it is permitted to run the ModPreCon block in "automatic mode" without its actuating signals affecting the process because there is no risk of integrator windup.

"Manual mode"

You can find general information on "Manual mode", switching modes and bumpless switchover in the Manual and automatic mode for control blocks (Page 72) section.

"Out of service"

You can find general information about the "Out of service" mode in the Out of service (Page 71) section.

See also

ModPreCon block diagram (Page 720)

ModPreCon I/Os (Page 709)

ModPreCon messaging (Page 709)

ModPreCon error handling (Page 708)

Description of ModPreCon (Page 689)

5.6.3 ModPreCon functions

Functions of ModPreCon

The functions for this block are listed below.

Generating and limiting the manipulated variable

The manipulated variable $MV1 \dots MV4$ (hereinafter referred to as MV_x , $x = 1 \dots 4$) can be generated as follows:

ManAct	MVxTrkOn	MVx	Limit monitoring	State
1	-	Manx	ManxHiLim ManxLoLim	"Manual mode", set by the operator
0	1	MVxTrk	MVxHiLim MVxLoLim	Tracking with limitation
0	0	Automatic manipulated variable	MVxHiLim MVxLoLim	"Automatic mode": Predictive controller algorithm

Remark

If the controller is in "Out of service" mode, the output parameters $MV1 \dots MV4$, depending on the Feature Bit (Neutral position manipulated variable takes effect at startup (Page 166)), are set to the last valid value in manual mode or the corresponding neutral position manipulated variable ($SafePos1 \dots SafePos4$). Refer to the Out of service (Page 71) section for more on this.

The limited operating range (between MV_xHiLim and MV_xLoLim) is typically smaller in automatic mode than in manual mode. With regard to the limited range of validity of a linear process model for approximating a non-linear process response, this allows the stability of the closed control loop to be guaranteed within the control range in automatic mode.

The gradients of the manipulated variable (changes per second) are limited to $MV1RaLim$ to $MV4RaLim$ in "automatic mode". Gradient limitation applies both to the positive and negative directions.

Tracking and limiting a manipulated variable

The block provides the standard function Tracking and limiting a manipulated variable (Page 196).

In contrast to PID controllers, tracking the manipulated variables ($MV1 \dots MV4$) is enabled for specific channels via one of the input parameters $MV1TrkOn \dots MV4TrkOn$. The corresponding manipulated variable is then tracked by the interconnectable input parameters $MV1Trk \dots MV4Trk$.

Setting the setpoint internally

With this block, the setpoint must always be set internally at the I/Os SP1 ... SP4. These are normally operated in the faceplate. In special situations, you can interconnect the setpoints but they can then no longer be changed using the faceplate.

Setpoint tracking in manual mode

In this situation ($SP_TrackCV = 1$), the internal setpoints SP1 ... SP4 are tracked to the assigned process values CV1 ... CV4 in "manual mode". This function allows a bumpless transfer to "automatic mode". After the transfer, the setpoints can be changed by the operator again.

Setpoint filters

The setpoint filter is the only way of changing the action of the predictive controller without having to create a new user data block with the MPC Configurator and reinitialize the controller. The specified time constant $PreFilt1 \dots PreFilt4$ of the setpoint filter can be interpreted as the required settling time of this CV channel following a setpoint step change. As the time constant setting increases, the controller works more slowly and less aggressively. In particular, this reduces the influence of a setpoint step change in one control channel on neighboring control channels.

Internally, the ModPreCon block works with sets of future setpoints that are compared with the predicted movements of the controlled variables. Without the setpoint filter, it is assumed that the current setpoint will continue to remain valid in the future within the prediction horizon. If there is a setpoint step change, this means that the full value of the new setpoint will be required in the near future although the process cannot achieve this (according to the prediction). With the setpoint filter, an asymptotic setpoint trajectory (first order) is calculated from the current process value to the required setpoint so that the required setpoint is reached in the specified time.

Note

The setpoint filter also comes into effect without a setpoint step if the process value deviates significantly from the setpoint due to disturbances. This means that the filter not only slows down the control response but indirectly also the response to disturbances.

The control response can only be slowed down by the setpoint filter and not accelerated; when the value is 0, the prefilter is deactivated. It is therefore advisable to set the basic controller action in the MPC Configurator with the "Manipulated variable change penalty" parameter and then to optimize this in the software using the function for simulation of the closed control loop.

The setpoint filter should then only be used for fine tuning of the action in the operational system.

Note

Do not select an excessively long filter time constant. Values that are greater than the control horizon of the predictive controller (s. ModPreCon user DB, header comment of the SCL source: "control horizon" times "controller sample time" in seconds) can have undesirable effects when the dead band is used at the same time. If you wish to dramatically slow down the reaction of the controller, it is better to use the penalty of the manipulated variable changes in the MPC Configurator.

Simulating signals

The block provides the standard function Simulating signals (Page 58).

You can simulate the following values:

- Controlled variable ($SimCVx$, $SimCVxLi$)

Selecting a unit of measure

The block provides the standard function Selecting a unit of measure (Page 212).

Error signal generation and dead band

The block provides the standard function Error signal generation and dead band (Page 192).

In the predictive controller, the error signal is generated over the entire prediction horizon for each control channel as the deviation between the predicted movement of the process (starting at the current process value $CV1 \dots CV4$) and future setpoint settings (ending at $SP1 \dots SP4$) and used to calculate the manipulated variable.

In principle, the effect of the dead bands $SP1DeadBand$ to $SP4Deadband$ is the same as in a PID controller, but extends over the entire future prediction horizon. In other words, if, for example, the predicted controlled variable $CV1$ in the entire prediction horizon is within the band $SP1 \pm SP1DeadBand$, the controller sees no reason whatsoever to change any manipulated variable. These are therefore also known as CV bands. In contrast to the manipulated variable limits, these are not hard constraints that need to be adhered to at all costs.

In multivariable controllers, it is advisable to make use of the fact that from the perspective of the application only some of the controlled variables need to move to a specified setpoint exactly while others only need to remain within a defined range.

A typical example would be quality characteristics for which a tolerance band is specified. While a dead band in a PID controller tends to put stability at risk, CV bands in individual controller channels generally relieve the multivariable controller overall.

Using CV bands, the action of a soft override control can be achieved.

Use case for error signal generation with dead band

As long as the pressure in a reactor remains within the set safety limits, the controller is interested only in product quality. However, as soon as the pressure threatens to leave the permitted range (in other words, in the prediction it moves towards an illegal value in the future), the pressure control cuts in. By weighting the controlled variables in the performance index (see MPC Configurator), the user can specify that predicted violations of the pressure limits are given a particularly high weighting.

Predictive controller algorithm

The ModPreCon block is derived from the familiar DMC algorithm (**D**ynamic **M**atrix **C**ontrol) . Future changes to the manipulated variable within the control horizon are calculated according to the formula:

$$\Delta \underline{u}^r = \underline{C} \cdot (\underline{w}^r - \underline{f}^r)$$

Where:

- w contains the time series of the future setpoints
- f contains the predicted free movement of the controlled variables (with constant manipulated variables) in the future
- C is the constant controller matrix calculated by the MPC Configurator. C includes both the process model and the weighting of the manipulated variable changes and the controlled variables from the performance index of the optimization.

Based on the principle of the receding horizon, only the first value is taken from the vector of the optimum manipulated variable changes over the entire control horizon and applied to the process. In the next step, the newly arrived process values are taken into account and the calculation repeated over the entire prediction horizon.

With predictive controllers, the manipulated variable changes are based on the control deviations predicted in the future, while with a PID controller, they are based on error signal of the past (possibly also integrated). This can be interpreted as a "looking ahead" strategy.

Anti-windup

When manipulated variable limits are active, anti-windup measures are taken automatically within the controller. The prediction equations use the real limited values of the manipulated variable instead of theoretically calculated values.

Model-based disturbance compensation

Model-based disturbance compensation can and should be used when a known disturbance has a strong influence on the process and its cause can be measured.

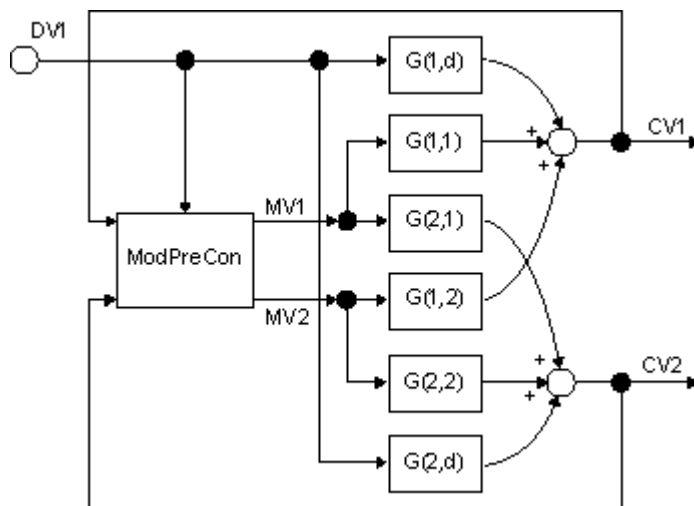

The effects of a measurable disturbance ($DV1$ I/O) on all controlled variables $CV1 \dots CV4$ can be estimated when the controller is taken into manual mode. This means that no movements of the controlled variables whatsoever result from changes to the manipulated variable and all movements result from the disturbance. If the disturbance can be measured but cannot be actively adjusted, it may be necessary to search through a data archive to find the time segments in which the disturbance changed.

The identification of the transfer functions from the disturbance variable $DV1$ to all controlled variables $CV1 \dots CV4$ (disturbance model, in the graphic above $G(1,d)$ and $G(2,d)$) is performed with the MPC Configurator and is analogous to the identification of the main transfer functions ($G(1.1)$ to $G(2.2)$). The measured disturbance variable is then switched to the $DV1$ input of the ModPreCon block and disturbance compensation is activated with $DV_On = 1$. As a result, the effect of the measurable disturbance is taken into account in the prediction and the controller can start counter measures in advance before the disturbance can have a massive influence on the controlled variables.

Such disturbance compensation is especially effective when the disturbance is constant in sections and changes from time to time. If a disturbance changes constantly or oscillates, however, the feedforward control is not enabled during operation of the controller to avoid constant oscillation of the manipulated variables, although it should be taken into account in the MPC Configurator when creating the process model.

If there is no disturbance model in the user data block, the $DV1$ input is ignored.

Typical examples of measurable disturbances are inlet volumes in distillation columns or throughput of continuous reactors.

Predictive controller with more than one measurable disturbance

If you want to plan for more than one measurable disturbance in an application, but do not need all four disturbances from the ModPreCon block, you can dedicate the first of the previously unused control channels for disturbance variable feedforwarding.

Example: You only have two control actions available, so only use `MV1` and `MV2`. Then connect the additional measurable disturbance variable `DV2` to the `MV3Trk` input parameter and set `MV3TrkOn = 1`. For recording training data for the predictive controller, declare `MV3Trk` as the third disturbance and also use the CFC trend recorder to record the effect of changes to `DV2` on all controlled variables.

Use the MPC Configurator to then determine a process model that describes the effects of `DV2`. However, if the `DV2` in "automatic mode" of the controller changes due to external influences, the effect of such change is taken into consideration for predicting future process reactions through `MV3Trk`, and predictive methods can be used to compensate. The performance of the disturbance compensation is exactly the same as that for regular feedforward control via the input parameters `DV` and `DV_On = 1`.

If you want to disable this disturbance compensation in runtime with the unused `MV3` manipulated variable, you need to insert a `MV3Trk` selector block in front of the `SelA02In` input. This allows you to set a constant zero for `MV3Trk` instead of the measured value `DV2`, which stops the effect of `MV3` on prediction. (Due to this reassignment, `MV3TrkOn` must always remain 1 to prevent the controller from changing the value of `MV3`.)

This way, up to four measurable disturbances can be selected. However, the sum of the manipulated variables and disturbances may not exceed a total number of five.

Control of square and non-square systems

In multivariable controllers, the number of manipulated variables should ideally be the same as the number of controlled variables. This is known as a "square system". As long as constraints do not influence operation, the controller can, in principle, track all controlled variables exactly to the selected setpoints.

If there are less manipulated variables than controlled variables, or individual manipulated variables have reached their limits, there is no freedom in the control problem. This means that it is not possible for all setpoints to be reached exactly.

The ModPreCon algorithm then finds a compromise that can be influenced by the selection of controlled variable weights (priorities) in the MPC Configurator: Controlled variables with higher priority will have lower control deviations.

Note

Since the ModPreCon block is a lean predictive controller algorithm without online optimization, there can be no general guarantee that the compromise found is optimum in a mathematical sense; in other words, it is the minimum of the fit function taking into account the manipulated variable limits. In most practical situations, however, the controller finds sensible compromises.

The static operating point optimization is not a dynamic online optimization in this sense, i.e. it does not change anything in the above-mentioned restriction.

If there are more manipulated variables than controlled variables or if some of the controlled variables are already within their setpoint bands, there is surplus freedom in the control problem. A lean predictive controller algorithm, however, cannot recognize this situation explicitly and use the free manipulated variables for optimization. The ModPreCon block therefore moves all manipulated variables to values that meet the aims in terms of controlled variables and then leaves them there. In some situations, however, it can be useful to provide

the controller with more manipulated variables than controlled variables, for example when the effect of individual manipulated variables is too restricted.

Another approach is to define the excess manipulated variables as pseudo controlled variables at the same time. You do this by assigning a setpoint with low priority to the pseudo controlled variables. The controller then attempts to achieve the important control aims as first priority and, at the same time, attempts to reach certain ideal values for the individual manipulated variables.

Control of linear and non-linear systems

The ModPreCon algorithm is based on a linear, time invariant process model. As a result, in much the same way as a PID controller, it is suitable above all for controlling non-linear systems around a fixed operating point.

Again analogous to the PID controller, there are, however, several possibilities with which the area of application can be extended with non-linear systems:

Compensation functions between controller and controlled system:

It is, for example, possible to compensate the effect of a non-linear valve characteristic curve using a polygon block between the **MV** output and the control input of the valve block. Care must be taken when implementing the manipulated variable limits. In the same way, the effect of a non-linearity at the output of the controlled system (for example a sensor characteristic curve) can be compensated by a polygon block before the **CV** input of the controller. Remember that the corresponding **SP** must also be transformed accordingly. In both cases, the compensation functions become part of the controlled system from the perspective of the controller. The aim is always to keep the overall response of the controlled system consisting of process and compensation elements as linear as possible.

Multimodel control:

This approach is related to the basic idea of operating-point-based parameter control with PID controllers. Since the model parameter of the ModPreCon block cannot be modified in runtime, however, the control strategy for selecting the suitable parameter set becomes a control strategy for selecting the suitable model.

Several ModPreCon instances with different models for different operating points run at the same time. The local optimal models are determined by starting the process at the various operating points with small amplitudes, so that only the reaction of the non-linear process in the ambience of this operating point is registered.

The final manipulated variable for each manipulated variable is formed as a weighted mean value of the manipulated variables proposed by the controller instances. (It is recommended that experiments for starting the process for the MPC Configurator are only performed after implementing the functions for adding the manipulated variables, in order to ensure that the same conditions applicable when the model is in operation actually take effect.)

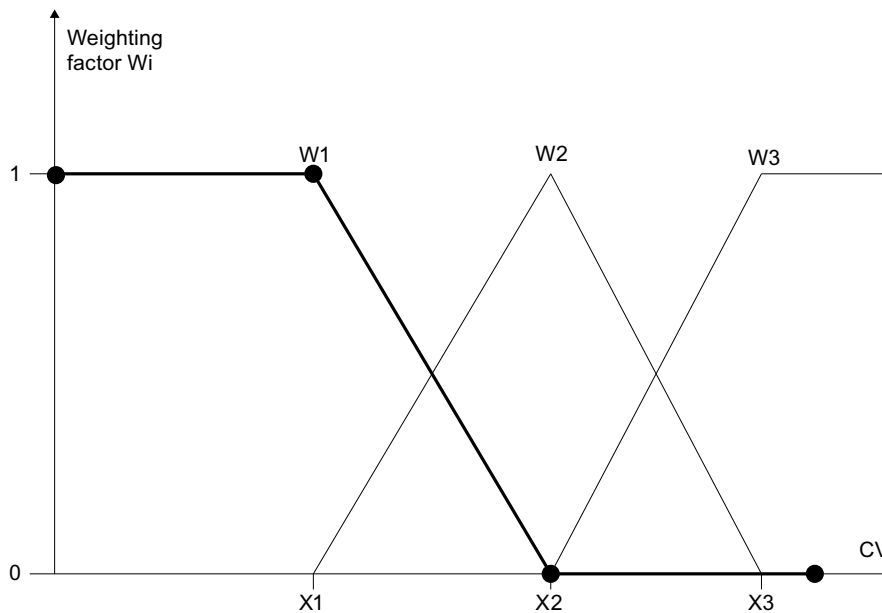

The weighting factors 0 ... 1 are formed in the same way as the membership functions known from fuzzy logic so that the sum of all weights is always one and each controller has the highest weighting at its own operating point. A polygon with 4 or 5 interpolation points is used to calculate each individual weighting factor. The weighting factors are calculated based on a specific measurable PV variable of the process, which is representative for the operating point of the process. This can be one of the CV_x controlled variables, although it does not have to be. The abscissa of the interpolation points of all polygons is selected in such a way that they cover the entire value range of PV in order to avoid extrapolation errors.

One should note in this regard that the only non-linear effects in the full multi-variable control loop that can be modeled are those that correlate exactly to a representative PV variable. This approach is therefore not suitable for cases in which individual partial transfer functions demonstrate non-linear effects that depend on various, totally independent variables.

To ensure the stability of the overall control loop, all subcontrollers must be at least stable at all operating points. In contrast to PID controllers however, an MPC is not affected by windup problems if it temporarily runs in "automatic mode" but cannot intervene in the real process (weighting factor zero).

One of the controller instances is defined as the main controller and shown in the operator faceplate on the OS. All others are connected in such a way that they adopt the operating mode ("manual"/"automatic mode") and the setpoints from the main controller. The manual manipulated variables are passed to the secondary controller via the tracking inputs. This means that no operator intervention is required on secondary controllers.

Note

The manipulated variables of the main controller can be used when switching from automatic to manual mode. If the process was in the operating range of a secondary controller beforehand, the current manipulated variables in the process can deviate significantly. In this case, you should apply the actual manipulated values in effect by manual input in the faceplate of the primary controller.

You can find an example for multi-model controlling in the example project of Advanced Process Library under Predictive control of a non-linear process (ModPreConNonLinSim) (Page 2381).

Trajectory control:

This approach neatly combines the advantages of an open loop controller (Feedforward Control) with those of a closed loop controller with process value feedback (Closed Loop Control). The controller follows a previously optimized trajectory of setpoints and manipulated variables; in other words, it only needs to compensate small deviations between the stored trajectory and the current plant state. A trajectory is an optimum series of manipulated variables over time and the process values that match them. The required manipulated variables are read via the inputs `MV1Traj ... MV4Traj` into the ModPreCon block and added to the values of the manipulated variable calculated by the algorithm (in automatic mode only). Among other things, the advantage of this is that the effective manipulated variable acting on the process can be configured and is limited to the sum of the trajectory and controller action. The process values from the trajectory are switched to the corresponding setpoint specifications `SP1 ... SP4` of the controller. As long as the process reacts exactly as planned in the trajectory, it will respond to the series of manipulated variables from the trajectory with the corresponding series of process values and the control deviation is zero. It is generally known that a non-linear dynamic process can be linearized around a fixed operating point or a steady state of the system. It is also possible to linearize it around a trajectory.

Forming the signal status for blocks

The block provides the standard function Forming and outputting the signal status for technologic blocks (Page 109).

The worst signal status `ST_Worst` for the block is formed from the following parameters:

- `DV1.ST`
- `CV1.ST`
- `CV2.ST`
- `CV3.ST`
- `CV4.ST`

Configurable reactions using the `Feature` parameter

You can find an overview of all reactions provided by the `Feature` parameter in the Configurable functions using the Feature I/O (Page 131). The following functionality is available for this block at the relevant bits:

Bit	Function
1	Reaction to the out of service mode (Page 177)
2	Resetting the commands for changing the mode (Page 161)
4	Setting switch or button mode (Page 167)
8	Delete history of MV and DV moves during restart (Page 187)
15	Neutral position manipulated variable takes effect with "out of service" operating mode (Page 166)

Bit	Function
16	Neutral position manipulated variable takes effect at startup (Page 166)
24	Enabling local operator authorization (Page 158)

Operator permissions

The block provides the standard function Operator control permissions (Page 254).

The block has the following permissions for the OS_Perm parameter:

Bit	Function
0	1 = Operator can switch to "automatic mode"
1	Not used
2	1 = Operator can switch to "Out of service" mode
3	Not used
4	Not used
5	1 = Operator can change the setpoint 1
6	1 = Operator can change the manipulated variables of all channels
7	1 = Operator can change operating high limits of the setpoints for all channels
8	1 = Operator can change operating low limits of the setpoints for all channels
9	1 = Operator can change the setpoint 2
10	1 = Operator can change the setpoint 3
11	1 = Operator can change the setpoint 4
12	1 = Operator can change the setpoint filter of all channels
13 - 16	Not used
17	1 = Operator can enable the track setpoint in "manual mode" function
18	1 = Operator can activate the model-based disturbance compensation function
19	1 = Operator can enable the function "Prediction without control response"
20 - 22	Not used
23	1 = Operator can change the dead band parameter of all channels
24	1 = Operator can change the tuning parameters
25	1 = Operator can change the simulation value SimPV1..4
26	1 = Operator can activate the Simulation function
27	1 = Operator can activate the Release for maintenance function
28	1 = Operator can change the manipulated variable limits of all channels
29	1 = Operator can change the gradient limits of manipulated variables of all channels
30	0 = Operator can set the integrated static operating point optimization
31	1 = Operator can set the integrated static operating point optimization

Note

If you interconnect a parameter that is also listed in OS_Perm as a parameter, you have to reset the corresponding OS_Perm bit.

Release for maintenance

The block provides the standard function Release for maintenance (Page 64).

Specifying the display area for process and setpoint values as well as operations

This block provides the standard function Display and operator input area for process values and setpoints (Page 207).

In contrast to PID controllers, there are no separate parameters for bar limits. The setpoints limits are used for all setpoint and actual value bars; manual limits are used as bar limits for all manipulated variable bars.

Opening additional faceplates

This block provides the standard function Opening additional faceplates (Page 208).

SIMATIC BATCH functionality

This block provides the standard function SIMATIC BATCH functionality (Page 67).

Integrated static operating point optimization

The integrated static operating point optimization can be used if no exact SP_i setpoint is specified for at least one controlled variable (index $i=1\dots4$), but rather the CV_i process value must remain within a tolerance range $SP_{iOptHiLim}\dots SP_{iOptLoLim}$. The tolerance range must, of course, be within the valid setpoint limits $SP_{iHiLim}\dots SP_{iLoLim}$ for this control channel. The tolerance range $SP_{iOptHiLim}\dots SP_{iOptLoLim}$ is not coupled to the operator-controlled setpoint SP_i . If the setpoint is changed, the tolerance range is not automatically shifted. If you want to do this nevertheless, interconnect the SP_{iOpOut} output parameters via two adders to the width of the tolerance range at the inputs $SP_{iOptHiLim}$ and $SP_{iOptLoLim}$.

From an economic perspective, different values within the tolerance range can be more or less favorable. With the help of the optimization function, the optimal economic point can be found within the tolerance range.

This is done by defining a target function (performance criterion), which depends on the manipulated variable and controlled variable of the predictive controller. This can be, for example, the economic yield of plant operation per time unit or it may involve specific costs or energy consumption.

$$\begin{aligned}
 J = & \text{GradMV1} \cdot \text{MV1} + \text{GradMV2} \cdot \text{MV2} + \text{GradMV3} \cdot \text{MV3} + \text{GradMV4} \cdot \text{MV4} \\
 & + \text{GradCV1} \cdot \text{CV1} + \text{GradCV2} \cdot \text{CV2} + \text{GradCV3} \cdot \text{CV3} + \text{GradCV4} \cdot \text{CV4} \\
 & + J_0
 \end{aligned}$$

You specify the individual GradXV_i coefficients of the gradient vector as input variables at the ModPreCon function block in the CFC or in the parameter view of the faceplate. If individual coefficients vary with time, e.g. they are dependent on current market prices, you can also interconnect these input variables. If individual manipulated or controlled variables have no influence on the performance criterion, leave the corresponding coefficients at the default value, zero.

You can use the binary `J_Mini` input parameter to specify whether the target function is to be maximized or minimized, based on whether this involves yields or costs (`J_Mini = 1` : minimization).

The term `J0` combines all contributions to the target function that do not depend on manipulated variables and controlled variables. These contributions have no effect on the optimum values in the decision variables, but are applied for calculating the current value of employed performance criterion similar to the above-mentioned formula.

Within the controller, the terms of the target function that depend on manipulated variables are converted to make their dependence on the controlled variables visible. To do this, the inverse stationary process model from the MPC Configurator is used. This requires that the number of manipulated variables matches the number of controlled variables. If the number of manipulated variables does not match the number of controlled variables, the largest possible square submodel in the matrix of the transfer functions is truncated from the top left. If there are more manipulated variables than controlled variables, for example, only the first manipulated variables are used, in accordance with the number of controlled variables.

Constraints for the controlled variables take the form of the above-mentioned tolerance ranges for setpoints. The controller takes care of adhering to the manipulated variable limits, in any case; they do not have to separately specified as constraints for the optimization.

Enable the optimization using the binary input variable `OptimizeOn` in the controller faceplate. The optimizer then returns setpoints within the tolerance ranges that are optimal for the performance criterion. These setpoints are then sent to the control algorithm, which handles them in the same way as conventionally specified setpoints (with or without dead band). The operable `SP1...SP4` setpoints are not tracked to the optimized setpoints; when optimization is disabled, the old setpoints from the faceplate take effect once again. When selecting variables for archiving and graphic plotter, ensure you use the `SP1Out...SP4Out` setpoint actually in effect and not the `SP1...SP4` input variables.

The current value of the performance criterion is displayed at the `J_Actual` output variables.

You can find additional information about the topic of static operating point optimization in the online help for the MPC configuration editor.

Display of the prediction of free movement

The prediction of free motion is a forecast for the future behavior of the process within the overall prediction horizon, under the assumption that all manipulated variables are frozen at their current values. The time length of the prediction horizon is indicated in the output parameter `PrediHorizon` in the [s] unit.

The prediction of free motion is recalculated in each sampling step within the control algorithm. If the manipulated variables is to a constant value in manual mode, the prediction of the free movement is actually a realistic prediction for the future process response. It can therefore be represented graphically in the faceplate at least in terms of quality. For this purpose, five equidistant interpolation values are copied from the prediction horizon, and displayed in the standard view of the faceplate as a vertical bar next to the current process value.

Example: The prediction horizon is $1800\text{s}=30\text{min}$ and the current time is labeled with the index `k`. The prediction for `k+6min`, and next to it `k+12min`, up to `k+30min` then appears on the right next to the bar of the current process value. If the upper border of the bar is conceptually connected with a line (red in the picture red), you can imagine the curve created by the future course of the process value over the next half hour.

In automatic mode, the value of the manipulated variables changes with each sampling step. The prediction of free movement is then only a fictional mathematical formulation within the algorithm, and not a realistic prediction for the future process response. This is why the prediction is only displayed in manual mode. The display can be generally suppressed using Feature.Bit31.

Prediction without control response

In this special "operating mode" (comparable to the block-internal simulation), the controller only monitors the process and indicates what it would like to do in the next sampling step without actively intervening in the process. This allows you as the user to build trust before "switching active" the controller the first time, i.e. actively intervening in the process.

"Prediction Mode" is activated via the binary input variable PredictMode or in "Parameters" in the faceplate view. Setpoints and process values are read as in normal automatic mode. The prediction of the free movement and manipulated variable change for the next sampling step are calculated as in normal automatic mode. The starting point for the prediction of the manipulated variable for the next sampling step, however, is the current process value of the follow-up control loop at the MV1Trk...MV4Trk tracking inputs. The predicted manipulated variables are not output at the normal outputs MV1...4, but rather at the MV1Pred...MV4Pred outputs, which were especially introduced for this purpose, and are displayed in the standard view of the faceplate on the left next to MV1...4, as long as "Prediction Mode" is active.

- When the controller is in automatic mode, in "Prediction Mode" all MV_i (i=1..4) are set to match the assigned MV_iTrk input parameters, similar to tracking mode.
- When the controller in manual mode, all MV_i are set to the desired manual values regardless of "Prediction Mode".
- When "Prediction Mode" is disabled, all MV_iPred always equal the assigned MV_i.

Automatic process trigger for model identification

In order to determine the process model for the model predictive controller, the process must be artificially triggered in order to observe its dynamic response and record it in the form of training data. This trigger can be specified manually in manual mode of the controller.

Alternatively, a suitable trigger signal can be generated automatically in the form a defined, symmetrical sequence of manipulated variable jumps. The trigger signals are calculated by an auxiliary function block, "AutoExcitation", which is built into the process tag type and interconnected with ModPreCon .

Additional MV1Excite...MV4Excite input variables are required for this on the controller. Process triggering performed in manual mode of the controller, because automatic mode cannot be activated before modeling. The new process trigger "operating mode" can only be controlled via the ExciteOn input bit on the Engineering System, and not on the operator station, since the CFC is needed for data recording in any case. However, process triggering must be displayed on the OS in standard view at the lower left.

Manual intervention per faceplate remains possible even during the triggering. The values of the MV1Excite...MV4Excite input parameters are therefore only written to the MV1Man...MV4Man manual values event-based, but only if they change.

You can find additional details on automatic process triggering in the online help for the MPC configuration editor.

See also

- Description of ModPreCon (Page 689)
- ModPreCon messaging (Page 709)
- ModPreCon I/Os (Page 709)
- ModPreCon block diagram (Page 720)
- ModPreCon error handling (Page 708)
- ModPreCon modes (Page 694)

5.6.4 ModPreCon error handling

Error handling of ModPreCon

Refer to section Error handling (Page 119) in the basic instructions for the error handling of all blocks.

The following errors can be displayed for this block:

- Error numbers

Overview of error numbers

The `ErrorNum` output parameter can be used to output the following error numbers:

Error number	Meaning of the error number
-1	Default value when the block is installed; this message is irrelevant.
0	There is no error.
3	Configuration error: Block is inserted in the wrong OB, cycle time of the OB is not suited for controller configuration.
32	The value of <code>CV1</code> can no longer be displayed in the real number field or is not a number.
33	The value of <code>CV2</code> can no longer be displayed in the real number field or is not a number.
34	The value of <code>CV3</code> can no longer be displayed in the real number field or is not a number.
35	The value of <code>CV4</code> can no longer be displayed in the real number field or is not a number.
36	The <code>MV_Trk1</code> value can no longer be displayed in the real number field or is not a number.
37	The <code>MV_Trk2</code> value can no longer be displayed in the real number field or is not a number.
38	The <code>MV_Trk3</code> value can no longer be displayed in the real number field or is not a number.
39	The <code>MV_Trk4</code> value can no longer be displayed in the real number field or is not a number.

Error number	Meaning of the error number
51	AutModLi = 1 and ManModLi = 1
90	The controller matrix could not be loaded from the user data block.

The ErrorOpt output parameter is used to output the status of the lower-level LPOptim block. See ModPreCon I/Os (Page 709) for more.

See also

ModPreCon block diagram (Page 720)

ModPreCon messaging (Page 709)

ModPreCon functions (Page 695)

ModPreCon modes (Page 694)

Description of ModPreCon (Page 689)

Description of LPOptim (Page 934)

5.6.5 ModPreCon messaging

Messaging

This block does not offer messaging.

See also

Description of ModPreCon (Page 689)

ModPreCon functions (Page 695)

ModPreCon I/Os (Page 709)

ModPreCon block diagram (Page 720)

ModPreCon error handling (Page 708)

ModPreCon modes (Page 694)

5.6.6 ModPreCon I/Os

I/Os of ModPreCon

Input parameters

Parameter	Description	Type	Default
AutModLi*	1 = Automatic mode via interconnection or SFC (controlled by ModLiOp = 1)	STRUCT <ul style="list-style-type: none"> Value: BOOL ST: BYTE 	- <ul style="list-style-type: none"> 0 16#80
AutModOp*	1 = Automatic mode via operator (controlled by ModLiOp = 0)	BOOL	0
BatchEn	1 = Enabled for allocation by batch control	BOOL	0
BatchID	Batch ID	DWORD	16#00000000
BatchName	Batch name	STRING[32]	"
CV1	Control variable 1 (process value)	STRUCT <ul style="list-style-type: none"> Value: REAL ST: BYTE 	- <ul style="list-style-type: none"> 0.0 16#80
CV1_Unit	Unit of measure for control variable 1 (process value)	INT	1001
CV2	Manipulated variable 2 (process value)	STRUCT <ul style="list-style-type: none"> Value: REAL ST: BYTE 	- <ul style="list-style-type: none"> 0.0 16#80
CV2_Unit	Unit of measure for manipulated variable 2 (process value)	INT	1001
CV3	Manipulated variable 3 (process value)	STRUCT <ul style="list-style-type: none"> Value: REAL ST: BYTE 	- <ul style="list-style-type: none"> 0.0 16#80
CV3_Unit	Unit of measure for manipulated variable 3 (process value)	INT	1001
CV4	manipulated variable 4 (process value)	STRUCT <ul style="list-style-type: none"> Value: REAL ST: BYTE 	- <ul style="list-style-type: none"> 0.0 16#80
CV4_Unit	Unit of measure for manipulated variable 4 (process value)	INT	1001
DB_No	Number of the data block in which the controller data is saved.	INT	0
DV_On	1 = Activate the feedforward control from DV1	BOOL	1
DV1	Disturbance variable	STRUCT <ul style="list-style-type: none"> Value: REAL ST: BYTE 	- <ul style="list-style-type: none"> 0.0 16#80
EN	1 = Called block will be processed	BOOL	1
ExciteOn	1 = Automatic process trigger; MViExcite input parameters are written to the MVi outputs	BOOL	0

Parameter	Description	Type	Default
Feature	I/O for additional ModPreCon functions (Page 695)	STRUCT <ul style="list-style-type: none"> • Bit 0: BOOL • ... • Bit 31: BOOL 	- <ul style="list-style-type: none"> • 0 • 0 • 0
GradCV1	Gradient vector for performance criterion, element (factor) for CV1	STRUCT <ul style="list-style-type: none"> • Value: REAL • ST: BYTE 	- <ul style="list-style-type: none"> • 0.0 • 16#80
GradCV2	Gradient vector for performance criterion, element (factor) for CV2	STRUCT <ul style="list-style-type: none"> • Value: REAL • ST: BYTE 	- <ul style="list-style-type: none"> • 0.0 • 16#80
GradCV3	Gradient vector for performance criterion, element (factor) for CV3	STRUCT <ul style="list-style-type: none"> • Value: REAL • ST: BYTE 	- <ul style="list-style-type: none"> • 0.0 • 16#80
GradCV3	Gradient vector for performance criterion, element (factor) for CV3	STRUCT <ul style="list-style-type: none"> • Value: REAL • ST: BYTE 	- <ul style="list-style-type: none"> • 0.0 • 16#80
GradCV4	Gradient vector for performance criterion, element (factor) for CV4	STRUCT <ul style="list-style-type: none"> • Value: REAL • ST: BYTE 	- <ul style="list-style-type: none"> • 0.0 • 16#80
GradMV1	Gradient vector for performance criterion, element (factor) for MV1	STRUCT <ul style="list-style-type: none"> • Value: REAL • ST: BYTE 	- <ul style="list-style-type: none"> • 0.0 • 16#80
GradMV2	Gradient vector for performance criterion, element (factor) for MV2	STRUCT <ul style="list-style-type: none"> • Value: REAL • ST: BYTE 	- <ul style="list-style-type: none"> • 0.0 • 16#80
GradMV3	Gradient vector for performance criterion, element (factor) for MV3	STRUCT <ul style="list-style-type: none"> • Value: REAL • ST: BYTE 	- <ul style="list-style-type: none"> • 0.0 • 16#80
GradMV4	Gradient vector for performance criterion, element (factor) for MV4	STRUCT <ul style="list-style-type: none"> • Value: REAL • ST: BYTE 	- <ul style="list-style-type: none"> • 0.0 • 16#80
J_Actual_Unit	Physical unit of performance J_Actual	INT	0
J_Mini	1 = Minimize, 0 = maximize	BOOL	0
J0	Value of the performance criterion in the operating point	REAL	0
ManModLi*	1 = Manual mode via interconnection or SFC (controlled by ModLiOp = 1)	STRUCT <ul style="list-style-type: none"> • Value: BOOL • ST: BYTE 	- <ul style="list-style-type: none"> • 0 • 16#80
ManModOp*	1 = Manual mode via OS operator (controlled by ModLiOp = 0)	BOOL	0

Controller blocks

5.6 ModPreCon - Model predictive controller

Parameter	Description	Type	Default
ModLiOp	Operating mode switchover by: <ul style="list-style-type: none"> • 0 = Operator • 1 = Interconnection or SFC 	STRUCT <ul style="list-style-type: none"> • Value: BOOL • ST: BYTE 	- <ul style="list-style-type: none"> • 0 • 16#80
MS_RelOp*	1 = Release for maintenance by OS operator	BOOL	0
MV1_Unit	Unit of measure for manipulated variable 1	INT	1342
MV1Excite	MV1 for automatic process trigger	STRUCT <ul style="list-style-type: none"> • Value: REAL • ST: BYTE 	- <ul style="list-style-type: none"> • 0.0 • 16#80
MV1HiLim	High limit of manipulated variable MV1	REAL	100.0
MV1LoLim	Low limit of manipulated variable MV1	REAL	• 0.0
MV1Man*	Manual value: Operator input for setting the manipulated variable MV1 in manual mode	REAL	0.0
MV1ManHiLim	High limit of manipulated variable MV1 in manual mode	REAL	100.0
MV1ManLoLim	Low limit of manipulated variable MV1 in manual mode	REAL	0.0
MV1RaLim	Gradient limit of the manipulated variable MV1 per sampling step	REAL	100.0
MV1Traj	Trajectory value that is added to the manipulated variable MV1	REAL	0.0
MV1Trk	Tracking value for the manipulated variable MV1	STRUCT <ul style="list-style-type: none"> • Value: REAL • ST: BYTE 	- <ul style="list-style-type: none"> • 0.0 • 16#80
MV1TrkOn	1 = Tracking of manipulated variable MV1	STRUCT <ul style="list-style-type: none"> • Value: BOOL • ST: BYTE 	- <ul style="list-style-type: none"> • 0 • 16#80
MV2_Unit	Unit of measure for manipulated variable 2	INT	1342
MV2Excite	MV2 for automatic process trigger	STRUCT <ul style="list-style-type: none"> • Value: REAL • ST: BYTE 	- <ul style="list-style-type: none"> • 0.0 • 16#80
MV2HiLim	High limit of manipulated variable MV2	REAL	100.0
MV2LoLim	Low limit of manipulated variable MV2	REAL	0.0
MV2Man*	Manual value: Operator input for setting the manipulated variable MV2 in manual mode	REAL	0.0
MV2ManHiLim	High limit of manipulated variable MV2 in manual mode	REAL	100.0
MV2ManLoLim	Low limit of manipulated variable MV2 in manual mode	REAL	0.0
MV2RaLim	Gradient limit of the manipulated variable MV2 per sampling step	REAL	100.0
MV2Traj	Trajectory value that is added to the manipulated variable MV2	REAL	0.0

5.6 ModPreCon - Model predictive controller

Parameter	Description	Type	Default
MV2Trk	Tracking value for the manipulated variable MV2	STRUCT <ul style="list-style-type: none"> Value: REAL ST: BYTE 	- <ul style="list-style-type: none"> 0.0 16#80
MV2TrkOn	1 = Tracking of manipulated variable MV2	STRUCT <ul style="list-style-type: none"> Value: BOOL ST: BYTE 	- <ul style="list-style-type: none"> 0 16#80
MV3_Unit	Unit of measure for manipulated variable 3	INT	1342
MV3Excite	MV3 for automatic process trigger	STRUCT <ul style="list-style-type: none"> Value: REAL ST: BYTE 	- <ul style="list-style-type: none"> 0.0 16#80
MV3HiLim	High limit of manipulated variable MV3	REAL	100.0
MV3LoLim	Low limit of manipulated variable MV3	REAL	0.0
MV3Man*	Manual value: Operator input for setting the manipulated variable MV3 in manual mode	REAL	0.0
MV3ManHiLim	High limit of manipulated variable MV3 in manual mode	REAL	100.0
MV3ManLoLim	Low limit of manipulated variable MV3 in manual mode	REAL	0.0
MV3RaLim	Gradient limit of the manipulated variable MV3 per sampling step	REAL	100.0
MV3Traj	Trajectory value that is added to the manipulated variable MV3	REAL	0.0
MV3Trk	Tracking value for the manipulated variable MV3	STRUCT <ul style="list-style-type: none"> Value: REAL ST: BYTE 	- <ul style="list-style-type: none"> 0.0 16#80
MV3TrkOn	1 = Tracking of manipulated variable MV3	STRUCT <ul style="list-style-type: none"> Value: BOOL ST: BYTE 	- <ul style="list-style-type: none"> 0 16#80
MV4_Unit	Unit of measure for manipulated variable 4	INT	1342
MV4Excite	MV4 for automatic process trigger	STRUCT <ul style="list-style-type: none"> Value: REAL ST: BYTE 	- <ul style="list-style-type: none"> 0.0 16#80
MV4HiLim	High limit of manipulated variable MV4	REAL	100.0
MV4LoLim	Low limit of manipulated variable MV4	REAL	0.0
MV4Man*	Manual value: Operator input for setting the manipulated variable MV4 in manual mode	REAL	0.0
MV4ManHiLim	High limit of manipulated variable MV4 in manual mode	REAL	100.0
MV4ManLoLim	Low limit of manipulated variable MV4 in manual mode	REAL	0.0
MV4RaLim	Gradient limit of the manipulated variable MV4 per sampling step	REAL	100.0
MV4Traj	Trajectory value that is added to the manipulated variable MV4	REAL	0.0

5.6 ModPreCon - Model predictive controller

Parameter	Description	Type	Default
MV4Trk	Tracking value for the manipulated variable MV4	STRUCT <ul style="list-style-type: none"> Value: REAL ST: BYTE 	- <ul style="list-style-type: none"> 0.0 16#80
MV4TrkOn	1 = Tracking of manipulated variable MV4	STRUCT <ul style="list-style-type: none"> Value: BOOL ST: BYTE 	- <ul style="list-style-type: none"> 0 16#80
Occupied	1 = Allocated by SIMATIC BATCH	BOOL	0
OosLi	1 = Out of service, via interconnection or SFC (0-1 edge transition)	STRUCT <ul style="list-style-type: none"> Value: BOOL ST: BYTE 	- <ul style="list-style-type: none"> 0 16#80
OosOp*	1 = Out of service, via OS operator	BOOL	0
OpSt_In	Input parameter for local operator authorization, connected with the <code>Out</code> output parameter of the upstream block, <code>OpStations</code>	DWORD	16#00000000
OptimOffOp	1 = Disable optimization, normal setpoints SP1...SP4 in effect	BOOL	0
OptimOnOp	1 = Enable optimization, optimized setpoints SP1Out ... SP4Out in effect	BOOL	0
OS_Perm	I/O for operator permissions	STRUCT <ul style="list-style-type: none"> Bit 0: BOOL Bit 25: BOOL Bit 31: BOOL 	- <ul style="list-style-type: none"> 1 1 1
PredictMode	1 = "Prediction mode" enabled, prediction only, no intervention in the process	BOOL	0
PreFilt1	Settling time [s] of the setpoint filter for setpoint SP1	REAL	0.0
PreFilt2	Time constant [s] of the setpoint filter for setpoint SP2	REAL	0.0
PreFilt3	Time constant [s] of the setpoint filter for setpoint SP3	REAL	0.0
PreFilt4	Time constant [s] of the setpoint filter for setpoint SP4	REAL	0.0
Restart*	1 = Restart of the block and adoption of the data from the user block that is entered at the input parameter <code>DB_No</code>	BOOL	1
SafePos1	Neutral position for MV1	BOOL	0
SafePos2	Neutral position for MV2	BOOL	0
SafePos3	Neutral position for MV3	BOOL	0
SafePos4	Neutral position for MV4	BOOL	0
SampleTime	Sampling time [s] (assigned automatically)	REAL	1.0
SelFp1	1 = Call a block saved in this parameter as an additional faceplate in the standard view	ANY	-
SelFp2	1 = Call a block saved in this parameter as an additional faceplate in the preview	ANY	-

Parameter	Description	Type	Default
SimCV1*	Controlled variable CV1 (process value) which is used with SimOn = 1	REAL	0.0
SimCV2*	Controlled variable CV2 (process value) which is used with SimOn = 1	REAL	0.0
SimCV3*	Controlled variable CV3 (process value) which is used with SimOn = 1	REAL	0.0
SimCV4	Controlled variable CV4 (process value) which is used with SimOn = 1	REAL	0.0
SimCV1Li	Controlled variable CV1 (process value) that is used for SimOnLi.Value = 1 (SimLiOp.Value = 1)	STRUCT <ul style="list-style-type: none"> Value: REAL ST: BYTE 	- <ul style="list-style-type: none"> 0.0 16#FF
SimCV2Li	Controlled variable CV2 (process value) that is used for SimOnLi.Value = 1 (SimLiOp.Value = 1)	STRUCT <ul style="list-style-type: none"> Value: REAL ST: BYTE 	- <ul style="list-style-type: none"> 0.0 16#FF
SimCV3Li	Controlled variable CV3 (process value) that is used for SimOnLi.Value = 1 (SimLiOp.Value = 1)	STRUCT <ul style="list-style-type: none"> Value: REAL ST: BYTE 	- <ul style="list-style-type: none"> 0.0 16#FF
SimCV4Li	Controlled variable CV4 (process value) that is used for SimOnLi.Value = 1 (SimLiOp.Value = 1)	STRUCT <ul style="list-style-type: none"> Value: REAL ST: BYTE 	- <ul style="list-style-type: none"> 0.0 16#FF
SimLiOp	Activation/deactivation of the simulation by: 0 = Operator 1 = Interconnection or SFC	STRUCT <ul style="list-style-type: none"> Value: BOOL ST: BYTE 	- <ul style="list-style-type: none"> 0 16#80
SimOnLi	1 = Simulation via interconnection or SFC (controlled by SimLiOp = 1)	STRUCT <ul style="list-style-type: none"> Value: BOOL ST: BYTE 	- <ul style="list-style-type: none"> 0 16#80
SimOn*	1 = Simulation on	BOOL	0
SP_TrkCV	1 = Setpoints follow the cvs in manual mode and in tracking	BOOL	0
SP1*	Setpoint 1 SP1.ST=FF: Operable in faceplate	STRUCT <ul style="list-style-type: none"> Value: REAL ST: BYTE 	- <ul style="list-style-type: none"> 0.0 16#FF
SP1DeadBand	Width of the dead band control of CV1	REAL	0.0
SP1HiLim	High limit for setpoint 1	REAL	100.0
SP1LoLim	Low limit for setpoint 1	REAL	0.0
SP1OptHiLim	High limit for optimization of setpoint 1	REAL	100.0
SP1OptLoLim	Low limit for optimization of setpoint 1	REAL	0.0
SP2*	Setpoint 2 SP2.ST=FF: Operable in faceplate	STRUCT <ul style="list-style-type: none"> Value: REAL ST: BYTE 	- <ul style="list-style-type: none"> 0.0 16#FF
SP2DeadBand	Width of the dead band control of CV2	REAL	0.0
SP2HiLim	High limit for setpoint 2	REAL	100.0

Controller blocks

5.6 ModPreCon - Model predictive controller

Parameter	Description	Type	Default
SP2LoLim	Low limit for setpoint 2	REAL	0.0
SP2OptHiLim	High limit for optimization of setpoint 2	REAL	100.0
SP2OptLoLim	Low limit for optimization of setpoint 2	REAL	0.0
SP3*	Setpoint 3 SP3.ST=FF: Operable in faceplate	STRUCT <ul style="list-style-type: none"> • Value: REAL • ST: BYTE 	- <ul style="list-style-type: none"> • 0.0 • 16#FF
SP3DeadBand	Width of the dead band control of CV3	REAL	0.0
SP3HiLim	High limit for setpoint 3	REAL	100.0
SP3LoLim	Low limit for setpoint 3	REAL	0.0
SP3OptHiLim	High limit for optimization of setpoint 3	REAL	100.0
SP3OptLoLim	Low limit for optimization of setpoint 3	REAL	0.0
SP4*	Setpoint 4 SP4.ST=FF: Operable in faceplate	STRUCT <ul style="list-style-type: none"> • Value: REAL • ST: BYTE 	- <ul style="list-style-type: none"> • 0.0 • 16#FF
SP4DeadBand	Width of the dead band control of CV4	REAL	0.0
SP4HiLim	High limit for setpoint 4	REAL	100.0
SP4LoLim	Low limit for setpoint 4	REAL	0.0
SP4OptHiLim	High limit for optimization of setpoint 4	REAL	100.0
SP4OptLoLim	Low limit for optimization of setpoint 4	REAL	0.0
StepNo	Batch step number	DWORD	16#00000000
UserStatus	Freely assignable bits for use in PCS 7 OS	BYTE	16#00

* Values can be written back to these inputs during processing of the block by the block algorithm.

Output parameters

Parameter	Description	Type	Default
AutAct	1 = Automatic mode is active 0 = Manual mode is active	STRUCT <ul style="list-style-type: none"> • Value: BOOL • ST: BYTE 	- <ul style="list-style-type: none"> • 0 • 16#80
CV1Out	Output of manipulated variable 1 (process value)	STRUCT <ul style="list-style-type: none"> • Value: REAL • ST: BYTE 	- <ul style="list-style-type: none"> • 0.0 • 16#80
CV2Out	Output of manipulated variable 2 (process value)	STRUCT <ul style="list-style-type: none"> • Value: REAL • ST: BYTE 	- <ul style="list-style-type: none"> • 0.0 • 16#80
CV3Out	Output of manipulated variable 3 (process value)	STRUCT <ul style="list-style-type: none"> • Value: REAL • ST: BYTE 	- <ul style="list-style-type: none"> • 0.0 • 16#80

Parameter	Description	Type	Default
CV4Out	Output of manipulated variable 4 (process value)	STRUCT <ul style="list-style-type: none"> Value: REAL ST: BYTE 	- <ul style="list-style-type: none"> 0.0 16#80
ENO	1 = Block algorithm completed without errors	BOOL	0
ErrorNum	Output of pending error number. You can find information via the error numbers that are output by this block at ModPreCon error handling (Page 708)	INT	-1
ErrorOpt	Error number of the integrated optimization function, see the description of function block LPOptim	INT	0
Fut1_y1... Fut1_y5	Prediction of free movement of CV1 for five future points in time within the prediction horizon	REAL	0
Fut2_y1... Fut2_y5	Prediction of free movement of CV2 for five future points in time within the prediction horizon	REAL	0
Fut3_y1... Fut3_y5	Prediction of free movement of CV3 for five future points in time within the prediction horizon	REAL	0
Fut4_y1... Fut4_y5	Prediction of free movement of CV4 for five future points in time within the prediction horizon	REAL	0
J_Actual	Current value of the performance criterion	REAL	0
Loop1Closed	1 = Control loop for CV1 closed 0 = Control loop for CV1 open	STRUCT <ul style="list-style-type: none"> Value: BOOL ST: BYTE 	- <ul style="list-style-type: none"> 0 16#80
Loop2Closed	1 = Control loop for CV2 closed 0 = Control loop for CV2 open	STRUCT <ul style="list-style-type: none"> Value: BOOL ST: BYTE 	- <ul style="list-style-type: none"> 0 16#80
Loop3Closed	1 = Control loop for CV3 closed 0 = Control loop for CV3 open	STRUCT <ul style="list-style-type: none"> Value: BOOL ST: BYTE 	- <ul style="list-style-type: none"> 0 16#80
Loop4Closed	1 = Control loop for CV4 closed 0 = Control loop for CV4 open	STRUCT <ul style="list-style-type: none"> Value: BOOL ST: BYTE 	- <ul style="list-style-type: none"> 0 16#80
ManAct	1 = Manual mode active	STRUCT <ul style="list-style-type: none"> Value: BOOL ST: BYTE 	- <ul style="list-style-type: none"> 0 16#80
MS_Release	Release for maintenance: 1 = Release by OS operator	STRUCT <ul style="list-style-type: none"> Value: BOOL ST: BYTE 	- <ul style="list-style-type: none"> 0 16#80

Controller blocks

5.6 ModPreCon - Model predictive controller

Parameter	Description	Type	Default
MV1	Control variable 1 (control signal)	STRUCT <ul style="list-style-type: none"> • Value: REAL • ST: BYTE 	- <ul style="list-style-type: none"> • 0.0 • 16#80
MV1HiAct	1 = High limit of manipulated variable 1 reached or exceeded	STRUCT <ul style="list-style-type: none"> • Value: BOOL • ST: BYTE 	- <ul style="list-style-type: none"> • 0 • 16#80
MV1LoAct	1 = Low limit of manipulated variable 1 reached or exceeded	STRUCT <ul style="list-style-type: none"> • Value: BOOL • ST: BYTE 	- <ul style="list-style-type: none"> • 0 • 16#80
MV1Pred	One-step prediction for MV1 in the "Prediction without control response" mode	REAL	0
MV2	Manipulated variable 2 (control signal)	STRUCT <ul style="list-style-type: none"> • Value: REAL • ST: BYTE 	- <ul style="list-style-type: none"> • 0.0 • 16#80
MV2HiAct	1 = High limit of manipulated variable 2 reached or exceeded	STRUCT <ul style="list-style-type: none"> • Value: BOOL • ST: BYTE 	- <ul style="list-style-type: none"> • 0 • 16#80
MV2LoAct	1 = Low limit of manipulated variable 2 reached or exceeded	STRUCT <ul style="list-style-type: none"> • Value: BOOL • ST: BYTE 	- <ul style="list-style-type: none"> • 0 • 16#80
MV2Pred	One-step prediction for MV2 in the "Prediction without control response" mode	REAL	0
MV3	Manipulated variable 3 (control signal)	STRUCT <ul style="list-style-type: none"> • Value: REAL • ST: BYTE 	- <ul style="list-style-type: none"> • 0.0 • 16#80
MV3HiAct	1 = High limit of manipulated variable 3 reached or exceeded	STRUCT <ul style="list-style-type: none"> • Value: BOOL • ST: BYTE 	- <ul style="list-style-type: none"> • 0 • 16#80
MV3LoAct	1 = Low limit of manipulated variable 3 reached or exceeded	STRUCT <ul style="list-style-type: none"> • Value: BOOL • ST: BYTE 	- <ul style="list-style-type: none"> • 0 • 16#80
MV3Pred	One-step prediction for MV3 in the "Prediction without control response" mode	REAL	0
MV4	Manipulated variable 4 (control signal)	STRUCT <ul style="list-style-type: none"> • Value: REAL • ST: BYTE 	- <ul style="list-style-type: none"> • 0.0 • 16#80
MV4HiAct	1 = High limit of manipulated variable 4 reached or exceeded	STRUCT <ul style="list-style-type: none"> • Value: BOOL • ST: BYTE 	- <ul style="list-style-type: none"> • 0 • 16#80
MV4LoAct	1 = Low limit of manipulated variable 4 reached or exceeded	STRUCT <ul style="list-style-type: none"> • Value: BOOL • ST: BYTE 	- <ul style="list-style-type: none"> • 0 • 16#80

Parameter	Description	Type	Default
MV4Pred	One-step prediction for MV4 in the "Prediction without control response" mode	REAL	0
NumberCVs	Number of controlled variables (process values) used	INT	0
NumberDVs	Number of disturbances used	INT	0
NumberMVs	Number of manipulated variables used	INT	4
OosAct	1 = Block is "out of service"	STRUCT <ul style="list-style-type: none"> • Value: BOOL • ST: BYTE 	- <ul style="list-style-type: none"> • 0 • 16#80
OpSt_Out	Value of the OpSt_In input parameter, for feedforwarding to other blocks. Bit 31 of this parameter is used by Feature bit 24	DWORD	16#00000000
OptimAct	1 = Optimization is active	BOOL	0
OptimAvailable	1 = Optimization available, 0 = Optimization not available, because old user data block is loaded	BOOL	0
OS_PermOut	Display of OS_Perm	DWORD	16#FFFFFFFF
OS_PermLog	Display of OS_Perm with settings changed by the block algorithm	DWORD	16#FFFFFFFF
PrediHorizon	Prediction horizon [s]	REAL	0
SP1OpOut	Copy of the operable setpoint 1 for step-enabling	STRUCT <ul style="list-style-type: none"> • Value: REAL • ST: BYTE 	- <ul style="list-style-type: none"> • 0.0 • 16#80
SP2OpOut	Copy of the operable setpoint 2 for step-enabling	STRUCT <ul style="list-style-type: none"> • Value: REAL • ST: BYTE 	- <ul style="list-style-type: none"> • 0.0 • 16#80
SP3OpOut	Copy of the operable setpoint 3 for step-enabling	STRUCT <ul style="list-style-type: none"> • Value: REAL • ST: BYTE 	- <ul style="list-style-type: none"> • 0.0 • 16#80
SP4OpOut	Copy of the operable setpoint 4 for step-enabling	STRUCT <ul style="list-style-type: none"> • Value: REAL • ST: BYTE 	- <ul style="list-style-type: none"> • 0.0 • 16#80
SP1Out	Setpoint 1 used by controller	STRUCT <ul style="list-style-type: none"> • Value: REAL • ST: BYTE 	- <ul style="list-style-type: none"> • 0.0 • 16#80
SP2Out	Setpoint 2 used by controller	STRUCT <ul style="list-style-type: none"> • Value: REAL • ST: BYTE 	- <ul style="list-style-type: none"> • 0.0 • 16#80
SP3Out	Setpoint 3 used by controller	STRUCT <ul style="list-style-type: none"> • Value: REAL • ST: BYTE 	- <ul style="list-style-type: none"> • 0.0 • 16#80

Parameter	Description	Type	Default
SP4Out	Setpoint 4 used by controller	STRUCT <ul style="list-style-type: none">• Value: REAL• ST: BYTE	- <ul style="list-style-type: none">• 0.0• 16#80
ST_Worst	Worst signal status	BYTE	16#80
Status1	Status word 1	DWORD	16#00
Status2	Status word 2	DWORD	16#00

See also

- Description of ModPreCon (Page 689)
- ModPreCon messaging (Page 709)
- ModPreCon block diagram (Page 720)
- ModPreCon modes (Page 694)
- Neutral position for motors, valves and controllers (Page 48)
- Opening additional faceplates (Page 208)
- Description of OpStations (Page 411)

5.6.7 ModPreCon block diagram

ModPreCon block diagram

A block diagram is not provided for this block.

See also

- ModPreCon I/Os (Page 709)
- ModPreCon messaging (Page 709)
- ModPreCon error handling (Page 708)
- ModPreCon functions (Page 695)
- ModPreCon modes (Page 694)
- Description of ModPreCon (Page 689)

5.6.8 Operator control and monitoring

5.6.8.1 ModPreCon views

Views of the ModPreCon block

The block ModPreCon provides the following views:

- ModPreCon standard view (Page 722)
- ModPreCon trend view (Page 731)
- ModPreCon parameter view (Page 726)
- ModPreCon parameter view channel 1 to 4 (Page 728)
- ModPreCon preview (Page 729)
- Memo view (Page 304)
- Batch view (Page 302)
- Block icon for ModPreCon (Page 732)

Refer to the sections Structure of the faceplate (Page 248) and Block icon structure (Page 230) for general information on the faceplate and block icon.

See also

Trend view (Page 305)

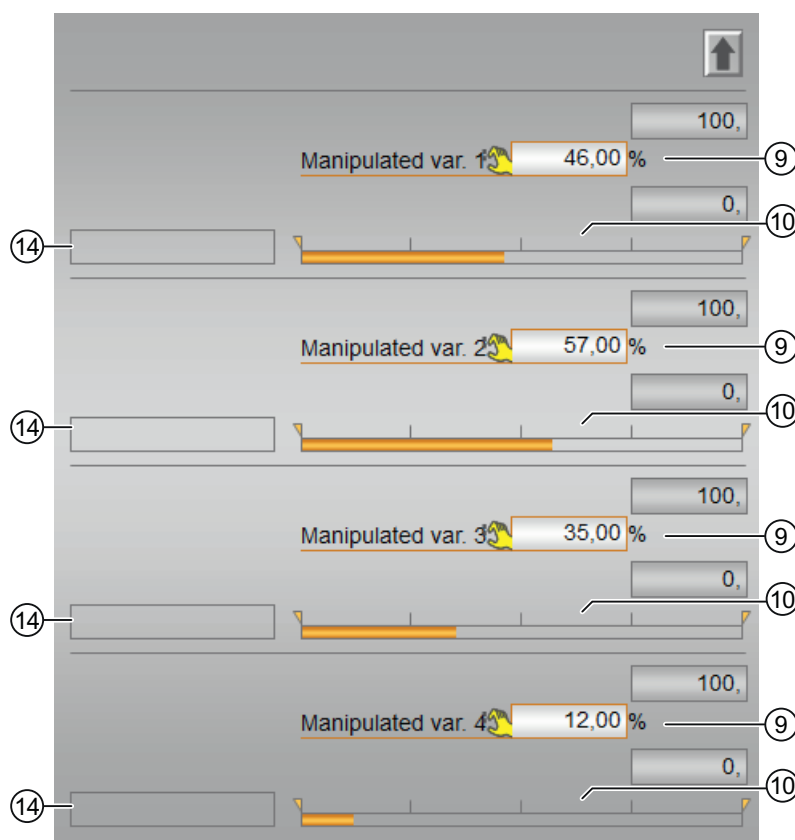

The standard view has an upper half and a lower half. You can change between the two halves with the arrow keys. The upper half shows all available controlled variable channels with their setpoints, while the lower half shows all available manipulated variable channels.

Upper screen half (controlled variables)

(1) Displaying and switching the operating mode

This area provides information on the currently valid operating mode. The following operating modes can be shown here:

- Manual mode (Page 72)
- Automatic mode (Page 72)
- Out of service (Page 71)

Refer to section Switching operating states and operating modes (Page 257) for information on switching the operating mode.

(2), (3), (4) and (5) Displaying and switching for values for channels 1 to 4

This area always has the same layout for channels 1 to 4:

(6) High and low scale range for the process value

These values provide information on the display range for the bar graph of the process value. The scale range is defined in the engineering system.

(7) Displaying and changing the process value including signal status

This area shows the current process value with the corresponding signal status.

(8) Displaying and changing the setpoint including signal status

This area shows the current setpoint with the corresponding signal status. Refer to the Changing values (Page 259) section for information on changing the setpoint.

(11) Navigation button for switching to the standard view of any faceplate

Use this navigation button to open the standard view of a block configured in the engineering system. The visibility of this navigation button depends on the configuration in the engineering system (ES).

You can find additional information on this in the section Opening additional faceplates (Page 208).

(12) Display area for block states

This area provides additional information on the operating state of the block:

- "Maintenance"

Additional information on this is available in section Release for maintenance (Page 64) Display area for block states.

- "Process excitation"

The automatic process trigger is fed forward using the upstream block AutoExcitation for recording learning data for the MPC configurator. The manipulated variable step changes are added to the manipulated values 1 to 4 according to schedule. Avoid external disturbances to the process while the process trigger is running. The manipulated variables can be changed manually while the process trigger is running.

(13) Display area for block states

This area provides additional information on the operating state of the block:

- "Simulation"

You can find additional information on this in the section Simulating signals (Page 58).

(15) Bar graph for the process value 1

There is a bar graph for the process value for every channel 1 to 4.

This area shows the current process value in the form of a bar graph. The visible area in the bar graph depends on the configuration in the engineering system (ES).

(16) Bar graph for the setpoint 1

There is a bar graph for the setpoint for every channel 1 to 4.

This area shows the current setpoint in the form of a bar graph. The visible area in the bar graph depends on the configuration in the engineering system (ES).

(17) Prediction of free movement

This area shows you the prediction of free movement in the form of a bar graph. For each channel from 1 to 4, there is a bar graph for the prediction of free movement, that is, for the future behavior of the process within the overall prediction horizon, under the assumption that all manipulated variables are frozen at their current values.

This is why the prediction of free movement is only displayed in manual mode.

The value range of the bar graph matches the value range of the assigned setpoint and current value bar.

ModPreCon functions (Page 695)

(18) Displaying the limits

These triangles show the SP_HiLim and SP_LoLim setpoint limits configured in the engineering system (ES).

(19) Static operating point optimization

Activate the optimization using the button at bottom right. Activation means that the optimized setpoints $SP1Out...SP4Out$ are actually used instead of the $SP1...SP4$ setpoints specified in the faceplate for the closed-loop control. (The actual calculation of the optimum setpoints depends on this, and is only performed if one of the input variables for the optimization has changed.) The current value the economic performance criterion J appears in the display field below.

When optimization is enabled, the optimum setpoints are displayed on the setpoint bar as small, horizontal lines and highlighted with the abbreviation "opt.". The numerical values of the optimum setpoints are then displayed left of the input fields for the setpoints.

Lower screen half (manipulated variables)

(9) Displaying and changing the manipulated variable including signal status

This area shows the current manipulated variable with the corresponding signal status. Refer to the Changing values (Page 259) section for information on changing the manipulated variable. You can only make a change in manual mode.

(10) Bar graph for the manipulated variable with limit display

This area shows the current manipulated variable in the form of a bar graph. The visible area in the bar graph depends on the configuration in the engineering system (ES):

- Limits: $MVxHiLim$ and $MVxLoLim$
- Display area: $MVxManHiLim$ and $MVxManLoLim$

(14) Display for block states

There is a display for the states of the block for every channel 1 to 4:

- "Tracking"

5.6.8.3 ModPreCon parameter view

Parameter view of ModPreCon

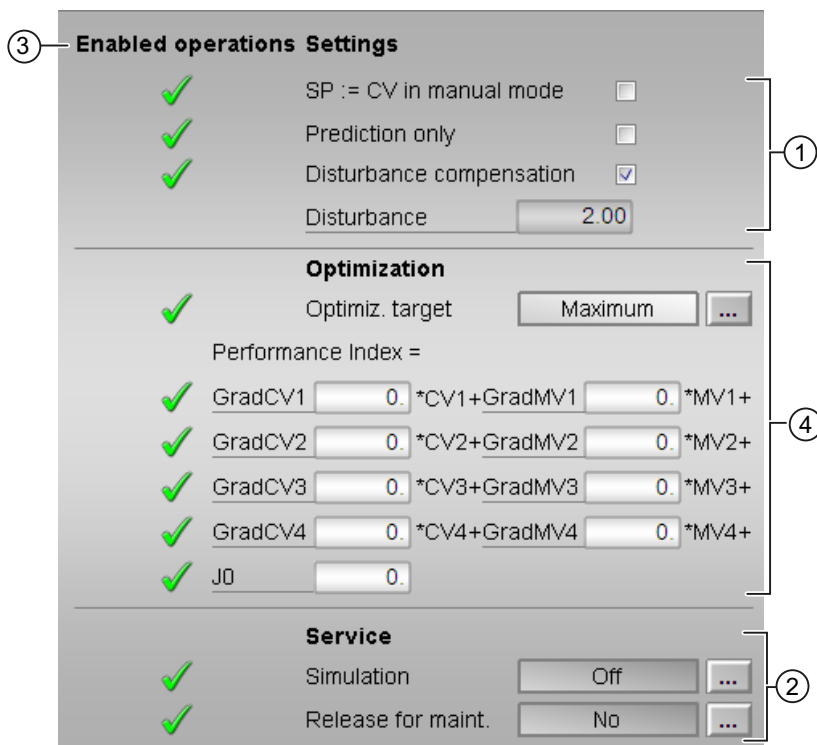

(1) Settings

You can activate the following functions for the controller in this area:

- "SP := CV in manual mode": Bumpless switchover from "manual mode" to "automatic mode"
- "Prediction only" activate this special "operating mode" by selecting the check box. The controller then only listens in on the process and indicates what it would like to do in the next sampling step without actively intervening in the process
- "Disturbance compensation": Select disturbance feedforward
- "Disturbance variable"

You cannot change the disturbance variable, it can only be displayed.

(2) Service

You can select the following functions in this area:

- "Simulation"
- "Release for maintenance"

Refer to the Switching operating states and operating modes (Page 257) section for more on this.

You can find information on this area in the section:

- Simulating signals (Page 58)
- Release for maintenance (Page 64)

(3) Enabled operation

This area shows all operations for which special operator permissions are assigned. They depend on the configuration in the engineering system (ES) that applies to this block.

Icons for enabled operation:

- **Green check mark:** the OS operator can control this parameter
- **Gray check mark:** the OS operator cannot control this parameter at this time due to the process
- **Red cross:** the OS operator cannot control this parameter due to the configured AS operator permissions (OS_Perm or OS1Perm).

(4) Optimization

Direction of the optimization (minimize or maximize)

By default, the optimizer seeks to maximize the performance function, in the assumption that it is dealing with economic yield. If you want to search a minimum, however, because you are dealing with costs or consumption values, click this button.

Specification of performance criterion for the operating point optimization

The performance criterion consists of a weighted sum of all manipulated and controlled variables. For each manipulated variable and controlled variable, enter the appropriate weighting factor, i.e. the coefficient of the gradient vector. Zero means that the value of the corresponding manipulated variable or controlled variable no direct influence on the economic yield. If the controller has less than four manipulated variables or controlled variables, the irrelevant variables are hidden automatically.

5.6.8.4 ModPreCon parameter view channel 1 to 4

Parameter view channel 1 to 4 for ModPreCon

The layout of the parameter view for channels 1 to 4 is always identical:

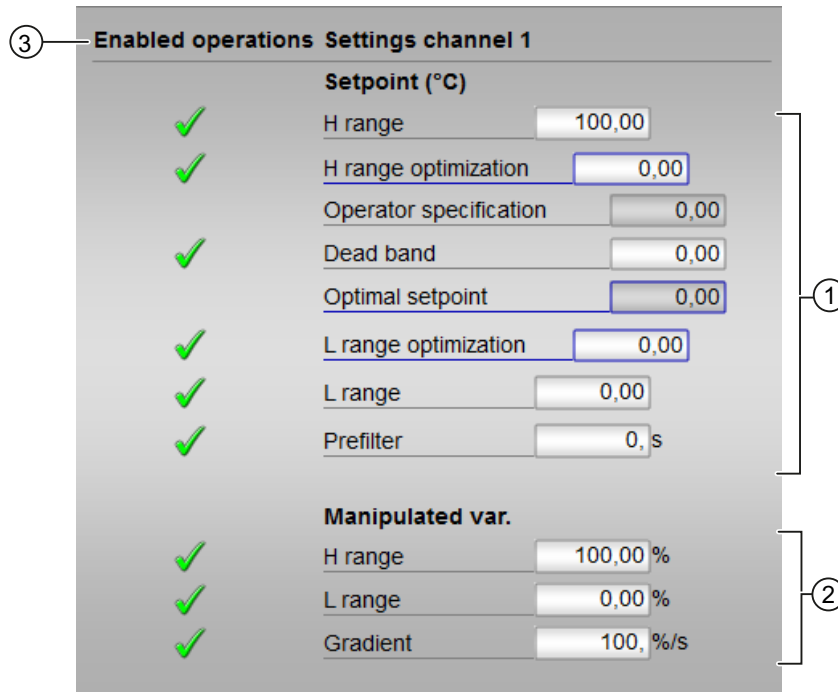

(1) Displaying and changing the limit parameters for the setpoint

You can change the following parameters for the setpoint in this area:

- "H range": High limit for setpoint operation
- "H range optimization": High limit for optimizing the setpoint
- "Operator input": Display of the setpoint entered in the standard view, cannot be operated here.
- "Dead band": Dead band (Page 61), Error signal generation and dead band section
- "Optimal setpoint": Calculated by the optimization, cannot be operated
- "L range optimization": Low limit for optimizing the setpoint
- "L range": Low limit for setpoint operation
- "Prefilter": ModPreCon functions (Page 695), Setpoint filter section

You can find additional information on this in the section Changing values (Page 259) .

(2) Displaying and changing the limit parameters for the manipulated variable

You can change the following parameters for the manipulated variable in this area:

- "H range": Upper limit of the manipulated variable for automatic mode
- "L range": Low limit of manipulated variable for automatic mode
- "Gradient limit": Maximum (absolute) change in the manipulated variable per sampling step

(3) Enabled operation

This area shows all operations for which special operator permissions are assigned. They depend on the configuration in the engineering system (ES) that applies to this block.

Icons for enabled operation:

- **Green check mark:** the OS operator can control this parameter
- **Gray check mark:** the OS operator cannot control this parameter at this time due to the process
- **Red cross:** the OS operator cannot control this parameter due to the configured AS operator permissions (OS_Perm or OS1Perm).

5.6.8.5 ModPreCon preview

Preview for ModPreCon

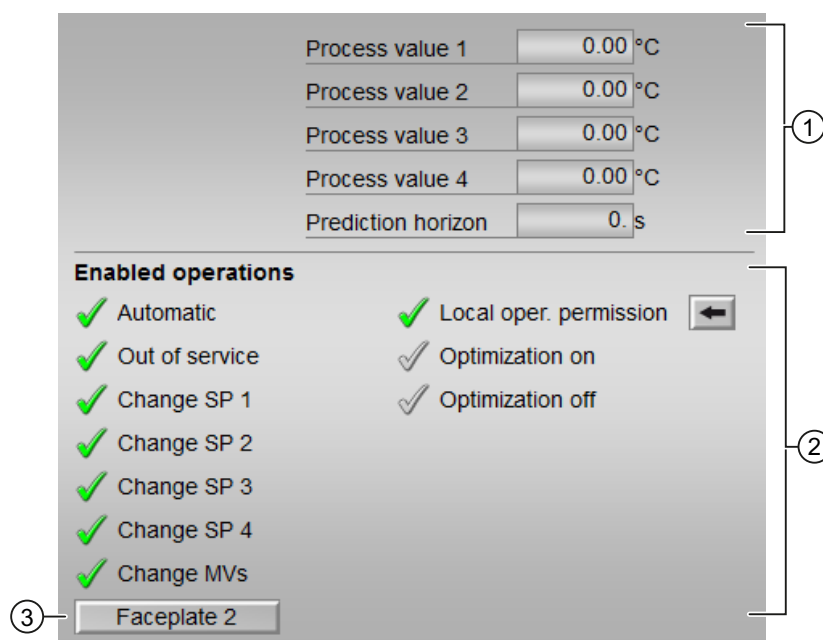

(1) Process value

This area displays the real process values (PV_x) and the prediction horizon.

Prediction horizon

The prediction horizon specifies how far the controller looks into the future of its calculation.

(2) Enabled operation

This area shows all operations for which special operator permissions are assigned. They depend on the configuration in the engineering system (ES) that applies to this block.

Icons for enabled operation:

- **Green check mark:** the OS operator can control this parameter
- **Gray check mark:** the OS operator cannot control this parameter at this time due to the process
- **Red cross:** the OS operator cannot control this parameter due to the configured AS operator permissions (`OS_Perm` or `OS1Perm`).

The following enabled operations for parameters are shown here:

- "Automatic": You can switch to "automatic mode".
- "Out of service": You can switch to "Out of service" operating mode.
- "Local operating permission": Use the ← button to switch to the standard view of the OpStations block. You can find additional information on this in the section Operator control permissions (Page 254) .
- "Change SP1": You can change the setpoint 1
- "Change SP2": You can change the setpoint 2
- "Change SP3": You can change the setpoint 3
- "Change SP4": You can change the setpoint 4
- "Change MVs": You can change the manipulated variables

Note

The OS operator must always be able to switch to "manual mode". That is why the switch to "manual mode" is not shown here in the faceplate.

(3) Navigation button for switching to the standard view of any faceplate

Use this navigation button to open the standard view of a block configured in the engineering system (ES). The visibility of this navigation button depends on the configuration in the engineering system (ES).

You can find additional information on this in the section Opening additional faceplates (Page 208) .

5.6.8.6 ModPreCon trend view

ModPreCon trend view

There is a block-specific trend view for ModPreCon which is supplied as file @PG_APL_TrendMPC.pdl and which you can modify if necessary.

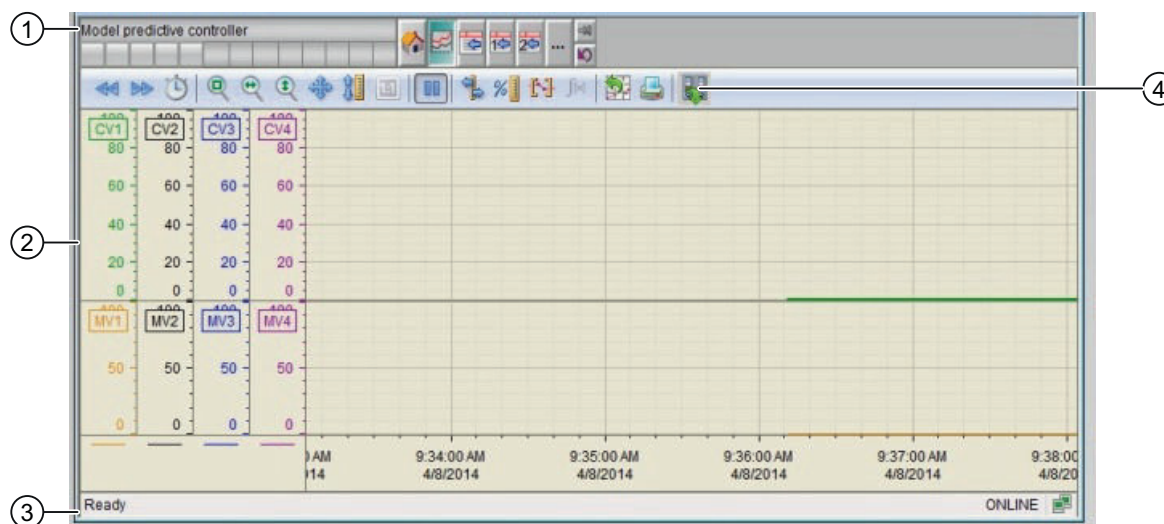

(1) Toolbar

(2) Display area for trends

(3) Status bar

(4) Button for switching between archive tags and online tags. The status bar shows if the trend view is working with online data or archive data.

The Export button is only visible and operable with the "Higher-level process control" operating permission.

For additional information about the trend view, refer to the *WinCC Information System* Online Help.

The trend view is divided into two screen halves.

The upper screen half shows all controlled variables with their associated setpoints. The setpoint is shown in the same color as the associated process value to allow the assignment to be identified straight away. Setpoints are dashed lines, process values are bold lines. If a controlled variable is exactly on the setpoint, it hides the setpoint.

The lower screen half shows all manipulated variables.

Both screen halves use the same color sequence for the individual channels. The sequence starts at channel 1 with green (standard color for the process value with the PID controller) and then goes through the color spectrum from top to bottom as far as gray and black. Each channel has its own y-axis in the corresponding color.

See also

ModPreCon views (Page 721)



5.6.8.7 Block icon for ModPreCon

Block icons for ModPreCon

A variety of block icons are available with the following functions:

- Process tag type
- Operating modes
- Signal status, release for maintenance
- Tracking
- Memo display
- Process value (black, with and without decimal places)

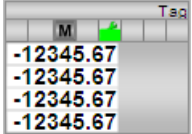
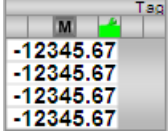
The block icons from template @TemplateAPLV8.PDL:

Icons	Selection of the block icon in CFC	Special features
	1	
	2	
	3	Block icon in the full display

The block icons from template @TemplateAPLV7.PDL:

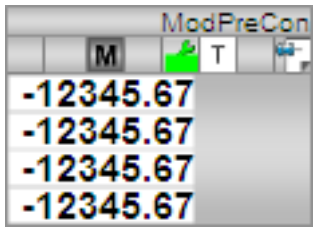
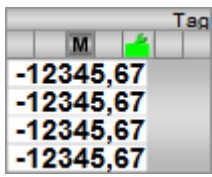
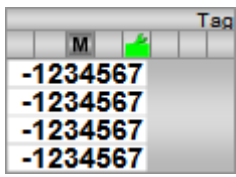
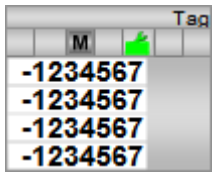
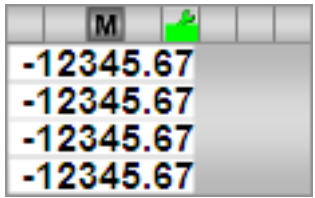
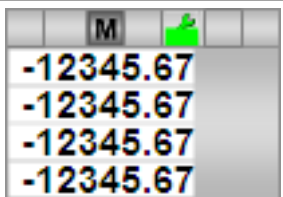
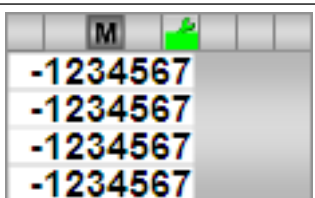
Icons	Selection of the block icon in CFC	Special features
 The icon shows a control block with a title bar 'ModPreCon'. It has a status bar with 'M' and a green bar chart. The main display area shows four stacked numerical values: -12345.67.	1	Block icon in the full display
 The icon shows a control block with a title bar 'Tag'. It has a status bar with 'M' and a green bar chart. The main display area shows four stacked numerical values: -12345,67.	2	
 The icon shows a control block with a title bar 'Tag'. It has a status bar with 'M' and a green bar chart. The main display area shows four stacked numerical values: -1234567.	3	
 The icon shows a control block with a title bar 'Tag'. It has a status bar with 'M' and a green bar chart. The main display area shows four stacked numerical values: -1234567.	4	
 The icon shows a control block with a title bar 'M'. It has a status bar with 'M' and a green bar chart. The main display area shows four stacked numerical values: -12345.67.	5	
 The icon shows a control block with a title bar 'M'. It has a status bar with 'M' and a green bar chart. The main display area shows four stacked numerical values: -12345.67.	6	
 The icon shows a control block with a title bar 'M'. It has a status bar with 'M' and a green bar chart. The main display area shows four stacked numerical values: -1234567.	7	

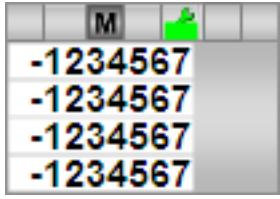
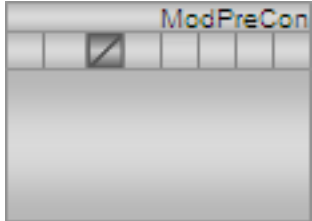
Icons	Selection of the block icon in CFC	Special features
	8	
	-	Block icon in "Out of service" mode (example with type 1 block icon)

Additional information on the block icon and the control options in the block icon is available in the following chapters:

- Configuring the block icons (Page 237)
- Block icon structure (Page 230)
- Operation via the block icon (Page 239).

5.7 PIDConL - Continuous PID controller (Large)

5.7.1 Description of PIDConL

Object name (type + number) and family

Type and number: FB 1874

Family: Control

Area of application for PIDConL

The block is used for the following applications:

- Fixed setpoint control
- Cascade control
- Ratio control
- Split-range control
- Smith predictor closed-loop control
- Override control (override)

How it works

The block is a PID controller with continuous output signal (manipulated variable). It is used to activate a final controlling element with continuous action input.

The block functions following the PID algorithm with a delayed D component and an integrator with double precision.

The block is suitable for controlling sluggish control loops, for example, for temperatures and filling levels, and high-speed control loops, for example, for flow rates and speed. For a given CPU, a compromise has to be made between the number of controllers and the frequency with which the individual controllers have to be processed. The faster the modulated control loops are, i.e. the more frequently the manipulated variables have to be calculated per time unit, the lower the number of controllers that can be installed.

Configuration

Use the CFC editor to install the block in a cyclic interrupt OB (OB30 to OB38). The block is also installed automatically in the startup OB (OB100).

For the control loop monitoring to work as planned in the trend view of the controller faceplates, the

```
S7_xarchive:='Value, shortterm;'
```

5.7 PIDConL - Continuous PID controller (Large)

attributes in the process tag types for control loops at the controller function block must be set for the following tags:

- Input parameters:
 - CPI_In
- Output parameters
 - MV
 - MV_HiAct
 - MV_LoAct
 - LoopClosed
 - SP
 - PV_Out
 - PV_ToleHi
 - PV_ToleLo

For the PIDConL block, the Advanced Process Library contains templates for process tag types as examples and there is a example project (APL_Example_xx, xx designates the language variant) containing different application cases for this block. Several application cases are simulated in the example project and serve to explain how the block works.

Examples of process tag types:

- PID controller with safety logic and control loop monitoring (PIDConL_ConPerMon) (Page 2324)
- Split-range controller with control loop monitoring through ConPerMon (SplitrangeControl) (Page 2335)
- Ratio control with control loop monitoring through ConPerMon (RatioControl) (Page 2338)
- Cascade control with control loop monitoring through ConPerMon (CascadeControl) (Page 2342)
- PID - control with operating-point-oriented parameter control (GainScheduling) (Page 2327)
- PID controller with dynamic feedforward control (FwdDisturbCompensat) (Page 2329)
- Override control (Page 2348)
- PID controller with Smith predictor (SmithPredictorControl) (Page 2332)
- PID controller for PA/FF devices (PIDControl_Lean_Fb) (Page 2323)

Application cases in example project:

- Process simulation including noise generator (ProcSimC; ProcSimS) (Page 2373)
- Cascade control of temperature by using the heat flow (CascadeSim) (Page 2375)
- Control loop monitoring for simulation with colored noise (ConPerMonSim) (Page 2377)
- Feedforward control to compensate a measurable disturbance variable (DisturbCompSim) (Page 2377)

- Operating point-oriented adaptation of parameters (gain scheduling) for non-linear processes (GainSchedSim) (Page 2378)
- Override control on a pipeline (OverrideSim) (Page 2379)
- Smith predictor for a dead time system (SmithPredictorSim) (Page 2379)
- Filtering of noisy measured values in a control loop (SigSmoothSim) (Page 2380)

Startup characteristics

Use the Feature bit Set startup characteristics (Page 138) to define the startup characteristics of this block.

The messages are suppressed after startup for the number of cycles set at `RunUpCyc`.

The following output parameters are written with the corresponding input parameters:

- `PV_HysOut`
- `PV_AH_Out`
- `PV_WH_Out`
- `PV_TH_Out`
- `PV_AL_Out`
- `PV_WL_Out`
- `PV_TL_Out`

Status word allocation for `Status1` parameter

You can find a description for each parameter in section PIDConL I/Os (Page 756).

Status bit	Parameter
0	Occupied
1	BatchEn
2	SimOn
3	<code>OosAct.Value</code>
4	<code>OosLi.Value</code>
5	<code>AutAct.Value</code>
6	Not used
7	<code>ManAct.Value</code>
8	<code>SP_ExtAct.Value</code>
9	<code>MV_ForOn.Value</code>
10	<code>MV_TrkOn.Value AND NOT (ManAct.Value OR OosAct.Value OR MV_ForOn.Value)</code>
11	<code>MV.Value > ManLoLim</code>
12	<code>SimLiOp.Value</code>
13	"Interlock" button is enabled OR <code>Intlock.ST ≠ 16#FF</code>
14	0 = Open padlock in the block icon 1 = Closed padlock in block icon

5.7 PIDConL - Continuous PID controller (Large)

Status bit	Parameter
15 - 17	Not used
18	SimOn AND ManAct
19	AdvCoAct
20	1 = Input parameter Rbk is not interconnected (RbkOut.ST = 16#FF)
21	NegGain
22	1 = SP ramp active
23	OptimEn
24	OptimOcc
25	Not used
26	Display of BypassAct.Value in faceplate (display and operator controls) and block icon
27 - 28	Not used
29	BypProt
30	Dead band is temporarily disabled
31	Not used

Status word allocation for status2 parameter

Status bit	Parameter
0	MsgLock
1	PV_AH_Act.Value
2	PV_WH_Act.Value
3	PV_TH_Act.Value
4	PV_TL_Act.Value
5	PV_WL_Act.Value
6	PV_AL_Act.Value
7	PV_AH_En
8	PV_WH_En
9	PV_TH_En
10	PV_TL_En
11	PV_WL_En
12	PV_AL_En
13	PV_AH_MsgEn
14	PV_WH_MsgEn
15	PV_TH_MsgEn
16	PV_TL_MsgEn
17	PV_WL_MsgEn
18	PV_AL_MsgEn
19	ER_AH_Act.Value
20	ER_AL_Act.Value
21	ER_AH_En
22	ER_AL_En

Status bit	Parameter
23	ER_AH_MsgEn
24	ER_AL_MsgEn
25	RbkWH_Act.Value
26	RbkWL_Act.Value
27	RbkWH_En
28	RbkWL_En
29	RbkWH_MsgEn
30	RbkWL_MsgEn
31	MS_RelOp

Status word allocation for status3 parameter

Status bit	Parameter
0	Effective signal 1 of the message block connected via EventTsIn
1	Effective signal 2 of the message block connected via EventTsIn
2	Effective signal 3 of the message block connected via EventTsIn
3	Effective signal 4 of the message block connected via EventTsIn
4	Effective signal 5 of the message block connected via EventTsIn
5	Effective signal 6 of the message block connected via EventTsIn
6	Effective signal 7 of the message block connected via EventTsIn
7	Effective signal 8 of the message block connected via EventTsIn
8	Delay of the PV_AH_Lim message
9	Delay of the PV_WH_Lim message
10	Delay of the PV_TH_Lim message
11	Delay of the PV_TL_Lim message
12	Delay of the PV_WL_Lim message
13	Delay of the PV_AL_Lim message
14	Delay of the ER_AH_Lim message
15	Delay of the ER_AL_Lim message
16	Collection of message delays
17	BypassAct.Value
18 - 23	Not used
24	Hidden bypass signal in Intlock
25	Feature2 bit 2: Separate bypass signal
26	LockAct.Value
27	SP_UpRaAct, SP_DnRaAct limits enabled for gradient mode (SP_RateOn = 1)
28	GrpErr.Value
29	RdyToStart.Value
30	1 = Input parameter MV_ChnST is interconnected
31	Not used

Status word allocation for status4 parameter

Status bit	Parameter
0 - 7	Effective signal 9..16 of the message block connected via <code>EventTsIn</code>
8 - 31	Not used

See also

- PIDConL functions (Page 741)
- PIDConL messaging (Page 753)
- PIDConL block diagram (Page 773)
- PIDConL error handling (Page 752)
- PIDConL modes (Page 740)

5.7.2 PIDConL modes

PIDConL operating modes

The block can be operated using the following modes:

- Automatic mode (Page 72)
- Manual mode (Page 72)
- Program mode for controllers (Page 78)
- Out of service (Page 71)

The next section provides additional block-specific information relating to the general descriptions.

"Automatic mode"

You can find general information on "Automatic mode", switching modes and bumpless switchover in the Manual and automatic mode for control blocks (Page 72) section.

"Manual mode"

You can find general information on "Manual mode", switching modes and bumpless switchover in the Manual and automatic mode for control blocks (Page 72) section.

"Program mode for controllers"

General information on "Program mode for controllers" is available in the section Program mode for controllers (Page 78).

"Out of service"

You can find general information about the "Out of service" mode in the Out of service (Page 71) section.

See also

PIDConL block diagram (Page 773)

PIDConL I/Os (Page 756)

PIDConL messaging (Page 753)

PIDConL error handling (Page 752)

PIDConL functions (Page 741)

Description of PIDConL (Page 735)

5.7.3 PIDConL functions**Functions of PIDConL**

The functions for this block are listed below.

Generation of manipulated variables

The manipulated variable *MV* can be generated as follows:

MV_For-On	Intlock	ManAct	MV_Trk On	AdvCoAct AND NOT AdvCoModSP	MV =	Limit monitoring	State
1	-	-	-	-	MV_Force d	none	Forced tracking through constraint without limitation
0	1	-	-	-	Neutral position: depends on SafePos, SafePos2	none	Interlock state
0	0	1	-	-	Man	ManHiLim ManLoLim	Manual mode, set by the operator
0	0	0	1	-	MV_Trk	MV_HiLim MV_LoLim	Tracking with limitation
0	0	0	0	1	AdvCoMV	MV_HiLim MV_LoLim	Higher-level program mode
0	0	0	0	0	P_Part + I_Part + D_Part + FFwd	MV_HiLim MV_LoLim	Automatic mode (PID algorithm)

5.7 PIDConL - Continuous PID controller (Large)

If the controller is in "out of service" mode, the output parameter `MV` is set to the last valid value in manual mode or the neutral position manipulated variable depending on the `Feature Bit` (Neutral position manipulated variable takes effect at startup (Page 166)). Refer to the Out of service (Page 71) section for more on this.

Tracking and limiting a manipulated variable

The block provides the standard function Tracking and limiting a manipulated variable (Page 196).

Neutral position

The block provides the standard function Neutral position for motors, valves and controllers (Page 48).

Group error

This block provides the standard function Outputting group errors (Page 122).

The following parameters are taken into consideration when forming the group error:

- CSF

Outputting a signal for start readiness

This block provides the standard function Outputting a signal for start readiness (Page 53).

"Actuator active" information

If the manipulated variable `MV` is greater than the minimum manual limit `ManLoLim`, this is recognized as actuator active. This status can be used to indicate a customized symbol in the process image, for example, and is saved in the status word (see Status word section in Description of PIDConL (Page 735)).

Limit monitoring of position feedback

The block provides the standard function Limit monitoring of the feedback (Page 94).

Group display `SumMsgAct` for limit monitoring, CSF and `ExtMsgx`

The block provides the standard function Group display for limit monitoring, CSF and `ExtMsgx` (Page 85).

External/internal setpoint specification

The block provides the standard function Setpoint specification - internal/external (Page 128).

Setpoint limiting for external setpoints

The block provides the standard function Setpoint limiting for external setpoints (Page 196).

Gradient limit of the setpoint

The block provides the standard function Gradient limit of the setpoint (Page 124).

Using setpoint ramp

The block provides the standard function Using setpoint ramp (Page 123).

Tracking setpoint in manual mode

The block provides the standard function Tracking setpoint in manual mode (Page 196).

Simulating signals

The block provides the standard function Simulating signals (Page 58).

You can simulate the following values:

- Process value (`SimPV`, `SimPV_Li`)
- Position feedback (`SimRbk`, `SimRbkLi`)

Bypass function

This block provides the standard function Bypassing signals (Page 107).

Limit monitoring of the process value

The block provides the standard function Limit monitoring of the process value (Page 86) with the alarm delay type Two time values per limit pair (Page 201). With the `Feature Bit Separate` delay times for each alarm (Page 170), the alarm delay type Two time values for each individual limit (Page 202) can be activated.

Providing PV limit at the output

For further connections to the other blocks, the following input parameters are also displayed with the corresponding output parameters:

- `PV_HysOut := PV_Hyst`
- `PV_AH_Out := PV_AH_Lim`
- `PV_WH_Out := PV_WH_Lim`
- `PV_TH_Out := PV_TH_Lim`
- `PV_TL_Out := PV_TL_Lim`

5.7 PIDConL - Continuous PID controller (Large)

- $PV_WL_Out := PV_WL_Lim$
- $PV_AL_Out := PV_AL_Lim$

Error signal generation and dead band

The block provides the standard function Error signal generation and dead band (Page 192).

The `Feature` bit 14 can be used to feedforward an external error signal `ER_Ext`. When the external error signal is activated, `ER_Ext` affects both the dead band and the error signal alarm generation.

Delay alarm for control deviation at setpoint step changes

The block provides the standard function Delay alarm for control deviation at setpoint step changes (Page 190).

Limit monitoring of error signal

The block provides the standard function Limit monitoring of setpoint, manipulated variable and control deviation (Page 95). The monitoring of error signal works with the alarm delay type Two time values per limit pair (Page 201). With the `Feature` Bit Separate delay times for each alarm (Page 170), the alarm delay type Two time values for each individual limit (Page 202) can be activated.

Inverting control direction

The block provides the standard function Inverting control direction (Page 192).

Physical standardization of setpoint, manipulated variable and process value

Controller gain `Gain` is entered either using a physical variable or as standardized value.

`Gain` as a physical variable:

The standardized variables retain their default values:

- `NormPV.High = 100` and `NormPV.Low = 0`
- `NormMV.High = 100` and `NormMV.Low = 0`

The effective gain is:

$GainEff = Gain$

Entering a standardized `Gain` (dimensionless):

Change the standardized variables to the actual range of the process values and manipulated variables.

- Internal and external setpoints; the process value and corresponding parameters are entered according to the physical measuring range of the process value.
- The manual value, the tracking value of the manipulated variable, feedforward control and the corresponding parameters are set according to the physical measuring range of the manipulated variable.

The effective gain is:

$$\text{GainEff} = (\text{NormMV.High} - \text{NormMV.Low}) / (\text{NormPV.High} - \text{NormPV.Low}) \cdot \text{Gain}$$

Selecting a unit of measure

The block provides the standard function Selecting a unit of measure (Page 212).

PID algorithm

The manipulated variable is generated in automatic mode according to the following algorithm:

$$\text{MV} = \text{GainEff} \cdot (1 + 1 / (\text{TI} \cdot s) + (\text{TD} \cdot s) / (1 + \text{TD} / \text{DiffGain} \cdot s)) \cdot \text{ER}$$

Where:

s = Complex number

The following step response occurs:

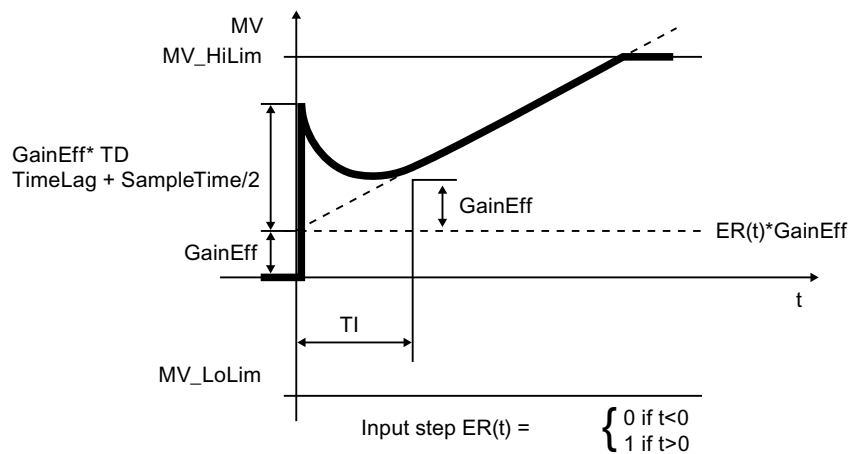

Note

The formula describes a standard application where P, I and D components are activated and the P and D components are not in the feedback circuit ($\text{PropSel} = 1$, $\text{TI} \neq 0$ and $\text{IntSel} = 1$, $\text{TD} \neq 0$ and $\text{DiffSel} = 1$, $\text{DiffToFbk} = 0$ and $\text{PropFacSP} = 1$).

5.7 PIDConL - Continuous PID controller (Large)

The D component delay is derived from $TD / DiffGain$.

- The P component is displayed at the `P_Part` I/O and can be deactivated using `PropSel = 0`.
- The I component is displayed at the `I_Part` I/O and can be deactivated using `TI = 0` or `IntSel = 0`. In deactivated state, `I_Part` is specified by `MV_Offset` and added to the manipulated variable. Make a selection for this value so that the remaining control deviation equals zero at the control loop's typical operating point, at least. `IntSel` is used for temporary deactivation of the I component. The I component is not reactivated until `TI <> 0` and `IntSel = 1`. After the I component is activated, the integrator continues working starting from `MV_Offset`.
- The D component is displayed at the `D_Part` I/O and can be deactivated using `TD = 0` or `DiffSel = 0`.

Structure segmentation at controllers

The block provides the standard function Structure segmentation at controllers (Page 198).

Anti-windup

The controller has an anti-windup function. The I component is frozen after the manipulated variable has reached limits (`MV_HiLim` or `MV_LoLim`).

Feedforwarding and limiting disturbance variables

The block provides the standard function Feedforwarding and limiting disturbance variables (Page 197).

Control zone

The block provides the standard function Using control zones (Page 194).

Forming the signal status for blocks

The block provides the standard function Forming and outputting the signal status for technologic blocks (Page 109).

- Signal status for the process value `PV_Out`:
The signal status of the output parameter `PV_Out` always corresponds to the signal status of input parameter `PV` or, if the block is in simulation mode, `16#60`.
- Signal status for the setpoint value `SP`:
The signal status of the `SP` output parameter is always equivalent to the signal status of input parameter `SP_Ext` or `SP_Int`, depending on how the setpoint is specified. If the internal setpoint `SP_Int` is used, the signal status is always output as `16#80`.

- **Signal status of the error signal ER:**
The signal status of output parameter ER is obtained from the worst signal status of the two output parameters PV_Out and SP and is output.
The signal status 16#60 (external simulation) is suppressed because the block acts as a sink with external simulation.
If the external error signal is activated (Feature bit14 = 1), the signal status of ER_Ext.ST is applied.
- **Signal status for the manipulated variable MV:**
The signal status of output parameter MV is obtained in "automatic mode" or in "program mode" with default setpoint from the worst signal status of the two parameters FFwd and ER and is output. In "manual mode", the signal status is output as good. The signal status 16#60 (external simulation) is suppressed because the block acts as a sink with external simulation. In "manual mode", the signal status is output as good.
- **Signal status for position feedback RbkOut:**
The signal status of RbkOut always corresponds to the signal status of input parameter Rbk or, if the block is in simulation mode, 16#60.
- **Worst signal status:**
The worst signal status ST_Worst for the block is formed from the following parameters:
Feature bit 14 = 1 (external error signal)
 - ER_Ext.ST;
 - FFwd.ST;
 - RbkOut.ST;
 - MV_ChnST.ST;
 Feature bit 14 = 0 (external error signal)
 - SP.ST;
 - PV_Out.ST;
 - FFwd.ST;
 - RbkOut.ST;
 - MV_ChnST.ST;

Configurable reactions using the Feature parameter

You can find an overview of all reactions provided by the Feature parameter in the Configurable functions using the Feature I/O (Page 131) . The following functionality is available for this block at the relevant bits:

Bit	Function
0	Set startup characteristics (Page 138)
1	Reaction to the out of service mode (Page 177)
2	Resetting the commands for changing the mode (Page 161)
4	Setting switch or button mode (Page 167)
6	Ramp rate calculation (Page 179)
8	Separate delay times for each alarm (Page 170)
9	Substitution value is active if the block is in bypass (Page 185)

5.7 PIDConL - Continuous PID controller (Large)

Bit	Function
11	Gradient limitation with time duration (Page 182)
12	Control zone with specified I component (Page 160)
13	Control zone with frozen I component (Page 160)
14	External control deviation (Page 151)
15	Neutral position manipulated variable takes effect with "out of service" operating mode (Page 166)
16	Neutral position manipulated variable takes effect at startup (Page 166)
18	Disabling bumpless switchover to automatic mode for controllers (Page 173)
22	Update acknowledgment and error status of the message call (Page 160)
23	SP following PV in open loop has no priority over SP_Ext and SP limits (Page 179)
24	Enabling local operator authorization (Page 158)
25	Suppression of all messages (Page 174)
26	Reaction of the switching points in the "Out of service" operating mode (Page 176)
28	Disabling operating points (Page 145)
29	Signaling limit violation (Page 170)
30	Dead band is temporarily disabled (Page 141)

Configurable reactions using the Feature2 parameter

Bit	Function
2	Separate evaluation for excluded and simulated interlock signals (Page 152)
11	Suppress MsgLock and "Out of service" mode for a connected message block (Page 188)

Operator permissions

The block provides the standard function Operator control permissions (Page 254).

The block has the following permissions for the OS_Perm parameter:

Bit	Function
0	1 = Operator can switch to "automatic mode" AutModOp
1	1 = Operator can switch to "manual mode" ManModOp
2	1 = Operator can switch to "Out of service" mode OosOp
3	1 = Operator can switch to "program mode" AdvCoEn
4	1 = Operator can switch the setpoint to "external" SP_ExtOp
5	1 = Operator can switch the setpoint to "internal" SP_IntOp
6	1 = Operator can change the internal setpoint SP_Int
7	1 = Operator can change the manual parameter Man
8	1 = Operator can change operation high limit of the setpoint SP_InHiLim
9	1 = Operator can change operation low limit of the setpoint SP_InLoLim
10	1 = Operator can change the operation high limit of the manipulated variable ManHiLim
11	1 = Operator can change the operation low limit of the manipulated variable ManLoLim
12	1 = Operator can enable the setpoint's gradient limitation function SP_RateOn
13	1 = Operator can change the setpoint's high limit for the ramp SP_UpRaLim

5.7 PIDConL - Continuous PID controller (Large)

Bit	Function
14	1 = Operator can change the setpoint's low limit for the ramp <code>SP_DnRaLim</code>
15	1 = Operator can switch between the time value or the value for the ramp <code>SP_RmpModTime</code>
16	1 = Operator can change the ramp time <code>SP_RmpTime</code>
17	1 = Operator can change the target setpoint <code>SP_RmpTarget</code> for the setpoint ramp
18	1 = Operator can enable the setpoint ramp function <code>SP_RmpOn</code>
19	1 = Operator can permit the PID optimization function <code>OptimEn</code>
20	1 = Operator can enable the track setpoint in "manual mode" function <code>SP_TrkPV</code>
21	1 = Operator can enable the bumpless switchover from external to internal <code>SP_TrkExt</code>
22	1 = Operator can change the gain parameter <code>Gain</code>
23	1 = Operator can change the integral time parameter <code>TI</code>
24	1 = Operator can change the derivative time parameter <code>TD</code>
25	1 = Operator can change the derivative gain parameter <code>DiffGain</code>
26	1 = Operator can change the dead band parameter <code>DeadBand</code>
27	1 = Operator can change the control zone parameter <code>ConZone</code>
28	1 = Operator can change the derivative gain parameter <code>ER_AH_DFac</code>
29	1 = Operator can change the derivative gain parameter <code>ER_AL_DFac</code>
30	Not used
31	Not used

The block has the following permissions for the `OS1Perm` parameter:

Bit	Function
0	1 = Operator can change the limit (process value) <code>PV_AH_Lim</code> for the high alarm
1	1 = Operator can change the limit (process value) <code>PV_WH_Lim</code> for the high warning
2	1 = Operator can change the limit (process value) <code>PV_TH_Lim</code> for the high tolerance
3	1 = Operator can change the hysteresis (process value) <code>PV_Hyst</code>
4	1 = Operator can change the limit (process value) <code>PV_TL_Lim</code> for the low tolerance
5	1 = Operator can change the limit (process value) <code>PV_WL_Lim</code> for the low warning
6	1 = Operator can change the limit (process value) <code>PV_AL_Lim</code> for the low alarm
7	1 = Operator can change the limit (error signal) <code>ER_AH_Lim</code> for the high alarm
8	1 = Operator can change the hysteresis (error signal) <code>ER_Hyst</code>
9	1 = Operator can change the limit (error signal) <code>ER_AL_Lim</code> for the low alarm
10	1 = Operator can change the limit (position feedback) <code>RbkWH_Lim</code> for the high warning
11	1 = Operator can change the hysteresis (position feedback) <code>RbkHyst</code>
12	1 = Operator can change the limit (position feedback) <code>RbkWL_Lim</code> for the low warning
13	"Interlock" button is enabled
14	1 = Operator can activate bypass functionality
15	1 = Operator can deactivate bypass functionality
16	1 = Operator can activate the Simulation function <code>SimOn</code>
17	1 = Operator can activate the Release for maintenance function <code>MS_RelOp</code>
18	1 = Operator can activate / deactivate messages via <code>PV_AH_MsgEn</code>
19	1 = Operator can activate / deactivate messages via <code>PV_WH_MsgEn</code>
20	1 = Operator can activate / deactivate messages via <code>PV_TH_MsgEn</code>

5.7 PIDConL - Continuous PID controller (Large)

Bit	Function
21	1 = Operator can activate / deactivate messages via PV_TL_MsgEn
22	1 = Operator can activate / deactivate messages via PV_WL_MsgEn
23	1 = Operator can activate / deactivate messages via PV_AL_MsgEn
24	1 = Operator can activate / deactivate messages via ER_AH_MsgEn
25	1 = Operator can activate / deactivate messages via ER_AL_MsgEn
26	1 = Operator can activate / deactivate messages via RbkWH_MsgEn
27	1 = Operator can activate / deactivate messages via RbkWL_MsgEn
28	1 = Operator can change the simulation value SimPV
29	1 = Operator can change the simulation value SimRbk
30	1 = Operator can activate the derivative action to the feedback path DiffToFbk
31	1 = Operator can change the proportional action to the feedback path PropFacSP

Note

If you interconnect a parameter that is also listed in OS_Perm as a parameter, you have to reset the corresponding OS_Perm bit.

Interlocks

This block provides the following interlocks:

- Interlock without reset ("Interlock")

If interlock is active without forcing (MV_ForOn =0) the manipulated value MV.Value is set to the neutral position value (Neutral position for motors, valves and controllers (Page 48)).

You can find additional information on this in the section Interlocks (Page 99).

Disabling interlocks

This block provides the standard function Disabling interlocks (Page 103).

Release for maintenance

The block provides the standard function Release for maintenance (Page 64)

Generating instance-specific messages

The block provides the standard function Generating instance-specific messages (Page 204) without the time stamp function in the I/O.

Suppressing messages using the MsgLock parameter

This block provides the standard function Suppressing messages using the MsgLock parameter (Page 205).

Button labels

This block provides the standard function Labeling of buttons and text (Page 209).

Instance-specific text can be configured for the following parameters:

- AutModOp
- ManModOp
- AdvCoOn
- OosOp
- SP_ExtOp
- SP_IntOp

Specifying the display area for process and setpoint values as well as operations

This block provides the standard function Display and operator input area for process values and setpoints (Page 207).

Opening additional faceplates

This block provides the standard function Opening additional faceplates (Page 208).

SIMATIC BATCH functionality

This block provides the standard function SIMATIC BATCH functionality (Page 67).

Connection of the time-stamped messages from EventTs or Event16Ts

This block provides the standard function Connection of the time-stamped messages from EventTs or Event16Ts (Page 207).

See also

PIDConL I/Os (Page 756)

PIDConL block diagram (Page 773)

PIDConL error handling (Page 752)

PIDConL modes (Page 740)

EventTs functions (Page 1660)

5.7.4 PIDConL error handling

Error handling of PIDConL

Refer to section Error handling (Page 119) in the basic instructions for the error handling of all blocks.

The following errors can be displayed for this block:

- Error numbers
- Control system fault (CSF)

Overview of error numbers

The `ErrorNum` output parameter can be used to output the following error numbers:

Error number	Meaning of the error number
-1	Predefined value when inserting the block; the block is not executed
0	There is no error.
30	The value of <code>PV</code> can no longer be displayed in the REAL number field.
31	The value of <code>SP_Ext</code> can no longer be displayed in the REAL number field.
32	The value of <code>FFwd</code> can no longer be displayed in the REAL number field.
33	The value of <code>MV_Trk</code> can no longer be displayed in the REAL number field.
34	The value of <code>MV_Forced</code> can no longer be displayed in the REAL number field.
35	The value of <code>Rbk</code> can no longer be displayed in the REAL number field.
36	The value of <code>MV</code> can no longer be displayed in the REAL number field.
51	<code>AutModLi = 1 and ManModLi = 1</code> <code>SP_LiOp = 1 and SP_IntLi = 1 and SP_ExtLi = 1</code>
59	<code>= 1, "Gain is negative"</code>
60	<code> TI < SampleTime / 2</code>
61	<code> TD < SampleTime</code>
62	<code>DiffGain < 1 or DiffGain > 10</code>
63	<code>TD / DiffGain < SampleTime / 2</code>
64	<code>PropFacSP < 0 or PropFacSP > 1</code>
66	<code>NormPV_High = NormPV_Low</code>
74	<code>ConZone = < 0.0</code>

Control system fault (CSF)

An external signal can be activated via the CSF input. A control system fault is triggered if this signal changes to 1. Refer to the Error handling (Page 119) section for more on this.

See also

PIDConL block diagram (Page 773)

PIDConL I/Os (Page 756)

PIDConL messaging (Page 753)
 PIDConL functions (Page 741)
 PIDConL modes (Page 740)
 Description of PIDConL (Page 735)
 Setting switch or button mode (Page 167)

5.7.5 PIDConL messaging

Messaging

The following messages can be generated for this block:

- Process control fault
- Process messages
- Instance-specific messages

Process control fault

The following control system error messages can be output:

Message instance	Message identifier	Message class	Event
MsgEvId2	SIG 6	AS process control message - fault	\$\$BlockComment\$\$ External error has occurred

Explanation:

\$\$BlockComment\$\$: Content of the instance-specific comment

You can interconnect an external fault (signal) to input parameter `CSF`. If it changes to `CSF = 1`, a process control fault is triggered (MsgEvId2, SIG 6).

Process messages

Message instance	Message identifier	Message class	Event
MsgEvId1	SIG 1	Alarm - high	\$\$BlockComment\$\$ PV - high alarm limit violated
	SIG 2	Warning - high	\$\$BlockComment\$\$ PV - high warning limit violated
	SIG 3	Tolerance - high	\$\$BlockComment\$\$ PV - high tolerance limit violated
	SIG 4	Tolerance - low	\$\$BlockComment\$\$ PV - low tolerance limit violated
	SIG 5	Warning - low	\$\$BlockComment\$\$ PV - low warning limit violated
	SIG 6	Alarm - low	\$\$BlockComment\$\$ PV - low alarm limit violated
	SIG 7	Alarm - high	\$\$BlockComment\$\$ ER - high alarm limit violated
	SIG 8	Alarm - low	\$\$BlockComment\$\$ ER - low alarm limit violated
MsgEvId2	SIG 7	Warning - high	\$\$BlockComment\$\$ Rbk - high warning limit violated
	SIG 8	Warning - low	\$\$BlockComment\$\$ Rbk - low warning limit violated

Explanation:

\$\$BlockComment\$\$: Content of the instance-specific comment

Instance-specific messages

You can use up to four instance-specific messages with this block.

Message instance	Message identifier	Message class	Event
MsgEvId2	SIG 1	AS process control message - fault	\$\$BlockComment\$\$ External message 1 Status 16#@5%x@
	SIG 2	AS process control message - fault	\$\$BlockComment\$\$ External message 2 Status 16#@6%x@
	SIG 3	AS process control message - fault	\$\$BlockComment\$\$ External message 3 Status 16#@7%x@
	SIG 4	AS process control message - fault	\$\$BlockComment\$\$ External message 4 Status 16#@8%x@

Explanation:

\$\$BlockComment\$\$: Content of the instance-specific comment

Associated values for message instance `MsgEvId1`

Associated value	Block parameters
1	BatchName
2	StepNo
3	BatchID
4	Process value PV_Out
5	Control deviation ER
6	ExtVa106
7	ExtVa107
8	Not allocated
9	Not allocated
10	Not allocated

The associated values 6 ... 7 are allocated to the parameters `ExtVa106` ... `ExtVa107` and can be used. Additional information is available in the "Process Control System PCS 7 - Engineering System" manual.

Associated values for message instance `MsgEvId2`

Associated value	Block parameters
1	BatchName
2	StepNo
3	BatchID
4	Position feedback Rbk
5	Signal status ExtMsg1
6	Signal status ExtMsg2
7	Signal status ExtMsg3
8	Signal status ExtMsg4
9	ExtVa209
10	ExtVa210

The associated values 9 ... 10 are allocated to the parameters `ExtVa209` ... `ExtVa210` and can be used. Additional information is available in the "Process Control System PCS 7 - Engineering System" manual.

See also

Description of PIDConL (Page 735)

PIDConL functions (Page 741)

PIDConL I/Os (Page 756)

5.7 PIDConL - Continuous PID controller (Large)

PIDConL block diagram (Page 773)

PIDConL error handling (Page 752)

PIDConL modes (Page 740)

5.7.6 PIDConL I/Os

I/Os of PIDConL

Input parameters

Parameter	Description	Type	Default
AdvCoEn	1 = Enable "program mode" via interconnection	STRUCT <ul style="list-style-type: none"> • Value: BOOL • ST: BYTE 	- <ul style="list-style-type: none"> • 0 • 16#80
AdvCoOn*	1 = Enable "program mode" via faceplate	BOOL	0
AdvCoModSP	Type of "program mode": 1 = Setpoint specification 0 = Manipulated variable specification	BOOL	1
AdvCoMstrOn	Activate (0-1) or deactivate (1-0) "program mode" via edge transition	STRUCT <ul style="list-style-type: none"> • Value: BOOL • ST: BYTE 	- <ul style="list-style-type: none"> • 0 • 16#80
AdvCoMV	Specified value from the external program	REAL	0.0
AutModLi*	1 = "Automatic mode" via interconnection or SFC (controlled by ModLiOp = 1)	STRUCT <ul style="list-style-type: none"> • Value: BOOL • ST: BYTE 	- <ul style="list-style-type: none"> • 0 • 16#80
AutModOp*	1 = "Automatic mode" via operator (controlled by ModLiOp = 0)	BOOL	0
BatchEn	1 = Enable allocation for batch control	BOOL	0
BatchID	Batch ID	DWORD	16#00000000
BatchName	Batch name	S7-String	
BypProt	1 = Interlock bypass during simulation	BOOL	0
BypLiOp	1 = Bypass commands via interconnection	STRUCT <ul style="list-style-type: none"> • Value: BOOL • ST: BYTE 	- <ul style="list-style-type: none"> • 0 • 16#80
BypLock	1 = Bypass activation or deactivation is locked for operator	STRUCT <ul style="list-style-type: none"> • Value: BOOL • ST: BYTE 	- <ul style="list-style-type: none"> • 0 • 16#80
BypPV	Substitution value if block is in bypass	REAL	0.0
BypPVLi	1 = Select bypass PV (via interconnection)	STRUCT <ul style="list-style-type: none"> • Value: BOOL • ST: BYTE 	- <ul style="list-style-type: none"> • 0 • 16#80

5.7 PIDConL - Continuous PID controller (Large)

Parameter	Description	Type	Default
BypPVOp	1 = Select bypass PV (via operator)	BOOL	0
ConZone	Width of control zone	REAL	0.0
CPI_In	Input for control performance index, which is calculated by the assigned ConPerMon block	STRUCT <ul style="list-style-type: none"> Value: REAL ST: BYTE 	- <ul style="list-style-type: none"> 0.0 16#78
CSF	1 = External error (control system fault) Error handling (Page 119)	STRUCT <ul style="list-style-type: none"> Value: BOOL ST: BYTE 	- <ul style="list-style-type: none"> 0 16#80
DeadBand	Width of dead band	REAL	0.0
DiffGain	Gain of differentiator [1..10] DiffGain = TD / (delay time of D component)	STRUCT <ul style="list-style-type: none"> Value: REAL ST: BYTE 	- <ul style="list-style-type: none"> 5.0 16#80
DiffSel	1 = D component activated	BOOL	1
DiffToFbk	1 = D component is placed in the feedback	BOOL	0
EN	1 = Called block will be processed	BOOL	1
ER_A_DC*	Delay time for incoming ER high/low or only low alarms [s]	REAL	0.0
ER_AH_DC*	Delay time for incoming ER high alarms [s]	REAL	0.0
ER_A_DG*	Delay time for outgoing ER high/low or only low alarms [s]	REAL	0.0
ER_AH_DG*	Delay time for outgoing ER high alarms [s]	REAL	0.0
ER_AH_En	1 = Activate alarm (high) for error signal monitoring	BOOL	1
ER_AH_DFac*	Delay factor at positive setpoint step changes for incoming alarms at the error signal monitoring ER_AH_Lim	REAL	0.0
ER_AH_Lim	Alarm limit (high) for error signal monitoring	REAL	100.0
ER_AH_MsgEn	1 = Activate messages for alarm (high) for error signal monitoring	BOOL	1
ER_AL_DFac*	Delay factor at negative setpoint step changes for incoming alarms at the error signal monitoring ER_AL_Lim	REAL	0.0
ER_AL_En	1 = Activate alarm (low) for error signal monitoring	BOOL	1
ER_AL_Lim	Alarm limit (low) for error signal monitoring	REAL	-100.0
ER_AL_MsgEn	1 = Activate messages for alarm (low) for error signal monitoring	BOOL	1
ER_Ext	External error signal	STRUCT <ul style="list-style-type: none"> Value: REAL ST: BYTE 	- <ul style="list-style-type: none"> 0.0 16#80

5.7 PIDConL - Continuous PID controller (Large)

Parameter	Description	Type	Default
ER_Hyst	Alarm hysteresis for error signal	REAL	1.0
EventTsIn	For interconnecting data between a technology block and the message blocks EventTs, Event16Ts. The EventTsIn input parameter serves to interconnect the EventTsOut output parameter of the EventTs, Event16Ts block. When this interconnection is configured, the messages of the EventTs, Event16Ts block are displayed on the OS in the alarm view of the technology block and can also be acknowledged there.	ANY	
ExtMsg1	1 = Binary input for freely selectable message 1 is used	STRUCT <ul style="list-style-type: none"> • Value: BOOL • ST: BYTE 	- <ul style="list-style-type: none"> • 0 • 16#80
ExtMsg2	1 = Binary input for freely selectable message 2 is used	STRUCT <ul style="list-style-type: none"> • Value: BOOL • ST: BYTE 	- <ul style="list-style-type: none"> • 0 • 16#80
ExtMsg3	1 = Binary input for freely selectable message 3 is used	STRUCT <ul style="list-style-type: none"> • Value: BOOL • ST: BYTE 	- <ul style="list-style-type: none"> • 0 • 16#80
ExtMsg4	1 = Binary input for freely selectable message 4 is used	STRUCT <ul style="list-style-type: none"> • Value: BOOL • ST: BYTE 	- <ul style="list-style-type: none"> • 0 • 16#80
ExtVa106	Associated value 6 for messages (MsgEvID1)	ANY	
ExtVa107	Associated value 7 for messages (MsgEvID1)	ANY	
ExtVa209	Associated value 9 for messages (MsgEvID2)	ANY	
ExtVa210	Associated value 10 for messages (MsgEvID2)	ANY	
Feature	I/O for additional functions (Page 741)	STRUCT <ul style="list-style-type: none"> • Bit 0: BOOL • ... • Bit 31: BOOL 	- <ul style="list-style-type: none"> • 0 • 0 • 0
Feature2	I/O for additional functions (Page 741)	STRUCT <ul style="list-style-type: none"> • Bit 0: BOOL • ... • Bit 31: BOOL 	- <ul style="list-style-type: none"> • 0 • 0 • 0
FFwd*	Input for additive disturbance variable activation	STRUCT <ul style="list-style-type: none"> • Value: REAL • ST: BYTE 	- <ul style="list-style-type: none"> • 0.0 • 16#80

5.7 PIDConL - Continuous PID controller (Large)

Parameter	Description	Type	Default
FFwdHiLim	Limit (high) for additive disturbance variable activation	STRUCT <ul style="list-style-type: none"> Value: REAL ST: BYTE 	- <ul style="list-style-type: none"> 100.0 16#80
FFwdLoLim	Limit (low) for additive disturbance variable activation	STRUCT <ul style="list-style-type: none"> Value: REAL ST: BYTE 	- <ul style="list-style-type: none"> -100.0 16#80
Gain	Proportional gain Gain.ST = 16#FF: Enabled in faceplate	STRUCT <ul style="list-style-type: none"> Value: REAL ST: BYTE 	- <ul style="list-style-type: none"> 1.0 16#FF
Intl_En	1 = Interlock without reset (interlock, Intlock parameter) is in effect	BOOL	1
IntHoldNeg	1 = Integrator cannot run in negative direction	STRUCT <ul style="list-style-type: none"> Value: BOOL ST: BYTE 	- <ul style="list-style-type: none"> 0 16#80
IntHoldPos	1 = Integrator cannot run in positive direction	STRUCT <ul style="list-style-type: none"> Value: BOOL ST: BYTE 	- <ul style="list-style-type: none"> 0 16#80
Intlock	0 = Interlock without reset is in effect Once the interlock condition has cleared, the block can be operated without reset 1 = Interlock not activated	STRUCT <ul style="list-style-type: none"> Value: BOOL ST: BYTE Bit 1: BOOL (Bypass information bit) 	- <ul style="list-style-type: none"> 1 16#FF 0
IntSel	1 = I component activated	BOOL	1
Man*	Manual specification for the manipulated variable	REAL	0.0
ManHiLim	Limit (high) for manual parameter <i>Man</i>	REAL	100.0
ManLoLim	Limit (low) for manual parameter <i>Man</i>	REAL	0.0
ManModLi*	1 = "Manual mode" via interconnection or SFC (controlled by <i>ModLiOp</i> = 1)	STRUCT <ul style="list-style-type: none"> Value: BOOL ST: BYTE 	- <ul style="list-style-type: none"> 0 16#80
ManModOp*	1 = "Manual mode" via OS operator (controlled by <i>ModLiOp</i> = 0)	BOOL	1
ModLiOp	Operating mode switchover between: 0 = Operator 1 = Interconnection or SFC	STRUCT <ul style="list-style-type: none"> Value: BOOL ST: BYTE 	- <ul style="list-style-type: none"> 0 16#80
MS_RelOp*	1 = Release for maintenance by OS operator	BOOL	0
MsgEvID1	Message number (assigned automatically)	DWORD	16#00000000
MsgEvID2	Message number (assigned automatically)	DWORD	16#00000000

Controller blocks

5.7 PIDConL - Continuous PID controller (Large)

Parameter	Description	Type	Default
MsgLock	1 = Suppress process messages. See also the section Hotspot-Text (Page 205) for more on this.	STRUCT • Value: BOOL • ST: BYTE	- • 0 • 16#80
MV_ChnST	Signal status of output channel for MV Should be connected to an output channel block	STRUCT • Value: REAL • ST: BYTE	- • 0.0 • 16#FF
MV_Forced*	Forced manipulated variable that is not limited and assumes top priority	STRUCT • Value: REAL • ST: BYTE	- • 0.0 • 16#80
MV_ForOn	1 = Output forced manipulated variable MV_Forced unlimited at output MV	STRUCT • Value: BOOL • ST: BYTE	- • 0 • 16#80
MV_HiLim	Limit (high) for manipulated variable MV	STRUCT • Value: REAL • ST: BYTE	- • 100.0 • 16#80
MV_LoLim	Limit (low) for manipulated variable MV	STRUCT • Value: REAL • ST: BYTE	- • 0.0 • 16#80
MV_Mean	Mean value of the MV in the time window	STRUCT • Value: REAL • ST: BYTE	- • 0.0 • 16#80
MV_Offset	Manipulated variable for ER=0, operating point for controller with deactivated I component	REAL	0.0
MV_OpScale	OS display range for manipulated variable MV	STRUCT • High: REAL • Low: REAL	- • 100.0 • 0.0
MV_SafePos	Manipulated variable neutral position	STRUCT • Value: REAL • ST: BYTE	- • 0.0 • 16#80
MV_Trk*	Tracking value for the manipulated variable MV	STRUCT • Value: REAL • ST: BYTE	- • 0.0 • 16#80
MV_TrkOn	1 = Tracking of manipulated variable MV	STRUCT • Value: BOOL • ST: BYTE	- • 0 • 16#80
MV_Unit	Unit of measure for manipulated variable	INT	1342
NegGain	0 = Effective proportional gain GainEff is positive 1 = Effective proportional gain GainEff is negative	STRUCT • Value: BOOL • ST: BYTE	- • 0 • 16#80

5.7 PIDConL - Continuous PID controller (Large)

Parameter	Description	Type	Default
NormMV	Manipulated variable range (MV) for standardizing the proportional gain (GAIN)	STRUCT <ul style="list-style-type: none"> • High: REAL • Low: REAL 	- <ul style="list-style-type: none"> • 100.0 • 0.0
NormPV	Process value range (PV) for standardizing the proportional gain (GAIN)	STRUCT <ul style="list-style-type: none"> • High: REAL • Low: REAL 	- <ul style="list-style-type: none"> • 100.0 • 0.0
Occupied	1 = Occupied by batch control	BOOL	0
OosLi	1 = "Out of service", via interconnection or SFC (0-1 edge transition)	STRUCT <ul style="list-style-type: none"> • Value: BOOL • ST: BYTE 	- <ul style="list-style-type: none"> • 0 • 16#80
OosOp*	1 = "Out of service", via OS operator	BOOL	0
OptimEn*	1 = Enable optimization of PID parameters by PID tuner	BOOL	0
OptimOcc*	1 = Optimization running	BOOL	0
OpSt_In	Input parameter for local operator authorization, connected with the <code>Out</code> output parameter of the upstream block, <code>OpStations</code> (Page 411)	DWORD	16#00000000
OS_Perm	I/O for operator permissions (Page 741)	STRUCT <ul style="list-style-type: none"> • Bit 0: BOOL • ... • Bit 31: BOOL 	- <ul style="list-style-type: none"> • 1 • 1 • 1
OS1Perm	I/O for operator permissions (Page 741)	STRUCT <ul style="list-style-type: none"> • Bit 0: BOOL • Bit 18: BOOL • Bit 19: BOOL • Bit 31: BOOL 	- <ul style="list-style-type: none"> • 1 • 1 • 1 • 1
PropFacSP	Applying the P component to the feedback [0..1]. 0 = P component fully in feedback	REAL	1.0
PropSel	1 = Activate P component	BOOL	1
PV*	Process value (controlled variable)	STRUCT <ul style="list-style-type: none"> • Value: REAL • ST: BYTE 	- <ul style="list-style-type: none"> • 0.0 • 16#80
PV_A_DC*	Delay time for incoming PV high/low or only low alarms [s]	REAL	0.0
PV_AH_DC*	Delay time for incoming PV high alarms [s]	REAL	0.0
PV_A_DG*	Delay time for outgoing PV high/low or only low alarms [s]	REAL	0.0
PV_AH_DG*	Delay time for outgoing PV high alarms [s]	REAL	0.0
PV_AH_En	1 = Enable PV alarm limit (high)	BOOL	1

Controller blocks

5.7 PIDConL - Continuous PID controller (Large)

Parameter	Description	Type	Default
PV_AH_Lim	Limit PV alarm (high)	REAL	95.0
PV_AH_MsgEn	1 = Enable PV alarm (high) message	BOOL	1
PV_AL_En	1 = Enable PV alarm limit (low)	BOOL	1
PV_AL_Lim	PV alarm limit (low)	REAL	5.0
PV_AL_MsgEn	1 = Enable PV alarm (low) message	BOOL	1
PV_Hyst	Hysteresis for PV alarm, warning and tolerance limits	REAL	1.0
PV_OpScale	Limit for scale in PV bar graph of face-plate	STRUCT <ul style="list-style-type: none"> High: REAL Low: REAL 	- <ul style="list-style-type: none"> 100.0 0.0
PV_T_DC*	Delay time for incoming PV high/low or only low tolerance messages [s]	REAL	0.0
PV_TH_DC*	Delay time for incoming PV high tolerance messages [s]	REAL	0.0
PV_T_DG*	Delay time for outgoing PV high/low or only low tolerance messages [s]	REAL	0.0
PV_TH_DG*	Delay time for outgoing PV high tolerance messages [s]	REAL	0.0
PV_TH_En	1 = Enable PV tolerance limit (high)	BOOL	0
PV_TH_Lim	Limit PV tolerance message (high)	REAL	85.0
PV_TH_MsgEn	1 = Enable message for PV tolerance message (high)	BOOL	1
PV_TL_En	1 = Enable PV tolerance limit (low)	BOOL	0
PV_TL_Lim	Limit PV tolerance message (low)	REAL	15.0
PV_TL_MsgEn	1 = Enable message for tolerance message (low)	BOOL	1
PV_Unit	Unit of measure for process value	INT	1001
PV_W_DC*	Delay time for incoming PV high/low or only low warnings [s]	REAL	0.0
PV_WH_DC*	Delay time for incoming PV high warnings [s]	REAL	0.0
PV_W_DG*	Delay time for outgoing PV high/low or only low warnings [s]	REAL	0.0
PV_WH_DG*	Delay time for outgoing PV high warnings [s]	REAL	0.0
PV_WH_En	1 = Enable PV warning limit (high)	BOOL	1
PV_WH_Lim	Limit PV warning (high)	REAL	90.0
PV_WH_MsgEn	1 = Enable PV warning (high) message	BOOL	1
PV_WL_En	1 = Enable PV warning limit (low)	BOOL	1
PV_WL_Lim	Limit PV warning (low)	REAL	10.0
PV_WL_MsgEn	1 = Enable PV warning (low) message	BOOL	1
Rbk*	Position feedback for display on OS	STRUCT <ul style="list-style-type: none"> Value: REAL ST: BYTE 	- <ul style="list-style-type: none"> 0.0 16#FF

5.7 PIDConL - Continuous PID controller (Large)

Parameter	Description	Type	Default
RbkHyst	Alarm hysteresis for position feedback	REAL	1.0
RbkWH_En	1 = Enable warning (high) for position feedback	BOOL	1
RbkWH_Lim	Limit for position feedback of warning (high)	REAL	100.0
RbkWH_MsgEn	1 = Enable messages for warning (high) for position feedback	BOOL	1
RbkWL_En	1 = Enable warning (low) for position feedback	BOOL	1
RbkWL_Lim	Limit for position feedback of warning (low)	REAL	0.0
RbkWL_MsgEn	1 = Enable messages for warning (low) for position feedback	BOOL	1
RefStdDevIn	Reference value of PV standard deviation (sigma) in defined "good" state of control loop	STRUCT <ul style="list-style-type: none"> Value: REAL ST: BYTE 	- <ul style="list-style-type: none"> 0.0 16#78
RstBypli	1 = Reset bypass PV (via interconnection)	STRUCT <ul style="list-style-type: none"> Value: BOOL ST: BYTE 	- <ul style="list-style-type: none"> 0 16#80
RstByOp	1 = Reset bypass PV (via operator)	BOOL	0
RunUpCyc	Number of cycles in startup; messages are suppressed during these cycles	INT	3
SafePos	1 = Neutral position (Page 48) for controller manipulated variable is <code>ManHiLim</code> 0 = Neutral position for controller manipulated variable is <code>ManLoLim</code>	BOOL	0
SafePos2	Neutral position for controller manipulated variable: 0 = <code>SafePos</code> is valid 1 = Neutral position is <code>MV_SafePos</code> 2 = Neutral position is last manipulated variable (stop)	INT	0
SampleTime	Sampling time [s] (assigned automatically)	REAL	0.1
SelFp1	1 = Call a block saved in this parameter as an additional faceplate (Page 208) in the standard view	ANY	-
SelFp2	1 = Call a block saved in this parameter as an additional faceplate (Page 208) in the preview	ANY	-
SettliTime	Settling time [s] of the control loop determined by the <code>ConPerMon</code> block	STRUCT <ul style="list-style-type: none"> Value: BOOL ST: BYTE 	- <ul style="list-style-type: none"> 0 16#78
SettliFactor	Factor to increase the settling time to adjust the dead band	REAL	2.0

Controller blocks

5.7 PIDConL - Continuous PID controller (Large)

Parameter	Description	Type	Default
SimLiOp	Activation/deactivation of the simulation by: 0 = Operator 1 = Interconnection or SFC	STRUCT • Vale: BOOL • ST: BYTE	- • 0 • 16#80
SimOnLi	1 = Simulation via interconnection or SFC (controlled by SimLiOp = 1)	STRUCT • Value: BOOL • ST: BYTE	- • 0 • 16#80
SimOn*	1 = Simulation on	BOOL	0
SimPV*	Process value used for SimOn = 1	REAL	0.0
SimPV_Li	Process value that is used for SimOnLi.Value = 1 (SimLiOp.Value = 1)	STRUCT • Value: REAL • ST: BYTE	- • 0.0 • 16#80
SimRbk*	Position feedback used for SimOn = 1	REAL	0.0
SimRbkLi	Position feedback used for SimOnLi.Value = 1 (SimLiOp.Value = 1)	STRUCT • Value: REAL • ST: BYTE	- • 0.0 • 16#80
SP_DnRaLim*	Limit (low) for the gradient of the setpoint [Unit/(Time unit)] Time unit depends on TimeFactor	REAL	100.0
SP_ExHiLim	Limit (high) for external setpoint	STRUCT • Value: REAL • ST: BYTE	- • 100.0 • 16#80
SP_ExLoLim	Limit (low) for external setpoint	STRUCT • Value: REAL • ST: BYTE	- • 0.0 • 16#80
SP_Ext*	external setpoint - (to interconnection)	STRUCT • Value: REAL • ST: BYTE	- • 0.0 • 16#80
SP_ExtLi*	1 = Select external setpoint (via interconnection)	STRUCT • Value: BOOL • ST: BYTE	- • 0 • 16#80
SP_ExtOp*	1 = Select external setpoint (via operator)	BOOL	0
SP_InHiLim	Limit (high) of internal setpoint	REAL	100.0
SP_InLoLim	Limit (low) of internal setpoint	REAL	0.0
SP_Int*	Internal setpoint for operation	REAL	0.0
SP_IntLi*	1 = Select internal setpoint (via interconnection)	STRUCT • Value: BOOL • ST: BYTE	- • 0 • 16#80
SP_IntOp*	1 = Select internal setpoint (via operator)	BOOL	0

5.7 PIDConL - Continuous PID controller (Large)

Parameter	Description	Type	Default
SP_LiDnRaLim	Linkable limit (low) for the gradient of the setpoint [Unit/(Time unit)] Time unit depends on TimeFactor	REAL	100.0
SP_LiOp	Select setpoint source (internal/external): 1 = Via interconnection 0 = Via operator	STRUCT <ul style="list-style-type: none"> Value: BOOL ST: BYTE 	- <ul style="list-style-type: none"> 0 16#80
SP_LiRmpTime	Linkable time [Time unit] for gradient limitation in ramp mode duration Time unit depends on TimeFactor	REAL	0.0
SP_LiUpRaLim	Linkable gradient limit (high) for the setpoint [Unit/(Time unit)] Time unit depends on TimeFactor	REAL	100.0
SP_RateOn*	1 = Activate limitation of setpoint gradients	BOOL	0
SP_RmpModTime	1 = Use time values (SP_RmpTime, SP_LiRmpTime) 0 = Use gradient limits (SP_DnRaLim, SP_LiDnRaLim, SP_UpRaLim, SP_LiUpRaLim)	BOOL	0
SP_RmpOn*	1 = Activate setpoint ramp to target setpoint SP_RmpTarget	BOOL	0
SP_RmpTarget*	Target setpoint for setpoint ramp	REAL	0.0
SP_RmpTime*	Time [Time unit] for setpoint ramp from current SP up to SP_RmpTarget or time [Time unit] for gradient limitation in ramp mode duration. Time unit depends on TimeFactor	REAL	0.0
SP_TrkExt	1 = Bumpless switchover from external to internal setpoint active	BOOL	1
SP_TrkPV	1 = Setpoint follows PV in "manual mode" and with tracking	BOOL	0
SP_UpRaLim*	Gradient limit (high) for the setpoint [Unit/(Time unit)] Time unit depends on TimeFactor	REAL	100.0
StepNo	Batch step number	DWORD	16#00000000
TD	Derivative time [s] TD.ST = 16#FF: Enabled in faceplate	STRUCT <ul style="list-style-type: none"> Value: REAL ST: BYTE 	- <ul style="list-style-type: none"> 0.0 16#FF
TI	Integral time [s] TI.ST = 16#FF: Enabled in faceplate	STRUCT <ul style="list-style-type: none"> Value: REAL ST: BYTE 	- <ul style="list-style-type: none"> 100.0 16#FF

Controller blocks

5.7 PIDConL - Continuous PID controller (Large)

Parameter	Description	Type	Default
TimeFactor	Time unit: 0 = Seconds 1 = Minutes 2 = Hours	INT	0
UserStatus	Freely assignable bits for use in PCS 7 OS	BYTE	16#00

* Values can be written back to these inputs during processing of the block by the block algorithm.

Output parameters

Parameter	Description	Type	Default
AdvCoAct	1 = "Program mode" enabled	STRUCT • Value: BOOL • ST: BYTE	- • 0 • 16#80
AdvCoRdy	1 = "Program mode" available	STRUCT • Value: BOOL • ST: BYTE	- • 0 • 16#80
AutAct	1 = "Automatic mode" enabled	STRUCT • Value: BOOL • ST: BYTE	- • 0 • 16#80
BypassAct	1 = Bypass is activated in this block	STRUCT • Value: BOOL • ST: BYTE	- • 0 • 16#80
CascaCut	Cascade connection: 1 = Control chain from primary to secondary controller is interrupted	STRUCT • Value: BOOL • ST: BYTE	- • 0 • 16#80
DynDeadBand	Dynamic dead band	REAL	0.0
D_Part	D component of PID algorithm	REAL	0.0
ENO	1 = Block algorithm completed without errors	BOOL	0
ER	Error signal	STRUCT • Value: REAL • ST: BYTE	- • 0.0 • 16#80
ER_A_DCOut	Effective delay time [s] for incoming alarms at the error signal monitoring	REAL	0.0
ER_AH_Act	1 = Alarm limit (high) for control deviation violated. You can change the reaction for this parameter with <code>Feature</code> bit 28 (Disabling operating points (Page 145)) and with <code>Feature</code> bit 29 (Signaling limit violation (Page 170)).	STRUCT • Value: BOOL • ST: BYTE • Bit 1: BOOL (Bypass information bit)	- • 0 • 16#80 • 0

5.7 PIDConL - Continuous PID controller (Large)

Parameter	Description	Type	Default
ER_AL_Act	1 = Alarm limit (low) for control deviation violated. You can change the reaction for this parameter with <code>Feature</code> bit 28 (Disabling operating points (Page 145)) and with <code>Feature</code> bit 29 (Signaling limit violation (Page 170)).	STRUCT <ul style="list-style-type: none"> Value: BOOL ST: BYTE Bit 1: BOOL (Bypass information bit) 	- <ul style="list-style-type: none"> 0 16#80 0
ErrorNum	Output of pending error number. For error numbers that can be output by this block, see PIDConL error handling (Page 752)	INT	-1
FFwdHiAct	1 = Limit (high) for additive disturbance variable activation violated	STRUCT <ul style="list-style-type: none"> Value: BOOL ST: BYTE 	- <ul style="list-style-type: none"> 0 16#80
FFwdLoAct	1 = Limit (low) for additive disturbance variable activation violated	STRUCT <ul style="list-style-type: none"> Value: BOOL ST: BYTE 	- <ul style="list-style-type: none"> 0 16#80
GainEff	Effective proportional gain depends on <code>NegGain</code> , <code>Gain</code> , <code>NormPV</code> , and <code>NormMV</code>	REAL	1.0
GrpErr	1 = Group error pending	STRUCT <ul style="list-style-type: none"> Value: BOOL ST: BYTE 	- <ul style="list-style-type: none"> 0 16#80
I_Part	I component of PID algorithm	REAL	0.0
LockAct	1 = Interlock is in effect	STRUCT <ul style="list-style-type: none"> Value: BOOL ST: BYTE 	- <ul style="list-style-type: none"> 0 16#80
LoopClosed	1 = Control loop closed 0 = Control loop open	STRUCT <ul style="list-style-type: none"> Value: BOOL ST: BYTE 	- <ul style="list-style-type: none"> 0 16#80
ManAct	1 = "Manual mode" enabled	STRUCT <ul style="list-style-type: none"> Value: BOOL ST: BYTE 	- <ul style="list-style-type: none"> 1 16#80
ManHiOut	Limit (high) for "manual mode", corresponds to input parameter <code>ManHiLim</code>	STRUCT <ul style="list-style-type: none"> Value: REAL ST: BYTE 	- <ul style="list-style-type: none"> 100.0 16#80
ManLoOut	Limit (low) for "manual mode", corresponds to input parameter <code>ManLoLim</code>	STRUCT <ul style="list-style-type: none"> Value: REAL ST: BYTE 	- <ul style="list-style-type: none"> 0.0 16#80
MS_Release	Release for maintenance: 1 = Release for OS operator	STRUCT <ul style="list-style-type: none"> Value: BOOL ST: BYTE 	- <ul style="list-style-type: none"> 0 16#80
MsgAckn1	Message acknowledgement status 1 (output <code>ACK_STATE</code> of first <code>ALARM_8P</code>)	WORD	16#0000

Controller blocks

5.7 PIDConL - Continuous PID controller (Large)

Parameter	Description	Type	Default
MsgAckn2	Message acknowledgement status 2 (output <code>ACK_STATE</code> of second <code>ALARM_8P</code>)	WORD	16#0000
MsgErr1	1 = Alarm error 1 (output <code>ERROR</code> of the first <code>ALARM_8P</code>)	BOOL	0
MsgErr2	1 = Alarm error 2 (output <code>ERROR</code> of the second <code>ALARM_8P</code>)	BOOL	0
MsgStat1	Message status 1 (output <code>STATUS</code> of first <code>ALARM_8P</code>)	WORD	16#0000
MsgStat2	Message status 2 (output <code>STATUS</code> of second <code>ALARM_8P</code>)	WORD	16#0000
MV	Manipulated variable	STRUCT <ul style="list-style-type: none"> • Value: REAL • ST: BYTE 	- <ul style="list-style-type: none"> • 0.0 • 16#80
MV_HiAct	1 = Limit (high) of manipulated variable violated	STRUCT <ul style="list-style-type: none"> • Value: BOOL • ST: BYTE 	- <ul style="list-style-type: none"> • 0 • 16#80
MV_LoAct	1 = Limit (low) of manipulated variable violated	STRUCT <ul style="list-style-type: none"> • Value: BOOL • ST: BYTE 	- <ul style="list-style-type: none"> • 0 • 16#80
MV_UnitOut	Unit of measure for manipulated variable, for interconnecting to the <code>MV_Unit</code> input parameter of the <code>ConPerMon</code> block	INT	0
OosAct	1 = Block is "Out of service"	STRUCT <ul style="list-style-type: none"> • Value: BOOL • ST: BYTE 	- <ul style="list-style-type: none"> • 0 • 16#80
OpSt_Out	Value of the <code>OpSt_In</code> input parameter, for feedforwarding to other blocks. Bit 31 of this parameter is used by <code>Feature</code> bit 24	DWORD	16#00000000
OS_PermOut	Display of <code>OS_Perm</code>	DWORD	16#FFFFFFFF
OS_PermLog	Display of <code>OS_Perm</code> with settings changed by the block algorithm	DWORD	16#FFFFFFFF
OS1PermOut	Display of <code>OS1Perm</code>	DWORD	16#FFFFFFFF
OS1PermLog	Display of <code>OS1Perm</code> with settings changed by the block algorithm	DWORD	16#FFFFFFFF
PhaseDeadBand	Phase for the dynamic adjustment of the dead band 0: Dead band enabled 1: Dead band disabled 2: Settling time	INT	0
P_Part	P component of PID algorithm	REAL	0.0

5.7 PIDConL - Continuous PID controller (Large)

Parameter	Description	Type	Default
PV_AH_Act	1 = PV alarm (high) active. You can change the reaction for this parameter with <code>Feature</code> bit 28 (Disabling operating points (Page 145)) and with <code>Feature</code> bit 29 (Signaling limit violation (Page 170)).	STRUCT <ul style="list-style-type: none"> Value: BOOL ST: BYTE Bit 1: BOOL (Bypass information bit) 	- <ul style="list-style-type: none"> 0 16#80 0
PV_AH_Out	PV - High alarm limit output	REAL	0.0
PV_AL_Act	1 = PV alarm (low) active. You can change the reaction for this parameter with <code>Feature</code> bit 28 (Disabling operating points (Page 145)) and with <code>Feature</code> bit 29 (Signaling limit violation (Page 170)).	STRUCT <ul style="list-style-type: none"> Value: BOOL ST: BYTE Bit 1: BOOL (Bypass information bit) 	- <ul style="list-style-type: none"> 0 16#80 0
PV_AL_Out	PV - Low alarm limit output	REAL	0.0
PV_HysOut	PV - Alarm hysteresis output	REAL	0.0
PV_Out	Output for process value	STRUCT <ul style="list-style-type: none"> Value: REAL ST: BYTE Bit 1: BOOL of internal fill byte (Bypass information bit) 	- <ul style="list-style-type: none"> 0.0 16#80 0
PV_TH_Act	1 = PV tolerance message (high) active. You can change the reaction for this parameter with <code>Feature</code> bit 28 (Disabling operating points (Page 145)) and with <code>Feature</code> bit 29 (Signaling limit violation (Page 170)).	STRUCT <ul style="list-style-type: none"> Value: BOOL ST: BYTE Bit 1: BOOL (Bypass information bit) 	- <ul style="list-style-type: none"> 0 16#80 0
PV_TH_Out	PV - High tolerance limit output	REAL	0.0
PV_TL_Act	1 = PV tolerance message (low) active. You can change the reaction for this parameter with <code>Feature</code> bit 28 (Disabling operating points (Page 145)) and with <code>Feature</code> bit 29 (Signaling limit violation (Page 170)).	STRUCT <ul style="list-style-type: none"> Value: BOOL ST: BYTE Bit 1: BOOL (Bypass information bit) 	- <ul style="list-style-type: none"> 0 16#80 0
PV_TL_Out	PV - Low tolerance limit output	REAL	0.0
PV_ToleHi	Limit (high) of 3-sigma band around the setpoint is calculated when a <code>ConPerMon</code> block is connected	STRUCT <ul style="list-style-type: none"> Value: REAL ST: BYTE 	- <ul style="list-style-type: none"> 0.0 16#80
PV_ToleLo	Limit (low) of 3-sigma band around the setpoint is calculated when a <code>ConPerMon</code> block is connected	STRUCT <ul style="list-style-type: none"> Value: REAL ST: BYTE 	- <ul style="list-style-type: none"> 0.0 16#80

5.7 PIDConL - Continuous PID controller (Large)

Parameter	Description	Type	Default
PV_WH_Act	1 = PV warning (high) active. You can change the reaction for this parameter with Feature bit 28 (Disabling operating points (Page 145)) and with Feature bit 29 (Signaling limit violation (Page 170)).	STRUCT <ul style="list-style-type: none"> Value: BOOL ST: BYTE Bit 1: BOOL (Bypass information bit) 	- <ul style="list-style-type: none"> 0 16#80 0
PV_WH_Out	PV - High warning limit output	REAL	0.0
PV_WL_Act	1 = PV warning (low) active. You can change the reaction for this parameter with Feature bit 28 (Disabling operating points (Page 145)) and with Feature bit 29 (Signaling limit violation (Page 170)).	STRUCT <ul style="list-style-type: none"> Value: BOOL ST: BYTE Bit 1: BOOL (Bypass information bit) 	- <ul style="list-style-type: none"> 0 16#80 0
PV_WL_Out	PV - Low warning limit output	REAL	0.0
PV_UnitOut	Unit of measure for process value, for interconnecting to the PV_Unit input parameter of the ConPerMon block	INT	0
RbkOut	Output for position feedback	STRUCT <ul style="list-style-type: none"> Value: REAL ST: BYTE 	- <ul style="list-style-type: none"> 0.0 16#80
RbkWH_Act	1 = Warning (high) for position feedback active. You can change the reaction for this parameter with Feature bit 28 (Disabling operating points (Page 145)) and with Feature bit 29 (Signaling limit violation (Page 170)).	STRUCT <ul style="list-style-type: none"> Value: BOOL ST: BYTE 	- <ul style="list-style-type: none"> 0 16#80
RbkWL_Act	1 = Warning (low) for position feedback active. You can change the reaction for this parameter with Feature bit 28 (Disabling operating points (Page 145)) and with Feature bit 29 (Signaling limit violation (Page 170)).	STRUCT <ul style="list-style-type: none"> Value: BOOL ST: BYTE 	- <ul style="list-style-type: none"> 0 16#80
RdyToStart	1 = Active start readiness	STRUCT <ul style="list-style-type: none"> Value: BOOL ST: BYTE 	- <ul style="list-style-type: none"> 0 16#80
SettlingTimer	Settling time for a closed control loop	REAL	0.0
SP	Setpoint used by controller	STRUCT <ul style="list-style-type: none"> Value: REAL ST: BYTE 	- <ul style="list-style-type: none"> 0.0 16#80
SP_DnRaAct	1 = Negative gradient limiting of setpoint is active	STRUCT <ul style="list-style-type: none"> Value: BOOL ST: BYTE 	- <ul style="list-style-type: none"> 0 16#80

Parameter	Description	Type	Default
SP_ExHiAct	1 = Limit (high) for external setpoint has been reached	STRUCT • Value: BOOL • ST: BYTE	- • 0 • 16#80
SP_ExLoAct	1 = Limit (low) for external setpoint has been reached	STRUCT • Value: BOOL • ST: BYTE	- • 0 • 16#80
SP_ExtAct	1 = External setpoint is active 0 = Internal setpoint is active	STRUCT • Value: BOOL • ST: BYTE	- • 0 • 16#80
SP_ExtOut	External setpoint, corresponds to input parameter SP_Ext	STRUCT • Value: REAL • ST: BYTE	- • 0.0 • 16#80
SP_InHiOut	Limit (high) for SP_Int corresponds to input parameter SP_InHiLim	STRUCT • Value: REAL • ST: BYTE	- • 100.0 • 16#80
SP_InLoOut	Limit (low) for SP_Int corresponds to input parameter SP_InLoLim	STRUCT • Value: REAL • ST: BYTE	- • 0.0 • 16#80
SP_RateTarget	Target setpoint for the gradient limitation	REAL	0.0
SP_UpRaAct	1 = Positive gradient limiting of setpoint is active	STRUCT • Value: BOOL • ST: BYTE	- • 0 • 16#80
SP_RemRT	Remaining ramp time of the setpoint	REAL	0.0
ST_Worst	Worst signal status	BYTE	16#80
Status1	Status word 1 (Page 735)	DWORD	16#00000000
Status2	Status word 2 (Page 735)	DWORD	16#00000000
Status3	Status word 2 (Page 735)	DWORD	16#00000000
SumMsgAct	1 = Active hardware interrupt	STRUCT • Value: BOOL • ST: BYTE	- • 0 • 16#80

Calculation of the output parameter ER_A_DCOut

ER_A_DC is assigned by default to the output before a setpoint change.

$$ER_A_DCOut = ER_A_DC$$

In the case of a setpoint change in the positive direction during automatic mode, the output is calculated as follows:

$$ER_A_DCOut = \text{Maximum}(ER_A_DC, ER_AH_DFac * \text{Setpoint difference})$$

5.7 PIDConL - Continuous PID controller (Large)

In the case of a setpoint change in the negative direction during automatic mode, the output is calculated as follows:

$$ER_A_DCOut = \text{Maximum} (ER_A_DC, -1 * ER_AH_DFac * \text{Setpoint difference})$$

When the control circuit has stabilized again, meaning

$$(ER_AL_Lim + ER_Hyst) \leq ER \leq (ER_AH_Lim - ER_Hyst)$$

and the delay time for outgoing alarms ER_A_DG has expired, the output is reset again to ER_A_DC: ER_A_DCOut = ER_A_DC

Activating and deactivating the function:

The function is deactivated (default) when the following applies: ER_AH_DFac = 0.0 and ER_AL_DFac = 0.0

See also

PIDConL messaging (Page 753)

PIDConL block diagram (Page 773)

PIDConL modes (Page 740)

5.7.7 PIDConL block diagram

PIDConL block diagram

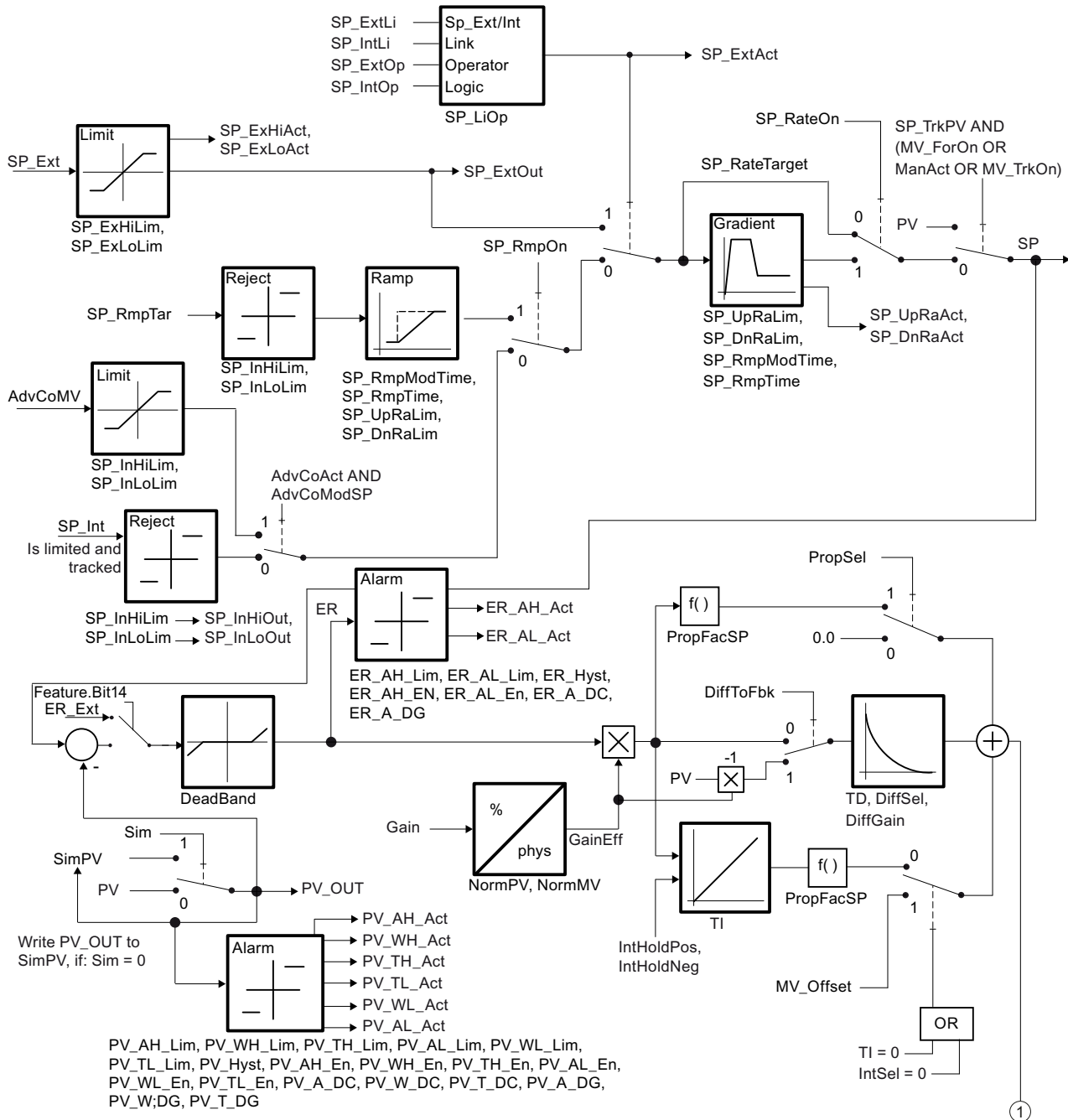

5.7 PIDConL - Continuous PID controller (Large)

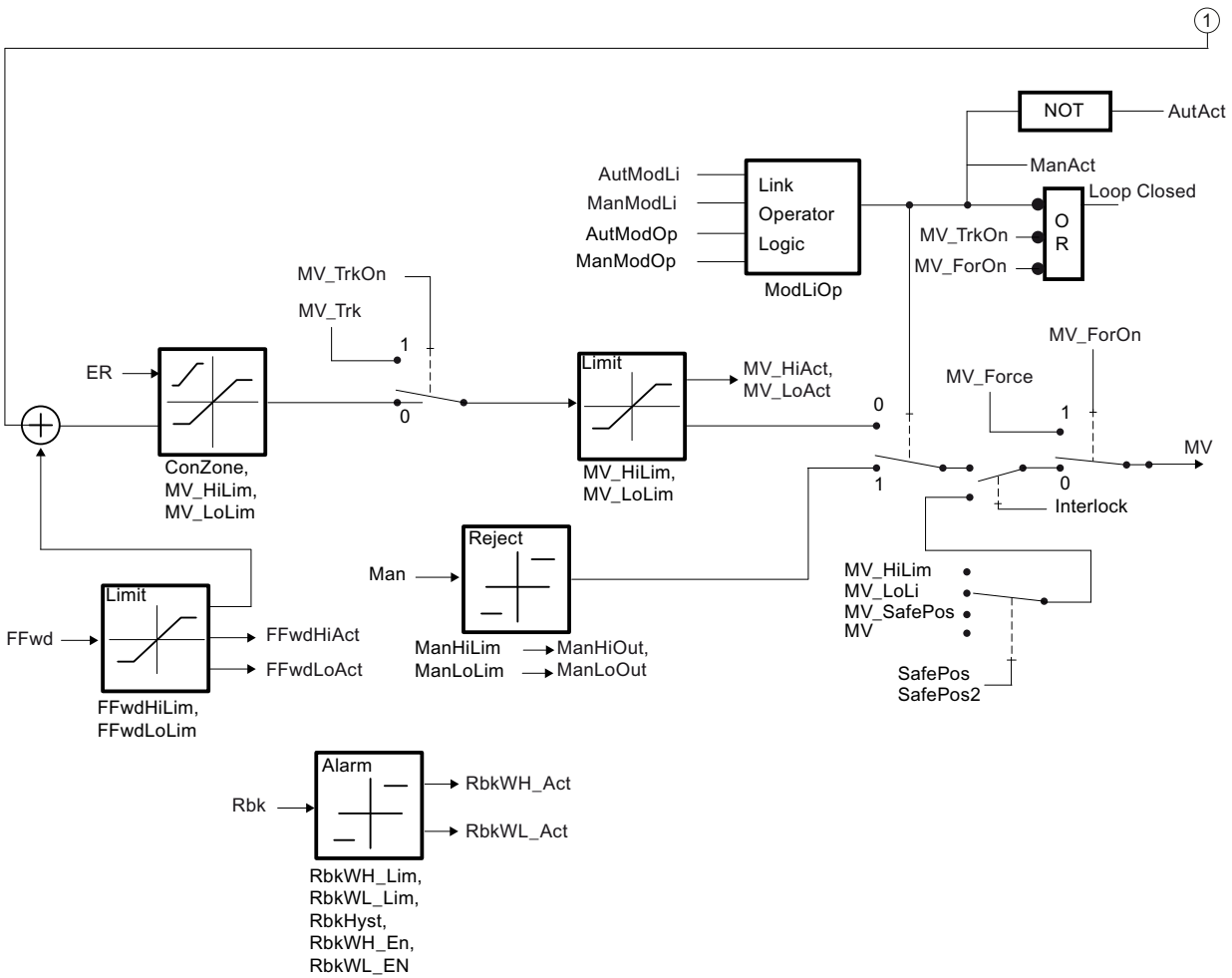

See also

- PIDConL I/Os (Page 756)
- PIDConL messaging (Page 753)
- PIDConL error handling (Page 752)
- PIDConL functions (Page 741)
- PIDConL modes (Page 740)
- Description of PIDConL (Page 735)

5.7.8 Operator control and monitoring

5.7.8.1 PIDConL views

Views of the PIDConL block

The block PIDConL provides the following views:

- PIDConL, PIDConS and PIDConR standard views (Page 776)
- Alarm view (Page 302)
- Limit view of PID controllers (Page 291)
- Trend view (Page 305)
- Ramp view (Page 300)
- Parameter view of PID controllers (Page 281)
- PIDConL, PIDConS and PIDConR previews (Page 781)
- Memo view (Page 304)
- Batch view (Page 302)
- Block icons for PID and FM controller (Page 239)

Refer to the Structure of the faceplate (Page 248) and Block icon structure (Page 230) sections for general information about the faceplate and block icon.

5.7.8.2 PIDConL, PIDConS and PIDConR standard views

PIDConL standard view

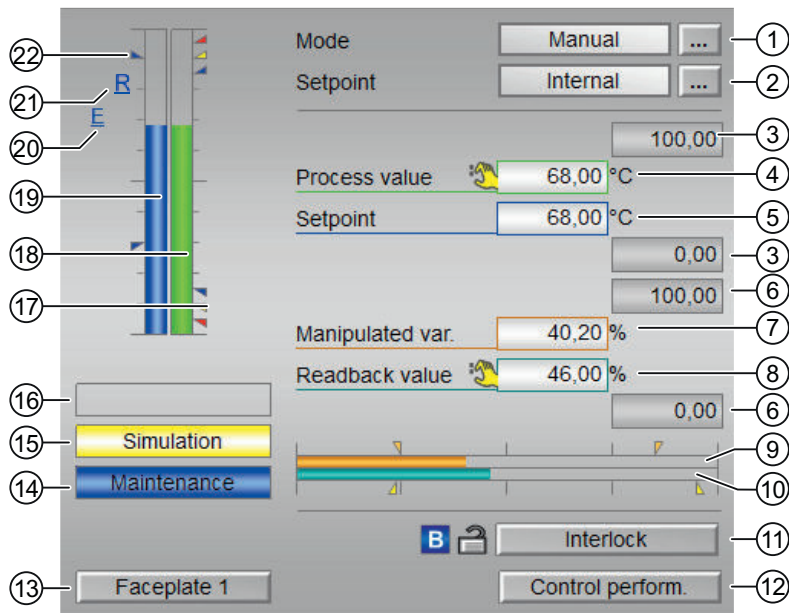

(1) Displaying and switching the operating mode

This area provides information on the currently valid operating mode. The following operating modes can be shown here:

- Manual mode (Page 72)
- Automatic mode (Page 72)
- Program mode for controllers (Page 78) (not with PIDConS)
- Out of service (Page 71)

Refer to section Switching operating states and operating modes (Page 257) for information on switching the operating mode.

(2) Displaying and switching the setpoint

This area shows how to specify the setpoint. The setpoint can be specified as follows:

- By the application ("External", CFC/SFC)
- By the user directly in the faceplate ("Internal").

Refer to the Switching operating states and operating modes (Page 257) section for information on switching the setpoint specification.

You can find additional information on this in the section Setpoint specification - internal/external (Page 128).

Note

With the PIDConR block, this area is only visible if you have set the `Feature Bit Switching` operator controls for external setpoint to visible (Page 144) to 1.

(3) High and low scale range for the process value

These values provide information on the display range for the bar graph of the process value. The scale range is defined in the engineering system.

(4) Display of the process value including signal status

This area shows the current process value with the corresponding signal status.

(5) Displaying and changing the setpoint including signal status

This area shows the current setpoint with the corresponding signal status.

Refer to the Changing values (Page 259) section for information on changing the setpoint. The setpoint specification also needs to be set to "Internal" for this block.

(6) High and low scale range for the setpoint

This area is already set and cannot be changed.

(7) Displaying and changing the manipulated variable including signal status

This area shows the current manipulated variable with the corresponding signal status.

Refer to the Changing values (Page 259) section for information on changing the manipulated variable. You can only make a change in manual mode.

(8) Display of the position feedback including signal status

This display is only visible when the corresponding block input is connected.

This area shows the current feedback of the manipulated variable with the corresponding signal status.

(9) Bar graph for the manipulated variable

This area shows the current manipulated variable in the form of a bar graph. The visible area in the bar graph depends on the configuration in the engineering system (ES).

(10) Bar graph for position feedback

This display is only visible when the corresponding block input is connected.

This area shows the current position feedback in the form of a bar graph. The visible area in the bar graph depends on the configuration in the engineering system (ES).

(10) Bar graph for position feedback

This display is only visible when the corresponding block input is connected.

This area shows the current position feedback in the form of a bar graph. The visible area in the bar graph depends on the configuration in the engineering system (ES).

(11) Operator control and display area for interlock functions of the block (not with PIDConS)

This display is only visible when the corresponding block input is connected.

You can use this button to control the interlock functions of the block. You can find additional information on this in the section Interlocking functions (Page 99).

The following is displayed in addition to the buttons:

- Interlock status (see Forming the group status for interlock information (Page 104)), e.g.:



- Signal status (see Forming and outputting the signal status for technologic blocks (Page 109)), e.g.:



- Bypass information (see Forming the group status for interlock information (Page 104)):



(12) Navigation button for the standard view of the ConPerMon block

Use this navigation button to open the standard view of the ConPerMon block. The visibility of this navigation button depends on the configuration in the engineering system (ES).

See also the section Opening additional faceplates (Page 208) for more on this.

(13) Navigation button for switching to the standard view of any faceplate

Use this navigation button to open the standard view of a block configured in the engineering system (ES). The visibility of this navigation button depends on the configuration in the engineering system (ES).

See also the section Opening additional faceplates (Page 208) for more on this.

(14) Display area for block states

This area provides additional information on the operating state of the block:

- "Maintenance"

Additional information on this is available in section Release for maintenance (Page 64) Display area for block states.

(15) Display area for block states

This area provides additional information on the operating state of the block:

- "Simulation"

You can find additional information on this in the section Simulating signals (Page 58).

(16) Display area for block states

This area provides additional information on the operating state of the block (from high to low according to priority):

- "Optimizing"
- "Tracking"
- "Forced tracking"
- "Load SP"
- "SP ramp active"

(17) Limit display

These colored triangles indicate the configured limits in the respective bar graph:

- Red: Alarm
- Yellow: Warning
- Blue: Tolerance

(18) Bar graph for the process value

This area shows the current process value in the form of a bar graph. The visible area in the bar graph depends on the configuration in the engineering system (ES).

(19) Bar graph for the setpoint

This area shows the current setpoint in the form of a bar graph. The visible area in the bar graph depends on the configuration in the engineering system (ES).

(20) Display of external setpoint

This display [E] is only visible when you have selected "Internal" setpoint specification. It shows the external setpoint that would apply if you were to change the setpoint specification to "external".

(21) Display for the target setpoint of the setpoint ramp

This display [R] shows the target setpoint and is only visible if you have enabled ramp generation in the Ramp view (Page 300).

(22) Limit display for the setpoint

These triangles show the `SP_HiLim` and `SP_LoLim` setpoint limits configured in the engineering system (ES).

5.7.8.3 PIDConL, PIDConS and PIDConR previews

Preview of PIDConL

The preview shows you the parameters that you, as an OS operator, can control. You cannot control anything in this view, however.

The screenshot displays the PIDConL preview interface with the following elements:

- Process value:** 60.00 °C (labeled 4)
- Bypass value:** 24.00 °C (labeled 6)
- SP external:** 0.00 °C
- SP internal:** 0.00 °C
- Rem. time SP ramp:** 0. s
- Control deviation:** -60.00 °C
- Program value:** 0.00 °C (labeled 1)
- Disturbance:** 0.00 %
- Track MV:** 0
- Tracking value:** 0.00 %
- Channel MV:** 0. %
- Enabled operations:**
 - SP external (checked)
 - SP internal (checked)
 - SP Change (checked)
 - Change MV (checked)
 - Program mode (checked)
 - Automatic (checked)
 - Manual (checked)
 - Out of service (checked)
 - Local oper. permission (checked) (labeled 2)
- Inputs and outputs:**
 - Interlock: 1 (labeled 3)
 - Bypass protection: 0 (labeled 5)
 - Faceplate 2 (labeled 3)

(1) Preview area

This area shows you a preview for the following values:

- "SP external": currently applicable external setpoint
 - With the PIDConR block, this area is only visible if you have set the `Feature Bit Switching operator controls for external setpoint` to visible (Page 144) to 1
- "SP internal": currently applicable internal setpoint
- "Rem. time SP ramp" : Remaining time to reach the ramp target value (not with PIDConS).
- "Error signal": Current control deviation
- "Program value": Default value for program mode (not with PIDConS)
- "Disturbance variable": Additive value for feedforward control (not with PIDConS)

- "Track MV": Track manipulated variable (value is 1)
- "Tracking value": effective manipulated variable for "Track manipulated variable"
- "Channel MV": Display of the manipulated variable by the output channel block

(2) Enable operations

This area shows all operations for which special operator permissions are assigned. They depend on the configuration in the engineering system (ES) that applies to this block.

Icons for enabled operation:

- **Green check mark:** the OS operator can control this parameter
- **Gray check mark:** the OS operator cannot control this parameter at this time due to the process
- **Red cross:** The OS operator cannot control this parameter due to the configured AS operator permissions (`OS_Perm` or `OS1Perm`).

The following enabled operations are shown here:

- "SP external": You can feedforward the external setpoint.
- "SP internal": You can feedforward the internal setpoint.
- "Change SP": You can change the setpoint.
- "Change MV": You can change the manipulated variable.
- "Program mode": You can switch to "program mode". (not with PIDConS)
- "Automatic": You can switch to "automatic mode".
- "Manual": You can switch to "manual mode".
- "Out of service": You can switch to "Out of service" operating mode.
- "Local operator permission": Use the ← button to switch to the standard view of the OpStations block. You can find additional information on this in the section Operator control permissions (Page 254).

(3) Navigation button for switching to the standard view of any faceplate

Use this navigation button to open the standard view of a block configured in the engineering system. The visibility of this navigation button depends on the configuration in the engineering system (ES).

See also the section Opening additional faceplates (Page 208) for more on this.

(4) Process value

This area displays the real process value (PV).

(5) Inputs and outputs

This area shows the following parameters:

- "Interlock" (not with PIDConS):
This display is only visible when the corresponding block input is connected.
 - 0 = Interlocking without reset is active; you can operate the block without reset once the interlocking condition has disappeared
 - 1 = "Good" state
- "Interlock deact." (not with PIDConS):
 - 0 = Bypass disabled
 - 1 = Bypassing interlock in "local mode" and in "simulation"

(6) Bypass value

This area displays the bypass value (BYP_{PV}).

5.8 PIDConS - Continuous PID controller (Small)

5.8.1 Description of PIDConS

Object name (type + number) and family

Type and number: FB 1830

Family: Control

Area of application for PIDConS

The block is used for the following applications:

- Fixed setpoint control

How it works

The block is a PID controller with continuous output signal (manipulated variable). It is used to activate a final controlling element with continuous action input.

The block functions following the PID algorithm with a delayed D component and an integrator with double precision.

The block is suitable for controlling sluggish control loops, for example, for temperatures and filling levels, and high-speed control loops, for example, for flow rates and speed. For a given CPU, a compromise has to be made between the number of controllers and the frequency with which the individual controllers have to be processed. The faster the modulated control loops are, i.e. the more frequently the manipulated variables have to be calculated per time unit, the lower the number of controllers that can be installed.

Configuration

Use the CFC editor to install the block in a cyclic interrupt OB (OB30 to OB38). The block is also installed automatically in the startup OB (OB100).

For the control loop monitoring to work as planned in the trend view of the controller faceplates, the

```
S7_xarchive:='Value, shortterm;'
```

attributes in the process tag types for control loops at the controller function block must be set for the following tags:

- Input parameters:
 - CPI_In
- Output parameters
 - MV
 - MV_HiAct
 - MV_LoAct
 - LoopClosed
 - SP
 - PV_Out
 - PV_ToleHi
 - PV_ToleLo

There are no templates for the PIDConS block for process tag types or simulated use cases in the example project (APL_Example_xx, xx represents the language variant). However, you can replace PIDConL with PIDConS in the following process tag types and use cases.

Examples of process tag types:

- PID controller with safety logic and control loop monitoring (PIDConL_ConPerMon) (Page 2324)

Application cases in example project:

- Process simulation including noise generator (ProcSimC; ProcSimS) (Page 2373)
- Control loop monitoring for simulation with colored noise (ConPerMonSim) (Page 2377)
- Operating point-oriented adaptation of parameters (gain scheduling) for non-linear processes (GainSchedSim) (Page 2378)
- Filtering of noisy measured values in a control loop (SigSmoothSim) (Page 2380)

Startup characteristics

Use the Feature bit Set startup characteristics (Page 138) to define the startup characteristics of this block.

The messages are suppressed after startup for the number of cycles set at `RunUpCyc`.

Status word allocation for `Status1` parameter

You can find a description for each parameter in section PIDConS I/Os (Page 797).

Status bit	Parameter
0	Occupied
1	BatchEn
2	SimOn

5.8 PIDConS - Continuous PID controller (Small)

Status bit	Parameter
3	OosAct.Value
4	OosLi.Value
5	AutAct.Value
6	Not used
7	ManAct.Value
8	SP_ExtAct.Value
9	1 = Input parameter MV_ChnST is interconnected
10	MV_TrkOn.Value AND NOT (ManAct.Value OR OosAct.Value)
11	MV.Value > MV_LoLim.Value
12 - 17	Not used
18	SimOn AND ManAct
19	Not used
20	1 = Input parameter Rbk is not interconnected (Rbk.ST = 16#FF)
21-22	Not used
23	OptimEn
24	OptimOcc
25 - 31	Not used

Status word allocation for status2 parameter

Status bit	Parameter
0	MsgLock
1	PV_AH_Act.Value
2	PV_WH_Act.Value
3-4	Not used
5	PV_WL_Act.Value
6	PV_AL_Act.Value
7	PV_AH_En
8	PV_WH_En
9-10	Not used
11	PV_WL_En
12	PV_AL_En
13	PV_AH_MsgEn
14	PV_WH_MsgEn
15-16	Not used
17	PV_WL_MsgEn
18	PV_AL_MsgEn
19	Delay of the PV_AH_Lim message
20	Delay of the PV_WH_Lim message
21	Delay of the PV_WL_Lim message
22	Delay of the PV_AL_Lim message
23	Collection of message delays

Status bit	Parameter
24-28	Not used
29	GrpErr.Value
30	RdyToStart.Value
31	MS_RelOp

See also

PIDConS modes (Page 787)

PIDConS functions (Page 788)

PIDConS error handling (Page 794)

PIDConS messaging (Page 795)

PIDConS block diagram (Page 804)

5.8.2 PIDConS modes**PIDConS operating modes**

The block can be operated using the following modes:

- Automatic mode (Page 72)
- Manual mode (Page 72)
- Out of service (Page 71)

The next section provides additional block-specific information relating to the general descriptions.

"Automatic mode"

You can find general information on "Automatic mode", switching modes and bumpless switchover in the Manual and automatic mode for control blocks (Page 72) chapter.

"Manual mode"

You can find general information on "Manual mode", switching modes and bumpless switchover in the Manual and automatic mode for control blocks (Page 72) chapter.

"Out of service"

You can find general information about the "Out of service" mode in the Out of service (Page 71) chapter.

See also

- Program mode for controllers (Page 78)
- PIDConS block diagram (Page 804)
- Description of PIDConS (Page 784)
- PIDConS functions (Page 788)
- PIDConS error handling (Page 794)
- PIDConS messaging (Page 795)
- PIDConS I/Os (Page 797)

5.8.3 PIDConS functions

Functions of PIDConS

The functions for this block are listed below.

Generation of manipulated variables

The manipulated variable *MV* can be generated as follows:

ManAct	MV_TrkOn	AdvCoAct AND NOT AdvCo- ModSP	MV =	Limit monitoring	State
1	-	-	Man	MV_HiLim MV_LoLim	Manual mode, set by the operator
0	1	-	MV_Trk	MV_HiLim MV_LoLim	Tracking with limitation
0	0	0	P_Part + I_Part + D_Part	MV_HiLim MV_LoLim	Automatic mode (PID algorithm)

If the controller is in "out of service" mode, the output parameter *MV* is set to the last valid value in manual mode or the neutral position manipulated variable depending on the *Feature Bit* (Neutral position manipulated variable takes effect at startup (Page 166)). Refer to the Out of service (Page 71) section for more on this.

Tracking and limiting a manipulated variable

The block provides the standard function Tracking and limiting a manipulated variable (Page 196).

Neutral position

The block provides the standard function Neutral position for motors, valves and controllers (Page 48).

Group error

This block provides the standard function Outputting group errors (Page 122).

The following parameters are taken into consideration when forming the group error:

- CSF

Outputting a signal for start readiness

This block provides the standard function Outputting a signal for start readiness (Page 53).

"Actuator active" information

If the manipulated variable *MV* is greater than the minimum manual limit *MV_LoLim.Value*, this is recognized as actuator active. This status can be used to indicate a customized symbol in the process image, for example, and is saved in the status word (see Status word section in Description of PIDConS (Page 784)).

External/internal setpoint specification

The block provides the standard function Setpoint specification - internal/external (Page 128).

Setpoint limitation

With this function, you can limit the setpoint to a range by means of the parameters *SP_HiLim* (high limit) and *SP_LoLim* (low limit). If the setpoint lies outside the range defined by you, it is limited to the valid range.

If the setpoint is at or above the limit *SP_HiLim*, this is displayed at the output *SP_HiAct* = 1.

If the setpoint is at or below the limit *SP_LoLim*, this is displayed at the output *SP_LoAct* = 1

Tracking setpoint in manual mode

The block provides the standard function Tracking setpoint in manual mode (Page 196).

Simulating signals

The block provides the standard function Simulating signals (Page 58).

You can simulate the following values:

- Process value (*SimPV*)

Limit monitoring of the process value

The block provides the standard function Limit monitoring of the process value (Page 86).

Error signal generation and dead band

The block provides the standard function Error signal generation and dead band (Page 192).

Selecting a unit of measure

The block provides the standard function Selecting a unit of measure (Page 212).

PID algorithm

The manipulated variable is generated in automatic mode according to the following algorithm:

$$MV = GainEff \cdot (1 + (1 / (TI \cdot s) + (TD \cdot s) / (1 + TD / DiffGain \cdot s)) \cdot ER$$

Where:

s = Complex number

The following step response occurs:

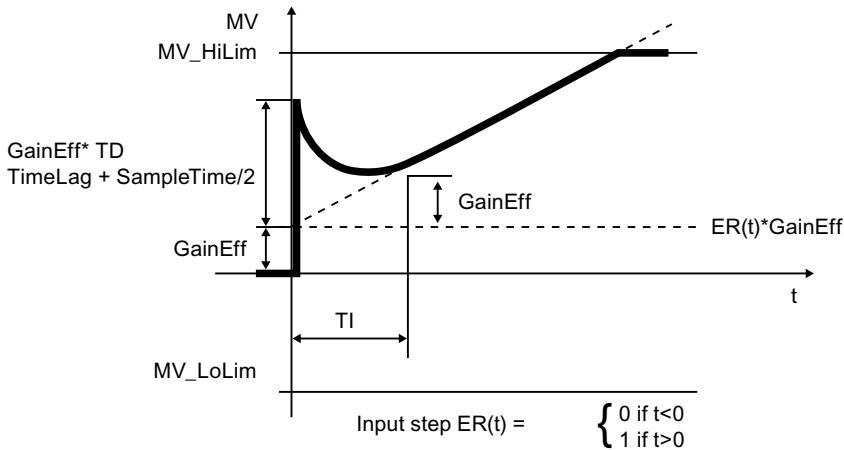

Note

The formula describes a standard application where P, I and D components are activated and the P and D components are not in the feedback circuit (PropSel = 1, TI <> 0, DiffToFbk = 0 and PropFacSP = 1).

The D component delay is derived from TD / DiffGain.

- The P component is displayed at the P_Part I/O and can be deactivated using PropSel = 0 .
- The I component is displayed at the I_Part I/O and can be deactivated using TI = 0 .
- The D component is displayed at the D_Part I/O and can be deactivated using TD = 0 .

Anti-windup

The controller has an anti-windup function. The I component is frozen after the manipulated variable has reached limits (`MV_HiLim` or `MV_LoLim`).

Forming the signal status for blocks

The block provides the standard function Forming and outputting the signal status for technologic blocks (Page 109).

- Signal status for the process value `PV_Out`:
The signal status of the output parameter `PV_Out` always corresponds to the signal status of input parameter `PV` or, if the block is in simulation mode, `16#60`.
- Signal status for the setpoint value `SP`:
The signal status of the `SP` output parameter is always equivalent to the signal status of the input parameter `SP_Ext` or `SP_Int`, depending on how the setpoint is specified. If the internal setpoint `SP_Int` is used, the signal status is always outputted as `16#80`.
- Signal status of the error signal `ER`:
The signal status of output parameter `ER` is obtained from the worst signal status of the two output parameters `PV_Out` and `SP`, and is outputted.
The signal status `16#60` (external simulation) is suppressed because the block acts as a sink with external simulation.
- Signal status for the manipulated variable `MV`:
The signal status of output parameter `MV` is formed in "Automatic mode" from the error signal `ER` and output. In "manual mode", the signal status is output as good. The signal status `16#60` (external simulation) is suppressed because the block acts as a sink with external simulation. In "manual mode", the signal status is output as good.
- Worst signal status:
The worst signal status `ST_Worst` for the block is formed from `SP`, `PV_Out`, `MV_ChnST` and `Rbk`.

Configurable reactions using the `Feature` parameter

You can find an overview of all reactions provided by the `Feature` parameter in the Configurable functions using the Feature I/O (Page 131). The following functionality is available for this block at the relevant bits:

Bit	Function
0	Set startup characteristics (Page 138)
1	Reaction to the out of service mode (Page 177)
2	Resetting the commands for changing the mode (Page 161)
4 - 14	Not used.
15	Neutral position manipulated variable takes effect with "out of service" operating mode (Page 166)
16	Neutral position manipulated variable takes effect at startup (Page 166)
17 - 22	Not used.
23	SP following PV in open loop has no priority over <code>SP_Ext</code> and SP limits (Page 179)
24	Enabling local operator authorization (Page 158)

Bit	Function
25	Suppression of all messages (Page 174)
26	Reaction of the switching points in the "Out of service" operating mode (Page 176)
27 - 31	Not used.

Operator permissions

The block provides the standard function Operator control permissions (Page 254).

The block has the following permissions for the `OS_Perm` parameter:

Bit	Function
0	1 = Operator can switch to "automatic mode" <code>AutModOp</code>
1	1 = Operator can switch to "manual mode" <code>ManModOp</code>
2	1 = Operator can switch to "Out of service" mode <code>OosOp</code>
3	1 = Operator can switch the setpoint to "external" <code>SP_ExtOp</code>
4	1 = Operator can switch the setpoint to "internal" <code>SP_IntOp</code>
5	1 = Operator can change the internal setpoint <code>SP_Int</code>
6	1 = Operator can change the manual parameter <code>Man</code>
7	1 = Operator can change the high operation limit of the setpoint <code>SP_HiLim</code>
8	1 = Operator can change the low operation limit of the setpoint <code>SP_LoLim</code>
9	1 = Operator can change the operation high limit of the manipulated variable <code>ManHiLim</code>
10	1 = Operator can change the operation low limit of the manipulated variable <code>ManLoLim</code>
11	1 = Operator can permit the PID optimization function <code>OptimEn</code>
12	1 = Operator can enable the track setpoint in "manual mode" function <code>SP_TrkPV</code>
13	1 = Operator can enable the bumpless switchover from external to internal <code>SP_TrkExt</code>
14	1 = Operator can change the gain parameter <code>Gain</code>
15	1 = Operator can change the integral time parameter <code>TI</code>
16	1 = Operator can change the derivative time parameter <code>TD</code>
17	1 = Operator can change the derivative gain parameter <code>DiffGain</code>
18	1 = Operator can change the dead band parameter <code>DeadBand</code>
19	1 = Operator can change the limit (process value) <code>PV_AH_Lim</code> for the high alarm
20	1 = Operator can change the limit (process value) <code>PV_WH_Lim</code> for the high warning
21	1 = Operator can change the hysteresis (process value) <code>PV_Hyst</code>
22	1 = Operator can change the limit (process value) <code>PV_WL_Lim</code> for the low warning
23	1 = Operator can change the limit (process value) <code>PV_AL_Lim</code> for the low alarm
24	1 = Operator can activate the Simulation function <code>SimOn</code>
25	1 = Operator can activate the Release for maintenance function <code>MS_RelOp</code>
26	1 = Operator can change the simulation value <code>SimPV</code>
27	1 = Operator can activate / deactivate messages via <code>PV_AH_MsgEn</code>
28	1 = Operator can activate / deactivate messages via <code>PV_WH_MsgEn</code>
29	1 = Operator can activate / deactivate messages via <code>PV_WL_MsgEn</code>
30	1 = Operator can activate / deactivate messages via <code>PV_AL_MsgEn</code>
31	Not used

Note

If you interconnect a parameter that is also listed in `OS_Perm` as a parameter, you have to reset the corresponding `OS_Perm` bit.

Release for maintenance

The block provides the standard function Release for maintenance (Page 64)

Generating instance-specific messages

The block provides the standard function Generating instance-specific messages (Page 204) without the time stamp function in the I/O.

Suppressing messages using the `MsgLock` parameter

This block provides the standard function Suppressing messages using the `MsgLock` parameter (Page 205).

Specifying the display area for process and setpoint values as well as operations

This block provides the standard function Display and operator input area for process values and setpoints (Page 207).

Opening additional faceplates

This block provides the standard function Opening additional faceplates (Page 208).

SIMATIC BATCH functionality

This block provides the standard function SIMATIC BATCH functionality (Page 67).

See also

Labeling of buttons and text (Page 209)

EventTs functions (Page 1660)

PIDConS modes (Page 787)

PIDConS error handling (Page 794)

PIDConS messaging (Page 795)

PIDConS I/Os (Page 797)

PIDConS block diagram (Page 804)

5.8.4 PIDConS error handling

Error handling of PIDConS

Refer to section Error handling (Page 119) in the basic instructions for the error handling of all blocks.

The following errors can be displayed for this block:

- Error numbers
- Control system fault (CSF)

Overview of error numbers

The `ErrorNum` output parameter can be used to output the following error numbers:

Error number	Meaning of the error number
-1	Predefined value when inserting the block; the block is not executed
0	There is no error.
30	The value of <code>PV</code> can no longer be displayed in the REAL number field.
31	The value of <code>SP_Ext</code> can no longer be displayed in the REAL number field.
33	The value of <code>MV_Trk</code> can no longer be displayed in the REAL number field.
35	The value of <code>Rbk</code> can no longer be displayed in the REAL number field.
36	The value of <code>MV</code> can no longer be displayed in the REAL number field.
51	<code>AutModLi = 1 and ManModLi = 1</code> <code>SP_LiOp = 1 and SP_IntLi = 1 and SP_ExtLi = 1</code>
60	$ TI < SampleTime / 2$
61	$ TD < SampleTime$
62	$DiffGain < 1$ or $DiffGain > 10$
63	$TD / DiffGain < SampleTime / 2$

Control system fault (CSF)

An external signal can be activated via the CSF input. A control system fault is triggered if this signal changes to 1. Refer to the section Error handling (Page 119).

See also

Description of PIDConS (Page 784)

PIDConS modes (Page 787)

PIDConS functions (Page 788)

PIDConS messaging (Page 795)

PIDConS I/Os (Page 797)

PIDConS block diagram (Page 804)

5.8.5 PIDConS messaging

Messaging

The following messages can be generated for this block:

- Process control fault
- Process messages
- Instance-specific messages

Process control fault

The following control system fault messages can be output:

Message instance	Message identifier	Message class	Event
MsgEvId1	SIG 5	AS process control message - fault	\$\$BlockComment\$\$ External error has occurred

Explanation:

\$\$BlockComment\$\$: Content of the instance-specific comment

You can interconnect an external fault (signal) to input parameter `CSF`. If it changes to `CSF = 1`, a process control fault is triggered (`MsgEvId1`, SIG 5).

Process messages

Message instance	Message identifier	Message class	Event
MsgEvId1	SIG 1	Alarm - high	\$\$BlockComment\$\$ PV - high alarm limit violated
	SIG 2	Warning - high	\$\$BlockComment\$\$ PV - high warning limit violated
	SIG 3	Warning - low	\$\$BlockComment\$\$ PV - low warning limit violated
	SIG 4	Alarm - low	\$\$BlockComment\$\$ PV - low alarm limit violated

Explanation:

\$\$BlockComment\$\$: Content of the instance-specific comment

Instance-specific messages

You have the option of using one or two instance-specific messages for this block.

Message instance	Message identifier	Message class	Event
MsgEvId1	SIG 6	AS process control message - fault	\$\$BlockComment\$\$ External message 1 Status 16#@8%x@
	SIG 7	AS process control message - fault	\$\$BlockComment\$\$ External message 2 Status 16#@9%x@

Explanation:

\$\$BlockComment\$\$: Content of the instance-specific comment

Associated values for message instance `MsgEvId1`

Associated value	Block parameters
1	BatchName
2	StepNo
3	BatchID
4	Process value PV_Out
5	Control deviation ER
6	Signal status ExtMsg1
7	Signal status ExtMsg2
8	ExtVa108
9	ExtVa109
10	Not allocated

The associated values 8 ... 9 are allocated to the parameters ExtVa108 ... ExtVa109 and can be used. Additional information is available in the "Process Control System PCS 7 - Engineering System" manual.

See also

- Description of PIDConS (Page 784)
- PIDConS modes (Page 787)
- PIDConS functions (Page 788)
- PIDConS error handling (Page 794)
- PIDConS I/Os (Page 797)
- PIDConS block diagram (Page 804)

5.8.6 PIDConS I/Os

I/Os of PIDConS

Input parameters

Parameter	Description	Type	Default
AutModLi*	1 = "Automatic mode" via interconnection or SFC (controlled by ModLiOp = 1)	STRUCT <ul style="list-style-type: none"> Value: BOOL ST: BYTE 	- <ul style="list-style-type: none"> 0 16#80
AutModOp*	1 = "Automatic mode" via operator (controlled by ModLiOp = 0)	BOOL	0
BatchEn	1 = Enable allocation for batch control	BOOL	0
BatchID	Batch ID	DWORD	16#00000000
BatchName	Batch name	S7-String	
CPI_In	Input for control performance index, which is calculated by the assigned ConPerMon block	STRUCT <ul style="list-style-type: none"> Value: REAL ST: BYTE 	- <ul style="list-style-type: none"> 0.0 16#78
CSF	1 = External error (control system fault) Error handling (Page 119)	STRUCT <ul style="list-style-type: none"> Value: BOOL ST: BYTE 	- <ul style="list-style-type: none"> 0 16#80
DeadBand	Width of dead band	REAL	0.0
DiffGain	Gain of differentiator [1..10] $DiffGain = TD /$ (delay time of D component)	STRUCT <ul style="list-style-type: none"> Value: REAL ST: BYTE 	- <ul style="list-style-type: none"> 5.0 16#80
EN	1 = Called block will be processed	BOOL	1
ExtMsg1	1 = Binary input for freely selectable message 1 is used	STRUCT <ul style="list-style-type: none"> Value: BOOL ST: BYTE 	- <ul style="list-style-type: none"> 0 16#80
ExtMsg2	1 = Binary input for freely selectable message 2 is used	STRUCT <ul style="list-style-type: none"> Value: BOOL ST: BYTE 	- <ul style="list-style-type: none"> 0 16#80
ExtVal08	Associated value 8 for messages (MsgEvID1)	ANY	
ExtVal09	Associated value 9 for messages (MsgEvID1)	ANY	
Feature	I/O for additional PIDConS functions (Page 788)	STRUCT <ul style="list-style-type: none"> Bit 0: BOOL ... Bit 31: BOOL 	- <ul style="list-style-type: none"> 0 0 0
Gain	Proportional gain Gain.ST = 16#FF: Enabled in faceplate	STRUCT <ul style="list-style-type: none"> Value: REAL ST: BYTE 	- <ul style="list-style-type: none"> 1.0 16#FF

Controller blocks

5.8 PIDConS - Continuous PID controller (Small)

Parameter	Description	Type	Default
IntHoldNeg	1 = Integrator cannot run in negative direction	STRUCT <ul style="list-style-type: none"> Value: BOOL ST: BYTE 	- <ul style="list-style-type: none"> 0 16#80
IntHoldPos	1 = Integrator cannot run in positive direction	STRUCT <ul style="list-style-type: none"> Value: BOOL ST: BYTE 	- <ul style="list-style-type: none"> 0 16#80
Man*	Manual specification for the manipulated variable	REAL	0.0
ManModLi*	1 = "Manual mode" via interconnection or SFC (controlled by ModLiOp = 1)	STRUCT <ul style="list-style-type: none"> Value: BOOL ST: BYTE 	- <ul style="list-style-type: none"> 0 16#80
ManModOp*	1 = "Manual mode" via OS operator (controlled by ModLiOp = 0)	BOOL	1
ModLiOp	Operating mode switchover between: 0 = Operator 1 = Interconnection or SFC	STRUCT <ul style="list-style-type: none"> Value: BOOL ST: BYTE 	- <ul style="list-style-type: none"> 0 16#80
MS_RelOp*	1 = Release for maintenance by OS operator	BOOL	0
MsgEvID1	Message number (assigned automatically)	DWORD	16#00000000
MsgLock	1 = Suppress process messages. See also the section Suppressing messages using the MsgLock parameter (Page 205) for more on this.	STRUCT <ul style="list-style-type: none"> Value: BOOL ST: BYTE 	- <ul style="list-style-type: none"> 0 16#80
MV_ChnST	Signal status of output channel for MV Should be connected to an output channel block	STRUCT <ul style="list-style-type: none"> Value: REAL ST: BYTE 	- <ul style="list-style-type: none"> 0.0 16#FF
MV_HiLim	Limit (high) for manipulated variable MV	STRUCT <ul style="list-style-type: none"> Value: REAL ST: BYTE 	- <ul style="list-style-type: none"> 100.0 16#80
MV_LoLim	Limit (low) for manipulated variable MV	STRUCT <ul style="list-style-type: none"> Value: REAL ST: BYTE 	- <ul style="list-style-type: none"> 0.0 16#80
MV_Offset	Manipulated variable for ER=0, operating point for controller with deactivated I component	REAL	0.0
MV_OpScale	OS display range for manipulated variable MV	STRUCT <ul style="list-style-type: none"> High: REAL Low: REAL 	- <ul style="list-style-type: none"> 100.0 0.0
MV_SafePos	Manipulated variable neutral position	STRUCT <ul style="list-style-type: none"> Value: REAL ST: BYTE 	- <ul style="list-style-type: none"> 0.0 16#80
MV_Trk*	Tracking value for the manipulated variable MV	STRUCT <ul style="list-style-type: none"> Value: REAL ST: BYTE 	- <ul style="list-style-type: none"> 0.0 16#80

5.8 PIDConS - Continuous PID controller (Small)

Parameter	Description	Type	Default
MV_TrkOn	1 = Tracking of manipulated variable <i>MV</i>	STRUCT <ul style="list-style-type: none"> Value: BOOL ST: BYTE 	- <ul style="list-style-type: none"> 0 16#80
MV_Unit	Unit of measure for manipulated variable	INT	1342
Occupied	1 = Occupied by batch control	BOOL	0
OosLi	1 = "Out of service", via interconnection or SFC (0-1 edge transition)	STRUCT <ul style="list-style-type: none"> Value: BOOL ST: BYTE 	- <ul style="list-style-type: none"> 0 16#80
OosOp*	1 = "Out of service", via OS operator	BOOL	0
OptimEn*	1 = Enable optimization of PID parameters by PID tuner	BOOL	0
OptimOcc*	1 = Optimization running	BOOL	0
OpSt_In	Input parameter for local operator authorization, connected with the <i>Out</i> output parameter of the upstream block, <i>OpStations</i> (Page 411)	DWORD	16#00000000
OS_Perm	I/O for operator permission (Page 788)	STRUCT <ul style="list-style-type: none"> Bit 0: BOOL ... Bit 31: BOOL 	- <ul style="list-style-type: none"> 1 1 1
PropSel	1 = Activate P component	BOOL	1
PV*	Process value (controlled variable)	STRUCT <ul style="list-style-type: none"> Value: REAL ST: BYTE 	- <ul style="list-style-type: none"> 0.0 16#80
PV_A_DC*	Delay time for incoming <i>PV</i> alarms [s]	REAL	0.0
PV_AH_En	1 = Enable <i>PV</i> alarm limit (high)	BOOL	1
PV_AH_Lim	Limit <i>PV</i> alarm (high)	REAL	95.0
PV_AH_MsgEn	1 = Enable <i>PV</i> alarm (high) message	BOOL	1
PV_AL_En	1 = Enable <i>PV</i> alarm limit (low)	BOOL	1
PV_AL_Lim	<i>PV</i> alarm limit (low)	REAL	5.0
PV_AL_MsgEn	1 = Enable <i>PV</i> alarm (low) message	BOOL	1
PV_Hyst	Hysteresis for <i>PV</i> alarm, warning and tolerance limits	REAL	1.0
PV_OpScale	Limit for scale in <i>PV</i> bar graph of faceplate	STRUCT <ul style="list-style-type: none"> High: REAL Low: REAL 	- <ul style="list-style-type: none"> 100.0 0.0
PV_Unit	Unit of measure for process value	INT	1001
PV_W_DC*	Delay time for incoming <i>PV</i> warnings [s]	REAL	0.0
PV_WH_En	1 = Enable <i>PV</i> warning limit (high)	BOOL	1
PV_WH_Lim	Limit <i>PV</i> warning (high)	REAL	90.0
PV_WH_MsgEn	1 = Enable <i>PV</i> warning (high) message	BOOL	1
PV_WL_En	1 = Enable <i>PV</i> warning limit (low)	BOOL	1

Controller blocks

5.8 PIDConS - Continuous PID controller (Small)

Parameter	Description	Type	Default
PV_WL_Lim	Limit PV warning (low)	REAL	10.0
PV_WL_MsgEn	1 = Enable PV warning (low) message	BOOL	1
Rbk*	Position feedback for display on OS	STRUCT <ul style="list-style-type: none"> • Value: REAL • ST: BYTE 	- <ul style="list-style-type: none"> • 0.0 • 16#FF
RunUpCyc	Number of cycles in startup; messages are suppressed during these cycles	INT	3
SafePos	1 = Neutral position (Page 48) for controller manipulated variable is MV_HiLim 0 = Neutral position for controller manipulated variable is MV_LoLim	BOOL	0
SafePos2	Neutral position for control valve: 0 = SafePos is valid 1 = Neutral position is MV_SafePos 2 = Neutral position is last manipulated variable (stop)	INT	0
SampleTime	Sampling time [s] (assigned automatically)	REAL	0.1
SelFp1	1 = Call a block saved in this parameter as an additional faceplate (Page 208) in the standard view	ANY	-
SimOn*	1 = Simulation on	BOOL	0
SimPV*	Process value used for SimOn = 1	REAL	0.0
SP_Ext*	external setpoint - (to interconnection)	STRUCT <ul style="list-style-type: none"> • Value: REAL • ST: BYTE 	- <ul style="list-style-type: none"> • 0.0 • 16#80
SP_ExtLi*	1 = Select external setpoint (via interconnection)	STRUCT <ul style="list-style-type: none"> • Value: BOOL • ST: BYTE 	- <ul style="list-style-type: none"> • 0 • 16#80
SP_ExtOp*	1 = Select external setpoint (via operator)	BOOL	0
SP_HiLim	Limit (high) of internal SP	STRUCT <ul style="list-style-type: none"> • Value: BOOL • ST: BYTE 	<ul style="list-style-type: none"> • 100.0 • 16#80
SP_Int*	Internal setpoint for operation	REAL	0.0
SP_IntLi*	1 = Select internal setpoint (via interconnection)	STRUCT <ul style="list-style-type: none"> • Value: BOOL • ST: BYTE 	- <ul style="list-style-type: none"> • 0 • 16#80
SP_IntOp*	1 = Select internal setpoint (via operator)	BOOL	0
SP_LiOp	Select setpoint source (internal/external): 1 = Via interconnection 0 = Via operator	STRUCT <ul style="list-style-type: none"> • Value: BOOL • ST: BYTE 	- <ul style="list-style-type: none"> • 0 • 16#80
SP_LoLim	Limit (low) of internal SP	STRUCT <ul style="list-style-type: none"> • Value: REAL • ST: BYTE 	- <ul style="list-style-type: none"> • 0 • 16#80

5.8 PIDConS - Continuous PID controller (Small)

Parameter	Description	Type	Default
SP_TrkPV	1 = Setpoint follows PV in "manual mode" and with tracking	BOOL	0
StepNo	Batch step number	DWORD	16#00000000
TD	Derivative time [s] TD.ST = 16#FF: Enabled in faceplate	STRUCT • Value: REAL • ST: BYTE	- • 0.0 • 16#FF
TI	Integral time [s] TI.ST = 16#FF: Enabled in faceplate	STRUCT • Value: REAL • ST: BYTE	- • 100.0 • 16#FF
UserStatus	Freely assignable bits for use in PCS 7 OS	BYTE	16#00

* Values can be written back to these inputs during processing of the block by the block algorithm.

Output parameters

Parameter	Description	Type	Default
AutAct	1 = "Automatic mode" enabled	STRUCT • Value: BOOL • ST: BYTE	- • 0 • 16#80
D_Part	D component of PID algorithm	REAL	0.0
ENO	1 = Block algorithm completed without errors	BOOL	0
ER	Error signal	STRUCT • Value: REAL • ST: BYTE	- • 0.0 • 16#80
ErrorNum	Output of pending error number. For error numbers that can be output by this block, see PIDConS error handling (Page 794)	INT	-1
GrpErr	1 = Group error pending	STRUCT • Value: BOOL • ST: BYTE	- • 0 • 16#80
I_Part	I component of PID algorithm	REAL	0.0
LoopClosed	1 = Control loop closed 0 = Control loop open	STRUCT • Value: BOOL • ST: BYTE	- • 0 • 16#80
ManAct	1 = "Manual mode" enabled	STRUCT • Value: BOOL • ST: BYTE	- • 1 • 16#80
MS_Release	Release for maintenance: 1 = Release for OS operator	STRUCT • Value: BOOL • ST: BYTE	- • 0 • 16#80

Controller blocks

5.8 PIDConS - Continuous PID controller (Small)

Parameter	Description	Type	Default
MV	Manipulated variable	STRUCT <ul style="list-style-type: none"> Value: REAL ST: BYTE 	- <ul style="list-style-type: none"> 0.0 16#80
MV_HiAct	1 = Limit (high) of manipulated variable violated	STRUCT <ul style="list-style-type: none"> Value: BOOL ST: BYTE 	- <ul style="list-style-type: none"> 0 16#80
MV_LoAct	1 = Limit (low) of manipulated variable violated	STRUCT <ul style="list-style-type: none"> Value: BOOL ST: BYTE 	- <ul style="list-style-type: none"> 0 16#80
MV_UnitOut	Unit of measure for manipulated variable, for interconnecting to the MV_Unit input parameter of the ConPerMon block	INT	0
OosAct	1 = Block is "Out of service"	STRUCT <ul style="list-style-type: none"> Value: BOOL ST: BYTE 	- <ul style="list-style-type: none"> 0 16#80
OpSt_Out	Value of the OpSt_In input parameter, for feedforwarding to other blocks. Bit 31 of this parameter is used by Feature bit 24	DWORD	16#00000000
OS_PermOut	Display of OS_Perm	DWORD	16#FFFFFFFF
OS_PermLog	Display of OS_Perm with settings changed by the block algorithm	DWORD	16#FFFFFFFF
P_Part	P component of PID algorithm	REAL	0.0
PV_AH_Act	1 = PV alarm (high) active. You can change the reaction for this parameter with Feature bit 28 (Disabling operating points (Page 145)) and with Feature bit 29 (Signaling limit violation (Page 170)).	STRUCT <ul style="list-style-type: none"> Value: BOOL ST: BYTE 	- <ul style="list-style-type: none"> 0 16#80
PV_AL_Act	1 = PV alarm (low) active. You can change the reaction for this parameter with Feature bit 28 (Disabling operating points (Page 145)) and with Feature bit 29 (Signaling limit violation (Page 170)).	STRUCT <ul style="list-style-type: none"> Value: BOOL ST: BYTE 	- <ul style="list-style-type: none"> 0 16#80
PV_Out	Output for process value	STRUCT <ul style="list-style-type: none"> Value: REAL ST: BYTE 	- <ul style="list-style-type: none"> 0.0 16#80
PV_ToleHi	Limit (high) of 3-sigma band around the setpoint is calculated when a ConPerMon block is connected	STRUCT <ul style="list-style-type: none"> Value: REAL ST: BYTE 	- <ul style="list-style-type: none"> 0.0 16#80
PV_ToleLo	Limit (low) of 3-sigma band around the setpoint is calculated when a ConPerMon block is connected	STRUCT <ul style="list-style-type: none"> Value: REAL ST: BYTE 	- <ul style="list-style-type: none"> 0.0 16#80

Parameter	Description	Type	Default
PV_WH_Act	1 = PV warning (high) active. You can change the reaction for this parameter with <code>Feature</code> bit 28 (Disabling operating points (Page 145)) and with <code>Feature</code> bit 29 (Signaling limit violation (Page 170)).	STRUCT • Value: BOOL • ST: BYTE	- • 0 • 16#80
PV_WL_Act	1 = PV warning (low) active. You can change the reaction for this parameter with <code>Feature</code> bit 28 (Disabling operating points (Page 145)) and with <code>Feature</code> bit 29 (Signaling limit violation (Page 170)).	STRUCT • Value: BOOL • ST: BYTE	- • 0 • 16#80
PV_UnitOut	Unit of measure for process value, for interconnecting to the <code>PV_Unit</code> input parameter of the <code>ConPerMon</code> block	INT	0
RdyToStart	1 = Active start readiness	STRUCT • Value: BOOL • ST: BYTE	- • 0 • 16#80
SP	Setpoint used by controller	STRUCT • Value: REAL • ST: BYTE	- • 0.0 • 16#80
SP_ExtAct	1 = External setpoint is active 0 = Internal setpoint is active	STRUCT • Value: BOOL • ST: BYTE	- • 0 • 16#80
SP_HiOut	Limit (high) for <code>SP</code> corresponds to input parameter <code>SP_HiLim</code>	STRUCT • Value: REAL • ST: BYTE	- • 100.0 • 16#80
SP_LoOut	Limit (low) for <code>SP</code> corresponds to input parameter <code>SP_LoLim</code>	STRUCT • Value: REAL • ST: BYTE	- • 0.0 • 16#80
ST_Worst	Worst signal status	BYTE	16#80
Status1	Status word 1 (Page 784)	DWORD	16#00000000
Status2	Status word 2 (Page 784)	DWORD	16#00000000
SumMsgAct	1 = Active hardware interrupt	STRUCT • Value: BOOL • ST: BYTE	- • 0 • 16#80

See also

PIDConS modes (Page 787)

PIDConS messaging (Page 795)

PIDConS block diagram (Page 804)

5.8.7 PIDConS block diagram

PIDConS block diagram

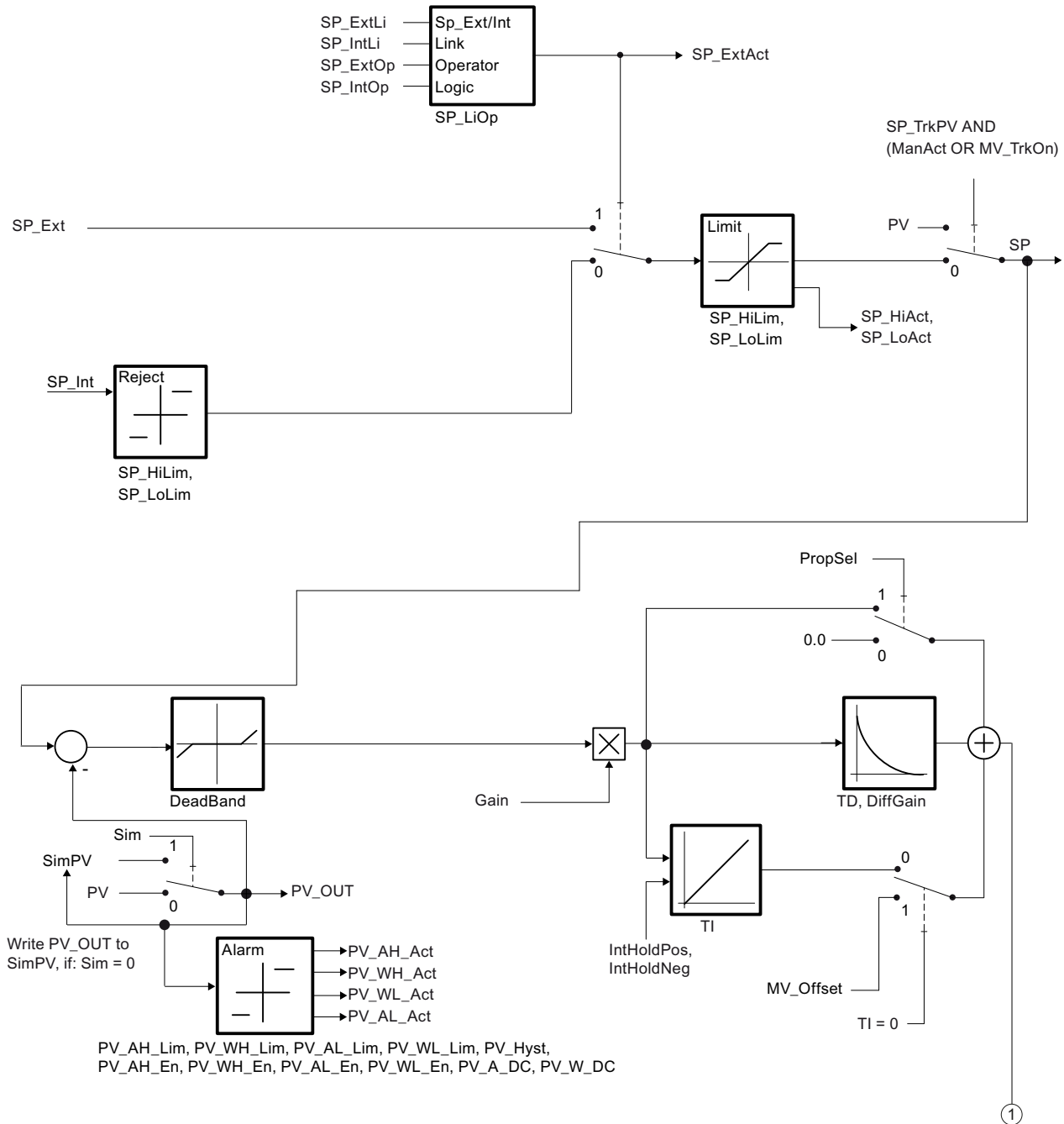

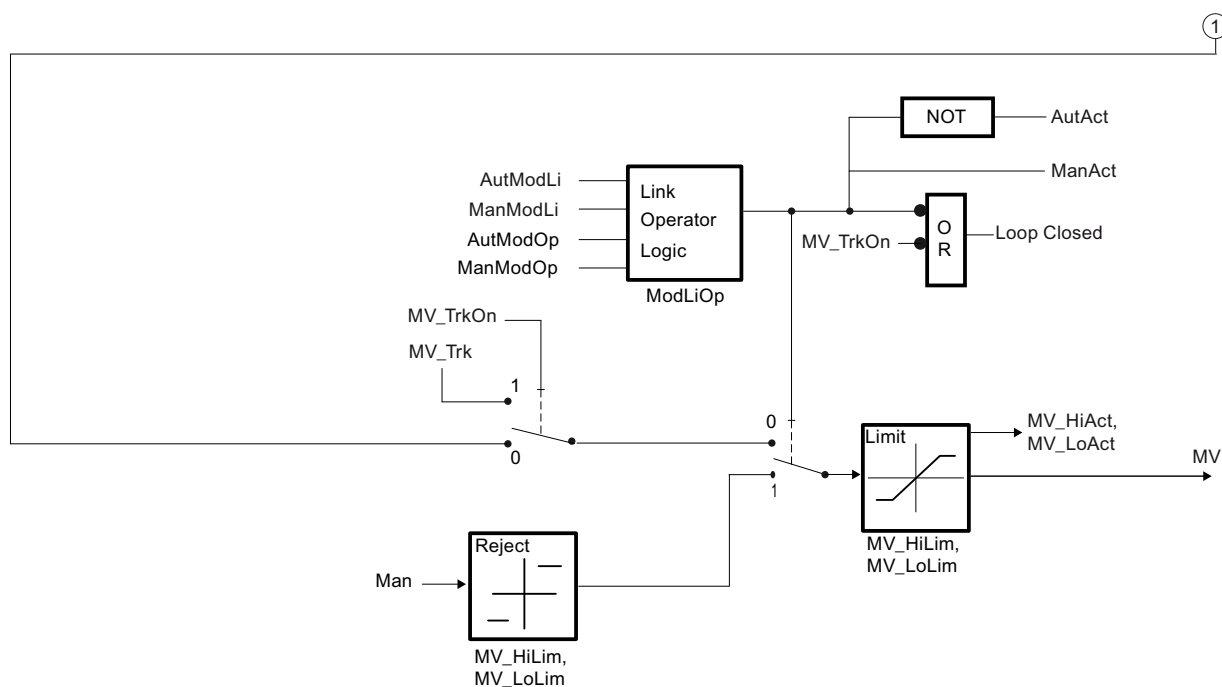

See also

- PIDConS I/Os (Page 797)
- PIDConS messaging (Page 795)
- PIDConS error handling (Page 794)

5.8 PIDConS - Continuous PID controller (Small)

PIDConS functions (Page 788)

PIDConS modes (Page 787)

Description of PIDConS (Page 784)

5.8.8 Operator control and monitoring

5.8.8.1 PIDConS views

Views of the PIDConS block

The block PIDConS provides the following views:

- PIDConL, PIDConS and PIDConR standard views (Page 776)
- Alarm view (Page 302)
- Limit view of PID controllers (Page 291)
- Trend view (Page 305)
- Parameter view of PID controllers (Page 281)
- PIDConL, PIDConS and PIDConR previews (Page 781)
- Memo view (Page 304)
- Batch view (Page 302)
- Block icons for PID and FM controller (Page 239)

Refer to the Structure of the faceplate (Page 248) and Block icon structure (Page 230) chapters for general information about the faceplate and block icon.

See also

Ramp view (Page 300)

5.9 PIDConR - Continuous PID controller with external reset

5.9.1 Description of PIDConR

Object name (type + number) and family

Type + number: FB 1875

Family: Control

Area of application for PIDConR

The block is used for the following applications:

- Fixed setpoint control
- Cascade control
- Ratio control
- Split-range control
- Smith predictor closed-loop control
- Override control (override)

Unlike PIDConL, the PIDConR permits an external reset and satisfies the special requirements of the US market.

How it works

The block is a PID controller with continuous output signal (manipulated variable). It is used to activate a final controlling element with continuous action input.

The block functions following the PID algorithm with a delayed D component and an integrator with double precision. Its particular feature is that it is an incremental control algorithm with a serial-interactive structure. Incremental means that the current manipulated variable is calculated from the old manipulated variable of the last sampling step. In place of the old manipulated variable, an output point for the manipulated variable calculation (external reset) can be specified externally by interconnection. The difference between the parallel controller structure of the PIDConL and the serial-interactive structure of the PIDConR is shown in the next two diagrams.

PIDConL

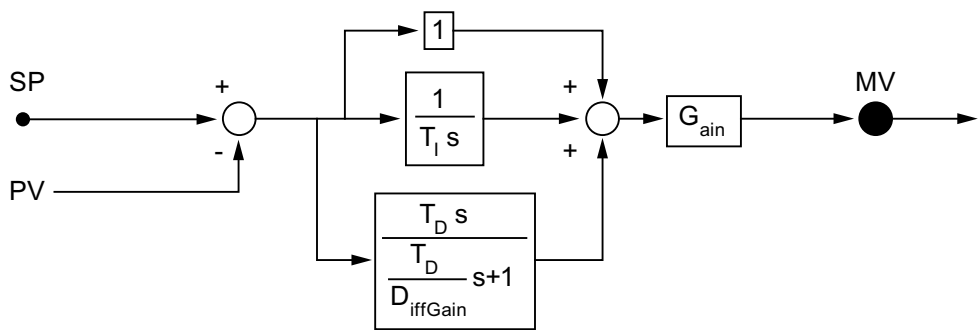

PIDConR

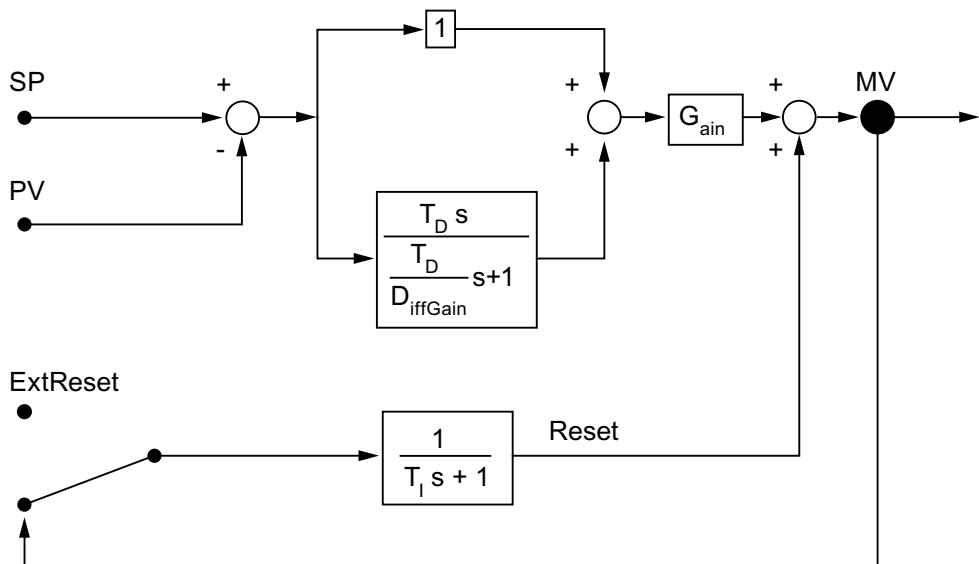

The block is suitable for controlling sluggish control loops, for example, for temperatures and filling levels, and high-speed control loops, for example, for flow rates and speed. For a given CPU, a compromise has to be made between the number of controllers and the frequency with which the individual controllers have to be processed. The faster the modulated control loops are, i.e. the more frequently the manipulated variables have to be calculated per time unit, the lower the number of controllers that can be installed.

Configuration

Use the CFC editor to install the block in a cyclic interrupt OB (OB30 to OB38). The block is also installed automatically in the startup OB (OB100).

For the control loop monitoring to work as planned in the trend view of the controller faceplates, the

```
S7_xarchive:='Value, shortterm;'
```

attributes in the process tag types for control loops at the controller function block must be set for the following tags:

- Input parameters:
 - CPI_In
- Output parameters
 - MV
 - MV_HiAct
 - MV_LoAct
 - LoopClosed
 - SP
 - PV_Out
 - PV_ToleHi
 - PV_ToleLo

For the PIDConR block, the Advanced Process Library contains templates for process tag types as examples with various application scenarios for this block.

Examples of process tag types:

- Cascade control with PIDConR (CascadeR) (Page 2345)
- Override control with PIDConR (OverrideR) (Page 2350)
- PIDConR with safety logic and control loop monitoring (PIDConR_ConPerMon) (Page 2325)
- Ratio control with PIDConR (RatioR) (Page 2341)

Note

The meaning of the controller parameters of both structures is different for all controller parameter settings with a D component. If you want to transfer parameter values from one structure to another, they have to be converted according to the formula in the PIDConR function .

Startup characteristics

Use the `Feature Bit Set` startup characteristics (Page 138) to define the startup characteristics of this block.

The messages are suppressed after startup for the number of cycles set at `RunUpCyc`.

The following output parameters are written with the corresponding input parameters:

- PV_HysOut
- PV_AH_Out
- PV_WH_Out
- PV_TH_Out
- PV_AL_Out

5.9 PIDConR - Continuous PID controller with external reset

- PV_WL_Out
- PV_TL_Out

Status word allocation for status1 parameter

You can find a description for each parameter in section PIDConR I/Os (Page 833).

Status bit	Parameter
0	Occupied
1	BatchEn
2	SimOn
3	OosAct.Value
4	OosLi.Value
5	AutAct.Value
6	Not used
7	ManAct.Value
8	SP_ExtAct.Value
9	MV_ForOn.Value
10	MV_TrkOn.Value AND NOT (ManAct.Value OR OosAct.Value OR MV_ForOn.Value)
11	MV.Value > ManLoLim
12	SimLiOp.Value
13	"Interlock" button is enabled OR Intlock.ST ≠ 16#FF
14	0 = Open padlock in the block icon 1 = Closed padlock in block icon
15	SP_LoadOn.Value
16	SP_LoadOn.Value AND NOT (MV_TrkOn.Value OR OosAct.Value OR MV_ForOn.Value)
17	Feature Bit 19
18	Feature Bit 21
19	AdvCoAct
20	1 = Input parameter Rbk is not interconnected (RbkOut.ST = 16#FF)
21	NegGain
22	1 = SP ramp active
23	OptimEn
24	OptimOcc
25	Not used
26	Display of BypassAct.Value in faceplate (display and operator controls) and block icon
27	Not used
28	SimOn AND ManAct
29	ByProt
30	Dead band is temporarily disabled
31	Not used

Status word allocation for `status2` parameter

Status bit	Parameter
0	MsgLock
1	PV_AH_Act.Value
2	PV_WH_Act.Value
3	PV_TH_Act.Value
4	PV_TL_Act.Value
5	PV_WL_Act.Value
6	PV_AL_Act.Value
7	PV_AH_En
8	PV_WH_En
9	PV_TH_En
10	PV_TL_En
11	PV_WL_En
12	PV_AL_En
13	PV_AH_MsgEn
14	PV_WH_MsgEn
15	PV_TH_MsgEn
16	PV_TL_MsgEn
17	PV_WL_MsgEn
18	PV_AL_MsgEn
19	ER_AH_Act.Value
20	ER_AL_Act.Value
21	ER_AH_En
22	ER_AL_En
23	ER_AH_MsgEn
24	ER_AL_MsgEn
25	RbkWH_Act.Value
26	RbkWL_Act.Value
27	RbkWH_En
28	RbkWL_En
29	RbkWH_MsgEn
30	RbkWL_MsgEn
31	MS_RelOp

Status word allocation for `status3` parameter

Status bit	Parameter
0	Effective signal 1 of the message block connected via <code>EventTsIn</code>
1	Effective signal 2 of the message block connected via <code>EventTsIn</code>
2	Effective signal 3 of the message block connected via <code>EventTsIn</code>
3	Effective signal 4 of the message block connected via <code>EventTsIn</code>
4	Effective signal 5 of the message block connected via <code>EventTsIn</code>

5.9 PIDConR - Continuous PID controller with external reset

Status bit	Parameter
5	Effective signal 6 of the message block connected via <code>EventTsIn</code>
6	Effective signal 7 of the message block connected via <code>EventTsIn</code>
7	Effective signal 8 of the message block connected via <code>EventTsIn</code>
8	Delay of the <code>PV_AH_Lim</code> message
9	Delay of the <code>PV_WH_Lim</code> message
10	Delay of the <code>PV_TH_Lim</code> message
11	Delay of the <code>PV_TL_Lim</code> message
12	Delay of the <code>PV_WL_Lim</code> message
13	Delay of the <code>PV_AL_Lim</code> message
14	Delay of the <code>ER_AH_Lim</code> message
15	Delay of the <code>ER_AL_Lim</code> message
16	Collection of message delays
17	<code>BypassAct.Value</code>
18 - 23	Not used
24	Hidden bypass signal in Intlock
25	Feature2 bit 2: Separate bypass signal
26	<code>LockAct.Value</code>
27	<code>SP_UpRaAct</code> , <code>SP_DnRaAct</code> limits enabled for gradient mode (<code>SP_RateOn = 1</code>)
28	<code>GrpErr.Value</code>
29	<code>RdyToStart.Value</code>
30	1 = Input parameter <code>MV_ChnST</code> is interconnected
31	Not used

Status word allocation for `status4` parameter

Status bit	Parameter
0 - 7	Effective signal 9..16 of the message block connected via <code>EventTsIn</code>
8 - 31	Not used

See also

- PIDConR block diagram (Page 850)
- PIDConR messaging (Page 830)
- PIDConR error handling (Page 829)
- PIDConR functions (Page 815)
- PIDConR modes (Page 813)

5.9.2 PIDConR modes

Operating modes of PIDConR

The block can be operated using the following modes:

- Automatic mode (Page 72)
- Manual mode (Page 72)
- Program mode for controllers (Page 78)
- Out of service (Page 71)

In "manual mode", the control settings for the device are made manually by the operator. The operator decides how to change the block's manipulated variable (output signal).

In "automatic mode", the controller's manipulated variable is calculated automatically by the block algorithm.

Changing between operating modes

The switchover between manual and automatic modes takes place as shown in the following schematic:

Switchover by using faceplates: The switchover between operating modes is carried out in the standard view of the faceplate. In the function block, the parameters `ManModOp` for "manual mode" and `AutModOp` for "automatic mode" are used.

Switchover via interconnection (CFC or SFC instance): The switchover between the operating modes is carried out by means of interconnection on the function block.

Note

You can access the variable parameters `AutModOp` and `ManModOp` from a normal SFC (in contrast to the instance of an SFC type). The SFC can thus change the operating mode without revoking the access rights of the operator.

Points to note for this block

With PIDConR the switchover between operating modes via interconnectable input parameters follows a different logic than that used for other controller blocks. This logic is oriented towards the special requirements of the US market. The basic approach is to issue the controller with certain commands by interconnection using an individual input parameter. The commands issued by interconnection take priority over the entries in the faceplate, i.e. if such a command input is made, the associated operator controls are locked in the faceplate:

- If the interconnectable `AutExtSet = 1` input parameter is set, the controller goes into "automatic mode" with an external setpoint. This is also known as the "cascade" operating mode.
- If the interconnectable `AutIntSet = 1` input parameter is set, the controller goes into "automatic" mode with internal setpoint. `AutIntSet` has higher priority than `AutExtSet`. For more information about the internal and external setpoint, refer to section PIDConR functions (Page 815).

- If the interconnectable input parameter `ManSet = 1` is set, the controller goes into "manual" mode. This command has higher priority than `AutIntSet` and `AutExtSet`.
- If one of the interconnectable input parameters `MV_Close` or `MV_Open` is set, the controller also goes into "manual" operating mode and performs the corresponding command.

The `ModLiOp`, `ManModLi` and `AutModLi` input parameters are not therefore present in PIDConR.

Switchover from automatic mode to manual mode

When changing over from "automatic mode" to "manual mode", the last valid control settings (**Manipulated Value** `MV`) for the controller set in "automatic mode" remain valid until you change the control settings manually.

Switchover from manual mode to automatic mode

The switchover from manual to automatic mode can take place with or without the internal setpoint tracking the process value. You specify this behavior on the `SP_TrkPV` I/O, which can also be operated from the faceplate in the parameter view (Option "`SP : = PV` in Manual").

Switchover with tracked internal setpoint

(`SP_TrkPV = 1`) means that in "manual" mode the setpoint (`SP`) tracks the process variable (`PV`). This results in bumpless switchover, which means the manipulated variable remains constant after switching back to "automatic mode" until the setpoint (`SP`) is changed or the process value (`PV`) changes.

Switchover without tracked internal setpoint

(`SP_TrkPV = 0`) means that the setpoint does not track the actual value in manual mode and that the block immediately recalculates the manipulated variable based on the setpoint and process value (`PV`) when the mode is changed. PIDConR only offers **switchover without P step**: During switchover, the I action (reset) of the controller is set in such a way that the switchover is carried out without a P step (virtually bumpless referring to the manipulated variable). In case of a large control deviation, when switching from the manual mode to the automatic mode, it may happen that the integral action is set far outside the manipulated variable limits. See `Feature` bit With accelerated return of the integral action from the manipulated variable limit (Page 180).

Reaction of signals when operating mode is changed

Using the `Feature` Bit Resetting the commands for changing the mode (Page 161), you can specify whether the block automatically resets the signal for changing the operating mode.

"Program mode for controllers"

You can find general information about the "Program mode for controller" in the section Program mode for controllers (Page 78).

In case of a large control deviation, when switching from the program mode with manipulated variable specification to the automatic mode, it may happen that the integral action is set far

outside the manipulated variable limits. See `Feature` bit With accelerated return of the integral action from the manipulated variable limit (Page 180).

"Out of service"

You can find general information about the "Out of service" mode in the section Out of service (Page 71).

See also

PIDConR block diagram (Page 850)

PIDConR I/Os (Page 833)

PIDConR messaging (Page 830)

PIDConR error handling (Page 829)

Description of PIDConR (Page 807)

Disabling bumpless switchover to automatic mode for controllers (Page 173)

5.9.3 PIDConR functions

Functions of PIDConR

The functions for this block are listed below.

Generation of manipulated variables

The manipulated variable `MV` can be generated as follows:

MV_For On	MV_Bump On	MV_Close	MV_Open	Man-Act	MV_Trk On	Adv-CoAct AND NOT AdvCo-ModSP	MV =	Limit monitoring	State
1	-	-	-	-	-	-	MV_Forced	none	Forced tracking through constraint without limitation
0	1	-	-	-	-	-	MV_Bump	Manual mode: ManHiLim ManLoLim Automatic mode: MV_HiLim MV_LoLim	Sudden manipulation of the manipulated variable

5.9 PIDConR - Continuous PID controller with external reset

MV_ForOn	MV_BumpOn	MV_Close	MV_Open	Man-Act	MV_TrkOn	Adv-CoAct AND NOT AdvCo-ModSP	MV =	Limit monitoring	State
0	0	1	-	-	-	-	ManLoLim	ManHiLim ManLoLim	Close by interconnection
0	0	0	1	-	-	-	ManHiLim	ManHiLim ManLoLim	Open by interconnection
0	0	0	0	1	-	-	Man	ManHiLim ManLoLim	Manual mode, set by the OS operator or via the ManSet = 1 command
0	0	0	0	0	1	-	MV_Trk	MV_HiLim MV_LoLim	Tracking with limitation
0	0	0	0	0	0	1	AdvCoMV	MV_HiLim MV_LoLim	Higher-level program mode
0	0	0	0	0	0	0	PID.OUT + FFwd	MV_HiLim MV_LoLim	Automatic mode (PID algorithm)

If the controller is in "out of service" mode, the output parameter MV is set to the last valid value in manual mode or the neutral position manipulated variable depending on the Feature Bit Neutral position manipulated variable takes effect at startup (Page 166). Refer to the Out of service (Page 71) section for more on this.

The PIDConR offers the following special ways of influencing the generation of manipulated variables via interconnectable input parameters. The commands issued by interconnection take priority over the entries in the faceplate, i.e. if such a command input is made, the associated operator controls are locked in the faceplate.

MV_BumpOn is used for sudden manipulation of the manipulated variable and has a similar effect to **MV_ForOn**, the difference being that the appropriate limits are applied. If **MV_BumpOn = 1** is set in "automatic mode", the **MV_Bump** manipulated variable is written in a limited manner between **MV_HiLim** and **MV_LoLim** to output MV. If **MV_BumpOn = 1** is set in "manual mode", the **MV_Bump** manipulated variable is written in a limited manner between **ManHiLim** and **ManLoLim** to output MV. If **MV_BumpOn** is reset to 0, the controller returns to its previous mode.

MV_Close is used to close the adjustment valve. **MV_Close = 1** switches the controller to "manual mode" with manipulated variable **MV = ManLoLim**. If **MV_Close** is reset to 0, the controller remains in "manual mode".

MV_Open is used to open the adjustment valve. **MV_Open = 1** switches the controller to "manual mode" with manipulated variable **MV = ManHiLim**. If **MV_Open** is reset to 0, the controller remains in "manual mode".

These commands have higher priority than "automatic mode", but lower priority than forced tracking by **MV_ForOn**.

For meshed controller structures, such as a cascade control and closed-loop control with the PIDConR block, the **ExtReset** input parameter is used with **ExtRstOn = 1** rather than **MV_Trk** with **MV_TrkOn = 1** (also refer to the process tag types Cascade control with PIDConR (Cascader) (Page 2345) and Override control with PIDConR (OverrideR) (Page 2350)).

Displaying additional information relating to the manipulated variable on the output

The manual manipulated variable limitations `ManLoLim` and `ManHiLim` are copied to the `ManLoOut` and `ManHiOut` output parameters so that they can be further interconnected to the secondary controller as setpoint limits `SP_ExtLoLim` and `SP_ExtHiLim`. If you want to use the same limit pairs for "manual" and "automatic" mode, you can interconnect output parameters `ManLoOut` and `ManHiOut` to input parameters `MV_LoLim` and `MV_HiLim` of the same block and thereby control the limits for manipulated variable limitation in the faceplate. In most cases, a valve's complete control range can be passed through in "manual" mode. You can then further interconnect the `ManLoOut` and `ManHiOut` output parameters to the `LoScale` and `HiScale` input parameters of the assigned analog output channel block. Caution: If the valves have an open neutral position (`SafePos = 1`), this interconnection must be crossed over: `LoScale = ManHiOut` and `HiScale = ManLoOut`. On the controller, 0% is always interpreted as the valve being closed and 100% as the valve being open, but the channel block then issues a control signal of 0% for a 100% controller manipulated variable.

Tracking and limiting a manipulated variable

The block provides the standard function Tracking and limiting a manipulated variable (Page 196).

In case of a large control deviation, when disabling the tracking or forced tracking function and switching to the automatic mode, it may happen that the integral action is set far outside the manipulated variable limits. See `Feature` bit With accelerated return of the integral action from the manipulated variable limit (Page 180).

Neutral position

The block provides the standard function Neutral position for motors, valves and controllers (Page 48).

Group error

This block provides the standard function Outputting group errors (Page 122).

The following parameters are taken into consideration when forming the group error:

- `CSF`

Outputting a signal for start readiness

This block provides the standard function Outputting a signal for start readiness (Page 53).

"Actuator active" information

If the manipulated variable `MV` is greater than the minimum manual limit `ManLoLim`, this is recognized as actuator active. This status can be used to display a custom symbol in the process image, for example, and is stored in the status word (you can find additional information under "Status word" in the Description of PIDConR (Page 807) section).

Limit monitoring of position feedback

The block provides the standard function Limit monitoring of the feedback (Page 94).

Group display SumMsgAct for limit monitoring, CSF and ExtMsgx

The block provides the standard function Group display for limit monitoring, CSF and ExtMsgx (Page 85).

External/internal setpoint specification

This input of setpoints is carried out either using a CFC/SFC program or using the faceplate (operator). The operator can specify an internal setpoint value (*SP_Int*) or a higher-level open-loop control will specify an external setpoint value (*SP_Ext*).

Setpoint specification internally and externally using faceplate

With PIDConR, the setpoint signal source is selected via the faceplate at the *SP_IntOp* = 1 parameter for the internal setpoint specification *SP_ExtOp* = 1 for external setpoint specification, just as it is with other controllers.

Note

In contrast to the other controllers, with PIDConR you can only switch to external setpoint specification via *SP_ExtOp* = 1 in automatic mode or in the program SP mode.

Setpoint specification internally and externally using interconnection

With PIDConR the switchover between internal and external setpoint via interconnectable input parameters follows a different logic than that used for other controller blocks. This logic is oriented towards the special requirements of the US market.

The setpoint signal source (internal/external) can be selected by interconnection along with selection of the operating mode using the *AutIntSet* input parameter for automatic with an internal setpoint and *AutExtSet* for automatic with an external setpoint (additional information is available in the PIDConR modes (Page 813) section). The commands issued by interconnection take priority over the entries in the faceplate, i.e. if such a command input is made, the associated operator controls are locked in the faceplate. Input parameters *SP_LiOp*, *SP_ExtLi* and *SP_IntLi* on PIDConR are not therefore needed.

The PIDConR also offers a special way of influencing the setpoint specification via interconnectable input parameters. Loading setpoints. If the *SP_LoadOn* = 1 input parameter is set, the controller goes into "automatic" mode. The value of the *SP_Load* input parameter is limited according to an internal setpoint and used for control purposes. If the parameter *SP_LoadOn* changes back from 1 to 0, the controller remains in "automatic" mode and sets the default setpoint back to the internal setpoint.

Loading a setpoint via *SP_LoadOn* takes priority over all other forms of setpoint specification.

Bumpless switchover from external to internal setpoint

The parameter `SP_TrkExt = 1` is used so that the internal setpoint tracks the external setpoint to achieve a bumpless switchover from the external to the internal setpoint. This allows unwanted jumps at the output parameter to be avoided.

Setpoint limiting for external setpoints

The block provides the standard function Setpoint limiting for external setpoints (Page 196).

Gradient limit of the setpoint

The block provides the standard function Gradient limit of the setpoint (Page 124).

Using setpoint ramp

The block provides the standard function Using setpoint ramp (Page 123).

Tracking setpoint in manual mode

The block provides the standard function Tracking setpoint in manual mode (Page 196).

Simulating signals

The block provides the standard function Simulating signals (Page 58).

You can simulate the following values:

- Process value (`SimPV`, `SimPV_Li`)
- Position feedback (`SimRbk`, `SimRbkLi`)

Bypass function

This block provides the standard function Bypassing signals (Page 107).

Limit monitoring of the process value

The block provides the standard function Limit monitoring of the process value (Page 86) with the alarm delay type Two time values for each individual limit (Page 202).

The PIDConR is the only block to have separate input parameters for the alarm delay at the high and low limits. Delay alarm for control deviation at setpoint step changes (Page 190)

Providing PV limit at the output

For further connections to the other blocks, the following input parameters are also displayed with the corresponding output parameters:

- `PV_HysOut := PV_Hyst`
- `PV_AH_Out := PV_AH_Lim`

5.9 PIDConR - Continuous PID controller with external reset

- `PV_WH_Out := PV_WH_Lim`
- `PV_TH_Out := PV_TH_Lim`
- `PV_TL_Out := PV_TL_Lim`
- `PV_WL_Out := PV_WL_Lim`
- `PV_AL_Out := PV_AL_Lim`

Error signal generation and dead band

The block provides the standard function Error signal generation and dead band (Page 192).

Delay alarm for control deviation at setpoint step changes

The block provides the standard function Delay alarm for control deviation at setpoint step changes (Page 190)

Limit monitoring of error signal

The block provides the standard function Limit monitoring of setpoint, manipulated variable and control deviation (Page 95). The monitoring of error signal works with the alarm delay type Two time values per limit pair (Page 201). With the `Feature Bit Separate delay times for each alarm` (Page 170), the alarm delay type Two time values for each individual limit (Page 202) can be activated.

Inverting control direction

The block provides the standard function Inverting control direction (Page 192).

Physical standardization of setpoint, manipulated variable and process value

Controller gain `Gain` is entered either using a physical variable or as standardized value.

Gain as a physical variable [`MV_Unit / PV_Unit`]:

The standardized variables retain their default values:

- `NormPV.High = 100` and `NormPV.Low = 0`
- `NormMV.High = 100` and `NormMV.Low = 0`

The effective gain is:

`GainEff = Gain`

Entering a standardized `Gain` (dimensionless):

Change the standardized variables to the actual range of the process values and manipulated variables.

- Internal and external setpoints; the process value and corresponding parameters are entered according to the physical measuring range of the process value.
- The manual value, the tracking value of the manipulated variable, disturbance variable feedforward and the corresponding parameters are set according to the physical measuring range of the manipulated variable.

The effective gain is:

$$\text{GainEff} = (\text{NormMV.High} - \text{NormMV.Low}) / (\text{NormPV.High} - \text{NormPV.Low}) \cdot \text{Gain}$$

Selecting a unit of measure

The block provides the standard function Selecting a unit of measure (Page 212).

PID algorithm

The manipulated variable is generated in automatic mode according to the following algorithm:

$$MV = \text{GainEff} \left[1 + \frac{T_D s}{\frac{T_D}{\text{DiffGain}} s + 1} \right] (PV - SP) + R_{reset} \left(\frac{1}{T_I s + 1} \right)$$

Where:

s = complex number of the Laplace transformation

This formula describes a standard application where P, I and D component is activated

Unlike with PIDConL, the Gain gain factor is not applied to the I component.

The D component delay is derived from TD / DiffGain.

- The P component can be deactivated by PropSel = 0 .
- The I component can be deactivated by IntSel = 0 . The MV_Offset input parameter can then be used to add a constant value to the manipulated variable. Select this value such that the remaining control deviation equals zero at least at the control loop's typical operating point.
- The D component can be deactivated by TD = 0 or DiffSel = 1.

Note

The formula describes a standard application where P, I and D components are activated and the D component is in the feedback circuit, while the P component is formed by the error signal (PropSel = 1, TI <> 0 and IntSel = 1, TD <> 0 and DiffSel = 1, DiffToFbk = 1, and PropFacSP = 1).

If you set the `Feature` Bit Enabling bumpless change to the proportional gain, derivative time and amplification of the differentiator (Page 172) to 1, changes in the proportional gain `Gain` are carried out in a bumpless manner in "automatic" mode by converting the internal reset.

If a `GainSched` block is linked to the controller, you have to make the parameter settings for the `Feature` Bit Enabling bumpless change to the proportional gain, derivative time and amplification of the differentiator (Page 172) with 0.

The PID core algorithm is implemented in the `PIDKernR` function block which in turn calls a series of auxiliary functions for the 64-bit arithmetic. Every edge transition on the `InitPid` input parameter forces initialization equations to be carried out by `PIDKernR`. In so doing, the internal reset is calculated such that the `MV` output does not suffer a P step.

During initialization in the automatic mode with a large control deviation, it may happen that the integral action is set far outside the manipulated variable limits. See `Feature` bit With accelerated return of the integral action from the manipulated variable limit (Page 180).

Note

The meaning of the controller parameters with `PIDConR` is different to that with the other PID controllers for all controller parameter settings with a D component. If you want to transfer parameter values from one kind of controller to another, they have to be converted using the following formulas. The calculation is based on an ideal transfer function without a delay in the D component, and all three control channels are applied to the $ER = PV - SP$ control deviation.

Parallel controller structure (for example, `PIDConL`):

$$MV = G_{ainEff} \left(1 + \frac{1}{T_I s} + T_D s \right) ER$$

The parameters of the serial-interactive controller structure (`PIDConR`):

$$MV = G'_{ainEff} (1 + T'_D s) \left(1 + \frac{1}{T'_I s} \right) ER$$

These parameters are marked using a speech mark. Both controllers calculate the same manipulated variable if the parameter values of the serial-interactive structure are determined by the following substitution:

$$G'_{ainEff} = \alpha G_{ainEff}, \quad T'_I = \alpha T_I, \quad T'_D = \frac{1}{\alpha} T_D$$

where α is the conversion factor:

$$\alpha = \frac{1}{2} \pm \sqrt{\frac{1}{4} - \frac{T_D}{T_I}}$$

The argument of the square root is negative and the conversion is impossible if:

$$\frac{T_D}{T_I} > \frac{1}{4}$$

In such cases, the output of PIDConL cannot be exactly replicated by PIDConR. In all other cases, there are two solutions for α and therefore two parameter sets that will generate the same control action of the ideal controller structures. The conversion in the other direction, from serial-interactive to parallel controller structure is always possible by:

$$\alpha = \frac{T_I'}{T_I' + T_D'}$$

You can see that the conversion factor only equals one if $T_D = 0$.

In PID-Tuner, the conversion for ideal controller structures is performed automatically before downloading of parameters to the PIDConR function block. The first of the two possible solutions (plus square root) is used. If the argument of the square root is negative, it will be set to zero, which implies that PIDConR control performance may deteriorate slightly.

Structure segmentation at controllers

The block provides the standard function Structure segmentation at controllers (Page 198).

Use output point for the manipulated variable calculation (external reset)

For the `ExtResOn = 0` input parameter (default setting), the starting point for the manipulated variable calculation within the block is taken from manipulated variable `MV`. In other words, this is the manipulated variable of the last sampling step. If `ExtResOn = 1`, the `ExtReset` start parameter is used. This is used in particular for networked control structures, such as cascade or transfer control.

Anti-windup

A controller with incremental algorithm (external reset) inherently has an anti-windup reaction because the starting point for the manipulated variable calculation (external reset value) is limited provided it is taken internally from manipulated variable `MV` or is taken from another signal source with limitation. If the starting point for the manipulated variable calculation (external reset value) is at the limit (`MV_HiLim` or `MV_LoLim`), the I component is automatically frozen.

Feedforwarding and limiting disturbance variables

The block provides the standard function Feedforwarding and limiting disturbance variables (Page 197).

Forming the signal status for blocks

The block provides the standard function Forming and outputting the signal status for technologic blocks (Page 109).

- Signal status for the process value `PV_Out`:
The signal status of the output parameter `PV_Out` always corresponds to the signal status of input parameter `PV` or, if the block is in simulation mode, `16#60`.
- Signal status for the setpoint value `SP`:
The signal status of the `SP` output parameter is always equivalent to the signal status of input parameter `SP_Ext` or `SP_Int`, depending on how the setpoint is specified. If the internal setpoint `SP_Int` is used, the signal status is always output as `16#80`.
- Signal status of the error signal `ER`:
The signal status of output parameter `ER` is obtained from the worst signal status of the two output parameters `PV_Out` and `SP` and is output. The signal status `16#60` (external simulation) is suppressed because the block acts as a sink with external simulation.
- Signal status for the manipulated variable `MV`:
The signal status of output parameter `MV` is obtained in "automatic mode" or in "program mode" with default setpoint from the worst signal status of the two parameters `FFwd` and `ER` and is output. In "manual mode", the signal status is output as good. The signal status `16#60` (external simulation) is suppressed because the block acts as a sink with external simulation. In "manual mode", the signal status is output as good.
- Signal status for position feedback `RbkOut`:
The signal status of `RbkOut` always corresponds to the signal status of input parameter `Rbk` or, if the block is in simulation mode, `16#60`.
- Worst signal status:
The worst signal status `ST_Worst` for the block is formed from the following parameters:
 - `SP.ST`;
 - `PV_Out.ST`;
 - `FFwd.ST`;
 - `RbkOut.ST`;
 - `MV_ChnST.ST`;

Configurable reactions using the `Feature` parameter

You can find an overview of all reactions provided by the `Feature` parameter in the Configurable functions using the `Feature` I/O (Page 131) . The following functionality is available for this block at the relevant bits:

Bit	Function
0	Set startup characteristics (Page 138)
1	Reaction to the out of service mode (Page 177)
2	Resetting the commands for changing the mode (Page 161)
6	Ramp rate calculation (Page 179)
8	Separate delay times for each alarm (Page 170)
9	Substitution value is active if the block is in bypass (Page 185)

Bit	Function
11	Gradient limitation with time duration (Page 182)
15	Neutral position manipulated variable takes effect with "out of service" operating mode (Page 166)
16	Neutral position manipulated variable takes effect at startup (Page 166)
17	With accelerated return of the integral action from the manipulated variable limit (Page 180)
19	Enabling program mode (Page 159)
20	Enabling bumpless change to the proportional gain, derivative time and amplification of the differentiator (Page 172)
21	Switching operator controls for external setpoint to visible (Page 144)
22	Update acknowledgment and error status of the message call (Page 160)
23	SP following PV in open loop has no priority over SP_Ext and SP limits (Page 179)
24	Enabling local operator authorization (Page 158)
25	Suppression of all messages (Page 174)
26	Reaction of the switching points in the "Out of service" operating mode (Page 176)
28	Disabling operating points (Page 145)
29	Signaling limit violation (Page 170)
30	Dead band is temporarily disabled (Page 141)

Configurable reactions using the Feature2 parameter

Bit	Function
2	Separate evaluation for excluded and simulated interlock signals (Page 152)
11	Suppress MsgLock and "Out of service" mode for a connected message block (Page 188)

Operator permissions

The block provides the standard function Operator control permissions (Page 254).

The block has the following permissions for the OS_Perm parameter:

Bit	Function
0	1 = Operator can switch to "automatic mode" AutModOp
1	1 = Operator can switch to "manual mode" ManModOp
2	1 = Operator can switch to "Out of service" mode OosOp
3	1 = Operator can switch to "program mode" AdvCoOn
4	1 = Operator can switch the setpoint to "external" SP_ExtOp
5	1 = Operator can switch the setpoint to "internal" SP_IntOp
6	1 = Operator can change the internal setpoint SP_Int
7	1 = Operator can change the manual parameter Man
8	1 = Operator can change operation high limit of the setpoint SP_InHiLim
9	1 = Operator can change operation low limit of the setpoint SP_InLoLim
10	1 = Operator can change the operation high limit of the manipulated variable ManHiLim

5.9 PIDConR - Continuous PID controller with external reset

Bit	Function
11	1 = Operator can change the operation low limit of the manipulated variable <code>ManLoLim</code>
12	1 = Operator can enable the setpoint's gradient limitation function <code>SP_RateOn</code>
13	1 = Operator can raise the gradient limit <code>SP_UpRaLim</code> of the setpoint
14	1 = Operator can lower the gradient limit <code>SP_DnRaLim</code> of the setpoint
15	1 = Operator can switch between the time value or the gradient value for specifying the ramp <code>SP_RmpModTime</code>
16	1 = Operator can change the ramp time <code>SP_RmpTime</code>
17	1 = Operator can change the target setpoint <code>SP_RmpTarget</code> for the setpoint ramp
18	1 = Operator can enable the setpoint ramp function <code>SP_RmpOn</code>
19	1 = Operator can permit the PID optimization function <code>OptimEn</code>
20	1 = Operator can enable the track setpoint in manual mode function <code>SP_TrkPV</code>
21	1 = Operator can enable the bumpless switchover from external to internal <code>SP_TrkExt</code>
22	1 = Operator can change the gain parameter <code>Gain</code>
23	1 = Operator can change the integral time parameter <code>TI</code>
24	1 = Operator can change the derivative time parameter <code>TD</code>
25	1 = Operator can change the derivative gain parameter <code>DiffGain</code>
26	1 = Operator can change the dead band parameter <code>DeadBand</code>
27	Not used
28	1 = Operator can change the derivative gain parameter <code>ER_AH_DF</code>
29	1 = Operator can change the derivative gain parameter <code>ER_AL_DF</code>
30 - 31	Not used

The block has the following permissions for the `OS1Perm` parameter:

Bit	Function
0	1 = Operator can change the limit (process value) <code>PV_AH_Lim</code> for the high alarm
1	1 = Operator can change the limit (process value) <code>PV_WH_Lim</code> for the high warning
2	1 = Operator can change the limit (process value) <code>PV_TH_Lim</code> for the high tolerance
3	1 = Operator can change the hysteresis (process value) <code>PV_Hyst</code>
4	1 = Operator can change the limit (process value) <code>PV_TL_Lim</code> for the low tolerance
5	1 = Operator can change the limit (process value) <code>PV_WL_Lim</code> for the low warning
6	1 = Operator can change the limit (process value) <code>PV_AL_Lim</code> for the low alarm
7	1 = Operator can change the limit (error signal) <code>ER_AH_Lim</code> for the high alarm
8	1 = Operator can change the hysteresis (error signal) <code>ER_Hyst</code>
9	1 = Operator can change the limit (error signal) <code>ER_AL_Lim</code> for the low alarm
10	1 = Operator can change the limit (position feedback) <code>RbkWH_Lim</code> for the high warning
11	1 = Operator can change the hysteresis (position feedback) <code>RbkHyst</code>
12	1 = Operator can change the limit (position feedback) <code>RbkWL_Lim</code> for the low warning
13	"Interlock" button is enabled
14	1 = Operator can activate bypass functionality
15	1 = Operator can deactivate bypass functionality
16	1 = Operator can activate the Simulation function <code>SimOn</code>
17	1 = Operator can activate the Release for maintenance function <code>MS_RelOp</code>
18	1 = Operator can activate / deactivate messages via <code>PV_AH_MsgEn</code>

Bit	Function
19	1 = Operator can activate / deactivate messages via PV_WH_MsgEn
20	1 = Operator can activate / deactivate messages via PV_TH_MsgEn
21	1 = Operator can activate / deactivate messages via PV_TL_MsgEn
22	1 = Operator can activate / deactivate messages via PV_WL_MsgEn
23	1 = Operator can activate / deactivate messages via PV_AL_MsgEn
24	1 = Operator can activate / deactivate messages via ER_AH_MsgEn
25	1 = Operator can activate / deactivate messages via ER_AL_MsgEn
26	1 = Operator can activate / deactivate messages via RbkWH_MsgEn
27	1 = Operator can activate / deactivate messages via RbkWL_MsgEn
28	1 = Operator can change the simulation value SimPV
29	1 = Operator can change the simulation value SimRbk
30	1 = Operator can activate the derivative action to the feedback path DiffToFbk
31	1 = Operator can change the proportional action to the feedback path PropFacSP

Note

If you interconnect a parameter that is also listed in OS_Perm as a parameter, you have to reset the corresponding OS_Perm bit.

Interlocks

This block provides the following interlocks:

- Interlock without reset ("Interlock")

You can find additional information on this in the section Interlocks (Page 99).

Disabling interlocks

This block provides the standard function Disabling interlocks (Page 103).

Release for maintenance

The block provides the standard function Release for maintenance (Page 64).

Generating instance-specific messages

The block provides the standard function Generating instance-specific messages (Page 204) without the time stamp function in the I/O.

Suppressing messages using the MsgLock parameter

This block provides the standard function Suppressing messages using the MsgLock parameter (Page 205).

Button labels

This block provides the standard function Labeling of buttons and text (Page 209).

Instance-specific text can be configured for the following parameters:

- AutModOp
- ManModOp
- AdvCoOn
- OosOp
- SP_ExtOp
- SP_IntOp

Specifying the display area for process and setpoint values as well as operations

This block provides the standard function Display and operator input area for process values and setpoints (Page 207).

Opening additional faceplates

This block provides the standard function Opening additional faceplates (Page 208).

SIMATIC BATCH functionality

This block provides the standard function SIMATIC BATCH functionality (Page 67).

Connection of the time-stamped messages from EventTs or Event16Ts

This block provides the standard function Connection of the time-stamped messages from EventTs or Event16Ts (Page 207).

See also

PIDConR I/Os (Page 833)

PIDConR messaging (Page 830)

PIDConR error handling (Page 829)

Program mode for controllers (Page 78)

EventTs functions (Page 1660)

5.9.4 PIDConR error handling

Error handling of PIDConR

Refer to section Error handling (Page 119) in the basic instructions for the error handling of all blocks.

The following errors can be displayed for this block:

- Error numbers
- Control system fault (CSF)

Overview of error numbers

The `ErrorNum` output parameter can be used to output the following error numbers:

Error number	Meaning of the error number
-1	Predefined value when inserting the block; the block is not executed
0	There is no error.
30	The value of <code>PV</code> can no longer be displayed in the REAL number field.
31	The value of <code>SP_Ext</code> can no longer be displayed in the REAL number field.
32	The value of <code>FFwd</code> can no longer be displayed in the REAL number field.
33	The value of <code>MV_Trk</code> can no longer be displayed in the REAL number field.
34	The value of <code>MV_Forced</code> can no longer be displayed in the REAL number field.
35	The value of <code>Rbk</code> can no longer be displayed in the REAL number field.
36	The value of <code>MV</code> can no longer be displayed in the REAL number field.
59	= 1 "Gain is negative"
60	$ TI < SampleTime / 2$
61	$ TD < SampleTime$
62	$DiffGain < 1$ or $DiffGain > 10$
63	$TD / DiffGain < SampleTime / 2$
64	$PropFacSP < 0$ or $PropFacSP > 1$
66	$NormPV_High = NormPV_Low$

Control system fault (CSF)

An external signal can be activated via the CSF input. A control system fault is triggered if this signal changes to 1. Refer to the Error handling (Page 119) section for more on this.

See also

- PIDConR block diagram (Page 850)
- PIDConR I/Os (Page 833)
- PIDConR messaging (Page 830)
- PIDConR functions (Page 815)

PIDConR modes (Page 813)

Description of PIDConR (Page 807)

5.9.5 PIDConR messaging

Messaging

The following messages can be generated for this block:

- Process control fault
- Process messages
- Instance-specific messages

Process control fault

The following control system error messages can be output:

Message instance	Message identifier	Message class	Event
MsgEvId2	SIG 6	AS process control message - fault	\$\$BlockComment\$\$ External error has occurred

Explanation:

\$\$BlockComment\$\$: Content of the instance-specific comment

You can interconnect an external fault (signal) to input parameter `CSF`. If it changes to `CSF = 1`, a process control fault is triggered (`MsgEvId2`, `SIG 6`).

Process messages

Message instance	Message identifier	Message class	Event
MsgEvId1	SIG 1	Alarm - high	\$\$BlockComment\$\$ PV - high alarm limit violated
	SIG 2	Warning - high	\$\$BlockComment\$\$ PV - high warning limit violated
	SIG 3	Tolerance - high	\$\$BlockComment\$\$ PV - high tolerance limit violated
	SIG 4	Tolerance - low	\$\$BlockComment\$\$ PV - low tolerance limit violated
	SIG 5	Warning - low	\$\$BlockComment\$\$ PV - low warning limit violated
	SIG 6	Alarm - low	\$\$BlockComment\$\$ PV - low alarm limit violated
	SIG 7	Alarm - high	\$\$BlockComment\$\$ ER - high alarm limit violated
	SIG 8	Alarm - low	\$\$BlockComment\$\$ ER - low alarm limit violated
MsgEvId2	SIG 7	Warning - high	\$\$BlockComment\$\$ Rbk - high warning limit violated
	SIG 8	Warning - low	\$\$BlockComment\$\$ Rbk - low warning limit violated

Explanation:

\$\$BlockComment\$\$: Content of the instance-specific comment

Instance-specific messages

You can use up to four instance-specific messages with this block.

Message instance	Message identifier	Message class	Event
MsgEvId2	SIG 1	AS process control message - fault	\$\$BlockComment\$\$ External message 1 Status 16#@5%x@
	SIG 2	AS process control message - fault	\$\$BlockComment\$\$ External message 2 Status 16#@6%x@
	SIG 3	AS process control message - fault	\$\$BlockComment\$\$ External message 3 Status 16#@7%x@
	SIG 4	AS process control message - fault	\$\$BlockComment\$\$ External message 4 Status 16#@8%x@

5.9 PIDConR - Continuous PID controller with external reset

Explanation:

\$\$BlockComment\$\$: Content of the instance-specific comment

Associated values for message instance `MsgEvId1`

Associated value	Block parameters
1	BatchName
2	StepNo
3	BatchID
4	Process value PV_Out
5	Control deviation ER
6	ExtVa106
7	ExtVa107
8	Not allocated
9	Not allocated
10	Not allocated

The associated values 6 ... 7 are allocated to the parameters ExtVa106 ... ExtVa107 and can be used. Additional information is available in the "Process Control System PCS 7 - Engineering System" manual.

Associated values for message instance `MsgEvId2`

Associated value	Block parameters
1	BatchName
2	StepNo
3	BatchID
4	Position feedback Rbk
5	Signal status ExtMsg1
6	Signal status ExtMsg2
7	Signal status ExtMsg3
8	Signal status ExtMsg4
9	ExtVa209
10	ExtVa210

The associated values 9 ... 10 are allocated to the parameters ExtVa209 ... ExtVa210 and can be used. Additional information is available in the "Process Control System PCS 7 - Engineering System" manual.

See also

PIDConR block diagram (Page 850)

PIDConR I/Os (Page 833)

PIDConR error handling (Page 829)

PIDConR functions (Page 815)

PIDConR modes (Page 813)

Description of PIDConR (Page 807)

5.9.6 PIDConR I/Os

I/Os of PIDConR

Input parameters

Parameter	Description	Type	Default
AdvCoEn	1 = Enable "program mode" via interconnection	STRUCT <ul style="list-style-type: none"> Value: BOOL ST: BYTE 	- <ul style="list-style-type: none"> 0 16#80
AdvCoOn*	1 = Enable "program mode" via faceplate	BOOL	0
AdvCoModSP	Type of "program mode": 1 = Setpoint specification 0 = Manipulated variable specification	BOOL	1
AdvCoMstrOn	1 = Enable (0-1) or disable (1-0) "program mode" via edge transition	STRUCT <ul style="list-style-type: none"> Value: BOOL ST: BYTE 	- <ul style="list-style-type: none"> 0 16#80
AdvCoMV	Specified value from the external program	REAL	0.0
AutExtSet*	1 = Activate "automatic" mode with external setpoint by interconnection (SP = SP_Ext)	STRUCT <ul style="list-style-type: none"> Value: BOOL ST: BYTE 	- <ul style="list-style-type: none"> 0 16#80
AutIntSet*	1 = Activate "automatic" mode with internal setpoint by interconnection (SP = SP_Op). AutIntSet has higher priority than AutExtSet.	STRUCT <ul style="list-style-type: none"> Value: BOOL ST: BYTE 	- <ul style="list-style-type: none"> 0 16#80
AutModOp*	1 = "Automatic" mode via operator	BOOL	0
BatchEn	1 = Enable allocation for batch control	BOOL	0
BatchID	Batch ID	DWORD	16#00000000
BatchName	Batch name	S7-String	
ByProt	1 = Interlock bypass during simulation	BOOL	0
ByLiOp	1 = Bypass commands via interconnection	STRUCT <ul style="list-style-type: none"> Value: BOOL ST: BYTE 	- <ul style="list-style-type: none"> 0 16#80
ByLock	1 = Bypass activation or deactivation is locked for operator	STRUCT <ul style="list-style-type: none"> Value: BOOL ST: BYTE 	- <ul style="list-style-type: none"> 0 16#80

Controller blocks

5.9 PIDConR - Continuous PID controller with external reset

Parameter	Description	Type	Default
BypPV	Substitution value if block is in bypass	REAL	0.0
BypPVLi	1 = Select bypass PV (via interconnection)	STRUCT <ul style="list-style-type: none"> Value: BOOL ST: BYTE 	- <ul style="list-style-type: none"> 0 16#80
BypPVOp	1 = Select bypass PV (via operator)	BOOL	0
CPI_In	Input for control performance index, which is calculated by the assigned ConPerMon block	STRUCT <ul style="list-style-type: none"> Value: REAL ST: BYTE 	- <ul style="list-style-type: none"> 0.0 16#78
CSF	1 = External error (control system fault) Error handling (Page 119)	STRUCT <ul style="list-style-type: none"> Value: BOOL ST: BYTE 	- <ul style="list-style-type: none"> 0 16#80
DeadBand	Width of dead band	REAL	0.0
DiffGain	Gain of differentiator [1..10] DiffGain = $T_D /$ (delay time of D component)	STRUCT <ul style="list-style-type: none"> Value: REAL ST: BYTE 	- <ul style="list-style-type: none"> 5.0 16#80
DiffSel	1 = D component activated	BOOL	1
DiffToFbk*	1 = D component is placed in the feedback	BOOL	1
EN	1 = Called block will be processed	BOOL	1
ER_A_DC*	Delay time for incoming ER high/low or only low alarms [s]	REAL	0.0
ER_AH_DC*	Delay time for incoming ER high alarms [s]	REAL	0.0
ER_AH_DFac*	Delay factor at positive setpoint step changes for incoming alarms at the error signal monitoring ER_AH_Lim	REAL	0.0
ER_A_DG*	Delay time for outgoing ER high/low or only low alarms [s]	REAL	0.0
ER_AH_DG*	Delay time for outgoing ER high alarms [s]	REAL	0.0
ER_AH_En	1 = Activate alarm (high) for error signal monitoring	BOOL	1
ER_AH_Lim	Alarm limit (high) for error signal monitoring	REAL	100.0
ER_AH_MsgEn	1 = Activate messages for alarm (high) for error signal monitoring	BOOL	1
ER_AL_DFac*	Delay factor at negative setpoint step changes for incoming alarms at the error signal monitoring ER_AL_Lim	REAL	0.0
ER_AL_En	1 = Activate alarm (low) for error signal monitoring	BOOL	1
ER_AL_Lim	Alarm limit (low) for error signal monitoring	REAL	-100.0
ER_AL_MsgEn	1 = Activate messages for alarm (low) for error signal monitoring	BOOL	1

5.9 PIDConR - Continuous PID controller with external reset

Parameter	Description	Type	Default
ER_Hyst	Alarm hysteresis for error signal	REAL	1.0
EventTsIn	For interconnecting data between a technology block and the message blocks <code>EventTs</code> , <code>Event16Ts</code> . The <code>EventTsIn</code> input parameter serves to interconnect the <code>EventTsOut</code> output parameter of the <code>EventTs</code> , <code>Event16Ts</code> block. When this interconnection is configured, the messages of the <code>EventTs</code> , <code>Event16Ts</code> block are displayed on the OS in the alarm view of the technology block and can also be acknowledged there.	ANY	
ExtMsg1	1 = Binary input for freely selectable message 1 is used	STRUCT <ul style="list-style-type: none"> Value: BOOL ST: BYTE 	- <ul style="list-style-type: none"> 0 16#80
ExtMsg2	1 = Binary input for freely selectable message 2 is used	STRUCT <ul style="list-style-type: none"> Value: BOOL ST: BYTE 	- <ul style="list-style-type: none"> 0 16#80
ExtMsg3	1 = Binary input for freely selectable message 3 is used	STRUCT <ul style="list-style-type: none"> Value: BOOL ST: BYTE 	- <ul style="list-style-type: none"> 0 16#80
ExtMsg4	1 = Binary input for freely selectable message 4 is used	STRUCT <ul style="list-style-type: none"> Value: BOOL ST: BYTE 	- <ul style="list-style-type: none"> 0 16#80
ExtReset	Value to which a reset is made if <code>ExtRstOn</code> = 1.	STRUCT <ul style="list-style-type: none"> Value: REAL ST: BYTE 	- <ul style="list-style-type: none"> 0.0 16#80
ExtRstOn	1 = Reset externally	STRUCT <ul style="list-style-type: none"> Value: BOOL ST: BYTE 	- <ul style="list-style-type: none"> 0 16#80
ExtVa106	Associated value 6 for messages (<code>MsgEvID1</code>)	ANY	
ExtVa107	Associated value 7 for messages (<code>MsgEvID1</code>)	ANY	
ExtVa209	Associated value 9 for messages (<code>MsgEvID2</code>)	ANY	
ExtVa210	Associated value 10 for messages (<code>MsgEvID2</code>)	ANY	
Feature	I/O for additional functions (Page 815)	STRUCT <ul style="list-style-type: none"> Bit 0: BOOL ... Bit 20: BOOL ... Bit 31: BOOL 	- <ul style="list-style-type: none"> 0 0 1 0 0

Controller blocks

5.9 PIDConR - Continuous PID controller with external reset

Parameter	Description	Type	Default
Feature2	I/O for additional functions (Page 815)	STRUCT <ul style="list-style-type: none"> • Bit 0: BOOL • ... • Bit 31: BOOL 	- <ul style="list-style-type: none"> • 0 • 0 • 0
FFwd*	Input for additive disturbance variable activation	STRUCT <ul style="list-style-type: none"> • Value: REAL • ST: BYTE 	- <ul style="list-style-type: none"> • 0.0 • 16#80
FFwdHiLim	Limit (high) for additive disturbance variable activation	STRUCT <ul style="list-style-type: none"> • Value: REAL • ST: BYTE 	- <ul style="list-style-type: none"> • 100.0 • 16#80
FFwdLoLim	Limit (low) for additive disturbance variable activation	STRUCT <ul style="list-style-type: none"> • Value: REAL • ST: BYTE 	- <ul style="list-style-type: none"> • -100.0 • 16#80
Gain	Proportional gain Gain.ST = 16#FF: Enabled in faceplate	STRUCT <ul style="list-style-type: none"> • Value: REAL • ST: BYTE 	- <ul style="list-style-type: none"> • 1.0 • 16#FF
InitPid*	InitPid edge transitions result in the PID algorithm's initialization equations being carried out. Is used, for example, for SP changes without MV jumps	STRUCT <ul style="list-style-type: none"> • Value: BOOL • ST: BYTE 	- <ul style="list-style-type: none"> • 0 • 16#80
Intl_En	1 = Interlock without reset (interlock, Intlock parameter) is in effect	BOOL	1
Intlock	0 = Interlock without reset is in effect Once the interlock condition has cleared, the block can be operated without reset 1 = Interlock not activated	STRUCT <ul style="list-style-type: none"> • Value: BOOL • ST: BYTE • Bit 1: BOOL (Bypass information bit) 	- <ul style="list-style-type: none"> • 1 • 16#FF • 0
IntSel	1 = I component activated	BOOL	1
Man*	Manual specification for the manipulated variable	REAL	0.0
ManHiLim	Limit (high) for manual parameter Man	REAL	100.0
ManLoLim	Limit (low) for manual parameter Man	REAL	0.0
ManModOp*	1 = "Manual" mode via OS operator	BOOL	1
ManSet*	1 = Activate "manual" mode via interconnection. ManSet has higher priority thanAutIntSet.	STRUCT <ul style="list-style-type: none"> • Value: BOOL • ST: BYTE 	- <ul style="list-style-type: none"> • 0 • 16#80
MS_RelOp*	1 = Release for maintenance by OS operator	BOOL	0
MsgEvID1	Message number (assigned automatically)	DWORD	16#00000000
MsgEvID2	Message number (assigned automatically)	DWORD	16#00000000

5.9 PIDConR - Continuous PID controller with external reset

Parameter	Description	Type	Default
MsgLock	1 = Suppress process messages. See also the section Suppressing messages using the MsgLock parameter (Page 205) for more on this.	STRUCT • Value: BOOL • ST: BYTE	- • 0 • 16#80
MV_Bump*	Default value for controller output MV if MV_BumpOn = 1	STRUCT • Value: REAL • ST: BYTE	- • 0.0 • 16#80
MV_BumpOn	1 = Set controller output MV:= MV_Bump without (!) taking the controller into "manual" mode.	STRUCT • Value: BOOL • ST: BYTE	- • 0 • 16#80
MV_ChnST	Signal status of output channel for MV Should be connected to an output channel block	STRUCT • Value: REAL • ST: BYTE	- • 0.0 • 16#FF
MV_Close	1 = Close adjustment valve by interconnection, i.e. MV:= MV_LoLim MV_Close has higher priority than MV_Open	STRUCT • Value: BOOL • ST: BYTE	- • 0 • 16#80
MV_Forced*	Forced manipulated variable that is not limited and assumes top priority	STRUCT • Value: REAL • ST: BYTE	- • 0.0 • 16#80
MV_ForOn	1 = Output forced manipulated variable MV_Forced unlimited at output MV	STRUCT • Value: BOOL • ST: BYTE	- • 0 • 16#80
MV_HiLim	Limit (high) for manipulated variable MV	STRUCT • Value: REAL • ST: BYTE	- • 100.0 • 16#80
MV_Mean	Mean value of the MV in the time window	STRUCT • Value: REAL • ST: BYTE	- • 0.0 • 16#00
MV_LoLim	Limit (low) for manipulated variable MV	STRUCT • Value: REAL • ST: BYTE	- • 0.0 • 16#80
MV_Offset	Manipulated variable for ER=0, operating point for controller with deactivated I component	REAL	0.0
MV_Open	1 = Open adjustment valve by interconnection, i.e. MV:= MV_HiLim MV_Open has higher priority than MV_TrkOn	STRUCT • Value: BOOL • ST: BYTE	- • 0 • 16#80
MV_OpScale	OS display range for manipulated variable MV	STRUCT • High: REAL • Low: REAL	- • 100.0 • 0.0

Controller blocks

5.9 PIDConR - Continuous PID controller with external reset

Parameter	Description	Type	Default
MV_SafePos	Manipulated variable neutral position	STRUCT <ul style="list-style-type: none"> Value: REAL ST: BYTE 	- <ul style="list-style-type: none"> 0 16#80
MV_Trk*	Tracking value for the manipulated variable MV	STRUCT <ul style="list-style-type: none"> Value: REAL ST: BYTE 	- <ul style="list-style-type: none"> 0.0 16#80
MV_TrkOn	1 = Tracking of manipulated variable MV	STRUCT <ul style="list-style-type: none"> Value: BOOL ST: BYTE 	- <ul style="list-style-type: none"> 0 16#80
MV_Unit	Unit of measure for manipulated variable	INT	1342
NegGain	0 = Effective proportional gain GainEff is positive 1 = Effective proportional gain GainEff is negative	STRUCT <ul style="list-style-type: none"> Value: BOOL ST: BYTE 	- <ul style="list-style-type: none"> 0 16#80
NormMV	Manipulated variable range (MV) for standardizing the proportional gain (GAIN)	STRUCT <ul style="list-style-type: none"> High: REAL Low: REAL 	- <ul style="list-style-type: none"> 100.0 0.0
NormPV*	Process value range (PV) for standardizing the proportional gain (GAIN)	STRUCT <ul style="list-style-type: none"> High: REAL Low: REAL 	- <ul style="list-style-type: none"> 100.0 0.0
Occupied	Occupied by batch control	BOOL	0
OosLi	1 = "Out of service", via interconnection or SFC (0-1 edge transition)	STRUCT <ul style="list-style-type: none"> Value: BOOL ST: BYTE 	- <ul style="list-style-type: none"> 0 16#80
OosOp*	1 = "Out of service", via OS operator	BOOL	0
OptimEn*	1 = Enable optimization of PID parameters by PID tuner	BOOL	0
OptimOcc*	1 = Optimization running	BOOL	0
OpSt_In	Input parameter for local operator authorization, connected with the Out output parameter of the upstream block, OpStations (Page 411)	DWORD	16#00000000
OS_Perm	I/O for operator permissions (Page 815)	STRUCT <ul style="list-style-type: none"> Bit 0: BOOL ... Bit 31: BOOL 	- <ul style="list-style-type: none"> 1 1 1
OSlPerm	I/O for operator permissions (Page 815)	STRUCT <ul style="list-style-type: none"> Bit 0: BOOL Bit 18: BOOL Bit 19: BOOL Bit 31: BOOL 	- <ul style="list-style-type: none"> 1 1 1 1

5.9 PIDConR - Continuous PID controller with external reset

Parameter	Description	Type	Default
PropFacSP	Applying the P component to the feedback [0..1]. 0 = P component fully in feedback	REAL	1.0
PropSel*	1 = Activate P component	BOOL	1
PV*	Process value (controlled variable)	STRUCT <ul style="list-style-type: none"> Value: REAL ST: BYTE 	- <ul style="list-style-type: none"> 0.0 16#80
PV_Unit	Unit of measure for process value	INT	1001
PV_AH_DC*	Delay time for incoming PV high alarms [s]	REAL	0.0
PV_AH_DG*	Delay time for outgoing PV high alarms [s]	REAL	0.0
PV_AH_En	1 = Enable PV alarm limit (high)	BOOL	1
PV_AH_Lim	Limit PV alarm (high)	REAL	95.0
PV_AH_MsgEn	1 = Enable PV alarm (high) message	BOOL	1
PV_AL_En	1 = Enable PV alarm limit (low)	BOOL	1
PV_AL_Lim	PV alarm limit (low)	REAL	5.0
PV_AL_MsgEn	1 = Enable PV alarm (low) message	BOOL	1
PV_AL_DC*	Delay time for incoming PV low alarms [s]	REAL	0.0
PV_AL_DG*	Delay time for outgoing PV low alarms [s]	REAL	0.0
PV_Hyst	Hysteresis for PV alarm, warning and tolerance limits	REAL	1.0
PV_OpScale	Limit for scale in PV bar graph of faceplate	STRUCT <ul style="list-style-type: none"> High: REAL Low: REAL 	- <ul style="list-style-type: none"> 100.0 0.0
PV_TH_DC*	Delay time for incoming PV high tolerance messages [s]	REAL	0.0
PV_TH_DG*	Delay time for outgoing PV high tolerance messages [s]	REAL	0.0
PV_TH_En	1 = Enable PV tolerance limit (high)	BOOL	0
PV_TH_Lim	Limit PV tolerance message (high)	REAL	85.0
PV_TH_MsgEn	1 = Enable message for PV tolerance message (high)	BOOL	1
PV_TL_DC*	Delay time for incoming PV low tolerance messages [s]	REAL	0.0
PV_TL_DG*	Delay time for outgoing PV low tolerance messages [s]	REAL	0.0
PV_TL_En	1 = Enable PV tolerance limit (low)	BOOL	0
PV_TL_Lim	Limit PV tolerance message (low)	REAL	15.0
PV_TL_MsgEn	1 = Activate message for PV tolerance message (low)	BOOL	1
PV_WH_DC*	Delay time for incoming PV high warnings [s]	REAL	0.0

Controller blocks

5.9 PIDConR - Continuous PID controller with external reset

Parameter	Description	Type	Default
PV_WH_DG*	Delay time for outgoing PV high warnings [s]	REAL	0.0
PV_WH_En	1 = Enable PV warning limit (high)	BOOL	1
PV_WH_Lim	Limit PV warning (high)	REAL	90.0
PV_WH_MsgEn	1 = Enable PV warning (high) message	BOOL	1
PV_WL_DC*	Delay time for incoming PV low warnings [s]	REAL	0.0
PV_WL_DG*	Delay time for outgoing PV low warnings [s]	REAL	0.0
PV_WL_En	1 = Enable PV warning limit (low)	BOOL	1
PV_WL_Lim	Limit PV warning (low)	REAL	10.0
PV_WL_MsgEn	1 = Enable PV warning (low) message	BOOL	1
Rbk*	Position feedback for display on OS	STRUCT • Value: REAL • ST: BYTE	- • 0.0 • 16#FF
RbkHyst	Alarm hysteresis for position feedback	REAL	1.0
RbkW_DC*	Delay time for incoming Rbk warnings [s]	REAL	0.0
RbkW_DG*	Delay time for outgoing Rbk warnings [s]	REAL	0.0
RbkWH_En	1 = Enable warning (high) for position feedback	BOOL	1
RbkWH_Lim	Limit for position feedback of warning (high)	REAL	100.0
RbkWH_MsgEn	1 = Enable messages for warning (high) for position feedback	BOOL	1
RbkWL_En	1 = Enable warning (low) for position feedback	BOOL	1
RbkWL_Lim	Limit for position feedback of warning (low)	REAL	0.0
RbkWL_MsgEn	1 = Enable messages for warning (low) for position feedback	BOOL	1
RefStdDevIn	Reference value of PV standard deviation (sigma) in defined "good" state of control loop	STRUCT • Value: REAL • ST: BYTE	- • 0.0 • 16#78
RstByPLi	1 = Reset bypass PV (via interconnection)	STRUCT • Value: BOOL • ST: BYTE	- • 0 • 16#80
RstByPOp	1 = Reset bypass PV (via operator)	BOOL	0
RunUpCyc	Number of cycles in startup; messages are suppressed during these cycles	INT	3
SafePos	1 = Neutral position (Page 48) for controller manipulated variable is ManHiLim 0 = Neutral position for controller manipulated variable is ManLoLim	BOOL	0

5.9 PIDConR - Continuous PID controller with external reset

Parameter	Description	Type	Default
SafePos2	Neutral position for controller manipulated variable: 0 = SafePos is valid 1 = Neutral position is MV_SafePos 2 = Neutral position is last manipulated variable (stop)	INT	0
SampleTime	Sampling time [s] (assigned automatically)	REAL	0.1
SelFp1	Call a block saved in this parameter as an additional faceplate (Page 208) in the standard view	ANY	-
SelFp2	Call a block saved in this parameter as an additional faceplate (Page 208) in the preview	ANY	-
SettliFactor	Factor to increase the settling time to adjust the dead band	REAL	2.0
SettliTime	Settling time [s] of the control loop determined by the ConPerMon block	STRUCT • Value: BOOL • ST: BYTE	- • 0 • 16#78
SimLiOp	Activation/deactivation of the simulation by: 0 = Operator 1 = Interconnection or SFC	STRUCT • Value: BOOL • ST: BYTE	- • 0 • 16#80
SimOnLi	1 = Simulation via interconnection or SFC (controlled by SimLiOp = 1)	STRUCT • Value: BOOL • ST: BYTE	- • 0 • 16#80
SimOn*	1 = Simulation on	BOOL	0
SimPV*	Process value used for SimOn = 1	REAL	0.0
SimPV_Li	Process value that is used for SimOnLi.Value = 1 (SimLiOp.Value = 1)	STRUCT • Value: REAL • ST: BYTE	- • 0.0 • 16#80
SimRbk*	Position feedback used for SimOn = 1	REAL	0.0
SimRbkLi	Position feedback used for SimOnLi.Value = 1 (SimLiOp.Value = 1)	STRUCT • Value: REAL • ST: BYTE	- • 0.0 • 16#80
SP_DnRaLim*	Limit (low) for the gradient of the setpoint [Unit/(Time unit)] Time unit depends on TimeFactor	REAL	100.0
SP_ExHiLim	Limit (high) for external setpoint	STRUCT • Value: REAL • ST: BYTE	- • 100.0 • 16#80
SP_ExLoLim	Limit (low) for external setpoint	STRUCT • Value: REAL • ST: BYTE	- • 0.0 • 16#80

Controller blocks

5.9 PIDConR - Continuous PID controller with external reset

Parameter	Description	Type	Default
SP_Ext*	external setpoint - (to interconnection)	STRUCT <ul style="list-style-type: none"> Value: REAL ST: BYTE 	- <ul style="list-style-type: none"> 0.0 16#80
SP_ExtOp*	1 = Select external setpoint (via operator)	BOOL	0
SP_InHiLim	Limit (high) of internal setpoint	REAL	100.0
SP_InLoLim	Limit (low) of internal setpoint	REAL	0.0
SP_Int*	Internal setpoint for operation	REAL	0.0
SP_IntOp*	1 = Select internal setpoint (via operator)	BOOL	0
SP_LiDnRaLim	Linkable limit (low) for the gradient of the setpoint [Unit/(Time unit)] Time unit depends on TimeFactor	REAL	100.0
SP_LiRmpTime	Linkable time [Time unit] for gradient limitation in ramp mode duration Time unit depends on TimeFactor	REAL	0.0
SP_LiUpRaLim	Linkable gradient limit (high) for the setpoint [Unit/(Time unit)] Time unit depends on TimeFactor	REAL	100.0
SP_Load*	Defined setpoint, if SP_LoadOn = 1	STRUCT <ul style="list-style-type: none"> Value: REAL ST: BYTE 	- <ul style="list-style-type: none"> 0.0 16#80
SP_LoadOn*	1 = Take controller into "automatic mode" with internal setpoint and set setpoint at SP:= SP_Load. This kind of setpoint specification has maximum priority.	STRUCT <ul style="list-style-type: none"> Value: BOOL ST: BYTE 	- <ul style="list-style-type: none"> 0 16#80
SP_RateOn*	1 = Activate limitation of setpoint gradients	BOOL	0
SP_RmpModTime	1 = Use time values (SP_RmpTime, SP_LiRmpTime) 0 = Use gradient limits (SP_DnRaLim, SP_LiDnRaLim, SP_UpRaLim, SP_LiUpRaLim)	BOOL	0
SP_RmpOn*	1 = Activate setpoint ramp to target setpoint SP_RmpTarget	BOOL	0
SP_RmpTarget*	Target setpoint for setpoint ramp	REAL	0.0
SP_RmpTime*	Time [Time unit] for setpoint ramp from current SP up to SP_RmpTarget or time [Time unit] for gradient limitation in ramp mode duration Time unit depends on TimeFactor	REAL	0.0
SP_TrkExt	1 = Bumpless switchover from external to internal setpoint active	BOOL	1
SP_TrkPV	1 = Setpoint follows PV in "manual mode" and with tracking	BOOL	0

5.9 PIDConR - Continuous PID controller with external reset

Parameter	Description	Type	Default
SP_UpRaLim*	Gradient limit (high) for the setpoint [Unit/(Time unit)]Time unit depends on TimeFactor	REAL	100.0
StepNo	Batch step number	DWORD	16#00000000
TD	Derivative time [s] TD.ST = 16#FF: Enabled in faceplate	STRUCT <ul style="list-style-type: none"> • Value: REAL • ST: BYTE 	- <ul style="list-style-type: none"> • 0.0 • 16#FF
TI	Integral time [s] TI.ST = 16#FF: Enabled in faceplate	STRUCT <ul style="list-style-type: none"> • Value: REAL • ST: BYTE 	- <ul style="list-style-type: none"> • 100.0 • 16#FF
TimeFactor	Time unit: 0 = Seconds 1 = Minutes 2 = Hours	INT	0
UserStatus	Freely assignable bits for use in PCS 7 OS	BYTE	16#00

* Values can be written back to these inputs during processing of the block by the block algorithm.

Output parameters

Parameter	Description	Type	Default
AdvCoAct	1 = "Program mode" enabled	STRUCT <ul style="list-style-type: none"> • Value: BOOL • ST: BYTE 	- <ul style="list-style-type: none"> • 0 • 16#80
AdvCoRdy	1 = "Program mode" available	STRUCT <ul style="list-style-type: none"> • Value: BOOL • ST: BYTE 	- <ul style="list-style-type: none"> • 0 • 16#80
AutAct	1 = "Automatic mode" enabled	STRUCT <ul style="list-style-type: none"> • Value: BOOL • ST: BYTE 	- <ul style="list-style-type: none"> • 0 • 16#80
BypassAct	1 = Bypass is activated in this block	STRUCT <ul style="list-style-type: none"> • Value: BOOL • ST: BYTE 	- <ul style="list-style-type: none"> • 0 • 16#80
CascaCut	Cascade connection: 1 = Control chain from primary to secondary controller is interrupted	STRUCT <ul style="list-style-type: none"> • Value: BOOL • ST: BYTE 	- <ul style="list-style-type: none"> • 0 • 16#80
DynDeadBand	Dynamic dead band	REAL	0.0

5.9 PIDConR - Continuous PID controller with external reset

Parameter	Description	Type	Default
PhaseDeadBand	Phase for the dynamic adjustment of the dead band 0: Dead band enabled 1: Dead band disabled 2: Settling time	INT	0
ENO	1 = Block algorithm completed without errors	BOOL	0
ER	Error signal	STRUCT • Value: REAL • ST: BYTE	- • 0.0 • 16#80
ER_A_DCOut	Effective delay time [s] for incoming alarms at the error signal monitoring	REAL	0.0
ER_AH_Act	1 = Alarm limit (high) for control deviation violated. You can change the reaction for this parameter with <i>Feature</i> bit 28 (Disabling operating points (Page 145)) and with <i>Feature</i> bit 29 (Signaling limit violation (Page 170)).	STRUCT • Value: BOOL • ST: BYTE • Bit 1: BOOL (Bypass information bit)	- • 0 • 16#80 • 0
ER_AL_Act	1 = Alarm limit (low) for control deviation violated. You can change the reaction for this parameter with <i>Feature</i> bit 28 (Disabling operating points (Page 145)) and with <i>Feature</i> bit 29 (Signaling limit violation (Page 170)).	STRUCT • Value: BOOL • ST: BYTE • Bit 1: BOOL (Bypass information bit)	- • 0 • 16#80 • 0
ErrorNum*	Output of pending error number. For error numbers that can be output by this block, see PIDConR error handling (Page 829)	INT	-1
FFwdHiAct	1 = Limit (high) for additive disturbance variable activation violated	STRUCT • Value: BOOL • ST: BYTE	- • 0 • 16#80
FFwdLoAct	1 = Limit (low) for additive disturbance variable activation violated	STRUCT • Value: BOOL • ST: BYTE	- • 0 • 16#80
GainEff	Effective proportional gain depends on <i>NegGain</i> , <i>Gain</i> , <i>NormPV</i> , and <i>NormMV</i>	REAL	1.0
GrpErr	1 = Group error pending	STRUCT • Value: BOOL • ST: BYTE	- • 0 • 16#80
LockAct	1 = Interlock is in effect	STRUCT • Value: BOOL • ST: BYTE	- • 0 • 16#80

5.9 PIDConR - Continuous PID controller with external reset

Parameter	Description	Type	Default
LoopClosed	1 = Control loop closed 0 = Control loop open	STRUCT • Value: BOOL • ST: BYTE	- • 0 • 16#80
ManAct	1 = "Manual mode" enabled	STRUCT • Value: BOOL • ST: BYTE	- • 1 • 16#80
ManHiOut	Limit (high) for "manual mode", corresponds to input parameter <code>ManHiLim</code>	STRUCT • Value: REAL • ST: BYTE	- • 100.0 • 16#80
ManLoOut	Limit (low) for "manual mode", corresponds to input parameter <code>ManLoLim</code>	STRUCT • Value: REAL • ST: BYTE	- • 0.0 • 16#80
MS_Release	Release for maintenance: 1 = Release for OS operator	STRUCT • Value: BOOL • ST: BYTE	- • 0 • 16#80
MsgAckn1	Message acknowledgement status 1 (output <code>ACK_STATE</code> of first <code>ALARM_8P</code>)	WORD	16#0000
MsgAckn2	Message acknowledgement status 2 (output <code>ACK_STATE</code> of second <code>ALARM_8P</code>)	WORD	16#0000
MsgErr1	Alarm error 1 (output <code>ERROR</code> of first <code>ALARM_8P</code>)	BOOL	0
MsgErr2	Alarm error 2 (output <code>ERROR</code> of second <code>ALARM_8P</code>)	BOOL	0
MsgStat1	Message status 1 (output <code>STATUS</code> of first <code>ALARM_8P</code>)	WORD	16#0000
MsgStat2	Message status 2 (output <code>STATUS</code> of second <code>ALARM_8P</code>)	WORD	16#0000
MV	Manipulated variable	STRUCT • Value: REAL • ST: BYTE	- • 0.0 • 16#80
MV_HiAct	1 = Limit (high) of manipulated variable violated	STRUCT • Value: BOOL • ST: BYTE	- • 0 • 16#80
MV_LoAct	1 = Limit (low) of manipulated variable violated	STRUCT • Value: BOOL • ST: BYTE	- • 0 • 16#80
MV_UnitOut	Unit of measure for manipulated variable, for interconnecting to the <code>MV_Unit</code> input parameter of the <code>ConPerMon</code> block	INT	0
OosAct	1 = Block is "out of service"	STRUCT • Value: BOOL • ST: BYTE	- • 0 • 16#80

Controller blocks

5.9 PIDConR - Continuous PID controller with external reset

Parameter	Description	Type	Default
OpSt_Out	Value of the OpSt_In input parameter, for feedforwarding to other blocks. Bit 31 of this parameter is used by Feature bit 24	DWORD	16#00000000
OS_PermOut	Display of OS_Perm	DWORD	16#FFFFFFFF
OS_PermLog	Display of OS_Perm with settings changed by the block algorithm	DWORD	16#FFFFFFFF
OS1PermOut	Display of OS1Perm	DWORD	16#FFFFFFFF
OS1PermLog	Display of OS1Perm with settings changed by the block algorithm	DWORD	16#FFFFFFFF
PV_AH_Act	1 = PV alarm (high) active. You can change the reaction for this parameter with Feature bit 28 (Disabling operating points (Page 145)) and with Feature bit 29 (Signaling limit violation (Page 170)).	STRUCT <ul style="list-style-type: none"> • Value: BOOL • ST: BYTE • Bit 1: BOOL (Bypass information bit) 	- <ul style="list-style-type: none"> • 0 • 16#80 • 0
PV_AH_Out	PV - High alarm limit output	REAL	0.0
PV_AL_Act	1 = PV alarm (low) active. You can change the reaction for this parameter with Feature bit 28 (Disabling operating points (Page 145)) and with Feature bit 29 (Signaling limit violation (Page 170)).	STRUCT <ul style="list-style-type: none"> • Value: BOOL • ST: BYTE • Bit 1: BOOL (Bypass information bit) 	- <ul style="list-style-type: none"> • 0 • 16#80 • 0
PV_AL_Out	PV - Low alarm limit output	REAL	0.0
PV_HysOut	PV - Alarm hysteresis output	REAL	0.0
PV_Out	Output for process value	STRUCT <ul style="list-style-type: none"> • Value: REAL • ST: BYTE • Bit 1: BOOL of internal fill byte (Bypass information bit) 	- <ul style="list-style-type: none"> • 0.0 • 16#80 • 0
PV_TH_Act	1 = PV tolerance message (high) active. You can change the reaction for this parameter with Feature bit 28 (Disabling operating points (Page 145)) and with Feature bit 29 (Signaling limit violation (Page 170)).	STRUCT <ul style="list-style-type: none"> • Value: BOOL • ST: BYTE • Bit 1: BOOL (Bypass information bit) 	- <ul style="list-style-type: none"> • 0 • 16#80 • 0
PV_TH_Out	PV - High tolerance limit output	REAL	0.0

5.9 PIDConR - Continuous PID controller with external reset

Parameter	Description	Type	Default
PV_TL_Act	1 = PV tolerance message (low) active. You can change the reaction for this parameter with <code>Feature</code> bit 28 (Disabling operating points (Page 145)) and with <code>Feature</code> bit 29 (Signaling limit violation (Page 170)).	STRUCT <ul style="list-style-type: none"> Value: BOOL ST: BYTE Bit 1: BOOL (Bypass information bit) 	- <ul style="list-style-type: none"> 0 16#80 0
PV_TL_Out	PV - Low tolerance limit output	REAL	0.0
PV_ToleHi	Limit (high) of 3-sigma band around the setpoint is calculated when a ConPerMon block is connected	STRUCT <ul style="list-style-type: none"> Value: REAL ST: BYTE 	- <ul style="list-style-type: none"> 0.0 16#80
PV_ToleLo	Limit (low) of 3-sigma band around the setpoint is calculated when a ConPerMon block is connected	STRUCT <ul style="list-style-type: none"> Value: REAL ST: BYTE 	- <ul style="list-style-type: none"> 0.0 16#80
PV_UnitOut	Unit of measure for process value, for interconnecting to the <code>PV_Unit</code> input parameter of the ConPerMon block	INT	0
PV_WH_Act	1 = PV warning (high) active. You can change the reaction for this parameter with <code>Feature</code> bit 28 (Disabling operating points (Page 145)) and with <code>Feature</code> bit 29 (Signaling limit violation (Page 170)).	STRUCT <ul style="list-style-type: none"> Value: BOOL ST: BYTE Bit 1: BOOL (Bypass information bit) 	- <ul style="list-style-type: none"> 0 16#80 0
PV_WH_Out	PV - High warning limit output	REAL	0.0
PV_WL_Act	1 = PV warning (low) active. You can change the reaction for this parameter with <code>Feature</code> bit 28 (Disabling operating points (Page 145)) and with <code>Feature</code> bit 29 (Signaling limit violation (Page 170)).	STRUCT <ul style="list-style-type: none"> Value: BOOL ST: BYTE Bit 1: BOOL (Bypass information bit) 	- <ul style="list-style-type: none"> 0 16#80 0
PV_WL_Out	PV - Low warning limit output	REAL	0.0
RbkOut	Output for position feedback	STRUCT <ul style="list-style-type: none"> Value: REAL ST: BYTE 	- <ul style="list-style-type: none"> 0.0 16#80
RbkWH_Act	1 = Warning (high) for position feedback active. You can change the reaction for this parameter with <code>Feature</code> bit 28 (Disabling operating points (Page 145)) and with <code>Feature</code> bit 29 (Signaling limit violation (Page 170)).	STRUCT <ul style="list-style-type: none"> Value: BOOL ST: BYTE 	- <ul style="list-style-type: none"> 0 16#80

Parameter	Description	Type	Default
RbkWL_Act	1 = Warning (low) for position feedback active. You can change the reaction for this parameter with <code>Feature</code> bit 28 (Disabling operating points (Page 145)) and with <code>Feature</code> bit 29 (Signaling limit violation (Page 170)).	STRUCT <ul style="list-style-type: none"> Value: BOOL ST: BYTE 	- <ul style="list-style-type: none"> 0 16#80
RdyToStart	1 = Active start readiness	STRUCT <ul style="list-style-type: none"> Value: BOOL ST: BYTE 	- <ul style="list-style-type: none"> 0 16#80
SettlingTimer	Settling time for a closed control loop	REAL	0.0
SP	Setpoint used by controller	STRUCT <ul style="list-style-type: none"> Value: REAL ST: BYTE 	- <ul style="list-style-type: none"> 0.0 16#80
SP_DnRaAct	1 = Negative gradient limiting of setpoint is active	STRUCT <ul style="list-style-type: none"> Value: BOOL ST: BYTE 	- <ul style="list-style-type: none"> 0 16#80
SP_ExHiAct	1 = Limit (high) for external setpoint has been reached	STRUCT <ul style="list-style-type: none"> Value: BOOL ST: BYTE 	- <ul style="list-style-type: none"> 0 16#80
SP_ExLoAct	1 = Limit (low) for external setpoint has been reached	STRUCT <ul style="list-style-type: none"> Value: BOOL ST: BYTE 	- <ul style="list-style-type: none"> 0 16#80
SP_ExtAct	1 = External setpoint is active 0 = Internal setpoint is active	STRUCT <ul style="list-style-type: none"> Value: BOOL ST: BYTE 	- <ul style="list-style-type: none"> 0 16#80
SP_ExtOut	External setpoint, corresponds to input parameter <code>SP_Ext</code>	STRUCT <ul style="list-style-type: none"> Value: REAL ST: BYTE 	- <ul style="list-style-type: none"> 0.0 16#80
SP_InHiOut	Limit (high) for <code>SP_Int</code> corresponds to input parameter <code>SP_InHiLim</code>	STRUCT <ul style="list-style-type: none"> Value: REAL ST: BYTE 	- <ul style="list-style-type: none"> 100.0 16#80
SP_InLoOut	Limit (low) for <code>SP_Int</code> corresponds to input parameter <code>SP_InLoLim</code>	STRUCT <ul style="list-style-type: none"> Value: REAL ST: BYTE 	- <ul style="list-style-type: none"> 0.0 16#80
SP_RateTarget	Target setpoint for the gradient limitation	REAL	0.0
SP_UpRaAct	Positive gradient limiting of setpoint is active	STRUCT <ul style="list-style-type: none"> Value: BOOL ST: BYTE 	- <ul style="list-style-type: none"> 0 16#80
SP_RemRT	Remaining ramp time of the setpoint	REAL	0.0
ST_Worst	Worst signal status	BYTE	16#80
Status1	Status word 1 (Page 807)	DWORD	16#00000000

Parameter	Description	Type	Default
Status2	Status word 2 (Page 807)	DWORD	16#00000000
Status3	Status word 2 (Page 807)	DWORD	16#00000000
SumMsgAct	1 = Active hardware interrupt	STRUCT <ul style="list-style-type: none"> • Value: BOOL • ST: BYTE 	- <ul style="list-style-type: none"> • 0 • 16#80

* Values can be written back to these inputs during processing of the block by the block algorithm.

Calculation of the output parameter ER_A_DCOut

ER_A_DC is assigned by default to the output before a setpoint change.

ER_A_DCOut = ER_A_DC

In the case of a setpoint change in the positive direction during automatic mode, the output is calculated as follows:

ER_A_DCOut = Maximum (ER_A_DC, ER_AH_DFac * Setpoint difference)

In the case of a setpoint change in the negative direction during automatic mode, the output is calculated as follows:

ER_A_DCOut = Maximum (ER_A_DC, -1*ER_AH_DFac * Setpoint difference)

When the control circuit has stabilized again, meaning

$(ER_AL_Lim + ER_Hyst) \leq ER \leq (ER_AH_Lim - ER_Hyst)$

and the delay time for outgoing alarms ER_A_DG has expired, the output is reset again to ER_A_DC: ER_A_DCOut = ER_A_DC

Activating and deactivating the function:

The function is deactivated (default) when the following applies: ER_AH_DFac = 0.0 and ER_AL_DFac = 0.0

See also

PIDConR block diagram (Page 850)

PIDConR messaging (Page 830)

PIDConR modes (Page 813)

5.9.7 PIDConR block diagram

PIDConR block diagram

A block diagram is not provided for this block.

See also

- PIDConR I/Os (Page 833)
- PIDConR messaging (Page 830)
- PIDConR error handling (Page 829)
- PIDConR functions (Page 815)
- PIDConR modes (Page 813)
- Description of PIDConR (Page 807)

5.9.8 Operator control and monitoring

5.9.8.1 PIDConR views

Views of the PIDConR block

This block has the same views as the PIDConL block. Refer to the section Operator control and monitoring (Page 775) of the PIDConL block.

5.10 PIDStepL - Step controller

5.10.1 Description of PIDStepL

Object name (type + number) and family

Type + number: FB 1878

Family: Control

Area of application for PIDStepL

The block is used for the following applications:

- Fixed setpoint control
- Cascade control
- Ratio control
- Split-range control
- Smith predictor closed-loop control
- Override control (override)

Note on restricting the area of application: The block is not intended for pulse-duration modulation. Examples of applications: Temperature control with electric heater, which can be switched on or off via a (semiconductor) relay. The heating power required by the controller, for example 80%, is output in the form of binary pulses, whereby the duration of the on pulses in this case is four times as long as the pause duration. Such control is built with a combination of a continuous controller (such as PIDConL) and the pulse generator module PULSEGEN from the CFC library ELEM_400.

How it works

The block is a PID step controller with binary output signals (manipulated variable signals). It is used to control integral action actuators (e.g. valves driven by motors).

The block functions following the PID algorithm with a delayed D component and an integrator with double precision.

The step controller can function both with and without a position feedback for the valve position.

The block is suitable for controlling sluggish control loops, for example, for temperatures and filling levels, and high-speed control loops, for example, for flow rates and speed. For a given CPU, a compromise has to be made between the number of controllers and the frequency with which the individual controllers have to be processed. The faster the modulated control loops are, i.e. the more frequently the manipulated variables have to be calculated per time unit, the lower the number of controllers that can be installed.

Configuration

Use the CFC editor to install the block in a cyclic interrupt OB (OB30 to OB38). The block is also installed automatically in the startup OB (OB100).

For the control loop monitoring to work as planned in the trend view of the controller faceplates, the

```
S7_xarchive:='Value, shortterm;'
```

attributes in the process tag types for control loops at the controller function block must be set for the following tags:

- Input parameters:
 - CPI_In
- Output parameters
 - MV
 - MV_HiAct
 - MV_LoAct
 - LoopClosed
 - SP
 - PV_Out
 - PV_ToleHi
 - PV_ToleLo

For the PIDStepL block, the Advanced Process Library contains templates for process tag types as examples and there is a example project (APL_Example_xx, xx designates the language variant) containing different application cases for this block.

Several process tag types are simulated in the example project and serve to explain the block function.

Examples of process tag types:

- Step controller with direct access to the actuator and without position feedback (StepControlDirect) (Page 2333)
- Step controller with assigned actuator block and position feedback (StepControlActor) (Page 2334)

Startup characteristics

Use the Feature Set startup characteristics (Page 138) to define the startup characteristics of this block.

The messages are suppressed after startup for the number of cycles set at RunUpCyc.

Status word allocation for status1 parameter

You can find a description for each parameter in section PIDStepL I/Os (Page 871).

Status bit	Parameter
0	Occupied
1	BatchEn
2	SimOn
3	OosAct.Value
4	OosLi.Value
5	AutAct.Value
6	Not used
7	ManAct.Value
8	SP_ExtAct.Value
9	MV_ForOn.Value
10	MV_TrkOn.Value
11	NOT RbkClosed.Value
12	Open.Value
13	Close.Value
14	Stop.Value
15	FbkOpened.Value
16	FbkClosed.Value
17	SimLiOp.Value
18	SimOn AND ManAct
19	AdvCoAct
20	1 = Input parameter Rbk is not interconnected (RbkOut.ST = 16#FF)
21	NegGain
22	1 = SP ramp active
23	OptimEn
24	OptimOcc
25	Not used
26	Display of BypassAct.Value in faceplate (display and operator controls) and block icon
27	Not used
28	1 = Input parameter OpenChnST is interconnected
29	1 = Input parameter CloseChnST is interconnected
30	1 = Input parameter StopChnST is interconnected
31	WithRbk = 1 (Step controller with position feedback)

Status word allocation for status2 parameter

Status bit	Parameter
0	MsgLock
1	PV_AH_Act.Value
2	PV_WH_Act.Value

5.10 PIDStepL - Step controller

Status bit	Parameter
3	PV_TH_Act.Value
4	PV_TL_Act.Value
5	PV_WL_Act.Value
6	PV_AL_Act.Value
7	PV_AH_En
8	PV_WH_En
9	PV_TH_En
10	PV_TL_En
11	PV_WL_En
12	PV_AL_En
13	PV_AH_MsgEn
14	PV_WH_MsgEn
15	PV_TH_MsgEn
16	PV_TL_MsgEn
17	PV_WL_MsgEn
18	PV_AL_MsgEn
19	ER_AH_Act.Value
20	ER_AL_Act.Value
21	ER_AH_En
22	ER_AL_En
23	ER_AH_MsgEn
24	ER_AL_MsgEn
25	RbkWH_Act.Value
26	RbkWL_Act.Value
27	RbkWH_En
28	RbkWL_En
29	RbkWH_MsgEn
30	RbkWL_MsgEn
31	MS_RelOp

Status word allocation for Status3 parameter

Status bit	Parameter
0	Effective signal 1 of the message block connected via EventTsIn
1	Effective signal 2 of the message block connected via EventTsIn
2	Effective signal 3 of the message block connected via EventTsIn
3	Effective signal 4 of the message block connected via EventTsIn
4	Effective signal 5 of the message block connected via EventTsIn
5	Effective signal 6 of the message block connected via EventTsIn
6	Effective signal 7 of the message block connected via EventTsIn
7	Effective signal 8 of the message block connected via EventTsIn
8	Delay of the PV_AH_Lim message

Status bit	Parameter
9	Delay of the PV_WH_Lim message
10	Delay of the PV_TH_Lim message
11	Delay of the PV_TL_Lim message
12	Delay of the PV_WL_Lim message
13	Delay of the PV_AL_Lim message
14	Delay of the ER_AH_Lim message
15	Delay of the ER_AL_Lim message
16	Collection of message delays
17	BypassAct.Value
18 - 26	Not used
27	SP_UpRaAct, SP_DnRaAct limits enabled for gradient mode (SP_RateOn = 1)
28	GrpErr.Value
29	RdyToStart.Value
30 - 31	Not used

Status word allocation for Status4 parameter

Status bit	Parameter
0 - 7	Effective signal 9..16 of the message block connected via EventTsIn
8 - 31	Not used

See also

- PIDStepL functions (Page 856)
- PIDStepL messaging (Page 868)
- PIDStepL modes (Page 855)
- PIDStepL error handling (Page 867)
- PIDStepL block diagram (Page 886)

5.10.2 PIDStepL modes

PIDStepL modes

The block can be operated using the following modes:

- Automatic mode (Page 72)
- Manual mode (Page 72)
- Program mode for controllers (Page 78)
- Out of service (Page 71)

The next section provides additional block-specific information relating to the general descriptions.

"Automatic mode"

You can find general information on "Automatic mode", switching modes and bumpless switchover in the section Manual and automatic mode for control blocks (Page 72).

"Manual mode"

You can find general information on "Manual mode", switching modes and bumpless switchover in the section Manual and automatic mode for control blocks (Page 72).

"Program mode for controllers"

You can find general information about the "Program mode for controller" in the section Program mode for controllers (Page 78).

"Out of service"

You can find general information about the "Out of service" mode in the section Out of service (Page 71).

See also

Description of PIDStepL (Page 851)

PIDStepL functions (Page 856)

PIDStepL error handling (Page 867)

PIDStepL messaging (Page 868)

PIDStepL I/Os (Page 871)

PIDStepL block diagram (Page 886)

5.10.3 PIDStepL functions

Functions of PIDStepL

The functions for this block are listed below.

Generation of manipulated variables with position feedback ($withRbk = 1$)

The manipulated variable MV and therefore the actuating signals $Open$, $Close$ and $Stop$ can be generated as follows:

MV_ForOn	ManAct	MV_TrkOn	AdvCoAct AND NOT AdvCoModSP	MV =	Limit monitoring	State	Open, Close, Stop
1	-	-	-	MV_Forced	none	Forced tracking through constraint without limitation	Depending on Rbk and MV , the output signals $Open$, $Close$ and $Stop$ are generated using the algorithm of a positioner.
0	1	-	-	Man	ManHiLim ManLoLim	Manual mode, set by the operator	
0	0	1	-	MV_Trk	MV_HiLim MV_LoLim	Tracking with limitation	
0	0	0	1	AdvCoMV	MV_HiLim MV_LoLim	Higher-level program mode	
0	0	0	0	P_Part + I_Part + D_Part + FFwd	MV_HiLim MV_LoLim	Automatic mode (PID algorithm)	

If the controller is in "out of service" mode, the output parameter MV is set to the last valid value in manual mode or the neutral position manipulated variable depending on the $Feature$ Bit (Neutral position manipulated variable takes effect at startup (Page 166)). Refer to the Out of service (Page 71) section for more on this.

Generation of actuating signal without position feedback ($withRbk = 0$)

The manipulated variable MV can be generated as follows:

ManAct	Open, Close, Stop	State
1	The output signals are generated using input signals $OpenOp/Li$, $CloseOp/Li$ or $StopOp/Li$	Manual mode, set by the operator
0	The output signals are generated using PD output variables P_Part , D_Part and $FFwd$	Automatic mode (PID algorithm)

If the controller is in "out of service" mode, the output parameter MV is set to the last valid value in manual mode or the neutral position manipulated variable depending on the $Feature$ Bit (Neutral position manipulated variable takes effect at startup (Page 166)). Refer to the Out of service (Page 71) section for more on this.

Three-position element with hysteresis and pulse generation

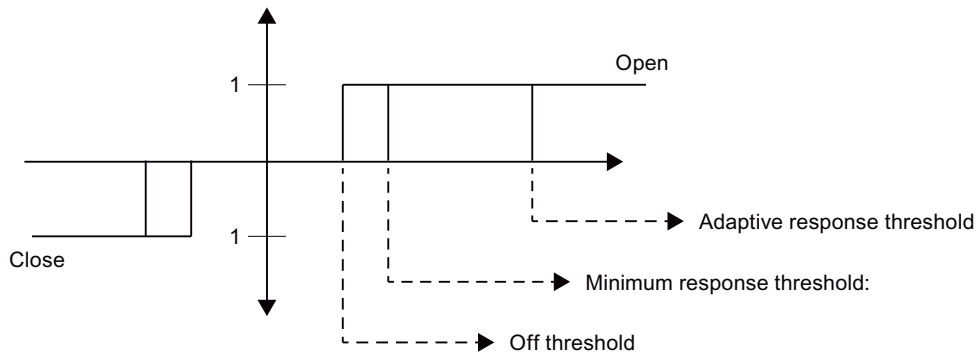

The difference $(MV - Rbk)$ for a step controller with position feedback forms the input for the three-position element. The difference for step controllers without position feedback is formed from the output of the PD block and an internal feedback, which is weighted by the common integration of the position signal $Open/Close$ $MotorTime$ and the I-component weighted by TI (see block diagram).

You can calculate the response threshold of the three position element as follows:

- Minimum response threshold: $100.0 * \text{Max}(\text{PulseTime}, \text{SampleTime}) / \text{MotorTime}$
- Off threshold: $0.5 * 110.0 / \text{MotorTime} * \text{SampleTime}$;

Using "ThrAdaOn" you can turn on an adaption of the response threshold to reduce the switching frequency. This only affects the closed control loop (automatic operation without tracking) and is limited to:

- Down: Minimum response threshold
- Up: 10

The currently effective response threshold can be read at the output "ThesOn".

The pulse generation after the three position element ensures that $PulseTime$ and $BreakTime$ are maintained during pulse generation.

Tracking and limiting a manipulated variable

The block provides the standard function Tracking and limiting a manipulated variable (Page 196).

Note

This function is only available to you if position feedback is enabled for the controller ($WithRbk = 1$).

Neutral position

The block provides the standard function Neutral position for motors, valves and controllers (Page 48).

Group error

This block provides the standard function Outputting group errors (Page 122).

The following parameters are taken into consideration when forming group errors:

- CSF

Outputting a signal for start readiness

This block provides the standard function Outputting a signal for start readiness (Page 53).

"Actuator active" information

If the parameter `FbkClosed = 0`, this is recognized as "Actuator active". This status can be used to indicate a customized symbol in the process image, for example, and is saved in the status word (see Status word section in Description of PIDStepL (Page 851)).

Limit monitoring of position feedback

The block provides the standard function Limit monitoring of the feedback (Page 94).

Note

This function is only available to you if position feedback is enabled for the controller (`WithRbk = 1`).

Group display SumMsgAct for limit monitoring, CSF and ExtMsgx

The block provides the standard function Group display for limit monitoring, CSF and ExtMsgx (Page 85).

External/internal setpoint specification

The block provides the standard function Setpoint specification - internal/external (Page 128).

Setpoint limiting for external setpoints

The block provides the standard function Setpoint limiting for external setpoints (Page 196).

Gradient limit of the setpoint

The block provides the standard function Gradient limit of the setpoint (Page 124).

Using setpoint ramp

The block provides the standard function Using setpoint ramp (Page 123).

Tracking setpoint in manual mode

The block provides the standard function Tracking setpoint in manual mode (Page 196).

Simulating signals

The block provides the standard function Simulating signals (Page 58).

You can simulate the following values:

- Process value (`SimPV`, `SimPV_Li`)
- Position feedback (`SimRbk`, `SimRbkLi`)

Bypass function

This block provides the standard function Bypassing signals (Page 107).

Limit monitoring of the process value

The block provides the standard function Limit monitoring of the process value (Page 86).

Error signal generation and dead band

The block provides the standard function Error signal generation and dead band (Page 192).

Limit monitoring of error signal

The block provides the standard function Limit monitoring of setpoint, manipulated variable and control deviation (Page 95).

Inverting control direction

The block provides the standard function Inverting control direction (Page 192).

Physical standardization of setpoint, manipulated variable and process value

Controller gain `Gain` is entered either using a physical variable or as standardized value.

`Gain` as a physical variable:

The standardized variables retain their default values:

- `NormPV.High = 100` and `NormPV.Low = 0`

The effective gain is:

$GainEff = Gain$

Entering a standardized `Gain` (dimensionless):

Change the standardized variables to the actual range of the process values and manipulated variables.

- Internal and external setpoints; the process value and corresponding parameters are entered according to the physical measuring range of the process value.
- The manual parameter, the tracking value of the manipulated variable, feedforward control and the corresponding parameters are entered as a percentage 0...100.

The effective gain is:

$$\text{GainEff} = 100.0 / (\text{NormPV.High} - \text{NormPV.Low}) \cdot \text{Gain}$$

Selecting a unit of measure

The block provides the standard function Selecting a unit of measure (Page 212).

PID algorithm

The manipulated variable is generated in automatic mode according to the following algorithm:

$$\text{MV} = \text{GainEff} \cdot (1 + 1 / (\text{TI} \cdot s) + (\text{TD} \cdot s) / (1 + \text{TD} / \text{DiffGain} \cdot s)) \cdot \text{ER}$$

Where:

s = Complex number

The following step response occurs:

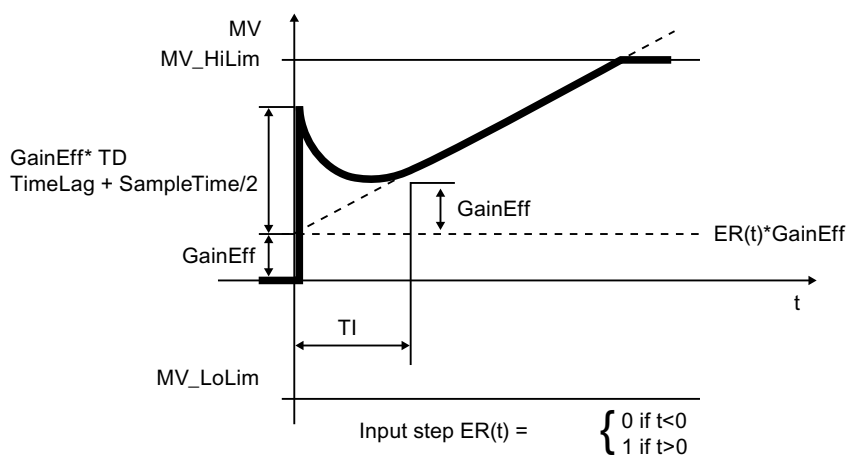

Note

The formula describes a standard application where P, I and D components are activated and the P and D components are not in the feedback circuit ($\text{PropSel} = 1$, $\text{TI} \neq 0$, $\text{DiffToFbk} = 0$ and $\text{IntSel} = 1$, $\text{DiffToFbk} = 0$ and $\text{PropFacSP} = 1$).

The D component delay is derived from $TD / DiffGain$.

- The P component is at the `P_Part` I/O and can be deactivated using `PropSel = 0`.
- The I component is displayed at the `I_Part` I/O and can be deactivated using `TI = 0` or `IntSel = 0`. In deactivated state, `I_Part` is specified by `MV_Offset` and added to the manipulated variable. Make a selection for this value so that the remaining control deviation equals zero at the control loop's typical operating point, at least. `IntSel` is used for temporary deactivation of the I component. The I component is not reactivated until `TI <> 0` and `IntSel = 1`. After the I component is activated, the integrator continues working starting from `MV_Offset`.
- The D component is displayed at the `D_Part` I/O and can be deactivated using `TD = 0` or `DiffSel = 0`.

Structure segmentation at controllers

The block provides the standard function Structure segmentation at controllers (Page 198).

Anti-windup

The controller has an anti-windup function. The I component is frozen after the manipulated variable has reached limits (`MV_HiLim` or `MV_LoLim`).

Feedforwarding and limiting disturbance variables

The block provides the standard function Feedforwarding and limiting disturbance variables (Page 197).

Forming the signal status for blocks

The block provides the standard function Forming and outputting the signal status for technologic blocks (Page 109).

- Signal status for the process value `PV_Out`:
The signal status of the output parameter `PV_Out` always corresponds to the signal status of input parameter `PV` or, if the block is in simulation mode, `16#60`.
- Signal status for the setpoint value `SP`:
The signal status of the `SP` output parameter is always equivalent to the signal status of input parameter `SP_Ext` or `SP_Int`, depending on how the setpoint is specified. If the internal setpoint `SP_Int` is used, the signal status is always output as `16#80`.
- Signal status of the error signal `ER`:
The signal status of output parameter `ER` is obtained from the worst signal status of the two output parameters `PV_Out` and `SP` and is output.
The signal status `16#60` (external simulation) is suppressed because the block acts as a sink with external simulation.
- Signal status for position feedback `RbkOut`:
The signal status of `RbkOut` always corresponds to the signal status of input parameter `Rbk` or, if the block is in simulation mode, `16#60`. `RbkOut` is always `16#80` for step controllers without position feedback.

- Signal status for the manipulated variable `MV`:
The signal status of output parameter `MV` is obtained in "automatic mode" from the worst signal status of the following parameters and is output:
`ER.STFFwd.STFbkOpened.STFbkClosed.STRbkOut.ST`The signal status `16#60` (external simulation) is suppressed because the block acts as a sink with external simulation. In "manual mode" and for step controllers without position feedback, the signal status is always output as good.
- Signal status for `Open`, `Close`, `Stop`:
The signal status is `16#60` when simulation is activated; otherwise, it is always `16#80`.
- Worst signal status:
The worst signal status `ST_Worst` for the block is formed from the following parameters:
 - `SP.ST`;
 - `PV_Out.ST`;
 - `FFwd.ST`;
 - `FbkOpened.ST`;
 - `FbkClosed.ST`;
 - `RbkOut.ST`;
 - `OpenChnST.ST`;
 - `CloseChnST.ST`;
 - `StopChnST.ST`;

Note

The `RbkOut.ST` parameter is always `16#80` for a step controller without position feedback (`WithFbk = 0`).

Configurable reactions using the `Feature` parameter

You can find an overview of all reactions provided by the `Feature` parameter in the Configurable functions using the `Feature` I/O (Page 131). The following functionality is available for this block at the relevant bits:

Bit	Function
0	Set startup characteristics (Page 138)
1	Reaction to the out of service mode (Page 177)
2	Resetting the commands for changing the mode (Page 161)
4	Setting switch or button mode (Page 167)
6	Ramp rate calculation (Page 179)
9	Substitution value is active if the block is in bypass (Page 185)
11	Gradient limitation with time duration (Page 182)
15	Neutral position manipulated variable takes effect with "out of service" operating mode (Page 166)
16	Neutral position manipulated variable takes effect at startup (Page 166)
18	Disabling bumpless switchover to automatic mode for controllers (Page 173)

Bit	Function
22	Update acknowledgment and error status of the message call (Page 160)
23	SP following PV in open loop has no priority over SP_Ext and SP limits (Page 179)
24	Enabling local operator authorization (Page 158)
25	Suppression of all messages (Page 174)
26	Reaction of the switching points in the "Out of service" operating mode (Page 176)
28	Disabling operating points (Page 145)
29	Signaling limit violation (Page 170)

Configurable reactions using the Feature2 parameter

Bit	Function
11	Suppress MsgLock and "Out of service" mode for a connected message block (Page 188)

Operator permissions

The block provides the standard function Operator control permissions (Page 254).

The block has the following permissions for the OS_Perm parameter:

Bit	Function
0	1 = Operator can switch to "automatic mode" AutModOp
1	1 = Operator can switch to "manual mode" ManModOp
2	1 = Operator can switch to "Out of service" mode OosOp
3	1 = Operator can switch to "program mode" AdvCoEn
4	1 = Operator can switch the setpoint to "external" SP_ExtOp
5	1 = Operator can switch the setpoint to "internal" SP_IntOp
6	1 = Operator can change the internal setpoint SP_Int
7	1 = Operator can change the manual parameter Man (WithRbk = 1)
8	1 = Operator can change operation high limit of the setpoint SP_InHiLim
9	1 = Operator can change operation low limit of the setpoint SP_InLoLim
10	1 = Operator can change the operation high limit of the manipulated variable ManHiLim
11	1 = Operator can change the operation low limit of the manipulated variable ManLoLim
12	1 = Operator can enable the setpoint's gradient limitation function SP_RateOn
13	1 = Operator can change the setpoint's high limit for the ramp SP_UpRaLim
14	1 = Operator can change the setpoint's low limit for the ramp SP_DnRaLim
15	1 = Operator can switch between the time value or the value for the ramp SP_RmpModTime
16	1 = Operator can change the ramp time SP_RmpTime
17	1 = Operator can change the target setpoint SP_RmpTarget for the setpoint ramp
18	1 = Operator can enable the setpoint ramp function SP_RmpOn
19	1 = Operator can permit the PID optimization function OptimEn
20	1 = Operator can enable the track setpoint in "manual mode" function SP_TrkPV
21	1 = Operator can enable the bumpless switchover from external to internal SP_TrkExt
22	1 = Operator can change the gain parameter Gain

Bit	Function
23	1 = Operator can change the integral time parameter <code>TI</code>
24	1 = Operator can change the derivative time parameter <code>TD</code>
25	1 = Operator can change the derivative gain parameter <code>DiffGain</code>
26	1 = Operator can change the dead band parameter <code>DeadBand</code>
27	1 = Operator can activate bypass functionality
28	1 = Operator can change the integral time parameter <code>MotorTime</code>
29	1 = Operator can change the integral time parameter <code>PulseTime</code>
30	1 = Operator can change the integral time parameter <code>BreakTime</code>
31	1 = Operator can deactivate bypass functionality

The block has the following permissions for the `OS1Perm` parameter:

Bit	Function
0	1 = Operator can change the limit (process value) <code>PV_AH_Lim</code> for the high alarm
1	1 = Operator can change the limit (process value) <code>PV_WH_Lim</code> for the high warning
2	1 = Operator can change the limit (process value) <code>PV_TH_Lim</code> for the high tolerance
3	1 = Operator can change the hysteresis (process value) <code>PV_Hyst</code>
4	1 = Operator can change the limit (process value) <code>PV_TL_Lim</code> for the low tolerance
5	1 = Operator can change the limit (process value) <code>PV_WL_Lim</code> for the low warning
6	1 = Operator can change the limit (process value) <code>PV_AL_Lim</code> for the low alarm
7	1 = Operator can change the limit (error signal) <code>ER_AH_Lim</code> for the high alarm
8	1 = Operator can change the hysteresis (error signal) <code>ER_Hyst</code>
9	1 = Operator can change the limit (error signal) <code>ER_AL_Lim</code> for the low alarm
10	1 = Operator can change the limit (position feedback) <code>RbkWH_Lim</code> for the high warning
11	1 = Operator can change the hysteresis (position feedback) <code>RbkHyst</code>
12	1 = Operator can change the limit (position feedback) <code>RbkWL_Lim</code> for the low warning
13	1 = Operator can open the valve: <code>OpenOp (WithRbk = 0)</code>
14	1 = Operator can close the valve: <code>CloseOp (WithRbk = 0)</code>
15	1 = Operator can stop the valve: <code>StopOp (WithRbk = 0)</code>
16	1 = Operator can activate the Simulation function <code>SimOn</code>
17	1 = Operator can activate the Release for maintenance function <code>MS_RelOp</code>
18	1 = Operator can activate / deactivate messages via <code>PV_AH_MsgEn</code>
19	1 = Operator can activate / deactivate messages via <code>PV_WH_MsgEn</code>
20	1 = Operator can activate / deactivate messages via <code>PV_TH_MsgEn</code>
21	1 = Operator can activate / deactivate messages via <code>PV_TL_MsgEn</code>
22	1 = Operator can activate / deactivate messages via <code>PV_WL_MsgEn</code>
23	1 = Operator can activate / deactivate messages via <code>PV_AL_MsgEn</code>
24	1 = Operator can activate / deactivate messages via <code>ER_AH_MsgEn</code>
25	1 = Operator can activate / deactivate messages via <code>ER_AL_MsgEn</code>
26	1 = Operator can activate / deactivate messages via <code>RbkWH_MsgEn</code>
27	1 = Operator can activate / deactivate messages via <code>RbkWL_MsgEn</code>
28	1 = Operator can change the simulation value <code>SimPV</code>
29	1 = Operator can change the simulation value <code>SimRbk</code>

Bit	Function
18 - 29	Not used
30	1 = Operator can activate the derivative action to the feedback path <code>DiffToFbk</code>
31	1 = Operator can change the proportional action to the feedback path <code>PropFacSP</code>

Note

If you interconnect a parameter that is also listed in `OS_Perm` as a parameter, you have to reset the corresponding `OS_Perm` bit.

Release for maintenance

The block provides the standard function Release for maintenance (Page 64).

Generating instance-specific messages

The block provides the standard function Generating instance-specific messages (Page 204) without the time stamp function in the I/O.

Suppressing messages using the `MsgLock` parameter

This block provides the standard function Suppressing messages using the `MsgLock` parameter (Page 205).

Specifying the display area for process and setpoint values as well as operations

This block provides the standard function Display and operator input area for process values and setpoints (Page 207).

Opening additional faceplates

This block provides the standard function Opening additional faceplates (Page 208).

SIMATIC BATCH functionality

This block provides the standard function SIMATIC BATCH functionality (Page 67).

Button labels

This block provides the standard function Labeling of buttons and text (Page 209)

Instance-specific text can be configured for the following parameters:

- `OpenOp`
- `StopOp`
- `CloseOp`

Connection of the time-stamped messages from EventTs or Event16Ts

This block provides the standard function Connection of the time-stamped messages from EventTs or Event16Ts (Page 207).

See also

PIDStepL messaging (Page 868)

PIDStepL I/Os (Page 871)

PIDStepL error handling (Page 867)

PIDStepL modes (Page 855)

PIDStepL block diagram (Page 886)

Evaluation of the signal status of the interlock signals (Page 142)

5.10.4 PIDStepL error handling

Error handling of PIDStepL

Refer to section Error handling (Page 119) in the basic instructions for the error handling of all blocks.

The following errors can be displayed for this block:

- Error numbers
- Control system fault (CSF)

Overview of error numbers

The `ErrorNum` output parameter can be used to output the following error numbers:

Error number	Meaning of the error number
-1	Predefined value when inserting the block; the block is not executed
0	There is no error.
30	The value of <code>PV</code> can no longer be displayed in the REAL number field.
31	The value of <code>SP_Ext</code> can no longer be displayed in the REAL number field.
32	The value of <code>FFwd</code> can no longer be displayed in the REAL number field.
33	The value of <code>MV_Trk</code> can no longer be displayed in the REAL number field.
34	The value of <code>MV_Forced</code> can no longer be displayed in the REAL number field.
35	The value of <code>Rbk</code> can no longer be displayed in the REAL number field.
36	The value of <code>MV</code> can no longer be displayed in the REAL number field.
50	The controller cannot be switched to program mode, because program mode with default setpoint (<code>AdvCoModSP = 0</code>) is not possible for step controllers without position feedback (<code>WithRbk = 0</code>).

Error number	Meaning of the error number
51	AutModLi = 1 and ManModLi = 1 SP_LiOp = 1 and SP_IntLi = 1 and SP_ExtLi = 1 OpenLi = 1 and StopLi = 1 CloseLi = 1 and StopLi = 1 OpenLi = 1 and CloseLi = 1
59	= 1 "Gain is negative"
60	$ TI < SampleTime / 2$
61	$ TD < SampleTime$
62	DiffGain < 1 or DiffGain > 10
63	$TD / DiffGain < SampleTime / 2$
64	PropFacSP < 0 or PropFacSP > 1
66	NormPV_High = NormPV_Low
67	MotorTime < SampleTime
68	PulseTime < SampleTime
69	BreakTime < SampleTime

Control system fault (CSF)

An external signal can be activated via the CSF input. A control system fault is triggered if this signal changes to 1. Refer to the Error handling (Page 119) section for more on this.

See also

- PIDStepL functions (Page 856)
- Description of PIDStepL (Page 851)
- PIDStepL modes (Page 855)
- PIDStepL messaging (Page 868)
- PIDStepL I/Os (Page 871)
- PIDStepL block diagram (Page 886)
- Setting switch or button mode (Page 167)

5.10.5 PIDStepL messaging

Messaging

The following messages can be generated for this block:

- Process control fault
- Process messages
- Instance-specific messages

Process control fault

The following control system error messages can be output:

Message instance	Message identifier	Message class	Event
MsgEvId2	SIG 6	AS process control message - fault	\$\$BlockComment\$\$ External error has occurred

Explanation:

\$\$BlockComment\$\$: Content of the instance-specific comment

You can interconnect an external fault (signal) to input parameter `CSF`. If it changes to `CSF = 1`, a process control fault is triggered (MsgEvId2, SIG 6).

Process messages

Message instance	Message identifier	Message class	Event
MsgEvId1	SIG 1	Alarm - high	\$\$BlockComment\$\$ PV - high alarm limit violated
	SIG 2	Warning - high	\$\$BlockComment\$\$ PV - high warning limit violated
	SIG 3	Tolerance - high	\$\$BlockComment\$\$ PV - high tolerance limit violated
	SIG 4	Tolerance - low	\$\$BlockComment\$\$ PV - low tolerance limit violated
	SIG 5	Warning - low	\$\$BlockComment\$\$ PV - low warning limit violated
	SIG 6	Alarm - low	\$\$BlockComment\$\$ PV - low alarm limit violated
	SIG 7	Alarm - high	\$\$BlockComment\$\$ ER - high alarm limit violated
	SIG 8	Alarm - low	\$\$BlockComment\$\$ ER - low alarm limit violated
MsgEvId2	SIG 7	Warning - high	\$\$BlockComment\$\$ Rbk - high warning limit violated
	SIG 8	Warning - low	\$\$BlockComment\$\$ Rbk - low warning limit violated

Explanation:

\$\$BlockComment\$\$: Content of the instance-specific comment

Instance-specific messages

You can use up to four instance-specific messages with this block.

Message instance	Message identifier	Message class	Event
MsgEvId2	SIG 1	AS process control message - fault	\$\$BlockComment\$\$ External message 1 Status 16#@5%x@
	SIG 2	AS process control message - fault	\$\$BlockComment\$\$ External message 2 Status 16#@6%x@
	SIG 3	AS process control message - fault	\$\$BlockComment\$\$ External message 3 Status 16#@7%x@
	SIG 4	AS process control message - fault	\$\$BlockComment\$\$ External message 4 Status 16#@8%x@

Explanation:

\$\$BlockComment\$\$: Content of the instance-specific comment

Associated values for message instance MsgEvId1

Associated value	Block parameters
1	BatchName
2	StepNo
3	BatchID
4	Process value PV_Out
5	Control deviation ER
6	ExtVa106
7	ExtVa107
8	Not allocated
9	Not allocated
10	Not allocated

The associated values 6 ... 7 are allocated to the parameters ExtVa106 ... ExtVa107 and can be used. Additional information is available in the "Process Control System PCS 7 - Engineering System" manual.

Associated values for message instance MsgEvId2

Associated value	Block parameters
1	BatchName
2	StepNo
3	BatchID

Associated value	Block parameters
4	Position feedback Rbk
5	Signal status ExtMsg1
6	Signal status ExtMsg2
7	Signal status ExtMsg3
8	Signal status ExtMsg4
9	ExtVa209
10	ExtVa210

The associated values 9 ... 10 are allocated to the parameters ExtVa209 ... ExtVa210 and can be used. Additional information is available in the "Process Control System PCS 7 - Engineering System" manual.

See also

Description of PIDStepL (Page 851)

PIDStepL functions (Page 856)

PIDStepL I/Os (Page 871)

PIDStepL modes (Page 855)

PIDStepL error handling (Page 867)

PIDStepL block diagram (Page 886)

5.10.6 PIDStepL I/Os

I/Os of PIDStepL

Input parameters

Parameter	Description	Type	Default
AdvCoEn	1 = Enable "program mode" via interconnection	STRUCT <ul style="list-style-type: none"> Value: BOOL ST: BYTE 	- <ul style="list-style-type: none"> 0 16#80
AdvCoOn*	1 = Enable "program mode" via faceplate	BOOL	0
AdvCoModSP	Type of "program mode": 1 = Setpoint specification 0 = Manipulated variable specification	BOOL	1
AdvCoMstrOn	Activate (0-1) or deactivate (1-0) "program mode" via edge transition	STRUCT <ul style="list-style-type: none"> Value: BOOL ST: BYTE 	- <ul style="list-style-type: none"> 0 16#80
AdvCoMV	Specified value from the external program	REAL	0.0

Controller blocks

5.10 PIDStepL - Step controller

Parameter	Description	Type	Default
AutModLi*	1 = "Automatic mode" via interconnection or SFC (controlled by ModLiOp = 1)	STRUCT <ul style="list-style-type: none"> Value: BOOL ST: BYTE 	- <ul style="list-style-type: none"> 0 16#80
AutModOp*	1 = "Automatic mode" via operator (controlled by ModLiOp = 0)	BOOL	0
BatchEn	1 = Enable allocation for batch control	BOOL	0
BatchID	Batch ID	DWORD	16#00000000
BatchName	Batch name	S7-String	
BreakTime	Minimum break duration [s]	REAL	1.0
BypliOp	1 = Bypass commands via interconnection	STRUCT <ul style="list-style-type: none"> Value: BOOL ST: BYTE 	- <ul style="list-style-type: none"> 0 16#80
BypLock	1 = Bypass activation or deactivation is locked for operator	STRUCT <ul style="list-style-type: none"> Value: BOOL ST: BYTE 	- <ul style="list-style-type: none"> 0 16#80
BypPV	Substitution value if block is in bypass	REAL	0.0
BypPVLi	1 = Select bypass PV (via interconnection)	STRUCT <ul style="list-style-type: none"> Value: BOOL ST: BYTE 	- <ul style="list-style-type: none"> 0 16#80
BypPVOp	1 = Select bypass PV (via operator)	BOOL	0
CloseChnST	Output channel state of Close Should be connected to an output channel block	STRUCT <ul style="list-style-type: none"> Value: BOOL ST: BYTE 	- <ul style="list-style-type: none"> 0 16#FF
CloseLi*	1 = Close via interconnection or CFC	STRUCT <ul style="list-style-type: none"> Value: BOOL ST: BYTE 	- <ul style="list-style-type: none"> 0 16#80
CloseOp*	1 = Close via operator	BOOL	0
CPI_In	Input for control performance index, which is calculated by the assigned ConPerMon block	STRUCT <ul style="list-style-type: none"> Value: REAL ST: BYTE 	- <ul style="list-style-type: none"> 0.0 16#78
CSF	1 = External error (control system fault) Error handling (Page 119)	STRUCT <ul style="list-style-type: none"> Value: BOOL ST: BYTE 	- <ul style="list-style-type: none"> 0 16#80
DeadBand	Width of dead band	REAL	0.0
DiffGain	Gain of differentiator [1..10] $DiffGain = TD /$ (delay time of D component)	STRUCT <ul style="list-style-type: none"> Value: REAL ST: BYTE 	- <ul style="list-style-type: none"> 5.0 16#FF
DiffSel	1 = D component activated	BOOL	1
DiffToFbk	1 = D component is placed in the feedback	BOOL	0
EN	1 = Called block will be processed	BOOL	1

Parameter	Description	Type	Default
ER_A_DC*	Delay for incoming alarms during error signal monitoring	REAL	0.0
ER_A_DG*	Delay for outgoing alarms during error signal monitoring	REAL	0.0
ER_AH_En	1 = Activate alarm (high) for error signal monitoring	BOOL	1
ER_AH_Lim	Alarm limit (high) for error signal monitoring	REAL	100.0
ER_AH_MsgEn	1 = Activate messages for alarm (high) for error signal monitoring	BOOL	1
ER_AL_En	1 = Activate alarm (low) for error signal monitoring	BOOL	1
ER_AL_Lim	Alarm limit (low) for error signal monitoring	REAL	-100.0
ER_AL_MsgEn	1 = Activate messages for alarm (low) for error signal monitoring	BOOL	1
ER_Hyst	Alarm hysteresis for error signal	REAL	1.0
EventTsIn	For interconnecting data between a technology block and the message blocks <code>EventTs</code> , <code>Event16Ts</code> . The <code>EventTsIn</code> input parameter serves to interconnect the <code>EventTsOut</code> output parameter of the <code>EventTs</code> , <code>Event16Ts</code> block. When this interconnection is configured, the messages of the <code>EventTs</code> , <code>Event16Ts</code> block are displayed on the OS in the alarm view of the technology block and can also be acknowledged there.	ANY	
ExtMsg1	1 = Binary input for freely selectable message 1 is used	STRUCT • Value: BOOL • ST: BYTE	- • 0 • 16#80
ExtMsg2	1 = Binary input for freely selectable message 2 is used	STRUCT • Value: BOOL • ST: BYTE	- • 0 • 16#80
ExtMsg3	1 = Binary input for freely selectable message 3 is used	STRUCT • Value: BOOL • ST: BYTE	- • 0 • 16#80
ExtMsg4	1 = Binary input for freely selectable message 4 is used	STRUCT • Value: BOOL • ST: BYTE	- • 0 • 16#80
ExtVa106	Associated value 6 for messages (<code>MsgEvID1</code>)	ANY	
ExtVa107	Associated value 7 for messages (<code>MsgEvID1</code>)	ANY	
ExtVa209	Associated value 9 for messages (<code>MsgEvID2</code>)	ANY	
ExtVa210	Associated value 10 for messages (<code>MsgEvID2</code>)	ANY	

Controller blocks

5.10 PIDStepL - Step controller

Parameter	Description	Type	Default
FbkClosed	Low limit stop signal of position feedback	STRUCT <ul style="list-style-type: none"> Value: BOOL ST: BYTE 	- 0 16#80
FbkOpened	High limit stop signal of position feedback	STRUCT <ul style="list-style-type: none"> Value: BOOL ST: BYTE 	- <ul style="list-style-type: none"> 0 16#80
Feature	I/O for additional functions (Page 856)	STRUCT <ul style="list-style-type: none"> Bit 0: BOOL ... Bit 31: BOOL 	- <ul style="list-style-type: none"> 0 0 0
FFwd*	Input for additive disturbance variable activation	STRUCT <ul style="list-style-type: none"> Value: REAL ST: BYTE 	- <ul style="list-style-type: none"> 0.0 16#80
FFwdHiLim	Limit (high) for additive disturbance variable activation	STRUCT <ul style="list-style-type: none"> Value: REAL ST: BYTE 	- <ul style="list-style-type: none"> 100.0 16#80
FFwdLoLim	Limit (low) for additive disturbance variable activation	STRUCT <ul style="list-style-type: none"> Value: REAL ST: BYTE 	- <ul style="list-style-type: none"> -100.0 16#80
Gain	Proportional gain Gain.ST = 16#FF: Enabled in faceplate	STRUCT <ul style="list-style-type: none"> Value: REAL ST: BYTE 	- <ul style="list-style-type: none"> 1.0 16#FF
IntHoldNeg	1 = Integrator cannot run in negative direction	STRUCT <ul style="list-style-type: none"> Value: BOOL ST: BYTE 	- <ul style="list-style-type: none"> 0 16#80
IntHoldPos	1 = Integrator cannot run in positive direction	STRUCT <ul style="list-style-type: none"> Value: BOOL ST: BYTE 	- <ul style="list-style-type: none"> 0 16#80
IntSel	1 = I component activated	BOOL	1
Man*	Manual specification for the manipulated variable	REAL	0.0
ManHiLim	Limit (high) for manual parameter <i>Man</i>	REAL	100.0
ManLoLim	Limit (low) for manual parameter <i>Man</i>	REAL	0.0
ManModLi*	1 = "Manual mode" via interconnection or SFC (controlled by <i>ModLiOp</i> = 1)	STRUCT <ul style="list-style-type: none"> Value: BOOL ST: BYTE 	- <ul style="list-style-type: none"> 0 16#80
ManModOp*	1 = "Manual mode" via OS operator (controlled by <i>ModLiOp</i> = 0)	BOOL	1
ModLiOp	Operating mode switchover between: 0 = Operator 1 = Interconnection or SFC	STRUCT <ul style="list-style-type: none"> Value: BOOL ST: BYTE 	- <ul style="list-style-type: none"> 0 16#80

Parameter	Description	Type	Default
MotorTime	Motor actuating time [s]	REAL	30.0
MS_RelOp*	1 = Release for maintenance by OS operator	BOOL	0
MsgEvID1	Message number (assigned automatically)	DWORD	16#00000000
MsgEvID2	Message number (assigned automatically)	DWORD	16#00000000
MsgLock	1 = Suppress process messages. See also the section Suppressing messages using the MsgLock parameter (Page 205) for more on this.	STRUCT <ul style="list-style-type: none"> Value: BOOL ST: BYTE 	- <ul style="list-style-type: none"> 0 16#80
MV_Forced*	Forced manipulated variable that is not limited and assumes top priority	STRUCT <ul style="list-style-type: none"> Value: REAL ST: BYTE 	- <ul style="list-style-type: none"> 0.0 16#80
MV_ForOn	1 = Output forced manipulated variable MV_Forced unlimited at output MV	STRUCT <ul style="list-style-type: none"> Value: BOOL ST: BYTE 	- <ul style="list-style-type: none"> 0 16#80
MV_HiLim	Limit (high) for manipulated variable MV	STRUCT <ul style="list-style-type: none"> Value: REAL ST: BYTE 	- <ul style="list-style-type: none"> 100.0 16#80
MV_LoLim	Limit (low) for manipulated variable MV	STRUCT <ul style="list-style-type: none"> Value: REAL ST: BYTE 	- <ul style="list-style-type: none"> 0.0 16#80
MV_Offset	Manipulated variable for ER = 0, operating point for controller with deactivated I component	REAL	0.0
MV_Trk*	Tracking value for the manipulated variable MV	STRUCT <ul style="list-style-type: none"> Value: REAL ST: BYTE 	- <ul style="list-style-type: none"> 0.0 16#80
MV_TrkOn	1 = Tracking of manipulated variable MV	STRUCT <ul style="list-style-type: none"> Value: BOOL ST: BYTE 	- <ul style="list-style-type: none"> 0 16#80
NegGain	0 = Effective proportional gain GainEff is positive 1 = Effective proportional gain GainEff is negative	STRUCT <ul style="list-style-type: none"> Value: BOOL ST: BYTE 	- <ul style="list-style-type: none"> 0 16#80
NormPV	Process value range (PV) for standardizing the proportional gain (GAIN)	STRUCT <ul style="list-style-type: none"> High: REAL Low: REAL 	- <ul style="list-style-type: none"> 100.0 0.0
Occupied	1 = Occupied by batch control	BOOL	0
OosLi	1 = "Out of service", via interconnection or SFC (0-1 edge transition)	STRUCT <ul style="list-style-type: none"> Value: BOOL ST: BYTE 	- <ul style="list-style-type: none"> 0 16#80
OosOp*	1 = "Out of service", via OS operator	BOOL	0

Controller blocks

5.10 PIDStepL - Step controller

Parameter	Description	Type	Default
OpenChnST	Output channel state of <code>Open</code> Should be connected to an output channel block	STRUCT • Value: BOOL • ST: BYTE	- • 0 • 16#FF
OpenLi*	1 = Open via interconnection or CFC	STRUCT • Value: BOOL • ST: BYTE	- • 0 • 16#80
OpenOp*	1 = Open via operator	BOOL	0
OptimEn*	1 = Enable optimization of PID parameters by PID tuner	BOOL	0
OptimOcc*	1 = Optimization running	BOOL	0
OpSt_In	Input parameter for local operator authorization, connected with the <code>Out</code> output parameter of the upstream block, <code>OpStations</code> (Page 411)	DWORD	16#00000000
OS_Perm	I/O for operator permissions (Page 856)	STRUCT • Bit 0: BOOL • ... • Bit 31: BOOL	- • 1 • 1 • 1
OSlPerm	I/O for operator permissions (Page 856)	STRUCT • Bit 0: BOOL • Bit 18: BOOL • Bit 19: BOOL • Bit 31: BOOL	- • 1 • 1 • 1 • 1
PropFacSP	Applying the P component to the feedback [0..1]. 0 = P component fully in feedback	REAL	1.0
PropSel	1 = Activate P component	BOOL	1
PulseTime	Minimum pulse duration [s]	REAL	1.0
PV*	Process value (controlled variable)	STRUCT • Value: REAL • ST: BYTE	- • 0.0 • 16#80
PV_Unit	Unit of measure for process value	INT	1001
PV_A_DC*	Delay time for incoming PV alarms [s]	REAL	0.0
PV_A_DG*	Delay time for outgoing PV alarms [s]	REAL	0.0
PV_AH_En	1 = Enable PV alarm limit (high)	BOOL	1
PV_AH_Lim	Limit PV alarm (high)	REAL	95.0
PV_AH_MsgEn	1 = Enable PV alarm (high) message	BOOL	1
PV_AL_En	1 = Enable PV alarm limit (low)	BOOL	1
PV_AL_Lim	PV alarm limit (low)	REAL	5.0
PV_AL_MsgEn	1 = Enable PV alarm (low) message	BOOL	1
PV_Hyst	Hysteresis for PV alarm, warning and tolerance limits	REAL	1.0

Parameter	Description	Type	Default
PV_OpScale	Limit for scale in PV bar graph of faceplate	STRUCT <ul style="list-style-type: none"> • High: REAL • Low: REAL 	- <ul style="list-style-type: none"> • 100.0 • 0.0
PV_T_DC*	Delay time for incoming PV tolerance messages [s]	REAL	0.0
PV_T_DG*	Delay time for outgoing PV tolerance messages [s]	REAL	0.0
PV_TH_En	1 = Enable PV tolerance limit (high)	BOOL	0
PV_TH_Lim	Limit PV tolerance message (high)	REAL	85.0
PV_TH_MsgEn	1 = Enable message for PV tolerance message (high)	BOOL	1
PV_TL_En	1 = Enable PV tolerance limit (low)	BOOL	0
PV_TL_Lim	Limit PV tolerance message (low)	REAL	15.0
PV_TL_MsgEn	1 = Activate message for PV tolerance message (low)	BOOL	1
PV_Unit	Unit of measure for process value	INT	1001; °C
PV_W_DC*	Delay time for incoming PV warnings [s]	REAL	0.0
PV_W_DG*	Delay time for outgoing PV warnings [s]	REAL	0.0
PV_WH_En	1 = Enable PV warning limit (high)	BOOL	1
PV_WH_Lim	Limit PV warning (high)	REAL	90.0
PV_WH_MsgEn	1 = Enable PV warning (high) message	BOOL	1
PV_WL_En	1 = Enable PV warning limit (low)	BOOL	1
PV_WL_Lim	Limit PV warning (low)	REAL	10.0
PV_WL_MsgEn	1 = Enable PV warning (low) message	BOOL	1
Rbk*	Position feedback	STRUCT <ul style="list-style-type: none"> • Value: REAL • ST: BYTE 	- <ul style="list-style-type: none"> • 0.0 • 16#FF
RbkHyst	Alarm hysteresis for position feedback	REAL	1.0
RbkWH_En	1 = Enable warning (high) for position feedback	BOOL	1
RbkWH_Lim	Limit for position feedback of warning (high)	REAL	100.0
RbkWH_MsgEn	1 = Enable messages for warning (high) for position feedback	BOOL	1
RbkWL_En	1 = Enable warning (low) for position feedback	BOOL	1
RbkWL_Lim	Limit for position feedback of warning (low)	REAL	0.0
RbkWL_MsgEn	1 = Enable messages for warning (low) for position feedback	BOOL	1
RefStdDevIn	Reference value of PV standard deviation (sigma) in defined "good" state of control loop	STRUCT <ul style="list-style-type: none"> • Value: REAL • ST: BYTE 	- <ul style="list-style-type: none"> • 0.0 • 16#78

Controller blocks

5.10 PIDStepL - Step controller

Parameter	Description	Type	Default
RstBypli	1 = Reset bypass PV (via interconnection)	STRUCT <ul style="list-style-type: none"> Value: BOOL ST: BYTE 	- <ul style="list-style-type: none"> 0 16#80
RstBypOp	1 = Reset bypass PV (via operator)	BOOL	0
RunUpCyc	Number of cycles in startup; messages are suppressed during these cycles	INT	3
S_RbkOnPIDTun	Simulation of position feedback on; For PCS 7 PID tuner only	BOOL	0
S_RbkPIDTun*	Simulated position feedback	REAL	50.0
SafePos	Neutral position (Page 48) for step controller actuating signals: 0 = Close 1 = Open 2 = Stop	INT	0
SampleTime	Sampling time [s] (assigned automatically)	REAL	0.1
SelFp1	1 = Call a block saved in this parameter as an additional faceplate (Page 208) in the standard view	ANY	-
SelFp2	1 = Call a block saved in this parameter as an additional faceplate (Page 208) in the preview	ANY	-
SimLiOp	Activation/deactivation of the simulation by: 0 = Operator 1 = Interconnection or SFC	STRUCT <ul style="list-style-type: none"> Value: BOOL ST: BYTE 	- <ul style="list-style-type: none"> 0 16#80
SimOnLi	1 = Simulation via interconnection or SFC (controlled by SimLiOp = 1)	STRUCT <ul style="list-style-type: none"> Value: BOOL ST: BYTE 	- <ul style="list-style-type: none"> 0 16#80
SimOn*	1 = Simulation on	BOOL	0
SimPV*	Process value used for SimOn = 1	REAL	0.0
SimPV_Li	Process value that is used for SimOnLi.Value = 1 (SimLiOp.Value = 1)	STRUCT <ul style="list-style-type: none"> Value: REAL ST: BYTE 	- <ul style="list-style-type: none"> 0.0 16#80
SimRbk*	Position feedback used for SimOn = 1	REAL	0.0
SimRbkLi	Position feedback used for SimOnLi.Value = 1 (SimLiOp.Value = 1)	STRUCT <ul style="list-style-type: none"> Value: REAL ST: BYTE 	- <ul style="list-style-type: none"> 0.0 16#80
SP_DnRaLim*	Limit (low) for the gradient of the setpoint [Unit/(Time unit)] Time unit depends on TimeFactor	REAL	100.0
SP_ExHiLim	Limit (high) for external setpoint	STRUCT <ul style="list-style-type: none"> Value: REAL ST: BYTE 	- <ul style="list-style-type: none"> 100.0 16#80

Parameter	Description	Type	Default
SP_ExLoLim	Limit (low) for external setpoint	STRUCT <ul style="list-style-type: none"> Value: REAL ST: BYTE 	- <ul style="list-style-type: none"> 0.0 16#80
SP_Ext*	External setpoint of - (to interconnection)	STRUCT <ul style="list-style-type: none"> Value: REAL ST: BYTE 	- <ul style="list-style-type: none"> 0.0 16#80
SP_ExtLi*	1 = Select external setpoint (via interconnection)	STRUCT <ul style="list-style-type: none"> Value: BOOL ST: BYTE 	- <ul style="list-style-type: none"> 0 16#80
SP_ExtOp*	1 = Select external setpoint (via operator)	BOOL	0
SP_InHiLim	Limit (high) of internal setpoint	REAL	100.0
SP_InLoLim	Limit (low) of internal setpoint	REAL	0.0
SP_Int*	Internal setpoint for operation	REAL	0.0
SP_IntLi*	1 = Select internal setpoint (via interconnection)	STRUCT <ul style="list-style-type: none"> Value: BOOL ST: BYTE 	- <ul style="list-style-type: none"> 0 16#80
SP_IntOp*	1 = Select internal setpoint (via operator)	BOOL	0
SP_LiDnRaLim	Linkable limit (low) for the gradient of the setpoint [Unit/(Time unit)] Time unit depends on TimeFactor	REAL	100.0
SP_LiOp	Select setpoint source (internal/external): 1 = Via interconnection 0 = Via operator	STRUCT <ul style="list-style-type: none"> Value: BOOL ST: BYTE 	- <ul style="list-style-type: none"> 0 16#80
SP_LiRmpTime	Linkable time [Time unit] for gradient limitation in ramp mode duration Time unit depends on TimeFactor	REAL	0.0
SP_LiUpRaLim	Linkable gradient limit (high) for the setpoint [Unit/(Time unit)] Time unit depends on TimeFactor	REAL	100.0
SP_RateOn*	1 = Activate limitation of setpoint gradients	BOOL	0
SP_RmpModTime	1 = Use time values (SP_RmpTime, SP_LiRmpTime) 0 = Use gradient limits (SP_DnRaLim, SP_LiDnRaLim, SP_UpRaLim, SP_LiUpRaLim)	BOOL	0
SP_RmpOn*	1 = Activate setpoint ramp to target setpoint SP_RmpTarget	BOOL	0
SP_RmpTarget*	Target setpoint for setpoint ramp	REAL	0.0
SP_RmpTime*	Time [Time unit] for setpoint ramp from current SP up to SP_RmpTarget or time [Time unit] for gradient limitation in ramp mode duration Time unit depends on TimeFactor	REAL	0.0

Controller blocks

5.10 PIDStepL - Step controller

Parameter	Description	Type	Default
SP_TrkExt	1 = Bumpless switchover from external to internal setpoint active	BOOL	1
SP_TrkPV	1 = Setpoint follows PV in "manual mode" and with tracking	BOOL	0
SP_UpRaLim*	Gradient limit (high) for the setpoint [Unit/ (Time unit)] Time unit depends on TimeFactor	REAL	100.0
StepNo	Batch step number	DWORD	16#00000000
StopChnST	Output channel state of Stop Should be connected to an output channel block	STRUCT <ul style="list-style-type: none"> Value: BOOL ST: BYTE 	- <ul style="list-style-type: none"> 0 16#FF
StopLi*	1 = Stop via interconnection or CFC	STRUCT <ul style="list-style-type: none"> Value: BOOL ST: BYTE 	- <ul style="list-style-type: none"> 0 16#80
StopOp*	1 = Stop via operator	BOOL	0
TD	Derivative time in [s] TD.ST = 16#FF: Enabled in faceplate	STRUCT <ul style="list-style-type: none"> Value: REAL ST: BYTE 	- <ul style="list-style-type: none"> 0.0 16#FF
ThrAdaOn	Adaptation of threshold 0 = Hold constant	BOOL	1
TI	Integral time [s] TI.ST = 16#FF: Enabled in faceplate	STRUCT <ul style="list-style-type: none"> Value: REAL ST: BYTE 	- <ul style="list-style-type: none"> 100.0 16#FF
TimeFactor	Time unit: 0 = Seconds 1 = Minutes 2 = Hours	INT	0
UserStatus	Freely assignable bits for use in PCS 7 OS	BYTE	16#00
WithRbk	1 = Feedback value available for the manipulated variable	BOOL	0

* Values can be written back to these inputs during processing of the block by the block algorithm.

Output parameters

Parameter	Description	Type	Default
AdvCoAct	1 = "Program mode" enabled	STRUCT <ul style="list-style-type: none"> Value: BOOL ST: BYTE 	- <ul style="list-style-type: none"> 0 16#80
AdvCoRdy	1 = "Program mode" available	STRUCT <ul style="list-style-type: none"> Value: BOOL ST: BYTE 	- <ul style="list-style-type: none"> 0 16#80

Parameter	Description	Type	Default
AutAct	1 = "Automatic mode" enabled	STRUCT <ul style="list-style-type: none"> Value: BOOL ST: BYTE 	- <ul style="list-style-type: none"> 0 16#80
BypassAct	1 = Bypass is activated in this block	STRUCT <ul style="list-style-type: none"> Value: BOOL ST: BYTE 	- <ul style="list-style-type: none"> 0 16#80
CascaCut	Cascade connection: 1 = Control chain from primary to secondary controller is interrupted	STRUCT <ul style="list-style-type: none"> Value: BOOL ST: BYTE 	- <ul style="list-style-type: none"> 0 16#80
Close	Control output: 1 = Closed is active	STRUCT <ul style="list-style-type: none"> Value: BOOL ST: BYTE 	- <ul style="list-style-type: none"> 0 16#80
D_Part	D component of PID algorithm	REAL	0.0
ENO	1 = Block algorithm completed without errors	BOOL	0
ER	Error signal	STRUCT <ul style="list-style-type: none"> Value: REAL ST: BYTE 	- <ul style="list-style-type: none"> 0.0 16#80
ER_AH_Act	1 = Alarm limit (high) for control deviation violated. You can change the reaction for this parameter with <code>Feature</code> bit 28 (Disabling operating points (Page 145)) and with <code>Feature</code> bit 29 (Signaling limit violation (Page 170)).	STRUCT <ul style="list-style-type: none"> Value: BOOL ST: BYTE Bit 1: BOOL (Bypass information bit) 	- <ul style="list-style-type: none"> 0 16#80 0
ER_AL_Act	1 = Alarm limit (low) for control deviation violated. You can change the reaction for this parameter with <code>Feature</code> bit 28 (Disabling operating points (Page 145)) and with <code>Feature</code> bit 29 (Signaling limit violation (Page 170)).	STRUCT <ul style="list-style-type: none"> Value: BOOL ST: BYTE Bit 1: BOOL (Bypass information bit) 	- <ul style="list-style-type: none"> 0 16#80 0
ErrorNum	Output of pending error number. For error numbers that can be output by this block, see PIDStepL error handling (Page 867)	INT	-1
FFwdHiAct	1 = Limit (high) for additive disturbance variable activation violated	STRUCT <ul style="list-style-type: none"> Value: BOOL ST: BYTE 	- <ul style="list-style-type: none"> 0 16#80
FFwdLoAct	1 = Limit (low) for additive disturbance variable activation violated	STRUCT <ul style="list-style-type: none"> Value: BOOL ST: BYTE 	- <ul style="list-style-type: none"> 0 16#80
GainEff	Effective proportional gain depends on <code>NegGain</code> , <code>Gain</code> , <code>NormPV</code> , and <code>NormMV</code>	REAL	1.0
GrpErr	1 = Group error pending	STRUCT <ul style="list-style-type: none"> Value: BOOL ST: BYTE 	- <ul style="list-style-type: none"> 0 16#80
I_Part	I component of PID algorithm	REAL	0.0

Controller blocks

5.10 PIDStepL - Step controller

Parameter	Description	Type	Default
LoopClosed	1 = Control loop closed 0 = Control loop open	STRUCT • Value: BOOL • ST: BYTE	- • 0 • 16#80
ManAct	1 = "Manual mode" enabled	STRUCT • Value: BOOL • ST: BYTE	- • 1 • 16#80
ManHiOut	Limit (high) for "manual mode", corresponds to input parameter <code>ManHiLim</code>	STRUCT • Value: REAL • ST: BYTE	- • 100.0 • 16#80
ManLoOut	Limit (low) for "manual mode", corresponds to input parameter <code>ManLoLim</code>	STRUCT • Value: REAL • ST: BYTE	- • 0.0 • 16#80
MS_Release	Release for maintenance: 1 = Release for OS operator	STRUCT • Value: BOOL • ST: BYTE	- • 0 • 16#80
MsgAckn1	Message acknowledgement status 1 (output <code>ACK_STATE</code> of first <code>ALARM_8P</code>)	WORD	16#0000
MsgAckn2	Message acknowledgement status 2 (output <code>ACK_STATE</code> of second <code>ALARM_8P</code>)	WORD	16#0000
MsgErr1	1 = Alarm error 1 (output <code>ERROR</code> of the first <code>ALARM_8P</code>)	BOOL	0
MsgErr2	1 = Alarm error 2 (output <code>ERROR</code> of the second <code>ALARM_8P</code>)	BOOL	0
MsgStat1	Message status 1 (output <code>STATUS</code> of first <code>ALARM_8P</code>)	WORD	16#0000
MsgStat2	Message status 2 (output <code>STATUS</code> of second <code>ALARM_8P</code>)	WORD	16#0000
MV	Manipulated variable	STRUCT • Value: REAL • ST: BYTE	- • 0.0 • 16#80
MV_HiAct	1 = Limit (high) of manipulated variable violated	STRUCT • Value: BOOL • ST: BYTE	- • 0 • 16#80
MV_LoAct	1 = Limit (low) of manipulated variable violated	STRUCT • Value: BOOL • ST: BYTE	- • 0 • 16#80
OosAct	1 = Block is "out of service"	STRUCT • Value: BOOL • ST: BYTE	- • 0 • 16#80
Open	Control output: 1 = Open is active	STRUCT • Value: BOOL • ST: BYTE	- • 0 • 16#80

Parameter	Description	Type	Default
OpSt_Out	Value of the OpSt_In input parameter, for feedforwarding to other blocks. Bit 31 of this parameter is used by Feature bit 24	DWORD	16#00000000
OS_PermOut	Display of OS_Perm	DWORD	16#FFFFFFFF
OS_PermLog	Display of OS_Perm with settings changed by the block algorithm	DWORD	16#FFFFFFFF
OS1PermOut	Display of OS1Perm	DWORD	16#FFFFFFFF
OS1PermLog	Display of OS1Perm with settings changed by the block algorithm	DWORD	16#FFFFFFFF
P_Part	P component of PID algorithm	REAL	0.0
PV_AH_Act	1 = PV alarm (high) active. You can change the reaction for this parameter with Feature bit 28 (Disabling operating points (Page 145)) and with Feature bit 29 (Signaling limit violation (Page 170)).	STRUCT <ul style="list-style-type: none"> Value: BOOL ST: BYTE Bit 1: BOOL (Bypass information bit) 	- <ul style="list-style-type: none"> 0 16#80 0
PV_AL_Act	1 = PV alarm (low) active. You can change the reaction for this parameter with Feature bit 28 (Disabling operating points (Page 145)) and with Feature bit 29 (Signaling limit violation (Page 170)).	STRUCT <ul style="list-style-type: none"> Value: BOOL ST: BYTE Bit 1: BOOL (Bypass information bit) 	- <ul style="list-style-type: none"> 0 16#80 0
PV_Out	Output for process value	STRUCT <ul style="list-style-type: none"> Value: REAL ST: BYTE Bit 1: BOOL of internal fill byte (Bypass information bit) 	- <ul style="list-style-type: none"> 0.0 16#80 0
PV_TH_Act	1 = PV tolerance message (high) active. You can change the reaction for this parameter with Feature bit 28 (Disabling operating points (Page 145)) and with Feature bit 29 (Signaling limit violation (Page 170)).	STRUCT <ul style="list-style-type: none"> Value: BOOL ST: BYTE Bit 1: BOOL (Bypass information bit) 	- <ul style="list-style-type: none"> 0 16#80 0
PV_TL_Act	1 = PV tolerance message (low) active. You can change the reaction for this parameter with Feature bit 28 (Disabling operating points (Page 145)) and with Feature bit 29 (Signaling limit violation (Page 170)).	STRUCT <ul style="list-style-type: none"> Value: BOOL ST: BYTE Bit 1: BOOL (Bypass information bit) 	- <ul style="list-style-type: none"> 0 16#80 0
PV_ToleHi	Limit (high) of 3-sigma band around the set-point is calculated when a ConPerMon block is connected	STRUCT <ul style="list-style-type: none"> Value: REAL ST: BYTE 	- <ul style="list-style-type: none"> 0.0 16#80
PV_ToleLo	Limit (low) of 3-sigma band around the set-point is calculated when a ConPerMon block is connected	STRUCT <ul style="list-style-type: none"> Value: REAL ST: BYTE 	- <ul style="list-style-type: none"> 0.0 16#80

Controller blocks

5.10 PIDStepL - Step controller

Parameter	Description	Type	Default
PV_UnitOut	Unit of measure for process value, for inter-connecting to the PV_Unit input parameter of the ConPerMon block	INT	0
PV_WH_Act	1 = PV warning (high) active. You can change the reaction for this parameter with Feature bit 28 (Disabling operating points (Page 145)) and with Feature bit 29 (Signaling limit violation (Page 170)).	STRUCT <ul style="list-style-type: none"> Value: BOOL ST: BYTE Bit 1: BOOL (Bypass information bit) 	- <ul style="list-style-type: none"> 0 16#80 0
PV_WL_Act	1 = PV warning (low) active. You can change the reaction for this parameter with Feature bit 28 (Disabling operating points (Page 145)) and with Feature bit 29 (Signaling limit violation (Page 170)).	STRUCT <ul style="list-style-type: none"> Value: BOOL ST: BYTE Bit 1: BOOL (Bypass information bit) 	- <ul style="list-style-type: none"> 0 16#80 0
RbkOut	Output for position feedback	STRUCT <ul style="list-style-type: none"> Value: REAL ST: BYTE 	- <ul style="list-style-type: none"> 0.0 16#80
RbkWH_Act	1 = Warning (high) for position feedback active. You can change the reaction for this parameter with Feature bit 28 (Disabling operating points (Page 145)) and with Feature bit 29 (Signaling limit violation (Page 170)).	STRUCT <ul style="list-style-type: none"> Value: BOOL ST: BYTE 	- <ul style="list-style-type: none"> 0 16#80
RbkWL_Act	1 = Warning (low) for position feedback active. You can change the reaction for this parameter with Feature bit 28 (Disabling operating points (Page 145)) and with Feature bit 29 (Signaling limit violation (Page 170)).	STRUCT <ul style="list-style-type: none"> Value: BOOL ST: BYTE 	- <ul style="list-style-type: none"> 0 16#80
RdyToStart	1 = Active start readiness	STRUCT <ul style="list-style-type: none"> Value: BOOL ST: BYTE 	- <ul style="list-style-type: none"> 0 16#80
SP	Setpoint used by controller	STRUCT <ul style="list-style-type: none"> Value: REAL ST: BYTE 	- <ul style="list-style-type: none"> 0.0 16#80
SP_DnRaAct	1 = Negative gradient limiting of setpoint is active	STRUCT <ul style="list-style-type: none"> Value: BOOL ST: BYTE 	- <ul style="list-style-type: none"> 0 16#80
SP_ExHiAct	1 = Limit (high) for external setpoint has been reached	STRUCT <ul style="list-style-type: none"> Value: BOOL ST: BYTE 	- <ul style="list-style-type: none"> 0 16#80
SP_ExLoAct	1 = Limit (low) for external setpoint has been reached	STRUCT <ul style="list-style-type: none"> Value: BOOL ST: BYTE 	- <ul style="list-style-type: none"> 0 16#80

Parameter	Description	Type	Default
SP_ExtAct	1 = External setpoint is active 0 = Internal setpoint is active	STRUCT <ul style="list-style-type: none"> Value: BOOL ST: BYTE 	- <ul style="list-style-type: none"> 0 16#80
SP_ExtOut	External setpoint, corresponds to input parameter SP_Ext	STRUCT <ul style="list-style-type: none"> Value: REAL ST: BYTE 	- <ul style="list-style-type: none"> 0.0 16#80
SP_InHiOut	Limit (high) for SP_Int corresponds to input parameter SP_InHiLim	STRUCT <ul style="list-style-type: none"> Value: REAL ST: BYTE 	- <ul style="list-style-type: none"> 100.0 16#80
SP_InLoOut	Limit (low) for SP_Int corresponds to input parameter SP_InLoLim	STRUCT <ul style="list-style-type: none"> Value: REAL ST: BYTE 	- <ul style="list-style-type: none"> 0.0 16#80
SP_RateTarget	Target setpoint for the gradient limitation	REAL	0.0
SP_UpRaAct	Positive gradient limiting of setpoint is active	STRUCT <ul style="list-style-type: none"> Value: BOOL ST: BYTE 	- <ul style="list-style-type: none"> 0 16#80
SP_RemRT	Remaining ramp time of the setpoint	REAL	0.0
ST_Worst	Worst signal status	BYTE	16#80
Status1	Status word 1 (Page 851)	DWORD	16#00000000
Status2	Status word 2 (Page 851)	DWORD	16#00000000
Status3	Status word 2 (Page 851)	DWORD	16#00000000
Stop	Control output: 1 = Stopped is active	STRUCT <ul style="list-style-type: none"> Value: BOOL ST: BYTE 	- <ul style="list-style-type: none"> 0 16#80
SumMsgAct	1 = Active hardware interrupt	STRUCT <ul style="list-style-type: none"> Value: BOOL ST: BYTE 	- <ul style="list-style-type: none"> 0 16#80
Threson	Adaptive threshold [%]	REAL	0.0

See also

PIDStepL messaging (Page 868)

PIDStepL modes (Page 855)

PIDStepL block diagram (Page 886)

5.10.7 PIDStepL block diagram

PIDStepL block diagram

There are two block diagrams for this block: the step controller with and without position feedback.

Step controller with position feedback

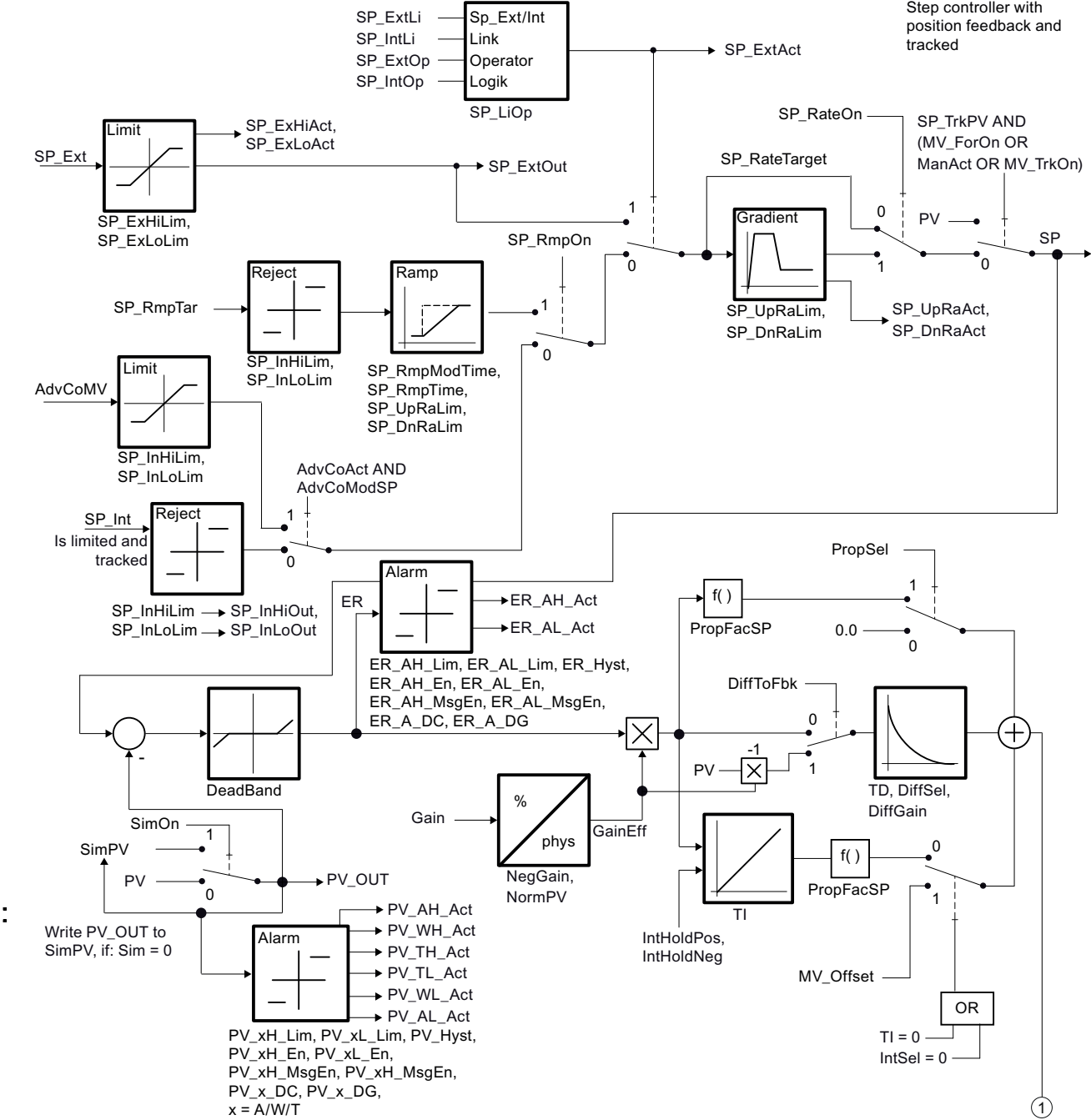

5.10 PIDStepL - Step controller

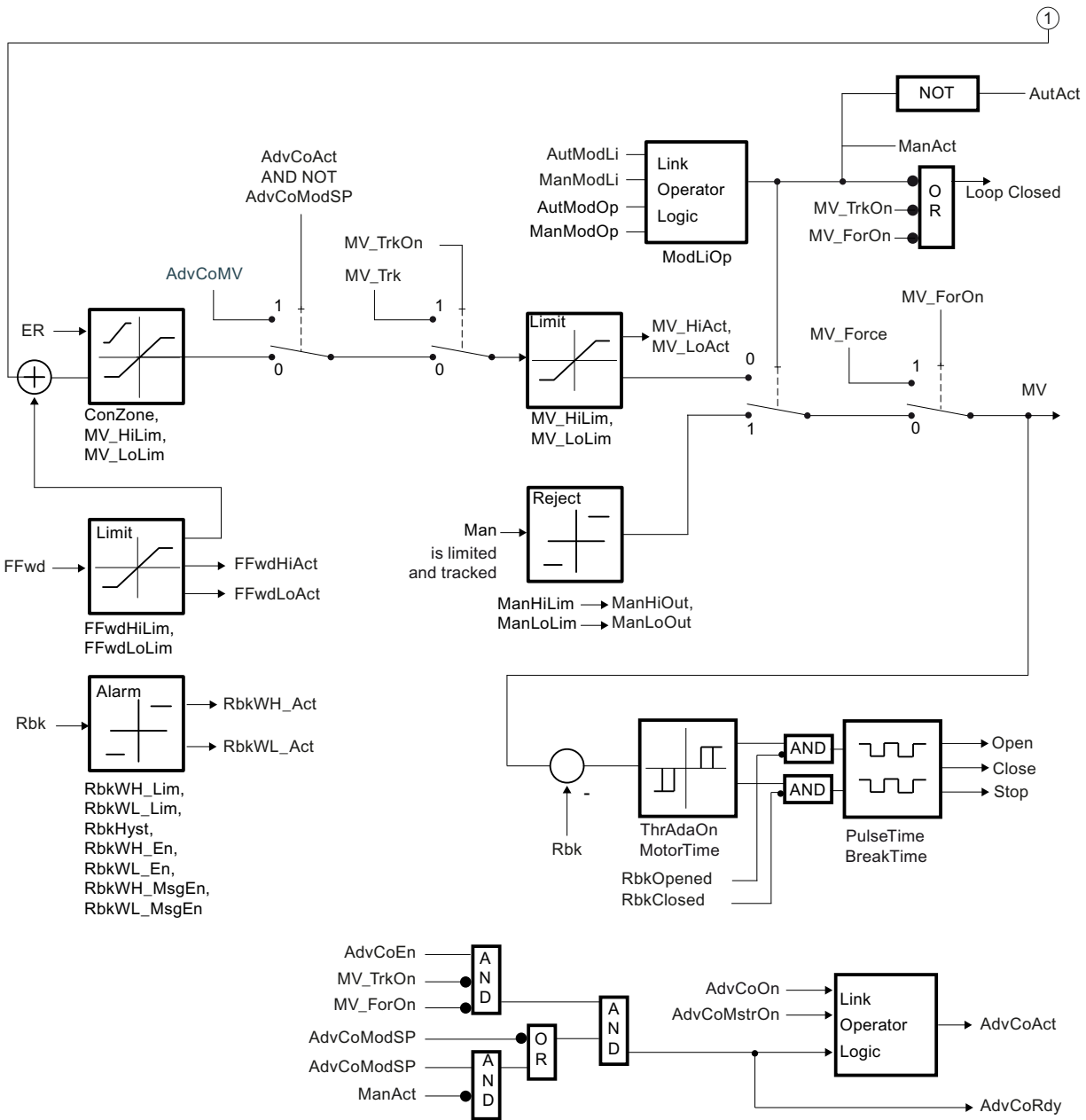

Step controller without position feedback

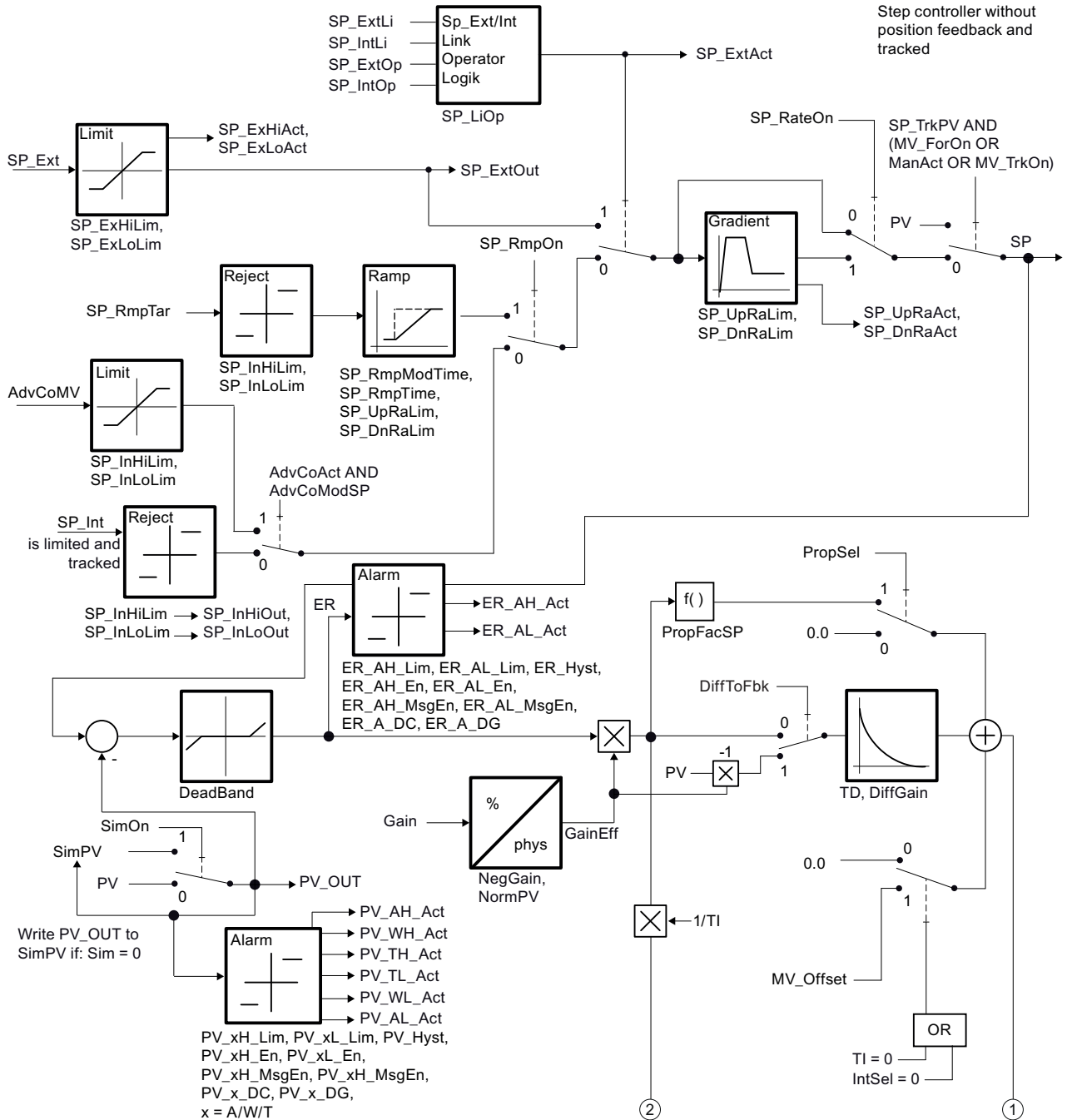

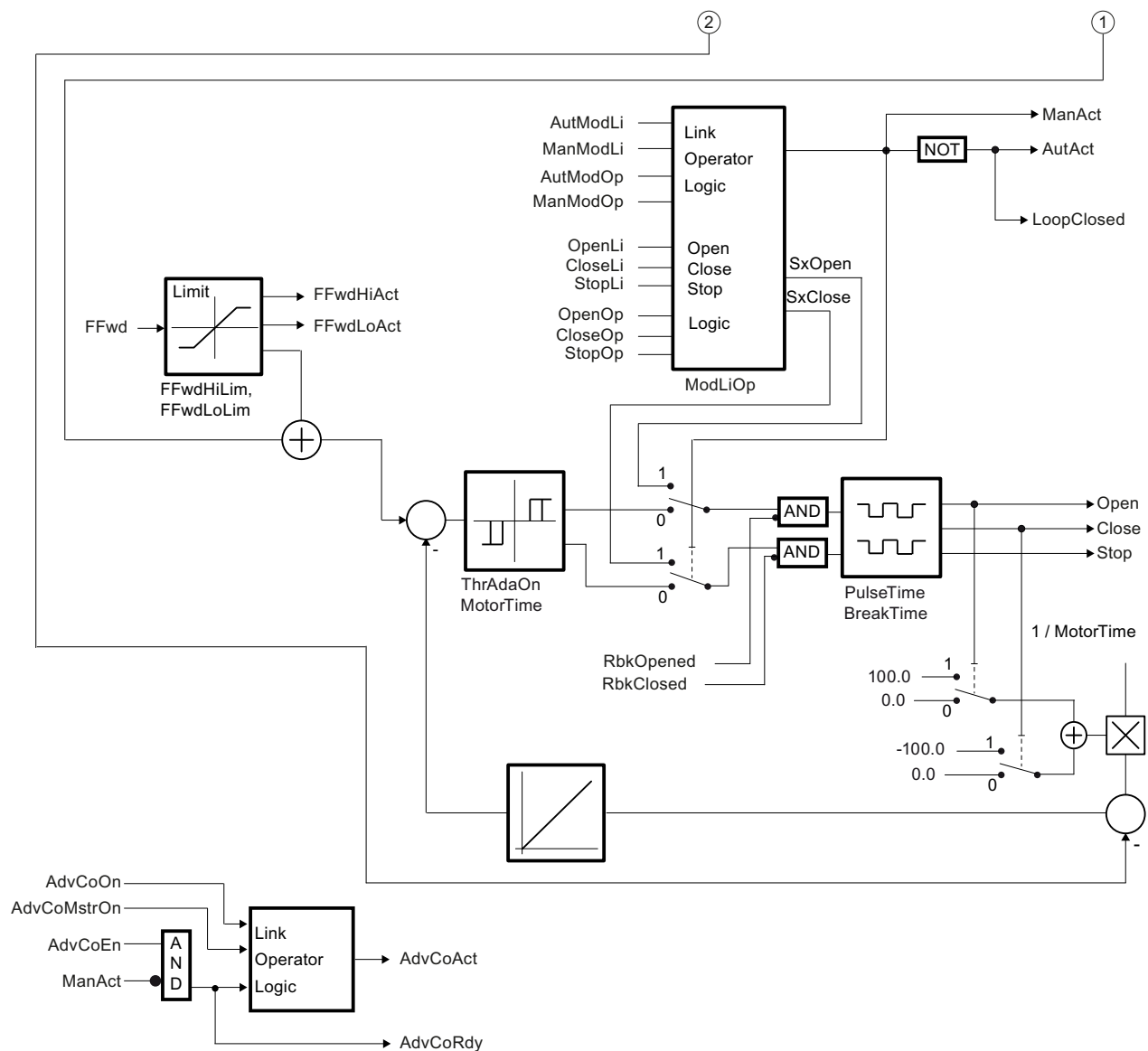

See also

- Description of PIDStepL (Page 851)
- PIDStepL modes (Page 855)
- PIDStepL functions (Page 856)
- PIDStepL error handling (Page 867)
- PIDStepL messaging (Page 868)
- PIDStepL I/Os (Page 871)

5.10.8 Operator control and monitoring

5.10.8.1 PIDStepL views

Views of the PIDStepL block

The block PIDStepL provides the following views:

- PIDStepL standard view without position feedback (Page 892)
- PIDStepL standard view with position feedback (Page 895)
- Alarm view (Page 302)
- Limit view of PID controllers (Page 291)
- Trend view (Page 305)
- Ramp view (Page 300)
- Parameter view of PID controllers (Page 281)
- PIDStepL preview (Page 899)
- Memo view (Page 304)
- Batch view (Page 302)
- Block icons for PID and FM controller (Page 239)

Refer to the Structure of the faceplate (Page 248) and Block icon structure (Page 230) sections for general information about the faceplate and block icon.

5.10.8.2 PIDStepL standard view without position feedback

PIDStepL standard view without position feedback

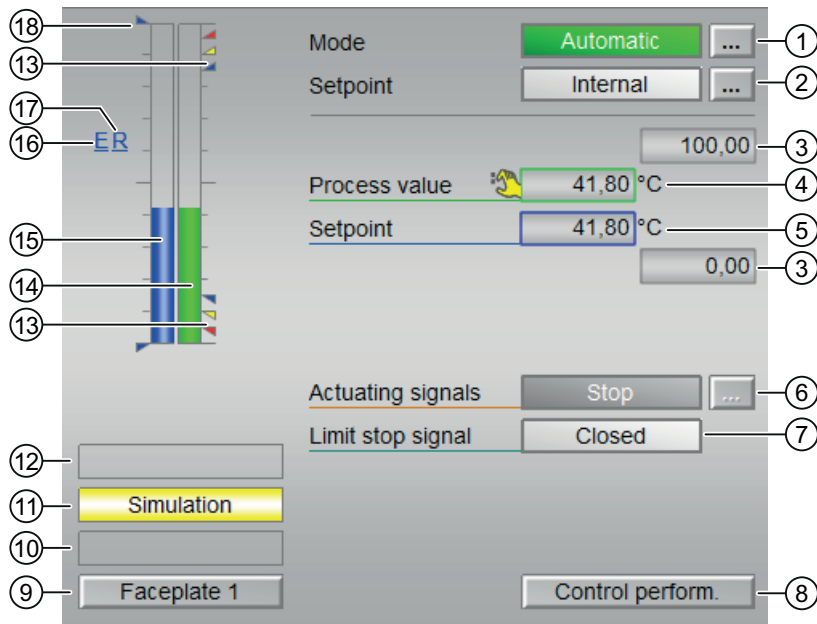

(1) Displaying and switching the operating mode

This area provides information on the currently valid operating mode. The following operating modes can be shown here:

- Manual mode (Page 72)
- Automatic mode (Page 72)
- Program mode for controllers (Page 78)
- Out of service (Page 71)

Refer to the Switching operating states and operating modes (Page 257) section for information on switching the operating mode.

(2) Displaying and switching the setpoint

This area shows how to specify the setpoint. The setpoint can be specified as follows:

- By the application ("External", CFC/SFC)
- By the user directly in the faceplate ("Internal").

Refer to the Switching operating states and operating modes (Page 257) section for information on switching the setpoint specification.

You can find additional information on this in the Setpoint specification - internal/external (Page 128) section.

(3) High and low scale range for the process value

These values provide information on the display range for the bar graph of the process value. The scale range is defined in the Engineering System (ES).

(4) Display of the process value including signal status

This area shows the current process value with the corresponding signal status.

(5) Displaying and changing the setpoint including signal status

This area shows the current setpoint with the corresponding signal status.

Refer to the Changing values (Page 259) section for information on changing the setpoint. The setpoint specification also needs to be set to "Internal" for this block.

(6) Displaying and changing manipulated variables

This area shows you the currently valid manipulated variable. Refer to the Switching operating states and operating modes (Page 257) section for information on changing the manipulated variable.

The following manipulated variables can be selected:

- "Open"
- "Stop"
- "Close"

If text is configured for these commands, it is displayed as status text and as button labels for command selection. You can find more information about this in the Section Labeling of buttons and text (Page 209).

(7) Displaying the feedback

The following feedback can be displayed:

- "Open"
- "Closed"

If text is configured for these commands, it is displayed as status text and as button labels for command selection. You can find more information about this in the Section Labeling of buttons and text (Page 209).

(8) Navigation button for switching to the standard view of the ConPerMon block

Use this navigation button to reach the standard view of the ConPerMon block. The visibility of this navigation button depends on the configuration in the engineering system (ES).

See also the Opening additional faceplates (Page 208) section for more on this.

(9) Navigation button for switching to the standard view of any faceplate

Use this navigation button to reach the standard view of a block configured in the Engineering System (ES). The visibility of this navigation button depends on the configuration in the engineering system (ES).

You can find additional information on this in the Opening additional faceplates (Page 208) section.

(10) Display area for block states

This area provides additional information on the operating state of the block:

- "Maintenance"

Additional information on the display area for states of the block is available in section Release for maintenance (Page 64).

(11) Display area for block states

This area provides additional information on the operating state of the block:

- "Simulation"

You can find additional information on this in the Simulating signals (Page 58) section.

(12) Display area for block states

This area provides additional information on the operating state of the block (from high to low according to priority):

- "Optimization"
- "Tracking"
- "Forced tracking"
- "SP ramp active"

(13) Limit display

These colored triangles show you the configured limits in the respective bar graph.

(14) Bar graph for the process value

This area shows the current process value in the form of a bar graph. The visible area in the bar graph depends on the configuration in the engineering system (ES).

(15) Bar graph for the setpoint

This area shows the current setpoint in the form of a bar graph. The visible area in the bar graph depends on the configuration in the engineering system (ES).

(16) Display of external setpoint

This display [E] is only visible when you have selected "Internal" setpoint specification. It shows the external setpoint that would apply if you were to change the setpoint specification to "external".

(17) Display for the target setpoint of the setpoint ramp

This display [R] shows you the target setpoint and is only visible if you have enabled ramp generation in the Ramp view (Page 300).

(18) Displaying the limits

These triangles show the SP_HiLim and SP_LoLim setpoint limits configured in the Engineering System (ES).

5.10.8.3 PIDStepL standard view with position feedback

PIDStepL standard view with position feedback

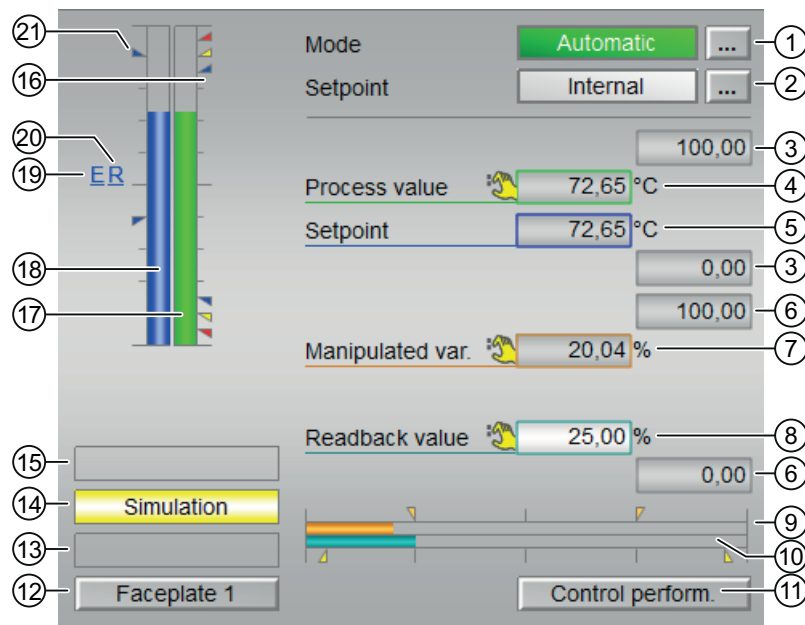

(1) Display and switch the operating mode

This area provides information on the currently valid operating mode. The following operating modes can be shown here:

- Manual mode (Page 72)
- Automatic mode (Page 72)

- Program mode for controllers (Page 78)
- Out of service (Page 71)

Refer to chapter Switching operating states and operating modes (Page 257) for information on switching the operating mode.

(2) Display and switch the setpoint specification

This area shows how to specify the setpoint. The setpoint can be specified as follows:

- By the application ("External", CFC/SFC)
- By the user directly in the faceplate ("Internal").

Refer to the Switching operating states and operating modes (Page 257) chapter for information on switching the setpoint specification.

You can find additional information on this in section Setpoint specification - internal/external (Page 128).

(3) High and low scale range for the process value

These values provide information on the display range for the bar graph of the process value. The scale range is defined in the Engineering System (ES).

(4) Display of the process value including signal status

This area shows the current process value with the corresponding signal status.

(5) Display and change the setpoint including signal status

This area shows the current setpoint with the corresponding signal status.

Refer to the Changing values (Page 259) chapter for information on changing the setpoint. The setpoint specification also needs to be set to "Internal" for this block.

(6) High and low limits of the manipulated variable

You can only display and change a manipulated variable in "manual mode".

(7) Displaying and changing the manipulated variable

You can only display and change a manipulated variable in "manual mode".

(8) Displaying the feedback

This display is only visible when the corresponding block input is interconnected.

The following feedback can be displayed:

- "Open"
- "Closed"

(9) Bar graph for the manipulated variable

The bar graph for the manipulated variable is only available in manual mode.

(10) Bar graph for the readback value

This display is only visible when the corresponding block input is interconnected.

The bar graph for the readback value is only available in manual mode.

(11) Button for switching to the standard view of the ConPerMon block

Use this button for the standard view of the ConPerMon block. The visibility of this button depends on the configuration in the engineering system (ES).

Refer also to chapter Opening additional faceplates (Page 208) for more on this.

(12) Button for switching to the standard view of any faceplate

Use this button for the standard view of a block configured in the Engineering System (ES). The visibility of this button depends on the configuration in the engineering system (ES).

You can find additional information on this in section Opening additional faceplates (Page 208).

(13) Display area for block states

This area provides additional information on the operating state of the block:

- "Maintenance"

Additional information on this is available in chapter Release for maintenance (Page 64) Display area for block states.

(14) Display area for block states

This area provides additional information on the operating state of the block:

- "Simulation"

You can find additional information on this in section Simulating signals (Page 58).

(15) Display area for block states

This area provides additional information on the operating state of the block (from high to low according to priority):

- "Optimization"
- "Tracking"
- "Forced tracking"
- "SP ramp active"

(16) Limit display

These colored triangles show you the configured limits in the respective bar graph.

(17) Bar graph for the process value

This area shows the current process value in the form of a bar graph. The visible area in the bar graph depends on the configuration in the engineering system (ES).

(18) Display of external setpoint

This display [E] is only visible when you have selected "Internal" setpoint specification. It shows the external setpoint that would apply if you were to change the setpoint specification to "external".

(19) Display for the target setpoint of the setpoint ramp

This display [R] shows the target setpoint and is only visible if you have enabled ramp generation in the Ramp view (Page 300).

(20) Bar graph for the setpoint

This area shows the current setpoint in the form of a bar graph. The visible area in the bar graph depends on the configuration in the engineering system (ES).

(21) Displaying the limits

These triangles show the `SP_HiLim` and `SP_LoLim` setpoint limits configured in the Engineering System (ES).

See also

Labeling of buttons and text (Page 209)

5.10.8.4 PIDStepL preview

Preview of PIDStepL

The screenshot displays the PIDStepL preview interface, which is divided into several sections. At the top, there is a list of parameters with their current values and units. Below this is a section for 'Enabled operations' with a list of checked items. The bottom section is 'Inputs and outputs', showing three channels with their respective status icons and values. A 'Faceplate 2' button is located at the bottom left. Circled numbers 1 through 5 indicate specific areas of interest: 1 points to the parameter list, 2 to the enabled operations, 3 to the Faceplate 2 button, 4 to the top right corner, and 5 to the inputs and outputs section.

Parameter	Value	Unit
Process value	50.00	°C
SP external	50.00	°C
SP internal	50.00	°C
Rem. time SP ramp	0.	s
Control deviation	0.00	°C
Program value	0.00	°C
Disturbance	0.00	%
Track MV	1	
Tracking value	0.00	%

Enabled operations

- ✓ Close
- ✓ Open
- ✓ Stop
- ✓ SP external
- ✓ SP internal
- ✓ SP Change
- ✓ Change MV
- ✓ Automatic
- ✓ Manual
- ✓ Out of service
- ✓ Program mode
- ✓ Local oper. permission

Inputs and outputs

Input/Output	Status	Value
Channel Open	Green checkmark	0
Channel Close	Red checkmark	0
Channel Stop	Yellow checkmark	0

Faceplate 2

(1) Preview area

This area shows you a preview for the following values:

- "SP external": currently applicable external setpoint
- "SP internal": currently applicable internal setpoint
- "Rem. time SP ramp": Remaining time to reach the ramp target value.
- "Error signal": Current control deviation
- "Program value": specified value for program mode
- "Disturbance variable": additive value for feedforward control

- "Track MV": Track manipulated variable (value is 1)
- "Tracking value": effective manipulated variable for "Track manipulated variable"

(2) Enable operations

This area shows all operations for which special operator permissions are assigned. They depend on the configuration in the engineering system (ES) that applies to this block.

Icons for enabled operation:

- **Green check mark:** the OS operator can control this parameter
- **Gray check mark:** the OS operator cannot control this parameter at this time due to the process
- **Red cross:** the OS operator cannot control this parameter due to the configured AS operator permissions (`OS_Perm` or `OS1Perm`)

The following enabled operations are shown here:

- "Close": You can select the manipulated variable "Close". If text is configured for this command, it is also displayed in brackets. You can find additional information on this in the section Labeling of buttons and text (Page 209) .
- "Open": You can select the manipulated variable "Open". If text is configured for this command, it is also displayed in brackets. You can find additional information on this in the section Labeling of buttons and text (Page 209) .
- "Stop": You can select the manipulated variable "Stop". If text is configured for this command, it is also displayed in brackets. You can find additional information on this in the section Labeling of buttons and text (Page 209) .
- "SP external": You can feedforward the external setpoint.
- "SP internal": You can feedforward the internal setpoint.
- "Change SP": You can change the setpoint.
- "Change MV": You can change the manipulated variable.
- "Program mode": You can switch to "program mode".
- "Automatic": You can switch to "automatic mode".
- "Manual": You can switch to "manual mode".
- "Out of service": You can switch to "Out of service" operating mode.
- "Local operator permission": Use the ← button to switch to the standard view of the OpStations block. You can find additional information on this in the section Operator control permissions (Page 254) .

(3) Navigation button for switching to the standard view of any faceplate

Use this navigation button to open the standard view of a block configured in the engineering system. The visibility of this navigation button depends on the configuration in the engineering system (ES).

You can find additional information on this in the section Opening additional faceplates (Page 208) .

(4) Process value

This area displays the real process value (PV).

(5) Display of the current control signal

This area shows the most important parameters for this block with the current selection

- "Channel Open": Signal from the output channel block for "Open"
- "Channel Close": Signal from the output channel block for "Close"
- "Channel Stop": Signal from the output channel block for "Stop"

5.11 Ratio - Ratio controlling

5.11.1 Description of Ratio

Object name (type + number) and family

Type + number: FB 1883

Family: Control

Area of application for Ratio

The block is used for the following applications:

- Forming a ratio

How it works

The block is used to create a ratio, for example, in a ratio control. It is also used to set elements (for example, synchronization control loop), or to influence the reference variable of a cascade.

The block operates according to the equation: $Out = In \cdot RatioOut + Offset$

Where:

- `RatioOut` is either the value from `RatioInt` or `RatioExt`
- `Offset` is the offset value that should be added to the output value

`In` is based on the interconnection whereas `RatioOut` is selected based on the internal/external selection.

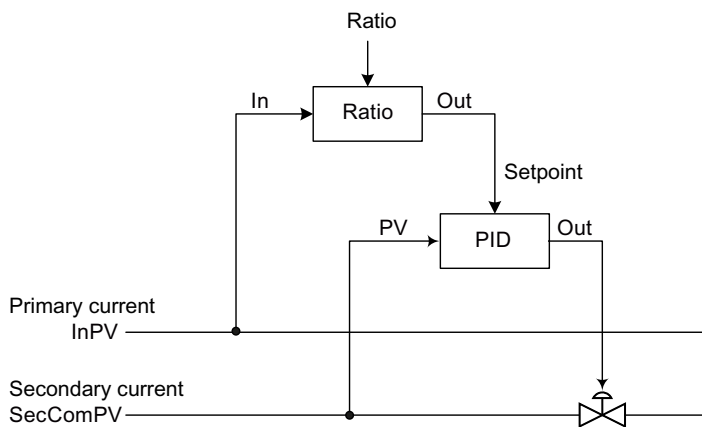

Also refer to the Ratio control with control loop monitoring through ConPerMon (RatioControl) (Page 2338) section for information on calculating the current ratio.

Configuring OBs

Use the CFC editor to install the block in a cyclic interrupt OB (OB30 to OB38). The block is also installed automatically in the startup OB (OB100).

Startup characteristics

Use the `Feature Bit Set` startup characteristics (Page 138) to define the startup characteristics of this block.

Status word allocation for `Status` parameter

The description for each parameter can be found in the `Ratio I/Os` (Page 908) section.

Status bit	Parameter
0	Occupied
1	BatchEn
2	SimOn
3	OosAct.Value
4	OosLi.Value
5	Not used
6	OnAct.Value
7	Not used
8	RatExtAct.Value
9	RatLoAct.Value
10	RatHiAct.Value
11	OutLoAct.Value
12	OutHiAct.Value
13	RatTrkExt
14	SimLiOp.Value
15 - 31	Not used

See also

Ratio functions (Page 904)
 Ratio messaging (Page 908)
 Ratio block diagram (Page 912)
 Ratio error handling (Page 907)
 Ratio modes (Page 904)

5.11.2 Ratio modes

Ratio operating modes

The block can be operated using the following modes:

- On (Page 71)
- Out of service (Page 71)

"On"

General information on the "On" mode is available in the section On (Page 71).

"Out of service"

You can find general information about the "Out of service" mode in the Out of service (Page 71) section.

The last valid value is provided at the `Out` output in this operating mode. The `OutHiAct`, `OutLoAct`, `RatHiAct` and `RatLoAct` output parameters are reset.

See also

- Ratio block diagram (Page 912)
- Ratio I/Os (Page 908)
- Ratio messaging (Page 908)
- Ratio error handling (Page 907)
- Ratio functions (Page 904)
- Description of Ratio (Page 902)

5.11.3 Ratio functions

Functions of Ratio

The functions for this block are listed below.

Internal or external ratio

You can use the `RatLiOp` parameter to specify if the ratio should be specified internally or externally:

- `RatLiOp = 0`: The ratio (`RatioInt`) is specified by the operator. The operator can decide if the specification should be made internally (`RatIntOp = 1`) or externally (`RatExtOp = 1`).
- `RatLiOp = 1`: The ratio (`RatioExt`) is specified by an interconnection. The interconnection is used to determine if the specification should be made internally (`RatIntLi = 1`) or externally (`RatExtLi = 1`).

Bumpless switchover from external to internal ratio

The parameter `RatTrkExt = 1` is used so that the internal ratio tracks the external setpoint to achieve a bumpless switchover from the external to the internal ratio. This allows unwanted jumps at the output parameter to be avoided.

Limiting the ratio

The ratio is limited by the `RatHiLim` parameter (high) or `RatLoLim` parameter (low).

The external ratio `RatioExt` is limited to the value you have specified if a limit is violated. This is then also used to form the output value `Out`. If these limits are reached or violated `RatioHiAct` or `RatioLoAct` are also set to 1.

The internal ratio `RatioInt` is checked against the value you have specified. If a value is outside the specified limit, it is reset to the most recent valid value.

Limiting the output value

The output value is limited by the `OutHiLim` parameter (high) or `OutLoLim` parameter (low).

The `OutHiAct` or `OutLoAct` output parameter is set to 1 as soon as the output value has reached or exceeded the limits

Simulating signals

This block provides the standard function Simulating signals (Page 58).

You can simulate the following values:

- Analog input value (`SimIn`, `SimInLi`)

Display and operator input area for process values and setpoints

This block provides the standard function Display and operator input area for process values and setpoints (Page 207).

Selecting a unit of measure

The block provides the standard function Selecting a unit of measure (Page 212).

Opening additional faceplates

This block provides the standard function Opening additional faceplates (Page 208).

Operator permissions

This block provides the standard function Operator control permissions (Page 254).

The block has the following permissions for the OS_Perm parameter:

Bit	Function
0	Not used
1	1 = Operator can switch to "On" mode
2	Not used
3	1 = Operator can switch to "Out of service" mode
4	1 = Operator can switch to external
5	1 = Operator can switch to internal
6	1 = Operator can specify the internal ratio
7 - 9	Not used
10	1 = Operator can change the simulation value SimIn
11	1 = Operator can switch to "Simulation" mode
12	1 = Operator can enable bumpless switchover
13	Not used
14	1 = Operator can change RatHiLim
15	1 = Operator can change RatLoLim
16	1 = Operator can change OutHiLim
17	1 = Operator can change OutLoLim
18 - 31	Not used

Note

If you interconnect a parameter that is also listed in OS_Perm as a parameter, you have to reset the corresponding OS_Perm bit.

Forming and outputting signal status for blocks

This block provides the standard function Forming and outputting the signal status for technologic blocks (Page 109).

The worst signal status ST_Worst is formed from the following parameters:

- Out.ST
- SecComPV.ST
- InPV.ST
- RatioExt.ST
- Offset.ST

The signal status of the `Out` output parameter corresponds to the input parameter `In`.

The signal status of the current ratio calculation corresponds to the status of the input parameter `SecComPV`.

Configurable reactions using the `Feature` parameter

You can find an overview of all reactions provided by the `Feature` parameter in the Configurable functions using the `Feature I/O` (Page 131) . The following functionality is available for this block at the relevant bits:

Bit	Function
0	Set startup characteristics (Page 138)
1	Reaction to the out of service mode (Page 177)
24	Enabling local operator authorization (Page 158)

SIMATIC BATCH functionality

This block provides the standard function SIMATIC BATCH functionality (Page 67).

See also

Description of Ratio (Page 902)

Ratio messaging (Page 908)

Ratio I/Os (Page 908)

Ratio block diagram (Page 912)

Ratio error handling (Page 907)

Ratio modes (Page 904)

5.11.4 Ratio error handling

Ratio error handling

Refer to section Error handling (Page 119) for basic instructions on how to troubleshoot all blocks.

The following errors can be displayed for this block:

- Error numbers

Overview of error numbers

The `ErrorNum` I/O can be used to output the following error numbers:

Error number	Meaning of the error number
-1	Predefined value when implementing the block; block will not be processed.
0	No active fault
30	The input value of <code>In</code> can no longer be displayed in the REAL number field.
51	<code>RatLiOp = 1</code> and <code>RatExtLi = 1</code> and <code>RatInLi = 1</code>

See also

- Ratio block diagram (Page 912)
- Ratio I/Os (Page 908)
- Ratio messaging (Page 908)
- Ratio functions (Page 904)
- Ratio modes (Page 904)
- Description of Ratio (Page 902)

5.11.5 Ratio messaging

Messaging

This block does not offer messaging.

See also

- Description of Ratio (Page 902)
- Ratio functions (Page 904)
- Ratio I/Os (Page 908)
- Ratio block diagram (Page 912)
- Ratio error handling (Page 907)
- Ratio modes (Page 904)

5.11.6 Ratio I/Os

I/Os of Ratio

Input parameters

Parameter	Description	Type	Default
BatchEn	1 = Enable allocation	BOOL	0
BatchID	Batch ID	DWORD	16#00000000
BatchName	Batch name	S7-String	
EN	1 = Called block will be processed	BOOL	1
Feature	I/O for additional functions (Page 904)	STRUCT <ul style="list-style-type: none"> • Bit 0: BOOL • ... • Bit 31: BOOL 	- <ul style="list-style-type: none"> • 0 • 0 • 0
In	Analog input	STRUCT <ul style="list-style-type: none"> • Value: REAL • ST: BYTE 	- <ul style="list-style-type: none"> • 0.0 • 16#80
InPV	Input for process variable	STRUCT <ul style="list-style-type: none"> • Value: REAL • ST: BYTE 	- <ul style="list-style-type: none"> • 0.0 • 16#80
InUnit	Unit of measure for input parameter In	INT	1001
Offset	Offset	STRUCT <ul style="list-style-type: none"> • Value: REAL • ST: BYTE 	- <ul style="list-style-type: none"> • 0.0 • 16#80
OnOp*	1 = "On" mode via operator	BOOL	0
OosLi	1 = "Out of service", via interconnection or SFC (0-1 edge transition)	STRUCT <ul style="list-style-type: none"> • Value: BOOL • ST: BYTE 	- <ul style="list-style-type: none"> • 0 • 16#80
OosOp*	1 = "Out of service", via OS operator	BOOL	0
OpSt_In	Input parameter for local operating permission, connected with the Out output parameter of the upstream block, OpStations (Page 411)	DWORD	16#00000000
OS_Perm	I/O for operator control permissions (Page 904)	STRUCT <ul style="list-style-type: none"> • Bit 0: BOOL • ... • Bit 31: BOOL 	- <ul style="list-style-type: none"> • 1 • 1 • 1
Occupied	1 = Occupied by batch control	BOOL	0
OutHiLim	High limit for output value	REAL	100.0
OutLoLim	Low limit for output value	REAL	0.0
RatExtLi	1 = Select external ratio (via interconnection)	STRUCT <ul style="list-style-type: none"> • Value: BOOL • ST: BYTE 	- <ul style="list-style-type: none"> • 0 • 16#80
RatExtOp*	1 = Select external ratio (via operator)	BOOL	0
RatHiLim	High limit	REAL	100.0

Controller blocks

5.11 Ratio - Ratio controlling

Parameter	Description	Type	Default
RatIntLi	1 = Select internal ratio (via interconnection)	STRUCT <ul style="list-style-type: none"> Value: BOOL ST: BYTE 	- <ul style="list-style-type: none"> 0 16#80
RatIntOp*	1 = Select internal ratio (via operator)	BOOL	1
RatioExt	External ratio	STRUCT <ul style="list-style-type: none"> Value: REAL ST: BYTE 	- <ul style="list-style-type: none"> 1.0 16#80
RatioInt*	Internal ratio	REAL	1.0
RatioUnit	Unit of measure for the <code>RationInt</code> , <code>RatioExt</code> input parameter or <code>RatioPV</code> (output parameter)	INT	0
RatLiOp	Select ratio source (internal/external): 1 = Via interconnection 0 = Via operator	STRUCT <ul style="list-style-type: none"> Value: BOOL ST: BYTE 	- <ul style="list-style-type: none"> 0 16#80
RatLoLim	Low limit	REAL	0.0
RatOpScale	Limit for scale in bar graph of faceplate	STRUCT <ul style="list-style-type: none"> High: REAL Low: REAL 	- <ul style="list-style-type: none"> 100.0 0.0
RatTrkExt	1 = Bumpless switchover from external to internal ratio active	BOOL	0
SecComPV*	Process value of secondary component	STRUCT <ul style="list-style-type: none"> Value: REAL ST: BYTE 	- <ul style="list-style-type: none"> 0.0 16#80
SecComUnit	Unit of measure for input parameter <code>SecComPV</code>	INT	1001
SelFp1	1 = Call a block saved in this parameter as an additional faceplate (Page 208) in the standard view	ANY	-
SelFp2	1 = Call a block saved in this parameter as an additional faceplate (Page 208) in the preview	ANY	-
SimIn*	Analog input value used for <code>SimOn = 1</code>	REAL	0.0
SimInLi	Value that is used for <code>SimOnLi.Value = 1</code> (<code>SimLiOp.Value = 1</code>)	STRUCT <ul style="list-style-type: none"> Value: REAL ST: BYTE 	- <ul style="list-style-type: none"> 0.0 16#80
SimLiOp	Activation/deactivation of the simulation by: 0 = Operator 1 = Interconnection or SFC	STRUCT <ul style="list-style-type: none"> Value: BOOL ST: BYTE 	- <ul style="list-style-type: none"> 0 16#80
SimOnLi	1 = Simulation via interconnection or SFC (controlled by <code>SimLiOp = 1</code>)	STRUCT <ul style="list-style-type: none"> Value: BOOL ST: BYTE 	- <ul style="list-style-type: none"> 0 16#80
SimOn*	1 = Simulation on	BOOL	0
StepNo	Batch step number	DWORD	16#00000000
UserStatus	Freely assignable bits for use in PCS 7 OS	BYTE	16#00

* Values can be written back to these inputs during processing of the block by the block algorithm.

Output parameters

Parameter	Description	Type	Default
ENO	1 = Block algorithm completed without errors	BOOL	0
ErrorNum	Output of current error number. For error numbers that can be output by this block, see Ratio error handling (Page 907)	INT	-1
OnAct	1 = "On" mode enabled	STRUCT <ul style="list-style-type: none"> Value: BOOL ST: BYTE 	- <ul style="list-style-type: none"> 1 16#80
OosAct	1 = Block is "Out of service"	STRUCT <ul style="list-style-type: none"> Value: BOOL ST: BYTE 	- <ul style="list-style-type: none"> 0 16#80
OpSt_Out	Value of the OpSt_In input parameter, for feedforwarding to other blocks. Bit 31 of this parameter is used by Feature bit 24	DWORD	16#00000000
OS_PermOut	Display of OS_Perm	DWORD	16#FFFFFFFF
OS_PermLog	Display of OS_Perm with settings changed by the block algorithm	DWORD	16#FFFFFFFF
Out	Output	STRUCT <ul style="list-style-type: none"> Value: REAL ST: BYTE 	- <ul style="list-style-type: none"> 0.0 16#80
OutHiAct	1 = High limit overshoot	STRUCT <ul style="list-style-type: none"> Value: BOOL ST: BYTE 	- <ul style="list-style-type: none"> 0 16#80
OutHiLmOut	Output of high limit	STRUCT <ul style="list-style-type: none"> Value: REAL ST: BYTE 	- <ul style="list-style-type: none"> 0.0 16#80
OutLoAct	1 = Low limit overshoot	STRUCT <ul style="list-style-type: none"> Value: BOOL ST: BYTE 	- <ul style="list-style-type: none"> 0 16#80
OutLoLmOut	Output of low limit	STRUCT <ul style="list-style-type: none"> Value: REAL ST: BYTE 	- <ul style="list-style-type: none"> 0.0 16#80
RatExtAct	1 = External ratio used 0 = Internal ratio used	STRUCT <ul style="list-style-type: none"> Value: BOOL ST: BYTE 	- <ul style="list-style-type: none"> 0 16#80
RatHiAct	1 = Limit (high) for ratio active	STRUCT <ul style="list-style-type: none"> Value: BOOL ST: BYTE 	- <ul style="list-style-type: none"> 0 16#80

5.11 Ratio - Ratio controlling

Parameter	Description	Type	Default
RatioPV	Current ratio	STRUCT <ul style="list-style-type: none"> • Value: REAL • ST: BYTE 	- <ul style="list-style-type: none"> • 0.0 • 16#80
RatioOut	Applied ratio (RatioInt or RatioExt)	STRUCT <ul style="list-style-type: none"> • Value: REAL • ST: BYTE 	- <ul style="list-style-type: none"> • 0.0 • 16#80
RatLoAct	1 = Limit (low) for ratio active	STRUCT <ul style="list-style-type: none"> • Value: BOOL • ST: BYTE 	- <ul style="list-style-type: none"> • 0 • 16#80
ST_Worst	Worst signal status	BYTE	16#80
Status	Status word (Page 902)	DWORD	16#00000000

See also

- Ratio messaging (Page 908)
- Ratio block diagram (Page 912)
- Ratio modes (Page 904)

5.11.7 Ratio block diagram

Ratio block diagram

A block diagram is not provided for this block.

See also

- Ratio I/Os (Page 908)
- Ratio messaging (Page 908)
- Ratio error handling (Page 907)
- Ratio functions (Page 904)
- Ratio modes (Page 904)
- Description of Ratio (Page 902)

5.11.8 Operator control and monitoring

5.11.8.1 Ratio views

Views of the Ratio block

The block Ratio provides the following views:

- Ratio standard view (Page 913)
- Trend view (Page 305)
- Ratio parameter view (Page 916)
- Ratio preview (Page 917)
- Memo view (Page 304)
- Batch view (Page 302)
- Block icon for Ratio (Page 918)

Refer to the sections Structure of the faceplate (Page 248) and Block icon structure (Page 230) for general information on the faceplate and block icon.

5.11.8.2 Ratio standard view

Ratio standard view

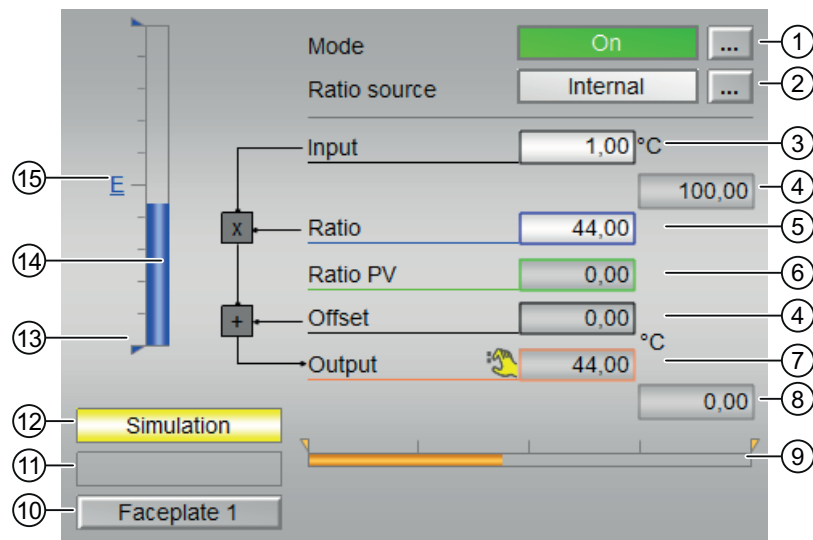

(1) Displaying and switching the operating mode

This area provides information on the currently valid operating mode. The following operating modes can be shown here:

- On (Page 71)
- Out of service (Page 71)

Refer to the Switching operating states and operating modes (Page 257) section for information on switching the operating mode.

(2) Displaying and switching the ratio source

This area shows you the currently valid signal source for the ratio setpoint. The following signal sources can be shown here:

- "External"
- "Internal"

Refer to the Switching operating states and operating modes (Page 257) section for information on switching the signal source.

(3) Displaying the input value

The faceplate is a schematic representation of the function of the Ratio block as a signal flow chart:

$$\text{Output} = \text{Input} \cdot \text{Ratio} + \text{Offset}$$

The input is typically the flow setpoint or actual value of the primary component of a ratio controller.

(4) High and low scale range for the ratio

The scale range is based on the bar graph for the ratio specification.

(5) Displaying and switching the default ratio

This area shows you the currently valid specification for the ratio.

The ratio source (2) needs to be set to "internal" in order to change this value.

Refer to the Changing values (Page 259) section for information on changing this value.

(6) Displaying the ratio PV

This area shows you the current ratio actual value with the corresponding signal status, i.e. the ratio of the actually measured PV from the active controller. The task of the ratio controller is to set the flow of all components so that the actual ratio approximates the specified ratio as closely as possible.

(7) Display of the Offset

This area shows the current `Offset`.

(8) Displaying the output value

This area shows the current output value `Out`, which typically serves as the setpoint for the flow of the secondary component.

(9) Bar graph for the output

This display graphically represents the output value with the limits set in the Engineering System (ES) (orange triangles, output parameters `OutHiLmOut` and `OutLoLmOut`).

(10) Displaying the limit

This status display is based on the limit of the output value `Out`.

(11) Display area for block states

This area shows if the output value has violated the range limits:

- "Output \geq HL"
- "Output \leq LL"

You can set the range limits in the parameter view (Page 916) of the block.

(12) Display area for block states

This area provides additional information on the operating state of the block:

- Simulation

You can find additional information on this in the Simulating signals (Page 58) section.

(13) Display of the limits for the ratio

This blue triangle shows the configured range limits for the ratio.

(14) Bar graph for the default ratio

This area shows you the currently valid specification for the ratio in the form of a bar graph. The visible area in the bar graph depends on the configuration of the ratio in the engineering system (ES).

(15) Display of external setpoint

This display [E] is only visible when you have selected "Internal" setpoint specification. It shows the external setpoint that would apply if you were to change the setpoint specification to "external".

5.11.8.3 Ratio parameter view

Parameter view of Ratio

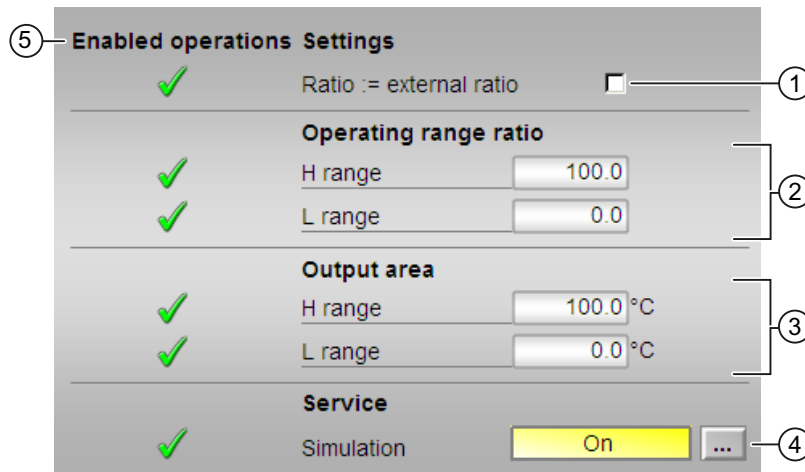

(1) Settings Ratio := external ratio

When the check box is selected , the ratio is bumplessly switched from external to internal. The internal ratio value is tracked to the external one.

(2) Operating range ratio

This is where you specify the operating range for the ratio (input parameters `RatHiLim` or `RatLoLim`). The range is indicated by a blue triangle in the standard view of the bar graph.

(3) Range for output value

This is where you specify the operating range for the output value (input parameters `OutHiLmOut` or `OutLoLmOut`).

(4) Service

You can select the following functions in this area:

- "Simulation"

You can find information about this in the following chapters:

- Switching operating states and operating modes (Page 257)
- Simulating signals (Page 58)
- Release for maintenance (Page 64).

(5) Enabled operations

This area shows all operations for which special operator control permissions are assigned. They depend on the configuration in the engineering system (ES) that applies to this block.

Symbols for enabled operations:

- **Green check mark:** the OS operator can control this parameter
- **Gray check mark:** the OS operator cannot control this parameter at this time due to the process
- **Red cross:** the OS operator cannot control this parameter due to the configured AS operator control permissions (OS_Perm or OS1Perm).

5.11.8.4 Ratio preview

Preview of Ratio

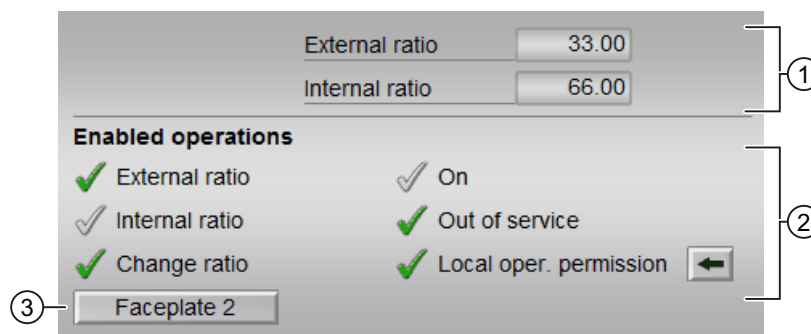

(1) Preview area

This area shows you a preview for the following values:

- "External ratio": currently applicable external ratio
- "Internal ratio": currently applicable internal ratio

(2) Enabled operations

This area shows all operations for which special operating permissions are assigned. They depend on the configuration in the Engineering System (ES) that applies to this block.

Symbols for enabled operations:

- **Green check mark:** the OS operator can control this parameter
- **Gray check mark:** the OS operator cannot control this parameter at this time due to the process
- **Red cross:** the OS operator cannot control this parameter at all due to the configured AS operating permissions (OS_Perm or OS1Perm).

The following enabled operations are shown here:

- "Ratio external": You can change the external ratio.
- "Ratio internal": You can change the internal ratio.
- "Change ratio": You can change the ratio.
- "On": You can switch to "On" operating mode.
- "Out of service": You can switch to "Out of service" operating mode.
- "Local operating permission": Use the ← button to switch to the standard view of the OpStations block. You can find additional information on this in chapter Operator control permissions (Page 254).

(3) Navigation button for switching to the standard view of any faceplate

Use this navigation button to reach the standard view of a block configured in the Engineering System (ES). The visibility of this navigation button depends on the configuration in the Engineering System (ES).

You can find additional information on this in chapter Opening additional faceplates (Page 208).

5.11.8.5 Block icon for Ratio

Block icons for Ratio



A variety of block icons are available with the following functions:

- Process tag type
- Display of the ratio
- Limits (high/low)
- Violation of alarm, warning, and tolerance limits
- Operating modes
- Internal and external setpoint specification
- Signal status, release for maintenance
- Displays for bypassing interlocks
- Interlocks
- Memo display

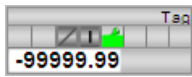
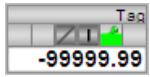
The block icons from template @TemplateAPLV8.PDL:

Icons	Selection of the block icon in CFC	Special features
	1	
	2	

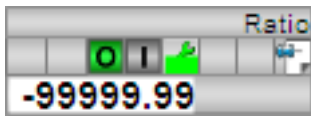
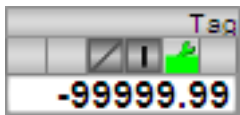
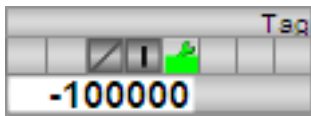
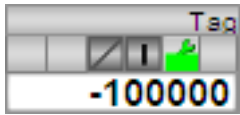
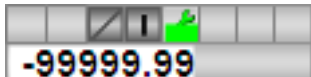
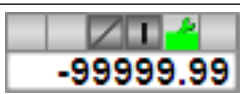
The block icons from template @TemplateAPLV7.PDL:

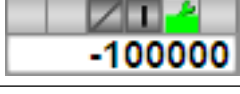
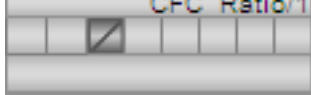
Icons	Selection of the block icon in CFC	Special features
	1	Block icon in the full display
	2	
	3	
	4	
	5	
	6	
	7	
	8	
	-	Block icon in "Out of service" mode (example with type 1 block icon)

Additional information on the block icon and the control options in the block icon is available in the following chapters:

- Configuring the block icons (Page 237)
- Block icon structure (Page 230)
- Operation via the block icon (Page 239).

5.12 SplRange - Signal splitter

5.12.1 Description of SplRange

Object name (type + number) and family

Type + number: FC 372

Family: Control

Area of application for SplRange

The block is used for the following applications:

- Splitting the output signal of a PID controller

How it works

The block is used to split signals output coming from a PID controller. You can use this controller to control two valves, for example.

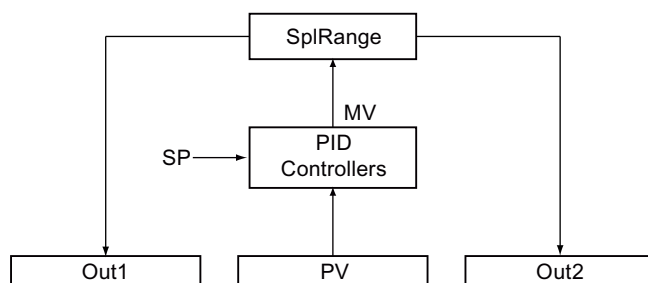

The output parameters are calculated as follows:

$$\text{Out1} = \text{Out1Scale.Low} + ((\text{NeutPos} - \text{DeadBand} - \text{In}) / (\text{NeutPos} - \text{DeadBand} - \text{InScale.Low})) \cdot (\text{Out1Scale.High} - \text{Out1Scale.Low})$$

$$\text{Out2} = \text{Out2Scale.Low} + ((\text{NeutPos} + \text{DeadBand} - \text{In}) / (\text{NeutPos} + \text{DeadBand} - \text{InScale.High})) \cdot (\text{Out2Scale.High} - \text{Out2Scale.Low})$$

The neutral position (*NeutPos*) forms the reference point for selecting the individual splitter profiles. For details, refer to the SplRange functions (Page 923) section.

Refer to SplRange I/Os (Page 927) to learn the meaning of the parameters.

The block is installed in the run sequence downstream of the controller block. The manipulated variable output (*MV*) of the controller block is interconnected to the input *In* of the SplRange block.

The neutral position (*NeutPos*) and the dead band zone (*DeadBand*) can be set by means of the corresponding parameters. *DeadBand* must be configured to be less than *NeutPos*.

Out1 and *Out2* are adapted to the physical variable by configuring the high/low limits of *Out1* and *Out2*.

5.12 SplRange - Signal splitter

The `Out1Act` or `Out2Act` output parameter indicates (= 1) that the corresponding `Out1` or `Out2` output parameter is enabled if the `In` input value is less than (for `Out1`) the neutral position (`NeutPos`) or the `In` input value is greater than the neutral position (`NeutPos`) depending on the dead band (`Deadband`).

Configuration

Use CFC editor to install the block in the OB in which the controller block runs whose manipulated variable is being processed.

There are templates (Templates) for the `SplRange` block for process tag types in the Advanced Process Library, one example (`APL_Example_xx`, `xx` refers to the language variant) with an application scenario for this block being:

- Split-range controller with control loop monitoring through `ConPerMon` (`SplrangeControl`) (Page 2335)

Startup characteristics

The block does not have any startup characteristics.

Status word allocation for `status` parameter

This block does not have the `status` parameter.

See also

[SplRange messaging \(Page 926\)](#)
[SplRange block diagram \(Page 928\)](#)
[SplRange error handling \(Page 926\)](#)
[SplRange modes \(Page 922\)](#)

5.12.2 SplRange modes

SplRange operating modes

This block does not have any modes.

See also

[SplRange I/Os \(Page 927\)](#)
[SplRange messaging \(Page 926\)](#)
[SplRange error handling \(Page 926\)](#)
[SplRange functions \(Page 923\)](#)

Description of SplRange (Page 921)

SplRange block diagram (Page 928)

5.12.3 SplRange functions

Functions of SplRange

The functions for this block are listed below.

Splitting of the output signal of a controller

The `In` block input can be used to split the output signal of a controller.

The table below shows the six types of signal splitting that are available:

Case	Signal splitting	Setting the I/Os
1		<code>Out1Scale.Low = 0.0 and Out1Scale.High = 100.0</code> <code>Out2Scale.Low = 0.0 und Out2Scale.High = 100.0</code> <code>DeadBand = 0.0 and NeutPos = 50.0</code>
2		<code>Out1Scale.Low = 100.0 and Out1Scale.High = 0.0</code> <code>Out2Scale.Low = 100.0 and Out2Scale.High = 0.0</code> <code>DeadBand = 0.0 and NeutPos = 50.0</code>

5.12 SplRange - Signal splitter

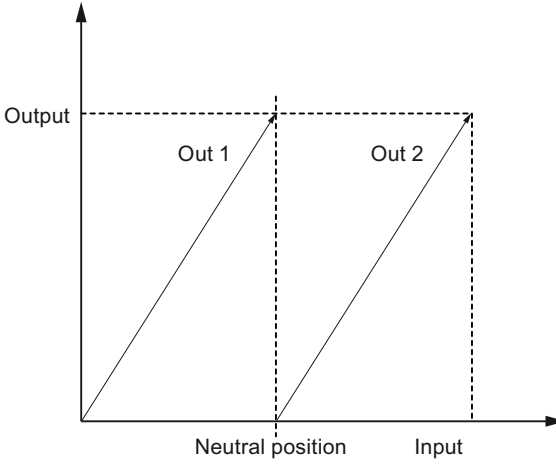
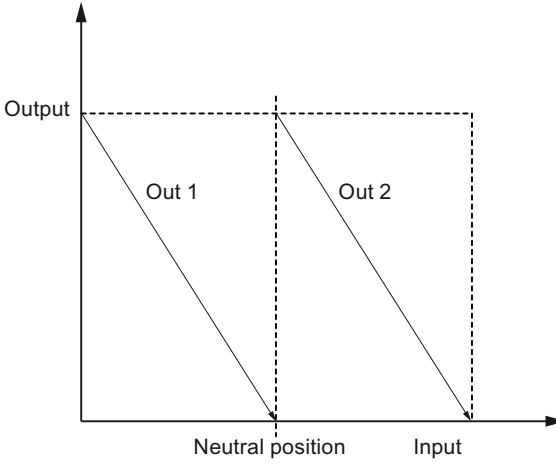
Case	Signal splitting	Setting the I/Os
3		<p>Out1Scale.Low = 100.0 and Out1Scale.High = 0.0 Out2Scale.Low = 0.0 and Out2Scale.High = 100.0 DeadBand = 0.0 and NeutPos = 50.0</p>
4		<p>Out1Scale.Low = 0.0 and Out1Scale.High = 100.0 Out2Scale.Low = 100.0 and Out2Scale.High = 0.0 DeadBand = 0.0 and NeutPos = 50.0</p>

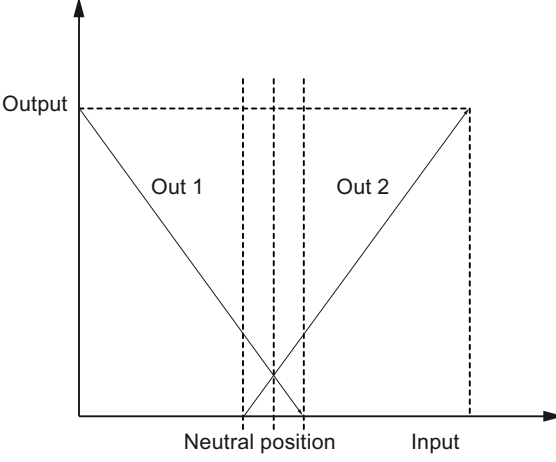
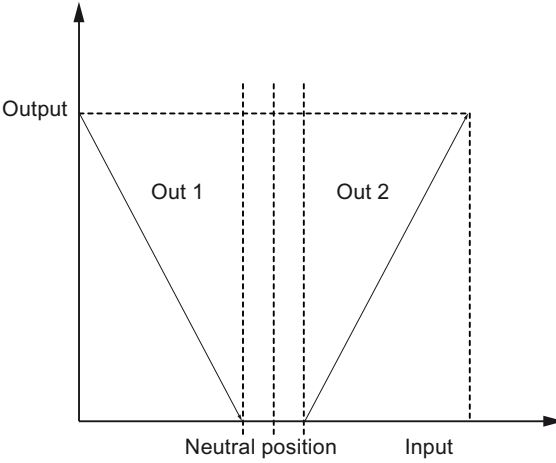
Case	Signal splitting	Setting the I/Os
5		<p> <code>Out1Scale.Low = 0.0 and Out1Scale.High = 100.0</code> <code>Out2Scale.Low = 0.0 and Out2Scale.High = 100.0</code> <code>DeadBand = -10.0 and NeutPos = 50.0</code> </p>
6		<p> <code>Out1Scale.Low = 0.0 and Out1Scale.High = 100.0</code> <code>Out2Scale.Low = 0.0 and Out2Scale.High = 100.0</code> <code>DeadBand = 10.0 and NeutPos = 50.0</code> </p>

See also

Description of SplRange (Page 921)

SplRange messaging (Page 926)

SplRange I/Os (Page 927)

SplRange block diagram (Page 928)

SplRange error handling (Page 926)

SplRange modes (Page 922)

5.12.4 SplRange error handling

Error handling of SplRange

Refer to the section Error handling (Page 119) in the basic instructions for the error handling of all blocks.

The following errors can be displayed for this block:

- Error numbers

Overview of error numbers

The `ErrorNum` I/O can be used to output the following error numbers:

Error number	Meaning of the error number
-1	Predefined value when inserting the block; the block is not processed.
0	There is no error.
30	The value of <code>In</code> can no longer be displayed in the REAL number field.

See also

SplRange block diagram (Page 928)

SplRange I/Os (Page 927)

SplRange messaging (Page 926)

SplRange functions (Page 923)

SplRange modes (Page 922)

Description of SplRange (Page 921)

5.12.5 SplRange messaging

Messaging

This block does not offer messaging.

See also

Description of SplRange (Page 921)

SplRange functions (Page 923)

SplRange I/Os (Page 927)

SplRange block diagram (Page 928)

SplRange error handling (Page 926)

SplRange modes (Page 922)

5.12.6 SplRange I/Os

I/Os of SplRange

Input parameters

Parameter	Description	Type	Default
DeadBand	Width of dead band	REAL	0.0
EN	1 = Called block will be processed	BOOL	1
In	Input value	STRUCT <ul style="list-style-type: none"> Value: REAL ST: BYTE 	- <ul style="list-style-type: none"> 0.0 16#80
InScale	Limit range for the input signal	STRUCT <ul style="list-style-type: none"> High: REAL Low: REAL 	- <ul style="list-style-type: none"> 100.0 0.0
NeutPos	Neutral position	REAL	50.0
Out1Scale	Limit range of output 1	STRUCT <ul style="list-style-type: none"> High: REAL Low: REAL 	- <ul style="list-style-type: none"> 100.0 0.0
Out2Scale	Limit range of output 2	STRUCT <ul style="list-style-type: none"> High: REAL Low: REAL 	- <ul style="list-style-type: none"> 100.0 0.0

Output parameters

Parameter	Description	Type	Default
ENO	1 = Block algorithm completed without errors	BOOL	0
ErrorNum	Output of current error number. For error numbers that can be output by this block, see SplRange error handling (Page 926).	INT	-1
Out1	Output value 1	STRUCT <ul style="list-style-type: none"> Value: REAL ST: BYTE 	- <ul style="list-style-type: none"> 0.0 16#80
Out1Act	1 = Output 1 is active	STRUCT <ul style="list-style-type: none"> Value: BOOL ST: BYTE 	- <ul style="list-style-type: none"> 0 16#80

5.12 SplRange - Signal splitter

Parameter	Description	Type	Default
Out2	Output value 2	STRUCT <ul style="list-style-type: none">Value: REALST: BYTE	- <ul style="list-style-type: none">0.016#80
Out2Act	1 = Output 2 is active	STRUCT <ul style="list-style-type: none">Value: BOOLST: BYTE	- <ul style="list-style-type: none">016#80

See also

- Description of SplRange (Page 921)
- SplRange functions (Page 923)
- SplRange messaging (Page 926)
- SplRange block diagram (Page 928)
- SplRange modes (Page 922)

5.12.7 SplRange block diagram

SplRange block diagram

A block diagram is not provided for this block.

See also

- SplRange I/Os (Page 927)
- SplRange messaging (Page 926)
- SplRange error handling (Page 926)
- SplRange functions (Page 923)
- Description of SplRange (Page 921)
- SplRange modes (Page 922)

5.13 AutoExcitation - Process trigger for predictive controller

5.13.1 Description of AutoExcitation

Object name (type + number) and family

Type + number: FB 1842

Family: Control

Area of application of AutoExcitation

This block is used to generate suitable excitation signals for the identification of dynamic multi-variable process models for the model-based predictive controllers ModPreCon and the large predictive controller MPC10x10. It is interconnected with aModPreCon or MPC10x10 block for this purpose.

How it works

The AutoExcitation block generates a sequence of abrupt trigger signals for the selected manipulated variables, MV1, MV2 to NumberMVs. A jump is initially made up, down, and then back to the starting point for each manipulated variable, so that the signals is symmetrical to the operating point.

The operating point taken from assigned controller via the MV1Actual...MV10Actual inputs. You set the jump height for each manipulated variable with the StepSiz1... StepSiz10 parameter and the jump duration via the Duratio1...Duratio10 parameter.

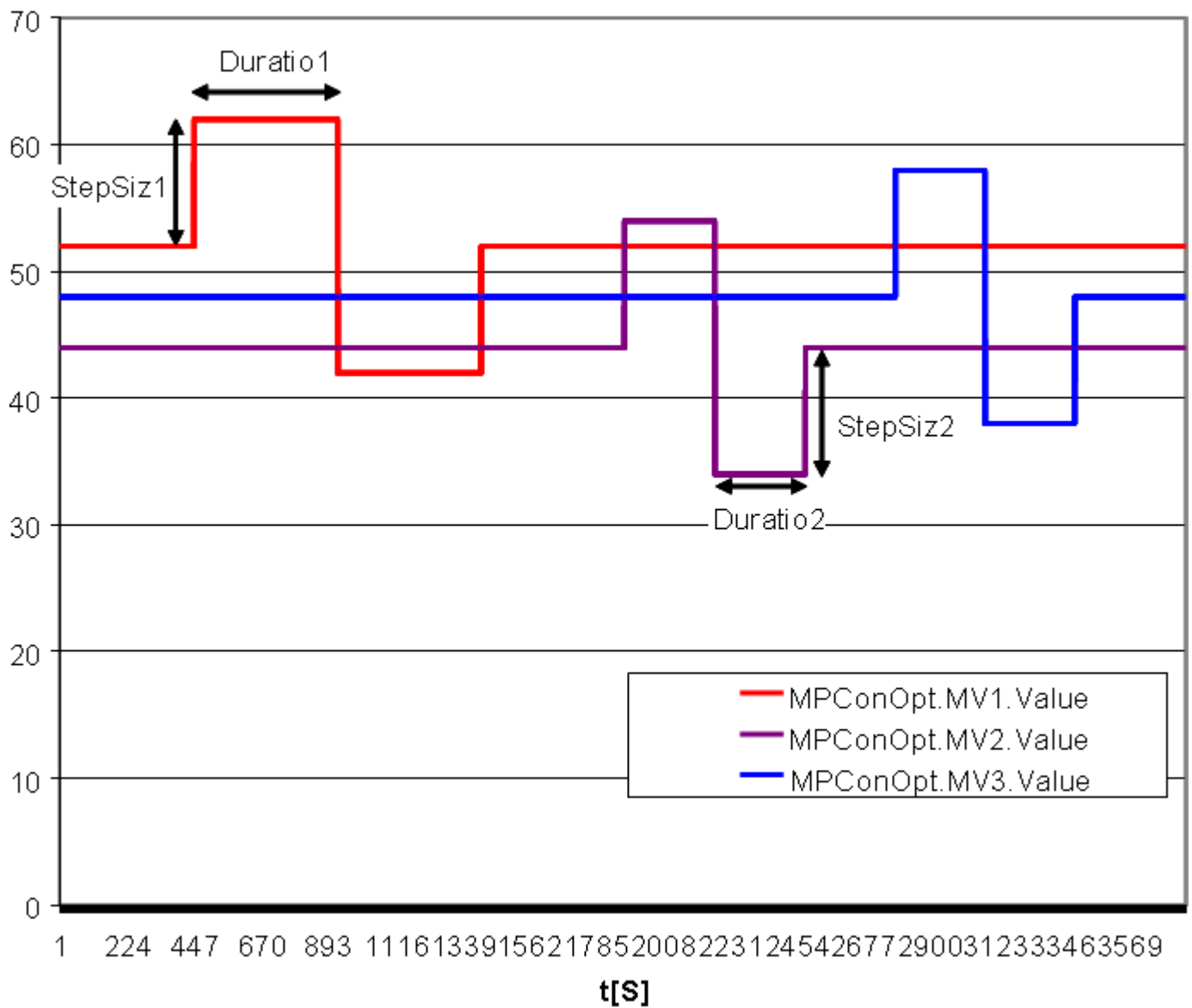

Configuration

The AutoExcitation block is part of the new process tag type, ModPreCon and MPC10x10. Only the new controller version has the necessary additional inputs for automatic triggering.

If the block retro-installed in an existing CFC, make sure that AutoExcitation and ModPreCon or MPC10x10 are in the same OB cycle.

- Supply the AutoExcitation.MV1Actual...MV10Actual input variables with the appropriate ModPreCon.MV1...MV4 or MPC10x10.MV1...MV10 values from the controller.
- Specify the input parameter AutoExcitation.NumberMVs according to the number of manipulated variables you want to use in your MPC application. Exception: If you do not want to automatically trigger all manipulated variables of the controller, specify the number of manipulated variables to be directly triggered at the AutoExcitation.NumberMVs input parameter .
- Connect the AutoExcitation.MV1Excite...MV10Excite output variables to the appropriate ModPreCon.MV1Excite... MV4Excite or MPC10x10.MV1Excite...MV10Exciteinput variables on the controller.
- Connect the AutoExcitation.ExciteAct output variable to the ModPreCon.ExciteOn or MPC10x10.ExciteOn input variables of the controller.

5.13.2 AutoExcitation modes

Operating modes of AutoExcitation

This block does not have any modes.

5.13.3 AutoExcitation functions

Using AutoExcitation

Start triggering by setting the StartExcite binary input variable to the value 1 .

If you cancel triggering during ongoing operation via StartExcite =0 , the manipulated variables are reset to the original operating point.

When the Next binary input parameter = 1 , you can start the next jump manually before the planned time has expired.

The StepPhase output variable shows the current phase of the attempted jump:

0: Constant

1: Jump up

2: Jump down

3: Jump back to the operating point

The StepTime output variable indicates the remaining time in [s] until the next jump.

5.13.4 AutoExcitation error handling

Overview of error numbers

The ErrorNum output parameter can be used to output the following error numbers:

Error number	Meaning of the error number
-1	Default value when the block is installed, the block is not executed
0	There is no error.
60	One of the input parameters, Duratio1,2,3,4...10 < SampleTime or SampleTime < 0.001
61	The trigger signals are not adopted correctly by the assigned controller.

5.13.5 AutoExcitation messaging

Messaging of AutoExcitation

This block does not offer messaging.

5.13.6 AutoExcitation I/Os

I/Os of AutExcite

Input parameters

Parameter	Description	Type	Default
Duration1...Duration10	Duration for jump in MV1...MV10 in s	REAL	20
MV1Actual...MV10Actual	Current value of MV1...MV10	STRUCT • Value: REAL • ST: BYTE	- • 0.0 • 16#80
Next*	1 = Manual start of the next trigger change	BOOL	0
SampleTime	Sampling time in s	REAL	1
StartExcite*	1 = Start of automatic triggering; 0= Cancel automatic triggering	BOOL	1
StepSize1...StepSize10	Step height of MV1...MV10	REAL	10

* Values can be written back to these inputs during processing of the block by the block algorithm.

Output parameters

Parameter	Description	Type	Default
ErrorNum	Output of pending error number	INT	0
ExciteAct	1 = Automatic triggering is active	BOOL	0
MV1Excitation...MV10Excitation	Value of the trigger for MV1...MV10	STRUCT <ul style="list-style-type: none"> • Value: REAL • ST: BYTE 	- <ul style="list-style-type: none"> • 0.0 • 16#80
StepPhase	Phase of the jump; 0 = Constant, 1= Jump up, 2 = Jump down, 3 = Return	INT	0
StepTime	Time remaining until the next jump phase in s	REAL	0

5.13.7 AutoExcitation block diagram**Block diagram of AutoExcitation**

A block diagram is not provided for this block.

5.14 LPOptim - Optimization after traversing the linear programming

5.14.1 Description of LPOptim

Object name (type + number) and family

Type + number: FB1844

Family: Control or system

Area of application of LPOptim

Optimization of a linear performance function taking into account constraints after traversing the linear programming.

The LPOptim block is used by the ModPreCon block for static operating point optimization (Page 695). However, it can also be used separately.

Operating principle

The performance function has a linear relationship to up to four decision variables, $x_1 \dots x_4$, with corresponding weighting factors, $g_1 \dots g_4$.

$$J = g_1 \cdot x_1 + g_2 \cdot x_2 + g_3 \cdot x_3 + g_4 \cdot x_4$$

The performance function is a hyper-level in a five dimensional space whose gradient direction is described by the gradient vector, Gradient = [g_1, g_2, g_3, g_4].

The block can determine both the maximum as well as the minimum of the J performance function. A minimization problem is transformed into an equivalent maximization problem by inverting the gradient vector.

The decision variables are positive and limited by a system of up to eight linear non-equivalence constraints .

The first constraint is, for example

$$a_{11} \cdot x_1 + a_{12} \cdot x_2 + a_{13} \cdot x_3 + a_{14} \cdot x_4 \leq b_1$$

All four elements of the first line from the A matrix are combined in the A1n data structure. All eight elements of the B vector are combined in the Begrenzungen data structure.

How it works

The block operates according to the simplex procedure, i.e. based on an iterative algorithm. Due to the linear performance criterion, the solution always lies at an intersection of multiple restrictions.

Configuration

The block can be installed in OB1 because no time-critical calculations are performed. If the block is called by ModPreCon, the user does not have to set parameters directly at LPOptim block.

5.14.2 LPOptim modes

Operating modes of LPOptim

This block does not have any modes.

5.14.3 LPOptim functions

Use of LPOptim

The algorithm is started with a positive edge at the Start parameter or if there is a change in one of the input variables (gradient vector and limitations), and displays the optimum variable found at the XOpt1...XOpt4 output parameters when execution is completed.

If no solution is found (non-plausible coefficient), execution is aborted with an error code.

5.14.4 LPOptim error handling

Overview of error numbers

The Status output parameter can be used to display the following states:

Status	Meaning
0	There is no error.
10	Unrestricted target function
15	No XOpt found
20	Infinite number of solutions
35	Unlimited permissible range
40	Configuration error

5.14.5 LPOptim messaging

Messaging

This block does not offer messaging.

5.14.6 LPOptim I/Os

I/Os of LPOptim

Input parameters

Parameter	Description	Type	Default
J_Mini	1= Search minimum 0= Search maximum	BOOL	0
Start*	1= Start optimization calculation immediately 0= Start optimization calculation only if one of the input variables has changed	BOOL	0
X1	Decision variable 1 for calculation of J_Act	REAL	0
X2	Decision variable 2 for calculation of J_Act	REAL	0
X3	Decision variable 3 for calculation of J_Act	REAL	0
X4	Decision variable 4 for calculation of J_Act	REAL	0
J_0	Constant part of the performance criterion, irrespective of the decision variables	REAL	0
N_X	Number of decision variables, N_X <= 4	INT	4
N_b	Number of constraints, N_b <= 8	INT	8
Gradient.g1*	Gradient vector with up to 4 REAL elements	STRUCT	[1, 1, 1, 1]
...			
Gradient.g4*			
Constraints.b1	Vector B of the limits with up to 8 REAL elements	STRUCT	[0, 0, 0, 0, 0, 0, 0, 0]
...			
Constraints.b8			
A1n.a11	1. Line of the A matrix contains factors for the elements of vector X in the first constraint	STRUCT	[0, 0, 0, 0]
A1n.a12			
A1n.a13			
A1n.a14			
A2n.a21	2. Line of the A matrix contains factors for the elements of vector X in the second constraint	STRUCT	[0, 0, 0, 0]
A2n.a22			
A2n.a23			
A2n.a24			
A3n.a31	3. Line of the A matrix contains factors for the elements of vector X in the third constraint	STRUCT	[0, 0, 0, 0]
A3n.a32			
A3n.a33			
A3n.a34			

5.14 LPOptim - Optimization after traversing the linear programming

Parameter	Description	Type	Default
A4n.a41 A4n.a42 A4n.a43 A4n.a44	4. Line of the A matrix contains factors for the elements of vector X in the fourth constraint	STRUCT	[0, 0, 0, 0]
A5n.a51 A5n.a52 A5n.a53 A5n.a54	5. Line of the A matrix contains factors for the elements of vector X in the fifth constraint	STRUCT	[0, 0, 0, 0]
A6n.a61 A6n.a62 A6n.a63 A6n.a64	6. Line of the A matrix contains factors for the elements of vector X in the sixth constraint	STRUCT	[0, 0, 0, 0]
A7n.a71 A7n.a72 A7n.a73 A7n.a74	7. Line of the A matrix contains factors for the elements of vector X in the seventh constraint	STRUCT	[0, 0, 0, 0]
A8n.a81 A8n.a82 A8n.a83 A8n.a84	8. Line of the A matrix contains factors for the elements of vector X in the eighth constraint	STRUCT	[0, 0, 0, 0]

* Values can be written back to these inputs during processing of the block by the block algorithm.

Output parameters

Parameter	Description	Type	Default
Bad	1= Status bad, optimization has failed	BOOL	0
ErrorNum	Output of current error number. For error numbers that can be output by this block, see the error handling of LPOptim.	INT	0
J_Opt	Value of the performance criterion at the optimum	REAL	0
J_Act	Value of the performance criterion for the current assignment of the decision variables in accordance with input parameters X1...X4	REAL	0
X1Opt	Optimum value of the 1st decision variable	REAL	0
X2Opt	Optimum value of the 2nd decision variable	REAL	0
X3Opt	Optimum value of the 3rd decision variable	REAL	0
X4Opt	Optimum value of the 4th decision variable	REAL	0

See also

LPOptim error handling (Page 935)

5.14.7 LPOptim block diagram

LPOptim block diagram

A block diagram is not provided for this block.

5.15 MPC10x10 - Large predictive controller

5.15.1 Description of MPC10x10

Object name (type + number) and family

Type + number: FB 1920

Family: Control

Area of application for MPC10x10

The block is used for multivariable control, similar to the ModPreCon, typically as master controller in cascade structures.

Compared to the lean multivariable controller ModPreCon, the MPC10x10 has the following functional expansions:

- Greater capacity: up to 10x10 interacting manipulated and controlled variables (compared with ModPreCon: 4x4), up to 4 measurable disturbances for a dynamic disturbance compensation (feedforward) (ModPreCon: 1). Unused MV channels can be rededicated to disturbance variables, whereby the total number of manipulated variables and disturbances is limited to 14 (ModPreCon: 5).
- Dynamic online optimization considering constraints in each sampling step. The optimization problem is resolved without constraints with ModPreCon and the manipulated variables are limited afterward. This may result in solutions that are less than optimal if several constraints are active simultaneously in automatic mode.
- Processing of (low-priority) target values for the manipulated variables, which is mainly of interest for control tasks in which there are more manipulated variables than controlled variables or in which some controlled variables do not have to be kept at an exact setpoint.
- Integrated steady state operating point optimization even for control tasks in which the number of manipulated variables does not match the number of controlled variables.

Method of operation and area of application

The block is used for Multivariable controller (Page 2390) dynamic processes. It can handle up to ten interacting manipulated and controlled variables as well as up to four measurable disturbances.

The MPC10x10 algorithm only works for stable processes with a step response that settles to a fixed value in a finite time. If the process is unstable in one of the main transfer functions or includes an integrator (level control, for example), the corresponding partial transfer function must be stabilized with a secondary controller.

A simple P controller (proportional component only) is sufficient as a slave controller for integrating processes. It is inserted between the manipulated variable output of MPC10x10 and the input of the unstable process section, and receives the output of the integrating process section as a manipulated variable. (Unstable data links are stabilized with this approach.)

You can find an explanation of "multivariable controls" and "non-phase-minimum response" in the Help on the Advanced Process Library > Definitions.

Note on the area of application of the controller: Longer run times

Due to the principle on which it works, the runtime of MPC10x10 is significantly longer than that of ModPreCon and obviously much longer than that for PID controllers, because very large matrices have to be multiplied in the algorithm. The runtime is also determined by the number of the process and manipulated variables in the control algorithm. This is why the MPC10x10 is unsuitable for high-speed controls and is usually used for slow, complex control tasks in which controller sample times of more than 4 s are permitted.

The computing time required on the CPU is compensated for by the fact that very slow sample times of > 20 s are used for the typical MPC10x10 applications (see Advanced control templates). The MPC10x10 is then typically located in OB30 and can be interrupted by faster OBs. Some parts of the MPC10x10 algorithm have been outsourced to auxiliary blocks due to the limitations of the address space for SIMATIC function blocks and data blocks. The MPC10x10 uses two outsourced optimization methods:

- MPC_LP_OptiFB for operating point optimization which, in turn, needs an auxiliary block MPC_LPOptiFC .
- MPC_ActSetFB

as well as auxiliary blocks for matrices that are created by the MPC Configurator and can all be identified by the prefix MPC_* in their name.

There are different forms of implementation for the matrices:

- User DBs that are filled with data by one or more FCs during initialization because large matrices cannot be pre-assigned with values in the source code for the DB:
- Data block MPC_g with initialization FCs MPC_g_FC, MPC_gb...ge;
- Data blocks MPC_ESP, MPC_Hu_FB, MPC_Hinv_FB, MPC_Omega_FB and MPC_M_FB each with a dedicated initialization function MPC_Esp_FC... as well as
- a data block MPC_RgMV_i (i=1..10) for each MV with initialization FCs MPC_RgMVia_FC and MPC_RgMVib_FC.
- User DBs filled with data by the MPC10x10 during runtime: MPC_Nn, MPC_Ms, MPC_MsOld.

As user, you only have to interconnect the main function block in the CFC and need not worry about the auxiliary blocks.

The static operating point optimization is called within the MPC10x10 block in the program section in which OB1 is executed. In cyclic operation OB3x, this avoids the additional computing time required by the optimizer, the acyclic time, i.e. which is only relevant for changes to the optimizer inputs.

Operating principle

The MPC10x10 block is a model-based predictive multivariable controller. It uses a mathematical model of the process dynamics including all interactions as part of the controller.

This model allows the process response to be predicted over a defined period in the future, also known as the prediction horizon.

Based on this prediction, a performance index

$$J = (\bar{w} - \bar{y})^T R (\bar{w} - \bar{y}) + \Delta \bar{u}^T Q \Delta \bar{u} + (\bar{u}_{soll} - \bar{u})^T S (\bar{u}_{soll} - \bar{u})$$

is optimized (minimized) where the following applies:

- w contains the time series of the future setpoints within the prediction horizon,
- y contains the vector of the controlled variables in the future,
- Δu contains the future changes of the manipulated variables within the control horizon,
- u_{soll} contains the target values for the manipulated variables u

The control horizon is generally significantly shorter than the prediction horizon. Changes of future manipulated variables are only planned within the control horizon.

If you increase the weighting in the Q diagonal matrix, the controller moves its manipulated variables more cautiously resulting in a slower but more robust control response. Using the weighting factors in the R diagonal matrix, you specify the relative significance of the individual controlled variables. A higher weighting (priority) for a controlled variable means that this CV moves more quickly towards the setpoint and remains more accurately at the setpoint in steady state if it is not possible to achieve all setpoints precisely.

The weightings for the target values of the manipulated variables in the S matrix are typically set much lower than the weightings of the controlled variables in the R matrix so that the controller must only handle the manipulated variable target values once it has reached all primary control aims regarding the controlled variables.

The algorithm is a variant of the DMC method (**D**ynamic **M**atrix **C**ontrol), comparable to the control algorithms in so-called "full-blown" MPC software packages that were previously linked to the process control system by external PCs.

The optimization problem is solved in ongoing automatic mode in each sampling step of the controller by initially neglecting the constraints. If a constraint violation is detected within the control horizon, an iterative optimization with the so-called "active set" method takes place. Only the currently active limitations are taken into consideration during each iteration step of the optimization. Manipulated variable limitations, both absolute and relating to the gradients, are treated in the algorithm of the function block as hard constraints that must not be violated. Precise setpoints or target zones for the controlled variables are taken into account during optimization as well as possible. The target zones for the controlled variables are therefore soft constraints, which are maintained as well as possible although they cannot be guaranteed. Using a reference variable filter for future setpoint trajectories, the control response of the controller can be fine-tuned during operation.

You can achieve significant improvements in control performance when individual disturbances can be measured, for example, variations in throughput. In this case, it is a good idea to take into account a model of the influence of this disturbance on the controlled variables when predicting the controlled variables so that the controller can react preemptively to such disturbances.

Operating point optimization

The integrated steady state operating point optimization can be used when at least one controlled variable provides certain degrees of freedom. No exact setpoint is specified for such controlled variables. Instead there is a tolerance band, e.g.

- SP2OptHiLim...SP2OptLoLim

within which the process value, CV2, must remain. These areas can be defined for any subset of the relevant controlled variables. From an economic perspective, different values within the tolerance band can be more or less favorable. With the help of the optimization function, the optimal economic point can be found within the tolerance range. This is done by defining a target function (performance criterion), which depends on the manipulated variable and controlled variable of the predictive controller. This can be, for example, the economic yield of plant operation per time unit or it may involve specific costs or energy consumption.

Configuration

Use the CFC editor to install the block in a cyclic interrupt OB (OB30 to OB38). The block is also installed automatically in the startup OB (OB100) and in OB 1.

MPC10x10 and all its auxiliary blocks are provided in the block folder "MPC10x10 blocks" of the Advanced Process Library. After you have placed the block in the CFC, you still need to copy the fixed addressed global data blocks DB1 to DB22 into the project. This will make all auxiliary blocks of MPC10x10 available in the project, thereby making it executable and allowing the SCL source of the MPC configurator to be later compiled.

In contrast to the ModPreCon, only one instance of the MPC10x10 can be configured per SIMATIC CPU. The addresses of the MPC auxiliary blocks are determined during compilation of the main block by the SCL Compiler and cannot be modified afterwards. The addresses for the auxiliary blocks (DBs and FCs) used by the MPC10x10 are defined in the following symbol table. If you already have other blocks in the project assigned to the specified addresses, you need to move them.

Icon	Address	Data type	Comment
MPC10x10	FB 1920	FB 1920	Model Predictive Controller with online optim.
MPC_LP_OptiFB	FB 1922	FB 1922	Linear Optimization
MPC_ActSetFB	FB 1923	FB 1923	Modified Simplex Optimization with Active Set Problem Reduction for ModPreConL
MPC_LPOptiFC	FC 400	FC 400	Linear Optimization
MPC_g_FC	FC 401	FC 401	MPC Configurator
MPC_gb_FC	FC 402	FC 402	MPC Configurator
MPC_gc_FC	FC 403	FC 403	MPC Configurator
MPC_gd_FC	FC 404	FC 404	MPC Configurator
MPC_ge_FC	FC 405	FC 405	MPC Configurator
MPC_gz_FC	FC 406	FC 406	MPC Configurator
MPC_Hu_FC	FC 407	FC 407	MPC Configurator
MPC_Hinv_FC	FC 408	FC 408	MPC Configurator
MPC_Omega_FC	FC 409	FC 409	MPC Configurator
MPC_M_FC	FC 410	FC 410	MPC Configurator

5.15 MPC10x10 - Large predictive controller

MPC_RgMV1a_FC	FC 411	FC 411	MPC Configurator
MPC_RgMV1b_FC	FC 412	FC 412	MPC Configurator
MPC_RgMV2a_FC	FC 413	FC 413	MPC Configurator
MPC_RgMV2b_FC	FC 414	FC 414	MPC Configurator
MPC_RgMV3a_FC	FC 415	FC 415	MPC Configurator
MPC_RgMV3b_FC	FC 416	FC 416	MPC Configurator
MPC_RgMV4a_FC	FC 417	FC 417	MPC Configurator
MPC_RgMV4b_FC	FC 418	FC 418	MPC Configurator
MPC_RgMV5a_FC	FC 419	FC 419	MPC Configurator
MPC_RgMV5b_FC	FC 420	FC 420	MPC Configurator
MPC_RgMV6a_FC	FC 421	FC 421	MPC Configurator
MPC_RgMV6b_FC	FC 422	FC 422	MPC Configurator
MPC_RgMV7a_FC	FC 423	FC 423	MPC Configurator
MPC_RgMV7b_FC	FC 424	FC 424	MPC Configurator
MPC_RgMV8a_FC	FC 425	FC 425	MPC Configurator
MPC_RgMV8b_FC	FC 426	FC 426	MPC Configurator
MPC_RgMV9a_FC	FC 427	FC 427	MPC Configurator
MPC_RgMV9b_FC	FC 428	FC 428	MPC Configurator
MPC_RgMV10a_FC	FC 429	FC 429	MPC Configurator
MPC_RgMV10b_FC	FC 430	FC 430	MPC Configurator
MPC_Esp_FC	FC 432	FC 432	MPC Configurator
MPC_Ms	DB 1	DB 1	MPC Configurator
MPC_Nn	DB 2	DB 2	MPC Configurator
MPC_MsOld	DB 3	DB 3	MPC Configurator
MPC_g	DB 4	DB 4	MPC Configurator
MPC_gz	DB 5	DB 5	MPC Configurator
MPC_Hu	DB 6	DB 6	MPC Configurator
MPC_Hinv	DB 7	DB 7	MPC Configurator
MPC_Om	DB 8	DB 8	MPC Configurator
MPC_M	DB 9	DB 9	MPC Configurator
MPC_RgMV1	DB 10	DB 10	MPC Configurator
MPC_RgMV2	DB 11	DB 11	MPC Configurator
MPC_RgMV3	DB 12	DB 12	MPC Configurator
MPC_RgMV4	DB 13	DB 13	MPC Configurator
MPC_RgMV5	DB 14	DB 14	MPC Configurator
MPC_RgMV6	DB 15	DB 15	MPC Configurator
MPC_RgMV7	DB 16	DB 16	MPC Configurator
MPC_RgMV8	DB 17	DB 17	MPC Configurator
MPC_RgMV9	DB 18	DB 18	MPC Configurator
MPC_RgMV10	DB 19	DB 19	MPC Configurator
MPC_Esp	DB 20	DB 20	MPC Configurator
MPC_LP_Opti	DB 21	FB 1922	Instance DB FB 1922
MPC_ActSet	DB 22	FB 1923	Instance DB FB 1923

After installation in CFC, follow the steps outlined below:

1. Excite the process with the controller in manual mode by applying a series of manipulated variable step changes. We recommend using the auxiliary function block, AutoExcitation, to generate excitation signals.
2. Record the measured data with the CFC trend display and export it to an archive file. You can also use a WinCC TagLogging TrendControl to record the data and to export the *.csv file. If the total number of manipulated and controlled variables exceeds the maximum number of trends in the CFC, you will have to use the WinCC TrendControl anyway.
3. Select the MPC10x10 instance in the CFC. Start the MPC Configurator under Edit > MPC Configurator.
The working steps process identification, controller design and simulation of the closed control loop are executed in the MPC Configurator. You can find a detailed description of this procedure in the MPC Configurator help. You can find the help with a button in the MPC Configurator or directly under ...\\Program Files (x86)\\SIEMENS\\STEP7\\S7JMPC\\s7jmpctb.chm.
4. Using the Configurator, create an SCL source code for the user data blocks (DBs) and other auxiliary blocks (FCs). The source contains all models and matrices required for an MPC10x10 instance.
5. Compile the SCL source with the S7-SCL compiler and archive the SCL source with the controller data.

Load the changes to the AS (with the option: Include user data blocks)

The values in the auxiliary blocks are applied in the controller by restarting the block by means of the input variable Restart:= true at the CFC block instance.

Note

During controller design in the MPC Configurator, a controller cycle time and an OB sampling time are calculated, displayed, and stored in the user data block. You yourself are responsible for ensuring that the MPC10x10 block is called in the cyclic interrupt level suitable for the OB sampling time. This is checked in the current MPC10x10 version during initialization. If the SampleTime parameter of the function block does not match the OB_SampleTime parameter of the user data block, a parameter assignment error (ErrorNum=3) is displayed. For controller cycle times greater than 5s, insert the MPC10x10 block in the OB30 and specify the appropriate cycle time for the OB30 in the hardware configuration of the SIMATIC CPU. Controller cycle times slower than 20 s cannot be set in the hardware configuration. The block would then be called every 20s and the slower sampling time automatically realized by an internal cycle reduction ratio in the block.

There are no templates for the MPC10x10 block for a process tag type in the Advanced Process Library because the controller is typically configured individually as master controller for several slave controllers.

Startup characteristics

When the CPU starts up, the block always starts in manual mode. It is only possible to change to automatic mode when a user data block is loaded and the internal measured value memory in MPC10x10 is filled with data.

Status word allocation for `Status1` parameter

You can find a description for each parameter in section I/Os of MPC10x10 I/Os (Page 959)

Status bit	Parameter
0	Occupied
1	BatchEn
2	SimOn
3	OosAct.Value
4	OosLi.Value
5	AutAct.Value
6	Not used
7	ManAct.Value
8 - 9	Not used
10	MV1TrkOn.Value AND NOT (ManAct.Value OR OosAct.Value)
11	MV2TrkOn.Value AND NOT (ManAct.Value OR OosAct.Value)
12	MV3TrkOn.Value AND NOT (ManAct.Value OR OosAct.Value)
13	MV4TrkOn.Value AND NOT (ManAct.Value OR OosAct.Value)
14	Not used
15	DB_Loaded
16	DV_Model Available
17	OptimAct
18	NOT (OptimAct)
19	Not used
20	J_Mini
21	NOT(J_Mini)
22	ExciteOn AND ManAct.Value
23	MV5TrkOn.Value AND NOT (ManAct.Value OR OosAct.Value)
24	MV6TrkOn.Value AND NOT (ManAct.Value OR OosAct.Value)
25	MV7TrkOn.Value AND NOT (ManAct.Value OR OosAct.Value)
26	MV8TrkOn.Value AND NOT (ManAct.Value OR OosAct.Value)
27	MV9TrkOn.Value AND NOT (ManAct.Value OR OosAct.Value)
28	MV10TrkOn.Value AND NOT (ManAct.Value OR OosAct.Value)
29	Tracking mode; i.e. at least one of the original manipulated variables (without pseudo MVs, which are used as DVs) is tracked.
30	Not allocated
31	Feature.Bit31: Display of the predictions in the faceplate

Status word allocation for status2 parameter

Status bit	Parameter
0 - 30	Not used
31	MS_RelOp

5.15.2 MPC10x10 modes

Operating modes of MPC10x10

The block can be operated using the following modes:

- Automatic mode (Page 72)
- Manual mode (Page 72)
- Out of service (Page 71)

The next section provides additional block-specific information relating to the general descriptions.

The aforementioned operating modes are valid for the block with all control channels (MV1 ... MV10). Moreover, individual control channels can be tracked; see section MPC10x10 functions (Page 947) for more information.

"Automatic mode"

You can find general information on "Automatic mode", switching modes and bumpless switchover in the section Manual and automatic mode for control blocks (Page 72) .

Note

In contrast to PID controllers, it is permitted to run the MPC10x10 block in "automatic mode" without its actuating signals affecting the process because there is no risk of integrator windup.

"Manual mode"

You can find general information on "Manual mode", switching modes and bumpless switchover in the section Manual and automatic mode for control blocks (Page 72) .

"Out of service"

You can find general information about the "Out of service" mode in the Out of service (Page 71) .

5.15.3 MPC10x10 functions

Functions of MPC10x10

The functions for this block are listed below.

Generating and limiting the manipulated variable

The manipulated variable $MV1 \dots MV4$ (hereinafter referred to as MV_x , $x = 1 \dots 10$) can be generated as follows:

ManAct	MVxTrkOn	MVx	Limit monitoring	State
1	-	Manx	ManxHiLim ManxLoLim	"Manual mode", set by the operator
0	1	MVxTrk	MVxHiLim MVxLoLim	Tracking with limitation
0	0	Automatic manipulated variable	MVxHiLim MVxLoLim	"Automatic mode": Predictive controller algorithm

Remark

If the controller is in "Out of service" mode, the output parameters $MV1 \dots MV10$, depending on the Feature Bit (Neutral position manipulated variable takes effect at startup (Page 166)), are set to the last valid value in manual mode or the corresponding neutral position manipulated variable ($SafePos1 \dots SafePos10$). Refer to the Out of service (Page 71) section for more on this.

The limited operating range (between MV_xHiLim and MV_xLoLim) is typically smaller in automatic mode than in manual mode. With regard to the limited range of validity of a linear process model for approximating a non-linear process response, this allows the stability of the closed control loop to be guaranteed within the control range in automatic mode.

The gradients of the manipulated variable (changes per second) are limited to $MV1RaLim$ to $MV10RaLim$ in "automatic mode". Gradient limitation applies both to the positive and negative directions.

Tracking and limiting a manipulated variable

The block provides the standard function Tracking and limiting a manipulated variable (Page 196).

In contrast to PID controllers, tracking the manipulated variables ($MV1 \dots MV10$) is enabled for specific channels via one of the input parameters $MV1TrkOn \dots MV10TrkOn$. The corresponding manipulated variable is then tracked by the interconnectable input parameters $MV1Trk \dots MV10Trk$.

Setting the setpoint internally

With this block, the setpoint must always be set internally at the I/Os $SP1 \dots SP10$. These are normally operated in the faceplate. In special situations, you can interconnect the setpoints but they can then no longer be changed using the faceplate.

Setpoint tracking in manual mode

In this situation ($SP_TrackCV = 1$), the internal setpoints $SP1 \dots SP10$ are tracked to the assigned process values $CV1 \dots CV10$ in "manual mode". This function allows a bumpless transfer to "automatic mode". After the transfer, the setpoints can be changed by the operator again.

Setpoint filters

The setpoint filter is the only way of changing the action of the predictive controller without having to create a new user data block with the MPC Configurator and reinitialize the controller. The specified time constant $PreFilt1 \dots PreFilt10$ of the setpoint filter can be interpreted as the required settling time of this CV channel following a setpoint step change. As the time constant setting increases, the controller works more slowly and less aggressively. In particular, this reduces the influence of a setpoint step change in one control channel on neighboring control channels.

Internally, the MPC10x10 block works with trajectories of future setpoints that are compared with the predicted movements of the controlled variables. Without the setpoint filter, it is assumed that the current setpoint will continue to remain valid in the future within the prediction horizon. If there is a setpoint step change, this means that the full value of the new setpoint will be required in the near future although the process cannot achieve this (according to the prediction). With the setpoint filter, an asymptotic setpoint trajectory (first order) is calculated from the current process value to the required setpoint so that the required setpoint is reached in the specified time.

Note

The setpoint filter also comes into effect without a setpoint step if the process value deviates significantly from the setpoint due to disturbances. This means that the filter not only slows down the control response but indirectly also the response to disturbances.

The control response can only be slowed down by the setpoint filter and not accelerated; when the value is 0, the prefilter is deactivated. It is therefore advisable to set the basic controller tuning in the MPC Configurator with the "Manipulated variable move penalty" parameter and then to optimize this inside the software using the function for simulation of the closed control loop. The setpoint filter should then only be used for fine tuning of the controller action in the real-world process.

Simulating signals

The block provides the standard function Simulating signals (Page 58).

You can simulate the following values:

- Controlled variable ($SimCVx$, $SimCVxLi$)

Selecting a unit of measure

The block provides the standard function Selecting a unit of measure (Page 212).

Error signal generation and dead band

The block provides the standard function Error signal generation and dead band (Page 192).

In the predictive controller, the error signal is generated over the entire prediction horizon for each control channel as the deviation between the predicted movement of the process (starting at the current process value $CV1 \dots CV4$) and future setpoint settings (ending at $SP1 \dots SP10$) and used to calculate the manipulated variable.

In principle, the effect of the dead bands $SP1DeadBand$ to $SP10Deadband$ is the same as in a PID controller, but extends over the entire future prediction horizon. In other words, if, for example, the predicted controlled variable $CV1$ in the entire prediction horizon is within the band $SP1 \pm SP1DeadBand$, the controller sees no reason whatsoever to change any manipulated variable. These are therefore also known as CV bands. In contrast to the manipulated variable limits, these are not hard constraints that need to be adhered to at all costs.

In multivariable controllers, it is advisable to make use of the fact that from the perspective of the application only some of the controlled variables need to move to a specified setpoint exactly while others only need to remain within a defined range.

A typical example would be product quality characteristics for which a tolerance band is specified. While a dead band in a PID controller tends to put stability at risk, CV bands in individual controller channels generally relieve the multivariable controller overall.

Using CV bands, the action of a soft override control can be achieved.

Use case for error signal generation with dead band

As long as the pressure in a reactor remains within the specified safety limits, the controller is interested only in product quality. However, as soon as the pressure threatens to leave the permitted range (in other words, inside the prediction horizon it moves towards an illegal value in the future), the pressure control cuts in. By weighting the controlled variables in the performance index (see MPC Configurator), the user can specify that predicted violations of the pressure limits are given a particularly high weighting.

Predictive controller algorithm

The MPC10x10 block is derived from the familiar DMC algorithm (**D**ynamic **M**atrix **C**ontrol) .

Future changes to the manipulated variable within the control horizon are calculated from future predictive control deviations. To accomplish this, first the ideal solution is determined in each sampling step using an analytical formula without consideration of constraints. If the ideal solution comes into conflict with a constraint, an iterative optimization process is used to find a solution of the dynamic quadratic optimization problem with constraints.

Based on the principle of the receding horizon, only the first value is taken from the calculated vector of the optimum manipulated variable moves over the entire control horizon and applied to the process. In the next step, the newly arrived process values are taken into account and the calculation repeated over the entire prediction horizon.

With predictive controllers, the manipulated variable moves are based on the control deviations predicted in the future, while with a PID controller, they are based on (typically integrated) error signals of the past. This can be interpreted as a "looking ahead" strategy.

Anti-windup

When manipulated variable limits are active, anti-windup measures are taken automatically within the controller. The prediction equations use the real limited values of the manipulated variables instead of theoretically calculated values.

Model-based disturbance compensation

Model-based disturbance compensation can and should be used if one or more known disturbances have a strong influence on the process and their causes can be measured.

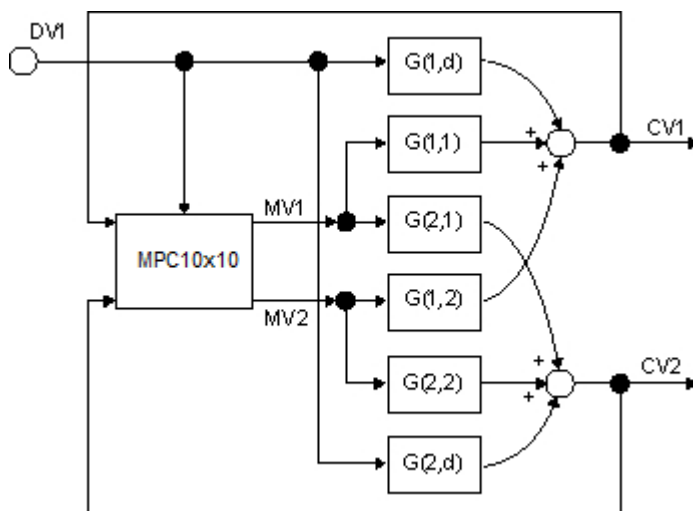

The effects of a measurable disturbance ($DV1 \dots DV4$ I/O) on all controlled variables $CV1 \dots CV10$ can be estimated when the controller is taken into manual mode. This means that no movements of the controlled variables whatsoever result from changes to the manipulated variables and all movements result from the disturbance. If the disturbance (e.g. ambient temperature) can be measured but cannot be actively adjusted, it may be necessary to search through a data archive to find the time segments in which the disturbance changed.

The identification of the transfer functions from disturbances $DV1 \dots DV4$ to all controlled variables $CV1 \dots CV10$ (disturbance models $G(1,d)$ and $G(2,d)$ in the graphic above) is performed with the MPC Configurator and is analogous to the identification of the main transfer functions ($G(1,1)$ to $G(2,2)$). The measured disturbances are then linked to the $DV1 \dots DV4$ inputs of the MPC10x10 block and disturbance compensation is activated with $DV_On = 1$. As a result, the effect of the measurable disturbances is taken into account in the prediction and the controller can start counter measures in advance before the disturbance has a massive influence on the controlled variables.

Such disturbance compensation is especially effective when the disturbance is constant at times and changes from time to time. If a disturbance fluctuates constantly or oscillates, however, the feedforward control should not be enabled during operation of the controller to avoid constant oscillation of the manipulated variables, although it should be taken into account in the MPC Configurator when creating the process model.

If there is no disturbance model in the user data block, the signals at the $DV1 \dots DV4$ input are ignored.

Typical examples of measurable disturbances are inlet flows in distillation columns or throughput of continuous reactors.

Predictive controller with more than four measurable disturbances

If you want to plan for more than four measurable disturbances in an application, but do not need all ten manipulated variable channels of the MPC10x10 block, you can dedicate the first of the previously unused MV channels for disturbance feedforwarding.

Example: You only have two control actions available, so only use MV1 and MV2. Then connect the additional measurable disturbance DV5 to the MV3Trk input parameter and set MV3TrkOn = 1. For recording of training data for the predictive controller, declare MV3Trk as the third disturbance and also use the CFC trend recorder to record the effect of changes to DV5 on all controlled variables.

Use the MPC Configurator to then determine a process model that describes the effects of DV5. However, if the disturbance variable DV5 in "automatic mode" of the controller fluctuates due to external influences, the effect of such changes is taken into consideration for predicting future process reactions through MV3Trk and predictive methods can be used to compensate this disturbance. The performance of the disturbance compensation is exactly the same as that for regular feedforward control via the input parameters DV1...DV4 and DV_On = 1.

If you want to disable this disturbance compensation in runtime with the unused MV5 manipulated variable, you need to insert a SelA02In selector block in front of the MV3Trk input. This allows you to set a constant zero for MV3Trk instead of the measured value DV5, which stops the effect of MV3 on prediction. (Due to this reassignment, MV3TrkOn must always remain 1 to prevent the controller from changing the value of MV3.)

This way, additional measurable disturbances can be selected. However, the sum of the manipulated variables and disturbances may not exceed a total number of 14.

At the output variables NumberOrigMVs, the number of original manipulated variables is displayed that can actively be influenced by the controller. The other manipulated variables (in the above example MV3) are only used for disturbance feedforward and are therefore always in tracking mode. They are referred to as pseudo MVs.

Control of square and non-square systems

In multivariable controllers, the number of manipulated variables should ideally be the same as the number of controlled variables. This is known as a "square system". As long as constraints do not influence operation, the controller can, in principle, track all controlled variables exactly to the selected setpoints.

If there are less manipulated variables than controlled variables or if individual manipulated variables have reached their limits, degrees of freedom are lacking in the control problem. This means that it is not possible for all setpoints to be reached exactly.

The MPC10x10 algorithm then finds a compromise that can be influenced by the selection of controlled variable weightings (priorities) in the MPC Configurator: Controlled variables with higher priority will have lower control deviations.

If there are more manipulated variables than controlled variables or if some of the controlled variables are already within their setpoint bands, there are surplus degrees of freedom in the control problem.

The MPC10x10 algorithm can use these degrees of freedom to move the manipulated variable in the direction of the specified target value, whereby the weighting of the manipulated variable target value in the performance index is typically substantially less than the weighting of setpoints for the controlled variables. If the manipulated variables result in costs (e.g. mass flows of steam or other forms of energy consumption), the manipulated variable target values

can be set somewhat lower than the values previously observed at the operating point. The controller then attempts to reduce the manipulated variables (the costs) in the direction of the target values as long as the achievement of the primary control target provides some degree of freedom. In general, the advantages of the dynamic online optimization in the MPC10x10 are especially attractive for non-quadratic systems, because the restrictions of the lean algorithm of ModPreCon are overcome.

Control of linear and non-linear systems

The MPC10x10 algorithm is based on a linear, time invariant process model. As a result, in much the same way as a PID controller, it is suitable above all for controlling non-linear systems around a fixed operating point.

Again analogous to the PID controller, there are, however, several possibilities with which the area of application can be extended in context of non-linear systems:

Compensation functions between controller and controlled system:

It is, for example, possible to compensate the effect of a non-linear valve characteristic curve using a polygon block between the `MV` output and the control input of the valve block. Care must be taken when implementing the manipulated variable limits. In the same way, the effect of a non-linearity at the output of the controlled system (for example a sensor characteristic curve) can be compensated by a polygon block before the `CV` input of the controller. Remember that the corresponding `SP` must also be equivalently transformed. In both cases, the compensation functions become part of the controlled system from the perspective of the controller. The aim is always to keep the overall response of the controlled system consisting of process and compensation elements as linear as possible.

Trajectory control:

This approach neatly combines the advantages of an open loop controller (Feedforward Control) with those of a closed loop controller with process value feedback (Closed Loop Control). The controller follows a previously optimized trajectory of setpoints and manipulated variables; in other words, it only needs to compensate small deviations between the stored trajectory and the current plant state. A trajectory is an optimum series of manipulated variables over time and the process values that match them. The required manipulated variables are read by means of the `MV10Traj` inputs into the MPC10x10 block and added to the values of the manipulated variable calculated by the algorithm (in automatic mode only). Among other things, the advantage of this is that the effective manipulated variable acting on the process as the sum of the trajectory and controller action is limited correctly as configured. The process values from the trajectory are linked to the corresponding setpoint specifications `SP1 ... SP10` of the controller. As long as the process reacts exactly as planned in the trajectory, it will respond to the series of manipulated variables from the trajectory with the corresponding series of process values and the control deviation is zero. It is generally known that a non-linear dynamic process can be linearized around a fixed operating point or a steady state of the system. It is also possible to linearize it around a trajectory.

Forming the signal status for blocks

The block provides the standard function Forming and outputting the signal status for technologic blocks (Page 109).

The worst signal status `ST_Worst` for the block is formed from the following parameters:

- `DV1.ST`
- `DV4.ST`
- `CV1.ST`
- `CV2.ST`
- ...
- `CV10.ST`

Configurable reactions using the `Feature` parameter

An overview of all the reactions that are provided by the `Feature` parameter is available in the section Configurable functions using the Feature I/O (Page 131). The following functionality is available for this block at the relevant bits:

Bit	Function
1	Reaction to the out of service mode (Page 177)
2	Resetting the commands for changing the mode (Page 161)
4	Setting switch or button mode (Page 167)
8	Delete history of MV and DV moves during restart (Page 187)
15	Neutral position manipulated variable takes effect with "out of service" operating mode (Page 166)
16	Neutral position manipulated variable takes effect at startup (Page 166)
24	Enabling local operator authorization (Page 158)

Operator permissions

The block provides the standard function Operator control permissions (Page 254).

The block has the following permissions for the `OS_Perm` parameter:

Bit	Function
0	1 = Operator can switch to "automatic mode"
1	Not used
2	1 = Operator can switch to "Out of service" mode
3	Not used
4	Not used
5	1 = Operator can change the setpoint 1
6	1 = Operator can change the manipulated variables of all channels
7	1 = Operator can change operating high limits of the setpoints for all channels
8	1 = Operator can change operating low limits of the setpoints for all channels
9	1 = Operator can change the setpoint 2
10	1 = Operator can change the setpoint 3
11	1 = Operator can change the setpoint 4
12	1 = Operator can change the setpoint filter of all channels

Bit	Function
13 - 16	1 = Operator can change the setpoint 5...8
17	1 = Operator can enable the track setpoint in "manual mode" function
18	1 = Operator can activate the model-based disturbance compensation function
19	1 = Operator can change the setpoint 9
20	1 = Operator can change the setpoint 10
21	1 = Operator can only activate the "Prediction Mode" function
22	1 = Operator can change the target values of all channels
23	1 = Operator can change the dead band parameter of all channels
24	1 = Operator can change all parameters of the operating point optimization
25	1 = Operator can change the simulation value <code>SimCV1 . . . 10</code>
26	1 = Operator can activate the Simulation function
27	1 = Operator can activate the Release for maintenance function
28	1 = Operator can change the manipulated variable limits of all channels
29	1 = Operator can change the gradient limits of manipulated variables of all channels
30	1 = Operator can activate the operating point optimization
31	1 = Operator can deactivate the operating point optimization

Note

If you interconnect a parameter that is also listed in `OS_Perm` as a parameter, you have to reset the corresponding `OS_Perm` bit.

Release for maintenance

The block provides the standard function Release for maintenance (Page 64).

Specifying the display area for process and setpoint values as well as operations

This block provides the standard function Display and operator input area for process values and setpoints (Page 207).

In contrast to PID controllers, there are no separate parameters for bar limits. The setpoints limits are used for all setpoint and actual value bars; manual limits are used as bar limits for all manipulated variable bars.

Opening additional faceplates

This block provides the standard function Opening additional faceplates (Page 208).

SIMATIC BATCH functionality

This block provides the standard function SIMATIC BATCH functionality (Page 67).

Integrated static operating point optimization

The integrated steady state operating point optimization can be used if no exact SP_i setpoint is specified for at least one controlled variable (index $i = 1 \dots 10$), but rather the CV_i process value must remain within a tolerance range $SP_{iOptHiLim} \dots SP_{iOptLoLim}$. The tolerance range must, of course, be within the valid setpoint limits $SP_{iHiLim} \dots SP_{iLoLim}$ for this control channel. The tolerance range $SP_{iOptHiLim} \dots SP_{iOptLoLim}$ is not coupled to the operator-controlled setpoint SP_i . If the setpoint is changed, the tolerance range is not automatically shifted. If you want to do this nevertheless, interconnect the SP_{iOpOut} output parameters via two adders using the width of the tolerance range to the inputs $SP_{iOptHiLim}$ and $SP_{iOptLoLim}$.

From an economic perspective, different values within the tolerance range can be more or less favorable. With the help of the optimization function, the optimal economic point can be found within the tolerance range.

This is done by defining a target function (performance criterion), which depends on the manipulated variable and controlled variable of the predictive controller. This can be, for example, the economic yield of plant operation per time unit or it may involve specific costs or energy consumption.

$$J = \text{GradMV1} * \text{MV1} + \text{GradMV2} * \text{MV2} + \dots + \text{GradMV10} * \text{MV10} \\ + \text{GradCV1} * \text{CV1} + \text{GradCV2} * \text{CV2} + \dots + \text{GradCV10} * \text{CV10} \\ + J_0$$

You specify the individual GradXVi coefficients of the gradient vector as input variables at the MPC10x10 function block in the CFC or in the parameter view of the faceplate. If individual coefficients vary with time, e.g. they are dependent on current market prices, you can also interconnect these input variables. If individual manipulated or controlled variables have no influence on the performance criterion, leave the corresponding coefficients at the default value, zero.

You can use the binary J_Mini input parameter to specify whether the target function is to be maximized or minimized, based on whether this involves yields or costs ($J_Mini = 1$: minimization).

The term J_0 combines all contributions to the target function that do not depend on manipulated variables and controlled variables. These contributions have no effect on the optimum values of the decision variables, but are applied for calculating the current value of specified performance index according to the above-mentioned formula.

Within the controller, the terms of the target function that depend on controlled variables are converted to make their dependence on the manipulated variables visible. To do this, the steady state process model from the MPC Configurator is used.

Constraints for the controlled variables take the form of the above-mentioned tolerance ranges for setpoints. The controller takes care of adhering to the manipulated variable constraints, in any case; they do not have to be separately specified as constraints for the optimization.

Enable the optimization using the binary input variable OptimizeOn in the controller faceplate. The optimizer then returns setpoints within the tolerance ranges that are optimal with respect to the performance index. These setpoints are then sent to the control algorithm, which handles them in the same way as conventionally specified setpoints (with or without dead band). The operable $SP_1 \dots SP_{10}$ setpoints are not tracked to the optimized setpoints; when optimization is disabled, the old setpoints from the faceplate take effect once again.

When selecting variables for archiving and graphic plotter, ensure you use the `SP1Out...SP10Out` setpoint actually in effect and not the `SP1...SP10` input variables.

The current value of the performance index is displayed at the `J_Actual` output variable.

You can find additional information about the topic of steady state operating point optimization in the online help for the MPC configurator.

Display of the prediction of free movement

The prediction of free motion ("future without control") is a forecast for the future behavior of the process within the overall prediction horizon, under the assumption that all manipulated variables are frozen at their current values. The time length of the prediction horizon is indicated in the output parameter `PrediHorizon` in the [s] unit.

The prediction of free motion is recalculated in each sampling step within the control algorithm. If the manipulated variables are at constant values in manual mode, the prediction of the free movement is actually a realistic prediction for the future process response. It can therefore be represented graphically in the faceplate at least in terms of quality. For this purpose, five equidistant interpolation values are copied from the prediction horizon, and displayed in the standard view of the faceplate as a vertical bar next to the current process value.

Example: The prediction horizon is 1800s=30min and the current time is labeled with the index `k`. The prediction for `k+6min`, and next to it `k+12min`, up to `k+30min` then appears on the right next to the bar of the current process value. If the upper borders of each bar are virtually connected with a line (red in the picture), you can imagine the curve created by the future course of the process value over the next half hour.

In automatic mode, the value of the manipulated variables fluctuates with each sampling step. The prediction of free movement is then only a fictional mathematical formulation within the algorithm, and not a realistic prediction for the future process response. This is why the prediction is only displayed in manual mode. The display can be generally suppressed using `Feature.Bit31`.

Prediction without control response

In this special "operating mode" (comparable to the block-internal simulation), the controller only monitors the process and indicates what it would like to do in the next sampling step without actively intervening in the process. This allows you as the user to build trust before "switching active" the controller the first time, i.e. actively intervening in the process.

"Prediction Mode" is activated via the binary input variable `PredictMode` or in "Parameters" in the faceplate view. Setpoints and process values are read as in normal automatic mode. The prediction of the free movement and manipulated variable change for the next sampling step are calculated as in normal automatic mode. The starting point for the prediction of the manipulated variable for the next sampling step, however, is the current process value of the follow-up control loop at the `MV1Trk...MV10Trk` tracking inputs. The predicted manipulated variables are not output at the normal outputs `MV1...10` but rather at the `MV1Pred...MV10Pred` outputs, which were especially introduced for this purpose, and are

displayed in the standard view of the faceplate on the left next to $MV1 \dots 10$ as long as "Prediction Mode" is active.

- When the controller is in automatic mode, in "Prediction Mode" all MV_i ($i=1 \dots 10$) are set to match the assigned MV_iTrk input parameters, similar to tracking mode.
- When the controller is in manual mode, all MV_i are set to the desired manual values regardless of "Prediction Mode".
- When "Prediction Mode" is disabled, all MV_iPred always equal the respective MV_i .

Automatic process excitation for model identification

In order to determine the process model for the model predictive controller, the process must be artificially excited in order to observe its dynamic response and record it in the form of training data. This excitation signal can be specified manually in manual mode of the controller.

Alternatively, a suitable signal can be generated automatically in the form a defined, symmetrical sequence of manipulated variable steps. The trigger signals are calculated by an auxiliary function block, "AutoExcitation", which is built into the process tag type and interconnected to MPC10x10 .

Additional $MV1Excite \dots MV10Excite$ input variables are required for this on the controller function block. Process excitation is performed in manual mode of the controller, because automatic mode cannot be activated before modeling. The new "Operating mode" process excitation can only be controlled via the $ExciteOn$ input bit on the engineering system, and not on the operator station, because the CFC is needed for configuration of the AutoExcitation block. However, process excitation must be displayed on the OS in standard view at the lower left.

Manual intervention via faceplate remains possible even during process excitation. The values of the $MV1Excite \dots MV10Excite$ input parameters are therefore only written event-based to the $MV1Man \dots MV10Man$ values that is only if they change.

You can find additional details on automatic process excitation in the online help for the MPC configurator.

See also

Predictive control of a non-linear process (ModPreConNonLinSim) (Page 2381)

5.15.4 MPC10x10 error handling

Error handling of MPC10x10

Refer to section Error handling (Page 119) in the basic instructions for the error handling of all blocks.

The following errors can be displayed for this block:

- Error numbers

Overview of error numbers

The `ErrorNum` output parameter can be used to output the following error numbers:

Error number	Meaning of the error number
-1	Default value when the block is installed; this message is irrelevant.
0	There is no error.
3	Configuration error: Block is inserted in the wrong OB, cycle time of the OB is not suited for controller configuration.
31	The value of <code>CV1</code> can no longer be displayed in the real number field or is not a number.
32	The value of <code>CV2</code> can no longer be displayed in the real number field or is not a number.
...	..
40	The value of <code>CV10</code> can no longer be displayed in the real number field or is not a number.
41	The <code>MV_Trk1</code> value can no longer be displayed in the real number field or is not a number.
42	The <code>MV_Trk2</code> value can no longer be displayed in the real number field or is not a number.
...	...
50	The <code>MV_Trk10</code> value can no longer be displayed in the real number field or is not a number.
51	<code>AutModLi = 1</code> and <code>ManModLi = 1</code>
90	The controller matrix could not be loaded from the user data block.

The `ErrorOpt` output parameter is used to output the status of the lower-level `LPOptim` block.

5.15.5 MPC10x10 messaging

Messaging

This block does not offer messaging.

5.15.6 MPC10x10 I/Os

Input parameters

Parameter	Description	Type	Default
AutModLi	1 = Automatic mode via interconnection or SFC (controlled by ModLiOp = 1)	STRUCT • Value: BOOL • ST: BYTE	- • 0 • 16#80
AutModOp	1 = Automatic mode via operator (controlled by ModLiOp = 0)	BOOL	0
BatchEn	1 = Enabled for allocation by batch control	BOOL	0
BatchID	Batch number	DWORD	16#00000000
BatchName	Batch name	S7-String	
CV1...CV10	Controlled variable 1...10 (process value)	STRUCT • Value: REAL • ST: BYTE	- • 0.0 • 16#80
CV1_Unit...CV10_Unit	Unit of measure for controlled variable 1...10	INT	1001
DV_On	1 = Activate the disturbance variable feedforward using DV	BOOL	1
DV1...DV4	Disturbance variable 1...4	STRUCT • Value: REAL • ST: BYTE	- • 0.0 • 16#80
DV1_Unit...DV4_Unit	Unit of measure for DV1...DV4	INT	1342
DV1DeadBand...DV4DeadBand	Dead band for DV1...DV4	REAL	1.0
DynOptOn	1 = Activate dynamic optimization with constraints. 0 = Ignore constraints for optimization.	BOOL	1
ExciteOn	1 = Automatic process trigger; MViExite input parameters are written to the MVi outputs	BOOL	0
Feature	I/O for additional functions (Page 947)	STRUCT • Bit 0: BOOL • ... • Bit 31: BOOL	- • 0 • 0 • 1

5.15 MPC10x10 - Large predictive controller

Parameter	Description	Type	Default
GradCV1... GradCV10	Gradient vector for performance criterion, element (factor) for CV1	STRUCT • Value: REAL • ST: BYTE	- • 0.0 • 16#80
GradMV1... GradMV10	Gradient vector for performance criterion, element (factor) for MV1	STRUCT • Value: REAL • ST: BYTE	- • 0.0 • 16#80
J_Actual_Unit	Physical unit of performance J_Actual	INT	0
J_Min1	1 = minimize J, 0 = maximize J	BOOL	0
J0	Value of the performance criterion in the operating point	REAL	0.0
ManModLi	1 = Manual mode via interconnection or SFC (effective if ModLiOp = 1)	STRUCT • Value: BOOL • ST: BYTE	- • 0 • 16#80
ManModOp	1 = Manual mode via OS operator (effective if ModLiOp = 0)	BOOL	0
ModLiOp	Operating mode switchover by: 1 = Interconnection or SFC 0 = Operator	STRUCT • Value: BOOL • ST: BYTE	- • 0 • 16#80
MS_RelOp	Operator input for release for maintenance 1 = MS release requested	BOOL	0
MV1_Unit...MV10_Unit	Unit of measure for manipulated variable 1...10	INT	1342
MV1Excite...MV10Excite	Default value for MV1..10 during the automatic process trigger for model generation	STRUCT • Value: REAL • ST: BYTE	- • 0.0 • 16#80
MV1HiLi	High limit of manipulated variable MV1	REAL	100.0
MV1LoLi	Low limit of manipulated variable MV1	REAL	0.0
MV1Man	Manual value: Operator input for setting the manipulated variable MV1 in manual mode	REAL	0.0
MV1ManHiLim	High limit of manipulated variable MV1 in manual mode	REAL	100.0
MV1ManLoLim	Low limit of manipulated variable MV1 in manual mode	REAL	0.0
MV1RaLim	Gradient limiting of the manipulated variable MV1 [MV1_Unit/ second]	REAL	100.0
MV1Target...MV10Target	Target value (optimum value) for manipulated variable MV1...MV10	REAL	0.0

Parameter	Description	Type	Default
MV1Trk	Tracking value for the manipulated variable MV1	STRUCT • Value: REAL • ST: BYTE	- • 0.0 • 16#80
MV1Traj	Trajectory value that is added to the manipulated variable MV1	REAL	0.0
MV1TrkOn...MV10TrkOn	1 = Tracking of manipulated variable MV1...MV10	STRUCT • Value: BOOL • ST: BYTE	- • 0 • 16#80
Occupied	1 = Allocated by SIMATIC BATCH	BOOL	0
OosLi	1 = Out of service, via interconnection or SFC (0-1 edge transition)	STRUCT • Value: BOOL • ST: BYTE	- • 0 • 16#80
OosOp	1 = Out of service, via OS operator	BOOL	0
OpSt_In	Input parameter for local operator authorization, to be connected with the Out output parameter of the upstream block OpStations	DWORD	16#00000000
OptimOffOp	1 = Disable operating point optimization, normal setpoints SP1...SP10 in effect	BOOL	0
OptimOnOp	1 = Enable operating point optimization, optimized setpoints SP1Out...SP10Out in effect	BOOL	0
OS_Perm	I/O for operating permissions (Page 947)	STRUCT • Bit 0: BOOL • ... • Bit 31: BOOL	- • 1 • 1 • 1
PredictMode	1 = "Prediction only mode" enabled, prediction only, no intervention in the process	BOOL	0
PreFilt1...PreFilt10	Settling time [s] of the setpoint filter for setpoint SP1...SP10	REAL	0.0
Restart	1 = Restart of the block and adoption of the data from the user block of the MPC Configurator	BOOL	0
SafePos1...SafePos10	1 = Safety setting for MV1...MV10 is Man1HiLim...Man10HiLim, 0 = Safety setting for MV1...MV10 is Man1LoLim...Man1LoLim,	BOOL	0
SampleTime	Sampling time [s] (assigned automatically)	REAL	1.0
SelFp1	1 = Call a block saved in this parameter as an additional faceplate in the standard view	ANY	
SelFp2	1 = Call a block saved in this parameter as an additional faceplate in the preview	ANY	

5.15 MPC10x10 - Large predictive controller

Parameter	Description	Type	Default
SimCV1... SimCV10	Simulation value for control variable CV1...CV10, which is used for SimOn = 1	REAL	0.0
SimCV1Li... SimCV10Li	Simulation value for control variable CV1...CV10, which is used for SimOnLi.Value = 1 (and SimLiOp.Value = 1)	STRUCT REAL • Value: • ST: BYTE	- • 0.0 • 16#80
SimLiOp	Activation/deactivation of the simulation by: 1 = Interconnection or SFC 0 = Operator	STRUCT BOOL • Value: • ST: BYTE	- • 0 • 16#80
SimOn	1 = Enable simulation	BOOL	0
SimOnLi	1 = Enable simulation via interconnection or SFC (if SimLiOp = 1))	STRUCT BOOL • Value: • ST: BYTE	- • 0 • 16#80
SP_TrkCV	1 = Setpoints follow the CVs in manual mode and in tracking	BOOL	0
SP1...SP10	Setpoint 1...10	STRUCT REAL • Value: • ST: BYTE	- • 0.0 • 16#FF
SP1DeadBand.. .SP10DeadBand	Width (radius) of the dead band control of CV1...CV10	REAL	0.0
SP1HiLim...SP 10HiLim	Setpoint high limit 1...10	REAL	100.0
SP1LoLim...SP 10LoLim	Setpoint low limit 1...10	REAL	0.0
SP1OptHiLim.. .SP10OptHiLim	High limit for optimization of setpoint 1...10	REAL	0.0
SP1OptLoLim.. .SP10OptLoLim	Low limit for optimization of setpoint 1...10	REAL	0.0
StepNo	Batch step number	DWORD	16#00000000
UserStatus	Freely assignable bits for use in PCS 7 OS	BYTE	16#00

Output parameters

Parameter	Description	Type	Default
AutAct	1 = Automatic mode is active 0 = Manual mode is active (applies to all manipulated variable channels)	STRUCT • Value: BOOL • ST: BYTE	- • 0 • 16#80
CV1Out...CV10Out	Copy CV1...CV10, preferably as output parameter	STRUCT • Value: REAL • ST: BYTE	- • 0.0 • 16#FF
ErrorEndless	Error: infinite iteration loop in the dynamic optimization	BOOL	0
ErrorNum	Output of pending error number. You can find information about the error numbers that are output by this block at MPC10x10 error handling (Page 957)	INT	-1
ErrorOpt	Error number of the integrated operating point optimization function, see MPC10x10 error handling (Page 957)	INT	0
Fut1_y1... Fut10_y5	Prediction of free movement of CV1...CV10 for five future points in time within the prediction horizon	REAL	0.0
J_Actual	Current value of the performance criterion	REAL	0.0
Loop1Closed... Loop10Closed	1 = MV1 is used by the algorithm for closed loop control, i.e. AutAct AND NOT MV1TrkOn 0 = Control loop for MV1 open	STRUCT • Value: BOOL • ST: BYTE	- • 0 • 16#80
ManAct	1 = Manual mode enabled, for all control channels	STRUCT • Value: BOOL • ST: BYTE	- • 0 • 16#80
MS_Release	Release for maintenance: 1 = Release by OS operator	STRUCT • Value: BOOL • ST: BYTE	- • 0 • 16#80
MV1...MV10	Manipulated variable 1..10 (controller output signal)	STRUCT • Value: REAL • ST: BYTE	- • 0.0 • 16#FF
MV1HiAct	1 = High limit of manipulated variable 1 reached	STRUCT • Value: BOOL • ST: BYTE	- • 0 • 16#80
MV1LoAct	1 = Low limit of manipulated variable 1 reached	STRUCT • Value: BOOL • ST: BYTE	- • 0 • 16#80
MV1Pred	One-step prediction for MV1 in the "Prediction without control response" mode	REAL	0.0
MV1TargOut... .MV10TargOut	Target value output (optimum value) for manipulated variable MV1...MV10	REAL	0.0
NumberCVs	Number of control variables used	INT	0

5.15 MPC10x10 - Large predictive controller

Parameter	Description	Type	Default
NumberDVs	Number of disturbances used	INT	0
NumberMVs	Number of manipulated variables used	INT	10
NumberOrigMVs	Number of original manipulated variables that are actively influenced by the controller (without pseudo MVs that are used as DVs)	INT	0
OosAct	1 = Block is "out of service"	STRUCT • Value: BOOL • ST: BYTE	- • 0 • 16#80
OpSt_Out	Value of the OpSt_In input parameter, for feed-forwarding to other blocks. Bit 31 of this parameter is used by Feature bit 24	DWORD	16#00000000
OptimAct	1 = Operating point optimization enabled, setpoints calculated by the optimization are used 0 = Optimization off	BOOL	0
OS_PermLog	Display of OS_Perm with settings changed by the block algorithm	DWORD	16#FFFFFFF
OS_PermOut	Display of OS_Perm	DWORD	16#FFFFFFF
PrediHorizon	Prediction horizon [s]	REAL	0.0
SP1OpOut...SP10OpOut	Copy of the operable setpoint 1 for step-enabling	STRUCT • Value: REAL • ST: BYTE	- • 0.0 • 16#FF
SP1Out...SP10Out	Setpoint 1 actually used by controller	STRUCT • Value: REAL • ST: BYTE	- • 0.0 • 16#FF
ST_Worst	Worst signal status	BYTE	16#80
Status1	Status word 1 (Page 939)	DWORD	16#00000000
Status2	Status word 2 (Page 939)	DWORD	16#00000000

5.15.7 MPC10x10 block diagram

MPC10x10 block diagram

A block diagram is not provided for this block.

5.15.8 Operator control and monitoring

5.15.8.1 MPC10x10 views

Views of the MPC10x10 block

The block MPC10x10 provides the following views:

- MPC10x10 standard view (Page 965)
- Trend view (Page 305)
- MPC10x10 parameter view (Page 971)
- MPC10x10 CV parameter view (Page 973)
- MPC10x10 MV parameter view (Page 974)
- MPC10x10 preview (Page 975)
- Memo view (Page 304)
- Batch view (Page 302)
- Block icon for MPC10x10 (Page 978)

Refer to the sections Structure of the faceplate (Page 248) and Block icon structure (Page 230) for general information on the faceplate and block icon.

See also

MPC10x10 trend view (Page 977)

5.15.8.2 MPC10x10 standard view

Standard view of MPC10x10

The standard view has an upper half and a lower half. You can change between the two halves with the arrow keys. The upper half shows all available controlled variable channels with their setpoints, while the lower half shows all available manipulated variable channels.

Upper screen half (controlled variables)

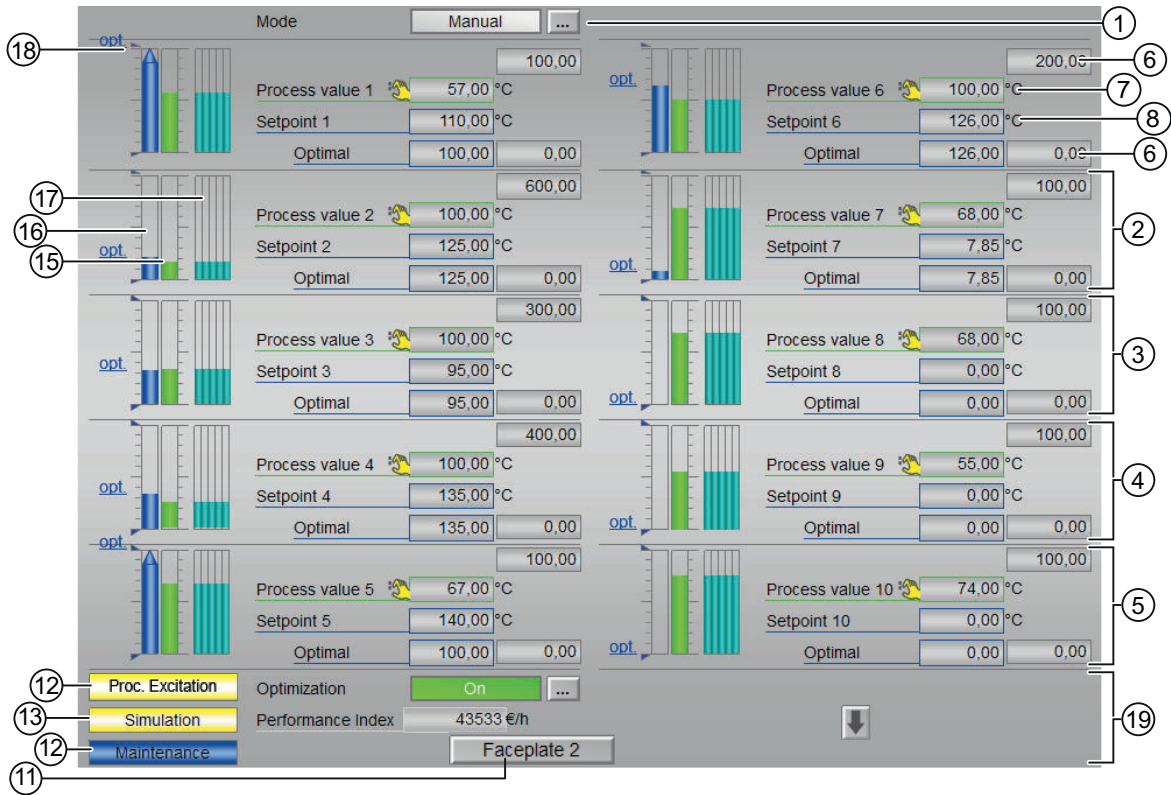

Lower screen half (manipulated variables)

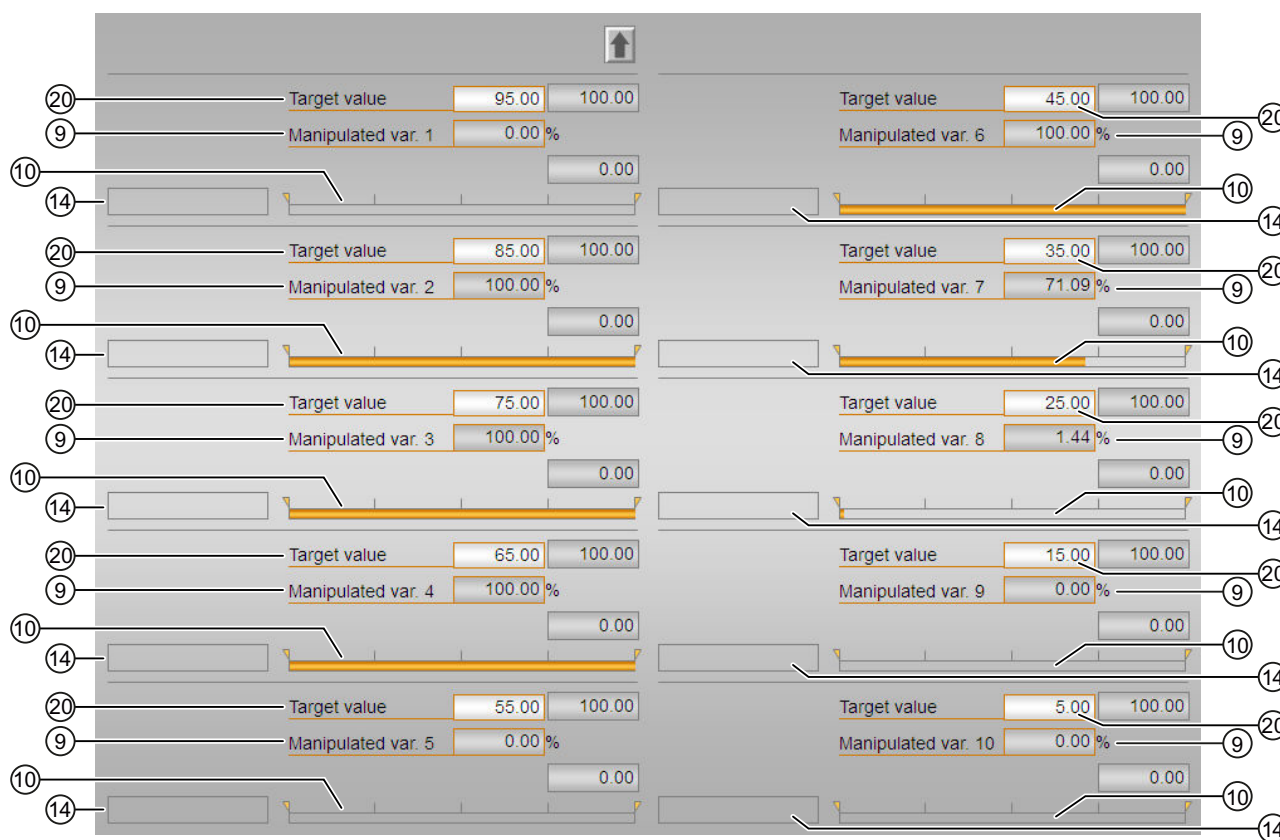

(1) Displaying and switching the operating mode

This area provides information on the currently valid operating mode. The following operating modes can be shown here:

- Manual mode (Page 72)
- Automatic mode (Page 72)
- Out of service (Page 71)

For information on switching the operating mode, refer to the section Switching operating states and operating modes (Page 257).

(2), (3), (4) and (5) Displaying and switching for values for channels 1 to 10

This area always has the same layout for channels 1 to 10:

(6) High and low scale range for the process value

These values provide information on the display range for the bar graph of the process value. The scale range is defined in the engineering system.

(7) Displaying and changing the process value including signal status

This area shows the current process value with the corresponding signal status.

The process value is normally displayed and cannot be operated. Process values in the faceplate can only be changed within the context of internal block simulation.

(8) Displaying and changing the setpoint including signal status

This area shows the current setpoint with the corresponding signal status. Refer to the Changing values (Page 259) section for information on changing the setpoint.

(11) Navigation button for switching to the standard view of any faceplate

Use this navigation button to open the standard view of a block configured in the engineering system. The visibility of this navigation button depends on the configuration in the engineering system (ES).

You can find additional information on this in the section Opening additional faceplates (Page 208) .

(12) Display area for block states

This area provides additional information on the operating state of the block:

- "Maintenance"

Additional information on the display area for states of the block is available in the Release for maintenance (Page 64) .

- "Process excitation"

The automatic process excitation is fed forward using the upstream block AutoExcitation for recording learning data for the MPC configurator. The manipulated variable step changes are added to the manipulated values 1 to 10 according to schedule. Avoid external disturbances to the process while the process excitation is running. The manipulated variables can be changed manually while the process excitation is running.

(13) Display area for block states

This area provides additional information on the operating state of the block:

- "Simulation"

You can find additional information on this in the section Simulating signals (Page 58) .

(15) Bar graph for the process value 1

There is a bar graph for the process value for every channel 1 to 10.

This area shows the current process value in the form of a bar graph. The visible area in the bar graph depends on the configuration in the engineering system (ES).

(16) Bar graph for the setpoint 1

There is a bar graph for the setpoint for every channel 1 to 10.

This area shows the current setpoint in the form of a bar graph. The visible area in the bar graph depends on the configuration in the engineering system (ES).

(17) Prediction of free movement

This area shows you the prediction of free movement in the form of a bar graph. For each channel from 1 to 10, there is a bar graph for the prediction of free movement, that is, for the future behavior of the process within the overall prediction horizon, under the assumption that all manipulated variables are frozen at their current values.

This is why the prediction of free movement is only displayed in manual mode.

The value range of the bar graph matches the value range of the respective setpoint and current value bar.

Functions of MPC10x10 (Page 947)

(18) Displaying the limits

These triangles show the `SP_HiLim` and `SP_LoLim` setpoint limits configured in the engineering system (ES).

(19) Steady state operating point optimization

Activate the optimization using the button at bottom right. Activation means that the optimized setpoints `SP1Out...SP4Out` are actually used instead of the `SP1...SP4` setpoints specified in the faceplate for closed-loop control. (The actual calculation of the optimum setpoints is not depending on this, and is only performed if one of the input variables for the optimization has changed.) The current value the economic performance index `J` appears in the display field below.

When optimization is enabled, the optimum setpoints are displayed on the setpoint bar as small, horizontal lines and highlighted with the abbreviation "opt.". The numerical values of the optimum setpoints are then displayed left of the input fields for the setpoints.

Lower screen half (manipulated variables)

(9) Displaying and changing the manipulated variable including signal status

This area shows the current manipulated variable with the corresponding signal status. Refer to the Changing values (Page 259) section for information on changing the manipulated variable. You can only make a change in manual mode.

(10) Bar graph for the manipulated variable with limit display

This area shows the current manipulated variable in the form of a bar graph. The visible area in the bar graph depends on the configuration in the engineering system (ES):

- Limits: `MVxHiLim` and `MVxLoLim`
- Display area: `MVxManHiLim` and `MVxManLoLim`

(14) Display for states of the manipulated channel

There is a display for the state of the manipulated channel for channels 1 to 10: the status display only appears if the respective channel is tracked:

- "Tracking"

(20) Displaying and changing the target value for the manipulated variable

This area shows the current target value for the manipulated variable. Refer to the section Changing values (Page 259) for more information on changing the target value. You can make a change only in the "Automatic" mode and also only if $OptimAct = 0$. This field is not displayed in "Manual" mode.

See also

MPC10x10 preview (Page 975)

5.15.8.3 MPC10x10 parameter view

Parameter view of MPC10x10

③

Enabled operations Settings

SP := CV in manual mode
 Prediction only
 Disturbance compensation
 Disturbance 1
 Disturbance 2
 Disturbance 3
 Disturbance 4

Optimization

Optimiz. target ...

Performance Index =

<input checked="" type="checkbox"/> GradCV1	<input type="text" value="13,"/>	*CV1+	GradMV1	<input type="text" value="34,"/>	*MV1+
<input checked="" type="checkbox"/> GradCV2	<input type="text" value="23,"/>	*CV2+	GradMV2	<input type="text" value="22,"/>	*MV2+
<input checked="" type="checkbox"/> GradCV3	<input type="text" value="33,"/>	*CV3+	GradMV3	<input type="text" value="26,"/>	*MV3+
<input checked="" type="checkbox"/> GradCV4	<input type="text" value="45,"/>	*CV4+	GradMV4	<input type="text" value="46,"/>	*MV4+
<input checked="" type="checkbox"/> GradCV5	<input type="text" value="48,"/>	*CV5+	GradMV5	<input type="text" value="67,"/>	*MV5+
<input checked="" type="checkbox"/> GradCV6	<input type="text" value="56,"/>	*CV6+	GradMV6	<input type="text" value="56,"/>	*MV6+
<input checked="" type="checkbox"/> GradCV7	<input type="text" value="15,"/>	*CV7+	GradMV7	<input type="text" value="45,"/>	*MV7+
<input checked="" type="checkbox"/> GradCV8	<input type="text" value="35,"/>	*CV8+	GradMV8	<input type="text" value="23,"/>	*MV8+
<input checked="" type="checkbox"/> GradCV9	<input type="text" value="45,"/>	*CV9+	GradMV9	<input type="text" value="34,"/>	*MV9+
<input checked="" type="checkbox"/> GradCV10	<input type="text" value="23,"/>	*CV10+	GradMV10	<input type="text" value="45,"/>	*MV10+
<input checked="" type="checkbox"/> J0	<input type="text" value="46,"/>				

Service

Simulation ...
 Release for maint. ...

①

④

②

(1) Settings

You can activate the following functions for the controller in this area:

- "SP := CV in manual mode": Bumpless switchover from "manual mode" to "automatic mode"
- "Prediction only" activate this special "operating mode" by selecting the check box. The controller then only listens to the process and indicates what it would like to do in the next sampling step (i.e. which manipulated variables it would output in the next sampling step) without actively intervening in the process
- "Disturbance compensation": Select feedforward disturbance compensation
- "Disturbance" DV1...DV4 depending on the number of configured measurable disturbances

You cannot change the disturbance values, they can only be displayed.

(2) Service

You can select the following functions in this area:

- "Simulation"
- "Release for maintenance"

Refer to the Switching operating states and operating modes (Page 257) section for more on this.

You can find information on this area in the section:

- Simulating signals (Page 58)
- Release for maintenance (Page 64)

(3) Enabled operation

This area shows all operations for which special operator permissions are assigned. They depend on the configuration in the engineering system (ES) that applies to this block.

Icons for enabled operation:

- **Green check mark:** the OS operator can control this parameter
- **Gray check mark:** the OS operator cannot control this parameter at this time due to the process
- **Red cross:** the OS operator cannot control this parameter due to the configured AS operator permissions (OS_Perm or OS1Perm).

(4) Optimization

Direction of the optimization (minimize or maximize)

By default, the optimizer seeks to maximize the performance function, in the assumption that it is dealing with economic yield. If you want to search a minimum, however, because you are dealing with costs or consumption values, click this button.

Specification of performance index for the operating point optimization

The performance index consists of a weighted sum of all manipulated and controlled variables. For each manipulated variable and controlled variable, enter the appropriate weighting factor, i.e. the coefficient of the gradient vector. Zero means that the value of the corresponding manipulated variable or controlled variable has no direct influence on the economic yield. If the controller has less than 10 manipulated variables or controlled variables, the irrelevant variables are hidden automatically.

J0 is the part of the performance index which does not depend on the controlled and manipulated variables of the MPC, e.g. fixed costs or costs calculated otherwise. Although this part of costs cannot be influenced during controller internal optimization, including it in the summation allows realistic numerical values to be displayed for the total costs.

See also

MPC10x10 views (Page 965)

MPC10x10 standard view (Page 965)

MPC10x10 trend view (Page 977)

MPC10x10 preview (Page 975)

5.15.8.4 MPC10x10 CV parameter view

CV parameter view for MPC10x10

The CV parameter view is a table which contains a row for each control channel:

Channel setpoint	H range	H range optimiz.	Operator specific	Optimal setpoint	L range optimiz.	L range	Dead band	Unit	Prefilter [s]
1	100,00	0,00	110,00	100,00	0,00	0,00	0,00	°C	0,00
2	600,00	0,00	125,00	125,00	0,00	0,00	0,00	°C	0,00
3	300,00	0,00	95,00	95,00	0,00	0,00	0,00	°C	0,00
4	400,00	0,00	135,00	135,00	0,00	0,00	0,00	°C	0,00
5	100,00	0,00	140,00	100,00	0,00	0,00	0,00	°C	0,00
6	200,00	0,00	126,00	126,00	0,00	0,00	0,00	°C	0,00
7	100,00	0,00	7,85	7,85	0,00	0,00	0,00	°C	0,00
8	100,00	0,00	0,00	0,00	0,00	0,00	0,00	°C	0,00
9	100,00	0,00	0,00	0,00	0,00	0,00	0,00	°C	0,00
10	100,00	0,00	0,00	0,00	0,00	0,00	0,00	°C	0,00

The channel number is at the far left. The physical unit applies to all values of this control channel except for the prefilter. The time constant of the prefilter is specified for all channels in seconds.

(1) Displaying and changing the limit parameters for the setpoint

You can change the following setpoint parameters for the relevant control channel in each row:

- "H range": High limit for setpoint operation
- "H range optimization": High limit for optimizing the setpoint
- "Operator specification": Display of the setpoint specified in the standard view, cannot be operated here.
- "Dead band": Error signal generation and dead band (Page 192), Error signal generation and dead band section
- "Optimal setpoint": Calculated by the optimization, cannot be operated
- "L range optimization": Low limit for optimizing the setpoint
- "L range": Low limit for setpoint operation
- "Prefilter": TimeTrig functions (Page 1793), Setpoint filter section

The numerical values for limits are arranged from left to right in descending order. The three values per channel relevant for the optimization are highlighted in blue.

You can find additional information on this in the section Changing values (Page 259) .

The enabled operations for the setpoint parameters are displayed in the preview.

5.15.8.5 MPC10x10 MV parameter view

MV parameter view for MPC10x10

The MV parameter view is a table which contains a row for each manipulated variable channel:

MV channel	H range	L range	Unit	Gradient [Unit/s]
1	100,00	0,00	%	100,00
2	100,00	0,00	%	100,00
3	100,00	0,00	%	100,00
4	100,00	0,00	%	100,00
5	100,00	0,00	%	100,00
6	100,00	0,00	%	100,00
7	100,00	0,00	%	100,00
8	100,00	0,00	%	100,00
9	100,00	0,00	%	100,00
10	100,00	0,00	%	100,00

The channel number is at the far left. The physical unit applies to the high and low limit of the respective channel. The gradient is limited in the respective manipulated variable unit per second.

(1) Displaying and changing the limit parameters for the manipulated variable

You can change the following parameters for the manipulated variable in this area:

- "H range": Upper limit of the manipulated variable for automatic mode
- "L range": Low limit of manipulated variable for automatic mode
- "Gradient limit": Maximum (absolute) change in the manipulated variable per second

The enabled operations for the setpoint parameters are displayed in the preview.

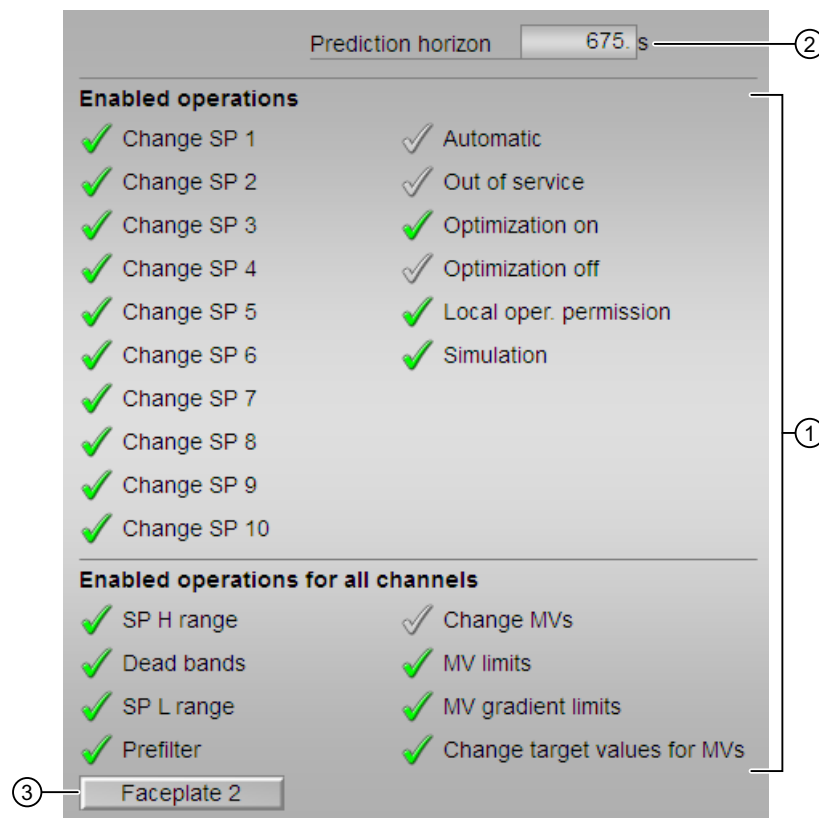
5.15.8.6 MPC10x10 preview**Preview for MPC10x10****(1) Enabled operation**

This area shows all operations for which special operator permissions are assigned. They depend on the configuration in the engineering system (ES) that applies to this block. The lower screen half shows operator permissions which apply to all manipulated and control channels.

The upper screen half shows operator permissions which are not channel-based on the left, and channel-specific operator permissions for the individual setpoints on the right.

Icons for enabled operation:

- **Green check mark:** the OS operator can control this parameter
- **Gray check mark:** the OS operator cannot control this parameter at this time due to the process
- **Red cross:** the OS operator cannot control this parameter due to the configured AS operator permissions (OS_Perm or OS1Perm).

The following enabled operations for parameters are shown here:

- "Automatic": You can switch to "automatic mode".
- "Out of service": You can switch to "Out of service" operating mode.
- "Optimization on": You can switch on the optimization.
- "Optimization off": You can switch off the optimization.
- "Local operator permission": Use the ← button to switch to the standard view of the OpStations block. You can find additional information on this in the section Operator permissions (Page 254) .
- "Change SP1..10": You can change the setpoint 1..10
- "Change MVs": You can change the manipulated variables

Note

The OS operator must always be able to switch to "manual mode". For this reason, there is no special operator permission for switching to "manual mode" in the faceplate.

The following operator permissions apply to all manipulated channels.

- "Change MVs": You can change the manipulated variables in manual mode
- "MV limits": You can change the high and low limits for all manipulated variables.
- "MV gradient limits": You can change the gradient limits for all manipulated variables. The following operator permissions apply to all control channels.
 - "SP high limits": You can change the high limits for all setpoints.
 - "Dead bands": You can change the dead bands for all controlled variables.
 - "SP low limits": You can change the low limits for all setpoints.
 - "Prefilter": You can change the time constants of the prefilter for all setpoints.
- "Change target values for MVs": You can change the target values for all manipulated variables.

(2) Prediction horizon

The prediction horizon specifies how far the controller looks into the future in its calculations. The value is set in the MPC Configurator and displayed in the faceplate for informational purposes.

(3) Navigation button for switching to the standard view of any faceplate

Use this navigation button to open the standard view of a block configured in the engineering system (ES). The visibility of this navigation button depends on the configuration in the engineering system (ES).

You can find additional information on this in the section *Opening additional faceplates* (Page 208) .

5.15.8.7 MPC10x10 trend view**MPC10x10 trend view**

There is a block-specific trend view for MPC10x10 which is supplied as file @PG_APL_TrendMPC_L.pdl and which you can modify if necessary.

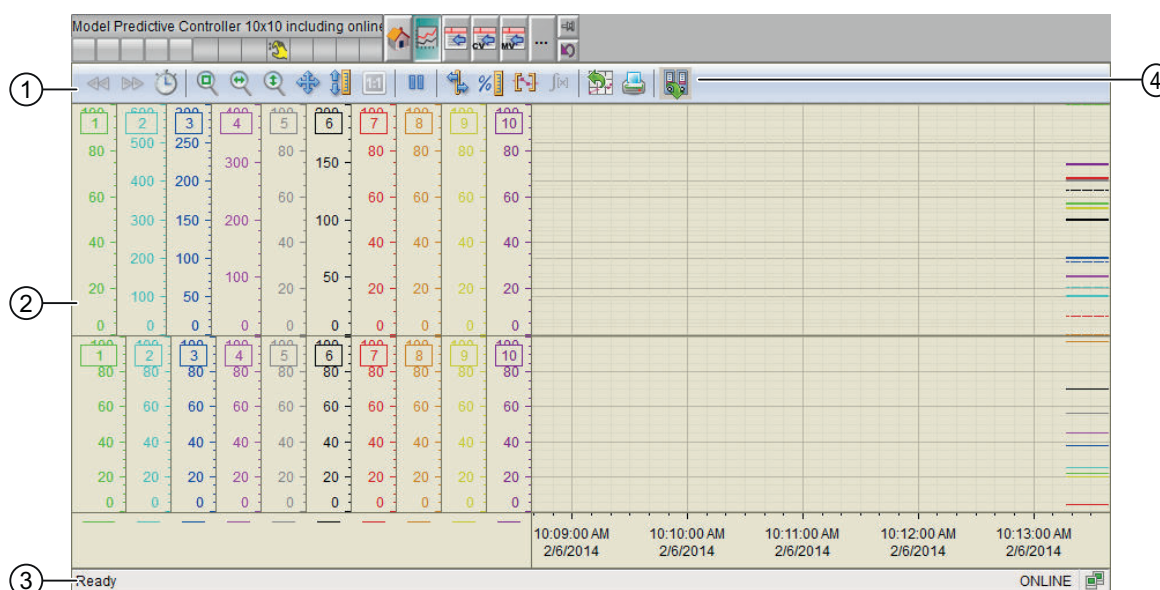

(1) Toolbar

(2) Display area for trends

(3) Status bar

(4) Button for switching between archive tags and online tags. The status bar shows if the trend view is working with online data or archive data.

The Export button is only visible and operable with the "Higher-level process control" operating permission.

For additional information about the trend view, refer to the *WinCC Information System* Online Help.

The trend view is divided into two screen halves.

The upper screen half shows all controlled variables with their associated setpoints. The setpoint is shown in the same color as the associated process value to allow the assignment

5.15 MPC10x10 - Large predictive controller

to be identified straight away. Setpoints are dashed lines, process values are bold lines. If a controlled variable is exactly on the setpoint, it hides the setpoint.

The lower screen half shows all manipulated variables.

Both screen halves use the same color sequence for the individual channels. The sequence starts at channel 1 with green (standard color for the process value with the PID controller) and then goes through the color spectrum from top to bottom as far as gray and black. From channel 7 (red), the rest of the spectrum is run through from top to bottom. Each channel has its own y-axis in the corresponding color.

5.15.8.8 Block icon for MPC10x10

Block icons for MPC10x10

A variety of block icons are available with the following functions:

- Process tag type
- Operating modes
- Signal status, release for maintenance
- Tracking
- Memo display
- Process value (black, with and without decimal places)

The display of the tag name can be activated centrally for all block instances with the WinCC variable @APLShowTag:

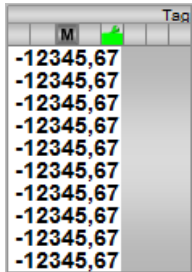
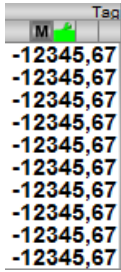
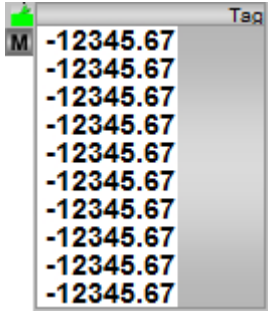
Icons	Selection of the block icon in CFC	Special features
	1	
	2	Narrow, without units
	3	Block icon in the full display

Additional information on the block icon and the control options in the block icon is available in the following sections:

- Configuring the block icons (Page 237)
- Operation via the block icon (Page 239)
- Block icon structure (Page 230).

5.16 KalFilt - State observer

5.16.1 Description of KalFilt

Object name (type + number) and family

Type + number: FB 1925

Family: Control

Area of application for KalFilt

The Kalman filter is a non-linear stochastic state observer. It forms a framework for parallel simulation of a dynamic process model, whose states are compared with real data in each cycle. During runtime, all internal state variables may be read from the model and used as a substitute for real measured values.

The state observer thus allows to determine the physical values of a process unit, which are not accessible or only measurable with high effort from other easily available measurements, for example, temperatures and mass flows.

It can therefore be used as a soft sensor, that is a piece of software that estimates values which are not measured.

In addition to its use as a state observer, it is also used as a model-based filter. The measured variables calculated from the estimated states are not subject to measurement noise and therefore generally run smoother than noisy measurements.

How it works

The extended Kalman filter

The block operates as a state observer, in which the algorithm of the extended Kalman filter is implemented, and the online calculation of the internal states of non-linear dynamic systems is performed. Both, the mathematical structure of the underlying dynamic system and the properties of the stochastic disturbances must be known.

The term "filter" indicates that the algorithm is able to reduce measurement noise and other disturbances of stochastic data.

The Kalman filter is an approach to solve the general problem of estimating the states of a time-discrete process, which is described by linear stochastic differential equations and is a generalization of the classical state observer (Luenberger observer) in this respect. The estimation problem is extended to non-linear processes that result from a non-linear state space model:

$$\underline{x}_{k+1} = \underline{f}(\underline{x}_k, \underline{u}_k) + \underline{w}_k$$

$$\underline{y}_k = \underline{h}(\underline{x}_k) + \underline{v}_k$$

Symbols	Meaning
\underline{x}_k	Vector of the (inner) state variables at the time t_k
\underline{u}_k	Vector of the input variables at the time t_k
\underline{y}_k	Vector of the measurable output variables at the time t_k
$\underline{\Phi}_k$	Dynamic matrix (Jakobi matrix), refer to FB KalMod
\underline{H}_k	Output matrix (Jakobi matrix), refer to FB KalMod
\underline{P}_k	Estimation error covariance at the time t_k
\underline{K}_k	Kalman gain at the time t_k
\underline{Q}_k	Covariance of the process noise at the time t_k
\underline{R}_k	Covariance of the measurement noise at the time t_k
$\underline{w}_k, \underline{v}_k$	Stochastic disturbances

For the Kalman algorithm, *a priori* knowledge about the process to be observed must be provided to the block. This includes the covariance of the process noise \underline{Q}_k , the covariance of the observation noise \underline{R}_k , and the initial values (initialization) for the *a priori* state estimate $\hat{\underline{x}}_0^-$. The *a priori* estimation error covariance \underline{P}_0^- is initialized with 0.

For more details on the configuration of the filter, refer to the *Kalman Configurator User Documentation*. The configuration, identification, simulation, and validation of the filter are performed in the Kalman Configurator.

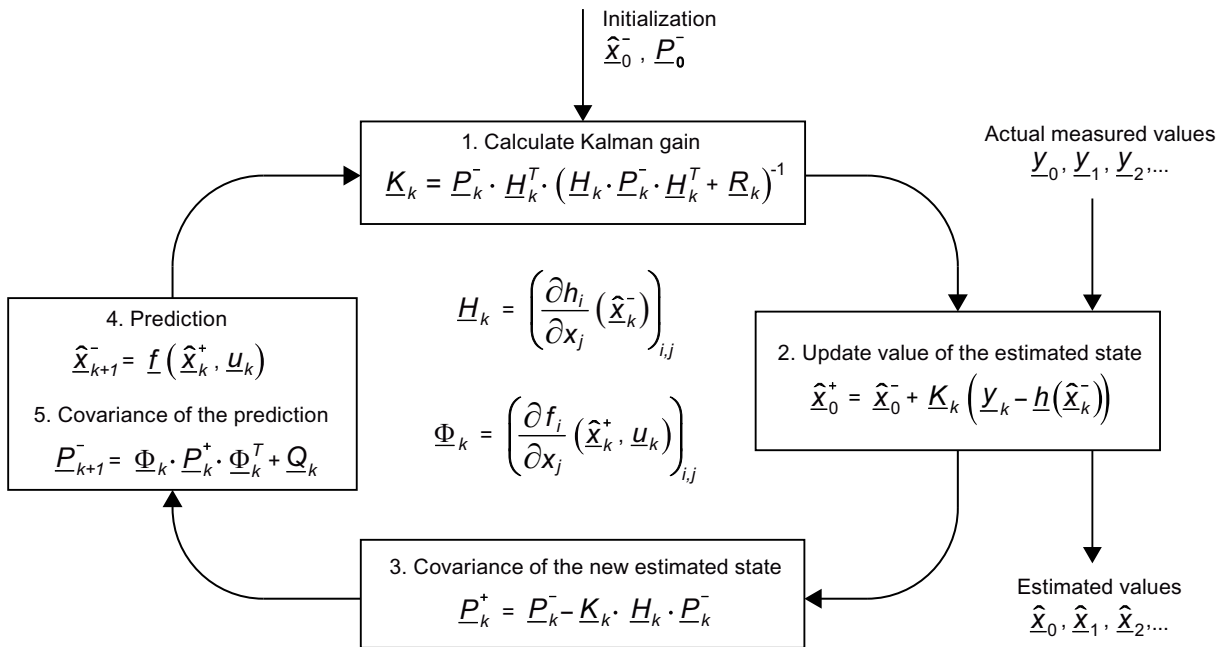

Figure 5-1 Implemented sequence of the extended Kalman filter

The sequence of the extended Kalman filter (EKF) corresponds to the linear filter: via the Kalman Gain K_k the predicted (*a priori*) state estimate \hat{x}_k^- is corrected using the actual measured values y_k , which results in the corrected (*a posteriori*) state estimate \hat{x}_k^+ . Only two additional intermediate steps for calculating the Jacobi matrices H_k and Φ_k are necessary for local linearization of non-linear models. The Jacobi matrices are calculated in the FB KalMod.

Consideration of sporadic laboratory measurements

If sporadic laboratory samples of relevant state variables are extracted from a process, the integration of these laboratory measurements in the extended Kalman filter can lead to significant improvements in estimation accuracy, since the unknown state variables can be compared with the laboratory results. The sample is taken sporadically. Once laboratory results are received, the laboratory values are provided to the EKF. The algorithm takes into account that the laboratory result is associated with a previous process state, which belongs to the past time instant where the sample was taken. For the usage of laboratory measurements, particular engineering steps are necessary. These steps are described in the section "Additional configuration tasks for inclusion of the laboratory measurements" under "Configuration".

Operating principle

The corrected states \hat{x}_k^+ ($x_1 \dots x_{15}$) are used for application as a state observer. These can be used for visualization, interconnections to further calculations, or feedback for control loops.

The output variables $\hat{y}_k^+ = h(\hat{x}_k^+)$ ($y_{1Filt} \dots y_{7Filt}$) calculated from the corrected states are used for application as a model-based filter.

The advantage compared to a simple low-pass filter is that the influences of the inputs are provided without additional delay to the output variables via the model. The signal status of the filtered output values y_{iFilt} are based on the worst signal status of the states.

To assess the quality of the Kalman filter, the following deviations can be used:

- The deviations of the predicted output values from the measured variables:

$$e_k^- = y_k - h(\hat{x}_k^-) \quad (e_{Y1} \dots e_{Y7})$$
- The deviations of the predicted state variables from the laboratory measurements:

$$e_{nk}^- = y_{nk} - h_n(\hat{x}_k^-) \quad (e_{Yn1} \dots e_{Yn5})$$

The deviations are usually caused by modeling inaccuracies and unknown disturbances (i.e. disturbances not considered in the model).

In many applications, there are not measurable outputs that can be calculated using algebraic equations from state and input variables, and which are relevant for the practical use of the Kalman filter, for example, heat flow generated by exothermic chemical reactions or specific conversion rates in organic fermenters. These variables can be defined as non-measurable process output variables ($z_{1Out} \dots z_{5Out}$) in the Kalman configurator, for which there is a respective output equation, but no measured values.

For application of the filter block as a process simulator, the input variables u_i are interconnected to the actual input values to simulate the behavior of the process and get simulated measured values at the output variables y_{jFilt} . Since there are no measurements for the process output variables y_j , the corresponding inputs at the block are connected to the output variables. The elements of the Q matrix are all set to zero, that is no model uncertainty is assumed for the simulation.

Kalman Configurator

Using the Kalman Configurator, you can conveniently configure the process model and specify all model-specific settings for the Kalman filter. As a result, the tool generates the source code of the FB KalMod. Once you have compiled the block, you can download it to the automation system. For more details, refer to the *Kalman Configurator User Documentation*.

Configuration

Use the CFC editor to install the block in a cyclic interrupt OB (OB30 to OB38). The block is also installed automatically in the startup OB (OB100).

Perform the following configuration tasks:

- Interconnect the input and output variables `U1...U7` and `Y1...Y7`
- Interconnect `UiLimScale`, `UiUnit` ($i = 1 \dots \text{NumberU}$) and `YiLimScale`, `YiUnit` ($i = 1 \dots \text{NumberY}$) and specify input limits (`UiLimScale.High/.Low`) and the measurement limits (`YiLimScale.High/.Low`)
- Specify self-explaining variable names for all configured inputs, measurable and non-measurable outputs, and state variables at the text attributes (identifiers)
- Select the associated process model in FB KalMod through `ModelNo` (1...5)
- Interconnect the initial values for the configured state variables. This connection is only necessary if the initial values are not constant, but time-varying, and a signal source for the actual values is available.
- Record measured data and configure the Kalman filter through the Kalman Configurator (refer to the *Kalman Configurator User Documentation*)

To compile the SCL sources generated by the configurator, the following user-defined data types are needed, which have to be copied from APL to the function block folder of the user project:

- UDT 43: Vector15
- UDT 44: Matrix15
- UDT 45: Kal_DB
- UDT 46: StcVector15
- UDT 47: StcMatrix15
- UDT 48: StcKalDB

The data types which you have declared must not be within this number range.

- In the "Component view" of SIMATIC Manager, right-click on the folder "Sources", select "Insert new object" and then select "External source".
- Double-click the SCL source to open/edit the code and click "Compile and load" to upload it to the CPU.
- Set the input variable `LoadParam = 1` at the KalFilt instance in the CFC to load the model in the filter.

Additional configuration tasks for inclusion of the laboratory measurements:

- Enable bit for lab measurements (`SampleEn = 1`)
- The number of lab data (`NumberYn`) is already determined in the configurator.

Laboratory data can be inserted using the faceplate or can be provided by interconnection. Therefore, the respective signal selectors `***_LiOp` have to be set, whereby `***_LiOp = 1` means that the link is relevant, and `***_LiOp = 0` means that the operation in the faceplate is relevant. Both the cases are described separately as follows:

- Inserting laboratory data in the faceplate:
 - Select the signal selectors (`SaPo_LiOp = 0`, `SaRe_LiOp = 0`)
 - The operation of the faceplate to insert laboratory data is described in section KalFilt standard view (Page 995).
- Providing laboratory data by interconnection:
 - Select the signal selectors (`SaPo_LiOp = 1`, `SaRe_LiOp = 1`)
 - At the time of taking the lab sample, set the input variable `SaPo_Ext = 1`. This command is detected via rising edge of `SaPo_Ext` and is acknowledged by setting the binary output variable `SampExtracted = 1`.
 - After laboratory analysis, provide the results to the input variables `Yn1_Ext...Yn5_Ext` and set the input variable `SaRe_Ext = 1`. This command is detected via rising edge of `SaRe_Ext` and is acknowledged by setting the binary output variable `LabResIncluded = 1`.
 - `Feature.Bit2` defines if the binary input variables are reset by the function block itself. If they should not be reset automatically, they have to be reset by interconnection, after the respective order was acknowledged by setting the respective binary output variable.

Diagonal elements of the covariance matrix of the measurement noise `Rn11...Rn55` are defined in the model FB from the Kalman Configurator.

Determining the monitoring time `TimeMon`:

- When this time has expired, waiting for the laboratory test results is terminated. It takes at least one cycle of the process model between the period when the lab sample is taken and the laboratory results are received.

The library contains the following blocks:

Icon	Address	Data type	Comment
KalFilt	FB 1925	FB 1925	State observer based on the algorithm of the extended Kalman filter.
KalFunct	FB 1926	FB 1926	Multiplexer for calling the correct model
KalMod1...Kal-Mod5	FB 471...FB 475	FB 471...FB 475	Process model including Jacobi matrices and filter parameters, created in the configurator
MxAdd	FC 466	FC 466	Adds two matrices (used internally)
MxCBnd	FC 467	FC 467	Merging by column (columnbind) of two matrices (used internally)
MxInv	FC 468	FC 468	Returns an inverse of a matrix (used internally)
MxMul	FC 469	FC 469	Multiplies two matrices (used internally)

Icon	Address	Data type	Comment
MxRBnd	FC 470	FC 470	Merging by row (rowbind) of two matrices (used internally)
MxSub	FC 471	FC 471	Subtracts two matrices (used internally)
MxTrans	FC 472	FC 472	Returns a transpose of a matrix (used internally)
MxUnity	FC 473	FC 473	Generates an identity matrix (used internally)
MxZero	FC 474	FC 474	Generates a zero matrix (used internally)
Vector15	UDT 43	UDT 43	Data type for vector calculations
Matrix15	UDT 44	UDT 44	Data type for matrix calculations
Kal_DB	UDT 45	UDT 45	Data type for user data
StcVector15	UDT 46	UDT 46	Structure to deliver arrays of type Vektor15
StcMatrix15	UDT 47	UDT 47	Structure to deliver arrays of type Matrix15
StcKal_DB	UDT 48	UDT 48	Structure to deliver arrays of type Kal_DB

Startup characteristics

At the start of a run or a batch, the algorithm must be initialized and all states must be set to their initial values. This initialization is triggered by the binary input variable `Reset`, which is automatically reset after executing the initialization and is also accessible in the faceplate.

If the initial values are to be read from the model FB generated by the Kalman Configurator during initialization, the binary input variable `LoadParam` should be used instead, which is also automatically reset after a successful read operation, but is not accessible in the faceplate. The current values set at the corresponding input variables or in the faceplate are overwritten (for example, initial values of the states) when the parameters are loaded from the FB.

When the CPU starts up, the block is reinitialized and the parameters are loaded from the FB (in accordance with `LoadParam`).

Status word allocation for `status1` parameter

You can find description of each parameter in the section KalFilt I/Os (Page 990).

Status bit	Parameter
0	Occupied
1	BatchEn
2	SimOn
3	OosAct
4	OosLi
5	Not used
6	OnAct
7	SampleEn, enable for introducing the laboratory values
8	SamplePoint, laboratory sample taken from process
9	SampleResult, lab results incorporated
10	Laboratory results are bad → lab results are ignored
11	Waiting period for laboratory results has expired
12	Laboratory results adapted to limits

Status bit	Parameter
13	SaPo_ExtAct, external lab sampling
14	SaRe_ExtAct, external lab measurement
15	Not used
16 - 25	UserAna1 to UserAna10 interconnected
26 - 31	Not used

See also

KalFilt modes (Page 986)

KalFilt functions (Page 987)

KalFilt error handling (Page 988)

KalFilt messaging (Page 994)

KalFilt block diagram (Page 994)

5.16.2 KalFilt modes

Operating modes of KalFilt

The block can be operated using the following modes:

- On (Page 71)
- Out of service (Page 71)

"On"

You can find general information about the "On" mode in the section On (Page 71).

"Out of service"

You can find general information about the "Out of service" mode in the section Out of service (Page 71).

See also

Description of KalFilt (Page 980)

KalFilt functions (Page 987)

KalFilt error handling (Page 988)

KalFilt I/Os (Page 990)

KalFilt messaging (Page 994)

KalFilt block diagram (Page 994)

5.16.3 KalFilt functions

Functions of KalFilt

The functions for this block are listed below.

Forming the signal status for blocks

The block provides the standard function Forming and outputting the signal status for technologic blocks (Page 109).

- Signal status for the estimated states values $X1...X15$:
 - When limited (to the high or low limit), the signal status 16#78 (uncertain, process-related) is set at the relevant state estimate.
 - If the REAL value of the input or output variables is "infinity" (+#INF and -#INF) or "not a number" (+#NAN and -#NAN), the signal status 16#28 (Bad) is assigned to all state variables.
 - If a signal status of the input variables (U) is bad, all state variables obtain the signal status `ST_Worst`.
 - If a signal status of the output variables (Y) is bad, the associated covariance element of the measurement noise `R` is set to $1.0e+10$ and all state variables obtain the signal status 16#68 (uncertain, device related).
 - If a signal status of the lab measured values (Y_n) is bad or the lab value cannot be shown in the REAL number field, all lab values are ignored. The signal status of the lab measured values has no affect on the signal status `ST_Worst`.
 - In all other cases, the state estimated values have the signal status 16#80 (Good).
- The worst signal status `ST_Worst` for the block is formed from the parameters (U1.ST to U7.ST).

Configurable reactions using the Feature parameter

An overview of all the reactions that are provided by the `Feature` parameter is available in the section Configurable functions using the Feature I/O (Page 131). The following functionality is available for this block at the relevant bits:

Bit	Function
0	Set startup characteristics (Page 138)
1	AUTOHOTSPOT
2	Resetting the commands for changing the mode (Page 161)
24	Enabling local operator authorization (Page 158)

Operator permissions

The block provides the standard function Operator control permissions (Page 254).

The block has the following permissions for the OS_Perm parameter:

Bit	Function
0	Not used
1	1 = Operator can switch the block to "On" mode
2	Not used
3	1 = Operator can switch the block to "Out of service" mode
4	Not used
5	1 = Operator can perform a block restart
6	1 = Operator can change SimUi simulation values
7	1 = Operator can change SimYi simulation values
8	1 = Operator can enter the initial values XiStart for state variables X1...X15
9	1 = Operator can change the high limit XiHiLim for state variables X1...X15
10	1 = Operator can change the low limits XiLoLim for state variables X1...X15
11	1 = Operator can enable the simulation function
12	Not used
13	1 = Operator can enter lab values and operate SaPo and SaRe
14	1 = Operator can specify the maximum duration for lab data and limits for errors in lab values
15	1 = Operator can change the scaling of the bar graph display for the estimation error in the standard view of the faceplate
16 - 31	Not used

See also

- Description of KalFilt (Page 980)
- KalFilt modes (Page 986)
- KalFilt error handling (Page 988)
- KalFilt I/Os (Page 990)
- KalFilt messaging (Page 994)
- KalFilt block diagram (Page 994)

5.16.4 KalFilt error handling

Error handling of KalFilt

Refer to section Error handling (Page 119) in the basic instructions for the error handling of all blocks.

The following errors can be displayed for this block:

- Error numbers in `ErrorNum`
- Output bit `ErrorPara = 1`
The occurrence of an error is depicted at the faceplate using the symbol  as function block status.

Overview of error numbers

The `ErrorNum` output parameter can be used to output the following error numbers:

Error number	Meaning of the error number
-1	Predefined value when the block is inserted; the block is not executed.
0	There is no error.
2	<code>SampleTime < 0.001</code> or required sampling time for Kalman filter is less than the cycle time of the cyclic interrupt OB in which the block is integrated.
3	FB <code>KalFunct</code> called internally returns an error, for example, if <code>ModelNo > 5</code>
4	Parameter assignment error <code>NumberU/NumberY/NumberX/NumberYn/NumberZ</code> , for example, number larger than possible
6	Error loading model FB from the Kalman Configurator. The following sources of error are possible: <ul style="list-style-type: none"> • FB is not available • FB is not Kalman Configurator FB • Required matrix dimensions are not supported
7	Only during startup: Initial values of the state variables are out of range
21 - 27	Signal status of the input variable <code>U1...U7</code> is bad
30	The value of an input variable <code>Y1...Y7</code> or <code>U1...U7</code> cannot be displayed in the REAL number field
31	Matrix inversion inside the Kalman filter algorithm fails. In this case, the internal filter states will not be updated according to current measurement data, but remain at their <i>a priori</i> values. If at the next sample step, with new measurement values, the matrix-inversion works correctly again, the <code>ErrorNum</code> is set back to zero.

See also

Description of KalFilt (Page 980)

KalFilt modes (Page 986)

KalFilt functions (Page 987)

KalFilt I/Os (Page 990)

KalFilt messaging (Page 994)

KalFilt block diagram (Page 994)

5.16.5 KalFilt I/Os

Input parameters

Parameters	Description	Type	Default
BatchEn	1 = Enable allocation for Batch control	BOOL	0
BatchID	Current batch ID	DWORD	16#00000000
BatchName	Current batch designation	STRING[32]	"
EN	1 = Called block will be processed	BOOL	1
EYn1Lim...EYn5Lim	Limits for the difference between lab results and associated state values	REAL	0.0
EYPScale	Scaling of the bar graph display of the estimation error in the faceplate	REAL	100.0
Feature	I/O for additional functions (Page 987)	STRUCT <ul style="list-style-type: none"> • Bit 0: BOOL • 0 • ... • 0 • Bit 31: BOOL • 0 	-
LoadParam	1 = Restart KalFilt with loading of the parameters (including the initial values for the states) from the FB	BOOL	Normal oper.
ModelNo	Process model number (assignment of the appropriate process model in KalFunc)	INT	1
Occupied	1 = Occupied by batch control	BOOL	0
OnOp	1=On Mode: On Mode by Operator	BOOL	0
OosLi	1 = "Out of service", via interconnection or SFC (0-1 edge transition)	STRUCT <ul style="list-style-type: none"> • Value: BOOL • 0 • ST: BYTE • 16#80 	-
OosOp	1 = "Out of service", via OS operator	BOOL	0
OS_Perm	I/O for operator permissions (Page 987)	STRUCT <ul style="list-style-type: none"> • Bit 0: BOOL • 1 • ... • 1 • Bit 31: BOOL • 1 	-
Q11...Q1515	Diagonal elements of the covariance matrix Q , related to uncertainty of the differential equation for respective states $X1...X15$	REAL	0.0
Reset	1 = Reset the states $X1...X15$ to their initial values defined at the input parameters	BOOL	Normal oper.
R11...R77	Diagonal elements of covariance matrix R , related to measurement noise of output variables $Y1...Y7$	REAL	0.0
Rn11...Rn55	Diagonal elements of covariance matrix Rn , related to measurement noise of lab results $Yn1...Yn5$	REAL	0.0
SampleEn	Enable for sporadic laboratory measurements	BOOL	0
SampleTime	Sample time in seconds (assigned automatically)	REAL	0.1

Parameters	Description	Type	Default
SaPo_LiOp	Select lab sampling (internal/external): 1 = Via interconnection (external) 0 = Via operator (internal)	BOOL	0
SaPo_Int	1 = Lab sampling internal (via operator)	BOOL	0
SaPo_Ext	1 = Lab sampling external (via interconnection)	BOOL	0
SaRe_LiOp	Select lab result (internal/external): 1 = Via interconnection (external) 0 = Via operator (internal)	BOOL	0
SaRe_Int	1 = Lab result internal (input by operator)	BOOL	0
SaRe_Ext	1 = Lab result external (values comes via interconnection)	BOOL	0
SelFp1	1 = Call a block saved in this parameter as an additional faceplate in the standard view	ANY	
SelFp2	1 = Call a block saved in this parameter as an additional faceplate in the preview	ANY	
SimOn	Switch on/off of the simulation	BOOL	0
SimU1...SimU7	Simulation values for U1...U7	REAL	0.0
SimY1	Simulation values for Y1...Y7	REAL	0.0
...			
SimY7			
StepNo	Batch step number	DWORD	16#00000000
TimeMon	Monitoring time for sampling in minutes	INT	60
U1...U7	Input variables	STRUCT	- • Value: BOOL • 0 • ST: BYTE • 16#80
U1Unit...U7Unit	Unit for input variables U1...U7	INT	1342
U1LimScale...U7LimScale	Limit of the value range and scaling for faceplate	STRUCT	- • High: REAL • 100.0 • Low: REAL • 0.0
UserAna1...UserAna10	Arbitrary analog values for display in the block icon	STRUCT	- • Value: REAL • 0.0 • ST: BYTE • 16#FF
UA1Unit...UA10Unit	Unit for UserAna1...UserAna10	INT	1001
UserStatus	Freely assignable user area for status word (bits 24-31)	BYTE	16#00
X1LimScale...X15LimScale	High and low limit for X1...X15	STRUCT	- • High: REAL • 100.0 • Low: REAL • 0.0
X1Start...X15Start	Initial value for the state variables X1...X15	REAL	0.0
X1Unit...X15Unit	Unit for the state variables X1...X15	INT	1001 (°K)

Parameters	Description	Type	Default
Y1...Y7	Measurable output variables	STRUCT • Value: BOOL • ST: BYTE	- • 0 • 16#80
Y1LimScale...Y7LimScale	Limitation of the value range of Y1...Y7 and scaling for faceplate	STRUCT • High: REAL • Low: REAL	- • 100.0 • 0.0
Y1Unit...Y7Unit	Unit for the output variables Y1...Y7	INT	1001
Yn1_Ext...Yn5_Ext	External lab result (input for interconnection)	STRUCT • Value: REAL • ST: BYTE	- • 0.0 • 16#80
Yn1_Int...Yn5_Int	Internal lab result Yn1_Int...Yn5_Int (input by operator)	REAL	0.0
Yn1Unit...Yn5Unit	Unit for the lab result Yn1...Yn5	INT	1342 (%)
Yn1LimScale...Yn5LimScale	Limitation of the value range of Yn1...Yn5 and scaling for faceplate	STRUCT • High: REAL • Low: REAL	- • 100.0 • 0.0
Z1Unit...Z5Unit	Unit of measurement for Z1...Z5	INT	1001

Output parameters

Parameters	Description	Type	Default
DTimeMon	Time since extraction of lab sample in minutes	REAL	0.0
ENO	1 = Block algorithm completed without errors	BOOL	0
ErrorNum	Output of pending error number. For definition of error numbers by this block, see KalFilt error handling (Page 988).	INT	-1
ErrorPara	1= Parameter assignment error	BOOL	0
EY1...EY7	Deviation between measured values (Y1...Y7) and prediction of the Kalman filter	REAL	0.0
EYn1...EYn5	Deviation between lab results and prediction of the Kalman filter	REAL	0.0
EY1P_k1...EY1P_k5	Percent deviation between measured value Y1 and prediction of the Kalman filter for 1 to 5 latest samples	REAL	0.0
EY2P_k1...EY2P_k5	Percent deviation between measured value Y2 and prediction of the Kalman filter for 1 to 5 latest samples	REAL	0.0
EY3P_k1...EY3P_k5	Percent deviation between measured value Y3 and prediction of the Kalman filter for 1 to 5 latest samples	REAL	0.0
EY4P_k1...EY4P_k5	Percent deviation between measured value Y4 and prediction of the Kalman filter for 1 to 5 latest samples	REAL	0.0
EY5P_k1...EY5P_k5	Percent deviation between measured value Y5 and prediction of the Kalman filter for 1 to 5 latest samples	REAL	0.0
EY6P_k1...EY6P_k5	Percent deviation between measured value Y6 and prediction of the Kalman filter for 1 to 5 latest samples	REAL	0.0

Parameters	Description	Type	Default
EY7P_k1...EY7P_k5	Percent deviation between measured value Y_7 and prediction of the Kalman filter for 1 to 5 latest samples	REAL	0.0
EYPScaleOut	Calculated scaling of the bar representation of estimation error in the standard view of the faceplate	STRUCT <ul style="list-style-type: none"> • High: REAL • Low: REAL 	- <ul style="list-style-type: none"> • 100.0 • 0.0
LabResIncluded	Laboratory results included	BOOL	0
NumberU	Number of input variables U	INT	7
NumberX	Number of state variables X	INT	15
NumberY	Number of output variables Y	INT	7
NumberYn	Number of lab sample variables Y_n	INT	1
NumberZ	Number of non-measurable output variables Z	INT	0
OnAct	1 = "On" mode enabled	STRUCT <ul style="list-style-type: none"> • Value: BOOL • ST: BYTE 	- <ul style="list-style-type: none"> • 1 • 16#80
OS_PermOut	Display of OS_Perm	DWORD	16#FFFFFFFF
OS_PermLog	Display of OS_Perm with the settings changed by the block algorithm	DWORD	16#FFFFFFFF
OosAct	1 = Block is "Out of service"	STRUCT <ul style="list-style-type: none"> • Value: BOOL • ST: BYTE 	- <ul style="list-style-type: none"> • 1 • 16#80
P11...P1515	Diagonal elements of covariance matrix P , related to uncertainty of differential equation for respective states $X_1...X_{15}$	REAL	0.0
SampExtracted	Laboratory sample extracted	BOOL	0
SaPo_ExtAct	1 = External lab sampling is active 0 = Internal lab sampling is active	STRUCT <ul style="list-style-type: none"> • Value: BOOL • ST: BYTE 	- <ul style="list-style-type: none"> • 0 • 16#80
SaRe_ExtAct	1 = External lab results active 0 = Internal lab results active	STRUCT <ul style="list-style-type: none"> • Value: BOOL • ST: BYTE 	- <ul style="list-style-type: none"> • 0 • 16#80
Status1	Status word 1	DWORD	16#00000000
Status2	Status word 2 (not used)	DWORD	16#00000000
ST_Worst	Worst signal status	BYTE	16#80
X1...X15	Corrected state estimation value	STRUCT <ul style="list-style-type: none"> • Value: REAL • ST: BYTE 	- <ul style="list-style-type: none"> • 0.0 • 16#80
U1Out...U7Out	Input variables set at the block input (copy of U1...U7)	STRUCT <ul style="list-style-type: none"> • Value: REAL • ST: BYTE 	- <ul style="list-style-type: none"> • 0.0 • 16#80
Y1Filt...Y7Filt	Process output variables calculated based on the corrected states $X_1...X_{15}$	STRUCT <ul style="list-style-type: none"> • Value: REAL • ST: BYTE 	- <ul style="list-style-type: none"> • 0.0 • 16#80

Parameters	Description	Type	Default
Y1Out...Y7Out	Process output variables set at the block input (copy of Y1...Y7)	STRUCT <ul style="list-style-type: none"> • Value: REAL • ST: BYTE 	- <ul style="list-style-type: none"> • 0.0 • 16#80
Yn1Out...Yn5Out	Lab results set at the block input	STRUCT <ul style="list-style-type: none"> • Value: REAL • ST: BYTE 	- <ul style="list-style-type: none"> • 0.0 • 16#80
Z1Out...Z5Out	Additional non-measurable output variables	STRUCT <ul style="list-style-type: none"> • Value: REAL • ST: BYTE 	- <ul style="list-style-type: none"> • 0.0 • 16#80

See also

- Description of KalFilt (Page 980)
- KalFilt modes (Page 986)
- KalFilt messaging (Page 994)
- KalFilt block diagram (Page 994)

5.16.6 KalFilt messaging

Messaging

This block does not offer messaging.

See also

- Description of KalFilt (Page 980)
- KalFilt modes (Page 986)
- KalFilt functions (Page 987)
- KalFilt error handling (Page 988)
- KalFilt I/Os (Page 990)
- KalFilt block diagram (Page 994)

5.16.7 KalFilt block diagram

KalFilt block diagram

A block diagram is not provided for this block.

See also

Description of KalFilt (Page 980)
KalFilt modes (Page 986)
KalFilt functions (Page 987)
KalFilt error handling (Page 988)
KalFilt I/Os (Page 990)
KalFilt messaging (Page 994)

5.16.8 Operator control and monitoring

5.16.8.1 KalFilt views

Views of the KalFilt block

The block KalFilt provides the following views:

- KalFilt standard view (Page 995)
- KalFilt parameter view (Page 999)
- KalFilt parameter view 2 (Page 1000)
- KalFilt preview (Page 1001)
- KalFilt measurements view (Page 1002)
- KalFilt trend view (Page 1003)
- Batch view (Page 302)
- Memo view (Page 304)
- Block icon for KalFilt (Page 1004)

Refer to the sections Structure of the faceplate (Page 248) and Block icon structure (Page 230) for general information on the faceplate and block icon.

5.16.8.2 KalFilt standard view

Standard view of KalFilt

The standard view has two parts; view 1 and view 2. You can change between the two views with the arrow keys.

View 1

Mode: **On** (1)

Restart (2)

Estimation error in process outputs: 0.1 s steps (3)

ey1 ey2 ey3 ey4 ey5 ey6 ey7

100 %

Laboratory data (4)

Sample Point (5) Sample Result (6)

60 (6)

Duration of Analysis: 0.00 min (6)

TextLabData1: 0.00% (7)

TextLabData2: 0.00% (7)

TextLabData3: 0.00% (7)

TextLabData4: 0.00% (7)

TextLabData5: 0.00% (7)

Z1: TextOutZ1: 0. °C (8)

Z2: TextOutZ2: 0. °C (8)

Z3: TextOutZ3: 0. °C (8)

Z4: TextOutZ4: 0. °C (8)

Z5: TextOutZ5: 0. °C (8)

Faceplate 1 (9)

11 (11)

10 (10)

View 2

The screenshot shows a parameter configuration window for the KalFilt block. It features a scrollable list of 15 state variables, each with a corresponding initial value. The state variables are labeled X1 through X15, each followed by 'TextStateX' and a temperature unit '°C'. The initial values are all set to '0.'. A green border highlights the state variable labels and their units. A grey border highlights the initial value input fields. A small upward-pointing arrow icon is located in the top right corner of the parameter view. Two callout boxes, labeled 12 and 13, are positioned on the left and right sides of the parameter view respectively, pointing to the state variable labels and the initial value input fields.

State variables	Initial values
X1: TextStateX1	0. °C
X2: TextStateX2	0. °C
X3: TextStateX3	0. °C
X4: TextStateX4	0. °C
X5: TextStateX5	0. °C
X6: TextStateX6	0. °C
X7: TextStateX7	0. °C
X8: TextStateX8	0. °C
X9: TextStateX9	0. °C
X10: TextStateX10	0. °C
X11: TextStateX11	0. °C
X12: TextStateX12	0. °C
X13: TextStateX13	0. °C
X14: TextStateX14	0. °C
X15: TextStateX15	0. °C

(1) Displaying and switching the operating mode

This area provides information on the currently active operating mode. The following operating mode can be shown here:

- On (Page 71)
- Out of service (Page 71)

Refer to chapter Switching operating states and operating modes (Page 257) for information on switching the operating mode.

(2) Restarting the block

Click "Restart" to restart the Kalman filter block.

The initial values specified at the block inputs (X1Start...X15Start) can be set with `Reset`.

(3) Display of the estimation error in process outputs

In this area, the percentage estimation errors in the existing measurement channels are displayed. These are based on the particular value range and are calculated for 5 consecutive sampling instants in the recent past. The estimation error at the current time is displayed on the far right and the most distant error in the past (5 sampling steps ago) can be seen at the far left. You can change the scaling of the bar in the parameter view (Page 999) of the faceplate.

(4) Sample Point

You can mark the time of extracting lab sample using "Sample Point" button (only if $SaPo_LiOp = 0$).

(5) Sample Result

Click this button to confirm the laboratory results entered in the "TextLabData1" fields. Refer to (7) **Laboratory results**.

(6) Duration of Analysis

This field displays the elapsed time since the extraction of lab sample. If this is greater than the specified limit ($TimeMon$, can be changed in the parameter view), which is displayed at the upper right field, the result of the laboratory measurement is no longer used.

(7) Laboratory results

You can enter the laboratory results (Yni_Int) directly in the "TextLabData1" fields. Once they are all fully entered, the entry must be confirmed with the "Sample Result" button. The counter stops and the laboratory data are considered in the calculations of the Kalman filter. If a sample is extracted but no meaningful result can be given, a new sample extraction can be started in the faceplate. If the laboratory data is given via interconnection, the description for engineering and operation can be found in the section Additional configuration tasks for inclusion of the laboratory measurements (Page 980).

(8) Additional output variables

If you have output variables which cannot be measured and are calculated from *a posteriori* state estimates, you can define and enter the calculation algorithm for a maximum of 5 additional output variables ($Z1Out...Z5Out$) in the Kalman Configurator.

(9) Navigation button for switching to the standard view of any faceplate

Use this navigation button to open the standard view of another function block, which is configured in the engineering system (ES).

The visibility of this navigation button depends on the configuration in the engineering system (ES).

For more information, refer to the section Opening additional faceplates (Page 208).

(10) Display area for block states

This area provides additional information on the operating state of the block:

- "Simulation"

You will find more detailed information on this in the sections Simulating signals (Page 58).

(11) Display area for block states

This area provides additional information on the operating state of the block:

- "Sample extracted"
- "Lab results included"
- "Error in lab results"
- "Time out in analysis"
- "Lab results limited"

(12) State variables

This area shows the current values of the estimated state variables.

(13) Initial values

You can specify initial values for the state variables, which are used for `Reset`.

5.16.8.3 KalFilt parameter view

Parameter view of KalFilt

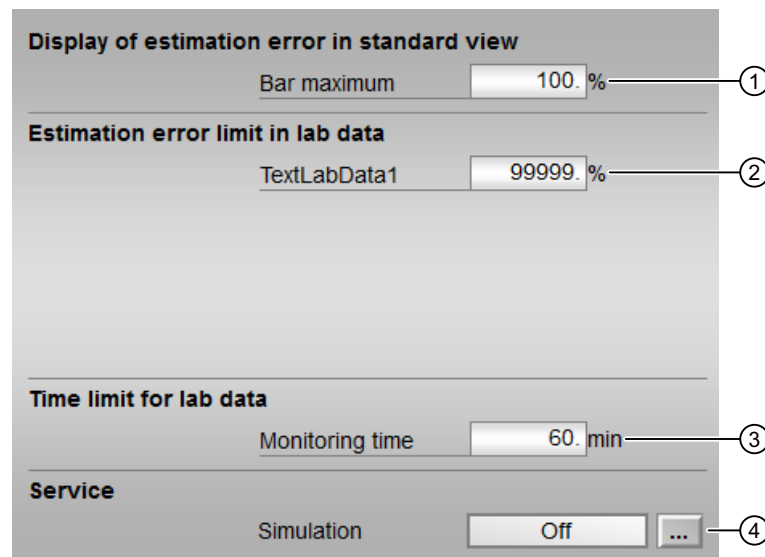

(1) Display of estimation error in standard view

You can set the scale of the bar diagram in the "Bar maximum" (`EYPScale`) field. The bar diagram is displayed in the KalFilt standard view (Page 995).

(2) Estimation error limits in lab data

You can change the maximum permissible deviation of the laboratory results from the estimated state variables in the "TextLabData1" field (EYniLim).

If the actual error is above this value, the lab results are regarded as implausible and not used for the Kalman filter.

(3) Duration limits in lab data

You can adjust the maximum duration for a laboratory measurement in the "Monitoring time" field.

(4) Service

You can enable and disable simulation of the block using the "Simulation" button.

5.16.8.4 KalFilt parameter view 2

Parameter view 2 of KalFilt

State variable limits	Lower limit	Upper limit
X1: TextStateX1	0. °C	100. °C
X2: TextStateX2	0. °C	100. °C
X3: TextStateX3	0. °C	100. °C
X4: TextStateX4	0. °C	100. °C
X5: TextStateX5	0. °C	100. °C
X6: TextStateX6	0. °C	100. °C
X7: TextStateX7	0. °C	100. °C
X8: TextStateX8	0. °C	100. °C
X9: TextStateX9	0. °C	100. °C
X10: TextStateX10	0. °C	100. °C
X11: TextStateX11	0. °C	100. °C
X12: TextStateX12	0. °C	100. °C
X13: TextStateX13	0. °C	100. °C
X14: TextStateX14	0. °C	100. °C
X15: TextStateX15	0. °C	100. °C

(1) Lower limit of state variables

You can specify the lower limit of the state variables.

(2) Upper limit of state variables

You can specify the upper limit of the state variables.

5.16.8.5 KalFilt preview

Preview of Kalfilt

The screenshot displays the 'KalFilt preview' interface, which is divided into three main sections:

- Estimation error in process outputs:** This section contains seven rows, each with a label (Estimation error Y1 through Y7) and a numerical value of 0.00 followed by a degree Celsius symbol (°C). A bracket on the right side of this section is labeled with a circled '1'.
- Estimation error in laboratory data:** This section contains five rows, each with a label (TextLabData1 through TextLabData5) and a numerical value of 0.00 followed by a percent sign (%). A bracket on the right side of this section is labeled with a circled '2'.
- Enabled operations:** This section features a green checkmark icon followed by the text 'Local oper. permission'. A bracket on the right side of this section is labeled with a circled '3'.

At the bottom left of the interface, there is a button labeled 'Faceplate 2', which is pointed to by a circled '4'.

(1) Estimation error in process variables

This area shows the estimation error in the output variables. The values of the estimation error are shown in physical units in preview and as percentage in the standard view (Page 995).

(2) Estimation error in laboratory data

This area shows the estimation error in the laboratory results. The values of the estimation error are shown in physical units in preview and as percentage in the standard view (Page 995).

(3) Enable operations

This area shows all operations for which special operator permissions are assigned. They depend on the configuration in the engineering system (ES) that applies to this block.

Icons for enabled operation:

- **Green check mark:** the OS operator can control this parameter
- **Gray check mark:** the OS operator cannot control this parameter at this time due to the process
- **Red cross:** the OS operator cannot control this parameter due to the configured AS operator permissions (OS_Perm or OS1Perm).

The following enabled operation is shown here:

- "Local operating permission": Use the ← button to switch to the standard view of the OpStations block. You can find additional information on this in the section Operator control permissions (Page 254).

(4) Navigation button for switching to the standard view of any faceplate

Use this navigation button to open the standard view of another function block, which is configured in the engineering system (ES).

The visibility of this navigation button depends on the configuration in the engineering system (ES).

For more information, refer to the section Opening additional faceplates (Page 208).

5.16.8.6 KalFilt measurements view

Measurements view of KalFilt

Process outputs		
Y1:	TextOutput1	0.00 °C
Y2:	TextOutput2	0.00 °C
Y3:	TextOutput3	0.00 °C
Y4:	TextOutput4	0.00 °C
Y5:	TextOutput5	0.00 °C
Y6:	TextOutput6	0.00 °C
Y7:	TextOutput7	0.00 °C

Process inputs		
U1:	TextInput1	0.00 %
U2:	TextInput2	0.00 %
U3:	TextInput3	0.00 %
U4:	TextInput4	0.00 %
U5:	TextInput5	0.00 %
U6:	TextInput6	0.00 %
U7:	TextInput7	0.00 %

(1) Process outputs

This area displays current values of the process outputs.

(2) Process inputs

This area displays current values of the process inputs.

5.16.8.7 KalFilt trend view

Trend view of KalFilt

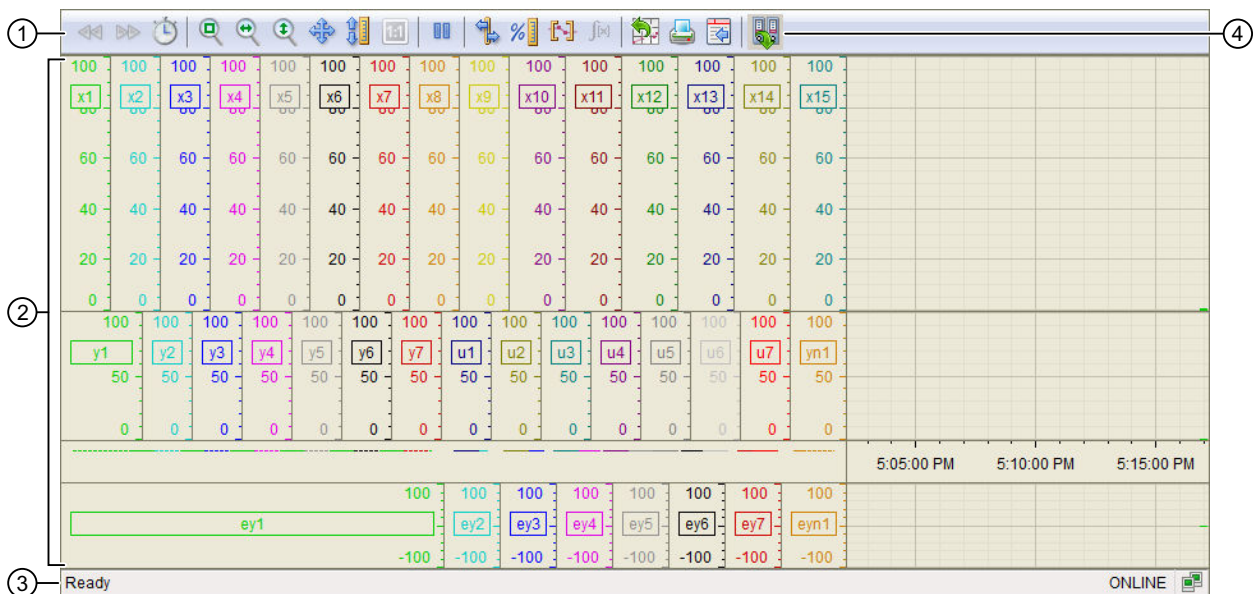

(1) Toolbar

(2) Display area for trends

(3) Status bar

(4) Button for switching between archive tags and online tags. The status bar shows if the trend view is working with online data or archive data.

For additional information about the trend view, refer to the *WinCC Information System* Online Help.

The trend view is divided into three areas. The top area shows the state variables, the middle area shows the input and output variables, and the lower area shows the estimation errors.

5.16.8.8 Block icon for KalFilt

Block icons for KalFilt

A single block icon is available with the following functions:

- Process tag type
- Operating modes
- Signal status, release for maintenance
- Memo display
- User analog values 1 to 10, typically a subset of the estimated states and additional output variables (black, with and without decimal places)

The display of the tag name can be activated centrally for all block instances with the WinCC variable @APLShowTag:

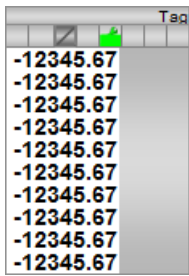
Icons	Selection of the block icon in CFC	Special features
	1	Block icon with full display for 10 freely assignable measured values: UserAna1...UserAna10

Additional information on the block icon and the control options in the block icon is available in the following sections:

- Configuring the block icons (Page 237)
- Operation via the block icon (Page 239)
- Block icon structure (Page 230)

Dosing blocks

6.1 DoseL - Dosing device

6.1.1 Description of DoseL

Object name (type + number) and family

Type + number: FB 1809

Family: Dosage

Area of application for DoseL

The block is used for the following applications:

- Single-component dosing using flow measurement
- Weighing of fill/removal volume using dosing scales

How it works

Processing is performed discretely via a coarse/fine flow control with flow monitoring and setpoint specification. The dosing flow can be determined via a maximum of 16 cycles.

A dribbling phase and post dosing can be implemented for both processes. The input value can also be supplied from a pulse module via the `PV1CycLi` output of the `Pcs7Cntx` (x=1...3) channel block.

Note

When using a pulse module, the counted pulses per cycle must be normalized via the I/Os "Gain" and "Ti" at DoseL .

Example:

A pulse of 35 Kg per hour means that I/O "Gain" must be configured to 35 and I/O "Ti" to 3600.

Configuration

Use the CFC editor to install the block in a cyclic interrupt OB (OB30 to OB38). The block is also installed automatically in the startup OB (OB100).

For the DoseL block, the Advanced Process Library contains templates for process tag types as examples with various application scenarios for this block.

6.1 DoseL - Dosing device

Examples of process tag types:

- Dosing (Dose_Lean) (Page 2358)
- Dosing with PA/FF devices (Dose_Lean_Fb) (Page 2359)

Startup characteristics

Use the `Feature Bit Set` startup characteristics (Page 138) to define the startup characteristics of this block.

The messages are suppressed after startup for the number of cycles set at `RunUpCyc`.

Status word allocation for `status1` parameter

You can find a description for each parameter in section `DoseL I/Os` (Page 1031).

Status bit	Parameter
0	Occupied
1	BatchEn
2	SimOn
3	OosAct.Value
4	OosLi.Value
5	AutoAct.Value
6	LocalAct.Value
7	0: Open padlock in the block icon 1: Closed padlock in the block icon
8	SP_ExtAct
9	Ctrl
10	Ctrl2
11	1 = Dosing by scale
12	0 = Dosing by scale for filling 1 = Dosing by scale for removal
13	BypProt active
14	Invalid signal status
15	Mode switchover error
16	1 = Intlock is active
17	1 = Permit is active
18	1 = Protect is active
19	DosOn
20	DosRelax
21	DosEnd
22	DosOff
23	DosPause
24	DosStart
25	1 = Post dosing
26	"Start" command

Status bit	Parameter
27	"Pause" command
28	"Continue" command
29	"Cancel" command
30	UserAna1 interconnected
31	UserAna2 interconnected

Status word allocation for status2 parameter

Status bit	Parameter
0	MsgLock
1	DQ_AH_Act xx_Act taking into account Feature Bit 29
2	DQ_AL_Act xx_Act taking into account Feature Bit 29
3	DQ_AH_En
4	DQ_AL_En
5	DQ_AH_MsgEn
6	DQ_AL_MsgEn
7	PV_AH_Act xx_Act taking into account Feature Bit 29
8	PV_AL_Act xx_Act taking into account Feature Bit 29
9	PV_AH_En and Feature Bit 7 = 1 or PV_AH_En and flow mode
10	PV_AL_En and Feature Bit 7 = 1 or PV_AL_En and flow mode
11	PV_AH_MsgEn
12	PV_AL_MsgEn
13	PV_AH2_Act xx_Act taking into account Feature Bit 29
14	PV_AL2_Act xx_Act taking into account Feature Bit 29
15	PV_AH2_En and Feature Bit 7 = 1 or PV_AH2_En and flow mode
16	PV_AL2_En and Feature Bit 7 = 1 or PV_AL2_En and flow mode
17	PV_AH2_MsgEn
18	PV_AL2_MsgEn
19	CR_AH_Act xx_Act taking into account Feature Bit 29
20	CR_AH_En and Feature Bit 7 = 1 or CR_AH_En and flow mode
21	CR_AH_MsgEn
22	Display for interlocks in block icon
23	1 = Scales tared
24	Automatic preview 1 = Dosing "On"
25	Automatic preview 1 = Dosing "Dribbling"
26	Automatic preview 1 = Dosing "End"
27	Automatic preview 1 = Dosing "Off"
28	Automatic preview 1 = Dosing "Pause"
29	Forcen active
30	Bypass information from previous function block
31	MS_RelOp

Status word allocation for status3 parameter

Status bit	Parameter
0	"Interlock" button is enabled
1	"Permission" button is enabled
2	"Protection" button is enabled
3	DosCancelMsgEn
4	Feature Bit 7 = 1 (Calculation of the flow rate for dosing by scale)
5	Feature Bit 7 = 1 or flow mode
6	Display flow setpoint in percent
7	Display flow setpoint bar
8	Reset request in automatic mode
9	Feature bit 8 = 1 (Fine dosing quantity setpoint absolute)
10	SimLiOp.Value
11	External error generated by FaultExt or external control system fault CSF with set Feature bit 18 Activating error state for external process control error CSF (Page 151)
12	0 = Button text "Ack underdose" is visible 1 = Button text "Ack overdose" is visible
13	Display "Ack Dos End" block state in the standard view
14 - 18	Not used
19	Display "Forced start"
20	Display "Force abort"
21	Display "Forced pause"
22	Display "Forced continue"
23 - 27	Not used
28	GrpErr.Value
29	RdyToStart.Value
30	1 = Input parameter CtrlChnST is interconnected
31	1 = Input parameter Ctrl2ChnST is interconnected

Status word allocation for status4 parameter

Status bit	Parameter
0	Effective signal 1 of the message block connected via EventTsIn
1	Effective signal 2 of the message block connected via EventTsIn
2	Effective signal 3 of the message block connected via EventTsIn
3	Effective signal 4 of the message block connected via EventTsIn
4	Effective signal 5 of the message block connected via EventTsIn
5	Effective signal 6 of the message block connected via EventTsIn
6	Effective signal 7 of the message block connected via EventTsIn
7	Effective signal 8 of the message block connected via EventTsIn
8	Delay of the DQ_AH_Tol message
9	Delay of the DQ_AL_Tol message

Status bit	Parameter
10	Delay of the PV_AH_Lim message
11	Delay of the PV_AL_Lim message
12	Delay of the PV_AH2_Lim message
13	Delay of the PV_AL2_Lim message
14	Delay of the CR_AH_Lim message
15	Collection of message delays
16 - 22	Not used
23	Hidden bypass signal in Permit
24	Hidden bypass signal in interlock
25	Hidden bypass signal in Protect
26	Feature2 bit 2: Separate bypass signal
27 - 31	Not used

Status word allocation for Status5 parameter

Status bit	Parameter
0 - 7	Effective signal 9..16 of the message block connected via EventTsIn
8 - 31	Not used

See also

DoseL functions (Page 1011)
 DoseL messaging (Page 1028)
 DoseL modes (Page 1009)
 DoseL error handling (Page 1025)
 DoseL block diagram (Page 1045)

6.1.2 DoseL modes

DoseL operating modes

The block can be operated using the following modes:

- Local mode (Page 79)
- Automatic mode (Page 75)
- Manual mode (Page 75)
- Out of service (Page 71)

The next section provides additional block-specific information relating to the general descriptions.

"Local mode"

You can find general information on "Local mode", switching modes and Bumpless switchover in the Local mode (Page 79) section.

Dosing actions you can control in "local mode":

- "Start" (positive edge StartLocal)
- "Cancel" (CancelLocal = 1)
- "Pause" (PauseLocal = 1)
- "Continue" (ContLocal = 1)

If you operate the block in "local mode", control will only take place via "local" signals (input parameters StartLocal = 1, CancelLocal = 1, PauseLocal = 1 and ContLocal = 1).

Note

Unlike the general description, at the LocalSetting parameter only the values 0, 1 and 3 can be set, i.e. tracking in "local" mode is not possible with DoseL.

"Automatic mode"

You can find general information on "Automatic mode", switching modes and Bumpless switchover in the Manual and automatic mode for motors, valves and dosers (Page 75) section.

Dosing actions you can control in "automatic mode":

- "Start" (positive edge StartAut)
- "Cancel" (CancelAut = 1)
- "Pause" (PauseAut = 1)
- "Continue" (ContAut = 1)

"Manual mode"

You can find general information on "Manual mode", switching modes and bumpless switchover in the section Manual and automatic mode for motors, valves and dosers (Page 75).

Dosing actions you can control in "manual mode":

- "Start" (StartMan = 1)
- "Cancel" (CancelMan = 1)
- "Pause" (PauseMan = 1)
- "Continue" (ContMan = 1)

"Out of service"

You can find general information about the "Out of service" mode in the section Out of service (Page 71).

See also

Description of DoseL (Page 1005)

DoseL functions (Page 1011)

DoseL error handling (Page 1025)

DoseL messaging (Page 1028)

DoseL I/Os (Page 1031)

DoseL block diagram (Page 1045)

6.1.3 DoseL functions**Functions of DoseL**

The functions for this block are listed below.

Status diagram

The block provides the following states:

- "End"
If an underdosage or overdosage is identified, the status display shows the state "Ack Dos End" in the standard view.
- "On"
- "Dribbling"
- "Off"
- "Pause"

The following commands can initiate a state change:

- "Start"
- "Cancel"

- "Pause"
- "Continue"

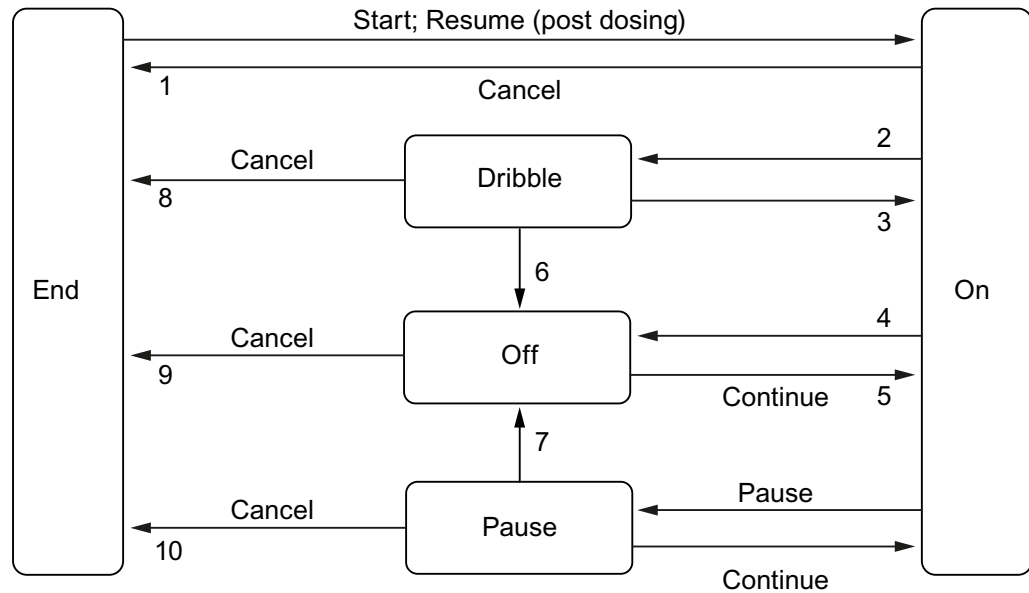

Dosing can only be started if the dosing setpoint is greater than the current dosing quantity (DQ_Out) or if Feature Bit 6 is set and no interlock is pending. With Feature Bit 14, scale dosing can be started only if $StandStill = 1$.

However, the following status changes are also performed automatically:

Number in graphic (top)	Function
1	When the dosing quantity is reached, dosing terminates ($DQ_Out \geq DQ_SP$).
2	If the dosing quantity reaches the dribbling quantity (relative to dosing setpoint $DQ_Out \geq DQ_SP - DribbOut$) the dribbling status becomes active.
3	Automatic post dosing in automatic mode via the Feature Bit 12, if an underdosage was identified after the dribbling time ($RelaxTime$).
4	<ul style="list-style-type: none"> • Flow alarm (see input parameter Feature Bit 11) or • Interlock. • The dosing process of the DoseL block is set to the "Off" state with a process value status "Bad, device-related" or "Bad, process-related". The response can be set using Feature bit parameter assignment.
5	<ul style="list-style-type: none"> • The flow alarm is acknowledged (also provided via the "Continue" command if Feature Bit 9 = 1) or • The interlock is acknowledged (also provided via the "Continue" command if Feature Bit 9 = 1). • "Continue" command after underdosing.
6	Underdosage identified after the dribbling time ($RelaxTime$). Overdosage identified after the dribbling time (only with Feature2 bit 24 = 1).
7	Interlock
8	Dribbling time ($RelaxTime$) has expired and dosing quantity is above the low tolerance limit ($DQ_Out \geq DQ_SP_Tol - DQ_AL_Tol$)

Number in graphic (top)	Function
9	The underdosage is acknowledged or the dosing quantity has been reached ($DQ_Out \geq DQ_SP$) via creep flow, for example
10	Dosing quantity has been reached ($DQ_Out \geq DQ_SP$) via creep flow, for example

Control outputs

The coarse flow (Ctrl) or fine flow (Ctrl2) control outputs are issued in the "On" status.

The coarse flow control output is active if:

- $DQ_Out < DQ_SP - DQ2_SP$

The fine flow control output is active if:

- $DQ_Out \geq DQ_SP - DQ2_SP$
- Where DQ_Out : Dosing quantity actual value
- DQ_SP : Dosing quantity setpoint
- $DQ2_SP$: fine dosing quantity setpoint ("calculated")

Output signal as a pulse signal or static signal

This block provides the standard function Output signal as a static signal or pulse signal (Page 51).

In addition to the static control outputs Ctrl, Ctrl2, the block also has pulse outputs P_Ctrl, P_Ctrl2, which are dependent on the static control outputs.

Determining the dosing quantity when using flow dosing

You can activate flow dosing using Feature Bit 5 = 0 (Specifying the dosing type (Page 146).)

When using flow dosing, the dosing quantity is determined using the following equation:

$$DQ_Out = DQ_Out + \frac{SampleTime}{TI} \cdot \frac{(PV_Out_{alt} + PV_Out)}{2}$$

Where:

- DQ_Out : Dosing quantity actual value
- $SampleTime$: Sampling time [s]
- TI : dimensionless conversion factor for the time basis of the measured value acquisition in the time basis 1 s
- PV_Out_{alt} : Last value PV_OUT

The output parameter PV_OUT is determined using an average calculation:

$$PV_Out := \frac{PV_Out_{(t)} + PV_Out_{(t-1)} + \dots + PV_Out_{(t-(n-1))}}{NumSample_{(N)}}$$

Where:

- $PV_Out(t) = PV \cdot Gain$

The average calculation is only active if $NumSample > 1$ and $NumSample \leq 16$ and serves to smooth systematically pulsating measuring signals.

Note

Integration of the flow for the dosing quantity

The integration of the flow for the dosing quantity is implemented using the trapezoid rule. Compared to the summation of rectangles rule, in which the values are simply added up, the procedural error in the case of the trapezoid rule is smaller for the determination of the numerical integral value.

The dosing quantity is determined in the "On" and "Dribbling" state. In the "End", "Off" and "Pause" states, the flow (creep flow) is determined depending on the Feature Bit 13 (Creep rate is always detected in the dosing quantity (Page 168)) and the value CR_AH_Lim . Creep flow monitoring is disabled with $CR_AH_En = 0$.

Determining the dosing quantity when dosing using scales

You can activate scale dosing via the Feature Bit 5 = 1 (Specifying the dosing type (Page 146).)

The dosing quantity is determined for a scale dosing in the "Start" state following a positive edge at the input parameter $StandStill$. The $StandStill$ input parameter is a feedback signal of the scale.

The process of determining the dosing quantity stops after the dosing quantity is reset in the "End" state.

If the signal is no longer available, you need to configure $StandStill$ with 1 permanently; the dosing quantity will then be determined right at the start of the dosing.

When weighing the fill volume ($MeterType = 0$), the dosing quantity is determined using the following equations:

$$DQ_Out = PV_Out - DQ_Tare$$

When weighing the removal volume ($MeterType = 1$):

$$DQ_Out = DQ_Tare - PV_Out$$

with $PV_Out = PV \cdot Gain$

In the "Start" state, the DQ_Tare tare memory is set with PV_Out with the first positive edge of $StandStill$.

If you have permanently configured $StandStill$ with 1, the tare memory is set right at the start of dosing.

With Feature Bit 14, scale dosing can be started only if `StandStill = 1`.

Note

The `DQ_Out` output parameter is the dosing quantity and not the actual scale value. In the "End" state (= following resetting of the dosing quantity), nothing further is displayed, since the dosing procedure is complete. When dosing starts, the actual scale value is transferred to the tare memory, and therefore the dosing quantity always remains 0 after the start of dosing. Therefore, the actual scale value is not displayed in the "End" state.

Calculation of the flow rate for dosing by scale

You can activate the calculation of the flow rate via the Feature Bit 7 = 1 (Activating calculation of the flow rate for dosing by scale (Page 144)).

The flow rate for scale dosing is determined by the following equations:

$$PV_Out = (avPV(t) - avPV(t-1)) \cdot \frac{GainEff}{SampleTime}$$

with

$$avPV(t) = \frac{PV(t) + PV(t-1) + \dots + PV(t-(N+1))}{NumSample(N)}$$

where `avPV(t)` = internal variable for the mean dosing quantity

Dribbling

The "Dribbling" status is entered automatically in accordance with

- $DQ_Out \geq DQ_SP - DribbOut$

Where:

- `DQ_Out`: Dosing quantity actual value
- `DQ_SP`: Dosing quantity setpoint
- `DribbOut`: Dribbling quantity

The dribbling quantity is specified with the input `DribbIn`.

`DribCor = 1` can be used to automatically determine the dribbling quantity from previous dosing actions:

- $DribbOut = DribbOut - (DQ_SP - DQ_Out) \cdot DCF / 100$

`DCF` represents the weighting factor of the last dosing action as a percentage and cannot be set to below 0 or above 100. `DribbOut` is calculated at the end of dosing or the first time an underdosage occurs, and is limited to `DribbMax`. Post dosing is not taken into account.

The "Dribbling" status is active for the period `RelaxTime`. `DribbOut = 0` deactivates the "Dribbling" status.

When the "Enable configuration of the dribbling quantity (Page 159)" function is enabled (Feature bit 27 = 1) and automatic determination of the dribbling quantity is disabled (DribCor = 0), the quantity can also be configured during dosing, but not in the "Dribbling" state.

Overdosing/underdosing

Once the "Dribbling" state has expired, the dosing quantity is checked for overdosages or underdosages. In the "End" status, no check is performed for over- or underdosages.

An overdose has occurred if:

- $DQ_Out > DQ_SP_Tol + DQ_AH_Tol$

An underdosage has occurred if:

- $DQ_Out < DQ_SP_Tol - DQ_AL_Tol$
- Where DQ_Out : Dosing quantity actual value
- DQ_SP_Tol : Dosing quantity setpoint for forming tolerance. This is the same as the dosing quantity setpoint (DQ_SP) before and after the check that determines overdosing/underdosing.
- DQ_AH_Tol : High tolerance limit
- DQ_AL_Tol : Low tolerance limit

If an underdosage is identified after the "Dribbling" state, the "Off" state is entered. The underdosage can be acknowledged in "Off" state ($U_AckOp = 1$ or positive edge U_AckLi) and the dosing action completed, or post dosing can be started with the "Continue" command. The dosing end state display in the standard view shows "Ack Dos End".

With Feature2 bit 24 = 0:

If an overdose is identified after the "Dribbling" state, the dosing "End" state is entered at once. A message for overdose comes and goes in next cycle.

With Feature2 bit 24 = 1:

If an overdose is identified after the "Dribbling" state, the "Off" state is entered. The overdose can be acknowledged in the "Off" state ($U_AckOp = 1$ or positive edge U_AckLi) and the dosing action is completed.

Generally, dosages which enter the "Off" state with overdose, have to be acknowledged.

Post dosing

If an underdosage is detected after dribbling, post dosing can be performed using the "Continue" command. In automatic mode, Feature Bit 12 can be used to start post dosing automatically. Post dosing is active for the period $P_DoseTime$. The block then enters the "Dribbling" state or, if that state is deactivated, the "End" state. If the conditions for the "Dribbling" or "End" states are met within the period $P_DoseTime$, the block switches to these states immediately.

Post dosing can also be carried out in the "End" state by increasing the dosing quantity setpoint and issuing the "Continue" command. Once the dosing quantity has been reset, post dosing can no longer be carried out by means of increasing the setpoint.

If the dribbling correction quantity is smaller than the dribbling quantity, dosing is started for time `P_DoseTime`. If no parameter assignment has been made for `P_DoseTime`, the coarse flow (`Ctrl`) or fine flow (`Ctrl2`) control outputs are set for one cycle.

If no parameter assignment has been made for the dribbling quantity, or the dribbling correction quantity is larger than the dribbling quantity, the dosing procedure is continued without taking time `P_DoseTime` into account.

Information on post dosing via setpoint increase:

- After the setpoint has been increased, the tolerance limits are only updated when the "Continue" command is issued. This ensures the overdosage/underdosage display remains consistent.
- Post dosing can only be carried out after a dosing procedure has been aborted if the setpoint for the dosing quantity has been increased and an actual-value quantity is present.
- In "Automatic" and "Local" modes, the "Continue" command must be issued on a positive edge to prevent unwanted dosing procedures from taking place after a setpoint increase.

With `Feature2` bit 24 = 0:

If an overdosage is identified during or after a post dosing, the dosage enters in the "End" state.

With `Feature2` bit 24 = 1:

If an overdosage is identified after a post dosing or a drain, the dosage continues to be in the "Off" state. Only with acknowledge overdosage, the block enters to the "End" state with the status display "Ack Dos End" in the standard view.

Resetting the dosing quantity

The dosing quantity can only be reset in the "End" state using `RstDQ_Op` = 1 or positive edge `RstDQ_Li`.

The state display "Ack Dos End" is also reset to "End".

`Feature` Bit 6 can be used to reset the dosing quantity automatically when dosing starts.

External/internal setpoint specification

This block provides the standard function Setpoint specification - internal/external (Page 128).

The block always requires the setpoint for the dosing quantity (dosing setpoint). All I/Os for the dosing setpoint start with `DQ_ . . .`. The dosing setpoint is comprised of the coarse and fine setpoints for the coarse/fine flow control. All I/Os for the fine setpoint start with `DQ2_ . . .`. The coarse setpoint is generated internally from the dosing and fine setpoints and is displayed at the output with `DQ1_SP`. If no fine setpoint is available, the coarse setpoint is equal to the dosing setpoint.

Flow setpoints can be specified for the coarse/fine flow setpoint specification. All I/Os for the coarse flow start with `SP_ . . .`, and all I/Os for the fine flow with `SP2_ . . .`. The setpoint for coarse or fine flow is displayed at the output `SP` in the "On" status, depending on the coarse/fine flow control.

Setpoint limitation

The setpoints are limited in the block using shared parameters:

- Coarse metering volume: DQ_HiLim, DQ_LoLim
- Fine metering volume: DQ2_HiLim, DQ2_LoLim
- Coarse flow rate: SP_HiLim, SP_LoLim
- Fine flow rate: SP2_HiLim, SP2_LoLim

If the setpoint limit is violated, external setpoints are limited to the limit you specified. If there are internal setpoints, the last valid value is output.

Bumpless switchover from external to internal setpoint

The parameter `SP_TrkExt = 1` is used so that the internal setpoint tracks the external setpoint to achieve a bumpless switchover from the external to the internal setpoint. This allows unwanted jumps at the output parameter to be avoided.

Limit monitoring of the process value

This block provides the standard function Limit monitoring of the process value (Page 86). The calculated flow `PV_Out` is monitored in terms of the limit pairs `PV_AH_Lim / PV_AL_Lim` (coarse flow) or `PV_AH2_Lim / PV_AL2_Lim` (fine flow), depending on the coarse/fine flow control. Monitoring is only active in the "On" status.

The calculated flow `PV_Out` is monitored in terms of the limit pairs `PV_AH_Lim / PV_AL_Lim` (coarse flow) or `PV_AH2_Lim / PV_AL2_Lim` (fine flow), depending on the coarse/fine flow control. Monitoring is only active in the "On" status.

Group display SumMsgAct for limit monitoring, CSF and ExtMsgx

The block provides the standard function Group display for limit monitoring, CSF and ExtMsgx (Page 85).

Suppressing messages using the MsgLock parameter

This block provides the standard function Suppressing messages using the MsgLock parameter (Page 205).

Forcing operating modes

This block provides the standard function Forcing operating modes (Page 41). The inputs `StartForce`, `CancelForce`, `PauseForce` and `ContForce` force the block into the states "On", "End" or "Pause".

The "Pause" status can only be forced if the block is in the "On" status.

The "On" state can only be forced from the states

- "Off"
- "Pause"
- "End" if the quantity actual valve is less than the quantity setpoint.

Simulating signals

This block provides the standard function Simulating signals (Page 58).

The flow is simulated with `SimPV`. This input is not active in scale mode, even when the flow is formed by changing quantities (`Feature Bit 7 = 1`)

You can simulate the following values:

- Flow dosing: The flow (`PV`) is specified in the setpoint view with the input (`SimPV`, `SimPV_Li`).
- Dosing using scales: The dosing quantity (`DQ_Out`) is specified in the standard view with the input (`SimDQ`, `SimDQ_Li`).

Interlocks

This block provides the following interlocks:

- Activation enable
- Interlock without reset ("Interlock")
- Interlock with reset ("Protection")

Refer to the section Interlocks (Page 99).

Dosing can only be started if no interlock is present. The interlock function is not active in the "Dribbling" status; nor is the activation enable active in the "On" status. An interlock in the "On" or "Pause" states will cause the block to enter the "Off" status.

Disabling interlocks

This block provides the standard function Disabling interlocks (Page 103).

Resetting the block in case of interlocks or errors

This block provides the standard function Resetting the block in case of interlocks or errors (Page 43).

External error (`FaultExt`), external control system fault (`CSF`)

This block provides the possibility to pass an external error via the `FaultExt` parameter or an external control system fault via the `CSF` parameter. See DoseL error handling (Page 1025)

Group error

This block provides the standard function Outputting group errors (Page 122).

The following parameters are taken into consideration when forming the group error:

- CSF
- FaultExt

Outputting a signal for start readiness

This block provides the standard function Outputting a signal for start readiness (Page 53).

Forming the group status for interlocks

This block provides the standard function Forming the group status for interlock information (Page 104).

Forming the signal status for blocks

This block provides the standard function Forming and outputting the signal status for technologic blocks (Page 109).

The worst signal status `ST_Worst` for the block is formed from the following parameters:

- PV_Out.ST
- DQ_Out.ST
- DQ_SP.ST
- SP.ST
- Standstill.ST
- LocalLi.ST
- StartLocal.ST
- CancelLocal.ST
- PauseLocal.ST
- ContLocal.ST
- CtrlChnST
- Ctrl2ChnST
- StartAut.ST (only if Feature2.Bit10 = 1)
- CancelAut.ST (only if Feature2.Bit10 = 1)
- PauseAut.ST (only if Feature2.Bit10 = 1)
- ContAut.ST (only if Feature2.Bit10 = 1)
- SP_Ext.ST (only if Feature2.Bit10 = 1)

The following signal status is formed by:

Signal status	Used status
DQ_Out.ST	Formed by the signal status PV_Out.ST. The last DQ_Out.St signal status is also included for flow dosing and the DQ_Tare.ST signal status is included for scale dosing. The worst signal status is applied. The signal status is reset with reset of the dosing quantity.
DQ_SP.ST	With an external setpoint DQ_Ext.ST (for DQ_HiLim.ST or DQ_LoLim.ST limit), otherwise good status
SP.ST	With an external setpoint SP_Ext.ST (coarse flow) / SP2_Ext.ST (fine flow) (with SP_HiLim.ST / SP_LoLim.ST or SP2_HiLim.ST / SP2_LoLim.ST limit), otherwise good status

Considering bad quality of automatic commands or external values

If the Feature2 bit Considering bad quality of automatic commands or external values (Page 186) is set to 1 and one of the following parameters has bad signal status (16#00 or 16#28), the block goes to the neutral position in the "Automatic" mode:

- StartAut.ST
- CancelAut.ST
- PauseAut.ST
- ContAut.ST
- SP_Ext.ST

Release for maintenance

This block provides the standard function Release for maintenance (Page 64).

Alarm delays with two time values per limit pair

This block includes the standard function alarm delay for Two time values per limit pair (Page 201).

Display and operator input area for process values and setpoints

This block provides the standard function Display and operator input area for process values and setpoints (Page 207).

Selecting a unit of measure

This block provides the standard function Selecting a unit of measure (Page 212).

Opening additional faceplates

This block provides the standard function Opening additional faceplates (Page 208).

Generating instance-specific messages

This block provides the standard function Generating instance-specific messages (Page 204).

Configurable reactions using the Feature parameter

You can find an overview of all reactions provided by the Feature parameter in the Configurable functions using the Feature I/O (Page 131) . The following functionality is available for this block at the relevant bits:

Bit	Function
0	Set startup characteristics (Page 138)
1	Reaction to the out of service mode (Page 177)
2	Resetting the commands for changing the mode (Page 161)
3	Enabling resetting of commands for the control settings (Page 161)
4	Setting switch or button mode (Page 167)
5	Specifying the dosing type (Page 146)
6	Resetting the dosing quantity when dosing starts (Page 162)
7	Activating calculation of the flow rate for dosing by scale (Page 144)
8	Use an internal or external setpoint for the absolute fine dosing quantity (Page 153)
9	Resetting via input signals in the event of interlocking (Protection) or errors (Page 163)
10	Exiting local mode (Page 177)
11	Stopping dosing at a flow alarm (Page 137)
12	Automatic post dosing for underdosing in automatic mode (Page 143)
13	Creep rate is always detected in the dosing quantity (Page 168)
14	Scale dosing can be started only if StandStill = 1 (Page 187)
15	Flow setpoints in percent (Page 146)
17	Enabling bumpless switchover to automatic mode for valves, motors, and dosers (Page 173)
18	Activating error state for external process control error CSF (Page 151)
21	Enable bumpless switchover to "Automatic" mode for operator only (Page 172)
22	Update acknowledgment and error status of the message call (Page 160)
23	Specifying the influence of the signal status on the dosing process (Page 147)
24	Enabling local operator authorization (Page 158)
25	Suppression of all messages (Page 174)
26	Reaction of the switching points in the "Out of service" operating mode (Page 176)
27	Enable configuration of the dribbling quantity (Page 159)
28	Disabling operating points (Page 145)
29	Signaling limit violation (Page 170)
30	Set reset depending on the operating mode or the LiOp parameter (Page 163)
31	Activating reset of protection / error in manual mode (Page 165)

Comments on table:

Feature Bit 4:

- Button mode (Feature Bit 4 = 0): The automatic commands in automatic mode are pulse signals, in other words `StartAut`, `CancelAut`, `PauseAut`, `ContAut` can be reset to 0 after switchover to the selected status. In "manual" and "local" modes, however, the automatic commands are static signals, the block state is tracked in the absence of automatic commands.
- Switch mode (Feature Bit 4 = 1): The conditions are selected via the inputs `StartAut` (0: Cancel, 1: Start) and `PauseAut` (0: Continue, 1: Pause) with static signals.

Feature Bit 23:**Note**

When there is a bad signal status and Feature Bit 23 = 1, the flow is no longer recorded in the dosing quantity in any state. The configure creep rate alarm is output.

Configurable reactions using the Feature2 parameter

Bit	Function
2	Separate evaluation for excluded and simulated interlock signals (Page 152)
3	Control priority in the event of an invalid input command (Page 175)
5	Evaluation of the signal status of the interlock signals (Page 142)
8	Forcing operating modes in the "Local" mode (Page 184)
10	Considering bad quality of automatic commands or external values (Page 186)
11	Suppress <code>MsgLock</code> and "Out of service" mode for a connected message block (Page 188)
24	With acknowledge overdosage (Page 179)

Operator permissions

This block provides the standard function Operator control permissions (Page 254).

The block has the following permissions for the `OS_Perm` parameter:

Bit	Function
0	1 = Operator can switch to "automatic mode"
1	1 = Operator can switch to "manual mode"
2	1 = Operator can switch to "local mode"
3	1 = Operator can switch to "Out of service" mode
4	1 = Operator can start dosing
5	1 = Operator can pause dosing
6	1 = Operator can continue dosing
7	1 = Operator can cancel dosing
8	1 = Operator can reset interlock and flow alarms
9	1 = Operator can reset dosing quantity

6.1 DoseL - Dosing device

Bit	Function
10	1 = Operator can acknowledge overdosage and underdosage
11	1 = Operator can select external setpoints
12	1 = Operator can select internal setpoints
13	1 = Operator can enter dosing setpoint
14	1 = Operator can enter dosing setpoint factor for fine dosing
15	1 = Operator can enter flow setpoint for coarse flow
16	1 = Operator can enter flow setpoint factor for fine flow
17	1 = Operator can activate external/internal bumpless switchover
18	1 = Operator can enable simulation function
19	1 = Operator can activate the Release for maintenance function
20	Not used
21	1 = Operator can enter dribbling quantity
22	1 = Operator can enter maximum dribbling quantity
23	1 = Operator can activate/deactivate automatic generation of dribbling quantity
24	1 = Operator can enter weighting factor for generation of dribbling quantity
25	1 = Operator can change the simulation value SimPV
26	1 = Operator can change the simulation value SimDQ
27 - 31	Not used

The block has the following operator permissions for the `OS1Perm` parameter:

Bit	Function
0	1 = Operator can change the limit for the high alarm for PV_OUT (coarse flow)
1	1 = Operator can change the limit for the low alarm for PV_OUT (coarse flow)
2	1 = Operator can change the limit for the hysteresis PV_OUT (coarse flow)
3	1 = Operator can change the limit for the high alarm for PV_OUT (fine flow)
4	1 = Operator can change the limit for the low alarm for PV_OUT (fine flow)
5	1 = Operator can change the limit for the hysteresis PV_OUT (fine flow)
6	1 = Operator can change the operation high limit of the dosing setpoint
7	1 = Operator can change the operation low limit of the dosing setpoint
8	1 = Operator can change operation high limit of the dosing setpoint factor for fine dosing
9	1 = Operator can change operation low limit of the dosing setpoint factor for fine dosing
10	1 = Operator can change the tolerance value for overdosage
11	1 = Operator can change the tolerance value for overdosage
12	1 = Operator can change operation high limit of the flow setpoint for coarse flow
13	1 = Operator can change operation low limit of the flow setpoint for coarse flow
14	1 = Operator can change operation high limit of the flow setpoint for fine flow
15	1 = Operator can change operation low limit of the flow setpoint for fine flow
16	1 = Operator can change the dribbling time
17	1 = Operator can change the post dosing
18	1 = Operator can change the limit for the high alarm for PV_OUT (creep flow)
19	1 = Operator can change the limit for the hysteresis for PV_OUT (creep flow)
20	1 = Operator can activate / deactivate messages via DQ_AH_MsgEn

Bit	Function
21	1 = Operator can activate / deactivate messages via DQ_AL_MsgEn
22	1 = Operator can activate / deactivate messages via PV_AH_MsgEn
23	1 = Operator can activate / deactivate messages via PV_AL_MsgEn
24	1 = Operator can activate / deactivate messages via PV_AH2_MsgEn
25	1 = Operator can activate / deactivate messages via PV_AL2_MsgEn
26	1 = Operator can activate / deactivate messages via CR_AH_MsgEn
27 - 31	Not used

Note

If you interconnect a parameter that is also listed in OS_Perm as a parameter, you have to reset the corresponding OS_Perm bit.

Displaying auxiliary values

This block provides the standard function Displaying auxiliary values (Page 211).

Connection of the time-stamped messages from EventTs or Event16Ts

This block provides the standard function Connection of the time-stamped messages from EventTs or Event16Ts (Page 207).

SIMATIC BATCH functionality

This block provides the standard function SIMATIC BATCH functionality (Page 67).

See also

Description of DoseL (Page 1005)

DoseL messaging (Page 1028)

DoseL I/Os (Page 1031)

DoseL modes (Page 1009)

DoseL block diagram (Page 1045)

EventTs functions (Page 1660)

6.1.4 DoseL error handling**Error handling of DoseL**

Refer to section Error handling (Page 119) in the basic instructions for the error handling of all blocks.

The following errors can be displayed for this block:

- Error numbers
- Mode switchover error
- Control system fault (CSF)

Overview of error numbers

The `ErrorNum` I/O can be used to output the following error numbers:

Error number	Meaning of the error number
-1	Predefined value when inserting the block; the block is not executed
0	There is no error.
11	Configuration error $TI \leq 0$
12	Configuration error: $PV_AH_Lim < PV_AL_Lim$ $PV_AH2_Lim \leq PV_AL2_Lim$ $DQ_HiLim.Value \leq DQ_LoLim.Value$ $DQ2_HiLim.Value \leq DQ2_LoLim.Value$ $SP_HiLim.Value \leq SP_LoLim.Value$ $SP2_HiLim.Value \leq SP2_LoLim.Value$
30	PV is not a valid number
31	PV_Out is not a valid number
32	DQ_Out is not a valid number
41	The value for the <code>LocalSetting</code> I/O is not within the approved limit of 0, 1 or 3.
42	<code>LocalSetting = 0</code> and <code>LocalLi = 1</code>
48	<code>SP_LiOp = 1</code> and <code>SP_IntLi = 1</code> and <code>SP_ExtLi = 1</code>
51	<code>AutModLi = 1</code> and <code>ManModLi = 1</code> and <code>Feature Bit Setting</code> switch or button mode (Page 167) = 0 or two I/Os are set at the same time: <ul style="list-style-type: none"> • in "local mode" <code>StartLocal</code> (pos. edge), <code>CancelLocal</code>, <code>PauseLocal</code>, <code>ContLocal</code> when forcing states: <code>StartForce</code>, <code>CancelForce</code>, <code>PauseForce</code>, <code>ContForce</code> in "automatic mode" with pushbutton operation: <code>StartAut</code> (pos. edge), <code>CancelAut</code>, <code>PauseAut</code>, <code>ContAut</code> • in "manual mode": <code>StartMan</code>, <code>CancelMan</code>, <code>PauseMan</code>, <code>ContMan</code>

Mode switchover error

This error can be output by the block, see the section Error handling (Page 119).

Control system fault (CSF)

An external signal can be activated via the CSF input. A control system fault is triggered if this signal changes to 1. Refer to the Error handling (Page 119) section for more on this.

Invalid input signal

These errors can be output by the block, see the section Error handling (Page 119).

For the following invalid input signals, the control output can be kept or switched to the neutral position. This depends on the function Control priority in the event of an invalid input command (Page 175).

Operating mode	Invalid input signal	Control reaction with Feature2 bit 3 =1
Local: Localsetting = 1 or Localsetting = 3	StartLocal = 1 (pos. edge) and CancelLocal = 1	Dosing canceled
	ContLocal = 1 and PauseLocal = 1	Dosing paused
Local: Localsetting = 1 or Localsetting = 3 and forcing	StartForce = 1 and CancelForce = 1	Dosing canceled
	ContForce = 1 and PauseForce = 1	Dosing paused
Forcing and no "local mode"	StartForce = 1 and CancelForce = 1	Dosing canceled
	ContForce = 1 and PauseForce = 1	Dosing paused
"Automatic mode" and no forcing	Pushbutton operation (Feature bit 4 = 0): StartAut = 1 (pos. edge) and CancelAut = 1	Dosing canceled
	Pushbutton operation (Feature bit 4 = 0): ContAut = 1 and PauseAut = 1	Dosing paused
	Pushbutton operation (Feature bit 4 = 0): StartAut = 1 (pos. edge) and PauseAut = 1	Dosing paused
"Manual mode" and no forcing	StartMan = 1 and CancelMan = 1	Dosing canceled
	ContMan = 1 and PauseMan = 1	Dosing paused

See also

Description of DoseL (Page 1005)

DoseL modes (Page 1009)

DoseL functions (Page 1011)

DoseL messaging (Page 1028)

DoseL I/Os (Page 1031)

DoseL block diagram (Page 1045)

6.1.5 DoseL messaging

Messaging

The following messages can be generated for this block:

- Process control fault
- Process messages
- Instance-specific messages

Process control fault

The following control system fault messages can be output:

Message instance	Message identifier	Message class	Event
MsgEvId2	SIG 1	AS process control message - fault	\$\$BlockComment\$\$ External error has occurred

Explanation:

\$\$BlockComment\$\$: Content of the instance-specific comment

You can interconnect an external fault (signal) to input parameter CSF. If it changes to CSF = 1, a control system fault is triggered (MsgEvId02, SIG 1).

Process messages

Message instance	Message identifier	Message class	Event
MsgEvId1	SIG 1	Alarm - high	\$\$BlockComment\$\$ Overdosage
	SIG 2	Alarm - low	\$\$BlockComment\$\$ Underdosage
	SIG 3	Alarm - high	\$\$BlockComment\$\$ PV - High alarm limit for coarse flow violated
	SIG4	Alarm - low	\$\$BlockComment\$\$ PV - Low alarm limit for coarse flow violated
	SIG 5	Alarm - high	\$\$BlockComment\$\$ PV - High alarm limit for coarse flow violated
	SIG 6	Alarm - low	\$\$BlockComment\$\$ PV - Low alarm limit for fine flow violated
	SIG 7	Alarm - high	\$\$BlockComment\$\$ PV – Creep flow too great
	SIG 8	Process message - with acknowledgment	\$\$BlockComment\$\$ Dosing canceled

Explanation:

\$\$BlockComment\$\$: Content of the instance-specific comment

Instance-specific messages

You can use up to three instance-specific messages with this block.

Message instance	Message identifier	Message class	Event
MsgEvId2	SIG 2	AS process control message - fault	\$\$BlockComment\$\$ External message 1
	SIG 3	AS process control message - fault	\$\$BlockComment\$\$ External message 2
	SIG 4	AS process control message - fault	\$\$BlockComment\$\$ External message 3

Explanation:

\$\$BlockComment\$\$: Content of the instance-specific comment

Associated values for message instance `MsgEvId1`

Associated value	Block parameters
1	BatchName
2	StepNo
3	BatchID
4	DQ_OUT
5	PV_OUT
6	ExtVa106
7	ExtVa107
8	ExtVa108
9	Reserved
10	Reserved

The associated values 6 ... 8 are allocated to the parameters `ExtVa106` ... `ExtVa108` and can be used. Additional information is available in the "Process Control System PCS 7 - Engineering System" manual.

Associated values for message instance `MsgEvId2`

Associated value	Block parameters
1	BatchName
2	StepNo
3	BatchID
4	ExtVa204
5	ExtVa205
6	ExtVa206
7	ExtVa207
8	ExtVa208
9	Reserved
10	Reserved

The associated values 4 ... 8 are allocated to the parameters `ExtVa204` ... `ExtVa208` and can be used. Additional information is available in the "Process Control System PCS 7 - Engineering System" manual.

See also

Description of DoseL (Page 1005)

DoseL functions (Page 1011)

DoseL I/Os (Page 1031)

DoseL modes (Page 1009)

DoseL error handling (Page 1025)

DoseL block diagram (Page 1045)

Time stamp (Page 205)

6.1.6 DoseL I/Os

I/Os of DoseL

Input parameters

Parameter	Description	Type	Default
AutModLi*	1= "Automatic mode" via interconnection or SFC (controlled by ModLiOp = 1)	STRUCT <ul style="list-style-type: none"> Value: BOOL ST: BYTE 	- <ul style="list-style-type: none"> 0 16#80
AutModOp*	1 = "Automatic mode" via operator (controlled by ModLiOp = 0)	BOOL	0
BatchEn	1 = Enable allocation	BOOL	0
BatchID	Batch ID	DWORD	16#00000000
BatchName	Batch name	S7-String	
BypProt	1 = Bypassing interlock in "local mode" and in "simulation"	BOOL	0
CancelAut*	1 = Select Cancel in "automatic mode"	STRUCT <ul style="list-style-type: none"> Value: BOOL ST: BYTE 	- <ul style="list-style-type: none"> 0 16#80
CancelForce	1 = Force cancel	STRUCT <ul style="list-style-type: none"> Value: BOOL ST: BYTE 	- <ul style="list-style-type: none"> 0 16#80
CancelLocal	1 = Select Cancel in "local mode"	STRUCT <ul style="list-style-type: none"> Value: BOOL ST: BYTE 	- <ul style="list-style-type: none"> 0 16#80
CancelMan*	1 = Select Cancel in "manual mode"	BOOL	0
ContAut*	1 = Select Continue in "automatic mode"	STRUCT <ul style="list-style-type: none"> Value: BOOL ST: BYTE 	- <ul style="list-style-type: none"> 0 16#80
ContForce	1 = Force continue	STRUCT <ul style="list-style-type: none"> Value: BOOL ST: BYTE 	- <ul style="list-style-type: none"> 0 16#80
ContLocal	1 = Select Continue in "local mode"	STRUCT <ul style="list-style-type: none"> Value: BOOL ST: BYTE 	- <ul style="list-style-type: none"> 0 16#80
ContMan*	1 = Select Continue in "manual mode"	BOOL	0
CR_A_DC*	Creep flow: Delay time for incoming alarms [s]	REAL	3.0

Dosing blocks

6.1 DoseL - Dosing device

Parameter	Description	Type	Default
CR_A_DG*	Creep flow: Delay time for outgoing alarms [s]	REAL	3.0
CR_AH_En	Creep flow: 1 = Enable high alarm	BOOL	1
CR_AH_Lim	Creep flow: Limit high alarm	REAL	0.0
CR_AH_MsgEn	Creep flow: 1 = Enable high alarm message	BOOL	1
CR_Hyst*	Creep flow: Hysteresis for alarm limit	REAL	0.0
CSF	1 = External error (control system fault) Error handling (Page 119)	STRUCT • Value: BOOL • ST: BYTE	- • 0 • 16#80
CtrlChnST	Signal status of output channel <code>Ctrl</code> Should be connected to an output channel block.	STRUCT • Value: BOOL • ST: BYTE	- • 0 • 16#FF
Ctrl2ChnST	Signal status of output channel <code>Ctrl2</code> Should be connected to an output channel block.	STRUCT • Value: BOOL • ST: BYTE	- • 0 • 16#FF
DCF	Dribbling correction [%]	REAL	25.0
DosCancelMsgEn	1 = Cancel dosing message	BOOL	1
DQ_A_DC*	Overdosage/underdosage: Delay time for incoming alarms [s]	REAL	0.0
DQ_A_DG*	Overdosage/underdosage: Delay time for outgoing alarms [s]	REAL	0.0
DQ_AH_En	Overdosage: 1 = Enable high alarm	BOOL	1
DQ_AH_MsgEn	Overdosage: 1 = Enable high alarm message	BOOL	1
DQ_AH_Tol	Overdosage: Limit high alarm (relative to dosing setpoint)	REAL	0.0
DQ_AL_En	Underdosage: 1 = Enable low alarm	BOOL	1
DQ_AL_MsgEn	Underdosage: 1 = Enable low alarm message	BOOL	1
DQ_AL_Tol*	Underdosage: Limit low alarm (relative to dosing setpoint)	REAL	0.0
DQ_Ext	Dosing quantity: External setpoint	STRUCT • Value: REAL • ST: BYTE	- • 0.0 • 16#80
DQ_HiLim	Dosing quantity: High setpoint limitation	STRUCT • Value: REAL • ST: BYTE	- • 100.0 • 16#80
DQ_Int*	Dosing quantity: Internal setpoint	REAL	0.0

Parameter	Description	Type	Default
DQ_LoLim	Dosing quantity: Low setpoint limitation	STRUCT <ul style="list-style-type: none"> Value: REAL ST: BYTE 	- <ul style="list-style-type: none"> 0.0 16#80
DQ_OpScale	Dosing quantity: Limit for scale in bar graph of faceplate	STRUCT <ul style="list-style-type: none"> High: REAL Low: REAL 	- <ul style="list-style-type: none"> 100.0 0.0
DQ_Unit	Unit of measure for dosing quantity	INT	1088
DQ2_Ext	Dosing quantity: External setpoint factor for fine dosing	STRUCT <ul style="list-style-type: none"> Value: REAL ST: BYTE 	- <ul style="list-style-type: none"> 0.0 16#80
DQ2_HiLim*	Dosing quantity: High limitation of setpoint factor for fine dosing	STRUCT <ul style="list-style-type: none"> Value: REAL ST: BYTE 	- <ul style="list-style-type: none"> 100.0 16#80
DQ2_Int*	Dosing quantity: Internal setpoint factor for fine dosing	REAL	0.0
DQ2_LoLim*	Dosing quantity: Low limitation of setpoint factor for fine dosing	STRUCT <ul style="list-style-type: none"> Value: REAL ST: BYTE 	- <ul style="list-style-type: none"> 0.0 16#80
DribbIn	Dribbling quantity	REAL	0.0
DribbMax	Maximum value of automatic determination of dribbling quantity	REAL	100.0
DribbCor	1 = Automatic determination of dribbling quantity	BOOL	0
EN	1 = Called block will be processed	BOOL	1
EventTsIn	For interconnecting data between a technology block and the message blocks <code>EventTs</code> , <code>Event16Ts</code> . The <code>EventTsIn</code> input parameter serves to interconnect the <code>EventTsOut</code> output parameter of the <code>EventTs</code> , <code>Event16Ts</code> block. When this interconnection is configured, the messages of the <code>EventTs</code> , <code>Event16Ts</code> block are displayed on the OS in the alarm view of the technology block and can also be acknowledged there.	ANY	
ExtMsg1	Binary input for freely selectable message 1	STRUCT <ul style="list-style-type: none"> Value: BOOL ST: BYTE 	- <ul style="list-style-type: none"> 0 16#80
ExtMsg2	Binary input for freely selectable message 2	STRUCT <ul style="list-style-type: none"> Value: BOOL ST: BYTE 	- <ul style="list-style-type: none"> 0 16#80

Dosing blocks

6.1 DoseL - Dosing device

Parameter	Description	Type	Default
ExtMsg3	Binary input for freely selectable message 3	STRUCT <ul style="list-style-type: none"> Value: BOOL ST: BYTE 	- <ul style="list-style-type: none"> 0 16#80
ExtVa106	Associated value 6 for messages (MsgEvID1)	ANY	
ExtVa107	Associated value 7 for messages (MsgEvID1)	ANY	
ExtVa108	Associated value 8 for messages (MsgEvID1)	ANY	
ExtVa204	Associated value 4 for messages (MsgEvID2)	ANY	
ExtVa205	Associated value 5 for messages (MsgEvID2)	ANY	
ExtVa206	Associated value 6 for messages (MsgEvID2)	ANY	
ExtVa207	Associated value 7 for messages (MsgEvID2)	ANY	
ExtVa208	Associated value 8 for messages (MsgEvID2)	ANY	
FaultExt	1 = External error Error handling (Page 119)	STRUCT <ul style="list-style-type: none"> Value: BOOL ST: BYTE 	- <ul style="list-style-type: none"> 0 16#80
Feature	I/O for additional functions (Page 1011)	STRUCT <ul style="list-style-type: none"> Bit 0: BOOL ... Bit 31: BOOL 	- <ul style="list-style-type: none"> 0 0 0
Feature2	I/O for additional functions (Page 1011)	STRUCT <ul style="list-style-type: none"> Bit 0: BOOL ... Bit 31: BOOL 	- <ul style="list-style-type: none"> 0 0 0
Gain	Gain factor	STRUCT <ul style="list-style-type: none"> Value: REAL ST: BYTE 	- <ul style="list-style-type: none"> 1.0 16#80
Intlock	0 = Interlocking without reset is active; you can operate the block without reset once the interlocking condition has disappeared 1 = Interlock not activated	STRUCT <ul style="list-style-type: none"> Value: BOOL ST: BYTE Bit 1: BOOL (Bypass information bit) 	- <ul style="list-style-type: none"> 1 16#FF 0
Intl_En	1 = Interlock without reset (interlock, Intlock parameter) is active	BOOL	1
LocalLi	1 = Activate "local mode" via plant signals	STRUCT <ul style="list-style-type: none"> Value: BOOL ST: BYTE 	- <ul style="list-style-type: none"> 0 16#80

Parameter	Description	Type	Default
LocalOp*	1 = "Local mode" via operator	BOOL	0
LocalSetting	Properties for the Local mode (Page 79)	INT	0
ManModLi*	1 = "Manual mode" via interconnection or SFC (controlled by ModLiOp = 1)	STRUCT <ul style="list-style-type: none"> • Value: BOOL • ST: BYTE 	- <ul style="list-style-type: none"> • 0 • 16#80
ManModOp*	1 = "Manual mode" via OS operator (controlled by ModLiOp = 0)	BOOL	1
MeterType	Dosing using scales: 0=Up 1=Down	BOOL	0
ModLiOp	Switchover of operating mode between: 0 = Operator 1 = Interconnection or SFC	STRUCT <ul style="list-style-type: none"> • Value: BOOL • ST: BYTE 	- <ul style="list-style-type: none"> • 0 • 16#80
MS_RelOp*	1= Release for maintenance via OS operator	BOOL	0
MsgEvId1	Message number (assigned automatically)	DWORD	16#00000000
MsgEvId2	Message number (assigned automatically)	DWORD	16#00000000
MsgLock	1 = Suppress process messages. See also the section Suppressing messages using the MsgLock parameter (Page 205) for more on this.	STRUCT <ul style="list-style-type: none"> • Value: BOOL • ST: BYTE 	- <ul style="list-style-type: none"> • 0 • 16#80
NumSample	Number of values for average calculation	INT	0
U_AckLi	1 = Acknowledgement of overdosage or underdosage via interconnection	STRUCT <ul style="list-style-type: none"> • Value: BOOL • ST: BYTE 	- <ul style="list-style-type: none"> • 0 • 16#80
U_AckOp*	1 = Acknowledgement of overdosage or underdosage via operator	BOOL	0
Occupied	1 = In use by a batch	BOOL	0
OosLi	1 = "Out of service", via interconnection or SFC	STRUCT <ul style="list-style-type: none"> • Value: BOOL • ST: BYTE 	- <ul style="list-style-type: none"> • 0 • 16#80
OosOp*	1 = "Out of service", via OS operator	BOOL	0
OpSt_In	Input parameter for local operator authorization, connected with the Out output parameter of the upstream block, OpStations (Page 411)	DWORD	16#00000000
OS_Perm	I/O for operator permissions (Page 1011)	STRUCT <ul style="list-style-type: none"> • Bit 0: BOOL • Bit 25: BOOL • Bit 26: BOOL • Bit 31: BOOL 	- <ul style="list-style-type: none"> • 1 • 1 • 1 • 1

Dosing blocks

6.1 DoseL - Dosing device

Parameter	Description	Type	Default
OSlPerm	I/O for operator permissions (Page 1011)	STRUCT <ul style="list-style-type: none"> • Bit 0: BOOL • ... • Bit 31: BOOL 	- <ul style="list-style-type: none"> • 1 • 1 • 1
P_DoseTime*	Duration of post dosing [s]	REAL	0.0
PauseAut*	1 = Select Pause in "automatic mode"	STRUCT <ul style="list-style-type: none"> • Value: BOOL • ST: BYTE 	- <ul style="list-style-type: none"> • 0 • 16#80
PauseForce	1 = Force pause	STRUCT <ul style="list-style-type: none"> • Value: BOOL • ST: BYTE 	- <ul style="list-style-type: none"> • 0 • 16#80
PauseLocal	1 = Select Pause in "local mode"	STRUCT <ul style="list-style-type: none"> • Value: BOOL • ST: BYTE 	- <ul style="list-style-type: none"> • 0 • 16#80
PauseMan*	1 = Select Pause in "manual mode"	BOOL	0
Perm_En	1 = Activation enable (enable, Permit parameter) is active	BOOL	1
Permit	1 = Enable for opening / closing from neutral position 0 = Valve activation not enabled on OS	STRUCT <ul style="list-style-type: none"> • Value: BOOL • ST: BYTE • Bit 1: BOOL (Bypass information bit) 	- <ul style="list-style-type: none"> • 1 • 16#FF • 0
Prot_En	1 = Protective interlock (protection, Protect parameter) is active	BOOL	1
Protect	0 = Protective interlocking is effective; once the interlocking condition has disappeared, you will have to reset the block 1 = Protective interlocking not activated	STRUCT <ul style="list-style-type: none"> • Value: BOOL • ST: BYTE • Bit 1: BOOL (Bypass information bit) 	- <ul style="list-style-type: none"> • 1 • 16#FF • 0
PulseWidth*	Pulse width of control signal [s]	REAL	3.0
PV	Process value	STRUCT <ul style="list-style-type: none"> • Value: REAL • ST: BYTE 	- <ul style="list-style-type: none"> • 0.0 • 16#80
PV_A_DC*	Delay time for incoming PV alarms [s] when using flow dosing (coarse dosing phase)	REAL	3.0
PV_A_DG*	Delay time for outgoing PV alarms [s] when using flow dosing (coarse dosing phase)	REAL	3.0
PV_A2_DC*	Delay time for incoming PV alarms [s] when using flow dosing (fine dosing phase)	REAL	3.0

Parameter	Description	Type	Default
PV_A2_DG*	Delay time for outgoing PV alarms [s] when using flow dosing (fine dosing phase)	REAL	3.0
PV_AH_En	1 = Enable PV alarm (high) limit when using flow dosing (coarse dosing phase)	BOOL	1
PV_AH_Lim	Limit PV alarm (high) when using flow dosing (coarse dosing phase)	REAL	100.0
PV_AH_MsgEn	1 = Enable PV alarm (high) message when using flow dosing (coarse dosing phase)	BOOL	1
PV_AH2_En	1 = Enable PV alarm (high) when using flow dosing (fine dosing phase)	BOOL	1
PV_AH2_Lim	Limit PV alarm (high) when using flow dosing (fine dosing phase)	REAL	100.0
PV_AH2_MsgEn	1 = Enable PV alarm (high) message when using flow dosing (fine dosing phase)	BOOL	1
PV_AL_En	1 = Enable PV alarm limit (low) when using flow dosing (coarse dosing phase)	BOOL	1
PV_AL_Lim	Limit PV alarm (low) when using flow dosing (coarse dosing phase)	REAL	0.0
PV_AL_MsgEn	1 = Enable PV alarm (low) message when using flow dosing (coarse dosing phase)	BOOL	1
PV_AL2_En	1 = Enable PV alarm (low) when using flow dosing (fine dosing phase)	BOOL	1
PV_AL2_Lim	Limit PV alarm (low) when using flow dosing (fine dosing phase)	REAL	0.0
PV_AL2_MsgEn	1 = Enable PV alarm (low) message when using flow dosing (fine dosing phase)	BOOL	1
PV_Hyst*	Hysteresis for PV alarm limits when using flow dosing (coarse dosing phase)	REAL	1.0
PV_Hyst2	Hysteresis for PV alarm limits when using flow dosing (fine dosing phase)	REAL	1.0
PV_OpScale	Limit for scale in PV bar graph of face-plate	STRUCT • High: REAL • Low: REAL	- • 100.0 • 0.0
PV_Unit	Unit of measure for process value	INT	1349
RelaxTime*	Duration of dribbling phase [s]	REAL	3.0
RstDQ_Li	1 = Reset dosing quantity via interconnection	STRUCT • Value: BOOL • ST: BYTE	- • 0 • 16#80
RstDQ_Op*	1 = Reset dosing quantity via operator	BOOL	0

Dosing blocks

6.1 DoseL - Dosing device

Parameter	Description	Type	Default
RstLi*	1 = Reset interlock/flow monitoring via interconnection	STRUCT <ul style="list-style-type: none"> Value: BOOL ST: BYTE 	- <ul style="list-style-type: none"> 0 16#80
RstOp*	1 = Reset interlock/flow monitoring via operator	BOOL	0
RunUpCyc	Number of cycles in startup; messages are suppressed during these cycles	INT	3
SampleTime	Sampling time [s] (assigned automatically)	REAL	0.1
SelFp1	Call a block saved in this parameter as an additional faceplate (Page 208) in the standard view	ANY	-
SelFp2	Call a block saved in this parameter as an additional faceplate (Page 208) in the preview	ANY	-
SimDQ*	Dosing quantity: Value used in scale mode for SimOn = 1	REAL	0.0
SimDQ_Li	Linkable simulation value DQ	STRUCT <ul style="list-style-type: none"> Value: REAL ST: BYTE 	- <ul style="list-style-type: none"> 0.0 16#80
SimLiOp	Activation/deactivation of the simulation by: 0 = Operator 1 = Interconnection or SFC	STRUCT <ul style="list-style-type: none"> Value: BOOL ST: BYTE 	- <ul style="list-style-type: none"> 0 16#80
SimOnLi	1 = Simulation via interconnection or SFC (controlled by SimLiOp = 1)	STRUCT <ul style="list-style-type: none"> Value: BOOL ST: BYTE 	- <ul style="list-style-type: none"> 0 16#80
SimOn*	1 = Simulation on	BOOL	0
SimPV*	Process value used in flow mode for SimOn = 1	REAL	0.0
SimPV_Li	Process value that is used for SimOnLi.Value = 1 (SimLiOp.Value = 1)	STRUCT <ul style="list-style-type: none"> Value: REAL ST: BYTE 	- <ul style="list-style-type: none"> 0.0 16#80
SP_Ext	External flow setpoint - coarse dosing	STRUCT <ul style="list-style-type: none"> Value: REAL ST: BYTE 	- <ul style="list-style-type: none"> 0.0 16#80
SP_ExtLi	1 = Select external setpoints via interconnection	STRUCT <ul style="list-style-type: none"> Value: BOOL ST: BYTE 	- <ul style="list-style-type: none"> 0 16#80
SP_ExtOp*	1 = Select external setpoints via operator	BOOL	0
SP_HiLim	High limit for flow setpoint - coarse dosing	STRUCT <ul style="list-style-type: none"> Value: REAL ST: BYTE 	- <ul style="list-style-type: none"> 100.0 16#80
SP_Int*	Internal flow setpoint - coarse dosing	REAL	0.0

Parameter	Description	Type	Default
SP_IntLi	1 = Select internal setpoints via interconnection	STRUCT <ul style="list-style-type: none"> Value: BOOL ST: BYTE 	- <ul style="list-style-type: none"> 0 16#80
SP_IntOp*	1 = Select internal setpoints via operator	BOOL	0
SP_LiOp	Select setpoint source (internal/external): 1 = Via interconnection 0 = Via operator	STRUCT <ul style="list-style-type: none"> Value: BOOL ST: BYTE 	- <ul style="list-style-type: none"> 0 16#80
SP_LoLim	Low limit for flow setpoint - coarse dosing	STRUCT <ul style="list-style-type: none"> Value: REAL ST: BYTE 	- <ul style="list-style-type: none"> 0.0 16#80
SP_TrkExt	1 = Bumpless switchover from external to internal setpoint active	BOOL	1
SP2_Ext	External flow setpoint - fine dosing	STRUCT <ul style="list-style-type: none"> Value: REAL ST: BYTE 	- <ul style="list-style-type: none"> 0.0 16#80
SP2_HiLim	High limit for flow setpoint - fine dosing	STRUCT <ul style="list-style-type: none"> Value: REAL ST: BYTE 	- <ul style="list-style-type: none"> 100.0 16#80
SP2_Int*	Internal flow setpoint - fine dosing	REAL	0.0
SP2_LoLim	Low limit for flow setpoint - fine dosing	STRUCT <ul style="list-style-type: none"> Value: REAL ST: BYTE 	- <ul style="list-style-type: none"> 0.0 16#80
StandStill	1 = Scales at a standstill, dosing device infeedback	STRUCT <ul style="list-style-type: none"> Value: BOOL ST: BYTE 	- <ul style="list-style-type: none"> 1 16#80
StartAut*	1 = Select Start in "automatic mode"	STRUCT <ul style="list-style-type: none"> Value: BOOL ST: BYTE 	- <ul style="list-style-type: none"> 0 16#80
StartForce	1 = Forced start	STRUCT <ul style="list-style-type: none"> Value: BOOL ST: BYTE 	- <ul style="list-style-type: none"> 0 16#80
StartLocal	1 = Select Start in "local mode"	STRUCT <ul style="list-style-type: none"> Value: BOOL ST: BYTE 	- <ul style="list-style-type: none"> 0 16#80
StartMan*	1 = Select Start in "manual mode"	BOOL	0
StepNo	Batch step number	DWORD	16#00000000
TI	Integral time [s]	STRUCT <ul style="list-style-type: none"> Value: REAL ST: BYTE 	- <ul style="list-style-type: none"> 1.0 16#80

Dosing blocks

6.1 DoseL - Dosing device

Parameter	Description	Type	Default
U_AckLi	1 = Acknowledgment of underdosage via interconnection	STRUCT <ul style="list-style-type: none"> Value: BOOL ST: BYTE 	- <ul style="list-style-type: none"> 0 16#80
U_AckOp*	1 = Acknowledgment of underdosage via operator	BOOL	0
UA1unit	Unit of measure for analog auxiliary value 1	INT	0
UA2unit	Unit of measure for analog auxiliary value 1	INT	0
UserAna1	Analog auxiliary value 1	STRUCT <ul style="list-style-type: none"> Value: REAL ST: BYTE 	- <ul style="list-style-type: none"> 0.0 16#FF
UserAna2	Analog auxiliary value 2	STRUCT <ul style="list-style-type: none"> Value: REAL ST: BYTE 	- <ul style="list-style-type: none"> 0.0 16#FF
UserStatus	Freely assignable bits for use in PCS 7 OS	BYTE	16#00

* Values can be written back to these inputs during processing of the block by the block algorithm.

Output parameters

Parameter	Description	Type	Default
AutAct	1 = "Automatic mode" enabled 0 = "Manual mode" is enabled	STRUCT <ul style="list-style-type: none"> Value: BOOL ST: BYTE 	- <ul style="list-style-type: none"> 0 16#80
AutoST	1 = Worst signal status of automatic commands	BYTE	16#80
CR_AH_Act	Creep flow: 1 = High alarm active. You can change the reaction for this parameter with <code>Feature</code> bit 28 (Disabling operating points (Page 145)) and with <code>Feature</code> bit 29 (Signaling limit violation (Page 170)).	STRUCT <ul style="list-style-type: none"> Value: BOOL ST: BYTE 	- <ul style="list-style-type: none"> 0 16#80
Ctrl	Control output for coarse dosing	STRUCT <ul style="list-style-type: none"> Value: BOOL ST: BYTE 	- <ul style="list-style-type: none"> 0 16#80
Ctrl2	Control output for fine dosing	STRUCT <ul style="list-style-type: none"> Value: BOOL ST: BYTE 	- <ul style="list-style-type: none"> 0 16#80
DosEnd	1 = End of dosing	STRUCT <ul style="list-style-type: none"> Value: BOOL ST: BYTE 	- <ul style="list-style-type: none"> 0 16#80

Parameter	Description	Type	Default
DosOff	1 = Dosing off	STRUCT <ul style="list-style-type: none"> Value: BOOL ST: BYTE 	- <ul style="list-style-type: none"> 0 16#80
DosOn	1 = Dosing on	STRUCT <ul style="list-style-type: none"> Value: BOOL ST: BYTE 	- <ul style="list-style-type: none"> 0 16#80
DosPause	1 = Dosing pause	STRUCT <ul style="list-style-type: none"> Value: BOOL ST: BYTE 	- <ul style="list-style-type: none"> 0 16#80
DosRelax	1 = Dosing dribbling	STRUCT <ul style="list-style-type: none"> Value: BOOL ST: BYTE 	- <ul style="list-style-type: none"> 0 16#80
DosStart	1 = Dosing started	STRUCT <ul style="list-style-type: none"> Value: BOOL ST: BYTE 	- <ul style="list-style-type: none"> 0 16#80
DQ_AH_Act	1 = Overdosing You can change the reaction for this parameter with <code>Feature</code> bit 28 (Disabling operating points (Page 145)) and with <code>Feature</code> bit 29 (Signaling limit violation (Page 170)).	STRUCT <ul style="list-style-type: none"> Value: BOOL ST: BYTE 	- <ul style="list-style-type: none"> 0 16#80
DQ_AL_Act	1 = Underdosing You can change the reaction for this parameter with <code>Feature</code> bit 28 (Disabling operating points (Page 145)) and with <code>Feature</code> bit 29 (Signaling limit violation (Page 170)).	STRUCT <ul style="list-style-type: none"> Value: BOOL ST: BYTE 	- <ul style="list-style-type: none"> 0 16#80
DQ_ExHiAct	Dosing quantity: 1 = High limit for external setpoint has been reached	STRUCT <ul style="list-style-type: none"> Value: BOOL ST: BYTE 	- <ul style="list-style-type: none"> 0 16#80
DQ_ExLoAct	Dosing quantity: 1 = Low limit for external setpoint has been reached	STRUCT <ul style="list-style-type: none"> Value: BOOL ST: BYTE 	- <ul style="list-style-type: none"> 0 16#80
DQ_ExtOut	Dosing quantity: External setpoint, corresponds to input parameter <code>DQ_Ext</code>	STRUCT <ul style="list-style-type: none"> Value: REAL ST: BYTE 	- <ul style="list-style-type: none"> 0.0 16#80
DQ_Out	Dosing quantity	STRUCT <ul style="list-style-type: none"> Value: REAL ST: BYTE 	- <ul style="list-style-type: none"> 0.0 16#80
DQ_SP	Dosing quantity setpoint used by block	STRUCT <ul style="list-style-type: none"> Value: REAL ST: BYTE 	- <ul style="list-style-type: none"> 0.0 16#80

Dosing blocks

6.1 DoseL - Dosing device

Parameter	Description	Type	Default
DQ_SP_Tol	Setpoint for determining tolerance limits	STRUCT <ul style="list-style-type: none"> Value: REAL ST: BYTE 	- <ul style="list-style-type: none"> 0.0 16#80
DQ_Tare	Tare memory when dosing using scales	STRUCT <ul style="list-style-type: none"> Value: REAL ST: BYTE 	- <ul style="list-style-type: none"> 0.0 16#80
DQ1_SP	Coarse dosing quantity setpoint used by block	STRUCT <ul style="list-style-type: none"> Value: REAL ST: BYTE 	- <ul style="list-style-type: none"> 0.0 16#80
DQ2_ExHiAct	Dosing quantity: 1 = High limit for external setpoint factor for fine dosing has been reached	STRUCT <ul style="list-style-type: none"> Value: BOOL ST: BYTE 	- <ul style="list-style-type: none"> 0 16#80
DQ2_ExLoAct	Dosing quantity: 1 = Low limit for external setpoint factor for fine dosing has been reached	STRUCT <ul style="list-style-type: none"> Value: BOOL ST: BYTE 	- <ul style="list-style-type: none"> 0 16#80
DQ2_ExtOut	Dosing quantity: External setpoint factor for fine dosing [%], corresponds to input parameter <code>DQ2_Ext</code>	STRUCT <ul style="list-style-type: none"> Value: REAL ST: BYTE 	- <ul style="list-style-type: none"> 0.0 16#80
DQ2_SP	Fine dosing quantity setpoint used by block	STRUCT <ul style="list-style-type: none"> Value: REAL ST: BYTE 	- <ul style="list-style-type: none"> 0.0 16#80
DribbOut	Dribbling quantity	STRUCT <ul style="list-style-type: none"> Value: REAL ST: BYTE 	- <ul style="list-style-type: none"> 0.0 16#80
ENO	1 = Block algorithm completed without errors	BOOL	0
ErrorNum	Output of pending error number. For error numbers that can be output by this block, see DoseL error handling (Page 1025)	INT	-1
GrpErr	1 = Group error pending	STRUCT <ul style="list-style-type: none"> Value: BOOL ST: BYTE 	- <ul style="list-style-type: none"> 0 16#80
LocalAct	1 = "Local mode" enabled	STRUCT <ul style="list-style-type: none"> Value: BOOL ST: BYTE 	- <ul style="list-style-type: none"> 0 16#80
LockAct	1 = Interlock (Intlock, Permit or Protect) is active	STRUCT <ul style="list-style-type: none"> Value: BOOL ST: BYTE 	- <ul style="list-style-type: none"> 0 16#80
ManAct	1 = "Manual mode" enabled	STRUCT <ul style="list-style-type: none"> Value: BOOL ST: BYTE 	- <ul style="list-style-type: none"> 1 16#80

Parameter	Description	Type	Default
MS_Release	Release for maintenance: 1 = Release for OS operator	STRUCT • Value: BOOL • ST: BYTE	- • 0 • 16#80
MsgAckn1	Message acknowledgement status 1 (output ACK_STATE of first ALARM_8P)	WORD	16#0000
MsgAckn2	Message acknowledgement status 2 (output ACK_STATE of second ALARM_8P)	WORD	16#0000
MsgErr1	Alarm error 1 (output ERROR of first ALARM_8P)	BOOL	0
MsgErr2	Alarm error 2 (output ERROR of second ALARM_8P)	BOOL	0
MsgStat1	Message status 1 (output STATUS of first ALARM_8P)	WORD	16#0000
MsgStat2	Message status 2 (output STATUS of second ALARM_8P)	WORD	16#0000
OosAct	1 = Block is "Out of service"	STRUCT • Value: BOOL • ST: BYTE	- • 0 • 16#80
OpSt_Out	Value of the OpSt_In input parameter, for feedforwarding to other blocks. Bit 31 of this parameter is used by Feature bit 24	DWORD	16#00000000
OS_PermLog	Display of OS_Perm with settings changed by the block algorithm	DWORD	16#FFFFFFFF
OS_PermOut	Displays of OS_Perm	DWORD	16#FFFFFFFF
OS1PermLog	Display of OS1Perm with settings changed by the block algorithm	DWORD	16#FFFFFFFF
OS1PermOut	Display of OS1Perm	DWORD	16#FFFFFFFF
P_Ctrl	1 = Pulse output for coarse dosing	STRUCT • Value: BOOL • ST: BYTE	- • 0 • 16#80
P_Ctrl2	1 = Pulse output for fine dosing	STRUCT • Value: BOOL • ST: BYTE	- • 0 • 16#80
P_Rst	1= Pulse output for reset The parameter persists for one cycle af- ter a reset.	STRUCT • Value: BOOL • ST: BYTE	- • 0 • 16#80
PV_AH_Act	1 = PV high alarm enabled (coarse dos- ing phase). You can change the reaction for this pa- rameter with Feature bit 28 (Disabling operating points (Page 145)) and with Feature bit 29 (Signaling limit violation (Page 170)).	STRUCT • Value: BOOL • ST: BYTE	- • 0 • 16#80

Dosing blocks

6.1 DoseL - Dosing device

Parameter	Description	Type	Default
PV_AH2_Act	1 = PV high alarm enabled (fine dosing phase). You can change the reaction for this parameter with <i>Feature</i> bit 28 (Disabling operating points (Page 145)) and with <i>Feature</i> bit 29 (Signaling limit violation (Page 170)).	STRUCT • Value: BOOL • ST: BYTE	- • 0 • 16#80
PV_AL_Act	1 = PV low alarm enabled (coarse dosing phase). You can change the reaction for this parameter with <i>Feature</i> bit 28 (Disabling operating points (Page 145)) and with <i>Feature</i> bit 29 (Signaling limit violation (Page 170)).	STRUCT • Value: BOOL • ST: BYTE	- • 0 • 16#80
PV_AL2_Act	1 = PV low alarm enabled (fine dosing phase). You can change the reaction for this parameter with <i>Feature</i> bit 28 (Disabling operating points (Page 145)) and with <i>Feature</i> bit 29 (Signaling limit violation (Page 170)).	STRUCT • Value: BOOL • ST: BYTE	- • 0 • 16#80
PV_Out	Output for process value	STRUCT • Value: REAL • ST: BYTE	- • 0.0 • 16#80
RdyToReset	1 = Ready for reset via <i>RstLi</i> input or commands in "automatic mode"	STRUCT • Value: BOOL • ST: BYTE	- • 0 • 16#80
RdyToStart	1 = Active start readiness	STRUCT • Value: BOOL • ST: BYTE	- • 0 • 16#80
SP	Active flow setpoint	STRUCT • Value: REAL • ST: BYTE	- • 0.0 • 16#80
SP_ExHiAct	Flow for coarse dosing: 1 = High limit for external setpoint has been reached	STRUCT • Value: BOOL • ST: BYTE	- • 0 • 16#80
SP_ExLoAct	Flow for coarse dosing: 1 = Low limit for external setpoint has been reached	STRUCT • Value: BOOL • ST: BYTE	- • 0 • 16#80
SP_ExtAct	1 = External setpoint is active 0 = Internal setpoint is active	STRUCT • Value: BOOL • ST: BYTE	- • 0 • 16#80
SP_ExtOut	Flow for coarse dosing: External setpoint, corresponds to input parameter <i>SP_Ext</i>	STRUCT • Value: REAL • ST: BYTE	- • 0.0 • 16#80

Parameter	Description	Type	Default
SP1	Coarse dosing flow setpoint used by block	STRUCT <ul style="list-style-type: none"> Value: REAL ST: BYTE 	- <ul style="list-style-type: none"> 0.0 16#80
SP2	Fine dosing flow setpoint used by block	STRUCT <ul style="list-style-type: none"> Value: REAL ST: BYTE 	- <ul style="list-style-type: none"> 0.0 16#80
SP2_ExHiAct	Flow for fine dosing: 1 = High limit for external setpoint has been reached	STRUCT <ul style="list-style-type: none"> Value: BOOL ST: BYTE 	- <ul style="list-style-type: none"> 0 16#80
SP2_ExLoAct	Flow for fine dosing: 1 = Low limit for external setpoint has been reached	STRUCT <ul style="list-style-type: none"> Value: BOOL ST: BYTE 	- <ul style="list-style-type: none"> 0 16#80
SP2_ExtOut	Flow for fine dosing: External setpoint, corresponds to input parameter SP2_Ext	STRUCT <ul style="list-style-type: none"> Value: REAL ST: BYTE 	- <ul style="list-style-type: none"> 0.0 16#80
ST_Worst	Worst signal status	BYTE	16#80
Status1	Status word 1 (Page 1005)	DWORD	16#00000000
Status2	Status word 2 (Page 1005)	DWORD	16#00000000
Status3	Status word 3 (Page 1005)	DWORD	16#00000000
Status4	Status word 4 (Page 1005)	DWORD	16#00000000

See also

DoseL messaging (Page 1028)
DoseL modes (Page 1009)
DoseL block diagram (Page 1045)
Error handling (Page 119)

6.1.7 DoseL block diagram**DoseL block diagram**

A block diagram is not provided for this block.

See also

Description of DoseL (Page 1005)
DoseL modes (Page 1009)
DoseL functions (Page 1011)

6.1 DoseL - Dosing device

DoseL error handling (Page 1025)

DoseL messaging (Page 1028)

DoseL I/Os (Page 1031)

6.1.8 Operator control and monitoring

6.1.8.1 DoseL views

Views of the DoseL block

The block DoseL provides the following views:

- DoseL standard view (Page 1047)
- Alarm view (Page 302)
- DoseL limit view (Page 1051)
- Trend view (Page 305)
- DoseL parameter view (Page 1053)
- DoseL flow setpoint view (Page 1055)
- DoseL quantity setpoint view (Page 1058)
- DoseL preview (Page 1060)
- Memo view (Page 304)
- Batch view (Page 302)
- Block icon for DoseL (Page 1062)

Refer to the sections Structure of the faceplate (Page 248) and Block icon structure (Page 230) for general information on the faceplate and block icon.

6.1.8.2 DoseL standard view

DoseL standard view

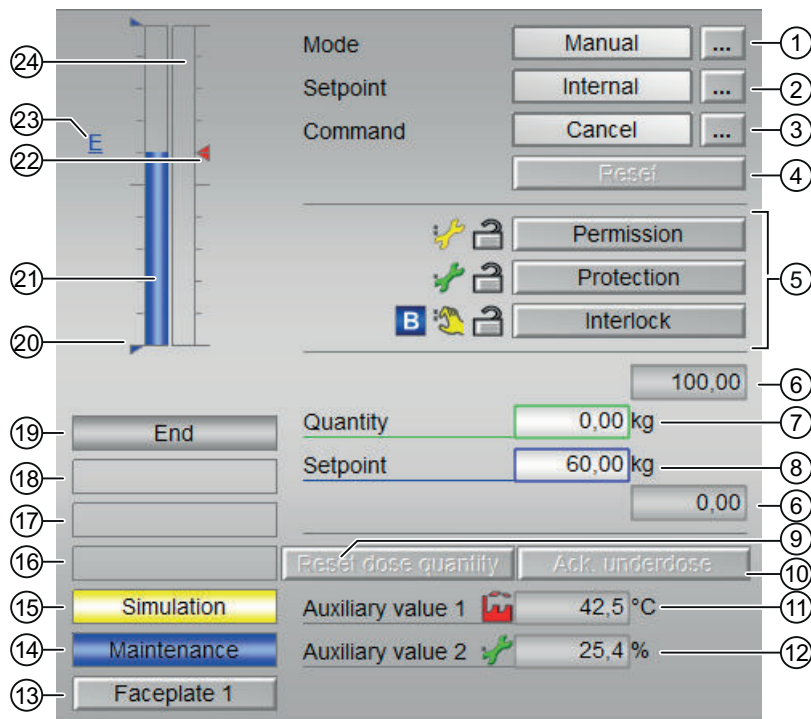

(1) Display and switch the operating mode

This area provides information on the currently valid operating mode. The following operating modes can be shown here:

- Manual mode (Page 75)
- Automatic mode (Page 75)
- Local mode (Page 79)
- Out of service (Page 71)

Refer to chapter Switching operating states and operating modes (Page 257) for information on switching the operating mode.

(2) Displaying and changing the setpoint

The following states can be shown and changed here:

- "Internal"
- "External"

You can find additional information on this in section Manual and automatic mode for motors, valves and dosers (Page 75).

(3) Displaying and changing: Start, continue, pause and cancel

This area shows you the default operating state for the doser. The following states can be shown and changed here:

- "Start"
- "Continue"
- "Pause"
- "Cancel"

You can find additional information on this in section Switching operating states and operating modes (Page 257).

(4) Resetting the block

Click "Reset" for interlocks or errors. You can find additional information on this in section Resetting the block in case of interlocks or errors (Page 43).

(5) Operating range for the interlock functions of the block

You can use this button to control the interlock functions of the block. You can find additional information on this in section Interlocks (Page 99).

- Bypass information (see Forming the group status for interlock information (Page 104)):



(6) High and low scale range for the setpoint

This area is already set and cannot be changed.

(7) Displaying and changing the quantity

You can find additional information on this in section Changing values (Page 259).

(8) Displaying and changing the setpoint

You can find additional information on this in section Changing values (Page 259).

(9) Button: Reset dose quantity

The dosing quantity can only be reset in the "End" or "Ack Dos End" state.

With resetting dose quantity also the display "Ack Dos End" is reset to "End".

(10) Button: Acknowledge overdosing and underdosing

Acknowledgment of overdosing and underdosing can only be made in the "Off" state.

Additional with `Feature2` bit 24 = 1:

- an acknowledgement of overdosing is possible.
- generally, overdosing or underdosing has to be acknowledged.

(11) and (12) Display of auxiliary values

You can use this area to display two auxiliary values that have been configured in the Engineering System (ES). You can find additional information on this in section Opening additional faceplates (Page 208).

(13) Button for switching to the standard view of any faceplate

Use this button for the standard view of a block configured in the Engineering System (ES). The visibility of this button depends on the configuration in the engineering system (ES).

You can find additional information on this in section Opening additional faceplates (Page 208).

(14) and (15) Display area for block states

This area provides additional information on the operating state of the block:

- "Simulation"
- "Maintenance"

You can find additional information on this in section Simulating signals (Page 58).

(16) Display area for block states

This area provides additional information on the operating state of the block:

- "Invalid signal"
- "Changeover error"
- "Flow"

(17) Display area for block states

This area provides additional information on the operating state of the block:

- "Forced start"
- "Force continue"
- "Force pause"
- "Forced stop"
- "Request 0/1": A reset to "automatic mode" is expected.

(18) Display area for block states

This area provides additional information on the operating state of the block:

- "Underdosed"
- "Overdosed"

(19) Display area for block states

This area provides additional information on the operating state of the block:

- "Coarse dosing"
- "Fine dosing"
- "Relax"
- "Pause"
- "Off"
- "End"

If an underdosage or overdosage is identified, the status display shows the state "Ack Dos End" in the standard view.

- "Taring"

(20) Limit display for the setpoint

These triangles show the SP_{HiLim} and SP_{LoLim} setpoint limits configured in the ES.

(21) Bar graph for the setpoint

This area shows the current setpoint in the form of a bar graph. The visible area in the bar graph depends on the configuration in the engineering system (ES).

(22) Limit display

These colored triangles indicate the configured limits in the respective bar graph:

- Red: Alarm
- Yellow: Warning
- Blue: Tolerance

(23) Display of external setpoint

This display [E] is only visible when you have selected "Internal" setpoint specification. It shows the external setpoint that would apply if you were to change the setpoint specification to "external".

(24) Bar graph for the quantity

This area shows you the current quantity in the form of a bar graph. The visible area in the bar graph depends on the configuration in the engineering system (ES).

6.1.8.3 DoseL limit view**Limit view of DoseL**

5 **Enabled operations Dosing limits**

Overdosing 0,00 kg

Underdosing 0,00 kg

Flow limits (coarse)

H alarm 100,00 m³/h

L alarm 0,00 m³/h

Hysteresis 1,00 m³/h

Flow limits (fine)

H alarm 100,00 m³/h

L alarm 0,00 m³/h

Hysteresis 1,00 m³/h

Limit creep rate

H alarm 0,00 m³/h

Hysteresis 0,00 m³/h

6 7

Note

In scale mode with Feature Bit 7 = 0, the displays (2), (3) and (4) are hidden.

(1) Displaying and changing the dosing limits

You can change the dosing limits in this area:

- "Overdosing"
- "Underdosing"

You can find additional information on this in the section Changing values (Page 259).

(2) Displaying and changing the flow limits (coarse)

You can change the flow limits (coarse) in this area:

- "H alarm"
- "L alarm"
- "Hysteresis"

You can find additional information on this in the section Changing values (Page 259).

(3) Displaying and changing the flow limits (fine)

You can change the flow limits (fine) in this area:

- "H alarm"
- "L alarm"
- "Hysteresis"

You can find additional information on this in the section Changing values (Page 259).

(4) Displaying and changing the limit for the creep flow

You can change the limit for the creep rate in this area:

- "H alarm"
- "Hysteresis"

You can find additional information on this in the section Changing values (Page 259).

(5) Enabled operation

This area shows all operations for which special operator permissions are assigned. They depend on the configuration in the engineering system (ES) that applies to this block.

Icons for enabled operation:

- **Green check mark:** the OS operator can control this parameter
- **Gray check mark:** the OS operator cannot control this parameter at this time due to the process
- **Red cross:** the OS operator cannot control this parameter due to the configured AS operator permissions (OS_Permission or OS1Permission)

(6) "Message suppression/delay"

Message suppression indicates whether or not the suppression of the associated message in the AS block is activated with the `xx_MsgEn` parameter. The output of messages is not suppressed when the block is installed (all `xx_MsgEn` parameters are preset to 1). Messages can only be output if limit monitoring of the additional analog value has been enabled.

Alarm delays are also displayed in this position; for more on this see section Area of application of the alarm delays (Page 199).

(7) Suppress messages

You can enable / disable messages by setting the check mark.

6.1.8.4 DoseL parameter view

Parameter view of DoseL

Enabled operations Settings	
✓	SP := SP external <input checked="" type="checkbox"/>
Parameter	
✓	Postdose time <input type="text" value="0. s"/>
✓	Dribbling time <input type="text" value="3. s"/>
✓	Dribbling quantity <input type="text" value="0.00 kg"/>
Automatic dribbling quantity	
✓	On <input checked="" type="checkbox"/>
✓	Weighting factor <input type="text" value="25. %"/>
✓	Maximum <input type="text" value="100.00 kg"/>
	Calc. value <input type="text" value="100.00 kg"/>
Service	
✓	Simulation <input type="button" value="On"/> ...
✓	Release for maint. <input type="button" value="Yes"/> ...

(1) Settings

You can select the following functions in this area:

- "SP:=SP external": Bumpless switchover of setpoint from external to internal. The internal setpoint is tracked to the external one.

(2) Parameter

In this area, you change parameters and therefore influence the doser. Refer also to the Changing values (Page 259) section for more on this.

You can influence the following parameters:

- "Relax time"
- "Dribble time"
- "Dribble value"

(3) Automatic dribbling quantity

In this area, you change the automatic dribbling quantity parameters, which affects the doser. Refer also to the Changing values (Page 259) section for more on this.

You can change the parameters when the "On" check box is selected .

You can influence the following parameters:

- "Weighting factor"
- "Maximum"
- "Calc. value"

(4) Service

You can select the following functions in this area:

- "Simulation"
- "Release for maintenance"

Refer to the Switching operating states and operating modes (Page 257) section for more on this.

You can find information on this area in the section:

- Simulating signals (Page 58)
- Release for maintenance (Page 64)

(5) Enabled operations

This area shows all operations for which special operator control permissions are assigned. They depend on the configuration in the engineering system (ES) that applies to this block.

Symbols for enabled operations:

- **Green check mark:** the OS operator can control this parameter
- **Gray check mark:** the OS operator cannot control this parameter at this time due to the process
- **Red cross:** the OS operator cannot control this parameter due to the configured AS operator control permissions (`OS_Perm` or `OS1Perm`).

6.1.8.5 DoseL flow setpoint view

Flow setpoint view for DoseL

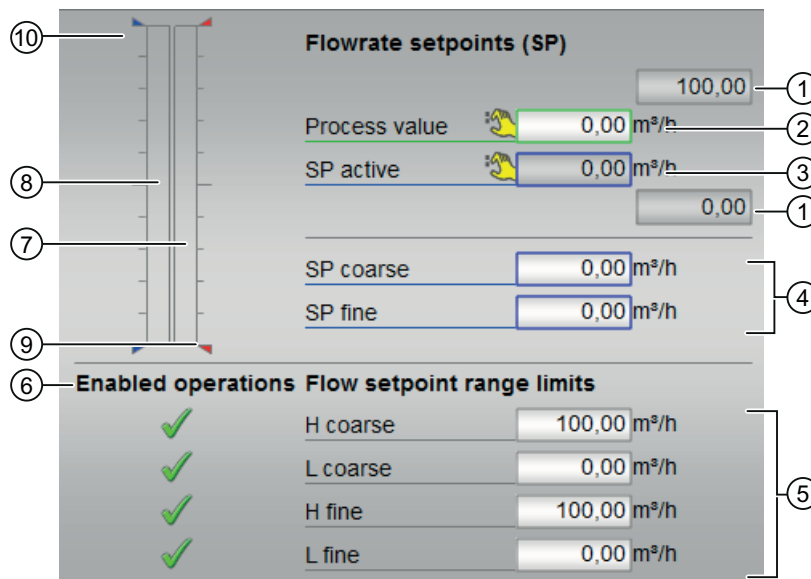

Note

- 1.) This view cannot be selected in scale mode with `Feature Bit 7 = 0`.
- 2.) In scale mode with `Feature Bit 7 = 1` the displays (3), (4), (5), (6) and (8) are hidden.
- 3.) If `Feature Bit 15 = 1`, the display of this setpoint view changes. For further information, refer to the description below.

(1) High and low scale range for the process value

These values provide information on the display range for the bar graph (7) of the process value. The scale range is defined in the engineering system.

(2) Display of the process value including signal status

This area shows the current process value with the corresponding signal status.

(3) Displaying and changing the SP active value

You can find additional information on this in the Changing values (Page 259) section.

(4) Additional setpoint parameters

You can change the following setpoint parameters in this area:

- "SP coarse"
- "SP fine"

You can find additional information on this in the Changing values (Page 259) section.

(5) Displaying and changing the limits

You can change the limits in this area:

- "H coarse"
- "L coarse"
- "H fine"
- "L fine"

You can find additional information on this in the Changing values (Page 259) section.

(6) Enabled operations

This area shows all operations for which special operator control permissions are assigned. They depend on the configuration in the engineering system (ES) that applies to this block.

Symbols for enabled operations:

- **Green check mark:** the OS operator can control this parameter
- **Gray check mark:** the OS operator cannot control this parameter at this time due to the process
- **Red cross:** the OS operator cannot control this parameter due to the configured AS operator control permissions (OS_Perm or OS1Perm).

(7) Bar graph for the process value

This area shows the current process value in the form of a bar graph. The visible area in the bar graph depends on the configuration in the engineering system (ES).

(8) Bar graph for the SP active setpoint

This area shows the current setpoint "SP active" in the form of a bar graph. The visible area in the bar graph depends on the configuration in the engineering system (ES).

Note

If Feature Bit 15 = 1, there are no (8) or (10) displays. For further information, refer to the description below.

(9) Limit display

These triangles show limits for the flow limits. The flow limits are set in the limit value view.

(10) Limit display for the setpoint

These triangles show the `SP_HiLim` and `SP_LoLim` setpoint limits configured in the Engineering System (ES).

Flow setpoint view for Feature Bit 15 = 1

If `Feature Bit 15 = 1`, the setpoint view changes in the following ways:

- Displays (8) and (10) are omitted.
- The "SP active" value (3) is displayed above the area (4).
- The values in the (3), (4) and (5) areas contain the unit "%".

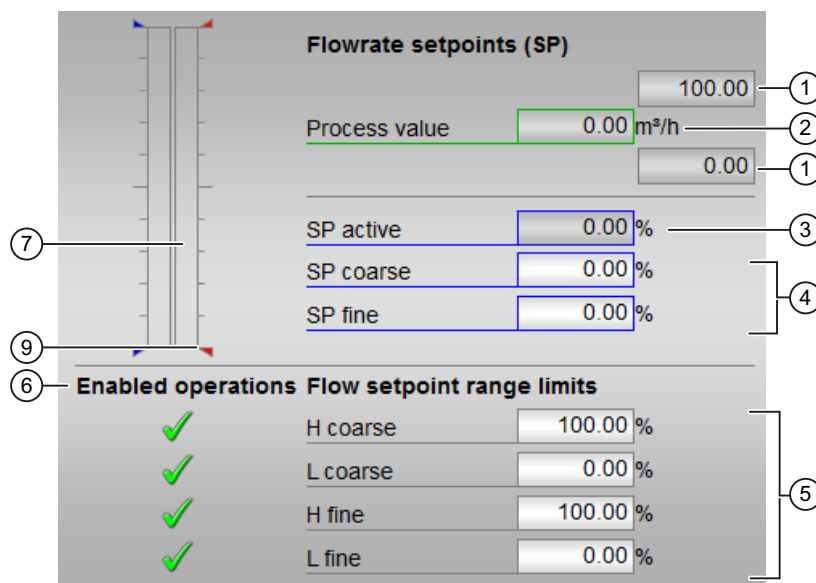

6.1.8.6 DoseL quantity setpoint view

Quantity setpoint view for DoseL

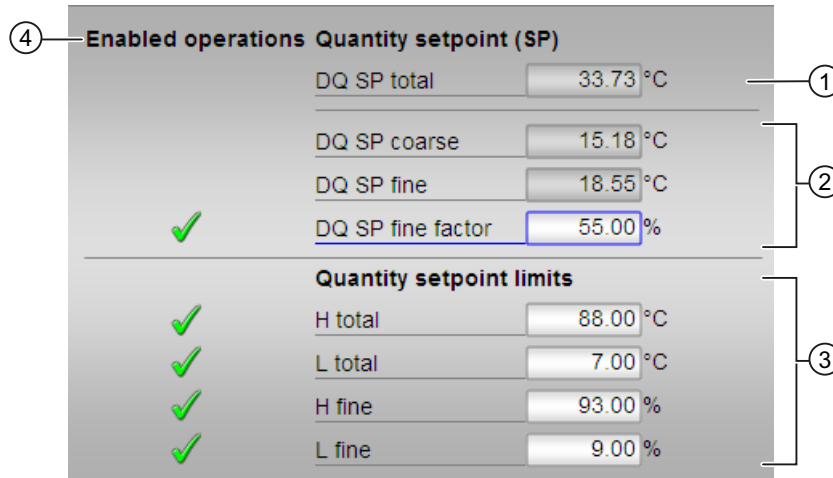

(1) Displaying and changing the DQ SP total setpoint

You can change the "DQ SP total" setpoint in this area.

Additional information is available in the section Changing values (Page 259).

(2) Displaying and changing additional setpoints

You can change the limits in this area:

- "DQ SP coarse"
- "DQ SP fine"
- "DQ SP fine factor"

Additional information is available in the section Changing values (Page 259).

Note

Special note for Feature Bit 8 = 1

If you set this Feature Bit with 1, DQ SP fine is no longer displayed in the faceplate. In addition, the display of the unit for DQ SP fine factor is omitted. The input is now performed in an absolute manner.

(3) Displaying and changing the limits

You can change the limits in this area:

- "H total"
- "L total"

- "H fine"
- "L fine"

Additional information is available in the section Changing values (Page 259).

Note**Special note for Feature Bit 8 = 1**

If you set this `Feature Bit` to 1, the display of the unit for H fine and L fine is switched to the unit configured at `DQ_Unit`. The input is now performed in an absolute manner.

(4) Enabled operations

This area shows all operations for which special operator control permissions are assigned. They depend on the configuration in the engineering system (ES) that applies to this block.

Symbols for enabled operations:

- **Green check mark:** the OS operator can control this parameter
- **Gray check mark:** the OS operator cannot control this parameter at this time due to the process
- **Red cross:** The OS operator cannot control this parameter due to the configured AS operator control permissions (`OS_Perm` or `OS1Perm`).

6.1.8.7 DoseL preview

Preview of DoseL

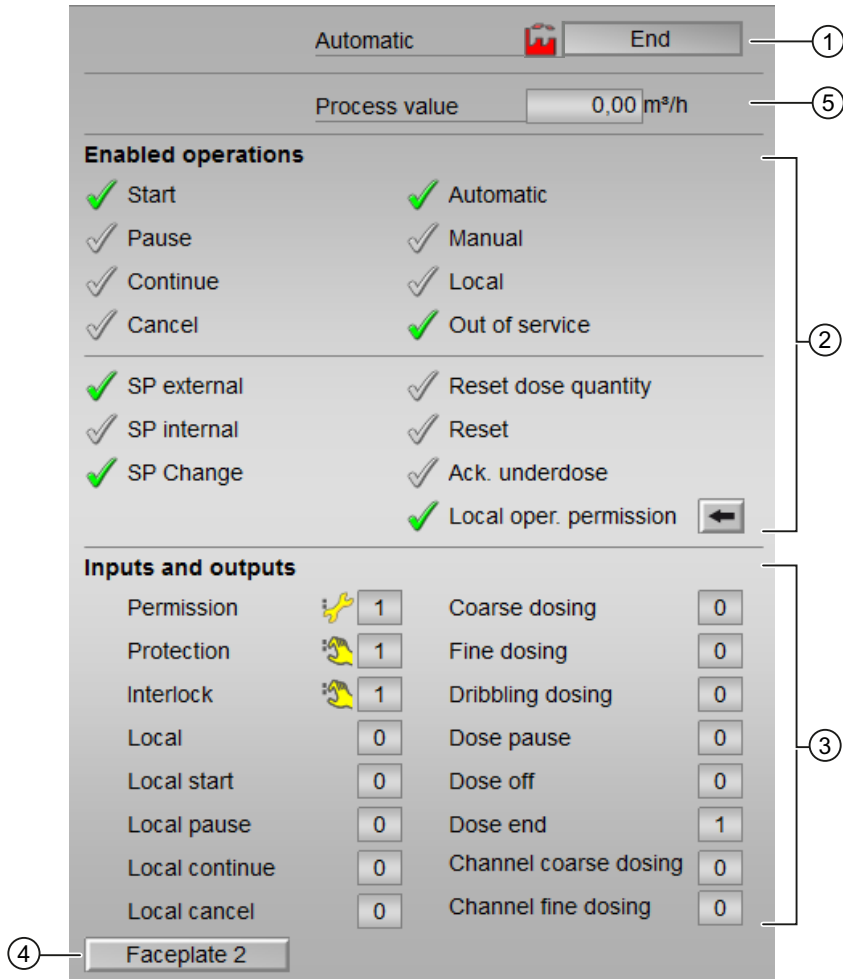

(1) Automatic preview

This area shows you the block status after it has switched from "manual" to "automatic" mode.

If the block is in "automatic mode", the current block state is displayed.

This area also displays the worst signal status of the following automatic commands:

- StartAut
- CancelAut
- PauseAut
- ContAut
- SP_Ext

(2) Enable operations

This area shows all operations for which special operator permissions are assigned. They depend on the configuration in the engineering system (ES) that applies to this block.

Icons for enabled operation:

- **Green check mark:** the OS operator can control this parameter
- **Gray check mark:** the OS operator cannot control this parameter at this time due to the process
- **Red cross:** the OS operator cannot control this parameter due to the configured AS operator permissions (`OS_Perm` or `OS1Perm`).

The following enabled operations are shown here:

- "Start": You can start the dosing procedure
- "Pause": You can pause the dosing procedure
- "Continue": You can continue the dosing procedure after a pause or an abort.
- "Cancel": You can abort the dosing procedure
- "Automatic": You can switch to "automatic mode".
- "Manual": You can switch to "manual mode".
- "Local": You can switch to "local mode".
- "Out of service": You can switch to "Out of service" operating mode.
- "SP external": You can use the external setpoint
- "SP internal": You can use the internal setpoint
- "Change SP": You can change the setpoint
- "Reset dose quantity": You can reset the dosing quantity
- "Reset": You can reset the block after interlocks or errors
- "Acknowledge underdosing": You can acknowledge underdosing
- "Local operator permission": Use the ← button to switch to the standard view of the OpStations block. You can find additional information on this in the section Operator control permissions (Page 254).

(3) Displaying current control signals

This area shows the most important parameters for this block with the current selection:

- "Permission":
 - 0 = No OS release for energizing motor
 - 1 = Enable for "starting"/"stopping" from the neutral position
- "Protection":
 - 0 = Protective interlocking is effective; once the interlocking condition has disappeared, you will have to reset the block
 - 1 = "Good" state

- "Interlock":
 - 0 = Interlocking without reset is active; you can operate the block without reset once the interlocking condition has disappeared
 - 1 = "Good" state
- "Local correct": 1 = Control signal for "Local mode" (LocalLi) is active
- "Local start": 1 = Block is started in "local mode"
- "Local pause": 1 = Dosing paused in "local mode"
- "Local continue": 1 = Dosing is continued in "local mode"
- "Local cancel": 1 = Dosing is canceled in "local mode"
- "Coarse dosing": 1 = Coarse dosing is performed
- "Fine dosing": 1 = Fine dosing is performed
- "Relax phase": 1 = Dosing procedure is in the relax phase
- "Dose pause": 1 = Dosing pause
- "Dose off": 1 = No dosing taking place
- "Dose end": 1 = Dosing is stopped
- "Channel Coarse Dosing": Signal from the output channel block for "Coarse dosing"
- "Channel Fine Dosing": Signal from the output channel block for "Fine dosing"

(4) Navigation button for switching to the standard view of any faceplate

Use this navigation button to open the standard view of a block configured in the engineering system. The visibility of this navigation button depends on the configuration in the engineering system (ES).

You can find additional information on this in the section Opening additional faceplates (Page 208).

(5) Process value

This area displays the real process value (PV).

6.1.8.8 Block icon for DoseL

Block symbols for DoseL

A variety of block icons are available with the following functions:



- Process tag type
- Limits (high/low)
- Violation of alarm, warning, and tolerance limits as well as control system faults



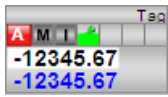
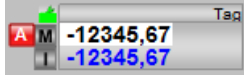

- Operating modes
- Internal and external setpoint specification
- Signal status, release for maintenance
- Track, force, and bypass
- Interlocks
- Memo display
- Process value (black, with and without decimal places)
- Setpoint (blue, with and without decimal places)

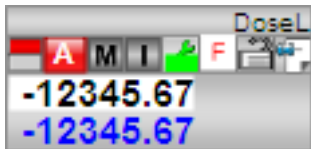
The block icons from template @TemplateAPLV8.PDL:

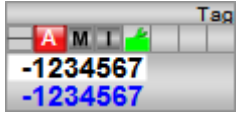
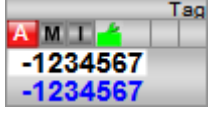
Icons	Selection of the block icon in CFC	Special features
	1	
	2	
	3	Block icon in the full display

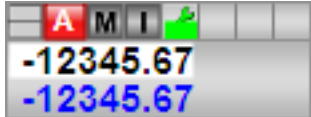
The block icons from template @TemplateAPLV7.PDL:

Icons	Selection of the block icon in CFC	Special features
	1	Block icon in the full display
	2	
	3	
	4	

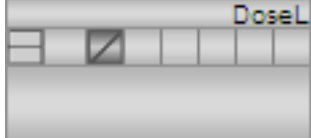
Icons	Selection of the block icon in CFC	Special features
	5	
	6	
	7	
	8	
	-	Block icon in "Out of service" mode (example with type 1 block icon)

Additional information on the block icon and the control options in the block icon is available in the following chapters:

- Configuring the block icons (Page 237)
- Block icon structure (Page 230)
- Operation via the block icon (Page 239).

Motor and valve blocks

7.1 Comparison of large & small blocks

7.1.1 MotL compared to MotS

Comparison of the MotL and MotS blocks

The following tables are intended to help you decide which block to use.

Memory and runtime savings of the small block compared to the large block

You save the following resources for each instance:

- Memory space: ~ 40%
- Runtime: ~ 25%

Block operating modes

	MotL	MotS
Local mode (Page 79)	X	X
Manual mode (Page 75)	X	X
Automatic mode (Page 75)	X	X
Out of service (Page 71)	X	X

Functions of the blocks

	MotL	MotS
Opening additional faceplates (Page 208)	X	X
Operator control permissions (Page 254)	X	X
Limit monitoring of an additional analog value (Page 91)	X	
Limit monitoring with hysteresis (Page 97)	X	
Suppressing messages using the MsgLock parameter (Page 205)	X	X
Interlocks (Page 99)	X	X

7.1 Comparison of large & small blocks

	MotL	MotS
Motor protection function (Page 99)	X	X
Disabling interlocks (Page 103)	X	X
Rapid stop for motors (Page 106)	X	
Resetting the block in case of interlocks or errors (Page 43)	X	X
Outputting group errors (Page 122)	X	X
Outputting a signal for start readiness (Page 53)	X	X
Restart lock after switching off the motor (Page 1078)	X	
Forming the group status for interlock information (Page 104)	X	X
Forming and outputting the signal status for technologic blocks (Page 109)	X	X
Forcing operating modes (Page 41)	X	
Monitoring the feedbacks (Page 97)	X	X
Release for maintenance (Page 64)	X	X
Specifying warning times for control functions at motors and valves (Page 51)	X	
Simulating signals (Page 58)	X	X
Selecting a unit of measure (Page 212)	X	
Neutral position for motors, valves and controllers (Page 48)	X	X
Output signal as a static signal or pulse signal (Page 51)	X	X
Generating instance-specific messages (Page 204)	X	X
Displaying auxiliary values (Page 211)	X	
Time stamp	X	
SIMATIC BATCH functionality (Page 67)	X	
Labeling of buttons and text (Page 209)	X	X
Displaying current control signals from output channel block	X	X
Display active monitoring time	X	X

	MotL	MotS
Control priority in the event of an invalid input command (Page 175)	X	X
Separate monitoring time for stopping the motor (Page 169)	X	X

Configurable functions using the Feature parameter

Bit number	Feature bit function	MotL	MotS
0	Set startup characteristics (Page 138)	X	X
1	Reaction to the out of service mode (Page 177)	X	X
2	Resetting the commands for changing the mode (Page 161)	X	X
3	Enabling resetting of commands for the control settings (Page 161)	X	X
4	Setting switch or button mode (Page 167)	X	
9	Resetting via input signals in the event of interlocking (Protection) or errors (Page 163)	X	X
10	Exiting local mode (Page 177)	X	X
11	Activating the run time of feedback signals (Page 153)	X	X
13	Separate monitoring time for stopping the motor (Page 169)	X	
14	Enabling rapid stop via faceplate (Page 168)	X	
17	Enabling bumpless switchover to automatic mode for valves, motors, and dosers (Page 173)	X	
19	Reset even with locked state (Page 165)	X	X
21	Enable bumpless switchover to "Automatic" mode for operator only (Page 172)	X	
22	Update acknowledgment and error status of the message call (Page 160)	X	
24	Enabling local operator authorization (Page 158)	X	X
25	Suppression of all messages (Page 174)	X	X
26	Reaction of the switching points in the "Out of service" operating mode (Page 176)	X	
27	Interlock display with LocalSetting 2 or 4 (Page 178)	X	X

7.1 Comparison of large & small blocks

Bit number	Feature bit function	MotL	MotS
28	Disabling operating points (Page 145)	X	
29	Signaling limit violation (Page 170)	X	
30	Set reset depending on the operating mode or the LiOp parameter (Page 163)	X	X
31	Activating reset of protection / error in manual mode (Page 165)	X	X

Configurable functions using the Feature2 parameter

Bit number	Feature2 bit function	MotL	MotS
3	Control priority in the event of an invalid input command (Page 175)	X	X
5	Evaluation of the signal status of the interlock signals (Page 142)	X	X

7.1.2 VivL compared to VivS

Comparison of the VivL and VivS blocks

The following tables are intended to help you decide which block to use.

Memory and runtime savings of the small block compared to the large block

You save the following resources for each instance:

- Memory space: ~ 25%
- Runtime: ~ 20%

Modes

	VivL	VivS
Local mode (Page 79)	X	X
Manual mode (Page 75)	X	X
Automatic mode (Page 75)	X	X
Out of service (Page 71)	X	X

Functions

	VivL	VivS
Opening additional faceplates (Page 208)	X	X
Operator control permissions (Page 254)	X	X
Interlocks (Page 99)	X	X
Disabling interlocks (Page 103)	X	X
Resetting the block in case of interlocks or errors (Page 43)	X	X
Outputting group errors (Page 122)	X	X
Outputting a signal for start readiness (Page 53)	X	X
Forming the group status for interlock information (Page 104)	X	X
Forming and outputting the signal status for technologic blocks (Page 109)	X	X
Forcing operating modes (Page 41)	X	
Monitoring the feedbacks (Page 97)	X	X
Disabling feedback for valves (Page 99)	X	
Suppressing messages using the MsgLock parameter (Page 205)	X	X
Release for maintenance (Page 64)	X	X
Specifying warning times for control functions at motors and valves (Page 51)	X	
Simulating signals (Page 58)	X	X
Selecting a unit of measure (Page 212)	X	
Neutral position for motors, valves and controllers (Page 48)	X	X
Generating instance-specific messages (Page 204)	X	X
Displaying auxiliary values (Page 211)	X	
SIMATIC BATCH functionality (Page 67)	X	X
Output signal as a static signal or pulse signal (Page 51)	X	
Time stamp (Page 1660)	X	

7.1 Comparison of large & small blocks

	VlvL	VlvS
Labeling of buttons and text (Page 209)	X	X
Displaying current control signals from output channel block	X	X

Configurable functions using the Feature parameter

Bit number	Feature bit function	VlvL	VlvS
0	Set startup characteristics (Page 138)	X	X
1	Reaction to the out of service mode (Page 177)	X	X
2	Resetting the commands for changing the mode (Page 161)	X	X
3	Enabling resetting of commands for the control settings (Page 161)	X	X
4	Setting switch or button mode (Page 167)	X	
9	Resetting via input signals in the event of interlocking (Protection) or errors (Page 163)	X	X
10	Exiting local mode (Page 177)	X	X
11	Activating the run time of feedback signals (Page 153)	X	X
17	Enabling bumpless switchover to automatic mode for valves, motors, and dosers (Page 173)	X	
21	Enable bumpless switchover to "Automatic" mode for operator only (Page 172)	X	
22	Update acknowledgment and error status of the message call (Page 160)	X	
24	Enabling local operator authorization (Page 158)	X	X
25	Suppression of all messages (Page 174)	X	X
27	Interlock display with LocalSetting 2 or 4 (Page 178)	X	X
30	Set reset depending on the operating mode or the LiOp parameter (Page 163)	X	X
31	Activating reset of protection / error in manual mode (Page 165)	X	X

Configurable functions using the Feature2 parameter

Bit number	Feature2 bit function	VivL	VivS
3	Control priority in the event of an invalid input command (Page 175)	X	X
5	Evaluation of the signal status of the interlock signals (Page 142)	X	X

7.1.3 ShrdResL compared to ShrdResS

Comparison of the ShrdResL and ShrdResS blocks

The following tables are intended to help you decide which block to use.

Memory and runtime savings of the small block compared to the large block

You save the following resources for each instance:

- Memory space: ~ 50%
- Runtime: ~ 25%

Parameters for channel

	ShrdResL	ShrdResS
Control commands for channel	12	6
External setpoints for channel	8	2
Additional strings for channel	2	-

Functions

	ShrdResL	ShrdResS
Opening additional faceplates (Page 208)	x	x
Operator control permissions (Page 254)	x	
Readiness signal (Page 1265)	x	x
Channel management (Page 1287)		x
Channel management with parameterized priority parameter and strategy mode (Page 1265)	x	
Allocate/enable channel (Page 1265)	x	x
Enable/disable channel (Page 1265)	x	x
Channel prioritization (Page 1265)	x	x
Cascading (Page 1287)		x
SIMATIC BATCH functionality (Page 67)	x	x

Configurable functions using the Feature parameter

Bit number	Feature bit function	ShrdResL	ShrdResS
0	Set startup characteristics (Page 138)	x	x

7.2 MotL - Motor (Large)

7.2.1 Description of MotL

Object name (type + number) and family

Type + number: FB 1850

Family: Drives

Area of application for MotL

The block is used for the following applications:

- Control of motors with one control signal

Note

This block is also available as a small block. A comparison of the MotL and MotS blocks is available in the section: MotL compared to MotS (Page 1065)

How it works

The block is used to control motors. Various inputs are available for controlling the motor.

Configuration

Use the CFC editor to install the block in a cyclic interrupt OB (OB30 to OB38). The block is also installed automatically in the startup OB (OB100).

Startup characteristics

Use the `Feature Bit Set` startup characteristics (Page 138) to define the startup characteristics of this block.

The messages are suppressed after startup for the number of cycles set at `RunUpCyc`.

Status word allocation for `Status1` parameter

You can find a description for each parameter in section MotL I/Os (Page 1088).

Status bit	Parameter
0	Occupied
1	BatchEn
2	SimOn
3	OosAct.Value

7.2 MotL - Motor (Large)

Status bit	Parameter
4	OosLi.Value
5	0 = ManAct.Value 1 = AutoAct.Value
6	LocalAct.Value
7	0: Open padlock in the block icon 1: Closed padlock in the block icon
8	Start.Value
9	Stop.Value
10	MonDynStopErr.Value
11	MonStaErr.Value
12	MonDynErr.Value
13	ByProt
14	Invalid signal status
15	Mode switchover error
16	1 = Intlock is active
17	1 = Permit is active
18	1 = Protect is active
19	Trip.Value
20	Display „Forced start“
21	Display „Forced stop“
22	Not used
23	"Interlock" button is enabled
24	Reset request in automatic preview
25	WarnAct.Value or Idle Time is active
26	Bypass information from previous function block
27	Automatic preview for "starting"
28	Automatic preview for "stopping"
29	External error generated by FaultExt or external control system fault CSF with set Feature bit 18 Activating error state for external process control error CSF (Page 151)
30	"Permission" button is enabled
31	"Protection" button is enabled

Status word allocation for status2 parameter

Status bit	Parameter
0	MsgLock
1	AV_AH_Act.Value
2	AV_WH_Act.Value
3	AV_TH_Act.Value
4	AV_TL_Act.Value
5	AV_WL_Act.Value

Status bit	Parameter
6	AV_AL_Act.Value
7	AV_AH_En
8	AV_WH_En
9	AV_TH_En
10	AV_TL_En
11	AV_WL_En
12	AV_AL_En
13	AV_AH_MsgEn
14	AV_WH_MsgEn
15	AV_TH_MsgEn
16	AV_TL_MsgEn
17	AV_WL_MsgEn
18	AV_AL_MsgEn
19	1 = No impact of input signals on "local mode" with LocalSetting = 2 and LocalSetting = 4
20	Motor is stopped
21	Motor is stopping
22	Motor is starting
23	Motor is running
24	Error in motor
25	1 = Input parameter StartChnST is interconnected
26 - 29	Not used
30	Display for interlocks in block icon
31	MS_RelOp

Status word allocation for Status3 parameter

Status bit	Parameter
0	Delay of the AV_AH_Lim message
1	Delay of the AV_WH_Lim message
2	Delay of the AV_TH_Lim message
3	Delay of the AV_TL_Lim message
4	Delay of the AV_WL_Lim message
5	Delay of the AV_AL_Lim message
6	Collection of message delays
7 - 10	Not used
11	Hidden bypass signal in Permit
12	Hidden bypass signal in interlock
13	Hidden bypass signal in Protect
14	Feature2 bit 2: Separate bypass signal
15 - 17	Current monitoring time is visible
18	SimLiOp.Value

Status bit	Parameter
19	1 = Enable for rapid stop (Feature Bit Enabling rapid stop via faceplate (Page 168))
20 - 22	Not used
23	Command for rapid stop
24	Output command for starting the motor
25	Output command for stopping the motor
26	Show automatic preview in the standard view
27	Not used
28	GrpErr.Value
29	RdyToStart.Value
30	Auxiliary value 1 visible
31	Auxiliary value 2 visible

Status word allocation for Status4 parameter

Status bit	Parameter
0	Effective signal 1 of the message block connected via EventTsIn
1	Effective signal 2 of the message block connected via EventTsIn
2	Effective signal 3 of the message block connected via EventTsIn
3	Effective signal 4 of the message block connected via EventTsIn
4	Effective signal 5 of the message block connected via EventTsIn
5	Effective signal 6 of the message block connected via EventTsIn
6	Effective signal 7 of the message block connected via EventTsIn
7	Effective signal 8 of the message block connected via EventTsIn
8	AV not connected
9	Motor protection display (Trip.Status ≠ 16#FF)
10	1 = Input parameter FbkRun is connected
11 - 15	Not used
16 - 23	Effective signal 9..16 of the message block connected via EventTsIn
24 - 30	Not used
31	Separate monitoring of shutdown of the motor (Feature bit 13)

Status word allocation for Status5 parameter

Status bit	Parameter
0 - 15	Effective signal 1...16 of the message block connected via EventTs2In
16 - 31	Not used

See also

MotL functions (Page 1078)

MotL messaging (Page 1086)

MotL block diagram (Page 1096)

MotL error handling (Page 1085)

MotL modes (Page 1077)

7.2.2 MotL modes

MotL operating modes

The block can be operated using the following modes:

- Local mode (Page 79)
- Automatic mode (Page 75)
- Manual mode (Page 75)
- Out of service (Page 71)

The next section provides additional block-specific information relating to the general descriptions.

"Local mode"

You can find general information on "Local mode", switching modes and Bumpless switchover in the Local mode (Page 79) section.

Motor actions you can control in local mode:

- "Start" (`StartLocal = 1`)
- "Stop" (`StopLocal = 1`)

A motor operated in "local mode" is controlled either by "local" signals or by the feedback signals (e.g the `FbkStart = 1` input parameter). Configuration takes place via the input parameter `LocalSetting`.

"Automatic mode"

You can find general information on "Automatic mode", switching modes and Bumpless switchover in the Manual and automatic mode for motors, valves and dosers (Page 75) section.

Motor actions you can control in auto mode:

- "Start" (`StartAut = 1`)
- "Stop" (`StopAut = 1`)

"Manual mode"

You can find general information on "Manual mode", switching modes and bumpless switchover in the section Manual and automatic mode for motors, valves and dosers (Page 75).

Motor actions you can control in manual mode:

- "Start" (StartMan = 1)
- "Stop" (StopMan = 1)

"Out of service"

You can find general information about the "Out of service" mode in the Out of service (Page 71) section.

See also

- MotL block diagram (Page 1096)
- MotL I/Os (Page 1088)
- MotL messaging (Page 1086)
- MotL error handling (Page 1085)
- MotL functions (Page 1078)
- Description of MotL (Page 1073)

7.2.3 MotL functions

Functions of MotL

The functions for this block are listed below.

Opening additional faceplates

This block provides the standard function Opening additional faceplates (Page 208).

Operator permissions

This block provides the standard function Operator control permissions (Page 254).

The block has the following permissions for the OS_Perm parameter:

Bit	Function
0	1 = Operator can switch to "automatic mode"
1	1 = Operator can switch to "manual mode"
2	1 = Operator can switch to "local mode"
3	1 = Operator can switch to "Out of service" mode
4	1 = Operator can stop the motor
5	1 = Operator can start the motor
6	Not used
7	1 = Operator can reset the motor

Bit	Function
8	1 = Operator can define or change the monitoring time for startup
9	1 = Operator can define the monitoring time for the status
10	1 = Operator can enable the monitoring time function (Bit 8 - 9)
11	1 = Operator can activate the Simulation function
12	1 = Operator can activate the Release for maintenance function
13	1 = Operator can change the high limit (AV) for the alarm
14	1 = Operator can change the high limit (AV) for the warning
15	1 = Operator can change the high limit (AV) for the tolerance
16	1 = Operator can change the limit (AV) for hysteresis
17	1 = Operator can lower the limit (AV) for the alarm
18	1 = Operator can lower the limit (AV) for the warning
19	1 = Operator can lower the limit (AV) for the tolerance
20	1 = Operator can activate / deactivate messages via AV_AH_MsgEn
21	1 = Operator can activate / deactivate messages via AV_WH_MsgEn
22	1 = Operator can activate / deactivate messages via AV_TH_MsgEn
23	1 = Operator can activate / deactivate messages via AV_TL_MsgEn
24	1 = Operator can activate / deactivate messages via AV_WL_MsgEn
25	1 = Operator can activate / deactivate messages via AV_AL_MsgEn
26	1 = Operator can change the simulation value SimAV
27- 29	Not used
30	1 = Operator can define the monitoring time for stopping
31	Not used

Note

If you interconnect a parameter that is also listed in OS_Perm as a parameter, you have to reset the corresponding OS_Perm bit.

Limit monitoring of an additional analog value

This block provides the standard function Limit monitoring of an additional analog value (Page 91).

Limit monitoring with hysteresis

This block provides the standard function Limit monitoring with hysteresis (Page 97).

Suppressing messages using the MsgLock parameter

This block provides the standard function Suppressing messages using the MsgLock parameter (Page 205).

Interlocks

This block provides the following interlocks:

- Activation enable
- Interlock without reset ("Interlock")
- Interlock with reset ("Protection")

Refer to the section Interlocks (Page 99) as well as Influence of the signal status on the interlock (Page 103).

Motor protection function

This block provides the standard function Motor protection function (Page 99).

Disabling interlocks

This block provides the standard function Disabling interlocks (Page 103).

Rapid stop for motors

This block provides the standard function Rapid stop for motors (Page 106).

Resetting the block in case of interlocks or errors

This block provides the standard function Resetting the block in case of interlocks or errors (Page 43).

External error (`FaultExt`), external control system fault (`CSF`)

This block provides the possibility to pass an external error via the `FaultExt` parameter or an external control system fault via the `CSF` parameter. See MotL error handling (Page 1085)

Group error

This block provides the standard function Outputting group errors (Page 122).

The following parameters are taken into consideration when forming the group error:

- `CSF`
- `Trip`
- `MonDynErr`
- `MonStaErr`
- `FaultExt`

Outputting a signal for start readiness

This block provides the standard function Outputting a signal for start readiness (Page 53).

Restart lock after switching off the motor

After switching off or stopping the motor, it can only be restarted after the time set with the `IdleTime` input parameter.

When the "Stop" command is given, the motor goes immediately into "Stop" mode, and `IdleTime` starts after the feedback (`FbkRun = 0`) is given. The motor cannot be started again until the `IdleTime` has expired.

The `IdleTime` parameter can be set independently of the `MonTiDynamic` parameter.

Forming the group status for interlocks

This block provides the standard function Forming the group status for interlock information (Page 104).

Forming the signal status for blocks

This block provides the standard function Forming and outputting the signal status for technologic blocks (Page 109).

The worst signal status `ST_Worst` for the block is formed from the following parameters:

- `LocalLi.ST`
- `StartLocal.ST`
- `StopLocal.ST`
- `Trip.ST`
- `FbkRunOut.ST`
- `AV_Out.ST`
- `StartChn.ST`
- `StartAut.ST` (only if `Feature2.Bit10 = 1`)
- `StopAut.ST` (only if `Feature2.Bit10 = 1`)

Considering bad quality of automatic commands or external values

If the `Feature2` bit Considering bad quality of automatic commands or external values (Page 186) is set to 1 and one of the following parameters has bad signal status (16#00 or 16#28), the block goes to the neutral position (motor stop) in the "Automatic" mode:

- `StartAut.ST`
- `StopAut.ST`

Forcing operating modes

This block provides the standard function Forcing operating modes (Page 41).

The following states can be enforced:

- "Start" (`StartForce`)
- "Stop" (`StopForce`)

Feedback monitoring

This block provides the standard function Monitoring the feedbacks (Page 97).

Release for maintenance

This block provides the standard function Release for maintenance (Page 64).

Specify warning times for control functions

This block provides the standard function Specifying warning times for control functions at motors and valves (Page 51).

You can generate warning signals when, for example, motors are started. Warning signals can be generated in the following modes:

- Manual mode (Page 75) (`WarnTiMan` input parameter)
- Automatic mode (Page 75) (`WarnTiAut` input parameter)

You specify the warning times in seconds using the input parameters `WarnTiMan` and `WarnTiAut`. If, for example, a motor is started, then this is displayed at the output parameter with `WarnAct = 1`. The motor then starts after the set warning time has expired and `WarnAct` then goes back to 0.

A corresponding warning is not output if the warning times (`WarnTiMan` or `WarnTiAut`) are specified with a smaller value than the `SampleTime` parameter.

Simulating signals

This block provides the standard function Simulating signals (Page 58).

You can simulate the following values:

- Additional value (`SimAV`, `SimAV_Li`)

Selecting a unit of measure

This block provides the standard function Selecting a unit of measure (Page 212).

Neutral position

This block provides the standard function Neutral position for motors, valves and controllers (Page 48).

Output signal as a pulse signal or static signal

This block provides the standard function Output signal as a static signal or pulse signal (Page 51).

Generating instance-specific messages

This block provides the standard function Generating instance-specific messages (Page 204).

Configurable reactions using the `Feature` parameter

You can find an overview of all reactions provided by the `Feature` parameter in the section Configurable functions using the Feature I/O (Page 131). The following functionality is available for this block at the relevant bits:

Bit	Function
0	Set startup characteristics (Page 138)
1	Reaction to the out of service mode (Page 177)
2	Resetting the commands for changing the mode (Page 161)
3	Enabling resetting of commands for the control settings (Page 161)
4	Setting switch or button mode (Page 167)
9	Resetting via input signals in the event of interlocking (Protection) or errors (Page 163)
10	Exiting local mode (Page 177)
11	Activating the run time of feedback signals (Page 153)
14	Enabling rapid stop via faceplate (Page 168)
13	Separate monitoring time for stopping the motor (Page 169)
17	Enabling bumpless switchover to automatic mode for valves, motors, and dosers (Page 173)
18	Activating error state for external process control error CSF (Page 151)
19	Reset even with locked state (Page 165)
20	Disable calculation of impulse control in LocalSetting 2 and 4 (Page 186)
21	Enable bumpless switchover to "Automatic" mode for operator only (Page 172)
22	Update acknowledgment and error status of the message call (Page 160)
24	Enabling local operator authorization (Page 158)
25	Suppression of all messages (Page 174)
26	Reaction of the switching points in the "Out of service" operating mode (Page 176)
27	Interlock display with LocalSetting 2 or 4 (Page 178)
28	Disabling operating points (Page 145)
29	Signaling limit violation (Page 170)
30	Set reset depending on the operating mode or the LiOp parameter (Page 163)
31	Activating reset of protection / error in manual mode (Page 165)

In pushbutton operation (Bit 4 = 0) the automatic commands in "automatic" mode are latching, in other words `StartAut`, `StopAut` can be reset to 0 after changing the control. In "manual" and "local" modes, however, the automatic commands are not saved and in the absence of automatic commands the automatic control is tracked.

In switching mode (Bit 4 = 1), the control is selected with the static signal `StartAut`. If `StartAut` input is not set the motor is stopped. Control via `StopAut` is not needed. If the

"Activate command reset for control" function (Bit 3 = 1) is also activated, the StartAut input is reset to the neutral position after evaluation in the block.

Configurable reactions using the Feature2 parameter

Bit	Function
2	Separate evaluation for excluded and simulated interlock signals (Page 152)
3	Control priority in the event of an invalid input command (Page 175)
4	Setting switch or button mode for local commands (Page 181)
5	Evaluation of the signal status of the interlock signals (Page 142)
8	Forcing operating modes in the "Local" mode (Page 184)
10	Considering bad quality of automatic commands or external values (Page 186)
11	Suppress MsgLock and "Out of service" mode for a connected message block (Page 188)

Displaying auxiliary values

This block provides the standard function Displaying auxiliary values (Page 211).

Connection of the time-stamped messages from EventTs or Event16Ts

This block provides the standard function Connection of the time-stamped messages from EventTs or Event16Ts (Page 207).

SIMATIC BATCH functionality

This block provides the standard function SIMATIC BATCH functionality (Page 67).

Button labels

This block provides the standard function Labeling of buttons and text (Page 209).

Instance-specific text can be configured for the following parameters:

- StartMan
- StopMan
- RapidStp

See also

MotL messaging (Page 1086)

MotL I/Os (Page 1088)

MotL block diagram (Page 1096)

MotL modes (Page 1077)

Description of MotL (Page 1073)

7.2.4 MotL error handling

Error handling of MotL

Refer to section Error handling (Page 119) in the basic instructions for the error handling of all blocks.

The following errors can be displayed for this block:

- Error numbers
- Mode switchover error
- Control system fault (CSF)
- Invalid input signals

Overview of error numbers

The `ErrorNum` I/O can be used to output the following error numbers:

Error number	Meaning of the error number
-1	Predefined value when inserting the block; the block is not executed.
0	There is no error.
41	The value for the <code>LocalSetting</code> I/O is not within the approved limit of 0 to 4.
42	<code>LocalSetting = 0 or LocalSetting = 3 or LocalSetting = 4 and LocalLi = 1</code>
51	<code>StartLocal = 1 and StopLocal = 1</code> <code>StartAut = 1 and StopAut = 1</code> <code>AutModLi = 1 and ManModLi = 1</code> <code>StartForce = 1 and StopForce = 1</code>
52	<code>LocalAct = 1 and LocalSetting = 2 or 4 and SimOn = 1</code>

Mode switchover error

This error can be output by the block, see the section Error handling (Page 119).

Invalid input signals

This error can be output by the block, see the section Error handling (Page 119).

For the following invalid input signals, the control output can be kept or switched to the neutral position. This depends on the function Control priority in the event of an invalid input command (Page 175).

Operating mode	Invalid input signal	Control reaction with Feature2 bit 3 = 1
Local: Localsetting = 1 or Localsetting = 3	Pushbutton operation for local mode (Feature2 bit 4 = 0): StartLocal = 1 and StopLocal = 1	Motor is stopped
Local: Localsetting = 1 or Localsetting = 3 and forcing	StartForce = 1 and StopForce = 1	
Forcing and no "local mode"	StartForce = 1 and StopForce = 1	
"Automatic mode" and no forcing	Pushbutton operation (Feature bit 4 = 0): StartAut = 1 and StopAut = 1	
"Manual mode" and no forcing	StopMan = 1 and StartMan = 1	

Control system fault (CSF)

An external signal can be activated via the CSF input. A control system fault is triggered if this signal changes to 1. Refer to the Error handling (Page 119) section for more on this.

See also

- MotL block diagram (Page 1096)
- MotL I/Os (Page 1088)
- MotL messaging (Page 1086)
- MotL functions (Page 1078)
- MotL modes (Page 1077)
- Description of MotL (Page 1073)

7.2.5 MotL messaging

Messaging

The following messages can be generated for this block:

- Process control fault
- Instance-specific messages

Process control fault

The following control system error messages can be output:

Message instance	Message identifier	Message class	Event
MsgEvId1	SIG 1	AS process control message - fault	\$\$BlockComment\$\$ Motor feedback error
	SIG 2	AS process control message - fault	\$\$BlockComment\$\$ Motor protection triggered
	SIG 3	AS process control message - fault	\$\$BlockComment\$\$ External error has occurred

Explanation:

\$\$BlockComment\$\$: Content of the instance-specific comment

You can interconnect an external fault (signal) to input parameter *CSF*. If it changes to *CSF* = 1, a process control fault is triggered (MsgEvId1, SIG 3).

Instance-specific messages

You can use up to three instance-specific messages with this block.

Message instance	Message identifier	Message class	Event
MsgEvId1	SIG 4	AS process control message - fault	\$\$BlockComment\$\$ External message 1
	SIG 5	AS process control message - fault	\$\$BlockComment\$\$ External message 2
	SIG 6	AS process control message - fault	\$\$BlockComment\$\$ External message 3

Explanation:

\$\$BlockComment\$\$: Content of the instance-specific comment

Associated values for message instance **MsgEvId1**

Associated value	Block parameters
1	BatchName
2	StepNo
3	BatchID
4	ExtVal04
5	ExtVal05
6	ExtVal06
7	ExtVal07
8	ExtVal08

7.2 MotL - Motor (Large)

Associated value	Block parameters
9	Reserved
10	Reserved

The associated values 4 ... 8 are allocated to the parameters ExtVa104 ... ExtVa108 , and can be used. Additional information is available in the "Process Control System PCS 7 - Engineering System" manual.

See also

- Description of MotL (Page 1073)
- MotL functions (Page 1078)
- MotL I/Os (Page 1088)
- MotL block diagram (Page 1096)
- MotL error handling (Page 1085)
- MotL modes (Page 1077)

7.2.6 MotL I/Os

I/Os of MotL

Input parameters

Parameter	Description	Type	Default
AutModLi*	1 = "Automatic mode" via interconnection or SFC (controlled by ModLiOp = 1)	STRUCT <ul style="list-style-type: none"> • Value: BOOL • ST: BYTE 	- <ul style="list-style-type: none"> • 0 • 16#80
AutModOp*	1 = "Automatic mode" via operator (controlled by ModLiOp = 0)	BOOL	0
AV	Input additional analog value, to be connected to AV_Tech of the AV block	ANY	
AV_AH_Lim	Limit high alarm	REAL	95.0
AV_AL_Lim	Limit low alarm	REAL	5.0
AV_Hyst	Hysteresis for alarm, warning and tolerance limits	REAL	1.0
AV_TH_Lim	Limit high tolerance	REAL	85.0
AV_TL_Lim	Limit low tolerance	REAL	15.0
AV_WH_Lim	Limit high warning	REAL	90.0
AV_WL_Lim	Limit low warning	REAL	10.0
BatchEn	1 = Enable allocation	BOOL	0
BatchID	Batch ID	DWORD	16#00000000
BatchName	Batch name	S7-String	

Parameter	Description	Type	Default
BypProt	1 = Bypassing interlock in "local mode" and in "simulation"	BOOL	0
CSF	1 = External error (control system fault) Error handling (Page 119)	STRUCT <ul style="list-style-type: none"> Value: BOOL ST: BYTE 	- <ul style="list-style-type: none"> 0 16#80
EN	1 = Called block will be processed	BOOL	1
EventTsIn	For interconnecting data between a technology block and the message blocks EventTs, Event16Ts. The EventTsIn input parameter serves to interconnect the EventTsOut output parameter of the EventTs, Event16Ts block. When this interconnection is configured, the messages of the EventTs, Event16Ts block are displayed on the OS in the alarm view of the technology block and can also be acknowledged there.	ANY	
EventTs2In	For interconnecting data between a technology block and the message blocks EventTs, Event16Ts. The EventTs2In input parameter serves to interconnect the EventTsOut output parameter of the EventTs, Event16Ts block. When this interconnection is configured, the messages of the EventTs, Event16Ts block are displayed on the OS in the alarm view of the technology block and can also be acknowledged there.	ANY	
ExtMsg1	Binary input for freely selectable message 1	STRUCT <ul style="list-style-type: none"> Value: BOOL ST: BYTE 	- <ul style="list-style-type: none"> 0 16#80
ExtMsg2	Binary input for freely selectable message 2	STRUCT <ul style="list-style-type: none"> Value: BOOL ST: BYTE 	- <ul style="list-style-type: none"> 0 16#80
ExtMsg3	Binary input for freely selectable message 3	STRUCT <ul style="list-style-type: none"> Value: BOOL ST: BYTE 	- <ul style="list-style-type: none"> 0 16#80
ExtVal04	Associated value 4 for messages (MsgEvID1)	ANY	
ExtVal05	Associated value 5 for messages (MsgEvID1)	ANY	
ExtVal06	Associated value 6 for messages (MsgEvID1)	ANY	
ExtVal07	Associated value 7 for messages (MsgEvID1)	ANY	

Motor and valve blocks

7.2 MotL - Motor (Large)

Parameter	Description	Type	Default
ExtVal108	Associated value 8 for messages (MsgEvID1)	ANY	
FaultExt	1 = External error Error handling (Page 119)	STRUCT • Value: BOOL • ST: BYTE	- • 0 • 16#80
FbkRun	Feedback for starting is present: 1 = Start 0 = Stop	STRUCT • Value: BOOL • ST: BYTE	- • 0 • 16#FF
Feature	I/O for additional functions (Page 1078) Separate monitoring time for stopping the motor	STRUCT • Bit 0: BOOL • ... • Bit 13: BOOL • ... • Bit 31: BOOL	- • 0 • 0 • 0 • 0 • 0
Feature2	I/O for additional functions (Page 1078)	STRUCT • Bit 0: BOOL • ... • Bit 31: BOOL	- • 0 • 0 • 0
IdleTime*	Wait time for restart in [s]	REAL	5.0
Intlock	0 = Interlocking without reset is active; you can operate the block without reset once the interlocking condition has dis- appeared 1 = Interlock not activated	STRUCT • Value: BOOL • ST: BYTE • Bit 1: BOOL (Bypass information bit)	- • 1 • 16#FF • 0
Intl_En	1 = Interlock without reset (interlock, Intlock parameter) is active	BOOL	1
LocalLi	1 = Activate "local mode" via plant signal	STRUCT • Value: BOOL • ST: BYTE	- • 0 • 16#80
LocalOp*	1 = "Local mode" via operator	BOOL	0
LocalSetting	Properties for the Local mode (Page 79)	INT	0
ManModLi*	1 = "Manual mode" via interconnection or SFC (controlled by ModLiOp = 1)	STRUCT • Value: BOOL • ST: BYTE	- • 0 • 16#80
ManModOp*	1 = "Manual mode" via OS operator (con- trolled by ModLiOp = 0)	BOOL	1
ModLiOp	Switchover of operating mode between: 0 = Operator 1 = Interconnection or SFC	STRUCT • Value: BOOL • ST: BYTE	- • 0 • 16#80
Monitor	1 = Feedback monitoring	BOOL	1

Parameter	Description	Type	Default
MonTiDynamic*	Monitoring time for feedback errors or feedback start error after successful operation in [s]	REAL	3.0
MonTiDyStop*	Monitoring time for feedback stop errors after successful operation in [s]	REAL	3.0
MonTiStatic*	Monitoring time for feedback errors without operation in [s]	REAL	3.0
MS_RelOp*	1= Release for maintenance via OS operator	BOOL	0
MsgEvId1	Message number (assigned automatically)	DWORD	16#00000000
MsgLock	1 = Suppress process messages. See also the section Suppressing messages using the MsgLock parameter (Page 205) for more on this.	STRUCT • Value: BOOL • ST: BYTE	- • 0 • 16#80
Occupied	1 = In use by a batch	BOOL	0
OosLi	1 = "Out of service", via interconnection or SFC (0-1 edge transition)	STRUCT • Value: BOOL • ST: BYTE	- • 0 • 16#80
OosOp*	1 = "Out of service", via OS operator	BOOL	0
OpSt_In	Input parameter for local operator authorization, connected with the <code>Out</code> output parameter of the upstream block, <code>OpStations</code> (Page 411)	DWORD	16#00000000
OS_Perm	I/O for operator permissions (Page 1078) 1 = Operator can set or change the monitoring time for "Control: Start" 1 = Operator can set or change the monitoring time for "Control: Stop"	STRUCT • Bit 0: BOOL • Bit 8: BOOL • Bit 20: BOOL • Bit 30: BOOL	- • 1 • 1 • 1 • 1
Permit	1 = OS activation enable for motor 0 = No OS release for energizing motor	STRUCT • Value: BOOL • ST: BYTE • Bit 1: BOOL (Bypass information bit)	- • 1 • 16#FF • 0
Perm_En	1 = Activation enable (enable, <code>Permit</code> parameter) is active	BOOL	1
Protect	0 = Protective interlocking is effective; once the interlocking condition has disappeared, you will have to reset the block 1 = Protective interlocking not activated	STRUCT • Value: BOOL • ST: BYTE • Bit 1: BOOL (Bypass information bit)	- • 1 • 16#FF • 0

Motor and valve blocks

7.2 MotL - Motor (Large)

Parameter	Description	Type	Default
Prot_En	1 = Protective interlock (protection, Protect parameter) is active	BOOL	1
PulseWidth*	Pulse width of control signal [s]	REAL	3.0
RapidStp*	Rapid stop for the motor: 0 = Motor On 1 = Motor Off	BOOL	0
RstLi*	1 = Reset via interconnection	STRUCT • Value: BOOL • ST: BYTE	- • 0 • 16#80
RstOp*	1 = Reset via operator	BOOL	0
RunUpCyc	Number of cycles in startup; messages are suppressed during these cycles	INT	3
SampleTime	Sampling time [s] (assigned automatically)	REAL	0.1
SimAV*	Additional value used for SimOn = 1	REAL	0.0
SimAV_Li	Additional analog value that is used for SimOnLi.Value = 1 (SimLiOp.Value = 1)	STRUCT • Value: REAL • ST: BYTE	- • 0 • 16#80
SimLiOp	Activation/deactivation of the simulation 0 = Operator 1 = Interconnection or SFC	STRUCT • Value: BOOL • ST: BYTE	- • 0 • 16#80
SimOnLi	1 = Simulation via interconnection or SFC (controlled by SimLiOp = 1)	STRUCT • Value: BOOL • ST: BYTE	- • 0 • 16#80
SimOn*	1 = Simulation on	BOOL	0
SelFp1	Call a block saved in this parameter as an additional faceplate (Page 208) in the standard view	ANY	-
SelFp2	Call a block saved in this parameter as an additional faceplate (Page 208) in the preview	ANY	-
StartAut*	1 = Starting the motor in "automatic mode"	STRUCT • Value: BOOL • ST: BYTE	- • 0 • 16#80
StartChnST	Signal status of output channel Start Should be connected to an output channel block	STRUCT • Value: BOOL • ST: BYTE	- • 0 • 16#FF
StartForce	1 = Force motor start	STRUCT • Value: BOOL • ST: BYTE	- • 0 • 16#80
StartLocal	1 = Starting the motor in "local mode"	STRUCT • Value: BOOL • ST: BYTE	- • 0 • 16#80

Parameter	Description	Type	Default
StartMan*	1 = Starting the motor in "manual mode"	BOOL	0
StepNo	Batch step number	DWORD	16#00000000
StopAut*	1 = Stopping the motor in "automatic mode"	STRUCT <ul style="list-style-type: none"> Value: BOOL ST: BYTE 	- <ul style="list-style-type: none"> 0 16#80
StopForce	1 = Force motor stop	STRUCT <ul style="list-style-type: none"> Value: BOOL ST: BYTE 	- <ul style="list-style-type: none"> 0 16#80
StopLocal	1 = Stopping the motor in "local mode"	STRUCT <ul style="list-style-type: none"> Value: BOOL ST: BYTE 	- <ul style="list-style-type: none"> 0 16#80
StopMan*	1 = Stopping the motor in "manual mode"	BOOL	0
Trip	1 = Motor is in "good" state	STRUCT <ul style="list-style-type: none"> Value: BOOL ST: BYTE 	- <ul style="list-style-type: none"> 1 16#FF
UserAna1	Analog auxiliary value 1	STRUCT <ul style="list-style-type: none"> Value: REAL ST: BYTE 	- <ul style="list-style-type: none"> 0.0 16#FF
UA1unit	Unit of measure for analog auxiliary value 1	INT	0
UserAna2	Analog auxiliary value 2	STRUCT <ul style="list-style-type: none"> Value: REAL ST: BYTE 	- <ul style="list-style-type: none"> 0.0 16#FF
UA2unit	Unit of measure for analog auxiliary value 2	INT	0
UserStatus	Freely assignable bits for use in PCS 7 OS	BYTE	16#00
WarnTiAut	Prewarning of motor start in "automatic mode" in [s]	REAL	0.0
WarnTiMan	Prewarning of motor start in "manual mode" in [s]	REAL	0.0

* Values can be written back to these inputs during processing of the block by the block algorithm.

Output parameters

Parameter	Description	Type	Default
AutAct	1 = "Automatic mode" enabled 0 = "Manual mode" is enabled	STRUCT <ul style="list-style-type: none"> Value: BOOL ST: BYTE 	- <ul style="list-style-type: none"> 0 16#80
AutoST	1 = Worst signal status of automatic commands	BYTE	16#80

Motor and valve blocks

7.2 MotL - Motor (Large)

Parameter	Description	Type	Default
AV_OpScale	Limit for scale in AV bar graph of face-plate	STRUCT <ul style="list-style-type: none"> • High: REAL • Low: REAL 	- <ul style="list-style-type: none"> • 100.0 • 0.0
AV_Out	Output additional analog value	STRUCT <ul style="list-style-type: none"> • Value: REAL • ST: BYTE 	- <ul style="list-style-type: none"> • 0.0 • 16#80
AV_Unit	Unit of measure for additional analog value	INT	0
CurrMon	Current monitoring time [s]	DINT	0
ENO	1 = Block algorithm completed without errors	BOOL	0
ErrorNum	Output of pending error number. For error numbers that can be output by this block, see MotL error handling (Page 1085)	INT	-1
FbkRunOut	Feedback for starting is present: 1 = Start 0 = Stop	STRUCT <ul style="list-style-type: none"> • Value: BOOL • ST: BYTE 	- <ul style="list-style-type: none"> • 0 • 16#80
GrpErr	1 = Group error pending	STRUCT <ul style="list-style-type: none"> • Value: BOOL • ST: BYTE 	- <ul style="list-style-type: none"> • 0 • 16#80
LocalAct	1 = "Local mode" enabled	STRUCT <ul style="list-style-type: none"> • Value: BOOL • ST: BYTE 	- <ul style="list-style-type: none"> • 0 • 16#80
LockAct	1 = Interlock (Intlock, Permit, Protect) or Trip is active	STRUCT <ul style="list-style-type: none"> • Value: BOOL • ST: BYTE 	- <ul style="list-style-type: none"> • 0 • 16#80
ManAct	1 = "Manual mode" enabled	STRUCT <ul style="list-style-type: none"> • Value: BOOL • ST: BYTE 	- <ul style="list-style-type: none"> • 1 • 16#80
MonDynErr	1 = Feedback error or feedback start error due to control change	STRUCT <ul style="list-style-type: none"> • Value: BOOL • ST: BYTE 	- <ul style="list-style-type: none"> • 0 • 16#80
MonDynStopErr	1 = Feedback stop error due to control change	STRUCT <ul style="list-style-type: none"> • Value: BOOL • ST: BYTE 	- <ul style="list-style-type: none"> • 0 • 16#80
MonStaErr	1 = Feedback error due to unexpected feedback change	STRUCT <ul style="list-style-type: none"> • Value: BOOL • ST: BYTE 	- <ul style="list-style-type: none"> • 0 • 16#80
MS_Release	Release for maintenance: 1 = Release for OS operator	STRUCT <ul style="list-style-type: none"> • Value: BOOL • ST: BYTE 	- <ul style="list-style-type: none"> • 0 • 16#80

Parameter	Description	Type	Default
MsgAckn1	Message acknowledgement status 1 (output <code>ACK_STATE</code> of first <code>ALARM_8P</code>)	WORD	16#0000
MsgErr1	Alarm error 1 (output <code>ERROR</code> of first <code>ALARM_8P</code>)	BOOL	0
MsgStat1	Message status 1 (output <code>STATUS</code> of first <code>ALARM_8P</code>)	WORD	16#0000
OosAct	1 = Block is "Out of service"	STRUCT <ul style="list-style-type: none"> Value: BOOL ST: BYTE 	- <ul style="list-style-type: none"> 0 16#80
OpSt_Out	Value of the <code>OpSt_In</code> input parameter, for feedforwarding to other blocks. Bit 31 of this parameter is used by <code>Feature</code> bit 24	DWORD	16#00000000
OS_PermOut	Display of <code>OS_Perm</code>	DWORD	16#FFFFFFFF
OS_PermLog	Display of <code>OS_Perm</code> with settings changed by the block algorithm	DWORD	16#FFFFFFFF
P_Rst	1= Pulse output for reset The parameter persists for one cycle after a reset.	STRUCT <ul style="list-style-type: none"> Value: BOOL ST: BYTE 	- <ul style="list-style-type: none"> 0 16#80
P_Stop	0 = Pulse signal for stopping the motor	STRUCT <ul style="list-style-type: none"> Value: BOOL ST: BYTE 	- <ul style="list-style-type: none"> 1 16#80
P_Start	1 = Pulse signal for starting the motor	STRUCT <ul style="list-style-type: none"> Value: BOOL ST: BYTE 	- <ul style="list-style-type: none"> 0 16#80
R_StpAct	1 = Rapid stop of the motor is active	STRUCT <ul style="list-style-type: none"> Value: BOOL ST: BYTE 	- <ul style="list-style-type: none"> 0 16#80
RdyToReset	1 = Ready for reset via <code>RstLi</code> input or commands in "local", "automatic", or "manual mode"	STRUCT <ul style="list-style-type: none"> Value: BOOL ST: BYTE 	- <ul style="list-style-type: none"> 0 16#80
RdyToStart	1 = Active start readiness	STRUCT <ul style="list-style-type: none"> Value: BOOL ST: BYTE 	- <ul style="list-style-type: none"> 0 16#80
Run	1 = Motor is running	STRUCT <ul style="list-style-type: none"> Value: BOOL ST: BYTE 	- <ul style="list-style-type: none"> 0 16#80
ST_Worst	Worst signal status	BYTE	16#80
Start	1 = Control of motor: started	STRUCT <ul style="list-style-type: none"> Value: BOOL ST: BYTE 	- <ul style="list-style-type: none"> 0 16#80
Status1	Status word 1 (Page 1073)	DWORD	16#00000000
Status2	Status word 2 (Page 1073)	DWORD	16#00000000

7.2 MotL - Motor (Large)

Parameter	Description	Type	Default
Status3	Status word 3 (Page 1073)	DWORD	16#00000000
Status4	Status word 4 (Page 1073)	DWORD	16#00000000
Stop	1 = Motor stopped	STRUCT <ul style="list-style-type: none">• Value: BOOL• ST: BYTE	- <ul style="list-style-type: none">• 0• 16#80
WarnAct	1 = Prewarning for motor start active (parameters WarnTiAut and WarnTiMan)	STRUCT <ul style="list-style-type: none">• Value: BOOL• ST: BYTE	- <ul style="list-style-type: none">• 0• 16#80

See also

MotL modes (Page 1077)

MotL block diagram (Page 1096)

MotL messaging (Page 1086)

7.2.7 MotL block diagram

MotL block diagram

A block diagram is not provided for this block.

See also

MotL I/Os (Page 1088)

MotL messaging (Page 1086)

MotL error handling (Page 1085)

MotL functions (Page 1078)

MotL modes (Page 1077)

Description of MotL (Page 1073)

7.2.8 Operator control and monitoring

7.2.8.1 MotL views

Views of the MotL block

The MotL block provides the following views:

- MotL standard view (Page 1097)
- Alarm view (Page 302)
- Limit view of motors (Page 294)
- Trend view (Page 305)
- Parameter view for motors and valves (Page 286)
- MotL preview (Page 1101)
- Memo view (Page 304)
- Batch view (Page 302)
- Block icon for MotL (Page 1104)

Refer to the sections Structure of the faceplate (Page 248) and Block icon structure (Page 230) for general information on the faceplate and block icon.

7.2.8.2 MotL standard view

MotLstandard view

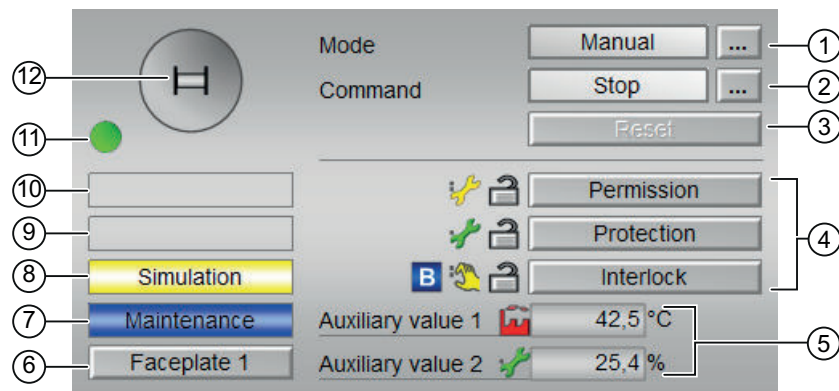

(1) Displaying and switching the operating mode

This area provides information on the currently valid operating mode. The following operating modes can be shown here:

- Manual and automatic mode for motors, valves and dosers (Page 75)
- Manual and automatic mode for motors, valves and dosers (Page 75)
- Local mode (Page 79)
- Out of service (Page 71)

Refer to section Switching operating states and operating modes (Page 257) for information on switching the operating mode.

(2) Starting and stopping the motor

This area shows you the default operating state for the motor. The following states can be shown and executed here:

- "Start"
- "Stop"
- "Rapid stop"

Refer to the Switching operating states and operating modes (Page 257) section for information on changing the state.

If text is configured for these commands, it is displayed as status text and as button labels for command selection. You can find more information about this in section Labeling of buttons and text (Page 209)

(3) Resetting the block

Click "Reset" for interlocks or errors. You can find additional information on this in the section Resetting the block in case of interlocks or errors (Page 43).

(4) Operator control and display area for interlock functions of the block

This display is only visible when the corresponding block input is connected.

You can use this button to control the interlock functions of the block. You can find additional information on this in the section Interlocking functions (Page 99).

The following is displayed in addition to the buttons:

- Interlock status (see Forming the group status for interlock information (Page 104)), e.g.:



- Signal status (see Forming and outputting the signal status for technologic blocks (Page 109)), e.g.:



- Bypass information (see Forming the group status for interlock information (Page 104)):



(5) Display of auxiliary values

This display is only visible when the corresponding block input is connected.

You can use this area to display two auxiliary values that have been configured in the engineering system (ES). You can find additional information on this in the section Displaying auxiliary values (Page 211).

(6) Navigation button for switching to the standard view of any faceplate

This display is only visible when the corresponding block input is connected.

Use this navigation button to open the standard view of a block configured in the engineering system (ES). The visibility of this navigation button depends on the configuration in the engineering system (ES).

You can find additional information on this in the section Opening additional faceplates (Page 208).

(7) Display area for block states

This area provides additional information on the operating state of the block:

- "Maintenance"

Additional information on this is available in section Release for maintenance (Page 64) Display area for block states.

(8) Display area for block states

This area provides additional information on the operating state of the block:

- "Simulation"
- "Delay"

You will find more detailed information on this in the sections Simulating signals (Page 58) and Display of delay times (Page 256).

(9) Display area for block states

This area provides additional information on the operating state of the block (from high to low according to priority):

- "Motor protection"
- "External error"
- "Status error"
- "Control error"
- "Invalid signal"
- "Changeover error"

Additional information on these errors is available in the sections Monitoring the feedbacks (Page 97) , Error handling (Page 119) (section "Invalid input signals" and "Mode switchover error") and Motor protection function (Page 99).

(10) Display area for block states

This area provides additional information on the operating state of the block:

- "Forced start"
- "Forced stop"
- "Request 0/1": A reset to "automatic mode" is expected.

You can find additional information on this in the section Forcing operating modes (Page 41).

(11) Automatic preview

This display is only visible in "manual mode", in "local mode", or with a reset request in "automatic mode", when the current output signals are not identical to the control in "automatic mode".

The display shows what state the motor would assume if you switched from "manual" or "local" mode to "automatic mode", or performed a reset to "automatic mode".

(12) Status display of the motor

The current status of the motor is graphically displayed here.

You can find more information about this in section Block icon for MotL (Page 1104)

7.2.8.3 MotL preview

Preview of MotL

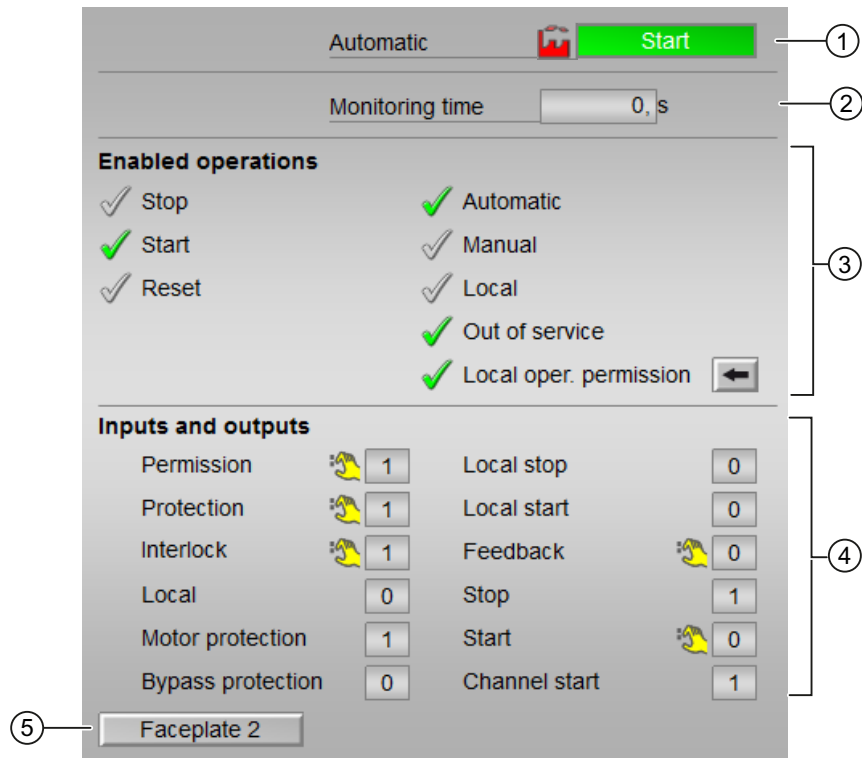

Display of the current monitoring time is visible.

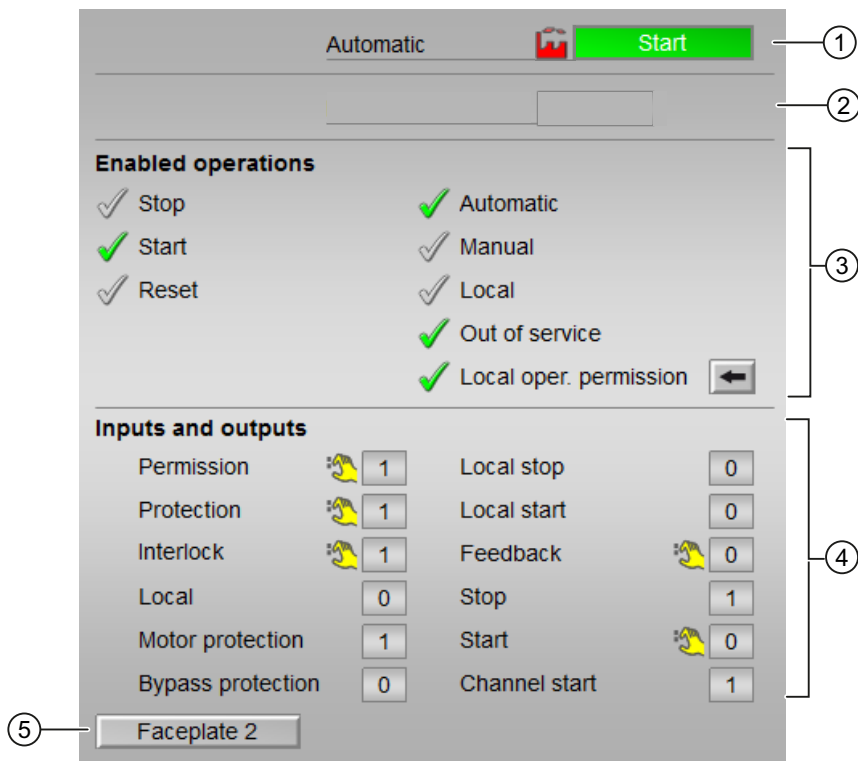

Display of the current monitoring time is not visible.

(1) Automatic preview

This area shows you the block status after it has switched from the "Manual" mode or "Local" mode to the "Automatic" mode.

If the block is in "Automatic" mode, the current block state is displayed.

This area also displays the worst signal status of the following automatic commands:

- StartAut
- StopAut

(2) Monitoring time

The current "Monitoring time" is displayed in this area.

(3) Enable operations

This area shows all operations for which special operator permissions are assigned. They depend on the configuration in the engineering system (ES) that applies to this block.

Icons for enabled operation:

- **Green check mark:** the OS operator can control this parameter
- **Gray check mark:** the OS operator cannot control this parameter at this time due to the process
- **Red cross:** the OS operator cannot control this parameter due to the configured AS operator permissions (OS_Perm or OS1Perm)

The following enabled operations are shown here:

- "Stop": You can stop the motor.
If text is configured for this command, it is also displayed in brackets. You can find additional information on this in the section Labeling of buttons and text (Page 209).
- "Start": You can start the motor.
If text is configured for this command, it is also displayed in brackets. You can find additional information on this in the section Labeling of buttons and text (Page 209).
- "Reset": You can reset the motor after interlocks or errors.
- "Automatic": You can switch to "automatic mode".
- "Manual": You can switch to "manual mode".
- "Local": You can switch to "local mode".
- "Out of service": You can switch to "Out of service" operating mode.
- "Local operator permission": Use the ← button to switch to the standard view of the OpStations block. You can find additional information on this in the section Operator control permissions (Page 254).
- "Monitoring time": Display of the current monitoring time.

(4) Displaying current control signals

This area shows the most important parameters for this block with the current selection:

- "Permission":
This display is only visible when the corresponding block input is connected.
 - 0 = No OS release for energizing motor
 - 1 = Enable for "starting"/"stopping" from the neutral position
- "Protection":
This display is only visible when the corresponding block input is connected.
 - 0 = Protective interlocking is effective; once the interlocking condition has disappeared, you will have to reset the block
 - 1 = "Good" state
- "Interlock":
This display is only visible when the corresponding block input is connected.
 - 0 = Interlocking without reset is active; you can operate the block without reset once the interlocking condition has disappeared
 - 1 = "Good" state

- "Local correct": 1 = Control signal for "Local mode" (LocalLi) is active
- "Motor protection": 1 = Motor is in "good" state
- "Interlock deact.":
 - 0 = Bypass disabled
 - 1 = Bypassing interlock in "local mode" and in "simulation"
- "Local stop": 1 = Stopping the motor in "local mode"
- "Local start": 1 = Starting the motor in "local mode"
- "Feedback →": 1 = Motor has started and is running
- "Stop": 1 = Stop motor
- "Start": 1 = Start motor
- "Channel Start": Signal from the output channel block "Start"

(5) Navigation button for switching to the standard view of any faceplate

This display is only visible when the corresponding block input is connected.

Use this navigation button to open the standard view of a block configured in the engineering system. The visibility of this navigation button depends on the configuration in the engineering system (ES).

You can find additional information on this in the section Opening additional faceplates (Page 208).





7.2.8.4 Block icon for MotL

Block symbols for MotL







A variety of block symbols are available with the following functions:



- Process tag type
- Limits (high/low)
- Violation of alarm, warning, and tolerance limits as well as control system faults
- Operating modes
- Signal status, release for maintenance
- Displays for bypassing interlocks
- Interlocks
- Memo display
- Motor state display

The block symbols from template @TemplateAPLV8.PDL:

Symbols	Selection of the block symbol in CFC	Special features
	1	
	2	
	3	
	4	
	5	
	6	

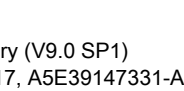
The block symbols from template @TemplateAPLV7.PDL:

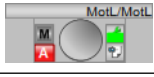
Symbols	Selection of the block symbol in CFC	Special features
	1	Block symbol in the full display
	2	
	3	
	4	
	5	
	6	
	7	
	8	







Symbols	Selection of the block symbol in CFC	Special features
	9	
	10	
	-	Block symbol in "Out of service" mode (example with type 1 block symbol)

Additional information on the block symbol and the control options in the block symbol is available in the following chapters:

- Configuring the block icons (Page 237)
- Block icon structure (Page 230)
- Operation via the block icon (Page 239)

Motor state display

The following motor states are shown here:

Symbol	Meaning
	Motor started (motor symbol changes)
	The motor is running
	Motor stopped (motor symbol changes)
	Motor idle
	Error at motor (monitoring error, motor protection)
	Motor out of service

7.3 MotS - Motor (Small)

7.3.1 Description of MotS

Object name (type + number)

Type + number: FB 1910

Family: Drives

Area of application for MotS

The block is used for the following applications:

- Controlling motors

Note

This block is also available as a large block. A comparison of the MotL and MotS blocks is available in the section: MotL compared to MotS (Page 1065)

How it works

The block is used to control motors. Various inputs are available for controlling the motor.

Configuration

Use the CFC editor to install the block in a cyclic interrupt OB (OB30 to OB38). The block is also installed automatically in the startup OB (OB100).

Startup characteristics

Use the `Feature Bit Set` startup characteristics (Page 138) to define the startup characteristics of this block.

The messages are suppressed after startup for the number of cycles set at `RunUpCyc`.

Status word allocation

For a description of the individual parameters, see the section MotS I/Os (Page 1118).

Status bit	Parameter
0	Occupied
1	BatchEn
2	SimOn
3	OosAct.Value

7.3 MotS - Motor (Small)

Status bit	Parameter
4	OosLi.Value
5	0 = ManAct.Value 1 = AutoAct.Value
6	LocalAct.Value
7	LockAct.Value
8	Start.Value
9	Motor is stopped
10	Not used
11	MonStaErr.Value
12	MonDynErr.Value
13	BypProt
14	Invalid signal status
15	Not used
16	1 = Intlock is active
17 - 18	Not used
19	Trip
20 - 22	Not used
23	"Interlock" button is enabled
24	Reset request in automatic preview
25	Not used
26	Bypass information from previous function block
27	Automatic preview for "starting"
28	Automatic preview for "stopping"
29	External error generated by FaultExt or external control system fault CSF with set Feature bit 18 Activating error state for external process control error CSF (Page 151)
30 - 31	Not used

Status word allocation for Status2 parameter

Status bit	Parameter
0	MsgLock
1 - 18	Not used
19	1 = No impact of input signals on "local mode" when LocalSetting = 2
20	Motor is stopped
21	Motor is stopping
22	Motor is starting
23	Motor is running
24	Error in motor
25	1 = Input parameter StartChnST is interconnected
26 - 29	Not used
30	Display for interlocks in block icon
31	MS_RelOp

Status word allocation for Status3 parameter

Status bit	Parameter
0 - 11	Not used
12	Hidden bypass signal in interlock
13	Not used
14	Feature2 bit 2: Separate bypass signal
15 - 23	Not used
24	Output command for "starting" the motor
25	Output command for "stopping" the motor
26	Show automatic preview in the standard view
27	Not used
28	GrpErr.Value
29	Enable for "starting" the motor
30	Not used
31	Not used

Status word allocation for Status4 parameter

Status bit	Parameter
0 - 8	Not used
9	Trip not connected
10	Do not connect FbkOutRun
11 - 31	Not used

See also

MotS messaging (Page 1116)
 MotS block diagram (Page 1123)
 MotS functions (Page 1111)
 MotS error handling (Page 1115)
 MotS modes (Page 1109)

7.3.2 MotS modes

MotS operating modes

The block can be operated using the following modes:

- Local mode (Page 79)
- Automatic mode (Page 75)

- Manual mode (Page 75)
- Out of service (Page 71)

The next section provides additional block-specific information relating to the general descriptions.

"Local mode"

You can find general information on "Local mode", switching modes and Bumpless switchover in the Local mode (Page 79) section.

Note

"Local mode" for the block MotS

In contrast to the "Large" blocks, it is only possible to perform settings in this block `LocalSetting` with 0 or 2. A "local operation" is accordingly possible only via the internal tracking of the feedback value.

"Automatic mode"

You can find general information on "Automatic mode", switching modes and Bumpless switchover in the Manual and automatic mode for motors, valves and dosers (Page 75) section.

Motor actions you can control in auto mode:

- "Start" (`StartAut = 1`)
- "Stop" (`StopAut = 1`)

Note

Information about the "Small" block

This "Small" block works with pushbutton operation. The automatic commands are therefore latching, in other words, `OpenAut`, `CloseAut` can be reset to 0 after the control is changed. In "manual" and "local" modes, however, the automatic commands are not saved and in the absence of automatic commands the automatic control is tracked.

"Manual mode"

You can find general information on "Manual mode", switching modes and bumpless switchover in the section Manual and automatic mode for motors, valves and dosers (Page 75).

Motor actions you can control in "manual mode":

- "Start" (`StartMan = 1`)
- "Stop" (`StopMan = 1`)

"Out of service"

You can find general information about the "Out of service" mode in the section Out of service (Page 71).

See also

Description of MotS (Page 1107)

MotS functions (Page 1111)

MotS error handling (Page 1115)

MotS messaging (Page 1116)

MotS I/Os (Page 1118)

MotS block diagram (Page 1123)

7.3.3 MotS functions

Functions of MotS

The functions for this block are listed below.

Opening additional faceplates

This block provides the standard function Opening additional faceplates (Page 208).

Operator permissions

This block provides the standard function Operator control permissions (Page 254).

The block has the following permissions for the `OS_Perm` parameter:

Bit	Function
0	1 = Operator can switch to "automatic mode"
1	1 = Operator can switch to "manual mode"
2	Not used
3	1 = Operator can switch to "Out of service" mode
4	1 = Operator can stop the motor
5	1 = Operator can start the motor
6	Not used
7	1 = Operator can reset the motor
8	1 = Operator can define the monitoring time for startup
9	Not used
10	1 = Operator can activate the monitoring time function (Bit 8)
12	1 = Operator can activate the Release for maintenance function
13 - 31	Not used

Note

If you interconnect a parameter that is also listed in `OS_Perm` as a parameter, you have to reset the corresponding `OS_Perm` bit.

Button labels

This block provides the standard function Labeling of buttons and text (Page 209).

Instance-specific text can be configured for the following parameters:

- `StartMan`
- `StopMan`

Interlocks

This block provides the following interlocks:

- Interlock without reset (interlock)

Refer to the section Interlocks (Page 99) as well as Influence of the signal status on the interlock (Page 103).

Suppressing messages using the `MsgLock` parameter

This block provides the standard function Suppressing messages using the `MsgLock` parameter (Page 205).

Motor protection function

This block provides the standard function Motor protection function (Page 99).

Disabling interlocks

This block provides the standard function Disabling interlocks (Page 103).

Resetting the block in case of interlocks or errors

This block provides the standard function Resetting the block in case of interlocks or errors (Page 43).

External error (`FaultExt`), external control system fault (`CSF`)

This block provides the possibility to pass an external error via the `FaultExt` parameter or an external control system fault via the `CSF` parameter. See MotS error handling (Page 1115).

Group error

This block provides the standard function Outputting group errors (Page 122).

The following parameters are taken into consideration when forming the group error:

- CSF
- Trip
- MonDynErr
- MonStaErr
- FaultExt

Forming the group status for interlocks

This block provides the standard function Forming the group status for interlock information (Page 104).

Forming the signal status for blocks

This block provides the standard function Forming and outputting the signal status for technologic blocks (Page 109).

The worst signal status `ST_Worst` for the block is formed from the following parameters:

- LocalLi.ST
- Trip.ST
- FbkRunOut.ST
- StartChn.ST
- StartAut.ST (only if `Feature2.Bit10 = 1`)
- StopAut.ST (only if `Feature2.Bit10 = 1`)

Considering bad quality of automatic commands or external values

If the `Feature2` bit Considering bad quality of automatic commands or external values (Page 186) is set to 1 and one of the following parameters has bad signal status (16#00 or 16#28), the block goes to the neutral position (motor stop) in the "Automatic" mode:

- StartAut.ST
- StopAut.ST

Outputting a signal for start readiness

This block provides the standard function Outputting a signal for start readiness (Page 53).

Feedback monitoring

This block provides the standard function Monitoring the feedbacks (Page 97).

Simulating signals

This block provides the standard function Simulating signals (Page 58).

Neutral position

This block provides the standard function Neutral position for motors, valves and controllers (Page 48).

Output signal as a static signal

This block provides the standard function Output signal as a static signal or pulse signal (Page 51).

Generating instance-specific messages

This block provides the standard function Generating instance-specific messages (Page 204).

Configurable reactions using the `Feature` parameter

You can find an overview of all reactions provided by the `Feature` parameter in the section Configurable functions using the Feature I/O (Page 131). The following functionality is available for this block at the relevant bits:

Bit	Function
0	Set startup characteristics (Page 138)
1	Reaction to the out of service mode (Page 177)
2	Resetting the commands for changing the mode (Page 161)
3	Enabling resetting of commands for the control settings (Page 161)
9	Resetting via input signals in the event of interlocking (Protection) or errors (Page 163)
10	Exiting local mode (Page 177)
11	Activating the run time of feedback signals (Page 153)
18	Activating error state for external process control error CSF (Page 151)
19	Reset even with locked state (Page 165)
24	Enabling local operator authorization (Page 158)
25	Suppression of all messages (Page 174)
27	Interlock display with LocalSetting 2 or 4 (Page 178)
30	Set reset depending on the operating mode or the LiOp parameter (Page 163)
31	Activating reset of protection / error in manual mode (Page 165)

Configurable reactions using the `Feature2` parameter

Bit	Function
2	Separate evaluation for excluded and simulated interlock signals (Page 152)
3	Control priority in the event of an invalid input command (Page 175)

Bit	Function
5	Evaluation of the signal status of the interlock signals (Page 142)
10	Considering bad quality of automatic commands or external values (Page 186)

SIMATIC BATCH functionality

This block provides the standard function SIMATIC BATCH functionality (Page 67).

Release for maintenance

This block provides the standard function Release for maintenance (Page 64).

See also

- Description of MotS (Page 1107)
- MotS messaging (Page 1116)
- MotS I/Os (Page 1118)
- MotS block diagram (Page 1123)
- MotS modes (Page 1109)
- Selecting a unit of measure (Page 212)

7.3.4 MotS error handling

Error handling of MotS

Refer to section Error handling (Page 119) in the basic instructions for the error handling of all blocks.

The following errors can be displayed for this block:

- Error numbers
- Mode switchover error
- Control system fault (CSF)
- Invalid input signals

Overview of error numbers

The `ErrorNum` I/O can be used to output the following error numbers.

Error number	Meaning of the error number
-1	Predefined value when inserting the block; the block is not executed.
0	There is no error.
41	The value for the <code>LocalSetting</code> I/O is not 0 or 2

Error number	Meaning of the error number
42	LocalSetting = 0 and LocalLi = 1
51	StartAut = 1 and StopAut = 1, AutModLi = 1 and ManModLi = 1
52	LocalAct = 1 and LocalSetting = 2 and SimOn = 1

Mode switchover error

This error can be output by the block, see the section Error handling (Page 119).

Invalid input signals

This error can be output by the block, see the section Error handling (Page 119).

For the following invalid input signals, the control output can be kept or switched to the neutral position. This depends on the function Control priority in the event of an invalid input command (Page 175).

Operating mode	Invalid input signals	Control reaction with Feature2 bit 3 =1
"Automatic mode"	StartAut = 1 and StopAut = 1	Motor is stopping
"Manual mode"	StopMan = 1 and StartMan = 1	

Control system fault (CSF)

An external signal can be activated via the CSF input. A control system fault is triggered if this signal changes to 1. Refer to the Error handling (Page 119) section for more on this.

See also

- MotS functions (Page 1111)
- MotS messaging (Page 1116)
- MotS I/Os (Page 1118)
- Description of MotS (Page 1107)
- MotS modes (Page 1109)
- MotS block diagram (Page 1123)

7.3.5 MotS messaging

Messaging

The following messages can be generated for this block:

- Process control fault
- Instance-specific messages

Process control fault

The following control system error messages can be output:

Message instance	Message identifier	Message class	Event
MsgEvId1	SIG 1	AS process control message - fault	\$\$BlockComment\$\$ Motor feedback error
	SIG 2	AS process control message - fault	\$\$BlockComment\$\$ Motor protection triggered
	SIG 3	AS process control message - fault	\$\$BlockComment\$\$ External error has occurred

Explanation:

\$\$BlockComment\$\$: Content of the instance-specific comment

You can interconnect an external fault (signal) to input parameter `CSF`. If it changes to `CSF = 1`, a process control fault is triggered (`MsgEvId1`, SIG 3).

Instance-specific messages

You have the option to use two instance-specific messages for this block.

Message instance	Message identifier	Message class	Event
MsgEvId1	SIG 4	AS process control message - fault	\$\$BlockComment\$\$ External message 1
	SIG 5	AS process control message - fault	\$\$BlockComment\$\$ External message 2

Explanation:

\$\$BlockComment\$\$: Content of the instance-specific comment.

Associated values for message instance `MsgEvId1`

Associated value	Block parameters
1	BatchName
2	StepNo
3	BatchID
4	ExtVa104
5	ExtVa105
6 - 10	Reserved

The associated values 4 ... 5 are allocated to the parameters `ExtVa104` ... `ExtVa105` and can be used. Additional information is available in the "Process Control System PCS 7 - Engineering System" manual.

See also

- Description of MotS (Page 1107)
- MotS functions (Page 1111)
- MotS error handling (Page 1115)
- MotS block diagram (Page 1123)
- MotS I/Os (Page 1118)
- MotS modes (Page 1109)

7.3.6 MotS I/Os

I/Os of MotS

Input parameters

Parameter	Description	Type	Default
AutModLi*	1 = "Automatic mode" via interconnection or SFC (controlled by ModLiOp = 1)	STRUCT <ul style="list-style-type: none"> • Value: BOOL • ST: BYTE 	- <ul style="list-style-type: none"> • 0 • 16#80
AutModOp*	1 = "Automatic mode" via operator (controlled by ModLiOp = 0)	BOOL	0
BatchEn	1 = Enable allocation	BOOL	0
BatchID	Batch ID	DWORD	16#00000000
BatchName	Batch name	S7-String	
ByProt	1 = Bypassing interlock in "local mode" and in "simulation"	BOOL	0
CSF	1 = External error (control system fault) Error handling (Page 119)	STRUCT <ul style="list-style-type: none"> • Value: BOOL • ST: BYTE 	- <ul style="list-style-type: none"> • 0 • 16#80
EN	1 = Called block will be processed	BOOL	1
ExtMsg1	Binary input for freely selectable message 1	STRUCT <ul style="list-style-type: none"> • Value: BOOL • ST: BYTE 	- <ul style="list-style-type: none"> • 0 • 16#80
ExtMsg2	Binary input for freely selectable message 2	STRUCT <ul style="list-style-type: none"> • Value: BOOL • ST: BYTE 	- <ul style="list-style-type: none"> • 0 • 16#80
ExtVa104	Associated value 4 for messages (MsgEvID1)	ANY	
ExtVa105	Associated value 5 for messages (MsgEvID1)	ANY	

Parameter	Description	Type	Default
FaultExt	1 = External error Error handling (Page 119)	STRUCT • Value: BOOL • ST: BYTE	- • 0 • 16#80
FbkRun	Feedback for starting is present: 1 = Start 0 = Stop	STRUCT • Value: BOOL • ST: BYTE	- • 0 • 16#FF
Feature	I/O for additional functions (Page 1111)	STRUCT • Bit 0: BOOL • ... • Bit 31: BOOL	- • 0 • 0 • 0
Feature2	I/O for additional functions (Page 1111)	STRUCT • Bit 0: BOOL • ... • Bit 31: BOOL	- • 0 • 0 • 0
Intlock	0 = Interlocking without reset is active; you can operate the block without reset once the interlocking condition has dis- appeared 1 = Interlock not activated	STRUCT • Value: BOOL • ST: BYTE • Bit 1: BOOL (Bypass information bit)	- • 1 • 16#FF • 0
Intl_En	1 = Interlock without reset (interlock, Intlock parameter) is active	BOOL	1
LocalLi	1 = Activate "local mode" via plant signal	STRUCT • Value: BOOL • ST: BYTE	- • 0 • 16#80
LocalSetting	Properties for the Local mode (Page 79)	INT	0
ManModLi*	1 = "Manual mode" via interconnection or SFC (controlled by ModLiOp = 1)	STRUCT • Value: BOOL • ST: BYTE	- • 0 • 16#80
ManModOp*	1 = "Manual mode" via OS operator (con- trolled by ModLiOp = 0)	BOOL	1
ModLiOp	Switchover of operating mode between: 0 = Operator 1 = Interconnection or SFC	STRUCT • Value: BOOL • ST: BYTE	- • 0 • 16#80
Monitor	1 = Feedback monitoring	BOOL	1
MonTiDynamic*	Monitoring time for feedback errors after operation in [s]	REAL	3.0
MS_RelOp*	1= Release for maintenance via OS op- erator	BOOL	0
MsgEvId1	Message number (assigned automati- cally)	DWORD	16#00000000

Motor and valve blocks

7.3 MotS - Motor (Small)

Parameter	Description	Type	Default
MsgLock	1 = Suppress process messages. See also the section Suppressing messages using the MsgLock parameter (Page 205) for more on this.	STRUCT <ul style="list-style-type: none"> Value: BOOL ST: BYTE 	- <ul style="list-style-type: none"> 0 16#80
Occupied	1 = In use by a batch	BOOL	0
OosLi	1 = "Out of service", via interconnection or SFC (0-1 edge transition)	STRUCT <ul style="list-style-type: none"> Value: BOOL ST: BYTE 	- <ul style="list-style-type: none"> 0 16#80
OosOp*	1 = "Out of service", via OS operator	BOOL	0
OpSt_In	Input parameter for local operator authorization, connected with the <code>Out</code> output parameter of the upstream block, <code>OpStations</code> (Page 411)	DWORD	16#00000000
OS_Perm	I/O for operator permissions (Page 1111)	STRUCT <ul style="list-style-type: none"> Bit 0: BOOL ... Bit 31: BOOL 	- <ul style="list-style-type: none"> 1 1 1
RstLi*	1 = Reset via interconnection	STRUCT <ul style="list-style-type: none"> Value: BOOL ST: BYTE 	- <ul style="list-style-type: none"> 0 16#80
RstOp*	1 = Reset via operator	BOOL	0
RunUpCyc	Number of cycles in startup; messages are suppressed during these cycles	INT	3
SampleTime	Sampling time [s] (assigned automatically)	REAL	0.1
SimOn	1 = Simulation on	BOOL	0
SelFp1	Call a block saved in this parameter as an additional faceplate (Page 208) in the standard view	ANY	-
StartAut*	1 = Starting the motor in "automatic mode"	STRUCT <ul style="list-style-type: none"> Value: BOOL ST: BYTE 	- <ul style="list-style-type: none"> 0 16#80
StartChnST	Signal status of output channel <code>Start</code> Should be connected to an output channel block	STRUCT <ul style="list-style-type: none"> Value: BOOL ST: BYTE 	- <ul style="list-style-type: none"> 0 16#FF
StartMan*	1 = Starting the motor in "manual mode"	BOOL	0
StepNo	Batch step number	DWORD	16#00000000
StopAut*	1 = Stopping the motor in "automatic mode"	STRUCT <ul style="list-style-type: none"> Value: BOOL ST: BYTE 	- <ul style="list-style-type: none"> 0 16#80
StopMan*	1 = Stopping the motor in "manual mode"	BOOL	0

Parameter	Description	Type	Default
Trip	1 = Motor is in "good" state	STRUCT • Value: BOOL • ST: BYTE	- • 1 • 16#FF
UserStatus	Freely assignable bits for use in PCS 7 OS	BYTE	16#00

* Values can be written back to these inputs during processing of the block by the block algorithm.

Output parameters

Parameter	Description	Type	Default
AutAct	1 = "Automatic mode" enabled 0 = "Manual mode" is enabled	STRUCT • Value: BOOL • ST: BYTE	- • 0 • 16#80
AutoST	1 = Worst signal status of automatic commands	BYTE	16#80
ENO	1 = Block algorithm completed without errors	BOOL	0
ErrorNum	Output of pending error number. For error numbers that can be output by this block, see MotS error handling (Page 1115)	INT	-1
FbkRunOut	Feedback for starting is present: 1 = Start 0 = Stop	STRUCT • Value: BOOL • ST: BYTE	- • 0 • 16#80
GrpErr	1 = Group error pending	STRUCT • Value: BOOL • ST: BYTE	- • 0 • 16#80
LocalAct	1 = "Local mode" enabled	STRUCT • Value: BOOL • ST: BYTE	- • 0 • 16#80
LockAct	1 = Interlock or Trip is active	STRUCT • Value: BOOL • ST: BYTE	- • 0 • 16#80
ManAct	1 = "Manual mode" enabled	STRUCT • Value: BOOL • ST: BYTE	- • 1 • 16#80
MonDynErr	1 = Feedback error due to control change	STRUCT • Value: BOOL • ST: BYTE	- • 0 • 16#80

Motor and valve blocks

7.3 MotS - Motor (Small)

Parameter	Description	Type	Default
MonStaErr	1 = Feedback error due to unexpected feedback change	STRUCT • Value: BOOL • ST: BYTE	- • 0 • 16#80
MS_Release	Release for maintenance: 1 = Release for OS operator	STRUCT • Value: BOOL • ST: BYTE	- • 0 • 16#80
P_Rst	1= Pulse output for reset The parameter persists for one cycle after a reset.	STRUCT • Value: BOOL • ST: BYTE	- • 0 • 16#80
OosAct	1 = Block is "Out of service"	STRUCT • Value: BOOL • ST: BYTE	- • 0 • 16#80
OpSt_Out	Value of the OpSt_In input parameter, for feedforwarding to other blocks. Bit 31 of this parameter is used by Feature bit 24	DWORD	16#00000000
OS_PermOut	Display of OS_Perm	DWORD	16#FFFFFFFF
OS_PermLog	Display of OS_Perm with settings changed by the block algorithm	DWORD	16#FFFFFFFF
RdyToReset	1 = Ready for reset via RstLi input or commands in "local", "automatic", or "manual mode"	STRUCT • Value: BOOL • ST: BYTE	- • 0 • 16#80
RdyToStart	1 = Active start readiness	STRUCT • Value: BOOL • ST: BYTE	- • 0 • 16#80
Run	1 = Motor is running	STRUCT • Value: BOOL • ST: BYTE	- • 0 • 16#80
ST_Worst	Worst signal status	BYTE	16#80
Start	1 = Control of motor: started	STRUCT • Value: BOOL • ST: BYTE	- • 0 • 16#80
Status1	Status word 1 (Page 1107)	DWORD	16#00000000
Status2	Status word 2 (Page 1107)	DWORD	16#00000000
Status3	Status word 3 (Page 1107)	DWORD	16#00000000
Status4	Status word 4 (Page 1107)	DWORD	16#00000000
Stop	1 = Motor stopped	STRUCT • Value: BOOL • ST: BYTE	- • 0 • 16#80

See also

MotS messaging (Page 1116)
MotS block diagram (Page 1123)
MotS modes (Page 1109)
Error handling (Page 119)

7.3.7 MotS block diagram

MotS block diagram

A block diagram is not provided for this block.

See also

Description of MotS (Page 1107)
MotS functions (Page 1111)
MotS messaging (Page 1116)
MotS I/Os (Page 1118)
MotS modes (Page 1109)
MotS error handling (Page 1115)

7.3.8 Operator control and monitoring

7.3.8.1 MotS views

Views of the MotS block

The block MotS provides the following views:

- MotS standard view (Page 1124)
- Alarm view (Page 302)
- Trend view (Page 305)
- Parameter view for motors and valves (Page 286)
- MotS preview (Page 1127)
- Memo view (Page 304)
- Batch view (Page 302)
- Block icon for MotS (Page 1128)

Refer to the sections Structure of the faceplate (Page 248) and Block icon structure (Page 230) for general information on the faceplate and block icon.

7.3.8.2 MotS standard view

MotSstandard view

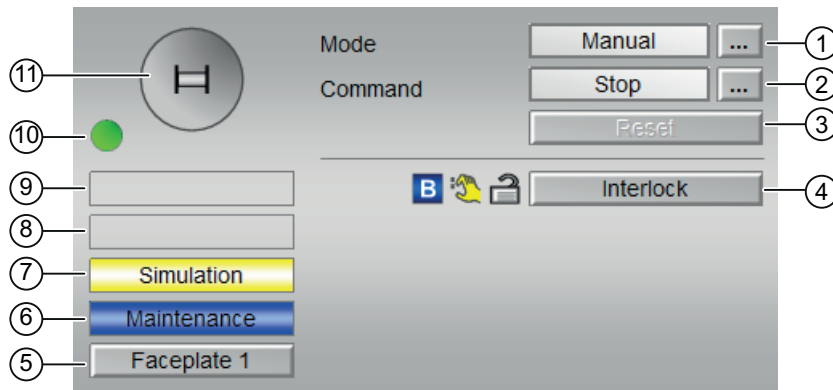

(1) Displaying and switching the operating mode

This area provides information on the currently valid operating mode. The following operating modes can be shown here:

- Manual and automatic mode for motors, valves and dosers (Page 75)
- Manual and automatic mode for motors, valves and dosers (Page 75)
- Local mode (Page 79)
- Out of service (Page 71)

Refer to section Switching operating states and operating modes (Page 257) for information on switching the operating mode.

(2) Starting and stopping the motor

This area shows you the default operating state for the motor. The following states can be shown and executed here:

- "Start"
- "Stop"

Refer to the Switching operating states and operating modes (Page 257) section for information on changing the state.

If text is configured for these commands, it is displayed as status text and as button labels for command selection. You can find more information about this in section Labeling of buttons and text (Page 209)

(3) Resetting the block

Click "Reset" for errors. You can find additional information on this in the section Resetting the block in case of interlocks or errors (Page 43).

(4) Operator control and display area for the interlock function of the block

This display is only visible when the corresponding block input is connected.

You can use this button to control the interlock function of the block. You can find additional information on this in the section Interlocks (Page 99).

The following is displayed in addition to the button:

- Interlock status (see Forming the group status for interlock information (Page 104)), e.g.:



- Signal status (see Forming and outputting the signal status for technologic blocks (Page 109)), e.g.:



- Bypass information (see Forming the group status for interlock information (Page 104)):



(5) Navigation button for switching to the standard view of any faceplate

This display is only visible when the corresponding block input is connected.

Use this navigation button to open the standard view of a block configured in the engineering system. The visibility of this navigation button depends on the configuration in the engineering system (ES).

You can find additional information on this in the section Opening additional faceplates (Page 208).

(6) Display area for block states

This area provides additional information on the operating state of the block:

- "Maintenance"

Additional information on this is available in section Release for maintenance (Page 64) Display area for block states.

(7) Display area for block states

This area provides additional information on the operating state of the block:

- "Simulation"

You can find additional information on this in the section Simulating signals (Page 58).

(8) Display area for block states

This area provides additional information on the operating state of the block (from high to low according to priority):

- "Motor protection"
- "External error"
- "Status error"
- "Control error"
- "Invalid signal"

Additional information on these errors is available in the sections Monitoring the feedbacks (Page 97) , Error handling (Page 119) (subsection "Invalid input signals") and Motor protection function (Page 99).

(9) Display area for block states

This area provides additional information on the operating state of the block:

- "Request 0/1": A reset to "automatic mode" is expected.

(10) Automatic preview

This display is only visible in "manual mode", in "local mode", or with a reset request in "automatic mode", when the current output signals are not identical to the control in "automatic mode".

The display shows what state the motor would assume if you switched from "manual" or "local" mode to "automatic mode", or performed a reset to "automatic mode".

(11) Status display of the motor

The current status of the motor is graphically displayed here:

- Green: Motor is running
- Gray: Motor idle
- Red: A fault has occurred

You can find additional information on this in the section Block icon for MotS (Page 1128).

7.3.8.3 MotS preview

Preview of MotS

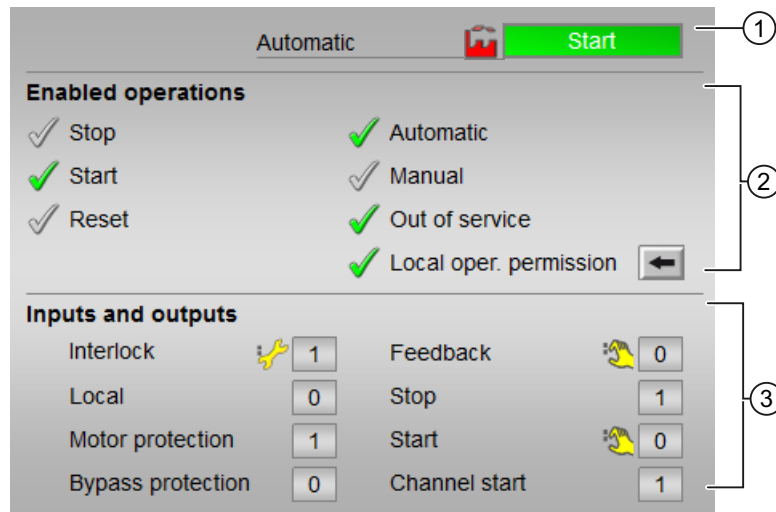

(1) Automatic preview

This area shows you the block status after it has switched from the "Manual" mode or "Local" mode to the "Automatic" mode.

If the block is in "Automatic" mode, the current block state is displayed.

This area also displays the worst signal status of the following automatic commands:

- StartAut
- StopAut

(2) Enable operations

This area shows all operations for which special operator permissions are assigned. They depend on the configuration in the engineering system (ES) that applies to this block.

Icons for enabled operation:

- **Green check mark:** the OS operator can control this parameter
- **Gray check mark:** the OS operator cannot control this parameter at this time due to the process
- **Red cross:** the OS operator cannot control this parameter due to the configured AS operator permissions (OS_Perm or OS1Perm)

The following enabled operations are shown here:

- "Stop": You can stop the motor.
If text is configured for this command, it is also displayed in brackets. You can find additional information on this in the section Labeling of buttons and text (Page 209).
- "Start": You can start the motor.
If text is configured for this command, it is also displayed in brackets. You can find additional information on this in the section Labeling of buttons and text (Page 209).
- "Reset": You can reset the motor after interlocks or errors.
- "Automatic": You can switch to "automatic mode".
- "Manual": You can switch to "manual mode".
- "Out of service": You can switch to "Out of service" operating mode.
- "Local operator permission": Use the ← button to switch to the standard view of the OpStations block. You can find additional information on this in the section section Operator control permissions (Page 254).

(3) Displaying current control signals

This area shows the most important parameters for this block with the current selection:

- "Interlock":
This display is only visible when the corresponding block input is connected.
 - 0 = Interlocking without reset is active; you can operate the block without reset once the interlocking condition has disappeared
 - 1 = "Good" state
- "Local correct": 1 = Control signal for "Local mode" (LocalLi) is active
- "Motor protection": 1 = Motor is in "good" state
- "Interlock deact."
 - 0 = Bypass disabled
 - 1 = Bypassing interlock in "local mode" and in "simulation"
- "Feedback →": 1 = Motor has started and is running
- "Stop": 1 = Stop motor
- "Start": 1 = Start motor
- "Channel Start": Signal from the output channel block for "Start"

7.3.8.4 Block icon for MotS





Block symbols for MotS

A variety of block symbols are available with the following functions:



- Process tag type
- Violation of alarm, warning, and tolerance limits as well as control system faults

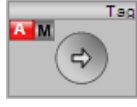
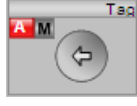

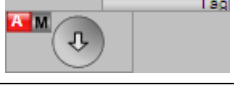

- Operating modes
- Signal status, release for maintenance
- Displays for bypassing interlocks
- Interlocks
- Memo display
- Motor state display

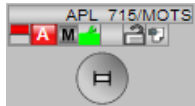
The block symbols from template @TemplateAPLV8.PDL:

Symbols	Selection of the block symbol in CFC	Special features
	1	
	2	
	3	
	4	
	5	
	6	

The block symbols from template @TemplateAPLV7.PDL:

Symbols	Selection of the block symbol in CFC	Special features
	1	Block symbol in the full display
	2	
	3	





Symbols	Selection of the block symbol in CFC	Special features
	4	
	5	
	6	
	-	Block symbol in "Out of service" mode (example with type 1 block symbol)

Additional information on the block symbol and the control options in the block symbol is available in the following chapters:

- Configuring the block icons (Page 237)
- Block icon structure (Page 230)
- Operation via the block icon (Page 239)

Motor state display

The following motor states are shown here:

Symbol	Meaning
	Motor started (motor symbol changes)
	The motor is running
	Motor stopped (motor symbol changes)
	Motor idle
	Error at motor (monitoring error, motor protection)

7.4 MotRevL - Reversible motor

7.4.1 Description of MotRevL

Object name (type + number) and family

Type + number: FB 1851

Family: Drives

Area of application for MotRevL

The block is used for the following applications:

- Control of reversible motors

How it works

The block is used to control reversible motors. Various inputs are available for controlling the motor.

Configuration

Use the CFC editor to install the block in a cyclic interrupt OB (OB30 to OB38). The block is also installed automatically in the startup OB (OB100).

For the MotRevL block, the Advanced Process Library contains a template for process tag types as an example with an application scenario for this block.

Example of process tag types:

- Reversing motor (MotorReversible) (Page 2363)

Startup characteristics

Use the `Feature Bit Set` startup characteristics (Page 138) to define the startup characteristics of this block.

The messages are suppressed after startup for the number of cycles set at `RunUpCyc`.

Status word allocation for `status1` parameter

You can find a description for each parameter in section MotRevL I/Os (Page 1148).

Status bit	Parameter
0	Occupied
1	BatchEn
2	SimOn
3	OosAct.Value

7.4 MotRevL - Reversible motor

Status bit	Parameter
4	OosLi.Value
5	0 = ManAct.Value 1 = AutoAct.Value
6	LocalAct.Value
7	0: Open padlock in the block icon 1: Closed padlock in the block icon
8	Fwd.Value
9	Motor is stopped
10	Rev.Value
11	MonStaErr.Value
12	MonDynErr.Value
13	BypProt
14	Invalid signal status
15	Mode switchover error
16	1 = Intlock is active
17	1 = Permit is active
18	1 = Protect is active
19	Trip.Value
20	Display „Forced forward“
21	Display „Forced stop“
22	Display „Forced reverse“
23	"Interlock" button is enabled
24	Reset request in automatic preview
25	WarnAct.Value or IdleTime active
26	Bypass information from previous function block
27	Automatic preview for forward mode
28	Automatic preview for "stopping"
29	Automatic preview for reverse mode
30	"Permission" button is enabled
31	"Protection" button is enabled

Status word allocation for Status2 parameter

Status bit	Parameter
0	MsgLock
1	AV_AH_Act.Value
2	AV_WH_Act.Value
3	AV_TH_Act.Value
4	AV_TL_Act.Value
5	AV_WL_Act.Value
6	AV_AL_Act.Value

Status bit	Parameter
7	AV_AH_En
8	AV_WH_En
9	AV_TH_En
10	AV_TL_En
11	AV_WL_En
12	AV_AL_En
13	AV_AH_MsgEn
14	AV_WH_MsgEn
15	AV_TH_MsgEn
16	AV_TL_MsgEn
17	AV_WL_MsgEn
18	AV_AL_MsgEn
19	1 = No impact of input signals on "local mode" with LocalSetting = 2 and LocalSetting = 4
20	Motor is stopped
21	Motor stops in forward mode
22	Motor stops in reverse mode
23	Motor starts in forward mode
24	Motor runs in forward mode
25	Motor starts in reverse mode
26	Motor runs in reverse mode
27	Error when stopping motor
28	Error in forward mode of motor
29	Error in reverse mode of motor
30	Display for interlocks in block icon
31	MS_RelOp

Status word allocation for Status3 parameter

Status bit	Parameter
0	Delay of the AV_AH_Lim message
1	Delay of the AV_WH_Lim message
2	Delay of the AV_TH_Lim message
3	Delay of the AV_TL_Lim message
4	Delay of the AV_WL_Lim message
5	Delay of the AV_AL_Lim message
6	Collection of message delays
7 - 14	Not used
15	Current monitoring time is visible
16	MonDynStopErr.Value
17 - 18	SimLiOp.Value
19	1 = Enable for rapid stop (Feature Bit Enabling rapid stop via faceplate (Page 168))

Status bit	Parameter
20	1 = Input parameter FwdChnST is interconnected
21	1 = Input parameter RevChnST is interconnected
22	Not used
23	Command for rapid stop
24	Command for starting → the motor
25	Command for starting ← the motor
26	Show automatic preview in the standard view
27	Not used
28	GrpErr.Value
29	RdyToStart.Value
30	Auxiliary value 1 visible
31	Auxiliary value 2 visible

Status word allocation for Status4 parameter

Status bit	Parameter
0	Effective signal 1 of the message block connected via EventTsIn
1	Effective signal 2 of the message block connected via EventTsIn
2	Effective signal 3 of the message block connected via EventTsIn
3	Effective signal 4 of the message block connected via EventTsIn
4	Effective signal 5 of the message block connected via EventTsIn
5	Effective signal 6 of the message block connected via EventTsIn
6	Effective signal 7 of the message block connected via EventTsIn
7	Effective signal 8 of the message block connected via EventTsIn
8	AV not connected
9	Motor protection display (Trip.Status ≠ 16#FF)
10	1 = Input parameter FbkFwd is connected
11	1 = Input parameter FbkRev is connected
12 - 19	Effective signal 1...8 of the message block connected via EventTs2In
20 - 21	Not used
22	External error generated by FaultExt or external control system fault from CSF with set Feature bit 18 Activating error state for external process control error CSF (Page 151)
23	Hidden bypass signal in Permit
24	Hidden bypass signal in interlock
25	Hidden bypass signal in Protect
26	Feature2 bit 2: Separate bypass signal
27	Feature2 bit 16: Separate interlock for each direction or position
28	Hidden bypass signal in Permit Reverse
29	Hidden bypass signal in Interlock Reverse
30	Hidden bypass signal in Protect Reverse
31	Separate monitoring of shutdown of the motor (Feature bit 13)

Status word allocation for Status5 parameter

Status bit	Parameter
0 - 7	Effective signal 9...16 of the message block connected via EventTsIn
8 - 15	Effective signal 9...16 of the message block connected via EventTs2In
16	The permission button for "Forward" is enabled
17	The permission button for "Reverse" is enabled
18	The interlock button for "Forward" is enabled
19	The Interlock button for "Reverse" is enabled
20	The protection button "Forward" is enabled
21	The protection button "Reverse" is enabled
22	1 = Permission button "Reverse" is active
23	1 = Interlock button "Reverse" is active
24	1 = Protection button "Reverse" is active
25 - 31	Not used

See also

MotRevL functions (Page 1137)

MotRevL messaging (Page 1146)

MotRevL block diagram (Page 1157)

MotRevL error handling (Page 1144)

MotRevL modes (Page 1135)

7.4.2 MotRevL modes**MotRevL operating modes**

The block can be operated using the following modes:

- Local mode (Page 79)
- Automatic mode (Page 75)
- Manual mode (Page 75)
- Out of service (Page 71)

The next section provides additional block-specific information relating to the general descriptions.

"Local mode"

You can find general information on "Local mode", switching modes and Bumpless switchover in the Local mode (Page 79) section.

Motor actions you can control in local mode:

- "Starting in forward" (`FwdLocal = 1`)
- "Starting in reverse" (`RevLocal = 1`)
- "Stopping" (`StopLocal = 1`)

A motor operated in "local mode" is controlled either by "local" signals or by the feedback signals (input parameters `FbkFwd = 1` and `FbkRev = 1`) . Configuration takes place via the input parameter `LocalSetting`.

"Automatic mode"

You can find general information on "Automatic mode", switching modes and Bumpless switchover in the Manual and automatic mode for motors, valves and dosers (Page 75) section.

Motor actions you can control in auto mode:

- "Starting in forward" (`FwdAut = 1`)
- "Starting in reverse" (`RevAut = 1`)
- "Stopping" (`StopAut = 1`)

"Manual mode"

You can find general information on "Manual mode", switching modes and bumpless switchover in the section Manual and automatic mode for motors, valves and dosers (Page 75).

Motor actions you can control in "manual mode":

- "Starting in forward" (`FwdMan = 1`)
- "Starting in reverse" (`RevMan = 1`)
- "Stopping" (`StopMan = 1`)

"Out of service"

You can find general information about the "Out of service" mode in the section Out of service (Page 71).

See also

MotRevL block diagram (Page 1157)

MotRevL I/Os (Page 1148)

MotRevL messaging (Page 1146)

MotRevL error handling (Page 1144)

MotRevL functions (Page 1137)

Description of MotRevL (Page 1131)

7.4.3 MotRevL functions

Functions of MotRevL

The functions for this block are listed below.

Opening additional faceplates

This block provides the standard function Opening additional faceplates (Page 208).

Operator permissions

This block provides the standard function Operator control permissions (Page 254).

The block has the following permissions for the `OS_Perm` parameter:

Bit	Function
0	1 = Operator can switch to "automatic mode"
1	1 = Operator can switch to "manual mode"
2	1 = Operator can switch to "local mode"
3	1 = Operator can switch to "Out of service" mode
4	1 = Operator can stop the motor
5	1 = Operator can start the motor in forward
6	1 = Operator can start the motor in reverse
7	1 = Operator can reset the motor
8	1 = Operator can define or change the monitoring time for startup
9	1 = Operator can define the monitoring time for the status
10	1 = Operator can enable the monitoring time function (Bit 8 - 9)
11	1 = Operator can activate the Simulation function
12	1 = Operator can activate the Release for maintenance function
13	1 = Operator can change the high limit (AV) for the alarm
14	1 = Operator can change the high limit (AV) for the warning
15	1 = Operator can change the high limit (AV) for the tolerance
16	1 = Operator can change the limit (AV) for hysteresis
17	1 = Operator can lower the limit (AV) for the alarm
18	1 = Operator can lower the limit (AV) for the warning
19	1 = Operator can lower the limit (AV) for the tolerance
20	1 = Operator can activate / deactivate messages via AV_AH_MsgEn
21	1 = Operator can activate / deactivate messages via AV_WH_MsgEn
22	1 = Operator can activate / deactivate messages via AV_TH_MsgEn
23	1 = Operator can activate / deactivate messages via AV_TL_MsgEn
24	1 = Operator can activate / deactivate messages via AV_WL_MsgEn
25	1 = Operator can activate / deactivate messages via AV_AL_MsgEn
26	1 = Operator can change the simulation value SimAV
27 - 29	Not used

Bit	Function
30	1 = Operator can define the monitoring time for stopping
31	Not used

Note

If you interconnect a parameter that is also listed in OS_Perm as a parameter, you have to reset the corresponding OS_Perm bit.

Restart lock after changing direction of rotation or switching off the motor

Use the input parameter IdleTime to enter a restart lock for changing the direction of rotation or restarting the motor. Use the Feature Bit Enabling direct changeover between forward and reverse (Page 146) to define how the change is to take place. When the "Stop" command is given, the motor goes immediately into "Stop" mode, and IdleTime starts after the feedback (FbkFwd and FbkRev = 0) is given. The motor cannot be started again until the IdleTime has expired.

The IdleTime parameter can be set independently of the MonTiDynamic parameter.

Limit monitoring of an additional analog value

This block provides the standard function Limit monitoring of an additional analog value (Page 91).

Limit monitoring with hysteresis

This block provides the standard function Limit monitoring with hysteresis (Page 97). It is performed via the input parameter AV_Hyst.

Suppressing messages using the MsgLock parameter

This block provides the standard function Suppressing messages using the MsgLock parameter (Page 205).

Interlocks

This block provides the following interlocks:

Feature 2 bit 16 = 0:

- Activation enable
- Interlock without reset ("Interlock")
- Interlock with reset ("Protection")

Feature 2 bit 16 = 1:

- Activation enable forward
- Activation enable reverse

- Interlock forward without reset ("Interlock forward")
- Interlock reverse without reset ("Interlock reverse")
- Interlock forward with reset ("Protection interlock forward")
- Interlock reverse with reset ("Protection interlock reverse")

Refer to the section Interlocks (Page 99) as well as Influence of the signal status on the interlock (Page 103).

Motor protection function

This block provides the standard function Motor protection function (Page 99).

Rapid stop for motors

This block provides the standard function Rapid stop for motors (Page 106).

Disabling interlocks

This block provides the standard function Disabling interlocks (Page 103).

Resetting the block in case of interlocks or errors

This block provides the standard function Resetting the block in case of interlocks or errors (Page 43).

External error (`FaultExt`), external control system fault (`CSF`)

This block provides the possibility to pass an external error via the `FaultExt` parameter or an external control system fault via the `CSF` parameter. See MotRevL error handling (Page 1144).

Group error

This block provides the standard function Outputting group errors (Page 122).

The following parameters are taken into consideration when forming the group error:

- `CSF`
- `Trip`
- `MonDynErr`
- `MonStaErr`
- `FaultExt`

Outputting a signal for start readiness

This block provides the standard function Outputting a signal for start readiness (Page 53).

Forming the group status for interlocks

This block provides the standard function Forming the group status for interlock information (Page 104).

Forming the signal status for blocks

This block provides the standard function Forming and outputting the signal status for technologic blocks (Page 109).

The worst signal status `ST_Worst` for the block is formed from the following parameters:

- `FbkFwdOut.ST`
- `FbkRevOut.ST`
- `LocalLi.ST`
- `FwdLocal.ST`
- `StopLocal.ST`
- `RevLocal.ST`
- `Trip.ST`
- `AV_Out.ST`
- `FwdChn.ST`
- `RevChn.ST`
- `FwdAut.ST` (only if `Feature2.Bit10 = 1`)
- `RevAut.ST` (only if `Feature2.Bit10 = 1`)
- `StopAut.ST` (only if `Feature2.Bit10 = 1`)

Considering bad quality of automatic commands or external values

If the `Feature2` bit Considering bad quality of automatic commands or external values (Page 186) is set to 1 and one of the following parameters has bad signal status (16#00 or 16#28), the block goes to the neutral position (motor stop) in the "Automatic" mode:

- `FwdAut.ST`
- `RevAut.ST`
- `StopAut.ST`

Forcing operating modes

This block provides the standard function Forcing operating modes (Page 41).

The following states can be enforced:

- "Start in forward" (FwdForce)
- "Start in reverse" (RevForce)
- "Stop" (StopForce)

Note

The `Feature Bit` Enabling direct changeover between forward and reverse (Page 146) for this block has no function with forced operating states. The motor can always be reversed directly.

Feedback monitoring

This block provides the standard function Monitoring the feedbacks (Page 97).

Release for maintenance

This block provides the standard function Release for maintenance (Page 64).

Specify warning times for control functions

This block provides the standard function Specifying warning times for control functions at motors and valves (Page 51).

You can generate warning signals when, for example, motors are started. Warning signals can be generated in the following modes:

- Manual mode (Page 75) (`WarnTiMan` input parameter)
- Automatic mode (Page 75) (`WarnTiAut` input parameter)

You specify the warning times in seconds using the input parameters `WarnTiMan` and `WarnTiAut`. If, for example, a motor is started, then this is displayed at the output parameter with `WarnAct = 1`. The motor then starts after the set warning time has expired and `WarnAct` then goes back to 0.

A corresponding warning is not output if the warning times (`WarnTiMan` or `WarnTiAut`) are specified with a smaller value than the `SampleTime` parameter.

Simulating signals

This block provides the standard function Simulating signals (Page 58).

You can simulate the following values:

- Additional value (`SimAV`, `SimAV_Li`)

Selecting a unit of measure

This block provides the standard function Selecting a unit of measure (Page 212).

Neutral position

This block provides the standard function Neutral position for motors, valves and controllers (Page 48).

Output signal as a pulse signal or static signal

This block provides the standard function Output signal as a static signal or pulse signal (Page 51).

Generating instance-specific messages

This block provides the standard function Generating instance-specific messages (Page 204).

Configurable reactions using the `Feature` parameter

You can find an overview of all reactions provided by the `Feature` parameter in the section Configurable functions using the Feature I/O (Page 131). The following functionality is available for this block at the relevant bits:

Bit	Function
0	Set startup characteristics (Page 138)
1	Reaction to the out of service mode (Page 177)
2	Resetting the commands for changing the mode (Page 161)
3	Enabling resetting of commands for the control settings (Page 161)
4	Setting switch or button mode (Page 167)
7	Enabling direct changeover between forward and reverse (Page 146)
9	Resetting via input signals in the event of interlocking (Protection) or errors (Page 163)
10	Exiting local mode (Page 177)
11	Activating the run time of feedback signals (Page 153)
13	Separate monitoring time for stopping the motor (Page 169)
14	Enabling rapid stop via faceplate (Page 168)
17	Enabling bumpless switchover to automatic mode for valves, motors, and dosers (Page 173)
18	Activating error state for external process control error CSF (Page 151)
19	Reset even with locked state (Page 165)
20	Disable calculation of impulse control in LocalSetting 2 and 4 (Page 186)
21	Enable bumpless switchover to "Automatic" mode for operator only (Page 172)
22	Update acknowledgment and error status of the message call (Page 160)
24	Enabling local operator authorization (Page 158)
25	Suppression of all messages (Page 174)
26	Reaction of the switching points in the "Out of service" operating mode (Page 176)
27	Interlock display with LocalSetting 2 or 4 (Page 178)
28	Disabling operating points (Page 145)
29	Signaling limit violation (Page 170)
30	Set reset depending on the operating mode or the LiOp parameter (Page 163)
31	Activating reset of protection / error in manual mode (Page 165)

In pushbutton operation (Bit 4 = 0) the automatic commands in "automatic" mode are latching; in other words, `FwdAut`, `RevAut`, `StopAut` can be reset to 0 after changing the control. In "manual" and "local" modes, however, the automatic commands are not saved and in the absence of automatic commands the automatic control is tracked.

In switching mode (Bit 4 = 1), control is selected with the static signals `FwdAut`, `RevAut`. If `FwdAut`, `RevAut` inputs are not set, the motor is stopped. Control via `StopAut` is not needed. If the "Activate command reset for control" function (Bit 3 = 1) is also enabled, the inputs `FwdAut`, `RevAut` are reset to the neutral position after evaluation in the block.

Configurable reactions using the `Feature2` parameter

Bit	Function
2	Separate evaluation for excluded and simulated interlock signals (Page 152)
3	Control priority in the event of an invalid input command (Page 175)
4	Setting switch or button mode for local commands (Page 181)
5	Evaluation of the signal status of the interlock signals (Page 142)
8	Forcing operating modes in the "Local" mode (Page 184)
10	Considering bad quality of automatic commands or external values (Page 186)
11	Suppress <code>MsgLock</code> and "Out of service" mode for a connected message block (Page 188)
16	Separate interlock for each direction or position (Page 170)

Displaying auxiliary values

This block provides the standard function Displaying auxiliary values (Page 211).

Connection of the time-stamped messages from `EventTs` or `Event16Ts`

This block provides the standard function Connection of the time-stamped messages from `EventTs` or `Event16Ts` (Page 207).

SIMATIC BATCH functionality

This block provides the standard function SIMATIC BATCH functionality (Page 67).

Button labels

This block provides the standard function Labeling of buttons and text (Page 209)

Instance-specific text can be configured for the following parameters:

- `FwdMan`
- `RevMan`
- `StopMan`
- `RapidStp`

See also

- Description of MotRevL (Page 1131)
- MotRevL messaging (Page 1146)
- MotRevL I/Os (Page 1148)
- MotRevL block diagram (Page 1157)
- MotRevL modes (Page 1135)
- EventTs functions (Page 1660)

7.4.4 MotRevL error handling

Error handling of MotRevL

Refer to section Error handling (Page 119) in the basic instructions for the error handling of all blocks.

The following errors can be displayed for this block:

- Error numbers
- Mode switchover error
- Invalid input signals
- Control system fault (CSF)

Overview of error numbers

The `ErrorNum` I/O can be used to output the following error numbers:

Error number	Meaning of the error number
-1	Predefined value when inserting the block; the block is not executed
0	There is no error.
41	The value for the <code>LocalSetting</code> I/O is not within the approved limit of 0 to 4.
42	<code>LocalSetting = 0</code> or <code>LocalSetting = 3</code> or <code>LocalSetting = 4</code> and <code>LocalLi = 1</code>
51	<code>FwdLocal = 1</code> and <code>StopLocal = 1</code> <code>RevLocal = 1</code> and <code>StopLocal = 1</code> <code>FwdLocal = 1</code> and <code>RevLocal = 1</code> <code>FwdAut = 1</code> and <code>StopAut = 1</code> <code>RevAut = 1</code> and <code>StopAut = 1</code> <code>FwdAut = 1</code> and <code>RevAut = 1</code> <code>AutModLi = 1</code> and <code>ManModLi = 1</code> <code>FwdForce = 1</code> and <code>StopForce = 1</code> <code>RevForce = 1</code> and <code>StopForce = 1</code> <code>FwdForce = 1</code> and <code>RevForce = 1</code>
52	<code>LocalAct = 1</code> and <code>LocalSetting = 2</code> or <code>4</code> and <code>SimOn = 1</code>

Mode switchover error

This error can be output by the block, see the section Error handling (Page 119).

Invalid input signals

This error can be output by the block, see the section Error handling (Page 119).

For the following invalid input signals, the control output can be kept or switched to the neutral position. This depends on the function Control priority in the event of an invalid input command (Page 175).

Operating mode	Invalid input signals	Control reaction with Feature2 bit 3 =1
Local: Localsetting = 1 or Localsetting = 3	Pushbutton operation for local mode (Feature2 bit 4 = 0): FwdLocal = 1 and RevLocal = 1 or FwdLocal = 1 and StopLocal = 1 or StopLocal = 1 and RevLocal = 1 Switching mode (Feature2 bit 4 = 1): FwdLocal = 1 and RevLocal = 1	Motor is stopped
Local: Localsetting = 1 or Localsetting = 3 and forcing	FwdForce = 1 and RevForce = 1 or FwdForce = 1 and StopForce = 1 or StopForce = 1 and RevForce = 1	
Forcing and no "local mode"	FwdForce = 1 and RevForce = 1 or FwdForce = 1 and StopForce = 1 or StopForce = 1 and RevForce = 1	
"Automatic mode" and no forcing	Pushbutton operation (Feature bit 4 = 0): FwdAut = 1 and RevAut = 1 or FwdAut = 1 and StopAut = 1 or StopAut = 1 and RevAut = 1 Switching mode (Featurebit 4 = 1): FwdAut = 1 and RevAut = 1	
"Manual mode" and no forcing	FwdMan = 1 and RevMan = 1 or FwdMan = 1 and StopMan = 1 or StopMan = 1 and RevMan = 1	

Control system fault (CSF)

An external signal can be activated via the CSF input. A control system fault is triggered if this signal changes to 1. Refer to the Error handling (Page 119) section for more on this.

See also

MotRevL block diagram (Page 1157)

MotRevL I/Os (Page 1148)

MotRevL messaging (Page 1146)

Description of MotRevL (Page 1131)

MotRevL modes (Page 1135)

MotRevL functions (Page 1137)

7.4.5 MotRevL messaging

Messaging

The following messages can be generated for this block:

- Process control fault
- Instance-specific messages

Process control fault

The following control system error messages can be output:

Message instance	Message identifier	Message class	Event
MsgEvId1	SIG 1	AS process control message - fault	\$\$BlockComment\$\$ Motor feedback error
	SIG 2	AS process control message - fault	\$\$BlockComment\$\$ Motor protection triggered
	SIG 3	AS process control message - fault	\$\$BlockComment\$\$ External error has occurred

Explanation:

\$\$BlockComment\$\$: Content of the instance-specific comment

You can interconnect an external fault (signal) to input parameter CSF. If it changes to CSF = 1, a process control fault is triggered (MsgEvId1, SIG 3).

Instance-specific messages

You can use up to three instance-specific messages with this block.

Message instance	Message identifier	Message class	Event
MsgEvId1	SIG 4	AS process control message - fault	\$\$BlockComment\$\$ External message 1
	SIG 5	AS process control message - fault	\$\$BlockComment\$\$ External message 2
	SIG 6	AS process control message - fault	\$\$BlockComment\$\$ External message 3

Explanation:

\$\$BlockComment\$\$: Content of the instance-specific comment

Associated values for message instance `MsgEvId1`

Associated value	Block parameters
1	BatchName
2	StepNo
3	BatchID
4	ExtVa104
5	ExtVa105
6	ExtVa106
7	ExtVa107
8	ExtVa108
9	Reserved
10	Reserved

The associated values 4 ... 8 are allocated to the parameters `ExtVa104` ... `ExtVa108` and can be used. Additional information is available in the "Process Control System PCS 7 - Engineering System" manual.

See also

Description of MotRevL (Page 1131)

MotRevL functions (Page 1137)

MotRevL I/Os (Page 1148)

MotRevL block diagram (Page 1157)

MotRevL error handling (Page 1144)

MotRevL modes (Page 1135)

7.4.6 MotRevL I/Os

I/Os of MotRevL

Input parameters

Parameter	Description	Type	Default
AutModLi*	1 = "Automatic mode" via interconnection or SFC (controlled by ModLiOp = 1)	STRUCT <ul style="list-style-type: none"> • Value: BOOL • ST: BYTE 	- <ul style="list-style-type: none"> • 0 • 16#80
AutModOp*	1 = "Automatic mode" via operator (controlled by ModLiOp = 0)	BOOL	0
AV	Input additional analog value, to be connected to AV_Out of the AV block	ANY	
AV_AH_Lim	Limit high alarm	REAL	95.0
AV_AL_Lim	Limit low alarm	REAL	5.0
AV_Hyst	Hysteresis for alarm, warning and tolerance limits	REAL	1.0
AV_TH_Lim	Limit high tolerance	REAL	85.0
AV_TL_Lim	Limit low tolerance	REAL	15.0
AV_WH_Lim	Limit high warning	REAL	90.0
AV_WL_Lim	Limit low warning	REAL	10.0
BatchEn	1 = Enable allocation	BOOL	0
BatchID	Batch ID	DWORD	16#00000000
BatchName	Batch name	S7-String	
ByProt	1 = Bypassing interlock in "local mode" and in "simulation"	BOOL	0
CSF	1 = External error (control system fault) Error handling (Page 119)	STRUCT <ul style="list-style-type: none"> • Value: BOOL • ST: BYTE 	- <ul style="list-style-type: none"> • 0 • 16#80
EN	1 = Called block will be processed	BOOL	1
EventTsIn	For interconnecting data between a technology block and the message blocks EventTs, Event16Ts. The EventTsIn input parameter serves to interconnect the EventTsOut output parameter of the EventTs, Event16Ts block. When this interconnection is configured, the messages of the EventTs, Event16Ts block are displayed on the OS in the alarm view of the technology block and can also be acknowledged there.	ANY	

Parameter	Description	Type	Default
EventTs2In	For interconnecting data between a technology block and the message blocks <code>EventTs</code> , <code>Event16Ts</code> . The <code>EventTs2In</code> input parameter serves to interconnect the <code>EventTsOut</code> output parameter of the <code>EventTs</code> , <code>Event16Ts</code> block. When this interconnection is configured, the messages of the <code>EventTs</code> , <code>Event16Ts</code> block are displayed on the OS in the alarm view of the technology block and can also be acknowledged there.	ANY	
ExtMsg1	Binary input for freely selectable message 1	STRUCT <ul style="list-style-type: none"> Value: BOOL ST: BYTE 	- <ul style="list-style-type: none"> 0 16#80
ExtMsg2	Binary input for freely selectable message 2	STRUCT <ul style="list-style-type: none"> Value: BOOL ST: BYTE 	- <ul style="list-style-type: none"> 0 16#80
ExtMsg3	Binary input for freely selectable message 3	STRUCT <ul style="list-style-type: none"> Value: BOOL ST: BYTE 	- <ul style="list-style-type: none"> 0 16#80
ExtVal04	Associated value 4 for messages (<code>MsgEvID1</code>)	ANY	
ExtVal05	Associated value 5 for messages (<code>MsgEvID1</code>)	ANY	
ExtVal06	Associated value 6 for messages (<code>MsgEvID1</code>)	ANY	
ExtVal07	Associated value 7 for messages (<code>MsgEvID1</code>)	ANY	
ExtVal08	Associated value 8 for messages (<code>MsgEvID1</code>)	ANY	
FaultExt	1 = External error Error handling (Page 119)	STRUCT <ul style="list-style-type: none"> Value: BOOL ST: BYTE 	- <ul style="list-style-type: none"> 0 16#80
FbkFwd	1 = Feedback for forward mode is present	STRUCT <ul style="list-style-type: none"> Value: BOOL ST: BYTE 	- <ul style="list-style-type: none"> 0 16#FF
FbkRev	1 = Feedback for reverse mode is present	STRUCT <ul style="list-style-type: none"> Value: BOOL ST: BYTE 	- <ul style="list-style-type: none"> 0 16#FF

7.4 MotRevL - Reversible motor

Parameter	Description	Type	Default
Feature	I/O for additional functions (Page 1137) 1 = Separate monitoring time for stopping the motor	STRUCT • Bit 0: BOOL • ... • Bit 13: BOOL • ... • Bit 31: BOOL	- • 0 • 0 • 0 • 0 • 0
Feature2	I/O for additional functions (Page 1137)	STRUCT • Bit 0: BOOL • ... • Bit 31: BOOL	- • 0 • 0 • 0
FwdAut*	1 = Activating forward mode of motor in automatic mode	STRUCT • Value: BOOL • ST: BYTE	- • 0 • 16#80
FwdChnST	Signal status of output channel Fwd Should be connected to an output channel block	STRUCT • Value: BOOL • ST: BYTE	- • 0 • 16#FF
FwdForce	1 = Forcing activation of motor forward mode	STRUCT • Value: BOOL • ST: BYTE	- • 0 • 16#80
FwdLocal	1 = Activation of forward motor operation in "local mode"	STRUCT • Value: BOOL • ST: BYTE	- • 0 • 16#80
FwdMan*	1 = Activation of forward motor operation in "manual mode"	BOOL	0
IdleTime*	Wait time for change of direction or restart in [s]	REAL	5.0
Intlock	0 = Interlock / interlock Motor Forward is activated Once the interlock condition has cleared, the block can be operated without reset. 1 = Interlock / interlock Motor Forward is deactivated.	STRUCT • Value: BOOL • ST: BYTE • Bit 1: BOOL (Bypass information bit)	- • 1 • 16#FF • 0
Intl_En	1 = Interlock / Interlock Motor Forward (interlock, Intlock parameter) is activated	BOOL	1
IntlRev	0 = Interlock Motor Reverse is activated. Once the interlock condition has cleared, the block can be operated without reset. 1 = Interlock Motor Reverse is deactivated.	STRUCT • Value: BOOL • ST: BYTE • Bit 1: BOOL (Bypass information bit)	- • 1 • 16#FF • 0
IntlRevEn	1 = Interlock Motor Reverse (interlock, IntlRev parameter) is activated	BOOL	1

Parameter	Description	Type	Default
LocalLi	1 = Activate "local mode" via plant signal	STRUCT • Value: BOOL • ST: BYTE	- • 0 • 16#80
LocalOp*	1 = "Local mode" via operator	BOOL	0
LocalSetting	Characteristics of Local mode (Page 79)	INT	0
ManModLi*	1 = "Manual mode" via interconnection or SFC (controlled by ModLiOp = 1)	STRUCT • Value: BOOL • ST: BYTE	- • 0 • 16#80
ManModOp*	1 = "Manual mode" via OS operator (controlled by ModLiOp = 0)	BOOL	1
ModLiOp	Switchover of operating mode between: 0 = Operator 1 = Interconnection or SFC	STRUCT • Value: BOOL • ST: BYTE	- • 0 • 16#80
Monitor	1 = Feedback monitoring	BOOL	1
MonTiDynamic*	Monitoring time for feedback errors or feedback start error after successful operation in [s]	REAL	3.0
MonTiDyStop*	Monitoring time for feedback stop errors after successful operation in [s]	REAL	3.0
MonTiStatic*	Monitoring time for feedback errors without operation in [s]	REAL	3.0
MsgEvIdl	Message number (assigned automatically)	DWORD	16#00000000
MsgLock	1 = Suppress process messages. See also the section Suppressing messages using the MsgLock parameter (Page 205) for more on this.	STRUCT • Value: BOOL • ST: BYTE	- • 0 • 16#80
MS_RelOp*	1 = Release for maintenance via OS operator	BOOL	0
Occupied	1 = In use by a batch	BOOL	0
OosLi	1 = "Out of service", via interconnection or SFC (0-1 edge transition)	STRUCT • Value: BOOL • ST: BYTE	- • 0 • 16#80
OosOp*	1 = "Out of service", via OS operator	BOOL	0
OpSt_In	Input parameter for local operator authorization, connected with the Out output parameter of the upstream block, OpStations (Page 411)	DWORD	16#00000000

7.4 MotRevL - Reversible motor

Parameter	Description	Type	Default
OS_Perm	I/O for operator permissions (Page 1137) 1 = Operator can set or change the monitoring time for "Control: Start" 1 = Operator can set or change the monitoring time for "Control: Stop"	STRUCT <ul style="list-style-type: none"> • Bit 0: BOOL • Bit 8: BOOL • Bit 20: BOOL • Bit 30: BOOL 	- <ul style="list-style-type: none"> • 1 • 1 • 1 • 1
Permit	1 = Activation enable / Activation enable Motor Forward 0 = No activation enable for motor/ Motor Forward	STRUCT <ul style="list-style-type: none"> • Value: BOOL • ST: BYTE • Bit 1: BOOL (Bypass information bit) 	- <ul style="list-style-type: none"> • 1 • 16#FF • 0
Perm_En	1 = Activation enable / (activation enable Motor Forward (enable, Permit parameter) is activated)	BOOL	1
PermRev	1 = Activation enable Motor Reverse 0 = No activation enable Motor Reverse	STRUCT <ul style="list-style-type: none"> • Value: BOOL • ST: BYTE • Bit 1: BOOL (Bypass information bit) 	- <ul style="list-style-type: none"> • 1 • 16#FF • 0
PermRevEn	1 = Activation enable Motor Reverse(enable, PermRev parameter) is activated	BOOL	1
Protect	0 = Protective interlock / protective interlock Motor Forward is activated. Once the interlock condition has cleared, the block must be reset 1 = Protective interlock / protective interlock Motor Forward is deactivated.	STRUCT <ul style="list-style-type: none"> • Value: BOOL • ST: BYTE • Bit 1: BOOL (Bypass information bit) 	- <ul style="list-style-type: none"> • 1 • 16#FF • 0
Prot_En	1 = Protective interlock / protective interlock Motor Forward (protection, Protect parameter) is activated	BOOL	1
ProtRev	0 = Protective interlock Motor Reverse is activated. Once the interlock condition has cleared, the block must be reset 1 = Protective interlock Motor Reverse is deactivated.	STRUCT <ul style="list-style-type: none"> • Value: BOOL • ST: BYTE • Bit 1: BOOL (Bypass information bit) 	- <ul style="list-style-type: none"> • 1 • 16#FF • 0
ProtRevEN	1 = Protective interlock Motor Reverse (protection, ProtRev parameter) is activated	BOOL	1
PulseWidth*	Pulse width of control signal [s]	REAL	3.0

Parameter	Description	Type	Default
RapidStp*	Rapid stop for the motor: 0 = Motor On 1 = Motor Off	BOOL	0
RevAut*	1 = Activation of reverse motor operation in "automatic mode"	STRUCT • Value: BOOL • ST: BYTE	- • 0 • 16#80
RevChnST	Signal status of output channel Rev Should be connected to an output channel block	STRUCT • Value: BOOL • ST: BYTE	- • 0 • 16#FF
RevForce	1 = Force activation of reverse motor operation	STRUCT • Value: BOOL • ST: BYTE	- • 0 • 16#80
RevLocal	1 = Activation of reverse motor operation in "local mode"	STRUCT • Value: BOOL • ST: BYTE	- • 0 • 16#80
RevMan*	1 = Activation of reverse motor operation in "manual mode"	BOOL	0
RstLi*	1 = Reset via interconnection	STRUCT • Value: BOOL • ST: BYTE	- • 0 • 16#80
RstOp*	1 = Reset via operator	BOOL	0
RunUpCyc	Number of cycles in startup; messages are suppressed during these cycles	INT	3
SampleTime	Sampling time [s] (assigned automatically)	REAL	0.1
SimAV*	Additional value used for SimOn = 1	REAL	0.0
SimAV_Li	Additional analog value that is used for SimOnLi.Value = 1 (SimLiOp.Value = 1)	STRUCT • Value: REAL • ST: BYTE	- • 0 • 16#80
SimLiOp	Activation/deactivation of the simulation by: 0 = Operator 1 = Interconnection or SFC	STRUCT • Value: BOOL • ST: BYTE	- • 0 • 16#80
SimOnLi	1 = Simulation via interconnection or SFC (controlled by SimLiOp = 1)	STRUCT • Value: BOOL • ST: BYTE	- • 0 • 16#80
SimOn*	1 = Simulation on	BOOL	0
SelFp1	Call a block saved in this parameter as an additional faceplate (Page 208) in the standard view	ANY	-
SelFp2	Call a block saved in this parameter as an additional faceplate (Page 208) in the preview	ANY	-

Motor and valve blocks

7.4 MotRevL - Reversible motor

Parameter	Description	Type	Default
StepNo	Batch step number	DWORD	16#00000000
StopAut*	1 = Stop the motor in automatic mode	STRUCT <ul style="list-style-type: none"> • Value: BOOL • ST: BYTE 	- <ul style="list-style-type: none"> • 0 • 16#80
StopForce	1 = Force motor stop	STRUCT <ul style="list-style-type: none"> • Value: BOOL • ST: BYTE 	- <ul style="list-style-type: none"> • 0 • 16#80
StopLocal	1 = Stopping the motor in "local mode"	STRUCT <ul style="list-style-type: none"> • Value: BOOL • ST: BYTE 	- <ul style="list-style-type: none"> • 0 • 16#80
StopMan*	1 = Stopping the motor in "manual mode"	BOOL	0
Trip	1 = Motor is in "good" state	STRUCT <ul style="list-style-type: none"> • Value: BOOL • ST: BYTE 	- <ul style="list-style-type: none"> • 1 • 16#FF
UserAna1	Analog auxiliary value 1	STRUCT <ul style="list-style-type: none"> • Value: REAL • ST: BYTE 	- <ul style="list-style-type: none"> • 0.0 • 16#FF
UA1unit	Unit of measure for analog auxiliary value 1	INT	0
UserAna2	Analog auxiliary value 2	STRUCT <ul style="list-style-type: none"> • Value: REAL • ST: BYTE 	- <ul style="list-style-type: none"> • 0.0 • 16#FF
UA2unit	Unit of measure for analog auxiliary value 2	INT	0
UserStatus	Freely assignable bits for use in PCS 7 OS	BYTE	16#00
WarnTiAut*	Prewarning of motor start in automatic mode in [s]	REAL	0.0
WarnTiMan*	Prewarning of motor start in manual mode in [s]	REAL	0.0

Output parameters

Parameter	Description	Type	Default
AutAct	1 = "Automatic mode" enabled 0 = "Manual mode" is enabled	STRUCT <ul style="list-style-type: none"> • Value: BOOL • ST: BYTE 	- <ul style="list-style-type: none"> • 0 • 16#80
AutoST	1 = Worst signal status of automatic commands	BYTE	16#80
AV_OpScale	Limit for scale in AV bar graph of face-plate	STRUCT <ul style="list-style-type: none"> • High: REAL • Low: REAL 	- <ul style="list-style-type: none"> • 100.0 • 0.0

Parameter	Description	Type	Default
AV_Out	Output additional analog value	STRUCT • Value: REAL • ST: BYTE	- • 0.0 • 16#80
AV_Unit	Unit of measure for additional analog value	INT	0
CurrMon	Current monitoring time [s]	DINT	0
ENO	1 = Block algorithm completed without errors	BOOL	0
ErrorNum	Output of pending error number. For error numbers that can be output by this block, see MotRevL error handling (Page 1144)	INT	-1
FbkFwdOut	Feedback: 1 = Forward operation active	STRUCT • Value: BOOL • ST: BYTE	- • 0 • 16#80
FbkRevOut	Feedback: 1 = Reverse operation active	STRUCT • Value: BOOL • ST: BYTE	- • 0 • 16#80
Fwd	1 = Control of motor forward	STRUCT • Value: BOOL • ST: BYTE	- • 0 • 16#80
GrpErr	1 = Group error pending	STRUCT • Value: BOOL • ST: BYTE	- • 0 • 16#80
LocalAct	1 = "Local mode" enabled	STRUCT • Value: BOOL • ST: BYTE	- • 0 • 16#80
LockAct	1 = Interlock (Intlock, Permit, Protect) or Trip is active	STRUCT • Value: BOOL • ST: BYTE	- • 0 • 16#80
ManAct	1 = "Manual mode" enabled	STRUCT • Value: BOOL • ST: BYTE	- • 1 • 16#80
MonDynErr	1 = Feedback error or feedback start error due to control change	STRUCT • Value: BOOL • ST: BYTE	- • 0 • 16#80
MonDynStopErr	1 = Feedback stop error due to control change	STRUCT • Value: BOOL • ST: BYTE	- • 0 • 16#80
MonStaErr	1 = Feedback error due to unexpected feedback change	STRUCT • Value: BOOL • ST: BYTE	- • 0 • 16#80

Motor and valve blocks

7.4 MotRevL - Reversible motor

Parameter	Description	Type	Default
MS_Release	Release for maintenance: 1 = Release for OS operator	STRUCT • Value: BOOL • ST: BYTE	- • 0 • 16#80
MsgAckn1	Message acknowledgement status 1 (output ACK_STATE of first ALARM_8P)	WORD	16#0000
MsgErr1	Alarm error 1 (output ERROR of first ALARM_8P)	BOOL	0
MsgStat1	Message status 1 (output STATUS of first ALARM_8P)	WORD	16#0000
OosAct	1 = Block is "Out of service"	STRUCT • Value: BOOL • ST: BYTE	- • 0 • 16#80
OpSt_Out	Value of the OpSt_In input parameter, for feedforwarding to other blocks. Bit 31 of this parameter is used by Feature bit 24	DWORD	16#00000000
OS_PermOut	Display of OS_Perm	DWORD	16#FFFFFFFF
OS_PermLog	Display of OS_Perm with settings changed by the block algorithm	DWORD	16#FFFFFFFF
P_Fwd	1 = Pulse signal for starting the motor in forward	STRUCT • Value: BOOL • ST: BYTE	- • 0 • 16#80
P_Rev	1 = Pulse signal for starting the motor in reverse	STRUCT • Value: BOOL • ST: BYTE	- • 0 • 16#80
P_Rst	1= Pulse output for reset The parameter persists for one cycle af- ter a reset.	STRUCT • Value: BOOL • ST: BYTE	- • 0 • 16#80
P_Stop	0 = Pulse signal for stopping the motor	STRUCT • Value: BOOL • ST: BYTE	- • 1 • 16#80
R_StpAct	1 = Rapid stop of the motor is active	STRUCT • Value: BOOL • ST: BYTE	- • 0 • 16#80
ST_Worst	Worst signal status	BYTE	16#80
RdyToReset	1 = Ready for reset via RstLi input or commands in "local", "automatic", or "manual mode"	STRUCT • Value: BOOL • ST: BYTE	- • 0 • 16#80
RdyToStart	1 = Active start readiness	STRUCT • Value: BOOL • ST: BYTE	- • 0 • 16#80

Parameter	Description	Type	Default
Rev	1 = Control of motor: Reverse	STRUCT <ul style="list-style-type: none"> Value: BOOL ST: BYTE 	- <ul style="list-style-type: none"> 0 16#80
RunFwd	1 = Motor is running forwards	STRUCT <ul style="list-style-type: none"> Value: BOOL ST: BYTE 	- <ul style="list-style-type: none"> 0 16#80
RunRev	1 = Motor is running in reverse	STRUCT <ul style="list-style-type: none"> Value: BOOL ST: BYTE 	- <ul style="list-style-type: none"> 0 16#80
Status1	Status word 1 (Page 1131)	DWORD	16#00000000
Status2	Status word 2 (Page 1131)	DWORD	16#00000000
Status3	Status word 3 (Page 1131)	DWORD	16#00000000
Status4	Status word 4 (Page 1131)	DWORD	16#00000000
Status5	Status word 5 (Page 1131)	DWORD	16#00000000
Stop	1 = Motor stopped	STRUCT <ul style="list-style-type: none"> Value: BOOL ST: BYTE 	- <ul style="list-style-type: none"> 0 16#80
WarnAct	1 = Prewarning for motor start active (parameters WarnTiAut and WarnTiMan)	STRUCT <ul style="list-style-type: none"> Value: BOOL ST: BYTE 	- <ul style="list-style-type: none"> 0 16#80

See also

[MotRevL messaging \(Page 1146\)](#)
[MotRevL block diagram \(Page 1157\)](#)
[MotRevL modes \(Page 1135\)](#)
[Error handling \(Page 119\)](#)

7.4.7 MotRevL block diagram**MotRevL block diagram**

A block diagram is not provided for this block.

See also

[MotRevL I/Os \(Page 1148\)](#)
[MotRevL messaging \(Page 1146\)](#)
[MotRevL error handling \(Page 1144\)](#)

7.4 MotRevL - Reversible motor

MotRevL functions (Page 1137)

MotRevL modes (Page 1135)

Description of MotRevL (Page 1131)

7.4.8 Operator control and monitoring

7.4.8.1 MotRevL views

Views of the MotRevL block

The block MotRevL provides the following views:

- MotRevL standard view (Page 1159)
- Alarm view (Page 302)
- Limit view of motors (Page 294)
- Trend view (Page 305)
- Parameter view for motors and valves (Page 286)
- MotRevL preview (Page 1163)
- Memo view (Page 304)
- Batch view (Page 302)
- Block icon for MotRevL (Page 1168)

Refer to the sections Structure of the faceplate (Page 248) and Block icon structure (Page 230) for general information on the faceplate and block icon.

7.4.8.2 MotRevL standard view

MotRevL standard view

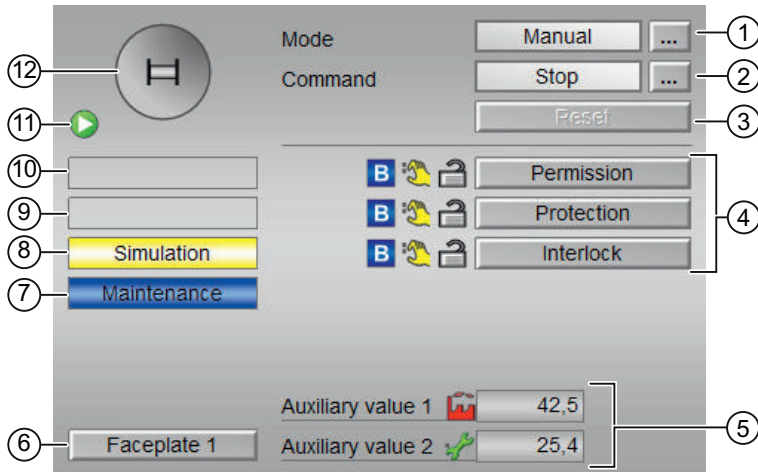

Feature2 bit 16 =0

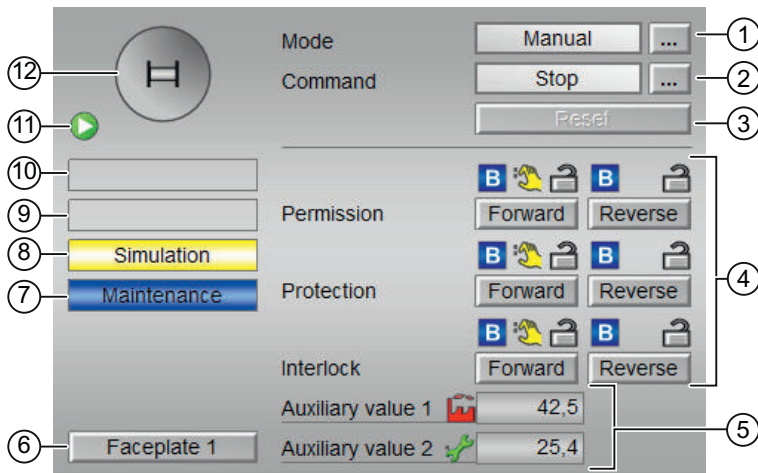

Feature2 bit 16 =1

(1) Displaying and switching the operating mode

This area provides information on the currently valid operating mode. The following operating modes can be shown here:

- Manual and automatic mode for motors, valves and dosers (Page 75)
- Manual and automatic mode for motors, valves and dosers (Page 75)
- Local mode (Page 79)
- Out of service (Page 71)

See also the section Switching operating states and operating modes (Page 257) for information on switching the operating mode.

(2) Starting and stopping the motor

This area shows you the default operating state for the motor. The following states can be shown and executed here:

- "Start→ "
- "Start ←"
- "Stop"
- "Rapid stop"

Refer to the Switching operating states and operating modes (Page 257) section for information on changing the state.

If text is configured for these commands, it is displayed as status text and as button labels for command selection. You can find more information about this in section Labeling of buttons and text (Page 209)

(3) Resetting the block

Click "Reset" for interlocks or errors. You can find additional information on this in the section Resetting the block in case of interlocks or errors (Page 43).

(4) Operating range for the interlock functions of the block

This display is only visible when the corresponding block input is connected.

You can use this button to control the interlock functions of the block. You can find additional information on this in the section Interlocking functions (Page 99).

The following is displayed in addition to the buttons:

- Interlock status (see Forming the group status for interlock information (Page 104)), e.g.:



- Signal status (see Forming and outputting the signal status for technologic blocks (Page 109)), e.g.:



- Bypass information (see Forming the group status for interlock information (Page 104)):



(5) Display of auxiliary values

This display is only visible when the corresponding block input is connected.

You can use this area to display two auxiliary values that have been configured in the engineering system (ES). You can find additional information on this in the section Displaying auxiliary values (Page 211).

(6) Navigation button for switching to the standard view of any faceplate

This display is only visible when the corresponding block input is connected.

Use this navigation button to open the standard view of a block configured in the engineering system (ES). The visibility of this navigation button depends on the configuration in the engineering system (ES).

You can find additional information on this in the section Opening additional faceplates (Page 208).

(7) Display area for block states

This area provides additional information on the operating state of the block:

- "Maintenance"

Additional information on this is available in section Release for maintenance (Page 64) Display area for block states.

(8) Display area for block states

This area provides additional information on the operating state of the block:

- "Simulation"
- "Delay"

You will find more detailed information on this in the sections Simulating signals (Page 58) and Display of delay times (Page 256).

(9) Display area for block states

This area provides additional information on the operating state of the block:

- "Motor protection"
- "External error"
- "Status error"
- "Control error"
- "Invalid signal"
- "Changeover error"

Additional information on these errors is available in the sections Monitoring the feedbacks (Page 97) , Error handling (Page 119) (section "Invalid input signals" and "Mode switchover error") and Motor protection function (Page 99).

(10) Display area for block states

This area provides additional information on the operating state of the block:

- "Forced stop"
- "Forced start →"
- "Forced start ←"
- "Request 0/1": A reset to "automatic mode" is expected.

You can find additional information on this in the section Forcing operating modes (Page 41).

(11) Automatic preview

This display is only visible in "manual mode", in "local mode", or with a reset request in "automatic mode", when the current output signals are not identical to the control in "automatic mode".

The display shows what state the motor would assume if you switched from "manual" or "local" mode to "automatic mode", or performed a reset to "automatic mode".

(12) Status display of the motor

The current status of the motor is graphically displayed here.

You can find more information about this in section Block icon for MotRevL (Page 1168)

7.4.8.3 MotRevL preview

Preview of MotRevL

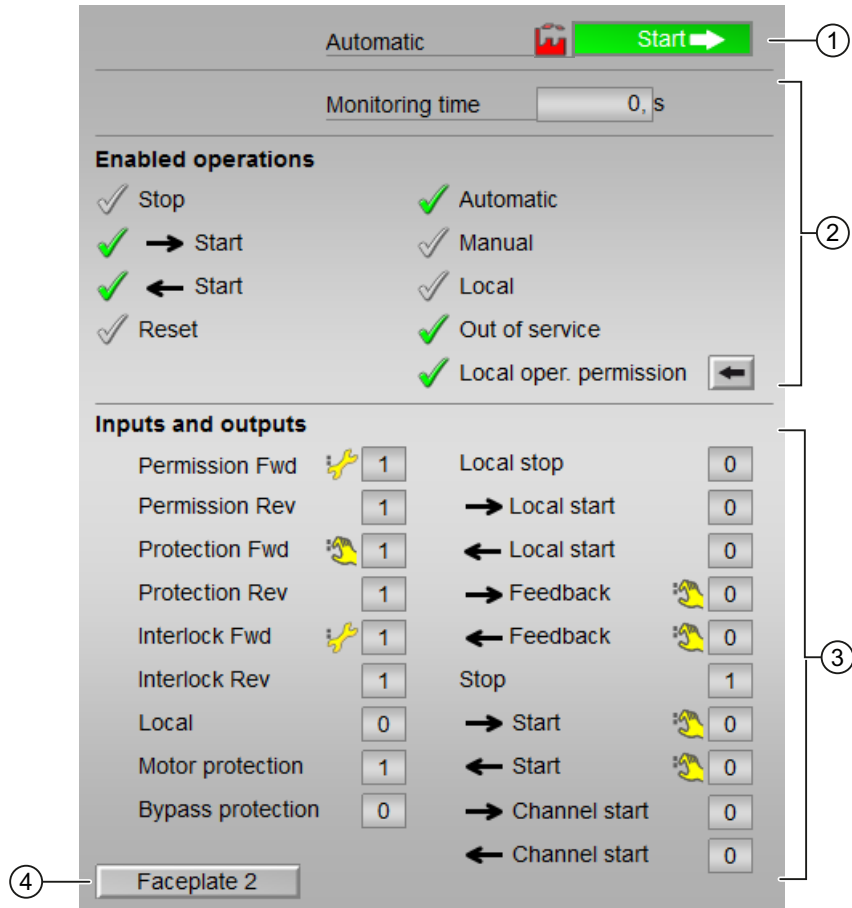

Display of the current monitoring time is visible.

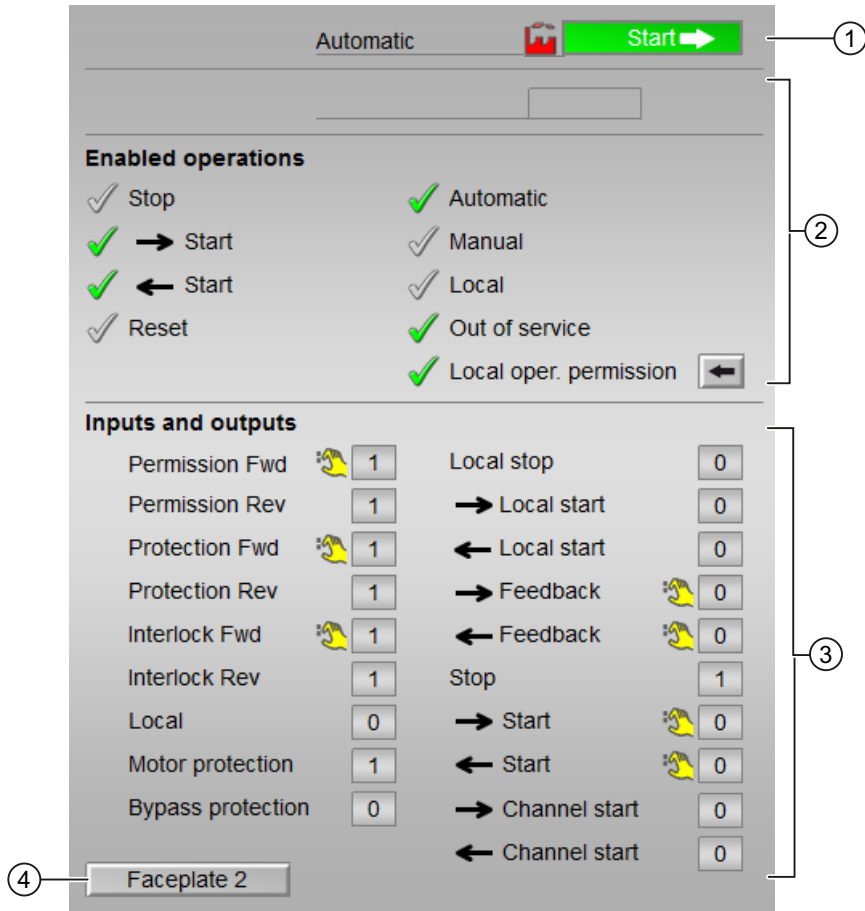

Display of the current monitoring time is not visible.

(1) Automatic preview

This area shows you the block status after it has switched from the "Manual" mode or "Local" mode to the "Automatic" mode.

If the block is in "Automatic" mode, the current block state is displayed.

This area also displays the worst signal status of the following automatic commands:

- FwdAut
- RevAut
- StopAut

(2) Enable operations

This area shows all operations for which special operator permissions are assigned. They depend on the configuration in the engineering system (ES) that applies to this block.

Icons for enabled operation:

- **Green check mark:** the OS operator can control this parameter
- **Gray check mark:** the OS operator cannot control this parameter at this time due to the process
- **Red cross:** the OS operator cannot control this parameter due to the configured AS operator permissions (OS_Perm or OS1Perm)

The following enabled operations are shown here:

- "Stop": You can stop the motor.
If text is configured for this command, it is also displayed in brackets. You can find additional information on this in the section Labeling of buttons and text (Page 209).
- "Start →": You can start the motor.
If text is configured for this command, it is also displayed in brackets. You can find additional information on this in the section Labeling of buttons and text (Page 209).
- "Start ←": You can start the motor.
If text is configured for this command, it is also displayed in brackets. You can find additional information on this in the section Labeling of buttons and text (Page 209).
- "Reset": You can reset the motor after interlocks or errors.
- "Automatic": You can switch to "automatic mode".
- "Manual": You can switch to "manual mode".
- "Local": You can switch to "local mode".
- "Out of service": You can switch to "Out of service" operating mode.
- "Local operator permission": Use the ← button to switch to the standard view of the OpStations block. You can find additional information on this in the section Operator control permissions (Page 254) .
- "Monitoring time": Display of the current monitoring time.

(3) Displaying current control signals

This area shows the most important parameters for this block with the current selection:

- "Permission":
This display is only visible when the corresponding block input is connected.
 - 0 = No OS release for energizing motor
 - 1 = Enable for "starting"/"stopping" from the neutral position
- "Enable" (**Feature 2 bit 16 =0**):
This display is only visible when the corresponding block input is connected.
 - 0 = No OS release for energizing motor
 - 1 = Enable for "Start" from the neutral position

- "Enable Fwd" (**Feature 2 bit 16 =1**):
This display is only visible when the corresponding block input is connected.
 - 0 = No OS release for energizing motor
 - 1 = Enable for "Start forward" from the neutral position
- "Enable Rev" (**Feature 2 bit 16 =1**):
This display is only visible when the corresponding block input is connected.
 - 0 = No OS release for energizing motor
 - 1 = Enable for "Start reverse" from the neutral position
- "Protection":
This display is only visible when the corresponding block input is connected.
 - 0 = Protective interlocking is effective; once the interlocking condition has disappeared, you will have to reset the block
 - 1 = "Good" state
- "Protection" (**Feature 2 bit 16 =0**):
This display is only visible when the corresponding block input is connected.
 - 0 = Protective interlocking is effective; once the interlocking condition has disappeared, you will have to reset the block
 - 1 = "Good" state
- "Protection Fwd" (**Feature 2 bit 16 =1**):
This display is only visible when the corresponding block input is connected.
 - 0 = Protective interlocking is effective; once the interlocking condition has disappeared, you will have to reset the block
 - 1 = "Good" state
- "Protection Rev" (**Feature 2 bit 16 =1**):
This display is only visible when the corresponding block input is connected.
 - 0 = Protective interlocking is effective; once the interlocking condition has disappeared, you will have to reset the block
 - 1 = "Good" state
- "Interlock":
This display is only visible when the corresponding block input is connected.
 - 0 = Interlocking without reset is active; you can operate the block without reset once the interlocking condition has disappeared
 - 1 = "Good" state
- "Interlock" (**Feature 2 bit 16 =0**):
This display is only visible when the corresponding block input is connected.
 - 0 = Interlocking without reset is active; you can operate the block without reset once the interlocking condition has disappeared
 - 1 = "Good" state

- "Interlock Fwd" (**Feature 2 bit 16 =1**):
This display is only visible when the corresponding block input is connected.
 - 0 = Interlocking without reset is active; you can operate the block without reset once the interlocking condition has disappeared
 - 1 = "Good" state
- "Interlock Rev" (**Feature 2 bit 16 =1**):
This display is only visible when the corresponding block input is connected.
 - 0 = Interlocking without reset is active; you can operate the block without reset once the interlocking condition has disappeared
 - 1 = "Good" state
- "Local correct": 1 = Control signal for "Local mode" (LocalLi) is active
- "Motor protection": 1 = Motor is in "good" state
- "Interlock deact.":
 - 0 = Bypass disabled
 - 1 = Bypassing interlock in "local mode" and in "simulation"
- "Local stop": 1 = Stopping the motor in "local mode"
- "Local start →": 1 = Starting the motor in "local mode"
- "Local start ←": 1 = Starting the motor in "local mode"
- "Feedback →": 1 = Motor has started and is running
- "Feedback ←": 1 = Motor has started and is running
- "Stop": 1 = Stop motor
- "Start →": 1 = Start motor
- "Start ←": 1 = Start motor
- "Channel Start →": Signal from the output channel block for "Start"
- "Channel Start ←": Signal from the output channel block for "Start"

(4) Navigation button for switching to the standard view of any faceplate

This display is only visible when the corresponding block input is connected.

Use this navigation button to open the standard view of a block configured in the engineering system (ES). The visibility of this navigation button depends on the configuration in the engineering system (ES).

You can find additional information on this in the section Opening additional faceplates (Page 208) .







7.4.8.4 Block icon for MotRevL

Block icons for MotRevL











A variety of block icons are available with the following functions:

- Process tag type
- Limits (high/low)
- Violation of alarm, warning, and tolerance limits as well as control system faults
- Operating modes
- Signal status, release for maintenance
- Displays for bypassing interlocks
- Interlocks
- Memo display
- Motor state display

The block icons from template @TemplateAPLV8.PDL:

Icons	Selection of the block icon in CFC	Special features
	1	
	2	
	3	Direction display inverted to symbol 1
	4	Direction display inverted to symbol 2
	5	"M" symbol with small direction display
	6	"M" symbol with small direction display

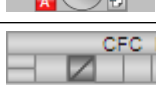
The block icons from template @TemplateAPLV7.PDL:

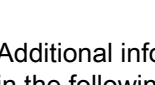





Icons	Selection of the block icon in CFC	Special features
	1	Block icon in the full display
	2	
	3	
	4	
	5	
	6	
	7	
	8	
	9	
	10	
	-	Block icon in "Out of service" mode (example with type 1 block icon)

Additional information on the block icon and the control options in the block icon is available in the following chapters:

- Configuring the block icons (Page 237)
- Block icon structure (Page 230)
- Operation via the block icon (Page 239)

Motor state display

The following motor states are shown here:

Icon	Meaning
	Motor started (motor symbol changes)
	The motor is running
	Motor stopped (motor symbol changes)
	Motor idle
	Error at motor (monitoring error, motor protection)
	Motor out of service

7.5 MotSpdCL - Controllable reversible motor

7.5.1 Description of MotSpdCL

Object name (type + number) and family

Type + number: FB 1854

Family: Drives

Area of application for MotSpdCL

The block is used for the following applications:

- Control of motors with two directions of rotation and different speeds
- Control of a device feed (optionally configurable via feature bit)

How it works

The block is used to control reversible motors for different speeds. Various inputs are available for controlling the motor.

Configuration

Use the CFC editor to install the block in a cyclic interrupt OB (OB30 to OB38). The block is also installed automatically in the startup OB (OB100).

For the MotSpdCL block, the Advanced Process Library contains a template for process tag types as an example with an application scenario for this block.

Example of process tag types:

- Reversible motor with controllable speed (MotorSpeedControlled) (Page 2364)

Startup characteristics

Use the `Feature Bit Set` startup characteristics (Page 138) to define the startup characteristics of this block.

Note

At a warm restart with the `Feature Bit` set to 0, the block is switched to manual mode and the setpoint is set to internal and to 0.

The messages are suppressed after startup for the number of cycles set at `RunUpCyc`.

Status word allocation for status1 parameter

For a description of the individual parameters, see the section MotSpdCL I/Os (Page 1194).

Status bit	Parameter
0	Occupied
1	BatchEn
2	SimOn
3	OosAct.Value
4	OosLi.Value
5	0 = ManAct.Value 1 = AutoAct.Value
6	LocalAct.Value
7	0: Open padlock in the block icon 1: Closed padlock in the block icon
8	Fwd.Value
9	SimLiOp.Value
10	Rev.Value
11	MonStaErr.Value
12	MonDynErr.Value
13	BypProt
14	Invalid signal status
15	Mode switchover error
16	1 = Intlock is active
17	1 = Permit is active
18	1 = Protect is active
19	Trip
20	Display „Forced forward“
21	Display „Forced stop“
22	Display „Forced reverse“
23	"Interlock" button is enabled
24	Reset request in automatic preview
25	WarnAct.Value or IdleTime active
26	Bypass information from previous function block
27	Automatic preview for forward mode
28	Automatic preview for "stopping"
29	Automatic preview for reverse mode
30	"Permission" button is enabled
31	"Protection" button is enabled

Status word allocation for status2 parameter

Status bit	Parameter
0	MsgLock
1	AV_AH_Act.Value
2	AV_WH_Act.Value
3	AV_TH_Act.Value
4	AV_TL_Act.Value
5	AV_WL_Act.Value
6	AV_AL_Act.Value
7	AV_AH_En
8	AV_WH_En
9	AV_TH_En
10	AV_TL_En
11	AV_WL_En
12	AV_AL_En
13	AV_AH_MsgEn
14	AV_WH_MsgEn
15	AV_TH_MsgEn
16	AV_TL_MsgEn
17	AV_WL_MsgEn
18	AV_AL_MsgEn
19	1 = No impact of input signals on "local mode" with LocalSetting = 2 and LocalSetting = 4
20	Motor is stopped
21	Motor stops in forward mode
22	Motor stops in reverse mode
23	Motor starts in forward mode
24	Motor runs in forward mode
25	Motor starts in reverse mode
26	Motor runs in reverse mode
27	Error when "stopping" the motor
28	Error in forward mode of motor
29	Error in reverse mode of motor
30	SP_ExtAct.Value
31	Display for interlocks in block icon

Status word allocation for status3 parameter

Status bit	Parameter
0	1 = SP ramp active
1	RbkWH_Act.Value
2	Delay of the AV_AH_Lim message
3	Delay of the AV_WH_Lim message

7.5 MotSpdCL - Controllable reversible motor

Status bit	Parameter
4	RbkWL_Act.Value
5	Delay of the AV_TH_Lim message
6	Delay of the AV_TL_Lim message
7	RbkWH_En
8	Delay of the AV_WL_Lim message
9	Delay of the AV_AL_Lim message
10	RbkWL_En
11	Delay of the RbkWH_Lim message
12	Delay of the RbkWL_Lim message
13	Collection of message delays
14	RbkWH_MsgEn
15	Current monitoring time is visible
16	MonDynStopErr.Value
17	RbkWL_MsgEn
18	Motor is stopped
19	1 = Enable for rapid stop (Feature Bit Enabling rapid stop via faceplate (Page 168))
20	SP_RmpModTime
21	SP_RmpOn
22	SP_UpRaAct, SP_DnRaAct limits enabled for gradient mode (SP_RateOn = 1)
23	Command for "rapid stop" of the motor
24	Command for "starting" → the motor
25	Command for "starting" ← the motor
26	Show automatic preview in the standard view
27	RdyToStart.Value
28	GrpErr.Value
29	MS_RelOp
30	Auxiliary value 1 visible
31	Auxiliary value 2 visible

Status word allocation for status4 parameter

Status bit	Parameter
0	Effective signal 1 of the message block connected via EventTsIn
1	Effective signal 2 of the message block connected via EventTsIn
2	Effective signal 3 of the message block connected via EventTsIn
3	Effective signal 4 of the message block connected via EventTsIn
4	Effective signal 5 of the message block connected via EventTsIn
5	Effective signal 6 of the message block connected via EventTsIn
6	Effective signal 7 of the message block connected via EventTsIn
7	Effective signal 8 of the message block connected via EventTsIn
8	AV not connected

Status bit	Parameter
9	Motor protection display (<code>Trip.Status</code> ≠ 16#FF)
10	1 = Input parameter <code>FbkFwd</code> is connected
11	1 = Input parameter <code>FbkRev</code> is connected
12	1 = Setpoint difference high limit violated (<code>ER_AH_Act.Value</code>)
13	1 = Setpoint difference low limit violated (<code>ER_AL_Act.Value</code>)
14	1 = Monitor setpoint difference high limit (<code>ER_AH_En</code>)
15	1 = Monitor setpoint difference low limit (<code>ER_AL_En</code>)
16	1 = Report setpoint difference high limit violation (<code>ER_AH_MsgEn</code>)
17	1 = Report setpoint difference low limit violation (<code>ER_AL_MsgEn</code>)
18	1 = Monitoring of setpoint difference "SP - Rbk" activated
19	<code>DvFdAct.Value</code> Device feed ON
20	NOT <code>DvFdAct.Value</code> Device feed OFF
21	Feature Bit 15 Frequency converter with separate device feed (Page 151)
22	External error generated by <code>FaultExt</code> or external control system fault from CSF with set feature bit 18 Activating error state for external process control error CSF (Page 151)
23	Hidden bypass signal in Permit
24	Hidden bypass signal in interlock
25	Hidden bypass signal in Protect
26	Feature2 bit 2: Separate bypass signal
27	Feature bit 16: Setpoint specification with separate display area and custom unit (Page 171)
28	1 = Input parameter <code>FwdChnST</code> is interconnected
29	1 = Input parameter <code>RevChnST</code> is interconnected
30	1 = Input parameter <code>SP_OutChnS</code> is interconnected
31	Separate monitoring of shutdown of the motor (Feature bit 13)

Status word allocation for `Status5` parameter

Status bit	Parameter
0 - 7	Effective signal 9..16 of the message block connected via <code>EventTsIn</code>
8	Delay of the <code>ER_AH_Lim</code> message
9	Delay of the <code>ER_AL_Lim</code> message
10 - 15	Not used
16 - 31	Effective signal 1...16 of the message block connected via <code>EventTs2In</code>

See also

MotSpdCL block diagram (Page 1207)

MotSpdCL messaging (Page 1192)

MotSpdCL error handling (Page 1189)

MotSpdCL functions (Page 1177)

MotSpdCL modes (Page 1176)

7.5.2 MotSpdCL modes

MotSpdCL operating modes

The block can be operated using the following modes:

- Local mode (Page 79)
- Automatic mode (Page 75)
- Manual mode (Page 75)
- Out of service (Page 71)

The next section provides additional block-specific information relating to the general descriptions.

"Local mode"

You can find general information on "Local mode", switching modes and Bumpless switchover in the Local mode (Page 79) .

Motor actions you can control in local mode:

- "Starting in forward" (`FwdLocal = 1`)
- "Starting in reverse" (`RevLocal = 1`)
- "Stopping" (`StopLocal = 1`)

A motor operated in "local mode" is controlled either by "local" signals or by the feedback signals (input parameters `FbkFwd = 1` and `FbkRev = 1`). Configuration takes place via the input parameter `LocalSetting`.

"Automatic mode"

You can find general information on "Automatic mode", switching modes and Bumpless switchover in the Manual and automatic mode for motors, valves and dosers (Page 75) .

Motor actions you can control in auto mode:

- "Starting in forward" (`FwdAut = 1`)
- "Starting in reverse" (`RevAut = 1`)
- "Stopping" (`StopAut = 1`)

"Manual mode"

You can find general information on "Manual mode", switching modes and bumpless switchover in the section Manual and automatic mode for motors, valves and dosers (Page 75).

Motor actions you can control in "manual mode":

- "Starting in forward" ($FwdMan = 1$)
- "Starting in reverse" ($RevMan = 1$)
- "Stopping" ($StopMan = 1$)

"Out of service"

You can find general information about the "Out of service" mode in the section Out of service (Page 71).

Note

In case of external setpoint value specification, the block switches to internal setpoint value specification.

See also

MotSpdCL block diagram (Page 1207)

MotSpdCL I/Os (Page 1194)

MotSpdCL messaging (Page 1192)

MotSpdCL error handling (Page 1189)

MotSpdCL functions (Page 1177)

Description of MotSpdCL (Page 1171)

7.5.3 MotSpdCL functions

Functions of MotSpdCL

The functions for this block are listed below.

Alarm delays with two time values per limit pair

This block has the standard alarm delay function for Two time values per limit pair (Page 201) limit monitoring of the feedback.

Opening additional faceplates

This block provides the standard function Opening additional faceplates (Page 208).

Operator permissions

This block provides the standard function Operator control permissions (Page 254).

The block has the following permissions for the OS_Perm parameter:

Bit	Function
0	1 = Operator can switch to "automatic mode"
1	1 = Operator can switch to "manual mode"
2	1 = Operator can switch to "local mode"
3	1 = Operator can switch to "Out of service" mode
4	1 = Operator can stop the motor
5	1 = Operator can start the motor in forward
6	1 = Operator can start the motor in reverse
7	1 = Operator can reset the motor
8	1 = Operator can define or change the monitoring time for startup
9	1 = Operator can define the monitoring time for the status
10	1 = Operator can activate the monitoring time
11	1 = Operator can activate the Simulation function
12	1 = Operator can activate the Release for maintenance function
13	1 = Operator can change the limit (AV) for high alarm
14	1 = Operator can change the limit (AV) for high warning
15	1 = Operator can change the limit (AV) for high tolerance
16	1 = Operator can change the limit (AV) for hysteresis
17	1 = Operator can change the limit (AV) for low alarm
18	1 = Operator can change the limit (AV) for low warning
19	1 = Operator can change the limit (AV) for low tolerance
20	1 = Operator can enable the bumpless switchover from external to internal SP_TrkExt
21	1 = Operator can change the internal setpoint SP_Int
22	1 = Operator can switch the setpoint to "external" SP_ExtOp
23	1 = Operator can switch the setpoint to "internal" SP_IntOp
24	1 = Operator can enable the setpoint's gradient limitation function SP_RateOn
25	1 = Operator can change the setpoint's high limit for the ramp SP_UpRaLim
26	1 = Operator can change the setpoint's low limit for the ramp SP_DnRaLim
27	1 = Operator can enable the setpoint ramp function SP_RmpOn
28	1 = Operator can switch between the time value or the value for the ramp SP_RmpModTime
29	1 = Operator can change the ramp time SP_RmpTime
30	1 = Operator can change the target setpoint SP_RmpTarget for the setpoint ramp
31	1 = Operator can enable rapid stop

The block has the following permissions for the OS1Perm parameter:

Bit	Function
0	Not used
1	1 = Operator can change the limit (Rbk) for high warning
2	Not used

Bit	Function
3	1 = Operator can change the limit (Rbk) for hysteresis
4	Not used
5	1 = Operator can change the limit (Rbk) for low warning
6	1 = Operator can change the limit (setpoint difference) ER_AH_Lim for the high alarm
7	1 = Operator can change the hysteresis (setpoint difference) ER_Hyst
8	1 = Operator can change the limit (setpoint difference) ER_AL_Lim for the low alarm
9	1 = Operator can change the simulation value SimRbk
10	1 = Operator can activate the device infeed DvFdOnMan
11	1 = Operator can deactivate the device infeed DvFdOffMan
12	1 = Operator can change the simulation value SimAV
13	1 = Operator can change the derivative gain parameter ER_AH_DFac
14	1 = Operator can change the derivative gain parameter ER_AL_DFac
15 - 19	Not used
20	1 = Operator can activate / deactivate messages via AV_AH_MsgEn
21	1 = Operator can activate / deactivate messages via AV_WH_MsgEn
22	1 = Operator can activate / deactivate messages via AV_TH_MsgEn
23	1 = Operator can activate / deactivate messages via AV_TL_MsgEn
24	1 = Operator can activate / deactivate messages via AV_WL_MsgEn
25	1 = Operator can activate / deactivate messages via AV_AL_MsgEn
26	1 = Operator can activate / deactivate messages via RbkWH_MsgEn
27	1 = Operator can activate / deactivate messages via RbkWL_MsgEn
28	1 = Operator can activate / deactivate messages via ER_AH_MsgEn
29	1 = Operator can activate / deactivate messages via ER_AL_MsgEn
30	1 = Operator can define the monitoring time for stopping
31	Not used

Note

If you interconnect a parameter that is also listed in OS_Perm as a parameter, you have to reset the corresponding OS_Perm bit.

Restart lock after changing direction of rotation or switching off the motor

Use the input parameter IdleTime to enter a restart lock for changing the direction of rotation or restarting the motor. Use the Feature Bit Enabling direct changeover between forward and reverse (Page 146) to define how the change is to take place. When the "Stop" command is given, the motor goes immediately into Stop mode and IdleTime starts after the feedback (FbkFwd and FbkRev = 0) is given. The motor cannot be started again until the IdleTime has expired.

The IdleTime parameter can be set independently of the MonTiDynamic parameter.

Limit monitoring of an additional analog value

This block provides the standard function Limit monitoring of an additional analog value (Page 91).

Limit monitoring of the feedback

The block provides the standard function Limit monitoring of the feedback (Page 94). This limit monitoring is only active when the motor has started.

Limit monitoring with hysteresis

This block provides the standard function Limit monitoring with hysteresis (Page 97). It is performed via the input parameter `AV_Hyst`.

Group display SumMsgAct for limit monitoring, CSF and ExtMsgx

The block provides the standard function Group display for limit monitoring, CSF and ExtMsgx (Page 85).

Suppressing messages using the MsgLock parameter

This block provides the standard function Suppressing messages using the MsgLock parameter (Page 205).

External/internal setpoint specification

The block provides the standard function Setpoint specification - internal/external (Page 128).

Setpoint adaption in motor stop and starting

With `Feature2.Bit7 = 1`; Define the setpoint after stop and start of the motor (Page 184), the setpoint can be set to a stop value and after start of the motor, the setpoint can be set to a minimal value (`SP_LoLim`).

Setpoint limitation

Limit the setpoint using the parameters:

- `SP_HiLim` (top)
- `SP_LoLim` (bottom)

Limit violations are displayed at the `SP_HiAct` and `SP_LoAct` output parameters with a 1.

With `Feature2.Bit7 = 1`; Define the setpoint after stop and start of the motor (Page 184), the lower limit value of the setpoint `SP_LoLim` will be limited to `SP_Off` and in case of violation, `SP_LoLim` will be written back to `SP_Off`.

Gradient limit of the setpoint

The block provides the standard function Gradient limit of the setpoint (Page 124).

Using setpoint ramp

The block provides the standard function Using setpoint ramp (Page 123).

Gear reduction or setpoint adaptation with factor

With the parameter *FactGR*, a factor can be entered for gear reduction. It affects the outputs *SP_Out*, *SP_Out2*, and *RbkOut*:

- $SP_Out = FactGR * SP_Ext$ if the setpoint is external ($SP_ExtAct = 1$)
- *SP_Out2* parameter:
 - If $FactGR \neq 0.0$ then $SP_Out2 = SP_Out / FactGR$
 - If $FactGR = 0.0$ then $SP_Out2 = SP_Out$

As a result, the readback value will also be adjusted:

$$RbkOut = FactGR * Rbk$$

Below is an example for the gear reduction from motor speed to machine speed in the ratio 10:1.

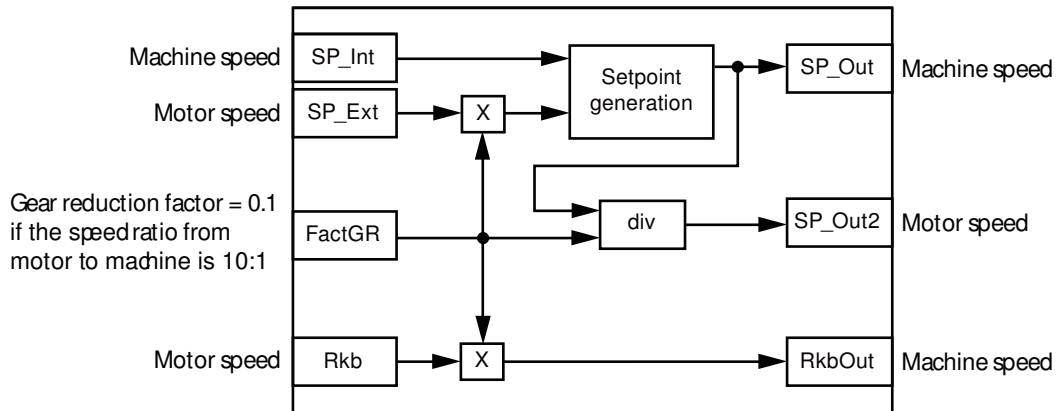

The factor *FactGR* can also be used for adapting the range in percentage.

Formation of the setpoint difference

The block always forms the setpoint difference:

$$ER.Value = SP_Out - RbkOut.Value.$$

Limit monitoring of the setpoint difference

The block provides the standard function Limit monitoring of setpoint, manipulated variable and control deviation (Page 95).

To transmit the messages, you need to enable `Feature` bit 5 Alarm setpoint difference (Page 171).

When the function activated, the message configuration should be adapted as follows:

Message instance	Message identifier	Message class	Event
MsgEvId1	SIG 7	Alarm - high	\$\$BlockComment\$\$ ER - high alarm limit SP - Rbk violated
	SIG 8	Alarm - low	\$\$BlockComment\$\$ ER - low alarm limit SP - Rbk violated

Explanation:

\$\$BlockComment\$\$: Content of the instance-specific comment

Interlocks

This block provides the following interlocks:

- Activation enable
- Interlock without reset ("Interlock")
- Interlock with reset ("Protection")

Refer to the section Interlocks (Page 99) as well as Influence of the signal status on the interlock (Page 103).

Motor protection function

This block provides the standard function Motor protection function (Page 99).

Rapid stop for motors

This block provides the standard function Rapid stop for motors (Page 106).

Disabling interlocks

This block provides the standard function Disabling interlocks (Page 103).

Resetting the block in case of interlocks or errors

This block provides the standard function Resetting the block in case of interlocks or errors (Page 43).

External error (`FaultExt`), external control system fault (`CSF`)

This block provides the possibility to pass an external error via the `FaultExt` parameter or an external control system fault via the `CSF` parameter. See MotSpdCL error handling (Page 1189).

Group error

This block provides the standard function Outputting group errors (Page 122).

The following parameters are taken into consideration when forming the group error:

- CSF
- Trip
- MonDynErr
- MonStaErr
- FaultExt

Outputting a signal for start readiness

This block provides the standard function Outputting a signal for start readiness (Page 53).

Forming the group status for interlocks

This block provides the standard function Forming the group status for interlock information (Page 104).

Forming the signal status for blocks

This block provides the standard function Forming and outputting the signal status for technologic blocks (Page 109).

The worst signal status `ST_Worst` for the block is formed from the following parameters:

- FbkFwdOut.ST
- FbkRevOut.ST
- LocalLi.ST
- FwdLocal.ST
- StopLocal.ST
- RevLocal.ST
- Trip.ST
- AV_Out.ST
- RbkOut.ST
- SP_Out.ST
- FwdChn.ST
- RevChn.ST
- SP_OutChn.ST
- FwdAut.ST (only if `Feature2.Bit10 = 1`)
- RevAut.ST (only if `Feature2.Bit10 = 1`)

- StopAut.ST (only if Feature2.Bit10 = 1)
- SP_Ext.ST (only if Feature2.Bit10 = 1)

The signal status of the SP_Out output parameter is always equivalent to the signal status of input parameter SP_Ext or SP_Int, depending on how the setpoint is specified. If the internal setpoint SP_Int is used, the signal status is always output as 16#80.

In case of Feature.Bit10 = 1, SP_Ext.ST influences ST_Worst independent of setpoint specification.

Considering bad quality of automatic commands or external values

If the Feature2 bit Considering bad quality of automatic commands or external values (Page 186) is set to 1 and one of the following parameters has bad signal status (16#00 or 16#28), the block goes to the neutral position (motor stop) in the "Automatic" mode:

- FwdAut.ST
- RevAut.ST
- StopAut.ST
- SP_Ext.ST

Forcing operating modes

This block provides the standard function Forcing operating modes (Page 41).

The following states can be enforced:

- "Start in forward" (FwdForce)
- "Start in reverse" (RevForce)
- "Stop" (StopForce)

Note

The Feature bit Enabling direct changeover between forward and reverse (Page 146) for this block has no function with forced operating states. The motor can always be reversed directly.

Feedback monitoring

This block provides the standard function Monitoring the feedbacks (Page 97).

Release for maintenance

This block provides the standard function Release for maintenance (Page 64).

Specify warning times for control functions

This block provides the standard function Specifying warning times for control functions at motors and valves (Page 51).

You can generate warning signals when, for example, motors are started. Warning signals can be generated in the following modes:

- Manual mode (Page 75) (`WarnTiMan` input parameter) Automatic mode (Page 75) (`WarnTiAut` input parameter)

You specify the warning times in seconds using the input parameters `WarnTiMan` and `WarnTiAut`. If, for example, a motor is started, then this is displayed at the output parameter with `WarnAct = 1`. The motor then starts after the set warning time has expired and `WarnAct` then goes back to 0 .

A corresponding warning is not output if the warning times (`WarnTiMan` or `WarnTiAut`) are specified with a smaller value than the `SampleTime` parameter.

Simulating signals

This block provides the standard function Simulating signals (Page 58).

You can simulate the following values:

- Additional value (`SimAV`, `SimAV_Li`)
- Position feedback (`SimRbk`, `SimRbkLi`)

Selecting a unit of measure

This block provides the standard function Selecting a unit of measure (Page 212).

Specifying the display and operator input area for process values and setpoints during operation

This block features the standard function Display and control fields for process values and setpoints (Page 207).

Neutral position

This block provides the standard function Neutral position for motors, valves and controllers (Page 48).

Output signal as a pulse signal or static signal

This block provides the standard function Output signal as a static signal or pulse signal (Page 51).

Generating instance-specific messages

This block provides the standard function Generating instance-specific messages (Page 204).

Delay alarm for control deviation at setpoint step changes

The block provides the standard function Delay alarm for control deviation at setpoint step changes (Page 190).

Configurable reactions using the Feature parameter

You can find an overview of all reactions provided by the Feature parameter in the Configurable functions using the Feature I/O (Page 131) . The following functionality is available for this block at the relevant bits:

Bit	Function
0	Set startup characteristics (Page 138)
1	Reaction to the out of service mode (Page 177)
2	Resetting the commands for changing the mode (Page 161)
3	Enabling resetting of commands for the control settings (Page 161)
4	Setting switch or button mode (Page 167)
5	Alarm setpoint difference (Page 171)
6	Ramp rate calculation (Page 179)
7	Enabling direct changeover between forward and reverse (Page 146)
8	Inverter enable (Page 187)
9	Resetting via input signals in the event of interlocking (Protection) or errors (Page 163)
10	Exiting local mode (Page 177)
11	Activating the run time of feedback signals (Page 153)
12	Gradient limitation with time duration (Page 182)
13	Separate monitoring time for stopping the motor (Page 169)
14	Enabling rapid stop via faceplate (Page 168)
15	Frequency converter with separate device feed (Page 151)
16	Setpoint specification with separate display area and custom unit (Page 171)
17	Enabling bumpless switchover to automatic mode for valves, motors, and dosers (Page 173)
18	Activating error state for external process control error CSF (Page 151)
19	Reset even with locked state (Page 165)
20	Disable calculation of impulse control in LocalSetting 2 and 4 (Page 186)
21	Enable bumpless switchover to "Automatic" mode for operator only (Page 172)
22	Update acknowledgment and error status of the message call (Page 160)
24	Enabling local operator authorization (Page 158)
25	Suppression of all messages (Page 174)
26	Reaction of the switching points in the "Out of service" operating mode (Page 176)
27	Interlock display with LocalSetting 2 or 4 (Page 178)
28	Disabling operating points (Page 145)
29	Signaling limit violation (Page 170)
30	Set reset depending on the operating mode or the LiOp parameter (Page 163)
31	Activating reset of protection / error in manual mode (Page 165)

In pushbutton operation (Bit 4 = 0) , the automatic commands in "automatic" mode are latching; in other words, FwdAut, RevAut, StopAut can be reset to 0 after changing the control. In "manual" and "local" modes, however, the automatic commands are not saved and in the absence of automatic commands the automatic control is tracked.

In switching mode (Bit 4 = 1), control is selected with the static signals FwdAut, RevAut. If FwdAut, RevAut inputs are not set, the motor is stopped. Control via StopAut is not needed. If the "Activate command reset for control" function (Bit 3 = 1) is also enabled, the inputs FwdAut, RevAut are reset to the neutral position after evaluation in the block.

Configurable reactions using the `Feature2` parameter

Bit	Function
2	Separate evaluation for excluded and simulated interlock signals (Page 152)
3	Control priority in the event of an invalid input command (Page 175)
4	Setting switch or button mode for local commands (Page 181)
5	Evaluation of the signal status of the interlock signals (Page 142)
6	Operator can change the setpoint via faceplate also in the "Local" mode (Page 183)
7	Define the setpoint after stop and start of the motor (Page 184)
8	Forcing operating modes in the "Local" mode (Page 184)
10	Considering bad quality of automatic commands or external values (Page 186)
11	Suppress <code>MsgLock</code> and "Out of service" mode for a connected message block (Page 188)

Displaying auxiliary values

This block provides the standard function Displaying auxiliary values (Page 211).

Connection of the time-stamped messages from `EventTs` or `Event16Ts`

This block provides the standard function Connection of the time-stamped messages from `EventTs` or `Event16Ts` (Page 207).

SIMATIC BATCH functionality

This block provides the standard function SIMATIC BATCH functionality (Page 67).

Button labels

This block provides the standard function Labeling of buttons and text (Page 209)

Instance-specific text can be configured for the following parameters:

- `FwdMan`
- `RevMan`
- `StopMan`
- `RapidStp`

Controlling a device infeed or an inverter enable

The function is activated via `Feature` bit 15 Frequency converter with separate device feed (Page 151) and specified via `Feature` bit 8 Inverter enable (Page 187).

When the function is activated, the motor can be started in two steps:

- Switch on device infeed or inverter enable first, then start the motor

7.5 MotSpdCL - Controllable reversible motor

When the function is activated, the motor can also be started directly:

- The device infeed or the inverter enable is also activated when starting in forward or reverse. The frequency converter itself ensures the correct order.

The motor can now be stopped and restarted without having to switch off the device infeed or the inverter enable.

The activation of the device infeed or the inverter enable by starting the motor can be performed in the automatic, manual and local operating modes with local setting 1 or 3, or by forcing.

With local setting 2 or 4, the controls are tracked based on feedback signals regardless of the status of the device infeed or the inverter enable.

With motors without device infeed or inverter enable (Feature bit 15 = 0 default), the `DvFdAct.Value` control is always zero.

Separate activation/deactivation of the device infeed or the inverter enable is performed in manual mode using `DvFdOnMan` and `DvFdOffMan` via the standard view of the faceplate. In automatic mode, activation/deactivation is performed via the input signals `DvFdOnAut` or `DvFdOffAut`. The Feature bits 3 (activate reset of commands for control) and 4 (set switch or pushbutton operation) are also based on the automatic inputs `DvFdOnAut` and `DvFdOffAut`.

The following table shows the effects on MotSpdCL block when parameterizing device infeed and inverter enable:

MotSpdCL specification	Effect on MotSpdCL block when parameterizing device infeed Feature bit 8 = 0	Effect on MotSpdCL block when parameterizing inverter enable Feature bit 8 = 1
Motor start - dependent (<code>Fwd = 1</code> or <code>Rev = 1</code>)	Device infeed is activated (<code>DvFdAct = 1</code>)	Inverter enable remains unchanged
Motor stop (<code>Fwd = 0</code> and <code>Rev = 0</code>)	Device infeed remains unchanged	Inverter enable remains unchanged
Activate device infeed or inverter enable (<code>DvFdAct = 1</code>)	Motor control remains unchanged	Motor control remains unchanged
Deactivate device infeed or inverter enable (<code>DvFdAct = 0</code>)	Motor control is reset (<code>Fwd = 0</code> , <code>Rev = 0</code>)	Motor control remains unchanged
Monitoring the feedback signals (<code>FbkFwd</code> , <code>FbkRev</code>)	Feedback signals are monitored for motor controls (<code>Fwd</code> , <code>Rev</code>)	Feedback signals are monitored for motor controls and the inverter enable: (<code>Fwd</code> and <code>DvFdAct</code>), (<code>Rev</code> and <code>DvFdAct</code>)
Monitoring fault, external fault, motor protection, or interlock	Motor control is reset (<code>Fwd = 0</code> , <code>Rev = 0</code>) Device infeed remains unchanged	Motor control is reset (<code>Fwd = 0</code> , <code>Rev = 0</code>) Inverter enable remains unchanged
Limit value monitoring of the feedback Limit value monitoring of the set-point difference	Only active when: <code>Fwd = 1</code> or <code>Rev = 1</code>	Only active if the inverter enable is also activated: <code>Fwd = 1</code> or <code>Rev = 1</code> ; And <code>DvFdAct = 1</code>

Commands for starting the motor have higher priority than commands for a device infeed or the inverter enable.



DANGER

Separate switching on/off of the device infeed

With switch mode (Feature Bit 4 = 1) and deactivated control reset (Feature Bit 3 = 0), the `DvFdOnAut` input is also set for controlling the device infeed or the inverter enable when starting in forward or in reverse in automatic mode.

See also

MotSpdCL block diagram (Page 1207)

MotSpdCL I/Os (Page 1194)

MotSpdCL messaging (Page 1192)

MotSpdCL modes (Page 1176)

Description of MotSpdCL (Page 1171)

EventTs functions (Page 1660)

7.5.4 MotSpdCL error handling

Error handling of MotSpdCL

Refer to section Error handling (Page 119) in the basic instructions for the error handling of all blocks.

The following errors can be displayed for this block:

- Error numbers
- Mode switchover error
- Control system fault (CSF)
- Invalid input signals

Overview of error numbers

The `ErrorNum` I/O can be used to output the following error numbers:

Error number	Meaning of the error number
-1	Predefined value when inserting the block; the block is not executed
0	There is no error.
41	The value for the <code>LocalSetting</code> I/O is not within the approved limit of 0 to 4.
42	<code>LocalSetting = 0</code> or <code>LocalSetting = 3</code> or <code>LocalSetting = 4</code> and <code>LocalLi = 1</code>

Error number	Meaning of the error number
51	FwdLocal = 1 and StopLocal = 1 RevLocal = 1 and StopLocal = 1 FwdLocal = 1 and RevLocal = 1 FwdAut = 1 and StopAut = 1 RevAut = 1 and StopAut = 1 FwdAut = 1 and RevAut = 1 AutModLi = 1 and ManModLi = 1 FwdForce = 1 and StopForce = 1 RevForce = 1 and StopForce = 1 FwdForce = 1 and RevForce = 1 SP_LiOp = 1 and SP_IntLi = 1 and SP_ExtLi = 1 DvFdOnMan and DvFdOffMan and feature bit 15 DvFdOnAut and DvFdOffAut and feature bit 15
52	LocalAct = 1 and LocalSetting = 2 or 4 and SimOn = 1

Note

The relationship of the pushbutton/switch mode feature bit 4 is not taken into account

Mode switchover error

This error can be output by the block, see the section Error handling (Page 119).

Invalid input signals

This error can be output by the block, see the section Error handling (Page 119).

For the following invalid input signals, the control output can be kept or switched to the neutral position. This depends on the function Control priority in the event of an invalid input command (Page 175).

Operating mode	Invalid input signals	Control reaction with Feature2 bit 3 =1
Local: Localsetting = 1 or Localsetting = 3	Pushbutton operation for local mode (Feature2 bit 4 = 0): FwdLocal = 1 and RevLocal = 1 or FwdLocal = 1 and StopLocal = 1 or StopLocal = 1 and RevLocal = 1 Switching mode (Feature2 bit 4 = 1): FwdLocal = 1 and RevLocal = 1	Motor is stopped
Local: Localsetting = 1 or Localsetting = 3 and forcing	FwdForce = 1 and RevForce = 1 or FwdForce = 1 and StopForce = 1 or StopForce = 1 and RevForce = 1	
Forcing and no "local mode"	FwdForce = 1 and RevForce = 1 or FwdForce = 1 and StopForce = 1 or StopForce = 1 and RevForce = 1	
"Automatic mode" and no forcing	Pushbutton operation (Feature bit 4 = 0): FwdAut = 1 and RevAut = 1 or FwdAut = 1 and StopAut = 1 or StopAut = 1 and RevAut = 1 Switching mode (Featurebit 4 = 1): FwdAut = 1 and RevAut = 1	
"Manual mode" and no forcing	FwdMan = 1 and RevMan = 1 or FwdMan = 1 and StopMan = 1 or StopMan = 1 and RevMan = 1	

Control system fault (CSF)

An external signal can be activated via the CSF input. A control system fault is triggered if this signal changes to 1. Refer to the Error handling (Page 119) section for more on this.

See also

- MotSpdCL block diagram (Page 1207)
- MotSpdCL I/Os (Page 1194)
- MotSpdCL messaging (Page 1192)
- MotSpdCL functions (Page 1177)
- MotSpdCL modes (Page 1176)
- Description of MotSpdCL (Page 1171)

7.5.5 MotSpdCL messaging

Messaging

The following messages can be generated for this block:

- Process control fault
- Instance-specific messages

Process control fault

The following control system error messages can be output:

Message instance	Message identifier	Message class	Event
MsgEvId1	SIG 1	AS process control message - fault	\$\$BlockComment\$\$ Motor feedback error
	SIG 2	AS process control message - fault	\$\$BlockComment\$\$ Motor protection triggered
	SIG 3	AS process control message - fault	\$\$BlockComment\$\$ External error has occurred
	SIG 4	Warning - high	\$\$BlockComment\$\$ Rbk - high warning limit violated
	SIG 5	Warning - low	\$\$BlockComment\$\$ Rbk - low warning limit violated

Explanation:

\$\$BlockComment\$\$: Content of the instance-specific comment

You can interconnect an external fault (signal) to input parameter `CSF`. If it changes to `CSF = 1`, a process control fault is triggered (`MsgEvId1`, SIG 3).

Instance-specific messages

You can use up to three instance-specific messages with this block.

Message instance	Message identifier	Message class	Event
MsgEvId1	SIG 6	AS process control message - fault	\$\$BlockComment\$\$ External message 1
	SIG 7	Alarm - high	\$\$BlockComment\$\$ ER - high alarm limit violated
	SIG 8	Alarm - low	\$\$BlockComment\$\$ ER - low alarm limit violated

Explanation:

\$\$BlockComment\$\$: Content of the instance-specific comment

Associated values for message instance `MsgEvId1`

Associated value	Block parameters
1	BatchName
2	StepNo
3	BatchID
4	ExtVa104
5	ExtVa105
6	ExtVa106
7	ExtVa107
8	ExtVa108
9	Reserved
10	Reserved

The associated values 4 ... 8 are allocated to the parameters `ExtVa104` ... `ExtVa108`, and can be used. Additional information is available in the "Process Control System PCS 7 - Engineering System" manual.

See also

MotSpdCL block diagram (Page 1207)

MotSpdCL I/Os (Page 1194)

MotSpdCL error handling (Page 1189)

MotSpdCL functions (Page 1177)

MotSpdCL modes (Page 1176)

Description of MotSpdCL (Page 1171)

7.5.6 MotSpdCL I/Os

I/Os of MotSpdCL

Input parameters

Parameter	Description	Type	Default
AutModLi*	1 = "Automatic mode" via interconnection or SFC (controlled by ModLiOp = 1)	STRUCT <ul style="list-style-type: none"> • Value: BOOL • ST: BYTE 	- <ul style="list-style-type: none"> • 0 • 16#80
AutModOp*	1 = "Automatic mode" via operator (controlled by ModLiOp = 0)	BOOL	0
AV	Input additional analog value, to be connected to AV_Tech of the AV block	ANY	
AV_AH_Lim	Limit high alarm	REAL	95.0
AV_AL_Lim	Limit low alarm	REAL	5.0
AV_Hyst	Hysteresis for alarm, warning and tolerance limits	REAL	1.0
AV_TH_Lim	Limit high tolerance	REAL	85.0
AV_TL_Lim	Limit low tolerance	REAL	15.0
AV_WH_Lim	Limit high warning	REAL	90.0
AV_WL_Lim	Limit low warning	REAL	10.0
BatchEn	1 = Enable allocation	BOOL	0
BatchID	Batch ID	DWORD	16#00000000
BatchName	Batch name	S7-String	
BypProt	1 = Bypassing interlock in "local mode" and in "simulation"	BOOL	0
CSF	1 = External error (control system fault) Error handling (Page 119)	STRUCT <ul style="list-style-type: none"> • Value: BOOL • ST: BYTE 	- <ul style="list-style-type: none"> • 0 • 16#80
DvFdOnAut*	1 = Activation of device infeed in "automatic mode"	STRUCT <ul style="list-style-type: none"> • Value: BOOL • ST: BYTE 	- <ul style="list-style-type: none"> • 0 • 16#80
DvFdOffAut*	1 = Deactivation of device infeed in "automatic mode"	STRUCT <ul style="list-style-type: none"> • Value: BOOL • ST: BYTE 	- <ul style="list-style-type: none"> • 0 • 16#80
DvFdOnMan*	1 = Activation of device infeed in "manual mode"	BOOL	0
DvFdOffMan*	1 = Deactivation of device infeed in "manual mode"	BOOL	0
EN	1 = Called block will be processed	BOOL	1
ER_A_DC*	Reserved	REAL	0.0
ER_A_DG*	Reserved	REAL	0.0

Parameter	Description	Type	Default
ER_AH_En	1 = Activate alarm (high) for setpoint difference monitoring	BOOL	1
ER_AH_DFac*	Delay factor at the positive setpoint step changes for incoming alarms at the error signal monitoring <code>ER_AH_Lim</code>	REAL	0.0
ER_AH_Lim	Alarm limit (high) for setpoint difference monitoring	REAL	100.0
ER_AH_MsgEn	1 = Activate messages for alarm (high) for setpoint difference monitoring Messages are only output if you have also enabled the <code>Feature</code> bit 5 Alarm setpoint difference (Page 171).	BOOL	1
ER_AL_DFac*	Delay factor at the negative setpoint step changes for incoming alarms at the error signal monitoring <code>ER_AL_Lim</code>	REAL	0.0
ER_AL_En	1 = Activate alarm (low) for setpoint difference monitoring	BOOL	1
ER_AL_Lim	Alarm limit (low) for setpoint difference monitoring	REAL	-100.0
ER_AL_MsgEn	1 = Activate messages for alarm (low) for setpoint difference monitoring Messages are only output if you have also enabled the <code>Feature</code> bit 5 Alarm setpoint difference (Page 171).	BOOL	1
ER_Hyst	Alarm hysteresis for error signal	REAL	1.0
EventTsIn	For interconnecting data between a technology block and the message blocks <code>EventTs</code> , <code>Event16Ts</code> . The <code>EventTsIn</code> input parameter serves to interconnect the <code>EventTsOut</code> output parameter of the <code>EventTs</code> , <code>Event16Ts</code> block. When this interconnection is configured, the messages of the <code>EventTs</code> , <code>Event16Ts</code> block are displayed on the OS in the alarm view of the technology block and can also be acknowledged there.	ANY	
EventTs2In	For interconnecting data between a technology block and the message blocks <code>EventTs</code> , <code>Event16Ts</code> . The <code>EventTs2In</code> input parameter serves to interconnect the <code>EventTsOut</code> output parameter of the <code>EventTs</code> , <code>Event16Ts</code> block. When this interconnection is configured, the messages of the <code>EventTs</code> , <code>Event16Ts</code> block are displayed on the OS in the alarm view of the technology block and can also be acknowledged there.	ANY	

Motor and valve blocks

7.5 MotSpdCL - Controllable reversible motor

Parameter	Description	Type	Default
ExtMsg1	Binary input for freely selectable message 1	STRUCT <ul style="list-style-type: none"> • Value: BOOL • ST: BYTE 	- <ul style="list-style-type: none"> • 0 • 16#80
ExtMsg2	Binary input for freely selectable message 2	STRUCT <ul style="list-style-type: none"> • Value: BOOL • ST: BYTE 	- <ul style="list-style-type: none"> • 0 • 16#80
ExtMsg3	Binary input for freely selectable message 3	STRUCT <ul style="list-style-type: none"> • Value: BOOL • ST: BYTE 	- <ul style="list-style-type: none"> • 0 • 16#80
ExtVa104	Associated value 4 for messages (MsgEvID1)	ANY	
ExtVa105	Associated value 5 for messages (MsgEvID1)	ANY	
ExtVa106	Associated value 6 for messages (MsgEvID1)	ANY	
ExtVa107	Associated value 7 for messages (MsgEvID1)	ANY	
ExtVa108	Associated value 8 for messages (MsgEvID1)	ANY	
FactGR	Gear reducing factor	STRUCT <ul style="list-style-type: none"> • Value: REAL • ST: BYTE 	- <ul style="list-style-type: none"> • 1.0 • 16#80
FaultExt	1 = External error Error handling (Page 119)	STRUCT <ul style="list-style-type: none"> • Value: BOOL • ST: BYTE 	- <ul style="list-style-type: none"> • 0 • 16#80
FbkFwd	1 = Feedback for forward mode is present	STRUCT <ul style="list-style-type: none"> • Value: BOOL • ST: BYTE 	- <ul style="list-style-type: none"> • 0 • 16#FF
FbkRev	1 = Feedback for reverse mode is present	STRUCT <ul style="list-style-type: none"> • Value: BOOL • ST: BYTE 	- <ul style="list-style-type: none"> • 0 • 16#FF
Feature	I/O for additional functions (Page 1177) 1 = Separate monitoring time for stopping the motor 1 = Setpoint with own scale and unit of the parameter	STRUCT <ul style="list-style-type: none"> • Bit 0: BOOL • ... • Bit 13: BOOL • Bit 16: BOOL • ... • Bit 31: BOOL 	- <ul style="list-style-type: none"> • 0 • 0 • 0 • 0 • 0 • 0
Feature2	I/O for additional functions (Page 1177)	STRUCT <ul style="list-style-type: none"> • Bit 0: BOOL • ... • Bit 31: BOOL 	- <ul style="list-style-type: none"> • 0 • 0 • 0

7.5 MotSpdCL - Controllable reversible motor

Parameter	Description	Type	Default
FwdAut*	1 = Activation of forward motor operation in "automatic mode"	STRUCT • Value: BOOL • ST: BYTE	- • 0 • 16#80
FwdChnST	Signal status of output channel for Fwd Should be connected to an output channel block	STRUCT • Value: BOOL • ST: BYTE	- • 0 • 16#FF
FwdForce	1 = Forcing activation of motor forward mode	STRUCT • Value: BOOL • ST: BYTE	- • 0 • 16#80
FwdLocal	1 = Activation of forward motor operation in "local mode"	STRUCT • Value: BOOL • ST: BYTE	- • 0 • 16#80
FwdMan*	1 = Activation of forward motor operation in "manual mode"	BOOL	0
IdleTime*	Wait time for change of direction or re-start in [s]	REAL	5.0
Intlock	0 = Interlocking without reset is active; you can operate the block without reset once the interlocking condition has disappeared 1 = Interlock not activated	STRUCT • Value: BOOL • ST: BYTE • Bit 1: BOOL (Bypass information bit)	- • 1 • 16#FF • 0
Intl_En	1 = Interlock without reset (interlock, Intlock parameter) is active	BOOL	1
LocalLi	1 = Activate "local mode" via plant signal	STRUCT • Value: BOOL • ST: BYTE	- • 0 • 16#80
LocalOp*	1 = "Local mode" via operator	BOOL	0
LocalSetting	Characteristics of Local mode (Page 79)	INT	0
ManModLi*	1 = "Manual mode" via interconnection or SFC (controlled by ModLiOp = 1)	STRUCT • Value: BOOL • ST: BYTE	- • 0 • 16#80
ManModOp*	1 = "Manual mode" via OS operator (controlled by ModLiOp = 0)	BOOL	1
ModLiOp	Switchover of operating mode between: 0 = Operator 1 = Interconnection or SFC	STRUCT • Value: BOOL • ST: BYTE	- • 0 • 16#80
Monitor	1 = Feedback monitoring	BOOL	1
MonTiDynamic*	Monitoring time for feedback errors or feedback start error after successful operation in [s]	REAL	3.0
MonTiDyStop*	Monitoring time for feedback stop errors after successful operation in [s]	REAL	3.0

7.5 MotSpdCL - Controllable reversible motor

Parameter	Description	Type	Default
MonTiStatic*	Monitoring time for feedback errors without operation in [s]	REAL	3.0
MS_RelOp*	1 = Release for maintenance via OS operator	BOOL	0
MsgEvId1	Message number (assigned automatically)	DWORD	16#00000000
MsgLock	1 = Suppress process messages. See also the section Suppressing messages using the MsgLock parameter (Page 205) for more on this.	STRUCT <ul style="list-style-type: none"> • Value: BOOL • ST: BYTE 	- <ul style="list-style-type: none"> • 0 • 16#80
Occupied	1 = In use by a batch	BOOL	0
OosLi	1 = "Out of service", via interconnection or SFC (0-1 edge transition)	STRUCT <ul style="list-style-type: none"> • Value: BOOL • ST: BYTE 	- <ul style="list-style-type: none"> • 0 • 16#80
OosOp*	1 = "Out of service", via OS operator	BOOL	0
OpSt_In	Input parameter for local operator authorization, connected with the <code>Out</code> output parameter of the upstream block, <code>OpStations</code> (Page 411)	DWORD	16#00000000
OS_Perm	I/O for operator permissions (Page 1177) 1 = Operator can set or change the monitoring time for "Control: Start"	STRUCT <ul style="list-style-type: none"> • Bit 0: BOOL • Bit 8: BOOL • Bit 10: BOOL • Bit 31: BOOL 	- <ul style="list-style-type: none"> • 1 • 1 • 1 • 1
OSlPerm	I/O for operator permissions (Page 1177) 1 = Operator can set or change the monitoring time for "Control: Stop"	STRUCT <ul style="list-style-type: none"> • Bit 0: BOOL • Bit 9: BOOL • Bit 30: BOOL • Bit 31: BOOL 	- <ul style="list-style-type: none"> • 1 • 1 • 1 • 1
Permit	1 = OS activation enable for motor 0 = No OS release for energizing motor	STRUCT <ul style="list-style-type: none"> • Value: BOOL • ST: BYTE • Bit 1: BOOL (Bypass information bit) 	- <ul style="list-style-type: none"> • 1 • 16#FF • 0
Perm_En	1 = Activation enable (enable, <code>Permit</code> parameter) is active	BOOL	1
Protect	0 = Protective interlocking is effective; once the interlocking condition has disappeared, you will have to reset the block 1 = Protective interlocking not activated	STRUCT <ul style="list-style-type: none"> • Value: BOOL • ST: BYTE • Bit 1: BOOL (Bypass information bit) 	- <ul style="list-style-type: none"> • 1 • 16#FF • 0

Parameter	Description	Type	Default
Prot_En	1 = Protective interlock (protection, <i>Protect</i> parameter) is active	BOOL	1
PulseWidth*	Pulse width of control signal [s]	REAL	3.0
RapidStp*	Rapid stop for the motor: 0 = Motor On 1 = Motor Off	BOOL	0
Rbk	Position feedback for display on OS	STRUCT • Value: REAL • ST: BYTE	- • 0.0 • 16#80
RbkW_DC*	Delay time for incoming warnings [s]	REAL	0.0
RbkW_DG*	Delay time for outgoing warnings [s]	REAL	0.0
RbkHyst	Hysteresis for warning limits	REAL	1.0
RbkOpScale	Limit for scale in bar graph of faceplate	STRUCT • High: REAL • Low: REAL	- • 100.0 • 0.0
RbkUnit	Unit of measure for additional analog value	INT	0
RbkWH_En	1 = Enable high warning	BOOL	1
RbkWH_Lim	Limit high warning	REAL	90.0
RbkWH_MsgEn	1 = Enable high warning message	BOOL	1
RbkWL_En	1 = Enable low warning	BOOL	1
RbkWL_Lim	Limit low warning	REAL	10.0
RbkWL_MsgEn	1 = Enable low warning message	BOOL	1
RevAut*	1 = Activation of reverse motor operation in "automatic mode"	STRUCT • Value: BOOL • ST: BYTE	- • 0 • 16#80
RevChnST	Signal status of output channel for <i>Rev</i> Should be connected to an output channel block	STRUCT • Value: BOOL • ST: BYTE	- • 0 • 16#FF
RevForce	1 = Force activation of reverse motor operation	STRUCT • Value: BOOL • ST: BYTE	- • 0 • 16#80
RevLocal	1 = Activation of reverse motor operation in "local mode"	STRUCT • Value: BOOL • ST: BYTE	- • 0 • 16#80
RevMan*	1 = Activation of reverse motor operation in "manual mode"	BOOL	0
RstLi*	1 = Reset via interconnection	STRUCT • Value: BOOL • ST: BYTE	- • 0 • 16#80
RstOp*	1 = Reset via operator	BOOL	0

7.5 MotSpdCL - Controllable reversible motor

Parameter	Description	Type	Default
RunUpCyc	Number of cycles in startup; messages are suppressed during these cycles	INT	3
SampleTime	Sampling time [s] (assigned automatically)	REAL	0.1
SelFp1	Call a block saved in this parameter as an additional faceplate (Page 208) in the standard view	ANY	
SelFp2	Call a block saved in this parameter as an additional faceplate (Page 208) in the preview	ANY	
SimAV*	Additional value used for SimOn = 1	REAL	0.0
SimAV_Li	Additional analog value that is used for SimOnLi.Value = 1 (SimLiOp.Value = 1)	STRUCT <ul style="list-style-type: none"> Value: REAL ST: BYTE 	- <ul style="list-style-type: none"> 0 16#80
SimOn*	1 = Simulation on	BOOL	0
SimLiOp	Activation/deactivation of the simulation by: 0 = Operator 1 = Interconnection or SFC	STRUCT <ul style="list-style-type: none"> Value: BOOL ST: BYTE 	- <ul style="list-style-type: none"> 0 16#80
SimOnLi	1 = Simulation via interconnection or SFC (controlled by SimLiOp = 1)	STRUCT <ul style="list-style-type: none"> Value: BOOL ST: BYTE 	- <ul style="list-style-type: none"> 0 16#80
SimRbk*	Position feedback used for SimOn = 1	REAL	0.0
SimRbkLi	Position feedback used for SimOnLi.Value = 1 (SimLiOp.Value = 1)	STRUCT <ul style="list-style-type: none"> Value: REAL ST: BYTE 	- <ul style="list-style-type: none"> 0 16#80
SP_DnRaLim*	Limit (low) for the gradient of the setpoint [Unit/(Time unit)] Time unit depends on TimeFactor	REAL	100.0
SP_Ext	external setpoint - (to interconnection)	STRUCT <ul style="list-style-type: none"> Value: REAL ST: BYTE 	- <ul style="list-style-type: none"> 0.0 16#80
SP_ExtLi	1 = Select external setpoint (via interconnection)	STRUCT <ul style="list-style-type: none"> Value: BOOL ST: BYTE 	- <ul style="list-style-type: none"> 0 16#80
SP_ExtOp*	1 = Select external setpoint (via operator)	BOOL	0
SP_HiLim	Limit (high) of setpoint	REAL	100.0
SP_LoLim*	Limit (low) of setpoint; if Feature2.Bit7 = 1 then SP_LoLim is limited and written back to SP_Off.	REAL	0.0
SP_Int*	Internal setpoint for operation	REAL	1.0
SP_IntLi	1 = Select internal setpoint (via interconnection)	STRUCT <ul style="list-style-type: none"> Value: BOOL ST: BYTE 	- <ul style="list-style-type: none"> 0 16#80

Parameter	Description	Type	Default
SP_IntOp*	1 = Select internal setpoint (via operator)	BOOL	1
SP_LiDnRaLim	Linkable limit (low) for the gradient of the setpoint [Unit/(Time unit)] Time unit depends on TimeFactor	REAL	100.0
SP_LiOp	Select setpoint source (internal/external): 1 = Via interconnection 0 = Via operator	STRUCT • Value: BOOL • ST: BYTE	- • 0 • 16#80
SP_LiRmpTime	Linkable time [Time unit] for gradient limitation in ramp mode duration Time unit depends on TimeFactor	REAL	0.0
SP_LiUpRaLim	Linkable gradient limit (high) for the setpoint [Unit/(Time unit)] Time unit depends on TimeFactor	REAL	100.0
SP_Off	Setpoint if the motor is off	REAL	0.0
SP_OpScale	SP bar limit display for OS	ScaVal	
SP_OutChnST	Signal status of output channel SP_Out Should be connected to an output channel block	STRUCT • Value: REAL • ST: BYTE	- • 0.0 • 16#FF
SP_RateOn*	1 = Activate limitation of setpoint gradients	BOOL	0
SP_RmpModTime	1 = Use time values (SP_RmpTime, SP_LiRmpTime) 0 = Use gradient limits (SP_DnRaLim, SP_LiDnRaLim, SP_UpRaLim, SP_LiUpRaLim)	BOOL	0
SP_RmpOn*	1 = Activate setpoint ramp to target setpoint SP_RmpTarget	BOOL	0
SP_RmpTarget*	Target setpoint for setpoint ramp	REAL	0.0
SP_RmpTime*	Time [Time unit] for setpoint ramp from current SP up to SP_RmpTarget or time [Time unit] for gradient limitation in ramp mode duration Time unit depends on TimeFactor	REAL	0.0
SP_TrkExt	1 = Bumpless switchover from external to internal setpoint active	BOOL	0
SP_Unit	Operator inputs	INT	0
SP_UpRaLim*	Gradient limit (high) for the setpoint [Unit/(Time unit)] Time unit depends on TimeFactor	REAL	100.0
StepNo	Batch step number	DWORD	16#00000000
StopAut*	1 = Stopping the motor in "automatic mode"	STRUCT • Value: BOOL • ST: BYTE	- • 0 • 16#80

7.5 MotSpdCL - Controllable reversible motor

Parameter	Description	Type	Default
StopForce	1 = Force motor stop	STRUCT • Value: BOOL • ST: BYTE	- • 0 • 16#80
StopLocal	1 = Stopping the motor in "local mode"	STRUCT • Value: BOOL • ST: BYTE	- • 0 • 16#80
StopMan*	1 = Stopping the motor in "manual mode"	BOOL	0
TimeFactor	Time unit: 0 = Seconds 1 = Minutes 2 = Hours	INT	0
Trip	1 = Motor is in "good" state	STRUCT • Value: BOOL • ST: BYTE	- • 1 • 16#FF
UserAna1	Analog auxiliary value 1	STRUCT • Value: REAL • ST: BYTE	- • 0.0 • 16#FF
UA1unit	Unit of measure for analog auxiliary value 1	INT	0
UserAna2	Analog auxiliary value 2	STRUCT • Value: REAL • ST: BYTE	- • 0.0 • 16#FF
UA2unit	Unit of measure for analog auxiliary value 2	INT	0
UserStatus	Freely assignable bits for use in PCS 7 OS	BYTE	16#00
WarnTiAut*	Prewarning of motor start in "automatic mode" in [s]	REAL	0.0
WarnTiMan*	Prewarning of motor start in "manual mode" in [s]	REAL	0.0

* Values can be written back to these inputs during processing of the block by the block algorithm.

Output parameters

Parameter	Description	Type	Default
AutAct	1 = "Automatic mode" enabled 0 = "Manual mode" is enabled	STRUCT • Value: BOOL • ST: BYTE	- • 0 • 16#80
AutoST	1 = Worst signal status of automatic commands	BYTE	16#80

Parameter	Description	Type	Default
AV_OpScale	Limit for scale in AV bar graph of face-plate	STRUCT • High: REAL • Low: REAL	- • 100.0 • 0.0
AV_Out	Output additional analog value	STRUCT • Value: REAL • ST: BYTE	- • 0.0 • 16#80
AV_Unit	Unit of measure for additional analog value	INT	0
DvFdAct	1 = Device infeed enabled	STRUCT • Value: BOOL • ST: BYTE	- • 0 • 16#80
CurrMon	Current monitoring time [s]	DINT	0
ENO	1 = Block algorithm completed without errors	BOOL	0
ER	Error signal	STRUCT • Value: REAL • ST: BYTE	- • 0.0 • 16#80
ER_A_DCOut	Effective delay time [s] for incoming alarms at the error signal monitoring	REAL	0.0
ER_AH_Act	1 = Alarm limit (high) for control deviation violated.	STRUCT • Value: BOOL • ST: BYTE	- • 0 • 16#80
ER_AL_Act	1 = Alarm limit (low) for control deviation violated.	STRUCT • Value: BOOL • ST: BYTE	- • 0 • 16#80
ErrorNum	Output of pending error number. For error numbers that can be output by this block, see MotSpdCL error handling (Page 1189)	INT	-1
FbkFwdOut	Feedback: 1 = Forward operation active	STRUCT • Value: BOOL • ST: BYTE	- • 0 • 16#80
FbkRevOut	Feedback: 1 = Reverse operation active	STRUCT • Value: BOOL • ST: BYTE	- • 0 • 16#80
Fwd	1 = Control of motor forward	STRUCT • Value: BOOL • ST: BYTE	- • 0 • 16#80
GrpErr	1 = Group error pending	STRUCT • Value: BOOL • ST: BYTE	- • 0 • 16#80

Motor and valve blocks

7.5 MotSpdCL - Controllable reversible motor

Parameter	Description	Type	Default
LocalAct	1 = "Local mode" enabled	STRUCT <ul style="list-style-type: none"> Value: BOOL ST: BYTE 	- <ul style="list-style-type: none"> 0 16#80
LockAct	1 = Interlock (Intlock, Permit, Protect) or Trip is active	STRUCT <ul style="list-style-type: none"> Value: BOOL ST: BYTE 	- <ul style="list-style-type: none"> 0 16#80
ManAct	1 = "Manual mode" enabled	STRUCT <ul style="list-style-type: none"> Value: BOOL ST: BYTE 	- <ul style="list-style-type: none"> 1 16#80
MonDynErr	1 = Feedback error or feedback start error due to control change	STRUCT <ul style="list-style-type: none"> Value: BOOL ST: BYTE 	- <ul style="list-style-type: none"> 0 16#80
MonDynStopErr	1 = Feedback stop error due to control change	STRUCT <ul style="list-style-type: none"> Value: BOOL ST: BYTE 	- <ul style="list-style-type: none"> 0 16#80
MonStaErr	1 = Feedback error due to unexpected feedback change	STRUCT <ul style="list-style-type: none"> Value: BOOL ST: BYTE 	- <ul style="list-style-type: none"> 0 16#80
MS_Release	Release for maintenance: 1 = Release for OS operator	STRUCT <ul style="list-style-type: none"> Value: BOOL ST: BYTE 	- <ul style="list-style-type: none"> 0 16#80
MsgAckn1	Message acknowledgement status 1 (output ACK_STATE of first ALARM_8P)	WORD	16#0000
MsgErr1	Alarm error 1 (output ERROR of first ALARM_8P)	BOOL	0
MsgStat1	Message status 1 (output STATUS of first ALARM_8P)	WORD	16#0000
OosAct	1 = Block is "out of service"	STRUCT <ul style="list-style-type: none"> Value: BOOL ST: BYTE 	- <ul style="list-style-type: none"> 0 16#80
OpSt_Out	Value of the OpSt_In input parameter, for feedforwarding to other blocks. Bit 31 of this parameter is used by Feature bit 24	DWORD	16#00000000
OS_PermOut	Display of OS_Perm	DWORD	16#FFFFFFFF
OS_PermLog	Display of OS_Perm with settings changed by the block algorithm	DWORD	16#FFFFFFFF
OS1PermOut	Display of OS1Perm	DWORD	16#FFFFFFFF
OS1PermLog	Display of OS1Perm with settings changed by the block algorithm	DWORD	16#FFFFFFFF
P_Fwd	1 = Pulse signal for starting the motor in forward	STRUCT <ul style="list-style-type: none"> Value: BOOL ST: BYTE 	- <ul style="list-style-type: none"> 0 16#80

Parameter	Description	Type	Default
P_Rev	1 = Pulse signal for starting the motor in reverse	STRUCT <ul style="list-style-type: none"> • Value: BOOL • ST: BYTE 	- <ul style="list-style-type: none"> • 0 • 16#80
P_Rst	1= Pulse output for reset The parameter persists for one cycle after a reset.	STRUCT <ul style="list-style-type: none"> • Value: BOOL • ST: BYTE 	- <ul style="list-style-type: none"> • 0 • 16#80
P_Stop	0 = Pulse signal for stopping the motor	STRUCT <ul style="list-style-type: none"> • Value: BOOL • ST: BYTE 	- <ul style="list-style-type: none"> • 1 • 16#80
R_StpAct	1 = Rapid stop of the motor is active	STRUCT <ul style="list-style-type: none"> • Value: BOOL • ST: BYTE 	- <ul style="list-style-type: none"> • 0 • 16#80
RbkOut	Output of readback value	STRUCT <ul style="list-style-type: none"> • Value: REAL • ST: BYTE 	- <ul style="list-style-type: none"> • 0.0 • 16#80
RbkWH_Act	1 = Warning (high) enabled. You can change the reaction for this parameter with <code>Feature</code> bit 28 (Disabling operating points (Page 145)) and with <code>Feature</code> bit 29 (Signaling limit violation (Page 170)).	STRUCT <ul style="list-style-type: none"> • Value: BOOL • ST: BYTE 	- <ul style="list-style-type: none"> • 0 • 16#80
RbkWL_Act	1 = Warning (low) enabled. You can change the reaction for this parameter with <code>Feature</code> bit 28 (Disabling operating points (Page 145)) and with <code>Feature</code> bit 29 (Signaling limit violation (Page 170)).	STRUCT <ul style="list-style-type: none"> • Value: BOOL • ST: BYTE 	- <ul style="list-style-type: none"> • 0 • 16#80
RdyToReset	1 = Ready for reset via <code>RstLi</code> input or commands in "local", "automatic", or "manual mode"	STRUCT <ul style="list-style-type: none"> • Value: BOOL • ST: BYTE 	- <ul style="list-style-type: none"> • 0 • 16#80
RdyToStart	1 = Active start readiness	STRUCT <ul style="list-style-type: none"> • Value: BOOL • ST: BYTE 	- <ul style="list-style-type: none"> • 0 • 16#80
Rev	1 = Control of motor: Reverse	STRUCT <ul style="list-style-type: none"> • Value: BOOL • ST: BYTE 	- <ul style="list-style-type: none"> • 0 • 16#80
RunFwd	1 = Motor is running forwards	STRUCT <ul style="list-style-type: none"> • Value: BOOL • ST: BYTE 	- <ul style="list-style-type: none"> • 0 • 16#80
RunRev	1 = Motor is running in reverse	STRUCT <ul style="list-style-type: none"> • Value: BOOL • ST: BYTE 	- <ul style="list-style-type: none"> • 0 • 16#80

7.5 MotSpdCL - Controllable reversible motor

Parameter	Description	Type	Default
SP_DnRaAct	1 = Negative gradient limiting of setpoint is active	STRUCT • Value: BOOL • ST: BYTE	- • 0 • 16#80
SP_ExtAct	1 = External setpoint is active 0 = Internal setpoint is active	STRUCT • Value: BOOL • ST: BYTE	- • 0 • 16#80
SP_HiAct	1 = Limit (high) for setpoint has been reached	STRUCT • Value: BOOL • ST: BYTE	- • 0 • 16#80
SP_LoAct	1 = Limit (low) for setpoint has been reached	STRUCT • Value: BOOL • ST: BYTE	- • 0 • 16#80
SP_Out	Setpoint used by controller	STRUCT • Value: REAL • ST: BYTE	- • 0.0 • 16#80
SP_Out2	Additional setpoint, without gear reducing factor	STRUCT • Value: REAL • ST: BYTE	- • 0.0 • 16#80
SP_RateTarget	Target setpoint for the gradient limitation	REAL	0.0
SP_UpRaAct	1 = Positive gradient limiting of setpoint is active	STRUCT • Value: BOOL • ST: BYTE	- • 0 • 16#80
SP_RemRT	Remaining ramp time of the setpoint	REAL	0.0
Starting	1 = Motor will start	STRUCT • Value: BOOL • ST: BYTE	- • 0 • 16#80
Status1	Status word 1 (Page 1171)	DWORD	16#00000000
Status2	Status word 2 (Page 1171)	DWORD	16#00000000
Status3	Status word 3 (Page 1171)	DWORD	16#00000000
Status4	Status word 4 (Page 1171)	DWORD	16#00000000
ST_Worst	Worst signal status	BYTE	16#80
Stop	1 = Motor is stopping	STRUCT • Value: BOOL • ST: BYTE	- • 0 • 16#80
Stopping	1 = Motor will stop	STRUCT • Value: BOOL • ST: BYTE	- • 0 • 16#80
WarnAct	1 = Prewarning for motor start active (parameters WarnTiAut and WarnTiMan)	STRUCT • Value: BOOL • ST: BYTE	- • 0 • 16#80

See also

MotSpdCL block diagram (Page 1207)
MotSpdCL messaging (Page 1192)
MotSpdCL modes (Page 1176)
Setpoint specification with separate display area and custom unit (Page 171)
Error handling (Page 119)

7.5.7 MotSpdCL block diagram**MotSpdCL block diagram**

A block diagram is not provided for this block.

See also

MotSpdCL I/Os (Page 1194)
MotSpdCL messaging (Page 1192)
MotSpdCL error handling (Page 1189)
MotSpdCL functions (Page 1177)
MotSpdCL modes (Page 1176)
Description of MotSpdCL (Page 1171)

7.5.8 Operator control and monitoring**7.5.8.1 MotSpdCL views****Views of the MotSpdCL block**

The block MotSpdCL provides the following views:

- MotSpdCL standard view (Page 1208)
- Alarm view (Page 302)
- Limit view of motors (Page 294)
- MotSpdCL limit view for readback values (Page 1217)
- Trend view (Page 305)
- Ramp view (Page 300)
- MotSpdCL parameter view (Page 1219)

7.5 MotSpdCL - Controllable reversible motor

- MotSpdCL preview (Page 1214)
- Memo view (Page 304)
- Batch view (Page 302)
- Block icon for MotSpdCL (Page 1222)

Refer to the sections Structure of the faceplate (Page 248) and Block icon structure (Page 230) for general information on the faceplate and block icon.

7.5.8.2 MotSpdCL standard view

MotSpdCL standard view

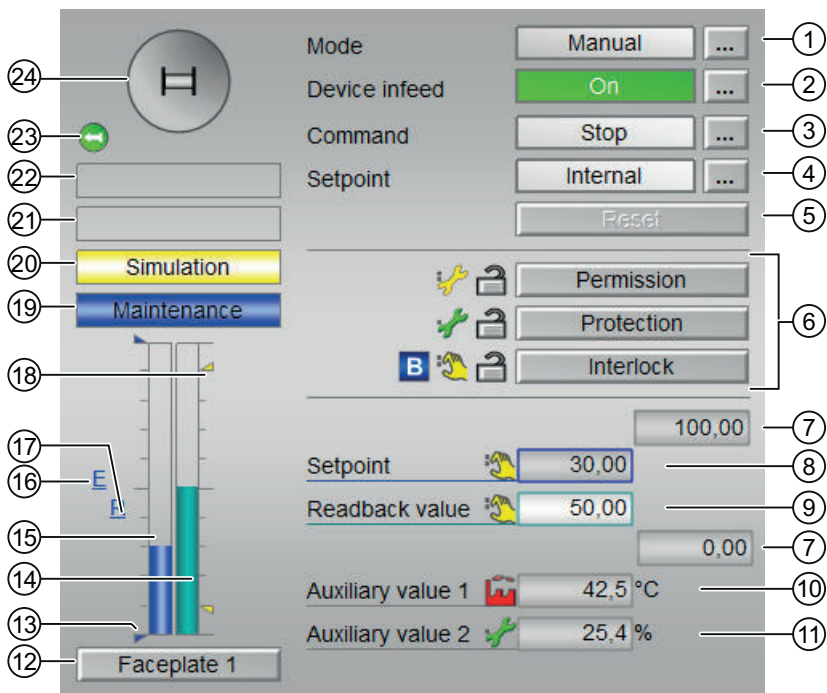

Feature bit 16 = 0: Setpoint and readback value have the same area of the readback value

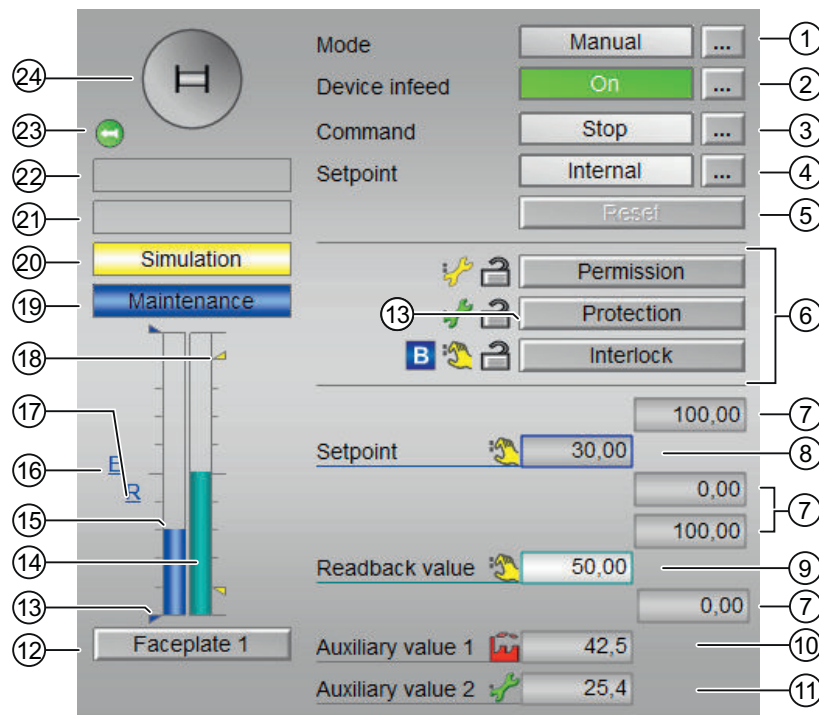

Feature bit 16 = 1: Setpoint and readback value have separate areas

(1) Displaying and switching the operating mode

This area provides information on the currently valid operating mode. The following operating modes can be shown here:

- Manual and automatic mode for motors, valves and dosers (Page 75)
- Manual and automatic mode for motors, valves and dosers (Page 75)
- Local mode (Page 79)
- Out of service (Page 71)

See also the section Switching operating states and operating modes (Page 257) for information on switching the operating mode.

(2) Separate switching on/off of the device infeed or the inverter enable

This area shows you the default operating state for the device infeed or the inverter enable. The following states can be shown and executed here:

- "On"
- "Off"

If the inverter enable is parameterized (Feature bit 15 = 1 and Feature bit 8 = 1), the text "Device infeed" is replaced by "Inverter enable".

Refer to the Switching operating states and operating modes (Page 257) section for information on changing the state.

If text is configured for these commands, it is displayed as status text and as button labels for command selection. You can find additional information on this in the section Labeling of buttons and text (Page 209).

(3) Starting and stopping the motor

This area shows you the default operating state for the variable motor. The following states can be shown and executed here:

- "Start |→"
- "Start ←|"
- "Stop"
- "Rapid stop"

Refer to the Switching operating states and operating modes (Page 257) section for information on changing the state.

If text is configured for these commands, it is displayed as status text and as button labels for command selection. You can find more information about this in section Labeling of buttons and text (Page 209)

(4) Switching the setpoint internal/external

This area shows how to specify the setpoint. The setpoint can be specified as follows:

- By the application ("External", CFC/SFC)
- By the user directly in the faceplate ("Internal").

Refer to the Switching operating states and operating modes (Page 257) section for information on switching the setpoint specification.

You can find additional information on this in the section Setpoint specification - internal/external (Page 128).

(5) Resetting the block

Click "Reset" for interlocks or errors. You can find additional information on this in the section Resetting the block in case of interlocks or errors (Page 43).

(6) Operating range for the interlock functions of the block

This display is only visible when the corresponding block input is connected.

You can use this button to control the interlock functions of the block. You can find additional information on this in the section Interlocking functions (Page 99).

The following is displayed in addition to the buttons:

- Interlock status (see Forming the group status for interlock information (Page 104)), e.g.:



- Signal status (see Forming and outputting the signal status for technologic blocks (Page 109)), e.g.:



- Bypass information (see Forming the group status for interlock information (Page 104)):



(7) High and low scale range for the setpoint

This area is already set and cannot be changed.

(8) Display and change the setpoint including signal status

This area shows the current setpoint with the corresponding signal status.

Refer to the Changing values (Page 259) section for information on changing the setpoint. The setpoint specification also needs to be set to "Internal" for this block.

(9) Displaying the readback value

This area shows you the current readback value with the corresponding signal status.

(10) and (11) Display of auxiliary values

This display is only visible when the corresponding block input is connected.

You can use this area to display two auxiliary values that have been configured in the engineering system (ES). You can find additional information on this in the section Displaying auxiliary values (Page 211).

(12) Navigation button for switching to the standard view of any faceplate

This display is only visible when the corresponding block input is connected.

Use this navigation button to open the standard view of a block configured in the engineering system (ES). The visibility of this navigation button depends on the configuration in the engineering system (ES).

You can find additional information on this in the section Opening additional faceplates (Page 208).

(13) Displaying the limits

These triangles show the SP_HiLim and SP_LoLim setpoint limits configured in the engineering system (ES).

(14) Bar graph for the readback value

This area shows you the current readback value in the form of a bar graph. The visible area in the bar graph depends on the configuration in the engineering system (ES).

(15) Bar graph for the setpoint

This area shows the current setpoint in the form of a bar graph. The visible area in the bar graph depends on the configuration in the engineering system (ES).

(16) Display of external setpoint

This display [E] is only visible when you have selected "Internal" setpoint specification. It shows the external setpoint that would apply if you were to change the setpoint specification to "external".

(17) Display for the target setpoint of the setpoint ramp

This display [R] shows the target setpoint and is only visible if you have enabled ramp generation in the Ramp view (Page 300).

(18) Limit display

These colored triangles show you the configured limits in the respective bar graph.

(19) Display area for block states

This area provides additional information on the operating state of the block:

- "Maintenance"

Additional information on this topic is available in sections Release for maintenance (Page 64) Display area for block states.

(20) Display area for block states

This area provides additional information on the operating state of the block:

- "Simulation"
- "Delay"

You will find more detailed information on this in the sections Simulating signals (Page 58) and Display of delay times (Page 256).

(21) Display area for block states

This area provides additional information on the operating state of the block:

- "Motor protection"
- "External error"

- "Status error"
- "Control error"
- "Invalid signal"
- "Changeover error"

Additional information on these errors is available in the sections Monitoring the feedbacks (Page 97) , Error handling (Page 119) (section "Invalid input signals" and "Mode switchover error") and Motor protection function (Page 99).

(22) Display area for block states

This area provides additional information on the operating state of the block:

- "Forced stop"
- "Forced start |→"
- "Forced start ←|"
- "Request 0/1": A reset to "automatic mode" is expected.
- "SP ramp active"

You can find additional information on this in the section Forcing operating modes (Page 41).

(23) Automatic preview

This display is only visible in "manual mode", in "local mode", or with a reset request in "automatic mode", when the current output signals are not identical to the control in "automatic mode".

The display shows what state the motor would assume if you switched from "manual" or "local" mode to "automatic mode", or performed a reset to "automatic mode".

(24) Status display of the motor

The current status of the motor is graphically displayed here.

You can find more information about this in section Block icon for MotSpdCL (Page 1222)

7.5.8.3 MotSpdCL preview

Preview of MotSpdCL

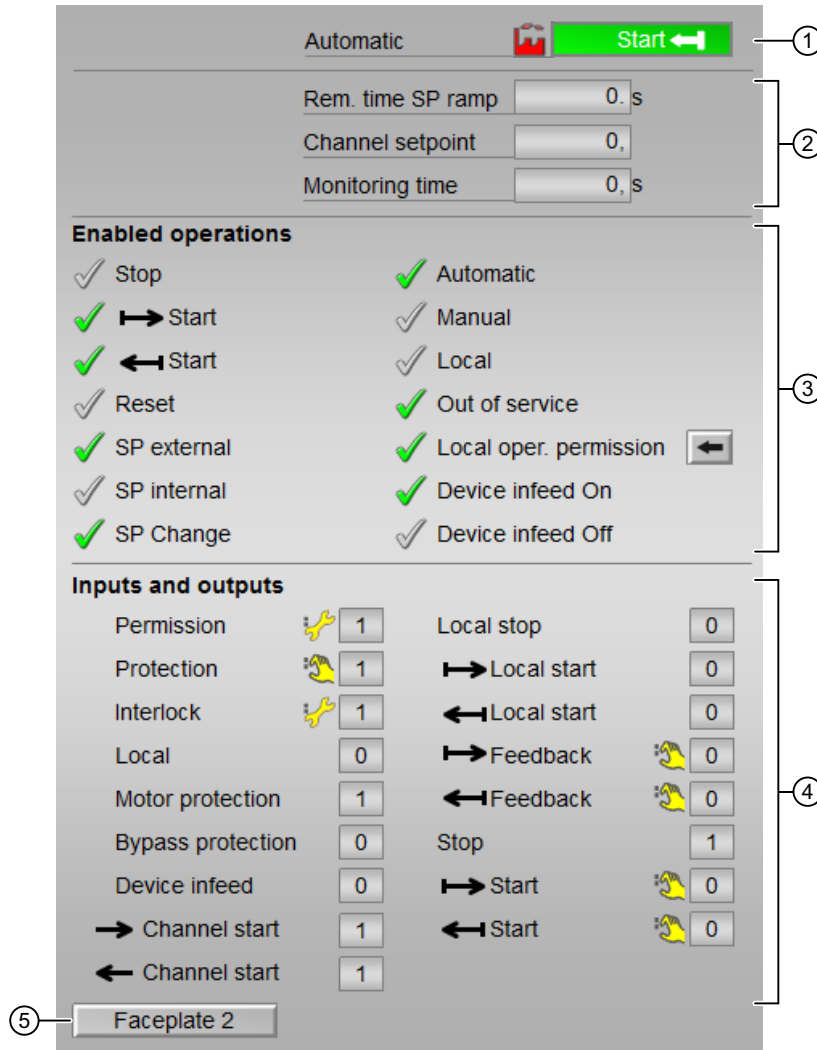

(1) Automatic preview

This area shows you the block status after it has switched from the "Manual" mode or "Local" mode to the "Automatic" mode.

If the block is in "Automatic" mode, the current block state is displayed.

This area also displays the worst signal status of the following automatic commands:

- FwdAut
- RevAut
- StopAut
- SP_Ext

(2) Preview area

This area shows you a preview of the following values:

- "Rem. time SP ramp" : Remaining time to reach the ramp target value.
- "Channel Setpoint": Setpoint from the output channel block.
- "Monitoring time": Display of the current monitoring time.

(3) Enable operations

This area shows all operations for which special operator permissions are assigned. They depend on the configuration in the engineering system (ES) that applies to this block.

Icons for enabled operation:

- **Green check mark:** the OS operator can control this parameter
- **Gray check mark:** the OS operator cannot control this parameter at this time due to the process
- **Red cross:** the OS operator cannot control this parameter due to the configured AS operator permissions (OS_Perm or OS1Perm)

The following enabled operations are shown here:

- "Stop": You can stop the motor.
If text is configured for this command, it is also displayed in brackets. You can find additional information on this in the section Labeling of buttons and text (Page 209)
- "Start |→ ": You can start the motor.
If text is configured for this command, it is also displayed in brackets. You can find additional information on this in the section Labeling of buttons and text (Page 209) .
- "Start ←|": You can start the motor.
If text is configured for this command, it is also displayed in brackets. You can find additional information on this in the section Labeling of buttons and text (Page 209) .
- "Reset": You can reset the motor after interlocks or errors.
- "SP external": You can feedforward the external setpoint.
- "SP internal": You can feedforward the internal setpoint.
- "Change SP": You can change the setpoint.
- "Automatic": You can switch to "automatic mode".
- "Manual": You can switch to "manual mode".
- "Local": You can switch to "local mode".
- "Out of service": You can switch to "Out of service" operating mode.
- "Local operator permission": Use the ← button to switch to the standard view of the OpStations block. You can find additional information on this in the section Operator control permissions (Page 254) .
- "Device infeed On": You can activate the device infeed
- "Device infeed Off": You can deactivate the device infeed

(4) Displaying current control signals

This area shows the most important parameters for this block with the current selection:

- "Permission":
This display is only visible when the corresponding block input is connected.
 - 0 = No OS release for energizing motor
 - 1 = Enable for "opening"/"closing" from the neutral position
- "Protection":
This display is only visible when the corresponding block input is connected.
 - 0 = Protective interlocking is effective; once the interlocking condition has disappeared, you will have to reset the block
 - 1 = "Good" state
- "Interlock":
This display is only visible when the corresponding block input is connected.
 - 0 = Interlocking without reset is active; you can operate the block without reset once the interlocking condition has disappeared
 - 1 = "Good" state
- "Local correct": 1 = Control signal for "Local mode" (LocalLi) is active
- "Motor protection": 1 = Motor is in "good" state
- "Interlock deact.":
 - 0 = Bypass disabled
 - 1 = Bypassing interlock in "local mode" and in "simulation"
- "Local stop": 1= Block is operated in "local mode"
- "Local start |→": 1= Block is operated in a controlled manner in "local mode"
- "Local start ←|": 1= Block is operated in a controlled manner in "local mode"
- "Feedback |→": 1 = Motor has started and is running
- Feedback←|: 1 = Motor has started and is running
- "Stop": 1 = Stop motor
- "Start | →" 1 = Start motor
- "Start ←|": 1 = Start motor
- "Device infeed": 1 = Enable device infeed
- "Channel Start →":Signal from the output channel block for "Start"
- "Channel Start ←":Signal from the output channel block for "Start"

(5) Navigation button for switching to the standard view of any faceplate

This display is only visible when the corresponding block input is connected.

Use this navigation button to open the standard view of a block configured in the engineering system. The visibility of this navigation button depends on the configuration in the engineering system (ES).

You can find additional information on this in the section Opening additional faceplates (Page 208) .

7.5.8.4 MotSpdCL limit view for readback values

Limit view for readback values of MotSpdCL

Several values are set in this view by default:

- Readback value limits

The toolbars of the faceplate and the block icon indicate when the limits are reached or violated.

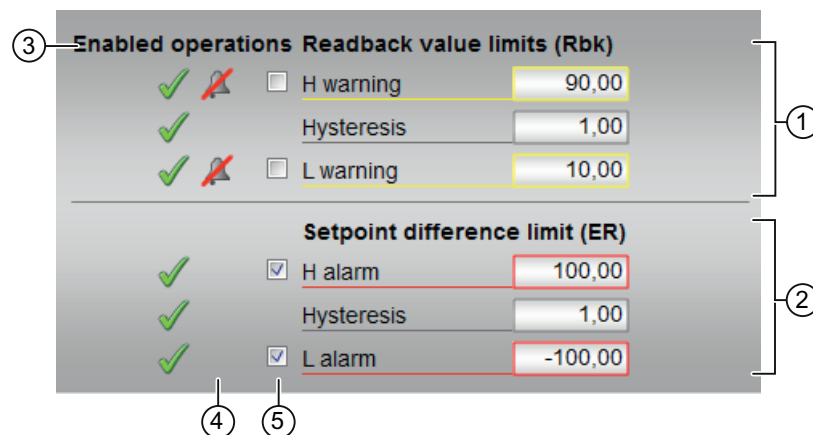

(1) Displaying and changing the limits for the readback value

In this area, you can enter the limits for the readback value. Refer to the Changing values (Page 259) section for more on this.

You can change the following limits:

- "H warning": Warning high
- "Hysteresis"
- "L warning": Warning low

(2) Displaying and changing the limits for the setpoint difference

In this area, you can enter the limits for the setpoint difference. Refer to the Changing values (Page 259) section for more on this.

You can change the following limits:

- "H alarm": Alarm high
- "Hysteresis"
- "L alarm": Alarm low

(3) Enabled operation

This area shows all operations for which special operator permissions are assigned. They depend on the configuration in the engineering system (ES) that applies to this block.

Icons for enabled operation:

- **Green check mark:** the OS operator can control this parameter
- **Gray check mark:** the OS operator cannot control this parameter at this time due to the process
- **Red cross:** the OS operator cannot control this parameter due to the configured AS operator permissions (OS_Perm or OS1Perm)

(4) "Message suppression/delay"

Message suppression indicates whether or not the suppression of the associated message in the AS block is activated with the `xx_MsgEn` parameter. The output of messages is not suppressed when the block is installed (all `xx_MsgEn` parameters are preset to 1). Messages can only be output if limit monitoring of the additional analog value has been enabled.

Alarm delays are also displayed in this position; for more on this see section Area of application of the alarm delays (Page 199).

(5) Suppress messages

You can enable / disable messages by setting the check mark.

7.5.8.5 MotSpdCL parameter view

Parameter view of MotSpdCL

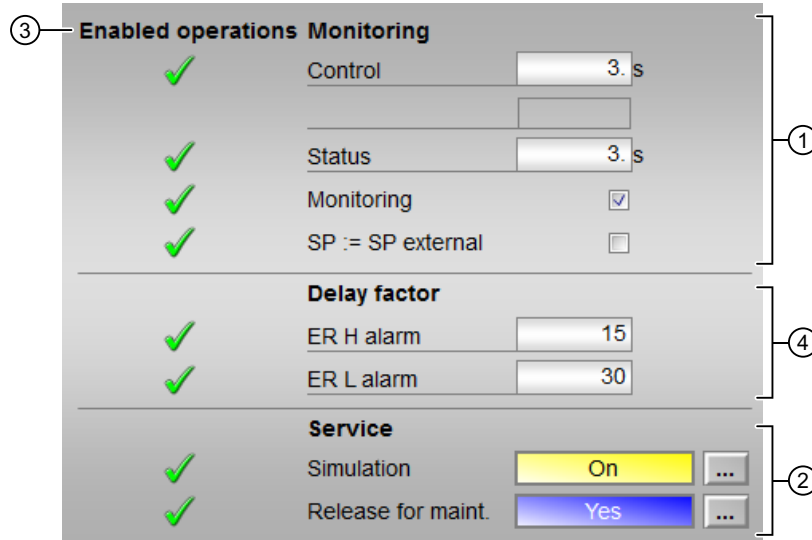

Parameter view of MotSpdCL with Feature bit 13 = 0

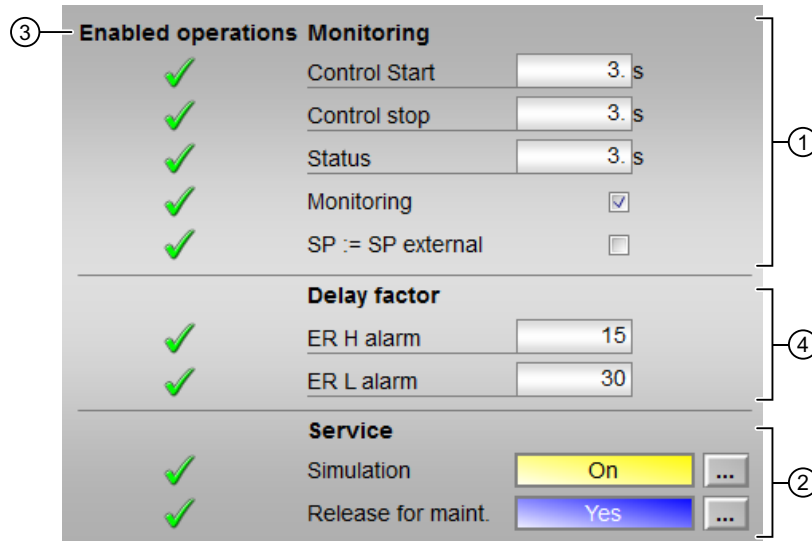

Parameter view of MotSpdCL with Feature bit 13 = 1

(1) Monitoring

In this area, you change parameters and therefore influence the motor. Refer to the Changing values (Page 259) section for more on this.

You can influence the following parameters:

- Feature bit **13 = 0**
 - "Control": Monitoring time during startup and shutdown of the motor (dynamic)
- Feature bit **13 = 1**
 - "Control stop": Monitoring time during shutdown of the motor (dynamic)
 - "Control start": Monitoring time during startup of the motor (dynamic)

"Status" monitoring

You can monitor time during permanent operation of the motor (static).

Enable monitoring

You can enable monitoring by selecting the check box .

You can find additional information on this in the section Monitoring the feedbacks (Page 97).

Activating bumpless switchover

"SP := SP external": Bumpless switchover of setpoint from external to internal. The internal setpoint is tracked to the external one.

(2) Service

You can select the following functions in this area:

- Simulation
- Release for maintenance

Refer to the Switching operating states and operating modes (Page 257) section for more on this.

You can find information on this area in the section:

- Simulating signals (Page 58)
- Release for maintenance (Page 64)

(3) Enabled operation

This area shows all operations for which special operator permissions are assigned. They depend on the configuration in the engineering system (ES) that applies to this block.

Icons for enabled operation:

- **Green check mark:** the OS operator can control this parameter
- **Gray check mark:** the OS operator cannot control this parameter at this time due to the process
- **Red cross:** the OS operator cannot control this parameter due to the configured AS operator permissions (`OS_Perm` or `OS1Perm`).

(4) Delay factor

In this area, you can change the following parameters:

- "ER H alarm": Delay factor at the positive setpoint step changes for incoming alarms at the control deviation monitoring ER_AH_Lim.
- "ER L alarm": Delay factor at the negative setpoint step changes for incoming alarms at the control deviation monitoring ER_AL_Lim.

7.5.8.6 MotSpdCL trend view

Trend view of MotSpdCL

You can find general information in section Trend view (Page 305).

Depending on feature bit 16 (process value with separate scale range) either one or two value axes are shown in the trend view.

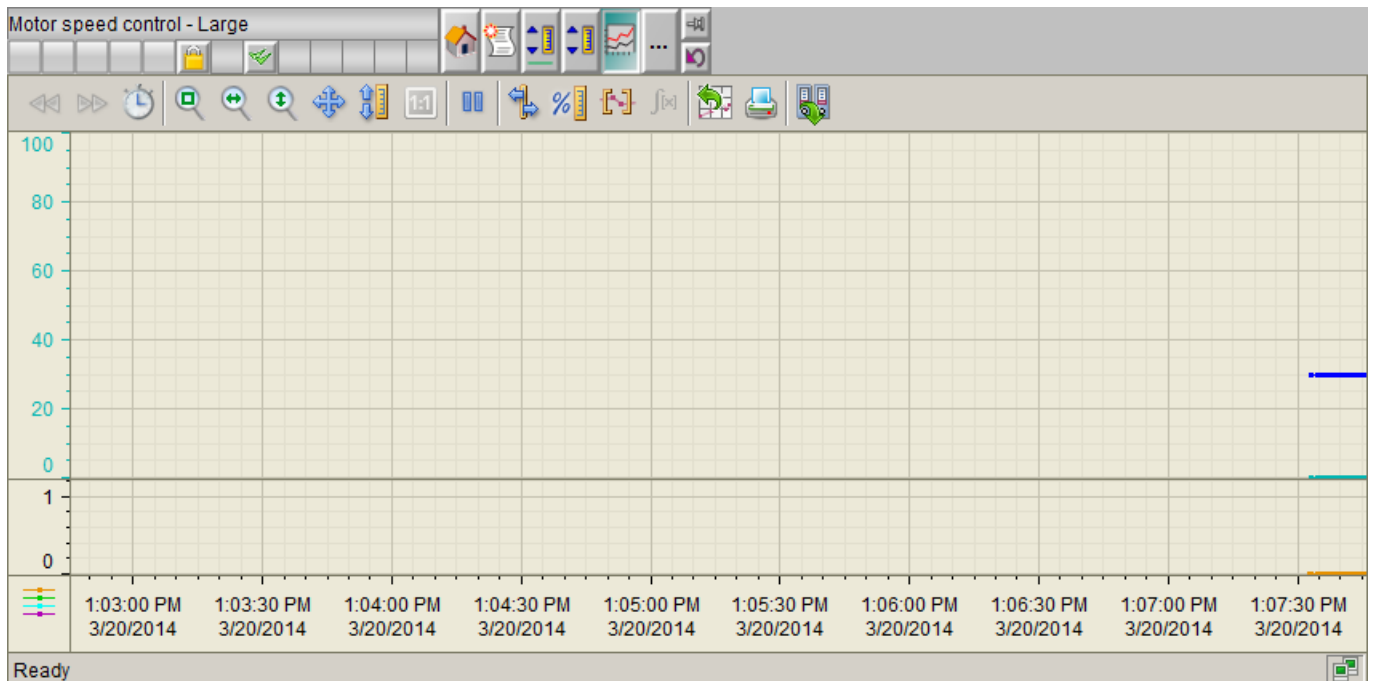

- Process value with separate scale range

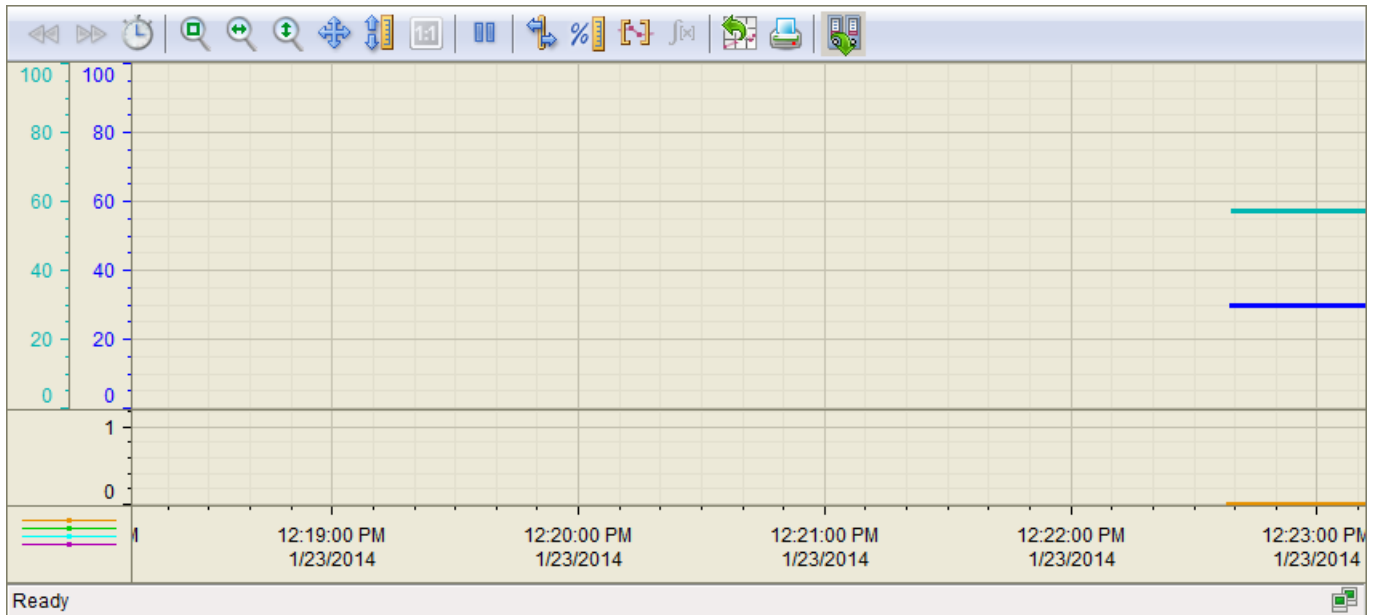

- Process value without separate scale range

Note

This function only has an effect when `SP_Out` is configured in "TrendConfiguration1" and `PV_In` is configured in "TrendConfiguration2" in the block icon (default).

7.5.8.7 Block icon for MotSpdCL

Block icons for MotSpdCL

A variety of block icons are available with the following functions:

- Process tag type
- Limits (high/low)
- Violation of alarm, warning, and tolerance limits as well as control system faults
- Operating modes
- Internal and external setpoint specification
- Signal status, release for maintenance
- Displays for bypassing interlocks
- Interlocks
- Memo display
- Motor state display





- Setpoint (blue, with decimal places)
- Feedback value (green, with decimal places)

The block icons from template @TemplateAPLV8.PDL:

Icons	Selection of the block icon in CFC	Special features
	1	
	2	
	3	Direction display inverted to symbol 1
	4	Direction display inverted to symbol 2
	5	"M" symbol with small direction display
	6	"M" symbol with small direction display

The block icons from template @TemplateAPLV7.PDL:

Icons	Selection of the block icon in CFC	Special features
	1	Block icon in the full display
	2	
	3	
	4	





Icons	Selection of the block icon in CFC	Special features
	5	
	6	
	7	
	8	
	-	Block icon in "Out of service" mode (example with type 1 block icon)

Additional information on the block icon and the control options in the block icon is available in the following chapters:

- Configuring the block icons (Page 237)
- Block icon structure (Page 230)
- Operation via the block icon (Page 239)

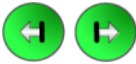
Motor state display

The following motor states are shown here:

Icon	Meaning
	Motor started (motor symbol changes)
	The motor is running
	Motor stopped (motor symbol changes)
	Motor idle
	Error at motor (monitoring error, Motor protection)
	Motor out of service

7.6 MotSpdL - Two-speed motor

7.6.1 Description of MotSpdL

Object name (type + number) and family

Type + number: FB 1856

Family: Drives

Area of application for MotSpdL

The block is used for the following applications:

- Control of two-speed motors

How it works

The block is used to control motors with two speeds. Various inputs are available for controlling the motor. You can add monitoring of a maximum of two feedbacks produced by the contactor relay and a switching mode with which the speed change can be performed.

Configuration

Use the CFC editor to install the block in a cyclic interrupt OB (OB3x). The block is also installed automatically in the startup OB (OB100).

Further addressing is not required.

For the MotSpdL block, the Advanced Process Library contains a template for process tag types as an example with an application scenario for this block.

Example of process tag types:

- Two-speed motor (Motor2Speed) (Page 2362)

Startup characteristics

Use the `Feature Bit Set` startup characteristics (Page 138) to define the startup characteristics of this block.

The messages are suppressed after startup for the number of cycles set at `RunUpCyc`.

Status word allocation for `status1` parameter

You can find a description for each parameter in section MotSpdL I/Os (Page 1241).

Status bit	Parameter
0	Occupied
1	BatchEn

7.6 MotSpdL - Two-speed motor

Status bit	Parameter
2	SimOn
3	OosAct.Value
4	OosLi.Value
5	0 = ManAct.Value 1 = AutoAct.Value
6	LocalAct.Value
7	0: Open padlock in the block icon 1: Closed padlock in the block icon
8	Spd1.Value
9	Motor is stopped
10	Spd2.Value
11	MonStaErr.Value
12	MonDynErr.Value
13	BypProt
14	Invalid signal status
15	Mode switchover error
16	1 = Intlock is active
17	1 = Permit is active
18	1 = Protect is active
19	Trip.Value
20	Display „Forced speed1“
21	Display „Forced stop“
22	Display „Forced speed2“
23	"Interlock" button is enabled
24	Reset request in automatic preview
25	WarnAct:Value, IdleTime or SwOverTi active
26	Bypass information
27	Automatic preview for (Speed1)
28	Automatic preview for (Stop)
29	Automatic preview for (Speed2)
30	"Permission" button is enabled
31	"Protection" button is enabled

Status word allocation for Status2 parameter

Status bit	Parameter
0	MsgLock
1	AV_AH_Act.Value
2	AV_WH_Act.Value
3	AV_TH_Act.Value

Status bit	Parameter
4	AV_TL_Act.Value
5	AV_WL_Act.Value
6	AV_AL_Act.Value
7	AV_AH_En
8	AV_WH_En
9	AV_TH_En
10	AV_TL_En
11	AV_WL_En
12	AV_AL_En
13	AV_AH_MsgEn
14	AV_WH_MsgEn
15	AV_TH_MsgEn
16	AV_TL_MsgEn
17	AV_WL_MsgEn
18	AV_AL_MsgEn
19	1 = No impact of input signals on "local mode" with LocalSetting = 2 and LocalSetting = 4
20	Motor is stopped
21	Motor stops at speed 1
22	Motor stops at speed 2
23	Motor starts at speed 1
24	Motor running at speed 1
25	Motor starts at speed 2
26	Motor running at speed 2
27	Error when stopping motor
28	Error with motor speed 1
29	Error with motor speed 2
30	Display for interlocks in block icon
31	MS_RelOp

Status word allocation for Status3 parameter

Status bit	Parameter
0	Delay of the AV_AH_Lim message
1	Delay of the AV_WH_Lim message
2	Delay of the AV_TH_Lim message
3	Delay of the AV_TL_Lim message
4	Delay of the AV_WL_Lim message
5	Delay of the AV_AL_Lim message
6	Collection of message delays
7 - 14	Not used
15	Current monitoring time is visible

7.6 MotSpdL - Two-speed motor

Status bit	Parameter
16	MonDynStopErr.Value
17	Not used
18	SimLiOp.Value
19	1 = Enable for rapid stop (Feature Bit Enabling rapid stop via faceplate (Page 168))
20	1 = Input parameter Spd1ChnST is interconnected
21	1 = Input parameter Spd2ChnST is interconnected
22	Not used
23	Command for rapid stop
24	Command for starting > the motor
25	Command for starting >> the motor
26	Show automatic preview in the standard view
27	Not used
28	GrpErr.Value
29	RdyToStart.Value
30	Auxiliary value 1 visible
31	Auxiliary value 2 visible

Status word allocation for Status4 parameter

Status bit	Parameter
0	Effective signal 1 of the message block connected via EventTsIn
1	Effective signal 2 of the message block connected via EventTsIn
2	Effective signal 3 of the message block connected via EventTsIn
3	Effective signal 4 of the message block connected via EventTsIn
4	Effective signal 5 of the message block connected via EventTsIn
5	Effective signal 6 of the message block connected via EventTsIn
6	Effective signal 7 of the message block connected via EventTsIn
7	Effective signal 8 of the message block connected via EventTsIn
8	AV not connected
9	Motor protection display (Trip.Status ≠ 16#FF)
10	1 = Input parameter FbkSpd1 is connected
11	1 = Input parameter FbkSpd2 is connected
12 - 21	Not used
22	External error generated by FaultExt or external control system fault CSF with set Feature bit 18 Activating error state for external process control error CSF (Page 151)
23	Hidden bypass signal in Permit
24	Hidden bypass signal in interlock
25	Hidden bypass signal in Protect
26	Feature2 bit 2: Separate bypass signal
27-30	Not used
31	Separate monitoring of shutdown of the motor (Feature bit 13)

Status word allocation for Status5 parameter

Status bit	Parameter
0 - 7	Effective signal 9..16 of the message block connected via <code>EventTsIn</code>
8 - 31	Not used

See also

MotSpdL functions (Page 1230)
 MotSpdL messaging (Page 1240)
 MotSpdL block diagram (Page 1250)
 MotSpdL error handling (Page 1238)
 MotSpdL modes (Page 1229)

7.6.2 MotSpdL modes**MotSpdL modes**

The block can be operated using the following modes:

- Local mode (Page 79)
- Automatic mode (Page 75)
- Manual mode (Page 75)
- Out of service (Page 71)

The next section provides additional block-specific information relating to the general descriptions. This includes, for example, the parameters for mode changes.

"Local mode"

You can find general information on "Local mode", switching modes and Bumpless switchover in the Local mode (Page 79) section.

Motor actions you can control in local mode:

- starting with speed 1 (`Spd1Local = 1`)
- starting with speed 2 (`Spd2Local = 1`)
- stopping (`StopLocal = 1`).

A motor operated in "local" mode is controlled either by "local" signals (input parameters `Spd1Local = 1`, `Spd2Local = 1` and `StopLocal = 1`) or feedback signals (input parameters `FbkSpd1 = 1` and `FbkSpd2 = 1`). Configuration takes place via the input parameter `LocalSetting`.

"Automatic mode"

You can find general information on "Automatic mode", switching modes and Bumpless switchover in the Manual and automatic mode for motors, valves and dosers (Page 75) section.

Motor actions you can control in auto mode:

- starting with speed 1 (Spd1Aut = 1)
- starting with speed 2 (Spd2Aut = 1)
- stopping (StopAut = 1).

"Manual mode"

You can find general information on "Manual mode", switching modes and bumpless switchover in the section Manual and automatic mode for motors, valves and dosers (Page 75).

Motor actions you can control in "manual mode":

- starting with speed 1 (Spd1Man = 1)
- starting with speed 2 (Spd2Man = 1)
- stopping (StopMan = 1).

"Out of service"

You can find general information about the "Out of service" mode in the section Out of service (Page 71)

See also

MotSpdL block diagram (Page 1250)

MotSpdL I/Os (Page 1241)

MotSpdL messaging (Page 1240)

MotSpdL error handling (Page 1238)

MotSpdL functions (Page 1230)

Description of MotSpdL (Page 1225)

7.6.3 MotSpdL functions

Functions of MotSpdL

The functions for this block are listed below.

Opening additional faceplates

This block provides the standard function Opening additional faceplates (Page 208).

Operator permissions

This block provides the standard function Operator control permissions (Page 254).

The block has the following permissions for the `OS_Perm` parameter:

Bit	Function
0	1 = Operator can switch to "automatic mode"
1	1 = Operator can switch to "manual mode"
2	1 = Operator can switch to "local mode"
3	1 = Operator can switch to "Out of service" mode
4	1 = Operator can stop the motor
5	1 = Operator can start the motor at speed 1
6	1 = Operator can start the motor at speed 2
7	1 = Operator can reset the motor
8	1 = Operator can define or change the monitoring time for startup
9	1 = Operator can define the monitoring time for the status
10	1 = Operator can activate the monitoring time function (Bit 8 - 9)
11	1 = Operator can activate the Simulation function
12	1 = Operator can activate the Release for maintenance function
13	1 = Operator can change the limit (AV) for high alarm
14	1 = Operator can change the limit (AV) for high warning
15	1 = Operator can change the limit (AV) for high tolerance
16	1 = Operator can change the limit (AV) for hysteresis
17	1 = Operator can change the limit (AV) for low alarm
18	1 = Operator can change the limit (AV) for low warning
19	1 = Operator can change the limit (AV) for low tolerance
20	1 = Operator can activate / deactivate messages via AV_AH_MsgEn
21	1 = Operator can activate / deactivate messages via AV_WH_MsgEn
22	1 = Operator can activate / deactivate messages via AV_TH_MsgEn
23	1 = Operator can activate / deactivate messages via AV_TL_MsgEn
24	1 = Operator can activate / deactivate messages via AV_WL_MsgEn
25	1 = Operator can activate / deactivate messages via AV_AL_MsgEn
26	1 = Operator can change the simulation value SimAV
27 - 29	Not used
30	1 = Operator can define the monitoring time for stopping
31	1 = Operator can execute the rapid stop

Note

If you interconnect a parameter that is also listed in `OS_Perm` as a parameter, you have to reset the corresponding `OS_Perm` bit.

Restart lock after switching off the motor

After switching off or stopping the motor, it can only be restarted after the time set with the `IdleTime` input parameter. When the "Stop" command is given, the motor goes immediately into "Stop" mode, and `IdleTime` starts after the feedback (`FbkSpd1` and `FbkSpd2 = 0`) is given. The motor cannot be started again until the `IdleTime` has expired.

The `IdleTime` parameter can be set independently of the `MonTiDynamic` parameter.

Limit monitoring of an additional analog value

This block provides the standard function Limit monitoring of an additional analog value (Page 91).

Limit monitoring with hysteresis

This block provides the standard function Limit monitoring with hysteresis (Page 97).

Suppressing messages using the `MsgLock` parameter

This block provides the standard function Suppressing messages using the `MsgLock` parameter (Page 205).

Interlocks

This block provides the following interlocks:

- Activation enable
- Interlock without reset ("Interlock")
- Interlock with reset ("Protection")

Refer to the section Interlocks (Page 99) as well as Influence of the signal status on the interlock (Page 103).

Motor protection function

This block provides the standard function Motor protection function (Page 99).

Rapid stop for motors

This block provides the standard function Rapid stop for motors (Page 106).

Disabling interlocks

This block provides the standard function Disabling interlocks (Page 103).

Resetting the block in case of interlocks or errors

This block provides the standard function Resetting the block in case of interlocks or errors (Page 43).

External error (`FaultExt`), external control system fault (`CSF`)

This block provides the possibility to pass an external error via the `FaultExt` parameter or an external control system fault via the `CSF` parameter. See MotSpdL error handling (Page 1238).

Group error

This block provides the standard function Outputting group errors (Page 122).

The following parameters are taken into consideration when forming the group error:

- `CSF`
- `Trip`
- `MonDynErr`
- `MonStaErr`
- `FaultExt`

Outputting a signal for start readiness

This block provides the standard function Outputting a signal for start readiness (Page 53).

Forming the group status for interlocks

This block provides the standard function Forming the group status for interlock information (Page 104).

Forming the signal status for blocks

This block provides the standard function Forming and outputting the signal status for technologic blocks (Page 109).

The worst signal status `ST_Worst` for the block is formed from the following parameters:

- `FbkSpd1Out.ST`
- `FbkSpd2Out.ST`
- `LocalLi.ST`
- `Spd1Local.ST`
- `StopLocal.ST`
- `Spd2Local.ST`
- `Trip.ST`
- `AV_Out.ST`

- Spd1Chn.ST
- Spd2Chn.ST
- Spd1Aut.ST (only if Feature2.Bit10 = 1)
- Spd2Aut.ST (only if Feature2.Bit10 = 1)
- StopAut.ST (only if Feature2.Bit10 = 1)

Considering bad quality of automatic commands or external values

If the Feature2 bit Considering bad quality of automatic commands or external values (Page 186) is set to 1 and one of the following parameters has bad signal status (16#00 or 16#28), the block goes to the neutral position (motor stop) in the "Automatic" mode:

- Spd1Aut.ST
- Spd2Aut.ST
- StopAut.ST

Forcing operating modes

This block provides the standard function Forcing operating modes (Page 41).

The following states can be enforced:

- Speed 1 (Spd1Force)
- Speed 2 (Spd2Force)
- Stop (StopForce)

Feedback monitoring

This block provides the standard function Monitoring the feedbacks (Page 97).

Release for maintenance

This block provides the standard function Release for maintenance (Page 64).

Specify warning times for control functions

This block provides the standard function Specifying warning times for control functions at motors and valves (Page 51).

You can generate warning signals when, for example, motors are started. Warning signals can be generated in the following modes:

- Manual mode (Page 75) (WarnTiMan input parameter)
- Automatic mode (Page 75) (WarnTiAut input parameter)

You specify the warning times in seconds using the input parameters WarnTiMan and WarnTiAut. If, for example, a motor is started, then this is displayed at the output parameter

with `WarnAct = 1`. The motor then starts after the set warning time has expired and `WarnAct` then goes back to 0.

A corresponding warning is not output if the warning times (`WarnTiMan` or `WarnTiAut`) are specified with a smaller value than the `SampleTime` parameter.

Step control mode for the speed change

Use the input parameter `SwiOverTi` and the `Feature Bit 5` (Specifying switching mode (Page 168)) to specify how the motor is to carry out the speed change.

In so doing use the input parameter `SwiOverTi` to adjust the switching time. You have the following options:

- Switching on and off occurs immediately
- Switching on via speed 1
- Switching off via speed 1

Switching on and off occurs immediately: This setting enables you to switch directly from the "Off" state to speed 2 or from speed 2 (`Spd2`) to "Off".

Switching on via speed 1: The speed change from the "Off" condition to speed 2 (`Spd2`) is accomplished via speed 1 (`Spd1`) and after expiration of the time at the parameter `SwiOverTi`.

Switching off via speed 1: The speed change from speed 2 (`Spd2`) to the "Off" state is accomplished via speed 1 (`Spd1`) and after expiration of the time at parameter `SwiOverTi`.

Step control mode	<code>SwiOverTi</code>	<code>Feature Bit 5</code>
Switching on and off occurs immediately	= 0.0	0/1
Switching on only via speed 1	> 0.0	0
Switching on and off via speed 1	> 0.0	1

Simulating signals

This block provides the standard function Simulating signals (Page 58).

You can simulate the following values:

- Additional value (`SimAV`, `SimAV_Li`)

Selecting a unit of measure

This block provides the standard function Selecting a unit of measure (Page 212).

Neutral position

This block provides the standard function Neutral position for motors, valves and controllers (Page 48).

Output signal as a pulse signal or static signal

This block provides the standard function Output signal as a static signal or pulse signal (Page 51).

Generating instance-specific messages

This block provides the standard function Generating instance-specific messages (Page 204).

Configurable reactions using the Feature parameter

You can find an overview of all reactions provided by the Feature parameter in the section Configurable functions using the Feature I/O (Page 131). The following functionality is available for this block at the relevant bits:

Bit	Function
0	Set startup characteristics (Page 138)
1	Reaction to the out of service mode (Page 177)
2	Resetting the commands for changing the mode (Page 161)
3	Enabling resetting of commands for the control settings (Page 161)
4	Setting switch or button mode (Page 167)
5	Specifying switching mode (Page 168)
9	Resetting via input signals in the event of interlocking (Protection) or errors (Page 163)
10	Exiting local mode (Page 177)
11	Activating the run time of feedback signals (Page 153)
13	Separate monitoring time for stopping the motor (Page 169)
14	Enabling rapid stop via faceplate (Page 168)
17	Enabling bumpless switchover to automatic mode for valves, motors, and dosers (Page 173)
18	Activating error state for external process control error CSF (Page 151)
19	Reset even with locked state (Page 165)
20	Disable calculation of impulse control in LocalSetting 2 and 4 (Page 186)
21	Enable bumpless switchover to "Automatic" mode for operator only (Page 172)
22	Update acknowledgment and error status of the message call (Page 160)
24	Enabling local operator authorization (Page 158)
25	Suppression of all messages (Page 174)
26	Reaction of the switching points in the "Out of service" operating mode (Page 176)
27	Interlock display with LocalSetting 2 or 4 (Page 178)
28	Disabling operating points (Page 145)
29	Signaling limit violation (Page 170)
30	Set reset depending on the operating mode or the LiOp parameter (Page 163)
31	Activating reset of protection / error in manual mode (Page 165)

In pushbutton operation (Bit 4 = 0) the automatic commands in "automatic" mode are latching, in other words Spd1Aut, Spd2Aut, StopAut can be reset to 0 after changing the control. In "manual" and "local" modes, however, the automatic commands are not saved and in the absence of automatic commands the automatic control is tracked.

In switching mode (Bit 4 = 1), control is selected with the static signals `Spd1Aut`, `Spd2Aut`. If `Spd1Aut`, `Spd2Aut` inputs are not set, the motor is stopped. Control via `StopAut` is not needed. If the "Activate command reset for control" function (Bit 3 = 1) is also enabled, the inputs `Spd1Aut`, `Spd2Aut` are reset to the neutral position after evaluation in the block.

Configurable reactions using the `Feature2` parameter

Bit	Function
2	Separate evaluation for excluded and simulated interlock signals (Page 152)
3	Control priority in the event of an invalid input command (Page 175)
4	Setting switch or button mode for local commands (Page 181)
5	Evaluation of the signal status of the interlock signals (Page 142)
8	Forcing operating modes in the "Local" mode (Page 184)
10	Considering bad quality of automatic commands or external values (Page 186)
11	Suppress <code>MsgLock</code> and "Out of service" mode for a connected message block (Page 188)

Displaying auxiliary values

This block provides the standard function `Displaying auxiliary values` (Page 211).

Connection of the time-stamped messages from `EventTs` or `Event16Ts`

This block provides the standard function `Connection of the time-stamped messages from EventTs or Event16Ts` (Page 207).

SIMATIC BATCH functionality

This block provides the standard function `SIMATIC BATCH functionality` (Page 67).

Button labels

This block provides the standard function `Labeling of buttons and text` (Page 209)

Instance-specific text can be configured for the following parameters:

- `Spd1Man`
- `Spd2Man`
- `StopMan`
- `RapidStp`

See also

`MotSpdL` block diagram (Page 1250)

`MotSpdL` modes (Page 1229)

EventTs functions (Page 1660)

MotSpdL I/Os (Page 1241)

7.6.4 MotSpdL error handling

Error handling of MotSpdL

Refer to section Error handling (Page 119) in the basic instructions for the error handling of all blocks.

The following errors can be displayed for this block:

- Error numbers
- Mode switchover error
- Invalid input signals
- Control system fault (CSF)

Overview of error numbers

The `ErrorNum` I/O can be used to output the following error numbers:

Error number	Meaning of the error number
-1	Predefined value when inserting the block; the block is not executed
0	There is no error.
41	The value for the <code>LocalSetting</code> I/O is not within the approved limit of 0 to 4.
42	<code>LocalSetting = 0 or LocalSetting = 3 or LocalSetting = 4 and LocalLi = 1</code>
51	<code>Spd1Local = 1 and StopLocal = 1</code> <code>Spd2Local = 1 and StopLocal = 1</code> <code>Spd1Local = 1 and Spd2Local = 1</code> <code>Spd1Aut = 1 and StopAut = 1</code> <code>Spd2Aut = 1 and StopAut = 1</code> <code>Spd1Aut = 1 and Spd2Aut = 1</code> <code>AutModLi = 1 and ManModLi = 1</code> <code>Spd1Force = 1 and StopForce = 1</code> <code>Spd2Force = 1 and StopForce = 1</code> <code>Spd1Force = 1 and Spd2Force = 1</code>
52	<code>LocalAct = 1 and LocalSetting = 2 or 4 and SimOn = 1</code>

Mode switchover error

This error can be output by the block, see the section Error handling (Page 119).

Invalid input signals

This error can be output by the block, see the section Error handling (Page 119).

For the following invalid input signals, the control output can be kept or switched to the neutral position. This depends on the function Control priority in the event of an invalid input command (Page 175).

Operating mode	Invalid input signals	Control reaction with Feature2 bit 3 =1
Local: Localsetting = 1 or Localsetting = 3	Pushbutton operation for local mode (Feature2 bit 4 = 0): Spd1Local = 1 and Spd2Local = 1 or Spd1Local = 1 and StopLocal = 1 or StopLocal = 1 and Spd2Local = 1 Switching mode (Feature2 bit 4 = 1): Spd1Local = 1 and Spd2Local = 1	Motor is stopped
Local: Localsetting = 1 or Localsetting = 3 and forcing	Spd1Force = 1 and Spd2Force = 1 or Spd1Force = 1 and StopForce = 1 or StopForce = 1 and Spd2Force = 1	
Forcing and no "local mode"	Spd1Force = 1 and Spd2Force = 1 or Spd1Force = 1 and StopForce = 1 or StopForce = 1 and Spd2Force = 1	
"Automatic mode" and no forcing	Pushbutton operation (Feature bit 4 = 0): Spd1Aut = 1 and Spd2Aut = 1 or Spd1Aut = 1 and StopAut = 1 or StopAut = 1 and Spd2Aut = 1 Switching mode (Featurebit 4 = 1): Spd1Aut = 1 and Spd2Aut = 1	
"Manual mode" and no forcing	Spd1Man = 1 and Spd2Man = 1 or Spd1Man = 1 and StopMan = 1 or StopMan = 1 and Spd2Man = 1	

Control system fault (CSF)

An external signal can be activated via the CSF input. A control system fault is triggered if this signal changes to 1. Refer to the Error handling (Page 119) section for more on this.

See also

MotSpdL block diagram (Page 1250)

MotSpdL I/Os (Page 1241)

MotSpdL functions (Page 1230)

MotSpdL modes (Page 1229)

Description of MotSpdL (Page 1225)

MotSpdL messaging (Page 1240)

7.6.5 MotSpdL messaging

Messaging

The following messages can be generated for this block:

- Process control fault
- Instance-specific messages

Process control fault

The following control system error messages can be output:

Message instance	Message identifier	Message class	Event
MsgEvId1	SIG 1	AS process control message - fault	\$\$BlockComment\$\$ Motor feedback error
	SIG 2	AS process control message - fault	\$\$BlockComment\$\$ Motor protection triggered
	SIG 3	AS process control message - fault	\$\$BlockComment\$\$ External error has occurred

Explanation:

\$\$BlockComment\$\$: Content of the instance-specific comment

You can interconnect an external fault (signal) to input parameter `CSF`. If it changes to `CSF = 1`, a process control fault is triggered (`MsgEvId1`, SIG 3).

Instance-specific messages

You can use up to three instance-specific messages with this block.

Message instance	Message identifier	Message class	Event
MsgEvId1	SIG 4	AS process control message - fault	\$\$BlockComment\$\$ External message 1
	SIG 5	AS process control message - fault	\$\$BlockComment\$\$ External message 2
	SIG 6	AS process control message - fault	\$\$BlockComment\$\$ External message 3

Explanation:

\$\$BlockComment\$\$: Content of the instance-specific comment

Associated values for message instance `MsgEvId1`

Associated value	Block parameters
1	BatchName
2	StepNo
3	BatchID
4	ExtVal104
5	ExtVal105
6	ExtVal106
7	ExtVal107
8	ExtVal108
9	Reserved
10	Reserved

The associated values 4 ... 8 are allocated to the parameters `ExtVal104` ... `ExtVal108` and can be used. Additional information is available in the "Process Control System PCS 7 - Engineering System" manual.

See also

MotSpdL block diagram (Page 1250)

MotSpdL modes (Page 1229)

MotSpdL error handling (Page 1238)

7.6.6 MotSpdL I/Os

I/Os of MotSpdL

Input parameters

Table 7-1

Parameter	Description	Type	Default
<code>AutModLi*</code>	1 = "Automatic mode" via interconnection or SFC (controlled by <code>ModLiOp = 1</code>)	STRUCT <ul style="list-style-type: none"> • Value: BOOL • ST: BYTE 	- <ul style="list-style-type: none"> • 0 • 16#80
<code>AutModOp*</code>	1 = "Automatic mode" via operator (controlled by <code>ModLiOp = 0</code>)	BOOL	0
<code>AV</code>	Input additional analog value, to be connected to <code>AV_Tech</code> of the AV block	ANY	
<code>AV_AH_Lim</code>	Limit high alarm	REAL	95.0
<code>AV_AL_Lim</code>	Limit low alarm	REAL	5.0
<code>AV_Hyst</code>	Hysteresis for alarm, warning and tolerance limits	REAL	1.0

Motor and valve blocks

7.6 MotSpdL - Two-speed motor

Parameter	Description	Type	Default
AV_TH_Lim	Limit high tolerance	REAL	85.0
AV_TL_Lim	Limit low tolerance	REAL	15.0
AV_WH_Lim	Limit high warning	REAL	90.0
AV_WL_Lim	Limit low warning	REAL	10.0
BatchEn	1 = Enable allocation	BOOL	0
BatchID	Batch ID	DWORD	16#00000000
BatchName	Batch name	S7-String	
ByProt	1 = Bypassing interlock in "local mode" and in "simulation"	BOOL	0
CSF	1 = External error (control system faultError handling (Page 119))	STRUCT <ul style="list-style-type: none"> • Value: BOOL • ST: BYTE 	- <ul style="list-style-type: none"> • 0 • 16#80
EN	1 = Called block will be processed	BOOL	1
EventTsIn	For interconnecting data between a technology block and the message blocks EventTs, Event16Ts. The EventTsIn input parameter serves to interconnect the EventTsOut output parameter of the EventTs, Event16Ts block. When this interconnection is configured, the messages of the EventTs, Event16Ts block are displayed on the OS in the alarm view of the technology block and can also be acknowledged there.	ANY	
ExtMsg1	Binary input for freely selectable message 1	STRUCT <ul style="list-style-type: none"> • Value: BOOL • ST: BYTE 	- <ul style="list-style-type: none"> • 0 • 16#80
ExtMsg2	Binary input for freely selectable message 2	STRUCT <ul style="list-style-type: none"> • Value: BOOL • ST: BYTE 	- <ul style="list-style-type: none"> • 0 • 16#80
ExtMsg3	Binary input for freely selectable message 3	STRUCT <ul style="list-style-type: none"> • Value: BOOL • ST: BYTE 	- <ul style="list-style-type: none"> • 0 • 16#80
ExtVa104	Associated value 4 for messages (MsgEvID1)	ANY	
ExtVa105	Associated value 5 for messages (MsgEvID1)	ANY	
ExtVa106	Associated value 6 for messages (MsgEvID1)	ANY	
ExtVa107	Associated value 7 for messages (MsgEvID1)	ANY	
ExtVa108	Associated value 8 for messages (MsgEvID1)	ANY	

Parameter	Description	Type	Default
FaultExt	1 = External error Error handling (Page 119)	STRUCT • Value: BOOL • ST: BYTE	- • 0 • 16#80
FbkSpd1	1 = Feedback for speed 1 is present	STRUCT • Value: BOOL • ST: BYTE	- • 0 • 16#FF
FbkSpd2	1 = Feedback for speed 2 is present	STRUCT • Value: BOOL • ST: BYTE	- • 0 • 16#FF
Feature	I/O for additional functions (Page 1230) 1 = Separate monitoring time for stopping the motor	STRUCT • Bit 0: BOOL • ... • Bit 13: BOOL • ... • Bit 31: BOOL	- • 0 • 0 • 0 • 0 • 0
Feature2	I/O for additional functions (Page 1230)	STRUCT • Bit 0: BOOL • ... • Bit 31: BOOL	- • 0 • 0 • 0
IdleTime*	Wait time for restart of motor in [s]	REAL	5.0
Intlock	0 = Interlocking without reset is active; you can operate the block without reset once the interlocking condition has disappeared 1 = Interlock not activated	STRUCT • Value: BOOL • ST: BYTE • Bit 1: BOOL (Bypass information bit)	- • 1 • 16#FF • 0
Intl_En	1 = Interlock without reset (interlock, Intlock parameter) is active	BOOL	1
LocalLi	1 = Activate "local mode" via plant signal	STRUCT • Value: BOOL • ST: BYTE	- • 0 • 16#80
LocalOp*	1 = "Local mode" via operator	BOOL	0
LocalSetting	Properties for the Local mode (Page 79)	INT	0
ManModLi*	1 = "Manual mode" via interconnection or SFC (controlled by ModLiOp = 1)	STRUCT • Value: BOOL • ST: BYTE	- • 0 • 16#80
ManModOp*	1 = "Manual mode" via OS operator (controlled by ModLiOp = 0)	BOOL	1
ModLiOp	Switchover of operating mode between: 0 = Operator 1 = Interconnection or SFC	STRUCT • Value: BOOL • ST: BYTE	- • 0 • 16#80
Monitor	1 = Feedback monitoring	BOOL	1

Motor and valve blocks

7.6 MotSpdL - Two-speed motor

Parameter	Description	Type	Default
MonTiDynamic*	Monitoring time for feedback errors or feedback start error after successful operation in [s]	REAL	3.0
MonTiDyStop*	Monitoring time for feedback stop errors after successful operation in [s]	REAL	3.0
MonTiStatic*	Monitoring time for feedback errors without operation in [s]	REAL	3.0
MS_RelOp	1 = Release for maintenance via OS operator	BOOL	0
MsgEvId1	Message number (assigned automatically)	DWORD	16#00000000
MsgLock	1 = Suppress process messages. See also the section Suppressing messages using the MsgLock parameter (Page 205) for more on this.	STRUCT • Value: BOOL • ST: BYTE	- • 0 • 16#80
MS_RelOp*	1 = Release for maintenance via OS operator	BOOL	0
Occupied	1 = In use by a batch	BOOL	0
OosLi	1 = "Out of service", via interconnection or SFC (0-1 edge transition)	STRUCT • Value: BOOL • ST: BYTE	- • 0 • 16#80
OosOp*	1 = "Out of service", via OS operator	BOOL	0
OpSt_In	Input parameter for local operator authorization, connected with the <code>Out</code> output parameter of the upstream block, <code>OpStations</code> (Page 411)	DWORD	16#00000000
OS_Perm	I/O for operator permissions (Page 1230) 1 = Operator can set or change the monitoring time for "Control: Start" 1 = Operator can set the monitoring time for "Control:Stop"	STRUCT • Bit 0: BOOL • Bit 8: BOOL • Bit 20: BOOL • Bit 30: BOOL	- • 1 • 1 • 1 • 1
Permit	1 = OS activation enable for motor 0 = No OS release for energizing motor	STRUCT • Value: BOOL • ST: BYTE • Bit 1: BOOL (Bypass information bit)	- • 1 • 16#FF • 0
Perm_En	1 = Activation enable (enable, <code>Permit</code> parameter) is active	BOOL	1

Parameter	Description	Type	Default
Protect	0 = Protective interlocking is effective; once the interlocking condition has disappeared, you will have to reset the block 1 = Protective interlocking not activated	STRUCT <ul style="list-style-type: none"> Value: BOOL ST: BYTE Bit 1: BOOL (Bypass information bit) 	- <ul style="list-style-type: none"> 1 16#FF 0
Prot_En	1 = Protective interlock (protection, <i>Protect</i> parameter) is active	BOOL	1
PulseWidth*	Pulse width of control signal [s]	REAL	3.0
RapidStp*	Rapid stop for the motor: 0 = Motor On 1 = Motor Off	BOOL	0
Spd1Aut*	1 = Activation of motor speed 1 in "automatic mode"	STRUCT <ul style="list-style-type: none"> Value: BOOL ST: BYTE 	- <ul style="list-style-type: none"> 0 16#80
Spd2Aut*	1 = Activation of motor speed 2 in "automatic mode"	STRUCT <ul style="list-style-type: none"> Value: BOOL ST: BYTE 	- <ul style="list-style-type: none"> 0 16#80
Spd1ChnST	Signal status of output channel for <i>Fwd</i> Should be connected to an output channel block	STRUCT <ul style="list-style-type: none"> Value: BOOL ST: BYTE 	- <ul style="list-style-type: none"> 0 16#FF
Spd2ChnST	Signal status of output channel for <i>Rev</i> Should be connected to an output channel block	STRUCT <ul style="list-style-type: none"> Value: BOOL ST: BYTE 	- <ul style="list-style-type: none"> 0 16#FF
Spd1Force	1 = Force activation of motor speed 1 in "manual mode" or in "automatic mode"	STRUCT <ul style="list-style-type: none"> Value: BOOL ST: BYTE 	- <ul style="list-style-type: none"> 0 16#80
Spd2Force	1 = Force activation of motor speed 2 in "manual mode" or in "automatic mode"	STRUCT <ul style="list-style-type: none"> Value: BOOL ST: BYTE 	- <ul style="list-style-type: none"> 0 16#80
Spd1Local	1 = Activation of motor speed 1 in "local mode"	STRUCT <ul style="list-style-type: none"> Value: BOOL ST: BYTE 	- <ul style="list-style-type: none"> 0 16#80
Spd2Local	1 = Activation of motor speed 2 in "local mode"	STRUCT <ul style="list-style-type: none"> Value: BOOL ST: BYTE 	- <ul style="list-style-type: none"> 0 16#80
Spd1Man*	1 = Activation of motor speed 1 in "manual mode"	BOOL	0
Spd2Man*	1 = Activation of motor speed 2 in "manual mode"	BOOL	0

Motor and valve blocks

7.6 MotSpdL - Two-speed motor

Parameter	Description	Type	Default
RstLi*	1 = Reset via interconnection	STRUCT <ul style="list-style-type: none"> Value: BOOL ST: BYTE 	- <ul style="list-style-type: none"> 0 16#80
RstOp*	1 = Reset via operator	BOOL	0
RunUpCyc	Number of cycles in startup; messages are suppressed during these cycles	INT	3
SampleTime	Sampling time [s] (assigned automatically)	REAL	0.1
SimAV*	Additional value used for SimOn = 1	REAL	0.0
SimAV_Li	Additional analog value that is used for SimOnLi.Value = 1 (SimLiOp.Value = 1)	STRUCT <ul style="list-style-type: none"> Value: REAL ST: BYTE 	- <ul style="list-style-type: none"> 0 16#80
SimLiOp	Activation/deactivation of the simulation by: 0 = Operator 1 = Interconnection or SFC	STRUCT <ul style="list-style-type: none"> Value: BOOL ST: BYTE 	- <ul style="list-style-type: none"> 0 16#80
SimOnLi	1 = Simulation via interconnection or SFC (controlled by SimLiOp = 1)	STRUCT <ul style="list-style-type: none"> Value: BOOL ST: BYTE 	- <ul style="list-style-type: none"> 0 16#80
SimOn*	1 = Simulation on	BOOL	0
SelFp1	Call a block saved in this parameter as an additional faceplate (Page 208) in the standard view	ANY	
SelFp2	Call a block saved in this parameter as an additional faceplate (Page 208) in the preview	ANY	
StepNo	Batch step number	DWORD	16#00000000
StopAut*	1 = Stopping the motor in "automatic mode"	STRUCT <ul style="list-style-type: none"> Value: BOOL ST: BYTE 	- <ul style="list-style-type: none"> 0 16#80
StopForce	1 = Force motor stop	STRUCT <ul style="list-style-type: none"> Value: BOOL ST: BYTE 	- <ul style="list-style-type: none"> 0 16#80
StopLocal	1 = Stopping the motor in "local mode"	STRUCT <ul style="list-style-type: none"> Value: BOOL ST: BYTE 	- <ul style="list-style-type: none"> 0 16#80
StopMan*	1 = Stopping the motor in "manual mode"	BOOL	0
SwOverTi*	Time for speed change	REAL	0.0
Trip	1 = Motor is in "good" state	STRUCT <ul style="list-style-type: none"> Value: BOOL ST: BYTE 	- <ul style="list-style-type: none"> 1 16#FF

Parameter	Description	Type	Default
UserAna1	Analog auxiliary value 1	STRUCT • Value: REAL • ST: BYTE	- • 0.0 • 16#FF
UA1unit	Unit of measure for analog auxiliary value 1	INT	0
UserAna2	Analog auxiliary value 2	STRUCT • Value: REAL • ST: BYTE	- • 0.0 • 16#FF
UA1unit	Unit of measure for analog auxiliary value 1	INT	0
UA2unit	Unit of measure for analog auxiliary value 2	INT	0
UserStatus	Freely assignable bits for use in PCS 7 OS	BYTE	16#00
WarnTiAut*	Prewarning of motor start in "automatic mode" in [s]	REAL	0.0
WarnTiMan*	Prewarning of motor start in "manual mode" in [s]	REAL	0.0

* Values can be written back to these inputs during processing of the block by the block algorithm.

Output parameters

Parameter	Description	Type	Default
AutAct	1 = "Automatic mode" enabled 0 = "Manual mode" is enabled	STRUCT • Value: BOOL • ST: BYTE	- • 0 • 16#80
AutoST	1 = Worst signal status of automatic commands	BYTE	16#80
AV_OpScale	Limit for scale in AV bar graph of face-plate	STRUCT • High: REAL • Low: REAL	- • 100.0 • 0.0
AV_Out	Output additional analog value	STRUCT • Value: REAL • ST: BYTE	- • 0.0 • 16#80
AV_Unit	Unit of measure for additional analog value	INT	0
CurrMon	Current monitoring time [s]	DINT	0
ENO	1 = Block algorithm completed without errors	BOOL	0
ErrorNum	Output of pending error number. For error numbers that can be output by this block, see MotSpdL error handling (Page 1238)	INT	-1

Motor and valve blocks

7.6 MotSpdL - Two-speed motor

Parameter	Description	Type	Default
FbkSpd1Out	Feedback: 1 = Speed 1 active	STRUCT • Value: BOOL • ST: BYTE	- • 0 • 16#80
FbkSpd2Out	Feedback: 1 = Speed 2 active	STRUCT • Value: BOOL • ST: BYTE	- • 0 • 16#80
GrpErr	1 = Group error pending	STRUCT • Value: BOOL • ST: BYTE	- • 0 • 16#80
LocalAct	1 = "Local mode" enabled	STRUCT • Value: BOOL • ST: BYTE	- • 0 • 16#80
LockAct	1 = Interlock (Intlock, Permit, Protect) or Trip is active	STRUCT • Value: BOOL • ST: BYTE	- • 0 • 16#80
ManAct	1 = "Manual mode" enabled	STRUCT • Value: BOOL • ST: BYTE	- • 1 • 16#80
MonDynErr	1 = Feedback error or feedback start error due to control change	STRUCT • Value: BOOL • ST: BYTE	- • 0 • 16#80
MonDynStopErr	1 = Feedback stop error due to control change	STRUCT • Value: BOOL • ST: BYTE	- • 0 • 16#80
MonStaErr	1 = Feedback error due to unexpected feedback change	STRUCT • Value: BOOL • ST: BYTE	- • 0 • 16#80
MS_Release	Release for maintenance: 1 = Release for OS operator	STRUCT • Value: BOOL • ST: BYTE	- • 0 • 16#80
MsgAckn1	Message acknowledgement status 1 (output ACK_STATE of first ALARM_8P)	WORD	16#0000
MsgErr1	Alarm error 1 (output ERROR of first ALARM_8P)	BOOL	0
MsgStat1	Message status 1 (output STATUS of first ALARM_8P)	WORD	16#0000
OosAct	1 = Block is "Out of service"	STRUCT • Value: BOOL • ST: BYTE	- • 0 • 16#80

Parameter	Description	Type	Default
OpSt_Out	Value of the OpSt_In input parameter, for feedforwarding to other blocks. Bit 31 of this parameter is used by Feature bit 24	DWORD	16#00000000
OS_PermOut	Display of OS_Perm	DWORD	16#FFFFFFFF
OS_PermLog	Display of OS_Perm with settings changed by the block algorithm	DWORD	16#FFFFFFFF
P_Rst	1= Pulse output for reset The parameter persists for one cycle after a reset.	STRUCT • Value: BOOL • ST: BYTE	- • 0 • 16#80
P_Spd1	1 = Pulse signal for starting the motor with speed 1	STRUCT • Value: BOOL • ST: BYTE	- • 0 • 16#80
P_Spd2	1 = Pulse signal for starting the motor with speed 2	STRUCT • Value: BOOL • ST: BYTE	- • 0 • 16#80
P_Stop	0 = Pulse signal for stopping the motor	STRUCT • Value: BOOL • ST: BYTE	- • 1 • 16#80
R_StpAct	1 = Rapid stop of the motor is active	STRUCT • Value: BOOL • ST: BYTE	- • 0 • 16#80
RdyToReset	1 = Ready for reset via RstLi input or commands in "local", "automatic", or "manual mode"	STRUCT • Value: BOOL • ST: BYTE	- • 0 • 16#80
RdyToStart	1 = Active start readiness	STRUCT • Value: BOOL • ST: BYTE	- • 0 • 16#80
RunSpd1	1 = Motor running at speed 1	STRUCT • Value: BOOL • ST: BYTE	- • 0 • 16#80
RunSpd2	1 = Motor running at speed 2	STRUCT • Value: BOOL • ST: BYTE	- • 0 • 16#80
ST_Worst	Worst signal status	BYTE	16#80
Spd1	1 = Control of motor: Speed 1	STRUCT • Value: BOOL • ST: BYTE	- • 0 • 16#80
Spd2	1 = Control of motor: Speed 2	STRUCT • Value: BOOL • ST: BYTE	- • 0 • 16#80

7.6 MotSpdL - Two-speed motor

Parameter	Description	Type	Default
Starting	1 = Motor will start	STRUCT <ul style="list-style-type: none"> • Value: BOOL • ST: BYTE 	- <ul style="list-style-type: none"> • 0 • 16#80
Status1	Status word 1 (Page 1225)	DWORD	16#00000000
Status2	Status word 2 (Page 1225)	DWORD	16#00000000
Status3	Status word 3 (Page 1225)	DWORD	16#00000000
Status4	Status word 4 (Page 1225)	DWORD	16#00000000
Stop	1 = Motor is stopping	STRUCT <ul style="list-style-type: none"> • Value: BOOL • ST: BYTE 	- <ul style="list-style-type: none"> • 0 • 16#80
Stopping	1 = Motor will stop	STRUCT <ul style="list-style-type: none"> • Value: BOOL • ST: BYTE 	- <ul style="list-style-type: none"> • 0 • 16#80
WarnAct	1 = Prewarning for motor start active (parameters WarnTiAut and WarnTiMan)	STRUCT <ul style="list-style-type: none"> • Value: BOOL • ST: BYTE 	- <ul style="list-style-type: none"> • 0 • 16#80

See also

- MotSpdL messaging (Page 1240)
- MotSpdL block diagram (Page 1250)
- MotSpdL modes (Page 1229)
- Error handling (Page 119)

7.6.7 MotSpdL block diagram

MotSpdL block diagram

A block diagram is not provided for this block.

See also

- MotSpdL I/Os (Page 1241)
- MotSpdL messaging (Page 1240)
- MotSpdL error handling (Page 1238)
- MotSpdL functions (Page 1230)
- MotSpdL modes (Page 1229)
- Description of MotSpdL (Page 1225)

7.6.8 Operator control and monitoring

7.6.8.1 MotSpdL views

Views of the MotSpdL block

The block MotSpdL provides the following views:

- MotSpdL standard view (Page 1251)
- Alarm view (Page 302)
- Limit view of motors (Page 294)
- Trend view (Page 305)
- Parameter view for motors and valves (Page 286)
- MotSpdL preview (Page 1255)
- Memo view (Page 304)
- Batch view (Page 302)
- Block icon for MotSpdL (Page 1258)

Refer to the sections Structure of the faceplate (Page 248) and Block icon structure (Page 230) for general information on the faceplate and block icon.

7.6.8.2 MotSpdL standard view

MotSpdL standard view

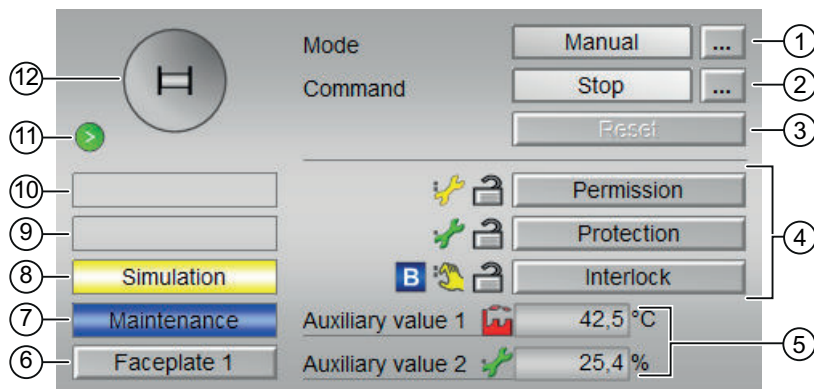

(1) Displaying and switching the operating mode

This area provides information on the currently valid operating mode. The following operating modes can be shown here:

- Manual and automatic mode for motors, valves and dosers (Page 75)
- Manual and automatic mode for motors, valves and dosers (Page 75)
- Local mode (Page 79)
- Out of service (Page 71)

Refer to section Switching operating states and operating modes (Page 257) for information on switching the operating mode.

(2) Starting and stopping the motor

This area shows you the default operating state for the motor. The following states can be shown and executed here:

- "Start >"
- "Start >>"
- "Stop"
- "Rapid stop"

Refer to the Switching operating states and operating modes (Page 257) section for information on changing the state.

If text is configured for these commands, it is displayed as status text and as button labels for command selection. You can find more information about this in section Labeling of buttons and text (Page 209)

(3) Resetting the block

Click "Reset" for interlocks or errors. You can find additional information on this in the section Resetting the block in case of interlocks or errors (Page 43).

(4) Operating range for the interlock functions of the block

This display is only visible when the corresponding block input is connected.

You can use this button to control the interlock functions of the block. You can find additional information on this in the section Interlocking functions (Page 99).

The following is displayed in addition to the buttons:

- Interlock status (see Forming the group status for interlock information (Page 104)), e.g.:



- Signal status (see Forming and outputting the signal status for technologic blocks (Page 109)), e.g.:



- Bypass information (see Forming the group status for interlock information (Page 104)):



(5) Display of auxiliary values

This display is only visible when the corresponding block input is connected.

You can use this area to display two auxiliary values that have been configured in the engineering system (ES). You can find additional information on this in the section Displaying auxiliary values (Page 211).

(6) Navigation button for switching to the standard view of any faceplate

This display is only visible when the corresponding block input is connected.

Use this navigation button to open the standard view of a block configured in the engineering system (ES). The visibility of this navigation button depends on the configuration in the engineering system (ES).

You can find additional information on this in the section Opening additional faceplates (Page 208).

(7) Display area for block states

This area provides additional information on the operating state of the block:

- "Maintenance"

Additional information on this is available in section Release for maintenance (Page 64) Display area for block states.

(8) Display area for block states

This area provides additional information on the operating state of the block:

- "Simulation"
- "Delay"

You will find more detailed information on this in the sections Simulating signals (Page 58) and Display of delay times (Page 256).

(9) Display area for block states

This area provides additional information on the operating state of the block:

- "Motor protection"
- "External error"
- "Status error"
- "Control error"
- "Invalid signal"
- "Changeover error"

Additional information on these errors is available in the sections Monitoring the feedbacks (Page 97) , Error handling (Page 119) (section "Invalid input signals" and "Mode switchover error") and Motor protection function (Page 99).

(10) Display area for block states

This area provides additional information on the operating state of the block:

- "Forced stop"
- "Forced start >"
- "Forced start >>"
- "Request 0/1": A reset to "automatic mode" is expected.

You can find additional information on this in the section Forcing operating modes (Page 41).

(11) Automatic preview

This display is only visible in "manual mode", in "local mode", or with a reset request in "automatic mode", when the current output signals are not identical to the control in "automatic mode".

The display shows what state the motor would assume if you switched from "manual" or "local" mode to "automatic mode", or performed a reset to "automatic mode".

(12) Status display of the motor

The current status of the motor is graphically displayed here.

You can find more information about this in section Block icon for MotSpdL (Page 1258)

See also

Functions of the blocks (Page 41)

7.6.8.3 MotSpdL preview

Preview of MotSpdL

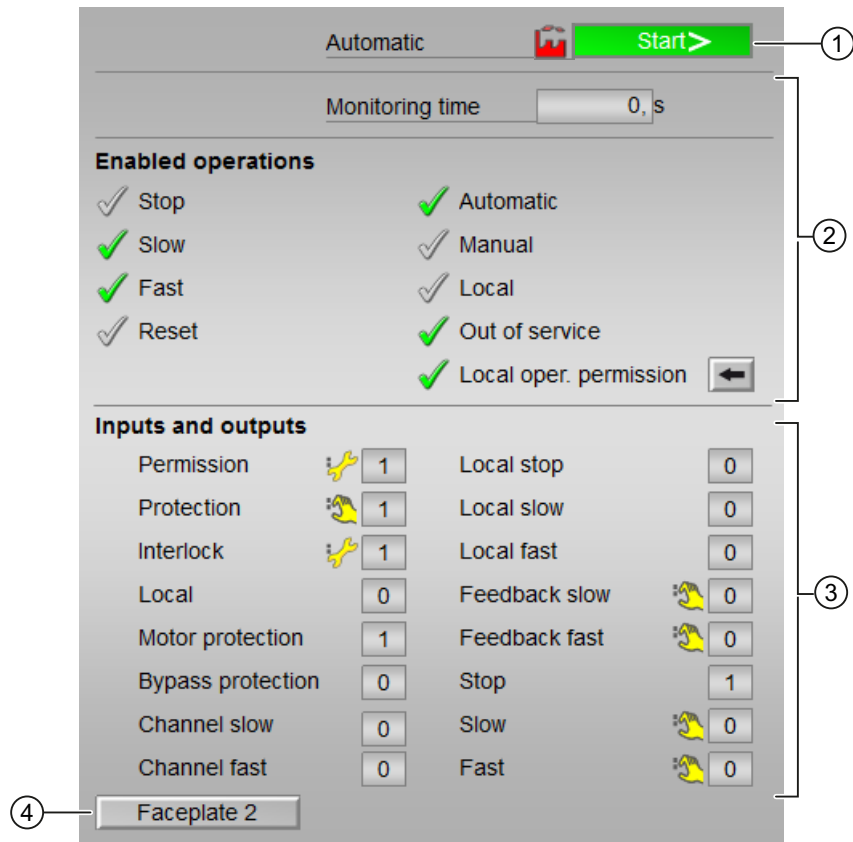

Display of the current monitoring time is visible.

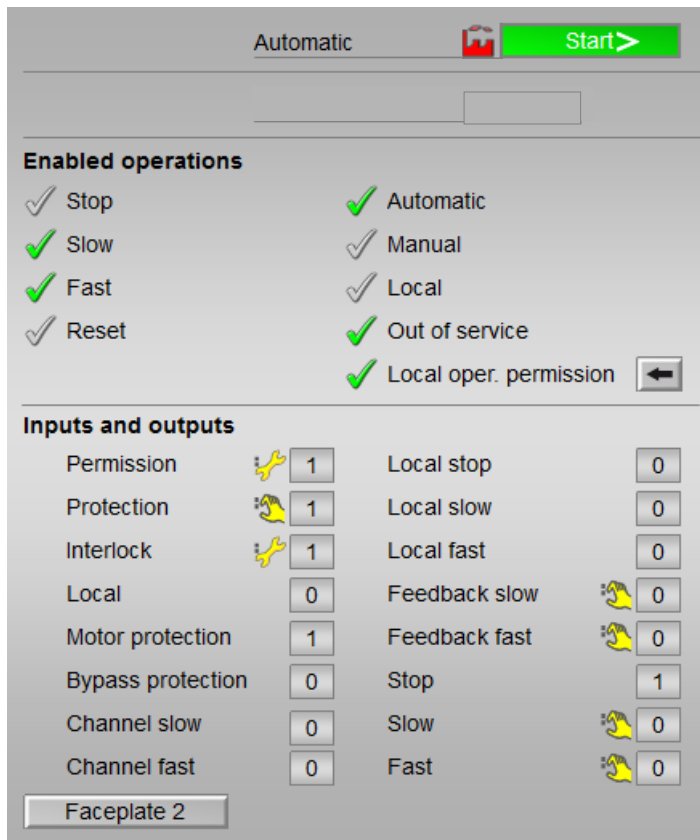

Display of the current monitoring time is not visible.

(1) Automatic preview

This area shows you the block status after it has switched from the "Manual" mode or "Local" mode to the "Automatic" mode.

If the block is in "Automatic" mode, the current block state is displayed.

This area also displays the worst signal status of the following automatic commands:

- Spd1Aut
- Spd2Aut
- StopAut

(2) Enable operations

This area shows all operations for which special operator permissions are assigned. They depend on the configuration in the engineering system (ES) that applies to this block.

Icons for enabled operation:

- **Green check mark:** the OS operator can control this parameter
- **Gray check mark:** the OS operator cannot control this parameter at this time due to the process
- **Red cross:** the OS operator cannot control this parameter due to the configured AS operator permissions (OS_Perm or OS1Perm)

The following enabled operations are shown here:

- "Stop": You can stop the motor.
If text is configured for this command, it is also displayed in brackets. You can find additional information on this in the section Labeling of buttons and text (Page 209).
- "Slow": You can start the motor in the "slow" state.
If text is configured for this command, it is also displayed in brackets. You can find additional information on this in the section Labeling of buttons and text (Page 209).
- "Fast": You can start the motor in the "fast" state.
If text is configured for this command, it is also displayed in brackets. You can find additional information on this in the section Labeling of buttons and text (Page 209).
- "Reset": You can reset the motor after interlocks or errors.
- "Automatic": You can switch to "automatic mode".
- "Manual": You can switch to "manual mode".
- "Local": You can switch to "local mode".
- "Out of service": You can switch to "Out of service" operating mode.
- "Local operator permission": Use the ← button to switch to the standard view of the OpStations block. You can find additional information on this in the section Operator control permissions (Page 254) .
- "Monitoring time": Display of the current monitoring time.

(3) Displaying current control signals

This area shows the most important parameters for this block with the current selection:

- "Permission":
This display is only visible when the corresponding block input is connected.
 - 0 = No OS release for energizing motor
 - 1 = Enable for "starting"/"stopping" from the neutral position
- "Protection":
This display is only visible when the corresponding block input is connected.
 - 0 = Protective interlocking is effective; once the interlocking condition has disappeared, you will have to reset the block
 - 1 = "Good" state

- "Interlock":
This display is only visible when the corresponding block input is connected.
 - 0 = Interlocking without reset is active; you can operate the block without reset once the interlocking condition has disappeared
 - 1 = "Good" state
- "Local correct": 1 = Control signal for "Local mode" (LocalLi) is active
- "Motor protection": 1 = Motor is in "good" state
- "Interlock deact.":
 - 0 = Bypass disabled
 - 1 = Bypassing interlock in "local mode" and in "simulation"
- "Local stop": 1 = Stopping the motor in "local mode"
- "Local slow": 1 = Starting the motor in "local mode", slow
- "Local fast": 1 = Starting the motor in "local mode", fast
- "Feedback slow": 1 = Motor has started and is running slow
- "Feedback fast": 1 = Motor has started and is running fast
- "Stop": 1 = Stop motor
- "Slow": 1 = Motor is running slow
- "Fast": 1 = Motor is running fast
- "Channel Slow": Signal from the output channel block for "Slow"
- "Channel Fast": Signal from the output channel block for "Fast"

(4) Navigation button for switching to the standard view of any faceplate

This display is only visible when the corresponding block input is connected.

Use this navigation button to open the standard view of a block configured in the engineering system. The visibility of this navigation button depends on the configuration in the engineering system (ES).

You can find additional information on this in the section Opening additional faceplates (Page 208) .

7.6.8.4 Block icon for MotSpdL







Properties of the MotSpdLblock icon

A variety of block icons are available with the following functions:





- Process tag type
- Limits (high/low)
- Violation of alarm, warning, and tolerance limits as well as control system faults
- Operating modes





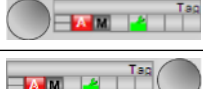
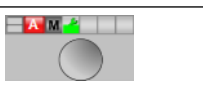

- Signal status, release for maintenance
- Displays for bypassing interlocks
- Interlocks
- Memo display
- Motor state display

The block icons from template @TemplateAPLV8.PDL:

Icons	Selection of the block icon in CFC	Special features
	1	
	2	
	3	
	4	
	5	"M" symbol with small speed display
	6	"M" symbol with small speed display

The block icons from template @TemplateAPLV7.PDL:

Icons	Selection of the block icon in CFC	Special features
	1	Block icon in the full display
	2	
	3	
	4	
	5	







Icons	Selection of the block icon in CFC	Special features
	6	
	7	
	8	
	9	
	10	
	-	Block icon in "Out of service" mode (example with type 1 block icon)

Additional information on the block icon and the control options in the block icon is available in the following chapters:

- Configuring the block icons (Page 237)
- Block icon structure (Page 230)
- Operation via the block icon (Page 239)

Motor state display

The following motor states are shown here:

Symbol	Meaning
	Motor started (motor symbol changes)
	The motor is running
	Motor stopped (motor symbol changes)
	Motor idle
	Error at motor (monitoring error, motor protection)
	Motor out of service

7.7 ShrdResL - Multiplexer for shared resources (Large)

7.7.1 Description of ShrdResL

Object name (type + number) and family

Type + number: FB 1917

Family: Drives

Area of application for ShrdResL

The block is used for the following application:

- Organize individual requests for downstream block from upstream applications.

How it works

The block coordinates the access from up to four CFC or SFC step sequencers to a technological block of the families "Drives" or "Dose". These blocks include:

- Motors
- Valves
- Dosers

The block has four channels, each with a standardized command interface.

7.7 ShrdResL - Multiplexer for shared resources (Large)

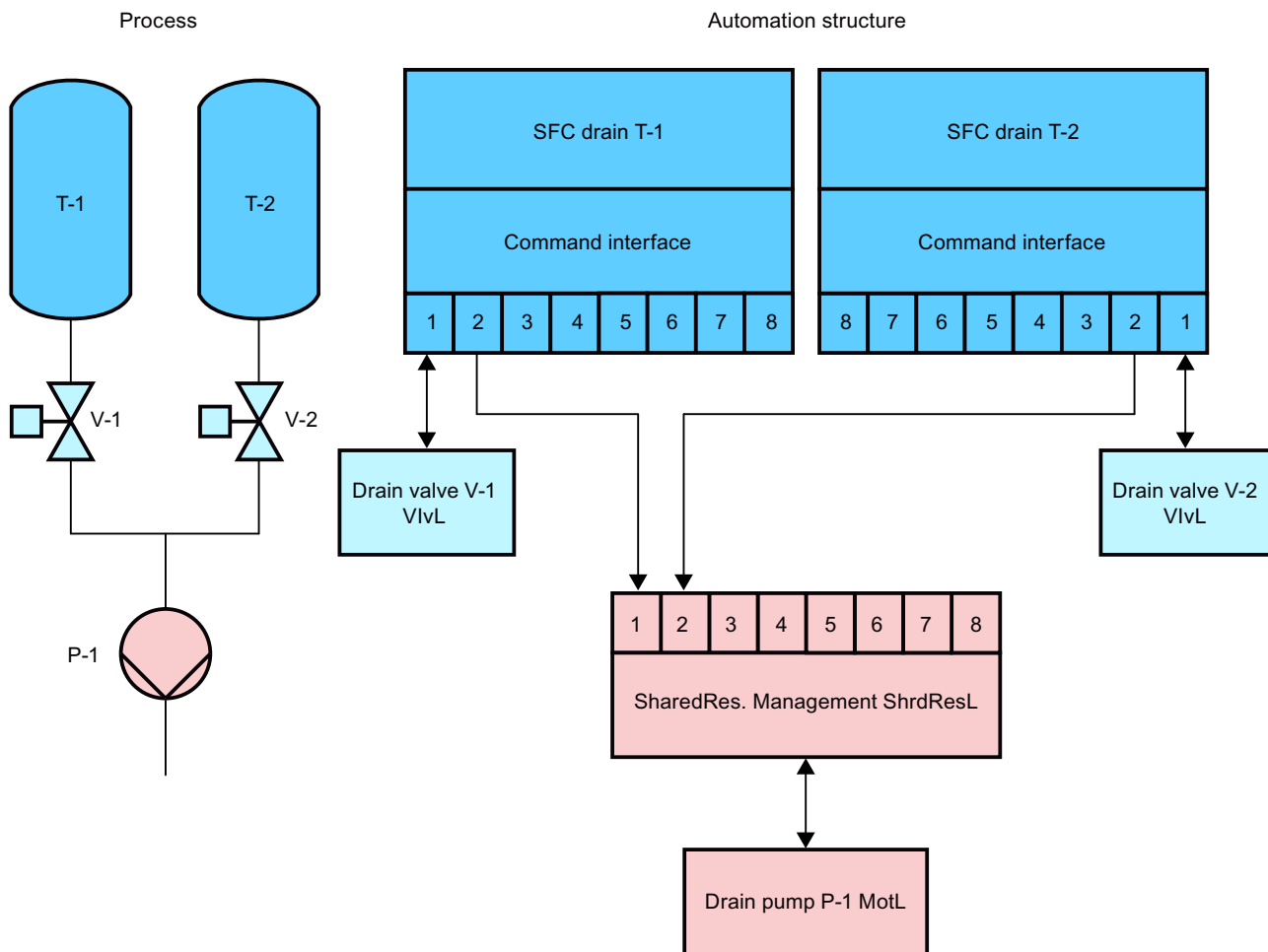

In case of multiple allocation requests, the channel to be allocated depends on the priority of each channel and a strategy mode which coordinates the sequence of the allocated channels.

As soon as a channel is allocated, its command interface is aligned in accordance with the command interface at the output.

Configuration

Use the CFC editor to install the block in a cyclic interrupt OB (OB30 to OB38). The block is also installed automatically in the startup OB (OB100).

Startup characteristics

Use the `Feature Bit Set` startup characteristics (Page 138) to define the startup characteristics of this block.

Status word allocation for status1 parameter

You can find a description for each parameter in the section ShrdResL I/Os (Page 1272).

Status bit	Parameter
0	ReadyIn, Readiness signal of the interconnected technological block
1	ChnEn_1
2	ChnEn_2
3	ChnEn_3
4	ChnEn_4
5	Ready, Channel allocation is possible
6	ActChnNo = 1, 1 = Channel 1 is enabled
7	ActChnNo = 2, 1 = Channel 2 is enabled
8	ActChnNo = 3, 1 = Channel 3 is enabled
9	ActChnNo = 4, 1 = Channel 4 is enabled
10	MultiOcc, 1 = Request for more than one channel
11	Not used
12	BatchEn
13	Occupied
14 - 16	Not used
17	NxtChnNo = 1, 1 = Channel 1 is the next allocated channel
18	NxtChnNo = 2, 1 = Channel 2 is the next allocated channel
19	NxtChnNo = 3, 1 = Channel 3 is the next allocated channel
20	NxtChnNo = 4, 1 = Channel 4 is the next allocated channel
21	BaEn_1
22	BaEn_2
23	BaEn_3
24	BaEn_4
25	Occ_1
26	Occ_2
27	Occ_3
28	Occ_4
29 - 31	Not used

Status word allocation for status2 parameter

You can find a description for each parameter in the section ShrdResL I/Os (Page 1272).

Status bit	Parameter
0	Not used
1	ChnEn_5
2	ChnEn_6
3	ChnEn_7
4	ChnEn_8
5	Not used

7.7 ShrdResL - Multiplexer for shared resources (Large)

Status bit	Parameter
6	ActChnNo = 5, 1 = Channel 5 is enabled
7	ActChnNo = 6, 1 = Channel 6 is enabled
8	ActChnNo = 7, 1 = Channel 7 is enabled
9	ActChnNo = 8, 1 = Channel 8 is enabled
10 - 16	Not used
17	NxtChnNo = 5, 1 = Channel 5 is the next allocated channel
18	NxtChnNo = 6, 1 = Channel 6 is the next allocated channel
19	NxtChnNo = 7, 1 = Channel 7 is the next allocated channel
20	NxtChnNo = 8, 1 = Channel 8 is the next allocated channel
21	BaEn_5
22	BaEn_6
23	BaEn_7
24	BaEn_8
25	Occ_5
26	Occ_6
27	Occ_7
28	Occ_8
29 - 31	Not used

See also

- ShrdResL modes (Page 1264)
- ShrdResL functions (Page 1265)
- ShrdResL error handling (Page 1271)
- ShrdResL messaging (Page 1271)
- ShrdResL block diagram (Page 1277)

7.7.2 ShrdResL modes

ShrdResL operating modes

This block does not have any modes.

See also

- Description of ShrdResL (Page 1261)
- ShrdResL functions (Page 1265)
- ShrdResL error handling (Page 1271)
- ShrdResL messaging (Page 1271)

ShrdResL I/Os (Page 1272)

ShrdResL block diagram (Page 1277)

7.7.3 ShrdResL functions

Functions of ShrdResL

The functions for this block are listed below.

Opening additional faceplates

This block provides the standard function Opening additional faceplates (Page 208).

Operator permissions

This block provides the standard function Operator control permissions (Page 254).

The block has the following permissions for the `OS_Perm` parameter:

Bit	Function
0 - 5	Not used
6	1 = Operator can change the priority of channel 1
7	1 = Operator can change the priority of channel 2
8	1 = Operator can change the priority of channel 3
9	1 = Operator can change the priority of channel 4
10	1 = Operator can change the priority of channel 5
11	1 = Operator can change the priority of channel 6
12	1 = Operator can change the priority of channel 7
13	1 = Operator can change the priority of channel 8
14 - 31	Not used

Note

If you interconnect a parameter that is also listed in `OS_Perm` as a parameter, you have to reset the corresponding `OS_Perm` bit.

Configurable reactions using the `Feature` parameter

You can find an overview of all reactions provided by the `Feature` parameter in the section Configurable functions using the Feature I/O (Page 131). The following functionality is available for this block at the relevant bit:

Bit	Function
0	Set startup characteristics (Page 138)

Readiness signal

In order to assign one of the channels, the ready signal must be `ReadyIn = 1` and at least one channel enable must be `ChnEn_x = 1` ($x = 1$ to 8). The ready signal is output at the `Ready` output.

Channel management

Overview of the channel management:

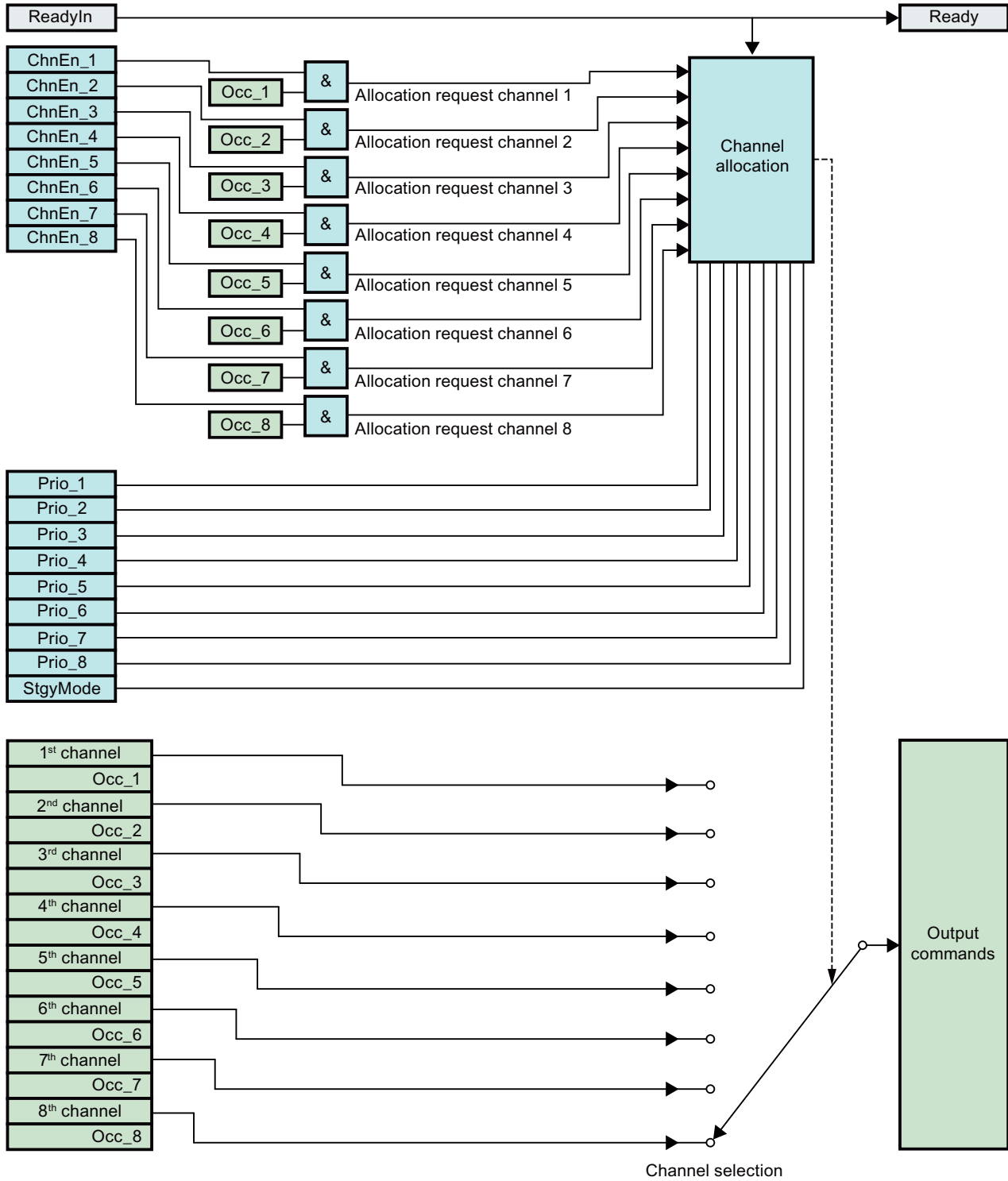

Allocate/enable channel

A channel can only be allocated if the readiness signal ($ReadyIn = 1$) and the respective channel enabling is available for the allocation $ChnEn_x = 1$.

With $ChnEn_x = 0$, the channel x is disabled and cannot be allocated.

The allocation request of a channel by the upstream application is accomplished via the input Occ_x . In case of multiple requests, the channel allocation function stores the requests in a buffer and calculates the allocated channel number with the help of the channel priorities $Prio_x$ ($x = 1$ to 8) and the strategy mode $StgyMode$.

Each channel has its own priority. It can be parameterized at the inputs $Prio_x$ ($x = 1$ to 8).

The strategy mode defines the order of storing the requests in the buffer.

Strategy 1	Strategy 2	Parameter value of $StgyMode$
First In First Out	Order	0
First In First Out	Maximum Priority; in case equal request Order is used	1
First In First Out	Minimum Priority; in case equal request Order is used	2
Last In First Out	Order	3
Last In First Out	Maximum Priority; in case equal request Order is used	4
Last In First Out	Minimum Priority; in case equal request Order is used	5
Maximum Priority	Order	6
Maximum Priority	First In First Out	7
Maximum Priority	Last In First Out	8
Minimum Priority	Order	9
Minimum Priority	First In First Out	10
Minimum Priority	Last In First Out	11

The allocation request will be evaluated with **Strategy 1**. If after the first evaluation, there are equal requests, the **Strategy 2** will be evaluated. This happens in the following cases:

- Two or more requests are in the same cycle and **Strategy 1** is “First In First Out” or “Last In First Out”.
- Two or more requests have the same priority and **Strategy 1** is “Maximum Priority” or “Minimum Priority”.

The parameterization “Order” in **Strategy 2** means that the priority of the request depends on the channel number:

- Channel 1 has the highest priority
- Channel 8 has the lowest priority

If **Strategy 2** is “Maximum Priority” or “Minimum Priority” and if after the evaluation, there are equal requests, the channel allocation is calculated with “Order”.

The applied commands are aligned in accordance with the output command interface.

The number of the allocated channel is displayed at the output $ActChnNo$ (INT format). If no channel is allocated, the output is 0.

Example for "Maximum Priority" Strategy mode (StgyMode = 6, 7, or 8)

The requirement with the highest priority will be released first.

The requirements that are coming in the same cycle will be evaluated after **Strategy 2**.

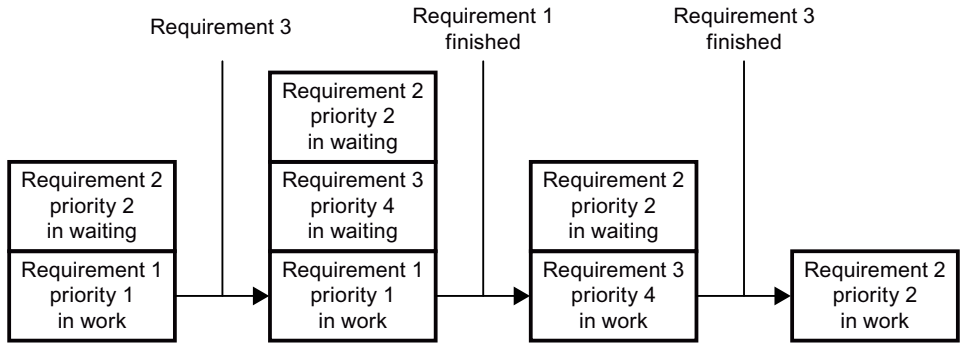

Example for "Minimum Priority" Strategy mode (StgyMode = 9, 10, or 11)

The requirement with the lowest priority will be released first.

The requirements that are coming in the same cycle will be evaluated after **Strategy 2**.

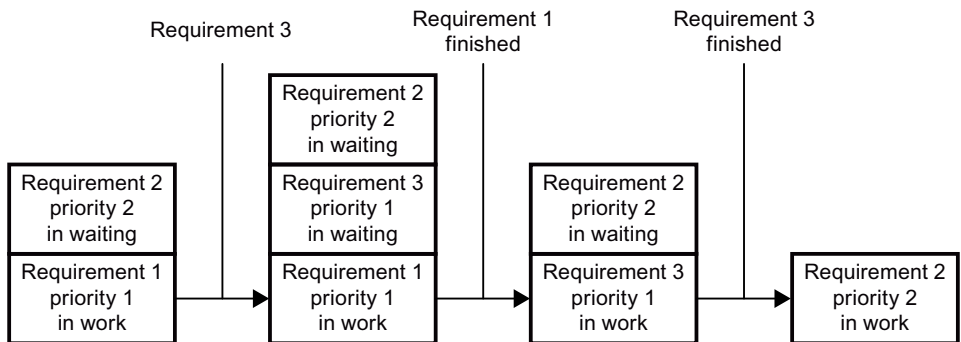

See also

Description of ShrdResL (Page 1261)

ShrdResL modes (Page 1264)

ShrdResL error handling (Page 1271)

ShrdResL messaging (Page 1271)

ShrdResL I/Os (Page 1272)

ShrdResL block diagram (Page 1277)

7.7.4 ShrdResL error handling

ShrdResL error handling

Please refer to the section Error handling (Page 119) in the basic instructions.

The following error can be displayed for this block:

- Error numbers

Overview of error numbers

The `ErrorNum` parameter can be used to output the following error numbers:

Error number	Meaning of the error number
-1	Predefined value when inserting the block; block is not processed.
0	There is no error.
49	Wrong strategy mode number: <code>StgyMode < 0</code> or <code>StgyMode > 11</code>

See also

Description of ShrdResL (Page 1261)

ShrdResL modes (Page 1264)

ShrdResL functions (Page 1265)

ShrdResL messaging (Page 1271)

ShrdResL I/Os (Page 1272)

ShrdResL block diagram (Page 1277)

7.7.5 ShrdResL messaging

Messaging

This block does not offer messaging.

See also

Description of ShrdResL (Page 1261)

ShrdResL modes (Page 1264)

ShrdResL functions (Page 1265)

ShrdResL error handling (Page 1271)

ShrdResL I/Os (Page 1272)

ShrdResL block diagram (Page 1277)

7.7.6 ShrdResL I/Os

I/Os of ShrdResL

Input parameters

Parameter	Description	Type	Default
AutMod_1*	1 = "Automatic mode" via interconnection	STRUCT	-
		<ul style="list-style-type: none"> • Value: BOOL • 0 • ST: BYTE • 16#80 	
...
AutMod_8*	1 = "Automatic mode" via interconnection	STRUCT	-
		<ul style="list-style-type: none"> • Value: BOOL • 0 • ST: BYTE • 16#80 	
BaEn_1	1 = Enable allocation for channel 1	BOOL	0
...
BaEn_8	1 = Enable allocation for channel 8	BOOL	0
BaID_1	Batch number for channel 1	DWORD	16#00000000
...
BaID_8	Batch number for channel 8	DWORD	16#00000000
BaName_1	Batch designation for channel 1	S7-String	
...
BaName_8	Batch designation for channel 8	S7-String	
ChnEn_1	1 = Channel 1 is enabled and can be allocated 0 = Channel 1 is blocked and cannot be allocated	STRUCT	-
		<ul style="list-style-type: none"> • Value: BOOL • 1 • ST: BYTE • 16#FF 	
...
ChnEn_8*	1 = Channel 8 is enabled and can be allocated 0 = Channel 8 is blocked and cannot be allocated	STRUCT	-
		<ul style="list-style-type: none"> • Value: BOOL • 1 • ST: BYTE • 16#FF 	
ChnCmd_1	Channel input 1 (reserved)	STRUCT	
...
ChnCmd_8	Channel input 8 (reserved)	STRUCT	
Ctrl01_1*	Control command 1 for channel 1	STRUCT	-
		<ul style="list-style-type: none"> • Value: BOOL • 0 • ST: BYTE • 16#80 	

7.7 ShrdResL - Multiplexer for shared resources (Large)

Parameter	Description	Type	Default
...
Ctrl12_8*	Control command 12 for channel 8	STRUCT • Value: BOOL • ST: BYTE	- • 0 • 16#80
CtrlW1_1*	Available user control word 1 for channel 1	DWORD	16#00000000
...
CtrlW1_8*	Available user control word 1 for channel 8	DWORD	16#00000000
CtrlW2_1*	Available user control word 2 for channel 1	DWORD	16#00000000
...
CtrlW2_8*	Available user control word 2 for channel 8	DWORD	16#00000000
EN	1 = Called block will be processed	BOOL	1
Feature	I/O for additional functions (Page 1265)	STRUCT • Bit 0: BOOL • ... • Bit 31: BOOL	- • 0 • 0 • 0
ManMod_1*	1 = "Manual mode" via interconnection for channel 1	STRUCT • Value: BOOL • ST: BYTE	- • 0 • 16#80
...
ManMod_8*	1 = "Manual mode" via interconnection for channel 8	STRUCT • Value: BOOL • ST: BYTE	- • 0 • 16#80
ModLi_1*	1 = Control via interconnection or SFC for channel 1	STRUCT • Value: BOOL • ST: BYTE	- • 0 • 16#80
...
ModLi_8*	1 = Control via interconnection or SFC for channel 8	STRUCT • Value: BOOL • ST: BYTE	- • 0 • 16#80
Occ_1*	1 = Occupied It is also used as a control signal for the channel allocation for channel 1	BOOL	0
...	..0
Occ_8*	1 = Occupied It is also used as a control signal for the channel allocation for channel 8	BOOL	0
Prio_1	Priority for channel 1	INT	1
...
Prio_8	Priority for channel 8	INT	8
ReadyIn	Readiness signal: 1 = Signal for channel enabling active	STRUCT • Value: BOOL • ST: BYTE	- • 0 • 16#80

Motor and valve blocks

7.7 ShrdResL - Multiplexer for shared resources (Large)

Parameter	Description	Type	Default
RstLi_1*	1 = Resetting via interconnection for channel 1	STRUCT • Value: BOOL • ST: BYTE	- • 0 • 16#80
...
RstLi_8*	1 = Resetting via interconnection for channel 8	STRUCT • Value: BOOL • ST: BYTE	- • 0 • 16#80
SelfpRes	Selection for faceplate resource	ANY	
SP_Ex_1	1 = Select external setpoint (via interconnection) for channel 1	STRUCT • Value: BOOL • ST: BYTE	- • 0 • 16#80
...
SP_Ex_8	1 = Select external setpoint (via interconnection) for channel 8	STRUCT • Value: BOOL • ST: BYTE	- • 0 • 16#80
SP_In_1*	1 = Select internal setpoint (via interconnection) for channel 1	STRUCT • Value: BOOL • ST: BYTE	- • 0 • 16#80
...
SP_In_8*	1 = Select internal setpoint (via interconnection) for channel 8	STRUCT • Value: BOOL • ST: BYTE	- • 0 • 16#80
SP1Ext_1*	External setpoint 1 for channel 1	STRUCT • Value: REAL • ST: BYTE	- • 0.0 • 16#80
...
SP8Ext_8*	External setpoint 8 for channel 8	STRUCT • Value: REAL • ST: BYTE	- • 0.0 • 16#80
StepNo_1	Step number for channel 1	DWORD	16#00000000
...
StepNo_8	Step number for channel 8	DWORD	16#00000000
StgyMode	Strategy mode (0 to 11)	INT	0
Strng1_1	Additional string 1 for channel 1	S7-String	
Strng2_1	Additional string 2 for channel 1	S7-String	
...
Strng1_8	Additional string 1 for channel 8	S7-String	
Strng2_8	Additional string 2 for channel 8	S7-String	
OpSt_In	Input parameter for local operator authorization, connected with the Out output parameter of the upstream block, OpStations (Page 411)	DWORD	16#00000000

7.7 ShrdResL - Multiplexer for shared resources (Large)

Parameter	Description	Type	Default
OS_Perm	I/O for operator permissions (Page 1265)	STRUCT • Bit 0: BOOL • ... • Bit 31: BOOL	- • 1 • 1 • 1
UserStatus	Freely assignable bits for use in PCS7 OS	BYTE	16#00

* Values can be written back to these inputs during processing of the block by the block algorithm.

Output parameters

Parameter	Description	Type	Default
ActChnNo	Displays the allocated channel	INT	0
AutMod	1= "Automatic mode" via interconnection	STRUCT • Value: BOOL • ST: BYTE	- • 0 • 16#80
BatchEn	1 = Enable allocation	BOOL	0
BatchID	Batch ID	DWORD	16#00000000
BatchName	Batch name	S7-String	
Ctrl101	Control command 1	STRUCT • Value: BOOL • ST: BYTE	- • 0 • 16#80
...
Ctrl112	Control command 12	STRUCT • Value: BOOL • ST: BYTE	- • 0 • 16#80
CtrlW1	Available user control word 1	DWORD	16#00000000
CtrlW2	Available user control word 2	DWORD	16#00000000
ENO	1 = Block algorithm completed without errors	BOOL	0
ErrorNum	Output of the current error number. For error numbers that can be outputted by this block, see ShrdResL error handling (Page 1271)	INT	-1
NxtChnNo	Next occupied channel number	INT	0
ManMod	1 = "Manual mode" via interconnection	STRUCT • Value: BOOL • ST: BYTE	- • 0 • 16#80
ModLi	1 = Control via interconnection or SFC	STRUCT • Value: BOOL • ST: BYTE	- • 0 • 16#80
MultiOcc	1 = More than one channel request is present	BOOL	0
Occupied	1 = Occupied Is also used as a control signal for the channel allocation.	BOOL	0

7.7 ShrdResL - Multiplexer for shared resources (Large)

Parameter	Description	Type	Default
Ready	1 = Active readiness	STRUCT • Value: BOOL • ST: BYTE	- • 0 • 16#80
RstLi	1 = Reset via interconnection	STRUCT • Value: BOOL • ST: BYTE	- • 0 • 16#80
SP_ExtLi	1 = Select external setpoint (via interconnection)	STRUCT • Value: BOOL • ST: BYTE	- • 0 • 16#80
SP_IntLi	1 = Select internal setpoint (via interconnection)	STRUCT • Value: BOOL • ST: BYTE	- • 0 • 16#80
SP1Ext	External setpoint 1	STRUCT • Value: REAL • ST: BYTE	- • 0.0 • 16#80
...
SP8Ext	External setpoint 8	STRUCT • Value: REAL • ST: BYTE	- • 0.0 • 16#80
Status1	Status word 1 (Page 1261)	DWORD	16#00000000
Status2	Status word 2 (Page 1261)	DWORD	16#00000000
StepNo	Step number	DWORD	16#00000000
Strng1	Additional string 1	S7-String	
Strng2	Additional string 2	S7-String	
OpSt_Out	Value of the OpSt_In input parameter, for feedforwarding to other blocks. Bit 31 of this parameter is used by Feature bit 24	DWORD	16#00000000
OS_PermLog	Display of OS_Perm with settings changed by the block algorithm	DWORD	16#FFFFFFFF
OS_PermOut	Display of OS_Perm	DWORD	16#FFFFFFFF

See also

- ShrdResL modes (Page 1264)
- ShrdResL messaging (Page 1271)
- ShrdResL block diagram (Page 1277)

7.7.7 ShrdResL block diagram

ShrdResL block diagram

A block diagram is not provided for this block.

See also

Description of ShrdResL (Page 1261)

ShrdResL modes (Page 1264)

ShrdResL functions (Page 1265)

ShrdResL error handling (Page 1271)

ShrdResL messaging (Page 1271)

ShrdResL I/Os (Page 1272)

7.7.8 Operator control and monitoring

7.7.8.1 ShrdResL views

Views of the ShrdResL block

The block ShrdResL provides the following views:

- ShrdResL standard view (Page 1278)
- ShrdResL general preview (Page 1280)
- ShrdResL preview (Page 1280)
- ShrdResL parameter view (Page 1281)
- Memo view (Page 304)
- Block icon for ShrdResL (Page 1282)

Refer to the sections Structure of the faceplate (Page 248) and Block icon structure (Page 230) for general information on the faceplate and block icon.

7.7.8.2 ShrdResL standard view

ShrdResL standard view

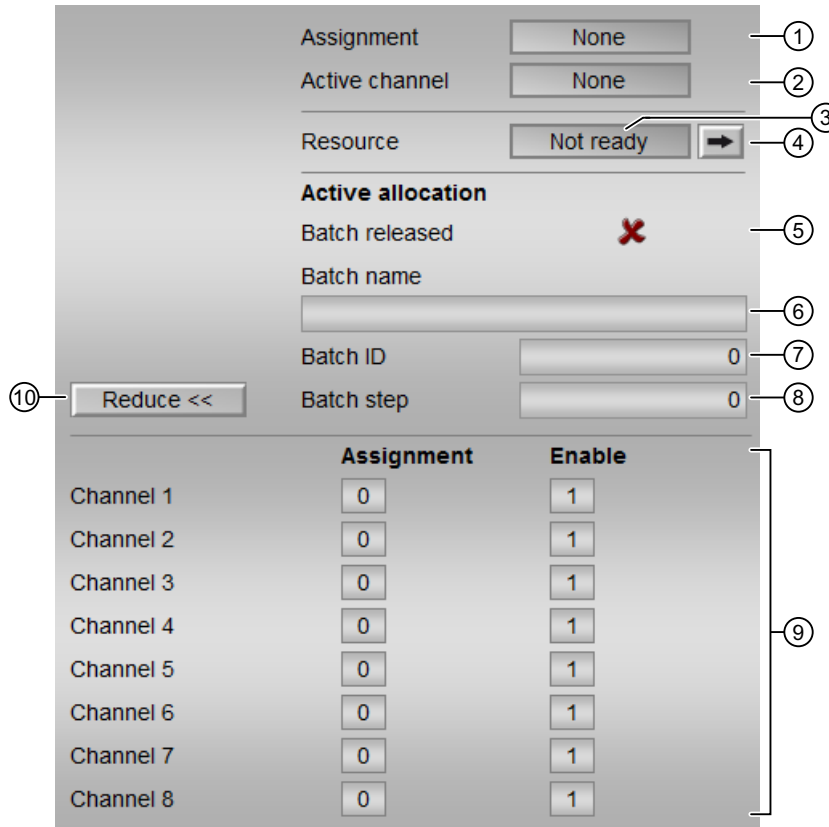

(1) Allocation

The allocation status is displayed in this area:

- "None": Display for all $Occ_1...Occ_4 = 0$ and $Occupied = 0$
- "Requested": Display for one of $Occ_1...Occ_4 = 1$ and $Occupied = 0$
- "Active": Display for $Occupied = 1$

(2) Active channel

The channel number of the active channel is displayed in this area.

If the text is configured for this command (Text 1 in the object properties), it is displayed as additional text and button label for command selection. Additional information is available in the section Labeling of buttons and text (Page 209).

(3) Resource

The status of the enable signal is displayed in this area:

- "Idle": Display for `ReadyIn = 1`
- "Not ready": Display for `ReadyIn = 0`

(4) Jump key to standard view of any faceplate

This display is only visible when the corresponding block input is interconnected.

Use this navigation button to jump to the standard view of a block configured in the engineering system (ES). The visibility of this navigation button depends on the configuration in the engineering system (ES).

You can find more information on this in the section *Opening additional faceplates* (Page 208).

(5) Release batch

This area displays if the block is released for operation via SIMATIC BATCH (`BatchEn = 1`).

(6) Batch name

This area displays the name of the batch that is currently running (`Batchname`).

(7) Batch ID

This area displays the identification number of the batch that is currently running (`BatchID`).

(8) Batch step

This area displays the step number of the batch that is currently running (`StepNo`).

(9) Display channel 1 to 8

This area is only visible when the (10) "Expand" button is pressed.

The "Allocation" and "Release" status of the channels 1 to 8 are displayed in this area.

The next channel for allocation, which is in waiting position, is marked with a yellow exclamation mark.

(11) Expand/Collapse

This button enables or disables the display areas (9). The label of the button changes accordingly.

7.7.8.3 ShrdResL general preview

ShrdResL general preview

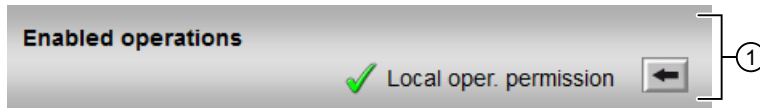

(1) Enabled operations

This area shows all operations for which special operator permissions are assigned. They depend on the configuration in the engineering system (ES) that applies to this block.

Icons for enabled operation:

- **Green check mark:** The OS operator can control this parameter.
- **Gray check mark:** The OS operator cannot control this parameter at this time due to the process.
- **Red cross:** The OS operator cannot control this parameter due to the configured AS operator permissions (OS_Perm).

The following enabled operation is shown here:

- "Local operator permission": Use the ← button to switch to the standard view of the OpStations block. You can find additional information on this in the section Operator control permissions (Page 254).

7.7.8.4 ShrdResL preview

ShrdResL preview

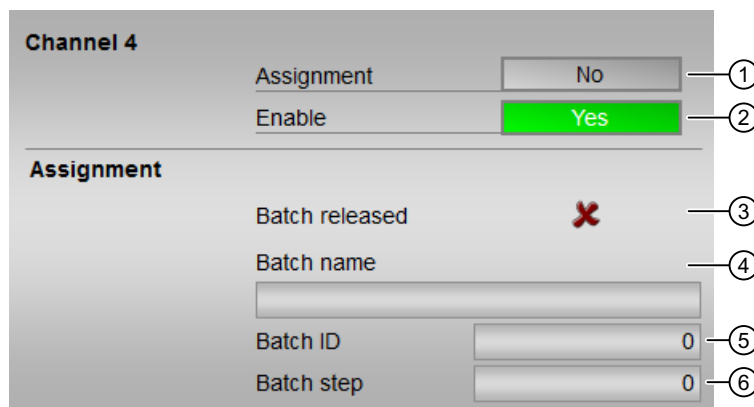

Each of the eight channels has its own preview. The previews of the individual channels are identical. The preview shown in this graphic is of channel 4.

(1) Allocation

The allocation status of the channel is displayed in this area.

- "No": Display for `Occ_1 = 0`
- "Requested": Display for `Occ_1 = 1` and `ActChnNo = 0`
- "Active": Display for `ActChnNo = 1`

(2) Enable

The status of the enable is displayed in this area.

- "Yes": Display for `ChnEn = 1`
- "No": Display for `ChnEn = 0`

(3) Release batch

This area displays if the block is released for operation via SIMATIC BATCH (`BatchEn = 1`).

(4) Batch name

This area displays the name of the batch that is currently running (`Batchname`).

(5) Batch ID

This area displays the identification number of the batch that is currently running (`BatchID`).

(6) Batch step

This area displays the step number of the batch that is currently running (`StepNo`).

7.7.8.5 ShrdResL parameter view

Parameter view of ShrdResL

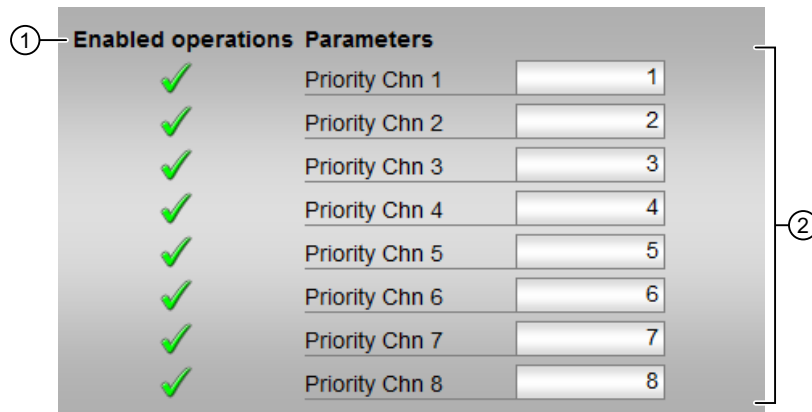

(1) Enabled operations

This area shows all operations for which special operator permissions are assigned. They depend on the configuration in the engineering system (ES) that applies to this block.

Icons for operation enable:

- **Green check mark:** The OS operator can control this parameter.
- **Gray check mark:** The OS operator cannot control this parameter at this time due to the process.
- **Red cross:** The OS operator cannot control this parameter due to the configured AS operator permissions (OS_Perm).

(2) Parameters

In this area, you can change the parameters and thereby influence the behavior of ShrdResL. You can find more information on this in the section Changing values (Page 259).

You can influence the following parameters:

- "Priority Chn 1": Priority for channel 1
- "Priority Chn 2": Priority for channel 2
- "Priority Chn 3": Priority for channel 3
- "Priority Chn 4": Priority for channel 4
- "Priority Chn 5": Priority for channel 5
- "Priority Chn 6": Priority for channel 6
- "Priority Chn 7": Priority for channel 7
- "Priority Chn 8": Priority for channel 8

7.7.8.6 Block icon for ShrdResL

Block icons for ShrdResL

A variety of block icons are available with the following functions:

- Display active channel
- Process tag type (2 only)
- Memo display (2 only)
- Fixed text (language dependent, 2 only)

The block icons from template @TemplateAPLV8.PDL:

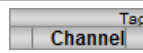
Icons	Selection of the block icon in CFC	Special features
	1	
	2	

Additional information on the block icon and the control options in the block icon is available in the following chapters:

- Configuring the block icons (Page 237)
- Block icon structure (Page 230)
- Operation via the block icon (Page 239)

7.8 ShrdResS - Multiplexer for shared resources (Small)

7.8.1 Description for ShrdResS

Object name (type + number) and family

Type + number: FB 1914

Family: Drives

Area of application for ShrdResS

The block is used for the following applications:

- Organize individual requests for downstream block from upstream applications

How it works

The block coordinates the access from up to four CFC or SFC step sequencers to a technologic block of the families "Drives" or "Dose". These blocks include:

- Motors
- Valves
- Dosers

The block has four channels, each with a standardized command interface.

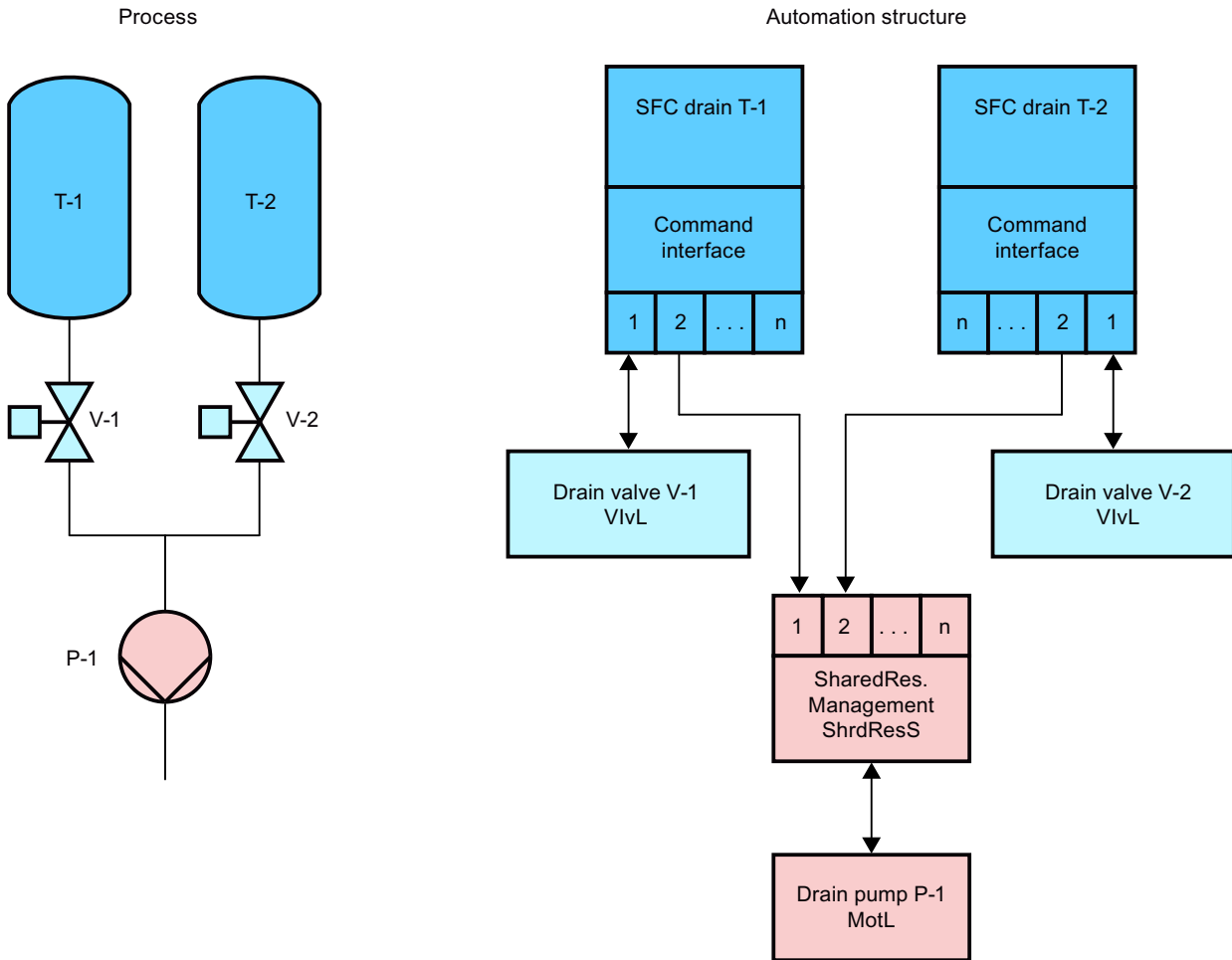

The block can be cascaded via the fourth channel so that accesses via more than four upstream applications are possible. Use the cascade by interconnecting the output parameter `CasOut` of the first block to the input parameter `CasIn` of the second block. The output interface of the upstream block is then used as channel 4 for the second block.

As soon as a channel is allocated, its command interface is aligned 1-to-1 with the command interface at the output.

The channel with the lower number always has priority with shared allocation. Cascaded blocks are always allocated to channel 4 of the upstream block; they are then in 4th place.

Configuration

Use the CFC editor to install the block in a cyclic interrupt OB (OB30 to OB38). The block is also installed automatically in the startup OB (OB100).

Startup characteristics

Use the `Feature Bit Set` startup characteristics (Page 138) to define the startup characteristics of this block.

Status word allocation for status parameter

You can find a description for each parameter in section ShrdResS I/Os (Page 1291).

Status bit	Parameter
0	ReadyIn, readiness signal of the interconnected technologic block
1	ChnEn_1
2	ChnEn_2
3	ChnEn_3
4	ChnEn_4
5	Ready, channel allocation is possible
6	ActChnNo = 1, 1 = Channel 1 enabled
7	ActChnNo = 2, 1 = Channel 2 enabled
8	ActChnNo = 3, 1 = Channel 3 enabled
9	ActChnNo = 4, 1 = Channel 4 enabled
10	MultiOcc, 1 = Request for more than one channel
11	Cascaded, 1 = 4. Channel is cascaded
12	BatchEn
13	Occupied
14 - 20	Not used
21	BaEn_1
22	BaEn_2
23	BaEn_3
24	BaEn_4
25	Occ_1
26	Occ_2
27	Occ_3
28	Occ_4
29 - 31	Not used

See also

- ShrdResS modes (Page 1286)
- ShrdResS functions (Page 1287)
- ShrdResS error handling (Page 1290)
- ShrdResS messaging (Page 1290)
- ShrdResS block diagram (Page 1299)

7.8.2 ShrdResS modes

ShrdResS operating modes

This block does not have any modes.

See also

Description for ShrdResS (Page 1284)
 ShrdResS functions (Page 1287)
 ShrdResS error handling (Page 1290)
 ShrdResS messaging (Page 1290)
 ShrdResS I/Os (Page 1291)
 ShrdResS block diagram (Page 1299)

7.8.3 ShrdResS functions**Functions of ShrdResS**

The functions for this block are listed below.

Opening additional faceplates

This block provides the standard function Opening additional faceplates (Page 208).

If the block is cascaded, the standard view of the ShrdResS block interconnected to `CasIn` can be opened in addition to the freely configured faceplate.

Configurable reactions using the `Feature` parameter

You can find an overview of all reactions provided by the `Feature` parameter in the section Configurable functions using the Feature I/O (Page 131). The following functionality is available for this block at the relevant bits:

Bit	Function
0	Set startup characteristics (Page 138)

Readiness signal

In order to assign one of the channels, the ready signal must be `ReadyIn = 1` and at least one channel enable must be `ChnEn_x = 1` ($x = 1...4$). The ready signal is output at the `Ready` output.

Channel management

Overview of the channel management

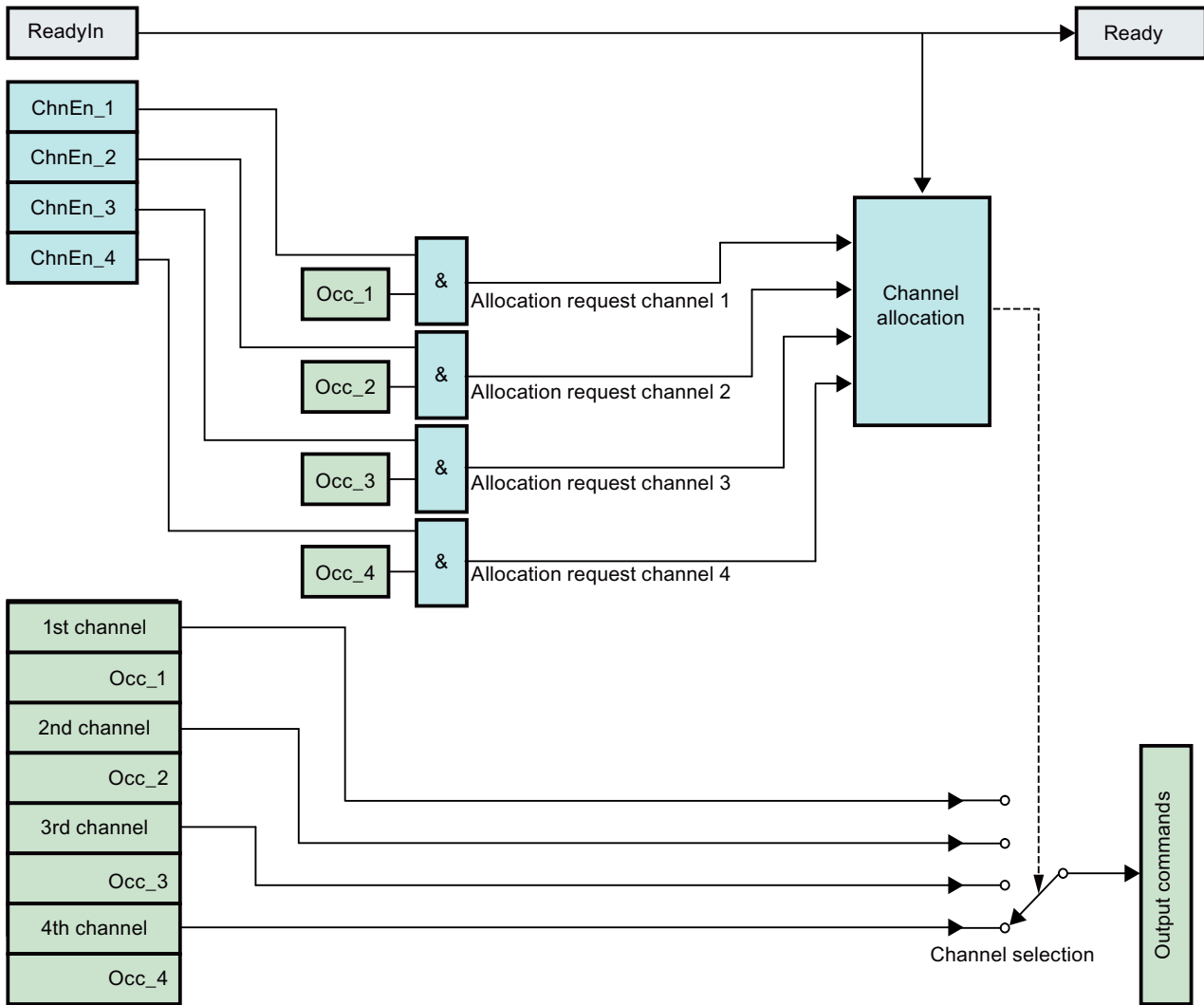

Allocate/enable channel

A channel can only be allocated if the readiness signal ($ReadyIn = 1$) and the respective channel enabling is available for the allocation $ChnEn_x = 1$.

With $ChnEn_x = 0$ the channel x is disabled and cannot be allocated.

The allocation of a channel by the upstream application is accomplished via the input Occ_x . As long as this input is 1, the channel is allocated and enabled. The applied commands are aligned 1-to-1 with the output command interface.

The number of the allocated channel is displayed at the output $ActChnNo$ (INT format). If no channel is allocated, the output is 0.

Enable/disable channel

If no channel enabling via $Occ_x = 0$ occurs or if the channel is disabled via $ChnEn_x = 0$, the next highest priority channel is automatically switched to the command outputs. If there is no other allocation request (every $Occ_x = 0$), the commands of the output interface are reset to the default values.

Channel prioritization

Channel 1 has the highest priority, channel 4 has the lowest. If the input Occ_x is set at multiple enabled channels, the channel with the highest priority is allocated and the output $MultiOcc = 1$ is set.

SIMATIC BATCH functionality

This block provides the standard function SIMATIC BATCH functionality (Page 67).

Cascading

For cascading, the output $CasOut$ of a ShrdResS block B must be connected with the input $CasIn$ of the downstream ShrdResS block A. Therefore, the fourth channel of the downstream block ShrdResS A is allocated by the ShrdResS B block connected to $CasIn$. The command interface of the fourth channel is tracked in this case to the output interface of the connected ShrdResS B block.

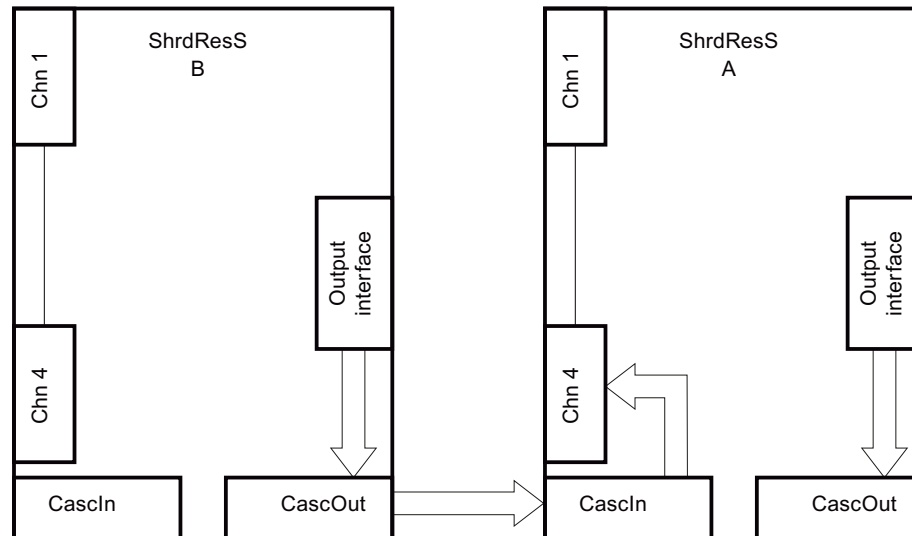

Any values applied via interconnection at the 4th channel of block A are not taken into account in the block code during cascading.

See also

Description for ShrdResS (Page 1284)

ShrdResS modes (Page 1286)

7.8 ShrdResS - Multiplexer for shared resources (Small)

- ShrdResS error handling (Page 1290)
- ShrdResS messaging (Page 1290)
- ShrdResS I/Os (Page 1291)
- ShrdResS block diagram (Page 1299)

7.8.4 ShrdResS error handling

ShrdResS error handling

Please refer to the section Error handling (Page 119) in the basic instructions.

The following errors can be displayed for this block:

- Error numbers

Overview of error numbers

The `ErrorNum` I/O can be used to output the following error numbers:

Error number	Meaning of the error number
-1	Predefined value when inserting the block; block will not be processed
0	There is no error.
40	Interconnection error on <code>CasIn</code> , incorrect block type interconnected

See also

- Description for ShrdResS (Page 1284)
- ShrdResS modes (Page 1286)
- ShrdResS functions (Page 1287)
- ShrdResS messaging (Page 1290)
- ShrdResS I/Os (Page 1291)
- ShrdResS block diagram (Page 1299)

7.8.5 ShrdResS messaging

Messaging

This block does not offer messaging.

See also

Description for ShrdResS (Page 1284)

ShrdResS modes (Page 1286)

ShrdResS functions (Page 1287)

ShrdResS error handling (Page 1290)

ShrdResS I/Os (Page 1291)

ShrdResS block diagram (Page 1299)

7.8.6 ShrdResS I/Os**I/Os of ShrdResS****Input parameters**

Parameter	Description	Type	Default
AutMod_1*	1= "Automatic mode" via interconnection	STRUCT <ul style="list-style-type: none"> Value: BOOL ST: BYTE 	- <ul style="list-style-type: none"> 0 16#80
AutMod_2*	1= "Automatic mode" via interconnection	STRUCT <ul style="list-style-type: none"> Value: BOOL ST: BYTE 	- <ul style="list-style-type: none"> 0 16#80
AutMod_3*	1= "Automatic mode" via interconnection	STRUCT <ul style="list-style-type: none"> Value: BOOL ST: BYTE 	- <ul style="list-style-type: none"> 0 16#80
AutMod_4*	1= "Automatic mode" via interconnection	STRUCT <ul style="list-style-type: none"> Value: BOOL ST: BYTE 	- <ul style="list-style-type: none"> 0 16#80
BaEn_1	1 = Enable allocation for channel 1	BOOL	0
BaEn_2	1 = Enable allocation for channel 2	BOOL	0
BaEn_3	1 = Enable allocation for channel 3	BOOL	0
BaEn_4	1 = Enable allocation for channel 4	BOOL	0
BaID_1	Batch number for channel 1	DWORD	16#00000000
BaID_2	Batch number for channel 2	DWORD	16#00000000
BaID_3	Batch number for channel 3	DWORD	16#00000000
BaID_4	Batch number for channel 4	DWORD	16#00000000
BaName_1	Batch designation for channel 1	S7-String	
BaName_2	Batch designation for channel 2	S7-String	
BaName_3	Batch designation for channel 3	S7-String	

7.8 ShrdResS - Multiplexer for shared resources (Small)

Parameter	Description	Type	Default
BaName_4	Batch designation for channel 4	S7-String	
CasIn	Input for cascade, to be interconnected with the output parameter <i>CasOut</i> of the preceding ShrdResS block	ANY	
ChnEn_1	1 = Channel 1 is enabled and can be allocated 0 = Channel 1 is blocked and cannot be allocated.	STRUCT • Value: BOOL • ST: BYTE	- • 1 • 16#FF
ChnEn_2	1 = Channel 2 is enabled and can be allocated 0 = Channel 2 is blocked and cannot be allocated.	STRUCT • Value: BOOL • ST: BYTE	- • 1 • 16#FF
ChnEn_3	1 = Channel 3 is enabled and can be allocated 0 = Channel 3 is blocked and cannot be allocated.	STRUCT • Value: BOOL • ST: BYTE	- • 1 • 16#FF
ChnEn_4*	1 = Channel 4 is enabled and can be allocated 0 = Channel 4 is blocked and cannot be allocated.	STRUCT • Value: BOOL • ST: BYTE	- • 1 • 16#FF
ChnCmd_1	Channel 1: Command interface (reserved)	STRUCT	
ChnCmd_2	Channel 2: Command interface (reserved)	STRUCT	
ChnCmd_3	Channel 3: Command interface (reserved)	STRUCT	
ChnCmd_4	Channel 4: Command interface (reserved)	STRUCT	
Ctrl01_1*	1. Control command for channel 1	STRUCT • Value: BOOL • ST: BYTE	- • 0 • 16#80
Ctrl02_1*	2. Control command for channel 1	STRUCT • Value: BOOL • ST: BYTE	- • 0 • 16#80
Ctrl03_1*	3. Control command for channel 1	STRUCT • Value: BOOL • ST: BYTE	- • 0 • 16#80
Ctrl04_1*	4. Control command for channel 1	STRUCT • Value: BOOL • ST: BYTE	- • 0 • 16#80
Ctrl05_1*	5. Control command for channel 1	STRUCT • Value: BOOL • ST: BYTE	- • 0 • 16#80

7.8 ShrdResS - Multiplexer for shared resources (Small)

Parameter	Description	Type	Default
Ctrl06_1*	6. Control command for channel 1	STRUCT • Value: BOOL • ST: BYTE	- • 0 • 16#80
Ctrl01_2*	1. Control command for channel 2	STRUCT • Value: BOOL • ST: BYTE	- • 0 • 16#80
Ctrl02_2*	2. Control command for channel 2	STRUCT • Value: BOOL • ST: BYTE	- • 0 • 16#80
Ctrl03_2*	3. Control command for channel 2	STRUCT • Value: BOOL • ST: BYTE	- • 0 • 16#80
Ctrl04_2*	4. Control command for channel 2	STRUCT • Value: BOOL • ST: BYTE	- • 0 • 16#80
Ctrl05_2*	5. Control command for channel 2	STRUCT • Value: BOOL • ST: BYTE	- • 0 • 16#80
Ctrl06_2*	6. Control command for channel 2	STRUCT • Value: BOOL • ST: BYTE	- • 0 • 16#80
Ctrl01_3*	1. Control command for channel 3	STRUCT • Value: BOOL • ST: BYTE	- • 0 • 16#80
Ctrl02_3*	2. Control command for channel 3	STRUCT • Value: BOOL • ST: BYTE	- • 0 • 16#80
Ctrl03_3*	3. Control command for channel 3	STRUCT • Value: BOOL • ST: BYTE	- • 0 • 16#80
Ctrl04_3*	4. Control command for channel 3	STRUCT • Value: BOOL • ST: BYTE	- • 0 • 16#80
Ctrl05_3*	5. Control command for channel 3	STRUCT • Value: BOOL • ST: BYTE	- • 0 • 16#80
Ctrl06_3*	6. Control command for channel 3	STRUCT • Value: BOOL • ST: BYTE	- • 0 • 16#80

Motor and valve blocks

7.8 ShrdResS - Multiplexer for shared resources (Small)

Parameter	Description	Type	Default
Ctrl01_4*	1. Control command for channel 4	STRUCT <ul style="list-style-type: none"> • Value: BOOL • ST: BYTE 	- <ul style="list-style-type: none"> • 0 • 16#80
Ctrl02_4*	2. Control command for channel 4	STRUCT <ul style="list-style-type: none"> • Value: BOOL • ST: BYTE 	- <ul style="list-style-type: none"> • 0 • 16#80
Ctrl03_4*	3. Control command for channel 4	STRUCT <ul style="list-style-type: none"> • Value: BOOL • ST: BYTE 	- <ul style="list-style-type: none"> • 0 • 16#80
Ctrl04_4*	4. Control command for channel 4	STRUCT <ul style="list-style-type: none"> • Value: BOOL • ST: BYTE 	- <ul style="list-style-type: none"> • 0 • 16#80
Ctrl05_4*	5. Control command for channel 4	STRUCT <ul style="list-style-type: none"> • Value: BOOL • ST: BYTE 	- <ul style="list-style-type: none"> • 0 • 16#80
Ctrl06_4*	6. Control command for channel 4	STRUCT <ul style="list-style-type: none"> • Value: BOOL • ST: BYTE 	- <ul style="list-style-type: none"> • 0 • 16#80
CtrlW1_1*	1. Available user control word for channel 1	DWORD	16#00000000
CtrlW1_2*	1. Available user control word for channel 2	DWORD	16#00000000
CtrlW1_3*	1. Available user control word for channel 3	DWORD	16#00000000
CtrlW1_4*	1. Available user control word for channel 4	DWORD	16#00000000
CtrlW2_1*	2. Available user control word for channel 1	DWORD	16#00000000
CtrlW2_2*	2. Available user control word for channel 2	DWORD	16#00000000
CtrlW2_3*	2. Available user control word for channel 3	DWORD	16#00000000
CtrlW2_4*	2. Available user control word for channel 4	DWORD	16#00000000
EN	1 = Called block will be processed	BOOL	1
Feature	I/O for additional functions (Page 1287)	STRUCT <ul style="list-style-type: none"> • Bit 0: BOOL • ... • Bit 31: BOOL 	- <ul style="list-style-type: none"> • 0 • 0 • 0
ManMod_1*	1 = "Manual mode" via interconnection for channel 1	STRUCT <ul style="list-style-type: none"> • Value: BOOL • ST: BYTE 	- <ul style="list-style-type: none"> • 0 • 16#80

7.8 ShrdResS - Multiplexer for shared resources (Small)

Parameter	Description	Type	Default
ManMod_2*	1 = "Manual mode" via interconnection for channel 2	STRUCT • Value: BOOL • ST: BYTE	- • 0 • 16#80
ManMod_3*	1 = "Manual mode" via interconnection for channel 3	STRUCT • Value: BOOL • ST: BYTE	- • 0 • 16#80
ManMod_4*	1 = "Manual mode" via interconnection for channel 4	STRUCT • Value: BOOL • ST: BYTE	- • 0 • 16#80
ModLi_1*	1 = Control via interconnection or SFC for channel 1	STRUCT • Value: BOOL • ST: BYTE	- • 0 • 16#80
ModLi_2*	1 = Control via interconnection or SFC for channel 2	STRUCT • Value: BOOL • ST: BYTE	- • 0 • 16#80
ModLi_3*	1 = Control via interconnection or SFC for channel 3	STRUCT • Value: BOOL • ST: BYTE	- • 0 • 16#80
ModLi_4*	1 = Control via interconnection or SFC for channel 4	STRUCT • Value: BOOL • ST: BYTE	- • 0 • 16#80
Occ_1	1 = Occupied Is also used as a control signal for the channel allocation for channel 1	BOOL	0
Occ_2	1 = Occupied Is also used as a control signal for the channel allocation for channel 2	BOOL	0
Occ_3	1 = Occupied Is also used as a control signal for the channel allocation for channel 3	BOOL	0
Occ_4*	1 = Occupied Is also used as a control signal for the channel allocation for channel 4	BOOL	0
ReadyIn	Readiness signal: 1 = Signal for channel enabling active	STRUCT • Value: BOOL • ST: BYTE	- • 0 • 16#80
RstLi_1*	1 = Resetting via interconnection for channel 1	STRUCT • Value: BOOL • ST: BYTE	- • 0 • 16#80
RstLi_2*	1 = Resetting via interconnection for channel 2	STRUCT • Value: BOOL • ST: BYTE	- • 0 • 16#80

7.8 ShrdResS - Multiplexer for shared resources (Small)

Parameter	Description	Type	Default
RstLi_3*	1 = Resetting via interconnection for channel 3	STRUCT • Value: BOOL • ST: BYTE	- • 0 • 16#80
RstLi_4*	1 = Resetting via interconnection for channel 4	STRUCT • Value: BOOL • ST: BYTE	- • 0 • 16#80
selFpRes	Selection for faceplate resource	ANY	
SP_Ex_1	1 = Select external setpoint (via interconnection) for channel 1	STRUCT • Value: BOOL • ST: BYTE	- • 0 • 16#80
SP_Ex_2	1 = Select external setpoint (via interconnection) for channel 2	STRUCT • Value: BOOL • ST: BYTE	- • 0 • 16#80
SP_Ex_3	1 = Select external setpoint (via interconnection) for channel 3	STRUCT • Value: BOOL • ST: BYTE	- • 0 • 16#80
SP_Ex_4	1 = Select external setpoint (via interconnection) for channel 4	STRUCT • Value: BOOL • ST: BYTE	- • 0 • 16#80
SP_In_1*	1 = Select internal setpoint (via interconnection) for channel 1	STRUCT • Value: BOOL • ST: BYTE	- • 0 • 16#80
SP_In_2*	1 = Select internal setpoint (via interconnection) for channel 2	STRUCT • Value: BOOL • ST: BYTE	- • 0 • 16#80
SP_In_3*	1 = Select internal setpoint (via interconnection) for channel 3	STRUCT • Value: BOOL • ST: BYTE	- • 0 • 16#80
SP_In_4*	1 = Select internal setpoint (via interconnection) for channel 4	STRUCT • Value: BOOL • ST: BYTE	- • 0 • 16#80
SP1Ext_1*	1. External setpoint for channel 1	STRUCT • Value: REAL • ST: BYTE	- • 0.0 • 16#80
SP2Ext_1*	2. External setpoint for channel 1	STRUCT • Value: REAL • ST: BYTE	- • 0.0 • 16#80
SP1Ext_2*	1. External setpoint for channel 2	STRUCT • Value: REAL • ST: BYTE	- • 0.0 • 16#80

7.8 ShrdResS - Multiplexer for shared resources (Small)

Parameter	Description	Type	Default
SP2Ext_2*	2. External setpoint for channel 2	STRUCT • Value: REAL • ST: BYTE	- • 0.0 • 16#80
SP1Ext_3*	1. External setpoint for channel 3	STRUCT • Value: REAL • ST: BYTE	- • 0.0 • 16#80
SP2Ext_3*	2. External setpoint for channel 3	STRUCT • Value: REAL • ST: BYTE	- • 0.0 • 16#80
SP1Ext_4*	1. External setpoint for channel 4	STRUCT • Value: REAL • ST: BYTE	- • 0.0 • 16#80
SP2Ext_4*	2. External setpoint for channel 4	STRUCT • Value: REAL • ST: BYTE	- • 0.0 • 16#80
StepNo_1	Step number for channel 1	DWORD	16#00000000
StepNo_2	Step number for channel 2	DWORD	16#00000000
StepNo_3	Step number for channel 3	DWORD	16#00000000
StepNo_4	Step number for channel 4	DWORD	16#00000000

* Values can be written back to these inputs during processing of the block by the block algorithm.

Output parameters

Parameter	Description	Type	Default
ActChnNo	Displaying the allocated channel	INT	0
AutMod	1= "Automatic mode" via interconnection	STRUCT • Value: BOOL • ST: BYTE	- • 0 • 16#80
BatchEn	1 = Enable allocation	BOOL	0
BatchID	Batch ID	DWORD	16#00000000
BatchName	Batch name	S7-String	
Cascaded	1 = Block is cascaded	BOOL	0
CasOut	1 = Output parameter for cascade formation, to be interconnected with the input parameter <i>CasIn</i> of the following ShrdResS block	DWORD	16#00000000
Ctrl01	1. Control command	STRUCT • Value: BOOL • ST: BYTE	- • 0 • 16#80

7.8 ShrdResS - Multiplexer for shared resources (Small)

Parameter	Description	Type	Default
Ctrl02	2. Control command	STRUCT <ul style="list-style-type: none"> Value: BOOL ST: BYTE 	- <ul style="list-style-type: none"> 0 16#80
Ctrl03	3. Control command	STRUCT <ul style="list-style-type: none"> Value: BOOL ST: BYTE 	- <ul style="list-style-type: none"> 0 16#80
Ctrl04	4. Control command	STRUCT <ul style="list-style-type: none"> Value: BOOL ST: BYTE 	- <ul style="list-style-type: none"> 0 16#80
Ctrl05	5. Control command	STRUCT <ul style="list-style-type: none"> Value: BOOL ST: BYTE 	- <ul style="list-style-type: none"> 0 16#80
Ctrl06	6. Control command	STRUCT <ul style="list-style-type: none"> Value: BOOL ST: BYTE 	- <ul style="list-style-type: none"> 0 16#80
CtrlW1	1. Available user control word	DWORD	16#00000000
CtrlW2	2. Available user control word	DWORD	16#00000000
ENO	1 = Block algorithm completed without errors	BOOL	0
ErrorNum	Output of current error number. For error numbers that can be output by this block, see ShrdResS error handling (Page 1290)	INT	-1
ManMod	1 = "Manual mode" via interconnection	STRUCT <ul style="list-style-type: none"> Value: BOOL ST: BYTE 	- <ul style="list-style-type: none"> 0 16#80
ModLi	1 = Control via interconnection or SFC	STRUCT <ul style="list-style-type: none"> Value: BOOL ST: BYTE 	- <ul style="list-style-type: none"> 0 16#80
MultiOcc	1 = More than one channel request is present	BOOL	0
Occupied	1 = Occupied Is also used as a control signal for the channel allocation	BOOL	0
Ready	1 = Active readiness	STRUCT <ul style="list-style-type: none"> Value: BOOL ST: BYTE 	- <ul style="list-style-type: none"> 0 16#80
RstLi	1 = Reset via interconnection	STRUCT <ul style="list-style-type: none"> Value: BOOL ST: BYTE 	- <ul style="list-style-type: none"> 0 16#80
SP_ExtLi	1 = Select external setpoint (via interconnection)	STRUCT <ul style="list-style-type: none"> Value: BOOL ST: BYTE 	- <ul style="list-style-type: none"> 0 16#80

Parameter	Description	Type	Default
SP_IntLi	1 = Select internal setpoint (via interconnection)	STRUCT <ul style="list-style-type: none"> Value: BOOL ST: BYTE 	- <ul style="list-style-type: none"> 0 16#80
SP1Ext	1. External setpoint	STRUCT <ul style="list-style-type: none"> Value: REAL ST: BYTE 	- <ul style="list-style-type: none"> 0.0 16#80
SP2Ext	2. External setpoint	STRUCT <ul style="list-style-type: none"> Value: REAL ST: BYTE 	- <ul style="list-style-type: none"> 0.0 16#80
Status1	Status word 1 (Page 1284)	DWORD	16#00000000
StepNo	Step number	DWORD	16#00000000

See also

[ShrdResS modes \(Page 1286\)](#)
[ShrdResS messaging \(Page 1290\)](#)
[ShrdResS block diagram \(Page 1299\)](#)

7.8.7 ShrdResS block diagram**ShrdResS block diagram**

A block diagram is not provided for this block.

See also

[Description for ShrdResS \(Page 1284\)](#)
[ShrdResS modes \(Page 1286\)](#)
[ShrdResS functions \(Page 1287\)](#)
[ShrdResS error handling \(Page 1290\)](#)
[ShrdResS messaging \(Page 1290\)](#)
[ShrdResS I/Os \(Page 1291\)](#)

7.8.8 Operator control and monitoring

7.8.8.1 ShrdResS views

Views of the ShrdResS block

The block ShrdResS provides the following views:

- ShrdResS standard view (Page 1300)
- ShrdResS preview (Page 1302)
- Memo view (Page 304)
- Block icon for ShrdResS (Page 1303)

Refer to the sections Structure of the faceplate (Page 248) and Block icon structure (Page 230) for general information on the faceplate and block icon.

7.8.8.2 ShrdResS standard view

ShrdResS standard view

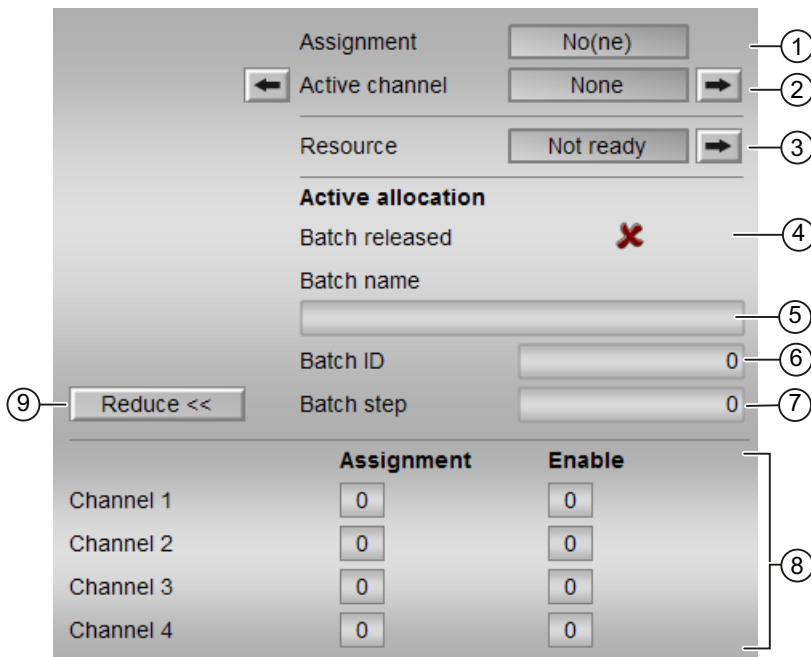

(1) Allocation

The allocation status is displayed in this area.

- "None": Display for `Status1.Bit 10 = 0` and `Status1.Bit 13 = 0`
- "Requested": Display for `Status1.Bit 10 = 1` and `Status1.Bit 13 = 0`
- "Active": Display for `Status1.Bit 13 = 1`

(2) Active channel

The channel number of the active channel is displayed in this area.

If text is configured for this command (Text 1 in the object properties), it is displayed as additional text and button label for command selection. Additional information is available in the section Labeling of buttons and text (Page 209).

Use the ← button to switch to the standard view of the connected `CasIn` block.

Use the → button to switch to the standard view of the connected `CasOut` block.

(3) Resource

The status of the general enable signal is displayed in this area.

- "Idle": Display for `ReadyIn = 1`
- "Not ready": Display for `ReadyIn = 0`

Use the → button to switch to the standard view of the connected `SelfPRes` block.

(4) Release batch:

This area shows you if the block is released for operation via SIMATIC BATCH (`BatchEn = 1`).

(5) Batch name

This area shows the name of the batch that is currently running (`Batchname`).

(6) Batch ID

This area shows the identification number of the batch that is currently running (`BatchID`).

(7) Batch step

This area shows you the step number of the batch that is currently running (`StepNo`).

(8) Display channel 1-4

This area is only visible when the (9) "Expand" button is pressed.

The "Allocation" und "Release" status of channels 1-4 are displayed in this area.

(9) Expand / Collapse

This button enables or disables the display area (8). The label of the button changes accordingly.

7.8.8.3 ShrdResS preview

ShrdResS preview

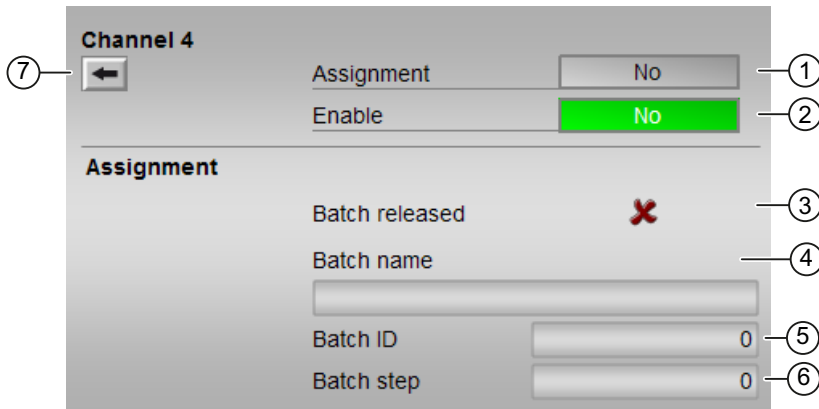

Each of the four channels has its own preview. The previews of the individual channels are identical except for number (7) . The preview described here is based on channel 4.

(1) Allocation

The allocation status of the channel is displayed in this area.

- "No": Display for `Occ_1 = 0`
- "Requested": Display for `Occ_1 = 1` and `ActChnNo = 0`
- "Active": Display for `ActChnNo = 1`

(2) Enable

The status of the enable is displayed in this area.

- "Yes": Display for `ChnEn = 1`
- "No": Display for `ChnEn = 0`

(3) Release batch:

This area shows you if the block is released for operation via SIMATIC BATCH (`BatchEn = 1`).

(4) Batch name

This area shows the name of the batch that is currently running (`Batchname`).

(5) Batch ID

This area shows the identification number of the batch that is currently running (BatchID).

(6) Batch step

This area shows you the step number of the batch that is currently running (StepNo).

(7) Button ←

Use the ← button to switch to the standard view of the cascaded ShrdResS block. This button is only available for channel 4.

7.8.8.4 Block icon for ShrdResS

Block icons for ShrdResS

A variety of block icons are available with the following functions:

- Display active channel
- Process tag type (2 only)
- Memo display (2 only)
- Fixed text (language dependent, 2 only)

The block icons from template @TemplateAPLV8.PDL:

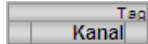
Icons	Selection of the block icon in CFC	Special features
	1	
	2	

The block icons from template @TemplateAPLV7.PDL:

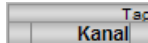
Icons	Selection of the block icon in CFC	Special features
	1	
	2	

Additional information on the block icon and the control options in the block icon is available in the following chapters:

- Configuring the block icons (Page 237)
- Block icon structure (Page 230)
- Operation via the block icon (Page 239)

7.9 Vlv2WayL - Two-way valve

7.9.1 Description of Vlv2WayL

Object name (type + number) and family

Type + number: FB 1897

Family: Drives

Area of application for Vlv2WayL

The block is used for the following applications:

- Control of multi-way valves with up to three switching positions. One of these positions is the neutral position (de-energized position)
- Control of three individual valves (valve network) to implement a 2-way valve circuit with neutral position (de-energized position)

How it works

The multi-way valve (or valve network) is controlled via position 0 (neutral position), position 1 (way 1), or position 2 (way 2). Various inputs are available for controlling the positions.

Configuration

Use the CFC editor to install the block in a cyclic interrupt OB (OB30 to OB38). The block is also installed automatically in the startup OB (OB100).

For the Vlv2WayL block, the Advanced Process Library contains a template for process tag types as an example with an application scenario for this block.

Example of process tag types:

- Two-way valve (Valve2Way) (Page 2368)

Startup characteristics

Use the `Feature Bit Set` startup characteristics (Page 138) to define the startup characteristics of this block.

The messages are suppressed after startup for the number of cycles set at `RunUpCyc`.

Status word allocation for status1 parameter

You can find a description for each parameter in section Vlv2WayL I/Os (Page 1321).

Status bit	Parameter
0	Occupied
1	BatchEn
2	SimOn
3	OosAct.Value
4	OosLi.Value
5	AutoAct.Value
6	LocalAct.Value
7	0: Open padlock in the block icon 1: Closed padlock in the block icon
8	"Open"/"Closed" command for v0
9	"Open"/"Closed" command for v1
10	"Open"/"Closed" command for v2
11	Feedback error without control change
12	Feedback error due to control change
13	BypProt active
14	Invalid signal status
15	Mode switchover error
16	1 = Intlock is active
17	1 = Permit is active
18	1 = Protect is active
19	Display „Force Pos0“
20	Display „Force Pos1“
21	Display „Force Pos2“
22	Feedback for Pos0 OK
23	Feedback for Pos1 OK
24	Feedback for Pos2 OK
25	Feedback for current position OK
26	Automatic preview Pos0
27	Automatic preview Pos1
28	Automatic preview Pos2
29	SafeV0
30	SafeV1
31	SafeV2

Status word allocation for status2 parameter

Status bit	Parameter
0	MsgLock
1	Forcing active

Status bit	Parameter
2	Display for interlocks in block icon
3	WarnAct.Value
4	External error generated by FaultExt or external control system fault from CSF with set Feature bit 18 Activating error state for external process control error CSF (Page 151)
5	For the status display error in the valve
6	Current monitoring time P0 is visible
7	Current monitoring time V0 is visible
8	Current monitoring time V1 is visible
9	Current monitoring time V2 is visible
10	Current monitoring time P1 is visible
11	Current monitoring time P2 is visible
12	1 = Input parameter FbkP1 is connected and Feature bit 12 = 1
13	1 = Input parameter FbkP2 is connected and Feature bit 12 = 1
14	1 = Input parameter FbkP0 is connected
15	1 = Input parameter FbkV0 is connected and Feature bit 12 = 0
16	1 = Input parameter FbkV1 is connected and Feature bit 12 = 0
17	1 = Input parameter FbkV2 is connected and Feature bit 12 = 0
18	Reset request in automatic
19	1 = No impact of input signals on "local mode" with LocalSetting = 2 and LocalSetting = 4
20	CtrlV0.Value
21	CtrlV1.Value
22	CtrlV2.Value
23	FbkV0Out.Value
24	FbkV1Out.Value
25	FbkV2Out.Value
26	FbkP0Out.Value
27	Feedback V0 (FbkV0), for OS display only
28	Feedback V1 (FbkV1), for OS display only
29	Feedback V2 (FbkV2), for OS display only
30	Bypass information from previous function block
31	MS_RelOp

Status word allocation for status3 parameter

Status bit	Parameter
0	"Interlock" button is enabled
1	"Permission" button is enabled
2	"Protection" button is enabled
3	Pos0Out
4	Travel in position 0
5	Monitoring error in position 0

7.9 Vlv2WayL - Two-way valve

Status bit	Parameter
6	Pos1Out
7	Travel in position 1
8	Monitoring error in position 1
9	Pos2Out
10	Travel in position 2
11	Monitoring error in position 2
12	Preview position 0 control CtrlV0
13	Preview position 0 control CtrlV1
14	Preview position 0 control CtrlV2
15	Preview position 1 control CtrlV0
16	Preview position 1 control CtrlV1
17	Preview position 1 control CtrlV2
18	Preview position 2 control CtrlV0
19	Preview position 2 control CtrlV1
20	Preview position 2 control CtrlV2
21	Preview for automatic control CtrlV0
22	Preview for automatic control CtrlV1
23	Preview for automatic control CtrlV2
24	UserAna1 interconnected
25	UserAna2 interconnected
26	Show automatic preview in the standard view
27	Not used
28	GrpErr.Value
29	RdyToStart.Value
30	1 = with position feedback messages (Feature bit 12)
31	Not used

Status word allocation for Status4 parameter

Status bit	Parameter
0	Effective signal 1 of the message block connected via EventTsIn
1	Effective signal 2 of the message block connected via EventTsIn
2	Effective signal 3 of the message block connected via EventTsIn
3	Effective signal 4 of the message block connected via EventTsIn
4	Effective signal 5 of the message block connected via EventTsIn
5	Effective signal 6 of the message block connected via EventTsIn
6	Effective signal 7 of the message block connected via EventTsIn
7	Effective signal 8 of the message block connected via EventTsIn
8 - 15	Effective signal 9..16 of the message block connected via EventTsIn
16 - 22	Not used
23	Hidden bypass signal in Permit
24	Hidden bypass signal in interlock

Status bit	Parameter
25	Hidden bypass signal in Protect
26	Feature2 bit 2: Separate bypass signal
27	1 = Input parameter CtrlV0ChnST is interconnected
28	1 = Input parameter CtrlV1ChnST is interconnected
29	1 = Input parameter CtrlV2ChnST is interconnected
30 - 31	Not used

See also

Vlv2WayL functions (Page 1310)

Vlv2WayL messaging (Page 1320)

Vlv2WayL block diagram (Page 1332)

Vlv2WayL error handling (Page 1318)

Vlv2WayL modes (Page 1309)

Resetting the block in case of interlocks or errors (Page 43)

7.9.2 Vlv2WayL modes

Vlv2WayL operating modes

The block can be operated using the following modes:

- Local mode (Page 79)
- Automatic mode (Page 75)
- Manual mode (Page 75)
- Out of service (Page 71)

The next section provides additional block-specific information relating to the general descriptions.

"Local mode"

You can find general information on "Local mode", switching modes and Bumpless switchover in the Local mode (Page 79) section.

Valve actions you can control in "local mode":

- Travel to neutral position ($Pos0Local = 1$)
- Moving to position 1 ($Pos1Local = 1$)
- Moving to position 2 ($Pos2Local = 1$).

A block operated in "local mode" is controlled either by "local" signals (input parameters $Pos0Local = 1$, $Pos1Local = 1$ and $Pos2Local = 1$) or by feedback signals (input

parameters `FdbV0`, `FdbV1`, `FdbV2` and `FdbP0`; if no position can be assigned, the last valid position is accepted). Configuration takes place via the input parameter `LocalSetting`.

"Automatic mode"

You can find general information on "Automatic mode", switching modes and Bumpless switchover in the Manual and automatic mode for motors, valves and dosers (Page 75) section.

Valve actions you can control in "automatic mode":

- Travel to neutral position (`Pos0Aut = 1`)
- Moving to position 1 (`Pos1Aut = 1`)
- Moving to position 2 (`Pos2Aut = 1`).

"Manual mode"

You can find general information on "Manual mode", switching modes and bumpless switchover in the section Manual and automatic mode for motors, valves and dosers (Page 75).

Valve actions you can control in "manual mode":

- Travel to neutral position (`Pos0Man = 1`)
- Moving to position 1 (`Pos1Man = 1`)
- Moving to position 2 (`Pos2Man = 1`).

"Out of service"

You can find general information about the "Out of service" mode in the section Out of service (Page 71).

See also

Vlv2WayL block diagram (Page 1332)

Vlv2WayL I/Os (Page 1321)

Vlv2WayL messaging (Page 1320)

Vlv2WayL error handling (Page 1318)

Vlv2WayL functions (Page 1310)

Description of Vlv2WayL (Page 1305)

7.9.3 Vlv2WayL functions

Functions of Vlv2WayL

The functions for this block are listed below.

Defining valve positions for individual valves

The control outputs for position 1 and position 2 can be selected individually with `DefPos1` and `DefPos2`:

Route 1 or route 2	Control outputs		
DefPos1 Or DefPos2	Valve v0 (CtrlV0)	Valve v1 (CtrlV1)	Valve v2 (CtrlV2)
0	closed	closed	closed
1	closed	closed	open
2	closed	open	closed
3	closed	open	open
4	open	closed	closed
5	open	closed	open
6	open	open	closed
7	open	open	open

Position 0 is the neutral position (de-energized state) and cannot be configured. In position 0 all control outputs are de-energized ($CtrlV_x = 0$).

Output signal as a pulse signal or static signal

This block provides the standard function Output signal as a static signal or pulse signal (Page 51). In addition to the static control outputs `CtrlV0`, `CtrlV1`, `CtrlV2`, `Pos0Out`, `Pos1Out`, `Pos2Out`, the block also has pulse outputs `P_CtrlV0`, `P_CtrlV1`, `P_CtrlV2`, `P_CtrlP0`, `P_CtrlP1`, `P_CtrlP2` which are output depending on the static control outputs.

Neutral position

This block provides the standard function Neutral position for motors, valves and controllers (Page 48). The neutral position (de-energized state) is set individually using parameters `SafeV0`, `SafeV1`, `SafeV2` for each valve (`CtrlV0`, `CtrlV1`, `CtrlV2`):

- `SafeVx = 0` means that at `CtrlVx = 0` the valve drive closes and at `CtrlVx = 1` it opens (de-energized state is "closed")
- `SafeVx = 1` means that at `CtrlVx = 0` the valve drive opens and at `CtrlVx = 1` it closes (de-energized state is "open")

Specify warning times for control functions

This block provides the standard function Specifying warning times for control functions at motors and valves (Page 51). The warning signal is output before the valve moves into position 1 or position 2. No warning signal is output for position 0 (neutral position).

You can generate warning signals when, for example, valves open. Warning signals can be generated in the following modes:

- Manual and automatic mode for motors, valves and dosers (Page 75) (Input parameter `WarnTiMan`)
- Manual and automatic mode for motors, valves and dosers (Page 75) (Input parameter `WarnTiAut`)

You specify the warning times in seconds using the input parameters `WarnTiMan` and `WarnTiAut`. If, for example, a valve opens then, this is displayed at the output parameter with `WarnAct = 1`. The valve then opens after the set warning time has expired and `WarnAct` then returns to `0`.

A corresponding warning is not output if the warning times (`WarnTiMan` or `WarnTiAut`) are specified with a smaller value than the `SampleTime` parameter.

Feedback monitoring

This block provides the standard function Monitoring the feedbacks (Page 97).

The monitoring of the feedback signal is dependent on Feature bit 12 "Position feedback signals are active (Page 169)".

Valve feedback signals are active (Feature bit 12 = 0):

Startup characteristic monitoring is individually set up for every output signal `CtrlV0`, `CtrlV1`, `CtrlV2` via parameters `MonTiV0Dynamic`, `MonTiV1Dynamic` and `MonTiV2Dynamic` and is set for position 0 via `MonTiP0Dynamic`. The parameter `MonTiStatic` monitors compliance with the position.

The position feedback signals (`FbkP1`, `FbkP2`) are not used to monitor the control outputs.

Note

The monitoring function does not take into consideration the neutral positions (`SafeV0`, `SafeV1`, `SafeV2`), which means the feedback messages `FbkV0`, `FbkV1`, `FbkV2` must correspond to the `CtrlV0`, `CtrlV1`, `CtrlV2` controls (e.g., `CtrlV0 = 1` means the feedback `FbkV0` is monitored for "1").

`FbkP0` must not occur for positions 1 or 2; at position 0, `FbkV0`, `FbkV1` and `FbkV2` must not occur.

If there are several feedback messages for position 0 (e.g. with a valve network), these must be combined using an upstream AND block at `FbkP0`.

Position feedback signals are active (Feature bit 12 = 1):

Startup characteristic monitoring is individually set up for the position feedback signals `Pos1Out` and `Pos2Out` via the parameters `MonTiP1Dynamic` and `MonTiVP2Dynamic` and for position 0 via `MonTiP0Dynamic`. The `MonTiStatic` parameter monitors compliance with the position.

The position feedback signals `FbkP0`, `FbkP1` and `FbkP2` are used to monitor the output signals `Pos0Out`, `Pos1Out` and `Pos2Out`.

Note

The separate valve feedback signals (`FbkV0`, `FbkV1`, `FbkV2`) are not used to monitor the control outputs.

Disabling feedback

This block provides the standard function Disabling feedback for valves (Page 99). Feedback monitoring can be deactivated separately for each feedback with `NoFbkV0`, `NoFbkV1`, `NoFbkV2`, `NoFbkP0`, `NoFbkP1`, `NoFbkP2`.

Suppressing messages using the `MsgLock` parameter

This block provides the standard function Suppressing messages using the `MsgLock` parameter (Page 205).

Forcing operating modes

This block provides the standard function Forcing operating modes (Page 41). The inputs `Pos0Force`, `Pos1Force`, `Pos2Force` force the block into position 0, position 1 or position 2.

Simulating signals

This block provides the standard function Simulating signals (Page 58)

Interlocks

This block provides the following interlocks:

- Activation enable
- Interlock without reset ("Interlock")
- Interlock with reset ("Protection")

Refer to the Interlocks (Page 99) section for more on this.

Disabling interlocks

This block provides the standard function Disabling interlocks (Page 103).

Resetting the block in case of interlocks or errors

This block provides the standard function Resetting the block in case of interlocks or errors (Page 43).

External error (`FaultExt`), external control system fault (`CSF`)

This block provides the possibility to pass an external error via the `FaultExt` parameter or an external control system fault via the `CSF` parameter. See Vlv2WayL error handling (Page 1318)

Group error

This block provides the standard function Outputting group errors (Page 122).

The following parameters are taken into consideration when forming the group error:

- CSF
- MonDynV0 only with valve feedback signals (Feature bit 12 = 0)
- MonDynV1 only with valve feedback signals (Feature bit 12 = 0)
- MonDynV2 only with valve feedback signals (Feature bit 12 = 0)
- MonDynP0
- MonDynP1 only with position feedback signals (Feature bit 12 = 1)
- MonDynP2 only with position feedback signals (Feature bit 12 = 1)
- MonStaV0
- MonStaV1
- MonStaV2
- MonStaP0
- FaultExt

Outputting a signal for start readiness

This block provides the standard function Outputting a signal for start readiness (Page 53).

Forming the group status for interlocks

This block provides the standard function Forming the group status for interlock information (Page 104).

Forming the signal status for blocks

This block provides the standard function Forming and outputting the signal status for technologic blocks (Page 109).

The worst signal status `ST_Worst` for the block is formed from the following parameters:

- `FbkV0Out.ST` only with valve feedback signals (Feature bit 12 = 0)
- `FbkV1Out.ST` only with valve feedback signals (Feature bit 12 = 0)
- `FbkV2Out.ST` only with valve feedback signals (Feature bit 12 = 0)
- `FbkP0Out.ST`
- `FbkP1Out.ST` only with position feedback signals (Feature bit 12 = 1)
- `FbkP2Out.ST` only with position feedback signals (Feature bit 12 = 1)
- `LocalLi.ST`
- `Pos0Local.ST`
- `Pos1Local.ST`
- `Pos2Local.ST`
- `V0P0ChnST.ST`

- V1P1ChnST.ST
- V2P2ChnST.ST
- Pos0Aut.ST (only if Feature2.Bit10 = 1)
- Pos1Aut.ST (only if Feature2.Bit10 = 1)
- Pos2Aut.ST (only if Feature2.Bit10 = 1)

Considering bad quality of automatic commands or external values

If the Feature2 bit Considering bad quality of automatic commands or external values (Page 186) is set to 1 and one of the following parameters has bad signal status (16#00 or 16#28), the block goes to the neutral position in the "Automatic" mode:

- Pos0Aut.ST
- Pos1Aut.ST
- Pos2Aut.ST

Release for maintenance

This block provides the standard function Release for maintenance (Page 64).

Selecting a unit of measure

This block provides the standard function Selecting a unit of measure (Page 212).

Opening additional faceplates

This block provides the standard function Opening additional faceplates (Page 208).

Generating instance-specific messages

This block provides the standard function Generating instance-specific messages (Page 204).

Operator permissions

This block provides the standard function Operator control permissions (Page 254).

The block has the following permissions for the OS_Perm parameter:

Bit	Function
0	1 = Operator can switch to "automatic mode"
1	1 = Operator can switch to "manual mode"
2	1 = Operator can switch to "local mode"
3	1 = Operator can switch to "Out of service" mode
4	1 = Operator can switch to position 0
5	1 = Operator can switch to position 1
6	1 = Operator can switch to position 2

Bit	Function
7	1 = Operator can reset the valve
8	1 = Operator can define the monitoring time for startup
9	1 = Operator can define the monitoring time for the end position
10	1 = Operator can activate the monitoring time function (Bit 8 - 9)
11	Not used
12	1 = Operator can activate the Release for maintenance function
13 - 31	Not used

Note

If you interconnect a parameter that is also listed in OS_Perm as a parameter, you have to reset the corresponding OS_Perm bit.

Configurable reactions with the Feature parameter

You can find an overview of all reactions provided by the Feature parameter in the Configurable functions using the Feature I/O (Page 131) . The following functionality is available for this block at the relevant bits:

Bit	Function
0	Set startup characteristics (Page 138)
1	Reaction to the out of service mode (Page 177)
2	Resetting the commands for changing the mode (Page 161)
3	Enabling resetting of commands for the control settings (Page 161)
4	Setting switch or button mode (Page 167)
9	Resetting via input signals in the event of interlocking (Protection) or errors (Page 163)
10	Exiting local mode (Page 177)
11	Activating the run time of feedback signals (Page 153)
12	Position feedback signals are active (Page 169)
17	Enabling bumpless switchover to automatic mode for valves, motors, and dosers (Page 173)
18	Activating error state for external process control error CSF (Page 151)
20	Disable calculation of impulse control in LocalSetting 2 and 4 (Page 186)
21	Enable bumpless switchover to "Automatic" mode for operator only (Page 172)
22	Update acknowledgment and error status of the message call (Page 160)
24	Enabling local operator authorization (Page 158)
25	Suppression of all messages (Page 174)
27	Interlock display with LocalSetting 2 or 4 (Page 178)
30	Set reset depending on the operating mode or the LiOp parameter (Page 163)
31	Activating reset of protection / error in manual mode (Page 165)

In pushbutton operation (Bit 4 = 0) the automatic commands in "automatic mode" are latching, in other words Pos0Aut, Pos1Aut, Pos2Aut can be reset to 0 after switching to the selected position. In "manual" and "local" modes, however, the automatic commands are not saved and in the absence of automatic commands the position is tracked.

In switching mode (Bit 4 = 1) positions 1 and 2 are selected by static signals via inputs Pos1Aut and Pos2Aut. If inputs Pos1Aut and Pos2Aut are not set, the block switches to position 0. Control via Pos0Aut is not needed.

Configurable reactions using the Feature2 parameter

Bit	Function
2	Separate evaluation for excluded and simulated interlock signals (Page 152)
3	Control priority in the event of an invalid input command (Page 175)
4	Setting switch or button mode for local commands (Page 181)
5	Evaluation of the signal status of the interlock signals (Page 142)
8	Forcing operating modes in the "Local" mode (Page 184)
10	Considering bad quality of automatic commands or external values (Page 186)
11	Suppress MsgLock and "Out of service" mode for a connected message block (Page 188)

Displaying auxiliary values

This block provides the standard function Displaying auxiliary values (Page 211).

Connection of the time-stamped messages from EventTs or Event16Ts

This block provides the standard function Connection of the time-stamped messages from EventTs or Event16Ts (Page 207).

SIMATIC BATCH functionality

This block provides the standard function SIMATIC BATCH functionality (Page 67).

Button labels

This block provides the standard function Labeling of buttons and text (Page 209)

Instance-specific text can be configured for the following parameters:

- Pos0Man
- Pos1Man
- Pos2Man

See also

Description of Vlv2WayL (Page 1305)

Vlv2WayL messaging (Page 1320)

Vlv2WayL I/Os (Page 1321)

Vlv2WayL block diagram (Page 1332)

Vlv2WayL modes (Page 1309)

EventTs functions (Page 1660)

7.9.4 Vlv2WayL error handling

Vlv2WayL error handling

Refer to the section Error handling (Page 119) in the basic instructions for the error handling of all blocks.

The following errors can be displayed for this block:

- Error numbers
- Mode switchover error
- Control system fault (CSF)
- Invalid input signals

Overview of error numbers

The `ErrorNum` I/O can be used to output the following error numbers:

Error number	Meaning of the error number
-1	Predefined value when inserting the block; the block is not executed.
0	There is no error.
41	The value for the <code>LocalSetting</code> I/O is not within the approved limit of 0 to 4.
42	<code>LocalSetting = 0 and LocalLi = 1</code>
51	For <code>ModLiOp = 1</code> : <ul style="list-style-type: none"> • <code>AutModLi = 1 and ManModLi = 1</code> If "local mode" is enabled: <ul style="list-style-type: none"> • <code>Pos0Local = 1 and Pos1Local = 1</code> • <code>Pos0Local = 1 and Pos2Local = 1</code> • <code>Pos1Local = 1 and Pos2Local = 1</code> If "automatic mode" is enabled: <ul style="list-style-type: none"> • <code>Pos0Aut = 1 and Pos1Aut = 1</code> • <code>Pos0Aut = 1 and Pos2Aut = 1</code> • <code>Pos1Aut = 1 and Pos2Aut = 1</code> Generally: <ul style="list-style-type: none"> • <code>Pos0Force = 1 and Pos1Force = 1</code> • <code>Pos0Force = 1 and Pos2Force = 1</code> • <code>Pos1Force = 1 and Pos2Force = 1</code>
52	<code>LocalAct = 1 and LocalSetting = 2 or 4 and SimOn = 1</code>

Mode switchover error

This error can be output by the block, see the section Error handling (Page 119).

Invalid input signals

This error can be output by the block, see the section Error handling (Page 119).

For the following invalid input signals, the control output can be kept or switched to the neutral position. This depends on the function Control priority in the event of an invalid input command (Page 175).

Operating mode	Invalid input signals	Control reaction with Feature2 bit 3 =1
Local: Localsetting = 1 or Localsetting = 3	Pushbutton operation for local mode (Feature2 bit 4 = 0): Pos1Local = 1 and Pos2Local = 1 or Pos1Local = 1 and Pos0Local = 1 or StopLocal = 1 and Pos2Local = 1 Switching mode (Feature2 bit 4 = 1): Pos1Local = 1 and Pos2Local = 1	Valve is set to Pos0.
Local: Localsetting = 1 or Localsetting = 3 and forcing	Pos1Force = 1 and Pos2Force = 1 or Pos1Force = 1 and Pos0Force = 1 or Pos0Force = 1 and Pos2Force = 1	
Forcing and no "local mode"	Pos1Force = 1 and Pos2Force = 1 or Pos1Force = 1 and Pos0Force = 1 or Pos0Force = 1 and Pos2Force = 1	
"Automatic mode" and no forcing	Pushbutton operation (Feature bit 4 = 0): Pos1Aut = 1 and Pos2Aut = 1 or Pos1Aut = 1 and Pos0Aut = 1 or Pos0Aut = 1 and Pos2Aut = 1 Switching mode (Featurebit 4 = 1): Pos1Aut = 1 and Pos2Aut = 1	
"Manual mode" and no forcing	Pos1Man = 1 and Pos0Man = 1 or Pos1Man = 1 and Pos2Man = 1 or Pos0Man = 1 and Pos2Man = 1	

Control system fault (CSF)

An external signal can be activated via the CSF input. A control system fault is triggered if this signal changes to 1. Refer to the Error handling (Page 119) section for more on this.

See also

Vlv2WayL block diagram (Page 1332)

Vlv2WayL I/Os (Page 1321)

Vlv2WayL messaging (Page 1320)

Vlv2WayL functions (Page 1310)

Vlv2WayL modes (Page 1309)

Description of Vlv2WayL (Page 1305)

7.9.5 Vlv2WayL messaging

Messaging

The following messages can be generated for this block:

- Process control fault
- Instance-specific messages

Process control fault

The following control system error messages can be output:

Message instance	Message identifier	Message class	Event
MsgEvId1	SIG 1	AS process control message - fault	\$\$BlockComment\$\$ Position 0 feedback error (neutral position)
	SIG 2	AS process control message - fault	\$\$BlockComment\$\$ Position 1 or 2 feedback error
	SIG 3	AS process control message - fault	\$\$BlockComment\$\$ External error has occurred

Explanation:

\$\$BlockComment\$\$: Content of the instance-specific comment

You can interconnect an external fault (signal) to input parameter `CSF`. If it changes to `CSF = 1`, a process control fault is triggered (`MsgEvId1`, SIG 3).

Instance-specific messages

You can use up to three instance-specific messages with this block.

Message instance	Message identifier	Message class	Event
MsgEvId1	SIG 4	AS process control message - fault	\$\$BlockComment\$\$ External message 1
	SIG 5	AS process control message - fault	\$\$BlockComment\$\$ External message 2
	SIG 6	AS process control message - fault	\$\$BlockComment\$\$ External message 3

Explanation:

\$\$BlockComment\$\$: Content of the instance-specific comment

Associated values for message instance `MsgEvId1`

Associated value	Block parameters
1	BatchName
2	StepNo
3	BatchID
4	ExtVal04
5	ExtVal05
6	ExtVal06
7	ExtVal07
8	ExtVal08
9	Reserved
10	Reserved

The associated values 4 ... 8 are allocated to the parameters `ExtVal04` ... `ExtVal08`, and can be used. Additional information is available in the "Process Control System PCS 7 - Engineering System" manual.

See also

Description of Vlv2WayL (Page 1305)

Vlv2WayL functions (Page 1310)

Vlv2WayL I/Os (Page 1321)

Vlv2WayL block diagram (Page 1332)

Vlv2WayL error handling (Page 1318)

Vlv2WayL modes (Page 1309)

7.9.6 Vlv2WayL I/Os

I/Os of Vlv2WayL

Input parameters

Parameter	Description	Type	Default
AutModLi*	1= "Automatic mode" via: Interconnection or SFC (controlled via <code>ModLiOp = 1</code>)	STRUCT <ul style="list-style-type: none"> • Value: BOOL • ST: BYTE 	- <ul style="list-style-type: none"> • 0 • 16#80
AutModOp*	1= "Automatic mode" via operator (con- trolled by <code>ModLiOp = 0</code>)	BOOL	0

Motor and valve blocks

7.9 Vlv2WayL - Two-way valve

Parameter	Description	Type	Default
BatchEn	1 = Enable allocation	BOOL	0
BatchID	Batch ID	DWORD	16#00000000
BatchName	Batch name	S7-String	
ByProt	1 = Bypassing interlock in "local mode" and in "simulation"	BOOL	0
CSF	1 = External error (control system fault) Error handling (Page 119)	STRUCT <ul style="list-style-type: none"> Value:BOOL ST:BYTE 	- <ul style="list-style-type: none"> 0 16#80
DefPos1	Output signal parameter setting for position 1	INT	3
DefPos2	Output signal parameter setting for position 2	INT	6
EN	1 = Called block will be processed	BOOL	1
EventTsIn	For interconnecting data between a technology block and the message blocks EventTs, Event16Ts. The EventTsIn input parameter serves to interconnect the EventTsOut output parameter of the EventTs, Event16Ts block. When this interconnection is configured, the messages of the EventTs, Event16Ts block are displayed on the OS in the alarm view of the technology block and can also be acknowledged there.	ANY	
ExtMsg1	Binary input for freely selectable message 1	STRUCT <ul style="list-style-type: none"> Value:BOOL ST:BYTE 	- <ul style="list-style-type: none"> 0 16#80
ExtMsg2	Binary input for freely selectable message 2	STRUCT <ul style="list-style-type: none"> Value:BOOL ST:BYTE 	- <ul style="list-style-type: none"> 0 16#80
ExtMsg3	Binary input for freely selectable message 3	STRUCT <ul style="list-style-type: none"> Value:BOOL ST:BYTE 	- <ul style="list-style-type: none"> 0 16#80
ExtVa104	Associated value 4 for messages (MsgEvID1)	ANY	
ExtVa105	Associated value 5 for messages (MsgEvID1)	ANY	
ExtVa106	Associated value 6 for messages (MsgEvID1)	ANY	
ExtVa107	Associated value 7 for messages (MsgEvID1)	ANY	
ExtVa108	Associated value 8 for messages (MsgEvID1)	ANY	

Parameter	Description	Type	Default
FaultExt	1 = External error Error handling (Page 119)	STRUCT • Value: BOOL • ST: BYTE	- • 0 • 16#80
FbkP0	1 = Feedback for position 0	STRUCT • Value:BOOL • ST:BYTE	- • 0 • 16#FF
FbkP1	1 = Feedback for position 1	STRUCT • Value:BOOL • ST:BYTE	- • 0 • 16#FF
FbkP2	1 = Feedback for position 2	STRUCT • Value:BOOL • ST:BYTE	- • 0 • 16#FF
FbkV0	1 = Feedback for control output CtrlV0	STRUCT • Value:BOOL • ST:BYTE	- • 0 • 16#FF
FbkV1	1 = Feedback for control output CtrlV1	STRUCT • Value:BOOL • ST:BYTE	- • 0 • 16#FF
FbkV2	1 = Feedback for control output CtrlV2	STRUCT • Value:BOOL • ST:BYTE	- • 0 • 16#FF
Feature	I/O for additional functions (Page 1310)	STRUCT • Bit:0: BOOL • ... • Bit 31: BOOL	- • 0 • 0 • 0
Feature2	I/O for additional functions (Page 1310)	STRUCT • Bit:0: BOOL • ... • Bit 31: BOOL	- • 0 • 0 • 0
Intlock	0 = Interlocking without reset is active; you can operate the block without reset once the interlocking condition has dis- appeared 1 = Interlock not activated	STRUCT • Value:BOOL • ST:BYTE • Bit 1: BOOL (Bypass information bit)	- • 1 • 16#FF • 0
Intl_En	1 = Interlock without reset (interlock, Intlock parameter) is active	BOOL	1
LocalLi	1 = Activate "local mode" via plant signals	STRUCT • Value:BOOL • ST:BYTE	- • 0 • 16#80
LocalOp*	1 = "Local mode" via operator	BOOL	0

Motor and valve blocks

7.9 Vlv2WayL - Two-way valve

Parameter	Description	Type	Default
LocalSetting	Properties for the Local mode (Page 79)	INT	0
ManModLi*	1 = "Manual mode" via interconnection or SFC (controlled by ModLiOp = 1)	STRUCT <ul style="list-style-type: none"> Value:BOOL ST:BYTE 	- <ul style="list-style-type: none"> 0 16#80
ManModOp*	1 = "Manual mode" via OS operator (controlled by ModLiOp = 0)	BOOL	1
ModLiOp	Switchover of operating mode between: 0 = Operator 1 = Interconnection or SFC	STRUCT <ul style="list-style-type: none"> Value:BOOL ST:BYTE 	- <ul style="list-style-type: none"> 0 16#80
Monitor	1 = Feedback monitoring	BOOL	1
MonSafePos	1 = Go to neutral position in the event of monitoring errors	BOOL	1
MonTiP0Dynamic*	Monitoring time for position 0 after operation in [s]	REAL	3.0
MonTiP1Dynamic*	Monitoring time for position 1 after operation in [s]	REAL	3.0
MonTiP2Dynamic*	Monitoring time for position 2 after operation in [s]	REAL	3.0
MonTiV0Dynamic*	Monitoring time for feedback errors FdbV0 after operation in [s]	REAL	3.0
MonTiV1Dynamic*	Monitoring time for feedback errors FdbV1 after operation in [s]	REAL	3.0
MonTiV2Dynamic*	Monitoring time for feedback errors FdbV2 after operation in [s]	REAL	3.0
MonTiStatic*	Monitoring time for feedback errors without operation in [s]	REAL	3.0
MS_RelOp*	1 = Release for maintenance via OS operator	BOOL	0
MsgEvId1	Message number (assigned automatically)	DWORD	16#00000000
MsgLock	1 = Suppress process messages. See also the section Suppressing messages using the MsgLock parameter (Page 205) for more on this.	STRUCT <ul style="list-style-type: none"> Value: BOOL ST: BYTE 	- <ul style="list-style-type: none"> 0 16#80
NoFbkP0	1 = Feedback for position 0 not present	BOOL	0
NoFbkP1	1 = Feedback for position 1 not present	BOOL	0
NoFbkP2	1 = Feedback for position 2 not present	BOOL	0
NoFbkV0	1 = Feedback for control output CtrlV0 not present	BOOL	0
NoFbkV1	1 = Feedback for control output CtrlV1 not present	BOOL	0
NoFbkV2	1 = Feedback for control output CtrlV2 not present	BOOL	0
Occupied	1 = In use by a batch	BOOL	0

Parameter	Description	Type	Default
OosLi	1 = "Out of service", via interconnection or SFC (0-1 edge transition)	STRUCT <ul style="list-style-type: none"> • Value: BOOL • ST: BYTE 	- <ul style="list-style-type: none"> • 0 • 16#80
OosOp*	1 = "Out of service", via OS operator	BOOL	0
OpSt_In	Input parameter for local operator authorization, connected with the <i>Out</i> output parameter of the upstream block, OpStations (Page 411)	DWORD	16#00000000
OS_Perm	I/O for operator permissions (Page 1310)	STRUCT <ul style="list-style-type: none"> • Bit 0: BOOL • ... • Bit 31: BOOL 	- <ul style="list-style-type: none"> • 1 • 1 • 1
Permit	1 = Enable for opening / closing from neutral position 0 = Valve activation not enabled on OS	STRUCT <ul style="list-style-type: none"> • Value:BOOL • ST:BYTE • Bit 1: BOOL (Bypass information bit) 	- <ul style="list-style-type: none"> • 1 • 16#FF • 0
Perm_En	1 = Activation enable (enable, Permit parameter) is active	BOOL	1
Pos0Aut*	1 = Select position 0 in "automatic mode"	STRUCT <ul style="list-style-type: none"> • Value:BOOL • ST:BYTE 	- <ul style="list-style-type: none"> • 0 • 16#80
Pos0Force	1 = Force position 0	STRUCT <ul style="list-style-type: none"> • Value:BOOL • ST:BYTE 	- <ul style="list-style-type: none"> • 0 • 16#80
Pos0Local	1 = Select position 0 in "local mode"	STRUCT <ul style="list-style-type: none"> • Value:BOOL • ST:BYTE 	- <ul style="list-style-type: none"> • 0 • 16#80
Pos0Man*	1 = Select position 0 in "manual mode"	BOOL	0
Pos1Aut*	1 = Select position 1 in "automatic mode"	STRUCT <ul style="list-style-type: none"> • Value:BOOL • ST:BYTE 	- <ul style="list-style-type: none"> • 0 • 16#80
Pos1Force	1 = Force position 1	STRUCT <ul style="list-style-type: none"> • Value:BOOL • ST:BYTE 	- <ul style="list-style-type: none"> • 0 • 16#80
Pos1Local	1 = Select position 1 in "local mode"	STRUCT <ul style="list-style-type: none"> • Value:BOOL • ST:BYTE 	- <ul style="list-style-type: none"> • 0 • 16#80
Pos1Man*	1 = Select position 1 in "manual mode"	BOOL	0

Motor and valve blocks

7.9 Vlv2WayL - Two-way valve

Parameter	Description	Type	Default
Pos2Aut*	1 = Select position 2 in "automatic mode"	STRUCT <ul style="list-style-type: none"> Value:BOOL ST:BYTE 	- <ul style="list-style-type: none"> 0 16#80
Pos2Force	1 = Force position 2	STRUCT <ul style="list-style-type: none"> Value:BOOL ST:BYTE 	- <ul style="list-style-type: none"> 0 16#80
Pos2Local	1 = Select position 2 in "local mode"	STRUCT <ul style="list-style-type: none"> Value:BOOL ST:BYTE 	- <ul style="list-style-type: none"> 0 16#80
Pos2Man*	1 = Select position 2 in "manual mode"	BOOL	0
Protect	0 = Protective interlocking is effective; once the interlocking condition has disappeared, you will have to reset the block 1 = Protective interlocking not activated	STRUCT <ul style="list-style-type: none"> Value:BOOL ST:BYTE Bit 1: BOOL (Bypass information bit) 	- <ul style="list-style-type: none"> 1 16#FF 0
Prot_En	1 = Protective interlock (protection, <i>Protect</i> parameter) is active	BOOL	1
PulseWidth*	Pulse width of control signal [s]	REAL	3.0
RstLi*	1 = Reset via interconnection	STRUCT <ul style="list-style-type: none"> Value:BOOL ST:BYTE 	- <ul style="list-style-type: none"> 0 16#80
RstOp*	1 = Reset via operator	BOOL	0
RunUpCyc	Number of cycles in startup; messages are suppressed during these cycles	INT	3
SafeV0	Neutral position for valve v0 (<i>CtrlV0</i>): 1= Open 0 = Closed	BOOL	0
SafeV1	Neutral position for valve v1 (<i>CtrlV1</i>): 1= Open 0 = Closed	BOOL	0
SafeV2	Neutral position for valve v2 (<i>CtrlV2</i>): 1= Open 0 = Closed	BOOL	0
SampleTime	Sampling time [s] (assigned automatically)	REAL	0.1
SimLiOp	Activation/deactivation of the simulation by: 0 = Operator 1 = Interconnection or SFC	STRUCT <ul style="list-style-type: none"> Value: BOOL ST: BYTE 	- <ul style="list-style-type: none"> 0 16#80
SimOnLi	1 = Simulation via interconnection or SFC (controlled by <i>SimLiOp</i> = 1)	STRUCT <ul style="list-style-type: none"> Value: BOOL ST: BYTE 	- <ul style="list-style-type: none"> 0 16#80

Parameter	Description	Type	Default
SimOn*	1 = Simulation on	BOOL	0
SelFp1	Call a block saved in this parameter as an additional faceplate (Page 208) in the standard view	ANY	
SelFp2	Call a block saved in this parameter as an additional faceplate (Page 208) in the preview	ANY	
StepNo	Batch step number	DWORD	16#00000000
UserAna1	Analog auxiliary value 1	STRUCT <ul style="list-style-type: none"> Value: REAL ST: BYTE 	- <ul style="list-style-type: none"> 0.0 16#FF
UA1unit	Unit of measure for analog auxiliary value 1	INT	0
UserAna2	Analog auxiliary value 2	STRUCT <ul style="list-style-type: none"> Value: REAL ST: BYTE 	- <ul style="list-style-type: none"> 0.0 16#FF
UA2unit	Unit of measure for analog auxiliary value 2	INT	0
UserStatus	Freely assignable bits for use in PCS 7 OS	BYTE	16#00
V0P0ChnST	Signal status of output channel for CtrlV0 or Pos0Out Should be connected to an output channel block	STRUCT <ul style="list-style-type: none"> Value: BOOL ST: BYTE 	- <ul style="list-style-type: none"> 0 16#FF
V1P1ChnST	Signal status of output channel for CtrlV1 or Pos1Out Should be connected to an output channel block	STRUCT <ul style="list-style-type: none"> Value: BOOL ST: BYTE 	- <ul style="list-style-type: none"> 0 16#FF
V2P2ChnST	Signal status of output channel for CtrlV2 or Pos2Out Should be connected to an output channel block	STRUCT <ul style="list-style-type: none"> Value: BOOL ST: BYTE 	- <ul style="list-style-type: none"> 0 16#FF
WarnTiAut	Prewarning for valve movement into position 1 or position 2 in "automatic mode" in [s]	REAL	0.0
WarnTiMan	Prewarning for valve movement into position 1 or position 2 in "manual mode" in [s]	REAL	0.0

* Values can be written back to these inputs during processing of the block by the block algorithm.

Output parameters

Parameter	Description	Type	Default
AutAct	1 = "Automatic mode" enabled 0 = "Manual mode" is enabled	STRUCT • Value:BOOL • ST:BYTE	- • 0 • 16#80
AutoST	1 = Worst signal status of automatic commands	BYTE	16#80
CtrlV0	Control output v0	STRUCT • Value:BOOL • ST:BYTE	- • 0 • 16#80
CtrlV1	Control output v1	STRUCT • Value:BOOL • ST:BYTE	- • 0 • 16#80
CtrlV2	Control output v2	STRUCT • Value:BOOL • ST:BYTE	- • 0 • 16#80
CurrMonP0	Current monitoring time P0 [s]	DINT	0
CurrMonP1	Current monitoring time P1 [s]	DINT	0
CurrMonP2	Current monitoring time P2 [s]	DINT	0
CurrMonV0	Current monitoring time v0 [s]	DINT	0
CurrMonV1	Current monitoring time v1 [s]	DINT	0
CurrMonV2	Current monitoring time v2 [s]	DINT	0
ENO	1 = Block algorithm completed without errors	BOOL	0
ErrorNum	Output of pending error number. For error numbers that can be output by this block, see Vlv2WayL error handling (Page 1318)	INT	-1
FbkP0Out	Feedback from position 0	STRUCT • Value:BOOL • ST:BYTE	- • 0 • 16#80
FbkP1Out	Feedback from position 1	STRUCT • Value:BOOL • ST:BYTE	- • 0 • 16#80
FbkP2Out	Feedback from position 2	STRUCT • Value:BOOL • ST:BYTE	- • 0 • 16#80
FbkV0Out	Control output feedback CtrlV0	STRUCT • Value:BOOL • ST:BYTE	- • 0 • 16#80
FbkV1Out	Control output feedback CtrlV1	STRUCT • Value:BOOL • ST:BYTE	- • 0 • 16#80

Parameter	Description	Type	Default
FbkV2Out	Control output feedback CtrlV2	STRUCT <ul style="list-style-type: none"> • Value:BOOL • ST:BYTE 	- <ul style="list-style-type: none"> • 0 • 16#80
GrpErr	1 = Group error pending	STRUCT <ul style="list-style-type: none"> • Value: BOOL • ST: BYTE 	- <ul style="list-style-type: none"> • 0 • 16#80
LocalAct	1 = "Local mode" enabled	STRUCT <ul style="list-style-type: none"> • Value:BOOL • ST:BYTE 	- <ul style="list-style-type: none"> • 0 • 16#80
LockAct	1 = Interlock (Intlock, Permit or Protect) is active	STRUCT <ul style="list-style-type: none"> • Value: BOOL • ST: BYTE 	- <ul style="list-style-type: none"> • 0 • 16#80
ManAct	1 = "Manual mode" enabled	STRUCT <ul style="list-style-type: none"> • Value:BOOL • ST:BYTE 	- <ul style="list-style-type: none"> • 1 • 16#80
MonDynP0	1 = Feedback error for position 0 due to a control change	STRUCT <ul style="list-style-type: none"> • Value:BOOL • ST:BYTE 	- <ul style="list-style-type: none"> • 0 • 16#80
MonDynP1	1 = Feedback error for position 1 due to a control change	STRUCT <ul style="list-style-type: none"> • Value:BOOL • ST:BYTE 	- <ul style="list-style-type: none"> • 0 • 16#80
MonDynP2	1 = Feedback error for position 2 due to a control change	STRUCT <ul style="list-style-type: none"> • Value:BOOL • ST:BYTE 	- <ul style="list-style-type: none"> • 0 • 16#80
MonDynV0	1 = Feedback error for FdbV0 due to control change	STRUCT <ul style="list-style-type: none"> • Value:BOOL • ST:BYTE 	- <ul style="list-style-type: none"> • 0 • 16#80
MonDynV1	1 = Feedback error for FdbV1 due to control change	STRUCT <ul style="list-style-type: none"> • Value:BOOL • ST:BYTE 	- <ul style="list-style-type: none"> • 0 • 16#80
MonDynV2	1 = Feedback error for FdbV2 due to control change	STRUCT <ul style="list-style-type: none"> • Value:BOOL • ST:BYTE 	- <ul style="list-style-type: none"> • 0 • 16#80
MonStaP0	1 = Feedback error for position 0 due to an unexpected feedback change	STRUCT <ul style="list-style-type: none"> • Value:BOOL • ST:BYTE 	- <ul style="list-style-type: none"> • 0 • 16#80
MonStaP1	1 = Feedback error for position 1 due to an unexpected feedback change	STRUCT <ul style="list-style-type: none"> • Value:BOOL • ST:BYTE 	- <ul style="list-style-type: none"> • 0 • 16#80

Motor and valve blocks

7.9 Vlv2WayL - Two-way valve

Parameter	Description	Type	Default
MonStaP2	1 = Feedback error for position 2 due to an unexpected feedback change	STRUCT • Value:BOOL • ST:BYTE	- • 0 • 16#80
MonStaV0	1 = Feedback error FdbV0 due to unexpected feedback change	STRUCT • Value:BOOL • ST:BYTE	- • 0 • 16#80
MonStaV1	1 = Feedback error FdbV1 due to unexpected feedback change	STRUCT • Value:BOOL • ST:BYTE	- • 0 • 16#80
MonStaV2	1 = Feedback error FdbV2 due to unexpected feedback change	STRUCT • Value:BOOL • ST:BYTE	- • 0 • 16#80
MS_Release	Release for maintenance: 1 = Release for OS operator	STRUCT • Value:BOOL • ST:BYTE	- • 0 • 16#80
MsgAckn1	Message acknowledgement status 1 (output ACK_STATE of first ALARM_8P)	WORD	16#0000
MsgErr1	Alarm error 1 (output ERROR of first ALARM_8P)	BOOL	0
MsgStat1	Message status 1 (output STATUS of first ALARM_8P)	WORD	16#0000
OosAct	1 = Block is "out of service"	STRUCT • Value:BOOL • ST:BYTE	- • 0 • 16#80
OpSt_Out	Value of the OpSt_In input parameter, for feedforwarding to other blocks. Bit 31 of this parameter is used by Feature bit 24	DWORD	16#00000000
OS_PermOut	Display of OS_Perm	DWORD	16#FFFFFFFF
OS_PermLog	Display of OS_Perm with settings changed by the block algorithm	DWORD	16#FFFFFFFF
P_CtrlP0	1 = Pulse signal for moving the valve to position 0	STRUCT • Value:BOOL • ST:BYTE	- • 0 • 16#80
P_CtrlP1	1 = Pulse signal for moving the valve to position 1	STRUCT • Value:BOOL • ST:BYTE	- • 0 • 16#80
P_CtrlP2	1 = Pulse signal for moving the valve to position 2	STRUCT • Value:BOOL • ST:BYTE	- • 0 • 16#80
P_CtrlV0	1 = Pulse signal for moving the valve to route 0 (V0)	STRUCT • Value:BOOL • ST:BYTE	- • 0 • 16#80

Parameter	Description	Type	Default
P_CtrlV1	1 = Pulse signal for moving the valve to route 1 (v1)	STRUCT <ul style="list-style-type: none"> Value:BOOL ST:BYTE 	- <ul style="list-style-type: none"> 0 16#80
P_CtrlV2	1 = Pulse signal for moving the valve to route 2 (v2)	STRUCT <ul style="list-style-type: none"> Value:BOOL ST:BYTE 	- <ul style="list-style-type: none"> 0 16#80
P_Rst	1= Pulse output for reset The parameter persists for one cycle after a reset.	STRUCT <ul style="list-style-type: none"> Value: BOOL ST: BYTE 	- <ul style="list-style-type: none"> 0 16#80
Pos0	1 = Pos0 is reached	STRUCT <ul style="list-style-type: none"> Value:BOOL ST:BYTE 	- <ul style="list-style-type: none"> 0 16#80
Pos1	1 = Pos1 is reached	STRUCT <ul style="list-style-type: none"> Value:BOOL ST:BYTE 	- <ul style="list-style-type: none"> 0 16#80
Pos2	1 = Pos2 is reached	STRUCT <ul style="list-style-type: none"> Value:BOOL ST:BYTE 	- <ul style="list-style-type: none"> 0 16#80
Pos0Out	1 = Position 0 is active	STRUCT <ul style="list-style-type: none"> Value:BOOL ST:BYTE 	- <ul style="list-style-type: none"> 0 16#80
Pos1Out	1 = Position 1 is active	STRUCT <ul style="list-style-type: none"> Value:BOOL ST:BYTE 	- <ul style="list-style-type: none"> 0 16#80
Pos2Out	1 = Position 2 is active	STRUCT <ul style="list-style-type: none"> Value:BOOL ST:BYTE 	- <ul style="list-style-type: none"> 0 16#80
RdyToReset	1 = Ready for reset via RstLi input or commands in "local", "automatic", or "manual mode"	STRUCT <ul style="list-style-type: none"> Value: BOOL ST: BYTE 	- <ul style="list-style-type: none"> 0 16#80
RdyToStart	1 = Active start readiness	STRUCT <ul style="list-style-type: none"> Value: BOOL ST: BYTE 	- <ul style="list-style-type: none"> 0 16#80
ST_Worst	Worst signal status	BYTE	16#80
Status1	Status word 1 (Page 1305)	DWORD	16#00000000
Status2	Status word 2 (Page 1305)	DWORD	16#00000000
Status3	Status word 3 (Page 1305)	DWORD	16#00000000
Status4	Status word 4 (Page 1305)	DWORD	16#00000000
WarnAct	1 = Prewarning for valve movement to position 1 or position 2 enabled (parameter WarnTiAut and WarnTiMan)	STRUCT <ul style="list-style-type: none"> Value:BOOL ST:BYTE 	- <ul style="list-style-type: none"> 0 16#80

See also

- Vlv2WayL messaging (Page 1320)
- Vlv2WayL block diagram (Page 1332)
- Vlv2WayL modes (Page 1309)
- Error handling (Page 119)

7.9.7 Vlv2WayL block diagram

Vlv2WayL block diagram

A block diagram is not provided for this block.

See also

- Vlv2WayL I/Os (Page 1321)
- Vlv2WayL messaging (Page 1320)
- Vlv2WayL error handling (Page 1318)
- Vlv2WayL functions (Page 1310)
- Vlv2WayL modes (Page 1309)
- Description of Vlv2WayL (Page 1305)

7.9.8 Operator control and monitoring

7.9.8.1 Vlv2WayL views

Views of the Vlv2WayL block

The block Vlv2WayL provides the following views:

- Vlv2WayL standard view (Page 1333)
- Alarm view (Page 302)
- Trend view (Page 305)
- Vlv2WayL parameter view (Page 1336)
- Vlv2WayL preview (Page 1338)
- Memo view (Page 304)
- Batch view (Page 302)
- Block icon for Vlv2WayL (Page 1343)

Refer to the sections Structure of the faceplate (Page 248) and Block icon structure (Page 230) for general information on the faceplate and block icon.

7.9.8.2 Vlv2WayL standard view

Vlv2WayL standard view

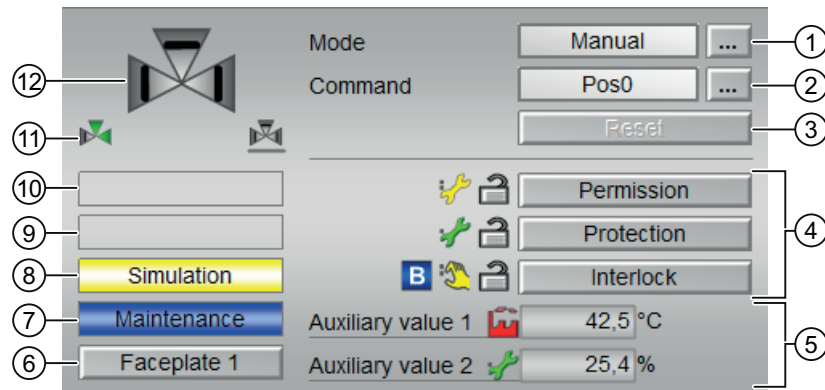

(1) Displaying and switching the operating mode

This area provides information on the currently valid operating mode. The following operating modes can be shown here:

- Manual and automatic mode for motors, valves and dosers (Page 75)
- Manual and automatic mode for motors, valves and dosers (Page 75)
- Local mode (Page 79)
- Out of service (Page 71)

Refer to section Switching operating states and operating modes (Page 257) for information on switching the operating mode.

(2) Selecting the position for 2-way valve

This area shows you the default operating state for the valve. The following states can be shown and executed here:

- "Pos0"
- "Pos1"
- "Pos2"

Refer to the Switching operating states and operating modes (Page 257) section for information on changing the state.

If text is configured for these commands, it is displayed as status text and as button labels for command selection. You can find more information about this in section Labeling of buttons and text (Page 209)

(3) Resetting the block

Click "Reset" for interlocks or errors. You can find additional information on this in the section Resetting the block in case of interlocks or errors (Page 43).

(4) Operating range for the interlock functions of the block

This display is only visible when the corresponding block input is connected.

You can use this button to control the interlock functions of the block. You can find additional information on this in the section Interlocking functions (Page 99).

The following is displayed in addition to the buttons:

- Interlock status (see Forming the group status for interlock information (Page 104)), e.g.:



- Signal status (see Forming and outputting the signal status for technologic blocks (Page 109)), e.g.:



- Bypass information (see Forming the group status for interlock information (Page 104)):



(5) Display of auxiliary values

This display is only visible when the corresponding block input is connected.

You can use this area to display two auxiliary values that have been configured in the engineering system (ES). You can find additional information on this in the section Displaying auxiliary values (Page 211).

(6) Navigation button for switching to the standard view of any faceplate

This display is only visible when the corresponding block input is connected.

Use this navigation button to open the standard view of a block configured in the engineering system (ES). The visibility of this navigation button depends on the configuration in the engineering system (ES).

You can find additional information on this in the section Opening additional faceplates (Page 208).

(7) Display area for block states

This area provides additional information on the operating state of the block:

- "Maintenance"

Additional information on this is available in section Release for maintenance (Page 64) Display area for block states.

(8) Display area for block states

This area provides additional information on the operating state of the block:

- "Simulation"
- "Delay"

You will find more detailed information on this in the sections Simulating signals (Page 58) and Display of delay times (Page 256).

(9) Display area for block states

This area provides additional information on the operating state of the block:

- "External error"
- "End position error"
- "Control error"
- "Invalid signal"
- "Changeover error"

Additional information on these errors is available in the sections Monitoring the feedbacks (Page 97) , Error handling (Page 119) (section "Invalid input signals" and "Mode switchover error") and Motor protection function (Page 99).

(10) Display area for block states

This area provides additional information on the operating state of the block:

- "Force Pos0"
- "Force Pos1"
- "Force Pos2"
- "Request 0/1": A reset to "automatic mode" is expected.

You can find additional information on this in the section Forcing operating modes (Page 41).

(11) Automatic preview

This display is only visible in "manual mode", in "local mode", or with a reset request in "automatic mode", when the current output signals are not identical to the control in "automatic mode".

The display shows what state the valve would assume if you switched from "manual" or "local" mode to "automatic mode", or performed a reset to "automatic mode".

(12) Status display of the valve

You can find additional information on this in the section Block icon for Vlv2WayL (Page 1343).

(13) Neutral position of the valve

The neutral position of the valve is shown here.

If the neutral position of the valve is "Closed" (SafePos = 0), a gray valve is shown.

If the neutral position of the valve is "Open" (SafePos = 0), a green valve is shown.

7.9.8.3 Vlv2WayL parameter view

Parameter view of Vlv2WayL

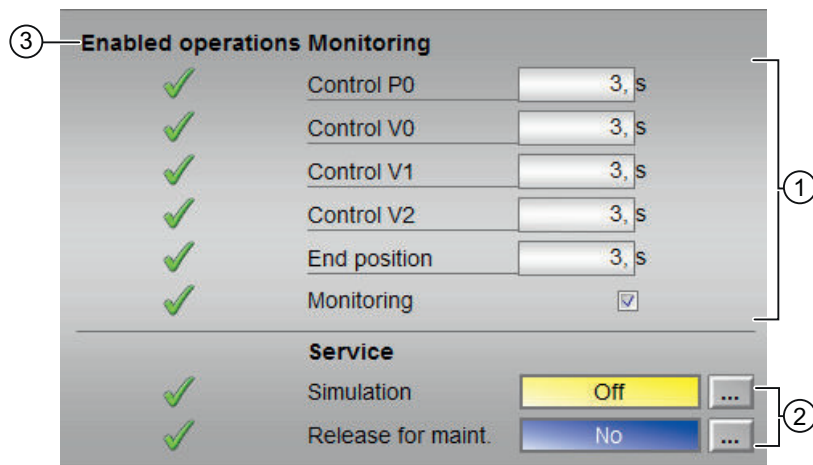

Two-way valve with separate valve feedback signals (Feature bit 12 = 0)

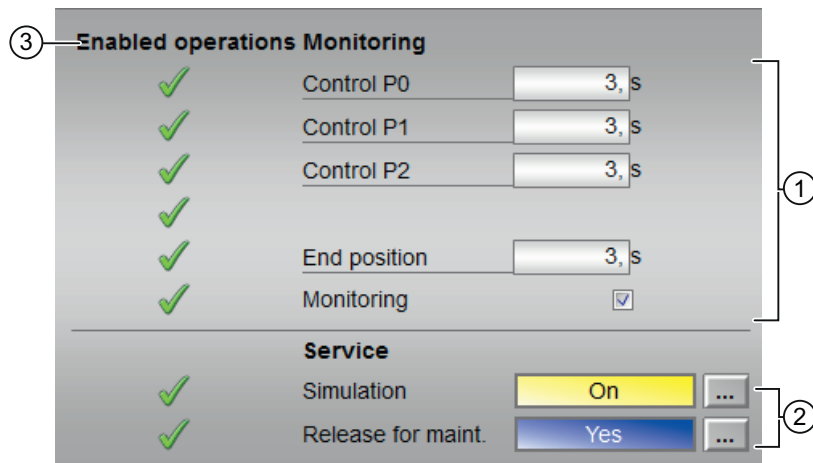

Two-way valve with position feedback signals (Feature bit 12 = 1)

(1) Monitoring

In this area, you change parameters and therefore influence the valve. Refer to the Changing values (Page 259) section for more on this.

You can influence the following parameters:

- "Control P0": Monitoring time while "opening"/"closing" the valve
- "Control P1": Monitoring time while "opening"/"closing" the valve
- "Control P2": Monitoring time while "opening"/"closing" the valve
- "Control V0": Monitoring time while "opening"/"closing" the valve
- "Control V1": Monitoring time while "opening"/"closing" the valve
- "Control V2": Monitoring time while "opening"/"closing" the valve
- "End position": Monitoring time for maintaining the valve position

Enable monitoring

You can enable monitoring by selecting the check box ()

You can find additional information on this in the section Monitoring the feedbacks (Page 97).

(2) Service

You can select the following functions in this area:

- "Simulation"
- "Release for maintenance"

Refer to the Switching operating states and operating modes (Page 257) section for more on this.

(3) Enabled operation

This area shows all operations for which special operator permissions are assigned. They depend on the configuration in the engineering system (ES) that applies to this block.

Icons for enabled operation:

- **Green check mark:** the OS operator can control this parameter
- **Gray check mark:** the OS operator cannot control this parameter at this time due to the process
- **Red cross:** the OS operator cannot control this parameter due to the configured AS operator permissions (OS_Permission or OS1Permission).

7.9.8.4 Vlv2WayL preview

Preview of Vlv2WayL

Two-way valve with single value feedback signals (Feature bit 12 = 0)

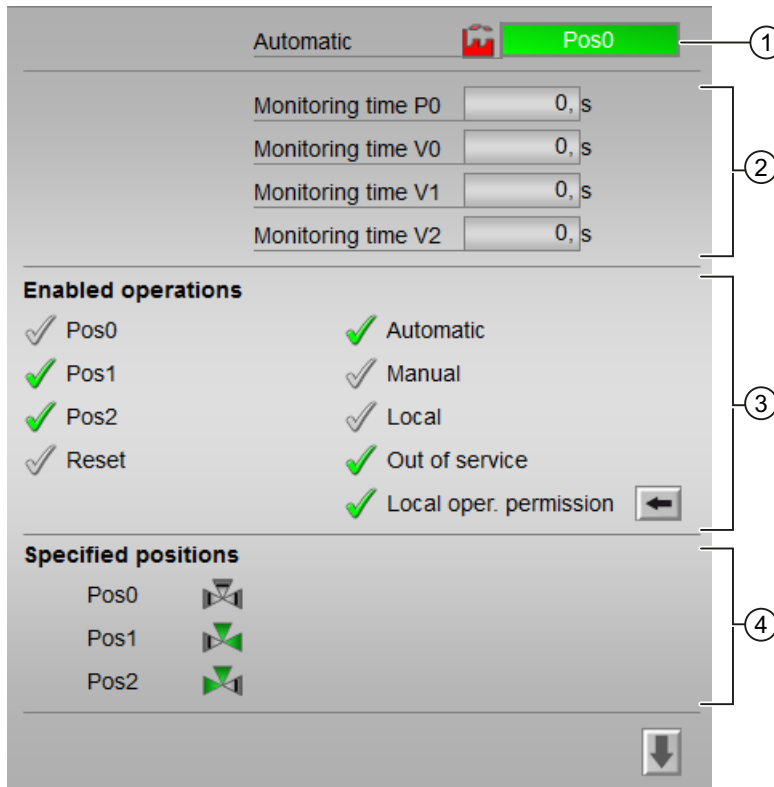

The preview has an upper half and a lower half. You can change between the two halves with the arrow keys.

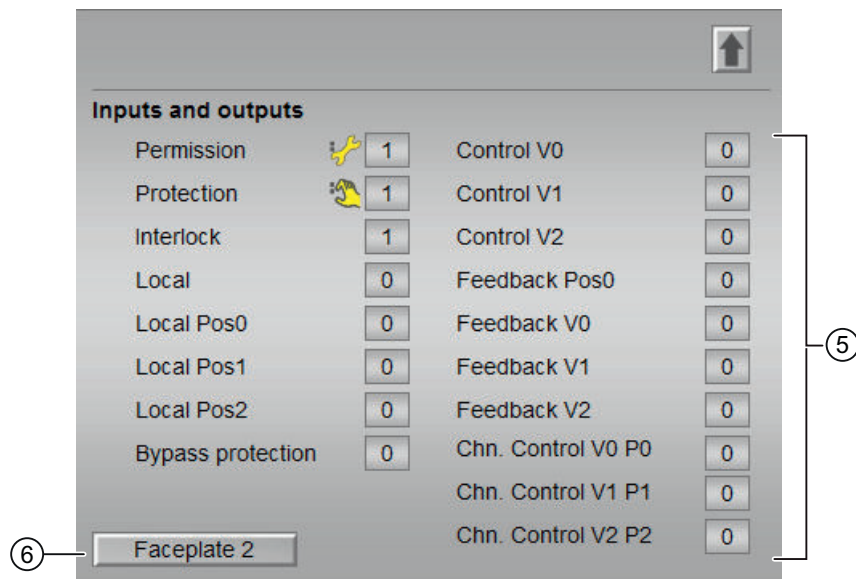

Two-way valve with position feedback signals (Feature bit 12 = 1)

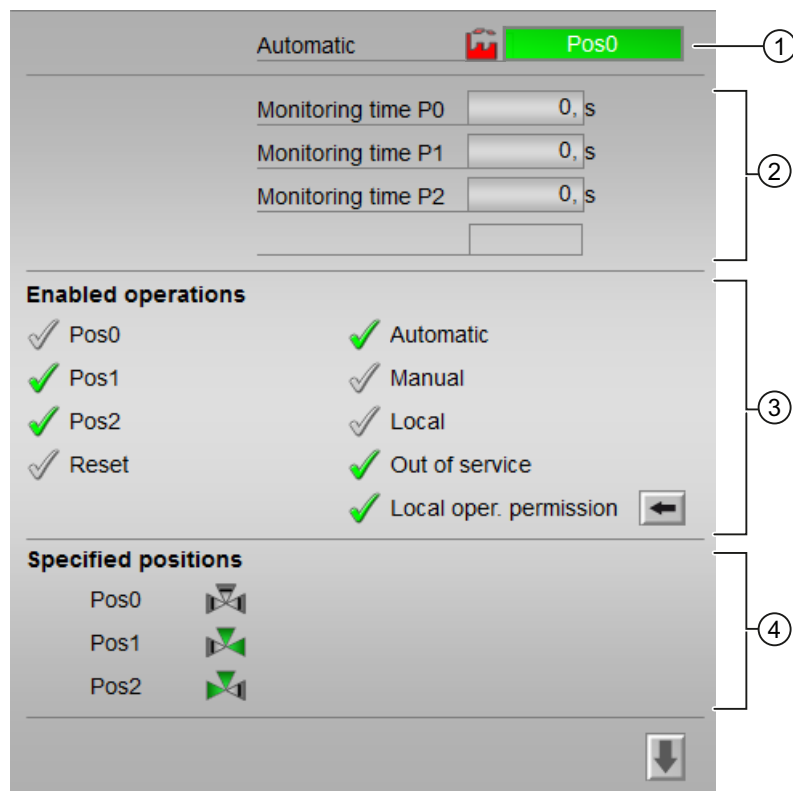

The preview has an upper half and a lower half. You can change between the two halves with the arrow keys.

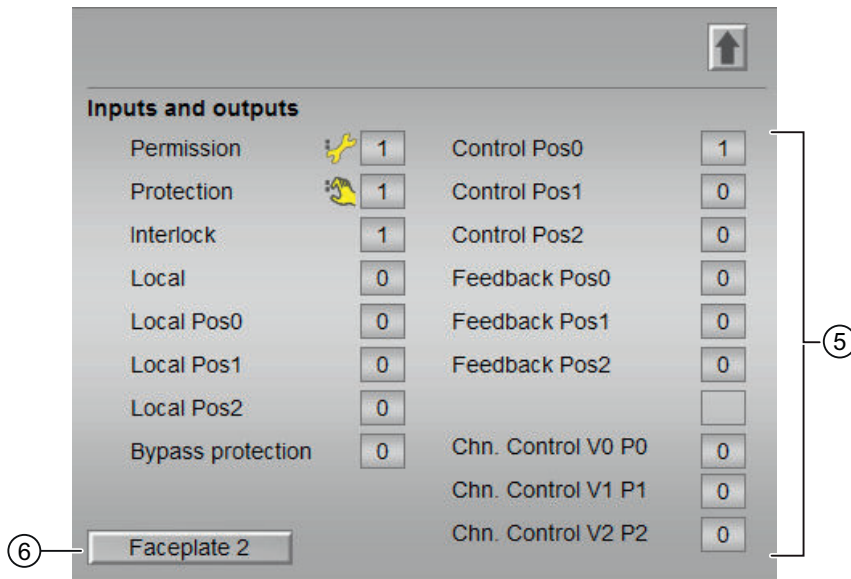

(1) Automatic preview

This area shows you the block status after it has switched from the "Manual" mode or "Local" mode to the "Automatic" mode.

If the block is in "Automatic" mode, the current block state is displayed.

This area also displays the worst signal status of the following automatic commands:

- Pos0Aut
- Pos1Aut
- Pos2Aut

(2) Preview area

The following enabled operations are shown here:

- "Monitoring time P0": Display of the current monitoring time P0 (Feature bit 12 = 1)
- "Monitoring time P1": Display of the current monitoring time P1 (Feature bit 12 = 1)
- "Monitoring time P2": Display of the current monitoring time P2 (Feature bit 12 = 1)
- "Monitoring time V0": Display of the current monitoring time V0 (Feature bit 12 = 0)
- "Monitoring time V1": Display of the current monitoring time V1 (Feature bit 12 = 0)
- "Monitoring time V2": Display of the current monitoring time V2 (Feature bit 12 = 0)

(3) Enable operations

This area shows all operations for which special operator permissions are assigned. They depend on the configuration in the engineering system (ES) that applies to this block.

Icons for enabled operation:

- **Green check mark:** the OS operator can control this parameter
- **Gray check mark:** the OS operator cannot control this parameter at this time due to the process
- **Red cross:** the OS operator cannot control this parameter due to the configured AS operator permissions (OS_Perm or OS1Perm)

The following enabled operations are shown here:

- "Pos0": You can set the valve to position 0.
If text is configured for this command, it is also displayed in brackets. You can find additional information on this in the section Labeling of buttons and text (Page 209).
- "Pos1": You can set the valve to position 1.
If text is configured for this command, it is also displayed in brackets. You can find additional information on this in the section Labeling of buttons and text (Page 209).
- "Pos2": You can set the valve to position 2.
If text is configured for this command, it is also displayed in brackets. You can find additional information on this in the section Labeling of buttons and text (Page 209).
- "Reset": You can reset the valve if errors occur.
- "Automatic": You can switch to "automatic mode".
- "Manual": You can switch to "manual mode".
- "Local": You can switch to "local mode".
- "Out of service": You can switch to "Out of service" operating mode.
- "Local operator permission": Use the ← button to switch to the standard view of the OpStations block. You can find additional information on this in the section Operator control permissions (Page 254).

(4) Specified Position

Preview of the valve positions, as configured in the engineering system (ES).

(5) Displaying current control signals

This area shows the most important parameters for this block with the current selection:

- "Permission":
This display is only visible when the corresponding block input is connected.
 - 0 = Valve activation not enabled on OS
 - 1 = Enable for "starting"/"stopping" from the neutral position
- "Protection":
This display is only visible when the corresponding block input is connected.
 - 0 = Protective interlocking is effective; once the interlocking condition has disappeared, you will have to reset the block
 - 1 = "Good" state

- "Interlock":
 - This display is only visible when the corresponding block input is connected.
 - 0 = Interlocking without reset is active; you can operate the block without reset once the interlocking condition has disappeared
 - 1 = "Good" state
- "Local correct": 1 = Control signal for "Local mode" (LocalLi) is active
- "Local Pos0": 1 = Block was set to position 0 in "local mode"
- "Local Pos1": 1 = Block was set to position 1 in "local mode"
- "Local Pos2": 1 = Block was set to position 2 in "local mode"
- "Interlock deact.":
 - 0 = Bypass disabled
 - 1 = Bypassing interlock in "local mode" and in "simulation"

Control and feedback signals with `Feature` bit 12 = 0

- "Control Pos0": 1 = Control signal for the position 0
- "Control V0": 1 = Control signal for the valve 0
- "Control V1": 1 = Control signal for the valve 1
- "Control V2": 1 = Control signal for the valve 2
- "Feedback Pos0": 1 = Valve is in position 0
- "Feedback V0": 1 = Feedback if valve 0 was opened
- "Feedback V1": 1 = Feedback if valve 1 was opened
- "Feedback V2": 1 = Feedback if valve 2 was opened

Control and feedback signals with `Feature` bit 12 = 1

- "Control Pos0": 1 = Control signal for the position 0
- "Control Pos1": 1 = Control signal for the position 1
- "Control Pos2": 1 = Control signal for the position 2
- "Feedback Pos0": 1 = Valve is in position 0
- "Feedback Pos1": 1 = Valve is in position 1
- "Feedback Pos2": 1 = Valve is in position 2

Control signals of the output channel block

- "Channel control V0 P0": Control signal for V0 or P0 of the output channel block
- "Channel control V1 P1": Control signal for V1 or P1 of the output channel block
- "Channel control V2 P2": Control signal for V2 or P2 of the output channel block

(6) Navigation button for switching to the standard view of any faceplate

This display is only visible when the corresponding block input is connected.

Use this navigation button to open the standard view of a block configured in the engineering system (ES). The visibility of this navigation button depends on the configuration in the engineering system (ES).

You can find additional information on this in the section Opening additional faceplates (Page 208).





7.9.8.5 Block icon for Vlv2WayL

Properties of the Vlv2WayL block icon

A variety of block icons are available with the following functions:

- Process tag type
- Limits (high/low)
- Violation of alarm, warning, and tolerance limits as well as the control system fault
- Operating modes
- Signal status, release for maintenance
- Forcing states
- Displays for bypassing interlocks
- Interlocks
- Memo display
- Valve status display

The block icons from template @TemplateAPLV8.PDL:

Icons	Selection of the block icon in CFC	Special features
	1	
	2	
	3	
	4	

The block icons from template @TemplateAPLV7.PDL:

Icons	Selection of the block icon in CFC	Special features
	1	Block icon in the full display
	2	
	3	
	4	
	5	
	6	
	7	
	8	
	9	
	10	
	-	Block icon in "Out of service" mode (example with type 1 block icon)



Additional information on the block icon and the control options in the block icon is available in the following sections:

- Configuring the block icons (Page 237)
- Block icon structure (Page 230)
- Operation via the block icon (Page 239)

Valve status display

The following valve states are shown here:

Icon	Meaning
	Valve open
	Error at valve
	Valve is opening

Icon	Meaning
 A black and white icon of a valve with a closed handle, consisting of a central vertical stem with two horizontal arms, one pointing up and one pointing down, both ending in rounded rectangular caps.	Valve closed
 A green icon of a valve with a closing handle, consisting of a central vertical stem with two horizontal arms, one pointing up and one pointing down, both ending in rounded rectangular caps.	Valve is closing

7.10 VlvL - Valve (Large)

7.10.1 Description of VlvL

Object name (type + number) and family

Type + number: FB 1899

Family: Drives

Area of application for VlvL

The block is used for the following applications:

- Controlling a valve in two positions ("open"/"closed") with adjustable neutral position

Note

This block is also available as a small block. A comparison of the VlvL and VlvS blocks is available in the section: VlvL compared to VlvS (Page 1068)

How it works

The valve is opened or closed by a control signal. The signal 0 corresponds to the de-energized state (neutral position) of the valve.

The control is monitored by the "open"/"close" (feedback) signals. Missing feedback can be derived from the control in the block.

Various inputs are available for control purposes. The next sections provide more detailed information on configuration, operating principles, visualization and operation.

Configuration

Use the CFC editor to install the block in a cyclic interrupt OB (OB30 to OB38). The block is also installed automatically in the startup OB (OB100).

For the VlvL block, the Advanced Process Library contains a template for process tag types as an example with an application scenario for this block.

Example of process tag types:

- Valve (Valve_Lean) (Page 2367)

Startup characteristics

Use the `Feature Bit Set` startup characteristics (Page 138) to define the startup characteristics of this block.

The messages are suppressed after startup for the number of cycles set at `RunUpCyc`.

Status word allocation for `Status1` parameter

You can find a description for each parameter in section VlvL I/Os (Page 1359).

Status bit	Parameter
0	Occupied
1	BatchEn
2	SimOn
3	OosAct.Value
4	OosLi.Value
5	AutoAct.Value
6	LocalAct.Value
7	0: Open padlock in the block icon 1: Closed padlock in the block icon
8	"Open"/"Closed" command (1 = "Open")
9	FbkOpenOut.Value
10	FbkCloseOut.Value
11	Feedback error without control change
12	Feedback error due to control change
13	BypProt
14	Invalid signal status
15	Mode switchover error
16	1 = Intlock is active
17	1 = Permit is active
18	1 = Protect is active
19	Display „Forced open“
20	Display „Forced close“
21	Force
22	Automatic preview (1 = "Open")
23	Bumpless switchover to "automatic mode" enabled
24	SafePos
25	UserAna1 interconnected
26	UserAna2 interconnected
27	WarnAct.Value
28	For the Error status display in the Closed valve
29	For the Error status display in the Opened valve
30	External error generated by FaultExt or external control system fault from CSF with set Feature bit 18 Activating error state for external process control error CSF (Page 151)
31	1 = Input parameter CtrlChnST is interconnected

Status word allocation for status2 parameter

Status bit	Parameter
0	MsgLock
1	Not used
2	Display for interlocks in block icon
3 - 15	Not used
16	1 = Input parameter FbkClose is connected
17	1 = Input parameter FbkOpen is connected
18	Reset request in automatic
19	1 = No impact of input signals on "local mode" with LocalSetting = 2 and LocalSetting = 4
20	1 = Valve open
21	1 = Valve closed
22	1 = Valve opens
23	1 = Valve closes
24 - 29	Not used
30	Bypass information from previous function block
31	MS_RelOp

Status word allocation for status3 parameter

Status bit	Parameter
0	Effective signal 1 of the message block connected via EventTsIn
1	Effective signal 2 of the message block connected via EventTsIn
2	Effective signal 3 of the message block connected via EventTsIn
3	Effective signal 4 of the message block connected via EventTsIn
4	Effective signal 5 of the message block connected via EventTsIn
5	Effective signal 6 of the message block connected via EventTsIn
6	Effective signal 7 of the message block connected via EventTsIn
7	Effective signal 8 of the message block connected via EventTsIn
8	"Interlock" button is enabled
9	"Permission" button is enabled
10	"Protection" button is enabled
11	Hidden bypass signal in Permit
12	Hidden bypass signal in interlock
13	Hidden bypass signal in Protect
14	Feature2 bit 2: Separate bypass signal
15	Current monitoring time is visible
15 - 25	Not used
26	Show automatic preview in the standard view
27	Not used
28	GrpErr.Value

Status bit	Parameter
29	RdyToStart.Value
30 - 31	Not used

Status word allocation for Status4 parameter

Status bit	Parameter
0 - 7	Effective signal 9..16 of the message block connected via EventTsIn
8 - 31	Not used

See also

- VlvL functions (Page 1350)
- VlvL messaging (Page 1358)
- Overview of the modes (Page 69)
- VlvL block diagram (Page 1366)
- VlvL error handling (Page 1356)
- VlvL modes (Page 1349)
- Resetting the block in case of interlocks or errors (Page 43)

7.10.2 VlvL modes

VlvL operating modes

The block supports all standard modes:

- Local mode (Page 79)
- Automatic mode (Page 75)
- Manual mode (Page 75)
- Out of service (Page 71)

The next section provides additional block-specific information relating to the general descriptions.

"Local mode"

You can find general information on "Local mode", switching modes and Bumpless switchover in the Local mode (Page 79) section.

Valve actions you can control in "local mode":

- "Open" (OpenLocal = 1)
- "Close" (CloseLocal = 1)

7.10 VlvL - Valve (Large)

A block operated in "local mode" is controlled either by "local" signals or by feedback signals (input parameters `FbkOpen` and `FbkClose`; if no position can be assigned, the last valid position is accepted). Configuration takes place via the input parameter `LocalSetting`.

"Automatic mode"

You can find general information on "Automatic mode", switching modes and Bumpless switchover in the Manual and automatic mode for motors, valves and dosers (Page 75) section.

Valve actions you can control in "automatic mode":

- "Open" (`OpenAut = 1`)
- "Close" (`CloseAut = 1`)

"Manual mode"

You can find general information on "Manual mode", switching modes and bumpless switchover in the section Manual and automatic mode for motors, valves and dosers (Page 75).

Valve actions you can control in "manual mode":

- "Open" (`OpenMan = 1`)
- "Close" (`CloseMan = 1`)

"Out of service"

You can find general information about the "Out of service" mode in the section Out of service (Page 71).

See also

- Description of VlvL (Page 1346)
- VlvL block diagram (Page 1366)
- VlvL I/Os (Page 1359)
- VlvL messaging (Page 1358)
- VlvL error handling (Page 1356)
- VlvL functions (Page 1350)

7.10.3 VlvL functions

Functions of VlvL

The functions for this block are listed below.

Opening additional faceplates

This block provides the standard function Opening additional faceplates (Page 208).

Operator permissions

This block provides the standard function Operator control permissions (Page 254).

The block has the following permissions for the `OS_Perm` parameter:

Bit	Function
0	1 = Operator can switch to "automatic mode"
1	1 = Operator can switch to "manual mode"
2	1 = Operator can switch to "local mode"
3	1 = Operator can switch to "Out of service" mode
4	1 = Operator can open the valve
5	1 = Operator can close the valve
6	1 = Operator can reset the valve
7	1 = Operator can define the monitoring time for startup
8	1 = Operator can define the monitoring time for the end position
9	1 = Operator can activate the monitoring time function (Bit 7 - 8)
10	Not used
11	1 = Operator can activate the Release for maintenance function
12 - 31	Not used

Note

If you interconnect a parameter that is also listed in `OS_Perm` as a parameter, you have to reset the corresponding `OS_Perm` bit.

Interlocks

This block provides the following interlocks:

- Activation enable
- Interlock without reset ("Interlock")
- Interlock with reset ("Protection")

Refer to the Interlocks (Page 99) section for more on this.

Disabling interlocks

This block provides the standard function Disabling interlocks (Page 103).

Resetting the block in case of interlocks

This block provides the standard function Resetting the block in case of interlocks or errors (Page 43).

External error (FaultExt), external control system fault (CSF)

This block provides the possibility to pass an external error via the FaultExt parameter or an external control system fault via the CSF parameter. See VivL error handling (Page 1356)

Group error

This block provides the standard function Outputting group errors (Page 122).

The following parameters are taken into consideration when forming the group error:

- CSF
- MonDynErr
- MonStaErr
- FaultExt

Outputting a signal for start readiness

This block provides the standard function Outputting a signal for start readiness (Page 53).

Forming the group status for interlocks

This block provides the standard function Forming the group status for interlock information (Page 104).

Forming the signal status for blocks

This block provides the standard function Forming and outputting the signal status for technologic blocks (Page 109).

The worst signal status ST_Worst for the block is formed from the following parameters:

- FbkOpenOut.ST
- FbkCloseOut.ST
- LocalLi.ST
- OpenLocal.ST
- CloseLocal.ST
- CtrlChn.ST
- OpenAut.ST (only if Feature2.Bit10 = 1)
- CloseAut.ST (only if Feature2.Bit10 = 1)

Considering bad quality of automatic commands or external values

If the `Feature2` bit Considering bad quality of automatic commands or external values (Page 186) is set to 1 and one of the following parameters has bad signal status (16#00 or 16#28), the block goes to the neutral position in the "Automatic" mode:

- `OpenAut.ST`
- `CloseAut.ST`

Forcing operating modes

This block provides the standard function Forcing operating modes (Page 41). Inputs `OpenForce` and `CloseForce` force the block to open or close.

Feedback monitoring

This block provides the standard function Monitoring the feedbacks (Page 97). Startup characteristics are monitored by setting parameter `MonTiDynamic`. The parameter `MonTiStatic` monitors compliance with the position.

Disabling feedback

This block provides the standard function Disabling feedback for valves (Page 99). Feedback monitoring can be deactivated separately for each feedback with `NoFbkOpen` or `NoFbkClose` as required.

Suppressing messages using the `MsgLock` parameter

This block provides the standard function Suppressing messages using the `MsgLock` parameter (Page 205).

Release for maintenance

This block provides the standard function Release for maintenance (Page 64).

Specify warning times for control functions

This block provides the standard function Specifying warning times for control functions at motors and valves (Page 51). The warning signal is output before the valve moves away from the neutral position. No signal is output for movement to the neutral position.

You can generate warning signals when, for example, valves open. Warning signals can be generated in the following modes:

- Manual and automatic mode for motors, valves and dosers (Page 75) (Input parameter `WarnTiMan`)
- Description of VlvL (Page 1346) (Input parameter `WarnTiAut`)

You specify the warning times in seconds using the input parameters `WarnTiMan` and `WarnTiAut`. If, for example, a valve opens then, this is displayed at the output parameter with

7.10 VlvL - Valve (Large)

WarnAct = 1. The valve then opens after the set warning time has expired and WarnAct then returns to 0.

A corresponding warning is not output if the warning times (WarnTiMan or WarnTiAut) are specified with a smaller value than the SampleTime parameter.

Simulating signals

This block provides the standard function Simulating signals (Page 58).

Selecting a unit of measure

This block provides the standard function Selecting a unit of measure (Page 212).

Neutral position

This block provides the standard function Neutral position for motors, valves and controllers (Page 48). The neutral position (de-energized state) is set using the SafePos parameter.

- SafePos = 0 means that at Ctrl = 0 the valve drive closes and at Ctrl = 1 it opens (de-energized state is "closed")
- SafePos = 1 means that at Ctrl = 0 the valve drive opens and at Ctrl = 1 it closes (de-energized state is "open")

Generating instance-specific messages

This block provides the standard function Generating instance-specific messages (Page 204).

Configurable reactions using the Feature parameter

You can find an overview of all reactions provided by the Feature parameter in the Configurable functions using the Feature I/O (Page 131) . The following functionality is available for this block at the relevant bits:

Bit	Function
0	Set startup characteristics (Page 138)
1	Reaction to the out of service mode (Page 177)
2	Resetting the commands for changing the mode (Page 161)
3	Enabling resetting of commands for the control settings (Page 161)
4	Setting switch or button mode (Page 167)
9	Resetting via input signals in the event of interlocking (Protection) or errors (Page 163)
10	Exiting local mode (Page 177)
11	Activating the run time of feedback signals (Page 153)
17	Enabling bumpless switchover to automatic mode for valves, motors, and dosers (Page 173)
18	Activating error state for external process control error CSF (Page 151)
20	Disable calculation of impulse control in LocalSetting 2 and 4 (Page 186)
21	Enable bumpless switchover to "Automatic" mode for operator only (Page 172)
22	Update acknowledgment and error status of the message call (Page 160)

Bit	Function
24	Enabling local operator authorization (Page 158)
25	Suppression of all messages (Page 174)
27	Interlock display with LocalSetting 2 or 4 (Page 178)
30	Set reset depending on the operating mode or the LiOp parameter (Page 163)
31	Activating reset of protection / error in manual mode (Page 165)

In pushbutton operation (Bit 4 = 0) the automatic commands in "automatic" mode are latching, in other words `OpenAut`, `CloseAut` can be reset to zero after changing the control. In "manual" and "local" modes, however, the automatic commands are not saved and in the absence of automatic commands the automatic control is tracked.

In switching mode (Bit 4 = 1), the control is selected with the static signal `OpenAut`. If input `OpenAut` is not set the valve is closed. Control via `CloseAut` is not needed. If the "Activate command reset for control" function (Bit 3 = 1) is also activated, the `OpenAut` input is reset to the neutral position after evaluation in the block.

Configurable reactions using the `Feature2` parameter

Bit	Function
2	Separate evaluation for excluded and simulated interlock signals (Page 152)
3	Control priority in the event of an invalid input command (Page 175)
4	Setting switch or button mode for local commands (Page 181)
5	Evaluation of the signal status of the interlock signals (Page 142)
8	Forcing operating modes in the "Local" mode (Page 184)
10	Considering bad quality of automatic commands or external values (Page 186)
11	Suppress <code>MsgLock</code> and "Out of service" mode for a connected message block (Page 188)

Displaying auxiliary values

This block provides the standard function Displaying auxiliary values (Page 211).

SIMATIC BATCH functionality

This block provides the standard function SIMATIC BATCH functionality (Page 67).

Output signal as a pulse signal or static signal

This block provides the standard function Output signal as a static signal or pulse signal (Page 51). In addition to the static control output `Out`, the block also has pulse outputs `P_Open`, `P_Close`, which are dependent on the static control output.

Connection of the time-stamped messages from `EventTs` or `Event16Ts`

This block provides the standard function Connection of the time-stamped messages from `EventTs` or `Event16Ts` (Page 207).

Button labels

This block provides the standard function Labeling of buttons and text (Page 209)

Instance-specific text can be configured for the following parameters:

- OpenMan
- CloseMan

See also

- VivL messaging (Page 1358)
- VivL I/Os (Page 1359)
- VivL modes (Page 1349)
- VivL block diagram (Page 1366)
- EventTs functions (Page 1660)

7.10.4 VivL error handling

Error handling of VivL

Refer to section Error handling (Page 119) in the basic instructions for the error handling of all blocks.

The following errors can be displayed for this block:

- Error numbers
- Mode switchover error
- Invalid input signals
- Control system fault (CSF)

Overview of error numbers

The `ErrorNum` I/O can be used to output the following error numbers:

Error number	Meaning of the error number
-1	Predefined value when inserting the block; the block is not executed
0	There is no error.
41	The value for the <code>LocalSetting</code> I/O is not within the approved limit of 0 to 4.
42	<code>LocalSetting = 0 or LocalSetting = 3 or LocalSetting = 4 and LocalLi = 1</code>
51	<code>AutModLi = 1 and ManModLi = 1</code> <code>OpenLocal = 1 and CloseLocal = 1</code> <code>OpenAut = 1 and CloseAut = 1</code> <code>OpenForce = 1 and CloseForce = 1</code>
52	<code>LocalAct = 1 and LocalSetting = 2 or 4 and SimOn = 1</code>

Mode switchover error

This error can be output by the block. Refer to the Error handling (Page 119) section for more on this.

Invalid input signals

This error can be output by the block. Refer to the Error handling (Page 119) section for more on this.

For the following invalid input signals, the control output can be kept or switched to the neutral position. This depends on the function Control priority in the event of an invalid input command (Page 175).

Operating mode	Invalid input signals	Control reaction with Feature2 bit 3 =1
Local: Localsetting = 1 or Localsetting = 3	Pushbutton operation for local mode (Feature2 bit 4 = 0): OpenLocal = 1 and CloseLocal = 1	Valve is set to its neutral position.
Local: Localsetting = 1 or Localsetting = 3 and forcing	OpenForce = 1 and CloseForce = 1	
Forcing and no "local mode"	OpenForce = 1 and CloseForce = 1	
"Automatic mode" and no forcing	Pushbutton operation (Feature bit 4 = 0): OpenAut = 1 and CloseAut = 1	
"Manual mode" and no forcing	OpenMan = 1 and CloseMan = 1	

Control system fault (CSF)

An external signal can be activated via the CSF input. A control system fault is triggered if this signal changes to 1. Refer to the Error handling (Page 119) section for more on this.

See also

- Description of VlvL (Page 1346)
- VlvL modes (Page 1349)
- VlvL block diagram (Page 1366)
- VlvL I/Os (Page 1359)
- VlvL messaging (Page 1358)
- VlvL functions (Page 1350)

7.10.5 VivL messaging

Messaging

The following messages can be generated for this block:

- Process control fault
- Instance-specific messages

Process control fault

Message instance	Message identifier	Message class	Event
MsgEvId1	SIG 1	AS process control message - fault	\$\$BlockComment\$\$ Feedback error
	SIG 2	AS process control message - fault	\$\$BlockComment\$\$ External error has occurred

Explanation:

\$\$BlockComment\$\$: Content of the instance-specific comment

You can interconnect an external fault (signal) to input parameter *CSF*. If it changes to *CSF* = 1, a process control fault is triggered (MsgEvId1, SIG 2).

Instance-specific messages

You can use up to three instance-specific messages with this block.

Message instance	Message identifier	Message class	Event
MsgEvId1	SIG 3	AS process control message - fault	\$\$BlockComment\$\$ External message 1
	SIG 4	AS process control message - fault	\$\$BlockComment\$\$ External message 2
	SIG 5	AS process control message - fault	\$\$BlockComment\$\$ External message 3

Explanation:

\$\$BlockComment\$\$: Content of the instance-specific comment

Associated values for message instance **MsgEvId1**

Associated value	Block parameters
1	BatchName
2	StepNo
3	BatchID

Associated value	Block parameters
4	ExtVa104
5	ExtVa105
6	ExtVa106
7	ExtVa107
8	ExtVa108
9	Reserved
10	Reserved

The associated values 4 ... 8 are allocated to the parameters ExtVa104 ... ExtVa108 and can be used. See the "Process Control System PCS 7 - Engineering System" manual.

See also

VivL modes (Page 1349)

VivL block diagram (Page 1366)

VivL error handling (Page 1356)

7.10.6 VivL I/Os

I/Os of VivL

Input parameters

Parameter	Description	Type	Default
AutModLi*	1 = "Automatic mode" via interconnection or SFC (controlled by ModLiOp = 1)	STRUCT <ul style="list-style-type: none"> • Value: BOOL • ST: BYTE 	- <ul style="list-style-type: none"> • 0 • 16#80
AutModOp*	1 = "Automatic mode" via operator (controlled by ModLiOp = 1)	BOOL	0
BatchEn	1 = Enable allocation	BOOL	0
BatchID	Batch ID	DWORD	16#00000000
BatchName	Batch name	S7-String	
ByProt	1 = Bypassing interlock is active in "local mode" and in simulation	BOOL	0
CloseAut*	1 = Select Close valve in "automatic mode"	STRUCT <ul style="list-style-type: none"> • Value: BOOL • ST: BYTE 	- <ul style="list-style-type: none"> • 0 • 16#80
CloseForce	1 = Force valve closure	STRUCT <ul style="list-style-type: none"> • Value: BOOL • ST: BYTE 	- <ul style="list-style-type: none"> • 0 • 16#80

Motor and valve blocks

7.10 VlvL - Valve (Large)

Parameter	Description	Type	Default
CloseLocal	1 = Select Close valve in "local mode"	STRUCT <ul style="list-style-type: none"> Value: BOOL ST: BYTE 	- <ul style="list-style-type: none"> 0 16#80
CloseMan*	1 = Select Close valve in "manual mode"	BOOL	0
CSF	1 = External error (control system fault) Error handling (Page 119)	STRUCT <ul style="list-style-type: none"> Value: BOOL ST: BYTE 	- <ul style="list-style-type: none"> 0 16#80
CtrlChnST	Signal status of output channel Ctrl Should be connected to an output channel block	STRUCT <ul style="list-style-type: none"> Value: BOOL ST: BYTE 	- <ul style="list-style-type: none"> 0 16#FF
EN	1 = Called block will be processed	BOOL	1
EventTsIn	For interconnecting data between a technological block and the message blocks EventTs, Event16Ts. The EventTsIn input parameter serves to interconnect the EventTsOut output parameter of the EventTs block. When this interconnection is configured, the messages of the EventTs block are displayed on the OS in the alarm view of the technological block and can also be acknowledged there.	ANY	
ExtMsg1	Binary input for freely selectable message 1	STRUCT <ul style="list-style-type: none"> Value: BOOL ST: BYTE 	- <ul style="list-style-type: none"> 0 16#80
ExtMsg2	Binary input for freely selectable message 2	STRUCT <ul style="list-style-type: none"> Value: BOOL ST: BYTE 	- <ul style="list-style-type: none"> 0 16#80
ExtMsg3	Binary input for freely selectable message 3	STRUCT <ul style="list-style-type: none"> Value: BOOL ST: BYTE 	- <ul style="list-style-type: none"> 0 16#80
ExtVa104	Associated value 4 for messages (MsgEvID1)	ANY	
ExtVa105	Associated value 5 for messages (MsgEvID1)	ANY	
ExtVa106	Associated value 6 for messages (MsgEvID1)	ANY	
ExtVa107	Associated value 7 for messages (MsgEvID1)	ANY	
ExtVa108	Associated value 8 for messages (MsgEvID1)	ANY	
FaultExt	1 = External error Error handling (Page 119)	STRUCT <ul style="list-style-type: none"> Value: BOOL ST: BYTE 	- <ul style="list-style-type: none"> 0 16#80

Parameter	Description	Type	Default
FbkOpen	1 = Valve open feedback signal	STRUCT • Value: BOOL • ST: BYTE	- • 0 • 16#FF
FbkClose	1 = Valve closed feedback signal	STRUCT • Value: BOOL • ST: BYTE	- • 0 • 16#FF
Feature	I/O for additional functions (Page 1350)	STRUCT • Bit 0: BOOL • ... • Bit 31: BOOL	- • 0 • 0 • 0
Feature2	I/O for additional functions (Page 1350)	STRUCT • Bit 0: BOOL • ... • Bit 31: BOOL	- • 0 • 0 • 0
Intlock	0 = Interlocking without reset is active; you can operate the block without reset once the interlocking condition has disappeared 1 = Interlock not activated	STRUCT • Value:BOOL • ST:BYTE • Bit 1: BOOL (Bypass information bit)	- • 1 • 16#FF • 0
Intl_En	1 = Interlock without reset (interlock, Intlock parameter) is active	BOOL	1
LocalLi	1 = Activate "local mode" via plant signal	STRUCT • Value: BOOL • ST: BYTE	- • 0 • 16#80
LocalOp*	1 = "Local mode" via operator	BOOL	0
LocalSetting	Properties for the Local mode (Page 79)	INT	0
ManModLi*	1 = "Manual mode" via interconnection or SFC (controlled by ModLiOp = 1)	STRUCT • Value: BOOL • ST: BYTE	- • 0 • 16#80
ManModOp*	1 = "Manual mode" via: OS operator (controlled via ModLiOp = 0)	BOOL	1
ModLiOp	Switchover of operating mode between: 0 = Operator 1 = Interconnection or SFC	STRUCT • Value: BOOL • ST: BYTE	- • 0 • 16#80
Monitor	1 = Feedback monitoring	BOOL	1
MonSafePos	1 = Go to neutral position in the event of monitoring errors	BOOL	1
MonTiDynamic*	Monitoring time after operation in [s]	REAL	3.0
MonTiStatic*	Monitoring time for feedback errors without operation in [s]	REAL	3.0
MS_RelOp*	1 = Release for maintenance via OS operator	BOOL	0

Motor and valve blocks

7.10 VlvL - Valve (Large)

Parameter	Description	Type	Default
MsgEvId1	Message number (assigned automatically)	DWORD	16#00000000
MsgLock	1 = Suppress process messages. See also the section Suppressing messages using the MsgLock parameter (Page 205) for more on this.	STRUCT <ul style="list-style-type: none"> Value: BOOL ST: BYTE 	- <ul style="list-style-type: none"> 0 16#80
NoFbkClose	1 = No feedback present for "valve closed"	BOOL	0
NoFbkOpen	1 = No feedback present for "valve open"	BOOL	0
Occupied	1 = In use by a batch	BOOL	0
OosLi	1 = "Out of service", via interconnection or SFC	STRUCT <ul style="list-style-type: none"> Value: BOOL ST: BYTE 	- <ul style="list-style-type: none"> 0 16#80
OosOp*	1 = "Out of service", via OS operator	BOOL	0
OpenAut*	1 = Select Open valve in "automatic mode"	STRUCT <ul style="list-style-type: none"> Value: BOOL ST: BYTE 	- <ul style="list-style-type: none"> 0 16#80
OpenForce	1 = Force valve opening	STRUCT <ul style="list-style-type: none"> Value: BOOL ST: BYTE 	- <ul style="list-style-type: none"> 0 16#80
OpenLocal	1 = Select Open valve in "local mode"	STRUCT <ul style="list-style-type: none"> Value: BOOL ST: BYTE 	- <ul style="list-style-type: none"> 0 16#80
OpenMan*	1 = Select Open valve in "manual mode"	BOOL	0
OpSt_In	Input parameter for local operator authorization, connected with the <code>Out</code> output parameter of the upstream block, <code>OpStations</code> (Page 411)	DWORD	16#00000000
OS_Perm	I/O for operator permissions (Page 1350)	STRUCT <ul style="list-style-type: none"> Bit 0: BOOL ... Bit 31: BOOL 	- <ul style="list-style-type: none"> 1 1 1
Permit	1 = Enable for opening / closing from neutral position 0 = Valve activation not enabled on OS	STRUCT <ul style="list-style-type: none"> Value:BOOL ST:BYTE Bit 1: BOOL (Bypass information bit) 	- <ul style="list-style-type: none"> 1 16#FF 0
Perm_En	1 = Activation enable (enable, <code>Permit</code> parameter) is active	BOOL	1

Parameter	Description	Type	Default
Protect	0 = Protective interlocking is effective; once the interlocking condition has disappeared, you will have to reset the block 1 = Protective interlocking not activated	STRUCT <ul style="list-style-type: none"> • Value: BOOL • ST: BYTE • Bit 1: BOOL (Bypass information bit) 	- <ul style="list-style-type: none"> • 1 • 16#FF • 0
Prot_En	1 = Protective interlock (protection, <i>Protect</i> parameter) is active	BOOL	1
PulseWidth*	Pulse width of control signal [s]	REAL	3.0
RstLi*	1 = Reset via interconnection	STRUCT <ul style="list-style-type: none"> • Value: BOOL • ST: BYTE 	- <ul style="list-style-type: none"> • 0 • 16#80
RstOp*	1 = Reset via operator	BOOL	0
RunUpCyc	Number of cycles in startup; messages are suppressed during these cycles	INT	3
SafePos	Neutral position for valve: 1= Open 0 = Closed	BOOL	0
SampleTime	Sampling time [s] (assigned automatically)	REAL	0.1
SimLiOp	Activation/deactivation of the simulation by: 0 = Operator 1 = Interconnection or SFC	STRUCT <ul style="list-style-type: none"> • Value: BOOL • ST: BYTE 	- <ul style="list-style-type: none"> • 0 • 16#80
SimOnLi	1 = Simulation via interconnection or SFC (controlled by <i>SimLiOp</i> = 1)	STRUCT <ul style="list-style-type: none"> • Value: BOOL • ST: BYTE 	- <ul style="list-style-type: none"> • 0 • 16#80
SimOn*	1 = Simulation on	BOOL	0
SelFp1	Call a block saved in this parameter as an additional faceplate (Page 208) in the standard view	ANY	-
SelFp2	Call a block saved in this parameter as an additional faceplate (Page 208) in the preview	ANY	-
StepNo	Batch step number	DWORD	16#00000000
UserAna1	Analog auxiliary value 1	STRUCT <ul style="list-style-type: none"> • Value: REAL • ST: BYTE 	- <ul style="list-style-type: none"> • 0.0 • 16#FF
UAlunit	Unit of measure for analog auxiliary value 1	INT	0
UserAna2	Analog auxiliary value 2	STRUCT <ul style="list-style-type: none"> • Value: REAL • ST: BYTE 	- <ul style="list-style-type: none"> • 0.0 • 16#FF

Motor and valve blocks

7.10 VlvL - Valve (Large)

Parameter	Description	Type	Default
UA2unit	Unit of measure for analog auxiliary value 2	INT	0
UserStatus	Freely assignable bits for use in PCS 7 OS	BYTE	16#00
WarnTiAut	Prewarning of valve movement from neutral position in "automatic mode" in [s]	REAL	0.0
WarnTiMan	Prewarning of valve movement from neutral position in "manual mode" in [s]	REAL	0.0

* Values can be written back to these inputs during processing of the block by the block algorithm.

Output parameters

Parameter	Description	Type	Default
AutAct	1 = "Automatic mode" enabled 0 = "Manual mode" is enabled	STRUCT • Value: BOOL • ST: BYTE	- • 0 • 16#80
AutoST	1 = Worst signal status of automatic commands	BYTE	16#80
Closed	1 = Valve is closed	STRUCT • Value: BOOL • ST: BYTE	- • 0 • 16#80
Closing	1 = Valve is closing	STRUCT • Value: BOOL • ST: BYTE	- • 0 • 16#80
Ctrl	Control output	STRUCT • Value: BOOL • ST: BYTE	- • 0 • 16#80
CurrMon	Current monitoring time [s]	DINT	0
ENO	1 = Block algorithm completed without errors	BOOL	0
ErrorNum	Output of pending error number. For error numbers that can be output by this block, see VlvL error handling (Page 1356)	INT	-1
FbkCloseOut	Valve closed feedback	STRUCT • Value: BOOL • ST: BYTE	- • 0 • 16#80
FbkOpenOut	Valve open feedback	STRUCT • Value: BOOL • ST: BYTE	- • 0 • 16#80

Parameter	Description	Type	Default
GrpErr	1 = Group error pending	STRUCT • Value: BOOL • ST: BYTE	- • 0 • 16#80
LocalAct	1 = "Local mode" enabled	STRUCT • Value: BOOL • ST: BYTE	- • 0 • 16#80
LockAct	1 = Interlock (Intlock, Permit or Protect) is active	STRUCT • Value: BOOL • ST: BYTE	- • 0 • 16#80
ManAct	1 = "Manual mode" enabled	STRUCT • Value: BOOL • ST: BYTE	- • 1 • 16#80
MonDynErr	1 = Feedback error due to control change	STRUCT • Value: BOOL • ST: BYTE	- • 0 • 16#80
MonStaErr	1 = Feedback error due to unexpected feedback change	STRUCT • Value: BOOL • ST: BYTE	- • 0 • 16#80
MS_Release	Release for maintenance: 1 = Release for OS operator	STRUCT • Value: BOOL • ST: BYTE	- • 0 • 16#80
MsgAckn1	Message acknowledgement status 1 (output ACK_STATE of first ALARM_8P)	WORD	16#0000
MsgErr1	Alarm error 1 (output ERROR of first ALARM_8P)	BOOL	0
MsgStat1	Message status 1 (output STATUS of first ALARM_8P)	WORD	16#0000
OosAct	1 = Block is "Out of service"	STRUCT • Value: BOOL • ST: BYTE	- • 0 • 16#80
Opened	1 = Valve is open	STRUCT • Value: BOOL • ST: BYTE	- • 0 • 16#80
Opening	1 = Valve is opening	STRUCT • Value: BOOL • ST: BYTE	- • 0 • 16#80
OpSt_Out	Value of the OpSt_In input parameter, for feedforwarding to other blocks. Bit 31 of this parameter is used by Feature bit 24	DWORD	16#00000000
OS_PermOut	Display of OS_Perm	DWORD	16#FFFFFFFF
OS_PermLog	Display of OS_Perm with settings changed by the block algorithm	DWORD	16#FFFFFFFF

7.10 VlvL - Valve (Large)

Parameter	Description	Type	Default
P_Close	1 = Pulse signal to close valve	STRUCT <ul style="list-style-type: none"> Value: BOOL ST: BYTE 	- <ul style="list-style-type: none"> 0 16#80
P_Open	1 = Pulse signal to open valve	STRUCT <ul style="list-style-type: none"> Value: BOOL ST: BYTE 	- <ul style="list-style-type: none"> 0 16#80
P_Rst	1= Pulse output for reset The parameter persists for one cycle after a reset.	STRUCT <ul style="list-style-type: none"> Value: BOOL ST: BYTE 	- <ul style="list-style-type: none"> 0 16#80
RdyToReset	1 = Ready for reset via RstLi input or commands in "local", "automatic", or "manual mode"	STRUCT <ul style="list-style-type: none"> Value: BOOL ST: BYTE 	- <ul style="list-style-type: none"> 0 16#80
RdyToStart	1 = Active start readiness	STRUCT <ul style="list-style-type: none"> Value: BOOL ST: BYTE 	- <ul style="list-style-type: none"> 0 16#80
ST_Worst	Worst signal status	BYTE	16#80
Status1	Status word 1 (Page 1346)	DWORD	16#00000000
Status2	Status word 2 (Page 1346)	DWORD	16#00000000
Status3	Status word 3 (Page 1346)	DWORD	16#00000000
WarnAct	1 = Prewarning for valve movement away from neutral position active (parameters WarnTiAut and WarnTiMan)	STRUCT <ul style="list-style-type: none"> Value: BOOL ST: BYTE 	- <ul style="list-style-type: none"> 0 16#80

See also

- VlvL messaging (Page 1358)
- VlvL modes (Page 1349)
- VlvL block diagram (Page 1366)
- Error handling (Page 119)

7.10.7 VlvL block diagram

VlvL block diagram

A block diagram is not provided for this block.

See also

- Description of VlvL (Page 1346)
- VlvL modes (Page 1349)

- VlvL error handling (Page 1356)
- VlvL messaging (Page 1358)
- VlvL I/Os (Page 1359)
- VlvL functions (Page 1350)

7.10.8 Operator control and monitoring

7.10.8.1 VlvL views

Views of the VlvL block

The block VlvL provides the following views:

- VlvL standard view (Page 1367)
- Alarm view (Page 302)
- Trend view (Page 305)
- Parameter view for motors and valves (Page 286)
- VlvL preview (Page 1371)
- Memo view (Page 304)
- Batch view (Page 302)
- VlvL block icon (Page 1374)

Refer to the sections Structure of the faceplate (Page 248) and Block icon structure (Page 230) for general information on the faceplate and block icon.

7.10.8.2 VlvL standard view

VlvL standard view

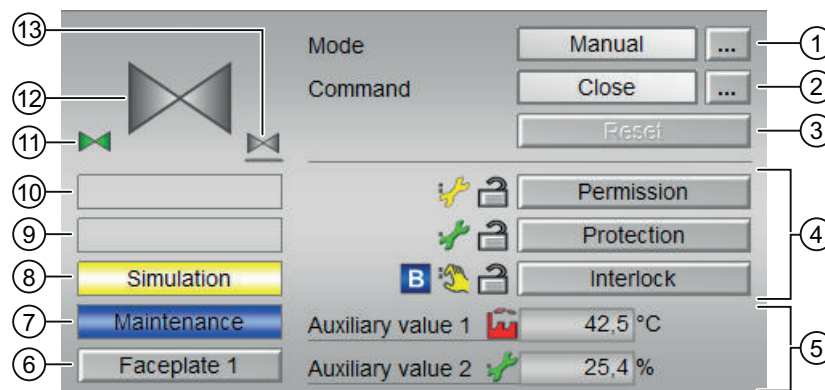

(1) Displaying and switching the operating mode

This area provides information on the currently valid operating mode. The following operating modes can be shown here:

- Manual and automatic mode for motors, valves and dosers (Page 75)
- Manual and automatic mode for motors, valves and dosers (Page 75)
- Local mode (Page 79)
- Out of service (Page 71)

Refer to section Switching operating states and operating modes (Page 257) for information on switching the operating mode.

(2) Opening and closing the valve

This area shows you the default operating state for the valve. The following states can be shown and executed here:

- "Open"
- "Close"

Refer to the Switching operating states and operating modes (Page 257) section for information on changing the state.

If text is configured for these commands, it is displayed as status text and as button labels for command selection. You can find more information about this in section Labeling of buttons and text (Page 209)

(3) Resetting the block

Click "Reset" for interlocks or errors. You can find additional information on this in the section Resetting the block in case of interlocks or errors (Page 43).

(4) Operating range for the interlock functions of the block

This display is only visible when the corresponding block input is connected.

You can use this button to control the interlock functions of the block. You can find additional information on this in the section Interlocking functions (Page 99).

The following is displayed in addition to the buttons:

- Interlock status (see Forming the group status for interlock information (Page 104)), e.g.:



- Signal status (see Forming and outputting the signal status for technologic blocks (Page 109)), e.g.:



- Bypass information (see Forming the group status for interlock information (Page 104)):



(5) Display of auxiliary values

This display is only visible when the corresponding block input is connected.

You can use this area to display two auxiliary values that have been configured in the engineering system (ES). You can find additional information on this in the section Displaying auxiliary values (Page 211).

(6) Navigation button for switching to the standard view of any faceplate

This display is only visible when the corresponding block input is connected.

Use this navigation button to open the standard view of a block configured in the engineering system (ES). The visibility of this navigation button depends on the configuration in the engineering system (ES).

You can find additional information on this in the section Opening additional faceplates (Page 208).

(7) Display area for block states

This area provides additional information on the operating state of the block:

- "Maintenance"

Additional information on this is available in section Release for maintenance (Page 64) Display area for block states.

(8) Display area for block states

This area provides additional information on the operating state of the block:

- "Simulation"
- "Delay"

You will find more detailed information on this in the sections Simulating signals (Page 58) and Display of delay times (Page 256).

(9) Display area for block states

This area provides additional information on the operating state of the block:

- "External error"
- "End position error"
- "Control error"
- "Invalid signal"
- "Changeover error"

Additional information on these errors is available in the sections Monitoring the feedbacks (Page 97) , Error handling (Page 119) (section "Invalid input signals" and "Mode switchover error") and Motor protection function (Page 99).

(10) Display area for block states

This area provides additional information on the operating state of the block:

- "Forced open"
- "Forced close"
- "Request 0/1": A reset to "automatic mode" is expected.

You can find additional information on this in the section Forcing operating modes (Page 41).

(11) Automatic preview

This display is only visible in "manual mode", in "local mode", or with a reset request in "automatic mode", when the current output signals are not identical to the control in "automatic mode".

The display shows what state the valve would assume if you switched from "manual" or "local" mode to "automatic mode", or performed a reset to "automatic mode".

(12) Status display of the valve

The current status of the valve is graphically displayed here.

You can find more information about this in section VlvL block icon (Page 1374)

(13) Neutral position of the valve

Display the neutral position for the valve:

- If the neutral position of the valve is "Closed" (`SafePos = 0`), a gray valve is shown.
- If the neutral position of the valve is "Open" (`SafePos = 1`), a green valve is shown.

7.10.8.3 VlvL preview

Preview of VlvL

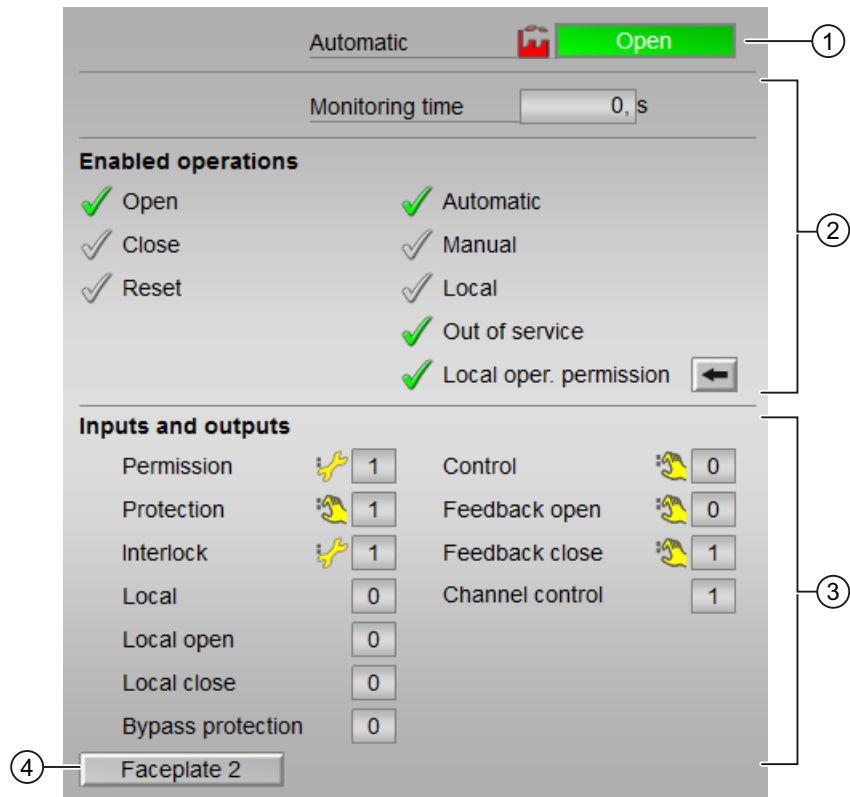

Display of the current monitoring time is visible.

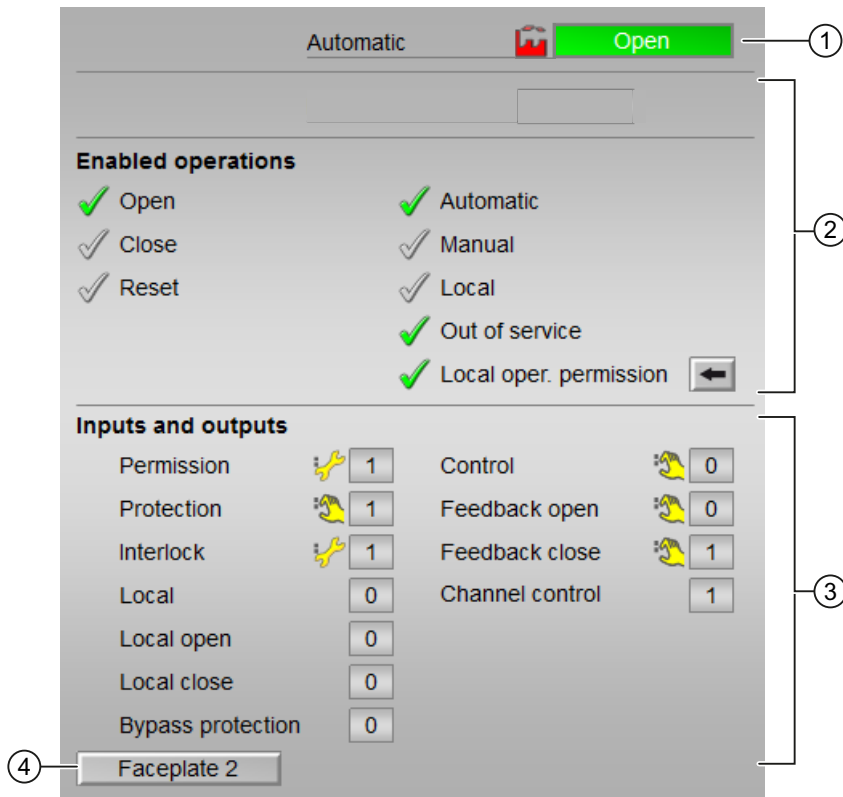

Display of the current monitoring time is not visible.

(1) Automatic preview

This area shows you the block status after it has switched from the "Manual" mode or "Local" mode to the "Automatic" mode.

If the block is in "Automatic" mode, the current block state is displayed.

This area also displays the worst signal status of the following automatic commands:

- OpenAut
- CloseAut

(2) Enable operations

This area shows all operations for which special operator permissions are assigned. They depend on the configuration in the engineering system (ES) that applies to this block.

Icons for enabled operation:

- **Green check mark:** the OS operator can control this parameter
- **Gray check mark:** the OS operator cannot control this parameter at this time due to the process
- **Red cross:** the OS operator cannot control this parameter due to the configured AS operator permissions (OS_Perm or OS1Perm)

The following enabled operations are shown here:

- "Open": You can open the valve.
If text is configured for this command, it is also displayed in brackets. You can find additional information on this in the section Labeling of buttons and text (Page 209).
- "Close": You can close the valve.
If text is configured for this command, it is also displayed in brackets. You can find additional information on this in the section Labeling of buttons and text (Page 209).
- "Reset": You can reset the valve if interlocks or errors occur.
- "Automatic": You can switch to "automatic mode".
- "Manual": You can switch to "manual mode".
- "Local": You can switch to "local mode".
- "Out of service": You can switch to "Out of service" operating mode.
- "Local operator permission": Use the ← button to switch to the standard view of the OpStations block. You can find additional information on this in the section Operator control permissions (Page 254) .
- "Monitoring time": Display of the current monitoring time.

(3) Displaying current control signals

This area shows the most important parameters for this block with the current selection:

- "Permission":
This display is only visible when the corresponding block input is connected.
 - 0 = Valve activation not enabled on OS
 - 1 = Enable for "opening"/"closing" from the neutral position
- "Protection":
This display is only visible when the corresponding block input is connected.
 - 0 = Protective interlocking is effective; once the interlocking condition has disappeared, you will have to reset the block
 - 1 = "Good" state
- "Interlock":
This display is only visible when the corresponding block input is connected.
 - 0 = Interlocking without reset is active; you can operate the block without reset once the interlocking condition has disappeared
 - 1 = "Good" state
- "Local correct": 1 = Control signal for "Local mode" (LocalLi) is active
- "Local open": 1 = Opening the valve in "local mode"
- "Local close": 1 = Closing the valve in "local mode"
- "Interlock deact.":
 - 0 = Bypass disabled
 - 1 = Bypassing interlock in "local mode" and in "simulation"

7.10 VivL - Valve (Large)

- "Control": Display for valve control:
 - 0 = Valve is closing
 - 1 = Valve is opening
- "Feedback open": 1 = Valve is open
- "Feedback close": 1 = Valve is closed
- "Channel Control": Control signal of the output channel block

(4) Navigation button for switching to the standard view of any faceplate

This display is only visible when the corresponding block input is connected.

Use this navigation button to open the standard view of a block configured in the engineering system. The visibility of this navigation button depends on the configuration in the engineering system (ES).

You can find additional information on this in the section Opening additional faceplates (Page 208) .





7.10.8.4 VivL block icon

Block icons for VivL





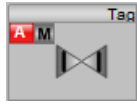

A variety of block icons are available with the following functions:

- Process tag type
- Limits (high/low)
- Violation of alarm, warning, and tolerance limits as well as control system faults
- Operating modes
- Signal status, release for maintenance
- Forcing states
- Displays for bypassing interlocks
- Interlocks
- Memo display
- Valve status display

The block icons from template @TemplateAPLV8.PDL:

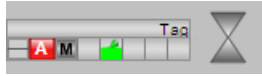
Icons	Selection of the block icon in CFC	Special features
	1	
	2	
	3	Non-rotating block icon
	4	Non-rotating block icon

The block icons from template @TemplateAPLV7.PDL:

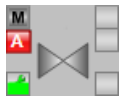
Icons	Selection of the block icon in CFC	Special features
	1	Block icon in the full display
	2	
	3	
	4	
	5	
	6	
	7	
	8	
	9	

7.10 VivL - Valve (Large)

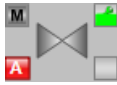
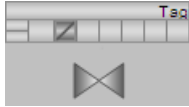





Icons	Selection of the block icon in CFC	Special features
	10	
	-	Block icon in "Out of service" mode (example with type 1 block icon)

Additional information on the block icon and the control options in the block icon is available in the following chapters:

- Configuring the block icons (Page 237)
- Block icon structure (Page 230)
- Operation via the block icon (Page 239)

Valve status display

The following valve states are shown here:

Icon	Meaning
	Valve open
	Valve closed
	Error at valve
	Valve is opening
	Valve is closing
	Valve closed
	Valve is closing

7.11 VlvS - Valve (small)

7.11.1 Description of VlvS

Object name (type + number) and family

Type + number: FB 1911

Family: Drives

Area of application for VlvS

The block is used for the following applications:

- Controlling a valve in two positions ("open"/"closed") with adjustable neutral position

Note

This block is also available as a large block. A comparison of the VlvL and VlvS blocks is available in the section: VlvL compared to VlvS (Page 1068)

How it works

The valve is opened or closed by a control signal. The signal 0 corresponds to the de-energized state (neutral position) of the valve.

The control is monitored by the "open"/"close" (feedback) signals. Missing feedback can be derived from the control in the block.

Various inputs are available for control purposes. The next sections provide more detailed information on configuration, operating principles, visualization and operation.

Configuration

Use the CFC editor to install the block in a cyclic interrupt OB (OB30 to OB38). The block is also installed automatically in the startup OB (OB100).

Startup characteristics

Use the **Feature Bit Set** startup characteristics (Page 138) to define the startup characteristics of this block.

The messages are suppressed after startup for the number of cycles set at **RunUpCyc**.

Status word allocation for status1 parameter

You can find a description for each parameter in section VlvS I/Os (Page 1388).

Status bit	Parameter
0	Occupied
1	BatchEn
2	SimOn
3	OosAct.Value
4	OosLi.Value
5	AutoAct.Value = 1; ManAct.Value = 0
6	LocalAct.Value
7	LockAct.Value
8	"Open"/"Closed" command (1 = "Open")
9	FbkOpenOut.Value
10	FbkCloseOut.Value
11	Feedback error without control change
12	Feedback error due to control change
13	BypProt
14	Invalid signal status
15	Not used
16	1 = Intlock is active
17 - 21	Not used
22	Automatic preview (1 = "Open")
23	Bumpless switchover to "automatic mode" enabled
24	SafePos
25 - 27	Not used
28	For the Error status display in the Closed valve
29	For the Error status display in the Opened valve
30	External error generated by FaultExt or external control system fault CSF with set Feature bit 18 Activating error state for external process control error CSF (Page 151)
31	1 = Input parameter CtrlChnST is interconnected

Status word allocation for status2 parameter

Status bit	Parameter
0	MsgLock
1	Not used
2	Display for interlocks in block icon
3 - 15	Not used
16	1 = Input parameter FbkClose is interconnected
17	1 = Input parameter FbkOpen is interconnected
18	Reset request in automatic
19	1 = No impact of input signals on "local mode" when LocalSetting = 2

Status bit	Parameter
20	1 = Valve open
21	1 = Valve closed
22	1 = Valve opens
23	1 = Valve closes
24 - 29	Not used
30	Bypass information from previous function block
31	MS_RelOp

Status word allocation for Status3 parameter

Status bit	Parameter
0 - 7	Not used
8	"Interlock" button is enabled
9 - 11	Not used
12	Hidden bypass signal in interlock
13	Not used
14	Feature2 bit 2: Separate bypass signal
15 - 25	Not used
26	Show automatic preview in the standard view
27	Not used
28	GrpErr.Value
29	RdyToStart.Value
30 - 31	Not used

See also

- VlvS modes (Page 1379)
- VlvS functions (Page 1381)
- VlvS error handling (Page 1385)
- VlvS reporting (Page 1386)
- VlvS block diagram (Page 1393)

7.11.2 VlvS modes

VlvS operating modes

The block supports all standard modes:

- Local mode (Page 79)
- Automatic mode (Page 75)

- Manual mode (Page 75)
- Out of service (Page 71)

The next section provides additional block-specific information relating to the general descriptions.

"Local mode"

You can find general information on "Local mode", switching modes and Bumpless switchover in the Local mode (Page 79) section.

Note

"Local mode" for the block VlvS

In contrast to the "Large" blocks, it is only possible to perform settings in this block `LocalSetting` with 0, 2 and 5.

"Automatic mode"

You can find general information on "Automatic mode", switching modes and Bumpless switchover in the Manual and automatic mode for motors, valves and dosers (Page 75) section.

Valve actions you can control in "automatic mode":

- "Open" (`OpenAut = 1`)
- "Close" (`CloseAut = 1`)

Note

Information about the "Small" block

This "Small" block works with pushbutton operation. The automatic commands are therefore latching, in other words, `OpenAut` and `CloseAut` can be reset to 0 after the control is changed. In "manual" and "local" modes, however, the automatic commands are not saved and in the absence of automatic commands the automatic control is tracked.

"Manual mode"

You can find general information on "Manual mode", switching modes and bumpless switchover in the section Manual and automatic mode for motors, valves and dosers (Page 75).

Valve actions you can control in "manual mode":

- "Open" (`OpenMan = 1`)
- "Close" (`CloseMan = 1`)

"Out of service"

You can find general information about the "Out of service" mode in the section Out of service (Page 71).

See also

Description of VlvS (Page 1377)

VlvS functions (Page 1381)

VlvS error handling (Page 1385)

VlvS reporting (Page 1386)

VlvS I/Os (Page 1388)

VlvS block diagram (Page 1393)

7.11.3 VlvS functions

Functions of VlvS

The functions for this block are listed below.

Opening additional faceplates

This block provides the standard function Opening additional faceplates (Page 208).

Operator permissions

This block provides the standard function Operator control permissions (Page 254).

The block has the following permissions for the `OS_Perm` parameter:

Bit	Function
0	1 = Operator can switch to "automatic mode"
1	1 = Operator can switch to "manual mode"
2	1 = Operator can switch to "local mode"
3	1 = Operator can switch to "Out of service" mode
4	1 = Operator can open the valve
5	1 = Operator can close the valve
6	1 = Operator can reset the valve
7	1 = Operator can define the monitoring time for startup
8	Not used
9	1 = Operator can activate the monitoring time function (Bit 7)
11	1 = Operator can activate the Release for maintenance function
12 - 31	Not used

Note

If you interconnect a parameter that is also listed in `OS_Perm` as a parameter, you have to reset the corresponding `OS_Perm` bit.

Button labels

This block provides the standard function Labeling of buttons and text (Page 209)

Instance-specific text can be configured for the following parameters:

- `OpenMan`
- `CloseMan`

Interlocks

This block provides the following interlocks:

- Interlock without reset ("Interlock")

Refer to the Interlocks (Page 99) section for more on this.

Disabling interlocks

This block provides the standard function Disabling interlocks (Page 103).

Resetting the block in case of interlocks

This block provides the standard function Resetting the block in case of interlocks or errors (Page 43).

Forming the group status for interlocks

This block provides the standard function Forming the group status for interlock information (Page 104).

External error (`FaultExt`), external control system fault (`CSF`)

This block provides the possibility to pass an external error via the `FaultExt` parameter or an external control system fault via the `CSF` parameter. See VlvS error handling (Page 1385)

Group error

This block provides the standard function Outputting group errors (Page 122)

The following parameters are taken into consideration when forming the group error:

- `CSF`
- `MonDynErr`

- `MonStaErr`
- `FaultExt`

Neutral position

This block provides the standard function Neutral position for motors, valves and controllers (Page 48). The neutral position (de-energized state) is set using the `SafePos` parameter.

- `SafePos = 0` means that at `Ctrl = 0` the valve drive closes and at `Ctrl = 1` it opens (de-energized state is "closed")
- `SafePos = 1` means that at `Ctrl = 0` the valve drive opens and at `Ctrl = 1` it closes (de-energized state is "open")

Outputting a signal for start readiness

This block provides the standard function Outputting a signal for start readiness (Page 53).

Forming the signal status for blocks

This block provides the standard function Forming and outputting the signal status for technologic blocks (Page 109).

The worst signal status `ST_Worst` for the block is formed from the following parameters:

- `FbkOpenOut.ST`
- `FbkCloseOut.ST`
- `LocalLi.ST`
- `CtrlChn.ST`
- `OpenAut.ST` (only if `Feature2.Bit10 = 1`)
- `CloseAut.ST` (only if `Feature2.Bit10 = 1`)

Considering bad quality of automatic commands or external values

If the `Feature2` bit Considering bad quality of automatic commands or external values (Page 186) is set to 1 and one of the following parameters has bad signal status (16#00 or 16#28), the block goes to the neutral position in the "Automatic" mode:

- `OpenAut.ST`
- `CloseAut.ST`

Feedback monitoring

This block provides the standard function Monitoring the feedbacks (Page 97). Startup characteristics are monitored by setting parameter `MonTiDynamic`. The parameter `MonTiStatic` monitors compliance with the position.

Suppressing messages using the `MsgLock` parameter

This block provides the standard function Suppressing messages using the `MsgLock` parameter (Page 205).

Release for maintenance

This block provides the standard function Release for maintenance (Page 64).

Simulating signals

This block provides the standard function Simulating signals (Page 58).

Generating instance-specific messages

This block provides the standard function Generating instance-specific messages (Page 204).

Configurable reactions using the `Feature` parameter

You can find an overview of all reactions provided by the `Feature` parameter in the Configurable functions using the `Feature` I/O (Page 131) . The following functionality is available for this block at the relevant bits:

Bit	Function
0	Set startup characteristics (Page 138)
1	Reaction to the out of service mode (Page 177)
2	Resetting the commands for changing the mode (Page 161)
3	Enabling resetting of commands for the control settings (Page 161)
9	Resetting via input signals in the event of interlocking (Protection) or errors (Page 163)
10	Exiting local mode (Page 177)
11	Activating the run time of feedback signals (Page 153)
18	Activating error state for external process control error CSF (Page 151)
25	Suppression of all messages (Page 174)
27	Interlock display with <code>LocalSetting</code> 2 or 5 (Page 178)
30	Set reset depending on the operating mode or the <code>LiOp</code> parameter (Page 163)
31	Activating reset of protection / error in manual mode (Page 165)

Configurable reactions using the `Feature2` parameter

Bit	Function
2	Separate evaluation for excluded and simulated interlock signals (Page 152)
3	Control priority in the event of an invalid input command (Page 175)
5	Evaluation of the signal status of the interlock signals (Page 142)
10	Considering bad quality of automatic commands or external values (Page 186)

SIMATIC BATCH functionality

This block provides the standard function SIMATIC BATCH functionality (Page 67).

See also

- Description of VlvS (Page 1377)
- VlvS modes (Page 1379)
- VlvS reporting (Page 1386)
- VlvS I/Os (Page 1388)
- VlvS block diagram (Page 1393)
- Disabling feedback for valves (Page 99)
- Selecting a unit of measure (Page 212)
- Enabling local operator authorization (Page 158)

7.11.4 VlvS error handling

Error handling of VlvS

Refer to section Error handling (Page 119) in the basic instructions for the error handling of all blocks.

The following errors can be displayed for this block:

- Error numbers
- Mode switchover error
- Invalid input signals
- Control system fault (CSF)

Overview of error numbers

The `ErrorNum` I/O can be used to output the following error numbers:

Error number	Meaning of the error number
-1	Predefined value when inserting the block; the block is not executed
0	There is no error.
41	The value for the <code>LocalSetting</code> I/O is not within the valid limit of 0, 2 or 5
42	<code>LocalSetting = 0</code> and <code>LocalLi = 1</code>
51	<code>AutModLi = 1</code> and <code>ManModLi = 1</code> <code>OpenAut = 1</code> and <code>CloseAut = 1</code>
52	<code>LocalAct = 1</code> and <code>LocalSetting = 2</code> or <code>5</code> and <code>SimOn = 1</code>

Mode switchover error

This error can be output by the block, see the section Error handling (Page 119).

Invalid input signals

This error can be output by the block, see the section Error handling (Page 119).

For the following invalid input signals, the control output can be kept or switched to the neutral position. This depends on the function Control priority in the event of an invalid input command (Page 175).

Operating mode	Invalid input signals	Control reaction with Feature2 bit 3 =1
"Automatic mode"	OpenAut = 1 and CloseAut = 1	Valve is set to its neutral position.
"Manual mode"	OpenMan = 1 and CloseMan = 1	

Control system fault (CSF)

An external signal can be activated via the CSF input. A control system fault is triggered if this signal changes to 1. Refer to the Error handling (Page 119) section for more on this.

See also

- Description of VlvS (Page 1377)
- VlvS modes (Page 1379)
- VlvS functions (Page 1381)
- VlvS reporting (Page 1386)
- VlvS I/Os (Page 1388)
- VlvS block diagram (Page 1393)

7.11.5 VlvS reporting

Messaging

The following messages can be generated for this block:

- Process control fault
- Instance-specific messages

Process control fault

Message instance	Message identifier	Message class	Event
MsgEvId1	SIG 1	AS process control message - fault	\$\$BlockComment\$\$ Feedback error
	SIG 2	AS process control message - fault	\$\$BlockComment\$\$ External error has occurred

Explanation:

\$\$BlockComment\$\$: Content of the instance-specific comment

You can interconnect an external fault (signal) to input parameter `CSF`. If it changes to `CSF = 1`, a process control fault is triggered (`MsgEvId1`, SIG 2).

Instance-specific messages

You have the option to use two instance-specific messages for this block.

Message instance	Message identifier	Message class	Event
MsgEvId1	SIG 3	AS process control message - fault	\$\$BlockComment\$\$ External message 1
	SIG 4	AS process control message - fault	\$\$BlockComment\$\$ External message 2

Explanation:

\$\$BlockComment\$\$: Content of the instance-specific comment

Associated values for message instance `MsgEvId1`

Associated value	Block parameters
1	<code>BatchName</code>
2	<code>StepNo</code>
3	<code>BatchID</code>
4	<code>ExtVa104</code>
5	<code>ExtVa105</code>
6 - 10	Reserved

The associated values 4 ... 5 are allocated to the parameters `ExtVa104` ... `ExtVa105` and can be used. Additional information is available in the "Process Control System PCS 7 - Engineering System" manual.

See also

Description of VlvS (Page 1377)

VlvS modes (Page 1379)

7.11 VlvS - Valve (small)

- VlvS functions (Page 1381)
- VlvS error handling (Page 1385)
- VlvS I/Os (Page 1388)
- VlvS block diagram (Page 1393)

7.11.6 VlvS I/Os

I/Os of VlvS

Input parameters

Parameter	Description	Type	Default
AutModLi*	1 = "Automatic mode" via interconnection or SFC (controlled by ModLiOp = 1)	STRUCT <ul style="list-style-type: none"> • Value: BOOL • ST: BYTE 	- <ul style="list-style-type: none"> • 0 • 16#80
AutModOp	1 = "Automatic mode" via operator (controlled by ModLiOp = 1)	BOOL	0
BatchEn	1 = Enable allocation	BOOL	0
BatchID	Batch ID	DWORD	16#00000000
BatchName	Batch name	S7-String	
BypProt	1 = Bypassing interlock is active in "local mode" and in simulation	BOOL	0
CloseAut*	1 = Select Close valve in "automatic mode"	STRUCT <ul style="list-style-type: none"> • Value: BOOL • ST: BYTE 	- <ul style="list-style-type: none"> • 0 • 16#80
CloseMan*	1 = Select Close valve in "manual mode"	BOOL	0
CSF	1 = External error (control system fault) Error handling (Page 119)	STRUCT <ul style="list-style-type: none"> • Value: BOOL • ST: BYTE 	- <ul style="list-style-type: none"> • 0 • 16#80
CtrlChnST	Signal status of output channel <code>Ctrl</code> Should be connected to an output channel block	STRUCT <ul style="list-style-type: none"> • Value: BOOL • ST: BYTE 	- <ul style="list-style-type: none"> • 0 • 16#FF
EN	1 = Called block will be processed	BOOL	1
ExtMsg1	Binary input for freely selectable message 1	STRUCT <ul style="list-style-type: none"> • Value: BOOL • ST: BYTE 	- <ul style="list-style-type: none"> • 0 • 16#80
ExtMsg2	Binary input for freely selectable message 2	STRUCT <ul style="list-style-type: none"> • Value: BOOL • ST: BYTE 	- <ul style="list-style-type: none"> • 0 • 16#80
ExtVa104	Associated value 4 for messages (<code>MsgEvID1</code>)	ANY	

Parameter	Description	Type	Default
ExtVal05	Associated value 5 for messages (MsgEvID1)	ANY	
FaultExt	1 = External error Error handling (Page 119)	STRUCT • Value: BOOL • ST: BYTE	- • 0 • 16#80
FbkOpen	1 = Valve open feedback signal	STRUCT • Value: BOOL • ST: BYTE	- • 0 • 16#FF
FbkClose	1 = Valve closed feedback signal	STRUCT • Value: BOOL • ST: BYTE	- • 0 • 16#FF
Feature	I/O for additional functions (Page 1381)	STRUCT • Bit 0: BOOL • ... • Bit 31: BOOL	- • 0 • 0 • 0
Feature2	I/O for additional functions (Page 1381)	STRUCT • Bit 0: BOOL • ... • Bit 31: BOOL	- • 0 • 0 • 0
Intlock	0 = Interlocking without reset is active; you can operate the block without reset once the interlocking condition has dis- appeared 1 = Interlock not activated	STRUCT • Value:BOOL • ST:BYTE • Bit 1: BOOL (Bypass information bit)	- • 1 • 16#FF • 0
Intl_En	1 = Interlock without reset (interlock, Intlock parameter) is active	BOOL	1
LocalLi	1 = Activate "local mode" via plant signal	STRUCT • Value: BOOL • ST: BYTE	- • 0 • 16#80
LocalSetting	Properties for the Local mode (Page 79)	INT	0
ManModLi*	1 = Manual mode via interconnection or SFC (controlled by ModLiOp = 1)	STRUCT • Value: BOOL • ST: BYTE	- • 0 • 16#80
ManModOp*	1 = Manual mode via: OS operator (con- trolled via ModLiOp = 0)	BOOL	1
ModLiOp	Switchover of operating mode between: 0 = Operator 1 = Interconnection or SFC	STRUCT • Value: BOOL • ST: BYTE	- • 0 • 16#80
Monitor	1 = Feedback monitoring	BOOL	1
MonSafePos	1 = Go to neutral position in the event of monitoring errors	BOOL	1

Motor and valve blocks

7.11 VlvS - Valve (small)

Parameter	Description	Type	Default
MonTiDynamic*	Monitoring time after operation in [s]	REAL	3.0
MS_RelOp*	1= Release for maintenance via OS operator	BOOL	0
MsgEvId1	Message number (assigned automatically)	DWORD	16#00000000
MsgLock	1 = Suppress process messages. See also the section Suppressing messages using the MsgLock parameter (Page 205) for more on this.	STRUCT <ul style="list-style-type: none"> • Value: BOOL • ST: BYTE 	- <ul style="list-style-type: none"> • 0 • 16#80
Occupied	1 = In use by a batch	BOOL	0
OosLi	1 = "Out of service", via interconnection or SFC	STRUCT <ul style="list-style-type: none"> • Value: BOOL • ST: BYTE 	- <ul style="list-style-type: none"> • 0 • 16#80
OosOp*	1 = "Out of service", via OS operator	BOOL	0
OpenAut*	1 = Select Open valve in "automatic mode"	STRUCT <ul style="list-style-type: none"> • Value: BOOL • ST: BYTE 	- <ul style="list-style-type: none"> • 0 • 16#80
OpenMan*	1 = Select Open valve in "manual mode"	BOOL	0
OpSt_In	Input parameter for local operator authorization, connected with the Out output parameter of the upstream block, OpStations (Page 411)	DWORD	16#00000000
OS_Perm	I/O for operator permissions (Page 1381)	STRUCT <ul style="list-style-type: none"> • Bit 0: BOOL • ... • Bit 31: BOOL 	- <ul style="list-style-type: none"> • 1 • 1 • 1
RstLi*	1 = Reset via interconnection	STRUCT <ul style="list-style-type: none"> • Value: BOOL • ST: BYTE 	- <ul style="list-style-type: none"> • 0 • 16#80
RstOp*	1 = Reset via operator	BOOL	0
RunUpCyc	Number of cycles in startup; messages are suppressed during these cycles	INT	3
SampleTime	Sampling time [s] (assigned automatically)	REAL	0.1
SafePos	Neutral position for valve: 1= Open 0 = Closed	BOOL	0
SimOn	1 = Simulation on	BOOL	0
SelFp1	Call a block saved in this parameter as an additional faceplate (Page 208) in the standard view	ANY	
StepNo	Batch step number	DWORD	16#00000000
UserStatus	Freely assignable bits for use in PCS 7 OS	BYTE	16#00

* Values can be written back to these inputs during processing of the block by the block algorithm.

Output parameters

Parameter	Description	Type	Default
AutAct	1 = "Automatic mode" enabled 0 = "Manual mode" is enabled	STRUCT • Value: BOOL • ST: BYTE	- • 0 • 16#80
AutoST	1 = Worst signal status of automatic commands	BYTE	16#80
Ctrl	Control output	STRUCT • Value: BOOL • ST: BYTE	- • 0 • 16#80
Closed	1 = Valve is closed	STRUCT • Value: BOOL • ST: BYTE	- • 0 • 16#80
Closing	1 = Valve is closing	STRUCT • Value: BOOL • ST: BYTE	- • 0 • 16#80
ENO	1 = Block algorithm completed without errors	BOOL	0
ErrorNum	Output of pending error number. For error numbers that can be output by this block, see VlvS error handling (Page 1385)	INT	-1
FbkCloseOut	Valve closed feedback	STRUCT • Value: BOOL • ST: BYTE	- • 0 • 16#80
FbkOpenOut	Valve open feedback	STRUCT • Value: BOOL • ST: BYTE	- • 0 • 16#80
GrpErr	1 = Group error pending	STRUCT • Value: BOOL • ST: BYTE	- • 0 • 16#80
LocalAct	1 = "Local mode" enabled	STRUCT • Value: BOOL • ST: BYTE	- • 0 • 16#80
LockAct	1 = Interlock is active	STRUCT • Value: BOOL • ST: BYTE	- • 0 • 16#80

Motor and valve blocks

7.11 VlvS - Valve (small)

Parameter	Description	Type	Default
ManAct	1 = "Manual mode" enabled	STRUCT <ul style="list-style-type: none"> • Value: BOOL • ST: BYTE 	- <ul style="list-style-type: none"> • 1 • 16#80
MonDynErr	1 = Feedback error due to control change	STRUCT <ul style="list-style-type: none"> • Value: BOOL • ST: BYTE 	- <ul style="list-style-type: none"> • 0 • 16#80
MonStaErr	1 = Feedback error due to unexpected feedback change	STRUCT <ul style="list-style-type: none"> • Value: BOOL • ST: BYTE 	- <ul style="list-style-type: none"> • 0 • 16#80
MS_Release	Release for maintenance: 1 = Release for OS operator	STRUCT <ul style="list-style-type: none"> • Value: BOOL • ST: BYTE 	- <ul style="list-style-type: none"> • 0 • 16#80
OosAct	1 = Block is "Out of service"	STRUCT <ul style="list-style-type: none"> • Value: BOOL • ST: BYTE 	- <ul style="list-style-type: none"> • 0 • 16#80
Opened	1 = Valve is open	STRUCT <ul style="list-style-type: none"> • Value: BOOL • ST: BYTE 	- <ul style="list-style-type: none"> • 0 • 16#80
Opening	1 = Valve is opening	STRUCT <ul style="list-style-type: none"> • Value: BOOL • ST: BYTE 	- <ul style="list-style-type: none"> • 0 • 16#80
OpSt_Out	Value of the OpSt_In input parameter, for feedforwarding to other blocks. Bit 31 of this parameter is used by Feature bit 24	DWORD	16#00000000
OS_PermOut	Display of OS_Perm	DWORD	16#FFFFFFFF
OS_PermLog	Display of OS_Perm with settings changed by the block algorithm	DWORD	16#FFFFFFFF
P_Rst	1= Pulse output for reset The parameter persists for one cycle after a reset.	STRUCT <ul style="list-style-type: none"> • Value: BOOL • ST: BYTE 	- <ul style="list-style-type: none"> • 0 • 16#80
RdyToReset	1 = Ready for reset via RstLi input or commands in "local", "automatic", or "manual mode"	STRUCT <ul style="list-style-type: none"> • Value: BOOL • ST: BYTE 	- <ul style="list-style-type: none"> • 0 • 16#80
RdyToStart	1 = Active start readiness	STRUCT <ul style="list-style-type: none"> • Value: BOOL • ST: BYTE 	- <ul style="list-style-type: none"> • 0 • 16#80
ST_Worst	Worst signal status	BYTE	16#80
Status1	Status word 1 (Page 1377)	DWORD	16#00000000
Status2	Status word 2 (Page 1377)	DWORD	16#00000000
Status3	Status word 3 (Page 1377)	DWORD	16#00000000

See also

VlvS modes (Page 1379)
VlvS block diagram (Page 1393)
VlvS reporting (Page 1386)
Error handling (Page 119)

7.11.7 VlvS block diagram

VlvS block diagram

A block diagram is not provided for this block.

See also

Description of VlvS (Page 1377)
VlvS modes (Page 1379)
VlvS functions (Page 1381)
VlvS error handling (Page 1385)
VlvS I/Os (Page 1388)
VlvS reporting (Page 1386)

7.11.8 Operator control and monitoring

7.11.8.1 VlvS views

Views of the VlvS block

The block VlvS provides the following views:

- VlvS standard view (Page 1394)
- Alarm view (Page 302)
- Trend view (Page 305)
- Parameter view for motors and valves (Page 286)
- VlvS preview (Page 1397)
- Memo view (Page 304)
- Batch view (Page 302)
- VlvS block icon (Page 1399)

Refer to the sections Structure of the faceplate (Page 248) and Block icon structure (Page 230) for general information on the faceplate and block icon.

7.11.8.2 VlvS standard view

VlvS standard view

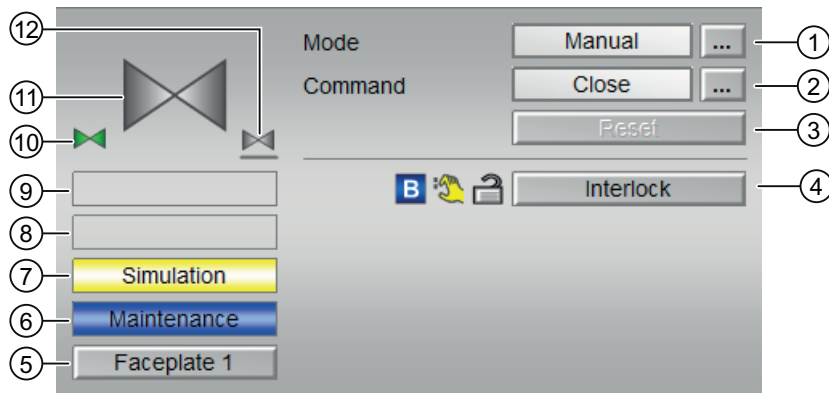

(1) Displaying and switching the operating mode

This area provides information on the currently valid operating mode. The following operating modes can be shown here:

- Manual and automatic mode for motors, valves and dosers (Page 75)
- Manual and automatic mode for motors, valves and dosers (Page 75)
- Local mode (Page 79)
- Out of service (Page 71)

Refer to section Switching operating states and operating modes (Page 257) for information on switching the operating mode.

(2) Opening and closing the valve

This area shows you the default operating state for the valve. The following states can be shown and executed here:

- "Open"
- "Close"

Refer to the Switching operating states and operating modes (Page 257) section for information on changing the state.

If text is configured for these commands, it is displayed as status text and as button labels for command selection. You can find more information about this in section Labeling of buttons and text (Page 209)

(3) Resetting the block

Click "Reset" for errors. You can find additional information on this in the section Resetting the block in case of interlocks or errors (Page 43).

(4) Operating range for the interlock functions of the block

This display is only visible when the corresponding block input is connected.

You can use this button to control the interlock functions of the block. You can find additional information on this in the section Interlocks (Page 99).

The following is displayed in addition to the buttons:

- Interlock status (see Forming the group status for interlock information (Page 104)), e.g.:



- Signal status (see Forming and outputting the signal status for technologic blocks (Page 109)), e.g.:



- Bypass information (see Forming the group status for interlock information (Page 104)):



(5) Navigation button for switching to the standard view of any faceplate

This display is only visible when the corresponding block input is connected.

Use this navigation button to open the standard view of a block configured in the engineering system (ES). The visibility of this navigation button depends on the configuration in the engineering system (ES).

You can find additional information on this in the section Opening additional faceplates (Page 208).

(6) Display area for block states

This area provides additional information on the operating state of the block:

- "Maintenance"

Additional information on this is available in section Release for maintenance (Page 64) Display area for block states.

(7) Display area for block states

This area provides additional information on the operating state of the block:

- "Simulation"

You can find additional information on this in the section Simulating signals (Page 58).

(8) Display area for block states

This area provides additional information on the operating state of the block:

- "External error"
- "End position error"
- "Control error"
- "Invalid signal"

Additional information on these errors is available in the sections Monitoring the feedbacks (Page 97) , Error handling (Page 119) (section "Invalid input signals" and "Mode switchover error") and Motor protection function (Page 99).

(9) Display area for block states

This area provides additional information on the operating state of the block:

- "Request 0/1": A reset to "automatic mode" is expected.

You can find additional information on this in the section Forcing operating modes (Page 41).

(10) Automatic preview

This display is only visible in "manual mode", in "local mode", or with a reset request in "automatic mode", when the current output signals are not identical to the control in "automatic mode".

The display shows what state the valve would assume if you switched from "manual" or "local" mode to "automatic mode", or performed a reset to "automatic mode".

(11) Status display of the valve

The current status of the valve is graphically displayed here.

- Green: Valve is open
- Gray: Valve is closed
- Red: Fault at valve

You can find more information about this in section VlvS block icon (Page 1399)

(12) Neutral position of the valve

Display the neutral position for the valve:

- If the neutral position of the valve is "Closed" (`SafePos = 0`) , , a gray valve is shown.
- If the neutral position of the valve is "Open" (`SafePos = 1`), a green valve is shown.

See also

Displaying auxiliary values (Page 211)

7.11.8.3 VlvS preview

Preview of VlvS

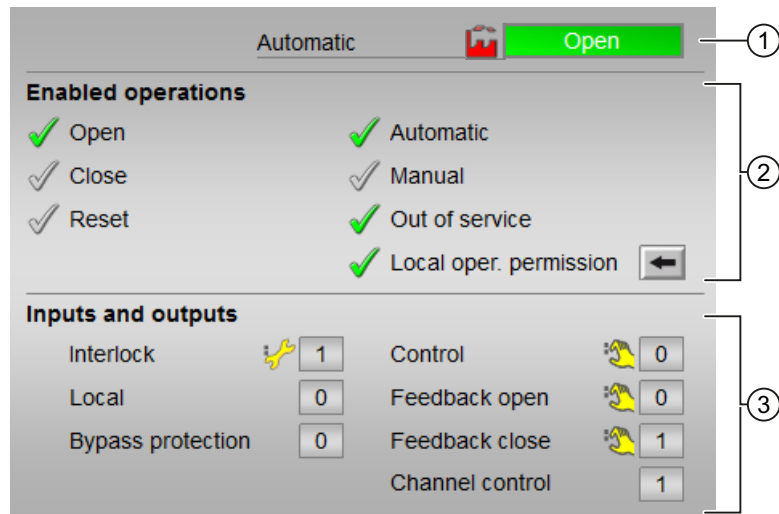

(1) Automatic preview

This area shows you the block status after it has switched from the "Manual" mode or "Local" mode to the "Automatic" mode.

If the block is in "Automatic" mode, the current block state is displayed.

This area also displays the worst signal status of the following automatic commands:

- OpenAut
- CloseAut

(2) Enable operations

This area shows all operations for which special operator permissions are assigned. They depend on the configuration in the engineering system (ES) that applies to this block.

Icons for enabled operation:

- **Green check mark:** the OS operator can control this parameter
- **Gray check mark:** the OS operator cannot control this parameter at this time due to the process
- **Red cross:** the OS operator cannot control this parameter due to the configured AS operator permissions (OS_Perm or OS1Perm)

The following enabled operations are shown here:

- "Open": You can open the valve.
If text is configured for this command, it is also displayed in brackets. You can find additional information on this in the section Labeling of buttons and text (Page 209).
- "Close": You can close the valve.
If text is configured for this command, it is also displayed in brackets. You can find additional information on this in the section Labeling of buttons and text (Page 209).
- "Reset": You can reset the valve if interlocks or errors occur.
- "Automatic": You can switch to "automatic mode".
- "Manual": You can switch to "manual mode".
- "Out of service": You can switch to "Out of service" operating mode.
- "Local operator permission": Use the ← button to switch to the standard view of the OpStations block. You can find additional information on this in the section Labeling of buttons and text (Page 209) .

(3) Displaying current control signals

This area shows the most important parameters for this block with the current selection:

- "Interlock":
This display is only visible when the corresponding block input is connected.
 - 0 = Interlocking without reset is active; you can operate the block without reset once the interlocking condition has disappeared
 - 1 = "Good" state
- "Local correct": 1 = Control signal for "Local mode" (LocalLi) is active
- "Interlock deact.":
 - 0 = Bypass disabled
 - 1 = Bypassing interlock in "local mode" and in "simulation"
- "Control": Display for valve control:
 - 0 = Valve is closing
 - 1 = Valve is opening
- "Feedback open": 1 = Valve is open
- "Feedback close": 1 = Valve is closed
- "Channel Control": Control signal of the output channel block

See also

Operator control permissions (Page 254)





7.11.8.4 VlvS block icon

Block icons for VlvS

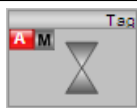

A variety of block icons are available with the following functions:



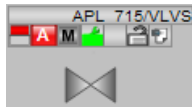

- Process tag type
- Violation of alarm, warning, and tolerance limits as well as control system faults
- Operating modes
- Signal status, release for maintenance
- Displays for bypassing interlocks
- Interlocks
- Memo display
- Valve status display

The block icons from template @TemplateAPLV8.PDL:

Icons	Selection of the block icon in CFC	Special features
	1	
	2	
	3	Non-rotating block icon
	4	Non-rotating block icon

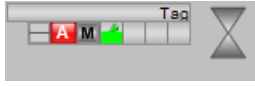
The block icons from template @TemplateAPLV7.PDL:

Icons	Selection of the block icon in CFC	Special features
	1	Block icon in the full display
	2	







Icons	Selection of the block icon in CFC	Special features
	3	
	4	
	5	
	6	
	-	Block icon in "Out of service" mode (example with type 1 block icon)

Additional information on the block icon and the control options in the block icon is available in the following chapters:

- Configuring the block icons (Page 237)
- Block icon structure (Page 230)
- Operation via the block icon (Page 239)

Valve status display

The following valve states are shown here:

Symbol	Meaning
	Valve open
	Valve closed
	Error at valve
	Valve is opening
	Valve is closing
	Valve closed
	Valve is closing

7.12 VlvMotL - Motor valve

7.12.1 Description of VlvMotL

Object name (type + number) and family

Type + number: FB 1900

Family: Drives

Area of application for VlvMotL

The block is used for the following applications:

- Motor valve control

How it works

Various operating modes are available for controlling the motor-driven valve. This functionality allows you to set specific valve states. All changes of modes or states and faults occurring in this context are monitored, visualized in the faceplate and reported to the operator. Operators with suitable permissions can use the block icon and the faceplate to view the current states of the motor-driven valve and to operate it.

Configuration

Use the CFC editor to install the block in a cyclic interrupt OB (OB30 to OB38). The block is also installed automatically in the startup OB (OB100).

For the VlvMotL block, the Advanced Process Library contains templates for process tag types as examples with various application scenarios for this block.

Examples of process tag types:

- Step controller with assigned actuator block and position feedback (StepControlActor) (Page 2334)
- Motor valve (ValveMotor) (Page 2369)

Startup characteristics

Use the `Feature Bit Set` startup characteristics (Page 138) to define the startup characteristics of this block.

The messages are suppressed after startup for the number of cycles set at `RunUpCyc`.

After a startup without control (`Open, Close = 0`), no monitoring of the feedback signals `FbkOpen` and `FbkClose` takes place during the `V_MonTiStatic` time. Changes to `FbkOpen` and `FbkClose` are applied. This means that the feedback is monitored again, also in stop state.

Status word allocation for status1 parameter

You can find a description for each parameter in section VlvMotL I/Os (Page 1421).

Status bit	Parameter
0	Occupied
1	BatchEn
2	SimOn
3	OosAct.Value
4	OosLi.Value
5	AutoAct.Value
6	LocalAct.Value
7	0: Open padlock in the block icon 1: Closed padlock in the block icon With Feature2.Bit16 = 1, a closed padlock is displayed if "Interlock Open" or "Interlock Close" is active.
8	Open.Value
9	Motor is stopped
10	Close.Value
11	Torque shutdown enabled (TorqOpen or TorqClose = 1) When the seal valve function is enabled, the torque shutoff is only active if the TorqClose signal is enabled before the valve feedback.
12	WarnAct.Value or IdleTime active
13	Feedback error without control change
14	Feedback error due to control change
15	Mode Switch Fail
16	1 = Intlock is active
17	1 = Permit is active
18	1 = Protect is active
19	Trip.Value
20	Display „Forced open“
21	Display „Forced stop“
22	Display „Forced close“
23	"Interlock" button is enabled
24	0 = Display neutral position "Closed" 1 = Display neutral position "Open"
25	1 = Display neutral position "Stop"
26	Bypass information from previous function block
27	Bypass enabled (ByProt = 1) and Local.Act = 1 or SimOn = 1
28	Invalid signal status
29	0 = closed 1 = open
30	"Permission" button is enabled
31	"Protection" button is enabled

Status word allocation for Status2 parameter

Status bit	Parameter
0	MsgLock
1	AV_AH_Act.Value
2	AV_WH_Act.Value
3	AV_TH_Act.Value
4	AV_TL_Act.Value
5	AV_WL_Act.Value
6	AV_AL_Act.Value
7	AV_AH_En
8	AV_WH_En
9	AV_TH_En
10	AV_TL_En
11	AV_WL_En
12	AV_AL_En
13	AV_AH_MsgEn
14	AV_WH_MsgEn
15	AV_TH_MsgEn
16	AV_TL_MsgEn
17	AV_WL_MsgEn
18	AV_AL_MsgEn
19	1 = No impact of input signals on "local mode" with LocalSetting = 2 and LocalSetting = 4
20	1 = Valve closes
21	1 = Valve closed
22	1 = Valve stopped
23	1 = Valve opens
24	1 = Valve open
25	For the Error status display in the Closed valve
26	For the Error status display in the Opened valve
27	Automatic preview for "opening"
28	Automatic preview for "closing"
29	Automatic preview for "stopping"
30	Display for interlocks in block icon
31	MS_RelOp

Status word allocation for Status3 parameter

Status bit	Parameter
0	M_MonStaErr.Value
1	M_MonDynErr.Value
2	V_MonStaErr.Value
3	V_MonDynErr.Value

Status bit	Parameter
4	M_MonStopErr.Value
5-7	Not used
8	Reset request in automatic
9	External error generated by FaultExt or external control system fault from CSF with set Feature bit 18 Activating error state for external process control error CSF (Page 151)
10	Not used
11	Motor protection display (Trip.Status ≠ 16#FF)
12	1 = Input parameter FbkClose is connected
13	1 = Input parameter FbkClosing is connected
14	1 = Input parameter FbkOpen is connected
15	1 = Input parameter FbkOpening is connected
16	1 = Input parameter TorOpen is connected
17	1 = Input parameter TorClose is connected
18	SimLiOp.Value
19	1 = Enable for "rapid stop"(Feature Bit Enabling rapid stop via faceplate (Page 168))
20	1 = Input parameter OpenChnST is interconnected
21	1 = Input parameter CloseChnST is interconnected
22	Not used
23	Command for "rapid stop"
24	"Open"/"Stop" command
25	"Close"/"Stop" command
26	Show automatic preview in the standard view
27	Not used
28	GrpErr.Value
29	RdyToStart.Value
30	Auxiliary value 1 visible
31	Auxiliary value 2 visible

Status word allocation for status4 parameter

Status bit	Parameter
0	Effective signal 1 of the message block connected via EventTsIn
1	Effective signal 2 of the message block connected via EventTsIn
2	Effective signal 3 of the message block connected via EventTsIn
3	Effective signal 4 of the message block connected via EventTsIn
4	Effective signal 5 of the message block connected via EventTsIn
5	Effective signal 6 of the message block connected via EventTsIn
6	Effective signal 7 of the message block connected via EventTsIn
7	Effective signal 8 of the message block connected via EventTsIn
8	AV not connected
9	Delay of the AV_AH_Lim message

Status bit	Parameter
10	Delay of the AV_WH_Lim message
11	Delay of the AV_TH_Lim message
12	Delay of the AV_TL_Lim message
13	Delay of the AV_WL_Lim message
14	Delay of the AV_AL_Lim message
15	Collection of message delays
16	"Permission Open" button is enabled
17	"Permission Close" button is enabled
18	"Interlock Open" button is enabled
19	"Interlock Close" button is enabled
20	"Protection Open" button is enabled
21	"Protection Close" button is enabled
22	1 = "Permission Close" is active
23	Hidden bypass signal in Permit
24	Hidden bypass signal in interlock
25	Hidden bypass signal in Protect
26	Feature2 bit 2: Separate bypass signal
27	1 = "Interlock Close" is active
28	1 = "Protection Close" is active
29	Current motor monitoring time is visible
30	Current valve monitoring time is visible
31	Separate monitoring of shutdown of the motor (Feature bit 13)

Status word allocation for status5 parameter

Status bit	Parameter
0 - 7	Effective signal 9..16 of the message block connected via EventTsIn
8	1 = Valve still closes (Status2 Bit 20) but the motor is not running
9	1 = Valve still opens (Status2 Bit 23) but the motor is not running
10	Hidden bypass signal in "Permission Close"
11	Hidden bypass signal in "Interlock Close"
12	Hidden bypass signal in "Protection Close"
13	Feature2.Bit16 Separate interlock for each direction or position (Page 170)
14 - 15	Not used
16 - 31	Effective signal 1...16 of the message block connected via EventTs2In

See also

- VlvMotL functions (Page 1407)
- VlvMotL messaging (Page 1420)
- VlvMotL block diagram (Page 1432)

VivMotL error handling (Page 1418)

VivMotL modes (Page 1406)

7.12.2 VivMotL modes

VivMotL operating modes

The block supports all standard modes:

- Local mode (Page 79)
- Automatic mode (Page 75)
- Manual mode (Page 75)
- Out of service (Page 71)

The next section provides additional block-specific information relating to the general descriptions.

"Local mode"

You can find general information on "Local mode", switching modes and Bumpless switchover in the Local mode (Page 79) section.

Motor valve actions you can control in "local mode"

- "Open" (`OpenLocal = 1`)
- "Close" (`CloseLocal = 1`)
- "Stop" (`StopLocal = 1`).

A block operated in "local mode" is controlled either by "local" signals or by feedback signals (input parameters `FbkOpen` and `FbkClose`; if no position can be assigned, the last valid position is accepted). Configuration takes place via the input parameter `LocalSetting`.

"Automatic mode"

You can find general information on "Automatic mode", switching modes and Bumpless switchover in the Manual and automatic mode for motors, valves and dosers (Page 75) section.

Motor valve actions you can control in "automatic mode":

- "Open" (`OpenAut = 1`)
- "Close" (`CloseAut = 1`)
- "Stop" (`StopAut = 1`)

"Manual mode"

You can find general information on "Manual mode", switching modes and bumpless switchover in the section Manual and automatic mode for motors, valves and dosers (Page 75).

Motor valve actions you can control in "manual mode":

- "Open" (OpenMan = 1)
- "Close" (CloseMan = 1)
- "Stop" (StopMan = 1)

"Out of service"

You can find general information about the "Out of service" mode in the section Out of service (Page 71).

See also

VlvMotL block diagram (Page 1432)

VlvMotL I/Os (Page 1421)

VlvMotL error handling (Page 1418)

VlvMotL functions (Page 1407)

VlvMotL messaging (Page 1420)

Description of VlvMotL (Page 1401)

7.12.3 VlvMotL functions

Functions of VlvMotL

The functions for this block are listed below.

Opening additional faceplates

This block provides the standard function Opening additional faceplates (Page 208).

Operator permissions

This block provides the standard function Operator control permissions (Page 254).

The block has the following permissions for the OS_Perm parameter:

Bit	Function
0	1 = Operator can switch to "automatic mode"
1	1 = Operator can switch to "manual mode"

Bit	Function
2	1 = Operator can switch to "local mode"
3	1 = Operator can switch to "Out of service" mode
4	1 = Operator can stop the motor
5	1 = Operator can open the valve
6	1 = Operator can close the valve
7	1 = Operator can reset the valve
8	1 = Operator can define the monitoring time for the valve startup
9	1 = Operator can define the monitoring time for the end position of the valve
10	1 = Operator can enable the monitoring time function of the valve (Bit 8 - 9)
11	1 = Operator can define or change the monitoring time for startup
12	1 = Operator can define the monitoring time for the motor status
13	1 = Operator can enable the monitoring time function of the motor (Bit 8 - 9)
14	1 = Operator can activate the Simulation function
15	1 = Operator can activate the Release for maintenance function
16	1 = Operator can change the limit (AV) for high alarm
17	1 = Operator can change the limit (AV) for high warning
18	1 = Operator can change the limit (AV) for high tolerance
19	1 = Operator can change the limit (AV) for hysteresis
20	1 = Operator can change the limit (AV) for low alarm
21	1 = Operator can change the limit (AV) for low warning
22	1 = Operator can change the limit (AV) for low tolerance
23	1 = Operator can activate / deactivate messages via AV_AH_MsgEn
24	1 = Operator can activate / deactivate messages via AV_WH_MsgEn
25	1 = Operator can activate / deactivate messages via AV_TH_MsgEn
26	1 = Operator can activate / deactivate messages via AV_TL_MsgEn
27	1 = Operator can activate / deactivate messages via AV_WL_MsgEn
28	1 = Operator can activate / deactivate messages via AV_AL_MsgEn
29	1 = Operator can change the simulation value SimAV
30	1 = Operator can define the monitoring time for stopping
31	Not used

Note

If you interconnect a parameter that is also listed in OS_Perm as a parameter, you have to reset the corresponding OS_Perm bit.

Restart lock after changing direction of rotation or switching off the motor

Use the input parameter IdleTime to enter a restart lock for changing the direction of rotation or restarting the motor. When the "Stop" command is given, the motor goes immediately into "Stop" mode, and IdleTime starts after the feedback (FbkOpening and FbkClosing = 0) is given. The motor cannot be started again (open or close) until the IdleTime has expired.

Limit monitoring of an additional analog value

This block provides the standard function Limit monitoring of an additional analog value (Page 91).

Limit monitoring with hysteresis

This block provides the standard function Limit monitoring with hysteresis (Page 97). It is performed via the input parameter `AV_Hyst`.

Suppressing messages using the `MsgLock` parameter

This block provides the standard function Suppressing messages using the `MsgLock` parameter (Page 205).

Interlocks

This block provides the following interlocks:

- `Feature2.Bit16 = 0`
 - Activation enable ("Permission")
 - Interlock without reset ("Interlock")
 - Interlock with reset ("Protection")
- `Feature2.Bit16 = 1`
 - Activation enable Open ("Permission Open")
 - Activation enable Close ("Permission Close")
 - Interlock open without reset ("Interlock Open")
 - Interlock close without reset ("Interlock Close")
 - Interlock open with reset ("Protection Open")
 - Interlock close with reset ("Protection Close")

Refer to the section Interlocks (Page 99) as well as Influence of the signal status on the interlock (Page 103).

Motor protection function

This block provides the standard function Motor protection function (Page 99).

Rapid stop for motors

This block provides the standard function Rapid stop for motors (Page 106).

Torque monitoring

The block provides torque monitoring.

The signals of the torque monitoring switches are interconnected to input parameters `TorqOpen` and `TorqClose` for opening and closing the motor valve.

An active torque shutdown is displayed in the parameter either by the value 0 or by the signal status 16#00 or 16#28.

If the torque shutdown is active, the motor is stopped. You have the option of moving the valve in the opposite direction.

If, for example, the torque shutdown is active when the valve opens, you can still close the valve.

Active torque shutoff appears in the standard view of the display area for block states.

When the "Seal valve" function is enabled via Feature bit 8, the torque shutoff for the closing `TorqClose` is also evaluated (see section Sealing the valve).

Reset of motor control after valve end position has been reached

After a motor control in the direction of one of the end positions, open or closed, the valve is opened or closed accordingly. After the end position is reached, the block is notified of this via the `FbkOpen` or `FbkClose` input. The `Feature` bit Motor stop in end position depends only on the corresponding feedback signal (Page 185) can affect the dependencies of the feedback signals to downscale the motor in the end position.

Note

If you deactivate one of the valve feedback signals via the inputs `NoFbkOpen`, `NoFbkClose`, the corresponding valve feedback signal `FbkOpen`, `FbkClose` for the motor switch off in the end position is no longer evaluated. After the valve monitoring time `V_MonTiDynamic` has expired, the corresponding output of the valve feedback signal `FbkOpenOut`, `FbkCloseOut` is set and the associated motor control `Open`, `Close` is reset again.

In the case of missing valve feedback signals, the corresponding signals of the torque monitoring with the inputs `TorqOpen` or `TorqClose` must be used.

Sealing the valve

The function is activated via `Featurebit 8` Sealing the valve (Page 176). The seal valve function combines the query of the end position `CLOSED` via the input parameter `FbkClose` with the limit violation of the configured torque via the input parameter `TorqClose`. This ensures that the valve is completely sealed.

The valve is only considered completely sealed when the feedback for the end position `CLOSE` has been received (0->1) and the torque cutoff for Closed is enabled. The torque shutoff should not come before the feedback in this case. The `FbkCloseOut` output shows whether the valve is sealed:

```
FbkCloseOut := FbkClose.Value has been received (0->1)
              And "Torque shutoff closed is enabled"
```

And "Torque shutoff closed is enabled" did not come before `FbkClose` (0->1)
"Torque shutoff closed is enabled" means that `TorqClose` = 0 or the signal status is 16#00 or 16#28.

When "Torque shutoff closed is enabled" comes before the end position feedback closed, this is displayed in the faceplate in the standard view and the motor stops. Opening the valve is still possible.

Note

The command text for Close in the standard view and preview can be changed to Seal in the CFC at the `CloseMan` parameter in Text 1. See Section Labeling of buttons and text (Page 209)

Disabling interlocks

This block provides the standard function Disabling interlocks (Page 103).

Resetting the block in case of interlocks

This block provides the standard function Resetting the block in case of interlocks or errors (Page 43).

External error (`FaultExt`), external control system fault (`CSF`)

This block provides the possibility to pass an external error via the `FaultExt` parameter or an external control system fault via the `CSF` parameter. See VlvMotL error handling (Page 1418)

Group error

This block provides the standard function Outputting group errors (Page 122).

The following parameters are taken into consideration when forming the group error:

- `CSF`
- `Trip`
- `V_MonDynErr`
- `V_MonStaErr`
- `M_MonDynErr`
- `M_MonStaErr`
- `FaultExt`

Outputting a signal for start readiness

This block provides the standard function Outputting a signal for start readiness (Page 53).

Forming the group status for interlocks

This block provides the standard function Forming the group status for interlock information (Page 104).

Forming the signal status for blocks

This block provides the standard function Forming and outputting the signal status for technologic blocks (Page 109).

The worst signal status for the block is formed from the following parameters:

- FbkClsgOut.ST
- FbkOpngOut.ST
- FbkOpenOut.ST
- FbkCloseOut.ST
- LocalLi.ST
- OpenLocal.ST
- StopLocal.ST
- TorqClose.ST
- CloseLocal.ST
- Trip.ST
- TorqOpen.ST
- AV_Out.ST
- OpenChn.ST
- CloseChn.ST
- OpenAut.ST (only if Feature2.Bit10 = 1)
- CloseAut.ST (only if Feature2.Bit10 = 1)
- StopAut.ST (only if Feature2.Bit10 = 1)

Considering bad quality of automatic commands or external values

If the Feature2 bit Considering bad quality of automatic commands or external values (Page 186) is set to 1 and one of the following parameters has bad signal status (16#00 or 16#28), the block goes to the neutral position in the "Automatic" mode:

- OpenAut.ST
- CloseAut.ST
- StopAut.ST

Forcing operating modes

This block provides the standard function Forcing operating modes (Page 41). Inputs OpenForce and CloseForce and StopForce force the block to open, close or stop.

Feedback monitoring

This block provides the standard function Monitoring the feedbacks (Page 97).

The `FbkOpen` and `FbkClose` feedback is monitored for the valve; the `FbkOpening` and `FbkClosing` feedback is monitored for the motor.

The monitoring of the feedback for the valve will not be active if it was stopped during opening or closing.

Monitoring valve feedback

The monitoring of valve feedback is set using the parameter `V_Monitor`.

Startup characteristics are monitored by setting parameter `V_MonTiDynamic`. The parameter `V_MonTiStatic` monitors compliance with the position.

Feedback errors are displayed at the corresponding parameters `V_MonDynErr` and/or `V_MonStaErr`.

Note

After the motor valve stops in the intermediate position or end position or after a startup without control (`Open, Close = 0`)" no monitoring of the feedback signals `FbkOpen` and `FbkClose` takes place during the `V_MonTiStatic` time. Changes to `FbkOpen` and `FbkClose` are applied. This means that the feedback is monitored again, also in stop state.

Note

When the "Seal valve" function is enabled via Feature bit 8, the torque shutoff for closing `TorqClose` is also evaluated (see section Sealing the valve (Page 176)).

Monitoring the motor feedback

The monitoring of motor feedback is set using the parameter `M_Monitor`.

Startup characteristics are monitored by setting parameter `M_MonTiDynamic`. The parameter `M_MonTiStatic` monitors compliance with the position.

Feedback errors are displayed at the corresponding parameters `M_MonDynErr` and/or `M_MonStaErr`.

Disabling feedback

This block provides the standard function Disabling feedback for valves (Page 99). Feedback monitoring can be deactivated separately for each feedback with `NoFbkOpen` or `NoFbkClose` as required.

Tracking the valve position after a motor stop or after a startup

Because of vibration or mass inertia after a motor stop the block tracks the valve position for the time `V_MonTiStatic`. During this time the static feedback monitoring is not active. The monitoring starts after the time `V_MonTiStatic`.

- Motor is stopped in end position open (`FbkOpen =1, FbkClose =0`):
Open and intermediate position will be tracked.
`FbkOpen =1, FbkClose =0`: valve goes to open position
`FbkOpen =0, FbkClose =0`: valve goes to intermediate position
- Motor is stopped in intermediate position (`FbkOpen =0, FbkClose =0`):
Open, Close and intermediate position can be tracked.
`FbkOpen =1, FbkClose =0`: valve goes to open position
`FbkOpen =0, FbkClose =0`: valve goes to intermediate position
`FbkOpen =0, FbkClose =1`: valve goes to close position
- Motor is stopped in end position close (`FbkOpen =0, FbkClose =1`):
Close and intermediate position can be tracked.
`FbkOpen =1, FbkClose =0`: valve goes to open position
`FbkOpen =0, FbkClose =0`: valve goes to intermediate position

Because of preparing the feedback signals after startup the block tracks the valve position for the time `V_MonTiStatic`.

- Open, Close and intermediate position can be tracked.
`FbkOpen =1, FbkClose =0`: valve goes to open position
`FbkOpen =0, FbkClose =0`: valve goes to intermediate position
`FbkOpen =0, FbkClose =1`: valve goes to close position

Note

After resetting the block, in the case of interlocks or errors, the valve position will always be tracked, depending on `FbkOpen` and `FbkClose`.

Release for maintenance

This block provides the standard function Release for maintenance (Page 64).

Specify warning times for control functions

This block provides the standard function Specifying warning times for control functions at motors and valves (Page 51).

You can generate warning signals when, for example, valves open. Warning signals can be generated in the following modes:

- Manual and automatic mode for motors, valves and dosers (Page 75) (Input parameter `WarnTiMan`)
- Manual and automatic mode for motors, valves and dosers (Page 75) (Input parameter `WarnTiAut`)

You specify the warning times in seconds using the input parameters `WarnTiMan` and `WarnTiAut`. If, for example, a valve opens, this is displayed at the output parameter with `WarnAct = 1`. The valve then opens after the set warning time has expired and `WarnAct` then returns to `0`.

A corresponding warning is not output if the warning times (`WarnTiMan` or `WarnTiAut`) are specified with a smaller value than the `SampleTime` parameter.

Note

The warning is activated for each actuation that causes the motor to start, even if this means that the valve is moved to the neutral position

Simulating signals

This block provides the standard function *Simulating signals* (Page 58).

You can simulate the following values:

- Additional value (`SimAV`, `SimAV_Li`)

In the case of internal simulation with immediate tracking of feedback, it is possible to simulate a position between the open and closed state (`FbkOpenOut = FbkCloseOut = 0`) by means of a stop command.

Selecting a unit of measure

This block provides the standard function *Selecting a unit of measure* (Page 212).

Neutral position

This block provides the standard function *Neutral position for motors, valves and controllers* (Page 48).

Output signal as a pulse signal or static signal

This block provides the standard function *Output signal as a static signal or pulse signal* (Page 51). In addition to the static control outputs `Open` and `Close`, the block also has pulse outputs `P_Open`, `P_Close`, and `P_Stop`, which are dependent on the static control output.

Generating instance-specific messages

This block provides the standard function *Generating instance-specific messages* (Page 204).

Configurable reactions using the Feature parameter

You can find an overview of all reactions provided by the Feature parameter in the Configurable functions using the Feature I/O (Page 131) . The following functionality is available for this block at the relevant bits:

Bit	Function
0	Set startup characteristics (Page 138)
1	Reaction to the out of service mode (Page 177)
2	Resetting the commands for changing the mode (Page 161)
3	Enabling resetting of commands for the control settings (Page 161)
4	Setting switch or button mode (Page 167)
8	Sealing the valve (Page 176)
9	Resetting via input signals in the event of interlocking (Protection) or errors (Page 163)
10	Exiting local mode (Page 177)
11	Activating the run time of feedback signals (Page 153)
12	Motor feedback is not available (Page 157)
13	Separate monitoring time for stopping the motor (Page 169)
14	Enabling rapid stop via faceplate (Page 168)
15	Motor stop in end position depends only on the corresponding feedback signal (Page 185)
17	Enabling bumpless switchover to automatic mode for valves, motors, and dosers (Page 173)
18	Activating error state for external process control error CSF (Page 151)
19	Reset even with locked state (Page 165)
20	Disable calculation of impulse control in LocalSetting 2 and 4 (Page 186)
21	Enable bumpless switchover to "Automatic" mode for operator only (Page 172)
22	Update acknowledgment and error status of the message call (Page 160)
24	Enabling local operator authorization (Page 158)
25	Suppression of all messages (Page 174)
26	Reaction of the switching points in the "Out of service" operating mode (Page 176)
27	Interlock display with LocalSetting 2 or 4 (Page 178)
28	Disabling operating points (Page 145)
29	Signaling limit violation (Page 170)
30	Set reset depending on the operating mode or the LiOp parameter (Page 163)
31	Activating reset of protection / error in manual mode (Page 165)

In switching mode (Bit 4 = 1), control is selected with the static signals `OpenAut` and `CloseAut`. If the `OpenAut` and `CloseAut` inputs are not set, the motor is stopped. Control via `StopAut` is not needed. If the "Activate command reset for control" function (Bit 3 = 1) is activated, the inputs `OpenAut` and `CloseAut` are reset to 0 after evaluation in the block.

Displaying auxiliary values

This block provides the standard function Displaying auxiliary values (Page 211).

Configurable reactions using the Feature2 parameter

Bit	Function
2	Separate evaluation for excluded and simulated interlock signals (Page 152)
3	Control priority in the event of an invalid input command (Page 175)
4	Setting switch or button mode for local commands (Page 181)
5	Evaluation of the signal status of the interlock signals (Page 142)
8	Forcing operating modes in the "Local" mode (Page 184)
10	Considering bad quality of automatic commands or external values (Page 186)
11	Suppress MsgLock and "Out of service" mode for a connected message block (Page 188)
16	Separate interlock for each direction or position (Page 170)

Connection of the time-stamped messages from EventTs or Event16Ts

This block provides the standard function Connection of the time-stamped messages from EventTs or Event16Ts (Page 207).

SIMATIC BATCH functionality

This block provides the standard function SIMATIC BATCH functionality (Page 67).

Button labels

This block provides the standard function Labeling of buttons and text (Page 209)

Instance-specific text can be configured for the following parameters:

- OpenMan
- CloseMan
- StopMan
- RapidStp

See also

Description of VlvMotL (Page 1401)

VlvMotL messaging (Page 1420)

VlvMotL I/Os (Page 1421)

VlvMotL block diagram (Page 1432)

VlvMotL modes (Page 1406)

EventTs functions (Page 1660)

7.12.4 VlvMotL error handling

Error handling of VlvMotL

Refer to section Error handling (Page 119) in the basic instructions for the error handling of all blocks.

The following errors can be displayed for this block:

- Error numbers
- Mode switchover error
- Invalid input signals
- Control system fault (CSF)

Overview of error numbers

The `ErrorNum` I/O can be used to output the following error numbers:

Error number	Meaning of the error number
-1	Predefined value when inserting the block; the block is not executed
0	There is no error.
41	The value for the <code>LocalSetting</code> I/O is not within the approved limit of 0 to 4.
42	<code>LocalSetting = 0</code> or <code>LocalSetting = 3</code> or <code>LocalSetting = 4</code> and <code>LocalLi = 1</code>
51	<code>OpenLocal = 1</code> and <code>StopLocal = 1</code> <code>CloseLocal = 1</code> and <code>StopLocal = 1</code> <code>OpenLocal = 1</code> and <code>CloseLocal = 1</code> <code>OpenAut = 1</code> and <code>StopAut = 1</code> <code>CloseAut = 1</code> and <code>StopAut = 1</code> <code>OpenAut = 1</code> and <code>CloseAut = 1</code> <code>AutModLi = 1</code> and <code>ManModLi = 1</code> <code>OpenForce = 1</code> and <code>StopForce = 1</code> <code>CloseForce = 1</code> and <code>StopForce = 1</code> <code>OpenForce = 1</code> and <code>CloseForce = 1</code>
52	<code>LocalAct = 1</code> and <code>LocalSetting = 2</code> or <code>4</code> and <code>SimOn = 1</code>

Mode switchover error

This error can be output by the block, see the section Error handling (Page 119).

Invalid input signals

This error can be output by the block, see the section Error handling (Page 119).

For the following invalid input signals, the control output can be kept or switched to the neutral position. This depends on the function Control priority in the event of an invalid input command (Page 175).

Operating mode	Invalid input signals	Control reaction with Feature2 bit 3 =1
Local: Localsetting = 1 or Localsetting = 3	Pushbutton operation for local mode (Feature2 bit 4 = 0): OpenLocal = 1 and CloseLocal = 1 or OpenLocal = 1 and StopLocal = 1 or StopLocal = 1 and CloseLocal = 1 Switching mode (Feature2 bit 4 = 1): OpenLocal = 1 and CloseLocal = 1	Motor is started in valve neutral position direction.
Local: Localsetting = 1 or Localsetting = 3 and forcing	OpenForce = 1 and CloseForce = 1 or OpenForce = 1 and StopForce = 1 or StopForce = 1 and CloseForce = 1	
Forcing and no "local mode"	OpenForce = 1 and CloseForce = 1 or OpenForce = 1 and StopForce = 1 or StopForce = 1 and CloseForce = 1	
"Automatic mode" and no forcing	Pushbutton operation (Feature bit 4 = 0): OpenAut = 1 and CloseAut = 1 or OpenAut = 1 and StopAut = 1 or StopAut = 1 and CloseAut = 1 Switching mode (Featurebit 4 = 1): OpenAut = 1 and CloseAut = 1	
"Manual mode" and no forcing	OpenMan = 1 and CloseMan = 1 or OpenMan = 1 and StopMan = 1 or StopMan = 1 and CloseMan = 1	

Control system fault (CSF)

An external signal can be activated via the CSF input. A control system fault is triggered if this signal changes to 1. Refer to the Error handling (Page 119) section for more on this.

See also

- VlvMotL block diagram (Page 1432)
- VlvMotL I/Os (Page 1421)
- VlvMotL functions (Page 1407)
- VlvMotL modes (Page 1406)
- Description of VlvMotL (Page 1401)

7.12.5 VivMotL messaging

Messaging

The following messages can be generated for this block:

- Process control fault
- Instance-specific messages

Process control fault

The following control system error messages can be output:

Message instance	Message identifier	Message class	Event
MsgEvId1	SIG 1	AS process control message - fault	\$\$BlockComment\$\$ Motor feedback error
	SIG 2	AS process control message - fault	\$\$BlockComment\$\$ Motor protection triggered
	SIG 3	AS process control message - fault	\$\$BlockComment\$\$ Valve feedback error
	SIG 4	AS process control message - fault	\$\$BlockComment\$\$ External error has occurred

Explanation:

\$\$BlockComment\$\$: Content of the instance-specific comment

You can interconnect an external fault (signal) to input parameter `CSF`. If it changes to `CSF = 1`, a process control fault is triggered (`MsgEvId1`, SIG 4).

Instance-specific messages

You can use up to three instance-specific messages with this block.

Message instance	Message identifier	Message class	Event
MsgEvId1	SIG 5	AS process control message - fault	\$\$BlockComment\$\$ External message 1
	SIG 6	AS process control message - fault	\$\$BlockComment\$\$ External message 2
	SIG 7	AS process control message - fault	\$\$BlockComment\$\$ External message 3

Explanation:

\$\$BlockComment\$\$: Content of the instance-specific comment

Associated values for message instance `MsgEvId1`

Associated value	Block parameters
1	BatchName
2	StepNo
3	BatchID
4	ExtVal104
5	ExtVal105
6	ExtVal106
7	ExtVal107
8	ExtVal108
9	Reserved
10	Reserved

The associated values 4 ... 8 are allocated to the parameters `ExtVal104` ... `ExtVal108`, and can be used. Additional information is available in the "Process Control System PCS 7 - Engineering System" manual.

See also

VlvMotL block diagram (Page 1432)

VlvMotL modes (Page 1406)

7.12.6 VlvMotL I/Os

I/Os of VlvMotL

Input parameters

Parameter	Description	Type	Default
<code>AutModLi*</code>	1= "Automatic mode" via interconnection or SFC (controlled by <code>ModLiOp = 1</code>)	STRUCT <ul style="list-style-type: none"> • Value: BOOL • ST: BYTE 	- <ul style="list-style-type: none"> • 0 • 16#80
<code>AutModOp*</code>	1 = "Automatic mode" via operator (controlled by <code>ModLiOp = 1</code>)	BOOL	0
<code>AV</code>	Input additional analog value, to be connected to <code>AV_Tech</code> of the AV block	ANY	
<code>AV_AH_Lim</code>	Limit high alarm	REAL	95.0
<code>AV_AL_Lim</code>	Limit low alarm	REAL	5.0
<code>AV_Hyst</code>	Hysteresis for alarm, warning and tolerance limits	REAL	1.0
<code>AV_TH_Lim</code>	Limit high tolerance	REAL	85.0
<code>AV_TL_Lim</code>	Limit low tolerance	REAL	15.0
<code>AV_WH_Lim</code>	Limit high warning	REAL	90.0

Parameter	Description	Type	Default
AV_WL_Lim	Limit low warning	REAL	10.0
BatchEn	1 = Enable allocation	BOOL	0
BatchID	Batch ID	DWORD	16#00000000
BatchName	Batch name	S7-String	
ByProt	1 = Bypassing interlock is active in "local mode" and in simulation	BOOL	0
CloseAut*	1 = Select Close valve in "automatic mode"	STRUCT <ul style="list-style-type: none"> • Value: BOOL • ST: BYTE 	- <ul style="list-style-type: none"> • 0 • 16#80
CloseChnST	Signal status of output channel for Close Should be connected to an output channel block	STRUCT <ul style="list-style-type: none"> • Value: BOOL • ST: BYTE 	- <ul style="list-style-type: none"> • 0 • 16#FF
CloseForce	1 = Force valve closure	STRUCT <ul style="list-style-type: none"> • Value: BOOL • ST: BYTE 	- <ul style="list-style-type: none"> • 0 • 16#80
CloseLocal	1 = Select Close valve in "local mode"	STRUCT <ul style="list-style-type: none"> • Value: BOOL • ST: BYTE 	- <ul style="list-style-type: none"> • 0 • 16#80
CloseMan*	1 = Select Close valve in "manual mode"	BOOL	0
CSF	1 = External error (control system fault) Error handling (Page 119)	STRUCT <ul style="list-style-type: none"> • Value: BOOL • ST: BYTE 	- <ul style="list-style-type: none"> • 0 • 16#80
EN	1 = Called block will be processed	BOOL	1
EventTsIn	For interconnecting data between a technology block and the message blocks EventTs, Event16Ts. The EventTsIn input parameter serves to interconnect the EventTsOut output parameter of the EventTs, Event16TS block. When this interconnection is configured, the messages of the EventTs, Event16TS block are displayed on the OS in the alarm view of the technology block and can also be acknowledged there.	ANY	

Parameter	Description	Type	Default
EventTs2In	For interconnecting data between a technology block and the message blocks <code>EventTs</code> , <code>Event16Ts</code> . The <code>EventTs2In</code> input parameter serves to interconnect the <code>EventTsOut</code> output parameter of the <code>EventTs</code> , <code>Event16Ts</code> block. When this interconnection is configured, the messages of the <code>EventTs</code> , <code>Event16Ts</code> block are displayed on the OS in the alarm view of the technology block and can also be acknowledged there.	ANY	
ExtMsg1	Binary input for freely selectable message 1	STRUCT <ul style="list-style-type: none"> • Value: BOOL • ST: BYTE 	- <ul style="list-style-type: none"> • 0 • 16#80
ExtMsg2	Binary input for freely selectable message 2	STRUCT <ul style="list-style-type: none"> • Value: BOOL • ST: BYTE 	- <ul style="list-style-type: none"> • 0 • 16#80
ExtMsg3	Binary input for freely selectable message 3	STRUCT <ul style="list-style-type: none"> • Value: BOOL • ST: BYTE 	- <ul style="list-style-type: none"> • 0 • 16#80
ExtVal04	Associated value 4 for messages (<code>MsgEvID1</code>)	ANY	
ExtVal05	Associated value 5 for messages (<code>MsgEvID1</code>)	ANY	
ExtVal06	Associated value 6 for messages (<code>MsgEvID1</code>)	ANY	
ExtVal07	Associated value 7 for messages (<code>MsgEvID1</code>)	ANY	
ExtVal08	Associated value 8 for messages (<code>MsgEvID1</code>)	ANY	
FaultExt	1 = External error Error handling (Page 119)	STRUCT <ul style="list-style-type: none"> • Value: BOOL • ST: BYTE 	- <ul style="list-style-type: none"> • 0 • 16#80
FbkClose	1 = Valve closed feedback signal	STRUCT <ul style="list-style-type: none"> • Value: BOOL • ST: BYTE 	- <ul style="list-style-type: none"> • 0 • 16#FF
FbkClosing	1 = Valve closing feedback signal	STRUCT <ul style="list-style-type: none"> • Value: BOOL • ST: BYTE 	- <ul style="list-style-type: none"> • 0 • 16#FF
FbkOpen	1 = Valve open feedback signal	STRUCT <ul style="list-style-type: none"> • Value: BOOL • ST: BYTE 	- <ul style="list-style-type: none"> • 0 • 16#FF

Motor and valve blocks

7.12 VlvMotL - Motor valve

Parameter	Description	Type	Default
FbkOpening	1 = Valve opening feedback signal	STRUCT <ul style="list-style-type: none"> Value: BOOL ST: BYTE 	- <ul style="list-style-type: none"> 0 16#FF
Feature	I/O for additional functions (Page 1407) 1 = Separate monitoring time for stopping the motor	STRUCT <ul style="list-style-type: none"> Bit 0: BOOL ... Bit 13: BOOL ... Bit 31: BOOL 	- <ul style="list-style-type: none"> 0 0 0 0 0
Feature2	I/O for additional functions (Page 1407)	STRUCT <ul style="list-style-type: none"> Bit 0: BOOL ... Bit 31: BOOL 	- <ul style="list-style-type: none"> 0 0 0
IdleTime*	Wait time for change of direction or re-start in [s]	REAL	5.0
Intlock	0 = Interlock / interlock Open is activated. Once the interlock condition has cleared, the block can be operated without reset. 1 = Interlock / interlock Open is deactivated.	STRUCT <ul style="list-style-type: none"> Value:BOOL ST:BYTE Bit 1: BOOL (Bypass information bit) 	- <ul style="list-style-type: none"> 1 16#FF 0
Intl_En	1 = Parameter Intlock is enabled	BOOL	1
IntlCls	0 = Interlock Close is activated. Once the interlock condition has cleared, the block can be operated without reset. 1 = Interlock Close is deactivated.	STRUCT <ul style="list-style-type: none"> Value:BOOL ST:BYTE Bit 1: BOOL (Bypass information bit) 	- <ul style="list-style-type: none"> 1 16#FF 0
IntlClsEn	1 = Parameter IntlCls is enabled	BOOL	1
LocalLi	1 = Activate "local mode" via plant signal	STRUCT <ul style="list-style-type: none"> Value: BOOL ST: BYTE 	- <ul style="list-style-type: none"> 0 16#80
LocalOp*	1 = "Local mode" via operator	BOOL	0
LocalSetting	Properties for the Local mode (Page 79)	INT	0
ManModLi*	1 = Manual mode via interconnection or SFC (controlled by ModLiOp = 1)	STRUCT <ul style="list-style-type: none"> Value: BOOL ST: BYTE 	- <ul style="list-style-type: none"> 0 16#80
ManModOp*	1 = "Manual mode" via: OS operator (controlled via ModLiOp = 0)	BOOL	1
ModLiOp	Switchover of operating mode between: 0 = Operator 1 = Interconnection or SFC	STRUCT <ul style="list-style-type: none"> Value: BOOL ST: BYTE 	- <ul style="list-style-type: none"> 0 16#80

Parameter	Description	Type	Default
MonSafePos	1 = Go to neutral position in the event of monitoring errors	BOOL	1
MonTiDynamic*	Monitoring time for feedback errors or feedback start error after successful operation in [s]	REAL	3.0
MonTiDyStop*	Monitoring time for feedback stop errors after successful operation in [s]	REAL	3.0
M_Monitor	1 = Motor feedback monitoring	BOOL	1
M_MonTiDynamic*	Motor monitoring time after operation in [s]	REAL	3.0
M_MonTiStatic*	Monitoring time for feedback errors without operation in [s]	REAL	3.0
MS_RelOp*	1= Release for maintenance via OS operator	BOOL	0
MsgEvId1	Message number (assigned automatically)	DWORD	16#00000000
MsgLock	1 = Suppress process messages. See also the section Suppressing messages using the MsgLock parameter (Page 205) for more on this.	STRUCT • Value: BOOL • ST: BYTE	- • 0 • 16#80
MS_RelOp	1 = Release for maintenance via OS operator	BOOL	0
NoFbkClose	1 = No feedback present for "valve closed"	STRUCT • Value: BOOL • ST: BYTE	- • 0 • 16#80
NoFbkOpen	1 = No feedback present for "valve open"	STRUCT • Value: BOOL • ST: BYTE	- • 0 • 16#80
Occupied	1 = In use by a batch	BOOL	0
OosLi	1 = "Out of service", via interconnection or SFC	STRUCT • Value: BOOL • ST: BYTE	- • 0 • 16#80
OosOp*	1 = "Out of service", via OS operator	BOOL	0
OpenAut*	1 = Select Open valve in "automatic mode"	STRUCT • Value: BOOL • ST: BYTE	- • 0 • 16#80
OpenChnST	Signal status of output channel for Open Should be connected to an output channel block	STRUCT • Value: BOOL • ST: BYTE	- • 0 • 16#FF
OpenForce	1 = Force valve opening	STRUCT • Value: BOOL • ST: BYTE	- • 0 • 16#80

Motor and valve blocks

7.12 VivMotL - Motor valve

Parameter	Description	Type	Default
OpenLocal	1 = Select Open valve in "local mode"	STRUCT <ul style="list-style-type: none"> Value: BOOL ST: BYTE 	- <ul style="list-style-type: none"> 0 16#80
OpenMan*	1 = Select Open valve in "manual mode"	BOOL	0
OpSt_In	Input parameter for local operator authorization, to be connected with the Out output parameter of the upstream block, OpStations (Page 411)	DWORD	16#00000000
OS_Perm	I/O for operator permissions (Page 1407) <p>1 = Operator can set or change the monitoring time for "Control: Start"</p> <p>1 = Operator can set or change the monitoring time for "Control: Stop"</p>	STRUCT <ul style="list-style-type: none"> Bit 0: BOOL Bit 11: BOOL Bit 20: BOOL Bit 30: BOOL 	- <ul style="list-style-type: none"> 1 1 1 1
Permit	1 = Activation / activation Open is activated 0 = Activation / activation Open is deactivated	STRUCT <ul style="list-style-type: none"> Value:BOOL ST:BYTE Bit 1: BOOL (Bypass information bit) 	- <ul style="list-style-type: none"> 1 16#FF 0
Perm_En	1 = Parameter Permit is enabled	BOOL	1
PermCls	1 = Activation Close is activated 0 = Activation Close is deactivated	STRUCT <ul style="list-style-type: none"> Value:BOOL ST:BYTE Bit 1: BOOL (Bypass information bit) 	- <ul style="list-style-type: none"> 1 16#FF 0
PermClsEn	1 = Parameter PermCls is enabled	BOOL	1
Protect	0 = Protective interlock / protective interlock Open is activated. Once the interlock condition has cleared, the block must be reset. 1 = Protective interlock / protective interlock Open is deactivated.	STRUCT <ul style="list-style-type: none"> Value:BOOL ST:BYTE Bit 1: BOOL (Bypass information bit) 	- <ul style="list-style-type: none"> 1 16#FF 0
Prot_En	1 = Parameter Protect is enabled	BOOL	1
ProtCls	0 = Protective interlock Close is activated. Once the interlock condition has cleared, the block must be reset. 1 = Protective interlock Close is deactivated.	STRUCT <ul style="list-style-type: none"> Value:BOOL ST:BYTE Bit 1: BOOL (Bypass information bit) 	- <ul style="list-style-type: none"> 1 16#FF 0
ProtClsEn	1 = Parameter ProtCls is enabled	BOOL	1

Parameter	Description	Type	Default
PulseWidth*	Pulse width of control signal [s]	REAL	3.0
RapidStp*	Rapid stop for the motor 0 = Motor On 1 = Motor Off	BOOL	0
RstLi*	1 = Reset via interconnection	STRUCT • Value: BOOL • ST: BYTE	- • 0 • 16#80
RstOp*	1 = Reset via operator	BOOL	0
RunUpCyc	Number of cycles in startup; messages are suppressed during these cycles	INT	3
SafePos	Neutral position for valve: 0 = Closed 1 = Open 2 = stop	INT	2
SampleTime	Sampling time [s] (assigned automatically)	REAL	0.1
SimAV*	Additional value used for SimOn = 1	REAL	0.0
SimAV_Li	Additional analog value that is used for SimOnLi.Value = 1 (SimLiOp.Value = 1)	STRUCT • Value: REAL • ST: BYTE	- • 0 • 16#80
SimLiOp	Activation/deactivation of the simulation by: 0 = Operator 1 = Interconnection or SFC	STRUCT • Value: BOOL • ST: BYTE	- • 0 • 16#80
SimOnLi	1= Simulation per interconnection or SFC (controlled by SimLiOp = 1)	STRUCT • Value: BOOL • ST: BYTE	- • 0 • 16#80
SimOn*	1 = Simulation on	BOOL	0
SelFp1	Call a block saved in this parameter as an additional faceplate (Page 208) in the standard view	ANY	
SelFp2	Call a block saved in this parameter as an additional faceplate (Page 208) in the preview	ANY	
StepNo	Batch step number	DWORD	16#00000000
StopAut*	1 = Stopping the motor in "automatic mode"	STRUCT • Value: BOOL • ST: BYTE	- • 0 • 16#80
StopForce	1 = Force motor stop	STRUCT • Value: BOOL • ST: BYTE	- • 0 • 16#80

Motor and valve blocks

7.12 VlvMotL - Motor valve

Parameter	Description	Type	Default
StopLocal	1 = Stopping the motor in "local mode"	STRUCT <ul style="list-style-type: none"> • Value: BOOL • ST: BYTE 	- <ul style="list-style-type: none"> • 0 • 16#80
StopMan*	1 = Stopping the motor in "manual mode"	BOOL	0
TorqOpen	0 = Torque shutdown active when opening 1 = "Good" state	STRUCT <ul style="list-style-type: none"> • Value: BOOL • ST: BYTE 	- <ul style="list-style-type: none"> • 1 • 16#FF
TorqClose	0 = Torque shutdown active when closing 1 = "Good" state	STRUCT <ul style="list-style-type: none"> • Value: BOOL • ST: BYTE 	- <ul style="list-style-type: none"> • 1 • 16#FF
Trip	1 = Motor is in "good" state	STRUCT <ul style="list-style-type: none"> • Value: BOOL • ST: BYTE 	- <ul style="list-style-type: none"> • 1 • 16#FF
UserAna1	Analog auxiliary value 1	STRUCT <ul style="list-style-type: none"> • Value: REAL • ST: BYTE 	- <ul style="list-style-type: none"> • 0.0 • 16#FF
UA1unit	Unit of measure for analog auxiliary value 1	INT	0
UserAna2	Analog auxiliary value 2	STRUCT <ul style="list-style-type: none"> • Value: REAL • ST: BYTE 	- <ul style="list-style-type: none"> • 0.0 • 16#FF
UA2unit	Unit of measure for analog auxiliary value 2	INT	0
UserStatus	Freely assignable bits for use in PCS 7 OS	BYTE	16#00
V_Monitor	1 = Valve feedback monitoring	BOOL	1
V_MonTiDynamic*	Valve monitoring time after operation in [s]	REAL	5.0
V_MonTiStatic*	Monitoring time for valve feedback errors without operation in [s]	REAL	5.0
WarnTiAut*	Prewarning of valve movement from neutral position in "automatic mode" in [s]	REAL	0.0
WarnTiMan*	Prewarning of valve movement from neutral position in "manual mode" in [s]	REAL	0.0

* Values can be written back to these inputs during processing of the block by the block algorithm.

Output parameters

Parameter	Description	Type	Default
AutAct	1 = "Automatic mode" enabled 0 = "Manual mode" is enabled	STRUCT • Value: BOOL • ST: BYTE	- • 0 • 16#80
AutoST	1 = Worst signal status of automatic commands	BYTE	16#80
AV_OpScale	Limit for scale in AV bar graph of faceplate	STRUCT • High: REAL • Low: REAL	- • 100.0 • 0.0
AV_Out	Output additional analog value	STRUCT • Value: REAL • ST: BYTE	- • 0.0 • 16#80
AV_Unit	Unit of measure for additional analog value	INT	0
CascaCut	Cascade connection: 1 = Control chain from master controller to secondary valve is interrupted	STRUCT • Value: BOOL • ST: BYTE	- • 0 • 16#80
Close	Control output 1= Close valve	STRUCT • Value: BOOL • ST: BYTE	- • 0 • 16#80
Closed	1 = Valve is closed	STRUCT • Value: BOOL • ST: BYTE	- • 0 • 16#80
Closing	1 = Valve is closing	STRUCT • Value: BOOL • ST: BYTE	- • 0 • 16#80
CurrMonV	Current valve monitoring time [s]	DINT	0
CurrMonM	Current motor monitoring time [s]	DINT	0
ENO	1 = Block algorithm completed without errors	BOOL	0
ErrorNum	Output of pending error number. For error numbers that can be output by this block, see VlvMotL error handling (Page 1418)	INT	-1
FbkCloseOut	Valve closed feedback	STRUCT • Value: BOOL • ST: BYTE	- • 0 • 16#80
FbkClsgOut	Valve closing feedback	STRUCT • Value: BOOL • ST: BYTE	- • 0 • 16#80

Motor and valve blocks

7.12 VlvMotL - Motor valve

Parameter	Description	Type	Default
FbkOpenOut	Valve open feedback	STRUCT <ul style="list-style-type: none"> • Value: BOOL • ST: BYTE 	- <ul style="list-style-type: none"> • 0 • 16#80
FbkOpngOut	Valve opening feedback	STRUCT <ul style="list-style-type: none"> • Value: BOOL • ST: BYTE 	- <ul style="list-style-type: none"> • 0 • 16#80
GrpErr	1 = Group error pending	STRUCT <ul style="list-style-type: none"> • Value: BOOL • ST: BYTE 	- <ul style="list-style-type: none"> • 0 • 16#80
LocalAct	1 = "Local mode" enabled	STRUCT <ul style="list-style-type: none"> • Value: BOOL • ST: BYTE 	- <ul style="list-style-type: none"> • 0 • 16#80
LockAct	1 = Interlock (Intlock, Permit, Protect) or Trip is active	STRUCT <ul style="list-style-type: none"> • Value: BOOL • ST: BYTE 	- <ul style="list-style-type: none"> • 0 • 16#80
ManAct	1 = "Manual mode" enabled	STRUCT <ul style="list-style-type: none"> • Value: BOOL • ST: BYTE 	- <ul style="list-style-type: none"> • 1 • 16#80
MonDynErr	1 = Feedback error or feedback start error due to control change	STRUCT <ul style="list-style-type: none"> • Value: BOOL • ST: BYTE 	- <ul style="list-style-type: none"> • 1 • 16#80
MonDynStopErr	1 = Feedback stop error due to control change	STRUCT <ul style="list-style-type: none"> • Value: BOOL • ST: BYTE 	- <ul style="list-style-type: none"> • 1 • 16#80
M_MonDynErr	1 = Motor feedback error due to control change	STRUCT <ul style="list-style-type: none"> • Value: BOOL • ST: BYTE 	- <ul style="list-style-type: none"> • 0 • 16#80
M_MonStaErr	1 = Motor feedback error due to unexpected feedback change	STRUCT <ul style="list-style-type: none"> • Value: BOOL • ST: BYTE 	- <ul style="list-style-type: none"> • 0 • 16#80
MS_Release	Release for maintenance: 1 = Release for OS operator	STRUCT <ul style="list-style-type: none"> • Value: BOOL • ST: BYTE 	- <ul style="list-style-type: none"> • 0 • 16#80
MsgAckn1	Message acknowledgment status 1 (output ACK_STATE of first ALARM_8P)	WORD	16#0000
MsgErr1	Alarm error 1 (output ERROR of first ALARM_8P)	BOOL	0
MsgStat1	Message status 1 (output STATUS of first ALARM_8P)	WORD	16#0000
OosAct	1 = Block is "Out of service"	STRUCT <ul style="list-style-type: none"> • Value: BOOL • ST: BYTE 	- <ul style="list-style-type: none"> • 0 • 16#80

Parameter	Description	Type	Default
Open	Control output: 1 = Open the valve	STRUCT • Value: BOOL • ST: BYTE	- • 0 • 16#80
Opened	1 = Valve is open	STRUCT • Value: BOOL • ST: BYTE	- • 0 • 16#80
Opening	1 = Valve is opening	STRUCT • Value: BOOL • ST: BYTE	- • 0 • 16#80
OpSt_Out	Value of the OpSt_In input parameter, for feedforwarding to other blocks. Bit 31 of this parameter is used by Feature bit 24	DWORD	16#00000000
OS_PermOut	Display of OS_Perm	DWORD	16#FFFFFFFF
OS_PermLog	Display of OS_Perm with settings changed by the block algorithm	DWORD	16#FFFFFFFF
P_Close	1 = Pulse signal to close valve	STRUCT • Value: BOOL • ST: BYTE	- • 0 • 16#80
P_Open	1 = Pulse signal to open valve	STRUCT • Value: BOOL • ST: BYTE	- • 0 • 16#80
P_Rst	1= Pulse output for reset The parameter persists for one cycle after a reset.	STRUCT • Value: BOOL • ST: BYTE	- • 0 • 16#80
P_Stop	0 = Pulse signal for stopping the valve	STRUCT • Value: BOOL • ST: BYTE	- • 1 • 16#80
R_StpAct	1 = Rapid stop of the motor is active	STRUCT • Value: BOOL • ST: BYTE	- • 0 • 16#80
RdyToReset	1 = Ready for reset via RstLi input or commands in "local", "automatic", or "manual mode"	STRUCT • Value: BOOL • ST: BYTE	- • 0 • 16#80
RdyToStart	1 = Active start readiness	STRUCT • Value: BOOL • ST: BYTE	- • 0 • 16#80
ST_Worst	Worst signal status	BYTE	16#80
Status1	Status word 1 (Page 1401)	DWORD	16#00000000
Status2	Status word 2 (Page 1401)	DWORD	16#00000000
Status3	Status word 3 (Page 1401)	DWORD	16#00000000
Status4	Status word 4 (Page 1401)	DWORD	16#00000000

Parameter	Description	Type	Default
Stop	1 = Motor stopped and valve is in intermediate position	STRUCT <ul style="list-style-type: none"> • Value: BOOL • ST: BYTE 	- <ul style="list-style-type: none"> • 0 • 16#80
V_MonDynErr	1 = Valve feedback error due to control change	STRUCT <ul style="list-style-type: none"> • Value: BOOL • ST: BYTE 	- <ul style="list-style-type: none"> • 0 • 16#80
V_MonStaErr	1 = Valve feedback error due to unexpected feedback change	STRUCT <ul style="list-style-type: none"> • Value: BOOL • ST: BYTE 	- <ul style="list-style-type: none"> • 0 • 16#80
WarnAct	1 = Prewarning for valve movement away from neutral position active (parameters WarnTiAut and WarnTiMan)	STRUCT <ul style="list-style-type: none"> • Value: BOOL • ST: BYTE 	- <ul style="list-style-type: none"> • 0 • 16#80

See also

- VivMotL messaging (Page 1420)
- VivMotL block diagram (Page 1432)
- VivMotL modes (Page 1406)
- Error handling (Page 119)

7.12.7 VivMotL block diagram

VivMotL block diagram

A block diagram is not provided for this block.

See also

- VivMotL I/Os (Page 1421)
- VivMotL messaging (Page 1420)
- VivMotL error handling (Page 1418)
- VivMotL functions (Page 1407)
- VivMotL modes (Page 1406)
- Description of VivMotL (Page 1401)

7.12.8 Operator control and monitoring

7.12.8.1 VlvMotL views

Views of the VlvMotL block

The VlvMotL block provides the following views:

- VlvMotL standard view (Page 1433)
- Limit view of motors (Page 294)
- Alarm view (Page 302)
- Trend view (Page 305)
- VlvMotL parameter view (Page 1437)
- VlvMotL preview (Page 1440)
- Memo view (Page 304)
- Batch view (Page 302)
- Block icon for VlvMotL (Page 1444)

Refer to the sections Structure of the faceplate (Page 248) and Block icon structure (Page 230) for general information on the faceplate and block icon.

7.12.8.2 VlvMotL standard view

VlvMotL standard view

With `Feature2.Bit16 = 0`:

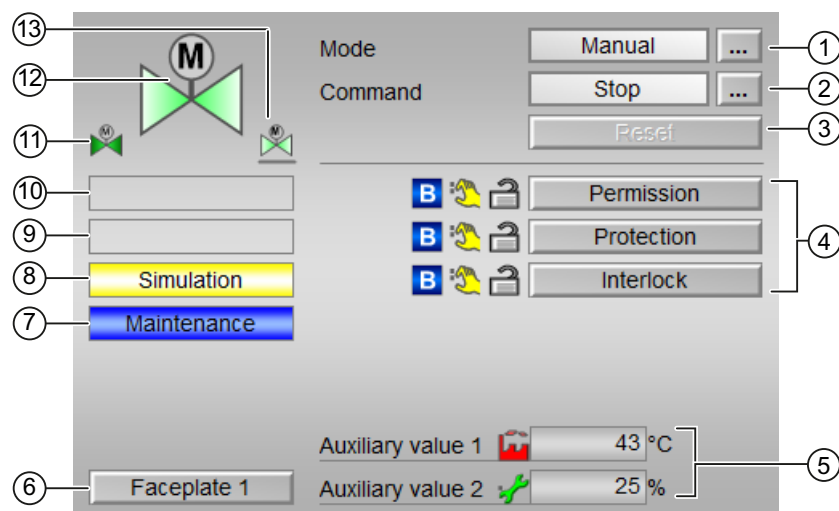

With `Feature2.Bit16 = 1`:

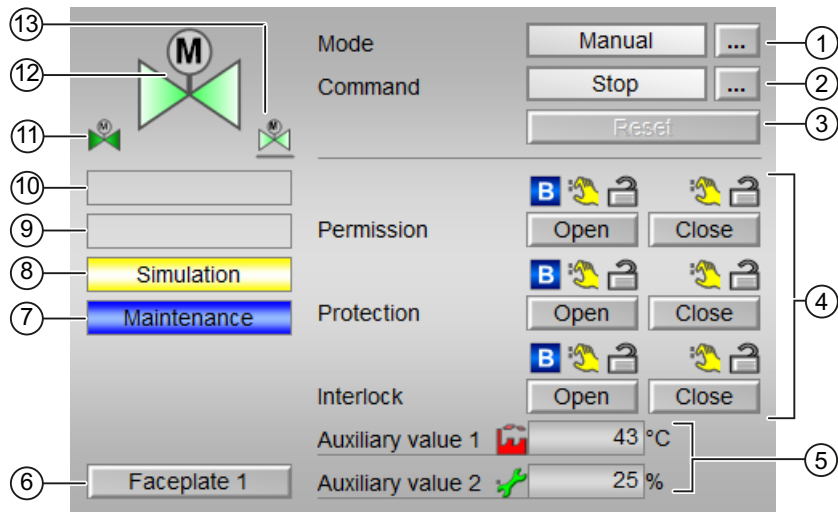

(1) Displaying and switching the operating mode

This area provides information on the currently valid operating mode. The following operating modes can be shown here:

- Manual and automatic mode for motors, valves and dosers (Page 75)
- Manual and automatic mode for motors, valves and dosers (Page 75)
- Local mode (Page 79)
- Out of service (Page 71)

Refer to section Switching operating states and operating modes (Page 257) for information on switching the operating mode.

(2) Open, close and stop the motor valve

This area shows you the default operating state for the motor valve. The following states can be shown and executed here:

- "Open"
- "Close"
- "Stop"
- "Rapid stop"

Refer to the Switching operating states and operating modes (Page 257) section for information on changing the state.

If text is configured for these commands, it is displayed as status text and as button labels for command selection. You can find more information about this in section Labeling of buttons and text (Page 209)

(3) Resetting the block

Click "Reset" for interlocks or errors. You can find additional information on this in the section Resetting the block in case of interlocks or errors (Page 43).

(4) Operating range for the interlock functions of the block

This display is only visible when the corresponding block input is connected.

You can use this button to control the interlock functions of the block. You can find additional information on this in the section Interlocking functions (Page 99).

The following is displayed in addition to the buttons:

- Interlock status (see Forming the group status for interlock information (Page 104)), e.g.:



- Signal status (see Forming and outputting the signal status for technologic blocks (Page 109)), e.g.:



- Bypass information (see Forming the group status for interlock information (Page 104)):



(5) Display of auxiliary values

This display is only visible when the corresponding block input is connected.

You can use this area to display two auxiliary values that have been configured in the engineering system. You can find additional information on this in the section Displaying auxiliary values (Page 211).

(6) Navigation button for switching to the standard view of any faceplate

This display is only visible when the corresponding block input is connected.

Use this navigation button to open the standard view of a block configured in the engineering system (ES). The visibility of this navigation button depends on the configuration in the engineering system (ES).

You can find additional information on this in the section Opening additional faceplates (Page 208).

(7) Display area for block states

This area provides additional information on the operating state of the block:

- "Maintenance"

Additional information on this is available in section Release for maintenance (Page 64) Display area for block states.

(8) Display area for block states

This area provides additional information on the operating state of the block:

- "Simulation"
- "Delay"

You will find more detailed information on this in the sections Simulating signals (Page 58) and Display of delay times (Page 256).

(9) Display area for block states

This area provides additional information on the operating state of the block:

- "Motor protection"
- "External error"
- "Torque active"
- "End position error"
- "Control error"
- "Invalid signal"
- "Changeover error"

Additional information on these errors is available in the sections Monitoring the feedbacks (Page 97) , Error handling (Page 119) (section "Invalid input signals" and "Mode switchover error") and Motor protection function (Page 99).

(10) Display area for block states

This area provides additional information on the operating state of the block:

- "Forced open"
- "Forced close"
- "Forced stop"
- "Request 0/1": A reset to "automatic mode" is expected.

You can find additional information on this in the section Forcing operating modes (Page 41).

(11) Automatic preview

This display is only visible in "manual mode", in "local mode", or with a reset request in "automatic mode", when the current output signals are not identical to the control in "automatic mode".

The display shows what state the valve would assume if you switched from "manual" or "local" mode to "automatic mode", or performed a reset to "automatic mode".

(12) Status display of the motor valve

The current status of the motor valve is graphically displayed here.

You can find more information about this in section Block icon for VlvMotL (Page 1444)

(13) Neutral position of the valve

This representation shows the neutral position for the valve:

- Green: Neutral position is "Open"
- Gray: Neutral position is "Closed"
- Light green: Neutral position is "Stop"

7.12.8.3 VlvMotL parameter view

Parameter view of VlvMotL

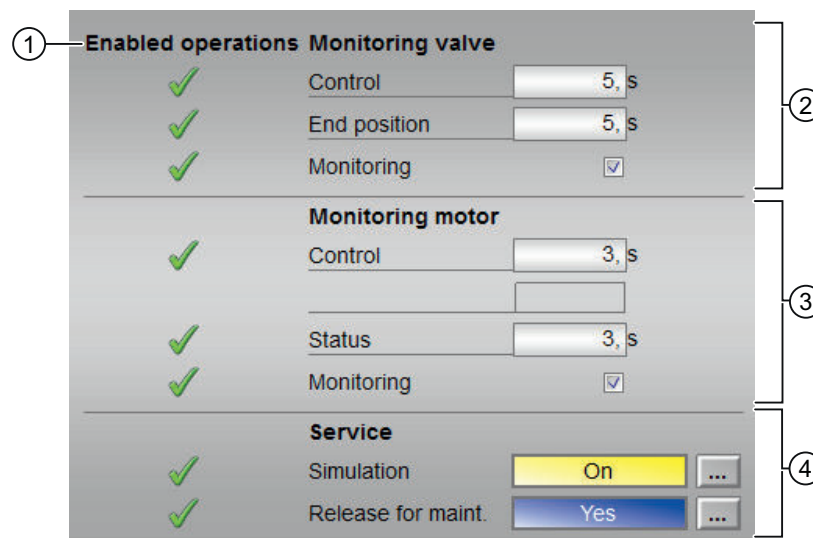

Parameter view for VlvMotL with Feature bit 13 = 0

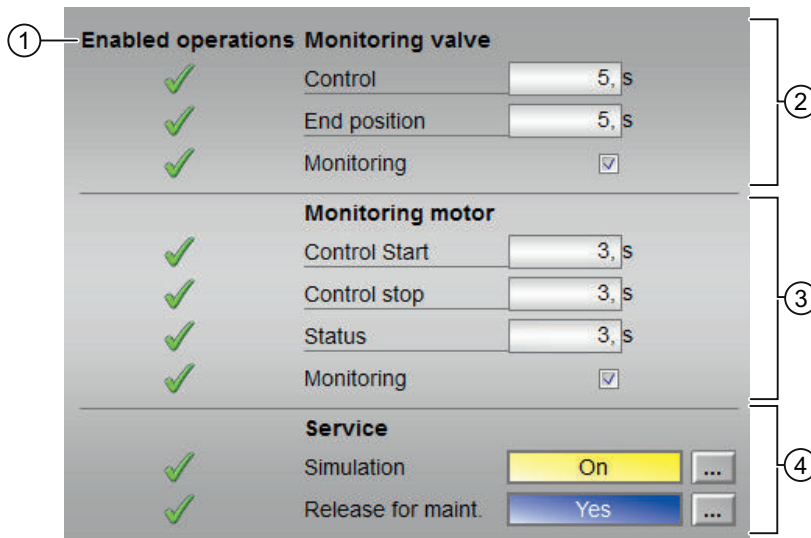

Parameter view for VlvMotL with Feature bit 13 = 1

(1) Enabled operation

This area shows all operations for which special operator permissions are assigned. They depend on the configuration in the engineering system (ES) that applies to this block.

Icons for enabled operation:

- **Green check mark:** the OS operator can control this parameter
- **Gray check mark:** the OS operator cannot control this parameter at this time due to the process
- **Red cross:** the OS operator cannot control this parameter due to the configured AS operator permissions (OS_Perm or OS1Perm).

(2) Monitoring valve

In this area, you change parameters and therefore influence the valve. You can find additional information on this in the section Changing values (Page 259).

You can influence the following parameters:

- "Control": Monitoring time for the valve run time (dynamic)
- "End position": Monitoring time for maintaining the valve position (static)
- "Monitoring":
You can enable monitoring by selecting the check box (☑)
You can find additional information on this in the section Monitoring the feedbacks (Page 97).

(3) Monitoring motor

In this area, you change parameters and therefore influence the motor. You can find additional information on this in the section Changing values (Page 259).

You can influence the following parameters:

Feature bit **13 = 0**

- "Control": Monitoring time during startup and shutdown of the motor (dynamic)
- "Status": Monitoring time during permanent operation of the motor (static)

Feature bit **13 = 1**

- "Control start": Monitoring time during startup of the motor (dynamic)
- "Control stop": Monitoring time during shutdown of the motor (dynamic)
- "Status": Monitoring time during permanent operation of the motor (static)
- "Monitoring":
You can enable monitoring by selecting the check box
You can find additional information on this in the section Monitoring the feedbacks (Page 97).

(4) Service

You can select the following functions in this area:

- "Simulation"
- "Release for maintenance" (with display for a maintenance request)

You can find additional information on this in the section Switching operating states and operating modes (Page 257).

You can find information on this area in the section:

- Simulating signals (Page 58)
- Release for maintenance (Page 64)

7.12.8.4 VlvMotL preview

Preview of VlvMotL

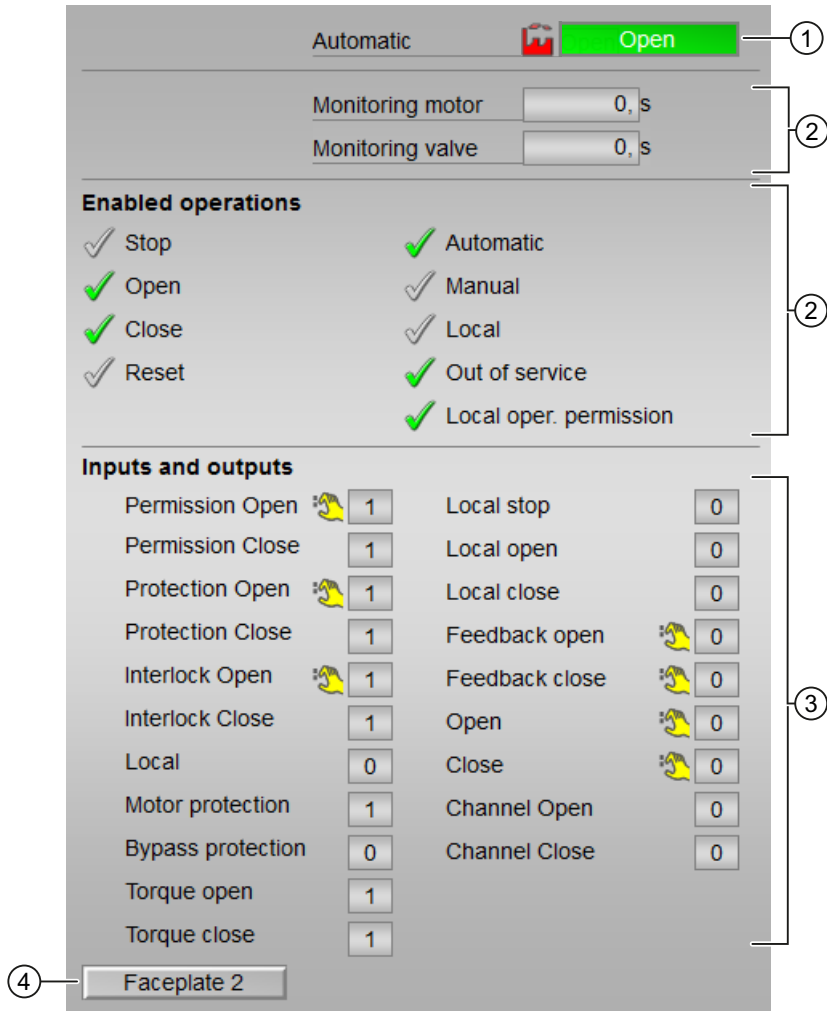

Display of the current monitoring time of the motor/valve is visible.

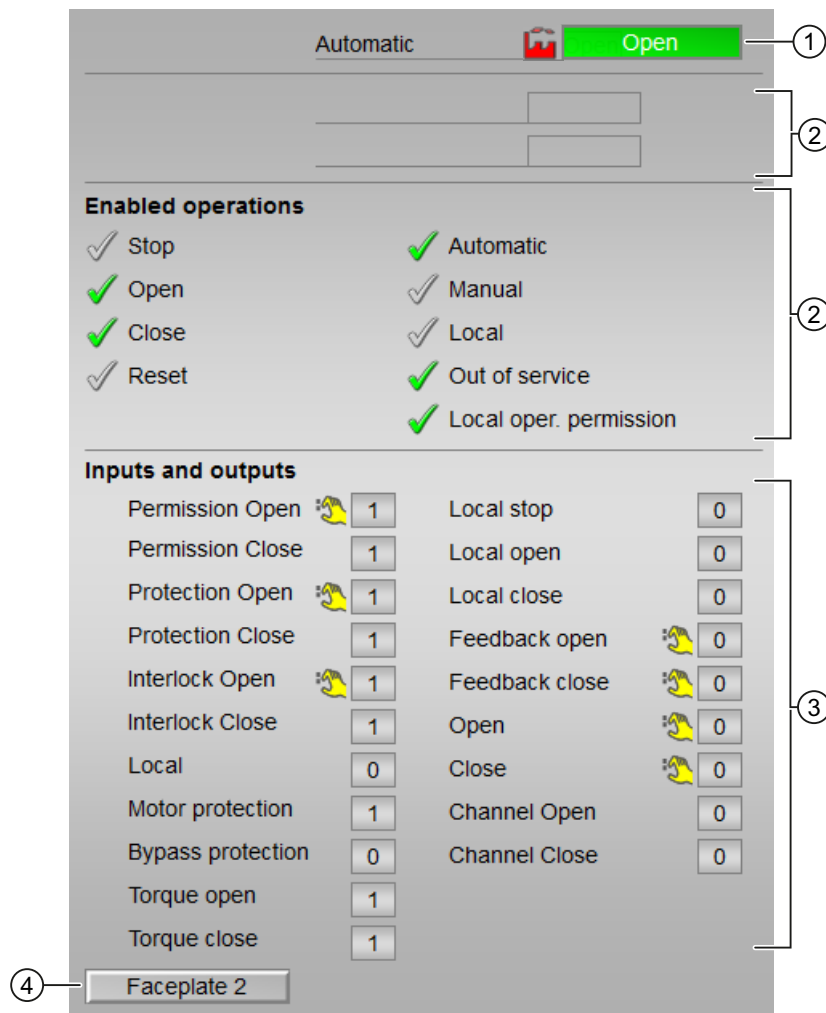

Display of the current monitoring time of the motor/valve is not visible.

(1) Automatic preview

This area shows you the block status after it has switched from the "Manual" mode or "Local" mode to the "Automatic" mode.

If the block is in "Automatic" mode, the current block state is displayed.

This area also displays the worst signal status of the following automatic commands:

- OpenAut
- CloseAut
- StopAut

(2) Enable operations

This area shows all operations for which special operator permissions are assigned. They depend on the configuration in the engineering system (ES) that applies to this block.

Icons for enabled operation:

- **Green check mark:** the OS operator can control this parameter
- **Gray check mark:** the OS operator cannot control this parameter at this time due to the process
- **Red cross:** the OS operator cannot control this parameter due to the configured AS operator permissions (`OS_Perm` or `OS1Perm`)

The following enabled operations are shown here:

- "Stop": You can stop the motor of the valve.
If text is configured for this command, it is also displayed in brackets. You can find additional information on this in the section Labeling of buttons and text (Page 209) .
- "Open": You can open the motor valve.
If text is configured for this command, it is also displayed in brackets. You can find additional information on this in the section Labeling of buttons and text (Page 209) .
- "Close": You can close the motor valve.
If text is configured for this command, it is also displayed in brackets. You can find additional information on this in the section Labeling of buttons and text (Page 209) .
- "Reset": You can reset the motor valve if interlocks or errors occur.
- "Automatic": You can switch to "automatic mode".
- "Manual": You can switch to "manual mode".
- "Local": You can switch to "local mode".
- "Out of service": You can switch to "Out of service" operating mode.
- "Local operator permission": Use the ← button to switch to the standard view of the OpStations block. You can find additional information on this in the section Operator control permissions (Page 254) .
- "Monitoring motor": Display of the current monitoring time of the motor.
- "Monitoring valve": Display of the current monitoring time of the valve.

(3) Displaying current control signals

This area shows the most important parameters for this block with the current selection:

- "Permission" (`Feature2.Bit16 = 0`):
This display is only visible when the corresponding block input is connected.
 - 0 = Motor valve activation not enabled on OS
 - 1 = Enable for "opening"/"closing" from the neutral position
- "Permission Open" (`Feature2.Bit16 = 1`):
This display is only visible when the corresponding block input is connected.
 - 0 = Motor valve activation not enabled on OS
 - 1 = Enable for "open" from the neutral position

- "Permission Close" (`Feature2.Bit16 = 1`):
This display is only visible when the corresponding block input is connected.
 - 0 = Motor valve activation not enabled on OS
 - 1 = Enable for "close" from the neutral position
- "Protection" (`Feature2.Bit16 = 0`):
This display is only visible when the corresponding block input is connected.
 - 0 = Protective interlocking is effective; once the interlocking condition has disappeared, you will have to reset the block
 - 1 = "Good" state
- "Protection Open" (`Feature2.Bit16 = 1`):
This display is only visible when the corresponding block input is connected.
 - 0 = Protective interlocking is effective; once the interlocking condition has disappeared, you will have to reset the block
 - 1 = "Good" state
- "Protection Close" (`Feature2.Bit16 = 1`):
This display is only visible when the corresponding block input is connected.
 - 0 = Protective interlocking is effective; once the interlocking condition has disappeared, you will have to reset the block
 - 1 = "Good" state
- "Interlock" (`Feature2.Bit16 = 0`):
This display is only visible when the corresponding block input is connected.
 - 0 = Interlocking without reset is active; you can operate the block without reset once the interlocking condition has disappeared
 - 1 = "Good" state
- "Interlock Open" (`Feature2.Bit16 = 1`):
This display is only visible when the corresponding block input is connected.
 - 0 = Interlocking without reset is active; you can operate the block without reset once the interlocking condition has disappeared
 - 1 = "Good" state
- "Interlock Close" (`Feature2.Bit16 = 1`):
This display is only visible when the corresponding block input is connected.
 - 0 = Interlocking without reset is active; you can operate the block without reset once the interlocking condition has disappeared
 - 1 = "Good" state
- "Local correct": 1 = Control signal for "Local mode" (LocalLi) is active
- "Motor protection": 1 = Motor is in "good" state
- "Interlock deact.":
 - 0 = Bypass disabled
 - 1 = Bypassing interlock in "local mode" and in "simulation"

- "Torque opening": 0 = Torque shutdown when opening
- "Torque closing": 0 = Torque shutdown when closing
- "Local stop": 1 = Stopping the motor valve in "local mode"
- "Local open": 1 = Opening the motor valve in "local mode"
- "Local close": 1 = Closing the motor valve in "local mode"
- "Feedback open": 1 = Motor valve is open
- "Feedback close": 1 = Motor valve is closed
- "Open": 1 = Motor valve is opened
- "Close": 1 = Motor valve is closed
- "Channel Open": Signal from the output channel block for "Open"
- "Channel Close": Signal from the output channel block for "Close"

(4) Navigation button for switching to the standard view of any faceplate

This display is only visible when the corresponding block input is connected.

Use this navigation button to open the standard view of a block configured in the engineering system. The visibility of this navigation button depends on the configuration in the engineering system (ES).

You can find additional information on this in the section Opening additional faceplates (Page 208) .





7.12.8.5 Block icon for VlvMotL

Block icons for VlvMotL





A variety of block icons are available with the following functions:



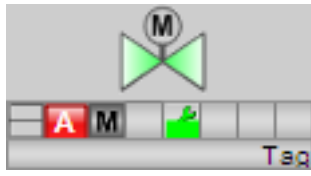

- Process tag type
- Limits (high/low)
- Violation of alarm, warning, and tolerance limits as well as control system faults
- Operating modes
- Signal status, release for maintenance
- Displays for bypassing interlocks
- Interlocks
- Memo display
- Valve status display

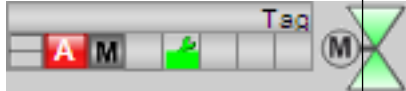
The block icons from template @TemplateAPLV8.PDL:

Icons	Selection of the block icon in CFC	Special features
	1	
	2	
	3	Non-rotating block icon
	4	Non-rotating block icon

The block icons from template @TemplateAPLV7.PDL:

Icons	Selection of the block icon in CFC	Special features
	1	Block icon in the full display
	2	
	3	
	4	
	5	
	6	





Icons	Selection of the block icon in CFC	Special features
	7	
	8	
	9	
	10	
	-	Block icon in "Out of service" mode (example with type 1 block icon)



Additional information on the block icon and the control options in the block icon is available in the following sections:

- Configuring the block icons (Page 237)
- Block icon structure (Page 230)
- Operation via the block icon (Page 239)

Valve status display

The following valve states are shown here:

Icon	Meaning
	Valve open
	Valve closed
	Error at valve
	Valve is opening
	Valve is closing

Icon	Meaning
	Valve stop
	Valve closed
	Valve is closing

7.13 VlvAnL - Control valve

7.13.1 Description of VlvAnL

Object name (type + number) and family

Type + number: FB 1896

Family: Drives

Area of application for VlvAnL

The block is used for the following applications:

- Control of an analog control valve and positioner with adjustable neutral position
- Control of an optional auxiliary valve for regulating the auxiliary power of the control valve

How it works

The control valve is brought to a specified position using an analog activation signal. The activation signal can be formed by a ramp function in this case.

The block forms the manipulated variable error from the difference between the activation signal and the acquired position feedback and can monitor it for adherence to high and low limits.

The control valve is monitored for the "Open"/"Closed" position. The block can be connected with a digital limit switch for this purpose. The block can generate the digital position signals itself through the adjustable limits for the "Open"/"Closed" position.

Missing feedback can be derived from the control in the block.

Various inputs are available for control purposes. The next sections provide more detailed information on configuration, operating principles, visualization and operation.

Configuration

Use the CFC editor to install the block in a cyclic interrupt OB (OB30 to OB38). The block is also installed automatically in the startup OB (OB100).

For the VlvAnL block, the Advanced Process Library contains templates for process tag types as examples with various application scenarios for this block.

Examples of process tag types:

- Control valve (VlvAnL) (Page 2370)
- Control valve for PA/FF devices (ValveAnalog_Fb) (Page 2371)

Startup characteristics

Use the `Feature Bit Set` startup characteristics (Page 138) to define the startup characteristics of this block.

The messages are suppressed after startup for the number of cycles set at `RunUpCyc`.

If `Feature Bit Set` startup characteristics (Page 138) = 0, the following applies to the startup characteristics:

- `Feature Bit 16 = 0` closes the main valve
- With `Feature Bit 16 = 1` the main valve is moved into the neutral position

Status word allocation for `status1` parameter

You can find a description for each parameter in section VlvAnL I/Os (Page 1470).

Status bit	Parameter
0	Occupied
1	BatchEn
2	SimOn
3	OosAct.Value
4	OosLi.Value
5	AutoAct.Value
6	LocalAct.Value
7	0: Open padlock in the block icon 1: Closed padlock in the block icon
8	Control valve "Open"/"Closed" command (0 = "Closed", 1 = "Open")
9	FbkOpenOut.Value control valve
10	FbkCloseOut.Value control valve
11	1 = Feedback error control valve without control change
12	1 = Feedback error control valve due to control change
13	ByProt
14	1 = Invalid signal status
15	1 = Mode changeover error
16	1 = Intlock is active
17	1 = Permit is active
18	1 = Protect is active
19	Display "Forced open"
20	Display "Forced stop"
21	1 = Force
22	Automatic preview of auxiliary valve (1 = "Open")
23	1 = Bumpless switchover to "automatic mode" enabled
24	1 = Actuator active ($PosDiClose < MV < PosDiOpen$)
25	UserAna1 interconnected
26	UserAna2 interconnected
27	Auxiliary valve "Open"/"Closed" command (0 = "Closed", 1 = "Open")

Status bit	Parameter
28	FbkOpenAuxVOut.Value (auxiliary valve)
29	FbkCloseAuxVOut.Value (auxiliary valve)
30	1 = Feedback error auxiliary valve without control change
31	1 = Feedback error auxiliary valve due to control change

Status word allocation for status2 parameter

Status bit	Parameter
0	1 = MsgLock message suppression active
1	1 = "Open" and "Close" commands deactivated (command line not visible)
2	1 = Display for interlocks in block icon
3	1 = Neutral position control valve "Open"
4	1 = Neutral position control valve "Closed"
5	1 = Neutral position control valve "Stop"
6	1 = Operator can reset the valve
7	WarnAct.Value
8	1 = External manipulated variable active (MV_ExtAct.Value)
9	1 = Forced manipulated variable (MV_Forced) is output without limit at output MV
10	1 = Tracking of manipulated variables MV, MV_TrkOn.Value = 1 and MV_ForOn.Value = 0
11	1 = Manipulated variable greater than limit (low) for manipulated variable MV (MV.Value > ManLoLim)
12	1 = Input parameter Rbk is not interconnected (RbkOut.ST = 16#FF)
13	1 = Input parameter FbkAuxVClose is connected
14	1 = Input parameter FbkAuxVOpen is connected
15	1 = Input parameter FbkClose is connected
16	1 = Input parameter FbkOpen is connected
17	For the Error status display in the Closed valve
18	Reset request in automatic
19	1 = No impact of input signals on "local mode" with LocalSetting = 2 and LocalSetting = 4
20	1 = Control valve open
21	1 = Control valve closed
22	1 = Control valve opening
23	1 = Control valve closing
24	1 = Control valve in intermediate position ("Stop")
25	1 = Position reached
26	Control of valve, open auxiliary valve
27	Control of valve, close auxiliary valve
28	1 = Control valve is in intermediate position
29	For the Error status display in the Opened valve
30	1 = Bypass information from previous function block
31	MS_RelOp

Status word allocation for Status3 parameter

Status bit	Parameter
0	Effective signal 1 of the message block connected via EventTsIn
1	Effective signal 2 of the message block connected via EventTsIn
2	Effective signal 3 of the message block connected via EventTsIn
3	Effective signal 4 of the message block connected via EventTsIn
4	Effective signal 5 of the message block connected via EventTsIn
5	Effective signal 6 of the message block connected via EventTsIn
6	Effective signal 7 of the message block connected via EventTsIn
7	Effective signal 8 of the message block connected via EventTsIn
8	1 = "Interlock" button is enabled
9	1 = "Permission" button is enabled
10	1 = "Protection" button is enabled
11	1 = Manipulated variable difference high limit violated (ER_AH_Act.Value)
12	1 = Manipulated variable difference low limit violated (ER_AL_Act.Value)
13	1 = Monitor manipulated variable difference high limit (ER_AH_En)
14	1 = Monitor manipulated variable difference low limit (ER_AL_En)
15	1 = Report manipulated variable difference high limit violation (ER_AH_MsgEn)
16	1 = Report manipulated variable difference low limit violation (ER_AL_MsgEn)
17	1 = Readback value high limit violated (RbkWH_Act.Value)
18	1 = Readback value low limit violated (RbkWL_Act.Value)
19	1 = Monitor readback value high limit (RbkWH_En)
20	1 = Monitor readback value low limit (RbkWL_En)
21	1 = Report readback value high limit violation (RbkWH_MsgEn)
22	1 = Report readback value low limit violation (RbkWL_MsgEn)
23	1 = Automatic preview control valve "Open"
24	1 = Automatic preview control valve "Closed"
25	1 = Automatic preview control valve "Stop"
26	1 = Show automatic preview in the standard view
27	1 = Auxiliary valve present
28	GrpErr.Value
29	RdyToStart.Value
30	MV_UpRaAct, MV_DnRaAct limits enabled for gradient mode (MV_RateOn = 1)
31	SimLiOp.Value

Status word allocation for Status4 parameter

Status bit	Parameter
0	External error generated by FaultExt or external control system fault CSF with set Feature bit 18 Activating error state for external process control error CSF (Page 151)
1	Delay of the ER_AH_Lim message
2	Delay of the ER_AL_Lim message

Status bit	Parameter
3	Delay of the RbkWH_Lim message
4	Delay of the RbkWL_Lim message
5	Collection of message delays
6	1 = MV ramp active
7 - 22	Not used
23	Hidden bypass signal in Permit
24	Hidden bypass signal in interlock
25	Hidden bypass signal in Protect
26	Feature2 bit 2: Separate bypass signal
27	1 = Input parameter MV_ChnST is interconnected
28	1 = Input parameter CtrlChnST is interconnected
29	Current monitoring time is visible
30	Current auxiliary valve monitoring time is visible
31	Not used

Status word allocation for status5 parameter

Status bit	Parameter
0 - 7	Effective signal 9..16 of the message block connected via EventTsIn
8 - 31	Not used

See also

- VlvAnL modes (Page 1452)
- VlvAnL functions (Page 1454)
- VlvAnL error handling (Page 1467)
- VlvAnL messaging (Page 1469)
- VlvAnL block diagram (Page 1483)

7.13.2 VlvAnL modes

VlvAnL operating modes

The block can be operated using the following modes:

- Local mode (Page 79)
- Automatic mode (Page 75)
- Manual mode (Page 75)
- Out of service (Page 71)

The next section provides additional block-specific information relating to the general descriptions.

"Local mode"

The block supports the local modes 2 and 4. Therefore, the control settings for the block are also made based on internal adjustment of the feedback value.

You can find general information on "Local mode", switching modes and Bumpless switchover in the Local mode (Page 79) section.

"Automatic mode"

You can find general information on "Automatic mode", switching modes and Bumpless switchover in the Manual and automatic mode for motors, valves and dosers (Page 75) section.

With auxiliary valve

In "automatic mode", the automatic commands affect the auxiliary valve, which you can

- "Open" (OpenAut = 1)
- "Close" (CloseAut = 1)

Without auxiliary valve

In "automatic mode", the automatic commands affect the control valve, which you can

- "Open" (OpenAut = 1)
- "Close" (CloseAut = 1)

Note

If no auxiliary valve is configured, no internal manipulated variable specifications can be made in "automatic mode". Manipulated variable specification is set to external when the mode is switched to "automatic".

"Manual mode"

You can find general information on "Manual mode", switching modes and bumpless switchover in the section Manual and automatic mode for motors, valves and dosers (Page 75).

With auxiliary valve:

In "manual mode", the operator actions affect the auxiliary valve, which you can:

- "Open" (OpenMan = 1)
- "Close" (CloseMan = 1)

Note

If no auxiliary valve is configured, no external manipulated variable specifications can be made in the manual operating mode. With an internal manipulated value, the switchover from "automatic mode" to "manual mode" is bumpless. With an external manipulated value, the switchover is bumpless only if `MV_TrkExt = 1` is parameterized.

Without auxiliary valve:

In "manual mode", the operator actions affect the control valve, which you can:

- "Open" (OpenMan = 1)
- "Close" (CloseMan = 1)

Note

If no auxiliary valve is configured, no external manipulated variable specifications can be made in the manual operating mode. Manipulated variable specification is set to internal when the mode is switched to manual. The switching is bumpless depending on the parameter `MV_TrkExt`.

"Out of service"

You can find general information about the "Out of service" mode in the section Out of service (Page 71).

See also

- Description of VlvAnL (Page 1448)
- VlvAnL functions (Page 1454)
- VlvAnL error handling (Page 1467)
- VlvAnL messaging (Page 1469)
- VlvAnL I/Os (Page 1470)
- VlvAnL block diagram (Page 1483)

7.13.3 VlvAnL functions

Functions of VlvAnL

The functions for this block are listed below.

Opening additional faceplates

This block provides the standard function Opening additional faceplates (Page 208).

Interlocks

This block provides the following interlocks:

- Activation enable ("Permission")
- Interlock without reset ("Interlock")
- Interlock with reset ("Protection")

Refer to the section Interlocks (Page 99) as well as Influence of the signal status on the interlock (Page 103).

Resetting the block in case of interlocks or errors

This block provides the standard function Resetting the block in case of interlocks or errors (Page 43).

External error (`FaultExt`), external control system fault (`CSF`)

This block provides the possibility to pass an external error via the `FaultExt` parameter or an external control system fault via the `CSF` parameter. See VlvAnL error handling (Page 1467)

Group error

This block provides the standard function Outputting group errors (Page 122).

The following parameters are taken into consideration when forming the group error:

- `CSF`
- `MonDynErr`
- `MonStaErr`
- `MonDynAuxVErr`
- `MonStaAuxVErr`
- `FaultExt`

Outputting a signal for start readiness

This block provides the standard function Outputting a signal for start readiness (Page 53).

SIMATIC BATCH functionality

This block provides the standard function SIMATIC BATCH functionality (Page 67).

Simulating signals

This block provides the standard function Simulating signals (Page 58).

You can simulate the following values:

- Position feedback (`SimRbk`, `SimRbkLi`)

Using a manipulated variable ramp

The block provides the standard function Using a manipulated variable ramp (Page 125)

This function is ignored with tracking and forced tracking.

Gradient limiting of the manipulated variable

This block provides the standard function Gradient limiting of the manipulated variable (Page 126)

Note

This function is ignored with tracking, forced tracking, forced operating states and travel to the neutral position.

Tracking and limiting a manipulated variable

You can correct the manipulated variable output to the tracking value MV_Trk or the manipulated variable feedback Rbk to realize Bumpless switchover. To track the manipulated variable output, you have to set the parameter $MV_TrkOn = 1$.

If the parameter is $MV_TrkRbk = 0$, the manipulated variable output is corrected to the tracking value MV_Trk . The manipulated variable output MV is limited to the MV_HiLim and MV_LoLim parameters.

If the parameter is $MV_TrkRbk = 1$, the manipulated variable output is tracked to the position feedback Rbk . There are no limits here.

The "Tracking" text is displayed additionally in the standard view of the faceplate.

Tracking has a higher priority than interlock for a control valve.

Forming the group status for interlocks

This block provides the standard function Forming the group status for interlock information (Page 104).

Forming the signal status for blocks

This block provides the standard function Forming and outputting the signal status for technologic blocks (Page 109).

The signal status of the output for the manipulated variable feedback $RbkOut$ always corresponds to the signal status of the Rbk input or when the block is in simulation, the signal status of the 16#60 output.

The signal status of the $FbkCloseOut$ and $FbkOpenOut$ outputs is fetched and sent from the worst signal status from the $RbkOut$ output and the corresponding feedback signal inputs $FbkClose$ and $FbkOpen$.

The signal status of the manipulated variable output MV always corresponds to the signal status of the input parameter MV_Ext or MV_Int , depending on how the setpoint is specified. If the internal manipulated variable MV_Int is used, the signal status is always output as 16#80.

The signal status of manipulated variable difference ER is fetched and sent from the worst signal status of the two outputs $RbkOut$ and MV .

The worst signal status `ST_Worst` for the block is formed from the following parameters:

- `FbkOpenOut.ST`
- `FbkCloseOut.ST`
- `FbkAuxVOpenOut.ST`
- `FbkAuxVCloseOut.ST`
- `RbkOut.ST`
- `LocalLi.ST`
- `MV_Chn.ST`
- `CtrlChn.ST`
- `OpenAut.ST` (only if `Feature2.Bit10 = 1`)
- `CloseAut.ST` (only if `Feature2.Bit10 = 1`)
- `MV_Ext.ST` (only if `Feature2.Bit10 = 1`)

Considering bad quality of automatic commands or external values

If the `Feature2` bit Considering bad quality of automatic commands or external values (Page 186) is set to 1 and one of the following parameters has bad signal status (16#00 or 16#28), the block goes to the neutral position in the "Automatic" mode:

- `OpenAut.ST`
- `CloseAut.ST`
- `MV_Ext.ST`

Forcing operating modes

This block provides the standard function Forcing operating modes (Page 41).

Note

If the block is operated with a auxiliary valve, the `OpenForce` and `CloseForce` commands also affect the auxiliary valve.

The high range limit (`MV_HiLim`) and the low range limit (`MV_LoLim`) are output at `MV` for `OpenForce` and `CloseForce` respectively.

With `CloseForce`, the auxiliary valve is closed, thereby triggering the neutral position of the control valve regardless of the `MV` output.

A configured ramp limit has no effect.

Feedback monitoring

This block provides the standard function Monitoring the feedbacks (Page 97).

Digital feedback signals for the "Open" and "Closed" positions are formed from the position feedback:

- Feedback for "Open" position: $Rbk \geq PosDiOpen$
- Feedback for "Closed" position: $Rbk \leq PosDiClose$

Specifying control valve positions:

There are the positions:

- Valve closed ("Closed")
- Valve closes
- Valve open ("Open")
- Valve opens
- Valve has reached defined position

Valve closed ("Closed")

When the control valve reaches the "Close" position, the output is $FbkCloseOut.Value = 1$:

- With a binary limit switch for the "Close" position ($NoFbkClose = 0$):
The valve is considered closed when $FbkCloseOut$ is set. $FbkCloseOut$ is set when $Rbk \leq PosDiClose$ and $FbkClose = 1$.
- Without a binary limit switch for the "Close" position ($NoFbkClose = 1$):
The valve is considered closed when $FbkCloseOut$ is set. $FbkCloseOut$ is set when $Rbk \leq PosDiClose$.

Valve closes

If the control valve travels in the direction of the "Close" position, the output is $FbkClsgOut = 1$:

- $FbkClsgOut$ is set when $MV.Value < RbkOut.Value$ and not when $PosReached.Value = 1$.

Valve open ("Open")

When the control valve reaches the "Open" position, the output is $FbkOpenOut.Value = 1$:

- With a binary limit switch for the "Open" position ($NoFbkOpen = 0$):
The valve is considered open when $FbkOpenOut$ is set. $FbkOpenOut$ is set when $Rbk \geq PosDiOpen$ and $FbkOpen = 1$.
- Without a binary limit switch for the "Open" position ($NoFbkOpen = 1$):
The valve is considered open when $FbkOpenOut$ is set. $FbkOpenOut$ is set, when $Rbk \geq PosDiOpen$.

Valve opens

If the control valve travels in the direction of the "Open" position, the output is $FbkOpngOut = 1$:

- $FbkOpngOut$ is set when $MV.Value > RbkOut.Value$ and is not $PosReached.Value = 1$.

Valve has reached defined position

If the control valve is sent to a specified intermediate position ($MV > PosDiClose$ and $MV < PosDiOpen$), the targeted position is reached when the difference $MV.Value - RbkOut.Value$ is within the configured tolerance range $\pm PosDeadBand$ and therefore $ER.Value = 0.0$.

If the control valve is set to the end position "Open" ($MV.Value \geq PosDiOpen$), this position is reached when $ER.Value = 0.0$ and also $FbkOpenOut.Value = 1$.

If the control valve is set to the end position "Closed" ($MV.Value \leq PosDiClose$), this position is reached when $ER.Value = 0.0$ and also $FbkCloseOut.Value = 1$.

When the control valve reaches the specified position, the $PosReached = 1$ output is set.

Dynamic monitoring

The monitoring is based on the effective feedback signals $FbkOpenOut$ and $FbkCloseOut$ and not directly on the feedback inputs $FbkOpen$ and $FbkClose$.

A dynamic monitoring error is generated if:

- The "Close" end position is targeted ($MV \leq PosDiClose$) and this position ($FbkCloseOut$) is not reached within the monitoring time $MonTiDynamic$.
- The "Close" end position is targeted ($MV \leq PosDiClose$) and the feedback of the binary limit switch $FbkClose$ is already within the control range.
- The "Open" position is targeted ($MV \geq PosDiOpen$) and this position ($FbkOpenOut$) is not reached within the monitoring time $MonTiDynamic$.
- The "Open" end position is targeted ($MV \geq PosDiOpen$) and the feedback for the binary limit switch $FbkOpen$ is already within the control range.
- A further intermediate position is controlled and this position is not reached ($PosReached = 0$) within the monitoring time $MonTiDynamic$.

Static monitoring

The monitoring is based on the effective feedback signals $FbkOpenOut$ and $FbkCloseOut$ and not on the feedback inputs $FbkOpen$ and $FbkClose$.

A static monitoring error is generated if:

- The "Close" end position ($FbkCloseOut = 1$) is abandoned without a command having been issued beforehand, and the monitoring time $MonTiStatic$ has expired.
- The "Close" end position is reached ($FbkCloseOut = 1$), the feedback of the binary limit switch $FbkClose$ is gone, and monitoring time $MonTiStatic$ has expired.
- The "Open" end position ($FbkOpenOut = 1$) is abandoned without a command having been issued beforehand and the monitoring time $MonTiStatic$ has expired.
- The "Open" end position is reached ($FbkOpenOut = 1$), the feedback of the binary limit switch $FbkOpen$ is gone, and monitoring time $MonTiStatic$ has expired.
- The valve is in intermediate position and with constant MV , the analog feedback Rbk has been changed so much that the position is no longer reached ($PosReached = 0$) and the monitoring time $MonTiStatic$ has expired.

Suppressing messages using the MsgLock parameter

This block provides the standard function Suppressing messages using the MsgLock parameter (Page 205).

Monitoring the feedback for the auxiliary valve

The auxiliary valve provides dynamic and static monitoring of the feedback. No special monitoring time can be configured for overseeing the retention of the end position of the auxiliary valve. If the end position is exited without the corresponding command, a "monitoring runtime error" is reported after expiration of the time configured under "Control".

Monitoring is disabled by default and no connections are displayed.

The following parameters can be used to monitor the auxiliary valve

Parameter	Function
FbkAuxVOpen	1 = Auxiliary valve open feedback signal
FbkAuxVClose	1 = Auxiliary valve closed feedback signal
NoFbkAuxVOpen	1 = No feedback present for Auxiliary valve open (default = 1)
NoFbkAuxVClose	1 = No feedback present for Auxiliary valve closed (default = 1)
MonitorAuxV	1 = Feedback monitoring of the auxiliary valve (default = 0)
MonAuxVTime	Monitoring time after auxiliary valve operation in [s]
MonDynAuxVErr	Dynamic monitoring error pending
MonStaAuxVErr	Static monitoring error pending

Otherwise, the monitoring works like the monitoring function of the control valve.

Selecting a unit of measure

This block provides the standard function Selecting a unit of measure (Page 212).

Neutral position

This block provides the standard function Neutral position for motors, valves and controllers (Page 48).

The neutral position (de-energized state) for the auxiliary valve is set using the `SafePosAux` parameter.

- `SafePosAux = 0` means that the auxiliary valve closes with `Ctrl = 0` and opens with `Ctrl = 1`.
- `SafePosAux = 1` means that the auxiliary valve opens with `Ctrl = 0` and closes with `Ctrl = 1`.

The setting is made with the `SafePos` parameter for the control valve.

- `SafePos = 0` means that the control valve closes in the de-energized state (MV is set to `MV_OpScale.Low`)
- `SafePos = 1` means that the control valve opens in the de-energized state (MV is set to `MV_OpScale.High`)
- `SafePos = 2` means that the control valve retains its position in the de-energized state. (MV remains unchanged)

The control valve is brought to the neutral position when the `FbkAuxVCloseOut = 1` control valve is closed.

Generating instance-specific messages

This block provides the standard function `Generating instance-specific messages` (Page 204).

Configurable reactions using the `Feature` parameter

You can find an overview of all reactions provided by the `Feature` parameter in the `Configurable functions using the Feature I/O` (Page 131) . The following functionality is available for this block at the relevant bits:

Bit	Function
0	Set startup characteristics (Page 138)
1	Reaction to the out of service mode (Page 177)
2	Resetting the commands for changing the mode (Page 161)
3	Enabling resetting of commands for the control settings (Page 161)
4	Setting switch or button mode (Page 167)
5	Control via auxiliary valve (Page 172)
6	Disabling opening and closing (Page 158)
7	Ramp rate calculation (Page 179)
9	Resetting via input signals in the event of interlocking (Protection) or errors (Page 163)
10	Exiting local mode (Page 177)
11	Activating the run time of feedback signals (Page 153)
12	Gradient limitation with time duration (Page 182)
15	Neutral position manipulated variable takes effect with "out of service" operating mode (Page 166)
16	Neutral position manipulated variable takes effect at startup (Page 166)
17	Enabling bumpless switchover to automatic mode for valves, motors, and dosers (Page 173)
18	Activating error state for external process control error CSF (Page 151)
21	Enable bumpless switchover to "Automatic" mode for operator only (Page 172)
22	Update acknowledgment and error status of the message call (Page 160)
24	Enabling local operator authorization (Page 158)
25	Suppression of all messages (Page 174)
26	Reaction of the switching points in the "Out of service" operating mode (Page 176)

Bit	Function
27	Interlock display with LocalSetting 2 or 4 (Page 178)
28	Disabling operating points (Page 145)
29	Signaling limit violation (Page 170)
30	Set reset depending on the operating mode or the LiOp parameter (Page 163)
31	Activating reset of protection / error in manual mode (Page 165)

With auxiliary valve (Feature bit 5 = 1):

In this case the automatic commands `OpenAut` and `CloseAut` control the auxiliary valve

In pushbutton operation (Bit 4 = 0) the automatic commands in automatic mode are latching, in other words `OpenAut`, and `CloseAut`, can be reset to 0 after changing the control. In manual and local modes, however, the automatic commands are not saved and in the absence of automatic commands the automatic control is tracked.

In switching mode (Bit 4 = 1), control is selected with the static signals `OpenAut`. If input `OpenAut` is not set the auxiliary valve is closed. Control via `CloseAut` is not needed. If the "Activate command reset for control settings" function (Bit 3 = 1) is activated, the `OpenAut` input is reset to the neutral position after evaluation in the block.

Without auxiliary valve (Feature bit 5 = 0):

The analog valve is opened or closed in automatic mode with the automatic commands `OpenAut` and `CloseAut`. If `OpenAut` and `CloseAut` are reset, the output `MV` is set to `MV_Ext`. For "Activate command reset for control settings" (Bit 3 = 1), `OpenAut` and `CloseAut` are reset and the control elements are self-locking. This means the output `MV` is only set to `MV_Ext` after a change of `MV_Ext`. Control via switch or button mode (bit 4) does not affect the behavior of `OpenAut` and `CloseAut`.

Configurable reactions using the `Feature2` parameter

Bit	Function
2	Separate evaluation for excluded and simulated interlock signals (Page 152)
3	Control priority in the event of an invalid input command (Page 175)
5	Evaluation of the signal status of the interlock signals (Page 142)
10	Considering bad quality of automatic commands or external values (Page 186)
11	Suppress <code>MsgLock</code> and "Out of service" mode for a connected message block (Page 188)

Displaying auxiliary values

This block provides the standard function Displaying auxiliary values (Page 211).

Alarm delays with two time values per limit pair

This block has the standard alarm delay function Two time values per limit pair (Page 201) for limit monitoring of the feedback and limit monitoring of the manipulated variable difference.

The function here relates solely to the limits of the manipulated variable difference.

Digital feedback from the readback value

This block forms a digital position feedback for "Closed" and "Open" from the configured operating points of the position feedback values `PosDiClose` and `PosDiOpen`.

Operator permissions

This block provides the standard function Operator control permissions (Page 254).

The block has the following permissions for the `OS_Perm` parameter:

Bit	Function
0	1 = Operator can switch to "automatic mode"
1	1 = Operator can switch to "manual mode"
2	1 = Operator can switch to "local mode"
3	1 = Operator can switch to "Out of service" mode
4	1 = Operator can open the valve
5	1 = Operator can close the valve
6	1 = Operator can reset the valve
7	1 = Operator can define the monitoring time for startup
8	1 = Operator can define the monitoring time for the end position
9	1 = Operator can enable the monitoring the control valve feedback function (Bit 7 - 8)
10	1 = Operator can activate the Simulation function
11	1 = Operator can activate the Release for maintenance function
12	1 = Operator can change the simulation value <code>SimRbk</code>
13 - 23	Not used
24	1 = Operator can define the monitoring time of the auxiliary valve for startup
25	Not used
26	1 = Operator can enable the monitoring the auxiliary valve feedback function (Bit 24)
27 - 31	Not used

The block has the following operator permissions for the `OS1Perm` parameter:

Bit	Function
0 - 3	Not used
4	1 = Operator can switch the manipulated variable to "external" <code>MV_ExtOp</code>
5	1 = Operator can switch the manipulated variable to "internal" <code>MV_IntOp</code>
6	Not used
7	1 = Operator can change the manual manipulated variable <code>MV_Int</code>
8 - 9	Not used
10	1 = Operator can change the operation high limit of the manipulated variable <code>MV_HiLim</code>
11	1 = Operator can change the operation low limit of the manipulated variable <code>MV_LoLim</code>
12	1 = Operator can enable the manipulated variable's gradient limitation function <code>MV_RateOn</code>
13	1 = Operator can change the manipulated variable's high limit for the ramp <code>MV_UpRaLim</code>
14	1 = Operator can change the manipulated variable's low limit for the ramp <code>MV_DnRaLim</code>

Bit	Function
15	1 = Operator can switch between the time value or the value for the ramp (MV_RmpModTime)
16	1 = Operator can change the ramp time MV_RmpTime
17	1 = Operator can change the target manipulated variable MV_RmpTarget for the manipulated variable ramp
18	1 = Operator can enable the manipulated variable ramp function MV_RmpOn
19	Not used
20	1 = Operator can enable the track manipulated variable function in tracking mode MV_TrkRbk
21	1 = Operator can enable the bumpless switchover from external to internal MV_TrkExt
22	1 = Operator can activate / deactivate messages via ER_AH_MsgEn
23	1 = Operator can activate / deactivate messages via ER_AL_MsgEn
24	1 = Operator can activate / deactivate messages via RbkWH_MsgEn
25	1 = Operator can activate / deactivate messages via RbkWL_MsgEn
26	1 = Operator can change the limit (manipulated variable difference) for the high alarm ER_AH_Lim
27	1 = Operator can change the hysteresis (manipulated variable difference) ER_Hyst
28	1 = Operator can change the limit (manipulated variable difference) for the low alarm ER_AL_Lim
29	1 = Operator can change the limit (position feedback) for the high warning RbkWH_Lim
30	1 = Operator can change the hysteresis (position feedback) RbkHyst
31	1 = Operator can change the hysteresis (position feedback) for low warning RbkWL_Lim

Note

If you interconnect a parameter that is also listed in OS_Perm as a parameter, you have to reset the corresponding OS_Perm bit.

Generation of manipulated variables

The manipulated variable MV is formed as follows:

MV_For On	Close Force	Open Force	Man Act	Aut Act	Local Act	MV_Trk On	MV_Trk Rbk	MV_Ext Act	MV =	Limit	State
1	0	0	-	-	-	-	-	-	MV_Forced	none	Forced tracking without limit
-	1	0	-	-	-	-	-	-	MV_OpScale.Low	MV_OpScale.Low	Forced close
-	0	1	-	-	-	-	-	-	MV_OpScale.High	MV_OpScale.High	Forced open
0	0	0	1	0	0	0	-	0	MV_Int	MV_HiLim MV_LoLim	Manual mode with internal manipulated variable

MV_For On	Close Force	OpenForce	Man Act	Aut Act	Local Act	MV_Trk On	MV_Trk Rbk	MV_Ext Act	MV =	Limit	State
0	0	0	1	0	0	0	-	1	MV_ExtOut	MV_HiLim MV_LoLim	Manual mode with external manipulated variable and limit
0	0	0	0	1	0	0	-	1	MV_Int	MV_HiLim MV_LoLim	Automatic with external manipulated variable and limit
0	0	0	0	1	0	0	-	1	MV_ExtOut	MV_HiLim MV_LoLim	Automatic with external manipulated variable and limit
0	0	0	-	-	0	1	0	-	MV_Trk	MV_HiLim MV_LoLim	Tracking with limitation
0	0	0	0	-	0	1	1	-	Rbk	none	Tracking to position feedback without limit
0	0	0	0	0	1	-	-	-	Rbk	None	Local mode with tracking to position feedback without limit

"Actuator active" information

- The following applies for `PosReached.Value = 0`:
With `PosDiClose < MV < PosDiOpen`, the control valve is detected as active and Bit 24 is set in `Status1`.
- The following applies for `PosReached.Value = 1`:
`Status1.Bit 24 = 0`

This status can be used to indicate a customized symbol in the process image, for example, and is saved in the status word (see Status word section in Description of VlvAnL (Page 1448)).

General function "MV difference"

The manipulated variable difference is sent to the `ER` output and is calculated with the following formula:

$$ER = MV - Rbk$$

If `ER` is within the dead band, `ER = 0` is set and the manipulated variable is considered reached.

Manipulated variable difference generation and dead band

The manipulated variable difference is formed by the effective manipulated variable MV and the position feedback Rbk , and sent to the ER output. A dead band can be set at the $PosDeadBand$ input:

- $PosDeadBand = 0$ Dead band is disabled
- $PosDeadBand \neq 0$ Dead band is enabled

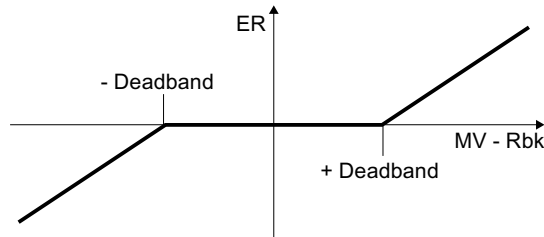

Limit monitoring of manipulated variable and error signal

The block provides the standard function Limit monitoring of setpoint, manipulated variable and control deviation (Page 95)

Monitoring is disabled in the following situations:

- The auxiliary valve is closed
- The control valve is in the neutral position

Group display SumMsgAct for limit monitoring, CSF and ExtMsgx

The block provides the standard function Group display for limit monitoring, CSF and ExtMsgx (Page 85).

Specifying warning times for control functions at motors and valves

This block provides the standard function Specifying warning times for control functions at motors and valves (Page 51)

The warning time affect the analog manipulated variable MV . The output is updated only with the specification of a new manipulated variable after the warning time has expired.

Warning time is ignored in tracking $MV_TrkOn = 1$ and in forced tracking MV_ForOn .

Disabling feedback

This block provides the standard function Disabling feedback for valves (Page 99).

This function is available for both the control valve and auxiliary valve. The feedback for the auxiliary valve is disabled by default, connections are not displayed.

The disable setting is made with the $NoFbkOpen$ and $NoFbkClose$ parameters for the control valve.

The disable setting is made with the $NoFbkAuxVOpen$ and $NoFbkAuxVClose$ parameters for the auxiliary valve.

Connection of the time-stamped messages from EventTs or Event16Ts

This block provides the standard function Connection of the time-stamped messages from EventTs or Event16Ts (Page 207).

Button labels

This block provides the standard function Labeling of buttons and text (Page 209)

Instance-specific text can be configured for the following parameters:

- OpenMan
- CloseMan

See also

EventTs functions (Page 1660)

VlvAnL modes (Page 1452)

VlvAnL messaging (Page 1469)

VlvAnL I/Os (Page 1470)

VlvAnL block diagram (Page 1483)

Disable calculation of impulse control in LocalSetting 2 and 4 (Page 186)

7.13.4 VlvAnL error handling

Error handling of VlvAnL

Refer to section Error handling (Page 119) in the basic instructions for the error handling of all blocks.

The following errors can be displayed for this block:

- Error numbers
- Mode switchover error
- Invalid input signals
- Control system fault (CSF)

Overview of error numbers

The `ErrorNum` I/O can be used to output the following error numbers:

Error number	Meaning of the error number
-1	Predefined value when inserting the block; the block is not executed
0	There is no error.
41	The value of the <code>LocalSetting</code> connection is outside the valid range. Valid values are 0, 2 and 4

Error number	Meaning of the error number
42	LocalSetting = 0 or LocalSetting = 4 and LocalLi = 1
51	AutModLi = 1 and ManModLi = 1 OpenAut = 1 and CloseAut = 1 OpenForce = 1 and CloseForce = 1
52	LocalSetting = 2 or 4 and SimOn = 1

Mode switchover error

This error can be output by the block, see the section Error handling (Page 119).

Invalid input signals

This error can be output by the block, see the section Error handling (Page 119).

For the following invalid input signals, the control output can be kept or switched to the neutral position. This depends on the function control priority for invalid input command (Page 175).

Operating mode	Invalid input signals	Control reaction with Feature2 bit 3 =1
Forcing	OpenForce = 1 and CloseForce = 1	Valve without auxiliary valve (Feature bit 5 = 0): Valve is set to its neutral position. Valve with auxiliary valve (Feature bit 5 = 1): Valve is set to its neutral position.
"Automatic mode" and no forcing	Pushbutton operation (Feature bit 4 = 0): OpenAut = 1 and CloseAut = 1	
"Manual mode" and no forcing	OpenMan = 1 and CloseMan = 1	

Control system fault (CSF)

An external signal can be activated via the CSF input. A control system fault is triggered if this signal changes to 1. Refer to the Error handling (Page 119) section for more on this.

See also

- VlvAnL messaging (Page 1469)
- Description of VlvAnL (Page 1448)
- VlvAnL modes (Page 1452)
- VlvAnL functions (Page 1454)
- VlvAnL I/Os (Page 1470)
- VlvAnL block diagram (Page 1483)

7.13.5 VivAnL messaging

Messaging

The following messages can be generated for this block:

- Process control fault
- Instance-specific messages
- Process messages

Process control fault

- The following control system error messages can be output:

Message instance	Message identifier	Message class	Event
MsgEvld1	SIG 1	AS process control message - fault	\$\$BlockComment\$\$ Feedback error
	SIG 6	AS process control message - fault	External error has occurred

Explanation:

\$\$BlockComment\$\$: Content of the instance-specific comment

You can interconnect an external fault (signal) to input parameter `CSF`. If it changes to `CSF = 1`, a process control fault is triggered (`MsgEvld1`, SIG 6).

Process messages

Message instance	Message identifier	Message class	Event
MsgEvld1	SIG 2	Alarm - high	\$\$BlockComment\$\$ ER - high alarm limit violated
	SIG 3	Alarm - low	\$\$BlockComment\$\$ ER - low alarm limit violated
	SIG 4	Warning - high	\$\$BlockComment\$\$ Rbk - high warning limit violated
	SIG 5	Warning - low	\$\$BlockComment\$\$ Rbk - low warning limit violated

Explanation:

\$\$BlockComment\$\$: Content of the instance-specific comment

Instance-specific messages

You have the option to use one or two instance-specific messages for this block.

Message instance	Message identifier	Message class	Event
MsgEvId1	SIG 7	AS process control message - fault	\$\$BlockComment\$\$ External message 1
	SIG 8	AS process control message - fault	\$\$BlockComment\$\$ External message 2

Explanation:

\$\$BlockComment\$\$: Content of the instance-specific comment

Associated values for message instance MsgEvId1

Associated value	Block parameters
1	BatchName
2	StepNo
3	BatchID
4	ExtVal04
5	ExtVal05
6	ExtVal06
7	ExtVal07
8	ExtVal08
9	Reserved
10	Reserved

The associated values 4 ... 8 are allocated to the parameters ExtVal04 ... ExtVal08 and can be used. Additional information is available in the "Process Control System PCS 7 - Engineering System" manual.

See also

- Description of VlvAnL (Page 1448)
- VlvAnL functions (Page 1454)
- VlvAnL I/Os (Page 1470)
- VlvAnL modes (Page 1452)
- VlvAnL error handling (Page 1467)
- VlvAnL block diagram (Page 1483)

7.13.6 VlvAnL I/Os

I/Os of VlvAnL

Input parameter master

Parameter	Description	Type	Default
AutModLi*	1 = "Automatic mode" via interconnection or SFC (controlled by ModLiOp = 1)	STRUCT <ul style="list-style-type: none"> • Value: BOOL • ST: BYTE 	- <ul style="list-style-type: none"> • 0 • 16#80
AutModOp*	1 = "Automatic mode" via operator (controlled by ModLiOp = 0)	BOOL	0
BatchEn	1 = Enable allocation	BOOL	0
BatchID	Batch ID	DWORD	16#00000000
BatchName	Batch name	S7-String	
BypProt	1 = Bypassing interlock is active in "local mode" and in simulation	BOOL	0
CloseAut*	1 = Select Close valve in "automatic mode"	STRUCT <ul style="list-style-type: none"> • Value: BOOL • ST: BYTE 	- <ul style="list-style-type: none"> • 0 • 16#80
CloseForce	1 = Force valve closure	STRUCT <ul style="list-style-type: none"> • Value: BOOL • ST: BYTE 	- <ul style="list-style-type: none"> • 0 • 16#80
CloseMan*	1 = Select Close valve in "manual mode"	BOOL	0
CSF	1 = External error (control system fault) Error handling (Page 119)	STRUCT <ul style="list-style-type: none"> • Value: BOOL • ST: BYTE 	- <ul style="list-style-type: none"> • 0 • 16#80
CtrlChnST	Signal status of output channel for Ctrl Should be connected to an output channel block	STRUCT <ul style="list-style-type: none"> • Value: BOOL • ST: BYTE 	- <ul style="list-style-type: none"> • 0 • 16#FF
EN	1 = Called block will be processed	BOOL	1
ER_A_DC*	Delay for incoming alarms during manipulated variable difference monitoring	REAL	0.0
ER_A_DG*	Delay for outgoing alarms during manipulated variable difference monitoring	REAL	0.0
ER_AH_En	1 = Activate alarm (high) for manipulated variable difference monitoring	BOOL	1
ER_AH_Lim	Alarm limit (high) for manipulated variable difference monitoring	REAL	100.0
ER_AH_MsgEn	1 = Activate messages for alarm (high) for manipulated variable difference monitoring	BOOL	1
ER_AL_Lim	Alarm limit (low) for manipulated variable difference monitoring	REAL	-100.0
ER_AL_En	1 = Activate alarm (low) for manipulated variable difference monitoring	BOOL	1
ER_AL_MsgEn	1 = Activate messages for alarm (low) for manipulated variable difference monitoring	BOOL	1

Parameter	Description	Type	Default
ER_Hyst	Alarm hysteresis for manipulated variable difference monitoring	REAL	1.0
EventTsIn	For interconnecting data between a technology block and the message blocks EventTs, Event16Ts. The EventTsIn input parameter serves to interconnect the EventTsOut output parameter of the EventTs, Event16Ts block. When this interconnection is configured, the messages of the EventTs, Event16Ts block are displayed on the OS in the alarm view of the technology block and can also be acknowledged there.	ANY	
ExtMsg1	Binary input for freely selectable message 1	STRUCT • Value: BOOL • ST: BYTE	- • 0 • 16#80
ExtMsg2	Binary input for freely selectable message 2	STRUCT • Value: BOOL • ST: BYTE	- • 0 • 16#80
ExtVa104	Associated value 4 for messages (MsgEvID1)	ANY	
ExtVa105	Associated value 5 for messages (MsgEvID1)	ANY	
ExtVa106	Associated value 6 for messages (MsgEvID1)	ANY	
ExtVa107	Associated value 7 for messages (MsgEvID1)	ANY	
ExtVa108	Associated value 8 for messages (MsgEvID1)	ANY	
FaultExt	1 = External error Error handling (Page 119)	STRUCT • Value: BOOL • ST: BYTE	- • 0 • 16#80
FbkAuxVClose	1 = Auxiliary valve closed feedback signal	STRUCT • Value: BOOL • ST: BYTE	- • 0 • 16#FF
FbkAuxVOpen	1 = Auxiliary valve open feedback signal	STRUCT • Value: BOOL • ST: BYTE	- • 0 • 16#FF
FbkClose	1 = Valve closed feedback signal	STRUCT • Value: BOOL • ST: BYTE	- • 0 • 16#FF
FbkOpen	1 = Valve open feedback signal	STRUCT • Value: BOOL • ST: BYTE	- • 0 • 16#FF

Parameter	Description	Type	Default
Feature	I/O for additional functions (Page 1454)	STRUCT <ul style="list-style-type: none"> • Bit 0: BOOL • ... • Bit 31: BOOL 	- <ul style="list-style-type: none"> • 0 • 0 • 0
Feature2	I/O for additional functions (Page 1454)	STRUCT <ul style="list-style-type: none"> • Bit 0: BOOL • ... • Bit 31: BOOL 	- <ul style="list-style-type: none"> • 0 • 0 • 0
Intl_En	1 = Interlock without reset (interlock, Intlock parameter) is active	BOOL	1
Intlock	0 = Interlocking without reset is active; you can operate the block without reset once the interlocking condition has disappeared 1 = Interlock not activated	STRUCT <ul style="list-style-type: none"> • Value: BOOL • ST: BYTE • Bit 1: BOOL (Bypass information bit) 	- <ul style="list-style-type: none"> • 1 • 16#FF • 0
LocalLi	1 = Activate "local mode" via plant signal	STRUCT <ul style="list-style-type: none"> • Value: BOOL • ST: BYTE 	- <ul style="list-style-type: none"> • 0 • 16#80
LocalOp*	1 = "Local mode" via operator	BOOL	0
LocalSetting	Properties for the Local mode (Page 79)	INT	0
ManModLi*	1 = "Manual mode" via interconnection or SFC (controlled by ModLiOp = 1)	STRUCT <ul style="list-style-type: none"> • Value: BOOL • ST: BYTE 	- <ul style="list-style-type: none"> • 0 • 16#80
ManModOp*	1 = "Manual mode" via: OS operator (controlled via ModLiOp = 0)	BOOL	1
ModLiOp	Switchover of operating mode between: 0 = Operator 1 = Interconnection or SFC	STRUCT <ul style="list-style-type: none"> • Value: BOOL • ST: BYTE 	- <ul style="list-style-type: none"> • 0 • 16#80
MonAuxVTime*	Monitoring time for feedback monitoring of the auxiliary valve	REAL	3.0
Monitor	1 = Monitoring of control valve feedback	BOOL	1
MonitorAuxV	1 = Monitoring of auxiliary valve feedback	BOOL	1
MonSafePos	1 = Go to neutral position in the event of monitoring errors	BOOL	1
MonTiDynamic*	Monitoring time after operation in [s]	REAL	3.0
MonTiStatic*	Monitoring time for feedback errors without operation in [s]	REAL	3.0
MS_RelOp*	1 = Release for maintenance via OS operator	BOOL	0
MsgEvId1	Message number (assigned automatically)	DWORD	16#00000000

7.13 VlvAnL - Control valve

Parameter	Description	Type	Default
MsgLock	1 = Suppress process messages. See also the section Suppressing messages using the MsgLock parameter (Page 205) for more on this.	STRUCT • Value: BOOL • ST: BYTE	- • 0 • 16#80
MV_ChnST	Signal status of output channel for MV Should be connected to an output channel block	STRUCT • Value: REAL • ST: BYTE	- • 0.0 • 16#FF
MV_DnRaLim*	Gradient limit (low) for manipulated variable [Unit/(Time unit)] Time unit depends on TimeFactor	REAL	100.0
MV_Ext	External manipulated variable	STRUCT • Value: REAL • ST: BYTE	- • 0.0 • 16#80
MV_ExtLi	Select external manipulated variable (via interconnection)	STRUCT • Value: BOOL • ST: BYTE	- • 0 • 16#80
MV_ExtOp*	Select external manipulated variable (via operator)	BOOL	0
MV_Forced	Forced manipulated variable that is not limited and assumes top priority	STRUCT • Value: REAL • ST: BYTE	- • 0.0 • 16#80
MV_ForOn	1 = Output forced manipulated variable MV_Forced unlimited at output MV	STRUCT • Value: BOOL • ST: BYTE	- • 0 • 16#80
MV_HiLim	Limit (high) for manipulated variable MV	REAL	100.0
MV_Int*	Internal manipulated variable	REAL	0.0
MV_IntLi	Select internal manipulated variable (via interconnection)	STRUCT • Value: BOOL • ST: BYTE	- • 0 • 16#80
MV_IntOp*	Select internal manipulated variable (via operator)	BOOL	1
MV_LiDnRaLim	Linkable limit (low) for the gradient of the manipulated variable [Unit/(Time unit)] Time unit depends on TimeFactor	REAL	100.0
MV_LiOp	Select manipulated variable source (internal/external): 1 = Via interconnection 0 = Via operator	STRUCT • Value: BOOL • ST: BYTE	- • 0 • 16#80
MV_LiRmpTime	Linkable time [Time unit] for gradient limitation in ramp mode duration Time unit depends on TimeFactor	REAL	0.0
MV_LiUpRaLim	Linkable gradient limit (high) for the manipulated variable [Unit/(Time unit)] Time unit depends on TimeFactor	REAL	100.0

Parameter	Description	Type	Default
MV_LoLim	Limit (low) for manipulated variable MV	REAL	0.0
MV_OpScale	OS display range for manipulated variable MV	STRUCT <ul style="list-style-type: none"> • High: REAL • Low: REAL 	- <ul style="list-style-type: none"> • 100.0 • 0.0
MV_RateOn*	Change of manipulated variable is limited by MV_UpRaLim and MV_DnRaLim	BOOL	0
MV_RmpModTime	1 = Use time values (MV_RmpTime, MV_LiRmpTime) 0 = Use gradient limits (MV_DnRaLim, MV_LiDnRaLim, MV_UpRaLim, MV_LiUpRaLim)	BOOL	0
MV_RmpOn*	1 = Activate manipulated variable ramp to target value MV_RmpTarget	BOOL	0
MV_RmpTarget*	Time value for manipulated variable ramp	REAL	0.0
MV_RmpTime*	Time [Time unit] for manipulated variable ramp from current MV up to MV_RmpTarget or time [Time unit] for gradient limitation in ramp mode duration Time unit depends on TimeFactor	REAL	0.0
MV_Trk	Tracking value for the manipulated variable MV	STRUCT <ul style="list-style-type: none"> • Value: REAL • ST: BYTE 	- <ul style="list-style-type: none"> • 0.0 • 16#80
MV_TrkExt	1 = Bumpless switchover from external to internal manipulated variable active	BOOL	0
MV_TrkOn	1 = Tracking of manipulated variable MV	STRUCT <ul style="list-style-type: none"> • Value: BOOL • ST: BYTE 	- <ul style="list-style-type: none"> • 0 • 16#80
MV_TrkRbk	1 = Bumpless switchover of manipulated variable tracking active (track manipulated variable to position feedback)	BOOL	0
MV_Unit	Unit of measure for manipulated variable	INT	1342
MV_UpRaLim*	Gradient limit (high) for manipulated variable [Unit/(Time unit)] Time unit depends on TimeFactor	REAL	100.0
NoFbkAuxVClose	1 = No "closed" feedback for auxiliary valve present	BOOL	1
NoFbkAuxVOpen	1 = No "open" feedback for auxiliary valve present	BOOL	1
NoFbkClose	1 = No feedback present for "control valve closed"	BOOL	0
NoFbkOpen	1 = No feedback present for "control valve open"	BOOL	0
Occupied	1 = In use by a batch	BOOL	0

7.13 VlvAnL - Control valve

Parameter	Description	Type	Default
OosLi	1 = "Out of service", via interconnection or SFC	STRUCT <ul style="list-style-type: none"> Value: BOOL ST: BYTE 	- <ul style="list-style-type: none"> 0 16#80
OosOp*	1 = "Out of service", via OS operator	BOOL	0
OpenAut*	1 = Select Open valve in "automatic mode"	STRUCT <ul style="list-style-type: none"> Value: BOOL ST: BYTE 	- <ul style="list-style-type: none"> 0 16#80
OpenForce	1 = Forced open of control valve	STRUCT <ul style="list-style-type: none"> Value: BOOL ST: BYTE 	- <ul style="list-style-type: none"> 0 16#80
OpenMan*	1 = Select Open valve in "manual mode"	BOOL	0
OpSt_In	Input parameter for local operator authorization, connected with the <code>Out</code> output parameter of the upstream block, <code>OpStations</code> (Page 411)	DWORD	16#00000000
OS_Perm	I/O for Operator control permissions (Page 254)	STRUCT <ul style="list-style-type: none"> Bit 0: BOOL Bit 12: BOOL Bit 31: BOOL 	- <ul style="list-style-type: none"> 1 1 1
OSlPerm	I/O for Operator control permissions (Page 254)	STRUCT <ul style="list-style-type: none"> Bit 0: BOOL ... Bit 31: BOOL 	- <ul style="list-style-type: none"> 1 1 1
Perm_En	1 = Activation enable (enable, <code>Permit</code> parameter) is active	BOOL	1
Permit	1 = Enable for opening / closing from neutral position 0 = No activation enable for the valve	STRUCT <ul style="list-style-type: none"> Value:BOOL ST:BYTE Bit 1: BOOL (Bypass information bit) 	- <ul style="list-style-type: none"> 1 16#FF 0
PosDeadBand	Dead band for forming manipulated variable difference	REAL	0.1
PosDiClose	Limit for control valve position "closed"	REAL	5.0
PosDiOpen	Limit for control valve position "open"	REAL	95.0
Prot_En	1 = Protective interlock (protection, <code>Protect</code> parameter) is active	BOOL	1
Protect	0 = Protective interlocking is effective; once the interlocking condition has disappeared, you will have to reset the block 1 = Protective interlocking not activated	STRUCT <ul style="list-style-type: none"> Value:BOOL ST:BYTE Bit 1: BOOL (Bypass information bit) 	- <ul style="list-style-type: none"> 1 16#FF 0

Parameter	Description	Type	Default
Rbk	Position feedback for display on OS	STRUCT • Value: REAL • ST: BYTE	- • 0.0 • 16#80
RbkHyst	Alarm hysteresis for position feedback	REAL	1.0
RbkW_DC*	Delay time for incoming warnings [s]	REAL	0.0
RbkW_DG*	Delay time for outgoing warnings [s]	REAL	0.0
RbkWH_En	1 = Enable warning (high) for position feedback	BOOL	0
RbkWH_Lim	Limit for position feedback of warning (high)	REAL	90.0
RbkWH_MsgEn	1 = Enable messages for warning (high) for position feedback	BOOL	1
RbkWL_En	1 = Enable warning (low) for position feedback	BOOL	0
RbkWL_Lim	Limit for position feedback of warning (low)	REAL	10.0
RbkWL_MsgEn	1 = Enable messages for warning (low) for position feedback	BOOL	1
RstLi*	1 = Reset via interconnection	STRUCT • Value: BOOL • ST: BYTE	- • 0 • 16#80
RstOp*	1 = Reset via operator	BOOL	0
RunUpCyc	Number of cycles in startup; messages are suppressed during these cycles	INT	3
SafePos	Neutral position for control valve: 0 = Closed 1 = Open 2 = Stop	INT	0
SafePosAux	Neutral position for auxiliary valve: 1 = Open 0 = Closed	BOOL	0
SampleTime	Sampling time [s] (assigned automatically)	REAL	0.1
SelFp1	Call a block saved in this parameter as an additional faceplate (Page 208) in the standard view	ANY	
SelFp2	Call a block saved in this parameter as an additional faceplate (Page 208) in the preview	ANY	
SimLiOp	Activation/deactivation of the simulation by: 0 = Operator 1 = Interconnection or SFC	STRUCT • Value: BOOL • ST: BYTE	- • 0 • 16#80

Parameter	Description	Type	Default
SimOnLi	1 = Simulation via interconnection or SFC (controlled by SimLiOp = 1)	STRUCT <ul style="list-style-type: none"> • Value: BOOL • ST: BYTE 	- <ul style="list-style-type: none"> • 0 • 16#80
SimOn*	1 = Simulation on	BOOL	0
SimRbk*	Position feedback used for SimOn = 1	REAL	0.0
SimRbkLi	Position feedback used for SimOnLi.Value = 1 (SimLiOp.Value = 1)	STRUCT <ul style="list-style-type: none"> • Value: REAL • ST: BYTE 	- <ul style="list-style-type: none"> • 0.0 • 16#80
StepNo	Batch step number	DWORD	16#00000000
TimeFactor	Time unit: 0 = Seconds 1 = Minutes 2 = Hours	INT	0
UA1unit	Unit of measure for analog auxiliary value 1	INT	0
UA2unit	Unit of measure for analog auxiliary value 2	INT	0
UserAna1	Analog auxiliary value 1	STRUCT <ul style="list-style-type: none"> • Value: REAL • ST: BYTE 	- <ul style="list-style-type: none"> • 0.0 • 16#FF
UserAna2	Analog auxiliary value 2	STRUCT <ul style="list-style-type: none"> • Value: REAL • ST: BYTE 	- <ul style="list-style-type: none"> • 0.0 • 16#FF
UserStatus	Freely assignable bits for use in PCS 7 OS	BYTE	16#00
WarnTiAut	Prewarning of valve movement in automatic mode in [s]	REAL	0.0
WarnTiMan	Prewarning of valve movement in manual mode in [s]	REAL	0.0

* Values can be written back to these inputs during processing of the block by the block algorithm.

Output parameters

Parameter	Description	Type	Default
AutAct	1 = "Automatic mode" enabled 0 = "Manual mode", "Local mode" or "Out of service" enabled	STRUCT <ul style="list-style-type: none"> • Value: BOOL • ST: BYTE 	- <ul style="list-style-type: none"> • 0 • 16#80
AutoST	1 = Worst signal status of automatic commands	BYTE	16#80

Parameter	Description	Type	Default
AuxClosed	1 = Auxiliary valve is closed	STRUCT • Value: BOOL • ST: BYTE	- • 0 • 16#80
AuxClsing	1 = Auxiliary valve is closing	STRUCT • Value: BOOL • ST: BYTE	- • 0 • 16#80
AuxOpened	1 = Valve is open	STRUCT • Value: BOOL • ST: BYTE	- • 0 • 16#80
AuxOpning	1 = Auxiliary valve is opening	STRUCT • Value: BOOL • ST: BYTE	- • 0 • 16#80
CascaCut	Cascade connection: 1 = Control chain from master controller to secondary valve is interrupted	STRUCT • Value: BOOL • ST: BYTE	- • 0 • 16#80
Closed	1 = Valve is closed	STRUCT • Value: BOOL • ST: BYTE	- • 0 • 16#80
Closing	1 = Valve is closing	STRUCT • Value: BOOL • ST: BYTE	- • 0 • 16#80
Ctrl	Control output for auxiliary valve (depends on <i>SafePosAuxV</i>)	STRUCT • Value: BOOL • ST: BYTE	- • 0 • 16#80
CurrMon	Current monitoring time [s]	DINT	0
CurrMonAuxV	Current auxiliary valve monitoring time [s]	DINT	0
ENO	1 = Block algorithm completed without errors	BOOL	0
ER	Manipulated variable difference	STRUCT • Value: REAL • ST: BYTE	- • 0.0 • 16#80
ER_AH_Act	1 = Alarm limit (high) for manipulated variable difference violated. You can change the reaction for this parameter with <i>Feature</i> bit 28 (Disabling operating points (Page 145)) and with <i>Feature</i> bit 29 (Signaling limit violation (Page 170)).	STRUCT • Value: BOOL • ST: BYTE	- • 0 • 16#80

7.13 VlvAnL - Control valve

Parameter	Description	Type	Default
ER_AL_Act	1 = Alarm limit (low) for manipulated variable difference violated. You can change the reaction for this parameter with <code>Feature</code> bit 28 (Disabling operating points (Page 145)) and with <code>Feature</code> bit 29 (Signaling limit violation (Page 170)).	STRUCT <ul style="list-style-type: none"> Value: BOOL ST: BYTE 	- <ul style="list-style-type: none"> 0 16#80
ErrorNum	Output of pending error number. For error numbers that can be output by this block, see VlvAnL error handling (Page 1467)	INT	-1
FbkAuxVCloseOut	1 = Auxiliary valve is closed	STRUCT <ul style="list-style-type: none"> Value: BOOL ST: BYTE 	- <ul style="list-style-type: none"> 0 16#80
FbkAuxVOpenOut	1 = Auxiliary valve open	STRUCT <ul style="list-style-type: none"> Value: BOOL ST: BYTE 	- <ul style="list-style-type: none"> 0 16#80
FbkCloseOut	1 = Control valve is open	STRUCT <ul style="list-style-type: none"> Value: BOOL ST: BYTE 	- <ul style="list-style-type: none"> 0 16#80
FbkClsgOut	Control valve closing feedback	STRUCT <ul style="list-style-type: none"> Value: BOOL ST: BYTE 	- <ul style="list-style-type: none"> 0 16#80
FbkOpenOut	1 = Control valve is open	STRUCT <ul style="list-style-type: none"> Value: BOOL ST: BYTE 	- <ul style="list-style-type: none"> 0 16#80
FbkOpngOut	Control valve opening feedback	STRUCT <ul style="list-style-type: none"> Value: BOOL ST: BYTE 	- <ul style="list-style-type: none"> 0 16#80
GrpErr	1 = Group error pending	STRUCT <ul style="list-style-type: none"> Value: BOOL ST: BYTE 	- <ul style="list-style-type: none"> 0 16#80
LocalAct	1 = "Local mode" enabled	STRUCT <ul style="list-style-type: none"> Value: BOOL ST: BYTE 	- <ul style="list-style-type: none"> 0 16#80
LockAct	1 = Interlock (Intlock, Permit or Protect) is active	STRUCT <ul style="list-style-type: none"> Value: BOOL ST: BYTE 	- <ul style="list-style-type: none"> 0 16#80
ManAct	1 = "Manual mode" enabled	STRUCT <ul style="list-style-type: none"> Value: BOOL ST: BYTE 	- <ul style="list-style-type: none"> 1 16#80

Parameter	Description	Type	Default
MonDynAuxVErr	1 = Feedback error auxiliary valve due to output change	STRUCT • Value: BOOL • ST: BYTE	- • 0 • 16#80
MonDynErr	1 = Feedback error control valve due to control change	STRUCT • Value: BOOL • ST: BYTE	- • 0 • 16#80
MonStaAuxVErr	1 = Feedback error from auxiliary valve due to unexpected feedback change	STRUCT • Value: BOOL • ST: BYTE	- • 0 • 16#80
MonStaErr	1 = Feedback error from control valve due to unexpected feedback change	STRUCT • Value: BOOL • ST: BYTE	- • 0 • 16#80
MS_Release	Release for maintenance: 1 = Release for OS operator	STRUCT • Value: BOOL • ST: BYTE	- • 0 • 16#80
MsgAckn1	Message acknowledgement status 1 (output ACK_STATE of first ALARM_8P)	WORD	16#0000
MsgErr1	Alarm error 1 (output ERROR of first ALARM_8P)	BOOL	0
MsgStat1	Message status 1 (output STATUS of first ALARM_8P)	WORD	16#0000
MV	Manipulated variable	STRUCT • Value: REAL • ST: BYTE	- • 0.0 • 16#80
MV_DnRaAct	Positive limit (low) for manipulated variable is active	STRUCT • Value: BOOL • ST: BYTE	- • 0 • 16#80
MV_ExtAct	1 = External manipulated variable active 0 = Internal manipulated variable active	STRUCT • Value: BOOL • ST: BYTE	- • 0 • 16#80
MV_ExtOut	Output for external manipulated variable	STRUCT • Value: REAL • ST: BYTE	- • 0.0 • 16#80
MV_HiAct	1 = Limit (high) of manipulated variable violated	STRUCT • Value: BOOL • ST: BYTE	- • 0 • 16#80
MV_LoAct	1 = Limit (low) of manipulated variable violated	STRUCT • Value: BOOL • ST: BYTE	- • 0 • 16#80
MV_RateTarget	Target manipulated variable for the gradient limitation	REAL	0.0
MV_UnitOut	Unit of measure for manipulated variable	INT	0

Motor and valve blocks

7.13 VlvAnL - Control valve

Parameter	Description	Type	Default
MV_UpRaAct	Positive limit (high) for manipulated variable is active	STRUCT <ul style="list-style-type: none"> Value: BOOL ST: BYTE 	- <ul style="list-style-type: none"> 0 16#80
MV_RemRT	Remaining ramp time of the manipulated variable	REAL	0.0
OosAct	1 = Block is "Out of service"	STRUCT <ul style="list-style-type: none"> Value: BOOL ST: BYTE 	- <ul style="list-style-type: none"> 0 16#80
Opened	1 = Valve is open	STRUCT <ul style="list-style-type: none"> Value: BOOL ST: BYTE 	- <ul style="list-style-type: none"> 0 16#80
Opening	1 = Valve is opening	STRUCT <ul style="list-style-type: none"> Value: BOOL ST: BYTE 	- <ul style="list-style-type: none"> 0 16#80
OpSt_Out	Value of the OpSt_In input parameter, for feedforwarding to other blocks. Bit 31 of this parameter is used by Feature bit 24	DWORD	16#00000000
OS_PermLog	Display of OS_Perm with settings changed by the block algorithm	DWORD	16#FFFFFFFF
OS_PermOut	Display of OS_Perm	DWORD	16#FFFFFFFF
OS1PermLog	Display of OS1Perm with settings changed by the block algorithm	DWORD	16#FFFFFFFF
OS1PermOut	Display of OS1Perm	DWORD	16#FFFFFFFF
P_Rst	1= Pulse output for reset The parameter persists for one cycle after a reset.	STRUCT <ul style="list-style-type: none"> Value: BOOL ST: BYTE 	- <ul style="list-style-type: none"> 0 16#80
PosReached	1 = Control valve has reached specified position	STRUCT <ul style="list-style-type: none"> Value: BOOL ST: BYTE 	- <ul style="list-style-type: none"> 0 16#80
RbkOut	Position feedback output	STRUCT <ul style="list-style-type: none"> Value: REAL ST: BYTE 	- <ul style="list-style-type: none"> 0.0 16#80
RbkWH_Act	1 = Warning (high) enabled. You can change the reaction for this parameter with Feature bit 28 (Disabling operating points (Page 145)) and with Feature bit 29 (Signaling limit violation (Page 170)).	STRUCT <ul style="list-style-type: none"> Value: BOOL ST: BYTE 	- <ul style="list-style-type: none"> 0 16#80
RbkWL_Act	1 = Warning (low) enabled. You can change the reaction for this parameter with Feature bit 28 (Disabling operating points (Page 145)) and with Feature bit 29 (Signaling limit violation (Page 170)).	STRUCT <ul style="list-style-type: none"> Value: BOOL ST: BYTE 	- <ul style="list-style-type: none"> 0 16#80

Parameter	Description	Type	Default
RdyToReset	1 = Ready for reset via RstLi input or commands in "local", "automatic", or "manual mode"	STRUCT <ul style="list-style-type: none"> • Value: BOOL • ST: BYTE 	- <ul style="list-style-type: none"> • 0 • 16#80
RdyToStart	1 = Active start readiness	STRUCT <ul style="list-style-type: none"> • Value: BOOL • ST: BYTE 	- <ul style="list-style-type: none"> • 0 • 16#80
ST_Worst	Worst signal status	BYTE	16#80
Status1	Status word 1 (Page 1448)	DWORD	16#00000000
Status2	Status word 2 (Page 1448)	DWORD	16#00000000
Status3	Status word 3 (Page 1448)	DWORD	16#00000000
Status4	Status word 3 (Page 1448)	DWORD	16#00000000
WarnAct	1 = Prewarning for control valve movement away from neutral position active (parameters WarnTiAut and WarnTiMan))	STRUCT <ul style="list-style-type: none"> • Value: BOOL • ST: BYTE 	- <ul style="list-style-type: none"> • 0 • 16#80

"local", "automatic", or "manual" mode"

See also

VlvAnL modes (Page 1452)

VlvAnL messaging (Page 1469)

VlvAnL block diagram (Page 1483)

Error handling (Page 119)

7.13.7 VlvAnL block diagram

VlvAnL block diagram

A block diagram is not provided for this block.

See also

Description of VlvAnL (Page 1448)

VlvAnL modes (Page 1452)

VlvAnL functions (Page 1454)

VlvAnL error handling (Page 1467)

VlvAnL messaging (Page 1469)

VlvAnL I/Os (Page 1470)

7.13.8 Operator control and monitoring

7.13.8.1 VlvAnL views

Views of the VlvAnL block

The VlvAnL block provides the following views:

- VlvAnL standard view with auxiliary valve (Page 1485)
- VlvAnL standard view without auxiliary valve (Page 1490)
- VlvAnL limit view (Page 1494)
- Alarm view (Page 302)
- Trend view (Page 305)
- VlvAnL parameter view (Page 1501)
- VlvAnL preview (Page 1497)
- Memo view (Page 304)
- Batch view (Page 302)
- Ramp view (Page 300)
- Block icon for VlvAnL (Page 1503)

Refer to the sections Structure of the faceplate (Page 248) and Block icon structure (Page 230) for general information on the faceplate and block icon.

See also

Parameter view for motors and valves (Page 286)

7.13.8.2 VlvAnL standard view with auxiliary valve

Standard view with auxiliary valve of VlvAnL

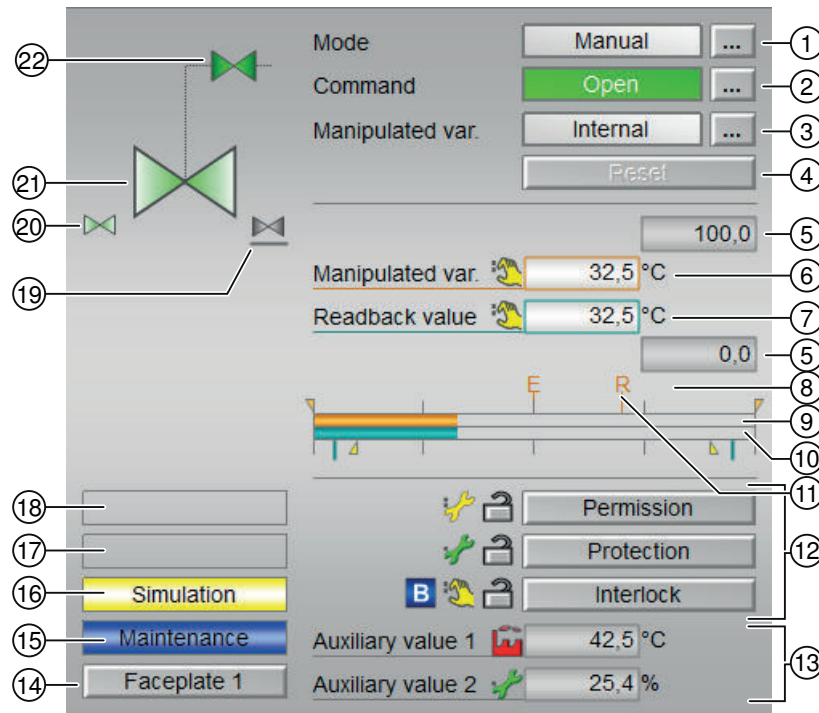

(1) Displaying and switching the operating mode

This area provides information on the currently valid operating mode. The following operating modes can be shown here:

- Manual and automatic mode for motors, valves and dosers (Page 75)
- Manual and automatic mode for motors, valves and dosers (Page 75)
- Local mode (Page 79)
- Out of service (Page 71)

Refer to section Switching operating states and operating modes (Page 257) for information on switching the operating mode.

(2) Opening, closing and stopping the control valve

This area shows you the default operating state for the valve. The following states can be shown and executed here:

- "Open"
- "Close"
- "Stop" (display only, no operation possible)

"Close"/"open" command relates to the auxiliary valve. If no auxiliary valve is required for controlling the control valve, the "Open" and "Close" commands affect the control valve.

If text is configured for these commands, it is displayed as status text and as button labels for command selection. You can find more information about this in section Labeling of buttons and text (Page 209)

Refer to the Switching operating states and operating modes (Page 257) section for information on changing the state.

(3) Displaying and switching the default manipulated variable

This area shows how to specify the manipulated variable. The manipulated variable can be specified as follows:

- By the application ("External", CFC/SFC)
- By the user directly in the faceplate ("Internal").

Refer to the Switching operating states and operating modes (Page 257) section for information on switching the setpoint specification.

(4) Resetting the block

Click "Reset" for interlocks or errors. You can find additional information on this in the section Resetting the block in case of interlocks or errors (Page 43).

(5) High and low scale range for the manipulated variable

These values provide information on the display range for the bar graph of the manipulated variable. The scale range is defined in the engineering system.

(6) Displaying and changing the manipulated variable including signal status:

This area shows the current manipulated variable with the corresponding signal status.

The manipulated variable can only be changed by

- Internal manipulated variable specification ($MV_ExtAct = 0$) and
- An opened auxiliary valve (due to the dependency on the standard function Neutral position for motors, valves and controllers (Page 48))

For more information on changing the manipulated variable, refer to section Changing values (Page 259).

(7) Display of the position feedback including signal status

This area shows the current feedback of the manipulated variable with the corresponding signal status.

(8) Display for the target manipulated variable of the manipulated variable ramp

This display [R] shows the target setpoint and is only visible if you have enabled ramp generation in the Ramp view (Page 300).

(9) Bar graph for the manipulated variable

This area shows the current manipulated variable in the form of a bar graph. The visible area in the bar graph depends on the configuration in the engineering system (ES).

(10) Bar graph for position feedback

This area shows the current position feedback in the form of a bar graph. The visible area in the bar graph depends on the configuration in the engineering system (ES).

The limits for the "open" and "close" positions are shown with 2 green lines.

(11) Display of external manipulated variable

This display [E] is only visible when you have selected "Internal" manipulated variable specification. It shows the external manipulated variable that would apply if you were to change the manipulated variable specification to "External".

(12) Operating range for the interlock functions of the block

This display is only visible when the corresponding block input is connected.

You can use this button to control the interlock functions of the block. You can find additional information on this in the section Interlocking functions (Page 99).

The following is displayed in addition to the buttons:

- Interlock status (see Forming the group status for interlock information (Page 104)), e.g.:



- Signal status (see Forming and outputting the signal status for technologic blocks (Page 109)), e.g.:



- Bypass information (see Forming the group status for interlock information (Page 104)):



If there is a bypass, it is displayed instead of the signal status.

(13) Display of auxiliary values

This display is only visible when the corresponding block input is connected.

You can use this area to display two auxiliary values that have been configured in the engineering system (ES). You can find additional information on this in the section Displaying auxiliary values (Page 211).

(14) Navigation button for switching to the standard view of any faceplate

This display is only visible when the corresponding block input is connected.

Use this navigation button to open the standard view of a block configured in the engineering system (ES). The visibility of this navigation button depends on the configuration in the engineering system (ES).

See also the section Opening additional faceplates (Page 208) for more on this.

(15) Display area for block states

This area provides additional information on the operating state of the block:

- "Maintenance"

Additional information on this is available in section Release for maintenance (Page 64) Display area for block states.

(16) Display area for block states

This area provides additional information on the operating state of the block:

- "Simulation"

You can find additional information on this in the section Simulating signals (Page 58).

(17) Display area for block states

This area provides additional information on the operating state of the block:

- "External error"
- "End position error"
- "Control error"
- "Invalid signal"
- "Changeover error"

Additional information on these errors is available in the sections Monitoring the feedbacks (Page 97), Error handling (Page 119) (section "Invalid input signals" and "Mode changeover error").

(18) Display area for block states

This area provides additional information on the operating state of the block:

- "Forced open" (`OpenForce`)
- "Forced close" (`CloseForce`)
- "Forced tracking" (`MV_ForOn`)
- "Tracking" (`MV_TrkOn`)
- "Request 0/1": A reset to "automatic mode" is expected.
- "MV ramp active"

You can find additional information on this in the section Forcing operating modes (Page 41).

(19) Representation of neutral position

This representation shows the neutral position for the control valve:

- Green: Neutral position is "Open"
- Gray: Neutral position is "Closed"
- Light green: Neutral position is "Stop"

(20) Automatic preview

This display is only visible in "manual mode", in "local mode", or with a reset request in "automatic mode", when the current output signals are not identical to the control in "automatic mode".

The display shows what state the valve would assume if you switched from "manual" or "local" mode to "automatic mode", or performed a reset to "automatic mode".

(21) Status display of the control valve

You can find more information about this in section Block icon for VlvAnL (Page 1503)

(22) Picture of auxiliary valve

The small auxiliary valve and the associated line are only shown when the control valve has an additional auxiliary valve and it can be controlled. This can be configured with `Feature Bit 5` on the block.

The current status of the auxiliary valve is graphically displayed here.

7.13.8.3 VivAnL standard view without auxiliary valve

Standard view without auxiliary valve of VivAnL

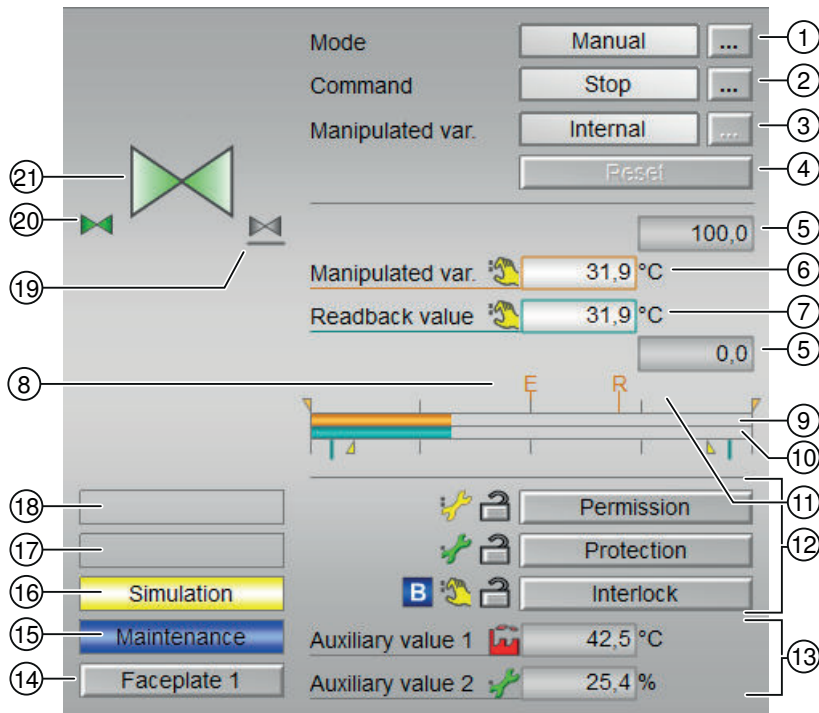

(1) Displaying and switching the operating mode

This area provides information on the currently valid operating mode. The following operating modes can be shown here:

- Manual and automatic mode for motors, valves and dosers (Page 75)
- Manual and automatic mode for motors, valves and dosers (Page 75)
- Local mode (Page 79)
- Out of service (Page 71)

Refer to section Switching operating states and operating modes (Page 257) for information on switching the operating mode.

(2) Opening, closing and stopping the control valve

This area shows you the default operating state for the valve. The following states can be shown and executed here:

- "Open"
- "Close"
- "Stop" (display only, no operation possible)

"Close"/"Open" command relates to the control valve.

The "Open" command sets the manipulated variable equal to the high limit of the control range (`MV_OpScale.High`).

The "Close" command sets the manipulated variable equal to the low limit of the control range (`MV_OpScale.Low`).

If there is no auxiliary valve (`Feature Bit 5 = 0`), the command line can be completely hidden with `Feature Bit 6`.

- 0: (default) line is displayed
- 1: Command line hidden.

If text is configured for these commands, it is displayed as status text and as button labels for command selection. You can find more information about this in section Labeling of buttons and text (Page 209)

Refer to the Switching operating states and operating modes (Page 257) section for information on changing the state.

(3) Displaying and switching the default manipulated variable

This area shows how to specify the manipulated variable. The manipulated variable can be specified as follows:

- By the application ("External", CFC/SFC)
- By the user directly in the faceplate ("Internal").

If there is no auxiliary valve, the specification of the manipulated variable depends on the mode, "manual" or "automatic". You cannot switch between "internal" and "external" here in this case.

Refer to the Switching operating states and operating modes (Page 257) section for information on switching the setpoint specification.

(4) Resetting the block

Click "Reset" for interlocks or errors. You can find additional information on this in the section Resetting the block in case of interlocks or errors (Page 43).

(5) High and low scale range for the manipulated variable

These values provide information on the display range for the bar graph of the manipulated variable. The scale range is defined in the engineering system.

(6) Displaying and changing the manipulated variable including signal status:

This area shows the current manipulated variable with the corresponding signal status.

The manipulated variable can only be changed by internal manipulated variable specification (`MV_ExtAct = 0`).

For more information on changing the manipulated variable, refer to section Changing values (Page 259).

(7) Display of the position feedback including signal status

This area shows the current feedback of the manipulated variable with the corresponding signal status.

(8) Display for the target manipulated variable of the manipulated variable ramp

This display [R] shows the target setpoint and is only visible if you have enabled ramp generation in the Ramp view (Page 300).

(9) Bar graph for the manipulated variable

This area shows the current manipulated variable in the form of a bar graph. The visible area in the bar graph depends on the configuration in the engineering system (ES).

(10) Bar graph for position feedback

This area shows the current position feedback in the form of a bar graph. The visible area in the bar graph depends on the configuration in the engineering system (ES).

The limits for the "open" and "close" positions are shown with 2 green lines.

(11) Display of external manipulated variable

This display [E] is only visible when you have selected "Internal" manipulated variable specification. It shows the external manipulated variable that would apply if you were to change the manipulated variable specification to "External".

(12) Operating range for the interlock functions of the block

This display is only visible when the corresponding block input is connected.

You can use this button to control the interlock functions of the block. You can find additional information on this in the section Interlocking functions (Page 99).

The following is displayed in addition to the buttons:

- Interlock status (see Forming the group status for interlock information (Page 104)), e.g.:



- Signal status (see Forming and outputting the signal status for technologic blocks (Page 109)), e.g.:



- Bypass information (see Forming the group status for interlock information (Page 104)):



If there is a bypass, it is displayed instead of the signal status.

(13) Display of auxiliary values

This display is only visible when the corresponding block input is connected.

You can use this area to display two auxiliary values that have been configured in the engineering system (ES). You can find additional information on this in the section *Displaying auxiliary values* (Page 211).

(14) Navigation button for switching to the standard view of any faceplate

This display is only visible when the corresponding block input is connected.

Use this navigation button to open the standard view of a block configured in the engineering system (ES). The visibility of this navigation button depends on the configuration in the engineering system (ES).

See also the section *Opening additional faceplates* (Page 208) for more on this.

(15) Display area for block states

This area provides additional information on the operating state of the block:

- "Maintenance"

Additional information on this is available in section *Release for maintenance* (Page 64) *Display area for block states*.

(16) Display area for block states

This area provides additional information on the operating state of the block:

- "Simulation"
- "Delay"

You will find more detailed information on this in the sections *Simulating signals* (Page 58) and *Display of delay times* (Page 256).

(17) Display area for block states

This area provides additional information on the operating state of the block:

- "External error"
- "End position error"
- "Control error"
- "Invalid signal"
- "Changeover error"

Additional information on these errors is available in the sections *Monitoring the feedbacks* (Page 97), *Error handling* (Page 119) (section "Invalid input signals" and "Mode changeover error").

(18) Display area for block states

This area provides additional information on the operating state of the block:

- "Forced open" (OpenForce)
- "Forced close" (CloseForce)
- "Forced tracking" (MV_ForOn)
- "Tracking" (MV_TrkOn)
- "Request 0/1": A reset to automatic mode is expected.
- "MV ramp active"

You can find additional information on this in the section Forcing operating modes (Page 41).

(19) Representation of neutral position

This representation shows the neutral position for the control valve:

- Green: Neutral position is "Open"
- Gray: Neutral position is "Closed"
- Light green: Neutral position is "Stop"

(20) Automatic preview

This display is only visible in "manual mode", in "local mode", or with a reset request in "automatic mode", when the current output signals are not identical to the control in "automatic mode".

The display shows what state the valve would assume if you switched from "manual" or "local" mode to "automatic mode", or performed a reset to "automatic mode".

(21) Picture of control valve

The current status of the control valve is graphically displayed here.

You can find more information about this in section Block icon for VlvAnL (Page 1503)

7.13.8.4 VlvAnL limit view

Limit view of VlvAnL

Several values are set in this view by default:

- Manipulated variable difference limits
- Readback value limits
- Manipulated variable operating range

The toolbars of the faceplate and the block icon indicate when the limits are reached or violated.

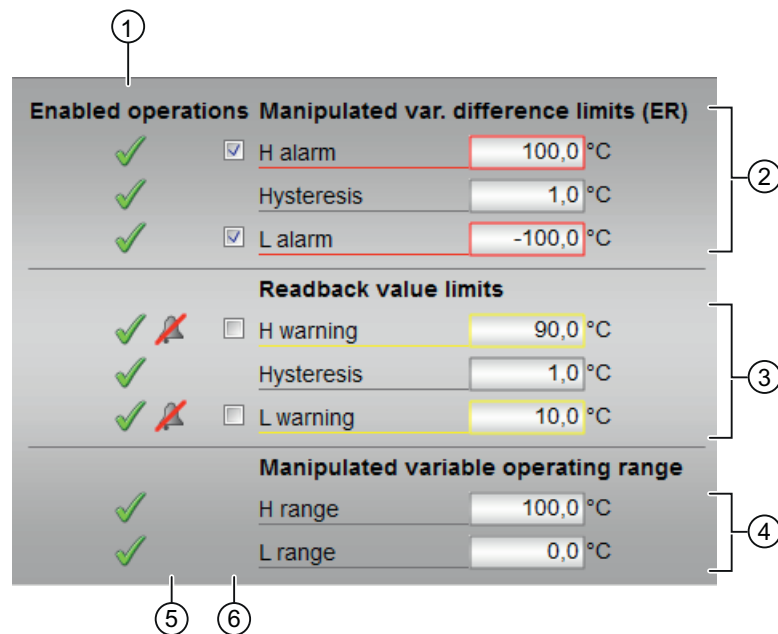

(1) Enabled operation

This area shows all operations for which special operator permissions are assigned. They depend on the configuration in the engineering system (ES) that applies to this block.

Icons for enabled operation:

- **Green check mark:** the OS operator can control this parameter
- **Gray check mark:** the OS operator cannot control this parameter at this time due to the process
- **Red cross:** the OS operator cannot control this parameter due to the configured AS operator permissions (OS_Perm or OS1Perm)

(2) Manipulated variable difference limits

In this area, you can enter the limits for the manipulated variable error. Refer to the Changing values (Page 259) section for more on this.

You can change the following limits:

- "H alarm": Alarm high
- "Hysteresis"
- "L alarm": Alarm low

(3) Readback value limits (mv)

In this area, you can enter the limits for the readback value (position feedback). Refer to the Changing values (Page 259) section for more on this.

You can change the following limits:

- "H warning": Warning high
- "Hysteresis"
- "L warning": Warning low

(4) Manipulated variable operating range (mv)

In this area, you can enter the limits for the manipulated variable operation range. Refer to the Changing values (Page 259) section for more on this.

You can change the following limits:

- "H range": Range limit high
- "L range": Range limit low

(5) Message suppression / delay

Message suppression indicates whether or not the suppression of the associated message in the AS block is activated with the `xx_MsgEn` parameter. The output of messages is not suppressed when the block is installed (all `xx_MsgEn` parameters are preset to 1). Messages can only be output if limit monitoring of the additional analog value has been enabled.

Alarm delays are also displayed in this position; for more on this see section

Area of application of the alarm delays (Page 199).

(6) Suppress messages

You can enable / disable messages by setting the check mark.

7.13.8.5 VlvAnL preview

Preview of VlvAnL

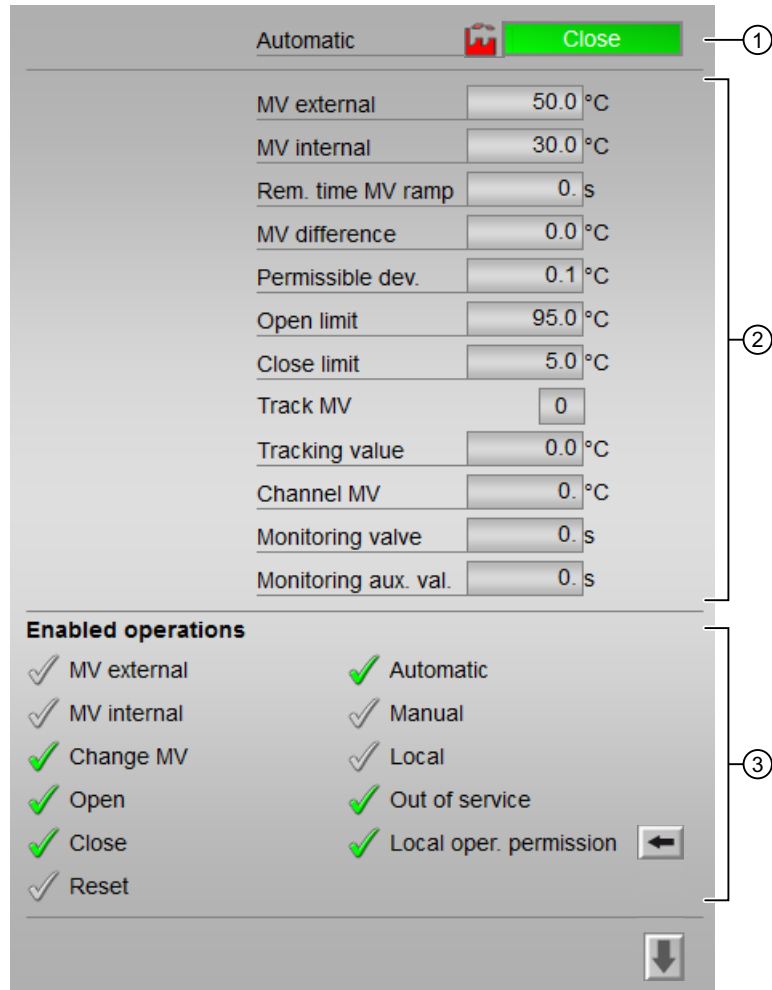

The preview has an upper half and a lower half. You can change between the two halves with the arrow keys.

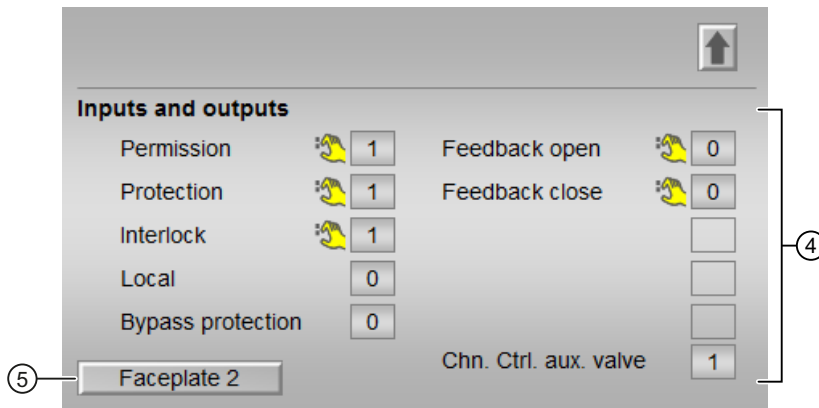

(1) Automatic preview

This area shows you the block status after it has switched from the "Manual" mode or "Local" mode to the "Automatic" mode.

If the block is in "Automatic" mode, the current block state is displayed.

This area also displays the worst signal status of the following automatic commands:

- OpenAut
- CloseAut
- MV_Ext

(2) Preview area

- "Manipulated variable external": Display current external manipulated variable (MV_ExtOut).
- "Manipulated variable internal": Display current internal manipulated variable (MV_Int).
- "Rem. time MV ramp": Remaining time to reach the ramp target value.
- "Manipulated variable difference": Current manipulated variable error (ER)
- "Permissible dev.": Permissible \pm deviation (PosDeadBand) of manipulated variable that is output. If the manipulated variable feedback Rbk is within this range, the manipulated variable is considered reached.
- "Open limit": Limit (PosDiOpen) for forming the "Control valve Open" signal (FbkOpenOut). If the position feedback reaches this limit, the control valve is open.
- "Close limit": Limit (PosDiClose) for forming the "Control valve Closed" signal (FbkCloseOut). If the position feedback reaches this limit, the control valve is closed.
- "Manipulated variable tracking": (MV_TrkOn = 1) manipulated variable is corrected to the tracking value. Tracking value for the effective manipulated variable for "Track manipulated variable"
- "Channel MV" Display of the manipulated variable by the output channel block
- "Auxiliary valve monitoring" Display of the current monitoring time of the auxiliary valve.
- "Monitoring valve" Display of the current monitoring time of the valve.

(3) Enable operations

This area shows all operations for which special operator permissions are assigned. They depend on the configuration in the engineering system (ES) that applies to this block.

Icons for enabled operation:

- **Green check mark:** the OS operator can control this parameter
- **Gray check mark:** the OS operator cannot control this parameter at this time due to the process
- **Red cross:** the OS operator cannot control this parameter due to the configured AS operator permissions (OS_Perm or OS1Perm)

The following enabled operations are shown here:

- "Manipulated variable external": You can enable external manipulated variable specification
- "Manipulated variable internal": You can enable internal manipulated variable specification
- "Change MV": You can change the manipulated variable
- "Open": You can open the valve. The display always relates to the auxiliary valve and control valve. Neither the auxiliary valve nor the control valve can be opened if there is no enable.

For the control valve this means: If a new manipulated variable is greater than the current valve position, this new manipulated variable take effect.

If text is configured for this command, it is also displayed in brackets. You can find additional information on this in the section Labeling of buttons and text (Page 209).

- "Close": You can close the valve. The display always relates to the auxiliary valve and control valve. Neither the auxiliary valve nor the control valve can be closed if there is no enable.

For the control valve this means: If a new manipulated variable is less than the current valve position, this new manipulated variable does not take effect and the control valve retains its position.

If text is configured for this command, it is also displayed in brackets. You can find additional information on this in the section Labeling of buttons and text (Page 209).

- "Reset": You can reset the valve if interlocks or errors occur.
- "Automatic": You can switch to "automatic mode".
- "Manual": You can switch to "manual mode".
- "Local": You can switch to "local mode".
- "Out of service": You can switch to "Out of service" operating mode.
- "Local operator permission": Use the ← button to switch to the standard view of the OpStations block. You can find additional information on this in the section Operator control permissions (Page 254) .

(4) Inputs and outputs

This area shows the most important parameters for this block with the current selection.

- "Permission":
This display is only visible when the corresponding block input is connected.
 - 0 = Valve activation not enabled on OS
 - 1 = Enable for "opening"/"closing" from the neutral position
- "Protection":
This display is only visible when the corresponding block input is connected.
 - 0 = Protective interlocking is in effect; once the interlocking condition in automatic mode has disappeared, you will have to reset the block
 - 1 = "Good" state
- "Interlock":
This display is only visible when the corresponding block input is connected.
 - 0 = Interlocking without reset is active; you can operate the block without reset once the interlocking condition has disappeared
 - 1 = "Good" state
- "Local correct": 1 = Control signal for "Local mode" (LocalLi) is active
- "Interlock deact.":
 - 0 = Bypass disabled
 - 1 = Bypassing interlock in "local mode" and in "simulation"

Since, depending on the configuration, the block itself forms the digital feedback signals internally via the "Open" and "Closed" positions, the following reaction results from the "Feedback open" and "Feedback closed" signals.

- Control valve:
 - "Feedback open": The display is derived from the `FbkOpenOut` output. However, this output is formed from the configured limit for the "Open" position.
 - "Feedback close": The display is derived from the `FbkCloseOut` output. However, this output is formed from the configured limit for the "Closed" position.
- "Control auxiliary valve": only visible when there is a auxiliary valve
 - Control binary control `Ctrl.Out`
 - "Feedback open auxiliary valve": `FbkAuxVOpenOut`.
 - "Feedback closed auxiliary valve": `FbkAuxCloseOut`.
 - "Channel Control auxiliary valve": Signal for controlling the auxiliary valve by the output channel block

(5) Navigation button for switching to the standard view of any faceplate

This display is only visible when the corresponding block input is connected.

Use this navigation button to open the standard view of a block configured in the engineering system (ES). The visibility of this navigation button depends on the configuration in the engineering system (ES).

You can find additional information on this in the section Opening additional faceplates (Page 208)

7.13.8.6 VlvAnL parameter view

Parameter view of VlvAnL

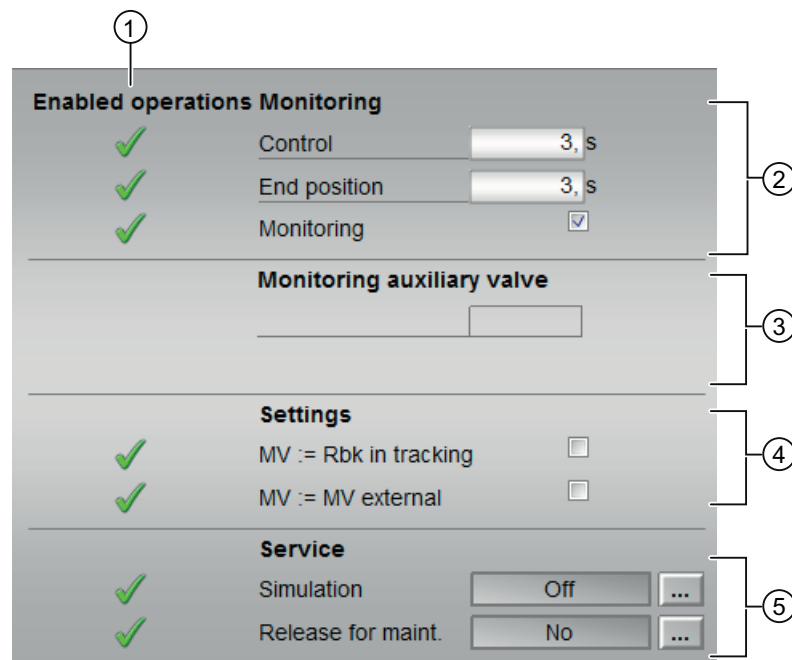

(1) Enabled operation

This area shows all operations for which special operator permissions are assigned. They depend on the configuration in the engineering system (ES) that applies to this block.

Icons for enabled operation:

- **Green check mark:** the OS operator can control this parameter
- **Gray check mark:** the OS operator cannot control this parameter at this time due to the process
- **Red cross:** the OS operator cannot control this parameter due to the configured AS operator permissions (OS_Perm or OS1Perm).

(2) Monitoring

In this area, you change parameters and therefore influence the control valve. Refer to the Changing values (Page 259) section for more on this.

You can influence the following parameters:

- "Control": Monitoring time during opening and closing of the control valve (dynamic)
- "End position": Monitoring time of the end position of the control valve (static)

Enable monitoring

You can enable monitoring by selecting the check box (☑)

You can find additional information on this in the section Monitoring the feedbacks (Page 97).

(3) Monitoring auxiliary valve

As under (2) Monitoring, but only visible when there is an auxiliary valve. Only one common monitoring time can be entered for dynamic and static monitoring.

(4) Settings

- **MV = Rbk in tracking mode:** Correction is performed with the position feedback Rbk instead of the MV_Trk tracking value. The switchover from "Track manipulated variable" (MV_TrkOn = 1) to "Do not track manipulated variable" is bumpless (MV_TrkOn = 0). Set MV_TrkRbk parameter.
- **MV = MV extern:** Bumpless switchover of manipulated variable from external to internal. The internal manipulated variable is tracked to the external one. Set MV_TrkExt parameter.

(5) Service

You can select the following functions in this area:

- "Simulation"
- "Release for maintenance" (with display for a maintenance request)

Refer to the Switching operating states and operating modes (Page 257) section for more on this.

You can find information on this area in the section:

- Simulating signals (Page 58)
- Release for maintenance (Page 64)

7.13.8.7 Block icon for VlvAnL

Block icons for VLVAnL



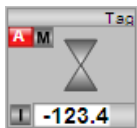
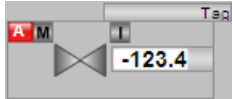
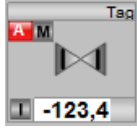
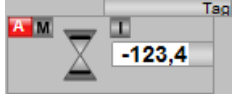

A variety of block icons are available with the following functions:

- Limits (high/low)
- Alarm violation. Warning and tolerance limits as well as control system faults
- Operating modes
- Signal status, release for maintenance
- Forcing states
- Displays for bypassing interlocks
- Interlocks
- Valve status display
- Display of feedback value (white, with decimal places)
- Operation of the manipulated variable
- Process tag type
- External/internal manipulated variable specification
- Memo display

The block icons from template @TemplateAPLV8.PDL:

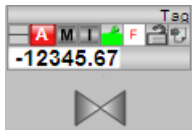
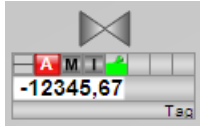
Icons	Selection of the block icon in CFC	Special features
	1	
	2	
	3	Non-rotating block icon
	4	Non-rotating block icon

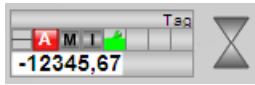
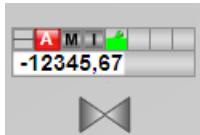
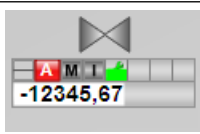
The block icons from template @TemplateAPLV7.PDL:

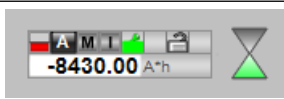
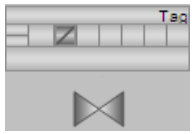







Icons	Selection of the block icon in CFC	Special features
	1	Block icon in the full display
	2	
	3	
	4	
	5	
	6	
	7	
	8	
	-	Block icon in "Out of service" mode (example with type 1 block icon)

Additional information on the block icon and the control options in the block icon is available in the following sections:

- Configuring the block icons (Page 237)
- Block icon structure (Page 230)
- Operation via the block icon (Page 239)

Valve status display

The following valve states are shown here:

Icon	Meaning
	Valve open
	Valve closed
	Error at valve
	Valve is opening
	Valve is closing
	Valve stopped
	Valve closed
	Valve is closing

7.14 VlvPosL - Valve positioner

7.14.1 Description of VlvPosL

Object name (type + number) and family

Type + number: FB 1918

Family: Drives

Area of application for VlvPosL

The block is used for the following application:

- Control of a motor valve with analog position feedback.

How it works

Various operating modes are available for controlling the motorized valve. This enables you to change the valve states individually. All changes of modes or states, as well as errors occurring in this context, are monitored, visualized in the faceplate and reported to the operator. Operators with suitable permissions can use the block icon and the faceplate to view the current state of the motorized valve and operate it.

The motor valve with analog position feedback can be controlled via binary signals such as "Open", "Close", or "Stop" or via analog manipulated variable signals. An internal position controller is activated when analog manipulated variable signals are used. This enables even motor valves with delayed reaction in their position feedback to be position controlled.

Configuration

Use the CFC editor to install the block in a cyclic interrupt OB (OB30 to OB38). The block is also installed automatically in the startup OB (OB100).

Startup characteristics

Use the `Feature Bit Set` startup characteristics (Page 138) to define the startup characteristics of this block.

Following startup, the messages are suppressed for the number of cycles assigned in the `RunUpCyc` parameter.

After a startup without control (`Open`, `Close` = 0) no monitoring of the feedback signals `FbkOpen` and `FbkClose` takes places during the `V_MonTiStatic` time. Changes to `FbkOpen` and `FbkClose` are applied. This means that the feedback is monitored again even in the stop state.

Status word assignment for status1 parameter

You can find a description of the individual parameters in the section VlvPosL I/Os (Page 1533).

Status bit	Parameter
0	Occupied
1	BatchEn
2	SimOn
3	OosAct.Value
4	OosLi.Value
5	AutoAct.Value
6	LocalAct.Value
7	0 = Open padlock in the block icon 1 = Closed padlock in block icon With Feature2.Bit16 = 1, a closed padlock is displayed if "Interlock Open" or "Interlock Close" is active.
8	Open.Value
9	Motor is stopped
10	Close.Value
11	Torque shutoff enabled (TorqOpen or TorqClose = 1) When the seal valve function is enabled, the torque shutoff is only active when the TorqClose signal is active before the valve feedback.
12	WarnAct.Value
13	Feedback error without control change
14	Feedback error due to control change
15	Mode switch fail
16	1 = Intlock is active
17	1 = Permit is active
18	1 = Protect is active
19	Displays forced operating state in the block icon: Force
20	Not used
21	1 = Position control is active
22	1 = Position control is not active
23	"Interlock" button is enabled
24	0 = Displays neutral position "Closed" 1 = Displays neutral position "Open"
25	1 = Displays neutral position "Stop"
26	Bypass information from the previous function block
27	Bypass active (ByProt = 1) and Local.Act = 1 or SimOn = 1
28	Invalid signal status
29	0 = Closed 1 = Open
30	"Permission" button is enabled
31	"Protection" button is enabled

Status word assignment for status2 parameter

Status bit	Parameter
0	MsgLock
1	AV_AH_Act.Value
2	AV_WH_Act.Value
3	AV_TH_Act.Value
4	AV_TL_Act.Value
5	AV_WL_Act.Value
6	AV_AL_Act.Value
7	AV_AH_En
8	AV_WH_En
9	AV_TH_En
10	AV_TL_En
11	AV_WL_En
12	AV_AL_En
13	AV_AH_MsgEn
14	AV_WH_MsgEn
15	AV_TH_MsgEn
16	AV_TL_MsgEn
17	AV_WL_MsgEn
18	AV_AL_MsgEn
19	1 = Input signals have no impact on "Local mode" when LocalSetting = 2 and LocalSetting = 4
20	1 = Valve is closing
21	1 = Valve is closed
22	1 = Valve is stopped
23	1 = Valve is opening
24	1 = Valve is open
25	For the error status display in the closed valve
26	For the error status display in the opened valve
27	Automatic preview for "Open"
28	Automatic preview for "Close"
29	Automatic preview for "Stop"
30	Display for interlocks in block icon
31	MS_RelOp

Status word assignment for status3 parameter

Status bit	Parameter
0	M_MonStaErr.Value
1	M_MonDynErr.Value
2	V_MonStaErr.Value
3	V_MonDynErr.Value

Status bit	Parameter
4	M_MonStopErr.Value
5	Automatic preview for "Position Control" on
6	Automatic preview for "Position Control" off
7	Torque shutoff opening enabled
8	Torque shutoff closing enabled
9	External fault generated by FaultExt or external control system fault CSF with set Feature.Bit18 Activating error state for external process control error CSF (Page 151)
10	Vibration successfully completed – Reset required
11	Display motor protection (Trip status, Trip.ST ≠ 16#FF)
12	1 = Input parameter FbkClose is interconnected
13	1 = Input parameter FbkClosing is interconnected
14	1 = Input parameter FbkOpen is interconnected
15	1 = Input parameter FbkOpening is interconnected
16	1 = Input parameter TorOpen is interconnected
17	1 = Input parameter TorClose is interconnected
18	SimLiOp.Value
19	1 = Enable for rapid stop (Feature.Bit14 Enabling rapid stop via faceplate (Page 168))
20	1 = Input parameter OpenChnST is interconnected
21	1 = Input parameter CloseChnST is interconnected
22	Not used
23	Command for rapid stop
24	"Open"/"Stop" command
25	"Close"/"Stop" command
26	Show automatic preview in the standard view
27	Not used
28	GrpErr.Value
29	RdyToStart.Value
30	Auxiliary value 1 visible
31	Auxiliary value 2 visible

Status word assignment for status4 parameter

Status bit	Parameter
0	Delay of message ER_AH_Lim
1	Delay of message ER_AL_Lim
2	Delay of message RbkWH_Lim
3	Delay of message RbkWL_Lim
4	Collection of message delays
5	1 = Monitor manipulated variable difference high limit (ER_AH_En)
6	1 = Monitor manipulated variable difference low limit (ER_AL_En)
7	1 = Signal manipulated variable difference high limit violation (ER_AH_MsgEn)

Status bit	Parameter
8	1 = Signal manipulated variable difference low limit violation (ER_AL_MsgEn)
9	1 = Monitor readback value high limit (RbkWH_En)
10	1 = Monitor readback value low limit (RbkWL_En)
11	1 = Signal readback value high limit violation (RbkWH_MsgEn)
12	1 = Signal readback value low limit violation (RbkWL_MsgEn)
13	OpenForce.Value
14	StopForce.Value
15	CloseForce.Value
16	1 = Forced manipulated variable MV_Forced is active
17	1 = Tracking value MV_Trk is active
18	Reset request in automatic mode
19	Trip.Value
20	1 = Vibrate enabled
21 - 22	Not used
23	Hidden bypass signal in "Permit"
24	Hidden bypass signal in "Interlock"
25	Hidden bypass signal in "Protect"
26	Feature2.Bit2 Separate evaluation for excluded and simulated interlock signals (Page 152)
27	Feature2.Bit16 Separate interlock for each direction or position (Page 170)
28	Current position feedback monitoring time is visible
29	Current motor monitoring time is visible
30	Current valve monitoring time is visible
31	Feature.Bit13 Separate monitoring time for stopping the motor (Page 169)

Status word assignment for status5 parameter

Status bit	Parameter
0 - 7	Effective signal 1 to 8 of the message block connected via EventTsIn
8 - 15	Effective signal 9 to 16 of the message block connected via EventTsIn
16	AV is not connected
17	Delay of the message AV_AH_Lim
18	Delay of the message AV_WH_Lim
19	Delay of the message AV_TH_Lim
20	Delay of the message AV_TL_Lim
21	Delay of the message AV_WL_Lim
22	Delay of the message AV_AL_Lim
23	Collection of the message delays
24	1 = High limit of the manipulated variable difference is violated (ER_AH_Act.Value)
25	1 = Low limit of the manipulated variable difference is violated (ER_AL_Act.Value)
26	1 = High limit of the readback value is violated (RbkWH_Act.Value)
27	1 = Low limit of the readback value is violated (RbkWL_Act.Value)

Status bit	Parameter
28	1 = Valve still closes (<i>Status2</i> Bit 20) but the motor is not running
29	1 = Valve still opens (<i>Status2</i> Bit 23) but the motor is not running
30 - 31	Not used

Status word allocation for *Status6* parameter

Status bit	Parameter
0 - 15	Effective signal 1 to 16 of the message block connected via <i>EventTs2In</i>
16	Hidden bypass signal in "Permission Close"
17	Hidden bypass signal in "Interlock Close"
18	Hidden bypass signal in "Protection Close"
19	"Permission Open" button is enabled
20	"Permission Close" button is enabled
21	"Interlock Open" button is enabled
22	"Interlock Close" button is enabled
23	"Protection Open" button is enabled
24	"Protection Close" button is enabled
25	1 = "Permission Close" is active
26	1 = "Interlock Close" is active
27	1 = "Protection Close" is active
28 - 31	Not used

See also

- VlvPosL functions (Page 1513)
- VlvPosL messaging (Page 1531)
- VlvPosL block diagram (Page 1546)
- VlvPosL error handling (Page 1528)
- VlvPosL modes (Page 1511)

7.14.2 VlvPosL modes

VlvPosL operating modes

The block supports all standard operating modes:

- Local mode (Page 79)
- Automatic mode (Page 75)
- Manual mode (Page 75)
- Out of service (Page 71)

The next section provides additional block-specific information relating to the general descriptions.

"Local mode"

You can find general information on "Local mode", switching modes, and bumpless switchover in the section Local mode (Page 79).

When you put a block into "Local mode", it is controlled either by "Local" signals or by feedback signals. With `LocalSetting = 1` or `3`, you can control the motor valve with the following "Local" signals:

- "Open" (`OpenLocal = 1`)
- "Close" (`CloseLocal = 1`)
- "Stop" (`StopLocal = 1`)

The feedback signals `FbkOpening`, `FbkClosing`, `FbkOpen`, `FbkClose`, and the analog readback `Rbk` will be monitored.

With `LocalSetting = 2` or `4`, the control outputs `Open.Value`, `Close.Value`, and the internal status `Open/Close/Stop` of the block will be tracked.

In the case where motor feedback signals are available (`Feature.Bit12 = 0`), the control outputs `Open.Value` and `Close.Value` will be tracked from the motor feedback signals `FbkOpening` and `FbkClosing`. The valve feedback signals `FbkOpen`, `FbkClose`, and the analog readback `Rbk` will be monitored.

In the case where no motor feedback signals are available (`Feature.Bit12 = 1`), the internal status `Open/Close/Stop` of the block will be tracked from the valve feedback signals `FbkOpen`, `FbkClose`, and the analog readback `Rbk`. It will only be monitored if the analog readback and valve feedback signals are not suitable together.

If no position can be identified, the last valid position is assumed.

"Automatic mode"

You can find general information on "Automatic mode", switching modes and bumpless switchover in the section Manual and automatic mode for motors, valves and dosers (Page 75).

You can control the motor valve in "Automatic mode" with analog position feedback:

- "Open" (`OpenAut = 1`)
- "Close" (`CloseAut = 1`)
- "Stop" (`StopAut = 1`)

Position control is terminated with "Open", "Close", or "Stop". It is enabled again with:

- "Activate position control" (`PosOnAut = 1`)

For position control, the motor valve is controlled via the `Open` and `Close` outputs such that the manipulated variable `MV` and position feedback `Rbk` come into agreement.

"Manual mode"

You can find general information on "Manual mode", switching modes and bumpless switchover in the section Manual and automatic mode for motors, valves and dosers (Page 75).

You can control the motor valve in "Manual mode" with analog position feedback:

- "Open" (`OpenMan = 1`)
- "Close" (`CloseMan = 1`)
- "Stop" (`StopMan = 1`)

Position control is terminated with "Open", "Close", or "Stop". It is enabled again with:

- "Activate position control" (`PosOnMan = 1`)

For position control, the motor valve is controlled via the `Open` and `Close` outputs such that the manual value `Man` and position feedback `Rbk` come into agreement.

"Out of service"

You can find general information about the "Out of service" mode in the section Out of service (Page 71).

See also

VlvPosL block diagram (Page 1546)

VlvPosL I/Os (Page 1533)

VlvPosL error handling (Page 1528)

VlvPosL functions (Page 1513)

VlvPosL messaging (Page 1531)

Description of VlvPosL (Page 1506)

7.14.3 VlvPosL functions

Functions of VlvPosL

The functions for this block are listed below.

Motor valve control

The motor valve is controlled via the `Open` and `Close` outputs or via the pulse outputs `P_Open`, `P_Close`, and `P_Stop`. The outputs are set by either of the following methods:

- Directly via the corresponding inputs:
 - `OpenMan`, `CloseMan`, and `StopMan` in manual mode
 - `OpenAut`, `CloseAut`, and `StopAut` in automatic mode
 - `OpenLocal`, `CloseLocal`, and `StopLocal` in local mode
 - `OpenForce`, `CloseForce`, and `StopForce` for the force operating states function.
- Calculated by a control algorithm after the position controller is switched on in such a way that the position feedback `Rbk` reaches a specified manipulated variable.

Position control is switched on by:

- `PosOnMan` in manual mode
- `PosOnAut` in automatic mode
- `MV_ForOn` for the force operating states functions.

In the local mode, the manipulated variable is always tracked to the position feedback.

For direct control via the `Open`, `Close`, `Stop` inputs above, position control is terminated and must be reactivated via the `PosOn` inputs.

Motor valve control with position control

When controlling with enabled position control, the motor valve is moved to the desired valve position using the specified manipulated variable.

Depending on the mode and function, the manipulated variable is specified by:

- `MV_Forced`: Manipulated variable specification with the "Force" operating states function (`MV_ForOn = 1`)
- `Man`: Manipulated variable specification in manual mode
- `MV`: Manipulated variable specification in automatic mode
- `MV_Trk`: Manipulated variable specification in automatic mode and for the "Track" manipulated variable function (`MV_TrkOn = 1`)

Except for the "Force" operating states function (`MV_ForOn = 1`), the manipulated variable is always limited by `MV_HiLim` and `MV_LoLim`. The effective manipulated variable is outputted at the `MV_Out` output.

The control and manipulated variable difference $MV_Out - RbkOut$ is controlled via a deadband with the deadband width `DeadBand` and displayed at the `ER` output.

Manipulated variable difference <code>ER</code>	Deadband range
$(MV_Out - RbkOut) - DeadBand$	$MV_Out - RbkOut \geq DeadBand$
0.0	$-DeadBand \leq MV_Out - RbkOut \leq DeadBand$
$(MV_Out - RbkOut) + DeadBand$	$MV_Out - RbkOut \leq -DeadBand$

The internal position controller is set with the following parameters:

- **Gain:** Controller gain
- **MotorTime:** Motor runtime from closed to fully open valve
- **TmLag:** Delay time caused, for example, by lag of the motor valve when switching on and off.

The pulse output is formed by a three-step element with hysteresis and set with the following parameters:

- **PulseTime:** Minimum pulse length of the outputs `Open` or `Close`
- **BreakTime:** Minimum pulse break between two pulse outputs of `Open` or `Close`

Note

PulseTime and **BreakTime** are limited to **SampleTime**. If they are smaller parameterized than **SampleTime** they will be written back to the input with the value of **SampleTime**.

PulseTime and **BreakTime** values which are too large, can reduce the precision of position control.

The effective trip threshold and response threshold of the three-step element is displayed at the **ThreshOff** and **ThreshOn** output parameters.

The **PosReached** output shows whether the specified position has been reached. This is the case when:

- **Intermediate position:**

$$\text{PosRbkHys} \geq \text{ABS}(\text{MV_Out} - \text{RbkOut})$$
- **End position open:**

$$\text{MV_Out} \geq \text{PosDiOpen} \text{ AND } \text{RbkOut} \geq \text{PosDiOpen} \text{ AND } \text{FbkOpenOut} \text{ AND NOT } \text{FbkCloseOut}$$
- **End position closed:**

$$\text{MV_Out} \leq \text{PosDiClose} \text{ AND } \text{RbkOut} \leq \text{PosDiClose} \text{ AND } \text{FbkCloseOut} \text{ AND NOT } \text{FbkOpenOut}$$

The control and feedback signals of the motor are at "Stopped" state.

Opening additional faceplates

This block provides the standard function Opening additional faceplates (Page 208).

Operator permissions

This block provides the standard function Operator control permissions (Page 254).

The block has the following permissions for the parameter **OS_Perm**:

Bit	Function
0	1 = Operator can switch to "Automatic mode"
1	1 = Operator can switch to "Manual mode"
2	1 = Operator can switch to "Local mode"

7.14 VlvPosL - Valve positioner

Bit	Function
3	1 = Operator can switch to "Out of service mode"
4	1 = Operator can stop the motor
5	1 = Operator can open the valve
6	1 = Operator can close the valve
7	1 = Operator can trigger rapid stop for motors
8	1 = Operator can activate position control
9	1 = Operator can reset the valve
10	1 = Operator can change the manual value <i>Man</i>
11	1 = Operator can change the simulation value <i>SimRbk</i>
12	1 = Operator can define the valve monitoring time for control
13	1 = Operator can define the valve monitoring time for end position
14	1 = Operator can activate the function valve monitoring time (bits 12 and 13)
15	1 = Operator can define the motor monitoring time for control start or stop
16	1 = Operator can define the monitoring time for control stop
17	1 = Operator can define the motor monitoring time for status
18	1 = Operator can activate the function motor monitoring time (bits 15,16, and 17)
19	1 = Operator can define the readback monitoring time
20	1 = Operator can activate the function readback monitoring time (bit 19)
21	Not used
22	1 = Operator can change proportional gain of the position control
23	Not used
24	1 = Operator can set the delay time of the motor valve
25	1 = Operator can set the deadband width of the manipulated variable difference
26	1 = Operator can set the motor run time
27	1 = Operator can set the minimum pulse duration
28	1 = Operator can set the minimum break duration
29	Not used
30	1 = Operator can activate the "Simulation" function
31	1 = Operator can activate the "Release for maintenance" function

The block has the following permissions for the parameter *OS1Perm*:

Bit	Function
0	1 = Operator can change the high operating limit of the manipulated variable <i>MV_HiLim</i>
1	1 = Operator can change the low operating limit of the manipulated variable <i>MV_LoLim</i>
2	Not used
3	1 = Operator can enable/disable messages via <i>ER_AH_MsgEn</i>
4	1 = Operator can enable/disable messages via <i>ER_AL_MsgEn</i>
5	1 = Operator can enable/disable messages via <i>RbkWH_MsgEn</i>
6	1 = Operator can enable/disable messages via <i>RbkWL_MsgEn</i>
7	1 = Operator can change the limit (manipulated variable difference) for the high alarm <i>ER_AH_Lim</i>
8	1 = Operator can change the hysteresis (manipulated variable difference) <i>ER_Hyst</i>

Bit	Function
9	1 = Operator can change the limit (manipulated variable difference) for the low alarm ER_AL_Lim
10	1 = Operator can change the limit (position feedback) for the high warning RbkWH_Lim
11	1 = Operator can change the hysteresis (position feedback) RbkHyst
12	1 = Operator can change the hysteresis (position feedback) for the low warning RbkWL_Lim
13	Not used
14	1 = Operator can change the simulation value SimAV
15	1 = Operator can change the limit (AV) for the high alarm
16	1 = Operator can change the limit (AV) for the high warning
17	1 = Operator can change the limit (AV) for the high tolerance
18	1 = Operator can change the limit (AV) for the hysteresis
19	1 = Operator can change the limit (AV) for the low alarm
20	1 = Operator can change the limit (AV) for the low warning
21	1 = Operator can change the limit (AV) for the low tolerance
22	1 = Operator can enable / disable messages via AV_AH_MsgEn
23	1 = Operator can enable / disable messages via AV_WH_MsgEn
24	1 = Operator can enable / disable messages via AV_TH_MsgEn
25	1 = Operator can enable / disable messages via AV_TL_MsgEn
26	1 = Operator can enable / disable messages via AV_WL_MsgEn
27	1 = Operator can enable / disable messages via AV_AL_MsgEn
28 - 31	Not used

Note

If you interconnect a parameter that is also listed in OS_Perm, OS1Perm as a parameter, you have to reset the corresponding OS_Perm, OS1Perm bit.

Limit monitoring for additional analog value

This block provides the standard function Limit monitoring of an additional analog value (Page 91).

Limit monitoring with hysteresis

This block provides the standard function Limit monitoring with hysteresis (Page 97). This is done using the input parameter AV_Hyst.

Suppress messages using the MsgLock parameter

This block provides the standard function Suppressing messages using the MsgLock parameter (Page 205).

Interlocks

This block provides the following interlocks:

- Feature2.Bit16 = 0
 - Activation enable ("Permission")
 - Interlock without reset ("Interlock")
 - Interlock with reset ("Protection")
- Feature2.Bit16 = 1
 - Activation enable Open ("Permission Open")
 - Activation enable Close ("Permission Close")
 - Interlock open without reset ("Interlock Open")
 - Interlock close without reset ("Interlock Close")
 - Interlock open with reset ("Protection Open")
 - Interlock close with reset ("Protection Close")

For more on this, see the sections Interlocks (Page 99) and Influence of the signal status on the interlock (Page 103).

When an interlock is pending and position control is enabled, the block remains in position control. The following manipulated variables are controlled based on the configured neutral position for an interlock with/without reset:

SafePos	Manipulated variable
0: Closed	MV_Out = MV_LoLim
1: Opened	MV_Out = MV_HiLim
2: Stopped	MV_Out = RbkOut

Note

The neutral position cannot be reached if the limit MV_HiLim is not configured greater than or equal to PosDiOpen or MV_LoLim is not configured less than or equal to PosDiClose.

With VlvPosL in position control, the neutral position is reached when:

SafePos	Neutral position is reached when
0: Closed	PosReached = 1, FBkOpenOut = 0, FBkCloseOut = 1
1: Opened	PosReached = 1, FBkOpenOut = 1, FBkCloseOut = 0
2: Stopped	PosReached = 1, independent of FBkOpenOut, FBkCloseOut

If VlvPosL is in the neutral position, it can only leave this position when an activation enable is set.

Motor protection function

This block provides the standard function Motor protection function (Page 99).

When motor protection is pending and position control is enabled, the block remains in position control. The manipulated variable is tracked to the feedback value ($MV_Out = RbkOut$) and with this, the motor is in the stop state.

Rapid stop for motors

This block provides the standard function Rapid stop for motors (Page 106).

When rapid stop is pending and position control is enabled, the block remains in position control. The manipulated variable is tracked to the feedback value ($MV_Out = RbkOut$) and with this, the motor is in the stop state.

Torque monitoring

This block provides torque monitoring.

The signals of the torque monitoring switches are interconnected to input parameters `TorqOpen` for opening and `TorqClose` for closing the motor valve.

The good state is indicated via this parameter with the value 1. In this case, the signal status cannot be 16#00 or 16#28.

Using `Feature2.Bit6` (Vibrate), you can define how to proceed in automatic mode when the torque has been reached. With `Feature2.Bit6 = 0` (no vibrating), position control is terminated and the motor is stopped. In the case where `TorqClose` is in end position close or `TorqOpen` is in end position open, the position control will not be terminated.

Vibration is disabled or VlvPosL is not in automatic mode:

If the torque monitoring is enabled, the motor is stopped. You can move the valve in the opposite direction.

If, for example, the torque shutdown is active when the valve opens, you can still close the valve.

Active torque shutoff appears in the standard view of the display area for block states.

When the "Seal valve" function is enabled by means of `Feature.Bit8`, the torque shutoff for the closing `TorqClose` is also evaluated (see section Sealing the valve (Page 176)).

Vibration is enabled and VlvPosL is in automatic mode:

If torque monitoring is enabled, the motor runs in the opposite direction. After traveling `VibrWidth` seconds or `VibrPerc` %, the motor runs in the opposite direction again to solve the cause of the torque shutoff using vibration. This procedure is repeated a maximum of `VibrNo` times.

With activated position control, the motor travels from the current position `VibrPerc` % in the opposite direction. When position control is disabled, the control outputs are immediately sent in the opposite direction for `VibrWidth` seconds.

If, for example, the torque shutdown is active when the valve opens with activated position control, the motor valve returns to the value:

$$RbkOut - (MV_HiLim - MV_LoLim) / 100.0 * VibrPerc$$

When this point is reached, the motor attempts to open to the previously set manipulated variable once again.

During reversing, the display area of the standard view, "Vibrate enabled" is displayed.

After attempting to correct the cause of the torque `VibrNo` times, the motor is stopped. The block must be reset before vibrating can be enabled again.

Sealing the valve

This function is enabled using `Feature.Bit8` Sealing the valve (Page 176). The seal valve function combines the query of the end position "Closed" via the input parameter `FbkClose` and `Rbk` with the limit violation of the configured torque via the input parameter `TorqClose`. This ensures that the valve is completely closed.

The valve is only considered completely closed when the feedback for the end position "Close" has been received (0->1), the position feedback `Rbk` is smaller than or equal to `PosDiClose`, and the torque shutdown for "Closed" is enabled. The torque shutoff should not come before the feedback in this case. The `FbkCloseOut` output shows whether the valve is sealed tight with the following conditions:

- `FbkCloseOut := FbkClose.Value AND RbkOut.Value <= PosDiClose` has come in (0->1)
- "Torque shutoff closed is enabled"
- "Torque shutoff closed is enabled" did not come before `FbkCloseOut` (0->1)

"Torque shutoff closed enabled" means `TorqClose = 0` or the signal status is `16#00` or `16#28`.

When "Torque shutoff closed is enabled" comes before the end position feedback closed, this is displayed in the faceplate in the standard view and the motor stops. Opening the valve is still possible.

Note

The command text for Close in the standard view and preview can be changed to Seal in the CFC at the `CloseMan` parameter in Text 1. See section Labeling of buttons and text (Page 209).

Disable interlocks

This block provides the standard function Disabling interlocks (Page 103).

Resetting the block in case of interlocks

This block provides the standard function Resetting the block in case of interlocks or errors (Page 43).

External fault (`FaultExt`), External control system fault (`CSF`)

This block provides the possibility to pass an external fault via the `FaultExt` parameter or an external control system fault via the `CSF` parameter. See VlvPosL error handling (Page 1528).

When an external fault or control system fault is pending (`Feature.Bit18 = 1`) and position control is enabled, the block remains in position control. The following manipulated variable is set based on the configured neutral position:

SafePos	Manipulated variable
0: Closed	MV_Out = MV_LoLim
1: Opened	MV_Out = MV_HiLim
2: Stopped	MV_Out = RbkOut

Note

The neutral position cannot be reached if the limit `MV_HiLim` is not configured greater than or equal to `PosDiOpen` or `MV_LoLim` is not configured less than or equal to `PosDiClose`.

Group error

This block provides the standard function, Outputting group errors (Page 122).

The following parameters are taken into consideration when forming the group error:

- CSF
- Trip
- V_MonDynErr
- V_MonStaErr
- M_MonDynErr
- M_MonStaErr
- RbkMonDynErr
- RbkMonStaErr
- FaultExt

Outputting a signal for start readiness

This block provides the standard function, Outputting a signal for start readiness (Page 53).

Forming the group status for interlocks

This block provides the standard function, Forming the group status for interlock information (Page 104).

Forming the signal status for blocks

This block provides the standard function, Forming and outputting the signal status for technologic blocks (Page 109).

The worst signal status for the block is formed from the following parameters:

- FbkClsgOut.ST
- FbkOpngOut.ST
- FbkOpenOut.ST
- FbkCloseOut.ST
- RbkOut.ST
- LocalLi.ST
- OpenLocal.ST
- StopLocal.ST
- CloseLocal.ST
- Trip.ST
- TorqOpen.ST
- TorqClose.ST
- AV_Out.ST
- OpenChn.ST
- CloseChn.ST
- OpenAut.ST (only if Feature2.Bit10 = 1)
- CloseAut.ST (only if Feature2.Bit10 = 1)
- StopAut.ST (only if Feature2.Bit10 = 1)
- MV.ST (only if Feature2.Bit10 = 1)
- PosOnAut.ST (only if Feature2.Bit10 = 1)

Considering bad quality of automatic commands or external values

If the `Feature2` bit Considering bad quality of automatic commands or external values (Page 186) is set to 1 and one of the following parameters has bad signal status (16#00 or 16#28), the block goes to the neutral position in the "Automatic" mode:

- OpenAut.ST
- CloseAut.ST
- StopAut.ST
- MV.ST
- PosOnAut.ST

Force operating states

This block provides the standard function, Forcing operating modes (Page 41). The `OpenForce`, `CloseForce`, and `StopForce` inputs force the block to open, close, or stop. With activated position control, this mode is terminated and must be separately reactivated.

With `MV_ForOn = 1`, position control is enabled and set to the manipulated variable `MV_Forced`.

Feedback monitoring

This block provides the standard function, Monitoring the feedbacks (Page 97).

The `FbkOpen`, `FbkClose`, and `Rbk` feedback is monitored for the valve, the `FbkOpening` and `FbkClosing` feedback is monitored for the motor.

Position control is terminated if a monitoring error of the feedback occurs. The configured neutral position is targeted if a monitoring error of the valve feedback occurs.

The control signals are switched to motor stop if a monitoring error of the motor feedback occurs.

Monitoring valve feedback

The monitoring of valve feedback is set using the `V_Monitor` parameter.

Startup characteristics are monitored by setting the `V_MonTiDynamic` parameter. When starting the motor valve, the current position feedback `Rbk` is taken into consideration and is included in the calculation of the monitoring time as follows:

Monitoring of the position feedback is switched on (`RbkMonitor = 1`):

- Monitoring time = $V_MonTiDynamic - MotorTime + Abs(MV_Out - RbkOut) * MotorTime/100$

Note

The dynamic monitoring time `V_MonTiDynamic` should be greater than motor actuating time `MotorTime`.

Monitoring of the position feedback is switched off (`RbkMonitor = 0`):

- Open or close motor valve: Monitoring time = `V_MonTiDynamic`

Monitoring of the position feedback `Rbk` with activated position control can be set separately using `RbkMonitor`, `RbkMonTi`.

The `V_MonTiStatic` parameter sets the compliance with the valve position.

Feedback errors are displayed at the corresponding parameters `V_MonDynErr` or `V_MonStaErr`.

The valve travel range is divided into three ranges for monitoring:

- Valve open: $RbkOut \geq PosDiOpen$
- Valve in intermediate position: $PosDiClose < RbkOut < PosDiOpen$
- Valve closed: $RbkOut \leq PosDiClose$

To monitor the end positions, the `FbkOpenOut` and `FbkCloseOut` outputs are formed as follows:

When the motor valve reaches the "Open" position, the output is $FbkOpenOut = 1$:

- With a binary limit switch for the "Open" position ($NoFbkOpen = 0$):
The valve is considered open if $FbkOpenOut$ is set. $FbkOpenOut$ is set if $RbkOut \geq PosDiOpen$ and $FbkOpen = 1$.
- Without binary end switch for the position "Open" ($NoFbkOpen = 1$):
The valve is considered open if $FbkOpenOut$ is set. $FbkOpenOut$ is set if $RbkOut \geq PosDiOpen$.

When the motor valve reaches the "Closed" position, the output is $FbkCloseOut = 1$:

- With a binary limit switch for the "Closed" position ($NoFbkClose = 0$):
The valve is considered closed if $FbkCloseOut$ is set. $FbkCloseOut$ is set if $RbkOut \leq PosDiClose$ and $FbkClose = 1$.
- Without binary end switch for the position "Closed" ($NoFbkClose = 1$):
The valve is considered closed if $FbkCloseOut$ is set. $FbkCloseOut$ is set if $RbkOut \leq PosDiClose$.

Note

After the motor valve stops in the intermediate position or end position or after a CPU startup without control ($Open, Close = 0$), no monitoring of the feedback signals $FbkOpen$ and $FbkClose$ takes place during the time $V_MonTiStatic$. Changes to $FbkOpen$ and $FbkClose$ are applied. This means that the feedback is monitored again, also in the stop state.

Note

When the "Seal valve" function is enabled by means of $Feature.Bit8$, the torque shutoff for the closing $TorqClose$ is also evaluated (see section Sealing the valve (Page 176)).

Monitoring the motor feedback

The monitoring of motor feedback is set using the $M_Monitor$ parameter.

Startup characteristics are monitored by setting the $M_MonTiDynamic$ parameter; the $M_MonTiStatic$ parameter monitors maintenance of the position.

Feedback errors are displayed at the corresponding parameters $M_MonDynErr$ or $M_MonStaErr$.

Monitoring of the position feedback Rbk with activated position control

The monitoring of position feedback Rbk is set using the $RbkMonitor$ parameter.

The monitoring of the startup characteristics is set at the $RbkMonTi$ parameter. The effective monitoring time is calculated as follows:

- Monitoring time = $ABS(MV_Out_n - MV_Out_{n-1}) * MotorTime/100 + RbkMonitor$
 MV_Out_n : Current manipulated variable to be reached
 MV_Out_{n-1} : Last manipulated variable reached

The monitoring of maintaining the valve position is set at the $RbkMonTi$

- Monitoring time = $RbkMonitor$

Feedback errors are displayed at the corresponding parameters `RbkMonDynErr` or `RbkMonStaErr`.

Release for maintenance

This block provides the standard function, Release for maintenance (Page 64).

Specify warning times for control functions

This block provides the standard function, Specifying warning times for control functions at motors and valves (Page 51).

You can generate warning signals when, for example, valves open. Warning signals can be generated in the following modes:

- Manual and automatic mode for motors, valves and dosers (Page 75) (input parameter `WarnTiMan`)
- Manual and automatic mode for motors, valves and dosers (Page 75) (input parameter `WarnTiAut`)

You specify the warning times in seconds using the input parameters `WarnTiMan` and `WarnTiAut`. If, for example, a valve opens, this is displayed at the output parameter with `WarnAct = 1`. The valve then opens after the set warning time has expired and `WarnAct` then returns to 0.

A corresponding warning is not outputted if the values specified for the warning times (`WarnTiMan` or `WarnTiAut`) are lower than the `SampleTime` parameter.

Note

The warning is activated for each actuation that causes the motor to start, even if this means that the valve is moved to the neutral position.

A parameterized warning time (`WarnTiMan`, `WarnTiAut`) is not active in the position control mode.

Simulating signals

This block provides the standard function, Simulating signals (Page 58).

You can simulate the following values:

- Additional value (`SimAV`, `SimAV_Li`)

With internal simulation with immediate tracking of feedback, it is possible to simulate a position between the open and closed state (`FbkOpenOut = FbkCloseOut = 0`) by means of a stop command.

Select unit of measure

This block provides the standard function, Selecting a unit of measure (Page 212).

Neutral position

This block provides the standard function, Neutral position for motors, valves and controllers (Page 48).

Output signal as pulse signal or static signal

This block provides the standard function Output signal as a static signal or pulse signal (Page 51). In addition to the static control outputs `Open` and `Close`, the block also has pulse outputs `P_Open`, `P_Close`, and `P_Stop`, which are dependent on the static control output.

Generate instance-specific messages

This block provides the standard function, Generating instance-specific messages (Page 204).

Configurable reactions using the `Feature` parameter

An overview of all the reactions that are provided by the `Feature` parameter is available in section Configurable functions using the Feature I/O (Page 131). The following functionality is available for this block at the relevant bits:

Bit	Function
0	Set startup characteristics (Page 138)
1	Reaction to the out of service mode (Page 177)
2	Resetting the commands for changing the mode (Page 161)
3	Enabling resetting of commands for the control settings (Page 161)
4	Setting switch or button mode (Page 167)
8	Sealing the valve (Page 176)
9	Resetting via input signals in the event of interlocking (Protection) or errors (Page 163)
10	Exiting local mode (Page 177)
11	Activating the run time of feedback signals (Page 153)
12	Motor feedback is not available (Page 157)
13	Separate monitoring time for stopping the motor (Page 169)
14	Enabling rapid stop via faceplate (Page 168)
17	Enabling bumpless switchover to automatic mode for valves, motors, and dosers (Page 173)
18	Activating error state for external process control error CSF (Page 151)
19	Reset even with locked state (Page 165)
20	Disable calculation of impulse control in LocalSetting 2 and 4 (Page 186)
21	Enable bumpless switchover to "Automatic" mode for operator only (Page 172)
22	Update acknowledgment and error status of the message call (Page 160)
24	Enabling local operator authorization (Page 158)
25	Suppression of all messages (Page 174)
26	Reaction of the switching points in the "Out of service" operating mode (Page 176)
27	Interlock display with LocalSetting 2 or 4 (Page 178)
28	Disabling operating points (Page 145)
29	Signaling limit violation (Page 170)

Bit	Function
30	Set reset depending on the operating mode or the LiOp parameter (Page 163)
31	Activating reset of protection / error in manual mode (Page 165)

In switching mode (`Feature.Bit4 = 1`), the control is selected with the static signals `OpenAut` and `CloseAut`. If the `OpenAut` and `CloseAut` inputs are not set, the motor is stopped. Control via `StopAut` is not required. If the "Enable reset of commands for control" function (`Feature.Bit3 = 1`) is also enabled, the `OpenAut` and `CloseAut` inputs are reset to 0 after evaluation in the block.

In switching mode (`Feature.Bit4 = 1`), the `PosOnAut` control acts as a switch. The "Enable resetting of commands for control" function (`Feature.Bit3 = 1`) has no influence on `PosOnAut`.

Display auxiliary values

This block provides the standard function, Displaying auxiliary values (Page 211).

Configurable reactions using the `Feature2` parameter

Bit	Function
2	Separate evaluation for excluded and simulated interlock signals (Page 152)
3	Control priority in the event of an invalid input command (Page 175)
4	Setting switch or button mode for local commands (Page 181)
5	Evaluation of the signal status of the interlock signals (Page 142)
6	Vibrate after torque monitoring (Page 178)
8	Forcing operating modes in the "Local" mode (Page 184)
10	Considering bad quality of automatic commands or external values (Page 186)
11	Suppress <code>MsgLock</code> and "Out of service" mode for a connected message block (Page 188)
16	Separate interlock for each direction or position (Page 170)

Connection of the time-stamped messages from `EventTs` or `Event16Ts`

This block provides the standard function Connection of the time-stamped messages from `EventTs` or `Event16Ts` (Page 207).

SIMATIC BATCH functionality

This block provides the standard function, SIMATIC BATCH functionality (Page 67).

Disable feedback

This block provides the standard function, Disabling feedback for valves (Page 99). Feedback monitoring can be disabled separately for each feedback signal with `NoFbkOpen` or `NoFbkClose`.

Labeling of buttons

This block provides the standard function, Labeling of buttons and text (Page 209).

Instance-specific text can be configured for the following parameters:

- OpenMan
- CloseMan
- StopMan
- RapidStp

See also

EventTs functions (Page 1660)

Description of VlvPosL (Page 1506)

VlvPosL messaging (Page 1531)

VlvPosL I/Os (Page 1533)

VlvPosL block diagram (Page 1546)

VlvPosL modes (Page 1511)

7.14.4 VlvPosL error handling

Error handling of VlvPosL

For troubleshooting all blocks, see also the Error handling (Page 119) section in the basics.

The following errors can be displayed for this block:

- Error numbers
- Mode switchover error
- Invalid input signals
- Control system fault (CSF)

Overview of error numbers

The `ErrorNum` parameter can be used to output the following error numbers:

Error number	Meaning of the error number
-1	Pre-defined value when inserting the block; the block is not executed.
0	No error pending.
41	The value for the <code>LocalSetting</code> connection is not within the valid limit of 0 to 4.
42	<code>LocalSetting = 0</code> or <code>LocalSetting = 3</code> or <code>LocalSetting = 4</code> and <code>LocalLi = 1</code>

Error number	Meaning of the error number
51	OpenLocal = 1 and StopLocal = 1 CloseLocal = 1 and StopLocal = 1 OpenLocal = 1 and CloseLocal = 1 OpenAut = 1 and StopAut = 1 CloseAut = 1 and StopAut = 1 OpenAut = 1 and CloseAut = 1 PosOnAut = 1 and StopAut = 1 PosOnAut = 1 and OpenAut = 1 PosOnAut = 1 and CloseAut = 1 AutModLi = 1 and ManModLi = 1 OpenForce = 1 and StopForce = 1 CloseForce = 1 and StopForce = 1 OpenForce = 1 and CloseForce = 1
52	LocalAct = 1 and LocalSetting = 2 or 4 and SimOn = 1

Mode switchover error

This error can be outputted by the block, see section Error handling (Page 119).

Invalid input signals

This error can be outputted by the block, see section Error handling (Page 119).

For the following invalid input signals, the control output can be stopped or switched to the neutral position. This depends on the function Control priority in the event of an invalid input command (Page 175).

Operating mode	Invalid input signals	Control reaction with Feature2.Bit3 = 1
Local: Localsetting = 1 or Localsetting = 3	Pushbutton operation for local mode (Feature2 bit 4 = 0): OpenLocal = 1 and CloseLocal = 1 or OpenLocal = 1 and StopLocal = 1 or StopLocal = 1 and CloseLocal = 1 Switching mode (Feature2 bit 4 = 1): OpenLocal = 1 and CloseLocal = 1	Motor is started in valve neutral position direction.
Local: Localsetting = 1 or Localsetting = 3 and forcing	OpenForce = 1 and CloseForce = 1 or OpenForce = 1 and StopForce = 1 or StopForce = 1 and CloseForce = 1	
Forcing and no "Local mode"	OpenForce = 1 and CloseForce = 1 or OpenForce = 1 and StopForce = 1 or StopForce = 1 and CloseForce = 1	
"Automatic mode" and no forcing	Pushbutton operation (Feature.Bit4 = 0): OpenAut = 1 and CloseAut = 1 or OpenAut = 1 and StopAut = 1 or StopAut = 1 and CloseAut = 1 or StopAut = 1 and PosOnAut = 1 or CloseAut = 1 and PosOnAut = 1 or OpenAut = 1 and PosOnAut = 1 Switch mode (Feature.Bit4 = 1): OpenAut = 1 and CloseAut = 1 or CloseAut = 1 and PosOnAut = 1 or OpenAut = 1 and PosOnAut = 1	
"Manual mode" and no forcing	OpenMan = 1 and CloseMan = 1 or OpenMan = 1 and StopMan = 1 or StopMan = 1 and CloseMan = 1	

Control system fault (CSF)

An external signal can be activated via the CSF input. If this signal CSF.Value = 1, a control system fault is triggered. For more information on this, see section Error handling (Page 119).

See also

- VlvPosL block diagram (Page 1546)
- VlvPosL I/Os (Page 1533)
- VlvPosL functions (Page 1513)
- VlvPosL modes (Page 1511)
- Description of VlvPosL (Page 1506)

7.14.5 VivPosL messaging

Message characteristics

The following messages can be generated for this block:

- Control system fault
- Process messages
- Instance-specific messages

Control system fault

The following control system fault messages can be outputted:

Message instance	Message ID	Message class	Event
MsgEvId1	SIG1	AS control system message - fault	\$\$BlockComment\$\$ Motor feedback error
	SIG2	AS control system message - fault	\$\$BlockComment\$\$ Motor protection triggered
	SIG3	AS control system message - fault	\$\$BlockComment\$\$ Valve feedback error
	SIG4	AS control system message - fault	\$\$BlockComment\$\$ External fault has occurred

Explanation:

\$\$BlockComment\$\$: Content of the instance-specific comment

You can interconnect an external fault (signal) to the input parameter `CSF`. If this `CSF = 1`, a control system fault is triggered (`MsgEvId1`, `SIG4`).

Process messages

Message instance	Message ID	Message class	Event
MsgEvId2	SIG1	Alarm - high	\$\$BlockComment\$\$ ER - Alarm high limit violated
	SIG2	Alarm - low	\$\$BlockComment\$\$ ER - Alarm low limit violated
	SIG3	Warning - high	\$\$BlockComment\$\$ Rbk - High warning limit violated
	SIG4	Warning - low	\$\$BlockComment\$\$ Rbk - Low warning limit violated

Instance-specific messages

You can use up to four instance-specific messages with this block.

Message instance	Message ID	Message class	Event
MsgEvId1	SIG5	AS control system message - fault	\$\$BlockComment\$\$ External message 1
	SIG6	AS control system message - fault	\$\$BlockComment\$\$ External message 2
MsgEvId2	SIG5	AS control system message - fault	\$\$BlockComment\$\$ External message 3
	SIG6	AS control system message - fault	\$\$BlockComment\$\$ External message 4

Explanation:

\$\$BlockComment\$\$: Content of the instance-specific comment

Associated values for the message instance **MsgEvId1**

Associated value	Block parameter
1	BatchName
2	StepNo
3	BatchID
4	ExtVa104
5	ExtVa105
6	ExtVa106
7	Reserved
8	Reserved
9	Reserved
10	Reserved

The associated values 4 to 6 are assigned to the parameters ExtVa104 to ExtVa106, and are usable. For more information on this, refer to the manual "*Process Control System PCS 7 - Engineering System*".

Associated values for the message instance **MsgEvId2**

Associated value	Block parameter
1	BatchName
2	StepNo
3	BatchID
4	ExtVa204
5	ExtVa205
6	ExtVa206
7	Reserved
8	Reserved

Associated value	Block parameter
9	Reserved
10	Reserved

The associated values 4 to 6 are assigned to the parameters `ExtVa204` to `ExtVa206`, and are usable. For more information on this, refer to the manual "*Process Control System PCS 7 - Engineering System*".

See also

Description of VlvPosL (Page 1506)

VlvPosL functions (Page 1513)

VlvPosL I/Os (Page 1533)

VlvPosL block diagram (Page 1546)

VlvPosL modes (Page 1511)

7.14.6 VlvPosL I/Os

I/Os of VlvPosL

Input parameters

Parameter	Description	Type	Default
<code>AutModLi*</code>	1 = "Automatic mode" via interconnection or SFC (controlled via <code>ModLiOp = 1</code>)	STRUCT <ul style="list-style-type: none"> Value: BOOL ST: BYTE 	- <ul style="list-style-type: none"> 0 16#80
<code>AutModOp*</code>	1 = "Automatic mode" via operator (controlled via <code>ModLiOp = 1</code>)	BOOL	0
<code>AV</code>	Input additional analog value, to be connected to <code>AV_Tech</code> of the AV block	ANY	
<code>AV_AH_Lim</code>	Limit high alarm	REAL	95.0
<code>AV_AL_Lim</code>	Limit low alarm	REAL	5.0
<code>AV_Hyst</code>	Hysteresis for alarm, warning and tolerance limits	REAL	1.0
<code>AV_TH_Lim</code>	Limit high tolerance	REAL	85.0
<code>AV_TL_Lim</code>	Limit low tolerance	REAL	15.0
<code>AV_WH_Lim</code>	Limit high warning	REAL	90.0
<code>AV_WL_Lim</code>	Limit low warning	REAL	10.0
<code>BatchEn</code>	1 = Enable allocation	BOOL	0
<code>BatchID</code>	Batch ID	DWORD	16#00000000
<code>BatchName</code>	Batch name	S7 string	
<code>BreakTime*</code>	Minimum break duration [s]	REAL	1.0
<code>BypProt</code>	1 = Bypass interlock is enabled in "Local mode" and in simulation	BOOL	0

7.14 VlvPosL - Valve positioner

Parameter	Description	Type	Default
CloseAut*	1 = Select Close valve in "Automatic mode"	STRUCT <ul style="list-style-type: none"> Value: BOOL ST: BYTE 	- <ul style="list-style-type: none"> 0 16#80
CloseChnST	Signal status of the output channel of Close. It should be connected to an output channel block.	STRUCT <ul style="list-style-type: none"> Value: BOOL ST: BYTE 	- <ul style="list-style-type: none"> 0 16#FF
CloseForce	1 = Force Close valve	STRUCT <ul style="list-style-type: none"> Value: BOOL ST: BYTE 	- <ul style="list-style-type: none"> 0 16#80
CloseLocal	1 = Select Close valve in "Local mode"	STRUCT <ul style="list-style-type: none"> Value: BOOL ST: BYTE 	- <ul style="list-style-type: none"> 0 16#80
CloseMan*	1 = Select Close valve in "Manual mode"	BOOL	0
CSF	1 = External fault (control system fault) Error handling (Page 119)	STRUCT <ul style="list-style-type: none"> Value: BOOL ST: BYTE 	- <ul style="list-style-type: none"> 0 16#80
EN	1 = Called block is executed	BOOL	1
ER_A_DC*	Delay for incoming alarms during monitoring of the manipulated variable difference	REAL	0.0
ER_A_DG*	Delay for outgoing alarms during monitoring of the manipulated variable difference	REAL	0.0
ER_AH_En	1 = Activate alarm (high) for manipulated variable difference monitoring	BOOL	1
ER_AH_Lim	Alarm limit (high) for manipulated variable difference monitoring	REAL	100.0
ER_AH_MsgEn	1 = Enable messages for alarm (high) for manipulated variable difference monitoring	BOOL	1
ER_AL_Lim	Alarm limit (low) for manipulated variable difference monitoring	REAL	-100.0
ER_AL_En	1 = Activate alarm (low) for manipulated variable difference monitoring	BOOL	1
ER_AL_MsgEn	1 = Enable messages for alarm (low) for manipulated variable difference monitoring	BOOL	1
ER_Hyst	Alarm hysteresis for manipulated variable difference monitoring	REAL	1.0
EventTsIn	For interconnecting data between a technology block and the message blocks EventTs, Event16Ts. Input parameter EventTsIn is used to interconnect output parameter EventTsOut of the EventTs, Event16TS block. When this interconnection is configured, the messages of the EventTs, Event16TS block are displayed and can also be acknowledged on the OS in the message view of the technological block.	ANY	

Parameter	Description	Type	Default
EventTs2In	For interconnecting data between a technology block and the message blocks <code>EventTs</code> , <code>Event16Ts</code> . The <code>EventTs2In</code> input parameter serves to interconnect the <code>EventTsOut</code> output parameter of the <code>EventTs</code> , <code>Event16Ts</code> block. When this interconnection is configured, the messages of the <code>EventTs</code> , <code>Event16Ts</code> block are displayed on the OS in the alarm view of the technology block and can also be acknowledged there.	ANY	
ExtMsg1	Binary input for freely selectable message 1	STRUCT <ul style="list-style-type: none"> Value: BOOL ST: BYTE 	- <ul style="list-style-type: none"> 0 16#80
ExtMsg2	Binary input for freely selectable message 2	STRUCT <ul style="list-style-type: none"> Value: BOOL ST: BYTE 	- <ul style="list-style-type: none"> 0 16#80
ExtMsg3	Binary input for freely selectable message 3	STRUCT <ul style="list-style-type: none"> Value: BOOL ST: BYTE 	- <ul style="list-style-type: none"> 0 16#80
ExtMsg4	Binary input for freely selectable message 4	STRUCT <ul style="list-style-type: none"> Value: BOOL ST: BYTE 	- <ul style="list-style-type: none"> 0 16#80
ExtVa104	Associated value 4 for messages (<code>MsgEvId1</code>)	ANY	
ExtVa105	Associated value 5 for messages (<code>MsgEvId1</code>)	ANY	
ExtVa106	Associated value 6 for messages (<code>MsgEvId1</code>)	ANY	
ExtVa204	Associated value 4 for messages (<code>MsgEvId2</code>)	ANY	
ExtVa205	Associated value 5 for messages (<code>MsgEvId2</code>)	ANY	
ExtVa206	Associated value 6 for messages (<code>MsgEvId2</code>)	ANY	
FaultExt	1 = External fault Error handling (Page 119)	STRUCT <ul style="list-style-type: none"> Value: BOOL ST: BYTE 	- <ul style="list-style-type: none"> 0 16#80
FbkClose	1 = Valve closed feedback signal	STRUCT <ul style="list-style-type: none"> Value: BOOL ST: BYTE 	- <ul style="list-style-type: none"> 0 16#FF
FbkClosing	1 = Valve closing feedback signal	STRUCT <ul style="list-style-type: none"> Value: BOOL ST: BYTE 	- <ul style="list-style-type: none"> 0 16#FF
FbkOpen	1 = Valve open feedback signal	STRUCT <ul style="list-style-type: none"> Value: BOOL ST: BYTE 	- <ul style="list-style-type: none"> 0 16#FF
FbkOpening	1 = Valve opening feedback signal	STRUCT <ul style="list-style-type: none"> Value: BOOL ST: BYTE 	- <ul style="list-style-type: none"> 0 16#FF

7.14 VivPosL - Valve positioner

Parameter	Description	Type	Default
Feature	I/O for additional functions (Page 1513)	STRUCT <ul style="list-style-type: none"> • Bit 0: BOOL • ... • Bit 31: BOOL 	- <ul style="list-style-type: none"> • 0 • 0 • 0
Feature2	I/O for additional functions (Page 1513)	STRUCT <ul style="list-style-type: none"> • Bit 0: BOOL • ... • Bit 31: BOOL 	- <ul style="list-style-type: none"> • 0 • 0 • 0
Gain	Position control gain	STRUCT <ul style="list-style-type: none"> • Value: REAL • ST: BYTE 	- <ul style="list-style-type: none"> • 1.0 • 16#FF
Intlock	0 = Interlock / Interlock Open is activated. Once the interlock condition has cleared, the block can be operated without reset. 1 = Interlock / Interlock Open is deactivated.	STRUCT <ul style="list-style-type: none"> • Value:BOOL • ST:BYTE • Bit 1: BOOL (Bypass information bit) 	- <ul style="list-style-type: none"> • 1 • 16#FF • 0
Intl_En	1 = Parameter Intlock is enabled	BOOL	1
IntlCls	0 = Interlock Close is activated. Once the interlock condition has cleared, the block can be operated without reset. 1 = Interlock Close is deactivated.	STRUCT <ul style="list-style-type: none"> • Value:BOOL • ST:BYTE • Bit 1: BOOL (Bypass information bit) 	- <ul style="list-style-type: none"> • 1 • 16#FF • 0
IntlClsEn	1 = Parameter IntlCls is enabled	BOOL	1
LocalLi	1 = Activate "Local mode" via plant signal	STRUCT <ul style="list-style-type: none"> • Value: BOOL • ST: BYTE 	- <ul style="list-style-type: none"> • 0 • 16#80
LocalOp*	1 = "Local mode" via operator	BOOL	0
LocalSetting	Properties for Local mode (Page 79)	INT	0
Man*	Manipulated variable in "manual mode"	REAL	0.0
ManModLi*	1 = "Manual mode" via interconnection or SFC (controlled via ModLiOp = 1)	STRUCT <ul style="list-style-type: none"> • Value: BOOL • ST: BYTE 	- <ul style="list-style-type: none"> • 0 • 16#80
ManModOp*	1= "Manual mode" via: OS operator (controlled via ModLiOp = 0)	BOOL	1
ModLiOp	Toggle operation between: 0 = Operator 1 = Interconnection or SFC	STRUCT <ul style="list-style-type: none"> • Value: BOOL • ST: BYTE 	- <ul style="list-style-type: none"> • 0 • 16#80
MonSafePos	1 = Go to neutral position in the event of monitoring errors	BOOL	1
MotorTime*	Motor actuating time [s]	REAL	30.0
M_Monitor	1 = Motor feedback monitoring	BOOL	1

Parameter	Description	Type	Default
M_MonTiDynamic*	Monitoring time for feedback errors or feedback start errors after successful operation in [s]	REAL	3.0
M_MonTiStatic*	Monitoring time for feedback errors without operation in [s]	REAL	3.0
M_MonTiStop*	Monitoring time for feedback stop errors after successful operation in [s]	REAL	3.0
MS_RelOp*	1= Release for maintenance via OS operator	BOOL	0
MsgEvId1	Message number (assigned automatically)	DWORD	16#00000000
MsgEvId2	Message number (assigned automatically)	DWORD	16#00000000
MsgLock	1 = Suppress process messages. For more on this, refer to the section Suppressing messages using the MsgLock parameter (Page 205).	STRUCT <ul style="list-style-type: none"> Value: BOOL ST: BYTE 	- <ul style="list-style-type: none"> 0 16#80
MV	Manipulated variable in "automatic mode"	STRUCT <ul style="list-style-type: none"> Value: REAL ST: BYTE 	- <ul style="list-style-type: none"> 0.0 16#80
MV_Forced	Forced manipulated variable that is not limited and has top priority	STRUCT <ul style="list-style-type: none"> Value: REAL ST: BYTE 	- <ul style="list-style-type: none"> 0.0 16#80
MV_ForOn	1 = Output forced manipulated variable MV_Forced unlimited at output MV	STRUCT <ul style="list-style-type: none"> Value: BOOL ST: BYTE 	- <ul style="list-style-type: none"> 0 16#80
MV_HiLim	Limit (high) for manipulated variable MV	REAL	100.0
MV_LoLim	Limit (low) for manipulated variable MV	REAL	0.0
MV_OpScale	OS display range for the manipulated variable MV	STRUCT <ul style="list-style-type: none"> High: REAL Low: REAL 	- <ul style="list-style-type: none"> 100.0 0.0
MV_Trk	Tracking value for manipulated variable MV	STRUCT <ul style="list-style-type: none"> Value: REAL ST: BYTE 	- <ul style="list-style-type: none"> 0.0 16#80
MV_TrkOn	1 = Tracking of manipulated variable MV	STRUCT <ul style="list-style-type: none"> Value: BOOL ST: BYTE 	- <ul style="list-style-type: none"> 0 16#80
NoFbkClose	1 = No feedback present for "valve closed"	STRUCT <ul style="list-style-type: none"> Value: BOOL ST: BYTE 	- <ul style="list-style-type: none"> 0 16#80
NoFbkOpen	1 = No feedback present for "valve open"	STRUCT <ul style="list-style-type: none"> Value: BOOL ST: BYTE 	- <ul style="list-style-type: none"> 0 16#80
Occupied	1 = Occupied by a batch	BOOL	0

7.14 VlvPosL - Valve positioner

Parameter	Description	Type	Default
OosLi	1 = "Out of service", via interconnection or SFC	STRUCT <ul style="list-style-type: none"> Value: BOOL ST: BYTE 	- <ul style="list-style-type: none"> 0 16#80
OosOp*	1 = "Out of service", via OS operator	BOOL	0
OpenAut*	1 = Select Open valve in "Automatic mode"	STRUCT <ul style="list-style-type: none"> Value: BOOL ST: BYTE 	- <ul style="list-style-type: none"> 0 16#80
OpenChnST	Signal status of the output channel of Open. It should be connected to an output channel block.	STRUCT <ul style="list-style-type: none"> Value: BOOL ST: BYTE 	- <ul style="list-style-type: none"> 0 16#FF
OpenForce	1 = Force Open valve	STRUCT <ul style="list-style-type: none"> Value: BOOL ST: BYTE 	- <ul style="list-style-type: none"> 0 16#80
OpenLocal	1 = Select Open valve in "Local mode"	STRUCT <ul style="list-style-type: none"> Value: BOOL ST: BYTE 	- <ul style="list-style-type: none"> 0 16#80
OpenMan*	1 = Select Open valve in "Manual mode"	BOOL	0
OpSt_In	Input parameter for local operator permission, to be connected with the Out output parameter of the upstream block OpStations (Page 411)	DWORD	16#00000000
OS_Perm	I/O for Operator control permissions (Page 254)	STRUCT <ul style="list-style-type: none"> Bit 0: BOOL ... Bit 31: BOOL 	- <ul style="list-style-type: none"> 1 1 1
OSlPerm	I/O for Operator control permissions (Page 254)	STRUCT <ul style="list-style-type: none"> Bit 0: BOOL ... Bit 31: BOOL 	- <ul style="list-style-type: none"> 1 1 1
Permit	1 = Activation / activation Open is activated 0 = Activation / activation Open is deactivated	STRUCT <ul style="list-style-type: none"> Value:BOOL ST:BYTE Bit 1: BOOL (Bypass information bit) 	- <ul style="list-style-type: none"> 1 16#FF 0
Perm_En	1 = Parameter Permit is enabled	BOOL	1
PermCls	1 = Activation Close is activated 0 = Activation Close is deactivated	STRUCT <ul style="list-style-type: none"> Value:BOOL ST:BYTE Bit 1: BOOL (Bypass information bit) 	- <ul style="list-style-type: none"> 1 16#FF 0
PermClsEn	1 = Parameter PermCls is enabled	BOOL	1
DeadBand	Deadband for forming manipulated variable difference	REAL	0.1

Parameter	Description	Type	Default
PosDiClose	Limit for control valve position "closed"	REAL	5.0
PosDiOpen	Limit for control valve position "open"	REAL	95.0
PosOnAut	1 = Select Activate position control in "Automatic mode"	STRUCT <ul style="list-style-type: none"> Value: BOOL ST: BYTE 	- <ul style="list-style-type: none"> 0 16#80
PosOnMan	1 = Select Activate position control in "Manual mode"	BOOL	0
Protect	0 = Protective interlock / protective interlock Open is activated. Once the interlock condition has cleared, the block must be reset. 1 = Protective interlock / protective interlock Open is deactivated.	STRUCT <ul style="list-style-type: none"> Value:BOOL ST:BYTE Bit 1: BOOL (Bypass information bit) 	- <ul style="list-style-type: none"> 1 16#FF 0
Prot_En	1 = Parameter Protect is enabled	BOOL	1
ProtCls	0 = Protective interlock Close is activated. Once the interlock condition has cleared, the block must be reset. 1 = Protective interlock Close is deactivated.	STRUCT <ul style="list-style-type: none"> Value:BOOL ST:BYTE Bit 1: BOOL (Bypass information bit) 	- <ul style="list-style-type: none"> 1 16#FF 0
ProtClsEn	1 = Parameter ProtCls is enabled	BOOL	1
PulseTime	Minimum pulse duration [s]	REAL	1.0
PulseWidth*	Pulse width of the control signal [s]	REAL	3.0
RapidStp*	Rapid stop for the motor 0 = Motor On 1 = Motor off	BOOL	0
Rbk	Position feedback	STRUCT <ul style="list-style-type: none"> Value: REAL ST: BYTE 	- <ul style="list-style-type: none"> 0.0 16#80
RbkHyst	Alarm hysteresis for position feedback	REAL	1.0
RbkMonitor	1 = Position feedback monitoring	BOOL	0
RbkMonTi	Monitoring time for the position feedback in [s]	REAL	5.0
RbkW_DC*	Delay time for incoming warnings [s]	REAL	0.0
RbkW_DG*	Delay time for outgoing warnings [s]	REAL	0.0
RbkWH_En	1 = Enable warning (high) for position feedback	BOOL	0
RbkWH_Lim	Limit for position feedback of warning (high)	REAL	90.0
RbkWH_MsgEn	1 = Enable messages for warning (high) for position feedback	BOOL	1
RbkWL_En	1 = Enable warning (low) for position feedback	BOOL	0
RbkWL_Lim	Limit for position feedback of warning (low)	REAL	10.0
RbkWL_MsgEn	1 = Enable messages for warning (low) for position feedback	BOOL	1

Motor and valve blocks

7.14 VlvPosL - Valve positioner

Parameter	Description	Type	Default
RstLi*	1 = Reset via interconnection	STRUCT • Value: BOOL • ST: BYTE	- • 0 • 16#80
RstOp*	1 = Reset via operator	BOOL	0
RunUpCyc	Number of cycles in startup; messages are suppressed during these cycles	INT	3
SafePos	Neutral position for valve: 0 = Closed 1 = Open 2 = stop	INT	2
SampleTime	Sampling time [s] (assigned automatically)	REAL	0.1
SelFp1	Call a block saved in this parameter as an Opening additional faceplates (Page 208) in the standard view	ANY	-
SelFp2	Call a block saved in this parameter as an Opening additional faceplates (Page 208) in the preview	ANY	-
SimAV*	Additional value used with SimOn = 1	REAL	0.0
SimAV_Li	Additional analog value used with SimOnLi.Value = 1 (SimLiOp.Value = 1)	STRUCT • Value: REAL • ST: BYTE	- • 0.0 • 16#80
SimLiOp	Activation/deactivation of the simulation by: 0 = Operator 1 = Interconnection or SFC	STRUCT • Value: BOOL • ST: BYTE	- • 0 • 16#80
SimOn*	1 = Simulation on	BOOL	0
SimOnLi	1 = Simulation via interconnection or SFC (controlled via SimLiOp = 1)	STRUCT • Value: BOOL • ST: BYTE	- • 0 • 16#80
SimRbk*	Position feedback used with SimOn = 1	REAL	0.0
SimRbkLi	Position feedback used with SimOnLi.Value = 1 (SimLiOp.Value = 1)	STRUCT • Value: REAL • ST: BYTE	- • 0.0 • 16#80
StepNo	Batch step number	DWORD	16#00000000
StopAut*	1 = Stop the motor in "Automatic mode"	STRUCT • Value: BOOL • ST: BYTE	- • 0 • 16#80
StopForce	1 = Force motor stop	STRUCT • Value: BOOL • ST: BYTE	- • 0 • 16#80
StopLocal	1 = Stop the motor in "Local mode"	STRUCT • Value: BOOL • ST: BYTE	- • 0 • 16#80
StopMan*	1 = Stop the motor in "Manual mode"	BOOL	0

Parameter	Description	Type	Default
TmLag	Delay time of the LeadLag filter [s]	REAL	0.0
TorqClose	0 = Torque shutdown active when closing 1 = Good state	STRUCT • Value: BOOL • ST: BYTE	- • 1 • 16#FF
TorqOpen	0 = Torque shutdown active when opening 1 = Good state	STRUCT • Value: BOOL • ST: BYTE	- • 1 • 16#FF
Trip	1 = Motor is in "good" state	STRUCT • Value: BOOL • ST: BYTE	- • 1 • 16#FF
UA1unit	Unit of measure for analog auxiliary value 1	INT	0
UA2unit	Unit of measure for analog auxiliary value 2	INT	0
UserAna1	Analog auxiliary value 1	STRUCT • Value: REAL • ST: BYTE	- • 0.0 • 16#FF
UserAna2	Analog auxiliary value 2	STRUCT • Value: REAL • ST: BYTE	- • 0.0 • 16#FF
UserStatus	Freely assignable bits for use in PCS 7 OS	BYTE	16#00
V_Monitor	1 = Valve feedback monitoring	BOOL	1
V_MonTiDynamic*	Valve monitoring time after operation in [s]	REAL	30.0
V_MonTiStatic*	Monitoring time for valve feedback errors without operation in [s]	REAL	5.0
WarnTiAut*	Prewarning of valve movement in "automatic mode" in [s]	REAL	0.0
WarnTiMan*	Prewarning of valve movement in "manual mode" in [s]	REAL	0.0

* Values can be written back to these inputs during execution of the block by the block algorithm.

Output parameters

Parameter	Description	Type	Default
AutAct	1 = "Automatic mode" enabled 0 = "Manual mode" is enabled	STRUCT • Value: BOOL • ST: BYTE	- • 0 • 16#80
AutoST	1 = Worst signal status of automatic commands	BYTE	16#80
AV_OpScale	Limit for scale in AV bar graph of faceplate	STRUCT • High: REAL • Low: REAL	- • 100.0 • 0.0

Motor and valve blocks

7.14 VlvPosL - Valve positioner

Parameter	Description	Type	Default
AV_Out	Output additional analog value	STRUCT • Value: REAL • ST: BYTE	- • 0.0 • 16#80
AV_Unit	Unit of measure for additional analog value	INT	0
CascaCut	Cascade connection: 1 = Control chain from master controller to secondary valve is interrupted	STRUCT • Value: BOOL • ST: BYTE	- • 0 • 16#80
Close	Control output 1= Close valve	STRUCT • Value: BOOL • ST: BYTE	- • 0 • 16#80
Closed	1 = Valve is closed	STRUCT • Value: BOOL • ST: BYTE	- • 0 • 16#80
Closing	1 = Valve is closing	STRUCT • Value: BOOL • ST: BYTE	- • 0 • 16#80
CurrMonM	Current motor monitoring time [s]	DINT	0
CurrMonRbk	Current monitoring time of position feedback [s]	DINT	0
CurrMonV	Current valve monitoring time [s]	DINT	0
ENO	1 = Block algorithm completed without errors	BOOL	0
ER	Difference of the manipulated variable and the position feedback (ER = MV_Out - RbkOut)	STRUCT • Value: REAL • ST: BYTE	- • 0.0 • 16#80
ER_AH_Act	1 = Alarm limit (high) for manipulated variable difference violated	STRUCT • Value: BOOL • ST: BYTE	- • 0 • 16#80
ER_AL_Act	1 = Alarm limit (low) for manipulated variable difference violated	STRUCT • Value: BOOL • ST: BYTE	- • 0 • 16#80
ErrorNum	Output of pending error number. For error numbers that can be output by this block, see the section VlvPosL error handling (Page 1528)	INT	-1
FbkCloseOut	Valve closed feedback	STRUCT • Value: BOOL • ST: BYTE	- • 0 • 16#80
FbkClsgOut	Valve closing feedback	STRUCT • Value: BOOL • ST: BYTE	- • 0 • 16#80
FbkOpenOut	Valve open feedback	STRUCT • Value: BOOL • ST: BYTE	- • 0 • 16#80

Parameter	Description	Type	Default
FbkOpngOut	Valve opening feedback	STRUCT • Value: BOOL • ST: BYTE	- • 0 • 16#80
GrpErr	1 = Group error pending	STRUCT • Value: BOOL • ST: BYTE	- • 0 • 16#80
LocalAct	1 = "Local mode" enabled	STRUCT • Value: BOOL • ST: BYTE	- • 0 • 16#80
LockAct	1 = Interlock (Intlock, Permit, Protect) or Trip is active	STRUCT • Value: BOOL • ST: BYTE	- • 0 • 16#80
ManAct	1 = "Manual mode" enabled	STRUCT • Value: BOOL • ST: BYTE	- • 1 • 16#80
M_MonDynErr	1 = Feedback error or feedback start error of the motor due to control change	STRUCT • Value: BOOL • ST: BYTE	- • 0 • 16#80
M_MonStaErr	1 = Motor feedback error due to unexpected feedback change	STRUCT • Value: BOOL • ST: BYTE	- • 0 • 16#80
M_MonStopErr	1 = Feedback stop error of the motor due to unexpected feedback change	STRUCT • Value: BOOL • ST: BYTE	- • 0 • 16#80
MS_Release	Release for maintenance: 1 = Enable for OS operator	STRUCT • Value: BOOL • ST: BYTE	- • 0 • 16#80
MsgAckn1	Message - acknowledgment status 1 (ACK_STATE output of the first ALARM_8P)	WORD	16#0000
MsgAckn2	Message - acknowledgment status 2 (ACK_STATE output of the first ALARM_8P)	WORD	16#0000
MsgErr1	Message error 1 (ERROR output of the first ALARM_8P)	BOOL	0
MsgErr2	Message error 2 (ERROR output of the first ALARM_8P)	BOOL	0
MsgStat1	Message status 1 (STATUS output of the first ALARM_8P)	WORD	16#0000
MsgStat2	Message status 2 (STATUS output of the first ALARM_8P)	WORD	16#0000
MV_HiAct	1 = Limit (high) of manipulated variable violated	STRUCT • Value: BOOL • ST: BYTE	- • 0 • 16#80
MV_LoAct	1 = Limit (low) of manipulated variable violated	STRUCT • Value: BOOL • ST: BYTE	- • 0 • 16#80

Motor and valve blocks

7.14 VlvPosL - Valve positioner

Parameter	Description	Type	Default
MV_Aut	Manipulated variable in automatic mode	REAL	0.0
MV_Out	Manipulated variable	STRUCT • Value: REAL • ST: BYTE	- • 0.0 • 16#80
OosAct	1 = Block is "Out of service"	STRUCT • Value: BOOL • ST: BYTE	- • 0 • 16#80
Open	Control output: 1 = Open the valve	STRUCT • Value: BOOL • ST: BYTE	- • 0 • 16#80
Opened	1 = Valve is open	STRUCT • Value: BOOL • ST: BYTE	- • 0 • 16#80
Opening	1 = Valve is opening	STRUCT • Value: BOOL • ST: BYTE	- • 0 • 16#80
OpSt_Out	Value of the input parameter OpSt_In for further interconnection with other blocks. Bit 31 of this parameter is used by Feature bit 24	DWORD	16#00000000
OS_PermOut	Display of OS_Perm	DWORD	16#FFFFFFFF
OS1PermOut	Display of OS1Perm	DWORD	16#FFFFFFFF
OS_PermLog	Display of OS_Perm with settings changed by the block algorithm	DWORD	16#FFFFFFFF
OS1PermLog	Display of OS1Perm with settings changed by the block algorithm	DWORD	16#FFFFFFFF
PosReached	1 = Control valve has reached specified position	STRUCT • Value: BOOL • ST: BYTE	- • 0 • 16#80
P_Close	1 = Pulse signal to close valve	STRUCT • Value: BOOL • ST: BYTE	- • 0 • 16#80
P_Open	1 = Pulse signal to open valve	STRUCT • Value: BOOL • ST: BYTE	- • 0 • 16#80
P_Rst	1= Pulse output for reset The parameter persists for one cycle after a reset.	STRUCT • Value: BOOL • ST: BYTE	- • 0 • 16#80
P_Stop	0 = Pulse signal for stopping the valve	STRUCT • Value: BOOL • ST: BYTE	- • 1 • 16#80

Parameter	Description	Type	Default
R_StpAct	1 = Rapid stop of the motor is active	STRUCT • Value: BOOL • ST: BYTE	- • 0 • 16#80
RbkMonDynErr	1 = Position feedback error due to control change	STRUCT • Value: BOOL • ST: BYTE	- • 0 • 16#80
RbkMonStaErr	1 = Position feedback error due to unexpected feedback change	STRUCT • Value: BOOL • ST: BYTE	- • 0 • 16#80
RbkOut	Position feedback output	STRUCT • Value: REAL • ST: BYTE	- • 0.0 • 16#80
RbkWH_Act	1 = Warning (high) enabled	STRUCT • Value: BOOL • ST: BYTE	- • 0 • 16#80
RbkWL_Act	1 = Warning (low) enabled	STRUCT • Value: BOOL • ST: BYTE	- • 0 • 16#80
RdyToReset	1 = Ready for reset via RstLi input or commands in "local", "automatic", or "manual mode"	STRUCT • Value: BOOL • ST: BYTE	- • 0 • 16#80
RdyToStart	1 = Ready to start	STRUCT • Value: BOOL • ST: BYTE	- • 0 • 16#80
ST_Worst	Worst signal status	BYTE	16#80
Status1	Status word 1 (Page 1506)	DWORD	16#00000000
Status2	Status word 2 (Page 1506)	DWORD	16#00000000
Status3	Status word 3 (Page 1506)	DWORD	16#00000000
Status4	Status word 4 (Page 1506)	DWORD	16#00000000
Status5	Status word 5 (Page 1506)	DWORD	16#00000000
Stop	1 = Motor stopped and valve is in intermediate position	STRUCT • Value: BOOL • ST: BYTE	- • 0 • 16#80
SumMsgAct	1 = Active hardware interrupt	STRUCT • Value: BOOL • ST: BYTE	- • 0 • 16#80
ThreshOff	Trip threshold of the three-step element	REAL	0.0
ThreshOn	Response threshold of the three-step element	REAL	0.0
V_MonDynErr	1 = Valve feedback error due to control change	STRUCT • Value: BOOL • ST: BYTE	- • 0 • 16#80

7.14 VlvPosL - Valve positioner

Parameter	Description	Type	Default
V_MonStaErr	1 = Valve feedback error due to unexpected feedback change	STRUCT <ul style="list-style-type: none">• Value: BOOL• ST: BYTE	- <ul style="list-style-type: none">• 0• 16#80
WarnAct	1 = Prewarning for control valve movement away from active (WarnTiAut and WarnTiMan parameters)	STRUCT <ul style="list-style-type: none">• Value: BOOL• ST: BYTE	- <ul style="list-style-type: none">• 0• 16#80

See also

- VlvPosL messaging (Page 1531)
- VlvPosL block diagram (Page 1546)
- VlvPosL modes (Page 1511)
- Disabling operating points (Page 145)
- Signaling limit violation (Page 170)
- Error handling (Page 119)

7.14.7 VlvPosL block diagram

Block diagram of VlvPosL

A block diagram is not provided for this block.

See also

- VlvPosL I/Os (Page 1533)
- VlvPosL messaging (Page 1531)
- VlvPosL error handling (Page 1528)
- VlvPosL functions (Page 1513)
- VlvPosL modes (Page 1511)
- Description of VlvPosL (Page 1506)

7.14.8 Operator control and monitoring

7.14.8.1 VlvPosL views

Views of the VlvPosL block

The VlvPosL block provides the following views:

- VlvPosL standard view (Page 1548)
- VlvPosL limit view (Page 1553)
- Alarm view (Page 302)
- Trend view (Page 305)
- VlvPosL parameter view (Page 1555)
- VlvPosL preview (Page 1559)
- Memo view (Page 304)
- Batch view (Page 302)
- Block icon for VlvPosL (Page 1564)

You can find general information about the faceplate and block icon in the sections Structure of the faceplate (Page 248) and Block icon structure (Page 230).

7.14.8.2 VlvPosL standard view

Standard view of VlvPosL

With Feature2.Bit16 = 0:

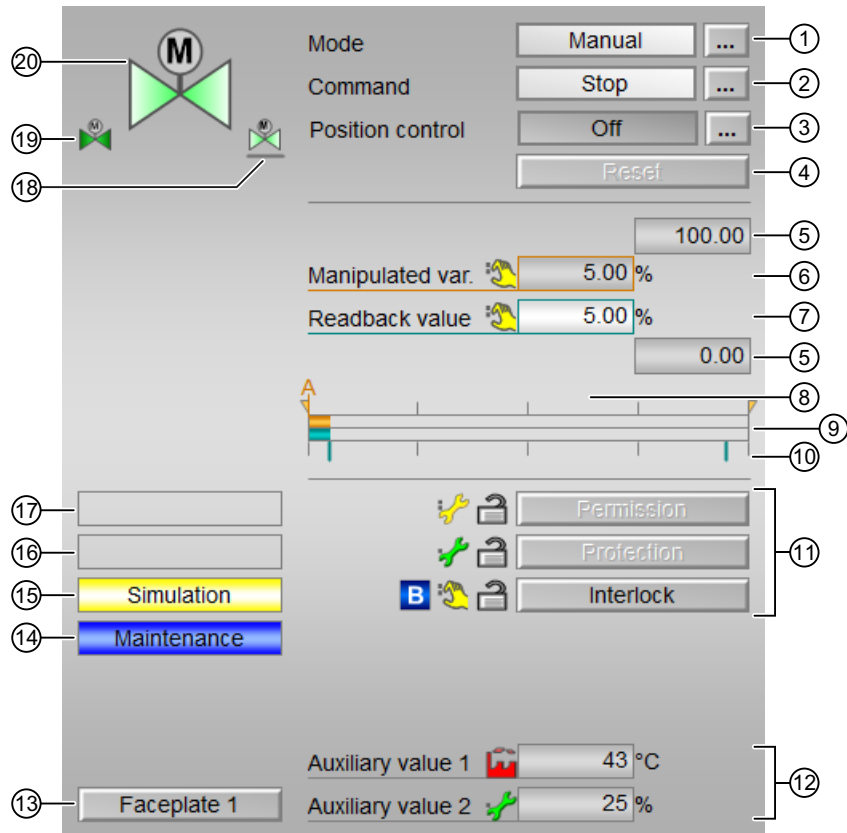

With Feature2.Bit16 = 1:

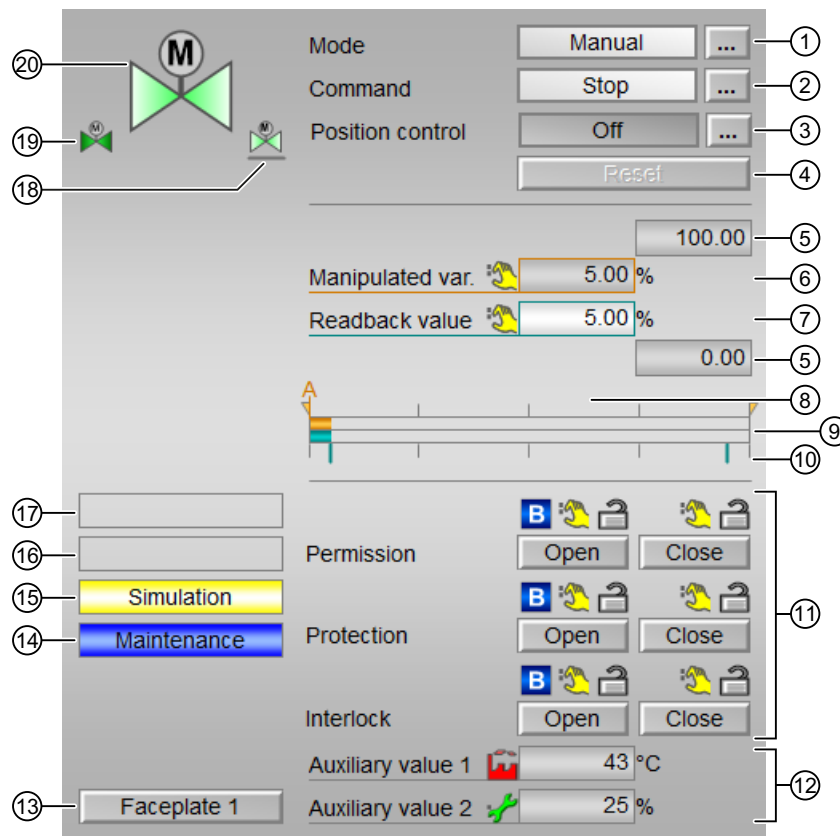

(1) Display and switch the operating mode

This area displays the current operating mode of the block. The following operating modes can be shown here:

- Manual and automatic mode for motors, valves and dosers (Page 75)
- Local mode (Page 79)
- Out of service (Page 71)

For information on switching the mode, see section Switching operating states and operating modes (Page 257).

(2) Open, close and stop the motor valve

This area displays the default operating state for the motor valve. The following states can be shown and executed here:

- "Open"
- "Close"
- "Stop"
- "Rapid stop"

Analog positioning mode is terminated if one of these commands is executed. Positioning mode can be reactivated using the (3) button.

For information on switching the mode, see section Switching operating states and operating modes (Page 257).

If text is configured for these commands, it is displayed as status text and as button labels for command selection. You can find more information on this in the section Labeling of buttons and text (Page 209).

(3) Activate positioning at an analog manipulated variable

This area shows you the default operating state for positioning to the analog manipulated variable. The following states can be shown here:

- "On"
- "Off"

Only the positioning mode is activated here:

- "On"

Positioning mode is terminated when the motor valve is operated using the **(2)** button.

(4) Reset the block

Click "Reset" in the event of interlocks or errors. You can find more information on this in the section Resetting the block in case of interlocks or errors (Page 43).

(5) High and low scale range for the manipulated variable

These values provide information on the display range for the bar graph of the manipulated variable. The scale range is defined in the engineering system.

(6) Display and change the manipulated variable including signal status

This area shows the current manipulated variable with the corresponding signal status.

The manipulated variable can only be changed in manual mode and active position control.

You can find more information about changing the manipulated variable in the section Changing values (Page 259).

(7) Display for position feedback including signal status

This area shows the current feedback of the manipulated variable with the corresponding signal status.

(8) Display of the manipulated variable for automatic mode

The display [A] is only visible when the block is not in automatic mode. In Automatic mode, it is displayed when it needs to be reset or when tracking or forced tracking is enabled.

This display shows the manipulated variable that would apply if you were to switch to automatic mode or if you were to reset in automatic mode or disable tracking or forced tracking.

(9) Bar display for manipulated variable

This area shows the current manipulated variable in the form of a bar graph. The visible area in the bar graph depends on the configuration in the engineering system (ES).

(10) Bar display for position feedback

This area shows the current position feedback in the form of a bar graph. The visible area in the bar graph depends on the configuration in the engineering system (ES).

The limits for the "open" and "closed" positions are shown with 2 green lines.

(11) Area for operating the interlock functions of the block

This display is only visible when the corresponding block input is interconnected.

You can use these buttons to control the interlock functions of the block. You can find more information on this in the section Interlocking functions (Page 99).

The following is displayed in addition to the buttons:

- Interlock status (see Forming the group status for interlock information (Page 104)), for example:



- Signal status (see Forming and outputting the signal status for technologic blocks (Page 109)), for example:



- Bypass information (see Forming the group status for interlock information (Page 104)):



(12) Display for auxiliary values

This display is only visible when the corresponding block input is interconnected.

You can use this area to display two auxiliary values that have been configured in the engineering system. You can find more information on this in the section Displaying auxiliary values (Page 211).

(13) Jump key to standard view of any faceplate

This display is only visible when the corresponding block input is interconnected.

Use this navigation button to jump to the standard view of a block configured in the engineering system (ES). The visibility of this navigation button depends on the configuration in the engineering system (ES).

You can find more information on this in the section Opening additional faceplates (Page 208).

(14) Display area for block states

This area provides additional information on the operating state of the block:

- "Maintenance"

You can find more information on this in the section Release for maintenance (Page 64) display area for block states.

(15) Display area for block states

This area provides additional information on the operating state of the block:

- "Simulation"
- "Time delay"

You can find more information on this in the sections Simulating signals (Page 58) and Display of delay times (Page 256).

(16) Display area for block states

This area provides additional information on the operating state of the block:

- "Motor protection"
- "External error"
- "Vibrate enabled"
- "End position error"
- "Control error"
- "Invalid signal"
- "Changeover error"
- "Torque active"

You can find more information on this in the sections Monitoring the feedbacks (Page 97), Error handling (Page 119) (headings "Invalid input signals" and "Mode switchover error") and Motor protection function (Page 99).

(17) Display area for block states

This area provides additional information on the operating state of the block:

- "Forced open" (`OpenForce`)
- "Forced closed" (`CloseForce`)
- "Forced stop" (`StopForce`)
- "Forced tracking" (`MV_ForOn`)
- "Tracking" (`MV_TrkOn`)
- "Request 0/1": A reset to "automatic mode" is expected.

You can find more information on this in the section Forcing operating modes (Page 41).

(18) Neutral position of the valve

This representation shows the neutral position for the valve:

- **Green:** Neutral position is "Open"
- **Gray:** Neutral position is "Closed"
- **Light green:** Neutral position is "Stop"

(19) Automatic preview

This display is only visible in "Manual mode", in "Local mode", or with a reset request in "Automatic mode", when the current output signals are not identical to the control in "Automatic mode".

The display shows what state the valve would assume if you switched from "Manual" or "Local" mode to "Automatic mode", or performed a reset to "Automatic mode".

(20) Status display of the motor valve

The current status of the motor valve is graphically displayed here.

You can find more information on this in the section Block icon for VlvPosL (Page 1564).

7.14.8.3 VlvPosL limit view**Limit view of VlvPosL**

Several values are set in this view by default:

- Manipulated variable difference limits
- Readback value limits
- Manipulated variable operating range

The toolbar of the faceplate and the block icon indicate when the limits are reached or violated.

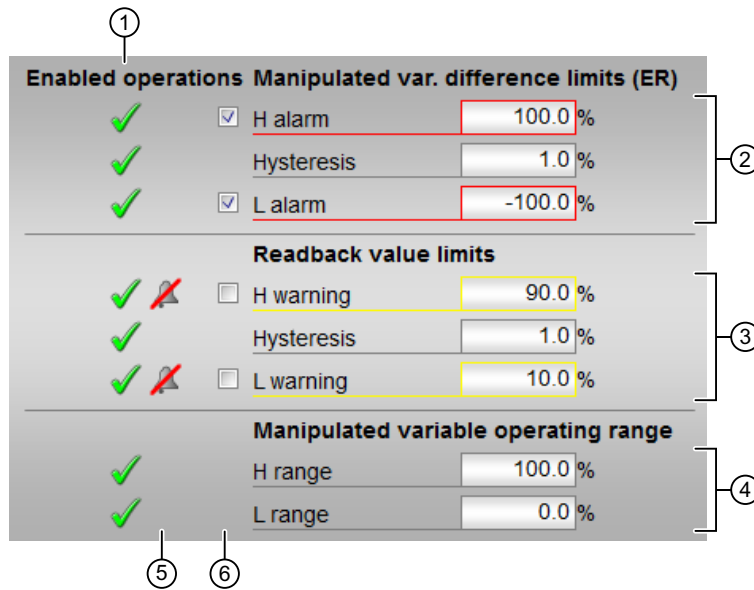

(1) Enabled operations

This area shows all operations for which special operator permissions are assigned. They depend on the configuration in the engineering system (ES) that applies to this block.

Icons for operation enable:

- **Green check mark:** The OS operator can control this parameter
- **Gray check mark:** The OS operator cannot control this parameter at this time due to the process
- **Red cross:** The OS operator cannot control this parameter due to the configured AS operator permissions (OS_Perm or OS1Perm)

(2) Limits of the manipulated variable difference

In this area, you can enter the limits for the manipulated variable difference. For more on this, see section Changing values (Page 259).

You can change the following limits:

- "H alarm": Alarm high
- "Hysteresis"
- "L alarm": Alarm low

(3) Readback value limits (Rbk)

In this area, you can enter the limits for the readback value (position feedback). For more on this, see section Changing values (Page 259).

You can change the following limits:

- "H warning": Warning high
- "Hysteresis"
- "L warning": Warning low

(4) Manipulated variable operating range

In this area, you can enter the limits for the manipulated variable operation range. For more on this, see section Changing values (Page 259).

You can change the following limits:

- "H range": Range limit high
- "L range": Range limit low

(5) Message suppression / delay

Message suppression indicates whether or not the suppression of the associated message in the AS block is activated with the `xx_MsgEn` parameter. The output of messages is not suppressed when you install the block (all `xx_MsgEn` parameters are assigned the default value 1). Messages can only be outputted if limit monitoring of the additional analog value has been enabled.

Alarm delays are also displayed in this position; for more on this, see section Area of application of the alarm delays (Page 199).

(6) Suppress messages

You can enable/disable messages by setting the check mark.

7.14.8.4 VlvPosL parameter view

Parameter view of VlvPosL

The parameter has an upper half and a lower half. You can navigate between the two halves with the arrow keys.

Upper half of the parameter view of VlvPosL with `Feature.Bit13 = 0`:

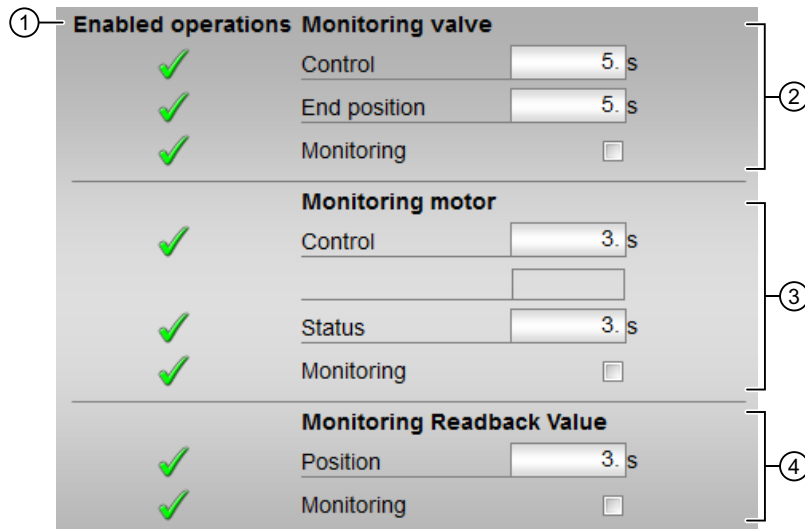

Upper half of the parameter view of VlvPosL with `Feature.Bit13 = 1`:

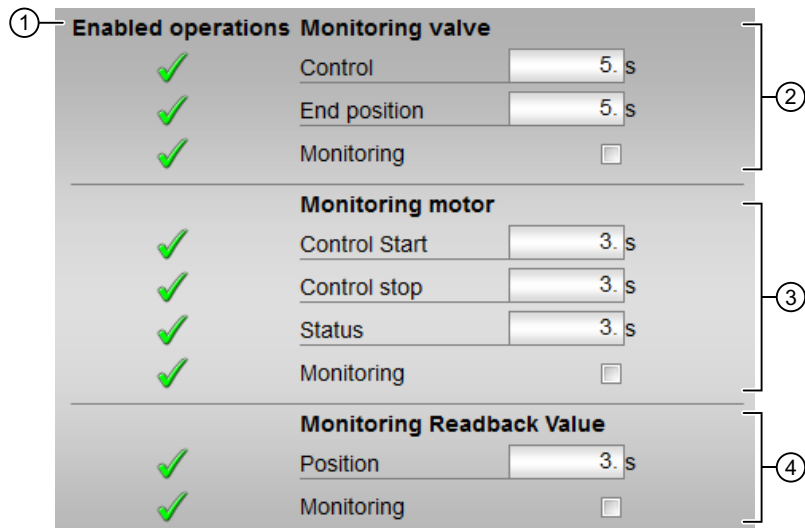

Lower half of the parameter view of VlvPosL:

Parameters	
✓	Dead band <input type="text" value="0. %"/>
✓	Gain <input type="text" value="1."/>
✓	Lag time <input type="text" value="4. s"/>
✓	Motor actuat. time <input type="text" value="40. s"/>
✓	Min. pulse durat. <input type="text" value="0.1 s"/>
✓	Min. break durat. <input type="text" value="0.1 s"/>
Service	
✓	Simulation <input type="button" value="Off"/> ...
✓	Release for maint. <input type="button" value="No"/> ...

(1) Enabled operations

This area shows all operations for which special operator permissions are assigned. They depend on the configuration in the engineering system (ES) that applies to this block.

Icons for operation enable:

- **Green check mark:** The OS operator can control this parameter.
- **Gray check mark:** The OS operator cannot control this parameter at this time due to the process.
- **Red cross:** The OS operator cannot control this parameter due to the configured AS operator permissions (OS_Perm or OS1Perm).

(2) Monitor valve

In this area, you can change parameters and thereby influence the valve. You can find more information on this in the section Changing values (Page 259).

You can influence the following parameters:

- "Control": Monitoring time while "Opening"/"Closing" the valve (dynamic)
- "End position": Monitoring time for maintaining the valve position (static)

Enable monitoring

You can enable monitoring by selecting the check box (☑).

You can find more information on this in the section Monitoring the feedbacks (Page 97).

(3) Monitor motor

In this area, you change parameters and thereby influence the motor. You can find more information on this in the section Changing values (Page 259).

You can influence the following parameters:

- "Control": Monitoring time during startup and stopping of the motor (dynamic)
Feature.Bit13 = 0
- "Control start": Monitoring time during startup of the motor (dynamic) Feature.Bit13 = 1
- "Control stop": Monitoring time during stopping of the motor (dynamic) Feature.Bit13 = 1
- "Status": Monitoring time during permanent operation of the motor (static)

Enable monitoring

You can enable monitoring by selecting the check box (☑).

You can find more information on this in the section Monitoring the feedbacks (Page 97).

(4) Monitoring the valve position

In this area, you change parameters and thereby influence the valve. You can find more information on this in the section Changing values (Page 259).

You can influence the following parameter:

- "Position": Monitoring time for the valve

Enable monitoring

You can enable monitoring by selecting the check box (☑).

You can find more information on this in the section Monitoring the feedbacks (Page 97).

(5) "Parameters"

In this area, you change parameters and thereby influence the controller. For more on this, see section Changing values (Page 259).

You can influence the following parameters:

- "Deadband": Width of deadband
- "Gain": Gain
- "Delay": Delay time in [s]
- "Motor actuating time": Motor actuating time [s]
- "Minimum pulse duration": Minimum pulse duration [s]
- "Minimum break duration": Minimum break duration [s]

(6) Service

You activate the following functions in this area:

- "Simulation"
- "Release for maintenance" (with display for maintenance demanded)

You can find more information on this in the section Switching operating states and operating modes (Page 257).

You can find information on this area in the sections:

- Simulating signals (Page 58)
- Release for maintenance (Page 64)

7.14.8.5 VlvPosL preview

Preview of VlvPosL

The preview has an upper half and a lower half. You can navigate between the two halves with the arrow keys.

Upper half of the preview of VlvPosL:

Automatic		Open
Auto. pos. control	Off	
MV automatic	49.0 %	
MV difference	0.0 %	
Open limit	95.0 %	
Close limit	5.0 %	
Track MV	0	
Tracking value	36.0 %	
Monitoring motor	0. s	
Monitoring valve	0. s	
Monitoring Rbk	0. s	

Lower half of the preview of VlvPosL:

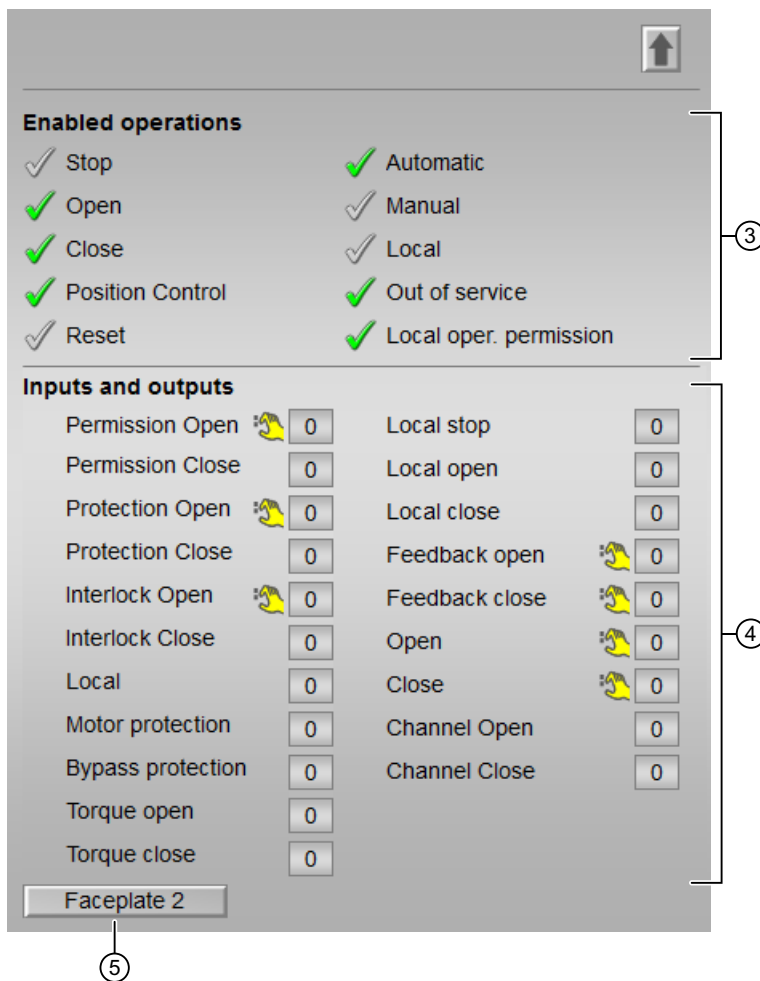

(1) Automatic preview

This area shows you the block status after it has switched from the "Manual" mode or "Local" mode to the "Automatic" mode.

If the block is in "Automatic" mode, the current block state is displayed.

This area also displays the worst signal status of the following automatic commands:

- OpenAut
- CloseAut
- StopAut
- PosOnAut
- MV

(2) Preview area

- "MV Automatic": Display of the current automatic manipulated variable (MV).
- "MV difference": Current manipulated variable difference (ER).

- "Open limit": Limit ($PosDiOpen$) for forming the "Control valve open" signal ($FbkOpenOut$). If the position feedback reaches this limit, the control valve is open.
- "Close limit": Limit ($PosDiClose$) for forming the "Control valve closed" signal ($FbkCloseOut$). If the position feedback reaches this limit, the control valve is closed.
- "Manipulated variable tracking": ($MV_TrkOn = 1$) Manipulated variable is tracked to the tracking value.
- "Tracking value": Effective manipulated variable for "Track manipulated variable"
- "Monitoring motor": Display of the current monitoring time of the motor. This display is only visible when monitoring is activated.
- "Monitor valve": Display of the current monitoring time of the valve. This display is only visible when monitoring is activated.
- "Monitoring Rbk": Display of the current monitoring time for the position feedback. This display is only visible when monitoring is activated.

(3) Enabled operations

This area shows all operations for which special operator permissions are assigned. They depend on the configuration in the engineering system (ES) that applies to this block.

Icons for operation enable:

- **Green check mark:** The OS operator can control this parameter.
- **Gray check mark:** The OS operator cannot control this parameter at this time due to the process.
- **Red cross:** The OS operator cannot control this parameter due to the configured AS operator permissions (OS_Perm or $OS1Perm$).

The following enabled operations are shown here:

- "Stop": You can stop the motor of the valve.
If text is configured for this command, it is also displayed in brackets. You can find more information on this in the section Labeling of buttons and text (Page 209).
- "Open": You can open the motor valve.
If text is configured for this command, it is also displayed in brackets. You can find more information on this in the section Labeling of buttons and text (Page 209).
- "Close": You can close the motor valve.
If text is configured for this command, it is also displayed in brackets. You can find more information on this in the section Labeling of buttons and text (Page 209).
- "Position Control": You can switch on the position control.
- "Reset": You can reset the motor valve if interlocks or errors occur.
- "Automatic": You can switch to "Automatic mode".
- "Manual": You can switch to "Manual mode".
- "Local": You can switch to "Local mode".

- "Out of service": You can switch to "Out of service" operating mode.
- "Local operating permission": Use the ← button to change to the standard view of the OpStations block. You can find more information on this in the section Operator control permissions (Page 254).

(4) Display current control signals

This area shows the most important parameters for this block with the current selection:

- "Permission" (`Feature2.Bit16 = 0`):
This display is only visible when the corresponding block input is connected.
 - 0 = Motor valve activation not enabled on OS
 - 1 = Enable for "opening"/"closing" from the neutral position
- "Permission Open" (`Feature2.Bit16 = 1`):
This display is only visible when the corresponding block input is connected.
 - 0 = Motor valve activation not enabled on OS
 - 1 = Enable for "open" from the neutral position
- "Permission Close" (`Feature2.Bit16 = 1`):
This display is only visible when the corresponding block input is connected.
 - 0 = Motor valve activation not enabled on OS
 - 1 = Enable for "close" from the neutral position
- "Protection" (`Feature2.Bit16 = 0`):
This display is only visible when the corresponding block input is connected.
 - 0 = Protective interlocking is effective; once the interlocking condition has disappeared, you will have to reset the block
 - 1 = "Good" state
- "Protection Open" (`Feature2.Bit16 = 1`):
This display is only visible when the corresponding block input is connected.
 - 0 = Protective interlocking is effective; once the interlocking condition has disappeared, you will have to reset the block
 - 1 = "Good" state
- "Protection Close" (`Feature2.Bit16 = 1`):
This display is only visible when the corresponding block input is connected.
 - 0 = Protective interlocking is effective; once the interlocking condition has disappeared, you will have to reset the block
 - 1 = "Good" state
- "Interlock" (`Feature2.Bit16 = 0`):
This display is only visible when the corresponding block input is connected.
 - 0 = Interlocking without reset is active; you can operate the block without reset once the interlocking condition has disappeared
 - 1 = "Good" state

- "Interlock Open" (`Feature2.Bit16 = 1`):
This display is only visible when the corresponding block input is connected.
 - 0 = Interlocking without reset is active; you can operate the block without reset once the interlocking condition has disappeared
 - 1 = "Good" state
- "Interlock Close" (`Feature2.Bit16 = 1`):
This display is only visible when the corresponding block input is connected.
 - 0 = Interlocking without reset is active; you can operate the block without reset once the interlocking condition has disappeared
 - 1 = "Good" state
- "Local correct": 1 = Control signal for "Local mode" (`LocalLi`) is active
- "Motor protection": 1 = Motor is in "good" state
- "Interlock deact.":
 - 0 = Bypass disabled
 - 1 = Bypass interlock in "Local mode" and in simulation
- "Torque opening": 0 = Torque shutoff when opening
- "Torque closing": 0 = Torque shutoff when closing
- "Local stop": 1 = Stop the motor valve in "Local mode"
- "Local open": 1 = Open the motor valve in "Local mode"
- "Local close": 1 = Close the motor valve in "Local mode"
- "Feedback open": 1 = Motor valve is opened
- "Feedback closed": 1 = Motor valve is closed
- "Open": 1 = Motor valve is opening
- "Close": 1 = Motor valve is closing
- "Channel Open": Signal from the output channel block for "Open"
- "Channel Close": Signal from the output channel block for "Close"

(5) Jump key to standard view of any faceplate

This display is only visible when the corresponding block input is interconnected.

Use this navigation button to jump to the standard view of a block configured in the engineering system. The visibility of this navigation button depends on the configuration in the engineering system (ES).

You can find more information on this in the section Opening additional faceplates (Page 208).



7.14.8.6 Block icon for VivPosL

Block icons for VivPosL

A variety of block icons are available with the following functions:

- Process tag type
- Limits (high/low)
- Violation of alarm, warning, and tolerance limits as well as control system faults
- Operating modes
- Signal status, release for maintenance
- Forcing states
- Operating the manipulated variable in manual mode
- Display of active position control
- Display of the position feedback (white, with decimal places)
- Display for bypassing interlocks
- Interlocks
- Memo display
- Valve status display

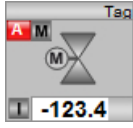
The block icons from template @TemplateAPLV8.PDL:

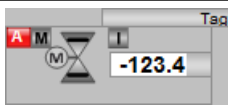







Icons	Selection of the block icon in CFC	Special features
	1	
	2	
	3	Non-rotating block icon
	4	Non-rotating block icon

Additional information on the block icon and the control options in the block icon is available in the following sections:

- Configuring the block icons (Page 237)
- Block icon structure (Page 230)
- Operation via the block icon (Page 239)

Valve status display

The following valve states are shown here:

Icon	Meaning
	Valve open
	Valve closed
	Error at valve
	Valve is opening
	Valve is closing
	Valve is stopping
	Valve closed
	Valve is closing

Interlock blocks

8.1 Intlk02 - Interlock display with 2 input signals

8.1.1 Description of Intlk02

Object name (type + number) and family

Type + number: FB 1824

Family: Interlock

Area of application for Intlk02

The block is used for the following applications:

- Standardized interlock with display

How it works

The block is used to calculate a standardized interlock that can be displayed on the OS. A maximum of 2 input signals can be supplied to the block. They are linked using selectable binary logic. The signal status of the output signal is also determined. You can assign an analog value with the signal status and unit to each input value for display in the faceplate.

The current state is displayed at the `Out` output parameter:

- `Out = 0`: Interlock
- `Out = 1`: "Good" state

Configuration

Use the CFC editor to install the block in a cyclic interrupt OB (OB30 to OB38).

For the Intlk02 block, the Advanced Process Library contains templates for process tag types as examples with various application scenarios for this block.

Examples of process tag types:

- Dosing (Dose_Lean) (Page 2358)
- Dosing with PA/FF devices (Dose_Lean_Fb) (Page 2359)
- Two-speed motor (Motor2Speed) (Page 2362)
- Reversing motor (MotorReversible) (Page 2363)
- Reversible motor with controllable speed (MotorSpeedControlled) (Page 2364)
- Two-way valve (Valve2Way) (Page 2368)

8.1 Intlk02 - Interlock display with 2 input signals

- Motor valve (ValveMotor) (Page 2369)
- Control valve (VlvAnL) (Page 2370)
- Control valve for PA/FF devices (ValveAnalog_Fb) (Page 2371)

Startup characteristics

The block does not have any startup characteristics.

Status word allocation for status1 parameter

You can find a description for each parameter in section Intlk02 I/Os (Page 1574).

Status bit	Parameter
0	1 = Logic = OR
1	1 = Logic = AND
2	Not used
3	Result of logic operation <code>Out.Value</code>
4	1 = At least one input value is excluded. See the section Excluding input values in Intlk02 functions (Page 1570).
5	1 = All input values are excluded
6	1 = No input value is interconnected or <code>NotUsed.Value</code>
7	Status display for simulation
8	Status display for not interlocked
9	Status display for interlocked
10	Activate OS_Perm bits
11	Feature bit 2: Separate evaluation for excluded and simulated interlock signals.
12 - 29	Not used
30	Occupied
31	BatchEn

Status word allocation for status2 parameter

Status bit	Parameter
0	<code>In01.Value</code>
1	<code>In02.Value</code>
2 - 31	Not used

Status word allocation for status3 parameter

Status bit	Parameter
0	<code>InvIn01</code>
1	<code>InvIn02</code>
2 - 31	Not used

Status word allocation for Status4 parameter

Status bit	Parameter
0	In01 with inversion
1	In02 with inversion
2 - 15	Not used
16	Bypass In01 (via interconnection)
17	Bypass In02 (via interconnection)
18 - 31	Not used

Status word allocation for Status5 parameter

Status bit	Parameter
0	BypIn01
1	BypIn02
2 - 15	Not used
16	In01 hidden bypass information
17	In02 hidden bypass information
18 - 31	Not used

Status word allocation for Status6 parameter

Status bit	Parameter
0	In01 not connected
1	In02 not connected
2 - 31	Not used

Status word allocation for Status7 parameter

Status bit	Parameter
0	AV01 not connected
1	AV02 not connected
2 - 31	Not used

Status word allocation for Status8 parameter

Identical to FirstIn.

See also

Intlk02 messaging (Page 1574)

Intlk02 block diagram (Page 1578)

8.1 Intlk02 - Interlock display with 2 input signals

Intlk02 error handling (Page 1573)

Intlk02 modes (Page 1570)

8.1.2 Intlk02 modes

Intlk02 modes

This block does not have any modes.

See also

Intlk02 block diagram (Page 1578)

Intlk02 I/Os (Page 1574)

Intlk02 messaging (Page 1574)

Intlk02 error handling (Page 1573)

Intlk02 functions (Page 1570)

Description of Intlk02 (Page 1567)

8.1.3 Intlk02 functions

Functions of Intlk02

The functions for this block are listed below.

Handling non-connected inputs

Inputs which are not interconnected are not evaluated. They are not displayed in the faceplate either.

Special situation: If no inputs are connected, the output value is defined using the `DefaultOut` parameter. The signal status is set to `16#FF`.

Opening additional faceplates

This block provides the standard function `Opening additional faceplates` (Page 208). However, only one additional faceplate can be called up using `SelFp1 = 1`.

First-in detection for interlock blocks

This block provides the standard function `Recording the first signal for interlock blocks` (Page 52). Note that a signal status change only has an effect on the first-in detection when the `Feature Bit Evaluation` of signal status (Page 142) and the input `FirstInEn` is set.

The response to deactivation via the `FirstInEn` input can be influenced by Feature bit `First-in detection response to deactivation` (Page 176).

Note

This function can only be executed in the faceplate with "process control" operating permission.

Forming the signal status for blocks

This block provides the standard function Forming and outputting the signal status for interlock blocks (Page 115).

The worst signal status `ST_Worst` for the block is formed from the following parameters:

- `Out.ST`

Bypass

Note

Bypassing the interlock means that the interlock signal (input signal) is excluded from the logic of the interlock block, in other words, this signal is ignored in the logic operation.

This function can only be executed in the faceplate with "high-level operating permission".

You can bypass interlock signals as follows:

- From operator over faceplate (`BypInx = 1`):
Independent `BypLix` is connected or not, the operator can bypass the input signal.
- By connecting `BypLix` in CFC (`BypLix.Value = 1`, `BypLix.ST <> 16#FF`)
Follow this if interlock signals are connected to parameters, which has no bypass information bit for bypass. Refer to section *Bypassing signals* (Page 107).
- By connected interlock signal `Inx`. For this the corresponding enable bit (`BypEn.Inx = 1`) and Feature Bit2 `Separate evaluation for excluded and simulated interlock signals` (Page 152) have to be set. Follow this if the interlock signals are all connected to parameters which has the bypass information. Refer to section *Bypassing signals* (Page 107).

The bypassed interlock signal is shown in the faceplate as the symbol below:



You can reset all the bypass of interlock signals as follows:

- From operator over faceplate (`RstBypOp = 0 -> 1`)
- Over CFC linkable parameter (`RstBypLi = 0 -> 1`)

Special situation: If all input parameters are bypassed, the output value is defined using the `DefaultOut` parameter.

Depending on the configuration of the Feature bit2 `Separate evaluation for excluded and simulated interlock signals` (Page 152), the output `BypAct` is formed and the bypass signal/information is set at the output `Out`.

8.1 Intlk02 - Interlock display with 2 input signals

Feature Bit2 = 0:

If one of the interlock inputs is bypassed by the operator or by connected `BypLix`, then the output `BypAct` is set. The bypass signal/information at the output `Out` is always reset.

- `BypAct.Value =`
`BypIn01 OR BypLi01`
`OR BypInx OR BypLix`
 The calculation is simplified and described.
- `Out.Bit1 = 0`

A bypassed interlock signal, that is switch-relevant, sets the status of `Out` to Simulation.

Feature Bit2 = 1:

If one of the interlock inputs is bypassed or the block which is connected to interlock signal is in bypass (signal is set at an interlock input `In01...Inx`), the output `BypAct` is set. The bypass information in the signal at the input `In01...Inx` can be read from the upstream interlock block at the output `BypAct` or from the upstream technical block with bypass functionality (`MonDiL`, `MonAnL`, `TotalL`, `PIDConL`, `PIDConR`, `PIDStepL`) at the output `BypassAct`.

The bypass signal information at the output `Out` is set to the value of `BypAct`.

- `BypAct.Value =`
`BypIn01 OR BypLi01 OR In01.Bit1`
`OR BypInx OR BypLix OR In01.Bitx`
`OR In01.Bit1 OR Inx.Bit1`
 The calculation is simplified and described.
- `Out.Bit1 = BypAct.Value`

An bypassed interlock input has no influence on the status of `Out`.

Note

Do **not** connect the input `BypLix` with the output `BypAct` from an interlock block because `BypAct` is calculated from the bypass signal information.

Operating permissions

This block provides the standard function Operator control permissions (Page 254).

The block has the following permissions for the `OS_Perm` parameter:

Bit	Function
0	1 = Operator can exclude values
1	1 = Operator can reset the exclusion of input values
2	1 = Operator can reset the recording of the first signal
3 - 15	Not used
16	1 = Operator can set or reset the exclusion of input value In01
17	1 = Operator can set or reset the exclusion of input value In02
18 - 31	Not used

Note

If you interconnect a parameter that is also listed in OS_Perm as a parameter, you have to reset the corresponding OS_Perm bit.

Configurable reactions using the Feature parameter

You can find an overview of all reactions provided by the Feature parameter in the chapter Configurable functions using the Feature I/O (Page 131). The following functionality is available for this block at the relevant bits:

Bit	Function
2	Separate evaluation for excluded and simulated interlock signals (Page 152)
5	Activate OS_Perm bits (Page 157) 0 = OS_Perm bits 16...17 inactive (evaluation only in faceplate) 1 = OS_Perm bits 16...17 active (evaluation only in faceplate)
21	First-in detection response to deactivation (Page 176)
23	Evaluation of signal status (Page 142)
24	Enabling local operator authorization (Page 158)
31	Activating recording of the first signal (Page 150)

SIMATIC BATCH functionality

This block provides the standard function SIMATIC BATCH functionality (Page 67).

See also

Description of Intlk02 (Page 1567)
Intlk02 messaging (Page 1574)
Intlk02 I/Os (Page 1574)
Intlk02 block diagram (Page 1578)
Intlk02 error handling (Page 1573)
Intlk02 modes (Page 1570)

8.1.4 Intlk02 error handling**Error handling of Intlk02**

Refer to the section Error handling (Page 119) in the basic instructions for the error handling of all blocks.

8.1 Intlk02 - Interlock display with 2 input signals

The following errors can be displayed for this block:

- Error numbers

Overview of error numbers

The `ErrorNum` I/O can be used to output the following error numbers:

Error number	Meaning of the error number
-1	Predefined value when inserting the block; the block is not processed.
0	There is no error.
13	The parameter <code>Logic</code> has not been set to 0 or 1.

See also

- Intlk02 block diagram (Page 1578)
- Intlk02 I/Os (Page 1574)
- Intlk02 messaging (Page 1574)
- Intlk02 functions (Page 1570)
- Intlk02 modes (Page 1570)
- Description of Intlk02 (Page 1567)

8.1.5 Intlk02 messaging

Messaging

This block does not offer messaging.

See also

- Description of Intlk02 (Page 1567)
- Intlk02 functions (Page 1570)
- Intlk02 I/Os (Page 1574)
- Intlk02 block diagram (Page 1578)
- Intlk02 error handling (Page 1573)
- Intlk02 modes (Page 1570)

8.1.6 Intlk02 I/Os

I/Os of Intlk02

Input parameters

Parameter	Description	Type	Default
AV01	Analog value of In01	STRUCT <ul style="list-style-type: none"> Value: REAL ST: BYTE 	- <ul style="list-style-type: none"> 0.0 16#FF
AV02	Analog value of In02	STRUCT <ul style="list-style-type: none"> Value: REAL ST: BYTE 	- <ul style="list-style-type: none"> 0.0 16#FF
AV01_Unit	Unit of measure for AV01	INT	0
AV02_Unit	Unit of measure for AV02	INT	0
BatchEn	1 = Enable allocation	BOOL	0
BatchID	Batch ID	DWORD	16#00000000
BatchName	Batch name	S7-String	
BypIn01*	1 = Input In01 is not used	BOOL	0
BypIn02*	1 = Input In02 is not used	BOOL	0
BypLi01	Bypass In01 (via interconnection)	STRUCT <ul style="list-style-type: none"> Value: BOOL ST: BYTE 	- <ul style="list-style-type: none"> 0 16#FF
BypLi02	Bypass In02 (via interconnection)	STRUCT <ul style="list-style-type: none"> Value: BOOL ST: BYTE 	- <ul style="list-style-type: none"> 0 16#FF
DefaultOut	Output value for cases where all inputs are excluded or not interconnected. Refer to the section Intlk02 functions (Page 1570) of the block.	BOOL	1
EN	1 = Called block will be processed	BOOL	1
Feature	I/O for additional functions (Page 1570)	STRUCT <ul style="list-style-type: none"> Bit 0: BOOL ... Bit 31: BOOL 	- <ul style="list-style-type: none"> 0 0 0
FirstInEn	First-in detection	STRUCT <ul style="list-style-type: none"> Value: BOOL ST: BYTE 	- <ul style="list-style-type: none"> 1 16#80
In01	Input In01	STRUCT <ul style="list-style-type: none"> Value: BOOL ST: BYTE Bit 1: BOOL (Bypass information bit) 	- <ul style="list-style-type: none"> 0 16#FF 0

Interlock blocks

8.1 Intlk02 - Interlock display with 2 input signals

Parameter	Description	Type	Default
In02	Input In02	STRUCT <ul style="list-style-type: none"> • Value: BOOL • ST: BYTE • Bit 1: BOOL (Bypass information bit) 	- <ul style="list-style-type: none"> • 0 • 16#FF • 0
InvIn01	Invert input In01	BOOL	0
InvIn02	Invert input In02	BOOL	0
Logic	Logical operation: 0 = Logical OR 1 = Logical AND	INT	0
NotUsed	1 = Block is not used (only for display in the faceplate). You can find additional information on this in the section Interlock blocks standard view (Page 276) / Color of the field.	STRUCT <ul style="list-style-type: none"> • Value: BOOL • ST: BYTE 	- <ul style="list-style-type: none"> • 0 • 16#80
Occupied	1 = Occupied by batch control	BOOL	0
OS_Perm	I/O for operating permissions (Page 1570)	STRUCT <ul style="list-style-type: none"> • Bit 0: BOOL • ... • Bit 31: BOOL 	- <ul style="list-style-type: none"> • 1 • 1 • 1
OpSt_In	Input parameter for local operator authorization, connected with the <code>Out</code> output parameter of the upstream block, <code>OpStations</code> (Page 411)	DWORD	16#00000000
RstBypOp*	1 = Reset via <code>BypIn01</code> and <code>BypIn02</code>	BOOL	0
RstLi	1 = Reset via interconnection	STRUCT <ul style="list-style-type: none"> • Value: BOOL • ST: BYTE 	- <ul style="list-style-type: none"> • 0 • 16#80
RstOp*	1 = Reset via operator	BOOL	0
SelfP1	Call a block saved in this parameter as an additional faceplate (Page 208) in the standard view	ANY	
StepNo	Batch step number	DWORD	16#00000000
UserStatus	Freely assignable bits for use in PCS 7 OS	BYTE	16#00

* Values can be written back to these inputs during processing of the block by the block algorithm.

Output parameters

Parameter	Description	Data type	Default
BypAct	1 = Bypass active	STRUCT <ul style="list-style-type: none"> Value: BOOL ST: BYTE Bit 1: BOOL (Bypass information bit) 	- <ul style="list-style-type: none"> 0 16#80 0
ENO	1 = Block algorithm completed without errors	BOOL	0
ErrorNum	Output of pending error number. For error numbers that can be output by this block, see Intlk02 error handling (Page 1573).	INT	-1
FirstIn	Bit-coded number of the first signal that has resulted in a change at the output	DWORD	16#00000000
OpSt_Out	Value of the OpSt_In input parameter for feedforwarding to other blocks. Bit 31 of this parameter is used by Feature bit 24	DWORD	16#00000000
OS_PermOut	Display of OS_Perm	DWORD	16#FFFFFFFF
OS_PermLog	Display of OS_Perm with settings changed by the block algorithm	DWORD	16#FFFFFFFF
Out	Output	STRUCT <ul style="list-style-type: none"> Value: BOOL ST: BYTE 	- <ul style="list-style-type: none"> 0 16#80
ST_Worst	Worst signal status	BYTE	16#80
Status1	Status word 1 (Page 1567)	DWORD	16#00000000
Status2	Status word 2 (Page 1567)	DWORD	16#00000000
Status3	Status word 3 (Page 1567)	DWORD	16#00000000
Status4	Status word 4 (Page 1567)	DWORD	16#00000000
Status5	Status word 5 (Page 1567)	DWORD	16#00000000
Status6	Status word 6 (Page 1567)	DWORD	16#00000000
Status7	Status word 7 (Page 1567)	DWORD	16#00000000
Status8	Status word 8 (Page 1567)	DWORD	16#00000000

See also

Intlk02 messaging (Page 1574)

Intlk02 block diagram (Page 1578)

Intlk02 modes (Page 1570)

8.1.7 Intlk02 block diagram

Intlk02 block diagram

A block diagram is not provided for this block.

See also

- Intlk02 I/Os (Page 1574)
- Intlk02 messaging (Page 1574)
- Intlk02 error handling (Page 1573)
- Intlk02 functions (Page 1570)
- Intlk02 modes (Page 1570)
- Description of Intlk02 (Page 1567)

8.1.8 Operator control and monitoring

8.1.8.1 Interlock block views

Views of the blocks Intlk02, Intlk04, Intlk08, Intlk16

The blocks provide the following views:

- Interlock blocks standard view (Page 276)
- Preview of interlock blocks (Page 299)
- Batch view (Page 302)
- Block icon for interlock blocks (Page 241)

Refer to the sections Structure of the faceplate (Page 248) and Block icon structure (Page 230) for general information on the faceplate and block icon.

8.2 Intlk04 - Interlock display with 4 input signals

8.2.1 Description of Intlk04

Object name (type + number) and family

Type + number: FB 1825

Family: Interlock

Area of application for Intlk04

The block is used for the following applications:

- Standardized interlock with display

How it works

The block is used to calculate a standardized interlock that can be displayed on the OS. A maximum of 4 input signals can be supplied to the block. They are linked using selectable binary logic. The signal status of the output signal is also determined. You can assign an analog value with the signal status and unit to each input value for display in the faceplate.

The current state is displayed at the `Out` output parameter:

- `Out = 0`: Interlock
- `Out = 1`: "Good" state

Configuration

Use the CFC editor to install the block in a cyclic interrupt OB (OB30 to OB38).

For the Intlk02 (Intlk04) block, the Advanced Process Library contains templates for process tag types as examples with various application scenarios for this block.

Refer to Description of Intlk02 (Page 1567) for more information.

Startup characteristics

The block does not have any startup characteristics.

Status word allocation for `status1` parameter

You can find a description for each parameter in section Intlk04 I/Os (Page 1587).

Status bit	Parameter
0	1 = Logic = OR
1	1 = Logic = AND
2	Not used

8.2 Intlk04 - Interlock display with 4 input signals

Status bit	Parameter
3	Result of logic operation <code>Out.Value</code>
4	1 = At least one input value is excluded. See the section Excluding input values in Intlk04 functions (Page 1582).
5	1 = All input values are excluded
6	1 = No input value is interconnected or <code>NotUsed.Value</code>
7	Status display for simulation
8	Status display for not interlocked
9	Status display for interlocked
10	Not used
11	Feature bit 2: Separate evaluation for excluded and simulated interlock signals
12 - 29	Not used
30	Occupied
31	BatchEn

Status word allocation for `Status2` parameter

Status bit	Parameter
0	<code>In01.Value</code>
1	<code>In02.Value</code>
2	<code>In03.Value</code>
3	<code>In04.Value</code>
4 - 31	Not used

Status word allocation for `Status3` parameter

Status bit	Parameter
0	<code>InvIn01</code>
1	<code>InvIn02</code>
2	<code>InvIn03</code>
3	<code>InvIn04</code>
4 - 31	Not used

Status word allocation for `Status4` parameter

Status bit	Parameter
0	<code>In01</code> with inversion
1	<code>In02</code> with inversion
2	<code>In03</code> with inversion
3	<code>In04</code> with inversion
4 - 15	Not used
16	Bypass <code>In01</code> (via interconnection)
17	Bypass <code>In02</code> (via interconnection)

Status bit	Parameter
18	Bypass In03 (via interconnection)
19	Bypass In04 (via interconnection)
20 - 31	Not used

Status word allocation for `status5` parameter

Status bit	Parameter
0	BypIn01
1	BypIn02
2	BypIn03
3	BypIn04
4 - 15	Not used
16	In01hidden bypass information
17	In02hidden bypass information
18	In03hidden bypass information
19	In04hidden bypass information
20-31	Not used

Status word allocation for `status6` parameter

Status bit	Parameter
0	In01 not connected
1	In02 not connected
2	In03 not connected
3	In04 not connected
4 - 31	Not used

Status word allocation for `status7` parameter

Status bit	Parameter
0	AV01 not connected
1	AV02 not connected
2	AV03 not connected
3	AV04 not connected
4 - 31	Not used

Status word allocation for `status8` parameter

Identical to `FirstIn`.

8.2 Intlk04 - Interlock display with 4 input signals

See also

- Intlk04 messaging (Page 1587)
- Intlk04 block diagram (Page 1591)
- Intlk04 error handling (Page 1586)
- Intlk04 modes (Page 1582)

8.2.2 Intlk04 modes

Intlk04 modes

This block does not have any modes.

See also

- Intlk04 block diagram (Page 1591)
- Intlk04 I/Os (Page 1587)
- Intlk04 messaging (Page 1587)
- Intlk04 error handling (Page 1586)
- Intlk04 functions (Page 1582)
- Description of Intlk04 (Page 1579)

8.2.3 Intlk04 functions

Functions of Intlk04

The functions for this block are listed below.

Inversion of logic signals

You can invert the input signals by setting the input parameter `InvInx` for the input concerned to `Inx = 1`, e.g. for input `In01` set the I/O `InvIn01`.

The inversion is displayed in the faceplate. If you invert signals using any other method this is not shown in the faceplate.

Bypass

Note

Bypassing the interlock means that the interlock signal (input signal) is excluded from the logic of the interlock block, in other words, this signal is ignored in the logic operation.

This function can only be executed in the faceplate with "high-level operating permission".

You can bypass interlock signals as follows:

- From operator over faceplate ($\text{BypInx} = 1$):
Independent BypLix is connected or not, the operator can bypass the input signal.
- By connecting BypLix in CFC ($\text{BypLix.Value} = 1$, $\text{BypLix.ST} \lt \> 16\#\text{FF}$)
Follow this if interlock signals are connected to parameters, which has no bypass information bit for bypass. Refer to section *Bypassing signals* (Page 107).
- By connected interlock signal Inx . For this the corresponding enable bit ($\text{BypEn.Inx} = 1$) and *Feature Bit2 Separate evaluation for excluded and simulated interlock signals* (Page 152) have to be set. Follow this if the interlock signals are all connected to parameters which has the bypass information. Refer to section *Bypassing signals* (Page 107).

The bypassed interlock signal is shown in the faceplate as the symbol below:



You can reset all the bypass of interlock signals as follows:

- From operator over faceplate ($\text{RstBypOp} = 0 \rightarrow 1$)
- Over CFC linkable parameter ($\text{RstBypLi} = 0 \rightarrow 1$)

Special situation: If all input parameters are bypassed, the output value is defined using the DefaultOut parameter.

Depending on the configuration of the *Feature bit2 Separate evaluation for excluded and simulated interlock signals* (Page 152), the output BypAct is formed and the bypass signal/information is set at the output Out .

Feature Bit2 = 0:

If one of the interlock inputs is bypassed by the operator or by connected BypLix , then the output BypAct is set. The bypass signal/information at the output Out is always reset.

- $\text{BypAct.Value} =$
 $\text{BypIn01 OR BypLi01}$
 $\text{OR BypInx OR BypLix}$
The calculation is simplified and described.
- $\text{Out.Bit1} = 0$

A bypassed interlock signal, that is switch-relevant, sets the status of Out to Simulation.

Feature Bit2 =1:

If one of the interlock inputs is bypassed or the block which is connected to interlock signal is in bypass (signal is set at an interlock input $\text{In01} \dots \text{Inx}$), the output BypAct is set. The bypass information in the signal at the input $\text{In01} \dots \text{Inx}$ can be read from the upstream interlock

8.2 Intlk04 - Interlock display with 4 input signals

block at the output `BypAct` or from the upstream technical block with bypass functionality (`MonDiL`, `MonAnL`, `TotalL`, `PIDConL`, `PIDConR`, `PIDStepL`) at the output `BypassAct`.

The bypass signal information at the output `Out` is set to the value of `BypAct`.

- `BypAct.Value =`
`BypIn01 OR BypLi01 OR In01.Bit1`
`OR BypInx OR BypLix OR In01.Bitx`
`OR In01.Bit1 OR Inx.Bit1`
The calculation and described.
- `Out.Bit1 = BypAct.Value`

A bypassed interlock input has no influence on the status of `Out`.

Note

Do **not** connect the input `BypLix` with the output `BypAct` from an interlock block because `BypAct` is calculated from the bypass signal information.

Handling non-connected inputs

Inputs which are not interconnected are not evaluated. They are not displayed in the faceplate either.

Special situation: If no inputs are connected, the output value is defined using the `DefaultOut` parameter. The signal status is set to `16#FF`.

Opening additional faceplates

This block provides the standard function Opening additional faceplates (Page 208). However, only one additional faceplate can be called up using `SelFp1 = 1`.

First-in detection for interlock blocks

This block provides the standard function Recording the first signal for interlock blocks (Page 52). Note that a signal status change only has an effect on the first-in detection when the `Feature Bit Evaluation` of signal status (Page 142) and the input `FirstInEn` is set.

The response to deactivation via the `FirstInEn` input can be influenced by Feature bit First-in detection response to deactivation (Page 176).

Note

This function can only be executed in the faceplate with "process control" operating permission.

Forming the signal status for blocks

This block provides the standard function Forming and outputting the signal status for interlock blocks (Page 115).

The worst signal status `ST_Worst` for the block is formed from the following parameters:

- `Out.ST`

Operating permissions

This block provides the standard function Operator control permissions (Page 254).

The block has the following permissions for the `OS_Perm` parameter:

Bit	Function
0	1 = Operator can exclude values
1	1 = Operator can reset the exclusion of input values
2	1 = Operator can reset the recording of the first signal
3 - 15	Not used
16	1 = Operator can set or reset the exclusion of input value In01
17	1 = Operator can set or reset the exclusion of input value In02
18	1 = Operator can set or reset the exclusion of input value In03
19	1 = Operator can set or reset the exclusion of input value In04
20 - 31	Not used

Note

If you interconnect a parameter that is also listed in `OS_Perm` as a parameter, you have to reset the corresponding `OS_Perm` bit.

Configurable reactions using the Feature I/O

You can find an overview of all reactions provided by the `Feature` parameter in the chapter Configurable functions using the Feature I/O (Page 131). The following functionality is available for this block at the relevant bits:

Bit	Function
2	Separate evaluation for excluded and simulated interlock signals (Page 152)
5	Activate <code>OS_Perm</code> bits (Page 157) 0 = <code>OS_Perm</code> bits 16...17 inactive (evaluation only in faceplate) 1 = <code>OS_Perm</code> bits 16...17 active (evaluation only in faceplate)
21	First-in detection response to deactivation (Page 176)
23	Evaluation of signal status (Page 142)
24	Enabling local operator authorization (Page 158)
31	Activating recording of the first signal (Page 150)

SIMATIC BATCH functionality

This block provides the standard function SIMATIC BATCH functionality (Page 67).

See also

- Description of Intlk04 (Page 1579)
- Intlk04 messaging (Page 1587)
- Intlk04 I/Os (Page 1587)
- Intlk04 block diagram (Page 1591)
- Intlk04 error handling (Page 1586)
- Intlk04 modes (Page 1582)

8.2.4 Intlk04 error handling

Error handling of Intlk04

Refer to the section Error handling (Page 119) in the basic instructions for the error handling of all blocks.

The following errors can be displayed for this block:

- Error numbers

Overview of error numbers

The `ErrorNum` I/O can be used to output the following error numbers:

Error number	Meaning of the error number
-1	Predefined value when inserting the block; the block is not processed.
0	There is no error.
13	The parameter <code>Logic</code> has not been set to 0 or 1.

See also

- Intlk04 block diagram (Page 1591)
- Intlk04 I/Os (Page 1587)
- Intlk04 messaging (Page 1587)
- Description of Intlk04 (Page 1579)
- Intlk04 modes (Page 1582)
- Intlk04 functions (Page 1582)

8.2.5 Intlk04 messaging

Messaging

This block does not offer messaging.

See also

Description of Intlk04 (Page 1579)

Intlk04 functions (Page 1582)

Intlk04 I/Os (Page 1587)

Intlk04 block diagram (Page 1591)

Intlk04 error handling (Page 1586)

Intlk04 modes (Page 1582)

8.2.6 Intlk04 I/Os

I/Os of Intlk04

Input parameters

Parameter	Description	Type	Default
AV01	Analog value of In01	STRUCT <ul style="list-style-type: none"> • Value: REAL • ST: BYTE 	- <ul style="list-style-type: none"> • 0.0 • 16#FF
AV02	Analog value of In02	STRUCT <ul style="list-style-type: none"> • Value: REAL • ST: BYTE 	- <ul style="list-style-type: none"> • 0.0 • 16#FF
AV03	Analog value of In03	STRUCT <ul style="list-style-type: none"> • Value: REAL • ST: BYTE 	- <ul style="list-style-type: none"> • 0.0 • 16#FF
AV04	Analog value of In04	STRUCT <ul style="list-style-type: none"> • Value: REAL • ST: BYTE 	- <ul style="list-style-type: none"> • 0.0 • 16#FF
AV01_Unit	Unit of measure for AV01	INT	0
AV02_Unit	Unit of measure for AV02	INT	0
AV03_Unit	Unit of measure for AV03	INT	0
AV04_Unit	Unit of measure for AV04	INT	0
BatchEn	1 = Enable allocation	BOOL	0
BatchID	Batch ID	DWORD	16#00000000
BatchName	Batch name	S7-String	

Interlock blocks

8.2 Intlk04 - Interlock display with 4 input signals

Parameter	Description	Type	Default
BypIn01*	1 = Input In01 is not used	BOOL	0
BypIn02*	1 = Input In02 is not used	BOOL	0
BypIn03*	1 = Input In03 is not used	BOOL	0
BypIn04*	1 = Input In04 is not used	BOOL	0
BypLi01...BypLi04	Bypass In01...In04 (via interconnection)	STRUCT <ul style="list-style-type: none"> • Value: BOOL • ST: BYTE 	- <ul style="list-style-type: none"> • 0 • 16#FF
DefaultOut	Output value for the case that all inputs are excluded or not connected. Refer to section Intlk04 functions (Page 1582) of the block.	BOOL	1
EN	1 = Called block will be processed	BOOL	1
Feature	I/O for additional functions (Page 1582)	STRUCT <ul style="list-style-type: none"> • Bit 0: BOOL • ... • Bit 31: BOOL 	- <ul style="list-style-type: none"> • 0 • 0 • 0
FirstInEn	First-in detection	STRUCT <ul style="list-style-type: none"> • Value: BOOL • ST: BYTE 	- <ul style="list-style-type: none"> • 1 • 16#80
In01	Input In01	STRUCT <ul style="list-style-type: none"> • Value: BOOL • ST: BYTE • Bit 1: BOOL (Bypass information bit) 	- <ul style="list-style-type: none"> • 0 • 16#FF • 0
In02	Input In02	STRUCT <ul style="list-style-type: none"> • Value: BOOL • ST: BYTE • Bit 1: BOOL (Bypass information bit) 	- <ul style="list-style-type: none"> • 0 • 16#FF • 0
In03	Input In03	STRUCT <ul style="list-style-type: none"> • Value: BOOL • ST: BYTE • Bit 1: BOOL (Bypass information bit) 	- <ul style="list-style-type: none"> • 0 • 16#FF • 0
In04	Input In04	STRUCT <ul style="list-style-type: none"> • Value: BOOL • ST: BYTE • Bit 1: BOOL (Bypass information bit) 	- <ul style="list-style-type: none"> • 0 • 16#FF • 0

8.2 Intlk04 - Interlock display with 4 input signals

Parameter	Description	Type	Default
InvIn01	Invert input In01	BOOL	0
InvIn02	Invert input In02	BOOL	0
InvIn03	Invert input In03	BOOL	0
InvIn04	Invert input In04	BOOL	0
Logic	Logical operation: 0 = Logical OR 1 = Logical AND	INT	0
NotUsed	1 = Block is not used (only for display in the faceplate). You can find additional information on this in the section Interlock blocks standard view (Page 276) / Color of the field.	STRUCT <ul style="list-style-type: none"> Value: BOOL ST: BYTE 	- <ul style="list-style-type: none"> 0 16#80
Occupied	1 = Occupied by batch control	BOOL	0
OpSt_In	Input parameter for local operator authorization, connected with the <code>Out</code> output parameter of the upstream block, OpStations (Page 411)	DWORD	16#00000000
OS_Perm	I/O for operating permissions (Page 1582)	STRUCT <ul style="list-style-type: none"> Bit 0: BOOL Bit 31: BOOL 	- <ul style="list-style-type: none"> 1 1 1
RstBypOp*	1 = Reset inputs <code>BypIn01</code> to <code>BypIn04</code>	BOOL	0
RstLi	1 = Reset via interconnection	STRUCT <ul style="list-style-type: none"> Value: BOOL ST: BYTE 	- <ul style="list-style-type: none"> 0 16#80
RstOp*	1 = Reset via operator	BOOL	0
SelfPl	Call a block saved in this parameter as an additional faceplate (Page 208) in the standard view	ANY	
StepNo	Batch step number	DWORD	16#00000000
UserStatus	Freely assignable bits for use in PCS 7 OS	BYTE	16#00

* Values can be written back to these inputs during processing of the block by the block algorithm.

Output parameters

Parameter	Description	Type	Default
BypAct	1 = Bypass active	STRUCT <ul style="list-style-type: none"> Value: BOOL ST: BYTE Bit 1: BOOL (Bypass information bit) 	- <ul style="list-style-type: none"> 0 16#80 0
ENO	1 = Block algorithm completed without errors	BOOL	0
ErrorNum	Output of pending error number. For error numbers that can be output by this block, see Intlk04 error handling (Page 1586)	INT	-1
FirstIn	Bit-coded number of the first signal that has resulted in a change at the output	DWORD	16#00000000
OpSt_Out	Value of the OpSt_In input parameter, for feedforwarding to other blocks. Bit 31 of this parameter is used by Feature bit 24	DWORD	16#00000000
OS_PermOut	Display of OS_Perm	DWORD	16#FFFFFFFF
OS_PermLog	Display of OS_Perm with settings changed by the block algorithm	DWORD	16#FFFFFFFF
Out	Output	STRUCT <ul style="list-style-type: none"> Value: BOOL ST: BYTE 	- <ul style="list-style-type: none"> 0 16#80
ST_Worst	Worst signal status	BYTE	16#80
Status1	Status word 1 (Page 1579)	DWORD	16#00000000
Status2	Status word 2 (Page 1579)	DWORD	16#00000000
Status3	Status word 3 (Page 1579)	DWORD	16#00000000
Status4	Status word 4 (Page 1579)	DWORD	16#00000000
Status5	Status word 5 (Page 1579)	DWORD	16#00000000
Status6	Status word 6 (Page 1579)	DWORD	16#00000000
Status7	Status word 7 (Page 1579)	DWORD	16#00000000
Status8	Status word 8 (Page 1579)	DWORD	16#00000000

See also

Intlk04 messaging (Page 1587)

Intlk04 block diagram (Page 1591)

Intlk04 modes (Page 1582)

8.2.7 Intlk04 block diagram

Intlk04 block diagram

A block diagram is not provided for this block.

See also

Intlk04 I/Os (Page 1587)

Intlk04 messaging (Page 1587)

Intlk04 error handling (Page 1586)

Intlk04 functions (Page 1582)

Intlk04 modes (Page 1582)

Description of Intlk04 (Page 1579)

8.2.8 Operator control and monitoring

8.2.8.1 Interlock block views

Views of the blocks Intlk02, Intlk04, Intlk08, Intlk16

The blocks provide the following views:

- Interlock blocks standard view (Page 276)
- Preview of interlock blocks (Page 299)
- Batch view (Page 302)
- Block icon for interlock blocks (Page 241)

Refer to the sections Structure of the faceplate (Page 248) and Block icon structure (Page 230) for general information on the faceplate and block icon.

8.3 Intlk08 - Interlock display with 8 input signals

8.3.1 Description of Intlk08

Object name (type + number) and family

Type + number: FB 1826

Family: Interlck

Area of application of Intlk08

The block is used for the following applications:

- Standardized interlock with display

How it works

The block is used to calculate a standardized interlock that can be displayed on the OS. A maximum of 8 input signals can be supplied to the block. They are linked using selectable binary logic. The signal status of the output signal is also determined. You can assign an analog value with the signal status and unit to each input value for display in the faceplate.

The current state is displayed at the `Out` output parameter:

- `Out = 0`: Interlock
- `Out = 1`: "Good" state

Configuration

Use the CFC editor to install the block in a cyclic interrupt OB (OB30 to OB38).

For the Intlk02 (Intlk08) block, the Advanced Process Library contains process tag type templates; these serve as examples by providing various application scenarios for this block.

Refer to Description of Intlk02 (Page 1567) for more information.

Startup characteristics

The block does not have any startup characteristics.

Status word allocation for `Status1` parameter

You can find a description for each parameter in section Intlk08 I/Os (Page 1601).

Status bit	Parameter
0	1 = Logic = OR
1	1 = Logic = AND
2	Not used

Status bit	Parameter
3	Result of logic operation <code>Out.Value</code>
4	1 = At least one input value is excluded. See the section Excluding input values in Intlk08 functions (Page 1596)
5	1 = All input values are excluded
6	1 = No input value is interconnected or <code>NotUsed.Value</code>
7	Status display for simulation
8	Status display for not interlocked
9	Status display for interlocked
10	Not used
11	Feature bit 2: Separate evaluation for excluded and simulated interlock signals
12 - 29	Not used
30	Occupied
31	BatchEn

Status word allocation for `Status2` parameter

Status bit	Parameter
0	<code>In01.Value</code>
1	<code>In02.Value</code>
2	<code>In03.Value</code>
3	<code>In04.Value</code>
4	<code>In05.Value</code>
5	<code>In06.Value</code>
6	<code>In07.Value</code>
7	<code>In08.Value</code>
8 - 31	Not used

Status word allocation for `Status3` parameter

Status bit	Parameter
0	<code>InvIn01</code>
1	<code>InvIn02</code>
2	<code>InvIn03</code>
3	<code>InvIn04</code>
4	<code>InvIn05</code>
5	<code>InvIn06</code>
6	<code>InvIn07</code>
7	<code>InvIn08</code>
8 - 31	Not used

Status word allocation for status4 parameter

Status bit	Parameter
0	In01 with inversion
1	In02 with inversion
2	In03 with inversion
3	In04 with inversion
4	In05 with inversion
5	In06 with inversion
6	In07 with inversion
7	In08 with inversion
8 - 15	Not used
16	Bypass In01 (via interconnection)
17	Bypass In02 (via interconnection)
18	Bypass In03 (via interconnection)
19	Bypass In04 (via interconnection)
20	Bypass In05 (via interconnection)
21	Bypass In06 (via interconnection)
22	Bypass In07 (via interconnection)
23	Bypass In08 (via interconnection)
24 - 31	Not used

Status word allocation for status5 parameter

Status bit	Parameter
0	BypIn01
1	BypIn02
2	BypIn03
3	BypIn04
4	BypIn05
5	BypIn06
6	BypIn07
7	BypIn08
8 - 15	Not used
16 - 23	In01..IN08 hidden bypass information
24 - 31	Not used

Status word allocation for status6 parameter

Status bit	Parameter
0	In01 not connected
1	In02 not connected
2	In03 not connected

Status bit	Parameter
3	In04 not connected
4	In05 not connected
5	In06 not connected
6	In07 not connected
7	In08 not connected
8 - 31	Not used

Status word allocation for `Status7` parameter

Status bit	Parameter
0	AV01 not connected
1	AV02 not connected
2	AV03 not connected
3	AV04 not connected
4	AV05 not connected
5	AV06 not connected
6	AV07 not connected
7	AV08 not connected
8 - 31	Not used

Status word allocation for `Status8` parameter

Identical to `FirstIn`.

See also

Intlk08 messaging (Page 1601)
 Intlk08 block diagram (Page 1606)
 Intlk08 error handling (Page 1600)
 Intlk08 modes (Page 1595)

8.3.2 Intlk08 modes

Intlk08 modes

This block does not have any modes.

See also

Intlk08 block diagram (Page 1606)
 Intlk08 I/Os (Page 1601)

8.3 Intlk08 - Interlock display with 8 input signals

Intlk08 messaging (Page 1601)

Intlk08 error handling (Page 1600)

Intlk08 functions (Page 1596)

Description of Intlk08 (Page 1592)

8.3.3 Intlk08 functions

Functions of Intlk08

The functions for this block are listed below.

Logic operators

Use the `Logic` input to specify the logic operator that the block should employ when determining the interlock state. Make the following settings:

- `Logic = 0`: OR
- `Logic = 1`: AND

Inversion of logic signals

You can invert the input signals by setting the input parameter `InvInx` for the input concerned to `Inx = 1`, e.g. for input `In01` set the I/O `InvIn01`.

The inversion is displayed in the faceplate. If you invert signals using any other method, this is not shown in the faceplate.

Bypass

Note

Bypassing the interlock means that the interlock signal (input signal) is excluded from the logic of the interlock block, in other words, this signal is ignored in the logic operation.

This function can only be executed in the faceplate with "high-level operating permission".

You can bypass interlock signals as follows:

- From operator over faceplate ($\text{BypInx} = 1$):
Independent BypLix is connected or not, the operator can bypass the input signal.
- By connecting BypLix in CFC ($\text{BypLix.Value} = 1, \text{BypLix.ST} \lt \text{16\#FF}$)
Follow this if interlock signals are connected to parameters, which has no bypass information bit for bypass. Refer to section *Bypassing signals* (Page 107).
- By connected interlock signal Inx . For this the corresponding enable bit ($\text{BypEn.Inx} = 1$) and *Feature Bit2 Separate evaluation for excluded and simulated interlock signals* (Page 152) have to be set. Follow this if the interlock signals are all connected to parameters which has the bypass information. Refer to section *Bypassing signals* (Page 107).

The bypassed interlock signal is shown in the faceplate as the symbol below:



You can reset all the bypass of interlock signals as follows:

- From operator over faceplate ($\text{RstBypOp} = 0 \rightarrow 1$)
- Over CFC linkable parameter ($\text{RstBypLi} = 0 \rightarrow 1$)

Special situation: If all input parameters are bypassed, the output value is defined using the *DefaultOut* parameter.

Depending on the configuration of the *Feature bit2 Separate evaluation for excluded and simulated interlock signals* (Page 152), the output BypAct is formed and the bypass signal/information is set at the output *Out*.

Feature Bit2 = 0:

If one of the interlock inputs is bypassed by the operator or by connected BypLix , the output BypAct is set. The bypass signal/information at the output *Out* is always reset.

- $\text{BypAct.Value} =$
 $\text{BypIn01 OR BypLi01}$
 $\text{OR BypInx OR BypLix}$
The calculation is simplified and described.
- $\text{Out.Bit1} = 0$

A bypassed interlock signal, that is switch-relevant, sets the status of *Out* to *Simulation*.

Feature Bit2 = 1:

If one of the interlock inputs is bypassed or the block which is connected to interlock signal is in bypass (signal is set at an interlock input $\text{In01} \dots \text{Inx}$), then the output BypAct is set. The bypass information in the signal at the input $\text{In01} \dots \text{Inx}$ can be read from the upstream interlock block at the output BypAct or from the upstream technical block with bypass functionality (*MonDiL, MonAnL, TotalL, PIDConL, PIDConR, PIDStepL*) at the output *BypassAct*.

8.3 Intlk08 - Interlock display with 8 input signals

The bypass signal information at the output `Out` is set to the value of `BypAct`.

- `BypAct.Value =`
`BypIn01 OR BypLi01 OR In01.Bit1`
`OR BypInx OR BypLix OR In01.Bitx`
`OR In01.Bit1 OR Inx.Bit1`
The calculation and described.
- `Out.Bit1 = BypAct.Value`

A bypassed interlock input has no influence on the status of `Out`.

Note

Do not connect the input `BypLix` with the output `BypAct` from an interlock block because `BypAct` is calculated from the bypass signal information.

Handling non-connected inputs

Inputs which are not interconnected are not evaluated. They are not displayed in the faceplate either.

Special situation: If no inputs are connected, the output value is defined using the `DefaultOut` parameter. The signal status is set to `16#FF`.

Opening additional faceplates

This block provides the standard function Opening additional faceplates (Page 208). However, only one additional faceplate can be called up using `SelFp1 = 1`.

First-in detection for interlock blocks

This block provides the standard function Recording the first signal for interlock blocks (Page 52). Note that a signal status change only has an effect on the first-in detection when the `Feature Bit Evaluation of signal status` (Page 142) and the input `FirstInEn` is set.

The response to deactivation via the `FirstInEn` input can be influenced by Feature bit `First-in detection response to deactivation` (Page 176).

Note

This function can only be executed in the faceplate with "process control" operating permission.

Forming the signal status for blocks

This block provides the standard function Forming and outputting the signal status for interlock blocks (Page 115).

The worst signal status `ST_Worst` for the block is formed from the following parameters:

- `Out.ST`

Operating permissions

This block provides the standard function Operator control permissions (Page 254).

The block has the following permissions for the `OS_Perm` parameter:

Bit	Function
0	1 = Operator can exclude values
1	1 = Operator can reset the exclusion of input values
2	1 = Operator can reset the recording of the first signal
3 - 15	Not used
16	1 = Operator can set or reset the exclusion of input value In01
17	1 = Operator can set or reset the exclusion of input value In02
18	1 = Operator can set or reset the exclusion of input value In03
19	1 = Operator can set or reset the exclusion of input value In04
20	1 = Operator can set or reset the exclusion of input value In05
21	1 = Operator can set or reset the exclusion of input value In06
22	1 = Operator can set or reset the exclusion of input value In07
23	1 = Operator can set or reset the exclusion of input value In08
24 - 31	Not used

Note

If you interconnect a parameter that is also listed in `OS_Perm` as a parameter, you have to reset the corresponding `OS_Perm` bit.

Configurable reactions using the `Feature` parameter

You can find an overview of all reactions provided by the `Feature` parameter in the chapter Configurable functions using the Feature I/O (Page 131). The following functionality is available for this block at the relevant bits:

Bit	Function
2	Separate evaluation for excluded and simulated interlock signals (Page 152)
5	Activate <code>OS_Perm</code> bits (Page 157) 0 = <code>OS_Perm</code> bits 16...17 inactive (evaluation only in faceplate) 1 = <code>OS_Perm</code> bits 16...17 active (evaluation only in faceplate)
21	First-in detection response to deactivation (Page 176)
23	Evaluation of signal status (Page 142)
24	Enabling local operator authorization (Page 158)
31	Activating recording of the first signal (Page 150)

SIMATIC BATCH functionality

This block provides the standard function SIMATIC BATCH functionality (Page 67).

See also

- Description of Intlk08 (Page 1592)
- Intlk08 messaging (Page 1601)
- Intlk08 I/Os (Page 1601)
- Intlk08 block diagram (Page 1606)
- Intlk08 error handling (Page 1600)
- Intlk08 modes (Page 1595)

8.3.4 Intlk08 error handling

Error handling of Intlk08

Refer to the section Error handling (Page 119) in the basic instructions for the error handling of all blocks.

The following errors can be displayed for this block:

- Error numbers

Overview of error numbers

The `ErrorNum` I/O can be used to output the following error numbers:

Error number	Meaning of the error number
-1	Predefined value when inserting the block; the block is not processed.
0	There is no error.
13	The parameter <code>Logic</code> has not been set to 0 or 1

See also

- Intlk08 block diagram (Page 1606)
- Intlk08 I/Os (Page 1601)
- Intlk08 messaging (Page 1601)
- Intlk08 functions (Page 1596)
- Intlk08 modes (Page 1595)
- Description of Intlk08 (Page 1592)

8.3.5 Intlk08 messaging

Messaging

This block does not offer messaging.

See also

Description of Intlk08 (Page 1592)

Intlk08 functions (Page 1596)

Intlk08 I/Os (Page 1601)

Intlk08 block diagram (Page 1606)

Intlk08 error handling (Page 1600)

Intlk08 modes (Page 1595)

8.3.6 Intlk08 I/Os

I/Os of Intlk08

Input parameters

Parameter	Description	Type	Default
AV01	Analog value of In01	STRUCT <ul style="list-style-type: none"> Value: REAL ST: BYTE 	- <ul style="list-style-type: none"> 0.0 16#FF
AV02	Analog value of In02	STRUCT <ul style="list-style-type: none"> Value: REAL ST: BYTE 	- <ul style="list-style-type: none"> 0.0 16#FF
AV03	Analog value of In03	STRUCT <ul style="list-style-type: none"> Value: REAL ST: BYTE 	- <ul style="list-style-type: none"> 0.0 16#FF
AV04	Analog value of In04	STRUCT <ul style="list-style-type: none"> Value: REAL ST: BYTE 	- <ul style="list-style-type: none"> 0.0 16#FF
AV05	Analog value of In05	STRUCT <ul style="list-style-type: none"> Value: REAL ST: BYTE 	- <ul style="list-style-type: none"> 0.0 16#FF
AV06	Analog value of In06	STRUCT <ul style="list-style-type: none"> Value: REAL ST: BYTE 	- <ul style="list-style-type: none"> 0.0 16#FF

Interlock blocks

8.3 Intlk08 - Interlock display with 8 input signals

Parameter	Description	Type	Default
AV07	Analog value of In07	STRUCT • Value: REAL • ST: BYTE	- • 0.0 • 16#FF
AV08	Analog value of In08	STRUCT • Value: REAL • ST: BYTE	- • 0.0 • 16#FF
AV01_Unit	Unit of measure for AV01	INT	0
AV02_Unit	Unit of measure for AV02	INT	0
AV03_Unit	Unit of measure for AV03	INT	0
AV04_Unit	Unit of measure for AV04	INT	0
AV05_Unit	Unit of measure for AV05	INT	0
AV06_Unit	Unit of measure for AV06	INT	0
AV07_Unit	Unit of measure for AV07	INT	0
AV08_Unit	Unit of measure for AV08	INT	0
BatchEn	1 = Enable allocation	BOOL	0
BatchID	Batch ID	DWORD	16#00000000
BatchName	Batch name	S7-String	
BypIn01*	1 = Input In01 is not used	BOOL	0
BypIn02*	1 = Input In02 is not used	BOOL	0
BypIn03*	1 = Input In03 is not used	BOOL	0
BypIn04*	1 = Input In04 is not used	BOOL	0
BypIn05*	1 = Input In05 is not used	BOOL	0
BypIn06*	1 = Input In06 is not used	BOOL	0
BypIn07*	1 = Input In07 is not used	BOOL	0
BypIn08*	1 = Input In08 is not used	BOOL	0
BypLi01...BypLi08	Bypass In01...In08 (via interconnection)	STRUCT • Value: BOOL • ST: BYTE	- • 0 • 16#FF
DefaultOut	Output value for cases where all inputs are excluded or not interconnected. Refer to the section Intlk08 functions (Page 1596) of the block.	BOOL	1
EN	1 = Called block will be processed	BOOL	1
Feature	I/O for additional functions (Page 1596)	STRUCT • Bit 0: BOOL • ... • Bit 31: BOOL	- • 0 • 0 • 0
FirstInEn	First-in detection	STRUCT • Value: BOOL • ST: BYTE	- • 1 • 16#80

8.3 Intlk08 - Interlock display with 8 input signals

Parameter	Description	Type	Default
In01	Input In01	STRUCT <ul style="list-style-type: none"> • Value: BOOL • ST: BYTE • Bit 1: BOOL (Bypass information bit) 	- <ul style="list-style-type: none"> • 0 • 16#FF • 0
In02	Input In02	STRUCT <ul style="list-style-type: none"> • Value: BOOL • ST: BYTE • Bit 1: BOOL (Bypass information bit) 	- <ul style="list-style-type: none"> • 0 • 16#FF • 0
In03	Input In03	STRUCT <ul style="list-style-type: none"> • Value: BOOL • ST: BYTE • Bit 1: BOOL (Bypass information bit) 	- <ul style="list-style-type: none"> • 0 • 16#FF • 0
In04	Input In04	STRUCT <ul style="list-style-type: none"> • Value: BOOL • ST: BYTE • Bit 1: BOOL (Bypass information bit) 	- <ul style="list-style-type: none"> • 0 • 16#FF • 0
In05	Input In05	STRUCT <ul style="list-style-type: none"> • Value: BOOL • ST: BYTE • Bit 1: BOOL (Bypass information bit) 	- <ul style="list-style-type: none"> • 0 • 16#FF • 0
In06	Input In06	STRUCT <ul style="list-style-type: none"> • Value: BOOL • ST: BYTE • Bit 1: BOOL (Bypass information bit) 	- <ul style="list-style-type: none"> • 0 • 16#FF • 0
In07	Input In07	STRUCT <ul style="list-style-type: none"> • Value: BOOL • ST: BYTE • Bit 1: BOOL (Bypass information bit) 	- <ul style="list-style-type: none"> • 0 • 16#FF • 0

Interlock blocks

8.3 Intlk08 - Interlock display with 8 input signals

Parameter	Description	Type	Default
In08	Input In08	STRUCT <ul style="list-style-type: none"> • Value: BOOL • ST: BYTE • Bit 1: BOOL (Bypass information bit) 	- <ul style="list-style-type: none"> • 0 • 16#FF • 0
InvIn01	Invert Input In01	BOOL	0
InvIn02	Invert Input In02	BOOL	0
InvIn03	Invert Input In03	BOOL	0
InvIn04	Invert Input In04	BOOL	0
InvIn05	Invert Input In05	BOOL	0
InvIn06	Invert Input In06	BOOL	0
InvIn07	Invert Input In07	BOOL	0
InvIn08	Invert Input In08	BOOL	0
Logic	Logical operation: 0 = Logical OR 1 = Logical AND	INT	0
NotUsed	1 = Block is not used (only for display in the faceplate). You can find additional information on this in the section Interlock blocks standard view (Page 276) / Color of the field.	STRUCT <ul style="list-style-type: none"> • Value: BOOL • ST: BYTE 	- <ul style="list-style-type: none"> • 0 • 16#80
Occupied	1 = Occupied by batch control	BOOL	0
OpSt_In	Input parameter for local operator authorization, connected with the Out output parameter of the upstream block, OpStations (Page 411)	DWORD	16#00000000
OS_Perm	I/O for operating permissions (Page 1596)	STRUCT <ul style="list-style-type: none"> • Bit 0: BOOL • ... • Bit 31: BOOL 	- <ul style="list-style-type: none"> • 1 • 1 • 1
RstBypOp*	1 = Reset inputs BypIn01 to BypIn08	BOOL	0
RstLi	1 = Reset via interconnection	STRUCT <ul style="list-style-type: none"> • Value: BOOL • ST: BYTE 	- <ul style="list-style-type: none"> • 0 • 16#80
RstOp*	1 = Reset via operator	BOOL	0
SelFp1	Call a block saved in this parameter as an additional faceplate (Page 208) in the standard view	ANY	
StepNo	Batch step number	DWORD	16#00000000
UserStatus	Freely assignable bits for use in PCS 7 OS	BYTE	16#00

* Values can be written back to these inputs during processing of the block by the block algorithm.

Output parameters

Parameter	Description	Type	Default
BypAct	1 = Bypass active	STRUCT <ul style="list-style-type: none"> Value: BOOL ST: BYTE Bit 1: BOOL (Bypass information bit) 	- <ul style="list-style-type: none"> 0 16#80 0
ENO	1 = Block algorithm completed without errors	BOOL	0
ErrorNum	Output of pending error number. For error numbers that can be output by this block, see Intlk08 error handling (Page 1600)	INT	-1
FirstIn	Bit-coded number of the first signal that has resulted in a change at the output	DWORD	16#00000000
OpSt_Out	Value of the OpSt_In input parameter, for feedforwarding to other blocks. Bit 31 of this parameter is used by Feature bit 24	DWORD	16#00000000
OS_PermOut	Display of OS_Perm	DWORD	16#FFFFFFFF
OS_PermLog	Display of OS_Perm with settings changed by the block algorithm	DWORD	16#FFFFFFFF
Out	Output	STRUCT <ul style="list-style-type: none"> Value: BOOL ST: BYTE 	- <ul style="list-style-type: none"> 0 16#80
ST_Worst	Worst signal status	BYTE	16#80
Status1	Status word 1 (Page 1592)	DWORD	16#00000000
Status2	Status word 2 (Page 1592)	DWORD	16#00000000
Status3	Status word 3 (Page 1592)	DWORD	16#00000000
Status4	Status word 4 (Page 1601)	DWORD	16#00000000
Status5	Status word 5 (Page 1592)	DWORD	16#00000000
Status6	Status word 6 (Page 1592)	DWORD	16#00000000
Status7	Status word 7 (Page 1592)	DWORD	16#00000000
Status8	Status word 8 (Page 1592)	DWORD	16#00000000

See also

Intlk08 block diagram (Page 1606)

Intlk08 modes (Page 1595)

8.3.7 Intlk08 block diagram

Intlk08 block diagram

A block diagram is not provided for this block.

See also

- Intlk08 I/Os (Page 1601)
- Intlk08 messaging (Page 1601)
- Intlk08 error handling (Page 1600)
- Intlk08 functions (Page 1596)
- Intlk08 modes (Page 1595)
- Description of Intlk08 (Page 1592)

8.3.8 Operator control and monitoring

8.3.8.1 Interlock block views

Views of the blocks Intlk02, Intlk04, Intlk08, Intlk16

The blocks provide the following views:

- Interlock blocks standard view (Page 276)
- Preview of interlock blocks (Page 299)
- Batch view (Page 302)
- Block icon for interlock blocks (Page 241)

Refer to the sections Structure of the faceplate (Page 248) and Block icon structure (Page 230) for general information on the faceplate and block icon.

8.4 Intlk16 - Interlock display with 16 input signals

8.4.1 Description of Intlk16

Object name (type + number) and family

Type + number: FB 1827

Family: Interlock

Area of application for Intlk16

The block is used for the following applications:

- Standardized interlock with display

How it works

The block is used to calculate a standardized interlock that can be displayed on the OS. A maximum of 16 input signals can be supplied to the block. They are linked using selectable binary logic. The signal status of the output signal is also determined. You can assign an analog value with the signal status and unit to each input value for display in the faceplate.

The current state is displayed at the `Out` output parameter:

- `Out = 0`: Interlock
- `Out = 1`: "Good" state

Configuration

Use the CFC editor to install the block in a cyclic interrupt OB (OB30 to OB38).

For the Intlk02 (Intlk16) block, the Advanced Process Library contains templates for process tag types as examples with various application scenarios for this block.

Refer to Description of Intlk02 (Page 1567) for more information.

Startup characteristics

The block does not have any startup characteristics.

Status word allocation for `status1` parameter

You can find a description for each parameter in section Intlk16 I/Os (Page 1617).

Status bit	Parameter
0	1 = Logic = OR
1	1 = Logic = AND
2	Not used

8.4 Intlk16 - Interlock display with 16 input signals

Status bit	Parameter
3	Result of logic operation <code>Out.Value</code>
4	1 = At least one input value is excluded. See the section Excluding input values in Intlk16 functions (Page 1612)
5	1 = All input values are excluded
6	1 = No input value is interconnected or <code>NotUsed.Value</code>
7	Status display for simulation
8	Status display for not interlocked
9	Status display for interlocked
10	Not used
11	Feature bit 2: Separate evaluation for excluded and simulated interlock signals
12 - 29	Not used
30	Occupied
31	BatchEn

Status word allocation for `status2` parameter

Status bit	Parameter
0	<code>In01.Value</code>
1	<code>In02.Value</code>
2	<code>In03.Value</code>
3	<code>In04.Value</code>
4	<code>In05.Value</code>
5	<code>In06.Value</code>
6	<code>In07.Value</code>
7	<code>In08.Value</code>
8	<code>In09.Value</code>
9	<code>In10.Value</code>
10	<code>In11.Value</code>
11	<code>In12.Value</code>
12	<code>In13.Value</code>
13	<code>In14.Value</code>
14	<code>In15.Value</code>
15	<code>In16.Value</code>
16 - 31	Not used

Status word allocation for `status3` parameter

Status bit	Parameter
0	<code>InvIn01</code>
1	<code>InvIn02</code>
2	<code>InvIn03</code>
3	<code>InvIn04</code>

Status bit	Parameter
4	InvIn05
5	InvIn06
6	InvIn07
7	InvIn08
8	InvIn09
9	InvIn10
10	InvIn11
11	InvIn12
12	InvIn13
13	InvIn14
14	InvIn15
15	InvIn16
16 - 31	Not used

Status word allocation for status4 parameter

Status bit	Parameter
0	In01 with inversion
1	In02 with inversion
2	In03 with inversion
3	In04 with inversion
4	In05 with inversion
5	In06 with inversion
6	In07 with inversion
7	In08 with inversion
8	In09 with inversion
9	In10 with inversion
10	In11 with inversion
11	In12 with inversion
12	In13 with inversion
13	In14 with inversion
14	In15 with inversion
15	In16 with inversion
16	Bypass In01 (via interconnection)
17	Bypass In02 (via interconnection)
18	Bypass In03 (via interconnection)
19	Bypass In04 (via interconnection)
20	Bypass In05 (via interconnection)
21	Bypass In06 (via interconnection)
22	Bypass In07 (via interconnection)
23	Bypass In08 (via interconnection)
24	Bypass In09 (via interconnection)

8.4 Intlk16 - Interlock display with 16 input signals

Status bit	Parameter
25	Bypass In10 (via interconnection)
26	Bypass In11 (via interconnection)
27	Bypass In12 (via interconnection)
28	Bypass In13 (via interconnection)
29	Bypass In14 (via interconnection)
30	Bypass In15 (via interconnection)
31	Bypass In16 (via interconnection)

Status word allocation for status5 parameter

Status bit	Parameter
0	BypIn01
1	BypIn02
2	BypIn03
3	BypIn04
4	BypIn05
5	BypIn06
6	BypIn07
7	BypIn08
8	BypIn09
9	BypIn10
10	BypIn11
11	BypIn12
12	BypIn13
13	BypIn14
14	BypIn15
15	BypIn16
16 - 31	In01..In16hidden bypass information

Status word allocation for status6 parameter

Status bit	Parameter
0	In01 not connected
1	In02 not connected
2	In03 not connected
3	In04 not connected
4	In05 not connected
5	In06 not connected
6	In07 not connected
7	In08 not connected
8	In09 not connected
9	In10 not connected

Status bit	Parameter
10	In11 not connected
11	In12 not connected
12	In13 not connected
13	In14 not connected
14	In15 not connected
15	In16 not connected
16 - 31	Not used

Status word allocation for Status7 parameter

Status bit	Parameter
0	AV01 not connected
1	AV02 not connected
2	AV03 not connected
3	AV04 not connected
4	AV05 not connected
5	AV06 not connected
6	AV07 not connected
7	AV08 not connected
8	AV09 not connected
9	AV10 not connected
10	AV11 not connected
11	AV12 not connected
12	AV13 not connected
13	AV14 not connected
14	AV15 not connected
15	AV16 not connected
16 - 31	Not used

Status word allocation for Status8 parameter

Identical to `FirstIn`.

See also

Intlk16 block diagram (Page 1625)

Intlk16 error handling (Page 1616)

Intlk16 modes (Page 1612)

Intlk16 messaging (Page 1617)

8.4.2 Intlk16 modes

Intlk16 modes

This block does not have any modes.

See also

Intlk16 block diagram (Page 1625)

Intlk16 I/Os (Page 1617)

Intlk16 messaging (Page 1617)

Intlk16 functions (Page 1612)

Intlk16 error handling (Page 1616)

Description of Intlk16 (Page 1607)

8.4.3 Intlk16 functions

Functions of Intlk16

The functions for this block are listed below.

Logic operators

Use the `Logic` input to specify the logic operator that the block should employ when determining the interlock state. Make the following settings:

- `Logic = 0`: OR
- `Logic = 1`: AND

Inversion of logic signals

You can invert the input signals by setting the input parameter `InvInx` for the input concerned to `Inx = 1`, e.g. for input `In01` set the I/O `InvIn01`.

The inversion is displayed in the faceplate. If you invert signals using any other method, this is not shown in the faceplate.

Bypass

Note

Bypassing the interlock means that the interlock signal (input signal) is excluded from the logic of the interlock block, in other words, this signal is ignored in the logic operation.

This function can only be executed in the faceplate with "high-level operating permission".

You can bypass interlock signals as follows:

- From operator over faceplate ($\text{BypInx} = 1$):
Independent BypLix is connected or not, the operator can bypass the input signal.
- By connecting BypLix in CFC ($\text{BypLix.Value} = 1, \text{BypLix.ST} \neq 16\#\text{FF}$)
Follow this if interlock signals are connected to parameters, which has no bypass information bit for bypass. Refer to section [Bypassing signals](#) (Page 107).
- By connected interlock signal Inx . For this the corresponding enable bit ($\text{BypEn.Inx} = 1$) and **Feature Bit2 Separate evaluation for excluded and simulated interlock signals** (Page 152) have to be set. Follow this if the interlock signals are all connected to parameters which has the bypass information. Refer to section [Bypassing signals](#) (Page 107).

The bypassed interlock signal is shown in the faceplate as the symbol below:



You can reset all the bypass of interlock signals as follows:

- From operator over faceplate ($\text{RstBypOp} = 0 \rightarrow 1$)
- Over CFC linkable parameter ($\text{RstBypLi} = 0 \rightarrow 1$)

Special situation: If all input parameters are bypassed, the output value is defined using the DefaultOut parameter.

Depending on the configuration of the **Featurebit2 Separate evaluation for excluded and simulated interlock signals** (Page 152), the output BypAct is formed and the bypass signal/information is set at the output Out .

Feature Bit2 = 0:

If one of the interlock inputs is bypassed by the operator or by connected BypLix , then the output BypAct is set. The bypass signal/information at the output Out is always reset.

- $\text{BypAct.Value} =$
 $\text{BypIn01 OR BypLi01}$
 $\text{OR BypInx OR BypLix}$
The calculation is simplified and described.
- $\text{Out.Bit1} = 0$

A bypassed interlock signal, that is switch-relevant, sets the status of Out to Simulation.

Feature Bit2 = 1:

If one of the interlock inputs is bypassed or the block which is connected to interlock signal is in bypass (signal is set at an interlock input $\text{In01} \dots \text{Inx}$), the output BypAct is set. The bypass information in the signal at the input $\text{In01} \dots \text{Inx}$ can be read from the upstream interlock

8.4 Intlk16 - Interlock display with 16 input signals

block at the output `BypAct` or from the upstream technical block with bypass functionality (`MonDiL`, `MonAnL`, `TotalL`, `PIDConL`, `PIDConR`, `PIDStepL`) at the output `BypassAct`.

The bypass signal information at the output `Out` is set to the value of `BypAct`.

- `BypAct.Value =`
`BypIn01 OR BypLi01 OR In01.Bit1`
`OR BypInx OR BypLix OR In01.Bitx`
`OR In01.Bit1 OR Inx.Bit1`
The calculation is simplified and described.
- `Out.Bit1 = BypAct.Value`

An bypassed interlock input has no influence on the status of `Out`.

Note

Do **not** connect the input `BypLix` with the output `BypAct` from an interlock block because `BypAct` is calculated from the bypass signal information.

Handling non-connected inputs

Inputs which are not interconnected are not evaluated. They are not displayed in the faceplate either.

Special situation: If no inputs are connected, the output value is defined using the `DefaultOut` parameter. The signal status is set to `16#FF`.

Opening additional faceplates

This block provides the standard function Opening additional faceplates (Page 208). However, only one additional faceplate can be called up using `SelFp1 = 1`.

First-in detection for interlock blocks

This block provides the standard function Recording the first signal for interlock blocks (Page 52). Note that a signal status change only has an effect on the first-in detection when the `Feature` Bit Evaluation of signal status (Page 142) and the input `FirstInEn` is set.

The response to deactivation via the `FirstInEn` input can be influenced by Feature bit First-in detection response to deactivation (Page 176).

Note

This function can only be executed in the faceplate with "process control" operating permission.

Forming the signal status for blocks

This block provides the standard function Forming and outputting the signal status for interlock blocks (Page 115).

The worst signal status `ST_Worst` for the block is formed from the following parameter:

- `OUT.ST`

Operating permissions

This block provides the standard function Operator control permissions (Page 254).

The block has the following permissions for the `OS_Perm` parameter:

Bit	Function
0	1 = Operator can exclude values
1	1 = Operator can reset the exclusion of input values
2	1 = Operator can reset the recording of the first signal
3 - 15	Not used
16	1 = Operator can set or reset the exclusion of input value In01
17	1 = Operator can set or reset the exclusion of input value In02
18	1 = Operator can set or reset the exclusion of input value In03
19	1 = Operator can set or reset the exclusion of input value In04
20	1 = Operator can set or reset the exclusion of input value In05
21	1 = Operator can set or reset the exclusion of input value In06
22	1 = Operator can set or reset the exclusion of input value In07
23	1 = Operator can set or reset the exclusion of input value In08
24	1 = Operator can set or reset the exclusion of input value In09
25	1 = Operator can set or reset the exclusion of input value In10
26	1 = Operator can set or reset the exclusion of input value In11
27	1 = Operator can set or reset the exclusion of input value In12
28	1 = Operator can set or reset the exclusion of input value In13
29	1 = Operator can set or reset the exclusion of input value In14
30	1 = Operator can set or reset the exclusion of input value In15
31	1 = Operator can set or reset the exclusion of input value In16

Note

If you interconnect a parameter that is also listed in `OS_Perm` as a parameter, you have to reset the corresponding `OS_Perm` bit.

Configurable reactions using the `Feature` parameter

You can find an overview of all reactions provided by the `Feature` parameter in the chapter Configurable functions using the Feature I/O (Page 131). The following functionality is available for this block at the relevant bits:

Bit	Function
2	Separate evaluation for excluded and simulated interlock signals (Page 152)
5	Activate OS_Perm bits (Page 157) 0 = OS_Perm bits 16...17 inactive (evaluation only in faceplate) 1 = OS_Perm bits 16...17 active (evaluation only in faceplate)
21	First-in detection response to deactivation (Page 176)
23	Evaluation of signal status (Page 142)
24	Enabling local operator authorization (Page 158)
31	Activating recording of the first signal (Page 150)

SIMATIC BATCH functionality

This block provides the standard function SIMATIC BATCH functionality (Page 67).

See also

Intlk16 block diagram (Page 1625)

Intlk16 error handling (Page 1616)

Intlk16 modes (Page 1612)

Description of Intlk16 (Page 1607)

Intlk16 I/Os (Page 1617)

Intlk16 messaging (Page 1617)

8.4.4 Intlk16 error handling

Error handling of Intlk16

Refer to the section Error handling (Page 119) in the basic instructions for the error handling of all blocks.

The following errors can be displayed for this block:

- Error numbers

Overview of error numbers

The `ErrorNum` I/O can be used to output the following error numbers:

Error number	Meaning of the error number
-1	Predefined value when inserting the block; the block is not processed.
0	There is no error.
13	The parameter <code>Logic</code> has not been set to 0 or 1.

See also

Intlk16 block diagram (Page 1625)

Intlk16 I/Os (Page 1617)

Intlk16 messaging (Page 1617)

Intlk16 functions (Page 1612)

Intlk16 modes (Page 1612)

Description of Intlk16 (Page 1607)

8.4.5 Intlk16 messaging

Messaging

This block does not offer messaging.

See also

Intlk16 block diagram (Page 1625)

Intlk16 error handling (Page 1616)

Intlk16 modes (Page 1612)

Description of Intlk16 (Page 1607)

Intlk16 I/Os (Page 1617)

Intlk16 functions (Page 1612)

8.4.6 Intlk16 I/Os

I/Os of Intlk16

Input parameters

Parameter	Description	Type	Default
AV01	Analog value of In01	STRUCT <ul style="list-style-type: none"> • Value: REAL • ST: BYTE 	- <ul style="list-style-type: none"> • 0.0 • 16#FF
AV02	Analog value of In02	STRUCT <ul style="list-style-type: none"> • Value: REAL • ST: BYTE 	- <ul style="list-style-type: none"> • 0.0 • 16#FF
AV03	Analog value of In03	STRUCT <ul style="list-style-type: none"> • Value: REAL • ST: BYTE 	- <ul style="list-style-type: none"> • 0.0 • 16#FF
AV04	Analog value of In04	STRUCT <ul style="list-style-type: none"> • Value: REAL • ST: BYTE 	- <ul style="list-style-type: none"> • 0.0 • 16#FF
AV05	Analog value of In05	STRUCT <ul style="list-style-type: none"> • Value: REAL • ST: BYTE 	- <ul style="list-style-type: none"> • 0.0 • 16#FF
AV06	Analog value of In06	STRUCT <ul style="list-style-type: none"> • Value: REAL • ST: BYTE 	- <ul style="list-style-type: none"> • 0.0 • 16#FF
AV07	Analog value of In07	STRUCT <ul style="list-style-type: none"> • Value: REAL • ST: BYTE 	- <ul style="list-style-type: none"> • 0.0 • 16#FF
AV08	Analog value of In08	STRUCT <ul style="list-style-type: none"> • Value: REAL • ST: BYTE 	- <ul style="list-style-type: none"> • 0.0 • 16#FF
AV09	Analog value of In09	STRUCT <ul style="list-style-type: none"> • Value: REAL • ST: BYTE 	- <ul style="list-style-type: none"> • 0.0 • 16#FF
AV10	Analog value of In10	STRUCT <ul style="list-style-type: none"> • Value: REAL • ST: BYTE 	- <ul style="list-style-type: none"> • 0.0 • 16#FF
AV11	Analog value of In11	STRUCT <ul style="list-style-type: none"> • Value: REAL • ST: BYTE 	- <ul style="list-style-type: none"> • 0.0 • 16#FF
AV12	Analog value of In12	STRUCT <ul style="list-style-type: none"> • Value: REAL • ST: BYTE 	- <ul style="list-style-type: none"> • 0.0 • 16#FF
AV13	Analog value of In13	STRUCT <ul style="list-style-type: none"> • Value: REAL • ST: BYTE 	- <ul style="list-style-type: none"> • 0.0 • 16#FF

8.4 Intlk16 - Interlock display with 16 input signals

Parameter	Description	Type	Default
AV14	Analog value of In14	STRUCT • Value: REAL • ST: BYTE	- • 0.0 • 16#FF
AV15	Analog value of In15	STRUCT • Value: REAL • ST: BYTE	- • 0.0 • 16#FF
AV16	Analog value of In16	STRUCT • Value: REAL • ST: BYTE	- • 0.0 • 16#FF
AV01_Unit	Unit of measure for AV01	INT	0
AV02_Unit	Unit of measure for AV02	INT	0
AV03_Unit	Unit of measure for AV03	INT	0
AV04_Unit	Unit of measure for AV04	INT	0
AV05_Unit	Unit of measure for AV05	INT	0
AV06_Unit	Unit of measure for AV06	INT	0
AV07_Unit	Unit of measure for AV07	INT	0
AV08_Unit	Unit of measure for AV08	INT	0
AV09_Unit	Unit of measure for AV09	INT	0
AV10_Unit	Unit of measure for AV10	INT	0
AV11_Unit	Unit of measure for AV11	INT	0
AV12_Unit	Unit of measure for AV12	INT	0
AV13_Unit	Unit of measure for AV13	INT	0
AV14_Unit	Unit of measure for AV14	INT	0
AV15_Unit	Unit of measure for AV15	INT	0
AV16_Unit	Unit of measure for AV16	INT	0
BatchEn	1 = Enable allocation	BOOL	0
BatchID	Batch ID	DWORD	16#00000000
BatchName	Batch name	S7-String	
BypIn01*	1 = Input In01 is not used	BOOL	0
BypIn02*	1 = Input In02 is not used	BOOL	0
BypIn03*	1 = Input In03 is not used	BOOL	0
BypIn04*	1 = Input In04 is not used	BOOL	0
BypIn05*	1 = Input In05 is not used	BOOL	0
BypIn06*	1 = Input In06 is not used	BOOL	0
BypIn07*	1 = Input In07 is not used	BOOL	0
BypIn08*	1 = Input In08 is not used	BOOL	0
BypIn09*	1 = Input In09 is not used	BOOL	0
BypIn10*	1 = Input In10 is not used	BOOL	0
BypIn11*	1 = Input In11 is not used	BOOL	0
BypIn12*	1 = Input In12 is not used	BOOL	0
BypIn13*	1 = Input In13 is not used	BOOL	0

Interlock blocks

8.4 Intlk16 - Interlock display with 16 input signals

Parameter	Description	Type	Default
BypIn14*	1 = Input In14 is not used	BOOL	0
BypIn15*	1 = Input In15 is not used	BOOL	0
BypIn16*	1 = Input In16 is not used	BOOL	0
BypLi01...BypLi16	Bypass In01...In16 (via interconnection)	STRUCT <ul style="list-style-type: none"> Value: BOOL ST: BYTE 	- <ul style="list-style-type: none"> 0 16#FF
DefaultOut	Output value for cases where all inputs are excluded or not interconnected. Refer to the section Intlk16 functions (Page 1612) of the block.	BOOL	1
EN	1 = Called block will be processed	BOOL	1
Feature	I/O for additional functions (Page 1612)	STRUCT <ul style="list-style-type: none"> Bit 0: BOOL ... Bit 31: BOOL 	- <ul style="list-style-type: none"> 0 0 0
FirstInEn	First-in detection	STRUCT <ul style="list-style-type: none"> Value: BOOL ST: BYTE 	- <ul style="list-style-type: none"> 1 16#80
In01	Input In01	STRUCT <ul style="list-style-type: none"> Value: BOOL ST: BYTE Bit 1: BOOL (Bypass information bit) 	- <ul style="list-style-type: none"> 0 16#FF 0
In02	Input In02	STRUCT <ul style="list-style-type: none"> Value: BOOL ST: BYTE Bit 1: BOOL (Bypass information bit) 	- <ul style="list-style-type: none"> 0 16#FF 0
In03	Input In03	STRUCT <ul style="list-style-type: none"> Value: BOOL ST: BYTE Bit 1: BOOL (Bypass information bit) 	- <ul style="list-style-type: none"> 0 16#FF 0
In04	Input In04	STRUCT <ul style="list-style-type: none"> Value: BOOL ST: BYTE Bit 1: BOOL (Bypass information bit) 	- <ul style="list-style-type: none"> 0 16#FF 0

8.4 Intlk16 - Interlock display with 16 input signals

Parameter	Description	Type	Default
In05	Input In05	STRUCT <ul style="list-style-type: none"> • Value: BOOL • ST: BYTE • Bit 1: BOOL (Bypass information bit) 	- <ul style="list-style-type: none"> • 0 • 16#FF • 0
In06	Input In06	STRUCT <ul style="list-style-type: none"> • Value: BOOL • ST: BYTE • Bit 1: BOOL (Bypass information bit) 	- <ul style="list-style-type: none"> • 0 • 16#FF • 0
In07	Input In07	STRUCT <ul style="list-style-type: none"> • Value: BOOL • ST: BYTE • Bit 1: BOOL (Bypass information bit) 	- <ul style="list-style-type: none"> • 0 • 16#FF • 0
In08	Input In08	STRUCT <ul style="list-style-type: none"> • Value: BOOL • ST: BYTE • Bit 1: BOOL (Bypass information bit) 	- <ul style="list-style-type: none"> • 0 • 16#FF • 0
In09	Input In09	STRUCT <ul style="list-style-type: none"> • Value: BOOL • ST: BYTE • Bit 1: BOOL (Bypass information bit) 	- <ul style="list-style-type: none"> • 0 • 16#FF • 0
In10	Input In10	STRUCT <ul style="list-style-type: none"> • Value: BOOL • ST: BYTE • Bit 1: BOOL (Bypass information bit) 	- <ul style="list-style-type: none"> • 0 • 16#FF • 0
In11	Input In11	STRUCT <ul style="list-style-type: none"> • Value: BOOL • ST: BYTE • Bit 1: BOOL (Bypass information bit) 	- <ul style="list-style-type: none"> • 0 • 16#FF • 0

Interlock blocks

8.4 Intlk16 - Interlock display with 16 input signals

Parameter	Description	Type	Default
In12	Input In12	STRUCT <ul style="list-style-type: none"> • Value: BOOL • ST: BYTE • Bit 1: BOOL (Bypass information bit) 	- <ul style="list-style-type: none"> • 0 • 16#FF • 0
In13	Input In13	STRUCT <ul style="list-style-type: none"> • Value: BOOL • ST: BYTE • Bit 1: BOOL (Bypass information bit) 	- <ul style="list-style-type: none"> • 0 • 16#FF • 0
In14	Input In14	STRUCT <ul style="list-style-type: none"> • Value: BOOL • ST: BYTE • Bit 1: BOOL (Bypass information bit) 	- <ul style="list-style-type: none"> • 0 • 16#FF • 0
In15	Input In15	STRUCT <ul style="list-style-type: none"> • Value: BOOL • ST: BYTE • Bit 1: BOOL (Bypass information bit) 	- <ul style="list-style-type: none"> • 0 • 16#FF • 0
In16	Input In16	STRUCT <ul style="list-style-type: none"> • Value: BOOL • ST: BYTE • Bit 1: BOOL (Bypass information bit) 	- <ul style="list-style-type: none"> • 0 • 16#FF • 0
InvIn01	Invert input In01	BOOL	0
InvIn02	Invert input In02	BOOL	0
InvIn03	Invert input In03	BOOL	0
InvIn04	Invert input In04	BOOL	0
InvIn05	Invert input In05	BOOL	0
InvIn06	Invert input In06	BOOL	0
InvIn07	Invert input In07	BOOL	0
InvIn08	Invert input In08	BOOL	0
InvIn09	Invert input In09	BOOL	0
InvIn10	Invert input In10	BOOL	0
InvIn11	Invert input In11	BOOL	0
InvIn12	Invert input In12	BOOL	0
InvIn13	Invert input In13	BOOL	0

8.4 Intlk16 - Interlock display with 16 input signals

Parameter	Description	Type	Default
InvIn14	Invert input In14	BOOL	0
InvIn15	Invert input In15	BOOL	0
InvIn16	Invert input In16	BOOL	0
Logic	Logical operation: 0 = Logical OR 1 = Logical AND	INT	0
NotUsed	1 = Block is not used (only for display in the faceplate). You can find additional information on this in the section Interlock blocks standard view (Page 276) / Color of the field.	STRUCT <ul style="list-style-type: none"> Value: BOOL ST: BYTE 	- <ul style="list-style-type: none"> 0 16#80
Occupied	1 = Occupied by batch control	BOOL	0
OpSt_In	Input parameter for local operator authorization, connected with the Out output parameter of the upstream block, OpStations (Page 411)	DWORD	16#00000000
OS_Perm	I/O for operating permissions (Page 1612)	STRUCT <ul style="list-style-type: none"> Bit 0: BOOL ... Bit 31: BOOL 	- <ul style="list-style-type: none"> 1 1 1
RstByOp*	1 = Reset inputs BypIn01 to BypIn16	BOOL	0
RstLi	1 = Reset via interconnection	STRUCT <ul style="list-style-type: none"> Value: BOOL ST: BYTE 	- <ul style="list-style-type: none"> 0 16#80
RstOp*	1 = Reset via operator	BOOL	0
SelFpl	Call a block saved in this parameter as Opening additional faceplates (Page 208) in standard view	ANY	
StepNo	Batch step number	DWORD	16#00000000
UserStatus	Freely assignable bits for use in PCS 7 OS	BYTE	16#00

* Values can be written back to these inputs during processing of the block by the block algorithm.

Output parameters

Parameter	Description	Type	Default
BypAct	1 = Bypass active	STRUCT <ul style="list-style-type: none"> Value: BOOL ST: BYTE Bit 1: BOOL (Bypass information bit) 	- <ul style="list-style-type: none"> 0 16#80 0
ENO	1 = Block algorithm completed without errors	BOOL	0
ErrorNum	Output of pending error number. For error numbers that can be output by this block, see Intlk16 error handling (Page 1616)	INT	-1
FirstIn	Bit-coded number of the first signal that has resulted in a change at the output	DWORD	16#00000000
OpSt_Out	Value of the OpSt_In input parameter, for feedforwarding to other blocks. Bit 31 of this parameter is used by Feature bit 24	DWORD	16#00000000
OS_PermOut	Display of OS_Perm	DWORD	16#FFFFFFFF
OS_PermLog	Display of OS_Prem with settings changed by the block algorithm	DWORD	16#FFFFFFFF
Out	Output	STRUCT <ul style="list-style-type: none"> Value: BOOL ST: BYTE 	- <ul style="list-style-type: none"> 0 16#80
ST_Worst	Worst signal status	BYTE	16#80
Status1	Status word 1 (Page 1607)	DWORD	16#00000000
Status2	Status word 2 (Page 1607)	DWORD	16#00000000
Status3	Status word 3 (Page 1607)	DWORD	16#00000000
Status4	Status word 4 (Page 1607)	DWORD	16#00000000
Status5	Status word 5 (Page 1607)	DWORD	16#00000000
Status6	Status word 6 (Page 1607)	DWORD	16#00000000
Status7	Status word 7 (Page 1607)	DWORD	16#00000000
Status8	Status word 8 (Page 1607)	DWORD	16#00000000

See also

Intlk16 block diagram (Page 1625)

Intlk16 modes (Page 1612)

Intlk16 messaging (Page 1617)

8.4.7 Intlk16 block diagram

Intlk16 block diagram

A block diagram is not provided for this block.

See also

Intlk16 I/Os (Page 1617)

Intlk16 messaging (Page 1617)

Intlk16 functions (Page 1612)

Intlk16 error handling (Page 1616)

Intlk16 modes (Page 1612)

Description of Intlk16 (Page 1607)

8.4.8 Operator control and monitoring

8.4.8.1 Interlock block views

Views of the blocks Intlk02, Intlk04, Intlk08, Intlk16

The blocks provide the following views:

- Interlock blocks standard view (Page 276)
- Preview of interlock blocks (Page 299)
- Batch view (Page 302)
- Block icon for interlock blocks (Page 241)

Refer to the sections Structure of the faceplate (Page 248) and Block icon structure (Page 230) for general information on the faceplate and block icon.

8.5 FirstIn - Transform output Intlck FirstIn for message associated value

8.5.1 Description of FirstIn

Object name (type + number) and family

Type + number: FC 1929

Family: Interlck

Area of application for FirstIn

The block is used for the following applications:

- To generate an external message that can be seen in the technological block.
- To generate an external message from EventTs or Event16Ts block.

How it works

FirstIn block works only with the combination of a technological block that has ExtMsgx and ExtValxx input parameters.

The block generates messages requiring acknowledgment that appear in the alarm view of the interconnected technological block.

The block must be connected to a technological block. Messages of the interconnected technological blocks are displayed in the message view.

FirstIn block also works with EventTs and Event16Ts blocks to generate an external message. External signals of FirstIn block should be connected with EventTs or Event16Ts block. When a fault occurs, EventTs or Event16Ts block is triggered and the message can be viewed in the interconnected technological block.

Configuration

Use the CFC editor to install the block in a cyclic interrupt OB (OB30 to OB38).

Connect the following output parameters with the input parameters as indicated in the following table:

Output parameter		Input parameter	
Parameter name	Block	Parameter name	Block
FirstIn	Interlock	FirstIn	FirstIn
Out	Interlock	Interlock	Technological
FirstInAct	FirstIn	ExtMsgx	Technological
ExtVal1FI	FirstIn	ExtValxx	Technological
ExtVa2FI	FirstIn	ExtValxx	Technological

For example:

- Output parameters `ExtValFI` and `ExtVa2FI` are connected to the input parameters `ExtVal104` and `ExtVal108` respectively.
- Output parameter `FirstInAct` is connected to the input parameter `ExtMsg2`.

In the PCS7 special message property of the external message 2 signal, add the following syntax:

“@4%s@@8%s@”.

With EventTs/Event16Ts blocks:

You can connect `FirstIn` block with the block `EventTs` or `Event16Ts`. Connect the input parameters `ExtVaxxx` (`ExtVal01...ExtVal03` in case of `EventTs` block and `ExtVal01...ExtVal06` in case of `Event16Ts` block) with the output parameters `ExtValFI` or `ExtVa2FI` of the `FirstIn` block.

The output parameter `FirstInAct` of the `FirstIn` block should be connected with any `Inx` input parameters of the `EventTs/Event16Ts` blocks.

Startup characteristics

The block does not have any startup characteristics.

Status word allocation for `Status` parameter

This block does not have the `Status` parameter.

See also

[FirstIn modes \(Page 1627\)](#)

[FirstIn functions \(Page 1628\)](#)

[FirstIn error handling \(Page 1628\)](#)

[FirstIn messaging \(Page 1629\)](#)

[FirstIn I/Os \(Page 1629\)](#)

[FirstIn block diagram \(Page 1630\)](#)

8.5.2 FirstIn modes

FirstIn operating modes

This block does not have any operating modes.

See also

- Description of FirstIn (Page 1626)
- FirstIn functions (Page 1628)
- FirstIn error handling (Page 1628)
- FirstIn messaging (Page 1629)
- FirstIn I/Os (Page 1629)
- FirstIn block diagram (Page 1630)

8.5.3 FirstIn functions

Functions of FirstIn

This block does not have any special function.

See also

- Description of FirstIn (Page 1626)
- FirstIn modes (Page 1627)
- FirstIn error handling (Page 1628)
- FirstIn messaging (Page 1629)
- FirstIn I/Os (Page 1629)
- FirstIn block diagram (Page 1630)

8.5.4 FirstIn error handling

Error handling of FirstIn

This block does not have any error handling.

See also

- Description of FirstIn (Page 1626)
- FirstIn modes (Page 1627)
- FirstIn functions (Page 1628)
- FirstIn messaging (Page 1629)
- FirstIn I/Os (Page 1629)
- FirstIn block diagram (Page 1630)

8.5.5 FirstIn messaging

Messaging

This block does not offer messaging.

See also

Description of FirstIn (Page 1626)

FirstIn modes (Page 1627)

FirstIn functions (Page 1628)

FirstIn error handling (Page 1628)

FirstIn I/Os (Page 1629)

FirstIn block diagram (Page 1630)

8.5.6 FirstIn I/Os

I/Os of FirstIn

Input parameters

Parameter	Description	Type	Default
EN	1 = Called block will be processed	BOOL	1
FirstIn	First active input	DWORD	16#00000000

Output parameters

Parameter	Description	Type	Default
ENO	1 = Block algorithm completed without errors	BOOL	0
FirstInAct	First signal active for ExtMsgX or EventTs message	STRUCT <ul style="list-style-type: none"> • Value: BOOL • ST: BYTE 	<ul style="list-style-type: none"> • 0 • 16#80

8.5 FirstIn - Transform output Intlck FirstIn for message associated value

Parameter	Description	Type	Default
ExtVa1FI		STRUCT <ul style="list-style-type: none">• Char1: CHAR• ...• Char15: CHAR	- <ul style="list-style-type: none">• ''• ''• ''
ExtVa2FI		STRUCT <ul style="list-style-type: none">• Char1: CHAR• ...• Char23: CHAR	- <ul style="list-style-type: none">• ''• ''• ''

See also

- Description of FirstIn (Page 1626)
- FirstIn modes (Page 1627)
- FirstIn functions (Page 1628)
- FirstIn error handling (Page 1628)
- FirstIn messaging (Page 1629)
- FirstIn block diagram (Page 1630)

8.5.7 FirstIn block diagram

Block diagram of FirstIn

A block diagram is not provided for this block.

See also

- Description of FirstIn (Page 1626)
- FirstIn modes (Page 1627)
- FirstIn functions (Page 1628)
- FirstIn error handling (Page 1628)
- FirstIn messaging (Page 1629)
- FirstIn I/Os (Page 1629)

Message blocks

9.1 Event - Creating messages

9.1.1 Description of Event

Object name (type + number) and family

Type + number: FB 1811

Family: Report

Area of application for Event

The block is used for the following applications:

- Generation of messages requiring acknowledgment

How it works

The block is used to simultaneously output up to eight different messages that require acknowledgment.

The individual messages are assigned to the monitored signals via the inputs and the messages released or blocked depending on the process status data. If a change is made to one or more of the monitored signals enabled for reporting, a message is output.

The signals to be monitored are interconnected with inputs *In1* ... *In8*. Each *In_x* signal can also be inverted via input *InvIn_x*. A message is output if a signal value is changed (but taking inversion into account).

Each input is assigned a separate message text. A message received at input *In5*, for example, is output with the message text for the SIG 5 signal.

Configuration

Use the CFC editor to install the block in a cyclic interrupt OB (OB30 to OB38). The block is also installed automatically in the startup OB (OB100).

Further addressing is not required.

Startup characteristics

During startup, the message block suppresses all messages. The duration (number of cycles) of message suppression is set at the *RunUpCyc* parameter. During restart (OB100) an internal counter that is initialized with this value decrements each time the block is executed. Messages are not generated if the counter value does not equal zero.

Messages whose alarm delay has not elapsed during this period are then output.

Status word allocation for status1 parameter

You can find a description for each parameter in section Event I/Os (Page 1639).

Status bit	Parameter
0	In1.Value
1	In2.Value
2	In3.Value
3	In4.Value
4	In5.Value
5	In6.Value
6	In7.Value
7	In8.Value
8	InvIn1
9	InvIn2
10	InvIn3
11	InvIn4
12	InvIn5
13	InvIn6
14	InvIn7
15	InvIn8
16	In1 with inversion
17	In2 with inversion
18	In3 with inversion
19	In4 with inversion
20	In5 with inversion
21	In6 with inversion
22	In7 with inversion
23	In8 with inversion
24	In1 not connected
25	In2 not connected
26	In3 not connected
27	In4 not connected
28	In5 not connected
29	In6 not connected
30	In7 not connected
31	In8 not connected

Status word allocation for status2 parameter

Status bit	Parameter
0	In1MsgEn
1	In2MsgEn
2	In3MsgEn
3	In4MsgEn
4	In5MsgEn
5	In6MsgEn
6	In7MsgEn
7	In8MsgEn
8	AV1 not connected
9	AV2 not connected
10	AV3 not connected
11	AV4 not connected
12	AV5 not connected
13	AV6 not connected
14	AV7 not connected
15	AV8 not connected
16	Active signal 1 for messages
17	Active signal 2 for messages
18	Active signal 3 for messages
19	Active signal 4 for messages
20	Active signal 5 for messages
21	Active signal 6 for messages
22	Active signal 7 for messages
23	Active signal 8 for messages
24	MsgLock
25	Occupied
26	BatchEn
27	Batch - parameter exists
28 - 31	Not used

See also

Event functions (Page 1634)

Event messaging (Page 1637)

Event block diagram (Page 1643)

Event error handling (Page 1636)

Event modes (Page 1634)

9.1.2 Event modes

Event operating modes

The block can be operated using the following modes:

- On (Page 71)
- Out of service (Page 71)

"On"

You can find general information about the "On" mode in the On (Page 71) section.

"Out of service"

You can find general information about the "Out of service" mode in the section Out of service (Page 71).

See also

Event block diagram (Page 1643)

Event I/Os (Page 1639)

Event messaging (Page 1637)

Event error handling (Page 1636)

Event functions (Page 1634)

Description of Event (Page 1631)

9.1.3 Event functions

Functions of Event

The functions for this block are listed below.

Activation and deactivation of messages

Set the I/Os `In1MsgEn` to `In8MsgEn` accordingly to activate or deactivate the messages applied to inputs `In1` to `In8`. All messages are activated by default.

To deactivate messages received at I/O `In4`, for example, you set I/O `In4MsgEn = 0` accordingly.

You can deactivate all messages via I/O `MsgLock = 1`.

Delay of alarms

You can delay the alarms indicating signal changes.

For incoming alarms (signal change 0 - 1), set the delay at parameter `AlmOnDly`; for outgoing alarms (signal change 1 - 0) set it at parameter `AlmOffDly`.

Enter 0 or a negative value to deactivate the delay.

Suppressing messages using the `MsgLock` parameter

This block provides the standard function Suppressing messages using the `MsgLock` parameter (Page 205).

Release for maintenance

This block provides the standard function Release for maintenance (Page 64).

Operator control permissions

The block has the following Operator control permissions (Page 254) for the `OS_Perm` parameter:

Bit	Function
0	Not used
1	1 = Operator can switch to "On" mode
2	Not used
3	1 = Operator can switch to "Out of service" mode
4 - 31	Not used

This block does not have a faceplate yet; the operator control permissions have already been assigned in the planning phase for these faceplates.

Note

If you interconnect a parameter that is also listed in `OS_Perm` as a parameter, you have to reset the corresponding `OS_Perm` bit.

Configurable reactions using the `Feature` parameter

You can find an overview of all reactions provided by the `Feature` parameter in the section Configurable functions using the `Feature` I/O (Page 131). The following functionality is available for this block at the relevant bits:

Bit	Function
1	Reaction to the out of service mode (Page 177)
8	Reporting with BATCH parameters (Page 156)
22	Update acknowledgment and error status of the message call (Page 160)
27	Selecting values associated with messages (Page 156)

Forming the signal status for blocks

The block provides the standard function Forming and outputting the signal status for technologic blocks (Page 109).

The block determines the worst signal status via all interconnected binary and analog inputs, and outputs this value at `ST_Worst`.

- In1
- etc. to
- In8
 - AV1
- etc. to
- AV8

See also

- Description of Event (Page 1631)
- Event messaging (Page 1637)
- Event I/Os (Page 1639)
- Event block diagram (Page 1643)
- Event error handling (Page 1636)
- Event modes (Page 1634)

9.1.4 Event error handling

Error handling of Event

Refer to the section Error handling (Page 119) in the basic instructions for the error handling of all blocks.

The following errors can be displayed for this block:

- Error numbers

Overview of error numbers

The `ErrorNum` I/O can be used to output the following error numbers:

Error number	Meaning of the error number
-1	Predefined value when inserting the block; the block is not processed.
0	There is no error.

See also

- Event block diagram (Page 1643)
- Event I/Os (Page 1639)
- Event messaging (Page 1637)
- Event functions (Page 1634)
- Event modes (Page 1634)
- Description of Event (Page 1631)

9.1.5 Event messaging

Messaging

Messages which can be acknowledged are generated using ALARM_8P. The block uses the PMC communication channel and has 8 digital inputs and 8 associated values.

Every edge transition detected for one or more digital inputs results in a message. The associated values are assigned consistently to the message at the time of edge evaluation. All 8 signals are assigned a common message number, which is split at the OS into 8 messages. The Engineering System (ES) assigns the message number automatically by calling the message server.

Process messages

Message instance	Message identifier	Message class	Event
MsgEvId	SIG 1	AS process control message - error	Text 1
	SIG 2	AS process control message - error	Text 2
	SIG 3	AS process control message - error	Text 3
	SIG 4	AS process control message - error	Text 4
	SIG 5	AS process control message - error	Text 5
	SIG 6	AS process control message - error	Text 6
	SIG 7	AS process control message - error	Text 7
	SIG 8	AS process control message - error	Text 8

You can change the message class and the event to meet your needs at the block type and/or block instance.

Depending on `Feature` bit 27 "Select message associated values", either the signal status or the associated analog value is written as message associated value (`Feature` bit 8 = 0).

Associated values for message instance `MsgEvId`(Feature bit 27 = 0)

Associated value	Block parameters
1	In1.ST
2	In2.ST
3	In3.ST
4	In4.ST
5	In5.ST
6	In6.ST
7	In7.ST
8	In8.ST
9	Not allocated
10	Not allocated

Associated values for message instance `MsgEvId` (Feature bit 27 = 1)

Associated value	Block parameters
1	AV1.Value
2	AV2.Value
3	AV3.Value
4	AV4.Value
5	AV5.Value
6	AV6.Value
7	AV7.Value
8	AV8.Value
9	Not allocated
10	Not allocated

The batch information is transmitted with Feature bit 8 =1:

The first three associated values are described as follows and are followed by the signal status of the input signal or the associated analog value, depending on Feature bit 27 "Selecting message associated values":

Associated value	Block parameters
1	BatchName
2	StepNo
3	BatchId
4	In1.ST / AV1.Value
5	In2.ST / AV2.Value
6	In3.ST / AV3.Value
7	In4.ST / AV4.Value
8	In5.ST / AV5.Value

Associated value	Block parameters
9	In6.ST / AV6.Value
10	In7.ST / AV7.Value

Enter the batch ID @1%s@ under "Properties - Block - Special properties - Messages extended - Message texts block".

See also

Description of Event (Page 1631)

Event functions (Page 1634)

Event I/Os (Page 1639)

Event block diagram (Page 1643)

Event error handling (Page 1636)

Event modes (Page 1634)

Selecting values associated with messages (Page 156)

9.1.6 Event I/Os

I/Os of Event

Input parameters

Parameter	Description	Type	Default
AlmOnDly	Alarm delay time [s] for signal transition 0 → 1	REAL	0.0
AlmOffDly	Alarm delay time [s] for signal transition 1 → 0	REAL	0.0
AV1	Message associated value for In1	STRUCT <ul style="list-style-type: none"> Value: REAL ST: BYTE 	- <ul style="list-style-type: none"> 0.0 16#FF
AV1_Unit	Unit for AV1	INT	0
AV2	Message associated value for In2	STRUCT <ul style="list-style-type: none"> Value: REAL ST: BYTE 	- <ul style="list-style-type: none"> 0.0 16#FF
AV2_Unit	Unit for AV2	INT	0
AV3	Message associated value for In3	STRUCT <ul style="list-style-type: none"> Value: REAL ST: BYTE 	- <ul style="list-style-type: none"> 0.0 16#FF

Message blocks

9.1 Event - Creating messages

Parameter	Description	Type	Default
AV3_Unit	Unit for AV3	INT	0
AV4	Message associated value for In4	STRUCT <ul style="list-style-type: none"> • Value: REAL • ST: BYTE 	- <ul style="list-style-type: none"> • 0.0 • 16#FF
AV4_Unit	Unit for AV4	INT	0
AV5	Message associated value for In5	STRUCT <ul style="list-style-type: none"> • Value: REAL • ST: BYTE 	- <ul style="list-style-type: none"> • 0.0 • 16#FF
AV5_Unit	Unit for AV5	INT	0
AV6	Message associated value for In6	STRUCT <ul style="list-style-type: none"> • Value: REAL • ST: BYTE 	- <ul style="list-style-type: none"> • 0.0 • 16#FF
AV6_Unit	Unit for AV6	INT	0
AV7	Message associated value for In7	STRUCT <ul style="list-style-type: none"> • Value: REAL • ST: BYTE 	- <ul style="list-style-type: none"> • 0.0 • 16#FF
AV7_Unit	Unit for AV7	INT	0
AV8	Message associated value for In8	STRUCT <ul style="list-style-type: none"> • Value: REAL • ST: BYTE 	- <ul style="list-style-type: none"> • 0.0 • 16#FF
AV8_Unit	Unit for AV8	INT	0
BatchEn	1 = Enable allocation	BOOL	0
BatchID	Batch ID	DWORD	16#00
BatchName	Batch name	S7-String	
EN	1 = Called block will be processed	BOOL	1
Feature	I/O for additional functions (Page 1634)	STRUCT <ul style="list-style-type: none"> • Bit 0: BOOL • ... • Bit 31: BOOL 	- <ul style="list-style-type: none"> • 0 • 0 • 0
In1	Input In1	STRUCT <ul style="list-style-type: none"> • Value: BOOL • ST: BYTE 	- <ul style="list-style-type: none"> • 0 • 16#FF
In1MsgEn	1 = Activate message for input In1	BOOL	1
In2	Input In2	STRUCT <ul style="list-style-type: none"> • Value: BOOL • ST: BYTE 	- <ul style="list-style-type: none"> • 0 • 16#FF
In2MsgEn	1 = Activate message for input In2	BOOL	1
In3	Input In3	STRUCT <ul style="list-style-type: none"> • Value: BOOL • ST: BYTE 	- <ul style="list-style-type: none"> • 0 • 16#FF
In3MsgEn	1 = Activate message for input In3	BOOL	1

Parameter	Description	Type	Default
In4	Input In4	STRUCT • Value: BOOL • ST: BYTE	- • 0 • 16#FF
In4MsgEn	1 = Activate message for input In4	BOOL	1
In5	Input In5	STRUCT • Value: BOOL • ST: BYTE	- • 0 • 16#FF
In5MsgEn	1 = Activate message for input In5	BOOL	1
In6	Input In6	STRUCT • Value: BOOL • ST: BYTE	- • 0 • 16#FF
In6MsgEn	1 = Activate message for input In6	BOOL	1
In7	Input In7	STRUCT • Value: BOOL • ST: BYTE	- • 0 • 16#FF
In7MsgEn	1 = Activate message for input In7	BOOL	1
In8	Input In8	STRUCT • Value: BOOL • ST: BYTE	- • 0 • 16#FF
In8MsgEn	1 = Activate message for input In8	BOOL	1
InvIn1	1 = Invert input In1	BOOL	0
InvIn2	1 = Invert input In2	BOOL	0
InvIn3	1 = Invert input In3	BOOL	0
InvIn4	1 = Invert input In4	BOOL	0
InvIn5	1 = Invert input In5	BOOL	0
InvIn6	1 = Invert input In6	BOOL	0
InvIn7	1 = Invert input In7	BOOL	0
InvIn8	1 = Invert input In8	BOOL	0
MS_RelOp	1 = Release for maintenance by OS operator	BOOL	0
MsgEvId	Message number (assigned automatically)	DWORD	16#00000000
MsgLock	1 = Suppress process messages. Refer also to the Suppressing messages using the MsgLock parameter (Page 205) section for more on this.	STRUCT • Value: BOOL • ST: BYTE	- • 0 • 16#80
Occupied	1 = In use by a batch	BOOL	0
OnOp*	1 = "On" mode via operator	BOOL	0
OosLi	1 = "Out of service", via interconnection or SFC (0-1 edge transition)	STRUCT • Value: BOOL • ST: BYTE	- • 0 • 16#80
OosOp*	1 = "Out of service", via OS operator	BOOL	0

Message blocks

9.1 Event - Creating messages

Parameter	Description	Type	Default
OS_Perm	I/O for operator control permissions (Page 1634)	STRUCT <ul style="list-style-type: none"> • Bit 0: BOOL • ... • Bit 31: BOOL 	- <ul style="list-style-type: none"> • 1 • 1 • 1
RunUpCyc	Number of cycles in startup; messages are suppressed during these cycles	INT	3
SampleTime	Sampling time [s] (assigned automatically)	REAL	0.1
SelFp1	1 = Call a block saved in this parameter as an additional faceplate (Page 208) in the standard view	ANY	
SelFp2	1 = Call a block saved in this parameter as an additional faceplate (Page 208) in the preview	ANY	
StepNo	Batch step number	DWORD	16#00
UserStatus	Freely assignable bits for use in PCS 7 OS	BYTE	16#00

* Values can be written back to these inputs during processing of the block by the block algorithm.

Output parameters

Parameter	Description	Type	Default
ENO	1 = Block algorithm completed without errors	BOOL	0
ErrorNum	Output of current error number. For error numbers that can be output by this block, see Event error handling (Page 1636)	INT	-1
MsgAckn	Message acknowledgment status (output ACK_STATE of ALARM_8P)	WORD	16#0000
MsgErr	1 = Alarm error (output ERROR of ALARM_8)	BOOL	0
MsgStat	Alarm status (output STATUS of ALARM_8P)	WORD	16#0000
MS_Release	Release for maintenance: 1 = Release for OS operator	STRUCT <ul style="list-style-type: none"> • Value: BOOL • ST: BYTE 	- <ul style="list-style-type: none"> • 0 • 16#80
OnAct	1 = "On" mode enabled	STRUCT <ul style="list-style-type: none"> • Value: BOOL • ST: BYTE 	- <ul style="list-style-type: none"> • 1 • 16#80
OosAct	1 = Block is "Out of service"	STRUCT <ul style="list-style-type: none"> • Value: BOOL • ST: BYTE 	- <ul style="list-style-type: none"> • 0 • 16#80
OS_PermOut	Display of OS_Perm	DWORD	16#FFFFFFFF
OS_PermLog	Display of OS_Perm with settings changed by the block algorithm	DWORD	16#FFFFFFFF

Parameter	Description	Type	Default
ST_Worst	Worst signal status	BYTE	16#80
Status1	Status word 1 (Page 1631)	DWORD	16#00000000
Status2	Status word 2 (Page 1631)	DWORD	16#00000000

See also

Event messaging (Page 1637)
Event block diagram (Page 1643)
Event modes (Page 1634)

9.1.7 Event block diagram

Event block diagram

A block diagram is not provided for this block.

See also

Event I/Os (Page 1639)
Event messaging (Page 1637)
Event error handling (Page 1636)
Event functions (Page 1634)
Event modes (Page 1634)
Description of Event (Page 1631)

9.2 EventNck - Generating messages without acknowledgment

9.2.1 Description of EventNck

Object name (type + number) and family

Type + number: FB 1904

Family: Report

Area of application for EventNck

The block is used for the following applications:

- Generation of messages not requiring acknowledgment

How it works

The block is used to simultaneously output up to eight different messages that do not require acknowledgment.

The individual messages are assigned to the monitored signals via the inputs and the messages released or blocked depending on the process status data. If a change is made to one or more of the monitored signals enabled for reporting, a message is output.

The signals to be monitored are interconnected with inputs `In1` to `In8`. Each `Inx` signal can also be inverted via input `InvInx`. A message is output if a signal value is changed (but taking inversion into account).

Each input is assigned a separate message text. A message received at input `In5`, for example, is output with the message text for the SIG 5 signal.

Configuration

Use the CFC editor to install the block in a cyclic interrupt OB (OB30 to OB38). The block is also installed automatically in the startup OB (OB100).

Further addressing is not required.

Startup characteristics

During startup, the message block suppresses all messages. The duration (number of cycles) of message suppression is set at the `RunUpCyc` parameter. During restart (OB100) an internal counter that is initialized with this value decrements each time the block is executed. Messages are not generated if the counter value does not equal zero.

Messages whose alarm delay has not elapsed during this period are then output.

Status word allocation for status1 parameter

You can find a description for each parameter in section EventNck I/Os (Page 1651).

Status bit	Parameter
0	In1.Value
1	In2.Value
2	In3.Value
3	In4.Value
4	In5.Value
5	In6.Value
6	In7.Value
7	In8.Value
8	InvIn1
9	InvIn2
10	InvIn3
11	InvIn4
12	InvIn5
13	InvIn6
14	InvIn7
15	InvIn8
16	In1 with inversion
17	In2 with inversion
18	In3 with inversion
19	In4 with inversion
20	In5 with inversion
21	In6 with inversion
22	In7 with inversion
23	In8 with inversion
24	In1 not connected
25	In2 not connected
26	In3 not connected
27	In4 not connected
28	In5 not connected
29	In6 not connected
30	In7 not connected
31	In8 not connected

Status word allocation for status2 parameter

Status bit	Parameter
0	In1MsgEn
1	In2MsgEn
2	In3MsgEn

9.2 EventNck - Generating messages without acknowledgment

Status bit	Parameter
3	In4MsgEn
4	In5MsgEn
5	In6MsgEn
6	In7MsgEn
7	In8MsgEn
8	AV1 not connected
9	AV2 not connected
10	AV3 not connected
11	AV4 not connected
12	AV5 not connected
13	AV6 not connected
14	AV7 not connected
15	AV8 not connected
16	Active signal 1 for messages
17	Active signal 2 for messages
18	Active signal 3 for messages
19	Active signal 4 for messages
20	Active signal 5 for messages
21	Active signal 6 for messages
22	Active signal 7 for messages
23	Active signal 8 for messages
24	MsgLock
25 - 31	Not used

See also

- EventNck modes (Page 1646)
- EventNck functions (Page 1647)
- EventNck error handling (Page 1649)
- EventNck messaging (Page 1650)
- EventNck block diagram (Page 1655)

9.2.2 EventNck modes

EventNck modes

The block provides the following modes:

- On (Page 71)
- Out of service (Page 71)

"On"

General information on the "On" mode is available in the section On (Page 71).

"Out of service"

You can find general information about the "Out of service" mode in the section Out of service (Page 71).

See also

Description of EventNck (Page 1644)

EventNck functions (Page 1647)

EventNck error handling (Page 1649)

EventNck messaging (Page 1650)

EventNck I/Os (Page 1651)

EventNck block diagram (Page 1655)

9.2.3 EventNck functions

Functions of EventNck

The functions for this block are listed below.

Activation and deactivation of messages

Set the I/Os `In1MsgEn ... In8MsgEn` accordingly to enable or disable the messages applied to inputs `In1 ... In8`. All messages are activated by default.

To deactivate messages received at I/O `In4`, for example, you set I/O `In4MsgEn = 0` accordingly.

You can deactivate all messages via I/O `MsgLock = 1`.

Delay of alarms

You can delay the alarms indicating signal changes.

For incoming alarms (signal change 0 - 1), set the delay at parameter `AlmOnDly`; for outgoing alarms (signal change 1 - 0) set it at parameter `AlmOffDly`.

Enter 0 or a negative value to deactivate the delay.

Suppressing messages using the `MsgLock` parameter

This block provides the standard function Suppressing messages using the `MsgLock` parameter (Page 205).

Release for maintenance

This block provides the standard function Release for maintenance (Page 64).

Operator control permissions

The block has the following Operator control permissions (Page 254) for the OS_Perm parameter:

Bit	Function
0	Not used
1	1 = Operator can switch to "On" mode
2	Not used
3	1 = Operator can switch to "Out of service" mode
4 - 31	Not used

This block does not have a faceplate yet; the operator control permissions have already been assigned in the planning phase for these faceplates.

Note

If you interconnect a parameter that is also listed in OS_Perm as a parameter, you have to reset the corresponding OS_Perm bit.

Configurable reactions using the Feature parameter

You can find an overview of all reactions provided by the Feature parameter in the section Configurable functions using the Feature I/O (Page 131). The following functionality is available for this block at the relevant bits:

Bit	Function
1	Reaction to the out of service mode (Page 177)
22	Update acknowledgment and error status of the message call (Page 160)
27	Selecting values associated with messages (Page 156)

Forming the signal status for blocks

The block provides the standard function Forming and outputting the signal status for technologic blocks (Page 109).

The block determines the worst signal status via all interconnected binary and analog inputs, and outputs this value at ST_Worst.

- In1
- etc. to
- In8
- AV1

etc. to

- AV8

See also

- Description of EventNck (Page 1644)
- EventNck modes (Page 1646)
- EventNck error handling (Page 1649)
- EventNck messaging (Page 1650)
- EventNck I/Os (Page 1651)
- EventNck block diagram (Page 1655)

9.2.4 EventNck error handling

Error handling of EventNck

Refer to the section Error handling (Page 119) in the basic instructions for the error handling of all blocks.

The following errors can be displayed for this block:

- Error numbers

Overview of error numbers

The `ErrorNum` I/O can be used to output the following error numbers:

Error number	Meaning of the error number
-1	Predefined value when inserting the block; the block is not processed.
0	There is no error.

See also

- Description of EventNck (Page 1644)
- EventNck modes (Page 1646)
- EventNck functions (Page 1647)
- EventNck messaging (Page 1650)
- EventNck I/Os (Page 1651)
- EventNck block diagram (Page 1655)

9.2.5 EventNck messaging

Messaging

Messages not requiring acknowledgment are generated with NOTIFY_8P . The block uses the PMC communication channel and has 8 digital inputs and 10 associated values.

Every edge transition detected for one or more digital inputs results in a message. The associated values are assigned consistently to the message at the time of edge evaluation. All 8 signals are assigned a common message number, which is split at the OS into 8 messages. The Engineering System (ES) assigns the message number automatically by calling the message server.

Process messages

Message instance	Message identifier	Message class	Event
MsgEvId	SIG 1	Operating message – without acknowledgment	Text 1
	SIG 2	Operating message – without acknowledgment	Text 2
	SIG 3	Operating message – without acknowledgment	Text 3
	SIG 4	Operating message – without acknowledgment	Text 4
	SIG 5	Operating message – without acknowledgment	Text 5
	SIG 6	Operating message – without acknowledgment	Text 6
	SIG 7	Operating message – without acknowledgment	Text 7
	SIG 8	Operating message – without acknowledgment	Text 8

You can change the message class and the event to meet your needs at the block type and/or block instance.

Associated values for message instance **MsgEvId**

You can use the **Feature Bit Selecting** values associated with messages (Page 156) to define whether the signal status of the signal or the associated analog value is to be used as the associated value for the message.

Associated value	Block parameters
1	In1.ST
2	In2.ST
3	In3.ST
4	In4.ST

Associated value	Block parameters
5	In5.ST
6	In6.ST
7	In7.ST
8	In8.ST
9	Not allocated
10	Not allocated

Associated values for message instance `MsgEvId`

Associated value	Block parameters
1	AV1.Value
2	AV2.Value
3	AV3.Value
4	AV4.Value
5	AV5.Value
6	AV6.Value
7	AV7.Value
8	AV8.Value
9	Not allocated
10	Not allocated

See also

- Description of EventNck (Page 1644)
- EventNck modes (Page 1646)
- EventNck functions (Page 1647)
- EventNck error handling (Page 1649)
- EventNck I/Os (Page 1651)
- EventNck block diagram (Page 1655)

9.2.6 EventNck I/Os

I/Os of EventNck

Input parameters

Parameter	Description	Type	Default
AlmOnDly	Alarm delay time [s] for signal transition 0 → 1	REAL	0.0
AlmOffDly	Alarm delay time [s] for signal transition 1 → 0	REAL	0.0
AV1	Message associated value for In1	STRUCT • Value: REAL • ST: BYTE	- • 0.0 • 16#FF
AV1_Unit	Unit for AV1	INT	0
AV2	Message associated value for In2	STRUCT • Value: REAL • ST: BYTE	- • 0.0 • 16#FF
AV2_Unit	Unit for AV2	INT	0
AV3	Message associated value for In3	STRUCT • Value: REAL • ST: BYTE	- • 0.0 • 16#FF
AV3_Unit	Unit for AV3	INT	0
AV4	Message associated value for In4	STRUCT • Value: REAL • ST: BYTE	- • 0.0 • 16#FF
AV4_Unit	Unit for AV4	INT	0
AV5	Message associated value for In5	STRUCT • Value: REAL • ST: BYTE	- • 0.0 • 16#FF
AV5_Unit	Unit for AV5	INT	0
AV6	Message associated value for In6	STRUCT • Value: REAL • ST: BYTE	- • 0.0 • 16#FF
AV6_Unit	Unit for AV6	INT	0
AV7	Message associated value for In7	STRUCT • Value: REAL • ST: BYTE	- • 0.0 • 16#FF
AV7_Unit	Unit for AV7	INT	0
AV8	Message associated value for In8	STRUCT • Value: REAL • ST: BYTE	- • 0.0 • 16#FF
AV8_Unit	Unit for AV8	INT	0
EN	1 = Called block will be processed	BOOL	1

9.2 EventNck - Generating messages without acknowledgment

Parameter	Description	Type	Default
Feature	I/O for additional functions (Page 1647)	STRUCT <ul style="list-style-type: none"> • Bit 0: BOOL • ... • Bit 31: BOOL 	- <ul style="list-style-type: none"> • 0 • 0 • 0
In1	Input In1	STRUCT <ul style="list-style-type: none"> • Value: BOOL • ST: BYTE 	- <ul style="list-style-type: none"> • 0 • 16#FF
In1MsgEn	1 = Activate message for input In1	BOOL	1
In2	Input In2	STRUCT <ul style="list-style-type: none"> • Value: BOOL • ST: BYTE 	- <ul style="list-style-type: none"> • 0 • 16#FF
In2MsgEn	1 = Activate message for input In2	BOOL	1
In3	Input In3	STRUCT <ul style="list-style-type: none"> • Value: BOOL • ST: BYTE 	- <ul style="list-style-type: none"> • 0 • 16#FF
In3MsgEn	1 = Activate message for input In3	BOOL	1
In4	Input In4	STRUCT <ul style="list-style-type: none"> • Value: BOOL • ST: BYTE 	- <ul style="list-style-type: none"> • 0 • 16#FF
In4MsgEn	1 = Activate message for input In4	BOOL	1
In5	Input In5	STRUCT <ul style="list-style-type: none"> • Value: BOOL • ST: BYTE 	- <ul style="list-style-type: none"> • 0 • 16#FF
In5MsgEn	1 = Activate message for input In5	BOOL	1
In6	Input In6	STRUCT <ul style="list-style-type: none"> • Value: BOOL • ST: BYTE 	- <ul style="list-style-type: none"> • 0 • 16#FF
In6MsgEn	1 = Activate message for input In6	BOOL	1
In7	Input In7	STRUCT <ul style="list-style-type: none"> • Value: BOOL • ST: BYTE 	- <ul style="list-style-type: none"> • 0 • 16#FF
In7MsgEn	1 = Activate message for input In7	BOOL	1
In8	Input In8	STRUCT <ul style="list-style-type: none"> • Value: BOOL • ST: BYTE 	- <ul style="list-style-type: none"> • 0 • 16#FF
In8MsgEn	1 = Activate message for input In8	BOOL	1
InvIn1	1 = Invert input In1	BOOL	0
InvIn2	1 = Invert input In2	BOOL	0
InvIn3	1 = Invert input In3	BOOL	0
InvIn4	1 = Invert input In4	BOOL	0
InvIn5	1 = Invert input In5	BOOL	0

Message blocks

9.2 EventNck - Generating messages without acknowledgment

Parameter	Description	Type	Default
InvIn6	1 = Invert input In6	BOOL	0
InvIn7	1 = Invert input In7	BOOL	0
InvIn8	1 = Invert input In8	BOOL	0
MS_RelOp	1 = Release for maintenance by OS operator	BOOL	0
MsgEvId	Message number (assigned automatically)	DWORD	16#00000000
MsgLock	1 = Suppress process messages. Refer also to the Suppressing messages using the MsgLock parameter (Page 205) section for more on this.	STRUCT <ul style="list-style-type: none"> Value: BOOL ST: BYTE 	- <ul style="list-style-type: none"> 0 16#80
OnOp*	1 = "On" mode via operator	BOOL	0
OosLi	1 = "Out of service", via interconnection or SFC (0-1 edge transition)	STRUCT <ul style="list-style-type: none"> Value: BOOL ST: BYTE 	- <ul style="list-style-type: none"> 0 16#80
OosOp*	1 = "Out of service", via OS operator	BOOL	0
OS_Perm	I/O for operator control permissions (Page 1647)	STRUCT <ul style="list-style-type: none"> Bit 0: BOOL ... Bit 31: BOOL 	- <ul style="list-style-type: none"> 1 1 1
RunUpCyc	Number of cycles in startup; messages are suppressed during these cycles	INT	3
SampleTime	Sampling time [s] (assigned automatically)	REAL	0.1
SelFp1	1 = Call a block saved in this parameter as an additional faceplate (Page 208) in the standard view	ANY	
SelFp2	1 = Call a block saved in this parameter as an additional faceplate (Page 208) in the preview	ANY	
UserStatus	Freely assignable bits for use in PCS 7 OS	BYTE	16#00

* Values can be written back to these inputs during processing of the block by the block algorithm.

Output parameters

Parameter	Description	Type	Default
ENO	1 = Block algorithm completed without errors	BOOL	0
ErrorNum	Output of current error number. For error numbers that can be output by this block, see EventNck error handling (Page 1649).	INT	-1
MsgErr	1 = Alarm error (output ERROR of NOTIFY_8P)	BOOL	0
MsgStat	Alarm status (output STATUS of NOTIFY_8P)	WORD	16#0000

9.2 EventNck - Generating messages without acknowledgment

Parameter	Description	Type	Default
MS_Release	Release for maintenance: 1 = Release for OS operator	STRUCT <ul style="list-style-type: none"> Value: BOOL ST: BYTE 	- <ul style="list-style-type: none"> 0 16#80
OnAct	1 = "On" mode enabled	STRUCT <ul style="list-style-type: none"> Value: BOOL ST: BYTE 	- <ul style="list-style-type: none"> 1 16#80
OosAct	1 = Block is "Out of service"	STRUCT <ul style="list-style-type: none"> Value: BOOL ST: BYTE 	- <ul style="list-style-type: none"> 0 16#80
OS_PermitOut	Display of OS_Permit	DWORD	16#FFFFFFFF
OS_PermitLog	Display of OS_Permit with settings changed by the block algorithm	DWORD	16#FFFFFFFF
ST_Worst	Worst signal status	BYTE	16#80
Status1	Status word 1 (Page 1644)	DWORD	16#00000000
Status2	Status word 2 (Page 1644)	DWORD	16#00000000

See also

- EventNck modes (Page 1646)
- EventNck messaging (Page 1650)
- EventNck block diagram (Page 1655)
- Configurable functions using the Feature I/O (Page 131)

9.2.7 EventNck block diagram**EventNck block diagram**

A block diagram is not provided for this block.

See also

- Description of EventNck (Page 1644)
- EventNck modes (Page 1646)
- EventNck functions (Page 1647)
- EventNck error handling (Page 1649)
- EventNck messaging (Page 1650)
- EventNck I/Os (Page 1651)

9.3 EventTs - Creating messages with time stamp

9.3.1 Description of EventTs

Object name (type + number) and family

Type + number: FB 1812

Family: Report

Area of application for EventTs

The block is used for the following applications:

- Generating messages which have to be acknowledged for time-stamped signals

How it works

The block must be linked to a channel block and monitors up to eight different binary signals. From these, it generates time-stamped messages requiring acknowledgment that appear in the alarm view of the technological block to which it is connected.

The individual messages are assigned to the monitored signals via the inputs and the messages released or blocked depending on the process status data. If a change is made to one or more of the monitored signals enabled for reporting, a message is output containing a time stamp for the signal change.

EventTs can operate independently or in combination with one of the technological blocks that has the EventTsIn or EventTs2In input parameter. When this interconnection is configured, the messages of the EventTs block are displayed in the OS of the alarm view of the technological block and can also be acknowledged there. The following functions are controlled by the technological block:

- Switching to "Out of service" mode and switching back to "On" mode: OosAct, OnAct
- Release for maintenance: MS_Release
- Suppressing messages using the MsgLock parameter
- Batch parameters: BatchEn, BatchID, BatchName, StepNo, Occupied

Note

The EventTs instance must be newly created between deleting the interconnection of EventTs and the technological block and a delta download.

Configuration

Use the CFC editor to install the block in a cyclic interrupt OB (OB30 to OB38). The block is also installed automatically in the startup OB (OB100) and in OB1 because of the time stamp.

If the `EventTs` operates together with a technological block, interconnect the output parameter `EventTsOut` of the `EventTs` block and the input parameter `EventTsIn` or `EventTs2In` of the technological block in the CFC.

Depending on how the time stamp is generated, the signals to be monitored for this are interconnected at inputs `In1 ... In8` or `InTS1 ... InTS8`. Each `Inx` or `InTSx` signal can also be inverted via input `Invx`. A message is output if a signal value is changed (but taking inversion into account).

Each input is assigned a separate message text. A message received at input `InTS5`, for example, is output with the message text for the SIG 5 signal.

Configuration of the alarms for negative edges `1 → 0` in HW Config only effects the signal inputs `InTS1 ... InTS8` of `EventTs`.

If `TimeStrampOn = 0`, meaning the inputs `In1 ... In8` are used, you will have to set the input `Invx = 1` to generate an alarm `1 → 0` at input `Inx` for a negative edge.

Note

Interconnection of the block to multiple technological blocks is not permitted.

For the `EventTs` block, the Advanced Process Library contains process tag type templates; these serve as examples by providing various application scenarios for this block.

Examples of process tag types:

- Motor with an additional analog value and time-stamped signals (`Motor_AV_EventTs`) (Page 2365)

Startup characteristics

During startup, the message block suppresses all messages. The duration (number of cycles) of message suppression is set at the `RunUpCyc` parameter. During restart (OB100) an internal counter that is initialized with this value decrements each time the block is executed. Messages are not generated if the counter value does not equal zero.

Status word allocation for `Status1` parameter

You can find a description for each parameter in section `EventTs I/Os` (Page 1666).

Status bit	Parameter
0	Active signal 1
1	Active signal 2
2	Active signal 3
3	Active signal 4
4	Active signal 5
5	Active signal 6
6	Active signal 7
7	Active signal 8
8	<code>InvIn1</code>
9	<code>InvIn2</code>

9.3 EventTs - Creating messages with time stamp

Status bit	Parameter
10	InvIn3
11	InvIn4
12	InvIn5
13	InvIn6
14	InvIn7
15	InvIn8
16	Active signal 1 with inversion
17	Active signal 2 with inversion
18	Active signal 3 with inversion
19	Active signal 4 with inversion
20	Active signal 5 with inversion
21	Active signal 6 with inversion
22	Active signal 7 with inversion
23	Active signal 8 with inversion
24	Active signal 1 not connected
25	Active signal 2 not connected
26	Active signal 3 not connected
27	Active signal 4 not connected
28	Active signal 5 not connected
29	Active signal 6 not connected
30	Active signal 7 not connected
31	Active signal 8 not connected

Status word allocation for status2 parameter

Status bit	Parameter
0	In1MsgEn
1	In2MsgEn
2	In3MsgEn
3	In4MsgEn
4	In5MsgEn
5	In6MsgEn
6	In7MsgEn
7	In8MsgEn
8	Effective signal 1 for message
9	Effective signal 2 for message
10	Effective signal 3 for message
11	Effective signal 4 for message
12	Effective signal 5 for message
13	Effective signal 6 for message
14	Effective signal 7 for message
15	Effective signal 8 for message

Status bit	Parameter
16	MsgLock
17 - 24	Not used
25	Occupied
26	BatchEn
27	Batch - parameter exists
28 - 31	Not used

See also

EventTs block diagram (Page 1670)

EventTs messaging (Page 1663)

EventTs error handling (Page 1662)

EventTs functions (Page 1660)

EventTs modes (Page 1659)

9.3.2 EventTs modes**EventTs operating modes**

The block provides the following modes:

- On (Page 71)
- Out of service (Page 71)

"On"

General information on the "On" mode is available in the section On (Page 71).

"Out of service"

You can find general information about the "Out of service" mode in the section Out of service (Page 71).

See also

EventTs block diagram (Page 1670)

EventTs I/Os (Page 1666)

EventTs messaging (Page 1663)

EventTs error handling (Page 1662)

EventTs functions (Page 1660)

Description of EventTs (Page 1656)

9.3.3 EventTs functions

Functions of EventTs

The functions for this block are listed below.

Activation and deactivation of messages

You can set the I/Os `InMsgEn1 ... InMsgEn8` to individually enable or disable the messages applied to inputs `In1 ... In8` or `InTS1 ... InTS8`. All messages are activated by default.

To deactivate messages received at I/O `InTS4`, for example, you set I/O `InMsgEn4 = 0` accordingly.

You can deactivate all messages via I/O `MsgLock = 1`.

Suppressing messages using the `MsgLock` parameter

This block provides the standard function Suppressing messages using the `MsgLock` parameter (Page 205).

Time stamp as associated value of a message

You can use input `TimeStampOn` to select how the time stamp for the signals of EventTs will be generated:

- If you want to use the high-precision time stamp from the I/O devices, set `TimeStampOn = 1`. Interconnect one of the `InTSx` inputs with output `TS_Out` of block `Pcs7DiIT`.
- If you want to use the time stamp from the CPU, set `TimeStampOn = 0`. Interconnect one of the `Inx` inputs with output `PV_Out` of block `Pcs7DiIT` or with an appropriate output of a different block.

For additional time stamp properties, refer to the description of the standard function Time stamp (Page 205).

Signal status as associated value of a message

The signal status as an associated value of the message is output for every signal, as is the time stamp.

Release for maintenance

This block provides the standard function Release for maintenance (Page 64).

Operator permissions

The block has the following Operator control permissions (Page 254) for the `OS_Perm` parameter:

Bit	Function
0	Not used
1	1 = Operator can switch to "On" mode
2	Not used
3	1 = Operator can switch to "Out of service" mode
4 - 31	Not used

This block does not have a faceplate yet; the operator permissions have already been assigned in the planning phase for these faceplates.

Note

If you interconnect a parameter that is also listed in `OS_Perm` as a parameter, you have to reset the corresponding `OS_Perm` bit.

Configurable functions using the `Feature` parameter

You can find an overview of all reactions provided by the `Feature` parameter in the Configurable functions using the Feature I/O (Page 131) . The following functionality is available for this block at the relevant bits:

Bit	Function
1	Reaction to the out of service mode (Page 177)
8	Reporting with BATCH parameters (Page 156)
9	Enable external message (Page 185)
22	Update acknowledgment and error status of the message call (Page 160)

Displaying and outputting the signal status

The block provides the standard function Forming and outputting the signal status for technologic blocks (Page 109).

9.3 EventTs - Creating messages with time stamp

The block determines the worst signal status via all interconnected binary inputs (according to `TimeStampOn`) and outputs this value at `ST_Worst`.

- `TimeStampOn = 0`
 - `In1`
 - etc. to
 - `In8`
- `TimeStampOn = 1`
 - `InTS1`
 - etc. to
 - `InTS8`

See also

- EventTs block diagram (Page 1670)
- EventTs I/Os (Page 1666)
- EventTs messaging (Page 1663)
- EventTs error handling (Page 1662)
- EventTs modes (Page 1659)
- Description of EventTs (Page 1656)

9.3.4 EventTs error handling

Error handling of EventTs

Refer to the section Error handling (Page 119) in the basic instructions for the error handling of all blocks.

The following errors can be displayed for this block:

- Error numbers

Overview of error numbers

The `ErrorNum` I/O can be used to output the following error numbers:

Error number	Meaning of the error number
-1	Predefined value when inserting the block; the block is not processed.
0	There is no error.

See also

- EventTs block diagram (Page 1670)
- EventTs I/Os (Page 1666)
- EventTs messaging (Page 1663)
- EventTs functions (Page 1660)
- EventTs modes (Page 1659)
- Description of EventTs (Page 1656)

9.3.5 EventTs messaging

Messaging

Messages which can be acknowledged are generated using ALARM_8P. The ALARM_8P has 8 digital inputs and 10 associated values. Every edge transition detected for one or more digital inputs results in a message. The associated values are assigned consistently to the message at the time of edge evaluation. All 8 signals are assigned a common message number, which is split at the OS into 8 messages. The Engineering System (ES) assigns the message number automatically by calling the message server.

Process messages

Message instance	Message identifier	Message class	Event
MsgEvId 1	SIG 1	AS process control message - fault	\$\$BlockComment\$\$ InTS1 Status 16#@1%x@
	SIG 2	AS process control message - fault	\$\$BlockComment\$\$ InTS2 Status 16#@2%x@
	SIG 3	AS process control message - fault	\$\$BlockComment\$\$ InTS3 Status 16#@3%x@
	SIG 4	AS process control message - fault	\$\$BlockComment\$\$ InTS1 Status 16#@4%x@
	SIG 5	AS process control message - fault	\$\$BlockComment\$\$ InTS5 Status 16#@5%x@
	SIG 6	AS process control message - fault	\$\$BlockComment\$\$ InTS6 Status 16#@6%x@
	SIG 7	AS process control message - fault	\$\$BlockComment\$\$ InTS7 Status 16#@7%x@
	SIG 8	AS process control message - fault	\$\$BlockComment\$\$ InTS8 Status 16#@8%x@

Explanation:

\$\$BlockComment\$\$: Content of the instance-specific comment

9.3 EventTs - Creating messages with time stamp

The following applies for `TimeStampOn = 0`: `16#@n%x@` (n = 1 ... 8): The value contains the signal status of `In1 ... In8`

The following applies for `TimeStampOn = 1`: `16#@n%x@` (n = 1 ... 8): Statement on the validity of the time stamp from `InTS0 ... InTS8`. If the value is 80, the time stamp is formed by the I/O. If the value is \neq 80, the time stamp of the I/O is invalid; the time stamp is generated by the CPU as a substitute and is therefore not exact.

You can change the message class and the event to meet your needs at the block type and/or block instance.

Associated values for message instance `MsgEvId`

Associated value	Block parameters
1	<code>TimeStampOn = 0: In1.ST</code>
2	<code>TimeStampOn = 0: In2.ST</code>
3	<code>TimeStampOn = 0: In3.ST</code>
4	<code>TimeStampOn = 0: In4.ST</code>
5	<code>TimeStampOn = 0: In5.ST</code>
6	<code>TimeStampOn = 0: In6.ST</code>
7	<code>TimeStampOn = 0: In7.ST</code>
8	<code>TimeStampOn = 0: In8.ST</code>
9	Not allocated
10	Not allocated

Associated values for message instance `MsgEvId`

Associated value	Block parameters
1	<code>TimeStampOn = 1: InTS1.ST</code>
2	<code>TimeStampOn = 1: InTS2.ST</code>
3	<code>TimeStampOn = 1: InTS3.ST</code>
4	<code>TimeStampOn = 1: InTS4.ST</code>
5	<code>TimeStampOn = 1: InTS5.ST</code>
6	<code>TimeStampOn = 1: InTS6.ST</code>
7	<code>TimeStampOn = 1: InTS7.ST</code>
8	<code>TimeStampOn = 1: InTS8.ST</code>
9	Not allocated
10	Not allocated

The batch information is transmitted with Feature bit 8 =1:

The first three associated values are described as follows and are followed by the signal status of the input signals or the validity of the time stamp depending on TimeStampOn:

Associated value	Block parameters
1	BatchName
2	StepNo
3	BatchId
4	In1.ST / InTS1.ST
5	In2.ST / InTS2.ST
6	In3.ST / InTS3.ST
7	In4.ST / InTS4.ST
8	In5.ST / InTS5.ST
9	In6.ST / InTS6.ST

The tenth associated value is not available.

Enter the batch ID @1%s@ under "Properties - Block - Special properties - Messages extended - Message texts block".

The associated values in the process messages (event) must be incremented by 3:

Message instance	Message identifier	Message class	Event
MsgEvId 1	SIG 1	AS process control message - fault	\$\$BlockComment\$\$ InTS1 Status 16#@4%x@
	SIG 2	AS process control message - fault	\$\$BlockComment\$\$ InTS2 Status 16#@5%x@
	SIG 3	AS process control message - fault	\$\$BlockComment\$\$ InTS3 Status 16#@6%x@
	SIG 4	AS process control message - fault	\$\$BlockComment\$\$ InTS1 Status 16#@7%x@
	SIG 5	AS process control message - fault	\$\$BlockComment\$\$ InTS5 Status 16#@8%x@
	SIG 6	AS process control message - fault	\$\$BlockComment\$\$ InTS6 Status 16#@9%x@
	SIG 7	AS process control message - fault	\$\$BlockComment\$\$ InTS7 Status ¹
	SIG 8	AS process control message - fault	\$\$BlockComment\$\$ InTS8 Status ¹

¹ You cannot specify a separate associated value here.

See also

EventTs block diagram (Page 1670)

EventTs I/Os (Page 1666)

9.3 EventTs - Creating messages with time stamp

- EventTs error handling (Page 1662)
- EventTs functions (Page 1660)
- EventTs modes (Page 1659)
- Description of EventTs (Page 1656)
- Selecting values associated with messages (Page 156)

9.3.6 EventTs I/Os

I/Os of EventTs

Inputs

Parameter	Description	Type	Default
BatchEn	1 = Enable allocation	BOOL	0
BatchID	Batch ID	DWORD	16#00
BatchName	Batch name	S7-string	
EN	1 = Called block will be processed	BOOL	1
ExtVal01	External message 1	ANY	
ExtVal02	External message 2	ANY	
ExtVal03	External message 3	ANY	
Feature	I/O for additional functions (Page 1660)	STRUCT <ul style="list-style-type: none"> • Bit 0: BOOL • ... • Bit 31: BOOL 	- <ul style="list-style-type: none"> • 0 • 0 • 0
In1	Signal 1 for CPU time stamp	STRUCT <ul style="list-style-type: none"> • Value: BOOL • ST: BYTE 	- <ul style="list-style-type: none"> • 0 • 16#FF
In2	Signal 2 for CPU time stamp	STRUCT <ul style="list-style-type: none"> • Value: BOOL • ST: BYTE 	- <ul style="list-style-type: none"> • 0 • 16#FF
In3	Signal 3 for CPU time stamp	STRUCT <ul style="list-style-type: none"> • Value: BOOL • ST: BYTE 	- <ul style="list-style-type: none"> • 0 • 16#FF
In4	Signal 4 for CPU time stamp	STRUCT <ul style="list-style-type: none"> • Value: BOOL • ST: BYTE 	- <ul style="list-style-type: none"> • 0 • 16#FF
In5	Signal 5 for CPU time stamp	STRUCT <ul style="list-style-type: none"> • Value: BOOL • ST: BYTE 	- <ul style="list-style-type: none"> • 0 • 16#FF

9.3 EventTs - Creating messages with time stamp

Parameter	Description	Type	Default
In6	Signal 6 for CPU time stamp	STRUCT <ul style="list-style-type: none"> • Value: BOOL • ST: BYTE 	- <ul style="list-style-type: none"> • 0 • 16#FF
In7	Signal 7 for CPU time stamp	STRUCT <ul style="list-style-type: none"> • Value: BOOL • ST: BYTE 	- <ul style="list-style-type: none"> • 0 • 16#FF
In8	Signal 8 for CPU time stamp	STRUCT <ul style="list-style-type: none"> • Value: BOOL • ST: BYTE 	- <ul style="list-style-type: none"> • 0 • 16#FF
InTS1	Signal 1 with I/O-device time stamp	ANY	
InTS2	Signal 2 with I/O-device time stamp	ANY	
InTS3	Signal 3 with I/O-device time stamp	ANY	
InTS4	Signal 4 with I/O-device time stamp	ANY	
InTS5	Signal 5 with I/O-device time stamp	ANY	
InTS6	Signal 6 with I/O-device time stamp	ANY	
InTS7	Signal 7 with I/O-device time stamp	ANY	
InTS8	Signal 8 with I/O-device time stamp	ANY	
Inv1	1 = Invert input In1 or InTS1	BOOL	0
Inv2	1 = Invert input In2 or InTS2	BOOL	0
Inv3	1 = Invert input In3 or InTS3	BOOL	0
Inv4	1 = Invert input In4 or InTS4	BOOL	0
Inv5	1 = Invert input In5 or InTS5	BOOL	0
Inv6	1 = Invert input In6 or InTS6	BOOL	0
Inv7	1 = Invert input In7 or InTS7	BOOL	0
Inv8	1 = Invert input In8 or InTS8	BOOL	0
MsgEn1	1 = Activate message for input In1 or InTS1	BOOL	1
MsgEn2	1 = Activate message for input In2 or InTS2	BOOL	1
MsgEn3	1 = Activate message for input In3 or InTS3	BOOL	1
MsgEn4	1 = Activate message for input In4 or InTS4	BOOL	1
MsgEn5	1 = Activate message for input In5 or InTS5	BOOL	1
MsgEn6	1 = Activate message for input In6 or InTS6	BOOL	1

Message blocks

9.3 EventTs - Creating messages with time stamp

Parameter	Description	Type	Default
MsgEn7	1 = Activate message for input In7 or InTS7	BOOL	1
MsgEn8	1 = Activate message for input In8 or InTS8	BOOL	1
MsgEvId	Message number (assigned automatically)	DWORD	16#00000000
MsgLock	1 = Suppress process messages. See also the section Suppressing messages using the MsgLock parameter (Page 205) for more on this.	STRUCT <ul style="list-style-type: none"> • Value: BOOL • ST: BYTE 	- <ul style="list-style-type: none"> • 0 • 16#80
MS_RelOp	1 = Release for maintenance by OS operator	BOOL	0
Occupied	1 = In use by a batch	BOOL	0
OnOp*	1 = "On" mode via operator	BOOL	0
OosLi	1 = "Out of service", via interconnection or SFC (0-1 edge transition)	STRUCT <ul style="list-style-type: none"> • Value: BOOL • ST: BYTE 	- <ul style="list-style-type: none"> • 0 • 16#80
OosOp*	1 = "Out of service", via OS operator	BOOL	0
OS_Perm	I/O for EventTs functions (Page 1660)	STRUCT <ul style="list-style-type: none"> • Bit 0: BOOL • ... • Bit 31: BOOL 	- <ul style="list-style-type: none"> • 1 • 1 • 1
RunUpCyc	Number of cycles in startup; messages are suppressed during these cycles	INT	3
SampleTime	Sampling time [s] (assigned automatically)	REAL	0.1
SelFp1	1 = Call a block saved in this parameter as an additional faceplate (Page 208) in the standard view	ANY	
SelFp2	1 = Call a block saved in this parameter as an additional faceplate (Page 208) in the standard view	ANY	
StepNo	Batch step number	DWORD	16#00
TimeStampOn	0 = Use time stamp of the CPU 1 = Use time stamp of the I/O devices	BOOL	0
UserStatus	Freely assignable bits for use in PCS 7 OS	BYTE	16#00

* Values can be written back to these inputs during processing of the block by the block algorithm.

Outputs

Parameter	Description	Type	Default
ENO	1 = Block algorithm completed without errors	BOOL	0
ErrorNum	Output of pending error number. For error numbers that can be output by this block, see EventTs error handling (Page 1662)	INT	-1
EventTsOut	For maneuvering of data between a technological block and the message blocks EventTs, Event16Ts.	STRUCT	
MS_Release	Release for maintenance: 1 = Release for OS operator	STRUCT • Value: BOOL • ST: BYTE	- • 0 • 16#80
MsgAckn	Message acknowledgment status (output ACK_STATE of ALARM_8P)	WORD	16#0000
MsgErr	1 = Message error (output ERROR of ALARM_8P)	BOOL	0
MsgStat	Message status (output STATUS of ALARM_8P)	WORD	16#0000
OnAct	1 = "On" mode enabled	STRUCT • Value: BOOL • ST: BYTE	- • 1 • 16#80
OosAct	1 = Block is "Out of service"	STRUCT • Value: BOOL • ST: BYTE	- • 0 • 16#80
OS_PermOut	Display of OS_Perm	DWORD	16#FFFFFFFF
OS_PermLog	Display of OS_Perm with settings changed by the block algorithm	DWORD	16#FFFFFFFF
ST_Worst	Worst signal status	BYTE	16#80
Status1	Status word 1 (Page 1656)	DWORD	16#00000000
Status2	Status word 2 (Page 1656)	DWORD	16#00000000

See also

EventTs block diagram (Page 1670)

EventTs messaging (Page 1663)

EventTs modes (Page 1659)

9.3.7 EventTs block diagram

EventTs block diagram

A block diagram is not provided for this block.

See also

- EventTs I/Os (Page 1666)
- EventTs messaging (Page 1663)
- EventTs error handling (Page 1662)
- EventTs functions (Page 1660)
- EventTs modes (Page 1659)
- Description of EventTs (Page 1656)

9.4 Event16Ts - Creating 16 messages with time stamp

9.4.1 Description of Event16Ts

Object name (type + number) and family

Type + number: FB 1887

Family: Report

Area of application for Event16Ts

The block is used for the following applications:

- Generating messages which have to be acknowledged for time-stamped signals

For Event16Ts block, use the templates for the process tag types of the EventTs block in the Advanced Process Library as examples with various use cases. Replace the EventTs block with the Event16Ts block.

How it works

The block monitors up to sixteen different binary signals, connect the block to a channel block.

The block generates time-stamped messages requiring acknowledgment that appear in the alarm view of the technological block to which it is connected.

The individual messages are assigned to the monitored signals via the inputs and the messages released or blocked depending on the process status data. If a change is made to one or more of the monitored signals enabled for reporting, a message is output containing a time stamp for the signal change.

Event16Ts can operate independently or in combination with one of the technological blocks that has the EventTsIn or EventTs2In input parameter. When the interconnection is configured, the messages of the Event16Ts block are displayed in the OS of the alarm view of the technological block and you can also acknowledge the messages. The following functions are controlled by the technological block:

- Switching to "Out of service" mode and switching back to "On" mode: OosAct, OnAct
- Release for maintenance: MS_Release
- Suppressing messages using the MsgLock parameter
- Batch parameters: BatchEn, BatchID, BatchName, StepNo, Occupied

Note

The Event16Ts instance must be newly created between deleting the interconnection of Event16Ts and the technological block and a delta download.

Configuration

Use the CFC editor to install the block in a cyclic interrupt OB (OB30 to OB38). The block is also installed automatically in the startup OB (OB100) and in OB1 because for time stamping.

If the Event16Ts operates together with a technological block, interconnect the output parameter EventTsOut of the Event16Ts block and the input parameter EventTsIn or EventTs2In of the technological block in the CFC.

Depending on how the time stamp is generated, the signals to be monitored for this are interconnected at inputs In1 ... In16 or InTS1 ... InTS16. Each Inx or InTSx signal can also be inverted via input Invx. If a signal value changes taking inversion into account, a message is output.

Note

1. The input parameters ExtVal01, ExtVal02, and ExtVal03 will be used for In1...In8 and InTS1...InTS8.
 2. The input parameters ExtVal04, ExtVal05, and ExtVal06 will be used for In9...In16 and InTS9...InTS16.
-

Each input is assigned a separate message text. A message received at input InTS5, for example, is output with the message text for the SIG 5 signal.

Configuration of the alarms for negative edges 1 → 0 in HW Config only effects the signal inputs InTS1 ... InTS16 of Event16Ts.

If TimeStrampOn = 0 , meaning the inputs In1 ... In16 are used, you will have to set the input Invx = 1 to generate an alarm 1 → 0 at input Inx for a negative edge.

Note

Interconnection of the block to multiple technological blocks is not permitted.

For the Event16Ts block, the Advanced Process Library contains templates for process tag types as an example with various application scenarios for this block.

Examples of process tag types:

- Motor with an additional analog value and time-stamped signals (Motor_AV_EventTs) (Page 2365)

Startup characteristics

During startup, the message block suppresses all messages. The duration (number of cycles) of message suppression is set at the RunUpCyc parameter. During restart (OB100) an internal counter that is initialized with this value decrements each time the block is executed. Messages are not generated if the counter value does not equal zero.

Status word allocation for status1 parameter

You can find a description for each parameter in section I/Os of Event16Ts.

Status bit	Parameter
0	Active signal 1 with inversion
1	Active signal 2 with inversion
2	Active signal 3 with inversion
3	Active signal 4 with inversion
4	Active signal 5 with inversion
5	Active signal 6 with inversion
6	Active signal 7 with inversion
7	Active signal 8 with inversion
8	Active signal 9 with inversion
9	Active signal 10 with inversion
10	Active signal 11 with inversion
11	Active signal 12 with inversion
12	Active signal 13 with inversion
13	Active signal 14 with inversion
14	Active signal 15 with inversion
15	Active signal 16 with inversion
16	Active signal 1 not connected
17	Active signal 2 not connected
18	Active signal 3 not connected
19	Active signal 4 not connected
20	Active signal 5 not connected
21	Active signal 6 not connected
22	Active signal 7 not connected
23	Active signal 8 not connected
24	Active signal 9 not connected
25	Active signal 10 not connected
26	Active signal 11 not connected
27	Active signal 12 not connected
28	Active signal 13 not connected
29	Active signal 14 not connected
30	Active signal 15 not connected
31	Active signal 16 not connected

Status word allocation for status2 parameter

Status bit	Parameter
0	Active signal 1
1	Active signal 2
2	Active signal 3

9.4 Event16Ts - Creating 16 messages with time stamp

Status bit	Parameter
3	Active signal 4
4	Active signal 5
5	Active signal 6
6	Active signal 7
7	Active signal 8
8	Active signal 9
9	Active signal 10
10	Active signal 11
11	Active signal 12
12	Active signal 13
13	Active signal 14
14	Active signal 15
15	Active signal 16
16	InvIn1
17	InvIn2
18	InvIn3
19	InvIn4
20	InvIn5
21	InvIn6
22	InvIn7
23	InvIn8
24	InvIn9
25	InvIn10
26	InvIn11
27	InvIn12
28	InvIn13
29	InvIn14
30	InvIn15
31	InvIn16

Status word allocation for Status3 parameter

Status bit	Parameter
0	In1MsgEn
1	In2MsgEn
2	In3MsgEn
3	In4MsgEn
4	In5MsgEn
5	In6MsgEn
6	In7MsgEn
7	In8MsgEn
8	In9MsgEn

Status bit	Parameter
9	In10MsgEn
10	In11MsgEn
11	In12MsgEn
12	In13MsgEn
13	In14MsgEn
14	In15MsgEn
15	In16MsgEn
16	Effective signal 1 for message
17	Effective signal 2 for message
18	Effective signal 3 for message
19	Effective signal 4 for message
20	Effective signal 5 for message
21	Effective signal 6 for message
22	Effective signal 7 for message
23	Effective signal 8 for message
24	Effective signal 9 for message
25	Effective signal 10 for message
26	Effective signal 11 for message
27	Effective signal 12 for message
28	Effective signal 13 for message
29	Effective signal 14 for message
30	Effective signal 15 for message
31	Effective signal 16 for message

Status word allocation for Status4 parameter

Status bit	Parameter
0-7	Not used
8 - 15	Not used
16	MsgLock
7 - 24	Not used
25	Occupied
26	BatchEn
27	Batch - parameter exists
28 - 31	Not used

See also

Event16Ts block diagram (Page 1687)

Event16Ts I/Os (Page 1685)

Event16Ts messages (Page 1679)

Event16Ts error handling (Page 1679)

9.4 Event16Ts - Creating 16 messages with time stamp

Event16Ts functions (Page 1676)

Event16Ts operating modes (Page 1676)

9.4.2 Event16Ts operating modes

Event16Ts operating modes

The block provides the following modes:

- On (Page 71)
- Out of service (Page 71)

"On"

General information on the "On" mode is available in the section On (Page 71).

"Out of service"

You can find general information about the "Out of service" mode in the section Out of service (Page 71).

See also

Event16Ts block diagram (Page 1687)

Event16Ts I/Os (Page 1685)

Event16Ts messages (Page 1679)

Event16Ts error handling (Page 1679)

Event16Ts functions (Page 1676)

Description of Event16Ts (Page 1671)

9.4.3 Event16Ts functions

Functions of Event16Ts

The functions for this block are listed below.

Activation and deactivation of messages

You can set the I/Os `InMsgEn1 ... InMsgEn8` to individually enable or disable the messages applied to inputs `In1 ... In8` or `InTS1 ... InTS8`. All messages are activated by default.

To deactivate messages received at I/O `InTS4`, for example, you set I/O `InMsgEn4 = 0` accordingly.

You can deactivate all messages via I/O `MsgLock = 1`.

Suppressing messages using the `MsgLock` parameter

This block provides the standard function Suppressing messages using the `MsgLock` parameter (Page 205).

Time stamp as associated value of a message

You can use input `TimeStampOn` to select how the time stamp for the signals of Event16Ts will be generated:

- If you want to use the high-precision time stamp from the I/O devices, set `TimeStampOn = 1`. Interconnect one of the `InTSx` inputs with output `TS_Out` of block `Pcs7DiIT`.
- If you want to use the time stamp from the CPU, set `TimeStampOn = 0`. Interconnect one of the `Inx` inputs with output `PV_Out` of block `Pcs7DiIT` or with an appropriate output of a different block.

For additional time stamp properties, refer to the description of the standard function Time stamp (Page 205).

Signal status as associated value of a message

The signal status as an associated value of the message is output for every signal, as is the time stamp.

Release for maintenance

This block provides the standard function Release for maintenance (Page 64).

Operator permissions

The block has the following Operator control permissions (Page 254) for the `OS_Perm` parameter:

Bit	Function
0	Not used
1	1 = Operator can switch to "On" mode
2	Not used
3	1 = Operator can switch to "Out of service" mode
4 - 31	Not used

This block does not have a faceplate yet; the operator permissions have already been assigned in the planning phase for these faceplates.

Note

If you interconnect a parameter that is also listed in OS_Perm as a parameter, you have to reset the corresponding OS_Perm bit.

Configurable functions using the Feature parameter

You can find an overview of all reactions provided by the Feature parameter in the Configurable functions using the Feature I/O (Page 131) . The following functionality is available for this block at the relevant bits:

Bit	Function
1	Reaction to the out of service mode (Page 177)
8	Reporting with BATCH parameters (Page 156)
9	Enable external message (Page 185)
22	Update acknowledgment and error status of the message call (Page 160)

Displaying and outputting the signal status

The block provides the standard function Forming and outputting the signal status for technologic blocks (Page 109).

The block determines the worst signal status via all interconnected binary inputs (according to TimeStampOn) and outputs this value at ST_Worst.

- TimeStampOn = 0
 - In1
 - etc. to
 - In16
- TimeStampOn = 1
 - InTS1
 - etc. to
 - InTS16

See also

- Event16Ts block diagram (Page 1687)
- Event16Ts I/Os (Page 1685)
- Event16Ts messages (Page 1679)
- Event16Ts error handling (Page 1679)

Event16Ts operating modes (Page 1676)

Description of Event16Ts (Page 1671)

9.4.4 Event16Ts error handling

Error handling of EventTs

Refer to the section Error handling (Page 119) in the basic instructions for the error handling of all blocks.

The following errors can be displayed for this block:

- Error numbers

Overview of error numbers

The `ErrorNum` I/O can be used to output the following error numbers:

Error number	Meaning of the error number
-1	Predefined value when inserting the block; the block is not executed.
0	There is no error.

See also

Event16Ts block diagram (Page 1687)

Event16Ts I/Os (Page 1685)

Event16Ts messages (Page 1679)

Event16Ts functions (Page 1676)

Event16Ts operating modes (Page 1676)

Description of Event16Ts (Page 1671)

9.4.5 Event16Ts messages

Messaging

Messages which can be acknowledged are generated using `ALARM_8P`. The `ALARM_8P` has 8 digital inputs and 10 associated values. Every edge transition detected for one or more digital inputs results in a message. The associated values are assigned consistently to the message at the time of edge evaluation. All 8 signals are assigned a common message number, which is split at the OS into 8 messages. The Engineering System (ES) assigns the message number automatically by calling the message server.

Process messages (MsgEvd1)

Message instance	Message identifier	Message class	Event
MsgEvd1	SIG 1	AS process control message - fault	\$\$BlockComment\$\$ InTS1 Status 16#@1%x@
	SIG 2	AS process control message - fault	\$\$BlockComment\$\$ InTS2 Status 16#@2%x@
	SIG 3	AS process control message - fault	\$\$BlockComment\$\$ InTS3 Status 16#@3%x@
	SIG 4	AS process control message - fault	\$\$BlockComment\$\$ InTS4 Status 16#@4%x@
	SIG 5	AS process control message - fault	\$\$BlockComment\$\$ InTS5 Status 16#@5%x@
	SIG 6	AS process control message - fault	\$\$BlockComment\$\$ InTS6 Status 16#@6%x@
	SIG 7	AS process control message - fault	\$\$BlockComment\$\$ InTS7 Status 16#@7%x@
	SIG 8	AS process control message - fault	\$\$BlockComment\$\$ InTS8 Status 16#@8%x@

Explanation:

\$\$BlockComment\$\$: Content of the instance-specific comment

The following applies for TimeStampOn = 0 : 16#@n%x@ (n = 1 ... 8): The value contains the signal status of In1 ... In8

The following applies for TimeStampOn = 1 : 16#@n%x@ (n = 1 ... 8): Statement on the validity of the time stamp from InTS0 ... InTS8. If the value is 80, the time stamp is formed by the I/O. If the value is ≠ 80, the time stamp of the I/O is invalid; the time stamp is generated by the CPU as a substitute and is therefore not exact.

You can change the message class and the event to meet your needs at the block type and/or block instance.

Process messages (MsgEvid2)

Message instance	Message identifier	Message class	Event
MsgEvid2	SIG 1	AS process control message - fault	\$\$BlockComment\$\$ InTS9 Status 16#@1%x@
	SIG 2	AS process control message - fault	\$\$BlockComment\$\$ InTS10 Status 16#@2%x@
	SIG 3	AS process control message - fault	\$\$BlockComment\$\$ InTS11 Status 16#@3%x@
	SIG 4	AS process control message - fault	\$\$BlockComment\$\$ InTS12 Status 16#@4%x@
	SIG 5	AS process control message - fault	\$\$BlockComment\$\$ InTS13 Status 16#@5%x@
	SIG 6	AS process control message - fault	\$\$BlockComment\$\$ InTS14 Status 16#@6%x@
	SIG 7	AS process control message - fault	\$\$BlockComment\$\$ InTS15 Status 16#@7%x@
	SIG 8	AS process control message - fault	\$\$BlockComment\$\$ InTS16 Status 16#@8%x@

Explanation:

\$\$BlockComment\$\$: Content of the instance-specific comment

The following applies for TimeStampOn = 0 : 16#@n%x@ (n = 1 ... 8): The value contains the signal status of In9 ... In16

The following applies for TimeStampOn = 1 : 16#@n%x@ (n = 1 ... 8): Statement on the validity of the time stamp from InTS9 ... InTS16. If the value is 80, the time stamp is formed by the I/O. If the value is ≠ 80, the time stamp of the I/O is invalid; the time stamp is generated by the CPU as a substitute and is therefore not exact.

You can change the message class and the event to meet your needs at the block type and/or block instance.

Associated values for message instance MsgEvid1

Associated value	Block parameters
1	TimeStampOn = 0: In1.ST
2	TimeStampOn = 0: In2.ST
3	TimeStampOn = 0: In3.ST
4	TimeStampOn = 0: In4.ST
5	TimeStampOn = 0: In5.ST
6	TimeStampOn = 0: In6.ST
7	TimeStampOn = 0: In7.ST
8	TimeStampOn = 0: In8.ST
9	Not allocated
10	Not allocated

Associated values for message instance `MsgEvId2`

Associated value	Block parameters
1	TimeStampOn = 1: In9.ST
2	TimeStampOn = 1: In10.ST
3	TimeStampOn = 1: In11.ST
4	TimeStampOn = 1: In12.ST
5	TimeStampOn = 1: In13.ST
6	TimeStampOn = 1: In14.ST
7	TimeStampOn = 1: In15.ST
8	TimeStampOn = 1: In16.ST
9	Not allocated
10	Not allocated

Associated values for message instance `MsgEvId1`

Associated value	Block parameters
1	TimeStampOn = 0: InTS1.ST
2	TimeStampOn = 0: InTS2.ST
3	TimeStampOn = 0: InTS3.ST
4	TimeStampOn = 0: InTS4.ST
5	TimeStampOn = 0: InTS5.ST
6	TimeStampOn = 0: InTS6.ST
7	TimeStampOn = 0: InTS7.ST
8	TimeStampOn = 0: InTS8.ST
9	Not allocated
10	Not allocated

Associated values for message instance `MsgEvId2`

Associated value	Block parameters
1	TimeStampOn = 0: InTS9.ST
2	TimeStampOn = 0: InTS10.ST
3	TimeStampOn = 0: InTS11.ST
4	TimeStampOn = 0: InTS12.ST
5	TimeStampOn = 0: InTS13.ST
6	TimeStampOn = 0: InTS614.ST
7	TimeStampOn = 0: InTS15.ST
8	TimeStampOn = 0: InTS16.ST
9	Not allocated
10	Not allocated

The batch information is transmitted with Feature bit 8 =1:

The first three associated values are described as follows and are followed by the signal status of the input signals or the validity of the time stamp depending on TimeStampOn:

MsgEvid1

Associated value	Block parameters
1	BatchName
2	StepNo
3	BatchId
4	In1.ST / InTS1.ST
5	In2.ST / InTS2.ST
6	In3.ST / InTS3.ST
7	In4.ST / InTS4.ST
8	In5.ST / InTS5.ST
9	In6.ST / InTS6.ST

MsgEvid2

Associated value	Block parameters
1	BatchName
2	StepNo
3	BatchId
4	In7.ST / InTS7.ST
5	In8ST / InTS8.ST8
6	In9.ST / InTS9.ST
7	In10.ST / InTS10.ST
8	In11.ST / InTS11.ST
9	I12.ST / InTS12.ST

The tenth associated value is not available.

Enter the batch ID @1@s@ under "Properties - Block - Special properties - Messages extended - Message texts block".

9.4 Event16Ts - Creating 16 messages with time stamp

The associated values in the process messages (event) must be incremented by 3:

Message instance	Message identifier	Message class	Event
MsgEvId1	SIG 1	AS process control message - fault	\$\$BlockComment\$\$ InTS1 Status 16#@4%x@
	SIG 2	AS process control message - fault	\$\$BlockComment\$\$ InTS2 Status 16#@5%x@
	SIG 3	AS process control message - fault	\$\$BlockComment\$\$ InTS3 Status 16#@6%x@
	SIG 4	AS process control message - fault	\$\$BlockComment\$\$ InTS4 Status 16#@7%x@
	SIG 5	AS process control message - fault	\$\$BlockComment\$\$ InTS5 Status 16#@8%x@
	SIG 6	AS process control message - fault	\$\$BlockComment\$\$ InTS6 Status 16#@9%x@
	SIG 7	AS process control message - fault	\$\$BlockComment\$\$ InTS7 Status ¹
	SIG 8	AS process control message - fault	\$\$BlockComment\$\$ InTS8 Status ¹

¹ You cannot specify a separate associated value here.

Message instance	Message identifier	Message class	Event
MsgEvId2	SIG 1	AS process control message - fault	\$\$BlockComment\$\$ InTS9 Status 16#@4%x@
	SIG 2	AS process control message - fault	\$\$BlockComment\$\$ InTS10 Status 16#@5%x@
	SIG 3	AS process control message - fault	\$\$BlockComment\$\$ InTS11 Status 16#@6%x@
	SIG 4	AS process control message - fault	\$\$BlockComment\$\$ InTS12 Status 16#@7%x@
	SIG 5	AS process control message - fault	\$\$BlockComment\$\$ InTS13 Status 16#@8%x@
	SIG 6	AS process control message - fault	\$\$BlockComment\$\$ InTS14 Status 16#@9%x@
	SIG 7	AS process control message - fault	\$\$BlockComment\$\$ InTS15 Status ¹
	SIG 8	AS process control message - fault	\$\$BlockComment\$\$ InTS16 Status ¹

¹ You cannot specify a separate associated value here.

See also

- Event16Ts block diagram (Page 1687)
- Event16Ts I/Os (Page 1685)
- Event16Ts error handling (Page 1679)
- Event16Ts functions (Page 1676)
- Event16Ts operating modes (Page 1676)
- Description of Event16Ts (Page 1671)
- Selecting values associated with messages (Page 156)

9.4.6 Event16Ts I/Os

I/Os of EventTs

Inputs

Parameter	Description	Type	Default
BatchEn	1 = Enable allocation	BOOL	0
BatchID	Batch ID	DWORD	16#00000000
BatchName	Batch name	S7-string	
EN	1 = Called block will be processed	BOOL	1
Feature	I/O for additional functions (Page 1676)	STRUCT <ul style="list-style-type: none"> • Bit 0: BOOL • ... • Bit 31: BOOL 	- <ul style="list-style-type: none"> • 0 • 0 • 0
ExtVal01	External message 1	ANY	
ExtVal02	External message 2	ANY	
ExtVal03	External message 3	ANY	
ExtVal04	External message 4	ANY	
ExtVal05	External message 5	ANY	
ExtVal06	External message 6	ANY	
In1..In16	Signal 1..16 for CPU time stamp	STRUCT <ul style="list-style-type: none"> • Value: BOOL • ST: BYTE 	- <ul style="list-style-type: none"> • 0 • 16#FF
InTS1..InTS16	Signal 1..16 with I/O-device time stamp	ANY	
In1..In16	1 = Invert input In1..In16 or InTS1..InTS16	BOOL	0
MsgEn1..MsgEn16	1 = Activate message for input In1..In16 or InTS1..InTS16	BOOL	1

Message blocks

9.4 Event16Ts - Creating 16 messages with time stamp

Parameter	Description	Type	Default
MsgEvId1	Message number (assigned automatically)	DWORD	16#00000000
MsgEvId2	Message number (assigned automatically)	DWORD	16#00000000
MsgLock	1 = Suppress process messages. See also the section Suppressing messages using the MsgLock parameter (Page 205) for more on this.	STRUCT <ul style="list-style-type: none"> • Value: BOOL • ST: BYTE 	- <ul style="list-style-type: none"> • 0 • 16#80
MS_RelOp	1 = Release for maintenance by OS operator	BOOL	0
Occupied	1 = In use by a batch	BOOL	0
OnOp*	1 = "On" mode via operator	BOOL	0
OosLi	1 = "Out of service", via interconnection or SFC (0-1 edge transition)	STRUCT <ul style="list-style-type: none"> • Value: BOOL • ST: BYTE 	- <ul style="list-style-type: none"> • 0 • 16#80
OosOp*	1 = "Out of service", via OS operator	BOOL	0
OS_Perm	I/O for Event16Ts functions (Page 1676)	STRUCT <ul style="list-style-type: none"> • Bit 0: BOOL • ... • Bit 31: BOOL 	- <ul style="list-style-type: none"> • 1 • 1 • 1
RunUpCyc	Number of cycles in startup; messages are suppressed during these cycles	INT	3
SampleTime	Sampling time [s] (assigned automatically)	REAL	0.1
SelFp1	1 = Call a block saved in this parameter as an additional faceplate (Page 208) in the standard view	ANY	
SelFp2	1 = Call a block saved in this parameter as an additional faceplate (Page 208) in the standard view	ANY	
StepNo	Batch step number	DWORD	16#00000000
TimeStampOn	0 = Use time stamp of the CPU 1 = Use time stamp of the I/O devices	BOOL	0
UserStatus	Freely assignable bits for use in PCS 7 OS	BYTE	16#00000000

* Values can be written back to these inputs during processing of the block by the block algorithm.

Outputs

Parameter	Description	Type	Default
ENO	1 = Block algorithm completed without errors	BOOL	0
ErrorNum	Output of pending error number. For error numbers that can be output by this block, see Event16Ts error handling (Page 1679)	INT	-1
EventTsOut	For maneuvering of data between a technological block and the message blocks EventTs, Event16Ts.	STRUCT	
MS_Release	Release for maintenance: 1 = Release for OS operator	STRUCT • Value: BOOL • ST: BYTE	- • 0 • 16#80
MsgAckn1..MsgAckn2	Message acknowledgment status (output ACK_STATE of ALARM_8P)	WORD	16#0000
MsgErr1..MsgErr2	1 = Message error (output ERROR of ALARM_8P)	BOOL	0
MsgStat1..MsgStat2	Message status (output STATUS of ALARM_8P)	WORD	16#0000
OS_PermLog	Display of OS_Perm with settings changed by the block algorithm	DWORD	16#FFFFFFFF
ST_Worst	Worst signal status	BYTE	16#80
Status1	Status word 1 (Page 1671)	DWORD	16#00000000
Status2	Status word 2 (Page 1671)	DWORD	16#00000000
Status3	Status word 3 (Page 1676)	DWORD	16#00000000
Status4	Status word 4 (Page 1676)	DWORD	16#00000000

See also

Event16Ts block diagram (Page 1687)

Event16Ts messages (Page 1679)

9.4.7 Event16Ts block diagram

EventTs block diagram

A block diagram is not provided for this block.

See also

Event16Ts I/Os (Page 1685)

Event16Ts messages (Page 1679)

Event16Ts error handling (Page 1679)

Event16Ts functions (Page 1676)

Event16Ts operating modes (Page 1676)

Description of Event16Ts (Page 1671)

Counter blocks

10.1 CountScL - Counter with up and down counting direction

10.1.1 Description of CountScL

Object name (type + number) and family

Type + number: FB 1806

Family: Count

Area of application for CountScL

The block is used for the following applications:

- Count up or count down with rising edge of the binary input signal.

How it works

Positive edges at the binary input signal In increment or decrement the count value at Out, depending on settings.

1. Count up (UpOp = 1 or UpLi = 1)
The block counts up for each rising edge of In. (Output parameter CountMode = 1)
2. Count down (DnOp = 1 or DnLi = 1)
The block counts down for each rising edge of In. (Output parameter CountMode = 2)
3. Off (OffOp = 1 or OffLi = 1)
The block is disabled (output parameter CountMode = 0). No counting takes place.

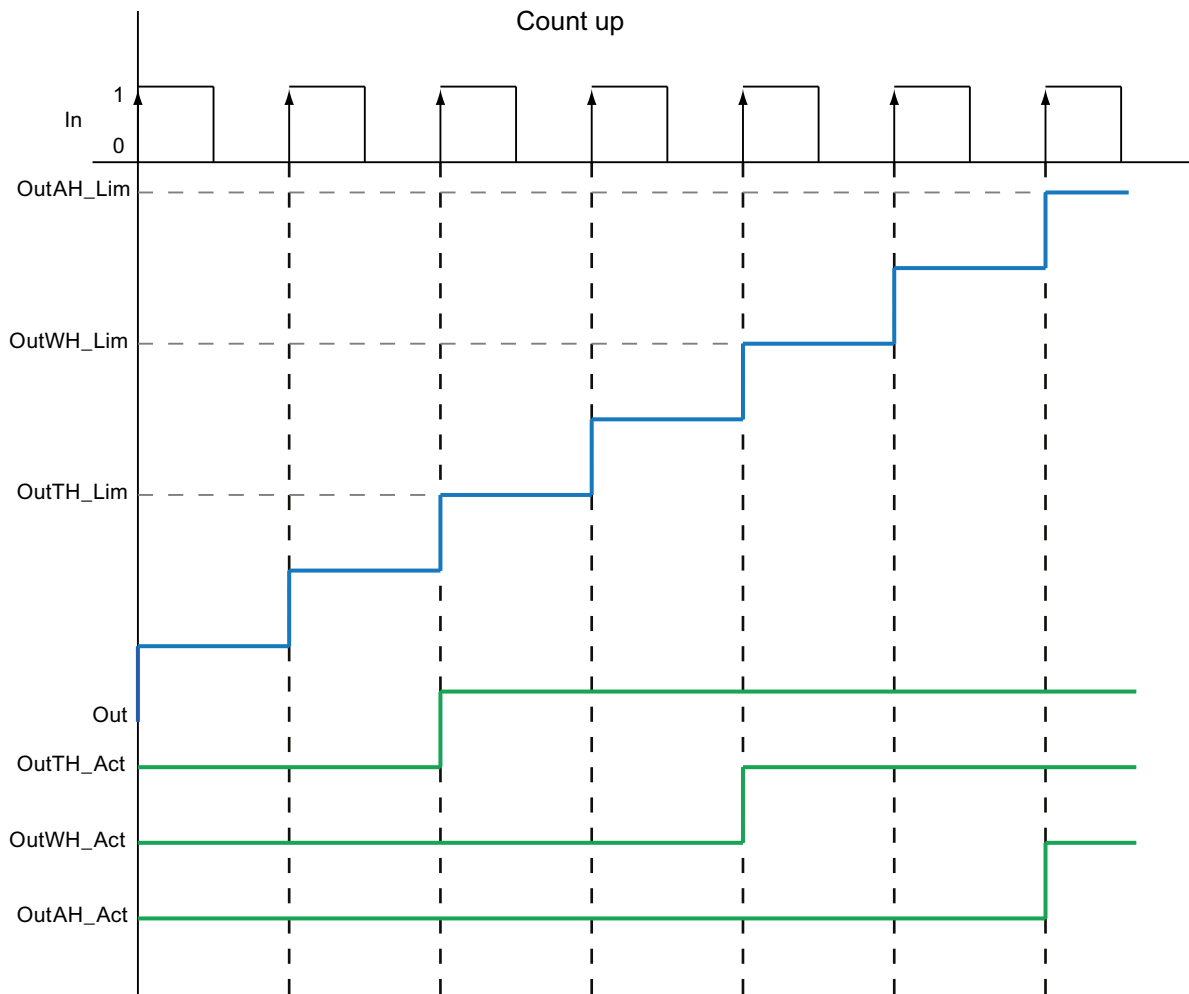

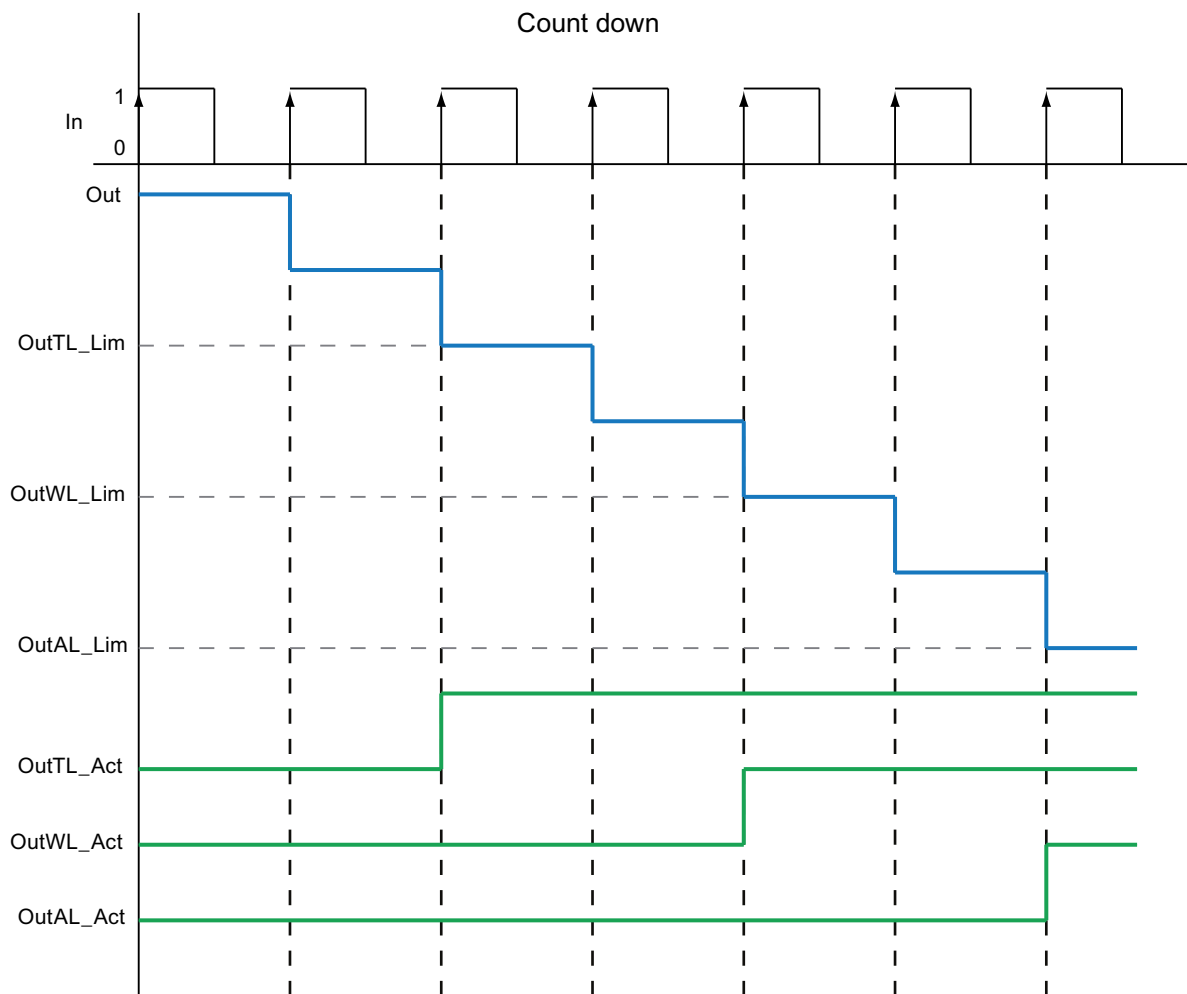

Configuration

Use the CFC editor to install the block in a cyclic interrupt OB (OB30 to OB38). The block is also installed automatically in the startup OB (OB100).

Startup characteristics

Define the startup characteristics for this block via two `Feature Bits`:

Bit 0: Set startup characteristics (Page 138)

Bit 5: Use the last value following a complete download as the current value during startup of the block (Page 154)

Time response

The block does not have any time response.

Status word allocation for status1 parameter

You can find a description for each parameter in section CountScl I/Os (Page 1699).

Status bit	Parameter
0	Occupied
1	BatchEn
2	Not used
3	OosAct.Value
4	OosLi.Value
5	Not used
6	OnAct.Value
7 - 10	Not used
11	LiOp
12 - 13	Not used
14	1 = Invalid signal status
15 - 31	Not used

Status word allocation for status2 parameter

Status bit	Parameter
0	MsgLock.Value
1	OutAH_Act.Value
2	OutWH_Act.Value
3	OutTH_Act.Value
4	OutTL_Act.Value
5	OutWL_Act.Value
6	OutAL_Act.Value
7	OutAH_En
8	OutWH_En
9	OutTH_En
10	OutTL_En
11	OutWL_En
12	OutAL_En
13	OutAH_MsgEn
14	OutWH_MsgEn
15	OutTH_MsgEn
16	OutTL_MsgEn
17	OutWL_MsgEn
18	OutAL_MsgEn
19	Not used
20	Count up
21	Counter off
22	Count down

Status bit	Parameter
23 - 30	Not used
31	MS_RelOp

See also

CountScL functions (Page 1694)
CountScL messaging (Page 1698)
CountScL block diagram (Page 1702)
CountScL error handling (Page 1697)
CountScL modes (Page 1693)

10.1.2 CountScL modes

CountScL operating modes

This block provides the following operating modes:

- On (Page 71)
- Out of service (Page 71)

"On"

General information on the "On" mode is available in the section On (Page 71).

"Out of service"

You can find general information about the "Out of service" mode in the section Out of service (Page 71).

See also

CountScL block diagram (Page 1702)
CountScL I/Os (Page 1699)
CountScL messaging (Page 1698)
CountScL error handling (Page 1697)
Description of CountScL (Page 1689)
CountScL functions (Page 1694)

10.1.3 CountScL functions

Functions of CountScL

The functions for this block are listed below.

Limit monitoring of the count value

This block provides the standard function Limit monitoring of the count value (Page 89).

Group display SumMsgAct for limit monitoring, CSF and ExtMsgx

The block provides the standard function Group display for limit monitoring, CSF and ExtMsgx (Page 85).

Read back the last counted value

When counting (visible at the `Out` output parameter), this count value is passed directly to the `OldOut` input parameter:

`OldOut = Out` If a warm restart is performed at this point, the count value (`Out`) is automatically reset to the default value, if the `Feature Bit Set` startup characteristics (Page 138) is set accordingly (`= 0`) (`OldOut ≠ Out`). In this case, the value from `OldOut` is only updated when the (`Out`) count value is changed again by a pulse. `OldOut = Out` now applies again.

Reset counter to zero

The counted value at the `Out` output parameter is reset with the interconnectable `ResetCount` parameter. The reset is made with a 0 - 1 edge.

The count cannot be reset to zero from the faceplate.

You can use `Feature bit 30 "Set reset depending on operating mode or the LiOp parameter"` to configure a reset depending on the `LiOp` parameter:

`Feature bit 30 =0`: The reset does not depend on `LiOp`

`Feature bit 30 =1`: The reset is only possible when `LiOp =1`.

Setting the count value to the default setting

You can use the `PresetVal` input parameter to enter a value at which the count should start, if the command has been given for setting the count to the default via the `PresetEn` input parameter with 1. This can also be done with the faceplate.

In this case, the `Out` output parameter is set to the `PresetVal` value.

You can use `Feature bit 30 "Set reset depending on operating mode or the LiOp parameter"` to configure the setting of the count value to a default depending on the `LiOp` parameter:

`Feature bit 30 =0`: Setting the count value to the default setting does not depend on `LiOp`

`Feature bit 30 =1`: Setting the count value to the default is only possible if `LiOp =0`.

Suppressing messages using the `MsgLock` parameter

This block provides the standard function Suppressing messages using the `MsgLock` parameter (Page 205).

Selecting a unit of measure

This block provides the standard function Selecting a unit of measure (Page 212).

Forming the signal status for blocks

This block provides the standard function Forming and outputting the signal status for technologic blocks (Page 109).

The worst signal status `ST_Worst` for the block is formed from the following parameter:

- `In.ST`
- `OutST`

The following signal status is formed by:

Signal status	Used status
<code>OutST</code>	Count up, count down: Formed from the signal status <code>In.ST</code> and the last signal status <code>OutST</code> . Counter off: Signal status <code>OutST</code> is frozen. Resetting <code>CountScL</code> also resets the signal status: <code>OutST := 16#80</code>

Configurable reactions using the `Feature` parameter

You can find an overview of all reactions provided by the `Feature` I/O in the Configurable functions using the `Feature` I/O (Page 131) . The following functionality is available for this block at the relevant bits:

Bit	Function
0	Set startup characteristics (Page 138)
1	Reaction to the out of service mode (Page 177)
5	Use the last value following a complete download as the current value during startup of the block (Page 154)
22	Update acknowledgment and error status of the message call (Page 160)
24	Enabling local operator authorization (Page 158)
26	Reaction of the switching points in the "Out of service" operating mode (Page 176)
28	Disabling operating points (Page 145)
29	Signaling limit violation (Page 170)

Operator permissions

This block provides the standard function Operator control permissions (Page 254).

The block has the following permissions for the OS_Perm parameter:

Bit	Function
0	Not used
1	1 = Operator can switch to "On" mode
2	Not used
3	1 = Operator can switch to "Out of service" mode
4	1 = Operator can stop counting
5	1 = Operator can switch to incrementing mode
6	1 = Operator can switch to decrementing mode
7 - 11	Not used
12	1 = Operator can activate the Release for maintenance function
13	1 = Operator can change the limit (OutAH_Lim) for high alarm
14	1 = Operator can change the limit (OutWH_Lim) for high warning
15	1 = Operator can change the limit (OutTH_Lim) for high tolerance
16	Not used
17	1 = Operator can change the limit (OutAL_Lim) for low alarm
18	1 = Operator can change the limit (OutWL_Lim) for low warning
19	1 = Operator can change the limit (OutTL_Lim) for low tolerance
20	Not used
21	1 = Operator can set the count to the default value (PresetEn)
22	1 = Operator can specify the default value (PresetTime)
23	1 = Operator can activate / deactivate messages via OutAH_MsgEn
24	1 = Operator can activate / deactivate messages via OutWH_MsgEn
25	1 = Operator can activate / deactivate messages via OutTH_MsgEn
26	1 = Operator can activate / deactivate messages via OutTL_MsgEn
27	1 = Operator can activate / deactivate messages via OutWL_MsgEn
28	1 = Operator can activate / deactivate messages via OutAL_MsgEn
29 - 31	Not used

Note

If you interconnect a parameter that is also listed in OS_Perm as a parameter, you have to reset the corresponding OS_Perm bit.

Release for maintenance

This block provides the standard function Release for maintenance (Page 64).

Opening additional faceplates

This block provides the standard function Opening additional faceplates (Page 208).

SIMATIC BATCH functionality

This block provides the standard function SIMATIC BATCH functionality (Page 67).

See also

Description of CountScL (Page 1689)

CountScL messaging (Page 1698)

CountScL I/Os (Page 1699)

CountScL block diagram (Page 1702)

CountScL error handling (Page 1697)

CountScL modes (Page 1693)

10.1.4 CountScL error handling**Error handling of CountScL**

Refer to the section Error handling (Page 119) in the basic instructions for the error handling of all blocks.

The following errors can be displayed for this block:

- Error numbers

Overview of error numbers

The `ErrorNum` I/O can be used to output the following error numbers:

Error number	Meaning of the error number
-1	Predefined value when inserting the block; the block is not processed.
0	There is no error.
51	Invalid signal at $LiOp = 1$: <ul style="list-style-type: none"> • $OffLi = 1$ and $UpLi = 1$ and/or $DnLi = 1$ • $OffLi = 0$ and $UpLi = 1$ and $DnLi = 1$

See also

CountScL block diagram (Page 1702)

CountScL I/Os (Page 1699)

CountScL messaging (Page 1698)

Description of CountScL (Page 1689)

CountScL modes (Page 1693)

CountScL functions (Page 1694)

10.1.5 CountScL messaging

Messaging

The following messages can be generated for this block:

- Functions for displaying measured limits

Messages generated as a reaction to limit violations, can be suppressed by the settings `MsgEn` and `MsgLock`.

Associated values for message instance `MsgEvId`

Associated value	Block parameters
1	BatchName
2	StepNo
3	BatchID

Process messages

Message instance	Message identifier	Message class	Event
MsgEvId	SIG 1	Alarm - high	\$\$BlockComment\$\$ High alarm limit violated
	SIG 2	Warning - high	\$\$BlockComment\$\$ High warning limit violated
	SIG 3	Tolerance - high	\$\$BlockComment\$\$ High tolerance limit violated
	SIG 4	Tolerance - low	\$\$BlockComment\$\$ Low tolerance limit violated
	SIG 5	Warning - low	\$\$BlockComment\$\$ Low warning limit violated
	SIG 6	Alarm - low	\$\$BlockComment\$\$ Low alarm limit violated
	SIG 7	Reserved	\$\$BlockComment\$\$
	SIG 8	Reserved	\$\$BlockComment\$\$

Explanation:

\$\$BlockComment\$\$: Content of the instance-specific comment

See also

Description of CountScL (Page 1689)

CountScL functions (Page 1694)

CountScL I/Os (Page 1699)

CountScL block diagram (Page 1702)

CountScL modes (Page 1693)

CountScL error handling (Page 1697)

10.1.6 CountScL I/Os

I/Os of CountScL

Input parameters

Parameter	Description	Type	Default
BatchEn	1 = Enable allocation	BOOL	0
BatchID	Batch ID	DWORD	16#00000000
BatchName	Batch name	S7-String	
DnLi	1 = Down counter, via interconnection	STRUCT <ul style="list-style-type: none"> Value: BOOL ST: BYTE 	- <ul style="list-style-type: none"> 0 16#80
DnOp*	1 = Down counter, via operator	BOOL	0
EN	1 = Called block will be processed	BOOL	1
Feature	I/O for additional functions (Page 1694)	STRUCT <ul style="list-style-type: none"> Bit 0: BOOL ... Bit 31: BOOL 	- <ul style="list-style-type: none"> 0 0 0
In	Binary input value	STRUCT <ul style="list-style-type: none"> Value: BOOL ST: BYTE 	- <ul style="list-style-type: none"> 0 16#80
LiOp	1 = Interconnection 0 = Operator	STRUCT <ul style="list-style-type: none"> Value: BOOL ST: BYTE 	- <ul style="list-style-type: none"> 0 16#80
MsgEvId	Message number (assigned automatically)	DWORD	16#00000000
MsgLock	1 = Suppress process messages. See also the section Suppressing messages using the MsgLock parameter (Page 205) for more on this.	STRUCT <ul style="list-style-type: none"> Value: BOOL ST: BYTE 	- <ul style="list-style-type: none"> 0 16#80
MS_RelOp*	Operator can switch release for maintenance	BOOL	0
Occupied	1 = In use by a batch	BOOL	0
OffLi	1 = Counter disabled via interconnection	STRUCT <ul style="list-style-type: none"> Value: BOOL ST: BYTE 	- <ul style="list-style-type: none"> 0 16#80
OffOp*	1 = Counter disabled via operator	BOOL	1
OldOut*	Previous output value	DINT	0
OnOp*	1 = "On" mode via operator	BOOL	0

Counter blocks

10.1 CountSCL - Counter with up and down counting direction

Parameter	Description	Type	Default
OosLi	1 = "Out of service", via interconnection or SFC (0-1 edge transition)	STRUCT <ul style="list-style-type: none"> Value: BOOL ST: BYTE 	- <ul style="list-style-type: none"> 0 16#80
OosOp*	1 = "Out of service", via OS operator	BOOL	0
OpSt_In	Input parameter for local operator authorization, connected with the <code>Out</code> output parameter of the upstream block, OpStations (Page 411)	DWORD	16#00000000
OS_Perm	I/O for operator permissions (Page 1694)	STRUCT <ul style="list-style-type: none"> Bit 0: BOOL ... Bit 31: BOOL 	- <ul style="list-style-type: none"> 1 1 1
OutAH_En	1 = Enable alarm (high) for count	BOOL	1
OutAH_Lim	Limit for count alarm (high)	DINT	95
OutAH_MsgEn	1 = Enable message for count alarm (high)	BOOL	1
OutAL_En	1 = Enable alarm (low) for count	BOOL	1
OutAL_Lim	Limit for count alarm (low)	DINT	0
OutAL_MsgEn	1 = Enable message for count alarm (low)	BOOL	1
OutOpHiScale	High limit for scale in count bar graph of faceplate	DINT	100
OutOpLoScale	Low limit for scale in count bar graph of faceplate	DINT	0
OutTH_En	1 = Enable tolerance message (high)	BOOL	0
OutTH_Lim	Count tolerance limit message (high)	DINT	85
OutTH_MsgEn	1 = Enable message for count tolerance message (high)	BOOL	1
OutTL_En	1 = Enable count tolerance message (low)	BOOL	0
OutTL_Lim	Count tolerance message limit (low)	DINT	0
OutTL_MsgEn	1 = Enable message for count tolerance message (low)	BOOL	1
OutUnit	Unit of measure for count <code>Out</code>	INT	0
OutWH_En	1 = Enable count warning (high)	BOOL	1
OutWH_Lim	Count warning limit (high)	DINT	90
OutWH_MsgEn	1 = Enable message for count warning (high)	BOOL	1
OutWL_En	1 = Enable count warning (low)	BOOL	1
OutWL_Lim	Count warning limit (low)	DINT	0
OutWL_MsgEn	1 = Enable message for count warning (low)	BOOL	1
PresetEn*	1 = Set block to default count (<code>PresetVal</code>)	BOOL	0
PresetVal	Default setting for the count	DINT	0
ResetCount	1 = Counter restart	STRUCT <ul style="list-style-type: none"> Value: BOOL ST: BYTE 	- <ul style="list-style-type: none"> 0 16#80
RunUpCyc	Number of operating cycles for which all messages are suppressed	INT	3
SampleTime	Sampling time [s] (assigned automatically)	REAL	0.1
SelFp1	Call a block saved in this parameter as an additional faceplate (Page 208) in the standard view	ANY	

10.1 CountScL - Counter with up and down counting direction

Parameter	Description	Type	Default
SelFp2	Call a block saved in this parameter as an additional faceplate (Page 208) in the preview	ANY	
StepNo	Batch step number	DWORD	16#00000000
UpLi	1 = Forward counter, via interconnection	STRUCT <ul style="list-style-type: none"> Value: BOOL ST: BYTE 	- <ul style="list-style-type: none"> 0 16#80
UpOp*	1 = Forward counter, via operator	BOOL	0

* Values can be written back to these inputs during processing of the block by the block algorithm.

Output parameters

Parameter	Description	Type	Default
CountMode	0 = Counter off 1 = Count up 2 = Count down	INT	0
ENO	1 = Block algorithm completed without errors	BOOL	0
ErrorNum	Output of pending error number. For error numbers that can be output by this block, see CountScL error handling (Page 1697)	INT	-1
MsgAckn	Message acknowledgement status (output ACK_STATE of first ALARM_8P)	WORD	16#0000
MsgErr	1 = Message error (output ERROR of the first ALARM_8P)	BOOL	0
MsgStat	Message status (output STATUS of the first ALARM_8P)	WORD	16#0000
MS_Release	Release for maintenance	STRUCT <ul style="list-style-type: none"> Value: BOOL ST: BYTE 	- <ul style="list-style-type: none"> 0 16#80
O_MS_Ext	Reserved	DWORD	0
OnAct	1 = "On" mode enabled	STRUCT <ul style="list-style-type: none"> Value: BOOL ST: BYTE 	- <ul style="list-style-type: none"> 1 16#80
OosAct	1 = Block is "Out of service"	STRUCT <ul style="list-style-type: none"> Value: BOOL ST: BYTE 	- <ul style="list-style-type: none"> 0 16#80
OpSt_Out	Value of the OpSt_In input parameter, for feedforwarding to other blocks. Bit 31 of this parameter is used by Feature bit 24	DWORD	16#00000000
OS_PermLog	Display of OS_Perm with settings changed by the block algorithm	DWORD	16#FFFFFFFF
OS_PermOut	Display of OS_Perm	DWORD	16#FFFFFFFF
Out	Count	DINT	0

10.1 CountScL - Counter with up and down counting direction

Parameter	Description	Type	Default
OutAH_Act	1 = Count alarm (high) enabled. You can change the reaction for this parameter with <i>Feature</i> bit 28 (Disabling operating points (Page 145)) and with <i>Feature</i> bit 29 (Signaling limit violation (Page 170)).	STRUCT • Value: BOOL • ST: BYTE	- • 0 • 16#80
OutAL_Act	1 = Count alarm (low) enabled. You can change the reaction for this parameter with <i>Feature</i> bit 28 (Disabling operating points (Page 145)) and with <i>Feature</i> bit 29 (Signaling limit violation (Page 170)).	STRUCT • Value: BOOL • ST: BYTE	- • 0 • 16#80
OutST	Signal status for Out	BYTE	16#80
OutTH_Act	1 = Count tolerance message (high) enabled. You can change the reaction for this parameter with <i>Feature</i> bit 28 (Disabling operating points (Page 145)) and with <i>Feature</i> bit 29 (Signaling limit violation (Page 170)).	STRUCT • Value: BOOL • ST: BYTE	- • 0 • 16#80
OutTL_Act	1 = Count tolerance message (low) enabled. You can change the reaction for this parameter with <i>Feature</i> bit 28 (Disabling operating points (Page 145)) and with <i>Feature</i> bit 29 (Signaling limit violation (Page 170)).	STRUCT • Value: BOOL • ST: BYTE	- • 0 • 16#80
OutWH_Act	1 = Count warning (high) enabled. You can change the reaction for this parameter with <i>Feature</i> bit 28 (Disabling operating points (Page 145)) and with <i>Feature</i> bit 29 (Signaling limit violation (Page 170)).	STRUCT • Value: BOOL • ST: BYTE	- • 0 • 16#80
OutWL_Act	1 = Count warning (low) enabled. You can change the reaction for this parameter with <i>Feature</i> bit 28 (Disabling operating points (Page 145)) and with <i>Feature</i> bit 29 (Signaling limit violation (Page 170)).	STRUCT • Value: BOOL • ST: BYTE	- • 0 • 16#80
ST_Worst	Worst signal status	BYTE	16#80
Status1	Status word 1 (Page 1689)	DWORD	16#00000000
Status2	Status word 2 (Page 1689)	DWORD	16#00000000

See also

- CountScL messaging (Page 1698)
- CountScL block diagram (Page 1702)
- CountScL modes (Page 1693)

10.1.7 CountScL block diagram

CountScL block diagram

A block diagram is not provided for this block.

See also

Description of CountScL (Page 1689)
CountScL modes (Page 1693)
CountScL functions (Page 1694)
CountScL error handling (Page 1697)
CountScL messaging (Page 1698)
CountScL I/Os (Page 1699)

10.1.8 Operator control and monitoring**10.1.8.1 CountScL views****Views of the CountScL block**

The block CountScL provides the following views:

- CountScL standard view (Page 1704)
- Alarm view (Page 302)
- CountScL limit view (Page 1706)
- Trend view (Page 305)
- CountScL parameter view (Page 1707)
- CountScL preview (Page 1708)
- Memo view (Page 304)
- Batch view (Page 302)
- Block icon for CountScL (Page 1709)

Refer to the sections Structure of the faceplate (Page 248) and Block icon structure (Page 230) for general information on the faceplate and block icon.

10.1.8.2 CountScL standard view

CountScL standard view

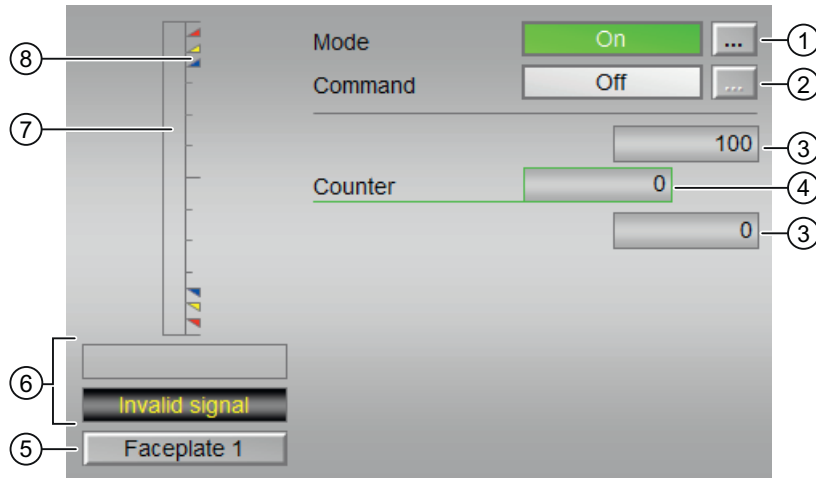

(1) Displaying and switching the operating mode

This area provides information on the currently valid operating mode. The following operating modes can be shown here:

- On (Page 71)
- Out of service (Page 71)

Refer to the Switching operating states and operating modes (Page 257) section for information on switching the operating mode.

(2) Enabling and disabling the counter

This area shows you the default operating state for the counter. The following states can be shown and executed here:

- "On ↑"
- "On ↓"
- "Off"

Refer to the Switching operating states and operating modes (Page 257) section for information on changing the state.

(3) High and low scale range for the count value

These values provide information on the display range for the bar graph of the count. The scale range is defined in the engineering system.

(4) Display of the count value

This area shows the current count value with the signal status `OutST`.

The name for the current count value can be set using the `s7_shortcut` attribute at the corresponding output parameter. The default text is displayed if nothing is specified.

You can find additional information on this in the section Labeling of buttons and text (Page 209) .

(5) Navigation button for switching to the standard view of any faceplate

Use this navigation button to open the standard view of a block configured in the engineering system (ES). The visibility of this navigation button depends on the configuration in the engineering system (ES).

You can find additional information on this in the section Opening additional faceplates (Page 208) .

(6) Display area for block states

This area provides additional information on the operating state of the block:

- "Maintenance"
- "Invalid signal"

(7) Graphic display of the current count value

This area shows you the current count in form of a bar graph. The visible area in the bar graph depends on the configuration in the engineering system (ES).

(8) Limit display

These colored triangles indicate the configured limits in the respective bar graph:

- Red: Alarm
- Yellow: Warning
- Blue: Tolerance

In counting mode "count up", only the colored triangles of the upper limits are visible; and in counting mode "count down", only the colored triangles of the lower limits are visible.

10.1.8.3 CountScL limit view

Limit view of CountScL

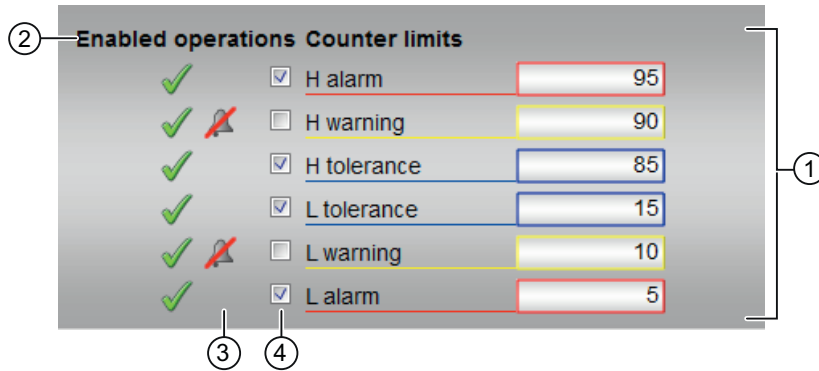

(1) Limits for the counter

In this area, you can enter the limits for the counter. Refer to the Changing values (Page 259) section for more on this.

You can change the following limits:

- "H alarm": Alarm high
- "H warning": Warning high
- "H tolerance": Tolerance high
- "L tolerance": Tolerance low
- "L warning": Warning low
- "L alarm": Alarm low

(2) Enabled operation

This area shows all operations for which special operator permissions are assigned. They depend on the configuration in the engineering system (ES) that applies to this block.

Icons for enabled operation:

- **Green check mark:** the OS operator can control this parameter
- **Gray check mark:** the OS operator cannot control this parameter at this time due to the process
- **Red cross:** the OS operator cannot control this parameter due to the configured AS operator permissions (OS_Perm or OS1Perm)

(3) "Message suppression"

Message suppression indicates whether or not the suppression of the associated message in the AS block is activated with the `xx_MsgEn` parameter. The output of messages is not suppressed when the block is installed (all `xx_MsgEn` parameters are preset to 1). Messages can only be output if limit monitoring of the additional analog value has been enabled.

(4) Suppress messages

You can enable / disable messages by setting the check mark.

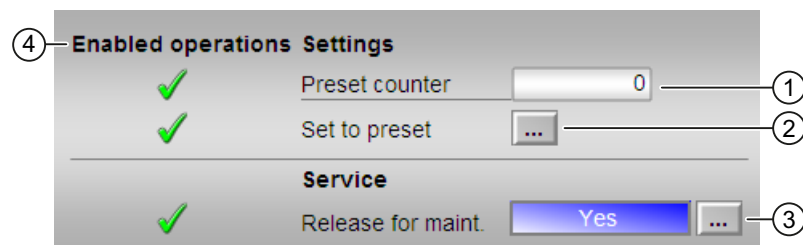
10.1.8.4 CountScL parameter view**Parameter view of CountScL****(1) Preset counter**

Enter the default setting here, where the counter should start. You can find additional information on this in the Changing values (Page 259) section.

(2) Set to default

Set the counter to the default value here. You can find additional information on this in the Switching operating states and operating modes (Page 257) section.

(3) Service

You can select the following function in this area:

- "Release for maintenance"

Refer to the Switching operating states and operating modes (Page 257) section for more on this.

You can find information on this area in the Release for maintenance (Page 64) section.

(4) Enabled operations

This area shows all operations for which special operator control permissions are assigned. They depend on the configuration in the engineering system (ES) that applies to this block.

Symbols for enabled operations:

- **Green check mark:** the OS operator can control this parameter
- **Gray check mark:** the OS operator cannot control this parameter at this time due to the process
- **Red cross:** the OS operator cannot control this parameter due to the configured AS operator control permissions (OS_Perm or OS1Perm).

10.1.8.5 CountScL preview

Preview of CountScL

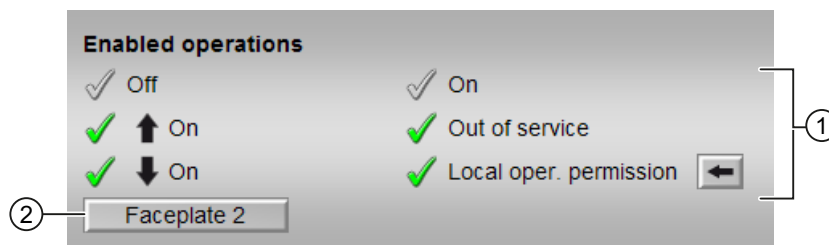

(1) Enabled operations

This area shows all operations for which special operator control permissions are assigned. They depend on the configuration in the engineering system (ES) that applies to this block.

Symbols for enabled operations:

- **Green check mark:** the OS operator can control this parameter
- **Gray check mark:** the OS operator cannot control this parameter at this time due to the process
- **Red cross:** the OS operator cannot control this parameter due to the configured AS operator control permissions (OS_Perm or OS1Perm)

The following enabled operations are shown here:

- "Off": You can disable the counter.
- "On ↑": You can operate the incremental counter.
- "On ↓": You can operate the decremental counter.
- "On": You can switch to "On" operating mode.
- "Out of service": You can switch to "Out of service" operating mode.
- "Local operating permission": Use the ← button to switch to the standard view of the OpStations block. Additional information is available in the section Operator control permissions (Page 254).

(2) Navigation button for switching to the standard view of any faceplate

Use this navigation button to reach the standard view of a block configured in the engineering system. The visibility of this navigation button depends on the configuration in the engineering system (ES).



You can find additional information on this in the Opening additional faceplates (Page 208) section.

10.1.8.6 Block icon for CountScL**Block icons for CountScL**

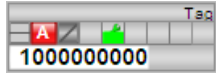

A variety of block icons are available with the following functions:

- Process tag type
- Limits (high/low)
- Violation of alarm, warning, and tolerance limits
- Operating modes
- Signal status, release for maintenance
- Memo display
- Display counter running

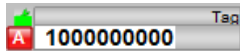
The block icons from template @TemplateAPLV8.PDL:

Icons	Selection of the block icon in the CFC	Special features
	1	
	2	
	3	Block icon in the full display

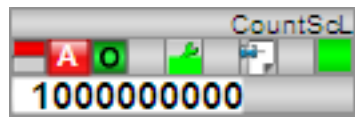
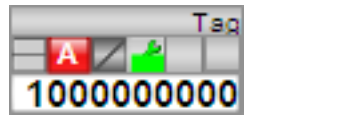
The block icons from template @TemplateAPLV7.PDL:

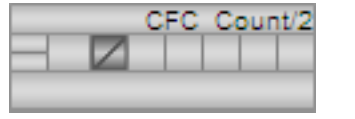
Icons	Selection of the block icon in CFC	Special features
	1	Block icon in the full display
	2	
	3	
	4	
	-	Block icon in "Out of service" mode (example with type 1 block icon)

Additional information on the block icon and the control options in the block icon is available in the following chapters:

- Configuring the block icons (Page 237)
- Block icon structure (Page 230)
- Operation via the block icon (Page 239).

10.2 CountOh - Determining runtime

10.2.1 Description of CountOh

Object name (type + number) and family

Type + number: FB 1864

Family: Count

Area of application for CountOh

The block is used for the following applications:

- Calculating the runtime of a unit

How it works

The block calculates the operating time of a unit.

1. Off ($OffOp = 1$ or $OffLi = 1$)
The block is disabled (output parameter $CountMode = 0$). No counting takes place.
2. Count up ($UpOp = 1$ or $UpLi = 1$)
The operating time of the connected unit is incremented (output parameter $CountMode = 1$).
3. Count down ($DnOp = 1$ or $DnLi = 1$)
The operating time of the connected unit is decremented (output parameter $CountMode = 2$).

The operating time is shown depending on the course of days, hours, minutes and seconds.

If the operating time exceeds the configured limits, an alarm is triggered.

10.2 CountOh - Determining runtime

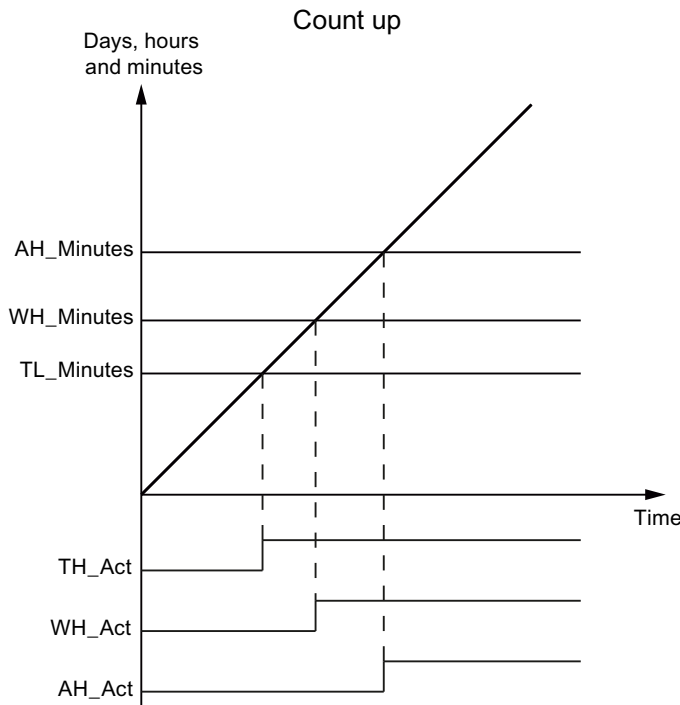

When the block counts up and the total operating time (TimeMin) of the connected unit is greater than or equal to the limits (TH_Minutes, WH_Minutes and AH_Minutes), the alarms TH_Act, WH_Act and AH_Act are set.

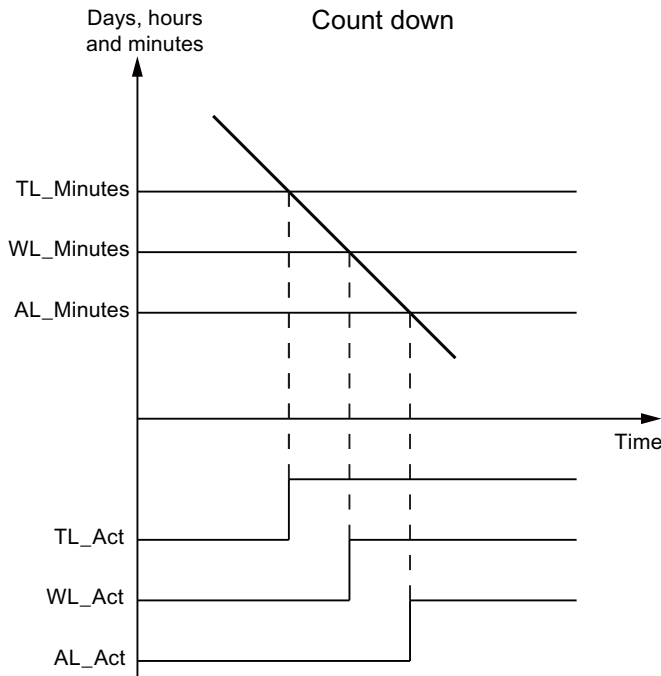

When the block counts up and the total operating time (TimeMin) of the connected unit is greater than or equal to the limits (TL_Minutes, WL_Minutes and AL_Minutes), the alarms TL_Act, WL_Act and AL_Act are set.

The operating time can be preset. The value can be specified by the operator. The operator can set values for days, hours and minutes to begin counting, if the required operator control permission has been issues for this.

The maximum configurable value for the operating time is 24855 days, 3 hours and 14 minutes.

Configuration

Use the CFC editor to install the block in a cyclic interrupt OB (OB30 to OB38). The block is first installed automatically in the startup OB (OB 100).

Startup characteristics

Define the startup characteristics for this block via two `Feature Bits`:

Bit 0: Set startup characteristics (Page 138)

Bit 5: Use the last value following a complete download as the current value during startup of the block (Page 154)

When `Feature bit 5` is set to 1, then:

- `Days := OldDays`
- `Hours := OldHours`
- `Minutes := OldMinutes`
- `Seconds := OldSeconds`

When you set `Feature bit 5` and `Feature bit 0` to 1, then:

- `TotalTime := PresetTime`

The output parameters `Days`, `Hours`, `Minutes` are converted accordingly based on `PresetTime`.

When you set `Feature bit 5` to 0 and `Feature bit 0` to 1, no preset is made.

Time response

The block only functions properly in a cyclic interrupt OB. To ensure correct time acquisition, it should be installed (if configured in CFC) in the same runtime group as the control block of the monitored unit.

Status word allocation for `Status1` parameter

You can find a description for each parameter in section `CountOh I/Os` (Page 1722).

Status bit	Parameter
0	Occupied
1	BatchEn
2	Not used
3	OosAct.Value
4	OosLi.Value

Status bit	Parameter
5	Not used
6	OnAct.Value
7 - 10	Not used
11	LiOp
12 - 13	Not used
14	1 = Invalid signal status
15 - 31	Not used

Status word allocation for Status2 parameter

Status bit	Parameter
0	MsgLock.Value
1	AH_Act.Value
2	WH_Act.Value
3	TH_Act.Value
4	TL_Act.Value
5	WL_Act.Value
6	AL_Act.Value
7	AH_En
8	WH_En
9	TH_En
10	TL_En
11	WL_En
12	AL_En
13	AH_MsgEn
14	WH_MsgEn
15	TH_MsgEn
16	TL_MsgEn
17	WL_MsgEn
18	AL_MsgEn
19	Not used
20	Count up
21	Counter off
22	Count down
23 - 30	Not used
31	MS_RelOp

See also

CountOh functions (Page 1715)

CountOh messaging (Page 1720)

CountOh block diagram (Page 1726)

CountOh error handling (Page 1720)

CountOh modes (Page 1715)

10.2.2 CountOh modes

CountOh operating modes

The block can be operated using the following modes:

- On (Page 71)
- Out of service (Page 71)

"On"

You can find general information about the "On" mode in the On (Page 71) section.

"Out of service"

You can find general information about the "Out of service" mode in the section Out of service (Page 71).

See also

CountOh block diagram (Page 1726)

CountOh I/Os (Page 1722)

CountOh messaging (Page 1720)

CountOh error handling (Page 1720)

Description of CountOh (Page 1711)

CountOh functions (Page 1715)

10.2.3 CountOh functions

Functions of CountOh

The block provides the following functions:

Limit monitoring of the operating time

The total time in minutes (`TimeIn`) is displayed for the following limits:

1. Alarm (`AH_Minutes` and `AL_Minutes`)
2. Warning (`WH_Minutes` and `WL_Minutes`)
3. Tolerance (`TH_Minutes` and `TL_Minutes`)

Note

Limit monitoring:

Limit monitoring depends on the counting direction:

- Operation mode 1 (counting up), limit monitoring top
 - `AH_Minutes`
 - `WH_Minutes`
 - `TH_Minutes`
 - Operation mode 2 (counting down), limit monitoring bottom
 - `AL_Minutes`
 - `WL_Minutes`
 - `TL_Minutes`
-

Group display `SumMsgAct` for limit monitoring, `CSF` and `ExtMsgx`

The block provides the standard function Group display for limit monitoring, `CSF` and `ExtMsgx` (Page 85).

Suppressing messages using the `MsgLock` parameter

This block provides the standard function Suppressing messages using the `MsgLock` parameter (Page 205).

Configurable reactions using the `Feature` parameter

You can find an overview of all reactions provided by the `Feature` parameter in the Configurable functions using the Feature I/O (Page 131) . The following functionality is available for this block at the relevant bits:

Bit	Function
0	Set startup characteristics (Page 138)
1	Reaction to the out of service mode (Page 177)
5	Use the last value following a complete download as the current value during startup of the block (Page 154)
22	Update acknowledgment and error status of the message call (Page 160)
24	Enabling local operator authorization (Page 158)
26	Reaction of the switching points in the "Out of service" operating mode (Page 176)

Bit	Function
28	Disabling operating points (Page 145)
29	Signaling limit violation (Page 170)

Read back the last counted value

When counting (`DeviceOn.Value = 1` and `CountMode = 1` or `2`), the inputs of the most recently valid operating time are updated:

- `OldDays := Days`
- `OldHours := Hours`
- `OldMinutes := Minutes`
- `OldSeconds := Seconds`

The inputs `OldDays`, `OldHours`, `OldMinutes`, `OldSeconds` are read back with a complete download.

After a warm restart, the outputs of the operating time are set depending on the configuration of the `Feature` parameter.

When `Feature` bit 5 is set to 1, then:

- `Days := OldDays`
- `Hours := OldHours`
- `Minutes := OldMinutes`
- `Seconds := OldSeconds`

When you set `Feature` bit 5 and `Feature` bit 0 to 1, then:

- `TotalTime := PresetTime`

The output parameters `Days`, `Hours`, `Minutes` are converted accordingly based on `PresetTime`.

When you set `Feature` bit 5 to 0 and `Feature` bit 0 to 1, no preset is made.

Display and operator input area for process values and setpoints

This block provides the standard function Display and operator input area for process values and setpoints (Page 207).

Reset counter to zero

The output parameters of the operating time are reset via the interconnectable `Reset` parameter. The reset is made with a 0 - 1 edge.

The count cannot be reset to zero from the faceplate.

You can use `Feature` bit 30 "Set reset depending on operating mode or the `LiOp` parameter" to configure a reset depending on the `LiOp` parameter:

`Feature` bit 30 =0: The reset does not depend on `LiOp`

`Feature` bit 30 =1: The reset is only possible when `LiOp =1`

Setting the count value to the default setting

You can enter the operating time at which counting should begin with the input parameters `PresetTime` and `PresetEn`.

When `PresetEn` is set, the following applies:

- `TotalTime := PresetTime`

The outputs `Days`, `Hours`, `Minutes` are converted accordingly based on `PresetTime`. `PresetTime` can also be entered in the faceplate.

The `PresetTime` time value is always indicated in seconds.

You can use the `Feature Bit 30` "Set reset depending on operating mode or the `LiOp` parameter" to configure the setting of the count value to a default depending on the `LiOp` parameter:

`Feature Bit 30 =0`: Setting to the default does not depend on `LiOp`

`Feature Bit 30 =1`: Setting to the default is only possible if `LiOp =0`.

Opening additional faceplates

This block provides the standard function `Opening additional faceplates` (Page 208).

Forming the signal status for blocks

This block provides the standard function `Forming and outputting the signal status for technologic blocks` (Page 109).

The worst signal status `ST_Worst` for the block is formed from the following parameter:

- `In.ST`
- `TmMinSt`

The following signal status is formed by:

Signal status	Used status
<code>TmMinST</code>	Count up, count down: Formed from the signal status <code>In.ST</code> and the last signal status <code>TmMinST</code> . Counter off: Signal status <code>TmMinST</code> is frozen. Resetting <code>CountOh</code> also resets the signal status: <code>TmMinST := 16#80</code>

Operator permissions

This block provides the standard function `Operator control permissions` (Page 254).

The block has the following permissions for the `OS_Perm` parameter:

Bit	Function
0	Not used
1	1 = Operator can start the block

Bit	Function
2	Not used
3	1 = Operator can switch to "Out of service" mode
4	1 = Operator can stop the block
5	1 = Operator can switch to incrementing mode
6	1 = Operator can switch to decrementing mode
7 - 11	Not used
12	1 = Operator can enable release for maintenance
13	1 = Operator can enter AH_Lim
14	1 = Operator can enter WH_Lim
15	1 = Operator can enter TH_Lim
16	Not used
17	1 = Operator can enter AL_Lim
18	1 = Operator can enter WL_Lim
19	1 = Operator can enter TL_Lim
20	Not used
21	1 = Operator can enable default
22	1 = Operator can apply configured time
23	1 = Operator can activate / deactivate messages via AH_MsgEn
24	1 = Operator can activate / deactivate messages via WH_MsgEn
25	1 = Operator can activate / deactivate messages via TH_MsgEn
26	1 = Operator can activate / deactivate messages via TL_MsgEn
27	1 = Operator can activate / deactivate messages via WL_MsgEn
28	1 = Operator can activate / deactivate messages via AL_MsgEn
29 - 31	Not used

Note

If you interconnect a parameter that is also listed in OS_Perm as a parameter, you have to reset the corresponding OS_Perm bit.

Release for maintenance

This block provides the standard function Release for maintenance (Page 64).

SIMATIC BATCH functionality

This block provides the standard function SIMATIC BATCH functionality (Page 67).

See also

Description of CountOh (Page 1711)

CountOh messaging (Page 1720)

CountOh I/Os (Page 1722)

CountOh block diagram (Page 1726)

CountOh error handling (Page 1720)

CountOh modes (Page 1715)

10.2.4 CountOh error handling

Error handling of CountOh

Refer to the section Error handling (Page 119) in the basic instructions for the error handling of all blocks.

The following errors can be displayed for this block:

- Error numbers

Overview of error numbers

The `ErrorNum` I/O can be used to output the following error numbers:

Error number	Meaning of the error number
-1	Predefined value when inserting the block; the block is not processed.
0	There is no error.
51	Invalid signal at <code>LiOp = 1</code> <ul style="list-style-type: none"> • <code>OffLi = 1</code> and <code>UpLi = 1</code> and/or <code>DnLi = 1</code> • <code>OffLi = 0</code> and <code>UpLi = 1</code> and <code>DnLi = 1</code>

See also

CountOh block diagram (Page 1726)

CountOh I/Os (Page 1722)

CountOh messaging (Page 1720)

CountOh functions (Page 1715)

CountOh modes (Page 1715)

Description of CountOh (Page 1711)

10.2.5 CountOh messaging

Messaging

The following messages can be generated for this block:

- Functions for displaying measured limits

Messages generated as a reaction to limit violations, can be suppressed by the settings `xx_MsgEn` and `MsgLock`.

Process messages

Message instance	Message identifier	Message class	Event
MsgEvId 1	SIG 1	Alarm - high	\$\$BlockComment\$\$ High alarm limit violated
	SIG 2	Warning - high	\$\$BlockComment\$\$ High warning limit violated
	SIG 3	Tolerance - high	\$\$BlockComment\$\$ High tolerance limit violated
	SIG 4	Tolerance - low	\$\$BlockComment\$\$ Low tolerance limit violated
	SIG 5	Warning - low	\$\$BlockComment\$\$ Low warning limit violated
	SIG 6	Alarm - low	\$\$BlockComment\$\$ Low alarm limit violated
	SIG 7	Reserved	\$\$BlockComment\$\$ For internal use
	SIG 8	Reserved	\$\$BlockComment\$\$ For internal use

Explanation:

\$\$BlockComment\$\$: Content of the instance-specific comment

Associated values for message instance `MsgEvId1`

Associated value	Block parameters
1	BatchName
2	StepNo
3	BatchID

See also

Description of CountOh (Page 1711)

CountOh functions (Page 1715)

CountOh I/Os (Page 1722)

CountOh block diagram (Page 1726)

CountOh error handling (Page 1720)

CountOh modes (Page 1715)

10.2.6 CountOh I/Os

I/Os of CountOh

Input parameters

Parameter	Description	Type	Default
AH_En	High alarm enabled	BOOL	1
AH_MsgEn	Message for high alarm enabled	BOOL	1
AL_En	Low alarm enabled	BOOL	1
AL_MsgEn	Message for low alarm enabled	BOOL	1
BatchEn	1 = Enable allocation	BOOL	0
BatchID	Batch number (Batch ID)	DWORD	16#00000000
BatchName	Batch name	S7-String	
DayOpHiScale*	Operating stage - High limit of bar display for OS	INT	100
DayOpLoScale*	Operating stage - Low limit of bar display for OS	INT	0
DaysAHLim*	Days - high limit alarm	INT	95
DaysALLim*	Days - low limit alarm	INT	0
DaysTHLim*	Days - high limit tolerance	INT	85
DaysTLLim*	Days - low limit tolerance	INT	0
DaysWHLim*	Days - limit for high warning	INT	90
DaysWLLim*	Days - limit for low warning	INT	0
DnLi	1 = Decrement via interconnection	STRUCT <ul style="list-style-type: none"> • Value: BOOL • ST: BYTE 	- <ul style="list-style-type: none"> • 0 • 16#80
DnOp*	1 = Decrement via OS operator	BOOL	0
EN	1 = Called block will be processed	BOOL	1
Feature	I/O for additional functions (Page 1715)	STRUCT <ul style="list-style-type: none"> • Bit 0: BOOL • ... • Bit 31: BOOL 	- <ul style="list-style-type: none"> • 0 • 0 • 0
HrsAHLim*	Hours - high limit alarm	INT	0
HrsALLim*	Hours - low limit alarm	INT	0
HrsOpHiScale*	Operating hours - high limit of bar display for OS	INT	23
HrsOpLoScale*	Operating hours - low limit of bar display for OS	INT	0
HrsTHLim*	Hours - high limit tolerance	INT	0
HrsTLLim*	Hours - low limit tolerance	INT	0
HrsWHLim*	Hours - high limit warning	INT	0
HrsWLLim*	Hours - low limit warning	INT	0

Parameter	Description	Type	Default
In	Device status: 1=On 0=Off	STRUCT • Value: BOOL • ST: BYTE	- • 0 • 16#80
LiOp	Switchover of operating mode between: 1 = Interconnection 0 = Operator	STRUCT • Value: BOOL • ST: BYTE	- • 0 • 16#80
MinOpHiScale*	Operating minutes - high limit of bar display for OS	INT	59
MinOpLoScale*	Operating minutes - low limit of bar display for OS	INT	0
MinsAHLim*	Minutes - high limit alarm	INT	0
MinsALLim*	Minutes - low limit alarm	INT	0
MinsTHLim*	Minutes - high limit tolerance	INT	0
MinsTLLim*	Minutes - low limit tolerance	INT	0
MinsWHLim*	Minutes - high limit warning	INT	0
MinsWLLim*	Minutes - low limit warning	INT	0
MS_RelOp*	Operator input for release for maintenance, 1: Release for maintenance demand	BOOL	0
MsgEvId	Message number (assigned automatically)	DWORD	16#00000000
MsgLock	1= Suppress process messages. See also the section Suppressing messages using the MsgLock parameter (Page 205) for more on this.	STRUCT • Value: BOOL • ST: BYTE	- • 0 • 16#80
Occupied	1 = In use by a batch	BOOL	0
OffLi	Counter disabled via interconnection: 1 = Off	STRUCT • Value: BOOL • ST: BYTE	- • 0 • 16#80
OffOp*	Counter disabled via operator: 1 = Off	BOOL	1
OldDays*	Previous day value	INT	0
OldHours*	Previous hour value	INT	0
OldMinutes*	Previous minute value	INT	0
OldSeconds*	Previous second value	INT	0
OnOp*	1 = "On" mode via operator	BOOL	0
OosLi	1 = "Out of service", via interconnection	STRUCT • Value: BOOL • ST: BYTE	- • 0 • 16#80
OosOp*	1 = "Out of service", via operator	BOOL	0
OpSt_In	Input parameter for local operator authorization, connected with the <code>Out</code> output parameter of the upstream block, <code>OpStations</code> (Page 411)	DWORD	16#00000000

Parameter	Description	Type	Default
OS_Perm	I/O for CountOh functions (Page 1715)	STRUCT <ul style="list-style-type: none"> • Bit 0: BOOL • ... • Bit 31: BOOL 	- <ul style="list-style-type: none"> • 1 • 1 • 1
PresetEn*	1 = Set block to default time value (PresetTime)	BOOL	0
PresetTime*	Default setting for the time value [s]	DWORD	16#00000000
Reset	1 = Reset counter	STRUCT <ul style="list-style-type: none"> • Value: BOOL • ST: BYTE 	- <ul style="list-style-type: none"> • 0 • 16#80
RunUpCyc	Number of cycles in startup; messages are suppressed during these cycles	INT	3
SampleTime	Sampling time [s]	REAL	0.1
SelFp1	Open faceplate 1	ANY	
SelFp2	Open faceplate 2	ANY	
StepNo	Batch step number	DWORD	16#00000000
TH_En	High tolerance enabled	BOOL	0
TH_MsgEn	Alarm for high tolerance enabled	BOOL	1
TL_En	Low tolerance enabled	BOOL	0
TL_MsgEn	Alarm for low tolerance enabled	BOOL	1
UpLi	1 = Increment (via interconnection)	STRUCT <ul style="list-style-type: none"> • Value: BOOL • ST: BYTE 	- <ul style="list-style-type: none"> • 0 • 16#80
UpOp*	1 = Increment (via faceplate)	BOOL	0
WH_En	High warning enabled	BOOL	1
WH_MsgEn	Alarm for high warning enabled	BOOL	1
WL_En	Low warning enabled	BOOL	1
WL_MsgEn	Alarm for low warning enabled	BOOL	1

* Values can be written back to these inputs during processing of the block by the block algorithm.

Output parameters

Parameter	Description	Type	Default
AH_Act	High alarm enabled. You can change the reaction for this parameter with <code>Feature</code> bit 28 (Disabling operating points (Page 145)) and with <code>Feature</code> bit 29 (Signaling limit violation (Page 170)).	STRUCT <ul style="list-style-type: none"> • Value: BOOL • ST: BYTE 	- <ul style="list-style-type: none"> • 0 • 16#80
AH_Minutes	High alarm time [in min]	DINT	0

Parameter	Description	Type	Default
AL_Act	Low alarm enabled You can change the reaction for this parameter with <code>Feature</code> bit 28 (Disabling operating points (Page 145)) and with <code>Feature</code> bit 29 (Signaling limit violation (Page 170)).	STRUCT • Value: BOOL • ST: BYTE	- • 0 • 16#80
AL_Minutes	Low alarm time [in min]	DINT	0
BarOpHiScale	High limit for bar display [min]	DINT	100
BarOpLoScale	Low limit for bar display [min]	DINT	0
CountMode	Count mode: 0 = Off 1 = Increment 2 = Count down	INT	0
Days	Operating stage	INT	0
DeviceOn	1 = Unit on	STRUCT • Value: BOOL • ST: BYTE	- • 0 • 16#80
ENO	1 = Block algorithm completed without errors	BOOL	0
ErrorNum	Output of pending error number. For error numbers that can be output by this block, see CountOh error handling (Page 1720)	INT	-1
Hours	Operating hours	INT	0
Minutes	Operating minutes	INT	0
MS_Release	Release for maintenance	STRUCT • Value: BOOL • ST: BYTE	- • 0 • 16#80
MsgAckn	Message acknowledgment status (output <code>ACK_STATE</code> of <code>ALARM_8P</code>)	WORD	16#0000
MsgErr	1 = Message error (output <code>ERROR</code> of <code>ALARM_8P</code>)	BOOL	0
MsgStat	Message status (output <code>STATUS</code> of <code>ALARM_8P</code>)	WORD	16#0000
O_MS_Ext	Reserved	DWORD	16#00000000
OnAct	Block running	STRUCT • Value: BOOL • ST: BYTE	- • 1 • 16#80
OosAct	Block is "out of service"	STRUCT • Value: BOOL • ST: BYTE	- • 0 • 16#80
OpSt_Out	Value of the <code>OpSt_In</code> input parameter, for feedforwarding to other blocks. Bit 31 of this parameter is used by <code>Feature</code> bit 24	DWORD	16#00000000
OS_PermLog	Operator permission: Output for OS	DWORD	16#FFFFFFFF
OS_PermOut	Operator permission: Output for OS	DWORD	16#FFFFFFFF
Seconds	Operating time [in sec]	INT	0

Parameter	Description	Type	Default
ST_Worst	Worst signal status	BYTE	16#80
Status1	Status word 1 (Page 1711)	DWORD	16#00000000
Status2	Status word 2 (Page 1711)	DWORD	16#00000000
TH_Act	High tolerance enabled. You can change the reaction for this parameter with <code>Feature</code> bit 28 (Disabling operating points (Page 145)) and with <code>Feature</code> bit 29 (Signaling limit violation (Page 170)).	STRUCT <ul style="list-style-type: none"> Value: BOOL ST: BYTE 	- <ul style="list-style-type: none"> 0 16#80
TH_Minutes	Tolerance high	DINT	0
TimeMin	Operating period [min]	DINT	0
TL_Act	Low tolerance enabled. You can change the reaction for this parameter with <code>Feature</code> bit 28 (Disabling operating points (Page 145)) and with <code>Feature</code> bit 29 (Signaling limit violation (Page 170)).	STRUCT <ul style="list-style-type: none"> Value: BOOL ST: BYTE 	- <ul style="list-style-type: none"> 0 16#80
TL_Minutes	Low tolerance time [in min]	DINT	0
TotalTime	Total operating time	DWORD	16#00000000
WH_Act	High warning enabled. You can change the reaction for this parameter with <code>Feature</code> bit 28 (Disabling operating points (Page 145)) and with <code>Feature</code> bit 29 (Signaling limit violation (Page 170)).	STRUCT <ul style="list-style-type: none"> Value: BOOL ST: BYTE 	- <ul style="list-style-type: none"> 0 16#80
WH_Minutes	High warning time [in min]	DINT	0
WL_Act	Low warning enabled. You can change the reaction for this parameter with <code>Feature</code> bit 28 (Disabling operating points (Page 145)) and with <code>Feature</code> bit 29 (Signaling limit violation (Page 170)).	STRUCT <ul style="list-style-type: none"> Value: BOOL ST: BYTE 	- <ul style="list-style-type: none"> 0 16#80
WL_Minutes	Low alarm time [in min]	DINT	0

See also

- CountOh messaging (Page 1720)
- CountOh block diagram (Page 1726)
- CountOh modes (Page 1715)

10.2.7 CountOh block diagram**CountOh block diagram**

A block diagram is not provided for this block.

See also

CountOh I/Os (Page 1722)
CountOh messaging (Page 1720)
CountOh error handling (Page 1720)
CountOh functions (Page 1715)
CountOh modes (Page 1715)
Description of CountOh (Page 1711)

10.2.8 Operator control and monitoring**10.2.8.1 CountOh views****Views of the CountOh block**

The block CountOh provides the following views:

- CountOh standard view (Page 1728)
- Alarm view (Page 302)
- CountOh limit view (Page 1730)
- Trend view (Page 305)
- CountOh parameter view (Page 1731)
- CountOh preview (Page 1732)
- Memo view (Page 304)
- Batch view (Page 302)
- Block icon for CountOh (Page 1733)

Refer to the sections Structure of the faceplate (Page 248) and Block icon structure (Page 230) for general information on the faceplate and block icon.

10.2.8.2 CountOh standard view

CountOh standard view

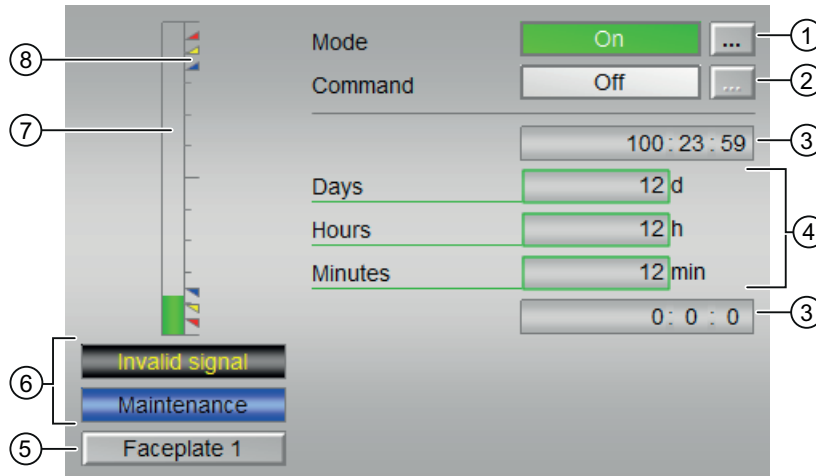

(1) Displaying and switching the operating mode

This area provides information on the currently valid operating mode. The following operating modes can be shown here:

- On (Page 71)
- Out of service (Page 71)

Refer to the Switching operating states and operating modes (Page 257) section for information on switching the operating mode.

(2) Enabling and disabling the counter

This area shows you the default operating state for the counter. The following states can be shown and executed here:

- "On ↑"
- "On ↓"
- "Off"

Refer to the Switching operating states and operating modes (Page 257) section for information on changing the state.

(3) High and low scale range for the count value

These values provide information on the display range for the bar graph (5) of the count value. The scale range is defined in the engineering system.

(4) Displaying the counts values

The following counts are shown here:

- "Days" with signal status `TmMinST`
- "Hours" with signal status `TmMinST`
- "Minutes" with signal status `TmMinST`

(5) Navigation button for switching to the standard view of any faceplate

Use this navigation button to open the standard view of a block configured in the engineering system (ES). The visibility of this navigation button depends on the configuration in the engineering system (ES).

You can find additional information on this in the section [Opening additional faceplates](#) (Page 208) .

(6) Display area for block states

This area provides additional information on the operating state of the block:

- "Maintenance"
- "Invalid signal"

(7) Graphic display of the current count value

This area shows you the current count in form of a bar graph. The visible area in the bar graph depends on the configuration in the engineering system (ES).

(8) Limits

These colored triangles indicate the configured limits in the respective bar graph:

- Red: Alarm
- Yellow: Warning
- Blue: Tolerance

In counting mode "count up", only the colored triangles of the upper limits are visible; and in counting mode "count down", only the colored triangles of the lower limits are visible.

10.2.8.3 CountOh limit view

Limit view of CountOh

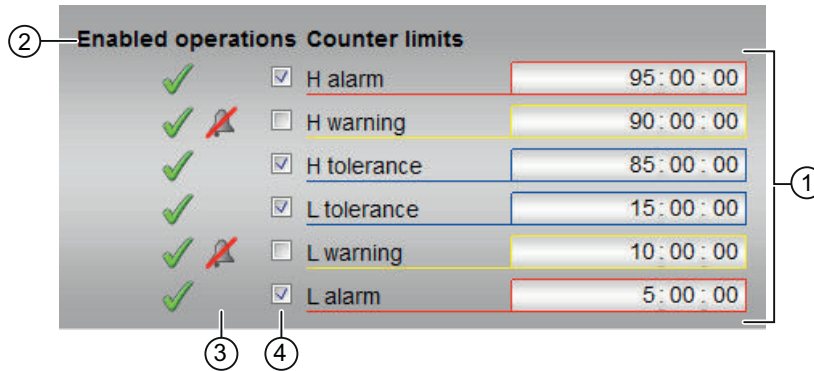

(1) Limits for the counter

In this area, you can enter the limits for the counter. Refer to the Changing values (Page 259) section for more on this.

You can change the following limits:

- "H alarm": Alarm high
- "H warning": Warning high
- "H tolerance": Tolerance high
- "L tolerance": Tolerance low
- "L warning": Warning low
- "L alarm": Alarm low

(2) Enabled operation

This area shows all operations for which special operator permissions are assigned. They depend on the configuration in the engineering system (ES) that applies to this block.

Icons for enabled operation:

- **Green check mark:** the OS operator can control this parameter
- **Gray check mark:** the OS operator cannot control this parameter at this time due to the process
- **Red cross:** the OS operator cannot control this parameter due to the configured AS operator permissions (OS_Perm or OS1Perm)

(3) "Message suppression"

Message suppression indicates whether or not the suppression of the associated message in the AS block is activated with the `xx_MsgEn` parameter. The output of messages is not suppressed when the block is installed (all `xx_MsgEn` parameters are preset to 1). Messages can only be output if limit monitoring of the additional analog value has been enabled.

(4) Suppress messages

You can enable / disable messages by setting the check mark.

10.2.8.4 CountOh parameter view

Parameter view of CountOh

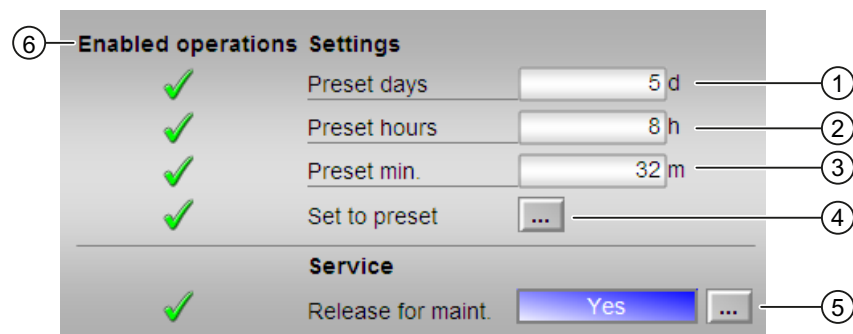

(1), (2) and (3) preset counter

Enter the default setting here, where the counter should start.

You can change the following presets:

- "Days"
- "Hours"
- "Minutes"

You can find additional information on this in the Changing values (Page 259) section.

(4) Set to default

Set the counter to the default value here. You can find additional information on this in the Switching operating states and operating modes (Page 257) section.

(5) Service

You can select the following function in this area:

- "Release for maintenance"

Refer to the Switching operating states and operating modes (Page 257) section for more on this.

You can find information on this area in the Release for maintenance (Page 64) section.

(6) Enabled operations

This area shows all operations for which special operator control permissions are assigned. They depend on the configuration in the engineering system (ES) that applies to this block.

Symbols for enabled operations:

- **Green check mark:** the OS operator can control this parameter
- **Gray check mark:** the OS operator cannot control this parameter at this time due to the process
- **Red cross:** the OS operator cannot control this parameter due to the configured AS operator control permissions (OS_Perm or OS1Perm).

10.2.8.5 CountOh preview

Preview of CountOh

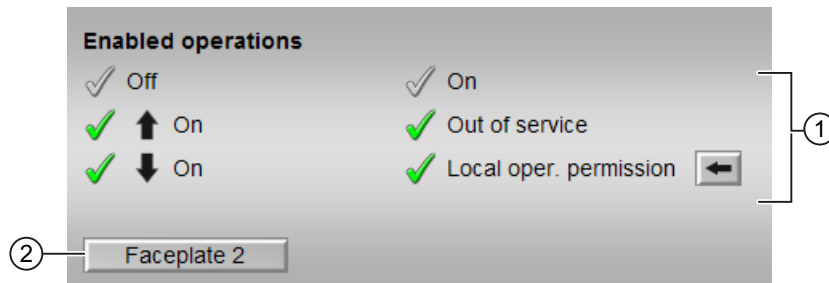

(1) Enabled operations

This area shows all operations for which special operator control permissions are assigned. They depend on the configuration in the engineering system (ES) that applies to this block.

Symbols for enabled operations:

- **Green check mark:** the OS operator can control this parameter
- **Gray check mark:** the OS operator cannot control this parameter at this time due to the process
- **Red cross:** the OS operator cannot control this parameter due to the configured AS operator control permissions (OS_Perm or OS1Perm)

The following enabled operations are shown here:

- "Off": You can disable the counter.
- "On ↑": You can operate the incremental counter.
- "On ↓": You can operate the decremental counter.

- "On": You can switch to "On" operating mode.
- "Out of service": You can switch to "Out of service" operating mode.
- "Local operating permission": Use the ← button to switch to the standard view of the OpStations block. Additional information is available in the section Operator control permissions (Page 254).

(2) Navigation button for switching to the standard view of any faceplate

Use this navigation button to reach the standard view of a block configured in the engineering system. The visibility of this navigation button depends on the configuration in the engineering system (ES).

You can find additional information on this in the Opening additional faceplates (Page 208) section.

10.2.8.6 Block icon for CountOh

Block icons for CountOh



A variety of block icons are available with the following functions:

- Process tag type
- Limits (high/low)
- Violation of alarm, warning, and tolerance limits
- Operating modes
- Signal status, release for maintenance
- Memo display
- Display counter running

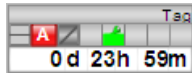
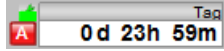
The block icons from template @TemplateAPLV8.PDL:

Icons	Selection of the block icon in CFC	Special features
	1	
	2	Block icon in the full display

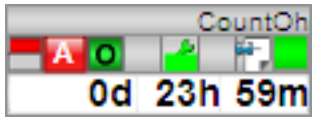
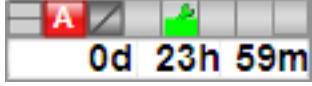
The block icons from template @TemplateAPLV7.PDL:

Icons	Selection of the block icon in CFC	Special features
	1	Block icon in the full display
	2	
	-	Block icon in "Out of service" mode (example with type 1 block icon)

Additional information on the block icon and the control options in the block icon is available in the following sections:

- Configuring the block icons (Page 237)
- Block icon structure (Page 230)
- Operation via the block icon (Page 239).

10.3 TotalL - Additive counter with upward or downward counting direction (totalizer)

10.3.1 Description of TotalL

Object name (type + number) and family

Type + number: FB 1906

Family: Count

Area of application for TotalL

The block is used for the following applications:

- Triggered upward or downward summing
- Continuous upward or downward summing
- Upward or downward integration of an analog input value

How it works

With a positive edge at the input parameter (pulse signal) `P_In` the output parameter `Out` is increased by a variable increment or reduced by a variable decrement.

Configure how it works via the following `Feature Bits`:

- `Feature Bit 6`: Block as summing unit or integrator (Page 143)
- `Feature Bit 7`: Summing characteristics continuous or triggered (Page 174)

10.3 TotalL - Additive counter with upward or downward counting direction (totalizer)

Using this parameterization, determine whether the block is to operate as an edge-triggered adder or summer, continuous adder or summer or as an integrator:

10.3 TotalL - Additive counter with upward or downward counting direction (totalizer)

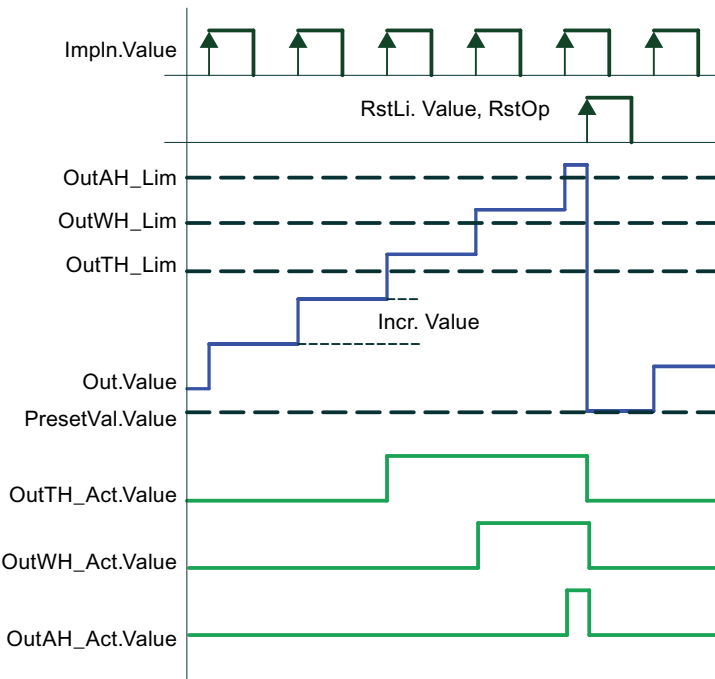
Parameterization on the Feature Bit	How the block operates
Feature Bit 6 = 0	Block operates as an edge-triggered adder or summer.
Feature Bit 7 = 0	<p>The calculation at the output parameter <code>Out</code> is performed with a 0 - 1 edge at input parameter <code>P_In</code>. The output parameter <code>Mode</code> shows whether the value is incremented or decremented. The pulses counted at the input parameter <code>P_In</code> are output to the output parameter <code>CntOut</code>.</p>
	<p>Triggered sum up</p> $\text{Out.Value} = \text{Out.Value}_{(n-1)} + \text{Incr.Value}$ 
	<p>Triggered sum down</p> $\text{Out.Value} = \text{Out.Value}_{(n-1)} - \text{Decr.Value}$

10.3 TotalL - Additive counter with upward or downward counting direction (totalizer)

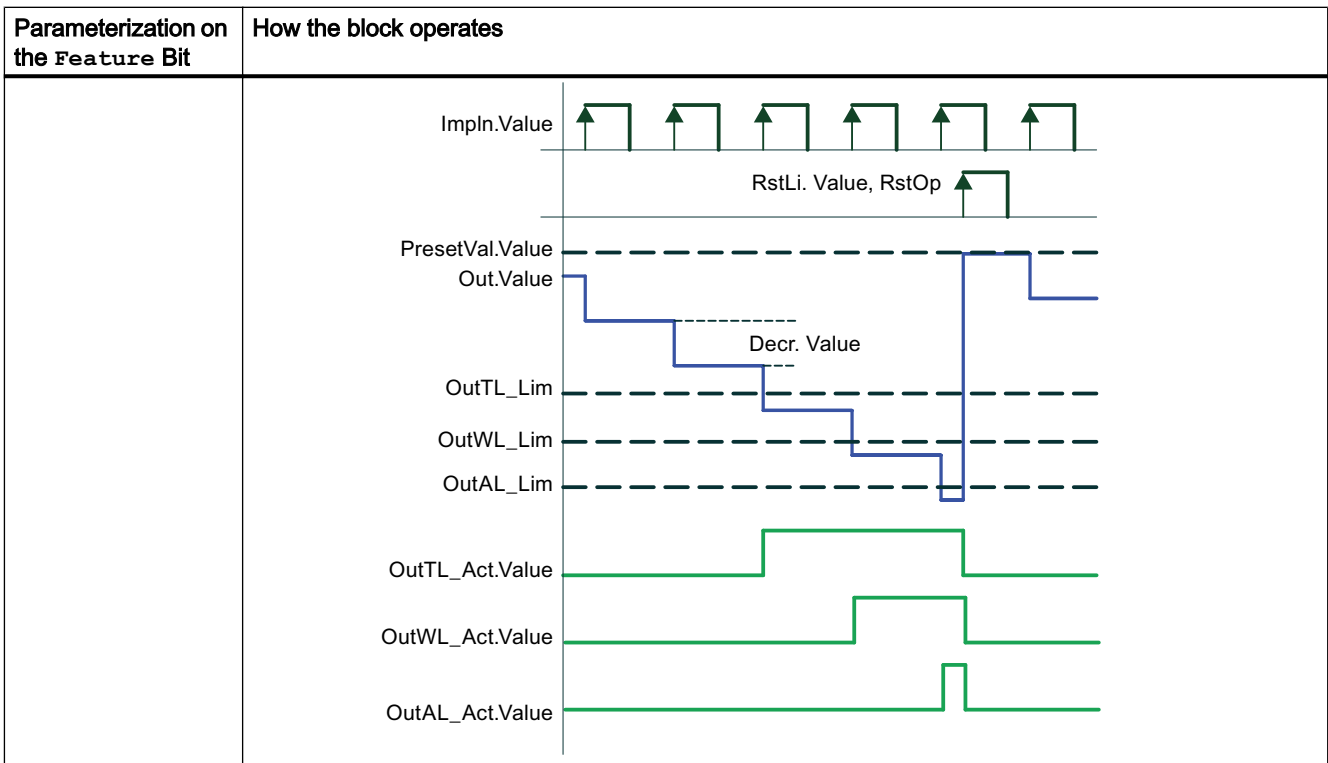

10.3 TotalL - Additive counter with upward or downward counting direction (totalizer)

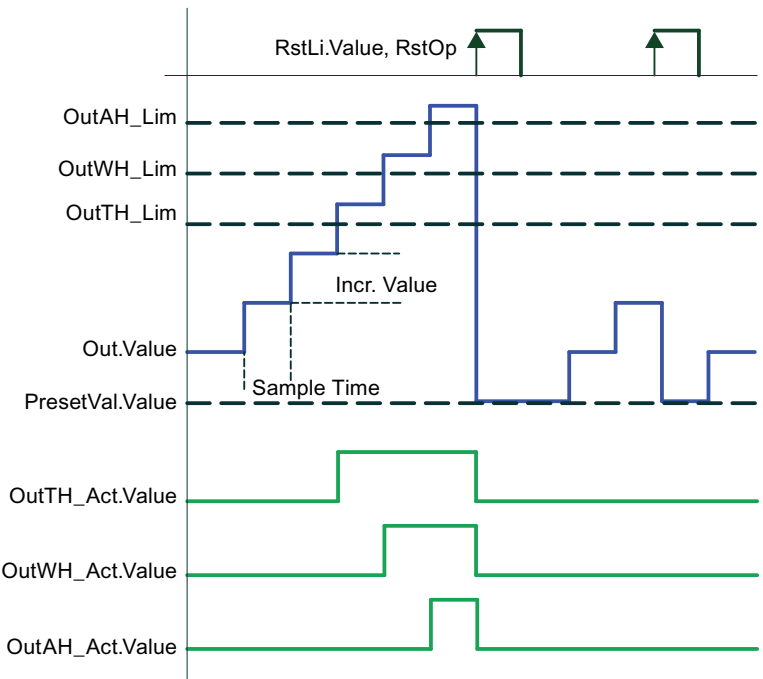
Parameterization on the Feature Bit	How the block operates
Feature Bit 6 = 0 Feature Bit 7 = 1	<p>Block operates as a continuous adder or summer.</p> <p>The calculation at the output parameter <code>Out</code> is performed continuously.</p> <p>The output parameter <code>Mode</code> shows whether the value is incremented or decremented.</p> <p>The result is output to the output parameter <code>Out</code>.</p> <p>The output parameter <code>CntOut</code> always includes the value 0.</p>
	<p>Continuously sum up</p> $\text{Out.Value} = \text{Out.Value}_{(n-1)} + \text{Incr.Value}$  <p>The diagram illustrates the continuous sum up operation. It shows the output value <code>Out.Value</code> (blue signal) increasing in steps over time. The step height is labeled <code>Incr.Value</code>. The signal <code>Out.Value</code> is sampled at regular intervals, with one interval labeled <code>Sample Time</code>. The output value is limited by <code>OutAH_Lim</code>, <code>OutWH_Lim</code>, and <code>OutTH_Lim</code> (dashed lines). The active limit signals <code>OutTH_Act.Value</code>, <code>OutWH_Act.Value</code>, and <code>OutAH_Act.Value</code> (green signals) show step-wise increases when the corresponding limits are reached. The reset signals <code>RstLi.Value</code> and <code>RstOp</code> (green signals) are shown as pulses that reset the counter.</p>
	<p>Continuously sum down</p> $\text{Out.Value} = \text{Out.Value}_{(n-1)} - \text{Decr.Value}$

10.3 TotalL - Additive counter with upward or downward counting direction (totalizer)

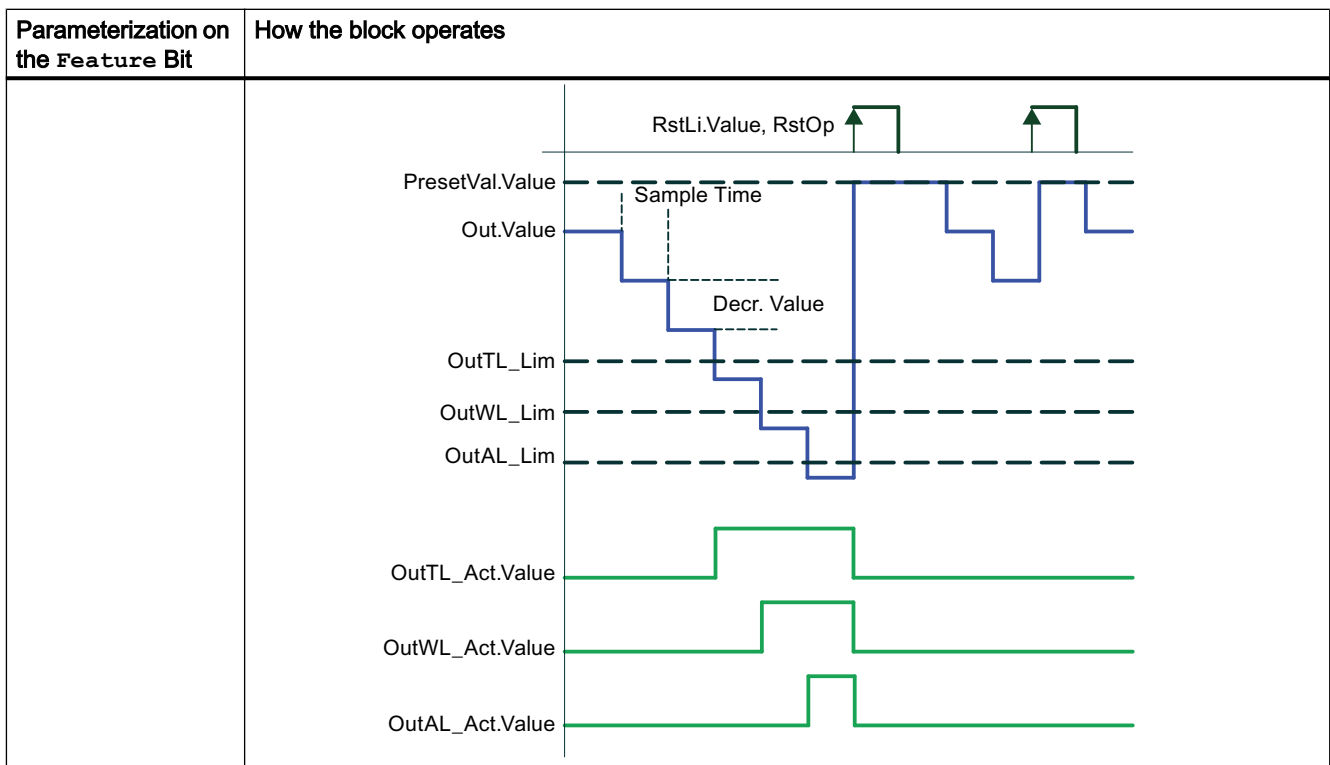

10.3 TotalL - Additive counter with upward or downward counting direction (totalizer)

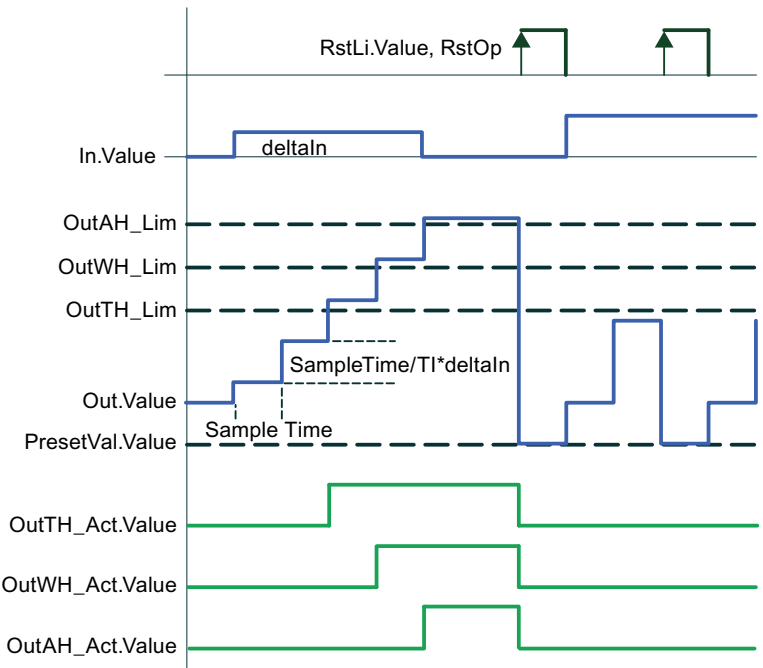
Parameterization on the Feature Bit	How the block operates
Feature Bit 6 = 1 Feature Bit 7 = non-operational	<p>Block operates as an continuous integrator.</p> <p>The direction of integration depends on the operation in the faceplate or from the interconnection.</p> <p>The input value In is integrated in accordance with the trapezoid rule dependent upon the counting direction according to the formula of the Integral block (Page 1857).</p> <p>The output parameter $Mode$ shows whether the value is integrated up or down.</p> <p>The result is output to the output parameter Out.</p> <p>The output parameter $CntOut$ always includes the value 0.</p>
	<p>Continuously integrate up</p> <p>$Mode = 1: Out.Value = Out.Value\ n-1 + SampleTime/TI * (In.Value + In.Value\ n-1)/2$</p> <p>Set direction of integration:</p> <ul style="list-style-type: none"> • Operation in the faceplate using the "On" command ($UpOp = 1$) Requirement: $LiOp.Value = 0$ • Interconnection $LiOp.Value = 1$ and $UpLi.Value = 1$ 
	<p>Continuously integrate down</p> <p>$Mode = 2: Out.Value = Out.Value\ n-1 - SampleTime/TI * (In.Value + In.Value\ n-1)/2$</p> <p>Set direction of integration:</p> <ul style="list-style-type: none"> • Operation in the faceplate using the "Off" command ($DnOp = 1$) Requirement: $LiOp.Value = 0$ • Interconnection $LiOp.Value = 1$ and $DnLi.Value = 1$

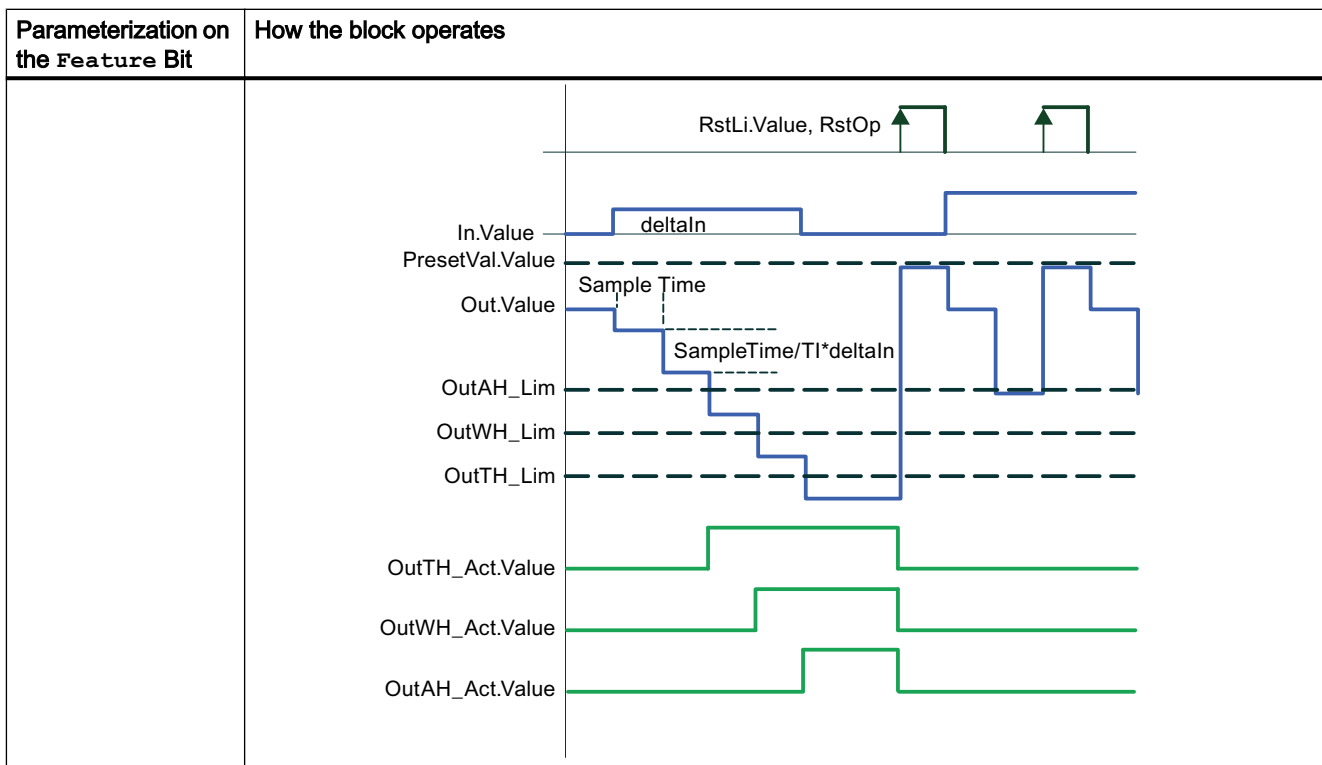

Configuration

Use the CFC editor to install the block in a cyclic interrupt OB (OB30 to OB38). The block is also installed automatically in the startup OB (OB100).

Startup characteristics

Define the startup characteristics for this block via two **Feature Bits**:

Bit 0: Set startup characteristics (Page 138)

Bit 5: Use the last value following a complete download as the current value during startup of the block (Page 154)

The messages are suppressed after startup for the number of cycles specified in the **RunUpCyc** parameter.

Time response

The block does not have any time response.

10.3 TotalL - Additive counter with upward or downward counting direction (totalizer)

Status word allocation for Status1 parameter

You can find a description for each parameter in section TotalL I/Os (Page 1752).

Status bit	Parameter
0	Occupied
1	BatchEn
2	SimOn
3	OosAct.Value
4	OosLi.Value
5	BypassAct.Value
6	OnAct.Value
7 - 8	Not used
9	Display of BypassAct.Value in faceplate (display and operator controls) and block icon
10	SimLiOp.Value
11	LiOp
12 - 13	Not used
14	1 = Invalid signal status
15	Triggered summing; Feature Bit 6 = 0, Bit 7 = 0
16	Continuous summing; Feature Bit 6 = 0, Bit 7 = 1
17	Integrate; Feature Bit 6 = 1
18 - 31	Not used

Status word allocation for Status2 parameter

Status bit	Parameter
0	MsgLock.Value
1	OutAH_Act.Value
2	OutWH_Act.Value
3	OutTH_Act.Value
4	OutTL_Act.Value
5	OutWL_Act.Value
6	OutAL_Act.Value
7	OutAH_En
8	OutWH_En
9	OutTH_En
10	OutTL_En
11	OutWL_En
12	OutAL_En
13	OutAH_MsgEn
14	OutWH_MsgEn
15	OutTH_MsgEn
16	OutTL_MsgEn
17	OutWL_MsgEn

Status bit	Parameter
18	OutAL_MsgEn
19	Not used
20	Mode = 1, upward summing or integration
21	Mode = 0, summer/integrator off
22	Mode = 2, downward summing or integration
23 - 30	Not used
31	MS_RelOp

See also

TotalL operating modes (Page 1744)

TotalL functions (Page 1745)

TotalL error handling (Page 1749)

TotalL messaging (Page 1750)

TotalL block diagram (Page 1757)

10.3.2 TotalL operating modes**TotalL operating modes**

This block provides the following operating modes:

- On (Page 71)
- Out of service (Page 71)

"On"

General information on the "On" mode is available in the section On (Page 71).

"Out of service"

You can find general information about the "Out of service" mode in the section Out of service (Page 71).

See also

Description of TotalL (Page 1735)

TotalL functions (Page 1745)

TotalL error handling (Page 1749)

TotalL messaging (Page 1750)

TotalL I/Os (Page 1752)

TotalL block diagram (Page 1757)

10.3.3 TotalL functions

Functions of TotalL

The functions for this block are listed below.

Limit monitoring of the count value

This block provides the standard function Limit monitoring of the count value (Page 89).

Group display SumMsgAct for limit monitoring, CSF and ExtMsgx

The block provides the standard function Group display for limit monitoring, CSF and ExtMsgx (Page 85).

Suppressing messages using the MsgLock parameter

This block provides the standard function Suppressing messages using the MsgLock parameter (Page 205).

Opening additional faceplates

This block provides the standard function Opening additional faceplates (Page 208).

Selecting a unit of measure

This block provides the standard function Selecting a unit of measure (Page 212).

For `In` and `Out` different units of measure can be entered.

Simulating signals

The block provides the standard function Simulating signals (Page 58).

You can simulate the following values:

- Output value (`SimOut`, `SimOutLi`)

Note

Note on the simulation of the output value `Out`

For the presetting of the summing or integration value `Out` via the `RstLi` input, a 0 → 1 signal change at the input parameter `RstLi` is necessary during simulation.

Bypass function

This block provides the standard function Bypassing signals (Page 107).

Forming the signal status for blocks

This block provides the standard function Forming and outputting the signal status for technologic blocks (Page 109).

The worst signal status `ST_Worst` for the block is always formed from the following parameters:

- `P_In.ST`
- `Incr.ST`
- `Decr.ST`,
- `PresetVal.ST`
- `In.ST`
- `Out.ST`

The following signal status is formed by:

Signal status	Used status
<code>Out.ST</code>	<p>Block operates as an edge-triggered adder or summer: Formed from the signal status <code>Incr.ST</code>, <code>Decr.ST</code>, <code>P_In.ST</code> and the last signal status <code>Out.St</code>.</p> <p>Block operates as continuous adder or summer: Formed from the signal status <code>Incr.ST</code>, <code>Decr.ST</code> and the last signal status <code>Out.St</code>.</p> <p>Block operates as continuous integrator: Formed from the signal status <code>In.ST</code> and the last signal status <code>Out.St</code>. Resetting <code>TotalL</code> also resets the signal status: <code>Out, ST := 16#80</code></p>

With internal simulation, `ST_Worst` and the status of `Out` become `16#60`.

If there is a non-displayable floating-point number at one of the following parameters `In`, `PresetVal`, `TI` or `Out` when integrating `Feature` bit 6 = 1, the result is `ST_Worst` and the status of `Out` is set to `16#28`, provided the internally calculated status of `Out` does not result in `16#0` or the block is in internal simulation.

In addition, the status of `Out` is also written to the status of the output parameter `UpDnAct`.

Configurable reactions using the `Feature` parameter

You can find an overview of all reactions provided by the `Feature` I/O in the Configurable functions using the `Feature` I/O (Page 131) . The following functionality is available for this block at the relevant bits:

Bit	Function
0	Set startup characteristics (Page 138)
1	Reaction to the out of service mode (Page 177)

10.3 TotalL - Additive counter with upward or downward counting direction (totalizer)

Bit	Function
2	Resetting the commands for changing the mode (Page 161)
5	Use the last value following a complete download as the current value during startup of the block (Page 154)
6	Block as summing unit or integrator (Page 143)
7	Summing characteristics continuous or triggered (Page 174)
9	Substitution value is active if the block is in bypass (Page 185)
22	Update acknowledgment and error status of the message call (Page 160)
24	Enabling local operator authorization (Page 158)
25	Suppression of all messages (Page 174)
26	Reaction of the switching points in the "Out of service" operating mode (Page 176)
28	Disabling operating points (Page 145)
29	Signaling limit violation (Page 170)
30	Set reset depending on the operating mode or the LiOp parameter (Page 163)

Operator permissions

This block provides the standard function Operator control permissions (Page 254).

The block has the following permissions for the `OS_Perm` parameter:

Bit	Function
0	Not used
1	1 = Operator can switch to "On" mode
2	Not used
3	1 = Operator can switch to "Out of service" mode
4	1 = Operator can stop the summing or integration
5	1 = Operator can activate the upward summing or integration
6	1 = Operator can activate the downward summing or integration
7	1 = Operator can preset the sum value (Out)
8 - 9	Not used
10	1 = Operator can change the simulation value <code>SimOut</code>
11	1 = Operator can activate the Simulation function
12	1 = Operator can activate the Release for maintenance function
13	1 = Operator can change the limit (<code>OutAH_Lim</code>) for high alarm
14	1 = Operator can change the limit (<code>OutWH_Lim</code>) for high warning
15	1 = Operator can change the limit (<code>OutTH_Lim</code>) for high tolerance
16	Not used
17	1 = Operator can change the limit (<code>OutAL_Lim</code>) for low alarm
18	1 = Operator can change the limit (<code>OutWL_Lim</code>) for low warning
19	1 = Operator can change the limit (<code>OutTL_Lim</code>) for low tolerance
20	1 = Operator can activate bypass functionality
21	1 = Operator can deactivate bypass functionality
22	1 = Operator can specify the default value (<code>PresetVal.Value</code>)
23	1 = Operator can specify the integration time constant (<code>TI</code>)

10.3 TotalL - Additive counter with upward or downward counting direction (totalizer)

Bit	Function
24	1 = Operator can specify the value for the increment (<code>Incr.Value</code>)
25	1 = Operator can specify the value for the decrement (<code>Decr.Value</code>)
26	1 = Operator can activate / deactivate messages via <code>OutAH_MsgEn</code>
27	1 = Operator can activate / deactivate messages via <code>OutAL_MsgEn</code>
28	1 = Operator can activate / deactivate messages via <code>OutWH_MsgEn</code>
29	1 = Operator can activate / deactivate messages via <code>OutTH_MsgEn</code>
30	1 = Operator can activate / deactivate messages via <code>OutTL_MsgEn</code>
31	1 = Operator can activate / deactivate messages via <code>OutWL_MsgEn</code>

Note

If you interconnect a parameter that is also listed in `OS_Perm` as a parameter, you have to reset the corresponding `OS_Perm` bit.

Readback of the most recently calculated sum

As long as the output parameter `Mode` \neq 0, the preceding sum value (`OldOut`) or the preceding count value (`OldCntOut`) is corrected to the current value:

- `OldOut = Out.Value`
- `OldCntOut = CntOut.Value`

After a warm restart, the sum value (`Out`) is automatically reset to the default value for the input parameter `PresetVal` if you have set the `Feature Set startup characteristics` (Page 138)Bit accordingly.

The count value `CntOut` in this case is always reset to 0.

The current sum and/or count value is set to the default predecessor values at startup via the `Feature bit Use the last value following a complete download as the current value during startup of the block` (Page 154).

- `Old.Value = OldOut`
- `CntOut.Value = OldCntOut`

Setting the summing/integrating value to the default

`PresetVal` is used to specify a summing/integrating value that is used in a warm restart.

As long as `RstLi` or `RstOp` is set, the following applies:

`Out.Value = PresetVal.Value.`

When the input `PresetVal` is not interconnected (`PresetVal.ST = FF`), the default setting for the count value can also be made from the parameter view of the block.

`RstLi` or `RstOp` reset the `CntOut` output to 0 at the same time.

You can use the `Feature Bit 30 "Set reset depending on operating mode or the LiOp parameter"` to configure the setting of the count value to a default depending on the `LiOp` parameter:

10.3 TotalL - Additive counter with upward or downward counting direction (totalizer)

Feature Bit 30 =0: The reset does not depend on LiOp

Feature Bit 30 =1: Setting to the default depends on LiOp

LiOp =0: Setting to the default PresetVal or resetting of CntOut can only take place via the faceplate or at the RstOp parameter for the faceplate.

LiOp =1: Setting to the default PresetVal or resetting of CntOut can only take place via the interconnectable RstLi input.

Release for maintenance

This block provides the standard function Release for maintenance (Page 64).

SIMATIC BATCH functionality

This block provides the standard function SIMATIC BATCH functionality (Page 67).

See also

Description of TotalL (Page 1735)

TotalL operating modes (Page 1744)

TotalL error handling (Page 1749)

TotalL messaging (Page 1750)

TotalL I/Os (Page 1752)

TotalL block diagram (Page 1757)

10.3.4 TotalL error handling

Error handling of TotalL

Refer to the section Error handling (Page 119) in the basic instructions for the error handling of all blocks.

The following errors can be displayed for this block:

- Error numbers

Overview of error numbers

The ErrorNum I/O can be used to output the following error numbers:

Error number	Meaning of the error number
-1	Predefined value when inserting the block; the block is not processed.
0	There is no error.

Error number	Meaning of the error number
11	The integration time constant T_I is within the range: $-SampleTime / 2 < T_I < SampleTime / 2$. The integration is stopped.
15	$PresetVal.Value > OutOpScale.High$ $PresetVal.Value < OutOpScale.Low$
30	The value of $In.Value$ can no longer be displayed in the REAL number field. The last valid value is provided at the $Out.Value$ output.
31	The value of Out can no longer be displayed in the REAL number field. The last valid value is provided at the Out output.
32	The value of $PresetVal.Value$ can no longer be displayed in the REAL number field. The last valid value is provided at the $Out.Value$ output.
33	The value of T_I can no longer be displayed in the REAL number field. The integration is stopped.
34	The value $Incr.Value$ or $Decr.Value$ can no longer be displayed in the REAL number field. The last valid value is provided at the $Out.Value$ output.
51	Invalid signal at $LiOp = 1$: $OffLi = 1$ and $UpLi = 1$ and/or $DnLi = 1$ $OffLi = 0$ and $UpLi = 1$ and $DnLi = 1$

See also

Description of TotalL (Page 1735)

TotalL operating modes (Page 1744)

TotalL functions (Page 1745)

TotalL messaging (Page 1750)

TotalL block diagram (Page 1757)

TotalL I/Os (Page 1752)

10.3.5 TotalL messaging**Messaging**

The following messages can be generated for this block:

- Functions for displaying measured limits

Messages generated as a reaction to limit violations, can be suppressed by the settings $MsgEn$ and $MsgLock$.

10.3 TotalL - Additive counter with upward or downward counting direction (totalizer)

Associated values for message instance `MsgEvId`

Associated value	Block parameters
1	BatchName
2	StepNo
3	BatchID
4	ExtVal104
5	ExtVal105

Process messages

Message instance	Message identifier	Message class	Event
MsgEvId	SIG 1	Alarm - high	\$\$BlockComment\$\$ High alarm limit violated
	SIG 2	Warning - high	\$\$BlockComment\$\$ High warning limit violated
	SIG 3	Tolerance - high	\$\$BlockComment\$\$ High tolerance limit violated
	SIG 4	Tolerance - low	\$\$BlockComment\$\$ Low tolerance limit violated
	SIG 5	Warning - low	\$\$BlockComment\$\$ Low warning limit violated
	SIG 6	Alarm - low	\$\$BlockComment\$\$ Low alarm limit violated
	SIG 7	AS process control message - fault	\$\$BlockComment\$\$ External message 1
	SIG 8	AS process control message - fault	\$\$BlockComment\$\$ External message 2

Explanation:

\$\$BlockComment\$\$: Content of the instance-specific comment

See also

- Description of TotalL (Page 1735)
- TotalL operating modes (Page 1744)
- TotalL functions (Page 1745)
- TotalL error handling (Page 1749)
- TotalL I/Os (Page 1752)
- TotalL block diagram (Page 1757)

10.3.6 TotalL I/Os

TotalL I/Os

Input parameters

Parameter	Description	Type	Default
BatchEn	1 = Enable allocation	BOOL	0
BatchID	Batch ID	DWORD	16#00000000
BatchName	Batch name	S7-String	
BypliOp	1 = Bypass commands via interconnection	STRUCT <ul style="list-style-type: none"> Value: BOOL ST: BYTE 	- <ul style="list-style-type: none"> 0 16#80
BypLock	1 = Bypass activation or deactivation is locked for operator	STRUCT <ul style="list-style-type: none"> Value: BOOL ST: BYTE 	- <ul style="list-style-type: none"> 0 16#80
BypOut	Substitution value if block is in bypass	REAL	0.0
BypOutLi	1 = Select bypass Out (via interconnection)	STRUCT <ul style="list-style-type: none"> Value: BOOL ST: BYTE 	- <ul style="list-style-type: none"> 0 16#80
BypOutOp	1 = Select bypass Out (via operator)	BOOL	0
Decr	Decrement for downward summing Decr.ST = FF via operator Decr.ST <> FF via interconnection	STRUCT <ul style="list-style-type: none"> Value: REAL ST: BYTE 	- <ul style="list-style-type: none"> 0.0 16#FF
DnLi*	1 = Down counter, via interconnection	STRUCT <ul style="list-style-type: none"> Value: BOOL ST: BYTE 	- <ul style="list-style-type: none"> 0 16#80
DnOp*	1 = Down counter, via operator	BOOL	0
EN	1 = Called block will be processed	BOOL	1
ExtMsg1	Binary input for freely selectable message 1	STRUCT <ul style="list-style-type: none"> Value: BOOL ST: BYTE 	- <ul style="list-style-type: none"> 0 16#80
ExtMsg2	Binary input for freely selectable message 2	STRUCT <ul style="list-style-type: none"> Value: BOOL ST: BYTE 	- <ul style="list-style-type: none"> 0 16#80
ExtVa104	Associated value 4 for messages (MsgEvId)	ANY	
ExtVa105	Associated value 5 for messages (MsgEvId)	ANY	
Feature	I/O for additional functions (Page 1745)	STRUCT <ul style="list-style-type: none"> Bit 0: BOOL ... Bit 31: BOOL 	- <ul style="list-style-type: none"> 0 0 0

10.3 TotalL - Additive counter with upward or downward counting direction (totalizer)

Parameter	Description	Type	Default
In	Input for integral value	STRUCT <ul style="list-style-type: none"> Value: REAL ST: BYTE 	- <ul style="list-style-type: none"> 0.0 16#80
Incr	Increment for upward summing Incr.ST = FF via operator Incr.ST <> FF via interconnection	STRUCT <ul style="list-style-type: none"> Value: REAL ST: BYTE 	- <ul style="list-style-type: none"> 0.0 16#FF
InUnit	Unit of measure for the input parameter In	INT	1351
LiOp	1 = Interconnection 0 = Operator	STRUCT <ul style="list-style-type: none"> Value: BOOL ST: BYTE 	- <ul style="list-style-type: none"> 0 16#80
MsgEvId	Message number (assigned automatically)	DWORD	16#00000000
MsgLock	1 = Suppress process messages. See also the section Suppressing messages using the MsgLock parameter (Page 205) for more on this.	STRUCT <ul style="list-style-type: none"> Value: BOOL ST: BYTE 	- <ul style="list-style-type: none"> 0 16#80
MS_RelOp*	Operator can switch release for maintenance	BOOL	0
Occupied	1 = In use by a batch	BOOL	0
OffLi*	1 = Counter disabled via interconnection	STRUCT <ul style="list-style-type: none"> Value: BOOL ST: BYTE 	- <ul style="list-style-type: none"> 0 16#80
OffOp*	1 = Counter disabled via operator	BOOL	1
OldCntOut*	Previous count value	DINT	0
OldOut*	Previous output value	REAL	0.0
OnOp*	1 = "On" mode via operator	BOOL	0
OosLi	1 = "Out of service", via interconnection or SFC (0-1 edge transition)	STRUCT <ul style="list-style-type: none"> Value: BOOL ST: BYTE 	- <ul style="list-style-type: none"> 0 16#80
OosOp*	1 = "Out of service", via OS operator	BOOL	0
OpSt_In	Input parameter for local operator authorization, connected with the Out output parameter of the upstream block, OpStations (Page 411)	DWORD	16#00000000
OS_Perm	I/O for operating permissions (Page 1745)	STRUCT <ul style="list-style-type: none"> Bit 0: BOOL Bit 10: BOOL Bit 31: BOOL 	- <ul style="list-style-type: none"> 1 1 1
OutAH_En	1 = Enable alarm (high) for count	BOOL	1
OutAH_Lim	Limit for count alarm (high)	REAL	95.0
OutAH_MsgEn	1 = Enable message for count alarm (high)	BOOL	1
OutAL_En	1 = Enable alarm (low) for count	BOOL	1
OutAL_Lim	Limit for count alarm (low)	REAL	0.0
OutAL_MsgEn	1 = Enable message for count alarm (low)	BOOL	1

Counter blocks

10.3 TotalL - Additive counter with upward or downward counting direction (totalizer)

Parameter	Description	Type	Default
OutOpScale	Limit for scale in Out bar graph of faceplate	STRUCT <ul style="list-style-type: none"> High: REAL Low: REAL 	- <ul style="list-style-type: none"> 100.0 0.0
OutTH_En	1 = Enable tolerance message (high)	BOOL	0
OutTH_Lim	Count tolerance limit message (high)	REAL	85.0
OutTH_MsgEn	1 = Enable message for count tolerance message (high)	BOOL	1
OutTL_En	1 = Enable count tolerance message (low)	BOOL	0
OutTL_Lim	Count tolerance message limit (low)	REAL	0.0
OutTL_MsgEn	1 = Enable message for count tolerance message (low)	BOOL	1
OutUnit	Unit of measure for count Out	INT	1038
OutWH_En	1 = Enable count warning (high)	BOOL	1
OutWH_Lim	Count warning limit (high)	REAL	90.0
OutWH_MsgEn	1 = Enable message for count warning (high)	BOOL	1
OutWL_En	1 = Enable count warning (low)	BOOL	1
OutWL_Lim	Count warning limit (low)	REAL	0.0
OutWL_MsgEn	1 = Enable message for count warning (low)	BOOL	1
P_In	Input for sum value (pulse input)	STRUCT <ul style="list-style-type: none"> Value: BOOL ST: BYTE 	- <ul style="list-style-type: none"> 0 16#80
PresetVal*	Default setting for the count	STRUCT <ul style="list-style-type: none"> Value: REAL ST: BYTE 	- <ul style="list-style-type: none"> 0.0 16#FF
RstBypLi	1 = Reset bypass Out (via interconnection)	STRUCT <ul style="list-style-type: none"> Value: BOOL ST: BYTE 	- <ul style="list-style-type: none"> 0 16#80
RstBypOp	1 = Reset bypass Out (via operator)	BOOL	0
RstLi	1 = Reset via interconnection	STRUCT <ul style="list-style-type: none"> Value: BOOL ST: BYTE 	- <ul style="list-style-type: none"> 0 16#80
RstOp*	1 = Reset via operator	BOOL	0
RunUpCyc	Number of cycles in startup; messages are suppressed during these cycles	INT	3
SampleTime	Sampling time [s] (assigned automatically)	REAL	0.1
SelFp1	Call a block saved in this parameter as an additional faceplate (Page 208) in the standard view	ANY	
SelFp2	Call a block saved in this parameter as an additional faceplate (Page 208) in the preview	ANY	
SimLiOp	Activation/deactivation of the simulation by: 0 = Operator 1 = Interconnection or SFC	STRUCT <ul style="list-style-type: none"> Value: BOOL ST: BYTE 	- <ul style="list-style-type: none"> 0 16#80

10.3 TotalL - Additive counter with upward or downward counting direction (totalizer)

Parameter	Description	Type	Default
SimOnLi	1 = Simulation via interconnection or SFC (controlled by SimLiOp = 1)	STRUCT <ul style="list-style-type: none"> Value: BOOL ST: BYTE 	- <ul style="list-style-type: none"> 0 16#80
SimOn*	1 = Simulation on	BOOL	0
SimOut*	Output value used for SimOn = 1	REAL	0.0
SimOutLi	Output value that is used for SimOnLi.Value = 1 (SimLiOp.Value = 1)	STRUCT <ul style="list-style-type: none"> Value: REAL ST: BYTE 	- <ul style="list-style-type: none"> 0 16#80
StepNo	Batch step number	DWORD	16#00000000
TI*	Integral component time	REAL	1.0
UpLi*	1 = Forward counter, via interconnection	STRUCT <ul style="list-style-type: none"> Value: BOOL ST: BYTE 	- <ul style="list-style-type: none"> 0 16#80
UpOp*	1 = Forward counter, via operator	BOOL	0

* Values can be written back to these inputs during processing of the block by the block algorithm.

Output parameters

Parameter	Description	Type	Default
BypassAct	1 = Bypass is activated in this block	STRUCT <ul style="list-style-type: none"> Value: BOOL ST: BYTE 	- <ul style="list-style-type: none"> 0 16#80
CntOut	Number of counted pulses	DINT	0
ENO	1 = Block algorithm completed without errors	BOOL	0
ErrorNum	Output of pending error number. For error numbers that can be output by this block, see TotalL error handling (Page 1749)	INT	-1
Mode	0 = Totalizer off 1 = Totalizer summed/integrated upward 2 = Totalizer summed/integrated downward	INT	0
MsgAckn	Message acknowledgment status (output ACK_STATE of ALARM_8P)	WORD	16#0000
MsgErr	1 = Message error (output ERROR of ALARM_8P)	BOOL	0
MsgStat	Message status (output STATUS of ALARM_8P)	WORD	16#0000
MS_Release	Release for maintenance	STRUCT <ul style="list-style-type: none"> Value: BOOL ST: BYTE 	- <ul style="list-style-type: none"> 0 16#80
O_MS_Ext	Reserved	DWORD	0
OnAct	1 = "On" mode enabled	STRUCT <ul style="list-style-type: none"> Value: BOOL ST: BYTE 	- <ul style="list-style-type: none"> 1 16#80

Counter blocks

10.3 TotalL - Additive counter with upward or downward counting direction (totalizer)

Parameter	Description	Type	Default
OosAct	1 = Block is "Out of service"	STRUCT <ul style="list-style-type: none"> Value: BOOL ST: BYTE 	- <ul style="list-style-type: none"> 0 16#80
OpSt_Out	Value of the OpSt_In input parameter, for feed-forwarding to other blocks. Bit 31 of this parameter is used by Feature bit 24	DWORD	16#00000000
OS_PermLog	Display of OS_Perm with settings changed by the block algorithm	DWORD	16#FFFFFFFF
OS_PermOut	Display of OS_Perm	DWORD	16#FFFFFFFF
Out	Count	STRUCT <ul style="list-style-type: none"> Value: REAL ST: BYTE Bit 1: BOOL of internal fill byte (Bypass information bit) 	- <ul style="list-style-type: none"> 0.0 16#80 0
OutAH_Act	1 = Count alarm (high) enabled. You can change the reaction for this parameter with Feature bit 28 (Disabling operating points (Page 145)) and with Feature bit 29 (Signaling limit violation (Page 170)).	STRUCT <ul style="list-style-type: none"> Value: BOOL ST: BYTE Bit 1: BOOL (Bypass information bit) 	- <ul style="list-style-type: none"> 0 16#80 0
OutAL_Act	1 = Count alarm (low) enabled. You can change the reaction for this parameter with Feature bit 28 (Disabling operating points (Page 145)) and with Feature bit 29 (Signaling limit violation (Page 170)).	STRUCT <ul style="list-style-type: none"> Value: BOOL ST: BYTE Bit 1: BOOL (Bypass information bit) 	- <ul style="list-style-type: none"> 0 16#80 0
OutTH_Act	1 = Count tolerance message (high) enabled. You can change the reaction for this parameter with Feature bit 28 (Disabling operating points (Page 145)) and with Feature bit 29 (Signaling limit violation (Page 170)).	STRUCT <ul style="list-style-type: none"> Value: BOOL ST: BYTE Bit 1: BOOL (Bypass information bit) 	- <ul style="list-style-type: none"> 0 16#80 0
OutTL_Act	1 = Count tolerance message (low) enabled. You can change the reaction for this parameter with Feature bit 28 (Disabling operating points (Page 145)) and with Feature bit 29 (Signaling limit violation (Page 170)).	STRUCT <ul style="list-style-type: none"> Value: BOOL ST: BYTE Bit 1: BOOL (Bypass information bit) 	- <ul style="list-style-type: none"> 0 16#80 0
OutWH_Act	1 = Count warning (high) enabled. You can change the reaction for this parameter with Feature bit 28 (Disabling operating points (Page 145)) and with Feature bit 29 (Signaling limit violation (Page 170)).	STRUCT <ul style="list-style-type: none"> Value: BOOL ST: BYTE Bit 1: BOOL (Bypass information bit) 	- <ul style="list-style-type: none"> 0 16#80 0

10.3 TotalL - Additive counter with upward or downward counting direction (totalizer)

Parameter	Description	Type	Default
OutWL_Act	1 = Count warning (low) enabled. You can change the reaction for this parameter with <code>Feature</code> bit 28 (Disabling operating points (Page 145)) and with <code>Feature</code> bit 29 (Signaling limit violation (Page 170)).	STRUCT <ul style="list-style-type: none"> Value: BOOL ST: BYTE Bit 1: BOOL (Bypass information bit) 	- <ul style="list-style-type: none"> 0 16#80 0
ST_Worst	Worst signal status	BYTE	16#80
Status1	Status word 1 (Page 1735)	DWORD	16#00000000
Status2	Status word 2 (Page 1735)	DWORD	16#00000000
UpDnAct	1 = Block counts/integrates 0 = Block has no activity	STRUCT <ul style="list-style-type: none"> Value: BOOL ST: BYTE 	- <ul style="list-style-type: none"> 0 16#80

See also

TotalL operating modes (Page 1744)
TotalL messaging (Page 1750)
TotalL block diagram (Page 1757)

10.3.7 TotalL block diagram**TotalL block diagram**

A block diagram is not provided for this block.

See also

Description of TotalL (Page 1735)
TotalL operating modes (Page 1744)
TotalL functions (Page 1745)
TotalL error handling (Page 1749)
TotalL I/Os (Page 1752)
TotalL messaging (Page 1750)

10.3.8 Operator control and monitoring

10.3.8.1 TotalL views

Views of the TotalL block

The block TotalL provides the following views:

- TotalL standard view (Page 1758)
- Alarm view (Page 302)
- TotalL limit view (Page 1761)
- Trend view (Page 305)
- TotalL parameter view (Page 1763)
- TotalL preview (Page 1765)
- Memo view (Page 304)
- TotalL block icon (Page 1766)
- Batch view (Page 302)

Refer to the sections Structure of the faceplate (Page 248) and Block icon structure (Page 230) for general information on the faceplate and block icon.

10.3.8.2 TotalL standard view

TotalL standard view

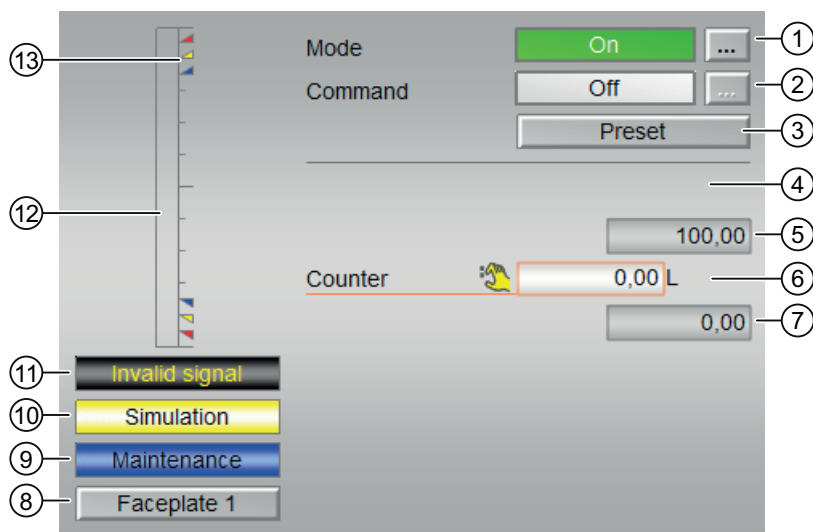

(1) Displaying and switching the operating mode

Operation of inputs `OosOp` and `OnOp`.

This area provides information on the currently valid operating mode. The following operating modes can be shown here:

- On (Page 71): `Status1 Bit 3 (OosAct.Value)`
- Out of service (Page 71): `Status1 Bit 6 (OnAct.Value)`

Refer to the Switching operating states and operating modes (Page 257) section for information on switching the operating mode.

(2) Enabling and disabling the counter

Operation of the inputs `UpOp`, `OffOp` and `DnOp`.

This area shows you the default operating state for the counter. The following states can be shown and executed here:

- "On ↑": `Status2 Bit 20 (Mode = 1)`
- "On ↓": `Status2 Bit 22 (Mode = 2)`
- "Off": `Status2 Bit 21 (Mode = 0)`

Refer to the Switching operating states and operating modes (Page 257) section for information on changing the state.

(3) Default setting

Operation of the input `RstOp`.

This button activates the preset value.

(4) Display of the count value

The current count values are displayed here:

Display of input In

Depending on `Feature Bit 6` and `Feature Bit 7`, either input `In` or an empty frame is displayed:

- "Input": `Feature Bit 6 = 1`, otherwise no display

The display is not operational. Format of `In` like display `Out`.

(5) High scale range for the count value

This value provides information on the display range for the bar graph (above) of the count value. The scale range is defined in the engineering system.

(6) Display of the count value

The current count values are displayed here:

Display Out

Depending on `Feature Bit 6`, the text for the display is switched over:

- "Counter": `Feature Bit 6 = 0`
- "Integrator": `Feature Bit 6 = 1`

The "Counter" display is not operational, not even in simulation. The format of `In` is like the `Out` display.

The "Integrator" display is only operational in simulation (operation input `SimOut`). The format corresponds to the block icon of `AnalogValueFormat1`.

(7) Low scale range for the count value

This value provides information on the display range for the bar graph (below) of the count value. The scale range is defined in the engineering system.

(8) Navigation button for switching to the standard view of any faceplate

Use this navigation button to open the standard view of a block configured in the engineering system. The visibility of this navigation button depends on the configuration in the engineering system (ES).

You can find additional information on this in the section [Opening additional faceplates](#) (Page 208).

(9) Display area for block states

This area provides additional information on the operating state of the block:

- "Maintenance"

You can find more information about this in the section [Release for maintenance](#) (Page 64).

(10) Display area for block states

This area provides additional information on the operating state of the block:

- "Simulation"

You can find additional information on this in the section [Simulating signals](#) (Page 58).

(11) Display area for block states

This area provides additional information on the operating state of the block:

- "Invalid signal"

You can find additional information on this in the section [Error handling](#) (Page 119).

(12) Graphic display of the current count value

This area shows you the current count in form of a bar graph. The visible area in the bar graph depends on the configuration in the engineering system (ES).

(13) Limit display

These colored triangles indicate the configured limits in the respective bar graph:

- Red: Alarm
- Yellow: Warning
- Blue: Tolerance

In counting mode "count up", only the colored triangles of the upper limits are visible; and in counting mode "count down", only the colored triangles of the lower limits are visible.

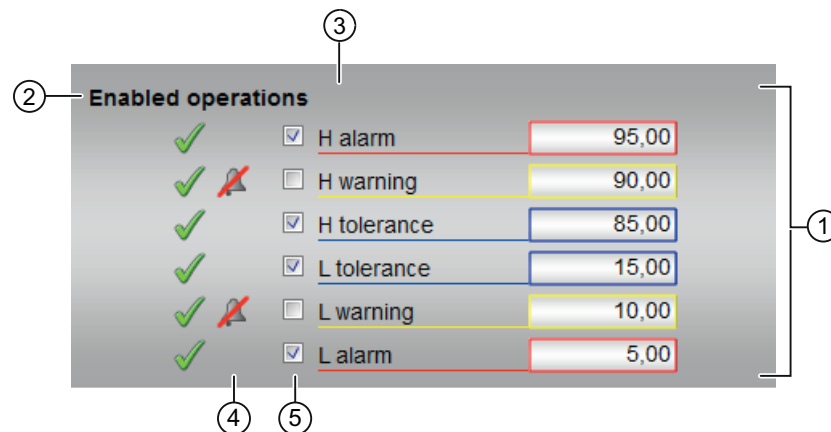
10.3.8.3 TotalL limit view**Limit view of TotalL****(1) Limits for the counter**

In this area, you can enter the limits for the counter. Refer to the Changing values (Page 259) section for more on this.

You can change the following limits:

- "H alarm": Alarm high
- "H warning": Warning high
- "H tolerance": Tolerance high
- "L tolerance": Tolerance low
- "L warning": Warning low
- "L alarm": Alarm low

Format and unit is like the `Out` display in the standard view.

(2) Enabled operation

This area shows all operations for which special operator permissions are assigned. They depend on the configuration in the engineering system (ES) that applies to this block.

Icons for enabled operation:

- **Green check mark:** the OS operator can control this parameter
- **Gray check mark:** the OS operator cannot control this parameter at this time due to the process
- **Red cross:** the OS operator cannot control this parameter due to the configured AS operator permissions (`OS_Perm` or `OS1Perm`)

(3) Dynamic text

Depending on `Feature` Bit 6, the text is switched:

- "Integrator limits (out)": Display for `Feature` Bit 6 = 1
- "Summer limits (out)": Display for `Feature` Bit 6 = 0

(4) "Message suppression"

Message suppression indicates whether or not the suppression of the associated message in the AS block is activated with the `xx_MsgEn` parameter. The output of messages is not suppressed when the block is installed (all `xx_MsgEn` parameters are preset to 1). Messages can only be output if limit monitoring of the additional analog value has been enabled.

(5) Suppress messages

You can enable / disable messages by setting the check mark.

10.3.8.4 TotalL parameter view

Parameter view of TotalL

With Feature bit 6 = 0:

Enabled operations		Settings
✓	Preset value	50.00 L
✓	Increment value	25.00 L
✓	Decrement value	0.00 L
Service		
✓	Bypass	On
✓	Simulation	Off
✓	Release for maint.	Yes

With Feature bit 6 = 1:

Enabled operations		Settings
✓	Preset value	50.00 L
✓	Integral time	1. s
Service		
✓	Bypass	On
✓	Simulation	Off
✓	Release for maint.	Yes

(1) Enabled operations

This area shows all operations for which special operator control permissions are assigned. They depend on the configuration in the engineering system (ES) that applies to this block.

Symbols for enabled operations:

- **Green check mark:** the OS operator can control this parameter
- **Gray check mark:** the OS operator cannot control this parameter at this time due to the process
- **Red cross:** the OS operator cannot control this parameter due to the configured AS operator control permissions (OS_Perm or OS1Perm).

(2) Default value

In this section you can enter the value from which the counting should begin. Additional information is available in the section Changing values (Page 259).

(3) Integral time

The currently integral time in seconds is displayed in this area.

- "Integral time" Display for Feature Bit 6 = 1, otherwise empty.

(4) Increment value

The increment value is displayed in this area.

- "Increment value": Display for Feature Bit 6 = 0, otherwise empty.

(5) Decrement value

The decrement value is displayed in this area.

- "Decrement value": Display for Feature Bit 6 = 0, otherwise empty.

(6) Service

You can select the following function in this area:

- "Bypass"
- "Simulation"
- "Release for maintenance"

Refer to the Switching operating states and operating modes (Page 257) section for more on this.

You can find information on this area in the section:

- Bypassing signals (Page 107)
- Simulating signals (Page 58)
- Release for maintenance (Page 64)

10.3.8.5 TotalL preview

Preview of TotalL

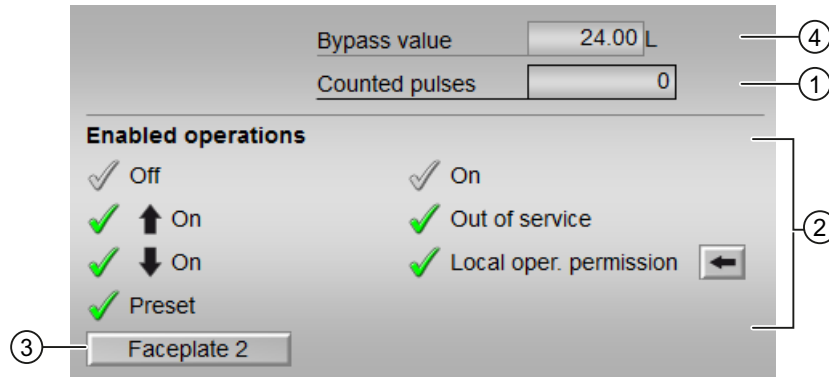

(1) Counted pulses

The number of pulses already counted is displayed in this area.

- "Counted pulses": Feature Bit 6 = 0 and Feature Bit 7 = 0, otherwise empty

(2) Enabled operations

This area shows all operations for which special operator control permissions are assigned. They depend on the configuration in the engineering system (ES) that applies to this block.

Symbols for enabled operations:

- **Green check mark:** the OS operator can control this parameter
- **Gray check mark:** the OS operator cannot control this parameter at this time due to the process
- **Red cross:** the OS operator cannot control this parameter due to the configured AS operator control permissions (OS_Perm or OS1Perm)

The following enabled operations are shown here:

- "Off": You can disable the counter.
- "On ↑": You can operate the incremental counter.
- "On ↓": You can operate the decremental counter.
- "Default": You can change the default setting.
- "On": You can switch to "On" operating mode.
- "Out of service": You can switch to "Out of service" operating mode.
- "Local operating permission": Use the ← button to switch to the standard view of the OpStations block. Additional information is available in the section Operator control permissions (Page 254).

(3) Navigation button for switching to the standard view of any faceplate

Use this navigation button to reach the standard view of a block configured in the engineering system. The visibility of this navigation button depends on the configuration in the engineering system (ES).

Additional information is available in the section Opening additional faceplates (Page 208).

(4) Bypass value

This area displays the bypass value (BypOut).

10.3.8.6 TotalL block icon

Block icons for TotalL

A variety of block icons are available with the following functions:

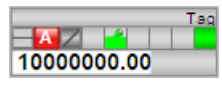
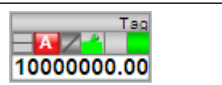
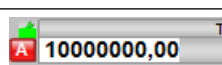

- Process tag type
- Limits (high/low)
- Violation of alarm, warning, and tolerance limits
- Operating modes
- Signal status, release for maintenance
- Memo display
- Display counter running

The block icons from template @TemplateAPLV8.PDL:

Icons	Selection of the block icon in CFC	Special features
	1	
	2	
	3	Block icon in the full display

10.3 TotalL - Additive counter with upward or downward counting direction (totalizer)

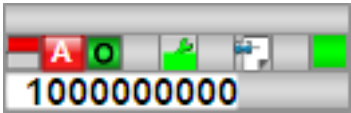
The block icons from template @TemplateAPLV7.PDL:

Icons	Selection of the block icon in CFC	Special features
	1	Block icon in the full display
	2	

Additional information on the block icon and the control options in the block icon is available in the following chapters:

- Configuring the block icons (Page 237)
- Block icon structure (Page 230)
- Operation via the block icon (Page 239).

10.4 CntOhSc - Runtime determination and counters with counting direction "up"

10.4.1 Description of CntOhSc

Object name (type + number) and family

Type + number: FB 1803

Family: Count

Area of application of CntOhSc

The block is used for the following applications:

- Incrementing of operating hours
- Incrementing a defined input value

How it works

The block determines the time in which a unit has been in operation and it counts a defined input value. The block can only count forwards.

1. Off ($OffOp = 1$)

The block is disabled (output parameter `CountMode = 0`). No counting takes place.

2. Increment ($UpOp = 1$)

The operating time of the connected unit is incremented (output parameter `CountMode = 1`).

The operating time is shown in days, hours, minutes and seconds. The maximum operating time is 32767 days and 23 hours.

Configuration

Use the CFC editor to install the block in a cyclic interrupt OB (OB30 to OB38). The block is first installed automatically in the startup OB (OB 100).

Startup characteristics

Define the startup characteristics for this block via two feature bits:

Bit 0: Set startup characteristics (Page 138)

Bit 5: Use the last value following a complete download as the current value during startup of the block (Page 154)

When you set feature bit 5 to 1, then:

- `Days := OldDays`
- `Hours := OldHours`

10.4 CntOhSc - Runtime determination and counters with counting direction "up"

- Minutes:= OldMinutes
- Seconds:= OldSeconds

Status word allocation for status1 parameter

Refer to the following section for a description of the individual parameters: CntOhSc I/Os (Page 1773)

Status bit	Parameter
0	Occupied
1	BatchEn
2	Not used
3	OosAct.Value
4	OosLi.Value
5	Not used
6	OnAct.Value
7 - 10	Not used
11	LiOp
12 - 13	Not used
14	1 = Invalid signal status
15 - 31	Not used

Status word allocation for status2 parameter

Status bit	Parameter
0	Not used
1	HrsHiL1Act.Value
2	HrsHiL2Act.Value
3	CntHiL1Act.Value
4	CntHiL2Act.Value
5 - 6	Not used
7	HrsHiL1En
8	HrsHiL2En
9	CntHiL1En
10	CntHiL2En
11 - 19	Not used
20	Count up
21	Counter off
22 - 31	Not used

10.4.2 CntOhSc operating modes

Operating modes of CntOhSc

The block can be operated using the following modes:

- On (Page 71)
- Out of service (Page 71)

"On"

General information on the "On" mode is available in the section On (Page 71).

"Out of service"

You can find general information about the "Out of service" mode in the section Out of service (Page 71).

10.4.3 CntOhSc functions

Functions of CntOhSc

The block provides the following functions:

Reset counter to zero

The output parameters of the operating time `Days`, `Hours`, `Minutes`, `Seconds`, `TimeHours` and `TotalTime` are reset via the interconnect `ResetOh` parameter. The reset is made with a 0 - 1 edge.

The counted value at the `Cnt` output parameter is reset with the interconnectable `ResetCnt` parameter. The reset is made with a 0 - 1 edge.

The count value and the output parameters of the operating time can also be reset to zero together in the standard view at the `ResetOp` parameter or the interconnectable `ResetLi` parameter via the faceplate.

You can use Feature bit 30 "Set reset depending on operating mode or the `LiOp` parameter" to configure a reset depending on the `LiOp` parameter:

Feature bit 30 =0: The reset does not depend on `LiOp`

Feature bit 30 =1: The reset depends on `LiOp`

`LiOp` =0: Separate reset via inputs `ResetOh` and `ResetCnt` is not possible. Simultaneous reset can only be made via the faceplate or at the `ResetOp` parameter.

`LiOp` =1: Separate reset is only possible via interconnectable inputs `ResetOh` and `ResetCnt`. Simultaneous reset can only be made via the interconnectable input `ResetLi`.

Configurable reactions using the Feature parameter

You can find an overview of all reactions provided by the `Feature` parameter in the Configurable functions using the Feature I/O (Page 131) . The following functionality is available for this block at the relevant bits:

Bit	Function
0	Set startup characteristics (Page 138)
1	Reaction to the out of service mode (Page 177)
5	Use the last value following a complete download as the current value during startup of the block (Page 154)
24	Enabling local operator authorization (Page 158)
26	Reaction of the switching points in the "Out of service" operating mode (Page 176)
29	Signaling limit violation (Page 170)
30	Set reset depending on the operating mode or the LiOp parameter (Page 163)

Operator permissions

This block provides the standard function Operator control permissions (Page 254).

The block has the following permissions for the `OS_Perm` parameter:

Bit	Function
0	Not used
1	1 = Operator can switch to "On" mode
2	Not used
3	1 = Operator can switch to "Out of service" mode
4	1 = Operator can stop counting
5	1 = Operator can switch to "Count up" mode
6	1 = Operator can reset the count
7 - 12	Not used
13	1 = Operator can change the operating hours high limit 1 (<code>HrsHi1Lim</code>)
14	1 = Operator can change the operating hours high limit 2 (<code>HrsHi2Lim</code>)
15	1 = Operator can change the counter high limit 1 (<code>CntHi1Lim</code>)
16	1 = Operator can change the counter high limit 2 (<code>CntHi2Lim</code>)
17 - 31	Not used

Forming the signal status for blocks

This block provides the standard function Forming and outputting the signal status for technologic blocks (Page 109).

The worst signal status `ST_Worst` for the block is formed from the following parameters:

- `InOh.ST`
- `InCnt.ST`
- `TmHoursST`
- `CntST`

The following signal status is formed by:

Signal status	Used status
TmHoursST	<p>Increment: Formed from the worst signal status of InOh . ST and the last signal status TmHoursST. This means that the worst signal status of InOh . ST is stored to TmHoursST during increment.</p> <p>Counter off: Signal status TmHoursST is frozen.</p> <p>Resetting CntOhSc or ResetOh also resets the signal status: TmHoursST := 16#80</p>
CntST	<p>Increment: Formed from the worst signal status of InCnt . ST and the last signal status CntST. This means that the worst signal status of InCnt . ST is stored to CntST during increment.</p> <p>Counter off: Signal status CntST is frozen.</p> <p>Resetting CntOhSc or ResetCnt also resets the signal status: CntST := 16#80</p>

Opening additional faceplates

This block provides the standard function Opening additional faceplates (Page 208).

SIMATIC BATCH functionality

This block provides the standard function SIMATIC BATCH functionality (Page 67).

10.4.4 CntOhSc error handling

Error handling of CntOhSc

Refer to the section Error handling (Page 119) in the basic instructions for the error handling of all blocks.

The following errors can be displayed for this block:

- Error numbers

Overview of error numbers

The ErrorNum I/O can be used to output the following error numbers:

Error number	Meaning of the error number
-1	Predefined value when inserting the block; block is not processed
0	No active fault
51	<p>Invalid signal at LiOp = 1:</p> <ul style="list-style-type: none"> • OffLi = 1 and UpLi = 1

10.4.5 CntOhSc messaging

Messaging

This block does not offer messaging.

10.4.6 CntOhSc I/Os

I/Os of CntOhSc

Input parameters

Parameter	Description	Type	Default
BatchEn	1 = Enable allocation	BOOL	0
BatchID	Batch ID	DWORD	16#00000000
BatchName	Batch name	S7-String	
CntHiL1En	1 = Counter high limit 1 is enabled	BOOL	0
CntHiL2En	1 = Counter high limit 2 is enabled	BOOL	0
CntHi1Lim	Counter high limit 1	DINT	95
CntHi2Lim	Counter high limit 2	DINT	90
CntOpHiScale	High limit for scale in count bar graph of face-plate	DINT	100
CntOpLoScale	Low limit for scale in count bar graph of face-plate	DINT	0
CntUnit	Unit of measure for count Cnt	INT	0
Feature	I/O for additional functions (Page 1770)	STRUCT	-
		<ul style="list-style-type: none"> • Bit 0: BOOL • ... • Bit 31: BOOL 	<ul style="list-style-type: none"> • 0 • 0 • 0
HrsHiL1En	1 = Operating hours high limit 1 is enabled	BOOL	0
HrsHiL2En	1 = Operating hours high limit 2 is enabled	BOOL	0
HrsHi1Lim	Operating hours high limit 1	DINT	2280
HrsHi2Lim	Operating hours high limit 2	DINT	2160
HrsOpHiScale	Operating hours high limit of bar display for OS	DINT	2400
HrsOpLoScale	Operating hours low limit of bar display for OS	DINT	0
InOh	Digital input value for operating hours counter	REAL	0.0
InCnt	Digital input value for up counter	REAL	0.0
LiOp	1= Interconnection 0 = Operator	STRUCT	-
		<ul style="list-style-type: none"> • Value: BOOL • ST: BYTE 	<ul style="list-style-type: none"> • 0 • 16#80
Occupied	1 = Occupied by batch control	BOOL	0

Counter blocks

10.4 CntOhSc - Runtime determination and counters with counting direction "up"

Parameter	Description	Type	Default
OffLi	Counter disabled via interconnection: 1 = Off	STRUCT • Value: BOOL • ST: BYTE	- • 0 • 16#80
OffOp*	Counter disabled via operator: 1 = Off	BOOL	1
OldCnt*	Previous count value	DINT	0
OldDays	Previous day value	INT	0
OldHours	Previous hour value	INT	0
OldMinutes	Previous minute value	INT	0
OldSeconds*	Previous second value	INT	0
OnOp*	1 = "On" mode via operator	BOOL	0
OosLi	1 = "Out of service", via interconnection	STRUCT • Value: BOOL • ST: BYTE	- • 0 • 16#80
OosOp*	1 = "Out of service", via operator	BOOL	0
OpSt_In	Input parameter for local operator authorization, connected with the <code>Out</code> output parameter of the upstream block, <code>OpStations</code> (Page 411)	DWORD	16#00000000
OS_Perm	I/O for CntOhSc functions (Page 1770)	STRUCT • Bit 0: BOOL • ... • Bit 31: BOOL	- • 1 • 1 • 1
ResetCnt	1 = Input <code>valueCnt</code> reset	BOOL	0
ResetLi	1 = Counter reset via interconnection	BOOL	0
ResetOh	1 = Operating hours reset	BOOL	0
ResetOp*	1 = Counter reset by operator	BOOL	0
SampleTime	Sampling time [s]	REAL	0.1
SelFp1	Open faceplate 1	ANY	
StepNo	Batch step number	DWORD	16#00000000
UpLi	1 = Increment (via interconnection)	STRUCT • Value: BOOL • ST: BYTE	- • 0 • 16#80
UpOp*	1 = Increment (via faceplate)	BOOL	0

* Values can be written back to these inputs during processing of the block by the block algorithm.

10.4 CntOhSc - Runtime determination and counters with counting direction "up"

Output parameters

Parameter	Description	Type	Default
CountMode	Count mode: 0 = Off 1 = Increment	INT	0
Cnt	Count	DINT	0
CntHiL1Act	1 = Counter high limit 1 is active	STRUCT • Value: BOOL • ST: BYTE	- • 0 • 16#80
CntHiL2Act	1 = Counter high limit 2 is active	STRUCT • Value: BOOL • ST: BYTE	- • 0 • 16#80
CntST	Signal status for Cnt	BYTE	16#80
Days	Operating stage	INT	0
DeviceOn	1 = Unit on	STRUCT • Value: BOOL • ST: BYTE	- • 0 • 16#80
ErrorNum	Output of pending error number. For error numbers that can be output by this block, see CntOhSc error handling (Page 1772)	INT	-1
Hours	Operating hours	INT	0
HrsHiL1Act	1 = Operating hours high limit 1 is active	BOOL	0
HrsHiL2Act	1 = Operating hours high limit 2 is active	BOOL	0
Minutes	Operating minutes	INT	0
O_MS_Ext	Reserved	DWORD	16#00000000
OnAct	Block running	STRUCT • Value: BOOL • ST: BYTE	- • 1 • 16#80
OosAct	Block is "out of service"	STRUCT • Value: BOOL • ST: BYTE	- • 0 • 16#80
OpSt_Out	Value of the OpSt_In input parameter, for feedforwarding to other blocks. Bit 31 of this parameter is used by Feature bit 24	DWORD	16#00000000
OS_PermLog	Operator permission: Output for OS	DWORD	16#FFFFFFFF
OS_PermOut	Operator permission: Output for OS	DWORD	16#FFFFFFFF
Seconds	Operating time [in sec]	INT	0
ST_Worst	Worst signal status	BYTE	16#80
Status1	Status word 1 (Page 411)	DWORD	16#00000000
Status2	Status word 2 (Page 411)	DWORD	16#00000000
TimeHours	Service life [h]	DINT	0
TmHoursST	Signal status for TimeHours	BYTE	16#80
TotalTime	Total operating time [in sec]	DWORD	16#00000000

10.4.7 CntOhSc block diagram

Block diagram of CntOhSc

A block diagram is not provided for this block.

10.4.8 Operator control and monitoring

10.4.8.1 CntOhSc views

Views of the CntOhSc block

The CntOhSc block provides the following views:

- CntOhSc standard view (Page 1777)
- CntOhSc limit view (Page 1779)
- Trend view (Page 305)
- CntOhSc preview (Page 1780)
- Memo view (Page 304)
- Batch view (Page 302)
- Block icon for CntOhSc (Page 1781)

Refer to the sections Structure of the faceplate (Page 248) and Block icon structure (Page 230) for general information on the faceplate and block icon.

10.4.8.2 CntOhSc standard view

Standard view of CntOhSc

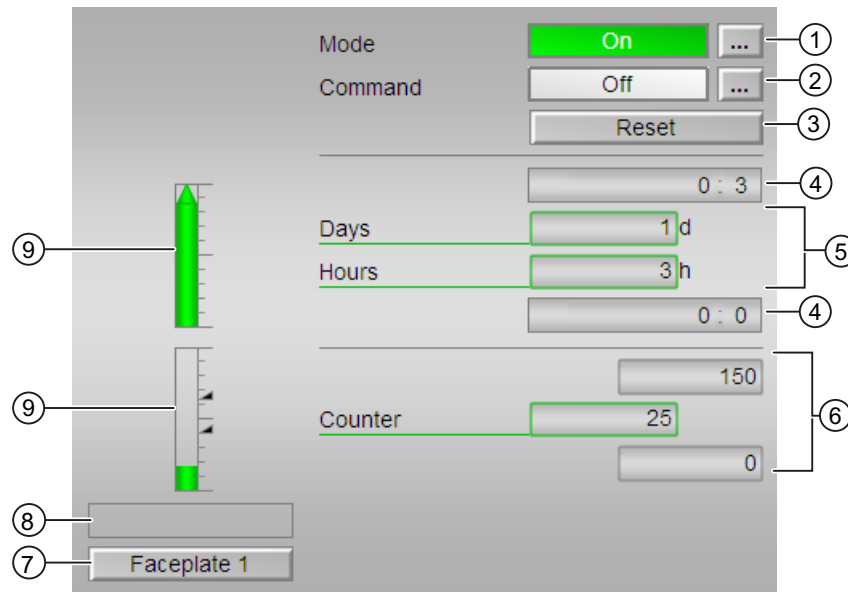

(1) Display and switch the operating mode

This area provides information on the currently valid operating mode. The following operating modes can be shown here:

- On (Page 71)
- Out of service (Page 71)

Refer to section Switching operating states and operating modes (Page 257) for information on switching the operating mode.

(2) Enable and disable the counter

This area shows you the default operating state for the counter. The following states can be shown and executed here:

- "On ↑"
- "Off"

Refer to the Switching operating states and operating modes (Page 257) section for information on changing the state.

(3) Reset

Operation of the input $RstOp$.

This button activates the preset value.

(4) High and low scale range for the count value

These values provide information on the display range for the bar graph of the count `HrsOpHiScale` or `HrsOpLoScale`. The scale range is defined in the engineering system.

(5) Display for counts

The following counts are shown here:

- "Days" with signal status `TmHoursST`
- "Hours" with signal status `TmHoursST`

(6) Counter

The following values are shown here:

- Current count value with the signal status `CntST`
- High and low scale range for the count

These values provide information on the display range for the bar graph of the count `CntOpHiScale` or `CntOpLoScale`. The scale range is defined in the engineering system.

(7) Navigation button for switching to the standard view of any faceplate

Use this navigation button to open the standard view of a block configured in the engineering system (ES). The visibility of this navigation button depends on the configuration in the engineering system (ES).

You can find additional information on this in the section [Opening additional faceplates](#) (Page 208).

(8) Display area for states of the block

This area provides additional information on the operating state of the block:

- "Invalid signal"

You can find additional information on this in the section [Error handling](#) (Page 119).

(9) Graphic display for the current count

These areas show the `Cnt` and `TimeHours` counts in the form of a bar graph. The visible area in the bar graph depends on the configuration in the engineering system (ES).

Limits

These colored triangles indicate the configured limits in the respective bar graph:

- Red: High limit 1
- Yellow: High limit 2

10.4.8.3 CntOhSc limit view

Limit view of CntOhSc

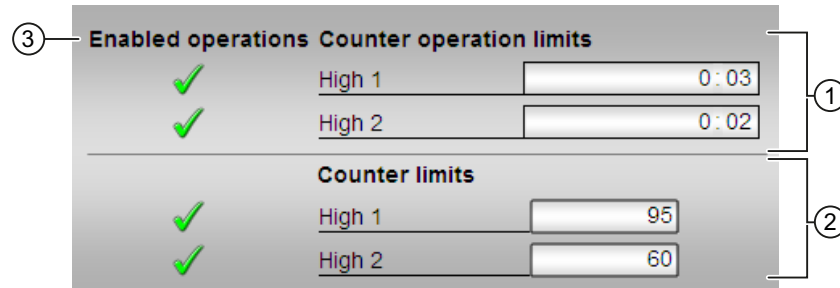

(1) Operating hours limits

In this area, you can enter the limits for the operating hours. You can find additional information on this in the section Changing values (Page 259) .

You can change the following limits:

- "High 1": Operating hours high limit 1
- "High 2": Operating hours high limit 2

(2) Counter limits

In this area, you can enter the limits for the counter. You can find additional information on this in the section Changing values (Page 259) .

You can change the following limits:

- "High 1": Counter high limit 1
- "High 2": Counter high limit 2

(3) Enabled operation

This area shows all operations for which special operator permissions are assigned. They depend on the configuration in the engineering system (ES) that applies to this block.

Icons for enabled operation:

- **Green check mark:** The OS operator can control this parameter.
- **Gray check mark:** The OS operator cannot control this parameter at this time due to the process.
- **Red cross:** The OS operator cannot control this parameter due to the configured AS operator permissions (OS_Perm).

(4) "Message suppression"

Message suppression indicates whether or not the suppression of the associated message in the AS block is activated with the `xx_MsgEn` parameter. The output of messages is not suppressed when the block is installed (all `xx_MsgEn` parameters are preset to 1). Messages can only be output if limit monitoring of the additional analog value has been enabled.

10.4.8.4 CntOhSc preview

Preview of CntOhSc

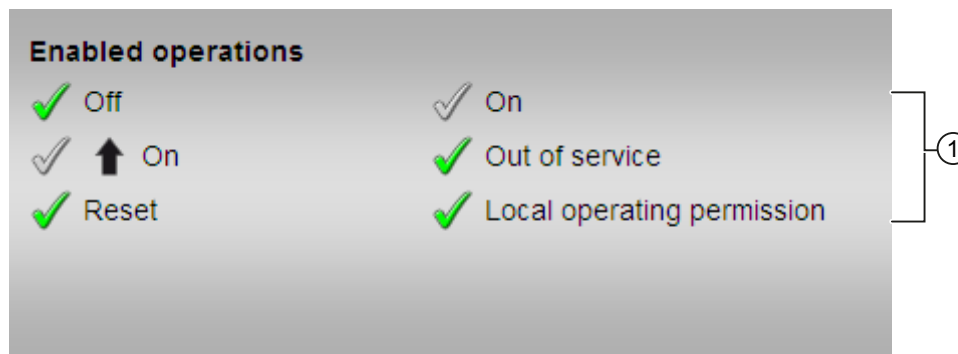

(1) Enabled operations

This area shows all operations for which special operator control permissions are assigned. They depend on the configuration in the engineering system (ES) that applies to this block.

Symbols for enabled operations:

- **Green check mark:** the OS operator can control this parameter
- **Gray check mark:** the OS operator cannot control this parameter at this time due to the process
- **Red cross:** the OS operator cannot control this parameter due to the configured AS operator control permissions (`OS_Perm`)

The following enabled operations are shown here:

- "Off": You can disable the counter.
- "On ↑": You can operate the counter.
- "Reset": You can reset the counter after interlocks or errors.
- "On": You can switch to "On" operating mode.
- "Out of service": You can switch to "Out of service" operating mode.
- "Local operating permission": Use the ← button to switch to the standard view of the OpStations block. Additional information is available in the section Operator control permissions (Page 254).

10.4.8.5 Block icon for CntOhSc

Block icons for CntOhSc

A variety of block icons are available with the following functions:

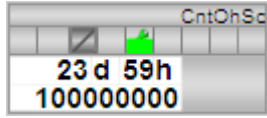
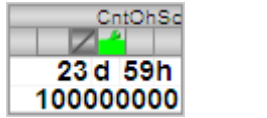
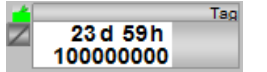

- Process tag type
- Limits (high/low)
- Violation of the limits
- Operating modes
- Signal status
- Memo display
- Display counter running

The block icons from template @TemplateAPLV8.PDL:

Icons	Selection of the block icon in the CFC	Special features
	1	
	2	
	3	Block icon in the full display

10.4 CntOhSc - Runtime determination and counters with counting direction "up"

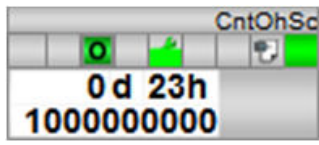
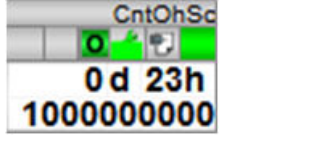
The block icons from template @TemplateAPLV7.PDL:

Icons	Selection of the block icon in the CFC	Special features
 <p>The image shows a block icon for 'CntOhSc' in full display mode. It features a top bar with a green bar chart, a counter value '0 d 23h', and a large numerical value '1000000000'.</p>	1	Block icon in the full display
 <p>The image shows a block icon for 'CntOhSc' in normal display mode. It features a top bar with a green bar chart, a counter value '0 d 23h', and a large numerical value '1000000000'.</p>	2	
 <p>The image shows a block icon for 'CntOhSc' in 'Out of service' mode. The top bar is greyed out and contains a diagonal line through a square icon.</p>	-	Block icon in "Out of service" mode (example with type block icon type 1)

Additional information on the block icon and the control options in the block icon is available in the following chapters:

- Configuring the block icons (Page 237)
- Block icon structure (Page 230)
- Operation via the block icon (Page 239).

Timers

11.1 TimerP - Time delays signal forwarding / pulse generator

11.1.1 Description of TimerP

Object name (type+number) and family

Type + number: FB 1810

Family: TIME

Area of application for TimerP

The block is used for the following fields of applications:

- Pulse generator
- Extended pulse
- ON delay
- ON delay with memory
- OFF delay

How it works

The TimerP block is used for delayed forwarding of start or stop actions through the `Out` output parameter.

New values at the `Ti` I/O are only applied when a change is made to the `In` I/O.

The inverted signal for `Out` is also provided at the `InvOut` output parameter.

Use the `Mode` input parameter to define how the block should be used. Refer to the TimerP functions (Page 1784) section for more on this.

Configuration

Use the CFC editor to install the block in a cyclic interrupt OB (OB30 to OB38).

Startup characteristics

The block does not have any startup characteristics.

A startup behavior can be reached with a connection of the input parameter `Init` to the output parameter `InitOut` of the Trigger block. For more information, refer to Startup characteristics over Trigger block (Page 69).

Status word allocation for status parameter

This block does not have the `Status` parameter.

See also

TimerP modes (Page 1784)

TimerP error handling (Page 1787)

TimerP messaging (Page 1788)

TimerP I/Os (Page 1788)

TimerP block diagram (Page 1790)

11.1.2 TimerP modes

TimerP operating modes

This block does not have any modes.

See also

Description of TimerP (Page 1783)

TimerP functions (Page 1784)

TimerP error handling (Page 1787)

TimerP messaging (Page 1788)

TimerP I/Os (Page 1788)

TimerP block diagram (Page 1790)

11.1.3 TimerP functions

Functions of TimerP

The functions for this block are listed below.

Specifying how TimerP works

Use the `Mode` input parameter to specify how the block should work:

Mode =	How the block works	Graphic representation
0	Start timer as pulse	<p>Timing diagram for Mode 0: Start timer as pulse. The In signal has five pulses. The Hold signal has a pulse of duration t_H. The Reset signal has a pulse. The Out signal shows pulses with durations: T_i, $< T_i$, and $T_i + t_H$.</p>
1	Start extended pulse timer	<p>Timing diagram for Mode 1: Start extended pulse timer. The In signal has five pulses. The Hold signal has a pulse of duration t_H. The Reset signal has a pulse. The Out signal shows pulses with durations: T_i, T_i, and $T_i + t_H$.</p>
2	Start ON delay timer	<p>Timing diagram for Mode 2: Start ON delay timer. The In signal has five pulses. The Hold signal has a pulse of duration t_H. The Reset signal has two pulses. The Out signal shows pulses with durations: T_i, $< T_i$, $T_i + t_H$, $< T_i$, and T_i.</p>

Mode =	How the block works	Graphic representation
3	Start ON delay timer with memory	<p>The diagram shows four input pulses (In) and their corresponding output pulses (Out). The output pulse width is T_i. A Hold signal (Hold) is shown as a pulse of duration t_H. A Reset signal (Reset) is shown as a pulse. The output pulse width is T_i. The output pulse width is T_i. The output pulse width is T_i. The output pulse width is T_i.</p>
4	Start OFF delay timer	<p>The diagram shows five input pulses (In) and their corresponding output pulses (Out). The output pulse width is $T_i + t_H$. A Hold signal (Hold) is shown as a pulse of duration t_H. A Reset signal (Reset) is shown as a pulse. The output pulse width is $<T_i$. The output pulse width is T_i. The output pulse width is T_i. The output pulse width is T_i.</p>

Setting the time

You can use the T_i parameter to time for operating the block.

Note

Be aware when configuring this, that the time interval between T_i and `SampleTime` should not be more than 10^7 .

Holding the Out and TimeRemaining output parameters

Use the `Hold.Value = 1` parameter to freeze the calculation of the outputs `Out` and `TimeRemaining.Value`.

Resetting the Out and TimeRemaining output parameters

Use the `Reset.Value = 1` parameter to reset the output parameters `Out` and `TimeRemaining.Value` to 0.

Initialization

With the input parameter `Init = 1`, the output parameters `Out` and `TimeRemaining` can be reset to 0 (same behavior as `Reset.Value = 1`). You can use the input parameter `Init` to realize a startup behavior.

To initialize the output parameters `Out` and `TimeRemaining` after a startup, connect the input parameter `Init` with the output parameter `InitOut` of the Trigger block. For more information, refer to Startup characteristics over Trigger block (Page 69).

Forming the signal status for blocks

The signal status for the block is formed using the following parameters and output at the `Out` and `InvOut` output parameters:

- `In.ST`

See also

Description of TimerP (Page 1783)

TimerP modes (Page 1784)

TimerP error handling (Page 1787)

TimerP messaging (Page 1788)

TimerP I/Os (Page 1788)

TimerP block diagram (Page 1790)

11.1.4 TimerP error handling

Error handling of TimerP

Refer to the section Error handling (Page 119) in the basic instructions for the error handling of all blocks.

The following errors can be displayed for this block:

- Error numbers

Overview of error numbers

The `ErrorNum` I/O can be used to output the following error numbers:

Error number	Meaning of the error number
-1	Predefined value when inserting the block; the block is not processed.
0	There is no error.
1	Invalid function type for the block set at the Mode input parameter
11	$Ti.Value < SampleTime$ This error causes the <code>TimeRemaining</code> and <code>Out</code> output parameters to be set to 0.
33	The value of <code>Ti</code> can no longer be displayed in the REAL number field.

See also

Description of TimerP (Page 1783)
 TimerP modes (Page 1784)
 TimerP functions (Page 1784)
 TimerP messaging (Page 1788)
 TimerP I/Os (Page 1788)
 TimerP block diagram (Page 1790)

11.1.5 TimerP messaging**Messaging**

This block does not offer messaging.

See also

Description of TimerP (Page 1783)
 TimerP modes (Page 1784)
 TimerP functions (Page 1784)
 TimerP error handling (Page 1787)
 TimerP I/Os (Page 1788)
 TimerP block diagram (Page 1790)

11.1.6 TimerP I/Os**I/Os of TimerP****Input parameters**

Parameter	Description	Type	Default
EN	1 = Called block will be processed	BOOL	1
Hold	Hold calculation process	STRUCT	-
		<ul style="list-style-type: none"> • Value: BOOL • ST: BYTE 	<ul style="list-style-type: none"> • 0 • 16#80

11.1 TimerP - Time delays signal forwarding / pulse generator

Parameter	Description	Type	Default
In	Input signal	STRUCT • Value: BOOL • ST: BYTE	- • 0 • 16#80
Init	Initialize function block	BOOL	0
Mode	How the block works: 0 = Start timer as pulse 1 = Start timer as extended pulse 2 = Start timer with ON delay 3 = Start timer with latching ON delay 4 = Start timer with OFF delay	INT	2
Reset	1 = Reset output <i>Out</i>	STRUCT • Value: BOOL • ST: BYTE	- • 0 • 16#80
SampleTime	Sampling time [s] (assigned automatically)	REAL	0.1
Ti*	Time [s]	REAL	0.0

* Values can be written back to these inputs during processing of the block by the block algorithm.

Output parameters

Parameter	Description	Type	Default
ENO	1 = Block algorithm completed without errors	BOOL	0
ErrorNum	Output of current error number. For error numbers that can be output by this block, see TimerP error handling (Page 1787).	INT	-1
InvOut	Inverted output signal	STRUCT • Value: BOOL • ST: BYTE	- • 1 • 16#80
Out	Output signal	STRUCT • Value: BOOL • ST: BYTE	- • 0 • 16#80
TimeRemaining	Remaining time [s]	STRUCT • Value: REAL • ST: BYTE	- • 0.0 • 16#80

See also

Description of TimerP (Page 1783)

TimerP modes (Page 1784)

TimerP functions (Page 1784)

11.1 TimerP - Time delays signal forwarding / pulse generator

TimerP messaging (Page 1788)

TimerP block diagram (Page 1790)

11.1.7 TimerP block diagram

TimerP block diagram

A block diagram is not provided for this block.

See also

Description of TimerP (Page 1783)

TimerP modes (Page 1784)

TimerP functions (Page 1784)

TimerP error handling (Page 1787)

TimerP messaging (Page 1788)

TimerP I/Os (Page 1788)

11.2 TimeTrig - Calculations with the date formats DT and TIME

11.2.1 Description of TimeTrig

Object name (type + number) and family

Type + number: FB 1802

Family: Time

Area of application of TimeTrig

The block is used for the following applications:

- Daily, weekly or monthly generation of a pulse (trigger) using a definable time in hours (0 to 23h) and day of the week (Sun to Sat) or one day (1 to 31) per month.
- Delayed generation a pulse (trigger) based on the current CPU time and a delay time in seconds (0 to 20 days).

How it works

When a trigger is enabled, the next trigger time point and the duration until the next trigger time point is determined based on the CPU time. A periodic trigger and additionally a single trigger can be generated:

1. Generate periodic trigger (`PerTrigOn.Value = 1`)
2. Generate single trigger (`SglTrigOn.Value = 1`)

The single trigger can be delayed by a specified period of time. The maximum delay is 20 days.

The period of time until the next trigger time point is displayed in days, hours, and minutes.

For calculations with the time formats DT and TIME, the block calls the following functions:

Name	as of APL V8.1	Family	No. in IEC	Symbol Comment
AD_DT_TM_APL	FC455	IEC	FC1	DT + add time
GE_DT_APL	FC456	IEC	FC12	Greater than or equal to DT
LE_DT_APL	FC452	IEC	FC18	Less than or equal to DT
LT_DT_APL	FC453	IEC	FC23	Smaller than DT
SB_DT_DT_APL	FC454	IEC	FC34	DT - DT subtract

They come from the standard library "IEC function blocks" and are now also applied in the APL.

F1 will open the help from the original IEC function block.

Configuration

Use the CFC editor to install the block in a cyclic interrupt OB (`OB30` to `OB38`). The block is first installed automatically in the startup OB (`OB100`).

Startup characteristics

Define the startup characteristics for this block via Feature bit 0:

- Bit 0: Set startup characteristics (Page 138)

Status word allocation for status parameter

Refer to the following section for a description of the individual parameters: TimeTrig I/Os (Page 1798).

Status bit	Parameter
0	Occupied
1	BatchEn
2	Not used
3	OosAct.Value
4	OosLi.Value
5	Not used
6	OnAct.Value
7	All triggers are switched off: NOT PerTrigOn.Value OR SglTrigOn.Value OR Trigger.Value
8	PerTrigOn.Value
9	NOT PerTrigOn.Value
10	SglTrigOn.Value
11	NOT SglTrigOn.Value
12	Trigger.Value
13	Not used
14	Next trigger is a daily trigger
15	Next trigger is a weekly trigger
16	Next trigger is a monthly trigger
17	Next trigger is a single trigger
18	DailyOn: Periodic trigger set to daily
19	WeeklyOn: Periodic trigger set to weekly
20	MonthlyOn: Periodic trigger set to monthly
21	Weekday is Sunday
22	Weekday is Monday
23	Weekday is Tuesday
24	Weekday is Wednesday
25	Weekday is Thursday
26	Weekday is Friday
27	Weekday is Saturday
28	LiOp.Value
29	1 = Invalid signal status SetPerLi.Value and RstPerLi.Value, SetSglLi.Value and RstSglLi.Value
30 - 31	Not used

See also

TimeTrig modes (Page 1793)
TimeTrig functions (Page 1793)
TimeTrig error handling (Page 1797)
TimeTrig messaging (Page 1798)
TimeTrig block diagram (Page 1802)

11.2.2 TimeTrig modes**TimeTrig operating modes**

The block can be operated using the following modes:

- On (Page 71)
- Out of service (Page 71)

"On"

General information on the "On" mode is available in the section On (Page 71).

"Out of service"

You can find general information about the "Out of service" mode in the section Out of service (Page 71).

See also

Description of TimeTrig (Page 1791)
TimeTrig functions (Page 1793)
TimeTrig error handling (Page 1797)
TimeTrig messaging (Page 1798)
TimeTrig I/Os (Page 1798)
TimeTrig block diagram (Page 1802)

11.2.3 TimeTrig functions**Functions of TimeTrig**

The functions for this block are listed below.

Periodic output of a trigger

Use the `LiOp` input parameter to define whether the periodic trigger can be enabled (0 - 1, `SetPerOp` or `SetPerLi` parameter) or disabled (1 - 0, `RstPerOp` or `RstPerLi` parameter) via the faceplate or an interconnection.

`LiOp = 0`: Enable/disable via faceplate (`SetPerOp` or `RstPerOp`)

`LiOp = 1`: Enable/disable via interconnection (`SetPerLi` or `RstPerLi`)

You can select the faceplate from three periodic trigger settings:

- Periodic daily output `DailyOn = 1`
You set the time in hours with the `HourOfDay` parameter.
- Periodic weekly output `WeeklyOn = 1`
You set the day of the week and time of day with the `HourOfDay` and `DayOfWeek` parameters.
- Periodic monthly output `MonthlyOn = 1`
You set the day of the month and time of day with the `HourOfDay` and `DayOfMonth` parameters. If the day of a month is greater than the last day, the last day is used.

Delayed output of a single trigger

Use the `LiOp` input parameter to define whether the single trigger can be set (0 - 1, `SetPerOp` or `SetPerLi` parameter) or reset (1 - 0, `RstPerOp` or `RstPerLi` parameter) via the faceplate or an interconnection.

`LiOp = 0`: Set/reset via faceplate (`SetPerOp` or `RstPerOp`)

`LiOp = 1`: Set/reset via interconnection (`SetPerLi` or `RstPerLi`)

The output is delayed by the delay time `DelayTime` starting from the current CPU time. The currently effective delay time is displayed at the `DlyTmEff` output.

Calculation of the next trigger time point

The next trigger time point is displayed at the `NxTrgDT`, `NxTrgYear`, `NxTrgMon`, `NxTrgDay`, `NxTrgHour`, `NxTrgMin` and `NxTrgSec` outputs. The next trigger time point is calculated from an enabled periodic trigger and an activated single trigger.

If no trigger is activated, the the minimum DT#1990-01-01-0:0:0.0 is output at the `NxTrgDT` output.

Calculating the time period until the next trigger time point

The period of time until the next trigger time point based on the current CPU time is output at the `DiffTmDay`, `DiffTmHour`, `DiffTmMin` and `DiffTmSec` outputs.

If no trigger is activated, 0 is set at the outputs.

Reading back the trigger states and the single trigger time point for a complete download

The `PerTrigOn`, `SglTrigOn` trigger states and the single trigger time point are written back to inputs:

- `InPerTrigOn := PerTrigOn`
- `InSglTrigOn := SglTrigOn`
- `InSglTrigDT := SglTrigDT`

If you want to use the reset for a complete download, you must read back the marked parameters in addition to the operated and monitored parameters before a complete download.

The values are written back to the outputs at startup and when feature bit 0 = 1.

Also, in section Set startup characteristics (Page 138), see under "Set startup characteristics for the TimeTrig block".

Configurable reactions using the `Feature` parameter

You can find an overview of all reactions provided by the `Feature` parameter in the Configurable functions using the Feature I/O (Page 131) . The following functionality is available for this block at the relevant bits:

Bit	Function
0	Set startup characteristics (Page 138)
1	Reaction to the out of service mode (Page 177)
24	Enabling local operator authorization (Page 158)

Operator permissions

This block provides the standard function Operator control permissions (Page 254).

The block has the following permissions for the `OS_Perm` parameter:

Bit	Function
0	Not used
1	1 = Operator can switch to "On" mode
2	Not used
3	1 = Operator can switch to "Out of service" mode
4	1 = Operator can enable the periodic trigger
5	1 = Operator can disable the periodic trigger
6	1 = Operator can set the single trigger
7	1 = Operator can reset the single trigger
8	Not used
9	used in <code>OSPermOut</code> , <code>OSPermLog</code> for the display of the Enabled operations symbol of Periodic mode
10	1 = Operator can enter <code>HourOfDay</code>
11	1 = Operator can enter <code>DayOfWeek</code>
12	1 = Operator can enter <code>DayOfMonth</code>
13	1 = Operator can enter <code>DelayDay</code>

Bit	Function
14	1 = Operator can enter DelayHour
15	1 = Operator can enter DelayMin
16	1 = Operator can enter PulseWidth
17	1 = Operator can set LocalTime
18	1 = Operator can enter periodic mode Daily
19	1 = Operator can enter periodic mode Weekly
20	1 = Operator can enter periodic mode Monthly
21 - 27	used in OSPermLog for the weekdays Sun, Mon ... Sat
28 - 31	Not used

Recognizing daylight saving time

The block reads the identifier for daylight saving time from the CPU and writes it to the SummerTime output. The update occurs only when

- The HourOfDay, DayOfWeek, DayOfMonth, DelayTime, DailyOn, WeeklyOn, MonthlyOn, or LocalTime parameters are changed
- A PerTrigOn or SglTrigOn trigger is enabled
- At startup or leaving Out of Service

If an error occurs when reading the daylight saving time, the status SummerTime.ST := 16#00 is set and the display is not updated. The status is not used in the calculation of ST_Worst.

Local time

In every cycle, the block reads the CPU time. With LocalTime = 1 the block calculates a local time. To this a correction value will be read from CPU and build a difference time, which is added to the CPU time. This correction takes into account the time zone and the time difference in summer time (daylight savings time) and winter time (standard time).

The update of the correction value occurs only when:

- The HourOfDay, DayOfWeek, DayOfMonth, DelayTime, DailyOn, WeeklyOn, MonthlyOn, or LocalTime parameters are changed.
- A PerTrigOn or SglTrigOn trigger is enabled.
- At startup or leaving "Out of Service" mode.

If an error occurs while reading the correction value, the status SummerTime.ST is set to 16#00 and the block does not changes the CPU time.

Forming the signal status for blocks

This block provides the standard function Forming and outputting the signal status for technologic blocks (Page 109).

The worst signal status `ST_Worst` for the block is formed from the following parameter:

- `SetSglLi.ST`
- `RstSglLi.ST`
- `SetPerLi.ST`
- `RstPerLi.ST`

The worst signal status `ST_Worst` is written to the following outputs:

- `SglTrigOn.ST`
- `PerTrigOn.ST`
- `Trigger.ST`

If an error occurs when reading the daylight saving time, the status `SummerTime.ST := 16#00` is set and the display is not updated. The status is not used in the calculation of `ST_Worst`.

Opening additional faceplates

This block provides the standard function `Opening additional faceplates` (Page 208).

See also

Description of TimeTrig (Page 1791)
TimeTrig modes (Page 1793)
TimeTrig error handling (Page 1797)
TimeTrig messaging (Page 1798)
TimeTrig I/Os (Page 1798)
TimeTrig block diagram (Page 1802)

11.2.4 TimeTrig error handling

Error handling for TimeTrig

Refer to the section `Error handling` (Page 119) in the basic instructions for the error handling of all blocks.

Overview of error numbers

The `ErrorNum` I/O can be used to output the following error numbers:

Error number	Meaning of the error number
-1	Predefined value when inserting the block; the block is not executed.
0	There is no error.
51	Invalid signal at <code>LiOp = 1</code> <ul style="list-style-type: none"> • <code>SetPerLi = 1</code> and <code>RstPerLi = 1</code> • <code>SetSglLi = 1</code> and <code>RstSglLi = 1</code>

See also

Description of TimeTrig (Page 1791)

TimeTrig modes (Page 1793)

TimeTrig functions (Page 1793)

TimeTrig I/Os (Page 1798)

TimeTrig block diagram (Page 1802)

11.2.5 TimeTrig messaging

Messaging

This block does not offer messaging.

See also

TimeTrig modes (Page 1793)

TimeTrig functions (Page 1793)

TimeTrig error handling (Page 1797)

TimeTrig I/Os (Page 1798)

TimeTrig block diagram (Page 1802)

Description of TimeTrig (Page 1791)

11.2.6 TimeTrig I/Os

I/Os of TimeTrig

11.2 TimeTrig - Calculations with the date formats DT and TIME

Input parameters

Parameter	Description	Type	Default
InPerTrigOn	Periodic trigger 'On' (stored in the input variable)	BOOL	0
InSglTrigOn	Single trigger 'On' (stored in the input variable)	BOOL	0
InSglTrigDT	Single trigger data and time (stored in the input variable)	DATE_AND_TIME	1990-01-01-0:00:00
LiOp	Switchover of operating mode between: 1 = Interconnection 0 = Operator	STRUCT • Value: BOOL • ST: BYTE	- • 0 • 16#80
SetPerOp	Set periodic trigger via operator	BOOL	0
RstPerOp	Reset periodic trigger via operator	BOOL	0
SetPerLi	Set periodic trigger via interconnection	STRUCT • Value: BOOL • ST: BYTE	- • 0 • 16#80
RstPerLi	Reset periodic trigger via interconnection	STRUCT • Value: BOOL • ST: BYTE	- • 0 • 16#80
SetSglOp	Set single trigger via operator	BOOL	0
RstSglOp	Reset single trigger via operator	BOOL	0
SetSglLi	Set single trigger via interconnection	STRUCT • Value: BOOL • ST: BYTE	- • 0 • 16#80
RstSglLi	Reset single trigger via interconnection	STRUCT • Value: BOOL • ST: BYTE	- • 0 • 16#80
PerMode	Periodic trigger; 1: daily, 2: weekly, 3: monthly	INT	1
DayOfWeek	Setpoint weekday for periodic trigger [1..7]	INT	1
DayOfMonth	Setpoint day of month for periodic trigger [1..31]	INT	1
HourOfDay	Setpoint hour of day for periodic trigger [0..23]	INT	0
DelayTime	Delay time [sec]	DINT	0
PulseWidth	Pulse width of trigger signal [s]	REAL	3.0
SampleTime	Sampling time [s]	REAL	0.1
LocalTime	1 = Local time ON	BOOL	0
OnOp*	1 = "On" mode via operator	BOOL	0
OosOp*	1 = "Out of service", via operator	BOOL	0
OosLi	1 = "Out of service", via interconnection	STRUCT • Value: BOOL • ST: BYTE	- • 0 • 16#80
UserStatus	Freely assignable bits for use in PCS 7 OS	BYTE	16#00
BatchEn	1 = Enable allocation	BOOL	0
BatchID	Batch ID	DWORD	16#00000000

Timers

11.2 TimeTrig - Calculations with the date formats DT and TIME

Parameter	Description	Type	Default
BatchName	Batch name	STRING[32]	"
StepNo	Batch step number	DWORD	16#00000000
Occupied	Occupied by batch	BOOL	0
SelFp1	Open faceplate 1	ANY	
SelFp2	Open faceplate 2	ANY	
OS_Perm	I/O for operator permissions (Page 1793)	STRUCT <ul style="list-style-type: none"> • Bit 0: BOOL • ... • Bit 31: BOOL 	- <ul style="list-style-type: none"> • 1 • 1 • 1
OpSt_In	Input parameter for local operator authorization, to be connected with the <code>Out</code> output parameter of the upstream block, "OpStations"	DWORD	16#00000000
Feature	I/O for additional functions (Page 1793)	STRUCT <ul style="list-style-type: none"> • Bit 0: BOOL • ... • Bit 31: BOOL 	- <ul style="list-style-type: none"> • 0 • 0 • 0

* Values can be written back to these inputs during processing of the block by the block algorithm.

Output parameters

Parameter	Description	Type	Default
PerTrigOn	1 = Periodic trigger On	STRUCT <ul style="list-style-type: none"> • Value: BOOL • ST: BYTE 	- <ul style="list-style-type: none"> • 0 • 16#80
SglTrigOn	1 = Single trigger On	STRUCT <ul style="list-style-type: none"> • Value: BOOL • ST: BYTE 	- <ul style="list-style-type: none"> • 0 • 16#80
Trigger	Trigger signal	STRUCT <ul style="list-style-type: none"> • Value: BOOL • ST: BYTE 	- <ul style="list-style-type: none"> • 0 • 16#80
CPU_Year	CPU time, year	INT	0
CPU_Mon	CPU time, month	INT	0
CPU_Day	CPU time, day	INT	0
CPU_Hour	CPU time, hour	INT	0
CPU_Min	CPU time, minute	INT	0
CPU_Sec	CPU time, minute	INT	0
CPU_DayOfWeek	CPU time, weekday	INT	0
SglTrigDT	Single trigger date and time	DATE_AND_TIME	1990-01-01-0:00:00
NxTrgDT	Next trigger time point date and time	DATE_AND_TIME	1990-01-01-0:00:00

11.2 TimeTrig - Calculations with the date formats DT and TIME

Parameter	Description	Type	Default
NxTrgYear	Next trigger time point year	INT	0
NxTrgMon	Next trigger time point months	INT	0
NxTrgDay	Next trigger time point days	INT	0
NxTrgHour	Next trigger time point hours	INT	0
NxTrgMin	Next trigger time point minutes	INT	0
NxTrgSec	Next trigger time point seconds		
DiffTmDay	Day: Period of time starting from the current CPU time until the next trigger time point	INT	0
DiffTmHour	Hours: Period of time starting from the current CPU time until the next trigger time point	INT	0
DiffTmMin	Minutes: Period of time starting from the current CPU time until the next trigger time point	INT	0
DiffTmSec	Seconds: Period of time starting from the current CPU time until the next trigger time point	INT	0
DlyTmEff	Current effective delay time [sec]	DINT	0
BarTmSec	Bar graph seconds	DINT	0
BarOpHiScale	Bar graph minutes	DINT	60
DayOpHiScale	Scale graph days	INT	1
HrsOpHiScale	Scale graph hours	INT	0
MinOpHiScale	Scale graph minutes	INT	0
SummerTime	Daylight saving time	STRUCT	- • Value: BOOL • 0 • ST: BYTE • 16#80
OosAct	1 = Block is "Out of service"	STRUCT	- • Value: BOOL • 0 • ST: BYTE • 16#80
OnAct	1 = Block is in service	STRUCT	- • Value: BOOL • 1 • ST: BYTE • 16#80
OS_PermOut	Operator permission: Output for OS	DWORD	16#FFFFFFFF
OS_PermLog	Operator permission: Output for OS	DWORD	16#FFFFFFFF
OpSt_Out	Value of the OpSt_In input parameter, for feedforwarding to other blocks. Bit 31 of this parameter is used by Feature bit 24	DWORD	16#00000000
ST_Worst	Worst signal status	BYTE	16#80
Status	Status word (Page 1791)	DWORD	16#00000000
ErrorNum	Output of pending error number. For error numbers that can be output by this block, see TimeTrig error handling (Page 1797).	INT	-1

See also

- TimeTrig modes (Page 1793)
- TimeTrig messaging (Page 1798)
- TimeTrig block diagram (Page 1802)

11.2.7 TimeTrig block diagram

Block diagram of TimeTrig

A block diagram is not provided for this block.

See also

- TimeTrig modes (Page 1793)
- TimeTrig functions (Page 1793)
- TimeTrig error handling (Page 1797)
- TimeTrig messaging (Page 1798)
- TimeTrig I/Os (Page 1798)

11.2.8 Operator control and monitoring

11.2.8.1 TimeTrig views

Views of the TimeTrig block

The block TimeTrig provides the following views:

- TimeTrig standard view (Page 1803)
- TimeTrig parameter view (Page 1805)
- TimeTrig preview (Page 1807)
- Memo view (Page 304)
- Block icon for TimeTrig (Page 1808)

Refer to the sections Structure of the faceplate (Page 248) and Block icon structure (Page 230) for general information on the faceplate and block icon.

11.2.8.2 TimeTrig standard view

Standard view of TimeTrig

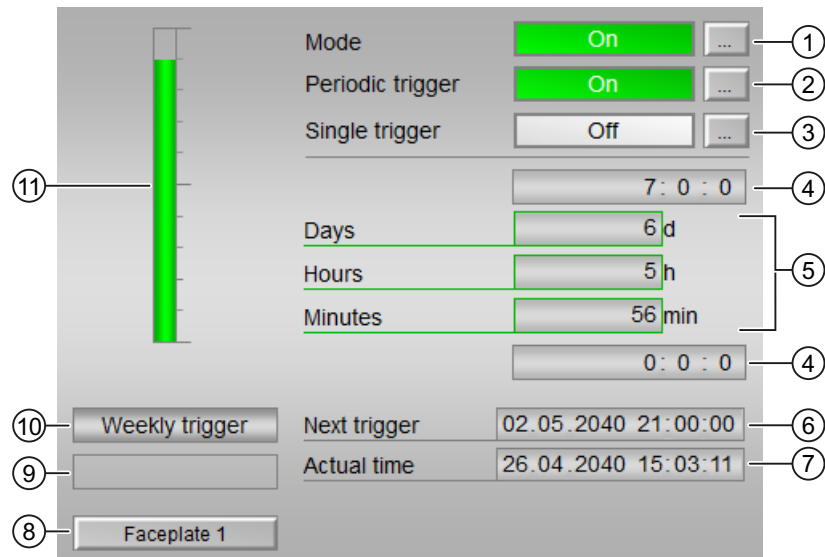

(1) Displaying and switching the operating mode

This area provides information on the currently valid operating mode. The following operating modes can be shown here:

- On (Page 71)
- Out of service (Page 71)

Refer to the Switching operating states and operating modes (Page 257) section for information on changing the state.

(2) Enabling and disabling the period trigger

This area shows the default operating mode of the trigger. The following operating modes can be displayed and set here:

- "On"
- "Off"

Refer to the Switching operating states and operating modes (Page 257) section for information on changing the state.

(3) Enabling and disabling the single trigger

This area shows the default operating mode of the trigger. The following operating modes can be displayed and set here:

- "On"
- "Off"

Refer to the Switching operating states and operating modes (Page 257) section for information on changing the state.

(4) High and low scale range for the count value

This value provides information on the display range for the bar graph (above) of the count value. The scale range is defined in the engineering system.

(5) Display of the count value

The following counts are shown here: The amount of time until the next trigger is shown here.

- "Days"
- "Hours"
- "Minutes"

(6) Display of the time point of the next trigger

This area shows the time of the next trigger.

(7) Displaying of the actual time of day

This area shows the actual time of day.

(8) Navigation button for switching to the standard view of any faceplate

Use this navigation button to open the standard view of a block configured in the engineering system (ES). The visibility of this navigation button depends on the configuration in the engineering system (ES).

You can find additional information on this in the section Opening additional faceplates (Page 208) .

(9) Display area for block states

This area provides additional information on the operating state of the block:

- "Invalid signal"

(10) Displaying of the actual trigger operating mode

- "Daily trigger"
- "Weekly trigger"
- "Monthly trigger"
- "Single trigger"

(11) Graphic display of the current count value

This area shows you the current count in form of a bar graph. The visible area in the bar graph depends on the configuration in the engineering system (ES).

See also

Release for maintenance (Page 64)

Simulating signals (Page 58)

Error handling (Page 119)

11.2.8.3 TimeTrig parameter view**Parameter view of TimeTrig**

Enabled operations Settings	
✓	Periodic mode: Daily
Parameter periodic trigger	
✓	Hour of day: 11
✓	Day of week: Monday
✓	Day of month: 10
Parameter single trigger	
✓	Day delay time: 8 d
✓	Hour delay time: 22 h
✓	Minute delay time: 5 min
Parameter trigger	
✓	Pulse duration: 63. s
✓	Local time: <input type="checkbox"/>

(1) Enabled operation

This area shows all operations for which special operator permissions are assigned. They depend on the configuration in the engineering system (ES) that applies to this block.

Icons for enabled operation:

- **Green check mark:** the OS operator can control this parameter
- **Gray check mark:** the OS operator cannot control this parameter at this time due to the process
- **Red cross:** the OS operator cannot control this parameter due to the configured AS operator permissions (OS_Perm or OS1Perm).

(2) Periodic operating mode

You can change the operating mode of the periodic trigger:

- "Daily": The trigger is activated once a day.
- "Weekly": The trigger is activated once a week.
- "Monthly": The trigger is activated once a month.

(3), (4) and (5) parameters for the periodic trigger

Enter the relevant parameters for the periodic mode:

- "Time": relevant for daily, weekly and monthly trigger
- "Weekday": relevant for weekly and monthly trigger
- "Day of the month": Relevant for monthly trigger. If the day of a month is greater than the last day, the last day is used.

(6), (7) and (8) parameters for single triggers

Enter the parameters for the single trigger:

- "Delay time day"
- "Delay time hour"
- "Delay time minute"

(9) and (10) parameters for the trigger

- "Pulse duration": Enter the duration of the trigger signal.
- "Local time": Activate local time by selecting the check box .

See also

Changing values (Page 259)

Switching operating states and operating modes (Page 257)

Simulating signals (Page 58)

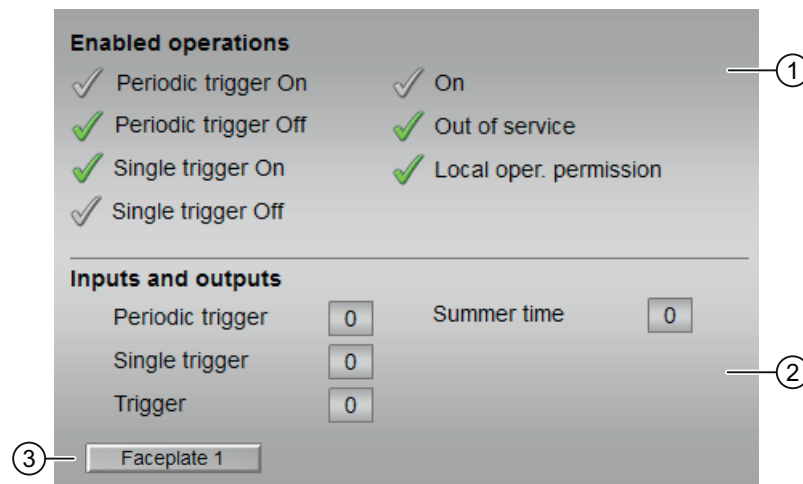
11.2.8.4 TimeTrig preview**Preview of TimeTrig****(1) Enable operations**

This area shows all operations for which special operator permissions are assigned. They depend on the configuration in the engineering system (ES) that applies to this block.

Icons for enabled operation:

- **Green check mark:** the OS operator can control this parameter
- **Gray check mark:** the OS operator cannot control this parameter at this time due to the process
- **Red cross:** the OS operator cannot control this parameter due to the configured AS operator permissions (`OS_Perm` or `OS1Perm`)

The following enabled operations are shown here:

- "Periodic trigger on": You can enable the periodic trigger.
- "Periodic trigger off": You can disable the periodic trigger.
- "Single trigger on": You can enable the single trigger.
- "Single trigger off": You can disable the single trigger.
- "On": You can operate the trigger.

- "Out of service": You can switch to "Out of service" operating mode.
- "Local operator permission": Use the ← button to switch to the standard view of the "OpStations" block.
You can find additional information on this in the section Operator control permissions (Page 254).

(2) Display of current operating signals

This area shows the most important parameters for this block with the current selection.

- "Periodic trigger":
 - 0 = Periodic trigger is enabled
 - 1 = Periodic trigger is disabled
- "Single trigger":
 - 0 = Single trigger is disabled
 - 1 = Single trigger is enabled
- "Trigger":
 - 0 = Output trigger signal is disabled
 - 1 = Output trigger signal is enabled
- "Daylight saving time":
 - 0 = Daylight saving time is disabled
 - 1 = Daylight saving time is enabled

(3) Navigation button for switching to the standard view of any faceplate

Use this navigation button to open the standard view of a block configured in the engineering system. The visibility of this navigation button depends on the configuration in the engineering system (ES).

You can find additional information on this in the section Opening additional faceplates (Page 208).

11.2.8.5 Block icon for TimeTrig

Block icons for TimeTrig

A variety of block icons are available with the following functions:

- Process tag type
- Operating modes
- Signal status, release for maintenance
- Memo display
- "Time until the next trigger" display is running

The block icons from template @TemplateAPLV8.PDL:

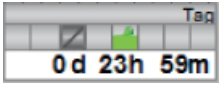
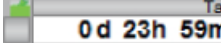
Icons	Selection of the block icon in CFC	Special features
	1	Block icon in the full display
	2	

Additional information on the block icon and the control options in the block icon is available in the following sections:

- Configuring the block icons (Page 237)
- Block icon structure (Page 230)
- Operation via the block icon (Page 239).

Mathematical blocks

12.1 AbsR - Absolute value of a real value

12.1.1 Description of AbsR

Object name (type + number) and family

Type + number: FC 395

Family: Math

Area of application for AbsR

The block is used for getting the absolute value of a real value.

How it works

The AbsR block provides the absolute value of a real value. The following equation is used for the calculation:

$$\text{Out} = |\text{In}|$$

Where:

In = Input value

Out = Absolute value

Configuration

Use the CFC editor to install the block in a cyclic interrupt OB (OB30 to OB38).

Startup characteristics

The block does not have any startup characteristics.

Status word allocation for Status parameter

This block does not have the Status parameter.

12.1.2 AbsR modes

AbsR operating modes

This block does not have any modes.

12.1.3 AbsR functions

Functions of AbsR

The functions for this block are listed below.

Forming the signal status for blocks

This block provides the standard function Forming and outputting the signal status for mathematical blocks (Page 117).

The worst signal status for the block is formed by the following parameter and output at the `Out` output parameter:

- `In.ST`

12.1.4 AbsR error handling

AbsR error handling

The block does not report any errors.

12.1.5 AbsR messaging

Messaging

This block does not offer messaging.

12.1.6 AbsR I/Os

AbsR I/Os

Input parameters

Parameter	Description	Type	Default
EN	1 = Called block will be processed	BOOL	1
In	Analog input value	STRUCT <ul style="list-style-type: none"> Value: REAL ST: BYTE 	- <ul style="list-style-type: none"> 0.0 16#80

Output parameters

Parameter	Description	Type	Default
ENO	1 = Block algorithm completed without errors	BOOL	0
Out	Analog output value	STRUCT <ul style="list-style-type: none"> Value: REAL ST: BYTE 	- <ul style="list-style-type: none"> 0.0 16#80

12.1.7 AbsR block diagram**AbsR block diagram**

A block diagram is not provided for this block.

12.2 Add04 - Adder with 4 values

12.2.1 Description of Add04

Object name (type + number) and family

Type + number: FC 351

Family: Math

Area of application for Add04

The block is used for the following applications:

- Adding values
- Output of the total value for further processing

How it works

The Add04 block calculates the sum of up to 4 values:

$$\text{Out} = \text{In1} + \dots + \text{Inn} \quad (n \leq 4),$$

Where:

Out = sum value

In1 ... In4 = values to be added

The sum of all input parameters and the worst input parameter signal status is always output.

The output value is checked to determine if it is within the value range of REAL. If it is outside the value range, the highest or lowest possible REAL value is output.

If the value is NAN, the last valid output value is output and the status of the output value is set to 16#28 (if none of the input statuses is worse).

You can find additional information on forming the signal status under Forming and outputting the signal status for mathematical blocks (Page 117)

Configuration

Use the CFC editor to install the block in a cyclic interrupt OB (OB30 to OB38).

Startup characteristics

The block does not have any startup characteristics.

Status word allocation for Status parameter

This block does not have the Status parameter.

See also

Add04 functions (Page 1815)
Add04 messaging (Page 1816)
Add04 I/Os (Page 1817)
Add04 block diagram (Page 1818)
Add04 error handling (Page 1816)
Add04 modes (Page 1815)

12.2.2 Add04 modes**Add04 operating modes**

This block does not have any modes.

See also

Add04 block diagram (Page 1818)
Add04 I/Os (Page 1817)
Add04 messaging (Page 1816)
Add04 error handling (Page 1816)
Description of Add04 (Page 1814)
Add04 functions (Page 1815)

12.2.3 Add04 functions**Functions of Add04**

The functions for this block are listed below.

Forming the signal status for blocks

This block provides the standard function Forming and outputting the signal status for mathematical blocks (Page 117).

The worst signal status for the block is formed by the following parameters and output at the `Out` output parameter:

- `In1.ST`
- `In2.ST`

12.2 Add04 - Adder with 4 values

- In3.ST
- In4.ST

See also

Description of Add04 (Page 1814)
Add04 messaging (Page 1816)
Add04 I/Os (Page 1817)
Add04 block diagram (Page 1818)
Add04 error handling (Page 1816)
Add04 modes (Page 1815)

12.2.4 Add04 error handling

Add04 error handling

The block does not report any errors.

See also

Add04 block diagram (Page 1818)
Add04 I/Os (Page 1817)
Add04 messaging (Page 1816)
Description of Add04 (Page 1814)
Add04 modes (Page 1815)
Add04 functions (Page 1815)

12.2.5 Add04 messaging

Messaging

This block does not offer messaging.

See also

Description of Add04 (Page 1814)
Add04 functions (Page 1815)
Add04 I/Os (Page 1817)

Add04 block diagram (Page 1818)

Add04 modes (Page 1815)

Add04 error handling (Page 1816)

12.2.6 Add04 I/Os

Add04 I/Os

Input parameters

Parameter	Description	Type	Default
EN	1 = Called block will be processed	BOOL	1
In1	Value 1 to add	STRUCT <ul style="list-style-type: none"> Value: REAL ST: BYTE 	- <ul style="list-style-type: none"> 0.0 16#80
In2	Value 2 to add	STRUCT <ul style="list-style-type: none"> Value: REAL ST: BYTE 	- <ul style="list-style-type: none"> 0.0 16#80
In3	Value 3 to add	STRUCT <ul style="list-style-type: none"> Value: REAL ST: BYTE 	- <ul style="list-style-type: none"> 0.0 16#80
In4	Value 4 to add	STRUCT <ul style="list-style-type: none"> Value: REAL ST: BYTE 	- <ul style="list-style-type: none"> 0.0 16#80

Output parameters

Parameter	Description	Type	Default
ENO	1 = Block algorithm completed without errors	BOOL	0
Out	Output of the sum	STRUCT <ul style="list-style-type: none"> Value: REAL ST: BYTE 	- <ul style="list-style-type: none"> 0.0 16#80

See also

Description of Add04 (Page 1814)

Add04 functions (Page 1815)

Add04 messaging (Page 1816)

Add04 block diagram (Page 1818)

12.2 Add04 - Adder with 4 values

Add04 modes (Page 1815)

Add04 error handling (Page 1816)

12.2.7 Add04 block diagram

Add04 block diagram

A block diagram is not provided for this block.

See also

Description of Add04 (Page 1814)

Add04 modes (Page 1815)

Add04 functions (Page 1815)

Add04 error handling (Page 1816)

Add04 messaging (Page 1816)

Add04 I/Os (Page 1817)

12.3 Add08 - Adder with 8 values

12.3.1 Description of Add08

Object name (type + number) and family

Type + number: FC 352

Family: Math

Area of application for Add08

The block is used for the following applications:

- Adding values
- Output of the total value for further processing

How it works

The Add08 block calculates the sum of up to 8 values:

$$\text{Out} = \text{In1} + \dots + \text{Inn} \quad (n \leq 8),$$

Where:

Out = sum value

In1 ... In8 = values to be added

The sum of all input parameters and the worst input parameter signal status is always output.

The output value is checked to determine if it is within the value range of REAL. If it is outside the value range, the highest or lowest possible REAL value is output.

If the value is NAN, the last valid output value is output and the status of the output value is set to 16#28 (if none of the input statuses is worse).

You can find additional information on forming the signal status under Forming and outputting the signal status for mathematical blocks (Page 117)

Configuration

Use the CFC editor to install the block in a cyclic interrupt OB (OB30 to OB38).

Startup characteristics

The block does not have any startup characteristics.

Status word allocation for status parameter

This block does not have the status parameter.

See also

- Add08 functions (Page 1820)
- Add08 messaging (Page 1821)
- Add08 I/Os (Page 1822)
- Add08 block diagram (Page 1823)
- Add08 error handling (Page 1821)
- Add08 modes (Page 1820)

12.3.2 Add08 modes

Add08 operating modes

This block does not have any modes.

See also

- Description of Add08 (Page 1819)
- Add08 functions (Page 1820)
- Add08 error handling (Page 1821)
- Add08 messaging (Page 1821)
- Add08 I/Os (Page 1822)
- Add08 block diagram (Page 1823)

12.3.3 Add08 functions

Functions of Add08

The functions for this block are listed below.

Forming the signal status for blocks

This block provides the standard function Forming and outputting the signal status for mathematical blocks (Page 117).

The worst signal status for the block is formed by the following parameters and output at the `Out` output parameter:

- `In1.ST`
- `In2.ST`
- `In3.ST`

- [In4.ST](#)
- [In5.ST](#)
- [In6.ST](#)
- [In7.ST](#)
- [In8.ST](#)

See also

[Description of Add08 \(Page 1819\)](#)
[Add08 messaging \(Page 1821\)](#)
[Add08 I/Os \(Page 1822\)](#)
[Add08 block diagram \(Page 1823\)](#)
[Add08 error handling \(Page 1821\)](#)
[Add08 modes \(Page 1820\)](#)

12.3.4 Add08 error handling

Add08 error handling

The block does not report any errors.

See also

[Add08 block diagram \(Page 1823\)](#)
[Add08 I/Os \(Page 1822\)](#)
[Add08 messaging \(Page 1821\)](#)
[Description of Add08 \(Page 1819\)](#)
[Add08 functions \(Page 1820\)](#)
[Add08 modes \(Page 1820\)](#)

12.3.5 Add08 messaging

Messaging

This block does not offer messaging.

See also

- Description of Add08 (Page 1819)
- Add08 functions (Page 1820)
- Add08 I/Os (Page 1822)
- Add08 error handling (Page 1821)
- Add08 modes (Page 1820)
- Add08 block diagram (Page 1823)

12.3.6 Add08 I/Os

Add08 I/Os

Input parameters

Parameter	Description	Type	Default
EN	1 = Called block will be processed	BOOL	1
In1	Value 1 to add	STRUCT <ul style="list-style-type: none"> • Value: REAL • ST: BYTE 	- <ul style="list-style-type: none"> • 0.0 • 16#80
In2	Value 2 to add	STRUCT <ul style="list-style-type: none"> • Value: REAL • ST: BYTE 	- <ul style="list-style-type: none"> • 0.0 • 16#80
In3	Value 3 to add	STRUCT <ul style="list-style-type: none"> • Value: REAL • ST: BYTE 	- <ul style="list-style-type: none"> • 0.0 • 16#80
In4	Value 4 to add	STRUCT <ul style="list-style-type: none"> • Value: REAL • ST: BYTE 	- <ul style="list-style-type: none"> • 0.0 • 16#80
In5	Value 5 to add	STRUCT <ul style="list-style-type: none"> • Value: REAL • ST: BYTE 	- <ul style="list-style-type: none"> • 0.0 • 16#80
In6	Value 6 to add	STRUCT <ul style="list-style-type: none"> • Value: REAL • ST: BYTE 	- <ul style="list-style-type: none"> • 0.0 • 16#80

Parameter	Description	Type	Default
In7	Value 7 to add	STRUCT <ul style="list-style-type: none"> Value: REAL ST: BYTE 	- <ul style="list-style-type: none"> 0.0 16#80
In8	Value 8 to add	STRUCT <ul style="list-style-type: none"> Value: REAL ST: BYTE 	- <ul style="list-style-type: none"> 0.0 16#80

Output parameters

Parameter	Description	Type	Default
ENO	1 = Block algorithm completed without errors	BOOL	0
Out	Output of the sum	STRUCT <ul style="list-style-type: none"> Value: REAL ST: BYTE 	- <ul style="list-style-type: none"> 0.0 16#80

See also

[Description of Add08 \(Page 1819\)](#)
[Add08 functions \(Page 1820\)](#)
[Add08 messaging \(Page 1821\)](#)
[Add08 block diagram \(Page 1823\)](#)
[Add08 error handling \(Page 1821\)](#)
[Add08 modes \(Page 1820\)](#)

12.3.7 Add08 block diagram

Add08 block diagram

A block diagram is not provided for this block.

See also

[Description of Add08 \(Page 1819\)](#)
[Add08 functions \(Page 1820\)](#)
[Add08 error handling \(Page 1821\)](#)
[Add08 I/Os \(Page 1822\)](#)
[Add08 modes \(Page 1820\)](#)
[Add08 messaging \(Page 1821\)](#)

12.4 Average - Mean value calculation

12.4.1 Description of Average

Object name (type + number) and family

Type + number: FB1804

Family: Math

Area of application for Average

The block is used for the following applications:

- Calculation of a time-based mean value

How it works

The block calculates the time-based mean value of an analog value In based on the time which has expired since its start. The equation below is used:

$$Out = \frac{Out_{(n-1)} \cdot gNumCycles + In}{NumCycles + 1}$$

Where:

In = input variable

Out = present average value

$Out_{(n-1)}$ = calculated average upon successful startup

$NumCycles$ = Number of cycles for creating the mean value from the 0 - 1 edge transition of the Run input parameter.

The calculation is started by a 0 - 1 edge at the Run input parameter. The Out output parameter is overwritten by the In input parameter.

The result at output value Out is recalculated in the next cycles, and cycle counter NumCycles is incremented.

The NumCycles cycle counter has the DINT data type and can therefore assume the maximum value of 2147483647. When this value is reached, the NumCycles cycle counter is reset to 1. The formation of the mean is then started once again. At a cycle time of 100 ms, this case occurs every 6.8 years.

Calculation is terminated by resetting (1 - 0 edge) the Run input parameter. The last results set at Out and NumCycles are saved.

The parameter Feature can be used to specify the startup characteristics of the block.

You can find additional information on forming the signal status under Forming and outputting the signal status for mathematical blocks (Page 117)

Configuration

Use the CFC editor to install the block in a cyclic interrupt OB (OB30 to OB38). The block is also installed automatically in the startup OB (OB100).

Startup characteristics

Use the `Feature Bit Set` startup characteristics (Page 138) to define the startup characteristics of this block.

Status word allocation for `Status1` parameter

This block does not have the `Status` parameter.

See also

- Average functions (Page 1826)
- Average messaging (Page 1827)
- Average I/Os (Page 1828)
- Average modes (Page 1825)
- Average error handling (Page 1826)
- Average block diagram (Page 1829)

12.4.2 Average modes

Average operating modes

This block does not have any modes.

See also

- Description of Average (Page 1824)
- Average functions (Page 1826)
- Average error handling (Page 1826)
- Average messaging (Page 1827)
- Average I/Os (Page 1828)
- Average block diagram (Page 1829)

12.4.3 Average functions

Functions of Average

The functions for this block are listed below.

Configurable reactions using the Feature parameter

You can find an overview of all reactions provided by the `Feature` parameter in section Configurable functions using the Feature I/O (Page 131). The following functionality is available for this block at the relevant bits:

Bit	Functions
0	Set startup characteristics (Page 138)

Forming the signal status for blocks

This block provides the standard function Forming and outputting the signal status for mathematical blocks (Page 117).

The signal status for the block is formed using the following parameters and output at the `Out` output parameter:

- `In.ST`

See also

Description of Average (Page 1824)

Average messaging (Page 1827)

Average I/Os (Page 1828)

Average modes (Page 1825)

Average error handling (Page 1826)

Average block diagram (Page 1829)

12.4.4 Average error handling

Error handling of Average

Refer to the section Error handling (Page 119) in the basic instructions for the error handling of all blocks.

The following errors can be displayed for this block:

- Error numbers

Overview of error numbers

The `ErrorNum` I/O can be used to output the following error numbers:

Error number	Meaning of the error number
-1	Default value displayed after installation in the block.
0	There is no error.
30	The <code>In</code> value can no longer be displayed in the REAL number field, the 16#28 status is also output. The last valid value is provided at the <code>Out</code> output and calculation is halted.
31	The <code>Out</code> value can no longer be displayed in the REAL number field, the 16#28 status is also output. The last valid value is provided at the <code>Out</code> output.

See also

[Average modes \(Page 1825\)](#)
[Average functions \(Page 1826\)](#)
[Description of Average \(Page 1824\)](#)
[Average messaging \(Page 1827\)](#)
[Average I/Os \(Page 1828\)](#)
[Average block diagram \(Page 1829\)](#)

12.4.5 Average messaging

Messaging

This block does not offer messaging.

See also

[Description of Average \(Page 1824\)](#)
[Average functions \(Page 1826\)](#)
[Average I/Os \(Page 1828\)](#)
[Average modes \(Page 1825\)](#)
[Average error handling \(Page 1826\)](#)
[Average block diagram \(Page 1829\)](#)

12.4.6 Average I/Os

I/Os of Average

Input parameters

Parameter	Description	Type	Default
EN	1 = Called block will be processed	BOOL	1
Feature	I/O for additional functions (Page 1826)	STRUCT <ul style="list-style-type: none"> • Bit 0: BOOL • ... • Bit 31: BOOL 	- <ul style="list-style-type: none"> • 0 • 0 • 0
In*	Analog input value for mean value calculation	STRUCT <ul style="list-style-type: none"> • Value: REAL • ST: BYTE 	- <ul style="list-style-type: none"> • 0.0 • 16#80
Run	1 = Start time-based mean value calculation	STRUCT <ul style="list-style-type: none"> • Value: BOOL • ST: BYTE 	- <ul style="list-style-type: none"> • 0 • 16#80

* Values can be written back to these inputs during processing of the block by the block algorithm.

Output parameters

Parameter	Description	Type	Default
EndTime	1 = Time for ending time-based mean value calculation	DT	1990-01-01-0:00:00
ENO	1 = Block algorithm completed without errors	BOOL	0
ErrorNum	Output of current error number. For error numbers that can be output by this block, see Average error handling (Page 1826)	INT	-1
NumCycles	Cycle counter	DINT	1
Out	Output for average value	STRUCT <ul style="list-style-type: none"> • Value: REAL • ST: BYTE 	- <ul style="list-style-type: none"> • 0.0 • 16#80
StartTime	1 = Time for starting time-based mean value calculation	DT	1990-01-01-0:00:00

See also

Description of Average (Page 1824)

Average messaging (Page 1827)

Average modes (Page 1825)

Average block diagram (Page 1829)

12.4.7 Average block diagram

Average block diagram

A block diagram is not provided for this block.

See also

Average modes (Page 1825)

Average functions (Page 1826)

Average error handling (Page 1826)

Average messaging (Page 1827)

Description of Average (Page 1824)

Average I/Os (Page 1828)

12.5 DeadTime - Delayed signal output

12.5.1 Description of DeadTime

Object name (type + number) and family

Type + number: FB 1807

Family: Math

Area of application for DeadTime

The block provides the following functions:

- Delay [s] of signal output

How it works

This block delays the output of an input value by a time `DeadTime` [s] selected by the user.

Dead times up to 100 times the `SampleTime` can be realized. If you want to set a longer dead time, you need to connect several dead time blocks in sequence. You can also insert the dead time block in a runtime group with a longer sampling time or scale down the runtime group, but this would lead to loss of input values.

The block operates as follows:

$$\text{Out} = \text{In} (t - \text{DeadTime})$$

Where:

`Out` = output value

`t` = current time

$\text{DeadTime} = \text{DeadT_Cyc} \cdot \text{SampleTime}$ where:

`DeadT_Cyc` = Number of cycles [0...100], by which the analog input value is delayed

An analog value of input `In` is only output after the variable dead time at `DeadTime` has expired. It is output at `Out`.

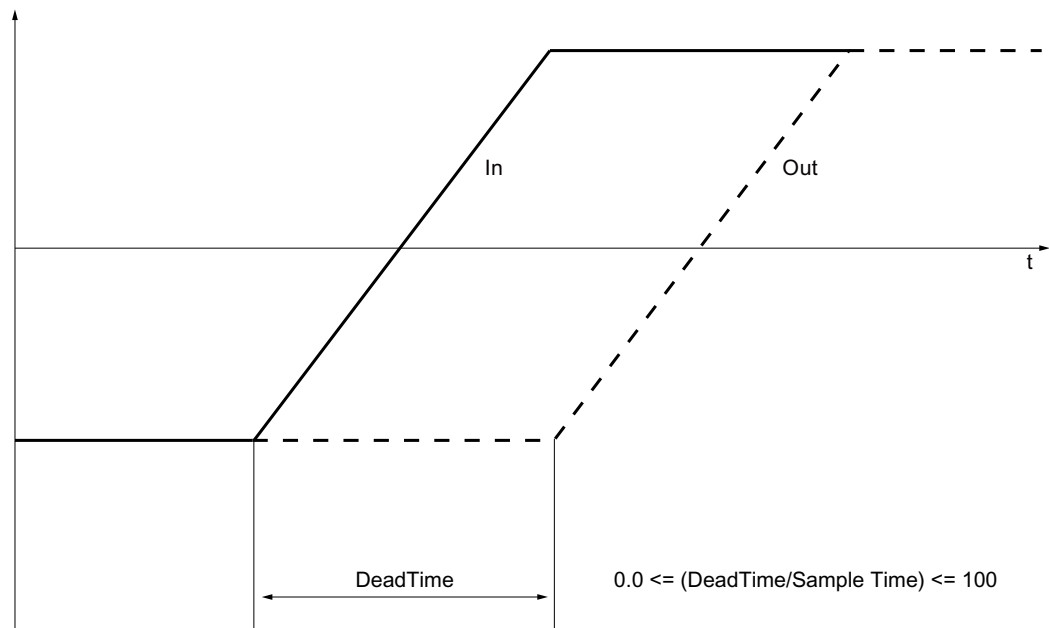

You can find additional information on forming the signal status under Forming and outputting the signal status for mathematical blocks (Page 117)

Note

If you change the value for the dead time during the runtime of the block, the input value is written to the output. The change to the dead time then takes effect.

Configuration

Use the CFC editor to install the block in a cyclic interrupt OB (OB30 to OB38). The block is also installed automatically in the startup OB (OB100).

The resulting sampling time of the block must be long enough for the desired dead time to be specified at the `DeadTime` parameter.

For the `DeadTime` block, the Advanced Process Library contains templates for process tag types as examples with various application scenarios for this block.

Examples of process tag types:

- PID controller with dynamic feedforward control (FwdDisturbCompensat) (Page 2329)
- PID controller with Smith predictor (SmithPredictorControl) (Page 2332)

Startup characteristics

Use the `Feature Bit Set` startup characteristics (Page 138) to define the startup characteristics of this block.

Status word allocation for `status1` parameter

This block does not have the `Status` parameter.

See also

DeadTime functions (Page 1832)

DeadTime messaging (Page 1834)

DeadTime I/Os (Page 1835)

DeadTime block diagram (Page 1836)

DeadTime modes (Page 1832)

DeadTime error handling (Page 1833)

12.5.2 DeadTime modes

DeadTime operating modes

This block does not have any modes.

See also

DeadTime block diagram (Page 1836)

DeadTime I/Os (Page 1835)

DeadTime messaging (Page 1834)

DeadTime error handling (Page 1833)

DeadTime functions (Page 1832)

Description of DeadTime (Page 1830)

12.5.3 DeadTime functions

Functions of DeadTime

The functions for this block are listed below.

Configurable reactions using the Feature I/O

You can find an overview of all reactions provided by the `Feature` parameter in the Configurable functions using the Feature I/O (Page 131) section. The following functionality is available for this block at the relevant bits:

Bit	Functions
0	Set startup characteristics (Page 138)

Forming the signal status for blocks

This block provides the standard function Forming and outputting the signal status for mathematical blocks (Page 117).

The signal status for the block is formed using the following parameters and output at the `Out` output parameter:

- `In.ST`

See also

Description of DeadTime (Page 1830)

DeadTime messaging (Page 1834)

DeadTime I/Os (Page 1835)

DeadTime block diagram (Page 1836)

DeadTime modes (Page 1832)

DeadTime error handling (Page 1833)

12.5.4 DeadTime error handling

Error handling of DeadTime

Refer to the section Error handling (Page 119) in the basic instructions for the error handling of all blocks.

The following errors can be displayed for this block:

- Error numbers

Overview of error numbers

The `ErrorNum` I/O can be used to output the following error numbers:

Error number	Meaning of the error number
-1	Predefined value when inserting the block; block is not processed.
0	There is no error.

12.5 DeadTime - Delayed signal output

Error number	Meaning of the error number
30	The value of <code>In</code> can no longer be displayed in the REAL number field. The last valid value is provided at the <code>Out</code> output.
32	The value of <code>DeadTime</code> can no longer be displayed in the REAL number field. The last valid value is provided at the <code>Out</code> output.
45	The value of <code>DeadTime</code> is outside the permitted range $0 \leq \text{INT}(\text{DeadTime} / \text{SampleTime}) \leq 100$ If the value of <code>DeadTime</code> is greater than $100 \cdot \text{SampleTime}$, the block works internally with the maximum dead time of $100 \cdot \text{SampleTime}$.

See also

- DeadTime block diagram (Page 1836)
- DeadTime I/Os (Page 1835)
- DeadTime messaging (Page 1834)
- DeadTime modes (Page 1832)
- Description of DeadTime (Page 1830)
- DeadTime functions (Page 1832)

12.5.5 DeadTime messaging

Messaging

This block does not offer messaging.

See also

- Description of DeadTime (Page 1830)
- DeadTime functions (Page 1832)
- DeadTime I/Os (Page 1835)
- DeadTime block diagram (Page 1836)
- DeadTime modes (Page 1832)
- DeadTime error handling (Page 1833)

12.5.6 DeadTime I/Os

I/Os of DeadTime

Input parameters

Parameter	Description	Type	Default
DeadTime*	Dead time [s]: Time by which the analog input value is delayed	REAL	1.0
EN	1 = Called block will be processed	BOOL	1
Feature	I/O for additional functions (Page 1832)	STRUCT <ul style="list-style-type: none"> • Bit 0: BOOL • ... • Bit 31: BOOL 	- <ul style="list-style-type: none"> • 0 • 0 • 0
In*	Analog input value	STRUCT <ul style="list-style-type: none"> • Value: REAL • ST: BYTE 	- <ul style="list-style-type: none"> • 0.0 • 16#80
SampleTime	Sampling time [s] (assigned automatically)	REAL	0.1

* Values can be written back to these inputs during processing of the block by the block algorithm.

Output parameters

Parameter	Description	Type	Default
ENO	1 = Block algorithm completed without errors	BOOL	0
ErrorNum	Output of current error number. For error numbers that can be output by this block, see DeadTime error handling (Page 1833).	INT	-1
DeadT_Cyc	Number of cycles [0 to 100] by which the analog input value is delayed	INT	0
Out	Analog output value	STRUCT <ul style="list-style-type: none"> • Value: REAL • ST: BYTE 	- <ul style="list-style-type: none"> • 0.0 • 16#80

See also

- Description of DeadTime (Page 1830)
- DeadTime messaging (Page 1834)
- DeadTime block diagram (Page 1836)
- DeadTime modes (Page 1832)

12.5.7 DeadTime block diagram

DeadTime block diagram

A block diagram is not provided for this block.

See also

DeadTime I/Os (Page 1835)

DeadTime messaging (Page 1834)

DeadTime error handling (Page 1833)

DeadTime functions (Page 1832)

DeadTime modes (Page 1832)

Description of DeadTime (Page 1830)

12.6 Derivative - Obtaining a derivative

12.6.1 Description of Derivative

Object name (type + number) and family

Type + number: FB 1808

Family: Math

Area of application for Derivative

The block is used for the following applications:

- Forming the D component for the controller design
- Forming a temporal derivative of the input signal

How it works

The block can be used as part of user-designed closed-loop controller. The block calculates a D component with delay. The derivative of the input signal is formed using the "trapezoid rule".

If only the derivative signal is to be calculated, $T_D = 1$ [s] must be set. The speed signal is then formed from the travel signal.

The output signal can be damped using the `LagTime` parameter. Damping is disabled by configuring `LagTime = 0`. The following figure shows the step response from the unit step of the `In` input variable.

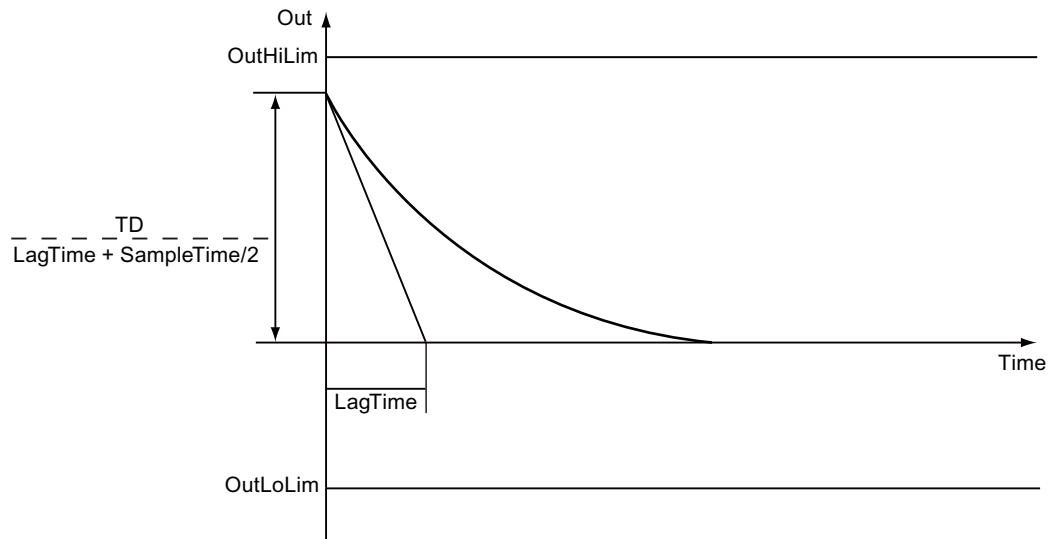

The block works according to the following formula:

$$Out_{(n)} = \left(\frac{TD}{LagTime + \frac{SampleTime}{2}} \right) (In_{(n)} - PrevIn_{(n)})$$

The $PrevIn_{(n)}$ value is calculated for the next sampling step by means of a first order low pass filter:

$$PrevIn_{(n+1)} = PrevIn_{(n)} + \frac{SampleTime}{TD} Out_{(n)}$$

The following applies for both formulas:

- $Out_{(n)}$ = output value
- TD = derivative time
- $In_{(n)}$ = input value
- $PrevIn_{(n)}$ = memory variable of the low pass filter
- SampleTime = sampling time [s]
- LagTime = delay time [s]

You can find additional information on forming the signal status under Forming and outputting the signal status for mathematical blocks (Page 117)

Configuration

Use the CFC editor to install the block in a cyclic interrupt OB (OB3x). The block is then installed automatically in startup OB (OB100).

Further addressing is not required.

For the Derivative block, the Advanced Process Library contains a template for process tag types as an example with an application scenario for this block.

Example of process tag types:

- PID controller with dynamic feedforward control (FwdDisturbCompensat) (Page 2329)

Startup characteristics

Use the `Feature Bit Set` startup characteristics (Page 138) to define the startup characteristics of this block.

Status word allocation for `Status` parameter

This block does not have the `Status` parameter.

See also

- Derivative messaging (Page 1841)
- Derivative error handling (Page 1841)
- Derivative modes (Page 1839)
- Derivative I/Os (Page 1842)
- Derivative functions (Page 1840)

12.6.2 Derivative modes

Derivative operating modes

This block does not have any modes.

See also

- Derivative block diagram (Page 1843)
- Derivative I/Os (Page 1842)
- Derivative messaging (Page 1841)
- Derivative error handling (Page 1841)
- Derivative functions (Page 1840)
- Description of Derivative (Page 1837)

12.6.3 Derivative functions

Functions of Derivative

The functions for this block are listed below.

Monitoring the output parameter for limits

The `Out` output parameter can be checked for limit values:

- `OutHiLim`: High limit
- `OutLoLim`: Low limit

If the limits are infringed, this is indicated to you at the corresponding output parameters (output parameter `OutHiAct` or `OutLoAct = 1`).

Configurable reactions using the `Feature` parameter

You can find an overview of all reactions provided by the `Feature` parameter in section Configurable functions using the `Feature` I/O (Page 131). The following behavior patterns are available for this block at the relevant bits

Bit	Function
0	Set startup characteristics (Page 138)

Forming the signal status for blocks

This block provides the standard function Forming and outputting the signal status for mathematical blocks (Page 117).

The signal status for the block is formed using the following parameters and output at the `Out`, `OutHiAct` and `OutLoAct` output parameters:

- `In.ST`

See also

Description of Derivative (Page 1837)

Derivative messaging (Page 1841)

Derivative I/Os (Page 1842)

Derivative block diagram (Page 1843)

Derivative error handling (Page 1841)

Derivative modes (Page 1839)

12.6.4 Derivative error handling

Error handling of Derivative

Refer to the section Error handling (Page 119) in the basic instructions for the error handling of all blocks.

The following errors can be displayed for this block:

- Error numbers

Overview of error numbers

The `ErrorNum` I/O can be used to output the following error numbers:

Error number	Meaning of the error number
-1	Predefined value when inserting the block; block is not processed
0	There is no error.
30	The value of <code>In</code> can no longer be displayed in the REAL number field. The last valid value is provided at the <code>Out</code> output.
31	The value of <code>Out</code> can no longer be displayed in the REAL number field. The last valid value is provided at the <code>Out</code> output.
32	The value of <code>LagTime</code> can no longer be displayed in the REAL number field. The last valid value is provided at the <code>Out</code> output.
33	The value of <code>TD</code> can no longer be displayed in the REAL number field. The last valid value is provided at the <code>Out</code> output.

See also

Derivative block diagram (Page 1843)

Derivative I/Os (Page 1842)

Derivative messaging (Page 1841)

Description of Derivative (Page 1837)

Derivative modes (Page 1839)

Derivative functions (Page 1840)

12.6.5 Derivative messaging

Messaging

This block does not offer messaging.

See also

- Description of Derivative (Page 1837)
- Derivative functions (Page 1840)
- Derivative I/Os (Page 1842)
- Derivative block diagram (Page 1843)
- Derivative modes (Page 1839)
- Derivative error handling (Page 1841)

12.6.6 Derivative I/Os

I/Os of Derivative

Input parameters

Parameter	Description	Type	Default
EN	1 = Called block will be processed	BOOL	1
Feature	I/O for additional functions (Page 1840)	STRUCT <ul style="list-style-type: none"> • Bit 0: BOOL • ... • Bit 31: BOOL 	- <ul style="list-style-type: none"> • 0 • 0 • 0
In*	Analog input value	STRUCT <ul style="list-style-type: none"> • Value: REAL • ST: BYTE 	- <ul style="list-style-type: none"> • 0.0 • 16#80
LagTime*	Delay time [s]	REAL	10.0
OutHiLim	Limit (high) for output value	REAL	100.0
OutLoLim	Limit (low) for output value	REAL	0.0
SampleTime	Sampling time [s] (assigned automatically)	REAL	0.1
TD*	Derivative time [s]	REAL	1.0

* Values can be written back to these inputs during processing of the block by the block algorithm.

Output parameters

Parameter	Description	Type	Default
ENO	1 = Block algorithm completed without errors	BOOL	0
ErrorNum	Output of current error number. For error numbers that can be output by this block, see Derivative error handling (Page 1841)	INT	-1

Parameter	Description	Type	Default
Out	Output value	STRUCT <ul style="list-style-type: none"> Value: REAL ST: BYTE 	- <ul style="list-style-type: none"> 0.0 16#80
OutHiAct	1= Limit (high) violated	STRUCT <ul style="list-style-type: none"> Value: BOOL ST: BYTE 	- <ul style="list-style-type: none"> 0 16#80
OutLoAct	1= Limit (low) violated	STRUCT <ul style="list-style-type: none"> Value: BOOL ST: BYTE 	- <ul style="list-style-type: none"> 0 16#80

See also

[Description of Derivative \(Page 1837\)](#)
[Derivative messaging \(Page 1841\)](#)
[Derivative block diagram \(Page 1843\)](#)
[Derivative modes \(Page 1839\)](#)

12.6.7 Derivative block diagram**Derivative block diagram**

A block diagram is not provided for this block.

See also

[Description of Derivative \(Page 1837\)](#)
[Derivative modes \(Page 1839\)](#)
[Derivative functions \(Page 1840\)](#)
[Derivative error handling \(Page 1841\)](#)
[Derivative messaging \(Page 1841\)](#)
[Derivative I/Os \(Page 1842\)](#)

12.7 Div02 - Division of two values

12.7.1 Description of Div02

Object name (type + number) and family

Type + number: FC 358

Family: Math

Area of application for Div02

The block is used for the following applications:

- Dividing two values
- Output of the division for further processing

How it works

The block is used to divide two values as follows:

$$\text{Out} = \text{In1} / \text{In2}$$

If the input parameter is $\text{In2} = 0$, the last valid output value is retained until another division is permitted mathematically.

The worst signal status is also always output at the output parameter.

The output value is checked to determine if it is within the value range of REAL. If it is outside the value range, the highest or lowest possible REAL value is output.

If the value is NAN or divided by 0, the last valid output value is output and the status of the output value is set to 16#28 (if none of the input statuses is worse).

You can find additional information on forming the signal status under Forming and outputting the signal status for mathematical blocks (Page 117)

Configuration

Use the CFC editor to install the block in a cyclic interrupt OB (OB30 to OB38).

Startup characteristics

The block does not have any startup characteristics.

Status word allocation for Status1 parameter

This block does not have the Status parameter.

See also

Div02 block diagram (Page 1848)
Div02 I/Os (Page 1847)
Div02 messaging (Page 1847)
Div02 error handling (Page 1846)
Div02 functions (Page 1845)
Div02 modes (Page 1845)

12.7.2 Div02 modes**Div02 operating modes**

This block does not have any modes.

See also

Div02 block diagram (Page 1848)
Div02 I/Os (Page 1847)
Div02 messaging (Page 1847)
Div02 error handling (Page 1846)
Div02 functions (Page 1845)
Description of Div02 (Page 1844)

12.7.3 Div02 functions**Functions of Div02**

The functions for this block are listed below.

Forming the signal status for blocks

This block provides the standard function Forming and outputting the signal status for mathematical blocks (Page 117).

The worst signal status for the block is formed by the following parameters and output at the `Out` output parameter:

- `In1.ST`
- `In2.ST`

See also

- Div02 block diagram (Page 1848)
- Div02 I/Os (Page 1847)
- Div02 messaging (Page 1847)
- Div02 error handling (Page 1846)
- Div02 modes (Page 1845)
- Description of Div02 (Page 1844)

12.7.4 Div02 error handling

Error handling of Div02

Refer to the section Error handling (Page 119) in the basic instructions for the error handling of all blocks.

The following errors can be displayed for this block:

- Error numbers

Overview of error numbers

The `ErrorNum` I/O can be used to output the following error numbers:

Error number	Meaning of the error number
-1	Predefined value when inserting the block; block is not processed
0	There is no error.
30	It has been divided by 0.

See also

- Div02 block diagram (Page 1848)
- Div02 messaging (Page 1847)
- Div02 functions (Page 1845)
- Div02 modes (Page 1845)
- Description of Div02 (Page 1844)
- Div02 I/Os (Page 1847)

12.7.5 Div02 messaging

Messaging

This block does not offer messaging.

See also

Div02 block diagram (Page 1848)

Div02 I/Os (Page 1847)

Description of Div02 (Page 1844)

Div02 modes (Page 1845)

Div02 functions (Page 1845)

Div02 error handling (Page 1846)

12.7.6 Div02 I/Os

I/Os of Div02

Input parameters

Parameter	Description	Type	Default
EN	1 = Called block will be processed	BOOL	1
In1	Dividend	STRUCT <ul style="list-style-type: none"> • Value: REAL • ST: BYTE 	- <ul style="list-style-type: none"> • 0.0 • 16#80
In2	Divisor	STRUCT <ul style="list-style-type: none"> • Value: REAL • ST: BYTE 	- <ul style="list-style-type: none"> • 1.0 • 16#80

Output parameters

Parameter	Description	Type	Default
ENO	1 = Block algorithm completed without errors	BOOL	0
ErrorNum	Output of current error number. For error numbers that can be output by this block, see Div02 error handling (Page 1846).	INT	-1
Out	Output of division	STRUCT <ul style="list-style-type: none">Value: REALST: BYTE	- <ul style="list-style-type: none">0.016#80

See also

- Div02 block diagram (Page 1848)
- Description of Div02 (Page 1844)
- Div02 modes (Page 1845)
- Div02 functions (Page 1845)
- Div02 messaging (Page 1847)

12.7.7 Div02 block diagram

Div02 block diagram

A block diagram is not provided for this block.

See also

- Div02 I/Os (Page 1847)
- Div02 messaging (Page 1847)
- Div02 error handling (Page 1846)
- Div02 functions (Page 1845)
- Div02 modes (Page 1845)
- Description of Div02 (Page 1844)

12.8 FlowCorr - Flow correction

12.8.1 Description of FlowCorr

Object name (type + number) and family

Type + number: FB 1916

Family: Math

Area of application for FlowCorr

The block is used for the following applications:

- Pressure and/or temperature compensation for measurements of the differential pressure method

The block calculates the pressure and/or temperature compensation for measurements with the differential pressure method. This refers to measurements from restrictors, standard flow nozzles, venturi nozzles and pitot tubes. The block can be used for gases and vapors, saturated steam and liquids to calculate the volume flow rate or, for liquids, to calculate the mass flow rate.

How it works

The block cyclically calculates the volume/mass flow rate.

Mode 1: Gas and steam:

In mode 1, the flow is calculated as shown in the following equation:

$$Q_{\text{cal}} = Q_0 * \sqrt{\frac{\Delta P}{\Delta P_0} * \frac{(P + P_B)}{(P_0 + P_B)} * \frac{(T_0 + T_{\text{abs}})}{(T + T_{\text{abs}})}}$$

Mode 2: Saturated steam, mass flow in liquids:

In mode 2, the flow is calculated as shown in the following equation:

$$Q_{\text{cal}} = Q_0 * \sqrt{\frac{\Delta P}{\Delta P_0} * \frac{\rho}{\rho_0}}$$

Mode 3: Volume flow for liquids:

In mode 3, the flow is calculated as shown in the following equation:

$$Q_{cal} = Q_0 * \sqrt{\frac{\Delta P}{\Delta P_0} * \frac{\rho_0}{\rho}}$$

Block I/O	Icon	Type	Description
Flow	Q_{cal}	Result	Calculated flow
Flow0	Q_0	Parameter	Design flow
DiffP	ΔP	Measurement	Differential pressure ¹
DiffP0	ΔP_0	Parameter	Design differential pressure
P	P	Parameter or measurement	Pressure [bar (abs. or relative)] ²
P0	P_0	Parameter	Design pressure [bar (abs. or relative)] ³
P_Atmos	P_B	Parameter or measurement	Barometric pressure [mbar (abs.)] ⁴
Temp0	T_0	Parameter	Design temperature [0 °C]
Temp	T	Parameter or measurement	Temperature [0 °C]
TempAbs	T_{abs}	Parameter	[0 °C] in Kelvin (corresponds to 273.15K)
Density	ρ	Parameter or measurement	Density ⁵
Density0	ρ_0	Parameter	Design density

1 When the sensor extracts the square root of the differential pressure, the P_SqrtOn parameter must be set to 'true'. In this case, the differential pressure value is squared before the flow has been calculated by the above equation.

2 If a sensor is used for absolute pressure, P_Atmos must be set to '0'. If a sensor is used for differential pressure, P_Atmos must either be set to the local average ambient pressure or linked to the ambient pressure measurement.

3 'P0' must be the same size as 'P' (e.g.: if a sensor for absolute pressure is used for 'P', there must be a matching value for the absolute pressure 'P0').

4 Unit of P_Atmos = unit of P / 1000 (e.g.: P: bar; P_Atmos: mbar)

5 Real density measurement can be connected. An alternative method is often used in practice to determine the density (a process pressure measurement for saturated steam or a temperature measurement for liquids).

Configuration

Use the CFC editor to install the block in a cyclic interrupt OB (OB30 to OB38).

Startup characteristics

The block does not have any startup characteristics.

Status word allocation for `Status` parameter

This block does not have the `Status` parameter.

See also

FlowCorr block diagram (Page 1856)

FlowCorr I/Os (Page 1854)

FlowCorr messaging (Page 1854)

FlowCorr error handling (Page 1853)

FlowCorr functions (Page 1852)

FlowCorr modes (Page 1851)

Forming and outputting the signal status for mathematical blocks (Page 117)

12.8.2 FlowCorr modes**FlowCorr operating modes**

This block does not have any operating modes.

See also

FlowCorr block diagram (Page 1856)

FlowCorr I/Os (Page 1854)

FlowCorr messaging (Page 1854)

FlowCorr error handling (Page 1853)

FlowCorr functions (Page 1852)

Description of FlowCorr (Page 1849)

12.8.3 FlowCorr functions

Functions of FlowCorr

The functions for this block are listed below.

Forming the signal status for blocks

This block provides the standard function Forming and outputting the signal status for mathematical blocks (Page 117).

The worst signal status for the block is formed from the following parameters and output at the `Flow.ST` output parameter:

- `DiffP.ST`
- `DiffP0.ST`
- `P.ST`
- `P0.ST`
- `P_Atmos.ST`
- `Temp.ST`
- `Temp0.ST`
- `Density.ST`
- `Density0.ST`
- `Flow0.ST`
- `TempAbs.ST`

When one of the following conditions applies and depending on `Feature Bit 8` (Switch to substitute value (Page 149)), the last valid value is retained at the `Flow` output or the substitute value `SubsFlow` is applied:

- One of the inputs relevant to the calculation or the `Flow` output is outside the `REAL` counter range
- A division by zero occurs in the calculation
- The `Mode` parameter is not 1, 2 or 3

`Feature Bit 8 =0`: Last valid value is retained and the signal status is set to bad, process-related 16#28 (assuming the signal status is not 16#0).

`Feature Bit 8 =1`: Substitute value `SubsFlow` is applied and the signal status is set to manipulated value (for example, substitute value, simulation, last valid value) 16#60.

See also

FlowCorr block diagram (Page 1856)

FlowCorr I/Os (Page 1854)

FlowCorr messaging (Page 1854)
FlowCorr error handling (Page 1853)
FlowCorr modes (Page 1851)
Description of FlowCorr (Page 1849)

12.8.4 FlowCorr error handling

Error handling of FlowCorr

The block does not report any errors.

Refer to the section Error handling (Page 119) in the basic instructions for the error handling of all blocks.

When one of the following conditions applies and depending on feature bit 8 (Switch to substitute value (Page 149)) at the `Flow` output, the last valid value is retained or the substitute value `SubsFlow` is applied:

- One of the inputs relevant to the calculation or the `Flow` output is outside the `REAL` counter range
- A division by zero occurs in the calculation
- The Mode parameter is not 1, 2 or 3

Feature Bit 8 =0: Last valid value is retained and the signal status is set to bad, process-related 16#28 (assuming the signal status is not 16#0).

Feature Bit 8 =1: Substitute value `SubsFlow` is applied and the signal status is set to manipulated value (for example, substitute value, simulation, last valid value) 16#60.

The `Bad.Value` output is set to `true` when the following applies:

- When the signal status is formed, the value is bad, device-related or process-related (16#00, 16#28)
- One of the inputs relevant to the calculation or the `Flow` output is outside the `REAL` counter range
- A division by zero occurs in the calculation
- The Mode parameter is not 1, 2 or 3

Overview of error numbers

The block has no `ErrorNum` I/O.

See also

FlowCorr block diagram (Page 1856)
FlowCorr I/Os (Page 1854)
FlowCorr messaging (Page 1854)

- FlowCorr functions (Page 1852)
- FlowCorr modes (Page 1851)
- Description of FlowCorr (Page 1849)

12.8.5 FlowCorr messaging

Messaging

This block does not offer messaging.

See also

- FlowCorr block diagram (Page 1856)
- FlowCorr I/Os (Page 1854)
- FlowCorr error handling (Page 1853)
- FlowCorr functions (Page 1852)
- FlowCorr modes (Page 1851)
- Description of FlowCorr (Page 1849)

12.8.6 FlowCorr I/Os

I/Os of FlowCorr

Input parameters

Parameter	Description	Type	Default
Density	Density	STRUCT <ul style="list-style-type: none"> • Value: REAL • ST: BYTE 	- <ul style="list-style-type: none"> • 0.0 • 16#80
Density0	Design density	STRUCT <ul style="list-style-type: none"> • Value: REAL • ST: BYTE 	- <ul style="list-style-type: none"> • 0.0 • 16#80
DiffP	Differential pressure [bar]	STRUCT <ul style="list-style-type: none"> • Value: REAL • ST: BYTE 	- <ul style="list-style-type: none"> • 1.0 • 16#80
DiffP0	Design differential pressure [bar]	STRUCT <ul style="list-style-type: none"> • Value: REAL • ST: BYTE 	- <ul style="list-style-type: none"> • 100.0 • 16#80

Parameter	Description	Type	Default
Feature	I/O for additional functions (Page 1852)	STRUCT <ul style="list-style-type: none"> • Bit 0: BOOL • ... • Bit 31: BOOL 	- <ul style="list-style-type: none"> • 0 • 0 • 0
Flow0	Design flow	STRUCT <ul style="list-style-type: none"> • Value: REAL • ST: BYTE 	- <ul style="list-style-type: none"> • 0.0 • 16#80
Mode	Mode 1..3	INT	1
P_Atmos	Barometric pressure [mbar (abs)]	STRUCT <ul style="list-style-type: none"> • Value: REAL • ST: BYTE 	- <ul style="list-style-type: none"> • 100.0 • 16#80
P_SqrtOn	1 = Sensor calculates the square root	BOOL	0
P	Pressure [bar (abs or relative)]	STRUCT <ul style="list-style-type: none"> • Value: REAL • ST: BYTE 	- <ul style="list-style-type: none"> • 0.0 • 16#80
P0	Design pressure [bar (abs or relative)]	STRUCT <ul style="list-style-type: none"> • Value: REAL • ST: BYTE 	- <ul style="list-style-type: none"> • 1.0 • 16#80
SubsFlow	Substitute value	STRUCT <ul style="list-style-type: none"> • Value: REAL • ST: BYTE 	- <ul style="list-style-type: none"> • 0.0 • 16#80
Temp	Temperature [°C]	STRUCT <ul style="list-style-type: none"> • Value: REAL • ST: BYTE 	- <ul style="list-style-type: none"> • 0.0 • 16#80
Temp0	Design temperature [°C]	STRUCT <ul style="list-style-type: none"> • Value: REAL • ST: BYTE 	- <ul style="list-style-type: none"> • 20.0 • 16#80
TempAbs	Absolute temperature [K] at 0°C (corresponds to 273.15K)	STRUCT <ul style="list-style-type: none"> • Value: REAL • ST: BYTE 	- <ul style="list-style-type: none"> • 273.15 • 16#80

Output parameters

Parameter	Description	Type	Default
Bad	1 = Process value is not valid	STRUCT <ul style="list-style-type: none"> • Value: BOOL • ST: BYTE 	- <ul style="list-style-type: none"> • 0 • 16#80
Flow	Calculated flow	STRUCT <ul style="list-style-type: none"> • Value: REAL • ST: BYTE 	- <ul style="list-style-type: none"> • 0.0 • 16#80

See also

FlowCorr block diagram (Page 1856)

FlowCorr messaging (Page 1854)

FlowCorr error handling (Page 1853)

FlowCorr modes (Page 1851)

Description of FlowCorr (Page 1849)

12.8.7 FlowCorr block diagram

FlowCorr block diagram

A block diagram is not provided for this block.

See also

FlowCorr I/Os (Page 1854)

FlowCorr messaging (Page 1854)

FlowCorr error handling (Page 1853)

FlowCorr functions (Page 1852)

FlowCorr modes (Page 1851)

Description of FlowCorr (Page 1849)

12.9 Integral - Generating a time integral

12.9.1 Description of Integral

Object name (type + number) and family

Type + number: FB 1823

Family: Math

Area of application for Integral

The block is used for the following application:

- Forming the time integral of the connected input signal
- Forming the D component for the controller design

How it works

The block can be used as part of user-designed closed-loop controller. It integrates the input signal In based on the trapezoid rule and outputs the result, the integral action component, at Out . If the block should calculate the pure time integral, $TI = 1$ [s] must be set.

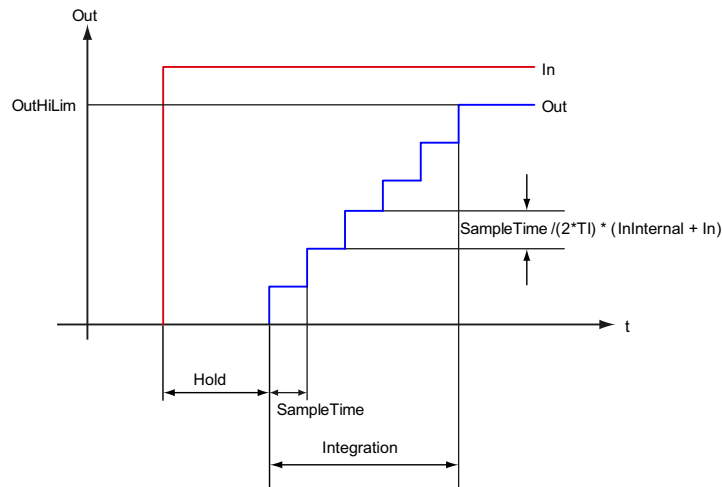

The block works according to the following formula:

$$Out_{(n)} = Out_{(n-1)} + \frac{SampleTime}{2 \cdot TI} \cdot (In_{(n-1)} + In_{(n)})$$

Where:

- Out = Integrated value between high and low limits
- $SampleTime$ = Sampling time [s]

12.9 Integral - Generating a time integral

- T_I = Integration time constant [s]
- I_n = Input value
- $I_{n(n-1)}$ = Last input value
- $Out_{(n-1)}$ = Last output value

You can find additional information on forming the signal status under Forming and outputting the signal status for mathematical blocks (Page 117)

Configuration

Use the CFC editor to install the block in a cyclic interrupt OB (OB30 to OB38). The block is also installed automatically in the startup OB (OB100).

There is an example project for the Integral block (APL_Example_xx, xx refers to the language variant) with an application scenario for this block, which explains how the block works.

Application scenario in the example project:

- Process simulation including noise generator (ProcSimC; ProcSimS) (Page 2373)

Startup characteristics

Use the feature bit Set startup characteristics (Page 138) to define the startup characteristics of this block.

Status word allocation for status parameter

This block does not have the `Status` parameter.

See also

Integral functions (Page 1859)

Integral messaging (Page 1862)

Integral I/Os (Page 1862)

Integral block diagram (Page 1863)

Integral error handling (Page 1861)

Integral modes (Page 1858)

12.9.2 Integral modes

Integral modes

This block does not have any modes.

See also

Integral block diagram (Page 1863)
 Integral I/Os (Page 1862)
 Integral messaging (Page 1862)
 Integral error handling (Page 1861)
 Integral functions (Page 1859)
 Description of Integral (Page 1857)

12.9.3 Integral functions**Functions of Integral**

The functions for this block are listed below.

Monitoring limits

Use the `OutHiLim` and `OutLoLim` I/Os to define the limits of the integrated value `Out`.

If limits are reached or exceeded (`OutHiAct` or `OutLoAct` = 1 I/Os), the output value is set to user-defined limits and output at `Out`.

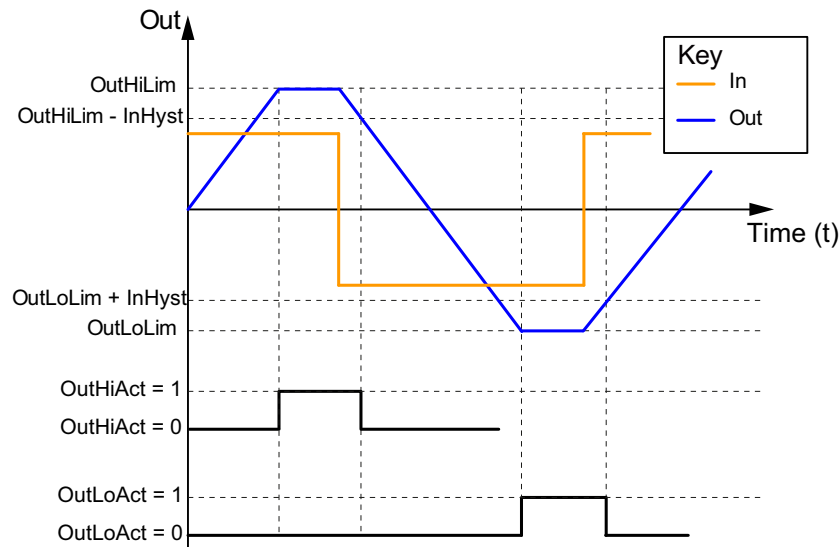
**Tracking values**

You use input parameter `OutTrkOn` = 1 to activate tracking of a value, which is in turn defined at input parameter `OutTrk`.

After tracking mode has been terminated, the block uses the value currently set at `Out` as the value to be integrated.

In tracking mode, the signal status of `Out` is set to the signal status of `OutTrk`.

Note

If the integration is stopped, the function (`Hold = 1`) has priority over the tracking.

Stopping integration

Set input parameter `Hold = 1` if you want to stop the integration. Limits are no longer monitored and the updating of the `OutHiAct` and `OutLoAct` limit outputs stops. A change to the monitoring limits remains ineffective when integration is stopped. If you start the integration again, the value currently pending at `Out` output parameter is used for the integration process.

Configurable reactions using the `Feature` parameter

You can find an overview of all reactions provided by the `Feature` parameter in the Configurable functions using the Feature I/O (Page 131) . The following functionality is available for this block at the relevant bits:

Bit	Function
0	Set startup characteristics (Page 138)
8	Status output calculation (Page 188)

Forming the signal status for blocks

This block provides the standard function Forming and outputting the signal status for technologic blocks (Page 109).

The signal status for the block is formed using the following parameters and output at the `Out`, `OutHiAct` and `OutLoAct` output parameters:

- `In.ST`
- `Out.ST` Signal status from the last cycle

Note

Special notes for the Integral mathematical block

Due to its application area (time integral, I-component for the configuration of a controller), the Integral block generates the signal status like the technological blocks.

See also

- Description of Integral (Page 1857)
- Integral messaging (Page 1862)
- Integral I/Os (Page 1862)
- Integral block diagram (Page 1863)

Integral error handling (Page 1861)

Integral modes (Page 1858)

Forming and outputting the signal status for mathematical blocks (Page 117)

12.9.4 Integral error handling

Error handling of Integral

Refer to the section Error handling (Page 119) in the basic instructions for the error handling of all blocks.

The following errors can be displayed for this block:

- Error numbers

Overview of error numbers

The `ErrorNum` I/O can be used to output the following error numbers:

Error number	Meaning of the error number
-1	Predefined value when inserting the block; the block is not processed.
0	There is no error.
11	The integration time constant <code>TI</code> is within the range: $-SampleTime / 2 < TI < SampleTime / 2$. The integration is stopped.
15	<code>OutTrk > OutHiLim</code> <code>OutTrk < OutLoLim</code>
30	The value of <code>In</code> can no longer be displayed in the REAL number field. The last valid value is provided at the <code>Out</code> output.
32	The value of <code>OutTrk</code> can no longer be displayed in the REAL number field. The last valid value is provided at the <code>Out</code> output.
33	The value of <code>TI</code> can no longer be displayed in the REAL number field. The integration is stopped.

See also

Integral I/Os (Page 1862)

Integral messaging (Page 1862)

Integral functions (Page 1859)

Integral modes (Page 1858)

Description of Integral (Page 1857)

Integral block diagram (Page 1863)

12.9.5 Integral messaging

Messaging

This block does not offer messaging.

See also

Description of Integral (Page 1857)

Integral functions (Page 1859)

Integral I/Os (Page 1862)

Integral block diagram (Page 1863)

Integral error handling (Page 1861)

Integral modes (Page 1858)

12.9.6 Integral I/Os

I/Os of Integral

Input parameters

Parameter	Description	Type	Default
EN	1 = Called block will be processed	BOOL	1
Feature	I/O for additional functions (Page 1859)	STRUCT <ul style="list-style-type: none"> • Bit 0: BOOL • ... • Bit 31: BOOL 	- <ul style="list-style-type: none"> • 0 • 0 • 0
Hold	1 = Integration is held	STRUCT <ul style="list-style-type: none"> • Value: BOOL • ST: BYTE 	- <ul style="list-style-type: none"> • 0 • 16#80
In*	Analog input value	STRUCT <ul style="list-style-type: none"> • Value: REAL • ST: BYTE 	- <ul style="list-style-type: none"> • 0.0 • 16#80
InHyst*	Hysteresis	REAL	0.0
OutHiLim	High limit of output value	REAL	100.0
OutLoLim	Low limit of output value	REAL	0.0
OutTrkOn	1 = Output <i>Out</i> tracks the set value (<i>OutTrk</i> I/O)	STRUCT <ul style="list-style-type: none"> • Value: BOOL • ST: BYTE 	- <ul style="list-style-type: none"> • 0 • 16#80

Parameter	Description	Type	Default
OutTrk*	Predefined value used for OutTrkOn = 1	STRUCT <ul style="list-style-type: none"> • Value: REAL • ST: BYTE 	- <ul style="list-style-type: none"> • 0.0 • 16#80
SampleTime	Sampling time [s] (assigned automatically)	REAL	0.1
TI*	Integral time constant [s]	REAL	1.0

* Values can be written back to these inputs during processing of the block by the block algorithm.

Output parameters

Parameter	Description	Type	Default
ENO	1 = Block algorithm completed without errors	BOOL	0
ErrorNum	Output of current error number. For error numbers that can be output by this block, see Integral error handling (Page 1861)	INT	-1
Out	Integral value output	STRUCT <ul style="list-style-type: none"> • Value: REAL • ST: BYTE 	- <ul style="list-style-type: none"> • 0.0 • 16#80
OutHiAct	1 = High limit (OutHiLim) reached	STRUCT <ul style="list-style-type: none"> • Value: BOOL • ST: BYTE 	- <ul style="list-style-type: none"> • 0 • 16#80
OutLoAct	1 = Low limit (OutLoLim) reached	STRUCT <ul style="list-style-type: none"> • Value: BOOL • ST: BYTE 	- <ul style="list-style-type: none"> • 0 • 16#80

See also

Description of Integral (Page 1857)

Integral messaging (Page 1862)

Integral block diagram (Page 1863)

Integral modes (Page 1858)

12.9.7 Integral block diagram

Integral block diagram

A block diagram is not provided for this block.

See also

Integral I/Os (Page 1862)

Integral messaging (Page 1862)

Integral functions (Page 1859)

Integral modes (Page 1858)

Description of Integral (Page 1857)

Integral error handling (Page 1861)

12.10 Lag - Low-pass filter

12.10.1 Description of Lag

Object name (type + number) and family

Type + number: FB 1828

Family: Math

Area of application for Lag

The block is used for the following application:

- Smoothing the Input value (low-pass filter)

How it works

The block smoothes the input variable (In input) using a 1. order time delay. This delay time can be configured ($LagTime$ connection). The block works according to the following formula:

$$Out_{(n)} = In_{(n)} + (Out_{(n-1)} - In_{(n)}) \cdot e^{\left(\frac{-SampleTime}{LagTime}\right)}$$

Where:

- Out = Output value
- $LagTime$ = Delay time
- $SampleTime$ = Sampling time
- In = Input value

The formula only applies to $LagTime > 0$. If $LagTime = 0$, the input is passed directly to the output. If the input value is outside the REAL range limits, the calculation is stopped. If the input value is outside the range limits again, the calculation is resumed automatically.

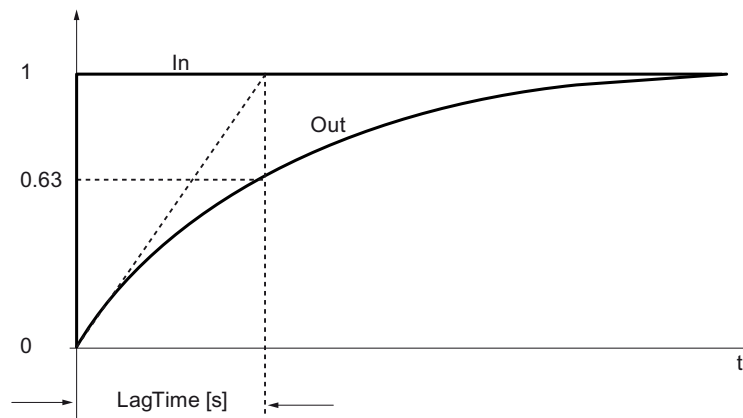

You can find additional information on forming the signal status under Forming and outputting the signal status for mathematical blocks (Page 117)

Configuration

Use the CFC editor to install the block in a cyclic interrupt OB (OB3x). The block is also installed automatically in the startup OB (OB100).

Further addressing is not required.

For the Lag block, the Advanced Process Library contains templates for process tag types as examples and there is an example project (APL_Example_xx, xx designates the language variant) containing different application cases for this block. Several application cases are simulated in the example project and serve to explain how the block works.

Examples of process tag types:

- PID controller with dynamic feedforward control (FfwdDisturbCompensat) (Page 2329)
- PID - control with operating-point-oriented parameter control (GainScheduling) (Page 2327)
- Model-based predictive control (ModPreCon) (Page 2351)
- PIDConR with safety logic and control loop monitoring (PIDConR_ConPerMon) (Page 2325)
- PID controller with safety logic and control loop monitoring (PIDConL_ConPerMon) (Page 2324)
- Ratio control with control loop monitoring through ConPerMon (RatioControl) (Page 2338)
- Ratio control with PIDConR (RatioR) (Page 2341)
- PID controller with Smith predictor (SmithPredictorControl) (Page 2332)
- Cascade control with control loop monitoring through ConPerMon (CascadeControl) (Page 2342)
- Split-range controller with control loop monitoring through ConPerMon (SplitrangeControl) (Page 2335)

Application scenario in the example project:

- Process simulation including noise generator (ProcSimC; ProcSimS) (Page 2373)

Startup characteristics

Use the `Feature Bit Set` startup characteristics (Page 138) to define the startup characteristics of this block.

Status word allocation for `Status` parameter

This block does not have the `Status` parameter.

See also

- Lag functions (Page 1867)
- Lag messaging (Page 1869)
- Lag I/Os (Page 1870)
- Lag block diagram (Page 1871)
- Lag error handling (Page 1868)
- Lag modes (Page 1867)

12.10.2 Lag modes

Lag modes

This block does not have any modes.

See also

- Lag block diagram (Page 1871)
- Lag I/Os (Page 1870)
- Lag messaging (Page 1869)
- Lag error handling (Page 1868)
- Lag functions (Page 1867)
- Description of Lag (Page 1865)

12.10.3 Lag functions

Functions of Lag

The functions for this block are listed below.

Hold and restart calculation

You can interrupt the calculation by setting `Hold = 1` . The output value is frozen. Continue calculation by setting `Hold = 0` . The calculation is continued with the last output value.

Reset values

You need to set the `Reset = 1` I/O if you want to reset the output value back to the input value. The output is reset by a rising 0 - 1 edge.

Configurable reactions using the `Feature` parameter

You can find an overview of all reactions provided by the `Feature` parameter in the Configurable functions using the Feature I/O (Page 131) section. The following functionality is available for this block at the relevant bits:

Bit	Function
0	Set startup characteristics (Page 138)

Forming the signal status for blocks

This block provides the standard function Forming and outputting the signal status for mathematical blocks (Page 117).

The signal status for the block is formed using the following parameters and output at the `Out` output parameter:

- `In.ST`

See also

Description of Lag (Page 1865)

Lag messaging (Page 1869)

Lag I/Os (Page 1870)

Lag block diagram (Page 1871)

Lag error handling (Page 1868)

Lag modes (Page 1867)

12.10.4 Lag error handling

Error handling of Lag

Refer to the section Error handling (Page 119) in the basic instructions for the error handling of all blocks.

The following errors can be displayed for this block:

- Error numbers

Overview of error numbers

The `ErrorNum` I/O can be used to output the following error numbers:

Error number	Meaning of the error number
-1	Predefined value when inserting the block; block is not processed
0	There is no error.
11	<code>LagTime < 0</code>
30	The value of <code>In</code> can no longer be displayed in the REAL number field. The last valid value is provided at the <code>Out</code> output.
32	The value of <code>LagTime</code> can no longer be displayed in the REAL number field. The last valid value is provided at the <code>Out</code> output.

See also

Lag block diagram (Page 1871)

Lag I/Os (Page 1870)

Lag messaging (Page 1869)

Lag functions (Page 1867)

Lag modes (Page 1867)

Description of Lag (Page 1865)

12.10.5 Lag messaging

Messaging

This block does not offer messaging.

See also

Description of Lag (Page 1865)

Lag functions (Page 1867)

Lag I/Os (Page 1870)

Lag block diagram (Page 1871)

Lag modes (Page 1867)

Lag error handling (Page 1868)

12.10.6 Lag I/Os

I/Os of Lag

Input parameters

Parameter	Description	Type	Default
EN	1 = Called block will be processed	BOOL	1
Feature	I/O for additional functions (Page 1867)	STRUCT <ul style="list-style-type: none"> • Bit 0: BOOL • ... • Bit 31: BOOL 	- <ul style="list-style-type: none"> • 0 • 0 • 0
Hold	1 = Hold calculation	STRUCT <ul style="list-style-type: none"> • Value: BOOL • ST: BYTE 	- <ul style="list-style-type: none"> • 0 • 16#80
In*	Analog input value	STRUCT <ul style="list-style-type: none"> • Value: REAL • ST: BYTE 	- <ul style="list-style-type: none"> • 0.0 • 16#80
LagTime*	Delay time [s]	REAL	1.0
Reset	1 = Reset Out output to the value of the In input	STRUCT <ul style="list-style-type: none"> • Value: BOOL • ST: BYTE 	- <ul style="list-style-type: none"> • 0 • 16#80
SampleTime	Sampling time [s] (assigned automatically)	REAL	0.1

* Values can be written back to these inputs during processing of the block by the block algorithm.

Output parameters

Parameter	Description	Type	Default
ENO	1 = Block algorithm completed without errors	BOOL	0
ErrorNum	Output of current error number. For error numbers that can be output by this block, see Lag error handling (Page 1868)	INT	-1
Out	Delayed value output	STRUCT <ul style="list-style-type: none"> • Value: REAL • ST: BYTE 	- <ul style="list-style-type: none"> • 0.0 • 16#80

See also

Description of Lag (Page 1865)

Lag messaging (Page 1869)

Lag block diagram (Page 1871)

Lag modes (Page 1867)

12.10.7 Lag block diagram

Lag block diagram

A block diagram is not provided for this block.

See also

Lag I/Os (Page 1870)

Lag messaging (Page 1869)

Lag error handling (Page 1868)

Lag functions (Page 1867)

Lag modes (Page 1867)

Description of Lag (Page 1865)

12.11 MeanTime - Averaging

12.11.1 Description of MeanTime

Object name (type + number) and family

Type + number: FB 1832

Family: Math

Area of application for MeanTime

The block is used for the following applications:

- Averaging an analog value over a previous, definable period

How it works

The MeanTime block is used to calculate the time-based mean value of an analog input signal `In` over a previous, definable period (`TimeWindow` input), according to the formula:

$$\text{Out} = (\text{In1} + \dots + \text{Inn}) / (\text{TimeWindow} / \text{SampleTime})$$

Where:

- `In1 ... Inn` the `n` are the detected values used for averaging.
- The time window for the averaging is set at the `TimeWindow` parameter.
- The block determines the number of values to be saved based on the integer part of the `TimeWindow / SampleTime` quotient.
- The block can save up to 32 previous values in its internal memory. By interconnecting the `Mem` input parameter with the `Mem` output parameter of the MemR256 block, the memory size can be expanded to 256 previous values. If the time window is longer than memory spaces are available, an internal message is triggered in addition.

If `SampleTime` or `TimeWindow` is changed, the mean time value is reset.

The signal status is passed from the input parameter directly to the output parameter.

You can find additional information on forming the signal status under Forming and outputting the signal status for mathematical blocks (Page 117)

Configuration

Use the CFC editor to install the block in a cyclic interrupt OB (all OB3x blocks). The block is also installed automatically in the startup OB (OB 100). When using the MemR256 block, the `Mem` output parameter of the MemR256 block must be interconnected with the `Mem` input parameter of the MeanTime block. The MemR256 block can be inserted in any cyclic interrupt level.

Startup characteristics

Use the `Feature Bit Set` startup characteristics (Page 138) to define the startup characteristics of this block.

Status word allocation for `Status` parameter

This block does not have the `Status` parameter.

See also

- MeanTime functions (Page 1873)
- MeanTime messaging (Page 1876)
- MeanTime I/Os (Page 1877)
- MeanTime block diagram (Page 1878)
- MeanTime error handling (Page 1876)
- MeanTime modes (Page 1873)

12.11.2 MeanTime modes

MeanTime operating modes

This block does not have any operating modes.

See also

- MeanTime block diagram (Page 1878)
- MeanTime I/Os (Page 1877)
- MeanTime messaging (Page 1876)
- MeanTime error handling (Page 1876)
- MeanTime functions (Page 1873)
- Description of MeanTime (Page 1872)

12.11.3 MeanTime functions

Functions of MeanTime

The functions for this block are listed below.

Stopping the calculation of mean values

Mean value calculation can be stopped by setting the `Hold` input. To do this, make the following parameter settings:

- `Hold = 1` and calculation is stopped. The output value is retained for the duration of this period.
- `Hold = 0` and calculation is resumed

If the hold functionality is active, the output `HoldAct` will be set by the block.

With `Feature` bit 5 Retain last output value in case of bad input signal status (Page 184), you can specify that the calculation of mean value is stopped and the last output value is retained if the signal status of `In` is bad (`In.ST = 16#00` or `16#28`). In this case, the block sets both the outputs `HoldAct` and `Inbad`.

Setting a mean value constant

You can set the mean value using the `Reset` input. To do this, make the following parameter setting:

- `Reset = 0 -> 1`

The value at the `In` input is now set directly at the `Out` output. All internal values of the block are also adapted to the input value.

Configurable reactions using the `Feature` parameter

You can find an overview of all reactions provided by the `Feature` parameter in the Configurable functions using the `Feature` I/O (Page 131) . The following functionality is available for this block at the relevant bits:

Bit	Function
0	Set startup characteristics (Page 138)
5	Retain last output value in case of bad input signal status (Page 184)

Forming the signal status for blocks

This block provides the standard function Forming and outputting the signal status for mathematical blocks (Page 117).

The signal status for the block is formed using the following parameters and output at the `Out` output parameter:

- `In.ST`

Increasing the internal memory to 256 previous values

MeanTime can save up to 32 previous values internally. If the ratio of time window and sampling time gets too large, the number of internal memory slots can be expanded to 256 previous values by using the MemR256 block. To do so insert the MemR256 block into a CFC chart. Interconnect the `Mem` output parameter of the MemR256 block with the `Mem` input parameter of the MeanTime block. Each MeanTime block must be interconnected with its own separate MemR256 block. An internal averaging is automatically activated if the time window is still too large. You detect whether internal averaging is active at the `ExcessCnt` output parameter:

- `ExcessCnt = 0`: no internal averaging active.
- `ExcessCnt > 0`: internal averaging active.
Without MemR256: $\text{ExcessCnt} = \text{TimeWindow} / \text{SampleTime} \text{ Div } 32 + 1$
Where MemR256: $\text{ExcessCnt} = \text{TimeWindow} / \text{SampleTime} \text{ Div } 256 + 1$

When internal averaging is activated, the `In.Value` input is summed using `ExcessCnt` values (`SumIntern`) and after `ExcessCnt` cycles the internal average is stored as a past value at a memory location (`1..UsedBuffer`). The current value of the `Out` output is then calculated as follows:

- $\text{Out} := (\text{ExcessCnt} * \text{Sum} + \text{SumIntern}) / (\text{UsedBuffer} * \text{ExcessCnt} + \text{Index})$
- `UsedBuffer`: $\text{TimeWindow} / \text{SampleTime} \text{ Div } \text{ExcessCnt}$
- `Sum`: Sum of all storage locations (`UsedBuffer`)
- `SumIntern`: Sum of the internal average value from 1 to index
- `Index`: Running index from 1 to `ExcessCnt`

Note

The ratio of the time window and sampling time is limited internally to 25600. If the time window is set too large, an error number is output at the `ErrorNum` output parameter.

See also

Description of MeanTime (Page 1872)

MeanTime messaging (Page 1876)

MeanTime I/Os (Page 1877)

MeanTime block diagram (Page 1878)

MeanTime error handling (Page 1876)

MeanTime modes (Page 1873)

12.11.4 MeanTime error handling

Error handling of MeanTime

Refer to the section Error handling (Page 119) in the basic instructions for the error handling of all blocks.

The following errors can be displayed for this block:

- Error numbers

Overview of error numbers

The `ErrorNum` I/O can be used to output the following error numbers:

Error number	Meaning
-1	Predefined value when inserting the block; the block is not executed.
0	There is no error.
30	The value of <code>In</code> can no longer be displayed in the REAL number field. The last valid value is provided at the <code>Out</code> output.
31	The value of <code>Out</code> can no longer be displayed in the REAL number field. The <code>In</code> value is output unmodified at the <code>Out</code> output.
50	The quotient <code>TimeWindow / SampleTime</code> is greater than 25600. The block calculates with a smaller time window, so that the quotient <code>TimeWindow / SampleTime</code> does not exceed the value 25600.

See also

MeanTime block diagram (Page 1878)

MeanTime I/Os (Page 1877)

MeanTime messaging (Page 1876)

Description of MeanTime (Page 1872)

MeanTime modes (Page 1873)

MeanTime functions (Page 1873)

12.11.5 MeanTime messaging

Messaging

This block does not offer messaging.

See also

Description of MeanTime (Page 1872)
MeanTime functions (Page 1873)
MeanTime I/Os (Page 1877)
MeanTime block diagram (Page 1878)
MeanTime modes (Page 1873)
MeanTime error handling (Page 1876)

12.11.6 MeanTime I/Os

I/Os of MeanTime

Input parameters

Parameter	Description	Type	Default
EN	1 = Called block will be processed	BOOL	1
Feature	I/O for additional functions (Page 1873)	STRUCT <ul style="list-style-type: none"> • Bit 0: BOOL • ... • Bit 31: BOOL 	- <ul style="list-style-type: none"> • 0 • 0 • 0
Hold	1 = Hold calculation of mean value	STRUCT <ul style="list-style-type: none"> • Value: BOOL • ST: BYTE 	- <ul style="list-style-type: none"> • 0 • 16#80
In*	Analog input value	STRUCT <ul style="list-style-type: none"> • Value: REAL • ST: BYTE 	- <ul style="list-style-type: none"> • 0.0 • 16#80
Mem	Input for Mem Block	ANY	-
Reset	1 = Reset output Out	STRUCT <ul style="list-style-type: none"> • Value: BOOL • ST: BYTE 	- <ul style="list-style-type: none"> • 0 • 16#80
SampleTime	Sampling time [s] (assigned automatically)	REAL	0.1
TimeWindow	Size of the time window [s]	REAL	32.0

* Values can be written back to these inputs during processing of the block by the block algorithm.

Output parameters

Parameter	Description	Type	Default
ENO	1 = Block algorithm completed without errors	BOOL	0
ErrorNum	Output of pending error number. For error numbers that can be output by this block, see MeanTime error handling (Page 1876)	INT	-1
ExcessCnt	Counter for internal averaging; 0: no internal averaging. All values of In can be saved as previous values with the current TimeWindow. x: internal averaging of In across x cycles. The internal averaging is saved as previous value.	INT	0
HoldAct	The block is on hold.	STRUCT • Value: BOOL • ST: BYTE	- • 0 • 16#80
InBad	1 = Signal status of the analog input In is bad (16#00 or 16#28)	BOOL	0
Out	Output for the average time	STRUCT • Value: REAL • ST: BYTE	- • 0.0 • 16#80

See also

- Description of MeanTime (Page 1872)
- MeanTime messaging (Page 1876)
- MeanTime block diagram (Page 1878)
- MeanTime modes (Page 1873)

12.11.7 MeanTime block diagram

MeanTime block diagram

This block is not provided a block diagram.

See also

- Description of MeanTime (Page 1872)
- MeanTime modes (Page 1873)
- MeanTime functions (Page 1873)
- MeanTime error handling (Page 1876)
- MeanTime messaging (Page 1876)
- MeanTime I/Os (Page 1877)

12.12 Mul04 - Multiplier with 4 values

12.12.1 Description of Mul04

Object name (type + number) and family

Type + number: FC 360

Family: Math

Area of application for Mul04

The block is used for the following applications:

- Multiplication of values
- Output of the product for further processing

How it works

The Mul04 block calculates the product of up to 4 values and returns the result at the `Out` output.

$$\text{Out} = \text{In1} \cdot \dots \cdot \text{Inn} \quad (n \leq 4),$$

Where:

`Out` = Product

`In1 ... In4` = values to be multiplied

The product of all input parameters and the worst input parameter signal status is always output.

The output value is checked to determine if it is within the value range of REAL. If it is outside the value range, the highest or lowest possible REAL value is output.

If the value is NAN, the last valid output value is output and the status of the output value is set to 16#28 (if none of the input statuses is worse).

You can find additional information on forming the signal status under Forming and outputting the signal status for mathematical blocks (Page 117)

Configuration

Use the CFC editor to install the block in a cyclic interrupt OB (OB30 to OB38).

For the Mul04 block, the Advanced Process Library contains templates for process tag types as examples and there is an example project (APL_Example_xx, xx designates the language variant) containing an application case for this block. An application case is simulated in the example project and serves to explain how the block works.

Examples of process tag types:

- PID controller with dynamic feedforward control (FfwdDisturbCompensat) (Page 2329)
- PID - control with operating-point-oriented parameter control (GainScheduling) (Page 2327)
- Model-based predictive control (ModPreCon) (Page 2351)
- PID controller with safety logic and control loop monitoring (PIDConL_ConPerMon) (Page 2324)
- PIDConR with safety logic and control loop monitoring (PIDConR_ConPerMon) (Page 2325)
- Ratio control with PIDConR (RatioR) (Page 2341)
- Ratio control with control loop monitoring through ConPerMon (RatioControl) (Page 2338)
- PID controller with Smith predictor (SmithPredictorControl) (Page 2332)
- Cascade control with control loop monitoring through ConPerMon (CascadeControl) (Page 2342)
- Split-range controller with control loop monitoring through ConPerMon (SplitrangeControl) (Page 2335)

Application scenario in the example project:

- Process simulation including noise generator (ProcSimC; ProcSimS) (Page 2373)

Startup characteristics

The block does not have any startup characteristics.

Status word allocation for `Status1` parameter

This block does not have the `Status` parameter.

See also

- Mul04 functions (Page 1881)
- Mul04 messaging (Page 1882)
- Mul04 I/Os (Page 1883)
- Mul04 block diagram (Page 1884)
- Mul04 error handling (Page 1882)
- Mul04 modes (Page 1881)

12.12.2 Mul04 modes

Mul04 operating modes

This block does not have any modes.

See also

Mul04 block diagram (Page 1884)

Mul04 I/Os (Page 1883)

Mul04 messaging (Page 1882)

Mul04 error handling (Page 1882)

Mul04 functions (Page 1881)

Description of Mul04 (Page 1879)

12.12.3 Mul04 functions

Functions of Mul04

The functions for this block are listed below.

Forming the signal status for blocks

This block provides the standard function Forming and outputting the signal status for mathematical blocks (Page 117).

The worst signal status for the block is formed by the following parameters and output at the `Out` output parameter:

- `In1.ST`
- `In2.ST`
- `In3.ST`
- `In4.ST`

See also

Description of Mul04 (Page 1879)

Mul04 messaging (Page 1882)

Mul04 I/Os (Page 1883)

Mul04 error handling (Page 1882)

Mul04 block diagram (Page 1884)

Mul04 modes (Page 1881)

12.12.4 Mul04 error handling

Mul04 error handling

The block does not report any errors.

See also

- Mul04 functions (Page 1881)
- Mul04 block diagram (Page 1884)
- Mul04 I/Os (Page 1883)
- Mul04 messaging (Page 1882)
- Description of Mul04 (Page 1879)
- Mul04 modes (Page 1881)

12.12.5 Mul04 messaging

Messaging

This block does not offer messaging.

See also

- Description of Mul04 (Page 1879)
- Mul04 functions (Page 1881)
- Mul04 I/Os (Page 1883)
- Mul04 block diagram (Page 1884)
- Mul04 modes (Page 1881)
- Mul04 error handling (Page 1882)

12.12.6 Mul04 I/Os

Mul04 I/Os

Input parameters

Parameter	Description	Type	Default
EN	1 = Called block will be processed	BOOL	1
In1	Value 1 to multiply	STRUCT <ul style="list-style-type: none"> Value: REAL ST: BYTE 	- <ul style="list-style-type: none"> 1.0 16#80
In2	Value 2 to multiply	STRUCT <ul style="list-style-type: none"> Value: REAL ST: BYTE 	- <ul style="list-style-type: none"> 1.0 16#80
In3	Value 3 to multiply	STRUCT <ul style="list-style-type: none"> Value: REAL ST: BYTE 	- <ul style="list-style-type: none"> 1.0 16#80
In4	Value 4 to multiply	STRUCT <ul style="list-style-type: none"> Value: REAL ST: BYTE 	- <ul style="list-style-type: none"> 1.0 16#80

Output parameters

Parameter	Description	Type	Default
ENO	1 = Block algorithm completed without errors	BOOL	0
Out	Product version	STRUCT <ul style="list-style-type: none"> Value: REAL ST: BYTE 	- <ul style="list-style-type: none"> 0.0 16#80

See also

- Description of Mul04 (Page 1879)
- Mul04 functions (Page 1881)
- Mul04 messaging (Page 1882)
- Mul04 block diagram (Page 1884)
- Mul04 modes (Page 1881)
- Mul04 error handling (Page 1882)

12.12.7 Mul04 block diagram

Mul04 block diagram

A block diagram is not provided for this block.

See also

Description of Mul04 (Page 1879)

Mul04 modes (Page 1881)

Mul04 functions (Page 1881)

Mul04 error handling (Page 1882)

Mul04 messaging (Page 1882)

Mul04 I/Os (Page 1883)

12.13 Mul08 - Multiplier with 8 values

12.13.1 Description of Mul08

Object name (type + number) and family

Type + number: FC 361

Family: Math

Area of application for Mul08

The block is used for the following applications:

- Multiplication of values
- Output of the product for further processing

How it works

The Mul08 block calculates the product of up to 8 values and returns the result at the `Out` output.

$$\text{Out} = \text{In1} \cdot \dots \cdot \text{Inn} \quad (n \leq 8),$$

Where:

`Out` = Product

`In1 ... In8` = values to be multiplied

The product of all input parameters and the worst input parameter signal status is always output.

The output value is checked to determine if it is within the value range of REAL. If it is outside the value range, the highest or lowest possible REAL value is output.

If the value is NAN, the last valid output value is output and the status of the output value is set to 16#28 (if none of the input statuses is worse).

You can find additional information on forming the signal status under Forming and outputting the signal status for mathematical blocks (Page 117)

Configuration

Use the CFC editor to install the block in a cyclic interrupt OB (OB30 to OB38).

For the Mul04 (Mul08) block, the Advanced Process Library contains process tag type templates; these serve as examples by providing various application scenarios for this block.

Refer to Description of Mul04 (Page 1879) for more information.

Startup characteristics

The block does not have any startup characteristics.

Status word allocation for `status1` parameter

This block does not have the `Status` parameter.

See also

- Mul08 functions (Page 1886)
- Mul08 messaging (Page 1888)
- Mul08 I/Os (Page 1888)
- Mul08 block diagram (Page 1889)
- Mul08 error handling (Page 1887)
- Mul08 modes (Page 1886)

12.13.2 Mul08 modes

Mul08 operating modes

This block does not have any modes.

See also

- Mul08 block diagram (Page 1889)
- Mul08 I/Os (Page 1888)
- Mul08 messaging (Page 1888)
- Mul08 error handling (Page 1887)
- Description of Mul08 (Page 1885)
- Mul08 functions (Page 1886)

12.13.3 Mul08 functions

Functions of Mul08

The functions for this block are listed below.

Forming the signal status for blocks

This block provides the standard function Forming and outputting the signal status for mathematical blocks (Page 117).

The worst signal status for the block is formed by the following parameters and output at the `Out` output parameter:

- `In1.ST`
- `In2.ST`
- `In3.ST`
- `In4.ST`
- `In5.ST`
- `In6.ST`
- `In7.ST`
- `In8.ST`

See also

Description of Mul08 (Page 1885)

Mul08 messaging (Page 1888)

Mul08 I/Os (Page 1888)

Mul08 block diagram (Page 1889)

Mul08 error handling (Page 1887)

Mul08 modes (Page 1886)

12.13.4 Mul08 error handling

Mul08 error handling

The block does not report any errors.

See also

Mul08 block diagram (Page 1889)

Mul08 I/Os (Page 1888)

Mul08 messaging (Page 1888)

Mul08 modes (Page 1886)

Mul08 functions (Page 1886)

Description of Mul08 (Page 1885)

12.13.5 Mul08 messaging

Messaging

This block does not offer messaging.

See also

Description of Mul08 (Page 1885)

Mul08 functions (Page 1886)

Mul08 I/Os (Page 1888)

Mul08 block diagram (Page 1889)

Mul08 modes (Page 1886)

Mul08 error handling (Page 1887)

12.13.6 Mul08 I/Os

Mul08 I/Os

Input parameters

Parameter	Description	Type	Default
EN	1 = Called block will be processed	BOOL	1
In1	Value 1 to multiply	STRUCT <ul style="list-style-type: none"> • Value: REAL • ST: BYTE 	- <ul style="list-style-type: none"> • 1.0 • 16#80
In2	Value 2 to multiply	STRUCT <ul style="list-style-type: none"> • Value: REAL • ST: BYTE 	- <ul style="list-style-type: none"> • 1.0 • 16#80
In3	Value 3 to multiply	STRUCT <ul style="list-style-type: none"> • Value: REAL • ST: BYTE 	- <ul style="list-style-type: none"> • 1.0 • 16#80
In4	Value 4 to multiply	STRUCT <ul style="list-style-type: none"> • Value: REAL • ST: BYTE 	- <ul style="list-style-type: none"> • 1.0 • 16#80
In5	Value 5 to multiply	STRUCT <ul style="list-style-type: none"> • Value: REAL • ST: BYTE 	- <ul style="list-style-type: none"> • 1.0 • 16#80

Parameter	Description	Type	Default
In6	Value 6 to multiply	STRUCT <ul style="list-style-type: none"> Value: REAL ST: BYTE 	- <ul style="list-style-type: none"> 1.0 16#80
In7	Value 7 to multiply	STRUCT <ul style="list-style-type: none"> Value: REAL ST: BYTE 	- <ul style="list-style-type: none"> 1.0 16#80
In8	Value 8 to multiply	STRUCT <ul style="list-style-type: none"> Value: REAL ST: BYTE 	- <ul style="list-style-type: none"> 1.0 16#80

Output parameters

Parameter	Description	Type	Default
ENO	1 = Block algorithm completed without errors	BOOL	0
Out	Product output	STRUCT <ul style="list-style-type: none"> Value: REAL ST: BYTE 	- <ul style="list-style-type: none"> 0.0 16#80

See also

[Description of Mul08 \(Page 1885\)](#)
[Mul08 functions \(Page 1886\)](#)
[Mul08 messaging \(Page 1888\)](#)
[Mul08 block diagram \(Page 1889\)](#)
[Mul08 modes \(Page 1886\)](#)
[Mul08 error handling \(Page 1887\)](#)

12.13.7 Mul08 block diagram

Mul08 block diagram

A block diagram is not provided for this block.

See also

[Mul08 I/Os \(Page 1888\)](#)
[Mul08 messaging \(Page 1888\)](#)
[Mul08 error handling \(Page 1887\)](#)
[Mul08 functions \(Page 1886\)](#)

12.13 Mul08 - Multiplier with 8 values

Mul08 modes (Page 1886)

Description of Mul08 (Page 1885)

12.14 Polygon - Converting the first signal (non-linear)

12.14.1 Description of Polygon

Object name (type + number) and family

Type + number: FB 1881

Family: Math

Area of application for Polygon

The block is used for the following applications:

- Conversion of the input signal according to a non-linear characteristic

How it works

An input In is converted to output Out based on a non-linear characteristic with up to 16 interpolation points per polygon block. The number of interpolation points can be increased by cascading multiple blocks. In cascade mode, the `Cascaded = 1` output is set.

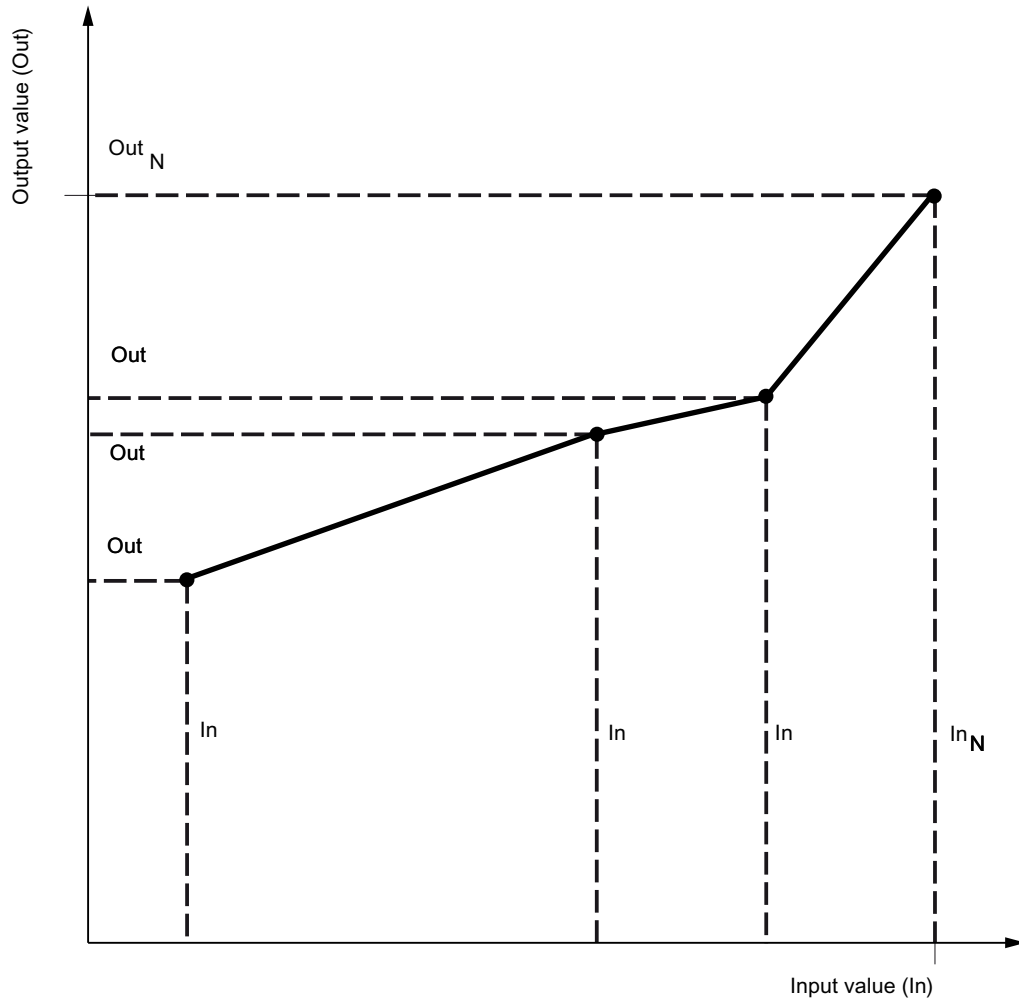

- Num (N) - Number of intermediate points in the curve
 Minimum number of points = 2
 Maximum number of points = 16
- In - Analog input value
- Out - Corresponding output value

After you have defined the N interpolation points (coordinate pairs In_i, Out_i with $i = 1 \dots N$ in a sequence with no gaps) and configured the number Num, the block operates as follows:

- Interpolation between the interpolation points is linear
- Beyond the end interpolation points, extrapolation is based on the first two or last two interpolation points.

You can find additional information on forming the signal status under Forming and outputting the signal status for mathematical blocks (Page 117)

Configuration

The block is installed in the CFC editor in a cyclic interrupt OB (OB30 to OB38). The block is installed automatically in OB100.

Cascade mode

For the cascading of multiple polygon blocks, the `CasOut` output is interconnected to the `CasIn` input of the following block.

In cascade mode, the interpolation points in all polygon blocks must be configured in ascending order and without gaps. The cascaded polygon blocks must be configured in the same runtime group in ascending run sequence.

The analog input value `In` may only be interconnected at the first polygon block. The `In` input of the next block is tracked to this value.

For the Polygon block, the Advanced Process Library contains templates for process tag types as an example with various application scenarios for this block.

Example of process tag types:

- Source chart for GainSched function block (gain scheduling) (Page 2347)

Startup characteristics

The block does not have any startup characteristics.

Status word allocation for `Status` parameter

This block does not have the `Status` parameter.

See also

Polygon functions (Page 1894)

Polygon messaging (Page 1896)

Polygon I/Os (Page 1897)

Polygon block diagram (Page 1900)

Polygon error handling (Page 1895)

Polygon modes (Page 1894)

12.14.2 Polygon modes

Polygon modes

This block does not have any modes.

See also

Polygon block diagram (Page 1900)

Polygon I/Os (Page 1897)

Polygon messaging (Page 1896)

Polygon error handling (Page 1895)

Polygon functions (Page 1894)

Description of Polygon (Page 1891)

12.14.3 Polygon functions

Functions of Polygon

The functions for this block are listed below.

Forming the signal status for blocks

This block provides the standard function Forming and outputting the signal status for mathematical blocks (Page 117).

The signal status for the block is formed using the following parameters and output at the `Out` output parameter:

- `In.ST`

Configurable reactions using the `Feature` parameter

An overview of all the reactions that are provided by the parameter `Feature` is available in the section Configurable functions with the `Feature` I/O (Page 131). The following functionality is available for this block at the relevant bits:

Bit	Function
5	Limit output <code>Out</code> (Page 144)
6	Substitute value switch in the event of an error (Page 149)

Cascading

- Specifying the number of interpolation points
When `n` polygon blocks are cascaded, the interpolation points can be increased by the number set for the `Num` parameter. The configuration of the interpolation points over all cascaded blocks is subject to the same configuration rules as for an individual block, i.e. the interpolation points must be configured in sequence in ascending order and without gaps.
- Data communication
The data communication 2 interconnected polygon blocks is made using an output -> input interconnection.

See also

Description of Polygon (Page 1891)
 Polygon messaging (Page 1896)
 Polygon I/Os (Page 1897)
 Polygon block diagram (Page 1900)
 Polygon error handling (Page 1895)
 Polygon modes (Page 1894)

12.14.4 Polygon error handling

Error handling of Polygon

Refer to the section Error handling (Page 119) in the basic instructions for the error handling of all blocks.

The following errors can be displayed for this block:

- Error numbers

Overview of error numbers

The `ErrorNum` I/O can be used to output the following error numbers:

Error number	Meaning of the error number
-1	Predefined value when inserting the block; block is not processed
0	There is no error.
30	The value <code>In</code> or <code>SubV_In</code> can no longer be displayed in the REAL- number field. The last valid value is provided at the <code>Out</code> output.
31	The calculation of the output <code>Out</code> leads to a result that can no longer be displayed in a REAL- numerical field. The last valid value is provided at the <code>Out</code> output.
48	No valid interconnection to <code>CasIn</code> . The last valid value is provided at the <code>Out</code> output.

12.14 Polygon - Converting the first signal (non-linear)

Error number	Meaning of the error number
49	Num < 2 or Num > 16 In _(N) ≤ In _(N-1) , in the event of an error, the last valid value is output
≥ 1xx	Error in one of the upstream xx = ErrorNum block. The last valid value is provided at the Out output.

Note

The substitute value SubV_In can be output instead of the last valid value via the Feature bit 6 = 1 .

Substitute values that cannot be displayed in the REAL- number format have no effect. The last valid value is provided at the Out output in this case.

See also

- Polygon block diagram (Page 1900)
- Polygon I/Os (Page 1897)
- Polygon messaging (Page 1896)
- Description of Polygon (Page 1891)
- Polygon modes (Page 1894)
- Polygon functions (Page 1894)

12.14.5 Polygon messaging

Messaging

This block does not offer messaging.

See also

- Description of Polygon (Page 1891)
- Polygon functions (Page 1894)
- Polygon I/Os (Page 1897)
- Polygon block diagram (Page 1900)
- Polygon error handling (Page 1895)
- Polygon modes (Page 1894)

12.14.6 Polygon I/Os

I/Os of Polygon

Input parameters

Parameter	Description	Type	Default
CasIn*	Input for cascade, to be interconnected with the output parameter CasOut of the preceding polygon block	STRUCT <ul style="list-style-type: none"> Value: REAL ST: BYTE 	- <ul style="list-style-type: none"> 0.0 16#FF
EN	1 = Called block will be processed	BOOL	1
Feature	I/O for additional functions (Page 1894)	STRUCT <ul style="list-style-type: none"> Bit 0: BOOL ... Bit 31: BOOL 	- <ul style="list-style-type: none"> 0 0 0
In*	Analog input value	STRUCT <ul style="list-style-type: none"> Value: REAL ST: BYTE 	- <ul style="list-style-type: none"> 0.0 16#80
In1	Interpolation point In1	STRUCT <ul style="list-style-type: none"> Value: REAL ST: BYTE 	- <ul style="list-style-type: none"> 0.0 16#80
In2	Interpolation point In2	STRUCT <ul style="list-style-type: none"> Value: REAL ST: BYTE 	- <ul style="list-style-type: none"> 0.0 16#80
In3	Interpolation point In3	STRUCT <ul style="list-style-type: none"> Value: REAL ST: BYTE 	- <ul style="list-style-type: none"> 0.0 16#80
In4	Interpolation point In4	STRUCT <ul style="list-style-type: none"> Value: REAL ST: BYTE 	- <ul style="list-style-type: none"> 0.0 16#80
In5	Interpolation point In5	STRUCT <ul style="list-style-type: none"> Value: REAL ST: BYTE 	- <ul style="list-style-type: none"> 0.0 16#80
In6	Interpolation point In6	STRUCT <ul style="list-style-type: none"> Value: REAL ST: BYTE 	- <ul style="list-style-type: none"> 0.0 16#80
In7	Interpolation point In7	STRUCT <ul style="list-style-type: none"> Value: REAL ST: BYTE 	- <ul style="list-style-type: none"> 0.0 16#80

12.14 Polygon - Converting the first signal (non-linear)

Parameter	Description	Type	Default
In8	Interpolation point In8	STRUCT <ul style="list-style-type: none"> • Value: REAL • ST: BYTE 	- <ul style="list-style-type: none"> • 0.0 • 16#80
In9	Interpolation point In9	STRUCT <ul style="list-style-type: none"> • Value: REAL • ST: BYTE 	- <ul style="list-style-type: none"> • 0.0 • 16#80
In10	Interpolation point In10	STRUCT <ul style="list-style-type: none"> • Value: REAL • ST: BYTE 	- <ul style="list-style-type: none"> • 0.0 • 16#80
In11	Interpolation point In11	STRUCT <ul style="list-style-type: none"> • Value: REAL • ST: BYTE 	- <ul style="list-style-type: none"> • 0.0 • 16#80
In12	Interpolation point In12	STRUCT <ul style="list-style-type: none"> • Value: REAL • ST: BYTE 	- <ul style="list-style-type: none"> • 0.0 • 16#80
In13	Interpolation point In13	STRUCT <ul style="list-style-type: none"> • Value: REAL • ST: BYTE 	- <ul style="list-style-type: none"> • 0.0 • 16#80
In14	Interpolation point In14	STRUCT <ul style="list-style-type: none"> • Value: REAL • ST: BYTE 	- <ul style="list-style-type: none"> • 0.0 • 16#80
In15	Interpolation point In15	STRUCT <ul style="list-style-type: none"> • Value: REAL • ST: BYTE 	- <ul style="list-style-type: none"> • 0.0 • 16#80
In16	Interpolation point In16	STRUCT <ul style="list-style-type: none"> • Value: REAL • ST: BYTE 	- <ul style="list-style-type: none"> • 0.0 • 16#80
Num	Number of interpolation points	INT	16
Out1	Sampling point 1	STRUCT <ul style="list-style-type: none"> • Value: REAL • ST: BYTE 	- <ul style="list-style-type: none"> • 0.0 • 16#80
Out2	Sampling point 2	STRUCT <ul style="list-style-type: none"> • Value: REAL • ST: BYTE 	- <ul style="list-style-type: none"> • 0.0 • 16#80
Out3	Sampling point 3	STRUCT <ul style="list-style-type: none"> • Value: REAL • ST: BYTE 	- <ul style="list-style-type: none"> • 0.0 • 16#80
Out4	Sampling point 4	STRUCT <ul style="list-style-type: none"> • Value: REAL • ST: BYTE 	- <ul style="list-style-type: none"> • 0.0 • 16#80

12.14 Polygon - Converting the first signal (non-linear)

Parameter	Description	Type	Default
Out5	Sampling point 5	STRUCT • Value: REAL • ST: BYTE	- • 0.0 • 16#80
Out6	Sampling point 6	STRUCT • Value: REAL • ST: BYTE	- • 0.0 • 16#80
Out7	Sampling point 7	STRUCT • Value: REAL • ST: BYTE	- • 0.0 • 16#80
Out8	Sampling point 8	STRUCT • Value: REAL • ST: BYTE	- • 0.0 • 16#80
Out9	Sampling point 9	STRUCT • Value: REAL • ST: BYTE	- • 0.0 • 16#80
Out10	Sampling point 10	STRUCT • Value: REAL • ST: BYTE	- • 0.0 • 16#80
Out11	Sampling point 11	STRUCT • Value: REAL • ST: BYTE	- • 0.0 • 16#80
Out12	Sampling point 12	STRUCT • Value: REAL • ST: BYTE	- • 0.0 • 16#80
Out13	Sampling point 13	STRUCT • Value: REAL • ST: BYTE	- • 0.0 • 16#80
Out14	Sampling point 14	STRUCT • Value: REAL • ST: BYTE	- • 0.0 • 16#80
Out15	Sampling point 15	STRUCT • Value: REAL • ST: BYTE	- • 0.0 • 16#80
Out16	Sampling point 16	STRUCT • Value: REAL • ST: BYTE	- • 0.0 • 16#80
SubV_In*	Substitute value	STRUCT • Value: REAL • ST: BYTE	- • 0.0 • 16#80

* Values can be written back to these inputs during processing of the block by the block algorithm.

Output parameters

Parameter	Description	Type	Default
Cascaded	1 = Block is cascaded	BOOL	0
CasOut	Output parameter for cascade formation, to be interconnected with the input parameter <code>CasIn</code> of the following polygon block	STRUCT <ul style="list-style-type: none"> • Value: REAL • ST: BYTE 	- <ul style="list-style-type: none"> • 0.0 • 16#80
ENO	1 = Block algorithm completed without errors	BOOL	0
ErrorNum	Output of current error number. For error numbers that can be output by this block, see Polygon error handling (Page 1895)	INT	-1
Out	Output value	STRUCT <ul style="list-style-type: none"> • Value: REAL • ST: BYTE 	- <ul style="list-style-type: none"> • 0.0 • 16#80

See also

- Description of Polygon (Page 1891)
- Polygon messaging (Page 1896)
- Polygon block diagram (Page 1900)
- Polygon modes (Page 1894)

12.14.7 Polygon block diagram

Polygon block diagram

A block diagram is not provided for this block.

See also

- Polygon I/Os (Page 1897)
- Polygon messaging (Page 1896)
- Polygon error handling (Page 1895)
- Polygon functions (Page 1894)
- Polygon modes (Page 1894)
- Description of Polygon (Page 1891)

12.15 Smooth - Low pass filter

12.15.1 Description of Smooth

Object name (type + number) and family

Type + number: FB 1890

Family: Math

Area of application for Smooth

The block is used for the following applications:

- Butterworth low-pass filter, 2nd order with maverick detection

How it works

The block is used as a low pass filter. This filter allows the signal portions with frequencies below the cutoff frequency to pass practically unattenuated, whereas portions with high frequencies are attenuated. This enables you to filter out high frequency interference in the signal (for example, signal noise) and smooth the signal.

In comparison to a first order low pass filter, the Butterworth filter has the advantage that the transition from the passing section to the blocking section is sharper in the Bode diagram. If the frequency area of the interference is known, it can be filtered out with minimal influence on the wanted signal.

The maverick (Page 2387) detection monitors adjacent signals. If signal mavericks are detected, they are not processed any further. The block outputs the last valid signal.

The signal status is passed from the input directly to the output.

You can find additional information on forming the signal status under Forming and outputting the signal status for mathematical blocks (Page 117)

Configuration

Use the CFC editor to install the block in a cyclic interrupt OB (OB30 to OB38). The block is also installed automatically in the startup OB (OB100).

You then set the filter time constant for the low pass filter to achieve the desired effect.

To set the filter time constant, it is helpful to observe the original and filtered signals in the CFC trend plotter. The filtered signal should be smoothed as required but not too delayed. An increase in the filter time constant increases the smoothing effect but also increases the delay. Typical starting values for the time constant are around ten times the sample rate of the signal.

There is a sample project for the Smooth block (APL_Example_xx, xx refers to the language variant) with an application case for this block:

- Filtering of noisy measured values in a control loop (SigSmoothSim) (Page 2380)

Startup characteristics

When OB100 is called, the state variables of the Butterworth filter are initialized based on the current process values.

Status word allocation for `Status1` parameter

The block does not have a status word allocation.

See also

Smooth functions (Page 1902)

Smooth messaging (Page 1904)

Smooth I/Os (Page 1905)

Smooth block diagram (Page 1906)

Smooth error handling (Page 1903)

Smooth modes (Page 1902)

12.15.2 Smooth modes

Smooth operating modes

This block does not have any modes.

See also

Smooth block diagram (Page 1906)

Smooth I/Os (Page 1905)

Smooth messaging (Page 1904)

Smooth error handling (Page 1903)

Smooth functions (Page 1902)

Description of Smooth (Page 1901)

12.15.3 Smooth functions

Smooth functions

The block provides the following functions:

- Restart low pass filter
- Activate and deactivate maverick detection

Restart low pass filter

You can recalculate the coefficients of the Butterworth filter. To do this, you must restart filter (`Restart = 1`).

The filter algorithm is then reinitialized, exactly as it is when the CPU is restarted or a change is made to the count value at the input parameter `TimeConstant`. The coefficients of the Butterworth filter are recalculated and the internal state memory of the filter is initialized so that the `CleanPV` output parameter is equal to the `PV` input parameter.

Activate and deactivate maverick detection

The maverick detection (`OutlDetOn = 1`) monitors the process value `PV` for the difference between two sequential sample values. These have to be within a tolerance range you have specified (`OutlTreshold`).

If the tolerance is violated, the maverick is set to the most recent valid value. The most recent valid measured value is then held constant by the block for a maximum of `OutlCycles` sample steps. If the maverick continues longer than this, it is accepted as a valid measured value.

Forming the signal status for blocks

This block provides the standard function `Forming` and outputting the signal status for mathematical blocks (Page 117).

The signal status for the block is formed using the following parameters and output at the `CleanPV` output parameter:

- `PV.ST`

See also

Description of `Smooth` (Page 1901)

Smooth messaging (Page 1904)

Smooth I/Os (Page 1905)

Smooth block diagram (Page 1906)

Smooth error handling (Page 1903)

Smooth modes (Page 1902)

12.15.4 Smooth error handling

Error handling of `Smooth`

Refer to the section `Error handling` (Page 119) in the basic instructions for the error handling of all blocks.

The following errors can be displayed for this block:

- Error numbers

Overview of error numbers

The `ErrorNum` I/O can be used to output the following error numbers:

Error number	Meaning of the error number
-1	Predefined value when inserting the block; the block is not processed.
0	There is no error.
2	$\text{SampleTime} < 0.001$ [s]
30	The value of <code>PV</code> can no longer be displayed in the REAL number field. The last valid value is provided at the <code>CleanPV</code> output.
61	$\text{TimeConstant} < 5 \cdot \text{SampleTime}$
62	$\text{TimeConstant}/\text{SampleTime} > 1000$ If there is a parametrization error because $\text{ratio} = \text{TimeConstant}/\text{SampleTime} > 1000$, move the function block into another SIMATIC OB with a slower sample time, preferably into the slowest cycle OB30 and recompile the CFC. If this is still not sufficient, you can set the reduction ratio of the CFC runtime group in which the Smooth function block is called.

See also

- Smooth block diagram (Page 1906)
- Smooth I/Os (Page 1905)
- Smooth messaging (Page 1904)
- Smooth functions (Page 1902)
- Smooth modes (Page 1902)
- Description of Smooth (Page 1901)

12.15.5 Smooth messaging

Messaging

This block does not offer messaging.

See also

- Description of Smooth (Page 1901)
- Smooth functions (Page 1902)
- Smooth I/Os (Page 1905)
- Smooth block diagram (Page 1906)
- Smooth error handling (Page 1903)
- Smooth modes (Page 1902)

12.15.6 Smooth I/Os

I/Os of Smooth

Input parameters

Parameter	Description	Type	Default
EN	1 = Called block will be processed	BOOL	1
Feature	This parameter currently has no use and is reserved for future functions.	STRUCT <ul style="list-style-type: none"> • Bit 0: BOOL • ... • Bit 31: BOOL 	- <ul style="list-style-type: none"> • 0 • 0 • 0
FilterOn	1 = Filter active	BOOL	1
OutlCycles	Number of sampling steps to bridge mavericks	INT	3
OutlDetOn	1 = Maverick detection is activated	BOOL	0
OutlThreshold	Limit (trigger threshold) for maverick detection	REAL	10.0
PV*	Analog input (process value)	STRUCT <ul style="list-style-type: none"> • Value: REAL • ST: BYTE 	- <ul style="list-style-type: none"> • 0.0 • 16#80
Restart*	Restart the filter algorithm	BOOL	1
SampleTime	Sampling time [s] (assigned automatically)	REAL	1.0
TimeConstant	Butterworth filter time constant [s]	REAL	10.0

* Values can be written back to these inputs during processing of the block by the block algorithm.

Output parameters

Parameter	Description	Type	Default
CleanPV	Output of the corrected process value	STRUCT <ul style="list-style-type: none"> • Value: REAL • ST: BYTE 	- <ul style="list-style-type: none"> • 0.0 • 16#80
ENO	1 = Block algorithm completed without errors	BOOL	0
ErrorNum*	Output of current error number. For error numbers that can be output by this block, see Smooth error handling (Page 1903).	INT	0
OutlDetected	1 = Maverick detected	BOOL	0

* Values can be written back to these inputs during processing of the block by the block algorithm.

See also

Description of Smooth (Page 1901)

Smooth functions (Page 1902)

Smooth messaging (Page 1904)

Smooth block diagram (Page 1906)

Smooth modes (Page 1902)

12.15.7 Smooth block diagram

Smooth block diagram

A block diagram is not provided for this block.

See also

Smooth I/Os (Page 1905)

Smooth messaging (Page 1904)

Smooth error handling (Page 1903)

Smooth functions (Page 1902)

Smooth modes (Page 1902)

Description of Smooth (Page 1901)

12.16 SqrRoot - Derive the root of a value

12.16.1 Description of SqrRoot

Object name (type + number) and family

Type + number: FC 394

Family: Math

Area of application for SqrRoot

The block is used to derive the root from a value as follows:

- `Out.Value = SquareRoot(In.Value)`

How it works

The input value is checked as to whether it is within the REAL value range and is not negative.

- If the input value is not a number (NaN), the last valid output value is displayed at the output. If the input status is not 16#00, the status of the output value is set to 16#28 and `ErrorNum` is set to 30
- If the input value is negative, the last valid output value is displayed at the output. If the input status is not 16#00, the status of the output value is set to 16#28 and `ErrorNum` is set to 30
- If the input value is positive infinity, the the greatest REAL value is displayed at the output. If the input status is not 16#00, the status of the output value is set to 16#28 and `ErrorNum` is set to 30
-
- The status of the output value is set to 16#28 (if the input status is not below this). `ErrorNum` is also set to 30.

Configuration

Use the CFC editor to install the block in a cyclic interrupt OB (OB30 to OB38).

Startup characteristics

The block does not have any startup characteristics.

Status word allocation for `Status1` parameter

This block does not have the `Status` parameter.

See also

SqrRoot block diagram (Page 1911)
SqrRoot I/Os (Page 1910)
SqrRoot messaging (Page 1909)
SqrRoot functions (Page 1908)
SqrRoot modes (Page 1908)
Source chart for GainSched function block (gain scheduling) (Page 2347)
PID controller with Smith predictor (SmithPredictorControl) (Page 2332)
Override control (Page 2348)
Forming and outputting the signal status for mathematical blocks (Page 117)

12.16.2 SqrRoot modes

Operating modes of SqrRoot

This block does not have any operating modes.

See also

SqrRoot block diagram (Page 1911)
SqrRoot I/Os (Page 1910)
SqrRoot messaging (Page 1909)
SqrRoot functions (Page 1908)
Description of SqrRoot (Page 1907)

12.16.3 SqrRoot functions

Functions of SqrRoot

The functions for this block are listed below.

Forming the signal status for blocks

The signal status of the block is formed using the following parameters and output at the Out output parameter:

- `Out.ST = In.ST`

See also

[SqrRoot block diagram \(Page 1911\)](#)
[SqrRoot I/Os \(Page 1910\)](#)
[SqrRoot messaging \(Page 1909\)](#)
[SqrRoot modes \(Page 1908\)](#)
[Description of SqrRoot \(Page 1907\)](#)
[Forming and outputting the signal status for mathematical blocks \(Page 117\)](#)

12.16.4 SqrRoot error handling**Error handling of SqrRoot**

The `ErrorNum` I/O can be used to output the following error numbers:

Error number	Meaning of the error number
-1	Predefined value when inserting the block; the block is not executed.
0	There is no error.
30	The input value is a negative number or it cannot be displayed in the REAL number field.

See also

[Sub02 block diagram \(Page 1916\)](#)
[Sub02 I/Os \(Page 1915\)](#)
[Sub02 messaging \(Page 1914\)](#)
[Sub02 functions \(Page 1913\)](#)
[Sub02 modes \(Page 1913\)](#)
[Description of Sub02 \(Page 1912\)](#)

12.16.5 SqrRoot messaging**Messaging**

This block does not offer messaging.

See also

[SqrRoot block diagram \(Page 1911\)](#)
[SqrRoot I/Os \(Page 1910\)](#)

12.16 SqrRoot - Derive the root of a value

- SqrRoot functions (Page 1908)
- SqrRoot modes (Page 1908)
- Description of SqrRoot (Page 1907)

12.16.6 SqrRoot I/Os

I/Os of SqrRoot

Input parameters

Parameter	Description	Type	Default
EN	1 = Called block will be processed	BOOL	1
IN	Signal status	STRUCT <ul style="list-style-type: none"> • Value: REAL • ST: BYTE 	- <ul style="list-style-type: none"> • 0.0 • 16#80

Output parameters

Parameter	Description	Type	Default
ENO	1 = Block algorithm completed without errors	BOOL	0
ErrorNum	Output of the pending error number. For error numbers that can be output by this block, see SqrRoot error handling (Page 1909).	INT	<ul style="list-style-type: none"> • -1
Out	Signal status	STRUCT <ul style="list-style-type: none"> • Value: REAL • ST: BYTE 	- <ul style="list-style-type: none"> • 0.0 • 16#80

See also

- SqrRoot block diagram (Page 1911)
- SqrRoot messaging (Page 1909)
- SqrRoot functions (Page 1908)
- SqrRoot modes (Page 1908)
- Description of SqrRoot (Page 1907)

12.16.7 SqrRoot block diagram

SqrRoot block diagram

A block diagram is not provided for this block.

See also

SqrRoot I/Os (Page 1910)

SqrRoot messaging (Page 1909)

SqrRoot functions (Page 1908)

SqrRoot modes (Page 1908)

Description of SqrRoot (Page 1907)

12.17 Sub02 - Subtracting two values

12.17.1 Description of Sub02

Object name (type + number) and family

Type + number: FC 381

Family: Math

Area of application for Sub02

The block is used for the following applications:

- Subtracting two values

How it works

The block subtracts one value from another and outputs the subtraction at the `Out` output parameter as follows:

- $Out = In1 - In2$

The worst signal status is also always output at the output parameter.

The output value is checked to determine if it is within the value range of REAL. If it is outside the value range, the highest or lowest possible REAL value is output.

If the value is NAN, the last valid output value is output and the status of the output value is set to 16#28 (if none of the input statuses is worse).

You can find additional information on forming the signal status under Forming and outputting the signal status for mathematical blocks (Page 117)

Configuration

Use the CFC editor to install the block in a cyclic interrupt OB (OB30 to OB38).

For the Sub02 block, the Advanced Process Library contains templates for process tag types as examples with various application scenarios for this block.

Examples of process tag types:

- Source chart for GainSched function block (gain scheduling) (Page 2347)
- PID controller with Smith predictor (SmithPredictorControl) (Page 2332)
- Override control (Page 2348)

Startup characteristics

The block does not have any startup characteristics.

Status word allocation for `status1` parameter

This block does not have the `status` parameter.

See also

Sub02 block diagram (Page 1916)

Sub02 I/Os (Page 1915)

Sub02 messaging (Page 1914)

Sub02 error handling (Page 1914)

Sub02 functions (Page 1913)

Sub02 modes (Page 1913)

12.17.2 Sub02 modes**Sub02 operating modes**

This block does not have any modes.

See also

Sub02 block diagram (Page 1916)

Sub02 I/Os (Page 1915)

Sub02 messaging (Page 1914)

Sub02 error handling (Page 1914)

Sub02 functions (Page 1913)

Description of Sub02 (Page 1912)

12.17.3 Sub02 functions**Functions of Sub02**

The functions for this block are listed below.

Forming the signal status for blocks

This block provides the standard function Forming and outputting the signal status for mathematical blocks (Page 117).

12.17 Sub02 - Subtracting two values

The worst signal status for the block is formed by the following parameters and output at the Out output parameter:

- In1.ST
- In2.ST

See also

Sub02 block diagram (Page 1916)

Sub02 I/Os (Page 1915)

Sub02 messaging (Page 1914)

Sub02 error handling (Page 1914)

Sub02 modes (Page 1913)

Description of Sub02 (Page 1912)

12.17.4 Sub02 error handling

Sub02 error handling

The block does not report any errors.

See also

Sub02 block diagram (Page 1916)

Sub02 I/Os (Page 1915)

Sub02 messaging (Page 1914)

Sub02 functions (Page 1913)

Sub02 modes (Page 1913)

Description of Sub02 (Page 1912)

12.17.5 Sub02 messaging

Messaging

This block does not offer messaging.

See also

Sub02 block diagram (Page 1916)

Sub02 I/Os (Page 1915)

Sub02 error handling (Page 1914)

Sub02 functions (Page 1913)

Sub02 modes (Page 1913)

Description of Sub02 (Page 1912)

12.17.6 Sub02 I/Os

Sub02 I/Os

Input parameters

Parameter	Description	Type	Default
EN	1 = Called block will be processed	BOOL	1
In1	Value 1 to subtract	STRUCT <ul style="list-style-type: none"> • Value: REAL • ST: BYTE 	- <ul style="list-style-type: none"> • 0.0 • 16#80
In2	Value 2 to subtract	STRUCT <ul style="list-style-type: none"> • Value: REAL • ST: BYTE 	- <ul style="list-style-type: none"> • 0.0 • 16#80

Output parameters

Parameter	Description	Type	Default
ENO	1 = Block algorithm completed without errors	BOOL	0
Out	Product version	STRUCT <ul style="list-style-type: none"> • Value: REAL • ST: BYTE 	- <ul style="list-style-type: none"> • 0.0 • 16#80

See also

Sub02 block diagram (Page 1916)

Sub02 messaging (Page 1914)

Sub02 error handling (Page 1914)

Sub02 functions (Page 1913)

Sub02 modes (Page 1913)

Description of Sub02 (Page 1912)

12.17.7 Sub02 block diagram

Sub02 block diagram

A block diagram is not provided for this block.

See also

- Sub02 I/Os (Page 1915)
- Sub02 messaging (Page 1914)
- Sub02 error handling (Page 1914)
- Sub02 functions (Page 1913)
- Sub02 modes (Page 1913)
- Description of Sub02 (Page 1912)

Analog logic blocks

13.1 CompAn02 - Comparison of two analog values

13.1.1 Description of CompAn02

Object name (type + number) and family

Type + number: FC 387

Family: LogicAn

Area of application for CompAn02

The block is used for the following applications:

- Comparison of the analog input values $In1$ and $In2$

How it works

The block compares the two analog input values $In1$ and $In2$ to see if they are "less than", "less than or equal to", "greater than", "greater than or equal to" and "equal".

There is an independent result output parameter for every comparison operation.

These outputs are formed as follows.

- $GT.Value = 1$, if $In1 > In2$
- $GE.Value = 1$, if $In1 \geq In2$
- $EQ.Value = 1$, if $In1 = In2$
- $LT.Value = 1$, if $In1 < In2$
- $LE.Value = 1$, if $In1 \leq In2$

Configuration

Use the CFC editor to install the block in a cyclic interrupt OB (OB30 to OB38).

Further addressing is not required.

Startup characteristics

The block does not have any startup characteristics.

Status word allocation for `status1` parameter

This block does not have the `Status` parameter.

See also

- CompAn02 modes (Page 1918)
- CompAn02 functions (Page 1918)
- CompAn02 error handling (Page 1919)
- CompAn02 messaging (Page 1920)
- CompAn02 I/Os (Page 1920)
- CompAn02 block diagram (Page 1921)

13.1.2 CompAn02 modes

CompAn02 operating modes

This block does not have any modes.

See also

- Description of CompAn02 (Page 1917)
- CompAn02 functions (Page 1918)
- CompAn02 messaging (Page 1920)
- CompAn02 error handling (Page 1919)
- CompAn02 I/Os (Page 1920)
- CompAn02 block diagram (Page 1921)

13.1.3 CompAn02 functions

Functions of CompAn02

The functions for this block are listed below.

Forming the signal status for blocks

This block provides the standard function Forming and outputting the signal status of analog logic blocks (Page 112).

See also

Description of CompAn02 (Page 1917)
CompAn02 modes (Page 1918)
CompAn02 error handling (Page 1919)
CompAn02 messaging (Page 1920)
CompAn02 I/Os (Page 1920)
CompAn02 block diagram (Page 1921)

13.1.4 CompAn02 error handling

CompAn02 error handling

The block does not report any errors.

Behavior of the block leaving the REAL number field

If one of the two input parameters $In1$ or $In2$ is outside the REAL number field, it is treated like a REAL number.

Example

- $In1 = \#e+INF$ and $In2 < \#e+INF$: $GT/GE := 1$, the other output parameters are then 0
- $In1 = \#e-INF$ and $In2 > \#e-INF$: $LT/LE := 1$, the other output parameters are then 0
- $In1 = \#NAN\#$ or $In2 = \#NAN\#$: all output parameters are set to 0

See also

Description of CompAn02 (Page 1917)
CompAn02 modes (Page 1918)
CompAn02 functions (Page 1918)
CompAn02 messaging (Page 1920)
CompAn02 I/Os (Page 1920)
CompAn02 block diagram (Page 1921)

13.1.5 CompAn02 messaging

Messaging

This block does not offer messaging.

See also

- Description of CompAn02 (Page 1917)
- CompAn02 modes (Page 1918)
- CompAn02 functions (Page 1918)
- CompAn02 error handling (Page 1919)
- CompAn02 block diagram (Page 1921)
- CompAn02 I/Os (Page 1920)

13.1.6 CompAn02 I/Os

CompAn02 I/Os

Input parameters

Parameter	Description	Type	Default
EN	1 = Called block will be processed	BOOL	1
In1	Analog input value 1	STRUCT <ul style="list-style-type: none"> • Value: REAL • ST: BYTE 	- <ul style="list-style-type: none"> • 0.0 • 16#80
In2	Analog input value 2	STRUCT <ul style="list-style-type: none"> • Value: REAL • ST: BYTE 	- <ul style="list-style-type: none"> • 0.0 • 16#80

Output parameters

Parameter	Description	Type	Default
ENO	1 = Block algorithm completed without errors	BOOL	0
EQ	1= In1 = In2	STRUCT <ul style="list-style-type: none"> • Value: BOOL • ST: BYTE 	- <ul style="list-style-type: none"> • 0 • 16#80

Parameter	Description	Type	Default
GE	$1 = In1 \geq In2$	STRUCT <ul style="list-style-type: none"> Value: BOOL ST: BYTE 	- <ul style="list-style-type: none"> 0 16#80
GT	$1 = In1 > In2$	STRUCT <ul style="list-style-type: none"> Value: BOOL ST: BYTE 	- <ul style="list-style-type: none"> 0 16#80
LE	$1 = In1 \leq In2$	STRUCT <ul style="list-style-type: none"> Value: BOOL ST: BYTE 	- <ul style="list-style-type: none"> 0 16#80
LT	$1 = In1 < In2$	STRUCT <ul style="list-style-type: none"> Value: BOOL ST: BYTE 	- <ul style="list-style-type: none"> 0 16#80

See also

Description of CompAn02 (Page 1917)

CompAn02 modes (Page 1918)

CompAn02 functions (Page 1918)

CompAn02 error handling (Page 1919)

CompAn02 messaging (Page 1920)

CompAn02 block diagram (Page 1921)

13.1.7 CompAn02 block diagram**CompAn02 block diagram**

A block diagram is not provided for this block.

See also

Description of CompAn02 (Page 1917)

CompAn02 modes (Page 1918)

CompAn02 functions (Page 1918)

CompAn02 error handling (Page 1919)

CompAn02 messaging (Page 1920)

CompAn02 I/Os (Page 1920)

13.2 Limit - Limiting an analog value

13.2.1 Description of Limit

Object name (type + number) and family

Type + number: FB 1829

Family: LogicAn

Area of application for Limit

The block is used for the following applications:

- Limiting of values

How it works

The Limit block is used to limit an analog value to an adjustable range.

The limits are set at the `OutHiLim` (high limit) and `OutLoLim` (low limit) input parameters. If a limit is violated, the limit you entered is output. The limit violation is also shown at the two output parameters `OutHiAct` (high) or `OutLoAct` (low).

You can configure hysteresis (`OutHyst` input parameter) to suppress signal flutters close to the limits.

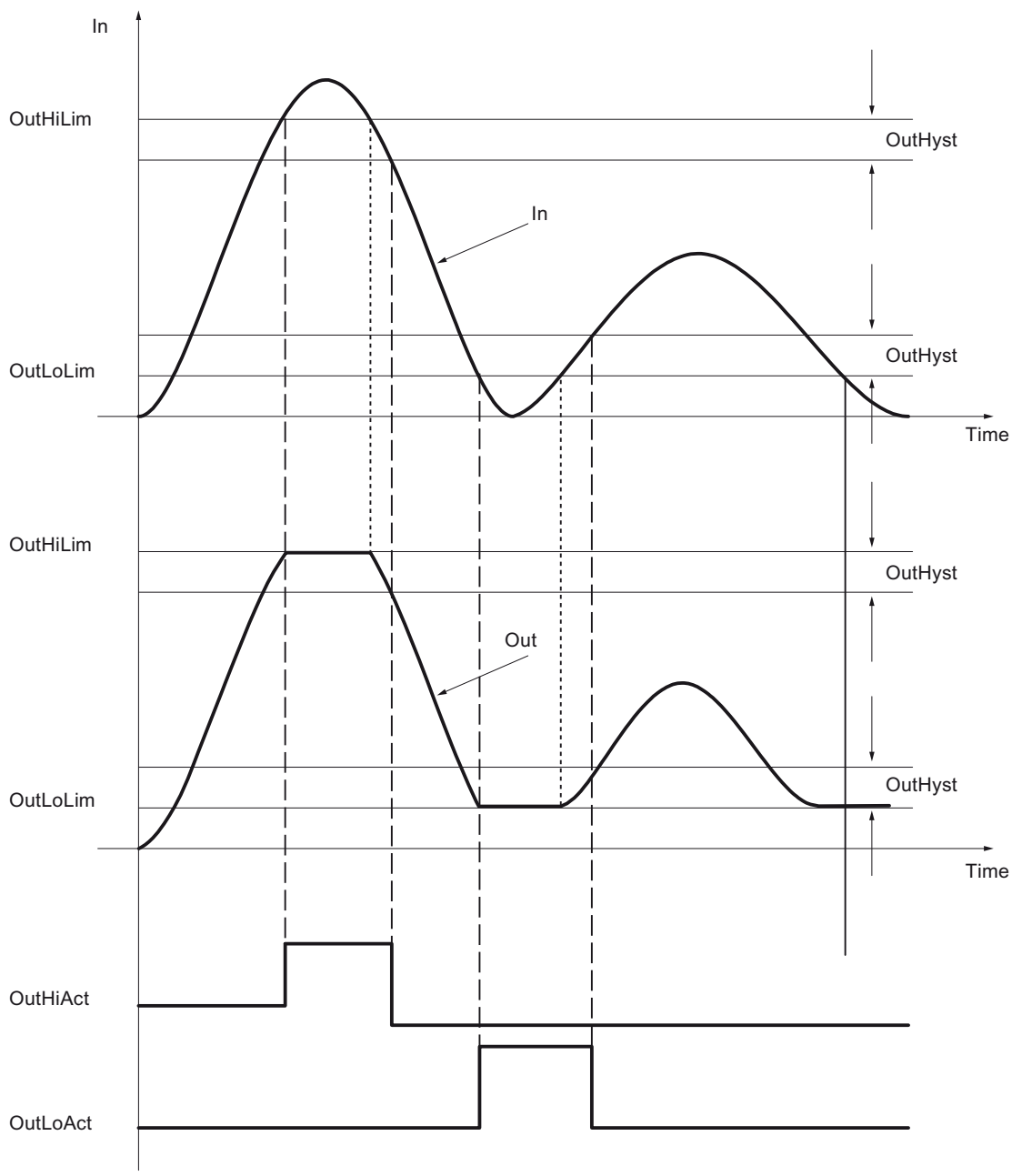

Active conditions for setting limit values

High limit active: $In \geq OutHiLim$

Low limit active: $In \leq OutLoLim$

Active conditions for resetting limit values

High limit active: $In < OutHiLim - OutHyst$

Low limit active: $In > OutLoLim + OutHyst$

Configuration

Use the CFC editor to install the block in a cyclic interrupt OB (OB30 to OB38).

Further addressing is not required.

Startup characteristics

The block does not have any startup characteristics.

A startup behavior can be reached with a connection of the input parameter `Init` to the output parameter `InitOut` of the Trigger block. For more information, refer to Startup characteristics over Trigger block (Page 69).

Status word allocation for `Status1` parameter

This block does not have the `Status` parameter.

See also

Limit block diagram (Page 1927)

Limit I/Os (Page 1926)

Limit messaging (Page 1926)

Limit error handling (Page 1925)

Limit functions (Page 1924)

Limit modes (Page 1924)

13.2.2 Limit modes

Limit modes

This block does not have any modes.

See also

Limit block diagram (Page 1927)

Limit I/Os (Page 1926)

Limit messaging (Page 1926)

Limit error handling (Page 1925)

Limit functions (Page 1924)

Description of Limit (Page 1922)

13.2.3 Limit functions

Functions of Limit

The function for this block is listed below.

Initialization

With the input parameter `Init`, the output parameters `OutHiAct` and `OutLoAct` can be initialized:

- `Init = 0` (default): Normal limitation behavior
If the input parameter `In` is in the hysteresis range, the output parameters `OutHiAct` and `OutLoAct` will remain unchanged.
- `Init = 1`:
If the input parameter `In` is in the hysteresis range, the output parameters `OutHiAct` and `OutLoAct` will be reset.

To initialize the output parameters `OutHiAct` and `OutLoAct` after a startup, connect the input parameter `Init` with the output parameter `InitOut` of the Trigger block. For more information, refer to Startup characteristics over Trigger block (Page 69).

See also

Limit block diagram (Page 1927)

Limit I/Os (Page 1926)

Limit messaging (Page 1926)

Limit error handling (Page 1925)

Limit modes (Page 1924)

Description of Limit (Page 1922)

13.2.4 Limit error handling

Limit error handling

The block does not report any errors.

See also

Limit block diagram (Page 1927)

Limit I/Os (Page 1926)

Limit messaging (Page 1926)

Limit functions (Page 1924)

Limit modes (Page 1924)

Description of Limit (Page 1922)

13.2.5 Limit messaging

Messaging

This block does not offer messaging.

See also

Limit block diagram (Page 1927)

Limit I/Os (Page 1926)

Limit error handling (Page 1925)

Limit functions (Page 1924)

Limit modes (Page 1924)

Description of Limit (Page 1922)

13.2.6 Limit I/Os

I/Os of Limit

Input parameters

Parameter	Description	Type	Default
EN	1 = Called block will be processed	BOOL	1
Feature	I/O for additional functions (Page 1924)	STRUCT <ul style="list-style-type: none"> • Bit 0: BOOL • ... • Bit 31: BOOL 	- <ul style="list-style-type: none"> • 0 • 0 • 0
In	Analog input value	STRUCT <ul style="list-style-type: none"> • Value: REAL • ST: BYTE 	- <ul style="list-style-type: none"> • 0.0 • 16#80
Init	Initialize function block	BOOL	0
OutHyst*	Hysteresis in %	REAL	0.0
OutHiLim	High limit of output value	REAL	100.0
OutLoLim	Low limit of output value	REAL	0.0

* Values can be written back to these inputs during processing of the block by the block algorithm.

Output parameters

Parameter	Description	Type	Default
ENO	1 = Block algorithm completed without errors	BOOL	0
ErrorNum	Output of current error number. For error numbers that can be output by this block, see Limit error handling (Page 1925)	INT	-1
Out	Analog output value	STRUCT <ul style="list-style-type: none"> • Value: REAL • ST: BYTE 	- <ul style="list-style-type: none"> • 0.0 • 16#80
OutHiAct	1 = High limit overshoot	STRUCT <ul style="list-style-type: none"> • Value: BOOL • ST: BYTE 	- <ul style="list-style-type: none"> • 0 • 16#80
OutLoAct	1 = Low limit undershoot	STRUCT <ul style="list-style-type: none"> • Value: BOOL • ST: BYTE 	- <ul style="list-style-type: none"> • 0 • 16#80

See also

Limit block diagram (Page 1927)

Limit messaging (Page 1926)

Limit modes (Page 1924)

Description of Limit (Page 1922)

13.2.7 Limit block diagram**Limit block diagram**

A block diagram is not provided for this block.

See also

Limit I/Os (Page 1926)

Limit messaging (Page 1926)

Limit error handling (Page 1925)

Limit functions (Page 1924)

Limit modes (Page 1924)

Description of Limit (Page 1922)

13.3 MuxAn03 - Selection of an analog value to increase availability / safety

13.3.1 Description of MuxAn03

Object name (type + number) and family

Type + number: FB 1860

Family: LogicAn

Area of application for MuxAn03

The block is used for the following applications:

- Selection of an analog value to increase availability or safety in the input of analog values

How it works

The block uses up to three process values `PV1 ... PV3` to determine an output value and outputs this with the corresponding signal status at the `PV` output parameter.

Configuration

Use the CFC editor to install the block in any OB.

Startup characteristics

The block does not have any special startup characteristics.

Status word allocation for `Status1` parameter

This block does not have the `Status` parameter.

See also

MuxAn03 block diagram (Page 1935)

MuxAn03 I/Os (Page 1933)

MuxAn03 messaging (Page 1933)

MuxAn03 error handling (Page 1932)

MuxAn03 functions (Page 1929)

MuxAn03 modes (Page 1929)

13.3.2 MuxAn03 modes

MuxAn03 operating modes

This block does not have any modes.

See also

MuxAn03 block diagram (Page 1935)

MuxAn03 I/Os (Page 1933)

MuxAn03 messaging (Page 1933)

MuxAn03 error handling (Page 1932)

MuxAn03 functions (Page 1929)

Description of MuxAn03 (Page 1928)

13.3.3 MuxAn03 functions

Functions of MuxAn03

The functions for this block are listed below.

Selection of output signal

Use the `SelValue` input parameter to select whether the output value is to offer higher availability or higher safety.

Increasing availability

- **Selection 1 of 2** (`SelValue = 0`): The block determines the input parameter with the higher priority from the two input parameters `PV1` and `PV2` based on their signal status. The value determined is written to the `PV` output parameter.

If both input parameters have the same signal status, the `PV1` input parameter is written to the `PV` output parameter.

Display of process parameters with bad signal status

If the signal status of `PV1` is bad (16#00, 16#28), the `PV1Bad` output is set.

If the signal status of `PV2` is bad (16#00, 16#28), the `PV2Bad` output is set.

Regardless of `PV3`, the `PV3Bad` output is always set to 0.

Mean, median, maximum and minimum

They are determined from `PV1` and `PV2`:

 - $PV_Mean = (PV1 + PV2) / 2$
 - $PV_Median = PV1$
 - $PV_Max = \text{Max}(PV1, PV2)$
 - $PV_Min = \text{Min}(PV1, PV2)$

The status is formed by `PV1.ST` and `PV2.ST`. If the status is the same, it is output at `PV_Mean.ST`, `PV_Median.ST`, `PV_Max.ST` and `PV_Min.ST`. If the statuses are different, the status with the lower priority is output.
- **Selection 1 of 3** (`SelValue = 1`): The block determines the input parameter with the highest priority from the three input parameters `PV1`, `PV2` and `PV3` based on their signal status. The value determined is written to the `PV` output parameter.

If two or more of the input parameters have the same signal status, the one with the lowest index is written to the `PV` output parameter.

Display of process parameters with bad signal status

If the signal status of `PV1` is bad (16#00, 16#28), the `PV1Bad` output is set.

If the signal status of `PV2` is bad (16#00, 16#28), the `PV2Bad` output is set.

If the signal status of `PV3` is bad (16#00, 16#28), the `PV3Bad` output is set

Mean, median, maximum and minimum

They are determined from `PV1`, `PV2` and `PV3`:

 - $PV_Mean = (PV1 + PV2 + PV3) / 3$
 - $PV_Median = \text{mean PV value of PV1, PV2 and PV3. If 2 of the 3 PV values are the same, the value of the same PVs is output as the mean PV value}$

Examples:

 - `PV1 =1, PV2 =2, PV3 =3: thus PV_Median =2.`
 - `PV1 =1, PV2 =1, PV3 =3: thus PV_Median =1.`
 - $PV_Max = \text{Max}(PV1, PV2, PV3)$
 - $PV_Min = \text{Min}(PV1, PV2, PV3)$

The status is formed by `PV1.ST`, `PV2.ST` and `PV3.ST`. If the status is the same, it is output at `PV_Mean.ST`, `PV_Max.ST` and `PV_Min.ST`. If the statuses are different, the status with the second highest priority is output.

Increasing safety

- **Selection 2 of 2** ($SelValue = 2$): The block determines whether the two input parameters PV1 and PV2 have the same signal status and whether they deviate from one another by no more than the setting at input parameter P1Diff. Only then does the PV output parameter also have this signal status. The analog value of PV is set to a value of PV1. If PV1 and PV2 deviate from one another by more than P1Diff, the PV signal status is set to "Bad, device-related". The analog value of PV is set to a value of PV1. If PV1 and PV2 do not deviate from one another by more than P1Diff, but have a different signal state, the PV output parameter is generated from the lower priority signal status of the two input parameters and the associated analog value.

Display of non-plausible or bad process parameters

If the process value PV1 is non-plausible or bad (16#00, 16#28), the PV1Bad output is set. If the process value PV2 is non-plausible or bad (16#00, 16#28), the PV2Bad output is set. Regardless of PV3, the PV3Bad output is always set to 0

Mean, median, maximum and minimum

They are determined from PV1 and PV2. If PV1 and PV2 deviate from one another by more than P1Diff, the signal status of PV_Mean, PV_Median, PV_Max and PV_Min is set to "Bad, device-related" (16#00) and the process values of PV_Mean, PV_Median, PV_Max and PV_Min are frozen. If the absolute deviation is less than or equal to P1Diff, the mean value, maximum and minimum are calculated as follows:

- $PV_Mean = (PV1 + PV2) / 2$
- $PV_Median = PV1$
- $PV_Max = Max(PV1, PV2)$
- $PV_Min = Min(PV1, PV2)$

The status is formed by PV1.ST and PV2.ST. If the status is the same, it is output at PV_Mean.ST, PV_Max.ST and PV_Min.ST. If the statuses are different, the status with the lower priority is output.

- **Selection 2 of 3** ($SelValue = 3$): The block determines whether two of the three input parameters PV1, PV2 and PV3 have the same high priority signal status and whether they deviate from one another by no more than the setting at input parameter P1Diff. Only if this is the case, does the PV output parameter also have this signal status. The analog value of PV is set to the value of the input parameter with the lowest index (PV1 or PV2) of the values determined.

If all input parameters PV1, PV2 and PV3 deviate from one another by more than P1Diff, the signal status of PV is set to "Bad, device-related". The analog value of PV is set to the value of the PV1 input parameter.

If at least two input parameters do not deviate from one another by more than P1Diff, but have a different signal state, the value from these input parameters with the signal status of the second highest priority is written to the PV output parameter.

Display of non-plausible or bad process parameters

If the process value PV1 is non-plausible or bad (16#00, 16#28), the PV1Bad output is set. If the process value PV2 is non-plausible or bad (16#00, 16#28), the PV2Bad output is set. If the process value PV3 is non-plausible or bad (16#00, 16#28), the PV3Bad output is set.

Mean value, maximum and minimum

They are determined from PV1, PV2 and PV3. An internal mean value is calculated first from PV1, PV2 and PV3.

This mean value is used to determine the deviations for each PV value. If all absolute deviations are less than or equal to P1Diff, the mean, median, maximum and minimum

are formed from PV1, PV2 and PV3 and the status with the second highest priority is output (see section Increasing availability, selection 1 to 3).

If at least one of the deviations is outside of PlDiff, the PV with the greatest deviation is excluded from further calculation.

If the two remaining process values (PVx1, PVx2) deviate from one another by more than PlDiff, the signal status of PV_Mean, PV_Median, PV_Max and PV_Min is set to "Bad, device-related" (16#00) and the process values of PV_Mean, PV_Median, PV_Max and PV_Min are frozen. If the absolute deviation is less than or equal to PlDiff, the mean value, maximum and minimum are calculated as follows:

- $PV_Mean = (PVx1 + PVx2) / 2$
- $PV_Median = PVx1$
- $PV_Max = Max(PVx1, PVx2)$
- $PV_Min = Min(PVx1, PVx2)$

The status is formed by PVx1.ST and PVx2.ST. If the status is the same, it is output at PV_Mean.ST, PV_Median, PV_Max.ST and PV_Min.ST. If the statuses are different, the status with the lower priority is output.

Forming the signal status for blocks

This block provides the standard function Forming and outputting the signal status for blocks with configurable status prioritization (Page 114).

See also

- MuxAn03 block diagram (Page 1935)
- MuxAn03 I/Os (Page 1933)
- MuxAn03 messaging (Page 1933)
- MuxAn03 error handling (Page 1932)
- MuxAn03 modes (Page 1929)
- Description of MuxAn03 (Page 1928)

13.3.4 MuxAn03 error handling

MuxAn03 error handling

Parameter assignment errors are handled as follows:

- If the input parameter is SelValue < 0, the parameter is automatically set to SelValue = 0.
- If the input parameter is SelValue > 3, the parameter is automatically set to SelValue = 3.
- If the input parameter is SelPrio < 0, the parameter is automatically set to SelPrio = 0.
- If the input parameter is SelPrio > 7, the parameter is automatically set to SelPrio = 7.

An error number is not output in any of these cases.

See also

MuxAn03 block diagram (Page 1935)
 MuxAn03 I/Os (Page 1933)
 MuxAn03 messaging (Page 1933)
 MuxAn03 functions (Page 1929)
 MuxAn03 modes (Page 1929)
 Description of MuxAn03 (Page 1928)

13.3.5 MuxAn03 messaging**Messaging**

This block does not offer messaging.

See also

MuxAn03 block diagram (Page 1935)
 MuxAn03 I/Os (Page 1933)
 MuxAn03 error handling (Page 1932)
 MuxAn03 functions (Page 1929)
 MuxAn03 modes (Page 1929)
 Description of MuxAn03 (Page 1928)

13.3.6 MuxAn03 I/Os

MuxAn03 I/Os

Input parameters

Parameter	Description	Type	Default
EN	1 = Called block will be processed	BOOL	1
PV1	Process value 1	STRUCT <ul style="list-style-type: none"> • Value: REAL • ST: BYTE 	- <ul style="list-style-type: none"> • 0.0 • 16#80
PV2	Process value 2	STRUCT <ul style="list-style-type: none"> • Value: REAL • ST: BYTE 	- <ul style="list-style-type: none"> • 0.0 • 16#80

13.3 MuxAn03 - Selection of an analog value to increase availability / safety

Parameter	Description	Type	Default
PV3	Process value 3	STRUCT <ul style="list-style-type: none"> • Value: REAL • ST: BYTE 	- <ul style="list-style-type: none"> • 0.0 • 16#80
PIDiff	Plausibility check value	REAL	0.0
SelPrio*	Setting of the prioritization for forming the best signal status	INT	6
SelValue*	Selection criterion for the search	INT	0

* Values can be written back to these inputs during processing of the block by the block algorithm.

Output parameters

Parameter	Description	Type	Default
ENO	1 = Block algorithm completed without errors	BOOL	0
PV	Process value determined	STRUCT <ul style="list-style-type: none"> • Value: REAL • ST: BYTE 	- <ul style="list-style-type: none"> • 0.0 • 16#80
PV_Max	Process value maximum	STRUCT <ul style="list-style-type: none"> • Value: REAL • ST: BYTE 	- <ul style="list-style-type: none"> • 0.0 • 16#80
PV_Mean	Process value mean	STRUCT <ul style="list-style-type: none"> • Value: REAL • ST: BYTE 	- <ul style="list-style-type: none"> • 0.0 • 16#80
PV_Median	Process value median	STRUCT <ul style="list-style-type: none"> • Value: REAL • ST: BYTE 	- <ul style="list-style-type: none"> • 0.0 • 16#80
PV_Min	Process value minimum	STRUCT <ul style="list-style-type: none"> • Value: REAL • ST: BYTE 	- <ul style="list-style-type: none"> • 0.0 • 16#80
PV1Bad	Process value PV1 is not plausible or bad (16#00 or 16#28)	BOOL	0
PV2Bad	Process value PV2 is not plausible or bad (16#00 or 16#28)	BOOL	0
PV3Bad	Process value PV3 is not plausible or bad (16#00 or 16#28)	BOOL	0

See also

- MuxAn03 block diagram (Page 1935)
- MuxAn03 messaging (Page 1933)
- MuxAn03 error handling (Page 1932)
- MuxAn03 functions (Page 1929)

MuxAn03 modes (Page 1929)

Description of MuxAn03 (Page 1928)

13.3.7 MuxAn03 block diagram

MuxAn03 block diagram

A block diagram is not provided for this block.

See also

MuxAn03 I/Os (Page 1933)

MuxAn03 messaging (Page 1933)

MuxAn03 error handling (Page 1932)

MuxAn03 functions (Page 1929)

MuxAn03 modes (Page 1929)

Description of MuxAn03 (Page 1928)

13.4 MuxAn08 - Selection of an analog value to increase availability / safety

13.4.1 Description of MuxAn08

Object name (type + number) and family

Type + number: FB 1831

Family: LogicAn

Area of application of MuxAn08

The block is used for the following applications

- Selection of an analog value to increase availability or safety in the input of analog values

How it works

The block uses up to eight `PV1` . . . `PV8` process values to determine an output value and outputs this with the corresponding signal status at the PV output parameter.

Configuration

Use the CFC editor to install the block in any OB.

Startup characteristics

The block does not have any special startup characteristics.

Status word allocation for `Status1` parameter

This block does not have the `Status` parameter.

13.4.2 MuxAn08 modes

MuxAn08 operating modes

This block does not have any operating modes.

13.4.3 MuxAn08 functions

Functions of MuxAn08

The functions for this block are listed below.

Selection of output signal

Use the `SelValue` input parameter to select whether the output value is to offer higher availability or higher safety.

Increasing availability

- **Selection 1 of 2, 1 of 3, ... 1 of 8** (`SelValue = 0..6`):
The input parameter `SelValue` defines the relevant input parameters of the process values to be considered for the determination of PV.

SelValue	Relevant input parameter	Irrelevant input parameter
0	PV1..PV2	PV3..PV8
1	PV1..PV3	PV4..PV8
2	PV1..PV4	PV5..PV8
3	PV1..PV5	PV6..PV8
4	PV1..PV6	PV7..PV8
5	PV1..PV7	PV8
6	PV1..PV8	-

The block determines the highest priority of the two input parameters from the relevant input parameters based on their signal status on and writes it to the output parameter PV. If several input parameters have the same level of signal status priority, the one with the lowest index is written to the output parameter.

Display of process parameters with "bad" signal status

When the relevant input parameters (PV1, PV2, ..., PV8) have a "bad" signal status (16#00 or 16#28), the corresponding output parameters (PV1Bad, PV2Bad..PV8Bad) are set. The output parameters of the irrelevant input parameters are always reset.

Mean value, maximum and minimum

- $PV_Mean = (PV1 + PV2 + \dots + PVn) / n$
- $PV_Max = \text{Max}(PV1, PV2 \dots PVn)$
- $PV_Min = \text{Min}(PV1, PV2 \dots PVn)$
n depends on SelValue

The status is formed from the PV1 . . PVn input parameters. If the status is the same, it is output at the `PV_Mean`, `PV_Max` and `PV_Min` output parameters. If the states are different, the status with the second highest priority is output at the `PV_Mean`, `PV_Max` and `PV_Min` output parameters.

Increasing safety

- **Selection 2 of 2..8** (SelValue = 7..13):
The input parameter SelValue defines the relevant input parameters of the process values to be considered for the determination of PV.

SelValue	Relevant input parameter	Irrelevant input parameter
7	PV1..PV2	PV3..PV8
8	PV1..PV3	PV4..PV8
9	PV1..PV4	PV5..PV8
10	PV1..PV5	PV6..PV8
11	PV1..PV6	PV7..PV8
12	PV1..PV7	PV8
13	PV1..PV8	-

The block determines whether two of the relevant input parameters have the same level of signal status priority and whether they deviate from one another by no more than the setting at input parameter PlDiff. Only then does the PV output parameter also have this signal status. The analog value of PV is set to the value of the input parameter with the lowest index of the values determined.

If all input parameters deviate from one another by more than PlDiff, the signal status of PV is set to "Bad, device-related". The analog value of PV is set to the value of the PV1 input parameter.

If the least two input parameters do not deviate from one another by more than PlDiff, but have a different signal state, the value with the signal status of the second highest priority from these input parameters is written to the PV output parameter.

Display of process parameters with "bad" signal status

When the relevant input parameters (PV1, PV2, .., PV8) are not plausible or have a "bad" signal status (16#00 or 16#28), the corresponding output parameters (PV1Bad, PV2Bad..PV8Bad) are set. The corresponding output parameters of the irrelevant input parameters are always reset.

Mean value, maximum and minimum

The PV values are plausible if the absolute values of the deviation are less than or equal to the PlDiff.

If the absolute deviation is less than or equal to PlDiff, the mean value, maximum and minimum are calculated as follows:

1. Determination of the mean from PV1.. PVn
n depends on SelValue
2. Determination of the deviations ABS(PVi - Mean value)
3. If all PV are plausible, then the mean, maximum and minimum are determined, as described in section "Increasing availability SelValue = 0..6".

4. If one or more PV are not plausible, repeat the calculation of the mean starting with 1. without PV input with the highest deviation. If there is more than one PV input with equally high deviation, only the first PV input is not used for further calculation.
5. If only 2 PV inputs remain and they are plausible, then the mean, maximum and minimum are determined, as described in section "Increasing availability SelValue = 0". When they are not plausible, the mean value, maximum and minimum are determined as follows:

```
PV_Max.Value: Keep old value
PV_Min.Value: Keep old value
PV_Mean.Value: Keep old value
PV_Max.ST = 16#00;
PV_Min.ST = 16#00;
PV_Mean.ST = 16#00;
```

Forming the signal status for blocks

This block provides the standard function Forming and outputting the signal status for blocks with configurable status prioritization (Page 114).

13.4.4 MuxAn08 error handling

Error handling of MuxAn08

Parameter assignment errors are handled as follows:

- If the input parameter is SelValue < 0, the parameter is automatically set to SelValue = 0.
- If the input parameter is SelValue > 13, the parameter is automatically set to SelValue = 13.
- If the input parameter is SelPrio < 0, the parameter is automatically set to SelPrio = 0.
- If the input parameter is SelPrio > 7, the parameter is automatically set to SelPrio = 7.

An error number is not output in any of these cases.

13.4.5 MuxAn08 messaging

Messaging

This block does not offer messaging.

13.4.6 MuxAn08 I/Os

I/Os of MuxAn08

Input parameters

Parameter	Description	Type	Default
EN	1 = Called block will be processed	BOOL	1
PV1	Process value 1	STRUCT <ul style="list-style-type: none"> • Value: REAL • ST: BYTE 	- <ul style="list-style-type: none"> • 0.0 • 16#80
PV2	Process value 2	STRUCT <ul style="list-style-type: none"> • Value: REAL • ST: BYTE 	- <ul style="list-style-type: none"> • 0.0 • 16#80
PV3	Process value 3	STRUCT <ul style="list-style-type: none"> • Value: REAL • ST: BYTE 	- <ul style="list-style-type: none"> • 0.0 • 16#80
PV4	Process value 4	STRUCT <ul style="list-style-type: none"> • Value: REAL • ST: BYTE 	- <ul style="list-style-type: none"> • 0.0 • 16#80
PV5	Process value 5	STRUCT <ul style="list-style-type: none"> • Value: REAL • ST: BYTE 	- <ul style="list-style-type: none"> • 0.0 • 16#80
PV6	Process value 6	STRUCT <ul style="list-style-type: none"> • Value: REAL • ST: BYTE 	- <ul style="list-style-type: none"> • 0.0 • 16#80
PV7	Process value 7	STRUCT <ul style="list-style-type: none"> • Value: REAL • ST: BYTE 	- <ul style="list-style-type: none"> • 0.0 • 16#80
PV8	Process value 8	STRUCT <ul style="list-style-type: none"> • Value: REAL • ST: BYTE 	- <ul style="list-style-type: none"> • 0.0 • 16#80
PlDiff	Plausibility check value	REAL	0.0
SelPrio*	Setting of the prioritization for forming the best signal status	INT	6
SelValue*	Selection criterion for the search	INT	0

* Values can be written back to these inputs during processing of the block by the block algorithm.

Output parameters

Parameter	Description	Type	Default
ENO	1 = Block algorithm completed without errors	BOOL	0
PV	Process value determined	STRUCT <ul style="list-style-type: none"> • Value: REAL • ST: BYTE 	- <ul style="list-style-type: none"> • 0.0 • 16#80

13.4 MuxAn08 - Selection of an analog value to increase availability / safety

Parameter	Description	Type	Default
PV_Mean	Process value mean	STRUCT • Value: REAL • ST: BYTE	- • 0.0 • 16#80
PV_Max	Process value maximum	STRUCT • Value: REAL • ST: BYTE	- • 0.0 • 16#80
PV_Min	Process value minimum	STRUCT • Value: REAL • ST: BYTE	- • 0.0 • 16#80
PV1Bad	Process value PV1 is not plausible or bad (16#00 or 16#28)	BOOL	0
PV2Bad	Process value PV2 is not plausible or bad (16#00 or 16#28)	BOOL	0
PV3Bad	Process value PV3 is not plausible or bad (16#00 or 16#28)	BOOL	0
PV4Bad	Process value PV4 is not plausible or bad (16#00 or 16#28)	BOOL	0
PV5Bad	Process value PV5 is not plausible or bad (16#00 or 16#28)	BOOL	0
PV6Bad	Process value PV6 is not plausible or bad (16#00 or 16#28)	BOOL	0
PV7Bad	Process value PV is not plausible or bad (16#00 or 16#28)	BOOL	0
PV8Bad	Process value PV8 is not plausible or bad (16#00 or 16#28)	BOOL	0

13.4.7 MuxAn08 block diagram

MuxAn08 block diagram

A block diagram is not provided for this block.

13.5 RateLim - Signal ramp

13.5.1 Description of RateLim

Object name (type + number) and family

Type + number: FB 1882

Family: LogicAn

Area of application for RateLim

The block is used for the following applications:

- Limitation of the slope of an analog signal
- Ramped approach to a target value

How it works

Slope limit: Starting from the current output value, the new output value is calculated in such a way that it does not exceed a specified positive or negative slope.

Ramp function: The current output value can be ramped up to a target value. The ramp slope can be configured by a time period or by a positive or negative ramp slope.

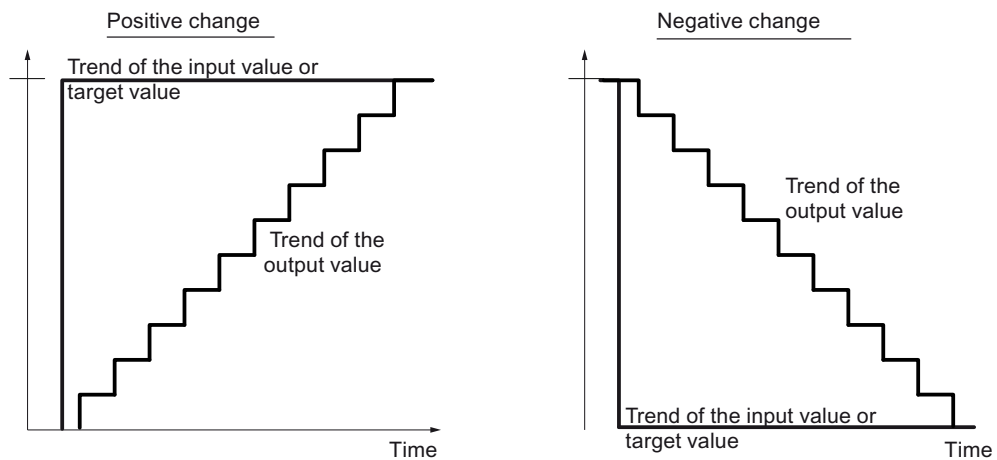

The input value is forwarded directly when the gradient and ramp function are switched off ($RmpOn.Value = 0, RateOn.Value = 0$): $Out.Value = In.Value$.

Configuration

Use the CFC editor to install the block in a cyclic interrupt OB (OB3x). The block is then installed automatically in startup OB (OB100).

Further addressing is not required.

Startup characteristics

Use the `Feature Bit Set` startup characteristics (Page 138) to define the startup characteristics of this block.

Status word allocation for `Status` parameter

This block does not have the `Status` parameter.

See also

- RateLim functions (Page 1943)
- RateLim messaging (Page 1946)
- RateLim I/Os (Page 1947)
- RateLim block diagram (Page 1949)
- RateLim error handling (Page 1946)
- RateLim modes (Page 1943)

13.5.2 RateLim modes

RateLim operating modes

This block does not have any modes.

See also

- RateLim block diagram (Page 1949)
- RateLim I/Os (Page 1947)
- RateLim messaging (Page 1946)
- RateLim error handling (Page 1946)
- RateLim functions (Page 1943)
- Description of RateLim (Page 1942)

13.5.3 RateLim functions

Functions of RateLim

The functions for this block are listed below.

Limitation of the slope of the analog signal `In.Value`

The block calculates the gradient of the input signal over time and compares it with the `UpRaLim` (positive change) `DnRaLim` (negative change) limits. See the table below.

- If the slope exceeds the amount of the respective limit (`UpRaLim` or `DnRaLim`), the output `Out` is corrected only by the valid limit and the corresponding limit display `UpRaAct = 1` or `DnRaAct = 1` is set.
- If the gradient is within the valid range, the input value is transferred (`In = Out`) and `UpRaAct = 1` or `DnRaAct = 1` are reset.
- If the corresponding limit is 0 (`UpRaLim` with positive gradient or `DnRaLim` with negative gradient), then the input value `In` is written directly to the output `Out`.

RateOn	$\Delta In / \Delta t$	Meaning	Output <code>Out</code>	UpRaAct	DnRaAct
1	$< DnRaLim $	Input value dropping too fast	$Out - (DnRaLim \cdot SampleTime) \cdot Time\ factor$	0	1
1	$ DnRaLim $ to $UpRaLim$	Change speed <code>In</code> is permitted	<code>In</code>	0	0
1	$> UpRaLim $	Input value <code>In</code> rising too fast	$Out + (UpRaLim \cdot SampleTime) \cdot Time\ factor$	1	0
0	-	RateOn is deactivated	<code>In</code>	0	0

In this case, the time factor is formed from the `TimeFactor` parameter.

TimeFactor	Time factor
0	1
1	1/60
2	1/(60*60)

Ramp function

Starting from the current output value `Out.Value`, the output value can be ramped to the target value `RmpTarget` when the ramp function is switched on or the target value is changed.

You can use the `RmpModTime` input parameter to specify whether the ramp is defined by time or gradients.

- If you select time (`RmpModTime = 1`): The gradient of the ramp is calculated automatically by the block so that after the start (`RmpOn.Value = 0 -> 1`) or a change of the target value (`RmpTarget.Value`), the target value is reached after the configured time (`RmpTime`). The unit of the ramp time (`RmpTime`) depends on `TimeFactor`.
- If you select gradients (`RmpModTime = 0`): The ramp slope corresponds to the configured rates of change `UpRaLim` (positive) or `DnRaLim` (negative).

When the output value has reached the target, the output value remains at the target value as long as the ramp function remains enabled.

Switching the ramp function and slope limiting function on or off

The ramp function is switched off with the `RmpOn = 0` input; the slope limiting function is switched off with the `RateOn = 0` input. If both are switched off, the `In` input value is written directly to the `Out` output. Limits are no longer monitored. If both functions are switched on, the ramp function has priority.

Stopping the calculation of the ramp output value

Set `Hold = 1` to interrupt the calculation of the ramp output value. The output value `Out` is held and the output parameters `UpRaAct` and `DnRaAct` are set to 0. The status of `Out`, `UpRaAct`, and `DnRaAct` are realized.

Set `Hold = 0` to continue the calculation of the ramp output value. The calculation is continued with the last output value.

Time base of the gradient limits

The gradient limits are set at the `UpRaLim` and `DnRaLim` parameters depending on the `TimeFactor`.

`TimeFactor = 0`: Unit of the gradient limiting is Unit/Second

`TimeFactor = 1`: Unit of the gradient limiting is Unit/Minute

`TimeFactor = 2`: Unit of the gradient limiting is Unit/Hour

Forming the signal status for blocks

The signal status of `Out` is formed from:

`RmpOn = 1`: `Out.ST := RmpTarget.ST`

Otherwise: `Out.ST := In.ST`

Configurable reactions using the `Feature` parameter

You can find an overview of all reactions provided by the `Feature` parameter in the Configurable functions using the `Feature` I/O (Page 131) .

The following functionality is available for this block at the relevant bits:

Bit	Function
0	Set startup characteristics (Page 138)
8	Unit for the rate of change (Page 147)

See also

Description of RateLim (Page 1942)

RateLim messaging (Page 1946)

RateLim I/Os (Page 1947)

RateLim block diagram (Page 1949)

RateLim modes (Page 1943)

RateLim error handling (Page 1946)

13.5.4 RateLim error handling

Error handling of RateLim

Refer to the section Error handling (Page 119) in the basic instructions for the error handling of all blocks.

The following errors can be displayed for this block:

- Error numbers

Overview of error numbers

The `ErrorNum` I/O can be used to output the following error numbers:

Error number	Meaning of the error number
-1	Predefined value when inserting the block; the block is not processed.
0	There is no error.
30	The value of <code>In</code> can no longer be displayed in the REAL number field.
43	Incorrect time unit set at <code>TimeFactor</code> .

See also

RateLim block diagram (Page 1949)

RateLim I/Os (Page 1947)

RateLim messaging (Page 1946)

RateLim modes (Page 1943)

Description of RateLim (Page 1942)

RateLim functions (Page 1943)

13.5.5 RateLim messaging

Messaging

This block does not offer messaging.

See also

Description of RateLim (Page 1942)
RateLim functions (Page 1943)
RateLim I/Os (Page 1947)
RateLim block diagram (Page 1949)
RateLim error handling (Page 1946)
RateLim modes (Page 1943)

13.5.6 RateLim I/Os

I/Os of RateLim

Input parameters

Parameter	Description	Type	Default
DnRaLim	Maximum negative change in the output value in units/s or %/s	REAL	3.0
EN	1 = Called block will be processed	BOOL	1
Feature	I/O for additional functions (Page 1943)	STRUCT <ul style="list-style-type: none"> • Bit 0: BOOL • ... • Bit 31: BOOL 	- <ul style="list-style-type: none"> • 0 • 0 • 0
Hold	Hold calculation	STRUCT <ul style="list-style-type: none"> • Value: BOOL • ST:BYTE 	- <ul style="list-style-type: none"> • 0 • 16#80
In*	Analog input value	STRUCT <ul style="list-style-type: none"> • Value: REAL • ST:BYTE 	- <ul style="list-style-type: none"> • 0.0 • 16#80
InScale	Scaling of the measuring range as a structure	STRUCT <ul style="list-style-type: none"> • High: REAL • Low: REAL 	- <ul style="list-style-type: none"> • 100.0 • 0.0
RateOn	1 = Switch on gradient function	STRUCT <ul style="list-style-type: none"> • Value: BOOL • ST:BYTE 	- <ul style="list-style-type: none"> • 0 • 16#80
RmpModTime	1 = Use time (RmpTime) for the ramp function 0 = Use gradients (UpRaLim, DnRaLim) for the ramp function	BOOL	0
RmpOn	1 = Switch on ramp function for target value RmpTarget	STRUCT <ul style="list-style-type: none"> • Value: BOOL • ST:BYTE 	- <ul style="list-style-type: none"> • 0 • 16#80

13.5 RateLim - Signal ramp

Parameter	Description	Type	Default
RmpTarget	Target value for the ramp function	STRUCT <ul style="list-style-type: none"> Value: REAL ST:BYTE 	- <ul style="list-style-type: none"> 0 16#80
RmpTime*	Duration [unit depends on TimeFactor] for ramp function from the current Out to RmpTarget	REAL	0.0
SampleTime	Sampling time [s] (assigned automatically)	REAL	0.1
TimeFactor	Time unit: 0 = Seconds 1 = Minutes 2 = Hours	INT	0
UpRaLim	Maximum positive change in the output value in units/s or %/s	REAL	3.0

* Values can be written back to these inputs during processing of the block by the block algorithm.

Output parameters

Parameter	Description	Type	Default
DnRaAct	1 = Negative change in the output value	STRUCT <ul style="list-style-type: none"> Value: BOOL ST:BYTE 	- <ul style="list-style-type: none"> 0 16#80
ENO	1 = Block algorithm completed without errors	BOOL	0
ErrorNum	Output of pending error number. For error numbers that can be output by this block, see RateLim error handling (Page 1946)	INT	-1
Out	Output value	STRUCT <ul style="list-style-type: none"> Value: REAL ST:BYTE 	- <ul style="list-style-type: none"> 0.0 16#80
UpRaAct	1 = Positive change in the output value	STRUCT <ul style="list-style-type: none"> Value: BOOL ST:BYTE 	- <ul style="list-style-type: none"> 0 16#80

See also

- Description of RateLim (Page 1942)
- RateLim messaging (Page 1946)
- RateLim block diagram (Page 1949)
- RateLim modes (Page 1943)

13.5.7 RateLim block diagram

RateLim block diagram

A block diagram is not provided for this block.

See also

- RateLim I/Os (Page 1947)
- RateLim messaging (Page 1946)
- RateLim error handling (Page 1946)
- RateLim functions (Page 1943)
- RateLim modes (Page 1943)
- Description of RateLim (Page 1942)

13.6 RedAn02 - 1 out of 2 selection for redundant analog values

13.6.1 Description of RedAn02

Object name (type + number) and family

Type + number: FC 385

Family: LogicAn

Area of application for RedAn02

The block is used for the following applications:

- 1 out of 2 selection for redundant analog values

How it works

The block selects from two input values the one with the best signal status and outputs it at the output `Out`. In addition, the outputs `SimAct`, `Uncertain` and `LossRed` are set according to the signal status.

Configuration

Use the CFC editor to install the block in a cyclic interrupt OB (OB30 to OB38).

Startup characteristics

The block does not have any startup characteristics.

Status word allocation for `Status` parameter

This block does not have the `Status` parameter.

See also

RedAn02 modes (Page 1951)

RedAn02 functions (Page 1951)

RedAn02 error handling (Page 1952)

RedAn02 messaging (Page 1952)

RedAn02 I/Os (Page 1953)

RedAn02 block diagram (Page 1954)

13.6.2 RedAn02 modes

RedAn02 operating modes

This block does not have any modes.

See also

Description of RedAn02 (Page 1950)

RedAn02 functions (Page 1951)

RedAn02 error handling (Page 1952)

RedAn02 messaging (Page 1952)

RedAn02 I/Os (Page 1953)

RedAn02 block diagram (Page 1954)

13.6.3 RedAn02 functions

Functions of RedAn02

The functions for this block are listed below.

Forming the signal status for blocks

This block provides the standard function Forming and outputting the signal status of redundancy blocks (Page 112).

See also

Description of RedAn02 (Page 1950)

RedAn02 modes (Page 1951)

RedAn02 error handling (Page 1952)

RedAn02 messaging (Page 1952)

RedAn02 I/Os (Page 1953)

RedAn02 block diagram (Page 1954)

13.6.4 RedAn02 error handling

RedAn02 error handling

The block does not report any errors.

See also

Description of RedAn02 (Page 1950)

RedAn02 modes (Page 1951)

RedAn02 functions (Page 1951)

RedAn02 messaging (Page 1952)

RedAn02 I/Os (Page 1953)

RedAn02 block diagram (Page 1954)

13.6.5 RedAn02 messaging

Messaging

This block does not offer messaging.

See also

Description of RedAn02 (Page 1950)

RedAn02 modes (Page 1951)

RedAn02 functions (Page 1951)

RedAn02 error handling (Page 1952)

RedAn02 block diagram (Page 1954)

RedAn02 I/Os (Page 1953)

13.6.6 RedAn02 I/Os

RedAn02 I/Os

Input parameters

Parameter	Description	Type	Default
EN	1 = Called block will be processed	BOOL	1
In1	Analog input value 1	STRUCT <ul style="list-style-type: none"> Value: REAL ST:BYTE 	- <ul style="list-style-type: none"> 0.0 16#80
In2	Analog input value 2	STRUCT <ul style="list-style-type: none"> Value: REAL ST:BYTE 	- <ul style="list-style-type: none"> 0.0 16#80

Output parameters

Parameter	Description	Type	Default
ENO	1 = Block algorithm completed without errors	BOOL	0
LossRed	1= Redundancy loss at one of the inputs	STRUCT <ul style="list-style-type: none"> Value: BOOL ST:BYTE 	- <ul style="list-style-type: none"> 0 16#80
Out	Output of the process value with the better signal status	STRUCT <ul style="list-style-type: none"> Value: REAL ST:BYTE 	- <ul style="list-style-type: none"> 0.0 16#80
SimAct	1 = one input value has the Simulation status	STRUCT <ul style="list-style-type: none"> Value: BOOL ST:BYTE 	- <ul style="list-style-type: none"> 0 16#80
Uncertain	1 = one input value has the "uncertain" status	STRUCT <ul style="list-style-type: none"> Value: BOOL ST:BYTE 	- <ul style="list-style-type: none"> 0 16#80

See also

Description of RedAn02 (Page 1950)

RedAn02 modes (Page 1951)

RedAn02 functions (Page 1951)

RedAn02 error handling (Page 1952)

RedAn02 messaging (Page 1952)

RedAn02 block diagram (Page 1954)

13.6.7 RedAn02 block diagram

RedAn02 block diagram

A block diagram is not provided for this block.

See also

Description of RedAn02 (Page 1950)

RedAn02 modes (Page 1951)

RedAn02 functions (Page 1951)

RedAn02 messaging (Page 1952)

RedAn02 I/Os (Page 1953)

RedAn02 error handling (Page 1952)

13.7 SelA02In - Output of two analog values

13.7.1 Description of SelA02In

Object name (type + number)

Type + number: FB 1886

Family: LogicAn

Area of application for SelA02In

The block is used for the following applications:

- Selecting one of two analog values and switching it through to the output.

How it works

Depending on the setting of parameter `SelMode` the block selects one of the two input parameters `In1` or `In2` and writes its value to the output parameter `Out`.

This is displayed at the `In2Selected` output parameter.

Configuration

Use the CFC editor to install the block in any OB.

For the SelA02In block, the Advanced Process Library contains templates for process tag types as examples and there is an example project (APL_Example_xx, xx designates the language variant) with an application scenario for this block, which describes how the block works.

Examples of process tag types:

- Source chart for GainSched function block (gain scheduling) (Page 2347)
- Override control (Page 2348)
- Override control with PIDConR (OverrideR) (Page 2350)

Application scenario in the example project:

- Process simulation including noise generator (ProcSimC; ProcSimS) (Page 2373)

Startup characteristics

The block does not have any startup characteristics.

Status word allocation for `Status` parameter

This block does not have the `Status` parameter.

See also

- SelA02In block diagram (Page 1959)
- SelA02In I/Os (Page 1958)
- SelA02In messaging (Page 1958)
- SelA02In error handling (Page 1957)
- SelA02In functions (Page 1956)
- SelA02In modes (Page 1956)

13.7.2 SelA02In modes

SelA02In modes

This block does not have any modes.

See also

- SelA02In block diagram (Page 1959)
- SelA02In I/Os (Page 1958)
- SelA02In messaging (Page 1958)
- SelA02In error handling (Page 1957)
- SelA02In functions (Page 1956)
- Description of SelA02In (Page 1955)

13.7.3 SelA02In functions

Functions of SelA02In

The functions for this block are listed below.

Select input parameter

The SelMode parameter can affect the selection as follows:

- SelMode \leq 0: The selection depends on the parameter Sel_In2
 - Sel_In2 = 0: Input parameter In1 is written with its signal status to output parameter Out.
 - Sel_In2 = 1: Input parameter In2 is written with its signal status to output parameter Out.
- SelMode = 1: The input parameter with the lower value (In1 or In2) is written with its signal status to the output parameter Out.
- SelMode \geq 2: The input parameter with the higher value (In1 or In2) is written with its signal status to the output parameter Out.

The signal status of Sel_In2 is output at the In2Selected output parameter.

See also

SelA02In block diagram (Page 1959)

SelA02In I/Os (Page 1958)

SelA02In messaging (Page 1958)

SelA02In error handling (Page 1957)

SelA02In modes (Page 1956)

Description of SelA02In (Page 1955)

13.7.4 SelA02In error handling

SelA02In error handling

The block does not report any errors.

See also

SelA02In block diagram (Page 1959)

SelA02In I/Os (Page 1958)

SelA02In messaging (Page 1958)

SelA02In functions (Page 1956)

SelA02In modes (Page 1956)

Description of SelA02In (Page 1955)

13.7.5 SelA02In messaging

Messaging

This block does not offer messaging.

See also

SelA02In block diagram (Page 1959)

SelA02In I/Os (Page 1958)

SelA02In error handling (Page 1957)

SelA02In functions (Page 1956)

SelA02In modes (Page 1956)

Description of SelA02In (Page 1955)

13.7.6 SelA02In I/Os

SelA02In I/Os

Input parameters

Parameter	Description	Type	Default
EN	1 = Called block will be processed	BOOL	1
In1	Analog process value 1	STRUCT <ul style="list-style-type: none"> • Value: REAL • ST: BYTE 	- <ul style="list-style-type: none"> • 0.0 • 16#80
In2	Analog process value 2	STRUCT <ul style="list-style-type: none"> • Value: REAL • ST: BYTE 	- <ul style="list-style-type: none"> • 0.0 • 16#80
SelMode	Selection of the function: 0 = Select with Sel_In2 1 = Minimum 2 = Maximum	INT	0
Sel_In2	Selecting the input parameter: 0 = In1 1 = In2	STRUCT <ul style="list-style-type: none"> • Value: BOOL • ST: BYTE 	- <ul style="list-style-type: none"> • 0 • 16#80

Output parameters

Parameter	Description	Type	Default
ENO	1 = Block algorithm completed without errors	BOOL	0
In2Selected	Selected input parameter: 0 = In1 1 = In2	STRUCT <ul style="list-style-type: none"> • Value: BOOL • ST: BYTE 	- <ul style="list-style-type: none"> • 0 • 16#80
Out	Analog process value	STRUCT <ul style="list-style-type: none"> • Value: REAL • ST: BYTE 	- <ul style="list-style-type: none"> • 0.0 • 16#80

See also

[SelA02In block diagram \(Page 1959\)](#)
[SelA02In messaging \(Page 1958\)](#)
[SelA02In error handling \(Page 1957\)](#)
[SelA02In functions \(Page 1956\)](#)
[SelA02In modes \(Page 1956\)](#)
[Description of SelA02In \(Page 1955\)](#)

13.7.7 SelA02In block diagram**SelA02In block diagram**

A block diagram is not provided for this block.

See also

[SelA02In I/Os \(Page 1958\)](#)
[SelA02In messaging \(Page 1958\)](#)
[SelA02In error handling \(Page 1957\)](#)
[SelA02In functions \(Page 1956\)](#)
[SelA02In modes \(Page 1956\)](#)
[Description of SelA02In \(Page 1955\)](#)

13.8 SelA16In - Output of 16 analog values

13.8.1 Description of SelA16In

Object name (type + number) and family

Type + number: FB 1888

Family: LogicAn

Area of application for SelA16In

The block is used for the following applications:

- Selecting one of 16 analog values and switching it through to the output.

How it works

The block writes the value of one of the input parameters `In01` through `In16` to the output parameter `Out`. The selection is performed via the `SelInt` input parameter.

The signal status of the selected input parameter is written to the signal status of the output parameter `Out`. There is no additional signal status evaluation.

The unit `InxUnit` of the selected input parameter `Inx` ($x = 01 \dots 16$) is written to the output parameter `OutUnit`.

The analog input 1 (`In01`) is operable only if `OS_Perm.Bit22` is set to 1.

It has an upper limit associated with the parameter `In01HiLim` and a lower limit associated with the parameter `In01LoLim`.

If `Feature Bit 7` is set to 1 and the permission is enabled (`OS_Perm.Bit22 = 1`), the analog input 1 (`In01`) can be reserved for the operator. If `Feature Bit 7` is set to 1, the analog input 1 (`In01`) is always visible independent of `Feature Bit 5`.

Configuration

Use the CFC editor to install the block in any OB.

Startup characteristics

The block does not have any startup characteristics.

Status word allocation for `status1` parameter

You can find a description for each parameter in section SelA16In I/Os (Page 1966).

Status bit	Parameter
0	Occupied
1	BatchEn
2	Not used
3	OosAct.Value
4	OosLi.Value
5	Not used
6	OnAct.Value
7 - 11	Not used
12 - 27	Used to highlight the green line in the standard view
28	1 = With internal/external selection from the operator (Feature Bit 6)
29	1 = SelExtAct
30 - 31	Not used

Status word allocation for `status2` parameter

Status bit	Parameter
0	1 = Display input 1
...	...
15	1 = Display input 16
16 - 31	Not used

See also

SelA16In block diagram (Page 1970)

SelA16In messaging (Page 1965)

SelA16In error handling (Page 1965)

SelA16In functions (Page 1962)

SelA16In modes (Page 1961)

13.8.2 SelA16In modes

SelA16In operating modes

The block can be operated using the following modes:

- On (Page 71)
- Out of service (Page 71)

"On"

You can find general information about the "On" mode in the section On (Page 71).

"Out of service"

You can find general information about the "Out of service" mode in the section Out of service (Page 71).

See also

- SelA16In block diagram (Page 1970)
- SelA16In I/Os (Page 1966)
- SelA16In messaging (Page 1965)
- SelA16In error handling (Page 1965)
- SelA16In functions (Page 1962)
- Description of SelA16In (Page 1960)

13.8.3 SelA16In functions

Functions of SelA16In

The functions for this block are listed below.

Opening additional faceplates

This block provides the standard function Opening additional faceplates (Page 208).

Operator control permissions

This block provides the standard function Operator control permissions (Page 254).

The block has the following permissions for the `OS_Perm` parameter:

Bit	Function
0	Not used
1	1 =Operator can switch to "On" mode
2	Not used
3	1 =Operator can switch to "Out of service" mode

Bit	Function
4	1 = Operator can set the input 1
5	1 = Operator can set the input 2
6	1 = Operator can set the input 3
7	1 = Operator can set the input 4
8	1 = Operator can set the input 5
9	1 = Operator can set the input 6
10	1 = Operator can set the input 7
11	1 = Operator can set the input 8
12	1 = Operator can set the input 9
13	1 = Operator can set the input 10
14	1 = Operator can set the input 11
15	1 = Operator can set the input 12
16	1 = Operator can set the input 13
17	1 = Operator can set the input 14
18	1 = Operator can set the input 15
19	1 = Operator can set the input 16
20	1 = Operator can switch to external selection
21	1 = Operator can switch to internal selection
22	1 = Operator can change the value of input 1
23 - 31	Not used

Note

If you interconnect a parameter that is also listed in `OS_Perm` as a parameter, you have to reset the corresponding `OS_Perm` bit.

Forming the signal status for blocks

This block provides the standard function Forming and outputting the signal status of analog logic blocks (Page 112).

The worst signal status `ST_Worst` for the block is formed from the following parameters:

- `In1.ST`
- etc. to
- `In16.ST`

Selecting a unit of measure

This block provides the standard function Selecting a unit of measure (Page 212).

Configurable reactions using the Feature parameter

You can find an overview of all reactions provided by the Feature parameter in the Configurable functions using the Feature I/O (Page 131) section. The following functionality is available for this block at the relevant bits:

Bit	Function
1	Reaction to the out of service mode (Page 177)
2	Resetting the commands for changing the mode (Page 161)
4	Setting switch or button mode (Page 167)
5	Display only input values that are interconnected in the faceplate (Page 157)
6	External/internal selection specification (Page 180)
7	Analog input 1 is reserved for the operator (Page 183)
24	Enabling local operator authorization (Page 158)

Cascading of SelA16In

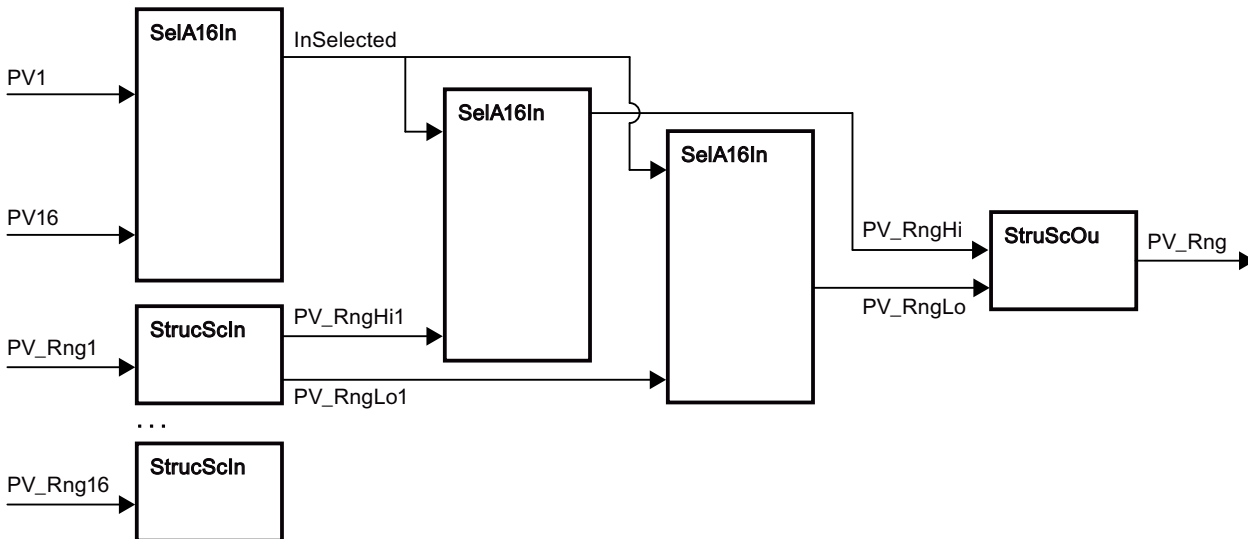

Figure 13-1 Process value area can be realized using conversion blocks and cascaded SelA16In blocks.

SIMATIC BATCH functionality

This block provides the standard function Auto-Hotspot (Page 67).

See also

- SelA16In block diagram (Page 1970)
- SelA16In I/Os (Page 1966)
- SelA16In messaging (Page 1965)
- SelA16In error handling (Page 1965)

SelA16In modes (Page 1961)

Description of SelA16In (Page 1960)

13.8.4 SelA16In error handling

Error handling of SelA16In

Refer to the section Error handling (Page 119) in the basic instructions for the error handling of all blocks.

The following errors can be displayed for this block:

- Error numbers

Overview of error numbers

The `ErrorNum` I/O can be used to output the following error numbers:

Error number	Meaning of the error number
-1	Predefined value when inserting the block; the block is not processed.
0	There is no error.
18	$1 > \text{SelExt} > 16$

See also

SelA16In block diagram (Page 1970)

SelA16In I/Os (Page 1966)

SelA16In messaging (Page 1965)

SelA16In functions (Page 1962)

SelA16In modes (Page 1961)

Description of SelA16In (Page 1960)

13.8.5 SelA16In messaging

Messaging

This block does not offer messaging.

See also

SelA16In block diagram (Page 1970)

SelA16In I/Os (Page 1966)

- SelA16In error handling (Page 1965)
- SelA16In functions (Page 1962)
- SelA16In modes (Page 1961)
- Description of SelA16In (Page 1960)

13.8.6 SelA16In I/Os

I/Os of SelA16In

Input parameters

Parameter	Description	Type	Default
BatchEn	1 = Enable allocation	BOOL	0
BatchID	Batch ID	DWORD	16#00000000
BatchName	Batch name	S7-String	
EN	1 = Called block will be processed	BOOL	1
Feature	I/O for additional functions (Page 1962)	STRUCT <ul style="list-style-type: none"> • Bit 0: BOOL • ... • Bit 31: BOOL 	- <ul style="list-style-type: none"> • 0 • 0 • 0
In01*	Analog input parameter 1	STRUCT <ul style="list-style-type: none"> • Value: REAL • ST: BYTE 	- <ul style="list-style-type: none"> • 0.0 • 16#FF
In01HiLim	High limit for the parameter In01	REAL	100.0
In01LoLim	Low limit for the parameter In01	REAL	0.0
In02	Analog input parameter 2	STRUCT <ul style="list-style-type: none"> • Value: REAL • ST: BYTE 	- <ul style="list-style-type: none"> • 0.0 • 16#FF
In03	Analog input parameter 3	STRUCT <ul style="list-style-type: none"> • Value: REAL • ST: BYTE 	- <ul style="list-style-type: none"> • 0.0 • 16#FF
In04	Analog input parameter 4	STRUCT <ul style="list-style-type: none"> • Value: REAL • ST: BYTE 	- <ul style="list-style-type: none"> • 0.0 • 16#FF
In05	Analog input parameter 5	STRUCT <ul style="list-style-type: none"> • Value: REAL • ST: BYTE 	- <ul style="list-style-type: none"> • 0.0 • 16#FF

Parameter	Description	Type	Default
In06	Analog input parameter 6	STRUCT • Value: REAL • ST: BYTE	- • 0.0 • 16#FF
In07	Analog input parameter 7	STRUCT • Value: REAL • ST: BYTE	- • 0.0 • 16#FF
In08	Analog input parameter 8	STRUCT • Value: REAL • ST: BYTE	- • 0.0 • 16#FF
In09	Analog input parameter 9	STRUCT • Value: REAL • ST: BYTE	- • 0.0 • 16#FF
In10	Analog input parameter 10	STRUCT • Value: REAL • ST: BYTE	- • 0.0 • 16#FF
In11	Analog input parameter 11	STRUCT • Value: REAL • ST: BYTE	- • 0.0 • 16#FF
In12	Analog input parameter 12	STRUCT • Value: REAL • ST: BYTE	- • 0.0 • 16#FF
In13	Analog input parameter 13	STRUCT • Value: REAL • ST: BYTE	- • 0.0 • 16#FF
In14	Analog input parameter 14	STRUCT • Value: REAL • ST: BYTE	- • 0.0 • 16#FF
In15	Analog input parameter 15	STRUCT • Value: REAL • ST: BYTE	- • 0.0 • 16#FF
In16	Analog input parameter 16	STRUCT • Value: REAL • ST: BYTE	- • 0.0 • 16#FF
In01Unit	Unit for parameter In01	INT	1001
In02Unit	Unit for parameter In02	INT	1001
In03Unit	Unit for parameter In03	INT	1001
In04Unit	Unit for parameter In04	INT	1001
In05Unit	Unit for parameter In05	INT	1001
In06Unit	Unit for parameter In06	INT	1001
In07Unit	Unit for parameter In07	INT	1001
In08Unit	Unit for parameter In08	INT	1001

Analog logic blocks

13.8 SelA16In - Output of 16 analog values

Parameter	Description	Type	Default
In09Unit	Unit for parameter In09	INT	1001
In10Unit	Unit for parameter In10	INT	1001
In11Unit	Unit for parameter In11	INT	1001
In12Unit	Unit for parameter In12	INT	1001
In13Unit	Unit for parameter In13	INT	1001
In14Unit	Unit for parameter In14	INT	1001
In15Unit	Unit for parameter In15	INT	1001
In16Unit	Unit for parameter In16	INT	1001
LiOp	<ul style="list-style-type: none"> • With <code>Feature.Bit6 = 0</code>: Selection of the input parameter via: <ul style="list-style-type: none"> - 0 = Operator (<code>SelInt</code>) - 1 = Interconnection or SFC (<code>SelExt</code>) • With <code>Feature.Bit6 = 1</code>: Internal/external selection via: <ul style="list-style-type: none"> - 0 = Operator (<code>SelIntOp</code> or <code>SelExtOp</code>) - 1 = Interconnection or SFC (<code>SelIntLi</code> or <code>SelExtLi</code>) 	STRUCT <ul style="list-style-type: none"> • Value: BOOL • ST: BYTE 	- <ul style="list-style-type: none"> • 0 • 16#80
Occupied	1 = Occupied by batch control	BOOL	0
OnOp*	1 = "On" mode via operator	BOOL	0
OosLi	1 = "Out of service", via interconnection or SFC (0-1 edge transition)	STRUCT <ul style="list-style-type: none"> • Value: BOOL • ST: BYTE 	- <ul style="list-style-type: none"> • 0 • 16#80
OosOp*	1 = "Out of service", via OS operator	BOOL	0
OpSt_In	Input parameter for local operating permission, connected with the <code>Out</code> output parameter of the upstream block, <code>OpStations</code> (Page 411)	DWORD	16#00000000
OS_Perm	I/O for operator control permissions (Page 1962)	STRUCT <ul style="list-style-type: none"> • Bit 0: BOOL • ... • Bit 31: BOOL 	- <ul style="list-style-type: none"> • 1 • 1 • 1
SelExt	External selection of the input parameter: 1 = In01 selected 16 = In16 selected Selection outside the range 1...16 is not possible	INT	1
SelFp1	Call a block saved in this parameter as an additional faceplate (Page 208) in the standard view	ANY	
SelFp2	Call a block saved in this parameter as an additional faceplate (Page 208) in the preview	ANY	
SelInt*	Selecting the input parameter: 1 = In01 selected 16 = In16 selected You cannot select anything outside the range of 1 to 16.	INT	1

Parameter	Description	Type	Default
SelExtLi	Linkable input for external selection: 1 = External selection Active only with <code>Feature.Bit6 = 1</code>	STRUCT • Value: BOOL • ST: BYTE	- • 0 • 16#80
SelExtOp	Operator input for external selection: 1 = External selection Active only with <code>Feature.Bit6 = 1</code>	BOOL	0
SelIntLi	Linkable input for internal selection: 1 = Internal selection Active only with <code>Feature.Bit6 = 1</code>	STRUCT • Value: BOOL • ST: BYTE	- • 0 • 16#80
SelIntOp	Operator Input for Internal Selection: 1 = Internal selection Active only with <code>Feature.Bit6 = 1</code>	BOOL	0
StepNo	Batch step number	DWORD	16#00000000
UserStatus	Freely assignable bits for use in PCS 7 OS	BYTE	16#00

* Values can be written back to these inputs during processing of the block by the block algorithm.

Output parameters

Parameter	Description	Type	Default
ENO	1 = Block algorithm completed without errors	BOOL	0
ErrorNum	Output of current error number. For error numbers that can be output by this block, see SelA16In error handling (Page 1965).	INT	-1
InSelected	Selected input parameter: 1 = In01 selected 16 = In16 selected	STRUCT • Value: INT • ST: BYTE	- • 1 • 16#80
OnAct	1 = "On" mode enabled	STRUCT • Value: BOOL • ST: BYTE	- • 1 • 16#80
OosAct	1 = Block is "Out of service"	STRUCT • Value: BOOL • ST: BYTE	- • 0 • 16#80
OpSt_Out	Value of the <code>OpSt_In</code> input parameter, for feedforwarding to other blocks. Bit 31 of this parameter is used by <code>Feature</code> bit 24	DWORD	16#00000000
OS_PermLog	Display of <code>OS_Perm</code> with settings changed by the block algorithm	DWORD	16#FFFFFFFF
OS_PermOut	Display of <code>OS_Perm</code>	DWORD	16#FFFFFFFF
Out	Output	STRUCT • Value: REAL • ST: BYTE	- • 0.0 • 16#80

Parameter	Description	Type	Default
OutUnit	Unit for parameter Out	INT	1001
SelExtAct	0 = Internal selection is active 1 = External selection is active	BOOL	0
ST_Worst	Worst signal status	BYTE	16#80
Status	Status word (Page 1960)	DWORD	16#00000000
Status2	Status word (Page 1960)	DWORD	16#00000000

See also

- SelA16In block diagram (Page 1970)
- SelA16In messaging (Page 1965)
- SelA16In modes (Page 1961)

13.8.7 SelA16In block diagram

SelA16In block diagram

A block diagram is not provided for this block.

See also

- SelA16In I/Os (Page 1966)
- SelA16In messaging (Page 1965)
- SelA16In error handling (Page 1965)
- SelA16In functions (Page 1962)
- SelA16In modes (Page 1961)
- Description of SelA16In (Page 1960)

13.8.8 Operator control and monitoring

13.8.8.1 SelA16In views

Views of the SelA16In block

The block SelA16In provides the following views:

- SelA16In standard view (Page 1971)
- SelA16In preview (Page 1973)

- Memo view (Page 304)
- Batch view (Page 302)
- Block icon for SelA16In (Page 1974)

Refer to the sections Structure of the faceplate (Page 248) and Block icon structure (Page 230) for general information on the faceplate and block icon.

13.8.8.2 SelA16In standard view

SelA16In standard view

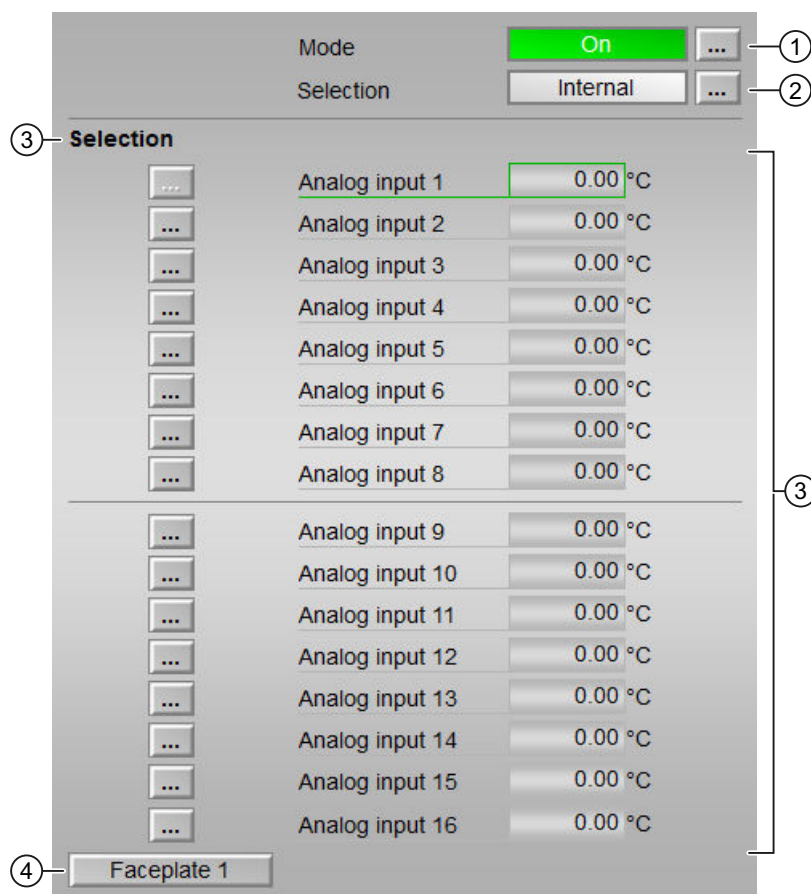

(1) Displaying and switching the operating mode

This area provides information on the currently valid operating mode. The following operating modes can be shown here:

- On (Page 71)
- Out of service (Page 71)

Refer to the Switching operating states and operating modes (Page 257) section for information on switching the operating mode.

(2) Displaying and switching the selection

This area provides information on the current selection. The following selection can be made:

- External: Selecting values externally (program)
- Internal: Selecting values internally (operator)

(3) Switching analog values

This area shows you the analog values connected in the ES for this block.

You can find additional information on this in Switching operating states and operating modes (Page 257).

(4) Navigation button for switching to the standard view of any faceplate

Use this navigation button to reach the standard view of a block configured in the engineering system. The visibility of this navigation button depends on the configuration in the engineering system (ES).

You can find additional information on this in the Opening additional faceplates (Page 208) section.

13.8.8.3 SelA16In preview

Preview of SelA16In

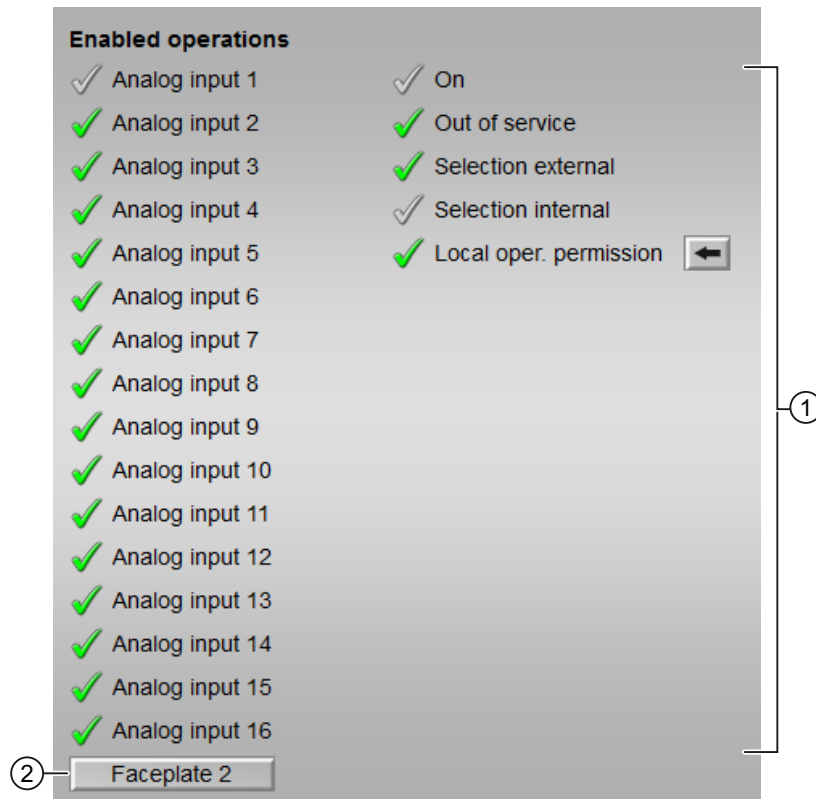

(1) Enabled operations

This area shows all operations for which special operator control permissions are assigned. They depend on the configuration in the engineering system (ES) that applies to this block.

Symbols for enabled operations:

- **Green check mark:** the OS operator can control this parameter
- **Gray check mark:** the OS operator cannot control this parameter at this time due to the process
- **Red cross:** the OS operator cannot control this parameter due to the configured AS operator control permissions (OS_Perm or OS1Perm)

The following enabled operations are shown here:

- Analog input 1 to 16: You can switch to this analog input.
- "On": You can switch to "On" operating mode.
- "Out of service": You can switch to "Out of service" operating mode.
- "Selection external": You can select values externally (program).

- "Selection internal": You can select values internally (operator).
- "Local operating permission": Use the ← button to switch to the standard view of the OpStations block. Additional information is available in the section Operator control permissions (Page 254).

(2) Navigation button for switching to the standard view of any faceplate

Use this navigation button to reach the standard view of a block configured in the engineering system. The visibility of this navigation button depends on the configuration in the engineering system (ES).

You can find additional information on this in the Opening additional faceplates (Page 208) section.

13.8.8.4 Block icon for SelA16In

Block icons for SelA16In



A variety of block icons are available with the following functions:

- Process tag type
- Operating modes
- Signal status, release for maintenance
- Memo display
- Display of the selected analog value

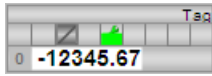
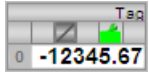
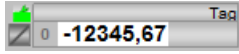
The block icons from template @TemplateAPLV8.PDL:

Icons	Selection of the block icon in CFC	Special features
	1	
	2	
	3	Block icon in the full display

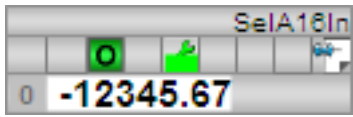
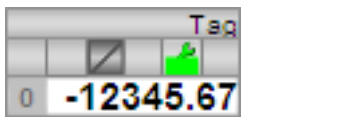
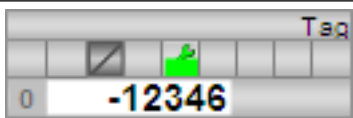
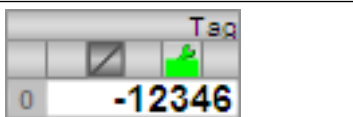
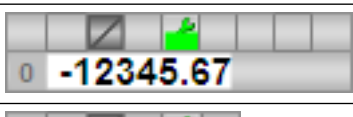
The block icons from template @TemplateAPLV7.PDL:

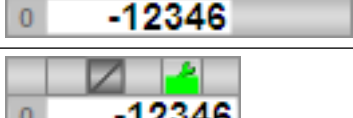
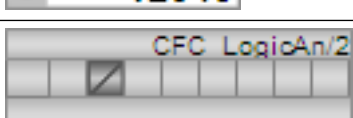
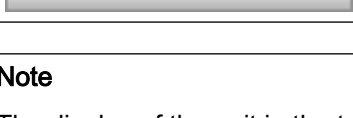
Icons	Selection of the block icon in CFC	Special features
	1	Block icon in the full display
	2	
	3	
	4	
	5	
	6	
	7	
	8	
	-	Block icon in "Out of service" mode (example with type 1 block icon)

Note

The display of the unit in the types 1/3/5/7 depends on the analog value used, although the unit can only be displayed correctly when the units of the inputs have been configured with a code (see "Selecting a unit of measure (Page 212)"). Units configured with the S7_unit attribute are not supported.

Additional information on the block icon and the control options in the block icon is available in the following sections:

- Configuring the block icons (Page 237)
- Block icon structure (Page 230)
- Operation via the block icon (Page 239).

Digital logic blocks

14.1 And04 - Forming an AND signal from 4 binary input signals

14.1.1 Description of And04

Object name (type + number) and family

Type + number: FC 355

Family: LogicDi

Area of application for And04

The block is used for the following applications:

- Forming an AND-output signal from four binary input values

How it works

Four input parameters are combined via the AND function ("and-ing") into one output value `Out`.

You can use this block to e.g. start or stop a device if all incoming signals are the same.

You can find additional information on forming the signal status under Forming and outputting the signal status of digital logic blocks (Page 110)

Configuration

Use the CFC editor to install the block in a cyclic interrupt OB (OB30 to OB38).

Startup characteristics

The block does not have any startup characteristics.

Status word allocation for `Status1` parameter

This block does not have the `Status` parameter.

See also

And04 block diagram (Page 1981)

And04 I/Os (Page 1980)

14.1 And04 - Forming an AND signal from 4 binary input signals

And04 messaging (Page 1979)

And04 error handling (Page 1979)

And04 functions (Page 1978)

And04 modes (Page 1978)

14.1.2 And04 modes

And04 modes

This block does not have any modes.

See also

And04 block diagram (Page 1981)

And04 I/Os (Page 1980)

And04 messaging (Page 1979)

And04 error handling (Page 1979)

And04 functions (Page 1978)

Description of And04 (Page 1977)

14.1.3 And04 functions

Functions of And04

This block does not have any other functions.

See also

And04 block diagram (Page 1981)

And04 I/Os (Page 1980)

And04 messaging (Page 1979)

And04 error handling (Page 1979)

And04 modes (Page 1978)

Description of And04 (Page 1977)

14.1.4 And04 error handling

And04 error handling

The block does not report any errors.

See also

And04 block diagram (Page 1981)

And04 I/Os (Page 1980)

And04 messaging (Page 1979)

And04 functions (Page 1978)

And04 modes (Page 1978)

Description of And04 (Page 1977)

14.1.5 And04 messaging

Messaging

This block does not offer messaging.

See also

And04 block diagram (Page 1981)

And04 I/Os (Page 1980)

And04 error handling (Page 1979)

And04 functions (Page 1978)

And04 modes (Page 1978)

Description of And04 (Page 1977)

14.1.6 And04 I/Os

And04 I/Os

Input parameters

Parameter	Description	Type	Default
EN	1 = Called block will be processed	BOOL	1
In1	Input 1	STRUCT <ul style="list-style-type: none"> • Value: BOOL • ST: BYTE 	- <ul style="list-style-type: none"> • 1 • 16#80
In2	Input 2	STRUCT <ul style="list-style-type: none"> • Value: BOOL • ST: BYTE 	- <ul style="list-style-type: none"> • 1 • 16#80
In3	Input 3	STRUCT <ul style="list-style-type: none"> • Value: BOOL • ST: BYTE 	- <ul style="list-style-type: none"> • 1 • 16#80
In4	Input 4	STRUCT <ul style="list-style-type: none"> • Value: BOOL • ST: BYTE 	- <ul style="list-style-type: none"> • 1 • 16#80

Output parameters

Parameter	Description	Type	Default
ENO	1 = Block algorithm completed without errors	BOOL	0
Out	Output	STRUCT <ul style="list-style-type: none"> • Value: BOOL • ST: BYTE 	- <ul style="list-style-type: none"> • 0 • 16#80

See also

- And04 block diagram (Page 1981)
- And04 messaging (Page 1979)
- And04 error handling (Page 1979)
- And04 functions (Page 1978)
- And04 modes (Page 1978)
- Description of And04 (Page 1977)

14.1.7 And04 block diagram

And04 block diagram

A block diagram is not provided for this block.

See also

And04 I/Os (Page 1980)

And04 messaging (Page 1979)

And04 error handling (Page 1979)

And04 functions (Page 1978)

And04 modes (Page 1978)

Description of And04 (Page 1977)

14.2 And08 - Forming an AND signal from 8 binary input signals

14.2.1 Description of And08

Object name (type + number) and family

Type + number: FC 356

Family: LogicDi

Area of application for And08

The block is used for the following applications:

- Forming an AND- output signal from eight binary input values

How it works

Eight input parameters are combined via the AND function ("and-ing") into one output value `Out`.

You can use this block to e.g. start or stop a device if all incoming signals are the same.

You can find additional information on forming the signal status under Forming and outputting the signal status of digital logic blocks (Page 110)

Configuration

Use the CFC editor to install the block in a cyclic interrupt OB (OB30 to OB38).

Startup characteristics

The block does not have any startup characteristics.

Status word allocation for `Status1` parameter

This block does not have the `Status` parameter.

See also

And08 block diagram (Page 1986)

And08 I/Os (Page 1984)

And08 messaging (Page 1984)

And08 error handling (Page 1983)

And08 functions (Page 1983)

And08 modes (Page 1983)

14.2.2 And08 modes

And08 modes

This block does not have any modes.

See also

And08 block diagram (Page 1986)

And08 I/Os (Page 1984)

And08 messaging (Page 1984)

And08 error handling (Page 1983)

And08 functions (Page 1983)

Description of And08 (Page 1982)

14.2.3 And08 functions

Functions of And08

This block does not have any other functions.

See also

And08 block diagram (Page 1986)

And08 I/Os (Page 1984)

And08 messaging (Page 1984)

And08 error handling (Page 1983)

And08 modes (Page 1983)

Description of And08 (Page 1982)

14.2.4 And08 error handling

And08 error handling

The block does not report any errors.

See also

- And08 block diagram (Page 1986)
- And08 I/Os (Page 1984)
- And08 messaging (Page 1984)
- And08 functions (Page 1983)
- And08 modes (Page 1983)
- Description of And08 (Page 1982)

14.2.5 And08 messaging

Messaging

This block does not offer messaging.

See also

- And08 block diagram (Page 1986)
- And08 I/Os (Page 1984)
- And08 error handling (Page 1983)
- And08 functions (Page 1983)
- And08 modes (Page 1983)
- Description of And08 (Page 1982)

14.2.6 And08 I/Os

And08 I/Os

Input parameters

Parameter	Description	Type	Default
EN	1 = Called block will be processed	BOOL	1
In1	Input 1	STRUCT <ul style="list-style-type: none"> • Value: BOOL • ST: BYTE 	- <ul style="list-style-type: none"> • 1 • 16#80
In2	Input 2	STRUCT <ul style="list-style-type: none"> • Value: BOOL • ST: BYTE 	- <ul style="list-style-type: none"> • 1 • 16#80

14.2 And08 - Forming an AND signal from 8 binary input signals

Parameter	Description	Type	Default
In3	Input 3	STRUCT <ul style="list-style-type: none"> Value: BOOL ST: BYTE 	- <ul style="list-style-type: none"> 1 16#80
In4	Input 4	STRUCT <ul style="list-style-type: none"> Value: BOOL ST: BYTE 	- <ul style="list-style-type: none"> 1 16#80
In5	Input 5	STRUCT <ul style="list-style-type: none"> Value: BOOL ST: BYTE 	- <ul style="list-style-type: none"> 1 16#80
In6	Input 6	STRUCT <ul style="list-style-type: none"> Value: BOOL ST: BYTE 	- <ul style="list-style-type: none"> 1 16#80
In7	Input 7	STRUCT <ul style="list-style-type: none"> Value: BOOL ST: BYTE 	- <ul style="list-style-type: none"> 1 16#80
In8	Input 8	STRUCT <ul style="list-style-type: none"> Value: BOOL ST: BYTE 	- <ul style="list-style-type: none"> 1 16#80

Output parameters

Parameter	Description	Type	Default
ENO	1 = Block algorithm completed without errors	BOOL	0
Out	Output	STRUCT <ul style="list-style-type: none"> Value: BOOL ST: BYTE 	- <ul style="list-style-type: none"> 0 16#80

See also

And08 block diagram (Page 1986)

And08 messaging (Page 1984)

And08 error handling (Page 1983)

And08 functions (Page 1983)

And08 modes (Page 1983)

Description of And08 (Page 1982)

14.2.7 And08 block diagram

And08 block diagram

A block diagram is not provided for this block.

See also

- And08 I/Os (Page 1984)
- And08 messaging (Page 1984)
- And08 error handling (Page 1983)
- And08 functions (Page 1983)
- And08 modes (Page 1983)
- Description of And08 (Page 1982)

14.3 FlipFlop - preparation of a bistabile flip-flop

14.3.1 Description of FlipFlop

Object name (type + number) and family

Type + number: FC 389

Family: LogicDi

Area of application for FlipFlop

The block is used for the following applications:

- Preparation of a bistabile flip-flop

How it works

The block provides the function of a bistabile flip-flop, whereby the Mode input parameter can be used to select between SR- (Mode = 0) and RS-FlipFlop (Mode = 1).

The flip-flop provides the two control inputs for setting and resetting:

- SetLi: Set
- RstLi: Reset

With a positive edge at the input parameter for setting SetLi, the output parameter Out is set to 1. Simultaneously, the output parameter InvOut is reset.

With a positive edge at the input parameter for resetting RstLi, the output parameter Out is reset. Simultaneously, the output parameter InvOut is set.

If the two input parameters are SetLi and RstLi = 0, then the block retains its state. In this case, nothing changes at the output parameters.

How the block operates as SR-FlipFlop (Mode = 0)

The input parameter for setting SetLi has priority over the input parameter for resetting RstLi.

Truth table:

RstLi	SetLi	Out	InvOut
0	0	Last value	Last value
0	1	1	0
1	0	0	1
1	1	1	0

How the block operates as RS-FlipFlop (mode = 1)

The input parameter for resetting `RstLi` has priority over the input parameter for setting `SetLi`.

Truth table:

<code>RstLi</code>	<code>SetLi</code>	<code>Out</code>	<code>InvOut</code>
0	0	Last value	Last value
0	1	1	0
1	0	0	1
1	1	0	1

Configuration

Use the CFC editor to install the block in a cyclic interrupt OB (OB30 to OB38).

Startup characteristics

The block does not have any startup characteristics.

A startup behavior can be reached with a connection of the input parameter `Init` to the output parameter `InitOut` of the Trigger block. For more information, refer to Startup characteristics over Trigger block (Page 69).

Status word allocation for status parameter

This block does not have the `Status` parameter.

See also

- FlipFlop modes (Page 1988)
- FlipFlop functions (Page 1989)
- FlipFlop error handling (Page 1990)
- FlipFlop messaging (Page 1991)
- FlipFlop I/Os (Page 1991)
- FlipFlop block diagram (Page 1992)

14.3.2 FlipFlop modes

FlipFlop operating modes

This block does not have any modes.

See also

Description of FlipFlop (Page 1987)

FlipFlop functions (Page 1989)

FlipFlop error handling (Page 1990)

FlipFlop messaging (Page 1991)

FlipFlop I/Os (Page 1991)

FlipFlop block diagram (Page 1992)

14.3.3 FlipFlop functions**Functions of FlipFlop**

The block provides the following functions:

Forming the signal status for blocks – SR-FlipFlop

The signal status is formed as follows:

RstLi	SetLi	Out.ST	InvOut.ST
0	0	Last signal status	Last signal status
0	1	= SetLi.ST	= SetLi.ST
1	0	= RstLi.ST	= RstLi.ST
1	1	= SetLi.ST	= SetLi.ST

Forming the signal status for blocks - RS-FlipFlop

The signal status is formed as follows:

RstLi	SetLi	Out.ST	InvOut.ST
0	0	Last signal status	Last signal status
0	1	= SetLi.ST	= SetLi.ST
1	0	= RstLi.ST	= RstLi.ST
1	1	= RstLi.ST	= RstLi.ST

Initialization

With the input parameter `Init`, the output parameters `Out` and `InvOut` can be initialized:

- `Init = 0` (default): Normal flip-flop behavior
If both input parameters `SetLi` and `RstLi` are reset, the output parameters `Out` and `InvOut` will remain unchanged.
- `Init = 1`: Outputs will be initialized as follow:

Mode	Out	InvOut	Out . ST and InvOut . ST
0	0	1	SetLi . ST
1	1	0	RstLi . ST

To initialize the output parameters `Out` and `InvOut` after a startup, connect the input parameter `Init` with the output parameter `InitOut` of the Trigger block. For more information, refer to Startup characteristics over Trigger block (Page 69).

See also

- Description of FlipFlop (Page 1987)
- FlipFlop modes (Page 1988)
- FlipFlop error handling (Page 1990)
- FlipFlop messaging (Page 1991)
- FlipFlop I/Os (Page 1991)
- FlipFlop block diagram (Page 1992)

14.3.4 FlipFlop error handling

FlipFlop error handling

The block does not report any errors.

See also

- Description of FlipFlop (Page 1987)
- FlipFlop modes (Page 1988)
- FlipFlop functions (Page 1989)
- FlipFlop messaging (Page 1991)
- FlipFlop I/Os (Page 1991)
- FlipFlop block diagram (Page 1992)

14.3.5 FlipFlop messaging

Messaging

This block does not offer messaging.

See also

Description of FlipFlop (Page 1987)

FlipFlop modes (Page 1988)

FlipFlop functions (Page 1989)

FlipFlop error handling (Page 1990)

FlipFlop I/Os (Page 1991)

FlipFlop block diagram (Page 1992)

14.3.6 FlipFlop I/Os

FlipFlop I/Os

Input parameters

Parameter	Description	Type	Default
EN	1 = Called block will be processed	BOOL	1
Init	Initialize function block	BOOL	0
Mode	Specifying how the block works: <ul style="list-style-type: none"> • 0 = SR-FlipFlop • 1 = RS-FlipFlop 	BOOL	0
RstLi	1 = Reset via interconnection	STRUCT <ul style="list-style-type: none"> • Value: BOOL • ST: BYTE 	- <ul style="list-style-type: none"> • 0 • 16#80
SetLi	1 = Set via interconnection	STRUCT <ul style="list-style-type: none"> • Value: BOOL • ST: BYTE 	- <ul style="list-style-type: none"> • 0 • 16#80

Output parameters

Parameter	Description	Type	Default
ENO	1 = Block algorithm completed without errors	BOOL	0
InvOut	Inverted output signal	STRUCT <ul style="list-style-type: none"> • Value: BOOL • ST: BYTE 	- <ul style="list-style-type: none"> • 1 • 16#80
Out	Output	STRUCT <ul style="list-style-type: none"> • Value: BOOL • ST: BYTE 	- <ul style="list-style-type: none"> • 0 • 16#80

See also

- Description of FlipFlop (Page 1987)
- FlipFlop modes (Page 1988)
- FlipFlop functions (Page 1989)
- FlipFlop error handling (Page 1990)
- FlipFlop messaging (Page 1991)
- FlipFlop block diagram (Page 1992)

14.3.7 FlipFlop block diagram

FlipFlop block diagram

A block diagram is not provided for this block.

See also

- Description of FlipFlop (Page 1987)
- FlipFlop modes (Page 1988)
- FlipFlop functions (Page 1989)
- FlipFlop error handling (Page 1990)
- FlipFlop messaging (Page 1991)
- FlipFlop I/Os (Page 1991)

14.4 Or04 - Forming an OR signal from 4 binary input signals

14.4.1 Description of Or04

Object name (type + number) and family

Type + number: FC 364

Family: LogicDi

Area of application for Or04

The block is used for the following applications:

- Forming an OR-output signal from four binary input values

How it works

Four input parameters are combined via the OR-function ("or-ing") into one output value `Out`.

You can find additional information on forming the signal status under Forming and outputting the signal status of digital logic blocks (Page 110)

Configuration

Use the CFC editor to install the block in a cyclic interrupt OB (OB30 to OB38).

For the Or04 block, the Advanced Process Library contains templates for process tag types as examples with various application scenarios for this block.

Examples of process tag types:

- Cascade control with control loop monitoring through ConPerMon (CascadeControl) (Page 2342)
- Cascade control with PIDConR (CascadeR) (Page 2345)
- Dosing (Dose_Lean) (Page 2358)
- PID controller with dynamic feedforward control (FwdDisturbCompensat) (Page 2329)
- PID - control with operating-point-oriented parameter control (GainScheduling) (Page 2327)
- Model-based predictive control (ModPreCon) (Page 2351)
- Override control (Page 2348)
- Override control with PIDConR (OverrideR) (Page 2350)
- PID controller with safety logic and control loop monitoring (PIDConL_ConPerMon) (Page 2324)
- PIDConR with safety logic and control loop monitoring (PIDConR_ConPerMon) (Page 2325)

- Ratio control with control loop monitoring through ConPerMon (RatioControl) (Page 2338)
- Ratio control with PIDConR (RatioR) (Page 2341)
- PID controller with Smith predictor (SmithPredictorControl) (Page 2332)
- Step controller with assigned actuator block and position feedback (StepControlActor) (Page 2334)
- Valve (Valve_Lean) (Page 2367)
- Dosing with PA/FF devices (Dose_Lean_Fb) (Page 2359)
- PID controller for PA/FF devices (PIDControl_Lean_Fb) (Page 2323)
- Control valve (VlvAnL) (Page 2370)
- Control valve for PA/FF devices (ValveAnalog_Fb) (Page 2371)
- Split-range controller with control loop monitoring through ConPerMon (SplitrangeControl) (Page 2335)

Startup characteristics

The block does not have any startup characteristics.

Status word allocation for `status1` parameter

This block does not have the `status` parameter.

See also

- Or04 block diagram (Page 1997)
- Or04 I/Os (Page 1996)
- Or04 messaging (Page 1996)
- Or04 error handling (Page 1995)
- Or04 functions (Page 1995)
- Or04 modes (Page 1994)

14.4.2 Or04 modes

Or04 modes

This block does not have any modes.

See also

Or04 block diagram (Page 1997)
Or04 I/Os (Page 1996)
Or04 messaging (Page 1996)
Or04 error handling (Page 1995)
Or04 functions (Page 1995)
Description of Or04 (Page 1993)

14.4.3 Or04 functions**Functions of Or04**

This block does not have any other functions.

See also

Or04 block diagram (Page 1997)
Or04 I/Os (Page 1996)
Or04 messaging (Page 1996)
Or04 error handling (Page 1995)
Or04 modes (Page 1994)
Description of Or04 (Page 1993)

14.4.4 Or04 error handling**Or04 error handling**

The block does not report any errors.

See also

Or04 block diagram (Page 1997)
Or04 I/Os (Page 1996)
Or04 messaging (Page 1996)
Or04 functions (Page 1995)
Or04 modes (Page 1994)
Description of Or04 (Page 1993)

14.4.5 Or04 messaging

Messaging

This block does not offer messaging.

See also

Or04 block diagram (Page 1997)

Or04 I/Os (Page 1996)

Or04 error handling (Page 1995)

Or04 functions (Page 1995)

Or04 modes (Page 1994)

Description of Or04 (Page 1993)

14.4.6 Or04 I/Os

Or04 I/Os

Input parameters

Parameter	Description	Type	Default
EN	1 = Called block will be processed	BOOL	1
In1	Value 1	STRUCT <ul style="list-style-type: none"> • Value: BOOL • ST: BYTE 	- <ul style="list-style-type: none"> • 0 • 16#80
In2	Value 2	STRUCT <ul style="list-style-type: none"> • Value: BOOL • ST: BYTE 	- <ul style="list-style-type: none"> • 0 • 16#80
In3	Value 3	STRUCT <ul style="list-style-type: none"> • Value: BOOL • ST: BYTE 	- <ul style="list-style-type: none"> • 0 • 16#80
In4	Value 4	STRUCT <ul style="list-style-type: none"> • Value: BOOL • ST: BYTE 	- <ul style="list-style-type: none"> • 0 • 16#80

Output parameters

Parameter	Description	Type	Default
ENO	1 = Block algorithm completed without errors	BOOL	0
Out	Output	STRUCT <ul style="list-style-type: none"> • Value: BOOL • ST: BYTE 	- <ul style="list-style-type: none"> • 0 • 16#80

See also

[Or04 block diagram \(Page 1997\)](#)
[Or04 messaging \(Page 1996\)](#)
[Or04 error handling \(Page 1995\)](#)
[Or04 functions \(Page 1995\)](#)
[Or04 modes \(Page 1994\)](#)
[Description of Or04 \(Page 1993\)](#)

14.4.7 Or04 block diagram

Or04 block diagram

A block diagram is not provided for this block.

See also

[Or04 I/Os \(Page 1996\)](#)
[Or04 messaging \(Page 1996\)](#)
[Or04 error handling \(Page 1995\)](#)
[Or04 functions \(Page 1995\)](#)
[Or04 modes \(Page 1994\)](#)
[Description of Or04 \(Page 1993\)](#)

14.5 Or08 - Forming an OR signal from 8 binary input signals

14.5.1 Description of Or08

Object name (type + number) and family

Type + number: FC 365

Family: LogicDi

Area of application for Or08

The block is used for the following applications:

- Forming an OR- output signal from eight binary input values

How it works

Eight input parameters are combined via the OR-function ("or-ing") into one output value `Out`.

You can find additional information on forming the signal status under Forming and outputting the signal status of digital logic blocks (Page 110)

Configuration

Use the CFC editor to install the block in a cyclic interrupt OB (OB30 to OB38).

For the Or08 block, the Advanced Process Library contains templates for process tag types as examples with various application scenarios for this block.

Examples of process tag types:

- Monitoring eight digital process tags (Digital8Monitoring) (Page 2355)
- Step controller with assigned actuator block and position feedback (StepControlActor) (Page 2334)
- Step controller with direct access to the actuator and without position feedback (StepControlDirect) (Page 2333)
- Two-speed motor (Motor2Speed) (Page 2362)
- Reversing motor (MotorReversible) (Page 2363)
- Reversible motor with controllable speed (MotorSpeedControlled) (Page 2364)
- Two-way valve (Valve2Way) (Page 2368)
- Motor valve (ValveMotor) (Page 2369)

Startup characteristics

The block does not have any startup characteristics.

Status word allocation for `Status1` parameter

This block does not have the `Status` parameter.

See also

Or08 block diagram (Page 2002)

Or08 I/Os (Page 2001)

Or08 messaging (Page 2000)

Or08 error handling (Page 2000)

Or08 functions (Page 1999)

Or08 modes (Page 1999)

14.5.2 Or08 modes**Or08 modes**

This block does not have any operating modes.

See also

Or08 block diagram (Page 2002)

Or08 I/Os (Page 2001)

Or08 messaging (Page 2000)

Or08 error handling (Page 2000)

Or08 functions (Page 1999)

Description of Or08 (Page 1998)

14.5.3 Or08 functions**Functions of Or08**

This block does not have any other functions.

See also

Or08 block diagram (Page 2002)

Or08 I/Os (Page 2001)

14.5 Or08 - Forming an OR signal from 8 binary input signals

- Or08 messaging (Page 2000)
- Or08 error handling (Page 2000)
- Or08 modes (Page 1999)
- Description of Or08 (Page 1998)

14.5.4 Or08 error handling

Or08 error handling

The block does not report any errors.

See also

- Or08 block diagram (Page 2002)
- Or08 I/Os (Page 2001)
- Or08 messaging (Page 2000)
- Or08 functions (Page 1999)
- Or08 modes (Page 1999)
- Description of Or08 (Page 1998)

14.5.5 Or08 messaging

Messaging

This block does not offer messaging.

See also

- Or08 block diagram (Page 2002)
- Or08 I/Os (Page 2001)
- Or08 error handling (Page 2000)
- Or08 functions (Page 1999)
- Or08 modes (Page 1999)
- Description of Or08 (Page 1998)

14.5.6 Or08 I/Os

Or08 I/Os

Input parameters

Parameter	Description	Type	Default
EN	1 = Called block will be processed	BOOL	1
In1	Value 1	STRUCT <ul style="list-style-type: none"> Value: BOOL ST: BYTE 	- <ul style="list-style-type: none"> 0 16#80
In2	Value 2	STRUCT <ul style="list-style-type: none"> Value: BOOL ST: BYTE 	- <ul style="list-style-type: none"> 0 16#80
In3	Value 3	STRUCT <ul style="list-style-type: none"> Value: BOOL ST: BYTE 	- <ul style="list-style-type: none"> 0 16#80
In4	Value 4	STRUCT <ul style="list-style-type: none"> Value: BOOL ST: BYTE 	- <ul style="list-style-type: none"> 0 16#80
In5	Value 5	STRUCT <ul style="list-style-type: none"> Value: BOOL ST: BYTE 	- <ul style="list-style-type: none"> 0 16#80
In6	Value 6	STRUCT <ul style="list-style-type: none"> Value: BOOL ST: BYTE 	- <ul style="list-style-type: none"> 0 16#80
In7	Value 7	STRUCT <ul style="list-style-type: none"> Value: BOOL ST: BYTE 	- <ul style="list-style-type: none"> 0 16#80
In8	Value 8	STRUCT <ul style="list-style-type: none"> Value: BOOL ST: BYTE 	- <ul style="list-style-type: none"> 0 16#80

Output parameters

Parameter	Description	Type	Default
ENO	1 = Block algorithm completed without errors	BOOL	0
Out	Output	STRUCT <ul style="list-style-type: none"> Value: BOOL ST: BYTE 	- <ul style="list-style-type: none"> 0 16#80

See also

- Or08 block diagram (Page 2002)
- Or08 messaging (Page 2000)
- Or08 error handling (Page 2000)
- Or08 functions (Page 1999)
- Or08 modes (Page 1999)
- Description of Or08 (Page 1998)

14.5.7 Or08 block diagram

Or08 block diagram

A block diagram is not provided for this block.

See also

- Or08 I/Os (Page 2001)
- Or08 messaging (Page 2000)
- Or08 error handling (Page 2000)
- Or08 functions (Page 1999)
- Or08 modes (Page 1999)
- Description of Or08 (Page 1998)

14.6 Not01 - Inversion of an input signal

14.6.1 Description of Not01

Object name (type + number) and family

Type + number: FC 382

Family: LogicDi

Area of application for Not01

The block is used for the following applications:

- Inversion of an input signal

How it works

The block inverts the binary signal available at the `In` input parameter and writes the result to its output parameter `Out`.

The signal status is passed from the input directly to the output.

You can find additional information on forming the signal status under Forming and outputting the signal status of digital logic blocks (Page 110)

Configuration

Use the CFC editor to install the block in a cyclic interrupt OB (OB30 to OB38).

For the Not01 block, the Advanced Process Library contains a template for process tag types as an example with an application scenario for this block.

Example of process tag types:

- Step controller with assigned actuator block and position feedback (StepControlActor) (Page 2334)
- Ratio control with control loop monitoring through ConPerMon (RatioControl) (Page 2338)

See also

Not01 block diagram (Page 2006)

Not01 I/Os (Page 2005)

Not01 messaging (Page 2005)

Not01 error handling (Page 2004)

Not01 functions (Page 2004)

Not01 modes (Page 2004)

14.6.2 Not01 modes

Not01 operating modes

This block does not have any operating modes.

See also

Not01 block diagram (Page 2006)

Not01 I/Os (Page 2005)

Not01 messaging (Page 2005)

Not01 error handling (Page 2004)

Not01 functions (Page 2004)

Description of Not01 (Page 2003)

14.6.3 Not01 functions

Functions of Not01

There are no other functions for this block.

See also

Not01 block diagram (Page 2006)

Not01 I/Os (Page 2005)

Not01 messaging (Page 2005)

Not01 error handling (Page 2004)

Not01 modes (Page 2004)

Description of Not01 (Page 2003)

14.6.4 Not01 error handling

Not01 error handling

The block does not report any errors.

See also

Not01 block diagram (Page 2006)

Not01 I/Os (Page 2005)

Not01 messaging (Page 2005)

Not01 functions (Page 2004)

Not01 modes (Page 2004)

Description of Not01 (Page 2003)

14.6.5 Not01 messaging**Messaging**

This block does not offer messaging.

See also

Not01 block diagram (Page 2006)

Not01 I/Os (Page 2005)

Not01 error handling (Page 2004)

Not01 functions (Page 2004)

Not01 modes (Page 2004)

Description of Not01 (Page 2003)

14.6.6 Not01 I/Os**Not01 I/Os****Input parameters**

Parameter	Description	Type	Default
EN	1 = Called block will be processed	BOOL	1
In	Input value	STRUCT	-
		<ul style="list-style-type: none"> • Value: BOOL • ST: BYTE 	<ul style="list-style-type: none"> • 0 • 16#80

Output parameters

Parameter	Description	Type	Default
ENO	1 = Block algorithm completed without errors	BOOL	0
Out	Output	STRUCT <ul style="list-style-type: none">• Value: BOOL• ST: BYTE	- <ul style="list-style-type: none">• 0• 16#80

See also

- Not01 block diagram (Page 2006)
- Not01 messaging (Page 2005)
- Not01 error handling (Page 2004)
- Not01 functions (Page 2004)
- Not01 modes (Page 2004)
- Description of Not01 (Page 2003)

14.6.7 Not01 block diagram

Not01 block diagram

A block diagram is not provided for this block.

See also

- Not01 I/Os (Page 2005)
- Not01 messaging (Page 2005)
- Not01 error handling (Page 2004)
- Not01 functions (Page 2004)
- Not01 modes (Page 2004)
- Description of Not01 (Page 2003)

14.7 RedDi02 - 1 out of 2 selection for redundant digital values

14.7.1 Description of RedDi02

Object name (type + number) and family

Type + number: FC 386

Family: LogicDi

Area of application for RedDi02

The block is used for the following applications:

- 1 out of 2 selection for redundant digital values

How it works

The block selects from two input values the one with the best signal status and outputs it at the output `Out`. In addition, the outputs `SimAct`, `Uncertain` and `LossRed` are set according to the signal status.

Configuration

Use the CFC editor to install the block in a cyclic interrupt OB (OB30 to OB38).

Startup characteristics

The block does not have any startup characteristics.

Status word allocation for `status1` parameter

This block does not have the `Status` parameter.

See also

RedDi02 modes (Page 2008)

RedDi02 functions (Page 2008)

RedDi02 error handling (Page 2009)

RedDi02 messaging (Page 2009)

RedDi02 I/Os (Page 2010)

RedDi02 block diagram (Page 2011)

14.7.2 RedDi02 modes

RedDi02 operating modes

This block does not have any operating modes.

See also

Description of RedDi02 (Page 2007)

RedDi02 functions (Page 2008)

RedDi02 error handling (Page 2009)

RedDi02 messaging (Page 2009)

RedDi02 I/Os (Page 2010)

RedDi02 block diagram (Page 2011)

14.7.3 RedDi02 functions

Functions of RedDi02

The functions for this block are listed below.

Forming the signal status for blocks

This block provides the standard function Forming and outputting the signal status of redundancy blocks (Page 112).

See also

Description of RedDi02 (Page 2007)

RedDi02 modes (Page 2008)

RedDi02 error handling (Page 2009)

RedDi02 messaging (Page 2009)

RedDi02 I/Os (Page 2010)

RedDi02 block diagram (Page 2011)

14.7.4 RedDi02 error handling

RedDi02 error handling

The block does not report any errors.

See also

Description of RedDi02 (Page 2007)

RedDi02 modes (Page 2008)

RedDi02 functions (Page 2008)

RedDi02 messaging (Page 2009)

RedDi02 I/Os (Page 2010)

RedDi02 block diagram (Page 2011)

14.7.5 RedDi02 messaging

Messaging

This block does not offer messaging.

See also

Description of RedDi02 (Page 2007)

RedDi02 modes (Page 2008)

RedDi02 functions (Page 2008)

RedDi02 error handling (Page 2009)

RedDi02 I/Os (Page 2010)

RedDi02 block diagram (Page 2011)

14.7.6 RedDi02 I/Os

I/Os of RedDi02

Input parameters

Parameter	Description	Type	Default
EN	1 = Called block will be processed	BOOL	1
In1	Digital input value 1	STRUCT <ul style="list-style-type: none"> • Value: BOOL • ST:BYTE 	- <ul style="list-style-type: none"> • 0 • 16#80
In2	Digital input value 2	STRUCT <ul style="list-style-type: none"> • Value: BOOL • ST:BYTE 	- <ul style="list-style-type: none"> • 0 • 16#80

Output parameters

Parameter	Description	Type	Default
ENO	1 = Block algorithm completed without errors	BOOL	0
LossRed	1= Redundancy loss at one of the inputs	STRUCT <ul style="list-style-type: none"> • Value: BOOL • ST:BYTE 	- <ul style="list-style-type: none"> • 0 • 16#80
Out	Output of the process value with the better signal status	STRUCT <ul style="list-style-type: none"> • Value: BOOL • ST:BYTE 	- <ul style="list-style-type: none"> • 0 • 16#80
SimAct	1 = one input value has the Simulation status	STRUCT <ul style="list-style-type: none"> • Value: BOOL • ST:BYTE 	- <ul style="list-style-type: none"> • 0 • 16#80
Uncertain	1 = one input value has the "uncertain" status	STRUCT <ul style="list-style-type: none"> • Value: BOOL • ST:BYTE 	- <ul style="list-style-type: none"> • 0 • 16#80

See also

- Description of RedDi02 (Page 2007)
- RedDi02 modes (Page 2008)
- RedDi02 functions (Page 2008)
- RedDi02 error handling (Page 2009)
- RedDi02 messaging (Page 2009)
- RedDi02 block diagram (Page 2011)

14.7.7 RedDi02 block diagram

RedDi02 block diagram

A block diagram is not provided for this block.

See also

Description of RedDi02 (Page 2007)

RedDi02 modes (Page 2008)

RedDi02 functions (Page 2008)

RedDi02 error handling (Page 2009)

RedDi02 messaging (Page 2009)

RedDi02 I/Os (Page 2010)

14.8 SelD02In - Output of one of two digital signals

14.8.1 Description of SelD02In

Object name (type + number) and family

Type + number: FC 391

Family: LogicDi

Area of application for SelD02In

The block is used for the following applications:

- Selection from two digital values

How it works

Depending on the value of the input `Sel_In2`, the block switches the value of the input `In1` or the input `In2` to the output `Out`.

Configuration

Use the CFC editor to install the block in a cyclic interrupt OB (OB30 to OB38).

Startup characteristics

The block does not have any startup characteristics.

Status word allocation for `Status1` parameter

This block does not have the `Status` parameter.

See also

SelD02In modes (Page 2013)

SelD02In functions (Page 2013)

SelD02In error handling (Page 2014)

SelD02In messaging (Page 2014)

SelD02In I/Os (Page 2015)

SelD02In block diagram (Page 2016)

14.8.2 SelD02In modes

SelD02In operating modes

This block does not have any operating modes.

See also

Description of SelD02In (Page 2012)

SelD02In functions (Page 2013)

SelD02In error handling (Page 2014)

SelD02In messaging (Page 2014)

SelD02In I/Os (Page 2015)

SelD02In block diagram (Page 2016)

14.8.3 SelD02In functions

Functions of SelD02In

The functions for this block are listed below.

Select input parameter

You can use the parameter `Sel_In2` to specify whether the input parameter `In1` or `In2` is to be output at the output parameter:

- `Sel_In2 = 0`: Input parameter `In1` is written with its signal status to output parameter `Out`.
- `Sel_In2 = 1`: Input parameter `In2` is written with its signal status to output parameter `Out`.

Display of selected value

The output parameter `In2Selected` indicates which of the two input parameters has just been output:

- `In2Selected = 0`: At the output parameter `Out`, the value of the input parameter `In1` is output.
- `In2Selected = 1`: At the output parameter `Out`, the value of the input parameter `In2` is output.

The signal status of `Sel_In2` is output at the `In2Selected` output parameter.

See also

- Description of SelD02In (Page 2012)
- SelD02In modes (Page 2013)
- SelD02In error handling (Page 2014)
- SelD02In messaging (Page 2014)
- SelD02In I/Os (Page 2015)
- SelD02In block diagram (Page 2016)

14.8.4 SelD02In error handling

SelD02In error handling

The block does not report any errors.

See also

- Description of SelD02In (Page 2012)
- SelD02In modes (Page 2013)
- SelD02In functions (Page 2013)
- SelD02In messaging (Page 2014)
- SelD02In I/Os (Page 2015)
- SelD02In block diagram (Page 2016)

14.8.5 SelD02In messaging

Messaging

This block does not offer messaging.

See also

- Description of SelD02In (Page 2012)
- SelD02In modes (Page 2013)
- SelD02In functions (Page 2013)
- SelD02In error handling (Page 2014)
- SelD02In I/Os (Page 2015)
- SelD02In block diagram (Page 2016)

14.8.6 SelD02In I/Os

SelD02In I/Os

Input parameters

Parameter	Description	Type	Default
EN	1 = Called block will be processed	BOOL	1
In1	Input 1	STRUCT <ul style="list-style-type: none"> Value: BOOL ST: BYTE 	- <ul style="list-style-type: none"> 0 16#80
In2	Input 2	STRUCT <ul style="list-style-type: none"> Value: BOOL ST: BYTE 	- <ul style="list-style-type: none"> 0 16#80
Sel_In2	Selecting the input parameter: 0 = In1 1 = In2	STRUCT <ul style="list-style-type: none"> Value: BOOL ST: BYTE 	- <ul style="list-style-type: none"> 0 16#80

Output parameters

Parameter	Description	Type	Default
ENO	1 = Block algorithm completed without errors	BOOL	0
In2Selected	Selected input parameter: 0 = In1 1 = In2	STRUCT <ul style="list-style-type: none"> Value: BOOL ST: BYTE 	- <ul style="list-style-type: none"> 0 16#80
Out	Output	STRUCT <ul style="list-style-type: none"> Value: BOOL ST: BYTE 	- <ul style="list-style-type: none"> 0 16#80

See also

Description of SelD02In (Page 2012)

SelD02In modes (Page 2013)

SelD02In functions (Page 2013)

SelD02In error handling (Page 2014)

SelD02In messaging (Page 2014)

SelD02In block diagram (Page 2016)

14.8.7 SelD02In block diagram

SelD02In block diagram

A block diagram is not provided for this block.

See also

Description of SelD02In (Page 2012)

SelD02In modes (Page 2013)

SelD02In functions (Page 2013)

SelD02In error handling (Page 2014)

SelD02In messaging (Page 2014)

SelD02In I/Os (Page 2015)

14.9 StrctCom - Structure composer for 32-bit structures

14.9.1 Description of StrctCom

Object name (type + number) and family

Type + number: FC 393

Family: LogicDi

Area of application for StrctCom

The block forms a structure type output with 32 binary structural elements from 32 binary input signals. The structure corresponds, for example, to the OS_Perm inputs of the technological blocks and can be interconnected to them.

How it works

The block is used for create a structure of 32 input bits.

Configuration

Use the CFC editor to install the block in a cyclic interrupt OB (OB30 to OB38).

Startup characteristics

The block does not have any startup characteristics.

Status word allocation for `status1` parameter

This block does not have the `Status` parameter.

See also

StrctCom block diagram (Page 2020)

StrctCom I/Os (Page 2019)

StrctCom messaging (Page 2019)

StrctCom error handling (Page 2019)

StrctCom functions (Page 2018)

StrctCom modes (Page 2018)

Forming and outputting the signal status of digital logic blocks (Page 110)

14.9.2 StrctCom modes

StrctCom operating modes

This block does not have any operating modes.

See also

StrctCom block diagram (Page 2020)

StrctCom I/Os (Page 2019)

StrctCom messaging (Page 2019)

StrctCom error handling (Page 2019)

StrctCom functions (Page 2018)

Description of StrctCom (Page 2017)

14.9.3 StrctCom functions

Functions of StrctCom

The functions for this block are listed below.

Any 32 bits at the input are assigned to the structure in the output.

`Out.Bit0 = Bit0`

`Out.Bit1 = Bit1`

.....

`Out.Bit31 = Bit31`

See also

StrctCom block diagram (Page 2020)

StrctCom I/Os (Page 2019)

StrctCom messaging (Page 2019)

StrctCom error handling (Page 2019)

StrctCom modes (Page 2018)

Description of StrctCom (Page 2017)

14.9.4 StrctCom error handling

Error handling of StrctCom

The block does not report any errors.

See also

StrctCom block diagram (Page 2020)

StrctCom I/Os (Page 2019)

StrctCom messaging (Page 2019)

StrctCom functions (Page 2018)

StrctCom modes (Page 2018)

Description of StrctCom (Page 2017)

14.9.5 StrctCom messaging

Messaging

This block does not offer messaging.

See also

StrctCom block diagram (Page 2020)

StrctCom I/Os (Page 2019)

StrctCom error handling (Page 2019)

StrctCom functions (Page 2018)

StrctCom modes (Page 2018)

Description of StrctCom (Page 2017)

14.9.6 StrctCom I/Os

I/Os of StrctCom

Input parameters

Parameter	Description	Type	Default
Bit0...Bit31	Binary input value Bit0...Bit 31	BOOL	0
EN	1 = Called block will be processed	BOOL	1
IN	Binary input value <ul style="list-style-type: none"> • Bit 0 .. 31 	<ul style="list-style-type: none"> • BOOL 	

Output parameters

Parameter	Description	Type	Default
ENO	1 = Block algorithm completed without errors	BOOL	0
Out	Structure of 0...31 binary signals	STRUCT <ul style="list-style-type: none"> • Bit0: BOOL • ... • Bit31: BOOL 	- <ul style="list-style-type: none"> • 0

See also

- StrctCom block diagram (Page 2020)
- StrctCom messaging (Page 2019)
- StrctCom error handling (Page 2019)
- StrctCom functions (Page 2018)
- StrctCom modes (Page 2018)
- Description of StrctCom (Page 2017)

14.9.7 StrctCom block diagram

Block diagram of StrctCom

A block diagram is not provided for this block.

See also

- StrctCom I/Os (Page 2019)
- StrctCom messaging (Page 2019)
- StrctCom error handling (Page 2019)
- StrctCom functions (Page 2018)

StrctCom modes (Page 2018)

Description of StrctCom (Page 2017)

14.10 StrctDeC - Structure decomposer for 32-bit structures

14.10.1 Description of StrctDeC

Object name (type + number) and family

Type + number: FC 396

Family: LogicDi

Area of application for StrctDeC

The block forms a DWORD type output and 32 single binary outputs from a structure type input with 32 binary structural elements. The input structure corresponds, for example, to the `OS_Perm` inputs of the technological blocks. If you use an `OS_Perm` input in a CFC source chart, you can use this block to transform the structured input in separate binary values inside the CFC source chart. For more information, refer to the Source chart for GainSched function block (gain scheduling) (Page 2347).

How it works

The block is used to create a DWORD or single binary outputs from the structure of 32 input bits.

Configuration

Use the CFC editor to install the block in a cyclic interrupt OB (OB30 to OB38).

Startup characteristics

The block does not have any startup characteristics.

Status word allocation for Status parameter

This block does not have the `Status` parameter.

See also

StrctDeC modes (Page 2023)

StrctDeC functions (Page 2023)

StrctDeC error handling (Page 2024)

StrctDeC messaging (Page 2024)

StrctDeC I/Os (Page 2024)

StrctDeC block diagram (Page 2025)

14.10.2 StrctDeC modes

StrctDeC operating modes

This block does not have any operating modes.

See also

Description of StrctDeC (Page 2022)

StrctDeC functions (Page 2023)

StrctDeC error handling (Page 2024)

StrctDeC messaging (Page 2024)

StrctDeC I/Os (Page 2024)

StrctDeC block diagram (Page 2025)

14.10.3 StrctDeC functions

Functions of StrctDeC

The functions for this block are listed below.

The input structure `In` is assigned to a DWORD output and to 32 single binary outputs.

```
OutDW = Structure In
```

```
Bit0 = In.Bit0
```

```
Bit1 = In.Bit1
```

```
...
```

```
Bit31 = In.Bit31
```

See also

Description of StrctDeC (Page 2022)

StrctDeC modes (Page 2023)

StrctDeC error handling (Page 2024)

StrctDeC messaging (Page 2024)

StrctDeC I/Os (Page 2024)

StrctDeC block diagram (Page 2025)

14.10.4 StrctDeC error handling

Error handling of StrctDeC

The block does not report any errors.

See also

Description of StrctDeC (Page 2022)

StrctDeC modes (Page 2023)

StrctDeC functions (Page 2023)

StrctDeC messaging (Page 2024)

StrctDeC I/Os (Page 2024)

StrctDeC block diagram (Page 2025)

14.10.5 StrctDeC messaging

Messaging

This block does not offer messaging.

See also

Description of StrctDeC (Page 2022)

StrctDeC modes (Page 2023)

StrctDeC functions (Page 2023)

StrctDeC error handling (Page 2024)

StrctDeC I/Os (Page 2024)

StrctDeC block diagram (Page 2025)

14.10.6 StrctDeC I/Os

I/Os of StrctDeC

Input parameters

Parameter	Description	Type	Default
EN	1 = Called block will be processed	BOOL	1
In	Structure of 0...31 binary signals Bit 0...31	STRUCT <ul style="list-style-type: none"> • Bit0: BOOL • ... • Bit31: BOOL 	- <ul style="list-style-type: none"> • 0 • 0 • 0

Output parameters

Parameter	Description	Type	Default
ENO	1 = Block algorithm completed without errors	BOOL	0
OutDW	DWORD output value	DWORD	16#00000000
Bit0	Binary output value	Bit0: BOOL	0
...
Bit31	Binary output value	Bit0: BOOL	0

See also

[Description of StrctDeC \(Page 2022\)](#)

[StrctDeC modes \(Page 2023\)](#)

[StrctDeC functions \(Page 2023\)](#)

[StrctDeC error handling \(Page 2024\)](#)

[StrctDeC messaging \(Page 2024\)](#)

[StrctDeC block diagram \(Page 2025\)](#)

14.10.7 StrctDeC block diagram

Block diagram of StrctDeC

A block diagram is not provided for this block.

See also

[Description of StrctDeC \(Page 2022\)](#)

[StrctDeC modes \(Page 2023\)](#)

[StrctDeC functions \(Page 2023\)](#)

[StrctDeC error handling \(Page 2024\)](#)

StrctDeC messaging (Page 2024)

StrctDeC I/Os (Page 2024)

14.11 Trigger - Detection of rising and falling edges

14.11.1 Description of Trigger

Object name (type + number) and family

Type + number: FB 1821

Family: LogicDi

Area of application for Trigger

The block is used for the following applications:

- Detection of rising and falling edges

How it works

This block checks the input variable Clk for occurrences of rising and falling edges, and signals them at the outputs `EdgeRising` and `EdgeFalling`.

Output `EdgeRising` is set to 1 for a block cycle at a rising edge. Output `EdgeFalling` is set to 1 for a block cycle at a falling edge.

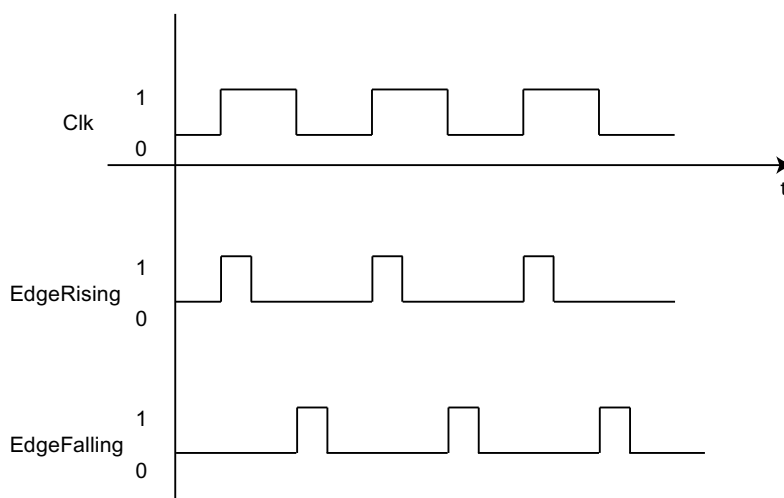

Configuration

Use the CFC editor to install the block in a cyclic interrupt OB (OB30 to OB38).

Startup characteristics

Edge detection is suppressed at startup or initial startup.

With the input parameter `InitOnRestart`, you can influence the startup behavior of the output parameters `InitOut`, `EdgeRising`, and `EdgeFalling`:

- `InitOnRestart = 0` (Default):
The output parameters `EdgeRising` and `EdgeFalling` remain unchanged and the output parameter `InitOut` will reset to false.
- `InitOnRestart = 1`:
The output parameters `EdgeRising` and `EdgeFalling` will reset to false and the output parameter `InitOut` will set to true. In the second cycle of OB30 to OB38, the output parameter `InitOut` will be reset. You can connect this output parameter with the input parameter `Init` of the block `Limit`, `TimerP`, or `FlipFlop` to initialize these blocks. For more information, refer to Startup characteristics over Trigger block (Page 69).

Status word allocation for `status` parameter

This block does not have the `Status` parameter.

See also

- Trigger modes (Page 2028)
- Trigger functions (Page 2029)
- Trigger error handling (Page 2029)
- Trigger messaging (Page 2030)
- Trigger I/Os (Page 2030)
- Trigger block diagram (Page 2031)

14.11.2 Trigger modes

Trigger operating modes

This block does not have any operating modes.

See also

- Description of Trigger (Page 2027)
- Trigger functions (Page 2029)
- Trigger error handling (Page 2029)
- Trigger messaging (Page 2030)
- Trigger I/Os (Page 2030)
- Trigger block diagram (Page 2031)

14.11.3 Trigger functions

Functions of Trigger

This block provides the function:

Forming the signal status for blocks

The `Clk.ST` status is transmitted with each cycle to `EdgeRising.ST` and `EdgeFalling.ST`.

Trigger forms the signal status as follows:

- `EdgeRising.ST := Clk.ST`
- `EdgeFalling.ST := Clk.ST`

See also

Description of Trigger (Page 2027)

Trigger modes (Page 2028)

Trigger error handling (Page 2029)

Trigger messaging (Page 2030)

Trigger I/Os (Page 2030)

Trigger block diagram (Page 2031)

14.11.4 Trigger error handling

Error handling of Trigger

The block does not report any errors.

See also

Description of Trigger (Page 2027)

Trigger modes (Page 2028)

Trigger functions (Page 2029)

Trigger messaging (Page 2030)

Trigger I/Os (Page 2030)

Trigger block diagram (Page 2031)

14.11.5 Trigger messaging

Messaging

This block does not offer messaging.

See also

Description of Trigger (Page 2027)

Trigger modes (Page 2028)

Trigger functions (Page 2029)

Trigger error handling (Page 2029)

Trigger I/Os (Page 2030)

Trigger block diagram (Page 2031)

14.11.6 Trigger I/Os

SeID02In I/Os

Input parameters

Parameter	Description	Type	Default
EN	1 = Called block will be processed	BOOL	1
clk	Input	STRUCT <ul style="list-style-type: none"> • Value: BOOL • ST: BYTE 	- <ul style="list-style-type: none"> • 0 • 16#80
InitOnRestart	1 = Initialization on warm restart	BOOL	0

Output parameters

Parameter	Description	Type	Default
ENO	1 = Block algorithm completed without errors	BOOL	0
EdgeRising	Output	STRUCT <ul style="list-style-type: none"> • Value: BOOL • ST: BYTE 	- <ul style="list-style-type: none"> • 0 • 16#80

Parameter	Description	Type	Default
EdgeFalling	Output	STRUCT <ul style="list-style-type: none"> • Value: BOOL • ST: BYTE 	- <ul style="list-style-type: none"> • 0 • 16#80
InitOut	Recognition of warm restart (OB100)	BOOL	0

See also

Description of Trigger (Page 2027)

Trigger modes (Page 2028)

Trigger functions (Page 2029)

Trigger error handling (Page 2029)

Trigger messaging (Page 2030)

Trigger block diagram (Page 2031)

14.11.7 Trigger block diagram**Trigger block diagram**

A block diagram is not provided for this block.

See also

Description of Trigger (Page 2027)

Trigger modes (Page 2028)

Trigger functions (Page 2029)

Trigger error handling (Page 2029)

Trigger messaging (Page 2030)

Trigger I/Os (Page 2030)

14.12 XOr04 - EXCLUSIVE OR logic operation

14.12.1 Description of XOr04

Object name (type + number) and family

Type + number: FC 388

Family: LogicDi

Area of application for XOr04

The block is used for the following applications:

- EXCLUSIVE OR logic operation with up to 4 inputs

How it works

The block performs a logic operation with up to four input parameters *In1* to *In4*. The output parameter *Out* then becomes exactly 1, if there is a 1 at an uneven number of inputs and 0 at the rest of them.

Truth table

	In1	In2	In3	In4	Out
0	0	0	0	0	0
1	0	0	0	1	1
2	0	0	1	0	1
3	0	0	1	1	0
4	0	1	0	0	1
5	0	1	0	1	0
6	0	1	1	0	0
7	0	1	1	1	1
8	1	0	0	0	1
9	1	0	0	1	0
10	1	0	1	0	0
11	1	0	1	1	1
12	1	1	0	0	0
13	1	1	0	1	1
14	1	1	1	0	1
15	1	1	1	1	0

Configuration

Use the CFC editor to install the block in a cyclic interrupt OB (OB30 to OB38).

Startup characteristics

The block does not have any startup characteristics.

Status word allocation for `Status` parameter

This block does not have the `Status` parameter.

See also

- XOr04 modes (Page 2033)
- XOr04 functions (Page 2033)
- XOr04 error handling (Page 2034)
- XOr04 messaging (Page 2034)
- XOr04 I/Os (Page 2035)
- XOr04 block diagram (Page 2036)

14.12.2 XOr04 modes

XOr04 operating modes

This block does not have any operating modes.

See also

- Description of XOr04 (Page 2032)
- XOr04 functions (Page 2033)
- XOr04 error handling (Page 2034)
- XOr04 messaging (Page 2034)
- XOr04 I/Os (Page 2035)
- XOr04 block diagram (Page 2036)

14.12.3 XOr04 functions

Functions of XOr04

The functions for this block are listed below.

Forming the signal status for blocks

This block provides the standard function Forming and outputting the signal status of digital logic blocks (Page 110).

See also

Description of XOr04 (Page 2032)

XOr04 modes (Page 2033)

XOr04 error handling (Page 2034)

XOr04 messaging (Page 2034)

XOr04 I/Os (Page 2035)

XOr04 block diagram (Page 2036)

14.12.4 XOr04 error handling

XOr04 error handling

The block does not report any errors.

See also

Description of XOr04 (Page 2032)

XOr04 modes (Page 2033)

XOr04 functions (Page 2033)

XOr04 messaging (Page 2034)

XOr04 I/Os (Page 2035)

XOr04 block diagram (Page 2036)

14.12.5 XOr04 messaging

Messaging

This block does not offer messaging.

See also

Description of XOr04 (Page 2032)

XOr04 modes (Page 2033)

XOr04 functions (Page 2033)

XOr04 error handling (Page 2034)

XOr04 I/Os (Page 2035)

XOr04 block diagram (Page 2036)

14.12.6 XOr04 I/Os

XOr04 I/Os

Input parameters

Parameter	Description	Type	Default
EN	1 = Called block will be processed	BOOL	1
In1	Input 1	STRUCT <ul style="list-style-type: none"> Value: BOOL ST: BYTE 	- <ul style="list-style-type: none"> 0 16#80
In2	Input 2	STRUCT <ul style="list-style-type: none"> Value: BOOL ST: BYTE 	- <ul style="list-style-type: none"> 0 16#80
In3	Input 3	STRUCT <ul style="list-style-type: none"> Value: BOOL ST: BYTE 	- <ul style="list-style-type: none"> 0 16#80
In4	Input 4	STRUCT <ul style="list-style-type: none"> Value: BOOL ST: BYTE 	- <ul style="list-style-type: none"> 0 16#80

Output parameters

Parameter	Description	Type	Default
ENO	1 = Block algorithm completed without errors	BOOL	0
Out	Output	STRUCT <ul style="list-style-type: none"> Value: BOOL ST: BYTE 	- <ul style="list-style-type: none"> 0 16#80

See also

Description of XOr04 (Page 2032)

XOr04 modes (Page 2033)

XOr04 functions (Page 2033)

XOr04 error handling (Page 2034)

XOr04 messaging (Page 2034)

XOr04 block diagram (Page 2036)

14.12.7 XOr04 block diagram

XOr04 block diagram

A block diagram is not provided for this block.

See also

Description of XOr04 (Page 2032)

XOr04 modes (Page 2033)

XOr04 functions (Page 2033)

XOr04 error handling (Page 2034)

XOr04 messaging (Page 2034)

XOr04 I/Os (Page 2035)

Generator blocks

15.1 NoiseGen - Generating signal noise

15.1.1 Description of NoiseGen

Object name (type + number) and family

Object name: FB 1863

Family: Genrator

Area of application for NoiseGen

The block is used for the following applications:

- Noise generator

The block can only be used for the simulation in the example project.

How it works

This block serves to generate signal noise. It is used for demonstration purposes in the example project so that the simulated signals react naturally.

You can employ it for simulation examples, demonstrations, trade fair models etc. It is never needed in real plants because real measuring devices always supply signals with noise.

There is an example project for the NoiseGen block (APL_Example_xx, xx refers to the language variant) with an application scenario for this block, which explains how the block works.

Application scenario in the example project:

- Process simulation including noise generator (ProcSimC; ProcSimS) (Page 2373)

See also

NoiseGen I/Os (Page 2038)

15.1.2 NoiseGen I/Os

NoiseGen I/Os

Input parameters

Parameter	Description	Type	Default
EN	1 = Called block will be processed	BOOL	1
Enable	1 = generate noise signals	BOOL	1
Offset	Mean temporal value of the <code>Noise</code> output signal	REAL	20.0
Restart*	1 = block restart	BOOL	1
StdDev	Standard deviation of the noise signal	REAL	1.0

* Values can be written back to these inputs during processing of the block by the block algorithm.

Output parameters

Parameter	Description	Type	Default
ENO	1 = Block algorithm completed without errors	BOOL	0
Noise	Generated noise signal	STRUCT <ul style="list-style-type: none"> • Value: REAL • ST: BYTE 	- <ul style="list-style-type: none"> • 0.0 • 16#80

See also

Description of NoiseGen (Page 2037)

Channel blocks

16.1 Information on using channel blocks

Information on using channel blocks

- The descriptions of the channel blocks specify the OBs in which the blocks are installed. Please note that not all OBs listed will be generated for all CPUs. You can find additional information in the online help of the particular OB.
- If the driver generator uses the channel blocks of the PCS 7 libraries, you require firmware version V3.1 or higher on the CPU.
- The CFC function "Generate module drivers" interconnects and configures the required I/Os automatically. The function is called and executed if hardware modifications are detected when compiling the program, for example.

Signal-processing blocks

Various types of channel blocks are provided in this PCS 7 library for processing signals from inputs and outputs:

1. Standard channel blocks

This applies to the following blocks:

- Pcs7AnIn
- Pcs7AnOu
- Pcs7DiIn
- Pcs7DiOu
- Pcs7DiIT

These blocks are used only for processing the signals of S7-300/400 SM modules. Use these standard blocks if you want to optimize memory and runtime utilization and do not need to process any PA devices.

2. FF/PA channel blocks

This applies to the following blocks:

- FbAnIn
- FbAnOu
- FbAnTot
- FbDiIn
- FbDiOu

These blocks are designed especially for use with PA field devices and the PROFIBUS 3.0 Class A and B or with FF field devices. In particular, you should use these blocks if you want to make use of the special features of these devices. In contrast to standard channel blocks, PA channel blocks not only process the signal itself but also all variables, according to the desired device configuration selected in the hardware configuration.

16.2 FbAnIn - Analog input channel block for field devices

16.2.1 Description of FbAnIn

Object name (type + number) and family

Type + number: FB 1813

Family: Channel

Area of application for FbAnIn

The block is used for the following applications:

- Signal processing (cyclic service) in accordance with "Transmitter" PROFIBUS PA profile of an analog input value:
 - Of a PA field device in accordance with PROFIBUS 3.0 class A and B
 - Of an auxiliary variable of a HART field device
 - Of an FF field device
- Processing of the redundant input channels.

How it works

Block FbAnIn cyclically reads the process value and the signal status of the field device from the process image (partition). The process value is available as a physical variable. The signal status contains information about the status of the field device.

Configuration

Use the CFC editor to install the block in a cyclic interrupt OB (OB30 to OB38).

Connect the symbol generated in HW Config (symbol table) for the input channel with the `PV` input parameter.

In case of redundant I/O configuration, use symbol of the channel of the master module.

When the CFC function "Generate module drivers" is used, the following occurs automatically:

- The in/out parameter `Mode` is interconnected with the corresponding output parameter `OMODE_XX` of the `MOD_PAL0`, `FF_MOD32-` or `MOD_PAX0` block.
- The in/out parameter `DataXchg` is interconnected with the corresponding output parameter `DXCHG_XX` of the `MOD_PAL0`, `FF_MOD32-` or `MOD_PAX0` block.

- The symbol for the signal status of the analog input channel is interconnected to input PV_ST.
- The MS parameter is interconnected to the O_MS output parameter of the diagnostics block.

Note

If you are not using the CFC function "Generate module drivers" you must set the in/out parameter Mode manually. Refer to the Mode settings for field devices (Page 2217) chapter for more on this.

In case of redundancy, connection with both quality bits and connection with the redundant slave channel:

- The in parameter PVS1v is interconnected with the symbol of the slave channel.
- The in parameter PV_ST is interconnected with the symbol of the quality byte of the master channel.
- The in parameter PVS1v_ST is interconnected with the symbol of the quality byte of the slave channel.

For the FbAnIn block, the Advanced Process Library contains templates for process tag types as examples with various application scenarios for this block.

Examples of process tag types:

- Monitoring of an analog process tag for PA/FF devices (AnalogMonitoring_Fb) (Page 2357)
- Dosing with PA/FF devices (Dose_Lean_Fb) (Page 2359)
- PID controller for PA/FF devices (PIDControl_Lean_Fb) (Page 2323)

Quality code (ET200 SP HA modules)

The quality code is read from the process image and has two states: "Good" or "Bad".

Redundancy

The block monitors the values of the redundant signals (master and slave) with quality code and:

- the value of the signal with "Good" quality code along with its quality code is transferred to the process when one of the signals delivers "Good" quality code.
- the value of the master signal along with its quality code is transferred to the process when both the signals deliver "Bad" quality code.

Startup characteristics

The block does not have any startup characteristics.

Status word allocation for Status parameter

This block does not have the Status parameter.

See also

FbAnIn block diagram (Page 2049)

FbAnIn I/Os (Page 2047)

FbAnIn messaging (Page 2046)

FbAnIn error handling (Page 2045)

FbAnIn functions (Page 2043)

FbAnIn modes (Page 2043)

16.2.2 FbAnIn modes

FbAnIn modes

This block does not have any operating modes.

See also

FbAnIn block diagram (Page 2049)

FbAnIn I/Os (Page 2047)

FbAnIn messaging (Page 2046)

FbAnIn error handling (Page 2045)

FbAnIn functions (Page 2043)

Description of FbAnIn (Page 2041)

16.2.3 FbAnIn functions

Functions of FbAnIn

The functions for this block are listed below.

Obtaining the standard value

The analog value of the process image (partition) is output as a standard value at the `PV_Li` output parameter.

Holding the last value if raw value is invalid

If the block is to hold its last valid value when the analog value is invalid or in the initialization phase of the device, you must activate this function at the `Feature Bit Outputting last valid value if raw value is invalid` (Page 154).

Output substitute value if raw value is invalid

If the block is to output a substitute value (`SubsPV`) when the analog value is invalid or in the initialization phase of the device, you must activate this function at the `Feature Bit Output substitute value if raw value is invalid` (Page 149).

Outputting an invalid value if analog value is invalid

If the block is to output an invalid value (`PV_Li = PV`), you must activate this function at the `Feature Bit Output invalid raw value` (Page 174).

This function is preset.

Flutter suppression

This block provides the standard function Flutter suppression for channel blocks (Page 67)

Signal status for Fb channel blocks

The block provides the standard function Forming and outputting the signal status for channel blocks for field devices (Page 119).

The signal status of process value `PV_Li` is generated from internal events such as channel errors, higher-level errors, or simulations, as well as from the signal status `PV_ST`, which comes directly from the device.

The signal status `PV_ST` can accept values of 16#00 - 16#FF.

The block recognizes a higher-level error, for example, failure of a DP/PA link, via the `Mode` input parameter.

- If the high byte is `Mode = 16#80`, then the values in the process image (partition) are valid.
- If the high byte `Mode = 16#40` (value status = higher-level error, `ModErr = 1`), then the analog value is treated as invalid.

The measuring type set in the low word of the `Mode` input parameter will be ignored.

The bit combinations of signal status `PV_ST` are output as output parameters (BOOL values). These conform to the bit combinations specified in PROFIBUS 3.0 "General Requirements".

For FF field devices only: The values of the signal status `PV_ST = 16#84 - 16#87` and `16#90 - 16#93` are evaluated by the link in the same way as signal status `16#80 - 16#83`.

If the signal status `PV_ST = 16#80` and a process value `PV` with the value `16#7FFFFFFF` (invalid) are transferred from the FF field device, the block will deal with the signal status `16#00` (invalid) from the FF field device.

Simulating signals

The block provides the standard function Simulating signals (Page 58).

Configurable reactions using the `Feature` parameter

You can find an overview of all reactions provided by the `Feature` parameter in the Configurable functions using the Feature I/O (Page 131) . The following functionality is available for this block at the relevant bits:

Bit	Function
10	Condition monitoring information at the channel blocks (Page 145)
28	Output invalid raw value (Page 174)
29	Output substitute value if raw value is invalid (Page 149)
30	Outputting last valid value if raw value is invalid (Page 154)

Sign-of-life monitoring

If an input value whose signal status is `16#80` (good) remains constant for a programmable time (monitoring time), the input value is detected as faulty and the outputs `Bad = 1` and `FrzVal = 1` are set.

The monitoring time is set at the `FrznTmIn` input parameter in seconds. With `FrznTmIn = 0` or `FrznEn = 0` (default setting), the sign-of-life monitoring is deactivated, any pending errors are reset.

The input value is considered as faulty as long as it seen as constant. The monitoring time is restarted each time the input value is changed.

See also

FbAnIn block diagram (Page 2049)
 FbAnIn I/Os (Page 2047)
 FbAnIn messaging (Page 2046)
 FbAnIn error handling (Page 2045)
 FbAnIn modes (Page 2043)
 Description of FbAnIn (Page 2041)

16.2.4 FbAnIn error handling

Error handling of FbAnIn

Please refer to the section Error handling (Page 119) in the basic instructions.

The following errors can be displayed for this block:

- Channel error
- Higher-level error

- Invalid measuring range
- Frozen input value (sign-of-life monitoring)

Channel error

At the output parameter `Bad`, channel errors are displayed with 1. The channel error is generated from the signal status `PV_ST`.

Higher-level error / invalid measuring range

A higher-level error is displayed at the output parameters `ModErr` and `Bad` with 1 if the signal status at `High Word` of the input parameter `Mode` accepts the value `16#40`.

A higher-level error is also present when an incorrect measuring type is entered in `Low Word` of the input parameter `Mode`.

In addition, at the output parameter `PV_Li` of the signal status, either `16#00` (in the event of an error) or `16#60` (for manipulated value (for example, substitute value, simulation, last valid value) is output.

See also

FbAnIn block diagram (Page 2049)

FbAnIn I/Os (Page 2047)

FbAnIn messaging (Page 2046)

FbAnIn functions (Page 2043)

FbAnIn modes (Page 2043)

Description of FbAnIn (Page 2041)

16.2.5 FbAnIn messaging

Messaging

This block does not offer messaging.

See also

FbAnIn block diagram (Page 2049)

FbAnIn I/Os (Page 2047)

FbAnIn error handling (Page 2045)

FbAnIn functions (Page 2043)

FbAnIn modes (Page 2043)

Description of FbAnIn (Page 2041)

16.2.6 FbAnIn I/Os

I/Os of FbAnIn

Input parameters

Parameter	Description	Type	Default
EN	1 = Called block will be processed	BOOL	1
Feature	I/O for additional functions (Page 2043)	STRUCT <ul style="list-style-type: none"> • Bit 0: BOOL • ... • Bit 28: BOOL • ... • Bit 31: BOOL 	- <ul style="list-style-type: none"> • 0 • 0 • 1 • 0 • 0
FlutEn	1 = Flutter suppression activated	BOOL	0
FlutTmIn*	Flutter time [s]	INT	0
FrznEn	1 = Sign-of-life monitoring activated	BOOL	0
FrznTmIn	Monitoring time in [s]	REAL	0.0
MS	Maintenance status	DWORD	16#00000000
MS_Release	Release for maintenance (interconnected with MS_Release of the technology block)	STRUCT <ul style="list-style-type: none"> • Value: BOOL • ST: BYTE 	- <ul style="list-style-type: none"> • 0 • 16#80
Ms_Ext	External maintenance status	DWORD	16#00000000
PV	Process value (analog value)	REAL	0.0
PVslv	Process value of the slave	REAL	0.0
PVslv_ST	State of the slave process value	BYTE	16#00
PV_ST	Signal status for the process value	BYTE	16#80
PV_Unit	Unit of measure for process value	INT	1001
SampleTime	Sampling time in [s]	REAL	0.1
Scale	Scaling of the process value as a structure	STRUCT <ul style="list-style-type: none"> • High: REAL • Low:REAL 	- <ul style="list-style-type: none"> • 100.0 • 0.0
SimOn	1 = Simulation on	STRUCT <ul style="list-style-type: none"> • Value: BOOL • ST: BYTE 	- <ul style="list-style-type: none"> • 0 • 16#80
SimPV	Process value used for SimOn = 1	STRUCT <ul style="list-style-type: none"> • Value: REAL • ST: BYTE 	- <ul style="list-style-type: none"> • 0.0 • 16#80
SubsPV	Substitute value	REAL	0.0
TextRef	Text reference	WORD	16#0000

* Values can be written back to these inputs during processing of the block by the block algorithm.

In/out parameters

Parameter	Description	Type	Default
DataXchg	Internal data exchange channel to the diagnostics block	DWORD	16#00000000
DataXchg1	Internal data exchange channel to the diagnostics block	DWORD	16#00000000
MS_Xchg	Exchange of the maintenance status	DWORD	16#00000000
Mode	Value status and measuring type	DWORD	16#00000000

Output parameters

Parameter	Description	Type	Default
Bad	1 = Process value is not valid	STRUCT • Value: BOOL • ST: BYTE	- • 0 • 16#80
ENO	1 = Block algorithm completed without errors	BOOL	0
ErrorNum	Output of pending error number. For error numbers that can be output by this block, see FbAnIn error handling (Page 2045)	INT	-1
FrznVal	Frozen process value	STRUCT • Value: BOOL • ST: BYTE	- • 0 • 16#80
ModErr	1 = Device/module is faulty	STRUCT • Value: BOOL • ST: BYTE	- • 0 • 16#80
MS_Dev	Maintenance state	DWORD	16#00000000
MS_Req	1 = Maintenance request from the diagnostic area	STRUCT • Value: BOOL • ST: BYTE	- • 0 • 16#80
OosAct	1 = Field device is undergoing maintenance	STRUCT • Value: BOOL • ST: BYTE	- • 0 • 16#80
PV_Li	Standard value (physical variable)	STRUCT • Value: REAL • ST: BYTE	- • 0.0 • 16#80
PV_LiUnit	Unit of the process value	INT	0
RemTime	Remaining monitoring time [s]	REAL	0.0
SampleTime	Sampling time [s]	REAL	0.1
ScaleOut	Scaling of the process value as a structure	STRUCT • High: REAL • Low: REAL	- • 100.0 • 0.0
SimAct	1 = Simulation active	STRUCT • Value: BOOL • ST: BYTE	- • 0 • 16#80

See also

FbAnIn block diagram (Page 2049)

FbAnIn messaging (Page 2046)

FbAnIn modes (Page 2043)

Description of FbAnIn (Page 2041)

16.2.7 FbAnIn block diagram

FbAnIn block diagram

A block diagram is not provided for this block.

See also

FbAnIn I/Os (Page 2047)

FbAnIn messaging (Page 2046)

FbAnIn error handling (Page 2045)

FbAnIn functions (Page 2043)

FbAnIn modes (Page 2043)

Description of FbAnIn (Page 2041)

16.3 FbAnOu - Analog output channel block for field devices

16.3.1 Description of FbAnOu

Object name (type + number) and family

Type + number: FB 1814

Family: Channel

Area of application for FbAnOu

The block is used for the following applications:

Signal processing (cyclic service) in accordance with "Actuator" PROFIBUS PA profile of an analog input value:

- Of a PA field device in accordance with PROFIBUS 3.0 class A and B
- Of an FF field device

How it works

Block FbAnOu cyclically reads the process values and the signal status of the field device from the process image (partition). The process values are available as physical variables. The signal status contains information about the status of the field device.

Configuration

Use the CFC editor to install the block in a cyclic interrupt OB (OB30 to OB38). The block is also installed automatically in the startup OB (OB100).

You must interconnect each used signal of the block with the symbols configured in HW Config or in the symbol table according to your user data configuration:

PA device connection	Data type	I/O
Rbk	REAL	Input
RCasOut	REAL	Input
PosD	BYTE	Input
SP	REAL	Output
RCasIn	REAL	Output

When the CFC function "Generate module drivers" is used, the following occurs automatically:

- The in/out parameter `Mode` is interconnected with the corresponding output parameter `OMode_xx` of the MOD_PAL0, FF_MOD32- or MOD_PAX0 block.
- The in/out parameter `DataXchg` is interconnected with the corresponding output parameter `DataXchg_xx` of the MOD_PAL0, FF_MOD32- or MOD_PAX0 block.

- The MS parameter is interconnected to the O_MS output parameter of the diagnostics block.
- The corresponding signal status is symbolically interconnected depending on your user data configuration:

I/O field device	Data type	I/O
RbkST	BYTE	Input
RCasOutST	BYTE	Input
PosD_ST	BYTE	Input
SP_ST	BYTE	Output
RCasIn_ST	BYTE	Output
CbkBy0	BYTE	Input
CbkBy1	BYTE	Input
CbkBy2	BYTE	Input

Note

If you are not using the CFC function "Generate module drivers" you must set the in/out parameter `Mode` manually. Refer to the Mode settings for field devices (Page 2217) chapter for more on this.

For the FbAnOu block, the Advanced Process Library contains templates for process tag types as examples with various application scenarios for this block.

Examples of process tag types:

- PID controller for PA/FF devices (PIDControl_Lean_Fb) (Page 2323)
- Control valve for PA/FF devices (ValveAnalog_Fb) (Page 2371)

Startup characteristics

The block is executed once in OB100 at system start. The output and in/out parameters are calculated.

Quality code (ET200 SP HA modules)

The quality code is read from the process image and has two states: "Good" or "Bad".

Redundancy

The block monitors the values of the redundant signals (master and slave) with quality code and the value of the signal with "Good" quality code along with its quality code is transferred to the process.

Status word allocation for `Status` parameter

This block does not have the `Status` parameter.

See also

FbAnOu block diagram (Page 2059)

FbAnOu I/Os (Page 2055)

FbAnOu error handling (Page 2054)

FbAnOu functions (Page 2052)

FbAnOu modes (Page 2052)

FbAnOu messaging (Page 2054)

16.3.2 FbAnOu modes

FbAnOu modes

This block does not have any modes.

16.3.3 FbAnOu functions

Functions of FbAnOu

The functions for this block are listed below.

Obtaining the standard value

The signals of the FF field device are read from the process image (partition) of the inputs and written to the process image (partition) of the outputs. The controlled variable `Rbk` and discrete position feedback `PosD`, are read, as well as the active reference variable `RCasOut`, together with its associated signal status `RbkST`, `PosD_ST` and `RCasOutST` are read and written to the output parameters `SP` and `RCasIn`, with the associated signal status `RbkST` and `RCasInST`.

Additional detailed device information (`Cbk0` - `Cbk2`) can be read as an option. The device information is available per bit at the block output.

The signal status `RbkST` or `RCasOutST` that comes directly from the device can have values from `16#00` – `16#FF`.

The values of the signal status `PosD_ST` and `RbkST` of `16#84` - `16#87` and `16#90` – `16#93` of the FF field device are evaluated like the signal status `16#80` – `16#83`.

Flutter suppression

This block provides the standard function Flutter suppression for channel blocks (Page 67)

Signal status for Fb channel blocks

The block provides the standard function Forming and outputting the signal status for channel blocks for field devices (Page 119).

The signal status of the process values (`RCasInLi` or `RbkLi`) is generated from internal events such as channel errors, higher-level errors, or simulations, as well as from the signal status `RbkST` or `RCasInST`, which comes directly from the device.

Value	Meaning
16#80	Valid value
16#60	Manipulated value (for example, substitute value, simulation, last valid value)
16#28	Bad, process related
16#68	Uncertain, device related
16#78	Uncertain, process related
16#A4	Maintenance request present
16#00	Invalid value

Simulating signals

The block provides the standard function Simulating signals (Page 58).

Configurable reactions using the `Feature` parameter

You can find an overview of all reactions provided by the `Feature` parameter in the Configurable functions using the Feature I/O (Page 131) . The following functionality is available for this block at the relevant bits:

Bit	Function
10	Condition monitoring information at the channel blocks (Page 145)
30	Outputting a de-energized value for block-external simulation (Page 148)

See also

FbAnOu block diagram (Page 2059)

FbAnOu I/Os (Page 2055)

FbAnOu error handling (Page 2054)

FbAnOu modes (Page 2052)

Description of FbAnOu (Page 2050)

FbAnOu messaging (Page 2054)

16.3.4 FbAnOu error handling

Error handling of FbAnOu

Refer to the section Error handling (Page 119) in the basic instructions for the error handling of all blocks.

The following errors can be displayed for this block:

- Channel error
- Higher-level error
- Invalid measuring range

Channel error

At the output parameter `Bad`, channel errors are displayed with 1.

The channel error is generated from the signal states `RbkST`, `RCasOutST`, and `PosD_ST`. In addition to this, a channel error (`Bad = 1`) also occurs if the signal status has a valid value (`RbkST` or `RCasOutST` is `16#80`) and the present position of actuator `Rbk` or `RCasOut` has the value `16#7FFFFFFF` (invalid).

Higher-level error / invalid measuring range

A higher-level error is displayed at the output parameters `ModErr` and `Bad` with 1 if the signal status at `High Word` of the input parameter `Mode` accepts the value `16#40`.

A higher-level error is also present when an incorrect measuring type is entered in `Low Word` of the input parameter `Mode`.

16.3.5 FbAnOu messaging

Messaging

This block does not offer messaging.

See also

Description of FbAnOu (Page 2050)

FbAnOu modes (Page 2052)

FbAnOu functions (Page 2052)

FbAnOu error handling (Page 2054)

FbAnOu I/Os (Page 2055)

FbAnOu block diagram (Page 2059)

16.3.6 FbAnOu I/Os

I/Os of FbAnOu

Input parameters

Parameter	Description	Type	Default
CbkBy0	Additional information on the actuator status	BYTE	16#00
CbkBy1	Additional information on the actuator status	BYTE	16#00
CbkBy2	Additional information on the actuator status	BYTE	16#00
EN	1 = Called block will be processed	BOOL	1
Feature	I/O for additional functions (Page 2052)	STRUCT <ul style="list-style-type: none"> • Bit 0: BOOL • ... • Bit 30: BOOL • Bit 31: BOOL 	- <ul style="list-style-type: none"> • 0 • 0 • 1 • 0
FlutEn	1 = Flutter suppression activated	BOOL	0
FlutTmIn*	Flutter time [s]	INT	0
MS	Maintenance status	DWORD	16#00000000
MS_Release	Release for maintenance (interconnected with MS_Release of the technology block)	STRUCT <ul style="list-style-type: none"> • Value: BOOL • ST: BYTE 	- <ul style="list-style-type: none"> • 0 • 16#80
Ms_Ext	External maintenance status	DWORD	16#00000000
PosD	Discrete position feedback (current position) of the valve: 0 = Not initialized 1 = Closed 2 = Opened 3 = Intermediate	BYTE	16#00
PosD_ST	Signal status of PosD	BYTE	16#80
PVslv_ST	State of the slave process value	BYTE	16#00
RCasInLi	Setpoint for the remote cascade operating mode	STRUCT <ul style="list-style-type: none"> • Value: REAL • ST: BYTE 	- <ul style="list-style-type: none"> • 0.0 • 16#80
RCasOut	Setpoint from function block in device	REAL	0.0
RCasOutST	Signal status of RCasOut	BYTE	16#80
Rbk	Current position of actuator (actual value)	REAL	0.0
RbkST	Signal status of Rbk	BYTE	16#80
Scale	Scaling of the process value as structure for display	STRUCT <ul style="list-style-type: none"> • High: REAL • Low:REAL 	- <ul style="list-style-type: none"> • 100.0 • 0.0

Channel blocks

16.3 FbAnOu - Analog output channel block for field devices

Parameter	Description	Type	Default
SP_Li	Setpoint	STRUCT <ul style="list-style-type: none"> Value: REAL ST: BYTE 	- <ul style="list-style-type: none"> 0.0 16#80
SP_LiUnit	Unit of measure for setpoint	INT	1342
SimOn	1 = Simulation on	STRUCT <ul style="list-style-type: none"> Value: BOOL ST: BYTE 	- <ul style="list-style-type: none"> 0 16#80
SimPosD	Discrete position feedback for (output parameter PosD_Li), that is used for SimOn = 1.	BYTE	16#00
SimRCasInLi	Setpoint for the remote cascade operating mode RCasInLi, used for SimOn = 1	STRUCT <ul style="list-style-type: none"> Value: REAL ST: BYTE 	- <ul style="list-style-type: none"> 0.0 16#80
SimRbk	Current position of the valve (actual value) Rbk, used for SimOn = 1	STRUCT <ul style="list-style-type: none"> Value: REAL ST: BYTE 	- <ul style="list-style-type: none"> 0.0 16#80
SimSP_Li	Setpoint SP_Li, used for SimOn = 1	STRUCT <ul style="list-style-type: none"> Value: REAL ST: BYTE 	- <ul style="list-style-type: none"> 0.0 16#80
TextRef	Text reference	WORD	16#0000

* Values can be written back to these inputs during processing of the block by the block algorithm.

In/out parameters

Parameter	Description	Type	Default
DataXchg	Internal data exchange channel to the diagnostics block	DWORD	16#00000000
DataXchg1	Internal data exchange channel to the diagnostics block	DWORD	16#00000000
MS_Xchg	Exchange of the maintenance status	DWORD	16#00000000
Mode	Value status and measuring type	DWORD	16#00000000

Output parameters

Parameter	Description	Type	Default
Bad	1 = Process value is not valid	STRUCT <ul style="list-style-type: none"> Value: BOOL ST: BYTE 	- <ul style="list-style-type: none"> 0 16#80
Cbk0	1 = Field device in safe position	STRUCT <ul style="list-style-type: none"> Value: BOOL ST: BYTE 	- <ul style="list-style-type: none"> 0 16#80

16.3 FbAnOu - Analog output channel block for field devices

Parameter	Description	Type	Default
Cbk1	1 = Request for "local operation"	STRUCT • Value: BOOL • ST: BYTE	- • 0 • 16#80
Cbk2	1 = Device is operated locally	STRUCT • Value: BOOL • ST: BYTE	- • 0 • 16#80
Cbk3	1 = Emergency operation is active	STRUCT • Value: BOOL • ST: BYTE	- • 0 • 16#80
Cbk4	1 = Deviation in direction of movement	STRUCT • Value: BOOL • ST: BYTE	- • 0 • 16#80
Cbk5	1 = Stop reached (actuator fully open)	STRUCT • Value: BOOL • ST: BYTE	- • 0 • 16#80
Cbk6	1 = Stop reached (actuator fully closed)	STRUCT • Value: BOOL • ST: BYTE	- • 0 • 16#80
Cbk7	1 = Runtime overshoot	STRUCT • Value: BOOL • ST: BYTE	- • 0 • 16#80
Cbk8	1 = Actuator is opening	STRUCT • Value: BOOL • ST: BYTE	- • 0 • 16#80
Cbk9	1 = Actuator is closing	STRUCT • Value: BOOL • ST: BYTE	- • 0 • 16#80
Cbk10	1 = Alarm generated by any change to the static data (FB and TB)	STRUCT • Value: BOOL • ST: BYTE	- • 0 • 16#80
Cbk11	1 = Simulation mode	STRUCT • Value: BOOL • ST: BYTE	- • 0 • 16#80
Cbk12	Not used	STRUCT • Value: BOOL • ST: BYTE	- • 0 • 16#80
Cbk13	1 = Internal control loop interrupted	STRUCT • Value: BOOL • ST: BYTE	- • 0 • 16#80

Channel blocks

16.3 FbAnOu - Analog output channel block for field devices

Parameter	Description	Type	Default
Cbk14	1 = Closed-loop control inactive	STRUCT • Value: BOOL • ST: BYTE	- • 0 • 16#80
Cbk15	1 = Self-test is active	STRUCT • Value: BOOL • ST: BYTE	- • 0 • 16#80
Cbk16	1 = Stroke integral exceeded	STRUCT • Value: BOOL • ST: BYTE	- • 0 • 16#80
Cbk17	1 = Additional input is active	STRUCT • Value: BOOL • ST: BYTE	- • 0 • 16#80
ENO	1 = Block algorithm completed without errors	BOOL	0
ErrorNum	Output of pending error number. For error numbers that can be output by this block, see FbAnOu error handling (Page 2054)	INT	-1
ModErr	1 = Device/module is faulty	STRUCT • Value: BOOL • ST: BYTE	- • 0 • 16#80
MS_Dev	Maintenance state	DWORD	16#00000000
MS_Req	1 = Maintenance request from the diagnostic area	STRUCT • Value: BOOL • ST: BYTE	- • 0 • 16#80
OosAct	1 = Field device is undergoing maintenance	STRUCT • Value: BOOL • ST: BYTE	- • 0 • 16#80
PosD_Li	Discrete position feedback (current position) of the valve: 0 = Not initialized 1 = Closed 2 = Opened 3 = Intermediate	BYTE	16#00
PosD_LiST	Signal status PosD_Li	BYTE	16#00
PosDCloseLi	1=feedback Close	STRUCT • Value: BOOL • ST: BYTE	- • 0 • 16#80
PosDOpenLi	1=feedback Open	STRUCT • Value: BOOL • ST: BYTE	- • 0 • 16#80
RCasIn	Setpoint for the remote cascade operating mode	REAL	0.0
RCasInST	Signal status of RCasIn	BYTE	16#00

16.3 FbAnOu - Analog output channel block for field devices

Parameter	Description	Type	Default
RCasOutLi	Setpoint from function block in device	STRUCT <ul style="list-style-type: none"> Value: REAL ST: BYTE 	- <ul style="list-style-type: none"> 0.0 16#80
RbkLi	Current position of actuator (actual value)	STRUCT <ul style="list-style-type: none"> Value: REAL ST: BYTE 	- <ul style="list-style-type: none"> 0.0 16#80
ScaleOut	Scaling of the process value as structure for display	STRUCT <ul style="list-style-type: none"> High: REAL Low:REAL 	- <ul style="list-style-type: none"> 100.0 0.0
SimAct	1 = Simulation active	STRUCT <ul style="list-style-type: none"> Value: BOOL ST: BYTE 	- <ul style="list-style-type: none"> 0 16#80
SP	Setpoint	REAL	0.0
SP_ST	Signal status of setpoint	BYTE	16#00
SP_Slv	Output setpoint of the slave device	REAL	0.0
SP_Unit	Unit of the process value (SP_LiUnit)	INT	0

16.3.7 FbAnOu block diagram

FbAnOu block diagram

A block diagram is not provided for this block.

16.4 FbDiln - Digital input channel block for field devices

16.4.1 Description of FbDiln

Object name (type + number) and family

Type + number: FB 1815

Family: Channel

Area of application for FbDiln

The block is used for the following applications:

Signal processing of digital input values (discrete input) of a field device (cyclic service in accordance with PROFIBUS PA):

- Of a PA field device in accordance with PROFIBUS 3.0 class A and B
- Of an FF field device

How it works

Block FbDiln cyclically reads the process values and the signal status of the field device from the process image (partition). The process values are grouped in one byte. The signal status contains information about the status of the field device.

Configuration

Use the CFC editor to install the block in a cyclic interrupt OB (OB30 to OB38).

When the CFC function "Generate module drivers" is used, the following occurs automatically:

- The in/out parameter `Mode` is interconnected with the corresponding output parameter `OMode_xx` of the MOD_PAL0, FF_MOD32- or MOD_PAX0 block.
- The in/out parameter `DataXchg` is interconnected with the corresponding output parameter `DataXchg_xx` of the MOD_PAL0, FF_MOD32- or MOD_PAX0 block.
- The symbol for the signal status of the analog input channel is interconnected to input `PV_ST`.
- The `MS` parameter is interconnected to the `O_MS` output parameter of the diagnostics block.

Note

If you are not using the CFC function "Generate module drivers" you must set the in/out parameter `Mode` manually. Refer to the Mode settings for field devices (Page 2217) chapter for more on this.

For the FbDiln block, the Advanced Process Library contains templates for process tag types as examples with various application scenarios for this block.

Examples of process tag types:

- Monitoring a digital process tag for PA/FF devices (DigitalMonitoring_Fb) (Page 2354)

Startup characteristics

The block does not have any startup characteristics.

Status word allocation for `Status` parameter

This block does not have the `Status` parameter.

See also

FbDiln block diagram (Page 2068)

FbDiln I/Os (Page 2065)

FbDiln messaging (Page 2064)

FbDiln error handling (Page 2064)

FbDiln functions (Page 2062)

FbDiln modes (Page 2061)

16.4.2 FbDiln modes

FbDiln modes

This block does not have any modes.

See also

FbDiln block diagram (Page 2068)

FbDiln I/Os (Page 2065)

FbDiln messaging (Page 2064)

FbDiln error handling (Page 2064)

FbDiln functions (Page 2062)

Description of FbDiln (Page 2060)

16.4.3 FbDiln functions

Functions of FbDiln

The functions for this block are listed below.

Obtaining the standard value

The digital values (WORD format) of the process image (partition) are output at the PV_Li0 - PV_Li7 output parameters.

The signal status PV_ST that comes directly from the device can have values from 16#00 – 16#FF.

The values of the signal status PV_ST of 16#84 - 16#87 and 16#90 – 16#93 of the FF field device are evaluated in the same way as 16#80 – 16#83.

Holding the last value if raw value is invalid

If the block is to hold its last valid value when the digital value is invalid or in the initialization phase of the device, you must activate this function at the Feature Bit Outputting last valid value if raw value is invalid (Page 154).

Output substitute value if raw value is invalid

If the block is to output a substitute value (SubsPV) when the digital value is invalid or in the initialization phase of the device, you must activate this function at the Feature Bit Output substitute value if raw value is invalid (Page 149).

Output of invalid value if raw value is invalid

If the block is to output an invalid value (PV_Li = PV), you must activate this function at the Feature Bit Output invalid raw value (Page 174).

This function is preset.

Flutter suppression

This block provides the standard function Flutter suppression for channel blocks (Page 67)

Signal status for Fb channel blocks

The block provides the standard function Forming and outputting the signal status for channel blocks for field devices (Page 119).

The signal status of the process value PV_Li0 - PV_Li7 is generated from internal events such as channel errors, higher-level errors, or simulations, as well as from the signal status PV_ST, which comes directly from the device.

Value	Meaning
16#80	Valid value
16#60	Manipulated value (for example, substitute value, simulation, last valid value)
16#28	Bad, process related
16#68	Uncertain, device related
16#78	Uncertain, process related
16#A4	Maintenance request present
16#00	Invalid value

Simulating signals

The block provides the standard function Simulating signals (Page 58).

Configurable reactions using the Feature parameter

You can find an overview of all reactions provided by the Feature parameter in the Configurable functions using the Feature I/O (Page 131) . The following functionality is available for this block at the relevant bits:

Bit	Function
10	Condition monitoring information at the channel blocks (Page 145)
28	Output invalid raw value (Page 174)
29	Output substitute value if raw value is invalid (Page 149)
30	Outputting last valid value if raw value is invalid (Page 154)

See also

FbDiIn block diagram (Page 2068)

FbDiIn I/Os (Page 2065)

FbDiIn messaging (Page 2064)

FbDiIn error handling (Page 2064)

FbDiIn modes (Page 2061)

Description of FbDiIn (Page 2060)

16.4.4 FbDiln error handling

Error handling of FbDiln

Refer to the section Error handling (Page 119) in the basic instructions for the error handling of all blocks.

The following errors can be displayed for this block:

- Channel error
- Higher-level error
- Invalid measuring range

Channel error

At the output parameter `Bad`, channel errors are displayed with 1. The channel error is generated from the signal status `PV_ST`.

Higher-level error / invalid measuring range

A higher-level error is displayed at the output parameters `ModErr` and `Bad` with 1 if the signal status at `High Word` of the input parameter `Mode` accepts the value 16#40.

A higher-level error is also present when an incorrect measuring type is entered in `Low Word` of the input parameter `Mode`.

In addition, at the output parameter `PV_LiX` of the signal status, either 16#00 (in the event of an error) or 16#60 (for manipulated value (for example, substitute value, simulation, last valid value) is output. (`PV_LiX: X = 0 ... 7`)

See also

FbDiln block diagram (Page 2068)

FbDiln I/Os (Page 2065)

FbDiln messaging (Page 2064)

FbDiln functions (Page 2062)

FbDiln modes (Page 2061)

Description of FbDiln (Page 2060)

16.4.5 FbDiln messaging

Messaging

This block does not offer messaging.

See also

FbDiIn block diagram (Page 2068)

FbDiIn I/Os (Page 2065)

FbDiIn error handling (Page 2064)

FbDiIn functions (Page 2062)

FbDiIn modes (Page 2061)

Description of FbDiIn (Page 2060)

16.4.6 FbDiIn I/Os

FbDiIn I/Os

Input parameters

Parameter	Description	Type	Default
EN	1 = Called block will be processed	BOOL	1
Feature	I/O for additional functions (Page 2062)	STRUCT <ul style="list-style-type: none"> • Bit 0: BOOL • ... • Bit 28: BOOL • ... • Bit 31: BOOL 	- <ul style="list-style-type: none"> • 0 • 0 • 1 • 0 • 0
FlutEn	1 = Flutter suppression activated	BOOL	0
FlutTmIn*	Flutter time [s]	INT	0
MS	Maintenance status	DWORD	16#00000000
MS_Release	Release for maintenance (interconnected with MS_Release of the technology block)	STRUCT <ul style="list-style-type: none"> • Value: BOOL • ST: BYTE 	- <ul style="list-style-type: none"> • 0 • 16#80
MS_Ext	External maintenance status	DWORD	16#00000000
PV	Process value (digital value)	BYTE	16#00
PV_ST	Signal status for the process value	BYTE	16#80
SimOn	1 = Simulation on	STRUCT <ul style="list-style-type: none"> • Value: BOOL • ST: BYTE 	- <ul style="list-style-type: none"> • 0 • 16#80
SimPV0	Process value used for SimOn = 1	STRUCT <ul style="list-style-type: none"> • Value: BOOL • ST: BYTE 	- <ul style="list-style-type: none"> • 0 • 16#80
SimPV1	Process value used for SimOn = 1	STRUCT <ul style="list-style-type: none"> • Value: BOOL • ST: BYTE 	- <ul style="list-style-type: none"> • 0 • 16#80

Channel blocks

16.4 FbDiln - Digital input channel block for field devices

Parameter	Description	Type	Default
SimPV2	Process value used for SimOn = 1	STRUCT • Value: BOOL • ST: BYTE	- • 0 • 16#80
SimPV3	Process value used for SimOn = 1	STRUCT • Value: BOOL • ST: BYTE	- • 0 • 16#80
SimPV4	Process value used for SimOn = 1	STRUCT • Value: BOOL • ST: BYTE	- • 0 • 16#80
SimPV5	Process value used for SimOn = 1	STRUCT • Value: BOOL • ST: BYTE	- • 0 • 16#80
SimPV6	Process value used for SimOn = 1	STRUCT • Value: BOOL • ST: BYTE	- • 0 • 16#80
SimPV7	Process value used for SimOn = 1	STRUCT • Value: BOOL • ST: BYTE	- • 0 • 16#80
SubsPV	Substitute value	BYTE	16#00
TextRef	Text reference	WORD	16#0000

* Values can be written back to these inputs during processing of the block by the block algorithm.

In/out parameters

Parameter	Description	Type	Default
DataXchg	Internal data exchange channel to the diagnostics block	DWORD	16#00000000
DataXchg1	Internal data exchange channel to the diagnostics block	DWORD	16#00000000
MS_Xchg	Exchange of the maintenance status	DWORD	16#00000000
Mode	Value status and measuring type	DWORD	16#00000000

Output parameters

Parameter	Description	Type	Default
Bad	1 = Process value is not valid	STRUCT • Value: BOOL • ST: BYTE	- • 0 • 16#80
ENO	1 = Block algorithm completed without errors	BOOL	0
ErrorNum	Output of pending error number. For error numbers that can be output by this block, see FbDiln error handling (Page 2064)	INT	-1

16.4 FbDiln - Digital input channel block for field devices

Parameter	Description	Type	Default
ModErr	1 = Device/module is faulty	STRUCT • Value: BOOL • ST: BYTE	- • 0 • 16#80
MS_Dev	Maintenance state	DWORD	16#00000000
MS_Req	1 = Maintenance request from the diagnostic area	STRUCT • Value: BOOL • ST: BYTE	- • 0 • 16#80
OosAct	1 = Field device is undergoing maintenance	STRUCT • Value: BOOL • ST: BYTE	- • 0 • 16#80
PV_Li0	Process value 0	STRUCT • Value: BOOL • ST: BYTE	- • 0 • 16#80
PV_Li1	Process value 1	STRUCT • Value: BOOL • ST: BYTE	- • 0 • 16#80
PV_Li2	Process value 2	STRUCT • Value: BOOL • ST: BYTE	- • 0 • 16#80
PV_Li3	Process value 3	STRUCT • Value: BOOL • ST: BYTE	- • 0 • 16#80
PV_Li4	Process value 4	STRUCT • Value: BOOL • ST: BYTE	- • 0 • 16#80
PV_Li5	Process value 5	STRUCT • Value: BOOL • ST: BYTE	- • 0 • 16#80
PV_Li6	Process value 6	STRUCT • Value: BOOL • ST: BYTE	- • 0 • 16#80
PV_Li7	Process value 7	STRUCT • Value: BOOL • ST: BYTE	- • 0 • 16#80
SimAct	1 = Simulation active	STRUCT • Value: BOOL • ST: BYTE	- • 0 • 16#80

See also

FbDiln block diagram (Page 2068)

FbDiln messaging (Page 2064)

FbDiln modes (Page 2061)

Description of FbDiln (Page 2060)

16.4.7 FbDiln block diagram

FbDiln block diagram

A block diagram is not provided for this block.

See also

FbDiln I/Os (Page 2065)

FbDiln messaging (Page 2064)

FbDiln error handling (Page 2064)

FbDiln modes (Page 2061)

FbDiln functions (Page 2062)

Description of FbDiln (Page 2060)

16.5 FbDiOu - Digital output channel block for field devices

16.5.1 Description of FbDiOu

Object name (type + number) and family

Type + number: FB 1816

Family: Channel

Area of application for FbDiOu

The block is used for the following applications:

Signal processing of max 8 digital input/output values of a field device (cyclic service in accordance with PROFIBUS PA):

- Of a PA field device in accordance with PROFIBUS 3.0 class A and B
- Of an FF field device

How it works

Block FbDiOu cyclically reads the process values and the signal status of the field device from the process image (partition). The eight process values are grouped in one byte for each of the input parameters `SP_Li` and `RCasInLi`. The signal status contains information about the status of the field device.

Configuration

Use the CFC editor to install the block in a cyclic interrupt OB (OB30 to OB38). The block is also installed automatically in the startup OB (OB100).

You must interconnect each used signal of the block with the symbols configured in HW Config or in the symbol table according to your user data configuration:

I/O field device	Data type	I/O
Rbk	BYTE	Input
RCasOut	BYTE	Input
SP	BYTE	Output
RCasIn	BYTE	Output

When the CFC function "Generate module drivers" is used, the following occurs automatically:

- The in/out parameter `Mode` is interconnected with the corresponding output parameter `OMode_xx` of the `MOD_PAL0`, `FF_MOD32-` or `MOD_PAX0` block.
- The in/out parameter `DataXchg` is interconnected with the corresponding output parameter `DataXchg_xx` of the `MOD_PAL0`, `FF_MOD32-` or `MOD_PAX0` block.

- The MS parameter is interconnected to the O_MS output parameter of the diagnostics block.
- The corresponding signal status is symbolically interconnected depending on your user data configuration:

I/O field device	Data type	I/O
RbkST	BYTE	Input
RCasOutST	BYTE	Input
SP_ST	BYTE	Output
RCasInST	BYTE	Output
CbkBy0	BYTE	Input
CbkBy1	BYTE	Input
CbkBy2	BYTE	Input

Note

If you are not using the CFC function "Generate module drivers" you must set the Mode in/out parameter manually. Refer to the Mode settings for field devices (Page 2217) section for more on this.

For the FbDiOu block, the Advanced Process Library contains templates for process tag types as examples with various application scenarios for this block.

Examples of process tag types:

- Dosing with PA/FF devices (Dose_Lean_Fb) (Page 2359)

Startup characteristics

The block will run through one time in OB100 at system start. The output and in/out parameters are calculated.

Status word allocation for Status parameter

This block does not have the Status parameter.

See also

- FbDiOu block diagram (Page 2078)
- FbDiOu I/Os (Page 2074)
- FbDiOu messaging (Page 2073)
- FbDiOu error handling (Page 2072)
- FbDiOu functions (Page 2071)
- FbDiOu modes (Page 2071)

16.5.2 FbDiOu modes

FbDiOu modes

This block does not have any modes.

See also

FbDiOu block diagram (Page 2078)

FbDiOu I/Os (Page 2074)

FbDiOu messaging (Page 2073)

FbDiOu error handling (Page 2072)

FbDiOu functions (Page 2071)

Description of FbDiOu (Page 2069)

16.5.3 FbDiOu functions

Functions of FbDiOu

The functions for this block are listed below.

Obtaining the standard value

The signals of the FF field device are read from the process image (partition) of the inputs and written to the process image (partition) of the outputs. The input parameter `Rbk` and the active reference variable `RCasOut`, together with its associated signal status `RbkST` and `RCasOutST` are read and written to the output parameters `SP` and `RCasIn` with the associated signal status `RbkST` and `RCasOutSt`. Additional detailed device information (`CbkBy0` - `CbkBy2`) can be read as an option. The device information is available per bit at the block output.

The signal status `RbkST` or `RCasOutST` that comes directly from the device can have values from `16#00` – `16#FF`.

The values of the signal status `RbkST` and `RCasOutST` of `16#84` - `16#87` and `16#90` – `16#93` of the FF field device are evaluated by the link as `16#80` – `16#83`.

Flutter suppression

This block provides the standard function Flutter suppression for channel blocks (Page 67)

Signal status for Fb channel blocks

The block provides the standard function Forming and outputting the signal status for channel blocks for field devices (Page 119).

The signal status of the process values (RCasIn or RbkLi) is generated from internal events such as channel errors, higher-level errors, or simulations, as well as from the signal status RbkLiST or RCasInST, which comes directly from the device.

Value	Meaning
16#80	Valid value
16#60	Manipulated value (for example, substitute value, simulation, last valid value)
16#28	Bad, process related
16#68	Uncertain, device related
16#78	Uncertain, process related
16#A4	Maintenance request present
16#00	Invalid value

Simulating signals

The block provides the standard function Simulating signals (Page 58).

Configurable reactions using the Feature parameter

You can find an overview of all reactions provided by the Feature parameter in the Configurable functions using the Feature I/O (Page 131) . The following functionality is available for this block at the relevant bits:

Bit	Function
0	Set startup characteristics (Page 138)
10	Condition monitoring information at the channel blocks (Page 145)
30	Outputting a de-energized value for block-external simulation (Page 148)

See also

FbDiOu block diagram (Page 2078)

FbDiOu I/Os (Page 2074)

FbDiOu messaging (Page 2073)

FbDiOu error handling (Page 2072)

FbDiOu modes (Page 2071)

Description of FbDiOu (Page 2069)

16.5.4 FbDiOu error handling

Error handling of FbDiOu

Refer to the section Error handling (Page 119) in the basic instructions for the error handling of all blocks.

The following errors can be displayed for this block:

- Channel error
- Higher-level error
- Invalid measuring range

Channel error

At the output parameter `Bad`, channel errors are displayed with 1. The channel error is generated from the signal states `RbkST` and `RCasOutSt`.

Higher-level error / invalid measuring range

A higher-level error is displayed at the output parameters `ModErr` and `Bad` with 1 if the signal status at `High Word` of the input parameter `Mode` accepts the value `16#40`.

A higher-level error is also present when an incorrect measuring type is entered in `Low Word` of the input parameter `Mode`.

See also

FbDiOu block diagram (Page 2078)

FbDiOu I/Os (Page 2074)

FbDiOu messaging (Page 2073)

FbDiOu functions (Page 2071)

FbDiOu modes (Page 2071)

Description of FbDiOu (Page 2069)

16.5.5 FbDiOu messaging

Messaging

This block does not offer messaging.

See also

FbDiOu block diagram (Page 2078)

FbDiOu I/Os (Page 2074)

FbDiOu error handling (Page 2072)

FbDiOu functions (Page 2071)

FbDiOu modes (Page 2071)

Description of FbDiOu (Page 2069)

16.5.6 FbDiOu I/Os

I/Os of FbDiOu

Input parameters

Parameter	Description	Type	Default
CbkBy0	Additional information on the actuator status	BYTE	16#00
CbkBy1	Additional information on the actuator status	BYTE	16#00
CbkBy2	Additional information on the actuator status	BYTE	16#00
EN	1 = Called block will be processed	BOOL	1
Feature	I/O for additional functions (Page 2071)	STRUCT	-
		• Bit 0: BOOL	• 0
		• ...	• 0
		• Bit 30: BOOL	• 0
		• Bit 31: BOOL	• 0
FlutEn	1 = Flutter suppression activated	BOOL	0
FlutTmIn*	Flutter time [s]	INT	0
MS	Maintenance status	DWORD	16#00000000
MS_Release	Release for maintenance (interconnected with MS_Release of the technology block)	STRUCT	-
		• Value: BOOL	• 0
		• ST: BYTE	• 16#80
MS_Ext	External maintenance status	DWORD	16#00000000
RCasInLi	Setpoint for the remote cascade operating mode	BYTE	16#00
RCasInLiST	Signal status for the setpoint value (RCasInLi)	BYTE	16#80
Rbk	Current position of actuator (actual value)	BYTE	16#00
RbkST	Signal status of Rbk	BYTE	16#80
RCasOut	Setpoint from function block in device	BYTE	16#00
RCasOutST	Signal status of RCasOut	BYTE	16#80
SP_Li	Setpoint	STRUCT	-
		• Value: BOOL	• 0
		• ST: BYTE	• 16#80
SimOn	1 = Simulation on	STRUCT	-
		• Value: BOOL	• 0
		• ST: BYTE	• 16#80
SimRCasInLi	Setpoint for the remote cascade operating mode RCasInLi, used for SimOn = 1	BYTE	16#00
SimRbk	0 = Actuator is closed 1 = Actuator is open	BOOL	0
SimSP_Li	1 = Setpoint SP_Li, used for SimOn = 1	BOOL	0
TextRef	Text reference	WORD	16#0000

* Values can be written back to these inputs during processing of the block by the block algorithm.

In/out parameters

Parameter	Description	Type	Default
DataXchg	Internal data exchange channel to the diagnostics block	DWORD	16#00000000
DataXchg1	Internal data exchange channel to the diagnostics block	DWORD	16#00000000
MS_Xchg	Exchange of the maintenance status	DWORD	16#00000000
Mode	Value status and measuring type	DWORD	16#00000000

Output parameters

Parameter	Description	Type	Default
Bad	1 = Process value is not valid	STRUCT • Value: BOOL • ST: BYTE	- • 0 • 16#80
Cbk0	1 = Field device in safe position active	STRUCT • Value: BOOL • ST: BYTE	- • 0 • 16#80
Cbk1	1 = Request for "manual mode"	STRUCT • Value: BOOL • ST: BYTE	- • 0 • 16#80
Cbk2	1 = Field device in "manual mode"	STRUCT • Value: BOOL • ST: BYTE	- • 0 • 16#80
Cbk3	1 = Emergency override active	STRUCT • Value: BOOL • ST: BYTE	- • 0 • 16#80
Cbk4	1 = Current position differs from expected position	STRUCT • Value: BOOL • ST: BYTE	- • 0 • 16#80
Cbk5	1 = Valve connection break	STRUCT • Value: BOOL • ST: BYTE	- • 0 • 16#80
Cbk6	1 = Indicates a short-circuit at the valve connection	STRUCT • Value: BOOL • ST: BYTE	- • 0 • 16#80
Cbk7	1 = Not used	STRUCT • Value: BOOL • ST: BYTE	- • 0 • 16#80
Cbk8	1 = Actuator is opening	STRUCT • Value: BOOL • ST: BYTE	- • 0 • 16#80

Channel blocks

16.5 FbDiOu - Digital output channel block for field devices

Parameter	Description	Type	Default
Cbk9	1 = Actuator is closing	STRUCT <ul style="list-style-type: none"> • Value: BOOL • ST: BYTE 	- <ul style="list-style-type: none"> • 0 • 16#80
Cbk10	1 = Alarm generated by any change to the static data (FB and TB)	STRUCT <ul style="list-style-type: none"> • Value: BOOL • ST: BYTE 	- <ul style="list-style-type: none"> • 0 • 16#80
Cbk11	1 = Simulation of process values is enabled	STRUCT <ul style="list-style-type: none"> • Value: BOOL • ST: BYTE 	- <ul style="list-style-type: none"> • 0 • 16#80
Cbk12	1 = Not used	STRUCT <ul style="list-style-type: none"> • Value: BOOL • ST: BYTE 	- <ul style="list-style-type: none"> • 0 • 16#80
Cbk13	1 = Internal control loop interrupted	STRUCT <ul style="list-style-type: none"> • Value: BOOL • ST: BYTE 	- <ul style="list-style-type: none"> • 0 • 16#80
Cbk14	1 = Valve not active	STRUCT <ul style="list-style-type: none"> • Value: BOOL • ST: BYTE 	- <ul style="list-style-type: none"> • 0 • 16#80
Cbk15	1 = Device under self test	STRUCT <ul style="list-style-type: none"> • Value: BOOL • ST: BYTE 	- <ul style="list-style-type: none"> • 0 • 16#80
Cbk16	1 = Valve travel limit has been exceeded	STRUCT <ul style="list-style-type: none"> • Value: BOOL • ST: BYTE 	- <ul style="list-style-type: none"> • 0 • 16#80
Cbk17	1 = Limit of break time exceeded when changing from OPEN to CLOSE	STRUCT <ul style="list-style-type: none"> • Value: BOOL • ST: BYTE 	- <ul style="list-style-type: none"> • 0 • 16#80
Cbk18	1 = Limit of break time exceeded when changing from CLOSE to OPEN	STRUCT <ul style="list-style-type: none"> • Value: BOOL • ST: BYTE 	- <ul style="list-style-type: none"> • 0 • 16#80
Cbk19	1 = Error occurred in the internal cycle test	STRUCT <ul style="list-style-type: none"> • Value: BOOL • ST: BYTE 	- <ul style="list-style-type: none"> • 0 • 16#80
Cbk20	1 = Timeout during the transition from OPEN to CLOSE	STRUCT <ul style="list-style-type: none"> • Value: BOOL • ST: BYTE 	- <ul style="list-style-type: none"> • 0 • 16#80
Cbk21	1 = Timeout during the transition from CLOSE to OPEN	STRUCT <ul style="list-style-type: none"> • Value: BOOL • ST: BYTE 	- <ul style="list-style-type: none"> • 0 • 16#80

16.5 FbDiOu - Digital output channel block for field devices

Parameter	Description	Type	Default
Cbk22	1 = Valve blocked mechanically	STRUCT • Value: BOOL • ST: BYTE	- • 0 • 16#80
Cbk23	1 = Zero point not reached	STRUCT • Value: BOOL • ST: BYTE	- • 0 • 16#80
ENO	1 = Block algorithm completed without errors	BOOL	0
ErrorNum	Output of pending error number. For error numbers that can be output by this block, see FbDiOu error handling (Page 2072)	INT	-1
ModErr	1 = Device/module is faulty	STRUCT • Value: BOOL • ST: BYTE	- • 0 • 16#80
MS_Dev	Maintenance state	DWORD	16#00000000
MS_Req	1 = Maintenance request from the diagnostic area	STRUCT • Value: BOOL • ST: BYTE	- • 0 • 16#80
OosAct	1 = Field device is undergoing maintenance	STRUCT • Value: BOOL • ST: BYTE	- • 0 • 16#80
RCasOutLi	Setpoint from function block in device	BYTE	16#00
RCasOutLiST	Signal status for setpoint from function block in device (RCasOutLi)	BYTE	16#00
RCasIn	Setpoint for the remote cascade operating mode	BYTE	16#00
RCasInST	Signal status of RCasIn	BYTE	16#00
RbkCloseLi	1 = Actuator closed feedback signal	STRUCT • Value: BOOL • ST: BYTE	- • 0 • 16#80
RbkLi	Current position of actuator (actual value)	BYTE	16#00
RbkLiST	Signal status of current position of actuator (RbkLi)	BYTE	16#00
RbkOpenLi	1 = Actuator open feedback signal	STRUCT • Value: BOOL • ST: BYTE	- • 0 • 16#80
SimAct	1 = The block is in simulation	STRUCT • Value: BOOL • ST: BYTE	- • 0 • 16#80
SP	Setpoint	BYTE	16#00
SP_ST	Signal status of setpoint	BYTE	16#00

See also

FbDiOu block diagram (Page 2078)

FbDiOu messaging (Page 2073)

FbDiOu modes (Page 2071)

Description of FbDiOu (Page 2069)

16.5.7 FbDiOu block diagram

FbDiOu block diagram

A block diagram is not provided for this block.

See also

FbDiOu I/Os (Page 2074)

FbDiOu messaging (Page 2073)

FbDiOu error handling (Page 2072)

FbDiOu functions (Page 2071)

FbDiOu modes (Page 2071)

Description of FbDiOu (Page 2069)

16.6 FbDrive - Channel block for compact drives

16.6.1 Description of FbDrive

Object name (type + number) and family

Type + number: FB 1905

Family: Channel

Area of application of FbDrive

The block is used for the following applications:

- Integration of compact drives in PCS 7

How it works

The FbDrive block integrates any compact drives that meet the following conditions and are detected by the system:

- Message frame type "1" with 2 input words and 2 output words
- Message frame type "20" with 6 input words and 2 output words

Configuration

The interconnection is made symbolic to the first input word. All other interconnections are updated automatically using a wizard.

Use the CFC editor to install the block in a cyclic interrupt OB (OB30 to OB38).

The block is also installed automatically in the startup OB (OB100).

Connect the symbol generated in HW Config (symbol table) for the input channel with the PZDIn1 input parameter.

When the CFC function "Generate module drivers" is used, the following occurs automatically:

- The Mode in/out parameter is interconnected to the corresponding OMODE_XX output parameter of the MOD_DRV block.
- The in/out parameter DataXchg is interconnected to the corresponding DXCHG_XX output parameter of the MOD_DRV block.
- With the "1" message frame type, the PZDIn1 and PZDIn2 inputs are interconnected to the PZDOutx outputs, with the "20" message frame type the PZDIn3 - PZDIn6 inputs are also interconnected.
- The MS parameter is interconnected to the O_MS output parameter of the diagnostics block.

Note

"Configuration of frequency converters with the APL channel block "FbDrive" in SIMATIC PCS 7 (<https://support.industry.siemens.com/cs/document/64181993/configuration-of-frequency-converters-with-the-apl-channel-block-%E2%80%99fbdrive%E2%80%9D-in-simatic-pcs-7?dti=0&lc=en-VW>)"

- The use of different channel block types for the same device type of drive or inverter is not allowed.
-

Startup characteristics

The block has startup characteristics.

16.6.2 FbDrive modes

Operating modes of FbDrive

This block does not have any modes.

16.6.3 FbDrive functions

Functions of FbDrive

The functions for this block are listed below.

Reading messages

You can specify the format of messages using the `Feature` bit Reading messages (Page 147).

Transmission of messages

If the block is to send messages to the upstream diagnostics block, you must activate this function at the `Feature` bit Transmission of status information of devices (Page 175).

Configurable reactions using the Feature parameter

You can find an overview of all reactions provided by the Feature parameter in the Configurable functions using the Feature I/O (Page 131) . The following functionality is available for this block at the relevant bits:

Bit	Function
5	Setting the scaling for the process values (Page 148)
6	Failure handling (Page 138)
10	Condition monitoring information at the channel blocks (Page 145)
28	Reading messages (Page 147)
29	Transmission of status information of devices (Page 175)
30	Outputting a de-energized value for block-external simulation (Page 148)

Forming the control word

When STW1(control word) is created and Stw1ST is simultaneously at 16#80, the Boolean control inputs listed below have no effect and the control word STW1 is set at the process value output PZDOUT1.

When the Stw1ST signal status has a bad value, the data is taken from the Boolean control inputs.

On	Control word 1 bit 0
NoCoastSt	Control word 1 bit 1
NoQuickSt	Control word 1 bit 2
EnOp	Control word 1 bit 3
EnRampGen	Control word 1 bit 4
UnfreeRamp	Control word 1 bit 5
EnSp	Control word 1 bit 6
Ackn	Control word 1 bit 7
Jogg1	Control word 1 bit 8
Jogg2	Control word 1 bit 9
Local	Control word 1 bit 10
InvSP	Control word 1 bit 11
Ctrl12	Control word 1 bit 12
Ctrl13	Control word 1 bit 13
Ctrl14	Control word 1 bit 14
Ctrl15	Control word 1 bit 15

Setting the limits for the process value or for the calculation limits

The limits for the process value or the calculation limits are set by the SP_LiScale input.

Calculation:

$$\text{SpeedLi.Value} := (\text{PZD2In} * ((\text{SP_LiScale.HIGH} - \text{SP_LiScale.LOW}) / 16384.0)) + \text{SP_LiScale.LOW};$$

16.6.4 FbDrive error handling

Error handling of FbDrive

Error handling of all the blocks is described in chapter Error handling (Page 119) in the basic instructions.

The following errors can be displayed for this block:

- Error numbers

Overview of error numbers

The ErrorNum I/O can be used to output the following error numbers:

Error number	Meaning of the error number
-1	Predefined value when inserting the block; the block is not processed.
0	There is no error.
1	Invalid process value (output parameter Bad = 1)

16.6.5 FbDrive messaging

Messaging of FbDrive

This block does not offer messaging.

16.6.6 FbDrive status word

Forming the status word

The ZSW1 (status word), or the Boolean status outputs, are set via the process value input PZDIN1.

Status word 1	Bit 0	RdyOn
Status word 1	Bit 1	RdyOp
Status word 1	Bit 2	OpEn
Status word 1	Bit 3	Fault
Status word 1	Bit 4	NoOff2
Status word 1	Bit 5	NoOff3
Status word 1	Bit 6	SwOn
Status word 1	Bit 7	Warning
Status word 1	Bit 8	SpeedErr
Status word 1	Bit 9	CtrlReq

Status word 1	Bit 10	F_N_Reach
Status word 1	Bit 11	Zsw1_11
Status word 1	Bit 12	Zsw1_12
Status word 1	Bit 13	Zsw1_13
Status word 1	Bit 14	Zsw1_14
Status word 1	Bit 15	Zsw1_15

16.6.7 FbDrive I/Os

I/Os of FbDrive

Input parameters

Parameter	Description	Type	Default
Ackn	OR operation with control word 1, bit 7	STRUCT <ul style="list-style-type: none"> Value: BOOL ST: BYTE 	- <ul style="list-style-type: none"> 0 16#80
Ctrl12	Control signal 12	STRUCT <ul style="list-style-type: none"> Value: BOOL ST: BYTE 	- <ul style="list-style-type: none"> 0 16#80
Ctrl13	Control signal 13	STRUCT <ul style="list-style-type: none"> Value: BOOL ST: BYTE 	- <ul style="list-style-type: none"> 0 16#80
Ctrl14	Control signal 14	STRUCT <ul style="list-style-type: none"> Value: BOOL ST: BYTE 	- <ul style="list-style-type: none"> 0 16#80
Ctrl15	Control signal 15	STRUCT <ul style="list-style-type: none"> Value: BOOL ST: BYTE 	- <ul style="list-style-type: none"> 0 16#80
EN	1 = Called block will be processed	BOOL	1
EnOp	Control word 1 bit 3 1= Operator control active 0 = Operator control deactivated	STRUCT <ul style="list-style-type: none"> Value: BOOL ST: BYTE 	- <ul style="list-style-type: none"> 0 16#80
EnRampGen	Control word 1 bit 4 1 = Ramp generation active 0 = Ramp generation reset	STRUCT <ul style="list-style-type: none"> Value: BOOL ST: BYTE 	- <ul style="list-style-type: none"> 0 16#80
EnSp	Control word 1 bit 6 1 = Setpoint active 0 = Setpoint deactivated	STRUCT <ul style="list-style-type: none"> Value: BOOL ST: BYTE 	- <ul style="list-style-type: none"> 0 16#80

Parameter	Description	Type	Default
Feature	I/O for additional functions	STRUCT <ul style="list-style-type: none"> • Bit 0: BOOL • ... • Bit 29 • ... • Bit 31: BOOL 	- <ul style="list-style-type: none"> • 0 • 0 • 1 • 0 • 0
FlutEn	1 = Flutter suppression on	BOOL	0
FlutTmIn*	Flutter time: If a certain number of status changes occur within this time, the flutter is suppressed	INT	0
InvSp	Setpoint inverted	STRUCT <ul style="list-style-type: none"> • Value: BOOL • ST: BYTE 	- <ul style="list-style-type: none"> • 0 • 16#80
Jogg1	Control word 1 bit 8	STRUCT <ul style="list-style-type: none"> • Value: BOOL • ST: BYTE 	- <ul style="list-style-type: none"> • 0 • 16#80
Jogg2	Control word 1 bit 9	STRUCT <ul style="list-style-type: none"> • Value: BOOL • ST: BYTE 	- <ul style="list-style-type: none"> • 0 • 16#80
Local	Control word 1 bit 10 1 = Control via AS 0 = No control via AS	STRUCT <ul style="list-style-type: none"> • Value: BOOL • ST: BYTE 	- <ul style="list-style-type: none"> • 0 • 16#80
MS*	Maintenance status	DWORD	16#00000000
MS_Release	Release for maintenance (interconnected with MS_Release of the technology block)	STRUCT <ul style="list-style-type: none"> • Value: BOOL • ST: BYTE 	- <ul style="list-style-type: none"> • 0 • 16#80
MS_Ext	Maintenance status external	DWORD	16#00000000
NoCoastSt	Control word 1 bit 1 1 = Do not de-energize and coast down drive 0 = De-energized and coast down drive	STRUCT <ul style="list-style-type: none"> • Value: BOOL • ST: BYTE 	- <ul style="list-style-type: none"> • 0 • 16#80
NoQuickSt	Control word 1 bit 2 1 = No rapid stop 0 = Rapid stop	STRUCT <ul style="list-style-type: none"> • Value: BOOL • ST: BYTE 	- <ul style="list-style-type: none"> • 0 • 16#80
PZDIn1	Input word 1 - ZSW1	WORD	16#0000
PZDIn2	Input word 2 - NIST_A_GLATT/ FIST_GLATT	WORD	16#0000
PZDIn3	Input word 3 - IAIST_GLATT	WORD	16#0000
PZDIn4	Input word 4 - ITIST_GLATT/ MIST_GLATT	WORD	16#0000
PZDIn5	Input word 5 - PIST_GLATT	WORD	16#0000
PZDIn6	Input word 6 - MsgNamur	WORD	16#0000

Parameter	Description	Type	Default
PZDIn2Unit	Unit of measure for process value	INT	1342
PZDIn2Scale	Scaling of the process value as a structure	STRUCT <ul style="list-style-type: none"> HIGH: REAL LOW: REAL 	- <ul style="list-style-type: none"> 100.0 0.0
PZDIn3Unit	Unit of measure for process value	INT	1342
PZDIn3Scale	Scaling of the process value as a structure	STRUCT <ul style="list-style-type: none"> HIGH: REAL LOW: REAL 	- <ul style="list-style-type: none"> 100.0 0.0
PZDIn4Unit	Unit of measure for process value	INT	1342
PZDIn4Scale	Scaling of the process value as a structure	STRUCT <ul style="list-style-type: none"> HIGH: REAL LOW: REAL 	- <ul style="list-style-type: none"> 100.0 0.0
PZDIn5Unit	Unit of measure for process value	INT	1342
PZDIn5Scale	Scaling of the process value as a structure	STRUCT <ul style="list-style-type: none"> HIGH: REAL LOW: REAL 	- <ul style="list-style-type: none"> 100.0 0.0
PZDIn6Unit	Unit of measure for process value	INT	1342
PZDIn6Scale	Scaling of the process value as a structure	STRUCT <ul style="list-style-type: none"> HIGH: REAL LOW: REAL 	- <ul style="list-style-type: none"> 100.0 0.0
SP_Li	Speed setpoint	STRUCT <ul style="list-style-type: none"> Value: REAL ST: BYTE 	- <ul style="list-style-type: none"> 0.0 16#80
SP_LiScale	Scaling of the process value as a structure (device data)	STRUCT <ul style="list-style-type: none"> HIGH: REAL LOW: REAL 	- <ul style="list-style-type: none"> 50.0 0.0
Stw1	Control word	WORD	16#0000
Stw1ST	Status control word	BYTE	16#00
On	Control word 1 bit 0 1 = ON 0 = OFF	STRUCT <ul style="list-style-type: none"> Value: BOOL ST: BYTE 	- <ul style="list-style-type: none"> 0 16#80
Telegram	Control object	INT	1
TextRef	Text reference	WORD	16#0000
UnfreeRamp	Control word 1 bit 5 1 = Ramp generation can be changed 0 = Ramp generation cannot be changed	STRUCT <ul style="list-style-type: none"> Value: BOOL ST: BYTE 	- <ul style="list-style-type: none"> 0 16#80

* Values can be written back to these inputs during processing of the block by the block algorithm.

In/out parameters

Parameter	Description	Type	Default
DataXchg	Internal data exchange channel to the diagnostics block	DWORD	16#00000000
DataXchg1	Internal data exchange channel to the diagnostics block	DWORD	16#00000000
Mode	Value status and measuring type	DWORD	16#00000000
MS_Xchg	Exchange of the maintenance status	DWORD	16#00000000

Output parameters

Parameter	Description	Type	Default
Bad	1 = Process value is not valid	STRUCT <ul style="list-style-type: none"> Value: BOOL ST: BYTE 	- <ul style="list-style-type: none"> 0 16#80
CtrlReq	1 = Control request	STRUCT <ul style="list-style-type: none"> Value: BOOL ST: BYTE 	- <ul style="list-style-type: none"> 0 16#80
CurrentLi	Normal value PZD 3	STRUCT <ul style="list-style-type: none"> Value: REAL ST: BYTE 	- <ul style="list-style-type: none"> 0.0 16#80
CurrentScale	Scaling PZD 3	STRUCT <ul style="list-style-type: none"> HIGH: REAL LOW: REAL 	- <ul style="list-style-type: none"> 100.0 0.0
CurrentUnit	Unit of measurement PZD 3	INT	0
ENO	1 = Block algorithm completed without errors	BOOL	0
ErrorNum	Output of pending error number	INT	-1
F_N_Reach	1 = f or n reached or exceeded 0 = f or n not reached	STRUCT <ul style="list-style-type: none"> Value: BOOL ST: BYTE 	- <ul style="list-style-type: none"> 0 16#80
Fault	1 = Error is present	STRUCT <ul style="list-style-type: none"> Value: BOOL ST: BYTE 	- <ul style="list-style-type: none"> 0 16#80
FreeLi	Normal value PZD 6	STRUCT <ul style="list-style-type: none"> Value: REAL ST: BYTE 	- <ul style="list-style-type: none"> 0.0 16#80
FreeScale	Scaling PZD 6	STRUCT <ul style="list-style-type: none"> HIGH: REAL LOW: REAL 	- <ul style="list-style-type: none"> 100.0 0.0
FreeUnit	Unit of measurement PZD 6	INT	0

Parameter	Description	Type	Default
MsgNamur	PZD 6 in VIK-NAMUR mode	WORD	16#0000
ModErr	1 = Device/module is faulty	STRUCT <ul style="list-style-type: none"> Value: BOOL ST: BYTE 	- <ul style="list-style-type: none"> 0 16#80
MS_Dev	Maintenance state	DWORD	16#00000000
MS_Req	1 = Maintenance request from the diagnostic area	STRUCT <ul style="list-style-type: none"> Value: BOOL ST: BYTE 	- <ul style="list-style-type: none"> 0 16#80
NoOff2	1 = De-energize and coast down not active	STRUCT <ul style="list-style-type: none"> Value: BOOL ST: BYTE 	- <ul style="list-style-type: none"> 0 16#80
NoOff3	1 = Rapid stop not active	STRUCT <ul style="list-style-type: none"> Value: BOOL ST: BYTE 	- <ul style="list-style-type: none"> 0 16#80
OosAct	1 = Field device is undergoing maintenance	STRUCT <ul style="list-style-type: none"> Value: BOOL ST: BYTE 	- <ul style="list-style-type: none"> 0 16#80
OpEn	1 = Enable setpoint operation	STRUCT <ul style="list-style-type: none"> Value: BOOL ST: BYTE 	- <ul style="list-style-type: none"> 0 16#80
Power1Li	Normal value PZD 4	STRUCT <ul style="list-style-type: none"> Value: REAL ST: BYTE 	- <ul style="list-style-type: none"> 0.0 16#80
Power1Scale	Scaling PZD 4	STRUCT <ul style="list-style-type: none"> HIGH: REAL LOW: REAL 	- <ul style="list-style-type: none"> 100.0 0.0
Power1Unit	Unit of measurement PZD 4	INT	0
Power2Li	Normal value PZD 5	STRUCT <ul style="list-style-type: none"> Value: REAL ST: BYTE 	- <ul style="list-style-type: none"> 0.0 16#80
Power2Scale	Scaling PZD 5	STRUCT <ul style="list-style-type: none"> HIGH: REAL LOW: REAL 	- <ul style="list-style-type: none"> 100.0 0.0
Power2Unit	Unit of measurement PZD 5	INT	0
PZDOut1	Output word 1 - STW1	WORD	16#0000
PZDOut2	Output word 2 - NSOLL_A/ FSOLL	WORD	16#0000
RdyOn	1 = Ready to switch on 0 = Not ready to switch on	STRUCT <ul style="list-style-type: none"> Value: BOOL ST: BYTE 	- <ul style="list-style-type: none"> 0 16#80

Parameter	Description	Type	Default
RdyOp	1 = Ready for operation 0 = Not ready for operation	STRUCT • Value: BOOL • ST: BYTE	- • 0 • 16#80
SpeedErr	1 = Error speed within the tolerance range 0 = Error speed outside the tolerance range	STRUCT • Value: BOOL • ST: BYTE	- • 0 • 16#80
SpeedLi	Normal value PZD 2	STRUCT • Value: REAL • ST: BYTE	- • 0.0 • 16#80
SpeedScale	Scaling PZD 2	STRUCT • HIGH: REAL • LOW: REAL	- • 100.0 • 0.0
SpeedUnit	Unit of measurement PZD 2	INT	%
SwOn	1 = Cannot switch on	STRUCT • Value: BOOL • ST: BYTE	- • 0 • 16#80
Warning	1 = Warning active 0 = No warning active	STRUCT • Value: BOOL • ST: BYTE	- • 0 • 16#80
Zsw1	Status word	WORD	0
Zsw1_11	Device-specific	STRUCT • Value: BOOL • ST: BYTE	- • 0 • 16#80
Zsw1_12	Device-specific	STRUCT • Value: BOOL • ST: BYTE	- • 0 • 16#80
Zsw1_13	Device-specific	STRUCT • Value: BOOL • ST: BYTE	- • 0 • 16#80
Zsw1_14	Device-specific	STRUCT • Value: BOOL • ST: BYTE	- • 0 • 16#80
Zsw1_15	Device-specific	STRUCT • Value: BOOL • ST: BYTE	- • 0 • 16#80

16.6.8 FbDrive block diagram

Block diagram of FbDrive

A block diagram is not provided for this block.

16.7 FbEnMe - Channel block for ET 200SP Energy Meter

16.7.1 Description of FbEnMe

Object name (type + number) and family

Type + Number: FB 1908

Family: Channel

Area of application for FbEnMe

The block is used for the following application:

- Integration of energy meter in ET 200SP with firmware V3.1 in PCS7.

How it works

The block FbEnMe integrates the above mentioned module if the following conditions are fulfilled:

- In the HW Config, user selects the dataset 253 or 252 or 251 or 250 or 159.
- Module version 32 bytes input data/12 bytes output data.

Configuration

The interconnection is made symbolic to the first input word. All other interconnections are updated automatically using a wizard.

Use the CFC editor to install the block in a cyclic interrupt OB (OB30 to OB38).

The block is also installed automatically in the startup OB (OB100).

Connect the symbol generated in HW Config (symbol table) for the input channel with the PZDIn1 input parameter.

When the CFC function "Generate module drivers" is used, the following occurs automatically:

- The in/out parameters `Mode`, `DataXchg`, `DataXchg1`, and `MS_Xchg` of the FbEnMe block are interconnected with the corresponding output parameters `OMODE_00`, `DXCHG_00`, `DXCHG1_00`, and `MS_XCHG_00` of the MOD_ENME block.
- The PZD1 to PZD32 input parameters and the PZDOut1 to PZDOut12 output parameters are interconnected with the corresponding symbols in the process image.
- The MS parameter is interconnected to the O_MS output parameter of the MOD_ENME diagnostic block.

Startup characteristics

The block has startup characteristics.

Status word allocation for `status` parameter

This block does not have the `status` parameter.

See also

- FbEnMe modes (Page 2091)
- FbEnMe functions (Page 2091)
- FbEnMe error handling (Page 2093)
- FbEnMe messaging (Page 2093)
- FbEnMe I/Os (Page 2094)
- FbEnMe block diagram (Page 2100)

16.7.2 FbEnMe modes

FbEnMe operating modes

This block does not have any modes.

See also

- Description of FbEnMe (Page 2090)
- FbEnMe functions (Page 2091)
- FbEnMe error handling (Page 2093)
- FbEnMe messaging (Page 2093)
- FbEnMe I/Os (Page 2094)
- FbEnMe block diagram (Page 2100)

16.7.3 FbEnMe functions

Functions of FbEnMe

The functions of this block are listed below.

Transmission of messages

If the block is to send messages to the upstream diagnostics block, you must activate this function at the `Feature` bit Transmission of status information of devices (Page 175).

Configurable reactions using the Feature parameter

You can find an overview of all reactions provided by the `Feature` parameter in the Configurable functions using the Feature I/O (Page 131). The following functionalities are available for this block at the relevant bits:

Bit	Function
10	Condition monitoring information at the channel blocks (Page 145)
29	Transmission of status information of devices (Page 175)
30	Outputting a de-energized value for block-external simulation (Page 148)

Forming the control word

When `STW1` (control word) is created and `Stw1ST` is simultaneously set at 16#80, the Boolean control inputs listed below have no effect and the control word `STW1` is set at the process value output `PZDOUT2`.

When the `Stw1ST` signal status has a bad value, the data is taken from the Boolean control inputs.

<code>PZDOut1</code>	Variant ID from the input word <code>PZDIn1</code>
<code>PZDOut2</code> Bit 6	<code>Opn_EnCnt</code>
<code>PZDOut2</code> Bit 7	<code>Rst_EnCnt</code>

Energy meter gate:

This function has to be activated in parameter 128 first before you can use the gate. Please refer to hardware manual. If the function is activated, the parameter "Opn_EnCnt" switches the gate to open or close.

"Reset on request":

With a high edge of the parameter `Rst_EnCnt` of this channel block, the values are adopted from energy meter data record 143.

Note

The data record 143 of the energy meter will not be written by the channel block `FbEnMe` to the device. This has to be set by the operator manually.

See also

Description of `FbEnMe` (Page 2090)

`FbEnMe` modes (Page 2091)

`FbEnMe` error handling (Page 2093)

`FbEnMe` messaging (Page 2093)

`FbEnMe` I/Os (Page 2094)

`FbEnMe` block diagram (Page 2100)

16.7.4 FbEnMe error handling

Error handling of FbEnMe

Error handling of all the blocks is described in chapter Error handling (Page 119) in the basic instructions.

The following error can be displayed for this block:

- Error numbers

Overview of error numbers

The `ErrorNum` parameter can be used to output the following error numbers:

Error number	Meaning of the error number
-1	Predefined value when inserting the block; the block is not processed.
0	There is no error.

See also

Description of FbEnMe (Page 2090)

FbEnMe modes (Page 2091)

FbEnMe functions (Page 2091)

FbEnMe messaging (Page 2093)

FbEnMe I/Os (Page 2094)

FbEnMe block diagram (Page 2100)

16.7.5 FbEnMe messaging

Messaging

This block does not offer messaging.

See also

Description of FbEnMe (Page 2090)

FbEnMe modes (Page 2091)

FbEnMe functions (Page 2091)

FbEnMe error handling (Page 2093)

FbEnMe I/Os (Page 2094)

FbEnMe block diagram (Page 2100)

16.7.6 FbEnMe I/Os

I/Os of FbEnMe

Input parameters

Parameter	Description	Type	Default
EN	1 = Called block will be processed	BOOL	1
PZDIn1	Input byte 0	BYTE	16#00
...
PZDIn32	Input byte 31	BYTE	16#00
MS_Release	Release for maintenance	STRUCT	-
		<ul style="list-style-type: none"> • Value: BOOL • ST: BYTE 	<ul style="list-style-type: none"> • 0 • 16#80
MS	Maintenance state	DWORD	16#00000000
MS_Ext	External maintenance status	DWORD	16#00000000
TextRef	Text 1 reference external messages	WORD	16#0000
FlutEn	1 = Flutter suppression on	BOOL	0
FlutTmIn	Flutter suppression time	INT	0
Stw1	Control word	BYTE	16#00
Stw1ST	Control word status	BYTE	16#00
Rst_EnCnt	Reset energy meter	STRUCT	-
		<ul style="list-style-type: none"> • Value: BOOL • ST: BYTE 	<ul style="list-style-type: none"> • 0 • 16#80
Opn_EnCnt	Open energy meter gate	STRUCT	-
		<ul style="list-style-type: none"> • Value: BOOL • ST: BYTE 	<ul style="list-style-type: none"> • 0 • 16#80
Feature	I/O for additional functions (Page 2091)	STRUCT	-
		<ul style="list-style-type: none"> • Bit 0: BOOL • ... • Bit 29: BOOL • Bit 30: BOOL • Bit 31: BOOL 	<ul style="list-style-type: none"> • 0 • 0 • 1 • 1 • 0

In/Out parameters

Parameter	Description	Type	Default
Mode0	Quality and mode - Phase 1	DWORD	16#00000000
Mode1	Quality and mode - Phase 2	DWORD	16#00000000
Mode2	Quality and mode - Phase 3	DWORD	16#00000000

Parameter	Description	Type	Default
DataXchg	Internal data exchange channel to the diagnostics block	DWORD	16#00000000
DataXchg1	Internal data exchange channel to the diagnostics block	DWORD	16#00000000
MS_Xchg	Exchange of the maintenance status	DWORD	16#00000000

Output parameters

Parameter	Description	Type	Default
ENO	1 = Block algorithm completed without errors	BOOL	0
PZDOut1	Output byte 0	BYTE	16#00
...
PZDOut12	Output byte 11	BYTE	16#00
Bad	1 = Process value is not valid	STRUCT <ul style="list-style-type: none"> Value: BOOL ST: BYTE 	- <ul style="list-style-type: none"> 0 16#80
ErrorNum	Error number	INT	-1
ModErr	1 = Device/module is faulty	STRUCT <ul style="list-style-type: none"> Value: BOOL ST: BYTE 	- <ul style="list-style-type: none"> 0 16#80
Variant	User data variant	INT	0
VarError	Configured user data variant is not supported	BOOL	1
CurL1Li	Current L1	STRUCT <ul style="list-style-type: none"> Value: REAL ST: BYTE 	- <ul style="list-style-type: none"> 0.0 16#80
CurL1LiScale	Scale factor of current L1	STRUCT <ul style="list-style-type: none"> High: REAL Low: REAL 	- <ul style="list-style-type: none"> 65.535 0.0
CurL1LiUnit	Unit of current L1	INT	1209
CurL2Li	Current L2	STRUCT <ul style="list-style-type: none"> Value: REAL ST: BYTE 	- <ul style="list-style-type: none"> 0.0 16#80
CurL2LiScale	Scale factor of current L2	STRUCT <ul style="list-style-type: none"> High: REAL Low: REAL 	- <ul style="list-style-type: none"> 65.535 0.0
CurL2LiUnit	Unit of current L2	INT	1209
CurL3Li	Current L3	STRUCT <ul style="list-style-type: none"> Value: REAL ST: BYTE 	- <ul style="list-style-type: none"> 0.0 16#80

Channel blocks

16.7 FbEnMe - Channel block for ET 200SP Energy Meter

Parameter	Description	Type	Default
CurL3LiScale	Scale factor of current L3	STRUCT • High: REAL • Low: REAL	- • 65.535 • 0.0
CurL3LiUnit	Unit of current L3	INT	1209
PL1Li	Power L1	STRUCT • Value: REAL • ST: BYTE	- • 0.0 • 16#80
PL1LiScale	Scale factor of power L1	STRUCT • High: REAL • Low: REAL	- • 27648.0 • -27648.0
PL1LiUnit	Unit of power L1	INT	0
PL2Li	Power L2	STRUCT • Value: REAL • ST: BYTE	- • 0.0 • 16#80
PL2LiScale	Scale factor of power L2	STRUCT • High: REAL • Low: REAL	- • 27648.0 • -27648.0
PL2LiUnit	Unit of power L2	INT	0
PL3Li	Power L3	STRUCT • Value: REAL • ST: BYTE	- • 0.0 • 16#80
PL3LiScale	Scale factor of power L3	STRUCT • High: REAL • Low: REAL	- • 27648.0 • -27648.0
PL3LiUnit	Unit of power L3	INT	0
PTotLi	Power L1L2L3	STRUCT • Value: REAL • ST: BYTE	- • 0.0 • 16#80
PTotLiScale	Scale factor of power L1L2L3	STRUCT • High: REAL • Low: REAL	- • 27648.0 • -27648.0
PTotLiUnit	Engineering units of power L1L2L3	INT	0
ETotLi	Energy L1L2L3	STRUCT • Value: REAL • ST: BYTE	- • 0.0 • 16#80
ETotLiScale	Scale factor of energy L1L2L3	STRUCT • High: REAL • Low: REAL	- • 4294967295.0 • 0.0
ETotLiUnit	Unit of energy L1L2L3	INT	0

16.7 FbEnMe - Channel block for ET 200SP Energy Meter

Parameter	Description	Type	Default
PFaL1Li	Power factor L1	STRUCT • Value: REAL • ST: BYTE	- • 0.0 • 16#80
PFaL1LiScale	Scale factor of power factor L1	STRUCT • High: REAL • Low: REAL	- • 1.0 • 0.0
PFaL1LiUnit	Unit of power factor L1	INT	0
PFaL2Li	Power factor L2	STRUCT • Value: REAL • ST: BYTE	- • 0.0 • 16#80
PFaL2LiScale	Scale factor of power factor L2	STRUCT • High: REAL • Low: REAL	- • 1.0 • 0.0
PFaL2LiUnit	Engineering units of power factor L2	INT	0
PFaL3Li	Power factor L3	STRUCT • Value: REAL • ST: BYTE	- • 0.0 • 16#80
PFaL3LiScale	Scale factor of power factor L3	STRUCT • High: REAL • Low: REAL	- • 1.0 • 0.0
PFaL3LiUnit	Unit of power factor L3	INT	0
PFaTotLi	Power factor L1L2L3	STRUCT • Value: REAL • ST: BYTE	- • 0.0 • 16#80
PFaTotLiScale	Scale factor of power factor L1L2L3	STRUCT • High: REAL • Low: REAL	- • 1.0 • 0.0
PFaTotLiUnit	Unit of power factor L1L2L3	INT	0
VL1Li	Voltage L1	STRUCT • Value: REAL • ST: BYTE	- • 0.0 • 16#80
VL1LiScale	Scale factor of voltage L1	STRUCT • High: REAL • Low: REAL	- • 300.0 • 0.0
VL1LiUnit	Engineering units of voltage L1	INT	1240
VL2Li	Voltage L2	STRUCT • Value: REAL • ST: BYTE	- • 0.0 • 16#80
VL2LiScale	Scale factor of voltage L2	STRUCT • High: REAL • Low: REAL	- • 300.0 • 0.0

Channel blocks

16.7 FbEnMe - Channel block for ET 200SP Energy Meter

Parameter	Description	Type	Default
VL2LiUnit	Unit of voltage L2	INT	1240
VL3Li	Voltage L3	STRUCT • Value: REAL • ST: BYTE	- • 0.0 • 16#80
VL3LiScale	Scale factor of voltage L3	STRUCT • High: REAL • Low: REAL	- • 300.0 • 0.0
VL3LiUnit	Unit of voltage L3	INT	1240
VL1L2Li	Voltage L1L2	STRUCT • Value: REAL • ST: BYTE	- • 0.0 • 16#80
VL1L2LiScale	Scale factor of voltage L1L2	STRUCT • High: REAL • Low: REAL	- • 600.0 • 0.0
VL1L2LiUnit	Unit of voltage L1L2	INT	1240
VL2L3Li	Voltage L2L3	STRUCT • Value: REAL • ST: BYTE	- • 0.0 • 16#80
VL2L3LiScale	Scale factor of voltage L2L3	STRUCT • High: REAL • Low: REAL	- • 600.0 • 0.0
VL2L3LiUnit	Unit of voltage L2L3	INT	1240
VL3L1Li	Voltage L3L1	STRUCT • Value: REAL • ST: BYTE	- • 0.0 • 16#80
VL3L1LiScale	Scale factor of voltage L3L1	STRUCT • High: REAL • Low: REAL	- • 600.0 • 0.0
VL3L1LiUnit	Unit of voltage L3L1	INT	1240
AcPwrLi	Active power L1	STRUCT • Value: REAL • ST: BYTE	- • 0.0 • 16#80
AcPwrLiScale	Scale factor of active power L1	STRUCT • High: REAL • Low: REAL	- • 27648.0 • -27648.0
AcPwrLiUnit	Unit of active power L1	INT	1186
RePwrLi	Reactive power L1	STRUCT • Value: REAL • ST: BYTE	- • 0.0 • 16#80

16.7 FbEnMe - Channel block for ET 200SP Energy Meter

Parameter	Description	Type	Default
RePwrLiScale	Scale factor of reactive power L1	STRUCT • High: REAL • Low: REAL	- • 27648.0 • -27648.0
RePwrLiUnit	Engineering units of reactive power L1	INT	0
ApPwrLi	Apparent power L1	STRUCT • Value: REAL • ST: BYTE	- • 0.0 • 16#80
ApPwrLiScale	Scale factor of apparent power L1	STRUCT • High: REAL • Low: REAL	- • 27648.0 • -27648.0
ApPwrLiUnit	Unit of apparent power L1	INT	0
AcErgLi	Active energy L1	STRUCT • Value: REAL • ST: BYTE	- • 0.0 • 16#80
AcErgLiScale	Scale factor of active energy L1	STRUCT • High: REAL • Low: REAL	- • 4294967295.0 • 0.0
AcErgLiUnit	Unit of active energy L1	INT	1175
ReErgLi	Reactive energy L1	STRUCT • Value: REAL • ST: BYTE	- • 0.0 • 16#80
ReErgLiScale	Scale factor of reactive energy L1	STRUCT • High: REAL • Low: REAL	- • 4294967295.0 • 0.0
ReErgLiUnit	Unit of reactive energy L1	INT	0
ApErgLi	Apparent energy L1	STRUCT • Value: REAL • ST: BYTE	- • 0.0 • 16#80
ApErgLiScale	Scale factor of apparent energy L1	STRUCT • High: REAL • Low: REAL	- • 4294967295.0 • 0.0
ApErgLiUnit	Unit of apparent energy L1	INT	0
OosAct	1 = Field device is undergoing maintenance	STRUCT • Value: BOOL • ST: BYTE	- • 0 • 16#80
Oms_Ext	Reserved	STRUCT • Value: BOOL • ST: BYTE	- • 0 • 16#80

16.7 FbEnMe - Channel block for ET 200SP Energy Meter

Parameter	Description	Type	Default
MS_Req	1 = Maintenance request from the diagnostic area	STRUCT <ul style="list-style-type: none">• Value: BOOL• ST: BYTE	- <ul style="list-style-type: none">• 0• 16#80
MS_Dev	Maintenance state	DWORD	16#00000000

See also

- Description of FbEnMe (Page 2090)
- FbEnMe modes (Page 2091)
- FbEnMe error handling (Page 2093)
- FbEnMe messaging (Page 2093)
- FbEnMe block diagram (Page 2100)

16.7.7 FbEnMe block diagram

Block diagram of FbEnMe

A block diagram is not provided for this block.

See also

- Description of FbEnMe (Page 2090)
- FbEnMe modes (Page 2091)
- FbEnMe functions (Page 2091)
- FbEnMe error handling (Page 2093)
- FbEnMe messaging (Page 2093)
- FbEnMe I/Os (Page 2094)

16.8 FbSwtMMS - Channel block for MM starter

16.8.1 Description of FbSwtMMS

Object name (type + number) and family

Type + number: FB 1907

Family: Channel

Area of application of FbSwtMMS

The block is used for the following applications:

- Signal processing of motor management starter with profile type 1.

NOTICE

Integration of the block into technological charts

Make sure when installing the block into the technological charts that the device is a switching device of slave family 2 (switching device).

Make sure that the device is installed according to profile type 1 for motor managed starters of the LVSG; otherwise, the block will not work correctly. The block is automatically connected with the process image according to the specifications of profile type 1.

How it works

The FbSwtMMS block integrates a motor management starter from any switch or starter object.

Configuration

The interconnection is made symbolic to the first input or output word. All other interconnections are updated automatically using a wizard.

Use the CFC editor to install the block in a cyclic interrupt OB (OB30 to OB38).

The block is also installed automatically in the startup OB (OB100).

When the CFC function "Generate module drivers" is used, the following occurs automatically:

- The `MODE` input is interconnected to the relevant `OMODE` output of the `MOD_SWT` block.
- The `PZDIn2` input and the `PZDOut1` output are interconnected using the icons of the compact drives.
- The `DataXchg` input is interconnected to the relevant `DXCHG_00` output of the `MOD_SWT` block.
- The `MS` input is interconnected to the relevant `O_MS` output of the `MOD_SWT` block.

Note

"Configuration of direct starters with the APL channel block "FbSwtMMS" in SIMATIC PCS 7 (https://support.industry.siemens.com/cs/document/64182525/configuration-of-direct-starters-with-the-apl-channel-block-%E2%80%9Efbswtmms%E2%80%9D-in-simatic-pcs-7?dti=0&lc=en-DE))"

Startup characteristics

The block has startup characteristics.

16.8.2 FbSwtMMS modes

Operating modes of FbSwtMMS

This block does not have any modes.

16.8.3 FbSwtMMS functions

Functions of FbSwtMMS

The functions for this block are listed below.

Transmission of messages

If the block is to send messages to the upstream diagnostics block, you must activate this function at the `Feature` bit Transmission of status information of devices (Page 175).

Configurable reactions using the `Feature` parameter

You can find an overview of all reactions provided by the `Feature` parameter in the chapter Configurable functions using the `Feature` I/O (Page 131). The following functionality is available for this block at the relevant bits:

Bit	Function
10	Condition monitoring information at the channel blocks (Page 145)
29	Transmission of status information of devices (Page 175)
30	Outputting a de-energized value for block-external simulation (Page 148)

Forming the control word

When STW1(control word) is created and Stw1ST is at 16#80, the Boolean control inputs listed below have no effect and the control word STW1 is set at the process value output PZDOUT1.

When the Stw1ST signal status has a bad value, the data is taken from the Boolean control inputs.

Rev	Control word 1 bit 0
Off	Control word 1 bit 1
Fwd	Control word 1 bit 2
StartTest	Control word 1 bit 3
StartEmerg	Control word 1 bit 4
Auto	Control word 1 bit 5
ResetTrip	Control word 1 bit 6
Ctrl17	Control word 1 bit 7
Ctrl18	Control word 1 bit 8
Ctrl19	Control word 1 bit 9
Ctrl110	Control word 1 bit 10
Ctrl111	Control word 1 bit 11
ManSpec1	Control word 1 bit 12
ManSpec2	Control word 1 bit 13
ManSpec3	Control word 1 bit 14
ManSpec4	Control word 1 bit 15

16.8.4 FbSwtMMS error handling

Error handling of FbSwtMMS

Error handling of all the blocks is described in chapter Error handling (Page 119) in the basic instructions.

The following errors can be displayed for this block:

- Error numbers

Note

If an error occurs during switching, all outputs are written as before to the field device. The inputs of the field device are displayed and the status with the value 16#00 is formed according to the MS.

Note

The outputs are locked during Drive, only the Local and Reset are transmitted to the device. The inputs react as with FbSwtMMS.

Overview of error numbers

The ErrorNum I/O can be used to output the following error numbers:

Error number	Meaning of the error number
-1	Predefined value when inserting the block; the block is not processed.
0	There is no error.
1	Invalid process value (output parameter Bad = 1)

16.8.5 FbSwtMMS messaging

Messaging

This block does not offer messaging.

16.8.6 FbSwtMMS status word

Forming the status word

The zsw1 (status word), or the Boolean status outputs, is set via the process value input PZDIN1.

Status word 1	Bit 0	RdyOn
Status word 1	Bit 1	RdyOp
Status word 1	Bit 2	OpEn
Status word 1	Bit 3	Fault
Status word 1	Bit 4	NoOff2
Status word 1	Bit 5	NoOff3
Status word 1	Bit 6	SwOn
Status word 1	Bit 7	Warning
Status word 1	Bit 8	SpeedErr
Status word 1	Bit 9	CtrlReq
Status word 1	Bit 10	F_N_Reach
Status word 1	Bit 11	Zsw1_11
Status word 1	Bit 12	Zsw1_12
Status word 1	Bit 13	Zsw1_13
Status word 1	Bit 14	Zsw1_14
Status word 1	Bit 15	Zsw1_15

16.8.7 FbSwtMMS I/Os

I/Os of FbSwtMMS

Input parameters

Parameter	Description	Type	Default
Auto	Control command for remote control I bit 0.5	STRUCT <ul style="list-style-type: none"> • Value: BOOL • ST: BYTE 	- <ul style="list-style-type: none"> • 0 • 16#80
Ctrl7	Control signal 7	STRUCT <ul style="list-style-type: none"> • Value: BOOL • ST: BYTE 	- <ul style="list-style-type: none"> • 0 • 16#80
Ctrl8	Control signal 8	STRUCT <ul style="list-style-type: none"> • Value: BOOL • ST: BYTE 	- <ul style="list-style-type: none"> • 0 • 16#80
Ctrl9	Control signal 9	STRUCT <ul style="list-style-type: none"> • Value: BOOL • ST: BYTE 	- <ul style="list-style-type: none"> • 0 • 16#80
Ctrl10	Control signal 10	STRUCT <ul style="list-style-type: none"> • Value: BOOL • ST: BYTE 	- <ul style="list-style-type: none"> • 0 • 16#80
Ctrl11	Control signal 11	STRUCT <ul style="list-style-type: none"> • Value: BOOL • ST: BYTE 	- <ul style="list-style-type: none"> • 0 • 16#80
EN	1 = Called block will be processed	BOOL	1
Feature	I/O for additional functions	STRUCT <ul style="list-style-type: none"> • Bit 0: BOOL • ... • Bit 29 • ... • Bit 31: BOOL 	- <ul style="list-style-type: none"> • 0 • 0 • 1 • 0 • 0
FlutEn	1 = Flutter suppression activated	BOOL	0
FlutTmln*	Flutter time: If a certain number of state changes occur within this time, fluttering is suppressed.	INT	0
Fwd	Control forward I bit 0.2	STRUCT <ul style="list-style-type: none"> • Value: BOOL • ST: BYTE 	- <ul style="list-style-type: none"> • 0 • 16#80
IScale	Scaling for measured current	STRUCT <ul style="list-style-type: none"> • High: REAL • Low: REAL 	- <ul style="list-style-type: none"> • 100.0 • 0.0

Parameter	Description	Type	Default
IUnit	Unit of measurement for measured current	INT	1342
ManSpec1	Device-specific command, functionality in accordance with manufacturer specifications 1 I bit 1.4	STRUCT • Value: BOOL • ST: BYTE	- • 0 • 16#80
ManSpec2	Device-specific command, functionality in accordance with manufacturer specifications 2 I bit 1.5	STRUCT • Value: BOOL • ST: BYTE	- • 0 • 16#80
ManSpec3	Device-specific command, functionality in accordance with manufacturer specifications 3 I bit 1.6	STRUCT • Value: BOOL • ST: BYTE	- • 0 • 16#80
ManSpec4	Device-specific command, functionality in accordance with manufacturer specifications 4 I bit 1.7	STRUCT • Value: BOOL • ST: BYTE	- • 0 • 16#80
MS*	Maintenance status	DWORD	16#00000000
MS_Release	Release for maintenance (interconnected with MS_Release of the technology block)	STRUCT • Value: BOOL • ST: BYTE	- • 0 • 16#80
MS_Ext	Maintenance status external	DWORD	16#00000000
Off	Control Off I bit 0.1	STRUCT • Value: BOOL • ST: BYTE	- • 0 • 16#80
PZDIn1	Connectable input word 1	WORD	16#0000
PZDIn2	Connectable input word 2	WORD	16#0000
ResetTrip	Undo last operation I bit 0.6	STRUCT • Value: BOOL • ST: BYTE	- • 0 • 16#80
Rev	Control backward I bit 0.0	STRUCT • Value: BOOL • ST: BYTE	- • 0 • 16#80
StartEmerg	Start command is issued despite a pending internal error I bit 0.4	STRUCT • Value: BOOL • ST: BYTE	- • 0 • 16#80
StartTest	Start command for an internal self-test I bit 0.3	STRUCT • Value: BOOL • ST: BYTE	- • 0 • 16#80
Stw1	Control word	WORD	16#0000
Swt1ST	Status control word	BYTE	16#00
TextRef	Text reference	WORD	16#0000

* Values can be written back to these inputs during processing of the block by the block algorithm.

In/out parameters

Parameter	Description	Type	Default
DataXchg	Internal data exchange channel to the diagnostics block	DWORD	16#00000000
DataXchg1	Internal data exchange channel to the diagnostics block	DWORD	16#00000000
Mode	Value status and measuring type	DWORD	16#00000000
MS_Xchg	Exchange of the maintenance status	DWORD	16#00000000

Output parameters

Parameter	Description	Type	Default
Bad	1 = Process value is not valid	STRUCT <ul style="list-style-type: none"> Value: BOOL ST: BYTE 	- <ul style="list-style-type: none"> 0 16#80
ENO	1 = Block algorithm completed without errors	BOOL	0
ErrAct	Status information internal device fault Q bit 0.6	STRUCT <ul style="list-style-type: none"> Value: BOOL ST: BYTE 	- <ul style="list-style-type: none"> 0 16#80
ErrorNum	Output of pending error number	INT	-1
FdkAuto	Feedback information for the remote control status Q bit 0.5	STRUCT <ul style="list-style-type: none"> Value: BOOL ST: BYTE 	- <ul style="list-style-type: none"> 0 16#80
FdkFwd	Feedback information forward Q bit 0.2	STRUCT <ul style="list-style-type: none"> Value: BOOL ST: BYTE 	- <ul style="list-style-type: none"> 0 16#80
FdkOff	Feedback information Off Q bit 0.1	STRUCT <ul style="list-style-type: none"> Value: BOOL ST: BYTE 	- <ul style="list-style-type: none"> 0 16#80
FdkRev	Feedback information backward Q bit 0.0	STRUCT <ul style="list-style-type: none"> Value: BOOL ST: BYTE 	- <ul style="list-style-type: none"> 0 16#80
Imax	Value for highest measured current	STRUCT <ul style="list-style-type: none"> Value: REAL ST: BYTE 	- <ul style="list-style-type: none"> 0.0 16#80
IScaleOut	Scaling for measured current	STRUCT <ul style="list-style-type: none"> High: REAL Low: REAL 	- <ul style="list-style-type: none"> 100.0 0.0

Parameter	Description	Type	Default
IUnitOut	Unit of measurement for measured current	INT	0
LockTmAct	Status information, the drive is temporarily locked Q bit 0.4	STRUCT <ul style="list-style-type: none"> • Value: BOOL • ST: BYTE 	- <ul style="list-style-type: none"> • 0 • 16#80
ManSpc01	Device-specific feedback, functionality in accordance with manufacturer specifications 1 Q bit 1.4	STRUCT <ul style="list-style-type: none"> • Value: BOOL • ST: BYTE 	- <ul style="list-style-type: none"> • 0 • 16#80
ManSpc02	Device-specific feedback, functionality in accordance with manufacturer specifications 2 Q bit 1.5	STRUCT <ul style="list-style-type: none"> • Value: BOOL • ST: BYTE 	- <ul style="list-style-type: none"> • 0 • 16#80
ManSpc03	Device-specific feedback, functionality in accordance with manufacturer specifications 3 Q bit 1.6	STRUCT <ul style="list-style-type: none"> • Value: BOOL • ST: BYTE 	- <ul style="list-style-type: none"> • 0 • 16#80
ManSpc04	Device-specific feedback, functionality in accordance with manufacturer specifications 4 Q bit 1.7	STRUCT <ul style="list-style-type: none"> • Value: BOOL • ST: BYTE 	- <ul style="list-style-type: none"> • 0 • 16#80
ManSpc05	Device-specific feedback, functionality in accordance with manufacturer specifications 5 Q bit 1.2	STRUCT <ul style="list-style-type: none"> • Value: BOOL • ST: BYTE 	- <ul style="list-style-type: none"> • 0 • 16#80
ManSpc06	Device-specific feedback, functionality in accordance with manufacturer specifications 6 Q bit 1.3	STRUCT <ul style="list-style-type: none"> • Value: BOOL • ST: BYTE 	- <ul style="list-style-type: none"> • 0 • 16#80
ModErrr	1 = Device/module is faulty	STRUCT <ul style="list-style-type: none"> • Value: BOOL • ST: BYTE 	- <ul style="list-style-type: none"> • 0 • 16#80
MS_Dev	Maintenance state	DWORD	16#00000000
MS_Req	1 = Maintenance request from the diagnostic area	STRUCT <ul style="list-style-type: none"> • Value: BOOL • ST: BYTE 	- <ul style="list-style-type: none"> • 0 • 16#80
OosAct	1 = Field device is undergoing maintenance	STRUCT <ul style="list-style-type: none"> • Value: BOOL • ST: BYTE 	- <ul style="list-style-type: none"> • 0 • 16#80
OverIAct	Status information internal warning overload active Q bit 0.3	STRUCT <ul style="list-style-type: none"> • Value: BOOL • ST: BYTE 	- <ul style="list-style-type: none"> • 0 • 16#80
PZDOut1	Connectable output word	WORD	16#0000

Parameter	Description	Type	Default
Status8	Status output 8	STRUCT	-
	Q bit 1.0	<ul style="list-style-type: none"> • Value: BOOL • ST: BYTE 	<ul style="list-style-type: none"> • 0 • 16#80
Status9	Status output 9	STRUCT	-
	Q bit 1.1	<ul style="list-style-type: none"> • Value: BOOL • ST: BYTE 	<ul style="list-style-type: none"> • 0 • 16#80
WarnAct	Status information internal maintenance active	STRUCT	-
	Q bit 0.7	<ul style="list-style-type: none"> • Value: BOOL • ST: BYTE 	<ul style="list-style-type: none"> • 0 • 16#80
Zsw1	Status word	WORD	16#0000

16.8.8 FbSwtMMS block diagram

Block diagram of FbSwtMMS

A block diagram is not provided for this block.

16.9 Pcs7AnIn - Analog input channel block

16.9.1 Description of Pcs7AnIn

Object name (type + number) and family

Type + number: FB 1869

Family: Channel

Area of application for Pcs7AnIn

The block is used for the following applications:

- Signal processing of an analog input value of S7-300/400 SM analog input modules including ET 200M Ex-io module in °C.
- Processing of the redundant input channels.

How it works

The block cyclically processes all channel-specific signal functions of an analog input module.

It reads a raw analog value from the process image (partition) and converts it to its physical value or calculates a percentage value based on this raw value. Use the status at input parameter `Mode` to define the format of the raw value and how it is processed.

Configuration

Use the CFC editor to install the block in a cyclic interrupt OB (OB30 to OB38).

The block is also installed automatically in the startup OB (OB100).

When the CFC function "Generate module drivers" is used, the following occurs automatically:

- The in/out parameter `Mode` is interconnected to the corresponding `OMode_xx` output parameter of the MOD block.
- The in/out parameter `DataXchg` is interconnected to the corresponding `DataXchg_xx` output parameter of the MOD block.
- The `MS` parameter is interconnected to the `O_MS` output parameter of the diagnostics block.

In case of redundancy, connection with both quality bits and connection with the redundant slave channel:

- The in parameter `PV_InSlv` is interconnected with the symbol of the slave channel.
- The in parameter `ProImQB` is interconnected with the symbol of the quality bit of the master channel.
- The in parameter `ProImQBSlv` is interconnected with the symbol of the quality bit of the slave channel.

Connect the symbol generated in HW Config (symbol table) for the input channel with the PV_In input parameter.

In case of redundant I/O configuration, use symbol of the channel of the master module.

Note

If you are not using the CFC function "Generate module drivers" you must set the Mode in/out parameter manually. Refer to the Mode Settings for SM Modules (Page 2206) section for more on this.

For the Pcs7AnIn block, the Advanced Process Library contains templates for process tag types as examples with various application scenarios for this block.

Examples of process tag types:

- Monitoring an analog process tag (AnalogMonitoring) (Page 2356)
- Cascade control with control loop monitoring through ConPerMon (CascadeControl) (Page 2342)
- Cascade control with PIDConR (CascadeR) (Page 2345)
- PID controller with dynamic feedforward control (FwdDisturbCompensat) (Page 2329)
- PID - control with operating-point-oriented parameter control (GainScheduling) (Page 2327)
- Override control (Page 2348)
- Override control with PIDConR (OverrideR) (Page 2350)
- PID controller with safety logic and control loop monitoring (PIDConL_ConPerMon) (Page 2324)
- PIDConR with safety logic and control loop monitoring (PIDConR_ConPerMon) (Page 2325)
- Ratio control with control loop monitoring through ConPerMon (RatioControl) (Page 2338)
- Ratio control with PIDConR (RatioR) (Page 2341)
- PID controller with Smith predictor (SmithPredictorControl) (Page 2332)
- Step controller with assigned actuator block and position feedback (StepControlActor) (Page 2334)
- Step controller with direct access to the actuator and without position feedback (StepControlDirect) (Page 2333)
- Model-based predictive control (ModPreCon) (Page 2351)
- Reversible motor with controllable speed (MotorSpeedControlled) (Page 2364)
- Dosing (Dose_Lean) (Page 2358)
- Control valve (VlvAnL) (Page 2370)
- Split-range controller with control loop monitoring through ConPerMon (SplitrangeControl) (Page 2335)

Startup characteristics

The accept value delay is started when `CountLim` \neq 0 .

Quality code (ET200 SP HA modules)

The quality code is read from the process image and has two states: "Good" or "Bad".

Redundancy

The block monitors the values of the redundant signals (master and slave) with quality code and the value of the signal with "Good" quality code along with its quality code is transferred to the process.

In case both the signals deliver "Bad" quality code, the substitute value with "Bad" quality code is transferred to the process.

Status word allocation for `Status` parameter

This block does not have the `Status` parameter.

See also

Pcs7AnIn block diagram (Page 2121)

Pcs7AnIn I/Os (Page 2118)

Pcs7AnIn messaging (Page 2118)

Pcs7AnIn error handling (Page 2117)

Pcs7AnIn functions (Page 2113)

Pcs7AnIn modes (Page 2112)

16.9.2 Pcs7AnIn modes

Pcs7AnIn modes

This block does not have any modes.

See also

Pcs7AnIn block diagram (Page 2121)

Pcs7AnIn I/Os (Page 2118)

Pcs7AnIn messaging (Page 2118)

Pcs7AnIn error handling (Page 2117)

Pcs7AnIn functions (Page 2113)

Description of Pcs7AnIn (Page 2110)

16.9.3 Pcs7AnIn functions

Functions of Pcs7AnIn

The functions for this block are listed below.

Checking the raw value

The nominal range sets the range for converting analog signals into digital values (raw values), depending on the measuring type and the range of the analog input module. The nominal range is defined in the hardware configuration and is automatically saved in the in/out parameter when the block driver `Mode` is created.

This includes an overshoot/undershoot range within which an analog signal can still be converted to a digital value. This range is defined in relation to the nominal range (roughly 18.5%). Outside this range an overflow or underflow occurs and output parameter `Bad = 1` is set.

- Output parameter `PV_LoAct = 1` is set if the value is outside the nominal low range.
- Output parameter `PV_HiAct = 1` is set if the value is outside the nominal high range.

NAMUR limit checking (only with modules of 4 to 20 mA)

In "Life Zero" monitoring, the process signal is invalid (`Bad = 1`), if the measured current is less than 3.6 mA or greater than 21 mA (defined by NAMUR).

The NAMUR limits are set as fixed defaults for limit monitoring. You can define other limits by setting input parameter `NamurOff = 1` and setting corresponding new limits in [mA] at the `HighLimit` and `LowLimit` input parameters. If the active limits are exceeded or undershot (`PV_HiAct` or `PV_LoAct = 1`), `Bad = 1` is set for a "Life Zero" analog signal.

Note

The limits that can be selected must lie within the overshoot and undershoot range of the module. Values outside the NAMUR range are also possible, if the module does not automatically limit the measured values.

Obtaining the standard value

The standard value (a physical quantity) is obtained from the raw value using parameters `Scale` and `Mode`. Set two scale values on the structured parameter `Scale`.

- High scale value (`Scale.High`)
- Low scale value (`Scale.Low`)

If you are not using the CFC function "Generate module drivers" you must set the `Mode` in/out parameter manually. Refer to the Mode Settings for SM Modules (Page 2206) section for more on this.

The settings of the parameter `Scale` are copied to the output parameter `ScaleOut`. The output parameter can be interconnected to a corresponding input parameter of a technologic block (e.g. `PV_OpScale`).

The standard value is obtained using a linear characteristic. `Scale.Low` is the lowest physical value that the process variable can take and `Scale.High` is the highest.

If `Scale.Low = 0` and `Scale.High = 100` a percentage is obtained.

Special cases when obtaining the standard value using the `Scale` parameter:

- If you set `Scale.High = Scale.Low`, you obtain the analog input module's electrical input signal (e.g., mA) according to the `Mode` parameter setting.
- If the raw value is already a physical quantity (for example, RTD or TC), set `Scale.Low = 0` and `Scale.High = 1`. This will cause the raw value to be output unchanged, as a physical quantity.
- When using measuring type PTC (**P**ositive **T**emperature **C**oefficient binary evaluation of resistance thermometers), the analog value contains an encoded binary signal. The `PV_Out` output provides the following information:
 - If the measured resistance is within the normal range, `PV_Out = 0.0`
 - If the measured resistance is within the prewarning range, `PV_Out = 4.0`
 - If the measured resistance is in the operating range, `PV_Out = 1.0`
This is only true if the input parameters are `Scale.Low = 0` and `Scale.High = 1`. During simulation or if the substitute value is output, you can only set the input parameters `SimPV_In` and `SubsPV_In` to 0.0 or 1.0.
- With the measuring type "External or internal comparison of thermocouple values", the raw value is adapted to the physical variable ± 80 mV range in S7 300 modules. You have to determine the temperature using the corresponding conversion tables in the module manual. The physical equivalent in [mV] is returned by the module as a raw value. Set `Scale` to ± 80 mV.

Holding the last value if raw value is invalid

If the block is to hold the most recent valid value when the raw value is invalid, you must activate this function at the `Feature` Bit Outputting last valid value if raw value is invalid (Page 154).

You can also influence this function via the input parameter `DeltaVal`.

- `DeltaVal ≤ 0`: the last value is retained and is not influenced
- `DeltaVal > 0`: the last or the next to last value is output

If you set the parameter `DeltaVal > 0`, the last `PV_Out(k - 1)` or next to last `PV_Out(k - 2)` valid output value is output (`PV_Out(k)` is the current value, `k` is the current time).

At parameter `DeltaVal` you can preset a permitted process value change (`PV_Out`) between two calls.

You have the following options:

- For invalid raw values and $\Delta_{\text{Val}} > 0$:
 - If $|\text{PV_Out}(k-1) - \text{PV_Out}(k-2)| > \Delta_{\text{Val}}$, then $\text{PV_Out} = \text{PV_Out}(k-2)$ (last but one valid output value is output)
 - If $|\text{PV_Out}(k) - \text{PV_Out}(k-1)| \leq \Delta_{\text{Val}}$, then $\text{PV_Out} = \text{PV_Out}(k-1)$ (last valid output value is output)
- For valid raw values and $\Delta_{\text{Val}} > 0$:
 - $|\text{PV_Out}(k) - \text{PV_Out}(k-1)| > \Delta_{\text{Val}}$, so for one cycle $\text{PV_Out} = \text{PV_Out}(k-1)$ is output, i.e. Δ_{Val} is used to limit the change made to the valid raw value. In addition, the signal status at the output parameter PV_Out is set to 16#60 and the output parameter is set to $\text{Bad} = 0$.
The value of Δ_{Val} should be selected with due care. If the value is too low, the quality code may flutter between 16#80 and 16#60, regardless whether or not the raw value is OK.

Output substitute value if raw value is invalid

If the block is to output a substitute value (SubsPV_In) when the raw value is invalid, you must activate this function at the **Feature Bit Output substitute value if raw value is invalid** (Page 149).

Output of invalid value if raw value is invalid

If the block is to output an invalid value ($\text{PV_Out} = \text{PV_In}$), you must activate this function at the **Feature Bit Output invalid raw value** (Page 174).

This function is preset.

Value application delay

After a restart, or if the output parameter Bad changes its value from 1 to 0 the signal status and the value of output parameter PV_Out are not updated until the number of cycles for delayed application of the value (input parameter CountLim) have elapsed. During the value application delay, the signal status at the output parameter is $\text{PV_Out} = 16\#00$ and $\text{Bad} = 1$. The last value is retained during the value application delay.

If $\text{CountLim} = 0$, the function is deactivated.

Flutter suppression

This block provides the standard function Flutter suppression for channel blocks (Page 67)

Signal status for PCS7 channel blocks

The block provides the standard function Forming and outputting the signal status for PCS 7 channel blocks (Page 118).

Simulating signals

The block provides the standard function Simulating signals (Page 58).

Configurable reactions using the `Feature` parameter

You can find an overview of all reactions provided by the `Feature` parameter in the Configurable functions using the Feature I/O (Page 131) . The following functionality is available for this block at the relevant bits:

Bit	Function
5	Activate LowCutOff (Page 155)
6	Scalable measuring range (Page 189)
7	2 decimal points (scalable measuring range) (Page 189)
8	3 decimal points (scalable measuring range) (Page 190)
10	Condition monitoring information at the channel blocks (Page 145)
28	Output invalid raw value (Page 174)
29	Output substitute value if raw value is invalid (Page 149)
30	Outputting last valid value if raw value is invalid (Page 154)

If `Feature` bit 5 = 1, the input parameter `LowCutOff` is compared with `PV_Out.Value`.

If `PV_Out.Value < LowCutOff`, then `PV_Out.Value = Scale.Low` and output parameter `PV_LcoAct.Value = 1`.

If `PV_Out.Value ≥ LowCutOff`, then `PV_LcoAct.Value = 0`.

Sign-of-life monitoring

If an input value whose signal status is `16#80` (good) remains constant for a programmable time (monitoring time), the input value is detected as faulty and the outputs `Bad = 1` and `FrzVal = 1` are set. The signal status is set to `PV_Out.ST = 16#00`.

The monitoring time is set at the `FrznTmIn` input parameter in seconds. With `FrznTmIn = 0` or `FrznEn = 0` (default setting), the sign-of-life monitoring is deactivated, any pending errors are reset.

The input value is considered as faulty as long as it seen as constant. The monitoring time is restarted each time the input value is changed.

Scalable measuring range

The scalable measuring range is a limited section of a measuring range supported by the module.

It allows you to increase the resolution for a configurable section.

- The "Measuring range resolution" parameter determines the resolution to 2 or 3 decimal places.
- The "Measuring range center" parameter determines the temperature over which the scalable measuring range is symmetrically spanned.

For more information, refer to the manual "*SIMATIC ET 200SP analog input module AI 4xRTD/TC 2-/3-/4-wire HF*".

See also

Pcs7AnIn block diagram (Page 2121)

Pcs7AnIn I/Os (Page 2118)

Pcs7AnIn messaging (Page 2118)

Pcs7AnIn error handling (Page 2117)

Pcs7AnIn modes (Page 2112)

Description of Pcs7AnIn (Page 2110)

16.9.4 Pcs7AnIn error handling

Error handling of Pcs7AnIn

Refer to the section Error handling (Page 119) in the basic instructions for the error handling of all blocks.

The following errors can be displayed for this block:

- Channel error
- Higher-level error
- Invalid measuring range
- Frozen input value (sign-of-life monitoring)

Channel error

At the output parameter `Bad`, channel errors are displayed with 1. Channel errors can be detected using the raw value, the NAMUR check or the sign-of-life monitoring.

`PV_LoAct` or `PV_HiAct` remain set to = 1 if a channel error occurs due to the module diagnoses "Undershoot or overshoot of the measurement range".

Higher-level error / invalid measuring range

A higher-level error is output (output parameter `ModErr` = 1 and `Bad` = 1) if either:

- the signal status in the `High Word` of input parameter `Mode` takes the value 16#40, or
- there is an invalid measuring type in the `Low Word` of the input parameter `Mode`.

See also

- Pcs7AnIn block diagram (Page 2121)
- Pcs7AnIn I/Os (Page 2118)
- Pcs7AnIn messaging (Page 2118)
- Pcs7AnIn functions (Page 2113)
- Pcs7AnIn modes (Page 2112)
- Description of Pcs7AnIn (Page 2110)

16.9.5 Pcs7AnIn messaging

Messaging

This block does not offer messaging.

See also

- Pcs7AnIn block diagram (Page 2121)
- Pcs7AnIn I/Os (Page 2118)
- Pcs7AnIn error handling (Page 2117)
- Pcs7AnIn functions (Page 2113)
- Pcs7AnIn modes (Page 2112)
- Description of Pcs7AnIn (Page 2110)

16.9.6 Pcs7AnIn I/Os

I/Os of Pcs7AnIn

Input parameters

Parameter	Description	Type	Default
CountLim	Startup counter limit	INT	0
DeltaVal	Delta value (PV_In - Last valid value)	REAL	0.0
EN	1 = Called block will be processed	BOOL	1

Parameter	Description	Type	Default
Feature	I/O for additional functions (Page 2113)	STRUCT <ul style="list-style-type: none"> • Bit 0: BOOL • ... • Bit 28: BOOL • ... • Bit 31: BOOL 	- <ul style="list-style-type: none"> • 0 • 0 • 1 • 0 • 0
FlutEn	1 = Flutter suppression activated	BOOL	0
FlutTmIn*	Flutter time [s]	INT	0
FrznEn	1 = Sign-of-life monitoring activated	BOOL	0
FrznTmIn	Monitoring time in [s]	REAL	0.0
HighLimit	High limit used if NAMUR check (NamurOff = 1) is deactivated	REAL	21.5
LowLimit	Low limit used if NAMUR check (NamurOff = 1) is deactivated	REAL	3.3
LowCutOff	Input value Lowcutoff	REAL	0.0
MS	Maintenance status	DWORD	16#00000000
MS_Release	Release for maintenance (interconnected with MS_Release of the technology block)	STRUCT <ul style="list-style-type: none"> • Value: BOOL • ST: BYTE 	- <ul style="list-style-type: none"> • 0 • 16#80
MS_Ext	External maintenance status	DWORD	16#00000000
NamurOff	1= NAMUR limit verification user-defined	BOOL	0
PV_In	Process value (raw value)	WORD	16#0000
PV_InUnit	Unit of measure for process value	INT	1001
PV_InSlv	Input value of the slave channel	WORD	16#0000
ProImQB	Quality bit from the process image	BOOL	0
ProImQBslv	Quality bit from the process image of the slave channel	BOOL	0
SampleTime	Sampling time in [s]	REAL	0.1
Scale	Scaling of the process value as a structure	STRUCT <ul style="list-style-type: none"> • High: REAL • Low:REAL 	- <ul style="list-style-type: none"> • 100.0 • 0.0
SimOn	1 = Simulation on	STRUCT <ul style="list-style-type: none"> • Value: BOOL • ST: BYTE 	- <ul style="list-style-type: none"> • 0 • 16#80
SimPV_In	Process value used for SimOn = 1	STRUCT <ul style="list-style-type: none"> • Value: REAL • ST: BYTE 	- <ul style="list-style-type: none"> • 0.0 • 16#80
SubsPV_In	Substitute value	REAL	0.0
TextRef	Text reference	WORD	16#0000

* Values can be written back to these inputs during processing of the block by the block algorithm.

In/out parameters

Parameter	Description	Type	Default
DataXchg	Internal data exchange channel to the diagnostics block	DWORD	16#00000000
DataXchg1	Internal data exchange channel to the diagnostics block	DWORD	16#00000000
MS_Xchg	Exchange of the maintenance status	DWORD	16#00000000
Mode	Value status and measuring type	DWORD	16#00000000

Output parameters

Parameter	Description	Type	Default
Bad	1 = Process value is not valid	STRUCT • Value: BOOL • ST: BYTE	- • 0 • 16#80
ENO	1 = Block algorithm completed without errors	BOOL	0
FrznVal	Frozen process value	STRUCT • Value: BOOL • ST: BYTE	- • 0 • 16#80
ErrorNum	Output of pending error number. For error numbers that can be output by this block, see Pcs7AnIn error handling (Page 2117)	INT	-1
ModErr	1 = Device/module is faulty	STRUCT • Value: BOOL • ST: BYTE	- • 0 • 16#80
MS_Dev	Maintenance state	DWORD	16#00000000
MS_Req	1 = Maintenance request from the diagnostic area	STRUCT • Value: BOOL • ST: BYTE	- • 0 • 16#80
OosAct	1 = Field device is undergoing maintenance	STRUCT • Value: BOOL • ST: BYTE	- • 0 • 16#80
PV_HiAct	1 = Overshoot of process value	STRUCT • Value: BOOL • ST: BYTE	- • 0 • 16#80
PV_LcoAct	Limited to within range limits Lowcutoff	STRUCT • Value: BOOL • ST: BYTE	- • 0 • 16#80
PV_LoAct	1 = Undershoot of process value	STRUCT • Value: BOOL • ST: BYTE	- • 0 • 16#80
PV_Out	Standard value (physical variable)	STRUCT • Value: REAL • ST: BYTE	- • 0.0 • 16#80

Parameter	Description	Type	Default
PV_OutUnit	Unit of the process value	INT	0
RemTime	Remaining monitoring time [s]	REAL	0.0
SampleTime	Sampling time [s]	REAL	0.1
ScaleOut	Scaling of the process value for display	STRUCT <ul style="list-style-type: none"> • High: REAL • Low:REAL 	- <ul style="list-style-type: none"> • 100.0 • 0.0
SimAct	1 = Simulation active	STRUCT <ul style="list-style-type: none"> • Value: BOOL • ST: BYTE 	- <ul style="list-style-type: none"> • 0 • 16#80

See also

[Pcs7AnIn block diagram \(Page 2121\)](#)
[Pcs7AnIn messaging \(Page 2118\)](#)
[Pcs7AnIn modes \(Page 2112\)](#)
[Description of Pcs7AnIn \(Page 2110\)](#)

16.9.7 Pcs7AnIn block diagram**Pcs7AnIn block diagram**

A block diagram is not provided for this block.

See also

[Pcs7AnIn I/Os \(Page 2118\)](#)
[Pcs7AnIn messaging \(Page 2118\)](#)
[Pcs7AnIn error handling \(Page 2117\)](#)
[Pcs7AnIn functions \(Page 2113\)](#)
[Pcs7AnIn modes \(Page 2112\)](#)
[Description of Pcs7AnIn \(Page 2110\)](#)

16.10 Pcs7AnOu - Analog output channel block

16.10.1 Description of Pcs7AnOu

Object name (type + number) and family

Type + number: FB 1870

Family: Channel

Area of application for Pcs7AnOu

The block is used for the following applications:

- Signal processing of an analog output value from S7-300/400 SM analog output groups
- Processing of the redundant output channels

How it works

The block outputs the process value as analog raw value for a process image (partition). Use the Mode in/out parameter to define how the raw value is to be obtained.

The current raw value is always output to the process image (partition).

Normally, the process value is written to both redundant channels.

If both redundant modules are working fine but cannot communicate with each other, the channel block Pcs7AnOu reduces the process value to 50%. And therefore, the two redundant channels use double the reduced process value $2 \times 50\% = 100\%$ and not $2 \times 100\% = 200\%$ which is incorrect.

Configuration

Use the CFC editor to install the block in a cyclic interrupt OB (OB30 to OB38). The block is also installed automatically in the startup OB (OB100).

When the CFC function "Generate module drivers" is used, the following occurs automatically:

- The in/out parameter `Mode` is interconnected to the corresponding `OMode_xx` output parameter of the MOD block.
- The in/out parameter `DataXchg` is interconnected to the corresponding `DataXchg_xx` output parameter of the MOD block.
- The `MS` parameter is interconnected to the `O_MS` output parameter of the diagnostics block.
- The `Feature Bit 0` (Set startup characteristics (Page 138)) is set with a default automatically when the module driver is generated.

In case of redundancy, connection with both quality bits and connection with the redundant slave channel:

- The out parameter `PV_OutSlv` is interconnected with the symbol of the slave channel.
- The in parameter `ProImQB` is interconnected with the symbol of the quality bit of the master channel.
- The in parameter `ProImQBSlv` is interconnected with the symbol of the quality bit of the slave channel.

Connect the symbol generated in HW Config (symbol table) for the output channel with the `PV_Out` output parameter.

In case of redundant I/O configuration, use symbol of the channel of the master module.

The templates of the Advanced Process Library contain an example of an Pcs7AnOu application.

Note

If you are not using the CFC function "Generate module drivers" you must set the in/out parameter `Mode` manually. Refer to the Mode Settings for SM Modules (Page 2206) chapter for more on this.

For the Pcs7AnOu block, the Advanced Process Library contains templates for process tag types as examples with various application scenarios for this block.

Examples of process tag types:

- Cascade control with control loop monitoring through ConPerMon (CascadeControl) (Page 2342)
- Cascade control with PIDConR (CascadeR) (Page 2345)
- PID controller with dynamic feedforward control (FwdDisturbCompensat) (Page 2329)
- PID - control with operating-point-oriented parameter control (GainScheduling) (Page 2327)
- Model-based predictive control (ModPreCon) (Page 2351)
- Reversible motor with controllable speed (MotorSpeedControlled) (Page 2364)
- Override control (Page 2348)
- Override control with PIDConR (OverrideR) (Page 2350)
- PID controller with safety logic and control loop monitoring (PIDConL_ConPerMon) (Page 2324)
- PIDConR with safety logic and control loop monitoring (PIDConR_ConPerMon) (Page 2325)
- Ratio control with control loop monitoring through ConPerMon (RatioControl) (Page 2338)
- Ratio control with PIDConR (RatioR) (Page 2341)
- PID controller with Smith predictor (SmithPredictorControl) (Page 2332)

- Control valve (VlvAnL) (Page 2370)
- Split-range controller with control loop monitoring through ConPerMon (SplitrangeControl) (Page 2335)

Startup characteristics

Use the `Feature Bit Set` startup characteristics (Page 138) to define the startup characteristics of this block.

Quality code (ET200 SP HA modules)

The quality code is read from the process image and has two states: “Good” or “Bad”.

Redundancy

The block monitors the values of the redundant signals (master and slave) with quality code and delivers 100% of the application program value to both the signals:

- when one of the signals delivers “Good” quality code, or
- when both signals deliver “Good” quality code and there is no “IO Redundancy Warning” (`Mode <> 16#x5xxxxxx`) reported

In case both the signals deliver “Good” quality code and there is “IO Redundancy Warning” (`Mode = 16#x5xxxxxx`) reported then 50% of the application program value is delivered to the process.

In case both the signals deliver “Bad” quality code, the last process value is retained.

Status word allocation for `status` parameter

This block does not have the `Status` parameter.

See also

Pcs7AnOu block diagram (Page 2131)

Pcs7AnOu I/Os (Page 2128)

Pcs7AnOu messaging (Page 2128)

Pcs7AnOu error handling (Page 2127)

Pcs7AnOu modes (Page 2125)

Pcs7AnOu functions (Page 2125)

16.10.2 Pcs7AnOu modes

Pcs7AnOu modes

This block does not have any modes.

See also

Pcs7AnOu block diagram (Page 2131)

Pcs7AnOu I/Os (Page 2128)

Pcs7AnOu messaging (Page 2128)

Pcs7AnOu error handling (Page 2127)

Description of Pcs7AnOu (Page 2122)

Pcs7AnOu functions (Page 2125)

16.10.3 Pcs7AnOu functions

Functions of Pcs7AnOu

The functions for this block are listed below.

Forming an I/O value

The peripheral value `PV_Out` is formed from:

- the scale value (input parameter `Scale`)
- the process value (input parameter `PV_In`)
- the measuring type (in/out parameter `Mode`)

Example of measuring type 4 ... 20 mA

If this measuring type is to be used, you must set the `Mode` parameter with 16#203 accordingly. In the measuring type, the peripheral value for 4mA is output for `PV_In = Scale.Low` and the peripheral value for 20 mA is output for `PV_In = Scale.High`.

The block writes the input parameter `Scale` directly to the output parameter `ScaleOut` and interconnects it directly to a technologic block. This can be, for example, the input parameter `MV_Opscale` of a control block.

Limiting the process or peripheral value

The peripheral value can be limited in two different ways:

- Limited to within range limits
- Limited to scale values

Limited to within range limits (physical limits of the module): If you want to restrict the peripheral value (`PV_Out`), you must activate this function via the `ScaleOff = 1` parameter.

The peripheral value is now limited to the following range limits:

- Top: 16#7EFF (32511 dec.)
- Bottom (unipolar): 0 or
- Bottom, unipolar (4 - 20 mA; 1 - 5 V): 16#E500 (-6912 dec.)
- Bottom (bipolar): 16#8100 (-32512 dec.)

If the limits are undershot or overshoot `PV_HiAct = 1` (top) or `PV_LowAct = 1` (bottom) is displayed at the output parameters. The signal status of the `PV_ChnST` output parameter is set to 16#78.

Limited to scale values: If you want to restrict the peripheral value (`PV_Out`) to the scale values, you must activate this function via the `ScaleOff = 0` parameter. You define the high and low scale limits in the `Scale` parameter. If one of the limits is violated, the limit you have entered is output at the `PV_Out` output parameter. This is displayed at the `PV_HiAct` or `PV_LoAct = 1` output parameter. The signal status of the `PV_ChnST` output parameter is set to 16#78.

Simulating signals

The block provides the standard function Simulating signals (Page 58).

Flutter suppression

This block provides the standard function Flutter suppression for channel blocks (Page 67)

Forming the signal status for PCS7 channel blocks

The block provides the standard function Forming and outputting the signal status for PCS 7 channel blocks (Page 118).

Configurable reactions using the `Feature` parameter

You can find an overview of all reactions provided by the `Feature` parameter in the Configurable functions using the Feature I/O (Page 131) section. The following functionality is available for this block at the relevant bits:

Bit	Function
0	Set startup characteristics (Page 138)
10	Condition monitoring information at the channel blocks (Page 145)
30	Outputting a de-energized value for block-external simulation (Page 148)

See also

Pcs7AnOu block diagram (Page 2131)
Pcs7AnOu I/Os (Page 2128)
Pcs7AnOu messaging (Page 2128)
Pcs7AnOu error handling (Page 2127)
Pcs7AnOu modes (Page 2125)
Description of Pcs7AnOu (Page 2122)

16.10.4 Pcs7AnOu error handling

Error handling of Pcs7AnOu

Refer to the section Error handling (Page 119) in the basic instructions for the error handling of all blocks.

The following errors can be displayed for this block:

- Channel error
- Higher-level error
- Invalid measuring range

Channel error

At the output parameter `Bad`, channel errors are displayed with 1. They can be detected using the raw value or the NAMUR check.

`PV_LoAct` or `PV_HiAct` remain set to = 1 if a channel error occurs due to the module diagnoses "Undershoot or overshoot of the measurement range".

Higher-level error / invalid measuring range

A higher-level error is output (output parameter `ModErr` = 1 and `Bad` = 1) if either:

- the signal status in the `High Word` of input parameter `Mode` takes the value 16#40, or
- there is an invalid measuring type in the `Low Word` of the input parameter `Mode`.

See also

Pcs7AnOu block diagram (Page 2131)
Pcs7AnOu I/Os (Page 2128)
Pcs7AnOu messaging (Page 2128)
Pcs7AnOu modes (Page 2125)

16.10 Pcs7AnOu - Analog output channel block

Description of Pcs7AnOu (Page 2122)

Pcs7AnOu functions (Page 2125)

16.10.5 Pcs7AnOu messaging

Messaging

This block does not offer messaging.

See also

Pcs7AnOu block diagram (Page 2131)

Pcs7AnOu I/Os (Page 2128)

Pcs7AnOu error handling (Page 2127)

Pcs7AnOu modes (Page 2125)

Description of Pcs7AnOu (Page 2122)

Pcs7AnOu functions (Page 2125)

16.10.6 Pcs7AnOu I/Os

Pcs7AnOu I/Os

Input parameters

Parameter	Description	Type	Default
EN	1 = Called block will be processed	BOOL	1
Feature	I/O for additional functions (Page 2125)	STRUCT	-
		<ul style="list-style-type: none"> • Bit 0: BOOL • ... • Bit 30: BOOL • Bit 31: BOOL 	<ul style="list-style-type: none"> • 0 • 0 • 1 • 0
FlutEn	1 = Flutter suppression activated	BOOL	0
FlutTmIn*	Flutter time [s]	INT	0
MS	Maintenance status	DWORD	16#00000000
MS_Release	Release for maintenance (interconnected with MS_Release of the technology block)	STRUCT	-
		<ul style="list-style-type: none"> • Value: BOOL • ST: BYTE 	<ul style="list-style-type: none"> • 0 • 16#80
MS_Ext	External maintenance status	DWORD	16#00000000

Parameter	Description	Type	Default
PV_In	Process value (raw value)	STRUCT • Value: REAL • ST: BYTE	- • 0.0 • 16#80
PV_InUnit	Unit of measure for process value	INT	1342
ProImQB	Quality bit from the process image	BOOL	0
ProImQBSlv	Quality bit from the process image of the slave channel	BOOL	0
Scale	Scaling of the process value as a structure	STRUCT • High: REAL • Low:REAL	- • 100.0 • 0.0
ScaleOff	0 = Limitation to scale limits (Scale) active 1 = Limitation to within range limits (physical limits of the module) active	BOOL	0
SimOn	1 = Simulation on	STRUCT • Value: BOOL • ST: BYTE	- • 0 • 16#80
SimPV_In	Process value used for SimOn = 1	STRUCT • Value: REAL • ST: BYTE	- • 0.0 • 16#80
StartVal	Starting value that is used on starting the block if Feature bit 0 = 1.	REAL	0.0
TextRef	Text reference	WORD	16#0000

* Values can be written back to these inputs during processing of the block by the block algorithm.

In/out parameters

Parameter	Description	Type	Default
DataXchg	Internal data exchange channel to the diagnostics block	DWORD	16#00000000
DataXchg1	Internal data exchange channel to the diagnostics block	DWORD	16#00000000
MS_Xchg	Exchange of the maintenance status	DWORD	16#00000000
Mode	Value status and measuring type	DWORD	16#00000000

Output parameters

Parameter	Description	Type	Default
Bad	1 = Process value is not valid	STRUCT • Value: BOOL • ST: BYTE	- • 0 • 16#80
ENO	1 = Block algorithm completed without errors	BOOL	0
ErrorNum	Reserved for future error numbers	INT	-1

Channel blocks

16.10 Pcs7AnOu - Analog output channel block

Parameter	Description	Type	Default
ModErr	1 = Device/module is faulty	STRUCT • Value: BOOL • ST: BYTE	- • 0 • 16#80
MS_Dev	Maintenance state	DWORD	16#00000000
MS_Req	1 = Maintenance request from the diagnostic area	STRUCT • Value: BOOL • ST: BYTE	- • 0 • 16#80
MS_Xchg	Exchange of the maintenance status	DWORD	16#00000000
OosAct	1 = Field device is undergoing maintenance	STRUCT • Value: BOOL • ST: BYTE	- • 0 • 16#80
PV_ChnST	Signal status of the output channel and value of PV_Out	STRUCT • Value: REAL • ST: BYTE	- • 0.0 • 16#80
PV_OutSlv	Output value of the slave channel	WORD	16#0000
PV_HiAct	1 = Overshoot of process value	STRUCT • Value: BOOL • ST: BYTE	- • 0 • 16#80
PV_LoAct	1 = Undershoot of process value	STRUCT • Value: BOOL • ST: BYTE	- • 0 • 16#80
PV_Out	Process value	WORD	16#0000
PV_OutUnit	Unit of the process value	INT	0
ScaleOut	Scaling of the process value as a structure	STRUCT • High: REAL • Low:REAL	- • 100.0 • 0.0
SimAct	1 = Simulation active	STRUCT • Value: BOOL • ST: BYTE	- • 0 • 16#80

See also

- Pcs7AnOu block diagram (Page 2131)
- Pcs7AnOu messaging (Page 2128)
- Pcs7AnOu error handling (Page 2127)
- Pcs7AnOu modes (Page 2125)
- Description of Pcs7AnOu (Page 2122)

16.10.7 Pcs7AnOu block diagram

Pcs7AnOu block diagram

A block diagram is not provided for this block.

See also

Pcs7AnOu I/Os (Page 2128)

Pcs7AnOu messaging (Page 2128)

Pcs7AnOu error handling (Page 2127)

Pcs7AnOu modes (Page 2125)

Description of Pcs7AnOu (Page 2122)

Pcs7AnOu functions (Page 2125)

16.11 FbAnTot - Analog totalizer channel block for field devices

16.11.1 Description of FbAnTot

Object name (type + number) and family

Type + number: FB 1817

Family: Channel

Area of application for FbAnTot

The FbAnTot block processes the cyclic parameters of the "Totalizer" PA profile of a PA field device according to PROFIBUS 3.0 class A and B.

How it works

The FbAnTot block reads the process value (PV) with the status byte (PV_ST) of the PROFIBUS field device (structure corresponds to the totalizer of the PA profiles) cyclically from the process image (partition). The process value is available as a physical variable. The status byte (PV_ST) contains information about the state of the PROFIBUS field device.

In addition to the status byte and to improve interconnectability, additional important detail information is provided at the output interface as structured variables or in the structures. These conform to the bit combinations specified in PROFIBUS 3.0 "General Requirements".

The PV_Set_Li and PV_Mode_Li input variables can be used to write to the process image (partition) as an option. For this, the values of input variables are transferred to the PV_Set and PV_Mode outputs, which are interconnected to the process image.

The block detects a higher-level error, for example, failure of a DP/PA link, via the Mode input parameter.

- If the high byte is Mode = 16#80, then the values in the process image (partition) are valid.
- If the high byte is Mode = 16#40 (value status = higher-level error, ModErr = TRUE), then the analog value is treated as invalid.

Configuration

The block is installed in the CFC editor in a cyclic interrupt OB (OB30 to OB38). The block is installed automatically in the startup OB (OB100).

When the CFC function "Generate module drivers" is used, the following occurs automatically:

- The symbol for the quality code of the analog input channel is interconnected with the `PV_ST` input parameter and other selected options.
The in/out parameter `Mode` is interconnected to the corresponding `OMODE_xx` output parameter of the MOD block.
- The `MS` parameter is interconnected to the `O_MS` output parameter of the diagnostics block.
- The in/out parameter `DataXchg` is interconnected to the corresponding `DataXchg` output parameter of the MOD block.

Startup characteristics

The block does not have any startup characteristics.

16.11.2 FbAnTot modes

FbAnTot modes

This block does not have any operating modes.

16.11.3 FbAnTot functions

FbAnTot functions

The functions for this block are listed below.

Obtaining the standard value

The analog value of the process image (partition) is output as a standard value at the `PV_Li` output parameter.

Holding the last value if raw value is invalid

If the block is to hold its last valid value when the analog value is invalid or in the initialization phase of the device, you must activate this function at the `Feature Bit Outputting last valid value if raw value is invalid` (Page 154).

Output substitute value if raw value is invalid

If the block is to output a substitute value (`SubsPV`) when the analog value is invalid or in the initialization phase of the device, you must activate this function at the `Feature Bit Output substitute value if raw value is invalid` (Page 149).

Outputting an invalid value if analog value is invalid

If the block is to output an invalid value ($PV_Li = PV$), you must activate this function at the `Feature` Bit Output invalid raw value (Page 174). This function is preset.

Flutter suppression

This block provides the standard function Flutter suppression for channel blocks (Page 67)

Signal status for Fb channel blocks

The block provides the standard function Forming and outputting the signal status for channel blocks for field devices (Page 119).

The signal status of process value PV_Li is generated from internal events such as channel errors, higher-level errors, or simulations, as well as from the signal status PV_ST , which comes directly from the device.

The signal status PV_ST can accept values of 16#00 - 16#FF.

The block recognizes a higher-level error, for example, failure of a DP/PA link, via the `Mode` input parameter.

- If the high byte is `Mode = 16#80`, then the values in the process image (partition) are valid.
- If the high byte `Mode = 16#40` (value status = higher-level error, `ModErr = 1`), then the analog value is treated as invalid.

The measuring type set in the low word of the `Mode` input parameter will be ignored.

The bit combinations of signal status PV_ST are output as output parameters (BOOL values). These conform to the bit combinations specified in PROFIBUS 3.0 "General Requirements".

For FF field devices only: The values of the signal status $PV_ST = 16#84 - 16#87$ and $16#90 - 16#93$ are evaluated by the link in the same way as signal status $16#80 - 16#83$.

If the signal status $PV_ST = 16#80$ and a process value PV with the value $16#7FFFFFFF$ (invalid) are transferred from the FF field device, the block will deal with the signal status $16#00$ (invalid) from the FF field device.

Simulating signals

The block provides the standard function Simulating signals (Page 58).

Configurable reactions using the `Feature` parameter

You can find an overview of all reactions provided by the `Feature` parameter in the Configurable functions using the `Feature` I/O (Page 131). The following functionality is available for this block at the relevant bits:

Bit	Function
10	Condition monitoring information at the channel blocks (Page 145)
28	Output invalid raw value (Page 174)

Bit	Function
29	Output substitute value if raw value is invalid (Page 149)
30	Outputting last valid value if raw value is invalid (Page 154)

Sign-of-life monitoring

If an input value whose signal status is 16#80 (good) remains constant for a programmable time (monitoring time), the input value is detected as faulty and the output parameters `Bad = 1` and `FrzVal = 1` are set.

The monitoring time is set at the `FrznTmIn` input parameter in seconds. With `FrznTmIn = 0` or `FrznEn = 0` (default setting), the sign-of-life monitoring is deactivated, any pending errors are reset.

The input value is considered as faulty as long as it seen as constant. The monitoring time is restarted each time the input value is changed.

16.11.4 FbAnTot error handling

Error handling of FbAnTot

The `ErrorNum` I/O can be used to output the following error numbers:

Error number	Meaning of the error number
-1	Predefined value when inserting the block; the block is not executed
0	There is no error. Bit is set during startup

See also

Error handling (Page 119)

16.11.5 FbAnTot messaging

Messaging

This block does not offer messaging.

16.11.6 FbAnTot I/Os

I/Os of FbAnTot

Input parameters

Parameter	Description	Type	Default
EN	1 = Called block will be processed	BOOL	0
Feature	I/O for additional functions (Page 2133)	STRUCT <ul style="list-style-type: none"> • Bit 0: BOOL • ... • Bit 28: BOOL • ... • Bit 31: BOOL 	- <ul style="list-style-type: none"> • 0 • 0 • 1 • 0 • 0
FlutEn	1 = Flutter suppression activated	BOOL	0
FlutTmIn*	Flutter time [s]	INT	0
FrznEn	1 = Sign-of-life monitoring activated	BOOL	0
FrznTmIn	Monitoring time in [s]	REAL	0.0
MS	Maintenance status	DWORD	16#00000000
MS_Release	Release for maintenance (interconnected with MS_Release of the technology block)	STRUCT <ul style="list-style-type: none"> • Value: BOOL • ST: BYTE 	- <ul style="list-style-type: none"> • 0 • 16#80
MS_Ext	External maintenance status	DWORD	16#00000000
PV	Process value (analog value)	REAL	0.0
PV_Mode_Li	Mode totalizer 0 = Balanced, 1 = pos_only, 2 = neg_only, 3 = hold	BYTE	16#00
PV_Set_Li	Algorithm 0 = total, 1 = reset assign 0 , 2 = Default assign PRESET_TOT	BYTE	16#00
PV_ST	Signal status for the process value	BYTE	16#80
PV_Unit	Unit of measure for process value	INT	1001
SampleTime	Sampling time in [s]	REAL	0.1
Scale	Scaling of the process value as a structure	STRUCT <ul style="list-style-type: none"> • High: REAL • Low:REAL 	- <ul style="list-style-type: none"> • 100.0 • 0.0
SimOn	1 = Simulation on	STRUCT <ul style="list-style-type: none"> • Value: BOOL • ST: BYTE 	- <ul style="list-style-type: none"> • 0 • 16#80
SimPV	Process value used for SimOn = 1	STRUCT <ul style="list-style-type: none"> • Value: REAL • ST: BYTE 	- <ul style="list-style-type: none"> • 0.0 • 16#80
SubsPV	Substitute value	REAL	0.0
TextRef	Text reference	WORD	16#0000

* Values can be written back to these inputs during processing of the block by the block algorithm.

In/out parameters

Parameter	Description	Type	Default
DataXchg	Internal data exchange channel to the diagnostics block	DWORD	16#00000000
DataXchg1	Internal data exchange channel to the diagnostics block	DWORD	16#00000000
MS_Xchg	Exchange of the maintenance status	DWORD	16#00000000
Mode	Value status and measuring type	DWORD	16#00000000

Output parameters

Parameter	Description	Type	Default
Bad	1 = Process value is not valid	STRUCT <ul style="list-style-type: none"> • Value: BOOL • ST: BYTE 	- <ul style="list-style-type: none"> • 0 • 16#80
ENO	1 = Block algorithm completed without errors	BOOL	0
ErrorNum	Output of pending error number. For error numbers that can be output by this block, see FbAnTot error handling (Page 2135)	INT	-1
FrznVal	Frozen process value	STRUCT <ul style="list-style-type: none"> • Value: BOOL • ST: BYTE 	- <ul style="list-style-type: none"> • 0 • 16#80
ModErr	1 = Device/module is faulty	STRUCT <ul style="list-style-type: none"> • Value: BOOL • ST: BYTE 	- <ul style="list-style-type: none"> • 0 • 16#80
MS_Dev	Maintenance state	DWORD	16#00000000
MS_Req	1 = Maintenance request from the diagnostic area	STRUCT <ul style="list-style-type: none"> • Value: BOOL • ST: BYTE 	- <ul style="list-style-type: none"> • 0 • 16#80
OosAct	1 = Field device is undergoing maintenance	STRUCT <ul style="list-style-type: none"> • Value: BOOL • ST: BYTE 	- <ul style="list-style-type: none"> • 0 • 16#80
PV_Li	Standard value (physical variable)	STRUCT <ul style="list-style-type: none"> • Value: REAL • ST: BYTE 	- <ul style="list-style-type: none"> • 0.0 • 16#80
PV_LiUnit	Unit of the process value	INT	0
PV_Mode	Adder in operation	BYTE	16#00
PV_Set	Add up algorithmically	BYTE	16#00
RemMonTm	Remaining monitoring time	REAL	0.0

Channel blocks

16.11 FbAnTot - Analog totalizer channel block for field devices

Parameter	Description	Type	Default
ScaleOut	Scaling of the process value as a structure	STRUCT <ul style="list-style-type: none">• High: REAL• Low: REAL	- <ul style="list-style-type: none">• 100.0• 0.0
SimAct	1 = Simulation active	STRUCT <ul style="list-style-type: none">• Value: BOOL• ST: BYTE	- <ul style="list-style-type: none">• 0• 16#80

16.11.7 FbAnTot block diagram

FbAnTot block diagram

A block diagram is not provided for this block.

16.12 Pcs7DiIn - Digital input channel block

16.12.1 Description of Pcs7DiIn

Object name (type + number) and family

Type + number: FB 1871

Family: Channel

Area of application for Pcs7DiIn

The block is used for the following applications:

- Signal processing of a digital input value from S7-300/400 SM digital input groups
- Processing of the redundant input channels

How it works

The block cyclically processes all channel-specific signal functions of a digital input module.

Configuration

Use the CFC editor to install the block in a cyclic interrupt OB (OB30 to OB38).

The block is also installed automatically in the startup OB (OB100).

When the CFC function "Generate module drivers" is used, the following occurs automatically:

- The in/out parameter `Mode` is interconnected to the corresponding `OMode_xx` output parameter of the MOD block.
- The in/out parameter `DataXchg` is interconnected to the corresponding `DataXchg_xx` output parameter of the MOD block.
- The `MS` parameter is interconnected to the `O_MS` output parameter of the diagnostics block.

In case of redundancy, connection with both quality bits and connection with the redundant slave channel:

- The in parameter `PV_InSlv` is interconnected with the symbol of the slave channel.
- The in parameter `ProImQB` is interconnected with the symbol of the quality bit of the master channel.
- The in parameter `ProImQBSlv` is interconnected with the symbol of the quality bit of the slave channel.

Connect the symbol generated in HW Config (symbol table) for the input channel with the `PV_In` input parameter.

In case of redundant I/O configuration, use symbol of the channel of the master module.

Note

If you are not using the CFC function "Generate module drivers" you must set the in/out parameter `Mode` manually. Refer to the Mode Settings for SM Modules (Page 2206) chapter for more on this.

If the process image (partition) also contains the value status (status bit) of the digital input channel, the corresponding symbol is connected with the input `ProImQB` and the input `SelQB = 1` is set.

For the Pcs7DiIn block, the Advanced Process Library contains templates for process tag types as examples with various application scenarios for this block.

Examples of process tag types:

- Monitoring eight digital process tags (Digital8Monitoring) (Page 2355)
- Monitoring of a digital process tag (DigitalMonitoring) (Page 2353)
- Reversible motor with controllable speed (MotorSpeedControlled) (Page 2364)
- Step controller with assigned actuator block and position feedback (StepControlActor) (Page 2334)
- Step controller with direct access to the actuator and without position feedback (StepControlDirect) (Page 2333)
- Two-speed motor (Motor2Speed) (Page 2362)
- Reversing motor (MotorReversible) (Page 2363)
- Valve (Valve_Lean) (Page 2367)
- Two-way valve (Valve2Way) (Page 2368)
- Motor valve (ValveMotor) (Page 2369)
- Control valve (VlvAnL) (Page 2370)

Startup characteristics

The block has startup characteristics.

Quality code (ET200 SP HA modules)

The quality code is read from the process image and has two states: "Good" or "Bad".

Redundancy

The block monitors the values of the redundant signals (master and slave) with quality code and:

- When one of the signals delivers “Good” quality code then the value of the signal with “Good” quality code along with its quality code is transferred to the process.
- When both the signals deliver “Good” quality code then the value of the master signal along with its quality code is transferred to the process.

In case both the signals deliver “Bad” quality code then either the substitution value or the last value depending on the selection of the user or neither when both are not selected is delivered to the process.

Status word allocation for `Status` parameter

This block does not have the `Status` parameter.

See also

Pcs7DiIn block diagram (Page 2146)

Pcs7DiIn I/Os (Page 2144)

Pcs7DiIn messaging (Page 2144)

Pcs7DiIn error handling (Page 2143)

Pcs7DiIn functions (Page 2142)

Pcs7DiIn modes (Page 2141)

16.12.2 Pcs7DiIn modes

Pcs7DiIn modes

This block does not have any modes.

See also

Pcs7DiIn block diagram (Page 2146)

Pcs7DiIn I/Os (Page 2144)

Pcs7DiIn messaging (Page 2144)

Pcs7DiIn error handling (Page 2143)

Pcs7DiIn functions (Page 2142)

Description of Pcs7DiIn (Page 2139)

16.12.3 Pcs7DiIn functions

Functions of Pcs7DiIn

The functions for this block are listed below.

Obtaining the standard value

The digital value of the process image (partition) is output at output parameter `PV_Out` with the signal status `16#80`.

If you are not using the CFC function "Generate module drivers" you must set the in/out parameter `Mode` manually for further settings. Refer to the Mode Settings for SM Modules (Page 2206) section for more on this.

Holding the last value if raw value is invalid

If the block is to hold the most recent valid value when the raw value is invalid, you must activate this function at the `Feature Bit Outputting last valid value if raw value is invalid` (Page 154).

Output substitute value if raw value is invalid

If the block is to output a substitute value (`SubsPV_In`) when the raw value is invalid, you must activate this function at the `Feature Bit Output substitute value if raw value is invalid` (Page 149).

Output of invalid value if raw value is invalid

If the block is to output an invalid value (`PV_Out = PV_In`), you must activate this function at the `Feature Bit Output invalid raw value` (Page 174).

This function is pre-selected.

Flutter suppression

This block provides the standard function Flutter suppression for channel blocks (Page 67)

Signal status for PCS7 channel blocks

The block provides the standard function Forming and outputting the signal status for PCS 7 channel blocks (Page 118).

Simulating signals

The block provides the standard function Simulating signals (Page 58).

Configurable reactions using the `Feature` parameter

You can find an overview of all reactions provided by the `Feature` parameter in the Configurable functions using the Feature I/O (Page 131) section. The following functionality is available for this block at the relevant bits:

Bit	Function
10	Condition monitoring information at the channel blocks (Page 145)
28	Output invalid raw value (Page 174)
29	Output substitute value if raw value is invalid (Page 149)
30	Outputting last valid value if raw value is invalid (Page 154)

See also

Pcs7DiIn block diagram (Page 2146)

Pcs7DiIn I/Os (Page 2144)

Pcs7DiIn messaging (Page 2144)

Pcs7DiIn error handling (Page 2143)

Pcs7DiIn modes (Page 2141)

Description of Pcs7DiIn (Page 2139)

16.12.4 Pcs7DiIn error handling

Error handling of Pcs7DiIn

Refer to the section Error handling (Page 119) in the basic instructions for the error handling of all blocks.

The following errors can be displayed for this block:

- Channel error
- Higher-level error
- Invalid measuring range

Channel error

At the output parameter `Bad`, channel errors are displayed with 1. They can be detected using the raw value or the NAMUR check.

Higher-level error / invalid measuring range

A higher-level error is output (output parameter `ModErr` = 1) if either:

- the signal status in the `High Word` of input parameter `Mode` takes the value 16#40, or
- there is an invalid measuring type in the `Low Word` of the input parameter `Mode`.

See also

- Pcs7DiIn block diagram (Page 2146)
- Pcs7DiIn I/Os (Page 2144)
- Pcs7DiIn messaging (Page 2144)
- Pcs7DiIn functions (Page 2142)
- Pcs7DiIn modes (Page 2141)
- Description of Pcs7DiIn (Page 2139)

16.12.5 Pcs7DiIn messaging

Messaging

This block does not offer messaging.

See also

- Pcs7DiIn block diagram (Page 2146)
- Pcs7DiIn I/Os (Page 2144)
- Pcs7DiIn error handling (Page 2143)
- Pcs7DiIn functions (Page 2142)
- Pcs7DiIn modes (Page 2141)
- Description of Pcs7DiIn (Page 2139)

16.12.6 Pcs7DiIn I/Os

I/Os of Pcs7DiIn

Input parameters

Parameter	Description	Type	Default
EN	1 = Called block will be processed	BOOL	1
Feature	I/O for additional functions (Page 2142)	STRUCT	-
		• Bit 0: BOOL	• 0
		• ...	• 0
		• Bit 28: BOOL	• 1
		•	• 0
		• Bit 31: BOOL	• 0
FlutEn	1 = Flutter suppression activated	BOOL	0

Parameter	Description	Type	Default
FlutTmIn*	Flutter time [s]	INT	0
MS	Maintenance status	DWORD	16#00000000
MS_Release	Release for maintenance (interconnected with MS_Release of the technology block)	STRUCT <ul style="list-style-type: none"> Value: BOOL ST: BYTE 	- <ul style="list-style-type: none"> 0 16#80
MS_Ext	External maintenance status	DWORD	16#00000000
ProImQB	Quality information from the process image	BOOL	0
PV_In	Process value (raw value)	BOOL	0
PV_InSlv	Input value of the slave channel	BOOL	0
ProImQB	Quality bit from the process image	BOOL	0
ProImQBslv	Quality bit from the process image of the slave channel	BOOL	0
SelQB	1 = Use the quality bit from the process image	BOOL	0
SimOn	1 = Simulation on	STRUCT <ul style="list-style-type: none"> Value: BOOL ST: BYTE 	- <ul style="list-style-type: none"> 0 16#80
SimPV_In	Process value used for SimOn = 1	STRUCT <ul style="list-style-type: none"> Value: BOOL ST: BYTE 	- <ul style="list-style-type: none"> 0 16#80
SubsPV_In	Substitute value	BOOL	0
TextRef	Text reference	WORD	16#0000

* Values can be written back to these inputs during processing of the block by the block algorithm.

In/out parameters

Parameter	Description	Type	Default
DataXchg	Internal data exchange channel to the diagnostics block	DWORD	16#00000000
DataXchg1	Internal data exchange channel to the diagnostics block	DWORD	16#00000000
MS_Xchg	Exchange of the maintenance status	DWORD	16#00000000
Mode	Value status and measuring type	DWORD	16#00000000

Output parameters

Parameter	Description	Type	Default
Bad	1 = Process value is not valid	STRUCT <ul style="list-style-type: none"> Value: BOOL ST: BYTE 	- <ul style="list-style-type: none"> 0 16#80
ENO	1 = Block algorithm completed without errors	BOOL	0
ErrorNum	Output of pending error number. For error numbers that can be output by this block, see Pcs7DiIn error handling (Page 2143)	INT	-1

Parameter	Description	Type	Default
ModErr	1 = Device/module is faulty	STRUCT <ul style="list-style-type: none"> • Value: BOOL • ST: BYTE 	- <ul style="list-style-type: none"> • 0 • 16#80
MS_Dev	Maintenance state	DWORD	16#00000000
MS_Req	1 = Maintenance request from the diagnostic area	STRUCT <ul style="list-style-type: none"> • Value: BOOL • ST: BYTE 	- <ul style="list-style-type: none"> • 0 • 16#80
OosAct	1 = Field device is undergoing maintenance	STRUCT <ul style="list-style-type: none"> • Value: BOOL • ST: BYTE 	- <ul style="list-style-type: none"> • 0 • 16#80
PV_Out	Standard value (physical variable)	STRUCT <ul style="list-style-type: none"> • Value: BOOL • ST: BYTE 	- <ul style="list-style-type: none"> • 0 • 16#80
SimAct	1 = Simulation active	STRUCT <ul style="list-style-type: none"> • Value: BOOL • ST: BYTE 	- <ul style="list-style-type: none"> • 0 • 16#80

See also

- Pcs7DiIn block diagram (Page 2146)
- Pcs7DiIn messaging (Page 2144)
- Pcs7DiIn modes (Page 2141)
- Description of Pcs7DiIn (Page 2139)

16.12.7 Pcs7DiIn block diagram

Pcs7DiIn block diagram

A block diagram is not provided for this block.

See also

- Pcs7DiIn I/Os (Page 2144)
- Pcs7DiIn messaging (Page 2144)
- Pcs7DiIn error handling (Page 2143)
- Pcs7DiIn functions (Page 2142)
- Pcs7DiIn modes (Page 2141)
- Description of Pcs7DiIn (Page 2139)

16.13 Pcs7DiIT - Digital input channel block with time stamp

16.13.1 Description of Pcs7DiIT

Object name (type + number) and family

Type + number: FB 1872

Family: Channel

Area of application for Pcs7DiIT

The block is used for the following applications:

- Signal processing of a digital input value from S7-300/400 SM digital input modules with time stamp.
- Processing of the redundant input channels.

How it works

The cyclic block processes all channel-specific signal functions of a digital input module with configured time stamp.

Configuration

Use the CFC editor to install the block in a cyclic interrupt OB (OB30 to OB38).

The block is also installed automatically in the startup OB (OB100).

Connect the symbol generated in HW Config (symbol table) for the input channel with the `PV_In` input parameter.

In case of redundant I/O configuration, use symbol of the channel of the master module.

When the CFC function "Generate module drivers" is used, the following occurs automatically:

- The in/out parameter `Mode` is interconnected to the corresponding `OMode_xx` output parameter of the MOD block.
- The in/out parameter `DataXchg` is interconnected to the corresponding `DataXchg_xx` output parameter of the MOD block.
- The `MS` parameter is interconnected to the `O_MS` output parameter of the diagnostics block.
- If the process image (partition) also contains the value status (status bit) of the digital input channel, the corresponding symbol is connected with input `ProImQB` and the input `SelQB = 1` is set.

- The `TS_In` parameter is interconnected to the `TS_XX` output parameter of the `IMDRV_TS` or `IM_TS_PN` block.
- The in/out parameter `TS_C` is interconnected to the corresponding `TS_C_XX` output parameter of the `IMDRV_TS` or `IM_TS_PN` block.

Note

If you are not using the CFC function "Generate module drivers" you must set the in/out parameter `Mode` manually. Refer to the Mode Settings for SM Modules (Page 2206) chapter for more on this.

In case of redundancy, connection with both quality bits and connection with the redundant slave channel:

- The in parameter `PV_InSlv` is interconnected with the symbol of the slave channel.
- The in parameter `ProImQB` is interconnected with the symbol of the quality bit of the master channel.
- The in parameter `ProImQBSlv` is interconnected with the symbol of the quality bit of the slave channel.

If the time stamp for the input channel is deactivated, the aforementioned connections to the block `IMDRV_TS` or `IM_TS_PN` are not used. The block can be used as a simple channel block. When the charts are compiled, a warning is issued as the module driver is generated.

Refer to the section on configuring the channel blocks for information on configuration.

Startup characteristics

The block has startup characteristics.

Quality code (ET200 SP HA modules)

The quality code is read from the process image and has two states: "Good" or "Bad".

Redundancy

The block monitors the values of the redundant signals (master and slave) with quality code and:

- When one of the signals delivers "Good" quality code then the value of the signal with "Good" quality code along with its quality code is transferred to the process.
- When both the signals deliver "Good" quality code then the value of the master signal along with its quality code is transferred to the process.

In case both the signals deliver "Bad" quality code then either the substitution value or the last value depending on the selection of the user or neither when both are not selected is delivered to the process.

Status word allocation for `Status` parameter

This block does not have the `Status` parameter.

See also

Pcs7DiIT block diagram (Page 2155)

Pcs7DiIT I/Os (Page 2152)

Pcs7DiIT messaging (Page 2152)

Pcs7DiIT error handling (Page 2151)

Pcs7DiIT functions (Page 2149)

Pcs7DiIT modes (Page 2149)

16.13.2 Pcs7DiIT modes**Pcs7DiIT modes**

This block does not have any modes.

See also

Pcs7DiIT block diagram (Page 2155)

Pcs7DiIT I/Os (Page 2152)

Pcs7DiIT messaging (Page 2152)

Pcs7DiIT error handling (Page 2151)

Pcs7DiIT functions (Page 2149)

Description of Pcs7DiIT (Page 2147)

16.13.3 Pcs7DiIT functions**Functions of Pcs7DiIT**

The functions for this block are listed below.

Obtaining the standard value

The digital value of the process image (partition) is output at output parameter `PV_Out` with the signal status `16#80`.

If you are not using the CFC function "Generate module drivers" you must set the in/out parameter `Mode` manually for further settings. Refer to the section Mode Settings for SM Modules (Page 2206).

Holding the last value if raw value is invalid

If the block is to hold the most recent valid value when the raw value is invalid, you must activate this function at the `Feature Bit Outputting last valid value if raw value is invalid` (Page 154).

Output substitute value if raw value is invalid

If the block is to output a substitute value (`SubsPV_In`) when the raw value is invalid, you must activate this function at the `Feature Bit Output substitute value if raw value is invalid` (Page 149).

Output of invalid value if raw value is invalid

If the block is to output an invalid value (`PV_Out = PV_In`), you must activate this function at the `Feature Bit Output invalid raw value` (Page 174).

This function is pre-selected.

Flutter suppression

This block provides the standard function Flutter suppression for channel blocks (Page 67)

Signal status for PCS7 channel blocks

The block provides the standard function Forming and outputting the signal status for PCS 7 channel blocks (Page 118).

Simulating signals

The block provides the standard function Simulating signals (Page 58).

Time stamp

The block provides the standard function Time stamp (Page 205).

Interconnect the signal with the time stamp from the I/O devices with input parameter `TS_In`.

Interconnect input parameter `TS_In` with the channel-specific output parameter `TS_Oxx` of block `IMDRV_TS` or `IM_TS_PN`.

Interconnect in/out parameter `TS_C` with the channel-specific output parameter `TS_Cxx` of block `IMDRV_TS` or `IM_TS_PN`. This happens automatically when the CFC function "Generate module drivers" is used.

Configurable reactions using the Feature parameter

You can find an overview of all reactions provided by the Feature parameter in the section Configurable functions using the Feature I/O (Page 131). The following functionality is available for this block at the relevant bits:

Bit	Function
10	Condition monitoring information at the channel blocks (Page 145)
28	Output invalid raw value (Page 174)
29	Output substitute value if raw value is invalid (Page 149)
30	Outputting last valid value if raw value is invalid (Page 154)

See also

Pcs7DiIT block diagram (Page 2155)

Pcs7DiIT I/Os (Page 2152)

Pcs7DiIT messaging (Page 2152)

Pcs7DiIT error handling (Page 2151)

Pcs7DiIT modes (Page 2149)

Description of Pcs7DiIT (Page 2147)

16.13.4 Pcs7DiIT error handling

Error handling of Pcs7DiIT

Refer to the section Error handling (Page 119) in the basic instructions for the error handling of all blocks.

The following errors can be displayed for this block:

- Channel error
- Higher-level error
- Invalid measuring range

Channel error

At the output parameter `Bad`, channel errors are displayed with 1. The channel error is generated from the signal status `PV_ST`.

Higher-level error / invalid measuring range

A higher-level error is displayed at the output parameters `ModErr` and `Bad` with 1 if the signal status at `High Word` of the input parameter `Mode` accepts the value `16#40`.

A higher-level error is also present when an incorrect measuring type is entered in `Low Word` of the input parameter `Mode`.

See also

- Pcs7DiIT block diagram (Page 2155)
- Pcs7DiIT I/Os (Page 2152)
- Pcs7DiIT messaging (Page 2152)
- Pcs7DiIT functions (Page 2149)
- Pcs7DiIT modes (Page 2149)
- Description of Pcs7DiIT (Page 2147)

16.13.5 Pcs7DiIT messaging

Messaging

This block does not offer messaging.

See also

- Pcs7DiIT block diagram (Page 2155)
- Pcs7DiIT I/Os (Page 2152)
- Pcs7DiIT error handling (Page 2151)
- Pcs7DiIT functions (Page 2149)
- Pcs7DiIT modes (Page 2149)
- Description of Pcs7DiIT (Page 2147)

16.13.6 Pcs7DiIT I/Os

I/Os of Pcs7DiIT

Input parameters

Parameter	Description	Type	Default
EN	1 = Called block will be processed	BOOL	1
Feature	I/O for additional functions (Page 2149)	STRUCT <ul style="list-style-type: none"> • Bit 0: BOOL • ... • Bit 28: BOOL • ... • Bit 31: BOOL 	- <ul style="list-style-type: none"> • 0 • 0 • 1 • 0 • 0
FlutEn	1 = Flutter suppression activated	BOOL	0

16.13 Pcs7DiIT - Digital input channel block with time stamp

Parameter	Description	Type	Default
FlutTmIn*	Flutter time [s]	INT	0
MS	Maintenance status	DWORD	16#00000000
MS_Ext	External maintenance status	DWORD	16#00000000
MS_Release	Release for maintenance (interconnected with MS_Release of the technology block)	STRUCT <ul style="list-style-type: none"> Value: BOOL ST: BYTE 	- <ul style="list-style-type: none"> 0 16#80
PV_In	Process value (raw value)	BOOL	0
PV_InSlv	Input value of the slave channel	BOOL	0
ProImQB	Quality bit from the process image	BOOL	0
ProImQBSlv	Quality bit from the process image of the slave channel	BOOL	0
SimOn	1 = Simulation on	STRUCT <ul style="list-style-type: none"> Value: BOOL ST: BYTE 	- <ul style="list-style-type: none"> 0 16#80
SimPV_In	Process value used for SimOn = 1	STRUCT <ul style="list-style-type: none"> Value: BOOL ST: BYTE 	- <ul style="list-style-type: none"> 0 16#80
SelQB	1 = Use the quality bit from the process image	BOOL	0
SubsPV_In	Substitute value	BOOL	0
TextRef	Text reference	WORD	16#0000
TS_In	Time stamp of IMDRV_TS; The time is in ISP format	STRUCT <ul style="list-style-type: none"> MsgSig: BOOL TriInf: BOOL HdSh: BOOL ST: BYTE TS0: DWORD TS1: DWORD 	- <ul style="list-style-type: none"> 0 0 0 16#80 16#00000000 16#00000000
TS_In_PN	Time stamp from IM_TS_PN The time is in ISP format	STRUCT <ul style="list-style-type: none"> MsgSig: BOOL TriInf: BOOL HdSh: BOOL ST: BYTE TS0: DWORD TS1: DWORD TS2: DWORD 	- <ul style="list-style-type: none"> 0 0 0 16#80 16#00000000 16#00000000 16#00000000

* Values can be written back to these inputs during processing of the block by the block algorithm.

In/out parameters

Parameter	Description	Type	Default
DataXchg	Internal data exchange channel to the diagnostics block	DWORD	16#00000000
DataXchg1	Internal data exchange channel to the diagnostics block	DWORD	16#00000000
MS_Xchg	Exchange of the maintenance status	DWORD	16#00000000
TS_C	Time-stamp communication	BYTE	16#00

Output parameters

Parameter	Description	Type	Default
Bad	1 = Process value is not valid	STRUCT <ul style="list-style-type: none"> Value: BOOL ST: BYTE 	- <ul style="list-style-type: none"> 0 16#80
ENO	1 = Block algorithm completed without errors	BOOL	0
ErrorNum	Reserved for future error numbers	INT	-1
ModErr	1 = Device/module is faulty	STRUCT <ul style="list-style-type: none"> Value: BOOL ST: BYTE 	- <ul style="list-style-type: none"> 0 16#80
MS_Dev	Maintenance state	DWORD	16#00000000
MS_Req	1 = Maintenance request from the diagnostic area	STRUCT <ul style="list-style-type: none"> Value: BOOL ST: BYTE 	- <ul style="list-style-type: none"> 0 16#80
OosAct	1 = Field device is undergoing maintenance	STRUCT <ul style="list-style-type: none"> Value: BOOL ST: BYTE 	- <ul style="list-style-type: none"> 0 16#80
PV_Out	1 = Standard value (physical variable)	STRUCT <ul style="list-style-type: none"> Value: BOOL ST: BYTE 	- <ul style="list-style-type: none"> 0 16#80
SimAct	1 = Simulation active	STRUCT <ul style="list-style-type: none"> Value: BOOL ST: BYTE 	- <ul style="list-style-type: none"> 0 16#80
TS_Out	Time stamp	STRUCT <ul style="list-style-type: none"> MsgSig: BOOL TrInf: BOOL HdSh: BOOL ST: BYTE TS0: DWORD TS1: DWORD Link: BOOL 	- <ul style="list-style-type: none"> 0 0 0 16#80 16#00000000 16#00000000 0

See also

Pcs7DiIT block diagram (Page 2155)

Pcs7DiIT messaging (Page 2152)

Pcs7DiIT error handling (Page 2151)

Pcs7DiIT modes (Page 2149)

Description of Pcs7DiIT (Page 2147)

16.13.7 Pcs7DiIT block diagram**Pcs7DiIT block diagram**

A block diagram is not provided for this block.

See also

Pcs7DiIT I/Os (Page 2152)

Pcs7DiIT messaging (Page 2152)

Pcs7DiIT error handling (Page 2151)

Pcs7DiIT functions (Page 2149)

Pcs7DiIT modes (Page 2149)

Description of Pcs7DiIT (Page 2147)

16.14 Pcs7DiOu - Digital output channel block

16.14.1 Description of Pcs7DiOu

Object name (type + number) and family

Type + number: FB 1873

Family: Channel

Area of application for Pcs7DiOu

The block is used for the following applications:

- Signal processing of a digital output value from S7-300/400 SM digital output groups.
- Processing of the redundant output channels.

How it works

The cyclic block processes all channel-specific signal functions of a digital output module.

Normally, the process value is written to both redundant channels.

Configuration

Use the CFC editor to install the block in a cyclic interrupt OB (OB30 to OB38).

The block is also installed automatically in the startup OB (OB100).

When the CFC function "Generate module drivers" is used, the following occurs automatically:

- The in/out parameter `Mode` is interconnected to the corresponding `OMode_xx` output parameter of the MOD block.
- The in/out parameter `DataXchg` is interconnected to the corresponding `DataXchg_xx` output parameter of the MOD block.
- The `MS` parameter is interconnected to the `O_MS` output parameter of the diagnostics block.
- The `Feature` Bit 0 (Set startup characteristics (Page 138)) is set with a default automatically when the module driver is generated.

In case of redundancy, connection with both quality bits and connection with the redundant slave channel:

- The out parameter `PV_OutSlv` is interconnected with the symbol of the slave channel.
- The in parameter `ProImQB` is interconnected with the symbol of the quality bit of the master channel.
- The in parameter `ProImQBSlv` is interconnected with the symbol of the quality bit of the slave channel.

Connect the symbol generated in HW Config (symbol table) for the output channel with the `PV_Out` output parameter.

In case of redundant I/O configuration, use symbol of the channel of the master module.

The templates of the Advanced Process Library contain an example of an Pcs7DiOu application.

Note

If you are not using the CFC function "Generate module drivers" you must set the in/out parameter `Mode` manually. Refer to the Mode Settings for SM Modules (Page 2206) chapter for more on this.

For the Pcs7DiOu block, the Advanced Process Library contains templates for process tag types as examples with various application scenarios for this block.

Examples of process tag types:

- Dosing (Dose_Lean) (Page 2358)
- Two-speed motor (Motor2Speed) (Page 2362)
- Reversing motor (MotorReversible) (Page 2363)
- Reversible motor with controllable speed (MotorSpeedControlled) (Page 2364)
- Step controller with assigned actuator block and position feedback (StepControlActor) (Page 2334)
- Step controller with direct access to the actuator and without position feedback (StepControlDirect) (Page 2333)
- Valve (Valve_Lean) (Page 2367)
- Two-way valve (Valve2Way) (Page 2368)
- Motor valve (ValveMotor) (Page 2369)

Startup characteristics

Use the `Feature Bit Set` startup characteristics (Page 138) to define the startup characteristics of this block.

Quality code (ET200 SP HA modules)

The quality code is read from the process image and has two states: "Good" or "Bad".

Redundancy

The block monitors the values of the redundant signals (master and slave) with quality code and the application program value is delivered to both the signals when one or both of the signals deliver(s) "Good" quality code along with the quality code is transferred to the process.

In case both the signals deliver "Bad" quality code, the application program value is delivered to the process with "Bad" quality code.

Status word allocation for status parameter

This block does not have the `Status` parameter.

See also

Pcs7DiOu block diagram (Page 2162)

Pcs7DiOu I/Os (Page 2160)

Pcs7DiOu messaging (Page 2160)

Pcs7DiOu error handling (Page 2159)

Pcs7DiOu functions (Page 2158)

Pcs7DiOu modes (Page 2158)

16.14.2 Pcs7DiOu modes

Pcs7DiOu modes

The block does not have any operating modes.

See also

Pcs7DiOu block diagram (Page 2162)

Pcs7DiOu I/Os (Page 2160)

Pcs7DiOu messaging (Page 2160)

Pcs7DiOu error handling (Page 2159)

Pcs7DiOu functions (Page 2158)

Description of Pcs7DiOu (Page 2156)

16.14.3 Pcs7DiOu functions

Functions of Pcs7DiOu

The functions for this block are listed below.

Forming a peripheral value

The digital value is written to the process image (partition). The signal status of the process value (`PV_ChnST`) is set to "good" (16#80).

Simulating signals

The block provides the standard function Simulating signals (Page 58).

Flutter suppression

This block provides the standard function Flutter suppression for channel blocks (Page 67)

Configurable reactions using the `Feature` parameter

You can find an overview of all reactions provided by the `Feature` parameter in section Configurable functions using the Feature I/O (Page 131). The following functionality is available for this block at the relevant bits:

Bit	Function
0	Set startup characteristics (Page 138)
10	Condition monitoring information at the channel blocks (Page 145)
30	Outputting a de-energized value for block-external simulation (Page 148)

See also

Pcs7DiOu block diagram (Page 2162)

Pcs7DiOu I/Os (Page 2160)

Pcs7DiOu messaging (Page 2160)

Pcs7DiOu error handling (Page 2159)

Pcs7DiOu modes (Page 2158)

Description of Pcs7DiOu (Page 2156)

16.14.4 Pcs7DiOu error handling

Error handling of Pcs7DiOu

Refer to the section Error handling (Page 119) in the basic instructions for the error handling of all blocks.

The following errors can be displayed for this block:

- Channel error
- Higher-level error
- Invalid measuring range

Channel error

At the output parameter `Bad`, channel errors are displayed with 1. The channel error is generated from the signal status `PV_ST`.

Higher-level error / invalid measuring range

A higher-level error is output (output parameter `ModErr` = 1) if either:

- the signal status in the `High Word` of input parameter `Mode` takes the value 16#40, or
- there is an invalid measuring type in the `Low Word` of the input parameter `Mode`.

See also

Pcs7DiOu block diagram (Page 2162)

Pcs7DiOu I/Os (Page 2160)

Pcs7DiOu messaging (Page 2160)

Pcs7DiOu functions (Page 2158)

Pcs7DiOu modes (Page 2158)

Description of Pcs7DiOu (Page 2156)

16.14.5 Pcs7DiOu messaging

Messaging

This block does not offer messaging.

See also

Pcs7DiOu block diagram (Page 2162)

Pcs7DiOu I/Os (Page 2160)

Pcs7DiOu error handling (Page 2159)

Pcs7DiOu functions (Page 2158)

Pcs7DiOu modes (Page 2158)

Description of Pcs7DiOu (Page 2156)

16.14.6 Pcs7DiOu I/Os

I/Os of Pcs7DiOu

Input parameters

Parameter	Description	Type	Default
EN	1 = Called block will be processed	BOOL	1
Feature	I/O for additional functions (Page 2158)	STRUCT <ul style="list-style-type: none"> • Bit 0: BOOL • ... • Bit 30: BOOL • Bit 31: BOOL 	- <ul style="list-style-type: none"> • 0 • 0 • 1 • 0
FlutEn	1 = Flutter suppression activated	BOOL	0
FlutTmIn*	Flutter time [s]	INT	0
MS	Maintenance status	DWORD	16#00000000
MS_Release	Release for maintenance (interconnected with MS_Release of the technology block)	STRUCT <ul style="list-style-type: none"> • Value: BOOL • ST: BYTE 	- <ul style="list-style-type: none"> • 0 • 16#80
MS_Ext	External maintenance status	DWORD	16#00000000
PV_In	Process value (raw value)	STRUCT <ul style="list-style-type: none"> • Value: BOOL • ST: BYTE 	- <ul style="list-style-type: none"> • 0 • 16#80
ProImQB	Quality bit from the process image	BOOL	0
ProImQBslv	Quality bit from the process image of the slave channel	BOOL	0
SimOn	1 = Simulation on	STRUCT <ul style="list-style-type: none"> • Value: BOOL • ST: BYTE 	- <ul style="list-style-type: none"> • 0 • 16#80
SimPV_In	Process value used for SimOn = 1	STRUCT <ul style="list-style-type: none"> • Value: BOOL • ST: BYTE 	- <ul style="list-style-type: none"> • 0 • 16#80
StartVal	Starting value that is used on starting the block if Feature bit 0 = 1.	BOOL	0
TextRef	Text reference	WORD	16#0000

* Values can be written back to these inputs during processing of the block by the block algorithm.

In/out parameters

Parameter	Description	Type	Default
DataXchg	Internal data exchange channel to the diagnostics block	DWORD	16#00000000
DataXchg1	Internal data exchange channel to the diagnostics block	DWORD	16#00000000
MS_Xchg	Exchange of the maintenance status	DWORD	16#00000000
Mode	Value status and measuring type	DWORD	16#00000000

Output parameters

Parameter	Description	Type	Default
Bad	1 = Process value is not valid	STRUCT • Value: BOOL • ST: BYTE	- • 0 • 16#80
ENO	1 = Block algorithm completed without errors	BOOL	0
ErrorNum	Output of pending error number. For error numbers that can be output by this block, see Pcs7DiOu error handling (Page 2159)	INT	-1
ModErr	1 = Device/module is faulty	STRUCT • Value: BOOL • ST: BYTE	- • 0 • 16#80
MS_Dev	Maintenance state	DWORD	16#00000000
MS_Req	1 = Maintenance request from the diagnostic area	STRUCT • Value: BOOL • ST: BYTE	- • 0 • 16#80
OosAct	1 = Field device is undergoing maintenance	STRUCT • Value: BOOL • ST: BYTE	- • 0 • 16#80
PV_ChnST	Signal status of the output channel and value of PV_Out	STRUCT • Value: BOOL • ST: BYTE	- • 0 • 16#80
PV_Out	Process value	BOOL	0
PV_OutSlv	Output value of the slave channel	BOOL	0
SimAct	1 = Simulation active	STRUCT • Value: BOOL • ST: BYTE	- • 0 • 16#80

See also

Pcs7DiOu block diagram (Page 2162)

Pcs7DiOu messaging (Page 2160)

Pcs7DiOu modes (Page 2158)

Description of Pcs7DiOu (Page 2156)

16.14.7 Pcs7DiOu block diagram

Pcs7DiOu block diagram

A block diagram is not provided for this block.

See also

Pcs7DiOu I/Os (Page 2160)

Pcs7DiOu messaging (Page 2160)

Pcs7DiOu error handling (Page 2159)

Pcs7DiOu functions (Page 2158)

Pcs7DiOu modes (Page 2158)

Description of Pcs7DiOu (Page 2156)

16.15 Pcs7Cnt1 - Controlling and reading FM 350 modules

16.15.1 Description of Pcs7Cnt1

Object name (type + number)

Type + number: FB 1833

Family: Channel

Area of application

The Pcs7Cnt1 block is used for controlling and reading count or measured values of an FM 350-1 or FM 350-2 module.

How it works

“FM 350” refers to the FM 350-1 and FM 350-2 modules in the following.

- The block only communicates through the process image for the FM 350-1. The data are written and read continuously.
- The control and status information and selected count and measured values are contained in the process image for the FM 350-2. The remaining count and measured values can be read via data records.

In HW Config (User_Type1 and User_Type2) you define how the count or measured values will be saved in the process image. The LoadPv1 and CmpVx parameters are loaded from the FM_CNT block to the FM 350-2 using data records. The writing of the parameters is first triggered in the subsequent cycle of the FM_CNT block.

If an FM 350-2 module is being used, the block writes the LoadPV1 (load count value immediately) or CmpVx (comparison value) parameters to the module (x = channel number) via data records. If the parameter LoadDir = 1 is set in the block, it writes LoadPV1. If LoadPre = 1 is set, it writes in preparation LoadPV1. The CmpVx parameter is written after every change.

The Mode input indicates in what format the count and/or measured value is available in the process image. If the high word of the input parameter Mode = 16#40xxxx (value status = higher-level error, ModErr= 1), the count or measured value is treated as invalid.

The measured values are written to the corresponding outputs, PV1, PV1_Li as well as PV2 and PV2_Li; a differential value between the old value and new value is formed for the PV1 via the last cycle and sent at the PV1CycLi output. If the read values are in order, the status of the outputs is set to 16#80.

The units for `PV1_UnitLi`, `ScalePV1_Li`, `PV2_UnitLi` and `ScalePV2_Li` are set with the extension "_IN" via the inputs of the same name.

Note

Status `CmpVal0` (comparator 1), `CmpVal1` (comparator 2), `ZeroSt` (zero crossing), `OFlow` (overflow) and `UFlow` (underflow) are automatically acknowledged. They are active for at least one cycle.

The measured value is output as a numeric value by the FM 350. Additional information on this is available in the manual for the module.

The block also supplies the counted pulses of `PV1` (`PV1_Li`) at the `PV1CycLi` output with each block call.

The `LoadPV1` input parameter is the relevant value which is passed to the module. If, however, `LoadPV1_Li` is interconnected or the status of `LoadPV1_Li` is `16#80`, the value is written to `LoadPV1` and applied.

Note

The display in PCS 7 is limited by the data type DINT. However, the settings in the module are permitted unsigned up to 32 bits.

Configuration

When the CFC function "**Generate module drivers**" is used, the following occurs automatically:

- The `Laddr` and `Channel` inputs are configured.
- The `Mode` input is interconnected with the `OMODEx` output of the `FM_CNT` block.
- The `FM_DATA` structure is interconnected with the structure of the same name of the `FM_CNT` block.
- The `DataXchg` input is interconnected to the relevant `DXCHG_00` output of the `MOD_D1` block.
- The `MS` input is interconnected to the relevant `O_MS` output of the `MOD_D1` block.

The block is installed in the CFC editor in a cyclic interrupt OB (OB30 to OB38) .

Startup characteristics

The block does not have any startup characteristics.

Status word allocation

This block does not have the `Status` parameter.

See also

Pcs7Cnt1 I/Os (Page 2169)

16.15.2 Pcs7Cnt1 modes

Pcs7Cnt1 operating modes

This block does not have any modes.

16.15.3 Pcs7Cnt1 functions

Functions of Pcs7Cnt1

The functions for this block are listed below.

Addressing

1. Create icons for the required count or measured values in the icon table, in accordance with the base address of the FM 350 module. Please note the following:

- FM 350-1: Count or measured value is always in the process image:
 - Select "ED base address" of the module (e.g. ED512) as the address.
- FM 350-2: Count or measured value of the desired channel is in the process image:
 - In "HW Config FM 350-2 configure counter" you can specify where count or measured values will be stored in the process image. Depending on the configuration of User_Type1 or User_Type2, you must select EW for WORD or ED for DWORD. The address is calculated according to the following table:

Count or measured value is defined as:	Measured or count value is in User_Type1:	Measured or count value is in User_Type2:
DWORD or LOW WORD	FM 350-2 base address + 8 bytes	FM 350-2 base address + 12 bytes
HIGH WORD	FM 350-2 base address + 10 bytes	FM 350-2 base address + 14 bytes

Example:

The desired count value of channel 2 is in User_Type2 in the high word. The address is calculated for a base address of 512 as: Address = EW 526.

- FM 350-2: Count or measured value of the desired channel is not in the process image:
 - Select as address: Input word "Base address of the module + channel number" interconnected (e.g. base address = 512, channel number = 5; EW517).

2. Connect the input `Connect` in the CFC chart with the previously created icon via "Interconnection to address...".

Count and measured values that are not in the process image of the FM 350-2 are read out of the module cyclically as a data record, if the inputs `PV1_EN` or `PV2_EN` = 1. Both inputs should be set to 0 for performance reasons, if count or measured value are not needed for the

channel in the user program. This prevents count or measured values from being read via data records, if they are not in the process image.

Note

Even if the PV1_EN or PV2_EN inputs are not set, a read can be performed via data records if the PV1_EN or PV2_EN are set inputs are set at a different instance of Pcs7Cnt1 (other channel) of the associated FM350-2.

Simulation

The block provides the standard function Simulating signals (Page 58)

With `SimOn = 1`, the simulation values `SimPV1` and `SimPV2` are written to the outputs `PV1`, `PV1_Li` as well as `PV2` and `PV2_Li`. The status of the outputs is set to `16#60` and `Bad = 1` in the process.

Simulation takes highest priority.

If the block is in simulation state, `SimAct = 1` is set.

Flutter suppression

This block provides the standard function Flutter suppression for channel blocks (Page 67).

Configurable reactions using the Feature parameter

You can find an overview of all reactions provided by the `Feature` parameter in the Configurable functions using the Feature I/O (Page 131). The following functionality is available for this block at the relevant bits:

Bit	Function
10	Condition monitoring information at the channel blocks (Page 145)
28	Output invalid raw value (Page 174)
29	Output substitute value if raw value is invalid (Page 149)
30	Outputting last valid value if raw value is invalid (Page 154)

Forming the signal status for blocks

This block provides the standard function Forming and outputting the signal status for channel blocks for field devices (Page 119).

Value	Meaning
16#80	Valid value
16#60	Manipulated value (for example, substitute value, simulation, last valid value)
16#00	Invalid value

The worst signal status `ST_Worst` for the block is formed from the following parameters:

- `LoadDir.ST`
- `LoadPre.ST`
- `LoadPV1_Li.ST`
- `CntRun.ST`
- `CntDir.ST`
- `PV1_Li.ST`
- `PV2_Li.ST`

16.15.4 Pcs7Cnt1 error handling

Error handling of Pcs7Cnt1

Refer to the section Error handling (Page 119) in the basic instructions for the error handling of all blocks.

The following errors can be displayed for this block:

- Error numbers
- Higher-level error

Overview of error numbers

The `ErrorNum` I/O can be used to output the following error numbers:

Error number	Meaning of the error number
-1	Predefined value when inserting the block; the block is not executed
0	There is no error.
21	Pulse counter overflow

Higher-level error

A higher-level error is displayed at the output parameters `ModErr` and `Bad` with 1 if the signal status in the high word of the input parameter `Mode` assumes the value `16#40`.

In addition, at the output parameter `PV_Li` of the signal status, either `16#00` (in the event of an error) or `16#60` (for manipulated value (for example, substitute value, simulation, last valid value) is output.

16.15.5 Pcs7Cnt1 messaging

Messaging

This block does not offer messaging.

16.15.6 Pcs7Cnt1 I/Os

I/Os of Pcs7Cnt1

Input parameters

Parameter	Meaning	Type	Default
Channel	Channel FM 350	INT	0
CmpV0	New comparison value 0	DINT	0
CmpV1	New comparison value 1	DINT	0
CmpV2	New comparison value 2	DINT	0
CmpV3	New comparison value 3	DINT	0
Connect	Connection value (WORD or DWORD)	ANY	
CtrlDO0	1 = Enable digital output DO	BOOL	1
CtrlDO1	1 = Enable digital output DO1 (FM 350-1 or FM 350-2 only, dosing mode)	BOOL	1
CtrlDO2	1 = Enable digital output DO2 (FM 350-2 only, dosing mode)	BOOL	1
CtrlDO3	1 = Enable digital output DO3 (FM 350-2 only, dosing mode)	BOOL	1
EnSetDn	1 = enable for setting in reverse direction	BOOL	1
EnSetUp	1 = Enable for setting in forward direction	BOOL	1
Feature	I/O for additional functions (Page 2166)	STRUCT	-
		• Bit 0: BOOL	• 0
		• ...	• 0
		• Bit 28: BOOL	• 1
		• ...	• 0
		• Bit 31: BOOL	• 0
FlutEn	1 = Flutter suppression active	BOOL	0
FlutTmIn*	Flutter suppression time	INT	0
Laddr	Logical address FM 350	INT	0
LoadPv1*	Load counter	DINT	0
LoadPV1_Li	Load counter structured	STRUCT	-
		• Value: REAL	• 0.0
		• ST: BYTE	• 16#80
LoadDir*	1 = Load counter directly	STRUCT	-
		• Value: BOOL	• 0
		• ST: BYTE	• 16#80

Parameter	Meaning	Type	Default
LoadPre*	1 = Load prepared counter	STRUCT • Value: BOOL • ST: BYTE	- • 0 • 16#80
MS	Maintenance status	DWORD	16#00000000
MS_Release	Release for maintenance	STRUCT • Value: BOOL • ST: BYTE	- • 0 • 16#80
MS_Ext	External maintenance status	DWORD	16#00000000
PV1En	1 = Counted value used	BOOL	1
PV2En	1 = Measured value used	BOOL	1
PV1_Unit	Unit of the count value	INT	0
PV2_Unit	Unit of the measured value	INT	0
RstOpErr	1 = Reset operator error	STRUCT • Value: BOOL • ST: BYTE	- • 0 • 16#80
RstSync*	1 = Reset synchronization	STRUCT • Value: BOOL • ST: BYTE	- • 0 • 16#80
ScalePV1	Range of the current count value	STRUCT • High: REAL • Low: REAL	- • 100.0 • 0.0
ScalePV2	Range of current measured value	STRUCT • High: REAL • Low: REAL	- • 100.0 • 0.0
SetDO0	1 = Open DO0	BOOL	1
SetDO1	1 = Open DO1 (FM 350-1 or FM 350-2 only, dosing mode)	BOOL	1
SetDO2	1 = Open DO2 (FM 350-2 only, dosing mode)	BOOL	1
SetDO3	1 = Open DO3 (FM 350-2 only, dosing mode)	BOOL	1
SimPV1	Simulation count value	STRUCT • Value: REAL • ST: BYTE	- • 0.0 • 16#80
SimPv2	Simulation measured value	STRUCT • Value: REAL • ST: BYTE	- • 0.0 • 16#80
SimON	1 = simulation active	STRUCT • Value: BOOL • ST: BYTE	- • 0 • 16#80
Stopgate	1 = General GATE stop	BOOL	0
StopGate	1 = Stop gate	BOOL	1
SubsPV1	Count substitute value	DINT	0
SubsPV2	Measured substitute value	DINT	0

Parameter	Meaning	Type	Default
SubsOn	1 = substitute value active	BOOL	0
SwGateEn	1 = Enable SW-TOR	BOOL	0
TextRef	Text reference	WORD	16#0000

* Values can be written back to these inputs during processing of the block by the block algorithm.

In/out parameters

Parameter	Meaning	Type	Default
DataXchg	Internal data exchange channel to the diagnostics block	DWORD	16#00000000
DataXchg1	Internal data exchange channel to the diagnostics block	DWORD	16#00000000
MS_Xchg	Exchange of the maintenance status	DWORD	16#00000000
Mode	Operating mode	DWORD	16#00000000

Output parameters

Parameter	Meaning	Type	Default
Bad	1 = invalid values	STRUCT <ul style="list-style-type: none"> • Value: BOOL • ST: BYTE 	- <ul style="list-style-type: none"> • 0 • 16#80
CmpVal0	1 = comparison value 1	BOOL	0
CmpVal1	1 = comparison value 2	BOOL	0
CmpVal2	1 = comparison value 3	BOOL	0
CmpVal3	1 = comparison value 4	BOOL	0
CntDir	Direction counter	STRUCT <ul style="list-style-type: none"> • Value: BOOL • ST: BYTE 	- <ul style="list-style-type: none"> • 0 • 16#80
CntRun	1 = status counter working	STRUCT <ul style="list-style-type: none"> • Value: BOOL • ST: BYTE 	- <ul style="list-style-type: none"> • 0 • 16#80
CntSync	1 = status counter synchronized	BOOL	0
ErrorNum	Parameter error	INT	-1
IntGate	1 = status of internal TOR	BOOL	0
ModErr	1 = higher-level error	STRUCT <ul style="list-style-type: none"> • Value: BOOL • ST: BYTE 	- <ul style="list-style-type: none"> • 0 • 16#80
MS_Dev	Maintenance state	DWORD	16#00000000
MS_Req	1 = Maintenance request from the diagnostic area	STRUCT <ul style="list-style-type: none"> • Value: BOOL • ST: BYTE 	- <ul style="list-style-type: none"> • 0 • 16#80
PV1	Current load or LATCH value/current count value	DINT	0

Parameter	Meaning	Type	Default
PV1CycLi	Pulses per cycle	STRUCT • Value: REAL • ST: BYTE	- • 0.0 • 16#80
PV1_Li	Count value as REAL structure	STRUCT • Value: REAL • ST: BYTE	- • 0.0 • 16#80
PV1_UnitLi	Unit of the current count value	INT	0
PV2	Measured value	DINT	0
PV2_Li	Measured value as REAL structure	STRUCT • Value: REAL • ST: BYTE	- • 0.0 • 16#80
PV2_UnitLi	Unit of the measured value	INT	0
NewLatch	1 = new LATCH value (in clock-synchronous mode only)	BOOL	0
OpErr	1 = operator error	BOOL	0
OosAct	Field device out of service, maintenance	STRUCT • Value: BOOL • ST: BYTE	- • 0 • 16#80
OFlow	1 = status overflow	BOOL	0
RstSync	1 = Reset synchronization	STRUCT • Value: BOOL • ST: BYTE	- • 0 • 16#80
ScalePV1_Li	Range of current counter values	STRUCT • High: REAL • Low: REAL	- • 100.0 • 0.0
ScalePV2_Li	Range of the measured values	STRUCT • High: REAL • Low: REAL	- • 100.0 • 0.0
SetDi	1 = status digital input DI set	BOOL	0
SimAct	1 = simulation values	STRUCT • Value: BOOL • ST: BYTE	- • 0 • 16#80
StartDI	1 = digital input DI start	BOOL	0
StCmpV0	1 = Saved status of comparator 1	BOOL	0
StCmpV1	1 = Saved status of comparator 2	BOOL	0
StCmpV2	1 = Saved status of comparator 3;	BOOL	0
StCmpV3	1 = Saved status of comparator 4;	BOOL	0
StopDI	1 = status digital input DI stop	BOOL	0
ST_Worst	Worst signal status	BYTE	16#80
SwGate	1 = Software gate	BOOL	0
UFlow	1 = status underflow	BOOL	0
ZeroSt	1 = status zero crossing	BOOL	0

See also

Pcs7Cnt1 functions (Page 2166)

16.15.7 Pcs7Cnt1 block diagram

Block diagram of Pcs7Cnt1

A block diagram is not provided for this block.

16.16 Pcs7Cnt2 - Control and read an 8-DI_NAMUR module of the ET 200iSP

16.16.1 Description of Pcs7Cnt2

Object name (type + number)

Type + number: FB 1834

Family: Channel

Area of application

The Pcs7Cnt2 block is used to control and read a count or frequency value from an 8-DI NAMUR module of the ET 200iSP. The block supports the following configurations of the module:

- 2 counters or 1 counter cascaded
- 2 frequency measurements

How it works

Depending on the mode setting of the module in HW Config, the user data of the module are stored in the process image. The Pcs7Cnt2 block differentiates between the following modes:

MODE (low word)	Operating mode	HW Config setting: "Configuration"	HW Config setting: "Channel (0 to 1) mode"
1	Counter (16 bits) without control function by means of digital signals	(Channel 0 to 1): COUNT(Channel 2 to 7): DI	Periodic or normal count functions (up or down counter)
2	Counter (32 bits) without control function by means of digital signals	(Channel 0 to 1): COUNT (Channel 2 to 7): DI	Cascade function (channel 0 only) (down counter)
3	Counter (16 bits) with control function by means of digital signals	(Channel 0 to 1): COUNT (Channel 2 to 7): CONTROL	Periodic or normal count functions (up or down counter)
4	Counter (32 bits) with control function by means of digital signals	(Channel 0 to 1): COUNT (Channel 2 to 7): CONTROL	Cascade function (channel 0 only) (down counter)
5	Frequency (16 bits)	(Channel 0 to 1): TRACE (Channel 2 to 7): DI	-

The driver generator sets the module mode configured in HW Config at the `MODE` input of the `MOD_D1` block on the appropriate channel of the module. The `Mode` input indicates in what format the count or frequency value is available in the process image. If the high word of the input parameter `MODE = 16#40xxxx` (value status = higher-level error, `ModErrr = 1`), the count or frequency value is treated as invalid.

Depending on the mode, either two independent counters (16 bits) or one counter (32 bits) exist in the process image. The `Channel` input specifies the module counter for which the block is responsible.

16.16 Pcs7Cnt2 - Control and read an 8-DI_NAMUR module of the ET 200iSP

The counter functions can be controlled by signals that can be influenced both over the digital inputs of the module or over the user data of the process image.

Note

Please note that the signals of the digital inputs are ORed with the equivalent signals from the PIO in the module.

The following signals are available:

Block input	Module	Meaning
-	Z1	Counter pulse counter 1
-	Z2	Counter pulse counter 2
StopGate (Channel = 0)	TOR1	With the active GATE signal, an active count operation can be interrupted. The GATE = "1" signal stops the count operation despite pending count pulses. At the same time, the assigned output is deactivated if it was active. This state remains until the GATE signal is set to "0". The output is brought to the previous state and the count operation is continued. The GATE signal is subordinate to the RSO and RSC signals, in other words, the RSO and RSC signals have the effect described above regardless of an active GATE signal.
StopGate (Channel = 1)	TOR2	See description of "GATE 1"
RstPV1 (Channel = 0)	RSZ1	The rising edge of the RSC signal sets the count of the assigned channel as follows: <ul style="list-style-type: none"> • When counting up (normal counter function), back to zero • When counting down (periodic counter function and cascade function), to the defined setpoint When counting down (periodic counter function and cascade function), any output that is set is also reset.
RstPV1 (Channel = 1)	RSZ2	See description of "RSC1"
RstDO (Channel = 0)	RSA1	On the rising edge of the RSO signal, the assigned output can be reset. The count is not influenced by setting RSO.
Rst_DO (CHANNEL = 1)	RSA2	See description of "RSO2"

The in/out parameters `RstPV1` and `RstDO` are always reset to zero. After resetting, the earliest point at which a renewed reset will be possible is in the next cycle but one (rising edge).

The count value or frequency value and their states are stored in the process image as shown below and are indicated at the following block outputs:

Bytes	Bit	Input signal	Block output	Meaning
0, 1	0-15	Proc. value counter 1	PV1_Li	16-bit counter 1 or 32-bit counter (bytes 0 to 3) or frequency value 1
2, 3	0-15	Proc. value counter 2		16-bit counter 2 (only with 16-bit counter 1) or frequency value 2
4	0	A 1	ZeroSt	Zero crossing counter 1
	1	A2		Zero crossing counter 2

Bytes	Bit	Input signal	Block output	Meaning
	2	TOR 1	PV1	Status gate 1
	3	TOR 2		Status gate 2
	4	RSZ1	SimAct	Status reset counter 1
	5	RSZ2		Status reset counter 2
	6	RSA1	RstDO_Out	Status reset outputs counter 1
	7	RSA2		Status reset outputs counter 2

The LoadPV1 parameter is always written to the process image. Depending on the mode set with HW Config, it is either the 16-bit or 32-bit setpoint (down counter) or the count limit (up counter).

Depending on the mode setting, only the following integer values of LoadPV1 or LoadPV1_Li are transferred to the module based on the status at LoadPV1_Li:

- 16-bit counter: 0 to 65 535
- 32-bit counter: 0 to 2 080 374 784

If the value for LoadPV1 or LoadPV1_Li is outside of these limits, the last valid value of LoadPV1 or LoadPV1_Li is retained in the module and OpErr = 1 is set.

The block also supplies the counted pulses of PV1(PV1_Li) at the PV1CycLi output with each block call.

The PV1_UnitLi and ScalePV1_Li outputs are written with the inputs of the same name PV1_Unit and ScalePV1.

The LoadPV1 input parameter is the relevant value which is passed to the module. If, however, LoadPV1_Li is interconnected or the status of LoadPV1_Li is 16#80, this value is written to LoadPV1 and applied.

Note

Make sure that no values with zero are loaded with the "Down counter" counter function.

Configuration

When the CFC function "Generate module drivers" is used, the following occurs automatically:

- The Laddr, Laddr1, Channel inputs are configured.
- The Mode input is interconnected with the OMODEx output of the MOD_D1 block.
- The DataXchg input is interconnected to the relevant DXCHG_00 output of the MOD_D1 block.
- The MS input is interconnected to the relevant O_MS output of the MOD_D1 block.

Note

In HW Config, it is possible to assign only digital signals DI2 to DI7 of the module (HW Config channel 2 to 7 = DI) instead of the control signals TOR 1 to RSA2. In this configuration of the DI NAMUR module, the states of outputs PV1, Zero, SimAct and RstDo_Out are based on the inputs of the block.

When using the digital control signals TOR 1 to RSA2 of the module (HW Config channel 2 to 7 = CONTROL), conflicts with the block digital signals may arise depending on the signal state. In this case, the digital signals do not take effect. If you want control over the block, you must not assign the control signals in HW Config.

Example:

Module	Block	Has the effect	
TOR 1 = 1	StopGate = 0		TOR on
TOR 1 = 0	StopGate = 1		TOR on
TOR 1 = 0	StopGate = 0		TOR off

Startup characteristics

The block does not have any startup characteristics.

Status word allocation

This block does not have the Status parameter.

See also

Pcs7Cnt2 I/Os (Page 2180)

16.16.2 Pcs7Cnt2 modes**Operating modes of Pcs7Cnt2**

This block does not have any modes.

16.16.3 Pcs7Cnt2 functions**Functions of Pcs7Cnt2**

The functions for this block are listed below.

Addressing

You must connect the icon (from the icon table) for the count or frequency value with the `Connect` input parameter.

Simulation

The block provides the standard function Simulating signals (Page 58).

With `SimOn = 1`, the simulation value `SimPV1` is written to the outputs `PV1` and `PV1_Li`. The status of the outputs is set to `16#60` and `Bad = 1` in the process.

Simulation takes highest priority.

If the block is in simulation state, `SimAct = 1` is set.

Flutter suppression

This block provides the standard function Flutter suppression for channel blocks (Page 67).

Configurable reactions using the `Feature` parameter

You can find an overview of all reactions provided by the `Feature` parameter in the Configurable functions using the Feature I/O (Page 131). The following functionality is available for this block at the relevant bits:

You need to assign parameters for three Feature bits for the response to an invalid raw value for the channel blocks.

If more than one of these Feature bits are set (=1), the following priority applies:

- Output invalid raw value (Feature bit 28 = highest priority)
- Output substitute value if raw value is invalid (Feature bit 29)
- Output the last valid value if raw value is invalid (Feature bit 30, lowest priority)

Bit	Function
10	Condition monitoring information at the channel blocks (Page 145)
28	Output invalid raw value (Page 174)
29	Output substitute value if raw value is invalid (Page 149)
30	Outputting last valid value if raw value is invalid (Page 154)

Forming the signal status for blocks

This block provides the standard function Forming and outputting the signal status for channel blocks for field devices (Page 119).

Value	Meaning
16#80	Valid value
16#60	Manipulated value (for example, substitute value, simulation, last valid value)
16#00	Invalid value

The worst signal status `ST_Worst` for the block is formed from the following parameters:

- `LoadPV1_Li.ST`
- `PV1_Li.ST`
- `RstDO.ST`
- `RstPV1.ST`

Redundancy

The higher-level `MOD_D1` block evaluates the redundancy of DP master systems operating in an H system.

16.16.4 Pcs7Cnt2 error handling

Error handling of Pcs7Cnt2

Refer to the section Error handling (Page 119) in the basic instructions for the error handling of all blocks.

The following errors can be displayed for this block:

- Error numbers
- Higher-level error

Overview of error numbers

The `ErrorNum` I/O can be used to output the following error numbers:

Error number	Meaning of the error number
-1	Predefined value when inserting the block; the block is not executed
0	There is no error.
21	Pulse counter overflow

Higher-level error

A higher-level error is displayed at the output parameters `ModErr` and `Bad` with 1 if the signal status in the high word of the input parameter `Mode` assumes the value `16#40`.

In addition, at the output parameter `PV_Li` of the signal status, either `16#00` (in the event of an error) or `16#60` (for manipulated value (for example, substitute value, simulation, last valid value) is output.

16.16.5 Pcs7Cnt2 messaging

Messaging

This block does not offer messaging.

16.16.6 Pcs7Cnt2 I/Os

I/Os of CH_CNT2

Input parameters

Parameter	Meaning	Type	Default
Channel	Channel 8 DI NAMUR (outputs)	INT	0
Connect	Connects values	ANY	
Feature	I/O for additional functions (Page 2177)	STRUCT <ul style="list-style-type: none"> • Bit 0: BOOL • ... • Bit 28: BOOL • ... • Bit 31: BOOL 	- <ul style="list-style-type: none"> • 0 • 0 • 1 • 0 • 0
FlutTmIn*	Flutter suppression time	INT	0
Laddr	Logical input address	INT	0
Laddr1	Logical output address	INT	0
LoadPV1*	Counter load value	DINT	0
LoadPV1_Li	Counter load value structured	STRUCT <ul style="list-style-type: none"> • Value: REAL • ST: BYTE 	- <ul style="list-style-type: none"> • 0.0 • 16#00
MS	Maintenance status	DWORD	16#00000000
MS_Release	Release for maintenance	STRUCT <ul style="list-style-type: none"> • Value: BOOL • ST: BYTE 	- <ul style="list-style-type: none"> • 0 • 16#80
MS_Ext	External maintenance status	DWORD	16#00000000
PV1_Unit	Unit of the current value	INT	0
RstDO*	1 = Reset digital outputs	STRUCT <ul style="list-style-type: none"> • Value: BOOL • ST: BYTE 	- <ul style="list-style-type: none"> • 0 • 16#80
RstPV1*	1 = Reset counter	STRUCT <ul style="list-style-type: none"> • Value: BOOL • ST: BYTE 	- <ul style="list-style-type: none"> • 0 • 16#80

16.16 Pcs7Cnt2 - Control and read an 8-DI_NAMUR module of the ET 200iSP

Parameter	Meaning	Type	Default
ScalePV1	Range of the current count value	STRUCT • High: REAL • Low: REAL	- • 100.0 • 0.0
SimOn	1 = simulation active	STRUCT • Value: BOOL • ST: BYTE	- • 0 • 16#80
SimPV1	Simulation value	STRUCT • Value: REAL • ST: BYTE	- • 0.0 • 16#80
StopGate	1 = Stop gate	BOOL	1
SubsPV1	Substitute value	DINT	0
TextRef	Text reference	WORD	16#0000

* Values can be written back to these inputs during processing of the block by the block algorithm.

In/out parameters

Parameter	Meaning	Type	Default
DataXchg	Internal data exchange channel to the diagnostics block	DWORD	16#00000000
DataXchg1	Internal data exchange channel to the diagnostics block	DWORD	16#00000000
Mode	Operating mode	DWORD	16#00000000
MS_Xchg	Exchange of the maintenance status	DWORD	16#00000000

Output parameters

Parameter	Meaning	Type	Default
Bad	1 = invalid values	STRUCT • Value: BOOL • ST: BYTE	- • 0 • 16#80
ErrorNum	Parameter error	INT	-1
Gate	1 = TOR on	BOOL	0
ModErr	1 = higher-level error	STRUCT • Value: BOOL • ST: BYTE	- • 0 • 16#80
MS_Dev	Maintenance state	DWORD	16#00000000
MS_Req	1 = Maintenance request from the diagnostic area	STRUCT • Value: BOOL • ST: BYTE	- • 0 • 16#80
OosAct	Field device out of service, maintenance is taking place	STRUCT • Value: BOOL • ST: BYTE	- • 0 • 16#80

Parameter	Meaning	Type	Default
OpErr	1 = operator error	BOOL	0
PV1	Current count value/frequency value	DINT	0
PV1CycLi	Pulses per cycle	STRUCT • Value: REAL • ST: BYTE	- • 0.0 • 16#80
PV1_Li	Current count value structured	STRUCT • Value: REAL • ST: BYTE	- • 0.0 • 16#80
PV1_UnitLi	Unit of the current count value	INT	
RstDO_Out	1 = Reset digital outputs	BOOL	0
RstPV1_Out	1 = Reset counter	BOOL	0
ScalePV1_Li	Range of the current count value	STRUCT • High: REAL • Low: REAL	- • 100.0 • 0.0
SimAct	1 = Simulation active	STRUCT • Value: BOOL • ST: BYTE	- • 0 • 16#80
ST_Worst	Worst signal value	BYTE	16#80
ZeroSt	1 = status zero crossing	BOOL	0

See also

Pcs7Cnt2 functions (Page 2177)

16.16.7 Pcs7Cnt2 block diagram

Block diagram of Pcs7Cnt2

A block diagram is not provided for this block.

16.17 Pcs7Cnt3 - Control and read the 1 COUNT 24V/100kHz module for count mode

16.17.1 Description of Pcs7Cnt3

Object name (type + number)

Type + number: FB 1835

Family: Channel

Area of application

The block is used to control and read count, measured and latch values of the "1 COUNT 24V/100kHz" module (as of 6ES7 138-4DA04-0AB0) for the count and measurement modes.

How it works

The block communicates via the process image. The data are written and read continuously.

In Mode 1- 3, the `LoadVal` parameter is sent to the module when a positive edge is detected either at the `LoadPre` in/out parameter (= load counter in preparation) or `LoadDir` (= load counter immediately). The parameters `CmpV1` (comparison value 1) and `CmpV2` (comparison value 2) are transferred to the module when they are changed and during startup.

In Mode 4- 6, the parameters `UFlowLi` (low limit) and `OFlowLi` (high limit) are transferred to the module when they are changed and during startup.

Depending on the mode setting of the module in HW Config, the user data of the module is stored in the process image. The block distinguishes between the following modes:

MODE (LowWord)	Operating mode	Description
1	Continuous counting	The 1Count24V/100kHz counts continuously from the load value in this mode
2	One-time counting	In this mode, 1Count24V/100kHz counts once, depending on the configured main counting direction
3	Periodic counting	In this mode, 1Count24V/100kHz counts periodically, depending on the configured main counting direction
4	Frequency measurement	1Count24V/100kHz determines the frequency of the pulse sequence at the input
5	Speed measurement	1Count24V/100kHz determines the speed of the device connected to the input
6	Period duration measurement	1Count24V/100kHz determines the pulse length of the pulse sequence at the input

The `Mode` input indicates the format in which the count and latch value or the count and measured value is available in the process image. If the high byte of input/output parameter is `Mode = 16#40` (value status = higher-level error, `ModErr = 1`), the count, measured and latch values are treated as invalid.

The states `PV1_sync` (synchronization), `CmpVal0` (comparator 0), `CmpVal1` (comparator 1), `OFlow` (overflow), `Uflow` (underflow) and `ZeroSt` (zero crossing) are acknowledged automatically by the block. They are active for at least one cycle.

The block also supplies the counted pulses of `PV1(PV1_Li)` at the `PV1CycLi` output with each block call.

The units for `PV1_UnitLi`, `ScalePV1_Li`, `PV2_UnitLi` and `ScalePV2_Li` are set with the `PV1_Unit`, `ScalePV1`, `PV2_Unit` and `ScalePV2` inputs of the same name.

The `LoadPV1` input parameter is the relevant value which is passed to the module. If, however, `LoadPV1_Li` is interconnected or the status of `LoadPV1_Li` is `16#80`, the value is written to `LoadPV1` and applied.

Calling OBs

OB100 and cyclic OB (recommendation 100 ms) in which the data will be received and sent.

Configuration

Connect the symbol (from the symbol table) for the count value with the `Connect` input parameter. You need to enter the symbol (Symbol column) in the symbol table and the supplement the row in the Address column with the ED base address of the module (e.g. ED512). When the CFC function "Generate module drivers" is used, the following occurs automatically:

- The `Laddr` input is configured.
- The `Mode` input is interconnected to the `OMODE_00` output of the `MOD_D1` block.
- The `DataXchg` input is interconnected to the relevant `DXCHG_00` output of the `MOD_D1` block.
- The `MS` input is interconnected to the relevant `O_MS` output of the `MOD_D1` block.

The block is also installed automatically in the startup OB (OB100).

Startup characteristics

In `Mode 1-3`, the parameters `CmpV1` (comparison value 1) and `CmpV2` (comparison value 2) are transferred to the module during startup.

In `Mode 4-6`, the parameters `UflowLi` (low limit) and `OFlowLi` (high limit) are transferred to the module during startup .

Status word allocation

This block does not have the `Status` parameter.

See also

Pcs7Cnt3 I/Os (Page 2187)

16.17.2 Pcs7Cnt3 modes**Operating modes of Pcs7Cnt3**

This block does not have any modes.

16.17.3 Pcs7Cnt3 functions**Functions of Pcs7Cnt3**

The functions for this block are listed below.

Addressing

Connect the symbol (from the symbol table) for the count value with the `Connect` input parameter.

You need to enter the symbol (Symbol column) in the symbol table and the supplement the row in the Address column with the ED base address of the module (e.g. ED512).

Simulation

The block provides the standard function Simulating signals (Page 58)

With `SimOn = 1`, the simulation values `SimPV1` and `SimPV2` are written to the outputs `PV1`, `PV1_Li` as well as `PV2` and `PV2_Li`. The status of the outputs is set to `16#60` and `Bad = 1` in the process.

Simulation takes highest priority.

If the block is in simulation state, `SimAct = 1` is set.

Flutter suppression

This block provides the standard function Flutter suppression for channel blocks (Page 67).

Configurable reactions using the Feature parameter

You can find an overview of all reactions provided by the `Feature` parameter in the Configurable functions using the Feature I/O (Page 131) . The following functionality is available for this block at the relevant bits:

Bit	Function
10	Condition monitoring information at the channel blocks (Page 145)
28	Output invalid raw value (Page 174)
29	Output substitute value if raw value is invalid (Page 149)
30	Outputting last valid value if raw value is invalid (Page 154)

Forming the signal status for blocks

This block provides the standard function Forming and outputting the signal status for channel blocks for field devices (Page 119).

Value	Meaning
16#80	Valid value
16#60	Manipulated value (for example, substitute value, simulation, last valid value)
16#00	Invalid value

The worst signal status `ST_Worst` for the block is formed from the following parameters:

- `LoadPV1_Li.ST`
- `PV1_Li.ST`
- `PV2_Li.ST`

16.17.4 Pcs7Cnt3 error handling

Error handling of Pcs7Cnt3

Refer to the section Error handling (Page 119) in the basic instructions for the error handling of all blocks.

The following errors can be displayed for this block:

- Higher-level error
- Error numbers

Overview of error numbers

The `ErrorNum` I/O can be used to output the following error numbers:

Error number	Meaning of the error number
-1	Predefined value when inserting the block; the block is not executed
0	There is no error.
21	Pulse counter overflow

Higher-level error

A higher-level error is displayed at the output parameters `ModErr` and `Bad` with 1 if the signal status in the high word of the input parameter `Mode` assumes the value 16#40.

In addition, at the output parameter `PV_Li` of the signal status, either 16#00 (in the event of an error) or 16#60 (for manipulated value (for example, substitute value, simulation, last valid value) is output.

16.17.5 Pcs7Cnt3 messaging

Messaging

This block does not offer messaging.

16.17.6 Pcs7Cnt3 I/Os

I/Os of Pcs7Cnt3

Input parameters

Parameter	Meaning	Type	Default
AckTrip	1 = Error detected	BOOL	0
CmpV1	Comparison value 1	DINT	0
CmpV2	Comparison value 2	DINT	0
Connect	Connection value	DWORD	16#00000000
CtrlDO1	1=Enable DO1	BOOL	1
CtrlDO2	1=Enable DO2	BOOL	1
CtrlSyncEn	1=Enable synchronization	BOOL	0

Parameter	Meaning	Type	Default
Feature	I/O for additional functions (Page 2185)	STRUCT <ul style="list-style-type: none"> • Bit 0: BOOL • ... • Bit 28: BOOL • ... • Bit 31: BOOL 	- <ul style="list-style-type: none"> • 0 • 0 • 1 • 0 • 0
FlutEn	1 = Flutter suppression active	BOOL	0
FlutTmIn*	Flutter suppression time	INT	0
Laddr	Logic address of the module	INT	0
LoadPV1*	Load counter	DINT	0
LoadPV1_Li	Load counter structured	STRUCT <ul style="list-style-type: none"> • Value: REAL • ST: BYTE 	- <ul style="list-style-type: none"> • 0.0 • 16#00
LoadDir	1 = Load counter directly	STRUCT <ul style="list-style-type: none"> • Value: BOOL • ST: BYTE 	- <ul style="list-style-type: none"> • 0 • 16#80
LoadPre	1 = Load prepared counter	STRUCT <ul style="list-style-type: none"> • Value: BOOL • ST: BYTE 	- <ul style="list-style-type: none"> • 0 • 16#80
MS	Maintenance status	DWORD	16#00000000
MS_Release	Release for maintenance	STRUCT <ul style="list-style-type: none"> • Value: BOOL • ST: BYTE 	- <ul style="list-style-type: none"> • 0 • 16#80
MS_Ext	External maintenance status	DWORD	16#00000000
PV1_Unit	Unit of the current value	INT	0
PV2_Unit	Unit of the measured value	INT	0
OFlow*	High limit	DINT	0
OFlowLi	High limit structured	STRUCT <ul style="list-style-type: none"> • Value: REAL • ST: BYTE 	- <ul style="list-style-type: none"> • 0.0 • 16#80
ScalePV1	Range of the current count value	STRUCT <ul style="list-style-type: none"> • High: REAL • Low: REAL 	- <ul style="list-style-type: none"> • 100.0 • 0.0
ScalePV2	Range of current measured value	STRUCT <ul style="list-style-type: none"> • High: REAL • Low: REAL 	- <ul style="list-style-type: none"> • 100.0 • 0.0
SetDO1	1= Open DO1	BOOL	0
SetDO2	1= Open DO2	BOOL	0
SimPV1	Simulation count value	STRUCT <ul style="list-style-type: none"> • Value: REAL • ST: BYTE 	- <ul style="list-style-type: none"> • 0.0 • 16#80

16.17 Pcs7Cnt3 - Control and read the 1 COUNT 24V/100kHz module for count mode

Parameter	Meaning	Type	Default
SimPV2	Simulation measured value/simulation latch value	STRUCT • Value: REAL • ST: BYTE	- • 0.0 • 16#80
SimOn	1= simulation on	STRUCT • Value: BOOL • ST: BYTE	- • 0 • 16#80
SubsPV1	Count substitute value	DINT	0
SubsPV2	Measured/latch substitute value	DINT	0
SwGateEn	1= enable software gate	BOOL	0
TextRef	Text reference	WORD	16#0000
UFlow*	Low limit	DINT	0
UFlowLi	Low limit structured	STRUCT • Value: REAL • ST: BYTE	- • 0.0 • 16#80

* Values can be written back to these inputs during processing of the block by the block algorithm.

In/out parameters

Parameter	Meaning	Data type	Default
DataXchg	Internal data exchange channel to the diagnostics block	DWORD	16#00000000
DataXchg1	Internal data exchange channel to the diagnostics block	DWORD	16#00000000
Mode	Operating mode	DWORD	16#00000000
MS_Xchg	Exchange of the maintenance status	DWORD	16#00000000

Output parameters

Parameter	Meaning	Data type	Default
Bad	1 = invalid process value	STRUCT • Value: BOOL • ST: BYTE	- • 0 • 16#80
CmpVal1	1 = status of comparator 1	BOOL	0
CmpVal2	1 = status of comparator 2	BOOL	0
DO1St	1 = status DO1	BOOL	0
DO1Err	1= short circuit / wire break / overtemperature	BOOL	0
DO2St	1 = status DO2	BOOL	0
ErrorNum	Error message	INT	-1
IntGate	1 = status of internal gate	BOOL	0
LoadErr	1= error in load function	BOOL	0

Parameter	Meaning	Data type	Default
ModErr	1= higher-level error	STRUCT • Value: BOOL • ST: BYTE	- • 0 • 16#80
MS_Dev	Maintenance state	DWORD	16#00000000
MS_Req	1 = Maintenance request from the diagnostic area	STRUCT • Value: BOOL • ST: BYTE	- • 0 • 16#80
OFlowSt	1 = high count value	BOOL	0
OosAct	Field device out of service, maintenance is taking place	STRUCT • Value: BOOL • ST: BYTE	- • 0 • 16#80
ParaErr	1= parameter assignment error	BOOL	0
PV1	Current count value	DINT	0
PV1CycLi	Pulses per cycle	STRUCT • Value: REAL • ST: BYTE	- • 0.0 • 16#80
PV1_Down	1 = status direction down	BOOL	0
PV1_Li	Current count value structured	STRUCT • Value: REAL • ST: BYTE	- • 0.0 • 16#80
PV1_UnitLi	Unit of the current count value	INT	0
PV1_Up	1 = status direction up	BOOL	0
PV1_Sync	1 = Count synchronous	BOOL	0
PV2	Measured value/latch value	DINT	0
PV2_Li	Structured measured value/latch value	STRUCT • Value: REAL • ST: BYTE	- • 0.0 • 16#80
PV2_UnitLi	Unit of the measured value	INT	0
ScalePV1_Li	Range of the current count value	STRUCT • High: REAL • Low: REAL	- • 100.0 • 0.0
ScalePV2_Li	Range of current measured values/latch values	STRUCT • High: REAL • Low: REAL	- • 100.0 • 0.0
SetDI	1 = Set digital input	BOOL	0
SimAct	1= simulation active	STRUCT • Value: BOOL • ST: BYTE	- • 0 • 16#80
ST_Worst	Worst signal status	BYTE	16#80
UFlowSt	1 = low count value	BOOL	0

16.17 Pcs7Cnt3 - Control and read the 1 COUNT 24V/100kHz module for count mode

Parameter	Meaning	Data type	Default
V24Err	1= short circuit sensor power supply	BOOL	0
ZeroSt	1= status zero crossing	BOOL	0

See also

Pcs7Cnt3 functions (Page 2185)

16.17.7 Pcs7Cnt3 block diagram**Block diagram of Pcs7Cnt3**

A block diagram is not provided for this block.

16.18 Pcs7HaAI - HART variable channel block for AI-HART modules

16.18.1 Description of Pcs7HaAI

Object name (type + number) and family

Type + number: FC 1931

Family: Channel

Area of application for Pcs7HaAI

The block is used for the following application:

Signal processing (cyclic service) of an analog input value:

- Of an auxiliary variable of a HART field device

How it works

Pcs7HaAI block cyclically reads the process value and the signal status of the field device from the process image (partition). The process value is available as a physical variable. The signal status contains information about the status of the field device.

Configuration

Use the CFC editor to install the block in a cyclic interrupt OB (OB30 to OB38).

Connect the symbol generated in HW Config (symbol table) for the input channel with the `PV` input parameter.

When the CFC function "Generate module drivers" is used, the following occurs automatically:

- The in/out parameter `MultiHART` is interconnected with the corresponding output parameter `MULTI_HART_xx` of the `MHA_CO` or `OR_MHA_CO` block.

Startup characteristics

The block does not have any startup characteristics.

Status word allocation for `Status` parameter

This block does not have the `Status` parameter.

See also

Pcs7HaAI modes (Page 2193)

Pcs7HaAI functions (Page 2193)

Pcs7HaAI error handling (Page 2194)

Pcs7HaAI messaging (Page 2194)

Pcs7HaAI I/Os (Page 2195)

Pcs7HaAI block diagram (Page 2197)

16.18.2 Pcs7HaAI modes

Pcs7HaAI operating modes

This block does not have any operating modes.

See also

Description of Pcs7HaAI (Page 2192)

Pcs7HaAI functions (Page 2193)

Pcs7HaAI error handling (Page 2194)

Pcs7HaAI messaging (Page 2194)

Pcs7HaAI I/Os (Page 2195)

Pcs7HaAI block diagram (Page 2197)

16.18.3 Pcs7HaAI functions

Functions of Pcs7HaAI

The functions for this block are listed below.

Obtaining the standard value

The HART variable value of the process image (partition) is outputted as a standard value at the HV_OutP/HV_OutS/HV_OutT/HV_OutQ output parameters.

See also

Description of Pcs7HaAI (Page 2192)

Pcs7HaAI modes (Page 2193)

Pcs7HaAI error handling (Page 2194)

Pcs7HaAI messaging (Page 2194)

Pcs7HaAI I/Os (Page 2195)

Pcs7HaAI block diagram (Page 2197)

16.18.4 Pcs7HaAI error handling

Error handling of Pcs7HaAI

The following errors can be displayed for this block:

- Invalid value

Invalid value

The invalid values are displayed with the value 1 at the output parameters HV_OutPBad/HV_OutSBad/HV_OutTBad/HV_OutQBad. The invalid value error is generated from the signal status HV_PriQC/HV_SecQC/HV_TerQC/HV_QuaQC of the MultiHART in/out parameter when the signal status is 16#00 (initial value from S7- System), 16#37 (initial value from analog module after module start), 16#23 (Communication error or HART-variable in field device not available), or 16#28, 16#29, 16#2A, 16#2B (Bad from HART field device) respectively.

See also

Description of Pcs7HaAI (Page 2192)

Pcs7HaAI modes (Page 2193)

Pcs7HaAI functions (Page 2193)

Pcs7HaAI messaging (Page 2194)

Pcs7HaAI I/Os (Page 2195)

Pcs7HaAI block diagram (Page 2197)

16.18.5 Pcs7HaAI messaging

Messaging

This block does not offer messaging.

See also

Description of Pcs7HaAI (Page 2192)

Pcs7HaAI modes (Page 2193)

Pcs7HaAI functions (Page 2193)

Pcs7HaAI error handling (Page 2194)

Pcs7HaAI I/Os (Page 2195)

Pcs7HaAI block diagram (Page 2197)

16.18.6 Pcs7HaAI I/Os

I/Os of Pcs7HaAI

Input parameters

Parameter	Description	Type	Default
EN	1 = Called block will be processed	BOOL	1
Feature	I/O for additional features	STRUCT <ul style="list-style-type: none"> • Bit0: BOOL • ... • Bit28: BOOL • ... • Bit31: BOOL 	- <ul style="list-style-type: none"> • 0 • 0 • 1 • 0 • 0
HV_PriEn	1= Read primary HART variable	BOOL	0
HV_SecEn	1= Read secondary HART variable	BOOL	0
HV_TerEn	1= Read tertiary HART variable	BOOL	0
HV_QuaEn	1= Read quaternary HART variable	BOOL	0
PV	Process value (analog value)	WORD	16#0000
HV_UnitP	Unit of primary HART variable	INT	1001
ScaleP	Range of primary HART variable	STRUCT <ul style="list-style-type: none"> • High: REAL • Low: REAL 	- <ul style="list-style-type: none"> • 100.0 • 0.0
HV_UnitS	Unit of secondary HART variable	INT	1001
ScaleS	Range of secondary HART variable	STRUCT <ul style="list-style-type: none"> • High: REAL • Low: REAL 	- <ul style="list-style-type: none"> • 100.0 • 0.0
HV_UnitT	Unit of tertiary HART variable	INT	1001
ScaleT	Range of tertiary HART variable	STRUCT <ul style="list-style-type: none"> • High: REAL • Low: REAL 	- <ul style="list-style-type: none"> • 100.0 • 0.0
HV_UnitQ	Unit of quaternary HART variable	INT	1001
ScaleQ	Range of quaternary HART variable	STRUCT <ul style="list-style-type: none"> • High: REAL • Low: REAL 	- <ul style="list-style-type: none"> • 100.0 • 0.0

In/out parameters

Parameter	Description	Type	Default
MultiHART	Internal data exchange channel to the diagnostics block	STRUCT <ul style="list-style-type: none"> • HV_PriEn: BOOL • HV_SecEn: BOOL • HV_TerEn: BOOL • HV_QuaEn: BOOL • HV_PriQC: BYTE • HV_SecQC: BYTE • HV_TerQC: BYTE • HV_QuaQC: BYTE • Command: BYTE • Ack: BYTE • HV_PriVal: REAL • HV_SecVal: REAL • HV_TerVal: REAL • HV_QuaVal: REAL 	- <ul style="list-style-type: none"> • 0 • 0 • 0 • 0 • 16#00 • 16#00 • 16#00 • 16#00 • 16#00 • 16#00 • 0.0 • 0.0 • 0.0 • 0.0

Output parameters

Parameter	Description	Type	Default
ENO	1 = Block algorithm completed without errors	BOOL	0
ErrorNum	Output of pending error number	INT	-1
HV_OutP	Primary HART variable with status	STRUCT <ul style="list-style-type: none"> • Value: REAL • ST: BYTE 	- <ul style="list-style-type: none"> • 0.0 • 16#80
HV_OutS	Secondary HART variable with status	STRUCT <ul style="list-style-type: none"> • Value: REAL • ST: BYTE 	- <ul style="list-style-type: none"> • 0.0 • 16#80
HV_OutT	Tertiary HART variable with status	STRUCT <ul style="list-style-type: none"> • Value: REAL • ST: BYTE 	- <ul style="list-style-type: none"> • 0.0 • 16#80
HV_OutQ	Quaternary HART variable with status	STRUCT <ul style="list-style-type: none"> • Value: REAL • ST: BYTE 	- <ul style="list-style-type: none"> • 0.0 • 16#80
HV_OutPBad	1 = Bad primary HART variable	STRUCT <ul style="list-style-type: none"> • Value: BOOL • ST: BYTE 	- <ul style="list-style-type: none"> • 0 • 16#80
HV_OutSBad	1 = Bad secondary HART variable	STRUCT <ul style="list-style-type: none"> • Value: BOOL • ST: BYTE 	- <ul style="list-style-type: none"> • 0 • 16#80

Parameter	Description	Type	Default
HV_OutTBad	1 = Bad tertiary HART variable	STRUCT • Value: BOOL • ST: BYTE	- • 0 • 16#80
HV_OutQBad	1 = Bad quaternary HART variable	STRUCT • Value: BOOL • ST: BYTE	- • 0 • 16#80
HV_OUniP	Unit of primary HART variable	INT	0
ScaleOuP	Range of primary HART variable	STRUCT • High: REAL • Low: REAL	- • 100.0 • 0.0
HV_OUniS	Unit of secondary HART variable	INT	0
ScaleOuS	Range of secondary HART variable	STRUCT • High: REAL • Low: REAL	- • 100.0 • 0.0
HV_OUniT	Unit of tertiary HART variable	INT	0
ScaleOuT	Range of tertiary HART variable	STRUCT • High: REAL • Low: REAL	- • 100.0 • 0.0
HV_OUniQ	Unit of quaternary HART variable	INT	0
ScaleOuQ	Range of quaternary HART variable	STRUCT • High: REAL • Low: REAL	- • 100.0 • 0.0

See also

Description of Pcs7HaAI (Page 2192)
 Pcs7HaAI modes (Page 2193)
 Pcs7HaAI functions (Page 2193)
 Pcs7HaAI error handling (Page 2194)
 Pcs7HaAI messaging (Page 2194)
 Pcs7HaAI block diagram (Page 2197)

16.18.7 Pcs7HaAI block diagram**Block diagram of Pcs7HaAI**

A block diagram is not provided for this block.

See also

Description of Pcs7HaAI (Page 2192)

Pcs7HaAI modes (Page 2193)

Pcs7HaAI functions (Page 2193)

Pcs7HaAI error handling (Page 2194)

Pcs7HaAI messaging (Page 2194)

Pcs7HaAI I/Os (Page 2195)

16.19 Pcs7HaAO - HART variable channel block for AO-HART modules

16.19.1 Description of Pcs7HaAO

Object name (type + number) and family

Type + number: FC 1932

Family: Channel

Area of application for Pcs7HaAO

The block is used for the following application:

Signal processing (cyclic service) of an analog input value:

- Of an auxiliary variable of a HART output field device

How it works

Pcs7HaAO block cyclically reads the process value and the signal status of the field device from the process image (partition). The process value is available as a physical variable. The signal status contains information about the status of the field device.

Configuration

Use the CFC editor to install the block in a cyclic interrupt OB (OB30 to OB38).

Connect the symbol generated in HW Config (symbol table) for the output channel with the `PV_Out` output parameter.

When the CFC function "Generate module drivers" is used, the following occurs automatically:

- The in/out parameter `MultiHART` is interconnected with the corresponding output parameter `MULTI_HART_xx` of the `MHA_CO` or `OR_MHA_CO` block.

Startup characteristics

The block does not have any startup characteristics.

Status word allocation for `status` parameter

This block does not have the `status` parameter.

See also

Pcs7HaAO modes (Page 2200)

Pcs7HaAO functions (Page 2200)

Pcs7HaAO error handling (Page 2201)

Pcs7HaAO messaging (Page 2201)

Pcs7HaAO I/Os (Page 2202)

Pcs7HaAO block diagram (Page 2204)

16.19.2 Pcs7HaAO modes

Pcs7HaAO operating modes

This block does not have any operating modes.

See also

Description of Pcs7HaAO (Page 2199)

Pcs7HaAO functions (Page 2200)

Pcs7HaAO error handling (Page 2201)

Pcs7HaAO messaging (Page 2201)

Pcs7HaAO I/Os (Page 2202)

Pcs7HaAO block diagram (Page 2204)

16.19.3 Pcs7HaAO functions

Functions of Pcs7HaAO

The functions for this block are listed below.

Obtaining the standard value

The HART variable value of the process image (partition) is outputted as a standard value at the HV_OutP/HV_OutS/HV_OutT/HV_OutQ output parameters.

See also

Description of Pcs7HaAO (Page 2199)

Pcs7HaAO modes (Page 2200)

Pcs7HaAO error handling (Page 2201)

Pcs7HaAO messaging (Page 2201)

Pcs7HaAO I/Os (Page 2202)

Pcs7HaAO block diagram (Page 2204)

16.19.4 Pcs7HaAO error handling

Error handling of Pcs7HaAO

The following errors can be displayed for this block:

- Invalid value

Invalid value

The invalid values are displayed with the value 1 at the output parameters HV_OutPBad/HV_OutSBad/HV_OutTBad/HV_OutQBad. The invalid value error is generated from the signal status HV_PriQC/HV_SecQC/HV_TerQC/HV_QuaQC of the MultiHART in/out parameter when the signal status is 16#00 (initial value from S7- System), 16#37 (initial value from analog module after module start), 16#23 (Communication error or HART-variable in field device not available), or 16#28, 16#29, 16#2A, 16#2B (Bad from HART field device) respectively.

See also

Description of Pcs7HaAO (Page 2199)

Pcs7HaAO modes (Page 2200)

Pcs7HaAO functions (Page 2200)

Pcs7HaAO messaging (Page 2201)

Pcs7HaAO I/Os (Page 2202)

Pcs7HaAO block diagram (Page 2204)

16.19.5 Pcs7HaAO messaging

Messaging

This block does not offer messaging.

See also

Description of Pcs7HaAO (Page 2199)

Pcs7HaAO modes (Page 2200)

Pcs7HaAO functions (Page 2200)

Pcs7HaAO error handling (Page 2201)

Pcs7HaAO I/Os (Page 2202)

Pcs7HaAO block diagram (Page 2204)

16.19.6 Pcs7HaAO I/Os

I/Os of Pcs7HaAO

Input parameters

Parameter	Description	Type	Default
EN	1 = Called block will be processed	BOOL	1
Feature	I/O for additional features	STRUCT <ul style="list-style-type: none"> • Bit0: BOOL • ... • Bit28: BOOL • ... • Bit31: BOOL 	- <ul style="list-style-type: none"> • 0 • 0 • 1 • 0 • 0
HV_PriEn	1= Read primary HART variable	BOOL	0
HV_SecEn	1= Read secondary HART variable	BOOL	0
HV_TerEn	1= Read tertiary HART variable	BOOL	0
HV_QuaEn	1= Read quaternary HART variable	BOOL	0
HV_UnitP	Unit of primary HART variable	INT	1001
ScaleP	Range of primary HART variable	STRUCT <ul style="list-style-type: none"> • High: REAL • Low: REAL 	- <ul style="list-style-type: none"> • 100.0 • 0.0
HV_UnitS	Unit of secondary HART variable	INT	1001
ScaleS	Range of secondary HART variable	STRUCT <ul style="list-style-type: none"> • High: REAL • Low: REAL 	- <ul style="list-style-type: none"> • 100.0 • 0.0
HV_UnitT	Unit of tertiary HART variable	INT	1001
ScaleT	Range of tertiary HART variable	STRUCT <ul style="list-style-type: none"> • High: REAL • Low: REAL 	- <ul style="list-style-type: none"> • 100.0 • 0.0
HV_UnitQ	Unit of quaternary HART variable	INT	1001
ScaleQ	Range of quaternary HART variable	STRUCT <ul style="list-style-type: none"> • High: REAL • Low: REAL 	- <ul style="list-style-type: none"> • 100.0 • 0.0

In/out parameters

Parameter	Description	Type	Default
MultiHART	Internal data exchange channel to the diagnostics block	STRUCT <ul style="list-style-type: none"> • HV_PriEn: BOOL • HV_SecEn: BOOL • HV_TerEn: BOOL • HV_QuaEn: BOOL • HV_PriQC: BYTE • HV_SecQC: BYTE • HV_TerQC: BYTE • HV_QuaQC: BYTE • Command: BYTE • Ack: BYTE • HV_PriVal: REAL • HV_SecVal: REAL • HV_TerVal: REAL • HV_QuaVal: REAL 	- <ul style="list-style-type: none"> • 0 • 0 • 0 • 0 • 16#00 • 16#00 • 16#00 • 16#00 • 16#00 • 16#00 • 0.0 • 0.0 • 0.0 • 0.0

Output parameters

Parameter	Description	Type	Default
ENO	1 = Block algorithm completed without errors	BOOL	0
ErrorNum	Output of pending error number	INT	-1
HV_OutP	Primary HART variable with status	STRUCT <ul style="list-style-type: none"> • Value: REAL • ST: BYTE 	- <ul style="list-style-type: none"> • 0.0 • 16#80
HV_OutS	Secondary HART variable with status	STRUCT <ul style="list-style-type: none"> • Value: REAL • ST: BYTE 	- <ul style="list-style-type: none"> • 0.0 • 16#80
HV_OutT	Tertiary HART variable with status	STRUCT <ul style="list-style-type: none"> • Value: REAL • ST: BYTE 	- <ul style="list-style-type: none"> • 0.0 • 16#80
HV_OutQ	Quaternary HART variable with status	STRUCT <ul style="list-style-type: none"> • Value: REAL • ST: BYTE 	- <ul style="list-style-type: none"> • 0.0 • 16#80
HV_OutPBad	1 = Bad primary HART variable	STRUCT <ul style="list-style-type: none"> • Value: BOOL • ST: BYTE 	- <ul style="list-style-type: none"> • 0 • 16#80
HV_OutSBad	1 = Bad secondary HART variable	STRUCT <ul style="list-style-type: none"> • Value: BOOL • ST: BYTE 	- <ul style="list-style-type: none"> • 0 • 16#80

Parameter	Description	Type	Default
HV_OutTBad	1 = Bad tertiary HART variable	STRUCT • Value: BOOL • ST: BYTE	- • 0 • 16#80
HV_OutQBad	1 = Bad quaternary HART variable	STRUCT • Value: BOOL • ST: BYTE	- • 0 • 16#80
PV_Out	Process value	WORD	16#0000
HV_OUniP	Unit of primary HART variable	INT	0
ScaleOuP	Range of primary HART variable	STRUCT • High: REAL • Low: REAL	- • 100.0 • 0.0
HV_OUniS	Unit of secondary HART variable	INT	0
ScaleOuS	Range of secondary HART variable	STRUCT • High: REAL • Low: REAL	- • 100.0 • 0.0
HV_OUniT	Unit of tertiary HART variable	INT	0
ScaleOuT	Range of tertiary HART variable	STRUCT • High: REAL • Low: REAL	- • 100.0 • 0.0
HV_OUniQ	Unit of quaternary HART variable	INT	0
ScaleOuQ	Range of quaternary HART variable	STRUCT • High: REAL • Low: REAL	- • 100.0 • 0.0

See also

- Description of Pcs7HaAO (Page 2199)
- Pcs7HaAO modes (Page 2200)
- Pcs7HaAO functions (Page 2200)
- Pcs7HaAO error handling (Page 2201)
- Pcs7HaAO messaging (Page 2201)
- Pcs7HaAO block diagram (Page 2204)

16.19.7 Pcs7HaAO block diagram

Block diagram of Pcs7HaAO

A block diagram is not provided for this block.

See also

Description of Pcs7HaAO (Page 2199)

Pcs7HaAO modes (Page 2200)

Pcs7HaAO functions (Page 2200)

Pcs7HaAO error handling (Page 2201)

Pcs7HaAO messaging (Page 2201)

Pcs7HaAO I/Os (Page 2202)

16.20 Annex for channel blocks

16.20.1 Mode Settings for SM Modules

Mode Structure

The structure and meaning of the input Mode of data type DWORD are shown below:

Byte 3:	16#80: Value status "valid value" 16#00: Value status "invalid value" 16#40: Value status "invalid value"	(Channel error) (Higher-level error)
Byte 2:	16#01: Restart (OB 100) has been carried out 16#02: Measuring range high limit violated 16#04: Measuring range low limit violated 16#xy: Variant identification with multiple mode assignment (see below)	(Channel-error diagnostics) (Channel-error diagnostics)
Byte 1, 0 (low word):	Measuring range coding (see below)	

Example:

16#80010203 = value status "valid value", restart has been carried out, current 4 mA to 20mA

Mode: Celsius and Fahrenheit

Variant	x	y	Unit of measurement
0	0, 1 (depending on the other variant IDs)	0,1,2,4	Celsius
1	8, 9 (depending on the other variant IDs)	0,1,2,4	Fahrenheit

Mode: 16#090C and variant

Variant	x	y	Measuring range
0	0	0,1,2,4	Ni 120 standard range
1	1	0,1,2,4	KTY84/110

Mode: 16#090D and variant

Variant	x	y	Measuring range
0	0	0,1,2,4	Ni 120 climate range
1	1	0,1,2,4	KTY84/130

Mode: 16#07 (Coding A) and variant

Variant	x	y	Measuring range
0	0	0,1,2,4	HART interface
1	1	0,1,2,4	Thermocouple, dynamic reference temperature

MODE: 16#08, 16#0A, 16#0B, 16#0D, 16#0E (coding A) and variant

Table 16-1 PCS 7 as of V8.1: MODE parameter variant

Variant	x	y	Measuring range
0	0	0,1,2,4	S7-300 module
1	3	0,1,2,4	S7-300, ET 200M Ex I/O module

Table 16-2 PCS 7 V7.x: MODE parameter variant

Variant	mode	Measuring range
0	16#08, 16#0A, 16#0B, 16#0D, 16#0E	S7-300 module
1	16#18, 16#1A, 16#1B, 16#1D, 16#1E	S7-300, ET 200M Ex I/O module

MODE: 1oo1-/1oo2 evaluation for F modules

Variant	x	y	Measuring range
0	0	0,1,2,4	1oo1 (1v1) evaluation
1	4	0,1,2,4	1oo2 (2v2) evaluation

Measuring range coding of the analog input modules

Depending on the measuring range coding of the analog input modules, the parameter `Mode` (low word = measuring range coding) corresponding to the channel must be specified in accordance with the table. When thermocouples are used there are various options for combining the measurement type (coding A) with the measuring range (coding B). In this case, the low word of parameter `Mode` must be calculated according to the following formula and the result entered at the `Mode` input parameter as an INTEGER value:

$$\text{Measuring range coding} = 256 \cdot \text{Code A} + \text{Code B}$$

Please note: The table shows codes **A** and **B** in binary format, and the measuring range coding as a hexadecimal number as the result.

Measuring type	Code (A)	Measuring range	Code(B)	Measuring range coding (256*A+B)
Disabled				16#0000
Voltage	2#0001	± 25 mV	2#1010	16#010A
		± 50mV	2#1011	16#010B
		± 80 mV	2#0001	16#0101
		± 250 mV	2#0010	16#0102
		± 500 mV	2#0011	16#0103
		± 1 V	2#0100	16#0104
		± 2,5 V	2#0101	16#0105
		± 5 V	2#0110	16#0106
		1 to 5 V	2#0111	16#0107
		0 to 10V	2#1000	16#0108
		± 10 V	2#1001	16#0109
		± 100 mV	2#1100	16#010C
4-wire measuring transducer	2#0010	± 3.2 mA	2#0000	16#0200
		± 5 mA	2#0101	16#0205
		± 10 mA	2#0001	16#0201
		0 to 20 mA	2#0010	16#0202
		4 to 20 mA	2#0011	16#0203
		± 20 mA	2#0100	16#0204
HART interface	2#0111	4 to 20 mA (variant 0)	2#1100	16#070C
2-wire measuring transducer	2#0011	0 to 20 mA	2#0010	16#0302
		4 to 20 mA	2#0011	16#0303
		± 20 mA	2#0100	16#0304
		0 to 10 mA	2#0110	16#0306
Resistor 4-wire connection	2#0100	48 Ω	2#0000	16#0400
		150 Ω	2#0010	16#0402
		300 Ω	2#0100	16#0404
		600 Ω	2#0110	16#0406
		1000 Ω	2#0111	16#040E
		3000 Ω	2#0111	16#0407
		6000 Ω	2#1000	16#0408
PTC	2#1111	16#040F		

Measuring type	Code (A)	Measuring range	Code(B)	Measuring range coding (256*A+B)
Resistor 3-wire connection	2#0101	48 Ω	2#0000	16#0500
		150 Ω	2#0010	16#0502
		300 Ω	2#0100	16#0504
		600 Ω	2#0110	16#0506
		1000 Ω	2#0111	16#050E
		3000 Ω	2#0111	16#0507
		6000 Ω	2#1000	16#0508
		PTC	2#1111	16#050F
Resistor 2-wire connection	2#0110	48 Ω	2#0000	16#0600
		150 Ω	2#0010	16#0602
		300 Ω	2#0100	16#0604
		600 Ω	2#0110	16#0606
		1000 Ω	2#0111	16#060E
		3000 Ω	2#0111	16#0607
		6000 Ω	2#1000	16#0608
		PTC	2#1111	16#060F

Measuring type	Code (A)	Measuring range	Code(B)	Measuring range coding (256*A+B)
Thermal resistance, linear, 4-wire connection	2#1000	Pt 100 climate range	2#0000	16#0800
		Pt 200 climate range	2#0111	16#0807
		Pt 500 climate range	2#1000	16#0808
		Pt 1000 climate range	2#1001	16#0809
		Ni 100 climate range	2#0001	16#0801
		Ni 1000 / LG-Ni 1000 climatic range	2#1010	16#080A
		Pt 100 standard range	2#0010	16#0802
		Pt 200 standard range	2#0011	16#0803
		Pt 500 standard range	2#0100	16#0804
		Pt 1000 standard range	2#0101	16#0805
		Ni 100 standard range	2#1011	16#080B
		Ni 1000 / LG-Ni 1000 standard range	2#0110	16#0806
		Ni 120 standard range	2#1100	16#080C
		Ni 120 climate range	2#1101	16#080D
		Cu 10 climate range	2#1110	16#080E
		Cu 10 standard range	2#1111	16#080F
		Ni 200 standard range	2#10000	16#0810
		Ni 200 climate range	2#10001	16#0811
		Ni 500 standard range	2#10010	16#0812
		Ni 500 climate range	2#10011	16#0813
		Pt 10 GOST climatic	2#10100	16#0814
		Pt 10 GOST standard (TC = 3910)	2#10101	16#0815
		Pt 50 GOST climatic	2#10110	16#0816
		Pt 50 GOST standard (TC = 3910)	2#10111	16#0817
		Pt 100 GOST climatic	2#11000	16#0818
		Pt 100 GOST standard (TC = 3910)	2#11001	16#0819
		Pt 500 GOST climatic	2#11010	16#081A
		Pt 500 GOST standard (TC = 3910)	2#11011	16#081B
		Cu 10 GOST climatic	2#11100	16#081C
		Cu 10 GOST standard (TC = 426)	2#11101	16#081D
		Cu 50 GOST climatic	2#11110	16#081E
		Cu 50 GOST standard (TC = 426)	2#11111	16#081F
Cu 100 GOST climatic	2#100000	16#0820		
Cu 100 GOST standard (TC = 426)	2#100001	16#0821		
Ni 100 GOST climatic	2#100010	16#0822		

Measuring type	Code (A)	Measuring range	Code(B)	Measuring range coding (256*A+B)
		Ni 100 GOST standard	2#100011	16#0823
		Pt 10 GOST standard (TC = 3850)	2#1010101	16#0855
		Pt 50 GOST standard (TC = 3850)	2#1010111	16#0857
		Pt 100 GOST standard (TC = 3850)	2#1011001	16#0859
		Pt 500 GOST standard (TC = 3850)	2#1011011	16#085B
		Cu 10 GOST standard (TC= 428)	2#1001110 1	16#089D
		Cu 50 GOST standard (TC= 428)	2#1001111 1	16#089F
		Cu 100 GOST stand- ard (TC= 428)	2#1010000 1	16#08A1

Measuring type	Code (A)	Measuring range	Code(B)	Measuring range coding (256*A+B)
Thermal resistance, linear, 3-wire connection	2#1001	Pt 100 climate range	2#0000	16#0900
		Pt 200 climate range	2#0111	16#0907
		Pt 500 climate range	2#1000	16#0908
		Pt 1000 climate range	2#1001	16#0909
		Ni 100 climate range	2#0001	16#0901
		Ni 1000 / LG-Ni 1000 climatic range	2#1010	16#090A
		Pt 100 standard range	2#0010	16#0902
		Pt 200 standard range	2#0011	16#0903
		Pt 500 standard range	2#0100	16#0904
		Pt 1000 standard range	2#0101	16#0905
		Ni 100 standard range	2#1011	16#090B
		Ni 1000 / LG-Ni 1000 standard range	2#0110	16#0906
		Ni 120 standard range (variant 0) KTY83/110 (variant 1)	2#1100	16#090C
		Ni 120 climate range (variant 0) KTY84/130 (variant 1)	2#1101	16#090D
		Cu 10 climate range	2#1110	16#090E
		Cu 10 standard range	2#1111	16#090F
		Ni 200 standard range	2#10000	16#0910
		Ni 200 climate range	2#10001	16#0911
		Ni 500 standard range	2#10010	16#0912
		Ni 500 climate range	2#10011	16#0913
		Pt 10 GOST climatic	2#10100	16#0914
		Pt 10 GOST standard (TC = 3910)	2#10101	16#0915
		Pt 50 GOST climatic	2#10110	16#0916
		Pt 50 GOST standard (TC = 3910)	2#10111	16#0917
		Pt 100 GOST climatic	2#11000	16#0918
		Pt 100 GOST standard (TC = 3910)	2#11001	16#0919
		Pt 500 GOST climatic	2#11010	16#091A
		Pt 500 GOST standard (TC = 3910)	2#11011	16#091B
		Cu 10 GOST climatic	2#11100	16#091C
		Cu 10 GOST standard (TC = 426)	2#11101	16#091D
		Cu 50 GOST climatic	2#11110	16#091E
		Cu 50 GOST standard (TC = 426)	2#11111	16#091F

Measuring type	Code (A)	Measuring range	Code(B)	Measuring range coding (256*A+B)
		Cu 100 GOST climatic	2#100000	16#0920
		Cu 100 GOST standard (TC = 426)	2#100001	16#0921
		Ni 100 GOST climatic	2#100010	16#0922
		Ni 100 GOST standard	2#100011	16#0923
		Pt 10 GOST standard (TC = 3850)	2#1010101	16#0955
		Pt 50 GOST standard (TC = 3850)	2#1010111	16#0957
		Pt 100 GOST standard (TC = 3850)	2#1011001	16#0959
		Pt 500 GOST standard (TC = 3850)	2#1011011	16#095B
		Cu 10 GOST standard (TC= 428)	2#10011101	16#099D
		Cu 50 GOST standard (TC= 428)	2#10011111	16#099F
		Cu 100 GOST standard (TC= 428)	2#10100001	16#09A1
Thermal resistance, linear, 2-wire connection	2#1111	Pt 100 climate range	2#0000	16#0F00
		Pt 200 climate range	2#0111	16#0F07
		Pt 500 climate range	2#1000	16#0F08
		Pt 1000 climate range	2#1001	16#0F09
		Ni 100 climate range	2#0001	16#0F01
		Ni 1000 / LG-Ni 1000 climatic range	2#1010	16#0F0A
		Pt 100 standard range	2#0010	16#0F02
		Pt 200 standard range	2#0011	16#0F03
		Pt 500 standard range	2#0100	16#0F04
		Pt 1000 standard range	2#0101	16#0F05
		Ni 100 standard range	2#1011	16#0F0B
		Ni 1000 / LG-Ni 1000 standard range	2#0110	16#0F06
		Ni 120 standard range	2#1100	16#0F0C
		Ni 120 climate range	2#1101	16#0F0D
		Cu 10 climate range	2#1110	16#0F0E
		Cu 10 standard range	2#1111	16#0F0F
		Ni 200 standard range	2#10000	16#0F10
		Ni 200 climate range	2#10001	16#0F11
		Ni 500 standard range	2#10010	16#0F12
		Ni 500 climate range	2#10011	16#0F13

Measuring type	Code (A)	Measuring range	Code(B)	Measuring range coding (256*A+B)
Thermocouple, linear, reference temperature 0 °C / No reference point	2#1010	Type B [PtRh-PtRh]	2#0000	16#0A00
		Type N [NiCrSi-NiSi]	2#0001	16#0A01
		Type E [NiCr-CuNi]	2#0010	16#0A02
		Type R [PtRh-Pt]	2#0011	16#0A03
		Type S [PtRh-Pt]	2#0100	16#0A04
		Type J [Fe-CuNi IEC]	2#0101	16#0A05
		Type L [Fe-CuNi DIN]	2#0110	16#0A06
		Type T [Cu-CuNi IEC]	2#0111	16#0A07
		Type K [NiCr-Ni]	2#1000	16#0A08
		Type U [Cu-CuNi DIN]	2#1001	16#0A09
		Type C	2#1010	16#0A0A
		Type TXK/XK(L)	2#1011	16#0A0B
Thermocouple, linear, reference temperature 50 °C	2#1011	Type B [PtRh-PtRh]	2#0000	16#0B00
		Type N [NiCrSi-NiSi]	2#0001	16#0B01
		Type E [NiCr-CuNi]	2#0010	16#0B02
		Type R [PtRh-Pt]	2#0011	16#0B03
		Type S [PtRh-Pt]	2#0100	16#0B04
		Type J [Fe-CuNi IEC]	2#0101	16#0B05
		Type L [Fe-CuNi DIN]	2#0110	16#0B06
		Type T [Cu-CuNi IEC]	2#0111	16#0B07
		Type K [NiCr-Ni]	2#1000	16#0B08
		Type U [Cu-CuNi DIN]	2#1001	16#0B09
		Type C	2#1010	16#0B0A
		Type TXK/XK(L)	2#1011	16#0B0B
Thermocouple, fixed ref. temp	2#1100	Type B [PtRh-PtRh]	2#0000	16#0C00
		Type N [NiCrSi-NiSi]	2#0001	16#0C01
		Type E [NiCr-CuNi]	2#0010	16#0C02
		Type R [PtRh-Pt]	2#0011	16#0C03
		Type S [PtRh-Pt]	2#0100	16#0C04
		Type J [Fe-CuNi IEC]	2#0101	16#0C05
		Type L [Fe-CuNi DIN]	2#0110	16#0C06
		Type T [Cu-CuNi IEC]	2#0111	16#0C07
		Type K [NiCr-Ni]	2#1000	16#0C08
		Type U [Cu-CuNi DIN]	2#1001	16#0C09
		Type C	2#1010	16#0C0A
		Type TXK/XK(L)	2#1011	16#0C0B

Measuring type	Code (A)	Measuring range	Code(B)	Measuring range coding (256*A+B)
Thermocouple, linear, internal compensation/internal reference point	2#1101	Type B [PtRh-PtRh]	2#0000	16#0D00
		Type N [NiCrSi-NiSi]	2#0001	16#0D01
		Type E [NiCr-CuNi]	2#0010	16#0D02
		Type R [PtRh-Pt]	2#0011	16#0D03
		Type S [PtRh-Pt]	2#0100	16#0D04
		Type J [Fe-CuNi IEC]	2#0101	16#0D05
		Type L [Fe-CuNi DIN]	2#0110	16#0D06
		Type T [Cu-CuNi IEC]	2#0111	16#0D07
		Type K [NiCr-Ni]	2#1000	16#0D08
		Type U [Cu-CuNi DIN]	2#1001	16#0D09
		Type C	2#1010	16#0D0A
		Type TXK/XK(L)	2#1011	16#0D0B
Thermocouple, linear, internal compensation/reference point RTD (0)	2#1110	Type B [PtRh-PtRh]	2#0000	16#0E00
		Type N [NiCrSi-NiSi]	2#0001	16#0E01
		Type E [NiCr-CuNi]	2#0010	16#0E02
		Type R [PtRh-Pt]	2#0011	16#0E03
		Type S [PtRh-Pt]	2#0100	16#0E04
		Type J [Fe-CuNi IEC]	2#0101	16#0E05
		Type L [Fe-CuNi DIN]	2#0110	16#0E06
		Type T [Cu-CuNi IEC]	2#0111	16#0E07
		Type K [NiCr-Ni]	2#1000	16#0E08
		Type U [Cu-CuNi DIN]	2#1001	16#0E09
		Type C	2#1010	16#0E0A
		Type TXK/XK(L)	2#1011	16#0E0B
Thermocouple, dynamic ref. temp	2#0111	Type B [PtRh-PtRh] (variant 1)	2#0000	16#0700
		Type N [NiCrSi-NiSi] (variant 1)	2#0001	16#0701
		Type E [NiCr-CuNi] (variant 1)	2#0010	16#0702
		Type R [PtRh-Pt] (variant 1)	2#0011	16#0703
		Type S [PtRh-Pt] (variant 1)	2#0100	16#0704
		Type J [Fe-CuNi IEC] (variant 1)	2#0101	16#0705
		Type L [Fe-CuNi DIN] (variant 1)	2#0110	16#0706
		Type T [Cu-CuNi IEC] (variant 1)	2#0111	16#0707
		Type K [NiCr-Ni] (variant 1)	2#1000	16#0708

Effect of the temperature coefficients on the measuring range

- Setting TC = 3850 at GOST Standard Pt 10, Pt 50, Pt 100, Pt 500 sets Bit 7 within the measuring range byte (0 x 40)
- Setting TC = 428 at GOST Standard Cu 10, Cu 50, Cu 100 sets Bit 8 within the measuring range byte (0 x 80)

Measuring range coding of the analog output modules

Depending on the measuring range coding of the analog output modules, the parameter `Mode` (measuring-range coding) corresponding to the channel must be specified in accordance with the table.

Measuring type	Measuring range	Mode
Voltage	± 5 V	16#0106
	1 to 5 V	16#0107
	0 to 10V	16#0108
	± 10 V	16#0109
Current	0 to 10 mA	16#0206
	0 to 20 mA	16#0202
	4 to 20 mA	16#0203
	± 20 mA	16#0204
HART interface	4 to 20 mA	16#070C

Measuring-Range Coding of the Digital Input and Output Modules

There is no measuring type and no measuring range for digital input modules and digital output modules:

- `Mode = 16#FFFF` (for DiIn)
- `Mode = 16#FFFE` (for DiOu)

Measuring range coding of the controller module

There is no measuring type and no measuring range for controller modules:

- `Mode = 16#FFFD`

Measuring range coding of the ET 200SP Analog Input Energy Meter module

There is no measuring type and no measuring range for analoge input energy meter moduls:

- `Mode = 16#200C`

16.20.2 Mode settings for field devices

Mode structure

The structure and meaning of the input Mode of data type DWORD are shown below:

Byte 3:	16#80: Value status "valid value" 16#00: Value status "invalid value" 16#40: Value status "invalid value"	(Channel error) (Higher-level error)
Byte 2:	16#01: Restart (OB 100) has been carried out 16#xy: Variant identification with multiple mode assignment (see below)	
Byte 1, 0 (low word):	Measuring range coding (see below)	

Example:

16#80010001 = Value status "valid value", restart has been carried out, PA device with analog input

PA/FF device variant identifier

Variant	x	y	Field device
0	0	0	PA device
1	1	0	FF device

Mode settings for field devices

MODE_xx input parameters are available for a maximum of 32 slots of a PA/FF field device. Their initial value is zero (no read/write access). You must set the combination selected from the options of the PROFIBUS PA 3.0 profile at the MODE_xx input of each slot channel xx:

Block	Parameter at blockand at field device	Input/output from block view (PLS view)	Mode 16#xyy O = xx I = yy	Configuration possible with field device
Analog input (PA_AI/ FbAnIn)	PV	OUT	I	16#0001	PA + FF
Totalizer (FbAnTot)	PV		I	16#000F	PA + FF
Totalizer (FbAnTot)	PV PV_Set		I O	16#070F	PA + FF
Totalizer (FbAnTot)	PV PV_Set PV_Mode		I O O	16#080F	PA + FF
Analog output (FbAnOu)	SP	SP	O	16#0100	PA + FF

Channel blocks

16.20 Annex for channel blocks

Block	Parameter at blockand at field device	Input/output from block view (PLS view)	Mode 16#xyy O = xx I = yy	Configuration possible with field device
Analog output (FbAnOu)	SP Rbk PosD	SP READBACK POS_D	O I I	16#0103	PA
Analog output (FbAnOu)	SP CbkJBy0 - CbkBy2	SP CHECK_BACK	O I	16#0104	PA
Analog output (FbAnOu)	SP Rbk PosD CbkJBy0 - CbkBy2	SP READBACK POS_D CHECK_BACK	O I I I	16#0105	PA
Analog output (FbAnOu)	RCasIn, RCasOut	RCAS_IN RCAS_OUT	O I	16#0206	PA
Analog output (FbAnOu)	RCasIn RCasOut CbkJBy0 - CbkBy2	RCAS_IN RCAS_OUT CHECK_BACK	O I I	16#0207	PA
Analog output (FbAnOu)	SP RCasIn Rbk RCasOut PosD CbkJBy0 - CbkBy2	SP RCAS_IN READBACK RCAS_OUT POS_D CHECK_BACK	O O I I I I	16#0308	PA
Binary input (FbDiIn)	PV	OUT_D	I	16#0002	PA + FF
Binary output (FbDiOu)	SP	SP_D	O	16#0400	PA + FF
Binary output (FbDiOu)	SP Rbk	SP_D READBACK_D	O I	16#0409	PA
Binary output (FbDiOu)	SP CbkJBy0 - CbkBy2	SP_D CHECKBACK_D	O I	16#040A	PA
Binary output (FbDiOu)	SP Rbk CbkJBy0 - CbkBy2	SP_D READBACK_D CHECK_BACK_D	O I I	16#040B	PA
Binary output (FbDiOu)	RCasIn RCasOut	RCAS_IN_D RCAS_OUT_D	O I	16#050C	PA
Binary output (FbDiOu)	RCasIn RCasOut CbkJBy0 - CbkBy2	RCAS_IN_D RCAS_OUT_D CHECK_BACK_D	O I I	16#050D	PA
Binary output (FbDiOu)	SP RCasIn Rbk RCasOut CbkJBy0 - CbkBy2	SP_D RCAS_IN_D READBACK_D RCAS_OUT_D CHECK_BACK_D	O O I I I	16#060E	PA

Conversion blocks

17.1 StrgToBy - String in byte structure (Struct of Byte)

17.1.1 Description of StrgToBy

Object name (type + number) and family

Type + number: FC 384

Family: Convert

Area of application for StrgToBy

The block converts a string with a maximum length of 32 into a byte structure (Struct of Byte). This enables strings to be interconnected via the StrgToBy block to the inputs for the associated values (`ExtValxx`) of the technological blocks.

How it works

The block uses the input string "StringIn", converts it to a byte structure and transfers it to the output parameter `StrctOut`.

Configuration

Use the CFC editor to install the block in any OB.

Startup characteristics

The block does not have any startup characteristics.

Status word allocation for `status` parameter

This block does not have the `status` parameter.

See also

StrgToBy modes (Page 2220)

StrgToBy functions (Page 2220)

StrgToBy error handling (Page 2221)

StrgToBy messaging (Page 2221)

17.1 StrgToBy - String in byte structure (Struct of Byte)

StrgToBy I/Os (Page 2221)

StrgToBy block diagram (Page 2222)

17.1.2 StrgToBy modes

Operating modes of StrgToBy

This block does not have any operating modes.

See also

Description of StrgToBy (Page 2219)

StrgToBy functions (Page 2220)

StrgToBy error handling (Page 2221)

StrgToBy messaging (Page 2221)

StrgToBy I/Os (Page 2221)

StrgToBy block diagram (Page 2222)

17.1.3 StrgToBy functions

Functions of StrgToBy

The block uses the input string "StringIn", converts it to a byte structure and transfers it to the output parameter StructOut".

See also

Description of StrgToBy (Page 2219)

StrgToBy modes (Page 2220)

StrgToBy error handling (Page 2221)

StrgToBy messaging (Page 2221)

StrgToBy I/Os (Page 2221)

StrgToBy block diagram (Page 2222)

17.1.4 StrgToBy error handling

Error handling of StrgToBy

The block does not report any errors.

See also

Description of StrgToBy (Page 2219)

StrgToBy modes (Page 2220)

StrgToBy functions (Page 2220)

StrgToBy messaging (Page 2221)

StrgToBy I/Os (Page 2221)

StrgToBy block diagram (Page 2222)

17.1.5 StrgToBy messaging

Messaging

This block does not offer messaging.

See also

Description of StrgToBy (Page 2219)

StrgToBy modes (Page 2220)

StrgToBy functions (Page 2220)

StrgToBy error handling (Page 2221)

StrgToBy I/Os (Page 2221)

StrgToBy block diagram (Page 2222)

17.1.6 StrgToBy I/Os

I/Os of StrgToBy

Input parameters

Parameter	Description	Type	Default
EN	1 = Called block will be processed	BOOL	1
StringIn	Input string	STRING[32]	"

Output parameters

Parameter	Description	Type	Default
ENO	1 = Block algorithm completed without errors	BOOL	1
StrctOut	Byte structure	STRUCT <ul style="list-style-type: none">• Byte1:BYTE• Byte2:BYTE• Byte3:BYTE• ...• Byte32:BYTE	- <ul style="list-style-type: none">• 16#00• 16#00• 16#00• 16#00• 16#00

See also

- Description of StrgToBy (Page 2219)
- StrgToBy modes (Page 2220)
- StrgToBy functions (Page 2220)
- StrgToBy error handling (Page 2221)
- StrgToBy messaging (Page 2221)
- StrgToBy block diagram (Page 2222)

17.1.7 StrgToBy block diagram

Block diagram of StrgToBy

A block diagram is not provided for this block.

See also

- Description of StrgToBy (Page 2219)
- StrgToBy modes (Page 2220)
- StrgToBy functions (Page 2220)
- StrgToBy error handling (Page 2221)
- StrgToBy messaging (Page 2221)
- StrgToBy I/Os (Page 2221)

17.2 StruAnIn - Separating an analog structured variable

17.2.1 Description of StruAnIn

Object name (type + number) and family

Type + number: FC 375

Family: Convert

Area of application for StruAnIn

The block is used for the following applications:

- Separation of an analog value with a structure into a variable of the REAL data type and a signal status

How it works

The block separates an analog value with a structure interconnected to the `In` input parameter into a variable (`Out`) of the REAL data type and a (`ST`) signal status.

Configuration

Use the CFC editor to install the block in any OB.

Startup characteristics

The block does not have any startup characteristics.

Status word allocation for parameter `status`

This block does not have the `Status` parameter.

See also

StruAnIn block diagram (Page 2226)

StruAnIn I/Os (Page 2225)

StruAnIn messaging (Page 2225)

StruAnIn error handling (Page 2224)

StruAnIn functions (Page 2224)

StruAnIn modes (Page 2224)

17.2.2 StruAnIn modes

StruAnIn modes

This block does not have any modes.

See also

StruAnIn block diagram (Page 2226)

StruAnIn I/Os (Page 2225)

StruAnIn messaging (Page 2225)

StruAnIn error handling (Page 2224)

StruAnIn functions (Page 2224)

Description of StruAnIn (Page 2223)

17.2.3 StruAnIn functions

Functions of StruAnIn

There are no other functions for this block.

See also

StruAnIn block diagram (Page 2226)

StruAnIn I/Os (Page 2225)

StruAnIn messaging (Page 2225)

StruAnIn error handling (Page 2224)

StruAnIn modes (Page 2224)

Description of StruAnIn (Page 2223)

17.2.4 StruAnIn error handling

StruAnIn error handling

The block does not report any errors.

See also

[StruAnIn block diagram \(Page 2226\)](#)
[StruAnIn I/Os \(Page 2225\)](#)
[StruAnIn messaging \(Page 2225\)](#)
[StruAnIn functions \(Page 2224\)](#)
[StruAnIn modes \(Page 2224\)](#)
[Description of StruAnIn \(Page 2223\)](#)

17.2.5 StruAnIn messaging**Messaging**

This block does not offer messaging.

See also

[StruAnIn block diagram \(Page 2226\)](#)
[StruAnIn I/Os \(Page 2225\)](#)
[StruAnIn error handling \(Page 2224\)](#)
[StruAnIn functions \(Page 2224\)](#)
[StruAnIn modes \(Page 2224\)](#)
[Description of StruAnIn \(Page 2223\)](#)

17.2.6 StruAnIn I/Os**StruAnIn I/Os****Input parameters**

Parameter	Description	Type	Default
EN	1 = Called block will be processed	BOOL	1
In	Analog value with structure	STRUCT	-
		<ul style="list-style-type: none"> • Value: REAL • ST: BYTE 	<ul style="list-style-type: none"> • 0.0 • 16#80

Output parameters

Parameter	Description	Type	Default
ENO	1 = Block algorithm completed without errors	BOOL	0
ST	Signal status	BYTE	16#80
Value	Analog value	REAL	0.0

See also

- StruAnIn block diagram (Page 2226)
- StruAnIn messaging (Page 2225)
- StruAnIn error handling (Page 2224)
- StruAnIn functions (Page 2224)
- StruAnIn modes (Page 2224)
- Description of StruAnIn (Page 2223)

17.2.7 StruAnIn block diagram

StruAnIn block diagram

A block diagram is not provided for this block.

See also

- StruAnIn I/Os (Page 2225)
- StruAnIn messaging (Page 2225)
- StruAnIn error handling (Page 2224)
- StruAnIn functions (Page 2224)
- StruAnIn modes (Page 2224)
- Description of StruAnIn (Page 2223)

17.3 StruAnOu - Creating an analog structured variable

17.3.1 Description of StruAnOu

Object name (type + number) and family

Type + number: FC 376

Family: Convert

Area of application for StruAnOu

The block is used for the following applications:

- Merging a variable of the REAL data type and a signal status into an analog process value.

How it works

The block merges an analog value (`Value`) of the REAL data type and a signal status (`ST`) to form an analog value (`Out`) with a structure.

Configuration

Use the CFC editor to install the block in any OB.

Startup characteristics

The block does not have any startup characteristics.

Status word allocation for `status` parameter

This block does not have the `status` parameter.

See also

StruAnOu modes (Page 2228)

StruAnOu functions (Page 2228)

StruAnOu error handling (Page 2228)

StruAnOu messaging (Page 2229)

StruAnOu I/Os (Page 2229)

StruAnOu block diagram (Page 2230)

17.3.2 StruAnOu modes

StruAnOu modes

This block does not have any modes.

See also

Description of StruAnOu (Page 2227)

StruAnOu functions (Page 2228)

StruAnOu error handling (Page 2228)

StruAnOu messaging (Page 2229)

StruAnOu I/Os (Page 2229)

StruAnOu block diagram (Page 2230)

17.3.3 StruAnOu functions

Functions of StruAnOu

There are no other functions for this block.

See also

Description of StruAnOu (Page 2227)

StruAnOu modes (Page 2228)

StruAnOu error handling (Page 2228)

StruAnOu messaging (Page 2229)

StruAnOu I/Os (Page 2229)

StruAnOu block diagram (Page 2230)

17.3.4 StruAnOu error handling

StruAnOu error handling

The block does not report any errors.

See also

Description of StruAnOu (Page 2227)

StruAnOu modes (Page 2228)

StruAnOu functions (Page 2228)

StruAnOu messaging (Page 2229)

StruAnOu I/Os (Page 2229)

StruAnOu block diagram (Page 2230)

17.3.5 StruAnOu messaging**Messaging**

This block does not offer messaging.

See also

Description of StruAnOu (Page 2227)

StruAnOu modes (Page 2228)

StruAnOu functions (Page 2228)

StruAnOu error handling (Page 2228)

StruAnOu I/Os (Page 2229)

StruAnOu block diagram (Page 2230)

17.3.6 StruAnOu I/Os**StruAnOu I/Os****Input parameters**

Parameter	Description	Type	Default
EN	1 = Called block will be processed	BOOL	1
ST	Signal status	BYTE	16#80
Value	Analog value	REAL	0.0

Output parameters

Parameter	Description	Type	Default
Bad	1 = (ST = 16#00 to 16#3F)	STRUCT <ul style="list-style-type: none"> • Value: BOOL • ST: BYTE 	- <ul style="list-style-type: none"> • 0 • 16#80
ENO	1 = Block algorithm completed without errors	BOOL	0
Out	Analog value with structure	STRUCT <ul style="list-style-type: none"> • Value: REAL • ST: BYTE 	- <ul style="list-style-type: none"> • 0.0 • 16#80

See also

- Description of StruAnOu (Page 2227)
- StruAnOu modes (Page 2228)
- StruAnOu functions (Page 2228)
- StruAnOu error handling (Page 2228)
- StruAnOu messaging (Page 2229)
- StruAnOu block diagram (Page 2230)

17.3.7 StruAnOu block diagram

StruAnOu block diagram

A block diagram is not provided for this block.

See also

- Description of StruAnOu (Page 2227)
- StruAnOu modes (Page 2228)
- StruAnOu functions (Page 2228)
- StruAnOu error handling (Page 2228)
- StruAnOu messaging (Page 2229)
- StruAnOu I/Os (Page 2229)

17.4 StruDiln - Separating a digital structured variable

17.4.1 Description of StruDiln

Object name (type + number) and family

Type + number: FC 377

Family: Convert

Area of application for StruDiln

The block is used for the following applications:

- Separating a binary process value into a variable of the BOOL data type, a process value and signal status.

How it works

The block separates a binary process value interconnected to the `In` input parameter into a variable of the BOOL data type and a signal status.

Configuration

Use the CFC editor to install the block in any OB

Startup characteristics

The block does not have any startup characteristics.

Status word allocation for `status` parameter

This block does not have the `status` parameter.

See also

StruDiln block diagram (Page 2234)

StruDiln I/Os (Page 2233)

StruDiln messaging (Page 2233)

StruDiln error handling (Page 2232)

StruDiln functions (Page 2232)

StruDiln modes (Page 2232)

17.4.2 StruDiln modes

StruDiln modes

This block does not have any modes.

See also

StruDiln block diagram (Page 2234)

StruDiln I/Os (Page 2233)

StruDiln messaging (Page 2233)

StruDiln error handling (Page 2232)

StruDiln functions (Page 2232)

Description of StruDiln (Page 2231)

17.4.3 StruDiln functions

Functions of StruDiln

There are no other functions for this block.

See also

StruDiln block diagram (Page 2234)

StruDiln I/Os (Page 2233)

StruDiln messaging (Page 2233)

StruDiln error handling (Page 2232)

StruDiln modes (Page 2232)

Description of StruDiln (Page 2231)

17.4.4 StruDiln error handling

StruDiln error handling

The block does not report any errors.

See also

[StruDiln block diagram \(Page 2234\)](#)
[StruDiln I/Os \(Page 2233\)](#)
[StruDiln messaging \(Page 2233\)](#)
[StruDiln functions \(Page 2232\)](#)
[StruDiln modes \(Page 2232\)](#)
[Description of StruDiln \(Page 2231\)](#)

17.4.5 StruDiln messaging**Messaging**

This block does not offer messaging.

See also

[StruDiln block diagram \(Page 2234\)](#)
[StruDiln I/Os \(Page 2233\)](#)
[StruDiln error handling \(Page 2232\)](#)
[StruDiln functions \(Page 2232\)](#)
[StruDiln modes \(Page 2232\)](#)
[Description of StruDiln \(Page 2231\)](#)

17.4.6 StruDiln I/Os**StruDiln I/Os****Input parameters**

Parameter	Description	Type	Default
EN	1 = Called block will be processed	BOOL	1
In	Binary process value	STRUCT	-
		<ul style="list-style-type: none"> • Value: BOOL • ST: BYTE 	<ul style="list-style-type: none"> • 0 • 16#80

Output parameters

Parameter	Description	Type	Default
ENO	1 = Block algorithm completed without errors	BOOL	0
ST	Signal status	BYTE	16#80
Value	Binary variable	BOOL	0

See also

- StruDiln block diagram (Page 2234)
- StruDiln messaging (Page 2233)
- StruDiln error handling (Page 2232)
- StruDiln functions (Page 2232)
- StruDiln modes (Page 2232)
- Description of StruDiln (Page 2231)

17.4.7 StruDiln block diagram

StruDiln block diagram

A block diagram is not provided for this block.

See also

- StruDiln I/Os (Page 2233)
- StruDiln messaging (Page 2233)
- StruDiln error handling (Page 2232)
- StruDiln functions (Page 2232)
- StruDiln modes (Page 2232)
- Description of StruDiln (Page 2231)

17.5 StruDiOu - Creating a digital structured variable

17.5.1 Description of StruDiOu

Object name (type + number) and family

Type + number: FC 378

Family: Convert

Area of application for StruDiOu

The block is used for the following applications:

- Merging a variable of the BOOL data type and a signal status into a binary process value.

How it works

The block merges a variable of the BOOL data type and a signal status into a binary process value.

Configuration

Use the CFC editor to install the block in any OB.

Startup characteristics

The block does not have any startup characteristics.

Status word allocation for `status` parameter

This block does not have the `status` parameter.

See also

StruDiOu block diagram (Page 2238)

StruDiOu I/Os (Page 2237)

StruDiOu messaging (Page 2237)

StruDiOu error handling (Page 2236)

StruDiOu functions (Page 2236)

StruDiOu modes (Page 2236)

17.5.2 StruDiOu modes

StruDiOu modes

This block does not have any modes.

See also

[StruDiOu block diagram \(Page 2238\)](#)

[StruDiOu I/Os \(Page 2237\)](#)

[StruDiOu messaging \(Page 2237\)](#)

[StruDiOu error handling \(Page 2236\)](#)

[StruDiOu functions \(Page 2236\)](#)

[Description of StruDiOu \(Page 2235\)](#)

17.5.3 StruDiOu functions

Functions of StruDiOu

There are no other functions for this block.

See also

[StruDiOu block diagram \(Page 2238\)](#)

[StruDiOu I/Os \(Page 2237\)](#)

[StruDiOu messaging \(Page 2237\)](#)

[StruDiOu error handling \(Page 2236\)](#)

[StruDiOu modes \(Page 2236\)](#)

[Description of StruDiOu \(Page 2235\)](#)

17.5.4 StruDiOu error handling

StruDiOu error handling

The block does not report any errors.

See also

[StruDiOu block diagram \(Page 2238\)](#)
[StruDiOu I/Os \(Page 2237\)](#)
[StruDiOu messaging \(Page 2237\)](#)
[StruDiOu functions \(Page 2236\)](#)
[StruDiOu modes \(Page 2236\)](#)
[Description of StruDiOu \(Page 2235\)](#)

17.5.5 StruDiOu messaging**Messaging**

This block does not offer messaging.

See also

[StruDiOu block diagram \(Page 2238\)](#)
[StruDiOu I/Os \(Page 2237\)](#)
[StruDiOu error handling \(Page 2236\)](#)
[StruDiOu functions \(Page 2236\)](#)
[StruDiOu modes \(Page 2236\)](#)
[Description of StruDiOu \(Page 2235\)](#)

17.5.6 StruDiOu I/Os**StruDiOu I/Os****Input parameters**

Parameter	Description	Type	Default
EN	1 = Called block will be processed	BOOL	1
ST	Signal status	BYTE	16#80
Value	Binary variable	BOOL	0

Output parameters

Parameter	Description	Type	Default
Bad	1 = (ST = 16#00 to 16#3F)	STRUCT <ul style="list-style-type: none"> • Value: BOOL • ST: BYTE 	- <ul style="list-style-type: none"> • 0 • 16#80
ENO	1 = Block algorithm completed without errors	BOOL	0
Out	Binary process value	STRUCT <ul style="list-style-type: none"> • Value: BOOL • ST: BYTE 	- <ul style="list-style-type: none"> • 0 • 16#80

See also

- StruDiOu block diagram (Page 2238)
- StruDiOu messaging (Page 2237)
- StruDiOu error handling (Page 2236)
- StruDiOu functions (Page 2236)
- StruDiOu modes (Page 2236)
- Description of StruDiOu (Page 2235)

17.5.7 StruDiOu block diagram

StruDiOu block diagram

A block diagram is not provided for this block.

See also

- StruDiOu I/Os (Page 2237)
- StruDiOu messaging (Page 2237)
- StruDiOu error handling (Page 2236)
- StruDiOu functions (Page 2236)
- StruDiOu modes (Page 2236)
- Description of StruDiOu (Page 2235)

17.6 StruScIn - Separating a display area into two variables

17.6.1 Description of StruScIn

Object name (type + number) and family

Type + number: FC 379

Family: Convert

Area of application for StruScIn

The block is used for the following applications:

- Separation of a display area into two variables of data type REAL.

How it works

The block separates a display area interconnected to the `Scale` input parameter into two variables of the REAL. data type

Configuration

Use the CFC editor to install the block in any OB.

Startup characteristics

The block does not have any startup characteristics.

Status word allocation for `Status` parameter

This block does not have the `Status` parameter.

See also

StruScIn block diagram (Page 2242)

StruScIn I/Os (Page 2241)

StruScIn messaging (Page 2241)

StruScIn error handling (Page 2240)

StruScIn functions (Page 2240)

StruScIn modes (Page 2240)

17.6.2 StruScIn modes

StruScIn modes

This block does not have any modes.

See also

StruScIn block diagram (Page 2242)

StruScIn I/Os (Page 2241)

StruScIn messaging (Page 2241)

StruScIn error handling (Page 2240)

StruScIn functions (Page 2240)

Description of StruScIn (Page 2239)

17.6.3 StruScIn functions

Functions of StruScIn

There are no other functions for this block.

See also

StruScIn block diagram (Page 2242)

StruScIn I/Os (Page 2241)

StruScIn messaging (Page 2241)

StruScIn error handling (Page 2240)

StruScIn modes (Page 2240)

Description of StruScIn (Page 2239)

17.6.4 StruScIn error handling

StruScIn error handling

The block does not report any errors.

See also

[StruScIn block diagram \(Page 2242\)](#)
[StruScIn I/Os \(Page 2241\)](#)
[StruScIn messaging \(Page 2241\)](#)
[StruScIn functions \(Page 2240\)](#)
[StruScIn modes \(Page 2240\)](#)
[Description of StruScIn \(Page 2239\)](#)

17.6.5 StruScIn messaging**Messaging**

This block does not offer messaging.

See also

[StruScIn block diagram \(Page 2242\)](#)
[StruScIn I/Os \(Page 2241\)](#)
[StruScIn error handling \(Page 2240\)](#)
[StruScIn functions \(Page 2240\)](#)
[StruScIn modes \(Page 2240\)](#)
[Description of StruScIn \(Page 2239\)](#)

17.6.6 StruScIn I/Os**StruScIn I/Os****Input parameters**

Parameter	Description	Type	Default
EN	1 = Called block will be processed	BOOL	1
Scale	Display area	STRUCT	-
		<ul style="list-style-type: none"> • High: REAL • Low: REAL 	<ul style="list-style-type: none"> • 100.0 • 0.0

Output parameters

Parameter	Description	Type	Default
ENO	1 = Block algorithm completed without errors	BOOL	0
HiScale	High limit of display area	REAL	100.0
LoScale	Low limit of display area	REAL	0.0

See also

- StruScIn block diagram (Page 2242)
- StruScIn messaging (Page 2241)
- StruScIn error handling (Page 2240)
- StruScIn functions (Page 2240)
- StruScIn modes (Page 2240)
- Description of StruScIn (Page 2239)

17.6.7 StruScIn block diagram

StruScIn block diagram

A block diagram is not provided for this block.

See also

- StruScIn I/Os (Page 2241)
- StruScIn messaging (Page 2241)
- StruScIn error handling (Page 2240)
- StruScIn functions (Page 2240)
- StruScIn modes (Page 2240)
- Description of StruScIn (Page 2239)

17.7 StruScOu - Merging two variables into a display area

17.7.1 Description of StruScOu

Object name (type + number) and family

Type + number: FC 380

Family: Convert

Area of application for StruScOu

The block is used for the following applications:

- Merging two variables of the REAL data type into a display area.

How it works

The block merges two variables of the REAL data type into a display area.

Configuration

Use the CFC editor to install the block in any OB.

Startup characteristics

The block does not have any startup characteristics.

Status word allocation for `status` parameter

This block does not have the `status` parameter.

See also

StruScOu block diagram (Page 2246)

StruScOu I/Os (Page 2245)

StruScOu messaging (Page 2245)

StruScOu error handling (Page 2244)

StruScOu functions (Page 2244)

StruScOu modes (Page 2244)

17.7.2 StruScOu modes

StruScOu modes

This block does not have any modes.

See also

StruScOu block diagram (Page 2246)

StruScOu I/Os (Page 2245)

StruScOu messaging (Page 2245)

StruScOu error handling (Page 2244)

StruScOu functions (Page 2244)

Description of StruScOu (Page 2243)

17.7.3 StruScOu functions

Functions of StruScOu

There are no other functions for this block.

See also

StruScOu block diagram (Page 2246)

StruScOu I/Os (Page 2245)

StruScOu messaging (Page 2245)

StruScOu error handling (Page 2244)

StruScOu modes (Page 2244)

Description of StruScOu (Page 2243)

17.7.4 StruScOu error handling

StruScOu error handling

The block does not report any errors.

See also

StruScOu block diagram (Page 2246)
 StruScOu I/Os (Page 2245)
 StruScOu messaging (Page 2245)
 StruScOu functions (Page 2244)
 StruScOu modes (Page 2244)
 Description of StruScOu (Page 2243)

17.7.5 StruScOu messaging**Messaging**

This block does not offer messaging.

See also

StruScOu block diagram (Page 2246)
 StruScOu I/Os (Page 2245)
 StruScOu error handling (Page 2244)
 StruScOu functions (Page 2244)
 StruScOu modes (Page 2244)
 Description of StruScOu (Page 2243)

17.7.6 StruScOu I/Os**StruScOu I/Os****Input parameters**

Parameter	Description	Type	Default
EN	1 = Called block will be processed	BOOL	1
HiScale	High limit of display area	REAL	100.0
LoScale	Low limit of display area	REAL	0.0

Output parameters

Parameter	Description	Type	Default
ENO	1 = Block algorithm completed without errors	BOOL	0
Scale	Display area	STRUCT <ul style="list-style-type: none">• High: REAL• Low: REAL	- <ul style="list-style-type: none">• 100.0• 0.0

See also

- StruScOu block diagram (Page 2246)
- StruScOu messaging (Page 2245)
- StruScOu error handling (Page 2244)
- StruScOu functions (Page 2244)
- StruScOu modes (Page 2244)
- Description of StruScOu (Page 2243)

17.7.7 StruScOu block diagram

StruScOu block diagram

A block diagram is not provided for this block.

See also

- StruScOu I/Os (Page 2245)
- StruScOu messaging (Page 2245)
- StruScOu error handling (Page 2244)
- StruScOu functions (Page 2244)
- StruScOu modes (Page 2244)
- Description of StruScOu (Page 2243)

17.8 STIn - Separating the signal status into individual binary displays

17.8.1 Description of STIn

Object name (type + number) and family

Type + number: FC 373

Family: Convert

Area of application for STIn

The block is used for the following applications:

- Separation of signal status into individual binary displays

How it works

The block separates a signal status interconnected to the input parameter into individual binary displays.

Configuration

Use the CFC editor to install the block in any OB.

Startup characteristics

The block does not have any startup characteristics.

Status word allocation for `status` parameter

This block does not have the `status` parameter.

See also

STIn block diagram (Page 2250)

STIn I/Os (Page 2249)

STIn messaging (Page 2249)

STIn error handling (Page 2248)

STIn functions (Page 2248)

STIn modes (Page 2248)

17.8.2 STIn modes

STIn modes

This block does not have any modes.

See also

STIn block diagram (Page 2250)

STIn I/Os (Page 2249)

STIn messaging (Page 2249)

STIn error handling (Page 2248)

STIn functions (Page 2248)

Description of STIn (Page 2247)

17.8.3 STIn functions

Functions of STIn

There are no other functions for this block.

See also

STIn block diagram (Page 2250)

STIn I/Os (Page 2249)

STIn messaging (Page 2249)

STIn error handling (Page 2248)

STIn modes (Page 2248)

Description of STIn (Page 2247)

17.8.4 STIn error handling

STIn error handling

The block does not report any errors.

See also

STIn block diagram (Page 2250)
 STIn I/Os (Page 2249)
 STIn messaging (Page 2249)
 STIn functions (Page 2248)
 STIn modes (Page 2248)
 Description of STIn (Page 2247)

17.8.5 STIn messaging**Messaging**

This block does not offer messaging.

See also

STIn block diagram (Page 2250)
 STIn I/Os (Page 2249)
 STIn error handling (Page 2248)
 STIn functions (Page 2248)
 STIn modes (Page 2248)
 Description of STIn (Page 2247)

17.8.6 STIn I/Os

I/Os of STIn

Input parameters

Parameter	Description	Type	Default
EN	1 = Called block will be processed	BOOL	1
In	Signal status	BYTE	16#80

Output parameters

Parameter	Description	Type	Default
ENO	1 = Block algorithm completed without errors	BOOL	0
ST_00	1 = Bad, device related	BOOL	0
ST_28	1 = Bad, process related	BOOL	0
ST_60	1 = Manipulated value (for example, substitute value, simulation, last valid value)	BOOL	0
ST_68	1 = Unknown, device related	BOOL	0
ST_78	1 = Unknown, process related	BOOL	0
ST_80	1 = Good	BOOL	0
ST_A4	1 = Maintenance request	BOOL	0

See also

- STIn error handling (Page 2248)
- STIn block diagram (Page 2250)
- Description of STIn (Page 2247)
- STIn modes (Page 2248)
- STIn functions (Page 2248)
- STIn messaging (Page 2249)

17.8.7 STIn block diagram

STIn block diagram

A block diagram is not provided for this block.

See also

- Description of STIn (Page 2247)
- STIn modes (Page 2248)
- STIn functions (Page 2248)
- STIn error handling (Page 2248)
- STIn messaging (Page 2249)
- STIn I/Os (Page 2249)

17.9 STOu - Merging individual binary signals into a signal status

17.9.1 Description of STOu

Object name (type + number) and family

Type + number: FC 374

Family: Convert

Area of application for STOu

The block is used for the following applications:

- Merging individual binary signals into a signal status

How it works

The block merges individual binary signals into a `Out` signal status.

If several binary signals are set, the one with the highest priority becomes effective, as described in the section Forming and outputting the signal status for technologic blocks (Page 109) for technologic blocks.

If no binary signal is set, the "Bad, process related" signal status is set.

Configuration

Use the CFC editor to install the block in any OB.

Startup characteristics

The block does not have any startup characteristics.

Status word allocation for `status` parameter

This block does not have the `Status` parameter.

See also

STOu block diagram (Page 2254)

STOu I/Os (Page 2253)

STOu messaging (Page 2253)

STOu error handling (Page 2252)

STOu functions (Page 2252)

STOu modes (Page 2252)

17.9.2 STOu modes

STOu modes

This block does not have any modes.

See also

STOu block diagram (Page 2254)

STOu I/Os (Page 2253)

STOu messaging (Page 2253)

STOu error handling (Page 2252)

STOu functions (Page 2252)

Description of STOu (Page 2251)

17.9.3 STOu functions

Functions of STOu

There are no other functions for this block.

See also

STOu block diagram (Page 2254)

STOu I/Os (Page 2253)

STOu messaging (Page 2253)

STOu error handling (Page 2252)

STOu modes (Page 2252)

Description of STOu (Page 2251)

17.9.4 STOu error handling

STOu error handling

The block does not report any errors.

See also

STOu block diagram (Page 2254)
 STOu I/Os (Page 2253)
 STOu messaging (Page 2253)
 STOu functions (Page 2252)
 STOu modes (Page 2252)
 Description of STOu (Page 2251)

17.9.5 STOu messaging**Messaging**

This block does not offer messaging.

See also

STOu block diagram (Page 2254)
 STOu I/Os (Page 2253)
 STOu error handling (Page 2252)
 STOu functions (Page 2252)
 STOu modes (Page 2252)
 Description of STOu (Page 2251)

17.9.6 STOu I/Os**STOu I/Os****Input parameters**

Parameter	Description	Type	Default
EN	1 = Called block will be processed	BOOL	1
ST_00	1 = Bad, device related	BOOL	0
ST_28	1 = Bad, process related	BOOL	0
ST_60	1 = Manipulated value (for example, substitute value, simulation, last valid value)	BOOL	0
ST_68	1 = Unknown, device related	BOOL	0
ST_78	1 = Unknown, process related	BOOL	0
ST_80	1 = Good	BOOL	0
ST_A4	1 = Maintenance request	BOOL	0

Output parameters

Parameter	Description	Type	Default
ENO	1 = Block algorithm completed without errors	BOOL	0
Out	Signal status	BYTE	16#80

See also

- STOu error handling (Page 2252)
- STOu block diagram (Page 2254)
- STOu messaging (Page 2253)
- STOu functions (Page 2252)
- STOu modes (Page 2252)
- Description of STOu (Page 2251)

17.9.7 STOu block diagram

STOu block diagram

A block diagram is not provided for this block.

See also

- STOu I/Os (Page 2253)
- STOu messaging (Page 2253)
- STOu error handling (Page 2252)
- STOu functions (Page 2252)
- STOu modes (Page 2252)
- Description of STOu (Page 2251)

17.10 MSTIn - Separating the maintenance status into individual status displays

17.10.1 Description of MSTIn

Object name (type + number) and family

Type + number: FB 1858

Family: Convert

Area of application for MSTIn

The block is used for the following applications:

- Separation of the maintenance status into individual status displays

How it works

The block separates a maintenance status interconnected to the `In` input parameter into individual status displays.

If the input parameter receives information that at least one value is simulated, for example (`In = 16#00000003`), this is indicated at output parameter `MST_03` with the value 1.

Configuration

Use the CFC editor to install the block in any OB.

Startup characteristics

The block does not have any startup characteristics.

Status word allocation for `status` parameter

This block does not have the `status` parameter.

See also

MSTIn block diagram (Page 2258)

MSTIn I/Os (Page 2257)

MSTIn messaging (Page 2257)

MSTIn error handling (Page 2256)

MSTIn functions (Page 2256)

MSTIn modes (Page 2256)

17.10.2 MSTIn modes

MSTIn modes

This block does not have any modes.

See also

MSTIn I/Os (Page 2257)
MSTIn messaging (Page 2257)
MSTIn error handling (Page 2256)
MSTIn functions (Page 2256)
MSTIn block diagram (Page 2258)
Description of MSTIn (Page 2255)

17.10.3 MSTIn functions

Functions of MSTIn

There are no other functions for this block.

See also

MSTIn block diagram (Page 2258)
MSTIn I/Os (Page 2257)
MSTIn messaging (Page 2257)
MSTIn error handling (Page 2256)
MSTIn modes (Page 2256)
Description of MSTIn (Page 2255)

17.10.4 MSTIn error handling

MSTIn error handling

The block does not report any errors.

See also

MSTIn block diagram (Page 2258)

MSTIn I/Os (Page 2257)

MSTIn messaging (Page 2257)

MSTIn functions (Page 2256)

MSTIn modes (Page 2256)

Description of MSTIn (Page 2255)

17.10.5 MSTIn messaging**Messaging**

This block does not offer messaging.

See also

MSTIn block diagram (Page 2258)

MSTIn I/Os (Page 2257)

MSTIn error handling (Page 2256)

MSTIn functions (Page 2256)

MSTIn modes (Page 2256)

Description of MSTIn (Page 2255)

17.10.6 MSTIn I/Os**MSTIn I/Os****Input parameters**

Parameter	Description	Type	Default
EN	1 = Called block will be processed	BOOL	1
In	Maintenance status	DWORD	16#00000000

Output parameters

Parameter	Description	Type	Default
ENO	1 = Block algorithm completed without errors	BOOL	0
MST_00	1 = Good	BOOL	0
MST_01	1 = Passivated	BOOL	0
MST_02	1 = "Out of service"	BOOL	0
MST_03	1 = At least one process value is simulated	BOOL	0
MST_04	1 = "Local mode"	BOOL	0
MST_05	1 = Maintenance requirement	BOOL	0
MST_06	1 = Maintenance request	BOOL	0
MST_07	1 = Maintenance alarm	BOOL	0
MST_08	1 = Unknown	BOOL	0
MST_09	1 = Configuration changed	BOOL	0

See also

- MSTIn block diagram (Page 2258)
- MSTIn messaging (Page 2257)
- MSTIn error handling (Page 2256)
- MSTIn functions (Page 2256)
- MSTIn modes (Page 2256)
- Description of MSTIn (Page 2255)

17.10.7 MSTIn block diagram

MSTIn block diagram

A block diagram is not provided for this block.

See also

- MSTIn I/Os (Page 2257)
- MSTIn messaging (Page 2257)
- MSTIn error handling (Page 2256)
- MSTIn functions (Page 2256)
- MSTIn modes (Page 2256)
- Description of MSTIn (Page 2255)

17.11 MSTOu - Merging individual status displays into a maintenance status

17.11.1 Description of MSTOu

Object name (type + number) and family

Type + number: FB 1859

Family: Convert

Area of application for MSTOu

The block is used for the following applications:

- Merging individual status displays into a maintenance status

How it works

The block merges individual status displays into a maintenance status. If several status displays are set, the status display with the highest number becomes effective.

If status display `MST_03 = 1` is set, for example, this is indicated at output parameter `Out` with the value `16#00000003`.

If no status display is set, the `Out = 16#00` maintenance status is set.

Configuration

Use the CFC editor to install the block in any OB.

Startup characteristics

The block does not have any startup characteristics.

Status word allocation for `status` parameter

This block does not have the `Status` parameter.

See also

MSTOu block diagram (Page 2262)

MSTOu I/Os (Page 2261)

MSTOu messaging (Page 2261)

MSTOu error handling (Page 2260)

MSTOu functions (Page 2260)

MSTOu modes (Page 2260)

17.11.2 MSTOu modes

MSTOu modes

This block does not have any modes.

See also

MSTOu block diagram (Page 2262)

MSTOu I/Os (Page 2261)

MSTOu messaging (Page 2261)

MSTOu error handling (Page 2260)

MSTOu functions (Page 2260)

Description of MSTOu (Page 2259)

17.11.3 MSTOu functions

Functions of MSTOu

There are no other functions for this block.

See also

MSTOu block diagram (Page 2262)

MSTOu I/Os (Page 2261)

MSTOu messaging (Page 2261)

MSTOu error handling (Page 2260)

MSTOu modes (Page 2260)

Description of MSTOu (Page 2259)

17.11.4 MSTOu error handling

MSTOu error handling

The block does not report any errors.

See also

MSTOu block diagram (Page 2262)

MSTOu I/Os (Page 2261)

MSTOu messaging (Page 2261)

MSTOu functions (Page 2260)

MSTOu modes (Page 2260)

Description of MSTOu (Page 2259)

17.11.5 MSTOu messaging**Messaging**

This block does not offer messaging.

See also

MSTOu block diagram (Page 2262)

MSTOu I/Os (Page 2261)

MSTOu error handling (Page 2260)

MSTOu functions (Page 2260)

MSTOu modes (Page 2260)

Description of MSTOu (Page 2259)

17.11.6 MSTOu I/Os**MSTOu I/Os****Input parameters**

Parameter	Description	Type	Default
EN	1 = Called block will be processed	BOOL	1
MST_00	1 = Good	BOOL	0
MST_01	1 = Passivated	BOOL	0
MST_02	1 = "Out of service"	BOOL	0
MST_03	1 = At least one process value is simulated	BOOL	0
MST_04	1 = "Local mode"	BOOL	0
MST_05	1 = Maintenance requirement	BOOL	0

17.11 MSTOu - Merging individual status displays into a maintenance status

Parameter	Description	Type	Default
MST_06	1 = Maintenance request	BOOL	0
MST_07	1 = Maintenance alarm	BOOL	0
MST_08	1 = Unknown	BOOL	0
MST_09	1 = Configuration changed	BOOL	0

Output parameters

Parameter	Description	Type	Default
ENO	1 = Block algorithm completed without errors	BOOL	0
Out	Maintenance status	DWORD	16#00000000

See also

- MSTOu block diagram (Page 2262)
- MSTOu messaging (Page 2261)
- MSTOu error handling (Page 2260)
- MSTOu functions (Page 2260)
- MSTOu modes (Page 2260)
- Description of MSTOu (Page 2259)

17.11.7 MSTOu block diagram

MSTOu block diagram

A block diagram is not provided for this block.

See also

- MSTOu I/Os (Page 2261)
- MSTOu messaging (Page 2261)
- MSTOu error handling (Page 2260)
- MSTOu functions (Page 2260)
- MSTOu modes (Page 2260)
- Description of MSTOu (Page 2259)

17.12 RealToDw - Converting REAL to DWORD

17.12.1 Description of RealToDw

Object name (type + number) and family

Type + number: FC 390

Family: Convert

Area of application for RealToDw

The block is used for the following applications:

- Converting a REAL number to a double word (DWORD)

Note

Converts the value of a REAL number into a double word (DWORD). You must use the R_DW block (CFC fundamental blocks) to convert the bit character string.

How it works

With a REAL number between 0 and 4.294967e09 at input `In`, the value is applied and output as a DWORD at the output `Out`.

Note

The floating-point numbers in STEP 7 are accurate to 6 decimal places. You can therefore specify a maximum of 6 decimal places for floating-point constants.

If `In` is outside these limits, the error number 30 is output at the `ErrorNum` output and the `Out` is set to these limits.

Configuration

Use the CFC editor to install the block in any OB.

Startup characteristics

The block does not have any startup characteristics.

Status word allocation for Status parameter

This block does not have the `Status` parameter.

17.12.2 RealToDw modes

Operating modes of RealToDw

This block does not have any modes.

17.12.3 RealToDw functions

Functions of RealToDw

There are no other functions for this block.

17.12.4 RealToDw error handling

Error handling of RealToDw

Refer to the section Error handling (Page 119) in the basic instructions for the error handling of all blocks.

The following errors can be displayed for this block:

- Error numbers

Overview of error numbers

The `ErrorNum` I/O can be used to output the following error numbers:

Error number	Meaning of the error number
-1	Predefined value when inserting the block; block is not processed
0	There is no error.
30	In cannot be displayed in DWORD format

17.12.5 RealToDw messaging

Messaging

This block does not offer messaging.

17.12.6 RealToDw I/Os

I/Os of RealToDw

Input parameters

Parameter	Description	Type	Default
In	Analog input value	REAL	0

Output parameters

Parameter	Description	Type	Default
ErrorNum	Error number	INT	-1
Out	Converted output value	DWORD	0
ST	Status	BYTE	16#80

17.12.7 RealToDw block diagram

Block diagram of RealToDw

A block diagram is not provided for this block.

17.13 StateMap - Conversion of other signal states into APL signal states

17.13.1 Description of StateMap

Object name (type + number)

Type + number: FC 383

Family: Convert

Area of application of StateMap

This block can map other signal states in an APL signal states.

How it works

This block converts the following signal states into APL signal states.

State	ST_In	ST_Out
Valid value	16#80	16#80
Manipulated value (for example, substitute value, simulation, last valid value)	16#60	16#60
Substitute value	16#48	16#60
Last valid value	16#44	16#60
Uncertain, device related	16#68	16#68
Uncertain, process related	16#78	16#78
Unknown, device related, range violation	16#54	16#68
Maintenance request	16#A4	16#A4
Invalid value (-STOP)	16#00	16#00
Uncertain, device related	Otherwise	16#68

Configuration

Use the CFC editor to install the block in any OB.

Startup characteristics

The block does not have any startup characteristics.

Status word allocation for Status parameter

This block does not have the Status parameter.

17.13.2 StateMap modes**StateMap modes**

This block does not have any operating modes.

17.13.3 StateMap functions**Functions of StateMap**

There are no other functions for this block.

17.13.4 StateMap error handling**StateMap error handling**

This block does not have any error handling.

17.13.5 StateMap messaging**Messaging**

This block does not offer messaging.

17.13.6 StateMap I/Os**I/Os of StateMap****Input parameters**

Parameter	Meaning	Data type	Default
EN	1 = Called block will be processed	BOOL	1
ST_In	Signal status input	BYTE	16#80

Output parameters

Parameter	Meaning	Data type	Default
ENO	1 = Block algorithm completed without errors	BOOL	0
ST_Out	Signal status output	BYTE	16#80

17.13.7 StateMap block diagram

StateMap block diagram

A block diagram is not provided for this block.

Maintenance blocks

18.1 MuxMST - Determination of the worst maintenance status

18.1.1 Description of MuxMST

Object name (type + number) and family

Type + number: FB 1861

Family: Maint

Area of application for MuxMST

The block is used for the following applications:

- Determination of the worst maintenance status (from a maximum of 10 statuses)

How it works

The block determines the worst of several maintenance states. Each status is made available to the block via interconnection to the `Inx` input parameter ($x = 01 \dots 10$). The states are compared and the highest value written to the `Out` output parameter.

Configuration

Use the CFC editor to install the block in a cyclic interrupt OB (OB30 to OB38).

Startup characteristics

During startup, the `Inx` input parameters ($x = 01 \dots 10$) and output parameter are reset to their defaults.

Status word allocation for `Status` parameter

This block does not have the `Status` parameter.

See also

MuxMST block diagram (Page 2272)

MuxMST I/Os (Page 2272)

MuxMST messaging (Page 2271)

18.1 MuxMST - Determination of the worst maintenance status

MuxMST error handling (Page 2271)

MuxMST functions (Page 2270)

MuxMST modes (Page 2270)

18.1.2 MuxMST modes

MuxMST operating modes

This block does not have any modes.

See also

MuxMST block diagram (Page 2272)

MuxMST I/Os (Page 2272)

MuxMST messaging (Page 2271)

MuxMST error handling (Page 2271)

MuxMST functions (Page 2270)

Description of MuxMST (Page 2269)

18.1.3 MuxMST functions

Functions of MuxMST

This block provides no other functions.

See also

MuxMST block diagram (Page 2272)

MuxMST I/Os (Page 2272)

MuxMST messaging (Page 2271)

MuxMST error handling (Page 2271)

MuxMST modes (Page 2270)

Description of MuxMST (Page 2269)

18.1.4 MuxMST error handling

MuxMST error handling

The block does not report any errors.

See also

MuxMST block diagram (Page 2272)

MuxMST I/Os (Page 2272)

MuxMST messaging (Page 2271)

MuxMST functions (Page 2270)

MuxMST modes (Page 2270)

Description of MuxMST (Page 2269)

18.1.5 MuxMST messaging

Messaging

This block does not offer messaging.

See also

MuxMST block diagram (Page 2272)

MuxMST I/Os (Page 2272)

MuxMST error handling (Page 2271)

MuxMST functions (Page 2270)

MuxMST modes (Page 2270)

Description of MuxMST (Page 2269)

18.1.6 MuxMST I/Os

MuxMST I/Os

Input parameters

Parameter	Description	Type	Default
EN	1 = Called block will be processed	BOOL	1
In01	Input for signal of maintenance status 0	DWORD	16#00000000
In02	Input for signal of maintenance status 1	DWORD	16#00000000
In03	Input for signal of maintenance status 2	DWORD	16#00000000
In04	Input for signal of maintenance status 3	DWORD	16#00000000
In05	Input for signal of maintenance status 4	DWORD	16#00000000
In06	Input for signal of maintenance status 5	DWORD	16#00000000
In07	Input for signal of maintenance status 6	DWORD	16#00000000
In08	Input for signal of maintenance status 7	DWORD	16#00000000
In09	Input for signal of maintenance status 8	DWORD	16#00000000
In10	Input for signal of maintenance status 9	DWORD	16#00000000

Output parameters

Parameter	Description	Type	Default
ENO	1 = Block algorithm completed without errors	BOOL	0
Out	Output signal with the worst signal status	DWORD	16#00000000

See also

- MuxMST block diagram (Page 2272)
- MuxMST messaging (Page 2271)
- MuxMST error handling (Page 2271)
- MuxMST functions (Page 2270)
- MuxMST modes (Page 2270)
- Description of MuxMST (Page 2269)

18.1.7 MuxMST block diagram

MuxMST block diagram

A block diagram is not provided for this block.

See also

- MuxMST I/Os (Page 2272)
- MuxMST messaging (Page 2271)
- MuxMST error handling (Page 2271)
- MuxMST functions (Page 2270)
- MuxMST modes (Page 2270)
- Description of MuxMST (Page 2269)

18.2 MuxST- Determination of the worst signal status

18.2.1 Description of MuxST

Object name (type + number) and family

Type + number: FB 1862

Family: Maint

Area of application for MuxST

The block is used for the following applications:

- Determination of the worst signal status (from a maximum of 10 statuses)

How it works

The block determines the worst of several signal states. Each status is made available to the block via interconnection to the `Inx` input parameter ($x = 1 \dots 10$). The states are compared and the value with the highest priority is written to the `Out` output parameter.

Also refer to the section Forming and outputting the signal status for blocks with configurable status prioritization (Page 114) for information on priorities.

Configuration

Use the CFC editor to install the block in a cyclic interrupt OB (OB30 to OB38).

Startup characteristics

During startup, the `Inx` input parameters ($x = 1 \dots 10$) and output parameter are reset to their defaults.

Status word allocation for `Status1` parameter

This block does not have the `Status` parameter.

See also

MuxST block diagram (Page 2278)

MuxST I/Os (Page 2277)

MuxST messaging (Page 2276)

MuxST error handling (Page 2276)

MuxST functions (Page 2275)

MuxST modes (Page 2275)

18.2.2 MuxST modes

MuxST operating modes

This block does not have any modes.

See also

MuxST block diagram (Page 2278)

MuxST I/Os (Page 2277)

MuxST messaging (Page 2276)

MuxST error handling (Page 2276)

MuxST functions (Page 2275)

Description of MuxST (Page 2274)

18.2.3 MuxST functions

Functions of MuxST

The functions for this block are listed below.

Selecting signals for processing

Using the `SelInput` input parameter, you select the number of interconnectable input parameters to be used for processing in the block. The selected number denotes the input parameters used `In1 ... Inn`.

If, for example, you set this input parameter to `SelInput = 3`, the input parameters `In1`, `In2` and `In3` will be used for processing.

Forming the signal status for blocks

This block provides the standard function Forming and outputting the signal status for blocks with configurable status prioritization (Page 114).

See also

MuxST block diagram (Page 2278)

MuxST I/Os (Page 2277)

18.2 MuxST- Determination of the worst signal status

- MuxST messaging (Page 2276)
- MuxST error handling (Page 2276)
- MuxST modes (Page 2275)
- Description of MuxST (Page 2274)

18.2.4 MuxST error handling

MuxST error handling

The block does not report any errors.

See also

- MuxST block diagram (Page 2278)
- MuxST I/Os (Page 2277)
- MuxST messaging (Page 2276)
- MuxST functions (Page 2275)
- MuxST modes (Page 2275)
- Description of MuxST (Page 2274)

18.2.5 MuxST messaging

Messaging

This block does not offer messaging.

See also

- MuxST block diagram (Page 2278)
- MuxST I/Os (Page 2277)
- MuxST error handling (Page 2276)
- MuxST functions (Page 2275)
- MuxST modes (Page 2275)
- Description of MuxST (Page 2274)

18.2.6 MuxST I/Os

MuxST I/Os

Input parameters

Parameter	Description	Type	Default
EN	1 = Called block will be processed	BOOL	1
In1	Input for signal of signal status 0	BYTE	16#80
In2	Input for signal of signal status 1	BYTE	16#80
In3	Input for signal of signal status 2	BYTE	16#80
In4	Input for signal of signal status 3	BYTE	16#80
In5	Input for signal of signal status 4	BYTE	16#80
In6	Input for signal of signal status 5	BYTE	16#80
In7	Input for signal of signal status 6	BYTE	16#80
In8	Input for signal of signal status 7	BYTE	16#80
In9	Input for signal of signal status 8	BYTE	16#80
In10	Input for signal of signal status 9	BYTE	16#80
SelInput*	Selection of the input parameter for forming the worst signal status	INT	2
SelPrio*	Setting of the prioritization for forming the worst signal status	INT	0

* Values can be written back to these inputs during processing of the block by the block algorithm.

Output parameters

Parameter	Description	Type	Default
ENO	1 = Block algorithm completed without errors	BOOL	0
Out	Output of the worst signal status	BYTE	16#80

See also

MuxST block diagram (Page 2278)

MuxST messaging (Page 2276)

MuxST error handling (Page 2276)

MuxST functions (Page 2275)

MuxST modes (Page 2275)

Description of MuxST (Page 2274)

18.2.7 MuxST block diagram

MuxST block diagram

A block diagram is not provided for this block.

See also

MuxST I/Os (Page 2277)

MuxST messaging (Page 2276)

MuxST error handling (Page 2276)

MuxST functions (Page 2275)

MuxST modes (Page 2275)

Description of MuxST (Page 2274)

18.3 STRep - Status display of block groups

18.3.1 Description of STRep

Object name (type + number) and family

Type + number: FB 1801

Family: MAINT

Area of application of STRep

The STRep block is used for displaying the status of a group of blocks that is designed for hiding messages automatically.

How it works

The block has 32 `STRUCT` type inputs that describe defined states. Depending on which `StateX` input is set, `QSTATE` is output at the INT output. If several `StateX` inputs are set, the most significant is output and the `MPSA` output is set.

The status of the `StateX` inputs does not influence the result at `QSTATE`.

Configuration

Use the CFC editor to install the block in a cyclic interrupt OB (OB30 to OB38). The block is also installed automatically in the startup OB (OB100).

Startup characteristics

The block does not have any startup characteristics.

Status word allocation for `status` parameter

This block does not have the `Status` parameter.

18.3.2 STRep modes

Operating modes of STRep

This block does not have any modes.

18.3 STRep - Status display of block groups

18.3.3 STRep functions

Functions of STRep

There are no other functions for this block.

18.3.4 STRep error handling

Error handling of STRep

The block does not report any errors.

18.3.5 STRep messaging

Messaging

This block does not offer messaging.

18.3.6 STRep I/Os

I/Os of STRep

Input parameters

Parameter	Description	Type	Default
State1 ... State32	Process status 1 ... 32	STRUCT <ul style="list-style-type: none">Value: BOOLST: BYTE	- <ul style="list-style-type: none">016#80
QERR	1 = Error	BOOL	1
QSTATE	Process status	INT	0

Output parameters

Parameter	Description	Type	Default
MPSA	1 = More than one process status is active	STRUCT <ul style="list-style-type: none">• Value: BOOL• ST: BYTE	- <ul style="list-style-type: none">• 1• 16#80
QSTATE	Process status of the type INT 0...32	INT	0

18.3.7 STRep block diagram**Block diagram of STRep**

A block diagram is not provided for this block.

18.4 AssetM - Process variable monitoring for violation of limits

18.4.1 Description of AssetM

Object name (type + number) and family

Type and number: FB 1840

Family: Maint

Area of application of AssetM

The block is used for the following applications:

Monitoring of up to 3 analog process variables for exceeding 3 limits respectively. It reports the maintenance status of the process variables:

- When overshooting a limit
- Via the device-based signal status or
- Via binary message inputs

How it works

The block monitors up to 3 inputs for high and low violations of three limits respectively. Upon reaching or exceeding a limit, the respective output is set and a corresponding message is generated.

The three process variables are equivalent for limit monitoring as long as the overshoot of a limit (e.g. maintenance request) is reported by one process variable. A new message will only be created again if all process variables have undershot this limit at least for one cycle.

The monitoring of individual limits can be deactivated.

In addition to limit monitoring, the signal status of the individual process variables is also analyzed. The device-specific signal status of a process value triggers the corresponding message that is also used by the limit monitoring.

Configuration

In the CFC editor, install the block in a cyclic interrupt OB (e.g. OB32). The block is also installed automatically in the startup OB (OB 100).

Startup characteristics

The messages are suppressed after startup for the number of cycles set at `RunUpCyc`.

Status word allocation for `Status` parameter

This block does not have the `Status` parameter.

Binary message inputs

Message1	Bad, maintenance alarm	Message (S) requires acknowledgement
Message2	Uncertain, maintenance request	Message (F) requires acknowledgement
Message3	Good, maintenance required	Message (M) requires acknowledgement
Message4	Bad, local operation/functional check	Message (S) requires acknowledgement
Message5	Uncertain, simulation	Message (SA) does not require acknowledgement
Message6	Bad, device out of service	Message (SA) does not require acknowledgement
Message7	bad, passivated	Message (SA) does not require acknowledgement

For each PVx, there is an input (PVx_Rst) and an output (P_PVx_Rst) that can be used to reset a technologic block.

The statuses are created with ALARM_8P for messages requiring acknowledgment and with NOTIFY_8P for those not requiring acknowledgment. The message function can be disabled by setting `MsgLock = 0`. In this case, `MS = 8` is set.

The detailed diagnostics is shown in the diagnostic view of the faceplate via the inputs `Diag1` to `Diag16`.

If one of the inputs is set to 1, then the status display is shown in front of the corresponding text.

The texts for the relevant inputs `Diag1` to `Diag16` are entered in the parameter data of the EDD for the relevant instance (see also section PLT ID).

If one of the inputs `Diag1` to `Diag16` is set to 1, the explanatory text "Additional status available" is output if an internal interrupt is triggered through `PV0`, `PV1` or `PV2`.

PLT-ID

The PLT-ID is a connection parameter between a PDM object (parameter data EDD) and the faceplate in the maintenance station. The PLT-ID is linked to the PDM object.

The PDM object is generated in the SIMATIC Manager as follows:

1. Select **View > Process Device Plant View** in SIMATIC Manager.
2. In SIMATIC PDM, select a project in which you want to insert the AssetM block.
3. Select **File > New object**.
4. Right-click the inserted tag object and select **Device selection (Reassign)...** from the context menu.
5. In the tree structure **Devices > DATA_OBJECTS > CFC >**, select AssetMon and click **OK**.
6. Right-click the tag object and select **Open object** from the context menu, and then enter all necessary data in the parameter assignment screen form.
7. Select **File > Save** and close the parameter assignment screen form.

You can then assign parameters for the generated PLT-ID at the associated parameter "PLT_ID".

Note

The PLT-IDs cannot be changed or deleted individually.

Creating the maintenance status (MS)

MS depends on:

- From the signal status of the signals PV0, PV1 and PV2
- from the binary message inputs (external MS)
- from the interconnectable input MS_In (external maintenance state)
- The interconnectable input STATUS. The process-related errors have no effect; only the device-based errors have an effect.

Of all these events the highest priority event will be displayed in the MS.

The 16 Diagx binary inputs do not have any influence on the MS; they are used only for visualization of the detail diagnostics in the diagnostics view of the faceplate.

Note

The table is valid exclusively for the MS and not for the signal status displays of the individual process values; these are created exclusively by the ST parameters.

The priority is similar to the MS coding. Therefore, the following applies: The greater the value of the MS, the higher the priority.

PVx.Value	PVx.ST	MS_In	Event	STATUS	Messa-gex.Value	O_MS
-	-	9	Configuration change	16#84 .. 87	-	9
-	-	8	Untested/unknown	-	-	8
PVx.Value >= PVx_AH	16#00	7	bad, maintenance alarm	16#00 .. 1B, 16#24 .. 27, 16#44 .. 4B	x = 1	7
PVx_AH > PVx.Value >= PVx_DH	16#68	6	uncertain, maintenance request	16#40 .. 43, 16#50 .. 5F, 16#64 .. 6B, 16#A8 .. AB	x = 2	6
PVx_DH > PVx.Value >= PVx_RH	16#A4	5	good, maintenance required	16#A4 .. A7	x = 3	5
-	-	4	bad, local operation/functional check	16#3C .. 3F	x = 4	4
-	16#60	3	Uncertain, manipulated value (for example, substitute value, simulation, last valid value)	16#60 .. 63, 16#70 .. 73	x = 5	3

PVx.Value	PVx.ST	MS_In	Event	STATUS	Messa- gex.Value	O_MS
-	-	2	bad, device out of service	16#1C .. 1F	x = 6	2
-	-	1	bad, passivated	16#23	x = 7	1
PVx_RH > PVx.Value	16#28, 16#78	0	process-related fault	16#28 .. 2B, 16#78 .. 7B, 16#A0 .. A3	-	

18.4.2 AssetM modes

Operating modes of AssetM

This block does not have any modes.

18.4.3 AssetM functions

Functions of AssetM

The functions for this block are listed below.

Configurable reactions using the `Feature` parameter

You can find an overview of all reactions provided by the `Feature` parameter in the Configurable functions using the Feature I/O (Page 131) section. The following functionality is available for this block at the relevant bits:

Bit	Function
22	Update acknowledgment and error status of the message call (Page 160)
28	Disabling operating points (Page 145)

Forming the signal status for blocks

This block provides the standard function Forming and outputting the signal status for interlock blocks (Page 115).

The worst signal status `ST_Worst` for the block is formed from the following parameters:

- `PV0.ST`
- `PV1.ST`
- `PV2.ST`

18.4.4 AssetM error handling

Error handling of AssetM

Refer to the section Error handling (Page 119) in the basic instructions for the error handling of all blocks.

The following errors can be displayed for this block:

- Error numbers

Overview of error numbers

The `ErrorNum` I/O can be used to output the following error numbers:

Error number	Meaning of the error number
-1	Predefined value when inserting the block; block is not processed
0	There is no error.

18.4.5 AssetM messages

Messaging

The following messages can be generated for this block:

- Process control fault
- Process messages

Process control fault

Message instance	Message identifier	Message class	Event
MsgEvId1	SIG 1	AS process control message - fault	Maintenance alarm @4W%t#AssetM_TXT@
	SIG 2	AS process control message - error	Maintenance demanded @4W%t#AssetM_TXT@
	SIG 3	Preventive maintenance - General	Maintenance required @4W%t#AssetM_TXT@
	SIG 4	Reserved	
	SIG 5	Reserved	
	SIG 6	Reserved	
	SIG 7	AS process control message - fault	Device out of service
	SIG 8	Reserved	

Process messages

Message instance	Message identifier	Message class	Event
MsgEvId2	1	Status AS	Passivated
	2	Reserved	
	3	Status AS	Manipulated value (for example, substitute value, simulation, last valid value)
	4	Status AS	Manipulated value (for example, substitute value, simulation, last valid value)
	5	Status AS	Configuration change
	6	Status AS	Process-related fault
	7	Reserved	
	8	Reserved	

Associated values

Message block	Associated value	Meaning
ALARM 8P		
MsgEvId1	4	Text number from AssetM_TXT

System text library AssetM

Index	Text
1	Further status available
2	No further status available

18.4.6 AssetM I/Os**I/Os of AssetM**

Input parameters

I/O (parameter)	Meaning	Type	Default
Diagx	Asset detail diagnosis (x = 1 to 16)	STRUCT • Value: BOOL • ST: BYTE	- • 0 • 16#80
Feature	I/O for additional functions (Page 2285)	STRUCT • Bit 0: BOOL • ... • Bit 31: BOOL	- • 0 • 0 • 0
Message1	1 = message: bad, maintenance alarm	BOOL	0
Message2	1 = message: uncertain, maintenance request	BOOL	0
Message3	1 = message: good, maintenance required	BOOL	0
Message4	1 = message: bad, local operation/functional check	BOOL	0
Message5	1 = message: uncertain, simulation	BOOL	0
Message6	1 = message: bad, out of service	BOOL	0
Message7	1 = message: passivated	BOOL	0
MS*	Maintenance status	DWORD	16#000000 00
MsgEvId1	Message event ID 1	DWORD	16#000000 24
MsgEvId2	Message event ID 2	DWORD	16#000000 25
MsgLock	1 = Suppress process messages. Refer also to the Suppressing messages using the MsgLock parameter (Page 205) chapter for more on this.	STRUCT • Value: BOOL • ST: BYTE	- • 0 • 16#80
MS_Release	Release for maintenance	STRUCT • Value: BOOL • ST: BYTE	- • 0 • 16#80
Ms_In	External interconnectable MS	DWORD	16#000000 00
PLT_ID	Asset ID of EDD	DWORD	16#000000 00
PV_Hyst	PV_Hysteresis for messages	REAL	5.0
PVx_AH	Limit PVx (x=0, 1, 2) maintenance alarm	REAL	100.0
PVx_AH_EN	1 = suppress monitoring of the limit PVx (x = 0, 1, 2), maintenance alarm exceeded	BOOL	0
PVx_DH	Limit PVx (x = 0, 1, 2) maintenance request	REAL	100.0
PVx_DH_EN	1 = suppress monitoring of the limit PVx (x = 0, 1, 2), maintenance request exceeded	BOOL	0
PVx_RH	Limit PVx (x = 0, 1, 2) maintenance required	REAL	100.0
PVx_RH_EN	1 = suppress monitoring of the limit PVx (x = 0, 1, 2), maintenance required exceeded	BOOL	0

I/O (parameter)	Meaning	Type	Default
PVx	Process value PVx (x = 0, 1, 2)	STRUCT • Value: REAL • ST: BYTE	- • 0.0 • 16#80
PVx_Rst*	1 = Reset PVx (x = 0, 1, 2)	BOOL	0
PVxUnit	Unit of the process value	INT	0
RunUpCyc	Number of run-up cycles	INT	3
Status	External status	BYTE	16#80

* Values can be written back to these inputs during processing of the block by the block algorithm.

Output parameters

I/O (parameter)	Meaning	Type	Default
ErrorNum	Program error	INT	-1
MsgAckn1	Message recognized	WORD	16#0000
MsgErrx	Message errors occurred (x = 1, 2)	WORD	16#0000
MsgStatx	Message error information (x = 1, 2)	WORD	16#0000
O_MS	Maintenance status	DWORD	16#000000 00
PVx_Diff	Differential value to the next expected alarm (x = 0, 1, 2)	STRUCT • Value: REAL • ST: BYTE	- • 0.0 • 16#80
PVx_AH_AcT	1 = Limit PVx (x = 0, 1, 2), maintenance alarm exceeded	BOOL	0
PVx_DH_AcT	1 = Limit PVx (x = 0, 1, 2), maintenance required exceeded	BOOL	0
PVx_RH_AcT	1 = Limit PVx (x = 0, 1, 2), maintenance request exceeded	BOOL	0
P_PVx_Rst	1 = Reset PVx (x = 0, 1, 2)	STRUCT • Value: BOOL • ST: BYTE	- • 0 • 16#80
ST_Worst	Worst signal status of the inputs PVx (x = 0, 1, 2)	BYTE	16#80

See also

AssetM functions (Page 2285)

18.4.7 AssetM block diagram

Block diagram of ASSETM

A block diagram is not provided for this block.

System blocks

19.1 AddInt64 - Addition of two 64-bit integer variables

19.1.1 Description of AddInt64

Object name (type + number) and family

Type + number: FC 353

Family: System

Area of application for AddInt64

The block is used for the following applications:

- Addition of two 64-bit integer variables

This block is used by the PIDConR block for calculations that are twice as accurate (64-bit number format).

Therefore this block will not be described in detail.

19.2 AddR64 - Addition of two 64-bit REAL variables

19.2.1 Description of AddR64

Object name (type + number) and family

Type + number: FC 354

Family: System

Area of application for AddR64

The block is used for the following applications:

- Addition of two 64-bit REAL variables

This block is used by the PIDConR block for calculations that are twice as accurate (64-bit number format).

Therefore this block will not be described in detail.

19.3 DiToInt64 - Converting from DINT to Int64

19.3.1 Description of DiToInt64

Object name (type + number) and family

Type + number: FC 357

Family: System

Area of application for DiToInt64

The block is used for the following applications:

- Converting from DINT to Int64

This block is used by the PIDConR block for calculations that are twice as accurate (64-bit number format).

Therefore this block will not be described in detail.

19.4 Int64ToDi - Converting from Int64 to DINT

19.4.1 Description of Int64ToDi

Object name (type + number) and family

Type + number: FC 359

Family: System

Area of application for Int64ToDi

The block is used for the following application:

- Converting from Int64 to DINT

This block will not be described in detail.

19.5 MemR256 - Increasing the number of internal previous values

19.5.1 Description of MemR256

Object name (type + number)

Object name (type + number) and family

Type and number: FB 1930

Family: System

Area of application

The block is used for the following applications:

- Increasing the internal previous values in the MeanTime block.

Therefore this block will not be described in detail.

19.6 NegInt64 - Negation of an Int64 variable

19.6.1 Description of NegInt64

Object name (type + number) and family

Type + number: FC 362

Family: System

Area of application for NegInt64

The block is used for the following applications:

- Negation of an Int64-variable

This block is used by the PIDConR block for calculations that are twice as accurate (64-bit number format).

Therefore this block will not be described in detail.

19.7 NegR64 - Negation of a Real64 variable

19.7.1 Description of NegR64

Object name (type + number) and family

Type + number: FC 363

Family: System

Area of application for NegR64

The block is used for the following application:

- Negation of an Real64-variable

This block will not be described in detail.

19.8 PIDCoefR - Calculation of coefficients

19.8.1 Description of PIDCoefR

Object name (type + number) and family

Type + number: FC 366

Family: System

Area of application for PIDCoefR

The block is used for the following applications:

- Calculation of coefficients of discrete-time difference equations for PIDConR from the continuous-time input parameters (e.g. T_I , T_D)

This block is used by the PIDConR block for calculations that are twice as accurate (64-bit number format).

Therefore this block will not be described in detail.

19.9 R64ToReal - Converting Real64 to REAL

19.9.1 Description of R64ToReal

Object name (type + number) and family

Type + number: FC 367

Family: System

Area of application for R64ToReal

The block is used for the following applications:

- Converting from Real64 to REAL (32 Bit)

This block is used by the PIDConR block for calculations that are twice as accurate (64-bit number format).

Therefore this block will not be described in detail.

19.10 RealToR64 - Converting REAL to Real64

19.10.1 Description of RealToR64

Object name (type + number) and family

Type + number: FC 368

Family: System

Area of application for RealToR64

The block is used for the following applications:

- Converting from REAL (32 Bit) to Real64

This block is used by the PIDConR block for calculations that are twice as accurate (64-bit number format).

Therefore this block will not be described in detail.

19.11 SelST16 - Output of the best or worst signal status

19.11.1 Description of SelST16

Object name (type + number) and family

Type and number: FC 369

Family: System

Area of application for SelST16

The block is used for the following applications:

- Output the best or worst signal status

This block is used by technologic blocks which edit and output a signal status.

Therefore this block will not be described in detail.

19.12 ShLeInt64 - Left shift of an Int64 variable

19.12.1 Description of ShLeInt64

Object name (type + number) and family

Type + number: FC 370

Family: System

Area of application for ShLeInt64

The block is used for the following applications:

- Left shift of a (positive) Int64- variable

This block is used by the PIDConR block for calculations that are twice as accurate (64-bit number format).

Therefore this block will not be described in detail.

19.13 ShRiInt64 - Right shift of an Int64 variable

19.13.1 Description of ShRiInt64

Object name (type + number) and family

Type + number: FC 371

Family: System

Area of application for ShRiInt64

The block is used for the following applications:

- Right shift of a (positive) Int64- variable

This block is used by the PIDConR block for calculations that are twice as accurate (64-bit number format).

Therefore this block will not be described in detail.

19.14 PIDKernR - Calculation of the manipulated variable

19.14.1 Description of PIDKernR

Object name (type + number) and family

Type and number: FB 1877

Family: System

Area of application for PIDKernR

The block is used for the following applications:

- Calculation of the manipulated variable in PIDConR

This block is used by the PIDConR block for calculations that are twice as accurate (64-bit number format).

Therefore this block will not be described in detail.

Communication blocks

20.1 Snd_DigVal - Send Boolean values including quality code (Snd_DigVal)

20.1.1 Description of Snd_DigVal

Object name (type + number) and family

Type + number: FB 1891

Family: COMM

Area of application for Snd_DigVal

The "Snd_DigVal" block represents a simple user interface to SFB 12 "BSEND". The "Snd_DigVal" block sends 128 DigVal structures via an MPI, PROFIBUS or Industrial Ethernet connection to another CPU. This CPU calls the function block "Rcv_DigVal" (FB 1892) of the PCS 7 Advanced Process Library to receive the data.

How it works

Data transfer is initiated by calling the block with the value 1 at the `SendEn` control input. While data is being sent, `SendAct` is set to 1.

If the job is completed without errors, `SendDone` is set to 1. `SendErr` = 1 if an error occurs. A new job is then automatically triggered with the current data until all data have been successfully sent.

If input `SendEn` = 0, incomplete sending is canceled. No further sending takes place afterward (`SendAct` = 0).

The ID parameter is the connection number specified in the connection configuration. and is applied only at the first call after a cold restart.

20.1 Snd_DigVal - Send Boolean values including quality code (Snd_DigVal)

The parameter R_ID is a random number. The R_ID parameter must be identical at the corresponding send and receive blocks. The R_ID parameter is applied only for the first call after a warm restart.

Note

Error code or message at the data block

When configuring a block pair for data transmission from an SND_AnaVal block to an RCV_AnaVal block, make sure that the settings for ID/R-ID are unique throughout the project.

Only one Rcv block may be assigned to each Snd block or only one connection via ID/R-ID may be configured.

Make sure that you perform the engineering clean and correctly because the data may otherwise be transferred to several blocks or an incorrect block.

Configuration

The block is installed in the CFC editor in a cyclic interrupt OB (OB30 to OB38).

Startup characteristics

The block does not have any startup characteristics.

Time characteristics

The block does not have any time response.

Status word allocation for status parameter

This block does not have the Status parameter.

20.1.2 Snd_DigVal modes

This block has no operating mode.

20.1.3 Snd_DigVal functions

Configurable reactions using the Feature parameter.

An overview of all the reactions that are provided by the Feature parameter is available in the section Configurable functions using the Feature I/O (Page 131).

The following functionality is available for this block at the relevant bits:

- Bit 29: Output substitute values if raw value is invalid

20.1.4 Snd_DigVal error handling

Error handling of the block is restricted to the error information of the lower-level SFB 12 "BSEND".

The bits of information are set at the `SendErr (ERR)` and `SendStat (STAT)` parameters.

If an error occurs, a new job is automatically triggered with the current data until all data have been successfully transferred.

20.1.5 Snd_DigVal messages

No message behavior is applicable to this block.

20.1.6 Snd_DigVal I/Os

Input parameters

Parameter	Description	Type	Default
EN	1 = Called block will be processed	BOOL	1
ID	ID of physical connection	WORD	16#0000
R_ID	ID of message frame connection	DWORD	16#00000000
SndEn	1 = Activate continuous sending	BOOL	1
PV_In0 ... PV_In127	Input_0 ... Input_127	STRUCT	-
		<ul style="list-style-type: none"> • Value: BOOL • ST: BYTE 	<ul style="list-style-type: none"> • 0 • 16#80

Output parameters

Parameter	Description	Type	Default
ENO	1 = Block algorithm completed without errors	BOOL	0
SndAct	1 = Command is active	BOOL	0
SndDone	1 = Command is executed	BOOL	0
SndErr	1 = Command is executed with error	BOOL	0
SndStat	Type of error	WORD	16#0000

20.1.7 Snd_DigVal block diagram

A block diagram is not provided for this block.

20.2 Rcv_DigVal - Receive Boolean values including quality code (Rcv_DigVal)

20.2.1 Description of Rcv_DigVal

Object name (type + number) and family

Type + number: FB 1892

Family: COMM

Area of application for Rcv_DigVal

The "Rcv_DigVal I" block represents a simple user interface to SFB 13 "BRCV". The block receives 128 DigVal structures via MPI, PROFIBUS or Industrial Ethernet connection to another CPU. This CPU must call the function block "Snd_DigVal" (FB 1891) of the PCS 7 Advanced Process Library to send the data.

In STEP 7, a uniform connection must be configured for both communication partners and transferred to the AS.

How it works

Data are entered in the data block asynchronously to user-program execution. After "Rcv_DigVal" has been called, instance DB data may not be processed as long as the job is in progress (`RcvNewData = 0`). If the job is completed without errors, the `RcvNewData` output is set to 1 for one cycle. In the next cycle, the receive enable is automatically sent by the FB to the operating system of the CPU.

The receive enable can take effect prior to the arrival of the first receive job. In this case, the receive enable is stored by the operating system.

The `ID` parameter is the connection number specified in the connection configuration. and is applied only at the first call after a cold restart.

The parameter `R_ID` is a random number. The `R_ID` parameter must be identical at the corresponding send and receive blocks. The `R_ID` parameter is applied only for the first call after a warm restart.

20.2 Rcv_DigVal - Receive Boolean values including quality code (Rcv_DigVal)

Call the "Rcv_DigVal" block for the ID/R_ID pair in each program cycle (cyclically or also via timeout alarm). Each message frame requires two calls of "Rcv_DigVal".

Note

Error code or message at the data block

When configuring a block pair for data transmission from an SND_AnaVal block to an RCV_AnaVal block, make sure that the settings for ID/R-ID are unique throughout the project.

Only one Rcv block may be assigned to each Snd block or only one connection via ID/R-ID may be configured.

Make sure that you perform the engineering clean and correctly because the data may otherwise be transferred to several blocks or an incorrect block.

The outputs `RcvErr` (Error) and `RcvStat` (Status) show the specific error information that correspond to SFB 13 "BRCV".

If an error occurs, use an appropriate substitute strategy with `Feature` (bit 29/30).

If you want to simulate the block, enable simulation via the `SimOn` input. In this case, the values from the inputs `SimPVX` are written to the outputs `PV_Outx`. The data sent are not applied, since data reception is switched off.

Configuration

The block is installed in the CFC editor in a cyclic interrupt OB (OB30 to OB38).

Startup characteristics

The block does not have any startup characteristics.

Time characteristics

The block does not have any time response.

Status word allocation for `Status` parameter

This block does not have the `Status` parameter.

20.2.2 Rcv_DigVal modes

This block has no operating mode.

20.2.3 Rcv_DigVal functions

Configurable reactions using the Feature parameter

An overview of all the reactions that are provided by the `Feature` parameter is available in the section Configurable functions using the Feature I/O (Page 131).

The following functionality is available for this block at the relevant bits:

- Bit 29: Output substitute values if raw value is invalid

20.2.4 Rcv_DigVal error handling

Error handling of the "Rcv_DigVal" block is restricted to the error information of the lower-level SFB 13 "BRCV".

You can find additional information in the manual "*System Software for S7-300/400 - System and Standard Functions*".

In the manual "*System Software for S7-300/400 - System and Standard Functions*", you can also find a description of the `RcvErr` and `RcvStat` outputs

The substitute value is output when bit 29 is set in the `Feature` structure and no new data is received after the expiration of "RcvMonCyc" (number of cycles). While the "REC_MON" cycles are running, the last received values are applied to the output.

If Bit29 is not set in the `Feature` structure and an error occurs, the last valid values are always applied to the output.

20.2.5 Rcv_DigVal messages

No message behavior is applicable to this block.

20.2.6 Rcv_DigVal I/Os

Input parameters

Parameter	Description	Type	Default
EN	1 = Called block will be processed	BOOL	1
ID	ID of physical connection	WORD	16#0000
R_ID	ID of message frame connection	DWORD	16#00000000
RcvMonCyc	Number of cycles for receiving monitoring error	INT	3

20.2 Rcv_DigVal - Receive Boolean values including quality code (Rcv_DigVal)

Parameter	Description	Type	Default
SimOn	1= simulation active	STRUCT <ul style="list-style-type: none"> Value: BOOL ST: BYTE 	- <ul style="list-style-type: none"> 0 16#80
SimPV0 ... SimPV127	Simulation value	BOOL	0
SubsPV1 ... SubsPV127	Substitute value	BOOL	0
Feature	I/O for additional functions (Page 2310)	STRUCT	-
	Reserved	<ul style="list-style-type: none"> Bit0 ... Bit28: BOOL 	<ul style="list-style-type: none"> 0
	1 = substitute value	<ul style="list-style-type: none"> Bit29: BOOL 	<ul style="list-style-type: none"> 0
	Reserved	<ul style="list-style-type: none"> Bit30 ... Bit31: BOOL 	<ul style="list-style-type: none"> 0

Output parameters

Parameter	Description	Type	Default
ENO	1 = Block algorithm completed without errors	BOOL	0
PV_Out0 ... PVOut127	Output_00 ... Output_07	STRUCT <ul style="list-style-type: none"> Value: BOOL ST: BYTE 	- <ul style="list-style-type: none"> 0 16#80
SimAct	1= simulation active	STRUCT <ul style="list-style-type: none"> Value: BOOL ST: BYTE 	- <ul style="list-style-type: none"> 0 16#80
RcvMonErr	1 = no data received	BOOL	0
RcvNewData	1 = no data received	BOOL	0
RcvErr	1 = Command is executed with error	BOOI	0
RcvStat	Type of error	WORD	16#0000

20.2.7 Rcv_DigVal block diagram

A block diagram is not provided for this block.

20.3 Snd_AnaVal - Send analog values including quality code (SND_AnaVal)

20.3.1 Description of Snd_AnaVal

Object name (type + number) and family

Type + number: FB 1893

Family: COMM

Area of application for Snd_AnaVal

The "Snd_AnaVal" block represents a simple user interface to SFB 12 "BSEND". The "Snd_AnaVal" block sends 32 analog structures via an MPI, PROFIBUS or Industrial Ethernet connection to another CPU. The other CPU calls the function module "Rcv_AnaVal" (FB 1894) of the PCS 7 Advanced Process Library to receive the data.

How it works

Data transfer is initiated by calling the block with the value 1 at the `SendEn` control input. The data are sent according to the settings `CycMin`, `CycMax` or `PV_In_HysXX`. While data is being sent, `SendAct` is set to 1. If the job is completed without errors, `SendDone` is set to 1. `SendErr` = 1 if an error occurs. A new job is then automatically sent with the current data until all data have been successfully transferred.

The ID parameter is the connection number specified in the connection configuration. and is applied only at the first call after a cold restart.

The parameter `R_ID` is a random number. The `R_ID` parameter must be identical at the corresponding send and receive blocks. The `R_ID` parameter is applied only for the first call after a warm restart.

Note

Error code or message at the data block

When configuring a block pair for data transmission from an `SND_AnaVal` block to an `RCV_AnaVal` block, make sure that the settings for ID/R-ID are unique throughout the project.

Only one `Rcv` block may be assigned to each `Snd` block or only one connection via ID/R-ID may be configured.

Make sure that you perform the engineering clean and correctly because the data may otherwise be transferred to several blocks or an incorrect block.

If input `SendEn` = 0, incomplete sending is canceled. No further sending takes place afterward; `SendAct` = 0.

You can use `CycMIN` to set the number of cycles to wait before triggering the transfer of the current input data, regardless of any changes to one or more values.

20.3 Snd_AnaVal - Send analog values including quality code (SND_AnaVal)

You can use `CycMAX` to specify how many cycles after the last valid data transfer to wait before sending the current input data. Sending is executed even when no value has changed or when the changes of a REAL value are within the hysteresis `PV_In_HysXX`.

The default hysteresis value is `PV_In_HysXX = 0`. If sending is not performed after each change, then configure the `PV_In_HysXX` input accordingly. This involves an absolute value.

When `CycMax` is reached, transfer is forced after the corresponding number of cycles.

Configuration

The block is installed in the CFC editor in a cyclic interrupt OB (OB30 to OB38).

Startup characteristics

The block does not have any startup characteristics.

Time characteristics

The block does not have any time response.

Status word allocation for `status` parameter

This block does not have the `status` parameter.

20.3.2 Snd_AnaVal modes

This block has no operating mode.

20.3.3 Snd_AnaVal functions

The block has no functions.

20.3.4 Snd_AnaVal error handling

Error handling of the block is restricted to the error information of the lower-level SFB 12 "BSEND".

The information is set at the outputs `SendErr(ERR)` and `SendStat(STAT)`.

If an error occurs, a new job is automatically triggered with the current data until all data have been successfully transferred.

20.3 Snd_AnaVal - Send analog values including quality code (SND_AnaVal)

20.3.5 Snd_AnaVal messages

No message behavior is applicable to this block.

20.3.6 Snd_AnaVal I/Os

Input parameters

Parameter	Description	Type	Default
EN	1 = Called block will be processed	BOOL	1
ID	ID of physical connection	WORD	16#0000
R_ID	ID of message frame connection	DWORD	16#00000000
SndEn	1 = Activate continuous sending	BOOL	1
CylMin	Minimum waiting cycle	INT	1
CylMax	Maximum waiting cycle	INT	10
PV_In_Hys00 ... PV_In_Hys31	EDC-Hysteresis PV_InR_00 ... EDC-Hysteresis PV_InR_31	REAL	0.0
PV_In0 ... PV_In31	Input_0 ... Input_31	STRUCT • Value: REAL • ST: BYTE	- • 0.0 • 16#80

Output parameters

Parameter	Description	Type	Default
ENO	1 = Block algorithm completed without errors	BOOL	0
SndAct	1 = Command is active	BOOL	0
SndDone	1 = Command is executed	BOOL	0
SndErr	1 = Command is executed with error	BOOL	0
SndStat	Type of error	WORD	16#00000

20.3.7 Snd_AnaVal block diagram

A block diagram is not provided for this block.

20.4 Rcv_AnaVal - Receive analog values including quality code (Rcv_AnaVal)

20.4.1 Description of Rcv_AnaVal

Object name (type + number) and family

Type + number: FB 1894

Family: COMM

Area of application for Rcv_AnaVal

The "Rcv_AnaVal" block represents a simple user interface to SFB 12 "BRCV". The block sends 32 analog structures via MPI, PROFIBUS or Industrial Ethernet connection to another CPU. The other CPU calls the function module "Snd_AnaVal" (FB 1893) of the PCS 7 Advanced Process Library to receive the data.

How it works

Data are entered in the data block asynchronously to user-program execution. After "Rcv_AnaVal" has been called, instance DB data may not be processed as long as the job is in progress (`RcvNewData = 0`). If the job is completed without errors, the `RcvNewData` output is set to 1 for one cycle. In the next cycle, the receive enable is automatically sent by the FB to the operating system of the CPU.

The receive enable can take effect prior to the arrival of the first receive job. In this case, the receive enable is stored by the operating system.

The `ID` parameter is the connection number specified in the connection configuration. and is applied only at the first call after a cold restart.

The parameter `R_ID` is a random number. The `R_ID` parameter must be identical at the corresponding send and receive blocks. The `R_ID` parameter is applied only for the first call after a warm restart.

Call the "Rcv_AnaVal" block for the `ID/R_ID` pair in each program cycle (cyclically or also via timeout alarm). Each message frame requires two calls of "Rcv_AnaVal".

Note

Error code or message at the data block

When configuring a block pair for data transmission from an `SND_AnaVal` block to an `RCV_AnaVal` block, make sure that the settings for ID/R-ID are unique throughout the project.

Only one Rcv block may be assigned to each Snd block or only one connection via ID/R-ID may be configured.

Make sure that you perform the engineering clean and correctly because the data may otherwise be transferred to several blocks or an incorrect block.

20.4 Rcv_AnaVal - Receive analog values including quality code (Rcv_AnaVal)

The outputs `RcvErr` (error) and `RcvStat` (status) show the specific error information that correspond to SFB 13 "BRCV".

If an error occurs, use an appropriate substitute strategy with `Feature` bit 29.

If you want to simulate the block, enable simulation via the `SimOn` input. In this case, the values from the inputs `SimPVX` are written to the outputs `PV_Outx`. The data sent are not applied, since data reception is switched off.

Configuration

The block is installed in the CFC editor in a cyclic interrupt OB (OB30 to OB38).

Startup characteristics

The block does not have any startup characteristics.

Time characteristics

The block does not have any time response.

Status word allocation for `status` parameter

This block does not have the `Status` parameter.

20.4.2 Rcv_AnaVal modes

This block has no operating mode.

20.4.3 Rcv_AnaVal functions

Configurable reactions using the `Feature` parameter

An overview of all the reactions that are provided by the `Feature` parameter is available in the section Configurable functions using the `Feature` I/O (Page 131).

The following functionality is available for this block at the relevant bits:

- Bit 29: Output substitute values if raw value is invalid.

20.4.4 Rcv_AnaVal error handling

Error handling of the "Rcv_AnaVal" block is restricted to the error information of the lower-level SFB 13 "BRCV". You can find additional information in the manual System Software for S7-300/400 - System and Standard Functions. There you can find a description for the `RcvErr` and `RcvStat` outputs.

20.4 Rcv_AnaVal - Receive analog values including quality code (Rcv_AnaVal)

The substitute value is output when Bit29 is set in the `Feature` structure and no new data is received after the expiration of `RcvMonCyc` (number of cycles). While the `RcvMonCyc` cycles are running, the last received values are applied to the output.

If Bit29 is not set in the `Feature` structure and an error occurs, the last valid values are always applied to the output.

20.4.5 Rcv_AnaVal messages

No message behavior is applicable to this block.

20.4.6 Rcv_AnaVal I/Os

Input parameters

Parameter	Description	Type	Default
EN	1 = Called block will be processed	BOOL	1
ID	ID of physical connection	WORD	16#0000
R_ID	ID of message frame connection	DWORD	16#00000000
RcvMonCyc	Number of cycles for receiving monitoring error	INT	3
SimOn	1 = Simulation active	STRUCT <ul style="list-style-type: none"> Value: BOOL ST: BYTE 	- <ul style="list-style-type: none"> 0 16#80
SimPV0...SimPV31	Simulation value	REAL	0.0
SubsPV0...SubsPV31	Substitute value	REAL	0.0
Feature	I/O for additional functions (Page 2316) Reserved 1 = substitute value Reserved	STRUCT <ul style="list-style-type: none"> Bit0 ... Bit28: BOOL Bit29: BOOL Bit30 ... 31: BOOL 	- <ul style="list-style-type: none"> 0 0 0

Output parameters

Parameter	Description	Type	Default
ENO	1 = Block algorithm completed without errors	BOOL	0
PV_Out0 ... PV_Out31	Output_0 ... Output_31	STRUCT <ul style="list-style-type: none"> Value: REAL ST: BYTE 	- <ul style="list-style-type: none"> 0.0 16#80

20.4 Rcv_AnaVal - Receive analog values including quality code (Rcv_AnaVal)

Parameter	Description	Type	Default
SimAct	1 = Simulation active	STRUCT <ul style="list-style-type: none">• Value: BOOL• ST: BYTE	- <ul style="list-style-type: none">• 0• 16#80
RcvMonErr	1 = no data received	BOOL	0
RcvNewData	1 = new data received	BOOL	0
RcvErr	1 = Command is executed with error	BOOL	0
RcvStat	Type of error	WORD	16#0000

20.4.7 Rcv_AnaVal block diagram

A block diagram is not provided for this block.

Process tag types (insertible templates)

21.1 Introduction to process tag types

Introduction

You can find control engineering information on the standard process tag types of the Advanced Process Library in a separate section in this help:

- PID controller with safety logic and control loop monitoring (PIDConL_ConPerMon) (Page 2324)
- PIDConR with safety logic and control loop monitoring (PIDConR_ConPerMon) (Page 2325)
- Step controller with direct access to the actuator and without position feedback (StepControlDirect) (Page 2333)
- Step controller with assigned actuator block and position feedback (StepControlActor) (Page 2334)
- Split-range controller with control loop monitoring through ConPerMon (SplitrangeControl) (Page 2335)
- Ratio control with control loop monitoring through ConPerMon (RatioControl) (Page 2338)
- Ratio control with PIDConR (RatioR) (Page 2341)
- Cascade control with control loop monitoring through ConPerMon (CascadeControl) (Page 2342)
- Cascade control with PIDConR (CascadeR) (Page 2345)
- Cascade control with PIDStepL (CascadeStepControl) (Page 2346)

If you want to do without control loop monitoring in order to reduce license costs or CPU resources, you can use accordingly simplified process tag types, which are identifiable by the suffix "Lean" in their names (for example, PIDControlLean, CascadeControlLean, RatioControlLean) or you can delete the ConPerMon block from the CFC charts for any of the process tag types.

In addition to the process tag types mentioned above, you will also find the following in the Templates folder of the library:

- PID controller with dynamic feedforward control (FwdDisturbCompensat) (Page 2329)
- PID controller for PA/FF devices (PIDControl_Lean_Fb) (Page 2323)
- PID - control with operating-point-oriented parameter control (GainScheduling) (Page 2327)
- Override control (Page 2348)
- Override control with PIDConR (OverrideR) (Page 2350)

- PID controller with Smith predictor (SmithPredictorControl) (Page 2332)
- Model-based predictive control (ModPreCon) (Page 2351)

This list contains prototype process tag types for several of the complex control loop structures shown in the example project (Page 2372). These prototypes are simply examples of how such process tag types might appear. In most process plants, it is assumed that high-level control loop structures must be configured individually some in combination with lower-level control loops. This means that mass production of high-level control loop structures as instances of process tag type represents the exception.

Descriptions for the following process tag types are also available:

- Monitoring eight digital process tags (Digital8Monitoring) (Page 2355)
- Monitoring of a digital process tag (DigitalMonitoring) (Page 2353)
- Monitoring a digital process tag for PA/FF devices (DigitalMonitoring_Fb) (Page 2354)
- Monitoring an analog process tag (AnalogMonitoring) (Page 2356)
- Monitoring of an analog process tag for PA/FF devices (AnalogMonitoring_Fb) (Page 2357)
- Dosing (Dose_Lean) (Page 2358)
- Dosing with PA/FF devices (Dose_Lean_Fb) (Page 2359)
- Two-speed motor (Motor2Speed) (Page 2362)
- Reversing motor (MotorReversible) (Page 2363)
- Reversible motor with controllable speed (MotorSpeedControlled) (Page 2364)
- Motor (Motor_Lean) (Page 2360)
- Motor with an additional analog value and time-stamped signals (Motor_AV_EventTs) (Page 2365)
- Motor valve (ValveMotor) (Page 2369)
- Valve (Valve_Lean) (Page 2367)
- Two-way valve (Valve2Way) (Page 2368)
- Control valve (VlvAnL) (Page 2370)
- Control valve for PA/FF devices (ValveAnalog_Fb) (Page 2371)

Using process tag types

When using process tag types in a PCS 7 multiproject, the following procedure is recommended:

- Copy all the required function blocks from the Advanced Process Library to the block folder of the master data library of the multiproject (<Projectname>_Lib).
- Then in the plant view, copy the required process tag types from the Advanced Process Library to the "Process_tag_types" folder of the master data library of the multiproject.
- Make any customizations of the process tag types.

Generating the process tags

Process tags are the instances of the process tag types.

There are two ways of generating process tags:

1. Copy the process tag type from the master data library and insert it in the target folder in the plant hierarchy. You can then set the parameters for and interconnect the CFC chart in the CFC Editor.
2. Using the Import-Export assistant, you can then generate the required process tags of the process tag type that you then assign parameters to and interconnect based on an import file.

Notes on the "Measured value failure" application scenario for controller block process tag types

If there is no valid measured value for PV , the controller must not remain in automatic mode because a closed control loop no longer exists. The controller is unable to calculate a useful manipulated variable if there is no feedback of the actual process state. The controller must then be changed to manual or tracking mode. OS operators must be made aware of this situation by a corresponding message. Various reactions to the loss of measured values are conceivable depending on the application background:

1. Tracking a fixed, configured neutral position manipulated variable, for example, Valve closed, Heater off, or similar.
2. Holding the last valid manipulated variable MV constant to retain a steady process state as far as possible (if the process was already in such a state).
3. Change to manual mode, so that the OS operator can take over responsibility for process control.

A combination of reactions 2 and 3 is implemented in the template. The controller changes to tracking with the last valid manipulated variable as start value. The switchover is made via the input MV_TrkOn of the PID block. Since manual mode already has priority over tracking, the OS operator can subsequently use the command.

Caution: It is not advisable to freeze the last valid manipulated value if the signals are subject to heavy noise, or in control loops with frequent setpoint changes. In such situations, it is advisable to change to variant 1.

If a controller intervenes locally in the process via an actuator (for example, a valve with electropneumatic positioner Sipart PS) specific measures similar to those for a cascade controller must be taken:

- If there is local intervention, the controller tracks the current actuator position. In this case, the feedback signal is applied to input MV_Trk and an OR element is set before input MV_TrkOn .

Notes on analog position feedback for controller block process tag types

If there is no position feedback, delete the associated analog input channel block at the MV_Rbk parameter in the CFC chart. This will also make the corresponding display elements in the standard view of the faceplate invisible.

21.2 PID controller (PIDControl_Lean)

PID controller

This process tag type forms the basis for generating PID control instances for continuous processes. In addition to the actual PID block, it contains functionality that should be implemented consistently in each control loop. This functionality is, however, not implemented within the PID block itself so that users can adapt the functions to a specific project:

- An analog input channel block for the actual value *PV* plus an analog output channel block for the manipulated variable *MV*.
- Certain logic blocks that change the control loop to a safe mode if the measurement of the process value fails. This state is signaled by the signal status of *PV*.

Note

Read the information for process tag types with controller blocks in Introduction to process tag types (Page 2319).

21.3 PID controller for PA/FF devices (PIDControl_Lean_Fb)

PID controller

This process tag type forms the basis for generating PID control instances for continuous processes. In addition to the actual PID block, it contains functionality that should be implemented consistently in each control loop. This functionality is, however, not implemented within the PID block itself so that users can adapt the functions to a specific project:

- An analog input channel block for the actual value PV plus an analog output channel block for the manipulated variable MV .
- Certain logic blocks that change the control loop to a safe mode if the measurement of the process value fails. This state is signaled by the signal status of PV .

Note

Read the information for process tag types with controller blocks in Introduction to process tag types (Page 2319).

21.4 PID controller with safety logic and control loop monitoring (PIDConL_ConPerMon)

PID controller with safety logic and control loop monitoring

This process tag type forms the basis for generating PID control instances for continuous processes. In addition to the actual PID block, it contains functionality that should be implemented consistently in each control loop. This functionality is, however, not implemented within the PID block itself so that users can adapt the functions to a specific project:

- An analog input channel block for the actual value PV and (if available) the position feedback (Rbk), plus an analog output channel block for the manipulated variable MV .
- A simple process simulation of the first order, controlled by the manipulated variable MV which provides simulation values to analog input PV . This functionality allows at least elementary function tests control loop before a real process is connected.
- Certain logic blocks that change the control loop to a safe mode if the measurement of the process value fails. This state is signaled by the signal status of PV .
- An additional function block for control loop monitoring that should be installed in all PID control loop.

Note

Read also the information on controller block process tag types in Introduction to process tag types (Page 2319).

You can find information on the use of control loop monitoring in ConPerMon functions (Page 569).

21.5 PIDConR with safety logic and control loop monitoring (PIDConR_ConPerMon)

PIDConR with safety logic and control loop monitoring

This process tag type corresponds to the process tag type PID controller with safety logic and control loop monitoring (PIDConL_ConPerMon) (Page 2324) and control loop monitoring when PIDConR is used rather than PIDConL.

21.6 PID controller with safety logic and manipulated variable ramp (PIDConR_MV_Ramp)

PID controller with safety logic and manipulated variable ramp

This process tag type is derived from the process tag type PIDConR with safety logic and control loop monitoring (PIDConR_ConPerMon) (Page 2325). But in this case, a manipulated variable ramp is realized instead of a control loop monitoring.

The degree of manipulated variable is limited outside of PIDConR with the block RateLim. The limited MV value is fed back to the input parameter `ExtReset` of the block PIDConR.

21.7 PID - control with operating-point-oriented parameter control (GainScheduling)

PID - control with operating-point-oriented parameter control

Many technical processes have a non-linear response due to non-linear physical, chemical or thermodynamic effects. When such a process needs to be kept in the close vicinity of a fixed operating point, the transfer response can be linearized around this operating point. A linear PID controller can be designed for this linearized transfer function. If, however, the process has a strongly non-linear response and/or operates at different operating points, no constantly good control response can be expected throughout the entire operating range. Due to the non-linearity, various gain factors or process time constants are in effect at different operating points. In keeping with this, different controller parameters will be considered to be optimum.

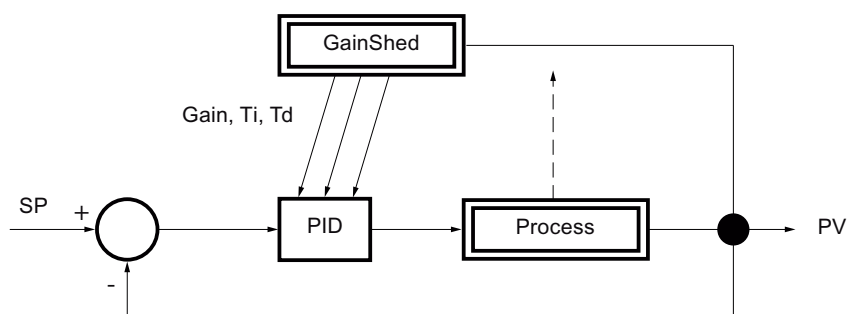

Figure 21-1 Operating-point-oriented parameter adaptation

One possible (the simplest) solution to this problem is known as gain scheduling or parameter scheduling. Using a tool such as the PCS 7 PID Tuner, various experiments are performed at different operating points, in each case with low signal amplitudes. This results in different PID parameter sets for each operating point. Up to three such parameter sets can be stored in the GainSched Function block. The suitable parameter set is selected depending on a continuously measurable variable that describes the state of the process, typically the control variable PV itself. Between the operating points for which there are exact parameter values, the values are calculated by linear interpolation of the neighboring interpolation points so that soft and bumpy transitions are possible between the operating points. The term "parameter scheduling" makes it clear that the "timetable" for adjusting the parameters is specified in advance. In contrast, an adaptive controller adapts itself automatically to the differing process response during operation.

The function block GainSched is produced from the CFC chart "fbGainSched" by compiling it as a block type. This CFC chart is supplied with the library so that the user has the option of

expanding the existing basic functionality as necessary, for example to more than three operating points.

Note

The combination of several locally optimized controllers by gain scheduling to form a non-linear controller does not necessarily represent an optimum non-linear controller for the non-linear process when considered from a mathematical point of view. This becomes clear even with benign non-linearities (that are continuous and can be differentiated) when setpoint step changes are made between different operating points. Great caution is needed with non-linearities that are discontinuous or cannot be differentiated or with non-monotonic non-linearities.

Examples of applications

- Control (especially temperature control) of batch processes, for example, batch reactors and batch columns
- pH value control
- Temperature control with phase transitions (for example, fluid/vapor form)
- Control of semi-batch plants (continuous plants with operating point changes, for example, polymerization reactors)
- Control in power plants with load changes

21.8 PID controller with dynamic feedforward control (FfwdDisturbCompensat)

PID controller with dynamic feedforward control

Feedforward can be used when a known, strong disturbance affects the process and its cause can be measured. In these cases, the following general strategy applies: "Control as much as possible (if known in advance and described by a model), control as much as necessary (the rest including the model error and immeasurable disturbances)".

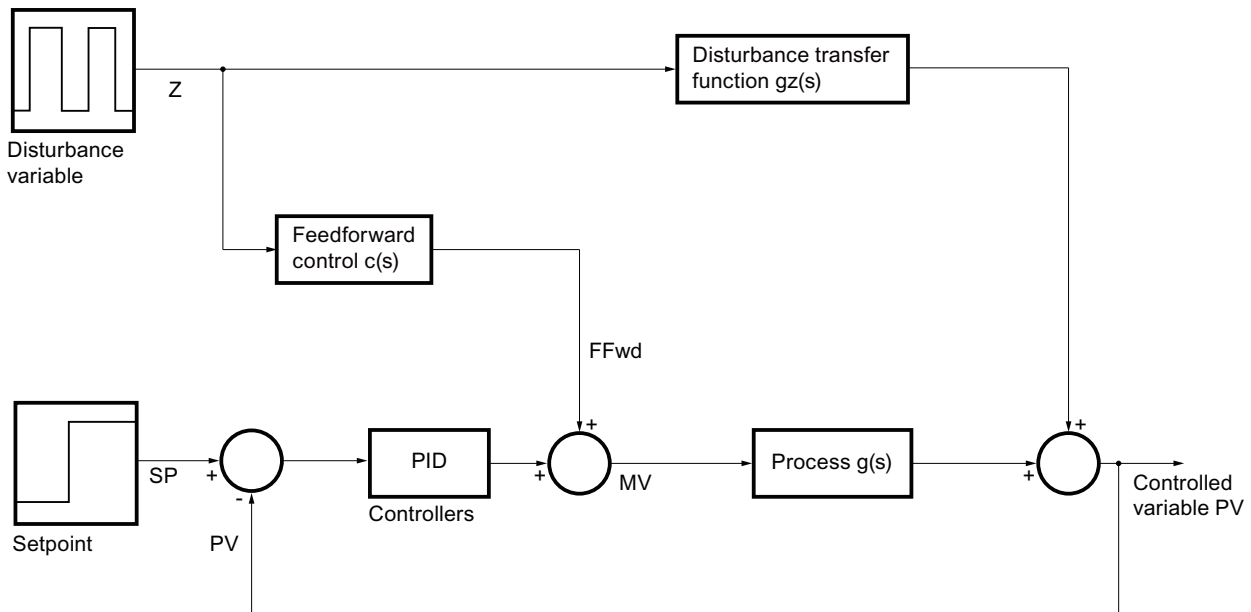

Figure 21-2 Dynamic feedforward control

The effect of a measurable disturbance can be estimated in the form of a transfer function $g_z(s) = y(s) / z(s)$ when the controller is running in manual mode so that no changes whatsoever to the controlled variable $y = PV$ are caused by the manipulated variable and all changes can be attributed to the disturbance $z(s)$.

The transfer function of an ideal feedforward control $c(s)$ can be derived from the requirement that the effect of z on y should be zero for any disturbance signal $z(s)$:

$$g_z(s) \cdot z + c(s) \cdot g(s) \cdot z = (g_z(s) \cdot g(s)) \cdot z = 0$$

To meet this equation, the compensation block must approximate the equation

$$c(s) = -\frac{g_z(s)}{g(s)}$$

as well as possible. For this to happen, the disturbance transfer function $g_z(s) = y(s) / z(s)$ must be known and the transfer function of the main controlled system $g(s) = y(s) / u(s)$, $u = MV$ must be inverted. If both transfer functions can be modeled as first order with dead time

$$g(s) = \frac{k_s}{1 + t_1 s} \cdot e^{-s\theta}$$

and

$$g(s) = \frac{k_{sz}}{1 + t_{1z} s} \cdot e^{-s\theta_z}$$

and $\theta < \theta_z$ applies, the resulting compensation element must represent the transfer

$$c(s) = -\frac{k_{sz}}{k_s} \frac{1 + t_1 s}{1 + t_{1z} s} e^{-s(\theta_z - \theta)}$$

function.

In general, the following dynamic transfer function is required for additive feedforward control:

$$FFwd(s) = -k_c \frac{t_{cd}s + 1}{t_{cl} + 1} \cdot e^{-\theta_c s} \cdot z(s)$$

where:

$$MV = MV_{PID} + FFwd$$

In the example above, this function includes the following parameters:

$$k_c = \frac{k_{sz}}{k_s}, \quad t_{cd} = t_1, \quad t_{cl} = t_{1z}, \quad \theta_c = \theta_z - \theta'$$

This transfer function can be created outside the controller with a combination of elementary CFC blocks: one DT1 (Diff), one PT1 (TimeLag) and one DeadTime block. As shown in the process tag type, the Diff block and TimeLag block are connected in parallel, and the DeadTime block as well as a multiplier are connected in series in front as a gain factor.

The input parameters k_c , t_{cd} , t_{cl} need to be configured by the user. For a static feedforward control, both time constants are set to zero.

Examples of applications

- Controlling the outlet temperature of a heat exchanger via steam pressure or heating/cooling medium flow. Flow and inlet temperature of the medium are measurable disturbance variables.
- Fill level control in a drum steam generator using the inlet volume. The outflow is the measurable disturbance variable that is determined by the variable steam consumption in the plant.

21.8 PID controller with dynamic feedforward control (FwdDisturbCompensat)

- Temperature control in a distillation column using the reflux ration or or heating steam volume. The measurable disturbance variable is the mixture inlet.
- Temperature and concentration control in an agitated tank reactor using cooling medium flow and discharge volume. The temperature and possibly also the concentration of the inflow are measurable disturbance variables.

21.9 PID controller with Smith predictor (SmithPredictorControl)

PID control with Smith predictor

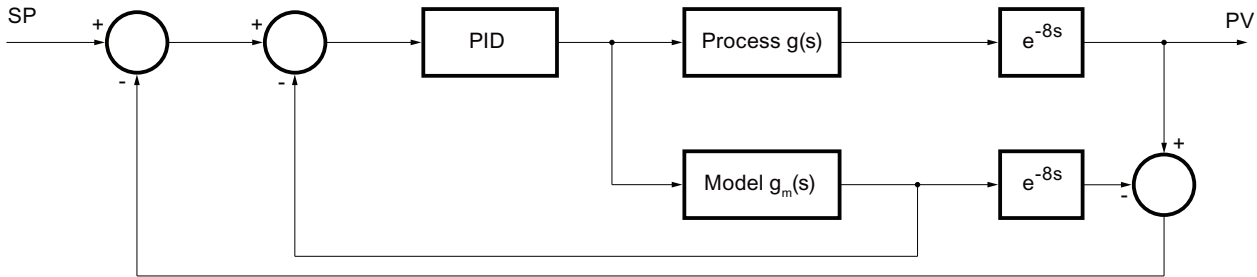

Figure 21-3 PID control with Smith predictor

In processes with large dead times (relative to the dominating time lag constant), a standard PI controller must be set very slowly and compromises must therefore be accepted in the control quality. The control quality can be significantly improved with a Smith predictor that can be derived from the IMC principle (Internal Model Control) of model-based control. To achieve this, the transfer function $g_s(s) = g(s) \cdot e^{-s\theta}$ of the controlled system is split up into a part without dead time $g(s)$ and a purely dead time slice $e^{-s\theta}$ with dead time θ . Only the controlled variable y affected by dead time can be measured in the real process. However, a virtual estimate of the controlled variable free of dead time can be taken from the process model (that will become part of the controller) and fed to the controller. This means that the controller itself can be designed for the process without a dead time slice and can therefore be set much more tightly. To compensate unknown disturbances, an estimate of the controlled variable affected by dead time is made in the model and compared with the genuine measured controlled variable. This difference is also fed back to the controller.

In terms of practical application, it must be pointed out that the performance of the Smith predictor depends largely on the model fit, in other words, the dead time must be known. The dead time must be constant or its value must be permanently adapted.

Note

To control processes with large dead times, a model predictive controller (see Description of ModPreCon (Page 689)) is also suitable in a single variable situation. It provides greater flexibility in the system modeling and is more convenient thanks to the integrated design procedures, it does however require more CPU resources.

21.10 Step controller with direct access to the actuator and without position feedback (StepControlDirect)

Step controller with direct access to the actuator and without position feedback

The output of the PIDStepL block is directly connected to the process via two digital output channel blocks. This is the simplest form of a step control. The operator can control the actuator (push-button open/close) in the faceplate of the controller. This push-button operation is preferable when operating simple actuators without position feedback since it allows bumpless switchover to auto mode. This switchover is not possible if actuators without position feedback are operated manually from any location outside the control block. For this reason, the template is designed with a PIDStepL block without position feedback.

21.11 Step controller with assigned actuator block and position feedback (StepControlActor)

Step controller with assigned actuator block and position feedback

The output of the PIDStepL block is directly interconnected with the process by way of an actuator block (for example, a motor or a valve). This additional effort is justified when special automation functions of the actuator block, for example motor current monitoring, motor protection and operation in local mode are required. The option of such combinations allows users to do without special functions for operation in local mode or actuator monitoring functions within the controller block.

If the actuator block is not in external default setpoint, or there is an interlock, motor protection or monitoring error, the actuator is incapable of accepting and executing controller commands.

In this context, the resulting structure must be interpreted as a "cascade circuit" consisting of the (primary) controller and actuator block (secondary controller) and measures similar to those for cascade control must be taken. For this purpose, the `CascaCut` output of the actuator block must be interconnected to the `TrkOn` input of the primary controller.

To ensure the bumpless switchover from local or manual mode back to cascade mode, the current actuator position must be fed back to the tracking input of the primary controller. This is, however, only possible when using actuators with position feedback. For this reason, the template is designed for operation with a PIDStepL block with position feedback.

Note

The Valve motor valve is configured for operation without motor feedback: Feature bit 12 = 1

21.12 Split-range controller with control loop monitoring through ConPerMon (SplitrangeControl)

Split-range controller with control loop monitoring (ConPerMon)

A PID closed-loop controller can use a Split-Range block downstream of the controller output to distribute its manipulated variable to several actuators that influence the same control variable based on different physical principles and in different directions. A typical example of such an application is a temperature control, with heating via a live steam valve and cooling via a cooling water valve. The controller can request heating or cooling energy, depending on the sign of the control deviation (or more precisely of the manipulated variable). In other words, it can work with a bidirectional MV output (for example: $-100\% < MV < 100\%$), although each actuator only supports unipolar operation (for example: $0\% < \text{valve position} < 100\%$).

The Split-Range function block contains two separate (static) characteristics for both actuators. Any significant difference between the two actuators in terms of performance (can be interpreted as different steady state gains for heating and cooling), can be compensated by setting different gradients for the characteristics, so that as far as possible, the controller is presented with a linear process response (independent of the sign).

Example: The cooling effect is not as strong as the heating effect.

If cooling is half as effective as heating, the split-range characteristic for cooling should have twice the gradient.

Note

The effective maximum values of the manipulated variables are obtained from the manipulated variable limits of the controller multiplied by the gradients of the split-range characteristics.

The cooling valve cannot go beyond fully open, in other words, the effective limitation for opening the valve is 100%. If a split range characteristic with gradient 2 is used for cooling, the low limit for the manipulated variable must be set to $MV_LoLim = -50\%$ on the controller.

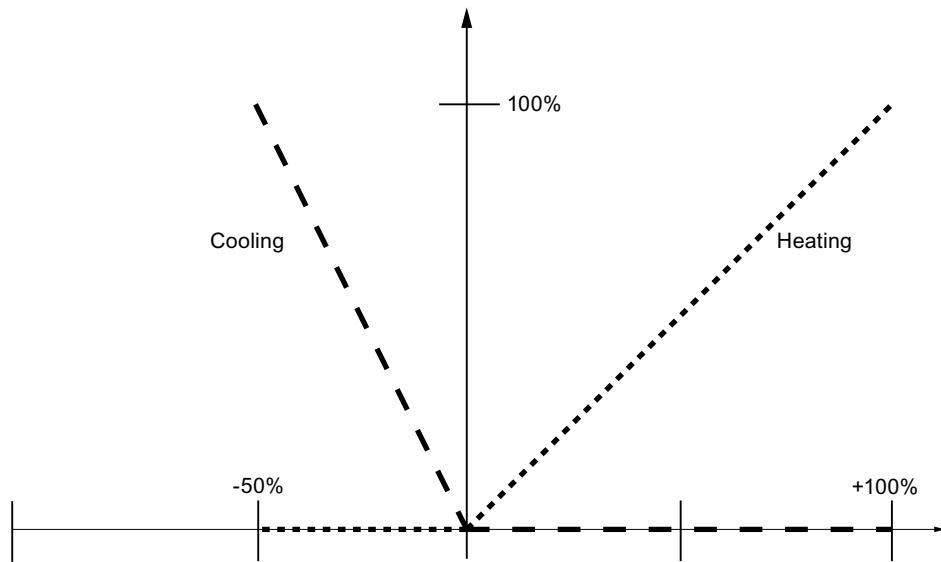

Figure 21-4 Split-range function of the example

The actual split-range function is supplied as separate SplitRange function block that is described in detail in the online help of the block.

Examples of applications:

- Control of the temperature of chemical reactors by means of steam heating valves and water cooling valves.
- Temperature control of glass furnaces or sprue channels by means of gas burners and cooling fans
- Temperature control of extruders by means of electrical heating and cooling fans
- Pressure control in a gas phase reactor by means of inlet and outlet valves
- Pressure control at a steam collecting track that supplies steam to several units by means of inlet valves from several steam generators, or the heating power of several steam generators.

21.13 Split-Range control (SplitRangeControl_Lean)

Split-range control

This process tag type is identical to the following process tag type:

Split-range controller with control loop monitoring through ConPerMon (SplitrangeControl)
(Page 2335)

The ConPerMon block is not included, however.

21.14 Ratio control with control loop monitoring through ConPerMon (RatioControl)

Ratio control

Specific mixtures of several liquids or gases can be produced by means of a ratio control system consisting of several flow controllers and a Ratio block. The flow setpoint of an additive is obtained from one of these values:

1. From the current PV value of the main flow.
This is the preferred alternative if the primary flow controller operates with steady-state deviation.
or
2. From the setpoint SP of the main flow.
This alternative provides a smooth, noise-free setpoint signal to the second controller, and allows for a more precise control of specified ratios in transition states where both flow control loops have approximately the same dynamic response.

It is generally advisable to use the second "setpoint-oriented" alternative for main flow controllers with I action.

Interconnect the selected reference value (actual value or setpoint of the main flow) to the In input parameter of the Ratio block.

The ratio control can be expanded by adding further components, in other words, setpoints 3 to n can be derived from SP1 (or PV1) with the help of additional Ratio blocks.

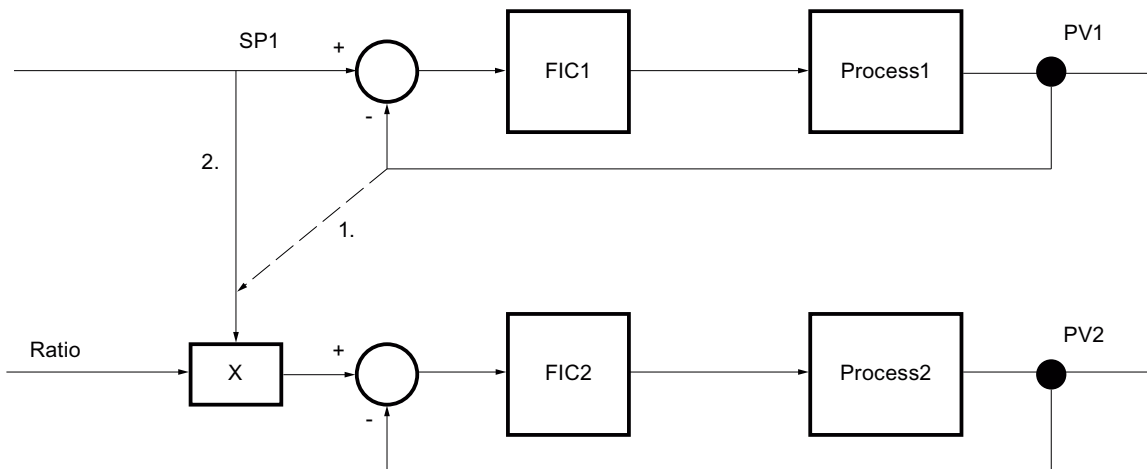

Figure 21-5 Ratio control, process value-oriented (1.) and setpoint-oriented (2.)

The main task of the Ratio block is to define the external setpoint of the secondary (added) component in accordance with

$$\text{Out} = \text{In} \cdot \text{Ratio} + \text{Offset}$$

. The actual ratio of the two flow actual values is also calculated in accordance with

$$\text{RatioPV} = \frac{\text{SecComPV} - \text{Offset}}{\text{InPV}}$$

21.14 Ratio control with control loop monitoring through ConPerMon (RatioControl)

and displayed on the control panel for checking purposes. In addition, interconnect the actual value of the main flow to the input parameter `InPV` of the Ratio block and the actual value of the flow of the secondary component to the input parameter `SecComPV`.

In both cases 1 and 2, the current value of the ratio is not controlled directly in the closed loop (no feedback-control) but rather uses feedforward-control.

Note

If the `PID_Componet1` secondary controller is switched from automatic to another operating mode, the `CascaCut` output parameter is set and the Ratio block is switched to external. In this case, the external setpoint is corrected to the actual value ratio for the ratio of the control actual value to the component actual value: $\text{RatioExt} = \text{RatioPV}$. This results in a soft transition to automatic mode.

An additional function block for control loop monitoring must be installed, because it should always be installed in every PID control loop.

21.15 Ratio control (RatioControl_Lean)

Ratio control

This process tag type is identical to the following process tag type:

Ratio control with control loop monitoring through ConPerMon (RatioControl) (Page 2338)

The ConPerMon block is not included, however.

21.16 Ratio control with PIDConR (RatioR)

Ratio control with PIDConR

This process tag type corresponds to the process tag type Ratio control with control loop monitoring through ConPerMon (RatioControl) (Page 2338) when PIDConR is used rather than PIDConL.

You need to set feature bit 21 Switching operator controls for external setpoint to visible (Page 144) to 1 with a flow controller for the secondary component.

21.17 Cascade control with control loop monitoring through ConPerMon (CascadeControl)

General information on cascade control

A cascade control involves two or more PID controllers connected in series. The manipulated variable of the primary controller is interconnected to the external setpoint of the secondary controller so that both control loops are nested. The advantage of cascade control is that disturbances affecting the inner loop can be compensated much more quickly in the secondary loop than in the slower primary loop. In some situations, non-linear effects of the actuator can be compensated in the secondary loop so that a linear process response can be created for the primary loop. Cascade control is possible only when there are further measurable variables in the process in addition to the main control variable and when the internal control loop is significantly faster than the external loop.

Aspects to be clarified for the cascade control

With any cascade control, the following aspects must be carefully considered and clarified:

- The actuation range of the primary controller must match the setpoint range of the secondary controller to ensure proper operation of the anti-Windup functions of the primary controller.
- If the secondary controller is not operated in "cascade" mode (automatic mode with external setpoint) but in any other mode (for example manual or automatic mode with local setpoint) and therefore does not respond to commands of the primary controller, the primary controller must be put into "tracking" mode to prevent integration of the I action in the primary controller. The manipulated value of the primary controller tracks the process value or setpoint of the secondary controller to allow a bumpless return to cascade mode. The difference between tracking the setpoint and tracking the process value becomes apparent when the secondary controller is put into manual mode. If the process value is tracked, the response is similar to the "Track setpoint to process value in manual mode" of a simple controller.
- If the secondary controller reaches a (high/low) manipulated variable limit, the integrator of the primary controller should be blocked to prevent it going any further in this direction (up / down). The secondary controller cannot go any further in this direction anyway. This prevents any windup of the primary controller when the real actuator has already reached its physical limits while the primary controller has not yet reached its manipulated variable limits.

Caution:

- Swap the two bits of this interconnection if the secondary controller has a negative gain.
- If the secondary controller then reaches a high or low limit, the integrator of the primary controller must be prevented from further integration in this direction.

Procedure

When you set up and commission the controller, you work from the "inside to the outside", in other words, you start by making the settings for the secondary controller and putting it into auto mode. You then set the primary controller parameters and change the secondary controller to cascade mode. When you set the parameters for the primary controller, remember that from its perspective the entire, inner closed control loop is the "controlled system". The parameters you set for the primary controller depend to a greater or lesser extent on the settings you made for the secondary controller. This becomes less important the greater the difference in dynamic response between the primary and secondary control loop.

Priorities

The tracking by the primary controller that is initiated by the secondary controller has lower priority than the manual mode on the primary controller. In turn, manual mode has lower priority than forced mode on the master controller as can, for example, be requested by external logic during an emergency shutdown of the plant (controller input `MV_Forced`, unlimited, activated by `MV_ForOn` with highest priority). For this reason, the PIDConL block for cascade control has an additional tracking input `MV_Trk` that is activated by `MV_TrkOn` and is subject to the normal manipulated variable limiting and has lower priority than manual mode.

Additional application examples

- Temperature control of a distillation column (primary controller) based on the reflux ratio (secondary controller at the top of the column), and heating steam flow rate (secondary controller at the column sump),
- Temperature control of a furnace using a secondary controller to control the fuel flow rate,
- Fill level control for a container using a secondary controller for the inlet and/or outlet flow.
- Position control (in drive engineering) with a secondary controller for the speed and torque.

Using secondary flow controllers

Secondary controllers are usually used for flow control to prevent detrimental effects on the primary controller resulting from changes in flow rate. The non-linearities frequently often found in a flow control element (for example a valve) are "hidden" in the secondary loop because the secondary closed loop has a linear response and non-linearities have no effect on the primary controller or its tuning.

Note

Control loop monitoring is only practical for primary controllers, as explained in the description of the ConPerMon block in the section, Functions/Cascade Control.

21.18 Cascade control (CascadeControl_Lean)

Cascade control

This process tag type is identical to the following process tag type:

Cascade control with control loop monitoring through ConPerMon (CascadeControl)
(Page 2342)

The ConPerMon block is not included, however.

21.19 Cascade control with PIDConR (CascadeR)

Cascade control with PIDConR

This process tag type corresponds to a large extent to the process tag type Cascade control with control loop monitoring through ConPerMon (CascadeControl) (Page 2342) when PIDConR is used rather than PIDConL.

Special note: The current `PV_Out` output of the `PID_Slave` secondary controller is used as an external `Reset ExtReset` on the primary controller. Unlike cascade control, the `PID_Master` primary controller does not therefore have to be changed to tracking when the cascade is disconnected with all other PID controllers. There is also no need for the direction-dependent blocking of the integrator for the primary controller.

Since the primary controller is reliant on the external `Reset`, any control deviations in the secondary closed loop interfere with the primary controller; secondary controllers without I action are not therefore recommended for PIDConR.

You need to set the Feature bit `Switching operator controls for external setpoint to visible` (Page 144) to 1 with a secondary controller of the cascade.

21.20 Cascade control with PIDStepL (CascadeStepControl)

Cascade control with a step controller as a valve positioner and a downstream actuator block

The step controller is used in this template as a positioner, which regulates the position of a valve that does not have an internal positioner and is only controlled via binary inputs (open, stop, close). The motorized control valve can thus include delay behavior, i.e. that does not stop immediately at a stop command. The output of the PIDStepL block is directly connected to the process via the actuator block VlvMotL (see StepControlActor template). The PIDStepL runs as a slave controller in a cascade structure and gets his external setpoint from a master controller (flow or pressure regulator).

The PIDStepL is configured as a step controller without position feedback (WithRbk =0). The position feedback signal is applied in this example to the PV input and controlled to the external setpoint, which is also set by higher-level master controller (PIDConL). Master and slave controllers are connected in such a way that the following conditions are met (see CascadeControl template):

- The calculated valve position of the master controller is forwarded to the external setpoint of the slave controller.
- The master controller is switched to tracking if there is a bad process value on the master controller or with an open loop by the PIDStepL slave controller or by the VlvMotL valve block. The tracking value corresponds to the valve position at the PV input of the PIDStepL step controller. In case of an open loop by the VlvMotL valve block, the open and close control signals of the PIDStepL slave controller are also tracked.
- If the valve position is fully open or fully closed, the I-component of the master controller is stopped (Windup measure).

The same rules as those set in the CascadeControl template and described in the Procedure section apply for the controller setting and commissioning.

21.21 Source chart for GainSched function block (gain scheduling)

Source chart for GainSched function block

In contrast to all other function blocks, the `GainSched` block is implemented as a CFC chart and is generated with the "Compile chart as block type" function. Several application options are available in this case:

- You can use the precompiled function block `GainSched` from the library if the standard functionality is adequate for your needs.
- If you require special additional functions for gain scheduling in your application (for example more than three operating points, additional logic functions for selecting the parameters), you will need to modify the CFC source chart and compile it as a block type with a different FB number.

Internally, the `GainSched` block consists essentially of three instances of the `Polygon` block, one for each of the three controller parameters, `Gain`, `TI` and `TD`.

The `polygon` block itself would extrapolate linearly outside of the boundary points and thereby exceed the value range of its interpolation points. However, as this presents too high a risk for controller parameters, the controller parameters which are output are effectively limited to the table values at the boundary operating points by the automatic introduction of additional interpolation points with a horizontal end tangent outside of the specified range.

21.22 Override control

Override control

In an override control, two or more controllers share a common actuator. Depending on the current process state, a decision is made as to which controller actually has access to the actuator, in other words, the various controllers can override each other.

A typical use case is a gas pipeline with pressure and flow control using a single valve. The main aim of the control is to achieve a certain flow rate, however due to safety considerations, the pressure must be kept within certain limits. The pressure controller is therefore known as the "limiting controller" or "secondary controller".

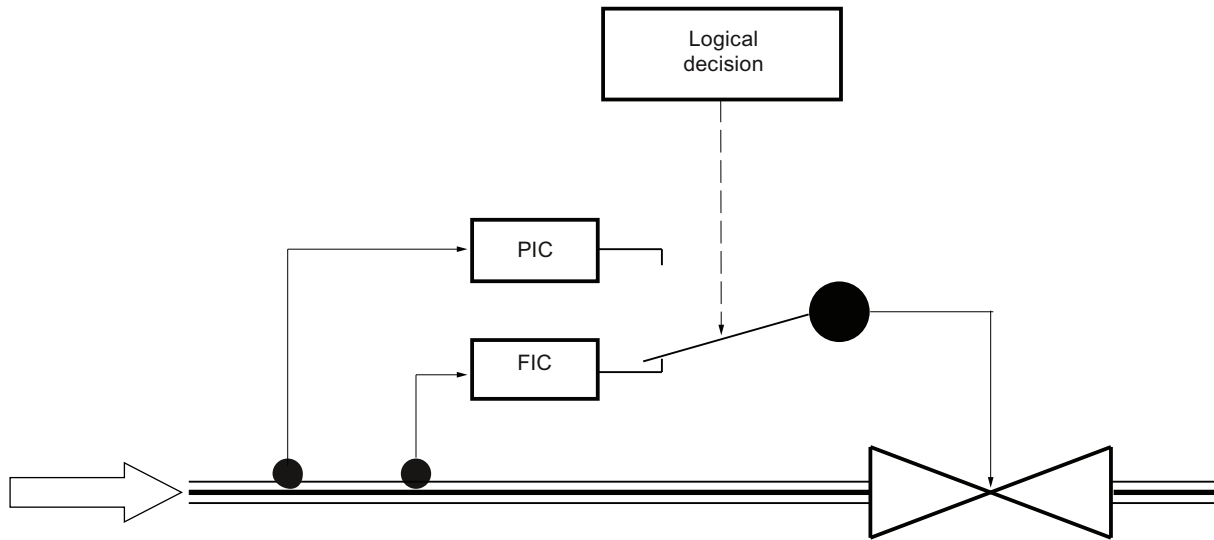

Figure 21-6 Override control with main controller FIC and limiting controller PIC

Criteria for the type of override control

The logical decision as to which controller should be active can be made based on two different criteria resulting in two different types of override controls:

1. The decision is based on a measurable process output variable, for example one of the two controlled variables. In the example above, the warning limits of the pressure controller can be used to decide whether the pressure controller should be active. The passive controller is in tracking mode to avoid Windup problems and to ensure bumpless transfer. The setpoint of the secondary controller must be somewhat lower than the switchover threshold so that the transfer can be reversed again. This type of override control is easy to understand and to implement. Its advantage is that the high and low limit of the secondary controlled variable (for example pressure) can be monitored; its disadvantage is that a limit cycle oscillation results as soon as the limiting controller needs to intervene. The secondary controller will always attempt to return its controlled variable to the safe range and to return command to the main controller (for example flow rate) so that the active and passive controllers swap over continuously. This variant is therefore only recommended when the secondary controller is seldom required and functions mainly as a safety or backup system.
2. The decision is based on a comparison of the manipulated variables of both controllers, for example the controller that demands the higher (or lower) controlled variable takes control of the actuator. In the example above, the controller that wants to open the valve further takes over control. The setpoint of the secondary controller defines the switching threshold. Both controllers run the entire time in automatic mode. To avoid Windup problems, the manipulated variable limits must be tracked in a crossover structure: When the higher (lower) manipulated variable wins, the low (high) limits of all controllers of the currently highest (lowest) manipulated variable must be corrected slightly up or down by, for example, 2% of the manipulated variable range. This means that this scheme can also be used in applications with more than two controlled variables. There is no Windup problem at the high limit because the highest manipulated variable takes over control anyway. This approach avoids the limit cycle oscillation of alternative 1 but is, in principle asymmetrical, in other words either a high or a low limit of the secondary controlled variable can be monitored but not both.
This type of override control is described in most control textbooks, particularly in the USA. It can, however, only be used with PID algorithms that allow online manipulation of the manipulated variable limits (in PCS 7 as of V6.0).

Additional application examples

- **Steam generator:** The primary controlled variable is the steam pressure but the water level in the steam tank must be monitored so that the heating coils remain completely covered by water and the tank does not overflow. The only manipulated variable is the outlet valve.
- **Compressor:** The primary controlled variable is the throughput but the pressure must be monitored to make sure it does not exceed a safety limit. The only manipulated variable is the motor speed.
- **Steam distribution system:** Every plant involving industrial processes has a network of pipes to distribute steam at various pressures throughout the plant. The high pressure of the steam is reduced to lower levels via a valve. The primary controlled variable is the pressure at the lower-level stage, however the pressure in the high pressure piping must also be monitored to make sure that it does not exceed a safety limit.

21.23 Override control with PIDConR (OverrideR)

Override control with PIDConR

This process tag type corresponds for the most part to the process tag type Override control (Page 2348) when PIDConR is used rather than PIDConL.

Special note: The current manipulated variable output at the final controlling element (e.g. the maximum `MaxMV.Out` manipulated variable proposed by the main controller and limiting controller) is used as the external `ResetExtReset` for both controllers. Unlike override control, the manipulated variable limits (e.g. `MV_LoLim`) of both controllers do not have to be tracked within a defined space (e.g. `MaxMV_Minus2.Out`) by the manipulated value output at the final controlling element with all other PID controllers.

21.24 Model-based predictive control (ModPreCon)

Model-based predictive control

The process tag type shows how users can expand the ModPreCon block by adding extra functions:

- External alarming with the MonAnL block
- Control quality monitoring with the ConPerMon block
- Safety logic for measure value loss.

You can find details about the ModPreCon block in Description of ModPreCon (Page 689).

Note on using the ConPerMon block in a system with multi-variable

The mathematical concept of the ConPerMon block is designed for single variable applications. If any increase of variance is detected in the channel of a multi-variable control, the ConPerMon algorithm is unable to determine whether this problem is caused by its own internal control channel or by interaction of neighboring channels. It may be helpful, however, to include a ConPerMon block for each control channel of a multi-variable system to monitor whether the control performance during operation remains within the range determined during commissioning. To achieve this, several logic operations must be performed before the `ManSuprCPI` input bit of each ConPerMon block:

- If one or several of the other channels of the multi-variable system are not in a steady state ("root caused in this channel") due to local causes (for example a setpoint step change) that is indicated by output bit `CPI_SuRoot = 1`, the increase of variance in its own channel cannot be avoided and should not trigger a CPI warning in its own channel.
- If one or several other channels of the multi-variable system exhibit strong variations as indicated by output bit `CPI_WrnAct = 1`, the increase in variance in its own channel cannot be avoided and should not trigger a CPI warning in its own channel. This may be helpful to localize the actual cause of the problem. The channel in which excessive variations are first detected outputs the first alarm; the other channels which may only be affected by errors resulting from the first error do not generate their own alarms.

Examples of applications

- Quality control in distillation columns, for example control of the column top and sump temperature based on the reflux ratio and heating steam volume
- Temperature control of several adjacent zones of furnaces with several burners, for example, tunnel furnaces, glass smelting plants, glass sprue channels etc.
- Quality control in chemical reactors by adjusting of reaction conditions such as pressure, temperature, feed/drain etc.

- Vaporizers, for example, drum steam generators
 - Mills, for example, cement mills, sieve mills: quality control (grain size) in combination with flow rate maximized, manipulated variables: sieve speed and mill feed
-

Note

The statistical evaluation of the service factor (time slice in automatic mode) and the time slices in the manipulated variable limits can be performed in a WinCC trend control, as in the customary case of a single variable. The binary variables from ModPreCon required for this are archived automatically. However, an appropriate trend control must be manually configured on the operator station, since the view archive in the ConPerMon block is not designed for such quantities.

21.25 Monitoring of a digital process tag (DigitalMonitoring)

Monitoring a digital process tag

This process tag type serves as a basis for monitoring a digital process tag using the MonDiL block.

The digital measurement signal is read from the I/O through the PCS7DiIn block.

The process tag type contains the required interconnections between Pcs7DiIn and MonDiL.

21.26 Monitoring a digital process tag for PA/FF devices (DigitalMonitoring_Fb)

Monitoring a digital process tag

This process tag type serves as a basis for monitoring a digital process tag using the MonDiL block.

The digital measurement signal is read from the I/O through the FbDiIn block.

The process tag type contains the required interconnections between FbDiIn and MonDiL.

21.27 Monitoring eight digital process tags (Digital8Monitoring)

Monitoring eight digital process tags

The process tag type serves as a basis for monitoring up to eight digital process tags using the MonDi08 block.

The digital measurement signals are read from the I/O through the PCS7DiIn block.

The process tag type contains the required interconnections between the eight Pcs7DiIn and MonDi08 blocks.

21.28 Monitoring an analog process tag (AnalogMonitoring)

Monitoring an analog process tag

This process tag type serves as a basis for monitoring an analog process tag using the MonAnL block.

The analog value is read from the I/O through the PCS7AnIn block.

The process tag type contains the required interconnections between Pcs7AnIn and MonAnL.

If you wish to monitor and forward the slope of the process value, you usually need to smooth the process value. You can insert a filter block such as Smooth between Pcs7AnIn and MonAnL for this purpose. The gradient of the process value can also be smoothed using the TimeLag parameter at MonAnL.

Procedure for smoothing the process value and its gradient:

1. Check the process value PV in the trend recorder and smooth it using a filter block such as Smooth only as much as is needed.
2. Check the gradient PV_Grad of the process value in the trend recorder and smooth the trend at the TimeLag parameter of MonAnL.

The sum of the time constants of Timelag from MonAnL and TimeConstant from Smooth approximately result in the length of a varying time window in which the gradient is averaged.

21.29 Monitoring of an analog process tag for PA/FF devices (AnalogMonitoring_Fb)

Monitoring an analog process tag

This process tag type serves as a basis for monitoring an analog process tag using the MonAnL block.

The analog value is read from the I/O through the FbAnIn block.

The process tag type contains the required interconnections between FbAnIn and MonAnL.

If you wish to monitor and forward the slope of the process value, you usually need to smooth the process value. You can insert a filter block such as Smooth between FbAnIn and MonAnL for this purpose. The gradient of the process value can also be smoothed using the TimeLag parameter at MonAnL.

Procedure for smoothing the process value and its gradient:

1. Check the process value PV in the trend recorder and smooth it using a filter block such as Smooth only as much as is needed.
2. Check the gradient PV_Grad of the process value in the trend recorder and smooth the trend at the TimeLag parameter of MonAnL.

The sum of the time constants of TimeLag from MonAnL and TimeConstant from Smooth approximately result in the length of a varying time window in which the gradient is averaged.

21.30 Dosing (Dose_Lean)

Dosing

This process tag type serves as a basis for dosing either as "Single component dosing via flow measurement" or as "Fill/extraction weighing via dosing scale" using the DoseL block.

The analog measurement signal is read from the I/O through the PCS7AnIn block.

The interlock signals of DoseL are interconnected to the Intlk02 interlock blocks. These interlock blocks in turn are connected to other blocks, for example, to digital process tags via Pcs7DiIn.

The digital output signals are sent to the I/O through the PCS7DiOu blocks.

The process tag type contains the required interconnections between the blocks mentioned above.

21.31 Dosing with PA/FF devices (Dose_Lean_Fb)

Dosing

This process tag type serves as a basis for dosing either as "Single component dosing via flow measurement" or as "Fill/extraction weighing via dosing scale" using the DoseL block.

The analog measurement signal is read from the I/O through the FbAnIn block.

The interlock signals of DoseL are interconnected to the Intlk02 interlock blocks. These interlock blocks in turn are connected to other blocks, for example, to digital process tags via FbDiIn.

The digital output signals are sent to the I/O through the FbDiOu blocks.

The process tag type contains the required interconnections between the blocks mentioned above.

21.32 Motor (Motor_Lean)

Motor with current monitoring

This process tag type serves as a basis for controlling motors with one control signal using the MotL block.

The feedback signal of the motor is read from the I/O through the PCS7DiIn block.

The interlock signals of MotL are interconnected to the IntLk02 interlock blocks. These interlock blocks in turn are connected to other blocks, for example, to digital process tags via Pcs7DiIn.

The digital output signals are sent to the I/O through the PCS7DiOu blocks.

The process tag type contains the required interconnections between the blocks mentioned above.

21.33 Motor with PROFIdrive Drive Profile telegram 1 and 20 (Namur)

Motor with adjustable speed and two directions of rotations according to the speed control mode with standard telegram 1 and 20

The process tag type serves as a basis for control of motors according to the profile "Speed control mode with standard telegram 1 and 20 with and without Namur" with the help of blocks FbDrive and MotSpdCL.

The interlock signals of MotSpdCL are connected to the IntLk02 interlock blocks. These interlock blocks in turn are connected to other blocks, for example, to digital process tags via Pcs7Diln.

The input/output signals of MotSpdCL are sent to the I/O through the FbDrive block.

The process tag type contains the required interconnections between the blocks mentioned above.

21.34 Two-speed motor (Motor2Speed)

Two-speed motor

This process tag type serves as a basis for controlling motors with two speeds using the MotSpdL block.

The speed feedback signals of the motor are read from the I/O through the PCS7DiIn blocks.

The interlock signals of MotSpdL are connected to the IntLk02 interlock blocks. These interlock blocks in turn are connected to other blocks, for example, to digital process tags via Pcs7DiIn.

The digital output signals are sent to the I/O through the PCS7DiOu blocks.

The process tag type contains the required interconnections between the blocks mentioned above.

21.35 Reversing motor (MotorReversible)

Reversing motor

This process tag type serves as a basis for controlling reversing motors using the MotRevL block.

The feedback signals of the motor are read from the I/O through the PCS7DiIn blocks.

The interlock signals of MotRevL are connected to the IntLk02 interlock blocks. These interlock blocks in turn are connected to other blocks, for example, to digital process tags via Pcs7DiIn.

The digital output signals are sent to the I/O through the PCS7DiOu blocks.

The process tag type contains the required interconnections between the blocks mentioned above.

21.36 Reversible motor with controllable speed (MotorSpeedControlled)

Reversible motor with controllable speed

This process tag type serves as a basis for controlling reversible motors with controllable speed using the MotSpdCL block.

The digital feedback signals of the motor are read from the I/O through the PCS7DiIn blocks.

The speed feedback of the motor is read from the I/O through the PCS7AnIn block.

The interlock signals of MotSpdCL are connected to the IntLk02 interlock blocks. These interlock blocks in turn are connected to other blocks, for example, to digital process tags via Pcs7DiIn.

The digital output signals are sent to the I/O through the PCS7DiOu blocks.

The speed control signal is output to the I/O through the PCS7AnOu block.

The process tag type contains the required interconnections between the blocks mentioned above.

21.37 Motor with an additional analog value and time-stamped signals (Motor_AV_EventTs)

Motor with an additional analog value and time-stamped signals

This process tag type shows the monitoring of an additional analog value, for example, for motor current monitoring (AV block) and additional binary signals (EventTs block) at a technologic block with MotL as an example.

By interconnecting the AV or EventTs block, messages of this block are displayed in the message view of the technologic block connected to it and can be acknowledged there.

Use of the AV block

The analog signal to be monitored can be read via the Pcs7AnIn block, for example. This has to be interconnected to the AV block. The AV_Tech output parameter of the AV block has to be interconnected to the AV input parameter of the technologic block.

Use of the EventTs block

A non-time-stamped binary signal from the I/O can be read via the Pcs7DiIn block, for example. The PV_Out output parameter of Pcs7DiIn has to be interconnected to the Inx input parameter of the EventTs block. The time stamp of this signal is generated by the EventTs block at signal change.

A time-stamped binary signal from the I/O must be read via the Pcs7DiIT block. The TS_Out output parameter of Pcs7DiIT has to be interconnected to the InTSx input parameter of the EventTs block.

The EventTsOut output parameter of the EventTs block has to be interconnected to the EventTsIn input parameter of the technologic block.

Additional interconnections

The interlock signals of MotL are interconnected to the IntLk02 interlock blocks. In turn, these interlock blocks are interconnected to other blocks, for example, to digital process tags via the Pcs7DiIn block.

The digital output signal is output to the I/O through the PCS7DiOu block.

The process tag type contains the required interconnections between the blocks mentioned above.

21.38 Motor according to the profile for low voltage switchgear devices with profile 1 of the MM_Starter

Reversible motor according to the manage motor starter with profile type 1

The process tag type serves as a basis for control of motors according to the profile "Manage motor starter - profile type 1" with the help of blocks FbSwtMMS and MotRevL.

The interlock signals of MotRevL are connected to the IntLk02 interlock blocks. These interlock blocks in turn are connected to other blocks, for example, to digital process tags via Pcs7Diln.

The input/output signals of MotRevL are sent to the I/O through the FbSwtMMS block.

The process tag type contains the required interconnections between the blocks mentioned above.

21.39 Valve (Valve_Lean)

Valve

This process tag type serves as a basis for controlling a valve with two positions (open/close) using the VlvL block.

The feedback signals of the valve are read from the I/O through the PCS7DiIn blocks.

The interlock signals of VlvL are connected to the IntLk02 interlock blocks. These interlock blocks in turn are connected to other blocks, for example, to digital process tags via Pcs7DiIn.

The digital output signals are sent to the I/O through the PCS7DiOu blocks.

The process tag type contains the required interconnections between the blocks mentioned above.

21.40 Two-way valve (Valve2Way)

Two-way valve

This serves as a basis for controlling a

- multi-way valves with up to three switching positions or
- three individual valves (valve network) to implement a 2-way valve circuit with neutral position

using the Vlv2WayL block.

The feedback signals of the valve or valves are read from the I/O through the PCS7DiIn blocks.

The interlock signals of Vlv2WayL are connected to the IntLk02 interlock blocks. These interlock blocks in turn are connected to other blocks, for example, to digital process tags via Pcs7DiIn.

The digital output signals are sent to the I/O through the PCS7DiOu blocks.

The process tag type contains the required interconnections between the blocks mentioned above.

21.41 Motor valve (ValveMotor)

Motor valve

This process tag type serves as a basis for controlling a motor valve using the VlvMotL block.

The feedback signals of the valve are read from the I/O through the PCS7DiIn blocks.

The interlock signals of VlvMotL are connected to the IntLk02 interlock blocks. These interlock blocks in turn are connected to other blocks, for example, to digital process tags via Pcs7DiIn.

The digital output signals are sent to the I/O through the PCS7DiOu blocks.

The process tag type contains the required interconnections between the blocks mentioned above.

21.42 Control valve (VlvAnL)

Analog control valve

This process tag type serves as a basis for controlling an analog control valve (0 to 100%) using the `VlvAnL` block.

The feedback signals of the valve's total travelled positions (open/closed) are read by the I/Os through the `Pcs7DiIn` blocks.

The feedback signal of the current analog position is read through the `Pcs7AnIn` block.

The interlock signals of `VlvAnL` are interconnected to the `IntLk02` interlock blocks. These interlock blocks in turn are connected to other blocks, for example, to digital process tags via `Pcs7DiIn`.

The analog actuating signal is output to the peripherals via the `Pcs7AnOu` blocks.

The process tag type contains the required interconnections between the blocks mentioned above.

21.43 Control valve for PA/FF devices (ValveAnalog_Fb)

Analog control valve

This process tag type serves as a basis for controlling an analog control valve (0 to 100%) using the `VlvAnL` block.

The feedback signals of the valve's total travelled positions (open/closed) and the current analog position of the valve are read by the I/Os through the `FbAnOu` blocks.

The analog actuating signal is output to the peripherals via the `FbAnOu` blocks.

The process tag type contains the required interconnections between the blocks mentioned above.

The interlock signals of `VlvAnL` are interconnected to the `Intlk02` interlock blocks. These interlock blocks in turn are connected to other blocks, for example, to digital process tags via `FbDiIn`.

21.44 Example project APL_Example_xx

21.44.1 Introduction to the PCS 7 example project for Advanced Process Control

Introduction

This document relates to the PCS 7 example project, Process Control (APL_Example_xx, xx indicates the language variant) for the PCS7 Advanced Process Library.

In contrast to the process tag types (insertible templates), the example project is primarily intended for training purposes:

The main aim was to familiarize users with with the new advanced process control structures by allowing them to experiment without having to intervene in the real process. The examples provide realistic process simulation. Working with these examples helps you to understand the concept and specific structural requirements, and to assess the uses of these functions before you implement them in a real system. For this reason, the examples contain a third-order simulation model with gain, equivalence value, and measurement noise but no analog channel blocks. The process model is supplied as the "ProcSimC" CFC chart and incorporated in the examples using the chart-in-chart technique.

The following examples are provided:

- Cascade control of temperature by using the heat flow (CascadeSim) (Page 2375)
- Control loop monitoring for simulation with colored noise (ConPerMonSim) (Page 2377)
- Feedforward control to compensate a measurable disturbance variable (DisturbCompSim) (Page 2377)
- Operating point-oriented adaptation of parameters (gain scheduling) for non-linear processes (GainSchedSim) (Page 2378)
- Override control on a pipeline (OverrideSim) (Page 2379)
- Smith predictor for a dead time system (SmithPredictorSim) (Page 2379)
- Filtering of noisy measured values in a control loop (SigSmoothSim) (Page 2380)
- Predictive control of a 2x2 multi-variable controlled system (ModPreConSim) (Page 2381)
- Predictive control of a non-linear process (ModPreConNonLinSim) (Page 2381)

A template for Fuzzy Control using the *PCS 7 add-on product FuzzyControl++* can be downloaded from the Internet pages of *Siemens I&S* and is therefore not included in the demo project.

A separate tree folder ("Unit") is provided for each example in the PCS7 example project. Each folder contains a CFC chart with an interconnection example, a brief explanatory text, and an assigned OS picture with self-explanatory visualization of the process example based on a pre-configured trend recorder. A short text in the OS picture describes commissioning and presentation.

21.44.2 Process simulation including noise generator (ProcSimC; ProcSimS)

Process simulation including noise generator

Users require only a few standard blocks to create a dynamic process model that reflects the response pattern of many technological processes with adequate precision. This model is used in all example projects (APL_Example_xx). However, you can also use this model for sales presentations or to test closed-loop control functions, in other words in a project phase in which the real plant is not yet available ("virtual process", "shadow plant"). Process simulation is supplied as an open source CFC chart "ProcSimC" that users can install in other CFC charts as a nested chart (chart-in-chart). It contains three first order delay elements, a gain factor, an equivalence value PV (for $MV = 0$), and a noise generator for white measurement noise. An additive input is provided for (artificial) interference of the input. The Laplace transformation function described below is implemented by means of this model.

$$PV(s) = \frac{Gain}{(TimeLag1 \cdot s + 1)(TimeLag2 \cdot s + 1)(TimeLag3 \cdot s + 1)} (MV(s) + DisV(s)) + PV_0 + Noise$$

Use cases

Users can adapt this flexible model to suit the requirements of various use cases, for example:

- **Simulation of temperature control systems:** $PV0$ represents the temperature without heating, for example, the ambient temperature. The value of $TimeLag1$ is typically significantly higher than $TimeLag2$ and $TimeLag3$. The value of the latter can also be zero. The sensor develops a typical quantization noise of 0.1°C . The gain is positive can be interpreted as the theoretical maximum temperature that can be reached at full heating power. However, in most situations this cannot be measured experimentally because many actuators are dimensioned so that they only require approximately one third of the heating power for constant operation at the operating point. The power reserve is only intended to cover operating point changes and heating up phases.
- **Simulation of pressure control systems:** If you define the valve position so that it is closed at 0% and open at 100%, the process Gain of a container pressure control system is normally a negative value because the pressure reduces (>0) when the outlet valve of the container is opened. In contrast to this, the gain of an overpressure value is positive. $PV0 > 0$ is the pressure when the valve is completely closed. The situation is, of course, the opposite when pressures below ambient pressure are involved, for example, in vacuum systems. Note that most valves do not return a reproducible characteristic in the region of their closed position (actuation ratio 1:20 or 1:50). The time constants for pressure control of liquids are typically fast, whereas with pressure control in gas tanks, particularly in large tanks, they are slower. The magnitude of the process gain depends largely on the physical units of pressure, for example, Bar or Pa. Pressure sensors typically develop higher measurement noise than temperature sensors.
- **Simulation of flow control systems:** If you define the valve position so that it is closed at 0% and open at 100%, the process Gain is usually positive, since the flow rate increases when the valve opens. $PV0 = 0$ if the flow stops completely when the valve is closed, in other words, the valve closes tight. The time constants are significantly faster than in temperature controls and are usually all of the same order. The magnitude of the process gain depends largely on the physical units of flow, for example, m^3/s or l/min . The measurement noise affecting flow sensors is normally higher than with temperature sensors.

To implement a dead time for process simulation, you can insert a DeadTime block before the ProcSimC input and call it in a different cyclic interrupt OB (OB3x).

Model variants

Two different model variants are supplied:

1. Continuous process simulation ProcSimC in which the MV input is an analog value, for example, heating power or valve position.
2. Process simulation ProcSimS for step controllers, with control of the actuator by two binary inputs "up"/"down" or "open"/"close". Internally, the actuator is modeled as an integrator, whereby:
 - MotorHiLim = 100%,
 - MotorLoLim = 0%
 - TI = MotorTime.

The integrator input is derived from the binary inputs according to the following formula:

$$I_{Integ.Input} = \begin{cases} 100 & \text{if } Up = True \\ -100 & \text{if } Down = True \\ 0 & \text{otherwise} \end{cases}$$

See also

NoiseGen I/Os (Page 2038)

21.44.3 Cascade control of temperature by using the heat flow (CascadeSim)

Cascade control of a temperature by using the heat flow

This template contains simulation models for a flow and temperature controlled system and the parameters of the noise generator block (see the I/O table). You can use this model to test the mode transitions described in the Cascade control (Page 2342) section. You can also try out the properties of different parameter sets for the primary and secondary controllers. The following features are typical for this type of application:

- The controlled temperature system is slower than the controlled flow system.
- There are two time constants that are far apart.
- There is an offset corresponding to ambient temperature.
- It has less noise than the controlled flow system.

Process parameters of the example project for cascade control

ProcSimC	Gain	TimeLag1	TimeLag2	PV0	NoiceVariance
Flow control loop	8	1	1	0	0.22
Temperature control loop	0.3	8	1	20	0.1

Parameters for PID controllers --> PI cascade with fast control response

The parameters listed in the table below apply to a fast control response with low control error but with strong actuator intervention.

PID	Gain	TI	TD
TIC101	10	8.8	2.6
FIC101	0.1	1.8	0

Controller parameters for PI --> P cascade with soft controller intervention

The advantage of the parameters listed in the table below is that the controller "goes easy" on final control element (for example a valve).

PID	Gain	TI	TD
TIC101	10	6.8	0
FIC101	0.1	0	0

It is generally advisable to make the secondary controller "simpler" than the primary controller, in other words to reduce the number of different dynamic channels so that it is genuinely secondary to the primary controller.

The steady state control error in the secondary loop is not normally relevant for the application. On the other hand, the reaction time of the secondary loop is important because the time constants of the secondary closed control loop are part of the controlled system for the primary controller. If you do without I action in the secondary controller for these reasons, it is not advisable limit the setpoint ranges of the secondary controller precisely to the achievable physical range of the process value in the secondary loop, as you would not be able to use the full actuating range of the secondary controller due to the steady state deviation. You should instead set more generous setpoint limits for the secondary controller and manipulated variable limits for the primary controller. The anti-Windup measures of the primary controller are oriented on the interconnection of `IntHoldNeg` and `IntHoldPos`. If the secondary controller does not have any I action, it will not be capable of a bumpless manual-automatic changeover. You should therefore set an `MV_Offset` that approximates the typical MV value for the operating point of the process.

A cascade temperature control system with a secondary controller for heating and/or cooling medium flow is commonly used for

- Heat exchangers
- Reactors without a cooling jacket

21.44.4 Control loop monitoring for simulation with colored noise (ConPerMonSim)

Control loop monitoring with simulation of colored noise

The interconnection of the ConPerMon block with a PID controller can be found in the process tag type PID_Control (see PID controller with safety logic and control loop monitoring (PIDConL_ConPerMon) (Page 2324)). The example project supports you and helps to familiarize you with the concept and the potential of closed control loop monitoring. To do this, the template includes a process simulation with disturbance model. The colored noise is generated with the aid of a shape filter from a white noise signal. This produces a spectrum of disturbance signals that also contains energy components in the lower frequency ranges of the bandwidth of the closed control loop. Part of the disturbances can therefore be compensated by the PID controller while the high-frequency measurement noise cannot be corrected by any controller.

Application

After commissioning the controller and ConPerMon block, you should be able to watch the effects of the following actions that demonstrate the potential of control loop monitoring:

- Switch the controller to manual mode:
The variance of the controlled variable will rise but the `CPI` becomes invalid because no statements can be made about the control fit unless the control loop is closed.
- Change the parameters of the process simulation, for example, change `TimeLag2` from 2s to 8s:
This deterioration of the dynamic characteristics of the process (for example due to wear and tear) brings about a deterioration of the control quality that becomes visible in the `CPI` value long before it can be seen with the naked eye in the standard `PV` trends. If the control quality drops below a defined level, a `CPI` warning or even an alarm is generated.
- Request a setpoint step change from the controller:
The `CPI` will become temporarily invalid because all stochastic characteristics of the control quality, such as the variance, are based on the assumption of a steady state with a constant mean value. Select the "Setpoint" view from the drop-down list box in the ConPerMon faceplate to be able to watch the deterministic characteristics such as overshoot and settling ratio. Once a steady state is achieved again at the new setpoint and the entire time window is filled with data from the steady state, the monitoring of the stochastic characteristics is reactivated automatically.

You can find detailed information on the ConPerMon block and notes on interpreting its displays in the online help on the block (Page 565).

21.44.5 Feedforward control to compensate a measurable disturbance variable (DisturbCompSim)

Feedforward control to compensate a measurable disturbance variable

The example is based on the process tag type PID controller with dynamic feedforward control (FfwdDisturbCompensat) (Page 2329) and uses the following parameter sets:

Main controlled system:

$$g(s) = \frac{2}{2s+1} e^{-1.2s}$$

Disturbance transfer function:

$$g_x(s) = \frac{1}{3s+1} e^{-1.6s}$$

- PID: Gain = 0.197
- TI= 1.9
- TD= 0

Feedforward control:

$$c(s) = -\frac{g_x(s)}{g(s)} = -\frac{1}{2} \cdot \frac{2s+1}{3s+1} e^{-0.4s}$$

The same process simulation is set up twice, one instance with disturbance feedforward and the other without (all other process and controller parameters identical). The advantages of the feedforward control can be tested in a direct comparison ("benchmark simulation", "parallel slalom").

21.44.6 Operating point-oriented adaptation of parameters (gain scheduling) for non-linear processes (GainSchedSim)

Operating point-oriented adaptation of parameters (gain scheduling) for non-linear processes

The example is based on the process tag type PID - control with operating-point-oriented parameter control (GainScheduling) (Page 2327).

In the simulation template, the settings of the two most important process parameters are changed based on polylines depending on the operating point. The process and controller parameters for the example are shown in the following table.

Operating point	X=PV	ProcSim.Gain	ProcSim.TmLag1	ProcSim.TmLag2	Gain	TI	TD
1	20	4	5	10	0.6	14.7	3.7
2	100	3	3	10	1	8.8	2.2
3	200	2	1	10	10	4.1	1.1

The same process simulation is set up twice, one instance with gain scheduling and the other without (all other process and controller parameters are identical). The advantages of the gain scheduling can be tested in a direct comparison ("benchmark simulation", "parallel slalom").

21.44.7 Override control on a pipeline (OverrideSim)

Override control on a pipeline

The example is based on the process tag type Override control (Page 2348) and uses the following parameter sets:

Primary process (flow control):

$$g(s) = \frac{3}{(2s+1)^2}$$

Flow increases when the valve is opened and it disappears when the valve is closed.

PI flow controller: Gain= 0.33 , TI= 2.7

Secondary process (pressure control):

$$g_p(s) = \frac{-0.8}{(7s+1)(1s+1)}$$

The pressure rises when the valve is opened and is 80 bar when it is fully open.

PI pressure controller: Gain= 2.8 , TI= 4

Switching limits 15 bar < pressure < 70 bar.

21.44.8 Smith predictor for a dead time system (SmithPredictorSim)

Smith predictor for a dead time system

The example is based on the process tag type PID controller with Smith predictor (SmithPredictorControl) (Page 2332).

In the example, the same process simulation is set up twice, one instance with Smith predictor and the other without (all other process parameters are identical). The advantages of the Smith predictor can be tested in a direct comparison ("benchmark simulation", "parallel slalom").

21.44.9 Filtering of noisy measured values in a control loop (SigSmoothSim)

Filtering of noisy measured values in a control loop

The example illustrates the use of the Smooth block in a closed control loop. The block can be connected to any signal source without specialist knowledge so there is no need for a special process tag type. The simulation template is useful in testing the effects of a low-pass filter on a closed control loop by simulation. Increasing the filter time constant improves the smoothing effect but also causes a phase lag in the control loop that can have detrimental effects on the control quality and even the stability.

Parameters used

The following parameters are used in the simulation example:

Process transfer function:

$$g(s) = \frac{3}{(15s+1)(2s+1)}$$

with white noise on the output signal.

PI controller:

- Gain = 0,5
- TI = 7 s
- Sample time = 0.1s

Butterworth filter:

- TimeConstant = 3 s.

At 0.3 seconds, hardly any smoothing effect can be recognized, at 15 seconds significant deterioration of the control quality is already noticeable.

Processes with signals strongly affected by noise are a typical area of application (for example pressure sensors) and sensitive actuators (for example valves).

You can find detailed information on the Smooth block in the online help on the block (Page 1901).

21.44.10 Predictive control of a 2x2 multi-variable controlled system (ModPreConSim)

Predictive control of a 2x2 multi-variable controlled system

The example is based on the process tag type Model-based predictive control (ModPreCon) (Page 2351).

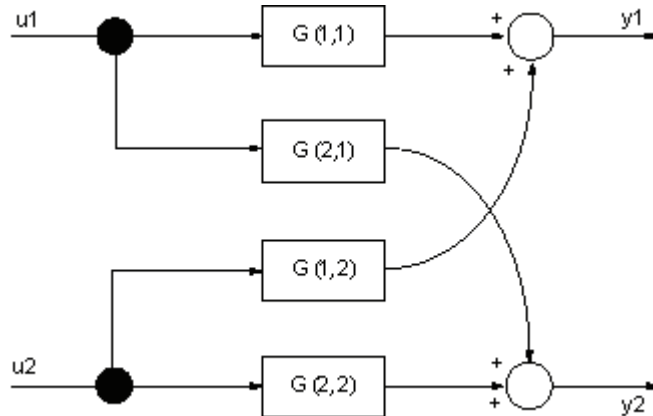

Figure 21-7 MIMO 2x2 process with a p-canonical structure

The example shows the application of the ModPreCon block for simulating a 2x2 multi-variable process consisting of the following four transfer functions:

$$\underline{G}(s) = \begin{bmatrix} G(1,1) & G(1,2) & \dots & G(1,n_u) \\ G(2,1) & G(2,2) & \dots & G(2,n_u) \\ \vdots & \vdots & \ddots & \vdots \\ G(n_y,1) & G(n_y,2) & \dots & G(n_y,n_u) \end{bmatrix} = \begin{bmatrix} \frac{3}{(30s+1)(4s+1)} & \frac{1.2}{(34s+1)(14s+1)(6s+1)} \\ \frac{1.3}{(28s+1)(12s+1)(6s+1)} & \frac{4}{(26s+1)(6s+1)} \end{bmatrix}$$

where $n_y = 2 =$ number of controlled variables, $n_u = 2 =$ number of manipulated variables, and $G(i_y, i_u)$ the transfer function from input i_u to output i_y . This simplest of multi-variable control systems helps familiarize newcomers with the concept and application of model-based multi-variable controllers.

21.44.11 Predictive control of a non-linear process (ModPreConNonLinSim)

Predictive control of a non-linear process

The example is based on the approach used by multi-model controlling as described in the section ModPreCon functions (Page 695), Controlling linear and non-linear processes.

A multi-variable process is observed with two input variables and two output variables. The non-linear reaction of four partial transfer functions Proc511, Proc512, Proc521 and Proc522 depends on a measurable process value, in this case the controlled variable PV511.

The assumption that all non-linearities of the multi-variable process depend on the current operating point, which is defined by a single measurable variable, restricts the range of application but is reasonable in many practical applications. The approach of the presented multi-model controlling only makes sense with this assumption.

In the example it is assumed that the operating point is defined by a temperature, and the process reaction is different at high temperatures (200° C) than it is at low temperatures (20° C).

Some parameters of the third order partial transfer function

$$Proc(i, j) = \frac{CV(i)}{MV(j)} = \frac{Gain}{(TmLag1 \cdot s + 1) \cdot (TmLag2 \cdot s + 1)(TmLag3 \cdot s + 1)}$$

are set using polylines continually depending on the operating point.

The extreme values of the operating-point-oriented parameters for the example are shown in the following table:

Operating point	PV511	Proc511.Gain	Proc511.TmLag2	Proc521.Gain	Proc512.TmLag2	Proc522.Gain
1	20	4	12	0,9	19	3
2	200	2	2	1,7	9	5

The changes of the process parameters are so substantial that a single linear controller cannot achieve enough control performance over the entire operating range. The changes, however, are continual and reproducible, which is an important requirement for the multi-model approach.

All other process parameters are constant:

	Gain	TmLag1	TmLag2	TmLag3
Proc511	variable	30	variable	0
Proc512	1,2	34	variable	6
Proc521	variable	28	12	6
Proc522	variable	26	6	0

The primary controller TIC511522Low was designed using the MPC Configurator for the low operating point at 20° C, the secondary controller TIC511522High is made for the high operating point at 200° C.

The matching functions for relevance of the two controllers are polylines with four interpolation points at 0, 30, 190 and 300° C. In the range between 0 and 30° C, only the controller designed for 20° C is active; only the controller designed for 200° C is active between 190 and 300° C. The manipulated variables of both controllers overlap between 30 and 190°.

Definitions

22.1 Batch process

Batch process

A batch process is a process control process, which is executed according to a recipe control batch by batch, i.e. intermittently, in a continually repeating sequence, for example, dosing raw material, tempering, performing chemical reactions, cooling, discharging reactors.

22.2 Approximation

Approximation

An approximation method in the mathematical sense.

22.3 Prediction horizon

Prediction horizon

For predictive controller: Time period running from the present to the future with a defined length. A process reaction is predicted within the prediction horizon.

22.4 Trajectory

Trajectory

In physics: refers to a flight path or track.

In control engineering: course of a variable over time, described by a sequence of values in a specified time scale.

22.5 Maverick

Maverick

A maverick in a continuous physical measurement is a numerical value that changes from one sampling point to another more than would be physically plausible. In other words, the difference between two neighboring values is greater than a specified tolerance range.

22.6 Ergodic process

Ergodic process

An ergodic process in mathematical statistics is a stationary process, in which the expected value can be estimated by generating the mean value over a time period of infinite length.

22.7 Conti process

Conti process

A Conti process is a process control process, whereby raw material is fed in a continual flow, and the products are continually output.

22.8 Multivariable controller

Multivariable controller

With a multivariable controller, one manipulated variable can influence several controlled variables and one controlled variable can be influenced by several manipulated variables, as is shown in the following diagram.

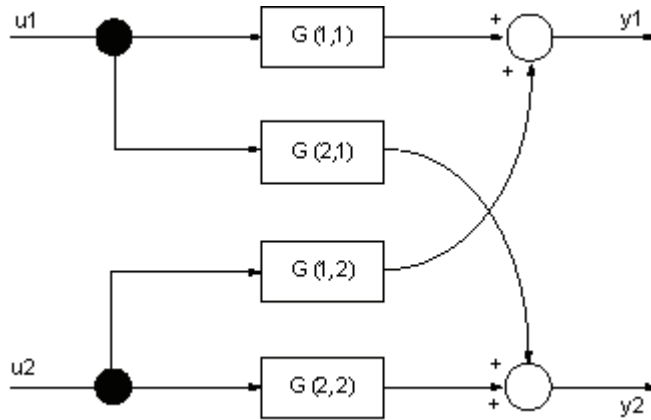

Figure 22-1 Example of a multivariable controller

When a multivariable section is automated using several individual PID controllers, the individual controllers do not take account of the interactions or links in the process. The stronger the links between the sub-sections, the harder it is to set individual controllers and the worse the control performance.

In such cases a multivariable controller offers higher control performance and simpler controller settings.

22.9 non-phase minimum

Non-phase minimum behavior mean

A phase minimum system is described by a linear, time-invariant transfer function, the frequency of which displays the smallest possible clockwise phase rotation for the given number of poles and zeros if the frequency interval is run through from negative to positive in full an infinite number of times. This means that both the transfer function and its inverse are stable.

Non-phase minimum behavior means for example that the process initially deflects downwards when the manipulated variable jumps positively before moving in a positive direction. Dead time systems are also non-phase minimal.

Index

0

0-1 edge transition, 78, 177

2

2-way valve circuit, 2368

A

AbsR

- Area of application, 1811
- Block diagram, 1813
- Configuration, 1811
- Error handling, 1812
- Forming the signal status for blocks, 1812
- Functions, 1812
- How it works, 1811
- I/Os, 1812
- Messaging, 1812
- Object name, 1811
- Operating modes, 1812
- Startup characteristics, 1811
- Status word allocation, 1811

Activate and deactivate maverick detection
Smooth, 1903

Activating error state for external process control error
CSF, 151

Activation and deactivation of messages

- Event, 1634
- Event16Ts, 1676
- EventNck, 1647
- EventTs, 1660

Activation enable, 100

Actuating signal, 570

Actuator, 807, 851, 2333, 2342, 2380

Actuator active information

- FmCont, 606
- FmTemp, 644
- PIDConL, 742
- PIDConR, 817
- PIDConS, 789
- PIDStepL, 859
- VlvAnL, 1465

Actuator block, 2334

Actuators, 2335, 2374

Adapting the color representation in the configured
message class

- MonDiL, 504

- MonDiS, 527

Add04

- Area of application, 1814
- Block diagram, 1818
- Configuration, 1814
- Error handling, 1816
- Forming the signal status for blocks, 1815
- Functions, 1815
- How it works, 1814
- I/Os, 1817
- Messaging, 1816
- Object name, 1814
- Operating modes, 1815
- Startup characteristics, 1814
- Status word allocation, 1814

Add08

- Area of application, 1819
- Block diagram, 1823
- Configuration, 1819
- Error handling, 1821
- Forming the signal status for blocks, 1820
- Functions, 1820
- How it works, 1819
- I/Os, 1822
- Messaging, 1821
- Object name, 1819
- Operating modes, 1820
- Startup characteristics, 1819
- Status word allocation, 1819

Adding additional values, 313

AddInt64

- Area of application, 2291
- Object name, 2291

Additional analog value

- Limit monitoring, 91

AddR64

- Area of application, 2292
- Object name, 2292

Advanced process control structures, 2372

Alarm delay

- Blocks with one time value per limit pair, 200

- Blocks with two time values per limit pair, 201

Alarm delays with a time value for all limits

- ConPerMon, 580

Alarm delays with one time value per limit pair

- AV, 441

- MonAnS, 482
- MotSpdCL, 1177
- VlvAnL, 1462
- Alarm delays with two time values per limit pair
 - DoseL, 1021
- Alarm thresholds, 199, 200, 201, 203
- Alternatives for determining the benchmark
 - ConPerMon, 575
- Analog driver blocks, 2372
- AND operation, 78
- And04
 - Area of application, 1977
 - Block diagram, 1981
 - Configuration, 1977
 - Error handling, 1979
 - Functions, 1978
 - How it works, 1977
 - I/Os, 1980
 - Messaging, 1979
 - Object name, 1977
 - Operating modes, 1978
 - Startup characteristics, 1977
 - Status word allocation, 1977
- And08
 - Area of application, 1982
 - Block diagram, 1986
 - Configuration, 1982
 - Error handling, 1983
 - Functions, 1983
 - How it works, 1982
 - I/Os, 1984
 - Messaging, 1984
 - Object name, 1982
 - Operating modes, 1983
 - Startup characteristics, 1982
 - Status word allocation, 1982
- Anti-windup
 - FmCont, 609
 - FmTemp, 648
 - ModPreCon, 698
 - MPC10x10, 950
 - PIDConL, 746
 - PIDConR, 823
 - PIDConS, 791
 - PIDStepL, 862
- AOTC, 313
 - Adding digital values, 307
 - Adding values, 307
 - AOTC window, 308
 - Deleting a trend, 318
 - Enabling/disabling a trend, 312
 - Enabling/disabling a value axis, 314
 - Opening, 307
 - Opening a related faceplate, 313
 - Opening a separate message window, 317
 - Saving and reopening a trend group, 315
- Area of application
 - AbsR, 1811
 - Add04, 1814
 - Add08, 1819
 - AddInt64, 2291
 - AddR64, 2292
 - And04, 1977
 - And08, 1982
 - AssetM, 2282
 - AV, 439
 - Average, 1824
 - CompAn02, 1917
 - ConPerMon, 565
 - CountOh, 1711
 - CountScL, 1689
 - DeadTime, 1830
 - Derivative, 1837
 - DiToInt64, 2293
 - DoseL, 1005
 - Event, 1631
 - Event16Ts, 1671
 - EventNck, 1644
 - EventTs, 1656
 - FbAnIn, 2041
 - FbAnOu, 2050
 - FbAnTot, 2132
 - FbDiIn, 2060
 - FbDiOu, 2069
 - FbEnMe, 2090
 - FbSwtMMS, 2101
 - FirstIn, 1626
 - FlipFlop, 1987
 - FlowCorr, 1849
 - FmCont, 599
 - FmTemp, 637
 - GainSched, 678
 - Int64ToDi, 2294
 - Integral, 1857
 - Intlk02, 1567
 - Intlk04, 1579
 - Intlk08, 1592
 - Intlk16, 1607
 - KalFilt, 980
 - Lag, 1865
 - Limit, 1922
 - MeanTime, 1872
 - MemR256, 2295
 - ModPreCon, 689

- MonAnL, 449
- MonDi08, 542
- MonDiL, 499
- MonDiS, 523
- MotL, 1073
- MotRevL, 1131
- MotS, 1107
- MotSpdCL, 1171
- MotSpdL, 1225
- MPC10x10, 939
- MSTIn, 2255
- MSTOu, 2259
- Mul04, 1879
- Mul08, 1885
- MuxAn03, 1928
- MuxAn08, 1936
- MuxMST, 2269
- MuxST, 2274
- NegInt64, 2296
- NegR64, 2297
- NoiseGen, 2037
- Not01, 2003
- OpAnL, 347
- OpAnS, 368
- OpDi01, 382
- OpDi03, 396
- OpStations, 411
- OpTrig, 423
- Or04, 1993
- Or08, 1998
- Pcs7AnIn, 2110
- Pcs7AnOu, 2122
- Pcs7Cnt2, 2174
- Pcs7Cnt3, 2183
- Pcs7DiIn, 2139
- Pcs7DiIT, 2147
- Pcs7DiOu, 2156
- Pcs7HaAI, 2192
- Pcs7HaAO, 2199
- PIDCoefR, 2298
- PIDConL, 735
- PIDConR, 807
- PIDConS, 784
- PIDKernR, 2304
- PIDStepL, 851
- Polygon, 1891
- Psc7Cnt1, 2164
- R64ToReal, 2299
- RateLim, 1942
- Ratio, 902
- Rcv_AnaVal, 2315
- Rcv_DigVal, 2308
- RealToR64, 2300
- RedAn02, 1950
- RedDi02, 2007
- SelA02In, 1955
- SelA16In, 1960
- SelD02In, 2012
- SelST16, 2301
- ShLeInt64, 2302
- ShrdResL, 1261
- ShrdResS, 1284
- ShRiInt64, 2303
- Smooth, 1901
- Snd_AnaVal, 2312
- Snd_DigVal, 2305
- SplRange, 921
- SqrRoot, 1907
- STIn, 2247
- STOu, 2251
- StrctCom, 2017
- StrctDeC, 2022
- StruAnIn, 2223
- StruAnOu, 2227
- StruDiln, 2231
- StruDiOu, 2235
- StruScIn, 2239
- StruScOu, 2243
- StruToBy, 2219
- Sub02, 1912
- TimerP, 1783
- TimeTrig, 1791
- TotalL, 1735
- Trigger, 2027
- Vlv2WayL, 1305
- VlvAnL, 1448
- VlvL, 1346
- VlvMotL, 1401
- VlvS, 1377
- XOr04, 2032
- AssetM, 2282
 - Area of application, 2282
 - Configurable reactions using the Feature parameter, 2285
 - Configuration, 2282
 - Description, 2282
 - Error handling, 2286
 - Functions, 2285
 - How it works, 2282
 - Signal status, 2285
 - Startup characteristics, 2282
 - Status word allocation, 2282
- Associated values
 - AV, 444

- ConPerMon, 582
 - CountOh, 1721
 - CountScL, 1698
 - DoseL, 1030
 - Event, 1638
 - EventNck, 1650
 - EventTs, 1664
 - FmCont, 618
 - FmTemp, 657
 - MonAnL, 461
 - MonAnS, 487
 - MonDi08, 549
 - MonDiL, 510
 - MonDiS, 531
 - MotL, 1087
 - MotRevL, 1147
 - MotS, 1117
 - MotSpdCL, 1193
 - MotSpdL, 1241
 - OpAnL, 353
 - PIDConL, 755
 - PIDConR, 832
 - PIDConS, 796
 - PIDStepL, 870
 - TotalL, 1751
 - Vlv2WayL, 1321
 - VlvAnL, 1470
 - VlvL, 1358
 - VlvMotL, 1421
 - VlvPosL, 1532
 - VlvS, 1387
 - Associated values (MsgEvid1)
 - Event16Ts, 1681, 1682
 - Associated values (MsgEvid2)
 - Event16Ts, 1682
 - Automatic closed-loop mode, 195
 - Automatic mode
 - Controller blocks, 72
 - Dosers, 75
 - Motors, 75
 - Valves, 75
 - Auxiliary values
 - Display, 211
 - AV
 - Alarm delays with one time value per limit pair, 441
 - Area of application, 439
 - Associated values, 444
 - Block diagram, 448
 - Configurable reactions using the Feature parameter, 442
 - Configuration, 439
 - Error handling, 443
 - Forming the signal status for blocks, 441
 - Functions, 441
 - Generating instance-specific messages, 442
 - How it works, 439
 - I/Os, 445
 - Limit monitoring of an additional analog value, 441
 - Limit monitoring with hysteresis, 441
 - Messaging, 443
 - Mode switchover error, 443
 - Operating modes, 440
 - Overview of error numbers, 443
 - Process messages, 444
 - Release for maintenance, 442
 - Selecting a unit of measure, 442
 - Simulating signals, 442
 - Startup characteristics, 439
 - Status word allocation, 440
 - Average
 - Area of application, 1824
 - Block diagram, 1829
 - Configurable reactions using the Feature parameter, 1826
 - Configuration, 1825
 - Error handling, 1826
 - Forming the signal status for blocks, 1826
 - Functions, 1826
 - How it works, 1824
 - I/Os, 1828
 - Messaging, 1827
 - Object name, 1824
 - Operating modes, 1825
 - Overview of error numbers, 1827
 - Startup characteristics, 1825
 - Status word allocation, 1825
- ## B
- Batch columns, 2328
 - Batch execution, 680
 - Batch process, 572, 2383
 - Batch reactors, 2328
 - Batch view, 302
 - Benchmark, 571
 - Benchmark simulation, 2378, 2379
 - Block diagram
 - AbsR, 1813
 - Add04, 1818
 - Add08, 1823
 - And04, 1981
 - And08, 1986

AV, 448
Average, 1829
CompAn02, 1921
ConPerMon, 589
CountOh, 1726
CountScL, 1702
DeadTime, 1836
Derivative, 1843
Div02, 1848
DoseL, 1045
Event, 1643
EventNck, 1655
EventTs, 1670, 1687
FbAnIn, 2049
FbAnOu, 2059
FbAnTot, 2138
FbDiIn, 2068
FbDiOu, 2078
FbEnME, 2100
FbSwtMMS, 2109
FirstIn, 1630
FlipFlop, 1992
FlowCorr, 1856
FmCont, 634
FmTemp, 675
GainSched, 685
Integral, 1863
Intlk02, 1578
Intlk04, 1591
Intlk08, 1606
Intlk16, 1625
KalFilt, 994
Lag, 1871
Limit, 1927
MeanTime, 1878
ModPreCon, 720
MonAnL, 470
MonAnS, 491
MonDi08, 554
MonDiL, 515
MonDiS, 535
MotL, 1096
MotRevL, 1157
MotS, 1123
MotSpdCL, 1207
MotSpdL, 1250
MPC10x10, 964
MSTIn, 2258
MSTOu, 2262
Mul04, 1884
Mul08, 1889
MuxAn03, 1935
MuxAn08, 1941
MuxMST, 2272
MuxST, 2278
Not01, 2006
OpAnL, 359
OpAnS, 376
OpDi01, 390
OpDi03, 405
OpStations, 418
OpTrig, 429
Or04, 1997
Or08, 2002
Pcs7AnIn, 2121
Pcs7AnOu, 2131
Pcs7Cnt3, 2191
Pcs7DiIn, 2146
Pcs7DiIT, 2155
Pcs7DiOu, 2162
Pcs7HaAI, 2197
Pcs7HaAO, 2204
PcsCnt2, 2182
PIDConL, 773
PIDConR, 850
PIDConS, 804
PIDStepL, 886
Polygon, 1900
Psc7Cnt1, 2173
RateLim, 1949
Ratio, 912
RedAn02, 1954
RedDi02, 2011
SelA02In, 1959
SelA16In, 1970
SelID02In, 2016
ShrdResL, 1277
ShrdResS, 1299
Smooth, 1906
SplRange, 928
STIn, 2250
STOu, 2254
StrctCom, 2020
StrctDeC, 2025
StrgToBy, 2222
StruAnIn, 2226
StruAnOu, 2230
StruDiln, 2234
StruDiOu, 2238
StruScIn, 2242
StruScOu, 2246
Sub02, 1911, 1916
TimerP, 1790
TimeTrig, 1802

- TotalL, 1757
- Trigger, 2031
- Vlv2WayL, 1332
- VlvAnL, 1483
- VlvL, 1366
- VlvMotL, 1432
- VlvPosL, 1546
- VlvS, 1393
- XOr04, 2036
- Block diagram of CntOhSc, 1776
- Block diagram of Rcv_DigVal, 2311
- Block diagram of RealToDw, 2265
- Block diagram of Snd_DigVal, 2307, 2314, 2318
- Block diagram of STRep, 2281
- Block icon
 - Configuring, 237
 - ConPerMon, 597
 - CountOh, 1733
 - DoseL, 1062
 - Interlock block, 241
 - KalFilt, 1004
 - ModPreCon, 732
 - MonDiL, 520, 539
 - MotRevL, 1168
 - MotSpdCL, 1222
 - MotSpdL, 1258
 - MPC10x10, 978
 - OpAnL, 366
 - OpAnS, 380
 - OpDi01, 394
 - OpDi03, 409
 - Operating, 239
 - OpStations, 422
 - OpTrig, 432
 - PIDConL, 239
 - PIDConS, 239
 - Ratio, 918
 - SelA16In, 1974
 - ShrdResL, 1282
 - ShrdResS, 1303
 - Static picture component, 245
 - TimeTrig, 1808
 - TotalL, 1766
 - Vlv2WayL, 1343
 - VlvAnL, 1503
 - VlvL, 1374
 - VlvMotL, 1444
 - VlvPosL, 1564
 - VlvS, 1399
- Block icon structure, 230
- Block icons for CntOhSc, 1781
- Block icons for SFC, 243
- Block symbol
 - MonAnL, 478
 - MonAnS, 497
 - MonDi08, 559
 - MotL, 1104
 - MotS, 1128
- Block-external simulation, 58
- Block-internal simulation, 58
- Blocks
 - Operator control permissions, 254
- Bumpless, 74, 178
- Bumpless switchover, 77, 121, 172, 173, 196, 282, 285
 - Controller blocks, 72
 - Dosers, 75
 - Manipulated variable, 131
 - Motors, 75
 - Setpoint, 129
 - Valves, 75
- Bumpless switchover from external to internal ratio
 - Ratio, 905
- Bumpless switchover from external to internal setpoint
 - DoseL, 1018
 - PIDConR, 819
- Button labels
 - FmCont, 614
 - MotL, 1084, 1112
 - MotRevL, 1143
 - MotSpdCL, 1187
 - MotSpdL, 1237
 - PIDStepL, 866
 - Vlv2WayL, 1317
 - VlvAnL, 1467
 - VlvL, 1356
 - VlvMotL, 1417
- Bypass
 - Intlk02, 1571
 - Intlk04, 1583
 - Intlk08, 1596
 - Intlk16, 1613
- Bypass function
 - MonAnL, 456
 - MonDiL, 506
 - PIDConL, 743
 - PIDConR, 819
 - PIDStepL, 860
 - TotalL, 1746
- Bypassing signals, 107

C

- Calculation of the flow rate for dosing by scale
 - DoseL, 1015
- Cascade, 902
- Cascade and ratio controls, 144
- Cascade circuit, 2334
- Cascade control, 196, 575, 599, 637, 689, 735, 807, 851, 2321, 2334, 2342, 2345, 2375
 - ConPerMon, 575
- Cascading
 - ShrdResS, 1289
- Changing labels on buttons and text
 - MonDi08, 547
 - MonDiL, 505
 - MonDiS, 528
 - OpDi01, 384
 - OpDi03, 399
- Channel block, 64
- Channel blocks, 138
- Channel driver block, 108, 174
- Channel error, 122
 - FbAnIn, 2046
 - FbAnOu, 2054
 - FbDiIn, 2064
 - FbDiIT, 2151
 - FbDiOu, 2073, 2159
 - Pcs7AnIn, 2117
 - Pcs7AnOu, 2127
 - Pcs7DiIn, 2143
- Channel function block, 207
- Channel management
 - ShrdResL, 1267
 - ShrdResS, 1288
- Channel prioritization
 - ShrdResL, 1269
 - ShrdResS, 1289
- CntOhSc
 - I/Os, 1773
- Coded unit of measure, 212
- CompAn02
 - Area of application, 1917
 - Block diagram, 1921
 - Configuration, 1917
 - Error handling, 1919
 - Forming the signal status for blocks, 1918
 - Functions, 1918
 - How it works, 1917
 - I/Os, 1920
 - Messaging, 1920
 - Object name, 1917
 - Operating modes, 1918
 - Startup characteristics, 1917
 - Status word allocation, 1918
- Configurable functions using the Feature parameter
 - Event16Ts, 1678
 - EventTs, 1661
- Configurable reactions using the Feature block
 - Event, 1635
- Configurable reactions using the Feature I/O
 - DeadTime, 1833
 - Intlk04, 1585
- Configurable reactions using the Feature parameter
 - AssetM, 2285
 - AV, 442
 - Average, 1826
 - ConPerMon, 579
 - CountOh, 1716
 - CountScL, 1695
 - Derivative, 1840
 - DoseL, 1022
 - EventNck, 1648
 - FbAnIn, 2045, 2063
 - FbAnOu, 2053
 - FbAnTot, 2134
 - FbDiOu, 2072
 - FbSwTMMMS, 2102
 - FmCont, 611
 - FmTemp, 650
 - GainSched, 681
 - Integral, 1860
 - Intlk02, 1573
 - Intlk08, 1599
 - Intlk16, 1616
 - KalFilt, 987
 - Lag, 1868
 - MeanTime, 1874
 - ModPreCon, 703
 - MonAnL, 456
 - MonAnS, 483
 - MonDi08, 546
 - MonDiL, 506
 - MonDiS, 529
 - MotL, 1083
 - MotRevL, 1142
 - MotS, 1114
 - MotSpdCL, 1186
 - MotSpdL, 1236
 - MPC10x10, 953
 - OpAnL, 350
 - OpAnS, 371
 - OpDi01, 386
 - OpDi03, 400

- OpTrig, 426
- Pcs7AnIn, 2116
- Pcs7AnOu, 2126
- Pcs7Cnt2, 2178
- Pcs7Cnt3, 2186
- Pcs7DiIn, 2143
- Pcs7DiIT, 2151
- Pcs7DiOu, 2159
- PcsCnt1, 2167
- PIDConL, 747
- PIDConR, 824
- PIDConS, 791
- PIDStepL, 863
- RateLim, 1945
- Ratio, 907
- SelA16In, 1964
- ShrdResL, 1265
- ShrdResS, 1287
- TotalL, 1746
- VlvAnL, 1461
- VlvL, 1354
- VlvMotL, 1416
- VlvPosL, 1526
- VlvS, 1384
- Configurable reactions using the Feature2 parameter, 1114
 - DoseL, 1023
 - FmCont, 611
 - FmTemp, 651
 - MotRevL, 1143
 - MotS, 1114
 - MotSpdCL, 1187
 - MotSpdL, 1237
 - PIDConL, 748
 - PIDStepL, 864
 - VlvS, 1384
- Configurable reactions using the Features parameter
 - Vlv2WayL, 1316
- Configuration
 - AbsR, 1811
 - Add04, 1814
 - Add08, 1819
 - And04, 1977
 - And08, 1982
 - AssetM, 2282
 - AV, 439
 - Average, 1825
 - CompAn02, 1917
 - ConPerMon, 566
 - CountOh, 1713
 - CountScL, 1691
 - DeadTime, 1831
 - Derivative, 1839
 - Div02, 1844
 - DoseL, 1005
 - Event, 1631
 - Event16Ts, 1672
 - EventNck, 1644
 - EventTs, 1656
 - FbAnIn, 2041
 - FbAnOu, 2050
 - FbAnTot, 2132
 - FbDiIn, 2060
 - FbDiOu, 2069
 - FbEnMe, 2090
 - FbSwtMMS, 2101
 - FirstIn, 1626
 - FlipFlop, 1988
 - FlowCorr, 1851
 - FmCont, 599
 - FmTemp, 637
 - GainSched, 679
 - Integral, 1858
 - Intlk02, 1567
 - Intlk04, 1579
 - Intlk08, 1592
 - Intlk16, 1607
 - KalFilt, 983
 - Lag, 1866
 - Limit, 1923
 - MeanTime, 1872
 - ModPreCon, 691
 - MonAnL, 449
 - MonAnS, 480
 - MonDi08, 542
 - MonDiL, 500
 - MonDiS, 524
 - MotL, 1073
 - MotRevL, 1131
 - MotS, 1107
 - MotSpdCL, 1171
 - MotSpdL, 1225
 - MPC10x10, 942
 - MSTIn, 2255
 - MSTOu, 2259
 - Mul04, 1879
 - Mul08, 1885
 - MuxAn03, 1928
 - MuxAn08, 1936
 - MuxMST, 2269
 - MuxST, 2274
 - Not01, 2003
 - OpAnL, 347
 - OpAnS, 368

- OpDi01, 382
- OpDi03, 396
- OpStations, 411
- OpTrig, 423
- Or04, 1993
- Or08, 1998
- Pcs7AnIn, 2110
- Pcs7AnOu, 2122
- Pcs7Cnt2, 2176
- Pcs7Cnt3, 2184
- Pcs7DiIn, 2139
- Pcs7DiIT, 2147
- Pcs7DiOu, 2156
- Pcs7HaAI, 2192
- Pcs7HaAO, 2199
- PIDConL, 735
- PIDConR, 808
- PIDConS, 784
- PIDStepL, 852
- Polygon, 1893
- Psc7Cnt1, 2165
- RateLim, 1942
- Ratio, 903
- Rcv_AnaVal, 2316
- Rcv_DigVal, 2309
- RedAn02, 1950
- RedDi02, 2007
- SelA02In, 1955
- SelA16In, 1960
- SelD02In, 2012
- ShrdResL, 1262
- ShrdResS, 1285
- Smooth, 1901
- Snd_DigVal, 2306, 2313
- SplRange, 922
- SqrRoot, 1907
- STIn, 2247
- STOu, 2251
- StrctCom, 2017
- StrctDeC, 2022
- StruAnIn, 2223
- StruAnOu, 2227
- StruDiln, 2231
- StruDiOu, 2235
- StruScIn, 2239
- StruScOu, 2243
- StruToBy, 2219
- Sub02, 1912
- TimerP, 1783
- TimeTrig, 1791
- TotalL, 1742
- Trigger, 2027
- Vlv2WayL, 1305
- VlvAnL, 1448
- VlvL, 1346
- VlvMotL, 1401
- VlvPosL, 1506
- VlvS, 1377
- XOr04, 2032
- Configured runtime monitoring, 81
- ConPerMon
 - Alarm delays with a time value, 580
 - Alternatives for determining the benchmark, 575
 - Area of application, 565
 - Associated values, 582
 - Block diagram, 589
 - Block icon, 597
 - Cascade control, 575
 - Configurable reactions using the Feature parameter, 579
 - Configuration, 566
 - Error handling, 581
 - Feedforward control, 576
 - Forming the signal status for blocks, 578
 - Functions, 569
 - Generating instance-specific messages, 580
 - How it works, 565
 - I/Os, 583
 - Instance-specific messages, 582
 - Limit operation and display in the faceplate, 580
 - Limit view, 592
 - Messaging, 581
 - Monitoring of deterministic characteristics of the control performance, 572
 - Monitoring of stochastic characteristics of the control performance, 570
 - Multivariable controller, 577
 - Object name, 565
 - Opening additional faceplates, 580
 - Operating modes, 569
 - Operator permissions, 579
 - Override control, 576
 - Overview of error numbers, 581
 - Parameter view, 593
 - PID controller with gain scheduler, 576
 - Preview, 594
 - Process messages, 582
 - Ratio control, 577
 - Selecting a unit of measure, 578
 - SIMATIC BATCH functionality, 580
 - Smith predictor, 576
 - Split-range control, 576
 - Standard view, 590
 - Startup characteristics, 567

- Status word allocation, 568
- Suppressing messages using the MsgLock parameter, 580
- Considering bad quality of automatic commands or external values
 - DoseL, 1021
 - MotL, 1081
 - MotRevL, 1140
 - MotS, 1113
 - MotSpdCL, 1184
 - MotSpdL, 1234
 - OpAnL, 350
 - OpAnS, 370
 - OpDi01, 385
 - OpDi03, 400
 - OpTrig, 425
 - Vlv2WayL, 1315
 - VlvAnL, 1457
 - VlvL, 1353
 - VlvMotL, 1412
 - VlvPosL, 1522
 - VlvS, 1383
- Conti process, 572, 679, 2389
- Conti reactors, 699, 950
- Continuous controller, 599, 604, 637, 642
- Control of linear and non-linear systems
 - ModPreCon, 701
 - MPC10x10, 952
- Control of square and non-square systems
 - ModPreCon, 700
 - MPC10x10, 951
- Control outputs
 - DoseL, 1013
- Control performance, 565, 571, 581, 591, 678, 691, 941, 2332, 2377, 2380, 2382
- Control performance index, 592
- Control performance index (CPI), 571
- Control quality monitoring, 2351
- Control system fault
 - VlvPosL, 1531
- Control system fault (CSF), 615, 654, 752, 794, 829, 867, 868, 1026, 1085, 1086, 1115, 1116, 1144, 1146, 1189, 1191, 1238, 1239, 1318, 1319, 1356, 1357, 1385, 1386, 1418, 1419, 1467, 1468, 1528, 1530
 - MonAnL, 459, 508
 - MonAnS, 486
 - MonDiS, 530
- Control zone
 - PIDConL, 746
 - Using, 194
- Control zone width, 195
- Control zone with frozen I component, 160, 161
- Controlled closed-loop mode, 195
- Controller blocks
 - Automatic mode, 72
 - Bumpless switchover, 72
 - Manual mode, 72
- Controller with I component, 570
- Controllers
 - Program mode, 78
- Controlling a device infeed or an inverter enable
 - MotSpdCL, 1187
- Conversion block, 207
- CountOh
 - Area of application, 1711
 - Associated values, 1721
 - Block diagram, 1726
 - Block icon, 1733
 - Configurable reactions using the Feature parameter, 1716
 - Configuration, 1713
 - Display and operator input area for process values and setpoints, 1717
 - Error handling, 1720
 - Forming the signal status for blocks, 1718
 - Functions, 1715
 - How it works, 1711
 - I/Os, 1722
 - Limit monitoring of the operating time, 1716
 - Limit view, 1730
 - Messaging, 1720
 - Object name, 1711
 - Opening additional faceplates, 1718
 - Operating modes, 1715
 - Operator permissions, 1718
 - Overview of error numbers, 1720
 - Parameter view, 1731
 - Preview, 1732
 - Process messages, 1721
 - Read back the last counted value, 1717
 - Release for maintenance, 1719
 - Reset counter to zero, 1717
 - Setting the count value to the default setting, 1718
 - SIMATIC BATCH functionality, 1719
 - Standard view, 1728
 - Startup characteristics, 1713
 - Status word allocation, 1713
 - Suppressing messages using the MsgLock parameter, 1716
 - Time response, 1713
- CountScl
 - Area of application, 1689
 - Associated values, 1698

- Block diagram, 1702
 - Configurable reactions using the Feature parameter, 1695
 - Configuration, 1691
 - CountScL block icon, 1709
 - Error handling, 1697
 - Forming the signal status for blocks, 1695
 - Functions, 1694
 - How it works, 1690
 - I/Os, 1699
 - Limit monitoring of the count value, 1694
 - Limit view, 1706
 - Messaging, 1698
 - Object name, 1689
 - Opening additional faceplates, 1696
 - Operating modes, 1693
 - Operator permissions, 1695
 - Overview of error numbers, 1697
 - Parameter view, 1707
 - Preview, 1708
 - Process messages, 1698
 - Read back the last counted value, 1694
 - Release for maintenance, 1696
 - Reset counter to zero, 1694
 - Selecting a unit of measure, 1695
 - Setting the count value to the default setting, 1694
 - SIMATIC BATCH functionality, 1697
 - Standard view, 1704
 - Startup characteristics, 1691
 - Status word allocation, 1692
 - Suppressing messages using the MsgLock parameter, 1695
 - Time response, 1691
 - CSF and ExtMsgx
 - Group display for limit monitoring, 85
 - Customer-specific units, 212
 - CV bands, 697, 949
 - Cycle counter, 1824
- D**
- D action, 198
 - D component, 195, 609, 735, 784, 807, 851
 - Dead band
 - Description, 61
 - MonAnL, 455
 - MonAnS, 483
 - Dead band zone, 921
 - DeadTime
 - Area of application, 1830
 - Block diagram, 1836
 - Configurable reactions using the Feature I/O, 1833
 - Configuration, 1831
 - Error handling, 1833
 - Forming the signal status for blocks, 1833
 - Functions, 1832
 - How it works, 1830
 - I/Os, 1835
 - Messaging, 1834
 - Object name, 1830
 - Operating modes, 1832
 - Overview of error numbers, 1833
 - Startup characteristics, 1831
 - Status word allocation, 1832
 - Deenergized state, 48
 - Defining valve positions for individual valves
 - Vlv2WayL, 1311
 - Delay of alarms
 - Event, 1635
 - EventNck, 1647
 - Delayed output of a single trigger
 - TimeTrig, 1794
 - Delaying the on and off switching functions
 - MonDiL, 504
 - Delaying the on function
 - MonDiS, 527
 - Derivative
 - Area of application, 1837
 - Block diagram, 1843
 - Configurable reactions using the Feature parameter, 1840
 - Configuration, 1839
 - Error handling, 1841
 - Forming the signal status for blocks, 1840
 - Functions, 1840
 - How it works, 1837
 - I/Os, 1842
 - Limit monitoring, 1840
 - Messaging, 1841
 - Object name, 1837
 - Operating modes, 1839
 - Overview of error numbers, 1841
 - Startup characteristics, 1839
 - Status word allocation, 1839
 - Description
 - Pcs7Cnt3, 2183
 - Description of, 2164, 2174
 - AssetM, 2282
 - MemR256, 2295
 - Pcs7Cnt2, 2174
 - Psc7Cnt1, 2164
 - StateMap, 2266

- Description of CntOhSc, 1768
- Description of RealToDw, 2263
- Description of STRep, 2279
- Detecting the creep rate, 168
- Determining the dosing quantity when dosing using scales
 - DoseL, 1014
- Determining the dosing quantity when using flow dosing
 - DoseL, 1013
- Deterministic characteristics, 565, 571, 2377
- Digital feedback from the readback value
 - VlvAnL, 1463
- Disable feedback
 - VlvPosL, 1527
- Disable interlocks
 - VlvPosL, 1520
- Disabling feedback
 - Vlv2WayL, 1313
 - VlvAnL, 1466
 - VlvL, 1353
 - VlvMotL, 1413
- Disabling interlocks
 - DoseL, 1019
 - MotL, 1080
 - MotRevL, 1139
 - MotS, 1112
 - MotSpdCL, 1182
 - MotSpdL, 1232
 - Vlv2WayL, 1313
 - VlvL, 1351
 - VlvMotL, 1411
 - VlvS, 1382
- Display and operator input area for process values and setpoints
 - CountOh, 1717
 - DoseL, 1021
 - Ratio, 905
- Display auxiliary values
 - VlvPosL, 1527
- Display of selected value
 - SeID02In, 2013
- Displaying additional information relating to the manipulated variable on the output
 - PIDConR, 817
- Displaying and outputting the signal status
 - Event16Ts, 1678
 - EventTs, 1661
- Displaying auxiliary values
 - DoseL, 1025
 - MonAnL, 454
 - MonDiL, 505
- MotL, 1084
- MotRevL, 1143
- MotSpdCL, 1187
- MotSpdL, 1237
- Vlv2WayL, 1317
- VlvAnL, 1462
- VlvL, 1355
- VlvMotL, 1416
- DiToInt64
 - Area of application, 2293
 - Object name, 2293
- Div02
 - Area of application, 1844
 - Block diagram, 1848
 - Configuration, 1844
 - Error handling, 1846
 - Forming the signal status for blocks, 1845
 - Functions, 1845
 - How it works, 1844
 - I/Os, 1847
 - Messaging, 1847
 - Object name, 1844
 - Operating modes, 1845
 - Overview of error numbers, 1846
 - Startup characteristics, 1844
 - Status word allocation, 1844
- DMC procedure (Dynamic Matrix Control), 691, 941
- DoseL
 - Alarm delays with two time values per limit pair, 1021
 - Area of application, 1005
 - Associated values, 1030
 - Block diagram, 1045
 - Block icon, 1062
 - Bumpless switchover from external to internal setpoint, 1018
 - Calculation of the flow rate for dosing by scale, 1015
 - Configurable reactions using the Feature parameter, 1022
 - Configurable reactions using the Feature2 parameter, 1023
 - Configuration, 1005
 - Considering bad quality of automatic commands or external values, 1021
 - Control outputs, 1013
 - Determining the dosing quantity when dosing using scales, 1014
 - Determining the dosing quantity when using flow dosing, 1013
 - Disabling interlocks, 1019

Display and operator input area for process values and setpoints, 1021
 Displaying auxiliary values, 1025
 Dribbling, 1015
 Error handling, 1025
 External/internal setpoint specification, 1017
 Forcing operating modes, 1018
 Forming the group status for interlocks, 1020
 Forming the signal status for blocks, 1020
 Functions, 1011
 Generating instance-specific messages, 1022
 Group error, 1020
 How it works, 1005
 I/Os, 1031
 Instance-specific messages, 1029
 Interlocks, 1019
 Limit monitoring of the process value, 1018
 Messaging, 1028
 Mode switchover error, 1026
 Object name, 1005
 Opening additional faceplates, 1021
 Operating modes, 1009
 Operator permissions, 1023
 Output signal as a pulse signal or static signal, 1013
 Outputting a signal for start readiness, 1020
 Overdosing/underdosing, 1016
 Overview of error numbers, 1026
 Post dosing, 1016
 Preview, 1060
 Process control fault, 1028
 Process messages, 1029
 Release for maintenance, 1021
 Resetting the block in case of interlocks or errors, 1019
 Resetting the dosing quantity, 1017
 Selecting a unit of measure, 1021
 Setpoint limitation, 1018
 Setpoint view, 1058
 SIMATIC BATCH functionality, 1025
 Simulating signals, 1019
 Startup characteristics, 1006
 Status diagram, 1011
 Status word allocation, 1006
 Suppressing messages using the MsgLock parameter, 1018
 Time-stamped messages, 1025
 Dribbling
 DoseL, 1015

E

Emergency stop for motors, 106
 Enable/disable channel
 ShrdResL, 1269
 ShrdResS, 1289
 Ergodic process, 2388
 Error handling
 AbsR, 1812
 Add04, 1816
 Add08, 1821
 And04, 1979
 And08, 1983
 AssetM, 2286
 AV, 443
 Average, 1826
 CompAn02, 1919
 ConPerMon, 581
 CountOh, 1720
 CountScL, 1697
 DeadTime, 1833
 Derivative, 1841
 Div02, 1846
 DoseL, 1025
 Event, 1636
 EventNck, 1649
 EventTs, 1662, 1679
 FbAnIn, 2045
 FbAnOu, 2054
 FbAnTot, 2135
 FbDiIn, 2064
 FbDiOu, 2072
 FbEnMe, 2093
 FbSwMMS, 2103
 FirstIn, 1628
 FlipFlop, 1990
 FlowCorr, 1853
 FmCont, 614
 FmTemp, 654
 GainSched, 682
 Integral, 1861
 Intlk02, 1573
 Intlk04, 1586
 Intlk08, 1600
 Intlk16, 1616
 KalFilt, 988
 Lag, 1868
 Limit, 1925
 MeanTime, 1876
 ModPreCon, 708
 MonAnL, 459

- MonAnS, 485
- MonDi08, 547
- MonDiL, 508
- MonDiS, 530
- MotL, 1085
- MotRevL, 1144
- MotS, 1115
- MotSpdCL, 1189
- MotSpdL, 1238
- MPC10x10, 957
- MSTIn, 2256
- MSTOu, 2260
- Mul04, 1882
- Mul08, 1887
- MuxAn03, 1932
- MuxAn08, 1939
- MuxMST, 2271
- MuxST, 2276
- Not01, 2004
- OpAnL, 352
- OpAnS, 372
- OpDi01, 386
- OpDi03, 401
- OpStations, 415
- OpTrig, 426
- Or04, 1995
- Or08, 2000
- Overview, 119
- Pcs7AnIn, 2117
- Pcs7AnOu, 2127
- Pcs7Cnt2, 2179
- Pcs7DiIn, 2143
- Pcs7DiIT, 2151
- Pcs7DiOu, 2159
- Pcs7HaAI, 2194
- Pcs7HaAO, 2201
- PcsCnt3, 2186
- PIDConL, 752
- PIDConR, 829
- PIDConS, 794
- PIDStepL, 867
- Polygon, 1895
- Psc7Cnt1, 2168
- RateLim, 1946
- Ratio, 907
- Rcv_AnaVal, 2316
- Rcv_DigVal, 2310
- RedAn02, 1952
- RedDi02, 2009
- SelA02In, 1957
- SelA16In, 1965
- SelD02In, 2014
- ShrdResL, 1271
- ShrdResS, 1290
- Smooth, 1903
- Snd_AnaVal, 2313
- Snd_DigVal, 2307
- SplRange, 926
- SqrRoot, 1909
- StateMap, 2267
- STIn, 2248
- STOu, 2252
- StrctCom, 2019
- StrctDeC, 2024
- StrgToBy, 2221
- StruAnIn, 2224
- StruAnOu, 2228
- StruDiln, 2232
- StruDiOu, 2236
- StruScIn, 2240
- StruScOu, 2244
- Sub02, 1914
- TimerP, 1787
- TimeTrig, 1797
- TotalL, 1749
- Trigger, 2029
- Vlv2WayL, 1318
- VlvAnL, 1467
- VlvL, 1356
- VlvMotL, 1418
- VlvPosL, 1528
- VlvS, 1385
- XOr04, 2034
- Error handling of RealToDw, 2264
- Error handling of STRep, 2280
- Error numbers
 - Tabular overview, 120
- Error signal, 95
- Error signal generation and dead band
 - FmCont, 607
 - FmTemp, 646
 - ModPreCon, 697
 - MPC10x10, 949
 - PIDConL, 744
 - PIDConR, 820
 - PIDConS, 790
 - PIDStepL, 860
- Event
 - Activation and deactivation of messages, 1634
 - Area of application, 1631
 - Associated values, 1638
 - Block diagram, 1643
 - Configurable reactions using the Feature block, 1635

- Configuration, 1631
- Delay of alarms, 1635
- Error handling, 1636
- Forming the signal status for blocks, 1636
- Functions, 1634
- How it works, 1631
- I/Os, 1639
- Messaging, 1637
- Object name, 1631
- Operating modes, 1634
- Operator control permissions, 1635
- Overview of error numbers, 1636
- Process messages, 1637
- Release for maintenance, 1635
- Startup characteristics, 1631
- Status word allocation, 1632
- Suppressing messages using the MsgLock parameter, 1635
- Event16Ts
 - Activation and deactivation of messages, 1676
 - Area of application, 1671
 - Associated values (MsgEvId1), 1681, 1682
 - Associated values (MsgEvId2), 1682
 - Configurable functions using the Feature parameter, 1678
 - Configuration, 1672
 - Displaying and outputting the signal status, 1678
 - Functions, 1676
 - How it works, 1671
 - Messaging, 1679
 - Object name, 1671
 - Operating modes, 1676
 - Operator permissions, 1677
 - Process messages (MsgEvId1), 1680
 - Process messages (MsgEvId2), 1681
 - Release for maintenance, 1677
 - Signal status as associated value of a message, 1677
 - Startup characteristics, 1672
 - Status word allocation, 1673
 - Suppressing messages using the MsgLock parameter, 1677
 - Time stamp as associated value of a message, 1677
- EventNck
 - Activation and deactivation of messages, 1647
 - Area of application, 1644
 - Associated values, 1650
 - Block diagram, 1655
 - Configuration, 1644
 - Delay of alarms, 1647
 - Error handling, 1649
 - Forming the signal status for blocks, 1648
 - Functions, 1647
 - How it works, 1644
 - I/Os, 1651
 - Messaging, 1650
 - Object name, 1644
 - Operating modes, 1646
 - Operator control permissions, 1648
 - Overview of error numbers, 1649
 - Process messages, 1650
 - Release for maintenance, 1648
 - Startup characteristics, 1644
 - Status word allocation, 1645
 - Suppressing messages using the MsgLock parameter, 1647
- EventTs
 - Activation and deactivation of messages, 1660
 - Area of application, 1656
 - Associated values, 1664
 - Block diagram, 1670, 1687
 - Configurable functions using the Feature parameter, 1661
 - Configuration, 1656
 - Displaying and outputting the signal status, 1661
 - Error handling, 1662, 1679
 - Functions, 1660
 - How it works, 1656
 - I/Os, 1666, 1685
 - Messaging, 1663
 - Object name, 1656
 - Operating modes, 1659
 - Operator permissions, 1661
 - Overview of error numbers, 1662, 1679
 - Process messages, 1663
 - Release for maintenance, 1660
 - Signal status as associated value of a message, 1660
 - Startup characteristics, 1657
 - Status word allocation, 1657
 - Suppressing messages using the MsgLock parameter, 1660
 - Time stamp as associated value of a message, 1660
- External manipulated variable, 126
- External process control error, 119
- External setpoint, 124
- External simulation, 59
- External/internal setpoint specification
 - DoseL, 1017
 - FmCont, 606
 - FmTemp, 645
 - MotSpdCL, 1180

PIDConL, 742
 PIDConR, 818
 PIDConS, 789
 PIDStepL, 859

F

FbAnIn

Area of application, 2041
 Block diagram, 2049
 Channel error, 2046
 Configurable reactions using the Feature parameter, 2045, 2063
 Configuration, 2041
 Error handling, 2045
 Flutter suppression, 2044
 Functions, 2043
 Higher-level error / invalid measuring range, 2046
 Holding the last value if raw value is invalid, 2043
 How it works, 2041
 I/Os, 2047
 Messaging, 2046
 Object name, 2041
 Obtaining the standard value, 2043
 Operating modes, 2043
 Output substitute value if raw value is invalid, 2044
 Outputting an invalid value if analog value is invalid, 2044
 Quality code, 2042
 Redundancy, 2042
 Signal status for Fb channel blocks, 2044
 Simulating signals, 2044, 2063
 Startup characteristics, 2042
 Status word allocation, 2042

FbAnOu

Area of application, 2050
 Block diagram, 2059
 Channel error, 2054
 Configurable reactions using the Feature parameter, 2053
 Configuration, 2050
 Error handling, 2054
 Flutter suppression, 2052
 Functions, 2052
 Higher-level error / invalid measuring range, 2054
 How it works, 2050
 I/Os, 2055
 Messaging, 2054
 Modes, 2052
 Object name, 2050
 Obtaining the standard value, 2052

Quality code, 2051
 Redundancy, 2051
 Signal status for Fb channel blocks, 2053
 Simulating signals, 2053
 Startup characteristics, 2051
 Status word allocation, 2051

FbAnTot

Area of application, 2132
 Block diagram, 2138
 Configurable reactions using the Feature parameter, 2134
 Configuration, 2132
 Error handling, 2135
 Flutter suppression, 2134
 Functions, 2133
 Holding the last value if raw value is invalid, 2133
 How it works, 2132
 I/Os, 2135
 Messaging, 2135
 Object name, 2132
 Obtaining the standard value, 2133
 Operating modes, 2133
 Output substitute value if raw value is invalid, 2133
 Outputting an invalid value if analog value is invalid, 2134
 Signal status for Fb channel blocks, 2134
 Simulating signals, 2134
 Startup characteristics, 2133

FbDiln

Area of application, 2060
 Block diagram, 2068
 Channel error, 2064
 Configuration, 2060
 Error handling, 2064
 Flutter suppression, 2062
 Functions, 2062
 Higher-level error / invalid measuring range, 2064
 Holding the last value if raw value is invalid, 2062
 How it works, 2060
 I/Os, 2065
 Messaging, 2064
 Object name, 2060
 Obtaining the standard value, 2062
 Operating modes, 2061
 Output of invalid value if raw value is invalid, 2062
 Output substitute value if raw value is invalid, 2062
 Signal status for Fb channel blocks, 2062
 Startup characteristics, 2061
 Status word allocation, 2061

- FbDiIT
 - Channel error, 2151
 - Higher-level error / invalid measuring range, 2151
- FbDiOu
 - Area of application, 2069
 - Block diagram, 2078
 - Channel error, 2073, 2159
 - Configurable reactions using the Feature parameter, 2072
 - Configuration, 2069
 - Error handling, 2072
 - Flutter suppression, 2071
 - Functions, 2071
 - Higher-level error / invalid measuring range, 2073
 - How it works, 2069
 - I/Os, 2074
 - Messaging, 2073
 - Modes, 2071
 - Object name, 2069
 - Obtaining the standard value, 2071
 - Signal status for Fb channel blocks, 2071
 - Simulating signals, 2072
 - Startup characteristics, 2070
 - Status word allocation, 2070
- FbDrive, 2361
 - Area of application, 2079
 - Configuration, 2079
 - Error handling, 2082
 - Functions, 2080
 - How it works, 2079
 - I/Os, 2083
 - Startup characteristics, 2080
- FbEnMe
 - Area of application, 2090
 - Block diagram,
 - Configuration, 2090
 - Error handling, 2093
 - Functions, 2091
 - How it works, 2090
 - I/Os, 2094
 - Messaging, 2093
 - Object name, 2090
 - Operating modes, 2091
 - Startup characteristics, 2090
 - Status word allocation, 2091
- FbSwtMMS, 2366
 - Area of application, 2101
 - Block diagram, 2109
 - Configurable reactions using the Feature parameter, 2102
 - Configuration, 2101
 - Error handling, 2103
 - Functions, 2102
 - How it works, 2101
 - I/Os, 2105
 - Messaging, 2104
 - Operating modes, 2102
 - Startup characteristics, 2102
 - Transmission of messages, 2102
- Feature
 - Bit assignment, 131
 - Control zone with frozen I component, 160, 161
 - Description, 131
 - First-in detection response to deactivation, 176
 - Frequency converter with separate device feed, 151
 - Process value with separate scale range, 162
 - Set startup characteristics, 138
 - Specifying the reaction to exiting local mode, 177
- Feedback monitoring, 97
 - MotL, 1082
 - MotRevL, 1141
 - MotS, 1113
 - MotSpdCL, 1184
 - MotSpdL, 1234
 - Vlv2WayL, 1312
 - VlvAnL, 1457
 - VlvL, 1353
 - VlvMotL, 1413
 - VlvPosL, 1523
 - VlvS, 1383
- Feedbacks
 - Disable monitoring, 97
 - Monitoring, 97
- Feedforward control, 2329
 - ConPerMon, 576
- Feedforward control and limitation, 197
- Feedforwarding and limiting disturbance variables
 - FmCont, 609
 - FmTemp, 648
 - PIDConL, 746
 - PIDConR, 823
 - PIDStepL, 862
- Final controlling element, 570, 606, 644, 735, 784, 2321, 2334, 2348, 2349, 2350, 2375
- FirstIn
 - Area of application, 1626
 - Block diagram, 1630
 - Configuration, 1626
 - Error handling, 1628
 - Functions, 1628
 - How it works, 1626
 - I/Os, 1629
 - Messaging, 1629

- Object name, 1626
- Operating modes, 1627
- Startup characteristics, 1627
- Status word allocation, 1627
- First-in detection
 - Intlk02, 1570
 - Intlk04, 1584
 - Intlk08, 1598
 - Intlk16, 1614
- First-in detection response to deactivation, 176
 - Feature parameter, 176
- Fixed setpoint control, 599, 637, 689, 735, 784, 807, 851
- FlipFlop
 - Area of application, 1987
 - Block diagram, 1992
 - Configuration, 1988
 - Error handling, 1990
 - Functions, 1989
 - How it works, 1987
 - How the block works as RS-FlipFlop (Mode = 1), 1988
 - How the block works as SR-FlipFlop (Mode = 0), 1987
 - I/Os, 1991
 - Initialization, 1990
 - Messaging, 1991
 - Object name, 1987
 - Operating modes, 1988
 - Startup characteristics, 1988
 - Status word allocation, 1988
- Flow alarm, 137
- FlowCorr
 - Area of application, 1849
 - Block diagram, 1856
 - Configuration, 1851
 - Error handling, 1853
 - Forming the signal status for blocks, 1852
 - Functions, 1852
 - How it works, 1849
 - I/Os, 1854
 - Messaging, 1854
 - Object name, 1849
 - Operating modes, 1851
 - Startup characteristics, 1851
 - Status word allocation, 1851
- Flutter alarm
 - MonDi08, 548
 - MonDiL, 508
- Flutter suppression, 67, 97
 - FbAnIn, 2044
 - FbAnOu, 2052
- FbAnTot, 2134
- FbDiIn, 2062
- FbDiOu, 2071
- Pcs7AnOu, 2126
- Pcs7Cnt2, 2178
- Pcs7DiIn, 2142
- Pcs7DiOu, 2159
- Psc7AnIn, 2115
- Psc7Cnt1, 2167
- Psc7Cnt3, 2185
- Psc7DiIT, 2150
- FM controller
 - Preview, 297
 - Standard view, 261, 265, 269, 273
- FmCont
 - Actuator active information, 606
 - Anti-windup, 609
 - Area of application, 599
 - Associated values, 618
 - Block diagram, 634
 - Button labels, 614
 - Configurable reactions using the Feature parameter, 611
 - Configurable reactions using the Feature2 parameter, 611
 - Configuration, 599
 - Error handling, 614
 - Error signal generation and dead band, 607
 - External/internal setpoint specification, 606
 - Feedforwarding and limiting disturbance variables, 609
 - Forming the signal status for blocks, 610
 - Functions, 604
 - Generating actuating signals for step controllers without position feedback (WithRbk = 0), 605
 - Generating instance-specific messages, 613
 - Generation of manipulated variables for controllers, 605
 - Gradient limit of the setpoint, 607
 - Group error, 606
 - How it works, 599
 - I/Os, 619
 - Instance-specific messages, 617
 - Inverting control direction, 607
 - Limit monitoring of error signal, 607
 - Limit monitoring of position feedback, 606
 - Limit monitoring of the process value, 607
 - Messaging, 616
 - Module types, 604
 - Neutral position, 606
 - Object name, 599
 - Opening additional faceplates, 613

- Operating modes, 603
- Operator permissions, 611
- Outputting a signal for start readiness, 606
- Overview of error numbers, 615
- Physical standardization of setpoint, manipulated variable and process value, 608
- PID algorithm, 608
- Preview,
 - Process control fault, 616
 - Process messages, 617
 - Release for maintenance, 613
 - Selecting a unit of measure, 608
 - Setpoint limiting for external setpoints, 607
 - SIMATIC BATCH functionality, 614
 - Simulating signals, 607
 - Specifying the display area for process and setpoint values as well as operations, 613
 - Startup characteristics, 600
 - Status word allocation, 600
 - Structure segmentation at controllers, 609
 - Suppressing messages using the MsgLock parameter, 613
 - Time-stamped messages, 614
 - Tracking and limiting a manipulated variable, 606
 - Tracking setpoint in manual mode, 607
 - Using setpoint ramp, 607
- FmTemp
 - Actuator active information, 644
 - Anti-windup, 648
 - Area of application, 637
 - Associated values, 657
 - Block diagram, 675
 - Button labels, 653
 - Configurable reactions using the Feature parameter, 650
 - Configurable reactions using the Feature2 parameter, 651
 - Configuration, 637
 - Error handling, 654
 - Error signal generation and dead band, 646
 - External/internal setpoint specification, 645
 - Feedforwarding and limiting disturbance variables, 648
 - Forming the signal status for blocks, 649
 - Functions, 642
 - Generating actuating signals for step controllers without position feedback (WithRbk = 0), 644
 - Generating instance-specific messages, 653
 - Generation of manipulated variables for controllers, 643
 - Group error, 644
 - How it works, 637
 - I/Os, 658
 - Instance-specific messages, 657
 - Inverting control direction, 646
 - Limit monitoring of error signal, 646
 - Limit monitoring of position feedback, 645
 - Limit monitoring of the process value, 645
 - Limitation of rate of change of setpoint, 645
 - Messaging, 655
 - Module types, 642
 - Neutral position, 644
 - Object name, 637
 - Online optimization of the PID controller parameters, 648
 - Opening additional faceplates, 653
 - Operating modes, 641
 - Operator permissions, 651
 - Outputting a signal for start readiness, 644
 - Overview of error numbers, 654
 - Physical standardization of setpoint, manipulated variable and process value, 646
 - PID algorithm, 647
 - Preview,
 - Process control fault, 655
 - Process messages, 656
 - Release for maintenance, 653
 - Selecting a unit of measure, 647
 - Setpoint limiting for external setpoints, 645
 - SIMATIC BATCH functionality, 653
 - Simulating signals, 645
 - Specifying the display area for process and setpoint values as well as operations, 653
 - Startup characteristics, 638
 - Status word allocation, 638
 - Structure segmentation at controllers, 647
 - Suppressing messages using the MsgLock parameter, 653
 - Time-stamped messages, 653
 - Tracking and limiting a manipulated variable, 644
 - Tracking setpoint in manual mode, 645
 - Using setpoint ramp, 645
- Force operating states
 - VlvPosL, 1522
- Forced tracking in closed-loop controllers, 41
- Forcing operating modes
 - DoseL, 1018
 - General description, 41
 - MotL, 1081
 - MotRevL, 1140
 - MotSpdCL, 1184
 - MotSpdL, 1234
 - Vlv2WayL, 1313
 - VlvAnL, 1457

- VlvL, 1353
- VlvMotL, 1412
- Formation of the setpoint difference
 - MotSpdCL, 1181
- Forming a peripheral value
 - Pcs7DiOu, 2158
- Forming an I/O value
 - Pcs7AnOu, 2125
- Forming the group status for interlocks
 - DoseL, 1020
 - MotL, 1081
 - MotRevL, 1140
 - MotS, 1113
 - MotSpdCL, 1183
 - MotSpdL, 1233
 - Vlv2WayL, 1314
 - VlvAnL, 1456
 - VlvL, 1352
 - VlvMotL, 1412
 - VlvPosL, 1521
 - VlvS, 1382
- Forming the signal status for blocks
 - AbsR, 1812
 - Add04, 1815
 - Add08, 1820
 - AV, 441
 - Average, 1826
 - CompAn02, 1918
 - ConPerMon, 578
 - CountOh, 1718
 - CountScL, 1695
 - DeadTime, 1833
 - Derivative, 1840
 - Div02, 1845
 - DoseL, 1020
 - Event, 1636
 - EventNck, 1648
 - FlowCorr, 1852
 - FmCont, 610
 - FmTemp, 649
 - Integral, 1860
 - Intlk02, 1571
 - Intlk04, 1584
 - Intlk08, 1598
 - Intlk16, 1614
 - KalFilt, 987
 - Lag, 1868
 - MeanTime, 1874
 - ModPreCon, 703
 - MonAnL, 455
 - MonAnS, 483
 - MonDi08, 545
 - MonDiL, 506
 - MonDiS, 528
 - MotL, 1081
 - MotRevL, 1140
 - MotS, 1113
 - MotSpdCL, 1183
 - MotSpdL, 1233
 - MPC10x10, 952
 - Mul04, 1881
 - Mul08, 1886
 - MuxAn03, 1932
 - MuxST, 2275
 - OpAnL, 349
 - OpAnS, 370
 - OpDi01, 385
 - OpDi03, 399
 - OpTrig, 425
 - PIDConL, 746
 - PIDConR, 824
 - PIDConS, 791
 - PIDStepL, 862
 - Polygon, 1894
 - Ratio, 906
 - RedAn02, 1951
 - RedDi02, 2008
 - SelA16In, 1963
 - Smooth, 1903
 - SqrRoot, 1908
 - Sub02, 1913
 - TimerP, 1787
 - TotalL, 1746
 - Trigger, 2029
 - Vlv2WayL, 1314
 - VlvAnL, 1456
 - VlvL, 1352
 - VlvMotL, 1412
 - VlvPosL, 1521
 - VlvS, 1383
 - XOr04, 2034
- Forming the signal status for the block
 - MuxAn08, 1939
- Frequency converter with separate device feed, 151
 - Feature parameter, 151
- Frequency converters, 128
- Functions
 - AbsR, 1812
 - Add04, 1815
 - Add08, 1820
 - And04, 1978
 - And08, 1983
 - AssetM, 2285
 - AV, 441

Average, 1826
CompAn02, 1918
ConPerMon, 569
CountOh, 1715
CountScL, 1694
DeadTime, 1832
Derivative, 1840
Div02, 1845
DoseL, 1011
Event, 1634
Event16Ts, 1676
EventNck, 1647
EventTs, 1660
FbAnIn, 2043
FbAnOu, 2052
FbAnTot, 2133
FbDiIn, 2062
FbDiOu, 2071
FbEnMe, 2091
FbSwtMMS, 2102
FirstIn, 1628
FlipFlop, 1989
FlowCorr, 1852
FmCont, 604
FmTemp, 642
GainSched, 681
Integral, 1859
Intlk02, 1570
Intlk04, 1582
Intlk08, 1596
Intlk16, 1612
KalFilt, 987
Lag, 1867
Limit, 1924
MeanTime, 1873
ModPreCon, 695
MonAnL, 452
MonAnS, 482
MonDi08, 545
MonDiL, 503
MonDiS, 527
MotL, 1078
MotRevL, 1137
MotS, 1111
MotSpdCL, 1177
MotSpdL, 1230
MPC10x10, 947
MSTIn, 2256
MSTOu, 2260
Mul04, 1881
Mul08, 1886
MuxAn03, 1929
MuxAn08, 1937
MuxMST, 2270
MuxST, 2275
Not01, 2004
OpAnL, 349
OpAnS, 370
OpDi01, 384
OpDi03, 398
OpStations, 414
OpTrig, 424
Or04, 1995
Or08, 1999
Pcs7AnIn, 2113
Pcs7AnOu, 2125
Pcs7Cnt2, 2177
Pcs7Cnt3, 2185
Pcs7DiIn, 2142
Pcs7DiIT, 2149
Pcs7DiOu, 2158
Pcs7HaAI, 2193
Pcs7HaAO, 2200
PIDConL, 741
PIDConR, 815
PIDConS, 788
PIDStepL, 856
Polygon, 1894
Psc7Cnt1, 2166
RateLim, 1943
Ratio, 904
Rcv_AnaVal, 2316
Rcv_DigVal, 2310
RedAn02, 1951
RedDi02, 2008
SelA02In, 1956
SelA16In, 1962
SelID02In, 2013
ShrdResL, 1265
ShrdResS, 1287
Smooth, 1902
Snd_AnaVal, 2313
Snd_DigVal, 2306
SplRange, 923
SqrRoot, 1908
STIn, 2248
STOu, 2252
StrctCom, 2018
StrctDeC, 2023
StrgToBy, 2220
StruAnIn, 2224
StruAnOu, 2228
StruDiln, 2232
StruDiOu, 2236

- StruScIn, 2240
- StruScOu, 2244
- Sub02, 1913
- TimerP, 1784
- TimeTrig, 1793
- TotalL, 1745
- Trigger, 2029
- Vlv2WayL, 1310
- VlvAnL, 1454
- VlvL, 1350
- VlvMotL, 1407
- VlvPosL, 1513
- VlvS, 1381
- XOr04, 2033
- Functions of CntOhSc, 1770
- Functions of RealToDw, 2264
- Functions of STRep, 2280

- G**
- Gain scheduling, 2327, 2347, 2378
 - GainSched, 679
- GainSched
 - Area of application, 678
 - Block diagram, 685
 - Configurable reactions using the Feature parameter, 681
 - Configuration, 679
 - Error handling, 682
 - Functions, 681
 - Gain scheduling, 679
 - How it works, 678
 - I/Os, 683
 - Messaging, 682
 - Object name, 678
 - Operating modes, 680
 - Preview, 688
 - Selecting a unit of measure, 681
 - Startup characteristics, 680
 - Status word allocation, 680
- General function MV difference
 - VlvAnL, 1465
- General preview
 - ShrdResL, 1280
- Generate instance-specific messages
 - VlvPosL, 1526
- Generating actuating signals for step controllers without position feedback (WithRbk = 0)
 - FmCont, 605
 - FmTemp, 644
- Generating and limiting the manipulated variable
 - ModPreCon, 695
 - MPC10x10, 947
- Generating instance-specific messages, 204
 - AV, 442
 - ConPerMon, 580
 - DoseL, 1022
 - FmCont, 613
 - FmTemp, 653
 - MonAnL, 458
 - MonAnS, 484
 - MonDiL, 505
 - MonDiS, 528
 - MotL, 1083
 - MotRevL, 1142
 - MotS, 1114
 - MotSpdCL, 1185
 - MotSpdL, 1236
 - PIDConL, 750
 - PIDConR, 827
 - PIDConS, 793
 - PIDStepL, 866
 - Vlv2WayL, 1315
 - VlvAnL, 1461
 - VlvL, 1354
 - VlvMotL, 1415
 - VlvS, 1384
- Generation of actuating signal without position feedback
 - PIDStepL, 857
- Generation of manipulated variables
 - PIDConL, 741
 - PIDConR, 815
 - PIDConS, 788
 - PIDStepL, 857
 - VlvAnL, 1464
- Generation of manipulated variables for controllers
 - FmCont, 605
 - FmTemp, 643
- Good state to locked, 52
- Gradient limit of the setpoint, 124
 - Activate, 301
 - FmCont, 607
 - MotSpdCL, 1181
 - OpAnL, 349
 - PIDConL, 743
 - PIDConR, 819
 - PIDStepL, 859
- Gradient limiting of the manipulated variable, 126
 - VlvAnL, 1456
- Gradient monitoring
 - MonAnL, 453

- Group display for limit monitoring
 - CSF and ExtMsgx, 85, 1716
 - SumMsgAct, 441, 453, 483, 574, 606, 645, 742, 818, 859, 1018, 1180, 1466, 1694, 1716, 1745
- Group error, 122
 - DoseL, 1020
 - FmCont, 606
 - FmTemp, 644
 - MotL, 1080, 1113
 - MotRevL, 1139
 - MotSpdCL, 1183
 - MotSpdL, 1233
 - PIDConL, 742
 - PIDConR, 817
 - PIDConS, 789
 - PIDStepL, 859
 - Vlv2WayL, 1313
 - VlvAnL, 1455
 - VlvL, 1352
 - VlvMotL, 1411
 - VlvPosL, 1521
- Group status
 - Forming, 104
- H**
- Handling non-connected inputs
 - Intlk02, 1570
 - Intlk04, 1584
 - Intlk08, 1598
 - Intlk16, 1614
- Harris index, 575
- Higher-level error / invalid measuring range
 - FbAnIn, 2046
 - FbAnOu, 2054
 - FbDiIn, 2064
 - FbDiIT, 2151
 - FbDiOu, 2073
 - Pcs7AnIn, 2117
 - Pcs7AnOu, 2127
 - Pcs7DiIn, 2143
 - Pcs7DiOu, 2160
- High-precision time stamp, 205
- Hold and restart calculation
 - Lag, 1868
- Hold last value
 - Pcs7AnIn, 2114
 - Pcs7DiIn, 2142
 - Pcs7DiIT, 2150
- Holding the last value if raw value is invalid
 - FbAnIn, 2043
 - FbAnTot, 2133
 - FbDiIn, 2062
- How it works
 - AbsR, 1811
 - Add04, 1814
 - Add08, 1819
 - And04, 1977
 - And08, 1982
 - AssetM, 2282
 - AV, 439
 - Average, 1824
 - CompAn02, 1917
 - ConPerMon, 565
 - CountOh, 1711
 - CountScL, 1690
 - DeadTime, 1830
 - Derivative, 1837
 - Div02, 1844
 - DoseL, 1005
 - Event, 1631
 - Event16Ts, 1671
 - EventNck, 1644
 - EventTs, 1656
 - FbAnIn, 2041
 - FbAnOu, 2050
 - FbAnTot, 2132
 - FbDiIn, 2060
 - FbDiOu, 2069
 - FbEnMe, 2090
 - FbSwMMS, 2101
 - FirstIn, 1626
 - FlipFlop, 1987
 - FlowCorr, 1849
 - FmCont, 599
 - FmTemp, 637
 - GainSched, 678
 - Integral, 1857
 - Intlk02, 1567
 - Intlk04, 1579
 - Intlk08, 1592
 - Intlk16, 1607
 - KalFilt, 980
 - Lag, 1865
 - Limit, 1922
 - MeanTime, 1872
 - ModPreCon, 689
 - MonAnL, 449
 - MonAnS, 480
 - MonDi08, 542
 - MonDiL, 499
 - MonDiS, 524
 - MotL, 1073

MotRevL, 1131
 MotS, 1107
 MotSpdCL, 1171
 MotSpdL, 1225
 MPC10x10, 939
 MSTIn, 2255
 MSTOu, 2259
 Mul04, 1879
 Mul08, 1885
 MuxAn03, 1928
 MuxAn08, 1936
 MuxMST, 2269
 MuxST, 2274
 NoiseGen, 2037
 Not01, 2003
 OpAnL, 347
 OpAnS, 368
 OpDi01, 382
 OpDi03, 396
 OpStations, 411
 OpTrig, 423
 Or04, 1993
 Or08, 1998
 Pcs7AnIn, 2110
 Pcs7AnOu, 2122
 Pcs7Cnt2, 2174
 Pcs7Cnt3, 2183
 Pcs7DiIn, 2139
 Pcs7DiIT, 2147
 Pcs7DiOu, 2156
 Pcs7HaAI, 2192
 Pcs7HaAO, 2199
 PIDConL, 735
 PIDConR, 807
 PIDConS, 784
 PIDStepL, 851
 Polygon, 1892
 Psc7Cnt1, 2164
 RateLim, 1942
 Ratio, 902
 Rcv_AnaVal, 2315
 Rcv_DigVal, 2308
 RedAn02, 1950
 RedDi02, 2007
 SelA02In, 1955
 SelA16In, 1960
 SelD02In, 2012
 ShrdResL, 1261
 ShrdResS, 1284
 Smooth, 1901
 Snd_AnaVal, 2312
 Snd_DigVal, 2305

SplRange, 921
 SqrRoot, 1907
 STIn, 2247
 STOu, 2251
 StrctCom, 2017
 StrctDeC, 2022
 StruAnIn, 2223
 StruAnOu, 2227
 StruDiln, 2231
 StruDiOu, 2235
 StruScIn, 2239
 StruScOu, 2243
 StruToBy, 2219
 Sub02, 1912
 TimerP, 1783
 TimeTrig, 1791
 TotalL, 1735
 Trigger, 2027
 Vlv2WayL, 1305
 VlvAnL, 1448
 VlvL, 1346
 VlvMotL, 1401
 VlvPosL, 1506
 VlvS, 1377
 XOr04, 2032
 How the block works as RS-FlipFlop (Mode = 1)
 FlipFlop, 1988
 How the block works as SR-FlipFlop (Mode = 0)
 FlipFlop, 1987
 Hysteresis, 88, 93, 95, 96, 97, 195, 319

I
 I action, 74, 2338, 2342, 2345, 2376
 I component, 609
 I/Os
 AbsR, 1812
 Add04, 1817
 Add08, 1822
 And04, 1980
 And08, 1984
 AV, 445
 Average, 1828
 CntOhSc, 1773
 CompAn02, 1920
 ConPerMon, 583
 CountOh, 1722
 CountScL, 1699
 DeadTime, 1835
 Derivative, 1842
 Div02, 1847
 DoseL, 1031

Event, 1639
 EventNck, 1651
 EventTs, 1666, 1685
 FbAnIn, 2047
 FbAnOu, 2055
 FbAnTot, 2135
 FbDiIn, 2065
 FbDiOu, 2074
 FbDrive, 2083
 FbEnMe, 2094
 FbSwMMS, 2105
 FirstIn, 1629
 FlipFlop, 1991
 FlowCorr, 1854
 FmCont, 619
 FmTemp, 658
 GainSched, 683
 Integral, 1862
 Intlk02, 1574
 Intlk08, 1601
 Intlk16, 1617
 Lag, 1870
 Limit, 1926
 MeanTime, 1877
 ModPreCon, 709
 MonAnL, 462
 MonAnS, 488
 MonDi08, 550
 MonDiL, 510
 MonDiS, 532
 MotL, 1088
 MotRevL, 1148
 MotS, 1118
 MotSpdCL, 1194, 1241
 MotSpdL, 1241
 MSTIn, 2257
 MSTOu, 2261
 Mul04, 1883
 Mul08, 1888
 MuxAn03, 1933
 MuxAn08, 1939
 MuxMST, 2272
 MuxST, 2277
 NoiseGen, 2038
 Not01, 2005
 OpAnL, 354
 OpAnS, 373
 OpDi01, 387
 OpDi03, 402
 OpStations, 416
 OpTrig, 427
 Or04, 1996
 Or08, 2001
 Pcs7AnIn, 2118
 Pcs7AnOu, 2128
 Pcs7Cnt2, 2180
 Pcs7Cnt3, 2187
 Pcs7DiIn, 2144
 Pcs7DiIT, 2152
 Pcs7DiOu, 2160
 Pcs7HaAI, 2195
 Pcs7HaAO, 2202
 PIDConL, 756
 PIDConLS, 797
 PIDConR, 833
 PIDStepL, 871
 Polygon, 1897
 Psc7Cnt1, 2169
 RateLim, 1947
 Ratio, 908
 RedAn02, 1953
 RedDi02, 2010
 SelA02In, 1958
 SelA16In, 1966
 SelD02In, 2015, 2030
 ShrdResL, 1272
 ShrdResS, 1291
 Smooth, 1905
 SplRange, 927
 SqrRoot, 1910
 StateMap, 2267
 STIn, 2249
 STOu, 2253
 StrctCom, 2019
 StrctDeC, 2024
 StrgToBy, 2221
 StruAnIn, 2225
 StruAnOu, 2229
 StruDiln, 2233
 StruDiOu, 2237
 StruScIn, 2241
 StruScOu, 2245
 Sub02, 1915
 TimerP, 1788
 TimeTrig, 1798
 TotalL, 1752
 Vlv2WayL, 1321
 VlvAnL, 1470
 VlvL, 1359
 VlvMotL, 1421
 VlvPosL, 1533
 VlvS, 1388
 XOr04, 2035
 I/Os of Rcv_AnaVal, 2317

- I/Os of Rcv_DigVal, 2310
- I/Os of RealToDw, 2265
- I/Os of Snd_AnaVal, 2314
- I/Os of Snd_DigVal, 2307
- I/Os of STRep, 2280
- IMC principle (internal model control), 2332
- Import/Export Assistant, 2321
- In progress
 - Operating mode, 64
- Increasing availability
 - MuxAn03, 1930
 - MuxAn08, 1937
- Increasing safety
 - MuxAn03, 1931
 - MuxAn08, 1937, 1938
- Influence of the signal status on the interlock, 103
- Information on areas of application
 - ModPreCon, 690
 - MPC10x10, 940
- Initialization
 - FlipFlop, 1990
 - Limit, 1925
 - TimerP, 1786
- Input parameter for feedback value
 - OpDi01, 384
 - OpDi03, 399
 - OpTrig, 425
- Instance-specific messages, 204, 616, 655, 753, 795, 830, 868
 - ConPerMon, 582
 - DoseL, 1029
 - FmCont, 617
 - FmTemp, 657
 - MonAnL, 461
 - MonAnS, 487
 - MotL, 1087
 - MotRevL, 1147
 - MotS, 1117
 - MotSpdCL, 1193
 - MotSpdL, 1240
 - PIDConL, 754
 - PIDConR, 831
 - PIDConS, 796
 - PIDStepL, 870
 - Vlv2WayL, 1320
 - VlvL, 1358
 - VlvMotL, 1420
 - VlvPosL, 1532
 - VlvS, 1387
- Int64ToDi
 - Area of application, 2294
 - Object name, 2294
- Integral
 - Area of application, 1857
 - Block diagram, 1863
 - Configurable reactions using the Feature parameter, 1860
 - Configuration, 1858
 - Error handling, 1861
 - Forming the signal status for blocks, 1860
 - Functions, 1859
 - How it works, 1857
 - I/Os, 1862
 - Messaging, 1862
 - Monitoring limits, 1859
 - Object name, 1857
 - Operating modes, 1858
 - Overview of error numbers, 1861
 - Startup characteristics, 1858
 - Status word allocation, 1858
 - Stopping integration, 1860
 - Tracking values, 1859
- Interface for the primary controller functions
 - Description, 78
- Interlock block
 - Activating recording of the first signal, 150
 - Block icon, 241
 - Preview, 299
 - Recording the first signal, 52
 - Standard view, 276
- Interlock blocks, 2358, 2359, 2360, 2361, 2362, 2363, 2364, 2365, 2366, 2367, 2368, 2369
- Interlock without reset, 100
- Interlocks
 - DoseL, 1019
 - MotL, 1080
 - MotRevL, 1138
 - MotS, 1112
 - MotSpdCL, 1182
 - MotSpdL, 1232
 - OpDi01, 384
 - OpDi03, 398
 - PIDConL, 750, 827
 - Vlv2WayL, 1313
 - VlvAnL, 1454
 - VlvL, 1351
 - VlvMotL, 1409
 - VlvPosL, 1518
 - VlvS, 1382
- Interlocks at blocks, 99
- Internal or external digital value
 - OpDi01, 384
 - OpDi03, 398

- Internal or external ratio
 - Ratio, 905
- Internal or external setpoint selection
 - OpAnL, 349
 - OpAnS, 370
- Internal simulation, 59
- Intlk04
 - Configurable reactions using the Feature I/O, 1585
- Intlk016
 - Bypass, 1613
- Intlk02
 - Area of application, 1567
 - Block diagram, 1578
 - Bypass, 1571
 - Configurable reactions using the Feature parameter, 1573
 - Configuration, 1567
 - Error handling, 1573
 - First-in detection, 1570
 - Forming the signal status for blocks, 1571
 - Functions, 1570
 - Handling non-connected inputs, 1570
 - How it works, 1567
 - I/Os, 1574
 - Installation in OBs, 1579
 - Messaging, 1574
 - Modes, 1570
 - Object name, 1567
 - Opening additional faceplates, 1570
 - Operating permissions, 1572
 - Overview of error numbers, 1574
 - Preview, 299
 - Standard view, 276
 - Startup characteristics, 1568
 - Status word allocation, 1568
- Intlk04
 - Area of application, 1579
 - Block diagram, 1591
 - Bypass, 1583
 - Configuration, 1579
 - Error handling, 1586
 - First-in detection, 1584
 - Forming the signal status for blocks, 1584
 - Functions, 1582
 - Handling non-connected inputs, 1584
 - How it works, 1579
 - I/Os, 1587
 - Inversion of logic signals, 1582
 - Messaging, 1587
 - Modes, 1582
 - Object name, 1579
- Opening additional faceplates, 1584
- Operating permissions, 1585
- Overview of error numbers, 1586
- Preview, 299
- Standard view, 276
- Startup characteristics, 1579
- Status word allocation, 1579
- Intlk08
 - Area of application, 1592
 - Block diagram, 1606
 - Bypass, 1596
 - Configurable reactions using the Feature parameter, 1599
 - Configuration, 1592
 - Error handling, 1600
 - First-in detection, 1598
 - Forming the signal status for blocks, 1598
 - Functions, 1596
 - Handling non-connected inputs, 1598
 - How it works, 1592
 - I/Os, 1601
 - Inversion of logic signals, 1596
 - Logic operators, 1596
 - Messaging, 1601
 - Object name, 1592
 - Opening additional faceplates, 1598
 - Operating modes, 1595
 - Operating permissions, 1599
 - Overview of error numbers, 1600
 - Preview, 299
 - Standard view, 276
 - Startup characteristics, 1592
 - Status word allocation, 1592
- Intlk16
 - Area of application, 1607
 - Block diagram, 1625
 - Configurable reactions using the Feature parameter, 1616
 - Configuration, 1607
 - Error handling, 1616
 - First-in detection, 1614
 - Forming the signal status for blocks, 1614
 - Functions, 1612
 - Handling non-connected inputs, 1614
 - How it works, 1607
 - I/Os, 1617
 - Inversion of logic signals, 1612
 - Logic operators, 1612
 - Messaging, 1617
 - Modes, 1612
 - Object name, 1607
 - Opening additional faceplates, 1614

- Operating permissions, 1615
- Overview of error numbers, 1617
- Preview, 299
- Standard view, 276
- Startup characteristics, 1607
- Status word allocation, 1607
- Invalid input signals
 - MotL, 1085
 - MotRevL, 1145
 - MotS, 1116
 - MotSpdCL, 1190
 - MotSpdL, 1239
 - Vlv2WayL, 1319
 - VlvAnL, 1468
 - VlvL, 1357
 - VlvMotL, 1418
 - VlvPosL, 1529
 - VlvS, 1386
- Invalid raw value, 150, 154, 175
- Invalid value
 - Pcs7HaAI, 2194
 - Pcs7HaAO, 2201
- Inversion of logic signals
 - Intlk04, 1582
 - Intlk08, 1596
 - Intlk16, 1612
- Inverting control direction, 192
 - FmCont, 607
 - FmTemp, 646
 - PIDConL, 744
 - PIDConR, 820
 - PIDStepL, 860
- Issuing a request for maintenance (MS → APL)
 - Request for maintenance release, 62
- Issuing trigger signal internally or externally
 - OpTrig, 425

K

- KalFilt
 - Area of application, 980
 - Block diagram, 994
 - Block icon, 1004
 - Configurable reactions using the Feature parameter, 987
 - Configuration, 983
 - Error handling, 988
 - Forming the signal status for blocks, 987
 - Functions, 987
 - How it works, 980
 - Kalman Configurator, 983
 - Measurements view, 1002

- Messaging, 994
- Object name, 980
- Operating modes, 986
- Operating principle, 982
- Operator permissions, 987
- Overview of error numbers, 989
- Parameter view, 999
- Parameter view 2, 1000
- Preview, 1001
- Standard view, 995
- Startup characteristics, 985
- Status word allocation, 985
- Trend view, 1003
- Kalman Configurator
 - KalFilt, 983

L

- Labeling of buttons
 - VlvPosL, 1528
- Lag
 - Area of application, 1865
 - Block diagram, 1871
 - Configurable reactions using the Feature parameter, 1868
 - Configuration, 1866
 - Error handling, 1868
 - Forming the signal status for blocks, 1868
 - Functions, 1867
 - Hold and restart calculation, 1868
 - How it works, 1865
 - I/Os, 1870
 - Messaging, 1869
 - Object name, 1865
 - Operating modes, 1867
 - Overview of error numbers, 1869
 - Reset values, 1868
 - Startup characteristics, 1867
 - Status word allocation, 1867

Limit

- Area of application, 1922
- Block diagram, 1927
- Configuration, 1923
- Error handling, 1925
- Functions, 1924
- How it works, 1922
- I/Os, 1926
- Initialization, 1925
- Messaging, 1926
- Object name, 1922
- Operating modes, 1924

- Startup characteristics, 1924
 - Status word allocation, 1924
 - Limit monitoring
 - Derivative, 1840
 - Error signal, 95
 - Manipulated variable difference, 95
 - Setpoint difference, 95
 - Limit monitoring for additional analog value
 - VlvPosL, 1517
 - Limit monitoring of an additional analog value
 - AV, 441
 - MotL, 1079
 - MotRevL, 1138
 - MotSpdCL, 1180
 - MotSpdL, 1232
 - VlvMotL, 1409
 - Limit monitoring of error signal
 - FmCont, 607
 - FmTemp, 646
 - PIDConL, 744
 - PIDConR, 820
 - PIDStepL, 860
 - Limit monitoring of manipulated variable and error signal
 - VlvAnL, 1466
 - Limit monitoring of position feedback
 - FmCont, 606
 - FmTemp, 645
 - PIDConL, 742
 - PIDConR, 818
 - PIDStepL, 859
 - Limit monitoring of the count value
 - CountScL, 1694
 - TotalL, 1745
 - Limit monitoring of the feedback
 - MotSpdCL, 1180
 - Limit monitoring of the operating time
 - CountOh, 1716
 - Limit monitoring of the process value
 - DoseL, 1018
 - FmCont, 607
 - FmTemp, 645
 - MonAnL, 453
 - MonAnS, 483
 - PIDConL, 743
 - PIDConR, 819
 - PIDConS, 790
 - PIDStepL, 860
 - Limit monitoring of the setpoint difference
 - MotSpdCL, 1181
 - Limit monitoring with hysteresis
 - AV, 441
 - MotL, 1079
 - MotRevL, 1138
 - MotSpdCL, 1180
 - MotSpdL, 1232
 - VlvMotL, 1409
 - VlvPosL, 1517
 - Limit operation and display in the faceplate
 - ConPerMon, 580
 - Limit view
 - DoseL, 1051
 - FM controller, 288
 - Motor, 294
 - MotSpdCL, 1217
 - PID controller, 291
 - Limit view of CntOhSc, 1779
 - Limit violation, 120
 - Limitation of rate of change of setpoint
 - FmTemp, 645
 - Limitation of the slope of an analog signal
 - RateLim, 1944
 - Limiting the output value
 - Ratio, 905
 - Limiting the peripheral value
 - Pcs7AnOu, 2126
 - Limiting the process value
 - Pcs7AnOu, 2126
 - Limiting the ratio
 - Ratio, 905
 - Local mode, 173
 - Logic operators
 - Intlk08, 1596
 - Intlk16, 1612
 - Low pass filter, 571
 - Low-pass filter, 2380
- ## M
- Main entry
 - Subentry, 1506
 - Manipulated variable, 75
 - Forced tracking, 196
 - Tracking, 196
 - Manipulated variable difference, 95
 - Manipulated variable difference generation and dead band
 - VlvAnL, 1466
 - Manipulated variable ramp
 - Using, 125
 - Manipulated variable specification
 - External, 129
 - Internal, 129
 - Manipulated variables, 2382

- Manual mode
 - Controller blocks, 72
 - Dosers, 75
 - Motors, 75
 - Valves, 75
- MeanTime
 - Area of application, 1872
 - Block diagram, 1878
 - Configurable reactions using the Feature parameter, 1874
 - Configuration, 1872
 - Error handling, 1876
 - Forming the signal status for blocks, 1874
 - Functions, 1873
 - How it works, 1872
 - I/Os, 1877
 - Messaging, 1876
 - Object name, 1872
 - Operating modes, 1873
 - Overview of error numbers, 1876
 - Setting a mean value constant, 1874
 - Startup characteristics, 1873
 - Status word allocation, 1873
 - Stopping the calculation of mean values, 1874
- Memo view
 - Description, 304
- MemR256
 - Area of application, 2295
 - Description, 2295
 - Description of, 2295
- Message characteristics
 - VlvPosL, 1531
- Message classes
 - User-configured, 41
- Message view, 302
- Messages
 - Generating instance-specific messages, 204
- Messaging
 - AbsR, 1812
 - Add04, 1816
 - Add08, 1821
 - And04, 1979
 - And08, 1984
 - AV, 443
 - Average, 1827
 - CompAn02, 1920
 - ConPerMon, 581
 - CountOh, 1720
 - CountScL, 1698
 - DeadTime, 1834
 - Derivative, 1841
 - Div02, 1847
 - DoseL, 1028
 - Event, 1637
 - Event16Ts, 1679
 - EventNck, 1650
 - EventTs, 1663
 - FbAnIn, 2046
 - FbAnOu, 2054
 - FbAnTot, 2135
 - FbDiIn, 2064
 - FbDiOu, 2073
 - FbEnMe, 2093
 - FbSwtMMS, 2104
 - FirstIn, 1629
 - FlipFlop, 1991
 - FlowCorr, 1854
 - FmCont, 616
 - FmTemp, 655
 - GainSched, 682
 - Integral, 1862
 - Intlk02, 1574
 - Intlk04, 1587
 - Intlk08, 1601
 - Intlk16, 1617
 - KalFilt, 994
 - Lag, 1869
 - Limit, 1926
 - MeanTime, 1876
 - ModPreCon, 709
 - MonAnL, 460
 - MonAnS, 486
 - MonDi08, 548
 - MonDiL, 509
 - MonDiS, 531
 - MotL, 1086
 - MotRevL, 1146
 - MotS, 1116
 - MotSpdCL, 1192
 - MotSpdL, 1240
 - MPC_10x10, 958
 - MSTIn, 2257
 - MSTOu, 2261
 - Mul04, 1882
 - Mul08, 1888
 - MuxAn03, 1933
 - MuxAn08, 1939
 - MuxMST, 2271
 - MuxST, 2276
 - Not01, 2005
 - OpAnL, 352
 - OpAnS, 373
 - OpDi01, 387
 - OpDi03, 402

- OpStations, 415
- OpTrig, 427
- Or04, 1996
- Or08, 2000
- Pcs7AnIn, 2118
- Pcs7AnOu, 2128
- Pcs7Cnt2, 2180
- Pcs7DiIn, 2144
- Pcs7DiIT, 2152
- Pcs7DiOu, 2160
- Pcs7HaAI, 2194
- Pcs7HaAO, 2201
- PcsCnt3, 2187
- PIDConL, 753
- PIDConR, 830
- PIDConS, 795
- PIDStepL, 868
- Polygon, 1896
- Psc7Cnt1, 2169
- RateLim, 1946
- Ratio, 908
- Rcv_AnaVal, 2317
- Rcv_DigVal, 2310
- RedAn02, 1952
- RedDi02, 2009
- SelA02In, 1958
- SelA16In, 1965
- SelD02In, 2014
- ShrdResL, 1271
- ShrdResS, 1290
- Smooth, 1904
- Snd_AnaVal, 2314
- Snd_DigVal, 2307
- SplRange, 926
- SqrRoot, 1909
- StateMap, 2267
- STIn, 2249
- STOu, 2253
- StrctCom, 2019
- StrctDeC, 2024
- StrgToBy, 2221
- StruAnIn, 2225
- StruAnOu, 2229
- StruDiln, 2233
- StruDiOu, 2237
- StruScIn, 2241
- StruScOu, 2245
- Sub02, 1914
- TimerP, 1788
- TimeTrig, 1798
- TotalL, 1750
- Trigger, 2030
- Vlv2WayL, 1320
- VlvAnL, 1469
- VlvL, 1358
- VlvMotL, 1420
- VlvS, 1386
- XOr04, 2034
- Messaging of RealToDw, 2264
- Messaging of STRep, 2280
- mode, 2206, 2217
- MODE settings for PA/FF field devices, 2217
- Mode Settings for SM Modules, 2207
- Mode switchover error
 - AV, 443
 - DoseL, 1026
 - MotL, 1085
 - MotRevL, 1145
 - MotS, 1116
 - MotSpdCL, 1190
 - MotSpdL, 1238
 - Vlv2WayL, 1319
 - VlvAnL, 1468
 - VlvL, 1357
 - VlvMotL, 1418
 - VlvPosL, 1529
 - VlvS, 1386
- Model performance, 2332
- Model-based disturbance compensation
 - ModPreCon, 699
 - MPC10x10, 950
- Modes
 - FbAnOu, 2052
 - FbDiOu, 2071
 - Intlk02, 1570
 - Intlk04, 1582
 - Intlk08, 1595
 - Intlk16, 1612
 - Pcs7AnIn, 2112
 - Pcs7AnOu, 2125
 - Pcs7DiIn, 2141
 - Pcs7DiIT, 2149
 - Pcs7DiOu, 2158
 - StruAnIn, 2224
 - StruAnOu, 2228
 - StruDiln, 2232
 - StruDiOu, 2236
 - StruScIn, 2240
- ModPreCon
 - Anti-windup, 698
 - Area of application, 689
 - Block diagram, 720
 - Block icon, 732

- Configurable reactions using the Feature parameter, 703
 - Configuration, 691
 - Control of linear and non-linear systems, 701
 - Control of square and non-square systems, 700
 - Error handling, 708
 - Error signal generation and dead band, 697
 - Forming the signal status for blocks, 703
 - Functions, 695
 - Generating and limiting the manipulated variable, 695
 - How it works, 689
 - I/Os, 709
 - Information on areas of application, 690
 - Messaging, 709
 - Model-based disturbance compensation, 699
 - Object name, 689
 - Opening additional faceplates, 705
 - Operating modes, 694
 - Operator permissions, 704
 - Overview of error numbers, 708
 - Parameter view, 726
 - Predictive controller algorithm, 698
 - Release for maintenance, 705
 - Selecting a unit of measure, 697
 - Setpoint filters, 696
 - Setpoint tracking in manual mode, 696
 - Setting the setpoint internally, 696
 - SIMATIC BATCH functionality, 705
 - Simulating signals, 697
 - Specifying the display area for process and setpoint values as well as operations, 705
 - Standard view, 722
 - Startup characteristics, 692
 - Status word allocation, 693
 - Tracking and limiting a manipulated variable, 695
- Module types
- FmCont, 604
 - FmTemp, 642
- MonAnL
- Area of application, 449
 - Associated values, 461
 - Block diagram, 470
 - Block symbol, 478
 - Bypass function, 456
 - Configurable reactions using the Feature parameter, 456
 - Configuration, 449
 - Control system fault (CSF), 459, 508
 - Dead band, 455
 - Displaying auxiliary values, 454
 - Error handling, 459
- Forming the signal status for blocks, 455
- Functions, 452
- Generating instance-specific messages, 458
- Gradient monitoring, 453
- How it works, 449
- I/Os, 462
- Instance-specific messages, 461
- Limit monitoring of the process value, 453
- Limit view, 474
- Messaging, 460
- Object name, 449
- Opening additional faceplates, 458
- Operating modes, 452
- Operator permissions, 457
- Overview of error numbers, 459, 508
- Parameter view, 476
- Preview, 477
- Process control fault, 460
- Process messages, 460
- Release for maintenance, 456
- Selecting a unit of measure, 456
- SIMATIC BATCH functionality, 458
- Simulating signals, 456
- Smoothing PV, 455
- Specifying the display area for process and setpoint values as well as operations, 458
- Standard view, 471
- Startup characteristics, 449
- Status word allocation, 450
- Suppressing messages using the MsgLock parameter, 453
- Time-stamped messages, 458
- MonAnS
- Alarm delays with one time value per limit pair, 482
 - Area of application, 480
 - Associated values, 487
 - Block diagram, 491
 - Block symbol, 497
 - Configurable reactions using the Feature parameter, 483
 - Configuration, 480
 - Control system fault (CSF), 486
 - Dead band, 483
 - Error handling, 485
 - Forming the signal status for blocks, 483
 - Functions, 482
 - Generating instance-specific messages, 484
 - How it works, 480
 - I/Os, 488
 - Instance-specific messages, 487
 - Limit monitoring of the process value, 483

- Limit view, 494
- Messaging, 486
- Object name, 480
- Opening additional faceplates, 485
- Operating modes, 482
- Operator permissions, 484
- Overview of error numbers, 485
- Parameter view, 495
- Preview, 496
- Process control fault, 486
- Process messages, 487
- Release for maintenance, 483
- Selecting a unit of measure, 483
- SIMATIC BATCH functionality, 485
- Simulating signals, 483
- Specifying the display area for process and setpoint values as well as operations, 485
- Startup characteristics, 480
- Status word allocation, 480
- Suppressing messages using the MsgLock parameter, 483
- MonDi08
 - Area of application, 542
 - Associated values, 549
 - Block diagram, 554
 - Block symbol, 559
 - Changing labels on buttons and text, 547
 - Configurable reactions using the Feature parameter, 546
 - Configuration, 542
 - Error handling, 547
 - Flutter alarm, 548
 - Forming the signal status for blocks, 545
 - Functions, 545
 - How it works, 542
 - I/Os, 550
 - Messaging, 548
 - Monitoring and output of digital signals, 545
 - Object name, 542
 - Opening additional faceplates, 546
 - Operating modes, 544
 - Operator control permissions, 546
 - Overview of error numbers, 548
 - Parameter view, 557
 - Preview, 558
 - Process messages, 549
 - Release for maintenance, 545
 - SIMATIC BATCH functionality, 547
 - Simulating signals, 545
 - Standard view, 555
 - Startup characteristics, 542
 - Status word allocation, 542
 - Suppressing messages using the MsgLock parameter, 545
 - Time-stamped messages, 547
- MonDiL
 - Adapting the color representation in the configured message class, 504
 - Area of application, 499
 - Associated values, 510
 - Block diagram, 515
 - Block icon, 520, 539
 - Bypass function, 506
 - Changing labels on buttons and text, 505
 - Configurable reactions using the Feature parameter, 506
 - Configuration, 500
 - Delaying the on and off switching functions, 504
 - Displaying auxiliary values, 505
 - Error handling, 508
 - Flutter alarm, 508
 - Forming the signal status for blocks, 506
 - Functions, 503
 - Generating instance-specific messages, 505
 - How it works, 499
 - I/Os, 510
 - Messaging, 509
 - Object name, 499
 - Opening additional faceplates, 507
 - Operating modes, 502
 - Operator permissions, 506
 - Parameter view, 518
 - Preview, 519
 - Process control fault, 509
 - Process messages, 509
 - Release for maintenance, 506
 - SIMATIC BATCH functionality, 507
 - Simulating signals, 506
 - Standard view, 516
 - Startup characteristics, 500
 - Status word allocation, 500
 - Suppressing messages using the MsgLock parameter, 506
 - Suppression and reporting of signal flutter, 503
 - Time-stamped messages, 507
- MonDiS
 - Adapting the color representation in the configured message class, 527
 - Area of application, 523
 - Associated values, 531
 - Block diagram, 535
 - Changing labels on buttons and text, 528
 - Configurable reactions using the Feature parameter, 529

- Configuration, 524
- Control system fault (CSF), 530
- Delaying the on function, 527
- Error handling, 530
- Forming the signal status for blocks, 528
- Functions, 527
- Generating instance-specific messages, 528
- How it works, 524
- I/Os, 532
- Messaging, 531
- Object name, 523
- Opening additional faceplates, 529
- Operating modes, 526
- Operator permissions, 529
- Overview of error numbers, 530
- Parameter view, 537
- Preview, 538
- Process control fault, 531
- Process messages, 531
- Release for maintenance, 528
- SIMATIC BATCH functionality, 529
- Simulating signals, 528
- Standard view, 536
- Startup characteristics, 524
- Status word allocation, 524
- Suppressing messages using the MsgLock parameter, 528
- Monitoring and output of digital signals
 - MonDi08, 545
- Monitoring error, 43
- Monitoring limits
 - Integral, 1859
- Monitoring of deterministic characteristics of the control performance, 572
- Monitoring of stochastic characteristics of the control performance, 570
- Monitoring the feedback for the auxiliary valve
 - VlvAnL, 1460
- MotL
 - Area of application, 1073
 - Associated values, 1087
 - Block diagram, 1096
 - Block symbol, 1104
 - Button labels, 1084, 1112
 - Configurable reactions using the Feature parameter, 1083
 - Configuration, 1073
 - Considering bad quality of automatic commands or external values, 1081
 - Disabling interlocks, 1080
 - Displaying auxiliary values, 1084
 - Error handling, 1085
 - Feedback monitoring, 1082
 - Forcing operating modes, 1081
 - Forming the group status for interlocks, 1081
 - Forming the signal status for blocks, 1081
 - Functions, 1078
 - Generating instance-specific messages, 1083
 - Group error, 1080, 1113
 - How it works, 1073
 - I/Os, 1088
 - Instance-specific messages, 1087
 - Interlocks, 1080
 - Invalid input signals, 1085
 - Limit monitoring of an additional analog value, 1079
 - Limit monitoring with hysteresis, 1079
 - Messaging, 1086
 - Mode switchover error, 1085
 - Motor protection function, 1080
 - Neutral position, 1082
 - Object name, 1073
 - Opening additional faceplates, 1078
 - Operating modes, 1077
 - Operator permissions, 1078
 - Output signal as a pulse signal or static signal, 1083
 - Outputting a signal for start readiness, 1080, 1113, 1183
 - Overview of error numbers, 1085
 - Preview, 1101
 - Process control fault, 1087
 - Rapid stop, 1080
 - Release for maintenance, 1082, 1115
 - Resetting the block in case of interlocks or errors, 1080
 - Selecting a unit of measure, 1082
 - SIMATIC BATCH functionality, 1084
 - Simulating signals, 1082
 - Specify warning times for control functions, 1082
 - Standard view, 1097
 - Startup characteristics, 1073
 - Status word allocation, 1073
 - Suppressing messages using the MsgLock parameter, 1079, 1112
 - Time delay after restart, 1081
 - Time-stamped messages, 1084
- Motor
 - Warning times, 51
- Motor protection function, 99
 - MotL, 1080
 - MotRevL, 1139
 - MotS, 1112
 - MotSpdCL, 1182

- MotSpdL, 1232
- VlvMotL, 1409
- VlvPosL, 1518
- MotRevL
 - Area of application, 1131
 - Associated values, 1147
 - Block diagram, 1157
 - Block icon, 1168
 - Button labels, 1143
 - Configurable reactions using the Feature parameter, 1142
 - Configurable reactions using the Feature2 parameter, 1143
 - Configuration, 1131
 - Considering bad quality of automatic commands or external values, 1140
 - Disabling interlocks, 1139
 - Displaying auxiliary values, 1143
 - Error handling, 1144
 - Feedback monitoring, 1141
 - Forcing operating modes, 1140
 - Forming the group status for interlocks, 1140
 - Forming the signal status for blocks, 1140
 - Functions, 1137
 - Generating instance-specific messages, 1142
 - Group error, 1139
 - How it works, 1131
 - I/Os, 1148
 - Instance-specific messages, 1147
 - Interlocks, 1138
 - Invalid input signals, 1145
 - Limit monitoring of an additional analog value, 1138
 - Limit monitoring with hysteresis, 1138
 - Messaging, 1146
 - Mode switchover error, 1145
 - Motor protection function, 1139
 - Neutral position, 1142
 - Object name, 1131
 - Opening additional faceplates, 1137
 - Operating modes, 1135
 - Operator permissions, 1137
 - Output signal as a pulse signal or static signal, 1142
 - Outputting a signal for start readiness, 1140
 - Overview of error numbers, 1144
 - Preview, 1163
 - Process control fault, 1146
 - Rapid stop, 1139
 - Release for maintenance, 1141
 - Resetting the block in case of interlocks or errors, 1139
 - Selecting a unit of measure, 1141
 - SIMATIC BATCH functionality, 1143
 - Simulating signals, 1141
 - Specify warning times for control functions, 1141
 - Standard view, 1159
 - Startup characteristics, 1131
 - Status word allocation, 1131
 - Suppressing messages using the MsgLock parameter, 1138
 - Time delay after changing direction of rotation or restart, 1138
 - Time-stamped messages, 1143
- MotS
 - Area of application, 1107
 - Associated values, 1117
 - Block diagram, 1123
 - Block symbol, 1128
 - Configurable reactions using the Feature parameter, 1114
 - Configuration, 1107
 - Considering bad quality of automatic commands or external values, 1113
 - Disabling interlocks, 1112
 - Error handling, 1115
 - Feedback monitoring, 1113
 - Forming the group status for interlocks, 1113
 - Forming the signal status for blocks, 1113
 - Functions, 1111
 - Generating instance-specific messages, 1114
 - How it works, 1107
 - I/Os, 1118
 - Instance-specific messages, 1117
 - Interlocks, 1112
 - Invalid input signals, 1116
 - Messaging, 1116
 - Mode switchover error, 1116
 - Motor protection function, 1112
 - Neutral position, 1114
 - Object name, 1107
 - Opening additional faceplates, 1111
 - Operating modes, 1109
 - Operator permissions, 1111
 - Output signal as a pulse signal or static signal, 1114
 - Overview of error numbers, 1115
 - Preview, 1127
 - Process control fault, 1117
 - Resetting the block in case of interlocks or errors, 1112
 - SIMATIC BATCH functionality, 1115
 - Simulating signals, 1114
 - Standard view, 1124

- Startup characteristics, 1107
- Status word allocation, 1107
- MotSpdCL
 - Alarm delays with one time value per limit pair, 1177
 - Area of application, 1171
 - Associated values, 1193
 - Block diagram, 1207
 - Block icon, 1222
 - Button labels, 1187
 - Configurable reactions using the Feature parameter, 1186
 - Configurable reactions using the Feature2 parameter, 1187
 - Configuration, 1171
 - Considering bad quality of automatic commands or external values, 1184
 - Controlling a device infeed or an inverter enable, 1187
 - Disabling interlocks, 1182
 - Displaying auxiliary values, 1187
 - Error handling, 1189
 - External/internal setpoint specification, 1180
 - Feedback monitoring, 1184
 - Forcing operating modes, 1184
 - Formation of the setpoint difference, 1181
 - Forming the group status for interlocks, 1183
 - Forming the signal status for blocks, 1183
 - Functions, 1177
 - Generating instance-specific messages, 1185
 - Gradient limit of the setpoint, 1181
 - Group error, 1183
 - How it works, 1171
 - I/Os, 1194
 - Instance-specific messages, 1193
 - Interlocks, 1182
 - Invalid input signals, 1190
 - Limit monitoring of an additional analog value, 1180
 - Limit monitoring of the feedback, 1180
 - Limit monitoring of the setpoint difference, 1181
 - Limit monitoring with hysteresis, 1180
 - Messaging, 1192
 - Mode switchover error, 1190
 - Motor protection function, 1182
 - Neutral position, 1185
 - Object name, 1171
 - Opening additional faceplates, 1177
 - Operating modes, 1176
 - Operator permissions, 1178
 - Output signal as a pulse signal or static signal, 1185
 - Overview of error numbers, 1189
 - Parameter view, 1219
 - Preview, 1214
 - Process control fault, 1192
 - Rapid stop, 1182
 - Release for maintenance, 1184
 - Resetting the block in case of interlocks or errors, 1182
 - Selecting a unit of measure, 1185
 - Setpoint limitation, 1180
 - Setpoint ramp, 1181
 - SIMATIC BATCH functionality, 1187
 - Simulating signals, 1185
 - Specify warning times for control functions, 1184
 - Specifying the display and operator input area for process values and setpoints, 1185
 - Standard view, 1208
 - Startup characteristics, 1171
 - Status word allocation, 1172
 - Subentry, 1180
 - Suppressing messages using the MsgLock parameter, 1180
 - Time delay after changing direction of rotation or restart, 1179
 - Time-stamped messages, 1187
- MotSpdL
 - Area of application, 1225
 - Associated values, 1241
 - Block diagram, 1250
 - Block icon, 1258
 - Button labels, 1237
 - Configurable reactions using the Feature parameter, 1236
 - Configurable reactions using the Feature2 parameter, 1237
 - Configuration, 1225
 - Considering bad quality of automatic commands or external values, 1234
 - Disabling interlocks, 1232
 - Displaying auxiliary values, 1237
 - Error handling, 1238
 - Feedback monitoring, 1234
 - Forcing operating modes, 1234
 - Forming the group status for interlocks, 1233
 - Forming the signal status for blocks, 1233
 - Functions, 1230
 - Generating instance-specific messages, 1236
 - Group error, 1233
 - How it works, 1225
 - I/Os, 1241
 - Instance-specific messages, 1240
 - Interlocks, 1232

- Invalid input signals, 1239
- Limit monitoring of an additional analog value, 1232
- Limit monitoring with hysteresis, 1232
- Messaging, 1240
- Mode switchover error, 1238
- Motor protection function, 1232
- Neutral position, 1235
- Object name, 1225
- Opening additional faceplates, 1231
- Operating modes, 1229
- Operator permissions, 1231
- Output signal as a pulse signal or static signal, 1236
- Outputting a signal for start readiness, 1233
- Overview of error numbers, 1238
- Preview, 1255
- Process control fault, 1240
- Rapid stop, 1232
- Release for maintenance, 1234
- Resetting the block in case of interlocks or errors, 1233
- Selecting a unit of measure, 1235
- SIMATIC BATCH functionality, 1237
- Simulating signals, 1235
- Specify warning times for control functions, 1234
- Startup characteristics, 1225
- Status word allocation, 1225
- Step control mode for the speed change, 1235
- Suppressing messages using the MsgLock parameter, 1232
- Time delay after restart, 1232
- Time-stamped messages, 1237
- MPC Configurator, 696, 948
- MPC_10x10
 - Messaging, 958
- MPC10x10
 - Anti-windup, 950
 - Area of application, 939
 - Block diagram, 964
 - Block icon, 978
 - Configurable reactions using the Feature parameter, 953
 - Configuration, 942
 - Control of linear and non-linear systems, 952
 - Control of square and non-square systems, 951
 - Error handling, 957
 - Error signal generation and dead band, 949
 - Forming the signal status for blocks, 952
 - Functions, 947
 - Generating and limiting the manipulated variable, 947
 - How it works, 939
 - Information on areas of application, 940
 - Model-based disturbance compensation, 950
 - Object name, 939
 - Opening additional faceplates, 954
 - Operating modes, 946
 - Operator permissions, 953
 - Overview of error numbers, 958
 - Parameter view, 971
 - Predictive controller algorithm, 949
 - Release for maintenance, 954
 - Selecting a unit of measure, 948
 - Setpoint filters, 948
 - Setpoint tracking in manual mode, 948
 - Setting the setpoint internally, 947
 - SIMATIC BATCH functionality, 954
 - Simulating signals, 948
 - Specifying the display area for process and setpoint values as well as operations, 954
 - Standard view, 965
 - Startup characteristics, 945
 - Status word allocation, 945
 - Tracking and limiting a manipulated variable, 947
- MSTIn
 - Area of application, 2255
 - Block diagram, 2258
 - Configuration, 2255
 - Error handling, 2256
 - Functions, 2256
 - How it works, 2255
 - I/Os, 2257
 - Messaging, 2257
 - Object name, 2255
 - Operating modes, 2256
 - Startup characteristics, 2255
 - Status word allocation, 2255
- MSTOu
 - Area of application, 2259
 - Block diagram, 2262
 - Configuration, 2259
 - Error handling, 2260
 - Functions, 2260
 - How it works, 2259
 - I/Os, 2261
 - Messaging, 2261
 - Object name, 2259
 - Operating modes, 2260
 - Startup characteristics, 2259
 - Status word allocation, 2259
- Mul04
 - Area of application, 1879
 - Block diagram, 1884

- Configuration, 1879
 - Error handling, 1882
 - Forming the signal status for blocks, 1881
 - Functions, 1881
 - How it works, 1879
 - I/Os, 1883
 - Messaging, 1882
 - Object name, 1879
 - Operating modes, 1881
 - Startup characteristics, 1880
 - Status word allocation, 1880
 - Mul08
 - Area of application, 1885
 - Block diagram, 1889
 - Configuration, 1885
 - Error handling, 1887
 - Forming the signal status for blocks, 1886
 - Functions, 1886
 - How it works, 1885
 - I/Os, 1888
 - Messaging, 1888
 - Object name, 1885
 - Operating modes, 1886
 - Startup characteristics, 1885
 - Status word allocation, 1886
 - Multi-model controlling, 2381
 - Multivariable controller
 - ConPerMon, 577
 - Definition, 2390
 - MuxAn03
 - Area of application, 1928
 - Block diagram, 1935
 - Configuration, 1928
 - Error handling, 1932
 - Forming the signal status for blocks, 1932
 - Functions, 1929
 - How it works, 1928
 - I/Os, 1933
 - Increasing availability, 1930
 - Increasing safety, 1931
 - Messaging, 1933
 - Object name, 1928
 - Operating modes, 1929
 - Selection of output signal, 1929
 - Startup characteristics, 1928
 - Status word allocation, 1928
 - MuxAn08
 - Area of application, 1936
 - Block diagram, 1941
 - Configuration, 1936
 - Error handling, 1939
 - Forming the signal status for blocks, 1939
 - Functions, 1937
 - How it works, 1936
 - I/Os, 1939
 - Increasing availability, 1937
 - Increasing safety, 1938
 - Messaging, 1939
 - Object name, 1936
 - Operating modes, 1936
 - Selection of output signal, 1937
 - Startup characteristics, 1936
 - Status word allocation, 1936
 - MuxMST
 - Area of application, 2269
 - Block diagram, 2272
 - Configuration, 2269
 - Error handling, 2271
 - Functions, 2270
 - How it works, 2269
 - I/Os, 2272
 - Messaging, 2271
 - Object name, 2269
 - Operating modes, 2270
 - Startup characteristics, 2269
 - Status word allocation, 2269
 - MuxST
 - Area of application, 2274
 - Block diagram, 2278
 - Configuration, 2274
 - Error handling, 2276
 - Forming the signal status for blocks, 2275
 - Functions, 2275
 - How it works, 2274
 - I/Os, 2277
 - Messaging, 2276
 - Object name, 2274
 - Operating modes, 2275
 - Selecting signals for processing, 2275
 - Startup characteristics, 2274
 - Status word allocation, 2274
- ## N
- NegInt64
 - Area of application, 2296
 - Object name, 2296
 - NegR64
 - Area of application, 2297
 - Object name, 2297
 - Neutral position, 48
 - FmCont, 606
 - FmTemp, 644
 - MotL, 1082

- MotRevL, 1142
 - MotS, 1114
 - MotSpdCL, 1185
 - MotSpdL, 1235
 - PIDConL, 742
 - PIDConR, 817
 - PIDConS, 789
 - PIDStepL, 858
 - Vlv2WayL, 1311
 - VlvAnL, 1460
 - VlvL, 1354
 - VlvMotL, 1415
 - VlvPosL, 1526
 - Noise generator block, 2375
 - NoiseGen
 - Area of application, 2037
 - How it works, 2037
 - I/Os, 2038
 - Object name, 2037
 - Not bumpless, 178
 - Not01
 - Area of application, 2003
 - Block diagram, 2006
 - Configuration, 2003
 - Error handling, 2004
 - Functions, 2004
 - How it works, 2003
 - I/Os, 2005
 - Messaging, 2005
 - Object name, 2003
 - Operating modes, 2004
- O**
- Object name
 - AbsR, 1811
 - Add04, 1814
 - Add08, 1819
 - AddInt64, 2291
 - AddR64, 2292
 - And04, 1977
 - And08, 1982
 - Average, 1824
 - CompAn02, 1917
 - ConPerMon, 565
 - CountOh, 1711
 - CountScL, 1689
 - DeadTime, 1830
 - Derivative, 1837
 - DiToInt64, 2293
 - Div02, 1844
 - DoseL, 1005
 - Event, 1631
 - Event16Ts, 1671
 - EventNck, 1644
 - EventTs, 1656
 - FbAnIn, 2041
 - FbAnOu, 2050
 - FbAnTot, 2132
 - FbDiIn, 2060
 - FbDiOu, 2069
 - FbEnMe, 2090
 - FirstIn, 1626
 - FlipFlop, 1987
 - FlowCorr, 1849
 - FmCont, 599
 - FmTemp, 637
 - GainSched, 678
 - Int64ToDi, 2294
 - Integral, 1857
 - Intlk02, 1567
 - Intlk04, 1579
 - Intlk08, 1592
 - Intlk16, 1607
 - KalFilt, 980
 - Lag, 1865
 - Limit, 1922
 - MeanTime, 1872
 - ModPreCon, 689
 - MonAnL, 449
 - MonAnS, 480
 - MonDi08, 542
 - MonDiL, 499
 - MonDiS, 523
 - MotRevL, 1131
 - MotS, 1107
 - MotSpdCL, 1171
 - MotSpdL, 1225
 - MPC10x10, 939
 - MSTIn, 2255
 - MSTOu, 2259
 - Mul04, 1879
 - Mul08, 1885
 - MuxAn03, 1928
 - MuxAn08, 1936
 - MuxMST, 2269
 - MuxST, 2274
 - NegInt64, 2296
 - NegR64, 2297
 - NoiseGen, 2037
 - Not01, 2003
 - OpAnL, 347
 - OpAnS, 368
 - OpDi01, 382

- OpDi03, 396
- OpStations, 411
- OpTrig, 423
- Or04, 1993
- Or08, 1998
- Pcs7AnIn, 2110
- Pcs7AnOu, 2122
- Pcs7DiIn, 2139
- Pcs7DiIT, 2147
- Pcs7DiOu, 2156
- Pcs7HaAI, 2192
- Pcs7HaAO, 2199
- PIDCoefR, 2298
- PIDConL, 735
- PIDConR, 807
- PIDConS, 784
- PIDKernR, 2304
- PIDStepL, 851
- Polygon, 1891
- R64ToReal, 2299
- RateLim, 1942
- Ratio, 902
- Rcv_AnaVal, 2315
- Rcv_DigVal, 2308
- RealToR64, 2300
- RedAn02, 1950
- RedDi02, 2007
- SelA02In, 1955
- SelA16In, 1960
- SelD02In, 2012
- SelST16, 2301
- ShLeInt64, 2302
- ShrdResL, 1261
- ShrdResS, 1284
- ShRiInt64, 2303
- Smooth, 1901
- Snd_AnaVal, 2312
- Snd_DigVal, 2305
- SplRange, 921
- SqrRoot, 1907
- STIn, 2247
- STOu, 2251
- StrctCom, 2017
- StrctDeC, 2022
- StruAnIn, 2223
- StruAnOu, 2227
- StruDiln, 2231
- StruDiOu, 2235
- StruScIn, 2239
- StruScOu, 2243
- StruToBy, 2219
- Sub02, 1912
- TimerP, 1783
- TotalL, 1735
- Trigger, 2027
- Vlv2WayL, 1305
- VlvAnL, 1448
- VlvL, 1346
- VlvMotL, 1401
- VlvPosL, 1506
- VlvS, 1377
- XOr04, 2032
- Obtaining the standard value
 - FbAnIn, 2043
 - FbAnOu, 2052
 - FbAnTot, 2133
 - FbDiIn, 2062
 - FbDiOu, 2071
 - Pcs7AnIn, 2113
 - Pcs7DiIn, 2142
 - Pcs7DiIT, 2149
 - Pcs7HaAI, 2193
 - Pcs7HaAO, 2200
- Online optimization of the PID controller parameters
 - FmTemp, 648
- OpAnL
 - Area of application, 347
 - Associated values, 353
 - Block diagram, 359
 - Block icon, 366
 - Configurable reactions using the Feature parameter, 350
 - Configuration, 347
 - Considering bad quality of automatic commands or external values, 350
 - Error handling, 352
 - Forming the signal status for blocks, 349
 - Functions, 349
 - Gradient limit of the setpoint, 349
 - How it works, 347
 - I/Os, 354
 - Internal or external setpoint selection, 349
 - Messaging, 352
 - Object name, 347
 - Opening additional faceplates, 351
 - Operating modes, 348
 - Operator permissions, 350
 - Overview of error numbers, 352
 - Parameter view, 363
 - Preview, 365
 - Process messages, 353
 - Selecting a unit of measure, 350
 - Setpoint limitation, 349
 - SIMATIC BATCH functionality, 351

- Simulating signals, 350
 - Specifying the display area for process and setpoint values as well as operations, 351
 - Standard view, 360
 - Startup characteristics, 347
 - Status word allocation, 347
 - Suppressing messages using the MsgLock parameter, 349
- OpAnL trend view, 363
- OpAnS
 - Area of application, 368
 - Block diagram, 376
 - Block icon, 380
 - Configurable reactions using the Feature parameter, 371
 - Configuration, 368
 - Considering bad quality of automatic commands or external values, 370
 - Error handling, 372
 - Forming the signal status for blocks, 370
 - Functions, 370
 - How it works, 368
 - I/Os, 373
 - Internal or external setpoint selection, 370
 - Messaging, 373
 - Object name, 368
 - Opening additional faceplates, 371
 - Operating modes, 369
 - Operator permissions, 371
 - Overview of error numbers, 372
 - Parameter view, 378
 - Preview, 379
 - Selecting a unit of measure, 370
 - SIMATIC BATCH functionality, 372
 - Simulating signals, 370
 - Specifying the display area for process and setpoint values as well as operations, 371
 - Standard view, 377
 - Startup characteristics, 368
 - Status word allocation, 368
- OpDi01
 - Area of application, 382
 - Block diagram, 390
 - Block icon, 394
 - Changing labels on buttons and text, 384
 - Configurable reactions using the Feature parameter, 386
 - Configuration, 382
 - Considering bad quality of automatic commands or external values, 385
 - Error handling, 386
 - Forming the signal status for blocks, 385
- Functions, 384
 - How it works, 382
 - I/Os, 387
 - Input parameter for feedback value, 384
 - Interlocks, 384
 - Internal or external digital value, 384
 - Messaging, 387
 - Object name, 382
 - Opening additional faceplates, 384
 - Operating modes, 383
 - Operator permissions, 385
 - Overview of error numbers, 387
 - Preview, 392
 - Standard view, 391
 - Startup characteristics, 382
 - Status word allocation, 382
- OpDi03
 - Area of application, 396
 - Block diagram, 405
 - Block icon, 409
 - Changing labels on buttons and text, 399
 - Configurable reactions using the Feature parameter, 400
 - Configuration, 396
 - Considering bad quality of automatic commands or external values, 400
 - Error handling, 401
 - Forming the signal status for blocks, 399
 - Functions, 398
 - How it works, 396
 - I/Os, 402
 - Input parameter for feedback value, 399
 - Interlocks, 398
 - Internal or external digital value, 398
 - Messaging, 402
 - Object name, 396
 - Opening additional faceplates, 399
 - Operating modes, 397
 - Operator permissions, 400
 - Overview of error numbers, 401
 - Preview, 408
 - Resetting all output values, 399
 - Standard view, 406
 - Startup characteristics, 396
 - Status word allocation, 396
- Opening additional faceplates, 208
 - ConPerMon, 580
 - CountOh, 1718
 - CountScL, 1696
 - DoseL, 1021
 - FmCont, 613
 - FmTemp, 653

- Intlk02, 1570
- Intlk04, 1584
- Intlk08, 1598
- Intlk16, 1614
- ModPreCon, 705
- MonAnL, 458
- MonAnS, 485
- MonDi08, 546
- MonDiL, 507
- MonDiS, 529
- MotL, 1078
- MotRevL, 1137
- MotS, 1111
- MotSpdCL, 1177
- MotSpdL, 1231
- MPC10x10, 954
- OpAnL, 351
- OpAnS, 371
- OpDi01, 384
- OpDi03, 399
- OpTrig, 425
- PIDConL, 751
- PIDConR, 828
- PIDConS, 793
- PIDStepL, 866
- Ratio, 906
- SelA16In, 1962
- ShrdResL, 1265
- ShrdResS, 1287
- TotalL, 1745
- Vlv2WayL, 1315
- VlvAnL, 1454
- VlvL, 1351
- VlvMotL, 1407
- VlvPosL, 1515
- VlvS, 1381
- Operating mode
 - Automatic for controller blocks, 72
 - Automatic for motors, valves and dosers, 75
 - In progress, 64
 - Local mode, 79
 - Manual for controller blocks, 72
 - Manual for motors, valves and dosers, 75
 - On, 71
 - Out of service, 64, 71
 - Overview for status change, 83
 - Program mode, 78
 - Rcv_AnaVal, 2316
 - Rcv_DigVal, 2309
 - Snd_DigVal, 2306, 2313
- Operating modes
 - AbsR, 1812
 - Add04, 1815
 - Add08, 1820
 - And04, 1978
 - And08, 1983
 - AV, 440
 - Average, 1825
 - CompAn02, 1918
 - ConPerMon, 569
 - CountOh, 1715
 - CountScL, 1693
 - DeadTime, 1832
 - Derivative, 1839
 - Div02, 1845
 - DoseL, 1009
 - Event, 1634
 - Event16Ts, 1676
 - EventNck, 1646
 - EventTs, 1659
 - FbAnIn, 2043
 - FbAnTot, 2133
 - FbDiIn, 2061
 - FbEnMe, 2091
 - FbSwtMMS, 2102
 - FirstIn, 1627
 - FlipFlop, 1988
 - FlowCorr, 1851
 - FmCont, 603
 - FmTemp, 641
 - GainSched, 680
 - Integral, 1858
 - KalFilt, 986
 - Lag, 1867
 - Limit, 1924
 - MeanTime, 1873
 - ModPreCon, 694
 - MonAnL, 452
 - MonAnS, 482
 - MonDi08, 544
 - MonDiL, 502
 - MonDiS, 526
 - MotL, 1077
 - MotRevL, 1135
 - MotS, 1109
 - MotSpdCL, 1176
 - MotSpdL, 1229
 - MPC10x10, 946
 - MSTIn, 2256
 - MSTOu, 2260
 - Mul04, 1881
 - Mul08, 1886
 - MuxAn03, 1929
 - MuxAn08, 1936

- MuxMST, 2270
- MuxST, 2275
- Not01, 2004
- OpAnL, 348
- OpAnS, 369
- OpDi01, 383
- OpDi03, 397
- OpStations, 413
- OpTrig, 424
- Or04, 1994
- Or08, 1999
- Pcs7Cnt2, 2177
- Pcs7Cnt3, 2185
- Pcs7HaAI, 2193
- Pcs7HaAO, 2200
- PIDConL, 740
- PIDConR, 813
- PIDConS, 787
- PIDStepL, 855
- Polygon, 1894
- Psc7Cnt1, 2166
- RateLim, 1943
- Ratio, 904
- RedAn02, 1951
- RedDi02, 2008
- SelA02In, 1956
- SelA16In, 1961
- SelD02In, 2013
- ShrdResL, 1264
- ShrdResS, 1286
- Smooth, 1902
- SplRange, 922
- SqrRoot, 1908
- STIn, 2248
- STOu, 2252
- StrctCom, 2018
- StrctDeC, 2023
- StrgToBy, 2220
- StruScOu, 2244
- Sub02, 1913
- TimerP, 1784
- TimeTrig, 1793
- TotalL, 1744
- Trigger, 2028
- Vlv2WayL, 1309
- VlvAnL, 1452
- VlvL, 1349
- VlvMotL, 1406
- VlvPosL, 1511
- VlvS, 1379
- XOr04, 2033
- Operating modes of AssetM, 2285
- Operating modes of CntOhSc, 1770
- Operating modes of RealToDw, 2264
- Operating modes of STRep, 2279
- Operating modes of the blocks
 - Overview, 69
- Operating permissions
 - Intlk02, 1572
 - Intlk04, 1585
 - Intlk08, 1599
 - Intlk16, 1615
- Operating principle
 - KalFilt, 982
- Operator control permissions
 - Blocks, 254
 - Event, 1635
 - EventNck, 1648
 - MonDi08, 546
 - OpStations, 414
 - OpTrig, 425
 - SelA16In, 1962
- Operator input area for process values and setpoints, 207
- Operator permissions
 - ConPerMon, 579
 - CountOh, 1718
 - CountScL, 1695
 - DoseL, 1023
 - Event16Ts, 1677
 - EventTs, 1661
 - FmCont, 611
 - FmTemp, 651
 - KalFilt, 987
 - ModPreCon, 704
 - MonAnL, 457
 - MonAnS, 484
 - MonDiL, 506
 - MonDiS, 529
 - MotL, 1078
 - MotRevL, 1137
 - MotS, 1111
 - MotSpdCL, 1178
 - MotSpdL, 1231
 - MPC10x10, 953
 - OpAnL, 350
 - OpAnS, 371
 - OpDi01, 385
 - OpDi03, 400
 - PIDConL, 748
 - PIDConR, 825
 - PIDConS, 792
 - PIDStepL, 864, 906
 - ShrdResL, 1265

- TotalL, 1747
- Vlv2WayL, 1315
- VlvAnL, 1463
- VlvL, 1351
- VlvMotL, 1407
- VlvPosL, 1515
- VlvS, 1381
- OpStations
 - Area of application, 411
 - Block diagram, 418
 - Block icon, 422
 - Configuration, 411
 - Error handling, 415
 - Functions, 414
 - How it works, 411
 - I/Os, 416
 - Messaging, 415
 - Object name, 411
 - Operating modes, 413
 - Operator control permissions, 414
 - Startup characteristics, 412
 - Status word allocation, 413
- OpTrig
 - Area of application, 423
 - Block diagram, 429
 - Block icon, 432
 - Configurable reactions using the Feature parameter, 426
 - Configuration, 423
 - Considering bad quality of automatic commands or external values, 425
 - Error handling, 426
 - Forming the signal status for blocks, 425
 - Functions, 424
 - How it works, 423
 - I/Os, 427
 - Input parameter for feedback value, 425
 - Issuing trigger signal internally or externally, 425
 - Messaging, 427
 - Object name, 423
 - Opening additional faceplates, 425
 - Operating modes, 424
 - Operator control permissions, 425
 - Preview, 431
 - Simulating signals, 426
 - Standard view, 430
 - Startup characteristics, 423
 - Status word allocation, 423
- Or04
 - Area of application, 1993
 - Block diagram, 1997
 - Configuration, 1993
- Error handling, 1995
- Functions, 1995
- How it works, 1993
- I/Os, 1996
- Messaging, 1996
- Object name, 1993
- Operating modes, 1994
- Startup characteristics, 1994
- Status word allocation, 1994
- Or08
 - Area of application, 1998
 - Block diagram, 2002
 - Configuration, 1998
 - Error handling, 2000
 - Functions, 1999
 - How it works, 1998
 - I/Os, 2001
 - Messaging, 2000
 - Object name, 1998
 - Operating modes, 1999
 - Startup characteristics, 1998
 - Status word allocation, 1999
- Out of service
 - Operating mode description, 71
- Output of invalid value if raw value is invalid
 - FbDiIn, 2062
 - Pcs7AnIn, 2115
 - Pcs7DiIn, 2142
 - Pcs7DiIT, 2150
- Output signal as a pulse signal or static signal
 - DoseL, 1013
 - MotL, 1083
 - MotRevL, 1142
 - MotS, 1114
 - MotSpdCL, 1185
 - MotSpdL, 1236
 - Vlv2WayL, 1311
 - VlvL, 1355
 - VlvMotL, 1415
- Output signal as pulse signal or static signal
 - VlvPosL, 1526
- Output substitute value if raw value is invalid
 - FbAnIn, 2044
 - FbAnTot, 2133
 - FbDiIn, 2062
 - Pcs7AnIn, 2115
 - Pcs7DiIn, 2142
 - Pcs7DiIT, 2150
- Outputting a signal for start readiness
 - DoseL, 1020
 - FmCont, 606
 - FmTemp, 644

- MotL, 1080, 1113, 1183
 - MotRevL, 1140
 - MotSpdL, 1233
 - PIDConL, 742
 - PIDConR, 817
 - PIDConS, 789
 - PIDStepL, 859
 - Vlv2WayL, 1314
 - VlvAnL, 1455
 - VlvL, 1352
 - VlvMotL, 1411
 - VlvPosL, 1521
 - Outputting an invalid value if analog value is invalid
 - FbAnIn, 2044
 - FbAnTot, 2134
 - Overdosing/underdosing
 - DoseL, 1016
 - Override control
 - ConPerMon, 576
 - Override control (override), 735, 807, 851
 - Overshoot, 566, 572, 581, 592, 2377
 - Overview of error numbers, 120
 - AV, 443
 - Average, 1827
 - ConPerMon, 581
 - CountOh, 1720
 - CountScL, 1697
 - DeadTime, 1833
 - Derivative, 1841
 - Div02, 1846
 - DoseL, 1026
 - Event, 1636
 - EventNck, 1649
 - EventTs, 1662, 1679
 - FmCont, 615
 - FmTemp, 654
 - Integral, 1861
 - Intlk02, 1574
 - Intlk04, 1586
 - Intlk08, 1600
 - Intlk16, 1617
 - KalFilt, 989
 - Lag, 1869
 - MeanTime, 1876
 - ModPreCon, 708
 - MonAnL, 459, 508
 - MonAnS, 485
 - MonDi08, 548
 - MonDiS, 530
 - MotL, 1085
 - MotRevL, 1144
 - MotS, 1115
 - MotSpdCL, 1189
 - MotSpdL, 1238
 - MPC10x10, 958
 - OpAnL, 352
 - OpAnS, 372
 - OpDi01, 387
 - OpDi03, 401
 - PIDConL, 752
 - PIDConR, 829
 - PIDConS, 794
 - PIDStepL, 867
 - Polygon, 1895
 - RateLim, 1946
 - Ratio, 908
 - SelA16In, 1965
 - ShrdResL, 1271
 - ShrdResS, 1290
 - Smooth, 1904
 - SplRange, 926
 - TimerP, 1787
 - TimeTrig, 1798
 - TotalL, 1749
 - Vlv2WayL, 1318
 - VlvAnL, 1467
 - VlvL, 1356
 - VlvMotL, 1418
 - VlvPosL, 1528
 - VlvS, 1385
- P**
- P action, 74, 198
 - P component, 195, 609
 - P controller, 690, 940
 - P step change, 173
 - PA/FF devices
 - Variant identifier, 2217
 - PA/FF devices variant identifier, 2217
 - PA/FF_MODE
 - Settings, 2217
 - Parameter view
 - DoseL, 1053
 - FM controller, 284
 - GainSched, 687
 - ModPreCon, 728
 - Motor, 286
 - MPC10x10, 973, 974
 - PID controller, 281
 - Ratio, 916
 - ShrdResL, 1281
 - Vlv2WayL, 1336
 - PCS 7 measuring point browser, 341

- PCS7 multiproject, 2320
- PCS7 PID tuner, 2327
- Pcs7AnIn
 - Area of application, 2110
 - Block diagram, 2121
 - Channel error, 2117
 - Configurable reactions using the Feature parameter, 2116
 - Configuration, 2110
 - Error handling, 2117
 - Functions, 2113
 - Higher-level error / invalid measuring range, 2117
 - Hold last value, 2114
 - How it works, 2110
 - I/Os, 2118
 - Messaging, 2118
 - Modes, 2112
 - Object name, 2110
 - Obtaining the standard value, 2113
 - Output of invalid value if raw value is invalid, 2115
 - Output substitute value if raw value is invalid, 2115
 - Quality code, 2112
 - Raw value check, 2113
 - Redundancy, 2112
 - Signal status for PCS7 channel blocks, 2115
 - Simulating signals, 2116
 - Startup characteristics, 2112
 - Status word allocation, 2112
 - Value application delay,
- Pcs7AnOu
 - Area of application, 2122
 - Block diagram, 2131
 - Channel error, 2127
 - Configurable reactions using the Feature parameter, 2126
 - Configuration, 2122
 - Error handling, 2127
 - Flutter suppression, 2126
 - Forming an I/O value, 2125
 - Forming the signal status for PCS7 channel blocks, 2126
 - Functions, 2125
 - Higher-level error / invalid measuring range, 2127
 - How it works, 2122
 - I/Os, 2128
 - Limiting the peripheral value, 2126
 - Limiting the process value, 2126
 - Messaging, 2128
 - Modes, 2125
 - Object name, 2122
- Quality code, 2124
- Redundancy, 2124
- Simulating signals, 2126
- Startup characteristics, 2124
- Status word allocation, 2124
- Pcs7Cnt2, 2174
 - Area of application, 2174
 - Block diagram, 2182
 - Configurable reactions using the Feature parameter, 2178
 - Configuration, 2176
 - Description, 2174
 - Error handling, 2179
 - Flutter suppression, 2178
 - Functions, 2177
 - How it works, 2174
 - I/Os, 2180
 - Messaging, 2180
 - Operating modes, 2177
 - Signal status, 2178
 - Startup characteristics, 2177
 - Status word allocation, 2177
- Pcs7Cnt3
 - Area of application, 2183
 - Block diagram, 2191
 - Configurable reactions using the Feature parameter, 2186
 - Configuration, 2184
 - Description of, 2183
 - Error handling, 2186
 - Functions, 2185
 - How it works, 2183
 - I/Os, 2187
 - Messaging, 2187
 - Operating modes, 2185
 - Signal status, 2186
 - Startup characteristics, 2184
 - Status word allocation, 2184
- Pcs7DiIn
 - Area of application, 2139
 - Block diagram, 2146
 - Channel error, 2143
 - Configurable reactions using the Feature parameter, 2143
 - Configuration, 2139
 - Error handling, 2143
 - Flutter suppression, 2142
 - Functions, 2142
 - Higher-level error / invalid measuring range, 2143
 - Hold last value, 2142
 - How it works, 2139
 - I/Os, 2144

- Messaging, 2144
- Modes, 2141
- Object name, 2139
- Obtaining the standard value, 2142
- Output of invalid value if raw value is invalid, 2142
- Output substitute value if raw value is invalid, 2142
- Quality code, 2140
- Redundancy, 2141
- Signal status for PCS7 channel blocks, 2142
- Simulating signals, 2142
- Startup characteristics, 2140
- Status word allocation, 2141
- Pcs7DiT
 - Area of application, 2147
 - Block diagram, 2155
 - Configurable reactions using the Feature parameter, 2151
 - Configuration, 2147
 - Error handling, 2151
 - Functions, 2149
 - Hold last value, 2150
 - How it works, 2147
 - I/Os, 2152
 - Messaging, 2152
 - Modes, 2149
 - Object name, 2147
 - Obtaining the standard value, 2149
 - Output of invalid value if raw value is invalid, 2150
 - Output substitute value if raw value is invalid, 2150
 - Quality code, 2148
 - Redundancy, 2148
 - Signal status for PCS7 channel blocks, 2150
 - Simulating signals, 2150
 - Startup characteristics, 2148
 - Status word allocation, 2148
 - Time stamp, 2150
- Pcs7DiOu
 - Area of application, 2156
 - Block diagram, 2162
 - Configurable reactions using the Feature parameter, 2159
 - Configuration, 2156
 - Error handling, 2159
 - Flutter suppression, 2159
 - Forming a peripheral value, 2158
 - Functions, 2158
 - Higher-level error / invalid measuring range, 2160
 - How it works, 2156
 - I/Os, 2160
 - Messaging, 2160
 - Modes, 2158
 - Object name, 2156
 - Quality code, 2157
 - Redundancy, 2157
 - Simulating signals, 2159
 - Startup characteristics, 2157
 - Status word allocation, 2158
- Pcs7HaAI
 - Area of application, 2192
 - Block diagram, 2197
 - Configuration, 2192
 - Error handling, 2194
 - Functions, 2193
 - How it works, 2192
 - I/Os, 2195
 - Invalid value, 2194
 - Messaging, 2194
 - Object name, 2192
 - Obtaining the standard value, 2193
 - Operating modes, 2193
 - Startup characteristics, 2192
 - Status word allocation, 2192
- Pcs7HaAO
 - Area of application, 2199
 - Block diagram, 2204
 - Configuration, 2199
 - Error handling, 2201
 - Functions, 2200
 - How it works, 2199
 - I/Os, 2202
 - Invalid value, 2201
 - Messaging, 2201
 - Object name, 2199
 - Obtaining the standard value, 2200
 - Operating modes, 2200
 - Startup characteristics, 2199
 - Status word allocation, 2199
- Periodic output of a trigger
 - TimeTrig, 1794
- Physical standardization of setpoint, manipulated variable and process value
 - FmCont, 608
 - FmTemp, 646
 - PIDConL, 744
 - PIDConR, 820
 - PIDStepL, 860
- PI controller, 2332
- PID algorithm
 - FmCont, 608
 - FmTemp, 647

- PIDConL, 745
- PIDConR, 821
- PIDConS, 790
- PIDStepL, 861
- PID controller, 78, 565, 678, 689, 698, 735, 784, 807, 921, 949, 2324, 2327, 2329, 2335, 2377
- PID controller with gain scheduler
 - ConPerMon, 576
- PID controllers, 694, 695, 946, 947, 2342, 2345, 2350
- PIDCoefR
 - Area of application, 2298
 - Object name, 2298
- PIDConL
 - Actuator active information, 742
 - Anti-windup, 746
 - Area of application, 735
 - Associated values, 755
 - Block diagram, 773
 - Block icon, 239
 - Bypass function, 743
 - Configurable reactions using the Feature parameter, 747
 - Configurable reactions using the Feature2 parameter, 748
 - Configuration, 735
 - Control zone, 746
 - Error handling, 752
 - Error signal generation and dead band, 744
 - External/internal setpoint specification, 742
 - Feedforwarding and limiting disturbance variables, 746
 - Forming the signal status for blocks, 746
 - Functions, 741
 - Generating instance-specific messages, 750
 - Generation of manipulated variables, 741
 - Gradient limit of the setpoint, 743
 - Group error, 742
 - How it works, 735
 - I/Os, 756
 - Instance-specific messages, 754
 - Interlocks, 750, 827
 - Inverting control direction, 744
 - Limit monitoring of error signal, 744
 - Limit monitoring of position feedback, 742
 - Limit monitoring of the process value, 743
 - Messaging, 753
 - Neutral position, 742
 - Object name, 735
 - Opening additional faceplates, 751
 - Operating modes, 740
 - Operator permissions, 748
 - Outputting a signal for start readiness, 742
 - Overview of error numbers, 752
 - Physical standardization of setpoint, manipulated variable and process value, 744
 - PID algorithm, 745
 - Preview, 781
 - Process control fault, 753
 - Process messages, 754, 1531
 - Providing PV limit at the output, 743
 - Release for maintenance, 750
 - Selecting a unit of measure, 745
 - Setpoint limiting for external setpoints, 743
 - Setpoint ramp, 743
 - SIMATIC BATCH functionality, 751
 - Simulating signals, 743
 - Specifying the display area for process and setpoint values as well as operations, 751
 - Startup characteristics, 737
 - Status word allocation, 737
 - Structure segmentation at controllers, 746
 - Suppressing messages using the MsgLock parameter, 750
 - Time-stamped messages, 751
 - Tracking and limiting a manipulated variable, 742
 - Tracking the setpoint, 743
- PIDConR
 - Actuator active information, 817
 - Anti-windup, 823
 - Area of application, 807
 - Associated values, 832
 - Block diagram, 850
 - Bumpless switchover from external to internal setpoint, 819
 - Bypass function, 819
 - Configurable reactions using the Feature parameter, 824
 - Configuration, 808
 - Displaying additional information relating to the manipulated variable on the output, 817
 - Error handling, 829
 - Error signal generation and dead band, 820
 - External/internal setpoint specification, 818
 - Feedforwarding and limiting disturbance variables, 823
 - Forming the signal status for blocks, 824
 - Functions, 815
 - Generating instance-specific messages, 827
 - Generation of manipulated variables, 815
 - Gradient limit of the setpoint, 819
 - Group error, 817
 - How it works, 807

- I/Os, 833, 871, 872, 873, 874, 875, 876, 877, 878, 879, 880
- Instance-specific messages, 831
- Inverting control direction, 820
- Limit monitoring of error signal, 820
- Limit monitoring of position feedback, 818
- Limit monitoring of the process value, 819
- Messaging, 830
- Neutral position, 817
- Object name, 807
- Opening additional faceplates, 828
- Operating modes, 813
- Operator permissions, 825
- Outputting a signal for start readiness, 817
- Overview of error numbers, 829
- Physical standardization of setpoint, manipulated variable and process value, 820
- PID algorithm, 821
- Preview, 781
- Process control fault, 830
- Process messages, 831
- Providing PV limit at the output, 819
- Release for maintenance, 827
- Selecting a unit of measure, 821
- Setpoint limiting for external setpoints, 819
- Setpoint ramp, 819
- SIMATIC BATCH functionality, 828
- Simulating signals, 819
- Specifying the display area for process and setpoint values as well as operations, 828
- Startup characteristics, 809
- Status word allocation, 810
- Suppressing messages using the MsgLock parameter, 827
- Time-stamped messages, 828
- Tracking and limiting a manipulated variable, 817
- Tracking the setpoint, 819
- Use output point for the manipulated variable calculation, 823
- PIDConS
 - Actuator active information, 789
 - Anti-windup, 791
 - Area of application, 784
 - Associated values, 796
 - Block diagram, 804
 - Block icon, 239
 - Configurable reactions using the Feature parameter, 791
 - Configuration, 784
 - Error handling, 794
 - Error signal generation and dead band, 790
 - External/internal setpoint specification, 789
 - Forming the signal status for blocks, 791
 - Functions, 788
 - Generating instance-specific messages, 793
 - Generation of manipulated variables, 788
 - Group error, 789
 - How it works, 784
 - I/Os, 797
 - Instance-specific messages, 796
 - Limit monitoring of the process value, 790
 - Messaging, 795
 - Neutral position, 789
 - Object name, 784
 - Opening additional faceplates, 793
 - Operating modes, 787
 - Operator permissions, 792
 - Outputting a signal for start readiness, 789
 - Overview of error numbers, 794
 - PID algorithm, 790
 - Preview, 781
 - Process control fault, 795
 - Process messages, 795
 - Release for maintenance, 793
 - Selecting a unit of measure, 790
 - Setpoint limitation, 789
 - SIMATIC BATCH functionality, 793
 - Simulating signals, 789
 - Specifying the display area for process and setpoint values as well as operations, 793
 - Startup characteristics, 785
 - Status word allocation, 785
 - Suppressing messages using the MsgLock parameter, 793
 - Tracking and limiting a manipulated variable, 788
 - Tracking the setpoint, 789
- PIDKernR
 - Area of application, 2304
 - Object name, 2304
- PIDStepL
 - Actuator active information, 859
 - Anti-windup, 862
 - Area of application, 851
 - Associated values, 870
 - Block diagram, 886
 - Button labels, 866
 - Bypass function, 860
 - Configurable reactions using the Feature parameter, 863
 - Configurable reactions using the Feature2 parameter, 864
 - Configuration, 852
 - Error handling, 867
 - Error signal generation and dead band, 860

- External/internal setpoint specification, 859
- Feedforwarding and limiting disturbance variables, 862
- Forming the signal status for blocks, 862
- Functions, 856
- Generating instance-specific messages, 866
- Generation of actuating signal without position feedback, 857
- Generation of manipulated variables, 857
- Gradient limit of the setpoint, 859
- Group error, 859
- How it works, 851
- Instance-specific messages, 870
- Inverting control direction, 860
- Limit monitoring of error signal, 860
- Limit monitoring of position feedback, 859
- Limit monitoring of the process value, 860
- Messaging, 868
- Neutral position, 858
- Object name, 851
- Opening additional faceplates, 866
- Operating modes, 855
- Operator permissions, 864, 906
- Outputting a signal for start readiness, 859
- Overview of error numbers, 867
- Physical standardization of setpoint, manipulated variable and process value, 860
- PID algorithm, 861
- Preview, 899
- Process control fault, 869
- Process messages, 869
- Release for maintenance, 866
- Selecting a unit of measure, 861
- Setpoint limiting for external setpoints, 859
- Setpoint ramp, 859
- SIMATIC BATCH functionality, 866
- Simulating signals, 860
- Specifying the display area for process and setpoint values as well as operations, 866
- Startup characteristics, 852
- Status word allocation, 853
- Structure segmentation at controllers, 862
- Suppressing messages using the MsgLock parameter, 866
- Time-stamped messages, 867
- Tracking and limiting a manipulated variable, 858
- Tracking the setpoint, 860
- Polygon
 - Area of application, 1891
 - Block diagram, 1900
 - Configuration, 1893
 - Error handling, 1895
 - Forming the signal status for blocks, 1894
 - Functions, 1894
 - How it works, 1892
 - I/Os, 1897
 - Messaging, 1896
 - Object name, 1891
 - Operating modes, 1894
 - Overview of error numbers, 1895
 - Startup characteristics, 1893
 - Status word allocation, 1893
- Positive edge, 53
- Post dosing
 - DoseL, 1016
- Prediction horizon, 2385
- Predictive controller, 696, 948
- Predictive controller algorithm
 - ModPreCon, 698
 - MPC10x10, 949
- Preview
 - ModPreCon, 729
 - MPC10x10, 975
 - ShrdResL, 1280
- Preview of CntOhSc, 1780
- Process control fault, 616, 655, 753, 795, 830, 868
 - DoseL, 1028
 - FmCont, 616
 - FmTemp, 655
 - MonAnL, 460
 - MonAnS, 486
 - MonDiL, 509
 - MonDiS, 531
 - MotL, 1087
 - MotRevL, 1146
 - MotS, 1117
 - MotSpdCL, 1192
 - MotSpdL, 1240
 - PIDConL, 753
 - PIDConR, 830
 - PIDConS, 795
 - PIDStepL, 869
 - Vlv2WayL, 1320
 - VlvAnL, 1469
 - VlvL, 1358
 - VlvMotL, 1420
 - VlvS, 1387
- Process control messages, 251
- Process dead time, 575
- Process messages, 616, 655, 753, 795, 830, 868
 - AV, 444
 - ConPerMon, 582
 - CountOh, 1721
 - CountScL, 1698

- DoseL, 1029
- Event, 1637
- EventNck, 1650
- EventTs, 1663
- FmCont, 617
- FmTemp, 656
- MonAnL, 460
- MonAnS, 487
- MonDi08, 549
- MonDiL, 509
- MonDiS, 531
- OpAnL, 353
- PIDConL, 754, 1531
- PIDConR, 831
- PIDConS, 795
- PIDStepL, 869
- TotalL, 1751
- VlvAnL, 1469
- Process messages (MsgEvid1)
 - Event16Ts, 1680
- Process messages (MsgEvid2)
 - Event16Ts, 1681
- Process simulation, 2373, 2377, 2378, 2379
- Process value with separate scale range, 162
- Program mode
 - Description, 78
- Proportional gain, 172
- Providing PV limit at the output
 - PIDConL, 743
 - PIDConR, 819
- Psc7AnIn
 - Flutter suppression, 2115
- Psc7Cnt1, 2164
 - Area of application, 2164
 - Block diagram, 2173
 - Configurable reactions using the Feature parameter, 2167
 - Configuration, 2165
 - Description, 2164
 - Error handling, 2168
 - Flutter suppression, 2167
 - Forming the signal status for blocks, 2172
 - Functions, 2166
 - How it works, 2164
 - I/Os, 2169
 - Messaging, 2169
 - Operating modes, 2166
 - Signal status, 2167
 - Startup characteristics, 2165
 - Status word allocation, 2165
- Psc7Cnt3
 - Flutter suppression, 2185

- Psc7DiIT
 - Flutter suppression, 2150
- Pulse controller, 599, 604, 637, 642
- Pulse signal with configurable pulse length, 51

Q

- Quality code
 - FbAnIn, 2042
 - FbAnOu, 2051
 - Pcs7AnIn, 2112
 - Pcs7AnOu, 2124
 - Pcs7DiIn, 2140
 - Pcs7DiIT, 2148
 - Pcs7DiOu, 2157

R

- R64ToReal
 - Area of application, 2299
 - Object name, 2299
- Ramp function, 301
- Ramp view, 123, 125, 300
- Rapid stop, 106
 - Description, 106
 - MotL, 1080
 - MotRevL, 1139
 - MotSpdCL, 1182
 - MotSpdL, 1232
 - VlvMotL, 1409
 - VlvPosL, 1519
- RateLim
 - Area of application, 1942
 - Block diagram, 1949
 - Configurable reactions using the Feature parameter, 1945
 - Configuration, 1942
 - Error handling, 1946
 - Functions, 1943
 - How it works, 1942
 - I/Os, 1947
 - Limitation of the slope of an analog signal, 1944
 - Messaging, 1946
 - Object name, 1942
 - Operating modes, 1943
 - Overview of error numbers, 1946
 - Startup characteristics, 1943
 - Status word allocation, 1943
 - Stopping the calculation of the ramp output value, 1945
 - Switching the limiting function on or off, 1945

Ratio

- Area of application, 902
- Block diagram, 912
- Block icon, 918
- Bumpless switchover from external to internal ratio, 905
- Configurable reactions using the Feature parameter, 907
- Configuration, 903
- Display and operator input area for process values and setpoints, 905
- Error handling, 907
- Forming and outputting signal status for blocks, 906
- Functions, 904
- How it works, 902
- I/Os, 908
- Internal or external ratio, 905
- Limiting the output value, 905
- Limiting the ratio, 905
- Messaging, 908
- Object name, 902
- Opening additional faceplates, 906
- Operating modes, 904
- Overview of error numbers, 908
- Preview, 917
- Selecting a unit of measure, 905
- Simulating signals, 905
- Standard view, 913
- Startup characteristics, 903
- Status word allocation, 903
- Ratio block, 2338
- Ratio control, 599, 637, 689, 735, 807, 851, 2338
 - ConPerMon, 577
- Raw value check
 - Pcs7AnIn, 2113
- Rcv_AnaVal
 - Area of application, 2315
 - Configuration, 2316
 - Error handling, 2316
 - Functions, 2316
 - How it works, 2315
 - Messaging, 2317
 - Object name, 2315
 - Operating mode, 2316
 - Startup characteristics, 2316
- Rcv_DigVal
 - Area of application, 2308
 - Configuration, 2309
 - Error handling, 2310
 - Functions, 2310
 - How it works, 2308

- Messaging, 2310
- Object name, 2308
- Operating mode, 2309
- Startup characteristics, 2309
- Time characteristics, 2309
- Read back the last counted value
 - CountOh, 1717
 - CountScL, 1694
- Readback of the most recently calculated sum
 - TotalL, 1748
- Readiness signal
 - ShrdResL, 1266
 - ShrdResS, 1287
- RealToR64
 - Area of application, 2300
 - Object name, 2300
- Recording the first signal
 - Activate, 150
 - Interlock block, 52
- RedAn02
 - Area of application, 1950
 - Block diagram, 1954
 - Configuration, 1950
 - Error handling, 1952
 - Forming the signal status for blocks, 1951
 - Functions, 1951
 - How it works, 1950
 - I/Os, 1953
 - Messaging, 1952
 - Object name, 1950
 - Operating modes, 1951
 - Startup characteristics, 1950
 - Status word allocation, 1950
- RedDi02
 - Area of application, 2007
 - Block diagram, 2011
 - Configuration, 2007
 - Error handling, 2009
 - Forming the signal status for blocks, 2008
 - Functions, 2008
 - How it works, 2007
 - I/Os, 2010
 - Messaging, 2009
 - Object name, 2007
 - Operating modes, 2008
 - Startup characteristics, 2007
 - Status word allocation, 2007
- Redundancy
 - FbAnIn, 2042
 - FbAnOu, 2051
 - Pcs7AnIn, 2112
 - Pcs7AnOu, 2124

- Pcs7DiIn, 2141
- Pcs7DiIT, 2148
- Pcs7DiOu, 2157
- Release for maintenance, 64
 - AV, 442
 - CountOh, 1719
 - CountScL, 1696
 - DoseL, 1021
 - Event, 1635
 - Event16Ts, 1677
 - EventNck, 1648
 - EventTs, 1660
 - FmCont, 613
 - FmTemp, 653
 - ModPreCon, 705
 - MonAnL, 456
 - MonAnS, 483
 - MonDi08, 545
 - MonDiL, 506
 - MonDiS, 528
 - MotL, 1082, 1115
 - MotRevL, 1141
 - MotSpdCL, 1184
 - MotSpdL, 1234
 - MPC10x10, 954
 - PIDConL, 750
 - PIDConR, 827
 - PIDConS, 793
 - PIDStepL, 866
 - TotalL, 1749
 - Vlv2WayL, 1315
 - VlvL, 1353
 - VlvMotL, 1414
 - VlvPosL, 1525
 - VlvS, 1384
- Request for maintenance release
 - Issuing a request for maintenance (MS → APL), 62
- Reset
 - Block, 43
 - Monitoring errors, 43
- Reset counter to zero
 - CountOh, 1717
 - CountScL, 1694
- Reset of motor control after valve end position has been reached
 - VlvMotL, 1410
- Reset values
 - Lag, 1868
- Resetting all output values
 - OpDi03, 399

- Resetting the block in case of interlocks
 - VlvL, 1351
 - VlvMotL, 1411
 - VlvPosL, 1520
 - VlvS, 1382
- Resetting the block in case of interlocks or errors
 - DoseL, 1019
 - MotL, 1080
 - MotRevL, 1139
 - MotS, 1112
 - MotSpdCL, 1182
 - MotSpdL, 1233
 - Vlv2WayL, 1313
 - VlvAnL, 1455
- Resetting the dosing quantity
 - DoseL, 1017
- Resetting the Out and TimeRemaining output parameters
 - TimerP, 1786
- Restart low pass filter
 - Smooth, 1903

S

- S7_unit, 213
- Sealing the valve
 - VlvMotL, 1410
 - VlvPosL, 1520
- SelA02In
 - Area of application, 1955
 - Block diagram, 1959
 - Configuration, 1955
 - Error handling, 1957
 - Functions, 1956
 - How it works, 1955
 - I/Os, 1958
 - Messaging, 1958
 - Object name, 1955
 - Operating modes, 1956
 - Select input parameter, 1957
 - Startup characteristics, 1955
 - Status word allocation, 1955
- SelA16In
 - Area of application, 1960
 - Block diagram, 1970
 - Block icon, 1974
 - Configurable reactions using the Feature parameter, 1964
 - Configuration, 1960
 - Error handling, 1965
 - Forming the signal status for blocks, 1963
 - Functions, 1962

- How it works, 1960
- I/Os, 1966
- Messaging, 1965
- Object name, 1960
- Opening additional faceplates, 1962
- Operating modes, 1961
- Operator control permissions, 1962
- Overview of error numbers, 1965
- Preview, 1973
- Selecting a unit of measure, 1963
- Standard view, 1971
- Startup characteristics, 1960
- Status word allocation, 1961
- SelD02In
 - Area of application, 2012
 - Block diagram, 2016
 - Configuration, 2012
 - Display of selected value, 2013
 - Error handling, 2014
 - Functions, 2013
 - How it works, 2012
 - I/Os, 2015, 2030
 - Messaging, 2014
 - Object name, 2012
 - Operating modes, 2013
 - Select input parameter, 2013
 - Startup characteristics, 2012
 - Status word allocation, 2012
- Select input parameter
 - SelA02In, 1957
 - SelD02In, 2013
- Select unit of measure
 - VlvPosL, 1525
- Selecting a unit of measure
 - AV, 442
 - ConPerMon, 578
 - CountScL, 1695
 - DoseL, 1021
 - FmCont, 608
 - FmTemp, 647
 - GainSched, 681
 - ModPreCon, 697
 - MonAnL, 456
 - MonAnS, 483
 - MotL, 1082
 - MotRevL, 1141
 - MotSpdCL, 1185
 - MotSpdL, 1235
 - MPC10x10, 948
 - OpAnL, 350
 - OpAnS, 370
 - PIDConL, 745
 - PIDConR, 821
 - PIDConS, 790
 - PIDStepL, 861
 - Ratio, 905
 - SelA16In, 1963
 - TotalL, 1745
 - Vlv2WayL, 1315
 - VlvAnL, 1460
 - VlvL, 1354
 - VlvMotL, 1415
- Selecting signals for processing
 - MuxST, 2275
- Selection of output signal
 - MuxAn03, 1929
 - MuxAn08, 1937
- SelST16
 - Area of application, 2301
 - Object name, 2301
- Setpoint adaption in motor stop and starting
 - Setpoint adaption in motor stop and starting, 1180
- Setpoint difference, 95
- Setpoint filters
 - ModPreCon, 696
 - MPC10x10, 948
- Setpoint input
 - External, 128
 - Internal, 128
- Setpoint limitation
 - DoseL, 1018
 - MotSpdCL, 1180
 - OpAnL, 349
 - PIDConS, 789
- Setpoint limiting for external setpoints
 - FmCont, 607
 - FmTemp, 645
 - PIDConL, 743
 - PIDConR, 819
 - PIDStepL, 859
- Setpoint ramp, 599, 637
 - MotSpdCL, 1181
 - PIDConL, 743
 - PIDConR, 819
 - PIDStepL, 859
 - Using, 123
- Setpoint specification
 - With separate display area and custom unit, 171
- Setpoint tracking in manual mode
 - ModPreCon, 696
 - MPC10x10, 948

- Setpoint view
 - ConPerMon, 595
 - DoseL, 1055
- Setpoint view (Feature bit 15 set)
 - DoseL, 1057
- Setting a mean value constant
 - MeanTime, 1874
- Setting the count value to the default setting
 - CountOh, 1718
 - CountScL, 1694
- Setting the setpoint internally
 - ModPreCon, 696
 - MPC10x10, 947
- Setting the summing/integrating value to the default
 - TotalL, 1748
- Setting the time
 - TimerP, 1786
- Setting warning times, 51
- ShLeInt64
 - Area of application, 2302
 - Object name, 2302
- ShrdResL
 - Allocate/enable channel, 1268
 - Area of application, 1261
 - Block diagram, 1277
 - Block icon, 1282
 - Channel management, 1267
 - Channel prioritization, 1269
 - Configuration, 1262
 - Enable/disable channel, 1269
 - Error handling, 1271
 - Functions, 1265
 - General preview, 1280
 - How it works, 1261
 - I/Os, 1272
 - Object name, 1261
 - Opening additional faceplates, 1265
 - Operating modes, 1264
 - Operator permissions, 1265
 - Overview of error numbers, 1271
 - Parameter view, 1281
 - Readiness signal, 1266
 - SIMATIC BATCH functionality, 1269
 - Startup characteristics, 1262
 - Status word allocation, 1263
- ShrdResS
 - Allocate/enable channel, 1288
 - Block diagram, 1299
 - Block icon, 1303
 - Cascading, 1289
 - Channel management, 1288
 - Channel prioritization, 1289
 - Configuration, 1285
 - Enable/disable channel, 1289
 - Error handling, 1290
 - Functions, 1287
 - How it works, 1284
 - I/Os, 1291
 - Messaging, 1290
 - Object name, 1284
 - Opening additional faceplates, 1287
 - Operating modes, 1286
 - Overview of error numbers, 1290
 - Readiness signal, 1287
 - SIMATIC BATCH functionality, 1289
 - Startup characteristics, 1285
 - Status word allocation, 1286
- ShrdResS ShrdResS
 - Area of application, 1284
- ShRilnt64
 - Area of application, 2303
 - Object name, 2303
- Signal status
 - AssetM, 2285
 - Pcs7Cnt3, 2186
 - PcsCnt1, 2167
 - PcsCnt2, 2178
- Signal status as associated value of a message
 - Event16Ts, 1677
 - EventTs, 1660
- Signal status for Fb channel blocks
 - FbAnIn, 2044
 - FbAnIOu, 2071
 - FbAnOu, 2053
 - FbAnTot, 2134
 - FbDiIn, 2062
- Signal status for PCS7 channel blocks
 - Pcs7AnIn, 2115
 - Pcs7AnOu, 2126
 - Pcs7DiIn, 2142
 - Pcs7DiIT, 2150
- Signal status of the block
 - Description, 108
 - Overview of the values, 108
- SIMATIC BATCH, 67, 679
- SIMATIC BATCH functionality, 67
 - ConPerMon, 580
 - CountOh, 1719
 - CountScL, 1697
 - DoseL, 1025
 - FmCont, 614
 - FmTemp, 653
 - ModPreCon, 705
 - MonAnL, 458

- MonAnS, 485
- MonDi08, 547
- MonDiL, 507
- MonDiS, 529
- MotL, 1084
- MotRevL, 1143
- MotS, 1115
- MotSpdCL, 1187
- MotSpdL, 1237
- MPC10x10, 954
- OpAnL, 351
- OpAnS, 372
- PIDConL, 751
- PIDConR, 828
- PIDConS, 793
- PIDStepL, 866
- ShrdResL, 1269
- ShrdResS, 1289
- TotalL, 1749
- Vlv2WayL, 1317
- VlvAnL, 1455
- VlvL, 1355
- VlvMotL, 1417
- VlvPosL, 1527
- VlvS, 1385
- Simulating signals
 - AV, 442
 - DoseL, 1019
 - FbAnIn, 2044, 2063
 - FbAnOu, 2053
 - FbAnTot, 2134
 - FbDiOu, 2072
 - FmCont, 607
 - FmTemp, 645
 - General description, 58
 - ModPreCon, 697
 - MonAnL, 456
 - MonAnS, 483
 - MonDi08, 545
 - MonDiL, 506
 - MonDiS, 528
 - MotL, 1082
 - MotRevL, 1141
 - MotS, 1114
 - MotSpdCL, 1185
 - MotSpdL, 1235
 - MPC10x10, 948
 - OpAnL, 350
 - OpAnS, 370
 - OpTrig, 426
 - Pcs7AnIn, 2116
 - Pcs7AnOu, 2126
 - Pcs7DiIn, 2142
 - Pcs7DiIT, 2150
 - Pcs7DiOu, 2159
 - PIDConL, 743
 - PIDConR, 819
 - PIDConS, 789
 - PIDStepL, 860
 - Ratio, 905
 - TotalL, 1745
 - Vlv2WayL, 1313
 - VlvAnL, 1455
 - VlvL, 1354
 - VlvMotL, 1415
 - VlvPosL, 1525
 - VlvS, 1384
- Smith predictor
 - ConPerMon, 576
- Smith predictor closed-loop control, 735, 807, 851
- Smith predictors, 2332, 2379
- Smooth
 - Activate and deactivate maverick detection, 1903
 - Area of application, 1901
 - Block diagram, 1906
 - Configuration, 1901
 - Error handling, 1903
 - Forming the signal status for blocks, 1903
 - Functions, 1902
 - How it works, 1901
 - I/Os, 1905
 - Messaging, 1904
 - Object name, 1901
 - Operating modes, 1902
 - Overview of error numbers, 1904
 - Restart low pass filter, 1903
 - Startup characteristics, 1902
 - Status word allocation, 1902
- Smoothing PV
 - MonAnL, 455
- Snd_AnaVal
 - Area of application, 2312
 - Error handling, 2313
 - Functions, 2313
 - How it works, 2312
 - Messaging, 2314
 - Object name, 2312
- Snd_DigVal
 - Area of application, 2305
 - Configuration, 2306, 2313
 - Error handling, 2307
 - Functions, 2306
 - How it works, 2305
 - Messaging, 2307

- Object name, 2305
- Operating mode, 2306, 2313
- Startup characteristics, 2306, 2313
- Time characteristics, 2306, 2313, 2316
- Specify warning times for control functions
 - MotL, 1082
 - MotRevL, 1141
 - MotSpdCL, 1184
 - MotSpdL, 1234
 - Vlv2WayL, 1311
 - VlvL, 1353
 - VlvMotL, 1414
 - VlvPosL, 1525
- Specifying how TimerP works
 - TimerP, 1785
- Specifying the display and operator input area for process values and setpoints
 - MotSpdCL, 1185
- Specifying the display area for process and setpoint values as well as operations
 - FmCont, 613
 - FmTemp, 653
 - ModPreCon, 705
 - MonAnL, 458
 - MonAnS, 485
 - MPC10x10, 954
 - OpAnL, 351
 - OpAnS, 371
 - Overview, 207
 - PIDConL, 751
 - PIDConR, 828
 - PIDConS, 793
 - PIDStepL, 866
- Specifying the reaction to exiting local mode
 - With the Feature parameter, 177
- Specifying warning times for control functions at motors and valves
 - VlvAnL, 1466
- Split-range characteristics, 2335
- Split-range control, 599, 637, 689, 735, 807, 851
 - ConPerMon, 576
- Splitting of the output signal of a controller
 - SplRange, 923
- SplRange
 - Area of application, 921
 - Block diagram, 928
 - Configuration, 922
 - Error handling, 926
 - Functions, 923
 - How it works, 921
 - I/Os, 927
 - Messaging, 926
- Object name, 921
- Operating modes, 922
- Overview of error numbers, 926
- Splitting of the output signal of a controller, 923
- Startup characteristics, 922
- Status word allocation, 922
- SqrRoot
 - Area of application, 1907
 - Block diagram, 1911
 - Configuration, 1907
 - Error handling, 1909
 - Forming the signal status for blocks, 1908
 - Functions, 1908
 - How it works, 1907
 - I/Os, 1910
 - Messaging, 1909
 - Object name, 1907
 - Operating modes, 1908
 - Startup characteristics, 1907
 - Status word allocation, 1907
- Standard monitoring functions, 85
- Standard view
 - DoseL, 1047
 - FM controller, 261, 265, 269, 273
 - GainSched, 686
 - MonAnS, 492
 - MotSpdL, 1251
 - OpStations, 420
 - PIDConL, 776
 - PIDConR, 776
 - PIDConS, 776
 - PIDStepL, 892, 895
 - ShrdResL, 1278
 - ShrdResS, 1300
 - VlvAnL, 1485
 - VlvMotL, 1433
 - VlvPosL, 1548
- Standard view of CntOhSc, 1777
- Start readiness, 53
- Startup characteristics
 - AbsR, 1811
 - Add04, 1814
 - Add08, 1819
 - And04, 1977
 - And08, 1982
 - AssetM, 2282
 - AV, 439
 - Average, 1825
 - CompAn02, 1917
 - ConPerMon, 567
 - CountOh, 1713
 - CountScL, 1691

DeadTime, 1831
 Derivative, 1839
 Div02, 1844
 DoseL, 1006
 Event, 1631
 Event16Ts, 1672
 EventNck, 1644
 EventTs, 1657
 FbAnIn, 2042
 FbAnOu, 2051
 FbAnTot, 2133
 FbDiIn, 2061
 FbDiOu, 2070
 FbEnMe, 2090
 FbSwtMMS, 2102
 Feature parameter, 138
 FirstIn, 1627
 FlipFlop, 1988
 FlowCorr, 1851
 FmCont, 600
 FmTemp, 638
 GainSched, 680
 Integral, 1858
 Intlk02, 1568
 Intlk04, 1579
 Intlk08, 1592
 Intlk16, 1607
 KalFilt, 985
 Lag, 1867
 Limit, 1924
 MeanTime, 1873
 ModPreCon, 692
 MonAnL, 449
 MonAnS, 480
 MonDi08, 542
 MonDiL, 500
 MonDiS, 524
 MotL, 1073
 MotRevL, 1131
 MotS, 1107
 MotSpdCL, 1171
 MotSpdL, 1225
 MPC10x10, 945
 MSTIn, 2255
 MSTOu, 2259
 Mul04, 1880
 Mul08, 1885
 MuxAn03, 1928
 MuxAn08, 1936
 MuxMST, 2269
 MuxST, 2274
 OpAnL, 347
 OpAnS, 368
 OpDi01, 382
 OpDi03, 396
 OpStations, 412
 OpTrig, 423
 Or04, 1994
 Or08, 1998
 Pcs7AnIn, 2112
 Pcs7AnOu, 2124
 Pcs7Cnt2, 2177
 Pcs7Cnt3, 2184
 Pcs7DiIn, 2140
 Pcs7DiIT, 2148
 Pcs7DiOu, 2157
 Pcs7HaAI, 2192
 Pcs7HaAO, 2199
 PIDConL, 737
 PIDConR, 809
 PIDConS, 785
 PIDStepL, 852
 Polygon, 1893
 Psc7Cnt1, 2165
 RateLim, 1943
 Ratio, 903
 Rcv_AnaVal, 2316
 Rcv_DigVal, 2309
 RedAn02, 1950
 RedDi02, 2007
 SelA02In, 1955
 SelA16In, 1960
 SelD02In, 2012
 ShrdResL, 1262
 ShrdResS, 1285
 Smooth, 1902
 Snd_DigVal, 2306, 2313
 Specifying, 138
 SplRange, 922
 SqrRoot, 1907
 STIn, 2247
 STOu, 2251
 StrctCom, 2017
 StrctDeC, 2022
 StruAnIn, 2223
 StruAnOu, 2227
 StruDiln, 2231
 StruDiOu, 2235
 StruScIn, 2239
 StruScOu, 2243
 StruToBy, 2219
 Sub02, 1912
 TimerP, 1783
 TimeTrig, 1792

- TotalL, 1742
- Trigger, 2027
- Vlv2WayL, 1305
- VlvAnL, 1449
- VlvL, 1346
- VlvMotL, 1401
- VlvPosL, 1506
- VlvS, 1377
- XOr04, 2033
- Startup characteristics over Trigger block, 69
- StateMap
 - Description, 2266
 - Description of, 2266
 - Error handling, 2267
 - I/Os, 2267
 - Messaging, 2267
- StateMap modes, 2267
- Static and dynamic errors, 97
- Static signal, 51
- Stationary reference operating point, 570
- Status diagram
 - DoseL, 1011
- Status word allocation
 - AbsR, 1811
 - Add04, 1814
 - Add08, 1819
 - And04, 1977
 - And08, 1982
 - AssetM, 2282
 - AV, 440
 - Average, 1825
 - CompAn02, 1918
 - ConPerMon, 568
 - CountScL, 1692
 - DeadTime, 1832
 - Derivative, 1839
 - Div02, 1844
 - DoseL, 1006
 - Event, 1632
 - Event16Ts, 1673
 - EventNck, 1645
 - EventTs, 1657
 - FbAnIn, 2042
 - FbAnOu, 2051
 - FbDiIn, 2061
 - FbDiOu, 2070
 - FbEnMe, 2091
 - FirstIn, 1627
 - FlipFlop, 1988
 - FlowCorr, 1851
 - FmCont, 600
 - FmTemp, 638
 - GainSched, 680
 - Integral, 1858
 - Intlk02, 1568
 - Intlk04, 1579
 - Intlk08, 1592
 - Intlk16, 1607
 - KalFilt, 985
 - Lag, 1867
 - Limit, 1924
 - MeanTime, 1873
 - ModPreCon, 693
 - MonAnL, 450
 - MonAnS, 480
 - MonDi08, 542
 - MonDiL, 500
 - MonDiS, 524
 - MotL, 1073
 - MotRevL, 1131
 - MotS, 1107
 - MotSpdCL, 1172
 - MotSpdL, 1225
 - MPC10x10, 945
 - MSTIn, 2255
 - MSTOu, 2259
 - Mul04, 1880
 - Mul08, 1886
 - MuxAn03, 1928
 - MuxAn08, 1936
 - MuxMST, 2269
 - MuxST, 2274
 - OpAnL, 347
 - OpAnS, 368
 - OpDi01, 382
 - OpDi03, 396
 - OpStations, 413
 - OpTrig, 423
 - Or04, 1994
 - Or08, 1999
 - Pcs7AnIn, 2112
 - Pcs7AnOu, 2124
 - Pcs7Cnt2, 2177
 - Pcs7Cnt3, 2184
 - Pcs7DiIn, 2141
 - Pcs7DiIT, 2148
 - Pcs7DiOu, 2158
 - Pcs7HaAI, 2192
 - Pcs7HaAO, 2199
 - PIDConL, 737
 - PIDConR, 810
 - PIDConS, 785
 - PIDStepL, 853
 - Polygon, 1893

- Psc7Cnt1, 2165
- RateLim, 1943
- Ratio, 903
- RedAn02, 1950
- RedDi02, 2007
- SelA02In, 1955
- SelA16In, 1961
- SelD02In, 2012
- ShrdResL, 1263
- ShrdResS, 1286
- Smooth, 1902
- SplRange, 922
- SqrRoot, 1907
- STIn, 2247
- STOu, 2251
- StrctCom, 2017
- StrctDeC, 2022
- StruAnIn, 2223
- StruAnOu, 2227
- StruDiln, 2231
- StruDiOu, 2235
- StruScIn, 2239
- StruScOu, 2243
- StruToBy, 2219
- Sub02, 1913
- TimerP, 1784
- TotalL, 1743
- Trigger, 2028
- Vlv2WayL, 1306
- VlvAnL, 1449
- VlvL, 1347
- VlvMotL, 1402
- VlvS, 1378
- XOr04, 2033
- Status word assignment
 - VlvPosL, 1507
- Step control mode for the speed change
 - MotSpdL, 1235
- Step controller, 50, 599, 604, 637, 642
- STIn
 - Area of application, 2247
 - Block diagram, 2250
 - Configuration, 2247
 - Error handling, 2248
 - Functions, 2248
 - How it works, 2247
 - I/Os, 2249
 - Messaging, 2249
 - Object name, 2247
 - Operating modes, 2248
 - Startup characteristics, 2247
 - Status word allocation, 2247
- Stochastic characteristics, 565, 571, 2377
- Stopping integration
 - Integral, 1860
- Stopping the calculation of the ramp output value
 - RateLim, 1945
- Stopping the calculation of mean values
 - MeanTime, 1874
- STOu
 - Area of application, 2251
 - Block diagram, 2254
 - Configuration, 2251
 - Error handling, 2252
 - Functions, 2252
 - How it works, 2251
 - I/Os, 2253
 - Messaging, 2253
 - Object name, 2251
 - Operating modes, 2252
 - Startup characteristics, 2251
 - Status word allocation, 2251
- StrctCom
 - Area of application, 2017
 - Block diagram, 2020
 - Configuration, 2017
 - Error handling, 2019
 - Functions, 2018
 - How it works, 2017
 - I/Os, 2019
 - Messaging, 2019
 - Object name, 2017
 - Operating modes, 2018
 - Startup characteristics, 2017
 - Status word allocation, 2017
- StrctDeC
 - Area of application, 2022
 - Block diagram, 2025
 - Configuration, 2022
 - Error handling, 2024
 - Functions, 2023
 - How it works, 2022
 - I/Os, 2024
 - Messaging, 2024
 - Object name, 2022
 - Operating modes, 2023
 - Startup characteristics, 2022
 - Status word allocation, 2022
- StrgToBy
 - Block diagram, 2222
 - Error handling, 2221
 - Functions, 2220
 - I/Os, 2221

- Messaging, 2221
- Operating modes, 2220
- StruAnIn
 - Area of application, 2223
 - Block diagram, 2226
 - Configuration, 2223
 - Error handling, 2224
 - Functions, 2224
 - How it works, 2223
 - I/Os, 2225
 - Messaging, 2225
 - Modes, 2224
 - Object name, 2223
 - Startup characteristics, 2223
 - Status word allocation, 2223
- StruAnOu
 - Area of application, 2227
 - Block diagram, 2230
 - Configuration, 2227
 - Error handling, 2228
 - Functions, 2228
 - How it works, 2227
 - I/Os, 2229
 - Messaging, 2229
 - Modes, 2228
 - Object name, 2227
 - Startup characteristics, 2227
 - Status word allocation, 2227
- Structure segmentation at controllers
 - FmCont, 609
 - FmTemp, 647
 - PIDConL, 746
 - PIDStepL, 862
- StruDiln
 - Area of application, 2231
 - Block diagram, 2234
 - Configuration, 2231
 - Error handling, 2232
 - Functions, 2232
 - How it works, 2231
 - I/Os, 2233
 - Messaging, 2233
 - Modes, 2232
 - Object name, 2231
 - Startup characteristics, 2231
 - Status word allocation, 2231
- StruDiOu
 - Area of application, 2235
 - Block diagram, 2238
 - Configuration, 2235
 - Error handling, 2236
 - Functions, 2236
 - How it works, 2235
 - I/Os, 2237
 - Messaging, 2237
 - Modes, 2236
 - Object name, 2235
 - Startup characteristics, 2235
 - Status word allocation, 2235
- StruScIn
 - Area of application, 2239
 - Block diagram, 2242
 - Configuration, 2239
 - Error handling, 2240
 - Functions, 2240
 - How it works, 2239
 - I/Os, 2241
 - Messaging, 2241
 - Object name, 2239
 - Operating modes, 2240
 - Startup characteristics, 2239
 - Status word allocation, 2239
- StruScOu
 - Area of application, 2243
 - Block diagram, 2246
 - Configuration, 2243
 - Error handling, 2244
 - Functions, 2244
 - How it works, 2243
 - I/Os, 2245
 - Messaging, 2245
 - Object name, 2243
 - Operating modes, 2244
 - Startup characteristics, 2243
 - Status word allocation, 2243
- StruToBy
 - Area of application, 2219
 - Configuration, 2219
 - How it works, 2219
 - Object name, 2219
 - Startup characteristics, 2219
 - Status word allocation, 2219
- Sub02
 - Area of application, 1912
 - Block diagram, 1916
 - Configuration, 1912
 - Error handling, 1914
 - Forming the signal status for blocks, 1913
 - Functions, 1913
 - How it works, 1912
 - I/Os, 1915
 - Messaging, 1914
 - Object name, 1912
 - Operating modes, 1913

- Startup characteristics, 1912
 - Status word allocation, 1913
 - SumMsgAct group display for limit monitoring
 - CSF and ExtMsgx, 441, 453, 483, 574, 606, 645, 742, 818, 859, 1018, 1180, 1466, 1694, 1745
 - Suppress messages using the MsgLock parameter
 - VlvPosL, 1517
 - Suppressing messages using the MsgLock parameter
 - ConPerMon, 580
 - CountOh, 1716
 - CountScL, 1695
 - DoseL, 1018
 - Event, 1635
 - Event16Ts, 1677
 - EventNck, 1647
 - EventTs, 1660
 - FmCont, 613
 - FmTemp, 653
 - MonAnL, 453
 - MonAnS, 483
 - MonDi08, 545
 - MonDiL, 506
 - MonDiS, 528
 - MotL, 1079, 1112
 - MotRevLL, 1138
 - MotSpdCL, 1180
 - MotSpdL, 1232
 - OpAnL, 349
 - PIDConL, 750
 - PIDConR, 827
 - PIDConS, 793
 - PIDStepL, 866
 - TotalL, 1745
 - Vlv2WayL, 1313
 - VlvAnL, 1460
 - VlvL, 1353
 - VlvMotL, 1409
 - Suppression and reporting of signal flutter
 - MonDiL, 503
 - Switching the limiting function on or off
 - RateLim, 1945
 - Switchover with P step, 74
 - Switchover without P step, 74
- T**
- Target setpoint, 123, 125
 - Time characteristics
 - Rcv_DigVal, 2309
 - Snd_DigVal, 2306, 2313, 2316
 - Time delay
 - MotRevL, 1138
 - VlvMotL, 1408
 - Time delay after changing direction of rotation or restart
 - MotSpdCL, 1179
 - Time delay after restart
 - MotL, 1081
 - MotSpdL, 1232
 - Time response
 - CountOh, 1713
 - CountScL, 1691
 - TotalL, 1742
 - Time stamp, 205
 - Pcs7DiIT, 2150
 - Time stamp as associated value of a message
 - Event16Ts, 1677
 - EventTs, 1660
 - TimerP
 - Area of application, 1783
 - Block diagram, 1790
 - Configuration, 1783
 - Error handling, 1787
 - Forming the signal status for blocks, 1787
 - Functions, 1784
 - How it works, 1783
 - I/Os, 1788
 - Initialization, 1786
 - Messaging, 1788
 - Object name, 1783
 - Operating modes, 1784
 - Overview of error numbers, 1787
 - Resetting the Out and TimeRemaining output parameters, 1786
 - Setting the time, 1786
 - Specifying the method of operation, 1785
 - Startup characteristics, 1783
 - Status word allocation, 1784
 - Time-stamped messages
 - DoseL, 1025
 - FmCont, 614
 - FmTemp, 653
 - MonAnL, 458
 - MonDi08, 547
 - MonDiL, 507
 - MotL, 1084
 - MotRevL, 1143
 - MotSpdCL, 1187
 - MotSpdL, 1237
 - PIDConL, 751
 - PIDConR, 828
 - PIDStepL, 867

- Vlv2WayL, 1317
- VlvAnL, 1467
- VlvL, 1355
- VlvMotL, 1417
- VlvPosL, 1527
- TimeTrig
 - Area of application, 1791
 - Block diagram, 1802
 - Block icon, 1808
 - Configuration, 1791
 - Error handling, 1797
 - Functions, 1793
 - How it works, 1791
 - I/Os, 1798
 - Messaging, 1798
 - Operating modes, 1793
 - Overview of error numbers, 1798
 - Parameter view, 1805
 - Periodic output of a trigger, 1794
 - Preview, 1807
 - Standard view, 1803
 - Startup characteristics, 1792
- Torque monitoring
 - VlvMotL, 1409
 - VlvPosL, 1519
- TotalL
 - Area of application, 1735
 - Associated values, 1751
 - Block diagram, 1757
 - Block icon, 1766
 - Bypass function, 1746
 - Configurable reactions using the Feature parameter, 1746
 - Configuration, 1742
 - Error handling, 1749
 - Forming the signal status for blocks, 1746
 - Functions, 1745
 - How it works, 1735
 - I/Os, 1752
 - Limit monitoring of the count value, 1745
 - Limit view, 1761
 - Messaging, 1750
 - Object name, 1735
 - Opening additional faceplates, 1745
 - Operating modes, 1744
 - Operator permissions, 1747
 - Overview of error numbers, 1749
 - Parameter view, 1763
 - Preview, 1765
 - Process messages, 1751
 - Readback of the most recently calculated sum, 1748
 - Release for maintenance, 1749
 - Selecting a unit of measure, 1745
 - Setting the summing/integrating value to the default, 1748
 - SIMATIC BATCH functionality, 1749
 - Simulating signals, 1745
 - Standard view, 1758
 - Startup characteristics, 1742
 - Status word allocation, 1743
 - Suppressing messages using the MsgLock parameter, 1745
 - Time response, 1742
- Tracking and limiting a manipulated variable
 - FmCont, 606
 - FmTemp, 644
 - ModPreCon, 695
 - MPC10x10, 947
 - PIDConL, 742
 - PIDConR, 817
 - PIDConS, 788
 - PIDStepL, 858
 - VlvAnL, 1456
- Tracking setpoint in manual mode
 - FmCont, 607
 - FmTemp, 645
- Tracking the setpoint, 196
 - PIDConL, 743
 - PIDConR, 819
 - PIDConS, 789
 - PIDStepL, 860
- Tracking values
 - Integral, 1859
- Trajectory, 2386
- Transmission of messages
 - FbSwtMMS, 2102
- Trend control, 2352
- Trend plotter, 566
- Trend view, 305
 - ModPreCon, 731
 - MPC 10x10, 977
- Trend view of MotSpdCI, 1221
- Trigger
 - Area of application, 2027
 - Block diagram, 2031
 - Configuration, 2027
 - Error handling, 2029
 - Forming the signal status for blocks, 2029
 - Functions, 2029
 - How it works, 2027
 - Messaging, 2030
 - Object name, 2027
 - Operating modes, 2028

- Startup characteristics, 2027
- Status word allocation, 2028
- Truth table
 - XOr04, 2032

U

- Unit of measure, 213
- Use output point for the manipulated variable calculation
 - PIDConR, 823
- User-configured message classes, 41
- Using a manipulated variable ramp
 - VlvAnL, 1455
- Using setpoint ramp
 - FmCont, 607
 - FmTemp, 645
 - OpAnL, 349
- Using the manipulated variable ramp, 125
- Using the setpoint ramp, 123

V

- Value application delay
 - Pcs7AnIn, 2115
- Valve
 - Warning times, 51
- Views of CntOhSc, 1776
- Vlv2WayL
 - Area of application, 1305
 - Associated values, 1321
 - Block diagram, 1332
 - Block icon, 1343
 - Button labels, 1317
 - Configurable reactions using the Features parameter, 1316
 - Configuration, 1305
 - Considering bad quality of automatic commands or external values, 1315
 - Defining valve positions for individual valves, 1311
 - Disabling feedback, 1313
 - Disabling interlocks, 1313
 - Displaying auxiliary values, 1317
 - Error handling, 1318
 - Feedback monitoring, 1312
 - Forcing operating modes, 1313
 - Forming the group status for interlocks, 1314
 - Forming the signal status for blocks, 1314
 - Functions, 1310
 - Generating instance-specific messages, 1315

- Group error, 1313
- How it works, 1305
- I/Os, 1321
- Instance-specific messages, 1320
- Interlocks, 1313
- Invalid input signals, 1319
- Messaging, 1320
- Mode switchover error, 1319
- Neutral position, 1311
- Object name, 1305
- Opening additional faceplates, 1315
- Operating modes, 1309
- Operator permissions, 1315
- Output signal as a pulse signal or static signal, 1311
- Outputting a signal for start readiness, 1314
- Overview of error numbers, 1318
- Preview, 1338
- Process control fault, 1320
- Release for maintenance, 1315
- Resetting the block in case of interlocks or errors, 1313
- Selecting a unit of measure, 1315
- SIMATIC BATCH functionality, 1317
- Simulating signals, 1313
- Specify warning times for control functions, 1311
- Standard view, 1333
- Startup characteristics, 1305
- Status word allocation, 1306
- Suppressing messages using the MsgLock parameter, 1313
- Time-stamped messages, 1317

VlvAnL

- Actuator active information, 1465
- Alarm delays with one time value per limit pair, 1462
- Area of application, 1448
- Associated values, 1470
- Block diagram, 1483
- Block icon, 1503
- Button labels, 1467
- Configurable reactions using the Feature parameter, 1461
- Configuration, 1448
- Considering bad quality of automatic commands or external values, 1457
- Digital feedback from the readback value, 1463
- Disabling feedback, 1466
- Displaying auxiliary values, 1462
- Error handling, 1467
- Feedback monitoring, 1457
- Forcing operating modes, 1457

- Forming the group status for interlocks, 1456
 - Forming the signal status for blocks, 1456
 - Functions, 1454
 - General function MV difference, 1465
 - Generating instance-specific messages, 1461
 - Generation of manipulated variables, 1464
 - Gradient limiting of the manipulated variable, 1456
 - Group error, 1455
 - How it works, 1448
 - I/Os, 1470
 - Interlocks, 1454
 - Invalid input signals, 1468
 - Limit monitoring of manipulated variable and error signal, 1466
 - Limit view, 1494, 1553
 - Manipulated variable difference generation and dead band, 1466
 - Messaging, 1469
 - Mode switchover error, 1468
 - Monitoring the feedback for the auxiliary valve, 1460
 - Neutral position, 1460
 - Object name, 1448
 - Opening additional faceplates, 1454
 - Operating modes, 1452
 - Operator permissions, 1463
 - Outputting a signal for start readiness, 1455
 - Overview of error numbers, 1467
 - Parameter view, 1501
 - Preview, 1497
 - Process control fault, 1469
 - Process messages, 1469
 - Resetting the block in case of interlocks or errors, 1455
 - Selecting a unit of measure, 1460
 - SIMATIC BATCH functionality, 1455
 - Simulating signals, 1455
 - Specifying warning times for control functions at motors and valves, 1466
 - Standard view, 1490
 - Startup characteristics, 1449
 - Status word allocation, 1449
 - Suppressing messages using the MsgLock parameter, 1460
 - Time-stamped messages, 1467
 - Tracking and limiting a manipulated variable, 1456
 - Using a manipulated variable ramp, 1455
- VlvL
- Area of application, 1346
 - Associated values, 1358
- Block diagram, 1366
 - Block icon, 1374
 - Button labels, 1356
 - Configurable reactions using the Feature parameter, 1354
 - Configuration, 1346
 - Considering bad quality of automatic commands or external values, 1353
 - Disabling feedback, 1353
 - Disabling interlocks, 1351
 - Displaying auxiliary values, 1355
 - Error handling, 1356
 - Feedback monitoring, 1353
 - Forcing operating modes, 1353
 - Forming the group status for interlocks, 1352
 - Forming the signal status for blocks, 1352
 - Functions, 1350
 - Generating instance-specific messages, 1354
 - Group error, 1352
 - How it works, 1346
 - I/Os, 1359
 - Instance-specific messages, 1358
 - Interlocks, 1351
 - Invalid input signals, 1357
 - Messaging, 1358
 - Mode switchover error, 1357
 - Neutral position, 1354
 - Object name, 1346
 - Opening additional faceplates, 1351
 - Operating modes, 1349
 - Operator permissions, 1351
 - Output signal as a pulse signal or static signal, 1355
 - Outputting a signal for start readiness, 1352
 - Overview of error numbers, 1356
 - Preview, 1371
 - Process control fault, 1358
 - Release for maintenance, 1353
 - Resetting the block in case of interlocks, 1351
 - Selecting a unit of measure, 1354
 - SIMATIC BATCH functionality, 1355
 - Simulating signals, 1354
 - Specify warning times for control functions, 1353
 - Standard view, 1367
 - Startup characteristics, 1346
 - Status word allocation, 1347
 - Suppressing messages using the MsgLock parameter, 1353
 - Time-stamped messages, 1355
- VlvMotL
- Area of application, 1401
 - Associated values, 1421

- Block diagram, 1432
- Block icon, 1444
- Button labels, 1417
- Configurable reactions using the Feature parameter, 1416
- Configuration, 1401
- Considering bad quality of automatic commands or external values, 1412
- Disabling feedback, 1413
- Disabling interlocks, 1411
- Displaying auxiliary values, 1416
- Error handling, 1418
- Feedback monitoring, 1413
- Forcing operating modes, 1412
- Forming the group status for interlocks, 1412
- Forming the signal status for blocks, 1412
- Functions, 1407
- Generating instance-specific messages, 1415
- Group error, 1411
- How it works, 1401
- I/Os, 1421
- Instance-specific messages, 1420
- Interlocks, 1409
- Invalid input signals, 1418
- Limit monitoring of an additional analog value, 1409
- Limit monitoring with hysteresis, 1409
- Messaging, 1420
- Mode switchover error, 1418
- Motor protection function, 1409
- Neutral position, 1415
- Object name, 1401
- Opening additional faceplates, 1407
- Operating modes, 1406
- Operator permissions, 1407
- Output signal as a pulse signal or static signal, 1415
- Outputting a signal for start readiness, 1411
- Overview of error numbers, 1418
- Parameter view, 1437
- Preview, 1440
- Process control fault, 1420
- Rapid stop, 1409
- Release for maintenance, 1414
- Reset of motor control after valve end position has been reached, 1410
- Resetting the block in case of interlocks, 1411
- Sealing the valve, 1410
- Selecting a unit of measure, 1415
- SIMATIC BATCH functionality, 1417
- Simulating signals, 1415
- Specify warning times for control functions, 1414
- Startup characteristics, 1401
- Status word allocation, 1402
- Suppressing messages using the MsgLock parameter, 1409
- Time delay after changing direction of rotation or restart, 1408
- Time-stamped messages, 1417
- Torque monitoring, 1409
- Tracking the valve position after a motor stop or after a startup, 1414
- VlvPosL
 - Associated values, 1532
 - Block diagram, 1546
 - Block icon, 1564
 - Configurable reactions using the Feature parameter, 1526
 - Configuration, 1506
 - Considering bad quality of automatic commands or external values, 1522
 - Control system fault, 1531
 - Disable feedback, 1527
 - Disable interlocks, 1520
 - Display auxiliary values, 1527
 - Error handling, 1528
 - Feedback monitoring, 1523
 - Force operating states, 1522
 - Forming the group status for interlocks, 1521
 - Forming the signal status for blocks, 1521
 - Functions, 1513
 - Generate instance-specific messages, 1526
 - Group error, 1521
 - How it works, 1506
 - I/Os, 1533
 - Instance-specific messages, 1532
 - Interlocks, 1518
 - Invalid input signals, 1529
 - Labeling of buttons, 1528
 - Limit monitoring for additional analog value, 1517
 - Limit monitoring with hysteresis, 1517
 - Message characteristics, 1531
 - Mode switchover error, 1529
 - Motor protection function, 1518
 - Neutral position, 1526
 - Object name, 1506
 - Opening additional faceplates, 1515
 - Operating modes, 1511
 - Operator permissions, 1515
 - Output signal as pulse signal or static signal, 1526
 - Outputting a signal for start readiness, 1521
 - Overview of error numbers, 1528
 - Parameter view, 1555

- Preview, 1559
- Rapid stop, 1519
- Release for maintenance, 1525
- Resetting the block in case of interlocks, 1520
- Sealing the valve, 1520
- Select unit of measure, 1525
- SIMATIC BATCH functionality, 1527
- Simulating signals, 1525
- Specify warning times for control functions, 1525
- Startup characteristics, 1506
- Subentry, 1506
- Suppress messages using the MsgLock parameter, 1517
- Time-stamped messages, 1527
- Torque monitoring, 1519
- VlvS
 - Area of application, 1377
 - Associated values, 1387
 - Block diagram, 1393
 - Block icon, 1399
 - Configurable reactions using the Feature parameter, 1384
 - Configurable reactions using the Feature2 parameter, 1384
 - Configuration, 1377
 - Considering bad quality of automatic commands or external values, 1383
 - Disabling interlocks, 1382
 - Error handling, 1385
 - Feedback monitoring, 1383
 - Forming the group status for interlocks, 1382
 - Forming the signal status for blocks, 1383
 - Functions, 1381
 - Generating instance-specific messages, 1384
 - Group error, 1382
 - How it works, 1377
 - I/Os, 1388
 - Instance-specific messages, 1387
 - Interlocks, 1382
 - Invalid input signals, 1386
 - Messaging, 1386
 - Mode switchover error, 1386
 - Neutral position, 1383
 - Object name, 1377
 - Opening additional faceplates, 1381
 - Operating modes, 1379
 - Operator permissions, 1381
 - Overview of error numbers, 1385
 - Preview, 1397
 - Process control fault, 1387
 - Release for maintenance, 1384
 - Resetting the block in case of interlocks, 1382
 - SIMATIC BATCH functionality, 1385
 - Simulating signals, 1384
 - Standard view, 1394
 - Startup characteristics, 1377
 - Status word allocation, 1378
- W
 - Warning signals, 51
- X
 - XOr04
 - Area of application, 2032
 - Block diagram, 2036
 - Configuration, 2032
 - Error handling, 2034
 - Forming the signal status for blocks, 2034
 - Functions, 2033
 - How it works, 2032
 - I/Os, 2035
 - Messaging, 2034
 - Object name, 2032
 - Operating modes, 2033
 - Startup characteristics, 2033
 - Status word allocation, 2033
 - Truth table, 2032

