

SIEMENS



SIRIUS

Stern-Dreieck-Kombination S00
 Star-Delta Combination S00
 Combination étoile-triangle S00
 Combinación estrella-triángulo S00
 Combinazione stella-triangolo S00
 Combinação de estrela-triângulo S00
 Yıldız-Üçgen-Kombinasyonu S00
 Схема переключения „звезда-треугольник“ S00
 星三角组合 S00

3RA241.-8X.3.-1
 3RA241.-8X.3.-2

CE IEC/EN 60947

Betriebsanleitung Operating Instructions Instructions de service Instructivo Istruzioni operative
 Instruções de Serviço İşletme kılavuzu Инструкция по эксплуатации 使用说明

	Deutsch	English	Français
	Vor der Installation, dem Betrieb oder der Wartung des Geräts muss diese Anleitung gelesen und verstanden werden.	Read and understand these instructions before installing, operating, or maintaining the equipment.	Ne pas installer, utiliser ou intervenir sur cet équipement avant d'avoir lu et assimilé les présentes instructions et notamment les conseils de sécurité et mises en garde qui y figurent.
	⚠ GEFÄHR	⚠ DANGER	⚠ DANGER
	Gefährliche Spannung. Lebensgefahr oder schwere Verletzungsgefahr. Vor Beginn der Arbeiten Anlage und Gerät spannungsfrei schalten.	Hazardous voltage. Will cause death or serious injury. Turn off and lock out all power supplying this device before working on this device.	Tension électrique. Danger de mort ou risque de blessures graves. Mettre hors tension avant d'intervenir sur l'appareil.
	VORSICHT	CAUTION	PRUDENCE
	Eine sichere Gerätefunktion ist nur mit zertifizierten Komponenten gewährleistet.	Reliable functioning of the equipment is only ensured with certified components.	La sécurité de fonctionnement de l'appareil n'est garantie qu'avec des composants certifiés.
	Español	Italiano	Português
	Leer y comprender este instructivo antes de la instalación, operación o mantenimiento del equipo.	Leggere con attenzione queste istruzioni prima di installare, utilizzare o eseguire manutenzione su questa apparecchiatura.	Ler e compreender estas instruções antes da instalação, operação ou manutenção do equipamento.
	⚠ PELIGRO	⚠ PERICOLO	⚠ PERIGO
	Tensión peligrosa. Puede causar la muerte o lesiones graves. Desconectar la alimentación eléctrica antes de trabajar en el equipo.	Tensione pericolosa. Può provocare morte o lesioni gravi. Scollegare l'alimentazione prima di eseguire interventi sull'apparecchiatura.	Tensão perigosa. Perigo de morte ou ferimentos graves. Desligue a alimentação elétrica e proteja contra o religamento, antes de iniciar o trabalho no equipamento.
	PRECAUCIÓN	CAUTELA	CUIDADO
	El funcionamiento seguro del aparato sólo está garantizado con componentes certificados.	Il funzionamento sicuro dell'apparecchiatura è garantito soltanto con componenti certificati.	O funcionamento seguro do aparelho apenas pode ser garantido se forem utilizados os componentes certificados.
	Türkçe	Русский	中文
	Cihazın kurulumundan, çalıştırılmasından veya bakıma tabi tutulmasından önce, bu kılavuzun okunmuş ve anlaşılması gerekmektedir.	Перед установкой, вводом в эксплуатацию или обслуживанием устройства необходимо прочесть и понять данное руководство.	安装、使用和维修本设备前必须先阅读并理解本说明。
	⚠ TEHLİKE	⚠ ОПАСНО	⚠ 危险
	Tehlikeli gerilim. Ölüm tehlikesi veya ağır yaralanma tehlikesi. Çalışmalara başlamadan önce, sistemin ve cihazın gerilim beslemesini kapatınız.	Опасное напряжение. Опасность для жизни или возможность тяжелых травм. Перед началом работ отключить подачу питания к установке и к устройству.	危险电压。可能导致生命危险或重伤危险。 操作设备时必须确保切断电源。
	ÖNEMLİ DİKKAT	ОСТОРОЖНО	小心
	Cihazın güvenli çalışması ancak sertifikalı bileşenler kullanılması halinde garanti edilebilir.	Безопасность работы устройства гарантируется только при использовании сертифицированных компонентов.	只有使用经过认证的部件才能保证设备的正常运转。

Technical Assistance: Telephone: +49 (0) 911-895-5900 (8° - 17° CET) Fax: +49 (0) 911-895-5907
 E-mail: technical-assistance@siemens.com
 Internet: www.siemens.de/lowvoltage/technical-assistance

DE	Montage	ES	Montaje	TR	Montaj
EN	Assembly	IT	Montaggio	PY	Монтаж
FR	Montage	PT	Montagem	中文	安装

3RA241.-8X.31-1

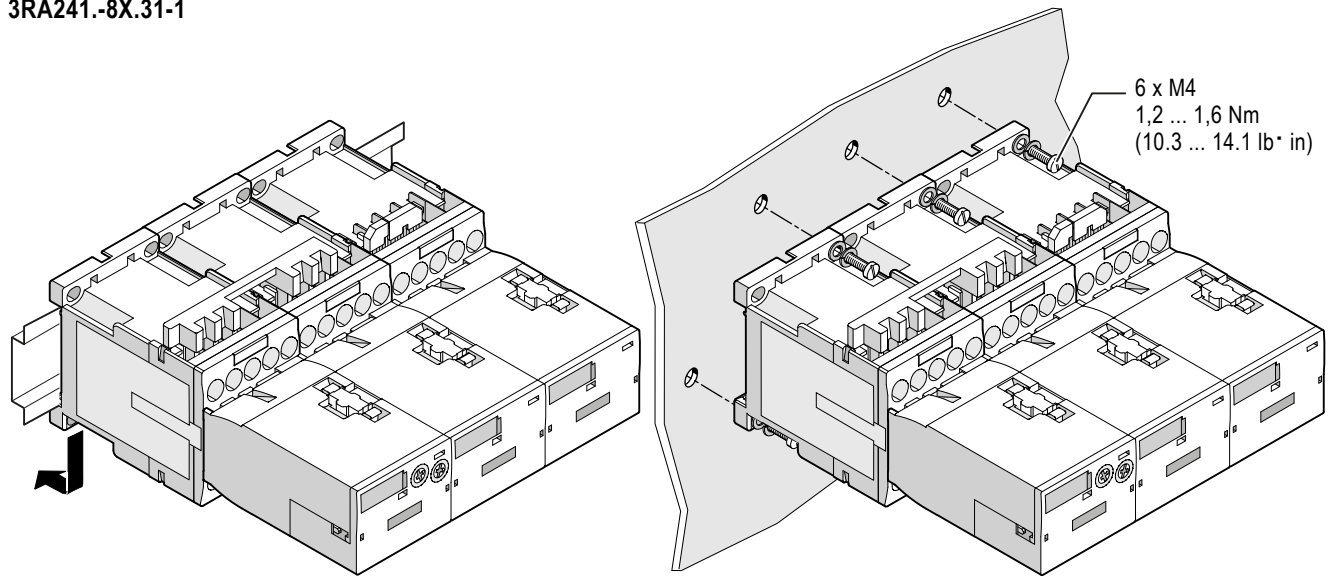





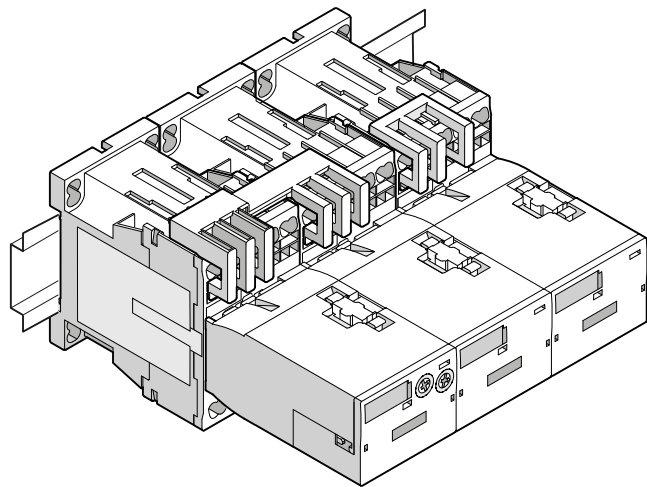

3RA241.-8X.31-2

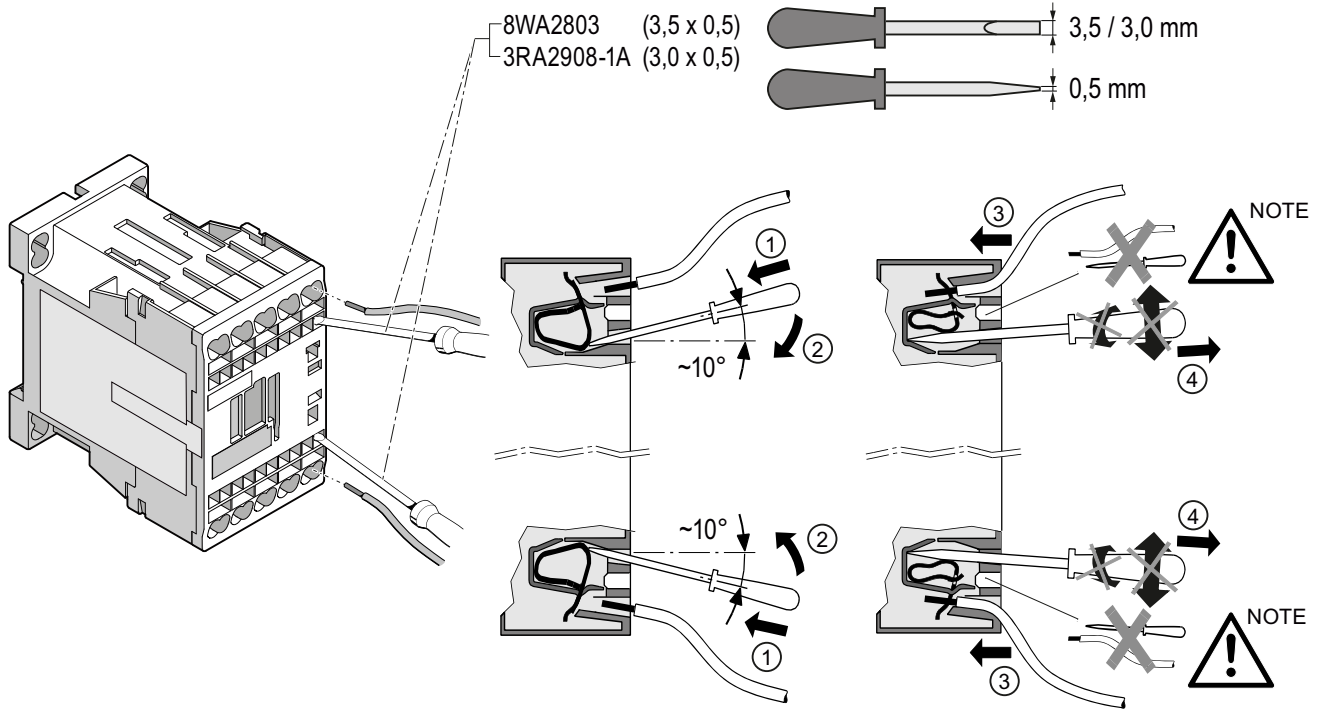
DE	Montage wie 3RA241.-8X.31-1
EN	Installation as 3RA241.-8X.31-1
FR	Montage comme 3RA241.-8X.31-1
ES	Montaje como 3RA241.-8X.31-1
IT	Montaggio come 3RA241.-8X.31-1
PT	Montagem como 3RA241.-8X.31-1
TR	Montaj şunun gibi: 3RA241.-8X.31-1
PY	Монтаж как 3RA241.-8X.31-1
中文	安装如 3RA241.-8X.31-1



DE	Anschließen	ES	Conexión	TR	Bağlantı
EN	Connect	IT	Collegamento	PY	Подсоединение
FR	Branchement	PT	Conexão	中文	连接



	3RA241.-8X.31-1	3RA241.-8X.31-2
	 M3: 0,8 ... 1,2 Nm PZ 2 (∅ 5 ... 6 mm) (7 to 10.3 lb in)	 8WA2803: ∅ (3,5 x 0,5) mm 3RA2908-1A: ∅ (3,0 x 0,5) mm
	2 x (0,5 ... 1,5) mm ² 2 x (0,75 ... 2,5) mm ² 2 x 0,5 ... 2 x 4 mm ²	2 x (0,5 ... 4,0) mm ²
	—	2 x (0,5 ... 2,5) mm ²
 DIN 46 228 T1	2 x (0,5 ... 1,5) mm ² 2 x (0,75 ... 2,5) mm ²	2 x (0,5 ... 2,5) mm ²
AWG	2 x (20 to 16) 2 x (18 to 14) 2 x 12	2 x (20 to 12)

DE	Schaltpläne	ES	Esquemas de circuitos	TR	Devre şemaları
EN	Circuit diagrams	IT	Schemi elettrici	PY	Коммутационные схемы
FR	Schémas de branchement	PT	Esquemas elétricos	中文	电路图

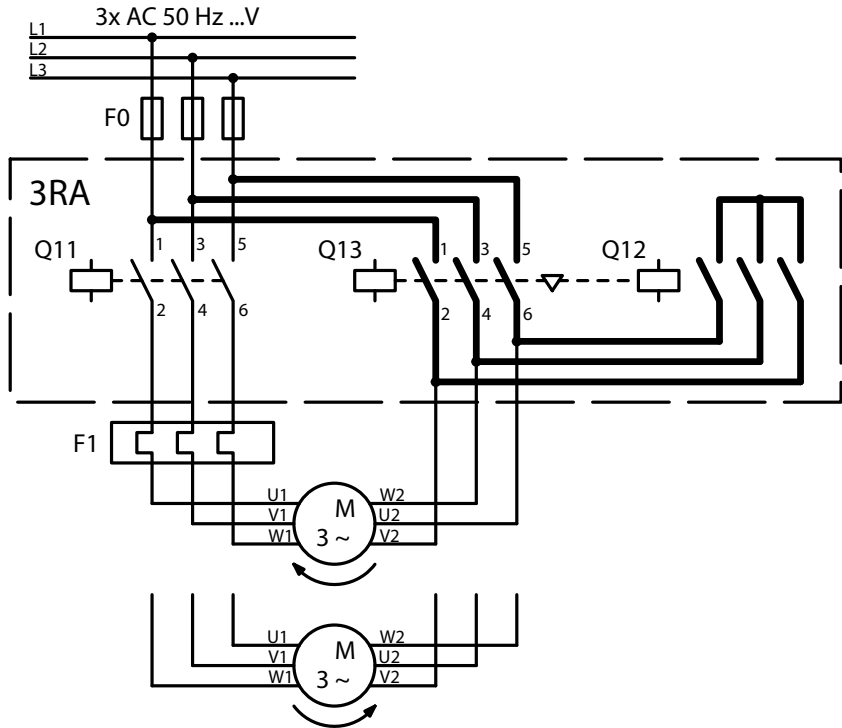

DE	Taster-Schaltung
EN	Pushbutton switching
FR	Commutation bouton-poussoir
ES	Comutación por botón pulsador
IT	Commutazione a pulsante
PT	Comutação por botão
TR	Tuş devrelemesi
PY	Кнопочное переключение
中文	键控切换

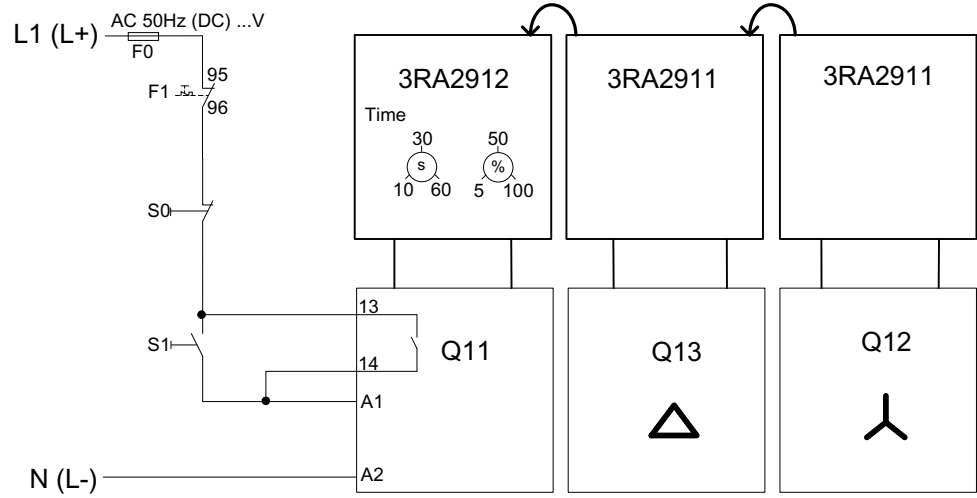

DE	Rastschaltung
EN	Maintained-contact switching
FR	Interruption
ES	Interr. de posición con retención
IT	Commutazione a scatto
PT	Interruptor de travamento
TR	Oturarak devreleme
PY	Фиксируемый переключатель
中文	锁定式切换

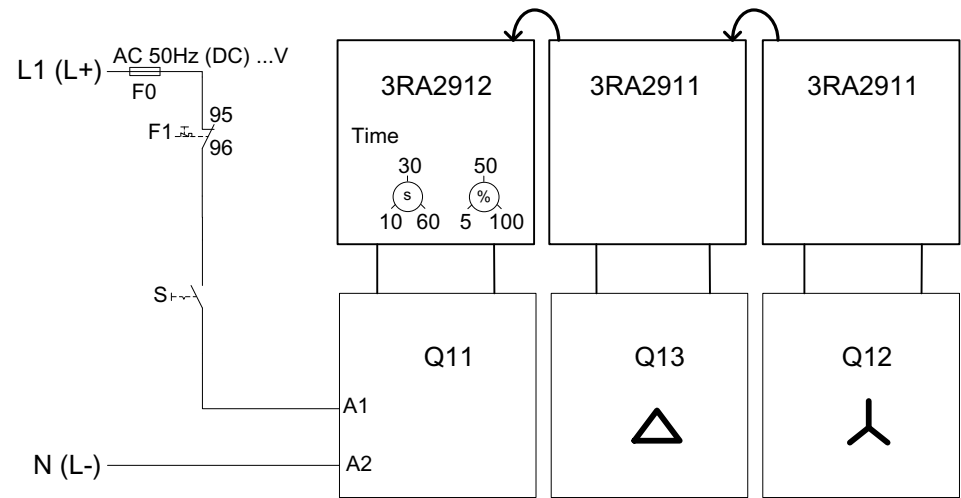

DE	Einbaulage	ES	Posición de montaje	TR	Montaj pozisyonu
EN	Mounting position	IT	Posizione di montaggio	РУ	Положение при монтаже
FR	Position de montage	PT	Posição de montagem	中文	安裝位置

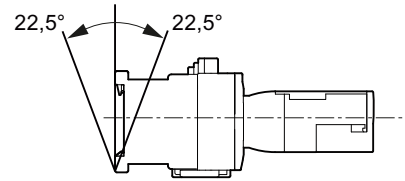
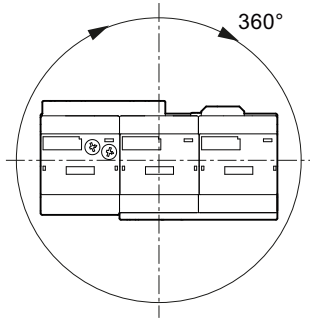

DE	Einstellungen	ES	Ajustes	TR	Ayarlar
EN	Settings	IT	Impostazioni	РУ	Настройки
FR	Réglages	PT	Configurações	中文	设置

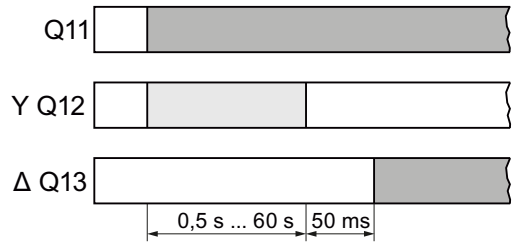
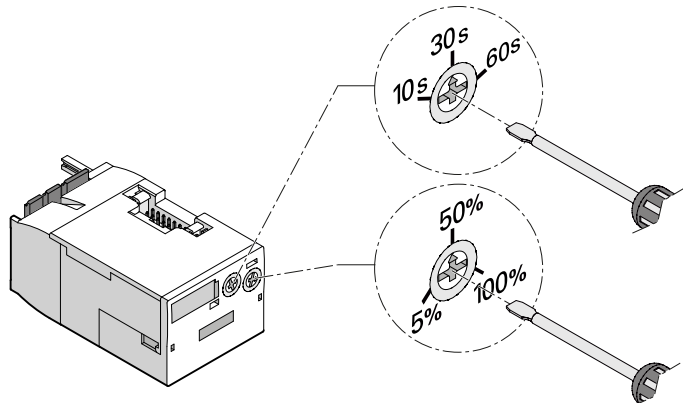

DE	Maßzeichnungen (Angaben in mm)	ES	Dibujos dimensionales (medidas en mm)	TR	Ölçü resimleri (Bilgiler mm olarak)
EN	Dimension drawings (all dimensions in mm)	IT	Disegni quotati (indicazioni in mm)	РУ	Размерные эскизы (Данные в мм)
FR	Encombremets (indications en mm)	PT	Desenhos cotados (dimensões em mm)	中文	尺寸图 (单位: mm)

3RA241.-8X.31-1

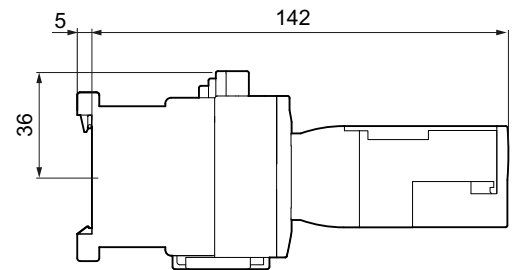
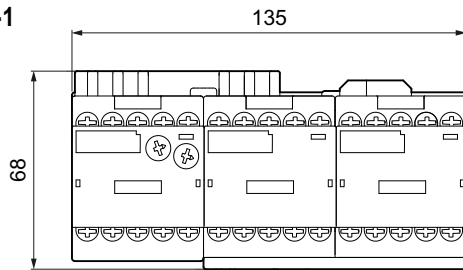

3RA241.-8X.31-2

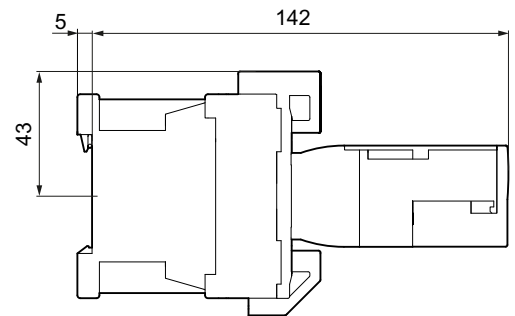
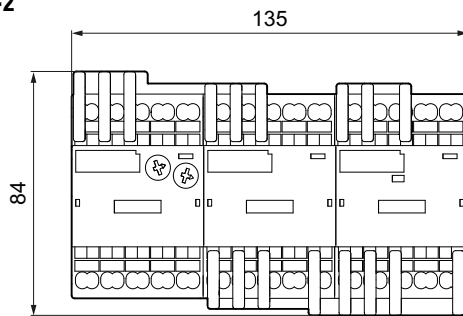

3RA241.-8X.31-1
3RA241.-8X.31-2

