

SD41
 Rev 13
 June 2012
 Supersedes Rev 12

Model 41 Nullmatic Pressure Regulators

INTRODUCTION

The Model 41 Nullmatic® Pressure Regulator, shown below, uses the null-balance principle, which holds the output pressure constant regardless of wide changes in flow or supply pressure. Each regulator is in essence a self-contained pressure controller that can deliver up to a 40 scfm flow rate.

This instruction has five major sections: Introduction, Installation, Principle of Operation, Maintenance, and Parts List.

Model Designation

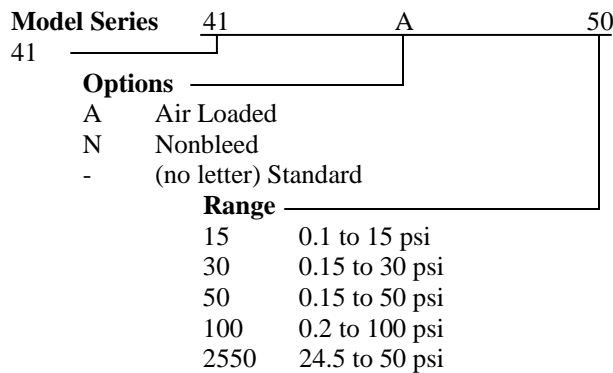

General Specifications

Supply PressureSee Table below

Model No	Recommended (psi)	Maximum (psi)	Minimum
41-15	75	150	5 psi above output setting to be used
41A15	75	150	
41N15	75	150	
41-30	120	150	7 psi above output setting to be used
41A30	120	150	
41-50	120	150	
41A50	120	150	
41-2550	120	150	
41-100	150	250	
41A100	150	250	

Note: Performance will be improved by increasing the supply pressure above the minimum value.

Maximum Capacity9 scfm with 100 psi supply and 25 psi output
 Maximum Air Loading100 psi (air loaded models only)
 Ambient Temperature Limits-40°C to 82°C (-40°F to 180°F)

INSTALLATION

Refer to Figure 1 for mounting dimensions, connections, and mounting configurations. The regulator may be mounted in any position in a reasonable vibration-free location.

CAUTION

Exceeding the ambient air temperature limits can adversely affect performance and may cause damage.

Pneumatic Connections

All connections are 1/8" NPT. Recommended piping to the regulator is 1/4" O.D. tubing, although any scale free piping may be used.

1. Blow out all piping before any connections are made to prevent dirt or chips from entering the regulator.
2. Use pipe sealant sparingly, and then only on the male threads. A non-hardening sealant is strongly recommended.
3. Connect the regulator to a source of clean, dry, oil-free instrument air. See Instrument Air Requirements.

CAUTION

Supply pressure in excess of the maximum value listed in General Specifications may cause damage. Air loading pressure in excess of 100 psi may cause damage in air loaded models.

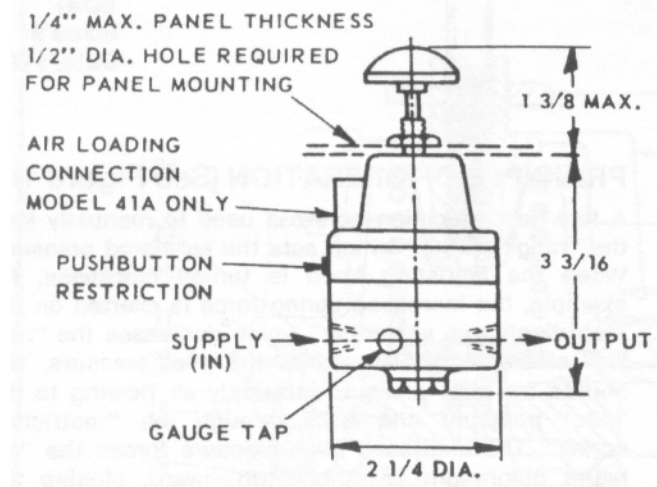

Figure 1 Dimensions and Mounting

Instrument Air Requirements

Connect the regulator to a source of clean, dry, oil-free instrument air. Failure to do so will increase the possibility of a malfunction or deviation from specified performance.

CAUTION



Use of process fluids other than instrument air is not recommended. No claim is made as to the suitability of this product for use with other process fluids, such as hazardous gases, except as listed on the appropriate certificate. Non-approved instruments are suitable for use with instrument air only. Optional features and modifications such as tapped exhaust do not imply suitability for use with hazardous gases except as listed on the approval certificate.

CAUTION

Synthetic compressor lubricants in the air stream at the regulator may cause the regulator to fail.

There are many types of synthetic lubricants. Some may not be compatible with the materials used in construction of the regulator. Wetting of these materials by such an oil mist or vapor, etc. may cause them to deteriorate. This may ultimately result in failure of the regulator. The following materials are in contact with instrument air: Aluminum, Brass, Buna-N, Delrin, Neoprene, Stainless Steel, and Teflon.

The requirements for a quality instrument air supply can be found in the Instrument Society of America's "Quality Standard for Instrument Air" (ISA-S7.3). Basically this standard calls for the following:

Particle Size - The maximum particle size in the air stream at the instrument should be no larger than 3 microns.

Dew Point - The dew point, at line pressure, should be at least 10° C (18° F) below the minimum temperature to which any part of the instrument air system is exposed at any season of the year. Under no circumstances should the dew point, at line pressure, exceed 2° C (35.6° F).

Oil Content - The maximum total oil or hydrocarbon content, exclusive of non-condensables, should not exceed 1 ppm under normal operating conditions.

PRINCIPLE OF OPERATION

A fine-turn, precision screw is used to manually load the "range spring" which sets the regulated pressure. When the adjusting knob is turned clockwise, for example, the increased spring force is exerted on the "top diaphragm assembly" which decreases the "nozzle" clearance and increases the pilot pressure. The source for pilot pressure is supply air flowing to the "pilot pressure chamber" through the "restriction screw". The increased pilot pressure forces the "exhaust diaphragm assembly" downward, closing the "exhaust port", contacting and moving the "valve plunger" and thereby opening the "supply port". This increases the "regulated output" which also feeds back to the "top diaphragm assembly." The regulator locks-up or throttles at the new output valve when the feedback force of the "top diaphragm assembly" equals the "range spring force."

On dead end service, regulators with no "N" in the model number will exhaust approximately 0.1 scfm out of the holes in the exhaust ring.

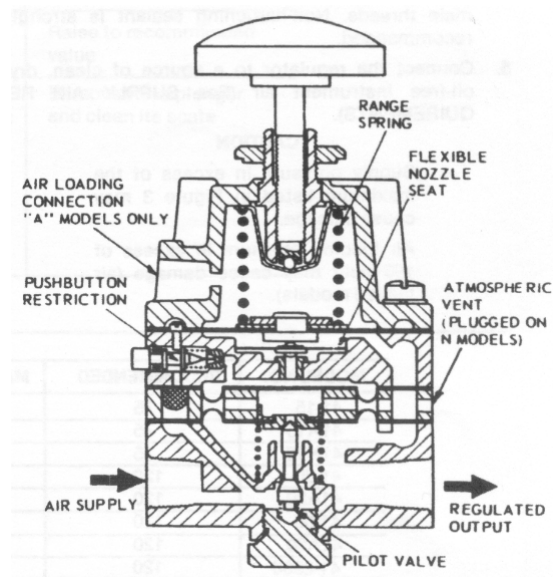

Figure 2 Schematic

MAINTENANCE

Most problems associated with pneumatic instruments can be prevented by providing clean, dry, oil-free instrument quality air as described in Installation, Instrument Air Requirements. No routine maintenance procedures are recommended if these requirements are observed.

Refer to the Trouble Analysis table on the next page when troubleshooting the regulator.

Lubricating the Adjusting Screw

An occasional application of light grease to the adjusting screw threads will facilitate easy turning of the adjusting knob, especially in the high-pressure models.

Cleaning the Restriction Screw

If the small orifice in the restriction becomes blocked, press the cleaning plunger built into the body of the regulator. The spring loading in the assembly permits it to return to its normal position.

Cleaning the Valve Plunger

1. Turn off supply air.
2. Remove the retaining nut on the bottom forging. The valve plunger and plunger spring will drop out when this nut is removed; be careful not to lose them.
3. Clean the valve plunger on both the ball and tapered-end surfaces. If necessary, use a non-abrasive solvent.
4. Clean the supply seat and exhaust seat. The exhaust seat can be reached using a tobacco pipe cleaner. Here again, use non-abrasive solvents.
5. Install removed parts; see the parts list for part orientation. Tighten the retaining nut securely.

Disassembling the Regulator

Before disassembling, back-off the adjusting knob to relieve spring tension. Also, make a diagonal mark across all mating parts to provide easier alignment of parts during reassembly. To disassemble the regulator, refer to the parts list drawings for part location and remove the body screws.

Assembling the Regulator

The exhaust diaphragm assembly and exhaust ring must be positioned so that none of the holes on the pilot base are blocked. The external holes on the exhaust ring line up under the output connection.

Position the cleaning plunger of the pilot ring assembly in line with the input connection of the pilot base. Locate the upper diaphragm and top housing in any position; insert and tighten body screws.

Trouble Analysis

Symptom	Cause	Remedy
No output	No supply air	Turn on supply air.
	Clogged restriction	Press cleaning plunger.
Output cannot be increased to full value	Supply air setting too low	Raise to recommended value.
	Valve plunger being held open on exhaust seat by a chip (e.g. pipe dope, Teflon tape, thread shaving, pipe scale). Usually detected by a heavy exhaust.	Remove valve plunger and clean the seat.

Changing the Range

The range of any Model 41 regulator may be changed by replacing the range spring, differential spring, the upper diaphragm assembly, and other parts as noted in the parts list.

Replacing Parts

Refer to the parts list(s) at the back of this instruction when performing maintenance on a Model 41. A parts list provides a list of replacement parts and an exploded view of the regulator.

Service kits containing spare and replacement parts are available from Siemens. See the Customer/Product Support section to contact Siemens. Refer to the Parts List section for kits and recommended on-hand spare parts.

Customer/Product Support

Support is available through an online Support Request service; a link is provided in the table at the end of this section.

When contacting Siemens for support:

- Please provide complete product information:
 - For hardware, this information is provided on the product nameplate (part number or model number, serial number, and/or version).
 - For most software, this information is given in the Help > About screen.
- If there is a problem with product operation:
 - Is the problem intermittent or repeatable? What symptoms have been observed?
 - What steps, configuration changes, loop modifications, etc. were performed before the problem occurred?
 - What status messages, error messages, or LED indications are displayed?
 - What troubleshooting steps have been performed?
 - Is the installation environment (e.g. temperature, humidity) within the product's specified operating parameters? For software, does the PC meet or exceed the minimum requirements (e.g. processor, memory, operating system)?
- A copy of the product Service Instruction, User's Manual, or other technical publication should be at hand. The Siemens public Internet site (see the table) has current revisions of technical literature, in Portable Document Format, for downloading.
- To send an instrument to Siemens for warranty or non-warranty service, call Customer Service and Return to request a Return Material Authorization (RMA); see the table below.

IMPORTANT

An instrument must be thoroughly cleaned (decontaminated) to remove any process materials, hazardous materials, or blood-borne pathogens prior to return for repair. Read and complete the Siemens RMA form(s).

For support and the location of your local Siemens representative, refer to the table below for the URL of the Process Instrumentation (PI) portion of the Siemens public Internet site. Once at the site, click **Support** in the right column and then **Product Support**. Next select the type of support desired: sales, technical (see the table below), documentation, or software.

Online Support Request	http://www.siemens.com/automation/support-request
Technical Support	1-800-333-7421; 8 a.m. to 4:45 p.m. eastern time, Monday through Friday (except holidays)
Customer Service & Returns	1-800-365-8766 (warranty and non-warranty)
Public Internet Site	http://www.usa.siemens.com/pi
Technical Publications in PDF	Click the above link to go to the Siemens Internet site and then click Process Instrumentation . In the column to the right, click Support > Manuals . In the column to the left, select the product line (e.g. Pressure or Temperature or Controllers) to open navigation and search panes. Note: Navigation may change as the site evolves.

Warranty

The sales contract contains the entire obligation of Siemens. The warranty contained in the contract between the parties is the sole warranty of Siemens. Any statements continued herein do not create new warranties or modify the existing warranty.

Teflon® is a registered trademark of E. I du Pont de Nemours and Company.

All product designations may be trademarks or product names of Siemens Industry, Inc. or other supplier companies whose use by third parties for their own purposes could violate the rights of the owners.

Siemens Industry, Inc. assumes no liability for errors or omissions in this document or for the application and use of information in this document. The information herein is subject to change without notice.

Procedures in this document have been reviewed for compliance with applicable approval agency requirements and are considered sound practice. Neither Siemens Industry, Inc. nor these agencies are responsible for product uses not included in the approval certification(s) or for repairs or modifications made by the user.

PARTS LIST

Siemens Nullmatic® Pressure Regulator, Model 41

Drawing 6751PL
12/81 Supersedes 1/81

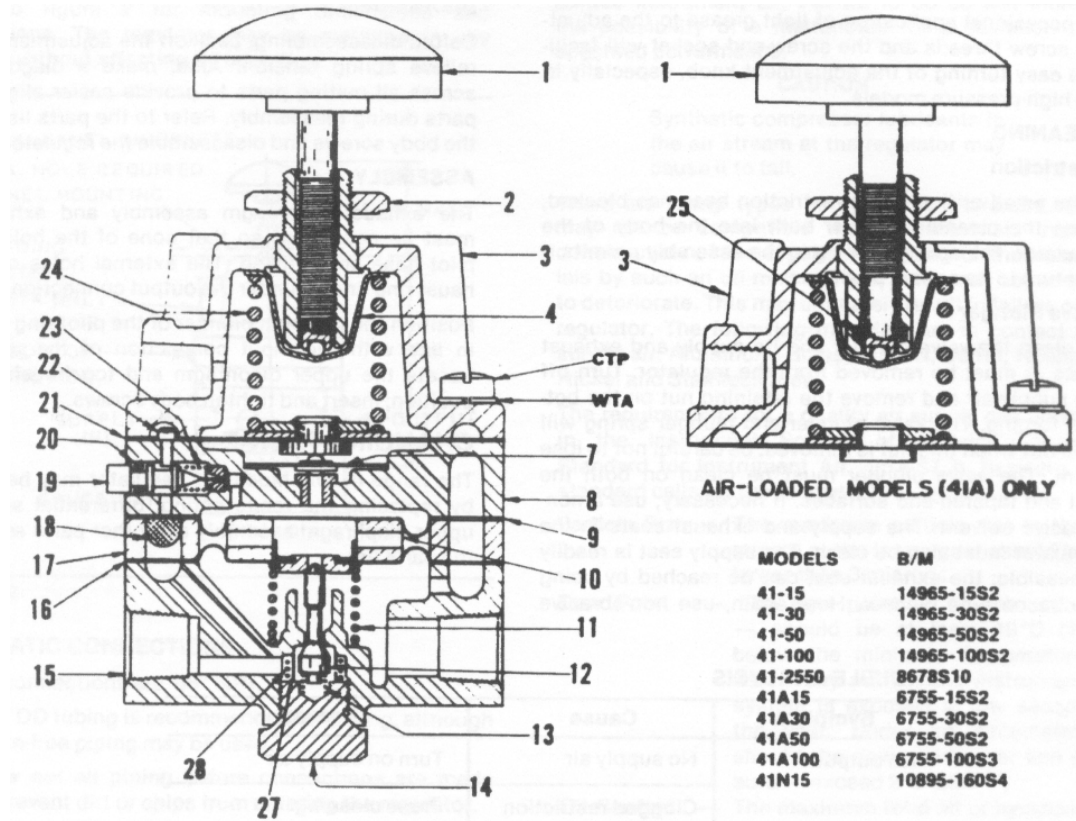

MODELS	B/M
41-15	14965-15S2
41-30	14965-30S2
41-50	14965-50S2
41-100	14965-100S2
41-2550	8678S10
41A15	6755-15S2
41A30	6755-30S2
41A50	6755-50S2
41A100	6755-100S3
41N15	10895-160S4

IMPORTANT

Service Parts Kits are available for servicing the instrument. Contact Siemens for currently available kits; refer to the Customer/Product Support section of this instruction. Some parts in this Parts List may not be available for separate purchase.

Item No.	Part No.	Description	Req'd.				Item No.	Part No.	Description	Req'd.			
			41	41A	41-2550	41N15				41	41A	41-2550	41N15
1a	6751-6	Adjusting Screw Assy.	1	—	1	—	18	6750-69	Screen	1	1	1	1
1b	6754-6	Adjusting Screw Assy.	—	1	—	—	*19	10320-17	Cleaning Plunger	1	1	1	1
1c	6751-26	Slotted Adjusting Screw	—	—	—	1	*20	2938-16	"O" Ring	1	1	1	1
1d	3603-22	Locknut	—	—	—	1	*21a	6750-83	Upper Diaphragm Assy. (Except 41A100)	1	1	1	1
2	6750-50	Mounting Nut	1	1	1	1	*21b	6750-136	Upper Diaphragm Assy. (41A100 Only)	—	1	—	—
3a	6751-7	Top Housing Assy.	1	—	1	1	*22	10320-25	Plunger Stop Screw	1	1	1	1
3b	6755-4	Top Housing Assy.	—	1	—	—	*23	10320-10	Plunger Spring	1	1	1	1
4	6750-6	Spring Seat	1	1	1	1	24a	6750-39	Spring (Blue) 0-15 psi	1	1	—	1
7	6750-12	Leaf Spring Assy.	1	1	1	1	24b	6750-40	Spring (Red) 0-30 psi	1	1	—	—
8	6751-29	Pilot Ring Assy. (Incl. Items 19, 20, 22 & 23)	1	1	1	1	24c	6750-37	Spring (Brown) 0-50 psi	1	1	—	—
*9	6750-17	Diaphragm	1	1	1	1	24d	6750-38	Spring (Green) 0-100 psi	1	1	—	—
10	6750-14	Spacer	1	1	1	1	24e	8678-7	Spring (Orange) 25-50 psi	—	—	1	—
11a	6750-45	Differential Spring (All -15 & -30 Models)	1	1	—	1	*25	2938-4	"O" Ring	—	1	—	—
11b	8678-6	Differential Spring (Except -15 & -30 Models)	1	1	—	1	26	10963-73	Mounting Bracket (Opt.)	1	1	1	1
*12	6750-21	Pilot Plunger	1	1	1	1	27	6750-137	Screen	1	1	1	1
*13	6750-49	Valve Spring	1	1	1	1	28	6750-139	Spring	1	1	1	1
14	6750-138	Retaining Nut	1	1	1	1							
15	6751-2	Pilot Base	1	1	1	1							
*16	6750-18	Lower Diaphragm Assy.	1	1	1	1							
17a	6750-68	Exhaust Ring (Incl. Item 18)	1	1	1	—							
17b	6750-102	Diaphragm Ring Assy. (Incl. Item 18)	—	—	—	1							
							Code	Hardware					
							CTP	#10-32 x 1-1/4 Lg. Fill. Hd. Screw	6	6	6	6	
							WTA	#10 Lockwasher	6	6	6	6	

* Recommended On-Hand Spare Parts. Always Specify Range, Serial No., or Other Nameplate Information When Ordering Spare Parts.

Printed in U.S.A. 12/81 Supersedes 1/81