

## Flow Measurement

### SITRANS FVA (variable area meters)

#### SITRANS FVA250

##### Overview



SITRANS FVA250 variable area meter

##### Benefits

- Standard version available at short notice
- Robust all-metal valve with impact-resistant housing cover
- Can also be used for corrosive and flammable media
- Can be used at high pressures and temperatures
- Product and percentage scales
- Can be optionally fitted with heating and cooling sheaths
- Contamination-resistant guiding for float

##### Application

The devices are particularly suitable for measuring:

- Water
- Liquids
- Anti-corrosives and lubricants
- Solvents
- Saturated and superheated steam
- Food and beverages
- Industrial gases

##### Design

Due to its full metal design, the SITRANS FVA250 variable area meter with a standard length of 250 mm (9.84 inch) can be used to measure many different types of liquids and gases passing through closed piping. The robust design means that it can also be used in harsh conditions. The various types of flange connections, linings and float materials satisfy the requirements of the pharmaceutical and chemical industries.

The measured value is displayed directly on the scale with the standard version. For process monitoring and control, the device can be equipped with a transmitter (MEM) as well as limit switches.

##### Function

Flow measurement with the SITRANS FVA250 is performed according to the float principle. The flowing medium lifts the conical float in the measuring ring. This increases the ring gap until an equilibrium is established between the buoyant force of the medium and the weight of the float. The height of the float is directly proportional to the flow rate. The movement of the float is transmitted from one magnet to another magnet in the display unit outside of the measuring tube.

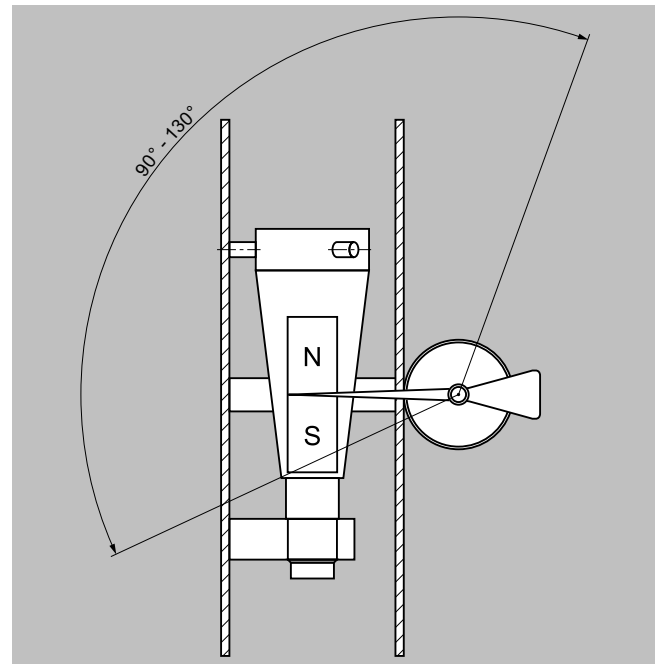

Measuring cone/scale angle

### Selection and ordering data

SITRANS FVA250 full metal variable area meter				Article No. 7ME586	●	-	●	●	●	●	-	●	●	●
Click on the Article No. for the online configuration in the PIA Life Cycle Portal.														
Flow tube														
<u>Liquid</u>		<u>Gas</u>												
5 ... 40 l/h		0.15 ... 1.3 m <sup>3</sup> /h												1
50 ... 600 l/h		1.5 ... 17 m <sup>3</sup> /h												2
1 000 ... 4 000 l/h		30 ... 110 m <sup>3</sup> /h												3
2.5 ... 6 m <sup>3</sup> /h		70 ... 170 m <sup>3</sup> /h												4
4 ... 25 m <sup>3</sup> /h		30 ... 700 m <sup>3</sup> /h												5
16 ... 50 m <sup>3</sup> /h		460 ... 1 350 m <sup>3</sup> /h												6
60 ... 100 m <sup>3</sup> /h		1 700 ... 3 000 m <sup>3</sup> /h												7
<b>Design</b>														
<u>Type: CF-S (standard)</u>														
Fitting: Stainless steel Flange: Stainless steel Float: Stainless steel														
<u>Type: EF-H</u>														
Fitting: Stainless steel, Hastelloy Flange: Stainless steel, Hastelloy Float: Hastelloy														
<u>Type: FF-P</u>														
Fitting: Stainless steel with PTFE lining Flange: Stainless steel with PTFE lining Float: PTFE														
<b>Diameter</b>														
DN 15/ANSI ½"														
DN 20/ANSI ¾"														
DN 25/ANSI 1"														
DN 32/ANSI 1¼"														
DN 40/ANSI 1½"														
DN 50/ANSI 2"														
DN 65/ANSI 2½"														
DN 80/ANSI 3"														
DN 100/ANSI 4"														
Female thread ¼"														
Female thread 3/8"														
Female thread ½"														
Female thread ¾"														
Female thread 1"														
Female thread 1¼"														
Female thread 1½"														
Female thread 2"														
<b>Process connection</b>														
EN 1092-1, PN 16, Form B1														
EN 1092-1, PN 40, Form B1														
EN 1092-1, PN 63, Form B2														
EN 1092-1, PN 100, Form B2														
ANSI B16.5, class 150 RF														
ANSI B16.5, class 300 RF														
ANSI B16.5, class 600 RF														
ISO 228-1 G pipe thread PN 63														
ISO 228-1 G pipe thread PN 100														
ANSI B1.20.1 NPT pipe thread 900 lbs														
ANSI B1.20.1 NPT pipe thread 1500 lbs														
<b>Measuring ranges</b>														
<u>Liquids</u>		<u>Gases</u>												
l/h	(USgpm)	m <sup>3</sup> /h	(scfm)											
0.5 ... 5	(0.0022 ... 0.022)	0.015 ... 0.15	(0.0088 ... 0.088)											1 0
0 ... 10	(0.0044 ... 0.044)	0.03 ... 0.3	(0.0177 ... 0.177)											1 1
1.6 ... 16	(0.007 ... 0.07)	0.045 ... 0.45	(0.0265 ... 0.283)											1 2

# Flow Measurement

## SITRANS FVA (variable area meters)

### SITRANS FVA250

#### Selection and ordering data (continued)

SITRANS FVA250 full metal variable area meter				Article No. 7ME586	● - ● ● ● ● ● - ● ● ● ●
2.5 ... 25	(0.011 ... 0.11)	0.075 ... 0.75	(0.0441 ... 0.441)		1 3
4 ... 40	(0.018 ... 0.18)	0.13 ... 1.3	(0.0765 ... 0.765)		1 4
5 ... 50	(0.022 ... 0.22)	0.15 ... 1.5	(0.0883 ... 0.883)		1 5
7 ... 70	(0.031 ... 0.31)	0.2 ... 2	(0.12 ... 1.24)		1 6
10 ... 100	(0.044 ... 0.44)	0.3 ... 3	(0.177 ... 1.77)		1 7
16 ... 160	(0.07 ... 0.7)	0.5 ... 5	(0.29 ... 2.71)		2 0
25 ... 250	(0.11 ... 1.1)	0.7 ... 7	(0.412 ... 4.12)		2 1
40 ... 400	(0.176 ... 1.76)	1.0 ... 11	(0.589 ... 6.47)		2 2
60 ... 600	(0.264 ... 2.64)	1.7 ... 17	(1 ... 10)		2 3
100 ... 1 000	(0.44 ... 4.4)	2 ... 30	(1.77 ... 17.66)		2 4
160 ... 1 600	(0.7 ... 7)	3 ... 46	(2.35 ... 27.07)		2 5
250 ... 2 500	(1.1 ... 11)	6 ... 70	(4.12 ... 41.2)		2 6
400 ... 4 000	(1.76 ... 17.6)	10 ... 110	(6.47 ... 64.74)		2 7
600 ... 6 000	(2.64 ... 26.4)	16 ... 170	(10 ... 100)		3 0
1 000 ... 10 000	(4.4 ... 44)	28 ... 290	(17.1 ... 170.7)		3 1
1 600 ... 16 000	(7 ... 70)	45 ... 460	(27.1 ... 270.7)		3 2
2 000 ... 20 000	(8.8 ... 88)	55 ... 550	(32.4 ... 323.7)		3 3
2 500 ... 25 000	(11 ... 110)	69 ... 700	(41.2 ... 412)		3 4
4 000 ... 40 000	(17.6 ... 176)	109 ... 1 100	(64.7 ... 647.4)		3 5
5 000 ... 50 000	(22 ... 220)	134 ... 1 350	(79.5 ... 794.6)		3 6
6 000 ... 60 000	(26.4 ... 264)	169 ... 1 700	(100 ... 1 000)		3 7
8 000 ... 80 000	(35.2 ... 352)	239 ... 2 400	(141.3 ... 1 413)		4 0
10 000 ... 100 000	(44 ... 440)	299 ... 3 000	(176.6 ... 1 766)		4 1
<b>Display unit / process temperature</b>					
Standard (aluminum) - up to 200 °C with local display/150 °C with electrical output					0
Standard (aluminum) with displaced display - up to 350 °C with local display and electrical outputs					1
Stainless steel IP66 - up to 200 °C with local display/150 °C with electrical outputs					2
Stainless steel IP66 with displaced display - up to 350 °C with local display and electrical outputs					3
<b>Heating/cooling jacket</b>					
Without (standard)					A
With flange connection EN1092-1 DN 15 PN 40					B
With flange connection ½" ANSI B16.5 Class 150 RF					C
<b>Display/outputs</b>					
With display					A
With display, 1 limit switch					B
With display, 2 limit switches					C
With display, HART and 4 to 20 mA					D
With display, HART, 4 to 20 mA, 2 limit switches					E
With display, HART, 4 to 20 mA, 1 limit switch					F
With display, PROFIBUS PA					G
<b>Calibration</b>					
Standard calibration					
• Without calibration certificate					0
• With calibration certificate					1

Other types of liquid and gas measurement	Order code
Please add "-Z" to Article No. and specify Order code.	
<b>Certificates</b>	
Certificate of compliance EN 10204-2.1	C10
Factory inspection certificate EN 10204-2.2	C11
Material certificate according to EN 10204-3.1	C12
Dye penetration test on pressure bearing weldings	C13
X-ray test of pressure bearing weldings	C14
Pressure test with acceptance test certificate 3.1 according to EN 10204	C15
PMI (positive material identification) test of pressure bearing metal parts	C16

## Selection and ordering data (continued)

Other types of liquid and gas measurement	Order code
<b>Float damping</b>	
With float damping	D01
<b>Flange sealing surface</b>	
Sealing surface according to EN 1092-1 welding neck flange	
• DN 15	N11
• DN 20	N12
• DN 25	N13
• DN 32	N14
• DN 40	N15
• DN 50	N16
• DN 65	N17
• DN 80	N18
• DN 100	N19
Sealing surface according to ANSI B16.5 welding neck flange	
• ½ inch	N21
• ¾ inch	N22
• 1 inch	N23
• 1¼ inch	N24
• 1½ inch	N25
• 2 inch	N26
• 2½ inch	N27
• 3 inch	N28
• 4 inch	N29
<b>Specification of medium process data (specify in plain text)</b>	
<b>Specification always required for each order:</b>	Y01
Medium Operating pressure Operating temperature Density (only for customer-specified medium) Viscosity (only for customer-specified medium) Measuring range	
<b>TAG plate</b>	
TAG plate in stainless steel (add plain text)	Y17
<b>Cleaning to company standard</b>	
Cleaning Class 2, with identification free of oil and grease	K46
Cleaning Class 1, with identification free of oil, grease and silicon	K48
<b>Approvals</b>	
With ATEX approval	M51
<b>Special version (specify in plain text)</b>	Y99

Note: For possible combinations of nominal sizes and flow tube, see tables under "Dimensional drawings".

**Operating instructions**

Description	Article-No.
<b>SITRANS FVA250</b>	
• English	A5E03821131
• German	A5E32108136

All literature is available to download for free, in a range of languages, at [www.siemens.com/processinstrumentation/documentation](http://www.siemens.com/processinstrumentation/documentation)

# Flow Measurement

## SITRANS FVA (variable area meters)

### SITRANS FVA250

#### Technical specifications

SITRANS FVA250	
Application	See under "Application"
Design and function	See under "Design" and "Function"
Principle of measurement	Variable-area flowmeter
<b>Input</b>	
Measuring range	See table on page 3/xx
Pressure ratings	PN 16 ... 100 (232 ... 1 450 psi) depending on the version (see table under "Measuring range availability guide")
Installation / flow direction	Vertical/from bottom to top
<b>Rated conditions</b>	
Ambient temperature	
• With local display	-40 ... +80 °C (-40 ... +176 °F)
• With limit switches	-40 ... +65 °C (-40 ... +149 °F)
• With electric remote encoder (MEM)	-40 ... +70 °C (-40 ... +158 °F)
Measuring accuracy acc. to VDI/VDE 3513-2	
• For liquids	± 1.6 % (q <sub>G</sub> = 50 %)
• For gases	± 2.0 % (q <sub>G</sub> = 50 %)
Reproducibility	0.5 % of the measuring range limit (URV)
Operating temperature	See table "Measuring range availability guide"
Operating pressure	Minimum operating pressure > 2x pressure drop (see table on page 3/xx)
<b>Design</b>	
Flanges	EN 1092-1, ANSI B16.5
Material	
• Fitting	Stainless steel, Hastelloy
• Float	Stainless steel, Hastelloy, PTFE
• Wetted parts materials	Stainless steel, PTFE, Hastelloy depending on version
Degree of protection (display unit)	
• Display unit made of aluminum	IP65
• Display unit made of stainless steel	IP66
<b>Electromagnetic compatibility</b>	
• EN 61000-6-2: 2011	Interference immunity industrial sector
• EN 61000-6-3	Interference immunity residential sector
• EN 55011: 2011	Group 1, Class B
• NAMUR recommendation	NE 21

#### Classification according to pressure equipment directive (PED 2014/68/EU)

	Article No. 7ME586.-	Permissible media	Category
DN 15	xAxxx-xxxx	Gases of fluid group 1 and liquids of fluid group 1	Article 4.3
DN 20	xBxxx-xxxx	Gases of fluid group 1 and liquids of fluid group 1	Article 4.3
DN 25	xCxxx-xxxx	Gases of fluid group 1 and liquids of fluid group 1	Article 4.3
DN 32	xDxxx-xxxx	Gases of fluid group 1 and liquids of fluid group 1	III
DN 40	xExxx-xxxx	Gases of fluid group 1 and liquids of fluid group 1	III
DN 50	xFxxx-xxxx	Gases of fluid group 1 and liquids of fluid group 1	III
DN 65	CGxxx-xxxx	Gases of fluid group 1 and liquids of fluid group 1	III
DN 80	xHxxx-xxxx	Gases of fluid group 1 and liquids of fluid group 1	III
DN 100	xJxxx-xxxx	Gases of fluid group 1 and liquids of fluid group 1	III

**Technical specifications (continued)****Technical specifications of contacts**

Limit switch	
Cable gland	M20x1.5
Auxiliary power supply	5 ... 25 V DC
Isolation (2 contacts)	Electrically isolated
Limit switch	SJ3.5-N-BU
• Switching function	NAMUR NC
Nominal voltage $U_0$	8.2 V DC ( $R_f$ approx. 1 k $\Omega$ )
Explosion protection	II 2G EEx ia IIC T6 - T4 Gb
EC Type Examination Certificate for Directive 2014/34/EU	PTB 99 ATEX 2219 X

Transmitter (MEM) with 4 to 20 mA, pulse output and limit switch	
Cable gland	M20x1.5
Auxiliary power supply	14 ... 30 V DC
Analog output	4 ... 20 mA (2-wire)
Binary output	Pulses, limit switch
• Pulses	Max. pulse rate 10 Hz
• Limit switch	SJ3.5-N-BU (NAMUR, IEC 60947-5-6:1999)
Temperature influence	$\leq \pm 0.5\%$ of the measuring range limit (URV)/10 K
Explosion protection	II 2G Ex ia IIC T6 Gb
EC Type Examination Certificate for Directive 2014/34/EU	BVS 07 ATEX E 033

Transmitter (MEM) PROFIBUS PA	
Cable gland	M20x1.5
Auxiliary power supply	10 ... 25 V DC
Basic current	< 16.5 mA
Fault current	< 18 mA
Transfer rate	31.25 Kbaud
Temperature influence	$\leq \pm 0.5\%$ of the measuring range limit (URV)/10 K
Explosion protection	II 2G Ex ia IIC T6 Gb
EC Type Examination Certificate for Directive 2014/34/EU	BVS 07 ATEX E 033

**Float damping**

Float damping is recommended

- Generally for gas measurement
- When air bubbles in the medium cannot be avoided
- When there are pressure surges in the lines caused by a delay in the flow, for example, due to rapid throttling or blocking
- When turbulence, pulsations or other instabilities cause the float to vibrate
- When the flow pressure cannot be built up slowly
- When vibrations in the line cannot be avoided

**Measuring range availability guide**

Version	CF-S	EF-H	FF-P
<b>Wetted parts materials</b>	Mat. No. 1.4404/AISI 316L	Hastelloy	PTFE
<b>Fitting</b>	Mat. No. 1.4404/AISI 316L	$\leq$ DN 25 (1"): Hastelloy > DN 25 (1"): Hastelloy/Mat. No. 1.4404/AISI 316L	Mat. No. 1.4404/AISI 316L with PTFE lining
<b>Flange</b>	Mat. No. 1.4404/AISI 316L	$\leq$ DN 25 (1"): Hastelloy > DN 25 (1"): Hastelloy/Mat. No. 1.4404/AISI 316L	Mat. Nno. 1.4404/AISI 316L with PTFE lining
<b>Float/flow tube</b>	Mat. No. 1.4404/AISI 316L	Hastelloy	PTFE

# Flow Measurement

## SITRANS FVA (variable area meters)

### SITRANS FVA250

#### Technical specifications (continued)

Version	CF-S	EF-H	FF-P
Max. media temperature	-20 ... +200 °C (-4 ... +392 °F) (optional -80 ... +350 °C (-112 ... +662 °F))	-20 ... +200 °C (-4 ... +392 °F) (optional -80 ... +350 °C (-112 ... +662 °F))	-20 ... +125 °C (-4 ... +257 °F)
Nominal pressure	DN15 ... 50 (1/2" ... 2") PN 40 (580 psi) DN 65 ... 100 (2 1/2" ... 4") PN 16 (232 psi)	DN 15 ... 50 (1/2" ... 2") PN 40 (580 psi) DN 65 ... 100 (2 1/2" ... 4") PN 16 (232 psi)	PN 16 (232 psi)
Reference data for measuring range specifications	Fluid in l/h with density: 1.0 kg/l, temperature 20 °C (68 °F), viscosity 1 mPa.s  Gas in m3/h with density: 1.293 kg/m3, temperature 0 °C (32 °F), viscosity: 0.0181 mPa.s, pe = 0 bar (0 psi)	Fluid in l/h with density: 1.0 kg/l, temperature 20 °C (68 °F), viscosity 1 mPa.s  Gas in m3/h with density: 1.293 kg/m3, temperature 0 °C (32 °F), viscosity: 0.0181 mPa.s, pe = 0 bar (0 psi)	Fluid in l/h with density: 1.0 kg/l, temperature 20 °C (68 °F), viscosity 1 mPa.s  Gas in m3/h with density: 1.293 kg/m3, temperature 0 °C (32 °F), viscosity: 0.0181 mPa.s, pe = 0 bar (0 psi)

Order code	Pressure loss [mbar]							Measuring ranges (dynamic 1:10)			
	Measurement cone							Liquids		Gases	
	1	2	3	4	5	6	7	[l/h]	[USgpm]	[m <sup>3</sup> /h]	[scfm]
10	40 <sup>1)</sup>	-	-	-	-	-	-	0.5 ... 5	0.0022 ... 0.022	0.015 ... 0.15	0.0088 ... 0.088
11	44 <sup>1)</sup>	-	-	-	-	-	-	0 ... 10	0.0044 ... 0.044	0.03 ... 0.3	0.0177 ... 0.177
12	40 <sup>1)</sup>	-	-	-	-	-	-	1.6 ... 16	0.007 ... 0.07	0.045 ... 0.48	0.0265 ... 0.283
13	40 <sup>1)</sup>	-	-	-	-	-	-	2.5 ... 25	0.011 ... 0.11	0.075 ... 0.75	0.0441 ... 0.441
14	40 <sup>1)</sup>	-	-	-	-	-	-	4 ... 40	0.018 ... 0.18	0.13 ... 1.3	0.0765 ... 0.765
15	-	40 <sup>2)</sup>	-	-	-	-	-	5 ... 50	0.022 ... 0.22	0.15 ... 1.5	0.0883 ... 0.883
16	-	40 <sup>2)</sup>	-	-	-	-	-	7 ... 70	0.031 ... 0.31	0.2 ... 2.1	0.12 ... 1.24
17	-	60	-	-	-	-	-	10 ... 100	0.044 ... 0.44	0.3 ... 3	0.177 ... 1.77
20	-	60	-	-	-	-	-	16 ... 160	0.07 ... 0.7	0.5 ... 4.6	0.29 ... 2.71
21	-	60	-	-	-	-	-	25 ... 250	0.011 ... 1.1	0.07 ... 7	0.412 ... 4.12
22	-	70	-	-	-	-	-	40 ... 400	0.176 ... 1.76	1.0 ... 11	0.589 ... 6.47
23	-	80	-	-	-	-	-	60 ... 600	0.264 ... 2.64	1.7 ... 17	1 ... 10
24	-	-	60	-	-	-	-	100 ... 1 000	0.44 ... 4.4	2 ... 30	1.77 ... 17.66
25	-	-	70	-	-	-	-	160 ... 1 600	0.7 ... 7	3 ... 46	2.35 ... 27.07
26	-	-	100	50 <sup>2)</sup>	-	-	-	250 ... 2 500	1.1 ... 11	6 ... 70	4.12 ... 41.2
27	-	-	240 <sup>2)</sup>	120 <sup>2)</sup>	80	-	-	400 ... 4 000	1.76 ... 17.6	10 ... 110	6.47 ... 64.74
30	-	-	-	180 <sup>2)</sup>	90	-	-	600 ... 6 000	2.64 ... 26.4	16 ... 170	10 ... 100
31	-	-	-	-	110	-	-	1 000 ... 10 000	4.4 ... 44	28 ... 290	17.1 ... 170.7
32	-	-	-	-	230	70	-	1 600 ... 16 000	7 ... 70	45 ... 460	27.1 ... 270.7
33	-	-	-	-	230	70 <sup>2)</sup>	-	2 000 ... 20 000	8.8 ... 88	55 ... 550	32.4 ... 323.7
34	-	-	-	-	500 <sup>2)</sup>	100	-	2 500 ... 25 000	11 ... 110	69 ... 700	41.2 ... 412
35	-	-	-	-	-	350 <sup>2)</sup>	120	4 000 ... 40 000	17.6 ... 176	109 ... 1 100	64.7 ... 647.4
36	-	-	-	-	-	350 <sup>2)</sup>	120 <sup>2)</sup>	5 000 ... 50 000	22 ... 220	134 ... 1 350	79.5 ... 794.6
37	-	-	-	-	-	-	360 <sup>2)</sup>	6 000 ... 60 000	26.4 ... 264	169 ... 1 700	100 ... 1 000
40	-	-	-	-	-	-	600 <sup>2)</sup>	8 000 ... 80 000	35.2 ... 352	239 ... 2 400	141.3 ... 1 413
41	-	-	-	-	-	-	600 <sup>2)</sup>	10 000 ... 100 000	44 ... 440	299 ... 3 000	176.6 ... 1 766

Note: Female thread connector (DIN ISO 228, NPT ANSI B 1.20.1) not available for FF-P.

- Not available

<sup>1)</sup> Not available for EF-H and FF-P

<sup>2)</sup> Not available for FF-P

## Technical specifications (continued)

## Sensor size availability guide

## Type CF-S and EF-H

Order code	Diameter		Flow tube						
	Flange		1	2	3	4	5	6	7
A	DN 15	½"	● <sup>1)</sup>	●	●	-	-	-	-
B	DN 20	¾"	● <sup>1)</sup>	●	●	-	-	-	-
C	DN 25	1"	● <sup>1)</sup>	●	●	● <sup>2)</sup>	-	-	-
D	DN 32	1¼"	● <sup>1)</sup>	●	●	●	-	-	-
E	DN 40	1½"	● <sup>1)</sup>	●	●	●	● <sup>2)</sup>	-	-
F	DN 50	2"	● <sup>1)</sup>	●	●	●	●	-	-
G	DN 65	2½"	-	-	●	●	●	● <sup>2)</sup>	-
H	DN 80	3"	-	-	-	●	●	●	-
J	DN 100	4"	-	-	-	-	●	●	●

## Type FF-P

Order code	Diameter		Flow tube						
	Flange		1	2	3	4	5	6	7
A	DN 15	½"	-	● <sup>2)</sup>	-	-	-	-	-
B	DN 20	¾"	-	● <sup>3)</sup>	-	-	-	-	-
C	DN 25	1"	-	●	●	-	-	-	-
D	DN 32	1¼"	-	-	-	-	-	-	-
E	DN 40	1½"	-	-	-	●	-	-	-
F	DN 50	2"	-	-	-	-	●	-	-
G	DN 65	2½"	-	-	-	-	-	-	-
H	DN 80	3"	-	-	-	-	-	●	-
J	DN 100	4"	-	-	-	-	-	-	●

## Type CF-S and EF-H

Order code	Diameter		Flow tube						
	Female thread		1	2	3	4	5	6	7
Q	G ¼"	¼" NPT	●	●	-	-	-	-	-
R	G 3/8"	3/8" NPT	●	●	-	-	-	-	-
S	G ½"	½" NPT	●	●	●	●	-	-	-
T	G ¾"	¾" NPT	●	●	●	●	-	-	-
U	G 1"	1" NPT	●	●	●	●	●	-	-
V	G 1¼"	1¼" NPT	●	●	-	●	●	-	-
W	G 1½"	1½" NPT	-	-	-	●	●	-	-
X	G 2"	2" NPT	-	-	-	-	●	-	-

Note: Female thread not available for type FF-P.

● Available

- Not available

1) Not available for type EF-H

2) Only with EN 1092-1 flange

3) Only with ANSI B16.5 flange

## Flange sealing surface selection guide

Order code	Diameter		Flow tube						
	flange	EN 1092-1	1	2	3	4	5	6	7
A	DN 15	N11	N11	N11	-	-	-	-	-
B	DN 20	N12	N12	N12	-	-	-	-	-
C	DN 25	-	-	N13	N13	-	-	-	-
D	DN 32	-	-	-	N14	-	-	-	-
E	DN 40	-	-	-	N15	N15	-	-	-
F	DN 50	-	-	-	-	N16	-	-	-
G	DN 65	-	-	-	-	-	N17	-	-
H	DN 80	-	-	-	-	-	N18	-	-
J	DN 100	-	-	-	-	-	-	-	N19



## Flow Measurement

### SITRANS FVA (variable area meters)

#### SITRANS FVA250

#### Technical specifications (continued)

##### Type FF-P

Order code	Diameter flange ASME B16.5	Flow tube						
		1	2	3	4	5	6	7
A	½"	N21	N21	N21	-	-	-	-
B	¾"	N22	N22	N22	-	-	-	-
C	1"	-	-	N23	-	-	-	-
D	1¼"	-	-	-	N24	-	-	-
E	1½"	-	-	-	N25	-	-	-
F	2"	-	-	-	-	N26	-	-
G	2½"	-	-	-	-	N27	-	-
H	3"	-	-	-	-	-	N28	-
J	4"	-	-	-	-	-	-	N29

- Not available

## Dimensional drawings

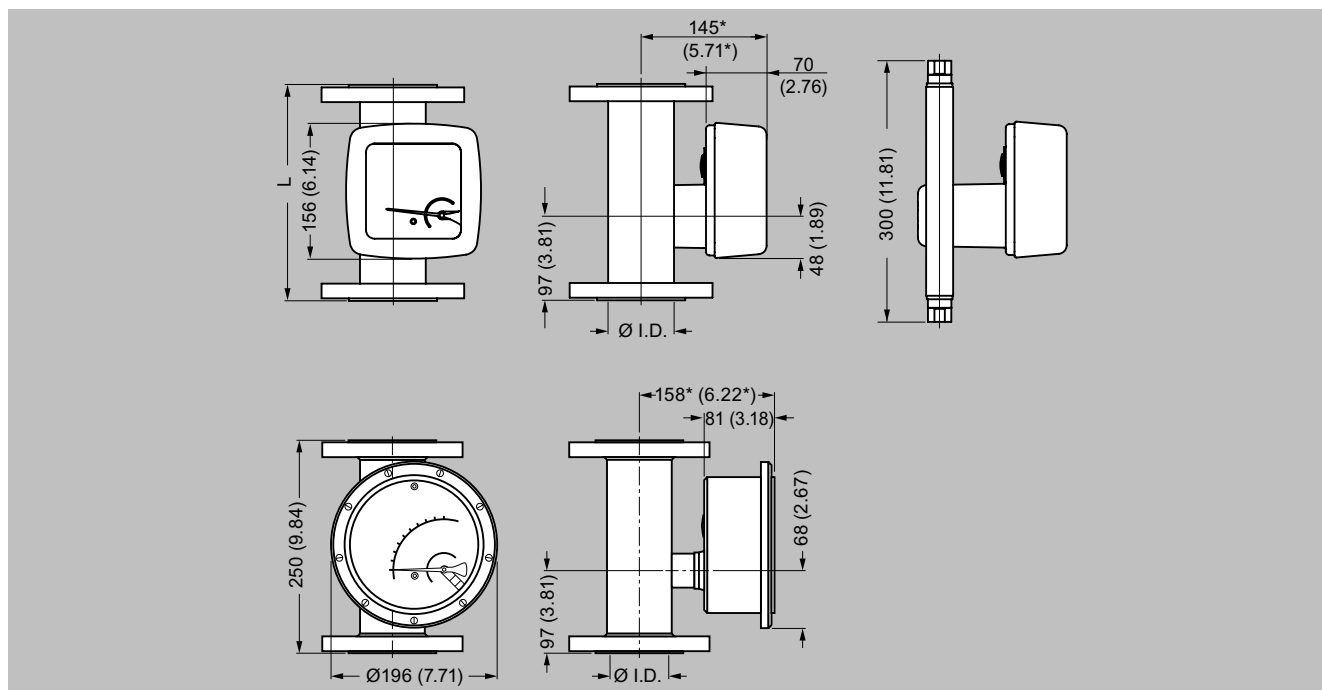

SITRANS FVA250, dimensions in mm

Order code	Diameter flange EN 1092-1	Flow tube I.D. [mm]						
		1	2	3	4	5	6	7
A	DN 15	26 <sup>1)</sup>	26 <sup>1)</sup>	32 <sup>1)</sup>	-	-	-	-
B	DN 20	26 <sup>1)</sup>	26 <sup>1)</sup>	32 <sup>1)</sup>	-	-	-	-
C	DN 25	26	26	32 <sup>1)</sup>	46 <sup>1)</sup>	-	-	-
D	DN 32	26	26	32	46 <sup>1)</sup>	-	-	-
E	DN 40	26	26	32	46 <sup>1)</sup>	70 <sup>1)</sup>	-	-
F	DN 50	26	26	32	46	70 <sup>1)</sup>	-	-
G	DN 65	-	-	32	46	70	102 <sup>1)</sup>	-
H	DN 80	-	-	-	46	70	102 <sup>1)</sup>	-
J	DN 100	-	-	-	-	70	102	125 <sup>1)</sup>

- Not available

\* +100 mm with pulled-out display unit

1) Flange sealing surface not according to EN 1092-1 (Please select N-option for EN 1092-1 compliant flange sealing surface)

Order code	Diameter flange EN 1092-1	Flow tube I.D. [mm]						
		1	2	3	4	5	6	7
A	½"	1.02 <sup>1)</sup>	1.02 <sup>1)</sup>	1.26 <sup>1)2)</sup>	-	-	-	-
B	¾"	1.02 <sup>1)</sup>	1.02 <sup>1)</sup>	1.26 <sup>1)</sup>	-	-	-	-
C	1"	1.02	1.02	1.26 <sup>1)</sup>	-	-	-	-
D	1¼"	1.02	1.02	1.26	1.81 <sup>1)</sup>	-	-	-
E	1½"	1.02	1.02	1.26	1.81 <sup>1)</sup>	-	-	-
F	2"	1.02	1.02	1.26	1.81	2.76 <sup>1)</sup>	-	-
G	2½"	-	-	1.26	1.81	2.76	-	-
H	3"	-	-	-	1.81	2.76	4.02 <sup>1)</sup>	-
J	4"	-	-	-	-	2.76	4.02	4.92 <sup>1)</sup>

- Not available

\* +3.94 inch with pulled-out display unit

1) Flange sealing surface not according to ANSI B16.5 (Please select N-option for ANSI B16.5 compliant flange sealing surface)

## Flow Measurement

### SITRANS FVA (variable area meters)

#### SITRANS FVA250

#### Dimensional drawings (continued)

2) Flange with threaded holes

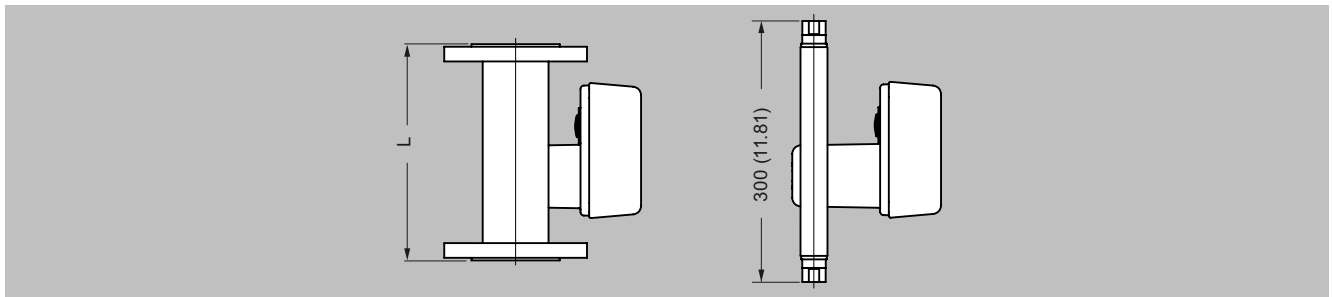

SITRANS FVA250 build-in length, dimensions in mm (inch)

Diameter	EN 1092-1				Diameter	ANSI B16.5		
	PN 16	PN 16	PN 16	PN 16		class 150	class 300	class 600
DN 15	-	250 (9.84)	-	250 (9.84)	½"	250 (9.84)	250 (9.84)	250 (9.84)
DN 20	-	250 (9.84)	-	250 (9.84)	¾"	250 (9.84)	250 (9.84)	250 (9.84)
DN 25	-	250 (9.84)	-	250 (9.84)	1"	250 (9.84)	250 (9.84)	250 (9.84)
DN 32	-	250 (9.84)	-	250 (9.84)	1¼"	250 (9.84)	250 (9.84)	250 (9.84)
DN 40	-	250 (9.84)	-	250 (9.84)	1½"	250 (9.84)	250 (9.84)	250 (9.84)
DN 50	-	250 (9.84)	250 (9.84)	300 (11.81)	2"	250 (9.84)	250 (9.84)	300 (11.81)
DN 65	250 (9.84)	250 (9.84)	-	-	2½"	250 (9.84)	300 (11.81)	300 (11.81)
DN 80	250 (9.84)	250 (9.84)	-	-	3"	250 (9.84)	300 (11.81)	300 (11.81)
DN 100	250 (9.84)	250 (9.84)	-	-	4"	250 (9.84)	300 (11.81)	300 (11.81)

- Not available

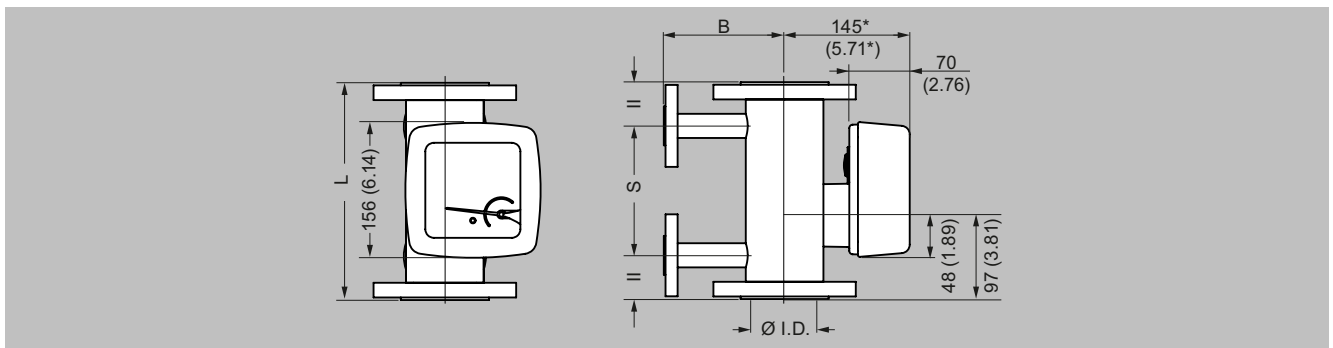

SITRANS FVA250 with heating/cooling jacket, dimensions, in mm (inch)

Diameter	B (flange)		B (Ermeto)		S		Weight	
	mm	inch	mm	inch	mm	inch	kg	lbs
15 (½")	110	4.33	53	2.09	150	5.91	3,0	6.6
20 (¾")	110	4.33	53	2.09	150	5.91	3,0	6.6
25 (1")	110	4.33	58,5	2.3	150	5.91	4,2	9.3
32 (1¼")	110	4.33	58,5	2.3	150	5.91	5,2	11.5
40 (1½")	130	5.12	63	2.48	150	5.91	6,0	13.2
50 (2")	140	5.51	77,5	3.05	150	5.91	7,5	16.5
65 (2½")	140	5.51	77,5	3.05	150	5.91	8,5	18.7
80 (3")	160	6.3	93,5	3.68	150	5.91	13	28.7
100 (4")	175	6.89	110	4.33	120	4.72	18	39.7

\* + 100 mm (3.94 inch) with pulled-out display unit